

📁 11 00 040 Testing compression with BMW Motorrad diagnostic system

+ 11 00 567

Preparatory work

- Remove the front seat
- Removing left bottom side panel
- Removing left radiator cowl
- Removing radiator hose cover
- Removing left side panel
- Removing right bottom side panel
- Removing right radiator cowl
- Remove the right side panel
- Draining cooling system
- Removing complete radiator
- Removing air guide
- Disconnecting distributor rail for secondary air system
- Removing direct ignition coils
- Removing spark plugs
- Connecting **BMW Motorrad** diagnostic system to motorcycle

Core activity

(-) Testing compression

Test

- Install diagnosis adapter (No. 11 7 846) with hose (No. 11 7 842).
- Connect the **MBOX** and follow the instructions.
- Test the compression with the **MBOX**.

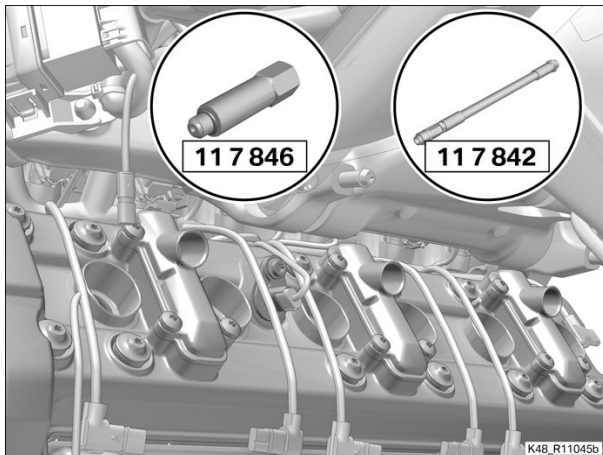

 Technical data		
Compression test pressure	Good	>14 bar
	Normal	12...14 bar
	Poor	<11 bar

Result: Compression loss greater than normal.

Measure:

- Carry out repairs as specified.

Finishing work

- Disconnecting **BMW Motorrad** diagnostic system from motorcycle
- Installing spark plugs
- Installing direct ignition coils
- Securing distributor rail for secondary air system
- Installing air guide
- Installing complete radiator
- Filling and priming cooling system
- Install the right side panel

Install the right radiator cowl
Installing right bottom side panel
Installing left side panel
Installing radiator hose cover
Installing left radiator cowl
Installing left bottom side panel
Installing front seat
Final check of work performed

📁 11 00 045 Testing for pressure loss with BMW Motorrad diagnostic system

+ 11 00 568

Preparatory work

- Remove the front seat
- Removing left bottom side panel
- Removing left radiator cowl
- Removing radiator hose cover
- Removing left side panel
- Removing right bottom side panel
- Removing right radiator cowl
- Remove the right side panel
- Draining cooling system
- Removing complete radiator
- Removing air guide
- Disconnecting distributor rail for secondary air system
- Removing direct ignition coils
- Removing spark plugs
- Connecting **BMW Motorrad** diagnostic system to motorcycle

Core activity

(-) Checking pressure loss

Test

- Install diagnosis adapter (No. 11 7 843) with hose (No. 11 7 842) and adapter for pressure loss (No. 11 7 841).
- Connect the **MBOX** and follow the instructions.
- Check pressure loss with the **MBOX**.

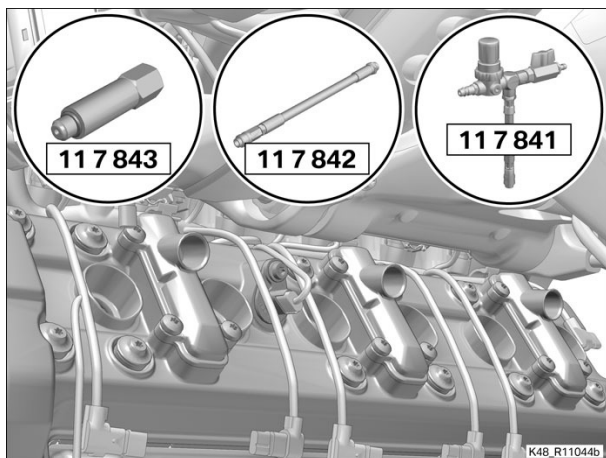

 Technical data			
Press loss through valves or cylinder	Engine at regular operating temperature	max 25 %	

Result: Pressure loss greater than maximum permissible value.

Measure:

- Pinpoint the cause of the fault.
- Possible causes:
 - Inlet valves
 - Exhaust valves
 - Piston and cylinder

Finishing work

- Disconnecting **BMW Motorrad** diagnostic system from motorcycle
- Installing spark plugs
- Installing direct ignition coils
- Securing distributor rail for secondary air system
- Installing air guide

Installing complete radiator
Filling and priming cooling system
Install the right side panel
Install the right radiator cowl
Installing right bottom side panel
Installing left side panel
Installing radiator hose cover
Installing left radiator cowl
Installing left bottom side panel
Installing front seat
Final check of work performed

 **11 00 050 Removing/installing engine 61 FRUs**

+ **11 00 541**

Equipment trim-level variant:

0266 - Preparation for audio system and navigation device

0267 - ECE audio system and preparation for navigation system

0417 - Central locking

Preparatory work

Remove the front seat

Disconnecting battery

Removing air guides for intake air pipes, left and right

Removing complete cover of fuel tank

Removing left bottom side panel

Removing left radiator cowl

Removing radiator hose cover

Removing left side panel

Removing left stowage compartment

Removing inner trim for left side panel

Removing gearbox cover

Removing right bottom side panel

Removing right radiator cowl

Removing cross-member for radiator cowls

Remove the right side panel

Removing inner trim for right side panel

Removing right stowage compartment

Draining engine oil

Removing adjusting plate

Disengaging seat support

Disengaging left and right intake air pipes

Removing complete intake air silencer

Removing fuel tank

Removing number-plate carrier

Remove the rear wheel

Removing right footrest plate

Removing left footrest plate

Removing left catalytic-converter shield

Disengaging clamp on left silencer

Removing left silencer

Removing right catalytic-converter shield

Disengaging clamp on right silencer

Removing right silencer

Removing rear brake caliper

Disengaging actuator rod from rear ride height sensor

Releasing **Paralever** link at rear

Removing bevel gears

Removing universal shaft

Removing rear wheel swinging arm

Draining cooling system
 Removing complete radiator
 Removing strut for radiator
 Removing air guide
 Disconnecting line for secondary air system
 Disengaging wiring harness for engine
 Removing intake manifold
 Disconnecting left oxygen sensor
 Removing exhaust manifold, left
 Disconnecting right oxygen sensor
 Removing exhaust manifold, right
 Disengaging shift lever
 Removing clutch slave cylinder

Core activity

(-) Releasing wiring harness from engine

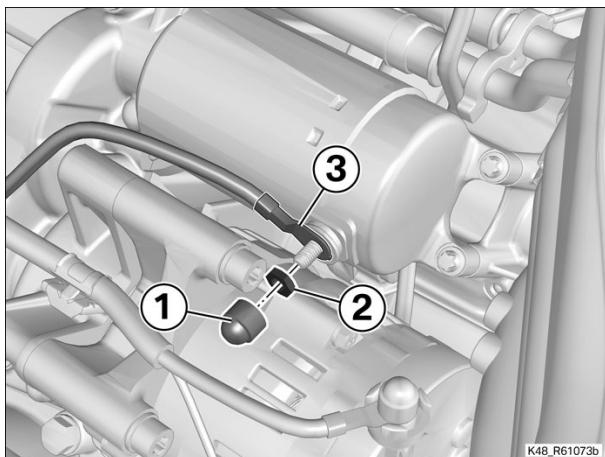

- Remove cap (1).
- Remove nut (2).
- Disengage cable (3) for the starter.

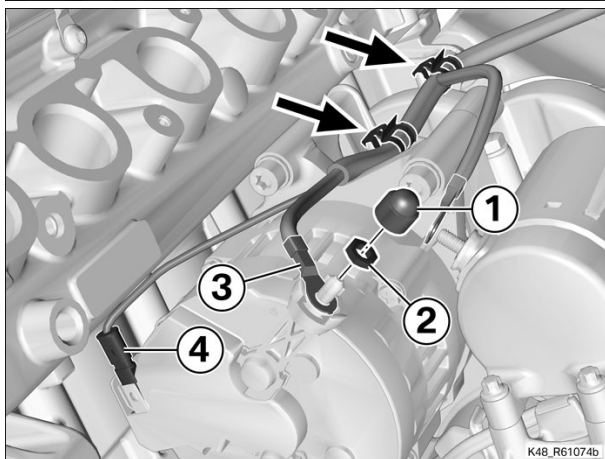

- Remove cap (1).
- Remove nut (2).
- Disengage positive lead (3) for the alternator.
- Disconnect plug (4) for the alternator.
- Disengage the cables from the clips (arrows).



Attention

The locking tab can be broken off if the correct procedure is not adopted for disconnecting the plug.

Push the plug away from the locking tab; do not attempt to raise or bend the locking tab.

- Disconnect plugs (1) for the direct ignition coils.
- Disconnect plug (2) for the camshaft sensor.

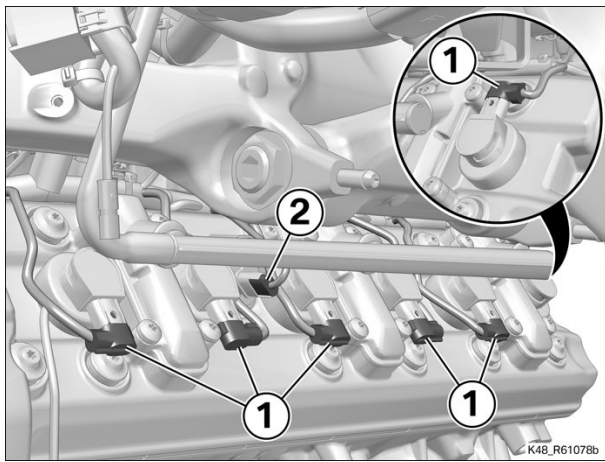

- Remove screws (1).
- Disengage earth lead (2).
- Disconnect plug (3) for the coolant-temperature sensor.

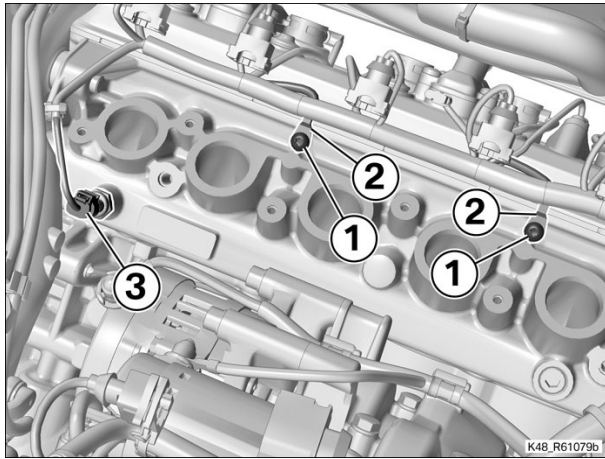

- Disengage cable (1) for the oil-level sensor and cable (2) for the side-stand switch from the clips (arrows).

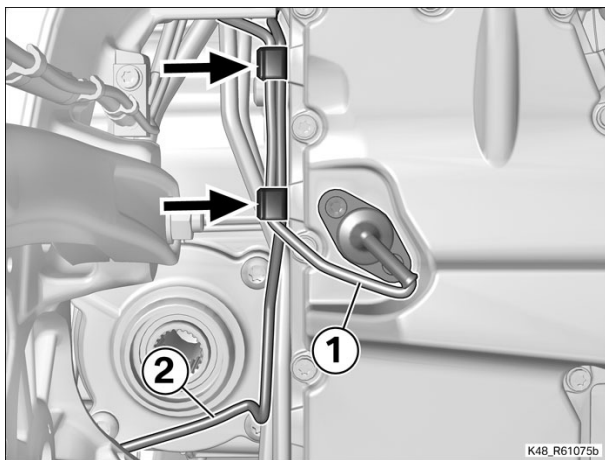

- Remove screw (1).
- Disengage earth cable (2).
- Remove cable tie (arrow).
- Unclip plug (3) for the oil-level sensor

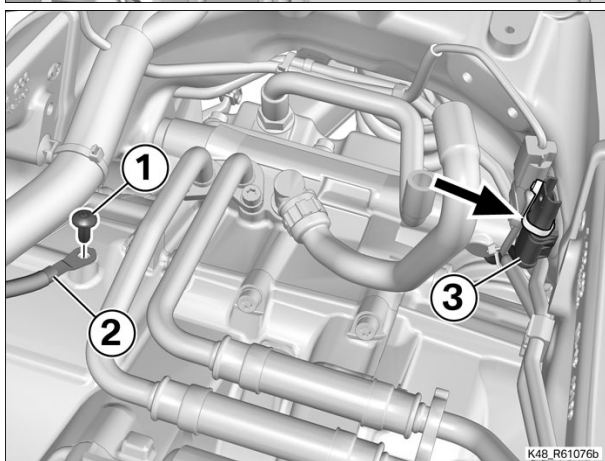

(-) Disengaging oil lines

-

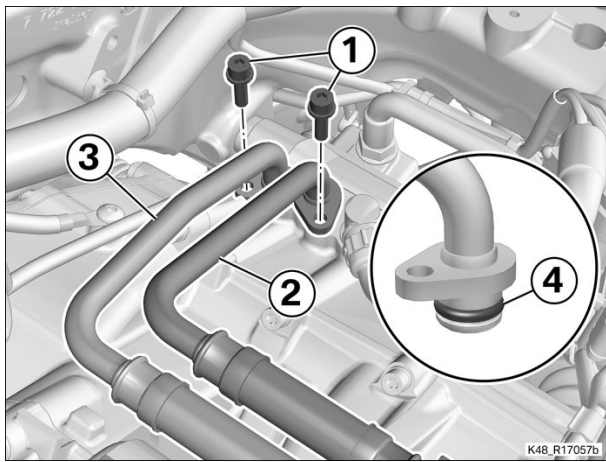

Remove screws (1).

- Disengage feed line (2) and return line (3), noting sealing rings (4).

(-) Removing side-stand pivot mount with side stand

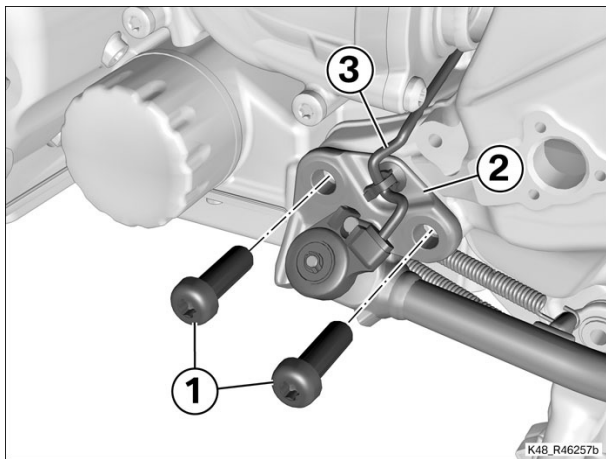

- Remove screws (1).
- Remove the side-stand pivot mount with side stand (2).
- Work line (3) for the side-stand switch clear.

(-) Removing blanking plugs

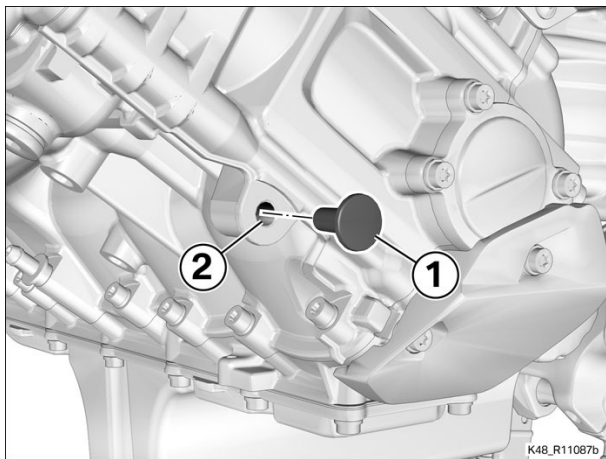

- Remove blanking plug (1) from bore (2).

- Remove blanking plugs (1) from bores (2).

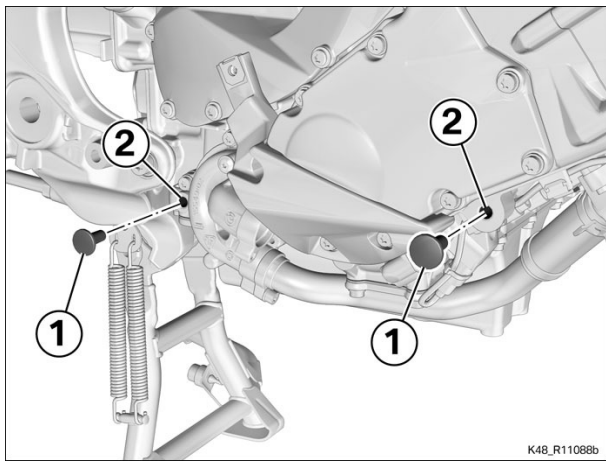

(-) Installing engine lifter

- Place support (A) from engine adapter (No. 00 1 582) in position.
- Install long screw (1), but do not tighten.

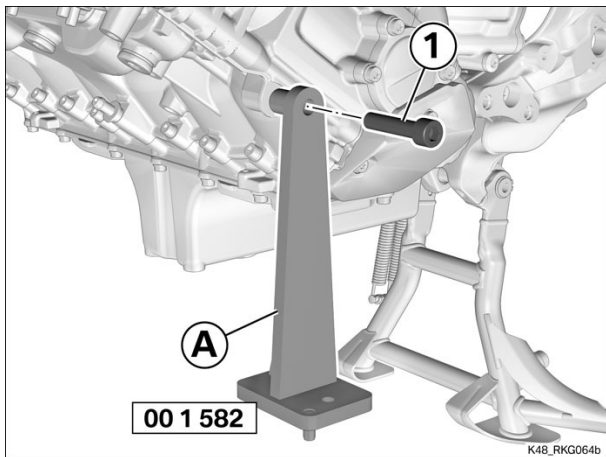

- Place supports (B) and (C) from engine adapter (No. 00 1 582) in position.
- Install long screws (1), but do not tighten.

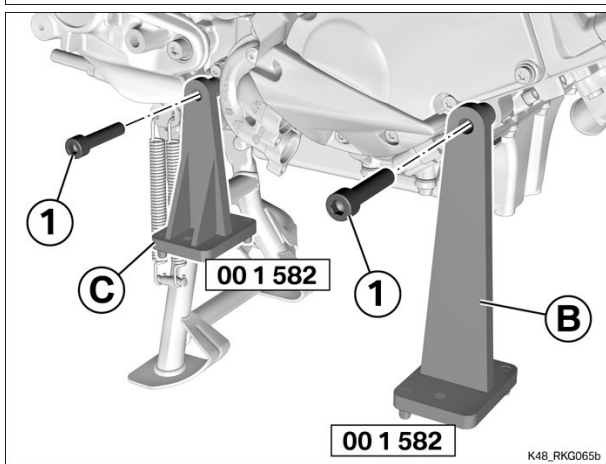

- Position engine adapter (No. 00 1 582) on supports (A), (B) and (C), noting the reamed pins (arrows).
- Install and tighten short screws (1).

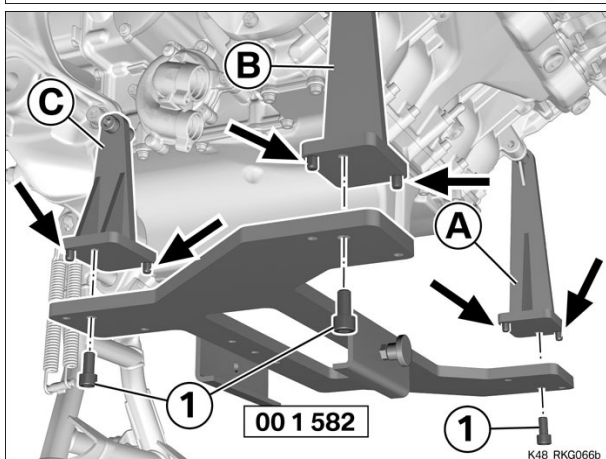

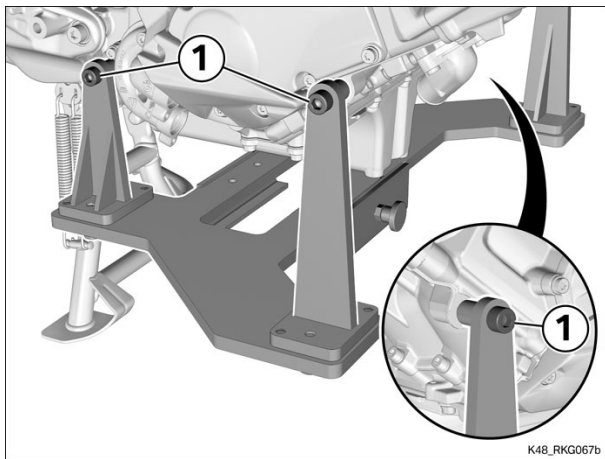

Tighten long screws (1).

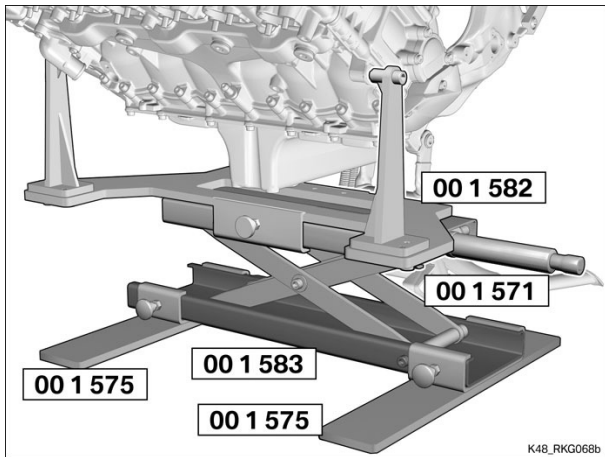

- Secure rail (No. 00 1 583) to scissor-type lifter (No. 00 1 571).
- Mount extensions (No. 00 1 575) at the very outside of rail (No. 00 1 583).
- Raise scissor-type lifter (No. 00 1 571) and install in engine adapter (No. 00 1 582), making sure that engine adapter is centred on scissor-type lifter .

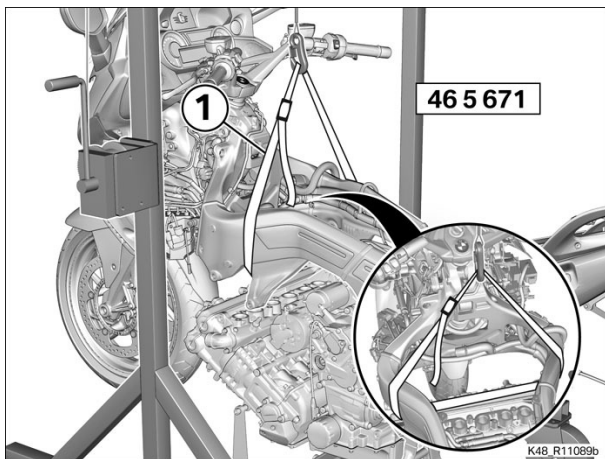

(-) Removing engine

- Secure strap (1) to the frame.
- Use straps to secure the motorcycle to the workshop crane, consisting of (No. 46 5 671), (No. 46 5 672), (No. 46 5 673), (No. 46 5 674).

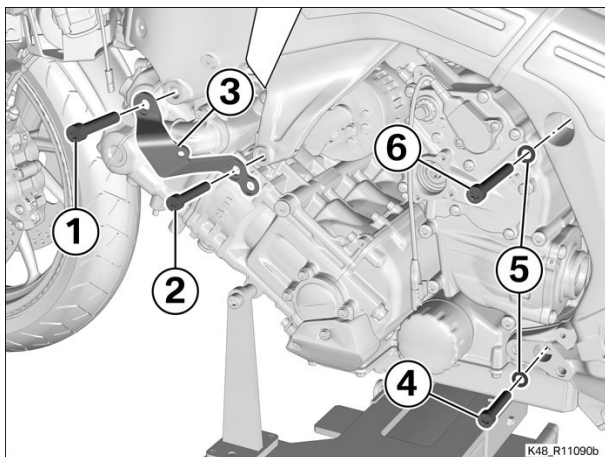

- Remove screws (1) and (2).
- Remove toppler preventer (3).
- Remove screw (4) with washer (5).
- Remove screw (6) with washer (5).

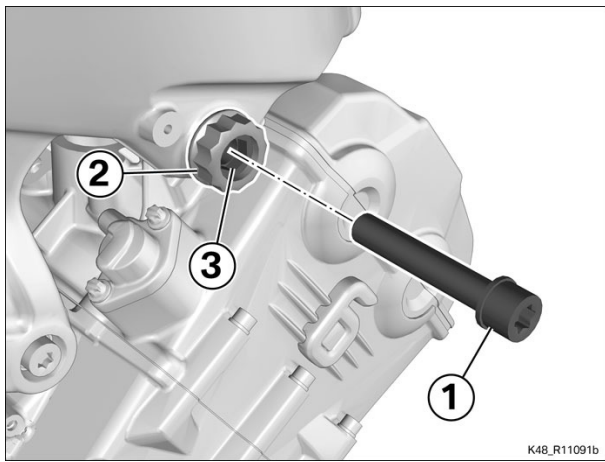

- Remove screw (1).
- Slacken collared nut (2).
- Slightly back off threaded sleeve (3).

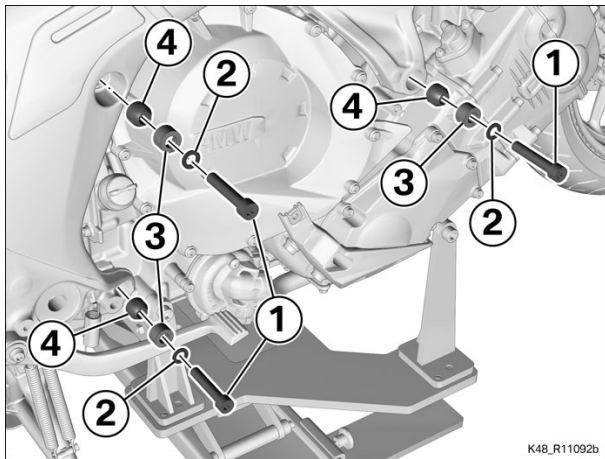

- Remove screws (1) with washers (2).
- Remove spreader sleeves (3) and red taper elements (4).

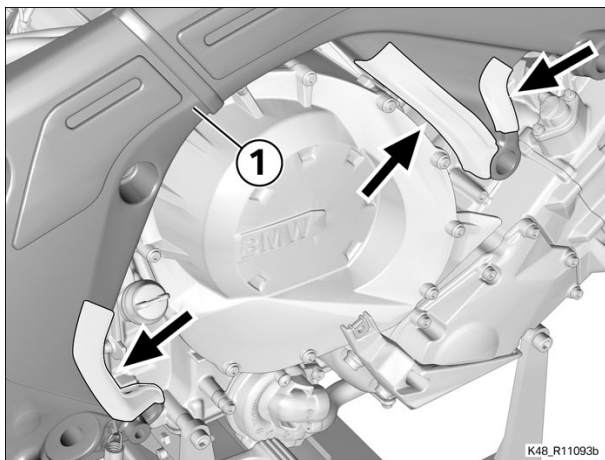

- Protect frame (1) by applying adhesive tape (arrows).

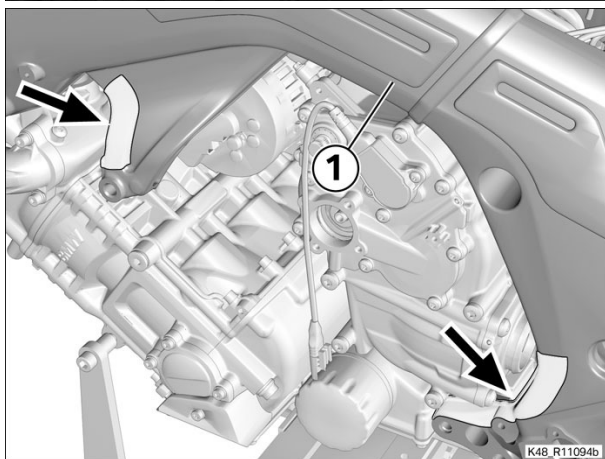

- Protect frame (1) by applying adhesive tape (arrows).

- Using the engine lifter, alternately lower the engine and pull it forward until the frame can be lifted up and clear of the engine. In this process, take particular care at the right-hand side to prevent collisions between

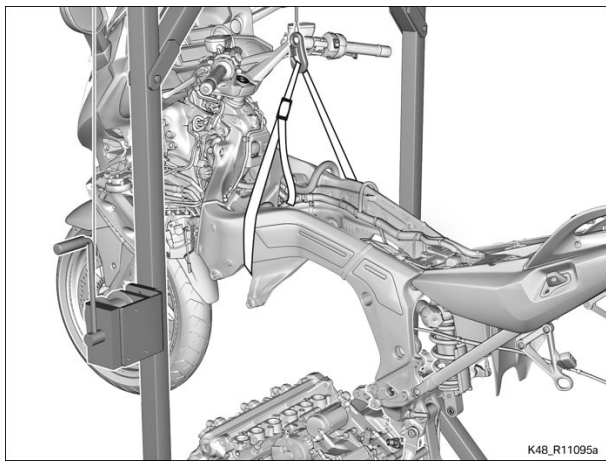

- the engine and the frame.
- Lift the motorcycle with the assembly crane and roll it clear.

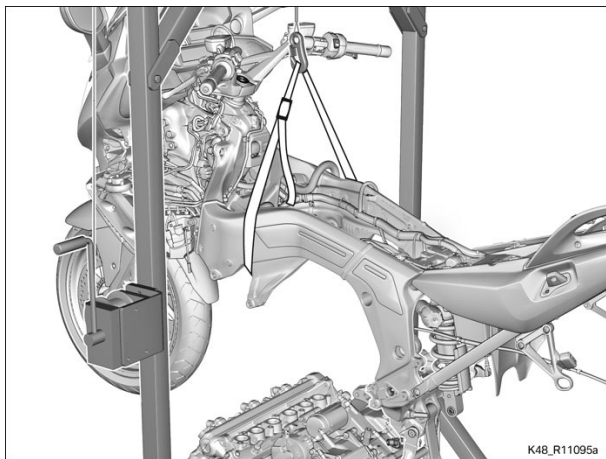

(-) Installing engine

- Lift the motorcycle with the assembly crane, position it over the engine and carefully lower it.
- Using the engine lifter, alternately raise the engine slightly and pull it to the rear, until the holes in the frame and the engine are in line. In this process, take particular care at the right-hand side to prevent collisions between the engine and the frame.

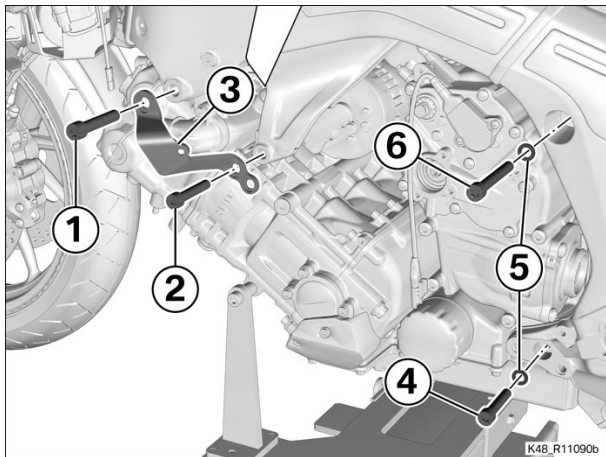

- Hold toppler preventer (3) in position.
- Loosely install screws (1) and (2).
- Loosely install screws (4) and (6) with washers (5).

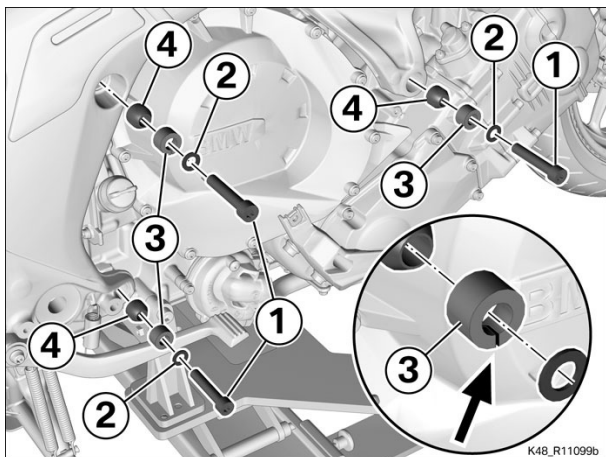

- Insert red taper elements (4).
- Insert spreader sleeves (3) with the gap (arrow) down.
- Loosely install screws (1) with washers (2).

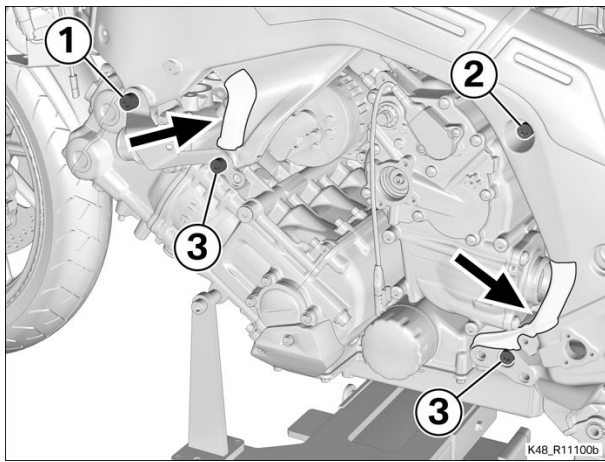

Remove the lengths of adhesive tape (arrows).

- Tighten screws (1), (2) and (3).

 Tightening torques		
Engine to frame, left side		
	Loosely install all bushings and screws on left and right	
	Tighten screws on left until hand-tight	
M12 x 1.5 x 60	66 Nm	
M10 x 80	38 Nm	
M10 x 55	38 Nm	

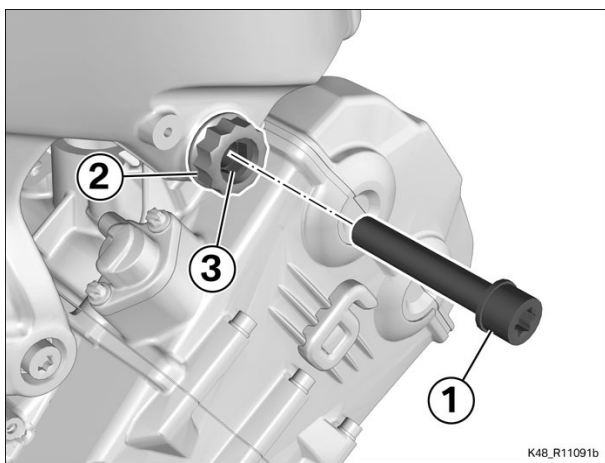

- Hold threaded sleeve (3) and collared nut (2) in position and align with the cylinder head, using suitable tools.

- Tighten threaded sleeve (3) and collared nut (2), install screw (1).

 Tightening torques		
Cylinder head, right, to frame		
Threaded sleeve, M24 x 1.25	1st step	
	2 Nm	
Collared nut, M24 x 1.25	2nd step	
	100 Nm	
M12 x 1.5 x 70	3rd step	
	66 Nm	

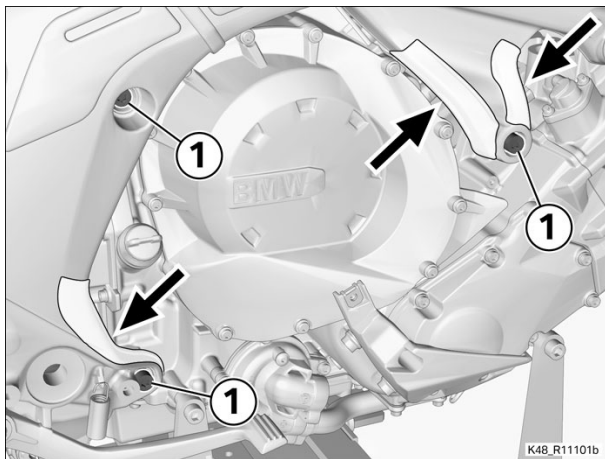

Remove the lengths of adhesive tape (arrows).

- Tighten screws (1).

 Tightening torques		
Engine to frame, rear, right side		
M10 x 55	38 Nm	

(-) Removing engine lifter



Attention

The motorcycle can topple and fall on its side.
Make sure that the motorcycle cannot topple sideways.

- Lower scissor-type lifter (No. 00 1 571) and remove it from engine adapter (No. 00 1 582).

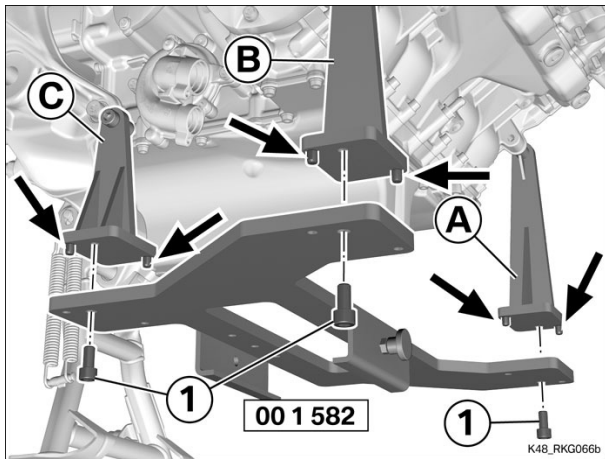
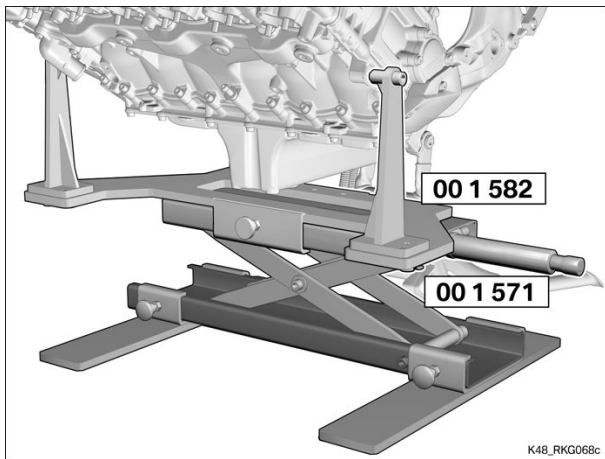

- Remove short screws (1).
- Remove engine adapter (No. 00 1 582) from supports (A), (B) and (C), noting the reamed pins (arrows).

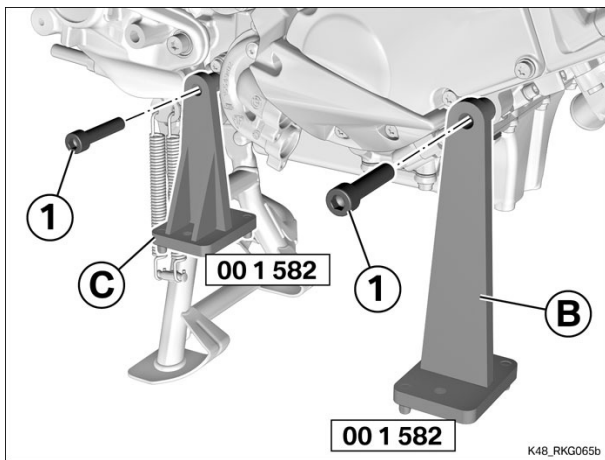

- Remove long screws (1).
- Remove supports (B) and (C) from engine adapter (No. 00 1 582).

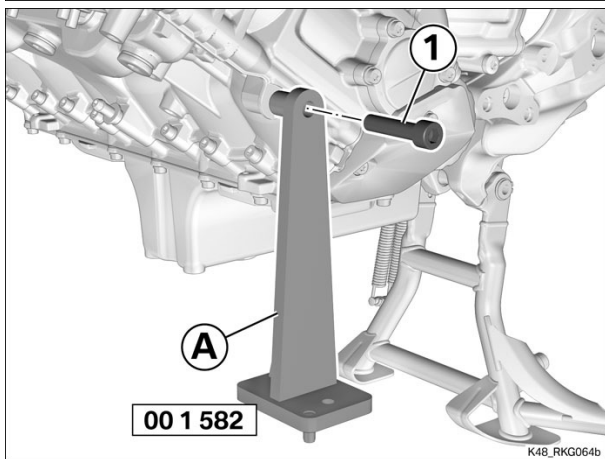

- Remove long screw (1).
- Remove support (A) from engine adapter (No. 00 1 582).

(-) Installing blanking plugs

-

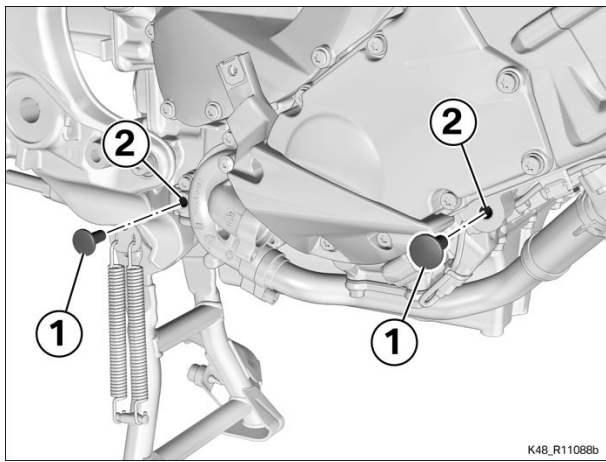

Install blanking plugs (1) in bores (2).

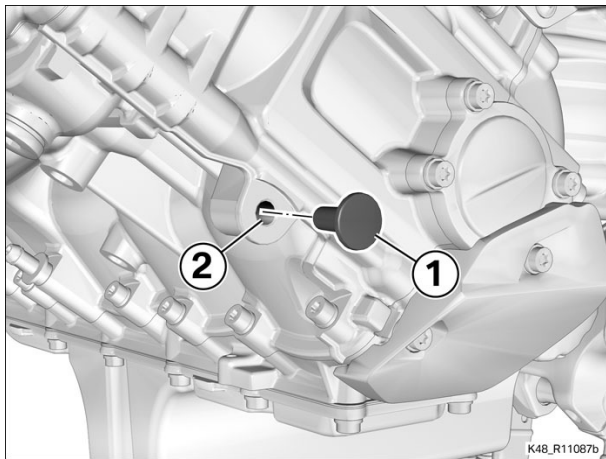

- Install blanking plug (1) in bore (2).

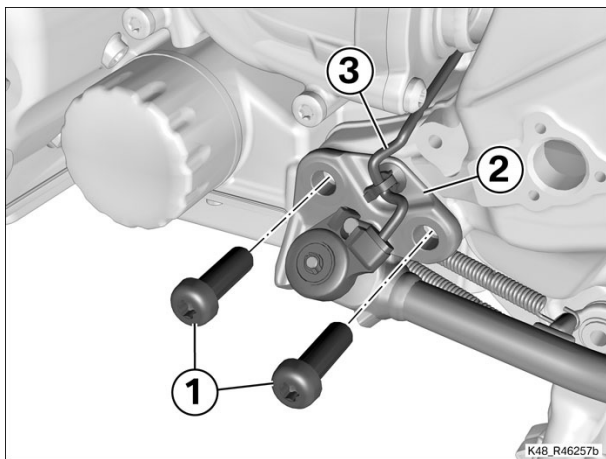

(-) Installing side-stand pivot mount with side stand

- Work line (3) for the side-stand switch up into position.
- Hold the side-stand pivot mount with side stand (2) in position.
- Install screws (1).

 Tightening torques		
Pivot mount (side stand) to frame		
M12 x 37, Replace screw	66 Nm	
Micro-encapsulated		

(-) Securing oil lines

- Check sealing rings (4) for damage; replace if necessary.
- Install feed line (2) and return line (3).
- Install screws (1).

 Tightening torques		
Oil cooler lines to crankcase		
M6 x 20	10 Nm	

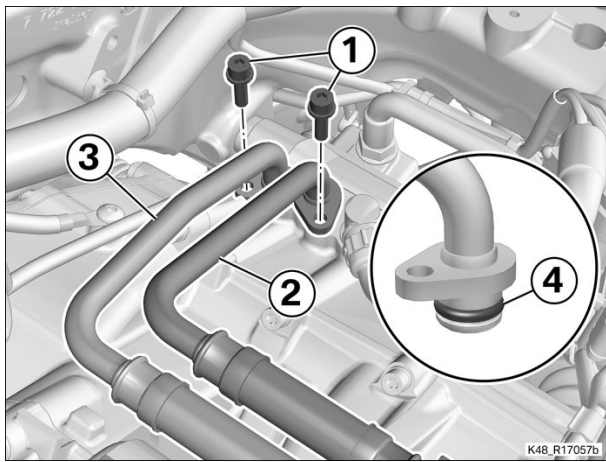

(-) Securing wiring harness to engine

- Hold earth cable (2) in position and install screw (1).

Tightening torques		
Wiring harness to crankcase		
M5 x 12	8 Nm	

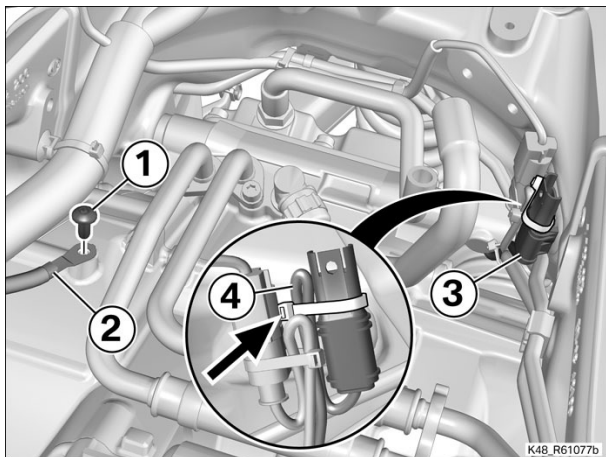

- Clip in plug (3) for the oil-level sensor.
- Secure excess length of line (4) for the oil-level sensor with a cable tie (arrow).

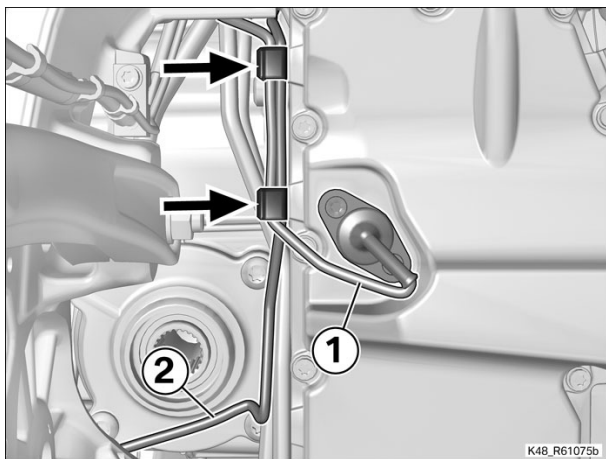

- Secure cable (1) for the oil-level sensor and cable (2) for the side-stand switch in the clips (arrows).

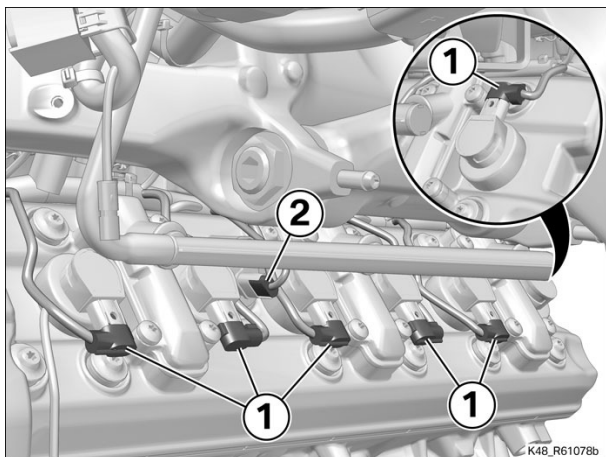

⚠ Attention

The locking tab can be broken off if the correct procedure is not adopted for disconnecting the plug.

Push the plug away from the locking tab; do not attempt to raise or bend the locking tab.

- Connect plugs (1) for the direct ignition coils.
- Connect plug (2) for the camshaft sensor.

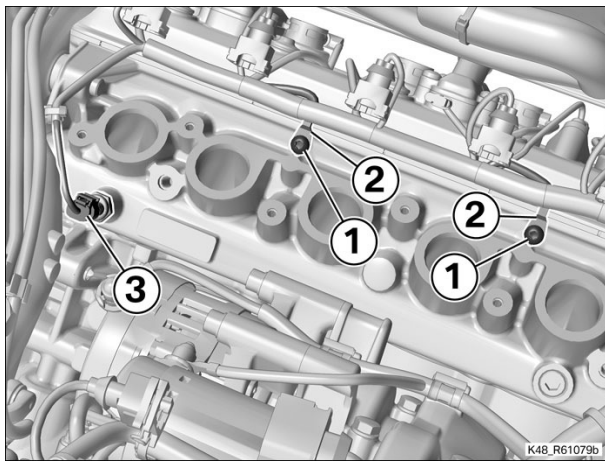

Install earth lead (2) with screws (1).

 Tightening torques		
Engine wiring harness to cylinder head		
M5 x 12	8 Nm	

- Connect plug (3) for the coolant-temperature sensor.

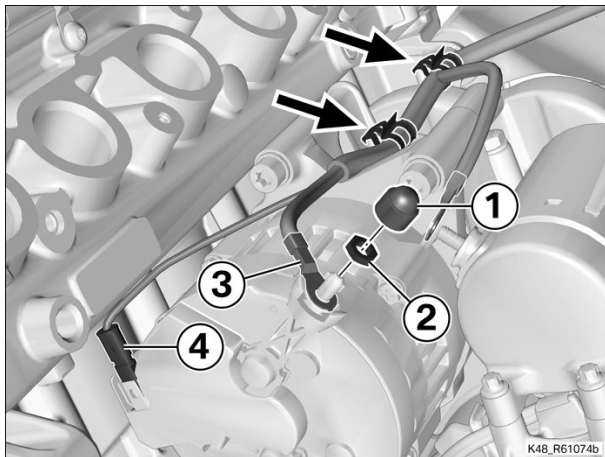

- Connect plug (4) for the alternator.
- Hold positive lead (3) for the alternator in position
- Install nut (2).

 Tightening torques		
Wiring harness to alternator		
M6	8 Nm	

- Install cap (1).
- Secure the cable in the clips (arrows).

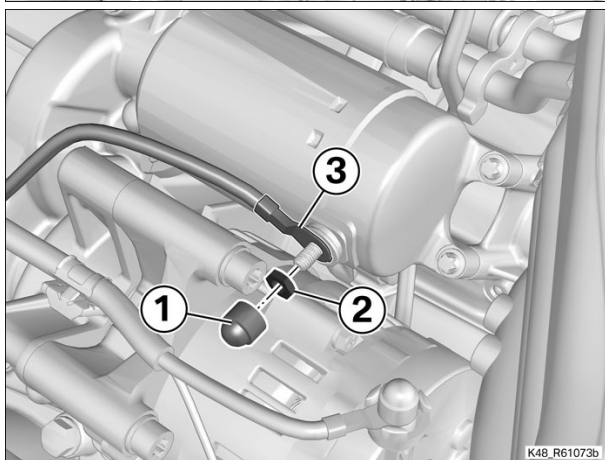

- Hold cable (3) for the starter in position.
- Install nut (2).

 Tightening torques		
Wiring harness to starter		
M6	8 Nm	

- Install cap (1).

Finishing work

- Securing clutch slave cylinder
- Securing selector lever
- Installing exhaust manifold, right
- Securing right oxygen sensor
- Installing exhaust manifold, left
- Securing left oxygen sensor
- Installing intake manifold
- Securing wiring harness for engine
- Connecting line for secondary air system
- Installing air guide
- Installing strut for radiator

Installing complete radiator
Filling and priming cooling system
Installing rear swinging arm
Installing universal shaft
Installing bevel gears
Securing **Paralever** link at rear
Securing actuator rod to rear ride height sensor
Securing rear brake caliper
Installing right silencer
Securing clamp on right silencer
Installing right catalytic-converter shield
Installing left silencer
Securing clamp on left silencer
Installing left catalytic-converter shield
Installing left footrest plate
Installing right footrest plate
Installing rear wheel
Installing number-plate carrier
Installing fuel tank
Installing complete intake air silencer
Securing left and right intake air pipes
Securing seat support
Installing adjusting plate
Installing right stowage compartment
Installing inner trim for right side panel
Install the right side panel
Installing cross-member for radiator cowls
Install the right radiator cowl
Installing right bottom side panel
Installing inner trim for left side panel
Installing left stowage compartment
Installing left side panel
Installing radiator hose cover
Installing left radiator cowl
Installing left bottom side panel
Installing complete cover of fuel tank
Installing air guides for intake air pipes, left and right
Connecting battery
Connecting **BMW Motorrad** diagnostic system to motorcycle
Reading fault memory with **BMW Motorrad** diagnostic system
and resetting adaptation values
Reset system time with **BMW Motorrad** diagnostic system
Disconnecting **BMW Motorrad** diagnostic system from motorcycle
Installing front seat
Pouring in engine oil
Final check of work performed

📁 11 00 209 Oil change, engine, with filter 3 FRUs

+ 11 00 611



Note

Change oil, warmed to normal operating temperature.

Core activity

(-) Engine oil change with filter

▶ Draining engine oil

- Place a suitable tray underneath the engine to catch escaping oil.



Warning

Parts of the exhaust system can be hot.
Do not touch hot parts of the exhaust system.

- Remove drain plug (1) with sealing ring (2) and drain the engine oil.
- Remove old sealing ring (2) from drain plug (1).

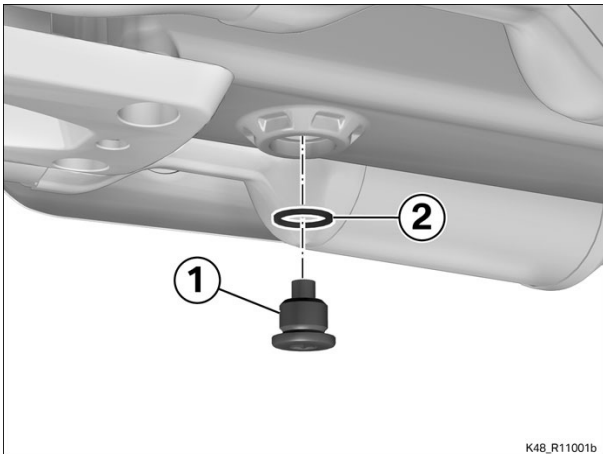

▷ Removing threaded plug, sump plate

- Remove threaded plug (1) with long 5 mm Allen key.

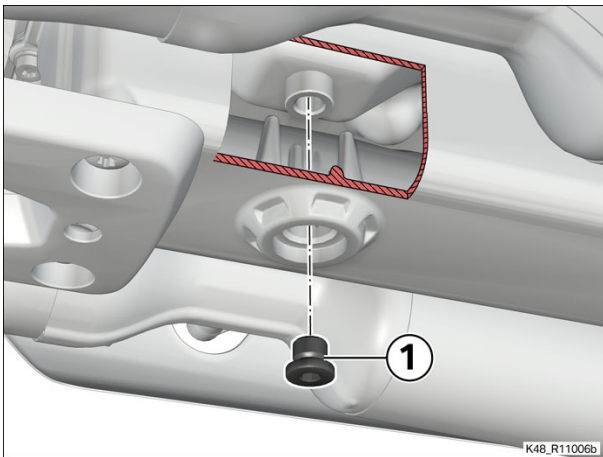

▷ Removing oil filter

- Push shift lever (1) down.
- Remove oil filter (2), using oil filter wrench (No. 11 4 661).
- Dispose of the oil filter in an environmentally friendly manner.
- Remove all oil stains from the manifold and engine.

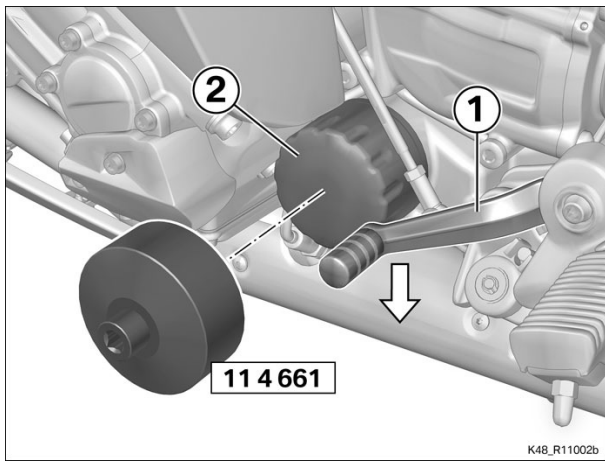

- ▷ Drain off all the engine oil.

▶ **Pouring in engine oil**

▷ **Installing oil filter**

- Clean the sealing face on the engine block (arrow).
- Wet sealing ring (3) of new oil filter (2) with engine oil.
- Push shift lever (1) down.
- Install new oil filter (2), using oil filter wrench (No. 11 4 661).

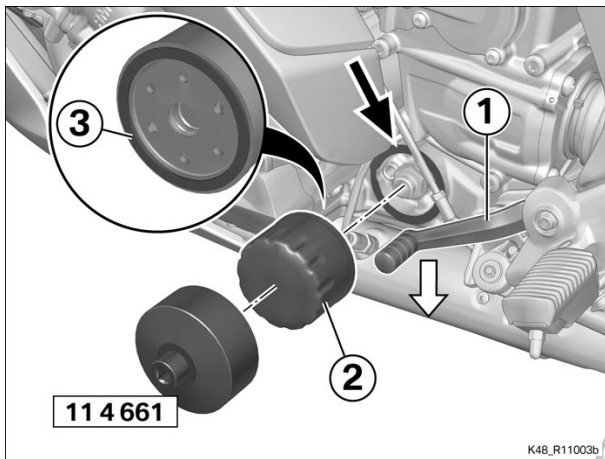

Tightening torques		
Oil filter to engine		
Coat seal with engine oil	11 Nm	

- Check that oxygen sensor cable (1) is correctly routed behind oil filter (2) and in engine block (3); correct the routing if necessary.

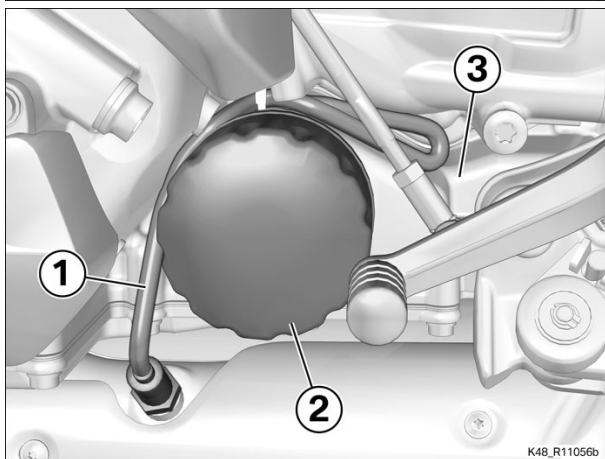

▷ **Installing threaded plug, sump plate**

- Install threaded plug (1) with long 5 mm Allen key.

Tightening torques		
Oil drain plug in sump plate		
M10 x 1	12 Nm	

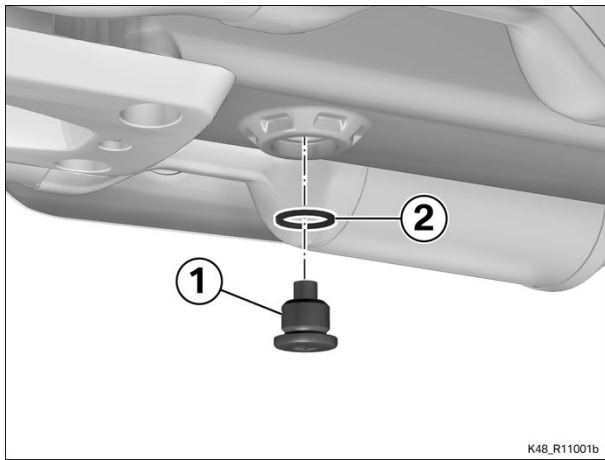
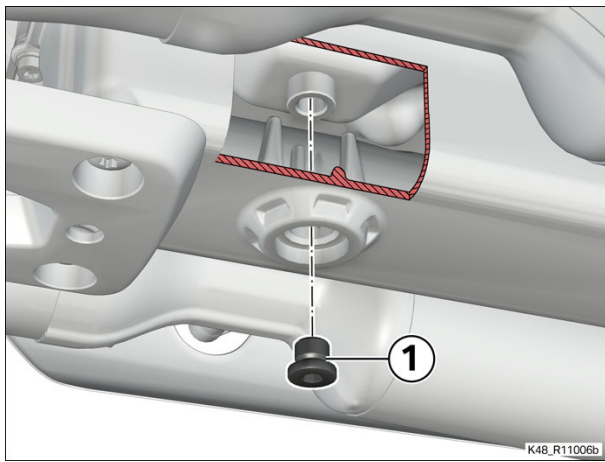

▷ **Installing drain plug for oil pan**

- Install drain plug (1) with new sealing ring **neuem** Dichtring (2).

 Tightening torques		
Oil drain plug to oil pan		
M16 x 1.5	28 Nm	



▷ **Pouring in engine oil**

- Prepare the correct total quantity of engine oil.

 Technical data		
Engine oil, capacity	with filter change	4.5 l
	Fluids and lubricants	
	products recommended by BMW Motorrad and generally admissible viscosity classes	

- Fill the oil tank to the **MAX** mark.
- Start the engine and allow it to run.
- Pour the rest of the oil into the oil tank.
- Close the oil tank.

▷ **Checking engine oil level**

- Position the motorcycle **upright** and allow the engine to idle until the fan starts up, then allow the engine to continue idling for one minute.
- Switch off the engine and wait for about one minute to allow the oil to drain into the sump.
- Remove oil dipstick (1) and clean the dipstick.

Test

- Seat oil dipstick (1) on the oil filler neck, but **do not engage the**

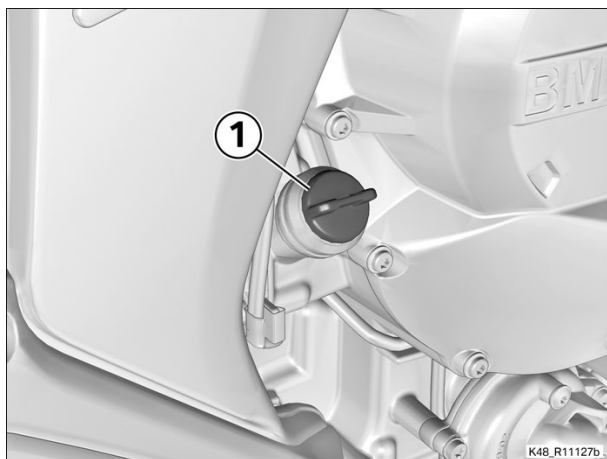

threads.

- Remove oil dipstick (1) and check the oil level.

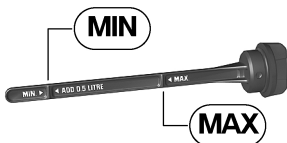
 Technical data			
Engine oil, specified level 	Engine at regular operating temperature	Between MIN and MAX marks	

Result: Oil level not between MIN and MAX marks

Measure:

- Correct the oil level.
- Install oil dipstick (1).



Finishing work

Final check of work performed

📁 11 00 609 Oil change in engine with filter (for maintenance) 2 FRUs



Note

Change oil, warmed to normal operating temperature.

Core activity

(-) Engine oil change with filter

▶ Draining engine oil

- Place a suitable tray underneath the engine to catch escaping oil.



Warning

Parts of the exhaust system can be hot.
Do not touch hot parts of the exhaust system.

- Remove drain plug (1) with sealing ring (2) and drain the engine oil.
- Remove old sealing ring (2) from drain plug (1).

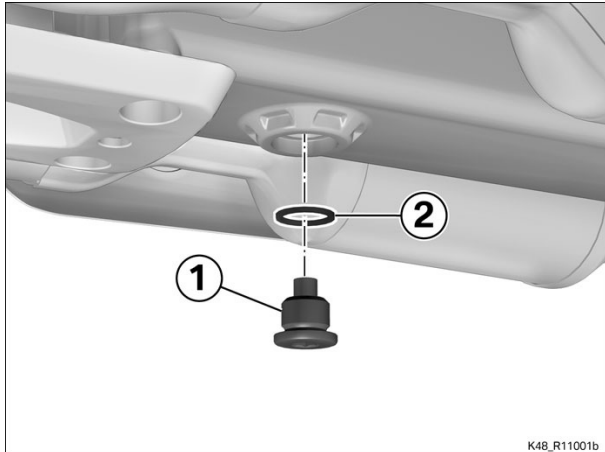

▷ Removing threaded plug, sump plate

- Remove threaded plug (1) with long 5 mm Allen key.

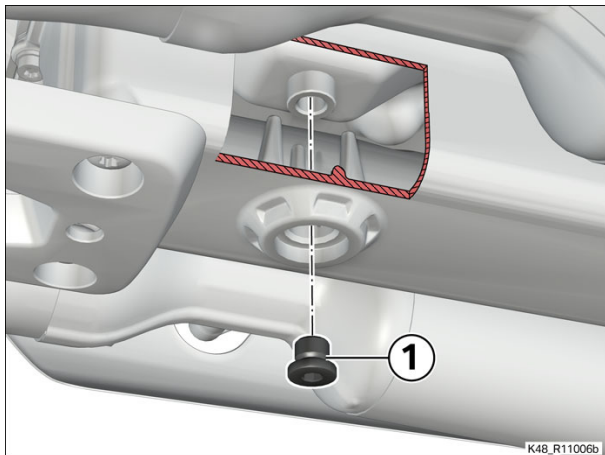

▷ Removing oil filter

- Push shift lever (1) down.
- Remove oil filter (2), using oil filter wrench (No. 11 4 661).
- Dispose of the oil filter in an environmentally friendly manner.
- Remove all oil stains from the manifold and engine.

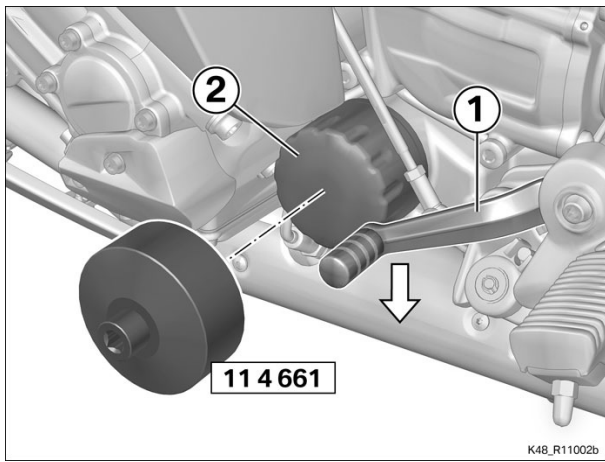

- Drain off all the engine oil.



► **Pouring in engine oil**

▷ **Installing oil filter**

- Clean the sealing face on the engine block (arrow).
- Wet sealing ring (3) of new oil filter (2) with engine oil.
- Push shift lever (1) down.
- Install new oil filter (2), using oil filter wrench (No. 11 4 661).

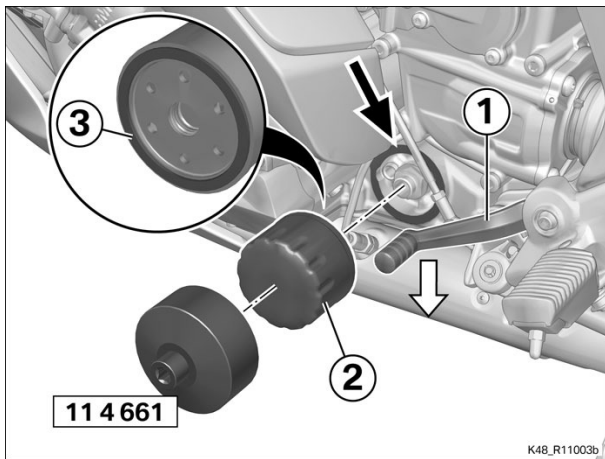

Tightening torques		
Oil filter to engine		
Coat seal with engine oil	11 Nm	

- Check that oxygen sensor cable (1) is correctly routed behind oil filter (2) and in engine block (3); correct the routing if necessary.

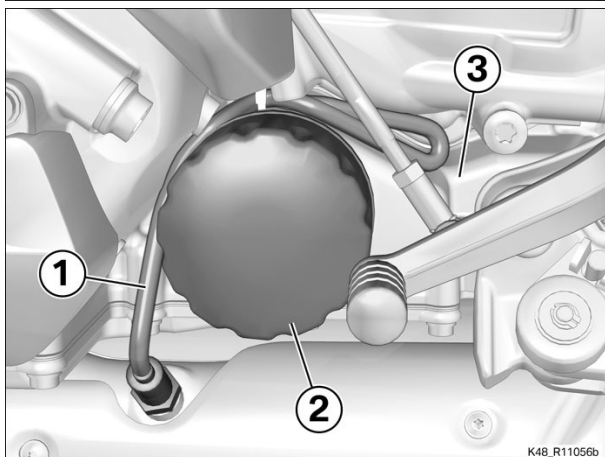

▷ **Installing threaded plug, sump plate**

- Install threaded plug (1) with long 5 mm Allen key.

Tightening torques		
Oil drain plug in sump plate		
M10 x 1	12 Nm	

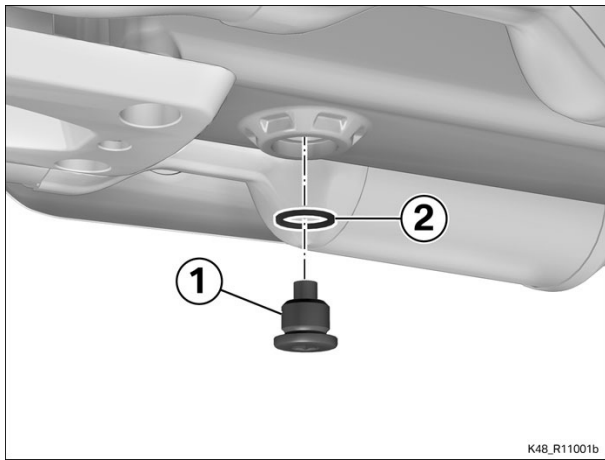
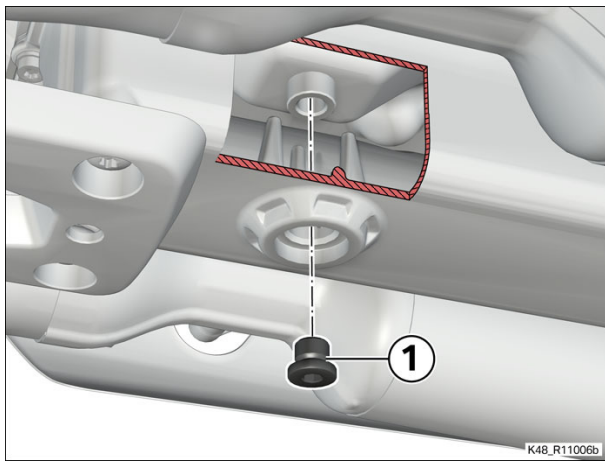

▷ **Installing drain plug for oil pan**

- Install drain plug (1) with new sealing ring **neuem** Dichtring (2).

 Tightening torques		
Oil drain plug to oil pan		
M16 x 1.5	28 Nm	



▷ **Pouring in engine oil**

- Prepare the correct total quantity of engine oil.

 Technical data		
Engine oil, capacity	with filter change	4.5 l
	Fluids and lubricants	
	products recommended by BMW Motorrad and generally admissible viscosity classes	

- Fill the oil tank to the **MAX** mark.
- Start the engine and allow it to run.
- Pour the rest of the oil into the oil tank.
- Close the oil tank.

▷ **Checking engine oil level**

- Position the motorcycle **upright** and allow the engine to idle until the fan starts up, then allow the engine to continue idling for one minute.
- Switch off the engine and wait for about one minute to allow the oil to drain into the sump.
- Remove oil dipstick (1) and clean the dipstick.

Test

- Seat oil dipstick (1) on the oil filler neck, but **do not engage the**

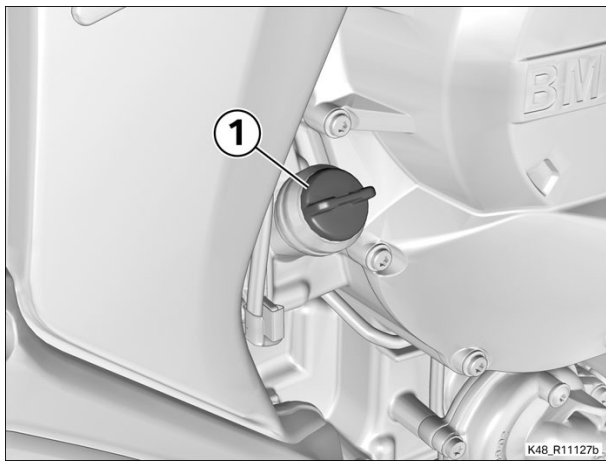

threads.

- Remove oil dipstick (1) and check the oil level.

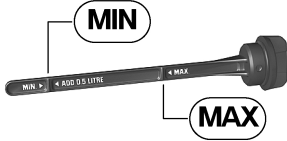
 Technical data			
Engine oil, specified level 	Engine at regular operating temperature	Between MIN and MAX marks	

Result: Oil level not between MIN and MAX marks

Measure:

- Correct the oil level.
- Install oil dipstick (1).



 **11 12 244 Replacing cylinder head**

+ 11 12 820

Equipment trim-level variant:

0266 - Preparation for audio system and navigation device

0267 - ECE audio system and preparation for navigation system

0417 - Central locking

Preparatory work

- Remove the front seat
- Removing air guides for intake air pipes, left and right
- Removing complete cover of fuel tank
- Removing left bottom side panel
- Removing left radiator cowl
- Removing radiator hose cover
- Removing left side panel
- Removing inner trim for left side panel
- Removing gearbox cover
- Removing right bottom side panel
- Removing right radiator cowl
- Remove the right side panel
- Removing inner trim for right side panel
- Removing right stowage compartment
- Removing adjusting plate
- Disengaging seat support
- Disengaging left and right intake air pipes
- Removing complete intake air silencer
- Removing fuel tank
- Removing left catalytic-converter shield
- Disengaging clamp on left silencer
- Removing left silencer
- Removing right catalytic-converter shield
- Disengaging clamp on right silencer
- Removing right silencer
- Draining cooling system
- Removing complete radiator
- Removing air guide
- Disconnecting distributor rail for secondary air system
- Removing direct ignition coils
- Removing spark plugs
- Removing cylinder head cover
- Disengaging wiring harness for engine
- Removing intake manifold
- Removing left drop-protection pad
- Removing crankshaft cover

Core activity

(-) Setting engine to TDC

-

Turn the crankshaft to firing TDC of cylinders 1 and 5.

(-) Locking engine at TDC

- Turn crankshaft (1) **counter-clockwise** until the hole (arrow) in the crankshaft is visible.
- Insert locating pin (No. 11 0 811) and lock crankshaft (1).

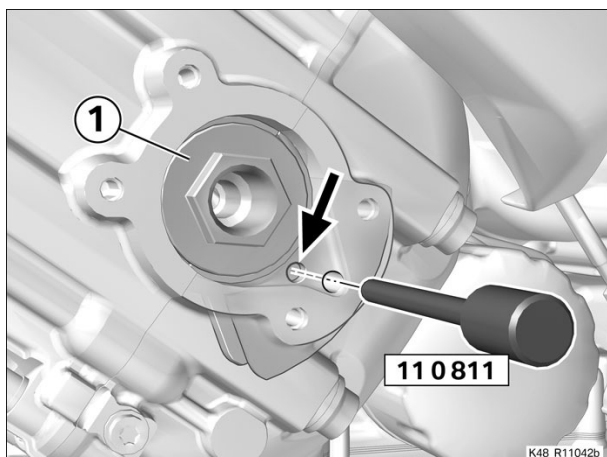

(-) Removing timing-chain tensioner

- Remove screws (1) and remove cover (2) with sealing ring (3).
- Remove timing-chain tensioner (4).

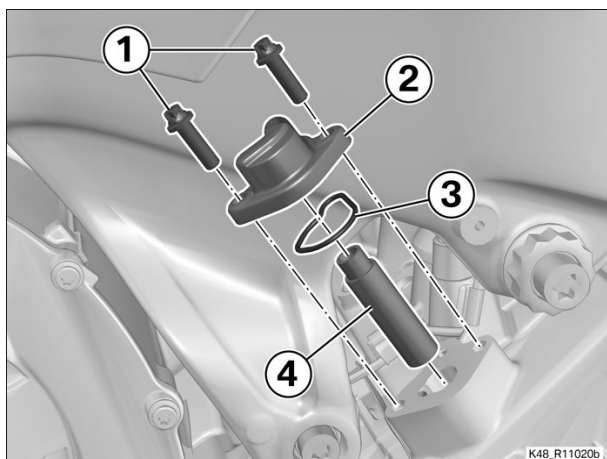

(-) Removing bearing cap for camshafts

- Screw stud bolts (No. 11 0 812) into spark-plug bores and tighten by hand until seated.
- Screw thrust nuts (No. 11 0 812) on to stud bolts and tighten by hand until seated.

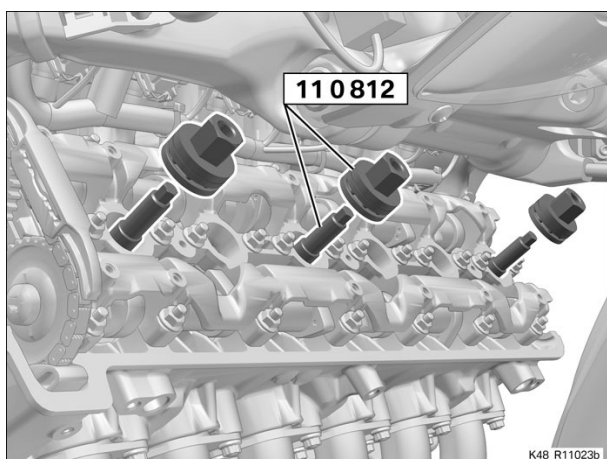

► Removing top guide for timing chain

- Remove nuts (1).
- Remove guide (2).

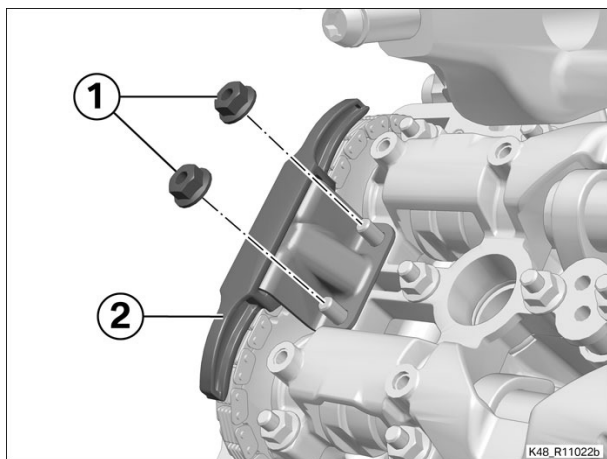

- Remove nuts (1).

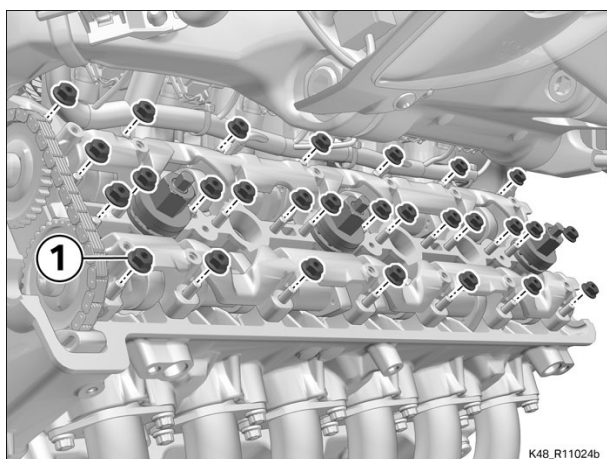

- Uniformly slacken thrust nuts (No. 11 0 812) and remove.
- Remove bearing cap (1).

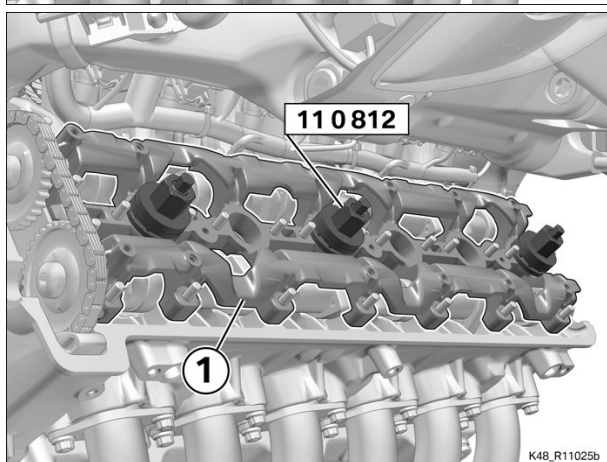

(-) Removing O-rings for camshaft bearing cap

- Remove large O-rings (1) and small O-rings (2).

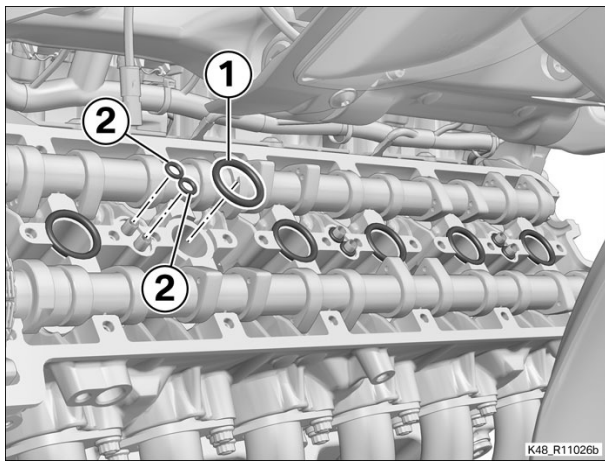

(-) Removing camshafts

- Mark the positions of sprocket (1) of exhaust camshaft and sprocket (2) of inlet camshaft relative to timing chain (3) (arrows).

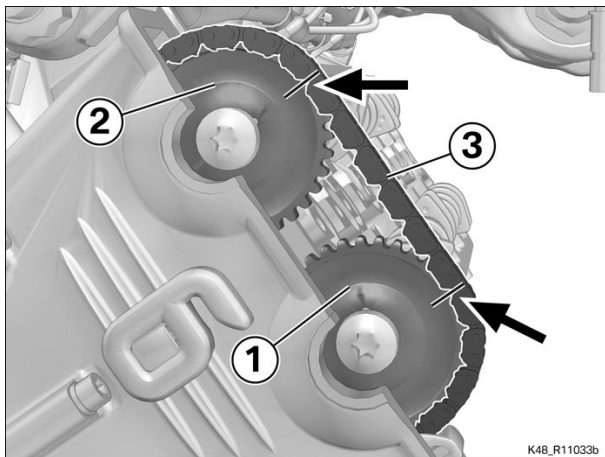

- Work exhaust camshaft (1) and inlet camshaft (with multi-pole sensor gear for camshaft sensor) (2) out of timing chain (3) and remove.
- Secure timing chain (3) in a suitable way to prevent it dropping out.

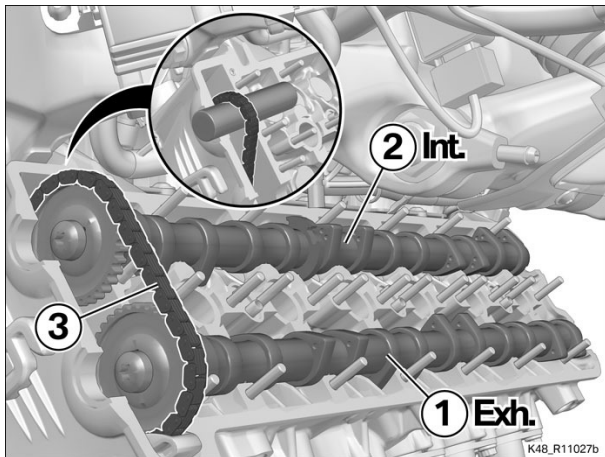

(-) Disconnecting left oxygen sensor

- Disengage cable (1) for the oxygen sensor from holder (2) and work it clear.

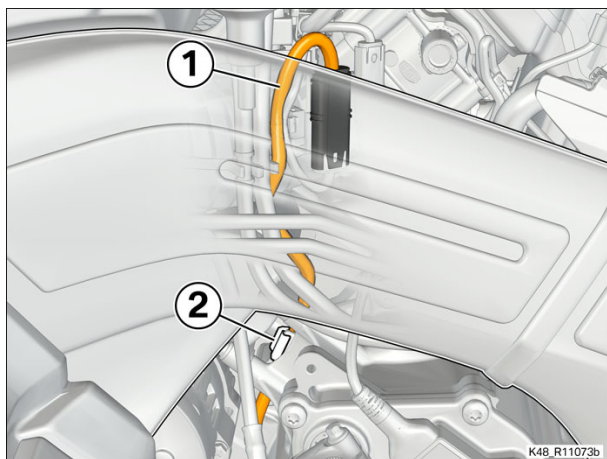

K48_R11073b

- Disengage cable (1) for the oxygen sensor between engine (2) and gearbox (3) and work it clear.

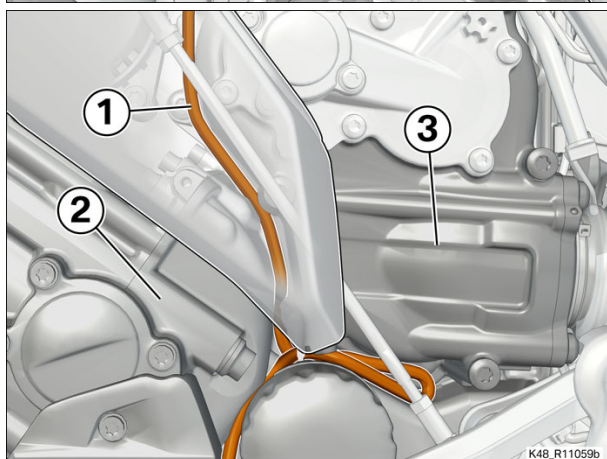

K48_R11059b

(-) Removing exhaust manifold, left

- Remove nuts (1) and remove exhaust manifold (2).
- Remove gaskets (3).

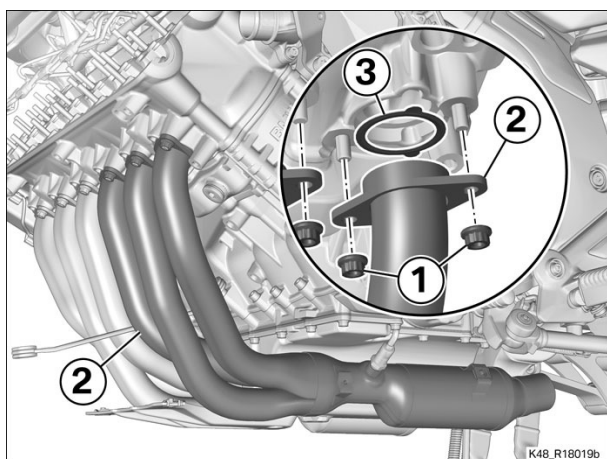

K48_R18019b

(-) Disconnecting right oxygen sensor

- Disengage cable (1) for the oxygen sensor from holders (2) and work it clear.

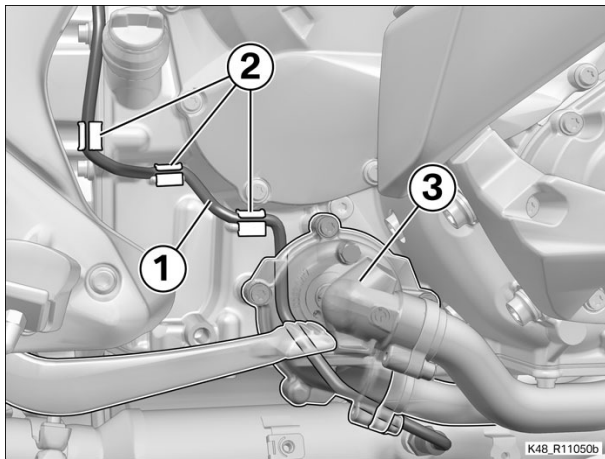
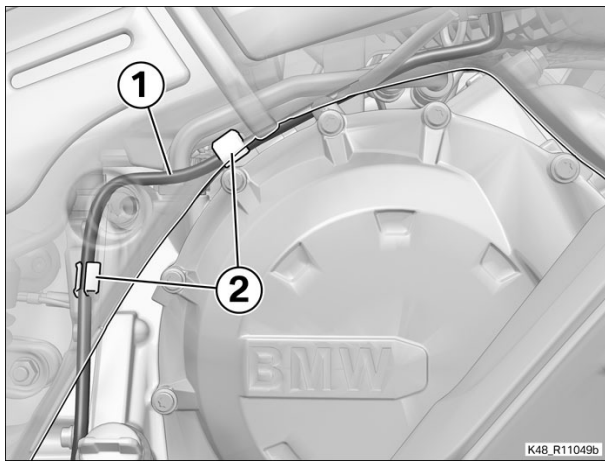

- Disengage cable (1) for the oxygen sensor from holders (2) and work it clear.
- Work cable (1) clear from behind coolant pump (3).

(-) Removing exhaust manifold, right

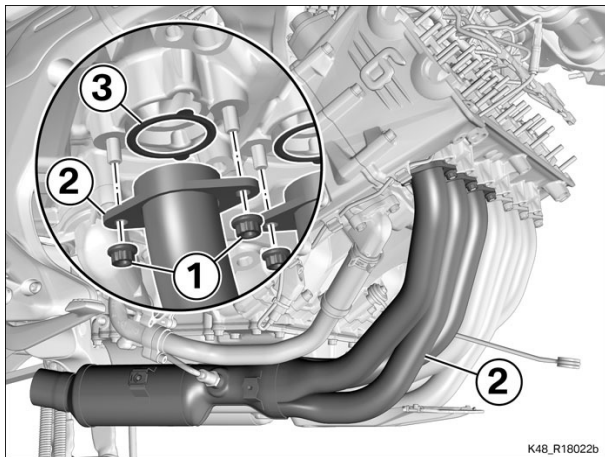

- Remove nuts (1) and remove exhaust manifold (2).
- Remove gaskets (3).

(-) Removing logotype

- Carefully pry out cover (1) at the bottom.
- Remove cover (1), noting the lugs (arrows).

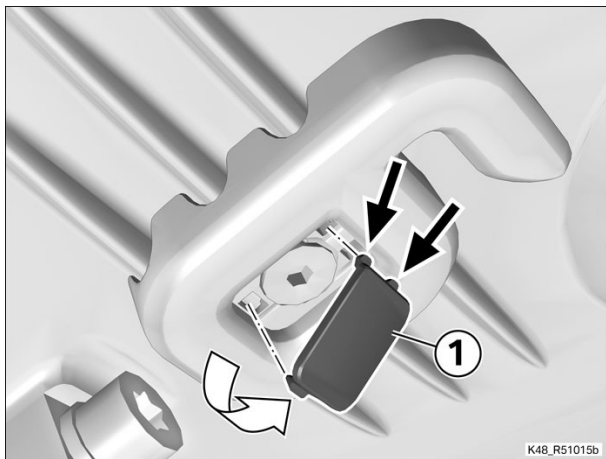

K48_R51015b

- Remove screw (1).
- Remove logotype (2).

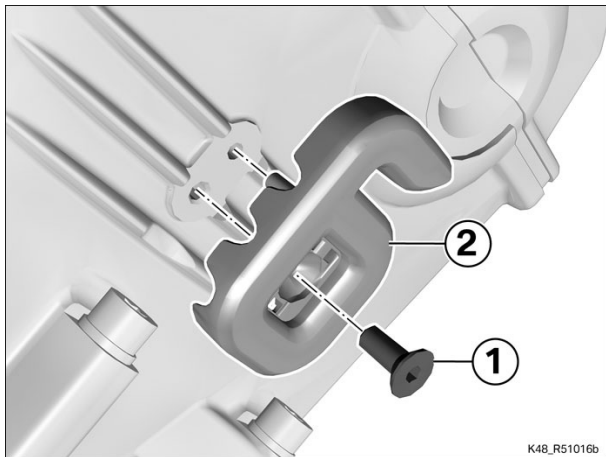

K48_R51016b

(-) Removing cylinder head

- Remove screws (1).
- Disengage earth lead (2).
- Disconnect plug (3) for the coolant-temperature sensor.

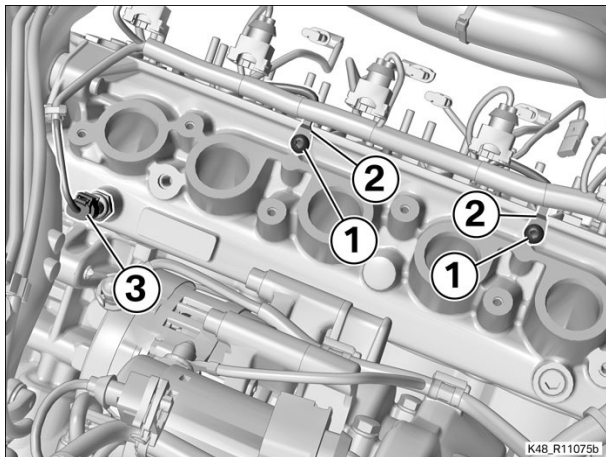

K48_R11075b

- Remove screws (1) with washers (2).
- Disengage cable (3) for the crankshaft sensor from holders (4).

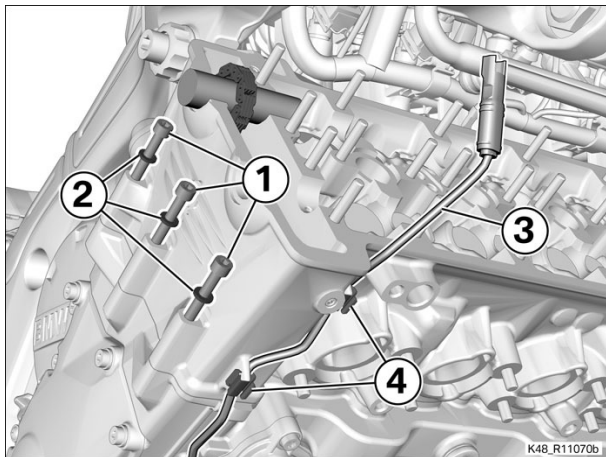

K48_R11070b

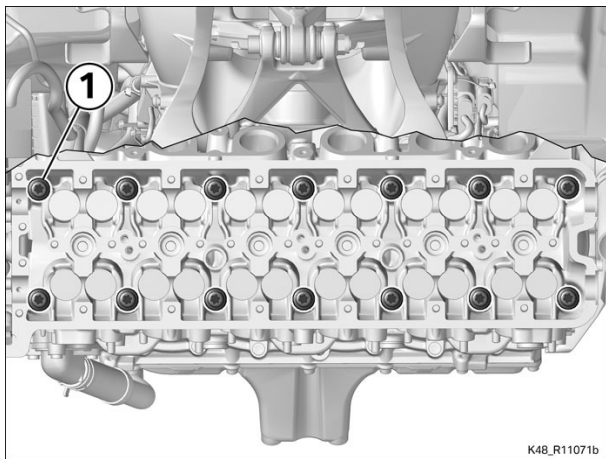

Starting at the outside, remove screws (1) in diagonally opposite sequence.

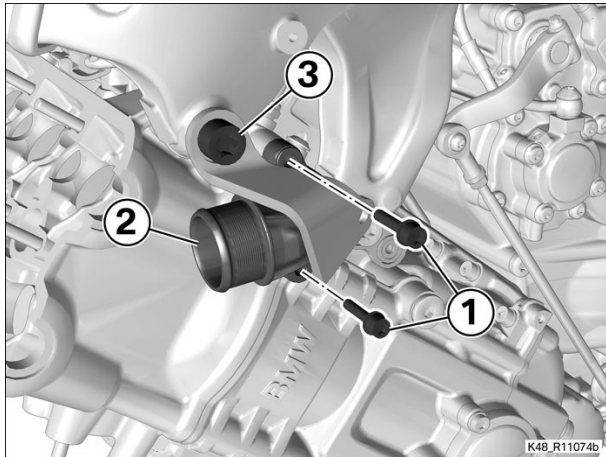

- Remove screws (1).
- Remove radiator adapter (2).
- Remove screw (3).

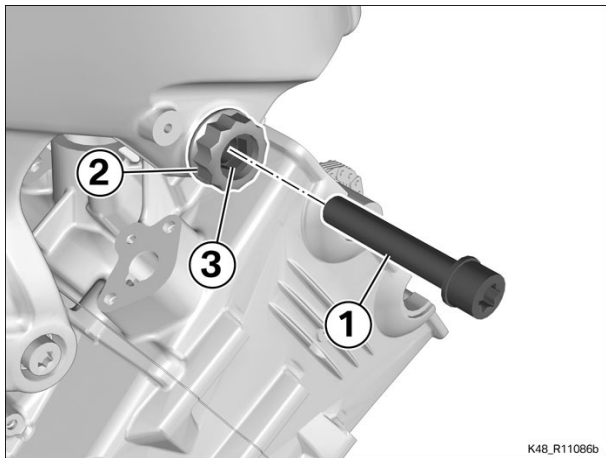

- Remove screw (1).
- Slacken collared nut (2).
- Slightly back off threaded sleeve (3).

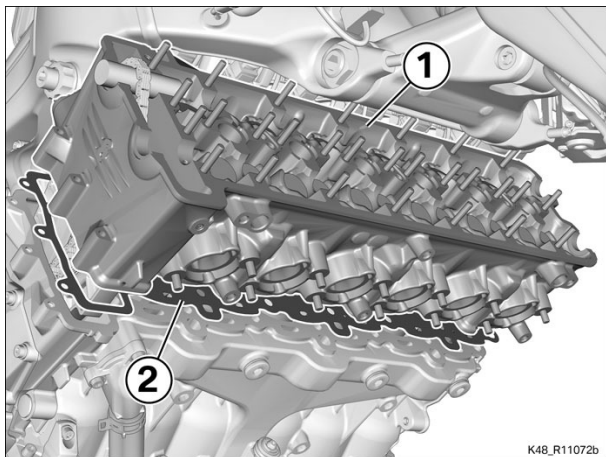

- Remove cylinder head (1).
- Remove gasket (2), tapping lightly to release if necessary, and dispose of in the correct manner.

(-) Removing bucket tappet

-

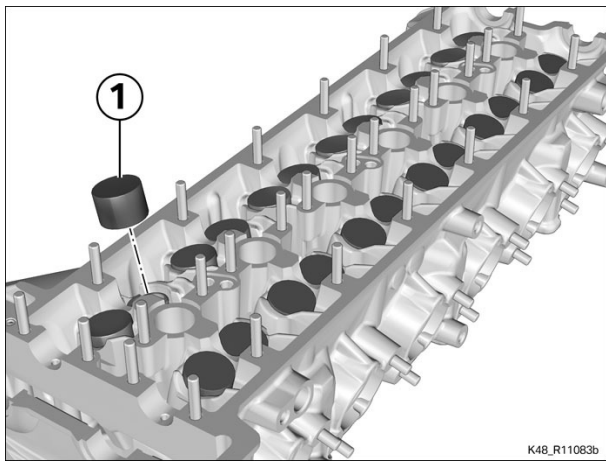

Remove bucket tappet (1).

(-) Removing coolant-temperature sensor

- Remove coolant-temperature sensor (1) with sealing ring (2).

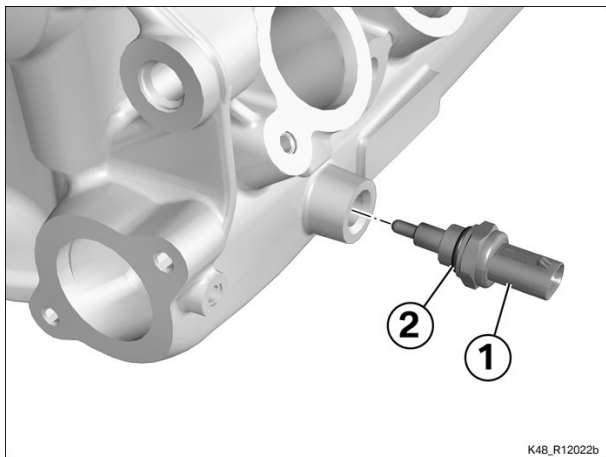

(-) Removing valves

- Install flat adapter (No. 11 0 762) in support plate (No. 11 0 761).

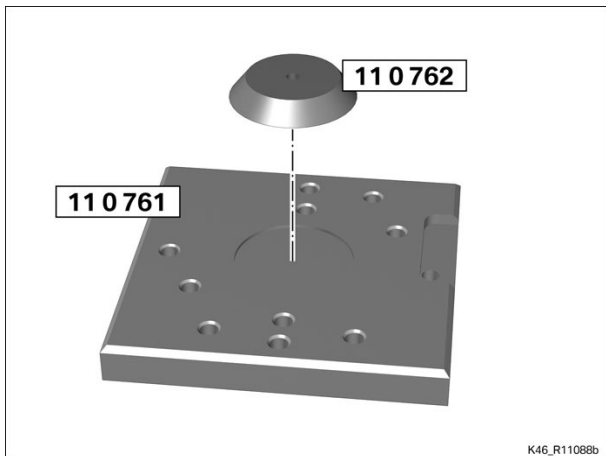

- Using suitable screws (2), secure cylinder head (1) to support plate (No. 11 0 761).

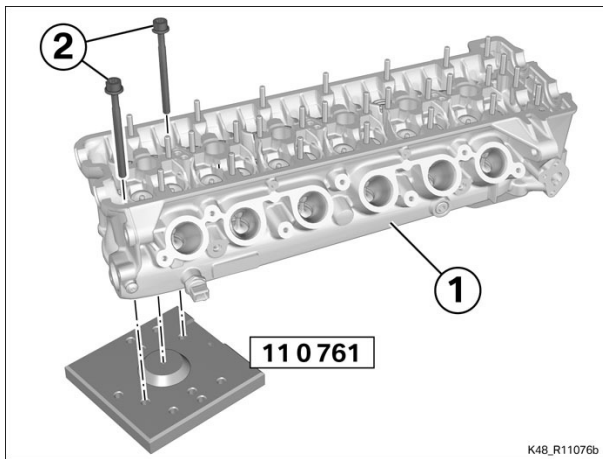

K48_R11076b

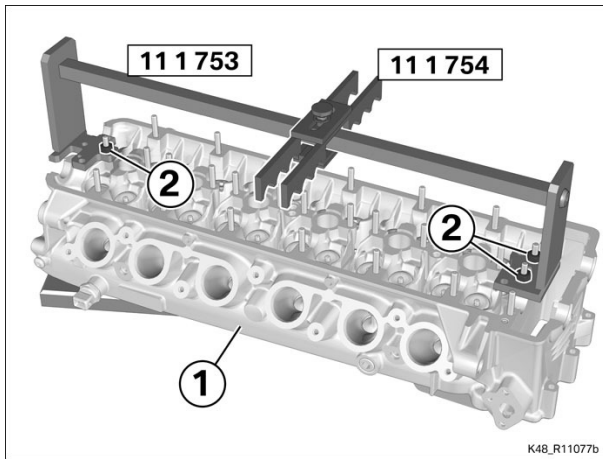

K48_R11077b

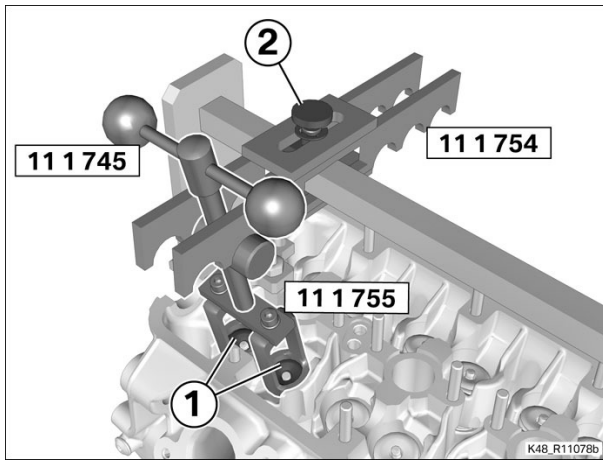

K48_R11078b

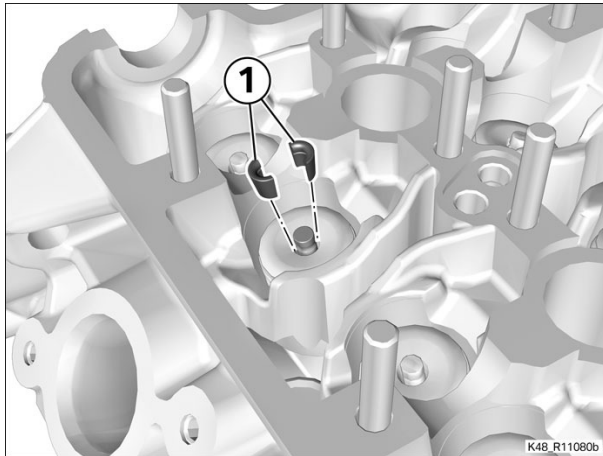

K48_R11080b

- Push support (No. 11 1 754) onto thruster (No. 11 1 753).
- Position thruster (No. 11 1 753) on cylinder head (1) and secure with suitable nuts (2).

- Seat thrust cage (No. 11 1 755) with spindle (No. 11 1 745) in support (No. 11 1 754) and position the assembly on valve heads (1).
- Adjust support (No. 11 1 754) and tighten clamping screw (2).
- Press down valve heads (1) with thrust cage (No. 11 1 755) and spindle (No. 11 1 745).

- Use a suitable tool to remove valve collets (1).

- Back off the special tool.
- Remove the following components:

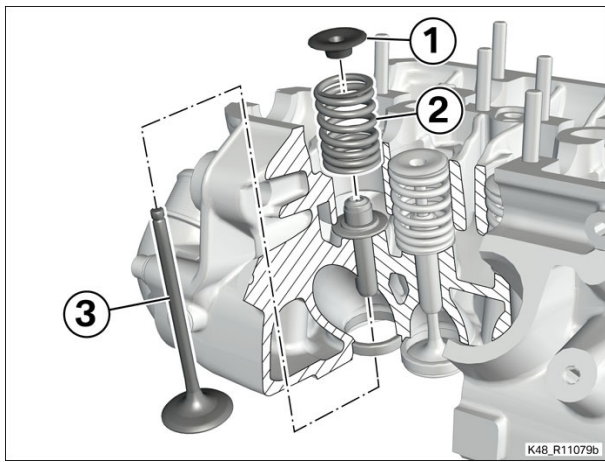

- Spring retainers (1)
- Valve spring (2)
- Valve (3)

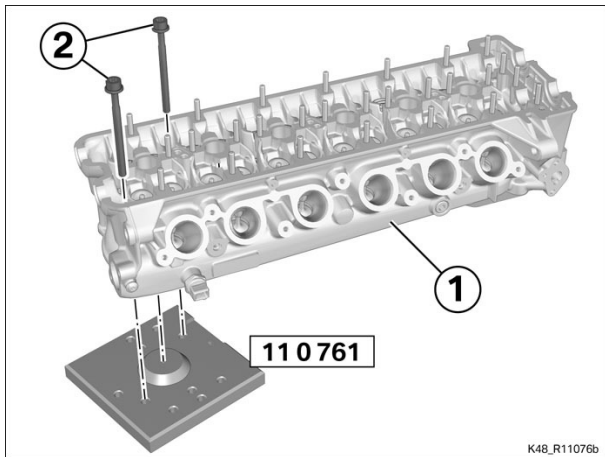

- Repeat this procedure with the other valves.
- In this process remove screws (2) and secure support plate (No. 11 0761) at the appropriate position on cylinder head (1).

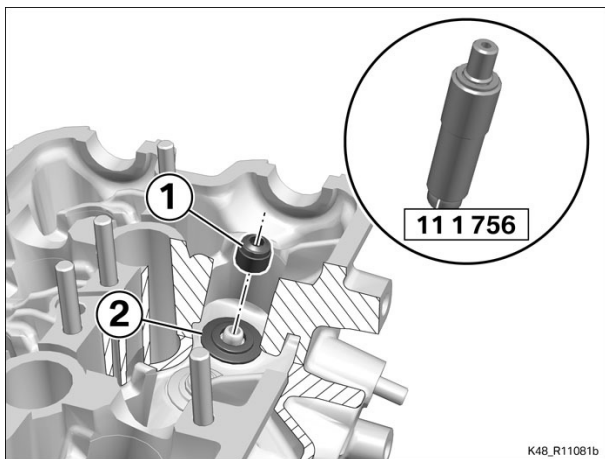

(-) Removing valve stem seals and spring retainers

- Remove valve stem seal (1) with puller (No. 11 1756).
- Remove spring retainer (2).

- Repeat this procedure for all valve stem seals and spring retainers.

(-) Installing valve stem seals and spring retainers

- Install spring retainer (2).
- Carefully seat **new** valve stem seal (1) with drift (No. 11 5602).

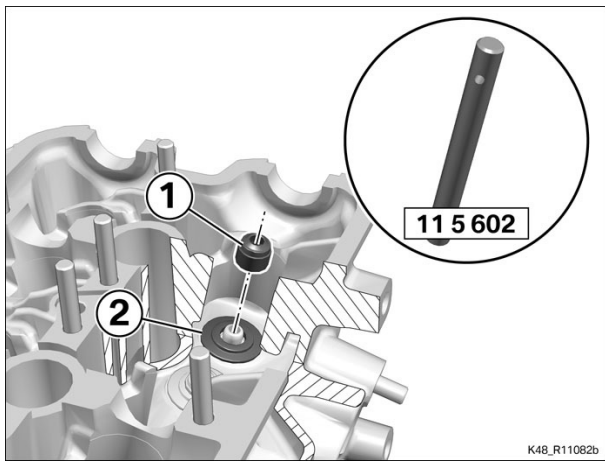

- Repeat this procedure for all valve stem seals and spring retainers.

(-) Installing valves

- Install the following components:

- Valve (3)
- Valve spring (2) with the coloured mark (arrow) up
- Spring retainers (1)

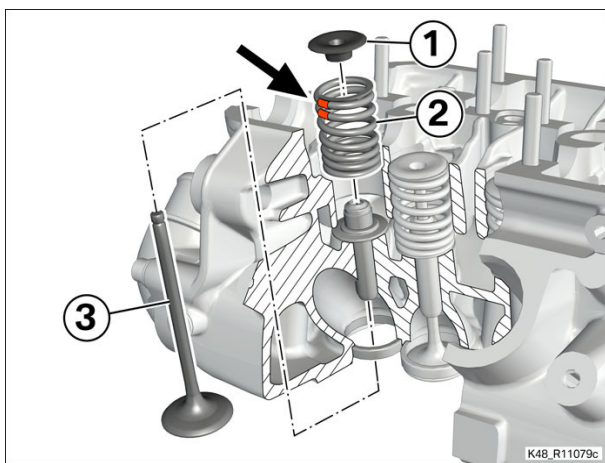

- Seat thrust cage (No. 11 1 755) with spindle (No. 11 1 745) in support (No. 11 1 754) and position the assembly on valve heads (1).
- Adjust support (No. 11 1 754) and tighten clamping screw (2).
- Press down valve heads (1) with thrust cage (No. 11 1 755) and spindle (No. 11 1 745).

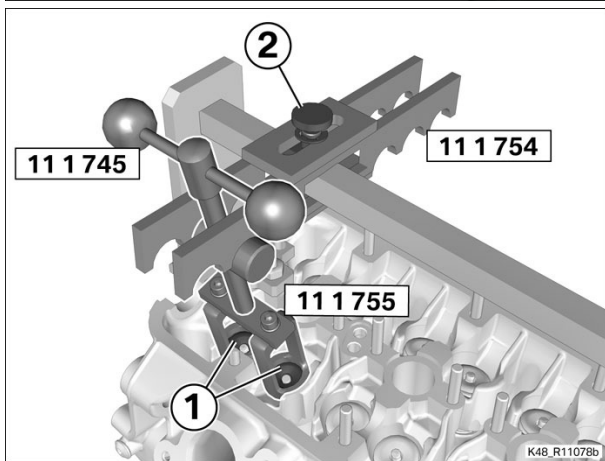

- Lightly lubricate valve collets (1) to keep them from slipping out.

 <p>Fluids and lubricants</p>		
Molykote D paste	Light-coloured paste-like lubricant for assembly and for running in metal components	

- Use a suitable tool to install valve collets (1). Make sure that they engage the groove in the valve (arrow).

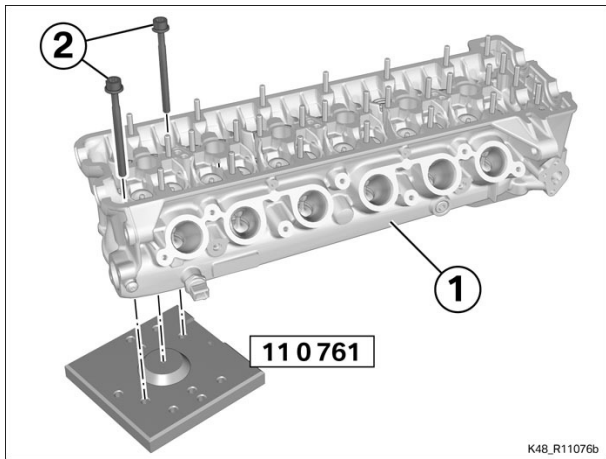
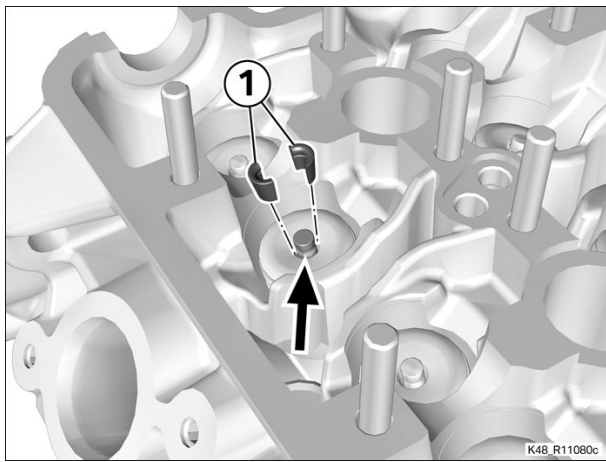

- Repeat this procedure with the other valves.
- In this process remove screws (2) and secure support plate (No. 11 0 761) at the appropriate position on cylinder head (1).

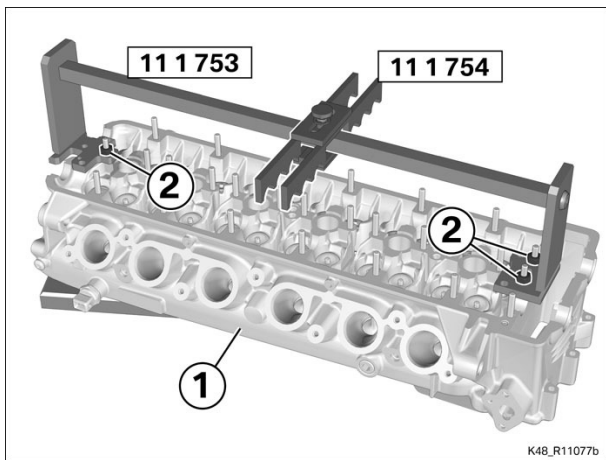

- Remove nuts (2).
- Remove support (No. 11 1 754) and thruster (No. 11 1 753).

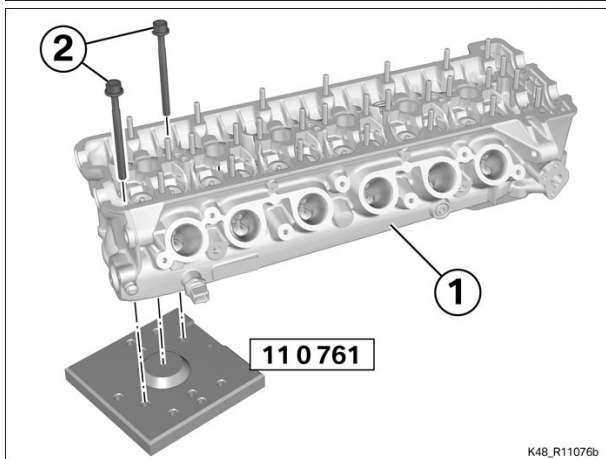

- Remove screws (2) and remove cylinder head (1) (No. 11 0 761) from the support plate.

(-) Installing coolant-temperature sensor

-

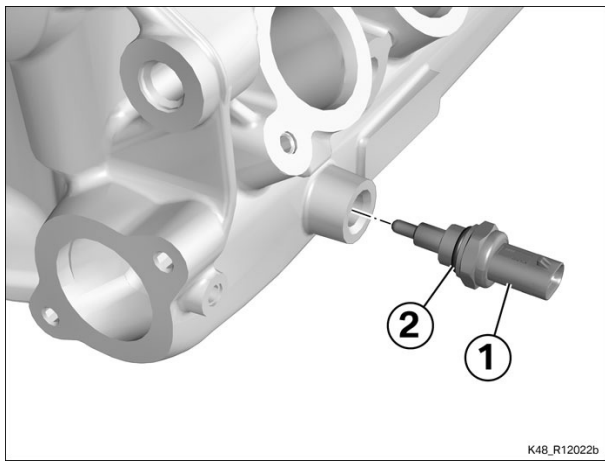

Install coolant-temperature sensor (1) with **new** sealing ring (2).

 Tightening torques		
Temperature sensor to cylinder head		
M12 x 1.5	15 Nm	

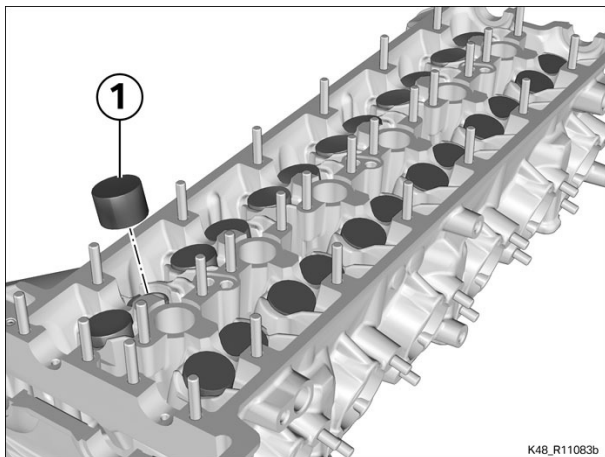

(-) Installing bucket tappet

- Lubricate bucket tappet (1) with engine oil and install.

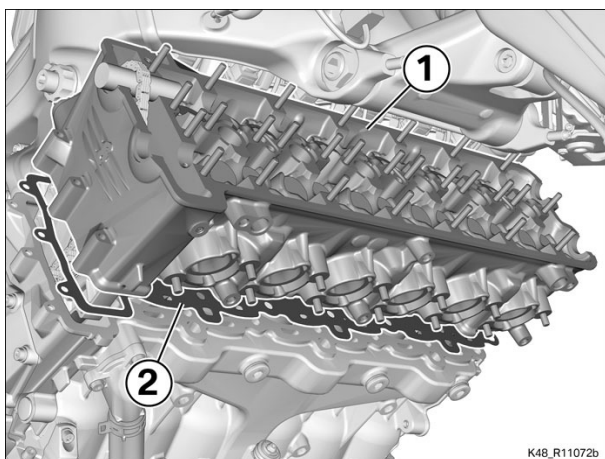

(-) Installing cylinder head

- Ease cylinder (1) with **new** gasket (2) into position.

- Starting from the inside, install screws (1) in diagonally opposite sequence.

 Tightening torques		
Cylinder head to crankcase		
M 9 x 1.25 x 126	Tightening sequence, working from the inside toward the outside	

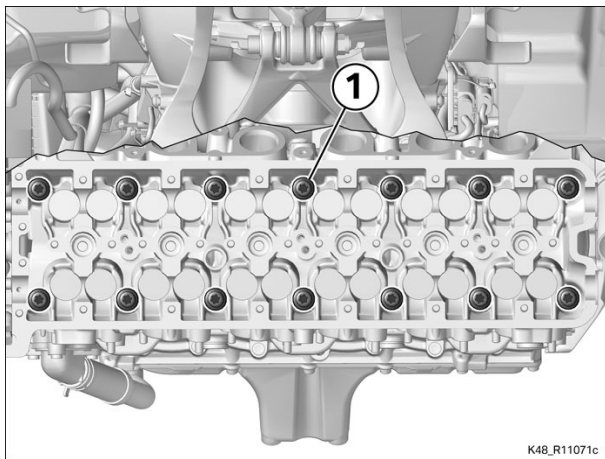

	Initial torque, 20 Nm	
	Closing torque, 100°	
	Back off fully	
	Initial torque, 20 Nm	
	Final torque, 100°	

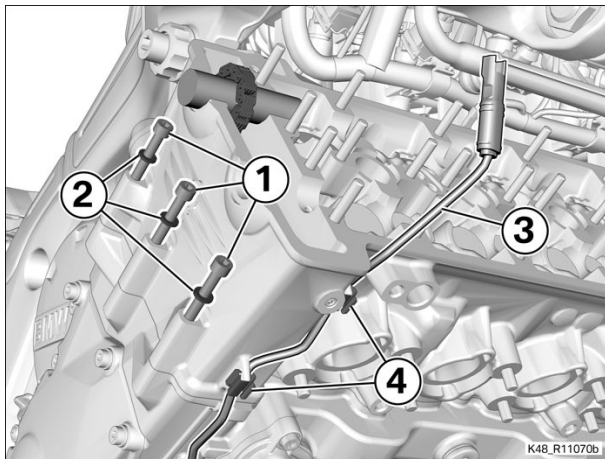

- Install screws (1) with washers (2).

Tightening torques		
Cylinder head to crankcase		
M6 x 50	10 Nm	

- Install cable (3) for the crankshaft sensor with holders (4).

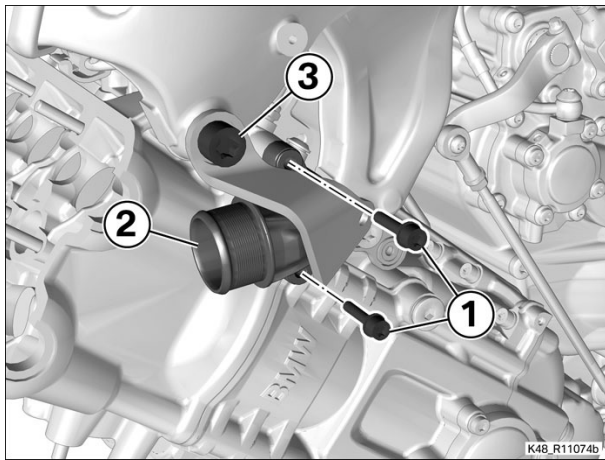

- Install radiator union (2) with screws (1).

Tightening torques		
Coolant adapter to cylinder head		
M6 x 25	10 Nm	

- Install screws (3).

Tightening torques		
Cylinder head, left, to frame		
M12 x 1.5 x 60	66 Nm	

- Install threaded sleeve (3), collared nut (2) and screw (1) and tighten.

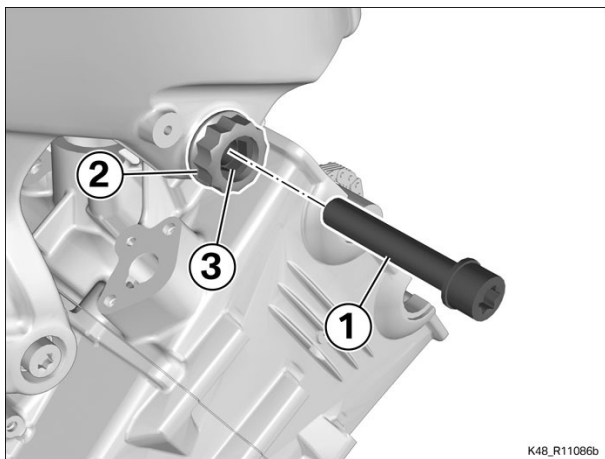

Tightening torques		
Cylinder head, right, to frame		
Threaded sleeve, M24 x 1.25	1st step	
	2 Nm	
Collared nut, M24 x 1.25	2nd step	
	100 Nm	
M12 x 1.5 x 70	3rd step	
	66 Nm	

- Install earth lead (2) with screws (1).

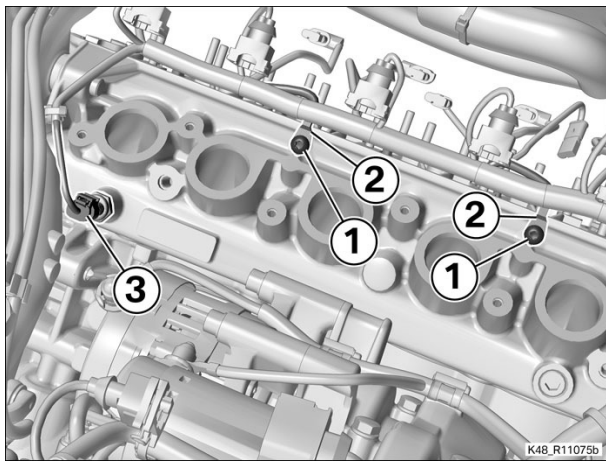



 Tightening torques		
Engine wiring harness to cylinder head		
M5 x 12	8 Nm	

- Connect plug (3) for the coolant-temperature sensor.

(-) Installing logotype

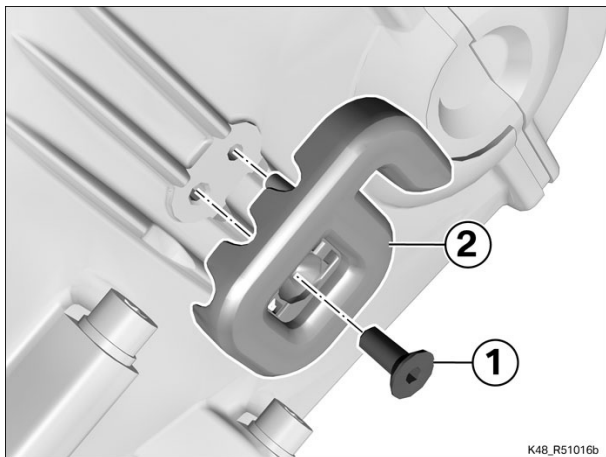
- Hold logotype (2) in position.
- Lubricate screw (1) and install.



 Fluids and lubricants		
Staburags NBU 30 PTM	High-performance lubricating grease	07 55 9 056 992

- Seat cover (1) with the top lugs (arrows).
- Clip cover (1) into position.

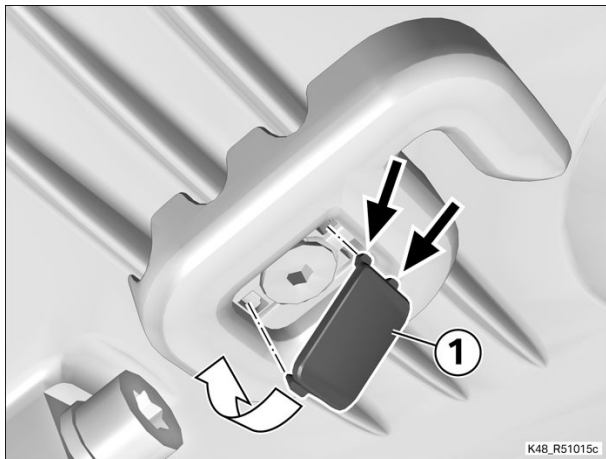

(-) Installing exhaust manifold, right

- Install gaskets (3), making sure they are correctly positioned.
- Hold exhaust manifold (2) in position and install nuts (1).

 Tightening torques		
Exhaust header to cylinder head		
M7	14 Nm	

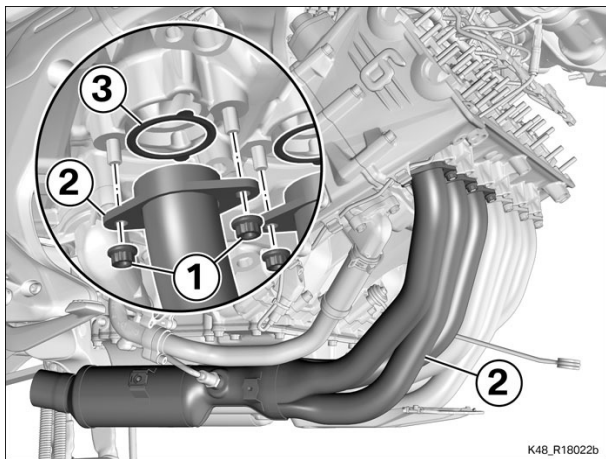

(-) Securing right oxygen sensor

- Route cable (1) behind coolant pump (3).
- Route cable (1) for the oxygen sensor and secure it in holders (2).

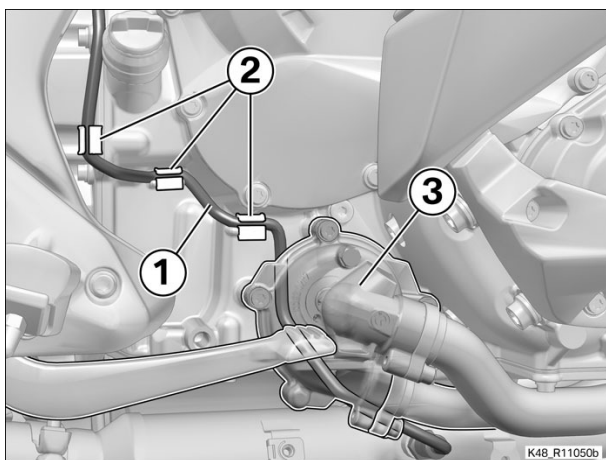

- Route cable (1) for the oxygen sensor and secure it in holders (2).

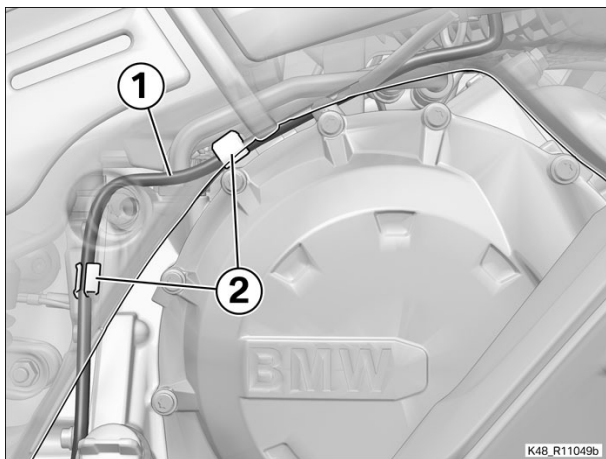

(-) Installing exhaust manifold, left

- Install gaskets (3), making sure they are correctly positioned.
- Hold exhaust manifold (2) in position and install nuts (1).

 Tightening torques		
Exhaust header to cylinder head		
M7	14 Nm	

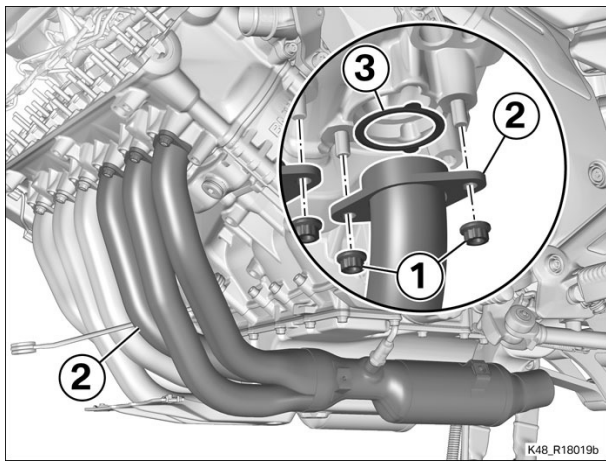

(-) Securing left oxygen sensor

- Route cable (1) for the oxygen sensor between engine (2) and gearbox (3) and secure it.

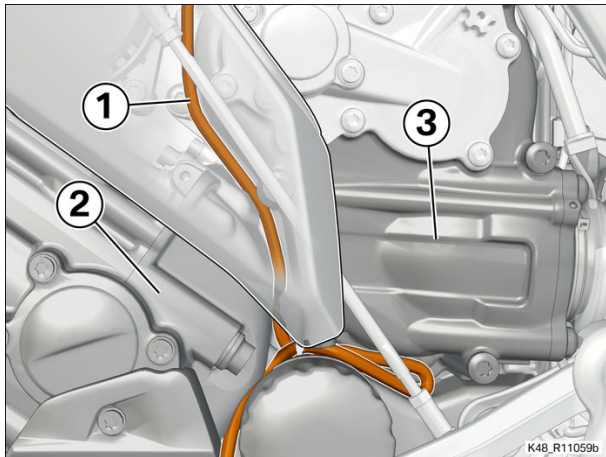

- Route cable (1) for the oxygen sensor and secure it in holder (2).

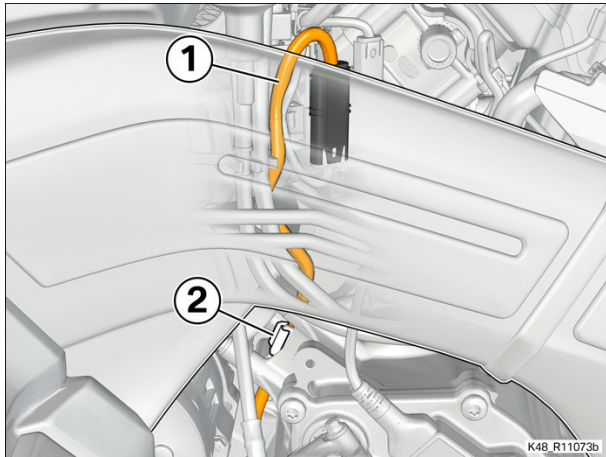

(-) Installing camshafts

- Insert inlet camshaft (with multi-pole sensor gear for camshaft sensor) (2) and exhaust camshaft (1) and loop timing chain (3) over the camshafts.

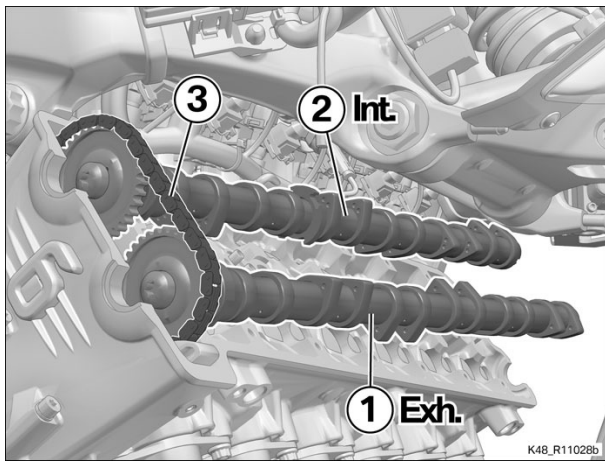

K48_R11026b

- Turn inlet camshaft (2) and exhaust camshaft (1) to top dead centre of cylinder No. 1, align them with the marks (arrows) applied before removal and engage timing chain (3) on sprockets.

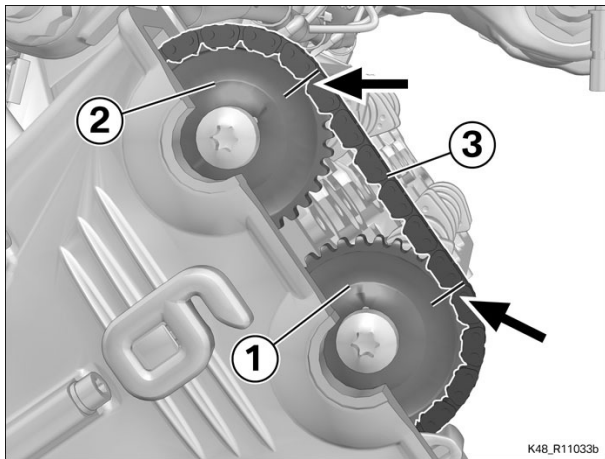

K48_R11033b

(-) Installing O-rings for camshaft bearing cap

- Check O-rings (1) and O-rings (2) for damage; replace if necessary.
- Install large O-rings (1) and small O-rings (2).

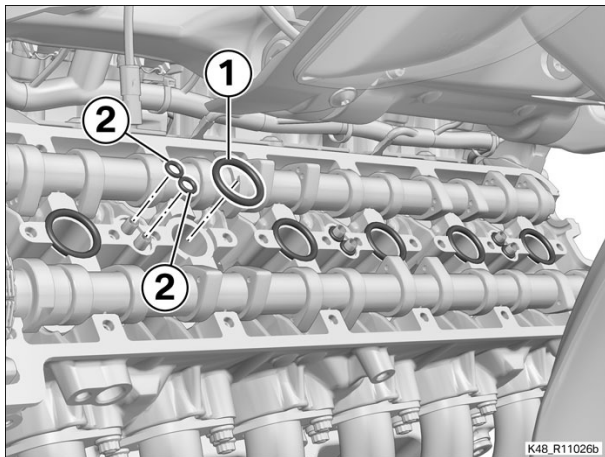

K48_R11026b

(-) Installing bearing cap for camshafts

- Lubricate the bearing seats with engine oil.
- Place camshaft bearing cap (1) in position.
- Install thrust nuts (No. 11 0 812) and tighten uniformly until camshaft bearing cap (1) is seated on cylinder head.

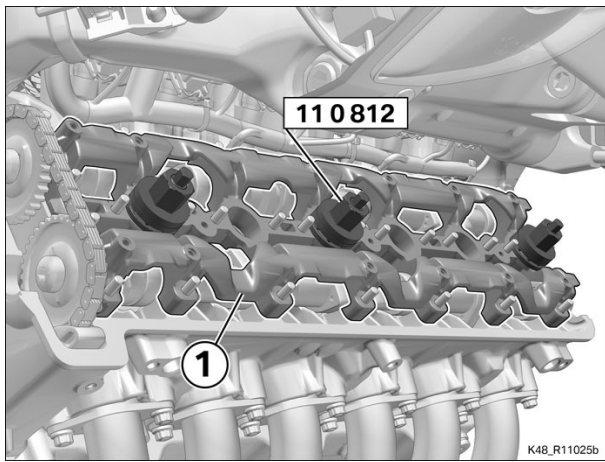

► **Checking timing**

Test

- Slip locating device (No. 11 0 813) into the recesses (arrows) of inlet camshaft (1) and exhaust camshaft (2).
- Locating device (No. 11 0 813) must slip in evenly and lie flat on sealing face (3).

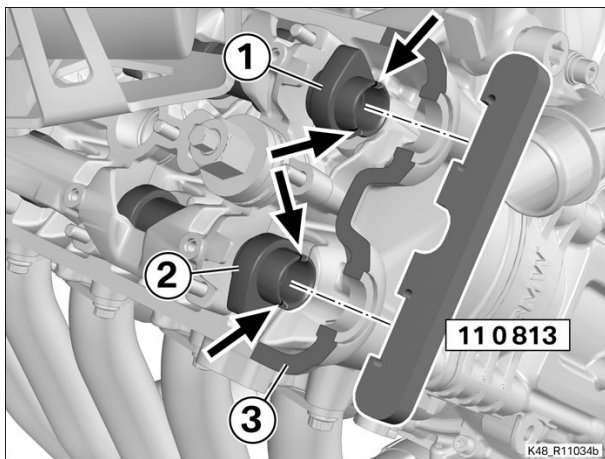

Result: Locating device cannot be slipped in or does not lie flat on the sealing face, because the recesses of the camshafts well off a common line.

Measure:

- Remove and re-install the bearing cap and turn the camshafts until the locating device can be slipped into position.

Result: Locating device cannot be slipped in or does not lie flat on the sealing face, because the recesses of the camshafts are slightly off a common line.

Measure:

▷ **Adjusting camshafts when checking timing**

- Remove locating pin (No. 11 0 811).
- Turn crankshaft (1) **slightly** until camshafts are in line and the special tool can be slipped into position
- Insert locating pin (No. 11 0 811) in the hole (arrow) and lock crankshaft (1).

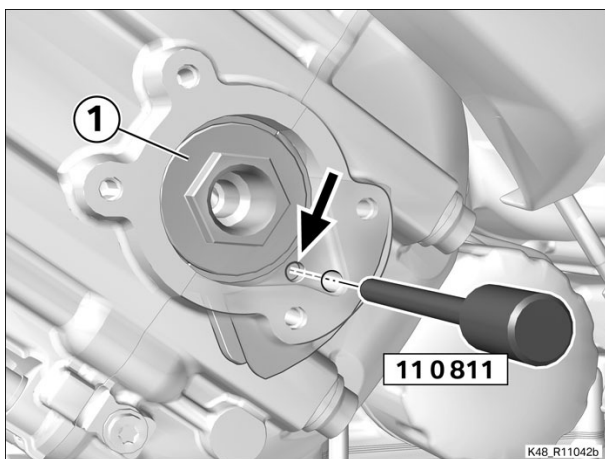

Result: Locating device can be slipped in and lies flat on the sealing face.

Measure:

▷ **Removing locating device for checking timing**

- Remove locating device (No. 11 0 813) from the recesses (arrows) of inlet camshaft (1) and exhaust camshaft (2).

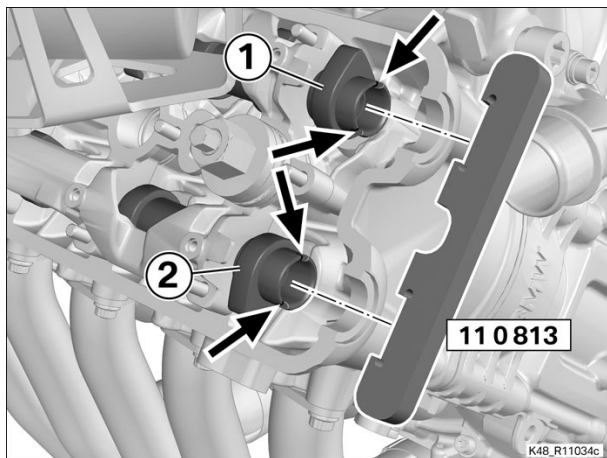

- Install nuts (1) until seated, but do not tighten.

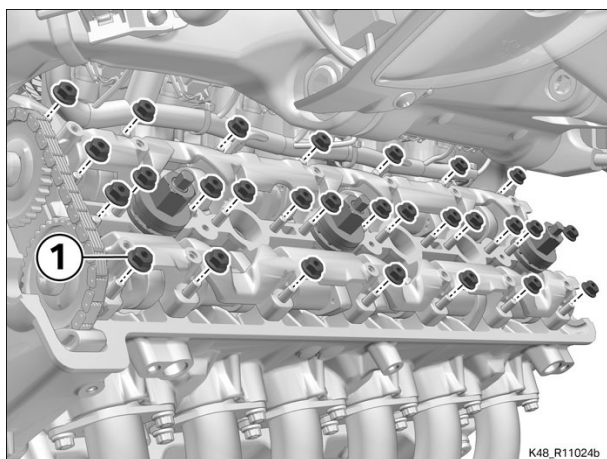

▶ **Installing top guide for timing chain**

- Install guide (2).
- Install nuts (1) until seated, but do not tighten.

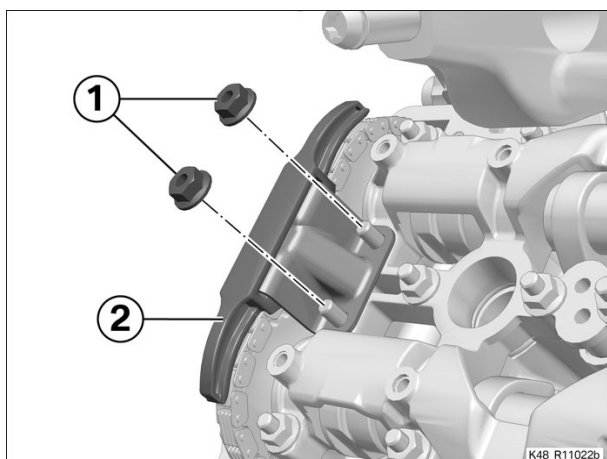

- Tighten nuts of camshaft bearing cap in specified tightening sequence (1) to (28).

 Tightening torques

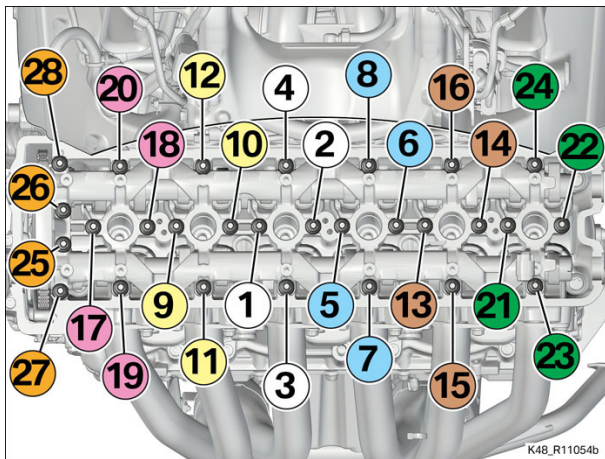

K48_R11054b

Camshaft bearing cap to cylinder head

M6	tighten uniformly, working from the inside toward the outside	
	10 Nm	

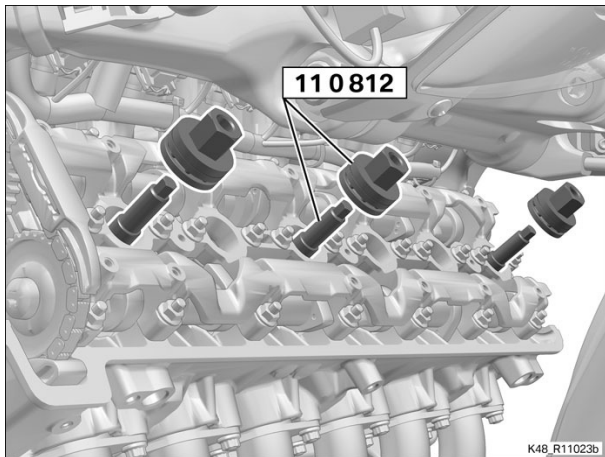

K48_R11023b

- Remove stud bolts with thrust nuts (No. 11 0 812) from the spark-plug bores.

(-) Installing timing chain tensioner

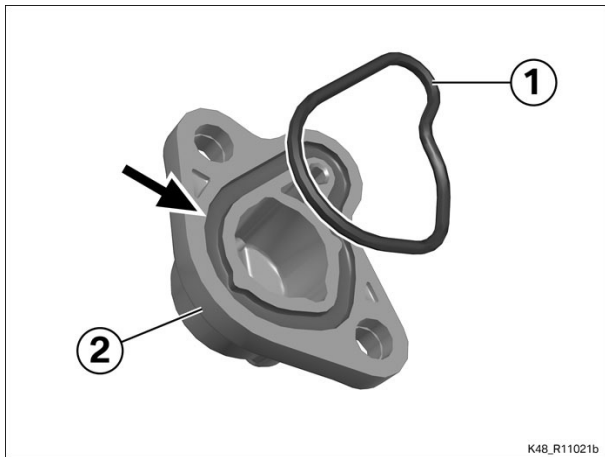

K48_R11021b

- Check sealing ring (1) for damage; replace if necessary.
- Position sealing ring (1) in the groove (arrow) of cover (2).

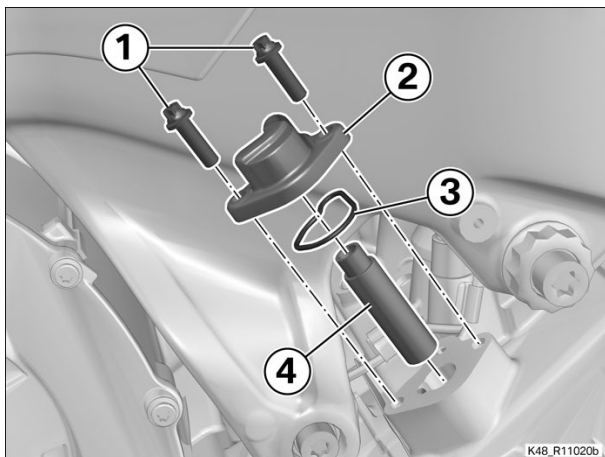

K48_R11020b

- Install timing-chain tensioner (4).
- Install cover (2) with sealing ring (3) and install screws (1).

 Tightening torques		
Cover of chain tensioner to cylinder head		
M6 x 20	8 Nm	

(-) Removing locating pin

- Remove locating pin (No. 11 0 811).

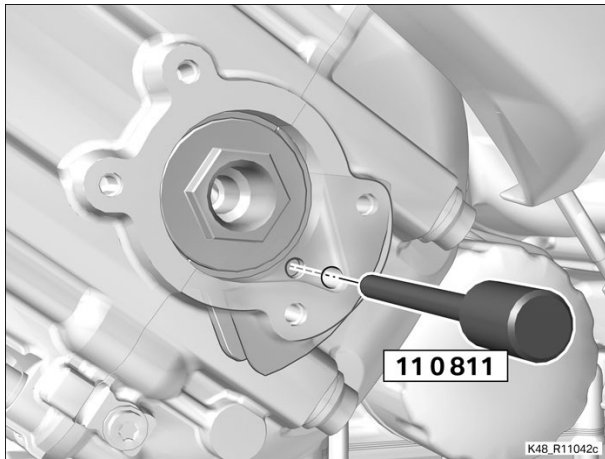

Finishing work

- Installing crankshaft cover
- Installing left drop-protection pad
- Installing intake manifold
- Securing wiring harness for engine
- Installing cylinder head cover
- Installing spark plugs
- Installing direct ignition coils
- Securing distributor rail for secondary air system
- Installing air guide
- Installing complete radiator
- Filling and priming cooling system
- Installing right silencer
- Securing clamp on right silencer
- Installing right catalytic-converter shield
- Installing left silencer
- Securing clamp on left silencer
- Installing left catalytic-converter shield
- Installing fuel tank
- Installing complete intake air silencer
- Securing left and right intake air pipes
- Securing seat support
- Installing adjusting plate
- Installing right stowage compartment
- Installing inner trim for right side panel
- Install the right side panel
- Install the right radiator cowl
- Installing right bottom side panel
- Installing inner trim for left side panel
- Installing left side panel
- Installing radiator hose cover
- Installing left radiator cowl
- Installing left bottom side panel

Installing complete cover of fuel tank
Installing air guides for intake air pipes, left and right
Installing front seat
Final check of work performed

📁 11 12 256 Removing/installing and sealing or replacing cylinder-head cover 16 FRUs

+ 11 12 821

Preparatory work

- Removing left bottom side panel
- Removing left radiator cowl
- Removing radiator hose cover
- Removing left side panel
- Removing right bottom side panel
- Removing right radiator cowl
- Remove the right side panel
- Draining cooling system
- Removing complete radiator
- Removing air guide
- Disconnecting distributor rail for secondary air system
- Removing direct ignition coils

Core activity

(-) Removing cylinder head cover

- Disconnect plug (1) for the camshaft sensor.
- Remove screws (2) with seals (3).

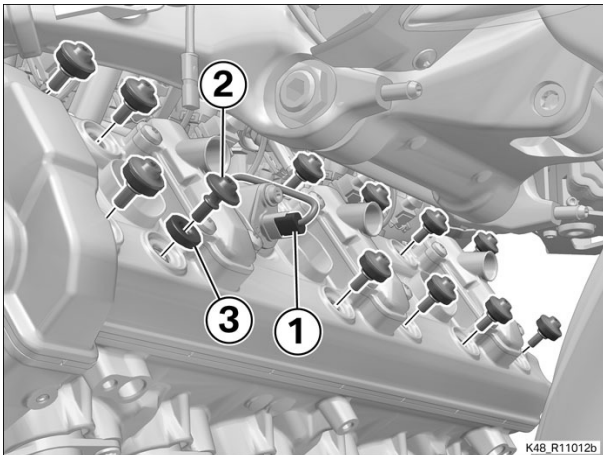

- Remove cylinder-head cover (1) with gasket (2).

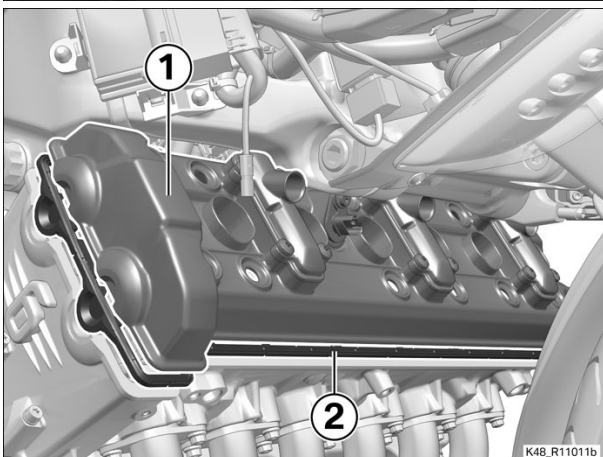

- Remove seal (1).

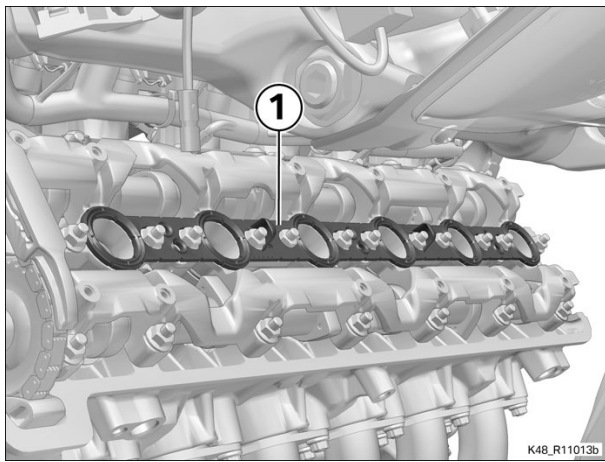

K48_R11013b

(-) Installing cylinder head cover

- Check the gasket for damage; replace if necessary.
- Apply surface sealant to the corners (arrows) of the half moons.

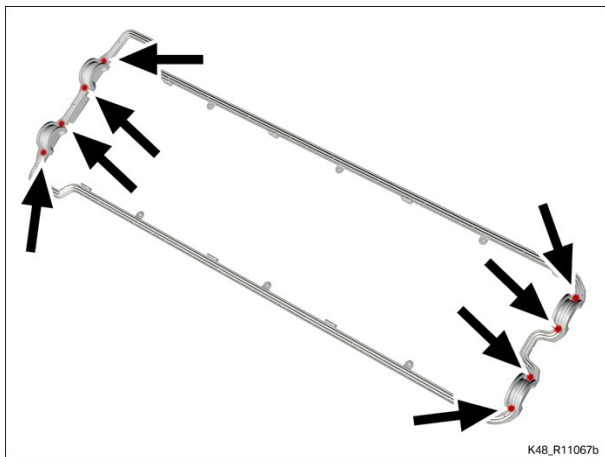

K48_R11067b



Fluids and lubricants

Dow Corning

Surface sealant

07 58 0 397
777

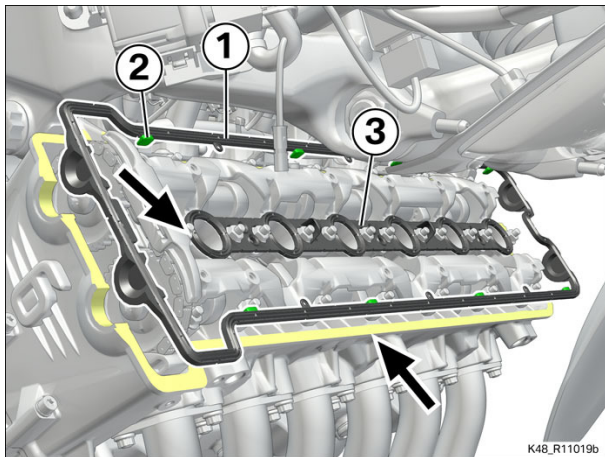

K48_R11019b

- Check gasket (3) for damage; replace if necessary.
- Clean the sealing faces (arrows) on the cylinder head.
- Lay large gasket (1) in position on the cylinder head, noting the position of the tabs (2) inside the cylinder head.
- Place gasket (3) in position.

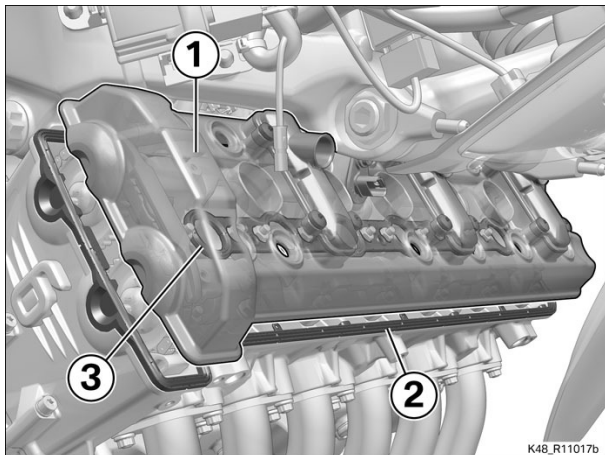

K48_R11017b

- Place cylinder-head cover (1) in position.
- Make sure that gaskets (2) and (3) do not slip out of position and are not pinched out of shape.

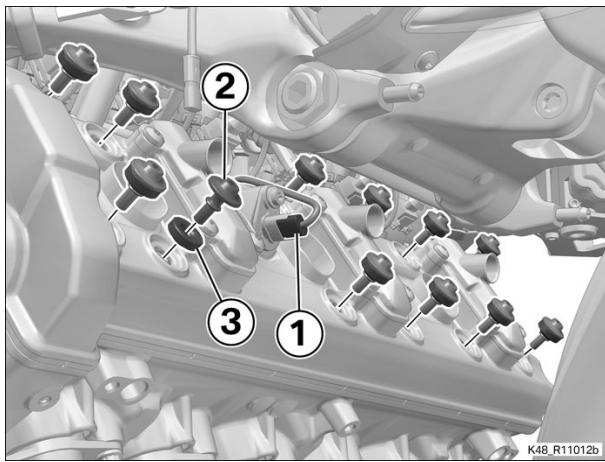

Install screws (2) with seals (3).



Tightening torques

Cylinder head cover to cylinder head (camshaft bearing cap)

M6 x 20

10 Nm

- Connect plug (1) for the camshaft sensor.

Finishing work

- Installing direct ignition coils
- Securing distributor rail for secondary air system
- Installing air guide
- Installing complete radiator
- Filling and priming cooling system
- Install the right side panel
- Install the right radiator cowl
- Installing right bottom side panel
- Installing left side panel
- Installing radiator hose cover
- Installing left radiator cowl
- Installing left bottom side panel
- Final check of work performed

11 13 000 Removing/installing or sealing oil pan 27 FRUs

+ 11 13 531

Preparatory work

- Remove the front seat
- Draining engine oil
- Removing left fuel-tank cover top section
- Removing left cover of fuel tank
- Removing gearbox cover
- Removing left catalytic-converter shield
- Removing left oxygen sensor
- Disengaging clamp on left silencer
- Removing left silencer
- Removing left radiator cowl
- Removing exhaust manifold, left
- Removing right fuel-tank cover top section
- Remove the right fuel-tank cover
- Removing right radiator cowl
- Remove the right side panel
- Draining cooling system
- Disconnecting feed line for coolant
- Removing right catalytic-converter shield
- Removing right oxygen sensor
- Disengaging clamp on right silencer
- Removing right silencer
- Removing exhaust manifold, right

Core activity

(-) Removing oil pan

- Remove screws (1).

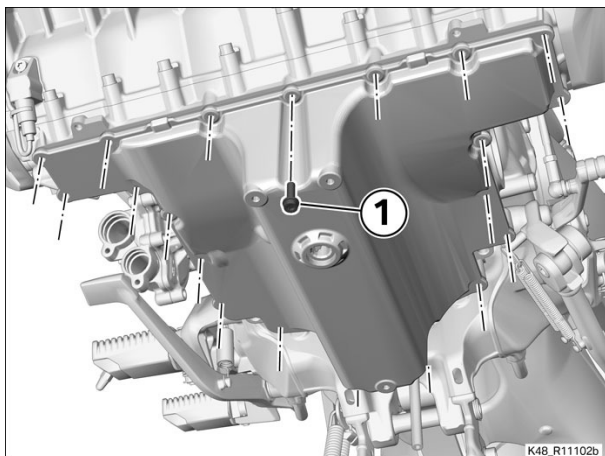

- Remove oil pan (1) and gasket (2).

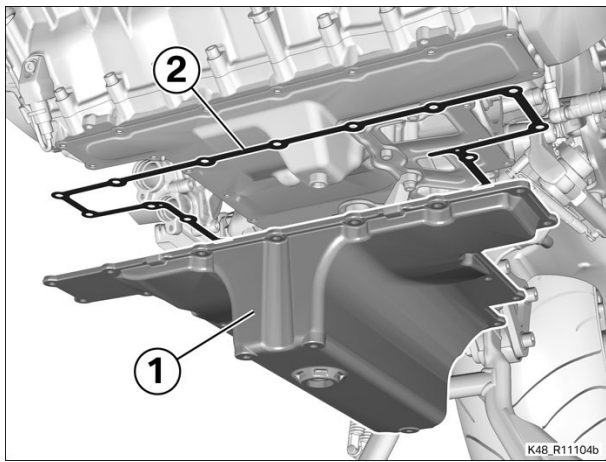

(-) Removing suction pipe for engine oil

- Remove screws (1).
- Remove intake (2), noting O-ring (3).

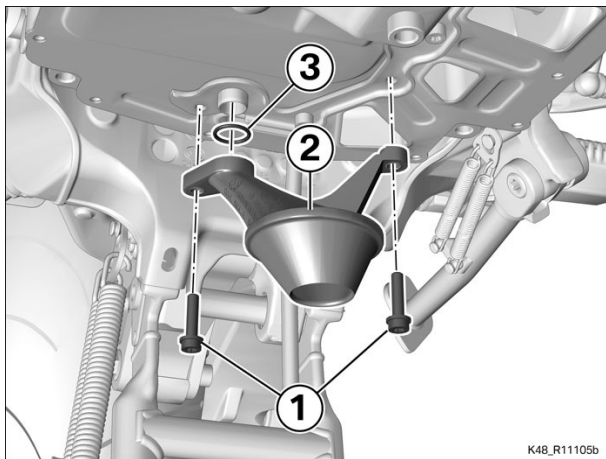

(-) Removing sump plate

- Remove screws (1).
- Remove reinforcement (2).

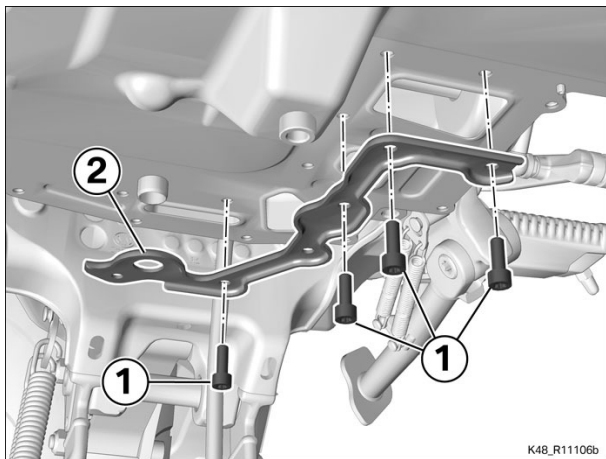

- Remove sump plate (1) and gasket (2).

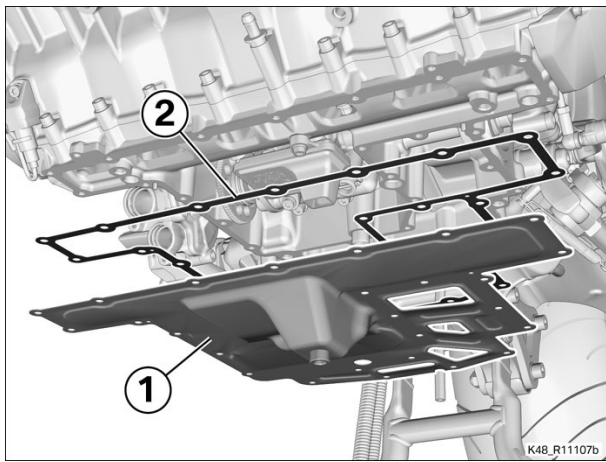

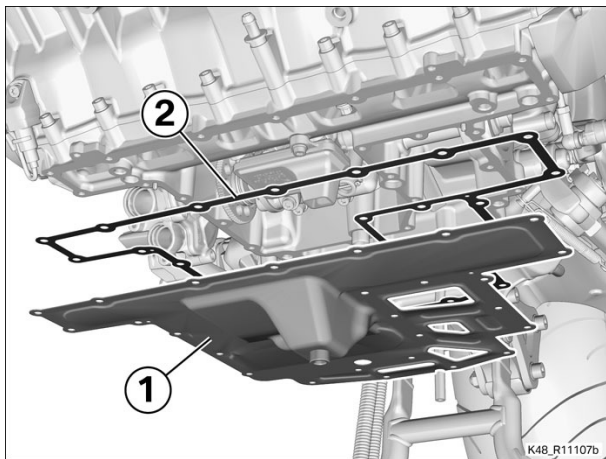

(-) Installing sump plate

- Place new gasket (2) and sump plate (1) in position.

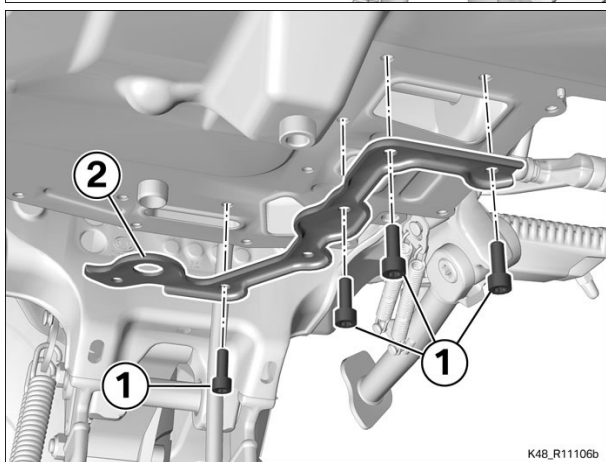

- Hold reinforcement (2) in position.
- Install screws (1).



 Tightening torques		
Reinforcement/sump plate to oil pan		
M6 x 16	10 Nm	

(-) Installing suction pipe for engine oil

- Check O-ring (3) for damage; replace if necessary.
- Hold suction pipe (2) with O-ring (3) in position.
- Install screws (1).

 Tightening torques		
Suction pipe to crankcase (lube-oil pump)		
M6 x 25	10 Nm	

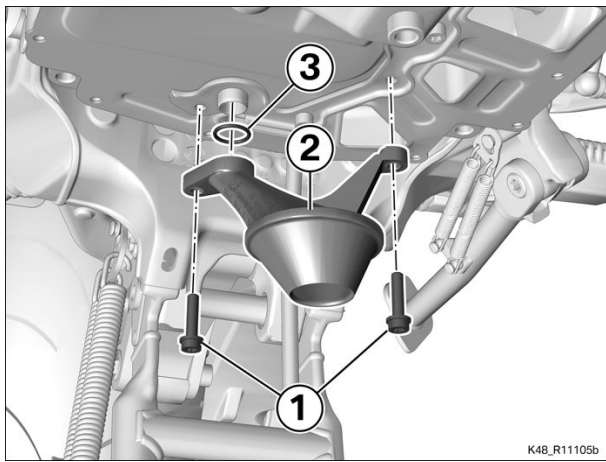

(-) Installing oil pan

- Clean the tapped holes.
- Place new gasket (2) and oil pan (1) in position.

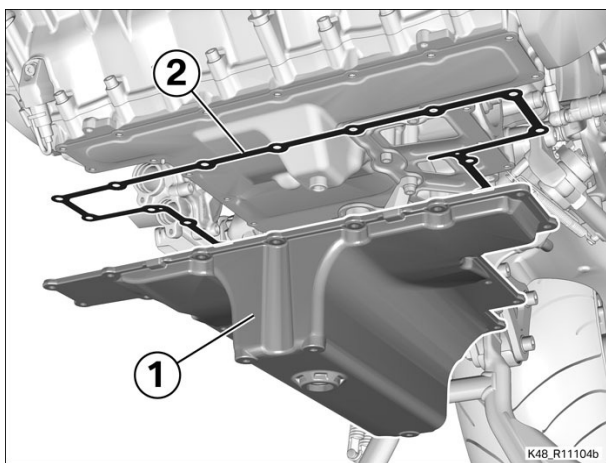

- Install new screws (1), but do not tighten at this point.

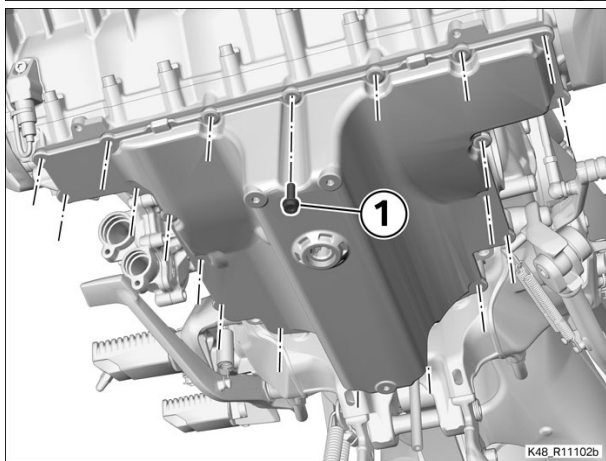

- Tighten screws (1).

 Tightening torques		
Oil pan with sump plate to crankcase		
M6 x 20, Replace screw Micro-encapsulated	Start at the middle and work outward when tightening	
	10 Nm	

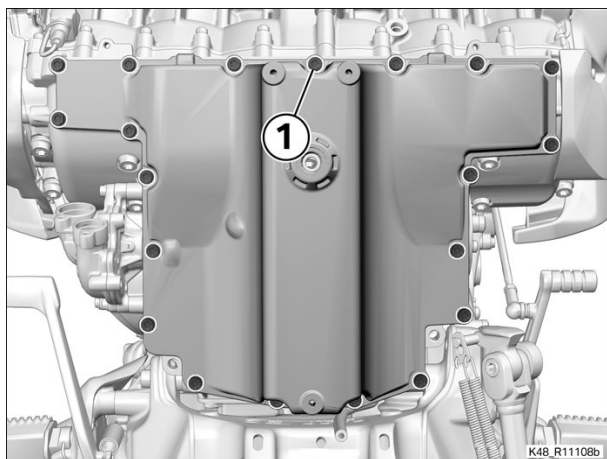

Finishing work

- Connecting feed line for coolant
- Filling and priming cooling system
- Installing exhaust manifold, right
- Installing right silencer
- Securing clamp on right silencer
- Installing right oxygen sensor
- Installing right catalytic-converter shield
- Install the right side panel
- Install the right radiator cowl
- Installing right fuel-tank cover
- Installing right fuel-tank cover top section
- Installing exhaust manifold, left
- Installing left radiator cowl
- Installing left silencer
- Securing clamp on left silencer
- Installing left oxygen sensor
- Installing left catalytic-converter shield
- Installing gearbox cover
- Installing left cover of fuel tank
- Installing left fuel-tank cover top section
- Installing front seat
- Pouring in engine oil
- Final check of work performed

11 14 003 Replacing valve-gear cover 5 FRUs

+ 11 14 802

Equipment trim-level variant:

0266 - Preparation for audio system and navigation device

0267 - ECE audio system and preparation for navigation system

Preparatory work

Removing right bottom side panel

Removing right drop-protection pad

Core activity

(-) Removing timing-gear cover

- Remove screws (1).
- Remove timing-gear cover (2) and sleeves (3).

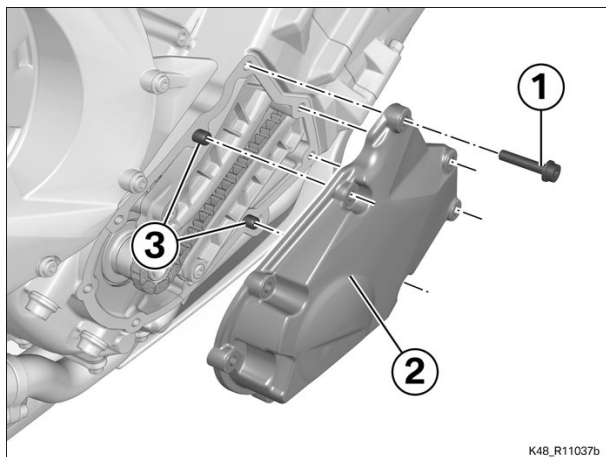

(-) Installing timing-gear cover

- Clean the sealing face (arrow) on the engine and in timing-gear cover (2).
- Apply a thin bead of sealing compound to the sealing face (arrow) of the engine block.

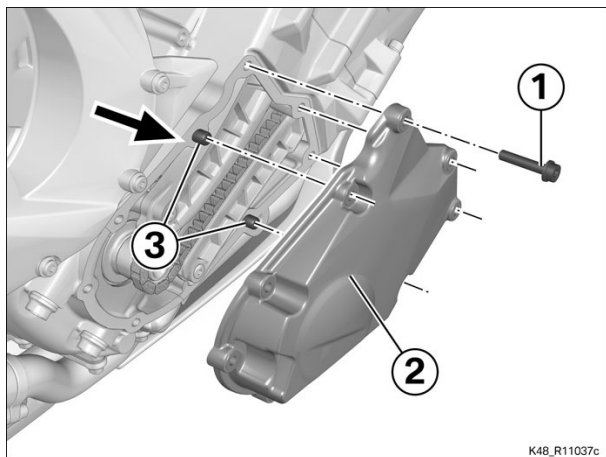

 Fluids and lubricants		
Dow Corning	Surface sealant	07 58 0 397 777

- Install sleeves (3).
- Install timing-gear cover (2).
- Install screws (1).

 Tightening torques		
Cover of timing gear (with drop-protection pad) to crankcase		
M6 x 30	10 Nm	

Finishing work

Installing right drop-protection pad

Installing right bottom side panel

Final check of work performed

11 14 004 Replacing right drop-protection pad 2 FRUs

+ 11 14 872

Equipment trim-level variant:

0266 - Preparation for audio system and navigation device

0267 - ECE audio system and preparation for navigation system

Preparatory work

Removing right bottom side panel

Core activity

(-) Removing right drop-protection pad

- Remove screw (1) and screws (2).
- Remove outer shell (3) with rubber damper (4).

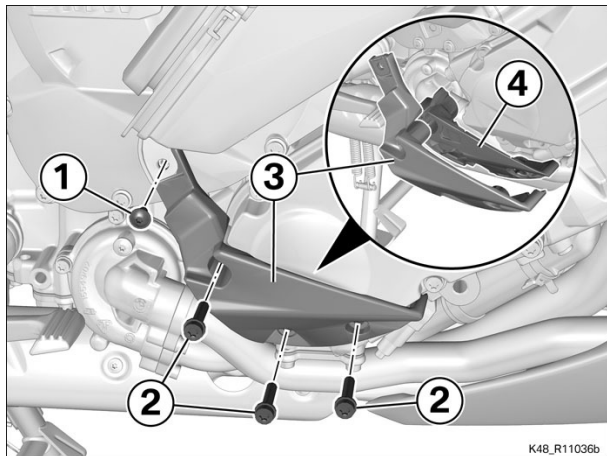



(-) Replacing drop-protection pad

- Transfer the necessary small items to the new drop-protection pad.

(-) Installing right drop-protection pad

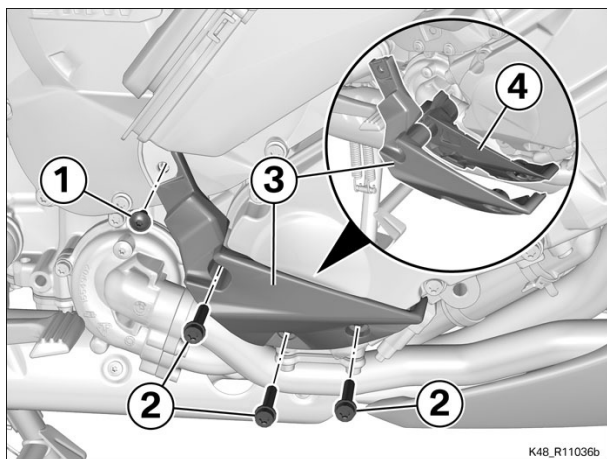
- Hold outer shell (3) with rubber damper (4) in position.
- Install screws (2) and screw (1).



 Tightening torques		
Cover of timing gear (with drop-protection pad) to crankcase		
M6 x 30	10 Nm	

Finishing work

Installing right bottom side panel

Final check of work performed

11 14 005 Replacing left drop-protection pad 2 FRUs

+ 11 14 873

Core activity

(-) Removing left drop-protection pad

- Remove screws (1) and (2).
- Remove outer shell (3) with rubber damper (4).

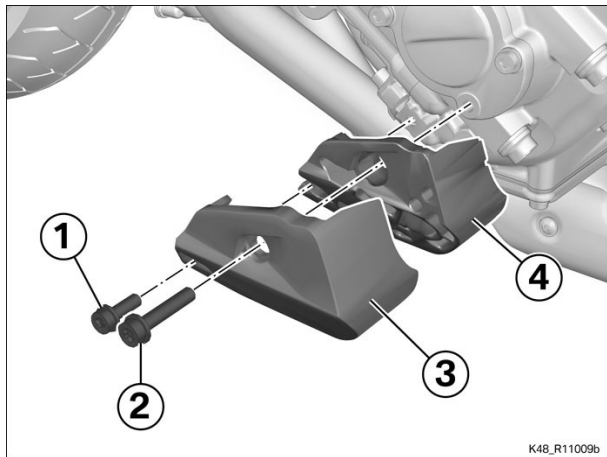

(-) Installing left drop-protection pad

- Hold rubber damper (4) with outer shell (3) in position.
- Install screws (1) and (2).

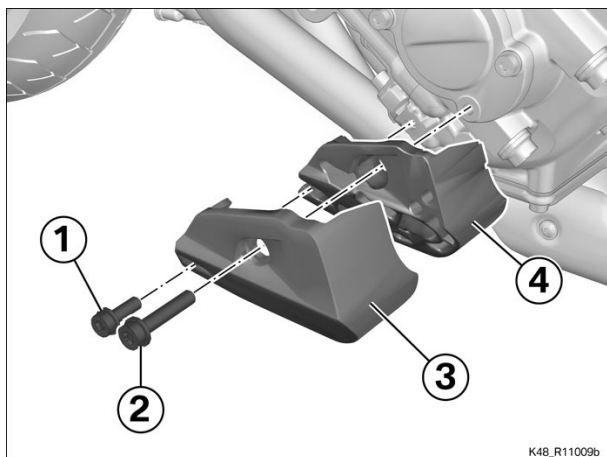

Tightening torques		
Drop-protection pad, left, to crankcase		
M6 x 18	10 Nm	
M6 x 30	10 Nm	

Finishing work

Final check of work performed

 **11 14 006 Replacing oil tank cap 18 FRUs**

+ 11 14 874

Equipment trim-level variant:

0416 - Electronic Suspension Adjustment (ESA)

Preparatory work

- Remove the front seat
- Removing left rear trim panel
- Removing left footrest plate
- Removing right footrest plate
- Removing number-plate carrier
- Remove the rear wheel
- Removing rear brake caliper
- Releasing **Paralever** link at rear
- Lowering bevel gears
- Removing flexible gaiter for bevel bears
- Removing universal shaft
- Removing rear wheel swinging arm
- Removing adjusting plate
- Removing seat support
- Removing spring strut
- Draining engine oil
- Removing oil-level/oil-temperature sensor

Core activity

(-) Removing oil-tank cap

- Disengage cable (1) for the oxygen sensor from holder (2).

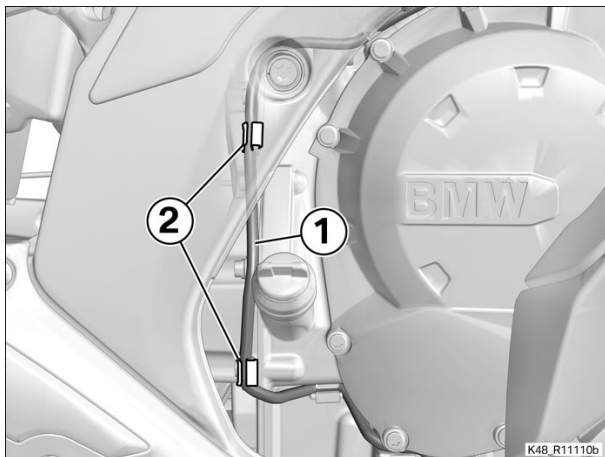

- Remove screws (1) and remove holder (2) for the breather line.
- Disengage oil-tank cap (3).

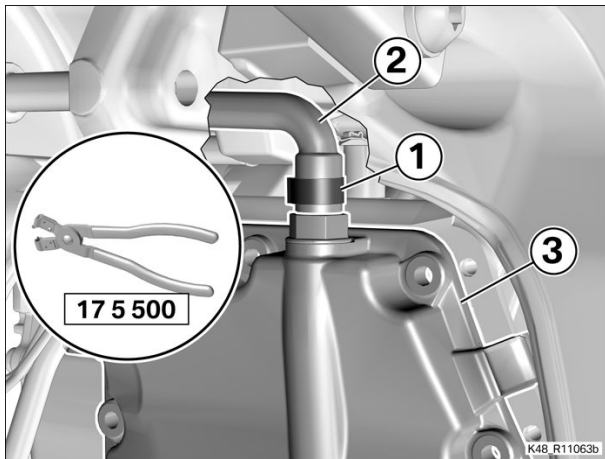
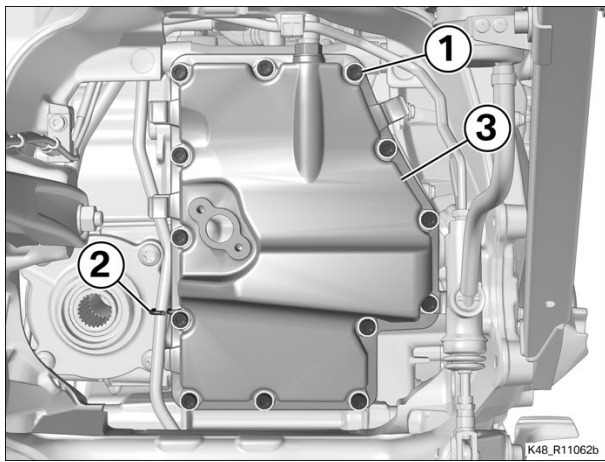

- Open clip (1) with pliers (No. 17 5 500).
- Disconnect oil return hose (2).
- Remove oil-tank cap (3).

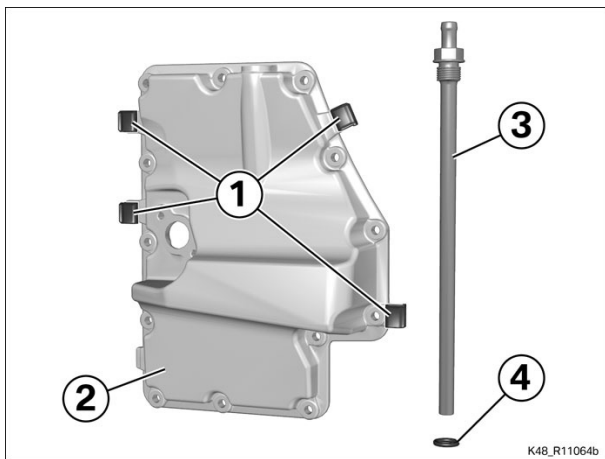

(-) Replacing oil tank cap

- Transfer holders (1) to new oil tank cap (2).
- Remove oil return pipe (3) with O-ring (4).
- Check O-ring (4); replace if necessary.
- Install oil return pipe (3) with O-ring (4) in new oil tank cap (2).

 Tightening torques		
Return adapter in oil reservoir cap		
M16 x 1.5	6 Nm	

(-) Installing oil-tank cap

- Clean the sealing face on the engine block (arrow).
- Apply a thin bead of sealing compound to the sealing face of the engine block (arrow).

 Fluids and lubricants		
Dow Corning	Surface sealant	07 58 0 397 777

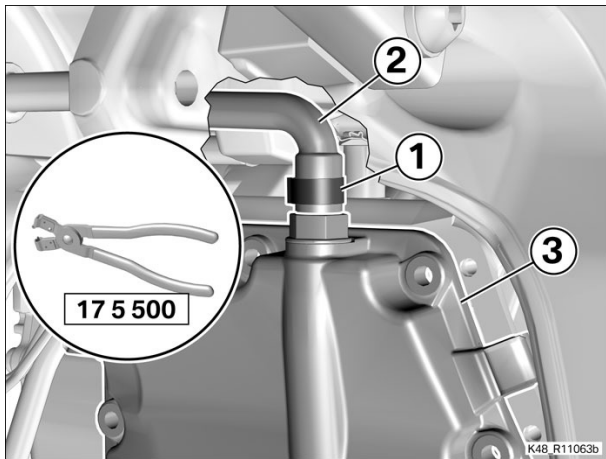
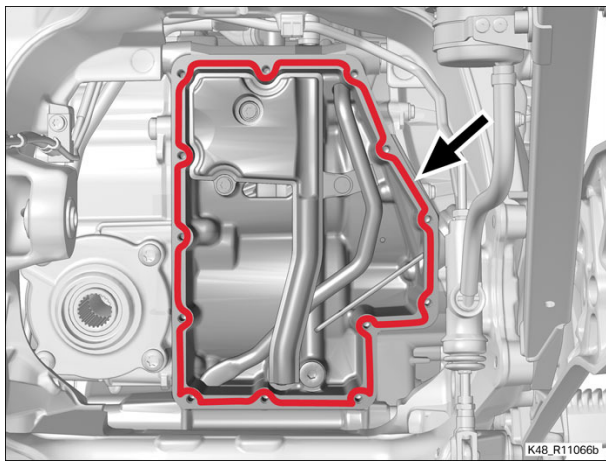

- Clean the sealing face of oil-tank cap (3).
- Install oil-tank cap (3)
- Connect oil return hose (2) with clip (1).
- Install clip (1) with pliers (No. 17 5 500).

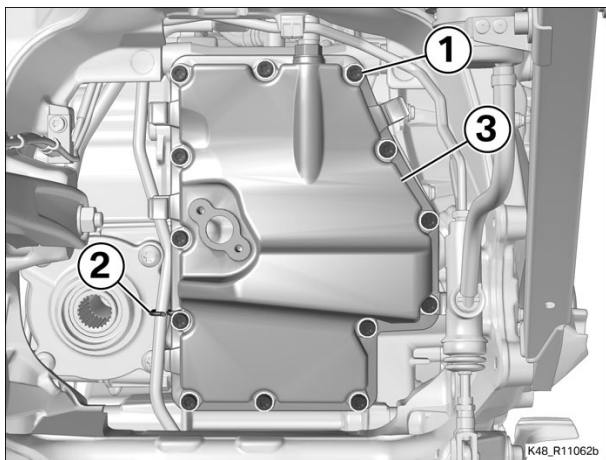

- Install oil-tank cap (3)
- Hold bracket for breather line (2) in position and install screws (1).

 Tightening torques		
Cover of oil tank to crankcase		
M6 x 25	tighten in diagonally opposite sequence	
	10 Nm	

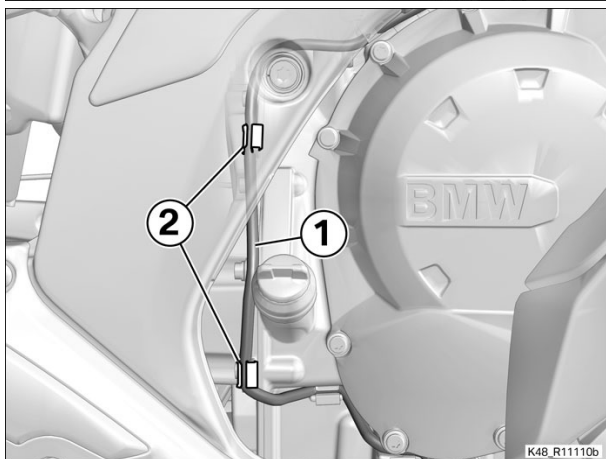

- Route cable (1) for the oxygen sensor and secure it in holder (2).

Finishing work

Installing oil-level/oil-temperature sensor
Installing spring strut
Installing seat support
Installing adjusting plate
Installing rear swinging arm
Installing universal shaft
Swinging bevel gears up
Securing **Paralever** link at rear
Securing rear brake caliper
Installing rear wheel
Installing number-plate carrier
Installing left footrest plate
Installing right footrest plate
Installing left rear trim panel
Installing front seat
Pouring in engine oil
Final check of work performed

11 14 075 Replacing engine-block cover, left 2 FRUs

+ 11 14 858

Preparatory work

Removing left drop-protection pad

Core activity

(-) Removing crankshaft cover

- Remove screws (1).
- Remove crankshaft cover (2) with sealing ring (3).

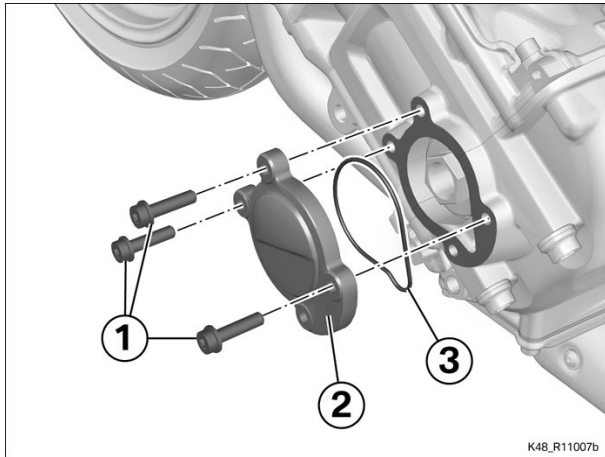

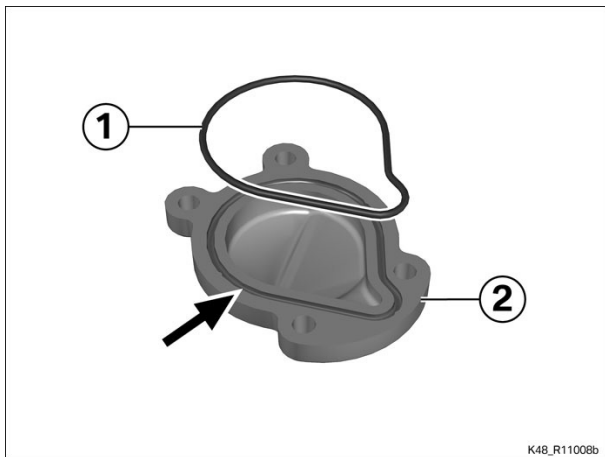

(-) Installing crankshaft cover

- Check sealing ring (1) for damage; replace if necessary.
- Position sealing ring (1) in the groove (arrow) of crankshaft cover (2).

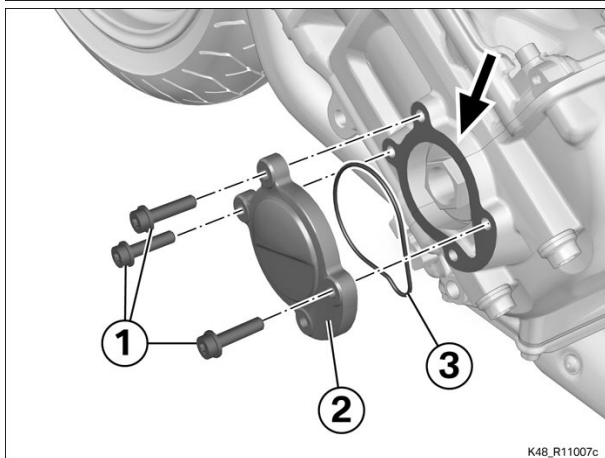

- Clean the sealing face (arrow).
- Place crankshaft cover (2) with sealing ring (3) in position.
- Install screws (1).



 Tightening torques		
Crankshaft cover to crankcase		
M6 x 25	10 Nm	

Finishing work

Installing left drop-protection pad

Final check of work performed

11 14 085 Replacing right engine-block cover 6 FRUs

+ 11 14 859

Equipment trim-level variant:

0266 - Preparation for audio system and navigation device

0267 - ECE audio system and preparation for navigation system

Preparatory work

Removing right bottom side panel

Disengaging right stowage compartment

Removing right drop-protection pad

Core activity

(-) Removing right crankcase cover

- Remove screws (1).

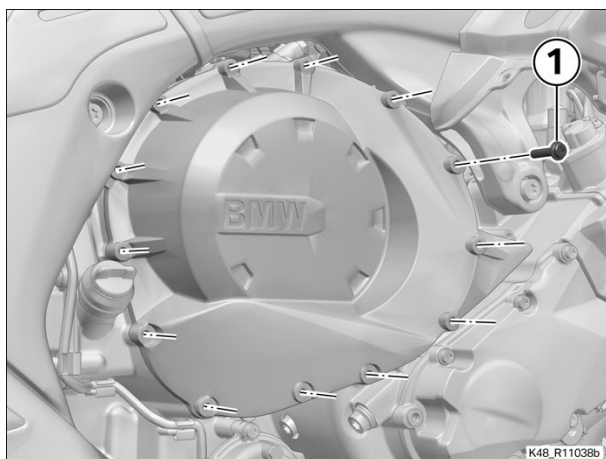

- Remove crankcase cover (1) with gasket (2).
- Remove sleeves (3).

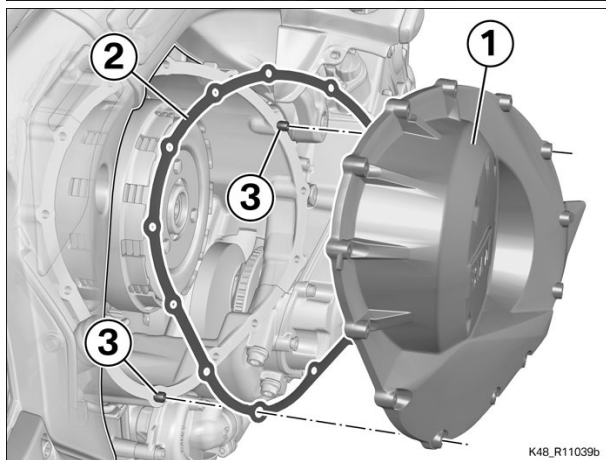

(-) Removing right crankcase cover

- Install the following components from the old right crankcase cover in the new cover:
 - Only remove screws (1)
 - Check damper (3) for damage; replace if necessary.
 - Retaining plate (2) and damper (3)
- Clean the tapped holes.
- Install new screws (1).

 Tightening torques	
Vibration damper to clutch cover	

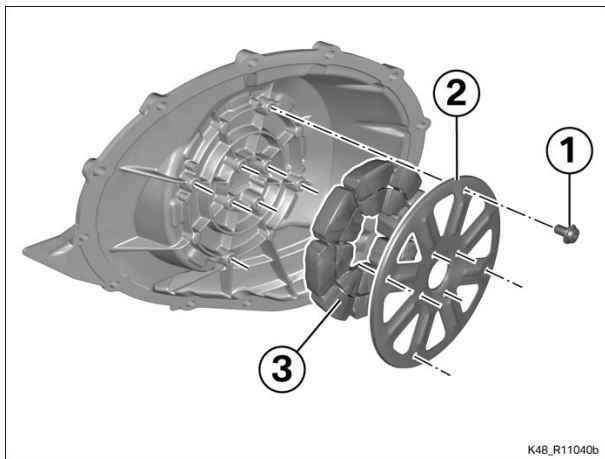

M6 x 10, Replace screw Micro-encapsulated	5 Nm	
--	------	--

(-) Installing right crankcase cover

- Clean the sealing face.
- Install sleeves (3).
- Install crankcase cover (1) with gasket (2).

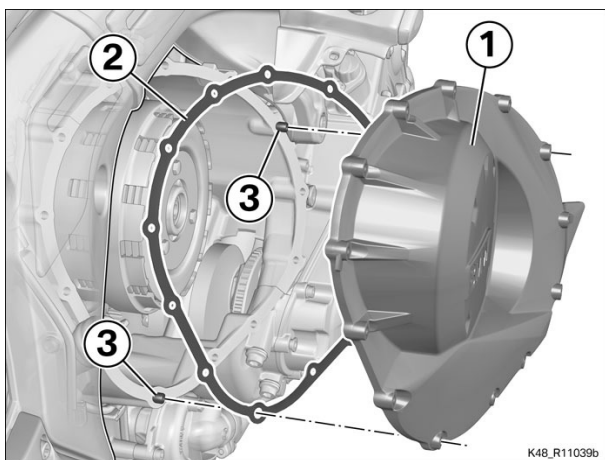

- Install new screws (1) but **do not tighten**.

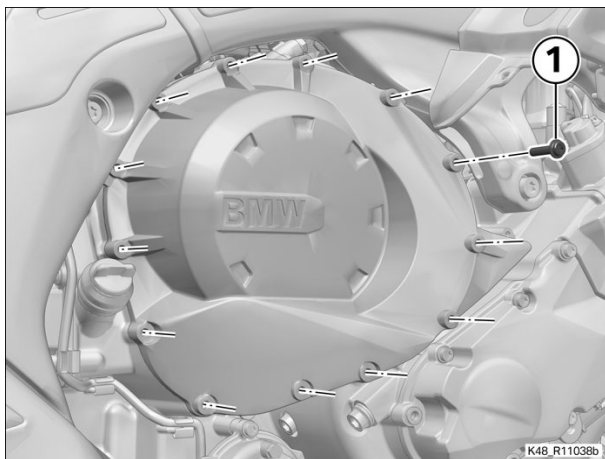

- Tighten screws (1) to (13) in the specified sequence to the specified initial torque.

 Tightening torques		
Clutch cover to crankcase (initial torque)		
M6 x 25, Replace screw	Initial torque, 3 Nm	

- Tighten screws (5) to (13) in the specified sequence to jointing torque and final torque.

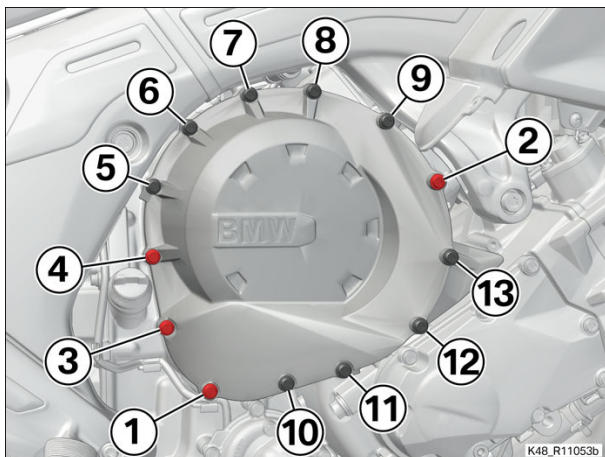

 Tightening torques		
Clutch cover to crankcase		

M6 x 25	Closing torque, 3 Nm	
	Final torque, 90°	

- Tighten screws (1) to (4) in the specified sequence to jointing torque and final torque.

 Tightening torques		
Clutch cover to crankcase		
M6 x 25	Closing torque, 3 Nm	
	Final torque, 30°	

Finishing work

Installing right drop-protection pad

Securing right stowage compartment

Installing right bottom side panel

Final check of work performed

11 15 001 Replacing breather tube for crankcase 6 FRUs

+ 11 15 552

Preparatory work

- Remove the front seat
- Removing air guides for intake air pipes, left and right
- Removing complete cover of fuel tank
- Removing left and right intake air pipes
- Removing adjusting plate
- Disengaging seat support
- Disengaging left and right intake air pipes
- Removing complete intake air silencer

Core activity

(-) Removing breather tube for crankcase

- Open clip (1) with pliers (No. 17 5 571) and disconnect breather hose (2).

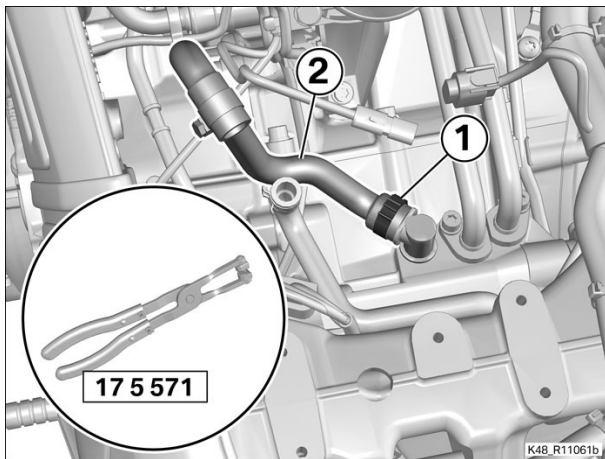

(-) Installing breather tube for crankcase

- Connect breather hose (2) and close hose clip (1) with pliers (No. 17 5 571).

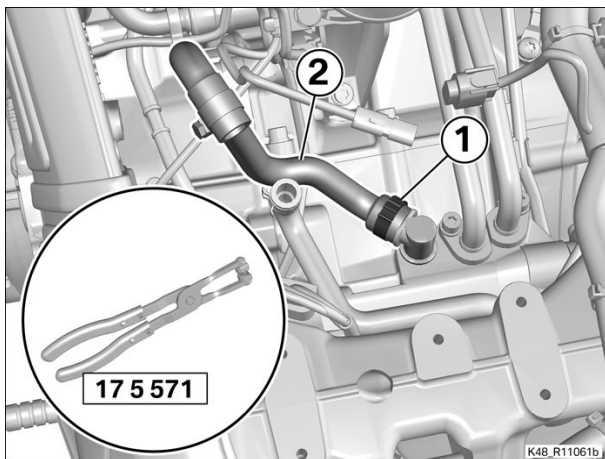

Finishing work

- Installing complete intake air silencer
- Securing left and right intake air pipes
- Securing seat support
- Installing adjusting plate
- Installing left and right intake air pipes
- Installing complete cover of fuel tank

Installing air guides for intake air pipes, left and right

Installing front seat

Final check of work performed

11 31 080 Removing/installing or replacing timing-chain tensioner 4 FRUs

+ 11 31 780

Equipment trim-level variant:

- 0266 - Preparation for audio system and navigation device
- 0267 - ECE audio system and preparation for navigation system
- 0417 - Central locking

Preparatory work

- Removing right bottom side panel
- Removing right radiator cowl
- Remove the right side panel
- Removing right stowage compartment

Core activity

(-) Removing timing-chain tensioner

- Remove screws (1) and remove cover (2) with sealing ring (3).
- Remove timing-chain tensioner (4).

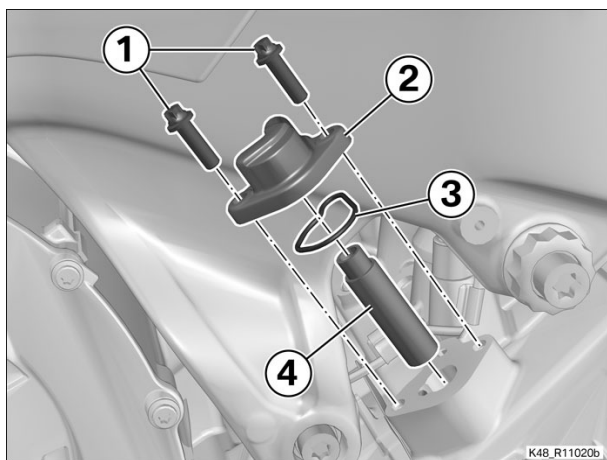

(-) Installing timing chain tensioner

- Check sealing ring (1) for damage; replace if necessary.
- Position sealing ring (1) in the groove (arrow) of cover (2).

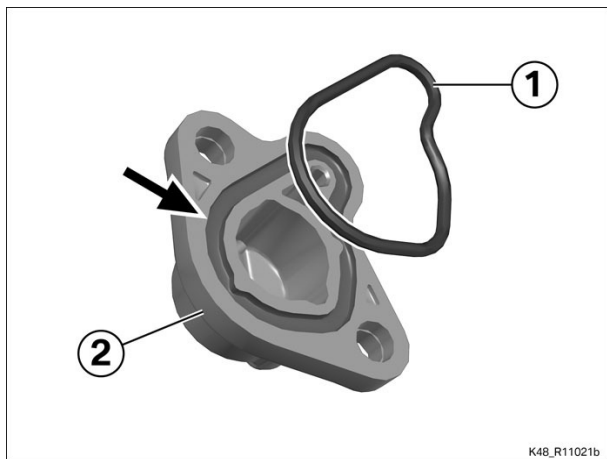

- Install timing-chain tensioner (4).
- Install cover (2) with sealing ring (3) and install screws (1).

 Tightening torques		
Cover of chain tensioner to cylinder head		
M6 x 20	8 Nm	

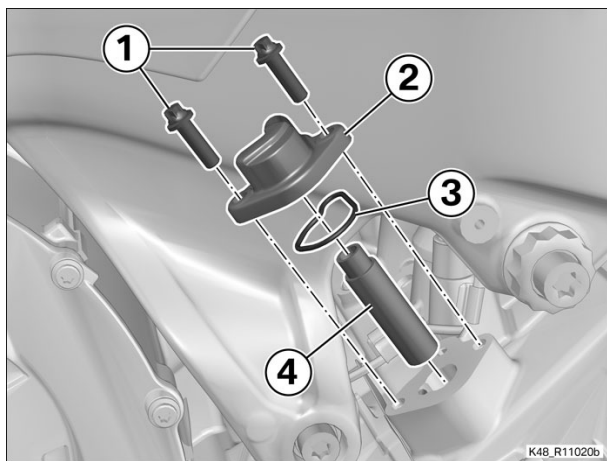

Finishing work

Installing right stowage compartment

Install the right side panel

Install the right radiator cowl

Installing right bottom side panel

Final check of work performed

📁 11 31 101 Replacing timing chain tensioning rail

+ 11 31 783

Equipment trim-level variant:

0266 - Preparation for audio system and navigation device

0267 - ECE audio system and preparation for navigation system

0417 - Central locking

Preparatory work

Removing left bottom side panel

Removing left radiator cowl

Removing radiator hose cover

Removing left side panel

Removing right bottom side panel

Removing right radiator cowl

Remove the right side panel

Draining cooling system

Removing complete radiator

Removing air guide

Disconnecting distributor rail for secondary air system

Removing direct ignition coils

Removing cylinder head cover

Removing right stowage compartment

Setting engine to TDC

Locking engine at TDC

Removing timing-chain tensioner

Removing bearing cap for camshafts

Removing O-rings for camshaft bearing cap

Core activity

(-) Removing camshafts

- Mark the positions of sprocket (1) of exhaust camshaft and sprocket (2) of inlet camshaft relative to timing chain (3) (arrows).

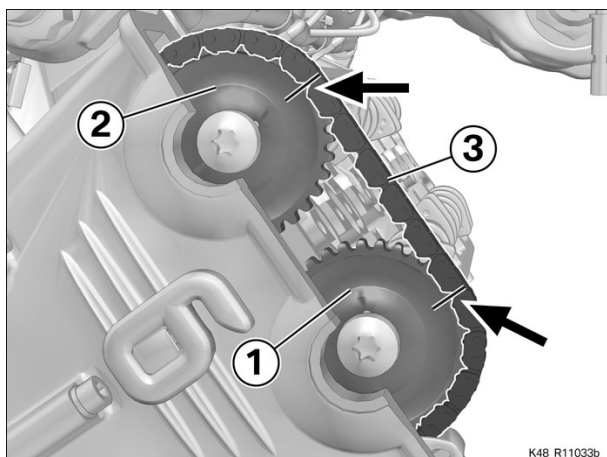

- Work exhaust camshaft (1) and inlet camshaft (with multi-pole sensor gear for camshaft sensor) (2) out of timing chain (3) and remove.
- Secure timing chain (3) in a suitable way to prevent it dropping out.

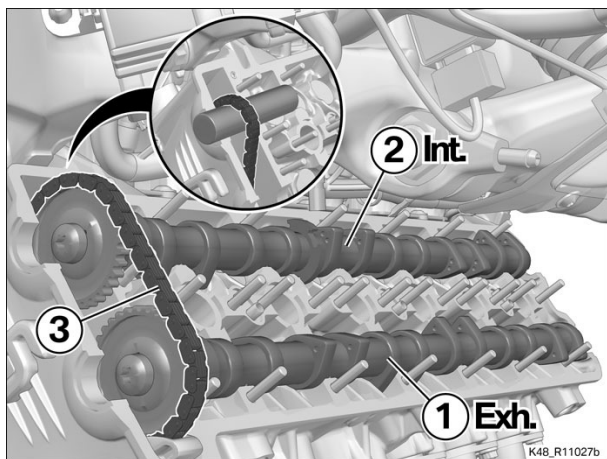

(-) Removing right drop-protection pad

- Remove screw (1) and screws (2).
- Remove outer shell (3) with rubber damper (4).

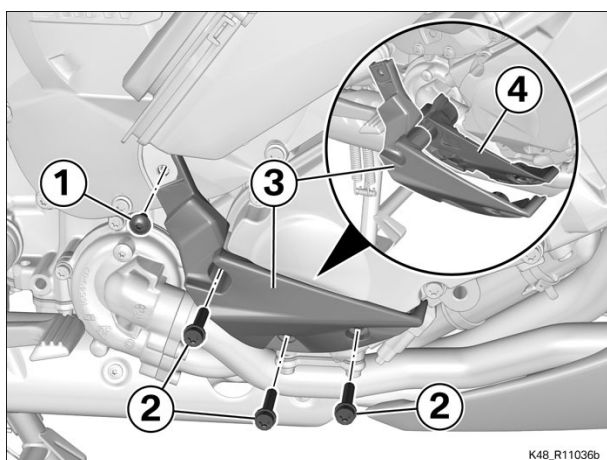

(-) Removing timing-gear cover

- Remove screws (1).
- Remove timing-gear cover (2) and sleeves (3).

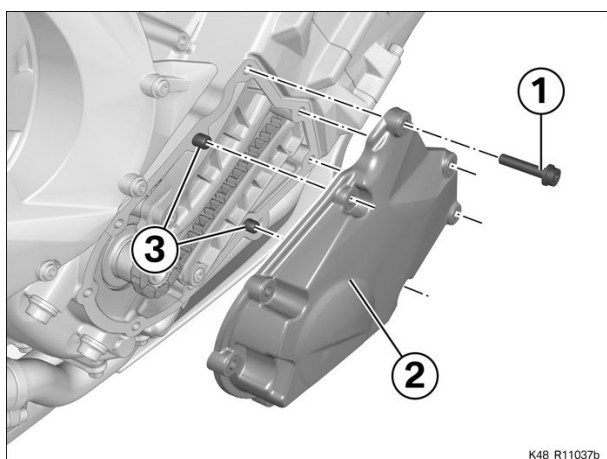

(-) Removing timing-chain tensioning rail

- Remove pivot-bearing screw (1).

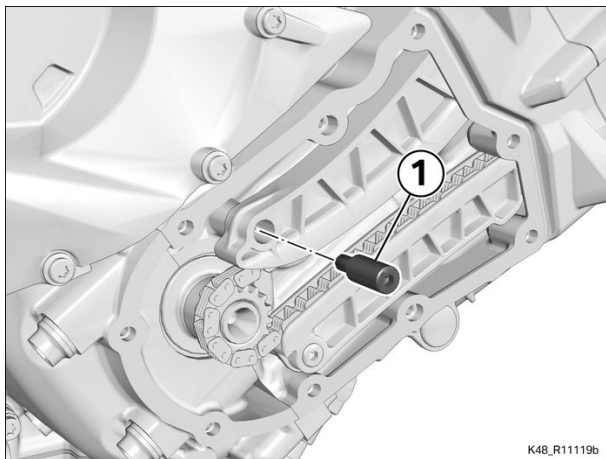

- Lift out timing-chain tensioning rail (1).

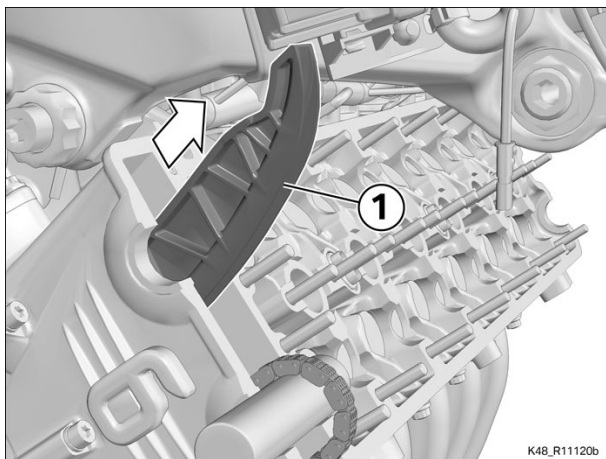

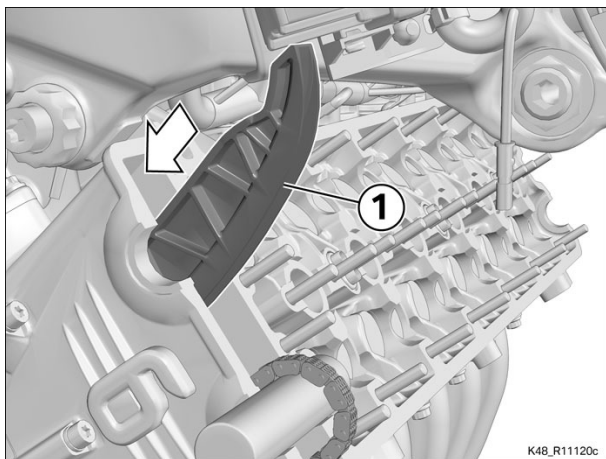

(-) Installing timing-chain tensioner rail

- Insert timing chain tensioning rail (1) from above.

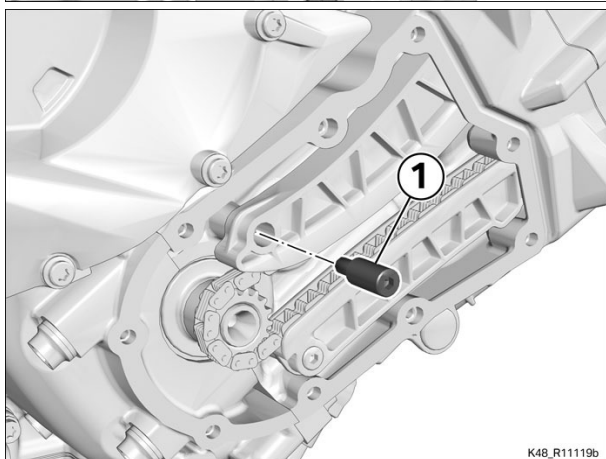

- Install pivot bearing screw (1).



 Tightening torques		
Timing-chain rail to crankcase		
M6 x 30	8 Nm	

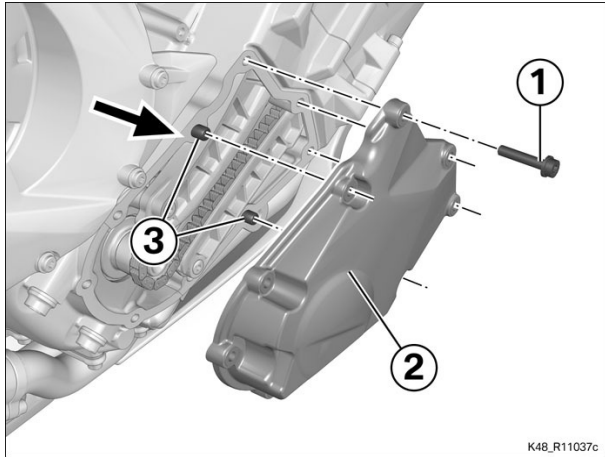

(-) Installing timing-gear cover

- Clean the sealing face (arrow) on the engine and in timing-gear cover (2).
- Apply a thin bead of sealing compound to the sealing face (arrow) of the engine block.

 Fluids and lubricants		
Dow Corning	Surface sealant	07 58 0 397 777

- Install sleeves (3).
- Install timing-gear cover (2).
- Install screws (1).

 Tightening torques		
Cover of timing gear (with drop-protection pad) to crankcase		
M6 x 30	10 Nm	

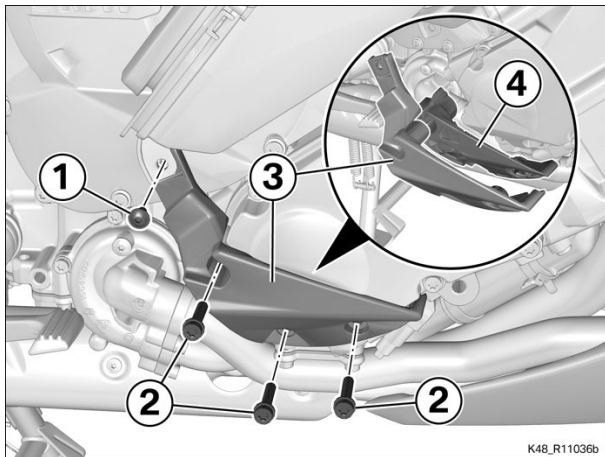

(-) Installing right drop-protection pad

- Hold outer shell (3) with rubber damper (4) in position.
- Install screws (2) and screw (1).

 Tightening torques		
Cover of timing gear (with drop-protection pad) to crankcase		
M6 x 30	10 Nm	

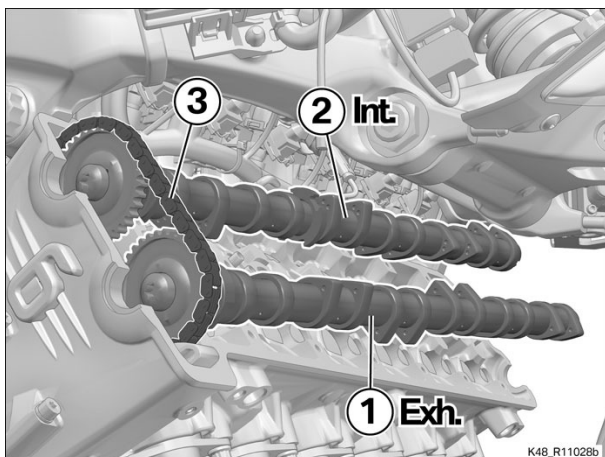

(-) Installing camshafts

- Insert inlet camshaft (with multi-pole sensor gear for camshaft sensor) (2) and exhaust camshaft (1) and loop timing chain (3) over the camshafts.

- Turn inlet camshaft (2) and exhaust camshaft (1) to top dead centre of cylinder No. 1, align them with the marks (arrows) applied before removal and engage timing chain (3) on sprockets.

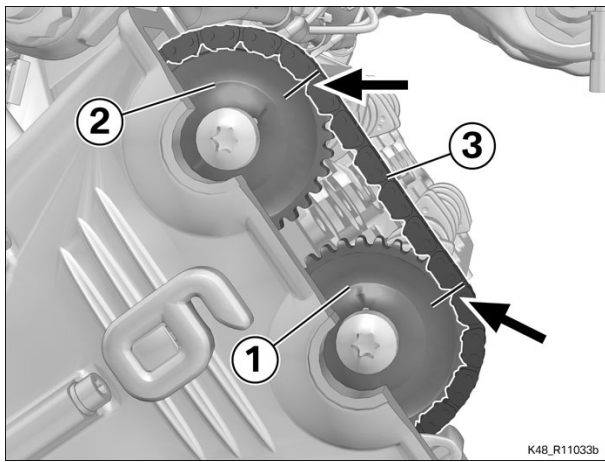

Finishing work

- Installing O-rings for camshaft bearing cap
- Installing bearing cap for camshafts
- Installing timing chain tensioner
- Removing locating pin
- Installing right stowage compartment
- Installing cylinder head cover
- Installing direct ignition coils
- Securing distributor rail for secondary air system
- Installing air guide
- Installing complete radiator
- Filling and priming cooling system
- Install the right side panel
- Install the right radiator cowl
- Installing right bottom side panel
- Installing left side panel
- Installing radiator hose cover
- Installing left radiator cowl
- Installing left bottom side panel
- Installing front seat
- Final check of work performed

📁 11 31 112 Replacing timing chain slide rails

+ 11 31 784

Equipment trim-level variant:

- 0266 - Preparation for audio system and navigation device
- 0267 - ECE audio system and preparation for navigation system
- 0417 - Central locking

Preparatory work

- Removing left bottom side panel
- Removing left radiator cowl
- Removing radiator hose cover
- Removing left side panel
- Removing right bottom side panel
- Removing right radiator cowl
- Remove the right side panel
- Draining cooling system
- Removing complete radiator
- Removing air guide
- Disconnecting distributor rail for secondary air system
- Removing direct ignition coils
- Removing cylinder head cover
- Removing right stowage compartment
- Setting engine to TDC
- Locking engine at TDC
- Removing timing-chain tensioner
- Removing bearing cap for camshafts
- Removing O-rings for camshaft bearing cap

Core activity

(-) Removing camshafts

- Mark the positions of sprocket (1) of exhaust camshaft and sprocket (2) of inlet camshaft relative to timing chain (3) (arrows).

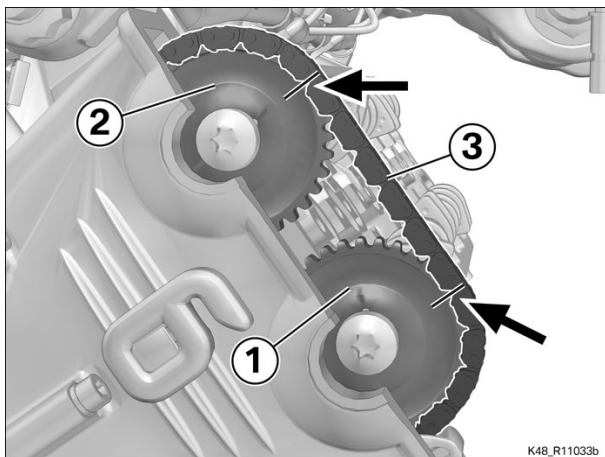

- Work exhaust camshaft (1) and inlet camshaft (with multi-pole sensor gear for camshaft sensor) (2) out of timing chain (3) and remove.
- Secure timing chain (3) in a suitable way to prevent it dropping out.

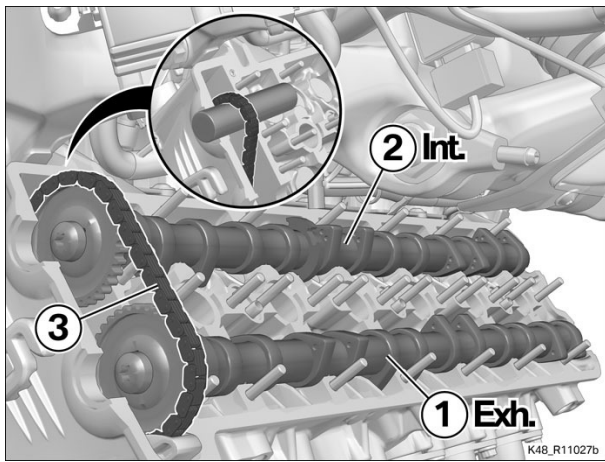

(-) Removing right drop-protection pad

- Remove screw (1) and screws (2).
- Remove outer shell (3) with rubber damper (4).

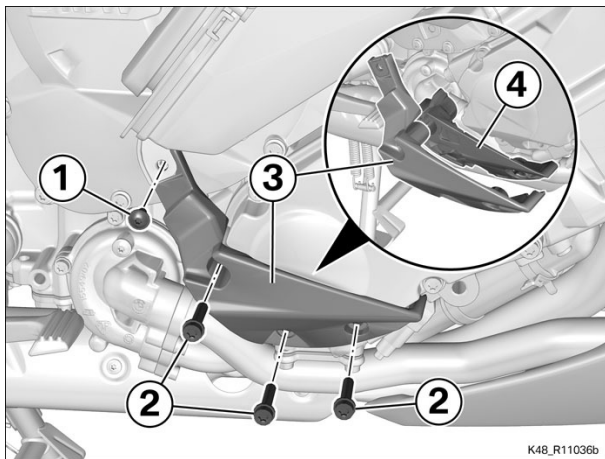

(-) Removing timing-gear cover

- Remove screws (1).
- Remove timing-gear cover (2) and sleeves (3).

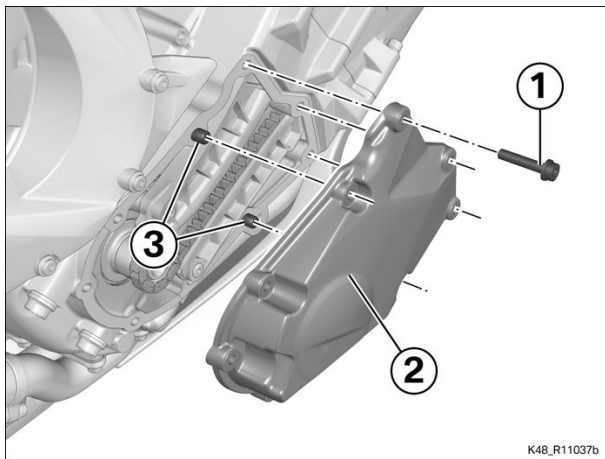

(-) Removing timing chain slide rail

- Remove pivot-bearing screw (1).

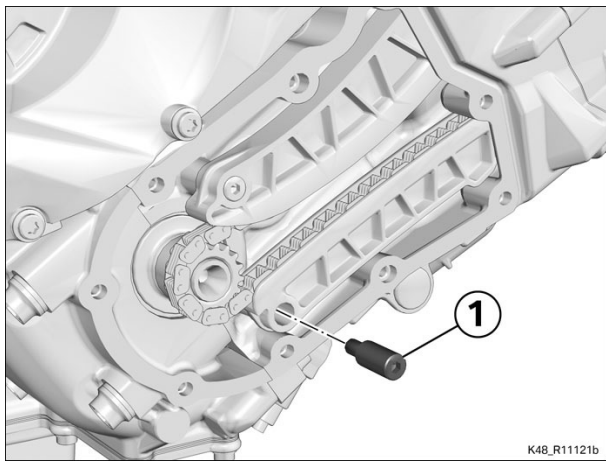

- Work timing-chain slide rail (1) up to remove.

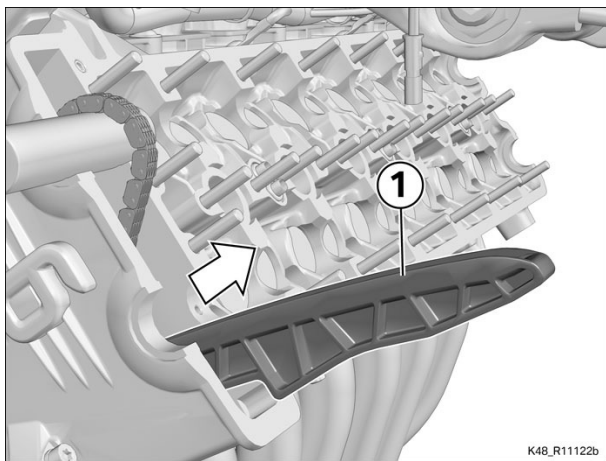

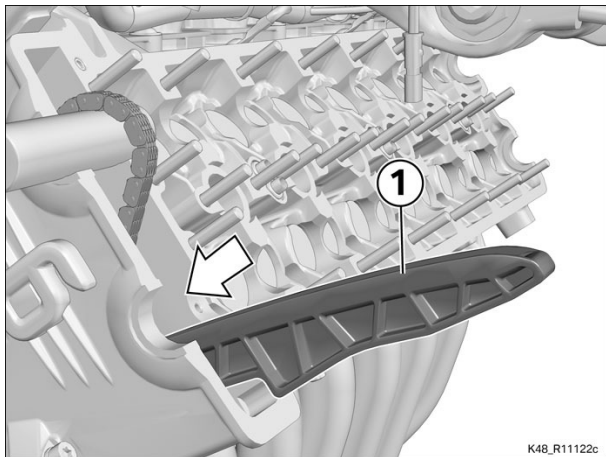

(-) Installing timing-chain slide rail

- Insert timing chain slide rail (1) from above.

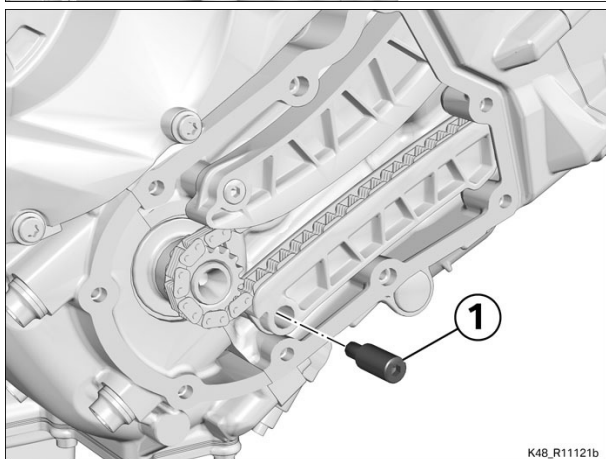

- Install pivot bearing screw (1).



 Tightening torques		
Timing-chain rail to crankcase		
M6 x 30	8 Nm	

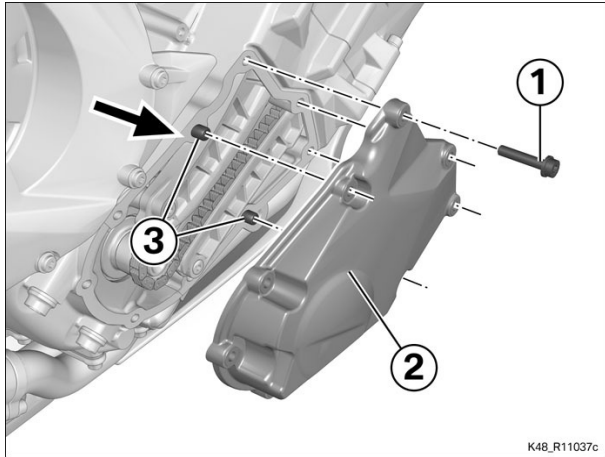

(-) Installing timing-gear cover

- Clean the sealing face (arrow) on the engine and in timing-gear cover (2).
- Apply a thin bead of sealing compound to the sealing face (arrow) of the engine block.

 Fluids and lubricants		
Dow Corning	Surface sealant	07 58 0 397 777

- Install sleeves (3).
- Install timing-gear cover (2).
- Install screws (1).

 Tightening torques		
Cover of timing gear (with drop-protection pad) to crankcase		
M6 x 30	10 Nm	

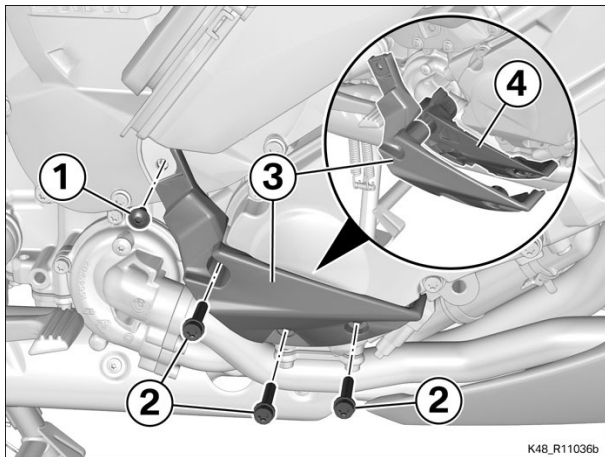

(-) Installing right drop-protection pad

- Hold outer shell (3) with rubber damper (4) in position.
- Install screws (2) and screw (1).

 Tightening torques		
Cover of timing gear (with drop-protection pad) to crankcase		
M6 x 30	10 Nm	

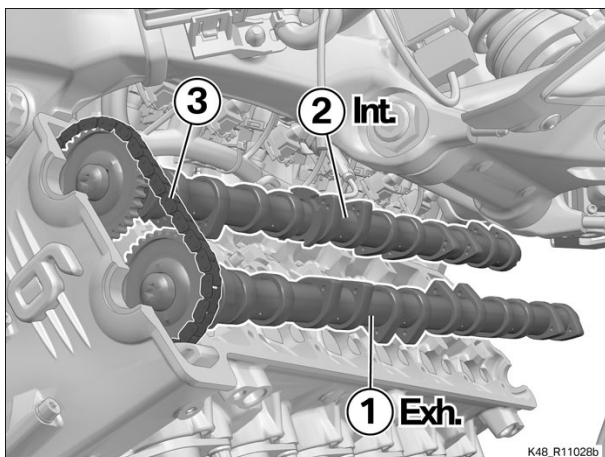

(-) Installing camshafts

- Insert inlet camshaft (with multi-pole sensor gear for camshaft sensor) (2) and exhaust camshaft (1) and loop timing chain (3) over the camshafts.

- Turn inlet camshaft (2) and exhaust camshaft (1) to top dead centre of cylinder No. 1, align them with the marks (arrows) applied before removal and engage timing chain (3) on sprockets.

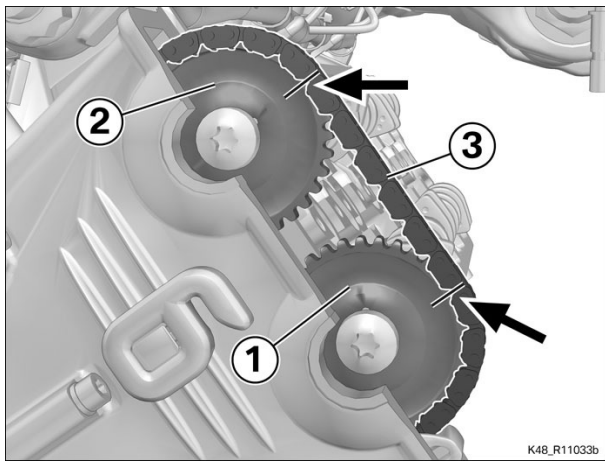

Finishing work

- Installing O-rings for camshaft bearing cap
- Installing bearing cap for camshafts
- Installing timing chain tensioner
- Removing locating pin
- Installing right stowage compartment
- Installing cylinder head cover
- Installing direct ignition coils
- Securing distributor rail for secondary air system
- Installing air guide
- Installing complete radiator
- Filling and priming cooling system
- Install the right side panel
- Install the right radiator cowl
- Installing right bottom side panel
- Installing left side panel
- Installing radiator hose cover
- Installing left radiator cowl
- Installing left bottom side panel
- Installing front seat
- Final check of work performed

11 31 125 Replacing chain guide 17 FRUs

+ 11 31 786

Preparatory work

- Removing left bottom side panel
- Removing left radiator cowl
- Removing radiator hose cover
- Removing left side panel
- Removing right bottom side panel
- Removing right radiator cowl
- Remove the right side panel
- Draining cooling system
- Removing complete radiator
- Removing air guide
- Disconnecting distributor rail for secondary air system
- Removing direct ignition coils

Core activity

(-) Removing cylinder head cover

- Disconnect plug (1) for the camshaft sensor.
- Remove screws (2) with seals (3).

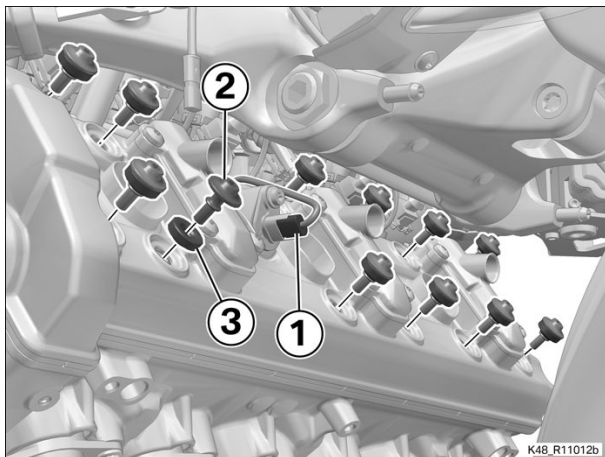

- Remove cylinder-head cover (1) with gasket (2).

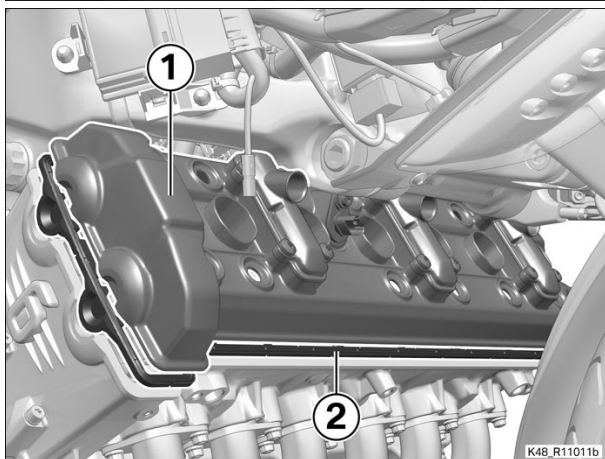

- Remove seal (1).

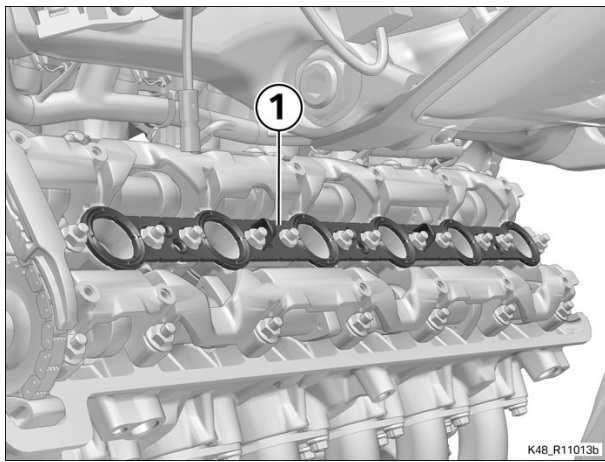

(-) Removing top guide for timing chain

- Remove nuts (1).
- Remove guide (2).

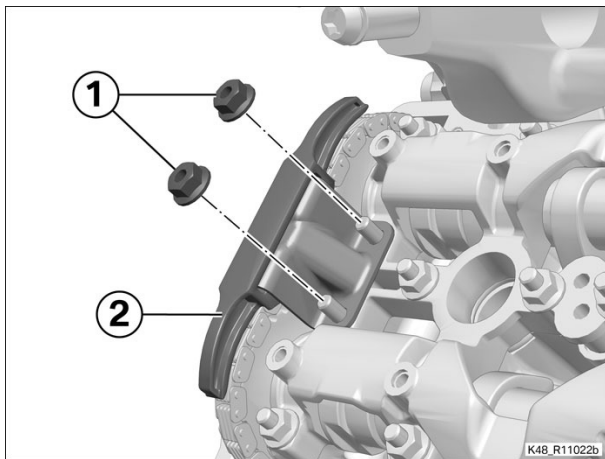

(-) Installing top guide for timing chain

- Install guide (2).
- Install nuts (1) until seated, but do not tighten.

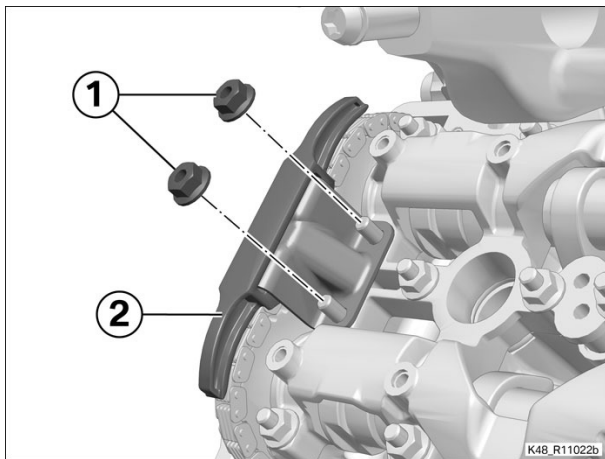

(-) Installing cylinder head cover

- Check the gasket for damage; replace if necessary.
- Apply surface sealant to the corners (arrows) of the half moons.

 <p>Fluids and lubricants</p>		
Dow Corning	Surface sealant	07 58 0 397 777

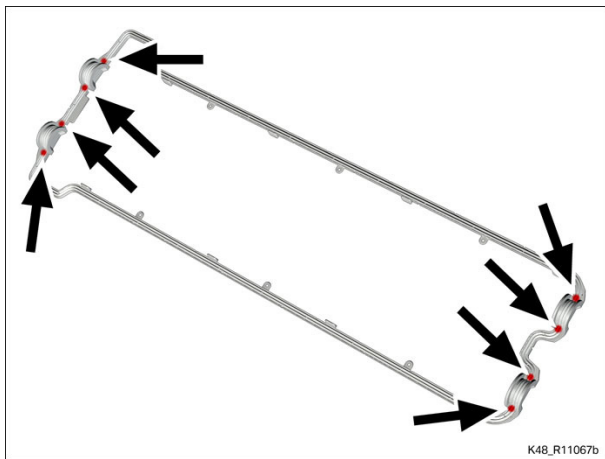

K48_R11067b

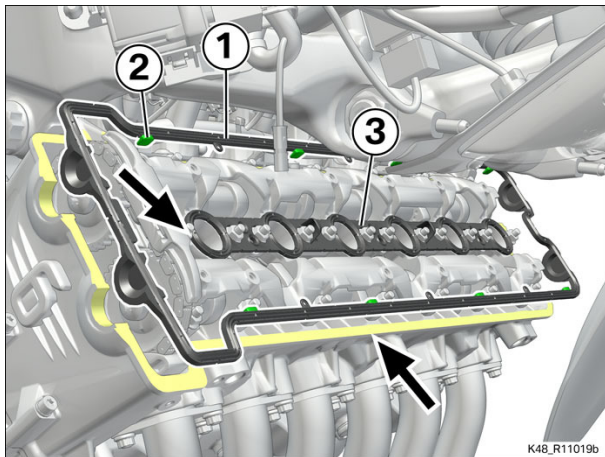

K48_R11019b

- Check gasket (3) for damage; replace if necessary.
- Clean the sealing faces (arrows) on the cylinder head.
- Lay large gasket (1) in position on the cylinder head, noting the position of the tabs (2) inside the cylinder head.
- Place gasket (3) in position.

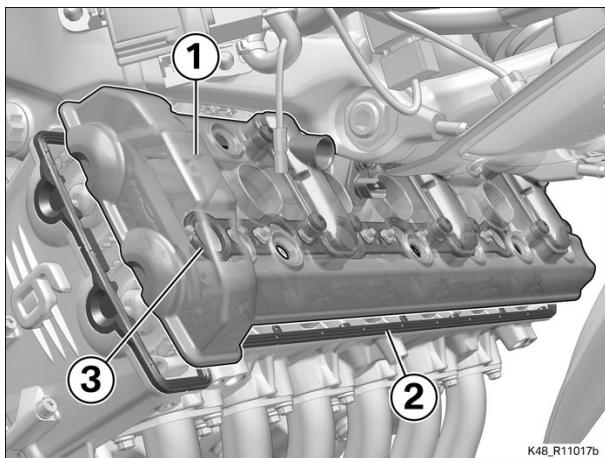

K48_R11017b

- Place cylinder-head cover (1) in position.
- Make sure that gaskets (2) and (3) do not slip out of position and are not pinched out of shape.

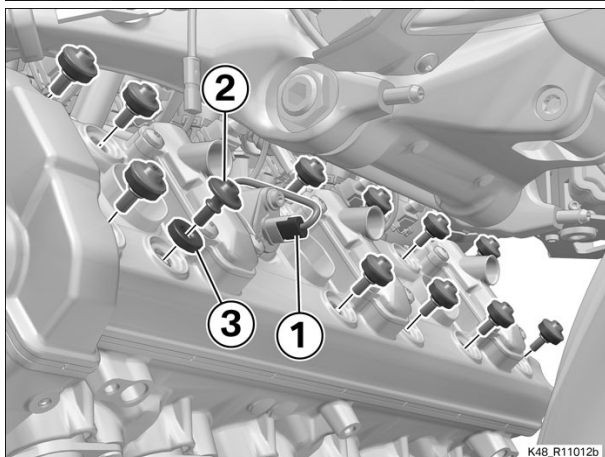

K48_R11012b

- Install screws (2) with seals (3).

 Tightening torques		
Cylinder head cover to cylinder head (camshaft bearing cap)		
M6 x 20	10 Nm	

- Connect plug (1) for the camshaft sensor.

Finishing work

- Installing direct ignition coils
- Securing distributor rail for secondary air system
- Installing air guide
- Installing complete radiator
- Filling and priming cooling system
- Install the right side panel
- Install the right radiator cowl
- Installing right bottom side panel
- Installing left side panel
- Installing radiator hose cover
- Installing left radiator cowl
- Installing left bottom side panel
- Final check of work performed

📁 11 31 539 Replacing all camshafts (cylinder-head cover removed) 10 FRUs

Equipment trim-level variant:

- 0266 - Preparation for audio system and navigation device
- 0267 - ECE audio system and preparation for navigation system
- 0417 - Central locking

Preparatory work

- Removing right stowage compartment
- Setting engine to TDC
- Locking engine at TDC
- Removing timing-chain tensioner
- Removing bearing cap for camshafts
- Removing O-rings for camshaft bearing cap

Core activity

(-) Removing camshafts

- Work exhaust camshaft (1) and inlet camshaft (with multi-pole sensor gear for camshaft sensor) (2) out of timing chain (3) and remove.
- Secure timing chain (3) in a suitable way to prevent it dropping out.

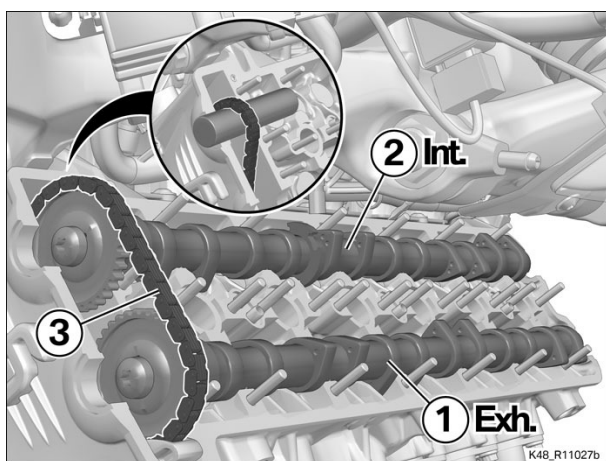

(-) Replacing camshafts

- Clamp camshafts (1) in a vice fitted with protective jaws.
- Remove screws (2).
- Remove camshaft sprockets (3).
- Position camshaft sprockets (3) on new camshafts (1) in such a way that the pins (arrow) engage the bores.
- Install **new** screws (2).

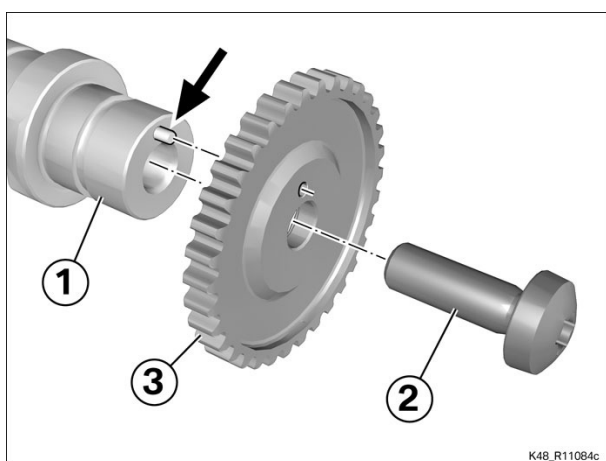

🔧 Tightening torques		
Sprocket to camshaft		
M10 x 1 x 30, Replace screw	Initial torque,	
	40 Nm	
	Final torque, 60°	

(-) Installing camshafts

- Insert inlet camshaft (with multi-pole sensor gear for camshaft sensor) (2) and exhaust camshaft (1) and loop timing chain (3) over the camshafts.

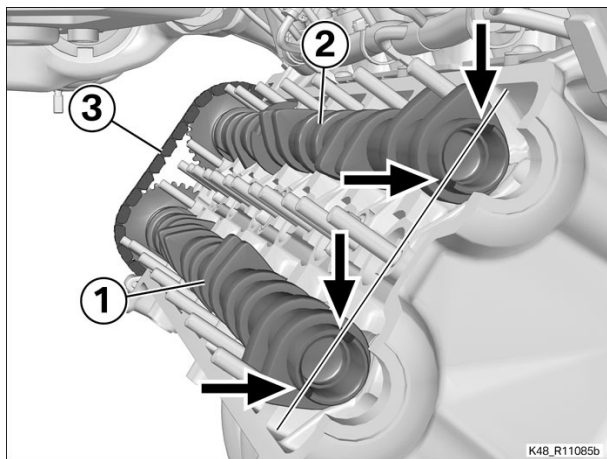
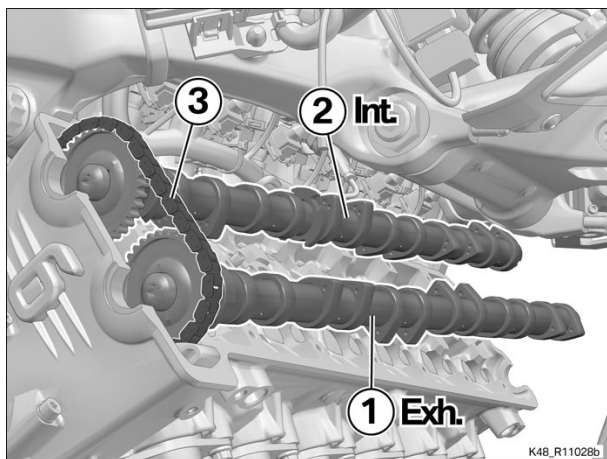

- Bring inlet camshaft (2) and exhaust camshaft (1) to top dead centre of cylinder No. 1.
- » The recesses (arrows) of both camshafts are slightly offset toward the top and in line.
- Engage inlet camshaft (2) and exhaust camshaft (1) in timing chain (3).

Finishing work

- Installing O-rings for camshaft bearing cap
- Installing bearing cap for camshafts
- Installing timing chain tensioner
- Removing locating pin
- Checking valve clearance
- Installing right stowage compartment

📁 11 34 001 Checking valve clearance 20 FRUs

+ 11 34 501

Preparatory work

- Removing left bottom side panel
- Removing left radiator cowl
- Removing radiator hose cover
- Removing left side panel
- Removing right bottom side panel
- Removing right radiator cowl
- Remove the right side panel
- Draining cooling system
- Removing complete radiator
- Removing air guide
- Disconnecting distributor rail for secondary air system
- Removing direct ignition coils
- Removing spark plugs
- Removing cylinder head cover
- Removing left drop-protection pad
- Removing crankshaft cover

Core activity

(-) Setting engine to TDC

- Turn the crankshaft to firing TDC of cylinders 1 and 5.

(-) Checking valve clearance

Test

- Use a feeler gauge (1) to check the valve clearance by measuring between the cams and the valve bucket.

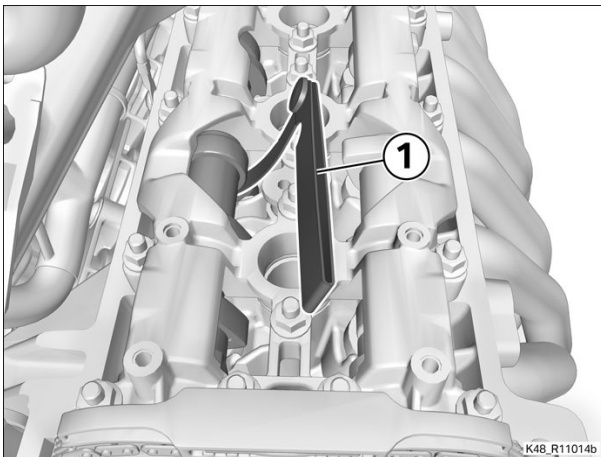

 Technical data			
Inlet valve clearance	Engine cold max 35 °C	0.13...0.23 mm	
Exhaust valve clearance	Engine cold max 35 °C	0.23...0.33 mm	

- Check cylinder 1.
- Check all the remaining cylinders as described below, using the crankshaft to turn the engine counter-clockwise until each cylinder at turn is at **valve overlap**:
 - Cylinder 5
 - Cylinder 3
 - Cylinder 6
 - Cylinder 2
 - Cylinder 4

► Noting measured results

- Note down the measured results on a record sheet.

Data sheet, valve clearance BMW Motorrad			
Type:	VIN:	Odometer reading:	Date:
		Name:	
	Direction of rotation		
	Cylinder 1 Cylinder 2 Cylinder 3		
Exhaust valve			
Specified [mm]			
Measured value [mm]			
Spacers needed			
Inlet valve			
Specified [mm]			
Measured value [mm]			
Spacers needed			
	Cylinder 4 Cylinder 5 Cylinder 6		
Exhaust valve			
Specified [mm]			
Measured value [mm]			
Spacers needed			
Inlet valve			
Specified [mm]			
Measured value [mm]			
Spacers needed			

K48_R11016b



Result: Valve clearance is outside specified range.

Measure:

=> 11 34 504, Adjusting valve clearance (cylinder-head cover removed)
(Billed as a separate item)

Finishing work

- Installing crankshaft cover
- Installing left drop-protection pad
- Installing cylinder head cover
- Installing spark plugs
- Installing direct ignition coils
- Securing distributor rail for secondary air system
- Installing air guide
- Installing complete radiator
- Filling and priming cooling system
- Install the right side panel
- Install the right radiator cowl
- Installing right bottom side panel
- Installing left side panel
- Installing radiator hose cover
- Installing left radiator cowl
- Installing left bottom side panel
- Remove the front seat
- Connecting **BMW Motorrad** diagnostic system to motorcycle
- Setting countdown distance
- Disconnecting **BMW Motorrad** diagnostic system from motorcycle
- Installing front seat
- Final check of work performed

📁 11 34 502 Checking valve clearance (for maintenance) 18 FRUs

Preparatory work

- Removing left bottom side panel
- Removing left radiator cowl
- Removing radiator hose cover
- Removing left side panel
- Removing right bottom side panel
- Removing right radiator cowl
- Remove the right side panel
- Draining cooling system
- Removing complete radiator
- Removing air guide
- Disconnecting distributor rail for secondary air system
- Removing direct ignition coils
- Removing cylinder head cover
- Removing left drop-protection pad
- Removing crankshaft cover

Core activity

(-) Setting engine to TDC

- Turn the crankshaft to firing TDC of cylinders 1 and 5.

(-) Checking valve clearance

Test

- Use a feeler gauge (1) to check the valve clearance by measuring between the cams and the valve bucket.

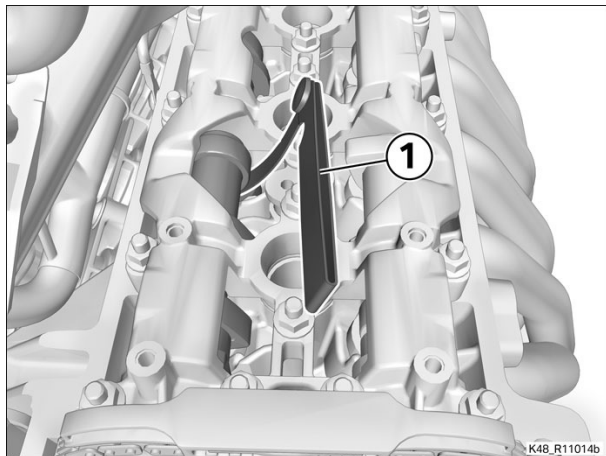

 Technical data			
Inlet valve clearance	Engine cold max 35 °C	0.13...0.23 mm	
Exhaust valve clearance	Engine cold max 35 °C	0.23...0.33 mm	

- Check cylinder 1.
- Check all the remaining cylinders as described below, using the crankshaft to turn the engine counter-clockwise until each cylinder at turn is at **valve overlap**:
 - Cylinder 5
 - Cylinder 3
 - Cylinder 6
 - Cylinder 2
 - Cylinder 4

► Noting measured results

- Note down the measured results on a record sheet.

Data sheet, valve clearance					
Type:	VIN:	Odometer reading:	Date:	Name:	
<div style="display: flex; justify-content: space-around;"> <div style="text-align: center;">Cylinder 1</div> <div style="text-align: center;">Cylinder 2</div> <div style="text-align: center;">Cylinder 3</div> </div>					
Exhaust valve					
Specified [mm]					
Measured value [mm]					
Spacers needed					
Inlet valve					
Specified [mm]					
Measured value [mm]					
Spacers needed					
<div style="display: flex; justify-content: space-around;"> <div style="text-align: center;">Cylinder 4</div> <div style="text-align: center;">Cylinder 5</div> <div style="text-align: center;">Cylinder 6</div> </div>					
Exhaust valve					
Specified [mm]					
Measured value [mm]					
Spacers needed					
Inlet valve					
Specified [mm]					
Measured value [mm]					
Spacers needed					

K48_R11016b



Result: Valve clearance is outside specified range.

Measure:

=> 11 34 504, Adjusting valve clearance (cylinder-head cover removed)
(Billed as a separate item)

Finishing work

- Installing crankshaft cover
- Installing left drop-protection pad
- Installing cylinder head cover
- Installing direct ignition coils
- Securing distributor rail for secondary air system
- Installing air guide
- Installing complete radiator
- Filling and priming cooling system
- Install the right side panel
- Install the right radiator cowl
- Installing right bottom side panel
- Installing left side panel
- Installing radiator hose cover
- Installing left radiator cowl
- Installing left bottom side panel
- Setting countdown distance
- Final check of work performed

11 34 504 Adjusting valve clearance (cylinder-head cover removed) 13 FRUs

Equipment trim-level variant:

- 0266 - Preparation for audio system and navigation device
- 0267 - ECE audio system and preparation for navigation system
- 0417 - Central locking

Preparatory work

- Removing right stowage compartment
- Setting engine to TDC
- Locking engine at TDC
- Removing timing-chain tensioner
- Removing bearing cap for camshafts
- Removing O-rings for camshaft bearing cap
- Removing camshafts

Core activity

(-) Adjusting valve clearance

► Removing bucket tappet



Attention

Friction faces in the engine have to run in against each other. If components are mixed up they have to run in again. This results in accelerated wear.

Do not mix up the bucket tappets.

- Remove bucket tappet (1).



Note

Make a note of which bucket tappets belong to which valve.

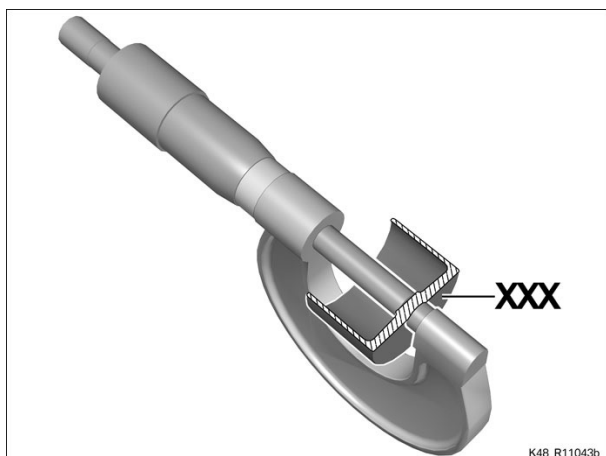
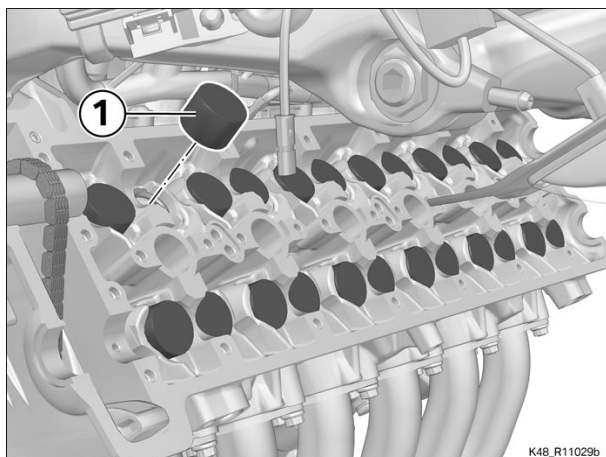

- Check the thickness of the bucket tappet with a caliper gauge.
- If measured valve play is not correct, calculate the thickness of the new bucket tappet.

► Installing bucket tappet



Attention

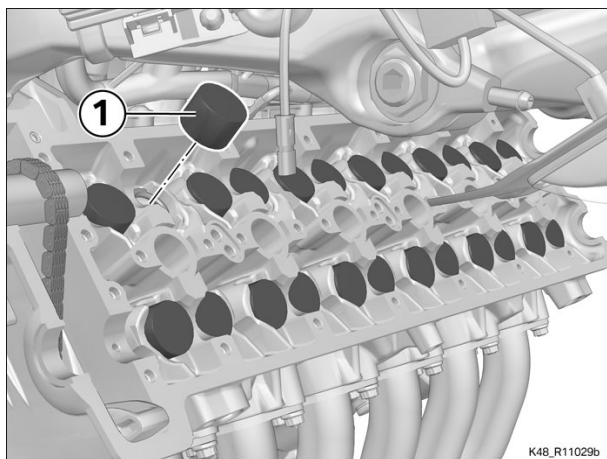

Friction faces in the engine have to run in against each other. If components are mixed up they have to run in again. This results in accelerated wear.

Do not mix up the bucket tappets.

-
- Lubricate bucket tappet (1) with engine oil and install.



Finishing work

Installing camshafts

Installing O-rings for camshaft bearing cap

Installing bearing cap for camshafts

Installing timing chain tensioner

Removing locating pin

Rechecking valve clearance

Installing right stowage compartment

📁 11 41 000 Removing/installing or replacing oil pump 31 FRUs

+ 11 41 651

Preparatory work

Remove the front seat
 Draining engine oil
 Removing left fuel-tank cover top section
 Removing left cover of fuel tank
 Removing gearbox cover
 Removing left catalytic-converter shield
 Removing left oxygen sensor
 Disengaging clamp on left silencer
 Removing left silencer
 Removing left radiator cowl
 Removing exhaust manifold, left
 Removing right fuel-tank cover top section
 Remove the right fuel-tank cover
 Removing right radiator cowl
 Remove the right side panel
 Draining cooling system
 Disconnecting feed line for coolant
 Removing right catalytic-converter shield
 Removing right oxygen sensor
 Disengaging clamp on right silencer
 Removing right silencer
 Removing exhaust manifold, right
 Removing oil pan
 Removing suction pipe for engine oil
 Removing sump plate

Core activity

(-) Removing oil pressure line

- Remove oil filter union (1).
- Remove oil pressure line (2).

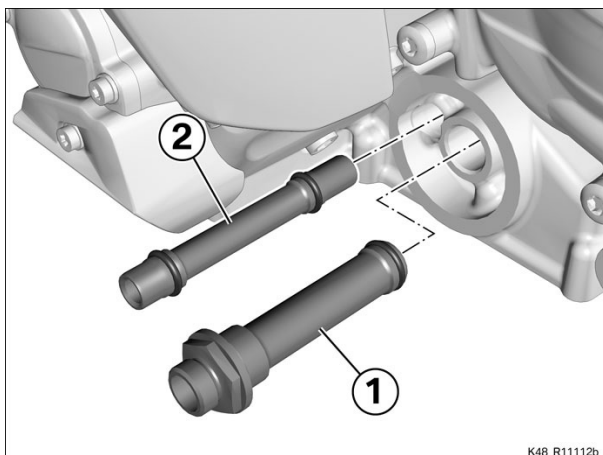

(-) Removing suction pipe for oil pump

- Remove screws (1).
- Remove intake (2), noting O-ring (3).

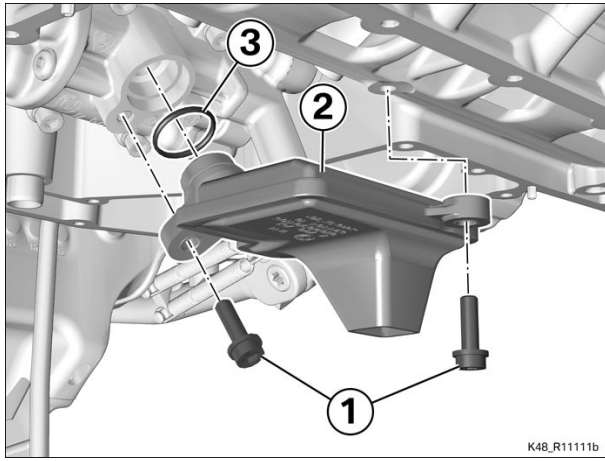

(-) Removing coolant pump

- Remove screws (1).
- Remove coolant pump (2), noting O-ring (3).

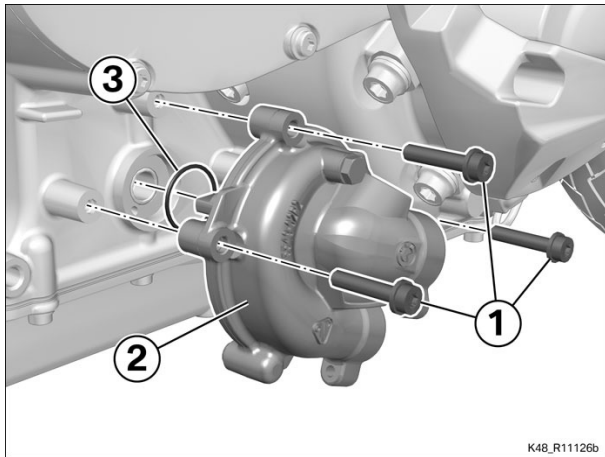

(-) Removing input shaft for oil pump

- Remove threaded plug (1) with sealing ring (2).
- Remove input shaft (3).

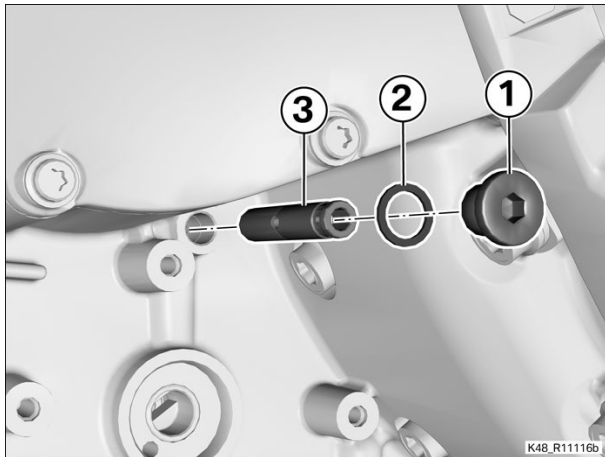

(-) Removing oil pump

- Remove screws (1).

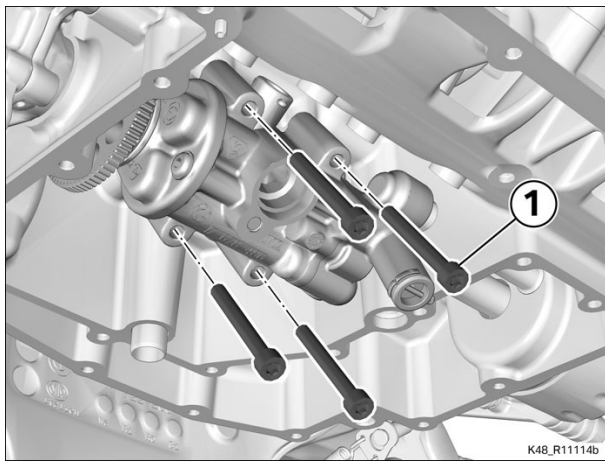

K48_R11114b

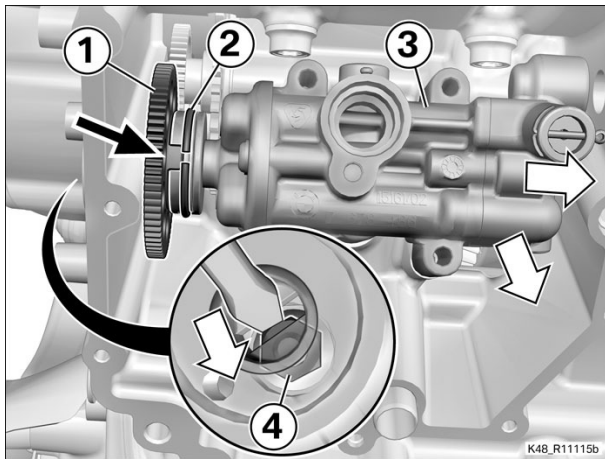

K48_R11115b

- Disengage circlip (2) and remove, turning the rear wheel to find the best position for easy removal.
- Turn the rear wheel to bring drive gear (1) to a position in which the input connection (arrow) is pointing forward and down.
- Push oil pump (3) to the right and down.
- Use a screwdriver to pry nut (4) down.
- Remove oil pump (3).

(-) Installing oil pump

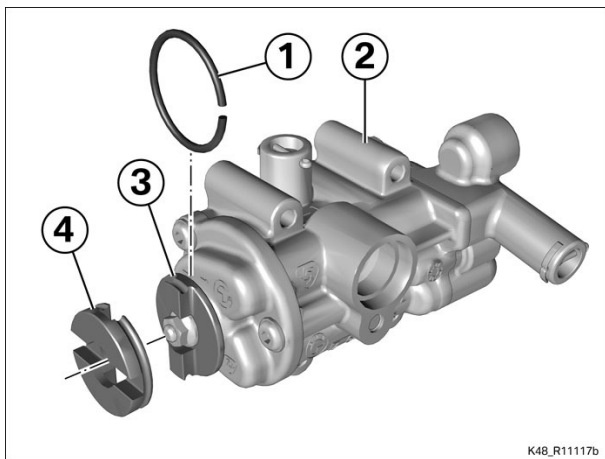

K48_R11117b

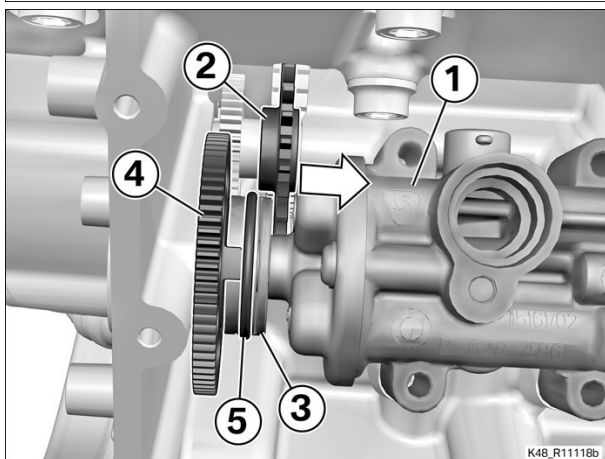

K48_R11118b

- Install circlip (1) between oil pump (2) and drive gear (3).
- Place idler gear (4) in position.

- Place oil pump (1) in position.
- Using a suitable tool, carefully ease layshaft gearwheel (2) toward oil pump.
- Engage idler gear (3) in drive gear (4).
- Engage circlip (5), turning the rear wheel to find the best position for easy engagement.

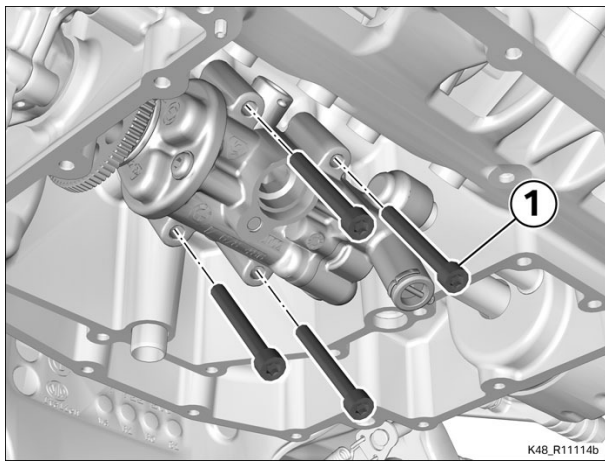



Install screws (1).

 Tightening torques		
Oil pump to crankcase		
M6 x 50	10 Nm	

(-) Installing input shaft for oil pump

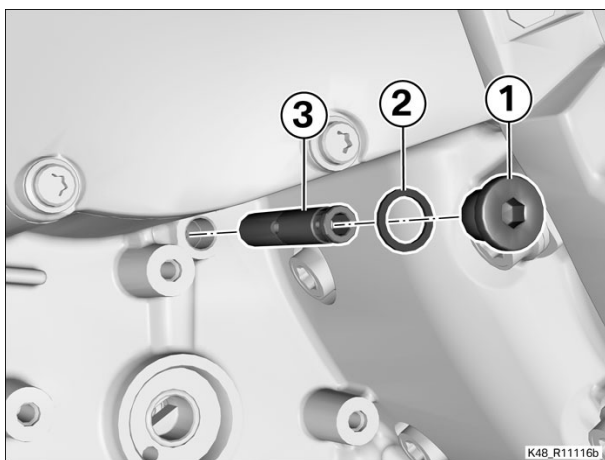
- Install input shaft (3).
- Install threaded plug (1) with **new** sealing ring (2).



 Tightening torques		
Threaded plug (shaft for oil-pump drive) in crankcase		
M10	15 Nm	

(-) Installing coolant pump

- Check O-ring (3) for damage; replace if necessary.
- Note the routing of oxygen-sensor cable (4).
- Install coolant pump (2), making sure that the drive engages (arrows).
- Install screws (1).

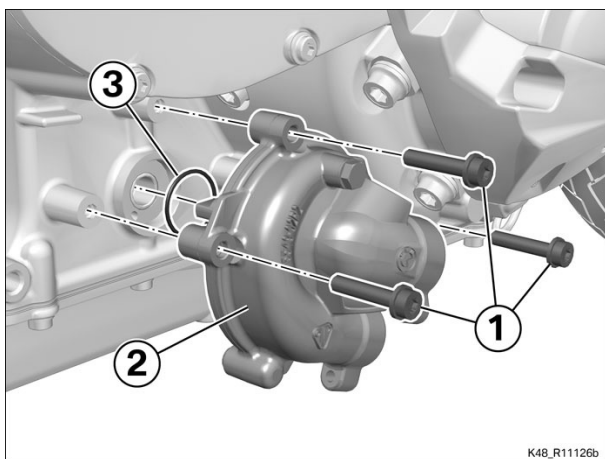

 Tightening torques		
Coolant pump to crankcase		
M6 x 30	10 Nm	

(-) Installing suction pipe for oil pump

- Check O-ring (3) for damage; replace if necessary.
- Hold suction pipe (2) with O-ring (3) in position.
- Install screws (1).

 Tightening torques		
Suction pipe to crankcase (return pump)		
M6 x 20	10 Nm	

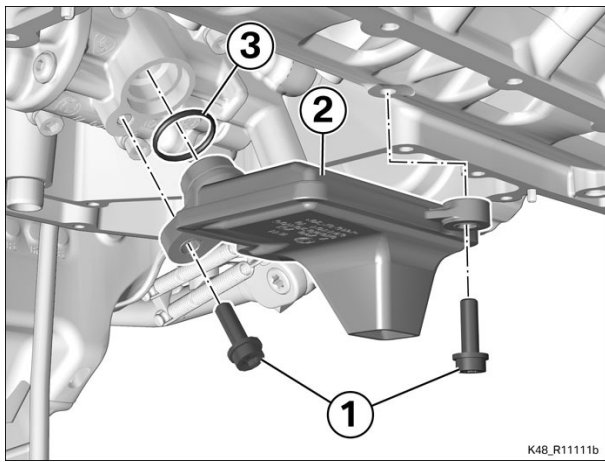

(-) Installing oil pressure line

- Check O-rings (3) and (4) for damage; replace if necessary.
- Install oil pressure line (2).
- Install oil filter union (1).

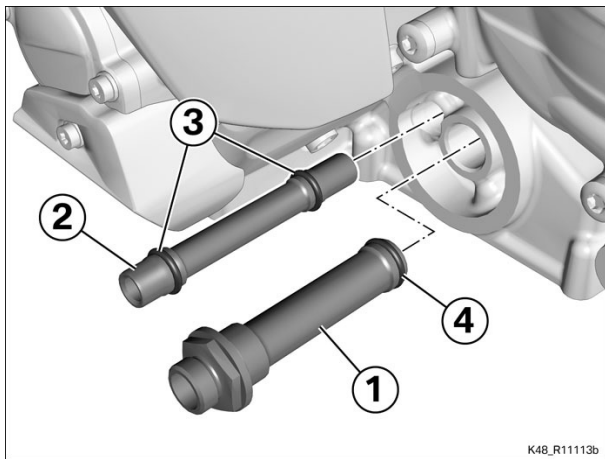

 Tightening torques		
Oil filter union to engine		
M22 x 1.5	40 Nm	

Finishing work

- Installing sump plate
- Installing suction pipe for engine oil
- Installing oil pan
- Connecting feed line for coolant
- Filling and priming cooling system
- Installing exhaust manifold, right
- Installing right silencer
- Securing clamp on right silencer
- Installing right oxygen sensor
- Installing right catalytic-converter shield
- Install the right side panel
- Install the right radiator cowl
- Installing right fuel-tank cover
- Installing right fuel-tank cover top section
- Installing exhaust manifold, left
- Installing left radiator cowl
- Installing left silencer
- Securing clamp on left silencer
- Installing left oxygen sensor
- Installing left catalytic-converter shield
- Installing gearbox cover

Installing left cover of fuel tank
Installing left fuel-tank cover top section
Installing front seat
Pouring in engine oil
Final check of work performed

11 51 002 Removing/installing coolant pump (without draining/refilling coolant system) 3 FRUs

+ 11 51 563

Preparatory work

=> **Draining coolant, refilling/bleeding system (Description in item: 17 00 504, Billed as a separate item)**

Disconnecting feed line for coolant

Core activity

(-) Removing coolant pump

- Remove screws (1).
- Remove coolant pump (2), noting O-ring (3).

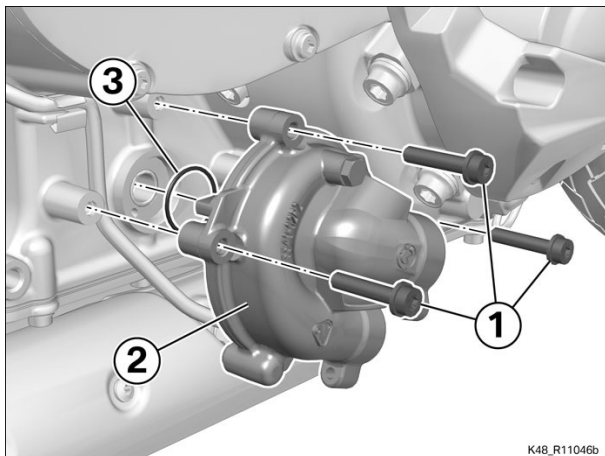

(-) Installing coolant pump

- Check O-ring (3) for damage; replace if necessary.
- Note the routing of oxygen-sensor cable (4).
- Install coolant pump (2), making sure that the drive engages (arrows).
- Install screws (1).

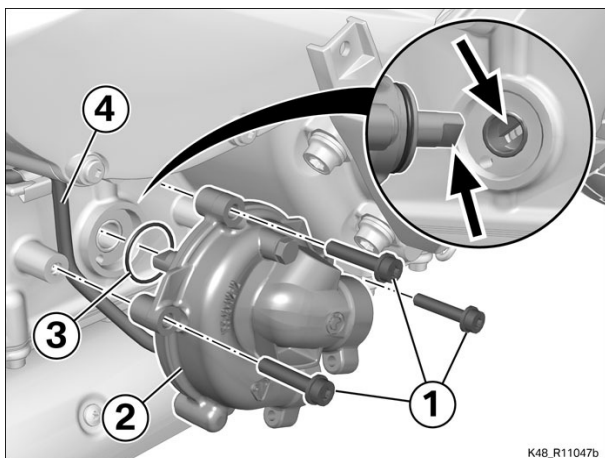

Tightening torques		
Coolant pump to crankcase		
M6 x 30	10 Nm	

Finishing work

Connecting feed line for coolant

Final check of work performed

📁 11 61 001 Replacing intake manifold 21 FRUs

+ 11 61 600

Preparatory work

- Remove the front seat
- Removing air guides for intake air pipes, left and right
- Removing complete cover of fuel tank
- Removing left bottom side panel
- Removing left radiator cowl
- Removing left side panel
- Removing inner trim for left side panel
- Removing right bottom side panel
- Removing right radiator cowl
- Remove the right side panel
- Removing inner trim for right side panel
- Removing adjusting plate
- Disengaging seat support
- Disengaging left and right intake air pipes
- Removing complete intake air silencer
- Removing fuel tank
- Disengaging wiring harness for engine

Core activity

(-) Removing intake manifold

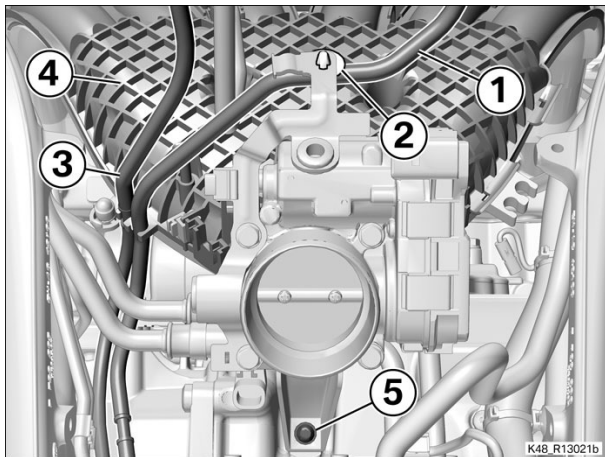

- Disengage breather hose (1) from holder (2).
- Disengage breather hoses (1) and (3) from intake manifold (4).
- Remove screw (5).

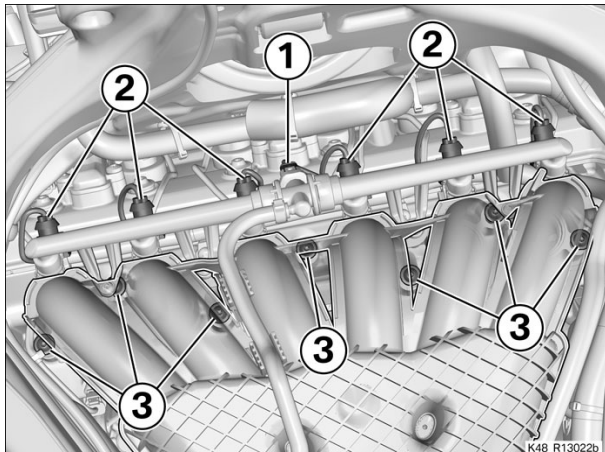

- Connect plug (1) for the fuel-pressure sensor.
- Mark plugs (2) for the injection valves for subsequent correct reassembly and disconnect.
- Loosen screws (3) **uniformly, but do not remove**.



Note

Take care not to remove the screws fully, as this would damage the captive adapter.

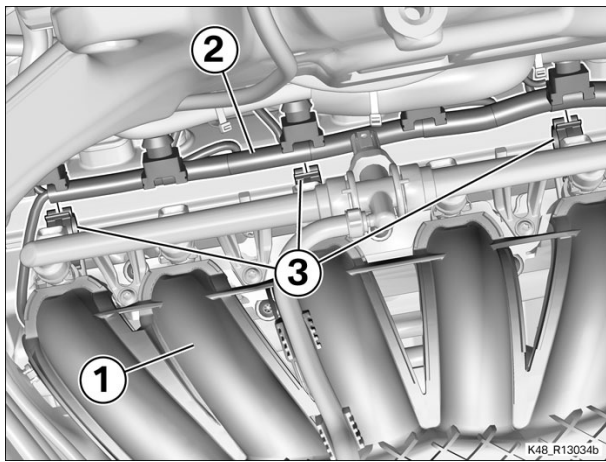

- Slightly raise intake manifold (1) and disengage wiring harness (2) from holders (3).

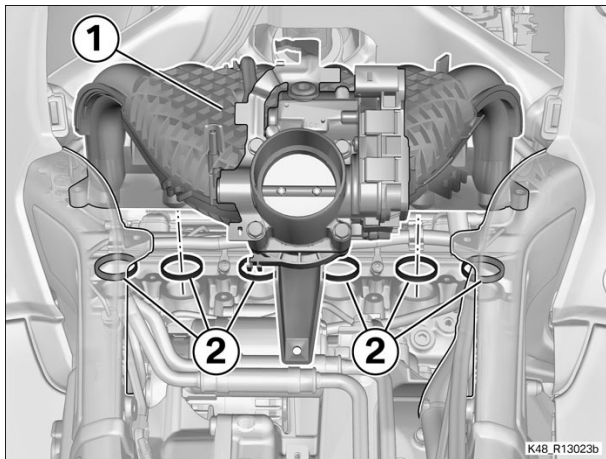

- Remove intake manifold (1) complete with sealing rings (2).

(-) Replacing intake manifold

► Removing injection rail

- Disengage fuel hose (1) from holder (2).
- Remove screws (3).
- Remove injection rail (4).

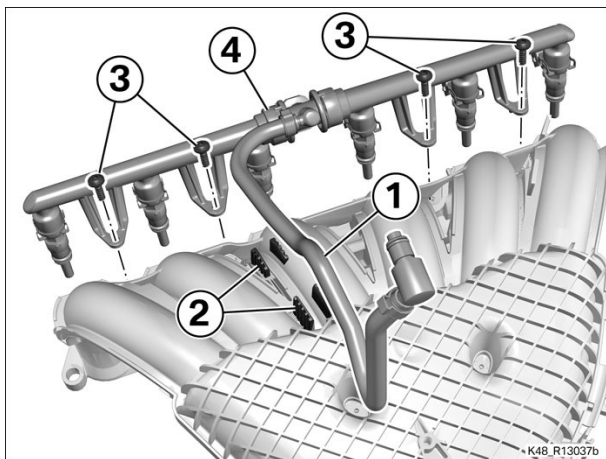

► Removing throttle-valve stub assembly

- Remove screws (1).
- Remove retaining plate (2).
- Remove throttle-valve stub assembly (3) with sealing ring (4).

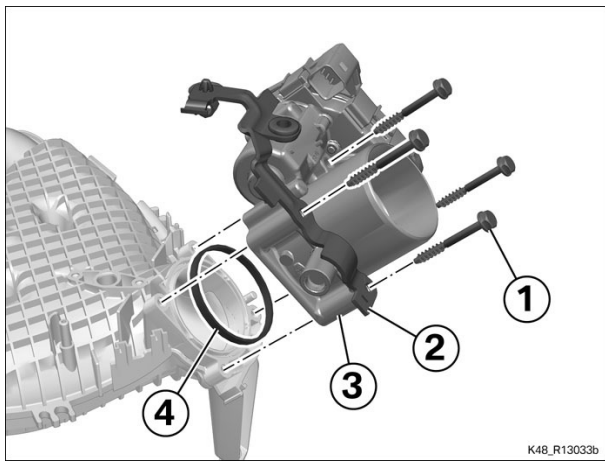

K48_R13033b

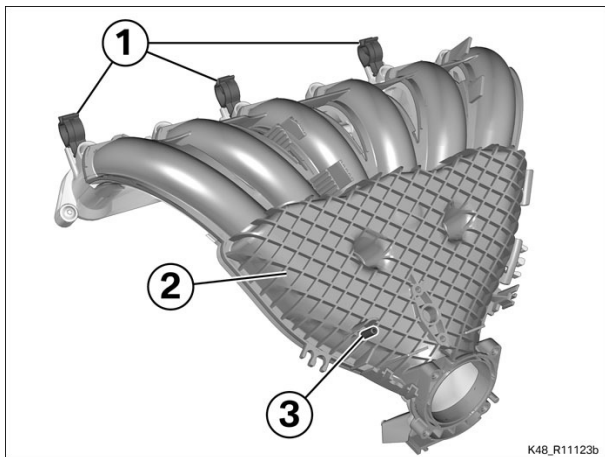

K48_R11123b



- Transfer bracket (1) to **new** intake manifold (2).
- Transfer sleeve (3) to **new** intake manifold (2).

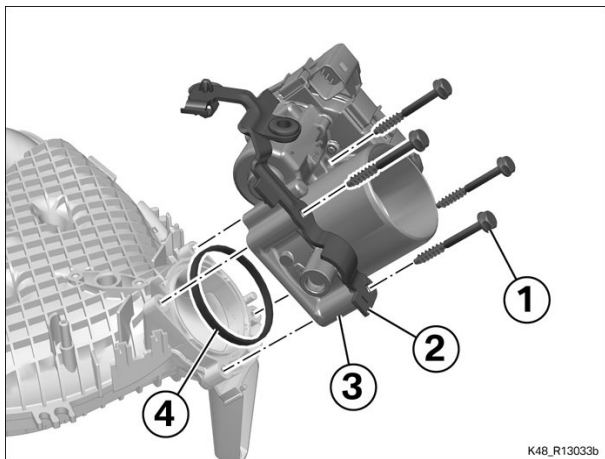

K48_R13033b

► **Installing throttle-valve stub assembly**

- Check sealing ring (4) for damage; replace if necessary.
- Install throttle-valve stub assembly (3) with sealing ring (4).
- Hold retaining plate (2) in position.
- Install screws (1).

 Tightening torques		
Throttle-valve assembly to intake assembly		
T60 x 53	6 Nm	



► **Installing injection rail**

- Check the O-rings (arrows); replace if necessary.
- Install injection rail (4).
- Install screws (3).
- Secure fuel hose (1) in holder (2).

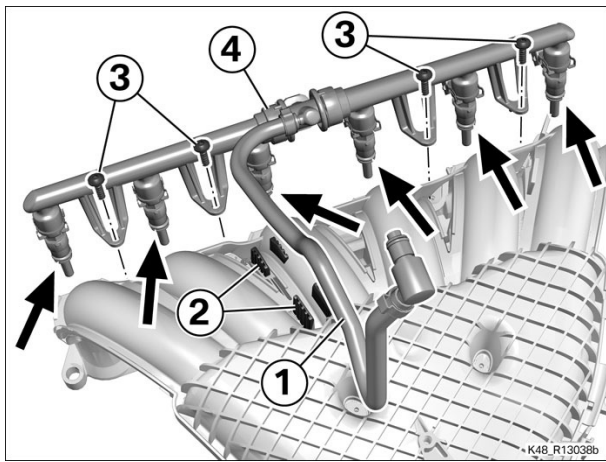

(-) Installing intake manifold

- Check sealing rings (1); replace if necessary.
- Insert sealing rings (1) in intake manifold (2). Make sure that sealing rings (1) are pressed into the retainer recesses (arrows).

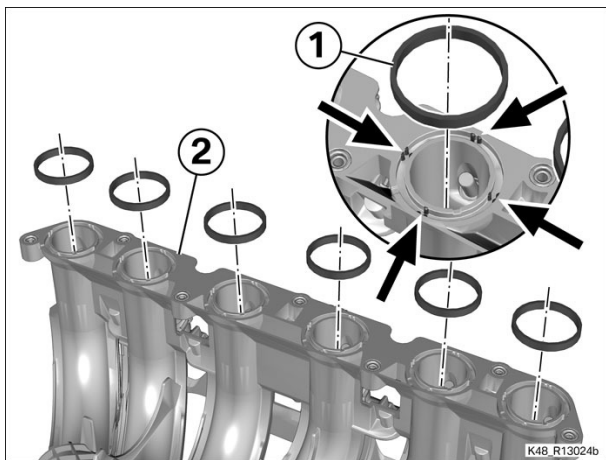

- Insert intake manifold (1) complete with sealing rings (2). Make sure that sealing rings (2) do not drop out of position during installation.

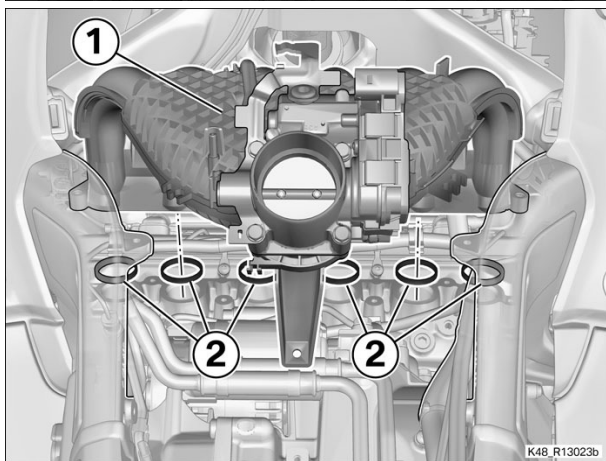

- Secure wiring harness (2) in holder (3) and hold intake manifold (1) in position.

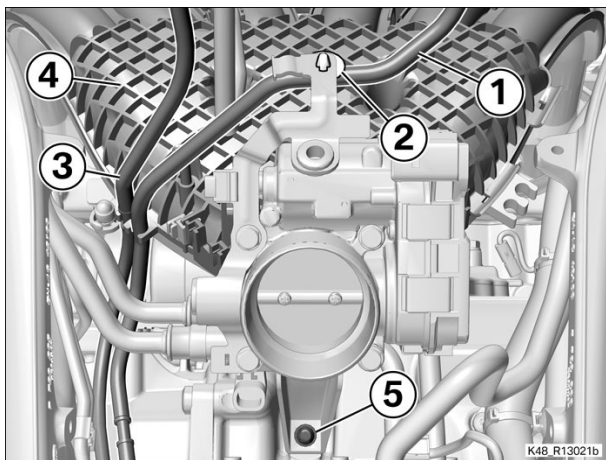
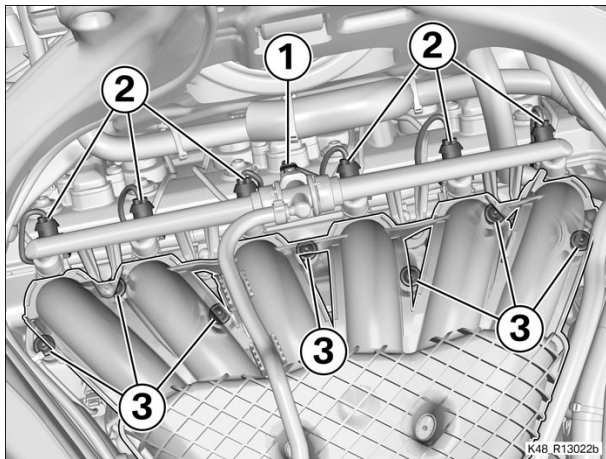
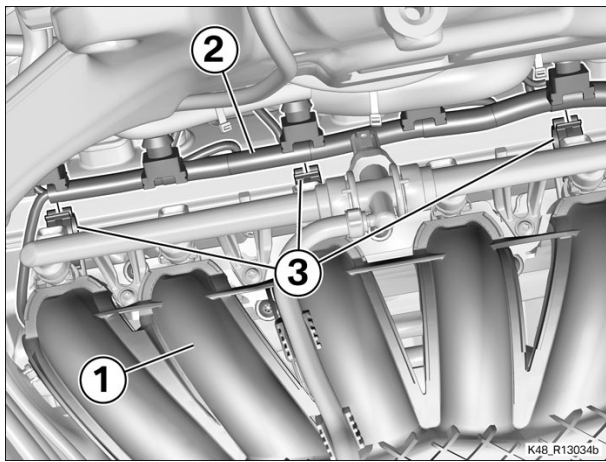

- Install screws (3) **uniformly**.

 Tightening torques		
Intake assembly to crankcase		
M6 x 25	8 Nm	

- Connect plugs (2) for the injection valves.
- Connect plug (1) for the fuel-pressure sensor.

- Install screw (5).

 Tightening torques		
Intake assembly to crankcase		
M6 x 16	8 Nm	

- Connect breather hoses (1) and (3) to intake manifold (4).
- Secure breather hose (1) in holder (2).

Finishing work

- Securing wiring harness for engine
- Installing fuel tank
- Installing complete intake air silencer
- Securing left and right intake air pipes
- Securing seat support
- Installing adjusting plate
- Installing inner trim for right side panel
- Install the right side panel
- Install the right radiator cowl
- Installing right bottom side panel
- Installing inner trim for left side panel

Install the left side panel
Installing left radiator cowl
Installing left bottom side panel
Installing complete cover of fuel tank
Installing air guides for intake air pipes, left and right
Installing front seat
Final check of work performed

📁 11 72 101 Removing/installing or replacing line for secondary air system 14 FRUs

+ 11 72 660



Warning

Fuel is flammable and a hazard to health.
Observe all applicable safety regulations.

Preparatory work

- Remove the front seat
- Removing air guides for intake air pipes, left and right
- Removing complete cover of fuel tank
- Removing left bottom side panel
- Removing left radiator cowl
- Removing left side panel
- Removing inner trim for left side panel
- Removing right bottom side panel
- Removing right radiator cowl
- Remove the right side panel
- Removing inner trim for right side panel
- Removing adjusting plate
- Disengaging seat support
- Disengaging left and right intake air pipes
- Removing complete intake air silencer
- Removing fuel tank

Core activity

(-) Removing line for secondary air system

- Disconnect line (1) from distributor rail (2).
- Work line (1) clear.

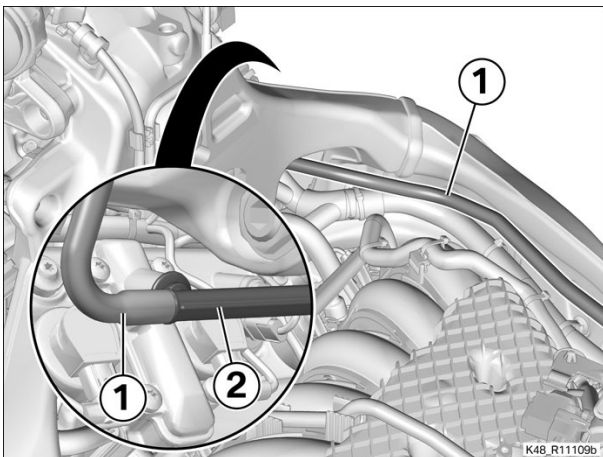

(-) Installing line for secondary air system

- Route line (1) and connect it to distributor rail (2).

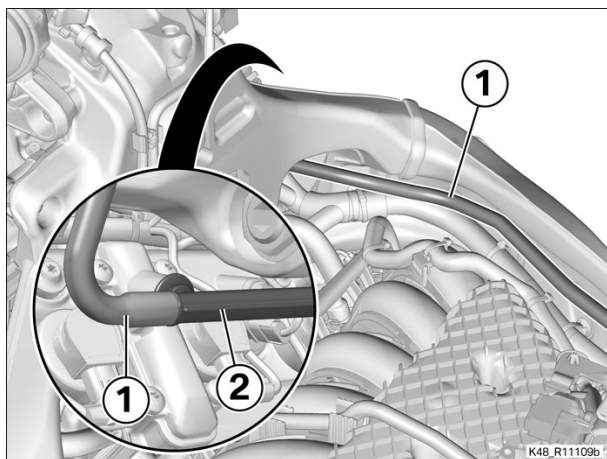

Finishing work

- Installing fuel tank
- Installing complete intake air silencer
- Securing left and right intake air pipes
- Securing seat support
- Installing adjusting plate
- Installing inner trim for right side panel
- Install the right side panel
- Install the right radiator cowl
- Installing right bottom side panel
- Installing inner trim for left side panel
- Install the left side panel
- Installing left radiator cowl
- Installing left bottom side panel
- Installing complete cover of fuel tank
- Installing air guides for intake air pipes, left and right
- Installing front seat
- Final check of work performed

📁 11 78 001 Replacing oxygen sensors 7 FRUs

+ 11 78 501



Warning

Risk of burns caused by the hot exhaust system.

Do not touch the exhaust system when it is hot; if necessary, allow the exhaust system ample time to cool before proceeding.

Preparatory work

Remove the front seat

Removing left fuel-tank cover top section

Removing left cover of fuel tank

Removing gearbox cover

Removing left catalytic-converter shield

Removing right fuel-tank cover top section

Remove the right fuel-tank cover

Removing right catalytic-converter shield

Core activity

(-) Removing left oxygen sensor

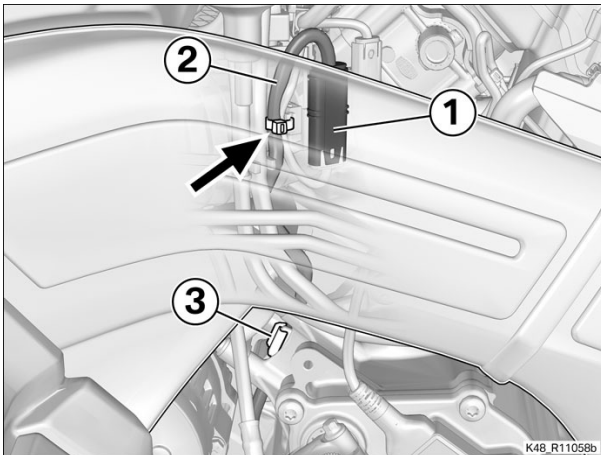

- Open the cable tie (arrow).
- Remove plug (1) for the oxygen sensor and disconnect.
- Disengage cable (2) for the oxygen sensor from holder (3) and work it clear.

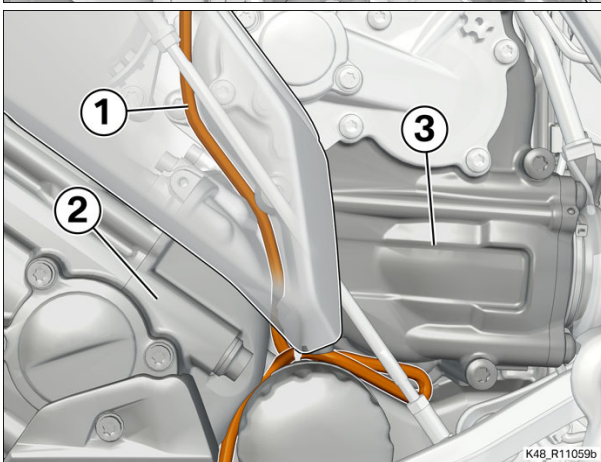

- Disengage cable (1) for the oxygen sensor between engine (2) and gearbox (3) and work it clear.

- Remove oxygen sensor (1).

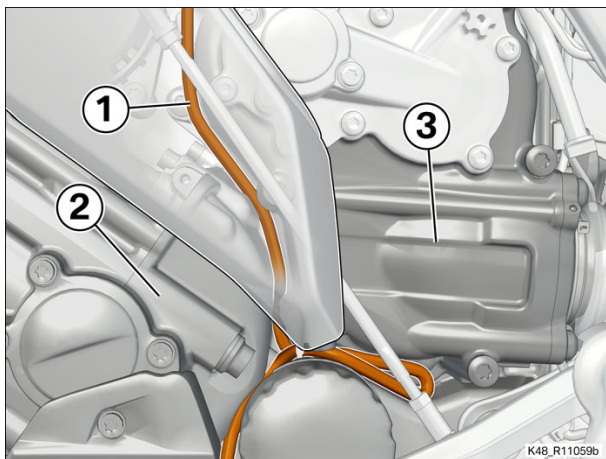
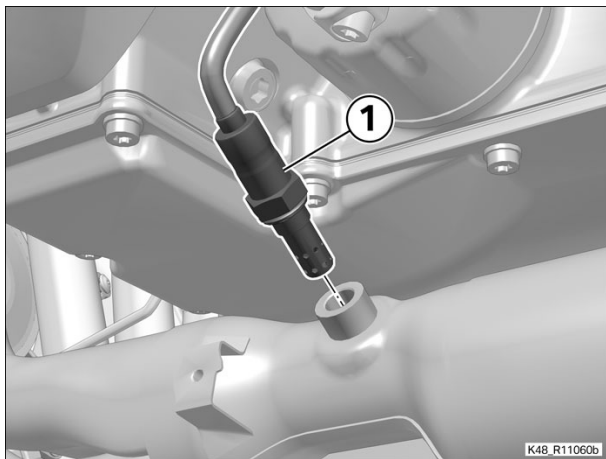
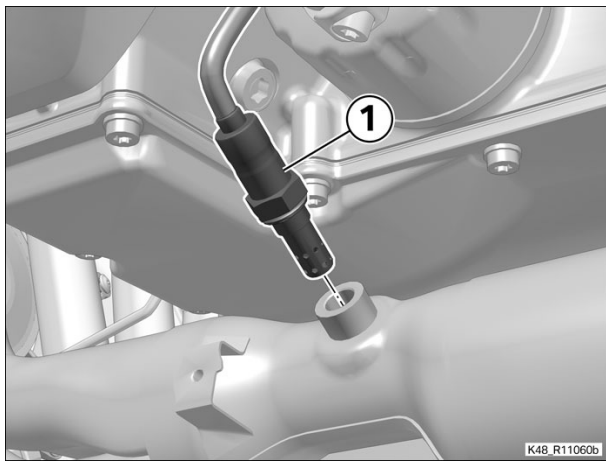

(-) Installing left oxygen sensor

- Thinly lubricate threads of oxygen sensor (1).

 Fluids and lubricants		
Optimoly TA	High-temperature assembly grease	18 21 9 062 599

- Install oxygen sensor (1).

 Tightening torques		
Oxygen sensor to exhaust manifold		
M12 x 1.25	25 Nm	
Thinly lubricate thread, Optimoly TA		

- Route cable (1) for the oxygen sensor between engine (2) and gearbox (3) and secure it.

- Route cable (2) for the oxygen sensor and secure it in holder (3).
- Connect plug (1) for the oxygen sensor and install.
- Secure the cable tie ([arrow](#)).

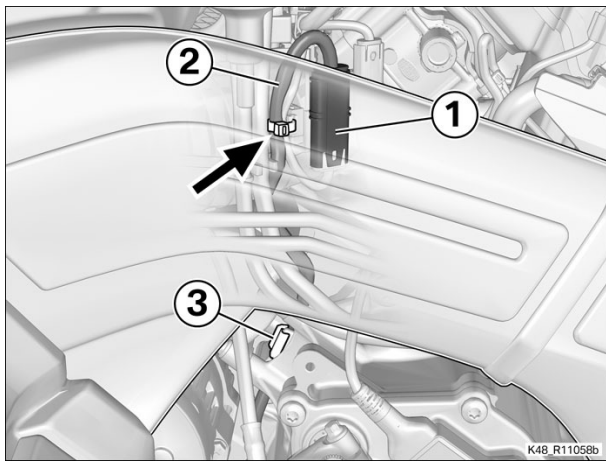

(-) Removing right oxygen sensor

- Open the cable tie (arrow).
- Remove plug (1) for the oxygen sensor and disconnect.

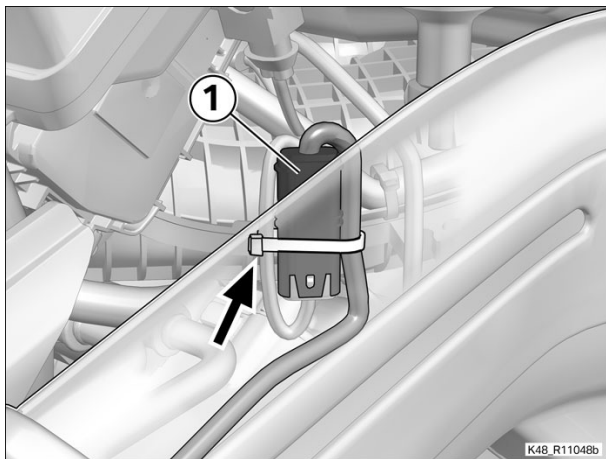

- Disengage cable (1) for the oxygen sensor from holders (2) and work it clear.

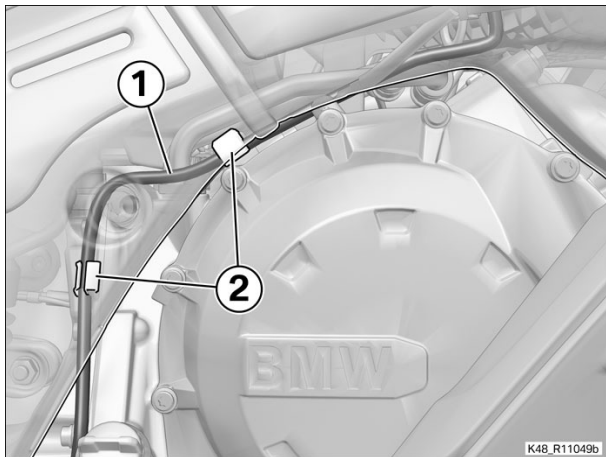

- Disengage cable (1) for the oxygen sensor from holders (2) and work it clear.
- Work cable (1) clear from behind coolant pump (3).

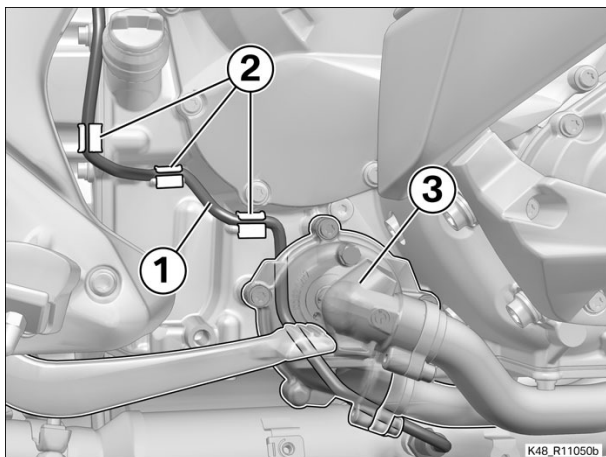

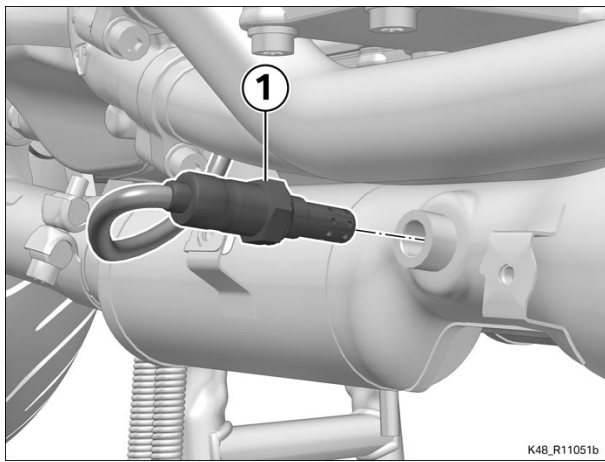

Remove oxygen sensor (1).

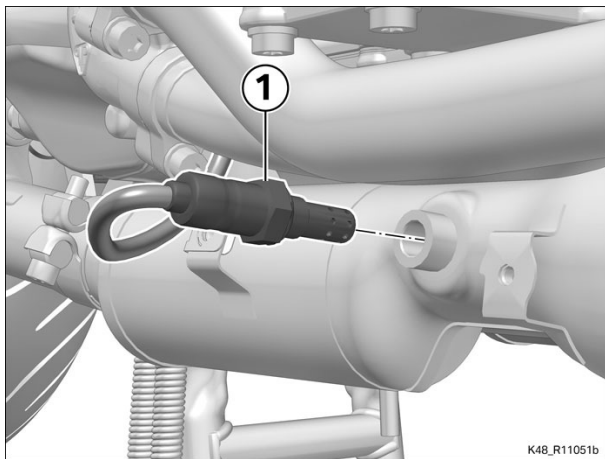

(-) Installing right oxygen sensor

- Thinly lubricate threads of oxygen sensor (1).

 Fluids and lubricants		
Optimoly TA	High-temperature assembly grease	18 21 9 062 599

- Install oxygen sensor (1).

 Tightening torques		
Oxygen sensor to exhaust manifold		
M12 x 1.25	25 Nm	
Thinly lubricate thread, Optimoly TA		

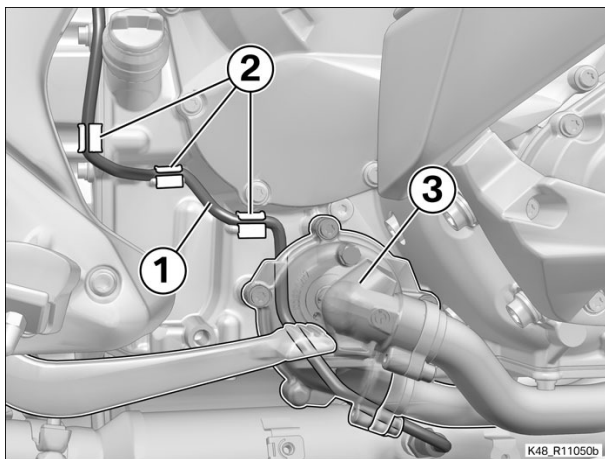

- Route cable (1) behind coolant pump (3).
- Route cable (1) for the oxygen sensor and secure it in holders (2).

- Route cable (1) for the oxygen sensor and secure it in holders (2).

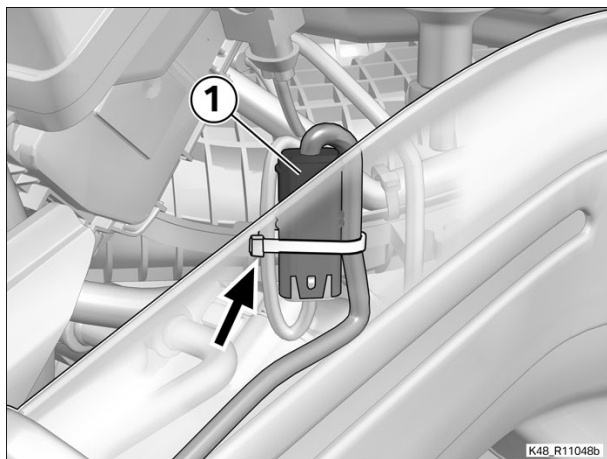
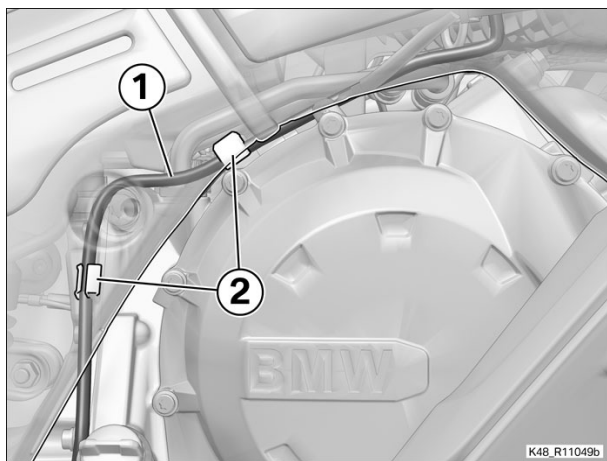

- Connect plug (1) for the oxygen sensor and install.
- Secure the cable tie (arrow).

Finishing work

- Installing right catalytic-converter shield
- Installing right fuel-tank cover
- Installing right fuel-tank cover top section
- Installing left catalytic-converter shield
- Installing gearbox cover
- Installing left cover of fuel tank
- Installing left fuel-tank cover top section

=> Resetting/learning adaptation values (with replacing component) (Description in item: 61 00 503, Billed as a separate item)

- Installing front seat
- Final check of work performed

📁 12 00 014 Performing vehicle test with BMW Motorrad diagnostic system 3 FRUs

+ 12 00 516

Preparatory work

Remove the front seat

Core activity

(-) Connecting BMW Motorrad diagnostic system to motorcycle

- Connect the **BMW Motorrad** battery charger.



Note

When carrying out diagnosis and programming, use a battery charger with 30 A approved by **BMW Motorrad** that ensures an **on-board system voltage of 13V**.

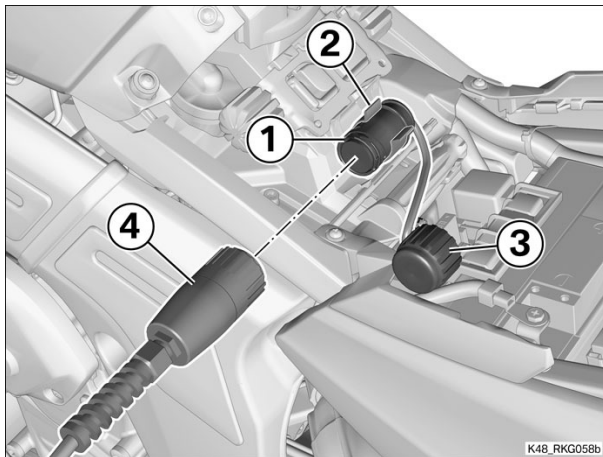

- Disengage diagnosis plug (1) from holder (2) and remove protective cap (3).
- Connect diagnosis plug (1) to connecting cable (4) for the diagnostic system.



Note

See the information about the **BMW Motorrad** diagnostic system for all other instructions.

(-) Performing vehicle test with BMW Motorrad diagnostic system

- Perform the vehicle test with the **BMW Motorrad** diagnostic system and read out the **fault memory**.



Note

When working with the **BMW Motorrad** diagnostic system, always follow the instructions it issues.

- Follow instructions or use the diagnosis options, as applicable.

(-) Disconnecting BMW Motorrad diagnostic system from motorcycle

- Close all diagnostic programs and switch off the ignition.
- Disconnect the connecting cable for the **BMW Motorrad** diagnostic system from the motorcycle's diagnosis plug and screw the cap onto the diagnosis plug.
- Disconnect the **BMW Motorrad** battery charger from the motorcycle.

Finishing work

Installing front seat

Final check of work performed

📁 12 12 011 Renewing all spark plugs 13 FRUs

+ 12 12 513

Preparatory work

Removing left bottom side panel
 Removing left radiator cowl
 Removing radiator hose cover
 Removing left side panel
 Removing right bottom side panel
 Removing right radiator cowl
 Remove the right side panel
 Draining cooling system
 Removing complete radiator
 Removing air guide
 Disconnecting distributor rail for secondary air system

Core activity

(-) Removing direct ignition coils

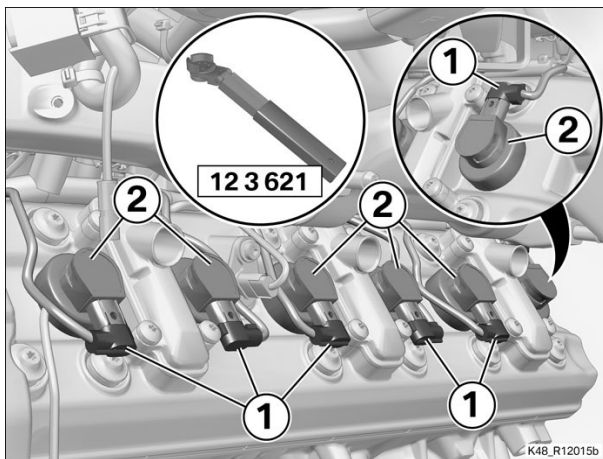

Attention

The locking tab can be broken off if the correct procedure is not adopted for disconnecting the plug.
 Push the plug away from the locking tab; do not attempt to raise or bend the locking tab.

- Clean the cylinder-head cover with compressed air prior to removal.
- Disconnect plugs (1) for the direct ignition coils.
- Remove direct ignition coils (2) with puller (No. 12 3 621).

(-) Removing spark plugs

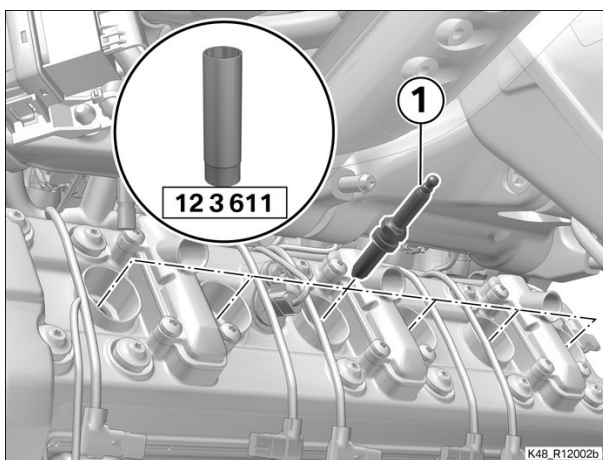

- Clean the spark-plug recess with compressed air.
- Remove spark plugs (1) with spark-plug wrench (No. 12 3 611).

(-) Changing spark plugs

- Install new spark plugs.



Technical data

Spark plugs,
manufacturer and
designation

NGK LMAR8AI-8

(-) Installing spark plugs

- Install spark plugs (1) with spark-plug wrench (No. 12 3 611).

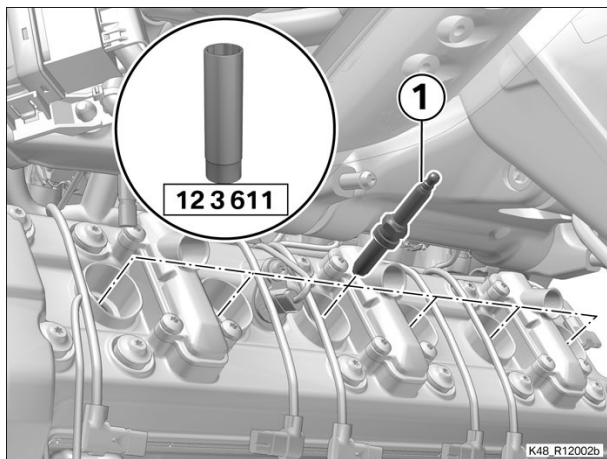

Tightening torques

Spark plug in cylinder head

M10 x 1

12 Nm

(-) Installing direct ignition coils

- Insert each direct ignition coil (2), seat it on the spark plug and make sure it engages.
- Connect plugs (1) for the direct ignition coils.

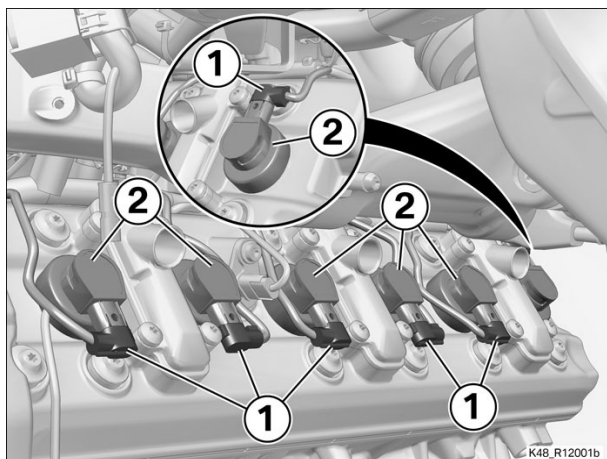

Finishing work

Securing distributor rail for secondary air system

Installing air guide

Installing complete radiator

Filling and priming cooling system

Install the right side panel

Install the right radiator cowl

Installing right bottom side panel

Installing left side panel

Installing radiator hose cover

Installing left radiator cowl

Installing left bottom side panel

Final check of work performed

📁 12 12 509 Replace all spark plugs (as part of maintenance) 2 FRUs

Core activity

(-) Removing spark plugs

- Clean the spark-plug recess with compressed air.
- Remove spark plugs (1) with spark-plug wrench (No. 12 3 611).

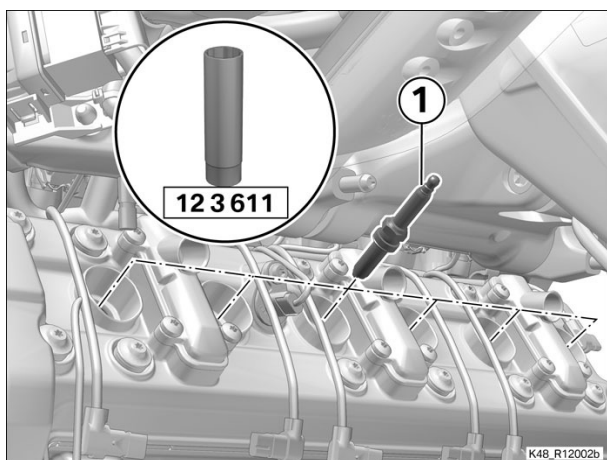

(-) Changing spark plugs

- Install new spark plugs.

 Technical data			
Spark plugs, manufacturer and designation		NGK LMAR8AI-8	

(-) Installing spark plugs

- Install spark plugs (1) with spark-plug wrench (No. 12 3 611).

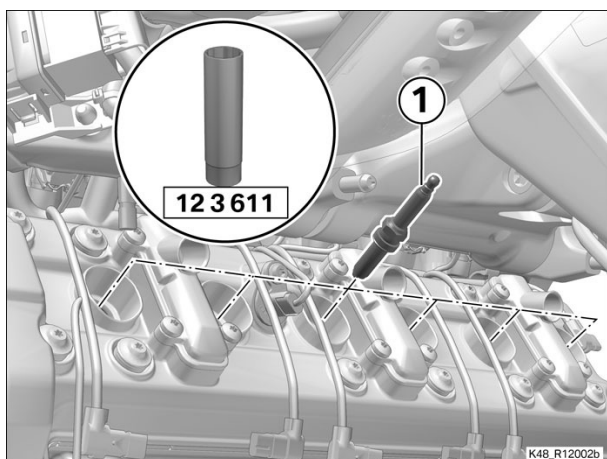

 Tightening torques		
Spark plug in cylinder head		
M10 x 1	12 Nm	

📁 12 13 155 Replacing direct ignition coil 10 FRUs

+ 12 13 655

Preparatory work

Removing left bottom side panel
 Removing left radiator cowl
 Removing radiator hose cover
 Removing left side panel
 Removing right bottom side panel
 Removing right radiator cowl
 Remove the right side panel
 Draining cooling system
 Removing complete radiator
 Removing air guide
 Disconnecting distributor rail for secondary air system

Core activity

(-) Removing direct ignition coils



Attention

The locking tab can be broken off if the correct procedure is not adopted for disconnecting the plug.
 Push the plug away from the locking tab; do not attempt to raise or bend the locking tab.

- Clean the cylinder-head cover with compressed air prior to removal.
- Disconnect plugs (1) for the direct ignition coils.
- Remove direct ignition coils (2) with puller (No. 12 3 621).

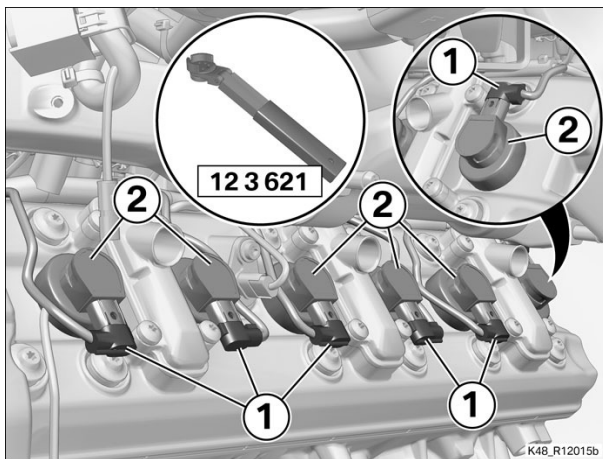

(-) Installing direct ignition coils

- Insert each direct ignition coil (2), seat it on the spark plug and make sure it engages.
- Connect plugs (1) for the direct ignition coils.

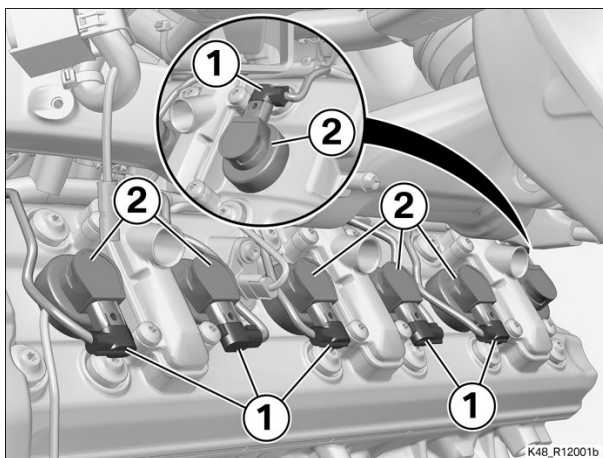

Finishing work

Securing distributor rail for secondary air system
 Installing air guide
 Installing complete radiator

Filling and priming cooling system
Install the right side panel
Install the right radiator cowl
Installing right bottom side panel
Installing left side panel
Installing radiator hose cover
Installing left radiator cowl
Installing left bottom side panel
Final check of work performed

📁 12 31 022 Replace generator 21 FRUs

+ 12 31 673

Preparatory work

Remove the front seat
 Removing air guides for intake air pipes, left and right
 Removing complete cover of fuel tank
 Removing left bottom side panel
 Removing left radiator cowl
 Removing left side panel
 Removing inner trim for left side panel
 Removing right bottom side panel
 Removing right radiator cowl
 Remove the right side panel
 Removing inner trim for right side panel
 Removing adjusting plate
 Disengaging seat support
 Disengaging left and right intake air pipes
 Removing complete intake air silencer
 Removing fuel tank
 Disconnecting battery
 Disengaging wiring harness for engine
 Removing intake manifold

Core activity

(-) Removing starter

- Remove the following components:
 - Cap (1)
 - Nut (2)
 - Positive lead (3) for the starter
 - Screws (4)
- Remove starter (5), noting the O-ring (arrow).

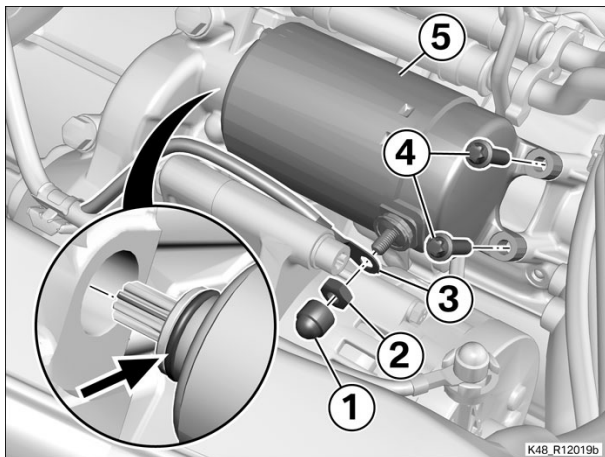

(-) Removing alternator

- Remove the following components:
 - Cap (1)
 - Nut (2)
 - Positive lead (3) for the alternator
 - Screws (4)
 - Alternator (5)
- Disconnect plug (6) for the alternator.

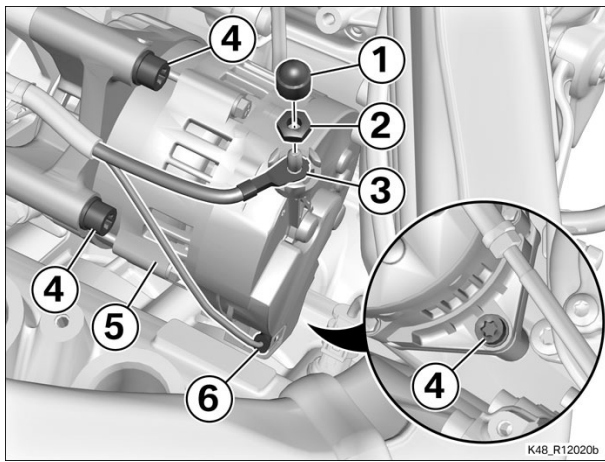

(-) Installing alternator

- Clean the sealing face (arrow).
- Check O-ring (1) for damage; replace if necessary.

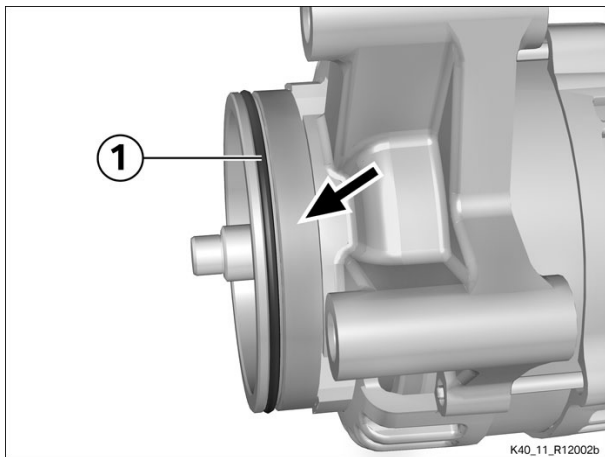

- Clean the sealing face (arrow).
- Check that judder dampers (1) are correctly positioned in the housing; reposition if necessary.

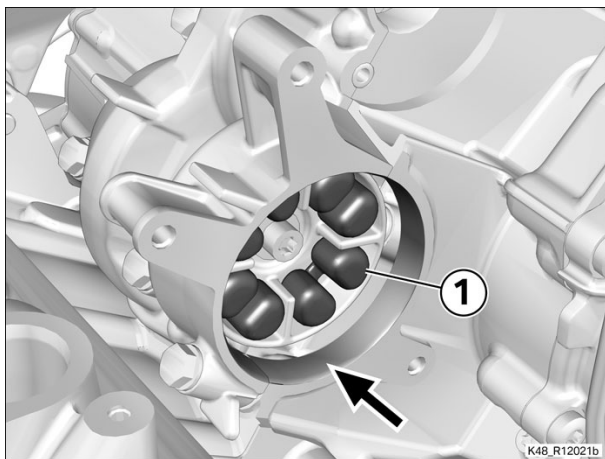

- Connect plug (6) for the alternator.
- Install alternator (5).
- Install screws (4).

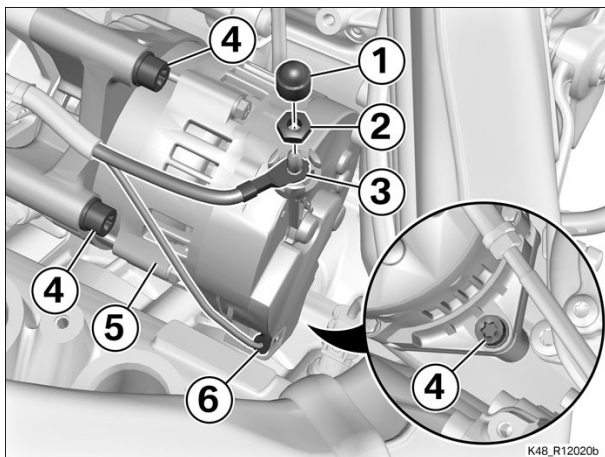

 Tightening torques		
Alternator to crankcase/alternator cover		
M6 x 65	20 Nm	

- Hold positive lead (3) for the alternator in position.
- Install nut (2).

 Tightening torques		
Wiring harness to alternator		
M6	8 Nm	

- Install cap (1).

(-) Installing starter

- Clean the sealing faces.
- Check the O-ring (arrow) for damage; replace if necessary.
- Hold starter (5) in position.
- Install screws (4).

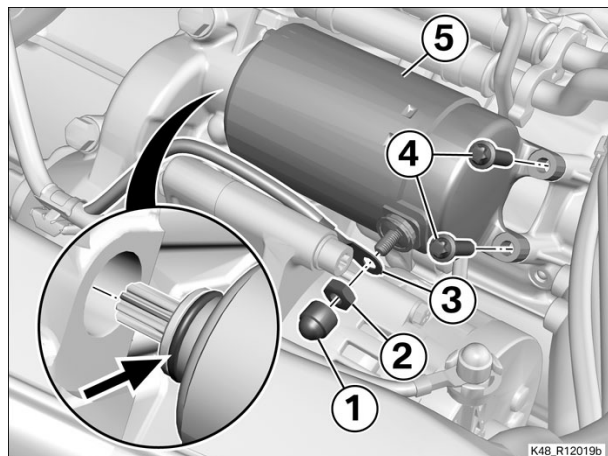

 Tightening torques		
Starter motor to gearbox housing		
M6 x 25	10 Nm	

- Hold positive lead (3) for the starter in position.
- Install nut (2).

 Tightening torques		
Wiring harness to starter		
M6	8 Nm	

- Install cap (1).

Finishing work

Installing intake manifold

Securing wiring harness for engine

Connecting battery

Installing fuel tank

Installing complete intake air silencer

Securing left and right intake air pipes

Securing seat support

Installing adjusting plate

Installing inner trim for right side panel

Install the right side panel

Install the right radiator cowl

Installing right bottom side panel

Installing inner trim for left side panel

Install the left side panel

Installing left radiator cowl

Installing left bottom side panel

Installing complete cover of fuel tank

Installing air guides for intake air pipes, left and right

Installing front seat

Final check of work performed

📁 12 41 025 Replacing starter 19 FRUs

+ 12 41 528

Preparatory work

Remove the front seat
 Removing air guides for intake air pipes, left and right
 Removing complete cover of fuel tank
 Removing left bottom side panel
 Removing left radiator cowl
 Removing left side panel
 Removing inner trim for left side panel
 Removing right bottom side panel
 Removing right radiator cowl
 Remove the right side panel
 Removing inner trim for right side panel
 Removing adjusting plate
 Disengaging seat support
 Disengaging left and right intake air pipes
 Removing complete intake air silencer
 Removing fuel tank
 Disconnecting battery
 Disengaging wiring harness for engine
 Removing intake manifold

Core activity

(-) Removing starter

- Remove the following components:
 - Cap (1)
 - Nut (2)
 - Positive lead (3) for the starter
 - Screws (4)
- Remove starter (5), noting the O-ring (arrow).

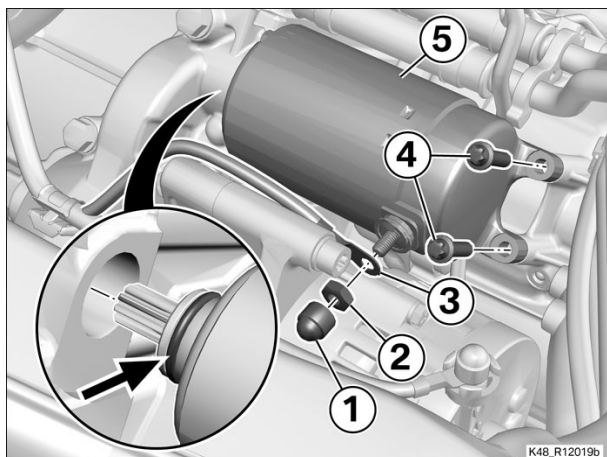

(-) Installing starter

- Clean the sealing faces.
- Check the O-ring (arrow) for damage; replace if necessary.
- Hold starter (5) in position.
- Install screws (4).

🔧 Tightening torques	
Starter motor to gearbox housing	

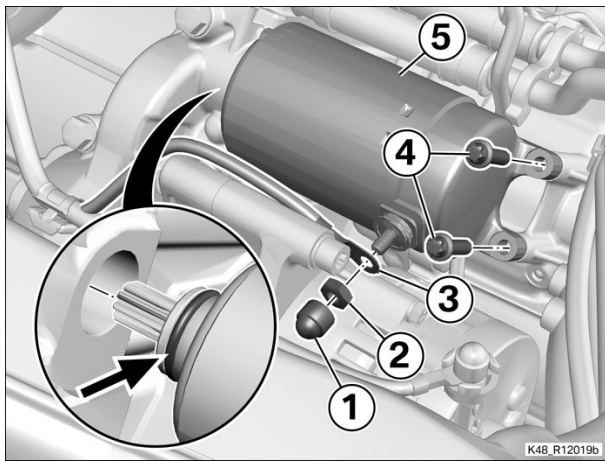

M6 x 25	10 Nm	
---------	-------	--

- Hold positive lead (3) for the starter in position.
- Install nut (2).

 Tightening torques		
---	--	--

Wiring harness to starter		
----------------------------------	--	--

M6	8 Nm	
----	------	--

- Install cap (1).

Finishing work

- Installing intake manifold
- Securing wiring harness for engine
- Connecting battery
- Installing fuel tank
- Installing complete intake air silencer
- Securing left and right intake air pipes
- Securing seat support
- Installing adjusting plate
- Installing inner trim for right side panel
- Install the right side panel
- Install the right radiator cowl
- Installing right bottom side panel
- Installing inner trim for left side panel
- Install the left side panel
- Installing left radiator cowl
- Installing left bottom side panel
- Installing complete cover of fuel tank
- Installing air guides for intake air pipes, left and right
- Installing front seat
- Final check of work performed

12 61 001 Replacing oil-level/oil-temperature sensor 3 FRUs

+ 12 61 567

Equipment trim-level variant:

0416 - Electronic Suspension Adjustment (ESA)

Additional line items for billing

12 61 502 Additional work for replacing oil-level/oil-temperature sensor (with ESA), 11 FRUs

Preparatory work

- Remove the front seat
- Remove the rear seat
- Removing left rear trim panel
- Removing right rear trim panel
- Removing adjusting plate
- Removing seat support
- Releasing expansion tank
- Removing right footrest plate
- Removing silencer
- Removing left footrest plate
- Disengaging actuator rod from rear ride height sensor
- Removing number-plate carrier
- Remove the rear wheel
- Raising rear frame
- Removing rear spring strut

Core activity

(-) Removing oil-level/oil-temperature sensor

- Remove cable tie (arrow).
- Remove cable holder (1).
- Remove and disconnect plug (2) for the oil-level/oil-temperature sensor.
- Work cable (3) for the oil-level/oil-temperature sensor clear and disengage it from holder (4).

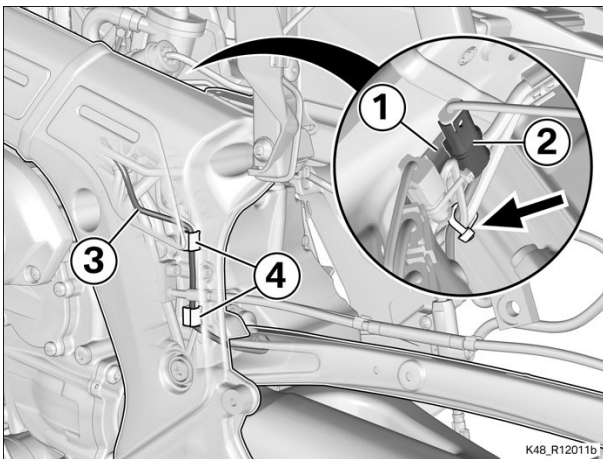

- Remove screws (1).
- Carefully work oil-level/oil-temperature sensor (2) with O-ring (3) clear and remove.

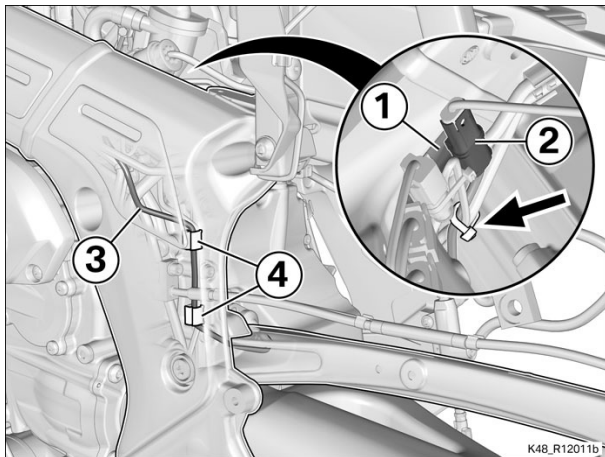
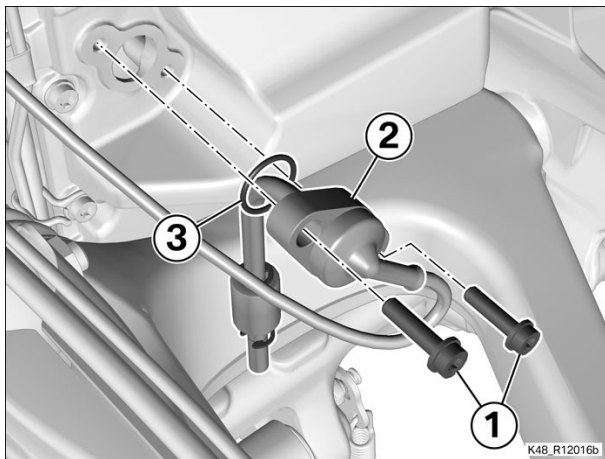
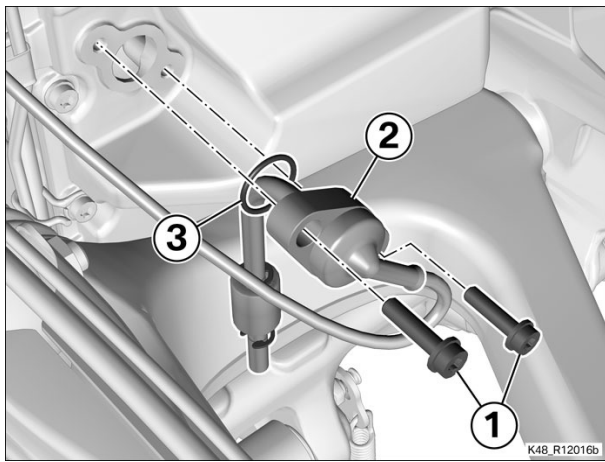

(-) Installing oil-level/oil-temperature sensor

- Check O-ring (3) for damage; replace if necessary.
- Carefully work oil-level/oil-temperature sensor (2) with O-ring (3) into position and install.
- Install screws (1).

Tightening torques		
Oil-level/oil-temperature sensor to oil tank cover		
M6 x 16	10 Nm	

- Route cable (3) for the oil-level/oil-temperature sensor and secure it in holder (4).
- Connect plug (2) for oil-level/oil-temperature sensor and install.
- Install cable holder (1).
- Secure the cable tie (arrow).

Finishing work

- Installing rear spring strut
- Lowering rear frame
- Installing rear wheel
- Installing number-plate carrier
- Securing actuator rod to rear ride height sensor
- Installing left footrest plate
- Securing silencer
- Installing right footrest plate
- Securing expansion tank
- Installing seat support

Installing adjusting plate
Installing right rear trim panel
Installing left rear trim panel

=> Resetting/learning adaptation values (with replacing component) (Description in item: 61 00 503, Billed as a separate item)

Installing rear seat
Installing front seat
Final check of work performed

12 62 010 Replacing coolant-temperature sensor 5 FRUs

+ 12 62 510

Preparatory work

- Removing left bottom side panel
- Removing left radiator cowl
- Removing left side panel
- Removing left stowage compartment
- Removing gearbox cover
- Disengaging shift lever

Core activity

(-) Removing coolant-temperature sensor

- Disconnect plug (1) for the coolant-temperature sensor.
- Remove coolant-temperature sensor (2) with sealing ring (3).
- Seal the bore for the coolant-temperature sensor.

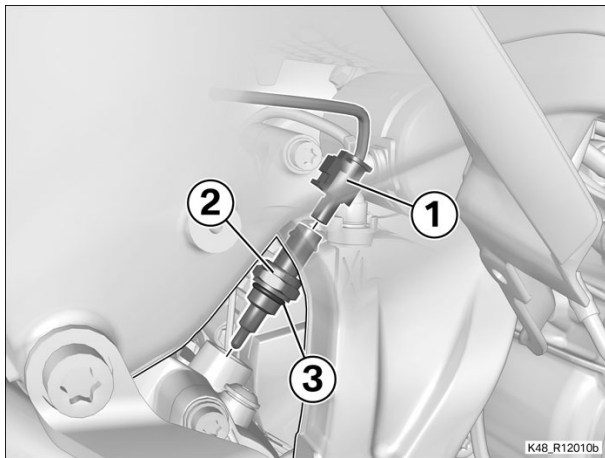

(-) Installing coolant-temperature sensor

- Install coolant-temperature sensor (2) with new sealing ring (3).

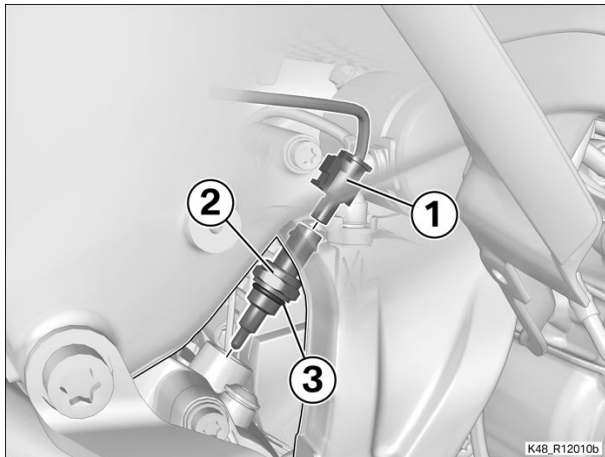

 Tightening torques		
Temperature sensor to cylinder head		
M12 x 1.5	15 Nm	

- Connect plug (1) for the coolant-temperature sensor.

Finishing work

- Securing selector lever
- Installing gearbox cover
- Installing left stowage compartment
- Install the left side panel
- Installing left radiator cowl
- Installing left bottom side panel
- Remove the front seat
- Connecting **BMW Motorrad** diagnostic system to motorcycle

Reading fault memory with **BMW Motorrad** diagnostic system
and resetting adaptation values

Disconnecting **BMW Motorrad** diagnostic system from motorcycle

Installing front seat

Checking coolant level

Final check of work performed

12 72 001 Replacing crankshaft sensor 3 FRUs

+ 12 72 501

Preparatory work

Removing right radiator cowl

Core activity

(-) Removing crankshaft sensor

- Remove cable tie (arrow).
- Disconnect plug (1) for the crankshaft sensor.

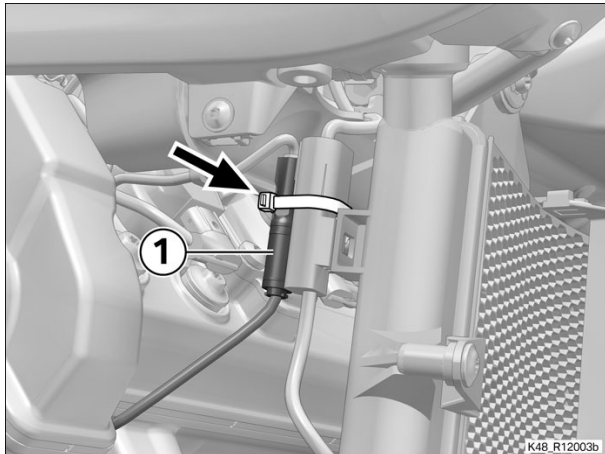

- Disengage cable (1) from holder (2).
- Remove screw (3) and crankshaft sensor (4) with O-ring (5).

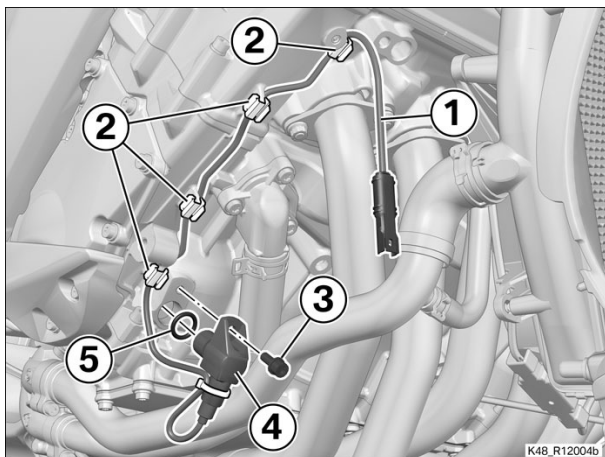

(-) Installing crankshaft sensor

- Check O-ring (5) for damage; replace if necessary.
- Install crankshaft sensor (4) with O-ring (5) and screw (3).

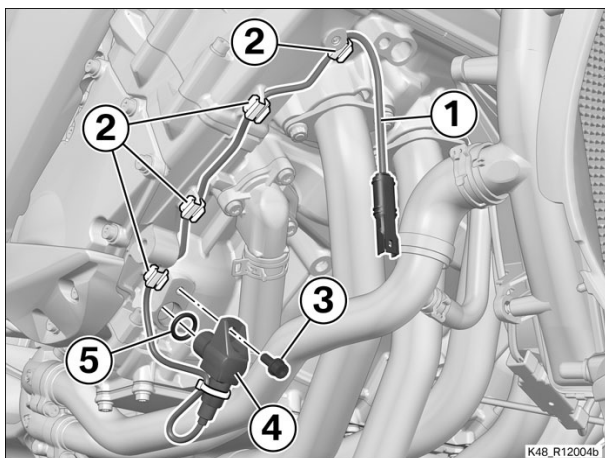

Tightening torques		
Crankshaft sensor on crankcase		
M6 x 16	10 Nm	

- Route cable (1) and secure it in holder (2).

- Connect plug (1) for the crankshaft sensor.
- Close the cable ties (arrows).

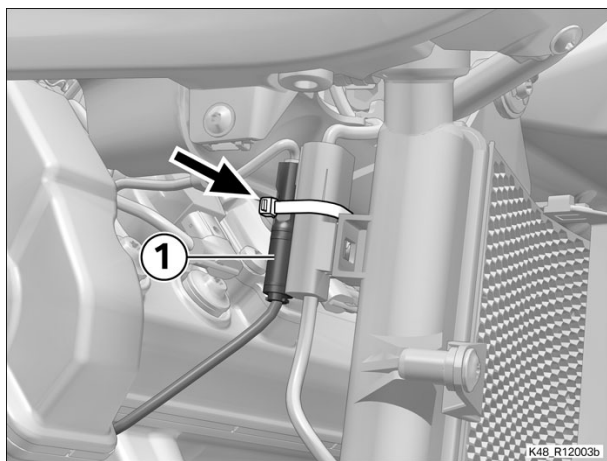

Finishing work

Install the right radiator cowl
Final check of work performed

12 72 020 Replacing camshaft sensor 11 FRUs

+ 12 72 520

Preparatory work

- Removing left bottom side panel
- Removing left radiator cowl
- Removing radiator hose cover
- Removing left side panel
- Removing right bottom side panel
- Removing right radiator cowl
- Remove the right side panel
- Draining cooling system
- Removing complete radiator
- Removing air guide
- Disconnecting distributor rail for secondary air system

Core activity

(-) Removing camshaft sensor

- Disconnect plug (1) for the camshaft sensor.
- Remove screw (2).
- Remove camshaft sensor (3) with O-ring (4).

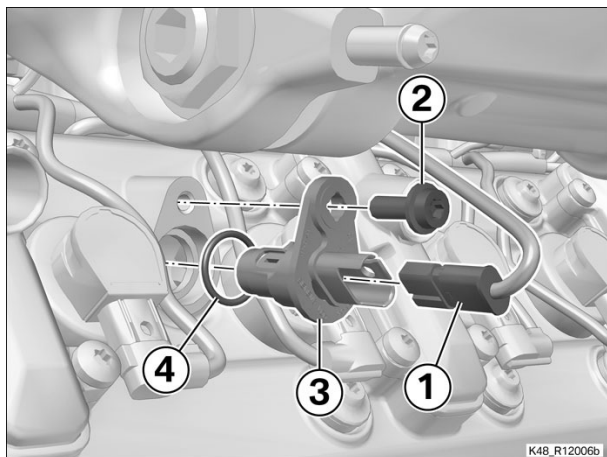

(-) Installing camshaft sensor

- Check O-ring (4) for damage; replace if necessary.
- Install camshaft sensor (3) with O-ring (4).
- Install new screw (2).

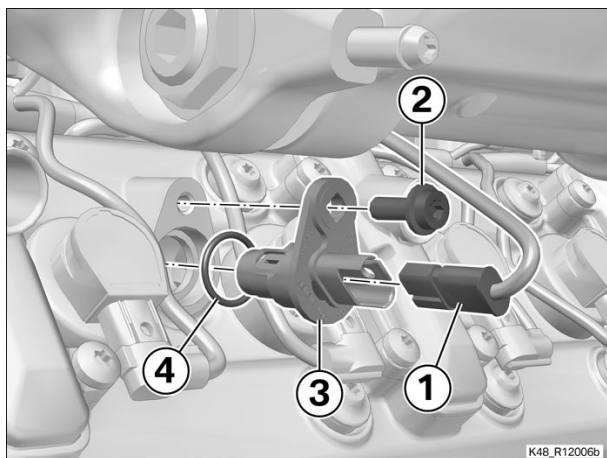

 Tightening torques		
Camshaft sensor to cylinder head cover		
M6 x 16, Replace screw	Initial torque, 3 Nm	
	Final torque, 90°	

- Connect plug (1) for the camshaft sensor.

Finishing work

- Securing distributor rail for secondary air system
- Installing air guide
- Installing complete radiator

Filling and priming cooling system

Install the right side panel

Install the right radiator cowl

Installing right bottom side panel

Installing left side panel

Installing radiator hose cover

Installing left radiator cowl

Installing left bottom side panel

Final check of work performed

📁 13 54 017 Replacing complete throttle-valve assembly 10 FRUs

+ 13 54 521



Warning

Fuel is flammable and a hazard to health.
Observe all applicable safety regulations.

Preparatory work

Remove the front seat

Removing air guides for intake air pipes, left and right

Removing complete cover of fuel tank

Removing adjusting plate

Disengaging seat support

Disengaging left and right intake air pipes

Disengaging complete intake air silencer

Core activity

(-) Removing throttle-valve stub assembly

- Remove the cable ties (arrows).
- Disconnect plug (1) for the throttle-valve stub assembly.
- Allow cable leg (2) to dangle to one side.

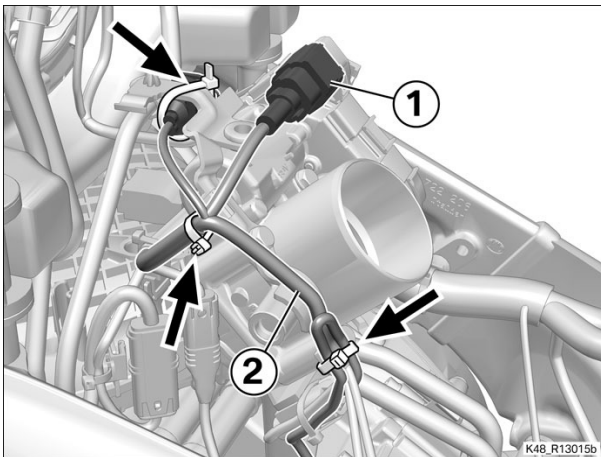

- Remove screws (1).
- Remove retaining plate (2).
- Remove throttle-valve stub assembly (3) with sealing ring (4).

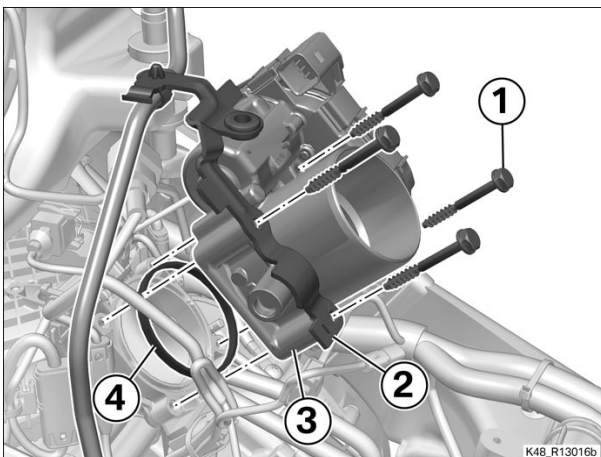

(-) Installing throttle-valve stub assembly

- Check sealing ring (4) for damage; replace if necessary.
- Install throttle-valve stub assembly (3) with sealing ring (4).
- Hold retaining plate (2) in position.
- Install screws (1).

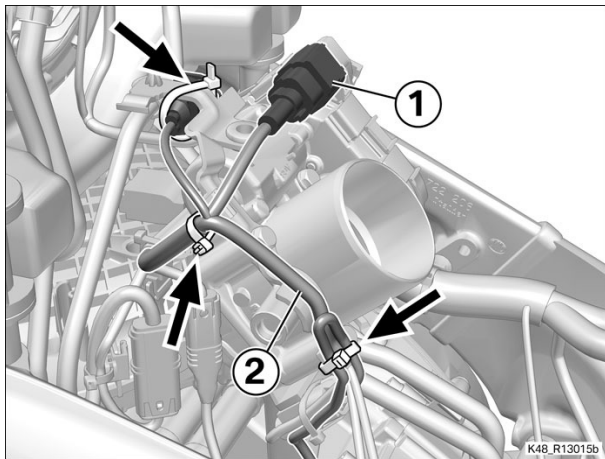
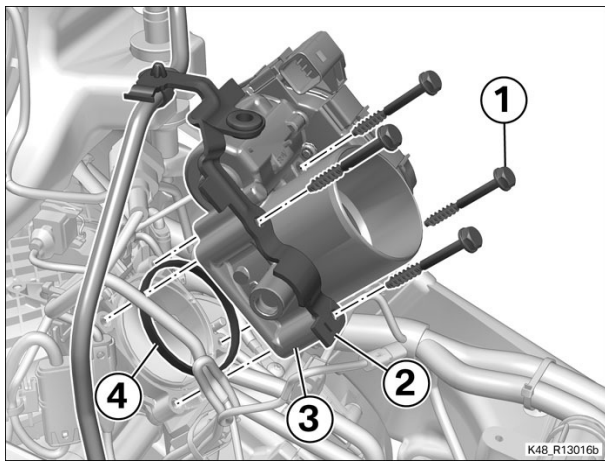

Tightening torques

Throttle-valve assembly to intake assembly

T60 x 53

6 Nm

- Connect plug (1) for the throttle-valve stub assembly.
- Position wiring-harness leg (2).
- Close the cable ties (arrows).

Finishing work

Securing complete intake air silencer

Securing left and right intake air pipes

Securing seat support

Installing adjusting plate

Installing complete cover of fuel tank

Installing air guides for intake air pipes, left and right

Connecting **BMW Motorrad** diagnostic system to motorcycle

Reading fault memory with **BMW Motorrad** diagnostic system and resetting adaptation values

Disconnecting **BMW Motorrad** diagnostic system from motorcycle

Installing front seat

Final check of work performed

 **13 61 522 Programming control unit of engine management system (along with testing software) 3 FRUs**

Core activity

(-) Programming engine-management control unit

- Start **ISTA/P**.
- Start the programming routine and follow the instructions issued by the **BMW Motorrad** diagnostic system.

13 61 510 Replacing engine management control unit (not including checking/programming software) 5 FRUs



Note

Before removal, test the control unit with the **BMW Motorrad** diagnostic system and make a backup copy of the data.

Preparatory work

Remove the front seat

Removing air guide for intake air pipe, right

Removing right fuel-tank cover top section

Remove the right fuel-tank cover

Removing right bottom side panel

Removing right radiator cowl

Remove the right side panel

Removing inner trim for right side panel

Disengaging expansion tank for coolant

Disengaging bracket for basic module and engine control unit

Core activity

(-) Removing engine control unit

- Disconnect plugs (1) and (2) for the engine control unit.
- Push back locking tabs (3) and remove engine control unit (4).

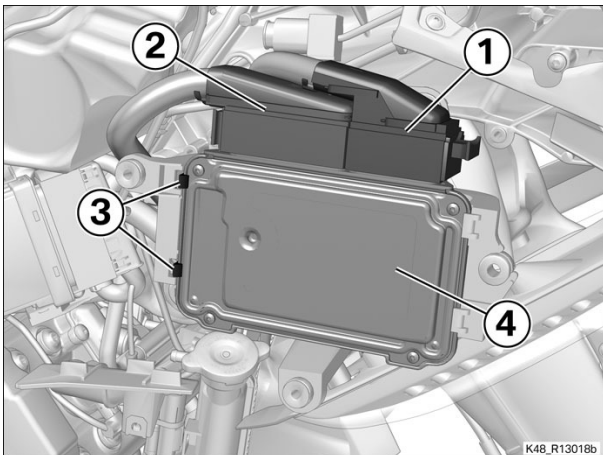

(-) Installing engine control unit



Note

Do not, **under any circumstances** temporarily install control units from other vehicles by way of testing.

The possible consequences include:

Coding data could be overwritten.

The control units could malfunction.

- Install engine control unit (4).
- Make sure that retaining tabs (3) are latched.
- Connect plugs (2) and (1) for the engine control unit.

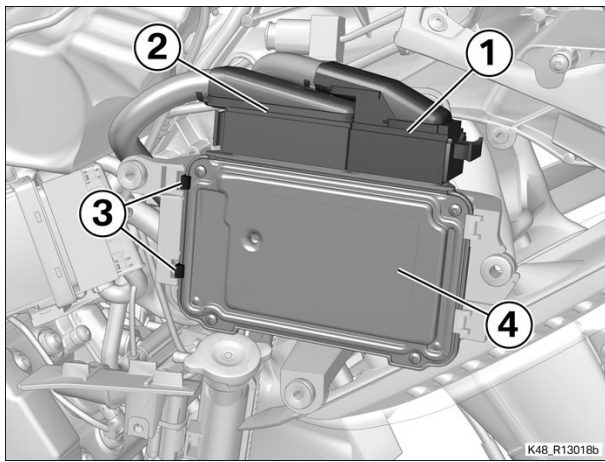

Finishing work

Securing bracket for basic module and engine control unit

Securing expansion tank for coolant

Installing inner trim for right side panel

Install the right side panel

Install the right radiator cowl

Installing right bottom side panel

Installing right fuel-tank cover

Installing right fuel-tank cover top section

Installing air guide for intake air pipe, right

=> Testing software (Description in item: 61 00 502, Billed as a separate item)

=> Programming control units of vehicle (along with testing software) (Description in item: 61 00 510, Billed as a separate item)

Installing front seat

Final check of work performed

📁 13 62 010 Replacing intake-air temperature sensor 5 FRUs

+ 13 62 501

Preparatory work

Remove the front seat

Removing air guide for intake air pipe, right

Removing right fuel-tank cover top section

Remove the right fuel-tank cover

Core activity

(-) Removing intake-air temperature sensor

- Disconnect plug (1) for the intake-air temperature sensor.
- Push the locking device (arrow) and remove intake-air temperature sensor (2) with sealing ring (3).

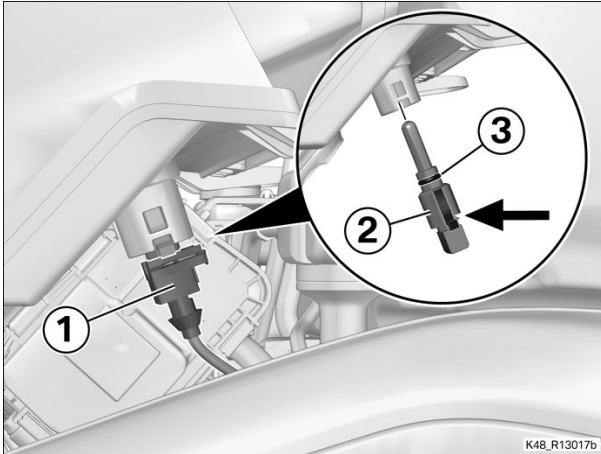

(-) Installing intake-air temperature sensor

- Check sealing ring (3) for damage; replace if necessary.
- Install air-temperature sensor (2) with sealing ring (3). Make sure that the locking device (arrow) engages.
- Connect plug (1) for the intake-air temperature sensor.

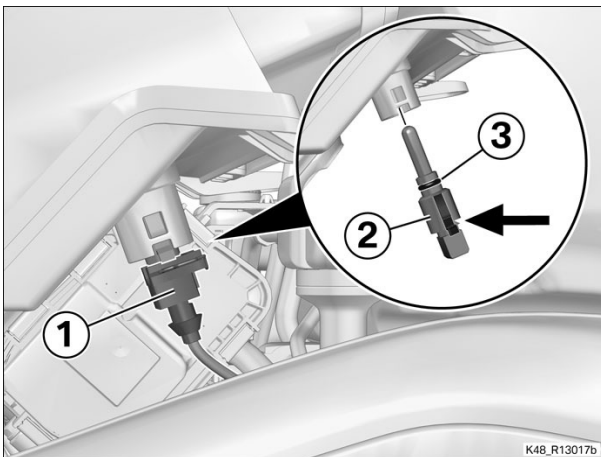

Finishing work

Installing right fuel-tank cover

Installing right fuel-tank cover top section

Installing air guide for intake air pipe, right

Connecting **BMW Motorrad** diagnostic system to motorcycle

Reading fault memory with **BMW Motorrad** diagnostic system and resetting adaptation values

Disconnecting **BMW Motorrad** diagnostic system from motorcycle

Installing front seat

Final check of work performed

📁 13 64 165 Renewing one injector 16 FRUs

+ 13 64 501



Warning

Fuel is flammable and a hazard to health.
Observe all applicable safety regulations.

Preparatory work

- Remove the front seat
- Removing air guides for intake air pipes, left and right
- Removing complete cover of fuel tank
- Removing left bottom side panel
- Removing left radiator cowl
- Removing left side panel
- Removing inner trim for left side panel
- Removing right bottom side panel
- Removing right radiator cowl
- Remove the right side panel
- Removing inner trim for right side panel
- Removing adjusting plate
- Disengaging seat support
- Disengaging left and right intake air pipes
- Removing complete intake air silencer
- Removing fuel tank

Core activity

(-) Removing injection rail

- Disconnect plug (1) for the fuel-pressure sensor and plugs (2) for the injection valves.

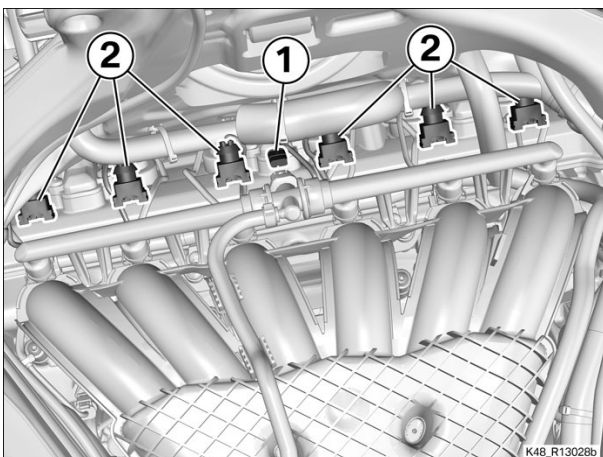

- Disengage fuel hose (1) from bracket (2).
- Remove screws (3).
- Remove injection rail (4).

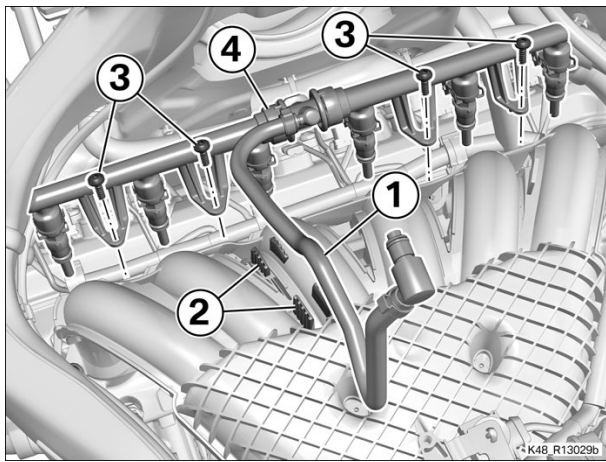

(-) Removing one injection valve



Attention

Fuel feed lines are pressurised. Fuel escapes when a connection is opened.

Catch escaping fuel in a suitable container.

- Remove spring clip (1).
- Remove injection valve (2) with O-ring (3) from injection rail (4).

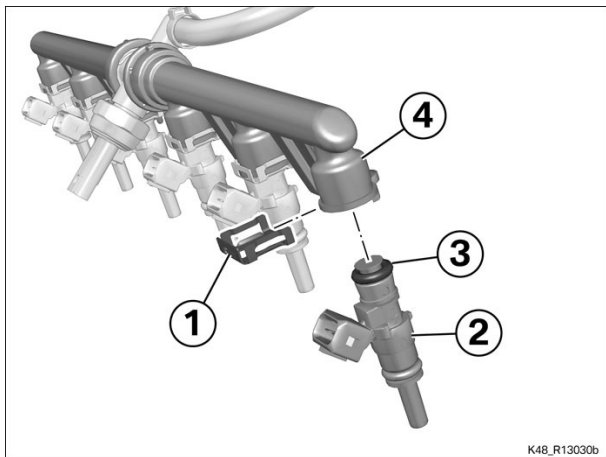

(-) Installing injection valve

- Check O-ring (3) for damage; replace if necessary.
- Lubricate O-ring (3).



Fluids and lubricants

Rubber care product	Lubricating and care of rubber grommets, O-rings and rubberised components	83 12 0 397 018
---------------------	--	-----------------

- Install injection valve (2) in injection rail (4), noting O-ring (3).
- Install spring clip (1).

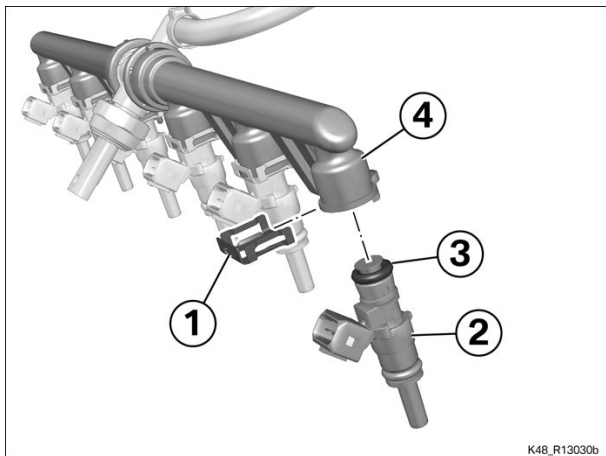

(-) Installing injection rail

- Check the O-rings (arrows); replace if necessary.
- Install injection rail (4).
- Install screws (3).
- Secure fuel hose (1) in holder (2).

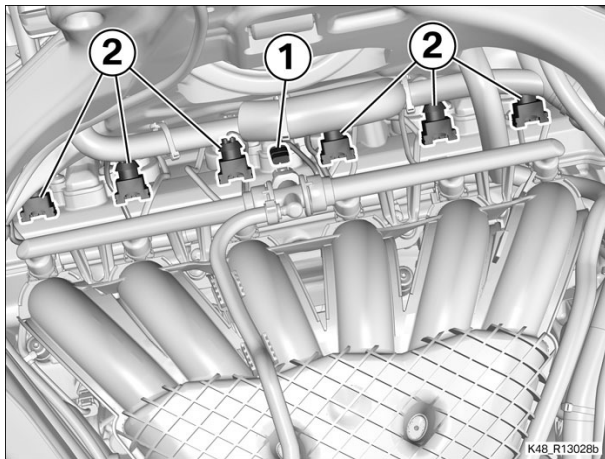
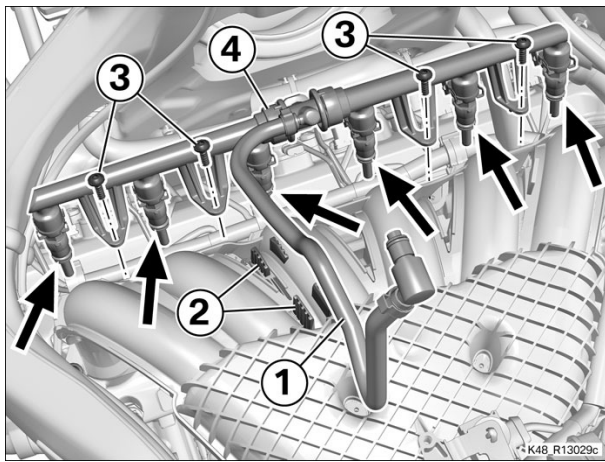

- Connect plug (1) for the fuel-pressure sensor and plugs (2) for the injection valves.

Finishing work

- Installing fuel tank
- Installing complete intake air silencer
- Securing left and right intake air pipes
- Securing seat support
- Installing adjusting plate
- Installing inner trim for right side panel
- Install the right side panel
- Install the right radiator cowl
- Installing right bottom side panel
- Installing inner trim for left side panel
- Install the left side panel
- Installing left radiator cowl
- Installing left bottom side panel
- Installing complete cover of fuel tank
- Installing air guides for intake air pipes, left and right

=> Resetting/learning adaptation values (with replacing component) (Description in item: 61 00 503, Billed as a separate item)

- Installing front seat
- Final check of work performed

13 71 010 Replace intake-air silencer 7 FRUs

+ 13 71 510

Equipment trim-level variant:

0530 - Tyre pressure monitoring (RDC)

Preparatory work

Remove the front seat

Removing air guides for intake air pipes, left and right

Removing complete cover of fuel tank

Removing left and right intake air pipes

Removing adjusting plate

Disengaging seat support

Core activity

(-) Removing intake air silencer front section

- Remove screws (1).

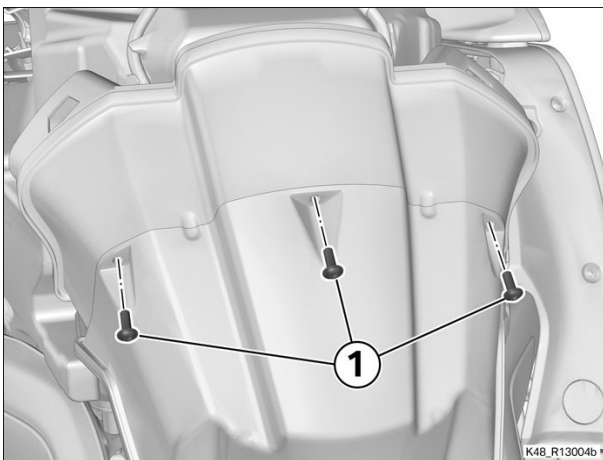

- Remove intake air silencer front section (1) with air filter (2).

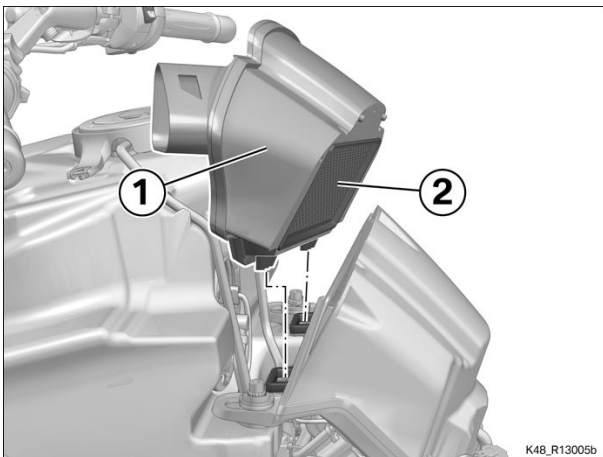

(-) Removing air filter

- Remove air filter (1) from intake air silencer front section (2).

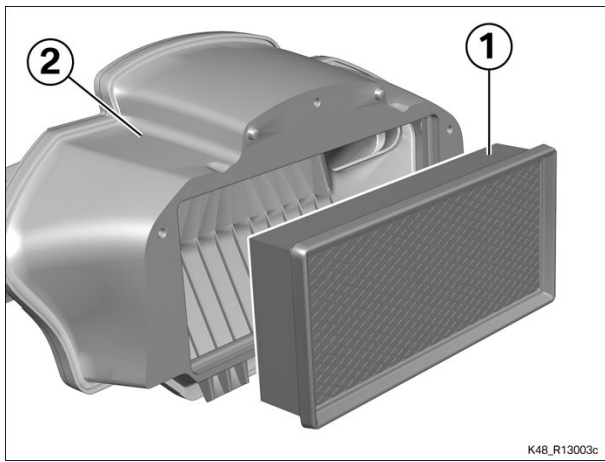

K48_R13003c

(-) Removing intake air silencer main section

- Disconnect plug (1) for the **RDC** control unit and disengage cable (2) from holder (3).

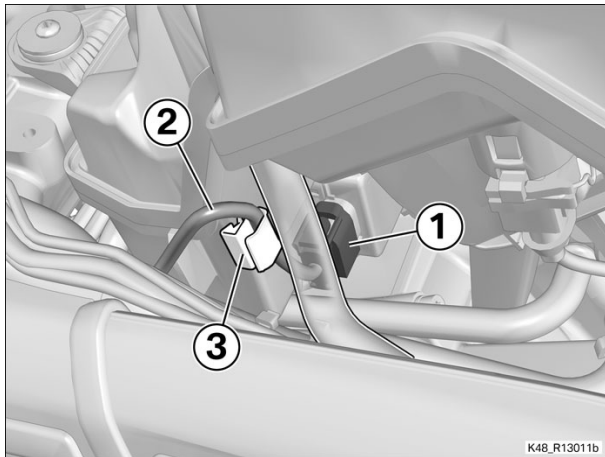

K48_R13011b

- Disconnect plug (1) for the air-temperature sensor.
- Disconnect hose (2) for the secondary air system.
- Remove screw (3) with washer (4).

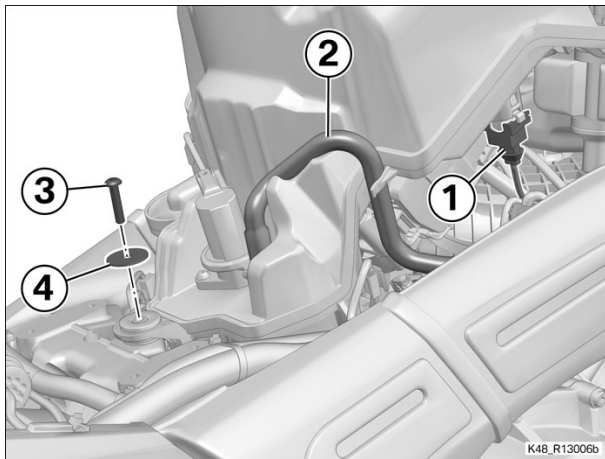

K48_R13006b

- Disconnect plug (1) for the secondary air system valve (SLS valve) and disengage the cable from holder (2).
- Open clip (3) and disconnect breather hose (4).
- Open clip (5) with pliers (No. 17 5 571) and disconnect breather hose (6).

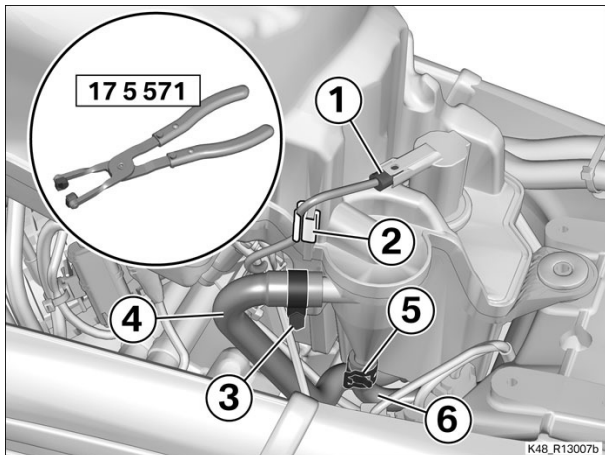

K48_R13007b

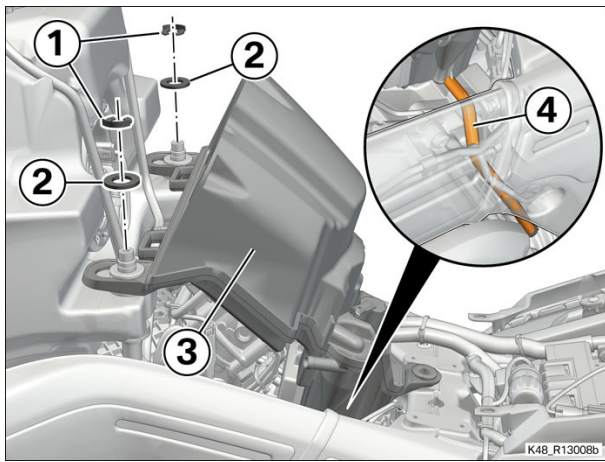

- Remove clips (1) and washers (2).
- Remove intake air silencer main section (3) and work hose (4) clear of the motorcycle.

(-) Removing tyre pressure monitoring control unit (RDC control unit)

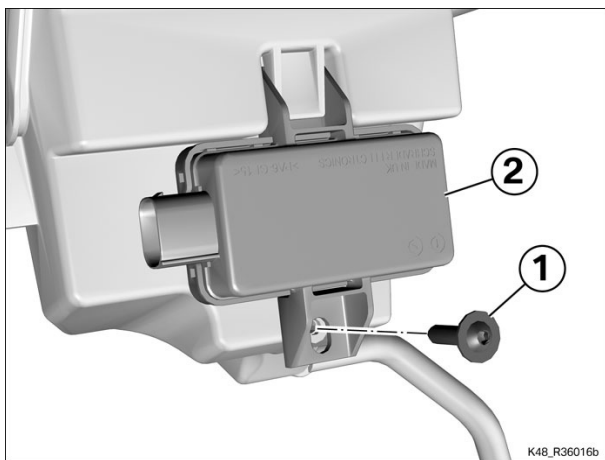

- Remove screw (1).
- Remove RDC control unit (2).

(-) Removing intake-air temperature sensor

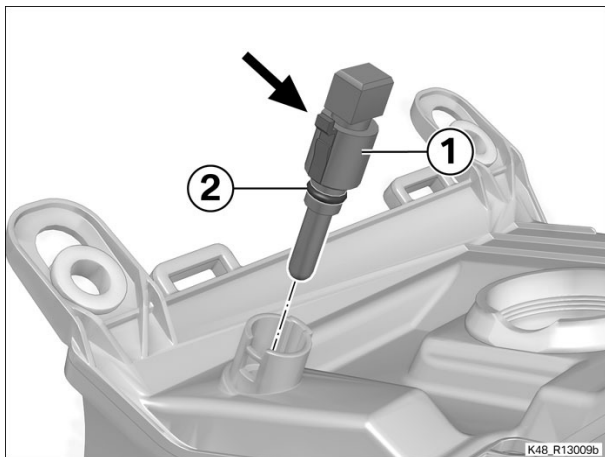

- Push the locking device (arrow) and remove intake-air temperature sensor (1) with sealing ring (2).

(-) Removing changeover valve for secondary air system

- Remove screws (1).
- Remove changeover valve (2), noting the O-ring (arrow).

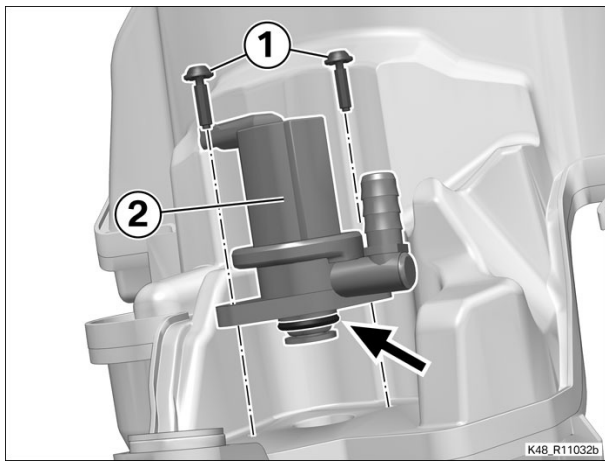

(-) Replacing intake air silencer

- Remove rubber grommets (1), bushing (2), rubber grommet (3) and condensate drain hose (4) from the old intake air silencer main section and transfer them to the new component.

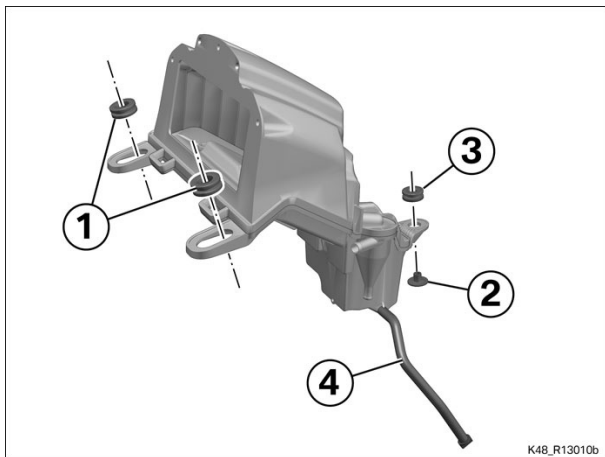

(-) Installing changeover valve for secondary air system

- Check O-ring (arrow) for damage; replace if necessary.
- Install changeover valve (2) with the O-ring (arrow).
- Install screws (1).

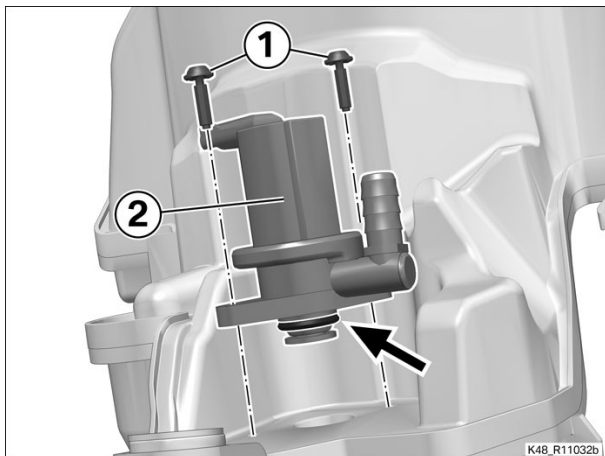

 Tightening torques		
Secondary air system changeover valve to intake air silencer		
PT40 x 1.5	3 Nm	

(-) Installing intake-air temperature sensor

- Check sealing ring (2) for damage; replace if necessary.
- Install air-temperature sensor (1) with sealing ring (2). Make sure that the locking device (arrow) engages.

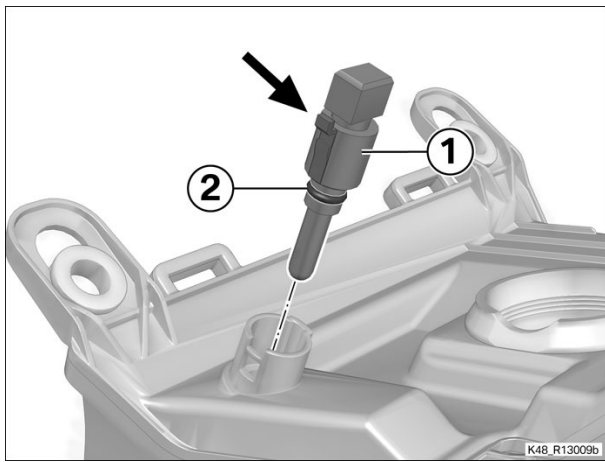

(-) Installing tyre pressure monitoring control unit (RDC control unit)

- Install **RDC control unit (2)**.
- Install screw **(1)**.

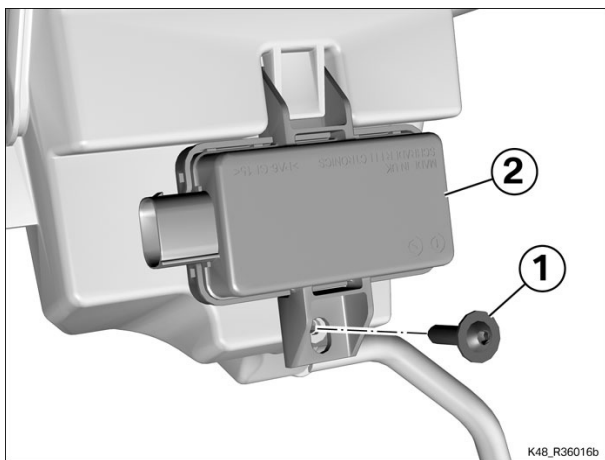

Tightening torques		
Tyre pressure monitoring (RDC) control unit to intake air silencer		
TS4 x 10	3 Nm	

(-) Installing intake air silencer main section

- Install intake air silencer main section **(3)**, working hose **(4)** into position.
- Install washers **(2)** and clips **(1)**.

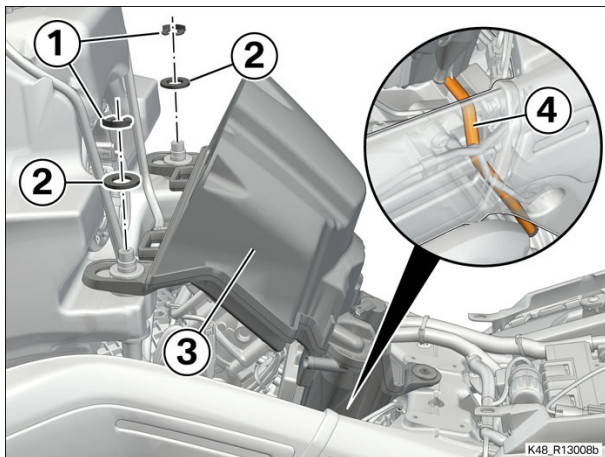

- Connect breather hose **(6)** and close hose clip **(5)** with pliers (**No. 17 5 571**).
- Connect breather hose **(4)** and secure hose clip **(3)**.
- Connect plug **(1)** for the secondary air system valve (SLS valve) and secure the cable in holder **(2)**.

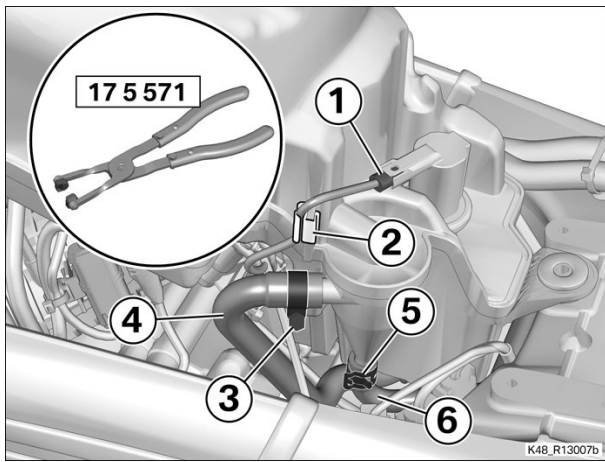

- Install screw (3) with washer (4).

 Tightening torques		
Intake air silencer to frame		
M6 x 25	8 Nm	

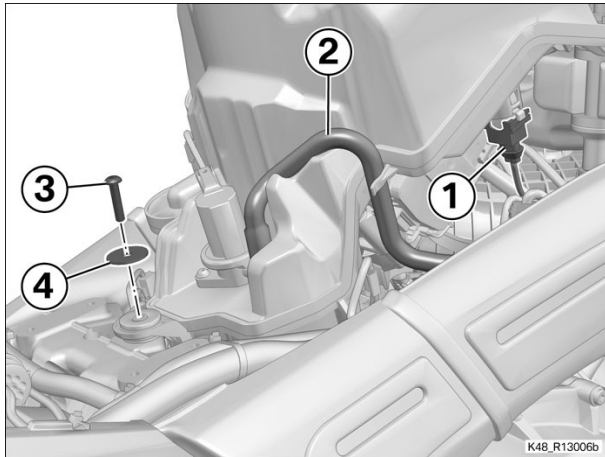

- Connect hose (2) for the secondary air system.
- Connect plug (1) for the air-temperature sensor.

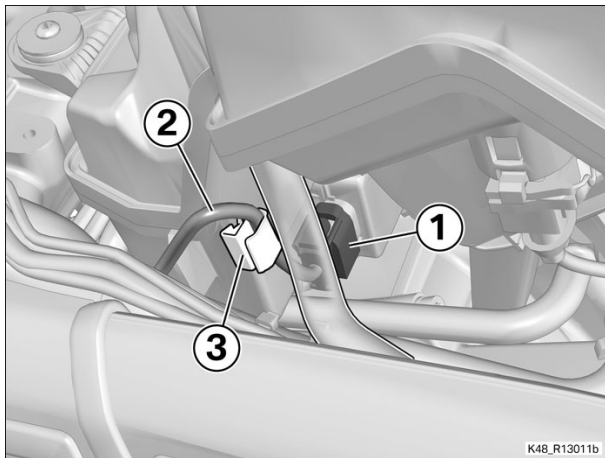

- Connect plug (1) for **RDC** control unit and secure cable (2) in holder (3).

(-) Installing air filter

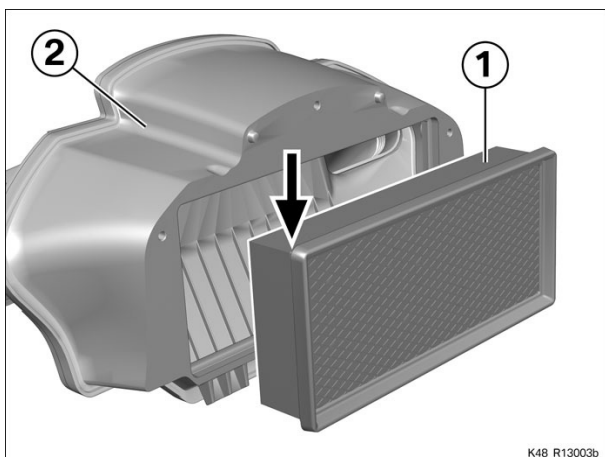

- Install air filter (1) in intake air silencer front section (2).
- Make sure that the gasket (arrow) is correctly seated.

(-) Installing intake air silencer front section

- Install intake air silencer front section (1) with air filter (2).
- Make sure that air filter (2) does not slip out of position and that the retaining lugs (arrows) are engaged in holder (3).

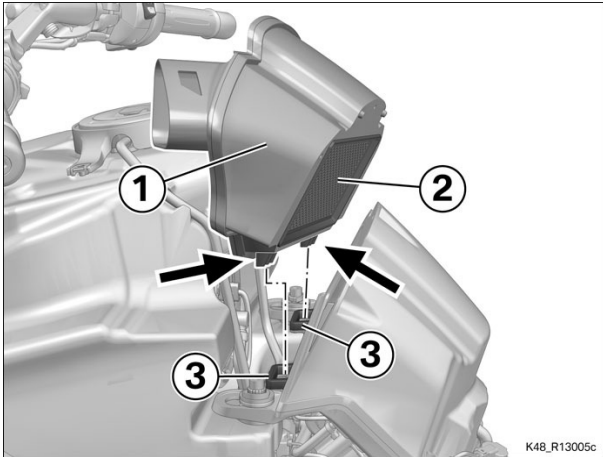

- Install screws (1).

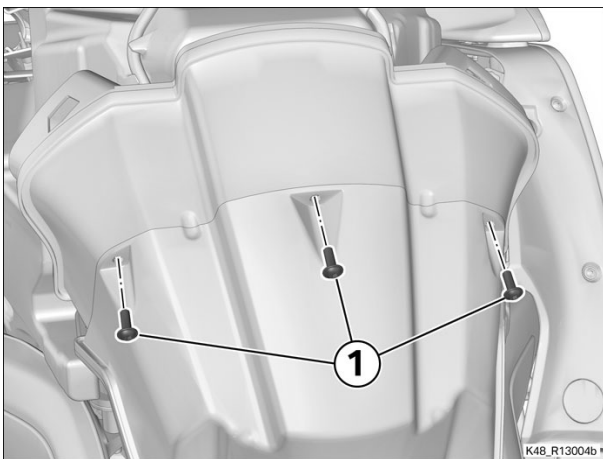

 Tightening torques		
Intake air silencer to filter housing		
M6 x 16	3 Nm	

Finishing work

- Securing seat support
- Installing adjusting plate
- Installing left and right intake air pipes
- Installing complete cover of fuel tank
- Installing air guides for intake air pipes, left and right
- Installing front seat
- Final check of work performed

 **13 72 001 Renewing air cleaner insert 4 FRUs**

+ 13 72 532

Preparatory work

Remove the front seat

Removing air guides for intake air pipes, left and right

Removing complete cover of fuel tank

Removing intake air silencer front section

Core activity

(-) Replacing air filter

- Remove air filter (1) from intake air silencer front section (2).
- Install new air filter (1) in intake air silencer front section (2).
- Make sure that the gasket (arrow) is correctly seated.

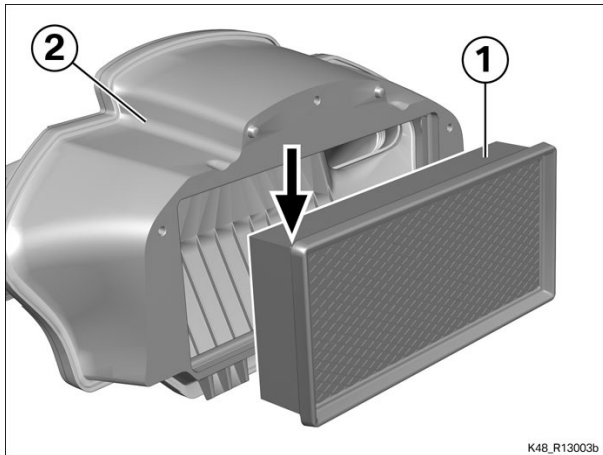

Finishing work

Installing intake air silencer front section

Installing complete cover of fuel tank

Installing air guides for intake air pipes, left and right

Installing front seat

Final check of work performed

📁 13 72 505 Replace air filter cartridge (for maintenance) 2 FRUs

Preparatory work

Remove the front seat

Removing air guides for intake air pipes, left and right

Removing complete cover of fuel tank

Removing intake air silencer front section

Core activity

(-) Replacing air filter

- Remove air filter (1) from intake air silencer front section (2).
- Install new air filter (1) in intake air silencer front section (2).
- Make sure that the gasket (arrow) is correctly seated.

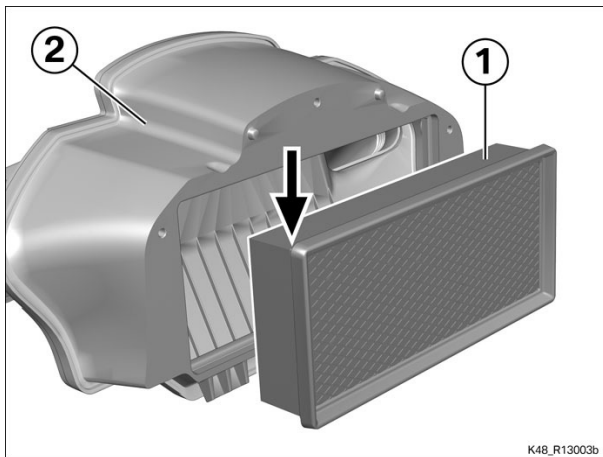

Finishing work

Installing intake air silencer front section

Installing complete cover of fuel tank

Installing air guides for intake air pipes, left and right

Installing front seat

Final check of work performed

📁 16 11 030 Removing/installing fuel tank 14 FRUs

+ 16 11 533



Warning

Fuel is flammable and a hazard to health.
Observe all applicable safety regulations.

Preparatory work

- Remove the front seat
- Removing air guides for intake air pipes, left and right
- Removing complete cover of fuel tank
- Removing left bottom side panel
- Removing left radiator cowl
- Removing left side panel
- Removing inner trim for left side panel
- Removing right bottom side panel
- Removing right radiator cowl
- Remove the right side panel
- Removing inner trim for right side panel
- Removing adjusting plate
- Disengaging seat support
- Disengaging left and right intake air pipes
- Removing complete intake air silencer

Core activity

(-) Removing fuel tank

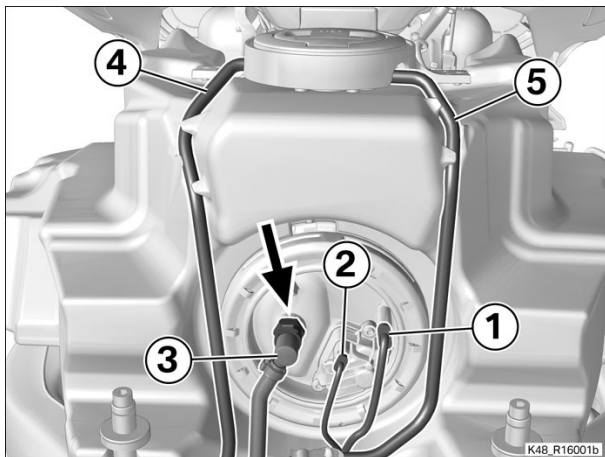

- Disconnect plug (1) for the fuel-level sensor and plug (2) for the fuel pump.
- Open the latch of the quick-action coupling of the fuel delivery line (arrow) and disconnect fuel line (3).
- Disconnect hoses (4) and (5).

- Slacken screws (1) on left and right.

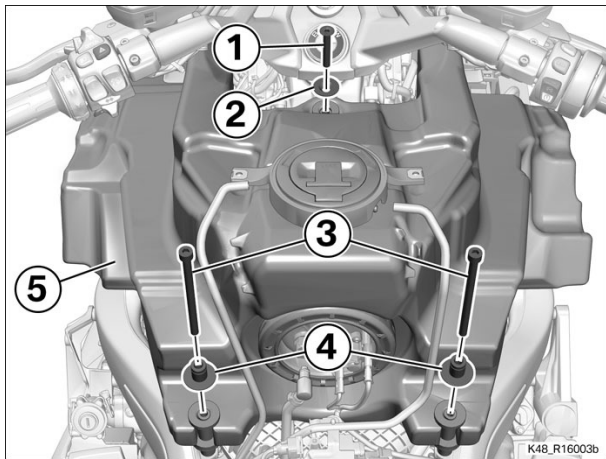
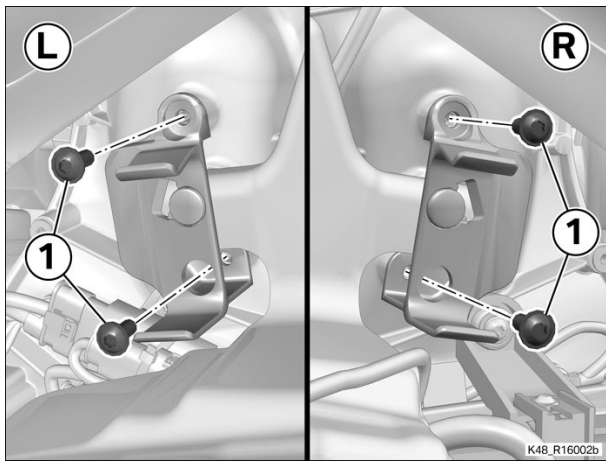

- Remove screw (1) with washer (2).
- Remove screws (3) with shouldered bushings (4).
- Remove fuel tank (5).

(-) Installing fuel tank

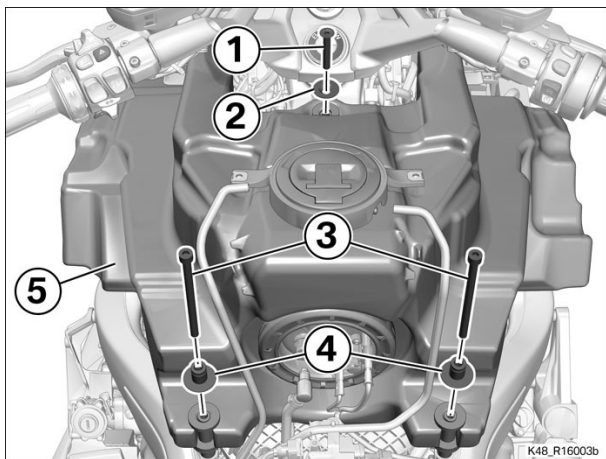

- Hold fuel tank (5) in position.
- Install screws (3) with shouldered bushings (4).

 Tightening torques		
Fuel tank to main frame, rear		
M8 x 120	14 Nm	

- Install screw (1) with washer (2).

 Tightening torques		
Fuel tank to main frame, front		
M8 x 55	19 Nm	

- Tighten screws (1) on left and right.

 Tightening torques		
Tank holder, front, to main frame		
M6 x 30	8 Nm	

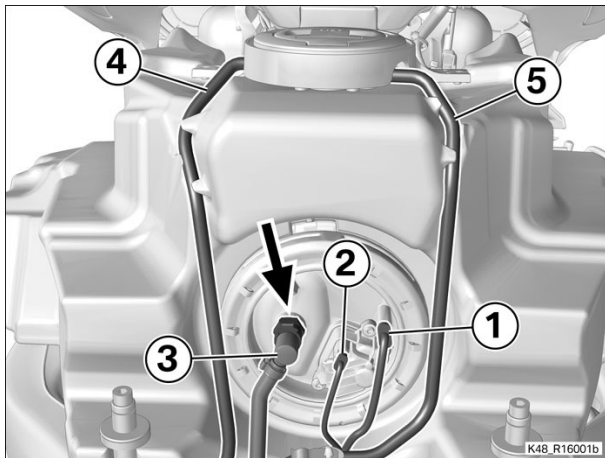
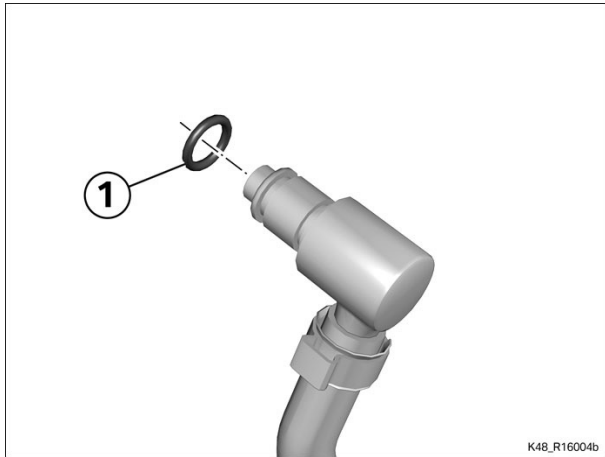
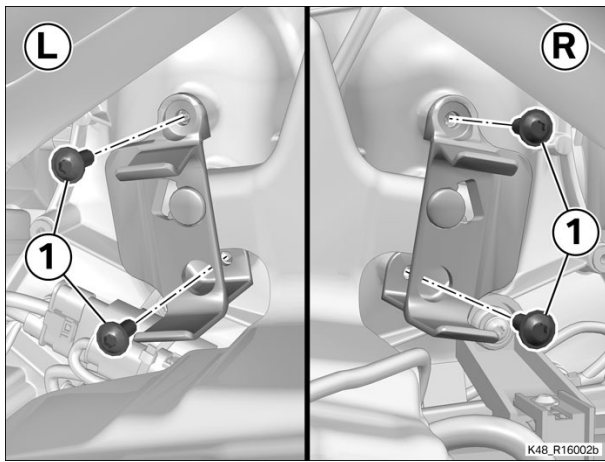

- Check O-ring of fuel delivery line (1) for damage; replace if necessary.



Attention

Lightly touching the latching pin of the female connector can cause the connector to latch. If this happens and force is applied in an attempt to close the male and female elements of the quick-action coupling, damage to the O-rings can result, and the O-rings will leak.

Make sure that the latch is open/pressed when you connect the two elements of the quick-action couplings in the fuel lines.

- Open the latch for fuel delivery line (arrow) and, applying light pressure, press male adapter of fuel delivery line (3) into the female coupling. Release the latch and check that the delivery line is correctly seated.
- Connect plug (1) for the fuel-level sensor and plug (2) for the fuel pump.
- Route hoses (4) and (5), secure them in holders on the tank and connect them.

Finishing work

- Installing complete intake air silencer
- Securing left and right intake air pipes
- Securing seat support
- Installing adjusting plate
- Installing inner trim for right side panel
- Install the right side panel
- Install the right radiator cowl
- Installing right bottom side panel

- Installing inner trim for left side panel
- Install the left side panel
- Installing left radiator cowl
- Installing left bottom side panel
- Installing complete cover of fuel tank
- Installing air guides for intake air pipes, left and right
- Installing front seat
- Final check of work performed

📁 16 11 531 Replacing fuel tank (fuel tank removed) 3 FRUs



Warning

Fuel is flammable and a hazard to health.
Observe all applicable safety regulations.

Preparatory work

=> **Removing/installing fuel tank (Description in item: 16 11 533, Billed as a separate item)**

Core activity

(-) Draining fuel tank



Warning

Fuel is flammable and a hazard to health.
Observe all applicable safety regulations.

- Drain the fuel tank, using the commercially available special tool.

(-) Removing fuel-pump unit

- Remove union nut (1) with pin wrench (No. 16 1 021).



Attention

Failure to follow the correct procedure for removing the fuel pump can damage the gasket at the fuel-pump flange, resulting in leaks
When removing the fuel pump, do not lever against the flange of the pump unit.

- Hold fuel-pump unit (2) by tab (3) and lift it **carefully** out of the fuel tank.
- Remove fuel-pump unit (1) with gasket (2) from the fuel tank, making sure that intake strainer (3) and lever-type sensor (4) do not catch in the fuel tank and suffer damage.

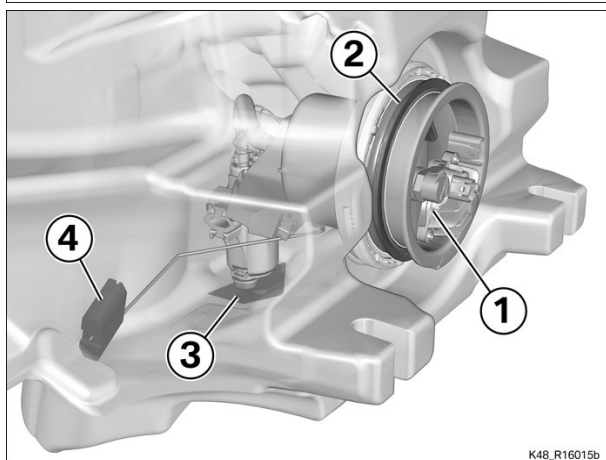
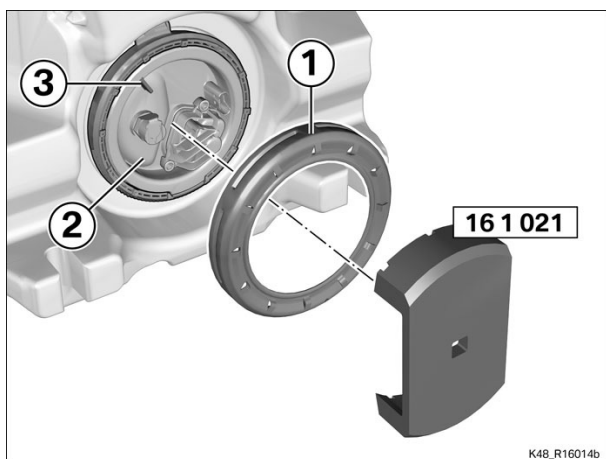

(-) Removing complete fuel filler cap

- Remove screws (1).
- Remove outer ring with fuel filler cap (2).

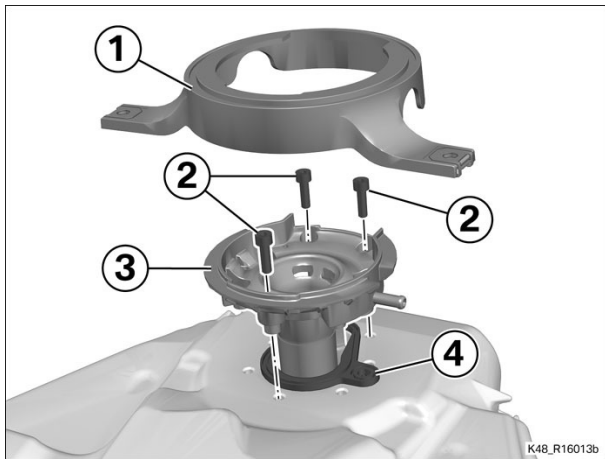
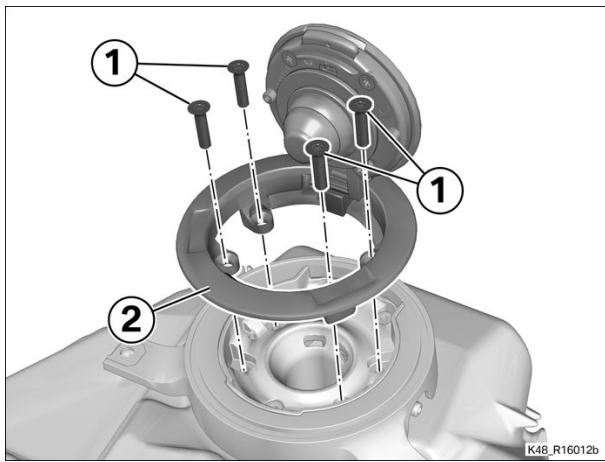

- Remove retaining ring (1) for the cover of fuel tank.
- Remove screws (2).
- Remove filler neck (3) with gasket (4).

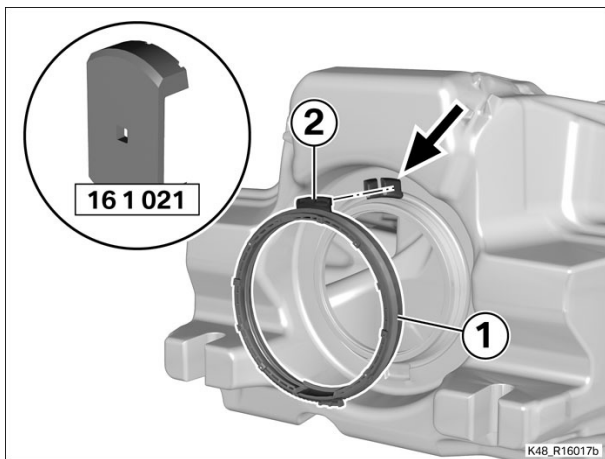

(-) Replacing fuel tank

- Remove retaining ring (1) from the old fuel tank by applying abrupt and firm pressure with pin wrench (No. 16 1 021).
- Clean retaining ring (1) and check for damage; replace if necessary.
- Install retaining ring (1) and position it with projection (2) seated in the corresponding recess (arrow) in the fuel tank.

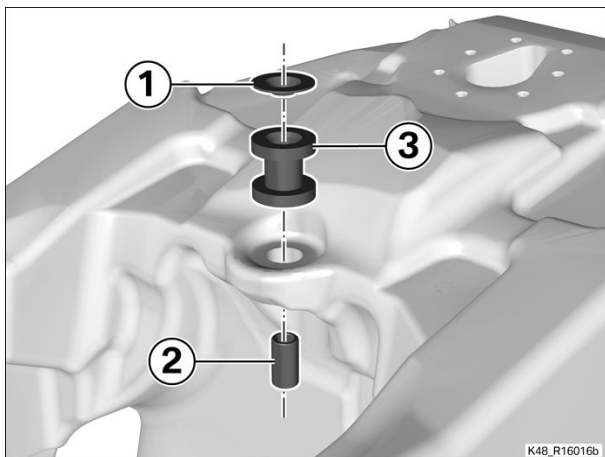

- Remove washer (1) with bushing (2) and rubber mount (3) from the old fuel tank and install them in the new component.

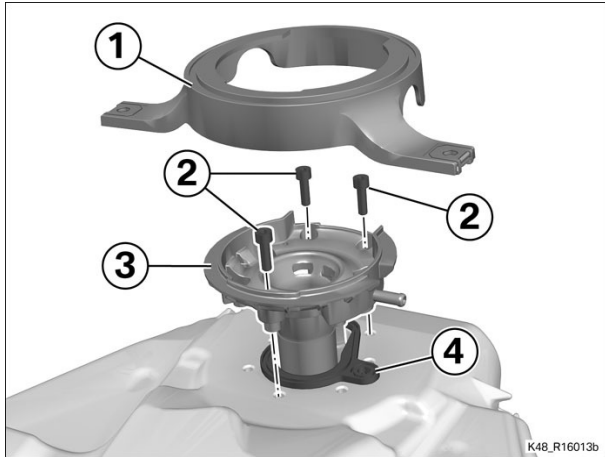

(-) Installing complete fuel filler cap

- Check gasket (4) for damage; replace if necessary.
- Install filler neck (3) with gasket (4).
- Install screws (2).

 Tightening torques		
Fuel filler cap to fuel tank		
M5 x 20	3 Nm	

- Place retaining ring (1) for the cover of fuel tank in position.

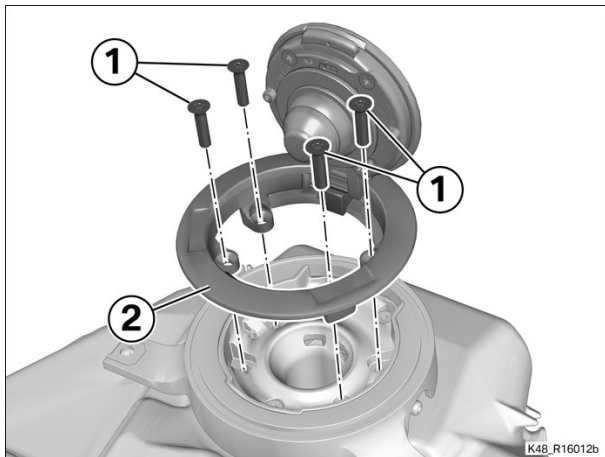

- Place outer ring with fuel filler cap (2) in position.
- Install screws (1).

 Tightening torques		
Fuel filler cap to fuel tank		
M5 x 20	3 Nm	

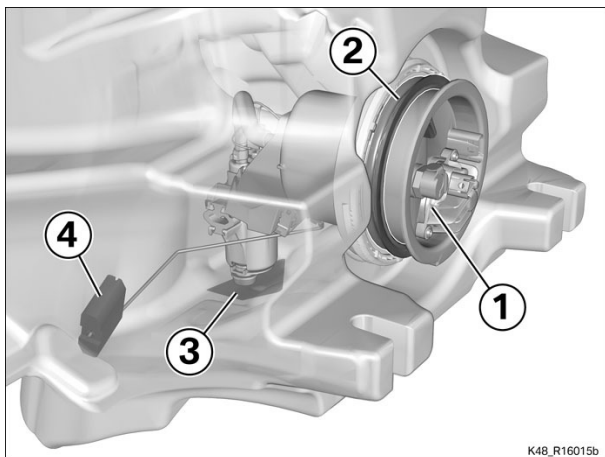

(-) Installing fuel-pump unit

- Check sealing ring (2) for damage; replace if necessary.
- Lubricate sealing ring (2) at the seating face for the union nut.

 Fluids and lubricants		
Tyre mounting paste	Assembly paste	81 22 0 433 046

- Install fuel pump (1) with sealing ring (2) in the fuel tank. Take care not to allow lever-type sensor (4) and intake strainer (3) to snag on the fuel tank and suffer damage.
- Insert sealing ring (2) in the fuel tank and install fuel pump (1).

- Position fuel pump (1) in the locator (arrow).
- Install union nut (2) with pin wrench (No. 16 1 021). Make sure that retaining ring (3) does not turn at the same time.

 Tightening torques		
Fuel pump to fuel tank		
Union nut	35 Nm	

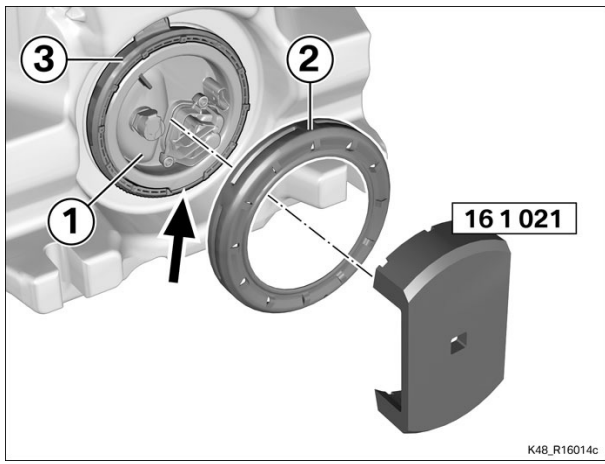

(-) Filling fuel tank



Warning

Fuel is flammable and a hazard to health.
Observe all applicable safety regulations.

- Fill the fuel tank with fuel.

 Technical data			
Recommended fuel grade		Super unleaded 95 ROZ/RON 89 AKI	

Finishing work

Final check of work performed

📁 16 14 009 Removing/installing fuel-pump unit 9 FRUs

+ 16 14 502



Warning

Fuel is flammable and a hazard to health.
Observe all applicable safety regulations.

Preparatory work

- Remove the front seat
- Removing air guides for intake air pipes, left and right
- Removing complete cover of fuel tank
- Removing adjusting plate
- Disengaging seat support
- Disengaging left and right intake air pipes
- Disengaging complete intake air silencer
- Draining fuel tank

Core activity

(-) Removing fuel-pump unit

- Disconnect plug (1) for the fuel-level sensor and plug (2) for the fuel pump.
- Open the latch of the quick-action coupling of the fuel delivery line (arrow) and disconnect fuel line (3).

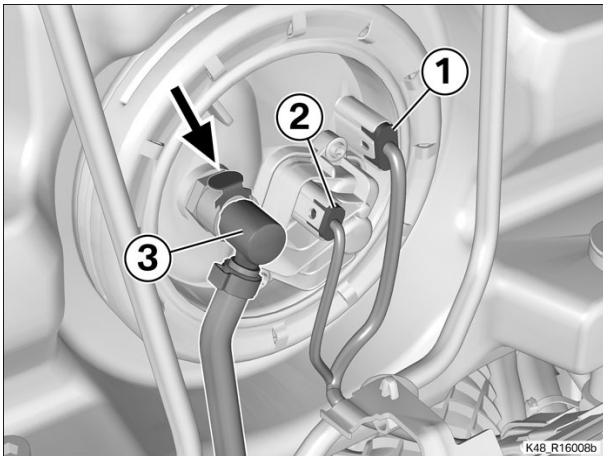

- Remove union nut (1) with pin wrench (No. 16 1 021).



Attention

Failure to follow the correct procedure for removing the fuel pump can damage the gasket at the fuel-pump flange, resulting in leaks
When removing the fuel pump, do not lever against the flange of the pump unit.

- Hold fuel-pump unit (2) by tab (3) and lift it **carefully** out of the fuel tank.
- Remove fuel-pump unit (1) with gasket (2) from the fuel tank, making sure that intake strainer (3) and lever-type sensor (4) do not catch in the fuel tank and suffer damage.

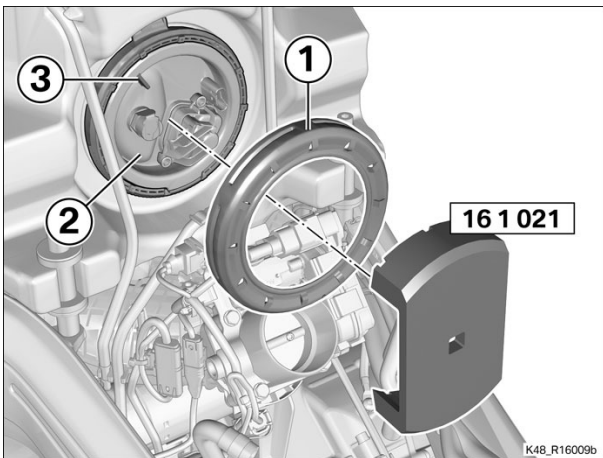

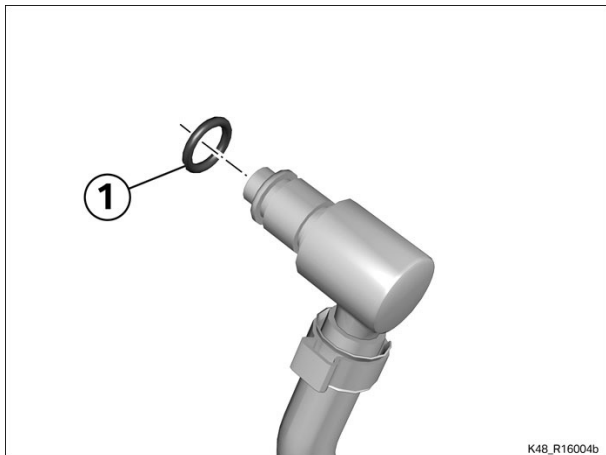
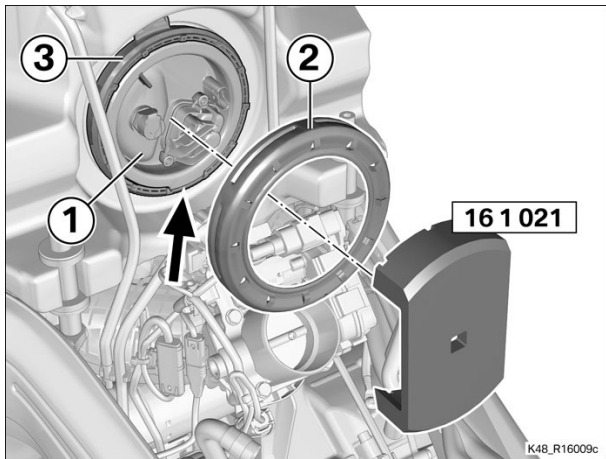
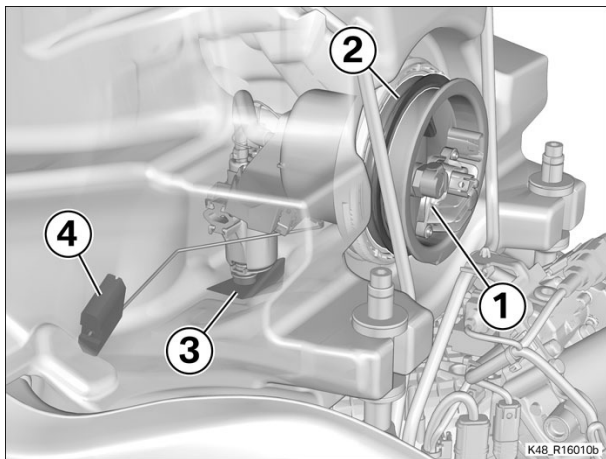
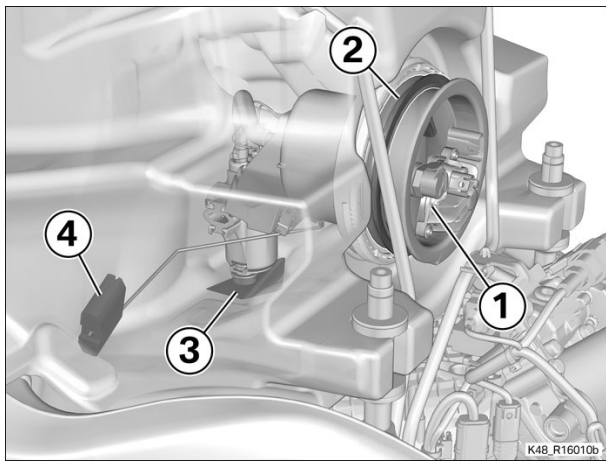

(-) Installing fuel-pump unit

- Check sealing ring (2) for damage; replace if necessary.
- Lubricate sealing ring (2) at the seating face for the union nut.

 Fluids and lubricants		
Tyre mounting paste	Assembly paste	81 22 0 433 046

- Install fuel pump (1) with sealing ring (2) in the fuel tank. Take care not to allow lever-type sensor (4) and intake strainer (3) to snag on the fuel tank and suffer damage.

- Position fuel pump (1) in the locator (arrow).
- Install union nut (2) with pin wrench (No. 16 1 021). Make sure that retaining ring (3) does not turn at the same time.

 Tightening torques		
Fuel pump to fuel tank		
Union nut	35 Nm	

- Check O-ring of fuel delivery line (1) for damage; replace if necessary.

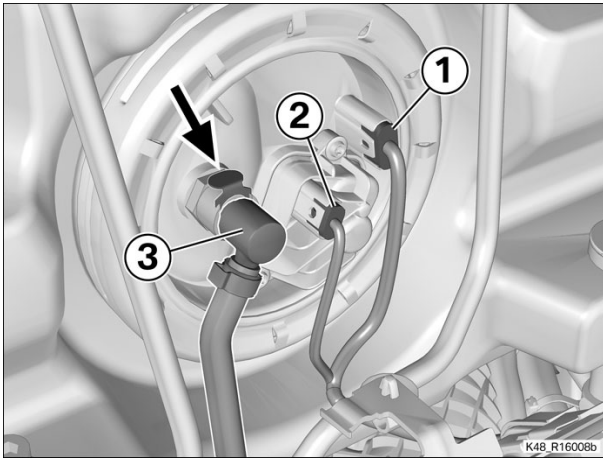

Attention

Lightly touching the latching pin of the female connector can cause the connector to latch. If this happens and force is applied in an attempt to close the male and female elements of the quick-action coupling, damage to the O-rings can result, and the O-rings will leak.

Make sure that the latch is open/pressed when you connect the two elements of the quick-action couplings in the fuel lines.

- Open the latch for fuel delivery line (arrow) and, applying light pressure, press male adapter of fuel delivery line (3) into the female coupling. Release the latch and check that the delivery line is correctly seated.
- Connect plug (1) for the fuel-level sensor and plug (2) for the fuel pump.

Finishing work

Filling fuel tank

Securing complete intake air silencer

Securing left and right intake air pipes

Securing seat support

Installing adjusting plate

Installing complete cover of fuel tank

Installing air guides for intake air pipes, left and right

=> Resetting/learning adaptation values (with replacing component) (Description in item: 61 00 503, Billed as a separate item)

Installing front seat

Final check of work performed

📁 16 14 010 Replace electronics of fuel pump 7 FRUs

+ 16 14 521

Preparatory work

- Remove the front seat
- Removing air guides for intake air pipes, left and right
- Removing complete cover of fuel tank
- Removing adjusting plate
- Disengaging seat support
- Disengaging left and right intake air pipes
- Disengaging complete intake air silencer

Core activity

(-) Removing electronic fuel pump

- Disconnect plug (1) for the electronics of the fuel pump.

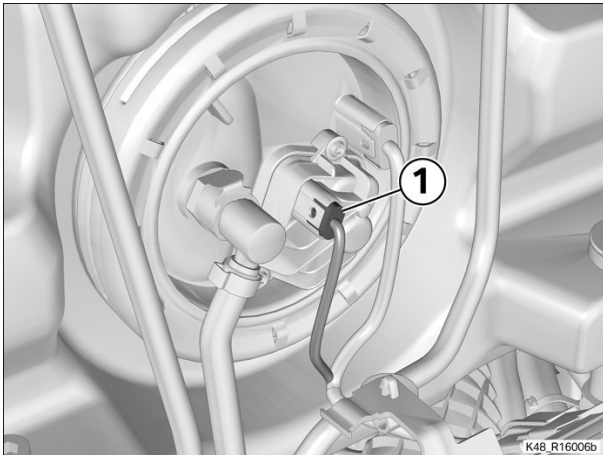

- Remove screws (1).
- Slightly lift electronics section (2) and disconnect plug (3) for the fuel pump.
- Remove electronics section (2) with sealing ring (4).

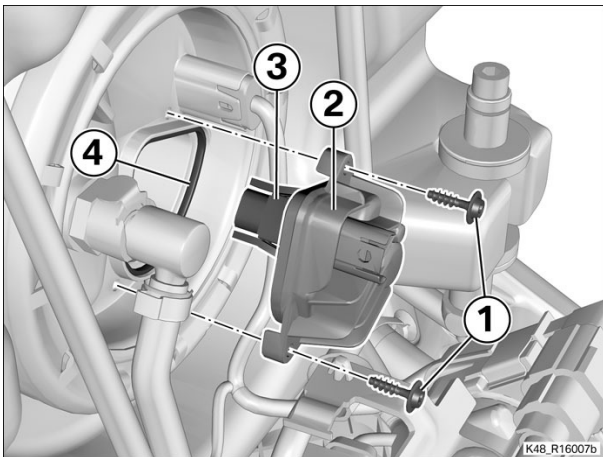

(-) Installing electronic fuel pump

► Checking electrical contacts

- When installing parts that were in use beforehand, check the condition of the electrical contacts.

Test

- Check the electrical contacts of the plug of the fuel-pump electronics.

Result: Significant signs of corrosion on the contacts.

Measure:

- Replace the fuel-pump electronics.

Test

- Check the electrical contacts of the fuel-pump unit
- Result:** Significant signs of corrosion on the contacts.

Measure:

- Replace the fuel-pump unit
- Remove all traces of water or moisture inside the cavity and on the plugs.

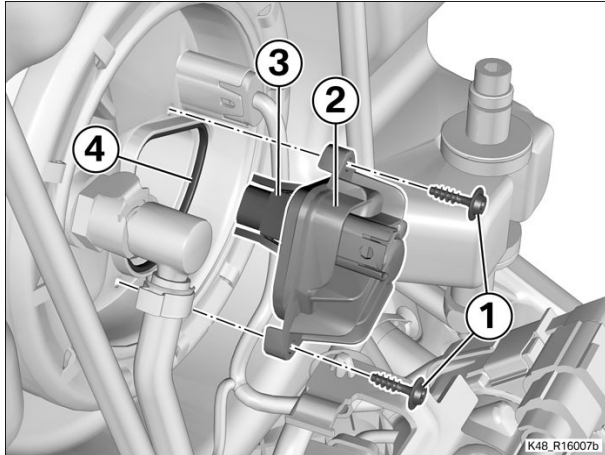

- Check sealing ring (4) for damage; replace if swollen out of shape or damaged.
- Position sealing ring (4) on electronics section (2).
- Connect plug (3) for the fuel pump.
- Carefully install electronics section (2), making sure that sealing ring (4) is correctly seated.
- Install screws (1).

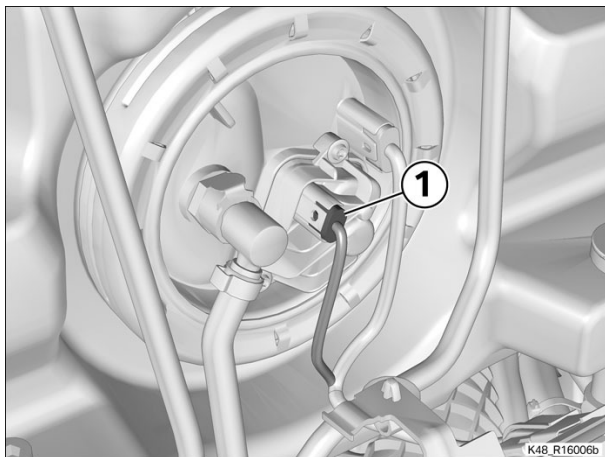

- Connect plug (1) for the electronics of the fuel pump.

Finishing work

- Securing complete intake air silencer
- Securing left and right intake air pipes
- Securing seat support
- Installing adjusting plate
- Installing complete cover of fuel tank
- Installing air guides for intake air pipes, left and right
- Installing front seat
- Final check of work performed

📁 16 14 011 Replacing fuel pump unit 11 FRUs

+ 16 14 503



Warning

Fuel is flammable and a hazard to health.
Observe all applicable safety regulations.

Preparatory work

- Remove the front seat
- Removing air guides for intake air pipes, left and right
- Removing complete cover of fuel tank
- Removing adjusting plate
- Disengaging seat support
- Disengaging left and right intake air pipes
- Disengaging complete intake air silencer
- Draining fuel tank

Core activity

(-) Removing fuel-pump unit

- Disconnect plug (1) for the fuel-level sensor and plug (2) for the fuel pump.
- Open the latch of the quick-action coupling of the fuel delivery line (arrow) and disconnect fuel line (3).

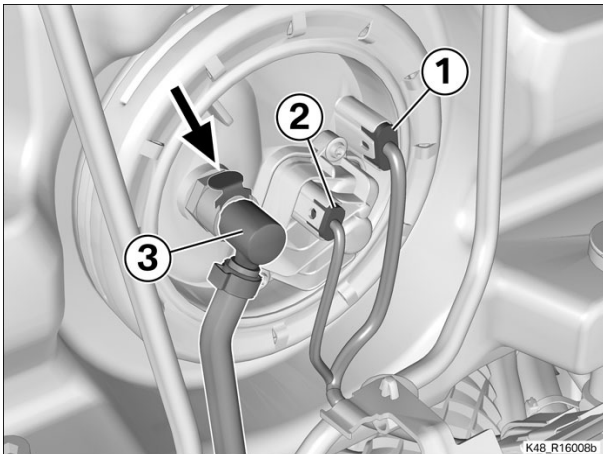

- Remove union nut (1) with pin wrench (No. 16 1 021).



Attention

Failure to follow the correct procedure for removing the fuel pump can damage the gasket at the fuel-pump flange, resulting in leaks
When removing the fuel pump, do not lever against the flange of the pump unit.

- Hold fuel-pump unit (2) by tab (3) and lift it **carefully** out of the fuel tank.
- Remove fuel-pump unit (1) with gasket (2) from the fuel tank, making sure that intake strainer (3) and lever-type sensor (4) do not catch in the fuel tank and suffer damage.

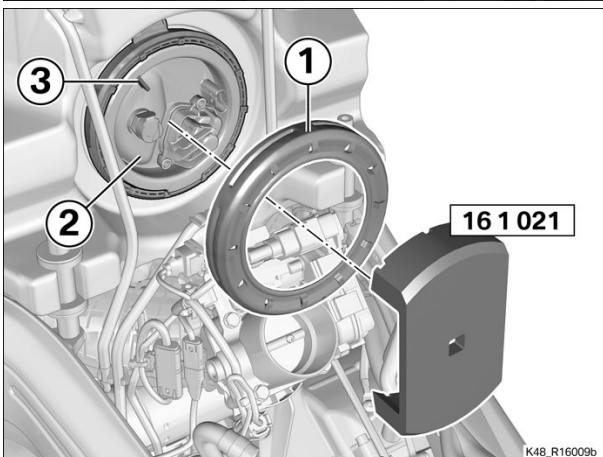

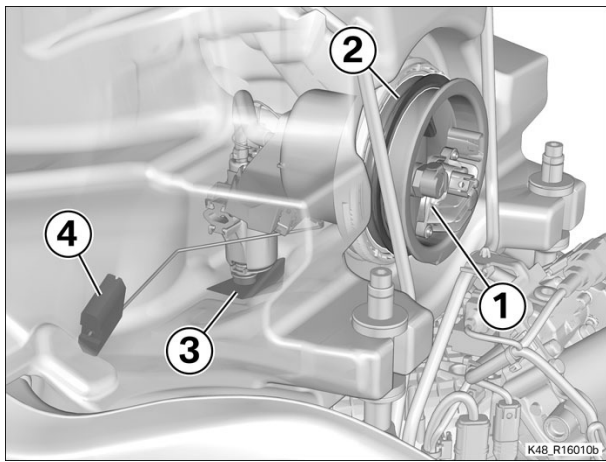

(-) Replacing fuel-pump unit

► Removing fuel-level sensor

- Disconnect plug (1) for the fuel-level sensor.
- Disengage the retaining tabs (arrows) and remove fuel-level sensor (2).

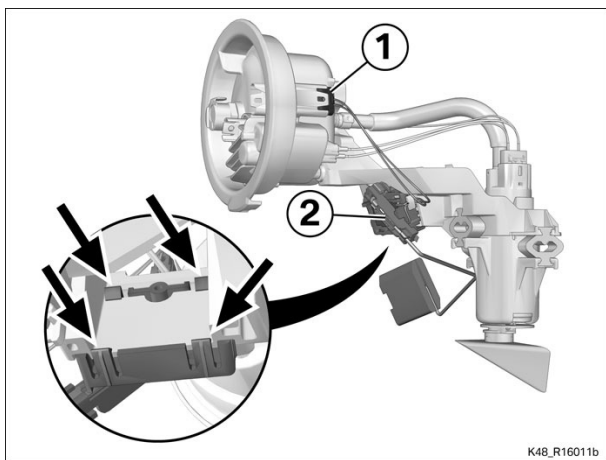

► Installing fuel-level sensor

- Install fuel-level sensor (2), making sure that the retaining tabs (arrows) engage.
- Connect plug (1) for the fuel-level sensor.

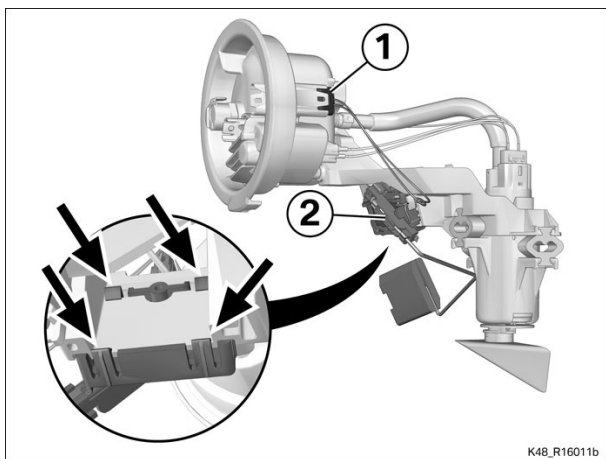

(-) Installing fuel-pump unit

- Check sealing ring (2) for damage; replace if necessary.
- Lubricate sealing ring (2) at the seating face for the union nut.



Fluids and lubricants

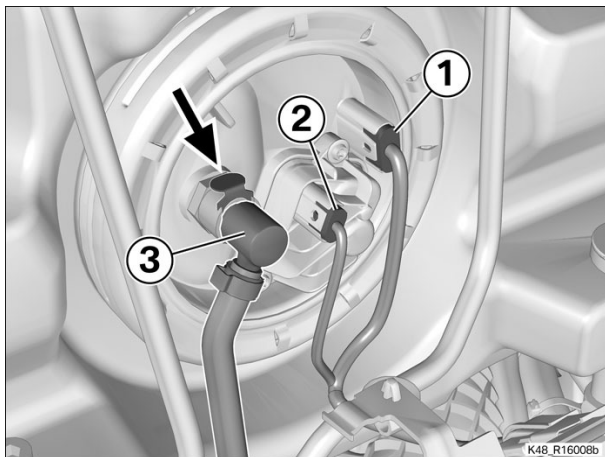
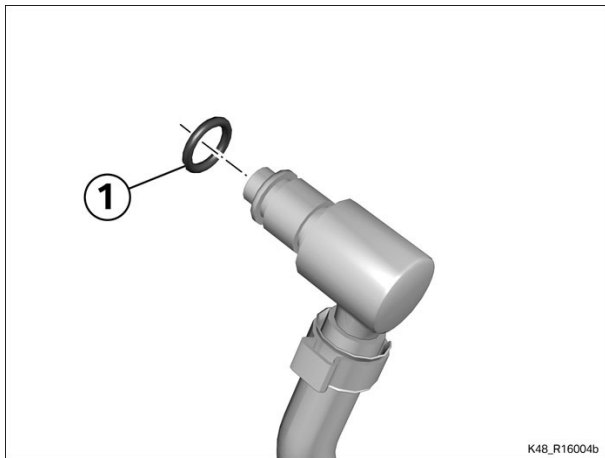
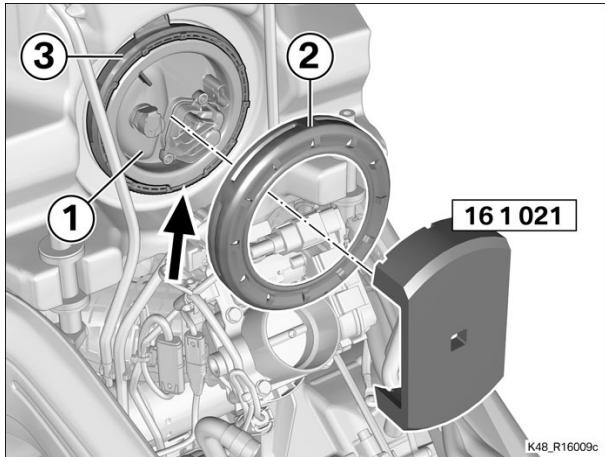
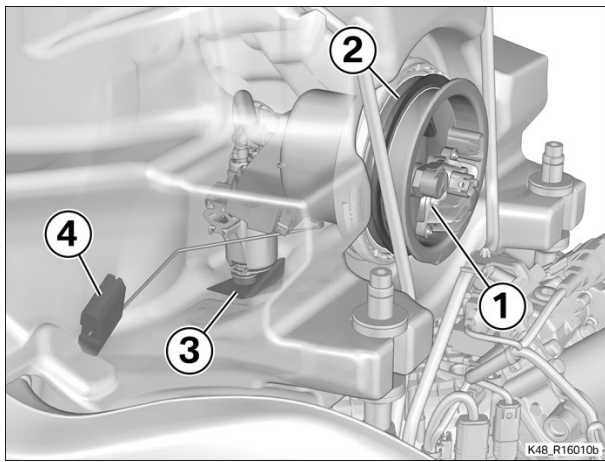

Tyre mounting paste	Assembly paste	81 22 0 433 046
---------------------	----------------	--------------------

- Install fuel pump (1) with sealing ring (2) in the fuel tank. Take care not to allow lever-type sensor (4) and intake strainer (3) to snag on the fuel tank and suffer damage.

- Position fuel pump (1) in the locator (arrow).
- Install union nut (2) with pin wrench (No. 16 1 021). Make sure that retaining ring (3) does not turn at the same time.

Tightening torques		
Fuel pump to fuel tank		
Union nut	35 Nm	

- Check O-ring of fuel delivery line (1) for damage; replace if necessary.

Attention

Lightly touching the latching pin of the female connector can cause the connector to latch. If this happens and force is applied in an attempt to close the male and female elements of the quick-action coupling, damage to the O-rings can result, and the O-rings will leak.

Make sure that the latch is open/pressed when you connect the two elements of the quick-action couplings in the fuel lines.

- Open the latch for fuel delivery line (arrow) and, applying light pressure, press male adapter of fuel delivery line (3) into the female coupling. Release the latch and check that the delivery line is correctly seated.
- Connect plug (1) for the fuel-level sensor and plug (2) for the fuel pump.

Finishing work

Filling fuel tank

Securing complete intake air silencer

Securing left and right intake air pipes

Securing seat support

Installing adjusting plate

Installing complete cover of fuel tank

Installing air guides for intake air pipes, left and right

Connecting **BMW Motorrad** diagnostic system to motorcycle

Reading fault memory with **BMW Motorrad** diagnostic system and resetting adaptation values

Disconnecting **BMW Motorrad** diagnostic system from motorcycle

Installing front seat

Final check of work performed

📁 16 14 513 Replacing fuel-level sensor (fuel-pump unit removed) 1 FRUs



Warning

Fuel is flammable and a hazard to health.
Observe all applicable safety regulations.

Core activity

(-) Removing fuel-level sensor

- Disconnect plug (1) for the fuel-level sensor.
- Disengage the retaining tabs (arrows) and remove fuel-level sensor (2).

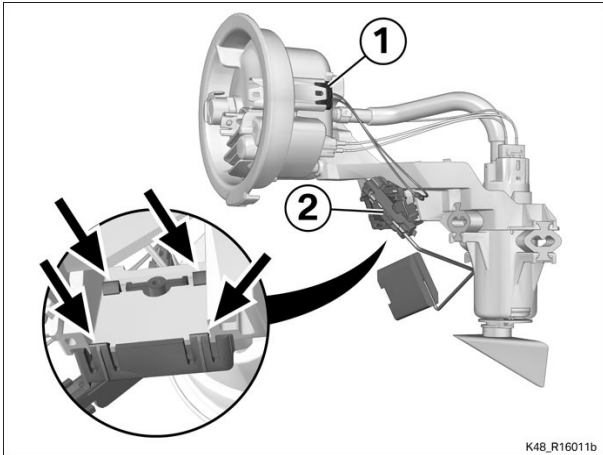

K48_R16011b

(-) Installing fuel-level sensor

- Install fuel-level sensor (2), making sure that the retaining tabs (arrows) engage.
- Connect plug (1) for the fuel-level sensor.

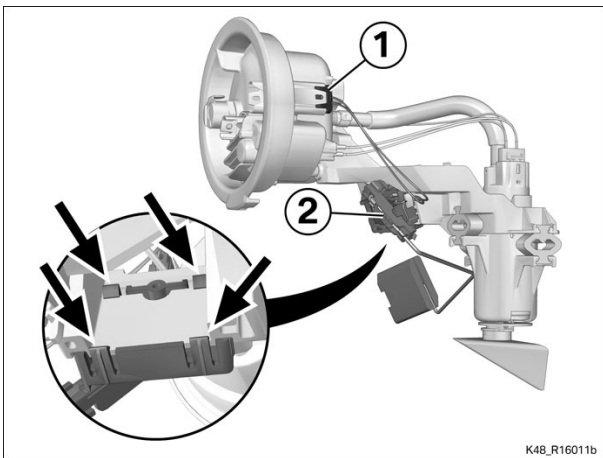

K48_R16011b

17 00 010 Checking cooling system for leaks (with cooling system tester) 4 FRUs

+ 17 00 502



Warning

Take care when working on the cooling system: risk of burns if the system is hot.

Do not work on the cooling system until it has had ample time to cool down.

Preparatory work

Removing right bottom side panel

Removing right radiator cowl

Remove the right side panel

Core activity

(-) Checking cooling system for leaks

Precondition

- Engine cold.



▶ Removing radiator cap

- Remove cap (1).

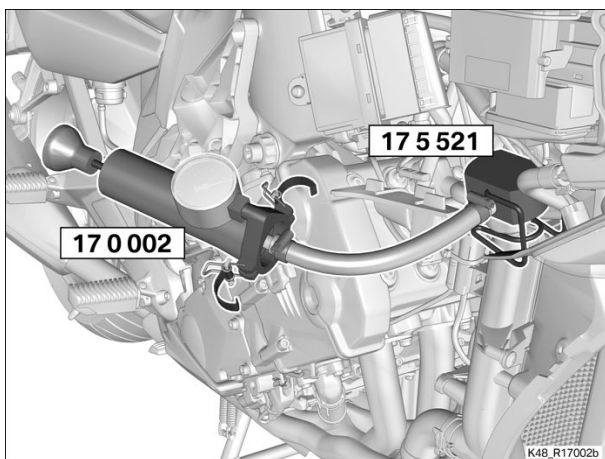
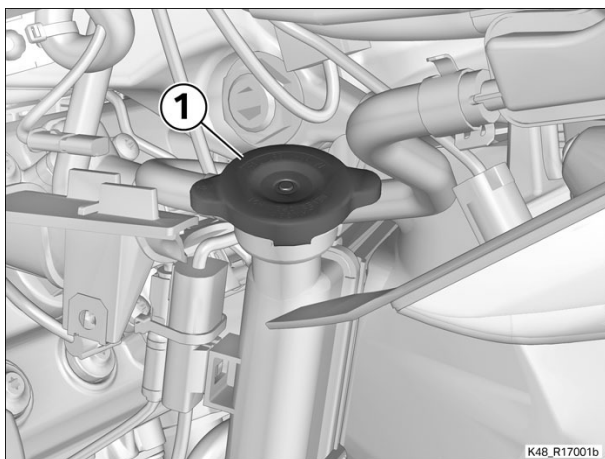

- Secure pump (No. 17 0 002) with adapter (No. 17 5 521) to the filler neck.

Test

- Pressure-test the cooling system; the pressure must remain unchanged for at least 5 minutes.

 Technical data			
Cooling system test pressure	Test pressure must remain unchanged: min 5 min	2 bar	

Result: Pressure loss

Measure:

-

Check for leaks and rectify.

► **Installing radiator cap**

- Install cap (1).

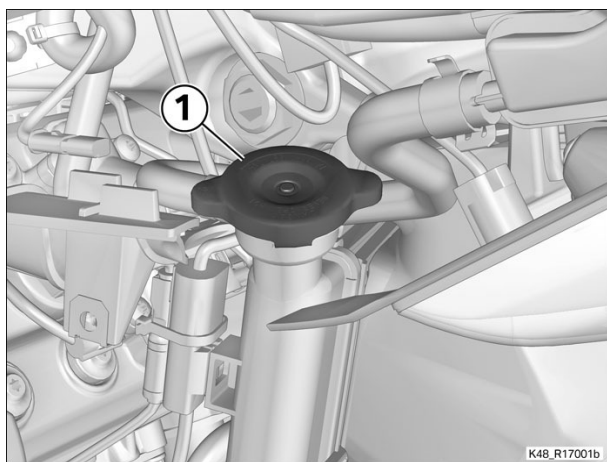

- Allow the engine to warm up until the fan cuts in.
- Allow the engine to cool down.
- Check the coolant level; top up if necessary.

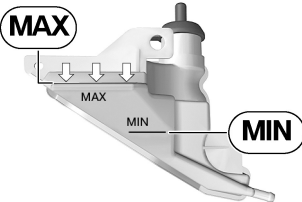
 Technical data			
Coolant, specified level 	engine cold	between MIN and MAX marks on the expansion tank	

Finishing work

- Install the right side panel
- Install the right radiator cowl
- Installing right bottom side panel
- Final check of work performed

17 00 020 Checking coolant concentration

+ 17 00 503



Warning

Take care when working on the cooling system: risk of burns if the system is hot.

Do not work on the cooling system until it has had ample time to cool down.

Core activity

(-) Checking coolant

Test

- Check the ability of the coolant in the expansion tank to resist freezing temperatures by checking the antifreeze concentration in the expansion tank.

 Technical data			
Coolant, frost protection		min -30 °C	

Result: Ability to resist freezing temperatures is not ensured.

Measure:

- If necessary, increase the proportion of antifreeze until ability to resist freezing temperatures is ensured.

 Technical data			
Coolant, total capacity	Expansion tank	0.5 l	
	Coolant system, total	3.5 l	
	Fluids and lubricants		
Antifreeze			

Finishing work

Final check of work performed

📁 17 00 035 Draining coolant, refilling/bleeding system 8 FRUs

+ 17 00 504



Warning

Take care when working on the cooling system: risk of burns if the system is hot.

Do not work on the cooling system until it has had ample time to cool down.

Preparatory work

Removing left bottom side panel

Removing left radiator cowl

Removing left side panel

Removing right bottom side panel

Removing right radiator cowl

Remove the right side panel

Core activity

(-) Completely draining cooling system

▶ Drawing off coolant from expansion tank

- Remove cap (1) and draw off coolant (2) with a suitable tool, such as a large syringe, for example.

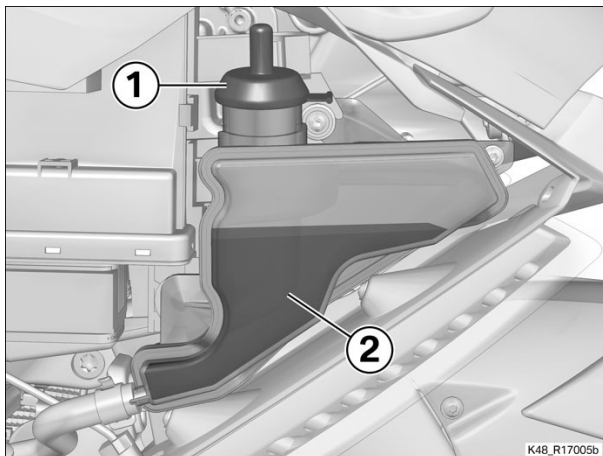

▶ Removing radiator cap

- Remove cap (1).

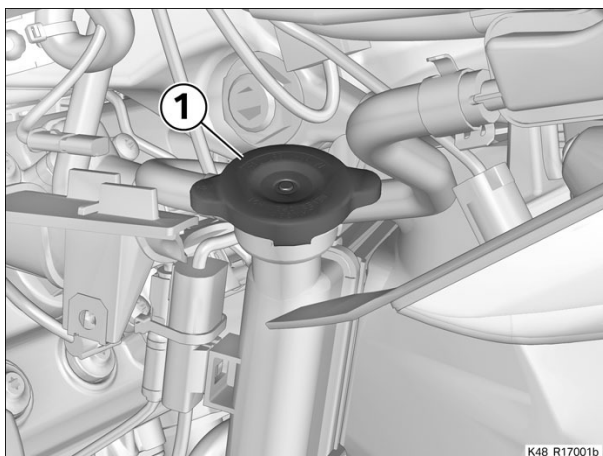

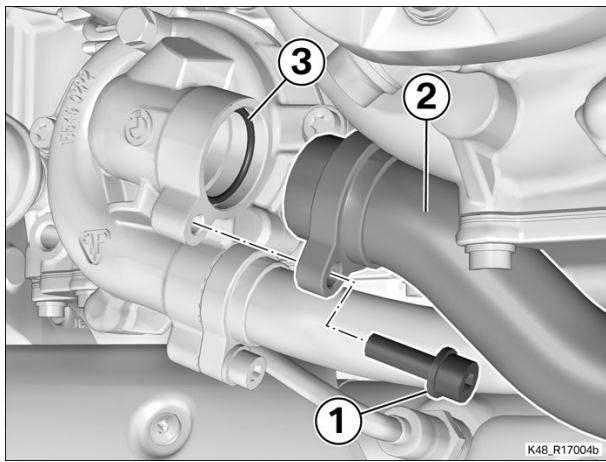

Warning

Take care when working on the cooling system: risk of burns if the system is hot.

Do not work on the cooling system until it has had ample time to cool down.

- Place a suitable container in position.
- Remove screw (1).
- Disconnect return line (2) for the coolant from the coolant pump, noting O-ring (3).
- Drain the coolant into the container.

(-) Filling and venting complete cooling system

- Clean the tapped hole.
- Check O-ring (3) for damage; replace if not in perfect condition.
- Make sure that O-ring (3) is seated in the groove (arrow).
- Push return line (2) for the coolant into the coolant pump.
- Install new screw (1).

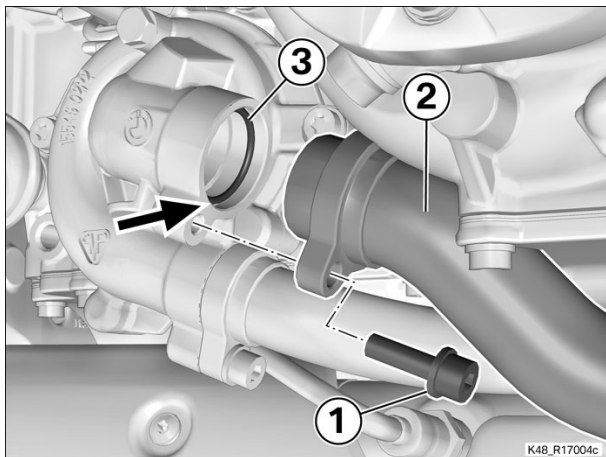

Tightening torques		
Coolant line to pump		
M6 x 20, Replace screw	10 Nm	
Micro-encapsulated		

- Slacken screw (1).

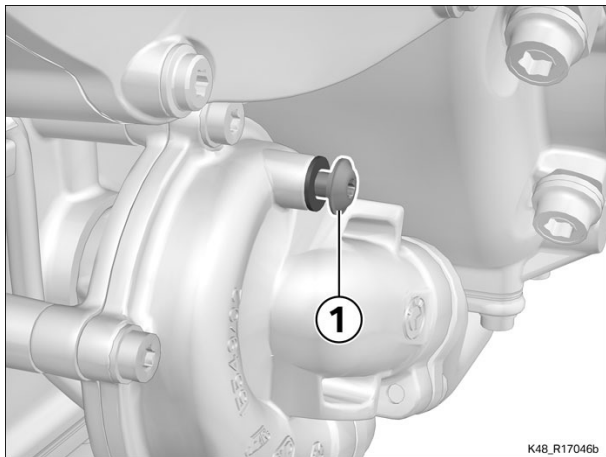

- Slacken screw (1).

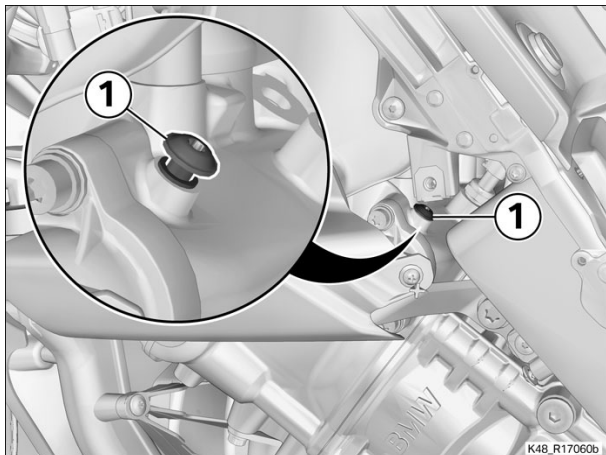

If the system is not refilled with fresh coolant, check the coolant to ensure that the proportion of antifreeze is sufficient to ensure resistance to freezing temperatures.

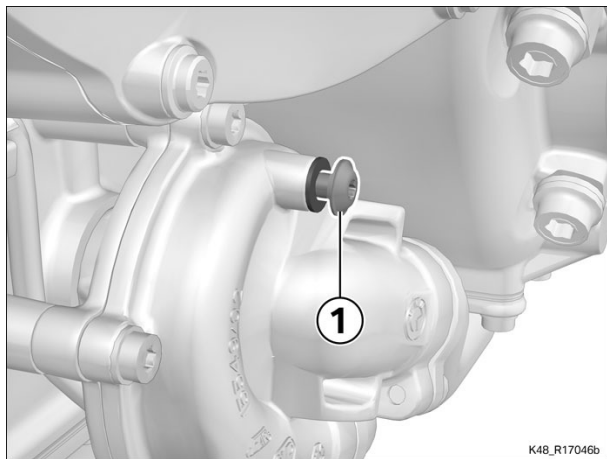

 Technical data			
Coolant, frost protection		min -30 °C	

- Fill the cooling system with coolant.

 Technical data			
Coolant, total capacity	Expansion tank	0.5 l	
	Coolant system, total	3.5 l	
Fluids and lubricants			
Antifreeze			

- » Air escapes initially, then coolant.
- Tighten screw (1).

 Tightening torques			
Vent screw in coolant pump			
M6 x 10		8 Nm	

- Continue filling the cooling system with coolant.

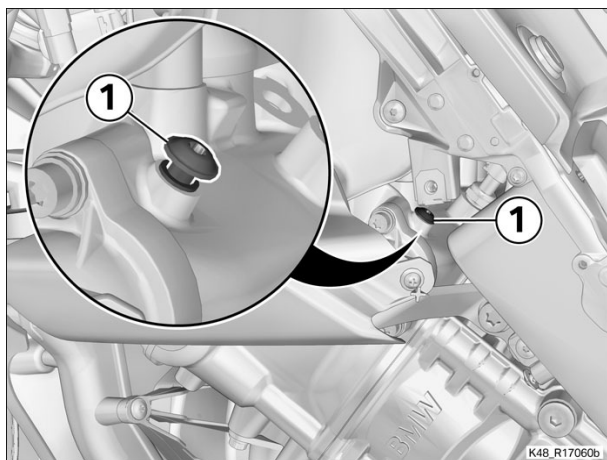

 Technical data			
Coolant, total capacity	Expansion tank	0.5 l	
	Coolant system, total	3.5 l	
Fluids and lubricants			
Antifreeze			

- » Air escapes initially, then coolant.
- Tighten screw (1).

 Tightening torques			
Breather screw to cylinder head			
M6 x 10		8 Nm	

- Completely fill the cooling system with coolant.

► **Filling expansion tank**

- Pour in coolant (2).

 Technical data			
Coolant, specified level	engine cold	between MIN and MAX marks on	

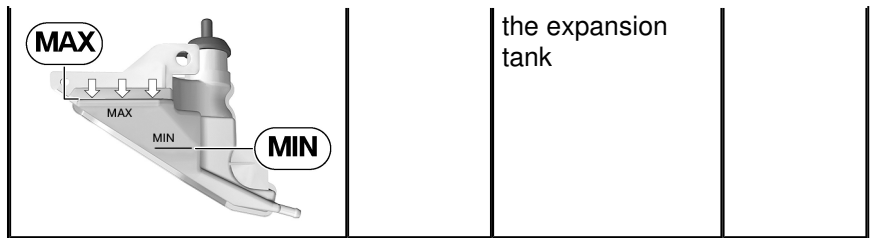
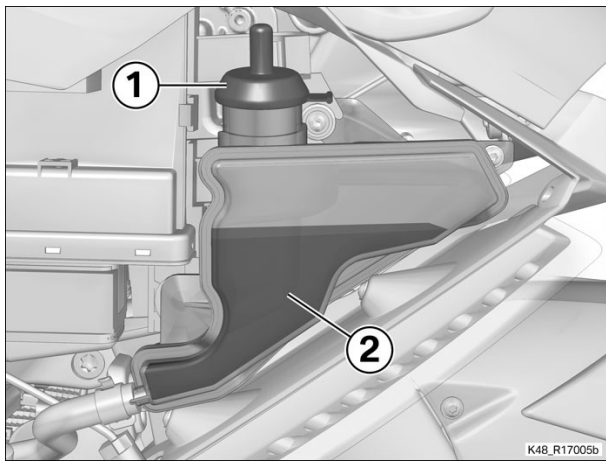

- Install cap (1).



(-) Checking cooling system for leaks

Precondition

- Engine cold.



- Secure pump (No. 17 0 002) with adapter (No. 17 5 521) to the filler neck.

Test

- Pressure-test the cooling system; the pressure must remain unchanged for at least 5 minutes.

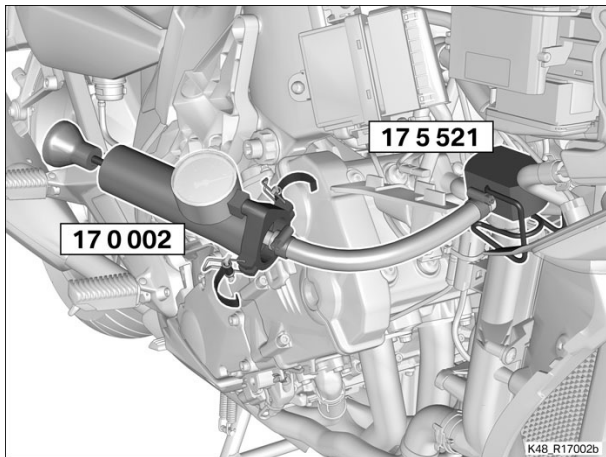

 Technical data			
Cooling system test pressure	Test pressure must remain unchanged: min 5 min	2 bar	

Result: Pressure loss

Measure:

- Check for leaks and rectify.

▶ Installing radiator cap

- Install cap (1).

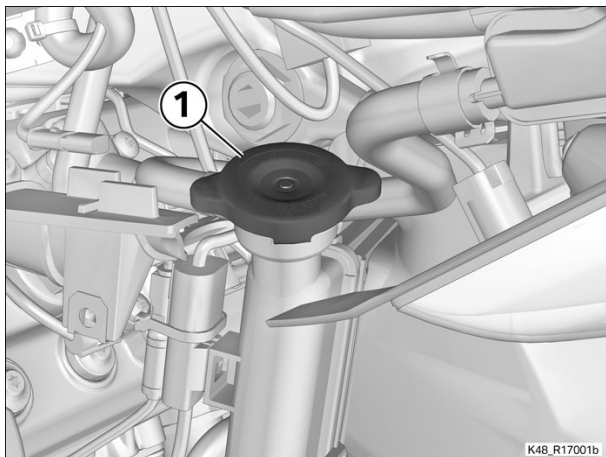

▶ Filling expansion tank

-

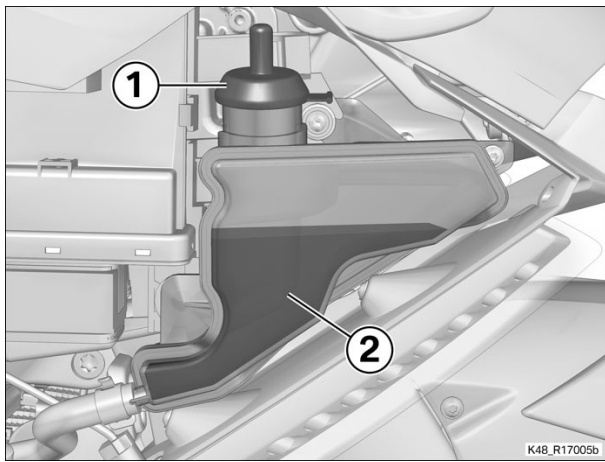

Pour in coolant (2).

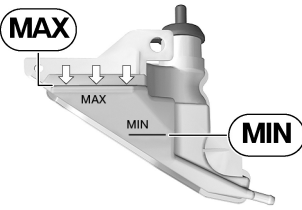
 Technical data			
Coolant, specified level	engine cold	between MIN and MAX marks on the expansion tank	
			

- Install cap (1).

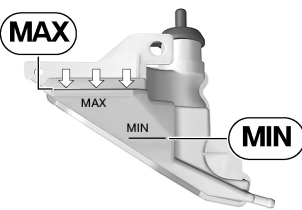

- Allow the engine to warm up until the fan cuts in.
- Allow the engine to cool down.
- Check the coolant level; top up if necessary.

 Technical data			
Coolant, specified level	engine cold	between MIN and MAX marks on the expansion tank	
			

Finishing work

- Install the right side panel
- Install the right radiator cowl
- Installing right bottom side panel
- Install the left side panel
- Installing left radiator cowl
- Installing left bottom side panel
- Final check of work performed

 **17 11 001 Replacing cap for radiator 3 FRUs**

+ 17 11 501



Warning

Take care when working on the cooling system: risk of burns if the system is hot.

Do not work on the cooling system until it has had ample time to cool down.

Preparatory work

Removing right bottom side panel

Removing right radiator cowl

Remove the right side panel

Core activity

(-) Removing radiator cap

- Replace cap (1).

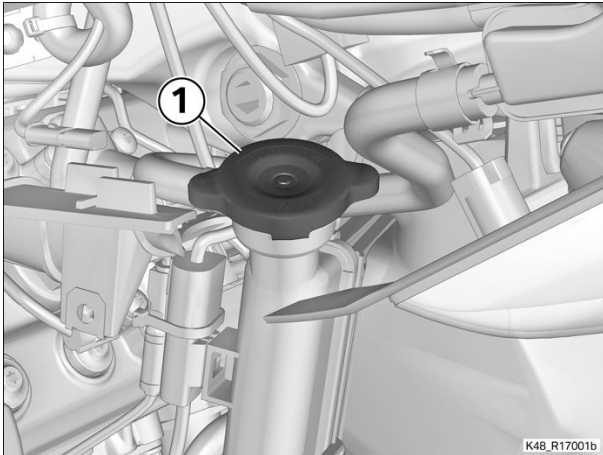

Finishing work

Install the right side panel

Install the right radiator cowl

Installing right bottom side panel

Final check of work performed

17 11 008 Removing/installing radiator (without draining/refilling coolant system) 3 FRUs

+ 17 11 508

Preparatory work

=> **Draining coolant, refilling/bleeding system**
(Description in item: 17 00 504, Billed as a separate item)

Disconnecting feed line for coolant
 Removing radiator hose cover

Core activity

(-) Removing complete radiator

► **Disconnecting coolant hose between engine and radiator at radiator**

- Open clip (1) with pliers (No. 17 5 571).
- Disconnect coolant hose (2).

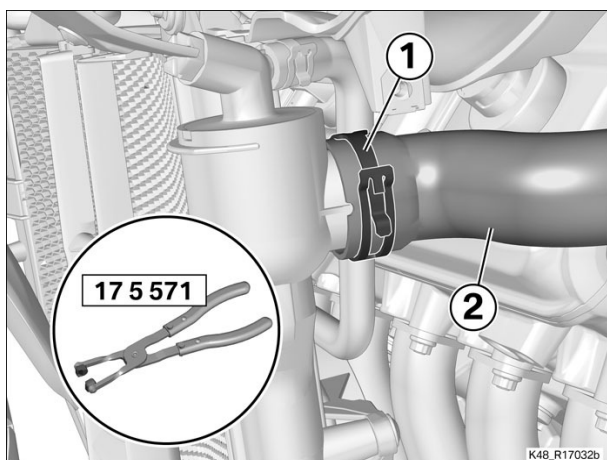

- ◄
- Remove clip (1) and washer (2).

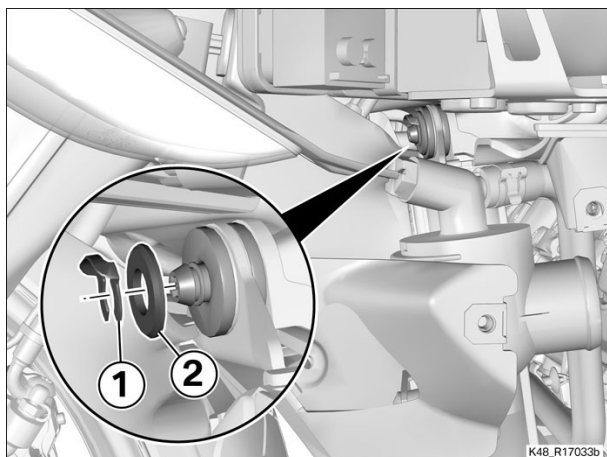

► **Releasing strut for radiator at bottom**

- Remove clip (1) and washer (2).
- Detach strut (3) from radiator (4).

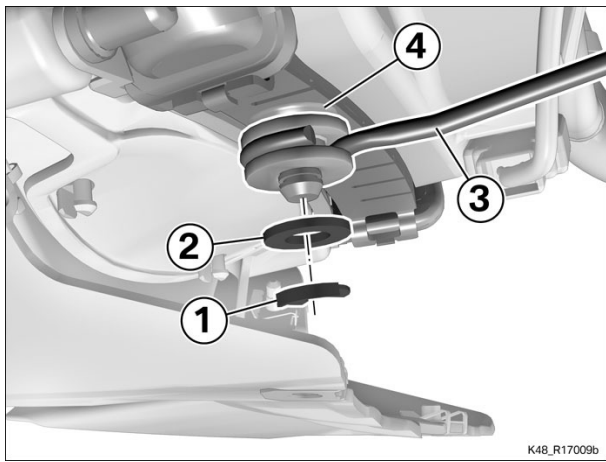

- Remove cable tie (arrow).
- Remove plug (1) for the crankshaft sensor.
- Remove and disconnect plug (2) for the fan.

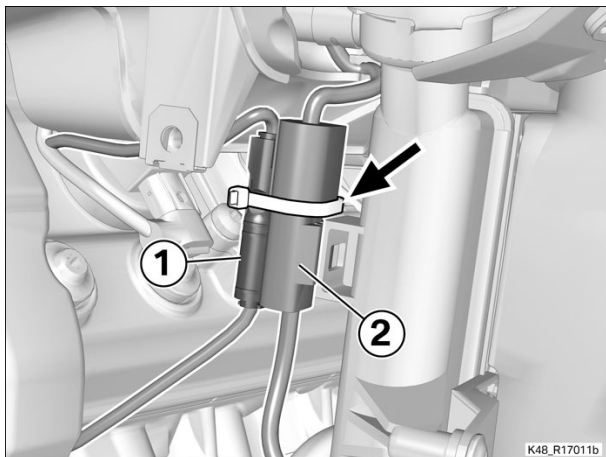

- Remove clip (1) and washer (2).

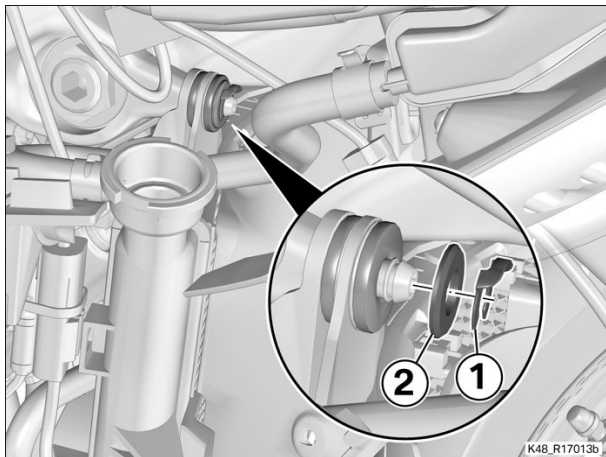

- Disengage radiator (1) complete with mounted parts from the retaining pins (arrow) of the air guide for oil cooler on left and right and remove.
- Take care not to damage the radiator and the mounted parts.

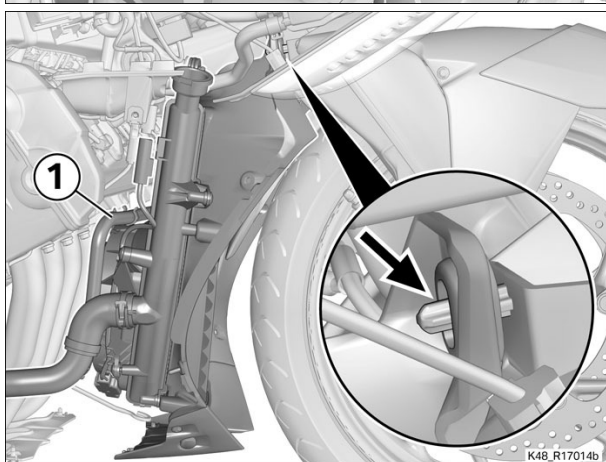

(-) Installing complete radiator

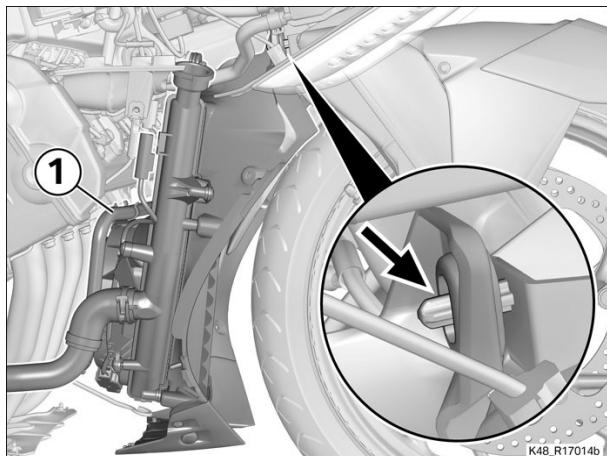

- Insert radiator (1) complete with mounted parts, seat it on the retaining pins (arrow) of the air guide for oil cooler on left and right and install.
- Take care not to damage the radiator and the mounted parts.

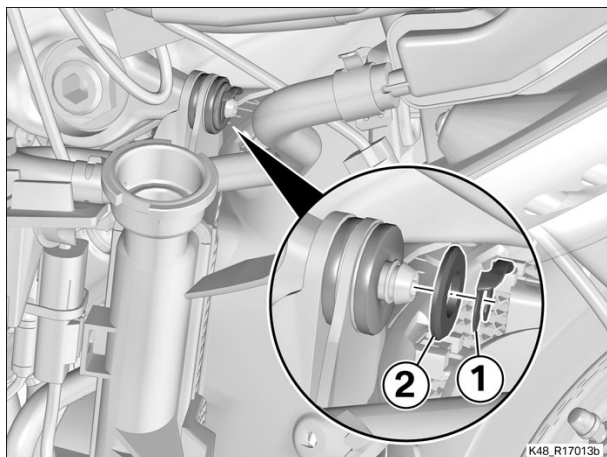

- Install washer (2) and clip (1).

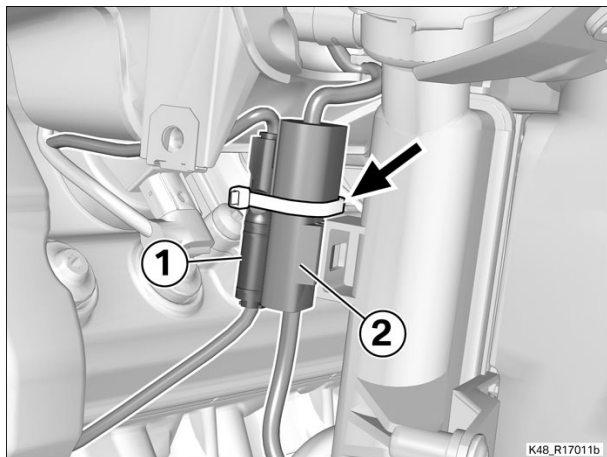

- Connect plug (2) for the fan and install.
- Hold plug (1) for the crankshaft sensor in position.
- Secure the cable tie (arrow).

► Securing strut for radiator at bottom

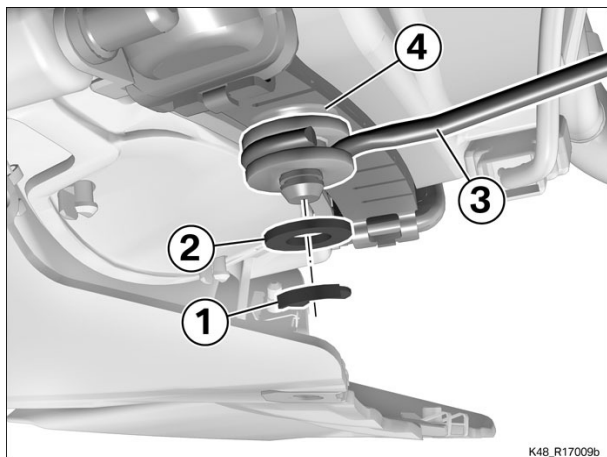

- Secure strut (3) to radiator (4).
- Install washer (2) and clip (1).

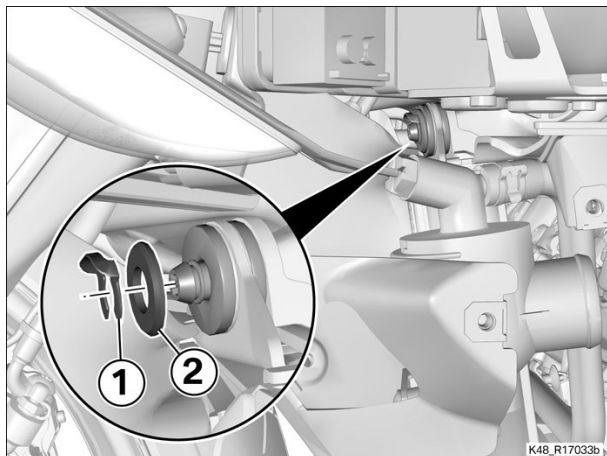

- ◀
- Install washer (2) and clip (1).

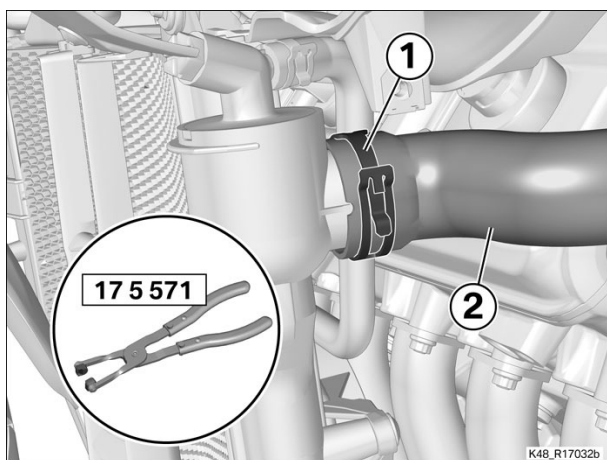

- ▶ **Connecting coolant hose between engine and radiator at engine**
- Connect coolant hose (2).
 - Secure clip (1) with pliers (No. 17 5 571).

- ◀
- Finishing work**
- Installing radiator hose cover
 - Connecting feed line for coolant
 - Final check of work performed

17 11 038 Removing/installing or replacing dirt deflector for radiator 2 FRUs

+ 17 11 546

Core activity

(-) Removing dirt deflector

- Unclip the holders (arrows) for dirt deflector (1).

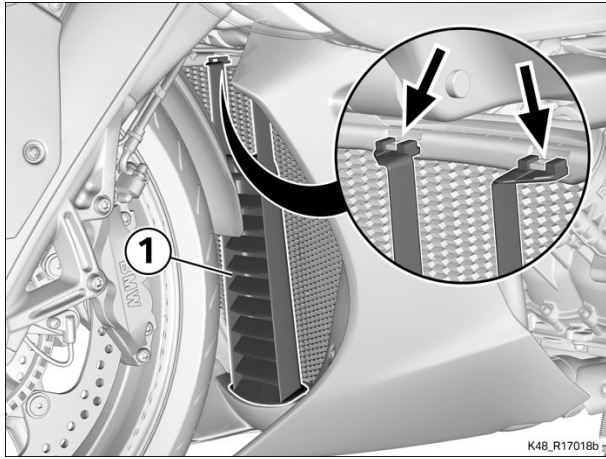

- Disengage dirt deflector (1) from air guide (2) and remove, noting the holders (arrows).

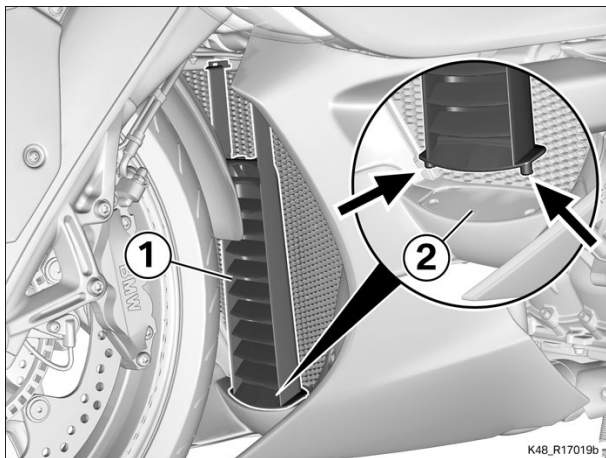

(-) Installing dirt deflector

- Seat dirt deflector (1) in air guide (2) and install. Make sure that the holders (arrows) engage with an audible click.

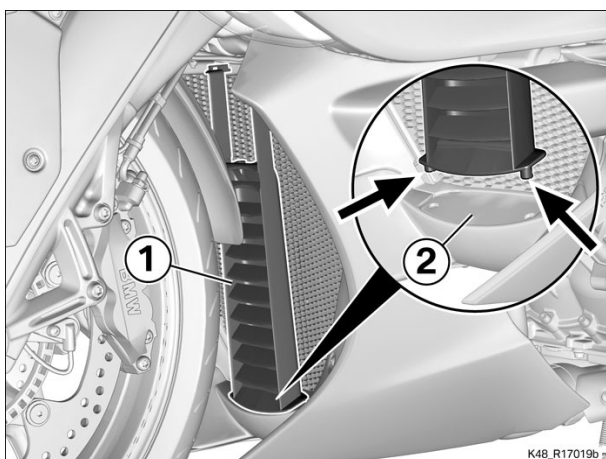

- Clip in the holders (arrows) for dirt deflector (1).

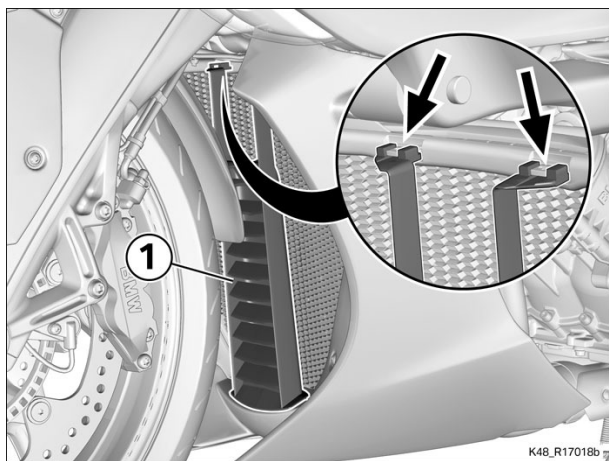

Finishing work

Final check of work performed

17 11 039 Removing/installing or replacing screen for radiator 5 FRUs

+ 17 11 547

Preparatory work

- Removing left bottom side panel
- Removing left radiator cowl
- Removing radiator hose cover
- Removing right radiator cowl
- Removing spoiler for radiator
- Removing air guide for radiator

Core activity

(-) Removing screen

- Remove screws (1).
- Disengage dirt screen (2) and remove.

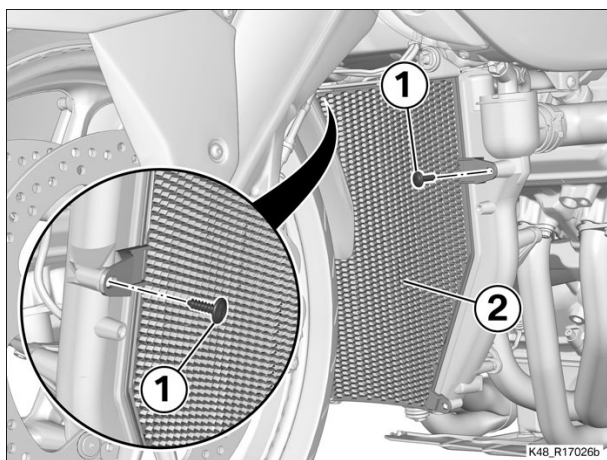

(-) Installing screen

- Hold screen (2) in position.
- Install screws (1).

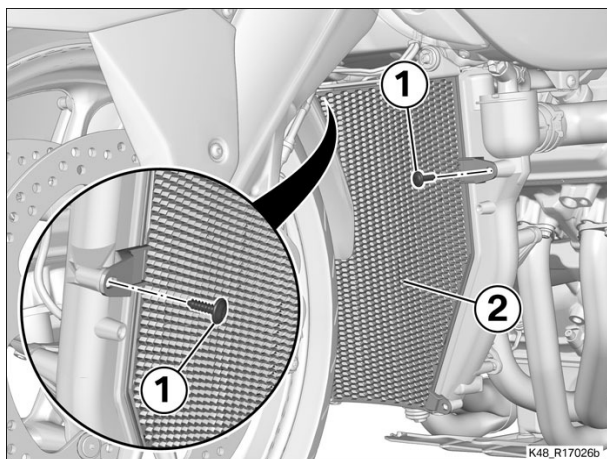

 Tightening torques		
Mesh screen and cooling-air guide to radiator		
TS5 x 18	3 Nm	

Finishing work

- Installing air guide for radiator
- Installing spoiler for radiator
- Install the right radiator cowl
- Installing radiator hose cover
- Installing left radiator cowl
- Installing left bottom side panel
- Final check of work performed

📁 17 11 510 Replacing radiator (radiator removed) 3 FRUs

Core activity

(-) Removing spoiler for radiator

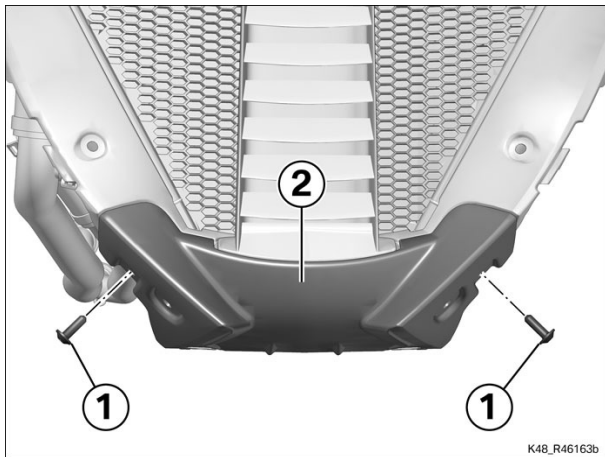

- Remove screws (1).
- Remove spoiler (2).

(-) Removing air guide with dirt deflector

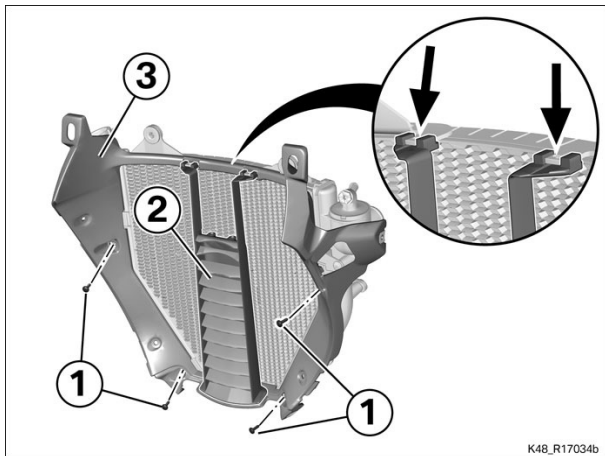

- Remove screws (1).
- Disengage the holders (arrows) for dirt deflector (2).
- Remove air guide (3) with dirt deflector (2).

(-) Removing screen

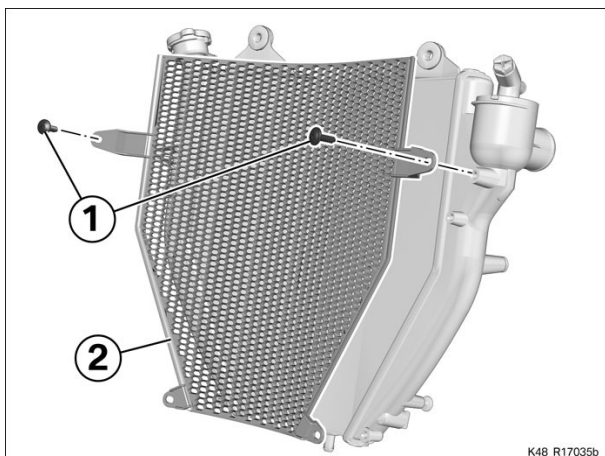

- Remove screws (1).
- Remove screen (2).

(-) Removing return line with bypass

- Open clip (1) with pliers (No. 17 5 571).
- Disconnect bypass (2) and disengage it from holder (3).

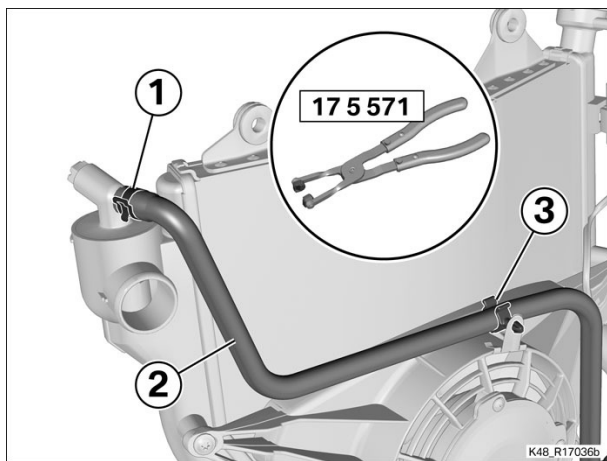

- Open clip (1) with pliers (No. 17 5 571).
- Disconnect return line (2) from radiator (3).

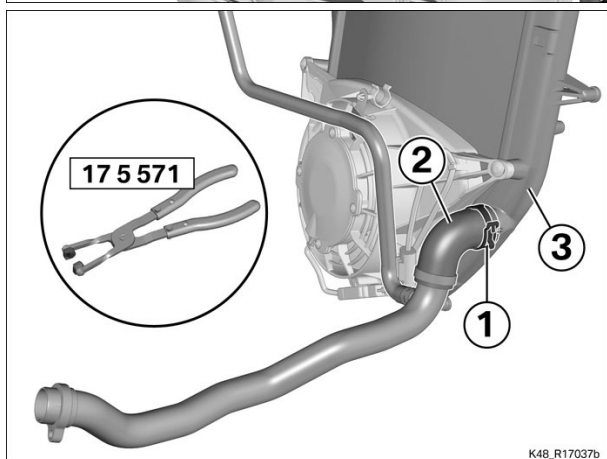

(-) Removing fan

- Remove screws (1).
- Remove fan (2).

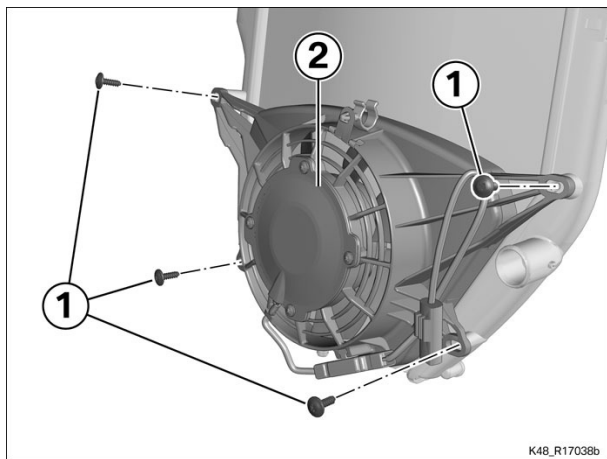

(-) Replacing radiator

- Transfer rubber grommets (1) and inserts (2) from old to new radiator (3).

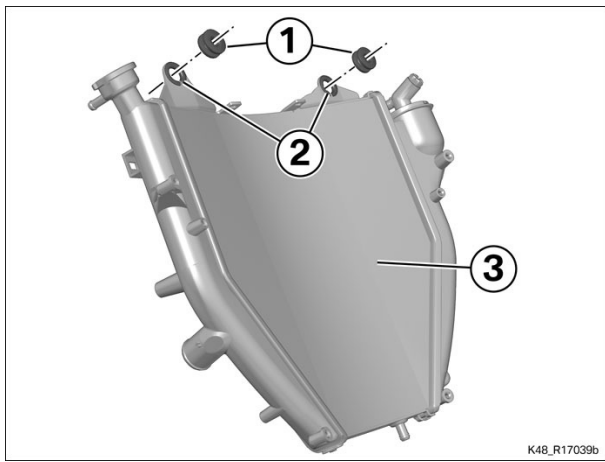

(-) Installing fan

- Hold fan (2) in position.
- Install screws (1).

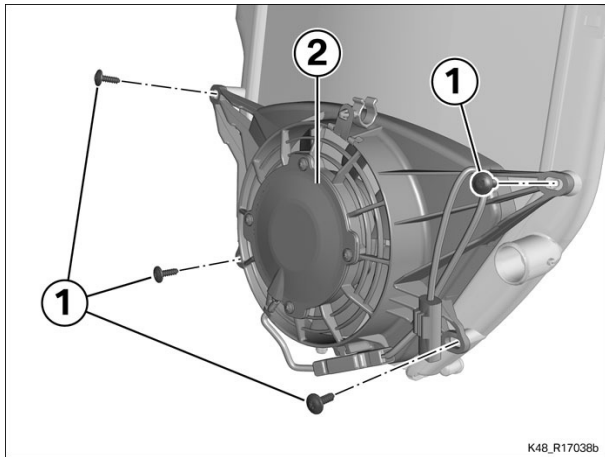

 Tightening torques		
Radiator cowl/screen to radiator		
Plastic screw, TS5 x 18	3 Nm	

(-) Installing return line with bypass

- Connect return line (2) to radiator (3).
- Secure clip (1) with pliers (No. 17 5 571).

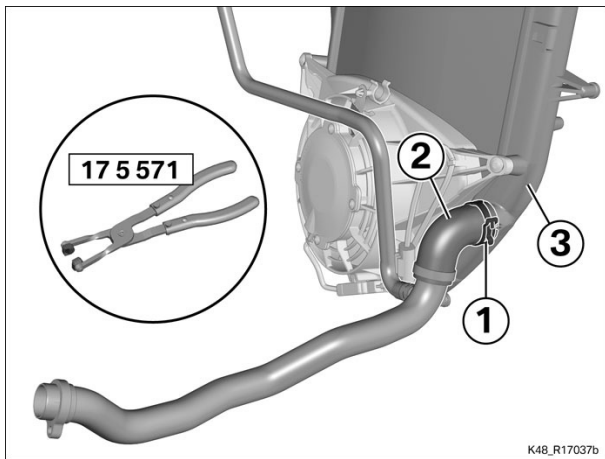

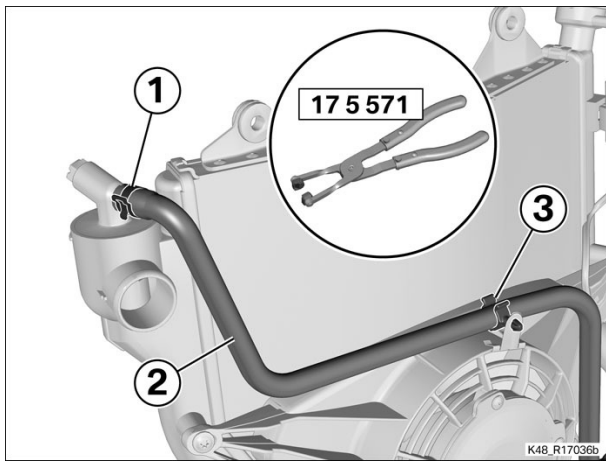

- Connect bypass (2) and secure it in holder (3).
- Secure clip (1) with pliers (No. 17 5 571).

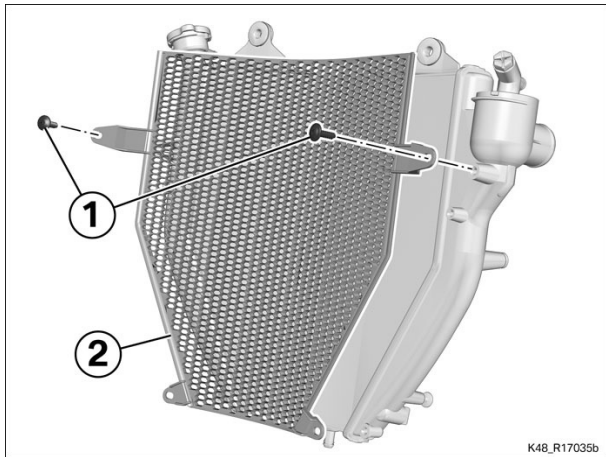

(-) Installing screen

- Hold screen (2) in position.
- Install screws (1).



 Tightening torques		
Mesh screen and cooling-air guide to radiator		
TS5 x 18	3 Nm	

(-) Installing air guide with dirt deflector

- Place air guide (3) with dirt deflector (2) in position.
- Secure the holders (arrows) for dirt deflector (2).
- Install screws (1).

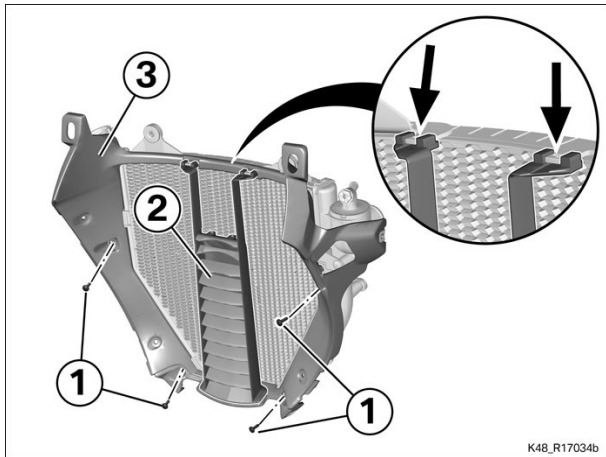

 Tightening torques		
Mesh screen and cooling-air guide to radiator		
TS5 x 18	3 Nm	

(-) Installing spoiler for radiator

- Install spoiler (2).
- Install screws (1) on left and right.

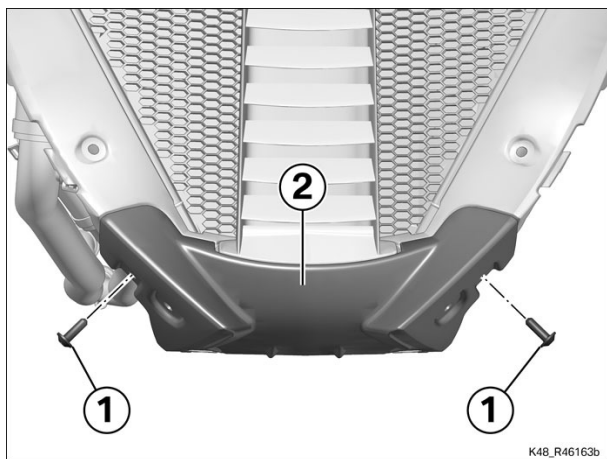

Finishing work

Final check of work performed

17 12 098 Replacing coolant hose from cylinder head (without draining/ refilling coolant system) 2 FRUs

+ 17 12 758



Warning

Take care when working on the cooling system: risk of burns if the system is hot.

Do not work on the cooling system until it has had ample time to cool down.

Core activity

(-) Removing coolant hose from cylinder head

- Open clip (1) with pliers (No. 17 5 571).
- Disconnect coolant hose (2) from adapter (3).

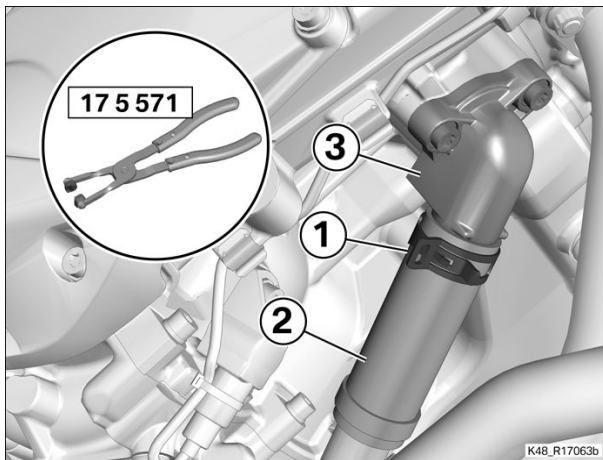

(-) Disconnecting feed line for coolant

- Remove screw (1).
- Disconnect feed line (2) for the coolant from the coolant pump, noting O-ring (3).

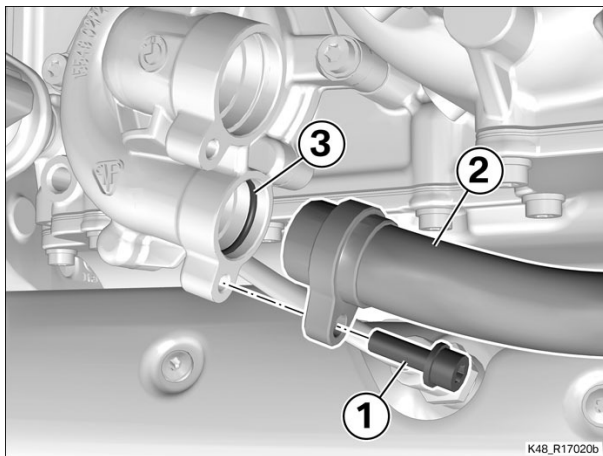

(-) Replacing coolant hose from cylinder head

- Transfer clip (1) with pliers (No. 17 5 571) to new coolant hose (2).

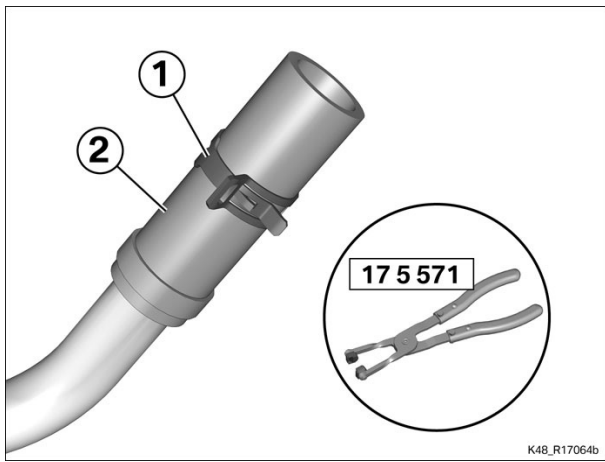

(-) Connecting feed line for coolant

- Clean the tapped hole.
- Check O-ring (3) for damage; replace if not in perfect condition.
- Make sure that O-ring (3) is seated in the groove (arrow).
- Push feed line (2) for the coolant into the coolant pump.
- Install new screw (1).

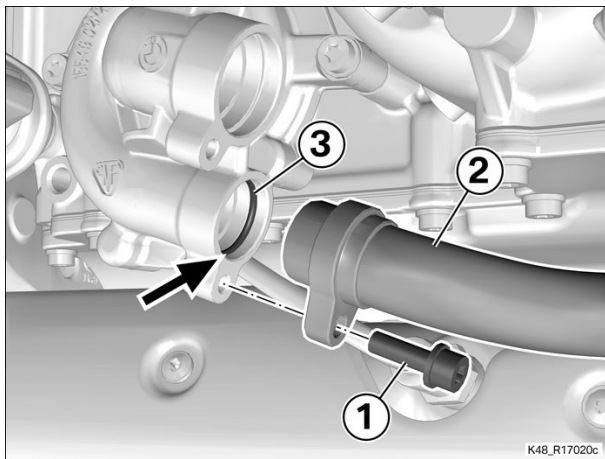

 Tightening torques		
Coolant line to pump		
M6 x 20, Replace screw	10 Nm	
Micro-encapsulated		

(-) Installing coolant hose from cylinder head

- Connect coolant hose (2) to adapter (3).
- Secure clip (1) with pliers (No. 17 5 571).

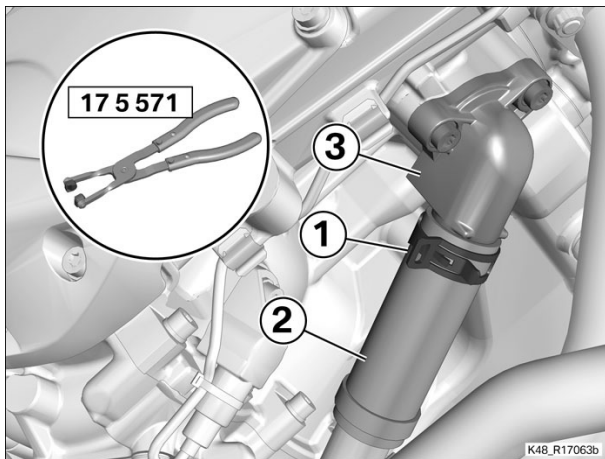

Finishing work

=> Draining coolant, refilling/bleeding system (Description in item: 17 00 504, Billed as a separate item)

Final check of work performed

📁 17 12 100 Replacing coolant hose from radiator (without draining/ refilling coolant system) 2 FRUs

+ 17 12 600



Warning

Take care when working on the cooling system: risk of burns if the system is hot.

Do not work on the cooling system until it has had ample time to cool down.

Core activity

(-) Removing coolant hose from radiator

- Release clips (1) and (2) with pliers (No. 17 5 571).
- Disconnect bypass line (3).
- Disconnect coolant hose (4) from radiator (5).

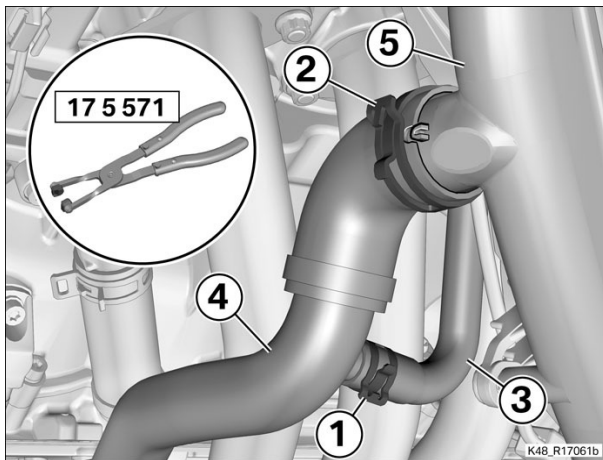

(-) Replacing coolant hose from radiator

- Transfer clip (1) with pliers (No. 17 5 571) to new coolant hose (2).

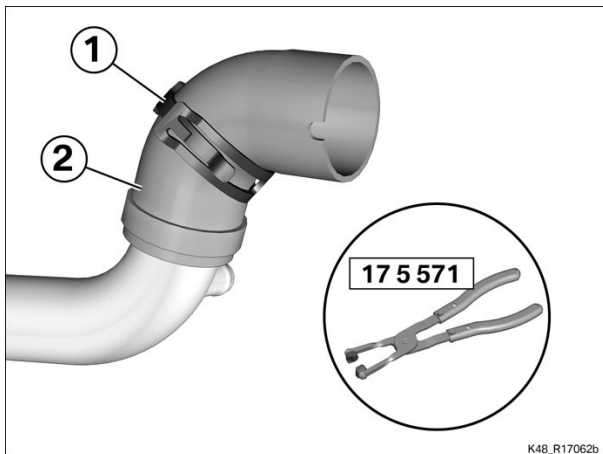

(-) Installing coolant hose from radiator

- Connect coolant hose (4) to radiator (5).
- » The lug (arrow) engages the recess of the hose.
- Connect bypass line (3).
- Secure clips (1) and (2) with pliers (No. 17 5 571).

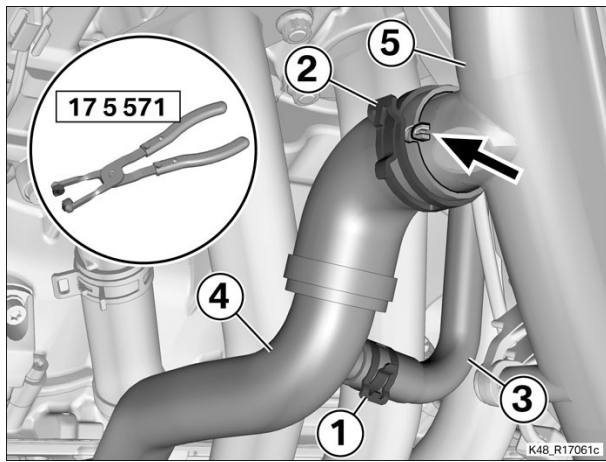

Finishing work

=> **Draining coolant, refilling/bleeding system**
(Description in item: 17 00 504, Billed as a separate item)

Final check of work performed

📁 17 12 105 Replacing coolant hose to radiator (without draining/ refilling coolant system) 2

FRUs

+ 17 12 605



Warning

Take care when working on the cooling system: risk of burns if the system is hot.

Do not work on the cooling system until it has had ample time to cool down.

Preparatory work

Removing radiator hose cover

Core activity

(-) Removing coolant hose to radiator

- Open clips (1) with pliers (No. 17 5 571).
- Disconnect coolant hose (2) from adapter (3) and radiator (4).

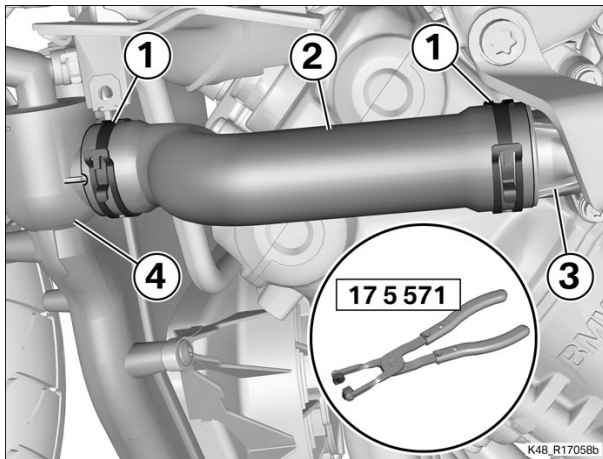

(-) Replacing coolant hose to radiator

- Transfer clips (1) with pliers (No. 17 5 571) to new coolant hose (2).

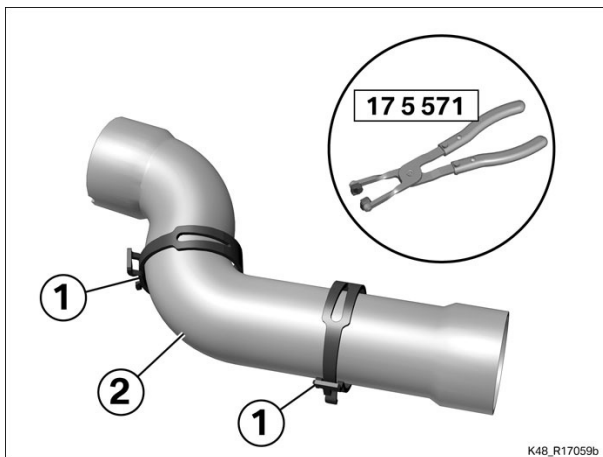

(-) Installing coolant hose to radiator

- Connect coolant hose (2) to adapter (3) and radiator (4).
- » The lug (arrow) engages the recess of the hose.
- Close clips (1) with pliers (No. 17 5 571).

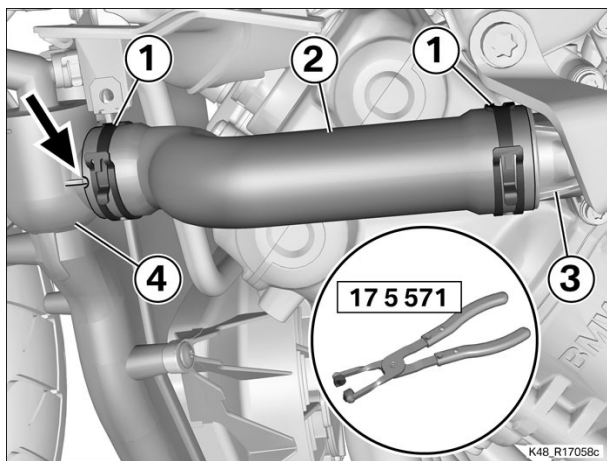

Finishing work

Installing radiator hose cover

**=> Draining coolant, refilling/bleeding system
(Description in item: 17 00 504, Billed as a separate
item)**

Final check of work performed

📁 17 12 200 Replacing coolant hose from expansion tank 4 FRUs

+ 17 12 755



Warning

Take care when working on the cooling system: risk of burns if the system is hot.

Do not work on the cooling system until it has had ample time to cool down.

Preparatory work

Removing right bottom side panel

Removing right radiator cowl

Remove the right side panel

Core activity

(-) Drawing off coolant from expansion tank

- Remove cap (1) and draw off coolant (2) with a suitable tool, such as a large syringe, for example.

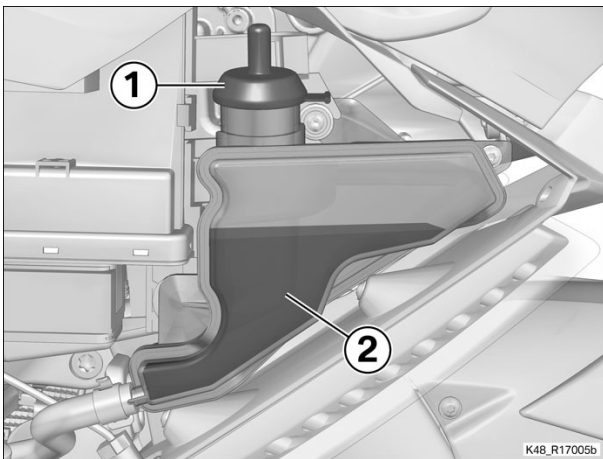

(-) Removing coolant hose for expansion tank

- Release clips (1) and (2) with pliers (No. 17 5 571).
- Disconnect hose (3) from expansion tank (4) and use suitable means to catch the remaining coolant as it escapes.
- Disconnect hose (3) from filler neck (5).
- Remove hose (3).

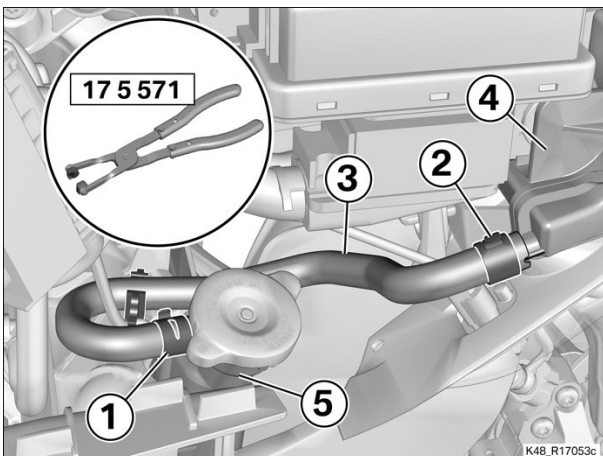

(-) Replacing coolant hose for expansion tank

- Transfer clips (1) with pliers (No. 17 5 571) to new coolant hose (2).

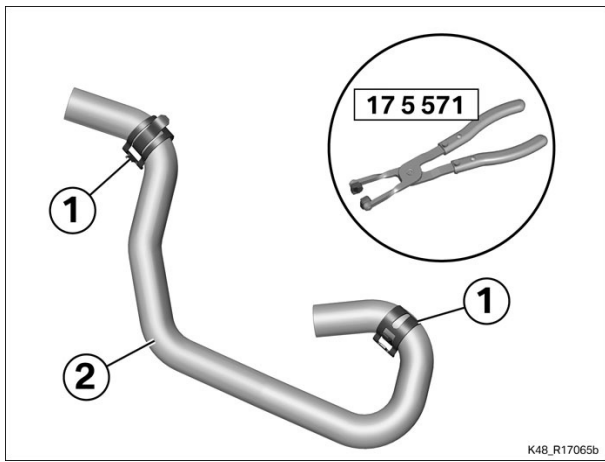

(-) Installing coolant hose for expansion tank

- Connect hose (3) to expansion tank (4).
- » The lug (arrow) engages the recess of the hose.
- Connect hose (3) to filler neck (5).
- Secure hose (3) in holder (6).
- Secure clips (1) and (2) with pliers (No. 17 5 571).

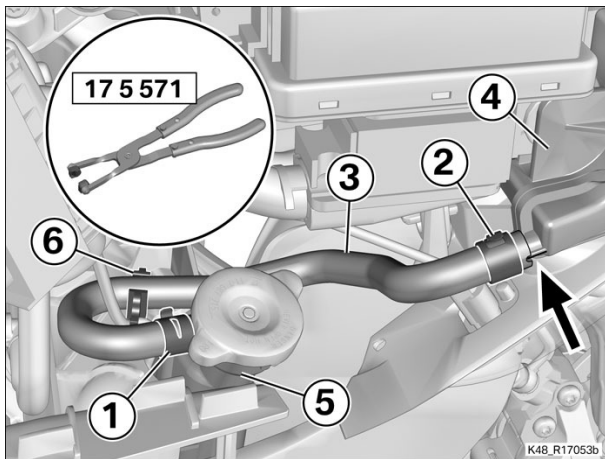

(-) Filling expansion tank

- Pour in coolant (2).

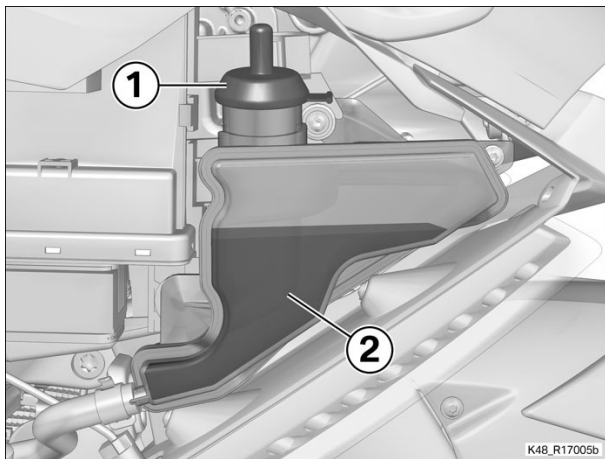

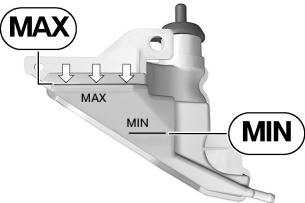
 Technical data			
Coolant, specified level	engine cold	between MIN and MAX marks on the expansion tank	
			

- Install cap (1).

Finishing work

- Install the right side panel
- Install the right radiator cowl
- Installing right bottom side panel
- Final check of work performed

17 13 001 Replace expansion tank 4 FRUs

+ 17 13 501



Warning

Take care when working on the cooling system: risk of burns if the system is hot.

Do not work on the cooling system until it has had ample time to cool down.

Preparatory work

Removing right bottom side panel

Removing right radiator cowl

Remove the right side panel

Core activity

(-) Drawing off coolant from expansion tank

- Remove cap (1) and draw off coolant (2) with a suitable tool, such as a large syringe, for example.

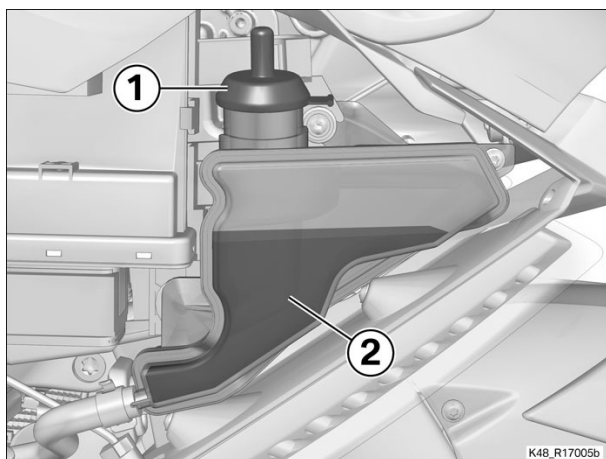

(-) Removing expansion tank for coolant

- Remove screw (1) with washer (2).
- Remove screw (3).
- Disengage expansion tank (4).

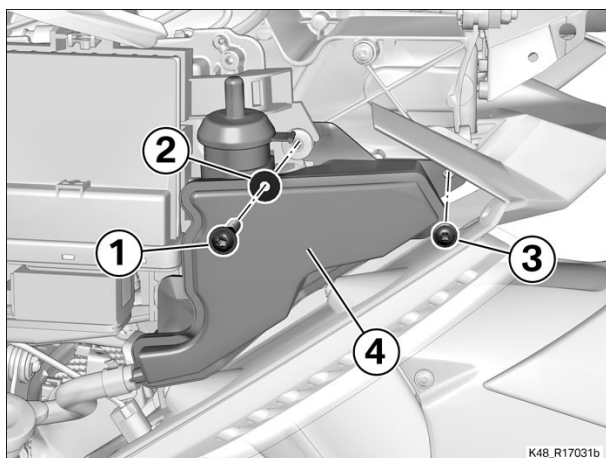

- Seal off hose (1) with hose clamp (No. 13 3 010).
- Open clip (2) with pliers (No. 17 5 571).
- Disconnect hose (1).
- Remove expansion tank (3).

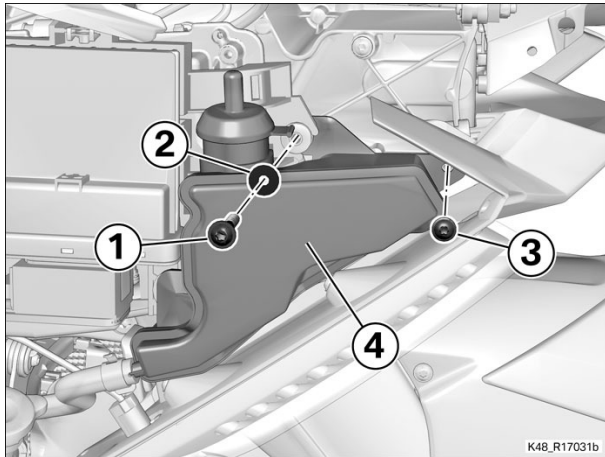
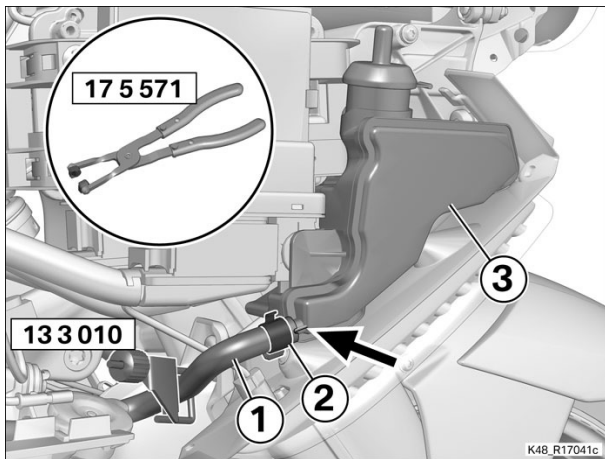
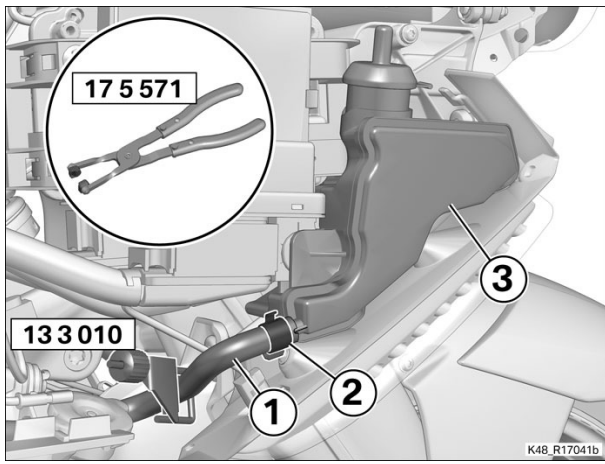

(-) Installing expansion tank for coolant

- Connect hose (1) to expansion tank (3) in such a way that the lug (arrow) engages the recess of the hose.
- Close clip (2) with pliers (No. 17 5 571).
- Remove hose clamp (No. 13 3 010).

- Engage expansion tank (4).
- Install screw (3).
- Install screw (1) with washer (2).

 Tightening torques		
Expansion tank to front panel carrier		
Special thread for light alloy, 5 x 30	6 Nm	
Special thread for light alloy, 5 x 16	6 Nm	

(-) Filling expansion tank

- Pour in coolant (2).

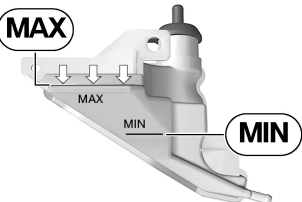
 Technical data			
Coolant, specified level	engine cold	between MIN and MAX marks on the expansion tank	
			

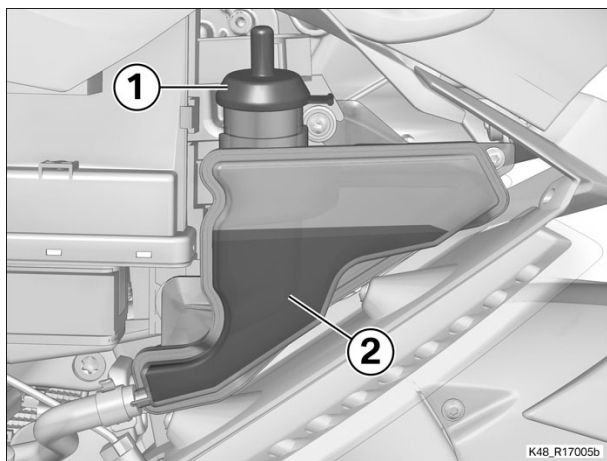

- Install cap (1).

Finishing work

- Install the right side panel
- Install the right radiator cowl
- Installing right bottom side panel
- Final check of work performed

17 21 000 Removing/installing or replacing oil cooler

+ 17 21 501

Equipment trim-level variant:

0266 - Preparation for audio system and navigation device

0267 - ECE audio system and preparation for navigation system

Preparatory work

Removing air guide for intake air pipe, right
 Removing right hand protector
 Removing right speaker
 Removing right mirror
 Removing finisher of air guide, right
 Removing top section of fairing, right
 Removing air guide for intake air pipe, left
 Removing left bottom side panel
 Removing left radiator cowl
 Removing left side panel
 Removing inner trim for left side panel
 Removing left hand protector
 Removing left speaker
 Removing finisher of air guide, left
 Removing top section of fairing, left
 Removing cover of instrument panel
 Disengaging left and right windscreen holders
 Removing top cover
 Removing cover for windscreen adjuster
 Removing air guide for oil cooler
 Removing headlight
 Removing oil cooler from front panel carrier

Core activity

(-) Removing oil cooler

- Close off feed hose (1) and return hose (2) with hose clamps (No. 13 3 010).

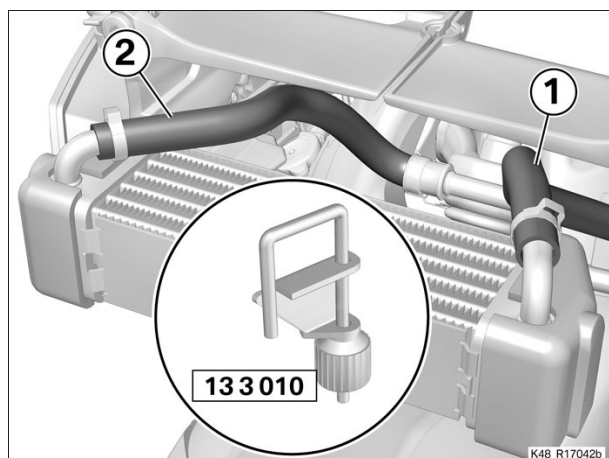

- Open clip (1) and disconnect feed line (2) from oil cooler (3).
- Open clip (4) and disconnect return line (5) from oil cooler (3).

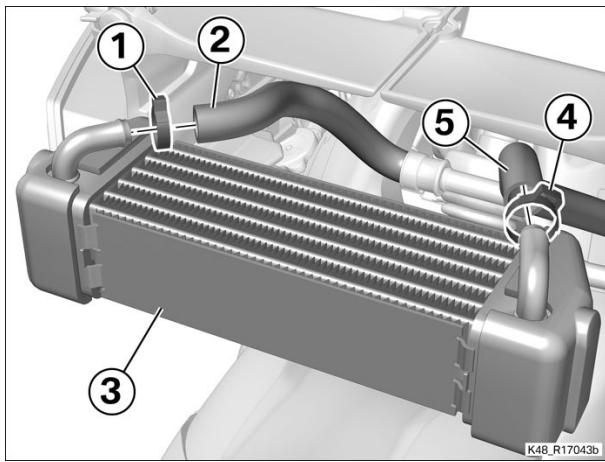

(-) Replacing oil cooler

- Transfer rubber mounts (1) to new oil cooler (2).

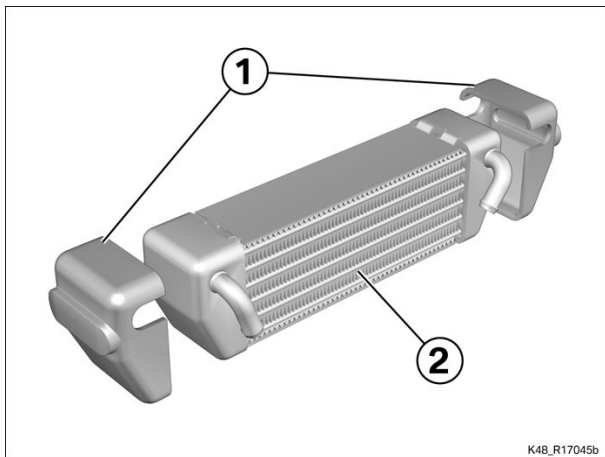

(-) Installing oil cooler

- Connect return line (5) to oil cooler (3).
- Connect feed line (2) to oil cooler (3).
- Secure clips (1) and (4) with pliers (No. 13 1 500).

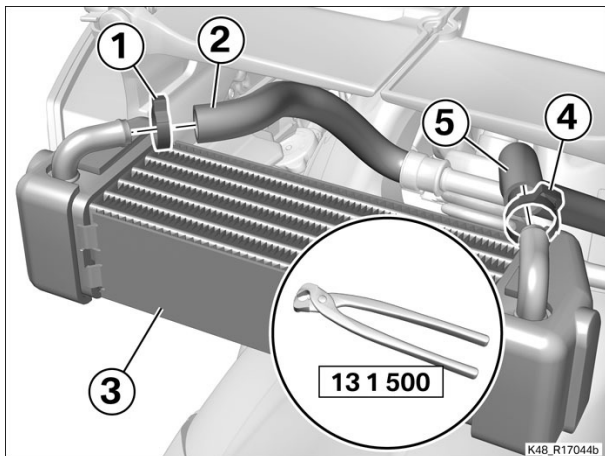

- Remove the hose clamps (No. 13 3 010) from feed line (1) and return line (2).

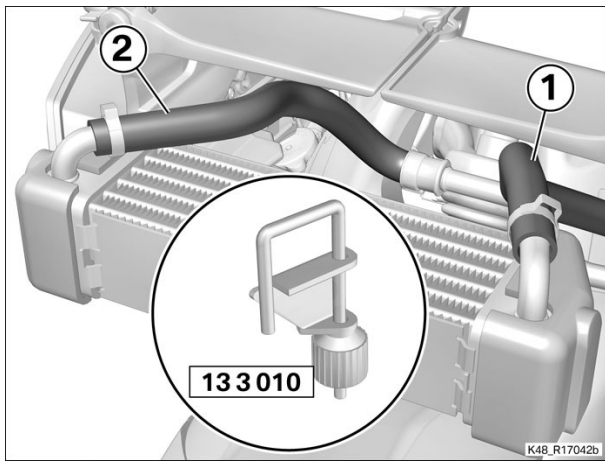

Finishing work

- Installing oil cooler in front panel carrier
- Installing headlight
- Installing air guide for oil cooler
- Installing cover for windscreen adjuster
- Installing top cover
- Securing left and right windscreen holders
- Installing cover of instrument panel
- Checking engine oil level
- Checking headlight beam throw
- Installing top section of fairing, left
- Installing finisher of air guide, left
- Installing left mirror
- Installing left speaker
- Installing left hand protector
- Installing inner trim for left side panel
- Install the left side panel
- Installing finisher of air guide, left
- Installing left radiator cowl
- Installing left bottom side panel
- Installing air guide for intake air pipe, left
- Installing top section of fairing, left
- Installing finisher of air guide, right
- Installing right mirror
- Installing right speaker
- Installing right hand protector
- Installing air guide for intake air pipe, right
- Final check of work performed

 **17 22 035 Removing/installing or replacing oil-cooler line, flow**

+ 17 22 501

Equipment trim-level variant:

0266 - Preparation for audio system and navigation device

0267 - ECE audio system and preparation for navigation system

Preparatory work

Remove the front seat
Removing adjusting plate
Removing air guides for intake air pipes, left and right
Removing complete cover of fuel tank
Disengaging left and right intake air pipes
Removing right hand protector
Removing right speaker
Removing right mirror
Removing finisher of air guide, right
Removing top section of fairing, right
Removing left bottom side panel
Removing left radiator cowl
Removing left side panel
Removing inner trim for left side panel
Removing left hand protector
Removing left speaker
Removing finisher of air guide, left
Removing left mirror
Removing top section of fairing, left
Removing air guide for oil cooler
Removing headlight
Disengaging seat support
Removing complete intake air silencer
Removing fuel tank
Disengaging wiring harness for engine
Removing intake manifold
Removing oil cooler from front panel carrier

Core activity

(-) Removing oil cooler line, feed

- Place a suitable tray underneath the oil cooler to catch escaping oil.
- Open clip (1) and disconnect oil cooler line (2) from oil cooler (3).

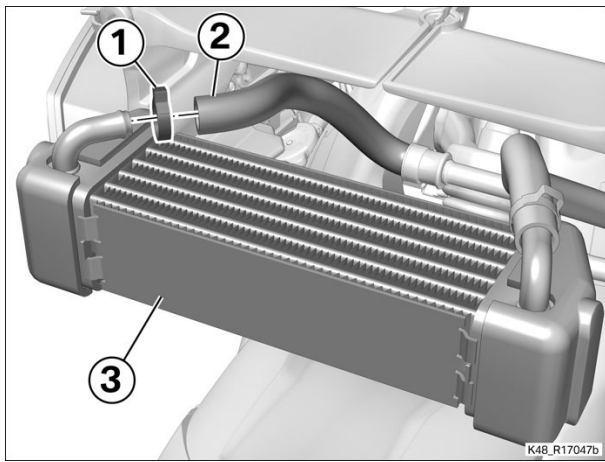

- Remove cable tie (arrow).
- Unclip oil cooler line (1) from holder (2).

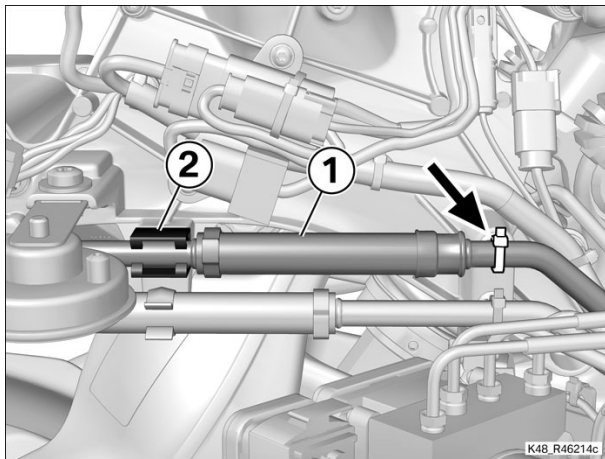

- Unclip oil cooler line (1) from the holders (arrows).

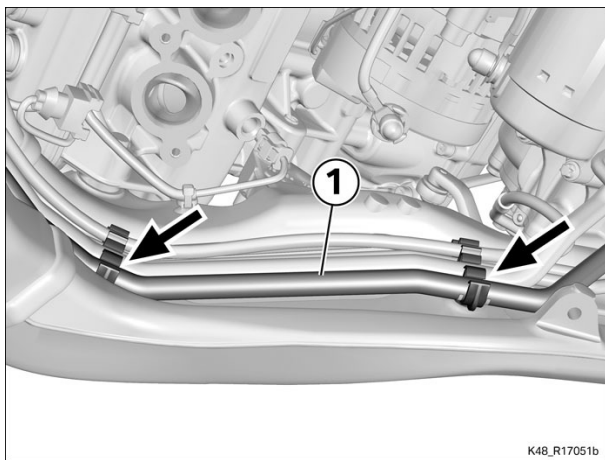

- Remove screw (1).
- Disconnect oil cooler line (2) and unclip it from the holder (arrow).
- Remove sealing ring (3) from oil cooler line (2).
- Work oil cooler line (2) to the rear until clear of the motorcycle and remove.
- Remove all oil stains from the vehicle.

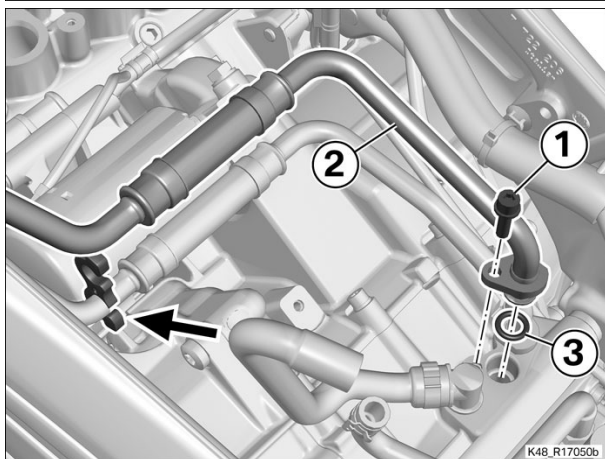

(-) Installing oil cooler line, feed

-

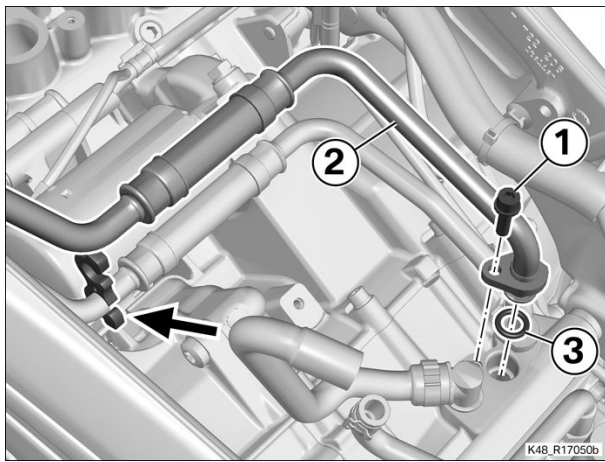

- Manoeuvre oil cooler line (2) into position on the motorcycle.
- Check sealing ring (3) for damage; replace if necessary.
- Install sealing ring (3) on oil cooler line (2).
- Connect oil cooler line (2) and clip the holder (arrow) to oil cooler line (2).
- Install screw (1).

 Tightening torques		
Oil cooler lines to crankcase		
M6 x 20	10 Nm	

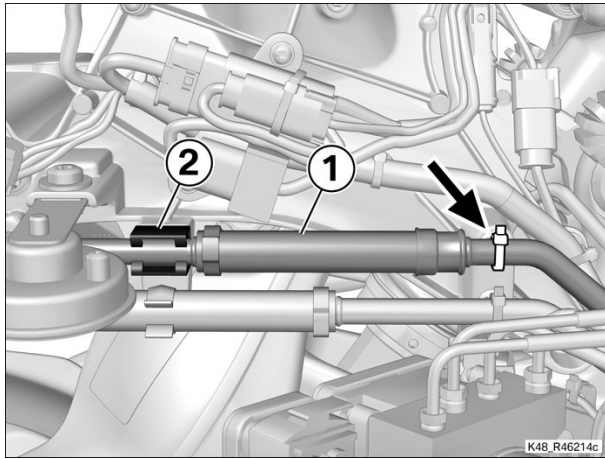

- Clip oil cooler line (1) of the oil cooler into holder (2) and secure it with a cable tie (arrow).

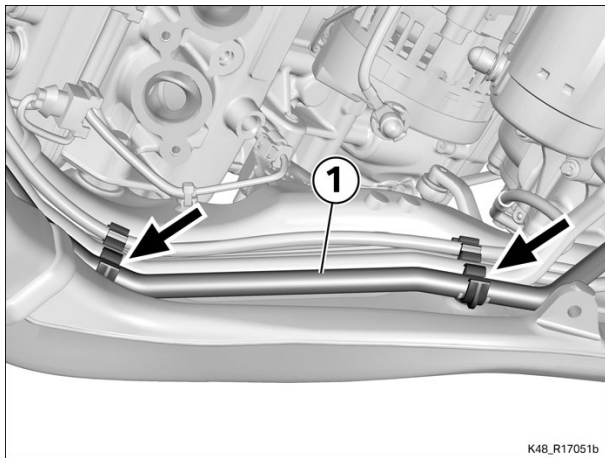

- Clip oil cooler line (1) into the holders (arrows).

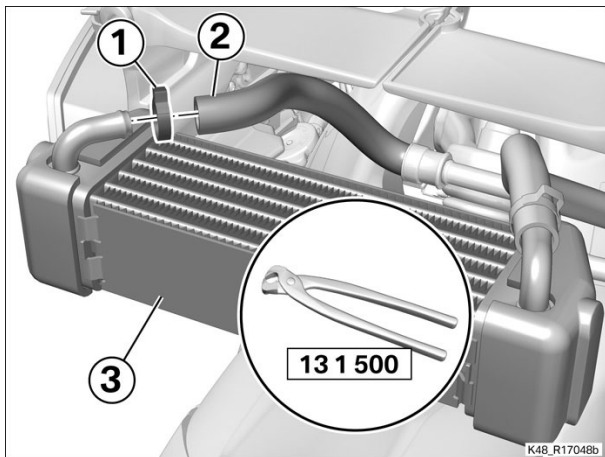

- Connect oil cooler line (2) to oil cooler (3) and close new clip (1) with pliers (No. 13 1 500).

Finishing work

- Installing oil cooler in front panel carrier
- Installing intake manifold
- Installing fuel tank
- Installing complete intake air silencer
- Securing seat support
- Installing headlight
- Installing air guide for oil cooler
- Installing top section of fairing, left
- Installing finisher of air guide, left
- Installing left speaker
- Installing left hand protector
- Installing inner trim for left side panel
- Installing left side panel
- Installing left radiator cowl
- Installing left bottom side panel
- Installing top section of fairing, right
- Installing finisher of air guide, right
- Installing right mirror
- Installing right speaker
- Installing right hand protector
- Securing left and right intake air pipes
- Installing complete cover of fuel tank
- Installing air guides for intake air pipes, left and right
- Installing adjusting plate
- Installing left mirror
- Installing front seat
- Checking engine oil level
- Checking headlight beam throw
- Final check of work performed

 **17 22 050 Removing/installing or replacing oil-cooler line, return**

+ 17 22 502

Equipment trim-level variant:

0266 - Preparation for audio system and navigation device

0267 - ECE audio system and preparation for navigation system

Preparatory work

Remove the front seat
Removing adjusting plate
Removing air guides for intake air pipes, left and right
Removing complete cover of fuel tank
Disengaging left and right intake air pipes
Removing right hand protector
Removing right speaker
Removing right mirror
Removing finisher of air guide, right
Removing top section of fairing, right
Removing left bottom side panel
Removing left radiator cowl
Removing left side panel
Removing inner trim for left side panel
Removing left hand protector
Removing left speaker
Removing finisher of air guide, left
Removing left mirror
Removing top section of fairing, left
Removing air guide for oil cooler
Removing headlight
Disengaging seat support
Removing complete intake air silencer
Removing fuel tank
Disengaging wiring harness for engine
Removing intake manifold
Removing oil cooler from front panel carrier

Core activity

(-) Removing oil cooler line, return

- Place a suitable tray underneath the oil cooler to catch escaping oil.
- Open clip (1) and disconnect oil cooler line (2) from oil cooler (3).

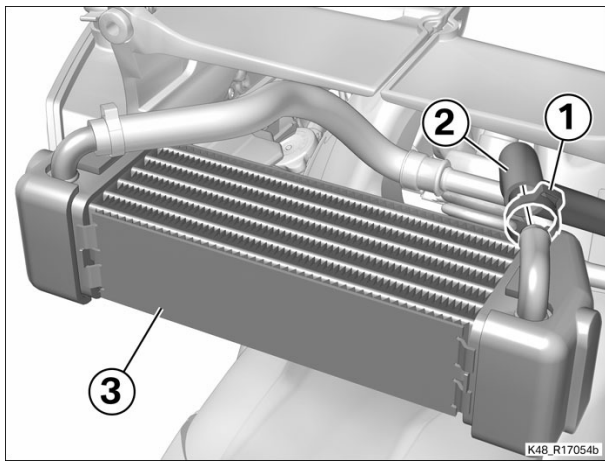

- Remove cable tie (arrow).
- Unclip oil cooler line (1) from holder (2).

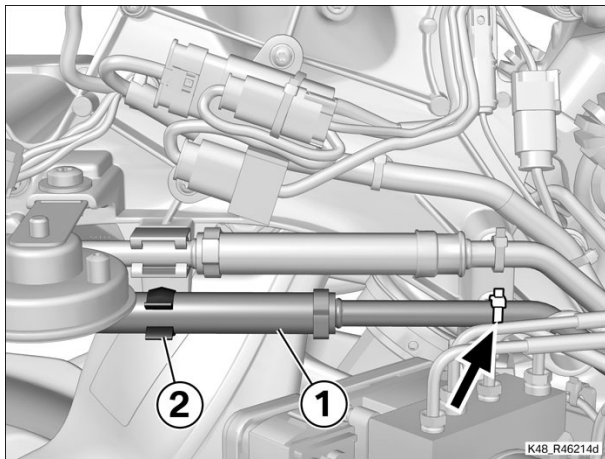

- Unclip oil cooler line (1) from the holders (arrows).

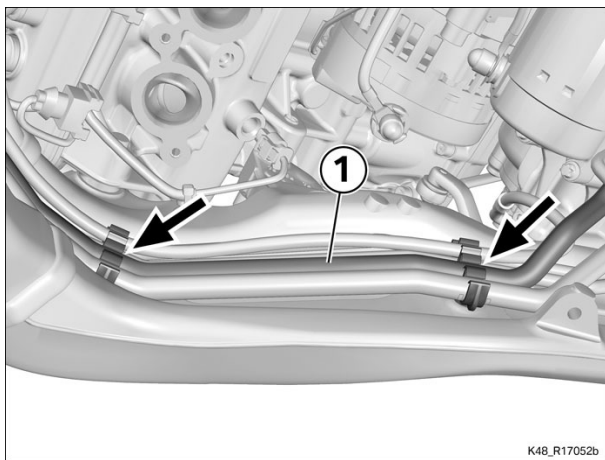

- Remove screw (1).
- Disconnect oil cooler line (2) and unclip it from the holder (arrow).
- Remove sealing ring (3) from oil cooler line (2).
- Work oil cooler line (2) to the rear until clear of the motorcycle and remove.
- Remove all oil stains from the vehicle.

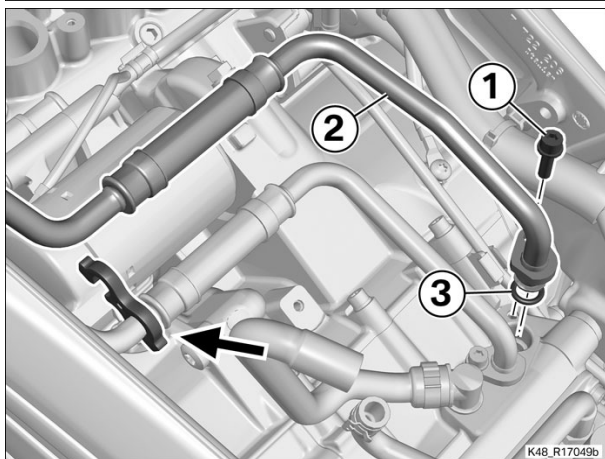

(-) Installing oil cooler line, return

-

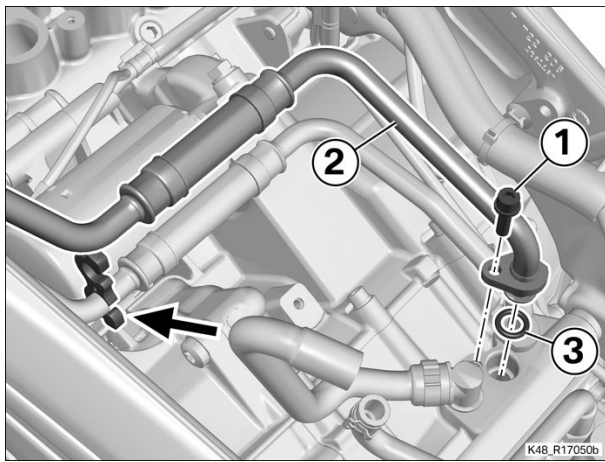

- Manoeuvre oil cooler line (2) into position on the motorcycle.
- Check sealing ring (3) for damage; replace if necessary.
- Install sealing ring (3) on oil cooler line (2).
- Connect oil cooler line (2) and clip the holder (arrow) to oil cooler line (2).
- Install screw (1).

 Tightening torques		
Oil cooler lines to crankcase		
M6 x 20	10 Nm	

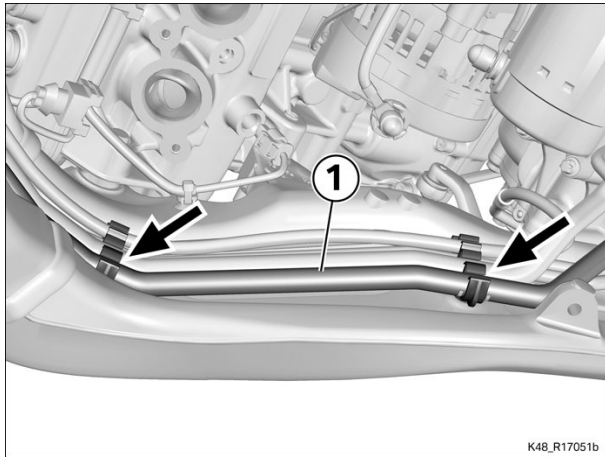

- Clip oil cooler line (1) into the holders (arrows).

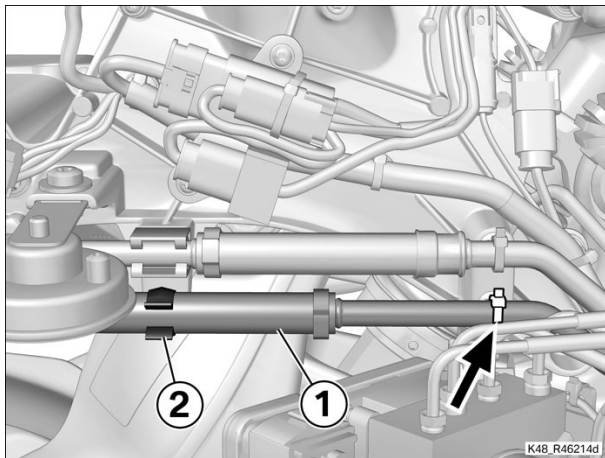

- Clip oil cooler line (1) of the oil cooler into holder (2) and secure it with a cable tie (arrow).

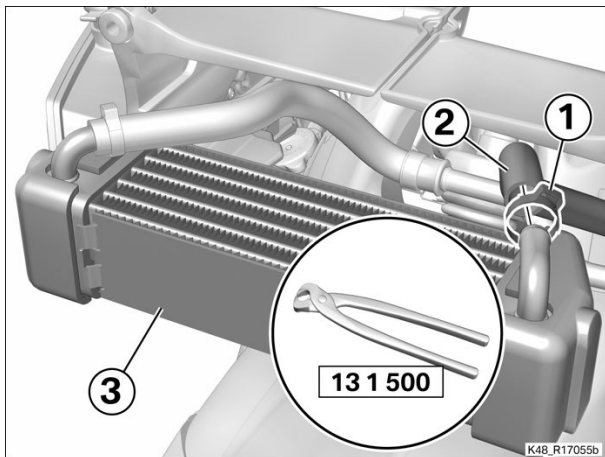

- Connect oil cooler line (2) to oil cooler (3) and close new clip (1) with pliers (No. 13 1 500).

Finishing work

- Installing oil cooler in front panel carrier
- Installing intake manifold
- Installing fuel tank
- Installing complete intake air silencer
- Securing seat support
- Installing headlight
- Installing air guide for oil cooler
- Installing top section of fairing, left
- Installing finisher of air guide, left
- Installing left speaker
- Installing left hand protector
- Installing inner trim for left side panel
- Installing left side panel
- Installing left radiator cowl
- Installing left bottom side panel
- Installing top section of fairing, right
- Installing finisher of air guide, right
- Installing right mirror
- Installing right speaker
- Installing right hand protector
- Securing left and right intake air pipes
- Installing complete cover of fuel tank
- Installing air guides for intake air pipes, left and right
- Installing adjusting plate
- Installing left mirror
- Installing front seat
- Checking engine oil level
- Checking headlight beam throw
- Final check of work performed

📁 17 40 000 Removing/installing or replacing fan 3 FRUs

+ 17 40 500

Preparatory work

Removing left radiator cowl

Removing right radiator cowl

Core activity

(-) Removing fan

- Remove cable tie (arrow).
- Remove plug (1) for the crankshaft sensor.
- Remove and disconnect plug (2) for the fan.

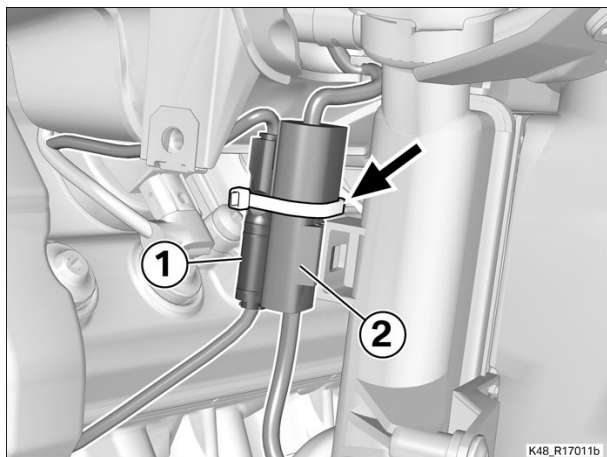

- Remove screws (1).

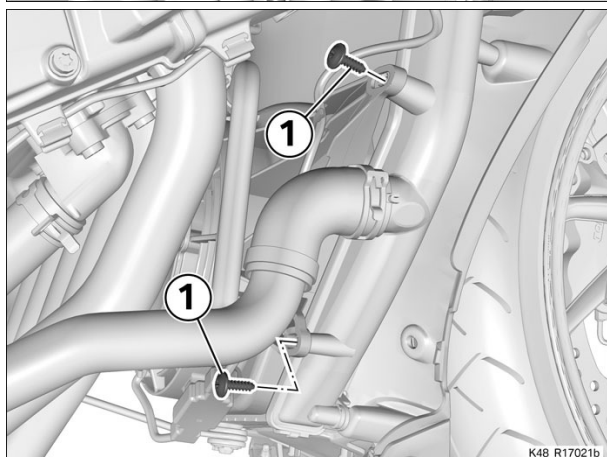

- Remove screws (1).
- Remove fan (2).

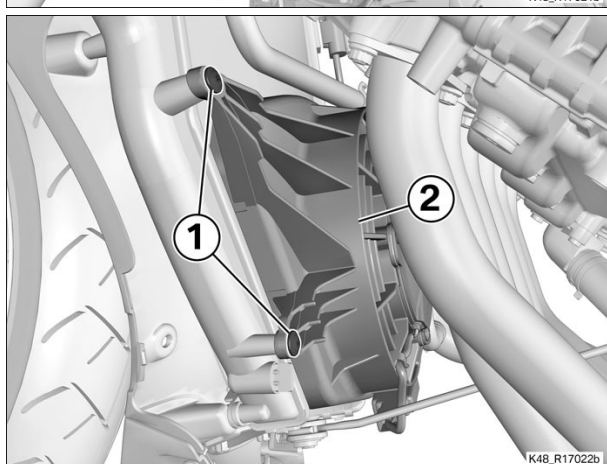

(-) Installing fan

- Install fan (2).
- Install screws (1).

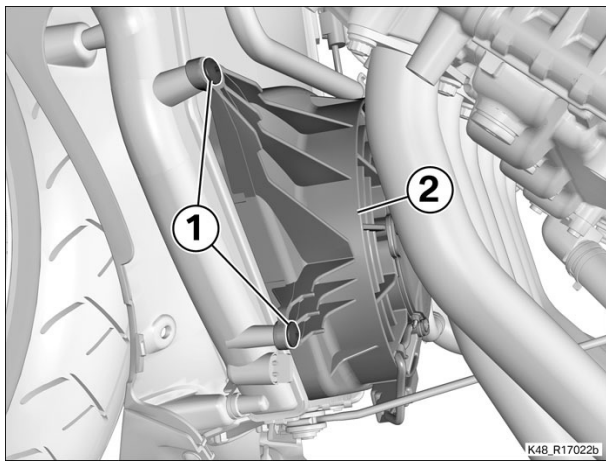

Tightening torques

Radiator cowl/screen to radiator

Plastic screw, TS5 x 18	3 Nm	
-------------------------	------	--

- Install screws (1).

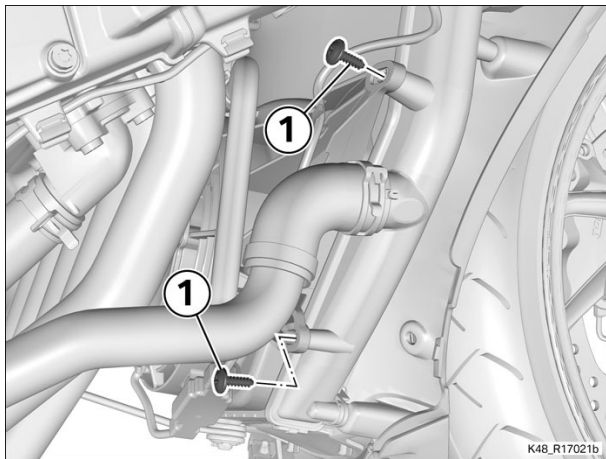

Tightening torques

Radiator cowl/screen to radiator

Plastic screw, TS5 x 18	3 Nm	
-------------------------	------	--

- Connect plug (2) for the fan and install.
- Hold plug (1) for the crankshaft sensor in position.
- Secure the cable tie (arrow).

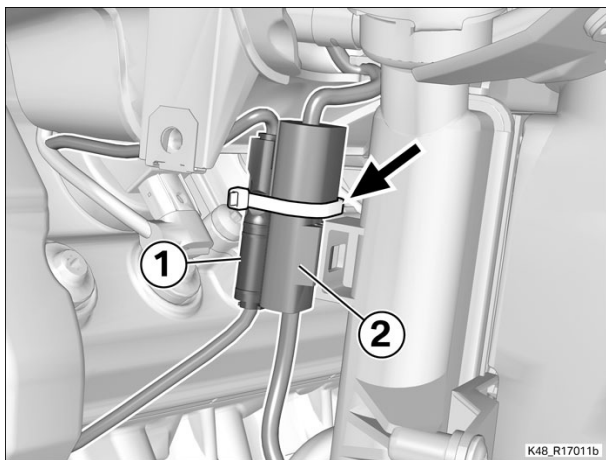

Finishing work

Install the right radiator cowl

Installing left radiator cowl

Final check of work performed

18 51 000 Replacing silencer 3 FRUs

+ 18 51 500



Warning

Risk of burns caused by the hot exhaust system.

Do not touch the exhaust system when it is hot; if necessary, allow the exhaust system ample time to cool before proceeding.

Preparatory work

Removing left catalytic-converter shield

Core activity

(-) Disengaging clamp on left silencer

- Slacken screw (1) until clamp (2) is loose.

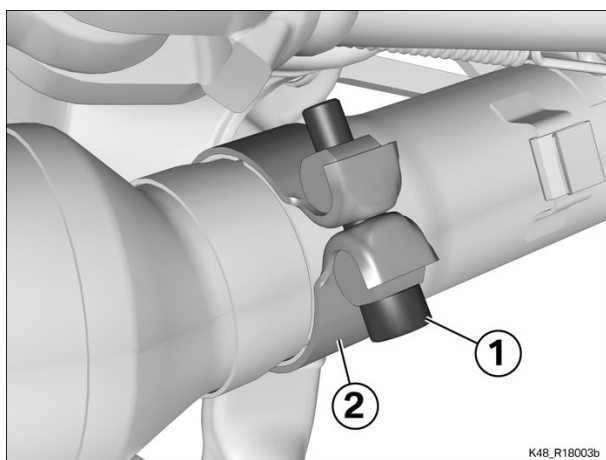

(-) Removing left silencer

- Remove screw (1) with thrust washer (2).
- Remove silencer (3).

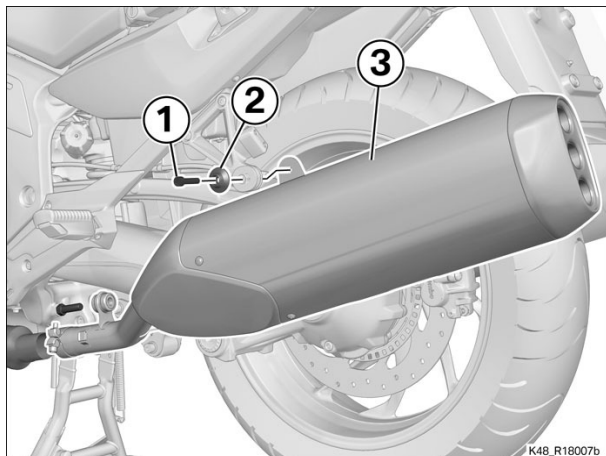

(-) Replacing silencer

- Remove clamp (1) from silencer (2).
- Transfer retaining clamp (3) to new silencer (2).

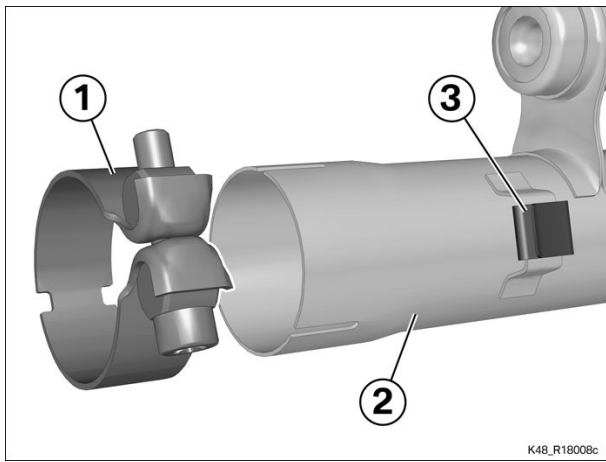

(-) Installing left silencer

► Lubricating clamp for silencer

- Thinly lubricate the inner face (arrow) of clamp (1).

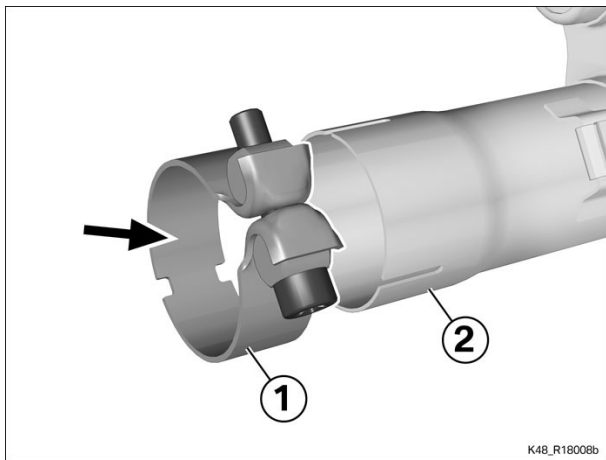



 Fluids and lubricants		
Optimoly TA	High-temperature assembly grease	18 21 9 062 599

- Slip clamp (1) on to silencer pipe (2).

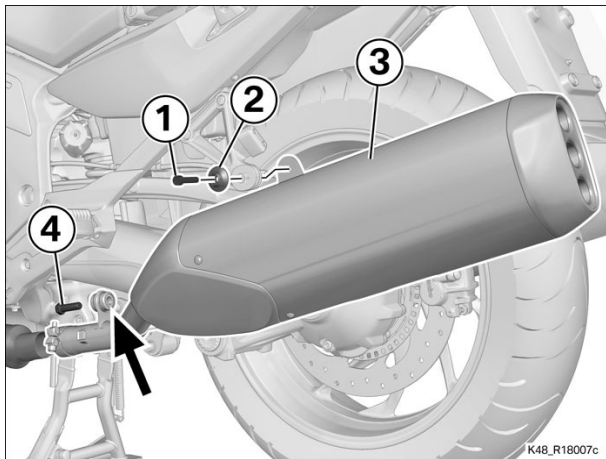

- Install silencer (3), slipping the guide (arrow) on to holder (4).
- Install screw (1) with thrust washer (2).



 Tightening torques		
Silencer to bracket		
M8 x 35	19 Nm	

(-) Securing clamp on left silencer

► Aligning silencer

- When installing silencers (1), make sure that they are
 - installed on the same level (A)
 - relative to tyre (2) parallel (B)
 - and with the outlets (arrows) forming a slightly V-shaped pattern (C).

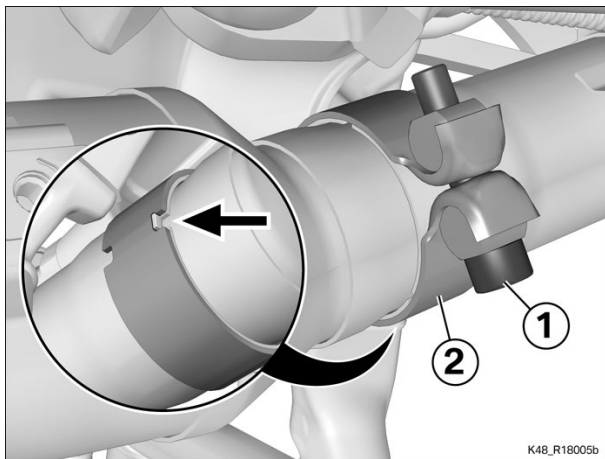
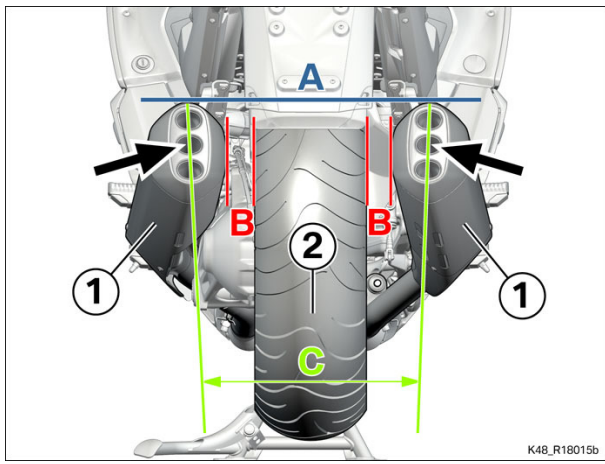

- Align clamp (2) with the retaining lug (arrow).
- Tighten screw (1).

 Tightening torques		
Clamp to silencer and exhaust manifold		
M8 x 40	30 Nm	

Finishing work

Installing left catalytic-converter shield

Final check of work performed

18 51 001 Replacing exhaust manifold

+ 18 51 502



Warning

Risk of burns caused by the hot exhaust system.

Do not touch the exhaust system when it is hot; if necessary, allow the exhaust system ample time to cool before proceeding.

Preparatory work

Removing left catalytic-converter shield

Removing left oxygen sensor

Disengaging clamp on left silencer

Removing left silencer

Removing left radiator cowl

Removing right catalytic-converter shield

Removing right oxygen sensor

Disengaging clamp on right silencer

Removing right silencer

Removing right radiator cowl

Core activity

(-) Removing exhaust manifold, left

- Remove nuts (1) and remove exhaust manifold (2).
- Remove gaskets (3).

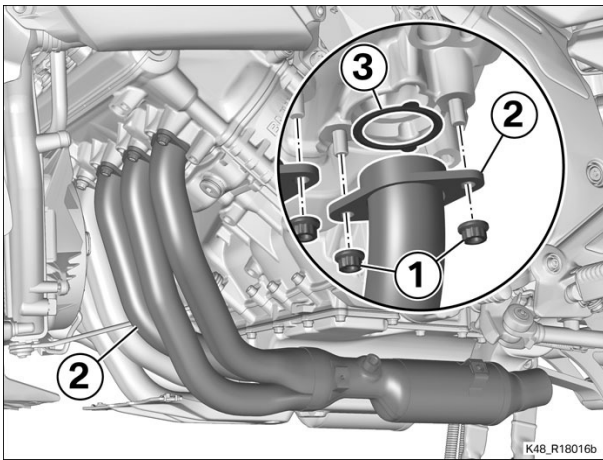

(-) Removing exhaust manifold, right

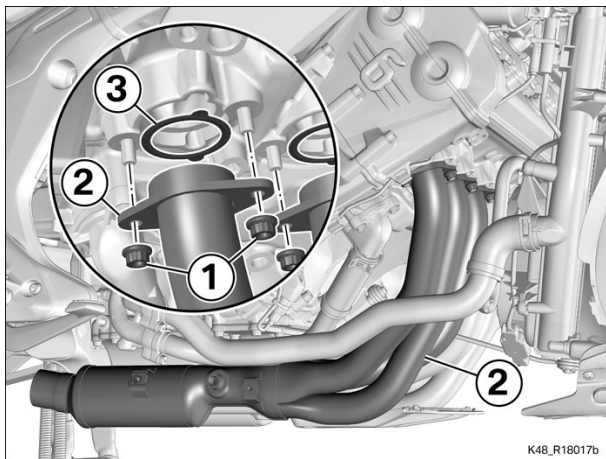

- Remove nuts (1) and remove exhaust manifold (2).
- Remove gaskets (3).

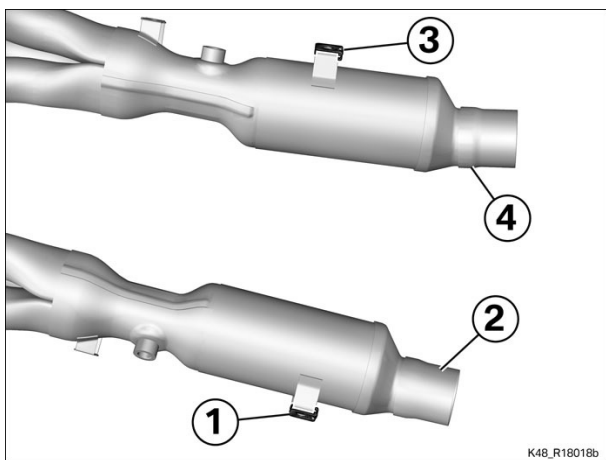

(-) Replacing exhaust manifold

- Transfer flat nut (1) to new left-hand exhaust manifold (2).
- Transfer flat nut (3) to new right-hand exhaust manifold (4).

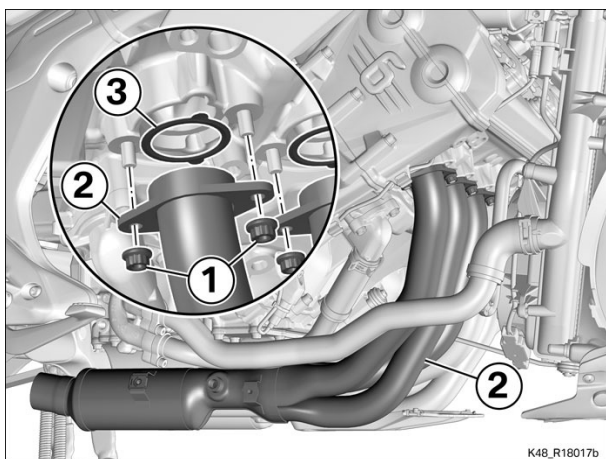

(-) Installing exhaust manifold, right

- Install gaskets (3), making sure they are correctly positioned.
- Hold exhaust manifold (2) in position and install nuts (1).

 Tightening torques		
Exhaust header to cylinder head		
M7	14 Nm	

(-) Installing exhaust manifold, left

- Install gaskets (3), making sure they are correctly positioned.
- Hold exhaust manifold (2) in position and install nuts (1).

 Tightening torques		
Exhaust header to cylinder head		
M7	14 Nm	

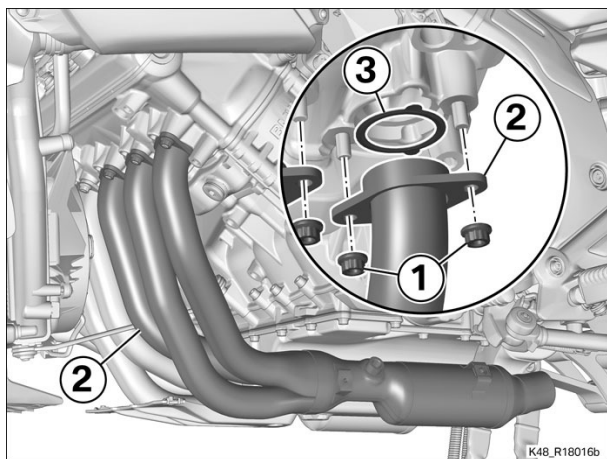

Finishing work

- Install the right radiator cowl
- Installing right silencer
- Securing clamp on right silencer
- Installing right oxygen sensor
- Installing right catalytic-converter shield
- Installing left radiator cowl
- Installing left silencer
- Securing clamp on left silencer
- Installing left oxygen sensor
- Installing left catalytic-converter shield
- Final check of work performed

📁 21 21 000 Removing and installing or replacing clutch 10 FRUs

+ 21 21 606

Equipment trim-level variant:

0266 - Preparation for audio system and navigation device

0267 - ECE audio system and preparation for navigation system

Preparatory work

Removing right bottom side panel

Removing right radiator cowl

Remove the right side panel

Disengaging right stowage compartment

Removing right drop-protection pad

Removing right crankcase cover

Core activity

(-) Removing clutch

- Engage 6th gear and turn the rear wheel to turn clutch (1) until conrod (2) of cylinder No. 5 is **no longer** visible.

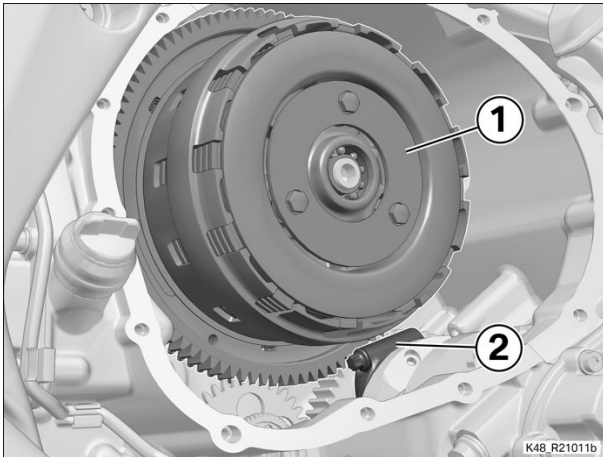

► Removing pressure plate

- Remove the following components:

- Screws (1)
- Spring retainers (2)
- Springs (3)
- Pressure plate (4)
- Thrust piece (5)

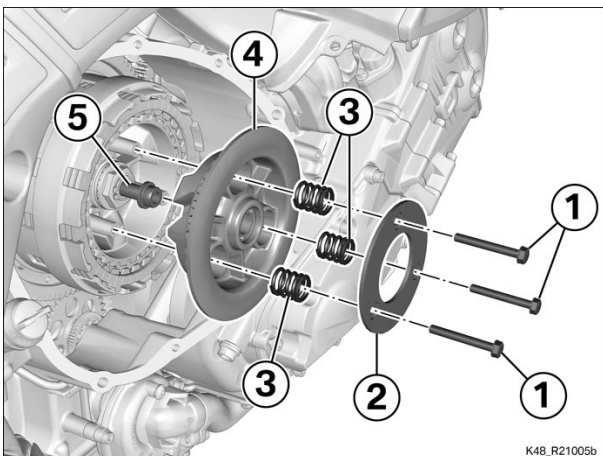

► Removing plate cluster

- Remove the following components:

- Friction plate (1) with **large inside diameter**
- Steel plate (2) with **large inside diameter**
- Friction plate (1) with **large inside diameter**

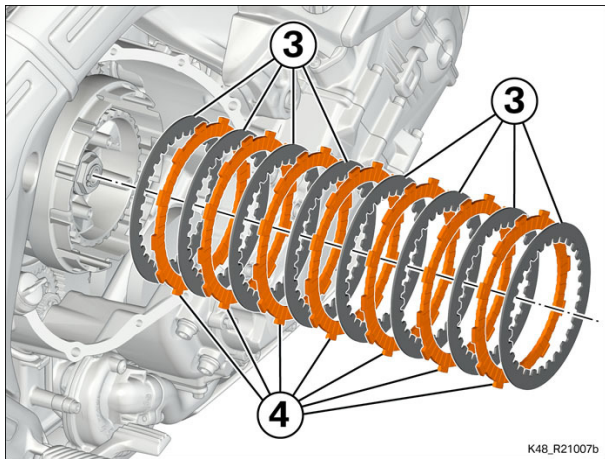
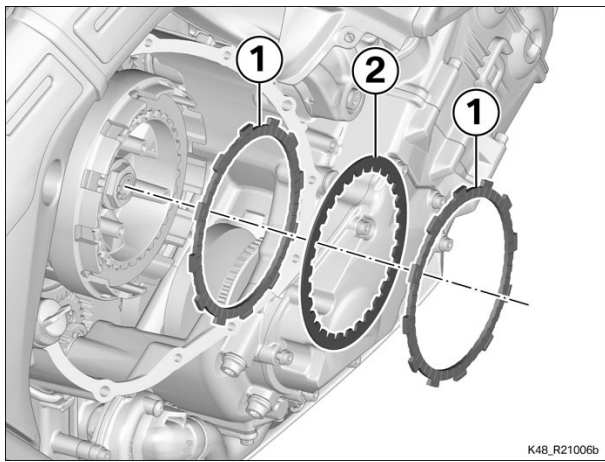

- Remove the following components:
 - Steel plates (3)
 - Friction plates (4)

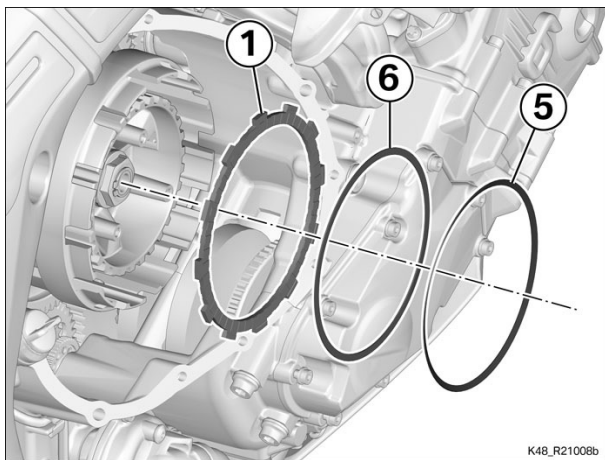

- Remove the following components:
 - Release spring (5)
 - Plate for release spring (6) with
 - Friction plate (1) with **large inside diameter**



► **Removing driver**

- Remove circlip (1) with suitable pliers.

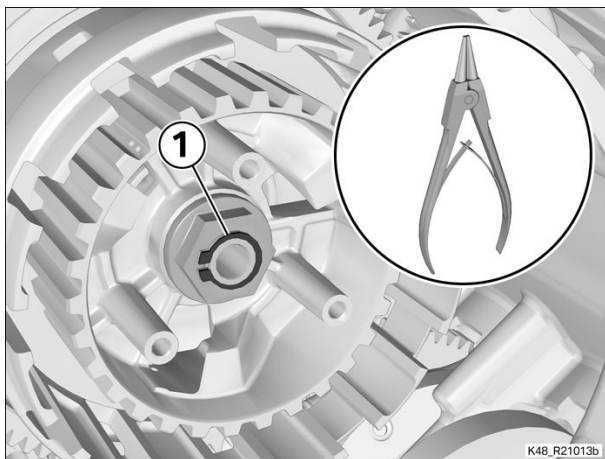

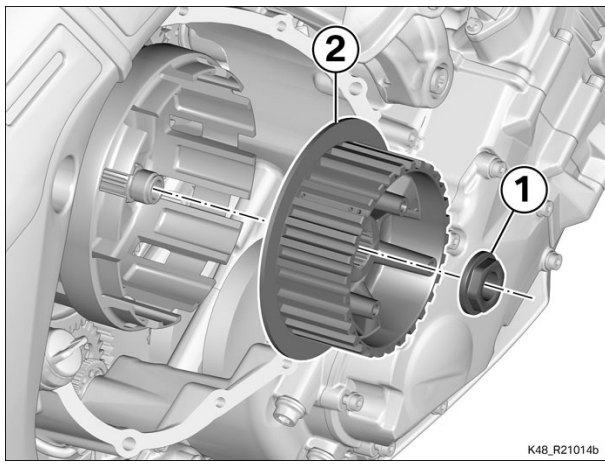

- Engage 6th gear on the motorcycle and apply the rear brake.
- Remove nut (1).
- Remove driver (2).

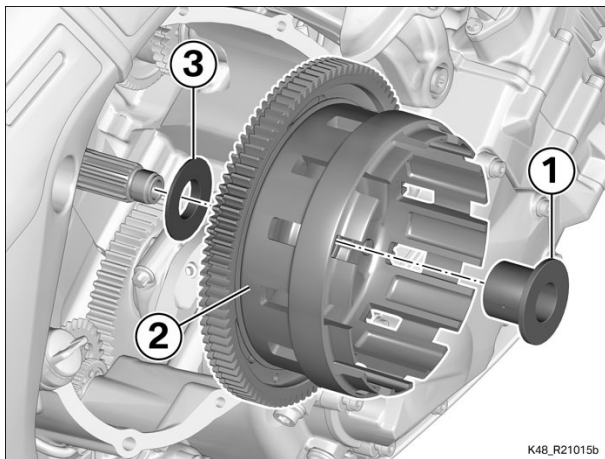

- Remove bearing bushing (1) and clutch cage (2)
- Remove thrust washer (3).

(-) Installing clutch

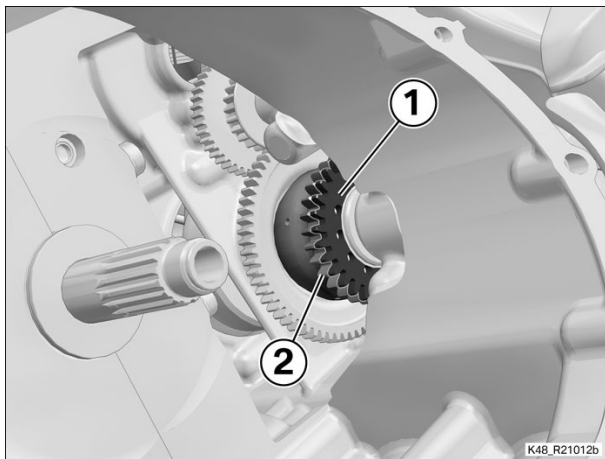

- Bring tensioning gear of countershaft (1) and gearwheel of countershaft (2) into alignment with each other.

- Install thrust washer (3).
- Position clutch cage (2) with bearing bushing (1) on gearbox shaft (4).

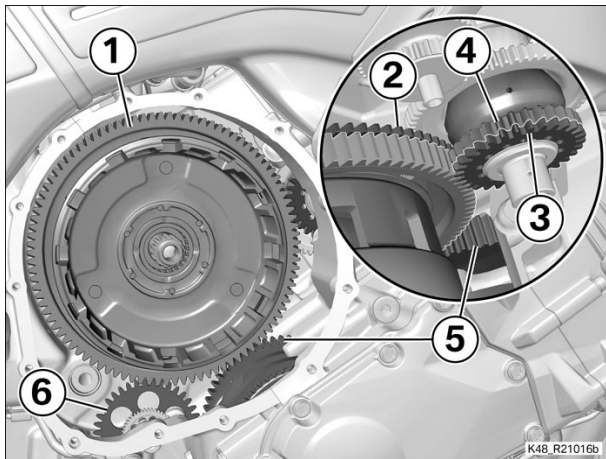
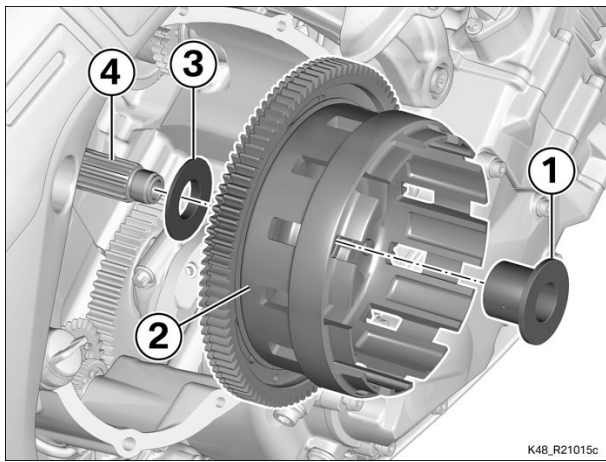

- Push clutch cage (1) onto the gearbox shaft until tensoning gear (2) engages the following gearwheels:
 - Tensoning gear of countershaft (3)
 - Gearwheel of countershaft (4)
 - Crankshaft gear (5)
 - Drive gear for oil pump (6)

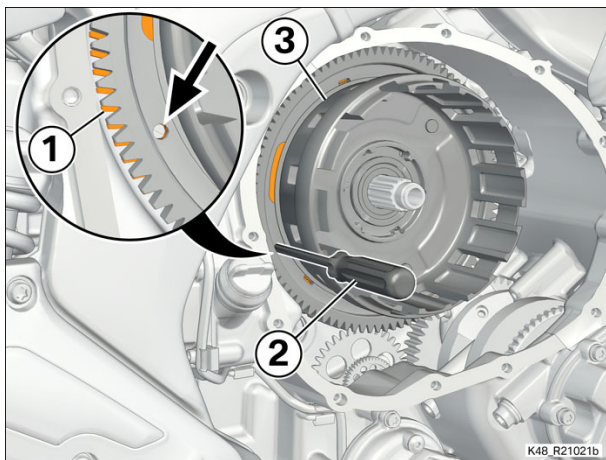

- Turn tensoning gear (1) by using the bore (arrow) to insert a suitable tool (2) and push in complete clutch cage (3).

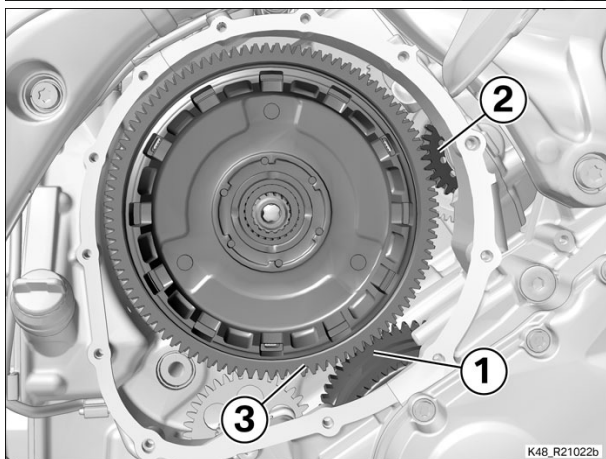

- Check that the gearwheels of crankshaft (1) and tensoning gear of countershaft (2) are **flush** with the gearwheel of clutch cage (3).

► **Installing driver**

- Install driver (2).

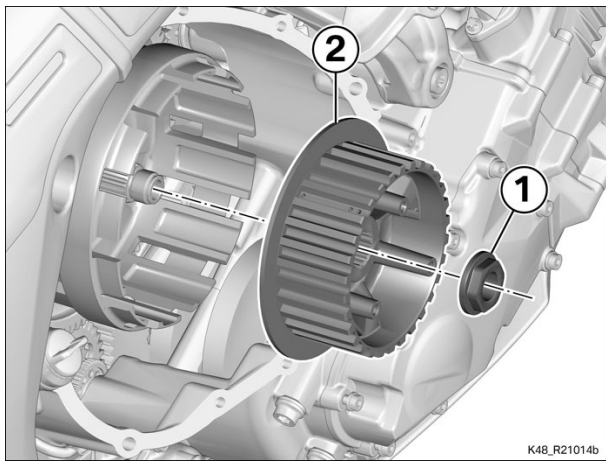

- Engage 6th gear on the motorcycle and apply the rear brake.
- Install nut (1).

 Tightening torques		
Clutch to gearbox input shaft		
M20 x 1.5	160 Nm	

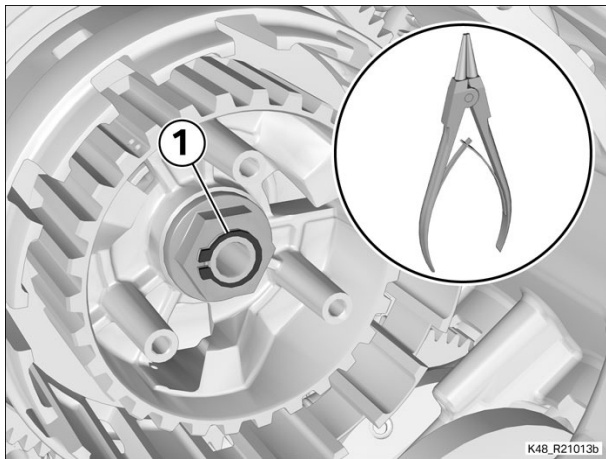

- Install circlip (1) with suitable pliers.



► **Installing plate cluster**



Attention

Clutch plates can burn if installed dry.
Immerse the new clutch-plate stack in clean engine oil before installing.

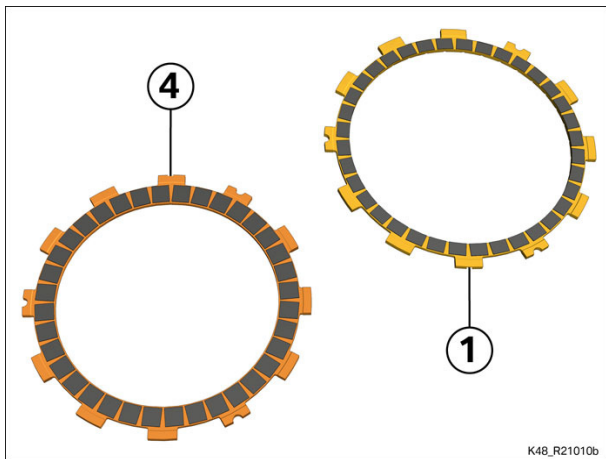

- The plate cluster is made up of different friction plates installed in a certain sequence:
 - Friction plates (1) with large inside diameter
 - Friction plates (4)

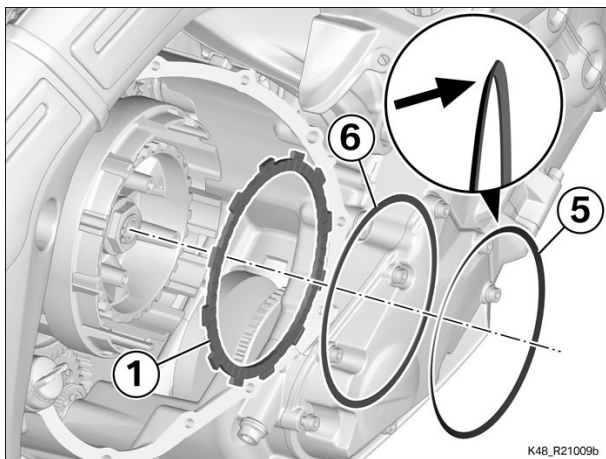

- Install the following components:
 - Friction plate (1) with **large inside diameter**
 - Plate for release spring (6)
 - Release spring (5) with the curvature (arrow) toward the inside

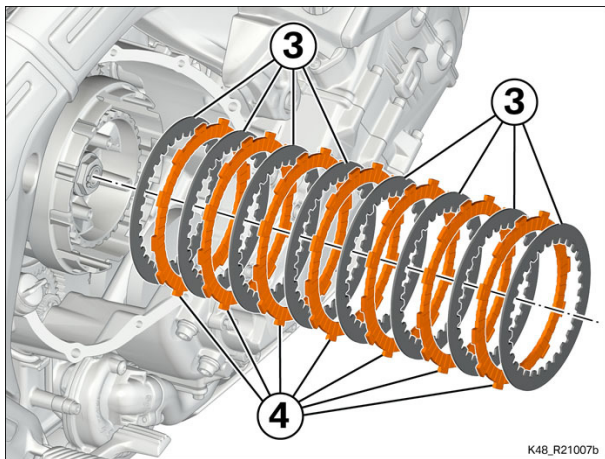

- Install the following components in alternate sequence:
 - Steel plates (3)
 - Friction plates (4)

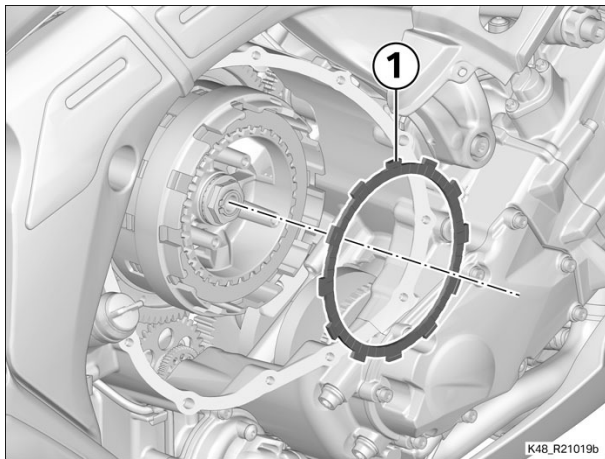

- Install friction plate (1) with **large inside diameter**.



► **Installing pressure plate**

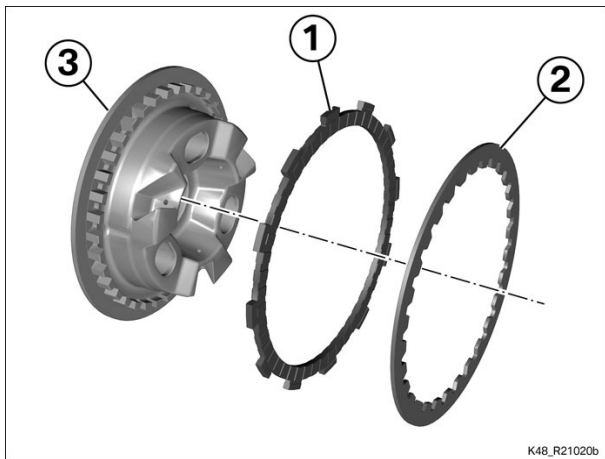

- Install friction plate (1) with **large inside diameter** and steel plate (2) with **large inside diameter** on pressure plate (3).

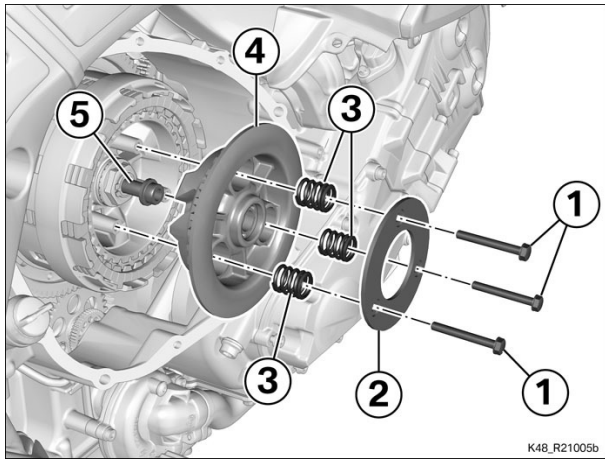

- Install the following components:
 - Thrust piece (5)
 - Pressure plate (4) complete
 - Springs (3)
 - Spring retainers (2)
- Lightly lubricate screws (1) and engage the threads.
- Install screws and tighten to specified torque in diagonally opposite sequence.

 Tightening torques	
Pressure plate to clutch hub	

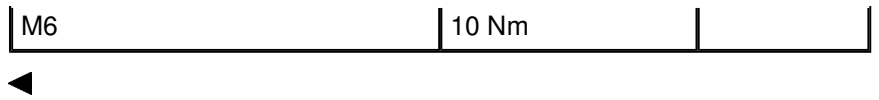

Finishing work

Installing right crankcase cover

Installing right drop-protection pad

Securing right stowage compartment

Install the right side panel

Install the right radiator cowl

Installing right bottom side panel

Final check of work performed

21 21 140 Removing and installing or replacing lined plates 9 FRUs

+ 21 21 609

Equipment trim-level variant:

0266 - Preparation for audio system and navigation device

0267 - ECE audio system and preparation for navigation system

Preparatory work

Removing right bottom side panel

Removing right radiator cowl

Remove the right side panel

Disengaging right stowage compartment

Removing right drop-protection pad

Removing right crankcase cover

Core activity

(-) Removing pressure plate

• Remove the following components:

- Screws (1)
- Spring retainers (2)
- Springs (3)
- Pressure plate (4)
- Thrust piece (5)

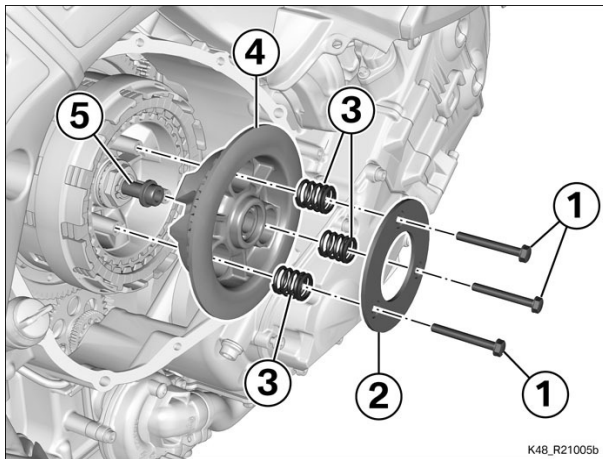

(-) Removing plate cluster

• Remove the following components:

- Friction plate (1) with **large inside diameter**
- Steel plate (2) with **large inside diameter**
- Friction plate (1) with **large inside diameter**

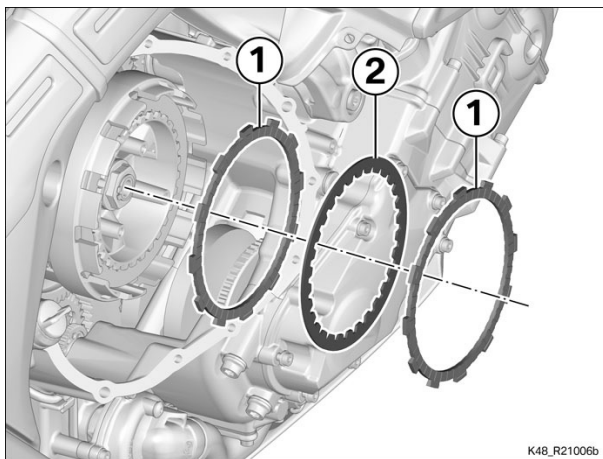

• Remove the following components:

- Steel plates (3)
- Friction plates (4)

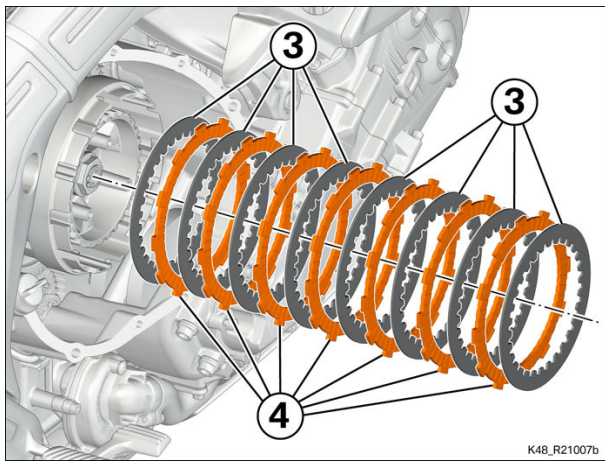

K48_R21007b

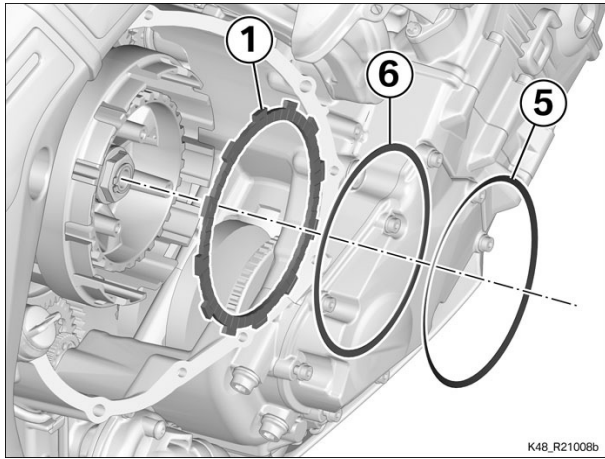

K48_R21008b

- Remove the following components:
 - Release spring (5)
 - Plate for release spring (6) with
 - Friction plate (1) with **large inside diameter**

(-) Installing plate cluster



Attention

Clutch plates can burn if installed dry.
Immerse the new clutch-plate stack in clean engine oil before installing.

- The plate cluster is made up of different friction plates installed in a certain sequence:
 - Friction plates (1) with large inside diameter
 - Friction plates (4)

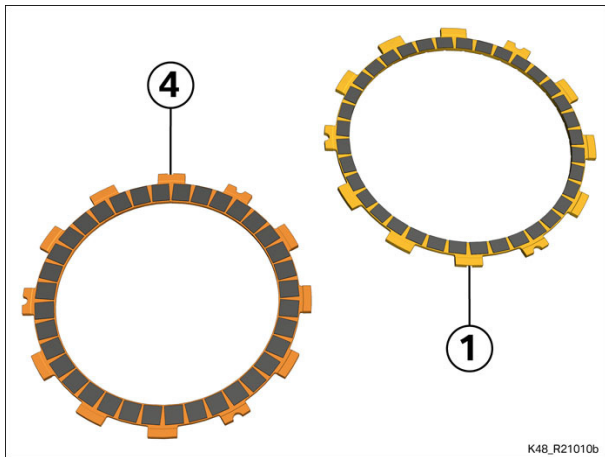

K48_R21010b

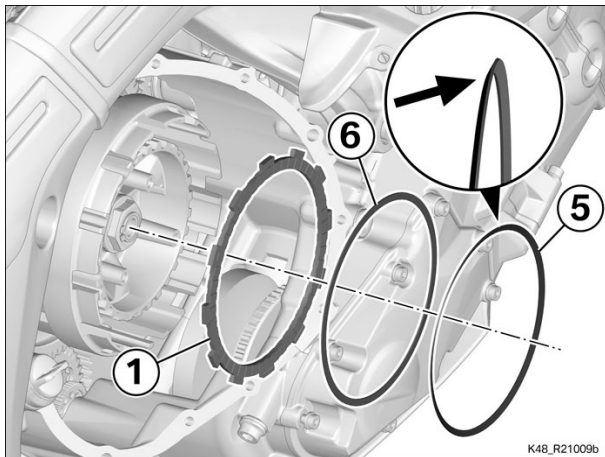

K48_R21009b

- Install the following components:
 - Friction plate (1) with **large inside diameter**
 - Plate for release spring (6)
 - Release spring (5) with the curvature (arrow) toward the inside

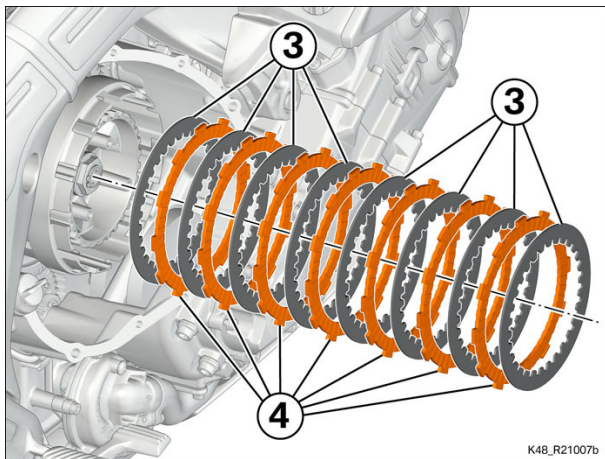

- Install the following components in alternate sequence:
- Steel plates (3)
 - Friction plates (4)

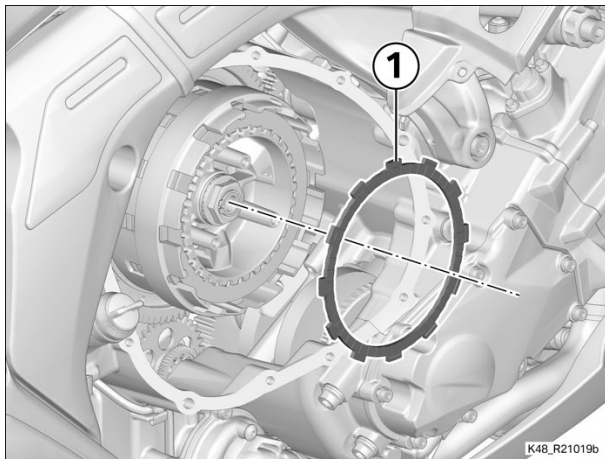

- Install friction plate (1) with **large inside diameter**.

(-) Installing pressure plate

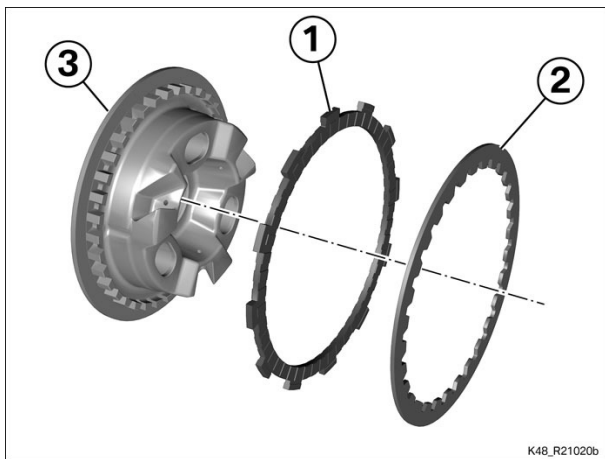

- Install friction plate (1) with **large inside diameter** and steel plate (2) with **large inside diameter** on pressure plate (3).

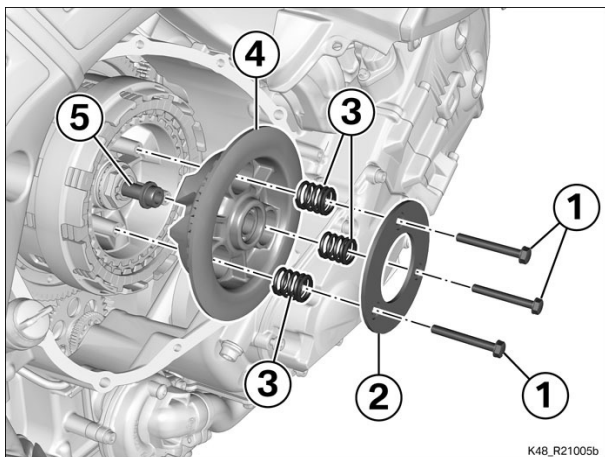

- Install the following components:
 - Thrust piece (5)
 - Pressure plate (4) complete
 - Springs (3)
 - Spring retainers (2)
- Lightly lubricate screws (1) and engage the threads.
- Install screws and tighten to specified torque in diagonally opposite sequence.

 Tightening torques		
Pressure plate to clutch hub		
M6	10 Nm	

Finishing work

Installing right crankcase cover

Installing right drop-protection pad

Securing right stowage compartment

Install the right side panel

Install the right radiator cowl

Installing right bottom side panel

Final check of work performed

21 52 005 Bleeding hydraulic clutch system 3 FRUs

+ 21 52 506

Preparatory work

Removing gearbox cover

Disengaging shift lever

Core activity

(-) Draining clutch system

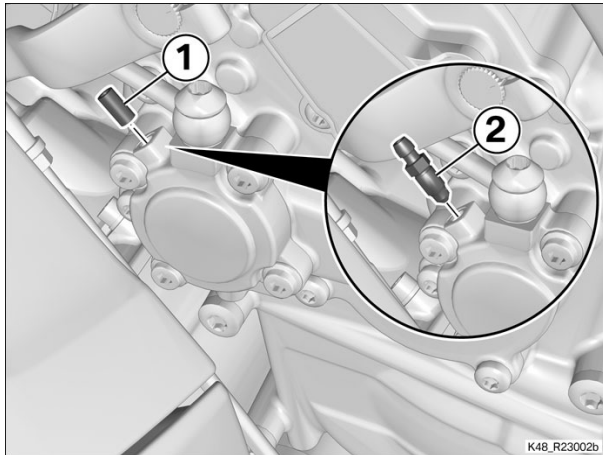

- Remove grub screw (1) and install bleed screw (2) and tighten until hand-tight.



Note

Order the bleed screw and dust cap through the electronic parts catalogue (ETK).

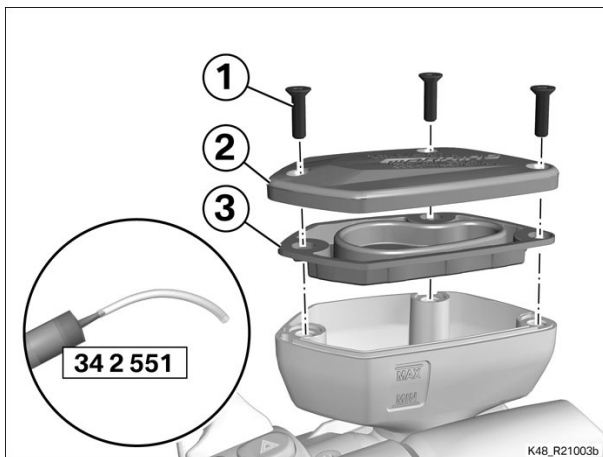

- Remove screws (1) and remove reservoir cap (2) and diaphragm (3).
- Clean reservoir, diaphragm (3) and cap (2).



Attention

Any mixture of oil, brake fluid and clutch fluid, even if the quantities involved are minute, can attack and damage seals.

Always use separate sets of syringes and hoses for the individual fluids, in order to avoid the risk of one fluid contaminating another.

- Use syringe (No. 34 2 551) to draw the clutch fluid out of the clutch-fluid reservoir.

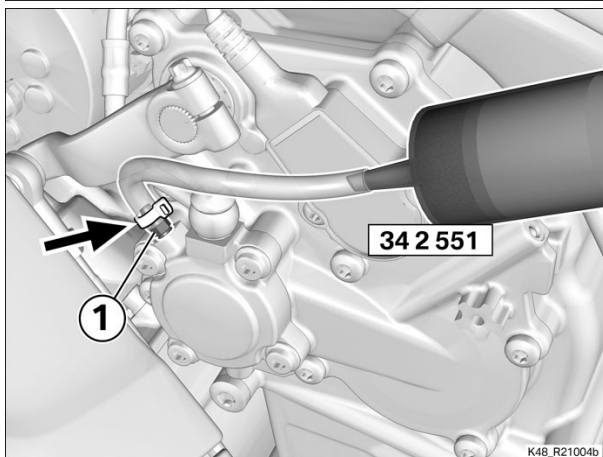

- Connect syringe (No. 34 2 551) to bleed screw (1) and secure it with a cable tie (arrow).
- Back off bleed screw (1).
- Use syringe (No. 34 2 551) to extract hydraulic fluid through bleed screw (1) until the line is empty.
- Slightly tighten bleed screw (1).
- Remove the cable tie (arrow) and disconnect syringe (No. 34 2 551) from bleed screw (1).

(-) Filling clutch system



Note

Order the bleed screw and dust cap through the electronic parts

catalogue (ETK).

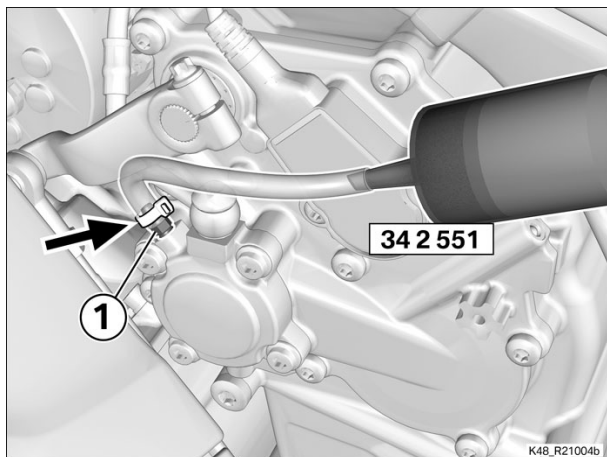



Attention

Any mixture of oil, brake fluid and clutch fluid, even if the quantities involved are minute, can attack and damage seals.

Always use separate sets of syringes and hoses for the individual fluids, in order to avoid the risk of one fluid contaminating another.



- Fill syringe (No. 34 2 551) to capacity with hydraulic fluid.
- Connect syringe (No. 34 2 551) to bleed screw (1) and secure it with a cable tie (arrow).
- Back off bleed screw (1).
- Use syringe (No. 34 2 551) to inject hydraulic fluid into the system through bleed screw (1) until the fluid level in the reservoir is correct.

 Technical data			
Clutch fluid level	with new clutch liner, motorcycle upright and handlebars centred	Max mark on reservoir	
			
Fluids and lubricants			
Vitamol V10			

- Tighten breather screw (1).

 Tightening torques		
Bleed screw/grubscrew to clutch slave cylinder		
M5	3 Nm	

- Disconnect syringe (No. 34 2 551) from bleed screw (1).
- Motorcycle upright, handlebars turned all the way to the right.
- Repeatedly pull the clutch lever until the pressure point is perceptible.
- Repeat the procedure with the handlebars turned all the way to the left.
- Correct the level in the clutch fluid reservoir by drawing off excess fluid or topping up with fresh hydraulic fluid, as necessary.

 Technical data			
Clutch fluid level	with new clutch liner, motorcycle upright and handlebars centred	Max mark on reservoir	
			
Fluids and lubricants			

Vitamol V10

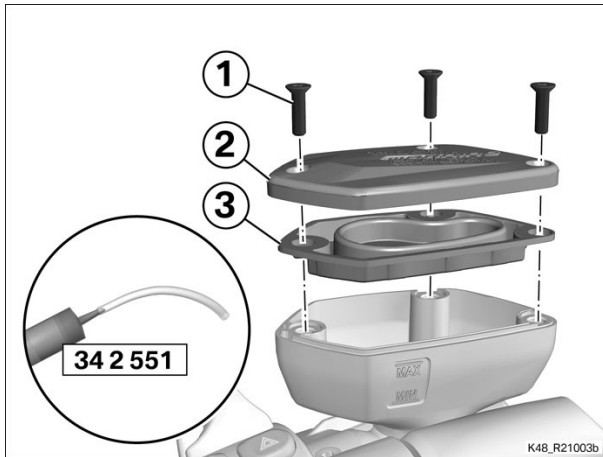

- Wipe the rim of the reservoir, diaphragm (3) and cap (2) to remove clutch fluid, carefully reassemble the components and install.
- Install screws (1).

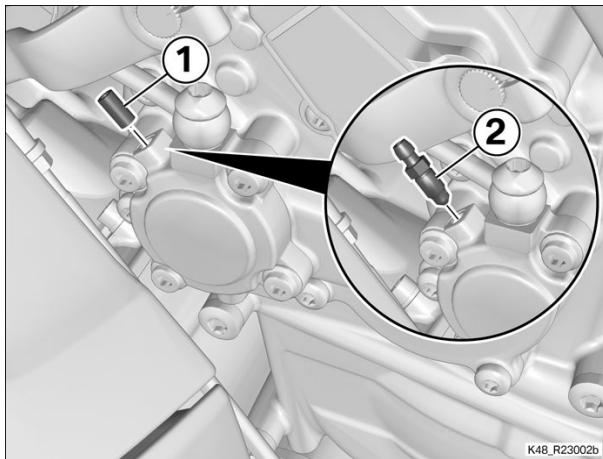

- Remove bleed screw (2) and install grubscrew (1).

Tightening torques		
Bleed screw/grubscrew to clutch slave cylinder		
M5	3 Nm	

Finishing work

- Securing selector lever
- Installing gearbox cover
- Final check of work performed

21 52 014 Replacing clutch line (without bleeding system)

+ 21 52 514

Preparatory work

- Remove the front seat
- Removing air guides for intake air pipes, left and right
- Removing complete cover of fuel tank
- Removing gearbox cover
- Removing left bottom side panel
- Removing left radiator cowl
- Removing left side panel
- Removing inner trim for left side panel
- Removing right bottom side panel
- Removing right radiator cowl
- Remove the right side panel
- Removing inner trim for right side panel
- Removing adjusting plate
- Disengaging seat support
- Disengaging left and right intake air pipes
- Removing complete intake air silencer
- Removing fuel tank
- Draining clutch system
- Disengaging shift lever

Core activity

(-) Removing clutch line

- Open rubber retaining band (1).
- Remove banjo bolt (2) with sealing rings (3).
- Disengage clutch line (4) from handlebar fitting (5).

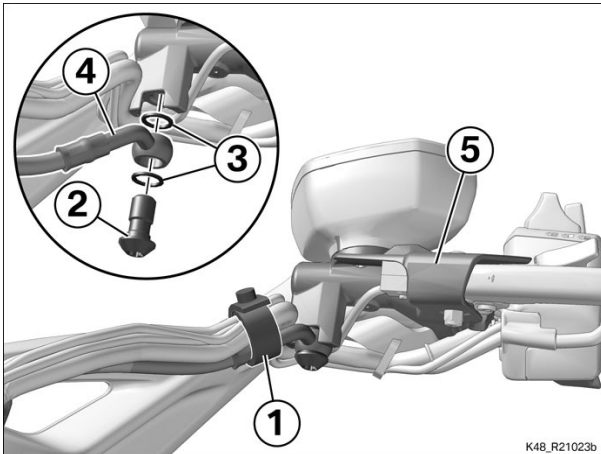

- Open rubber retaining bands (1).
- Remove screw (2) and remove clip (3).
- Unclip clutch line (4) from holder (5).

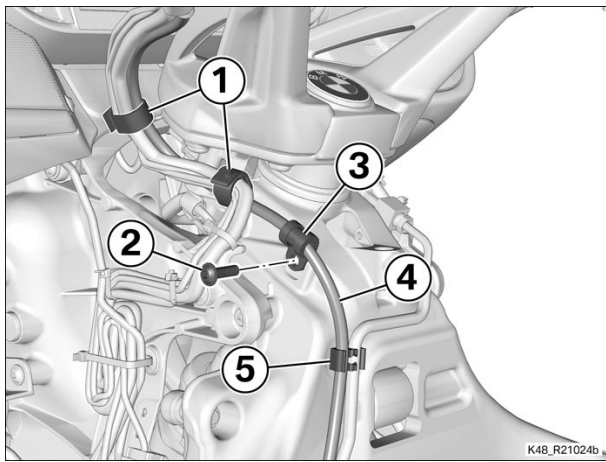

K48_R21024b

- Unclip clutch line (1) at **GT** marking rings (arrows) from holder (2).
- Unclip clutch line (1) from holders (3) and (4).

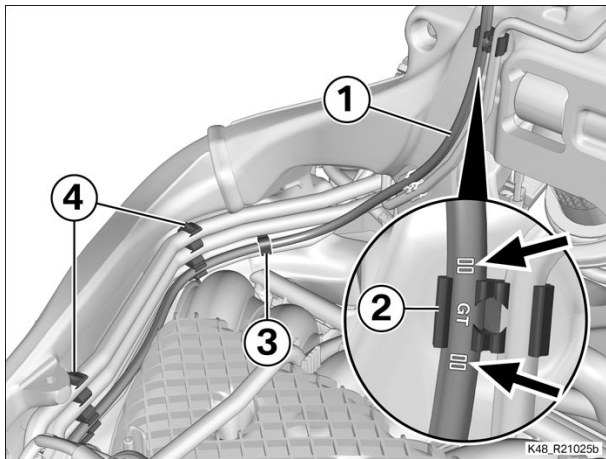

K48_R21025b

- Remove banjo bolt (1) with sealing rings (2).
- Disengage clutch line (3) from slave cylinder (4) and remove.

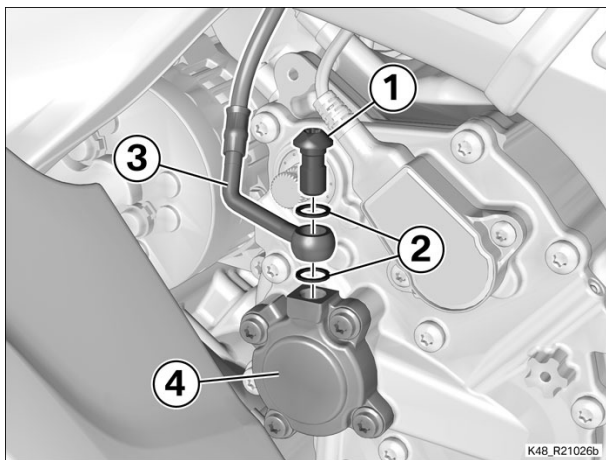

K48_R21026b

(-) Installing clutch line

- Route clutch line (3), position it correctly and hold it in position at slave cylinder (4).
- Install banjo bolt (1) with **new** sealing rings (2).

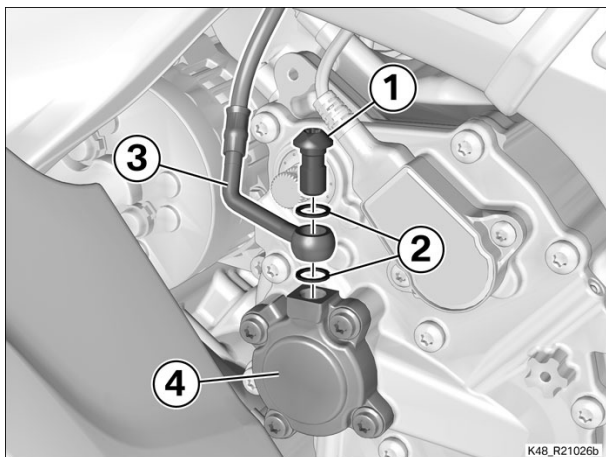

K48_R21026b

 Tightening torques		
Clutch line to clutch slave cylinder		
Banjo bolt, M10 x 1	18 Nm	

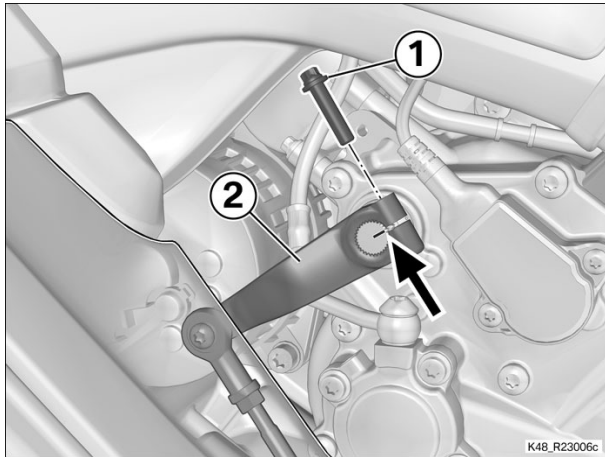

► **Securing selector lever**

- Align shift lever (2) with the mark on the selector shaft (arrow) and slip it into position.
- Install screw (1).

 Tightening torques		
Shift lever to gearbox selector shaft		
M6 x 25	8 Nm	

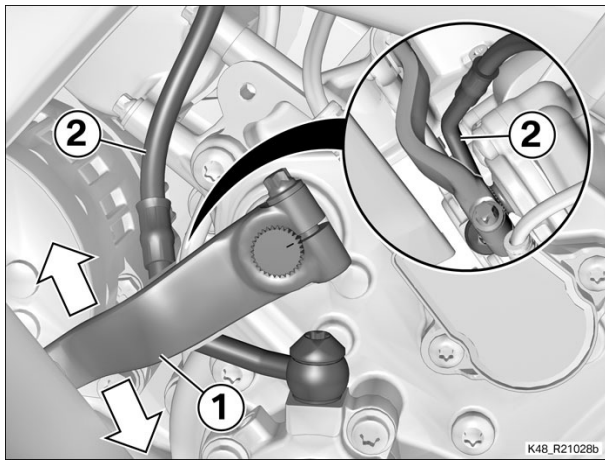

- Click shift lever (1) up and down, making sure that there is adequate clearance between shift lever (1) and clutch line (2).
- » If the clearance between clutch line and shift lever is **not adequate**, reposition the clutch line.

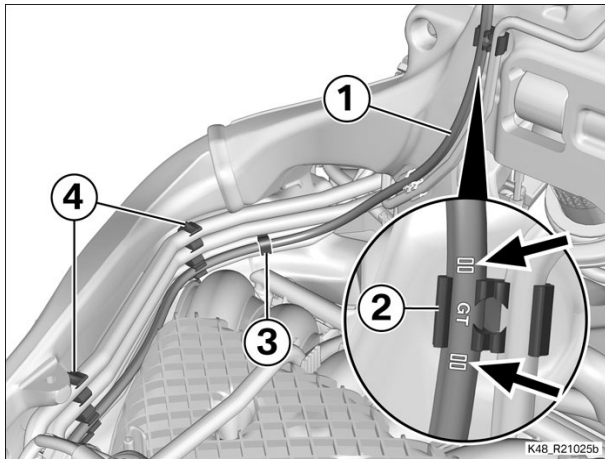

- Clip clutch line (1) centred at printed **GT** marking rings (arrows) into holder (2).
- Clip clutch line (1) into holders (3) and (4).

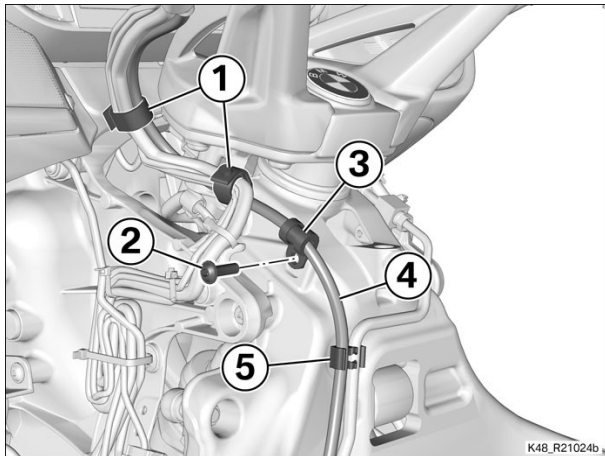

- Clip clutch line (4) into holder (5).
- Hold clip (3) in position and install screw (2), turning clip (3) counter-clockwise and counter-holding.

 Tightening torques		
Clamp with clutch line to frame steering head		
M6 x 15	8 Nm	

- Close rubber retaining bands (1).

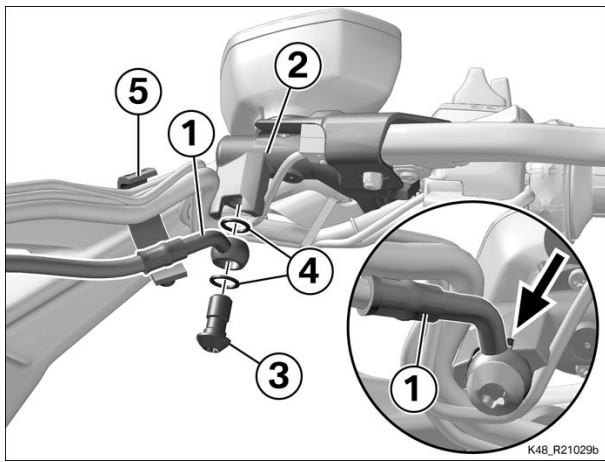

- Hold clutch line (1) in position at handlebar fitting (2).
- Install banjo bolt (3) with **new** sealing rings (4), but **do not tighten at this point**.
- Position clutch line (1) at the stop (arrow) and tighten banjo bolt (1).

Tightening torques	
Clutch line to clutch lever fitting	
Banjo bolt, M10 x 1	18 Nm

- Close rubber retaining band (5).

Finishing work

Securing selector lever

=> Bleeding hydraulic clutch system (Description in item: 21 52 506, Billed as a separate item)

Installing fuel tank

Installing complete intake air silencer

Securing left and right intake air pipes

Securing seat support

Installing adjusting plate

Installing inner trim for right side panel

Install the right side panel

Install the right radiator cowl

Installing right bottom side panel

Installing inner trim for left side panel

Install the left side panel

Installing left radiator cowl

Installing left bottom side panel

Installing gearbox cover

Installing complete cover of fuel tank

Installing air guides for intake air pipes, left and right

Installing front seat

Final check of work performed

 **23 00 020 Removing/installing gearbox 22 FRUs**

+ **23 00 659**

Equipment trim-level variant:

0266 - Preparation for audio system and navigation device

0267 - ECE audio system and preparation for navigation system

Preparatory work

- Removing gearbox cover
- Removing left bottom side panel
- Removing left radiator cowl
- Removing left side panel
- Removing left stowage compartment
- Removing right bottom side panel
- Removing right radiator cowl
- Remove the right side panel
- Disengaging right stowage compartment
- Removing right drop-protection pad
- Removing right crankcase cover
- Removing clutch
- Disengaging shift lever
- Removing left footrest plate
- Disengaging gearbox potentiometer
- Removing clutch slave cylinder
- Removing pushrod
- Disengaging mounted parts from gearbox
- Removing number-plate carrier
- Remove the rear wheel
- Removing rear brake caliper
- Releasing **Paralever** link at rear
- Lowering bevel gears
- Removing flexible gaiter for bevel bears
- Removing universal shaft

Core activity

(-) Removing gearbox



Attention

Components can be damaged by hard or sharp-edged objects.
Avoid scratching the components; use masking tape if necessary.

- Remove screws (1) and (2).

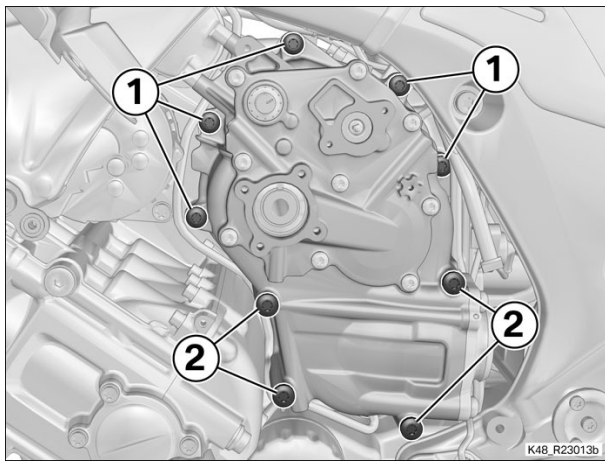

- Remove complete gearbox (1).

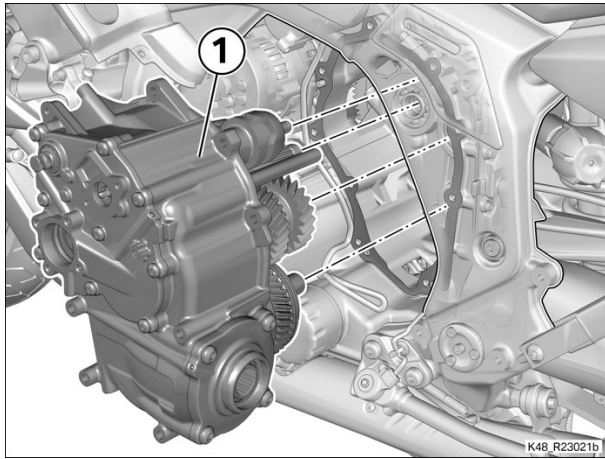

- Remove housing gasket (1).

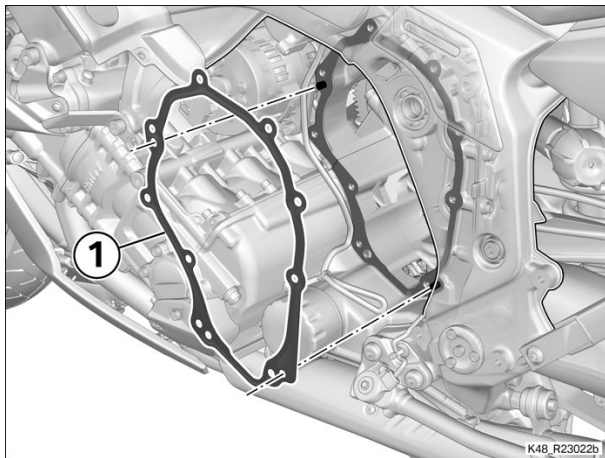

(-) Installing gearbox

- Clean sealing faces (1) on engine block and gearbox.
- Make sure that reamed pins (2) are correctly installed.
- Place housing gasket (3) in position.

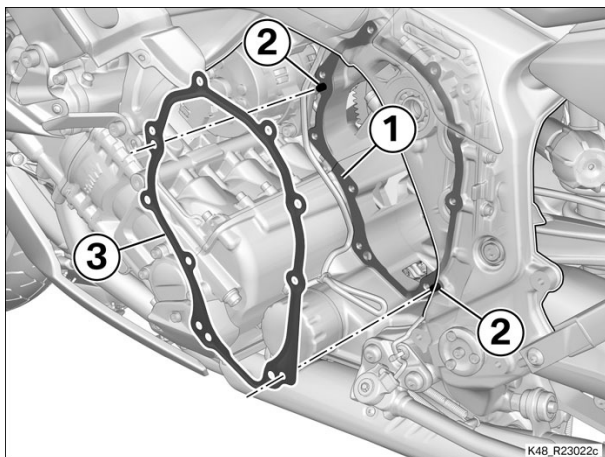

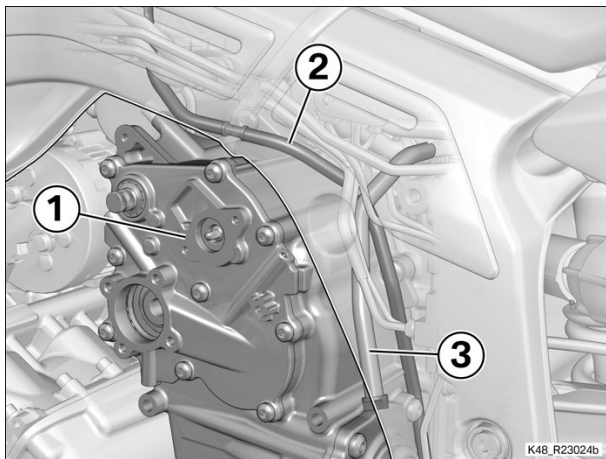

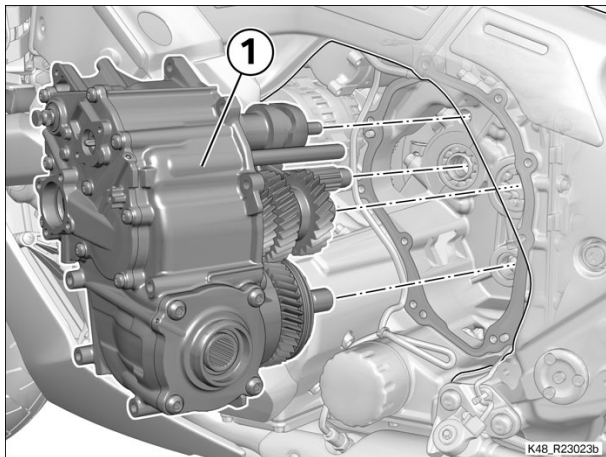

When installing gearbox (1), note breather hose (2) and drain hose (3) and route them correctly.

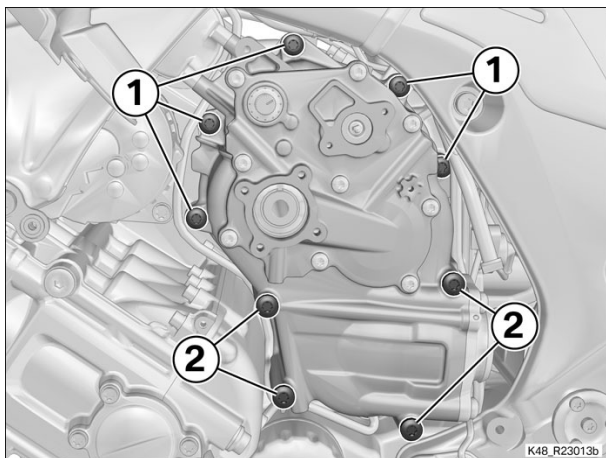

- Install complete gearbox (1).
- Make sure that all gearbox components can be slipped easily into the corresponding bearing seats in the engine block.



- Install screws (1) and (2).

 Tightening torques		
Gearbox to crankcase		
M8 x 30	19 Nm	
M8 x 125	19 Nm	

Finishing work

- Installing universal shaft
- Swinging bevel gears up
- Securing **Paralever** link at rear
- Securing rear brake caliper
- Installing rear wheel
- Installing number-plate carrier
- Securing mounted parts to gearbox
- Installing pushrod
- Securing clutch slave cylinder
- Securing gearbox potentiometer
- Installing left footrest plate

Securing selector lever
Installing clutch
Installing right crankcase cover
Installing right drop-protection pad
Securing right stowage compartment
Install the right side panel
Install the right radiator cowl
Installing right bottom side panel
Installing left stowage compartment
Install the left side panel
Installing left radiator cowl
Installing left bottom side panel
Installing gearbox cover
Final check of work performed

📁 23 14 051 Replacing potentiometer for gear indicator 6 FRUs

+ 23 14 507

Preparatory work

- Remove the front seat
- Removing air guide for intake air pipe, left
- Removing left fuel-tank cover top section
- Removing left cover of fuel tank
- Removing gearbox cover

Core activity

(-) Removing gearbox potentiometer

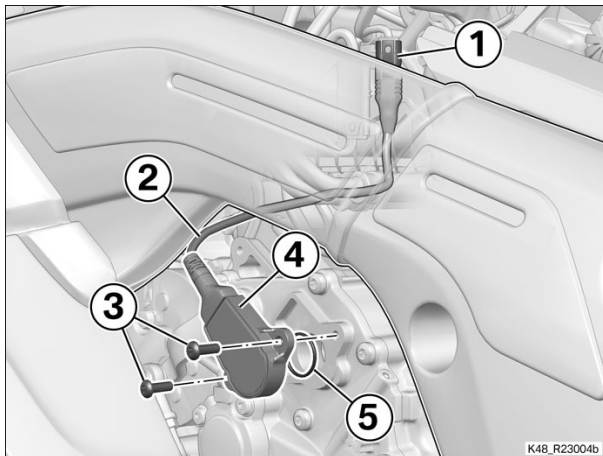

- Disconnect plug (1) for the gearbox potentiometer and work cable (2) clear of the motorcycle.
- Remove screws (3).
- Remove gearbox potentiometer (4) and O-ring (5).

(-) Installing gearbox potentiometer

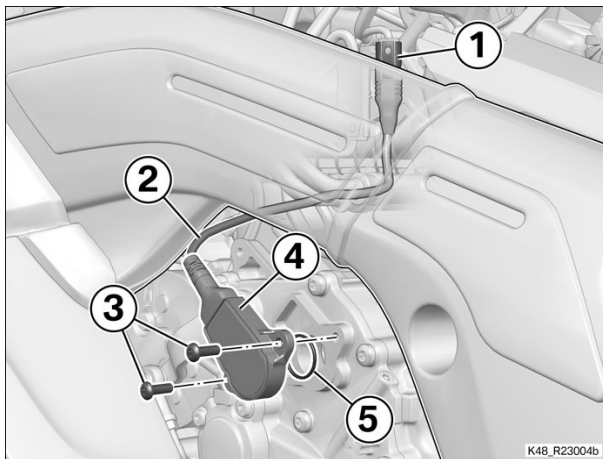

- Check O-ring (5) for damage; replace if necessary.
- Install gearbox potentiometer (4) with O-ring (5), noting O-ring (5).
- Install screws (3).

🔧 Tightening torques		
Gearbox potentiometer to selector-drum carrier		
M5 x 14	5 Nm	

- Route cable (2) in the motorcycle and connect plug (1) for the gearbox potentiometer.

Finishing work

- Installing gearbox cover
- Installing left cover of fuel tank
- Installing left fuel-tank cover top section
- Installing air guide for intake air pipe, left

=> Resetting/learning adaptation values (with replacing component) (Description in item: 61 00 503, Billed as a separate item)

- Installing front seat
- Final check of work performed

23 41 300 Removing/installing or replacing gearshift lever 3 FRUs

+ 23 41 551

Core activity

(-) Removing gearshift lever

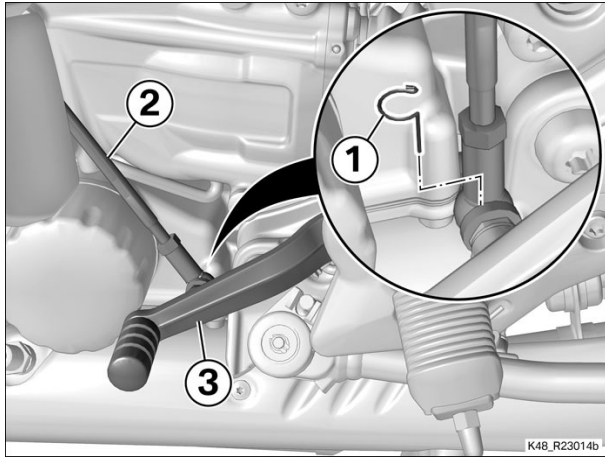

- Remove retaining clip (1).
- Disengage selector rod (2) from shift lever (3) and remove.

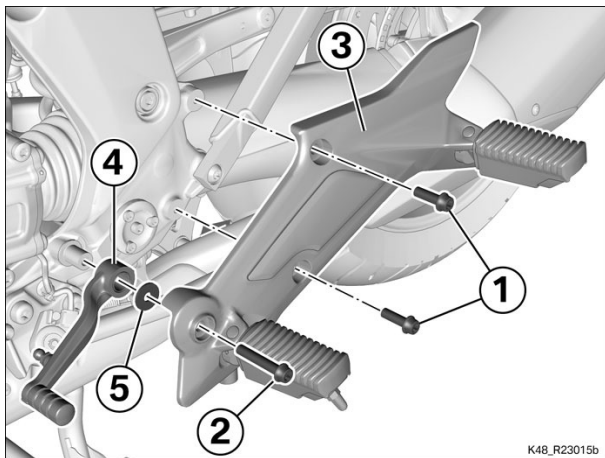

- Slacken screws (1) and remove screw (2).
- Lift footrest plate (3).
- Remove gearshift lever (4) with washer (5).

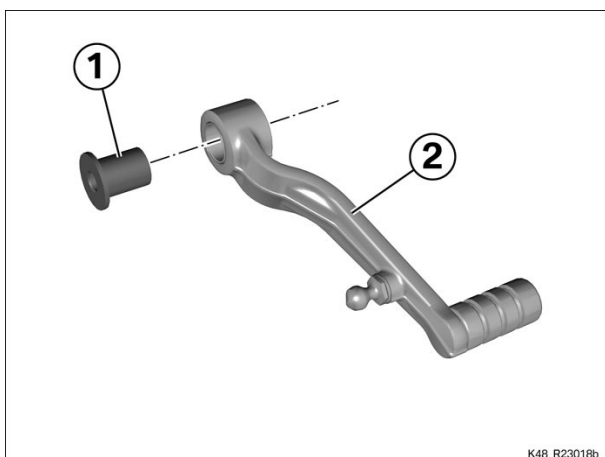

(-) Replacing gearshift lever

- Remove shouldered bushing (1) from shift lever (2) and check for damage; replace if necessary.
- Lubricate shouldered bushing (1) and install in new shift lever (2).

 Fluids and lubricants		
Staburags NBU 30 PTM	High-performance lubricating grease	07 55 9 056 992

(-) Installing gearshift lever

- Clean tapped hole for screw (2).
- Install shift lever (4) with washer (5), making sure that the components do not slip out of position.
- Hold footrest plate (3) in position.
-

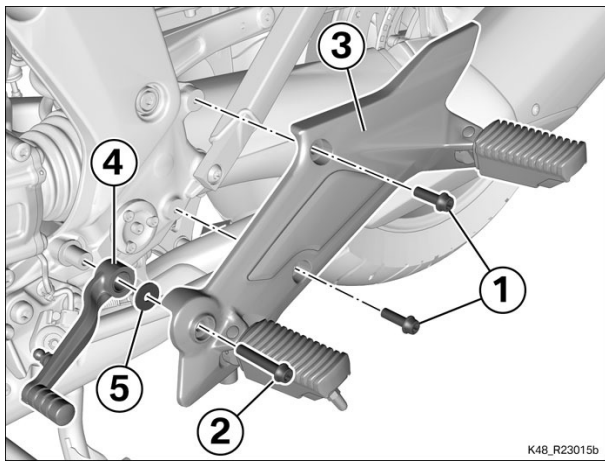

Make sure that gearshift lever (4) with washer (5) do not slip out of position.

- Install new screw (2) and screws (1).

 Tightening torques		
Footrest plate to frame		
M8 x 25	28 Nm	
M8 x 45, Replace screw Micro-encapsulated	28 Nm	

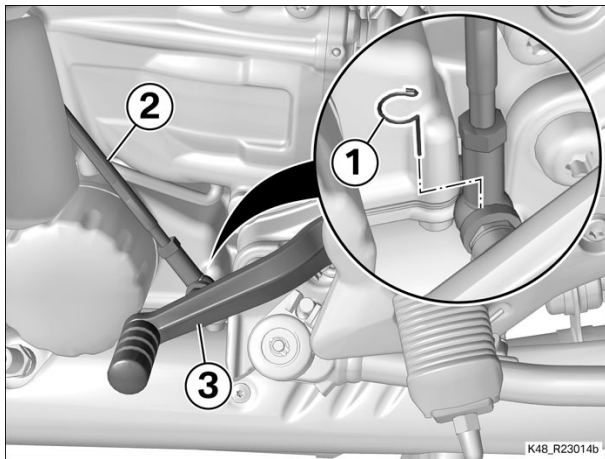

- Seat selector rod (2) on shift lever (3).
- Install retaining clip (1).

Finishing work

Final check of work performed

23 41 310 Adjusting gearshift lever 2 FRUs

+ 23 41 510

Preparatory work

Removing gearbox cover

Core activity

(-) Checking and, if necessary, adjusting position of gearshift lever

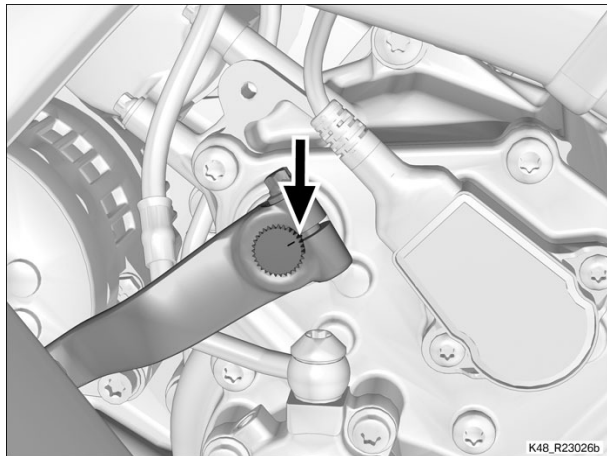

- Check the position of the shift lever on the selector shaft.
- Make sure that the mark (arrow) is aligned with the gap on the shift lever.
- Check the ease of movement of the components of the gearshift linkage; remove, clean and lubricate if necessary.

 Fluids and lubricants		
Staburags NBU 30 PTM	High-performance lubricating grease	07 55 9 056 992

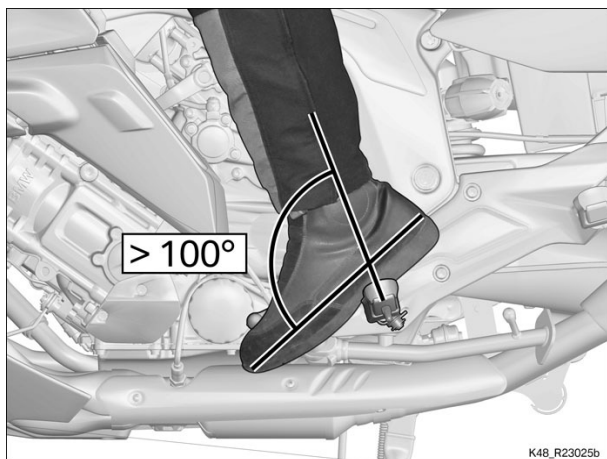

- Ensure that customer-specific settings for the seat, for example, are correct.
- Have the customer don suitable footwear and assume the usual riding position on the motorcycle.

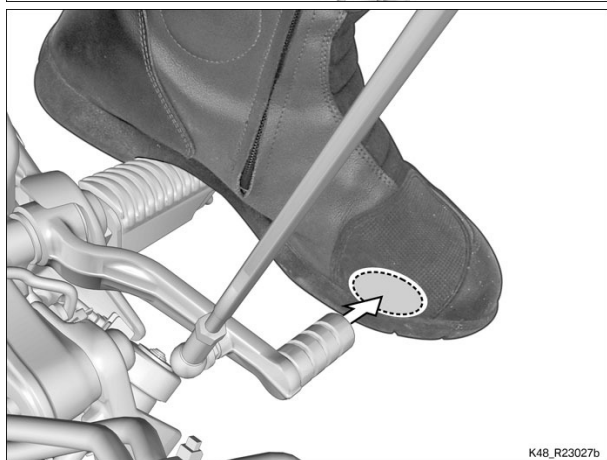

Test

Result: When not touched, the gearshift lever is not on a level with the

rider's toe joint.

Measure:

► **Installing gearshift lever**

- Slacken nuts (1) and (2).
- Correct position of shift lever (3) by turning selector rod (4).

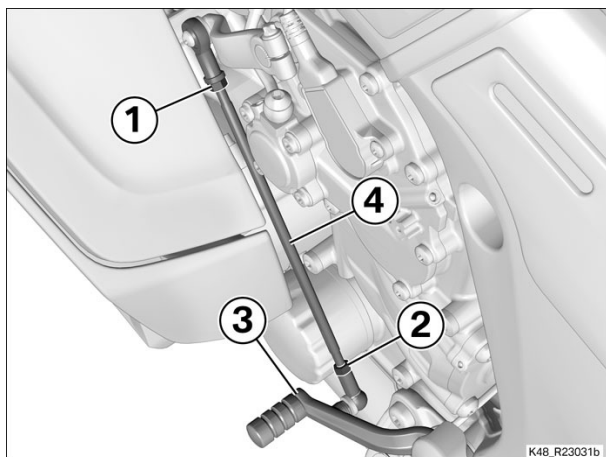

 Technical data			
Selector-rod rod-end setting	Screw-in depth in ball socket and rod end	screwed in at least 3 full threads	

- Tighten nuts (1) and (2).

 Tightening torques		
Ball end/rod end to selector rod		
Ball end, Left-hand thread, M6	8 Nm	
Rod end, M6	8 Nm	

- Check the clearance between the shift lever and the side stand; correct the setting if necessary.
- Have the customer take the motorcycle for a test ride to check the setting; readjust if necessary.



Note

A poorly adjusted shift lever has a negative effect on the shiftability of the gearbox.

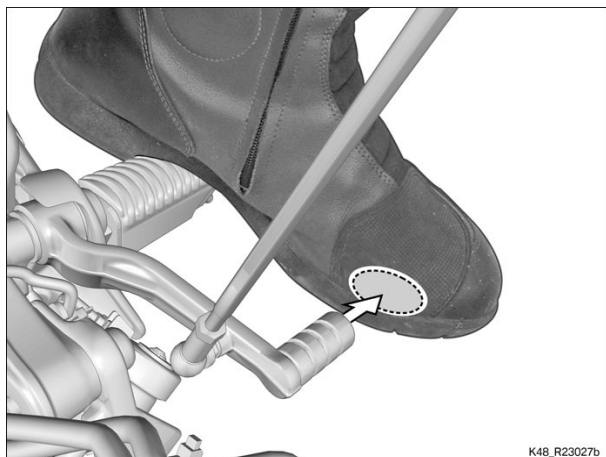

- Have the customer take the motorcycle for a test ride to check the setting; readjust if necessary.

Finishing work

Installing gearbox cover

Final check of work performed

23 41 325 Replacing selector rod on pedals 3 FRUs

+ 23 41 555

Preparatory work

Removing gearbox cover

Disengaging shift lever

Core activity

(-) Removing selector rod

- Remove screw (1) and remove shift lever (2) with washer (3).

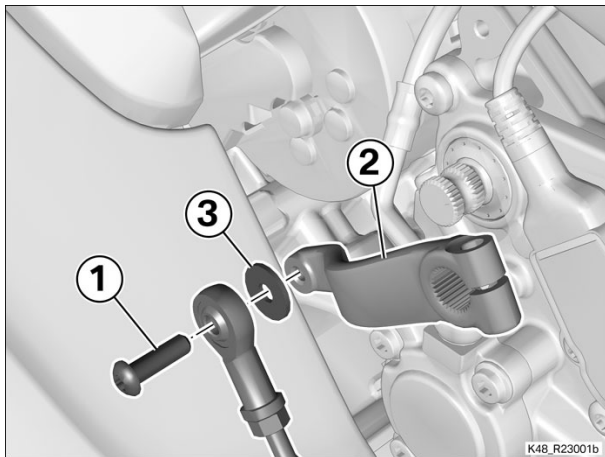

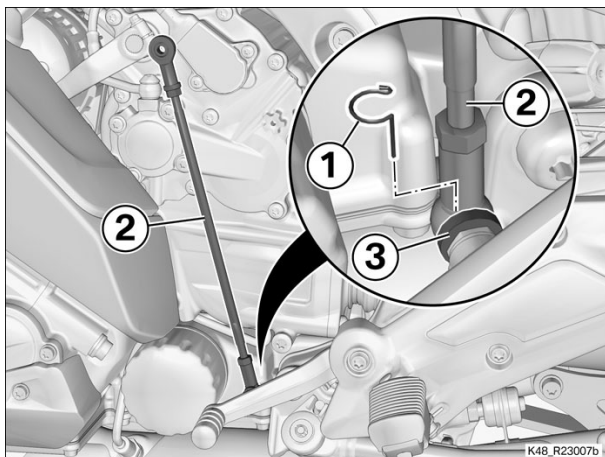

- Remove retaining clip (1).
- Disengage selector rod (2) from shift lever (3) and remove.

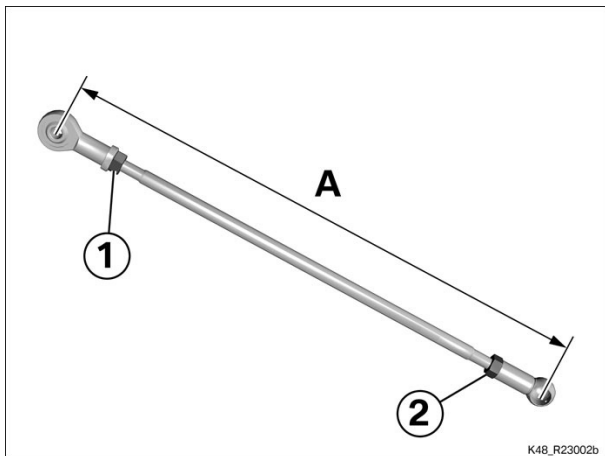

(-) Adjusting selector rod length

- Slacken nuts (1) and (2).
- Adjust length (A).



 Technical data			
Basic setting of selector rod		273.9 ^{+0.5} / _{-0.5} mm	

- Tighten nuts (1) and (2).

 Tightening torques			
Ball end/rod end to selector rod			
Ball end, Left-hand thread, M6		8 Nm	
Rod end, M6		8 Nm	

(-) Installing selector rod

- Install selector rod (2) and engage it on shift lever (3).
- Install retaining clip (1).

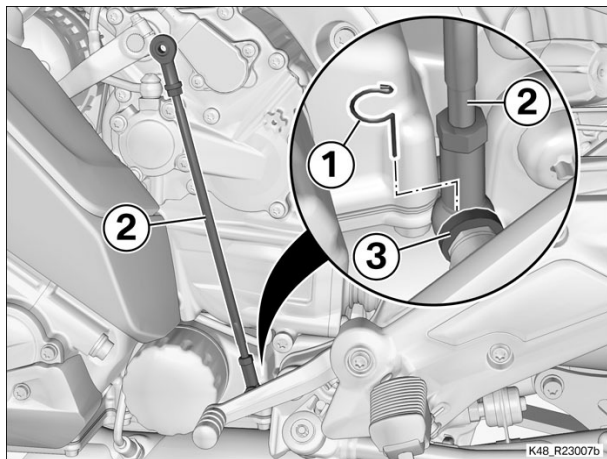

- Hold shift lever (2) with washer (3) in position and install screw (1).

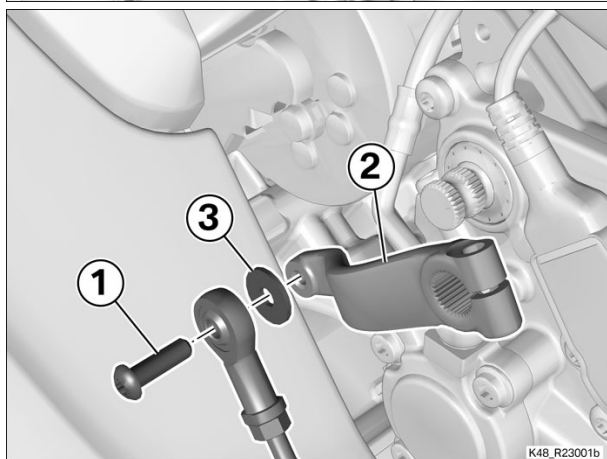

 Tightening torques		
Selector rod to shift lever		
M8 x 30	19 Nm	

Finishing work

- Securing selector lever
- Installing gearbox cover
- Final check of work performed

📁 31 48 001 Replacing front spring strut 20 FRUs

+ 31 48 512

Equipment trim-level variant:

0416 - Electronic Suspension Adjustment (ESA)

Additional line items for billing

31 48 510 Additional work for replacing front spring strut (with ESA), 1 FRUs

Preparatory work

- Remove the front seat
- Removing air guides for intake air pipes, left and right
- Removing complete cover of fuel tank
- Removing left bottom side panel
- Removing left radiator cowl
- Removing left side panel
- Removing inner trim for left side panel
- Removing right bottom side panel
- Removing right radiator cowl
- Remove the right side panel
- Removing inner trim for right side panel
- Removing adjusting plate
- Disengaging seat support
- Disengaging left and right intake air pipes
- Removing complete intake air silencer
- Removing fuel tank
- Removing air guide for oil cooler
- Disengaging front brake hose
- Releasing pressure modulator

Core activity

(-) Releasing spring strut at bottom

- Remove screw (1) for spring strut (2).

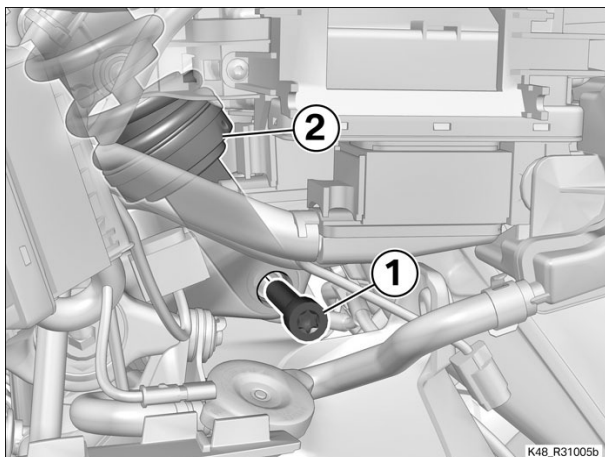

(-) Raising front suspension

Precondition

- Motorcycle is secured so that it cannot drop or topple.



- Remove nut (1).

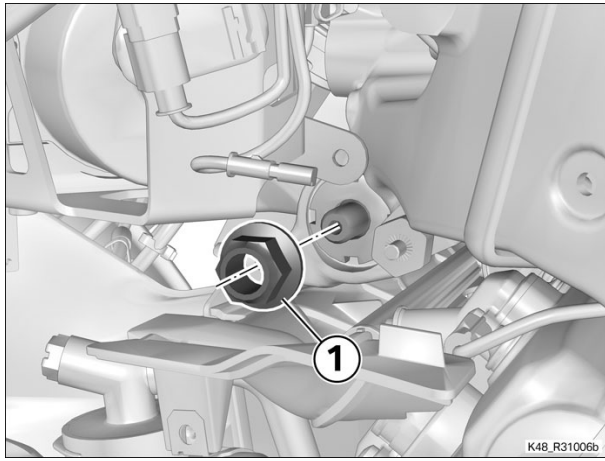

- Release collared nut (1) and remove quick-release axle (2).

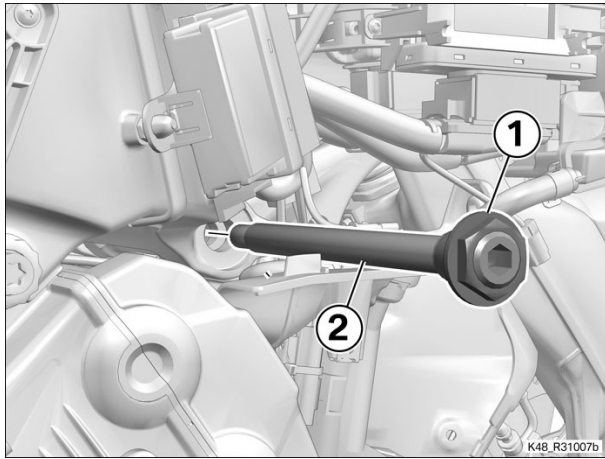

- Lift front suspension (1) on scissor-type lifter (No. 00 1 571), noting oil cooler (2).
- Carefully lower leading link (3).

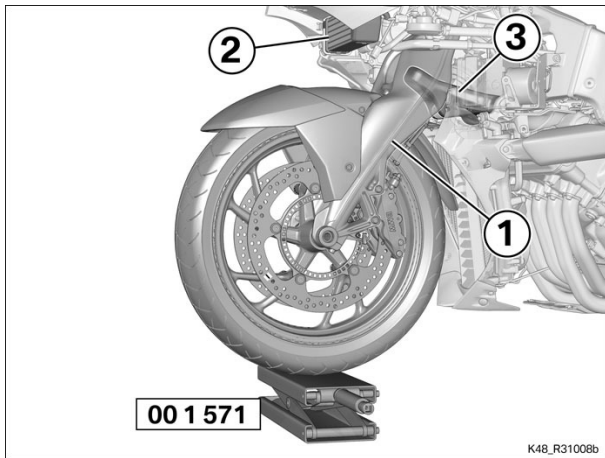

(-) Removing spring strut

- Remove the cable ties (arrows).
- Remove and disconnect plug (1) for the **ESA** spring strut.
- Work cable (2) clear of the motorcycle.

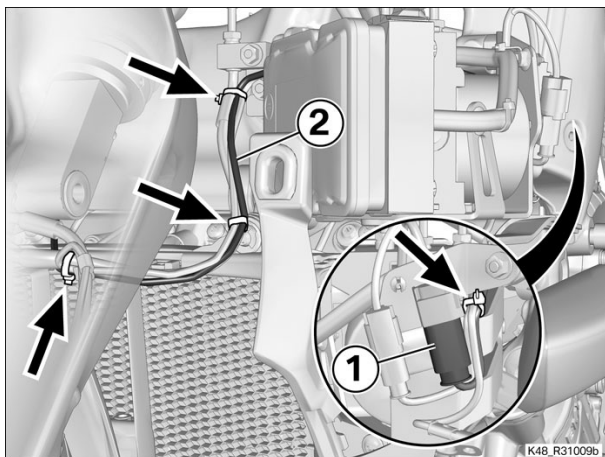

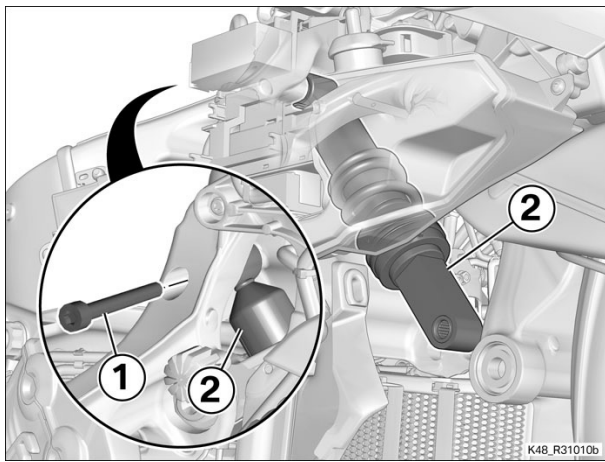

- Remove screw (1).
- Remove spring strut (2).

(-) Replacing spring strut

- Install bushing (1) with collar (arrow) on left in forward direction of travel in spring strut (2).

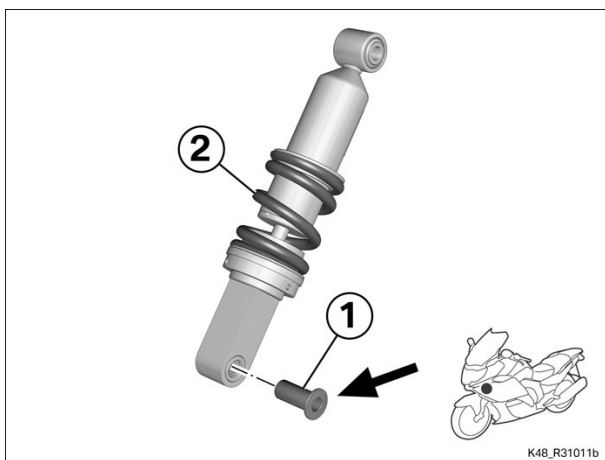

(-) Installing spring strut

- Clean the tapped hole.
- Lubricate the fitted head of screw (1).

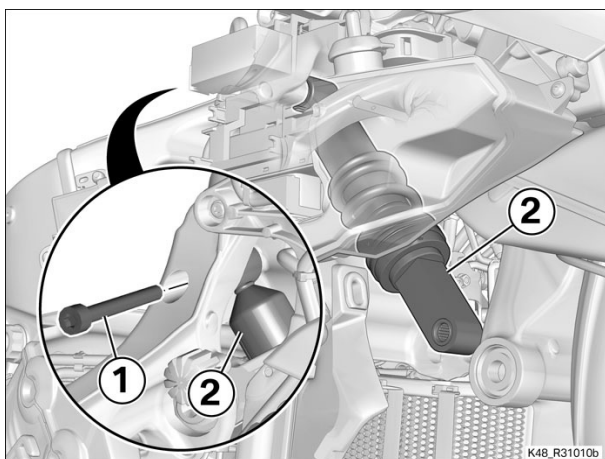

 Fluids and lubricants		
Staburags NBU 30 PTM	High-performance lubricating grease	07 55 9 056 992

- Install spring strut (2).
- Install screw (1).

 Tightening torques		
Spring strut, front, to frame and leading link		
M12 x 1.5 x 60, Replace screw Micro-encapsulated Lubricate the fitted head, Staburags NBU 30 PTM	50 Nm	

- Route cable (2) into position.
- Connect and install plug (1) for the **ESA** spring strut.
- Close the cable ties (arrows).

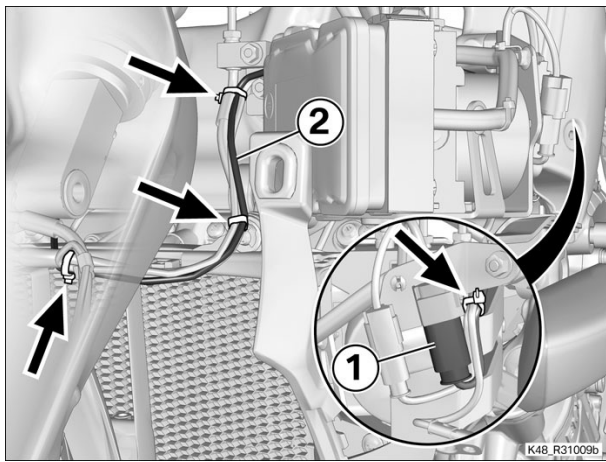

(-) Lowering front suspension

- Lower front suspension (1) on scissor-type lifter (No. 00 1 571), and at the same time guide the leading link (2) into position.

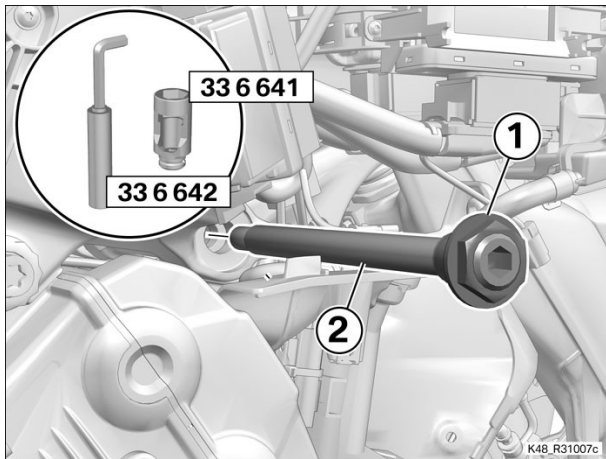
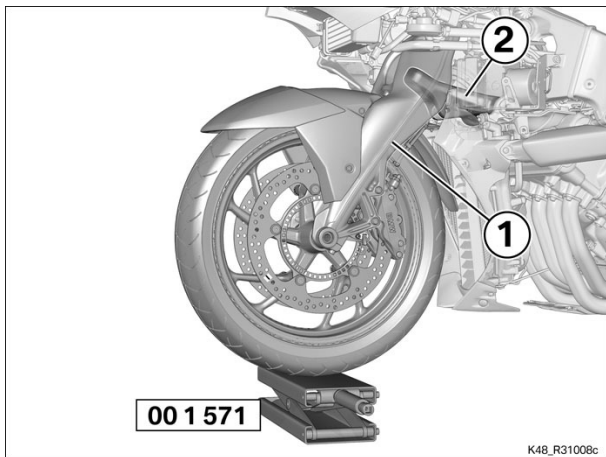

- Clean quick-release axle (2) and lubricate the shank.

 Fluids and lubricants		
Optimoly TA	High-temperature assembly grease	18 21 9 062 599

- Install quick-release axle (2).

 Tightening torques		
Leading link (quick-release axle) to frame		
M24 x 1.25 Lubricate thread, Optimoly TA	Initial torque, 15 Nm	
	Loosen	
	Final torque, 7 Nm	

 **Attention**

Overtightening the locknut of the quick-release axle can result in component damage.

Be sure to apply only the specified torque when tightening the collared nut of the quick-release axle.

- Install collared nut (1) with socket wrench insert (No. 33 6 641), counter-holding with Allen key (No. 33 6 642).

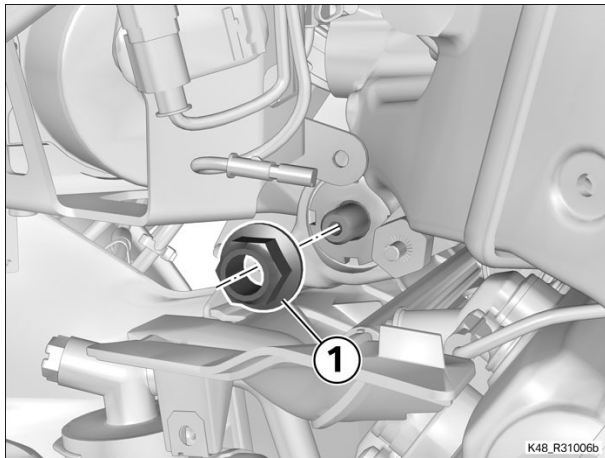

 Tightening torques		
Locknut on quick-release axle/bearing stud		
M24 x 1.25	145 Nm	

- Install nut (1).

 Tightening torques		
Nut on leading-link quick-release axle		
M14 x 1.5	30 Nm	

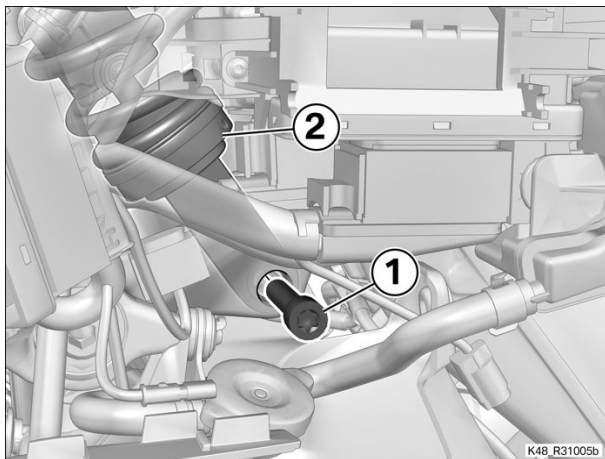

(-) Securing spring strut at bottom

- Clean the tapped hole.
- Lubricate the fitted head of screw (1).

 Fluids and lubricants		
Staburags NBU 30 PTM	High-performance lubricating grease	07 55 9 056 992

- Install screw (1) for spring strut (2).

 Tightening torques		
Spring strut, front, to frame and leading link		
M12 x 1.5 x 60, Replace screw Micro-encapsulated Lubricate the fitted head, Staburags NBU 30 PTM	50 Nm	

Finishing work

- Securing pressure modulator
- Securing front brake hose
- Installing air guide for oil cooler
- Installing fuel tank
- Installing complete intake air silencer
- Securing left and right intake air pipes
- Securing seat support
- Installing adjusting plate
- Installing inner trim for right side panel
- Install the right side panel
- Install the right radiator cowl
- Installing right bottom side panel

Installing inner trim for left side panel
Install the left side panel
Installing left radiator cowl
Installing left bottom side panel
Installing complete cover of fuel tank
Installing air guides for intake air pipes, left and right
Installing front seat
Final check of work performed

📁 32 71 001 Replacing top steering bridge

+ 32 71 501

Preparatory work

Covering cover for fuel tank

Covering instrument panel

Closing equalising bore of front brake

Removing **BMW** badge with carrier

Removing nut of handlebar bridge

Disconnecting plugs for ignition switch/steering lock and ring aerial

Core activity

(-) Removing handlebar bridge

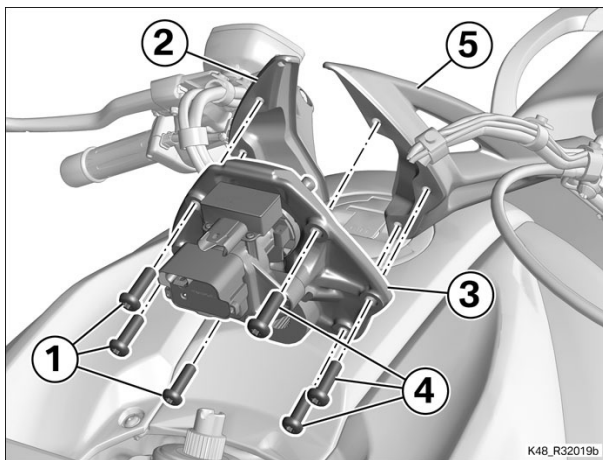

- Remove screws (1).
- Separate handlebar, right (2) from handlebar bridge (3).
- Allow handlebar, right (2) to dangle to one side. Make sure that no brake fluid escapes.
- Remove screws (4) and remove handlebar bridge (3).
- Allow handlebar, left (5) to dangle to one side. Make sure that no clutch fluid escapes.

(-) Replacing top handlebar bridge

► Removing ignition switch/steering lock with ring aerial

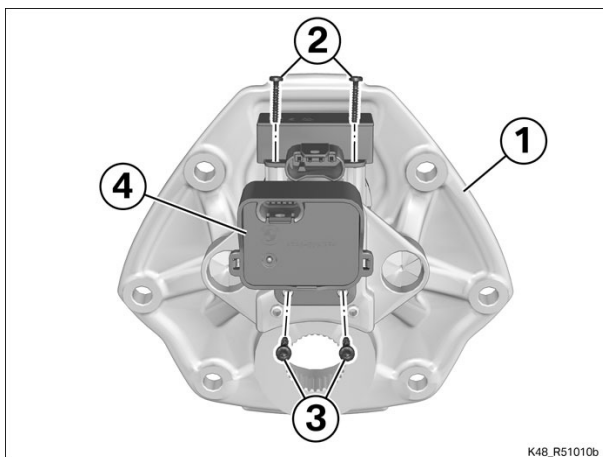

- Lay handlebar bridge (1) on a **padded** rest.
- Remove screws (2).
- Remove screws (3) and remove ignition switch (4).



Attention

Components can be damaged by hard or sharp-edged objects. Avoid scratching the components; use masking tape if necessary.

- Drill pilot holes into non-removable screws (1) and then continue drilling out the holes until the screw heads come off.

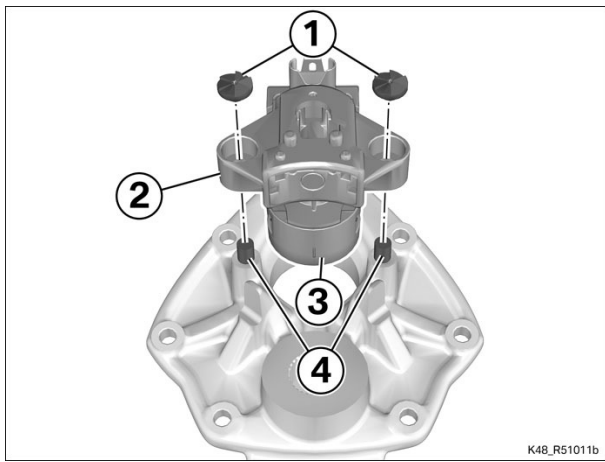

Technical data

Ignition switch/steering lock - drilling depth for drilling out non-removable screws	Pilot hole diameter 4 mm	min 5 mm	
	Diameter for drilling out fully 8.5 mm	5 mm	

- Use compressed air to remove metal particles.
- Remove steering lock (2) with ring aerial (3).
- Use a stud remover to remove shanks of non-removable screws (4).

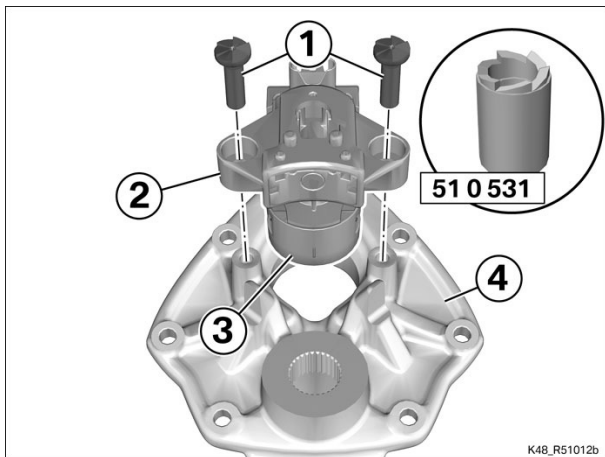

- Clean the threads.
- Install steering lock (2) with ring aerial (3) in **new** handlebar bridge (4).
- Install non-removable screws (1) with socket wrench insert (No. 51 0 531).



Tightening torques

Ignition and steering lock to handlebar yoke		
M8 x 26, Replace screw Micro-encapsulated	20 Nm	

- Hold ignition switch (3) in position and install screws (2).
- Install screws (1).

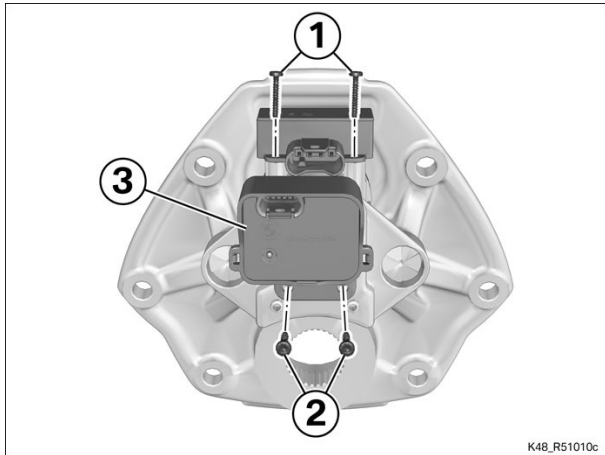

(-) Installing handlebar bridge

- Position left handlebar (5) on handlebar bridge (3).
- Install screws (4).



Tightening torques

Stub handlebar to handlebar bridge		
M8 x 25	19 Nm	

- Position right handlebar (2) on handlebar bridge (3).
- Install screws (1).

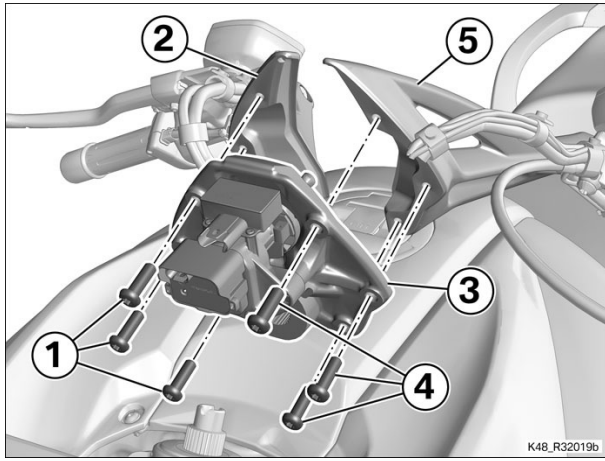

 Tightening torques		
Stub handlebar to handlebar bridge		
M8 x 25	19 Nm	

Finishing work

- Connecting plugs for ignition switch/steering lock and ring aerial
- Installing handlebars
- Installing **BMW** badge with carrier
- Opening equalising bore of front brake
- Removing blanket covering instrument panel
- Removing blanket covering fuel tank
- Final check of work performed

32 71 063 Renewing handlebar weight 2 FRUs

+ 32 71 515

Core activity

(-) Removing handlebar weight

- Remove screw (1).
- Remove handlebar weight (2).

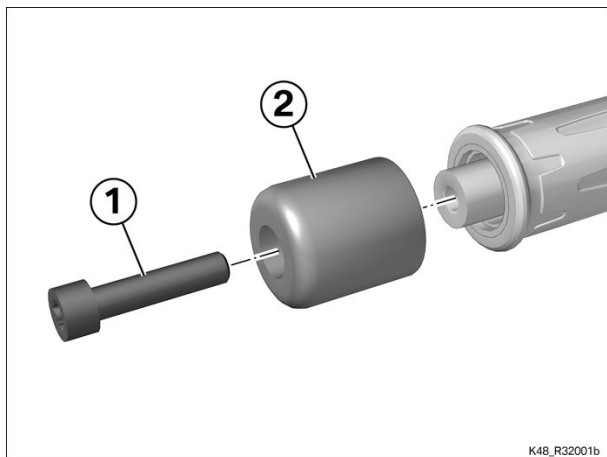

(-) Installing handlebar weight

- Hold handlebar weight (2) in position.
- Install screw (1).

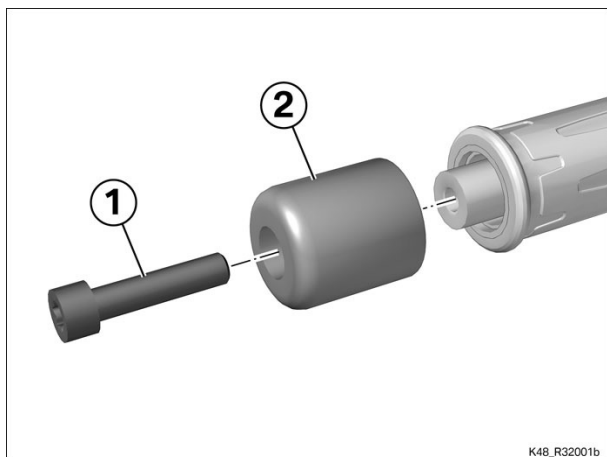

 Tightening torques		
Handlebar weight to handlebar half		
M8 x 35	19 Nm	

- On the throttle twistgrip side **make sure that the twist tube rotates freely.**

Finishing work

Final check of work performed

32 71 150 Removing/installing or replacing handlebar, left

+ 32 71 525

Preparatory work

- Covering cover for fuel tank
- Covering instrument panel
- Removing handlebar weight
- Removing left grip unit
- Removing handlebar lever fitting for clutch
- Closing equalising bore of front brake
- Removing **BMW** badge with carrier
- Removing nut of handlebar bridge
- Disconnecting plugs for ignition switch/steering lock and ring aerial

Core activity

(-) Removing left handlebar

- Remove screws (1).
- Remove handlebar (2) from handlebar bridge (3).

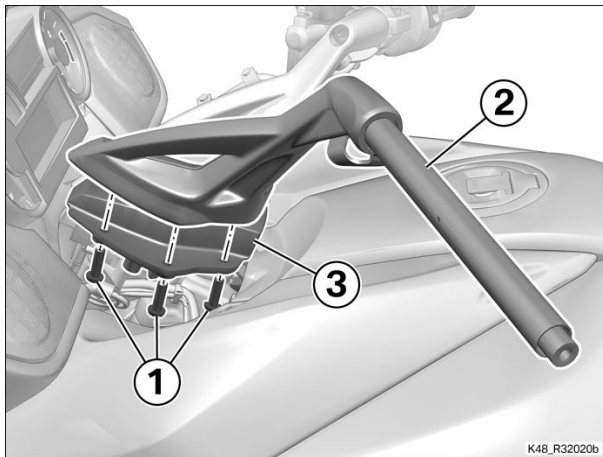

(-) Removing left handlebar

- Position handlebar (2) on handlebar bridge (3).
- Install screws (1).

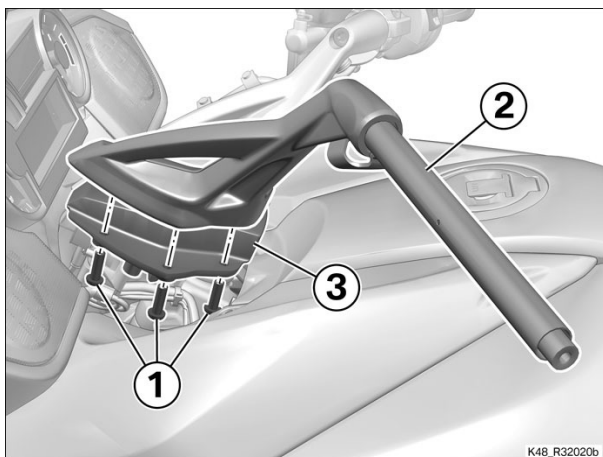

 Tightening torques		
Stub handlebar to handlebar bridge		
M8 x 25	19 Nm	

Finishing work

- Connecting plugs for ignition switch/steering lock and ring aerial
- Installing handlebars
- Installing **BMW** badge with carrier
- Opening equalising bore of front brake

Installing handlebar lever fitting for clutch
Installing left grip unit
Installing handlebar weight
Removing blanket covering instrument panel
Removing blanket covering fuel tank
Final check of work performed

32 71 160 Removing/installing or replacing handlebar, right

+ 32 71 527

Preparatory work

- Covering cover for fuel tank
- Covering instrument panel
- Removing handlebar weight
- Removing right multifunction switch
- Removing throttle twistgrip
- Removing handbrake lever fitting
- Removing **BMW** badge with carrier
- Removing nut of handlebar bridge
- Disconnecting plugs for ignition switch/steering lock and ring aerial

Core activity

(-) Removing right handlebar

- Remove screws (1).
- Remove handlebar (2) from handlebar bridge (3).

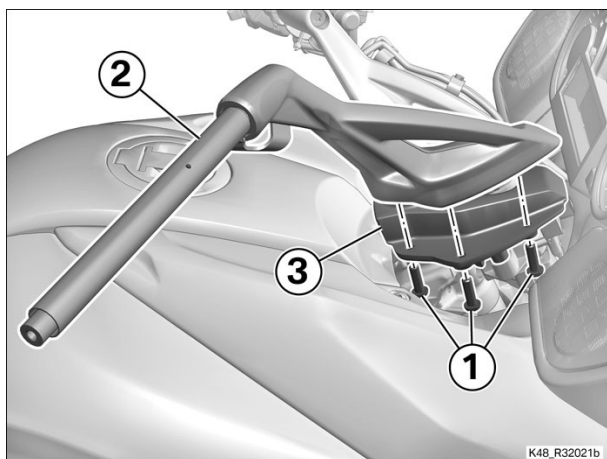

(-) Installing right handlebar

- Position handlebar (2) on handlebar bridge (3).
- Install screws (1).

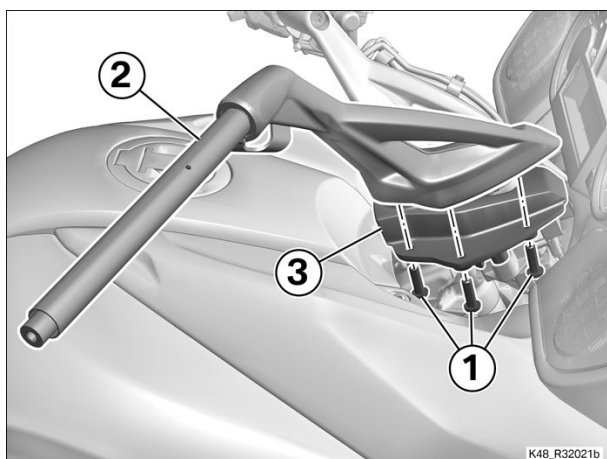

 Tightening torques		
Stub handlebar to handlebar bridge		
M8 x 25	19 Nm	

Finishing work

- Connecting plugs for ignition switch/steering lock and ring aerial
- Installing handlebars
- Installing **BMW** badge with carrier
- Installing handbrake fitting

Installing throttle twistgrip
Installing right multifunction switch
Installing handlebar weight
Removing blanket covering instrument panel
Removing blanket covering fuel tank
Final check of work performed

32 72 001 Replacing throttle twistgrip 3 FRUs

+ 32 72 620

Preparatory work

Removing handlebar weight

Removing right multifunction switch

Core activity

(-) Removing throttle twistgrip

- Remove screw (1).
- Remove throttle twistgrip (2).

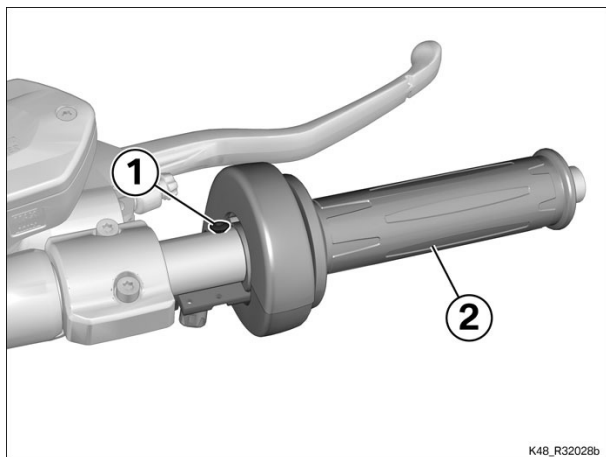

(-) Installing throttle twistgrip

- Install throttle twistgrip (2).
- Install screw (1).

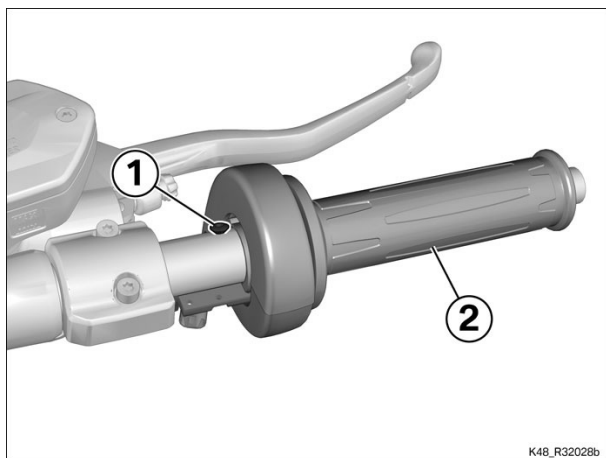

Tightening torques		
Throttle twistgrip to handlebar		
M3.5 x 32	2 Nm	

Finishing work

Installing right multifunction switch

Installing handlebar weight

Remove the front seat

=> Resetting/learning adaptation values (with replacing component) (Description in item: 61 00 503, Billed as a separate item)

Installing front seat

Final check of work performed

32 72 064 Replacing handlebar fitting for clutch actuation (without bleeding system) 2 FRUs
 + 32 72 664

Preparatory work

=> Bleeding hydraulic clutch system (Description in item: 21 52 506, Billed as a separate item)

Core activity

(-) Disengaging clutch switch

- Remove screw (1).
- Remove clutch switch (2), noting locating point (3).

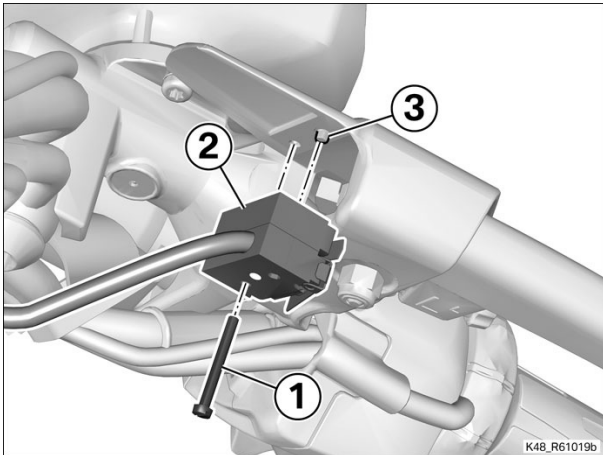

(-) Removing handlebar fitting for clutch actuation

- Open the retaining strap (arrow).
- Remove banjo bolt (1) with sealing washers (2).
- Disconnect clutch hose (3).

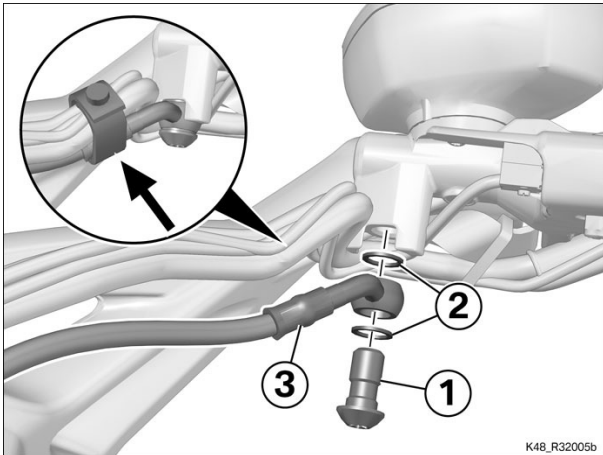

- Remove screws (1) and clamp (2).
- Remove clutch lever fitting (3).

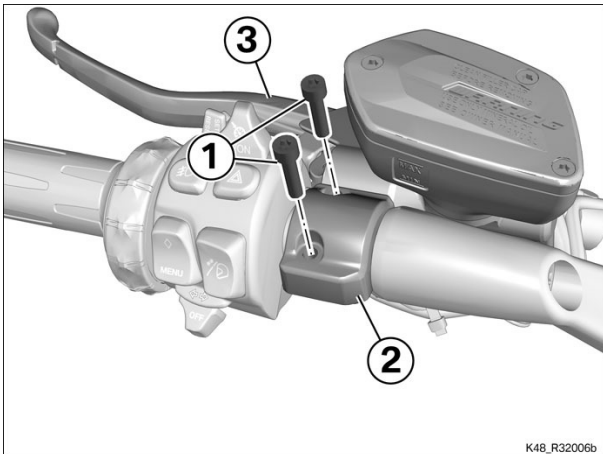

(-) Installing handlebar fitting for clutch

-

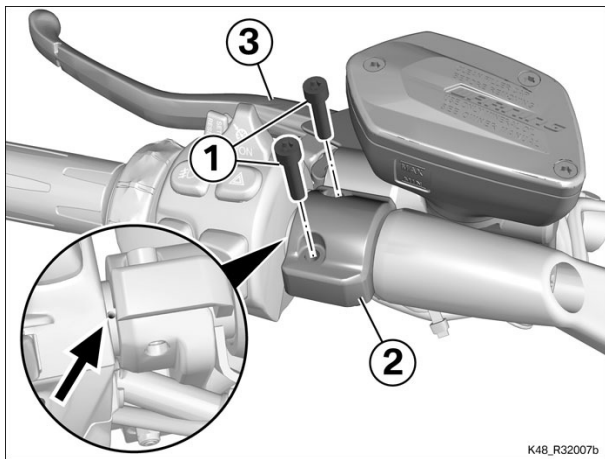

K48_R32007b

- Hold clutch lever fitting (3) in position.
- Hold clamp (2) in position and align with clutch fitting (3) at the mark (arrow).
- Install screws (1).

Tightening torques		
Handlebar fittings to handlebars		
M5 x 20	5 Nm	

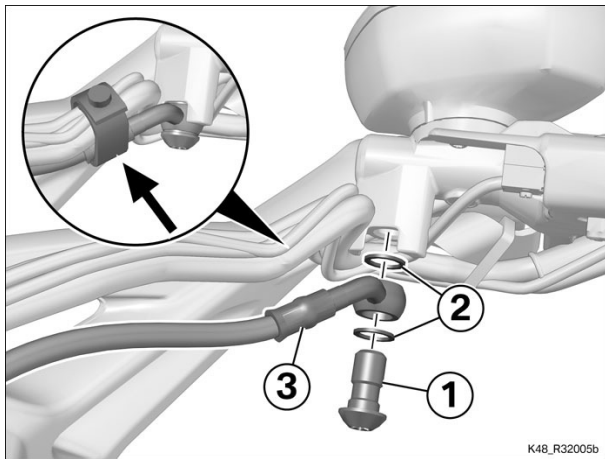

K48_R32005b

- Hold clutch hose (3) in position.
- Install banjo bolt (1) with new sealing washers (2).

Tightening torques		
Clutch line to clutch lever fitting		
Banjo bolt, M10 x 1	18 Nm	

- Close the retaining strap (arrow).

(-) Securing clutch switch

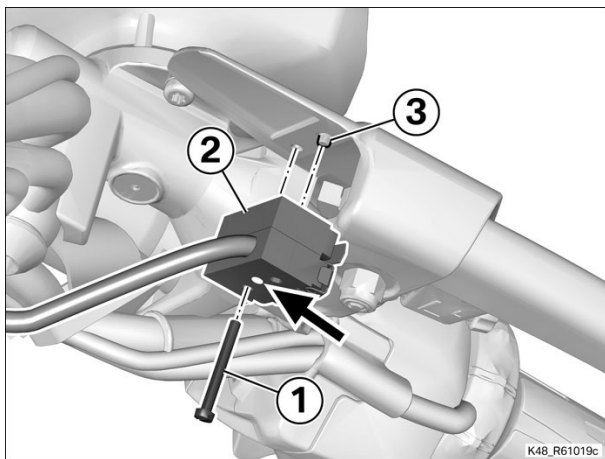

K48_R61019c

- Install clutch switch (2) with the **white mark** (arrow) pointing down, noting locating point (3).
- Install screw (1).

Tightening torques		
Clutch switch to handlebar fitting		
M2 x 18	0.3 Nm	

Finishing work

Final check of work performed

32 72 070 Replace clutch lever 2 FRUs

+ 32 72 627

Core activity

(-) Removing clutch lever

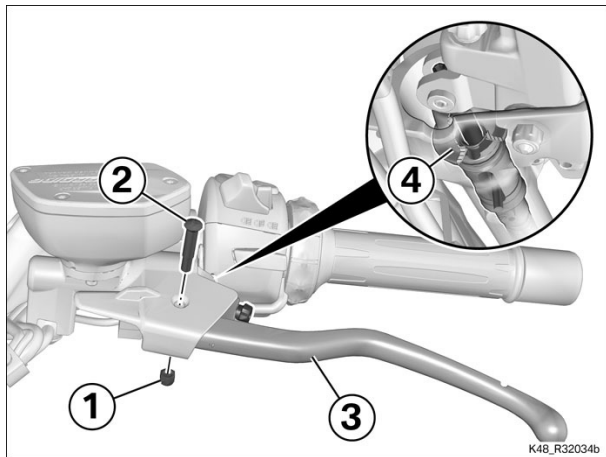

- Remove nut (1).
- Pull screw (2) up to remove.
- Pull out lever unit (3), noting rubber sleeve (4).

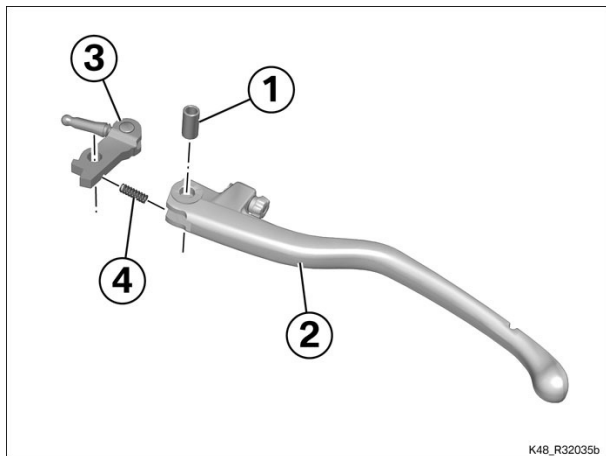

- Remove sleeve (1) from lever (2).
- Remove lever mount with pushrod (3) and spring (4).

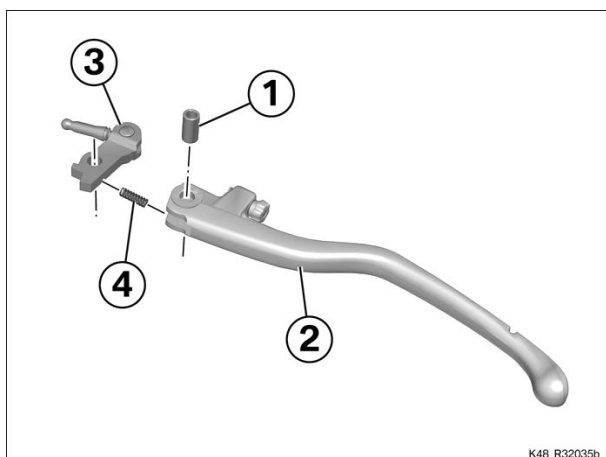

(-) Installing clutch lever

- Seat spring (4) and lever pivot with pushrod (3) in lever (2).
- Install sleeve (1) and lubricate.

 Fluids and lubricants		
Teflon spray	Gearbox shift shaft, foot-operated selector shaft	83 23 0 154 884

- Lubricate screw (2).

 Fluids and lubricants		
Teflon spray	Gearbox shift shaft, foot-operated	83 23 0 154 884

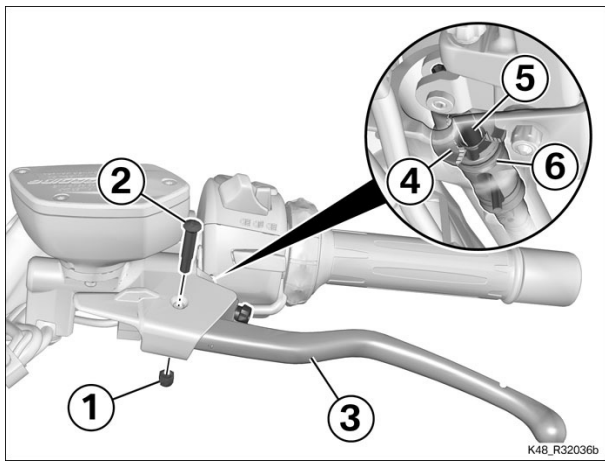

	selector shaft
--	----------------

- Install lever unit (3), making sure that pushrod (5) engages in piston seat (6) and that rubber sleeve (4) is correctly positioned.
- Install screw (2) with new nut (1).



Tightening torques

Handlebar lever to fitting

M5, Replace nut	7 Nm	
-----------------	------	--

Finishing work

Final check of work performed

📁 32 72 097 Replacing left handlebar grip

+ 32 72 632

Preparatory work

Covering cover for fuel tank

Covering instrument panel

Removing handlebar weight

Removing left grip unit

Core activity

(-) Removing left multifunction switch

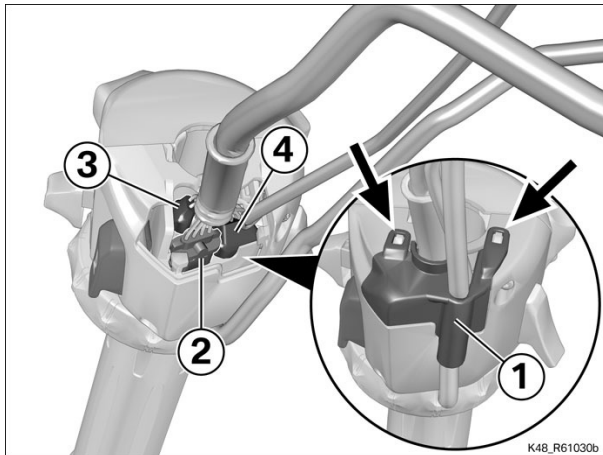

- Disengage the retaining tabs (arrows).
- Remove cover (1).
- Working in the following sequence, disconnect and remove the following plugs:
 - (2), 4-pin
 - (3) for the grip heating
 - (4), 8-pin

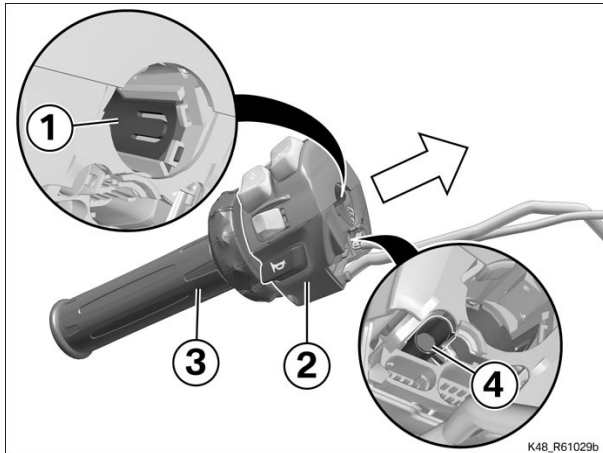

- Push up retainer (1).
- Remove multifunction switch (2) from grip (3) and remove plug (4) for the heated grip.

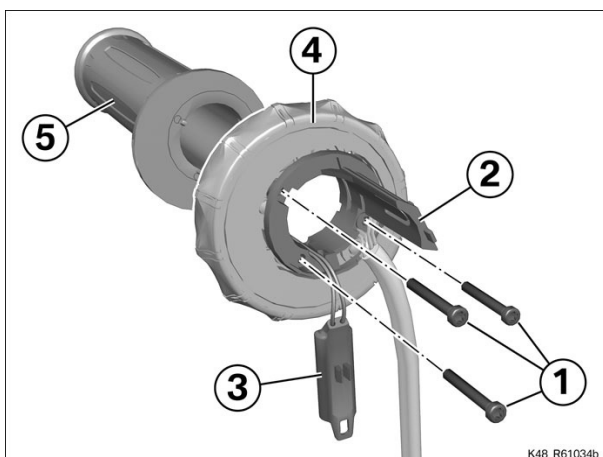

(-) Disengaging multi-controller

- Remove screws (1).
- Lift bracket (2) and work the cable from plug (3) for the heated grip clear.
- Remove bracket (2) and multi-controller (4) from grip (5).

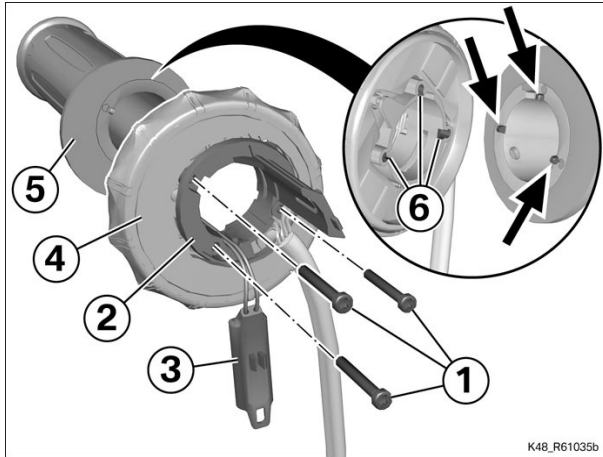

(-) Securing multi-controller

- Position multi-controller (4) on grip (5). Make sure that the retainers (arrows) and recesses (6) engage.
- Work the cable of plug (3) for the heated grip through bracket (2).
- Hold bracket (2) in position and install screws (1), **noting the grip-heating cable**.

Tightening torques		
Multi-controller to grip		
RS2.5 x 20	1.5 Nm	

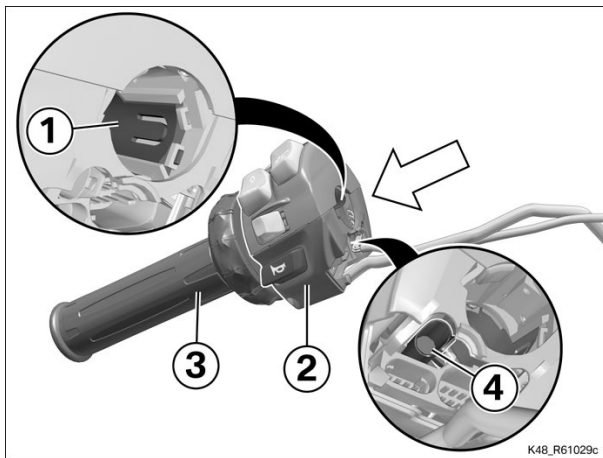

(-) Installing left multifunction switch

- Push multifunction switch (2) on to grip (3) and install plug (4) for the heated grip.
- » Retainer (1) engages.

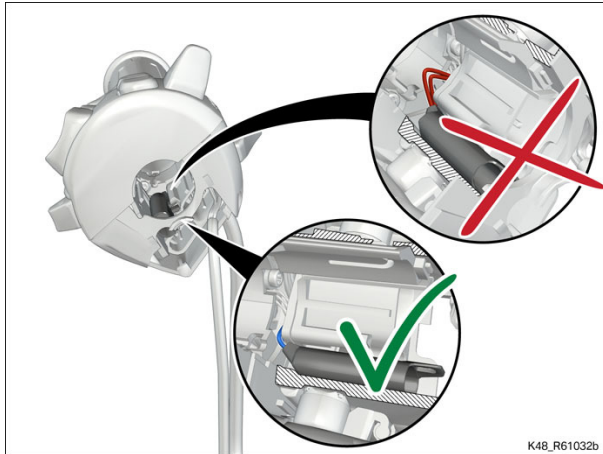

- Check that the grip-heating cable is correctly routed and does not project into the grip tube.

- Working in the following sequence, install and connect the plugs:
 - (4), 8-pin
 - (3) for the grip heating
 - (2), 4-pin
- Install cover (1).
- Make sure that the retaining tabs (arrows) engage.

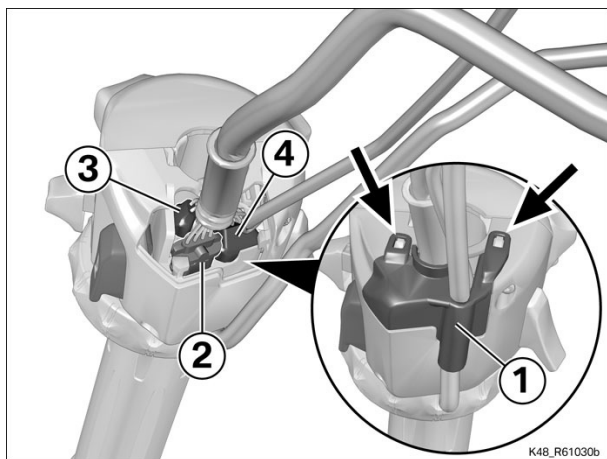

Finishing work

Installing left grip unit

Installing handlebar weight

Removing blanket covering instrument panel

Removing blanket covering fuel tank

Final check of work performed

32 72 119 Replacing handbrake lever 2 FRUs

+ 32 72 637

Core activity

(-) Removing handbrake lever

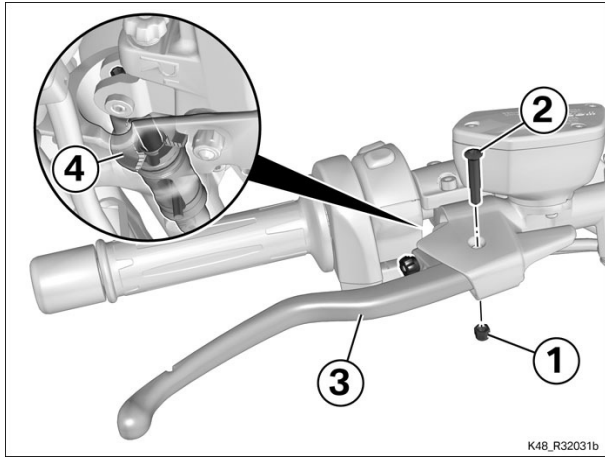

- Remove nut (1).
- Pull screw (2) up to remove.
- Pull out lever unit (3), noting rubber sleeve (4).

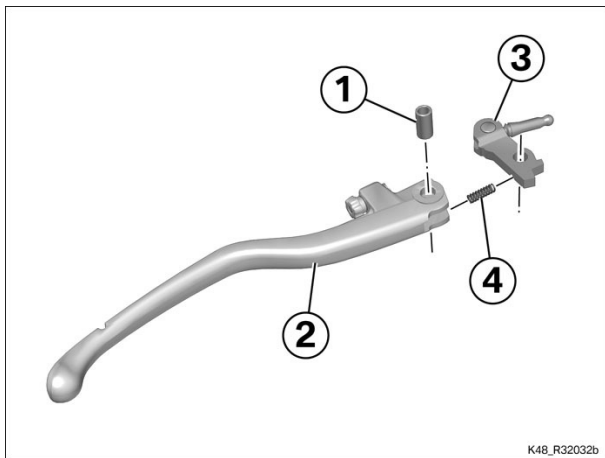

- Remove sleeve (1) from lever (2).
- Remove lever mount with pushrod (3) and spring (4).

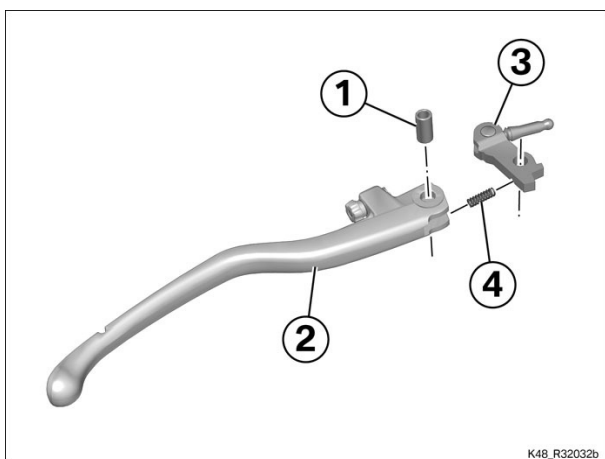

(-) Installing handbrake lever

- Seat spring (4) and lever pivot with pushrod (3) in lever (2).
- Install sleeve (1) and lubricate.

 Fluids and lubricants		
Teflon spray	Gearbox shift shaft, foot-operated selector shaft	83 23 0 154 884

- Lubricate screw (2).

 Fluids and lubricants		
Teflon spray	Gearbox shift shaft, foot-operated	83 23 0 154 884

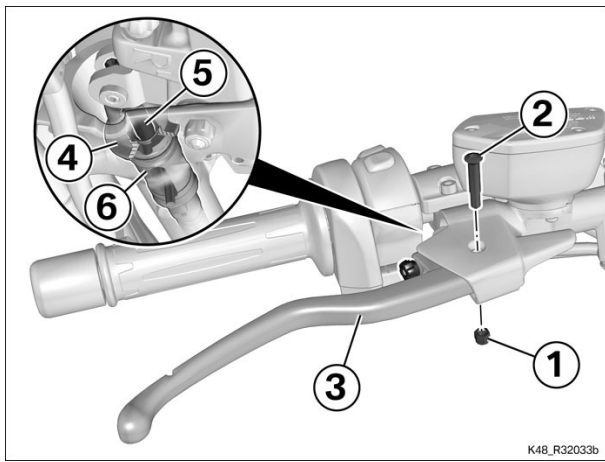

	selector shaft
--	----------------

- Install lever unit (3), making sure that pushrod (5) engages in piston seat (6) and that rubber sleeve (4) is correctly positioned.
- Install screw (2) with new nut (1).



Tightening torques

Handlebar lever to fitting

M5, Replace nut	7 Nm	
Mechanical thread lock		

Finishing work

Final check of work performed

📁 32 72 120 Replace handbrake fittings 4 FRUs

+ 32 72 638



Attention

Brake fluid attacks paintwork, plastic and rubber parts.

Do not allow brake fluid to come into contact with paintwork, plastic or rubber parts.

Preparatory work

Draining brake fluid reservoir on handbrake fitting

Core activity

(-) Removing handbrake fitting

- Remove banjo bolt (1) with sealing washers (2).
- Remove brake hose (3).

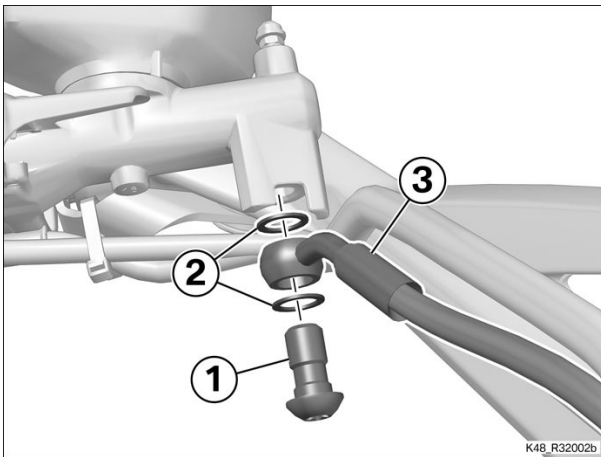

- Remove screws (1) and clamp (2).
- Remove handbrake fitting (3).

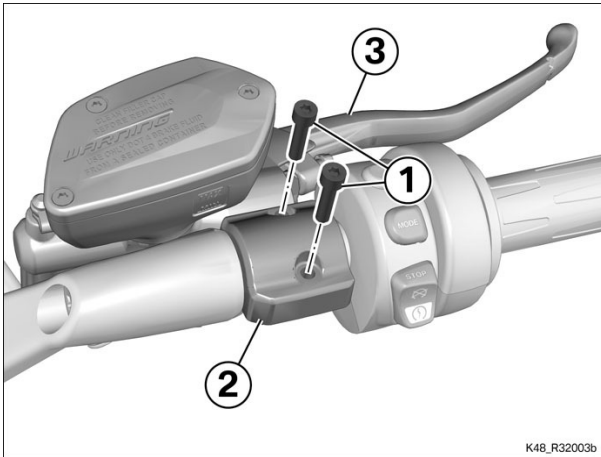

(-) Installing handbrake fitting

- Hold handbrake fitting (3) in position.
- Hold clamp (2) in position and align with handbrake fitting (3) at the mark (arrow).
- Install screws (1).



Tightening torques

Handlebar fittings to handlebars

M5 x 20

5 Nm

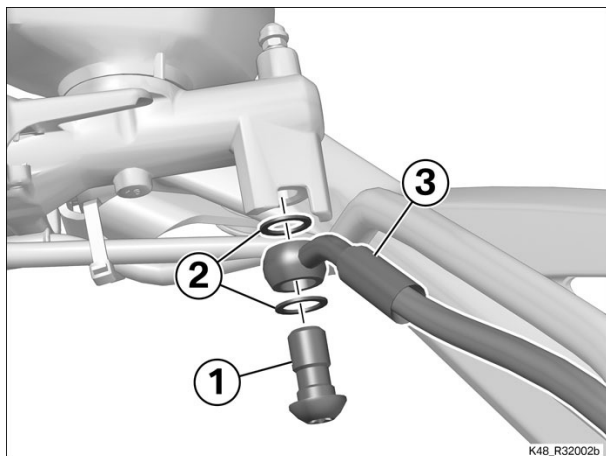
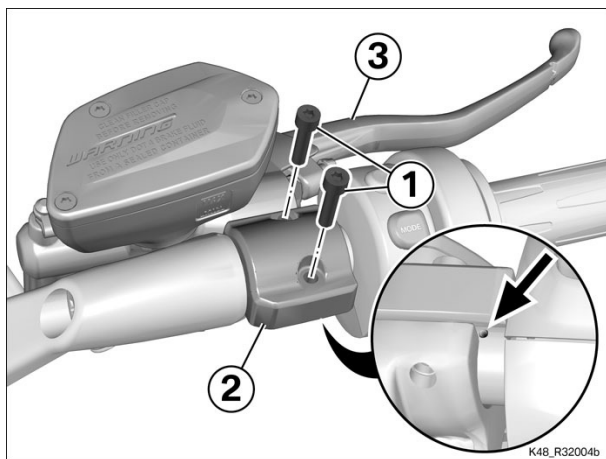

- Hold brake hose (3) in position.
- Install banjo bolt (1) with new sealing washers (2).

 Tightening torques		
Brake hose with banjo bolt to components		
M10 x 1	24 Nm	

Finishing work

Filling and bleeding front brake system

Final check of work performed

32 76 000 Replacing steering damper 15 FRUs

+ 32 76 500

Preparatory work

- Remove the front seat
- Removing air guides for intake air pipes, left and right
- Removing complete cover of fuel tank
- Removing left bottom side panel
- Removing left radiator cowl
- Removing left side panel
- Removing inner trim for left side panel
- Removing right bottom side panel
- Removing right radiator cowl
- Remove the right side panel
- Removing inner trim for right side panel
- Removing adjusting plate
- Disengaging seat support
- Disengaging left and right intake air pipes
- Removing complete intake air silencer
- Removing fuel tank

Core activity

(-) Removing steering damper

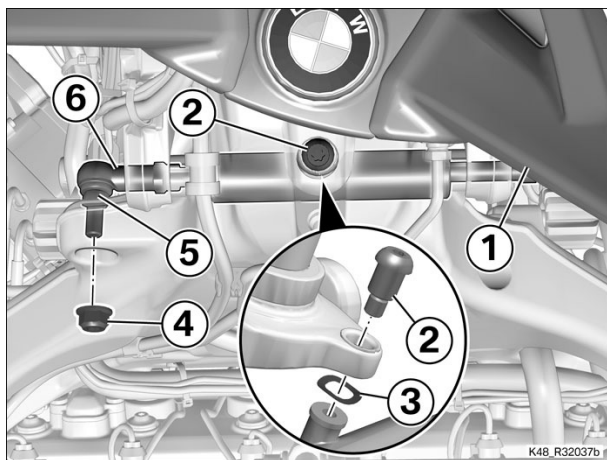

- Position handlebars (1) so that screw (2) is accessible.
- Remove screw (2) and remove corrugated washer (3).
- Remove nut (4), while counter-holding at ball head (5).
- Remove steering damper (6).

(-) Installing steering damper

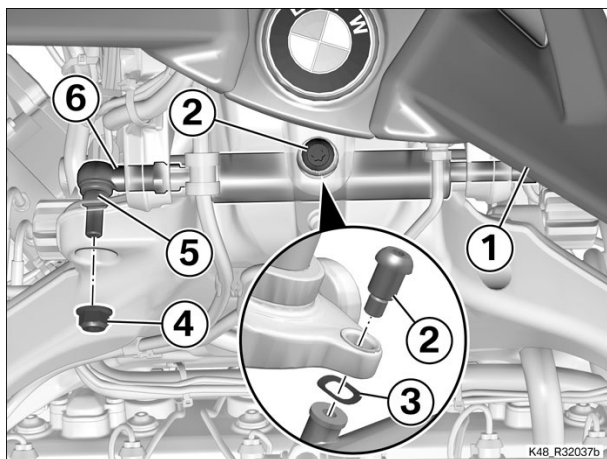

- Clean the threads in steering damper (6).
- Position handlebars (1) so that hole for screw of steering damper (6) is accessible.
- Hold steering damper (6) with corrugated washer (3) in position and install screw (2).

 Tightening torques		
Steering damper to steering unit		
M8 x 22, Replace screw	19 Nm	
Micro-encapsulated		

• Install nut (4), counter-holding at ball head (5).

 Tightening torques		
Steering damper to frame		
M8	19 Nm	

Finishing work

Installing fuel tank

Installing complete intake air silencer

Securing left and right intake air pipes

Securing seat support

Installing adjusting plate

Installing inner trim for right side panel

Install the right side panel

Install the right radiator cowl

Installing right bottom side panel

Installing inner trim for left side panel

Install the left side panel

Installing left radiator cowl

Installing left bottom side panel

Installing complete cover of fuel tank

Installing air guides for intake air pipes, left and right

Installing front seat

Final check of work performed

33 35 000 Replacing rear wheel swinging arm 13 FRUs

+ 33 35 501

Preparatory work

- Removing left footrest plate
- Removing right footrest plate
- Removing number-plate carrier
- Remove the rear wheel
- Removing rear brake caliper
- Releasing **Paralever** link at rear
- Disengaging actuator rod from rear ride height sensor
- Removing bevel gears

Core activity

(-) Removing universal shaft

- Remove cable tie (arrow).
- Work flexible gaiter (1) to the rear to remove.

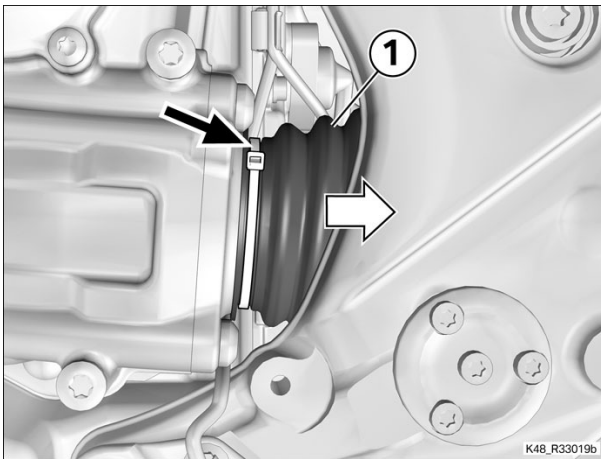

- Use a suitable tool to press universal shaft (1) to the rear.

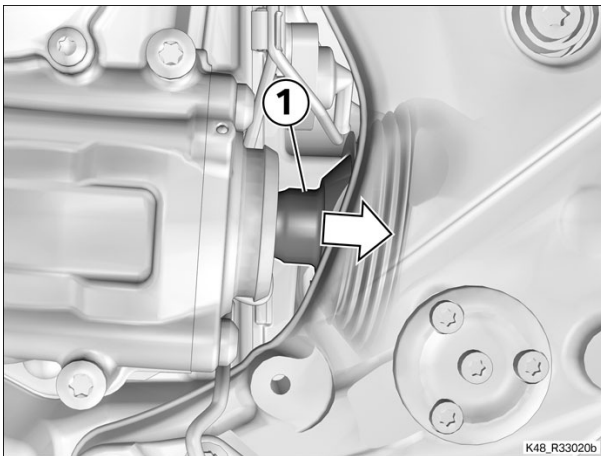

- Ease universal shaft (1) out of swinging arm (2).

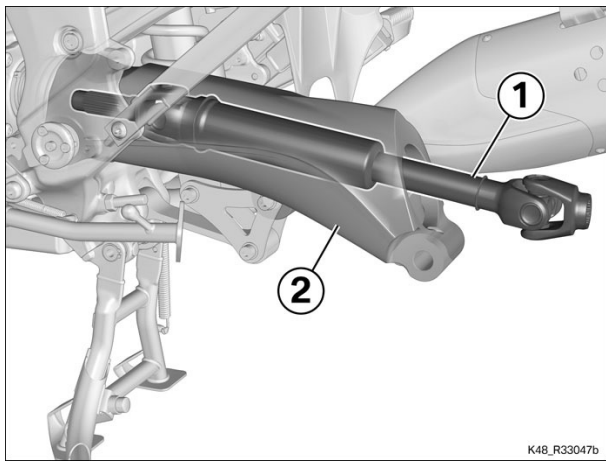

(-) Removing rear wheel swinging arm

- Secure swinging arm (1) with ratchet strap (2) to footrest bracket (3).

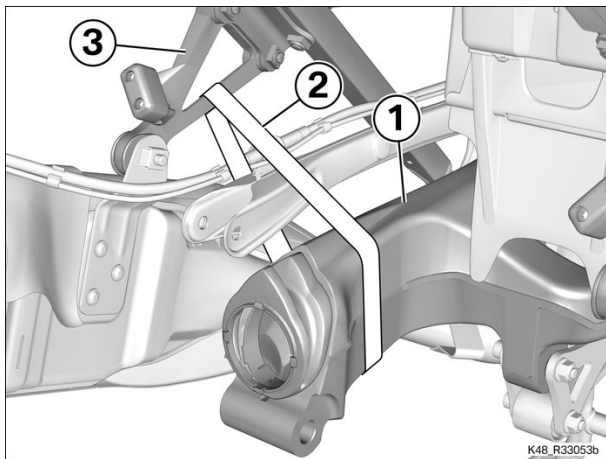

- Remove spray-guard clip (1) from link strut (2).

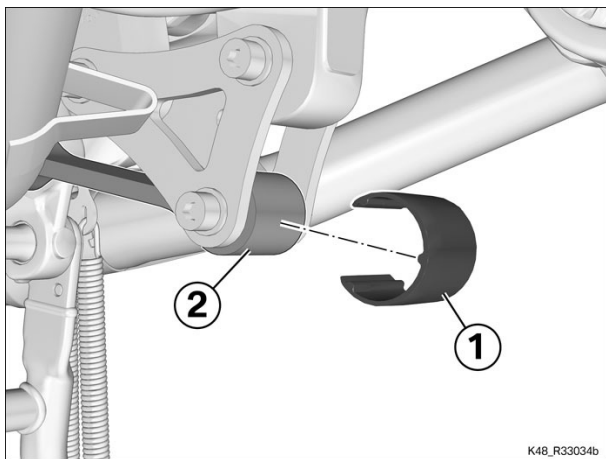

- Remove nut (1) and screw (2) with washer (3).
- Pivot link strut (4) down.

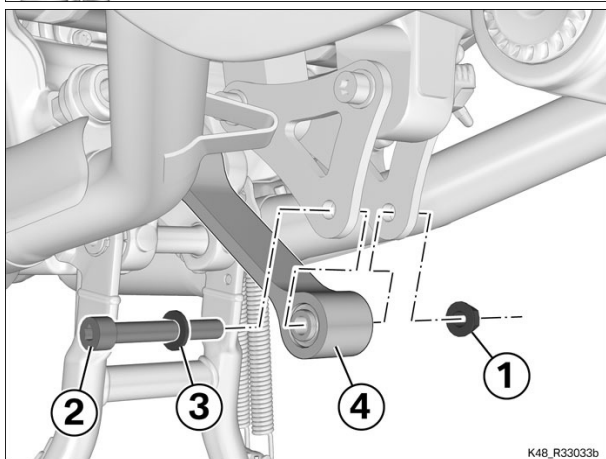

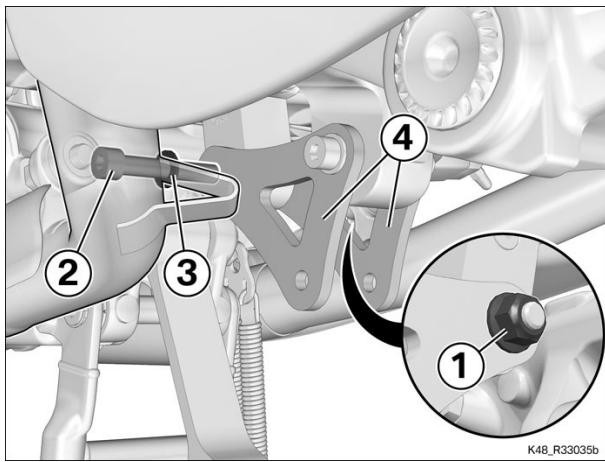

- Remove nut (1) and screw (2) with washer (3).
- Pivot relay plates (4) down.

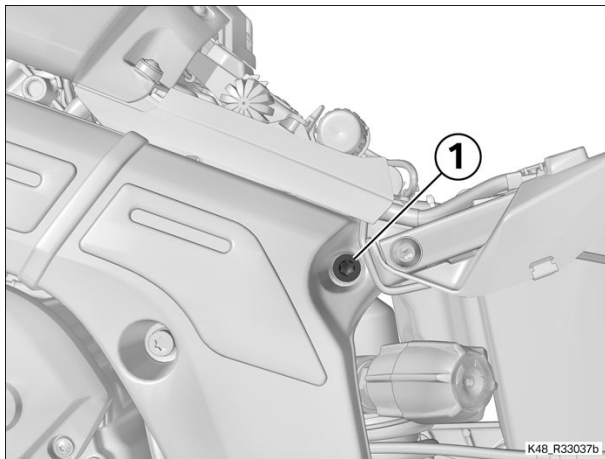

- Slacken screw (1), but **do not** remove.

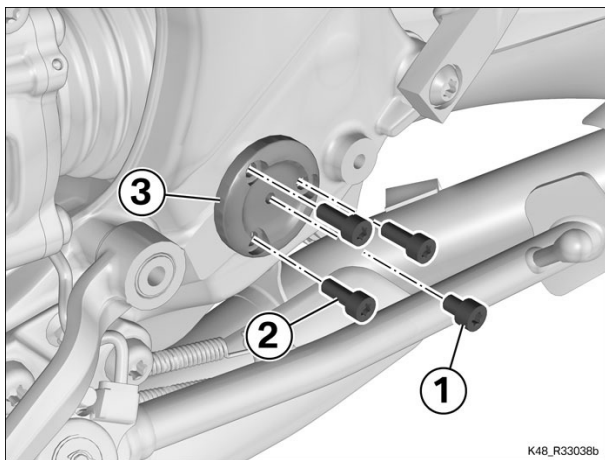

- Remove screw (1) and screws (2) for bearing stud (3).

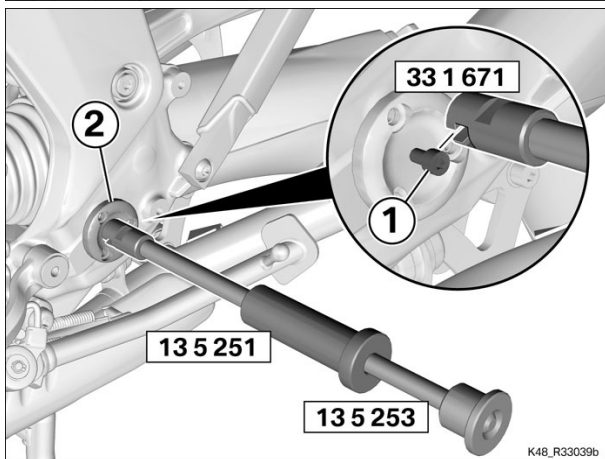

- Install a suitable screw (1) and tighten it until it can still just be gripped well by puller (No. 33 1 671).
- Mount pull rod (No. 13 5 251) and impact weight (No. 13 5 253) with puller (No. 33 1 671) on screw (1).
- Remove bearing stud (2).

- Slacken locknut (1) and remove with bearing stud (2).

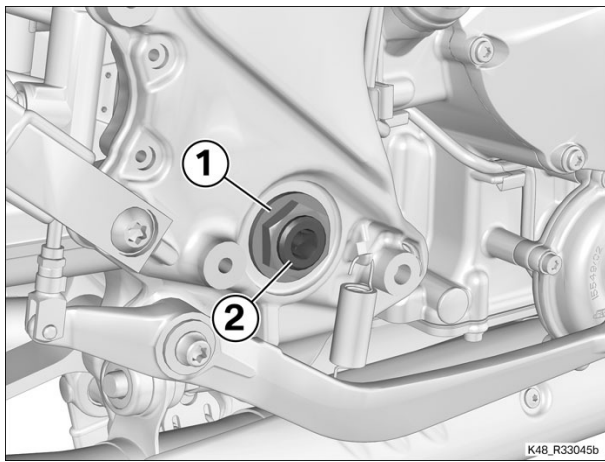

- Remove ratchet strap (1) from footrest bracket (3) and lower swinging arm (2).
- Turn swinging arm (2) slightly and work it to the rear to remove.

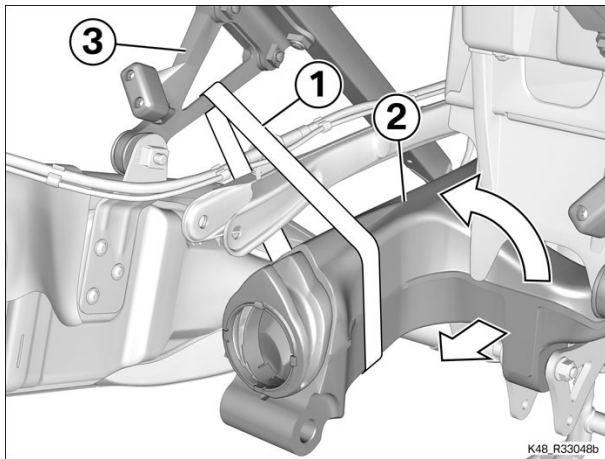

(-) Replacing swinging arm

- Remove nut (1) and screw (2) with washer (3).

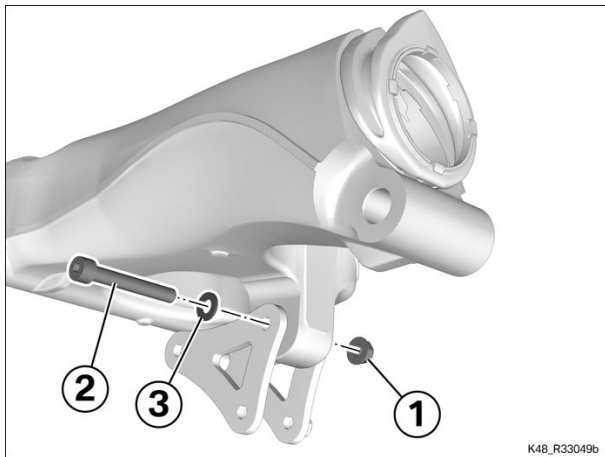

- Hold relay plates (1) in position on new swinging arm.
- » The marks (arrows) are at the top and face in the forward direction of travel.

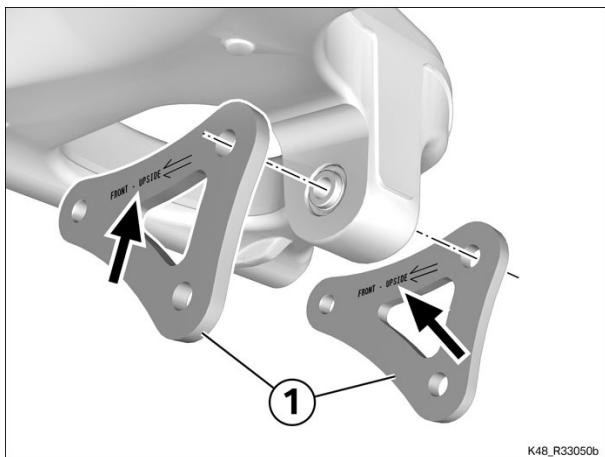

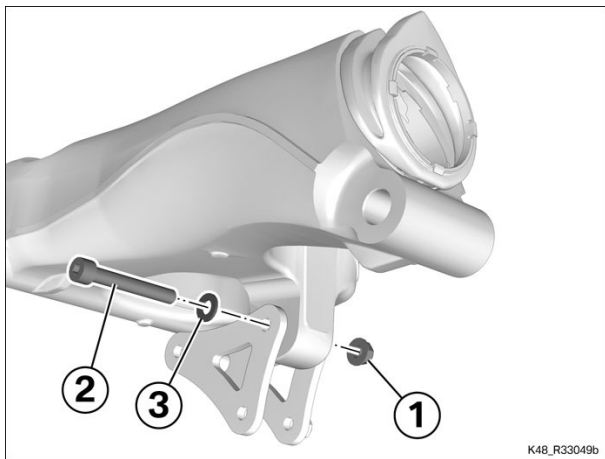

Install screw (2) with washer (3) and new nut (1).

Tightening torques	
Relay plate to swinging arm and relay lever	
M12 x 1.5 x 75 - 10.9, Replace nut	50 Nm
Mechanical thread lock	

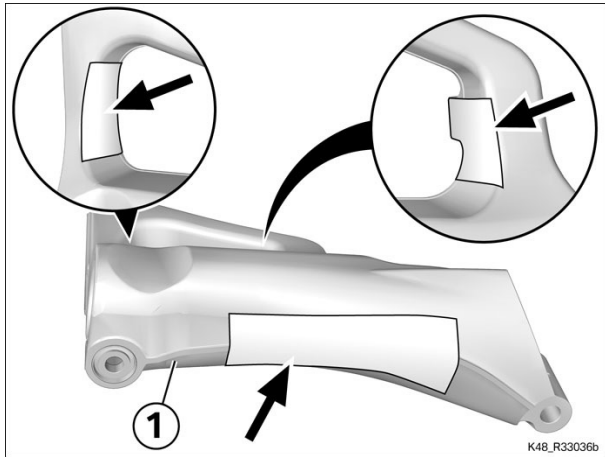

- Affix masking tape to new swinging arm (1) at the areas indicated (arrows).

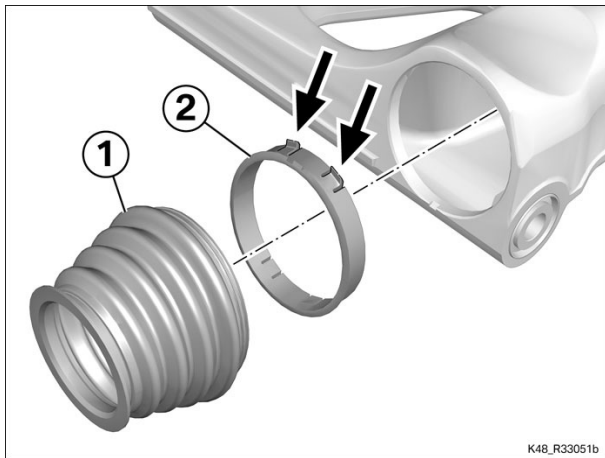

- Install flexible gaiter (1) and plastic insert (2) in the new swinging arm.
- » The retainers (arrows) snap into position.

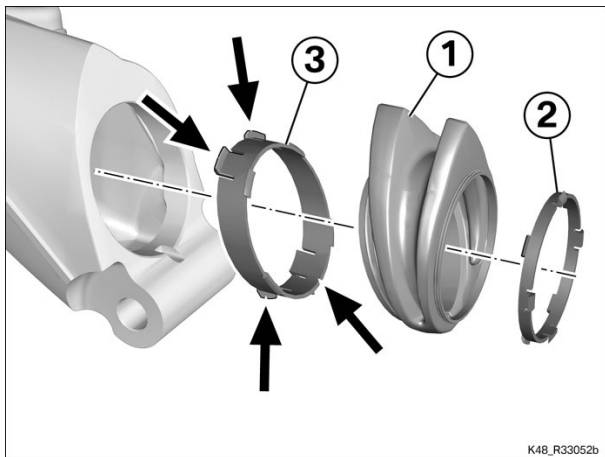

- Transfer flexible gaiter (1) and plastic inserts (2) and (3) to the new swinging arm.
- » The retainers (arrows) snap into position.

(-) Installing rear swinging arm

-

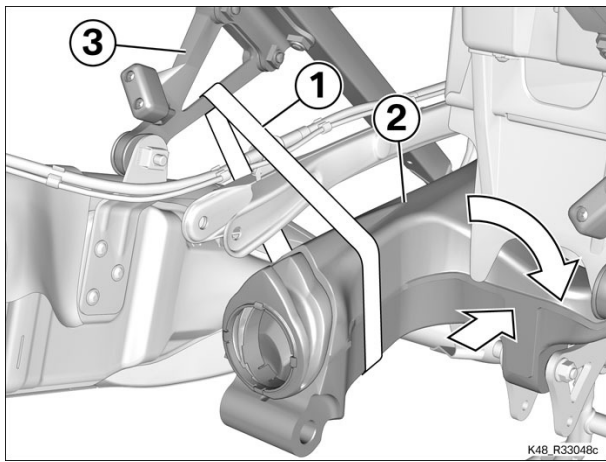

- Turn swinging arm (2) slightly and carefully work it into position in the main frame.
- Lift swinging arm (2) and secure it with ratchet strap (1) to footrest bracket (3).

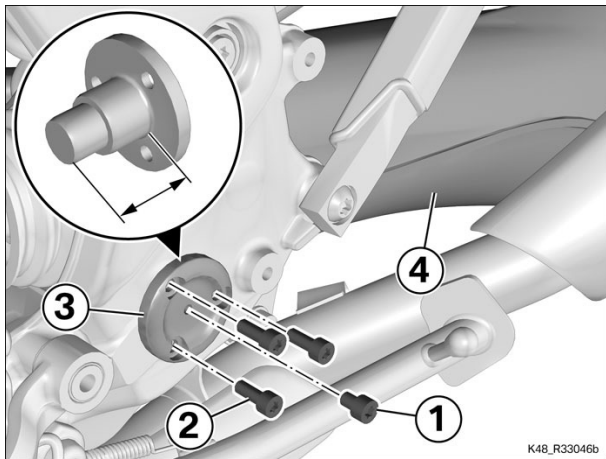

- Slightly lubricate bearing stud (3) where shown here.

 Fluids and lubricants		
Staburags NBU 30 PTM	High-performance lubricating grease	07 55 9 056 992

- Align swinging arm (4) and install bearing stud (3).
- Install screws (2).

 Tightening torques		
Bearing stud, swinging arm to frame, left		
M6 x 16	9 Nm	

- Install screw (1).

 Tightening torques		
Capping screw, bearing stud, left		
M6 x 8	9 Nm	

- Clean bearing stud (2) and lubricate at threads and bearing seat.

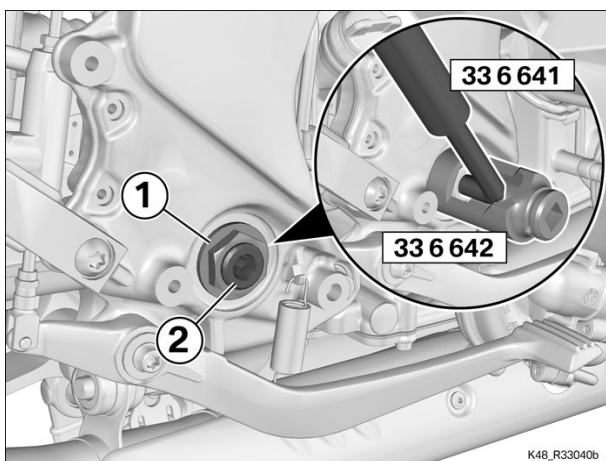



 Fluids and lubricants		
Optimoly TA	High-temperature assembly grease	18 21 9 062 599

- Align the swinging arm and install bearing stud (2).

 Tightening torques		
Floating bearing stud (swinging arm) to frame		
M24 x 1.25	Initial torque, 20 Nm	
Lubricate thread and bearing seat, Optimoly TA	Loosen	
	Final torque, 7 Nm	

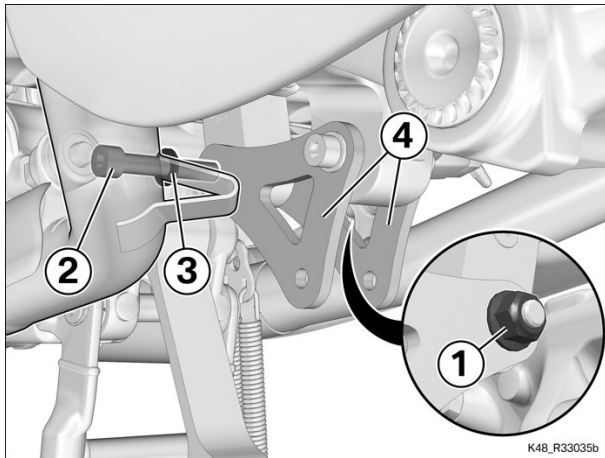
- Tighten locknut (1) with socket wrench insert (No. 33 6 641), while counter-holding bearing stud (2) with Allen key (No. 33 6 642).



 Tightening torques		
Locknut (bearing stud) to frame		
M24 x 1.25	145 Nm	

- Swing relay plates (4) up and hold in position.
- Install screw (2) with washer (3) and nut (1).

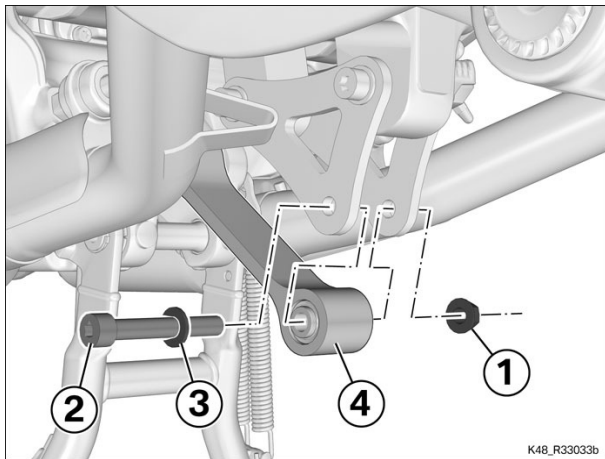

 Tightening torques		
Deflectors to spring strut		
M10 x 70 - 10.9, Replace nut Mechanical thread lock	42 Nm	

- Swing link strut (4) up and hold it in position.
- Install screw (2) with washer (3) and nut (1).

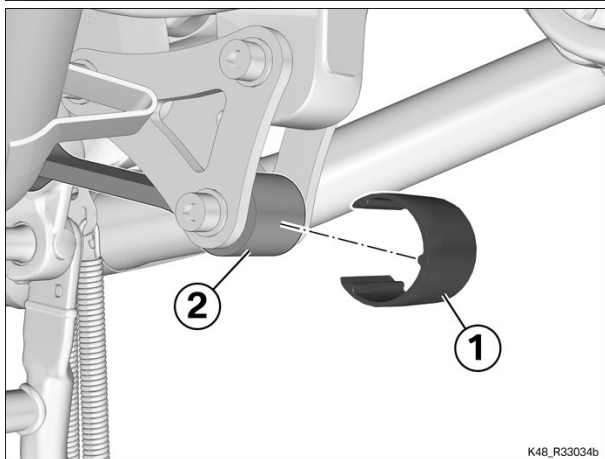

 Tightening torques		
Relay plate to swinging arm and relay lever		
M12 x 1.5 x 75 - 10.9, Replace nut Mechanical thread lock	50 Nm	

- Clip spray-protection clip (1) to link strut (2).

 Tightening torques		
Spring strut/link strut to frame		
M12 x 1.5 x 60, Replace screw Micro-encapsulated Lubricate the fitted head, Staburags NBU 30 PTM	50 Nm	

- Tighten screw (1).

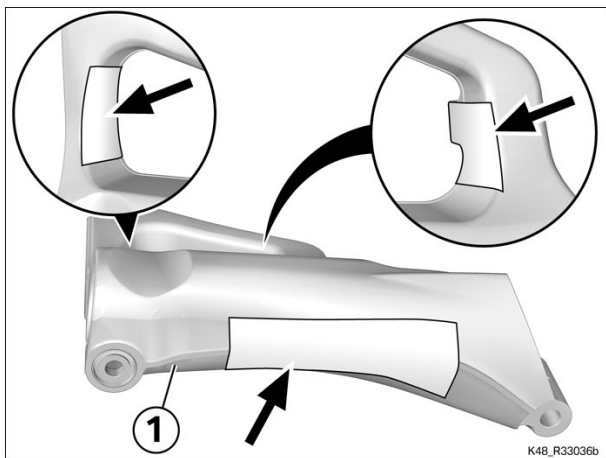
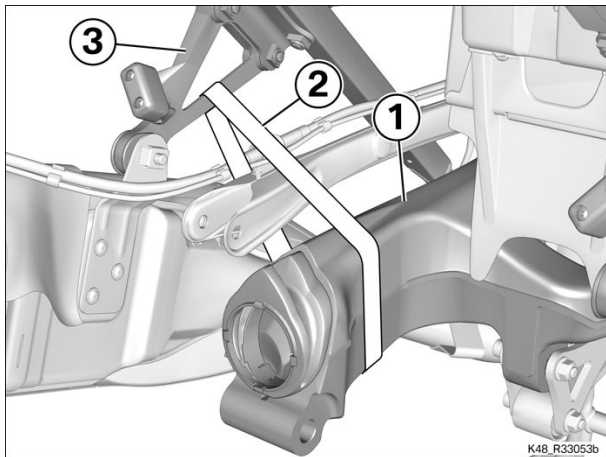
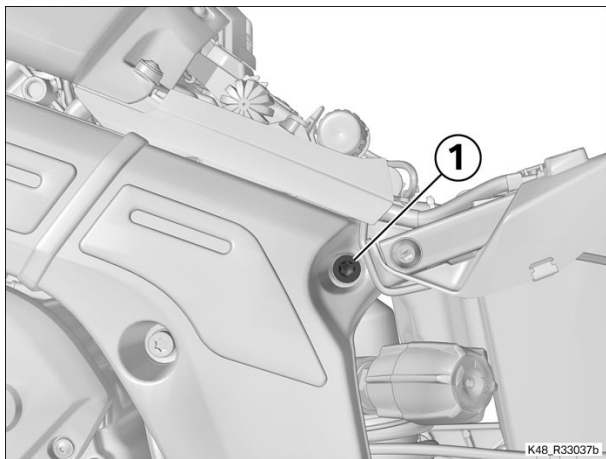



- Remove ratchet strap (2) from swinging arm (1) and footrest bracket (3).

- Remove the adhesive tapes (arrow) from swinging arm (1).

(-) Installing universal shaft

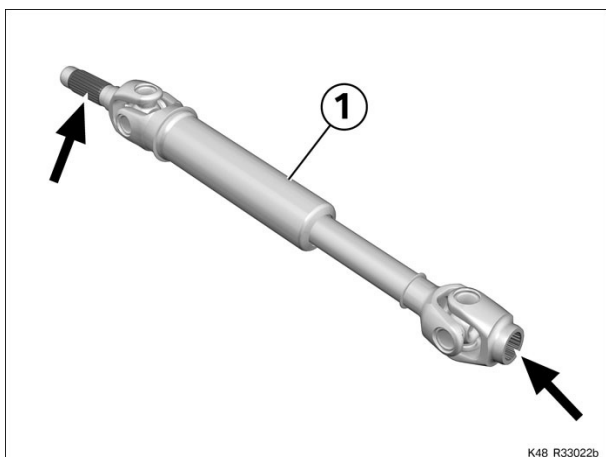
- Lubricate the splines (arrows) of universal shaft (1).



 Fluids and lubricants		
Optimoly TA	High-temperature assembly grease	18 21 9 062 599

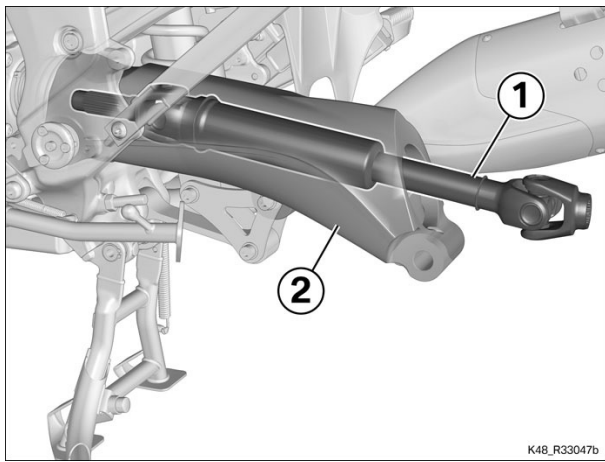

Insert universal shaft (1) into swinging arm (2).

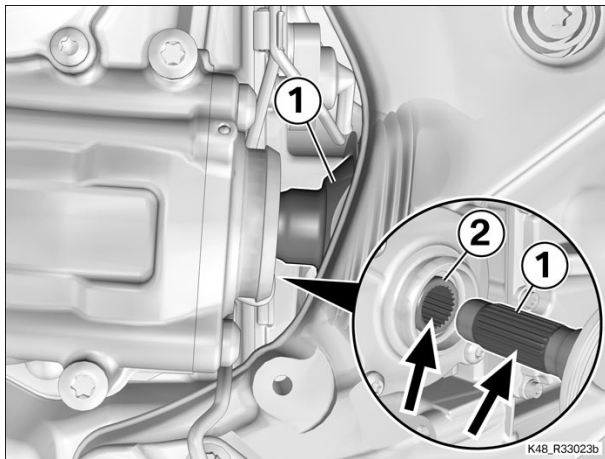

- Turn universal shaft (1) until the splines (arrows) engage.
- Slide universal shaft (1) into gearbox output shaft (2) until seated.

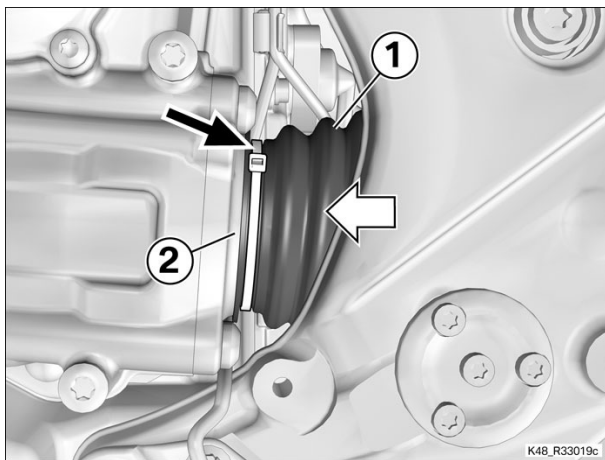

- Work flexible gaiter (1) forward on to gearbox cover (2).
- Secure the cable tie (arrow).

Finishing work

Installing bevel gears

Securing actuator rod to rear ride height sensor

Securing **Paralever** link at rear

Securing rear brake caliper

Installing rear wheel

Installing number-plate carrier

Installing left footrest plate

Installing right footrest plate

Final check of work performed

33 35 001 Replacing swinging-arm bearing

+ 33 35 502

Preparatory work

- Removing left footrest plate
- Removing right footrest plate
- Removing number-plate carrier
- Remove the rear wheel
- Removing rear brake caliper
- Releasing **Paralever** link at rear
- Disengaging actuator rod from rear ride height sensor
- Removing bevel gears
- Removing universal shaft
- Removing rear wheel swinging arm

Core activity

(-) Replacing swinging-arm bearing



Attention

Components can be damaged by hard or sharp-edged objects.
Avoid scratching the components; use masking tape if necessary.

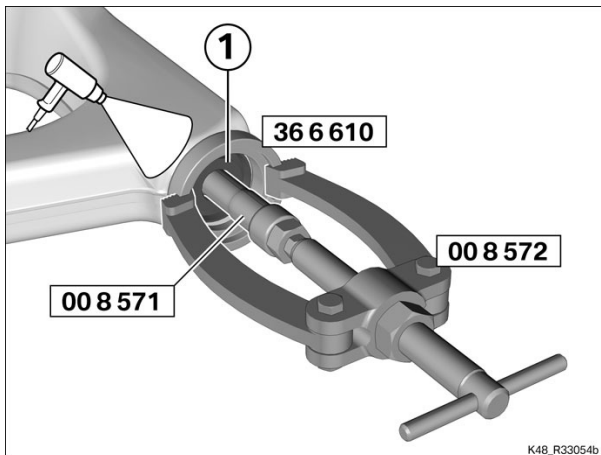

- Install reaction support (No. 00 8 572), support ring (No. 36 6 610) and internal puller 2 1/2 (No. 00 8 571).
- Heat the part of the swinging arm surrounding the bearing.



Technical data

Release/mating temperature, swinging-arm bearing		80 °C	
--	--	-------	--

- Remove bearing (1).
- Install new bearing (1) with drift (No. 33 5 700) until flush.

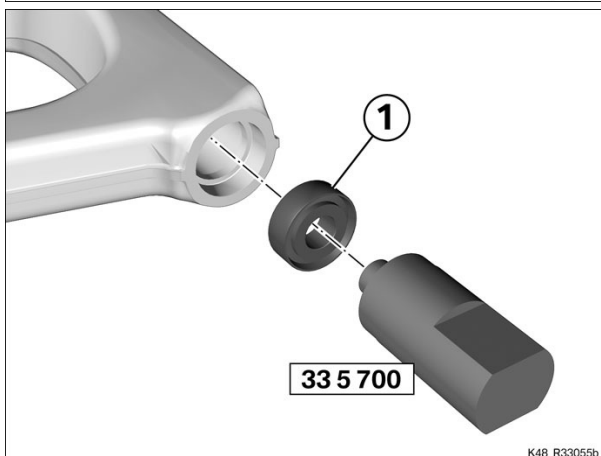

- Install the second bearing in the same way.

(-) Removing deflector panels

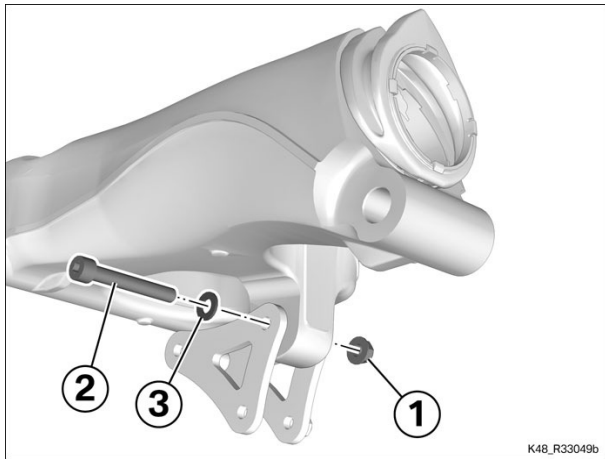

- Remove nut (1) and screw (2) with washer (3).

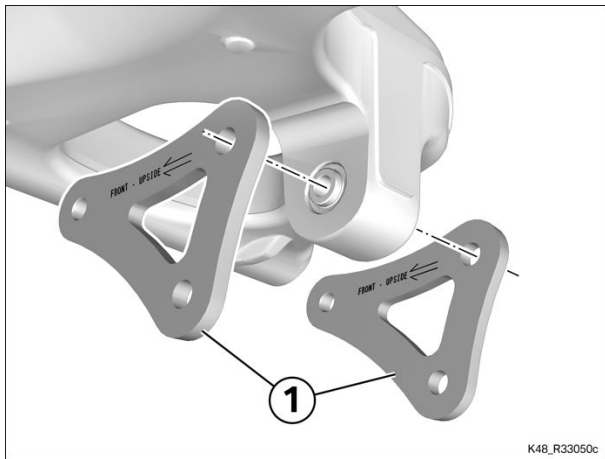

- Remove deflector panels (1).

(-) Removing relay bearing



Attention

Components can be damaged by hard or sharp-edged objects. Avoid scratching the components; use masking tape if necessary.

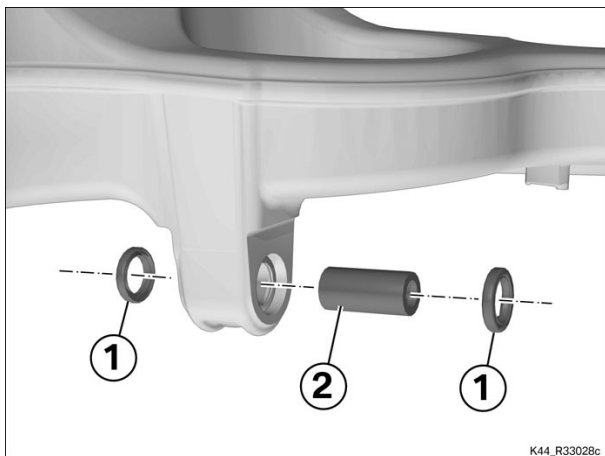

- Use a suitable tool to remove shaft sealing rings (1).
- Remove bearing bushing (2).

- Remove needle roller bearing (3) with drift (No. 36 3 700) and bushing (No. 33 2 533).

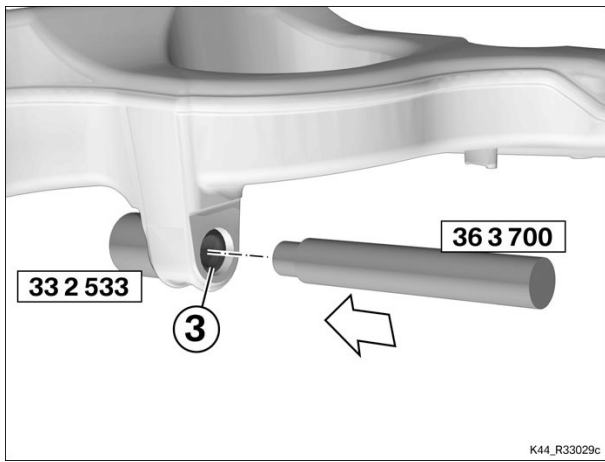

(-) Installing relay bearing



Attention

Components can be damaged by hard or sharp-edged objects. Avoid scratching the components; use masking tape if necessary.

- Position the swinging arm on bushing (No. 33 2 533).
- Install needle roller bearing (3) with drift (No. 36 3 700).

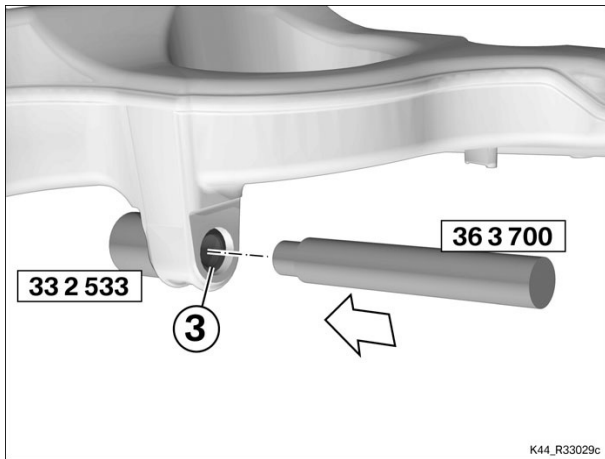

- Install bearing bushing (2).
- » Bearing bushing (2) is centred in the mount.
- Install shaft sealing rings (1).

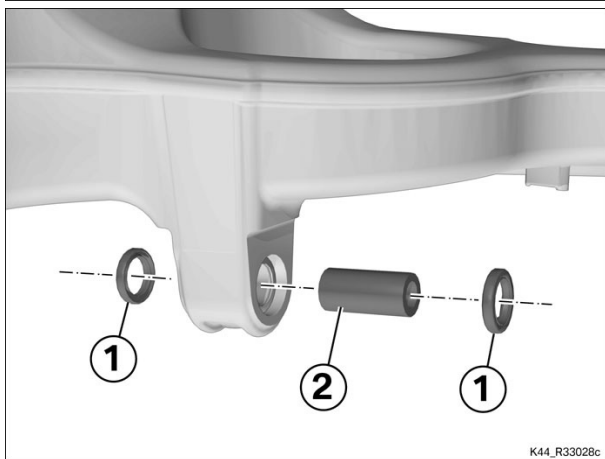

(-) Installing deflector panels

- Hold relay plates (1) in position.
- » The marks (arrows) are at the top and face in the forward direction of travel.

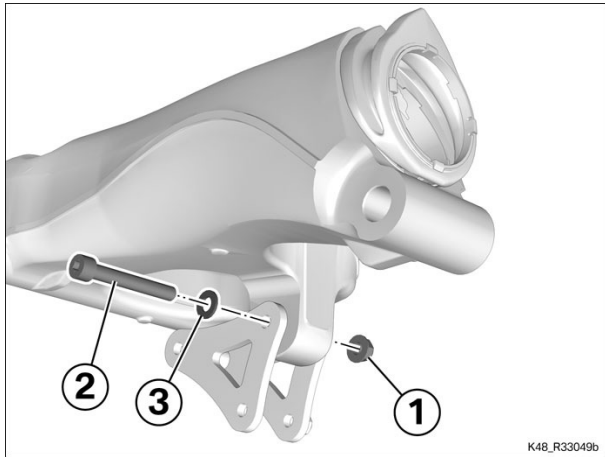
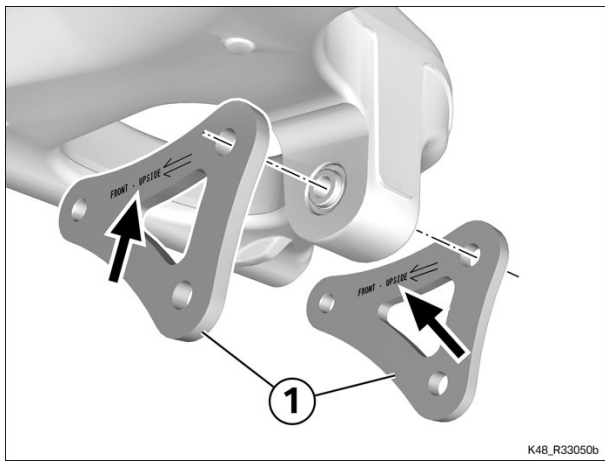

- Install screw (2) with washer (3) and nut (1).

 Tightening torques	
Relay plate to swinging arm and relay lever	
M12 x 1.5 x 75 - 10.9, Replace nut	50 Nm
Mechanical thread lock	

Finishing work

- Installing rear swinging arm
- Installing universal shaft
- Installing bevel gears
- Securing actuator rod to rear ride height sensor
- Securing **Paralever** link at rear
- Securing rear brake caliper
- Installing rear wheel
- Installing number-plate carrier
- Installing left footrest plate
- Installing right footrest plate
- Final check of work performed

📁 33 54 000 Replacing rear spring strut 11 FRUs

+ 33 54 500

Equipment trim-level variant:

0416 - Electronic Suspension Adjustment (ESA)

Preparatory work

- Remove the front seat
- Remove the rear seat
- Removing left rear trim panel
- Removing right rear trim panel
- Removing adjusting plate
- Removing seat support
- Releasing expansion tank
- Removing right footrest plate
- Removing silencer
- Removing left footrest plate
- Disengaging actuator rod from rear ride height sensor
- Raising rear frame

Core activity

(-) Removing rear spring strut

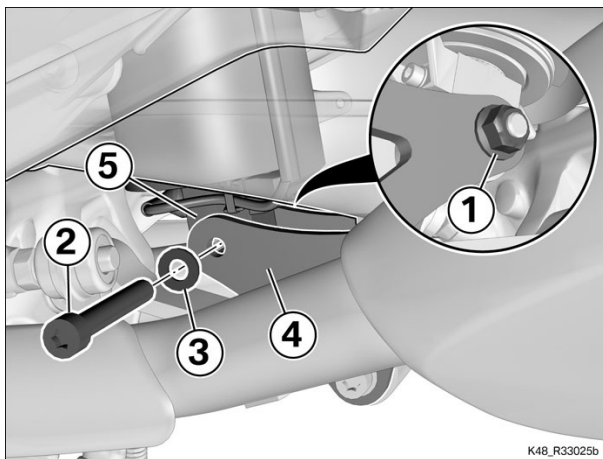

- Remove nut (1) and screw (2) with washer (3).
- Disengage deflectors (4) from spring strut (5).

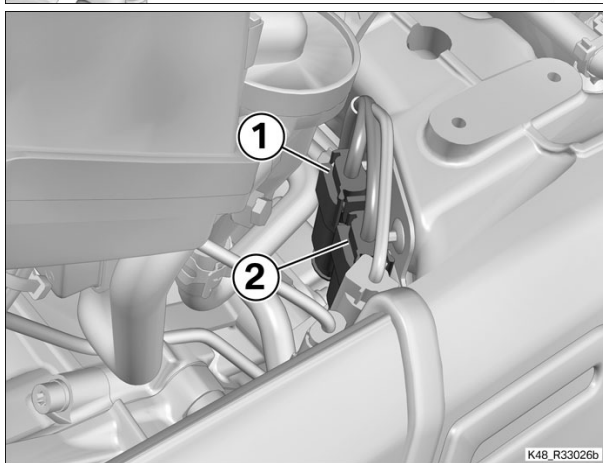

- Remove and disconnect plugs (1) and (2) for **ESA** spring strut and work them clear of the motorcycle.

- Remove screw (1).
- Remove spring strut (2).

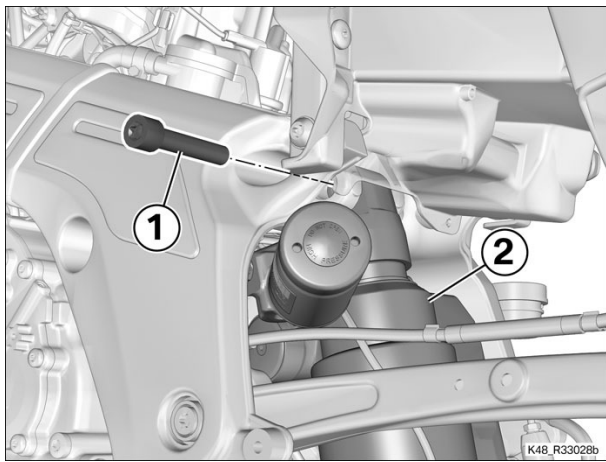

(-) Installing rear spring strut

- Install spring strut (5).
- Hold deflectors (4) in position on spring strut (5).
- Install screw (2) with washer (3) and new nut (1).

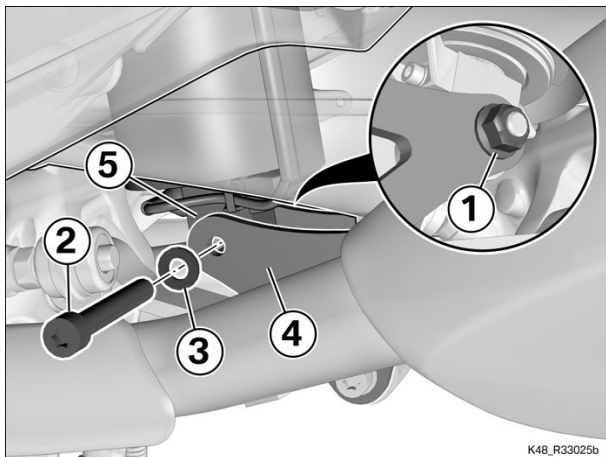

 Tightening torques		
Deflectors to spring strut		
M10 x 70 - 10.9, Replace nut	42 Nm	
Mechanical thread lock		

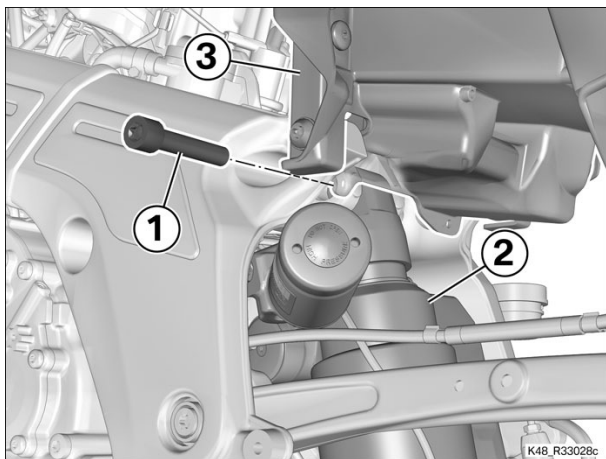

- Clean the tapped hole.
- Work spring strut (2) into position in rear frame (3) and install by moving rear frame (3).
- Lubricate new screw (1) and install.

 Tightening torques		
Spring strut/link strut to frame		
M12 x 1.5 x 60, Replace screw	50 Nm	
Micro-encapsulated		
Lubricate the fitted head, Staburags NBU 30 PTM		

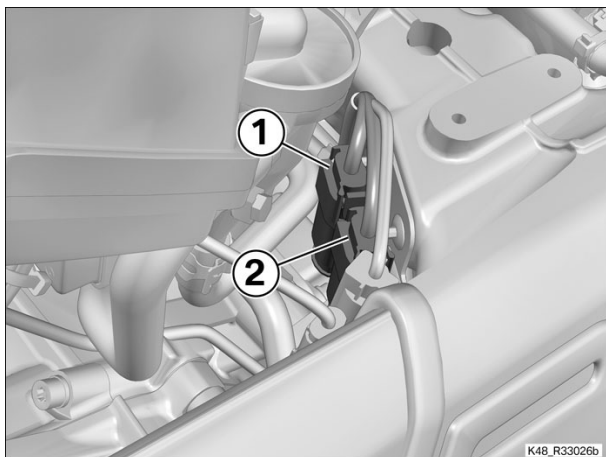

- Work plugs (1) and (2) for **ESA** spring strut into position, connect and install.
- Close the cable ties (arrows).

Finishing work

Lowering rear frame

Securing actuator rod to rear ride height sensor

Installing left footrest plate

Securing silencer

Installing right footrest plate

Securing expansion tank

Installing seat support

Installing adjusting plate

Installing right rear trim panel

Installing left rear trim panel

Connecting **BMW Motorrad** diagnostic system to motorcycle

Preparation for initialising/calibrating new parts

Disconnecting **BMW Motorrad** diagnostic system from motorcycle

Installing rear seat

Installing front seat

Final check of work performed

33 54 005 Replacing link strut 3 FRUs

+ 33 54 508

Preparatory work

Removing left catalytic-converter shield

Core activity

(-) Removing link strut

- Unclip spray guard (1) from link strut (2).

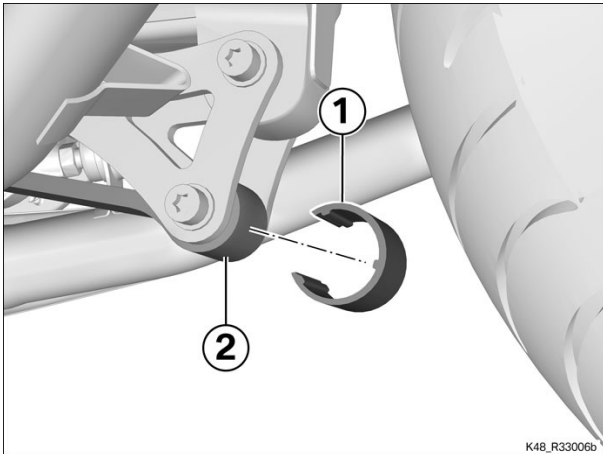

- Remove nut (1) and screw (2) with washer (3).
- Pivot link strut (4) down.

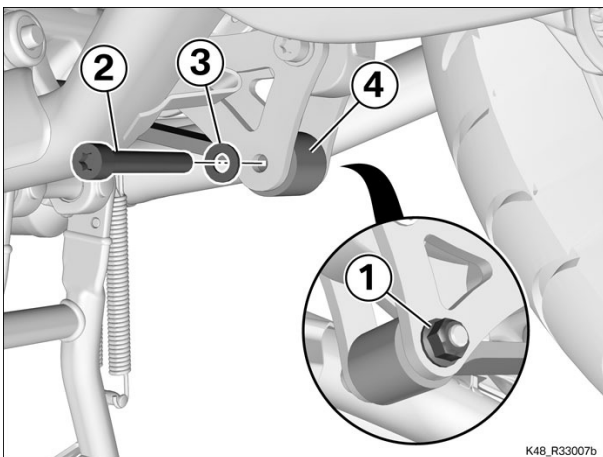

- Remove screw (1).
- Remove link strut (2).

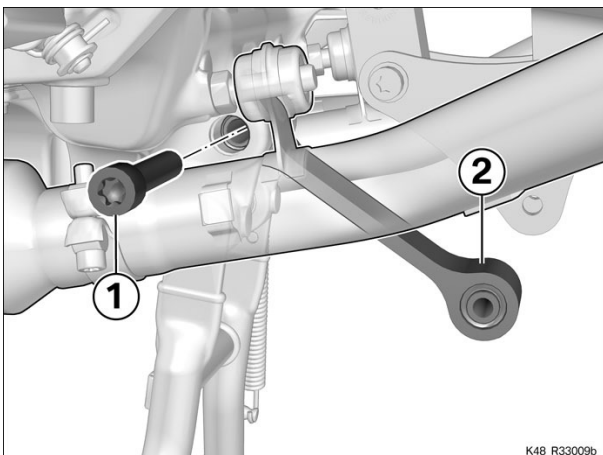

(-) Installing link strut

- Clean the tapped hole.
- Install link strut (2).
- Install new screw (1).

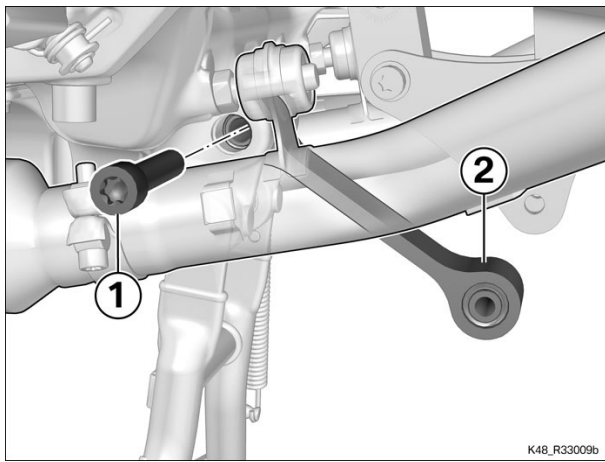

Tightening torques

Spring strut/link strut to frame

M12 x 1.5 x 60, Replace screw Micro-encapsulated Lubricate the fitted head, Staburags NBU 30 PTM	50 Nm	
---	-------	--

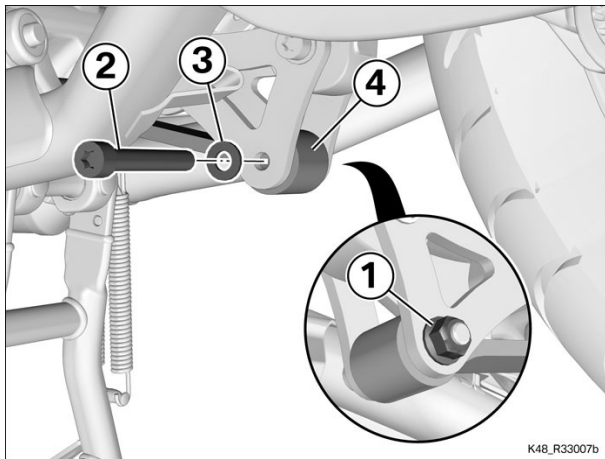

- Swing link strut (4) up and hold it in position.
- Install screw (2) with washer (3) and new nut (1).



Tightening torques

Relay plate to swinging arm and relay lever

M12 x 1.5 x 75 - 10.9, Replace nut Mechanical thread lock	50 Nm	
--	-------	--

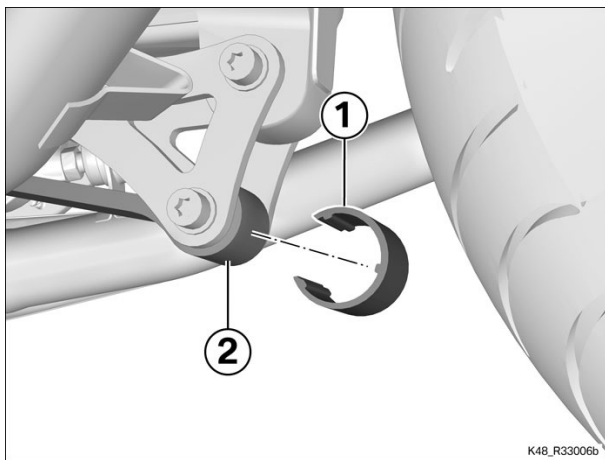

- Clip spray guard (1) (**black**) to link strut (2).

Finishing work

Installing left catalytic-converter shield

Final check of work performed

33 73 000 Removing/installing or replacing universal shaft 5 FRUs

+ 33 73 500

Preparatory work

- Removing number-plate carrier
- Remove the rear wheel
- Removing rear brake caliper
- Releasing **Paralever** link at rear
- Lowering bevel gears
- Removing flexible gaiter for bevel bears

Core activity

(-) Removing universal shaft

- Remove cable tie (arrow).
- Work flexible gaiter (1) to the rear to remove.

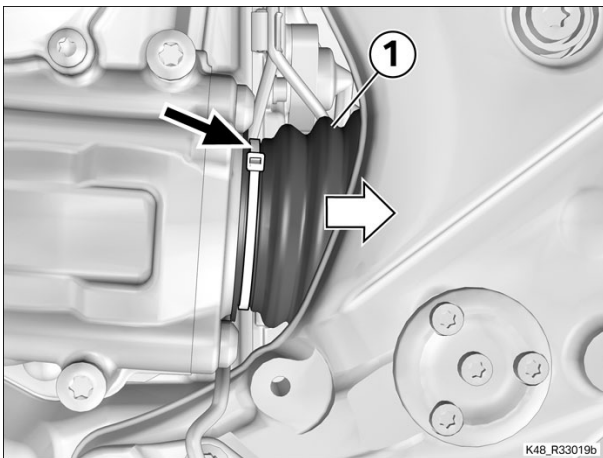

- Use a suitable tool to press universal shaft (1) to the rear.

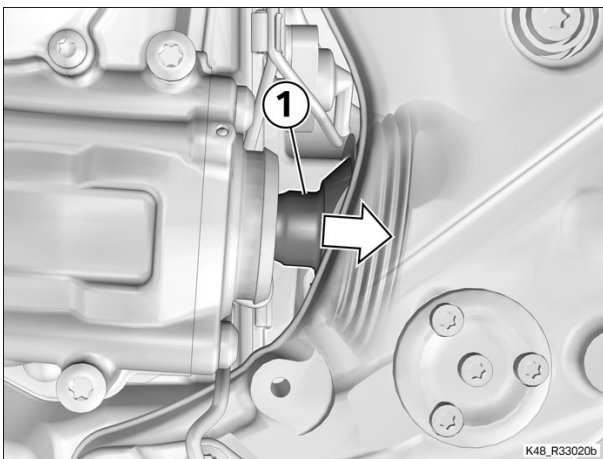

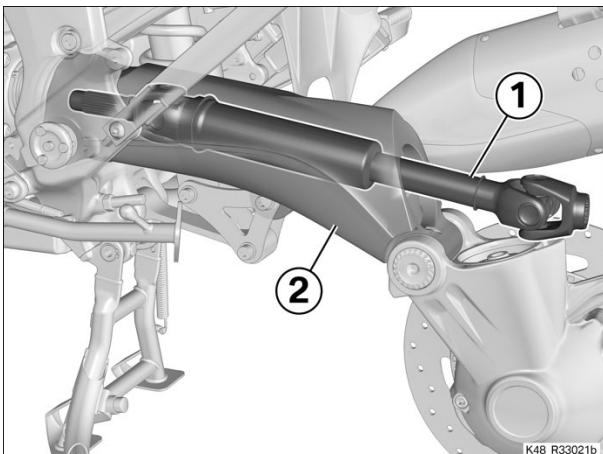

- Ease universal shaft (1) out of swinging arm (2).

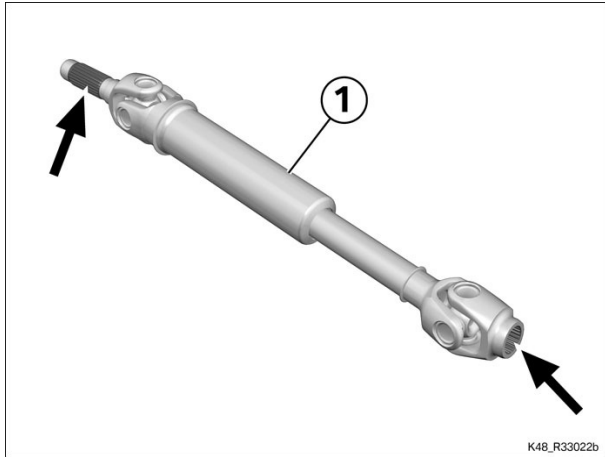

(-) Installing universal shaft

- Lubricate the splines (arrows) of universal shaft (1).



 <p>Fluids and lubricants</p>		
Optimoly TA	High-temperature assembly grease	18 21 9 062 599

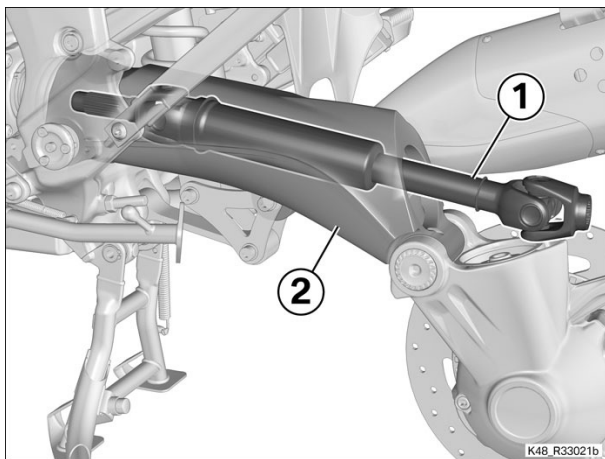

- Ease universal shaft (1) into swinging arm (2), moving the swinging arm back and forth slightly to facilitate installation.

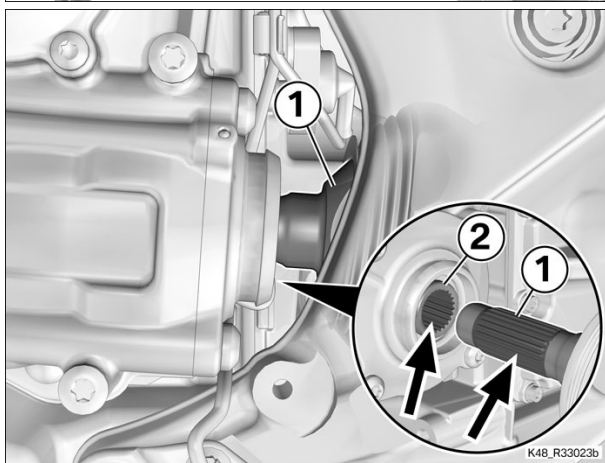

- Turn universal shaft (1) until the splines (arrows) engage.
- Slide universal shaft (1) into gearbox output shaft (2) until seated.

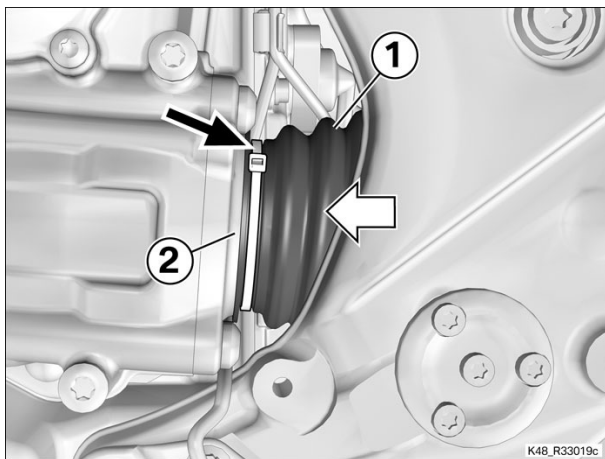

- Work flexible gaiter (1) forward on to gearbox cover (2).
- Secure the cable tie (arrow).

Finishing work

- Swinging bevel gears up
- Securing **Paralever** link at rear
- Securing rear brake caliper
- Installing rear wheel
- Installing number-plate carrier
- Final check of work performed

📁 33 74 000 Oil change in rear bevel gears 4 FRUs

+ 33 74 500

Preparatory work

Removing number-plate carrier

Remove the rear wheel

Core activity

(-) Changing oil in bevel gears



Note

Change gearbox oil, warmed to normal operating temperature.

▶ Draining oil in bevel gears

- Place a suitable tray underneath the bevel gears to catch escaping oil.

▷ Removing oil filler plug, bevel gears

- Remove oil filler plug (1) with O-ring (2).

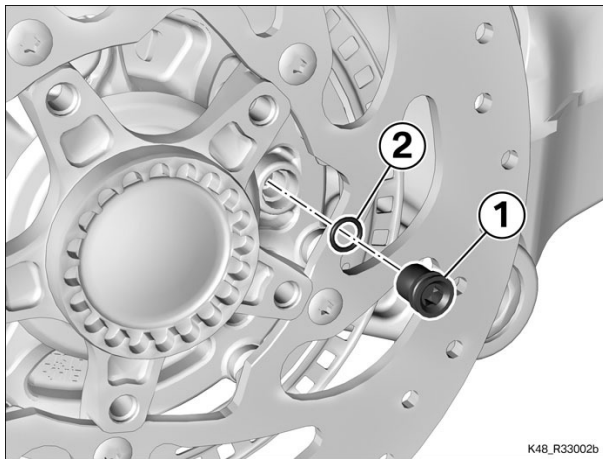

▷ Removing drain plug, bevel gears

- Remove drain plug (1) with O-ring (2).

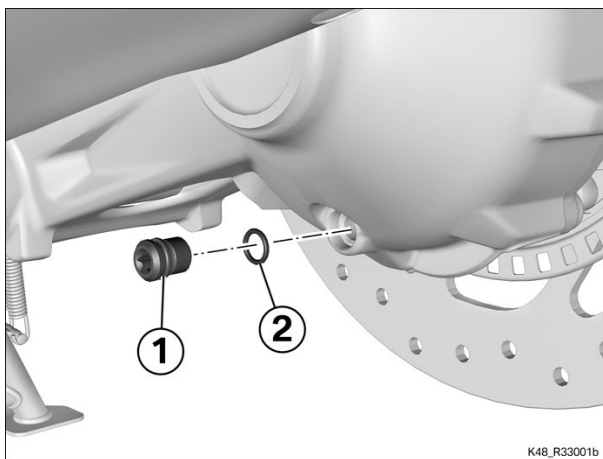

- Allow all the oil to drain off.



▶ Filling bevel gears with oil (oil change)

▷ Installing drain plug, bevel gears

- Check O-ring (2) for damage; replace if necessary.

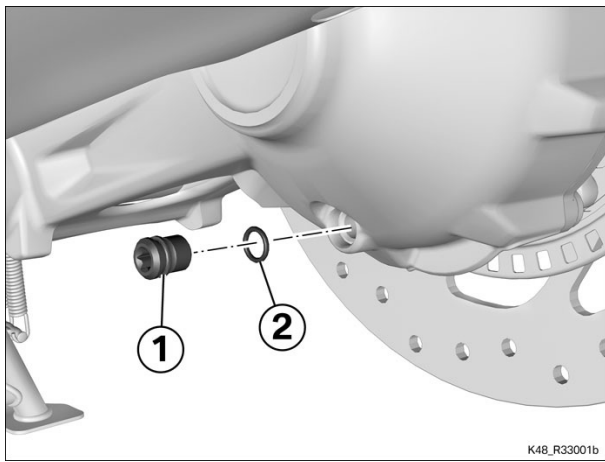

- Install drain plug (1) with O-ring (2).

 Tightening torques		
Drain plug in bevel gears		
M12 x 1	20 Nm	

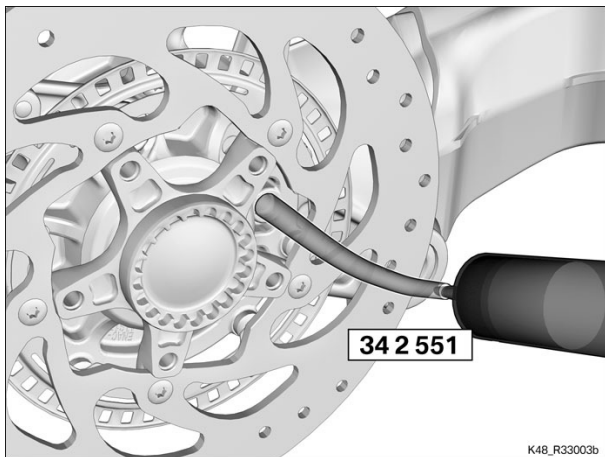

- ◁ Use syringe (No. 34 2 551) to inject the gear oil slowly through the filler neck into the housing.

 Technical data		
Bevel gears, oil capacity	oil change	180 ml
	Fluids and lubricants	
	Castrol SAF-XO	

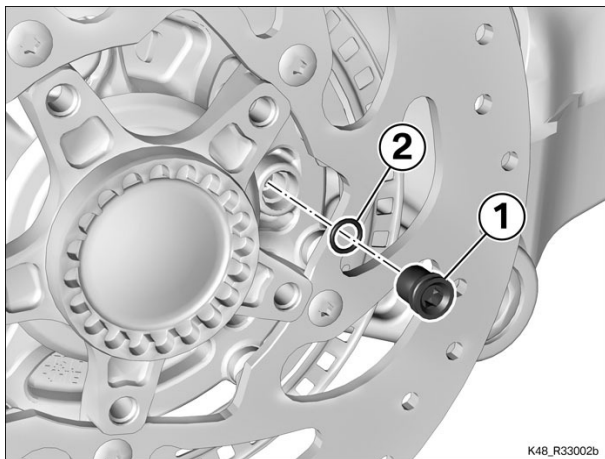

▷ **Installing oil filler plug, bevel gears**

- Check O-ring (2) for damage; replace if necessary.
- Install oil filler plug (1) with O-ring (2).

 Tightening torques		
Oil filler screw in cover of bevel gears		
M12 x 1	20 Nm	



Finishing work

- Installing rear wheel
- Installing number-plate carrier
- Final check of work performed

📁 33 74 001 Removing/installing rear bevel gears 7 FRUs

+ 33 74 501



Warning

Failure/breakage of the knuckle lever would cause the tail section to drop suddenly.

If a component that is part of the rear suspension has to be replaced because of an external effect/impact, it is important to replace the knuckle lever as well.

Preparatory work

Removing number-plate carrier

Remove the rear wheel

Removing rear brake caliper

Releasing **Paralever** link at rear

Core activity

(-) Removing bevel gears

► Lowering bevel gears

- Lower bevel gears (1), unclipping flexible gaiter (2).

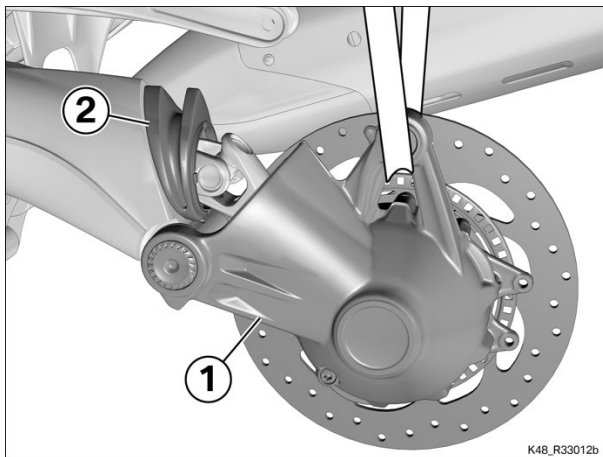

► Removing cover for bevel gears

- Drill a pilot hole in the centre of cover (1).

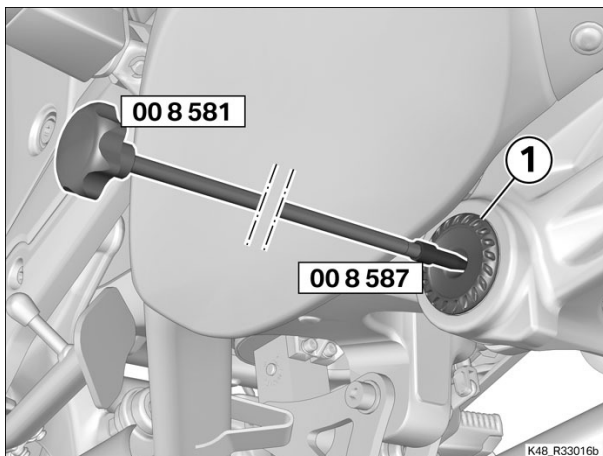

 Technical data			
Drill diameter		3 mm	

- Remove cover (1) with pull rod (No. 00 8 581) and adapter (No. 00 8 587).



- Remove screw (1) with bearing stud (2) and sealing ring (3), counter-holding bearing stud (4).

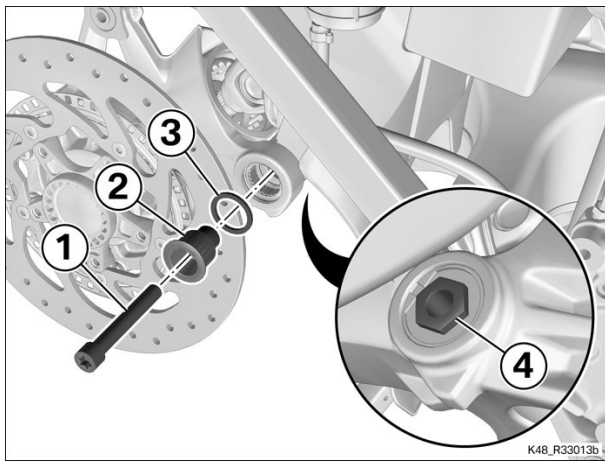

- Remove bearing stud (4), if necessary using a suitable tool to drive it out.

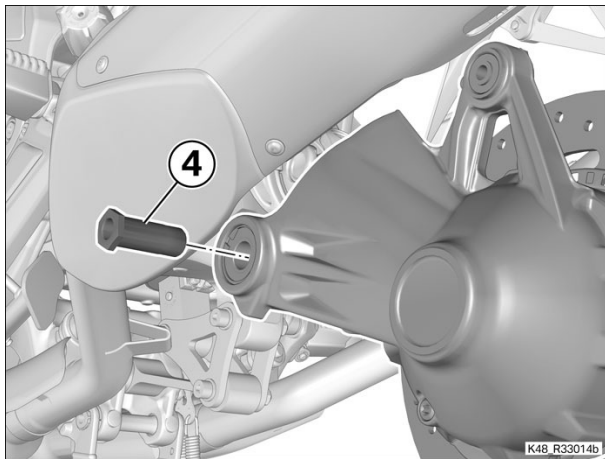

- Separate bevel gears (1) from universal shaft (2) and remove.
- When setting down bevel gears **always keep the assembly upright**, never lay it flat.

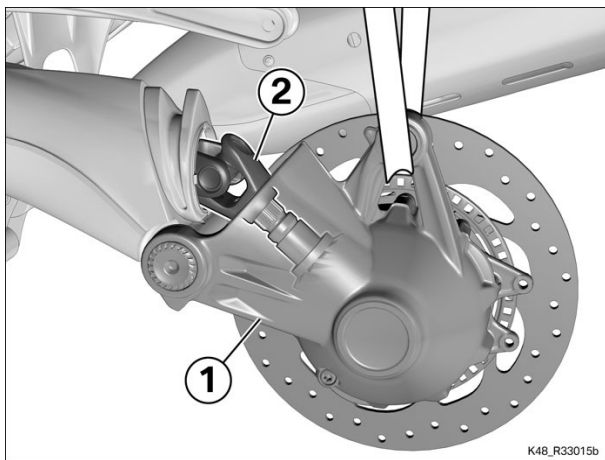

(-) Removing flexible gaiter for bevel bears

- Remove flexible gaiter (1) with clips (2) and (3).

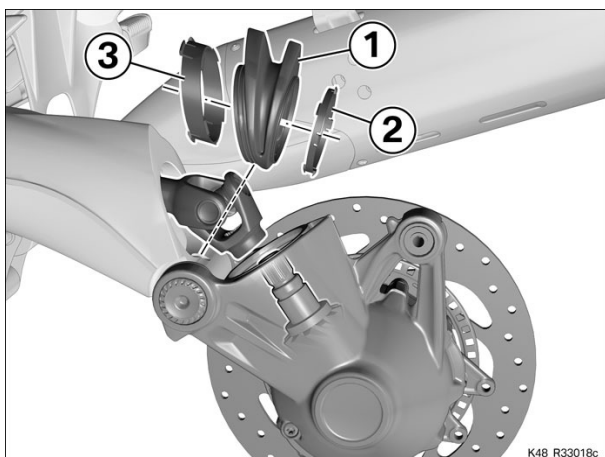

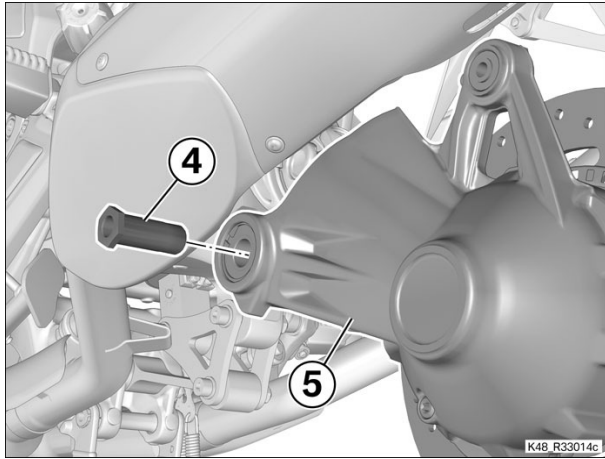

(-) Installing bevel gears

- Hold bevel gears (5) in position.
- Clean the tapped hole in bearing stud (4).
- Install bearing stud (4).

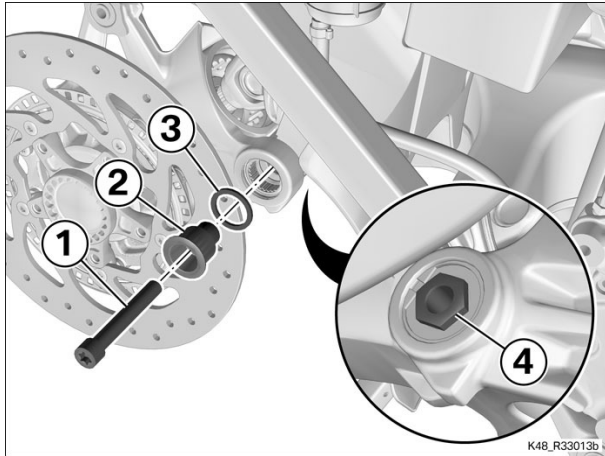

- Check sealing ring (3) for damage; replace if necessary.
- Install bearing stud (2) with sealing ring (3).
- Install new screw (1), while counter-holding at bearing stud (4).

 Tightening torques		
Bevel gears to swinging arm		
M12 x 1.5 x 80 - 10.9, Replace screw Micro-encapsulated	100 Nm	

► Installing cover of bevel gears

- Install new cover (1).

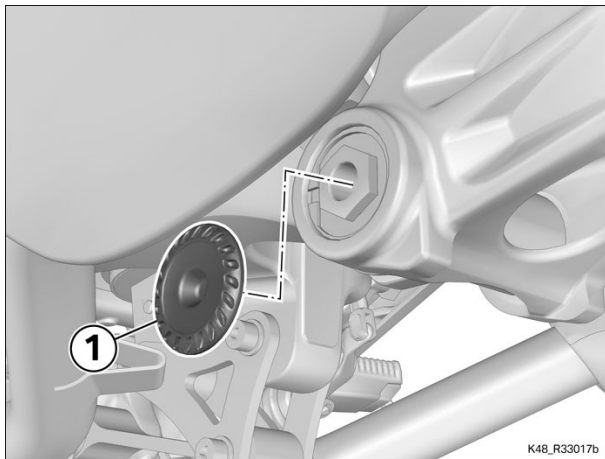

► Swinging bevel gears up

- Lubricate the splines of universal shaft (6) and the shaft of bevel gears (5).

 Fluids and lubricants		
Optimoly TA	High-temperature assembly grease	18 21 9 062 599

- Check that plastic inserts (1) and (2) are correctly seated in flexible gaiter (3).

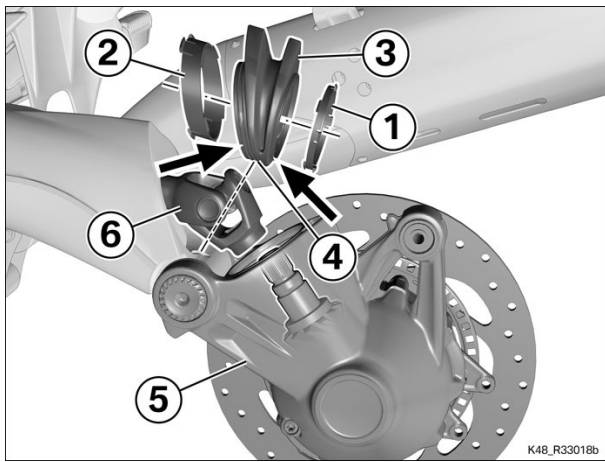

- Lubricate the mating faces (arrows) of flexible gaiter (3).

 Fluids and lubricants		
Staburags NBU 30 PTM	High-performance lubricating grease	07 55 9 056 992

- Introduce flexible gaiter (3) into the swinging arm and make sure that lug (4) engages the swinging arm.
- Swing bevel gears (5) up and introduce the shaft of the bevel gears into universal shaft (6).
- Engage flexible gaiter (3) in the threaded ring of bevel gears (5).
- Check the seat of flexible gaiter (3).



Finishing work

Securing **Paralever** link at rear

Securing rear brake caliper

Installing rear wheel

Installing number-plate carrier

Final check of work performed

📁 34 00 010 Change brake fluid in entire system 8 FRUs

+ 34 00 504

Core activity

(-) Changing brake fluid, front, and bleeding brake system



Warning

Air can be drawn into the system through the fluid replenishing hole if the fluid level in the reservoir is too low; the system has to be bled again if this happens.

Make sure that the fluid replenishing bore is always under the surface of the brake fluid throughout the entire process of fluid changing/system bleeding.



Note

This description applies for brake filling and bleeding units with vacuum extraction. If other devices are used, comply with the manufacturer's instructions.

- Set the brake lever to maximum span.

▶ Draining brake fluid reservoir on handbrake fitting



Attention

Brake fluid attacks paintwork, plastic and rubber parts.

Do not allow brake fluid to come into contact with paintwork, plastic or rubber parts.

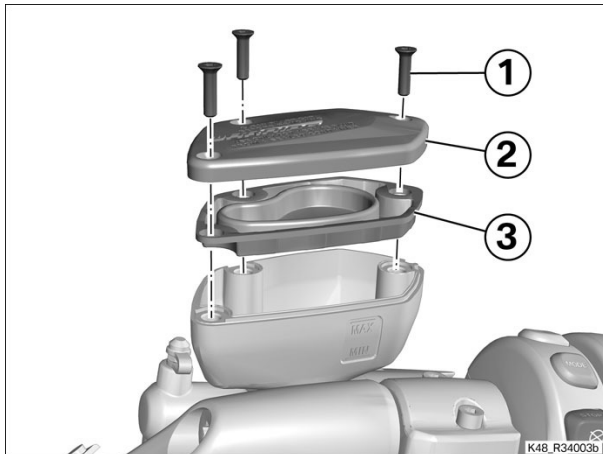

- Remove screws (1) and remove reservoir cap (2) and diaphragm (3).
- Clean reservoir, diaphragm (3) and cap (2).
- Draw off the old brake fluid.



▶ Removing front brake pads

- Remove screws (1) and remove brake-pad spring (2).

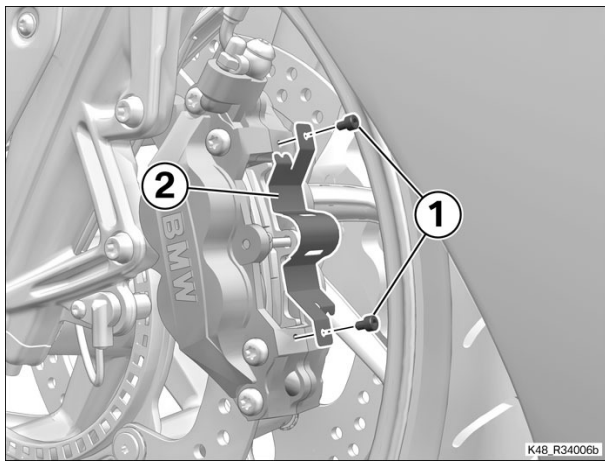

- Remove split-pin keeper (1) and locking pin (2).
- Remove brake pads (3).

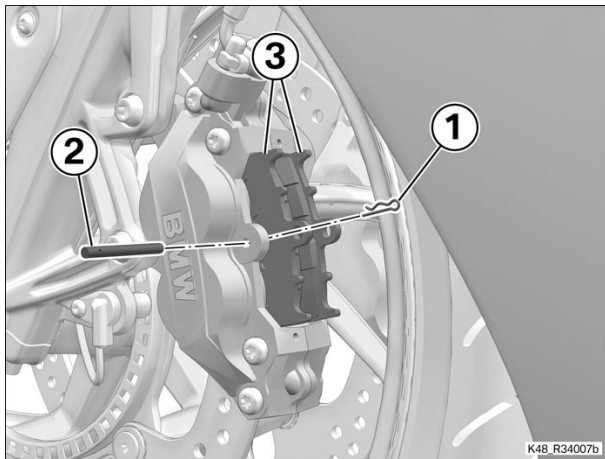

- Repeat this procedure on the other side.

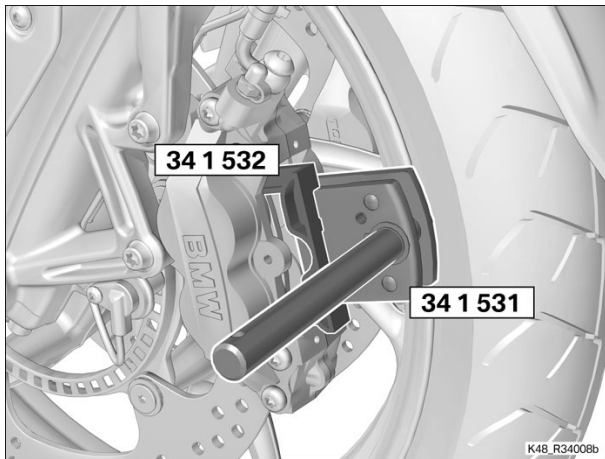

- In the **left and right** brake calipers, insert piston resetting device (No. 34 1 531) with locator (No. 34 1 532).
- Force the left and right pistons fully back with the piston resetting device.
- Draw off the excess brake fluid and clean the reservoir.

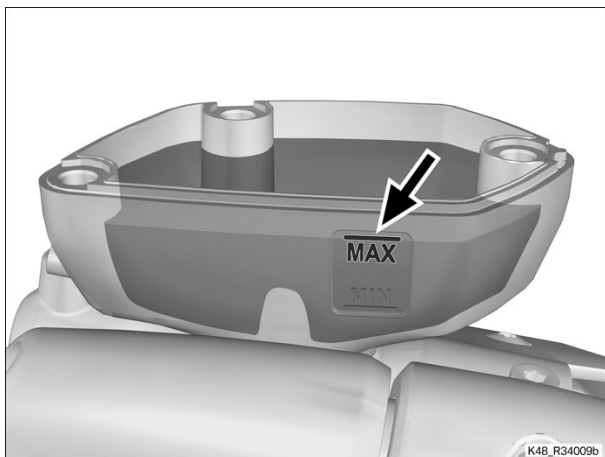

- Turn the handlebars to a position in which the brake fluid reservoir is horizontal.



Warning

Brake fluid is hygroscopic, which means that its boiling point drops once the container has been opened.

Use only new brake fluid from freshly opened containers.

- Top up with fresh brake fluid to the MAX mark (arrow).



Fluids and lubricants

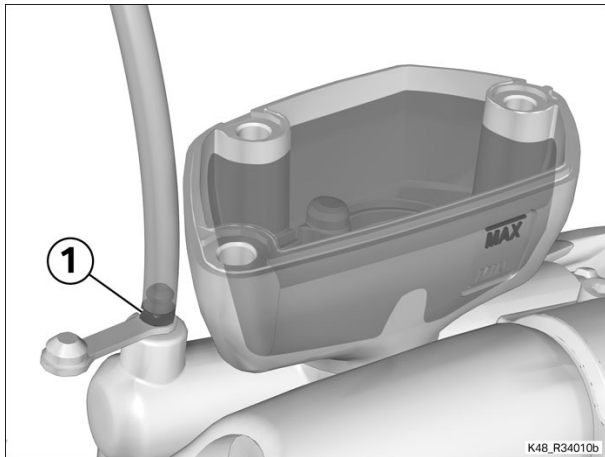

Brake fluid	Hydraulic systems	
-------------	-------------------	--

- Connect the brake bleeding device to bleed screw (1) in the handbrake cylinder.
- Slightly open bleed screw (1).
- Continue bleeding the brake system until the fresh brake fluid emerges clear and free from bubbles.
- Close bleed screw (1).

 Tightening torques		
Bleed screw to handlebar fitting		
M5	2.2 Nm	

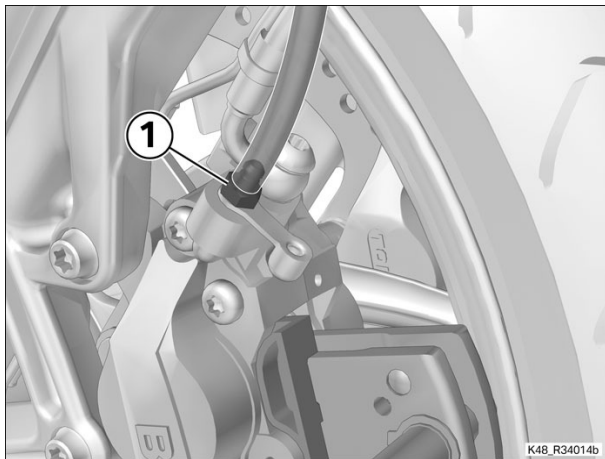

- Connect the brake bleeding device to bleed screw (1) in the left brake caliper.
- Slightly open bleed screw (1).
- Continue bleeding the brake system until fresh brake fluid emerges.



Warning

The brake-bleeding process might have been interrupted even though air remained in the system. On account of the vacuum extraction process, it is not possible to tell whether the brake fluid extracted from the system is free of bubbles.

On conclusion of the process, bleed the system manually (without vacuum extraction) until you are sure that the brake fluid expelled from the system is free of bubbles.

- Close bleed screw (1) of the left brake caliper.

 Tightening torques		
Bleed screw in front brake caliper		
M7	8 Nm	

- **Repeat the fluid-change procedure/procedure for bleeding the brakes at the right brake caliper.**
- Top up with fresh brake fluid to the MAX mark (arrow).

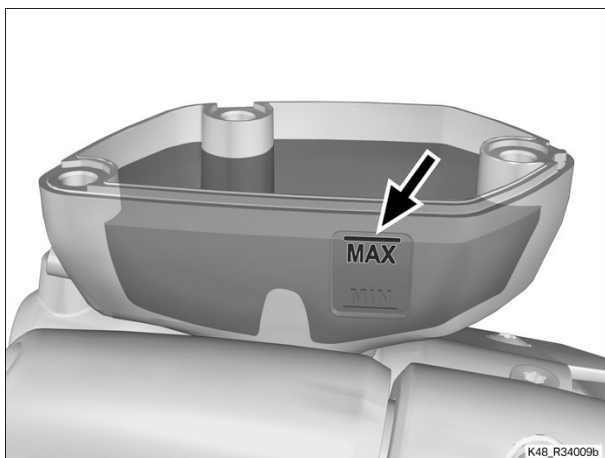

 Fluids and lubricants		
Brake fluid	Hydraulic systems	

- **Again** connect the brake bleeding device to bleed screw (1) in the handbrake cylinder.
- Slightly open bleed screw (1).
- Continue bleeding the brake system until the fresh brake fluid emerges

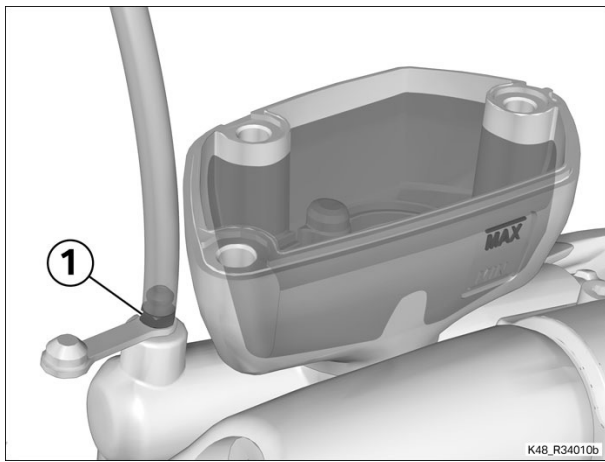

clear and free from bubbles.

- Close bleed screw (1).

Tightening torques		
Bleed screw to handlebar fitting		
M5	2.2 Nm	

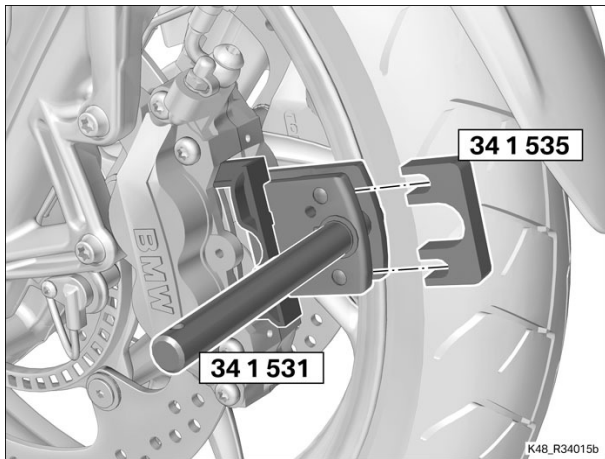

- Fit adapter 25 (No. 34 1 535) to the left and right of resetting device (No. 34 1 531) and **screw the resetting device together**.
- Pull the handbrake lever until the brake pistons are in contact with the piston resetting device.
- » This simulates the thickness of new brake pads and brake discs.

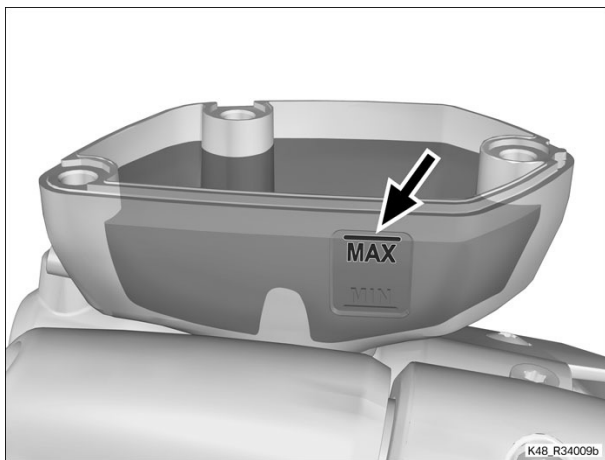

- Turn the handlebars to a position in which the brake fluid reservoir is horizontal.
- Top up with fresh brake fluid to the MAX mark (arrow).
- Expand the piston resetting device on left and right.
- » This forces back the brake pistons so that the brake pads can be installed.
- Remove the piston resetting device and locators left and right from the brake calipers.

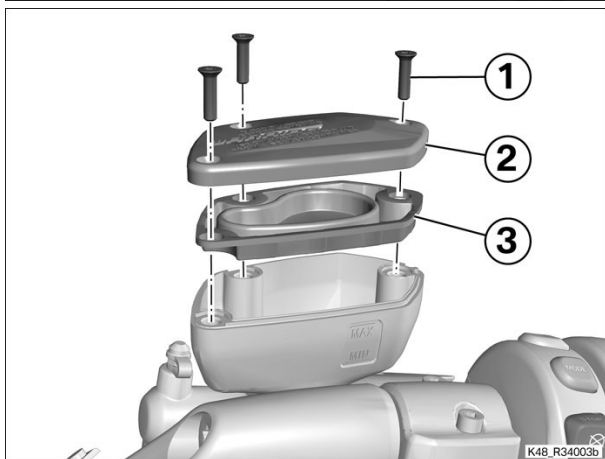

- Wipe the rim of the reservoir, diaphragm (3) and reservoir cap (2) to remove brake fluid and carefully reassemble the components.
- Install screws (1).

► Installing front brake pads

- Install brake pads (3).

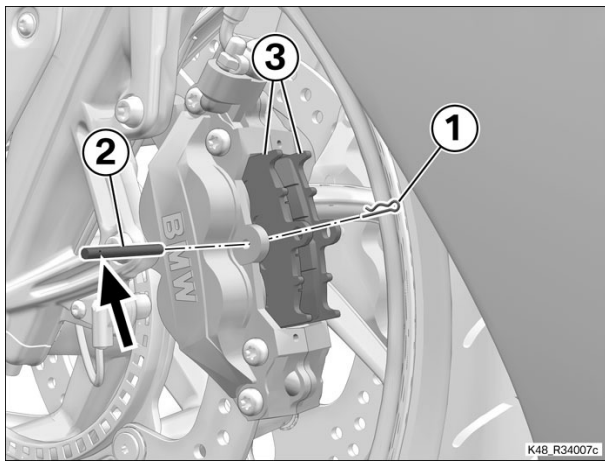

- Install locking pin (2) with the bore (arrow) facing up and secure it with split-pin keeper (1).

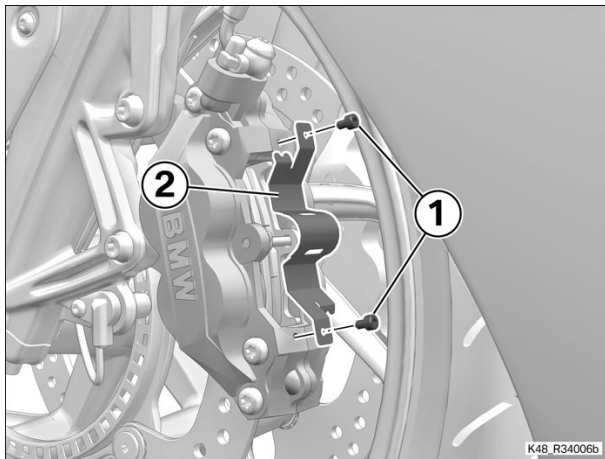

- Hold brake-pad spring (2) in position and install screws (1).

 Tightening torques		
Sheet metal spring on front brake caliper		
M4	3 Nm	

- Repeat this procedure on the other side.



► **Bedding in brake pads**

- Once the work has been completed, seat the pads against the brake discs and check operation of the brake system.



Test

- Check brake pressure by operating the brakes.

Result: Low brake pressure

Measure:

- Repeat the brake bleeding procedure **without removing the brake pads**.

(-) Change the brake fluid, rear, and bleed the brake system



Warning

Brake fluid is hygroscopic, which means that its boiling point drops once the container has been opened.

Use only new brake fluid from freshly opened containers.



Note

This description applies for brake filling and bleeding units with vacuum extraction. If other devices are used, comply with the manufacturer's instructions.

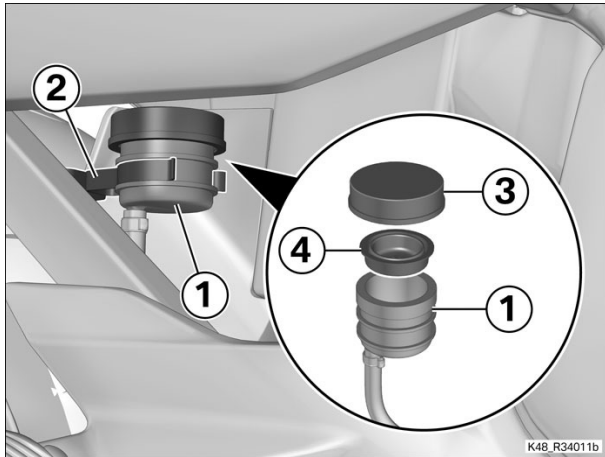

► **Draining rear reservoir**

- Disengage reservoir (1) from bracket (2).



Attention

Brake fluid attacks paintwork, plastic and rubber parts.

Do not allow brake fluid to come into contact with paintwork, plastic or rubber parts.

- Remove cap (3) while counter-holding reservoir (1).
- Remove flexible gaiter (4).
- Draw off the brake fluid from reservoir (1).

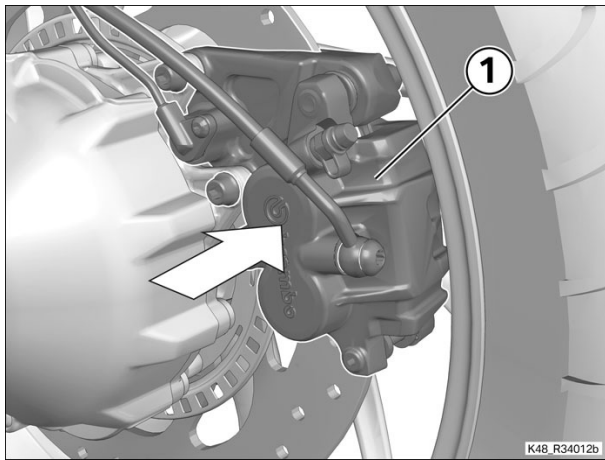

- Press brake caliper (1) against the brake disc to force the pistons back.
- Draw off the excess brake fluid that was forced back into the reservoir.

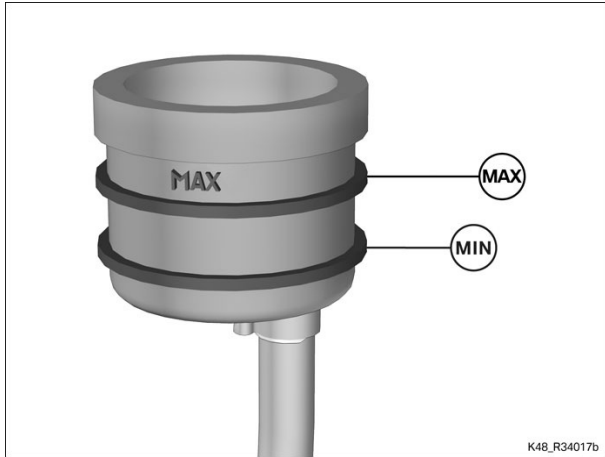

Warning

Brake fluid is hygroscopic, which means that its boiling point drops once the container has been opened.

Use only new brake fluid from freshly opened containers.

- Top up with fresh brake fluid to the (MAX) mark.



Fluids and lubricants

Brake fluid	Hydraulic systems	
-------------	-------------------	--

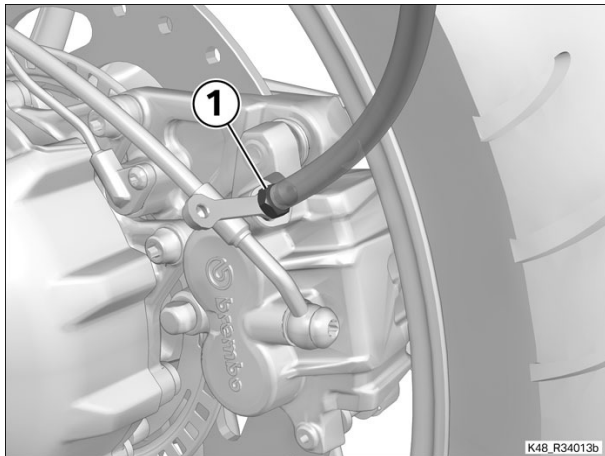

- Connect the brake bleeding device to bleed screw (1) in the brake caliper.
- Slightly open bleed screw (1).



Warning

Air can be drawn into the system through the fluid replenishing hole if the fluid level in the reservoir is too low; the system has to be bled again if this happens.

Make sure that the fluid replenishing bore is always under the surface of the brake fluid throughout the entire process of fluid changing/system bleeding.

- Continue bleeding the brake system until fresh brake fluid emerges.



Warning

The brake-bleeding process might have been interrupted even though air remained in the system. On account of the vacuum extraction process, it is not possible to tell whether the brake fluid extracted from the system is free of bubbles.

On conclusion of the process, bleed the system manually (without vacuum extraction) until you are sure that the brake fluid expelled from the system is free of bubbles.

- Close bleed screw (1) and remove the brake bleeding device.

 Tightening torques		
Bleed screw, rear, in banjo bolt		
	14 Nm	

► **Filling rear reservoir**



Warning

Brake fluid is hygroscopic, which means that its boiling point drops once the container has been opened.

Use only new brake fluid from freshly opened containers.

- Top up with fresh brake fluid to the (MAX) mark.

 Fluids and lubricants		
Brake fluid	Hydraulic systems	

- Clean all components.
- Install diaphragm (4).
- Install cap (3) while counter-holding reservoir (1).
- Secure reservoir (1) in bracket (2).

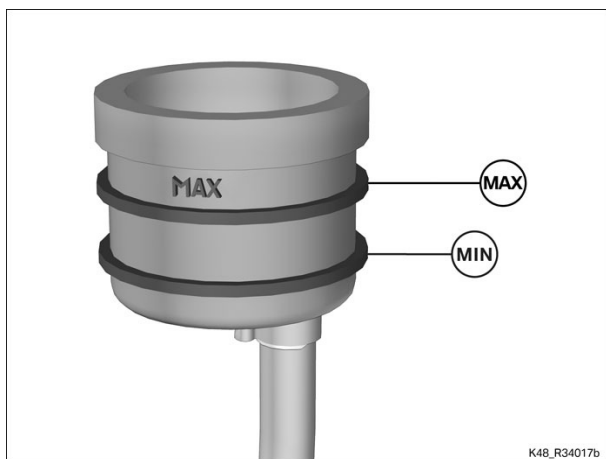

K48_R34017b

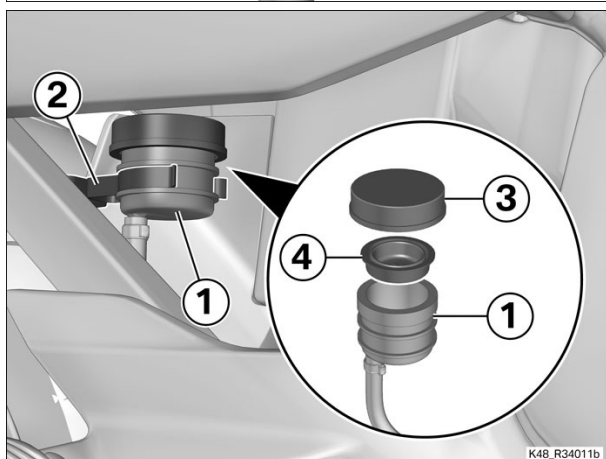

K48_R34011b



Test

- Check brake pressure by operating the brakes.

Result: Low brake pressure

Measure:

- Repeat the brake-bleeding process.

Finishing work

Final check of work performed

📁 34 00 033 Bleeding front brake system 4 FRUs

+ 34 00 507

Core activity

(-) Filling and bleeding front brake system



Warning

Air can be drawn into the system through the fluid replenishing hole if the fluid level in the reservoir is too low; the system has to be bled again if this happens.

Make sure that the fluid replenishing bore is always under the surface of the brake fluid throughout the entire process of fluid changing/system bleeding.



Note

This description applies for brake filling and bleeding units with vacuum extraction. If other devices are used, comply with the manufacturer's instructions.

- Set the brake lever to maximum span.

▶ Draining brake fluid reservoir on handbrake fitting



Attention

Brake fluid attacks paintwork, plastic and rubber parts.

Do not allow brake fluid to come into contact with paintwork, plastic or rubber parts.

- Remove screws (1) and remove reservoir cap (2) and diaphragm (3).
- Clean reservoir, diaphragm (3) and cap (2).
- Draw off the old brake fluid.

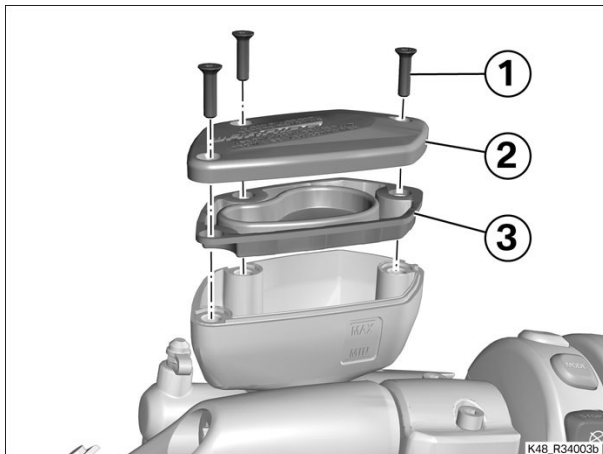

- Turn the handlebars to a position in which the brake fluid reservoir is horizontal.



Warning

Brake fluid is hygroscopic, which means that its boiling point drops once the container has been opened.

Use only new brake fluid from freshly opened containers.

- Top up with fresh brake fluid to the MAX mark (arrow).

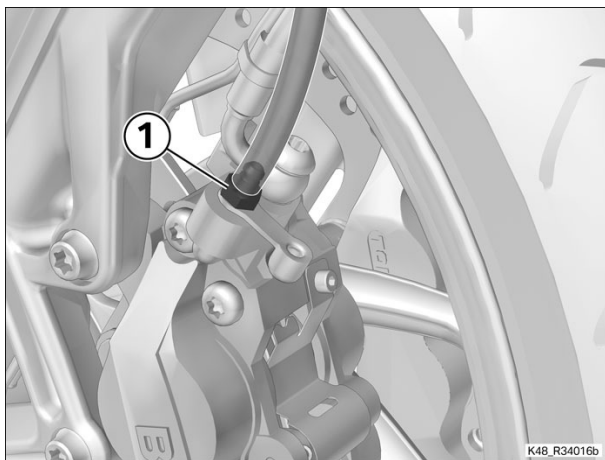
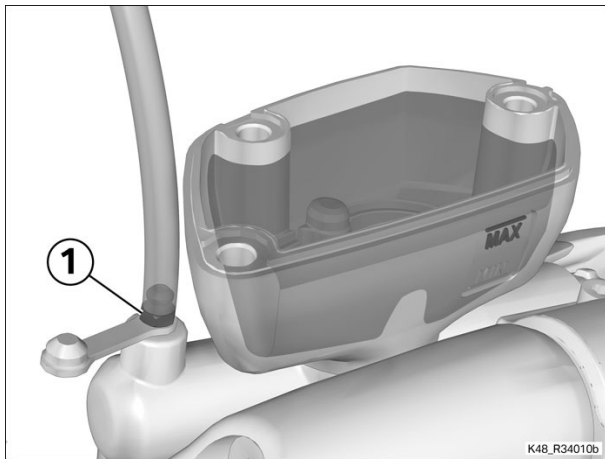
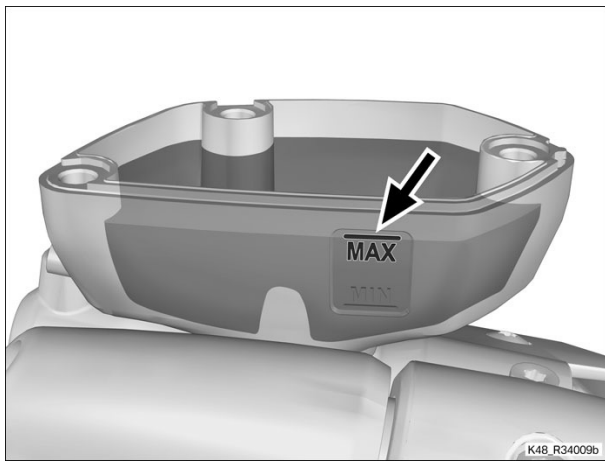

Fluids and lubricants

Brake fluid	Hydraulic systems	
-------------	-------------------	--

- Connect the brake bleeding device to bleed screw (1) in the handbrake cylinder.
- Slightly open bleed screw (1).
- Continue bleeding the brake system until the fresh brake fluid emerges clear and free from bubbles.
- Close bleed screw (1).



Tightening torques

Bleed screw to handlebar fitting		
M5	2.2 Nm	

- Connect the brake bleeding device to bleed screw (1) in the left brake caliper.
- Slightly open bleed screw (1).
- Continue bleeding the brake system until fresh brake fluid emerges.



Warning

The brake-bleeding process might have been interrupted even though air remained in the system. On account of the vacuum extraction process, it is not possible to tell whether the brake fluid extracted from the system is free of bubbles.

On conclusion of the process, bleed the system manually (without vacuum extraction) until you are sure that the brake fluid expelled from the system is free of bubbles.

- Close bleed screw (1) of the left brake caliper.



Tightening torques

Bleed screw in front brake caliper		
M7	8 Nm	

- **Repeat the fluid-change procedure/procedure for bleeding the brakes at the right brake caliper.**
- **Again** connect the brake bleeding device to bleed screw (1) in the handbrake cylinder.
- Slightly open bleed screw (1).
- Continue bleeding the brake system until the fresh brake fluid emerges clear and free from bubbles.
-

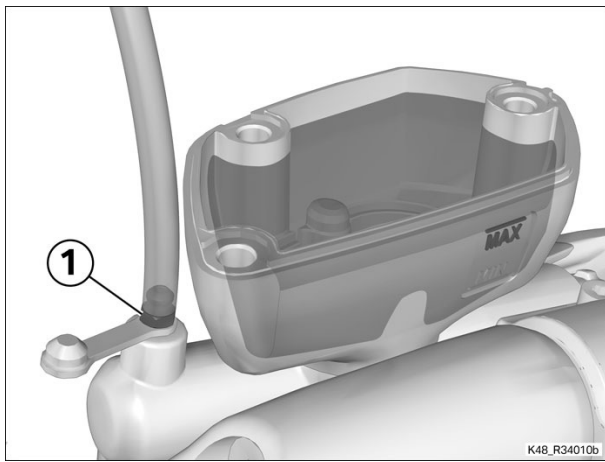

Close bleed screw (1).

Tightening torques		
Bleed screw to handlebar fitting		
M5	2.2 Nm	

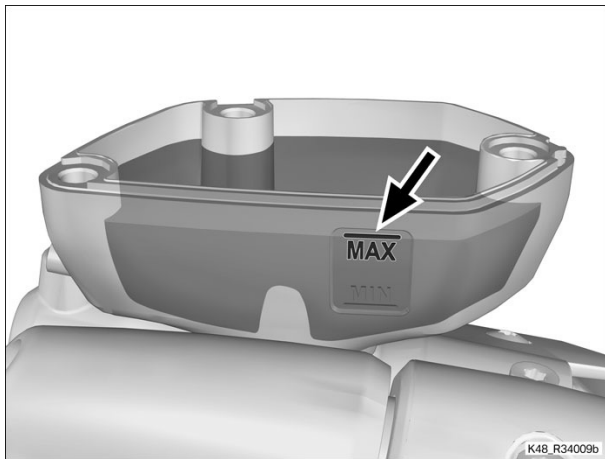

- Turn the handlebars to a position in which the brake fluid reservoir is horizontal.
- Top up with fresh brake fluid to the MAX mark (arrow).

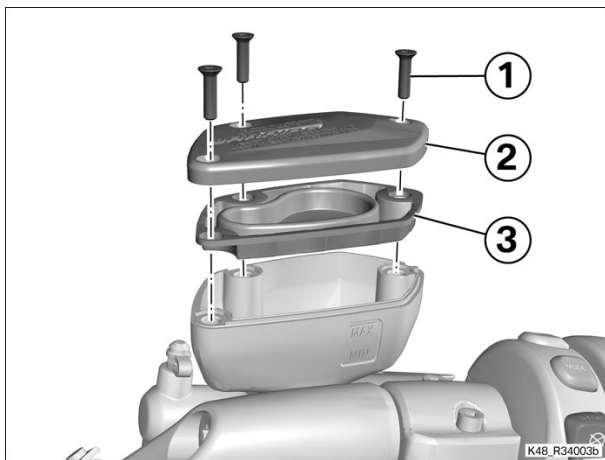

- Wipe the rim of the reservoir, diaphragm (3) and reservoir cap (2) to remove brake fluid and carefully reassemble the components.
- Install screws (1).

► Bedding in brake pads

- Once the work has been completed, seat the pads against the brake discs and check operation of the brake system.



Test

- Check brake pressure by operating the brakes.

Result: Low brake pressure

Measure:

- Repeat the brake bleeding procedure **without removing the brake pads**.

Finishing work

Final check of work performed

📁 34 00 035 Bleeding rear brake system 3 FRUs

+ 34 00 509

Core activity

(-) Bleeding rear brake system



Warning

Brake fluid is hygroscopic, which means that its boiling point drops once the container has been opened.

Use only new brake fluid from freshly opened containers.



Note

This description applies for brake filling and bleeding units with vacuum extraction. If other devices are used, comply with the manufacturer's instructions.

▶ Draining rear reservoir

- Disengage reservoir (1) from bracket (2).



Attention

Brake fluid attacks paintwork, plastic and rubber parts.

Do not allow brake fluid to come into contact with paintwork, plastic or rubber parts.

- Remove cap (3) while counter-holding reservoir (1).
- Remove flexible gaiter (4).
- Draw off the brake fluid from reservoir (1).

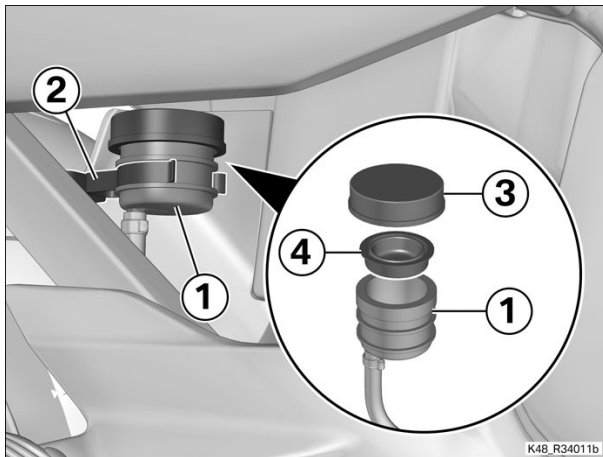

- Press brake caliper (1) against the brake disc to force the pistons back.
- Draw off the excess brake fluid that was forced back into the reservoir.

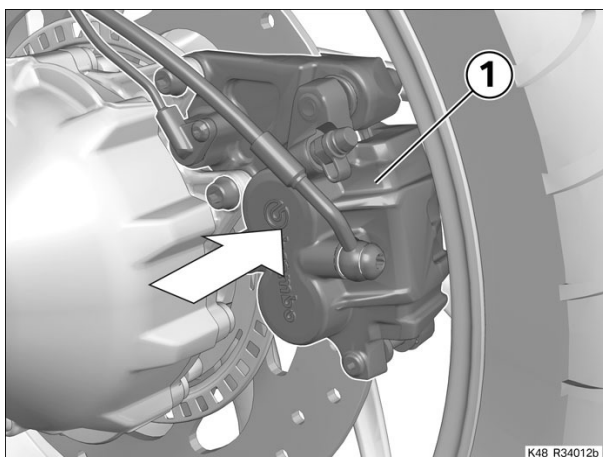

Warning

Brake fluid is hygroscopic, which means that its boiling point drops once the container has been opened.

Use only new brake fluid from freshly opened containers.

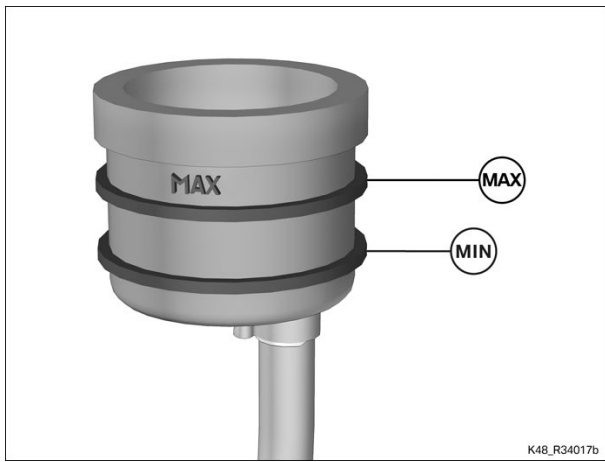

K48_R34017b

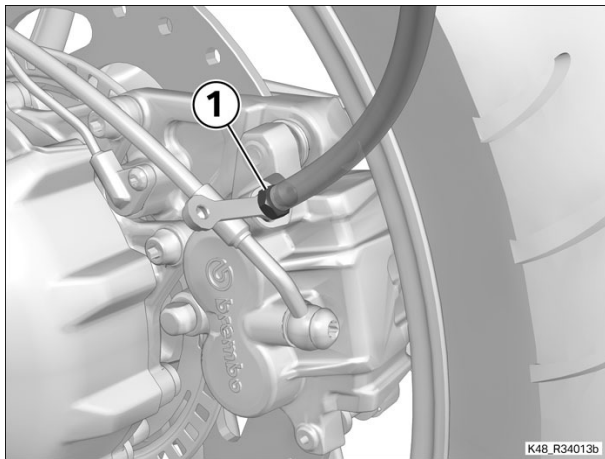

K48_R34013b

- Top up with fresh brake fluid to the (MAX) mark.

 Fluids and lubricants		
Brake fluid	Hydraulic systems	

- Connect the brake bleeding device to bleed screw (1) in the brake caliper.
- Slightly open the bleed screw.



Warning

Air can be drawn into the system through the fluid replenishing hole if the fluid level in the reservoir is too low; the system has to be bled again if this happens.

Make sure that the fluid replenishing bore is always under the surface of the brake fluid throughout the entire process of fluid changing/system bleeding.

- Continue bleeding the brake system until fresh brake fluid emerges.



Warning

The brake-bleeding process might have been interrupted even though air remained in the system. On account of the vacuum extraction process, it is not possible to tell whether the brake fluid extracted from the system is free of bubbles.

On conclusion of the process, bleed the system manually (without vacuum extraction) until you are sure that the brake fluid expelled from the system is free of bubbles.

- Close the bleed screw and remove the brake bleeding device.

 Tightening torques		
Bleed screw, rear, in banjo bolt		
	14 Nm	

► **Filling rear reservoir**



Warning

Brake fluid is hygroscopic, which means that its boiling point drops once the container has been opened.

Use only new brake fluid from freshly opened containers.

- Top up with fresh brake fluid to the (MAX) mark.

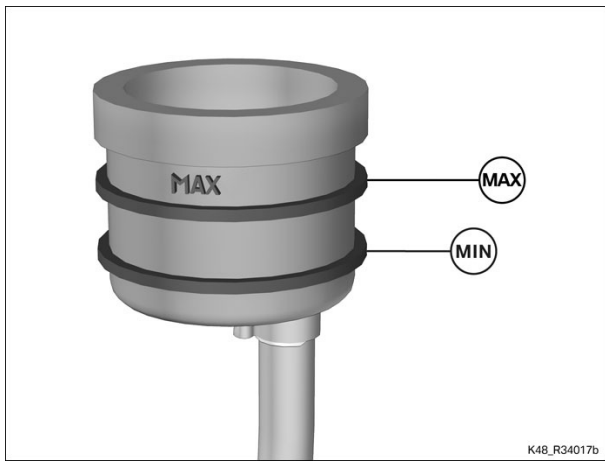

K48_R34017b

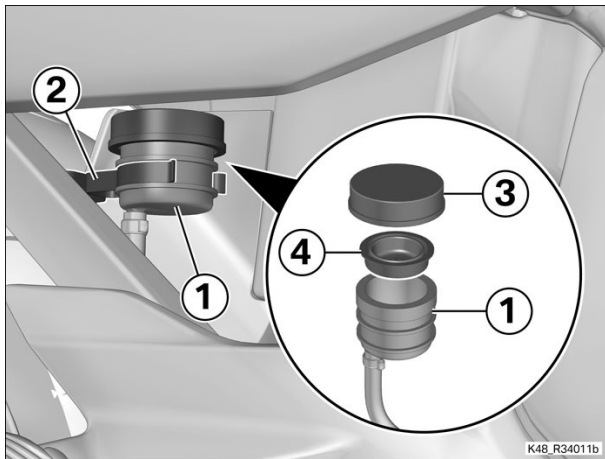

K48_R34011b



Fluids and lubricants

Brake fluid

Hydraulic systems

- Clean all components.
- Install diaphragm (4).
- Install cap (3) while counter-holding reservoir (1).
- Secure reservoir (1) in bracket (2).



Test

- Check brake pressure by operating the brakes.

Result: Low brake pressure

Measure:

- Repeat the brake-bleeding process.

Finishing work

Final check of work performed

📁 34 00 048 Changing brake fluid, front brakes 6 FRUs

+ 34 00 548

Core activity

(-) Changing brake fluid, front, and bleeding brake system



Warning

Air can be drawn into the system through the fluid replenishing hole if the fluid level in the reservoir is too low; the system has to be bled again if this happens.

Make sure that the fluid replenishing bore is always under the surface of the brake fluid throughout the entire process of fluid changing/system bleeding.



Note

This description applies for brake filling and bleeding units with vacuum extraction. If other devices are used, comply with the manufacturer's instructions.

- Set the brake lever to maximum span.

▶ Draining brake fluid reservoir on handbrake fitting



Attention

Brake fluid attacks paintwork, plastic and rubber parts.

Do not allow brake fluid to come into contact with paintwork, plastic or rubber parts.

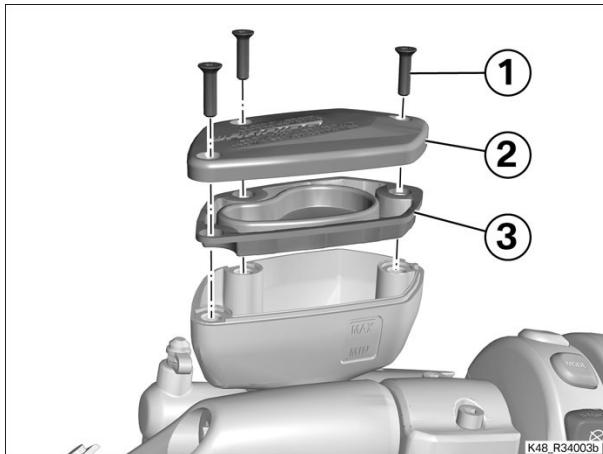

- Remove screws (1) and remove reservoir cap (2) and diaphragm (3).
- Clean reservoir, diaphragm (3) and cap (2).
- Draw off the old brake fluid.



▶ Removing front brake pads

- Remove screws (1) and remove brake-pad spring (2).

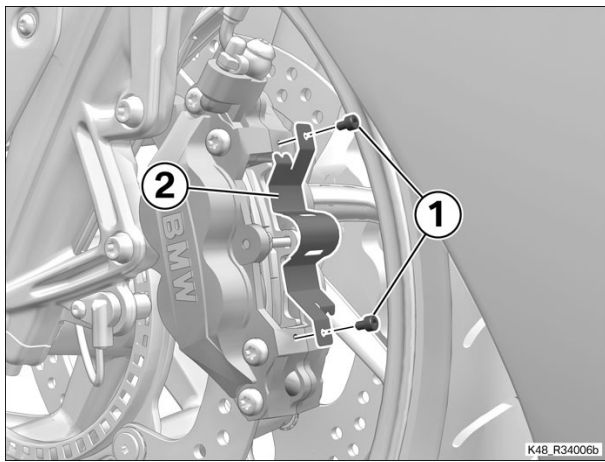

- Remove split-pin keeper (1) and locking pin (2).
- Remove brake pads (3).

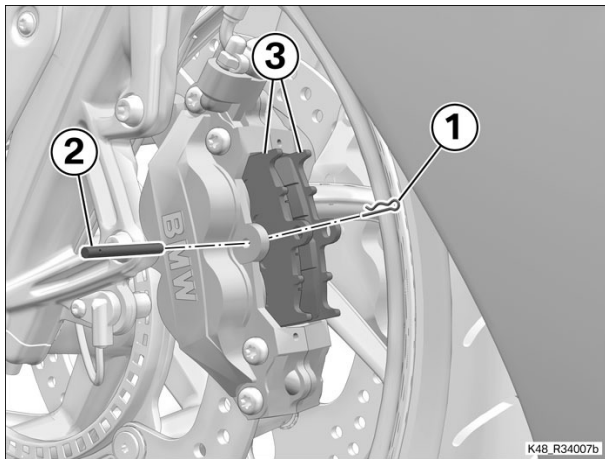

- Repeat this procedure on the other side.

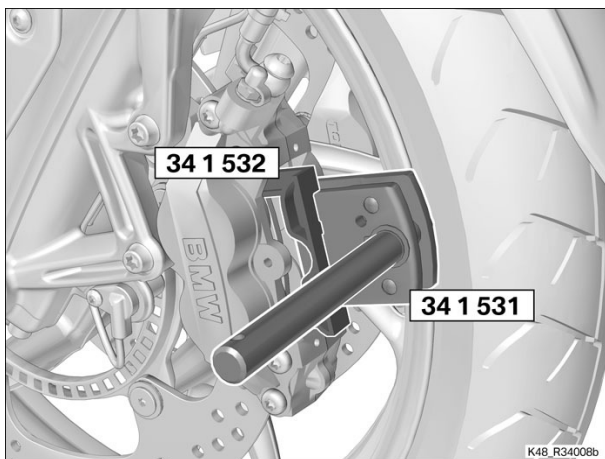

- In the **left and right** brake calipers, insert piston resetting device (No. 34 1 531) with locator (No. 34 1 532).
- Force the left and right pistons fully back with the piston resetting device.
- Draw off the excess brake fluid and clean the reservoir.

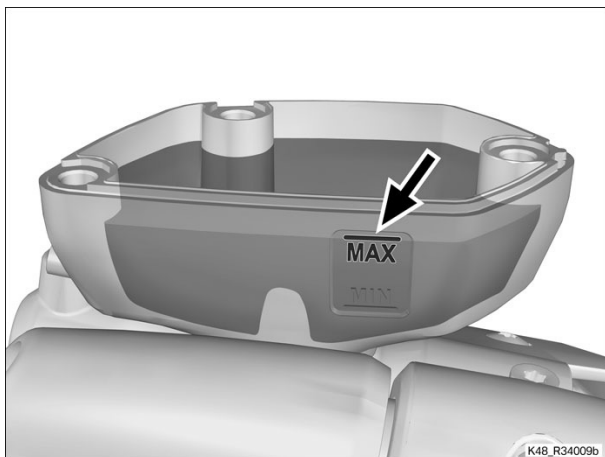

- Turn the handlebars to a position in which the brake fluid reservoir is horizontal.



Warning

Brake fluid is hygroscopic, which means that its boiling point drops once the container has been opened.

Use only new brake fluid from freshly opened containers.

- Top up with fresh brake fluid to the MAX mark (arrow).



Fluids and lubricants

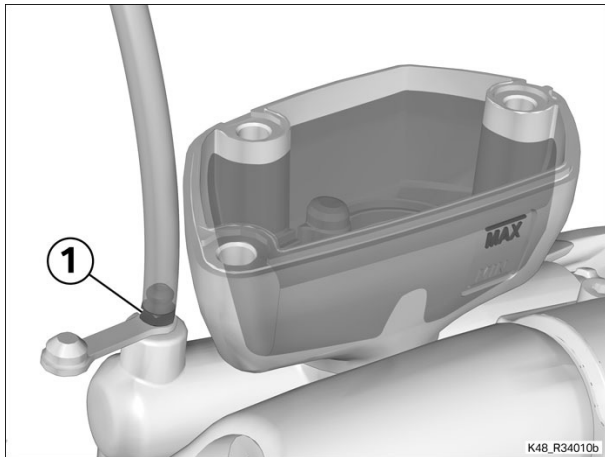

Brake fluid	Hydraulic systems	
-------------	-------------------	--

- Connect the brake bleeding device to bleed screw (1) in the handbrake cylinder.
- Slightly open bleed screw (1).
- Continue bleeding the brake system until the fresh brake fluid emerges clear and free from bubbles.
- Close bleed screw (1).

 Tightening torques		
Bleed screw to handlebar fitting		
M5	2.2 Nm	

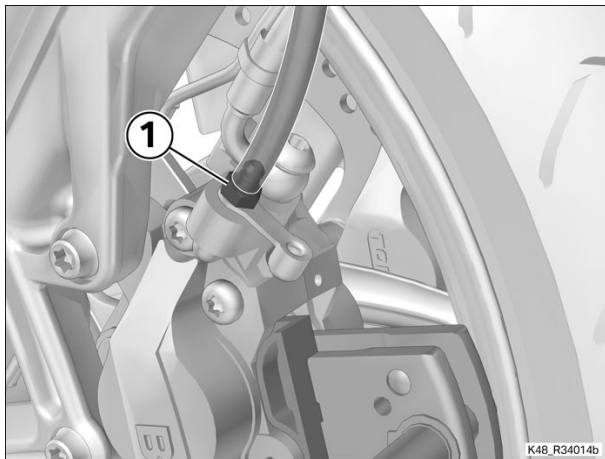

- Connect the brake bleeding device to bleed screw (1) in the left brake caliper.
- Slightly open bleed screw (1).
- Continue bleeding the brake system until fresh brake fluid emerges.



Warning

The brake-bleeding process might have been interrupted even though air remained in the system. On account of the vacuum extraction process, it is not possible to tell whether the brake fluid extracted from the system is free of bubbles.

On conclusion of the process, bleed the system manually (without vacuum extraction) until you are sure that the brake fluid expelled from the system is free of bubbles.

- Close bleed screw (1) of the left brake caliper.

 Tightening torques		
Bleed screw in front brake caliper		
M7	8 Nm	

- **Repeat the fluid-change procedure/procedure for bleeding the brakes at the right brake caliper.**
- Top up with fresh brake fluid to the MAX mark (arrow).

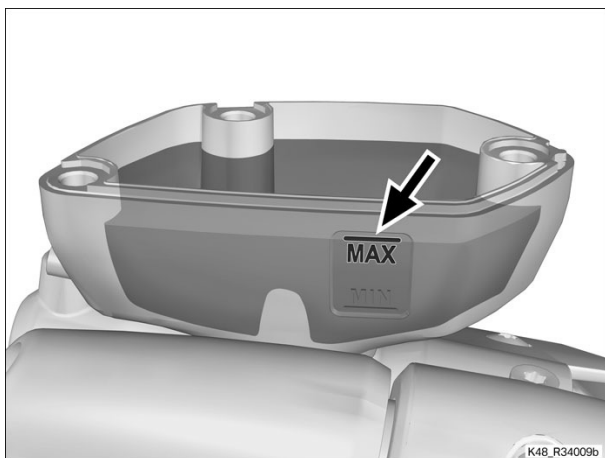

 Fluids and lubricants		
Brake fluid	Hydraulic systems	

- **Again** connect the brake bleeding device to bleed screw (1) in the handbrake cylinder.
- Slightly open bleed screw (1).
- Continue bleeding the brake system until the fresh brake fluid emerges

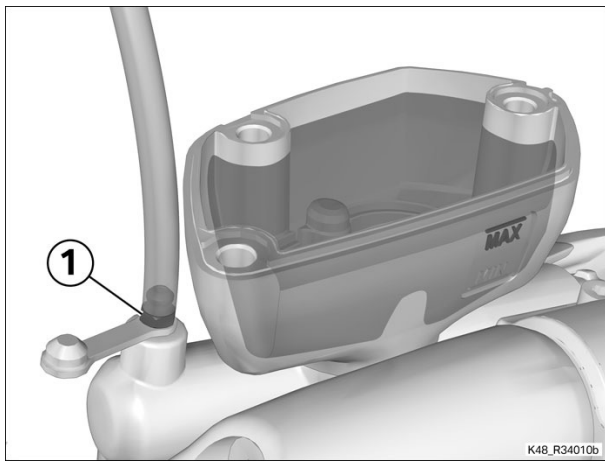

clear and free from bubbles.

- Close bleed screw (1).

 Tightening torques		
Bleed screw to handlebar fitting		
M5	2.2 Nm	

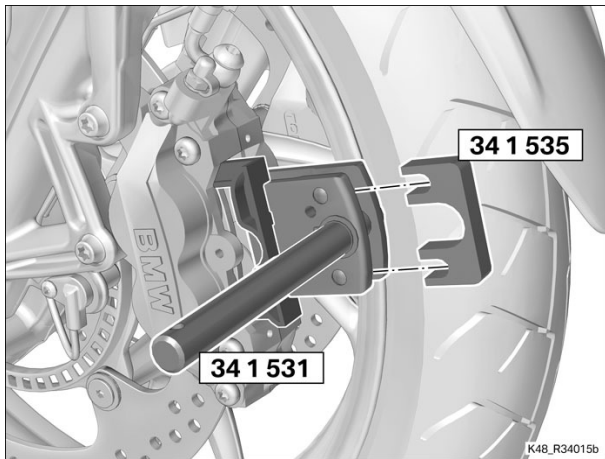

- Fit adapter 25 (No. 34 1 535) to the left and right of resetting device (No. 34 1 531) and **screw the resetting device together**.
- Pull the handbrake lever until the brake pistons are in contact with the piston resetting device.
- » This simulates the thickness of new brake pads and brake discs.

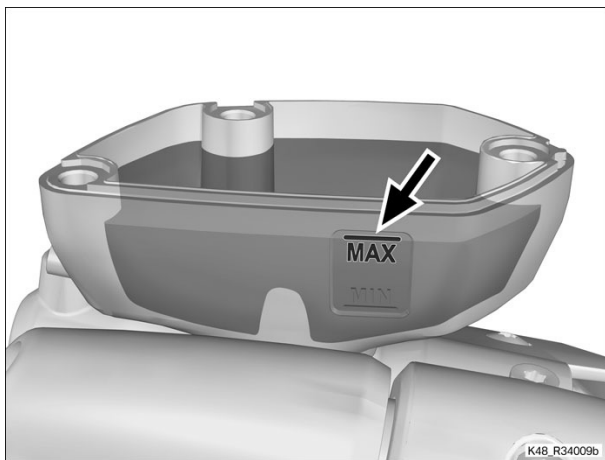

- Turn the handlebars to a position in which the brake fluid reservoir is horizontal.
- Top up with fresh brake fluid to the MAX mark (arrow).
- Expand the piston resetting device on left and right.
- » This forces back the brake pistons so that the brake pads can be installed.
- Remove the piston resetting device and locators left and right from the brake calipers.

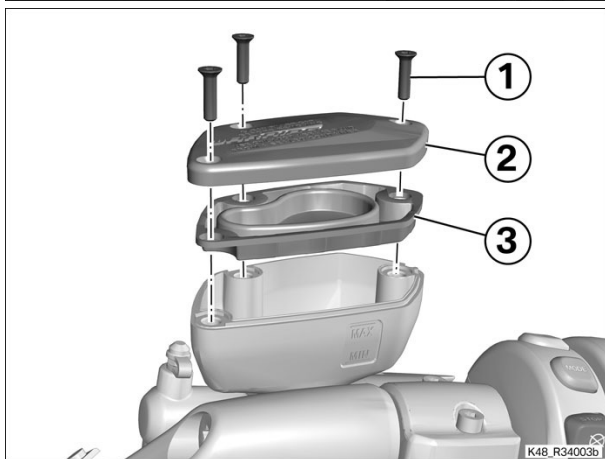

- Wipe the rim of the reservoir, diaphragm (3) and reservoir cap (2) to remove brake fluid and carefully reassemble the components.
- Install screws (1).

► **Installing front brake pads**

- Install brake pads (3).

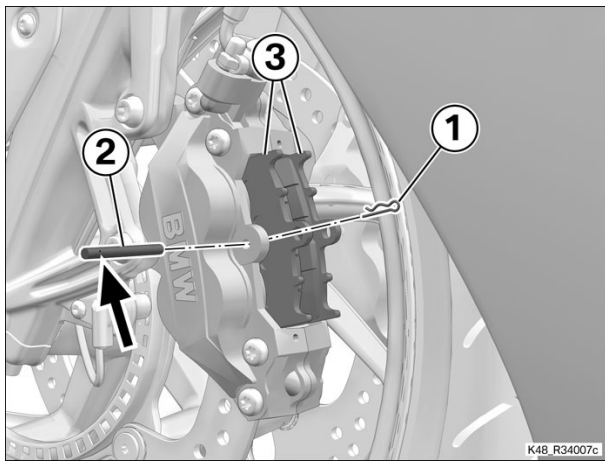

- Install locking pin (2) with the bore (arrow) facing up and secure it with split-pin keeper (1).

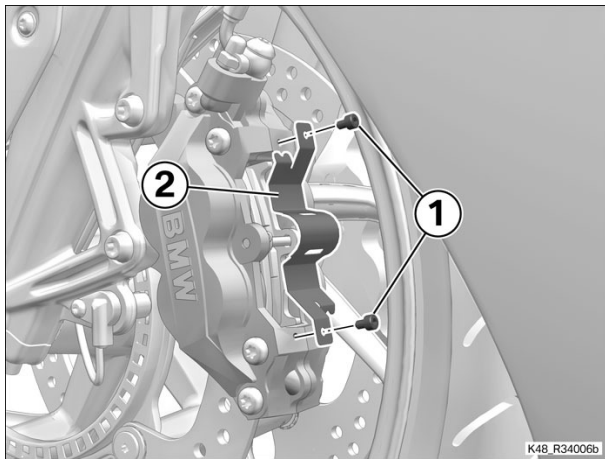

- Hold brake-pad spring (2) in position and install screws (1).

 Tightening torques		
Sheet metal spring on front brake caliper		
M4	3 Nm	

- Repeat this procedure on the other side.



▶ **Bedding in brake pads**

- Once the work has been completed, seat the pads against the brake discs and check operation of the brake system.



Test

- Check brake pressure by operating the brakes.

Result: Low brake pressure

Measure:

- Repeat the brake bleeding procedure **without removing the brake pads**.

Finishing work

Final check of work performed

📁 34 00 049 Changing brake fluid, rear brakes 3 FRUs

+ 34 00 549

Core activity

(-) Change the brake fluid, rear, and bleed the brake system



Warning

Brake fluid is hygroscopic, which means that its boiling point drops once the container has been opened.

Use only new brake fluid from freshly opened containers.



Note

This description applies for brake filling and bleeding units with vacuum extraction. If other devices are used, comply with the manufacturer's instructions.

▶ Draining rear reservoir

- Disengage reservoir (1) from bracket (2).



Attention

Brake fluid attacks paintwork, plastic and rubber parts.

Do not allow brake fluid to come into contact with paintwork, plastic or rubber parts.

- Remove cap (3) while counter-holding reservoir (1).
- Remove flexible gaiter (4).
- Draw off the brake fluid from reservoir (1).

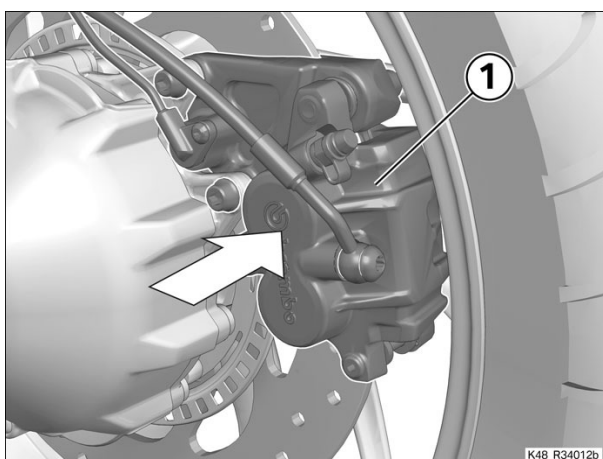
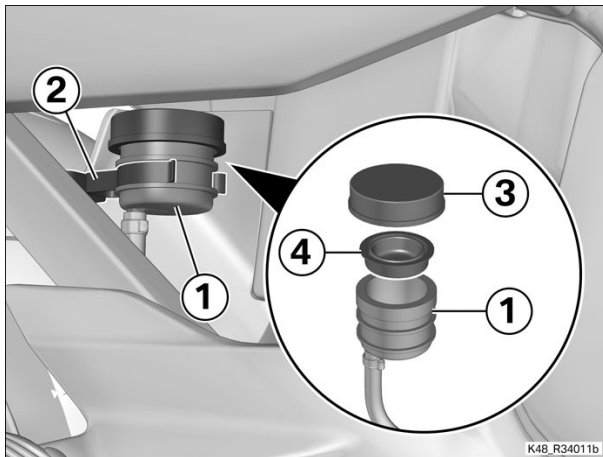

- Press brake caliper (1) against the brake disc to force the pistons back.
- Draw off the excess brake fluid that was forced back into the reservoir.



Warning

Brake fluid is hygroscopic, which means that its boiling point drops once the container has been opened.

Use only new brake fluid from freshly opened containers.

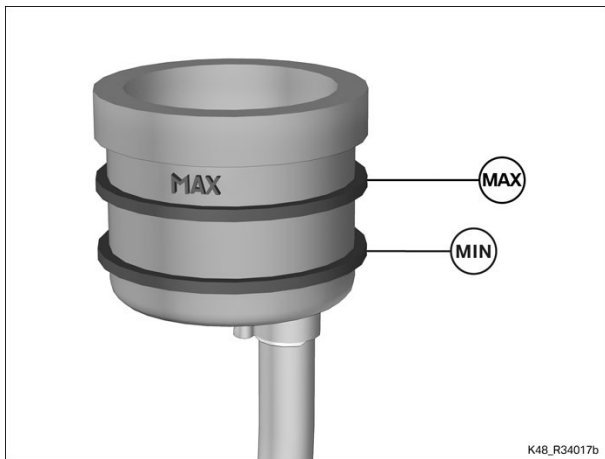

K48_R34017b

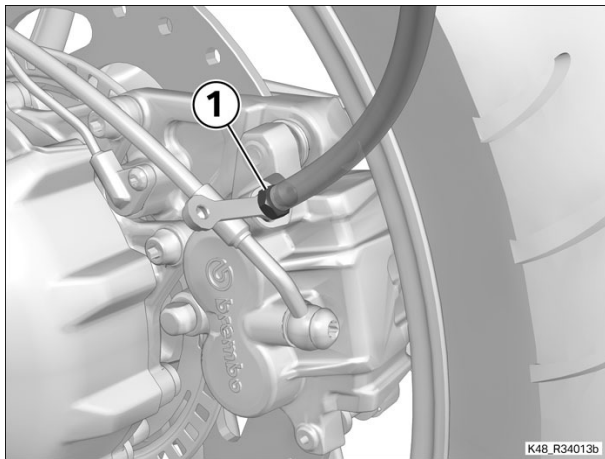

K48_R34013b

- Top up with fresh brake fluid to the (MAX) mark.

 Fluids and lubricants		
Brake fluid	Hydraulic systems	

- Connect the brake bleeding device to bleed screw (1) in the brake caliper.
- Slightly open bleed screw (1).



Warning

Air can be drawn into the system through the fluid replenishing hole if the fluid level in the reservoir is too low; the system has to be bled again if this happens.

Make sure that the fluid replenishing bore is always under the surface of the brake fluid throughout the entire process of fluid changing/system bleeding.

- Continue bleeding the brake system until fresh brake fluid emerges.



Warning

The brake-bleeding process might have been interrupted even though air remained in the system. On account of the vacuum extraction process, it is not possible to tell whether the brake fluid extracted from the system is free of bubbles.

On conclusion of the process, bleed the system manually (without vacuum extraction) until you are sure that the brake fluid expelled from the system is free of bubbles.

- Close bleed screw (1) and remove the brake bleeding device.

 Tightening torques		
Bleed screw, rear, in banjo bolt		
	14 Nm	

► **Filling rear reservoir**



Warning

Brake fluid is hygroscopic, which means that its boiling point drops once the container has been opened.

Use only new brake fluid from freshly opened containers.

- Top up with fresh brake fluid to the (MAX) mark.

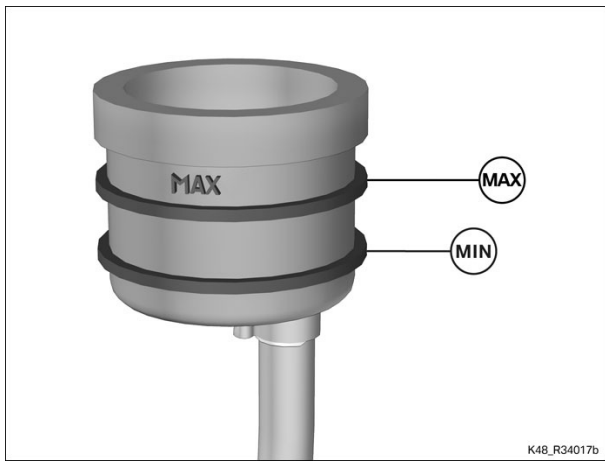

K48_R34017b

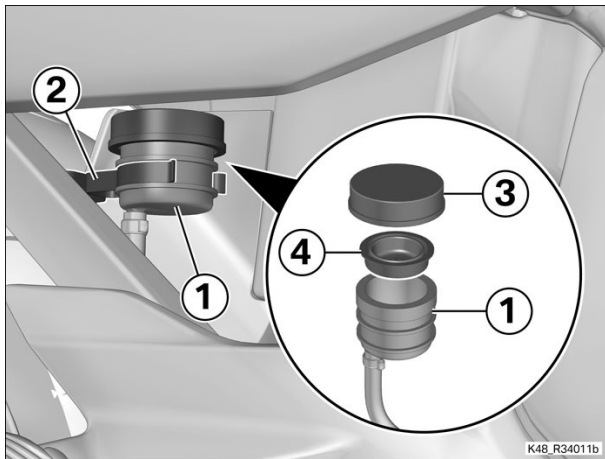

K48_R34011b



Fluids and lubricants

Brake fluid	Hydraulic systems	
-------------	-------------------	--

- Clean all components.
- Install diaphragm (4).
- Install cap (3) while counter-holding reservoir (1).
- Secure reservoir (1) in bracket (2).



Test

- Check brake pressure by operating the brakes.

Result: Low brake pressure

Measure:

- Repeat the brake-bleeding process.

Finishing work

Final check of work performed

34 11 001 Measuring front brake-disc run-out 4 FRUs

+ 34 11 844

Preparatory work

Releasing left and right front brake calipers

Core activity

(-) Checking front brake discs for runout

Precondition

- No burrs or scoring on brake disc, brake disc thickness above minimum.



- Raise the front wheel clear of the ground so that it can turn freely.

Test

- Check the mounts of the brake disc.
- Components of the rivet-package mounts (cannot be disassembled):
 - Washer (1)
 - Spring washers (2)
 - Thrust washers (3)
 - Rivet (4)

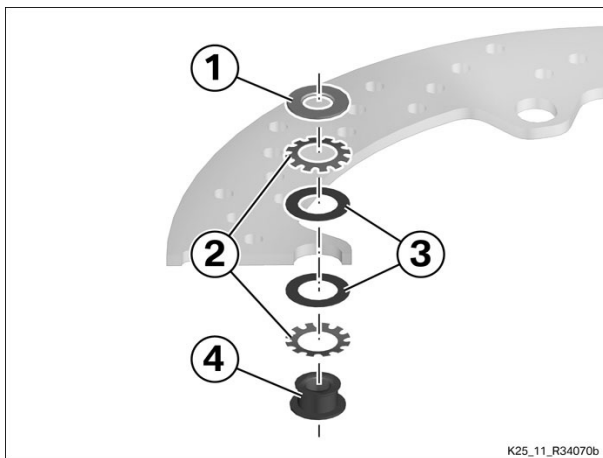

Result: Individual components missing, broken or installed in wrong sequence.

Measure:

- Brake-disc runout cannot be measured.

Result: Brake-disc mounts are OK

Measure:

► Measuring brake-disc runout

- Raise the front wheel clear of the ground so that it can turn freely.
- Install dial gauge (No. 00 2 510) in dial-gauge holder (No. 34 2 524) and install measuring adapter (No. 34 2 510).
- Install the dial-gauge holder with screw (1).
- Align dial gauge in such a way that the measuring adapter is in contact with the brake disc close to the outer circumference and the dial gauge is slightly preloaded.

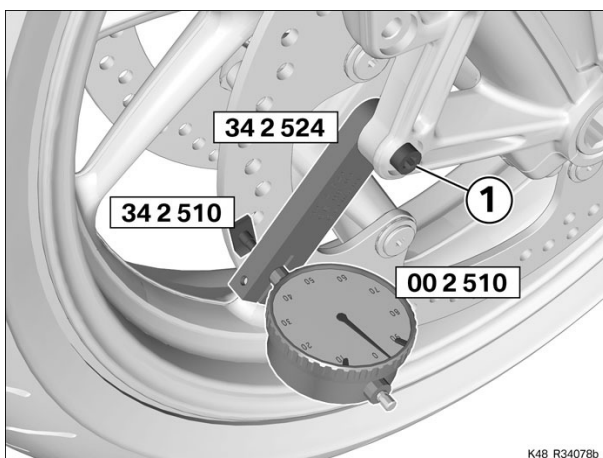

Test

- Set the dial gauge to "0".
- Slowly turn the wheel through at least one complete revolution and

observe the dial gauge reading.

- » The sum of the positive and negative dial-gauge readings is the total runout.

 Technical data			
Brake disc lateral runout, front	At circumference	max 0.15 mm	

Result: Lateral runout is excessive.

Measure:

- Check positioning of the brake disc/wheel rim.
- Check the wheel rim for damage.
- If necessary, check the brake disc.



Finishing work

Securing front brake calipers, left and right

Bedding in brake pads

Final check of work performed

📁 34 11 008 Replacing front brake pads 3 FRUs

+ 34 11 832

Core activity

(-) Replacing front brake pads

► Removing front brake pads

- Remove screws (1) and remove brake-pad spring (2).

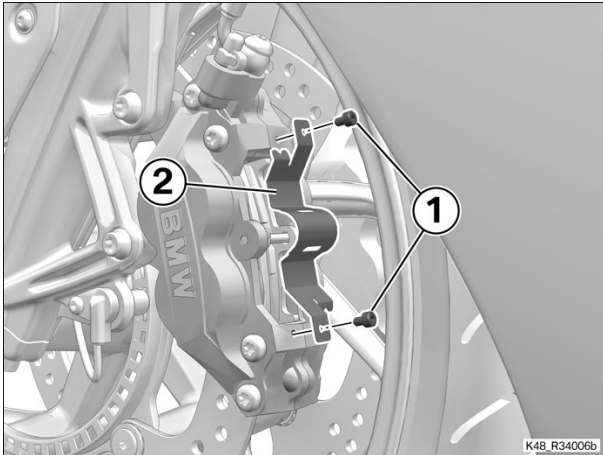

- Remove split-pin keeper (1) and locking pin (2).
- Remove brake pads (3).

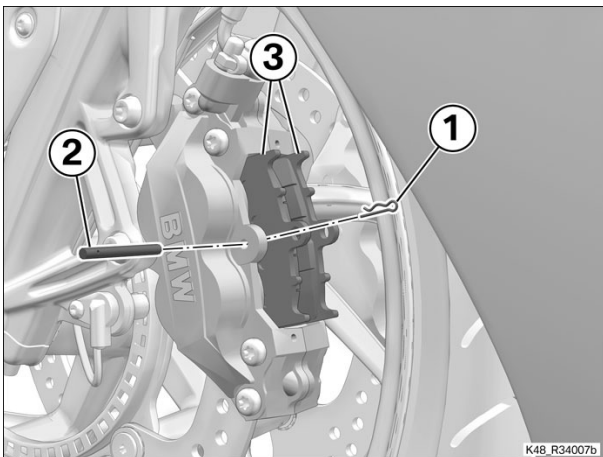

- Repeat this procedure on the other side.



- Install piston resetting device (No. 34 1 531) and locator (No. 34 1 532) in the **left and right** brake calipers.
- Push back the brake pistons.

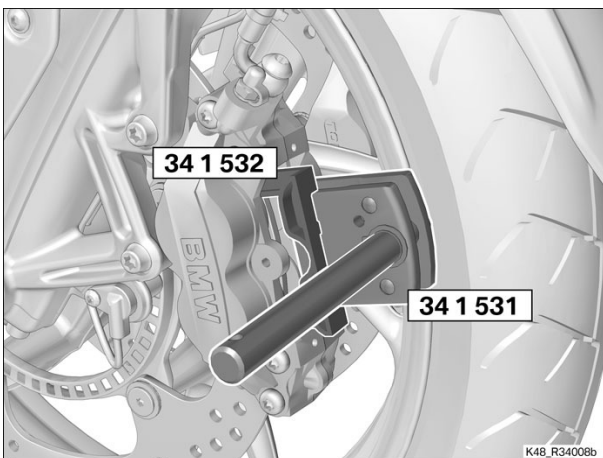

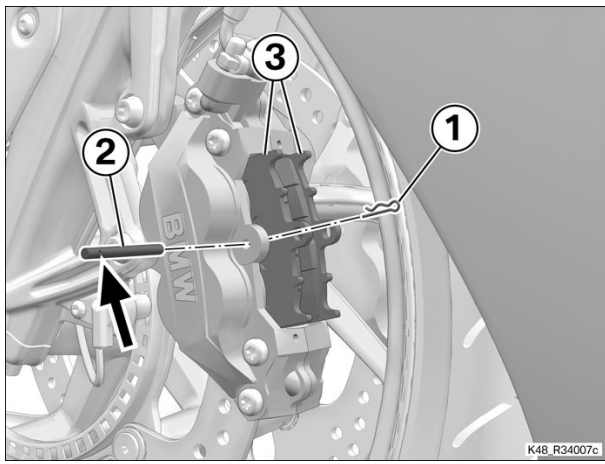

► Installing front brake pads

- Install brake pads (3).
- Install locking pin (2) with the bore (arrow) facing up and secure it with split-pin keeper (1).

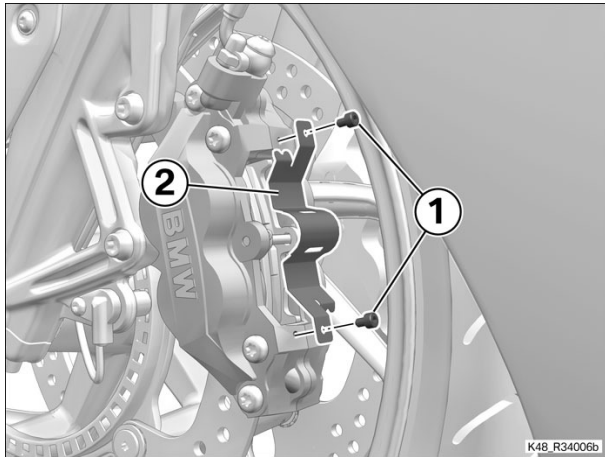

- Hold brake-pad spring (2) in position and install screws (1).



 Tightening torques		
Sheet metal spring on front brake caliper		
M4	3 Nm	

- Repeat this procedure on the other side.



Finishing work

Bedding in brake pads

Final check of work performed

34 11 060 Replacing front brake caliper (without bleeding brakes) 3 FRUs

+ 34 11 560

Preparatory work

Draining front brake system

Removing front brake pads

Core activity

(-) Removing front brake caliper

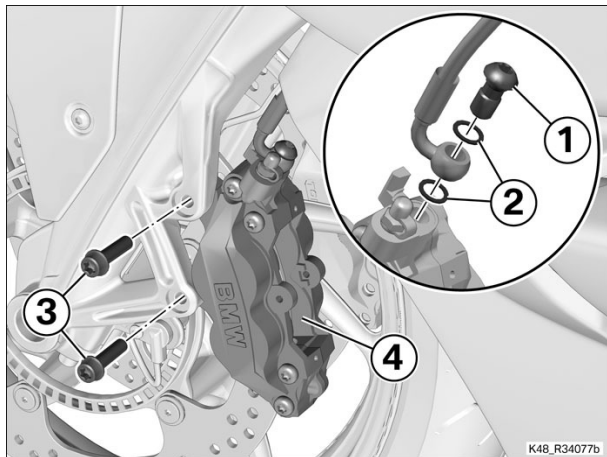

Attention

Brake fluid attacks paintwork, plastic and rubber parts.

Do not allow brake fluid to come into contact with paintwork, plastic or rubber parts.

- Remove banjo bolt (1) with sealing rings (2).
- Remove screws (3).
- Remove brake caliper (4).

(-) Installing front brake caliper

- Secure brake caliper (5) with screws (4).

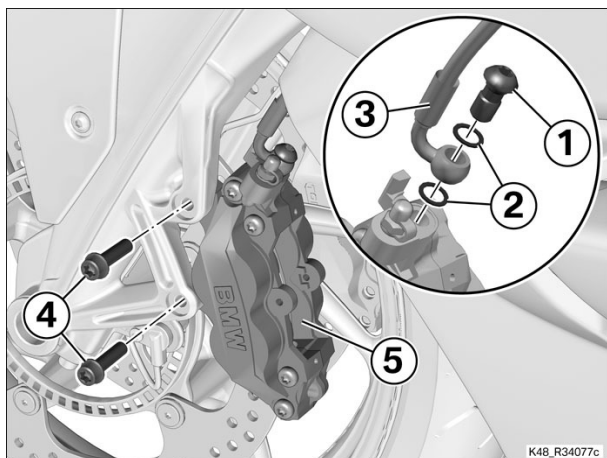

 Tightening torques		
Front brake caliper to wheel carrier		
M8 x 30 - 10.9	28 Nm	

- Install brake pipe (3) with banjo bolt (1) and new sealing rings (2).

 Tightening torques		
Brake hose with banjo bolt to components		
M10 x 1	24 Nm	

Finishing work

Installing front brake pads

=> Bleeding front brake system (Description in item: 34 00 507, Billed as a separate item)

Final check of work performed

34 11 220 Removing/installing front brake discs 11 FRUs

+ 34 11 840

Preparatory work

- Remove the complete front-wheel cover
- Releasing left and right front brake calipers
- Installing front-wheel stand
- Removing front wheel

Core activity

(-) Removing front left brake disc

- Remove screws (1).
- Remove brake disc (2) and sensor ring (3).

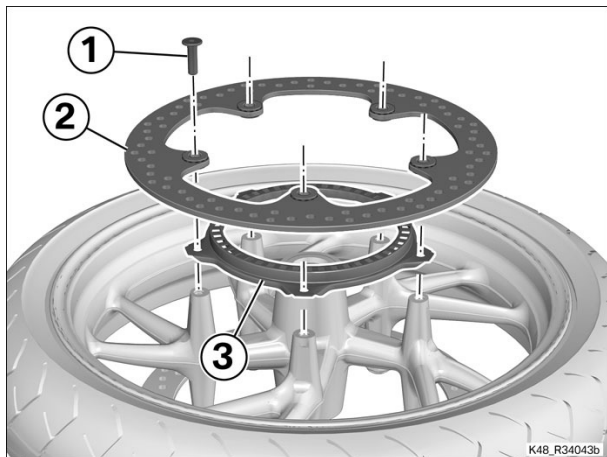

(-) Removing front right brake disc

- Remove screws (1).
- Remove brake disc (2).

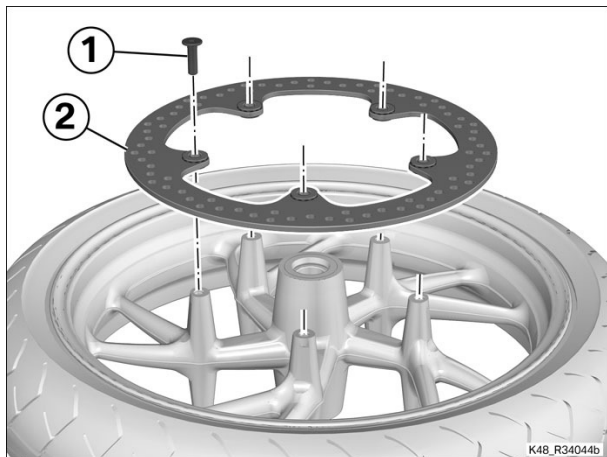

(-) Installing front left brake disc

- Clean the tapped holes in the wheel rim.
- Lay sensor ring (3) on the wheel rim.
- Lay brake disc (2) on the wheel rim with the wide flats (arrow) of the rivets to the outside and position it correctly.
- Install new screws (1).

 Tightening torques		
Brake disc to front wheel		
Flat-head screw, M8 x 27 - 10.9, Replace screw	tighten in diagonally	

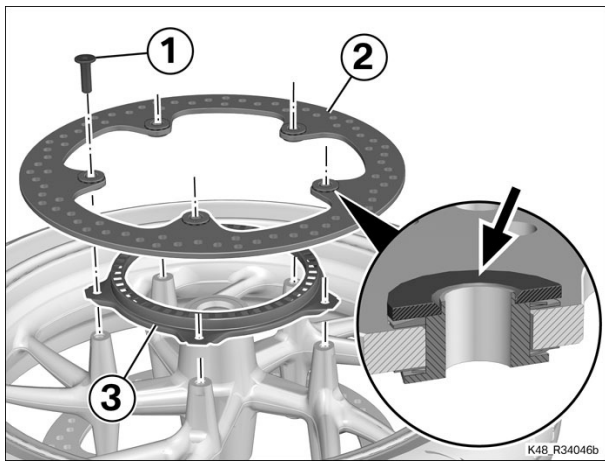

Micro-encapsulated	opposite sequence	
	19 Nm	

(-) Installing front right brake disc

- Clean the tapped holes in the wheel rim.
- Lay brake disc (2) on the wheel rim with the wide flats (arrow) of the rivets to the outside and position it correctly.
- Install new screws (1).

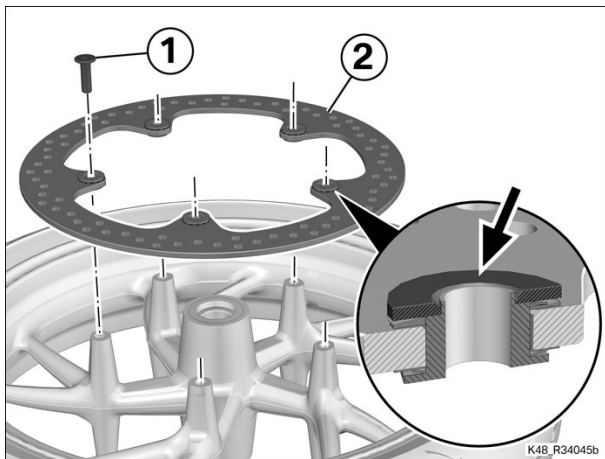

 Tightening torques		
Brake disc to front wheel		
Flat-head screw, M8 x 27 - 10.9, Replace screw Micro-encapsulated	tighten in diagonally opposite sequence	
	19 Nm	

Finishing work

- Install the front wheel
- Removing front-wheel stand
- Securing front brake calipers, left and right
- Bedding in brake pads
- Installing complete front-wheel cover
- Final check of work performed

34 21 200 Replacing rear brake pads 2 FRUs

+ 34 21 769

Core activity

(-) Removing rear brake pads

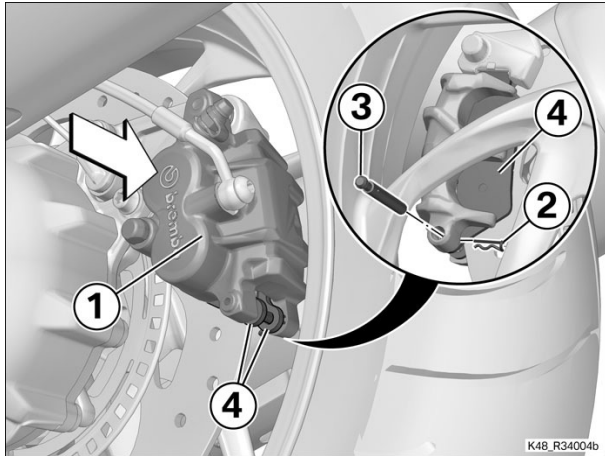

- Press brake caliper (1) against the brake disc to force back the brake pistons.
- Remove split-pin keeper (2) and locking pin (3).
- Remove brake pads (4).

(-) Installing rear brake pads

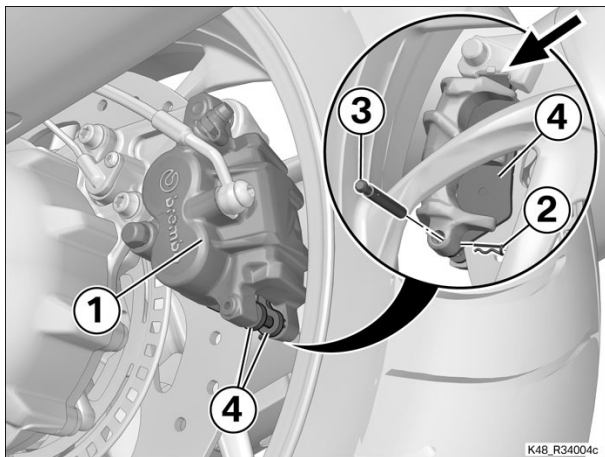

- Install brake pads (4). Make sure that they are engaged in the guide (arrow) at the brake caliper (1).
- Install locking pin (3) and secure it with split-pin keeper (2).

Finishing work

Bedding in brake pads

Final check of work performed

34 21 301 Removing/installing rear brake disc 7 FRUs

+ 34 21 772

Preparatory work

Removing number-plate carrier

Remove the rear wheel

Removing rear brake caliper

Core activity

(-) Removing rear brake disc

- Remove screws (1).
- Remove brake disc (2) and sensor ring (3).

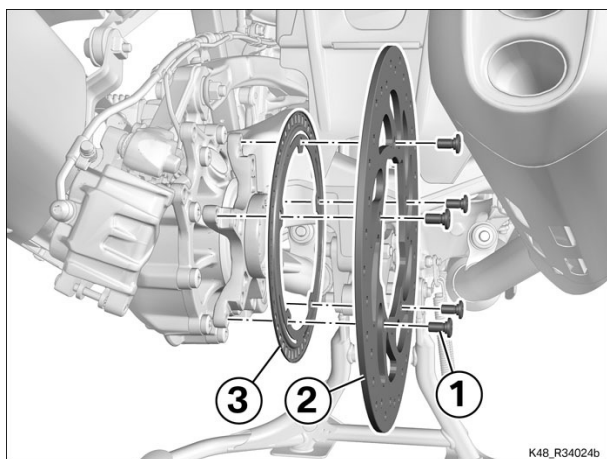

(-) Install the rear brake disc

- Clean the tapped holes.
- Install sensor ring (3) and brake disc (2) and position them correctly.
- Install new screws (1).

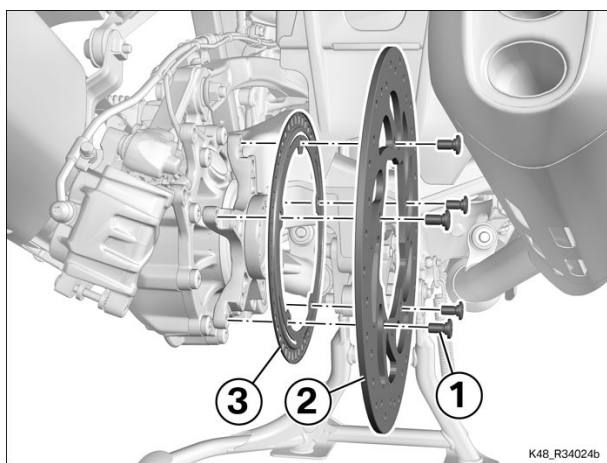

 Tightening torques		
Brake disc to wheel carrier		
M8 x 15.5, Replace screw Micro-encapsulated	tighten by stages in diagonally opposite sequence	
	Initial torque, 12 Nm	
	Final torque, 30 Nm	

Finishing work

Securing rear brake caliper

Installing rear wheel

Installing number-plate carrier

Final check of work performed

📁 34 31 002 Replacing footbrake cylinder (without bleeding brakes)

+ 34 31 502

Equipment trim-level variant:

0416 - Electronic Suspension Adjustment (ESA)



Attention

Brake fluid attacks paintwork, plastic and rubber parts.

Do not allow brake fluid to come into contact with paintwork, plastic or rubber parts.



Attention

Stretched, twisted or incorrectly fitted brake lines can become worn and start to leak.

Do not bend or clamp brake lines.

When fitting, check that they are correctly installed and secured and are not stretched, bent or clamped. Make sure that clearance relative to all other components is adequate in all situations.

Preparatory work

Draining rear brake system

Core activity

(-) Removing footbrake cylinder

- Disengage union screw (1).
- Disengage brake line (2) from footbrake cylinder (3).

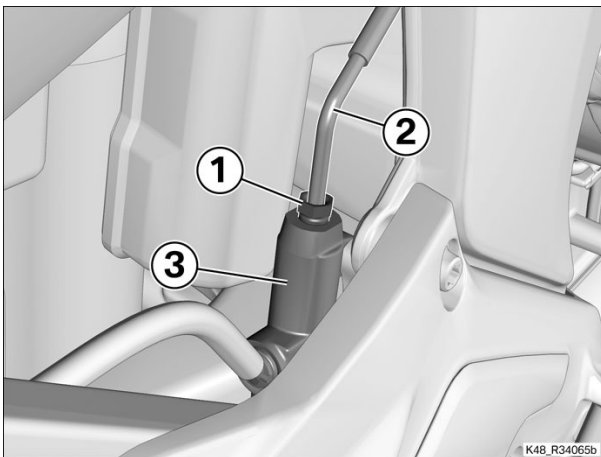

- Remove locking clip (1).
- Open clip (2) and disconnect hose (3).
- Remove screws (4) and remove footbrake cylinder (5).

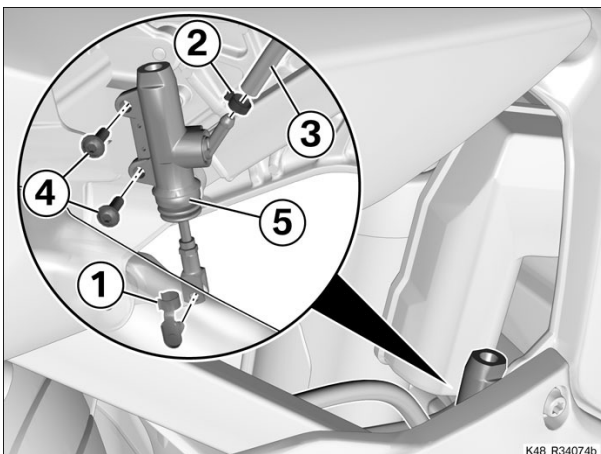

(-) Installing footbrake cylinder

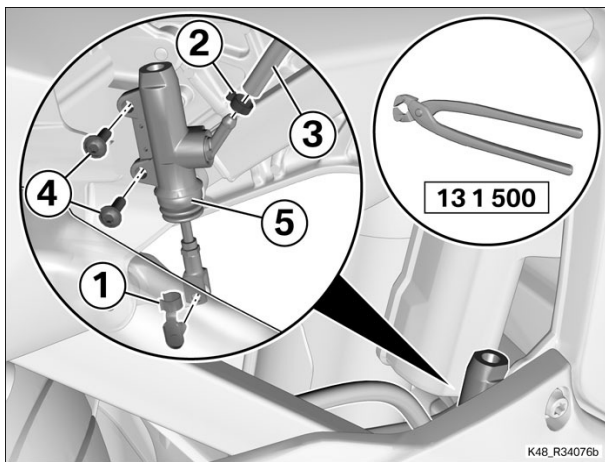

- Clean the threads.
- Hold footbrake cylinder (5) in position and install new screws (4).

 Tightening torques		
Footbrake cylinder to rear frame		
M6 x 20, Replace screw Micro-encapsulated	11 Nm	

- Connect hose (3) and close hose clip (2) with pliers (No. 13 1 500).
- Install locking clip (1).

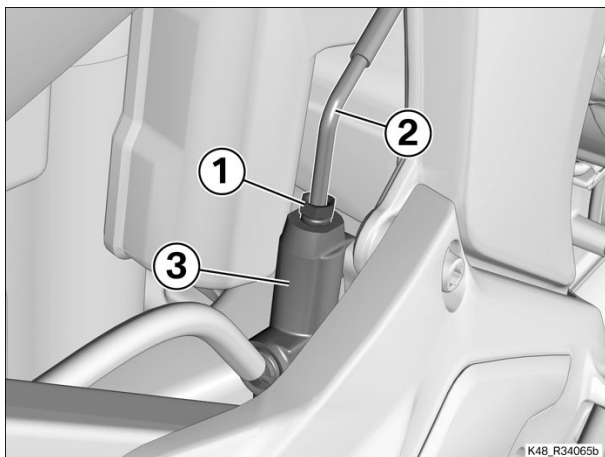

- Hold brake line (2) in position at footbrake cylinder (3) and tighten union screw (1).

 Tightening torques		
Brake line with union screw to components		
M10 x 1, M12 x 1	14 Nm	

Finishing work

=> **Bleeding rear brake system (Description in item: 34 00 509, Billed as a separate item)**

Final check of work performed

📁 34 32 038 Replacing rear brake hose to brake caliper (without bleeding brakes)

+ 34 32 538

Equipment trim-level variant:

0416 - Electronic Suspension Adjustment (ESA)



Attention

Brake fluid attacks paintwork, plastic and rubber parts.

Do not allow brake fluid to come into contact with paintwork, plastic or rubber parts.



Attention

Stretched, twisted or incorrectly fitted brake lines can become worn and start to leak.

Do not bend or clamp brake lines.

When fitting, check that they are correctly installed and secured and are not stretched, bent or clamped. Make sure that clearance relative to all other components is adequate in all situations.

Preparatory work

Draining rear brake system

Core activity

(-) Removing rear brake hose

- Disengage union screw (1).
- Disengage brake hose (2) from connector (3) for brake hose.

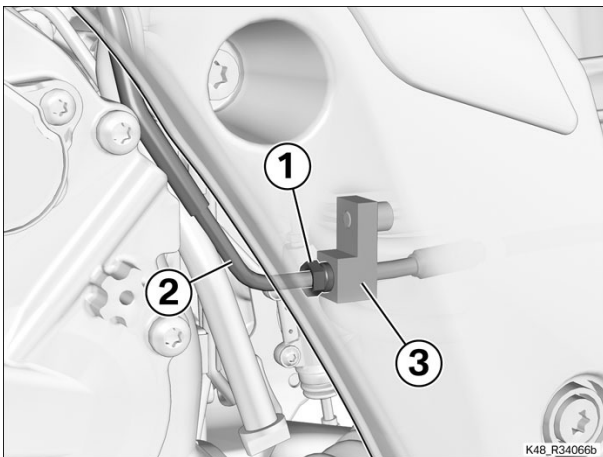

- Unclip holder (1) from brake hose (2).
- Remove screw (3).
- Disengage brake hose (2) from frame (4).

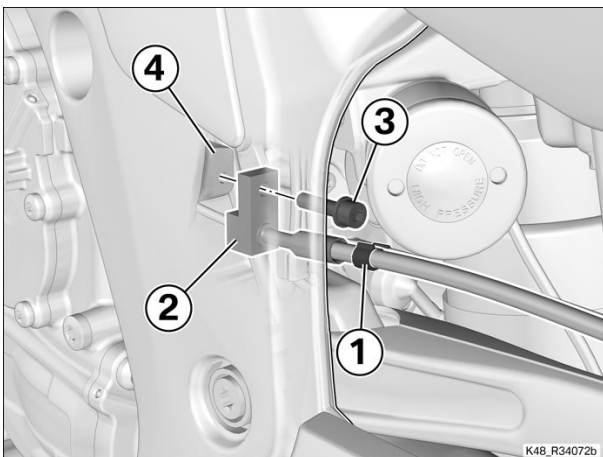

- Remove banjo bolt (1) with sealing rings (2).
-

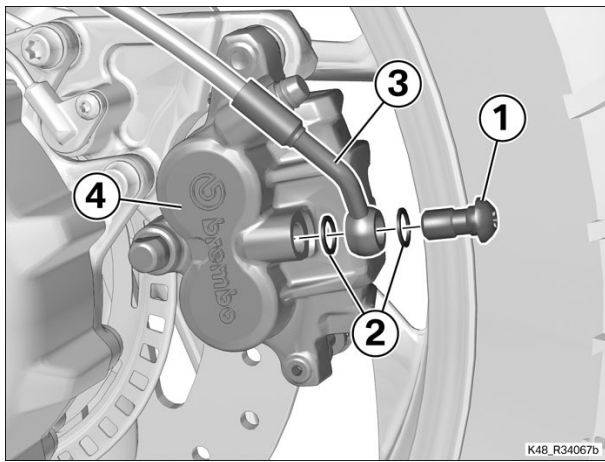

Disengage brake hose (3) from brake caliper (4).

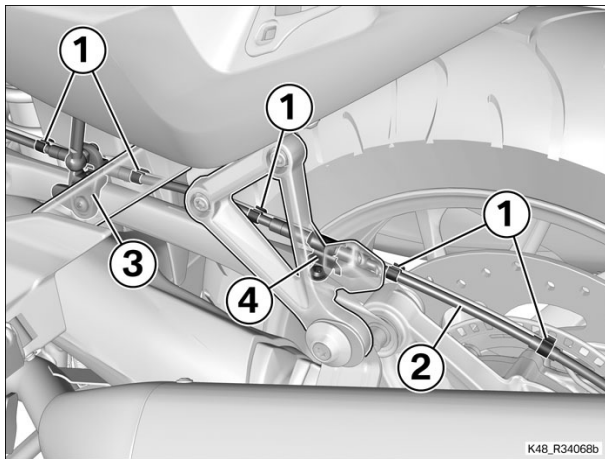

- Unclip holder (1) from brake hose (2).
- Work brake hose (2) to the rear and disengage it from bracket (3) for the thrust link and holder (4) for the brake hose.

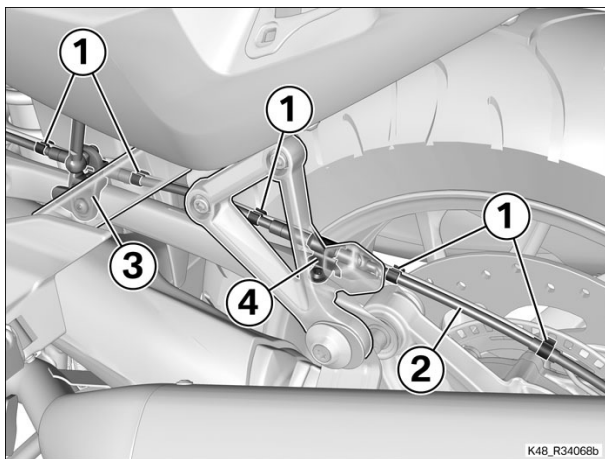

(-) Installing rear brake hose

- Seat brake hose (2) in bracket (3) for the thrust link and bracket (4) for the brake hose.
- Position brake hose (2) and clip in holder (1).

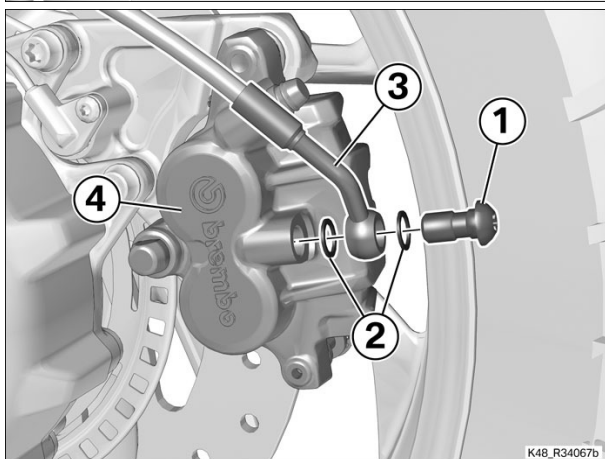

- Hold brake hose (3) in position at brake caliper (4).
- Install banjo bolt (1) with new sealing rings (2).

 Tightening torques		
Brake hose with banjo bolt to components		
M10 x 1	24 Nm	

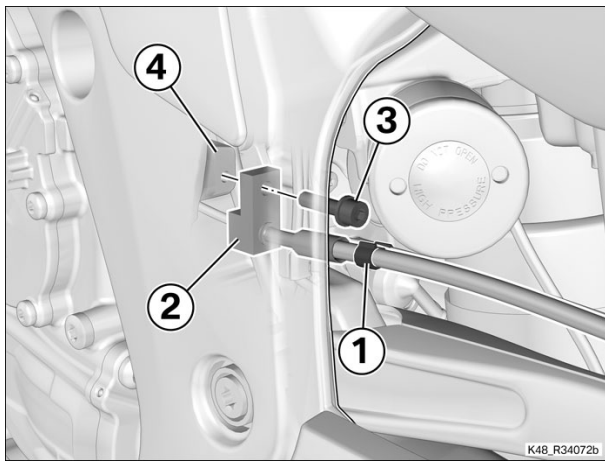

- Hold brake hose (2) in position at frame (4).
- Align brake hose (2) and install screw (3).

 Tightening torques		
Brake hose, rear, to frame		
M6 x 25	8 Nm	

- Clip holder (1) to brake hose (2).

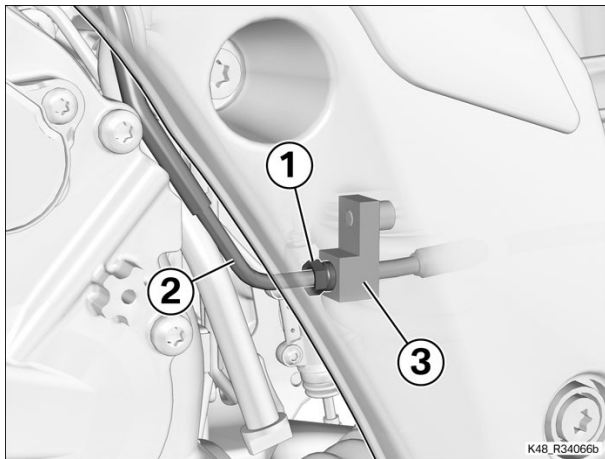

- Hold brake line (2) in position at connector (3) for brake hose and secure union screw (1).

 Tightening torques		
Brake line with union screw to components		
M10 x 1, M12 x 1	14 Nm	

Finishing work

=> **Bleeding rear brake system (Description in item: 34 00 509, Billed as a separate item)**

Final check of work performed

 **34 32 040 Replacing front brake line to pressure modulator (without bleeding brakes)**

+ 34 32 640

**Attention**

Brake fluid attacks paintwork, plastic and rubber parts.

Do not allow brake fluid to come into contact with paintwork, plastic or rubber parts.

**Attention**

Stretched, twisted or incorrectly fitted brake lines can become worn and start to leak.

Do not bend or clamp brake lines.

When fitting, check that they are correctly installed and secured and are not stretched, bent or clamped. Make sure that clearance relative to all other components is adequate in all situations.

Preparatory work

Remove the front seat

Removing air guides for intake air pipes, left and right

Removing complete cover of fuel tank

Removing left bottom side panel

Removing left radiator cowl

Removing left side panel

Removing inner trim for left side panel

Removing right bottom side panel

Removing right radiator cowl

Remove the right side panel

Removing inner trim for right side panel

Removing adjusting plate

Disengaging seat support

Disengaging left and right intake air pipes

Removing complete intake air silencer

Removing fuel tank

Draining front brake system

Core activity**(-) Removing brake line to pressure modulator**

- Unclip holder (1) from brake line (2).
- Disengage union screw (3).

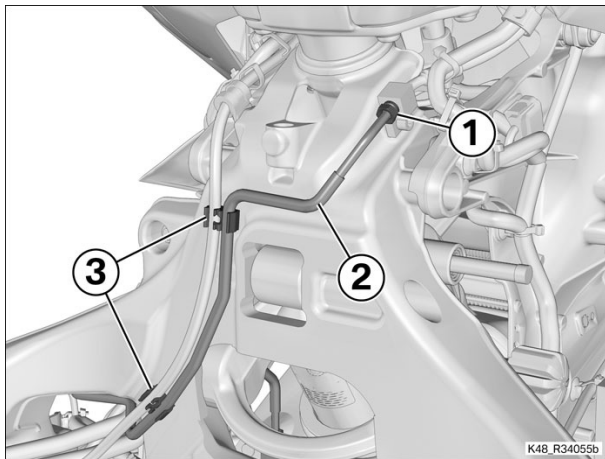
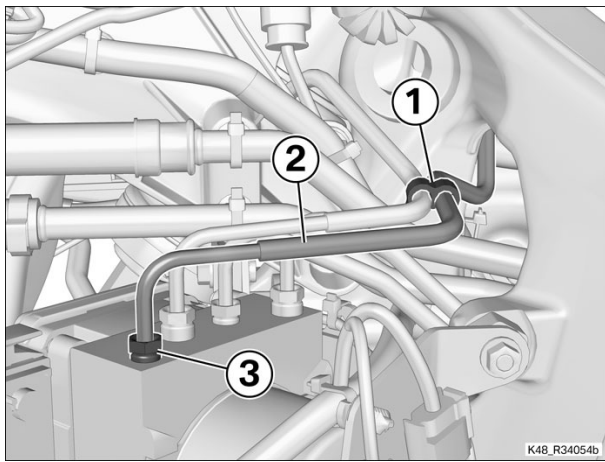

- Disengage union screw (1).
- Unclip brake line (2) from holder (3) and remove.

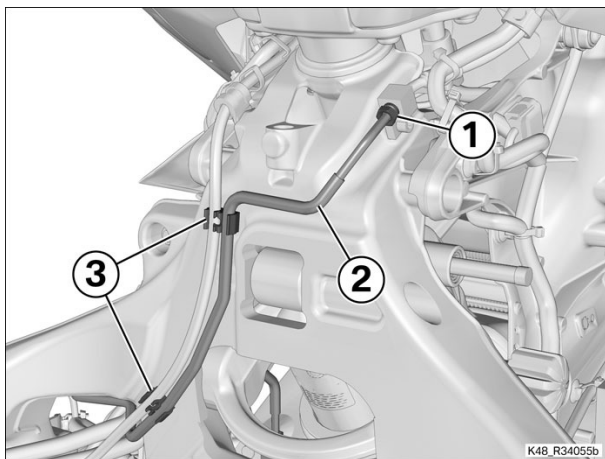

(-) Installing brake line to pressure modulator

- Work brake line (2) into position and route it correctly.
- Clip brake pipe (2) into holder (3).
- Tighten union screw (1).

 Tightening torques		
Brake line with union screw to components		
M10 x 1, M12 x 1	14 Nm	

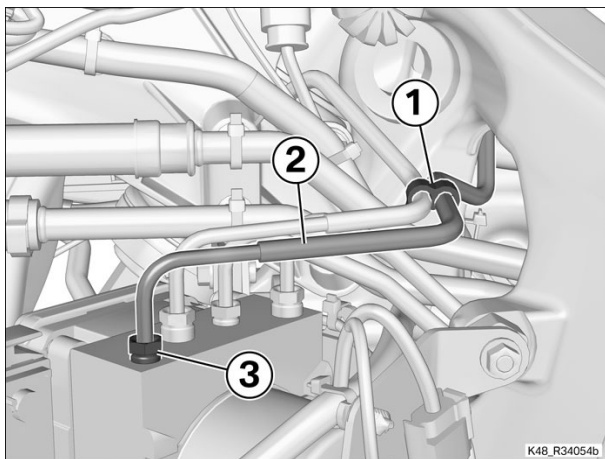

- Clip brake line (2) into holder (1).
- Tighten down union screw (3).

 Tightening torques		
Brake line with union screw to components		
M10 x 1, M12 x 1	14 Nm	

Finishing work

=> Bleeding front brake system (Description in item: 34 00 507, Billed as a separate item)

Installing fuel tank

Installing complete intake air silencer

Securing left and right intake air pipes

Securing seat support

Installing adjusting plate

Installing inner trim for right side panel

Install the right side panel

Install the right radiator cowl

Installing right bottom side panel

Installing inner trim for left side panel

Install the left side panel

Installing left radiator cowl

Installing left bottom side panel

Installing complete cover of fuel tank

Installing air guides for intake air pipes, left and right

Installing front seat

Final check of work performed

34 32 044 Replacing front brake line from pressure modulator (without bleeding brakes)

+ 34 32 644



Attention

Brake fluid attacks paintwork, plastic and rubber parts.

Do not allow brake fluid to come into contact with paintwork, plastic or rubber parts.

Preparatory work

Removing left bottom side panel

Removing left radiator cowl

Removing left side panel

Draining front brake system

Core activity

(-) Removing brake line from pressure modulator

- Unclip holder (1).
- Slacken union screws (2) and (3).
- Work brake line (4) clear and remove.

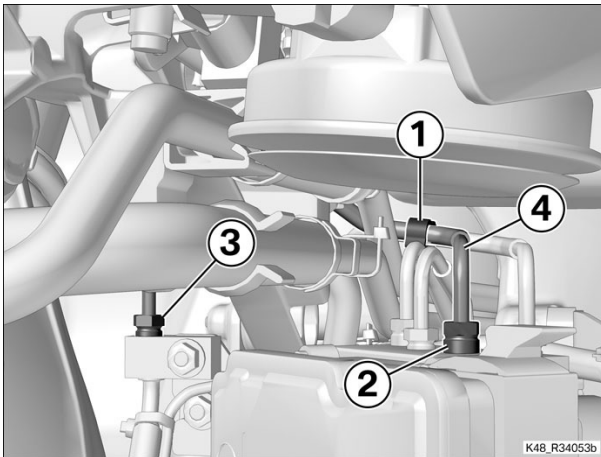

(-) Installing brake line from pressure modulator

- Work brake line (4) into position and route it correctly.
- Hold union screws (2) and (3) in position and tighten.

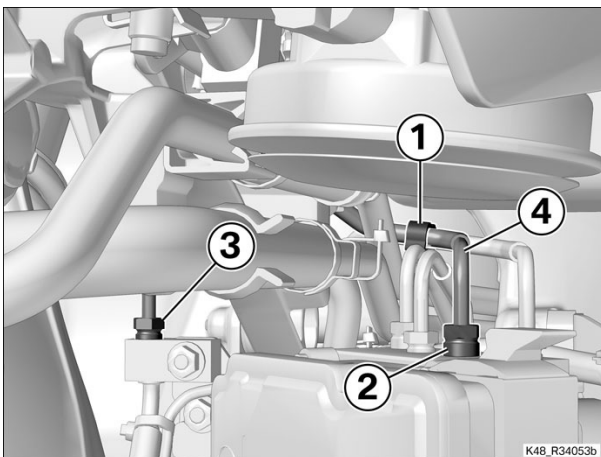

 Tightening torques		
Brake line with union screw to components		
M10 x 1, M12 x 1	14 Nm	

- Clip in holder (1).

Finishing work

=> **Bleeding front brake system (Description in item: 34 00 507, Billed as a separate item)**

Install the left side panel

Installing left radiator cowl

Installing left bottom side panel
Final check of work performed

34 32 050 Replacing rear brake line to pressure modulator (without bleeding brakes)

+ 34 32 650

Equipment trim-level variant:

0416 - Electronic Suspension Adjustment (ESA)



Attention

Brake fluid attacks paintwork, plastic and rubber parts.

Do not allow brake fluid to come into contact with paintwork, plastic or rubber parts.

Preparatory work

Remove the front seat

Removing air guides for intake air pipes, left and right

Removing complete cover of fuel tank

Removing left bottom side panel

Removing left radiator cowl

Removing left side panel

Removing inner trim for left side panel

Removing right bottom side panel

Removing right radiator cowl

Remove the right side panel

Removing inner trim for right side panel

Removing adjusting plate

Disengaging seat support

Disengaging left and right intake air pipes

Removing complete intake air silencer

Removing fuel tank

Draining rear brake system

Core activity

(-) Removing brake line to pressure modulator

- Disengage union screw (1).
- Disengage brake line (2) from pressure modulator (3).

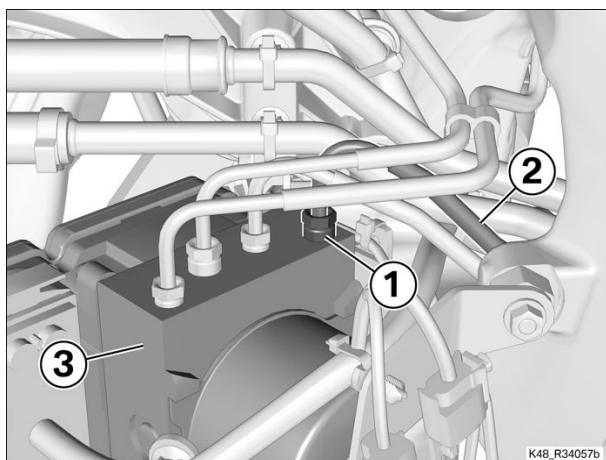

- Disengage union screw (1).
- Disengage brake line (2) from footbrake cylinder (3).

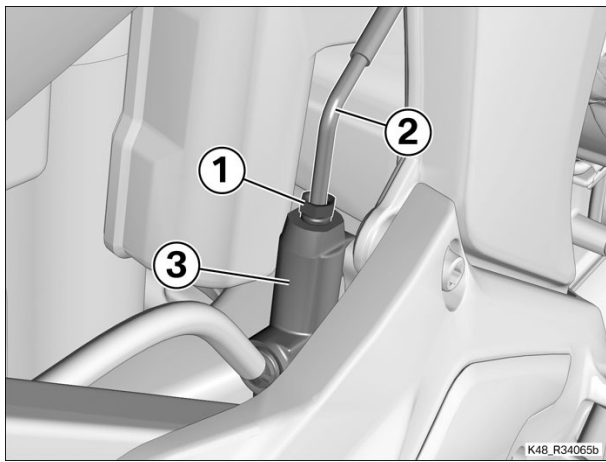

- Remove bracket (1).
- Unclip brake hose (2) from holder (3).

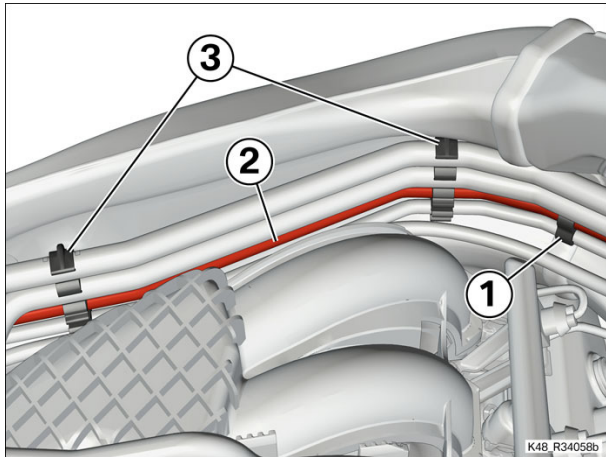

- Unclip brake hose (1) from holder (2).
- Remove the cable ties (arrows).
- Disengage brake line (1) and suspension wiring harness (3).
- Remove brake line (1).

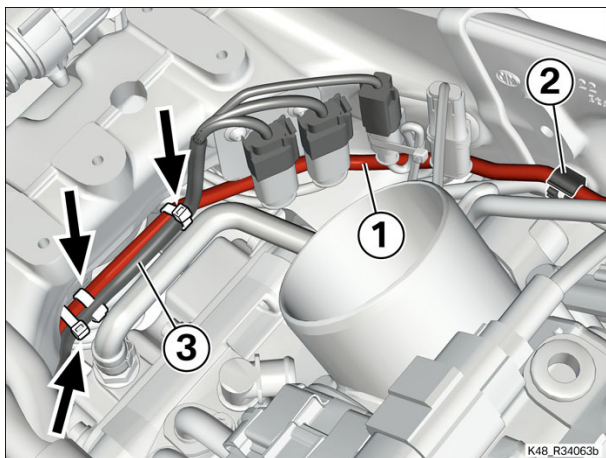

(-) Installing brake line to pressure modulator

- Work brake line (1) into position and route it correctly.
- Position brake line (1) and suspension harness adapter (3) and secure with cable ties (arrows).
- Clip brake line (1) into holder (2).

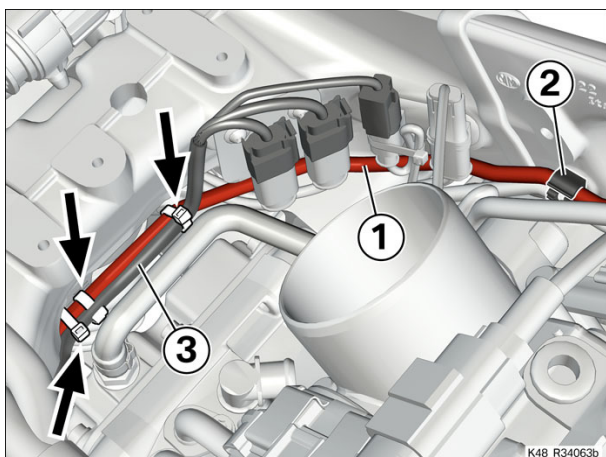

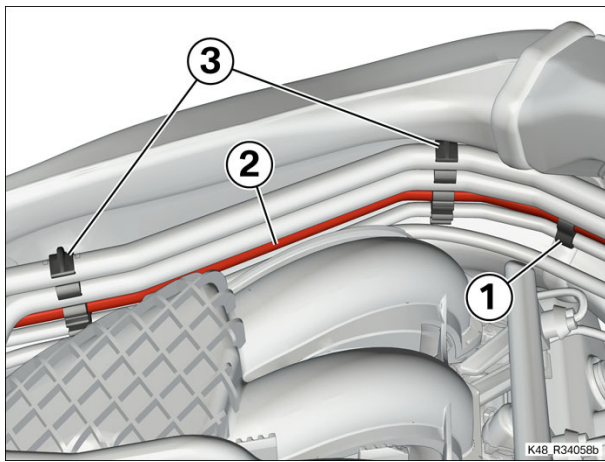

- Clip brake pipe (2) into holder (3).
- Install bracket (1).

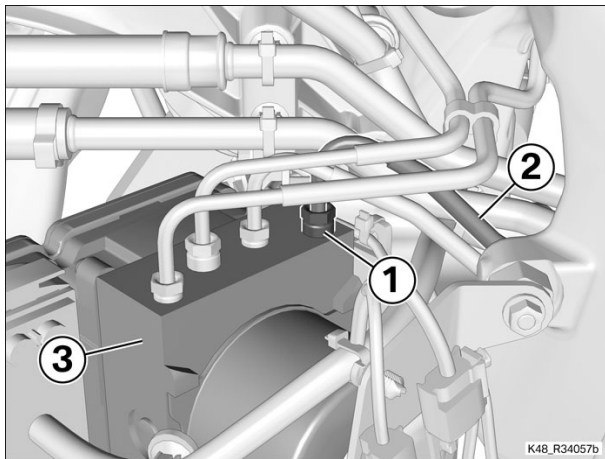

- Hold brake line (2) in position at pressure modulator (3) and tighten union screw (1).

 Tightening torques		
Brake line with union screw to components		
M10 x 1, M12 x 1	14 Nm	

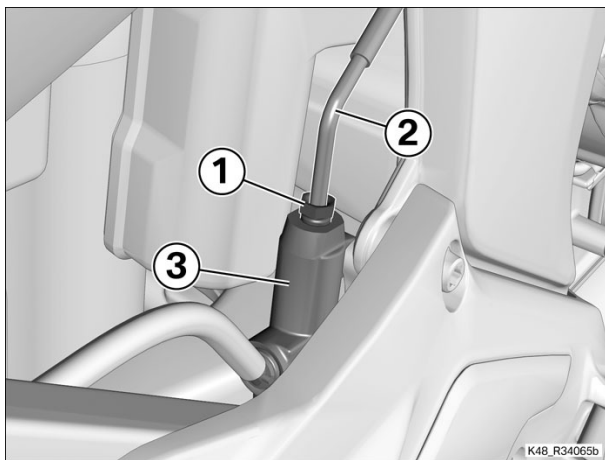

- Hold brake line (2) in position at footbrake cylinder (3) and tighten union screw (1).

 Tightening torques		
Brake line with union screw to components		
M10 x 1, M12 x 1	14 Nm	

Finishing work

=> **Bleeding rear brake system (Description in item: 34 00 509, Billed as a separate item)**

- Installing fuel tank
- Installing complete intake air silencer
- Securing left and right intake air pipes
- Securing seat support
- Installing adjusting plate
- Installing inner trim for right side panel
- Install the right side panel
- Install the right radiator cowl
- Installing right bottom side panel

Installing inner trim for left side panel
Install the left side panel
Installing left radiator cowl
Installing left bottom side panel
Installing complete cover of fuel tank
Installing air guides for intake air pipes, left and right
Installing front seat
Final check of work performed

34 32 051 Replacing rear brake line from pressure modulator (without bleeding brakes)

+ 34 32 651

Equipment trim-level variant:

0416 - Electronic Suspension Adjustment (ESA)



Attention

Brake fluid attacks paintwork, plastic and rubber parts.

Do not allow brake fluid to come into contact with paintwork, plastic or rubber parts.

Preparatory work

Remove the front seat

Removing air guides for intake air pipes, left and right

Removing complete cover of fuel tank

Removing left bottom side panel

Removing left radiator cowl

Removing left side panel

Removing inner trim for left side panel

Removing right bottom side panel

Removing right radiator cowl

Remove the right side panel

Removing inner trim for right side panel

Removing adjusting plate

Disengaging seat support

Disengaging left and right intake air pipes

Removing complete intake air silencer

Removing fuel tank

Draining rear brake system

Core activity

(-) Removing brake line from pressure modulator



Attention

Stretched, twisted or incorrectly fitted brake lines can become worn and start to leak.

Do not bend or clamp brake lines.

When fitting, check that they are correctly installed and secured and are not stretched, bent or clamped. Make sure that clearance relative to all other components is adequate in all situations.

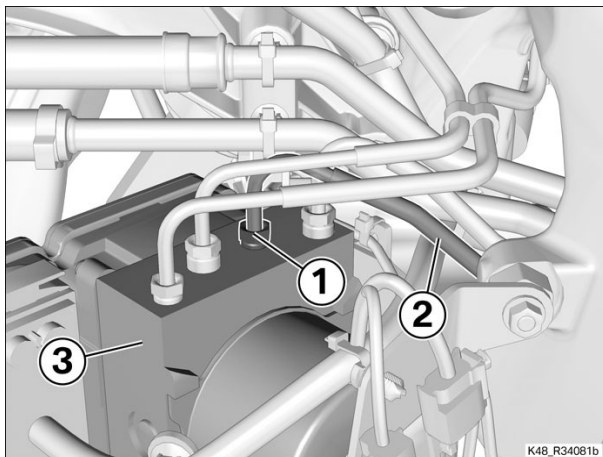

- Disengage union screw (1).
- Disengage brake line (2) from pressure modulator (3).

- Disengage union screw (1).
- Disengage brake line (2) from connector (3) for brake hose.

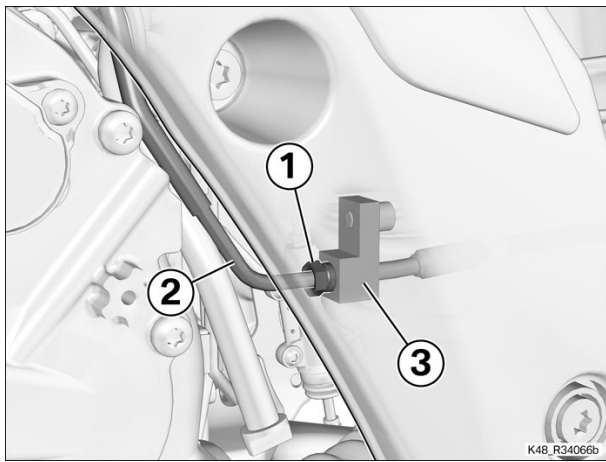

- Remove cable tie (arrow).
- Unclip brake hose (1) from holder (2).

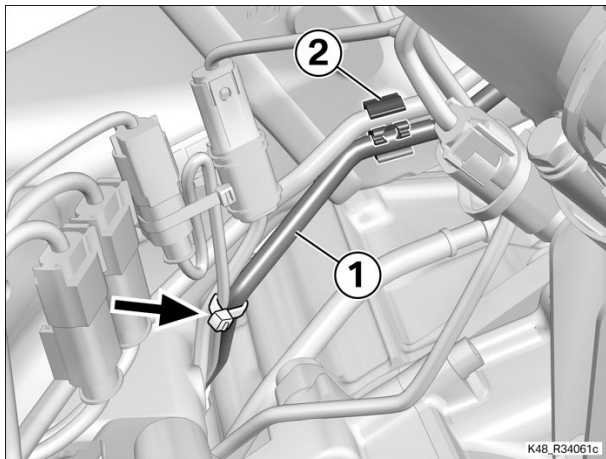

- Unclip brake line (1) from holder (2) and remove.

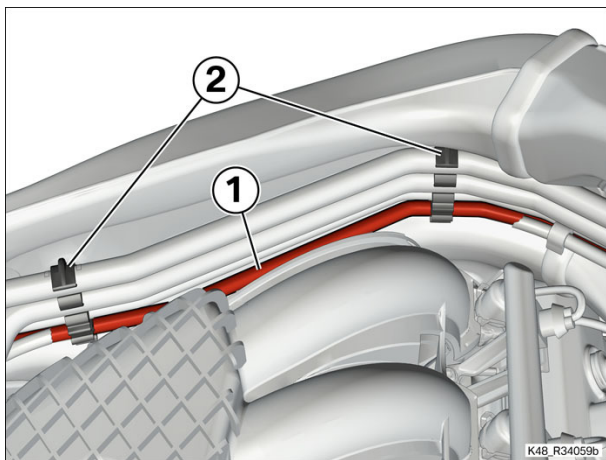

(-) Installing brake line from pressure modulator

- Work brake line (1) into position and route it correctly.
- Clip brake line (1) into holder (2).

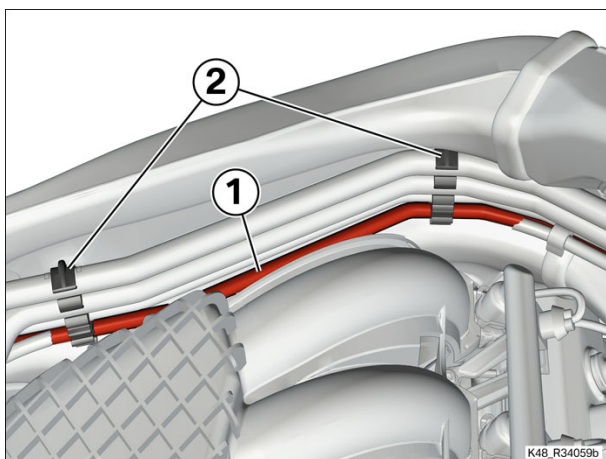

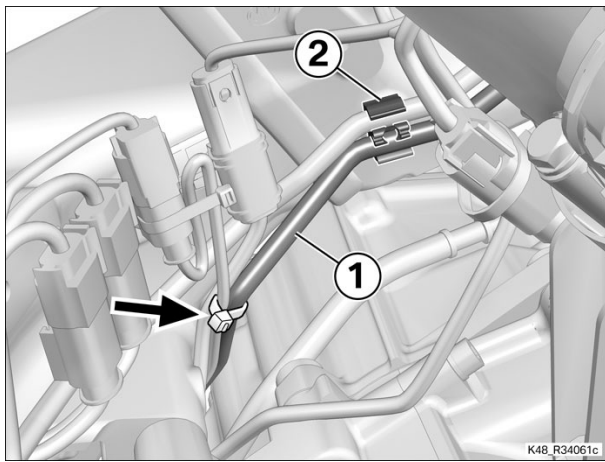

- Clip brake line (1) into holder (2).
- Secure the cable tie (arrow).

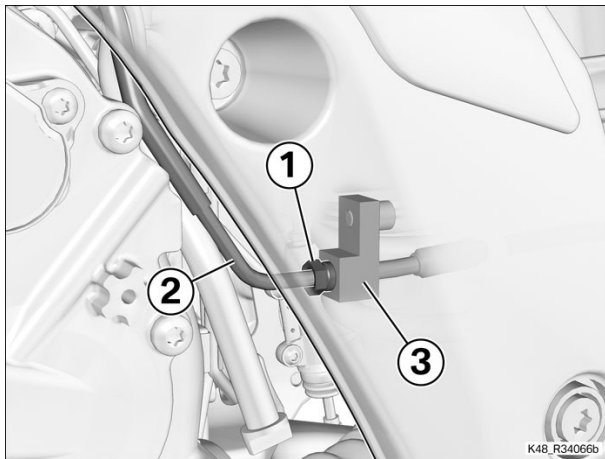

- Hold brake line (2) in position at connector (3) for brake hose and secure union screw (1).

 Tightening torques		
Brake line with union screw to components		
M10 x 1, M12 x 1	14 Nm	

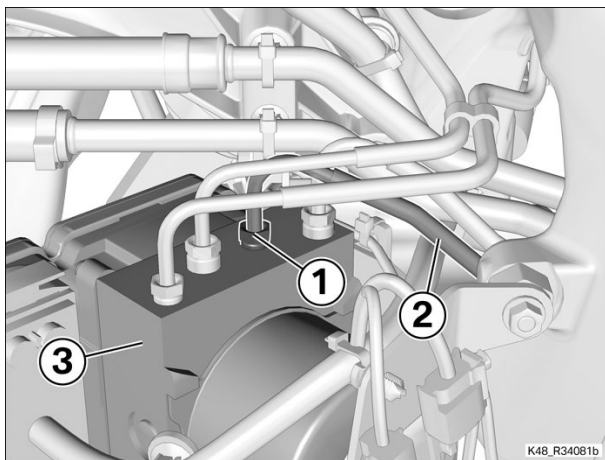

- Hold brake line (2) in position at pressure modulator (3) and tighten union screw (1).

 Tightening torques		
Brake line with union screw to components		
M10 x 1, M12 x 1	14 Nm	

Finishing work

=> **Bleeding rear brake system (Description in item: 34 00 509, Billed as a separate item)**

- Installing fuel tank
- Installing complete intake air silencer
- Securing left and right intake air pipes
- Securing seat support
- Installing adjusting plate
- Installing inner trim for right side panel
- Install the right side panel
- Install the right radiator cowl
- Installing right bottom side panel

Installing inner trim for left side panel
Install the left side panel
Installing left radiator cowl
Installing left bottom side panel
Installing complete cover of fuel tank
Installing air guides for intake air pipes, left and right
Installing front seat
Final check of work performed

34 32 499 Replacing hose, rear, to reservoir

+ 34 32 525



Attention

Brake fluid attacks paintwork, plastic and rubber parts.

Do not allow brake fluid to come into contact with paintwork, plastic or rubber parts.

Preparatory work

Draining rear brake system

Core activity

(-) Removing rear hose to reservoir

- Open clips (1) and remove hose (2).

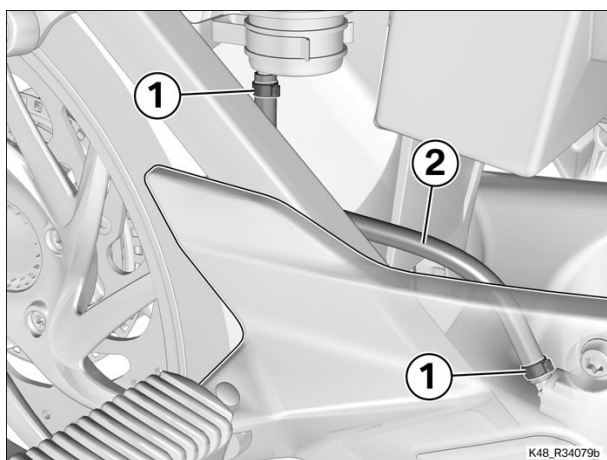

(-) Installing rear hose to reservoir

- Install hose (2) and close clips (1) with pliers (No. 13 1 500).
- Slowly top up with brake fluid to the (MAX) mark on the reservoir, making sure that the air is expelled from hose (2).

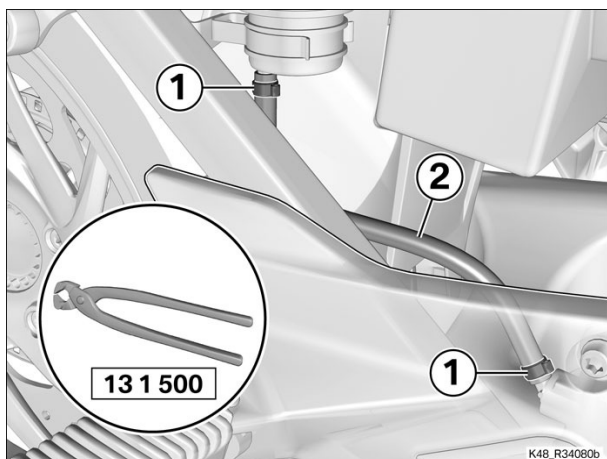

Fluids and lubricants

Brake fluid	Hydraulic systems	
-------------	-------------------	--

- Lightly tap hose (2) to enable the residual air to escape from hose (2) to the reservoir.
- Repeatedly depress the footbrake lever.
- Top up with fresh brake fluid, if necessary.

Finishing work

=> **Bleeding rear brake system (Description in item: 34 00 509, Billed as a separate item)**

Final check of work performed

34 51 011 Replacing pressure modulator (without bleeding/testing software/ programming) 7 FRUs

+ 34 51 511

Equipment trim-level variant:

0416 - Electronic Suspension Adjustment (ESA)



Attention

Brake fluid attacks paintwork, plastic and rubber parts.

Do not allow brake fluid to come into contact with paintwork, plastic or rubber parts.



Note

Before removal, test the control unit with the **BMW Motorrad** diagnostic system and make a backup copy of the data.

Preparatory work

=> **Change brake fluid in entire system (Description in item: 34 00 504, Billed as a separate item)**

Removing left bottom side panel

Removing left radiator cowl

Removing left side panel

Core activity

(-) Removing pressure modulator

- Remove the cable ties (arrows).
- Remove and disconnect plug (1) for the wheel-speed sensor and plug (2) for the **ESA** spring strut.
- Disconnect plug (3) for the pressure modulator.
- Allow cable leg (4) to dangle to one side.

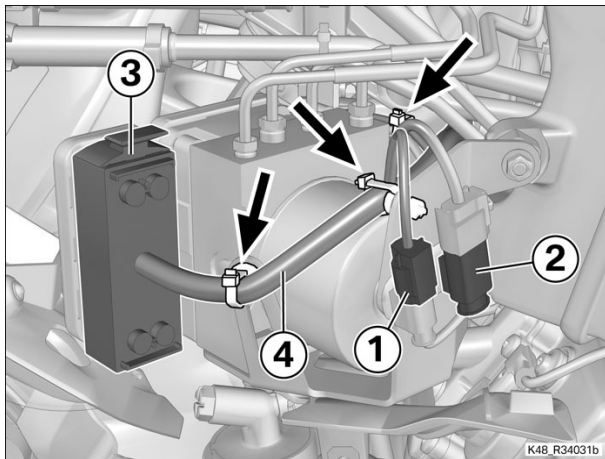

► Disconnecting brake lines from pressure modulator

- Slacken union screws (1) and (2).
- Disconnect the following brake lines:



Note

Use the protective cap from a bleed screw to seal the brake pipes.

- (3) for control circuit, front wheel
- (4) for brake circuit, front wheel
- (5) for brake circuit, rear wheel
- (6) for control circuit, rear wheel

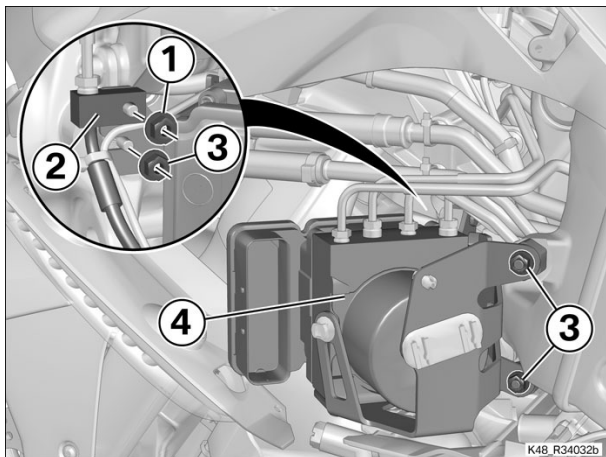
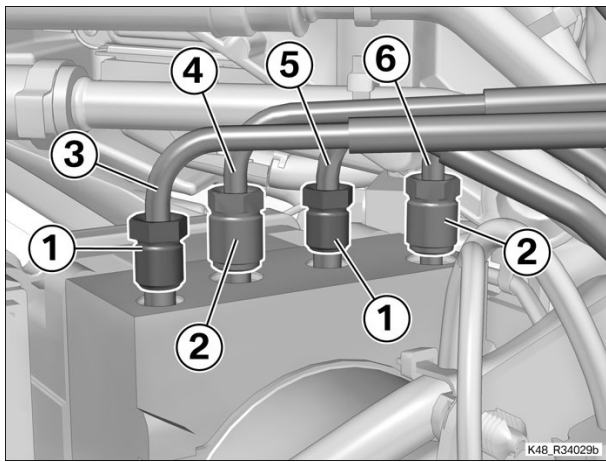

- Remove nut (1) and remove brake line (2).
- Remove nuts (3).
- Remove pressure modulator (4) with the bracket.

(-) Replacing pressure modulator

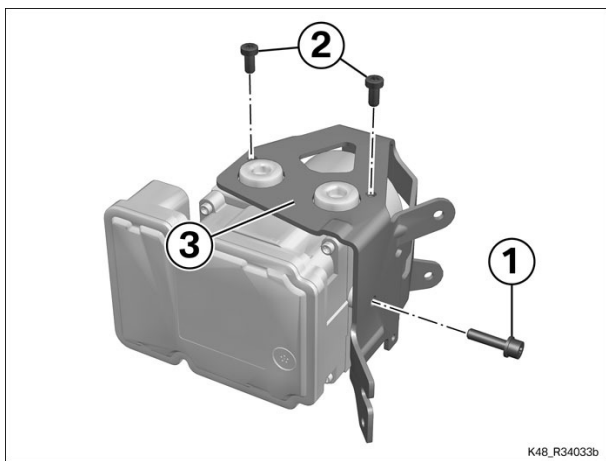

- Remove the following components and transfer them to the new pressure modulator:
 - Screw (1) with washer
 - Screws (2)
 - Holder (3)
- Tighten screws (1) and (2) to the specified tightening torque.

 Tightening torques		
Pressure modulator to bracket		
M6 x 12	8 Nm	
M6 x 25	8 Nm	

(-) Installing pressure modulator

- Hold pressure modulator (4) with the bracket in position.
- Install nuts (3).

 Tightening torques		
Bracket for pressure modulator to vibration damper		
M6	8 Nm	

- Hold brake line (2) in position and install nut (1).

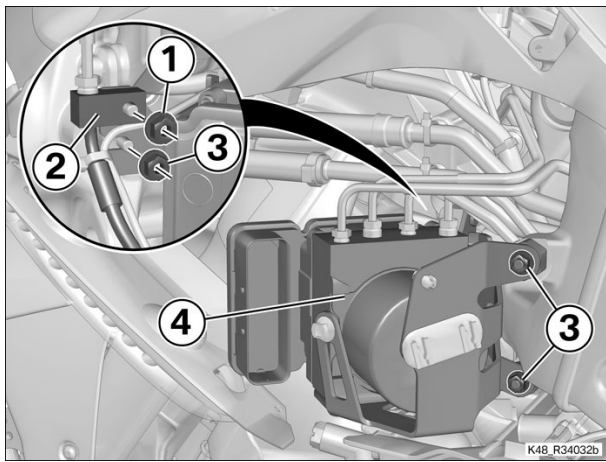

Tightening torques

Brake line, front, to bracket for pressure modulator

M6	8 Nm	
----	------	--

► **Connecting brake lines to pressure modulator**



Attention

Stretched, twisted or incorrectly fitted brake lines can become worn and start to leak.

Do not bend or clamp brake lines.

When fitting, check that they are correctly installed and secured and are not stretched, bent or clamped. Make sure that clearance relative to all other components is adequate in all situations.

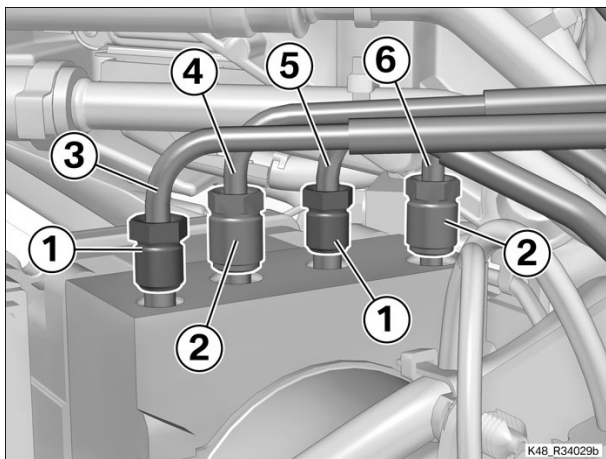

- Connect the following brake lines:
 - (6) for control circuit, rear wheel
 - (5) for brake circuit, rear wheel
 - (4) for brake circuit, front wheel
 - (3) for control circuit, front wheel
- Tighten union screws (1) and (2).



Tightening torques

Brake line with union screw to components

M10 x 1, M12 x 1	14 Nm	
------------------	-------	--

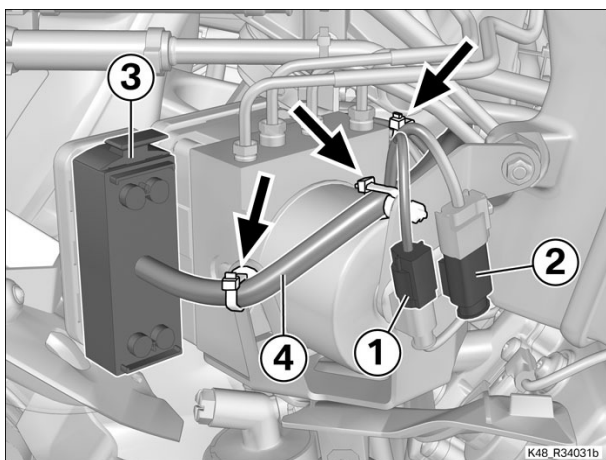

- Route cable leg (4).
- Connect plug (3) for the pressure modulator.
- Connect and install plug (1) for the wheel-speed sensor and plug (2) for the **ESA** spring strut.
- Close the cable ties (arrows).

Finishing work

Install the left side panel

Installing left radiator cowl

Installing left bottom side panel

**=> Testing software (Description in item: 61 00 502,
Billed as a separate item)**

**=> Programming control units of vehicle (along with
testing software) (Description in item: 61 00 510, Billed
as a separate item)**

Final check of work performed

35 21 000 Removing/installing or replacing footbrake lever 3 FRUs

+ 35 21 531

Core activity

(-) Removing footbrake lever

- Disengage tension spring (1) from footbrake lever (2).

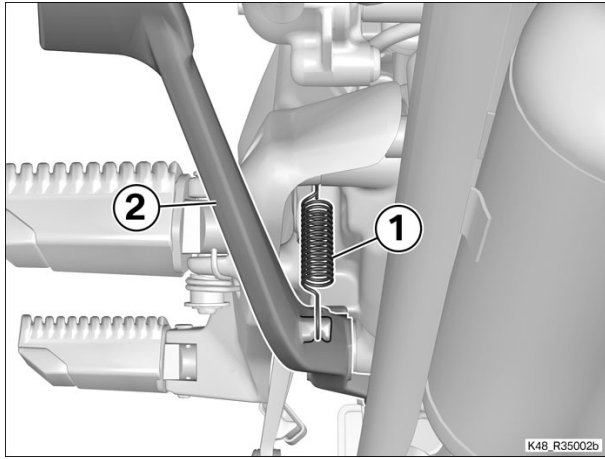

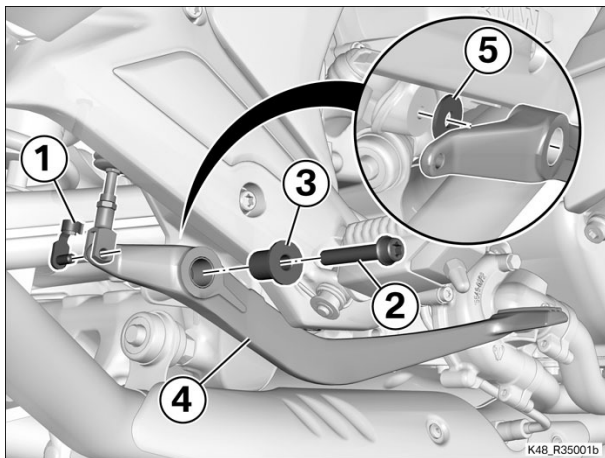

- Remove locking clip (1).
- Remove screw (2) with bushing (3) and remove footbrake lever (4) with washer (5).

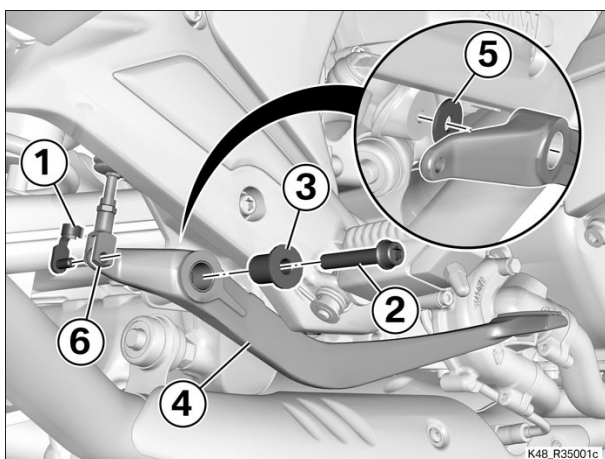

(-) Installing footbrake lever

- Clean the tapped hole.
- Introduce footbrake lever (4) into adapter (6) of the footbrake cylinder and hold it in position with washer (5).
- Lubricate bushing (3).



 Fluids and lubricants		
Staburags NBU 30 PTM	High-performance lubricating grease	07 55 9 056 992

- Install bushing (3) and new screw (2).

 Tightening torques		
Footbrake lever to frame		
M8 x 45 - 10.9, Replace screw Micro-encapsulated	28 Nm	

- Install locking clip (1).
- Engage tension spring (1) in footbrake lever (2).

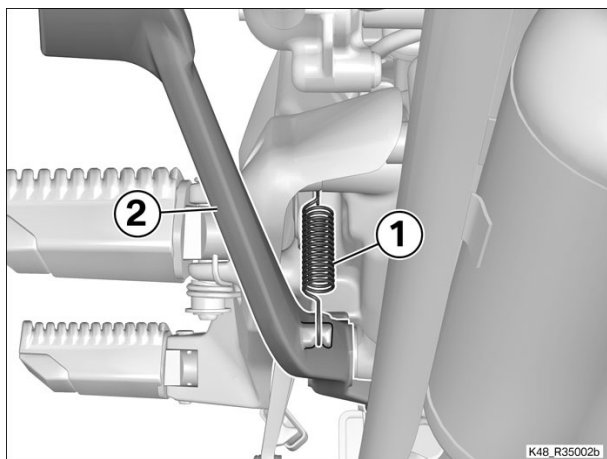

Finishing work

Adjusting play of footbrake lever

Final check of work performed

36 20 510 Replacing RDC control unit (without checking software/programming) 4 FRUs

Equipment trim-level variant:

0530 - Tyre pressure monitoring (RDC)



Note

Before removal, test the control unit with the **BMW Motorrad** diagnostic system and make a backup copy of the data.

Preparatory work

Remove the front seat

Removing air guides for intake air pipes, left and right

Removing complete cover of fuel tank

Removing adjusting plate

Disengaging seat support

Disengaging left and right intake air pipes

Disengaging complete intake air silencer

Core activity

(-) Removing tyre pressure monitoring control unit (RDC control unit)

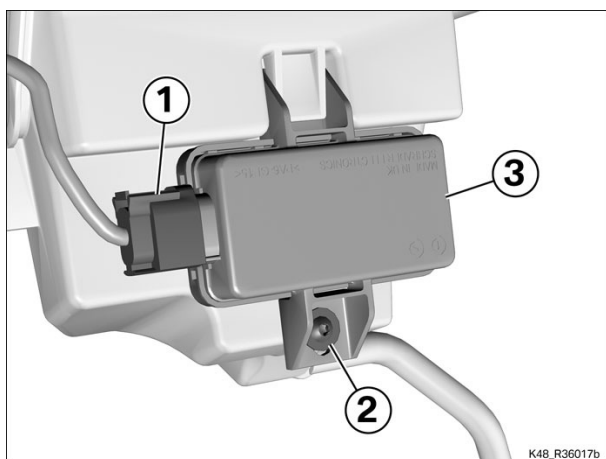

- Disconnect plug (1) for the **RDC** control unit.
- Remove screw (2).
- Remove **RDC** control unit (3).

(-) Installing tyre pressure monitoring control unit (RDC control unit)

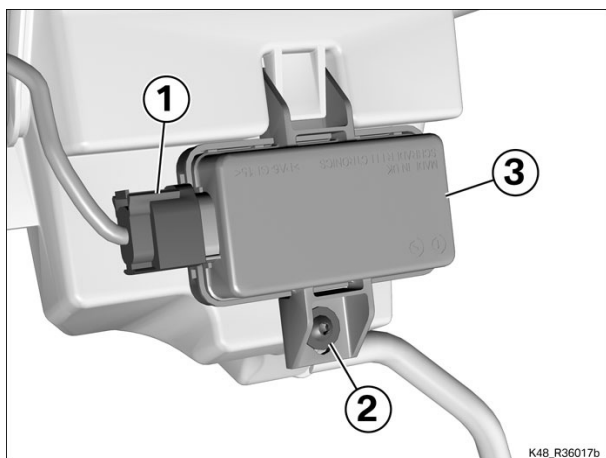

- Install **RDC** control unit (3).
- Install screw (2).



Tightening torques

Tyre pressure monitoring (RDC) control unit to intake air silencer

TS4 x 10	3 Nm	
----------	------	--

- Connect plug (1) for the **RDC** control unit.

Finishing work

Securing complete intake air silencer

Securing left and right intake air pipes

Securing seat support

Installing adjusting plate

Installing complete cover of fuel tank

Installing air guides for intake air pipes, left and right

**=> Testing software (Description in item: 61 00 502,
Billed as a separate item)**

Installing front seat

Final check of work performed

36 20 554 Replacing front RDC sensor (tyre removed) 2 FRUs

Equipment trim-level variant:
0530 - Tyre pressure monitoring (RDC)

Core activity

(-) Removing front tyre pressure monitoring sensor (RDC sensor)

- Remove screw (1).
- Remove **RDC** sensor (2).

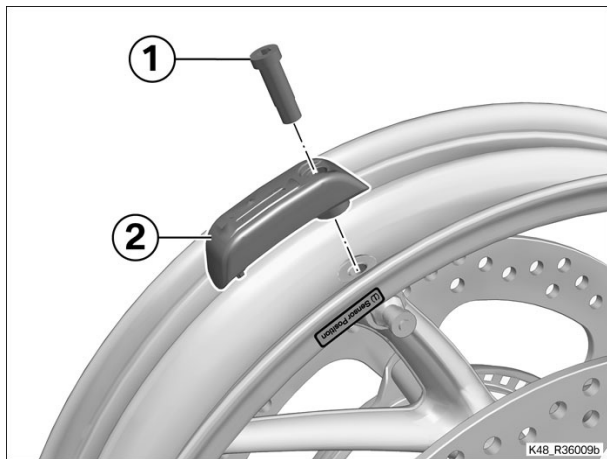

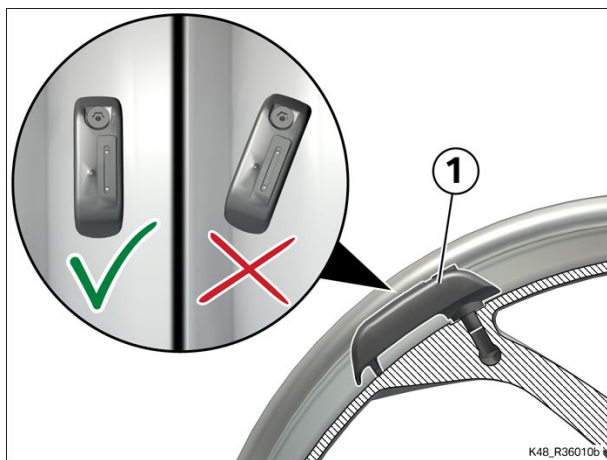

(-) Install the front tyre pressure monitoring sensor (RDC sensor)

- Clean the seat and the threaded bore for the **RDC** sensor.
- Parallel **RDC** sensor (1) with the wheel rim such that the plastic body does not touch the wheel rim.

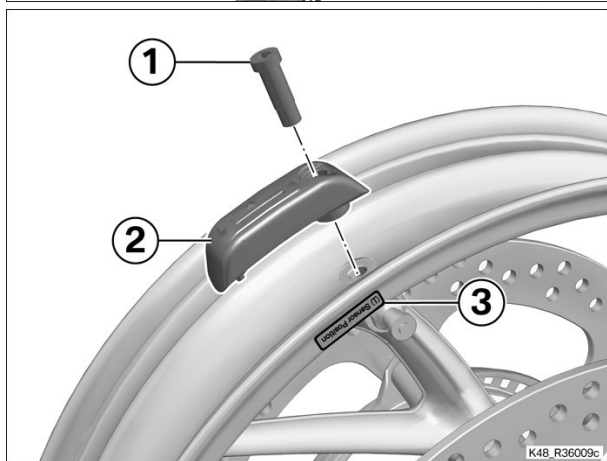

- When installing, make sure that **RDC** sensor (2) and **RDC** label (3) on the rim are aligned and install screw (1).



 Tightening torques		
RDC sensor to wheel rim		
M8 x 25, use thread-locking compound for repair Loctite 243	9 Nm	

Finishing work

Remove the front seat

Connecting **BMW Motorrad** diagnostic system to motorcycle
Teaching tyre pressure monitoring (**RDC**) sensor to control unit
Disconnecting **BMW Motorrad** diagnostic system from motorcycle
Installing front seat
Final check of work performed

📁 36 20 555 Replacing rear RDC sensor (tyre removed) 2 FRUs

Equipment trim-level variant:

0530 - Tyre pressure monitoring (RDC)

Core activity

(-) Remove the rear tyre pressure monitoring sensor (RDC sensor)

- Remove screw (1).
- Remove **RDC** sensor (2).

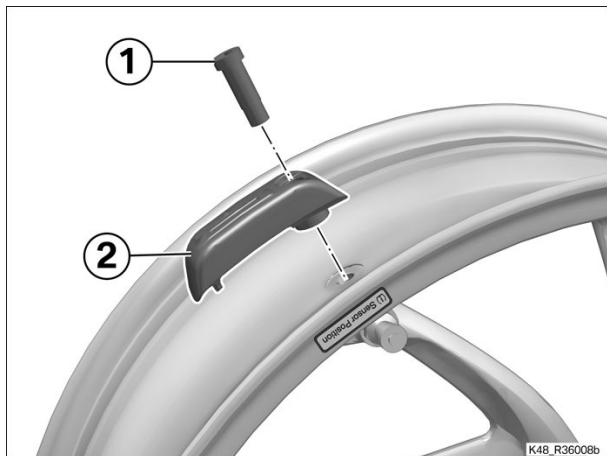

(-) Replacing rear tyre pressure monitoring sensor (RDC sensor)

- Clean the seat and the threaded bore for the **RDC** sensor.
- Parallel **RDC** sensor (1) with the wheel rim such that the plastic body does not touch the wheel rim.

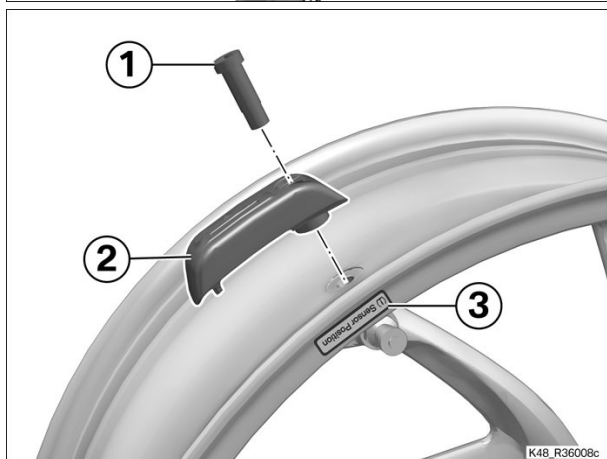
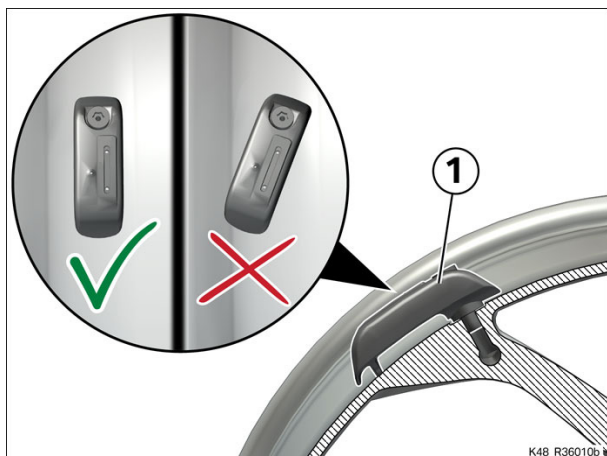

- When installing, make sure that **RDC** sensor (2) and **RDC** label (3) on the rim are aligned and install screw (1).

🔧 Tightening torques		
RDC sensor to wheel rim		
M8 x 25, use thread-locking compound for repair Loctite 243	9 Nm	

Finishing work

Remove the front seat

Connecting **BMW Motorrad** diagnostic system to motorcycle
Teaching tyre pressure monitoring (**RDC**) sensor to control unit
Disconnecting **BMW Motorrad** diagnostic system from motorcycle
Installing front seat
Final check of work performed

36 23 001 Replacing wheel-speed sensor, front 8 FRUs

+ 36 23 601

Preparatory work

- Remove the complete front-wheel cover
- Releasing left and right front brake calipers
- Installing front-wheel stand
- Removing front wheel
- Removing left bottom side panel
- Removing left radiator cowl
- Removing left side panel

Core activity

(-) Removing front wheel-speed sensor

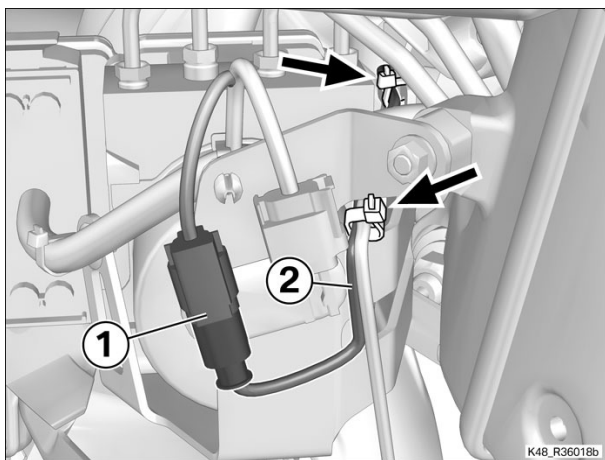

- Remove the cable ties (arrows).
- Remove plug (1) for the wheel-speed sensor and disconnect.
- Work cable (2) clear of the motorcycle.

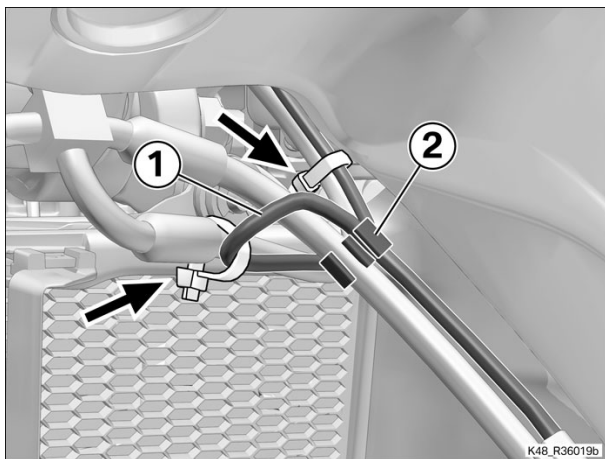

- Remove the cable ties (arrows).
- Disengage cable (1) from holder (2).

- Remove screws (1).
- Remove cable guide (2) and disengage cable (3).

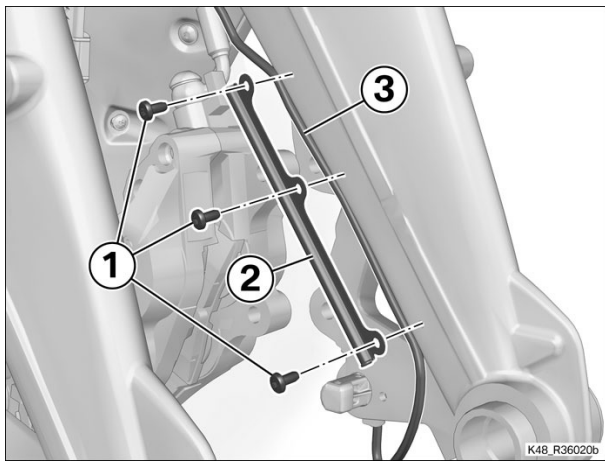

K48_R36020b

- Remove screw (1).
- Remove wheel-speed sensor (2).

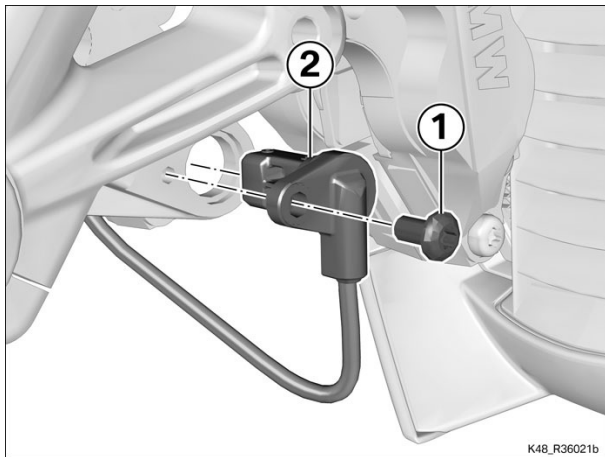

K48_R36021b

(-) Installing front wheel-speed sensor

- Clean the tapped hole.
- Install wheel-speed sensor (2).
- Install new screw (1).

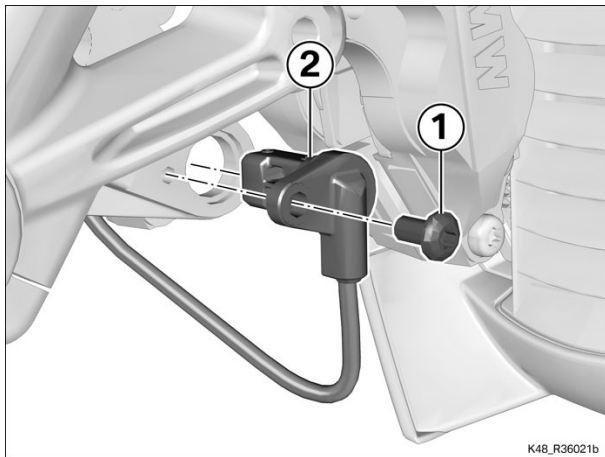

K48_R36021b

 Tightening torques		
Wheel-speed sensor to wheel carrier/ rear brake caliper		
M5 x 10 - 10.9, Replace screw	5 Nm	
Micro-encapsulated		

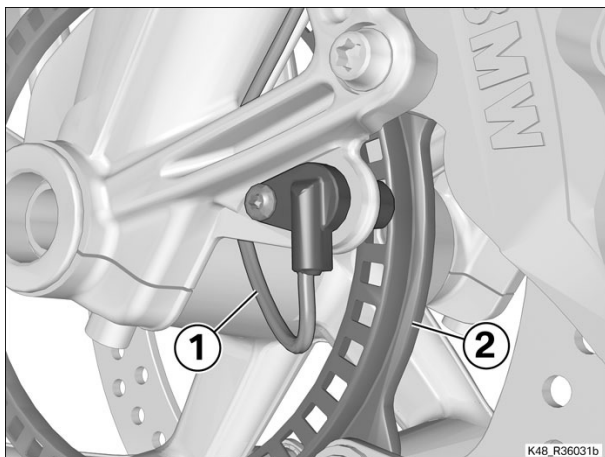

K48_R36031b

- When routing cable (1) for the wheel-speed sensor, make sure that with the front wheel installed, the cable cannot chafe against sensor ring (2).

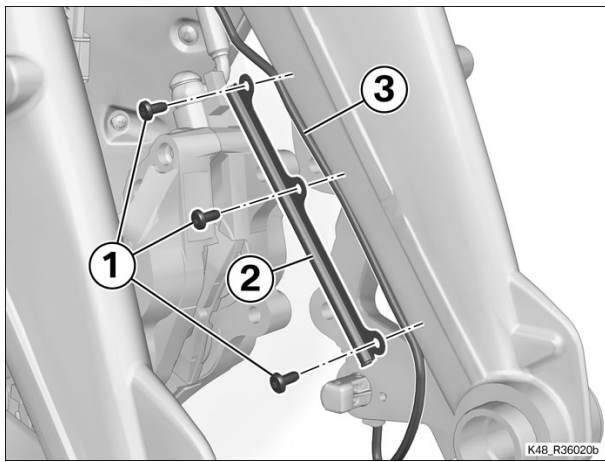

Clean the tapped hole.

- Secure cable (3) in cable guide (2) and hold cable guide (2) in position.
- Install new screws (1).

 Tightening torques		
Cable guide to wheel carrier		
M4 x 8, Replace screw	3 Nm	
Micro-encapsulated		

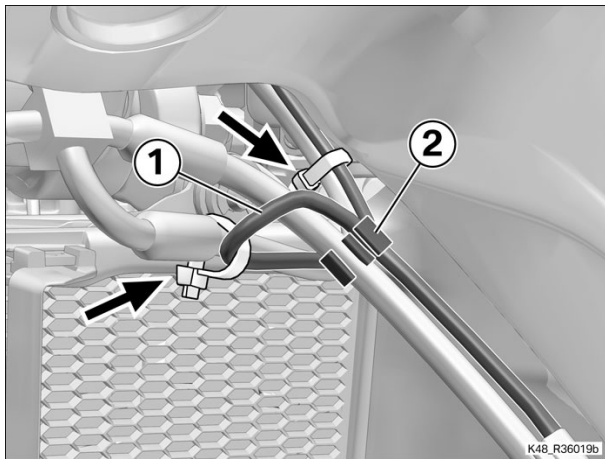

- Secure cable (1) in holder (2).
- Close the cable ties (arrows).

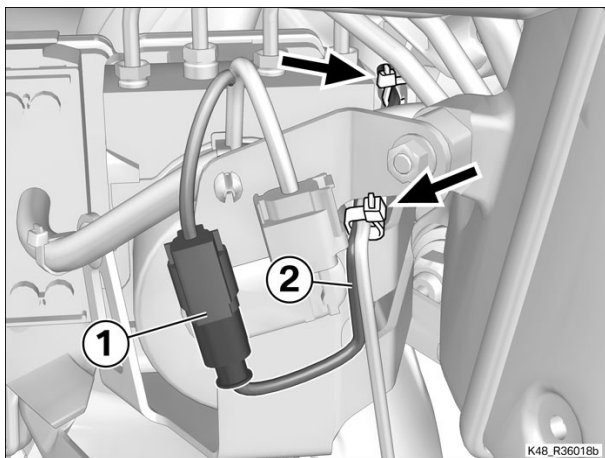

- Route cable (2) into position.
- Connect plug (1) for wheel-speed sensor and install.
- Close the cable ties (arrows).

Finishing work

- Install the left side panel
- Installing left radiator cowl
- Installing left bottom side panel
- Install the front wheel
- Removing front-wheel stand
- Securing front brake calipers, left and right
- Bedding in brake pads
- Installing complete front-wheel cover
- Final check of work performed

36 23 002 Replacing wheel-speed sensor, rear 4 FRUs

+ 36 23 602

Preparatory work

Remove the front seat

Removing air guide for intake air pipe, left

Removing left fuel-tank cover top section

Removing left cover of fuel tank

Core activity

(-) Removing rear wheel-speed sensor

- Remove cable tie (arrow).
- Remove plug (1) for the wheel-speed sensor and disconnect.

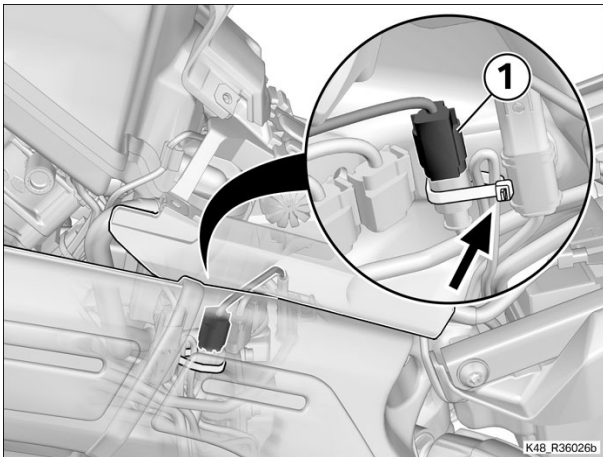

- Remove cable tie (arrow).
- Disengage cable (1) from holder (2) and work it clear.

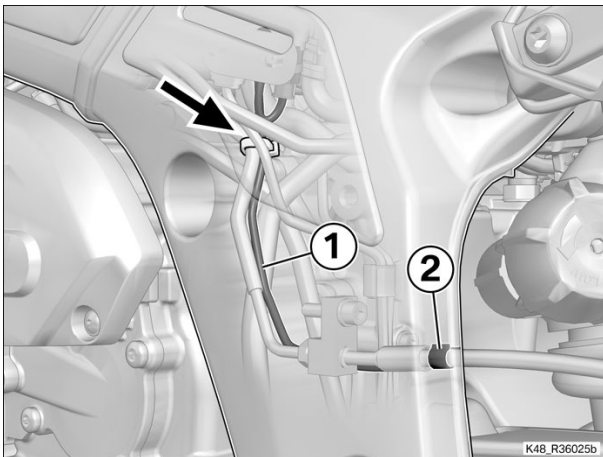

- Disengage cable (1) from holder (2).

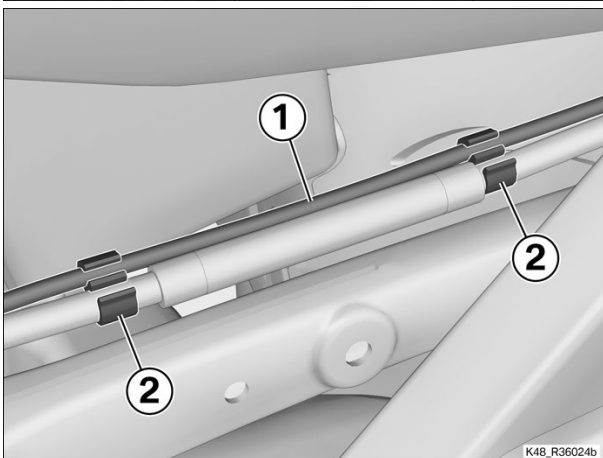

- Disengage cable (1) from holder (2).

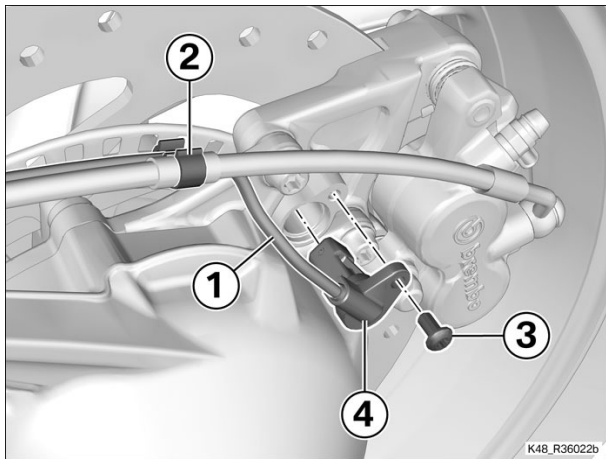
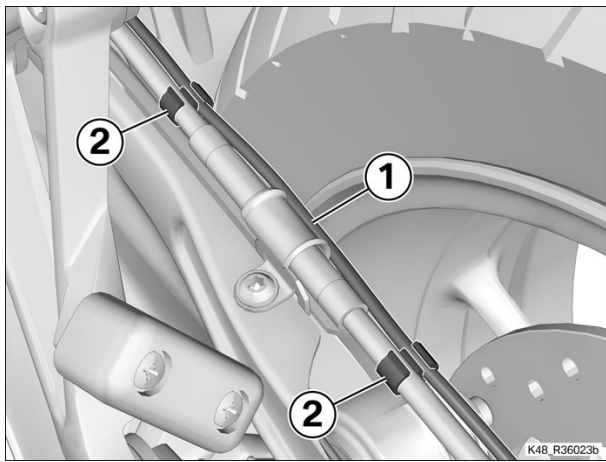

- Disengage cable (1) from holder (2).
- Remove screw (3).
- Remove wheel-speed sensor (4).

(-) Installing rear wheel-speed sensor

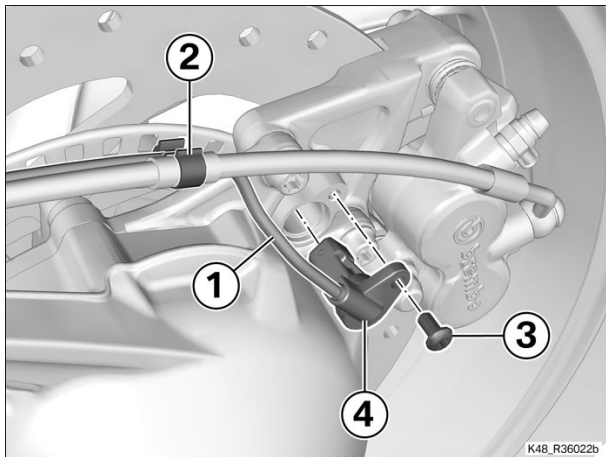

- Clean the tapped hole.
- Secure cable (1) in holder (2).
- Install wheel-speed sensor (4).
- Install new screw (3).

 Tightening torques		
Wheel-speed sensor to wheel carrier/ rear brake caliper		
M5 x 10 - 10.9, Replace screw Micro-encapsulated	5 Nm	

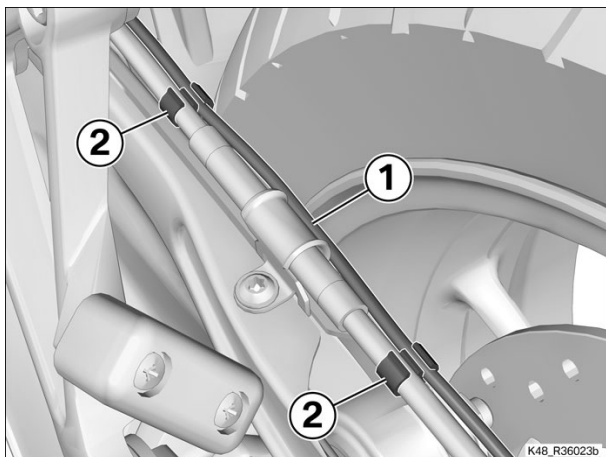

- Secure cable (1) in holder (2).

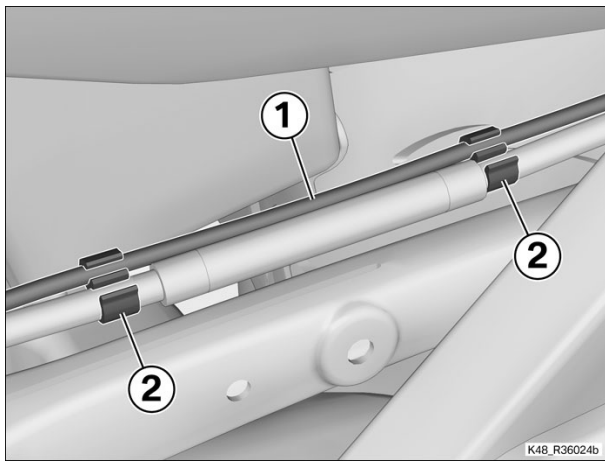

Secure cable (1) in holder (2).

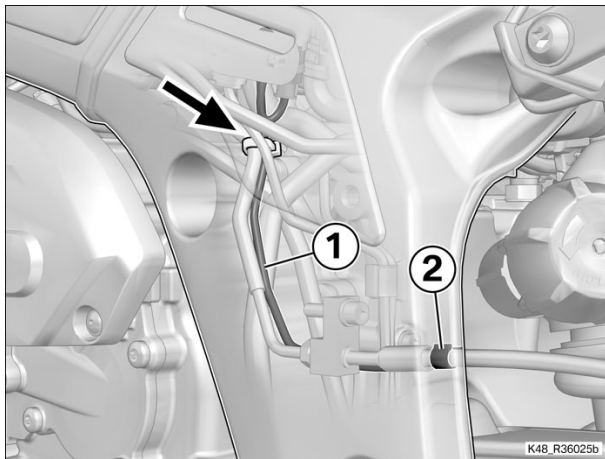

- Route cable (1) and secure it in holder (2).
- Secure the cable tie (arrow).

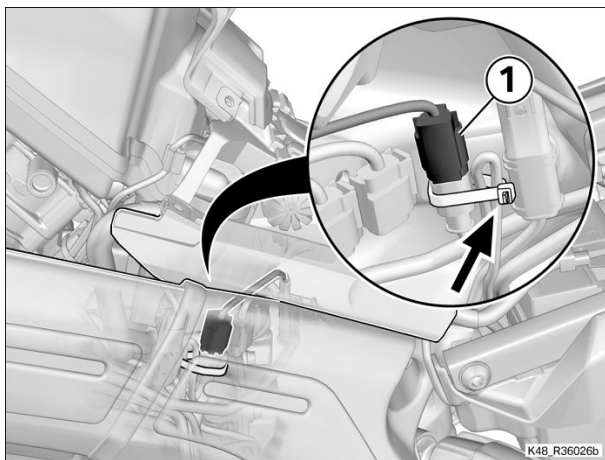

- Connect plug (1) for wheel-speed sensor and install.
- Secure the cable tie (arrow).

Finishing work

Installing left cover of fuel tank

Installing left fuel-tank cover top section

Installing air guide for intake air pipe, left

Installing front seat

Final check of work performed

36 23 003 Replacing sensor ring, front 8 FRUs

+ 36 23 603

Preparatory work

- Remove the complete front-wheel cover
- Releasing left and right front brake calipers
- Installing front-wheel stand
- Removing front wheel

Core activity

(-) Removing front sensor ring

- Remove screws (1).
- Remove brake disc (2) and sensor ring (3).

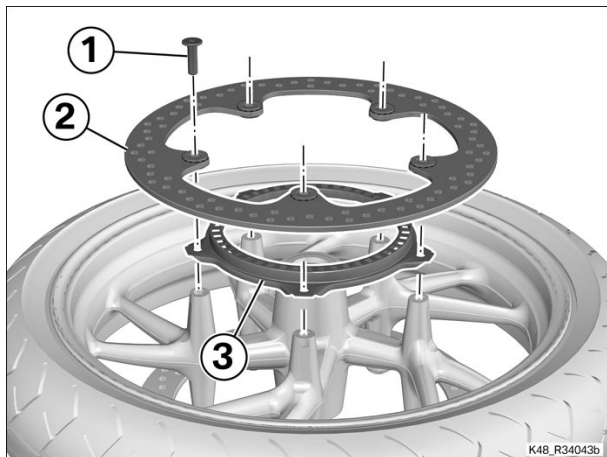

(-) Installing front sensor ring

- Clean the tapped holes in the wheel rim.
- Lay sensor ring (3) on the wheel rim.
- Lay brake disc (2) on the wheel rim with the wide flats (arrow) of the rivets to the outside and position it correctly.
- Install new screws (1).

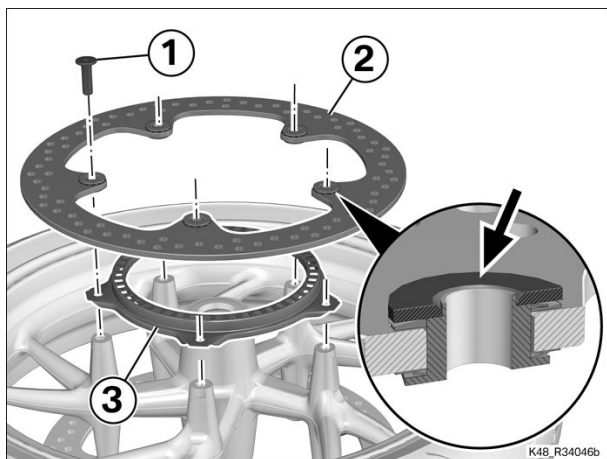

 Tightening torques		
Brake disc to front wheel		
Flat-head screw, M8 x 27 - 10.9, Replace screw Micro-encapsulated	tighten in diagonally opposite sequence	
	19 Nm	

Finishing work

- Install the front wheel
- Removing front-wheel stand
- Securing front brake calipers, left and right
- Bedding in brake pads
- Installing complete front-wheel cover
- Final check of work performed

36 23 004 Replacing sensor ring, rear 7 FRUs

+ 36 23 604

Preparatory work

Removing number-plate carrier

Remove the rear wheel

Removing rear brake caliper

Core activity

(-) Removing rear sensor ring

- Remove screws (1).
- Remove brake disc (2) and sensor ring (3).

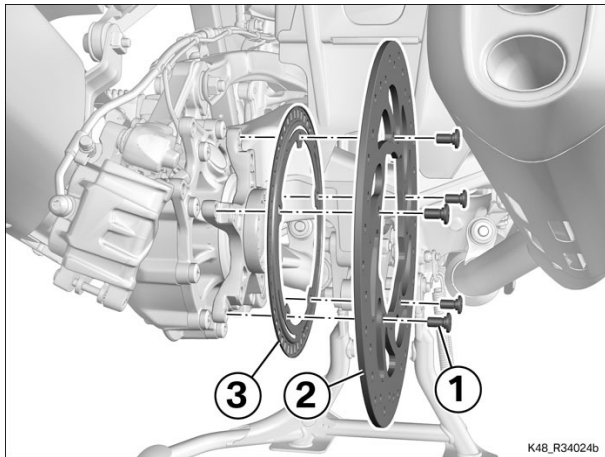

(-) Installing rear sensor ring

- Clean the tapped holes.
- Install sensor ring (3) and brake disc (2) and position them correctly.
- Install new screws (1).

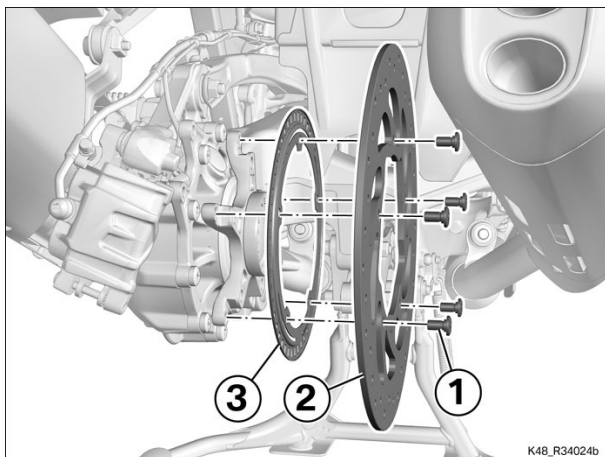

 Tightening torques		
Brake disc to wheel carrier		
M8 x 15.5, Replace screw Micro-encapsulated	tighten by stages in diagonally opposite sequence	
	Initial torque, 12 Nm	
	Final torque, 30 Nm	

Finishing work

Securing rear brake caliper

Installing rear wheel

Installing number-plate carrier

Final check of work performed

36 30 300 Removing/installing front wheel 5 FRUs

+ 36 30 628

Preparatory work

Releasing left and right front brake calipers

Remove the complete front-wheel cover

Installing front-wheel stand

Core activity

(-) Removing front wheel

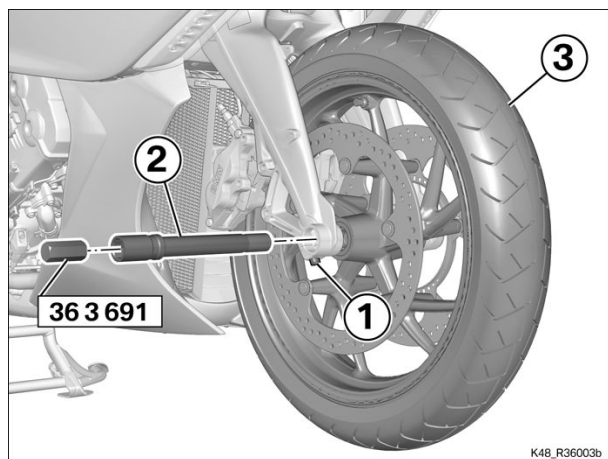

Attention

The left axle clamping screw locates the threaded bush in the front suspension. If the threaded bush is not correctly aligned the gap between the ABS sensor ring and the ABS sensor will not be correct and this can cause the ABS to malfunction or allow the ABS sensor to be damaged.

In order to ensure that the threaded bush remains correctly aligned, do not slacken or remove the left axle clamping screw.

- Slacken screw (1).
- Remove quick-release axle (2) with hexagon (No. 36 3 691).
- Remove front wheel (3).

(-) Install the front wheel

- Clean and lubricate quick-release axle (2).

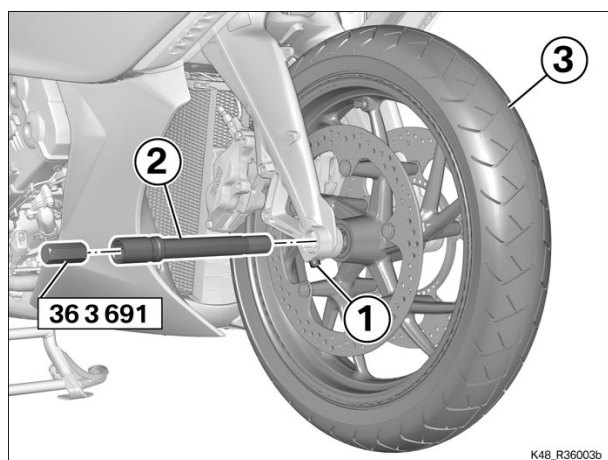

Fluids and lubricants

Optimoly TA	High-temperature assembly grease	18 21 9 062 599
-------------	----------------------------------	-----------------

- Install front wheel (3).
- Install quick-release axle (2) with hexagon (No. 36 3 691) and tighten.



Tightening torques

Quick-release axle in threaded bush (wheel carrier)

M24 x 1.5	50 Nm	
-----------	-------	--

- Tighten screw (1).



Tightening torques

Clamping screw for quick-release axle to wheel carrier

M8 x 30	19 Nm	
---------	-------	--

Finishing work

Removing front-wheel stand

Installing complete front-wheel cover

Securing front brake calipers, left and right

Bedding in brake pads
Final check of work performed

36 30 320 Removing/installing rear wheel 3 FRUs

+ 36 30 629

Preparatory work

Removing number-plate carrier

Core activity

(-) Remove the rear wheel

- Remove screws (1).
- Disengage rear wheel (2) and remove.

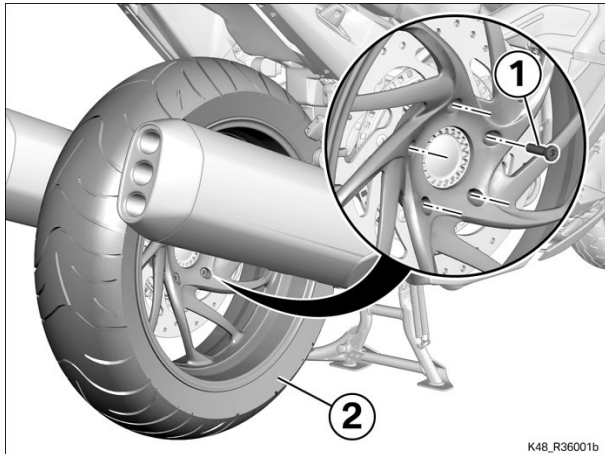

(-) Installing rear wheel

- Install rear wheel (2).
- Install screws (1).

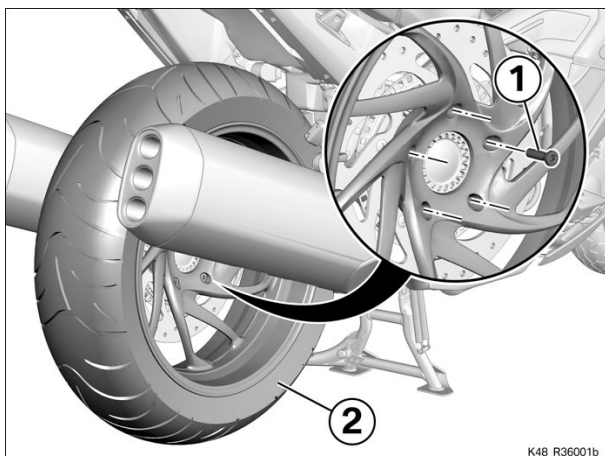

 Tightening torques		
Rear wheel to wheel flange		
M10 x 1.25 x 40	tighten in diagonally opposite sequence	
	60 Nm	

Finishing work

Installing number-plate carrier

Final check of work performed

36 30 508 Balancing front wheel (statically) (wheel removed) 1 FRUs

Core activity

(-) Static balancing of front wheel

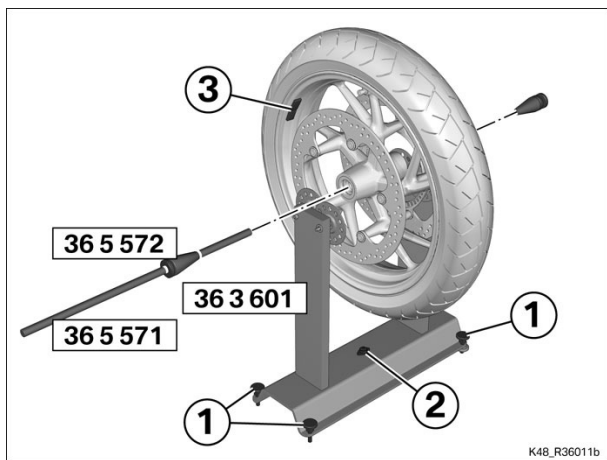

- Align balancer (No. 36 3 601) with knurled screws (1) and level gauge (2).
- Insert balancing shaft (No. 36 5 571) in front-wheel bearing and secure it with tensioner (No. 36 5 572), making sure that front-wheel bearing is **lightly** preloaded.
- Place the front wheel on the balancer and allow it to come to rest.
- Clean the attachment points for the adhesive weights.
- Affix adhesive weights (3) **opposite the heaviest point of the wheel.**

 Technical data			
Permissible front-wheel imbalance		max 5 g	
Balancing weight for front wheel Weight must be divided equally across both sides and weights attached to rim on left and right.		max 80 g	

- Repeat the balancing procedure as a check.

36 30 518 Balancing rear wheel (statically) (wheel removed) 2 FRUs

Core activity

(-) Static balancing of rear wheel

- Install balancing adapter (No. 36 5 561) with wheel studs (1).

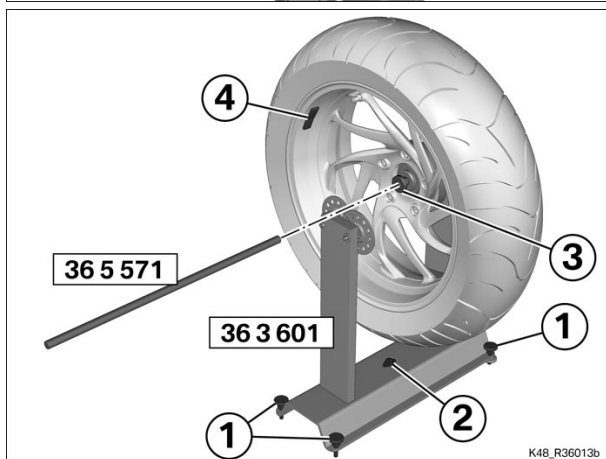
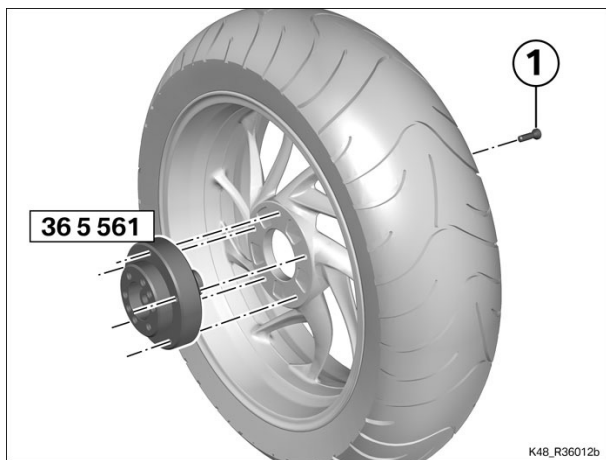

- Align balancer (No. 36 3 601) with knurled screws (1) and level gauge (2).
- Introduce balancing shaft (No. 36 5 571) into the rear wheel and secure it with tensioning device (3).
- Place the rear wheel on the balancer and allow it to come to rest.
- Clean the attachment points for the adhesive weights.
- Affix adhesive weights (4) **opposite the heaviest point of the wheel.**

 Technical data			
Permissible rear-wheel imbalance		max 45 g	
Balancing weight for rear wheel Weight must be divided equally across both sides and weights attached to rim on left and right.		max 80 g	

- Repeat the balancing procedure as a check.

36 30 601 Replacing rim for front wheel (wheel removed) 6 FRUs

Equipment trim-level variant:

0530 - Tyre pressure monitoring (RDC)

Preparatory work

Removing front left brake disc

Removing front right brake disc

Core activity

(-) Removing front tyre

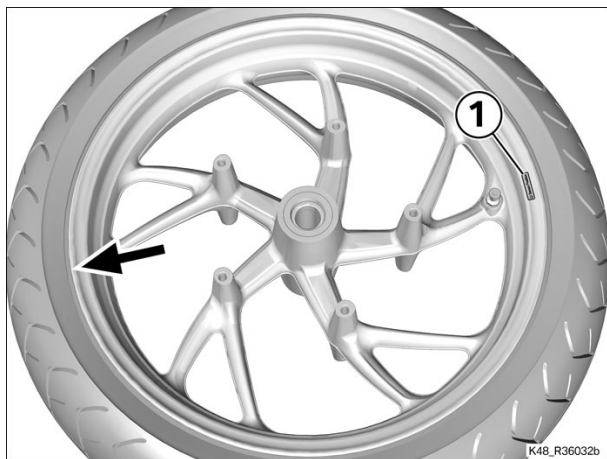

- Pry off the tyre opposite (arrow) the valve/tyre pressure monitoring sensor (**RDC** sensor).
- Apply the lever to the rim at **RDC** sticker (1), to prevent the tyre bead from damaging the **RDC** sensor.
- Remove the tyre with commercially available tools.

(-) Removing front tyre pressure monitoring sensor (RDC sensor)

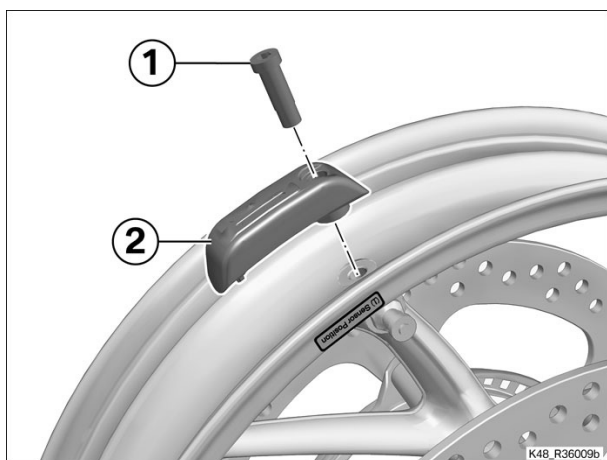

- Remove screw (1).
- Remove **RDC** sensor (2).

(-) Checking battery of tyre-pressure monitoring sensor (RDC sensor)

Test

- Check the battery of the **RDC** sensor with **RDC** test tool (No. 61 1 671).



Result: Battery too weak

Measure:

- Replace the **RDC** sensor.

(-) Installing front tyre pressure monitoring sensor (RDC sensor)

- Parallel **RDC** sensor (1) with the wheel rim such that the plastic body does not touch the wheel rim.

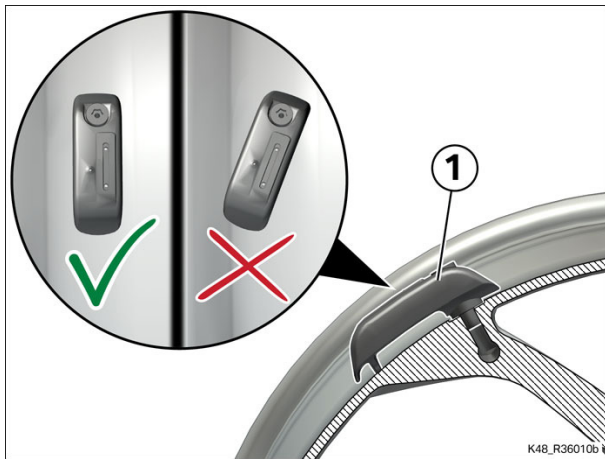

- Affix **RDC** label (3) at the position of **RDC** sensor (2).
- Install screw (1).

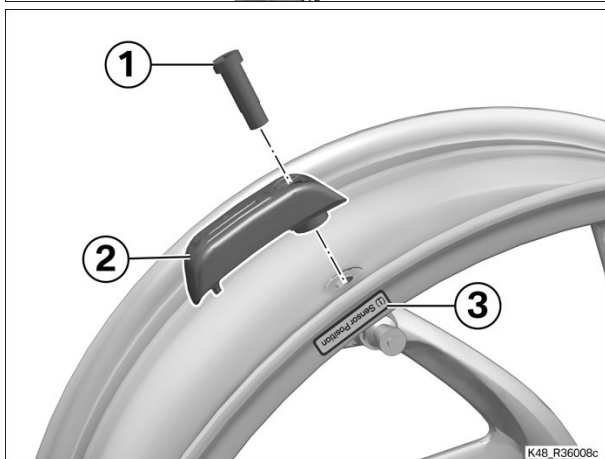

 Tightening torques		
RDC sensor to wheel rim		
M8 x 25, use thread-locking compound for repair Loctite 243	9 Nm	

(-) Installing front tyre

 **Attention**

Components can be damaged by hard or sharp-edged objects. Avoid scratching the components; use masking tape if necessary.

- Use commercially available tools and work to the manufacturer's

specifications to fit the tyres, and make sure that the direction-of-rotation arrows on tyre and rim point in the same direction.

Test

- Inflate the tyre to test pressure and check the valve for leaks.

 Technical data			
Wheel valve test pressure		4 bar	

Result: Valve leaking

Measure:

- Replace the valve insert.

Result: Valve leaktight

Measure:

- Correct the tyre pressure.

 Technical data			
Tyre pressure, front	Tyre cold	2.9 bar	

Finishing work

Installing front left brake disc

Installing front right brake disc

Static balancing of front wheel

📁 36 30 611 Replacing rim for rear wheel (wheel removed)

Equipment trim-level variant:

0530 - Tyre pressure monitoring (RDC)

Core activity

(-) Removing rear tyre

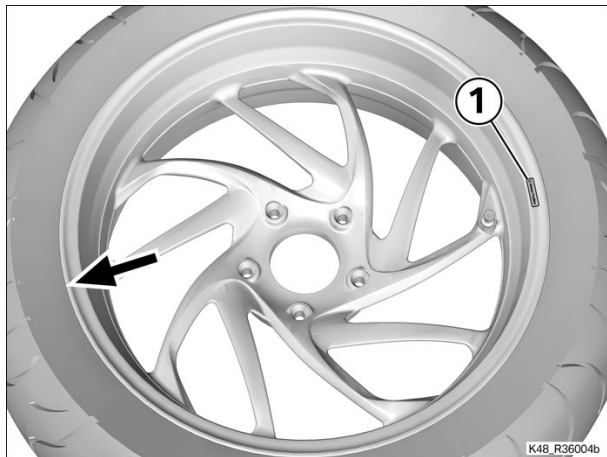

- Pry off the tyre opposite (arrow) the valve/tyre pressure monitoring sensor (**RDC** sensor).
- Apply the lever to the rim at **RDC** sticker (1), to prevent the tyre bead from damaging the **RDC** sensor.
- Remove the tyre with commercially available tools.

(-) Remove the rear tyre pressure monitoring sensor (RDC sensor)

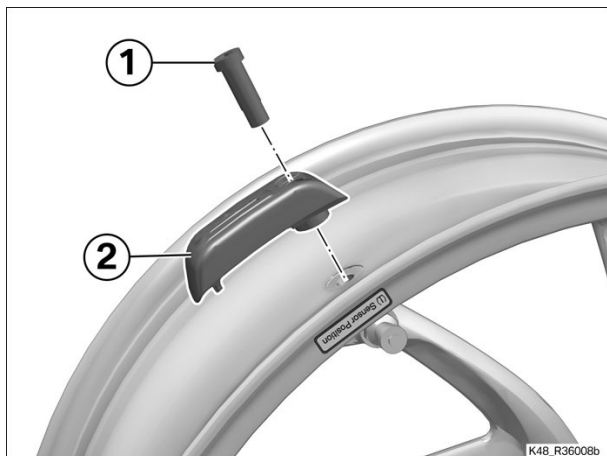

- Remove screw (1).
- Remove **RDC** sensor (2).

(-) Checking battery of tyre-pressure monitoring sensor (RDC sensor)

Test

- Check the battery of the **RDC** sensor with **RDC** test tool (No. 61 1 671).



Result: Battery too weak

Measure:

- Replace the **RDC** sensor.

(-) Installing rear tyre pressure monitoring sensor (RDC sensor)

- Parallel **RDC** sensor (1) with the wheel rim such that the plastic body does not touch the wheel rim.

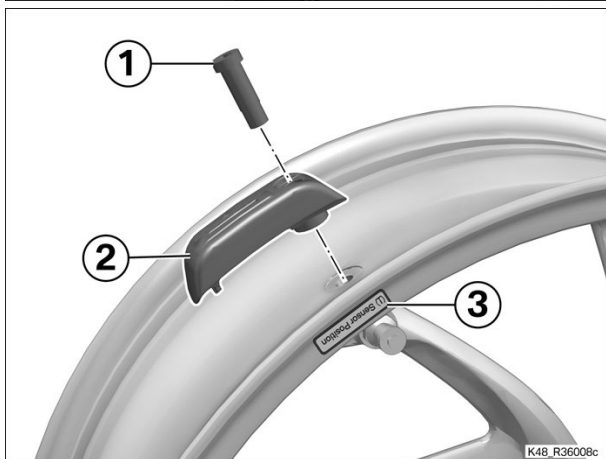
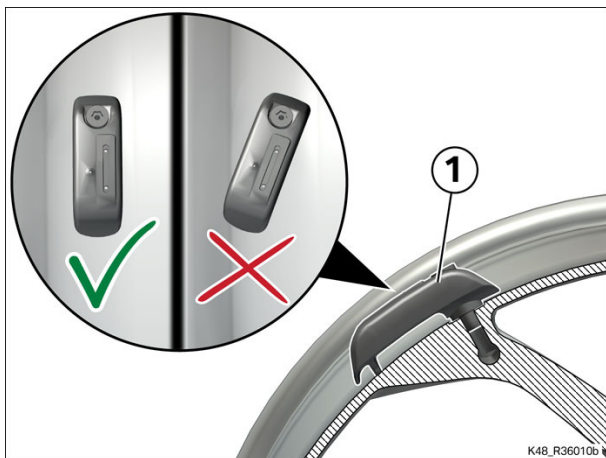

- Affix **RDC** label (3) at the position of **RDC** sensor (2).
- Install screw (1).

 Tightening torques		
RDC sensor to wheel rim		
M8 x 25, use thread-locking compound for repair Loctite 243	9 Nm	

(-) Installing rear tyre

 **Attention**

Components can be damaged by hard or sharp-edged objects. Avoid scratching the components; use masking tape if necessary.

- Use commercially available tools and work to the manufacturer's specifications to fit the tyres, and make sure that the direction-of-rotation arrows on tyre and rim point in the same direction.

Test

- Inflate the tyre to test pressure and check the valve for leaks.

 Technical data			
Wheel valve test pressure		4 bar	

Result: Valve leaking

Measure:

- Replace the valve insert.

Result: Valve leaktight

Measure:

- Correct the tyre pressure.

	Technical data		
Tyre pressure, rear	Tyre cold	2.9 bar	

- Check the tyre and make sure the line is at a uniform distance from the rim flange all the way round.

Finishing work

Static balancing of rear wheel

36 31 851 Renewing front wheel bearing (wheel removed)

Preparatory work

Removing radial shaft sealing rings, left and right

Core activity

(-) Removing wheel bearings

- Place support ring (No. 31 4 800) between the wheel hub on the right side of the wheel and reaction support (No. 00 8 572).
- Heat the bearing seat.

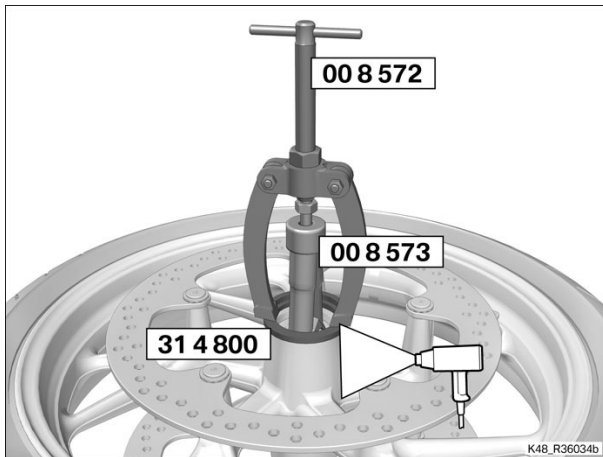

 Technical data			
Release temperature, front wheel bearing		100 °C	

- Use reaction support (No. 00 8 572) and internal puller (No. 00 8 573) to remove the wheel bearing.

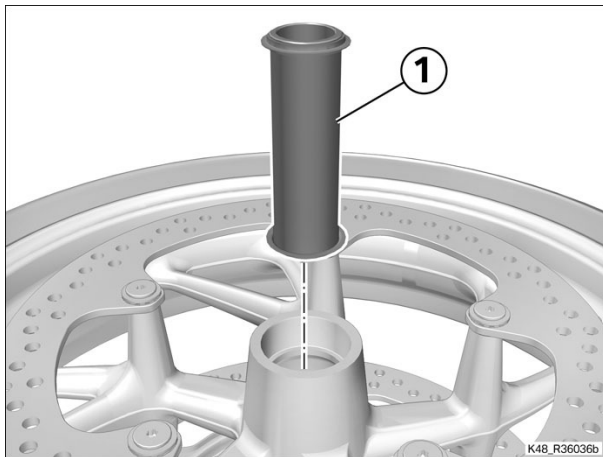

- Remove spacing bushing (1).

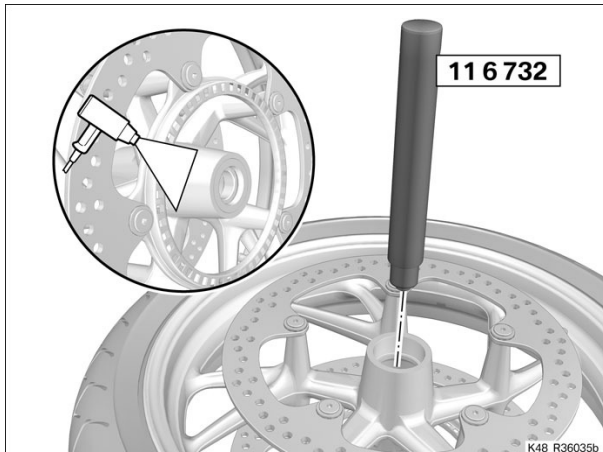

- Heat the left bearing seat (detail).

 Technical data			
Release temperature, front wheel bearing		100 °C	

- Drive out the left wheel bearing with drift (No. 11 6 732) from the inside.
- Allow the wheel hub to cool down.
- Degrease and clean the bearing seats and the spacing bushing.

(-) Installing left wheel bearing

- Introduce bearing (1) into the bearing seat.
- Install long spindle with pull-in nut (No. 36 5 551) washer without thread (No. 36 5 554) and washers with thread (No. 36 5 553):
 - Washer (A) dia. 47 mm
 - Washer (B) with thread dia. 25 mm

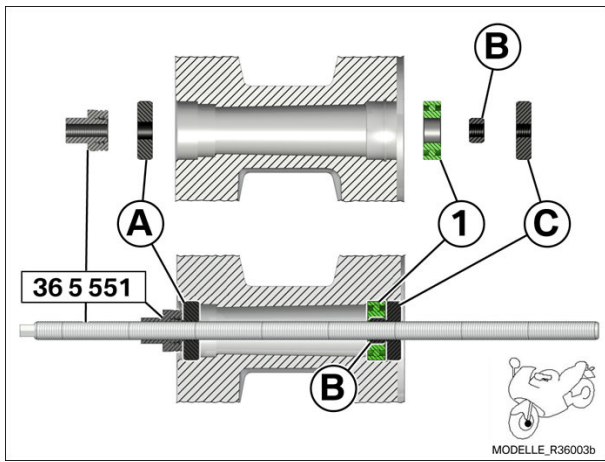

- Washer (C) with thread dia. 47 mm
- Pull in bearing (1) until seated.
- Remove washer (A) and pull-in nut.

(-) Installing right wheel bearing

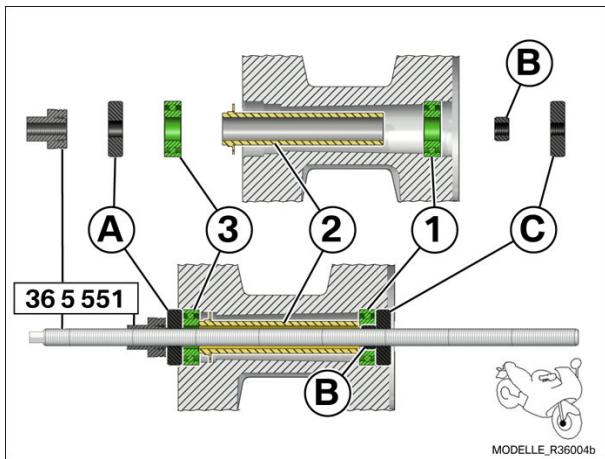

- Install spacing bushing (2).
- » Spacing bushing (2) sits flat and square on bearing (1).
- Introduce bearing (3) into the bearing seat.
- Install washer (A) and pull-in nut.
- Pull in bearing (3) until seated against spacing bushing (2).

Finishing work

Installing radial shaft sealing rings, left and right

36 32 501 Renewing front tyre (wheel removed) 3 FRUs

Equipment trim-level variant:

0530 - Tyre pressure monitoring (RDC)

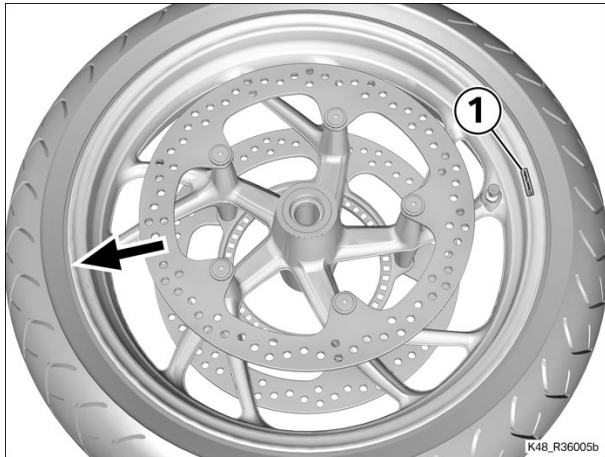

Core activity

(-) Remove the front tyre



Attention

Components can be damaged by hard or sharp-edged objects. Avoid scratching the components; use masking tape if necessary.

- Pry off the tyre opposite (arrow) the valve/tyre pressure monitoring sensor (**RDC** sensor).
- Apply the lever to the rim at **RDC** sticker (1), to prevent the tyre bead from damaging the **RDC** sensor.
- Remove the tyre with commercially available tools.

(-) Checking battery of front tyre-pressure monitoring sensor (RDC sensor)

Test

- Check the battery of the **RDC** sensor with **RDC** test tool (No. 61 1 671).



Result: Battery too weak

Measure:

=> 36 20 554, Replacing front RDC sensor (tyre removed) (Billed as a separate item)

(-) Installing front tyre



Attention

Components can be damaged by hard or sharp-edged objects. Avoid scratching the components; use masking tape if necessary.

- Use commercially available tools and work to the manufacturer's specifications to fit the tyres, and make sure that the direction-of-rotation arrows on tyre and rim point in the same direction.

Test

- Inflate the tyre to test pressure and check the valve for leaks.



Technical data

Wheel valve test pressure		4 bar	
---------------------------	--	-------	--

Result: Valve leaking

Measure:

- Replace the valve insert.

Result: Valve leaktight

Measure:

- Correct the tyre pressure.



Technical data

Tyre pressure, front	Tyre cold	2.9 bar	
----------------------	-----------	---------	--

(-) Static balancing of front wheel

- Align balancer (No. 36 3 601) with knurled screws (1) and level gauge (2).
- Insert balancing shaft (No. 36 5 571) in front-wheel bearing and secure it with tensioner (No. 36 5 572), making sure that front-wheel bearing is **lightly** preloaded.
- Place the front wheel on the balancer and allow it to come to rest.
- Clean the attachment points for the adhesive weights.
- Affix adhesive weights (3) **opposite the heaviest point of the wheel.**

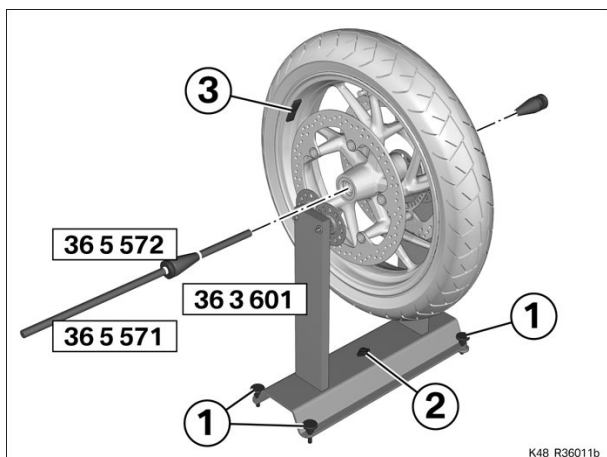

Technical data

Permissible front-wheel imbalance		max 5 g	
Balancing weight for front wheel Weight must be divided equally across both sides and weights attached to rim on left and right.		max 80 g	

- Repeat the balancing procedure as a check.

Finishing work

Final check of work performed

36 32 511 Removing rear tyre (wheel removed) 3 FRUs

Equipment trim-level variant:

0530 - Tyre pressure monitoring (RDC)

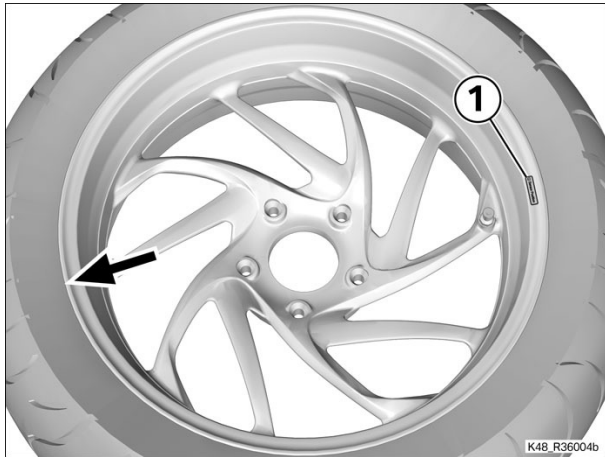

Core activity

(-) Removing rear tyre



Attention

Components can be damaged by hard or sharp-edged objects. Avoid scratching the components; use masking tape if necessary.

- Pry off the tyre opposite (arrow) the valve/tyre pressure monitoring sensor (**RDC** sensor).
- Apply the lever to the rim at **RDC** sticker (1), to prevent the tyre bead from damaging the **RDC** sensor.
- Remove the tyre with commercially available tools.

(-) Checking battery of rear tyre-pressure monitoring sensor (RDC sensor)

Test

- Check the battery of the **RDC** sensor with **RDC** test tool (No. 61 1 671).



Result: Battery too weak

Measure:

=> 36 20 555, Replacing rear RDC sensor (tyre removed) (Billed as a separate item)

(-) Installing rear tyre



Attention

Components can be damaged by hard or sharp-edged objects. Avoid scratching the components; use masking tape if necessary.

- Use commercially available tools and work to the manufacturer's specifications to fit the tyres, and make sure that the direction-of-rotation arrows on tyre and rim point in the same direction.

Test

- Inflate the tyre to test pressure and check the valve for leaks.



Technical data

Wheel valve test pressure		4 bar	
---------------------------	--	-------	--

Result: Valve leaking

Measure:

- Replace the valve insert.

Result: Valve leaktight

Measure:

- Correct the tyre pressure.



Technical data

Tyre pressure, rear	Tyre cold	2.9 bar	
---------------------	-----------	---------	--

- Check the tyre and make sure the line is at a uniform distance from the rim flange all the way round.

(-) Static balancing of rear wheel

- Install balancing adapter (No. 36 5 561) with wheel studs (1).

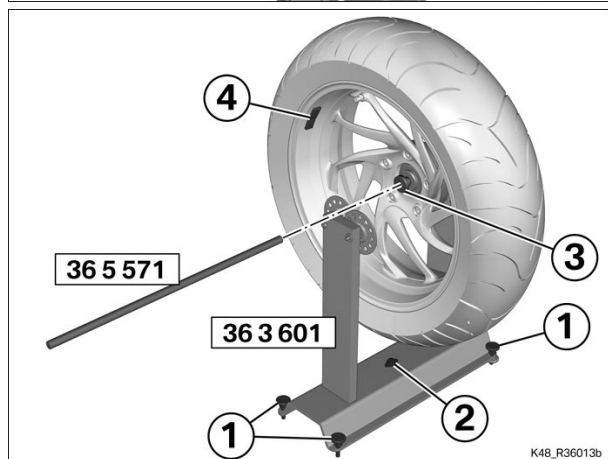
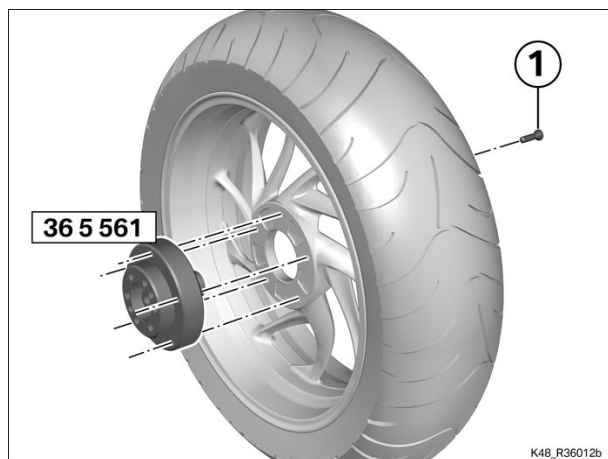

- Align balancer (No. 36 3 601) with knurled screws (1) and level gauge (2).
- Introduce balancing shaft (No. 36 5 571) into the rear wheel and secure it with tensioning device (3).
- Place the rear wheel on the balancer and allow it to come to rest.
- Clean the attachment points for the adhesive weights.
- Affix adhesive weights (4) **opposite the heaviest point of the wheel.**



Technical data

Permissible rear-wheel imbalance		max 45 g	
Balancing weight for rear wheel Weight must be divided equally across both sides and weights attached to rim on left and right.		max 80 g	

- Repeat the balancing procedure as a check.

📁 46 52 000 Removing/installing or replacing centre stand 4 FRUs

+ 46 52 502

Preparatory work

Installing engine lifter

Removing right catalytic-converter shield

Disengaging clamp on right silencer

Removing right silencer

Core activity

(-) Removing tension springs of centre stand



Warning

Components are spring-loaded. Risk of injury caused by flying parts. Proceed with care when decreasing or increasing spring tension.

- Remove tension springs (1), using hook (No. 46 5 721).
- Remove attachment plate (2).

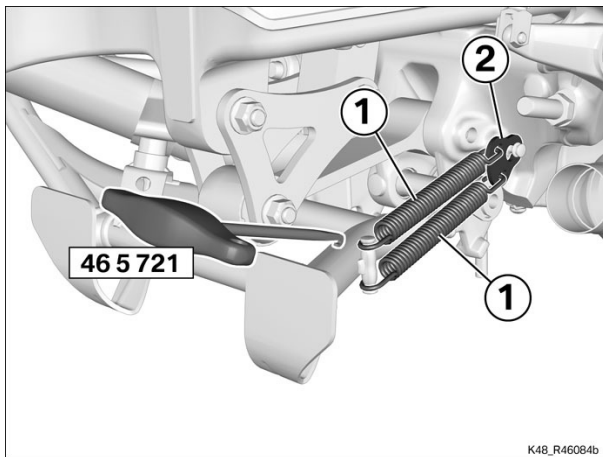

(-) Removing centre stand

- Remove circlip (1) with suitable pliers.

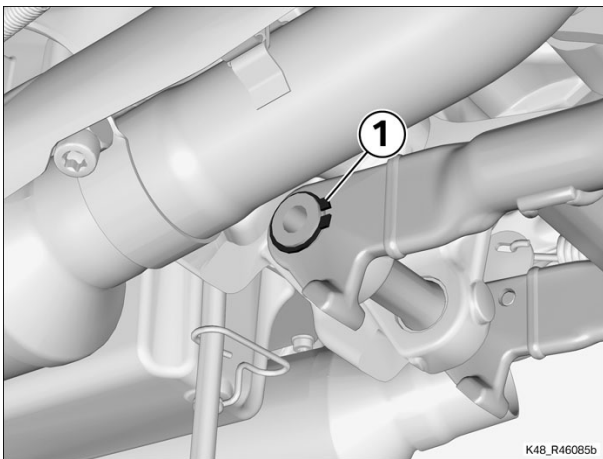

- Remove centre-stand axle (1) with O-rings (2).
- Remove centre stand (3).

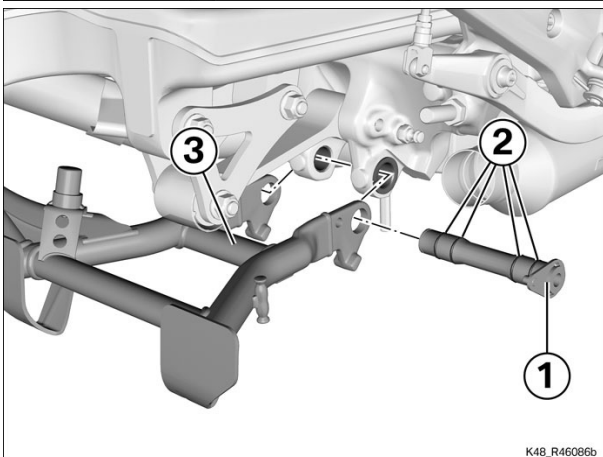

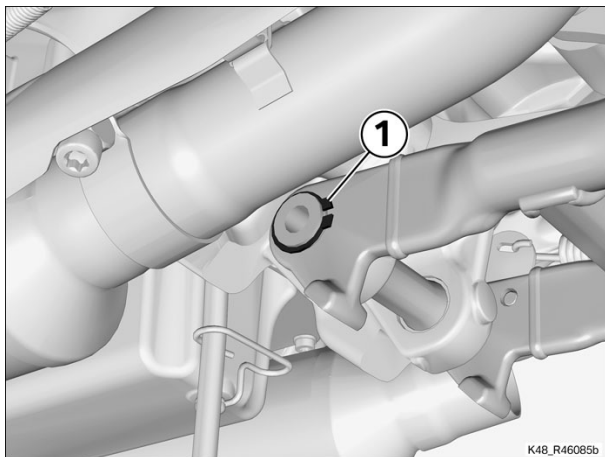
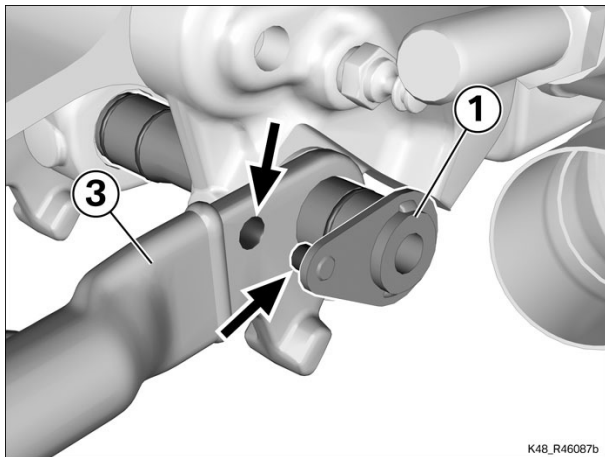
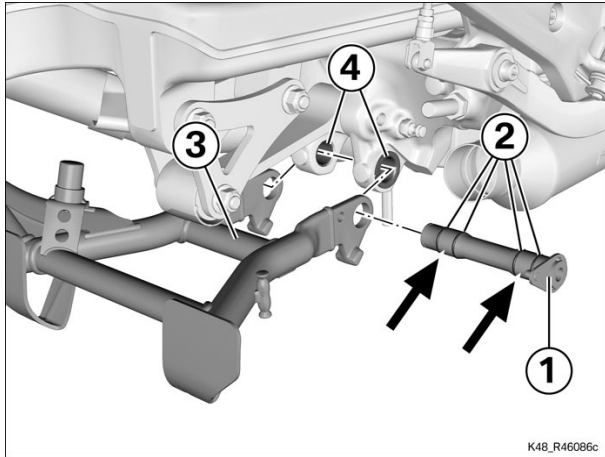

(-) Installing centre stand

- Check O-rings (2) and bearing bushings (4) for damage; replace if necessary.
- Lubricate bearing bushings (4) and centre-stand axle **between (arrows) O-rings (2)**.

 Fluids and lubricants		
Klüberplex BE 11-462	Lubricant	83 22 0 397 761

- Install centre stand (3).
- Install centre-stand axle (1) with O-rings (2).
- Make sure that centre-stand axle (1) is installed with **catch in recess (arrows)** of centre stand (3).
- Install circlip (1) with suitable pliers.

(-) Installing tension springs of centre stand

- Install attachment plate (2).



Warning

Components are spring-loaded. Risk of injury caused by flying parts. Proceed with care when decreasing or increasing spring tension.

- Install tension springs (1), using hook (No. 46 5 721).

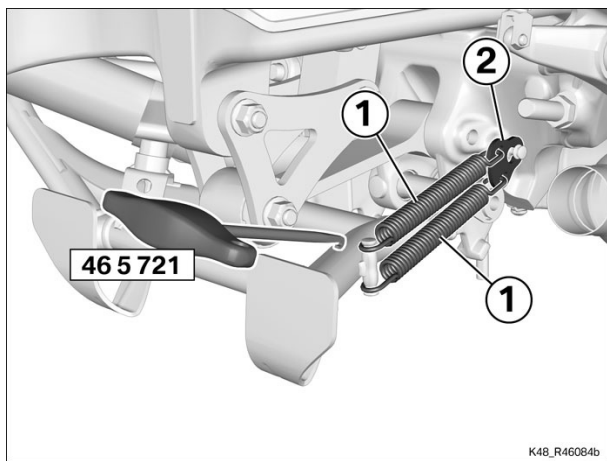

Finishing work

- Installing right silencer
- Securing clamp on right silencer
- Installing right catalytic-converter shield
- Removing engine lifter
- Final check of work performed

📁 46 52 009 Removing/installing or cleaning/ lubricating centre stand 4 FRUs

+ 46 52 509

Preparatory work

- Installing engine lifter
- Removing right catalytic-converter shield
- Disengaging clamp on right silencer
- Removing right silencer
- Removing tension springs of centre stand

Core activity

(-) Removing centre stand

- Remove circlip (1) with suitable pliers.

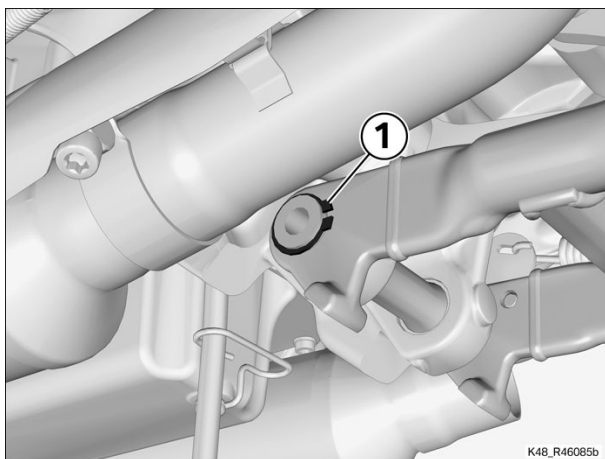

- Remove centre-stand axle (1) with O-rings (2).
- Remove centre stand (3).

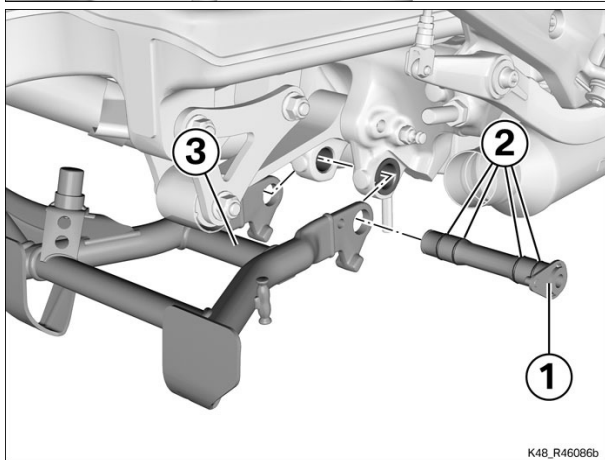

(-) Installing centre stand

- Check O-rings (2) and bearing bushings (4) for damage; replace if necessary.
- Lubricate bearing bushings (4) and centre-stand axle **between (arrows) O-rings (2)**.



Fluids and lubricants

Klüberplex BE 11-462	Lubricant	83 22 0 397 761
----------------------	-----------	--------------------

- Install centre stand (3).
- Install centre-stand axle (1) with O-rings (2).

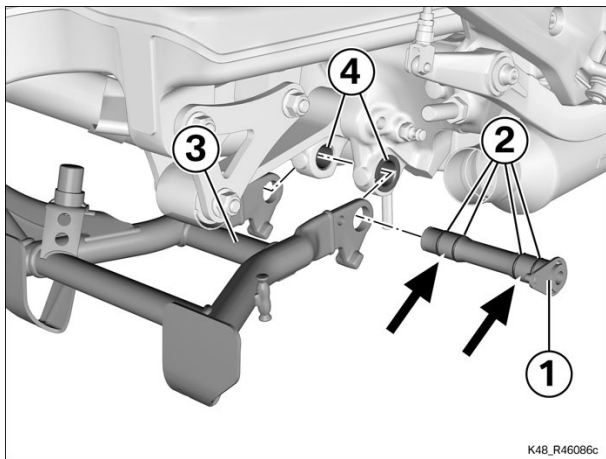

- Make sure that centre-stand axle (1) is installed with **catch in recess (arrows)** of centre stand (3).

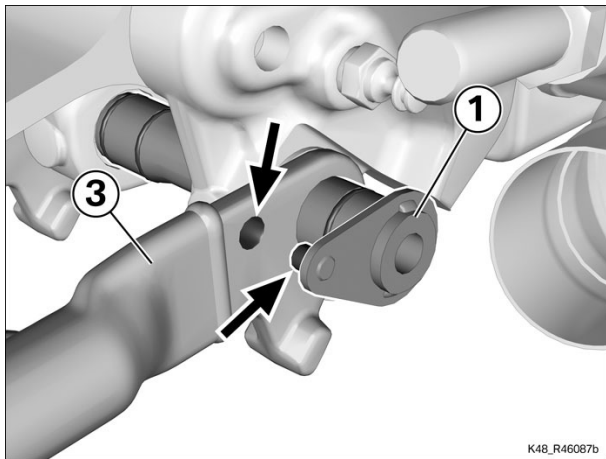

- Install circlip (1) with suitable pliers.

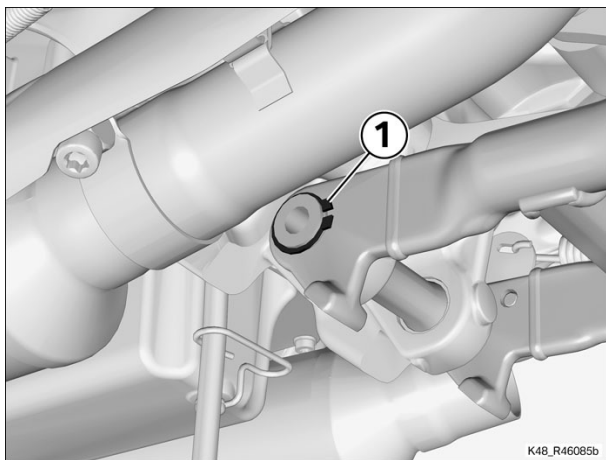

Finishing work

- Installing tension springs of centre stand
- Installing right silencer
- Securing clamp on right silencer
- Installing right catalytic-converter shield
- Removing engine lifter
- Final check of work performed

📁 46 53 000 Removing/installing or replacing side stand 5 FRUs

+ 46 53 601

Preparatory work

Removing left footrest plate

Disengaging side-stand switch

Core activity

(-) Removing side-stand pivot mount with side stand

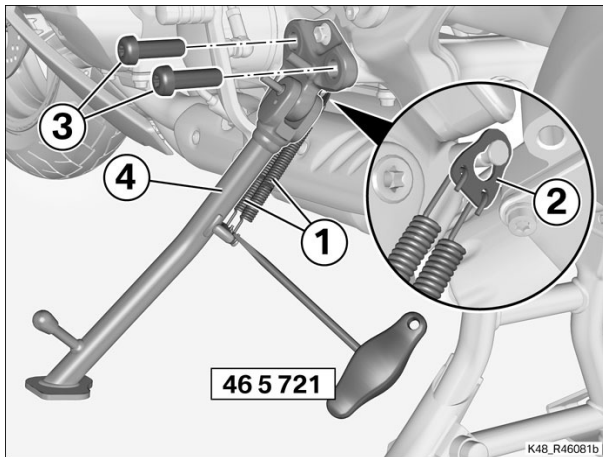

Warning

Components are spring-loaded. Risk of injury caused by flying parts. Proceed with care when decreasing or increasing spring tension.

- Remove tension springs (1), using hook (No. 46 5 721).
- Remove attachment plate (2).
- Remove screws (3).
- Remove the side-stand pivot mount with side stand (4).

(-) Removing side stand

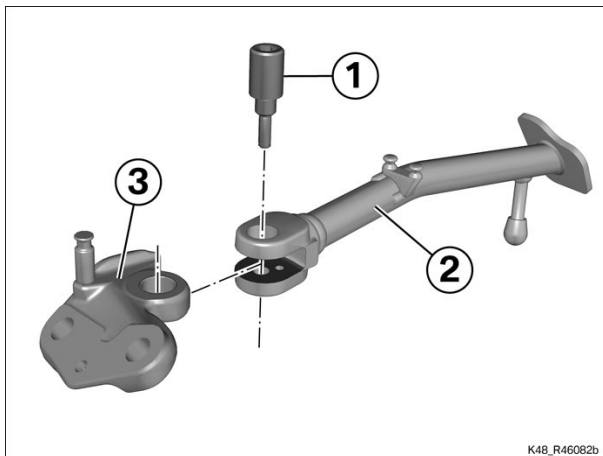

- Remove screw (1).
- Remove side stand (2) from pivot mount (3).

(-) Checking bearing bushing

Test

- Check bearing bushing (1) for scores, damage, etc.

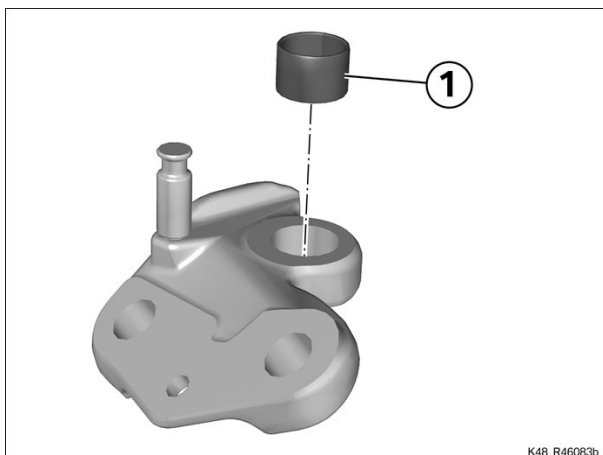

Result: Bearing bushing is worn.

Measure:

=> 46 53 501, Replacing pivot mount for side stand (side stand removed)
(Billed as a separate item)

(-) Installing side stand

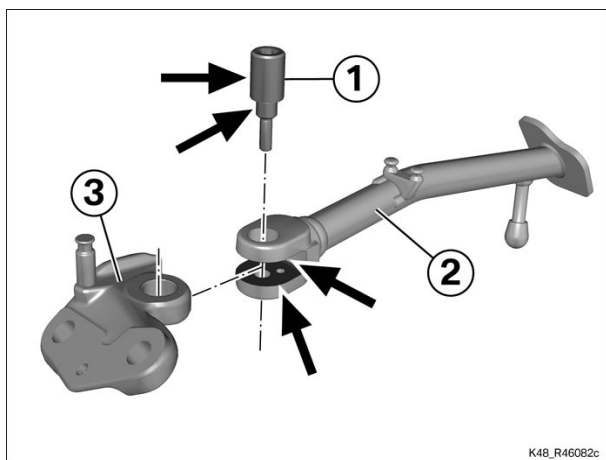

- Clean the tapped hole.
- Lubricate screw (1) and side stand (2) at the points indicated (arrows).

 Fluids and lubricants		
Klüberplex BE 11-462	Lubricant	83 22 0 397 761

- Insert pivot mount (3) into side stand (2).
- Install new screw (1) and tighten.

 Tightening torques		
Side stand to pivot mount		
M10 x 1, Replace screw Micro-encapsulated	40 Nm	

(-) Installing side-stand pivot mount with side stand

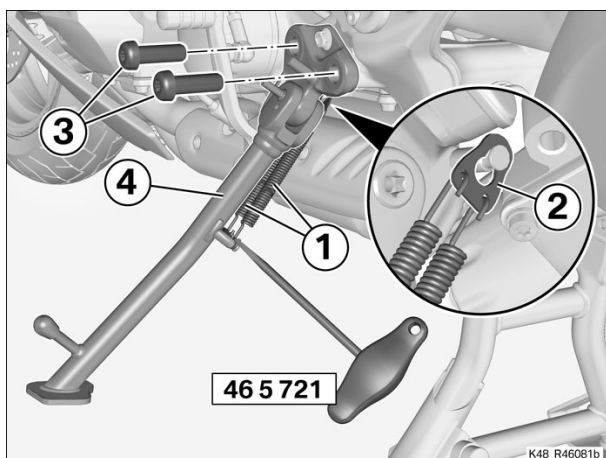

- Clean the tapped holes.
- Hold the side-stand pivot mount with side stand (4) in position.
- Install new screws (3).

 Tightening torques		
Pivot mount (side stand) to frame		
M12 x 37, Replace screw Micro-encapsulated	66 Nm	

- Install attachment plate (2).



Warning

Components are spring-loaded. Risk of injury caused by flying parts.
Proceed with care when decreasing or increasing spring tension.

- Engage tension springs (1), using hook (No. 46 5 721).

Finishing work

Securing side-stand switch

Installing left footrest plate

Final check of work performed

46 53 005 Removing/installing/cleaning and lubricating side stand 5 FRUs

+ 46 53 505

Preparatory work

Removing left footrest plate

Disengaging side-stand switch

Removing side-stand pivot mount with side stand

Core activity

(-) Removing side stand

- Remove screw (1).
- Remove side stand (2) from pivot mount (3).

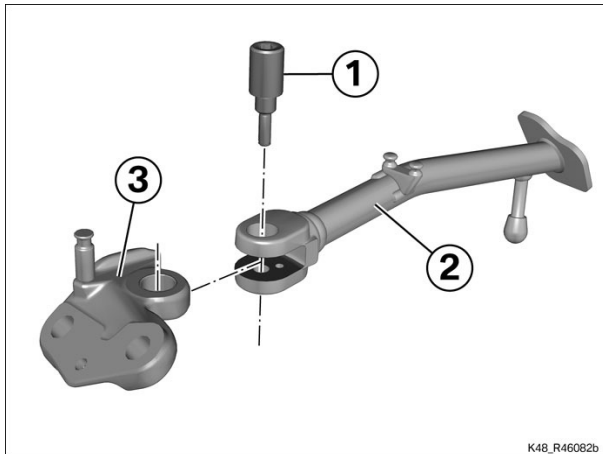

(-) Checking bearing bushing

Test

- Check bearing bushing (1) for scores, damage, etc.

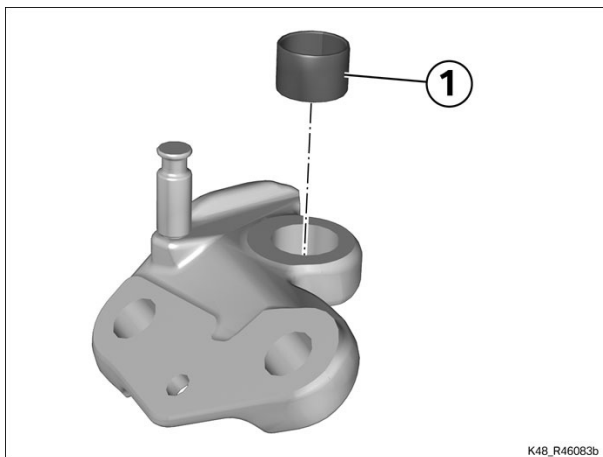

Result: Bearing bushing is worn.

Measure:

=> 46 53 501, Replacing pivot mount for side stand (side stand removed)
(Billed as a separate item)

(-) Installing side stand

- Clean the tapped hole.
- Lubricate screw (1) and side stand (2) at the points indicated (arrows).

 <p>Fluids and lubricants</p>		
Klüberplex BE 11-462	Lubricant	83 22 0 397 761

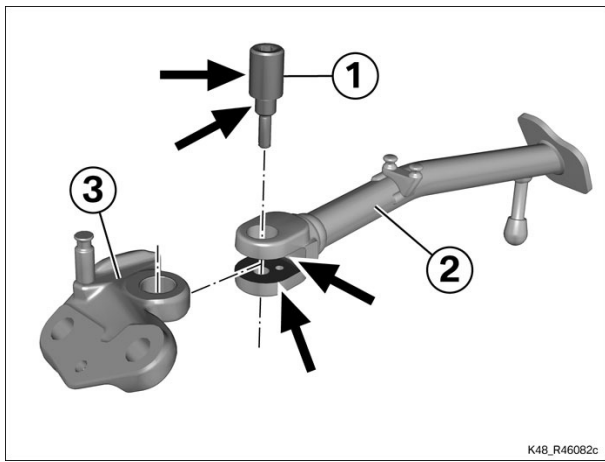

- Insert pivot mount (3) into side stand (2).
- Install new screw (1) and tighten.

 Tightening torques		
Side stand to pivot mount		
M10 x 1, Replace screw	40 Nm	
Micro-encapsulated		

Finishing work

Installing side-stand pivot mount with side stand

Securing side-stand switch

Installing left footrest plate

Final check of work performed

📁 46 53 011 Renewing tension spring for prop stand 2 FRUs

+ 46 53 602



Warning

Components are spring-loaded. Risk of injury caused by flying parts. Proceed with care when decreasing or increasing spring tension.

Core activity

(-) Removing tension springs of side stand

- Remove tension springs (1), using hook (No. 46 5 721).
- Remove attachment plate (2).
- Remove tension springs (1) from attachment plate (2).

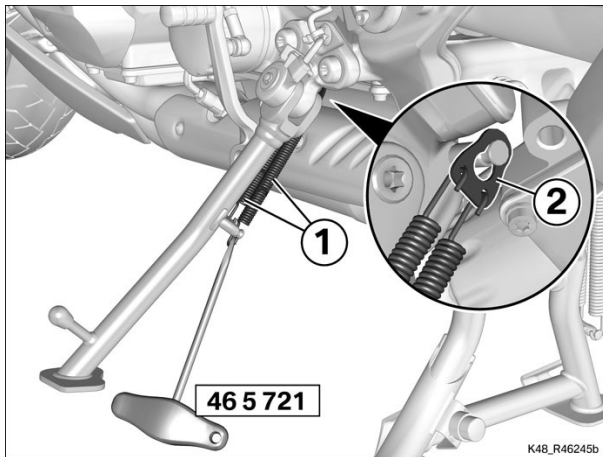

(-) Installing tension springs of side stand

- Insert tension springs (1) into attachment plate (2).
- Install attachment plate (2).
- Engage tension springs (1), using hook (No. 46 5 721).

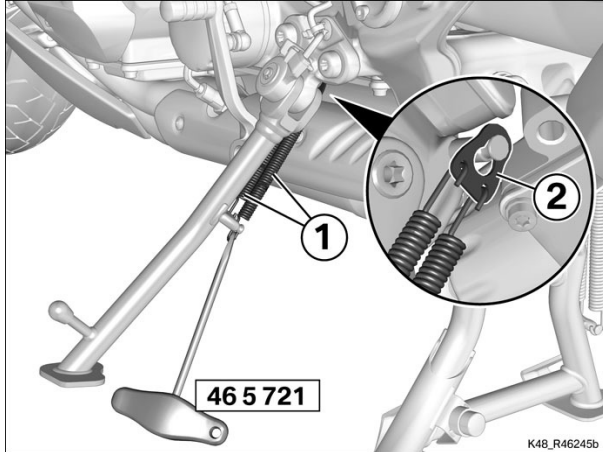

Finishing work

Final check of work performed

📁 46 53 501 Replacing pivot mount for side stand (side stand removed) 1 FRUs

Core activity

(-) Replacing bearing bushing of side stand

- Replace bearing bushing (1), using a suitable tool.
- Lubricate new bearing bushing (1).

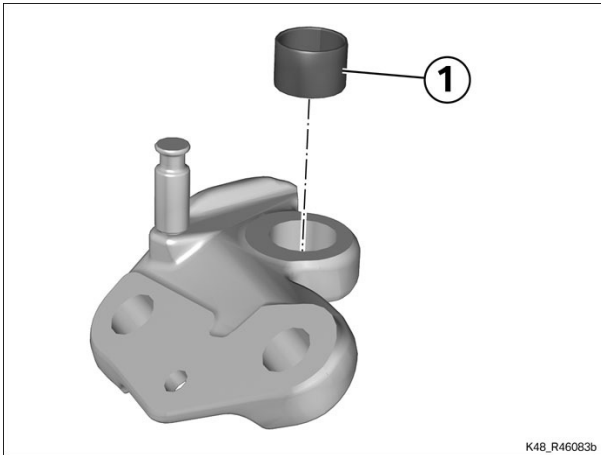

 <p>Fluids and lubricants</p>		
Klüberplex BE 11-462	Lubricant	83 22 0 397 761

Finishing work

Final check of work performed

46 54 200 Removing and installing or replacing complete luggage carrier 4 FRUs

+ 46 54 505

Preparatory work

Remove the front seat

Remove the rear seat

Removing number-plate carrier

Removing complete luggage carrier

Core activity

(-) Removing luggage carrier

- Remove screws (1).
- Remove grab handles (2) left and (3) right from luggage carrier (4).

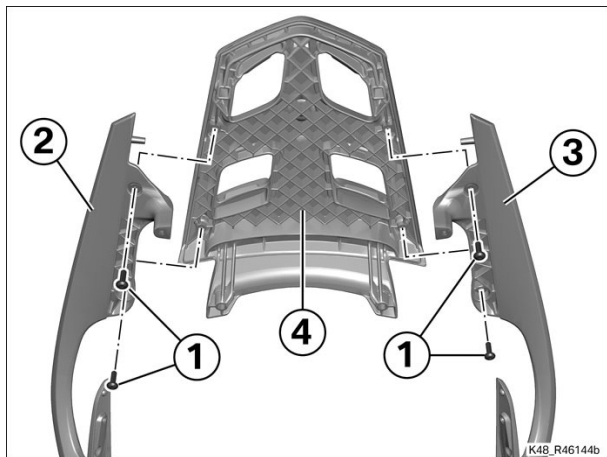

(-) Installing luggage carrier

- Clean the tapped holes.
- Hold grab handles (2) left and (3) right in position on luggage carrier (4).
- Make sure that the latching devices (arrows) engage in luggage carrier (4).
- Install new screws (1).

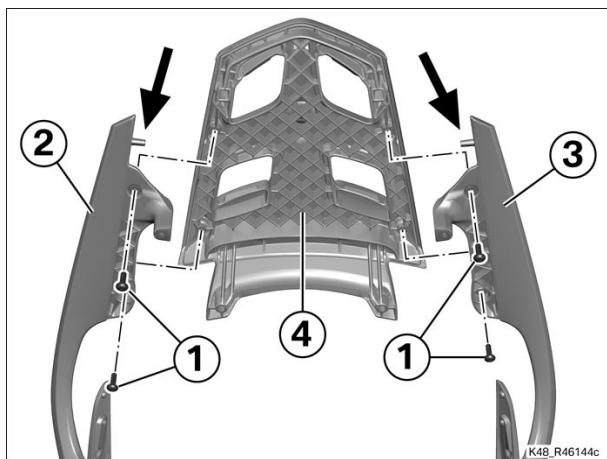

Tightening torques		
Grab handle to luggage carrier		
M6 x 20, Replace screw	8 Nm	
Micro-encapsulated		

Finishing work

Installing complete luggage carrier

Installing number-plate carrier

Installing rear seat

Installing front seat

Final check of work performed

📁 46 54 315 Replacing rear (trunk/boot) lid 3 FRUs

+ 46 54 510

Core activity

(-) Removing case lid

- Disengage holding strap (1) from bracket (2).



- Remove screws (1) and screw (2) with nut (3).
- Remove mating piece (4) with flat nut (5).
- Repeat this procedure with the other hinge.
- Remove cover (6).

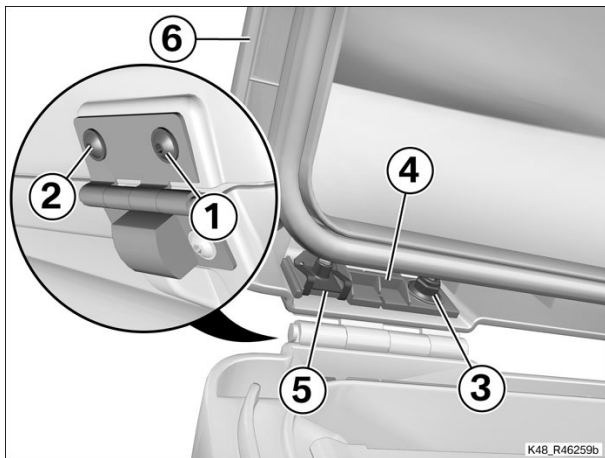

(-) Disassembling case lid

- Remove body-bound rivet (1).
- Remove screws (2).
- Remove cover (3).

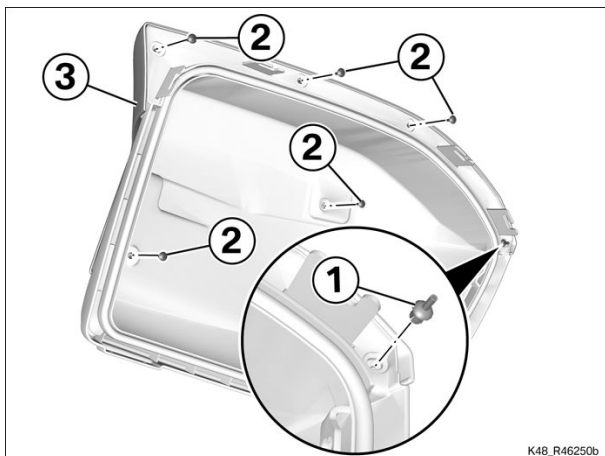

- Remove flat nuts (1).
- Remove cover (2).

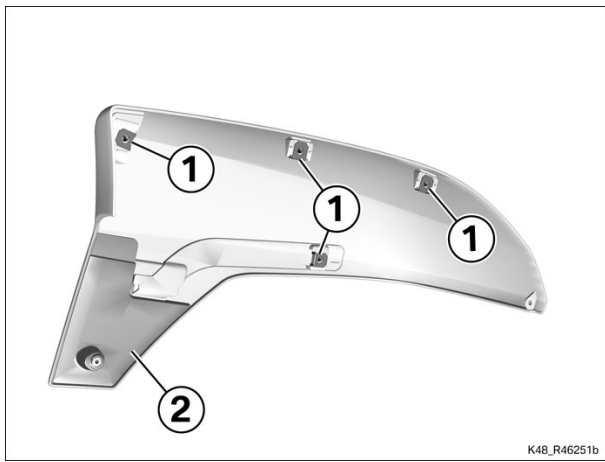

(-) Assembling case lid

- Install flat nuts (1).
- Insert cover (2) in such a way that it is held in place by the lug (arrow).

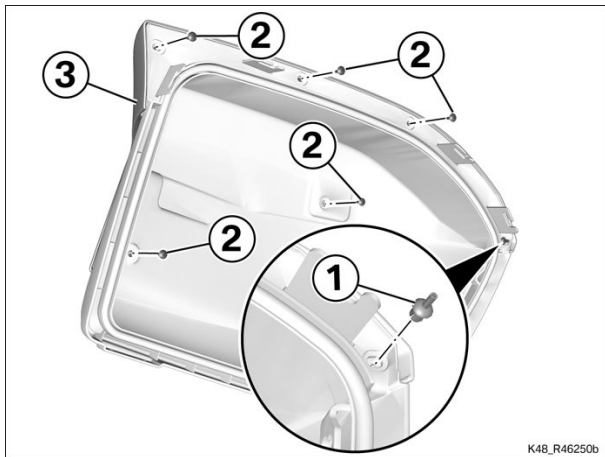
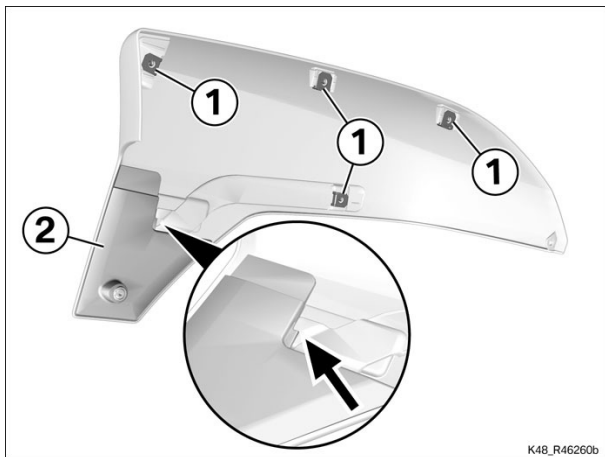

- Hold cover panel (3) in position.
- Install screws (2).
- Install body-bound rivet (1).

(-) Installing case lid

- Place lid (6) in position and align it correctly.
- Hold mating piece (4) in position and install screw (1) for flat nut (5).
- Hold nut (3) in position, locate it and install screw (2).
- Repeat this procedure with the other hinge.

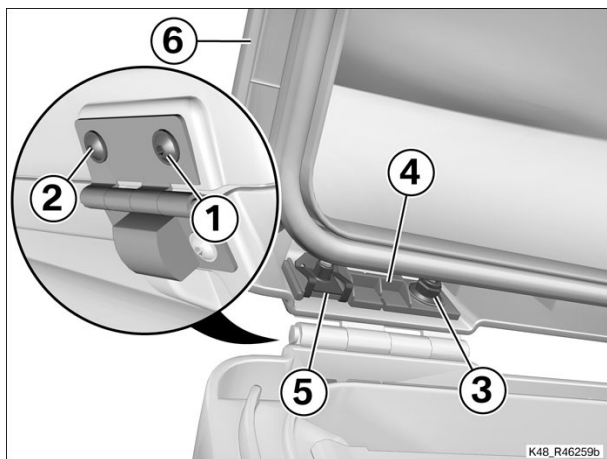

- Engage holding strap (1) on bracket (2).



Finishing work

Final check of work performed

46 61 000 Removing/installing front-wheel cover 2 FRUs

+ 46 61 500

Core activity

(-) Removing front-wheel cover (front section)

- Remove screws (1) on left and right.
- Remove front-wheel cover (front section) (2).

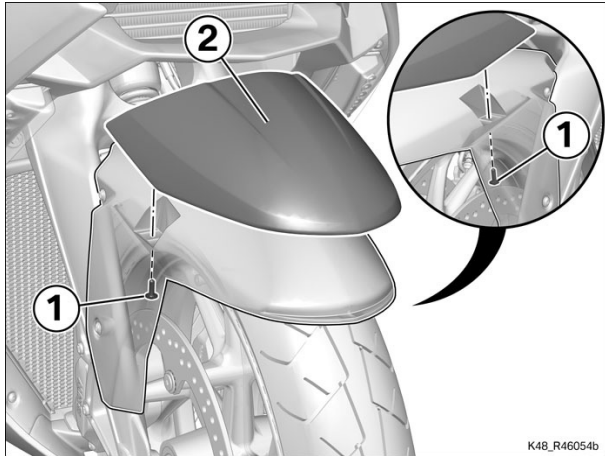

(-) Disassembling front-wheel cover (front section)

- Remove flat nuts (1) from front-wheel cover (front section) (2).

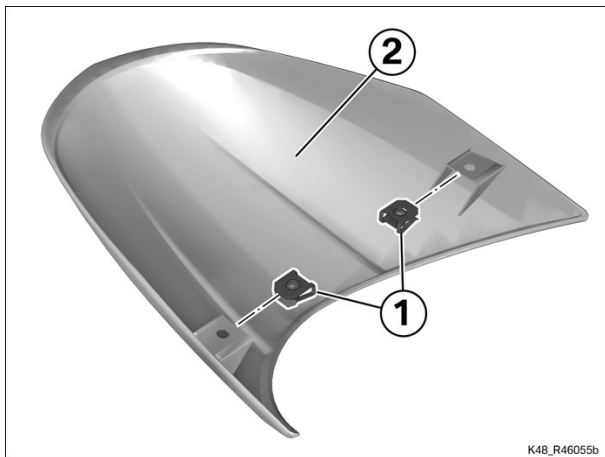

(-) Assembling front-wheel cover (front section)

- Install flat nuts (1) in front-wheel cover (front section) (2).

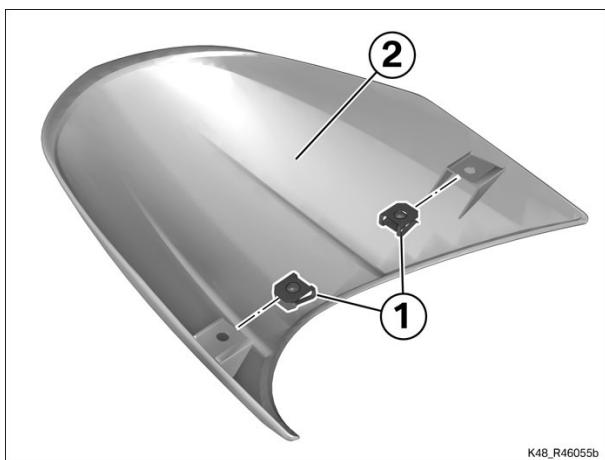

(-) Installing front-wheel cover (front section)

- Install front-wheel cover (front section) (2).
- Install screws (1) on left and right.

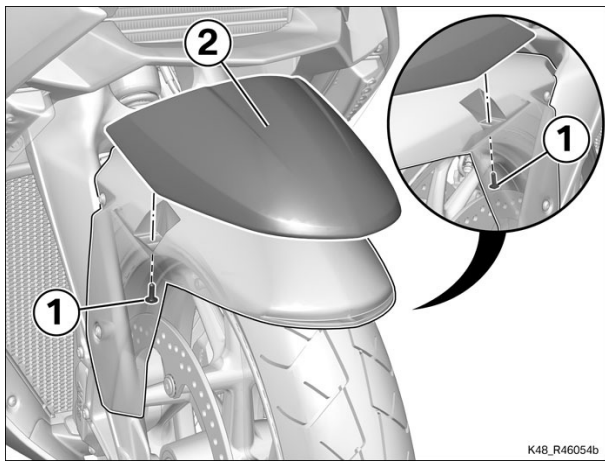

 Tightening torques		
Front-wheel cover, front, to front-wheel cover, rear		
M5 x 12	2.5 Nm	

Finishing work

Final check of work performed

46 61 008 Removing/installing rear front-wheel cover 2 FRUs

+ 46 61 502

Core activity

(-) Remove the complete front-wheel cover

- Remove screws (1).
- Remove complete front-wheel cover (2).

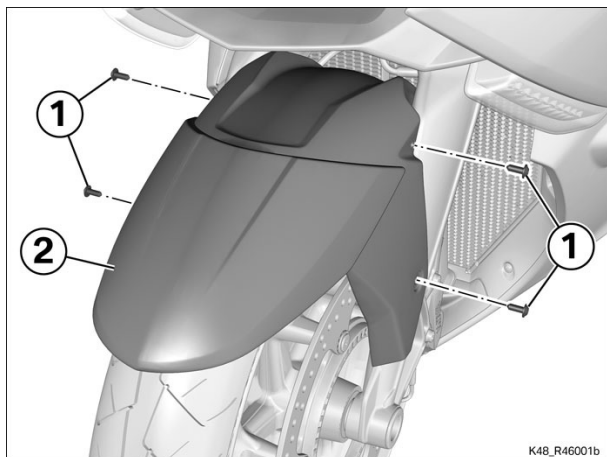

(-) Disassembling front-wheel cover (rear section)

- Remove screws (1).
- Remove front-wheel cover (front section) (2) from front-wheel cover (rear section) (3).

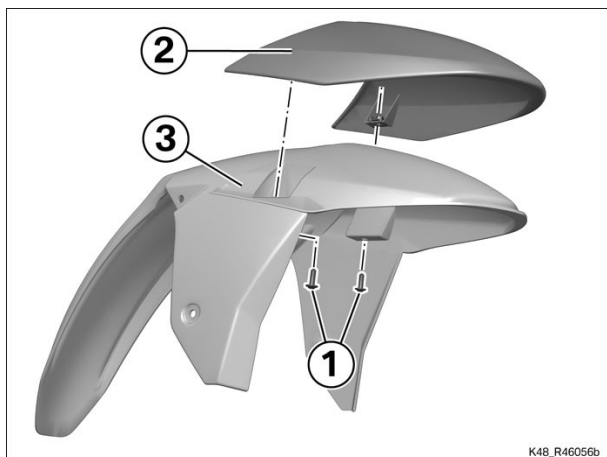

(-) Assembling front-wheel cover (rear section)

- Position front-wheel cover (front section) (2) on front-wheel cover (rear section) (3).
- Install screws (1).

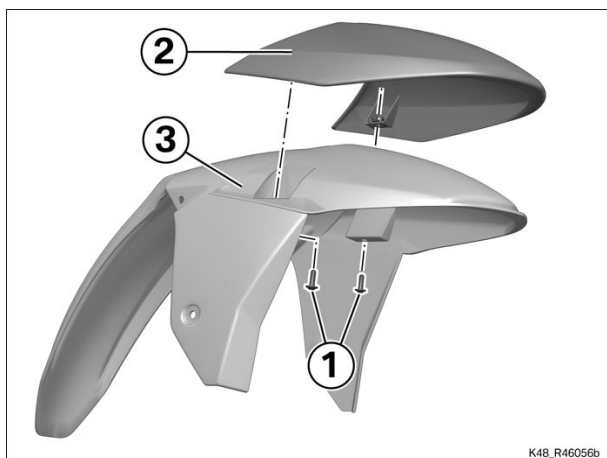

Tightening torques		
Front-wheel cover, front, to front-wheel cover, rear		
M5 x 12	2.5 Nm	

(-) Installing complete front-wheel cover

- Place complete front-wheel cover (2) in position.
- Install screws (1).

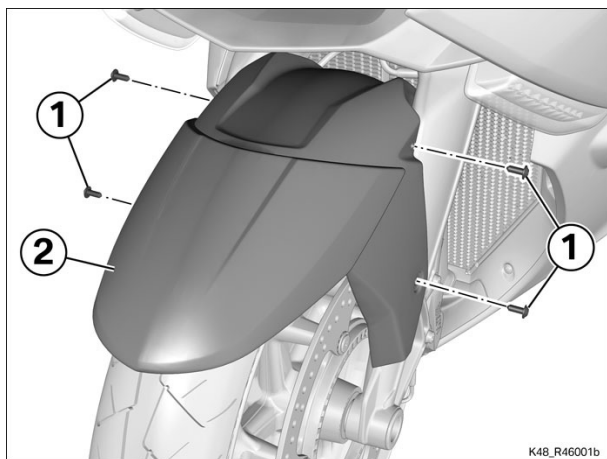

 Tightening torques		
Front-wheel cover to wheel carrier		
M6 x 12	2.5 Nm	

Finishing work

Final check of work performed

46 63 001 Replacing compartment cover for navigation device 1 FRUs

+ 46 63 981

Core activity

(-) Removing compartment cover for navigation device

- Using a suitable tool, disengage compartment cover (1) and remove, noting the retaining lugs (arrows).

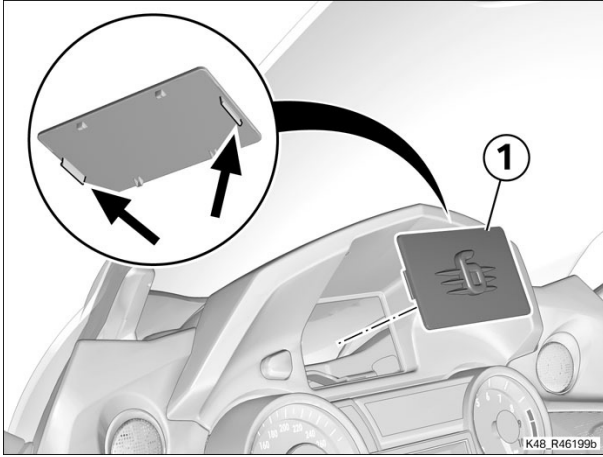

(-) Installing compartment cover for navigation device

- Install compartment cover (1), noting the retaining lugs (arrows).

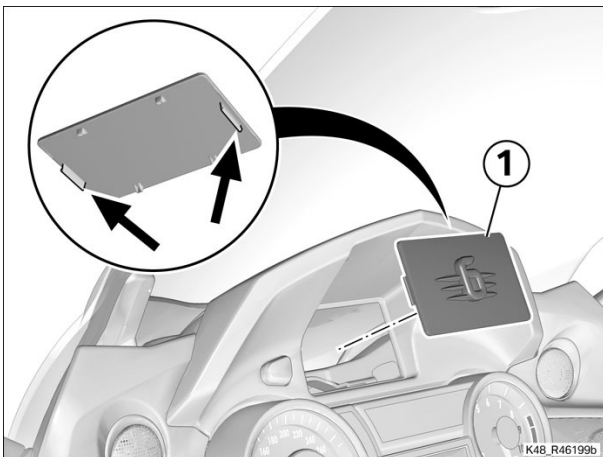

Finishing work

Final check of work performed

46 63 002 Replacing gearbox cover 2 FRUs

+ 46 63 975

Core activity

(-) Removing gearbox cover

- Remove screws (1).
- Remove gearbox cover (2).

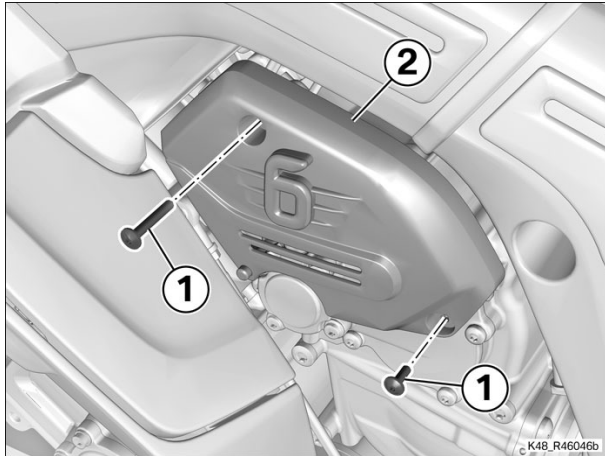

(-) Replacing gearbox cover

- Transfer rubber buffer (1) with bushings (2) and (3) from old to new gearbox cover (4).

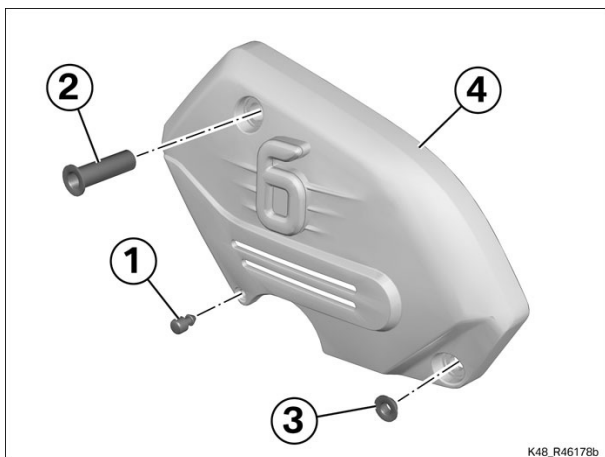

► Installing designation for gearbox cover

- Peel backing film (1) from designation (2).
- Position designation (2) with pins (arrows) on gearbox cover (3) and press it firmly into place.

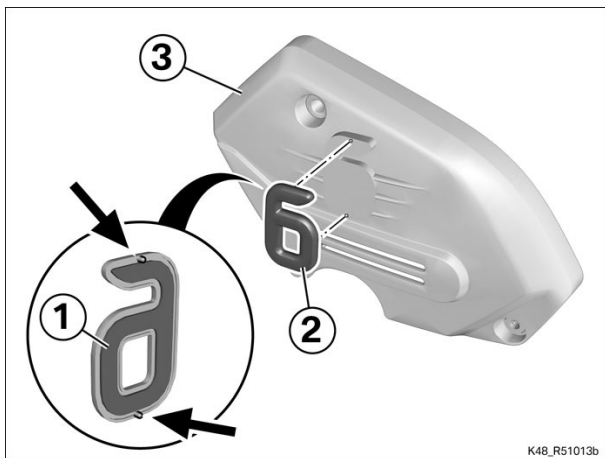

(-) Installing gearbox cover

- Hold gearbox cover (2) in position.
- Install screws (1).

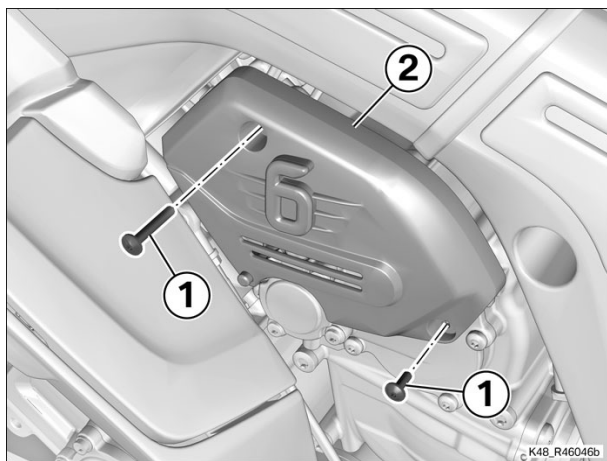

Finishing work

Final check of work performed

46 63 019 Replacing tail cover, centre section 4 FRUs

+ 46 63 982

Equipment trim-level variant:

0603 - Anti-theft alarm (DWA)

0417 - Central locking

Preparatory work

Remove the front seat

Remove the rear seat

Removing number-plate carrier

Removing complete luggage carrier

Core activity

(-) Removing tail cover centre panel

- Remove screws (1).
- Remove tail cover (2).

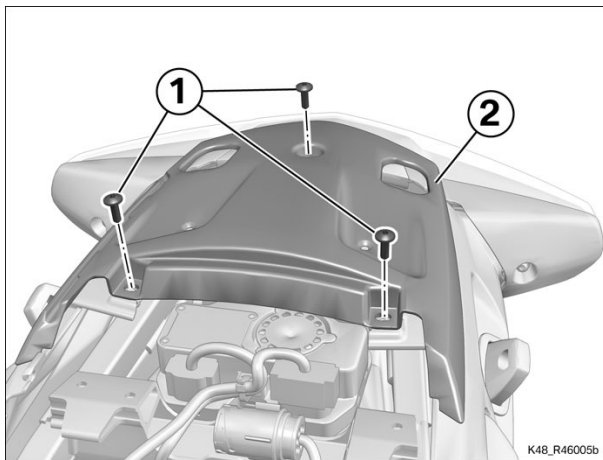

(-) Installing tail cover centre panel

- Hold tail cover (2) in position.
- Install screws (1).

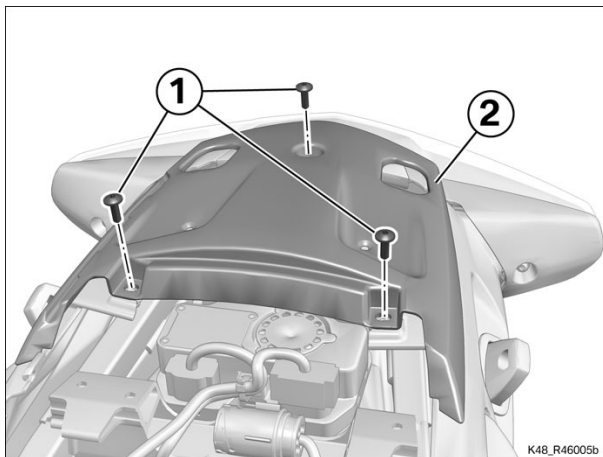

Finishing work

Installing complete luggage carrier

Installing number-plate carrier

Installing rear seat

Installing front seat

Final check of work performed

46 63 028 Replacing left or right hand protector 3 FRUs

+ 46 63 628

Preparatory work

Removing air guide for intake air pipe, left

Core activity

(-) Removing left hand protector

Precondition

- Windscreen is raised.



- Remove screws (1).
- Disengage hand protector (2) from the guides (arrows) and remove.

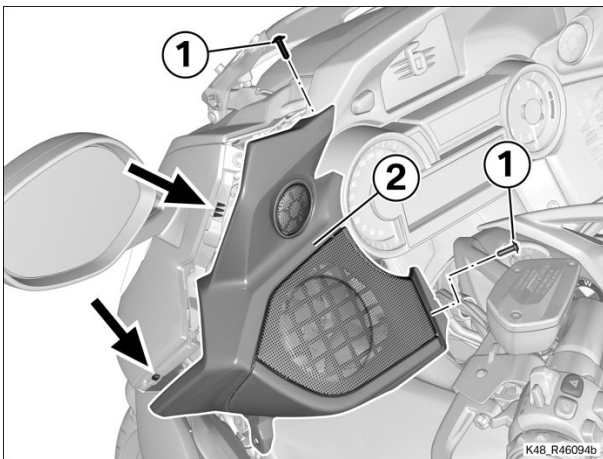

(-) Replacing left hand protector

► Removing cover for tweeter

- Disengage the retaining tabs (arrows) and remove cover (1).

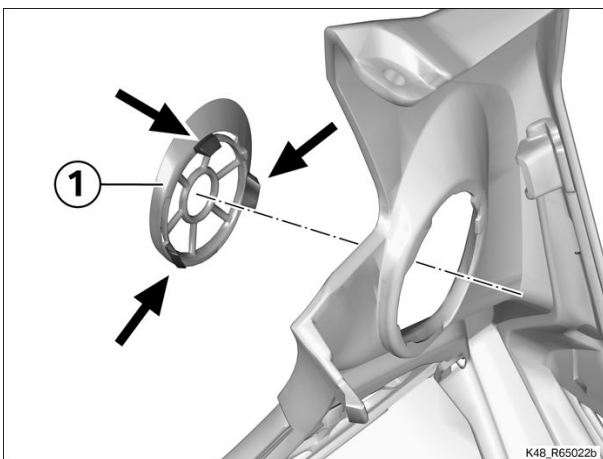

► Removing left speaker grille

- Remove screw (1).
- Disengage the retaining tabs (arrows) and remove speaker grille (2).

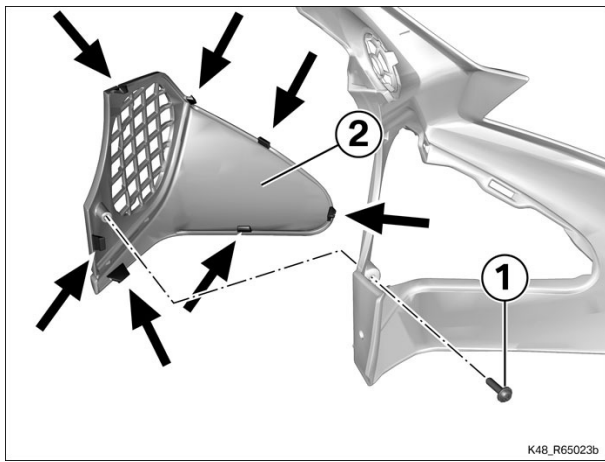

- Replace the hand protector.

► **Installing left speaker grille**

- Install speaker grille (2), making sure that the retaining tabs (arrows) engage.
- Install screw (1).

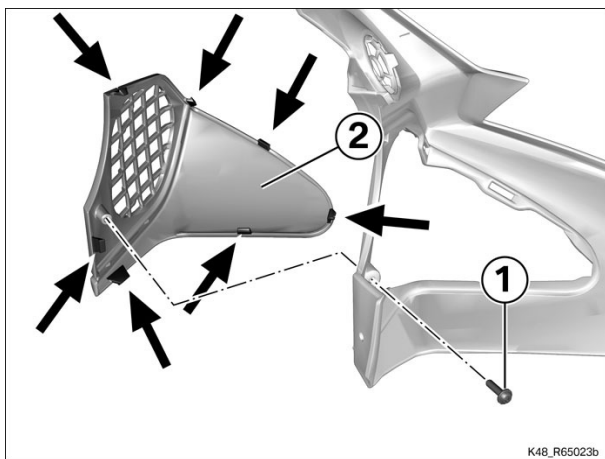

► **Installing cover for tweeter**

- Install cover (1), making sure that the retaining tabs (arrows) engage.

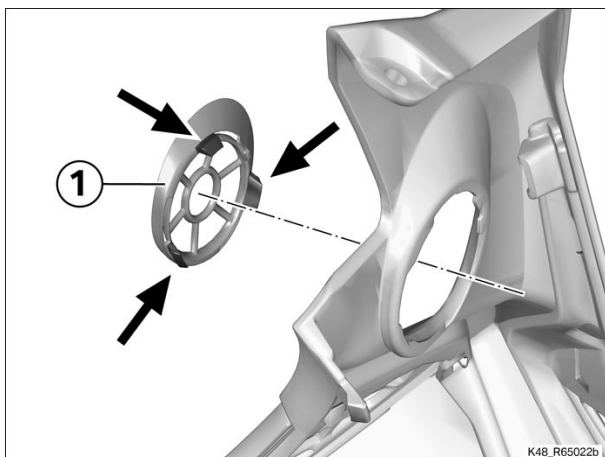

(-) Installing left hand protector

Precondition

- Windscreen is raised.



- Install hand protector (2), making sure that it is engaged in the guides (arrows).

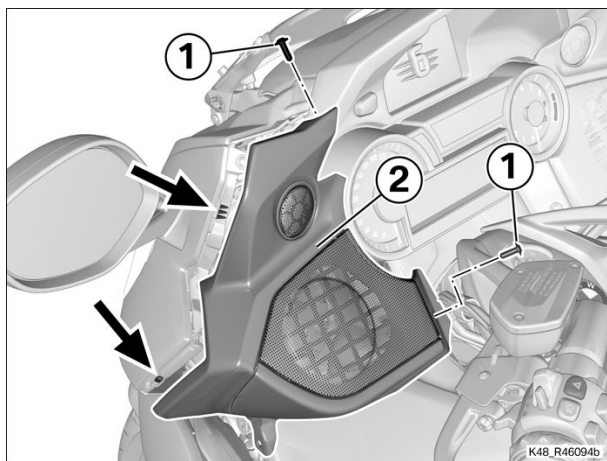

- Install screws (1).

Finishing work

Installing air guide for intake air pipe, left
Final check of work performed

46 63 031 Removing/installing windscreen 2 FRUs

+ 46 63 830

Core activity

(-) Removing windscreen

- Remove screws (1) and remove covers (2).
- Remove windscreen (3).

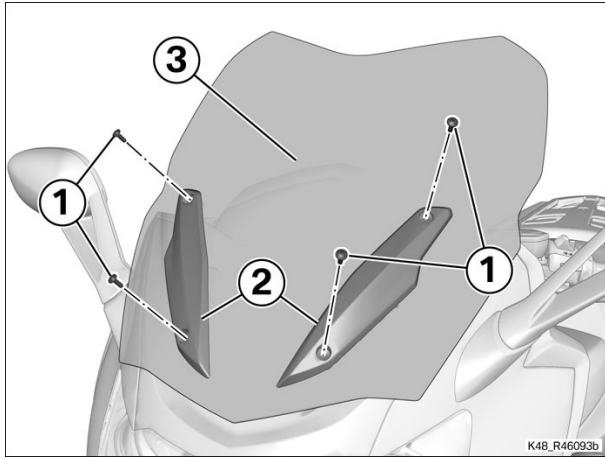

(-) Installing windscreen

- Hold windscreen (3) in position.
- Hold covers (2) in position and install screws (1).

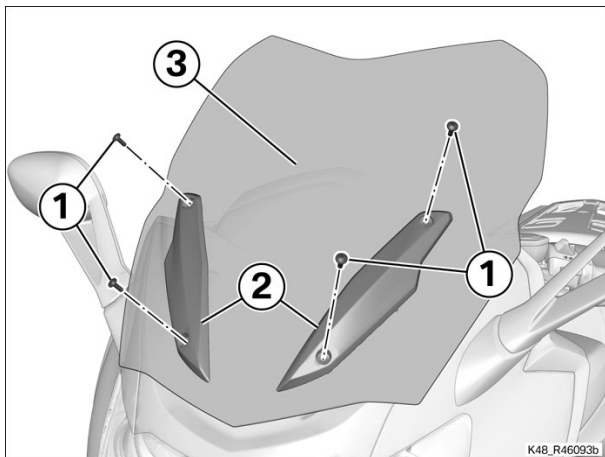

 Tightening torques		
Standard screws for trim panels/body panels		
M5	2.5 Nm	

Finishing work

Final check of work performed

46 63 032 Replace holders for windscreen, left and right 3 FRUs

+ 46 63 971

Preparatory work

Removing windscreen

Removing cross brace for windscreen

Core activity

(-) Removing left and right holders for windscreen

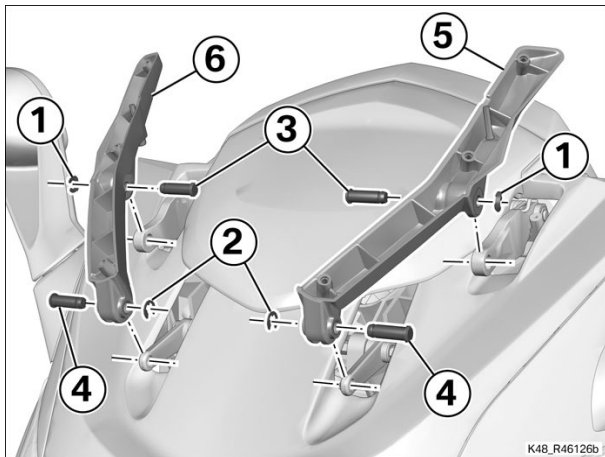

- Remove the following components:
 - Retaining clips (1) with collar
 - Retainers (2)
 - Pin, long (3)
 - Pin, short (4)
 - Holder for windscreen, left (5)
 - Holder for windscreen, right (6)

(-) Installing left and right windscreen holders

- Clean and lubricate pins (3) and (4).

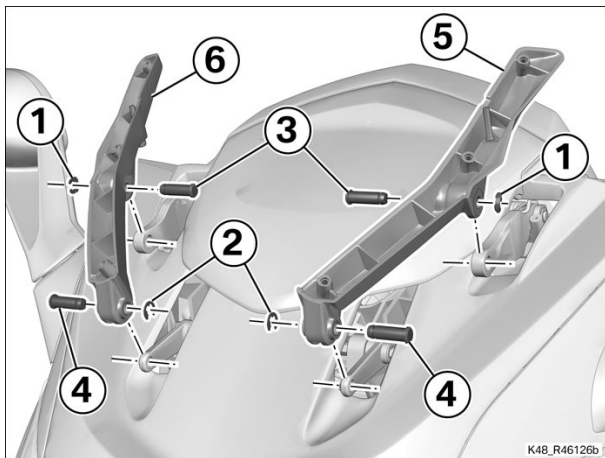

 Fluids and lubricants		
MP 3 paste	High-performance lubricating grease	07 55 9 062 476

- Install the following components:
 - Holder for windscreen, right (6)
 - Holder for windscreen, left (5)
 - Pin, short (4)
 - Pin, long (3)
 - Retainers (2)
 - Retaining clips (1) with collar

Finishing work

Installing cross brace for windscreen

Installing windscreen

Final check of work performed

46 63 189 Replacing top section of fairing, right 3 FRUs

+ 46 63 987

Equipment trim-level variant:

0266 - Preparation for audio system and navigation device

0267 - ECE audio system and preparation for navigation system

Preparatory work

Removing air guide for intake air pipe, right

Removing right hand protector

Removing right speaker

Removing right mirror

Removing finisher of air guide, right

Core activity

(-) Removing top section of fairing, right

- Remove screws (1).

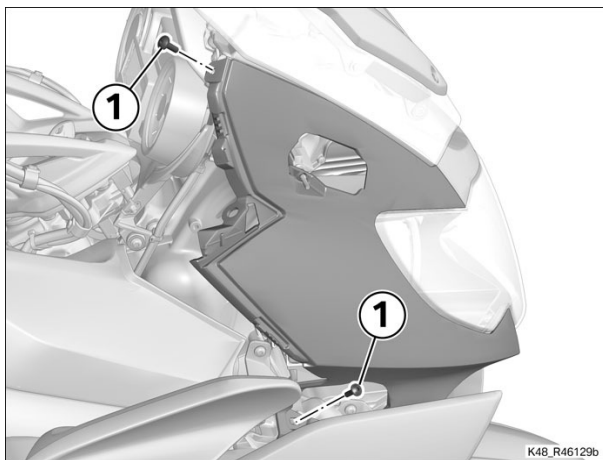

- Remove screw (1).
- Remove top section of fairing (2), noting the retaining lugs (arrows).

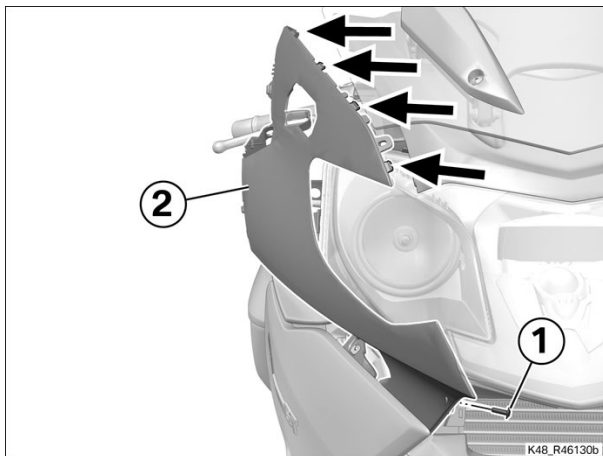

(-) Replacing right top section of fairing

- Transfer rubber buffer (1), flat nuts (2) and rubber nut (3) from old to new top section of fairing (4).

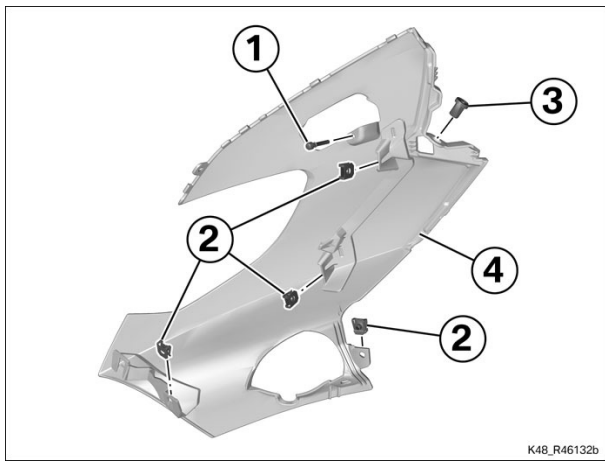

(-) Installing top section of fairing, right

- Install top section of fairing (2), noting the retaining lugs (arrows).
- Install screw (1).

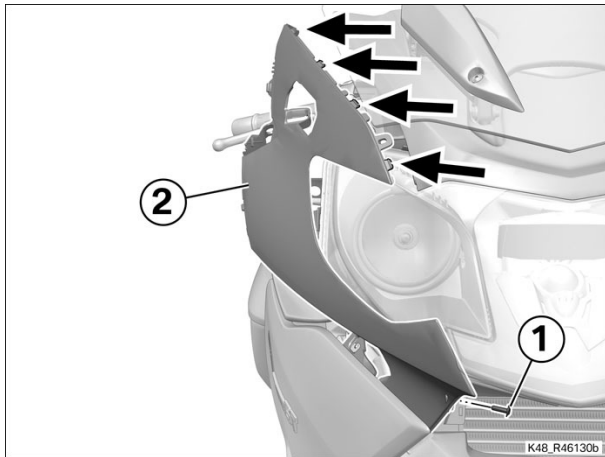

- Install screws (1).

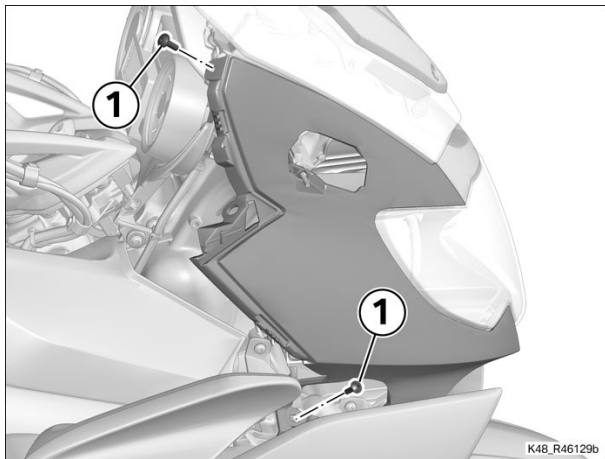

Finishing work

- Installing finisher of air guide, right
- Installing right mirror
- Installing right speaker
- Installing right hand protector
- Installing air guide for intake air pipe, right
- Final check of work performed

46 63 190 Replacing top section of fairing, left 3 FRUs

+ 46 63 853

Equipment trim-level variant:

0266 - Preparation for audio system and navigation device

0267 - ECE audio system and preparation for navigation system

Preparatory work

Removing air guide for intake air pipe, left

Removing left hand protector

Removing left speaker

Removing left mirror

Removing finisher of air guide, left

Core activity

(-) Removing top section of fairing, left

- Remove screws (1).

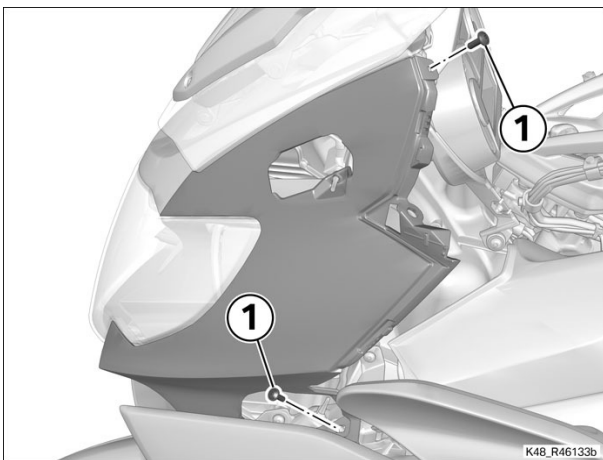

- Remove screw (1).
- Remove top section of fairing (2), noting the retaining lugs (arrows).

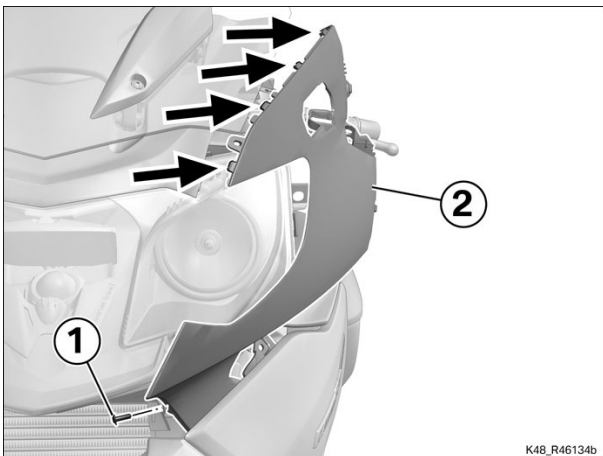

(-) Replacing left top section of fairing

- Transfer rubber buffer (1), flat nuts (2) and rubber nut (3) from old to new top section of fairing (4).

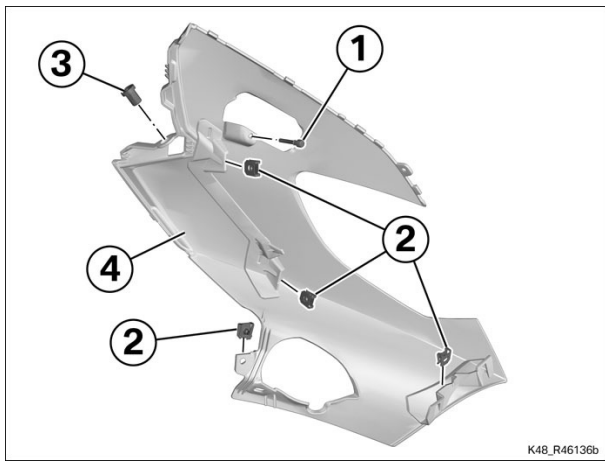

(-) Installing top section of fairing, left

- Install top section of fairing (2), noting the retaining lugs (arrows).
- Install screw (1).

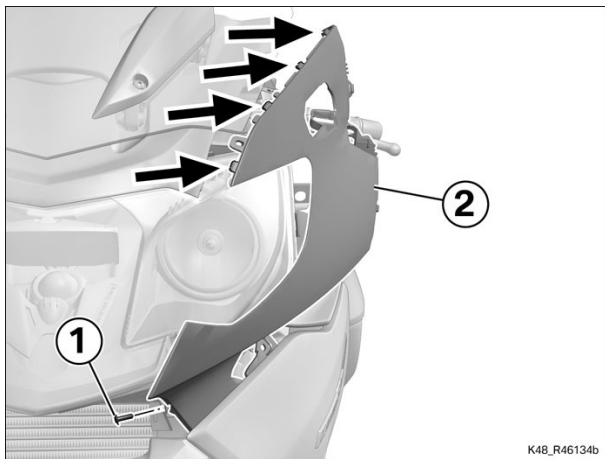

- Install screws (1).

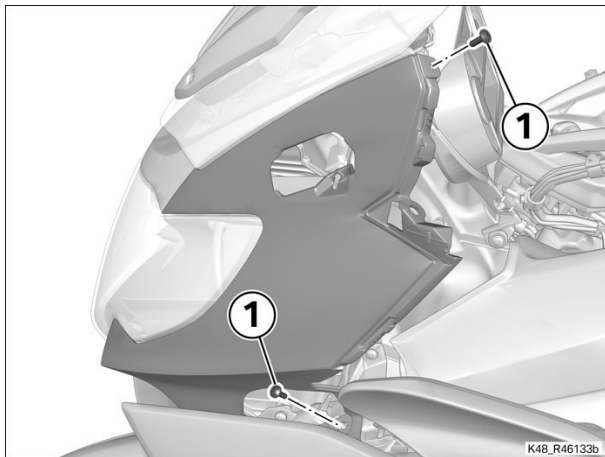

Finishing work

- Installing finisher of air guide, left
- Installing left mirror
- Installing left speaker
- Installing left hand protector
- Installing air guide for intake air pipe, left
- Final check of work performed

46 63 200 Replacing fuel-tank cover, middle 4 FRUs

+ 46 63 860

Preparatory work

Remove the front seat

Removing air guide for intake air pipe, left

Removing left fuel-tank cover top section

Removing left cover of fuel tank

Removing air guide for intake air pipe, right

Removing right fuel-tank cover top section

Remove the right fuel-tank cover

Core activity

(-) Removing centre cover of fuel tank

- Remove screws (1) and (2).

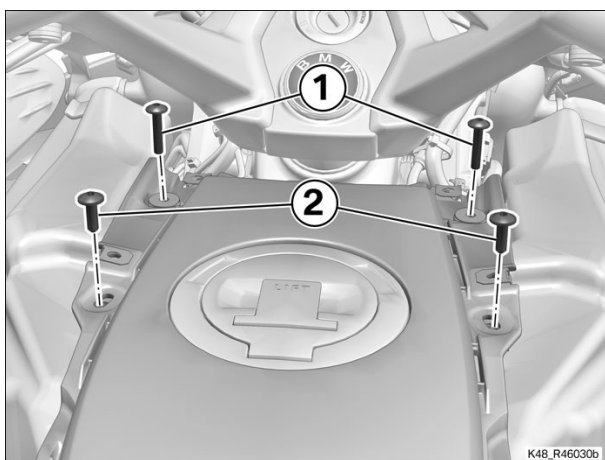

- Remove screw (1).
- Remove cover (2).

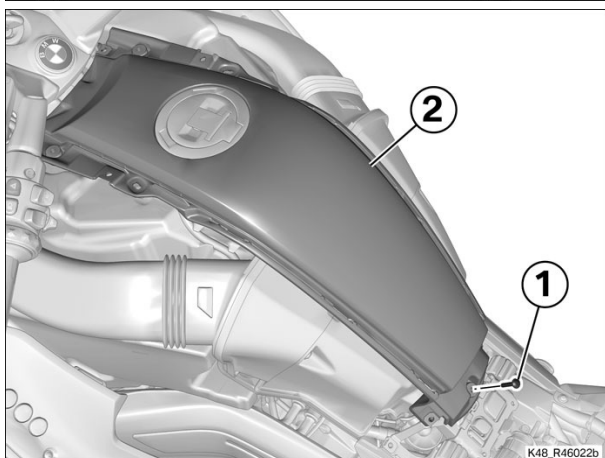

(-) Replacing centre cover of fuel tank

- Transfer the following components from old to new cover (1):
 - Bushings (2)
 - Rubber grommets (3)
 - Flat nuts (4)

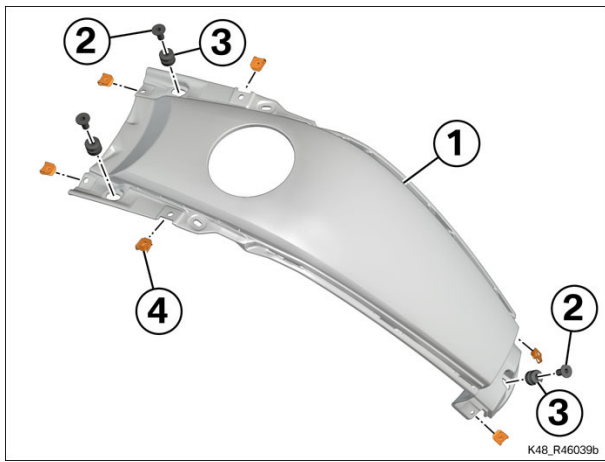

(-) Installing centre cover of fuel tank

- Place cover (2) in position.
- Install screw (1).

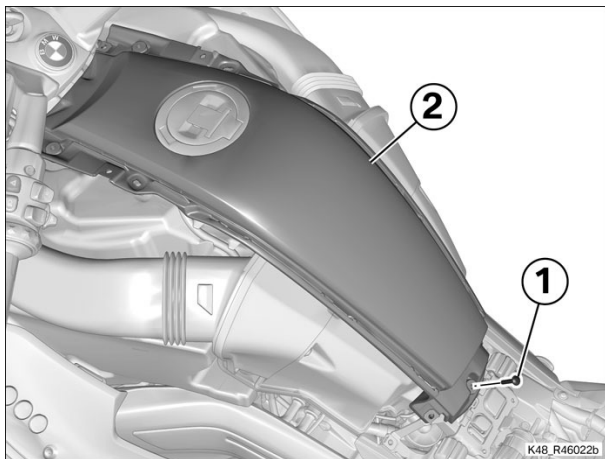

- Install screws (1) and (2).

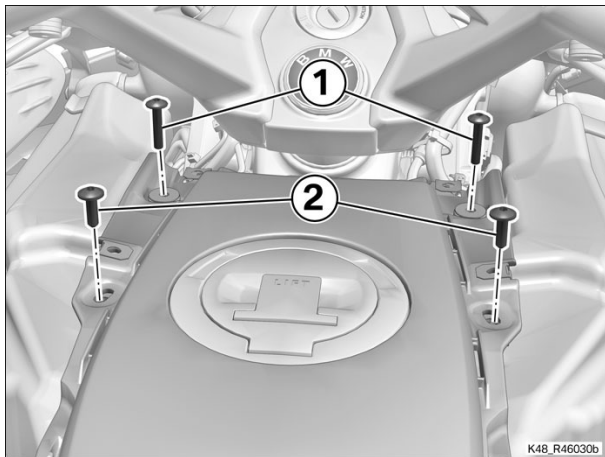

Finishing work

- Installing right fuel-tank cover
- Installing right fuel-tank cover top section
- Installing air guide for intake air pipe, right
- Installing left cover of fuel tank
- Installing left fuel-tank cover top section
- Installing air guide for intake air pipe, left
- Installing front seat
- Final check of work performed

 **46 63 217 Replace front carriers, left and right**

+ 46 63 717

Equipment trim-level variant:

0266 - Preparation for audio system and navigation device

0267 - ECE audio system and preparation for navigation system

Preparatory work

- Remove the front seat
- Removing air guides for intake air pipes, left and right
- Removing complete cover of fuel tank
- Disengaging left and right intake air pipes
- Removing left bottom side panel
- Removing left radiator cowl
- Removing left side panel
- Removing inner trim for left side panel
- Removing right bottom side panel
- Removing right radiator cowl
- Removing right side panel
- Removing inner trim for right side panel
- Removing right hand protector
- Removing right speaker
- Removing left hand protector
- Removing left speaker
- Removing cover of instrument panel
- Removing windscreen
- Removing left mirror
- Removing finisher of air guide, left
- Removing top section of fairing, left
- Removing right mirror
- Removing finisher of air guide, right
- Removing top section of fairing, right
- Removing cross brace for windscreen
- Disengaging left and right windscreen holders
- Removing top cover
- Removing cover for windscreen adjuster
- Removing inner trim with instrument panel
- Removing windscreen adjuster
- Removing headlight
- Disengaging expansion tank for coolant
- Disengaging bracket for basic module and engine control unit
- Removing height sensor, front
- Removing air guide for oil cooler
- Removing adjusting plate
- Disengaging seat support
- Removing complete intake air silencer
- Removing fuel tank
- Removing horn

Core activity

(-) Removing left front panel carrier

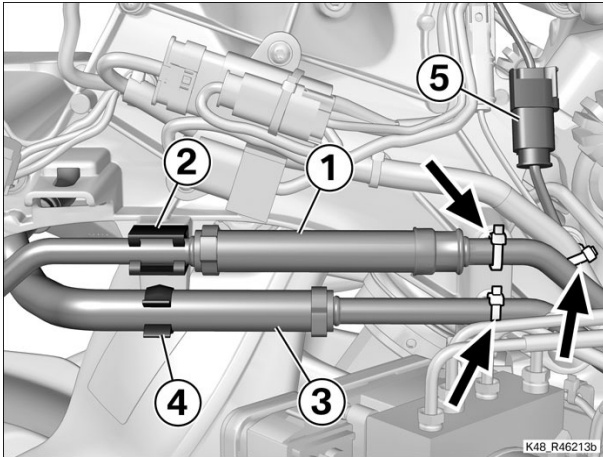

- Remove the cable ties (arrows).
- Unclip feed line (1) of the oil cooler from bracket (2).
- Unclip return line (3) of the oil cooler from bracket (4).
- Remove plug (5) for the clutch switch.

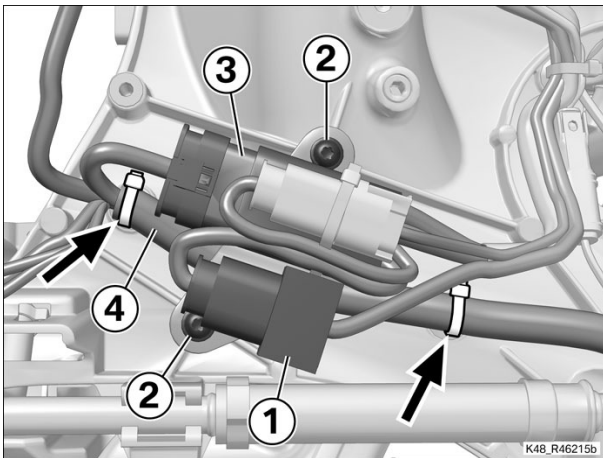

- Remove and disconnect plug (1) for the multi-controller.
- Remove screws (2) and remove plug (3) for the multifunction switch.
- Remove the cable ties (arrows) and disengage wiring harness (4).

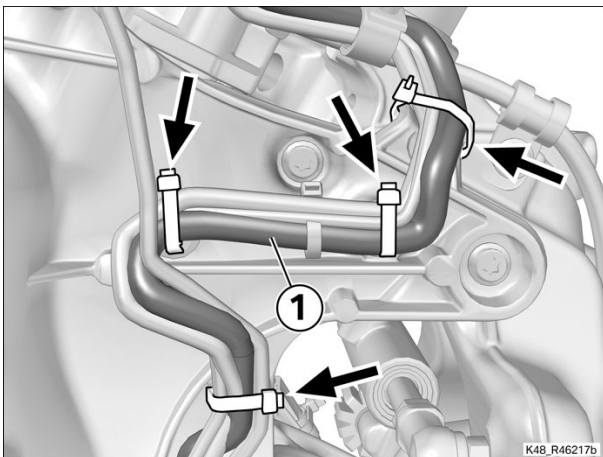

- Remove the cable ties (arrows) and disengage wiring harness (1).

- Remove screws (1) and (2) and disengage front panel carrier (3).

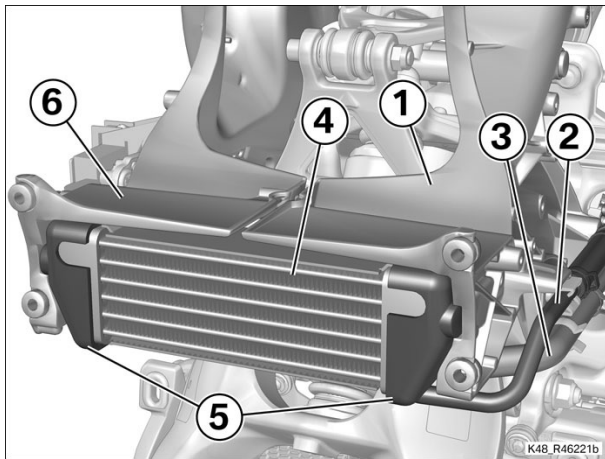
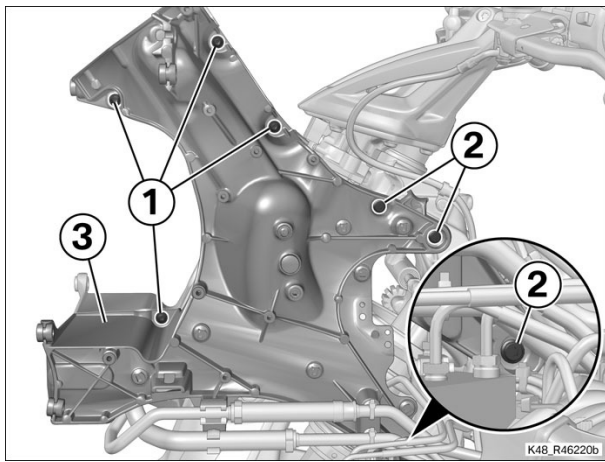

- Work left front panel carrier (1) clear, noting feed line (2) and return line (3) of oil cooler (4).
- Remove oil cooler (4) with rubber mounts (5) from right front panel carrier (6) and allow it to dangle to one side.

(-) Removing right front panel carrier

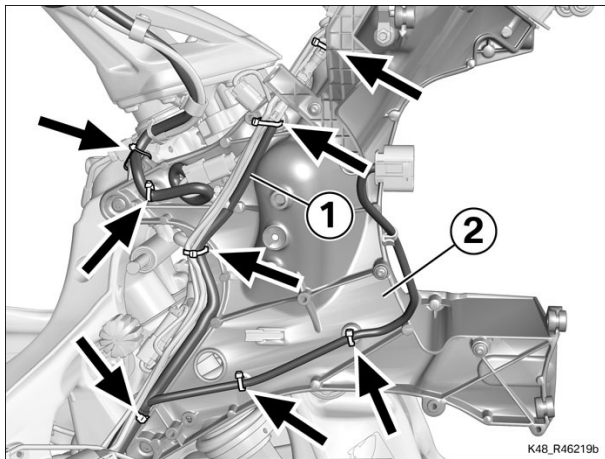

- Remove the cable ties (arrows) and disengage wiring harness (2) from front panel carrier (1).

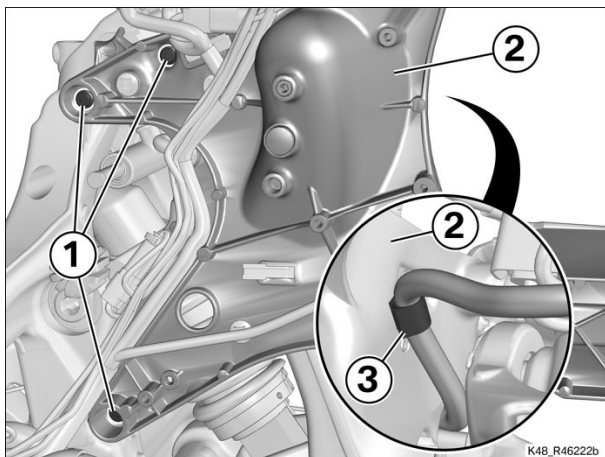

- Remove screws (1), raise front panel carrier (2) and unclip cable (3) for the ignition switch.

(-) Replacing front panel carrier, left

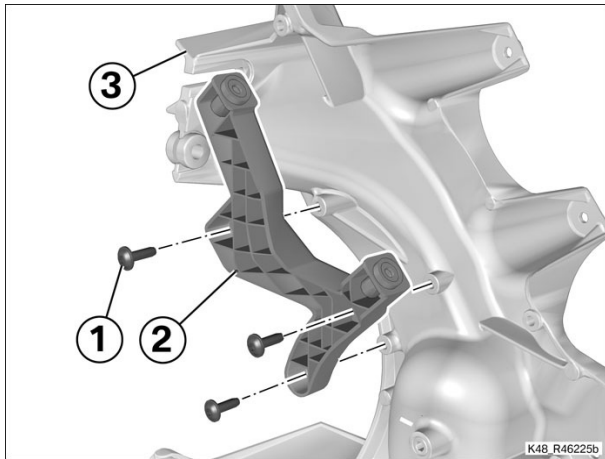

- Remove screws (1) and remove bracket (2) for the speaker from front panel carrier (3).

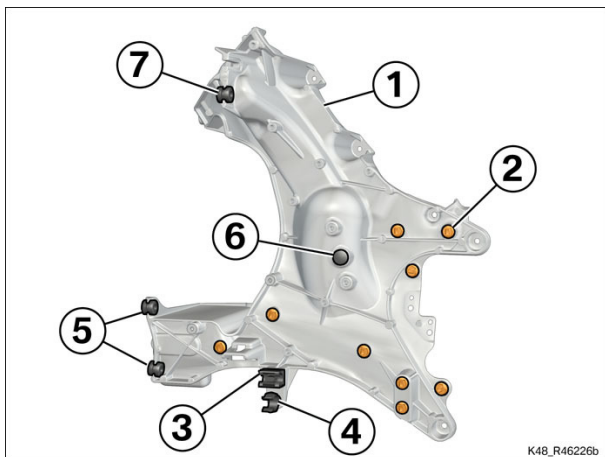

- Transfer the following parts to **new** front panel carrier (1) :
 - Bracket (2) for the cable ties
 - Bracket (3) for the flow line to oil cooler
 - Bracket (4) for the return line from oil cooler
 - Rubber grommets (5)
 - Rubber plug (6)
 - Rubber grommet (7) with metal bushing.

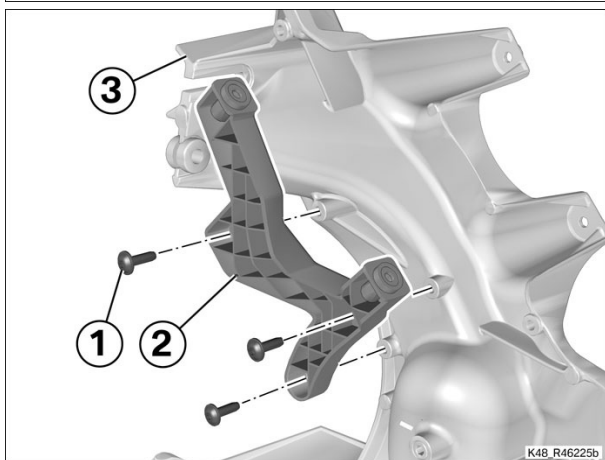

- Hold bracket (2) for speaker in position on new front panel carrier (3) and install screws (1).

 Tightening torques		
Bracket for speaker to front panel carrier		
M5 x 16	10 Nm	

(-) Replacing front panel carrier, right

- Remove screws (1) and remove bracket (2) for the speaker from front panel carrier (3).
- Remove screw (4) and remove earthing strap (5) for the aerial.

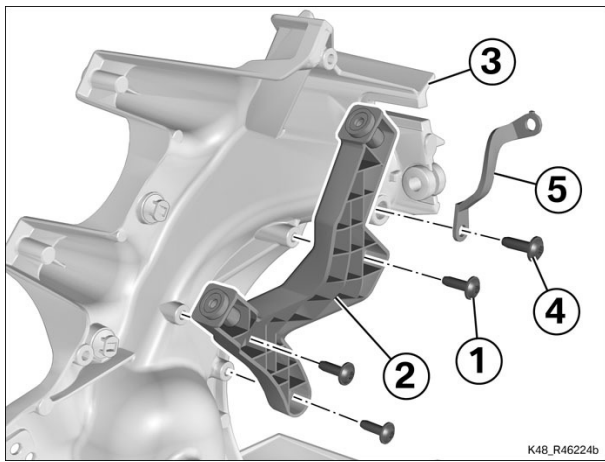

K48_R46224b

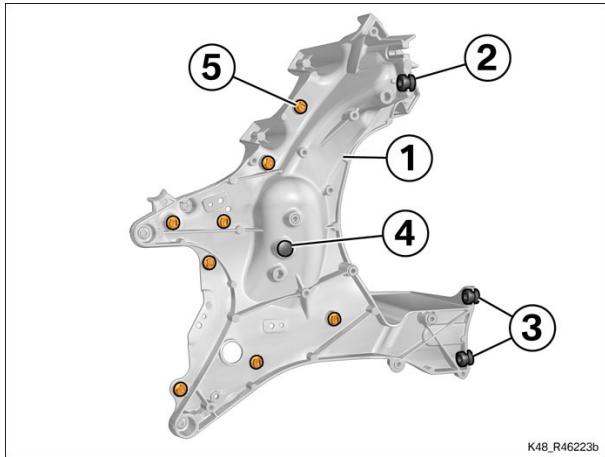

K48_R46223b

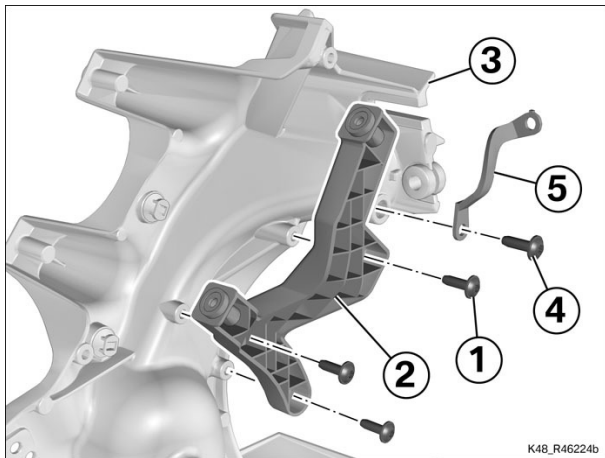

K48_R46224b

- Transfer the following parts to **new** front panel carrier (1) :
 - Rubber grommet (2) with metal bushing
 - Rubber plug (3)
 - Rubber grommet (4)
 - Bracket (5) for cable ties.

- Hold bracket (2) for speaker in position on **new** front panel carrier (3) and install screws (1).

 Tightening torques		
Bracket for speaker to front panel carrier		
M5 x 16	10 Nm	

- Hold earthing strap (5) for the aerial in position and install screw (4).

 Tightening torques		
Earthing strap (aerial) to front panel carrier		
M6 x 12	8 Nm	

(-) Installing right front panel carrier

- Hold front panel carrier (2) in position, clip cable (3) for the ignition switch to the inside of front panel carrier (2) and install screws (1).

 Tightening torques		
Front panel carrier to main frame		
M6 x 20	8 Nm	

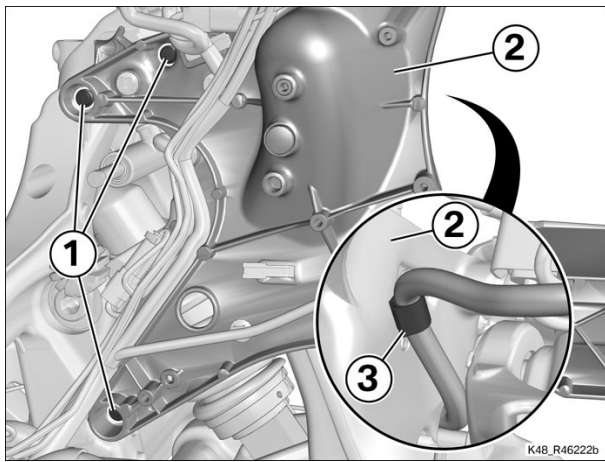

K48_R46222b

- Route wiring harness (1) to front panel carrier (2) and secure it with the cable ties (arrows).

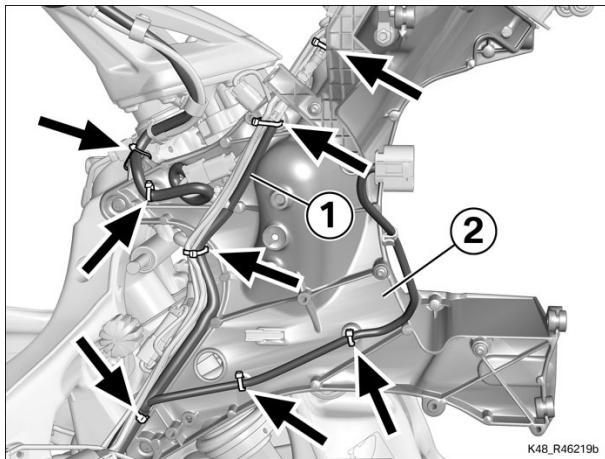

K48_R46219b

(-) Installing left front panel carrier

- Work left front panel carrier (1) into position, noting feed line (2) and return line (3) of oil cooler (4).
- Work oil cooler (4) with rubber mounts (5) into position from below between right front panel carrier (6) and left front panel carrier (1).

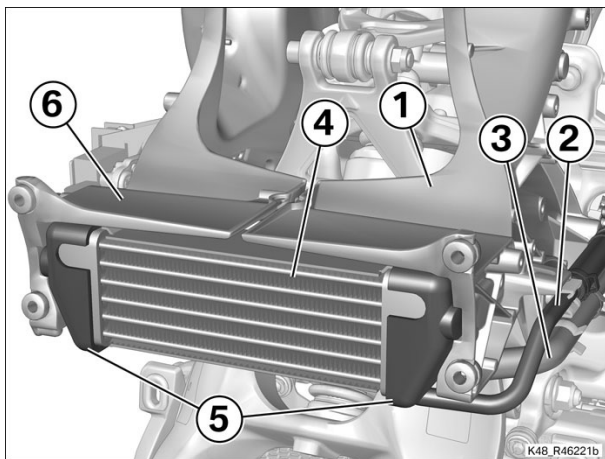

K48_R46221b

- Hold front panel carrier (3) in position, install screws (1) to secure the front panel carrier to the front panel carrier and screws (2) to secure the front panel carrier to the main frame.

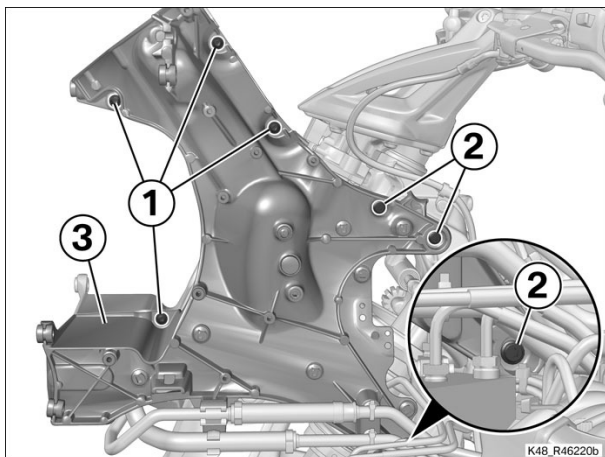

K48_R46220b

 Tightening torques		
Front panel carrier to front panel carrier		
Special thread for light alloy, 6 x 25	12 Nm	
Front panel carrier to main frame		
M6 x 20	8 Nm	

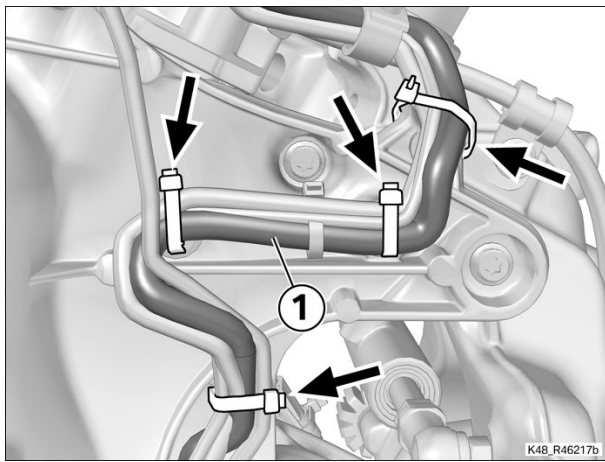

Route wiring harness (1) and secure it with the cable ties (arrows).

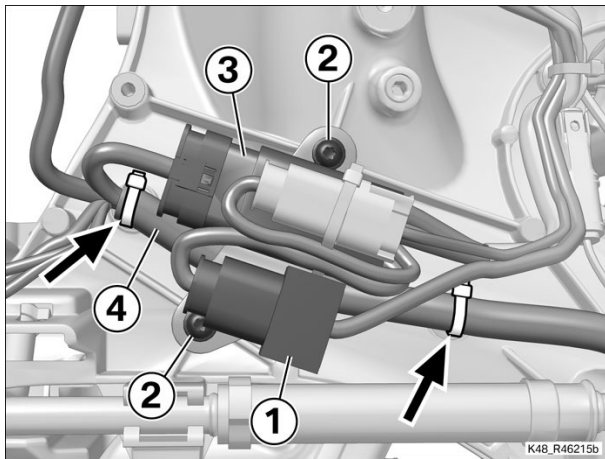

- Route wiring harness (4) and secure it with the cable ties (arrows).
- Hold plug (3) for the multifunction switch in position and install screws (2).
- Connect and install plug (1) for the multi-controller.

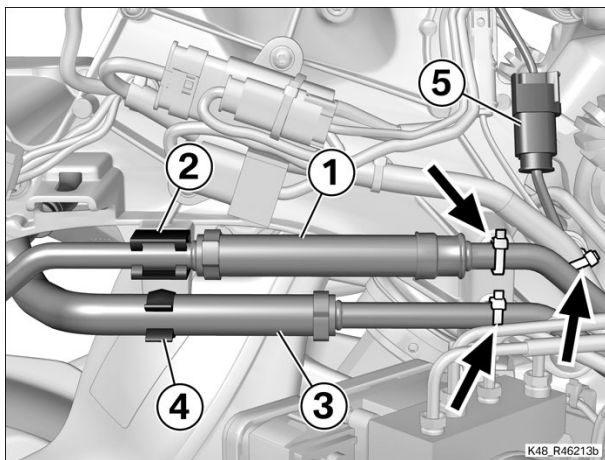

- Clip return line (3) of the oil cooler into holder (4) and secure it with a cable tie (arrow).
- Clip flow line (1) of the oil cooler into holder (2) and secure it with a cable tie (arrow).

Finishing work

Installing horn

Installing fuel tank

Installing complete intake air silencer

Securing seat support

Installing adjusting plate

Installing air guide for oil cooler

Installing height sensor, front

Securing bracket for basic module and engine control unit

Securing expansion tank for coolant

Installing headlight

Installing windscreen adjuster

Installing inner trim with instrument panel
Installing cover for windscreen adjuster
Installing top cover
Securing left and right windscreen holders
Installing cross brace for windscreen
Installing top section of fairing, right
Installing right mirror
Installing top section of fairing, left
Installing left mirror
Installing windscreen
Installing cover of instrument panel
Installing left speaker
Installing left hand protector
Installing right speaker
Installing right hand protector
Installing inner trim for right side panel
Installing right side panel
Installing finisher of air guide, right
Install the right radiator cowl
Installing right bottom side panel
Installing inner trim for left side panel
Installing left side panel
Installing finisher of air guide, left
Installing left radiator cowl
Installing left bottom side panel
Securing left and right intake air pipes
Installing complete cover of fuel tank
Installing air guides for intake air pipes, left and right
Installing front seat
Checking headlight beam throw
Final check of work performed

46 63 222 Removing/installing or replacing left or right radiator cowl 2 FRUs

+ 46 63 867

Core activity

(-) Removing left radiator cowl

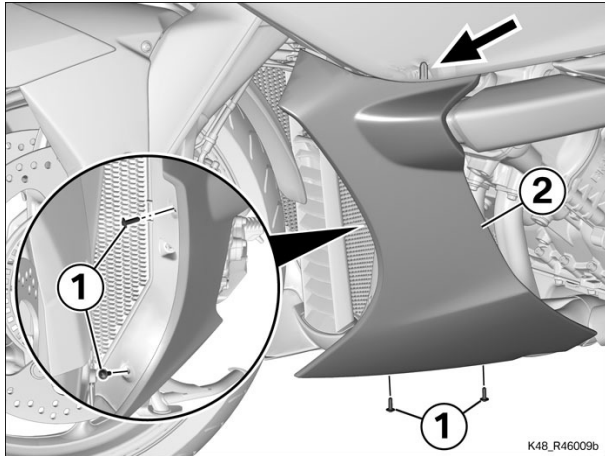

- Remove screws (1).
- Disengage radiator cowl (2) from the rubber grommet (arrow) and remove.

(-) Replacing left radiator cowl

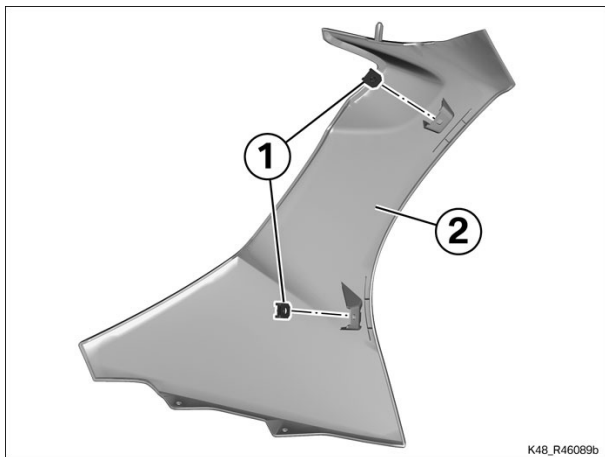

- Transfer flat nuts (1) from old to new radiator cowl (2).

(-) Installing left radiator cowl

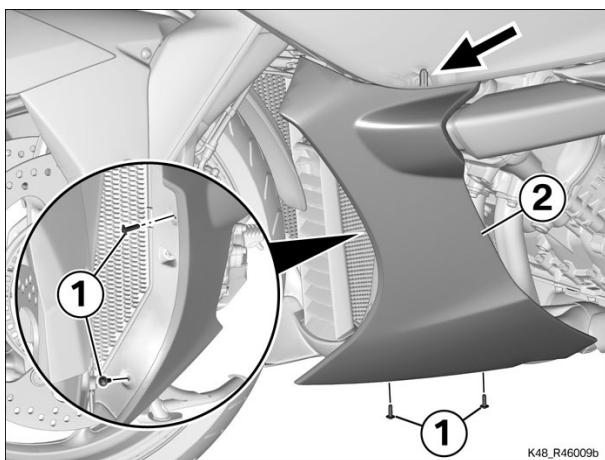

- Hold radiator cowl (2) in position, engage it in the rubber grommet (arrow) and install.
- Install screws (1).

Finishing work

Final check of work performed

📁 46 63 265 Removing/installing or replacing cover for instruments 3 FRUs

+ 46 63 928

Preparatory work

Removing air guide for intake air pipe, right

Removing right hand protector

Removing air guide for intake air pipe, left

Removing left hand protector

Core activity

(-) Removing cover of instrument panel

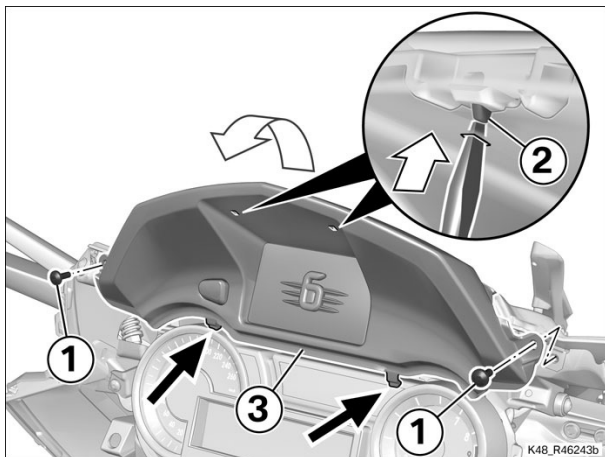

- Remove screws (1).
- Use a suitable tool to push back retainers (2) and disengage cover (3) at top.
- Remove cover (3), noting the retainers (arrows).

(-) Replacing cover for instruments

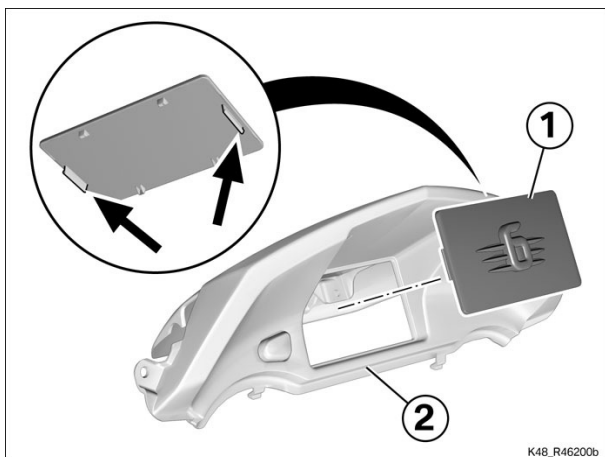

- Using a suitable tool, disengage compartment cover (1) and remove it from old cover (2) for the instruments, noting the retaining lugs (arrows).
- Install compartment cover (1) in new cover (2) for the instruments, noting the retaining lugs (arrows).

(-) Installing cover of instrument panel

- Install cover (1), noting the retainers (arrows).
- Press on cover (1) at top.
- » Retainers (2) engage with an audible click.
- Install screws (3).

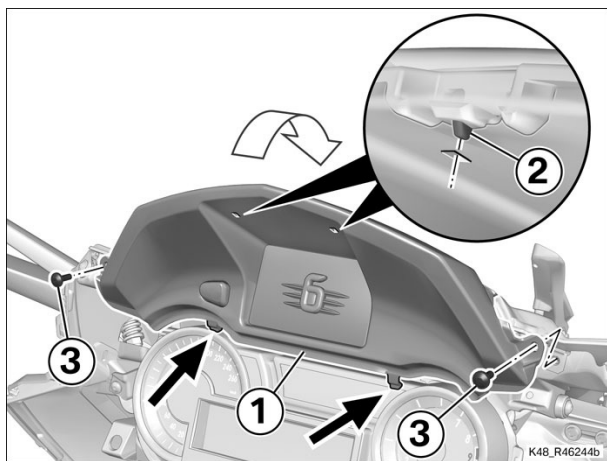

Finishing work

Installing left hand protector

Installing air guide for intake air pipe, left

Installing right hand protector

Installing air guide for intake air pipe, right

Final check of work performed

📁 46 63 274 Renewing wind deflector plate 4 FRUs

+ 46 63 884

Preparatory work

Removing left bottom side panel

Removing left radiator cowl

Removing left side panel

Core activity

(-) Removing left slipstream deflector

- Remove screws (1).
- Remove complete slipstream deflector (2).

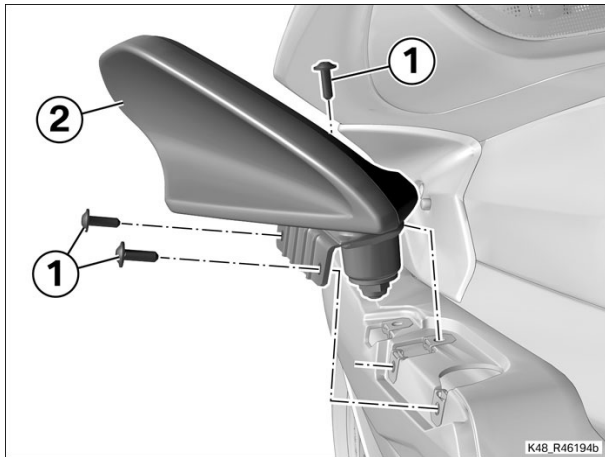

(-) Installing left slipstream deflector

- Install complete slipstream deflector (2).
- Install screws (1).

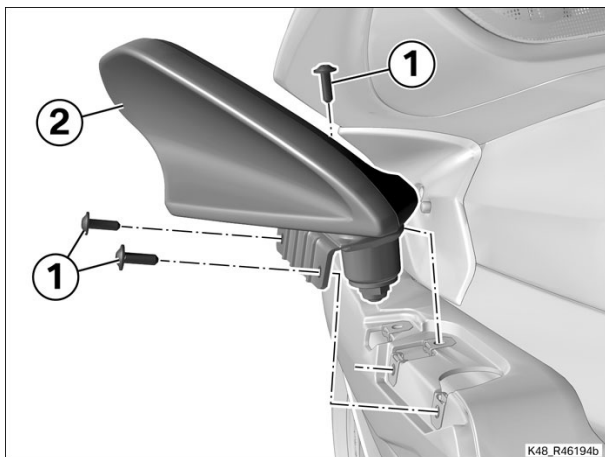

Finishing work

Install the left side panel

Installing left radiator cowl

Installing left bottom side panel

Final check of work performed

46 63 303 Replacing left stowage-compartment lid 2 FRUs

+ 46 63 988

Core activity

(-) Removing left stowage-compartment lid

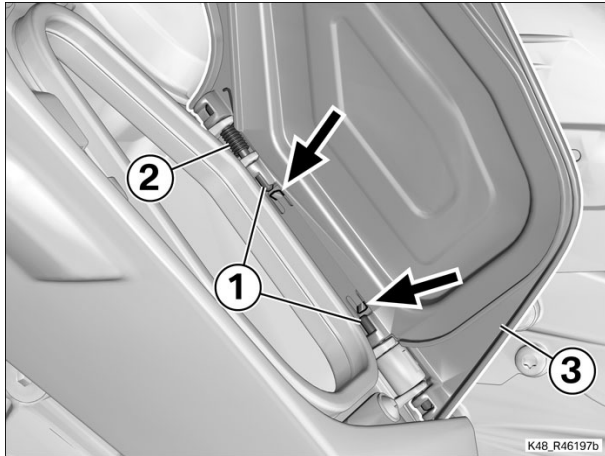

- Open the stowage compartment.
- Press the retainers (arrows) down and remove swivels (1) and spring (2).
- Remove stowage-compartment lid (3).

(-) Installing left stowage-compartment lid

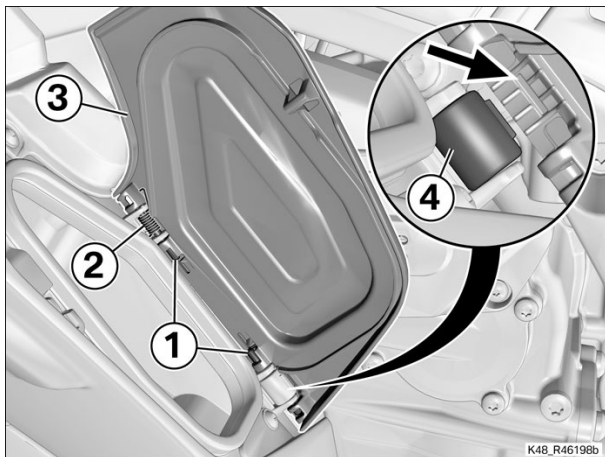

- Hold damper (4) in position.
- Install stowage-compartment lid (3), positioning it with the groove (arrow) at damper (4).
- Insert spring (2) with **long end** toward lid (3) and install swivels (1).

Finishing work

Final check of work performed

46 63 321 Replacing left or right rear trim panel 3 FRUs

+ 46 63 896

Preparatory work

Remove the front seat

Remove the front-seat trimmer, left

Removing cover for case carrier, left

Core activity

(-) Removing left rear trim panel

- Remove screws (1).

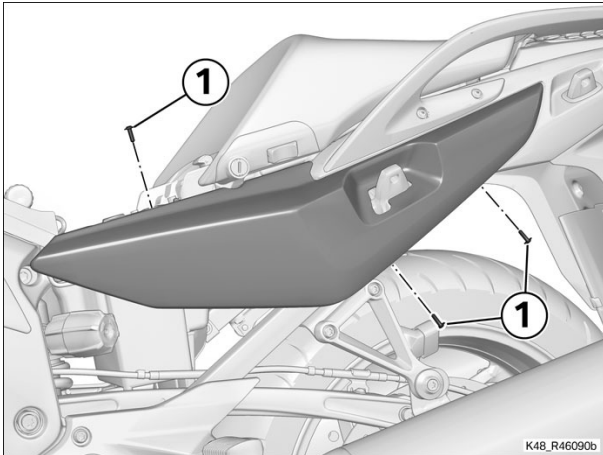

- Remove rear trim panel (1), noting the retaining lugs (arrows).

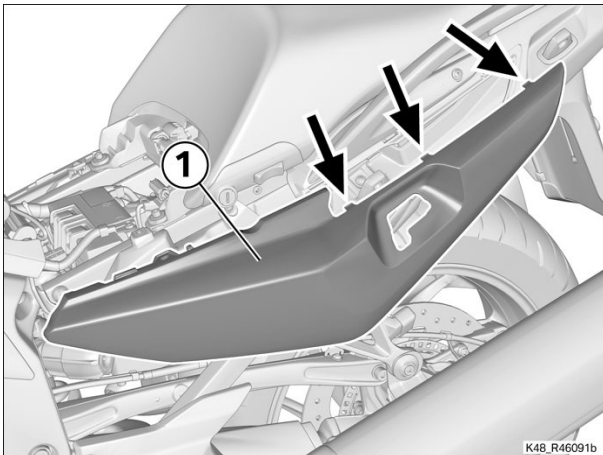

(-) Installing left rear trim panel

- Install rear trim panel (1), noting the retaining lugs (arrows).

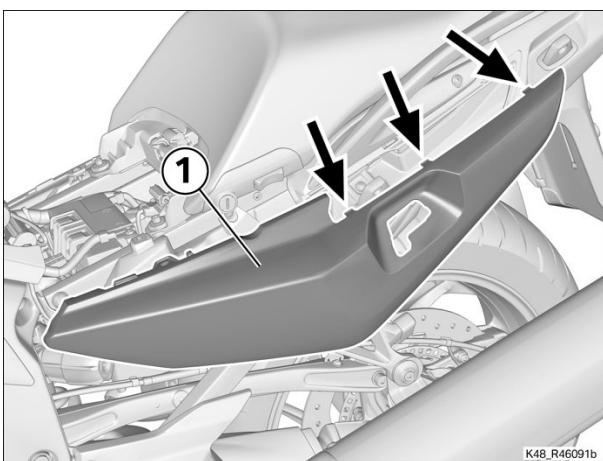

- Install screws (1).

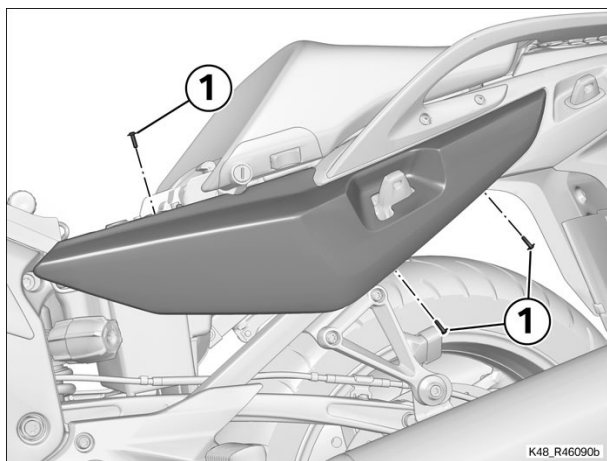

Finishing work

Installing cover for case carrier, left

Install the front-seat trimmer, left

Installing front seat

Final check of work performed

46 63 333 Replacing side panel, left 4 FRUs

+ 46 63 900

Preparatory work

Removing left bottom side panel

Removing left radiator cowl

Core activity

(-) Removing left side panel

- Turn slipstream deflector (1) to one side.
- Remove screw (2).

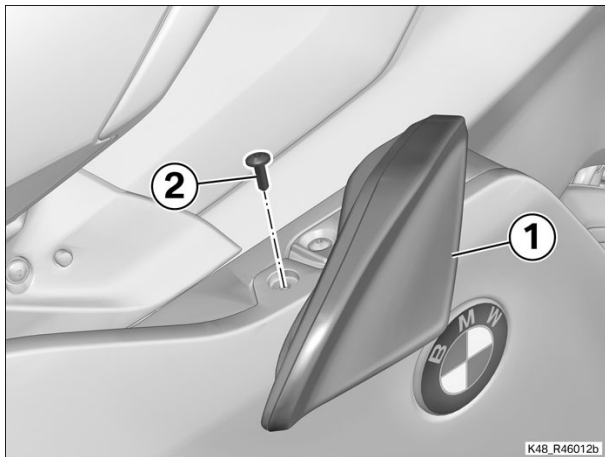

- Remove screws (1).

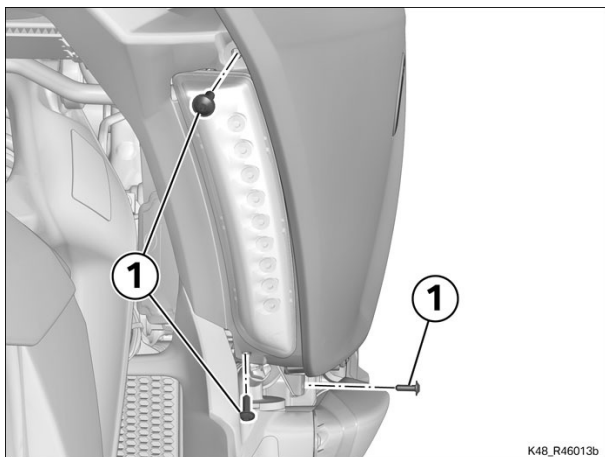

- Remove screws (1).
- Remove side panel (2).

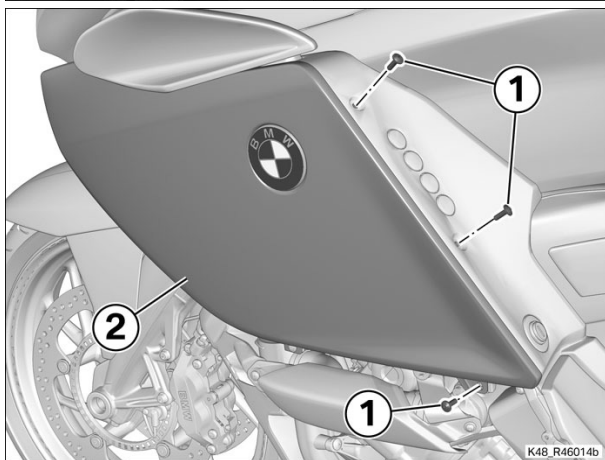

(-) Replacing side panel, left

- Transfer flat nuts (1) and rubber grommet (2) to new side panel (3).

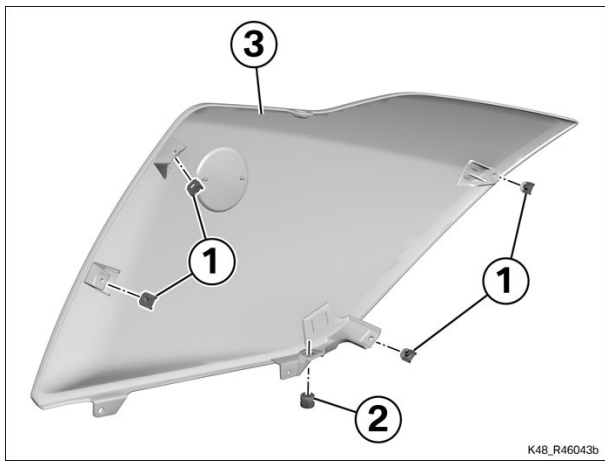

(-) Install the BMW badge

- Seat the pins (arrow) of the **BMW** badge (1) in **small bores** (2) of the trim panel.
- Press **BMW** badge (1) firmly against the trim panel.

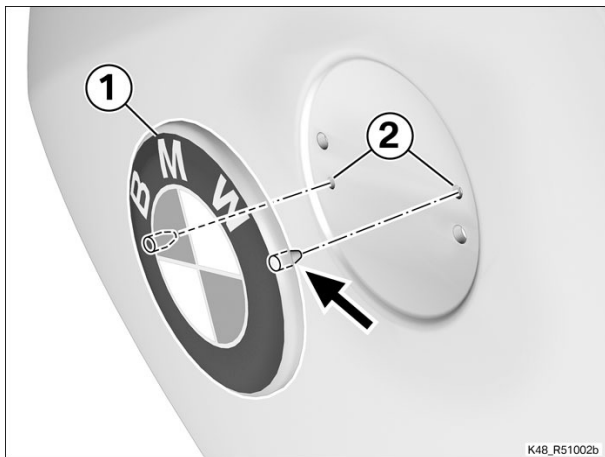

(-) Installing designation for side panel

- Peel backing films (1) off designations (2) and (3).
- Hold designations (2) and (3) in position and press on firmly.

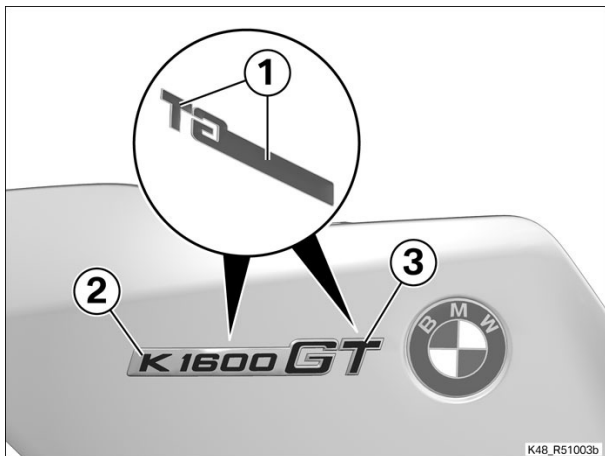

(-) Install the left side panel

- Install side panel (2).
- Install screws (1).

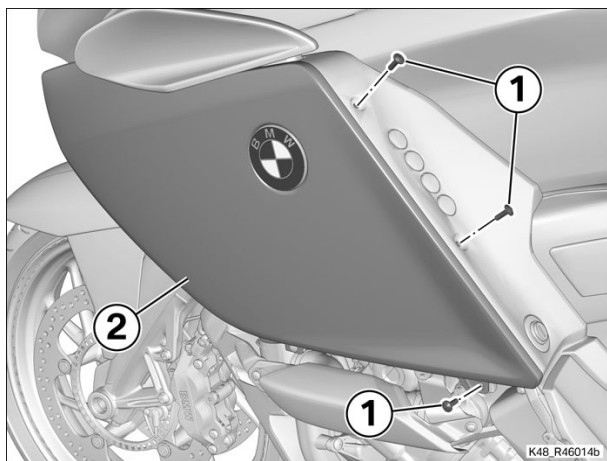

- Install screws (1).

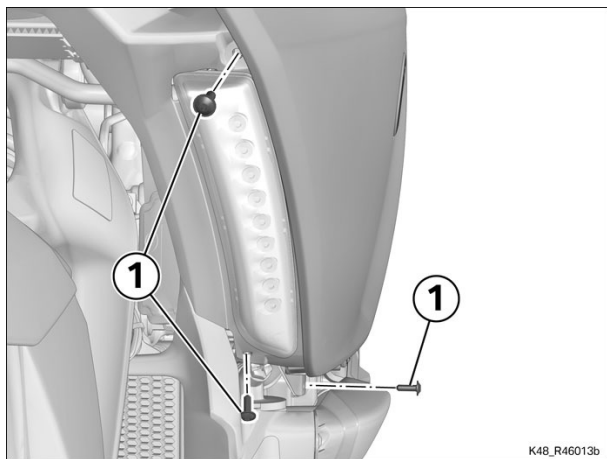

- Turn slipstream deflector (1) to one side.
- Install screw (2).

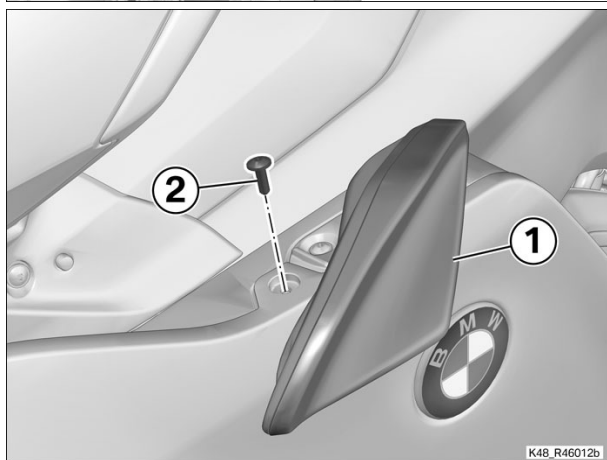

Finishing work

Installing left radiator cowl

Installing left bottom side panel

Final check of work performed

46 63 334 Replacing side panel, right 4 FRUs

+ 46 63 901

Preparatory work

Removing right bottom side panel

Removing right radiator cowl

Core activity

(-) Remove the right side panel

- Turn slipstream deflector (1) to one side.
- Remove screw (2).

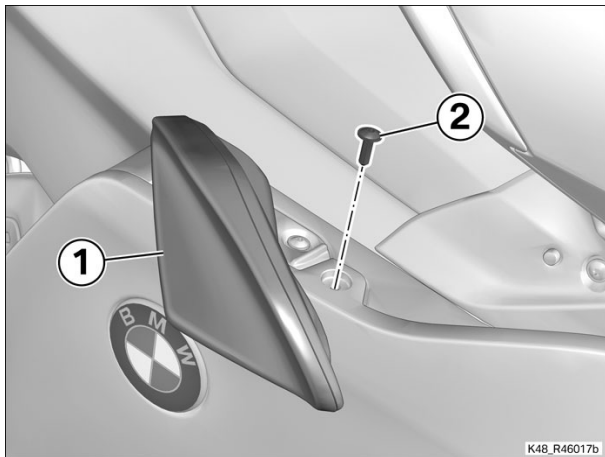

- Remove screws (1).

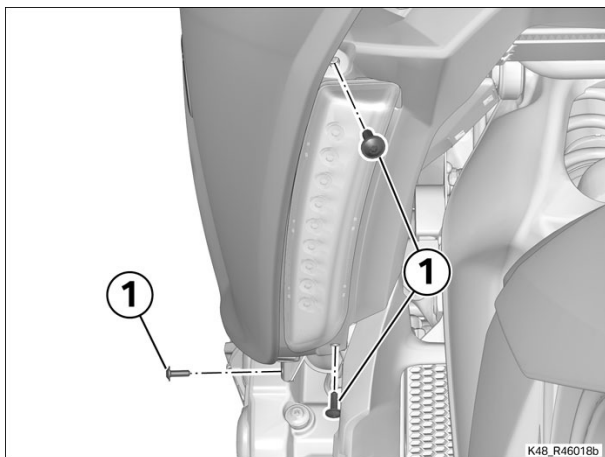

- Remove screws (1).
- Remove side panel (2).

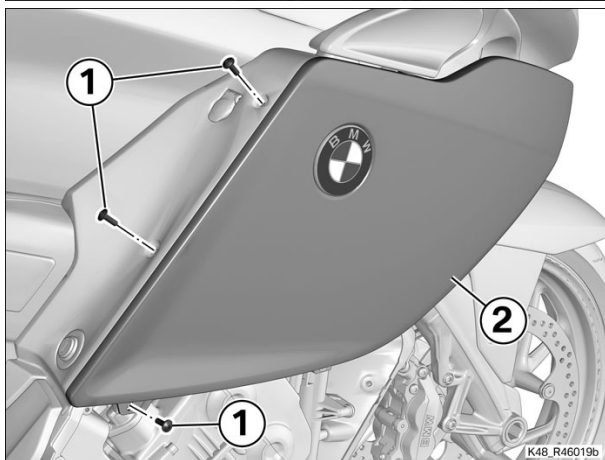

(-) Replacing right side panel

- Transfer flat nuts (1) and rubber grommet (2) to new side panel (3).

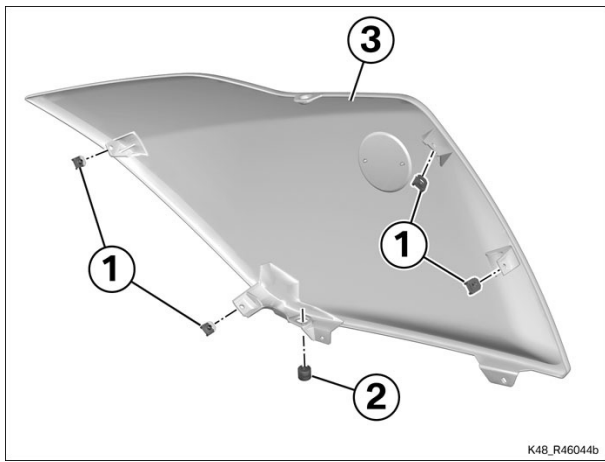

(-) Install the BMW badge

- Seat the pins (arrow) of the **BMW** badge (1) in **small bores** (2) of the trim panel.
- Press **BMW** badge (1) firmly against the trim panel.

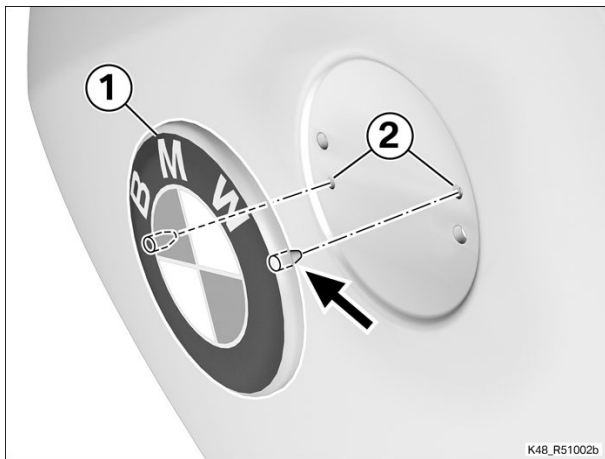

(-) Installing designation for side panel

- Peel backing films (1) off designations (2) and (3).
- Hold designations (2) and (3) in position and press on firmly.

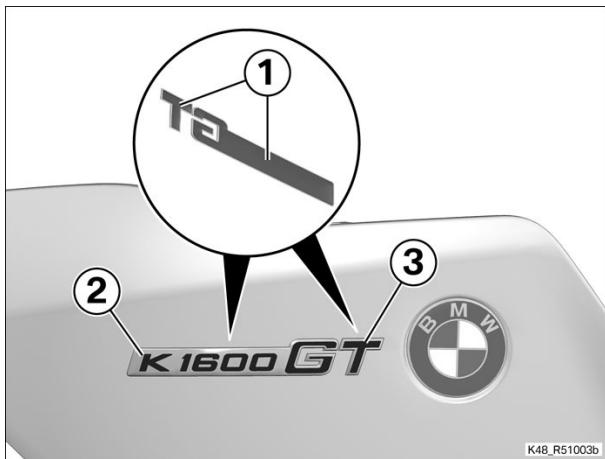

(-) Install the right side panel

- Install side panel (2).
- Install screws (1).

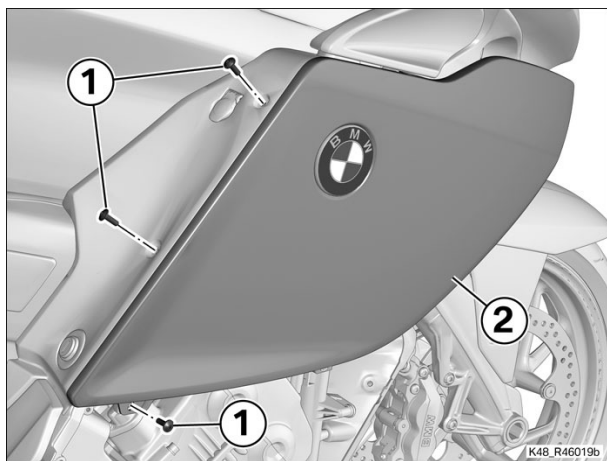

- Install screws (1).

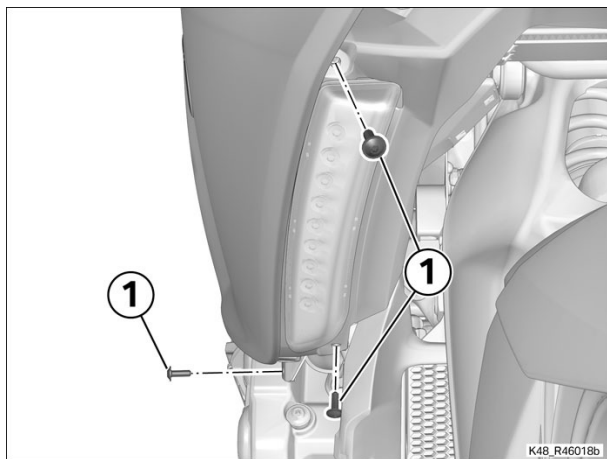

- Turn slipstream deflector (1) to one side.
- Install screw (2).

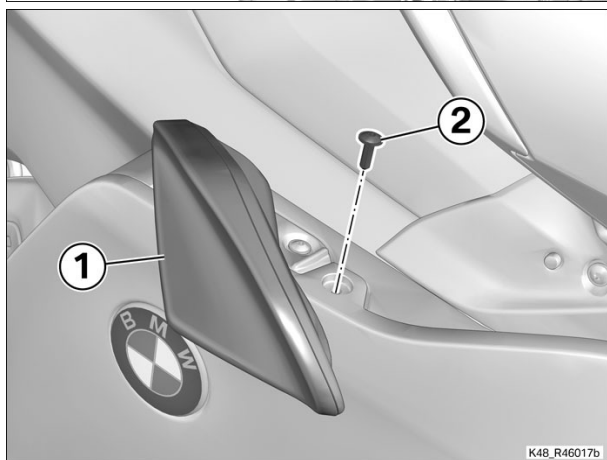

Finishing work

- Install the right radiator cowl
- Installing right bottom side panel
- Final check of work performed

46 63 340 Replacing interior trim for full fairing, left 5 FRUs

+ 46 63 906

Equipment trim-level variant:

0267 - ECE audio system and preparation for navigation system

0266 - Preparation for audio system and navigation device

Preparatory work

Removing air guide for intake air pipe, left

Removing left bottom side panel

Removing left radiator cowl

Removing left side panel

Core activity

(-) Removing inner trim for left side panel

- Disengage complete ambient-temperature sensor (1) from inner trim (2).

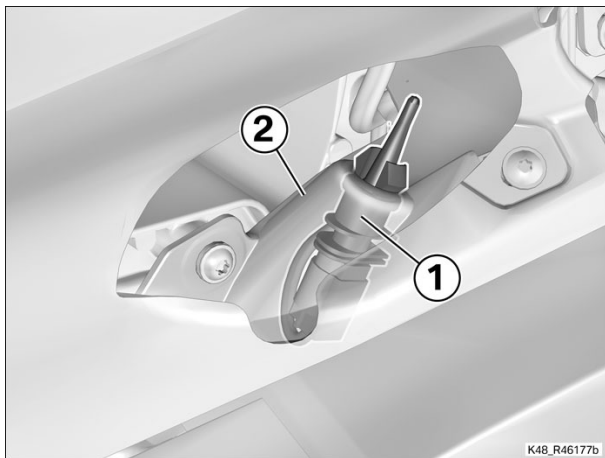

- Remove screws (1) with bushings (2).
- Remove screw (3).

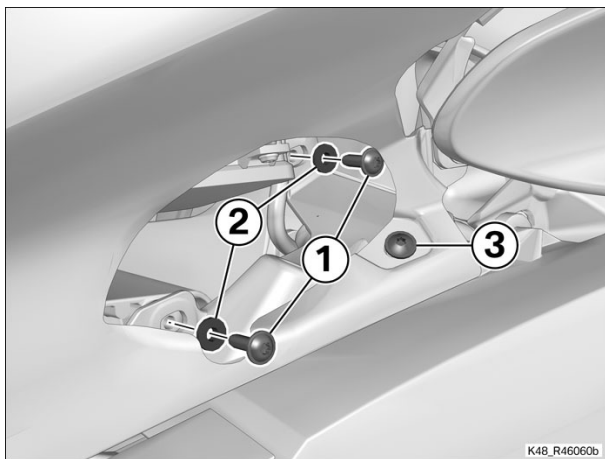

- Disconnect plug (1) for the operating unit.
- Remove screw (2).
- Remove inner trim (3) for the side panel.

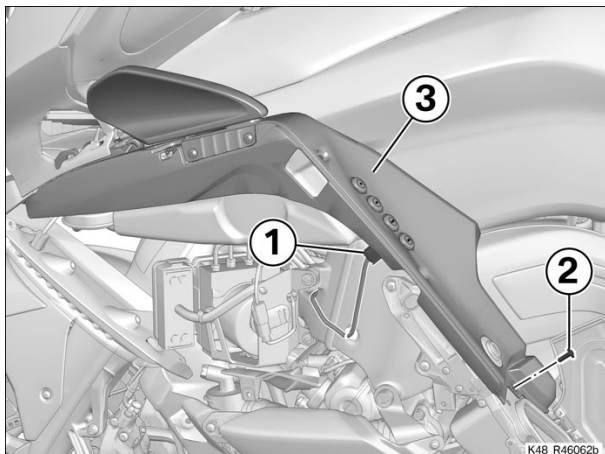

(-) Replacing left inner trim for side panel

► Removing operating unit for audio system

- Remove screws (1).
- Remove operating unit (2).

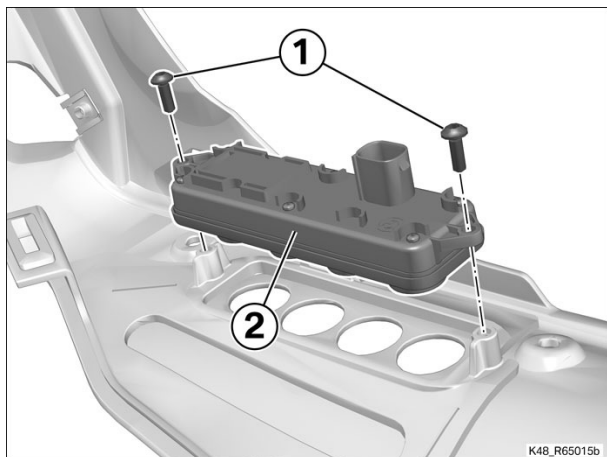

► Removing left slipstream deflector

- Remove screws (1).
- Remove slipstream deflector (2).

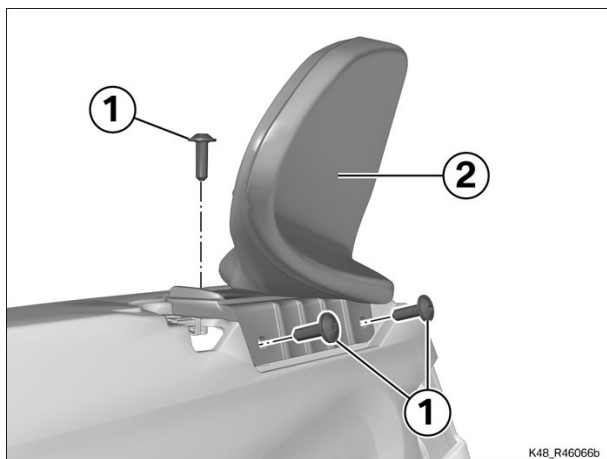

- Transfer rubber grommet (1), flat nuts (2) and rubber guides (3) to new inner trim (4).

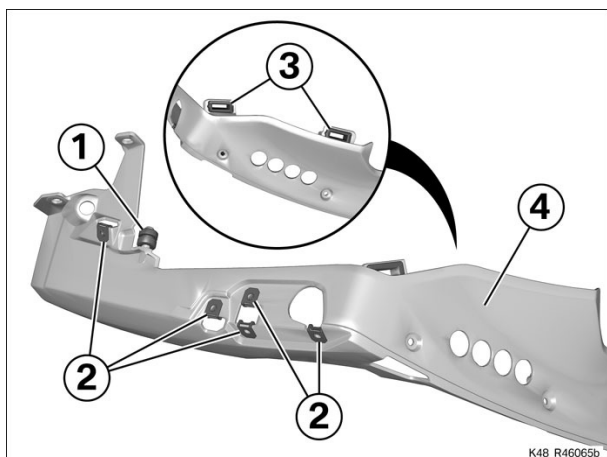

► Installing left slipstream deflector

- Install slipstream deflector (2).
- Install screws (1).

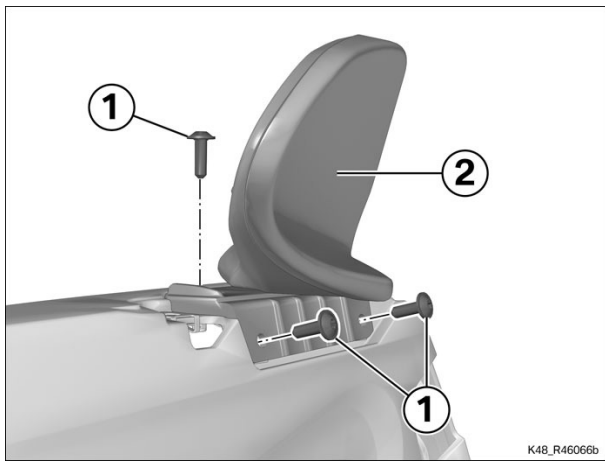

► **Installing operating unit for audio system**

- Install operating unit (2), making sure that the operating unit is located in the catch (arrow).
- Install screws (1).

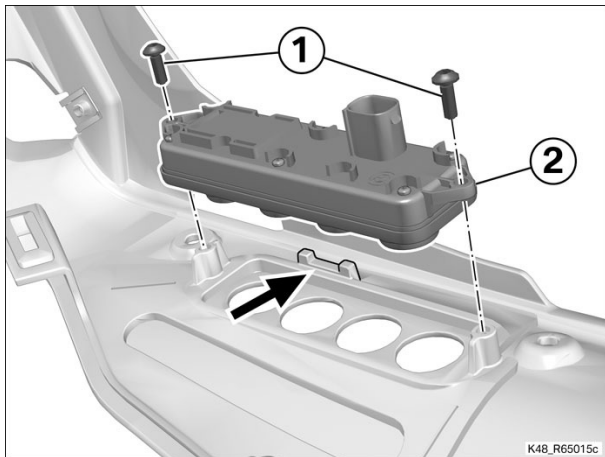

(-) **Installing inner trim for left side panel**

- Install inner trim (3) for the side panel.
- Install screw (2).
- Connect plug (1) for the operating unit.

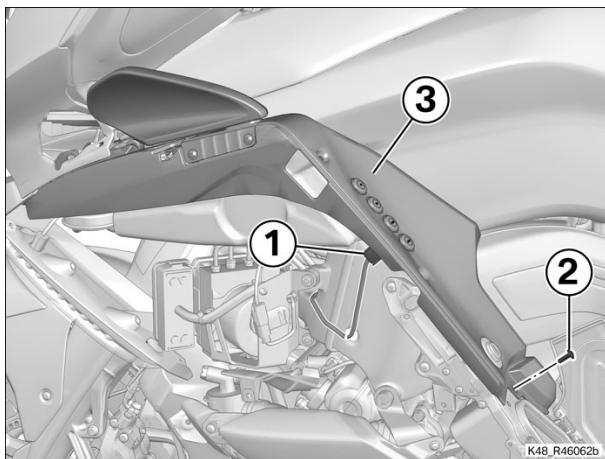

- Install screws (1) with bushings (2).
- Install screw (3).

Tightening torques		
Operating unit for audio system to fairing side panel		
TS4 x 10	1.5 Nm	

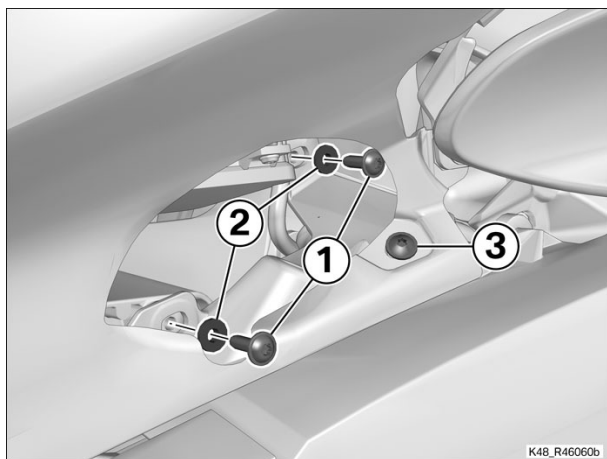

- Secure complete ambient-temperature sensor (1) in inner trim (2).

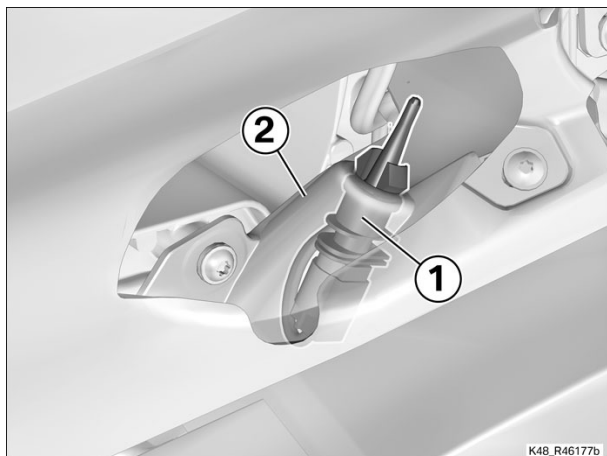

Finishing work

- Install the left side panel
- Installing left radiator cowl
- Installing left bottom side panel
- Installing air guide for intake air pipe, left
- Final check of work performed

46 63 343 Replace inner cover for instruments 7 FRUs

+ 46 63 907

Equipment trim-level variant:

0266 - Preparation for audio system and navigation device

0267 - ECE audio system and preparation for navigation system

Preparatory work

- Removing air guide for intake air pipe, right
- Removing right hand protector
- Removing right speaker
- Removing air guide for intake air pipe, left
- Removing left hand protector
- Removing left speaker
- Removing cover of instrument panel
- Removing windscreen
- Removing cross brace for windscreen
- Disengaging left and right windscreen holders
- Removing top cover

Core activity

(-) Removing inner trim with instrument panel

- Remove screws (1) and screws (2) with washers (3).

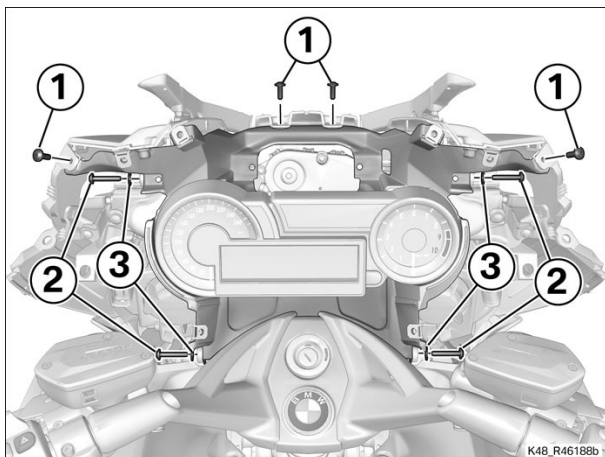

- Disengage plug (1) for windscreen adjuster from the holder (arrow).
- Disconnect plug (2) for the instrument panel.
- Remove inner trim (3) with the instrument panel.

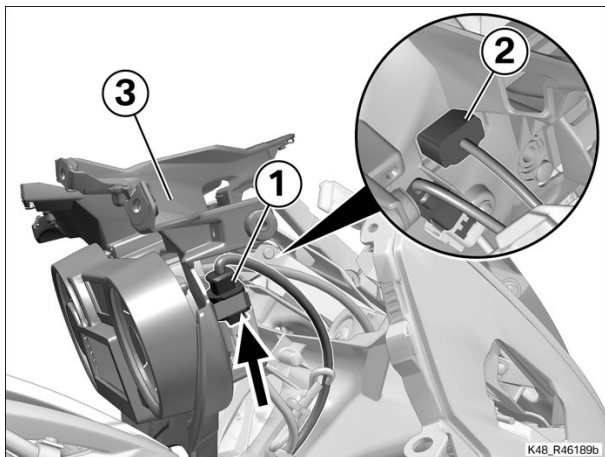

(-) Removing instrument panel

- Remove screws (1).
- Remove instrument panel (2) from inner trim (3).

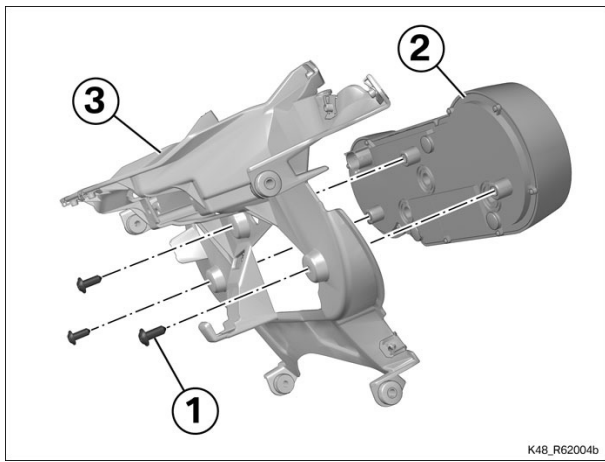

K48_R62004b

(-) Replacing inner trim

- Transfer the following components to new inner trim (4):
- Flat nuts (1)
- Bushings (2)
- Rubber grommets (3)

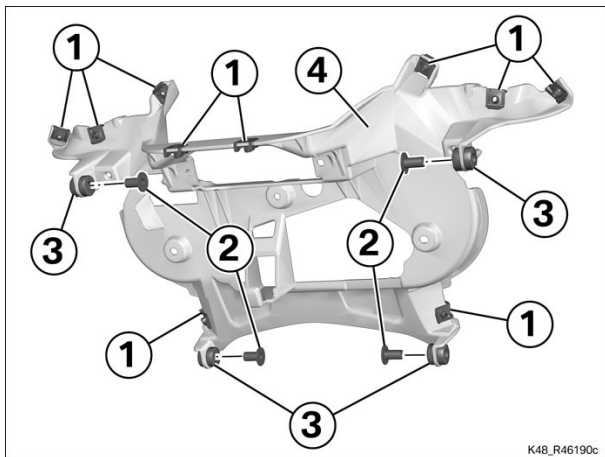

K48_R46190c

(-) Installing instrument panel

- Install instrument panel (2) in inner trim (3).
- Install screws (1).

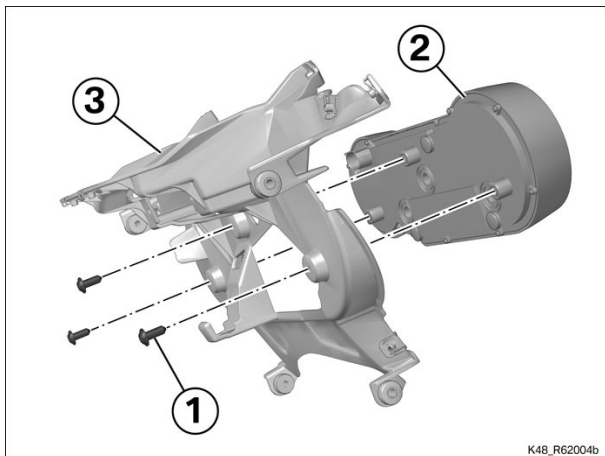

K48_R62004b

 Tightening torques		
Instrument panel to inner trim		
M6 x 16	5 Nm	

(-) Installing inner trim with instrument panel

- Install inner trim (3) with the instrument panel.
- Connect plug (2) for the instrument panel.
- Secure plug (1) for windscreen adjuster in the holder (arrow).

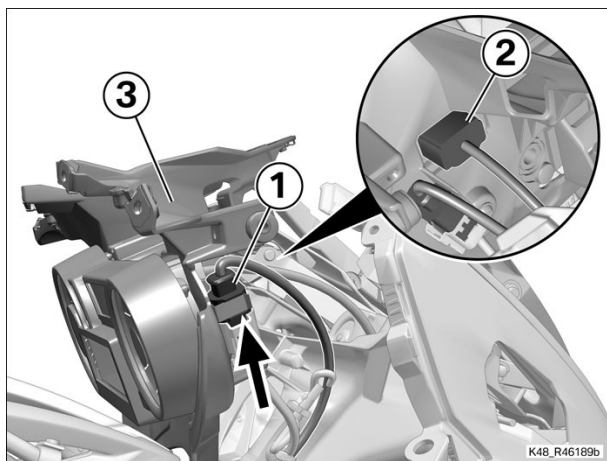

K48_R46189b

- Install screws (1) and screws (2) with washers (3).

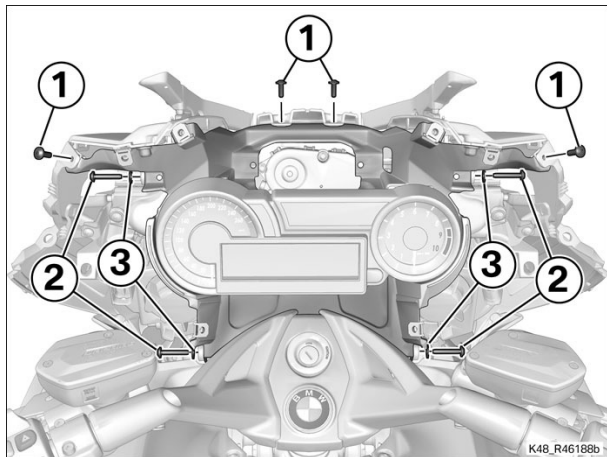

K48_R46188b

Finishing work

- Installing top cover
- Securing left and right windscreen holders
- Installing cross brace for windscreen
- Installing windscreen
- Installing cover of instrument panel
- Installing left speaker
- Installing left hand protector
- Installing air guide for intake air pipe, left
- Installing right speaker
- Installing right hand protector
- Installing air guide for intake air pipe, right
- Final check of work performed

46 63 345 Replacing interior trim for full fairing, right 5 FRUs

+ 46 63 908

Preparatory work

Removing air guide for intake air pipe, right

Removing right bottom side panel

Removing right radiator cowl

Remove the right side panel

Core activity

(-) Removing inner trim for right side panel

- Remove screws (1) with bushings (2).
- Remove screw (3).

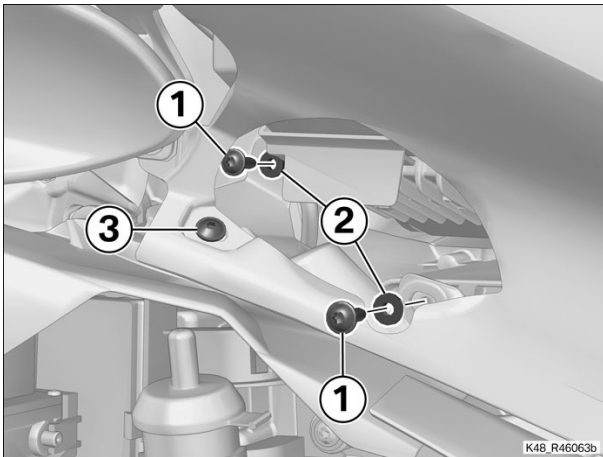

- Remove screw (1).
- Disconnect plug (2) for the on-board socket.
- Remove inner trim (3) for the side panel.

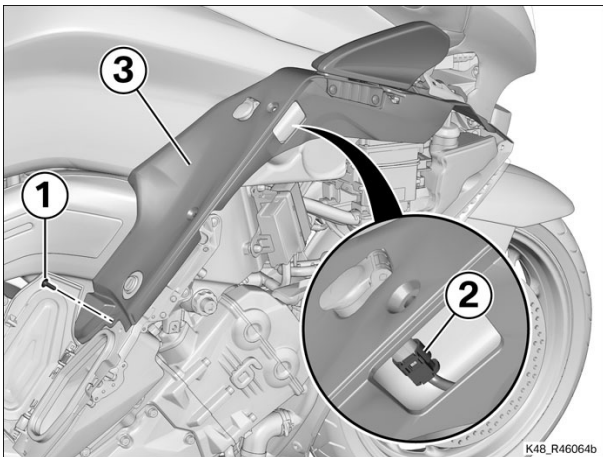

(-) Replacing right inner trim for side panel

► Removing right slipstream deflector

- Remove screws (1).
- Remove slipstream deflector (2).

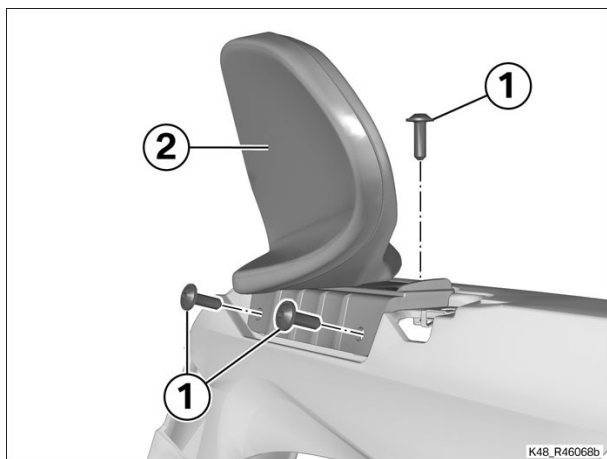

► **Removing on-board socket from inner trim**

- Remove nut (1).
- Remove on-board socket (2).

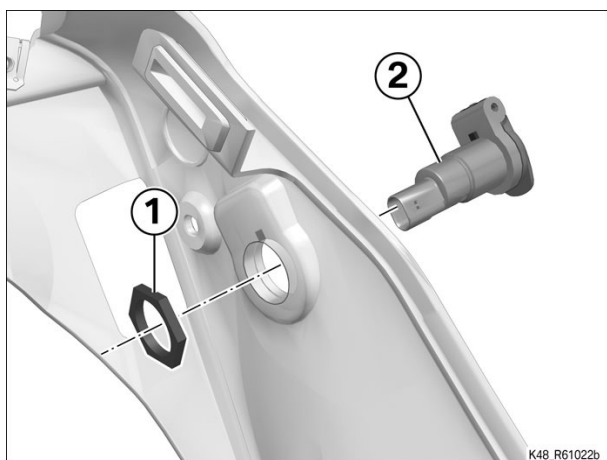

- Transfer rubber grommet (1), flat nuts (2) and rubber guides (3) from old to new inner trim (4).

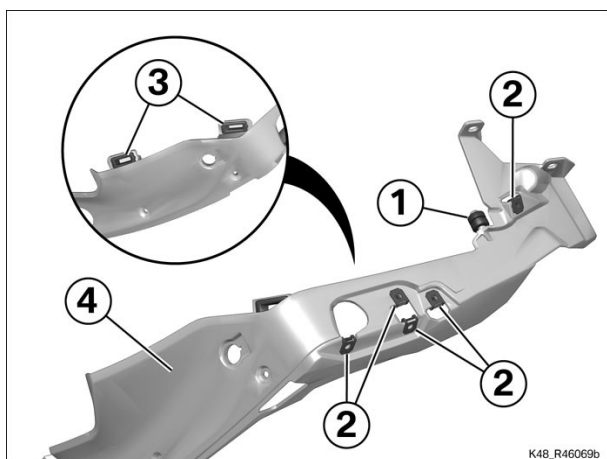

► **Installing on-board socket in interior trim**

- Install on-board socket (2), noting the locator (arrows).
- Tighten nut (1).

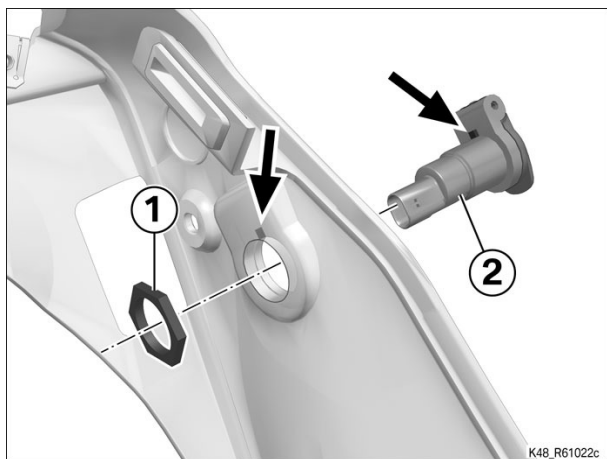

► Installing right slipstream deflector

- Install slipstream deflector (2).
- Install screws (1).

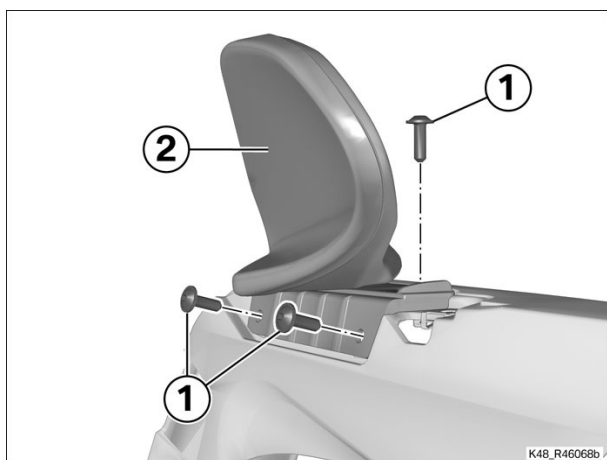

(-) Installing inner trim for right side panel

- Install inner trim (3) for the side panel.
- Connect plug (2) for the on-board socket.
- Install screw (1).

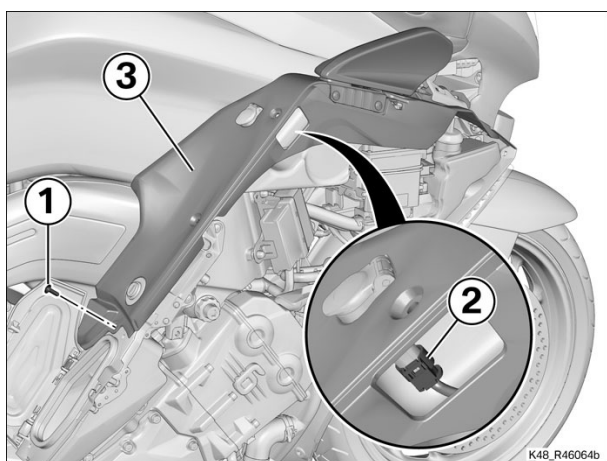

- Install screws (1) with bushings (2).
- Install screw (3).

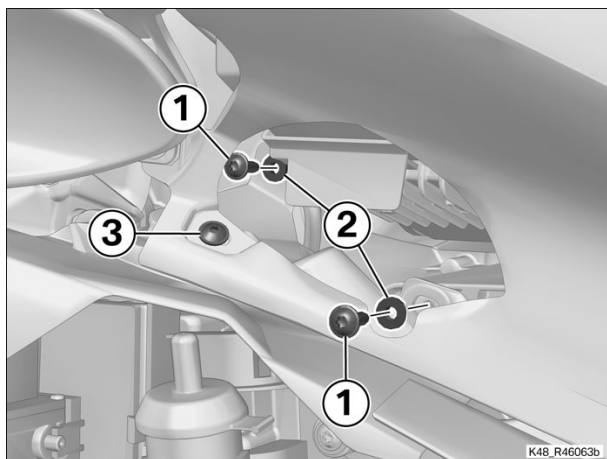

Finishing work

Install the right side panel

Install the right radiator cowl

Installing right bottom side panel

Installing air guide for intake air pipe, right

Final check of work performed

46 63 352 Replacing side panel, bottom right 2 FRUs

+ 46 63 989

Equipment trim-level variant:

0266 - Preparation for audio system and navigation device

0267 - ECE audio system and preparation for navigation system

Core activity

(-) Removing right bottom side panel

- Remove screws (1).
- Remove bottom side panel (2), disengaging the hook (arrow).

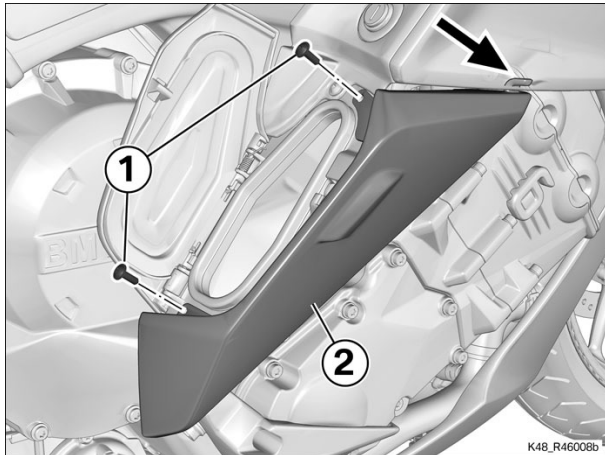

(-) Installing right bottom side panel

- Install bottom side panel (2), engaging the hook (arrow).
- Install screws (1).

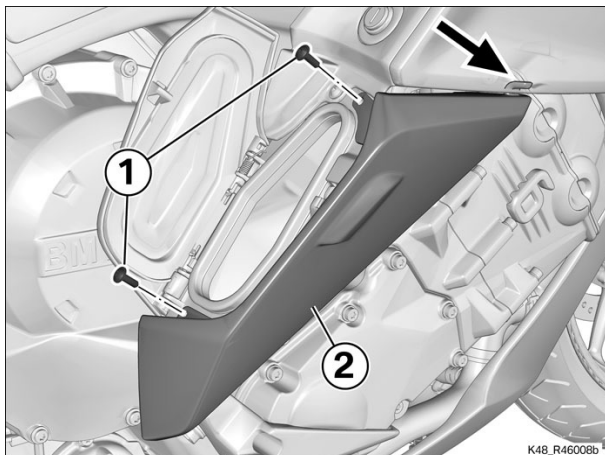

Finishing work

Final check of work performed

46 63 353 Replacing side panel, bottom left 2 FRUs

+ 46 63 990

Core activity

(-) Removing left bottom side panel

- Remove screws (1).
- Remove bottom side panel (2), disengaging the hook (arrow).

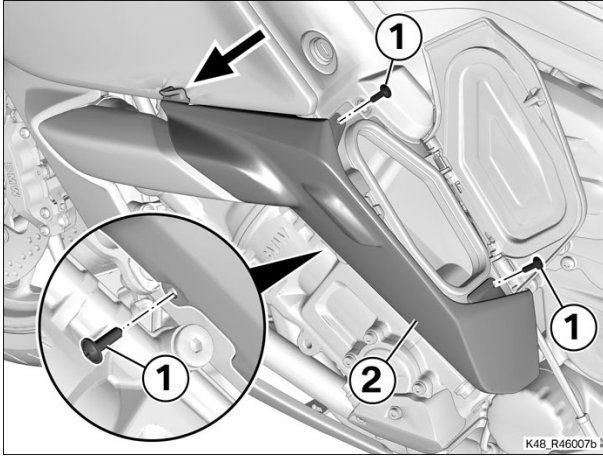

(-) Installing left bottom side panel

- Install bottom side panel (2), engaging the hook (arrow).
- Install screws (1).

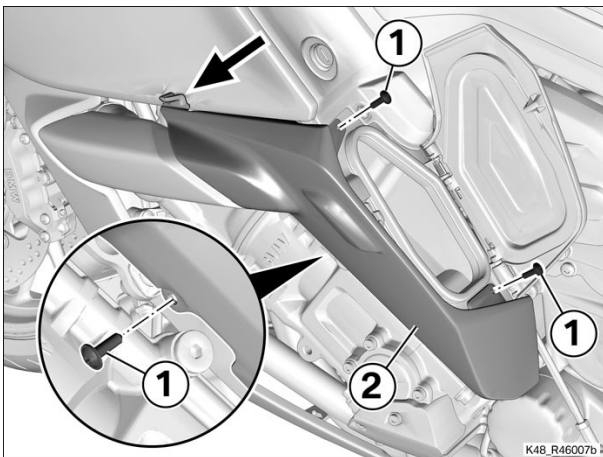

Finishing work

Final check of work performed

📁 46 71 061 Renewing complete left or right front footrest 2 FRUs

+ 46 71 810



Warning

Components are spring-loaded. Risk of injury caused by flying parts. Proceed with care when decreasing or increasing spring tension.

Core activity

(-) Removing front footrest

- Remove circlip (1) and pin (2).
- Remove sleeve (3) and spring (4).
- Remove complete footrest (5).

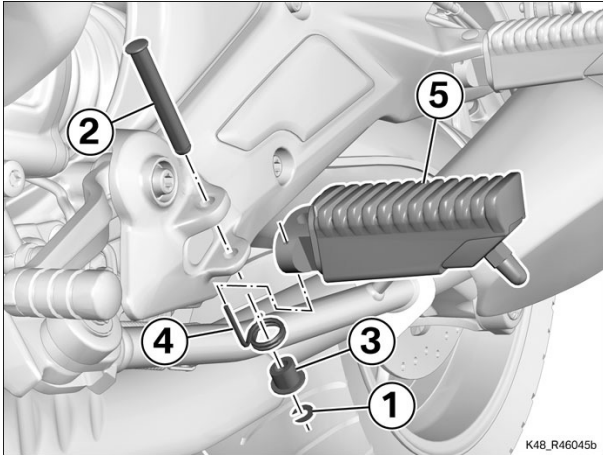

(-) Installing front footrest

- Lubricate pin (2).



Fluids and lubricants

Staburags NBU 30 PTM	High-performance lubricating grease	07 55 9 056 992
----------------------	-------------------------------------	-----------------

- Install complete footrest (5).
- Install spring (4) with sleeve (3).
- Install pin (2) and circlip (1).

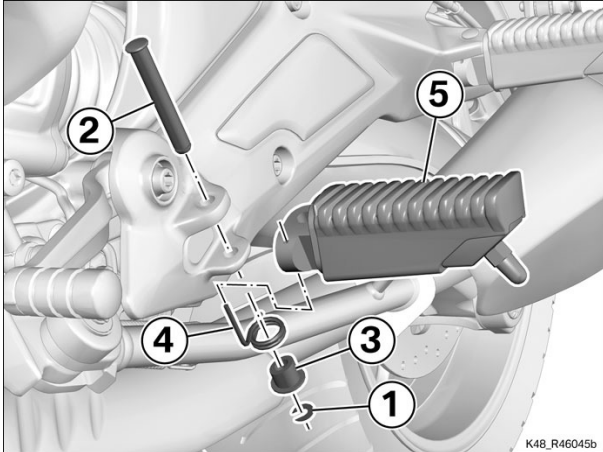

Finishing work

Final check of work performed

46 71 299 Renewing left footrest plate 3 FRUs

+ 46 71 829

Core activity

(-) Removing left footrest plate

- Remove screws (1) and screw (2).
- Secure gearshift lever (3) so that it cannot fall out.
- Remove footrest plate (4), removing washer (5).

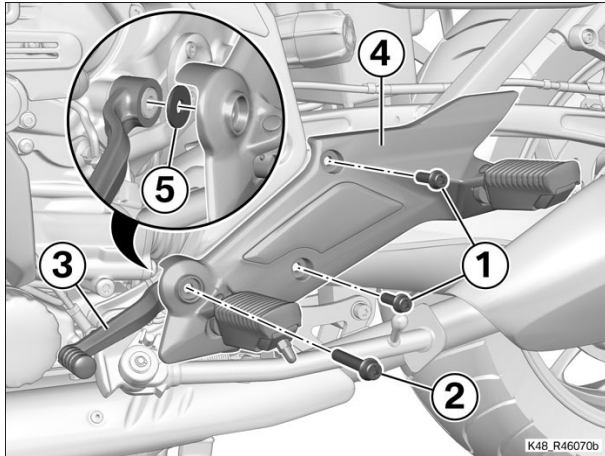

(-) Replacing left footrest plate

► Removing front footrest

- Remove circlip (1) and pin (2).
- Remove sleeve (3) and spring (4).
- Remove complete footrest (5).

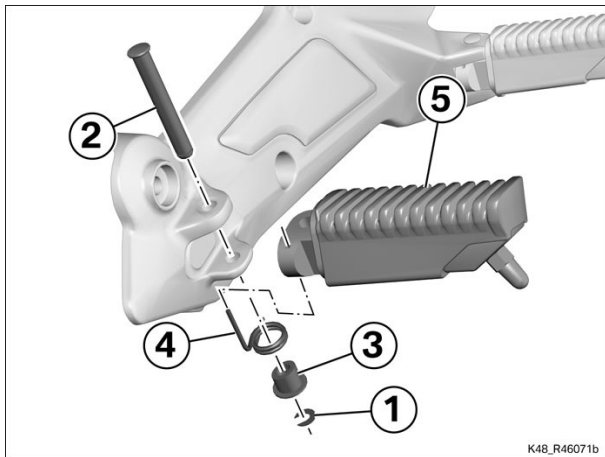

► Removing rear footrest

- Remove circlip (1) and pin (2).
- Remove complete footrest (3).

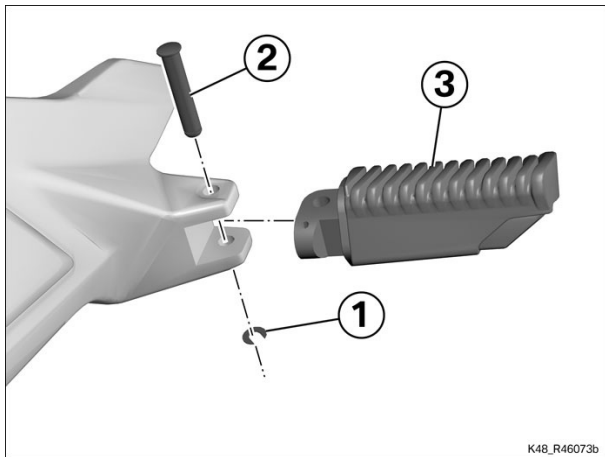

- Remove the following components and install them in the new footrest plate:

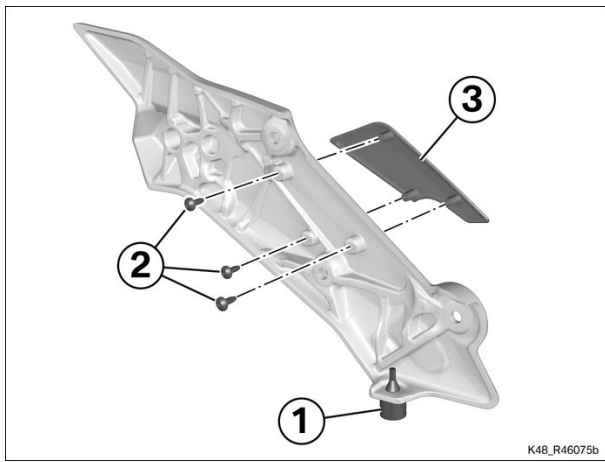

- Buffer (1)
- Screws (2)
- Cover (3)

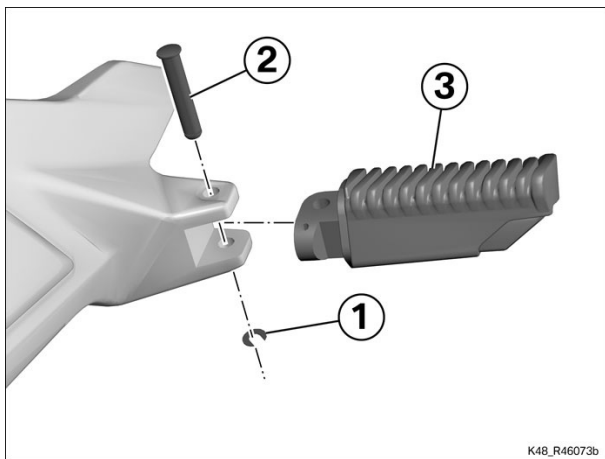

► **Installing rear footrest**

- Lubricate pin (2).

 <p>Fluids and lubricants</p>		
Staburags NBU 30 PTM	High-performance lubricating grease	07 55 9 056 992

- Install complete footrest (3).
- Install pin (2) and circlip (1).

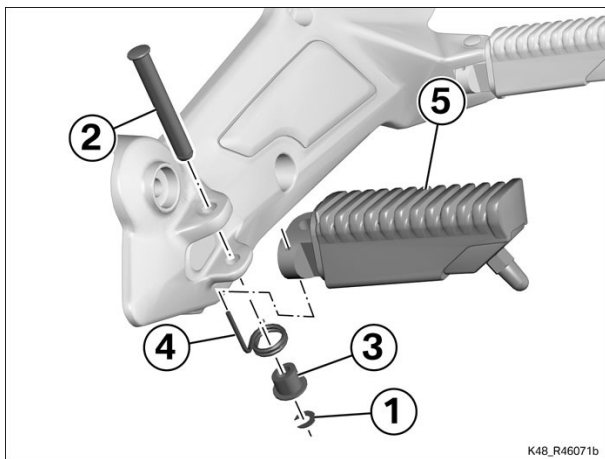

► **Installing front footrest**

- Lubricate pin (2).

 <p>Fluids and lubricants</p>		
Staburags NBU 30 PTM	High-performance lubricating grease	07 55 9 056 992

- Install complete footrest (5).
- Install spring (4) with sleeve (3).
- Install pin (2) and circlip (1).

◄ **(-) Installing left footrest plate**

- Hold shift lever (1) in position with washer (2), making sure that the components do not slip out of position.

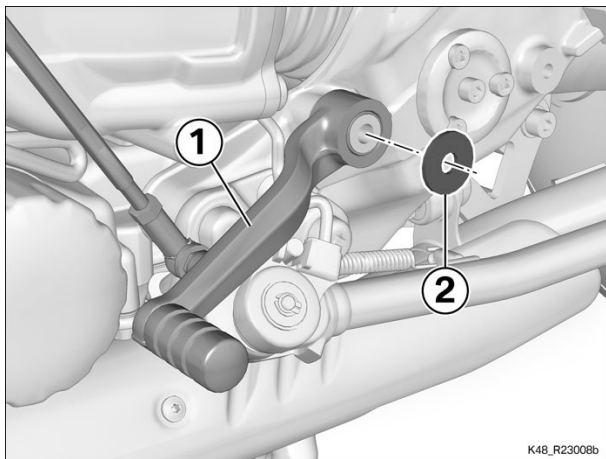

K48_R23008b

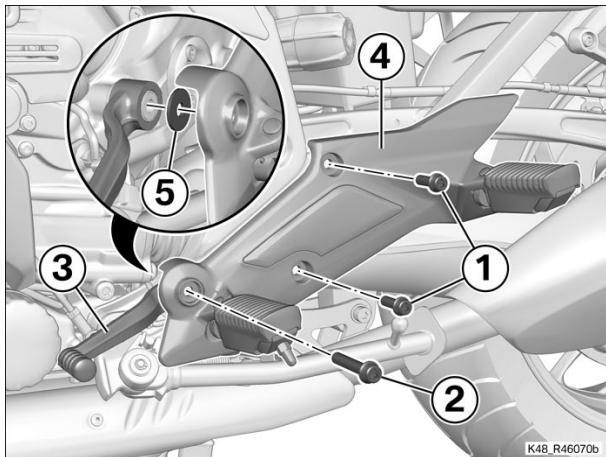

K48_R46070b

- Clean tapped hole for screw (2).
- Hold footrest plate (4) in position, noting washer (5) and gearshift lever (3), making sure that they do not slip out of position.
- Install new screw (2) and screws (1).

 Tightening torques		
Footrest plate to frame		
M8 x 25	28 Nm	
M8 x 45, Replace screw Micro-encapsulated	28 Nm	

Finishing work

Final check of work performed

46 71 312 Renewing right footrest plate 3 FRUs

+ 46 71 830

Core activity

(-) Removing right footrest plate

- Remove screws (1) and screw (2).
- Remove footrest plate (3).

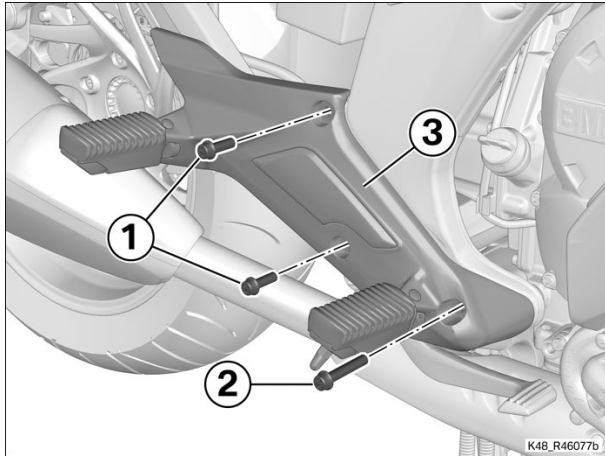

(-) Replacing right footrest plate

► Removing front footrest

- Remove circlip (1) and pin (2).
- Remove sleeve (3) and spring (4).
- Remove complete footrest (5).

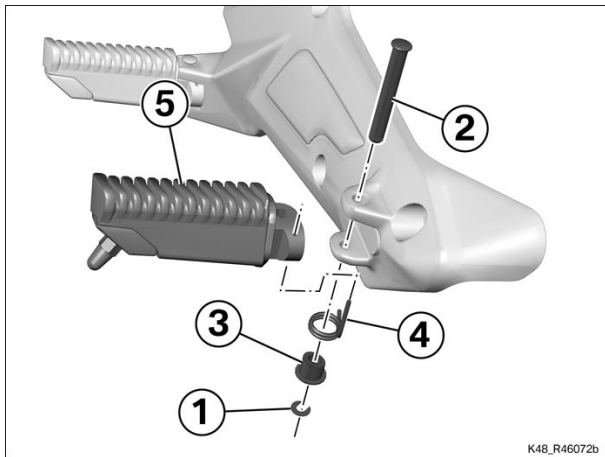

► Removing rear footrest

- Remove circlip (1) and pin (2).
- Remove complete footrest (3).

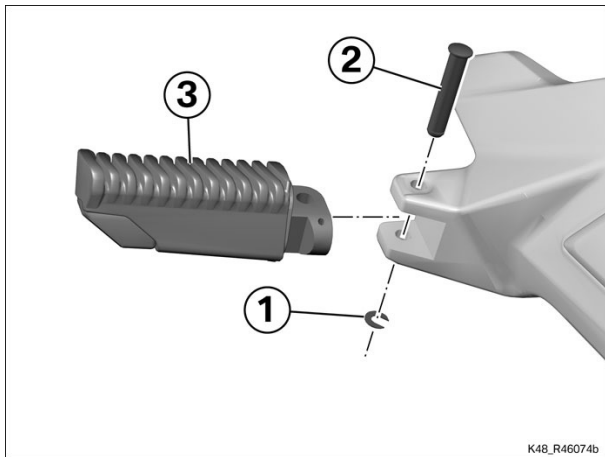

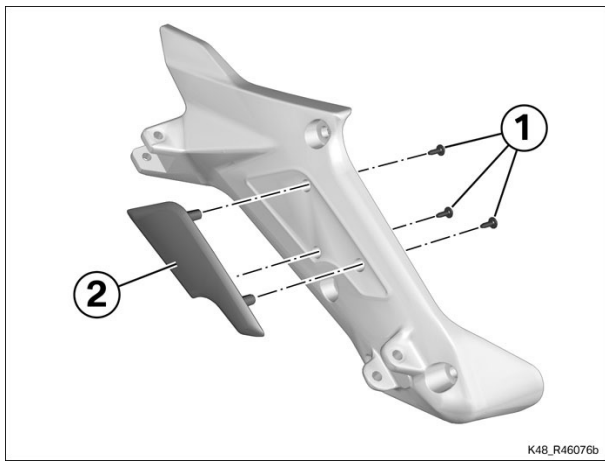

- Remove screws (1) and cover (2) and install them in the new footrest plate.

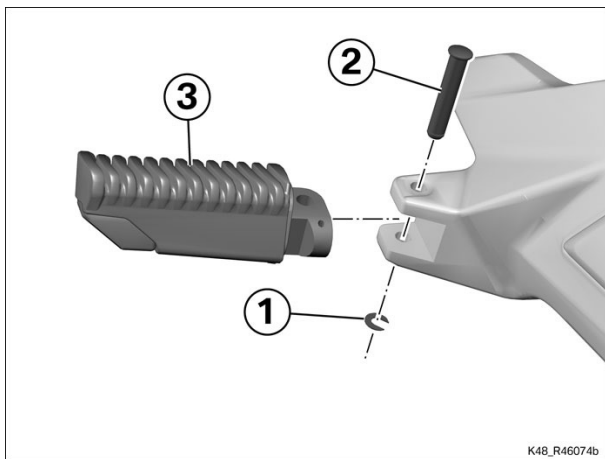

► **Installing rear footrest**

- Lubricate pin (2).



 Fluids and lubricants		
Staburags NBU 30 PTM	High-performance lubricating grease	07 55 9 056 992

- Install complete footrest (3).
- Install pin (2) and circlip (1).



► **Installing front footrest**

- Lubricate pin (2).

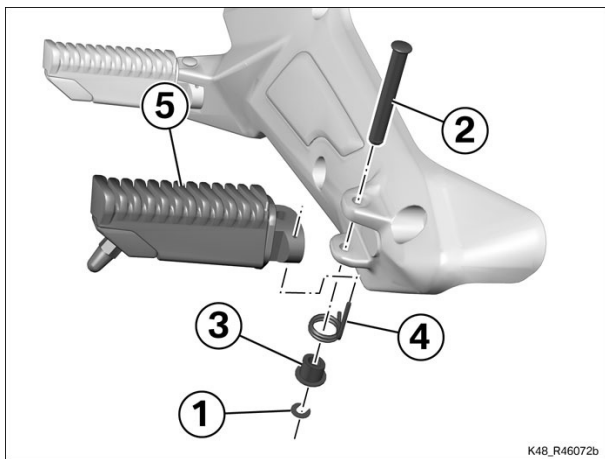

 Fluids and lubricants		
Staburags NBU 30 PTM	High-performance lubricating grease	07 55 9 056 992

- Install complete footrest (5).
- Install spring (4) with sleeve (3).
- Install pin (2) and circlip (1).



(-) Installing right footrest plate

- Clean tapped hole for screw (2).
- Hold footrest plate (3) in position.
- Install new screw (2) and screws (1).

 Tightening torques		
Footrest plate to frame		
M8 x 25	28 Nm	

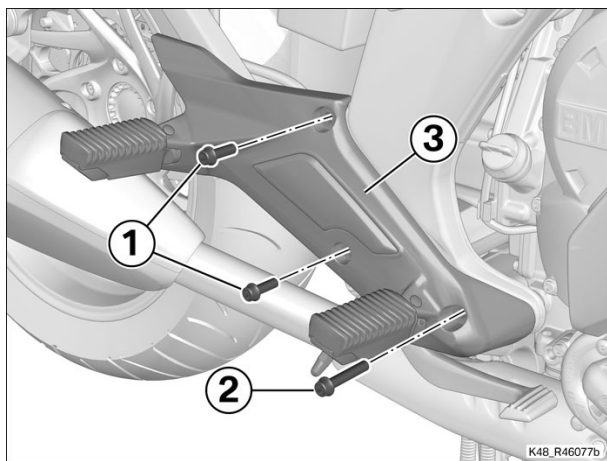

M8 x 45, Replace screw
Micro-encapsulated

28 Nm

Finishing work

Final check of work performed

 **51 16 041 Replace mirror glass**

+ 51 16 541

Core activity

(-) Removing mirror glass

- Turn mirror glass (1) inward.
- Using a suitable tool, unclip mirror glass (1) from the tabs (arrows) of mirror holder (2).
- Carefully remove mirror glass (1).

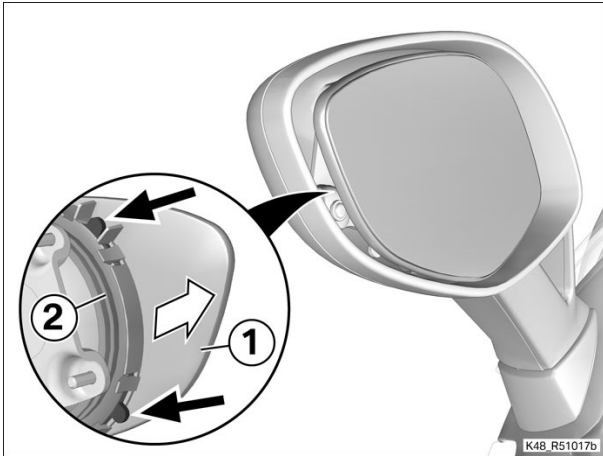

(-) Installing mirror glass

- Position mirror glass (1) on adjuster unit (2) and press on all round, taking care to apply pressure to mirror glass (1) only at adjuster unit (2).

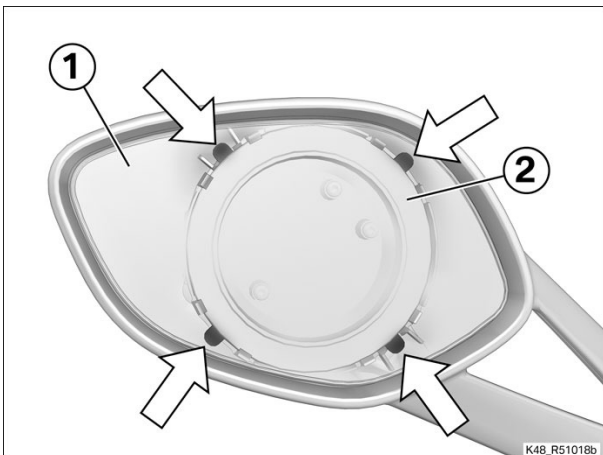

Finishing work

Final check of work performed

51 16 044 Replacing mirror, left 3 FRUs

+ 51 16 554

Equipment trim-level variant:

0266 - Preparation for audio system and navigation device

0267 - ECE audio system and preparation for navigation system

Preparatory work

Removing air guide for intake air pipe, left

Removing left hand protector

Removing left speaker

Core activity

(-) Removing left mirror

- Remove screws (1).
- Remove mirror (2).

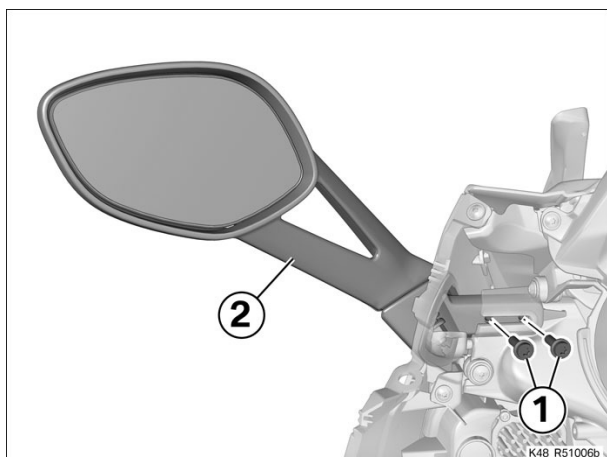

(-) Installing left mirror

- Install mirror (2).
- Install screws (1).

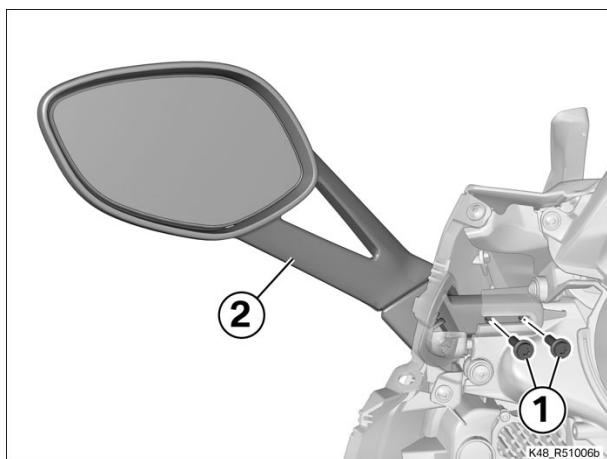

 Tightening torques		
Mirror to front panel carrier		
M6 x 25	5 Nm	

Finishing work

Installing left speaker

Installing left hand protector

Installing air guide for intake air pipe, left

Final check of work performed

51 16 045 Replacing mirror, right 3 FRUs

+ 51 16 555

Equipment trim-level variant:

0266 - Preparation for audio system and navigation device

0267 - ECE audio system and preparation for navigation system

Preparatory work

Removing air guide for intake air pipe, right

Removing right hand protector

Removing right speaker

Core activity

(-) Removing right mirror

- Remove cable tie (arrow).
- Disconnect plug (1) for the aerial and work cable (2) clear of the motorcycle.

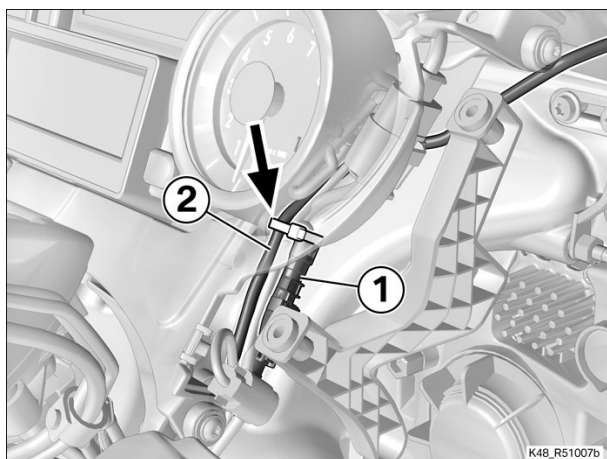

- Remove screw (1) for the earthing strap.
- Remove screws (2).
- Remove mirror (3) with cable (4).

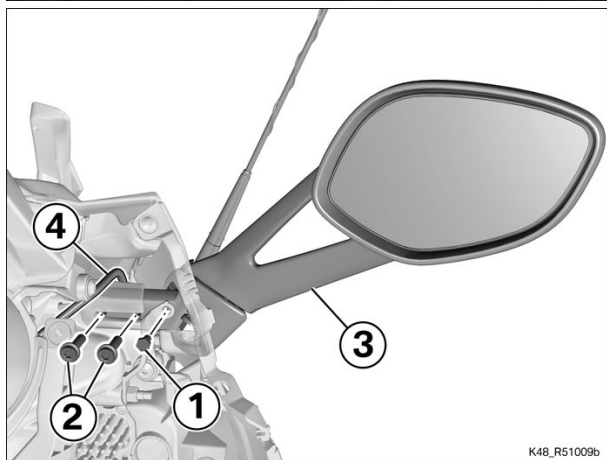

(-) Installing right mirror

- Install mirror (3) with cable (4).
- Install screws (2).

 Tightening torques		
Mirror to front panel carrier		
M6 x 25	5 Nm	

- Install screw (1) for the earthing strap.

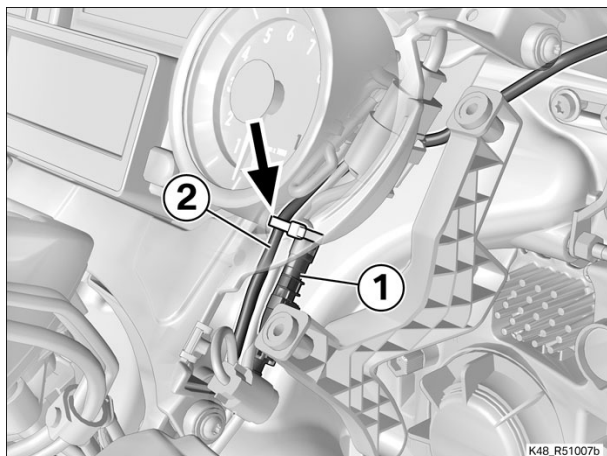
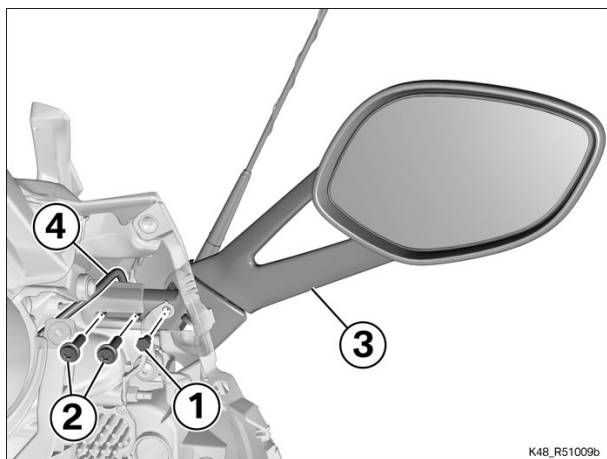

- Work cable (2) into position and connect plug (1) for the aerial.
- Secure the cable tie (arrow).

Finishing work

Installing right speaker

Installing right hand protector

Installing air guide for intake air pipe, right

Final check of work performed

📁 51 25 120 Replace lock barrel for stowage-compartment lid 4 FRUs

+ 51 25 620

Preparatory work

- Removing left bottom side panel
- Removing left radiator cowl
- Removing left side panel
- Removing left stowage compartment

Core activity

(-) Removing lock barrel for stowage compartment

- Insert ignition key (1) in lock barrel (2) and turn lock barrel (2) to the **open** position.
- Using a suitable provisional tool such as a length of wire, for example, press the locking pawl (arrow) in.
- Remove lock barrel (2) with ignition key (1).

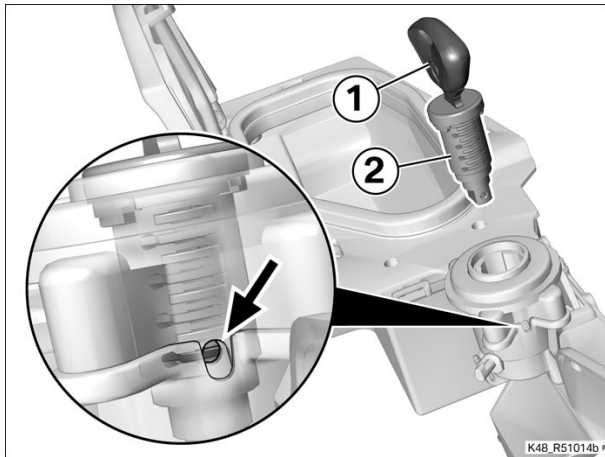

(-) Installing lock barrel for stowage compartment

- Lubricate lock barrel (2).

 Fluids and lubricants		
Grease for lock cylinders	Lubricating grease	81 22 9 407 421

- Install lock barrel (2) with ignition key (1).
- Make sure that the locking pawl (arrow) engages.

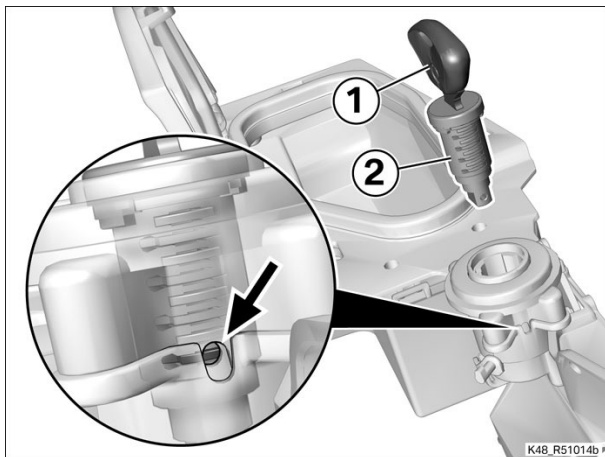

Finishing work

- Installing left stowage compartment
- Install the left side panel
- Installing left radiator cowl
- Installing left bottom side panel
- Final check of work performed

📁 61 00 002 Testing software 3 FRUs

+ 61 00 502

Preparatory work

Remove the front seat

Core activity

(-) Connecting BMW Motorrad diagnostic system to motorcycle

- Connect the **BMW Motorrad** battery charger.



Note

When carrying out diagnosis and programming, use a battery charger with 30 A approved by **BMW Motorrad** that ensures an **on-board system voltage of 13V**.

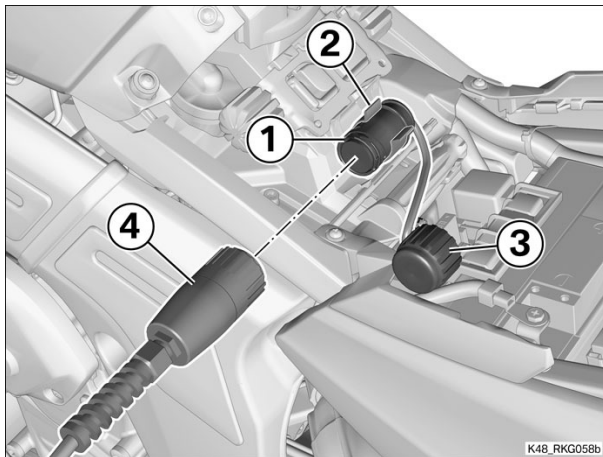

- Disengage diagnosis plug (1) from holder (2) and remove protective cap (3).
- Connect diagnosis plug (1) to connecting cable (4) for the diagnostic system.



Note

See the information about the **BMW Motorrad** diagnostic system for all other instructions.

(-) Checking software

- Start **ISTA/P**.
- Read out the software release.
- Perform diagnosis. Rectify faults, if found, **before** starting programming/coding.

=> Programming control unit of engine management system (along with testing software) (Description in item: 13 61 522, Billed as a separate item)

=> Programming control units of vehicle (along with testing software) (Description in item: 61 00 510, Billed as a separate item)

(-) Disconnecting BMW Motorrad diagnostic system from motorcycle

- Close all diagnostic programs and switch off the ignition.
- Disconnect the connecting cable for the **BMW Motorrad** diagnostic system from the motorcycle's diagnosis plug and screw the cap onto the diagnosis plug.
- Disconnect the **BMW Motorrad** battery charger from the motorcycle.

Finishing work

Installing front seat

Final check of work performed

📁 61 00 003 Resetting/learning adaptation values (with replacing component) 3 FRUs

+ 61 00 503

Core activity

(-) Connecting BMW Motorrad diagnostic system to motorcycle

- Connect the **BMW Motorrad** battery charger.



Note

When carrying out diagnosis and programming, use a battery charger with 30 A approved by **BMW Motorrad** that ensures an **on-board system voltage of 13V**.

- Disengage diagnosis plug (1) from holder (2) and remove protective cap (3).
- Connect diagnosis plug (1) to connecting cable (4) for the diagnostic system.



Note

See the information about the **BMW Motorrad** diagnostic system for all other instructions.

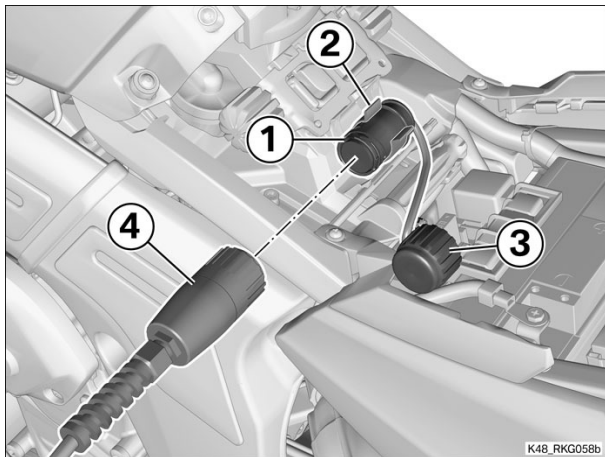

(-) Reading fault memory with BMW Motorrad diagnostic system and resetting adaptation values

- After replacing the component, be sure to read the fault memories of the control units with the **BMW Motorrad** diagnostic system and rectify the corresponding faults, if any. You must also reset the adaptation values. From this point on, follow the instructions issued by the **BMW Motorrad** diagnostic system. This is the only way of ensuring correct operation of the motorcycle.

(-) Disconnecting BMW Motorrad diagnostic system from motorcycle

- Close all diagnostic programs and switch off the ignition.
- Disconnect the connecting cable for the **BMW Motorrad** diagnostic system from the motorcycle's diagnosis plug and screw the cap onto the diagnosis plug.
- Disconnect the **BMW Motorrad** battery charger from the motorcycle.

Finishing work

Final check of work performed

 **61 00 510 Programming control units of vehicle (along with testing software)**

Core activity

(-) Programming vehicle control unit

- Start the programming routine and follow the instructions issued by the **BMW Motorrad** diagnostic system.

📁 61 11 013 Wiring-harness repair WT FRUs

+ 61 11 513

Core activity

(-) Installing wiring harness repair kit

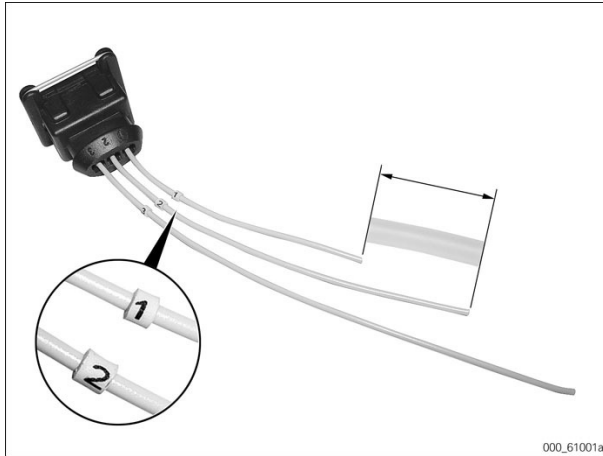

- Cut out the defective plug or length of cable, if possible making the cut at some point along a straight run where the wiring harness can be firmly secured.
- Cut the individual cores staggered along approximately the length of a shrink-on hose, so that the repaired points are not beside each other.
- Correlate the numbered cores of the repair kit with the corresponding cable colours of the original plug and cut them back to the appropriate staggered lengths.



Note

The cables are not colour-coded; instead, they have code numbers to ensure the universal usability of the repair kits.

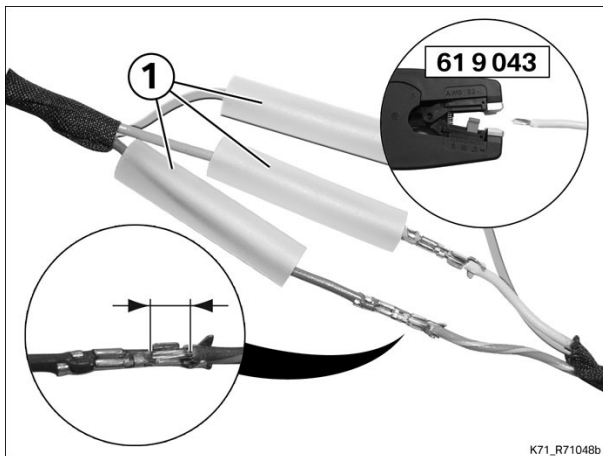

- Slip a shrink-fit hose (1) onto each of the cores.
- Use stripping pliers (No. 61 9 043) to strip the ends of all the wires.
- Seat the ends of the wires in push-in connectors of the correct cross-section size.
- » The crimp connectors always have to be crimped on to both the insulation and the stranded cable (detail).

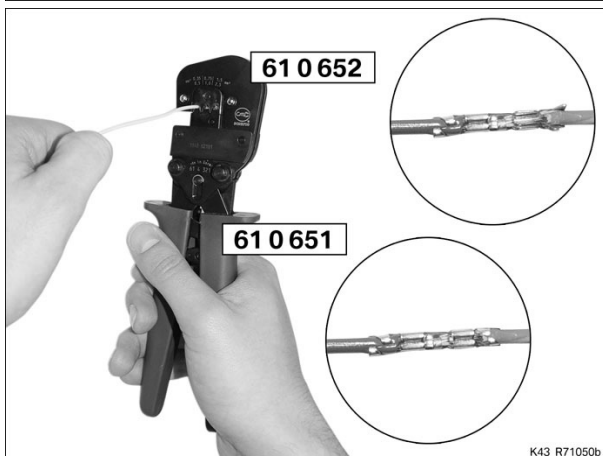

- Use crimping pliers (No. 61 0 651) and crimping head (No. 61 0 652) to crimp on the connectors.

- Slide the shrink-on hose into position over the connector and use a hot-air gun to heat the hose.
- » The shrink-on hose contracts, tightens round the surface of the cable and turns transparent. At the same time, hot glue (arrow) escapes and forms a seal around the repair.

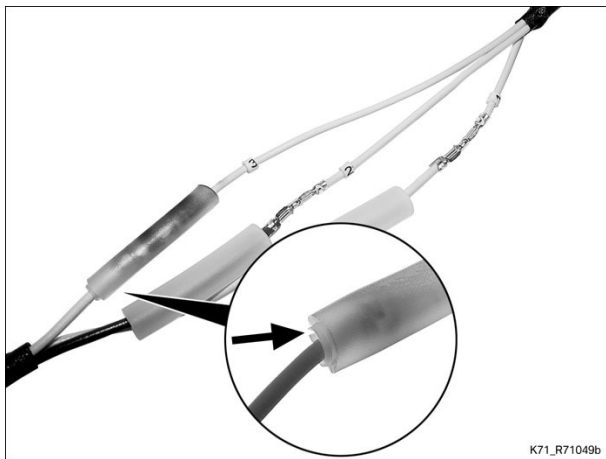

K71_R71049b

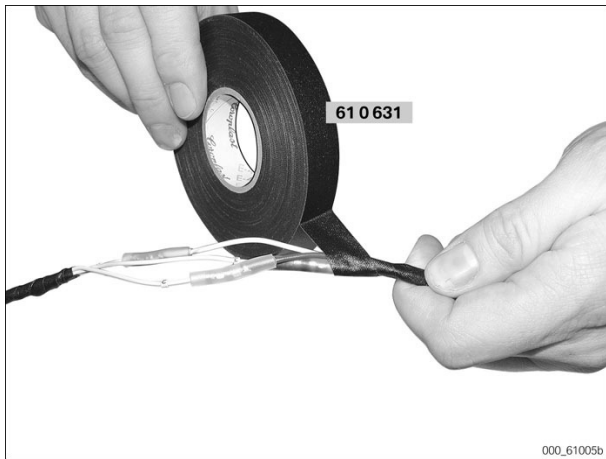

000_61005b

- Wrap fibre-reinforced insulating tape (No. 61 0 631) around the repair.
- If possible, secure the repaired cable to the frame.

📁 61 21 011 Renewing battery 2 FRUs

+ 61 21 522

Preparatory work

Remove the front seat

Core activity

(-) Removing battery



Attention

Disconnection in the wrong sequence increases the risk of short-circuits.

Always proceed in the correct sequence.

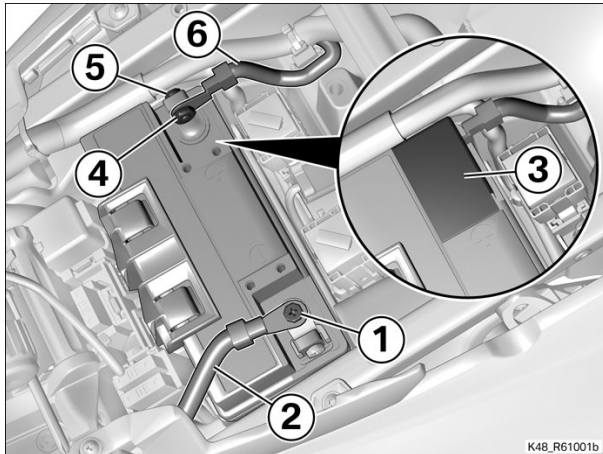

- Remove screw (1) and disconnect negative lead from negative terminal of battery (2).
- Remove protective cap (3) for positive terminal of battery.
- Remove nut (4) and screw (5) and disconnect positive lead from positive terminal of battery (6).

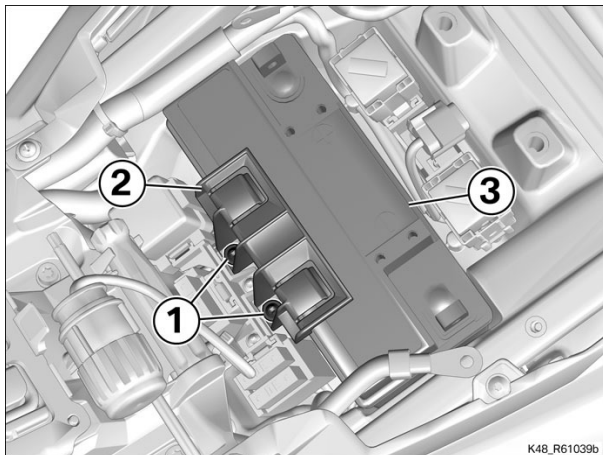

- Remove screws (1) and holder (2).
- Remove battery (3).

(-) Recharge the battery

- Set the **BMW Motorrad** battery charger to the correct charging characteristic.

Workshop equipment

BMW Motorrad battery charger (version for Europe without GB)

BMW Motorrad battery charger (GB/AUS/NZL version)

BMW Motorrad battery charger (Japan version)

BMW Motorrad battery charger (USA/CAN version)

- Charge the battery with the **BMW Motorrad** battery charger, taking care to comply with the instructions for use.

(-) Installing battery

- Install battery (3).
- Install holder (2) and screws (1).



Tightening torques

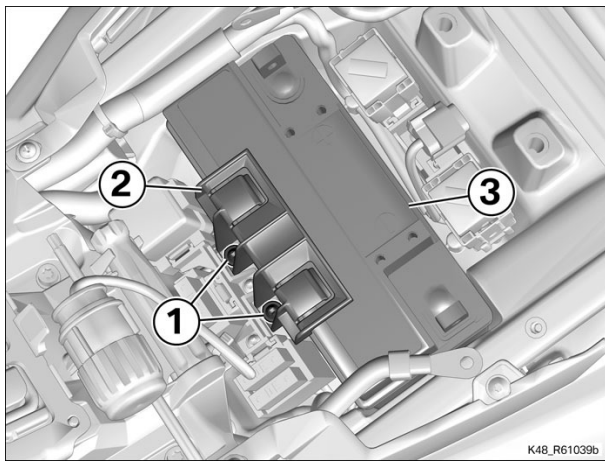

Battery holder to rear carrier

M5 x 10	3 Nm	
---------	------	--

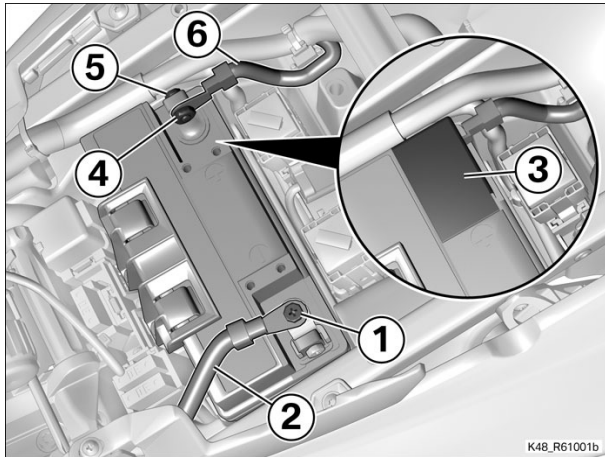

Attention

Connection in the wrong sequence increases the risk of short-circuits. Always proceed in the correct sequence.

- Position positive lead at positive terminal of battery (6), install screw (5) and nut (4).

 Tightening torques		
Wiring harness to battery		
M6 x 20	3.5 Nm	

- Install protective cap (3) for positive terminal.
- Hold negative lead in position at negative terminal of battery (2) and install screw (1).

 Tightening torques		
Wiring harness to battery		
M6 x 20	3.5 Nm	

Finishing work

=> **Checking or restoring system time (Description in item: 61 35 506, Billed as a separate item)**

Installing front seat

Final check of work performed

 **61 21 019 Charging battery 2 FRUs**

+ 61 21 523

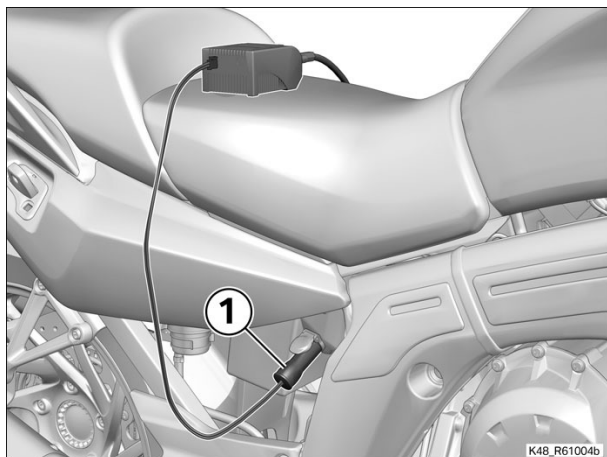

Core activity

(-) Checking battery charge state



Attention

Standard, commercially available chargers connected to the on-board socket could cause irreparable damage to the on-board electronics and themselves.

Use only chargers approved by **BMW Motorrad**.

- Set the **BMW Motorrad** battery charger to the correct charging characteristic.

Workshop equipment

BMW Motorrad battery charger (version for Europe without GB)

BMW Motorrad battery charger (GB/AUS/NZL version)

BMW Motorrad battery charger (Japan version)

BMW Motorrad battery charger (USA/CAN version)

- Disconnect electric consumers from the on-board socket or sockets, if connected.

Test

- Switch on the ignition.
- » Control units switch on.
- Switch off the ignition.

 Technical data			
Deactivation delay for control units	if no consumers are active	60 s	

- » Control units remain on, because of the deactivation delay.
- Within the deactivation delay, connect the **BMW Motorrad** battery charger with charging cable to on-board socket (1) **first**.
- » The battery charge state is displayed.

Result: Battery is not fully charged.

Measure:

- Connect the **BMW Motorrad** battery charger to the local power supply.



Note

If the battery charger indicates that on-board voltage has dropped to the lower voltage limit for the on-board system, you can recharge the battery only by connecting the charger directly to the battery terminals. The on-board socket is switched off if the voltage is below this lower voltage limit.

 Technical data			
Undervoltage in on-		≤7 V	

board system			
--------------	--	--	--

- Charge the battery with the **BMW Motorrad** battery charger, taking care to comply with the instructions for use.

Finishing work

Final check of work performed

📁 61 31 001 Replacing multi-controller 17 FRUs

+ 61 31 950

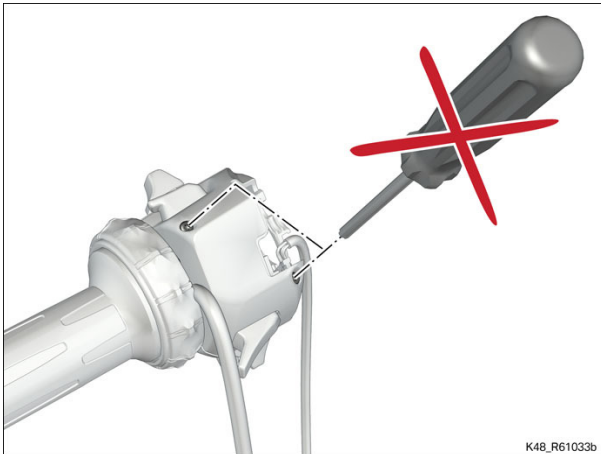

Attention

Any attempt to open the unit will result in damage to the printed circuits, which are lacquer-sealed.

The top and bottom parts of the switch unit are set in their relative positions by the manufacturer: do not attempt to separate the two parts of the switch.

Preparatory work

- Remove the front seat
- Removing air guides for intake air pipes, left and right
- Removing complete cover of fuel tank
- Removing left bottom side panel
- Removing left radiator cowl
- Removing left side panel
- Removing inner trim for left side panel
- Removing right bottom side panel
- Removing right radiator cowl
- Remove the right side panel
- Removing inner trim for right side panel
- Disengaging left and right intake air pipes
- Removing complete intake air silencer
- Removing fuel tank
- Removing handlebar weight
- Removing left grip unit
- Removing left multifunction switch

Core activity

(-) Removing multi-controller

- Remove the cable ties (arrows).
- Disconnect plug (1) for the multi-controller and disengage cable (2).

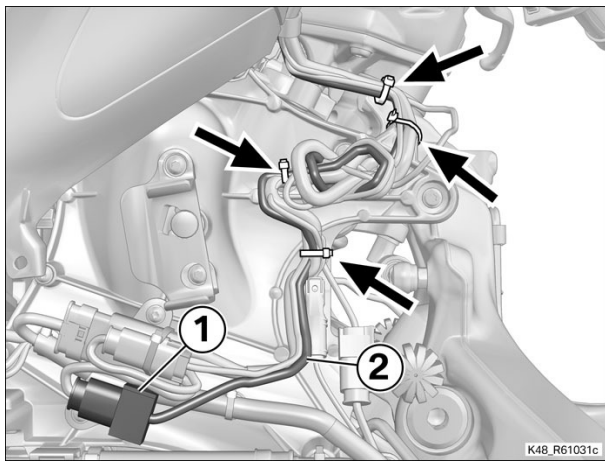

- Remove screws (1).
- Lift bracket (2) and work the cable from plug (3) for the heated grip clear.
- Remove bracket (2) and multi-controller (4) from grip (5).

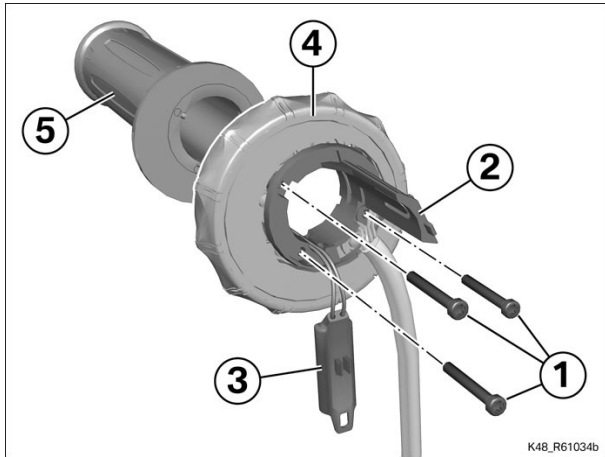

(-) Installing multi-controller

- Position multi-controller (4) on grip (5). Make sure that the retainers (arrows) and recesses (6) engage.
- Work the cable of plug (3) for the heated grip through bracket (2).
- Hold bracket (2) in position and install screws (1), **noting the grip-heating cable**.

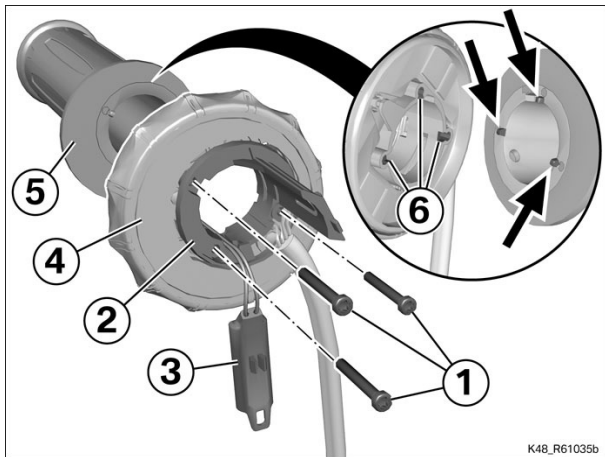

Tightening torques		
Multi-controller to grip		
RS2.5 x 20	1.5 Nm	

- Connect plug (1) for the multi-controller and route cable (2).
- Close the cable ties (arrows).

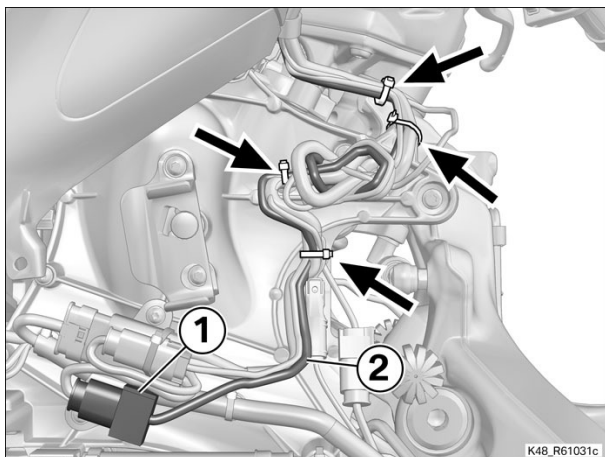

Finishing work

- Installing left multifunction switch
- Installing left grip unit
- Installing handlebar weight
- Installing fuel tank
- Installing complete intake air silencer
- Securing left and right intake air pipes
- Installing inner trim for right side panel
- Install the right side panel
- Install the right radiator cowl
- Installing right bottom side panel
- Installing inner trim for left side panel
- Install the left side panel
- Installing left radiator cowl
- Installing left bottom side panel
- Installing complete cover of fuel tank
- Installing air guides for intake air pipes, left and right
- Installing front seat
- Final check of work performed

📁 61 31 063 Renewing complete multi-function switch on left handlebar 16 FRUs

+ 61 31 904

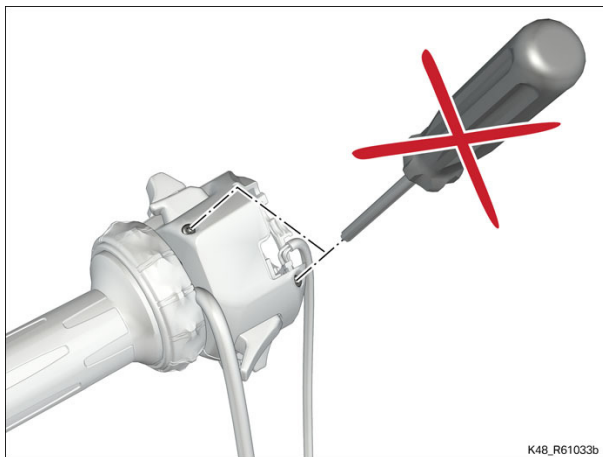

Attention

Any attempt to open the unit will result in damage to the printed circuits, which are lacquer-sealed.

The top and bottom parts of the switch unit are set in their relative positions by the manufacturer: do not attempt to separate the two parts of the switch.

Preparatory work

- Remove the front seat
- Removing air guides for intake air pipes, left and right
- Removing complete cover of fuel tank
- Removing left bottom side panel
- Removing left radiator cowl
- Removing left side panel
- Removing inner trim for left side panel
- Removing right bottom side panel
- Removing right radiator cowl
- Remove the right side panel
- Removing inner trim for right side panel
- Disengaging left and right intake air pipes
- Removing complete intake air silencer
- Removing fuel tank
- Removing handlebar weight

Core activity

(-) Removing left grip unit

- Remove cable holder (1) and the cable tie (arrow).

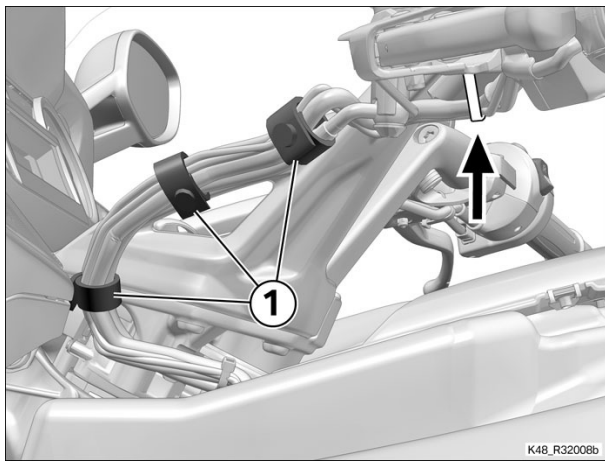

K48_R32008b

- Pull rubber grip (1) to the side and remove screw (2).
- Remove complete grip unit (3) from the handlebar.



Note

Carefully pull off the grip unit because it can catch on the anti-chafing film, making it difficult to move.

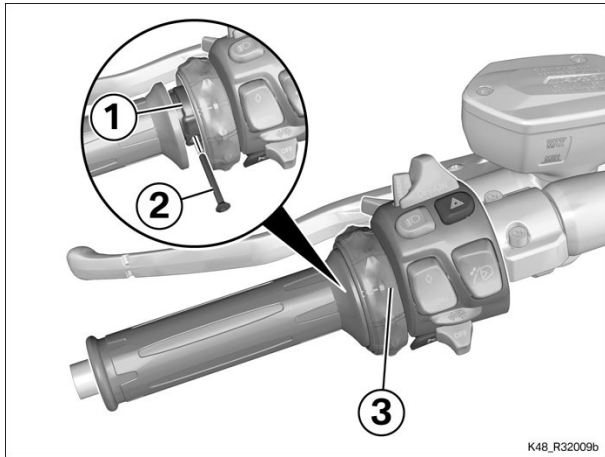

K48_R32009b

(-) Removing left multifunction switch

- Remove the cable ties (arrows).
- Disconnect plug (1) for the multifunction switch and disengage cable (2).

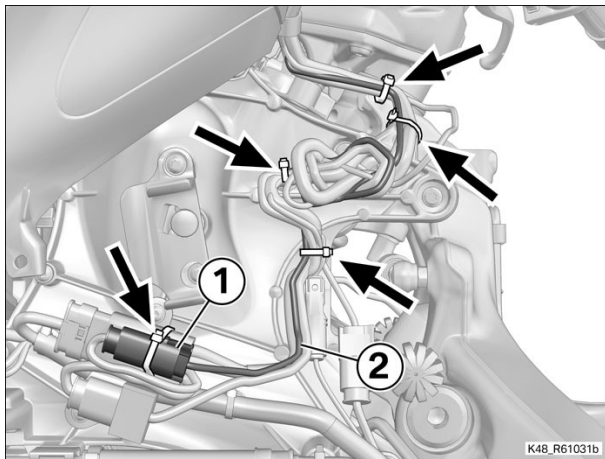

K48_R61031b

- Disengage the retaining tabs (arrows).
- Remove cover (1).
- Working in the following sequence, disconnect and remove the following plugs:
 - (2) small
 - (3) for the grip heating
 - (4) large

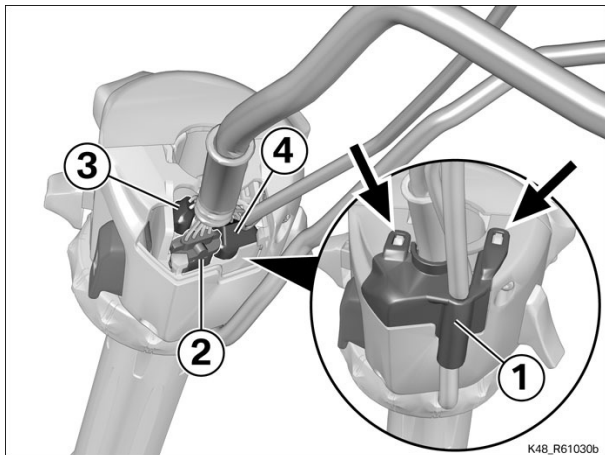

K48_R61030b

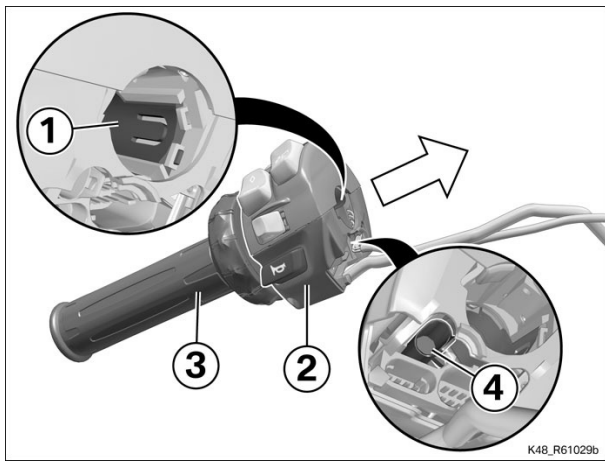

- Push up retainer (1).
- Remove multifunction switch (2) from grip (3) and remove plug (4) for the heated grip.

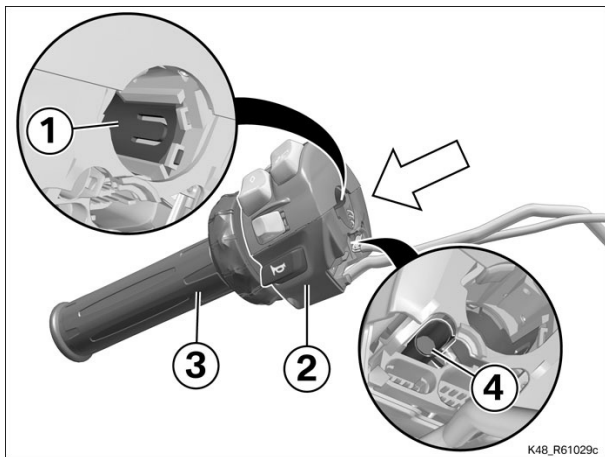

(-) Installing left multifunction switch

- Push multifunction switch (2) on to grip (3) and install plug (4) for the heated grip.
- » Retainer (1) engages.

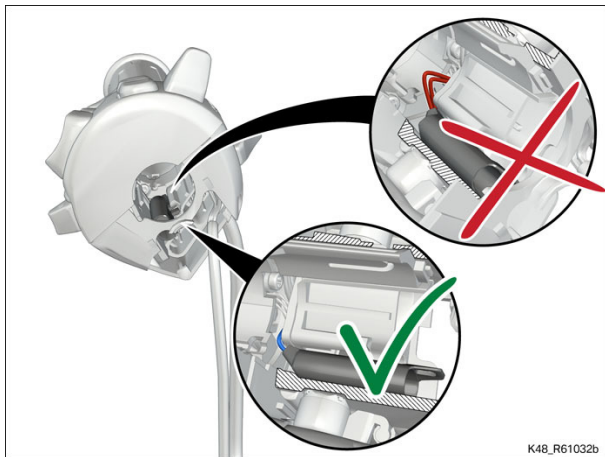

- Check that the grip-heating cable is correctly routed and does not project into the grip tube.

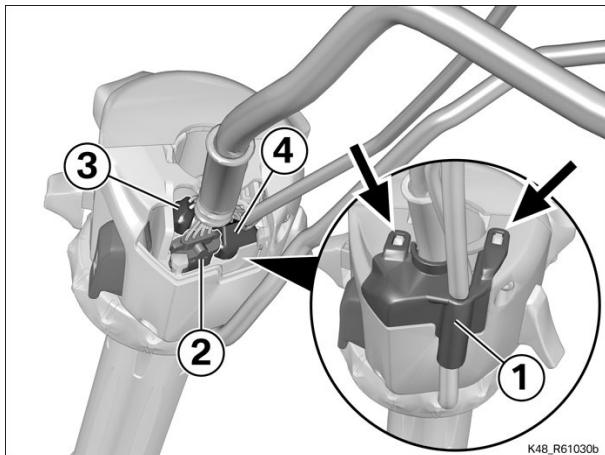

- Working in the following sequence, install and connect the plugs:
 - (4) large
 - (3) for the grip heating
 - (2) small
- Install cover (1).
- Make sure that the retaining tabs (arrows) engage.

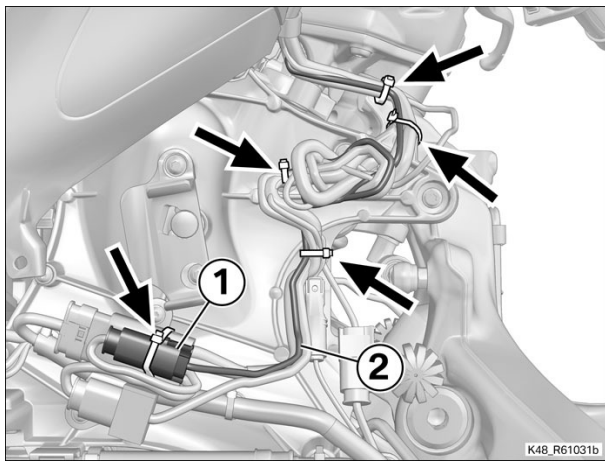

- Route cable (2) and connect plug (1) for the multifunction switch.
- Close the cable ties (arrows).

(-) Installing left grip unit

Test

- Check the condition of anti-chafing film (1)

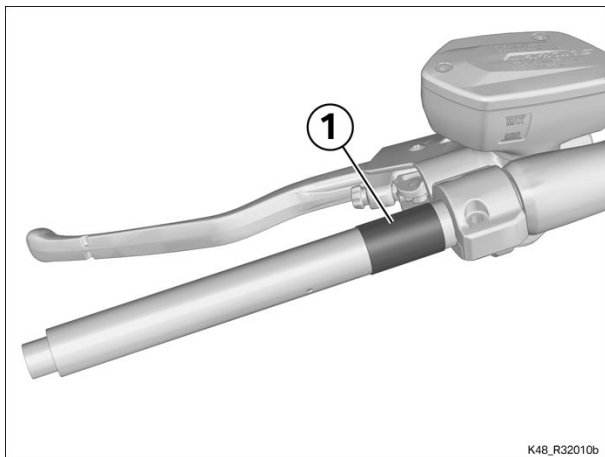

Result: Protective film is damaged, out of position or missing.

Measure:

► Replacing protective film on handlebar

- Remove old protective film (1).

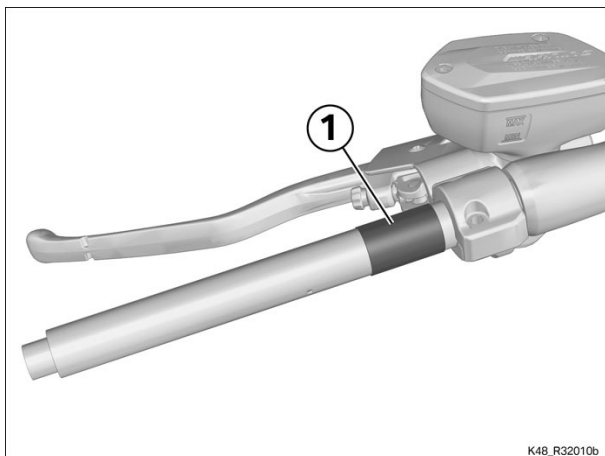

- Provisionally install grip unit (1) and mark the position of the edge (arrow) on the handlebar.
- Remove grip unit (1).

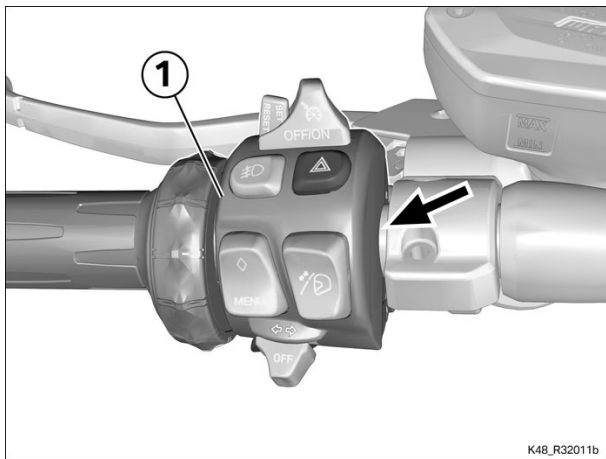

K48_R32011b

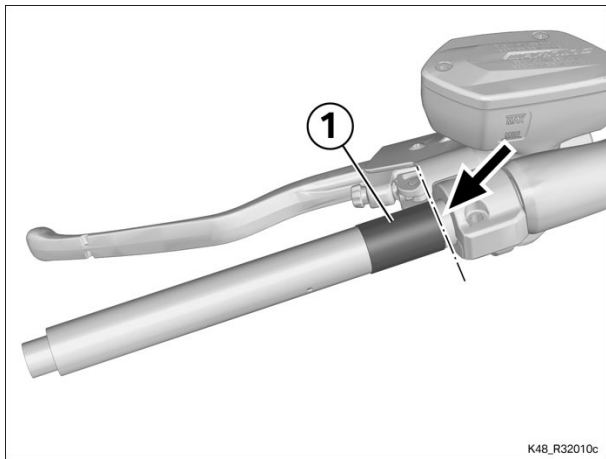

K48_R32010c

- Clean the area where the protective film will be applied.
- Apply protective film (1), noting the mark (arrow) for alignment and taking care not to affix the film over the mark.

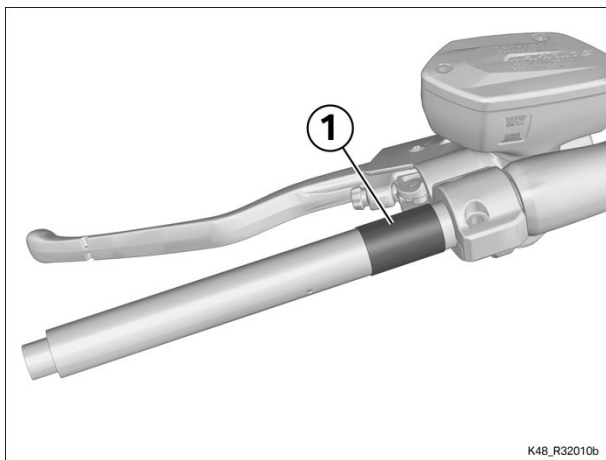

K48_R32010b

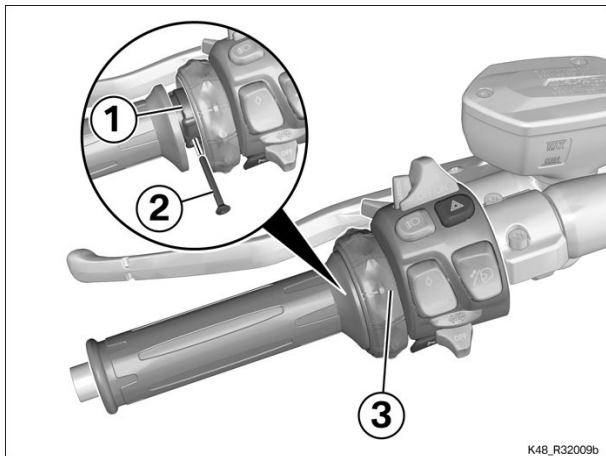

K48_R32009b

- Push complete grip unit (3) on to the handlebar.
- Pull rubber grip (1) to the side and install screw (2).

 Tightening torques		
Handlebar grip, left, to handlebar		
M3.5 x 32	2 Nm	

- Secure cable holder (1) and the cable tie (arrow).

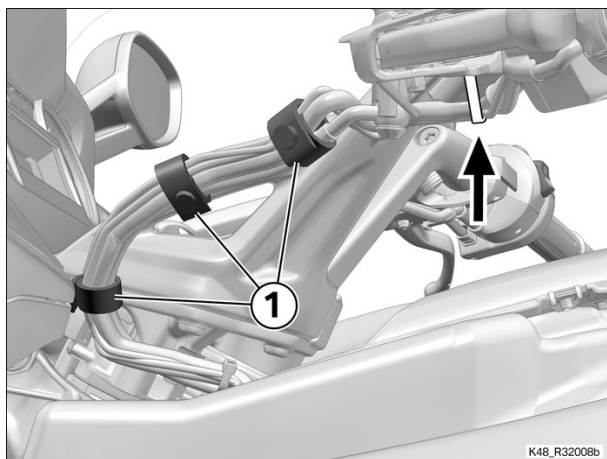

Finishing work

Installing handlebar weight

Installing fuel tank

Installing complete intake air silencer

Securing left and right intake air pipes

Installing inner trim for right side panel

Install the right side panel

Install the right radiator cowl

Installing right bottom side panel

Installing inner trim for left side panel

Install the left side panel

Installing left radiator cowl

Installing left bottom side panel

Installing complete cover of fuel tank

Installing air guides for intake air pipes, left and right

Installing front seat

Final check of work performed

61 31 073 Renewing complete multi-function switch on right handlebar 2 FRUs

+ 61 31 905

Core activity

(-) Removing right multifunction switch

► **Disconnecting plug for throttle twistgrip**

- Disconnect plug (1) for the throttle twistgrip.

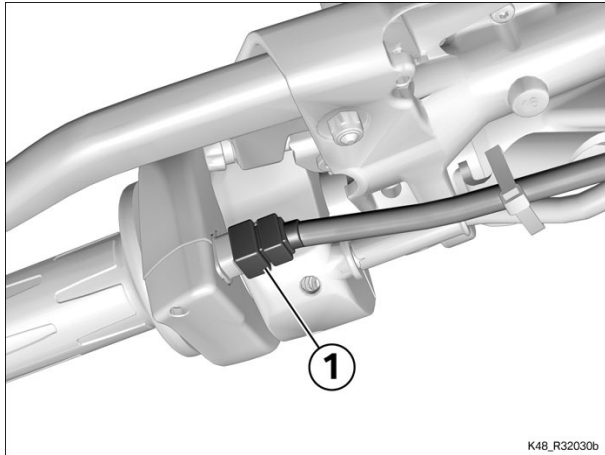

- Remove screw (1).
- Ease cover (2) down slightly until the multifunction switch is open (arrow).

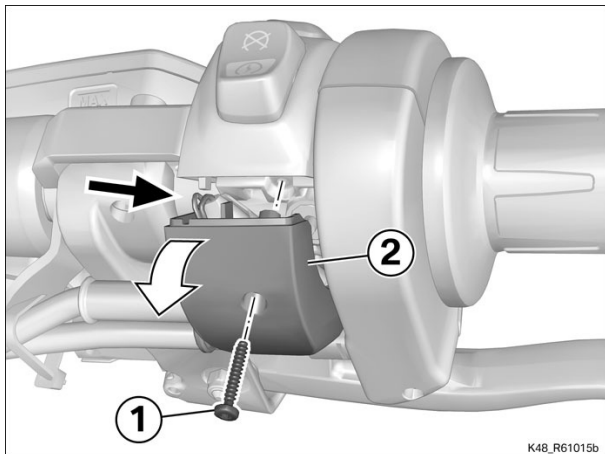

- Push cover (2) forward and up, noting retaining catches (3).

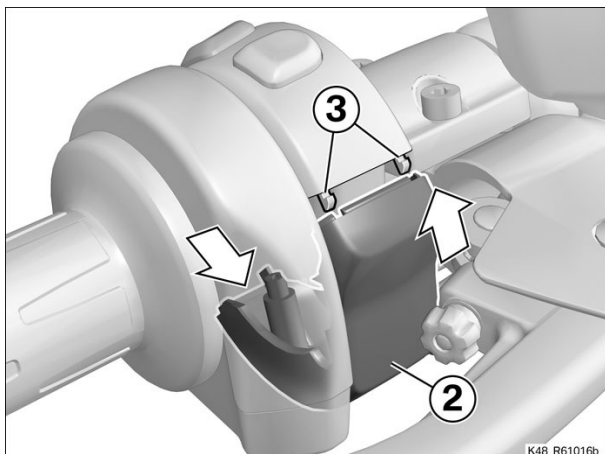

- Disconnect and remove plug (1) for the heated grip and plug (2) for the multifunction switch.
- Remove screw (3).
- Remove multifunction switch (4).

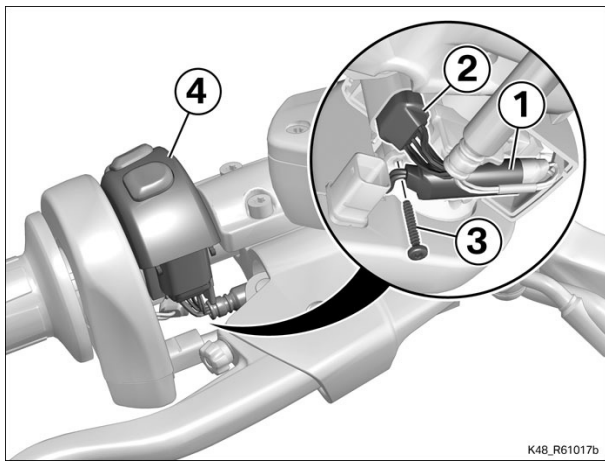

K48_R61017b

(-) Installing right multifunction switch

- Hold multifunction switch (4) in position.



Attention

Overtightened screws can lead to component damage.
Do not exceed the specified tightening torque.

- Install screw (3).

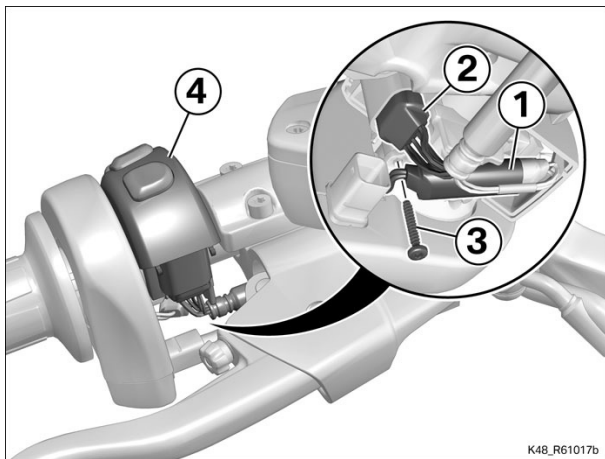

K48_R61017b

Tightening torques		
Multifunction switch to grip unit		
PT 2.5 x 15	0.4 Nm	

- Install and connect plug (2) for the multifunction switch and plug (1) for the heated handlebar grips.
- Position cover (2) and push backwards and down, paying attention to retaining catches (3).

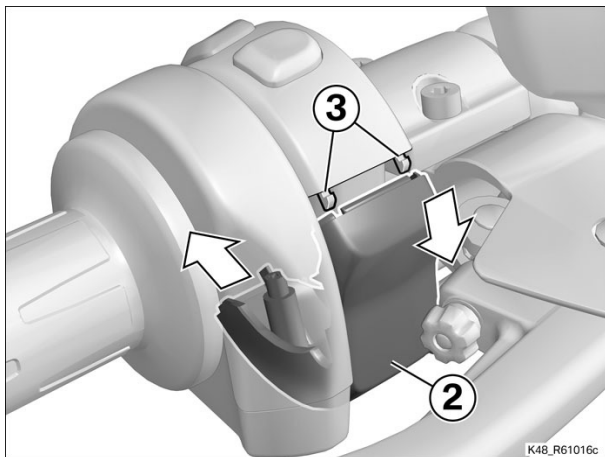

K48_R61016c

- Push cover (2) up until the multifunction switch is closed.



Attention

Overtightened screws can lead to component damage.
Do not exceed the specified tightening torque.

- Install screw (1).

Tightening torques		

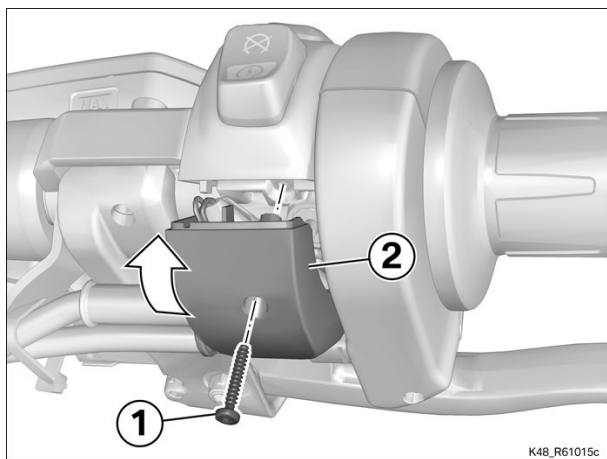

Cover to multifunction switch

PT2.5 x 15

0.4 Nm

► **Connecting plug for throttle twistgrip**

- Connect plug (1) for the throttle twistgrip.

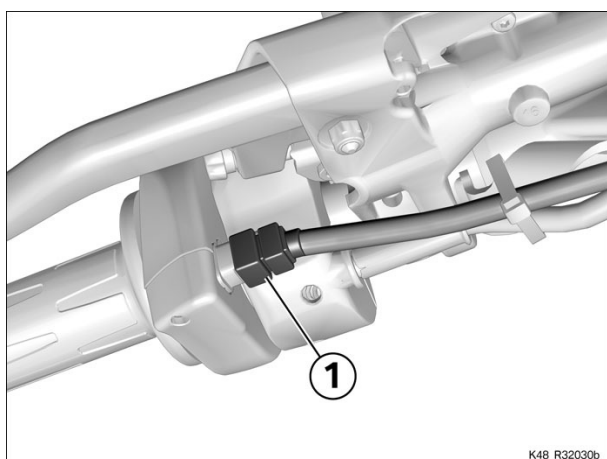

Finishing work

Final check of work performed

61 31 295 Removing/installing or replacing clutch switch 15 FRUs

+ 61 31 911

Preparatory work

- Remove the front seat
- Removing air guides for intake air pipes, left and right
- Removing complete cover of fuel tank
- Removing left bottom side panel
- Removing left radiator cowl
- Removing left side panel
- Removing inner trim for left side panel
- Removing right bottom side panel
- Removing right radiator cowl
- Remove the right side panel
- Removing inner trim for right side panel
- Disengaging left and right intake air pipes
- Removing complete intake air silencer
- Removing fuel tank

Core activity

(-) Removing clutch switch

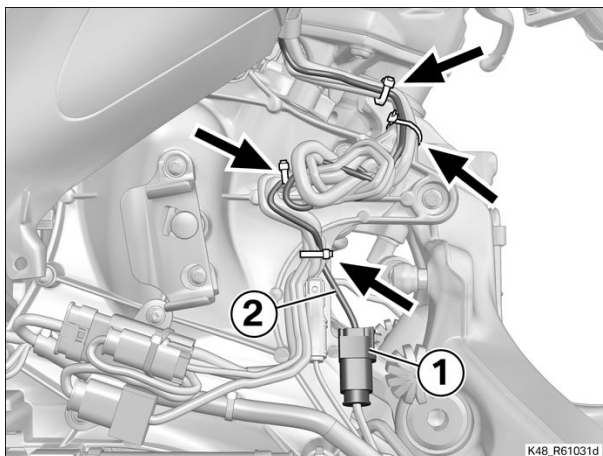

- Remove the cable ties (arrows).
- Remove plug (1) for the clutch switch and disconnect.
- Release cable (2).

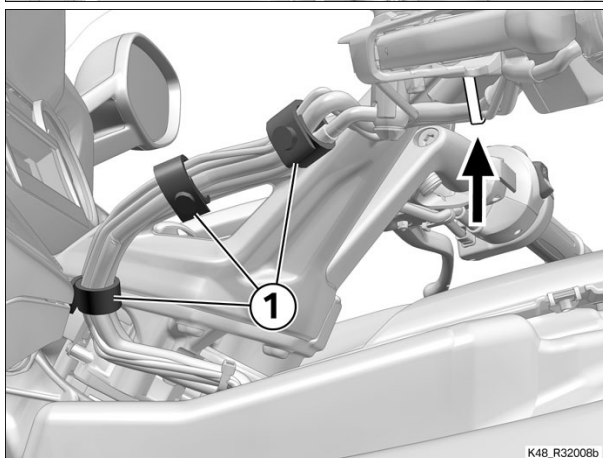

- Remove cable holder (1) and the cable tie (arrow).

- Remove screw (1).
- Remove clutch switch (2), noting locating point (3).

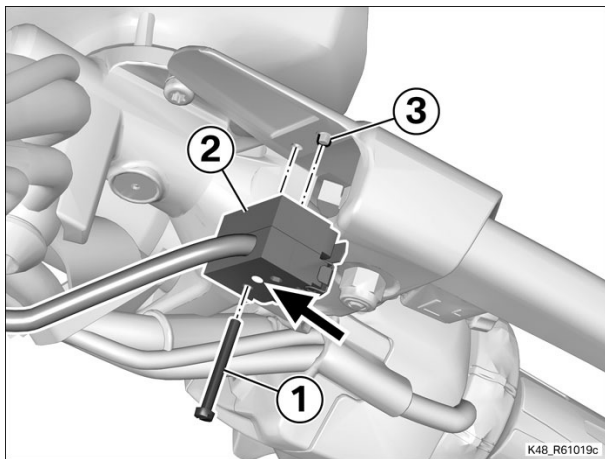
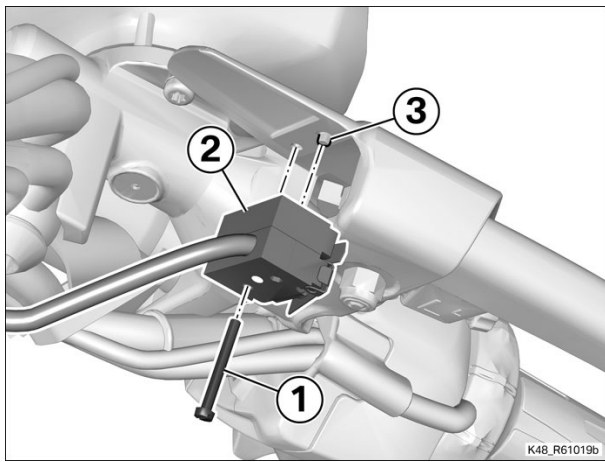

(-) Installing clutch switch

- Install clutch switch (2) with the **white mark (arrow)** pointing **down**, noting locating point (3).
- Install screw (1).

 Tightening torques		
Clutch switch to handlebar fitting		
M2 x 18	0.3 Nm	

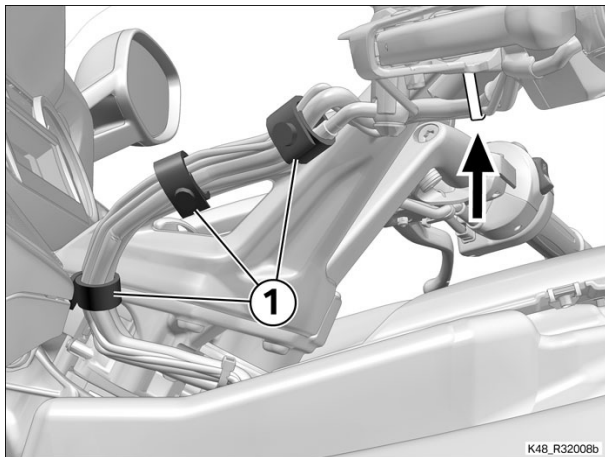

- Secure cable holder (1) and the cable tie (arrow).

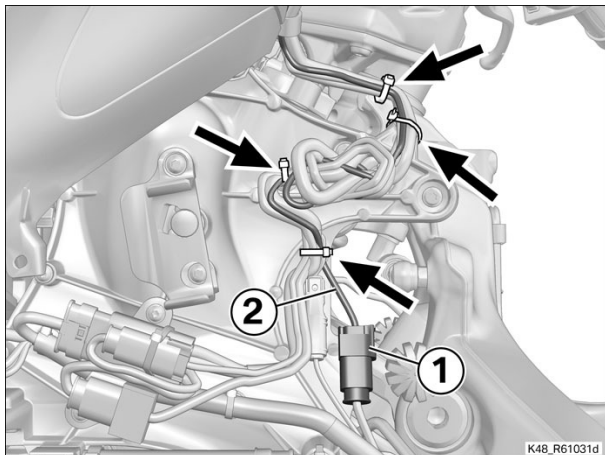

- Route cable (2) into position.
- Connect plug (1) for the clutch switch and install.
- Close the cable ties (arrows).

Finishing work

Installing fuel tank

Installing complete intake air silencer

Securing left and right intake air pipes

Installing inner trim for right side panel

Install the right side panel

Install the right radiator cowl

Installing right bottom side panel

Installing inner trim for left side panel

Install the left side panel

Installing left radiator cowl

Installing left bottom side panel

Installing complete cover of fuel tank

Installing air guides for intake air pipes, left and right

Installing front seat

Final check of work performed

61 31 302 Replacing switch for side stand 5 FRUs

+ 61 31 913

Preparatory work

- Remove the front seat
- Removing air guide for intake air pipe, left
- Removing left fuel-tank cover top section
- Removing left cover of fuel tank
- Removing left footrest plate

Core activity

(-) Removing side-stand switch

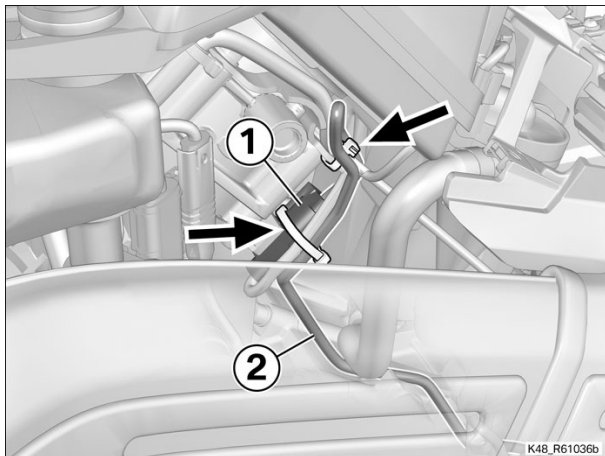

- Remove the cable ties (arrows).
- Disconnect plug (1) for the side-stand switch and work cable (2) clear of the motorcycle.

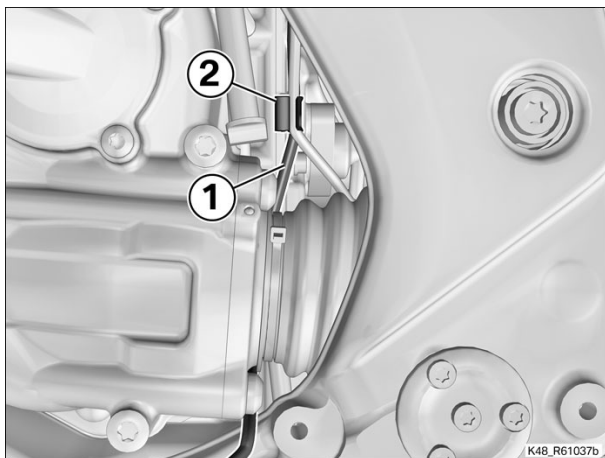

- Disengage cable (1) from holder (2) and work it clear.

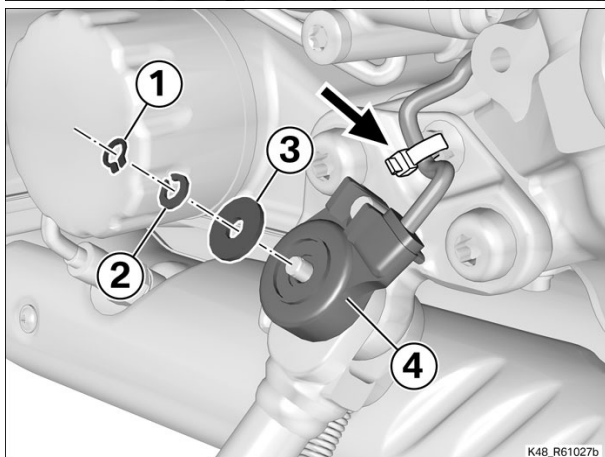

- Remove cable tie (arrow).
- Remove circlip (1), tensioning ring (2) and washer (3).
- Remove side-stand switch (4).

(-) Installing side-stand switch

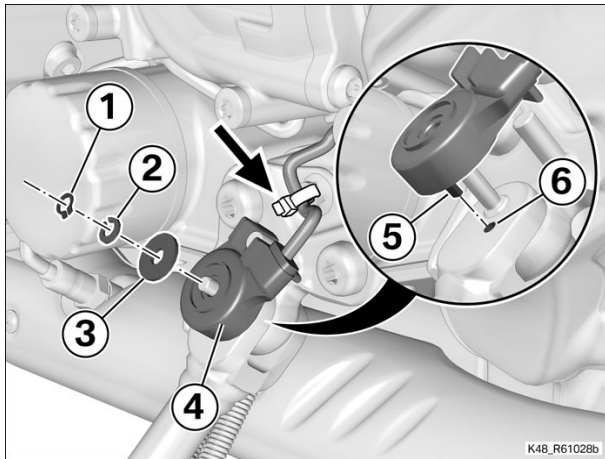

- Hold side-stand switch (4) in position, making sure that switch pin (5) is seated in bore (6).
- Install washer (3), tensioning ring (2) and circlip (1).
- Secure the cable tie (arrow).

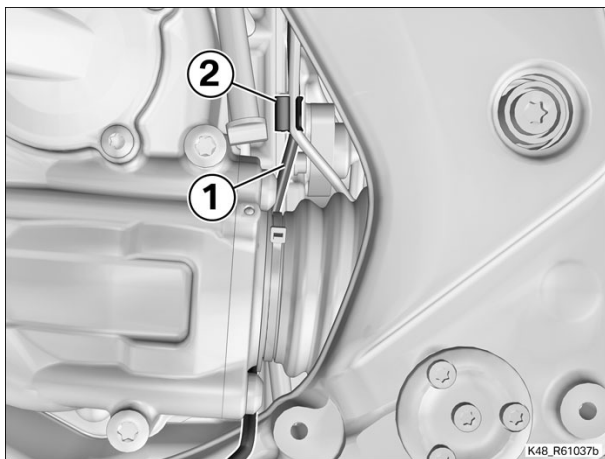

- Route cable (1) and secure it in holder (2).

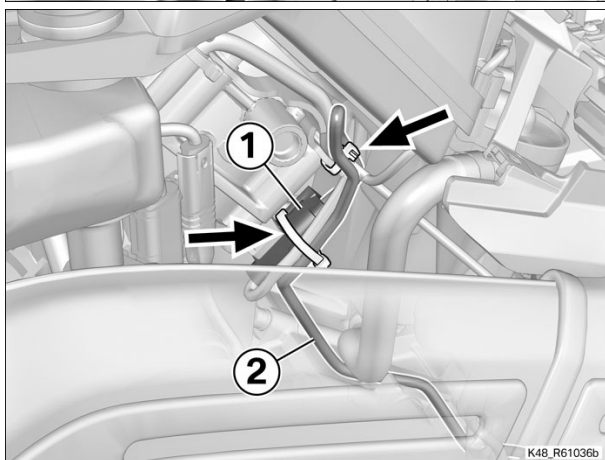

- Route cable (2) in the motorcycle and connect plug (1) for the side-stand switch.
- Close the cable ties (arrows).

Finishing work

Installing left footrest plate

Function test, engine start suppression

Installing left cover of fuel tank

Installing left fuel-tank cover top section

Installing air guide for intake air pipe, left

Installing front seat

Final check of work performed

61 31 341 Replacing switch for rear-seat heating 3 FRUs

+ 61 31 949

Preparatory work

Remove the front seat

Remove the rear seat

Core activity

(-) Removing switch for rear-seat heating

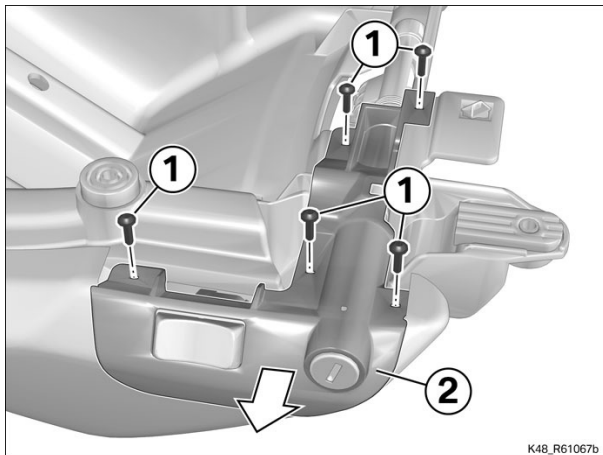

- Remove screws (1).
- Work switch cover (2) to the outside to remove.

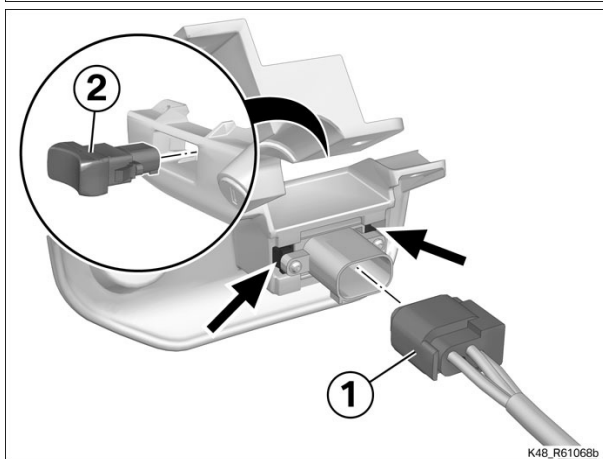

- Disconnect plug (1) for the switch.
- Using a suitable tool, unlatch switch (2) on left and right (arrows).
- Work switch (2) to the outside to remove.

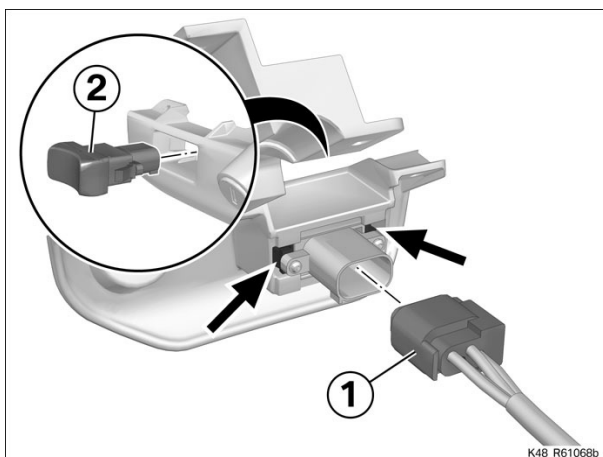

(-) Installing switch for rear-seat heating

- Install switch (2).
- » The retainers (arrows) snap into position.
- Connect plug (1) for the switch.

- Install switch cover (1), making sure that lock barrel (2) engages locking shaft (3).
- Install screws (4).

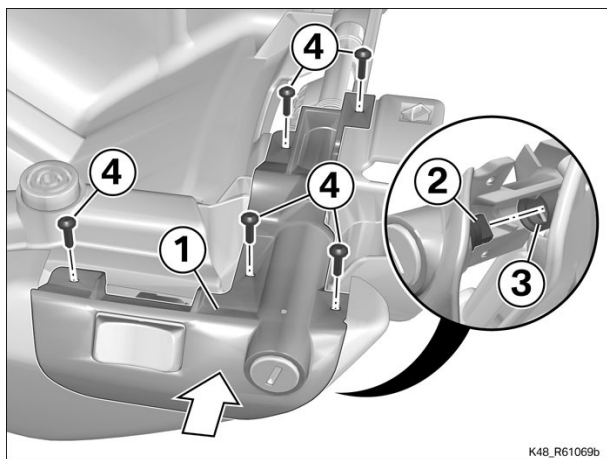

Finishing work

Installing rear seat

Installing front seat

Final check of work performed

61 31 390 Replacing starter relay 2 FRUs

+ 61 31 924

Preparatory work

Remove the front seat

Core activity

(-) Removing starter relay

- Using a suitable tool, remove starter relay (1) from bracket (2).

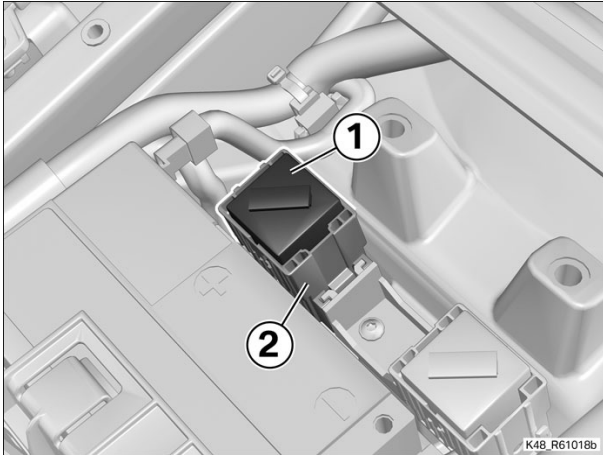

(-) Installing starter relay

- Using a suitable tool, install starter relay (1) in bracket (2).
- Make sure that starter relay (1) is securely installed.

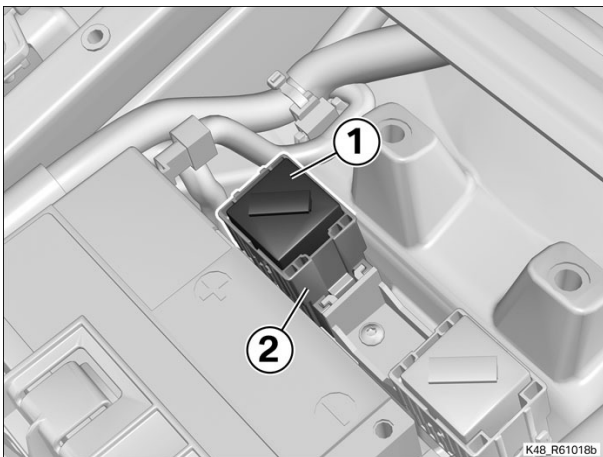

Finishing work

Installing front seat

Final check of work performed

61 32 000 Removing/installing or replacing ignition switch

+ 61 32 511

Preparatory work

- Covering cover for fuel tank
- Covering instrument panel
- Closing equalising bore of front brake
- Removing **BMW** badge with carrier
- Removing nut of handlebar bridge

Core activity

(-) Disconnecting plugs for ignition switch/steering lock and ring aerial

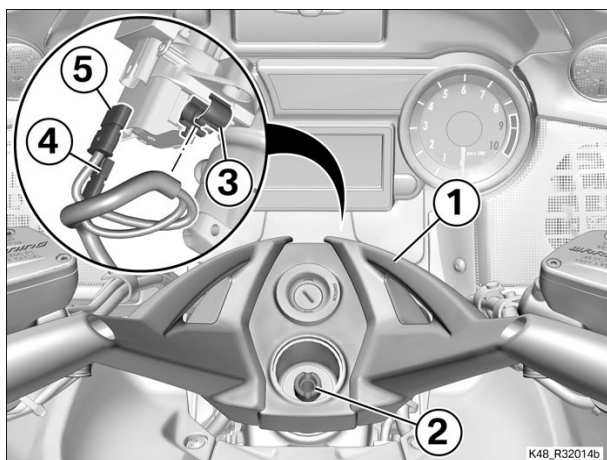

- Remove handlebars (1) from steering adapter (2).
- Unclip cable holder (3).
- Disconnect plugs (4) for the ignition switch/steering lock and (5) for the ring aerial.

(-) Removing ignition switch

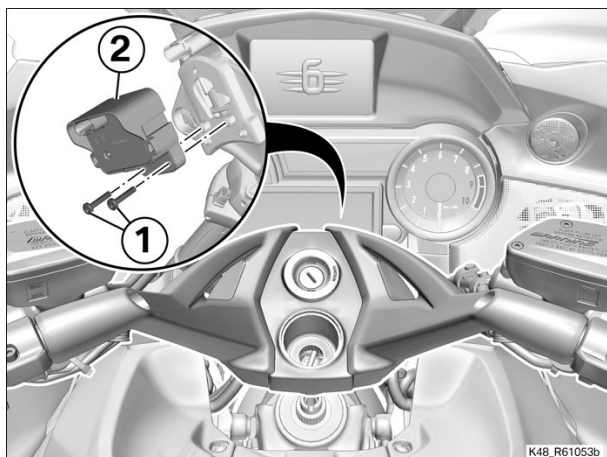

- Remove screws (1) and remove ignition switch (2).

(-) Installing ignition switch

- Hold ignition switch (2) in position and install screws (1).

 Tightening torques		
Ignition switch to steering lock		
M3	0.5 Nm	

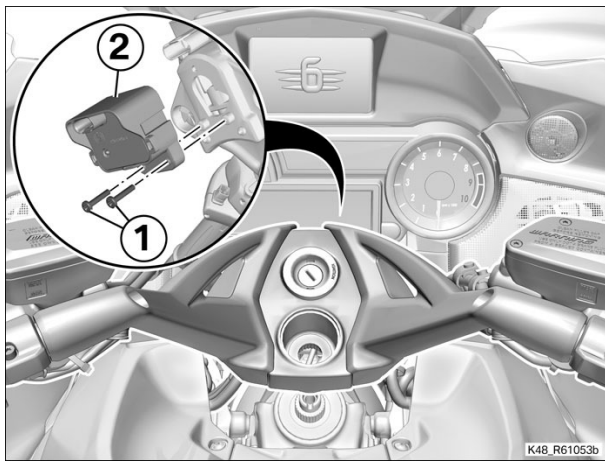

(-) Connecting plugs for ignition switch/steering lock and ring aerial

- Clean the threads of steering adapter (2).
- Connect plugs (4) for the ignition switch/steering lock and (5) for the ring aerial.
- Clip in cable holder (3).
- Position handlebar bridge (1) on steering adapter (2).

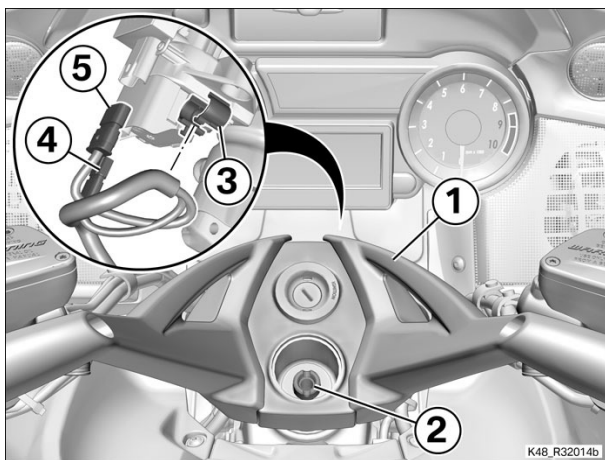

Finishing work

Installing handlebars

Installing **BMW** badge with carrier

Opening equalising bore of front brake

Removing blanket covering instrument panel

Removing blanket covering fuel tank

Final check of work performed

61 34 000 Replacing on-board socket, front

+ 61 34 550

Preparatory work

Removing air guide for intake air pipe, right

Removing right bottom side panel

Removing right radiator cowl

Remove the right side panel

Core activity

(-) Removing inner trim for right side panel

- Remove screws (1) with bushings (2).
- Remove screw (3).

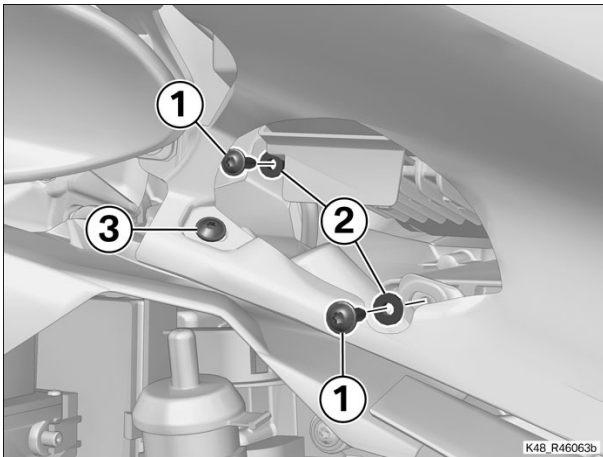

- Remove screw (1).
- Disconnect plug (2) for the on-board socket.
- Remove inner trim (3) for the side panel.

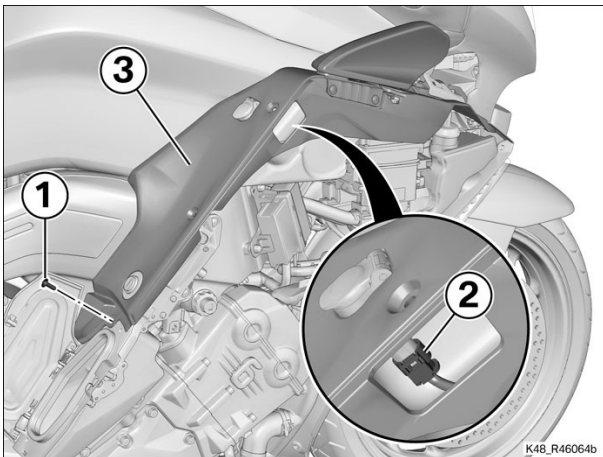

(-) Removing on-board socket from inner trim

- Remove nut (1).
- Remove on-board socket (2).

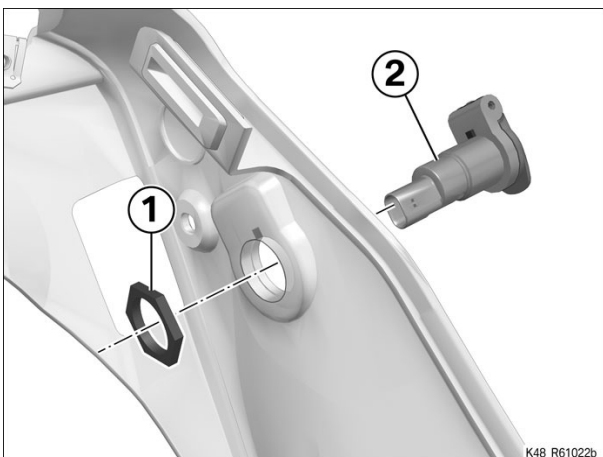

(-) Installing on-board socket in interior trim

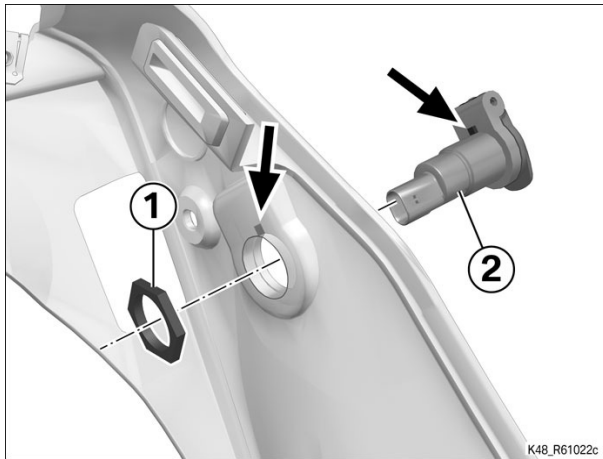

- Install on-board socket (2), noting the locator (arrows).
- Tighten nut (1).

(-) Installing inner trim for right side panel

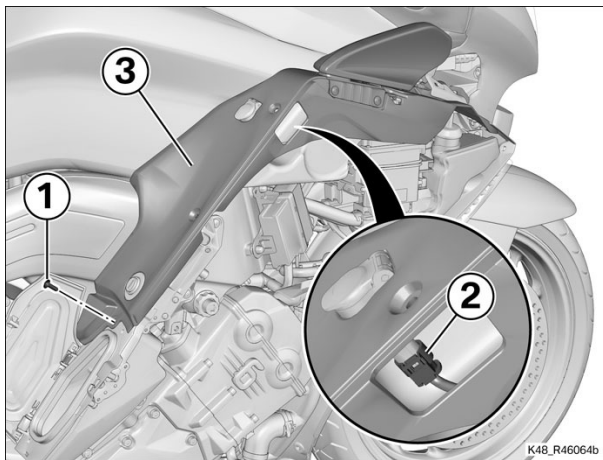

- Install inner trim (3) for the side panel.
- Connect plug (2) for the on-board socket.
- Install screw (1).

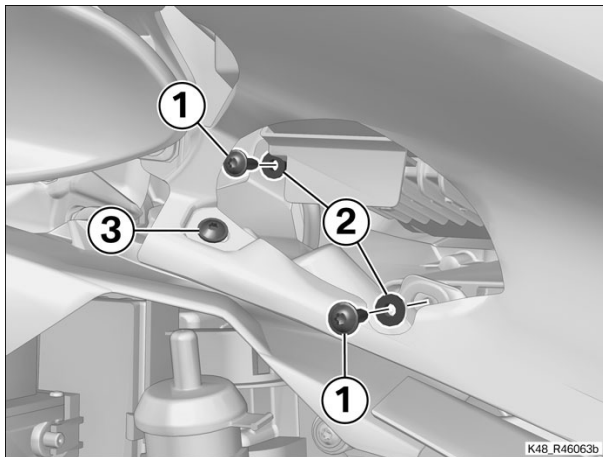

- Install screws (1) with bushings (2).
- Install screw (3).

Finishing work

Install the right side panel

Install the right radiator cowl

Installing right bottom side panel

Installing air guide for intake air pipe, right

Final check of work performed

 **61 34 001 Replacing on-board socket, rear**

+ 61 34 551

Preparatory work

- Remove the front seat
- Removing adjusting plate
- Removing seat support

Core activity

(-) Disengaging relay and fuse carrier

- Remove screws (1).
- Remove relay and fuse carrier (2).

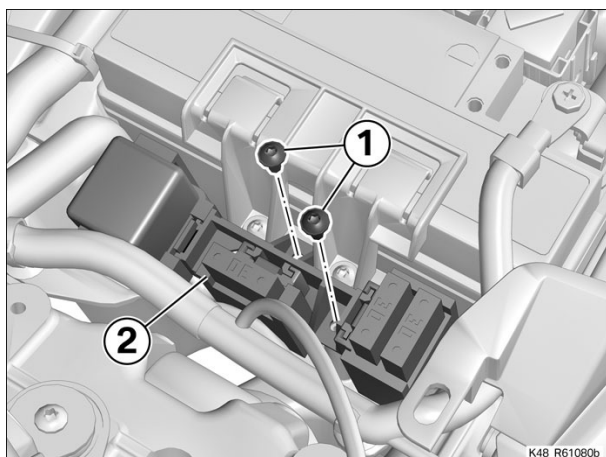

(-) Removing on-board socket, rear

- Disconnect plug (1) for the on-board socket.
- Remove nut (2).
- Remove on-board socket (3).

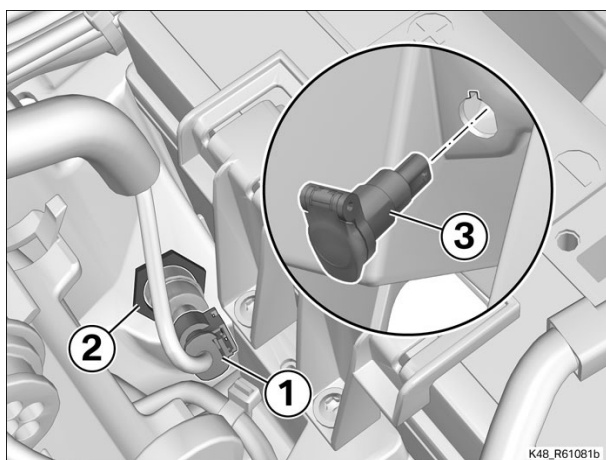

(-) Installing on-board socket, rear

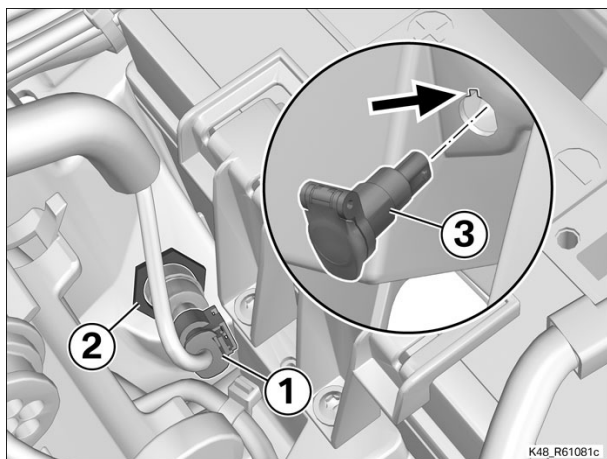

- Install on-board socket (3), noting the locator (arrow).
- Install nut (2).
- Connect plug (1) for the on-board socket.

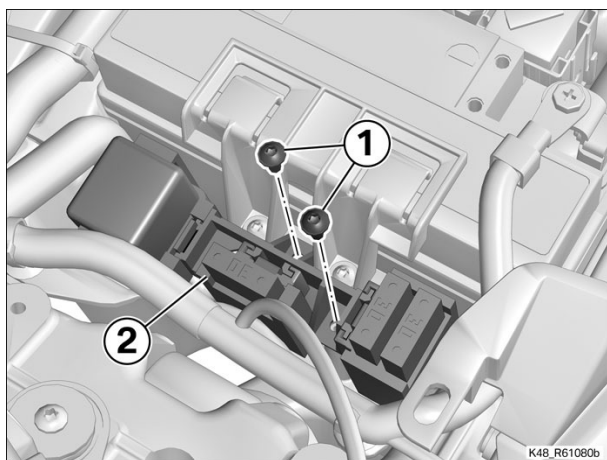

(-) Securing relay and fuse carrier

- Hold relay and fuse carrier (2) in position.
- Install screws (1).

Finishing work

- Installing seat support
- Installing adjusting plate
- Installing front seat
- Final check of work performed

📁 61 35 012 Checking or restoring system time 2 FRUs

+ 61 35 506

Core activity

(-) Connecting BMW Motorrad diagnostic system to motorcycle

- Connect the **BMW Motorrad** battery charger.



Note

When carrying out diagnosis and programming, use a battery charger with 30 A approved by **BMW Motorrad** that ensures an **on-board system voltage of 13V**.

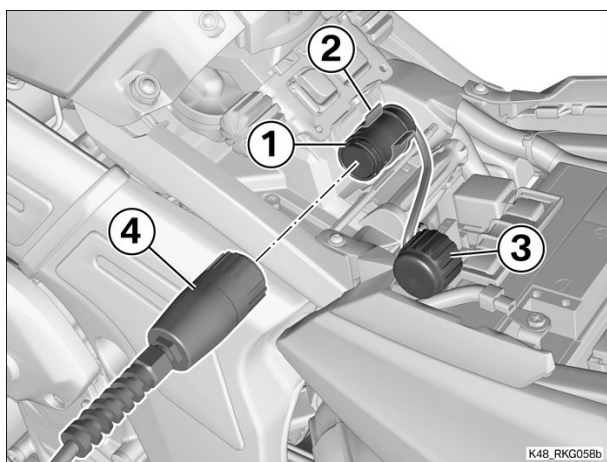

- Disengage diagnosis plug (1) from holder (2) and remove protective cap (3).
- Connect diagnosis plug (1) to connecting cable (4) for the diagnostic system.



Note

See the information about the **BMW Motorrad** diagnostic system for all other instructions.

(-) Reset system time with BMW Motorrad diagnostic system

- Select **Activities** from the menu and call up the **Service schedules**.
- Go to the **Read and set service date** menu option to calibrate the calendar date in the vehicle with the calendar date of the **BMW Motorrad** diagnostic system.

(-) Disconnecting BMW Motorrad diagnostic system from motorcycle

- Close all diagnostic programs and switch off the ignition.
- Disconnect the connecting cable for the **BMW Motorrad** diagnostic system from the motorcycle's diagnosis plug and screw the cap onto the diagnosis plug.
- Disconnect the **BMW Motorrad** battery charger from the motorcycle.

61 35 026 Replacing control unit basic module (without testing software/programming) 3 FRUs

+ 61 35 653

Equipment trim-level variant:

0416 - Electronic Suspension Adjustment (ESA)



Note

Before removal, test the control unit with the **BMW Motorrad** diagnostic system and make a backup copy of the data.

Preparatory work

Removing right bottom side panel

Removing right radiator cowl

Remove the right side panel

Disengaging **ESA** control unit

Core activity

(-) Removing control unit basic module

- Disconnect plug (1) for the basic module.
- Push back retaining tabs (2) and remove basic module (3).

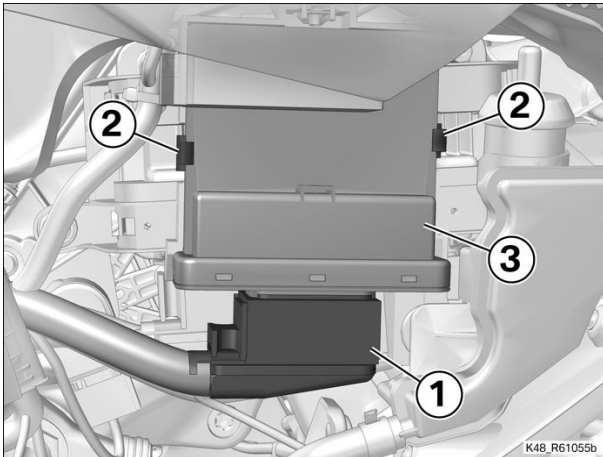

(-) Installing control unit basic module



Note

Do not, **under any circumstances** temporarily install control units from other vehicles by way of testing.

The possible consequences include:

Coding data could be overwritten.

The control units could malfunction.

- Install basic module (3).
- Make sure that retaining tabs (2) are latched.
- Connect plug (1) for the basic module.

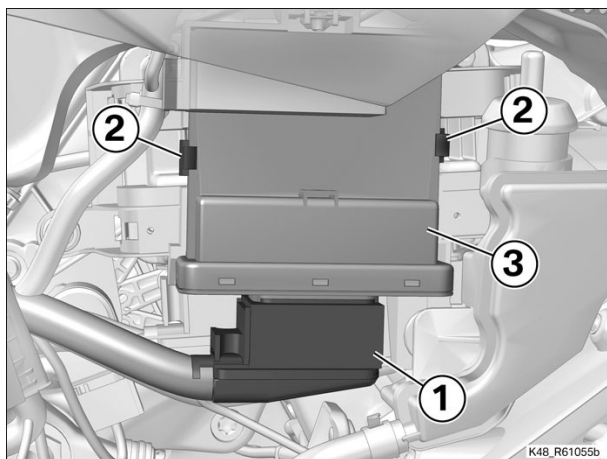

Finishing work

Securing **ESA** control unit

Install the right side panel

Install the right radiator cowl

Installing right bottom side panel

=> Testing software (Description in item: 61 00 502, Billed as a separate item)

=> Programming control units of vehicle (along with testing software) (Description in item: 61 00 510, Billed as a separate item)

Final check of work performed

61 35 027 Replacing control unit basic module satellite (without testing software/programming) 3 FRUs

+ 61 35 654



Note

Before removal, test the control unit with the **BMW Motorrad** diagnostic system and make a backup copy of the data.

Preparatory work

Removing right bottom side panel

Removing right radiator cowl

Remove the right side panel

Core activity

(-) Removing control unit basic module satellite

- Push back retaining tabs (1) and remove basic module satellite (2).
- Disconnect plug (3) for basic module satellite (2).

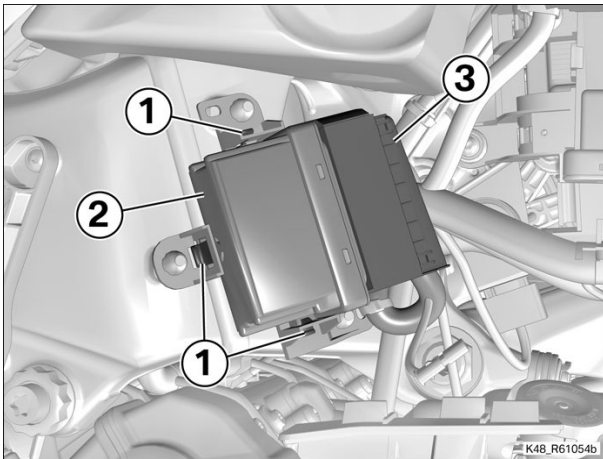

(-) Installing control unit basic module satellite



Note

Do not, **under any circumstances** temporarily install control units from other vehicles by way of testing.

The possible consequences include:

Coding data could be overwritten.

The control units could malfunction.

- Connect plug (3) to basic module satellite (2).
- Install basic module satellite (2).
- Make sure that retaining tabs (1) are latched.

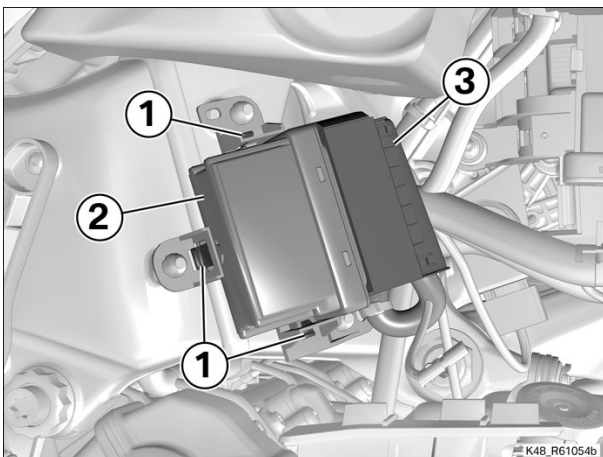

Finishing work

Install the right side panel

Install the right radiator cowl

Installing right bottom side panel

**=> Testing software (Description in item: 61 00 502,
Billed as a separate item)**

**=> Programming control units of vehicle (along with
testing software) (Description in item: 61 00 510, Billed
as a separate item)**

Final check of work performed

📁 61 35 150 Replacing ring aerial on ignition lock

+ 61 35 650

Preparatory work

Covering cover for fuel tank

Covering instrument panel

Closing equalising bore of front brake

Removing **BMW** badge with carrier

Removing nut of handlebar bridge

Disconnecting plugs for ignition switch/steering lock and ring aerial

Removing handlebar bridge

Core activity

(-) Removing ignition switch/steering lock with ring aerial

- Lay handlebar bridge (1) on a **padded** rest.
- Remove screws (2).
- Remove screws (3) and remove ignition switch (4).

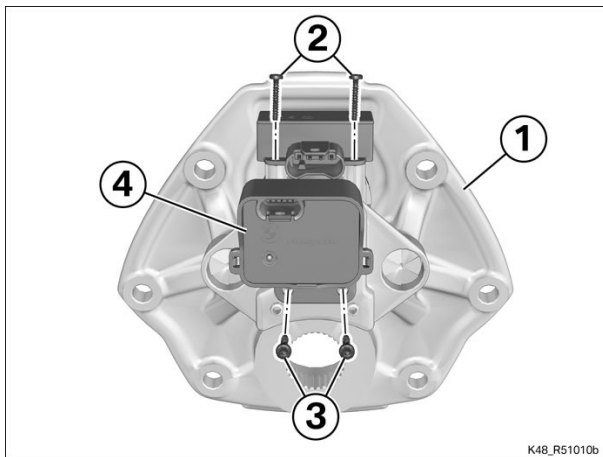

K48_R51010b

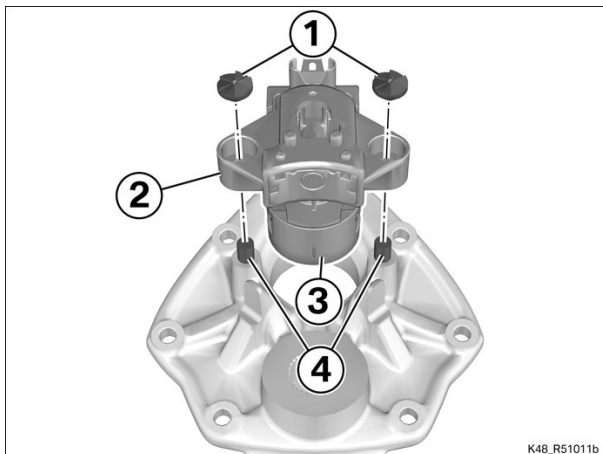

K48_R51011b



Attention

Components can be damaged by hard or sharp-edged objects. Avoid scratching the components; use masking tape if necessary.

- Drill pilot holes into non-removable screws (1) and then continue drilling out the holes until the screw heads come off.

 Technical data			
Ignition switch/steering lock - drilling depth for drilling out non-removable screws	Pilot hole diameter 4 mm	min 5 mm	
	Diameter for drilling out fully 8.5 mm	5 mm	

- Use compressed air to remove metal particles.
- Remove steering lock (2) with ring aerial (3).
- Use a stud remover to remove shanks of non-removable screws (4).

(-) Replacing ring aerial

- Remove ring aerial (1) and O-ring (2).
- Check O-ring (2); replace if necessary.
- Position O-ring (2) and **new** ring aerial (1) on steering-lock (3) and

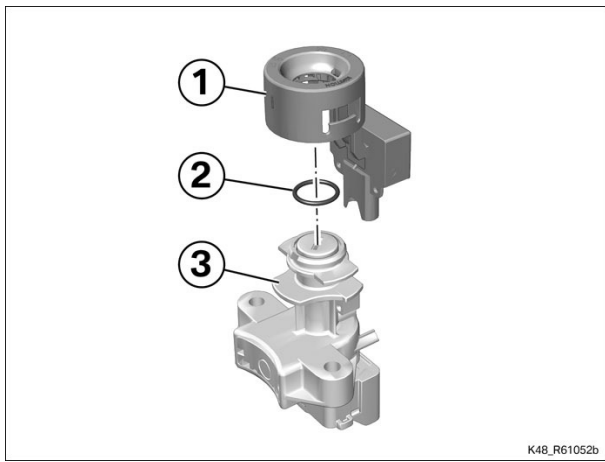

install.

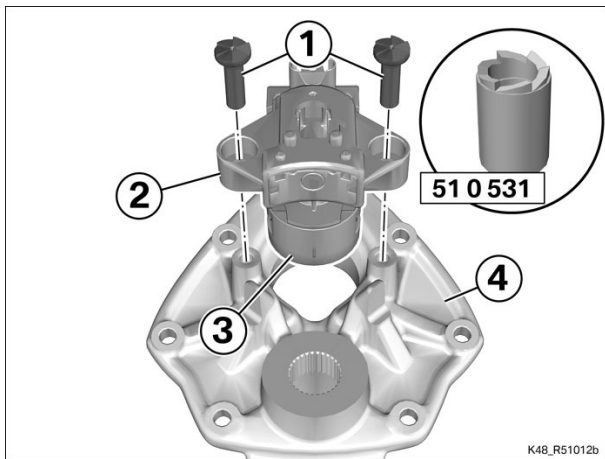

(-) Installing ignition switch/steering lock with ring aerial

- Clean the tapped holes.
- Install steering lock (2) with ring aerial (3) in handlebar bridge (4).
- Install **new** non-removable screws (1) with socket wrench insert (No. 51 0 531).

Tightening torques		
Ignition and steering lock to handlebar yoke		
M8 x 26, Replace screw	20 Nm	
Micro-encapsulated		

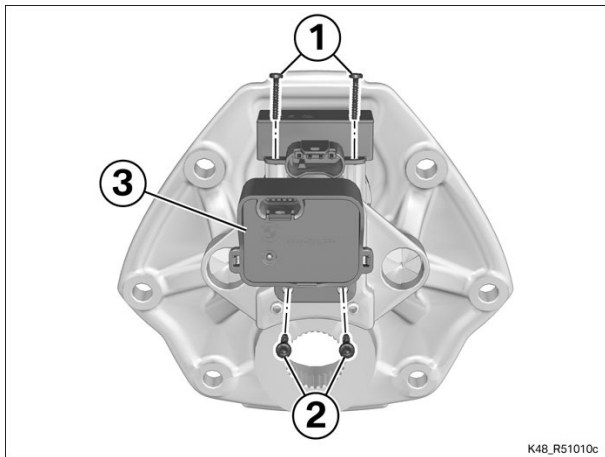

- Hold ignition switch (3) in position and install screws (2).
- Install screws (1).

Tightening torques		
Ring aerial to ignition switch/steering lock		
M3	0.5 Nm	

Finishing work

- Installing handlebar bridge
- Connecting plugs for ignition switch/steering lock and ring aerial
- Installing handlebars
- Installing **BMW** badge with carrier
- Opening equalising bore of front brake
- Removing blanket covering instrument panel
- Removing blanket covering fuel tank
- Final check of work performed

 **61 35 503 Setting service-due date with BMW Motorrad diagnostic system (for maintenance)**
1 FRUs

Core activity

(-) Setting service-due date

- Start **ISTA** and perform the vehicle test.
- Select **Activities** from the menu, call up the **Service schedules** and set the service date.

 **61 35 504 Setting service countdown distance with BMW Motorrad diagnostic system (for maintenance) 1 FRUs**

Core activity

(-) Setting service countdown distance

- Start **ISTA** and perform the vehicle test.
- Select **Activities** from the menu, call up the **Service schedules** and set the countdown distance.

 **61 35 505 Setting service-due date and service countdown distance with BMW Motorrad diagnostic system (for maintenance) 1 FRUs**

Core activity

(-) Setting service-due date and service countdown distance

- Start **ISTA** and perform the vehicle test.
- Select **Activities** from the menu, call up the **Service schedules** and set the service date and the countdown distance.

62 11 199 Replacing instrument cluster (without (testing software/programming) 7 FRUs

+ 62 11 510

Equipment trim-level variant:

0266 - Preparation for audio system and navigation device

0267 - ECE audio system and preparation for navigation system



Note

Before removal, test the control unit with the **BMW Motorrad** diagnostic system and make a backup copy of the data.

Preparatory work

- Removing air guide for intake air pipe, right
- Removing right hand protector
- Removing right speaker
- Removing air guide for intake air pipe, left
- Removing left hand protector
- Removing left speaker
- Removing cover of instrument panel
- Removing windscreen
- Removing cross brace for windscreen
- Disengaging left and right windscreen holders
- Removing top cover
- Removing inner trim with instrument panel

Core activity

(-) Removing instrument panel

- Remove screws (1).
- Remove instrument panel (2) from inner trim (3).

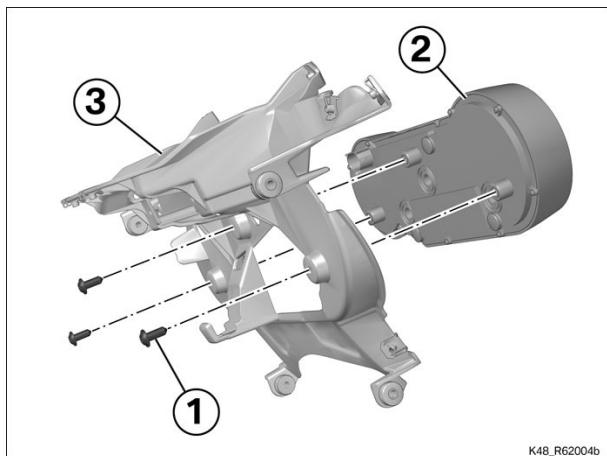

(-) Installing instrument panel

- Install instrument panel (2) in inner trim (3).
- Install screws (1).

Tightening torques		
Instrument panel to inner trim		
M6 x 16	5 Nm	

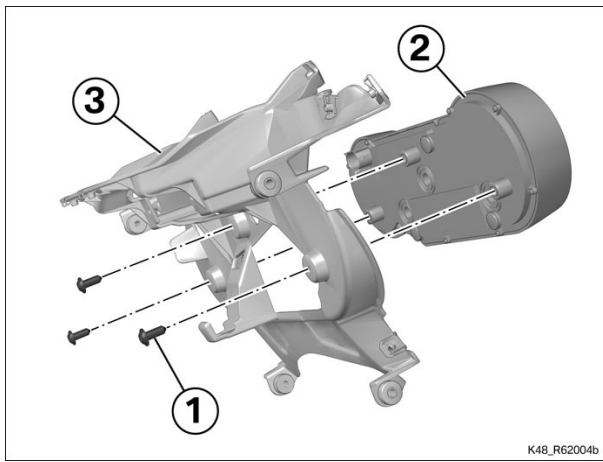

Finishing work

- Installing inner trim with instrument panel
- Installing top cover
- Securing left and right windscreen holders
- Installing cross brace for windscreen
- Installing windscreen
- Installing cover of instrument panel
- Installing left speaker
- Installing left hand protector
- Installing air guide for intake air pipe, left
- Installing right speaker
- Installing right hand protector
- Installing air guide for intake air pipe, right

=> Testing software (Description in item: 61 00 502, Billed as a separate item)

=> Programming control units of vehicle (along with testing software) (Description in item: 61 00 510, Billed as a separate item)

Final check of work performed

63 12 000 Adjust headlight 4 FRUs

+ 63 12 500

Equipment trim-level variant:

0266 - Preparation for audio system and navigation device

0267 - ECE audio system and preparation for navigation system

Preparatory work

Removing air guides for intake air pipes, left and right

Removing left hand protector

Removing left speaker

Removing right hand protector

Removing right speaker

Core activity

(-) Correcting headlight beam angle

- Adjust the lateral angle for the high-beam headlight by turning adjusting screw (1) with a suitable tool.

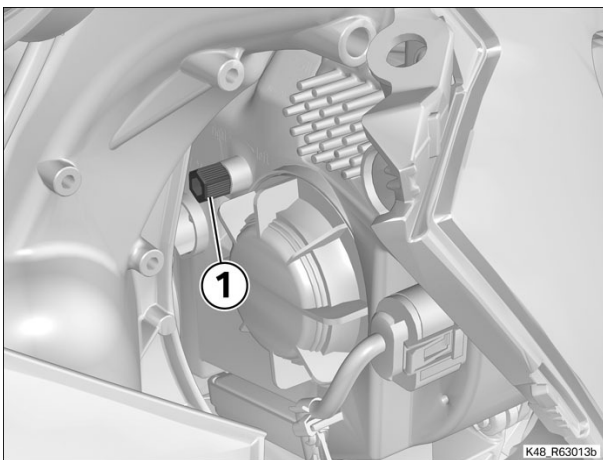

- Adjust the height of the beam throw by turning adjusting screw (1) or (2) with a suitable tool.

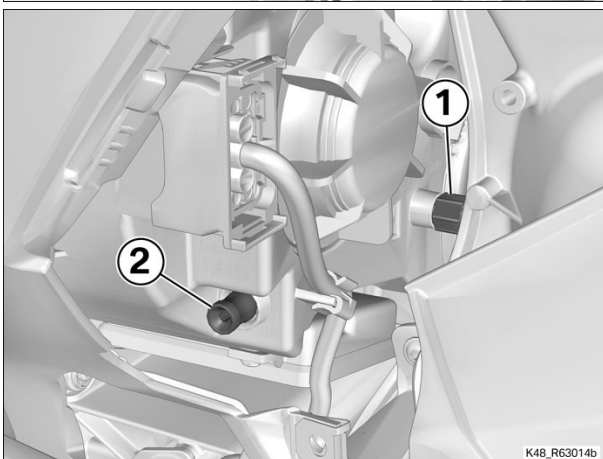

Finishing work

Installing right speaker

Installing right hand protector

Installing left speaker

Installing left hand protector

Installing air guides for intake air pipes, left and right

Final check of work performed

63 12 003 Replacing height sensor, rear

+ 63 12 672

Preparatory work

Remove the front seat

Remove the front-seat trimmer, left

Removing cover for case carrier, left

Removing left rear trim panel

Core activity

(-) Removing height sensor, rear

- Disconnect plug (1).
- Remove screws (2) and remove sensor (3) from bracket (4).

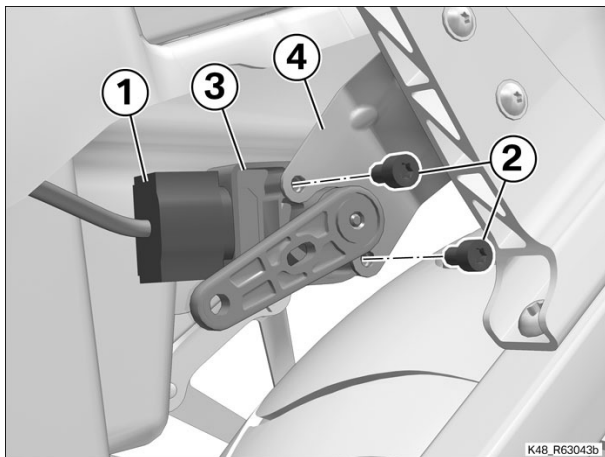

(-) Installing height sensor, rear

- Position sensor (3) on bracket (4) and install screws (2).
- Connect plug (1).

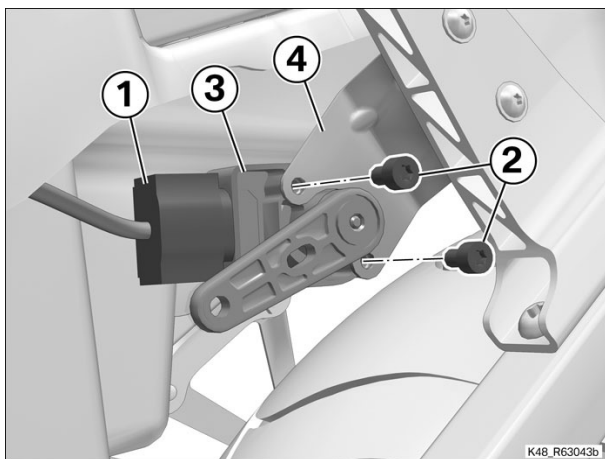

Finishing work

Installing left rear trim panel

Installing cover for case carrier, left

Install the front-seat trimmer, left

Connecting **BMW Motorrad** diagnostic system to motorcycle

Calibrating headlight

Disconnecting **BMW Motorrad** diagnostic system from motorcycle

Installing front seat

Checking headlight beam throw

Final check of work performed

📁 63 12 004 Replacing height sensor, front 7 FRUs

+ 63 12 669

Preparatory work

Remove the front seat

Removing air guide for intake air pipe, right

Removing right fuel-tank cover top section

Remove the right fuel-tank cover

Removing right bottom side panel

Removing right radiator cowl

Remove the right side panel

Removing inner trim for right side panel

Disengaging bracket for basic module and engine control unit

Core activity

(-) Removing height sensor, front

- Disconnect plug (1).
- Remove nut (2), while counter-holding at ball head (3).
- Disengage actuator rod (4).

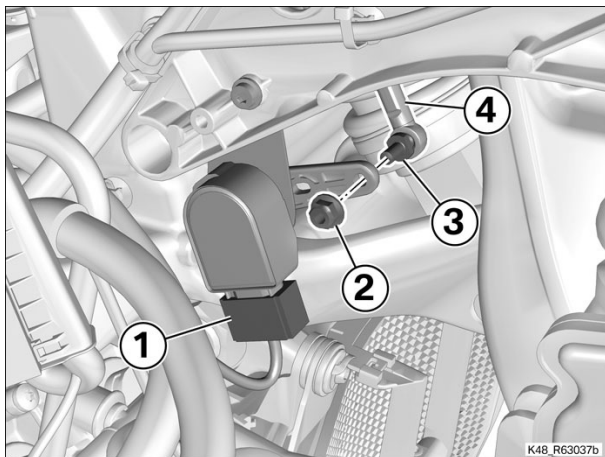

- Remove screw (1) and remove sensor (2).

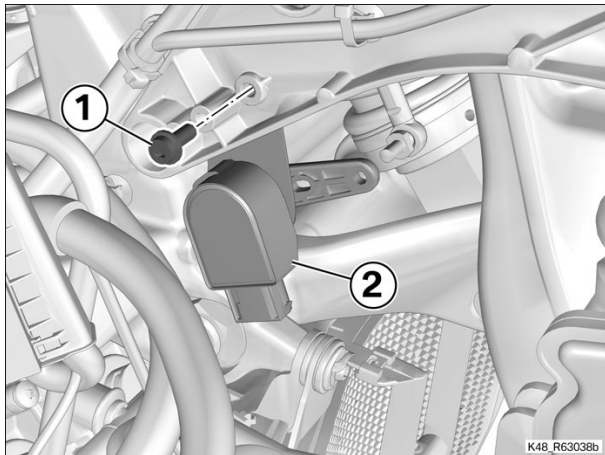

(-) Replacing height sensor, front

- Remove screws (1).
- Transfer bracket (2) to **new** sensor (3) and install screws (1).

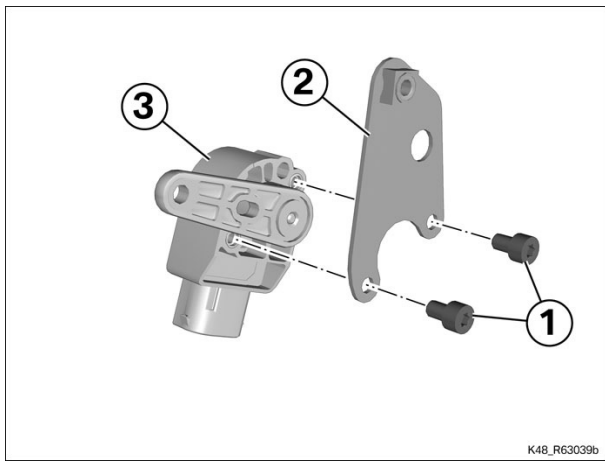

(-) Installing height sensor, front

- Hold sensor (2) in position, making sure that the position of the recess (arrow) relative to the lug (3) is correct, and install screw (1).

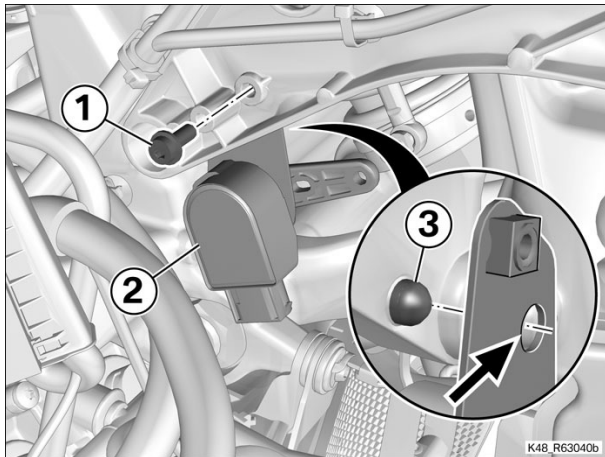

Tightening torques		
Bracket for height sensor to front panel carrier		
M6 x 20	5 Nm	

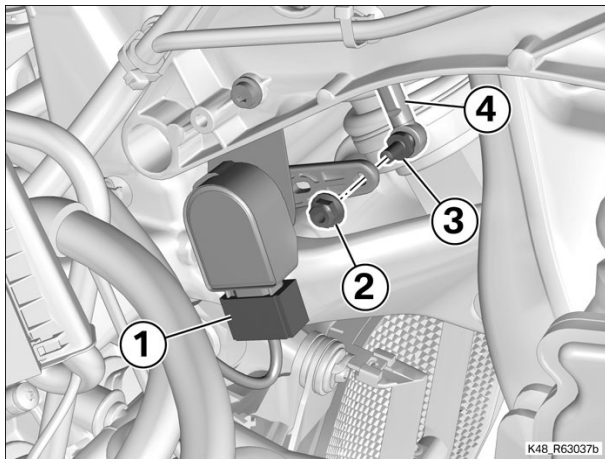

- Connect plug (1).
- Hold actuator rod (4) in position.
- Install nut (2), counter-holding at ball head (3).

Finishing work

- Securing bracket for basic module and engine control unit
- Installing inner trim for right side panel
- Install the right side panel
- Install the right radiator cowl
- Installing right bottom side panel
- Installing right fuel-tank cover
- Installing right fuel-tank cover top section
- Installing air guide for intake air pipe, right
- Connecting **BMW Motorrad** diagnostic system to motorcycle
- Calibrating headlight

Disconnecting **BMW Motorrad** diagnostic system from motorcycle
Installing front seat
Checking headlight beam throw
Final check of work performed

📁 63 12 006 Replacing bracket for height sensor, front 7 FRUs

+ 63 12 671

Preparatory work

Remove the front seat

Removing air guide for intake air pipe, right

Removing right fuel-tank cover top section

Remove the right fuel-tank cover

Removing right bottom side panel

Removing right radiator cowl

Remove the right side panel

Removing inner trim for right side panel

Disengaging bracket for basic module and engine control unit

Core activity

(-) Removing height sensor, front

- Disconnect plug (1).
- Remove nut (2), while counter-holding at ball head (3).
- Disengage actuator rod (4).

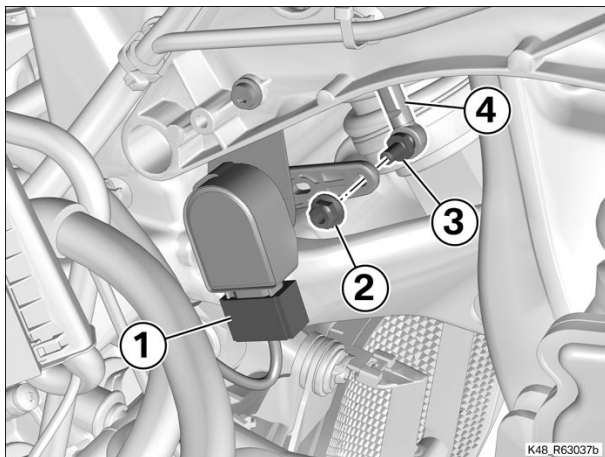

- Remove screw (1) and remove sensor (2).

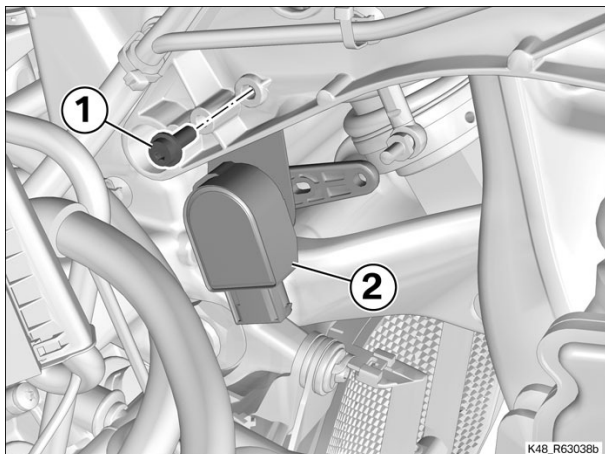

(-) Replacing bracket for height sensor, front

- Remove screws (1) and remove holder (2).
- Hold **new** bracket (2) in position at sensor (3) and install screws (1).

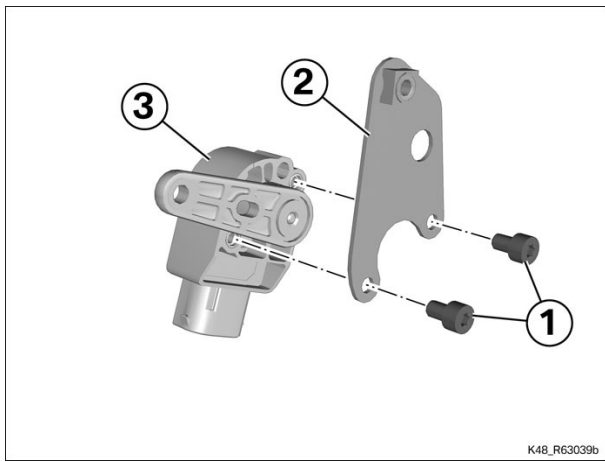

K48_R63039b

(-) Installing height sensor, front

- Hold sensor (2) in position, making sure that the position of the recess (arrow) relative to the lug (3) is correct, and install screw (1).

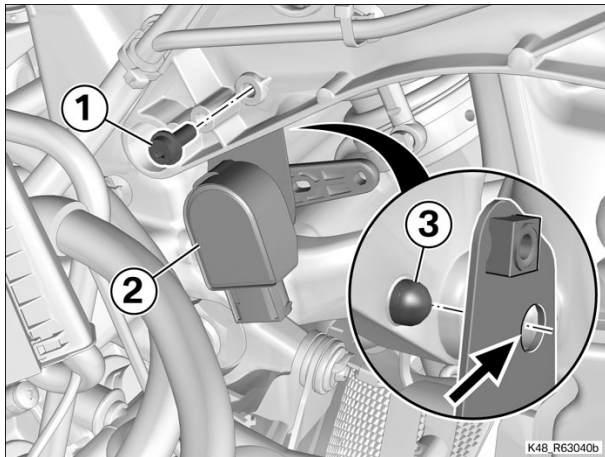

K48_R63040b

Tightening torques		
Bracket for height sensor to front panel carrier		
M6 x 20	5 Nm	

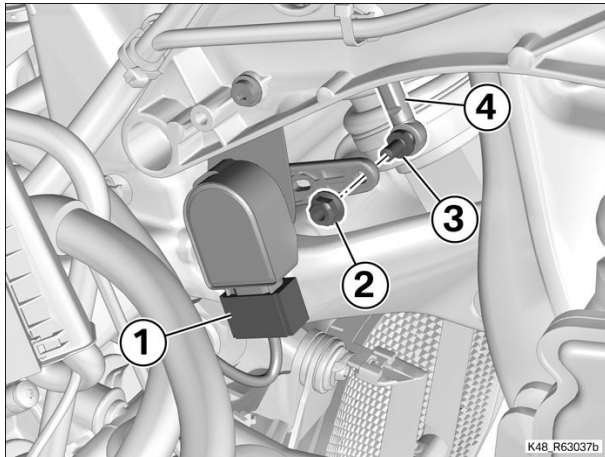

K48_R63037b

- Connect plug (1).
- Hold actuator rod (4) in position.
- Install nut (2), counter-holding at ball head (3).

Finishing work

- Securing bracket for basic module and engine control unit
- Installing inner trim for right side panel
- Install the right side panel
- Install the right radiator cowl
- Installing right bottom side panel
- Installing right fuel-tank cover
- Installing right fuel-tank cover top section
- Installing air guide for intake air pipe, right
- Installing front seat
- Final check of work performed

📁 63 12 091 Replacing headlight 11 FRUs

+ 63 12 637

Equipment trim-level variant:

0266 - Preparation for audio system and navigation device

0267 - ECE audio system and preparation for navigation system

Preparatory work

- Removing air guide for intake air pipe, right
- Removing right hand protector
- Removing right speaker
- Removing right mirror
- Removing finisher of air guide, right
- Removing top section of fairing, right
- Removing air guide for intake air pipe, left
- Removing left hand protector
- Removing left speaker
- Removing finisher of air guide, left
- Removing top section of fairing, left
- Removing cover of instrument panel
- Disengaging left and right windscreen holders
- Removing top cover
- Removing cover for windscreen adjuster

Core activity

(-) Removing headlight

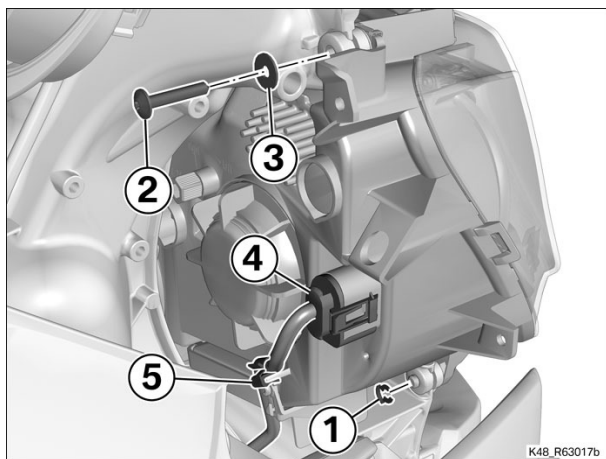

- Remove retaining clip (1) and screw (2) with washer (3).
- Disconnect plug (4) for the headlight and disengage with the cable from holder (5).

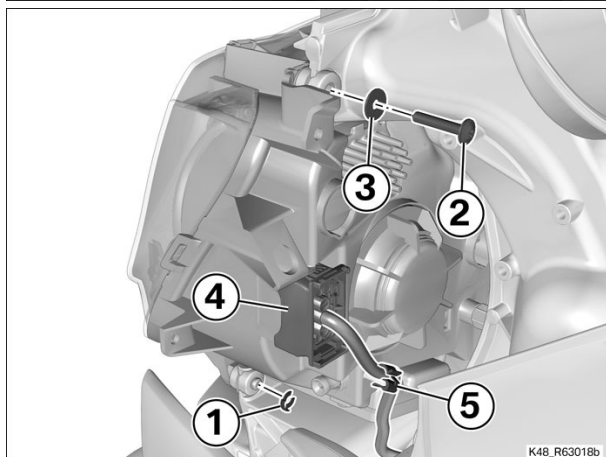

- Remove retaining clip (1) and screw (2) with washer (3).
- Disconnect plug (4) for the headlight and disengage with the cable from holder (5).

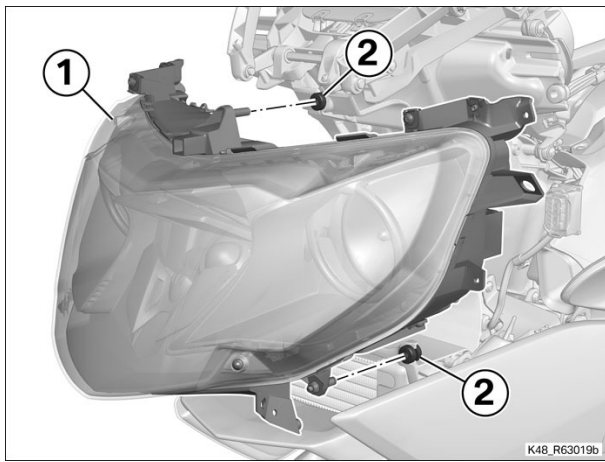

- Disengage headlight (1) from rubber grommets (2) and remove.

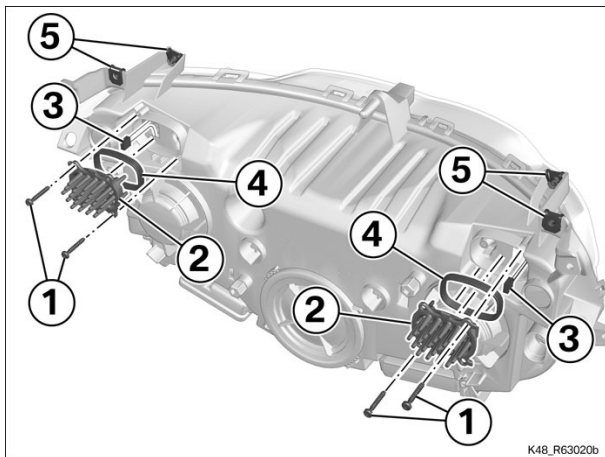

(-) Replacing headlight

- Remove screws (1).
- Remove the following components and transfer them to the new headlight; check seals (4) for damage and replace if necessary:
 - Disengage side-light modules (2) and disconnect plugs (3)
 - Side-light modules (2) with seals (4)
 - Flat nuts (5)
- Install screws (1).

 Tightening torques		
Mounted parts to headlight		
	1.5 Nm	

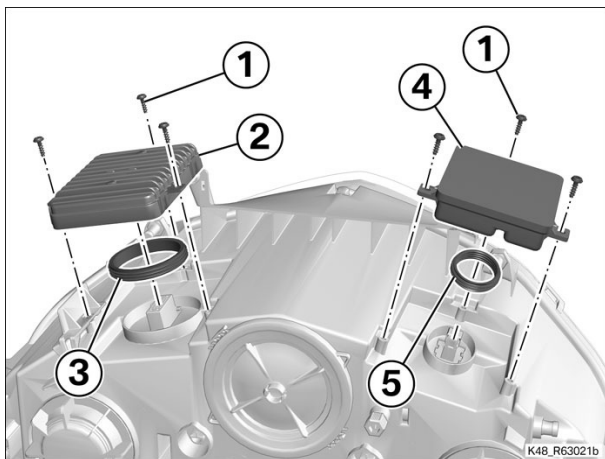

- Remove screws (1).
- Remove headlight control unit (2) with seal (3) and xenon control unit (4) with seal (5) and install in new headlight. Check seals (3) and (5) for damage; replace if necessary.
- Install screws (1).

 Tightening torques		
Mounted parts to headlight		
	1.5 Nm	

(-) Installing headlight

- Install headlight (1), seating the assembly in rubber grommets (2).

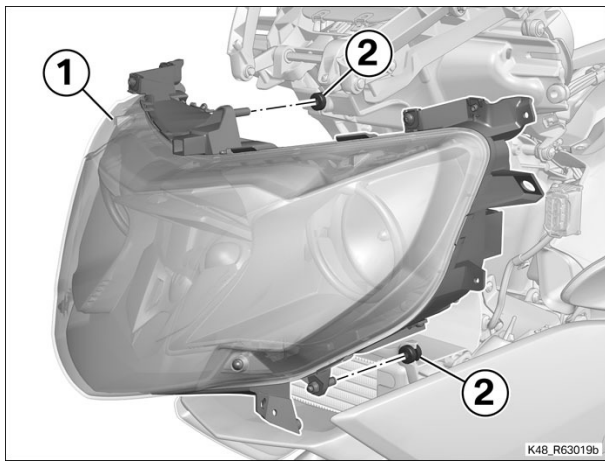

- Install retaining clip (1) and screw (2) with washer (3).

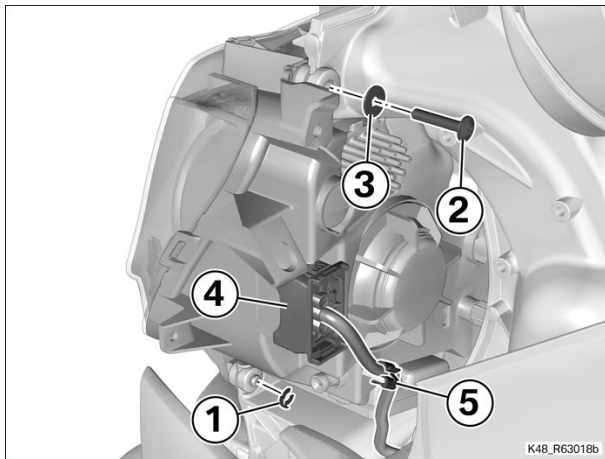

- Connect plug (4) for the headlight and secure it with cable in holder (5).

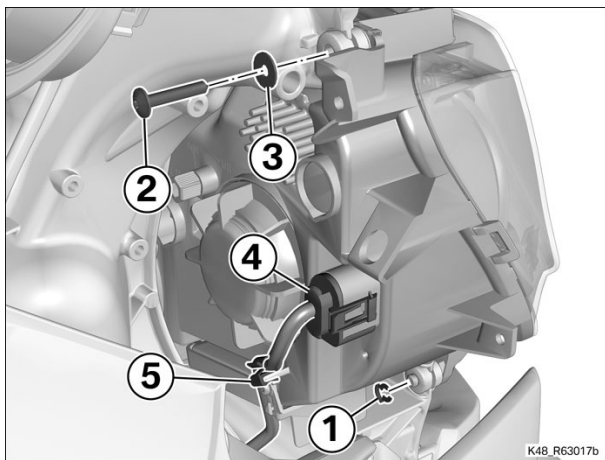

- Install retaining clip (1) and screw (2) with washer (3).

 Tightening torques		
Headlight to front panel carrier		
M5 x 30	2.5 Nm	

 Tightening torques		
Headlight to front panel carrier		
M5 x 30	2.5 Nm	

- Connect plug (4) for the headlight and secure it with cable in holder (5).

Finishing work

- Installing cover for windscreen adjuster
- Installing top cover
- Securing left and right windscreen holders
- Installing cover of instrument panel
- Installing top section of fairing, left
- Installing finisher of air guide, left
- Installing left mirror
- Installing left speaker
- Installing left hand protector
- Installing air guide for intake air pipe, left
- Installing top section of fairing, right

Installing finisher of air guide, right
Installing right mirror
Installing right speaker
Checking headlight beam throw
Installing right hand protector
Installing air guide for intake air pipe, right
Remove the front seat
Preparation for initialising/calibrating new parts
Installing front seat
Final check of work performed

63 13 012 Renewing complete front left or right flashing turn indicator 4 FRUs

+ 63 13 501

Preparatory work

Removing left bottom side panel

Removing left radiator cowl

Removing left side panel

Core activity

(-) Removing front left flashing turn indicator

- Disconnect plug (1) for the flashing turn indicators.
- Remove screws (2).
- Remove flashing turn indicators (3).

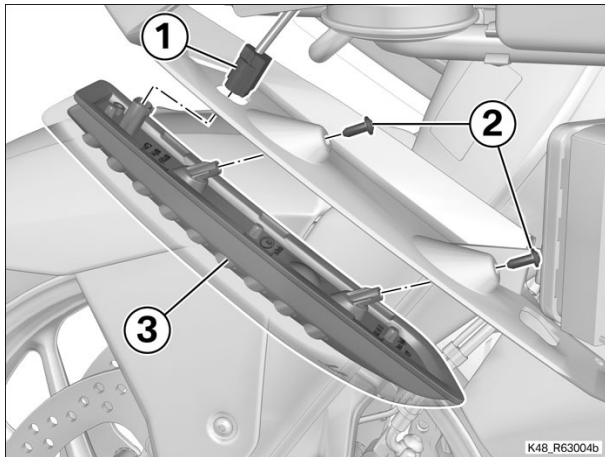

(-) Installing front left flashing turn indicator

- Install flashing turn indicator (3).
- Install screws (2).
- Connect plug (1) for the flashing turn indicators.

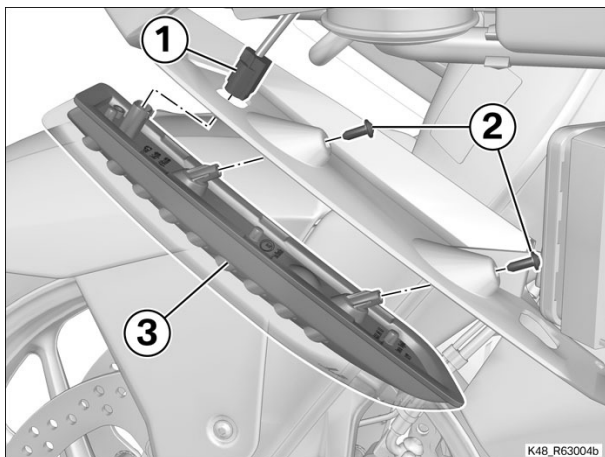

Finishing work

Install the left side panel

Installing left radiator cowl

Installing left bottom side panel

Final check of work performed

63 21 380 Removing and installing or replacing complete rear light 3 FRUs

+ 63 21 502

Preparatory work

Removing number-plate carrier

Removing cover panels for rear lights, left and right

Core activity

(-) Removing rear-light unit

- Disconnect plug (1) for the rear light.
- Remove clips (2) and washers (3).

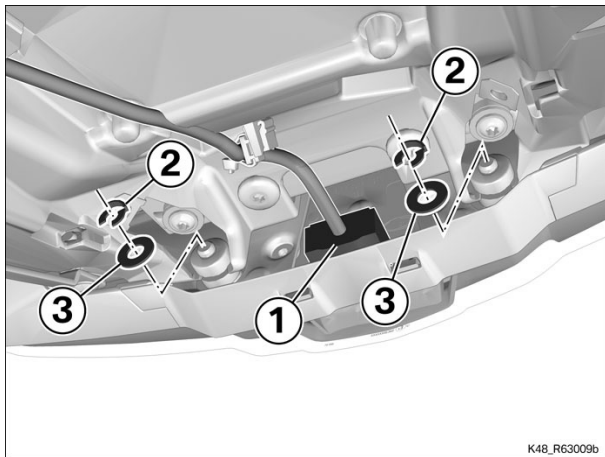

K48_R63009b

- Remove clips (1) and washers (2) on left and right.
- Remove rear light (3).

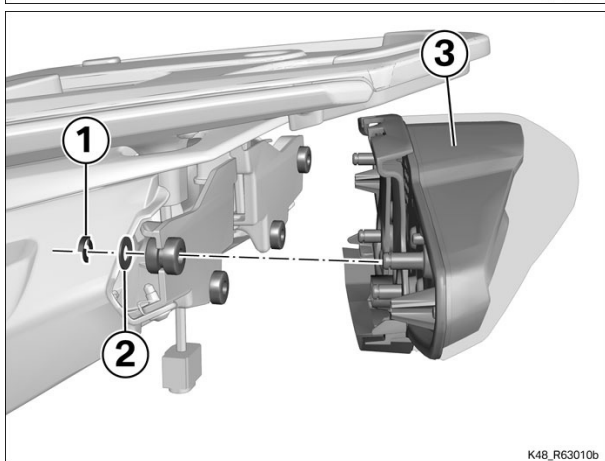

K48_R63010b

(-) Removing cover panel for rear light, centre section

- Remove screws (1).
- Remove cover panel (2) from rear light (3).

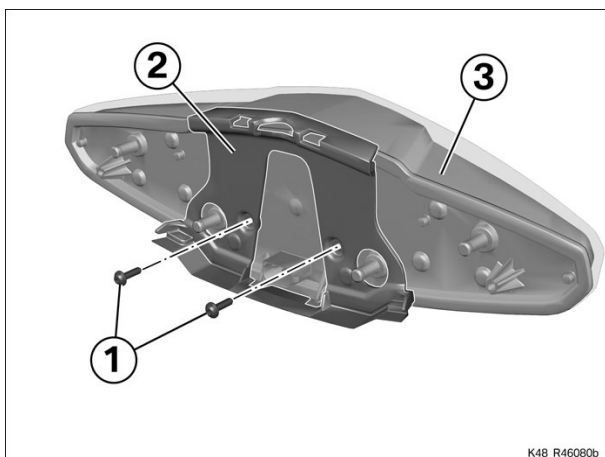

K48_R46080b

(-) Installing cover panel for rear light, centre section

- Position cover panel (2) on rear light (3).

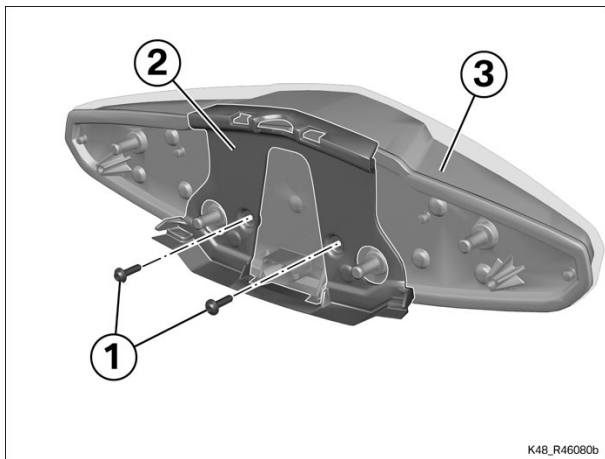

- Install screws (1).

 Tightening torques		
Cover, centre to rear-light cluster		
Screw for plastic, PT40 x 15	3 Nm	

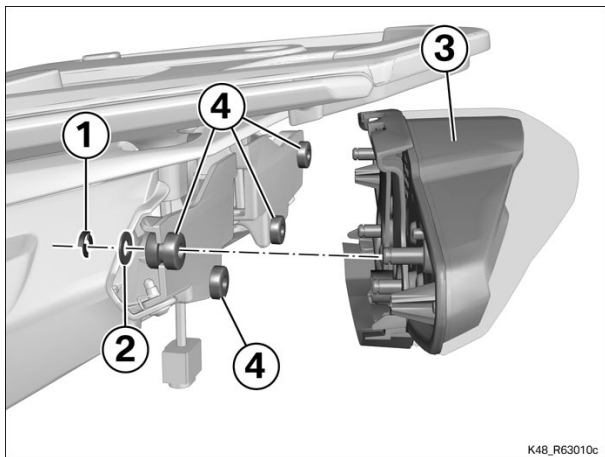

(-) Install the rear-light unit

- Seat rear light (3) in rubber grommets (4) and install.
- Install clips (1) and washers (2) on left and right.

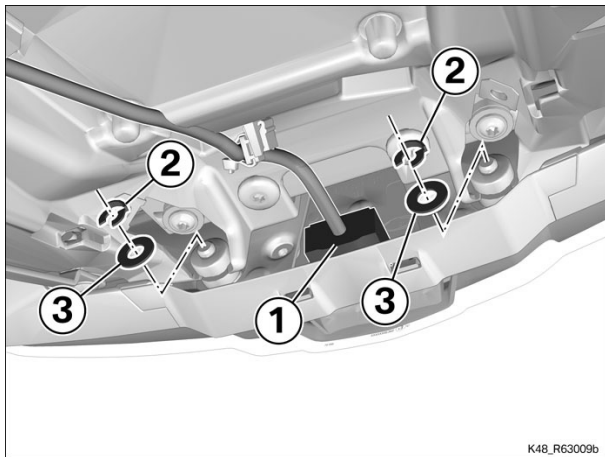

- Install clips (2) and washers (3).
- Connect plug (1) for the rear light.

Finishing work

- Installing cover panels for rear lights, left and right
- Installing number-plate carrier
- Final check of work performed

65 13 011 Removing/installing or replacing left and right front speakers 3 FRUs

+ 65 13 501

Equipment trim-level variant:

0266 - Preparation for audio system and navigation device

0267 - ECE audio system and preparation for navigation system

Preparatory work

Removing left hand protector

Removing right hand protector

Core activity

(-) Removing left speaker

- Disconnect plug (1) for the speaker.
- Remove screws (2).
- Remove speaker (3).

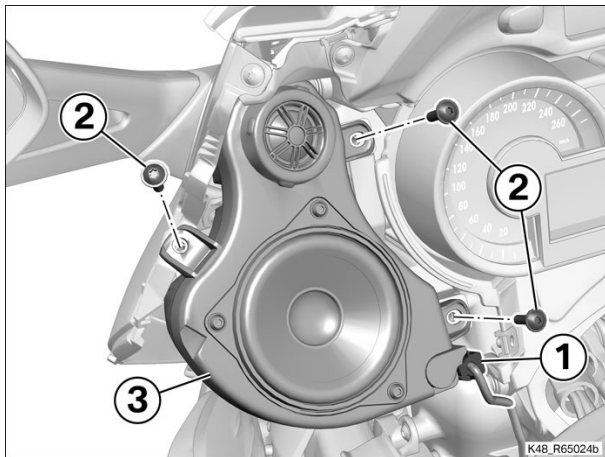

(-) Removing right speaker

- Disconnect plug (1) for the speaker.
- Remove screws (2).
- Remove speaker (3).

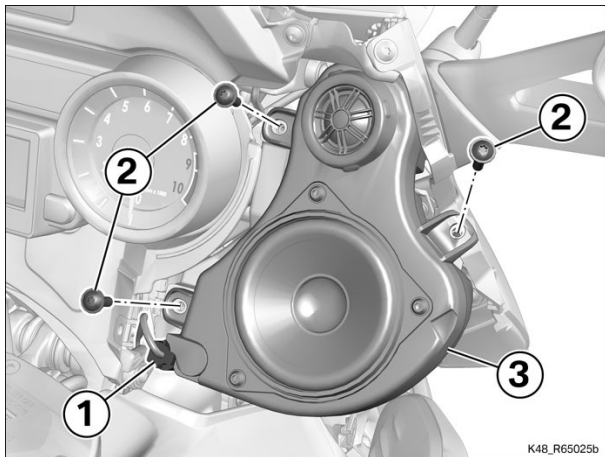

(-) Installing left speaker

- Install speaker (3).
- Install screws (2).

 Tightening torques		
Speaker to bracket/top section of fairing		
M5 x 20	2.5 Nm	

- Connect plug (1) for the speaker.

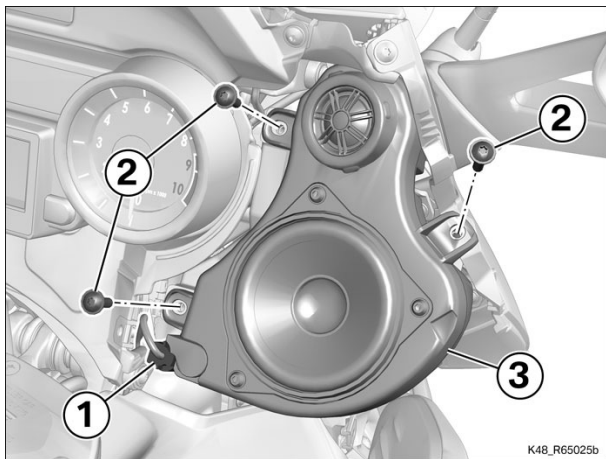
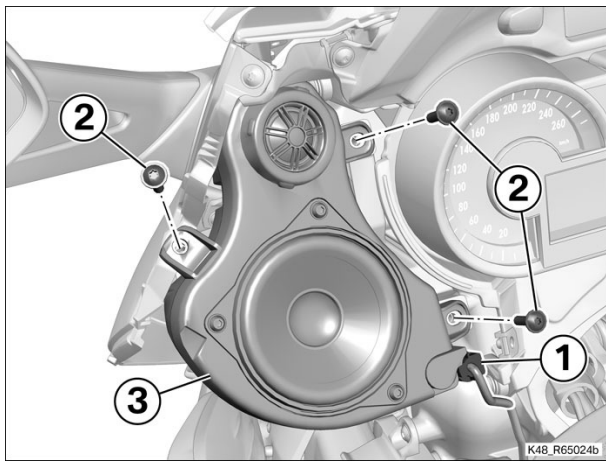

(-) Installing right speaker

- Install speaker (3).
- Install screws (2).

 Tightening torques		
Speaker to bracket/top section of fairing		
M5 x 20	2.5 Nm	

- Connect plug (1) for the speaker.

Finishing work

- Installing right hand protector
- Installing left hand protector
- Final check of work performed

65 14 505 Replacing operating unit for audio system (without (testing software/programming) 3 FRUs

Equipment trim-level variant:

0267 - ECE audio system and preparation for navigation system

0266 - Preparation for audio system and navigation device



Note

Before removal, test the control unit with the **BMW Motorrad** diagnostic system and make a backup copy of the data.

Preparatory work

Removing left bottom side panel

Removing left radiator cowl

Removing left side panel

Removing inner trim for left side panel

Core activity

(-) Removing operating unit for audio system

- Remove screws (1).
- Remove operating unit (2).

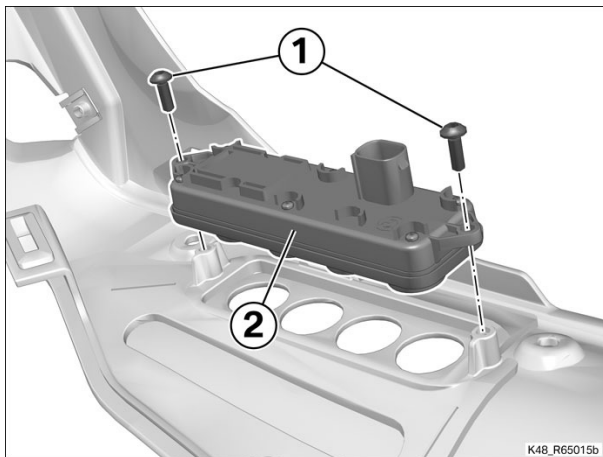

(-) Installing operating unit for audio system

- Install operating unit (2), making sure that the operating unit is located in the catch (arrow).
- Install screws (1).

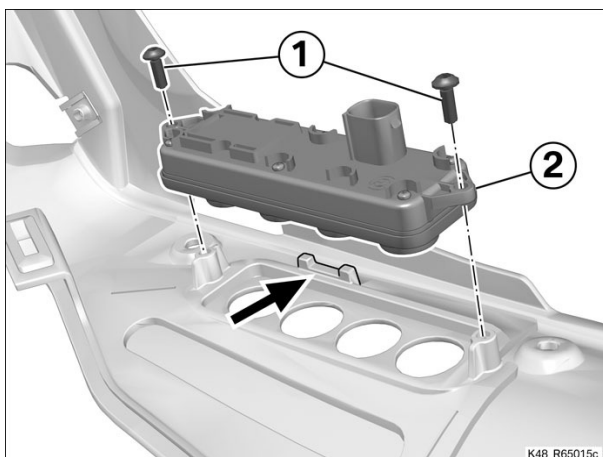

Tightening torques

Operating unit for audio system to fairing side panel

TS4 x 10

1.5 Nm

Finishing work

Installing inner trim for left side panel

Install the left side panel

Installing left radiator cowl

Installing left bottom side panel

**=> Testing software (Description in item: 61 00 502,
Billed as a separate item)**

**=> Programming control units of vehicle (along with
testing software) (Description in item: 61 00 510, Billed
as a separate item)**

Final check of work performed

📁 65 75 020 Replace batteries for control unit of anti-theft alarm system 5 FRUs

+ 65 75 520

Equipment trim-level variant:

0603 - Anti-theft alarm (DWA)

0417 - Central locking

Preparatory work

Remove the front seat

Remove the rear seat

Removing number-plate carrier

Removing complete luggage carrier

Removing tail cover centre panel

Core activity

(-) Removing batteries in control unit for anti-theft alarm system (DWA)

- Remove screws (1) and remove cover (2).

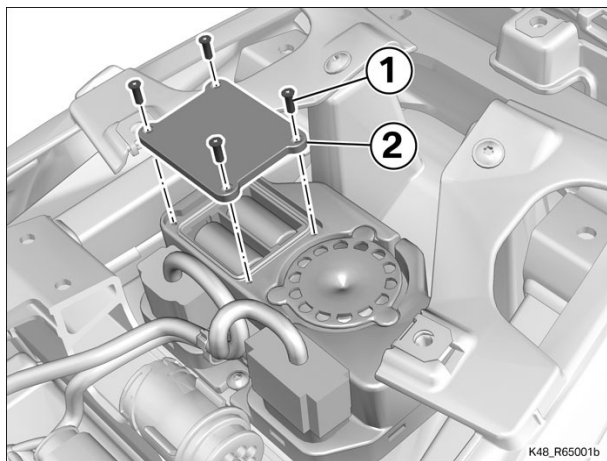

- Remove batteries (1).

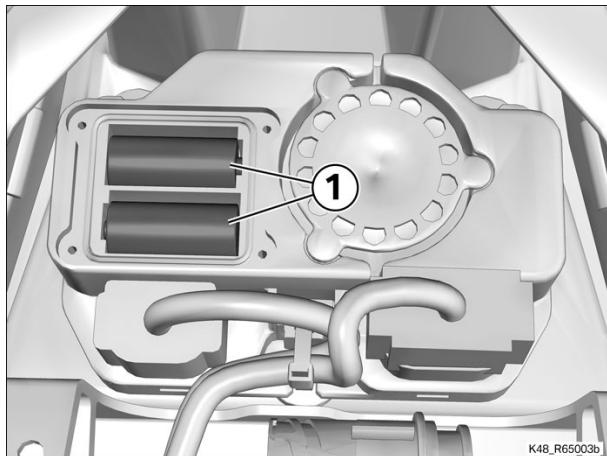

(-) Installing batteries in control unit of anti-theft alarm system

- Install batteries (1), making sure that polarity is correct.

 Technical data			
Battery type and rated voltage		CR 1632 lithium 3 V	

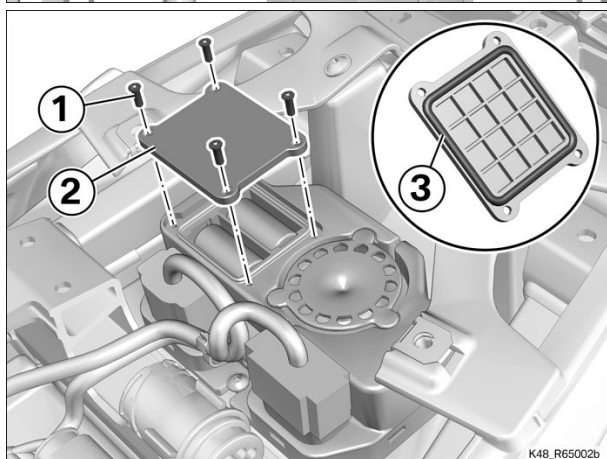
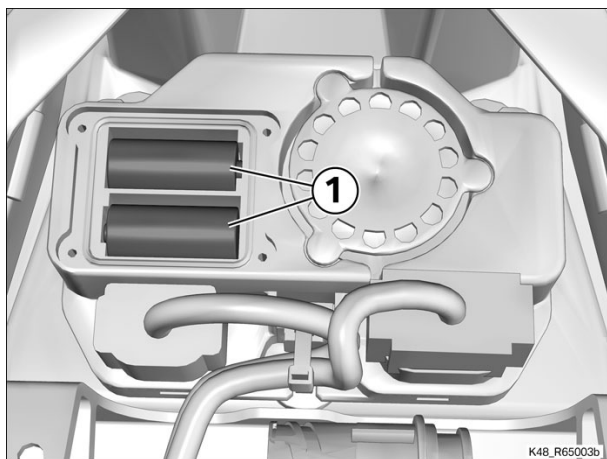

- Check seal (3) for damage; replace if necessary.
- Place cover (2) in position and install screws (1).

Finishing work

- Installing tail cover centre panel
- Installing complete luggage carrier
- Installing number-plate carrier
- Installing rear seat
- Installing front seat
- Final check of work performed

65 75 510 Replacing control unit of anti-theft alarm (without testing software/ programming) 4 FRUs

Equipment trim-level variant:

0603 - Anti-theft alarm (DWA)

0417 - Central locking



Note

Before removal, test the control unit with the **BMW Motorrad** diagnostic system and make a backup copy of the data.

Preparatory work

Remove the front seat

Remove the rear seat

Removing number-plate carrier

Removing complete luggage carrier

Removing tail cover centre panel

Core activity

(-) Removing anti-theft alarm

- Remove cable tie (arrow).
- Disconnect plug (1) for the anti-theft alarm and plug (2) for the central locking system.

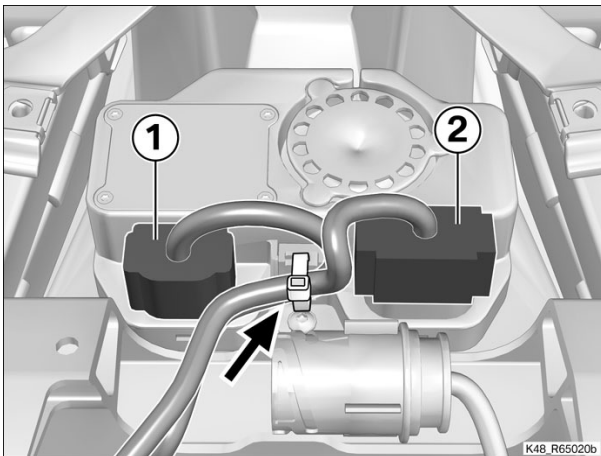

- Remove screws (1).
- Remove anti-theft alarm (2).

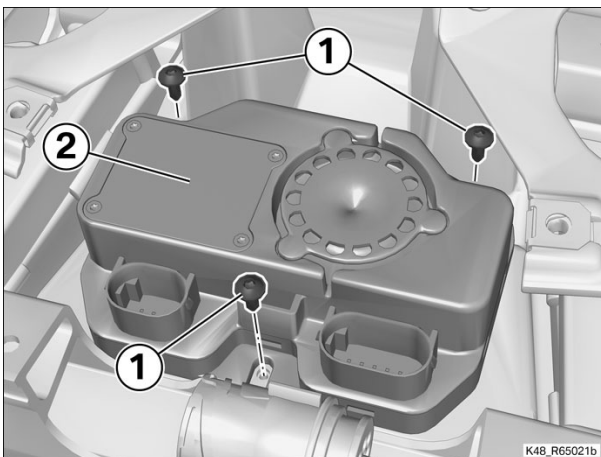

(-) Installing anti-theft alarm

- Install anti-theft alarm (2).
- Install screws (1).



Tightening torques

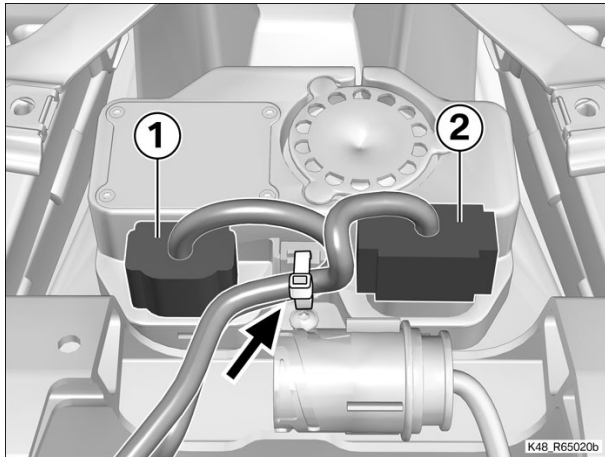
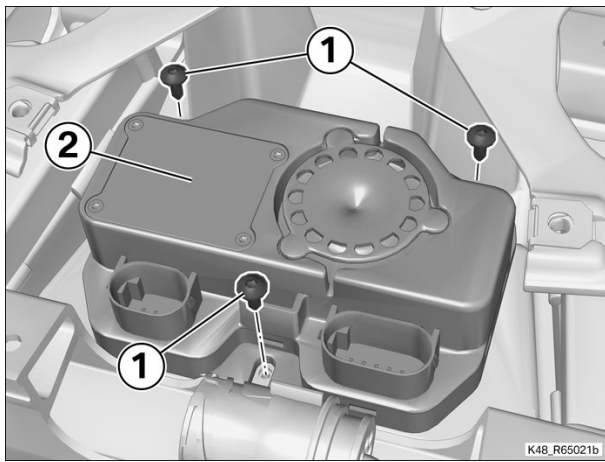

Control unit (anti-theft alarm) to rear carrier

TS4 x 10	1.5 Nm	
----------	--------	--

- Connect plug (1) for the anti-theft alarm and plug (2) for the central locking system.
- Secure the cable tie (arrow).

Finishing work

=> **Testing software (Description in item: 61 00 502, Billed as a separate item)**

=> **Programming control units of vehicle (along with testing software) (Description in item: 61 00 510, Billed as a separate item)**

Installing tail cover centre panel

Installing complete luggage carrier

Installing number-plate carrier

Installing rear seat

Installing front seat

Final check of work performed

65 81 050 Replacing ambient-temperature sensor 4 FRUs

+ 65 81 550

Preparatory work

Removing left bottom side panel

Removing left radiator cowl

Removing left side panel

Core activity

(-) Removing ambient-temperature sensor

- Disengage complete ambient-temperature sensor (1) from inner trim (2) and disconnect plug (3).

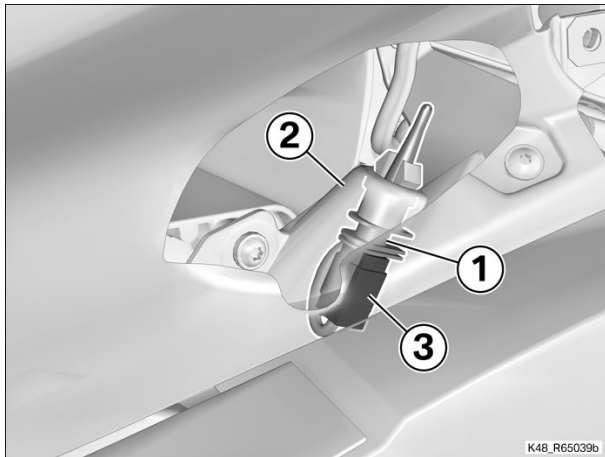

(-) Installing ambient-temperature sensor

- Secure complete ambient-temperature sensor (1) in inner trim (2) and connect plug (3).

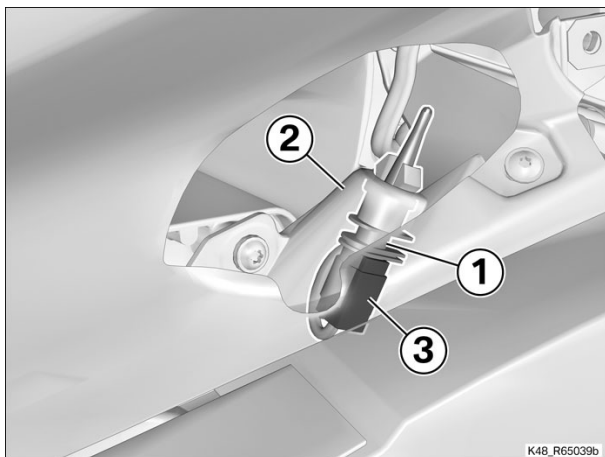

Finishing work

Install the left side panel

Installing left radiator cowl

Installing left bottom side panel

Final check of work performed

67 11 002 Replacing central-locking drive for case

+ 67 11 552

Equipment trim-level variant:
0417 - Central locking

Preparatory work

Remove the front seat

Removing cover for case carrier, left

Removing left rear trim panel

Core activity

(-) Removing central-locking unit for cases

- Disengage line (1) from the holder (arrow).
- Disconnect plug (2) for the central-locking drive.
- Remove screws (3).
- Remove central-locking unit (4).

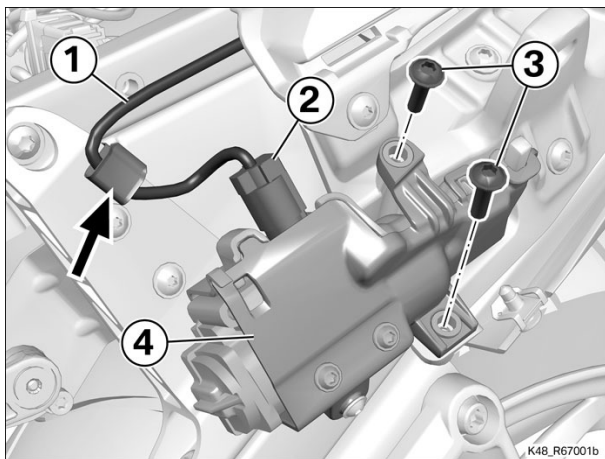

(-) Disassembling central-locking unit for cases

- Remove screw (1).
- Open the retainers (arrows).
- Remove housing cover (2).
- Remove screws (3).

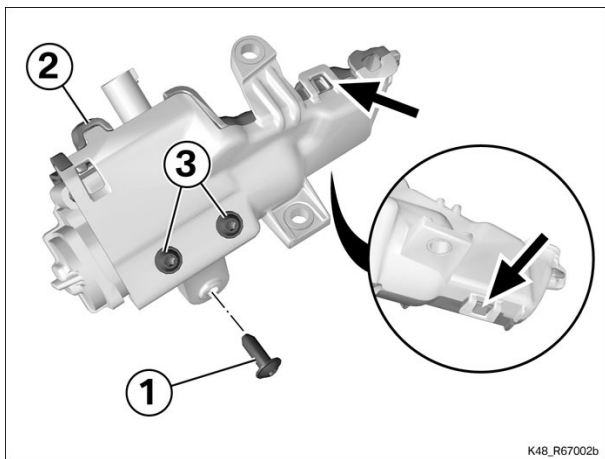

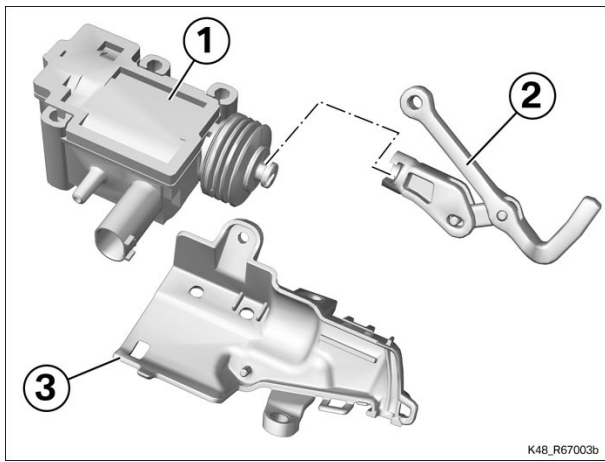

- Remove central-locking drive (1) with pivot lever (2) from housing (3).
- Remove lever (2) from drive (1).

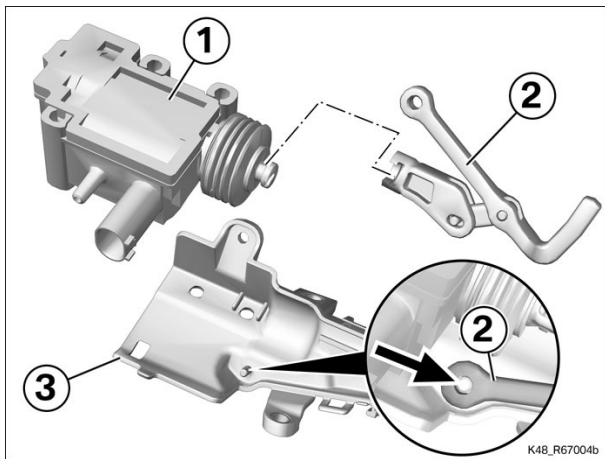

(-) Assembling central-locking unit for cases

- Install pivot lever (2) in central-locking drive (1).
- Seat drive (1) with lever (2) in housing (3).
- » Lever (2) is located by the lug (arrow).

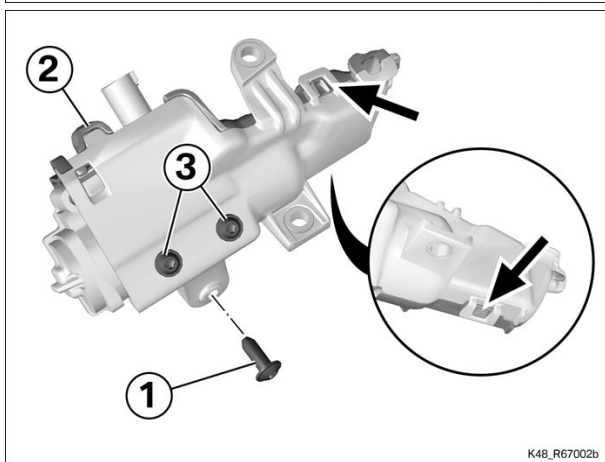

- Install screws (3).
- Install housing cover (2).
- » The retainers (arrows) snap into position.
- Install screw (1).

(-) Installing central-locking unit for cases

- Hold central-locking unit (4) in position.
- Install screws (3).
- Connect plug (2) for the central-locking unit.
- Secure line (1) in the holder (arrow).

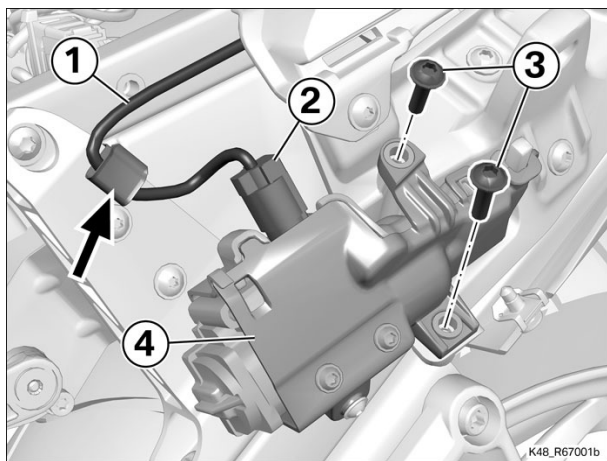

Finishing work

Installing left rear trim panel

Installing cover for case carrier, left

Installing front seat

Final check of work performed