



ALPINE TECHNICAL MANUAL

CONTENT

1/	EDITORIAL	3
2/	HISTORY	4-5
3/	SKI	
	HOLE SKI	6
	TECHNOLOGIES +	
	CONSTRUCTION	7-8
	BASE, FINISHES	9-10
	LENGTH RECOMMENDATION	
	ACC. TO TARGET GROUP	11
4/	SKI CARE AND	12
	PREPARATION	
5/	BINDINGS	13-61
6/	BOOTS	
	VACUUM-FIT	62-63
	HYBRID	64
	SOMA-TEC	65
	TECHNICAL FEATURES	66-67
	FFS	68-69
7/	APPENDIX BINDINGS	70-85
8/	ALPINE TERMINOLOGY	68-88

TECHNICAL HANDBOOK

THE FISCHER TECHNICAL HANDBOOK

As a salesperson you are extremely important to the future of Alpine skiing. You convey your knowledge and enjoyment of the sport directly to the customer. Only if you are able to provide proper advice will the customer be able to experience enthusiasm for the sport in the way you do.

At FISCHER we value your passion for skiing and want to help you convey this enthusiasm to your customers with the best products and the latest information. This technical handbook is intended as one of the tools to assist you. It should be a real help to everybody involved in skiing. We have input all our experience to support you with clear, useful information, and not just on FISCHER products. This handbook will extend your knowledge of Alpine skiing and make it easier for you to sell the FISCHER brand.

There are a number of information sources open to your customers in addition to this handbook (fischersports.com).

We are certain that this technical handbook will support you in your daily work. We would be pleased to hear from you with any suggestions for keeping the information up-to-date.

We wish you a successful winter!

Your FISCHER Alpine Team.

Ried, May 2012



THE HISTORY OF FISCHER

FISCHER IS AN OUTSTANDING INNOVATOR IN THE ALPINE SKI SECTOR.

From sledges to Skifahrwerk™ (the latest ski suspension technology). FISCHER has been at home in the snow for more than 80 years. Based in Ried im Innkreis, Upper Austria, the company offers a complete range of Alpine and cross country ski equipment. Skis, boots, bindings, tennis rackets and hockey sticks are sold worldwide.



The company was founded in 1924 by Josef Fischer senior, who in the beginning mainly produced rack wagons and toboggans, plus skis made to order. By 1934 the factory employed 85 staff and was making 40,000 pairs of skis.



In 1958 FISCHER evolved from being merely a ski manufacturer into a brand. Rudolf Ferch designed the corporate logo consisting of three equal triangles. At the time nobody could have guessed that it was to become one of the most famous symbols in the sport industry.

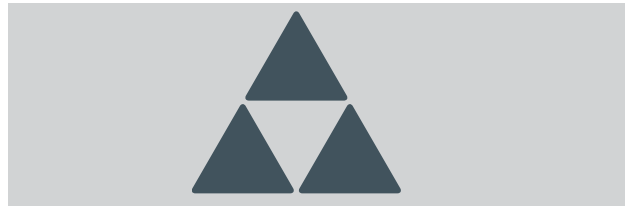

In 1964 all signs point to success: with Austrian Egon Zimmermann's victory in the Olympic Downhill in Innsbruck FISCHER wins the first Gold medal in its history. More than 250,000 pairs of skis are sold in this season. The winning "Alu-Steel" ski was the first metal ski to make a breakthrough with 40% of the market share worldwide.



Franz Klammer heralds a golden era on the FISCHER C4 starting in 1973. The national hero wins the Olympics in Innsbruck in 1976, dominates Alpine racing for years and goes down in the history books as the most successful downhill skier of all time.



In 2001 with the help of “Frequency Tuning” a start is made on improving the oscillation properties of skis. The result - much smoother running skis - conquer the market the very next season. In 2003 FISCHER enters new ground by launching Soma-Tec, the first ski boot to adapt to the anatomy of the human foot. The feet can now maintain their natural V-Position, even while skiing. Comfort that has a very positive influence on performance.



At ISPO 2006 FISCHER presents another revolutionary system: Flowflex, the world's first Skifahrwerk™ (ski suspension system), enabling skis to flex fully for the first time. Skiing specialists are delighted by the optimum distribution of force direct to the slope and perfect grip in all snow conditions.



The Hole Ski, already used by Fischer in the speed disciplines between 1975 and 1985, has been back in the World Cup since 07/08.



There was a milestone in the development of ski boots in 2011. Fischer launched VACUUM FIT at ISPO, causing a sensation with a development that has truly revolutionised the boot market. The first ski boot that has a 100% fit!



In the 10|11 season six of the eight possible large crystal globes went to Fischer athletes! World Cup winners such as Thomas Morgenstern (AUT), Justyna Kowalczyk (POL), Dario Cologna (SUI), Kaisa Mäkäräinen (FIN), Tarjei Boe (NOR) and Ivica Kostelić (CRO) counted on equipment from Innviertel in Austria – and won.



11|12 - High-end in all conditions: the new, revolutionary Fischer Hybrid Technology combines the best of both worlds! The patented Fischer Hybrid Technology transforms the ski at a click from a merciless piste pro into an extreme Freeski for awesome turns in powder. For the skiers who have two souls in their body and are torn between speed on-piste and breathtaking experiences away from the groomed slopes.



And the future? There will be plenty to look forward to!

HOLE SKI

Fischer stands for high tech. The technological leadership is the result of relentless research and development work. Work that produces revolutionary solutions again and again that set new standards. It is again the hole ski with which Fischer has surprised its competitors and thrilled its customers. Because the hole is by no means a marketing gag. The hole gives you substantial advantages that benefit any skier all the time. And why?

It's because the hole ski stands out from the rest due to its lower mass inertia moment. Thanks to this reduction in weight at the ski tip and tail, the mass is concentrated on the centre of the ski. The positive effects are a considerable improvement to ski oscillation and, as a result, optimised, smooth running and better turning and control.

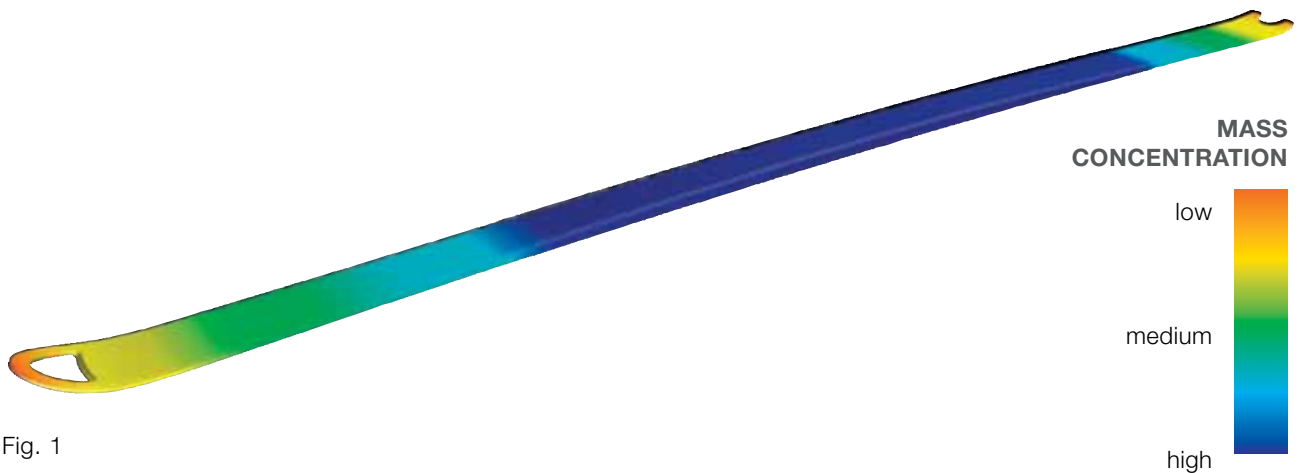

Fig. 1

HOLE SKI TECHNOLOGY OVERVIEW



Hole cutout especially for race pistes



Transparent hole with base for all-round use



Hole recess for all slopes

SMALL CAUSE – BIG EFFECT

Winner with the Hole Ski: Ivica Kostelić made use of the benefits of the Hole Ski. The reduction in weight may appear to be small, but it has a big impact on performance. The successes in the World Cup of Kostelić in particular speak for themselves.

TECHNOLOGIES

DUAL RADIUS SYSTEM

A metal reinforcement in combination with a special 3D on the proven Dual Radius System gives you added performance.



HYBRID

Unites two worlds: long and short radiuses – on- and off-piste. Made possible through ROCKER technology with on/off switching.



RACETRACK

Optimised flex with free flex action, best possible piste contact, direct power transfer and straight boot position.



ROCKER

The shorter contact length of the ski ensures that turn initiation is easier and requires less effort. Three different types: All Mountain ROCKER, Freeski ROCKER, Tour ROCKER.



CONSTRUCTIONS

AIR POWER

Ski core with less density. The reduced ski weight means easier handling and less energetic skiing.

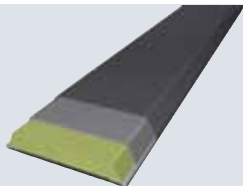

FUMA AIR CORE

Combination of the extremely light Fuma wood with Fischer's Air Core technology. Thanks to the sandwich construction, the skis also have magnificent torsional stiffness and stability – lightness in the ascent, stability and performance in the descent.



AIR CHANNEL

Air channels integrated into the glass fibre wood core save considerable weight. Extreme strength and optimum surface pressure distribution.

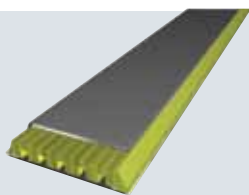

PAULOWNIA WOOD CORE

Ultralight wood used in ski making. Used specially for touring skis - either with cap or sandwich design.

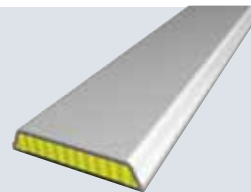

AIR CARBON

Ultra lightweight and extremely strong high-tech material from the aerospace industry. Improves handling and performance.

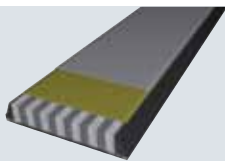

SANDWICH CONSTRUCTION

Laminated construction with a wooden core and sidewalls to support the edges for highest stability, strength and durability.

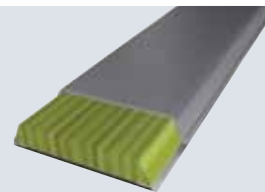

AIR CARBON TI

Extremely lightweight and strong combination of Air Carbon and titanium. Guarantees easier handling and optimum performance.

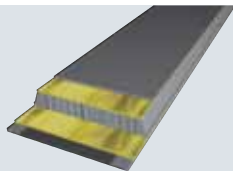

SANDWICH SIDEWALL CONSTRUCTION

Wood core combined with ABS sidewalls in a classic Sandwich Construction for balanced flex and perfect rebound.

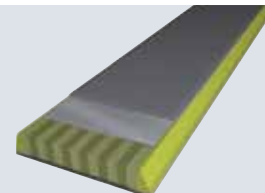

CARBON TECH

Special network of carbon fibres with exceptional torsion properties and a balanced stiffness pattern at the same time.

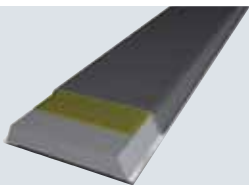

SIDEWALL CONSTRUCTION

Sidewall Construction to support the edges for highest stability, strength and durability.

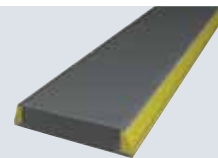

COMPOSITE FRAME

The self-supporting shell construction transfers the power to both edges. The ski delivers optimum skiing performance in all situations.

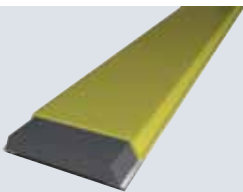

TITANAL 0.8/ TITANAL 0.5

Wood Core with double Titanal shell, reinforced with Air Carbon. Perfect edge grip and extremely smooth running as a result.

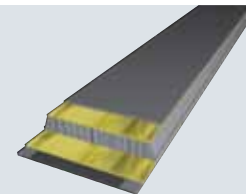

FIBER TECH

Special glass fibre network with harmonious bending properties. The ski stands out through excellent turning action.

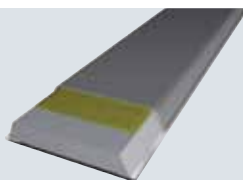

BASE, FINISHES

The base provides contact to the snow. The base gives the ski optimum gliding capabilities. Skiing "Schuss" or carving, a base that has been looked after and properly waxed reduces friction to increase enjoyment and make skiing easier.

TYPES OF BASE

SINTERED (GRAPHITE)

Sintering involves slowly melting polyethylene powder in a heated steel mould to form discs under high pressure. The ski bases are then peeled in strips from the sintered disc using a very sharp knife. Sintered bases have exceptional waxing properties and a very long service life.

TRANSPARENT

Sintered, transparent bases have an extremely pure material composition (no soot particles) and are therefore ideal for printing. The mechanical properties are the same as for a sintered graphite base.

EXTRUDED

Polyethylene granulate is melted in a heated extruder, rolled into mats and then cut into strips. The finished bases are then rolled up. Extruded base material is very hard-wearing, but does not possess as good waxing properties as sintered bases.

CUT BASES

A special cutting process is used on extruded or sintered bases to insert different colours of base material into the main base, achieving an eye-catching visual effect without compromising on the gliding properties of the ski base.

FINISH/STRUCTURE

To improve the gliding properties of the ski even further, the base is given different finishes, structures or embossed patterns to match different snow types and temperatures.

GRINDING

Various base structures are achieved using different grinding methods where the embossing process is not possible. Grinding with synthetic or natural diamonds gives the base the optimum structure. As a rule, deep and rough structures are ideal for damp and warm conditions, whereas for cold and dry conditions the ski base is given a finer structure for a flat running surface with perfect gliding properties.

EMBOSSING

The base of the ski is heated up and embossed under pressure using a roller with a defined structure. This process guarantees consistent base structures, especially on extruded bases.

BENEFIT TO THE CUSTOMER

Using various bases and structures fulfils the requirements of the customers and their respective target groups.

GRAPHITE BASES/
RACE SKI STRUCTURE
For optimum gliding.

TRANSPARENT BASES
For base designs.

CUT BASES
For design inserts in graphite bases, combines top gliding properties and design.

BASE, FINISHES

EDGES

The edges on our Alpine skis are made of special spring steels that can be easily hardened and ensure best elasticity and toughness. As a result this material is highly resistant to wear and provides a long service life.

STANDARD EDGES

Finish: base angles - 0.6 to 1.2 degrees, side edge angle - 3 to 4 degrees. The hanging base angle makes the ski easier to turn and easier to control.

RENTAL EDGES

Due to the wider, reinforced edge these edges can be reground up to 30 times on a ski servicing line. The service life of the skis is increased and the ski can be rented out more often than comparable rental skis. Wider edges for frequent ski servicing.



SLOPESTYLE

Park and Pipe skis require special edge specifications due to the high stresses that occur during jumps and slides over rails etc. This special edge is extremely wear-resistant and robust thanks to an edge geometry that is larger than on conventional steel edges. Extra robust and rounded for ideal sliding on rails and for jumping.

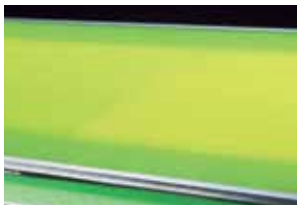

RACING EDGES

In racing it is about the fastest time. The requirements for a racing edge are to give athletes perfect grip at the same time as minimum friction. The fine tuning of the edges is decisive; the surfaces are ground as flat as possible. Fine structures and ground-sharp for lowest possible friction and perfect hold on hard slopes.



BENEFIT TO THE CUSTOMER

Using a variety of edges and edge angles caters perfectly for all the requirements of the customers and their respective target groups.

RENTAL EDGES: Broader, reinforced edges that can be ground up to 30 times.

SLOPESTYLE EDGES: Particularly robust and hard-wearing edges for landings on rails.

RACING EDGES: Optimally prepared edges for perfect grip.

FINISH/STRUCTURE STANDARD "T"

Edge angle on base side 0,3°, optical base structure hangs left or right 30-60°, surface finish roughness 3-5 µm, flatness 0.10 mm and stone pattern more widely-spaced.

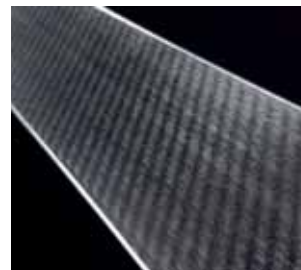

FINISH/STRUCTURE STANDARD "JR."

Edge angle on base side 0,6-1°, optical base structure hangs left 50-60°, surface finish roughness 3-4 µm, flatness 0.20 mm and stone pattern closely-spaced.



RECOMMENDED LENGTHS ACCORDING TO TARGET GROUPS

This chart shows the maximum and minimum ski length in relation to the skier's height. We recommend the lengths in the yellow area depending on the requirements and

skills of the various target groups. If the product features **ROCKER** technology we recommend adding 5 cm to the recommended ski length.

MEN

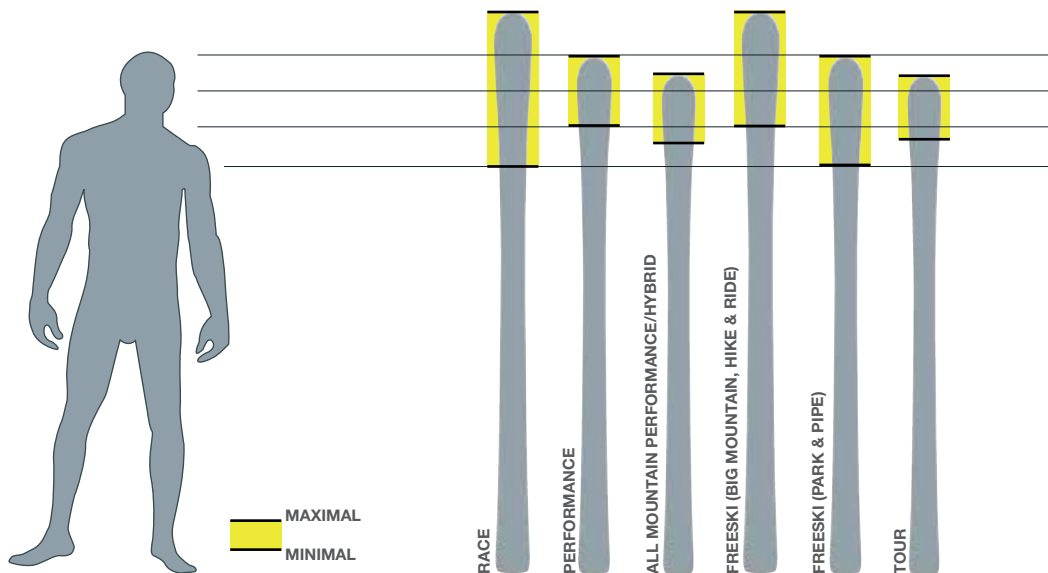

WOMEN

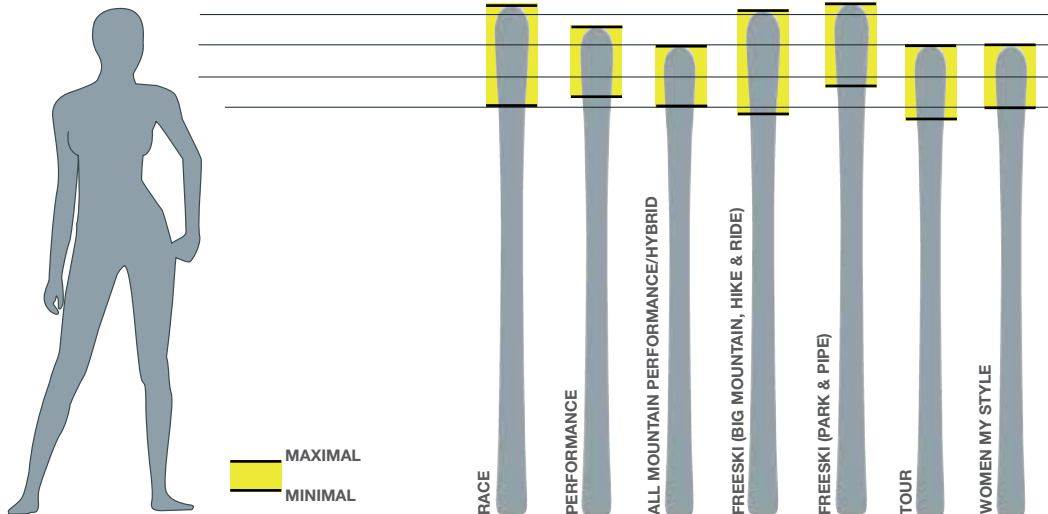

JUNIOR

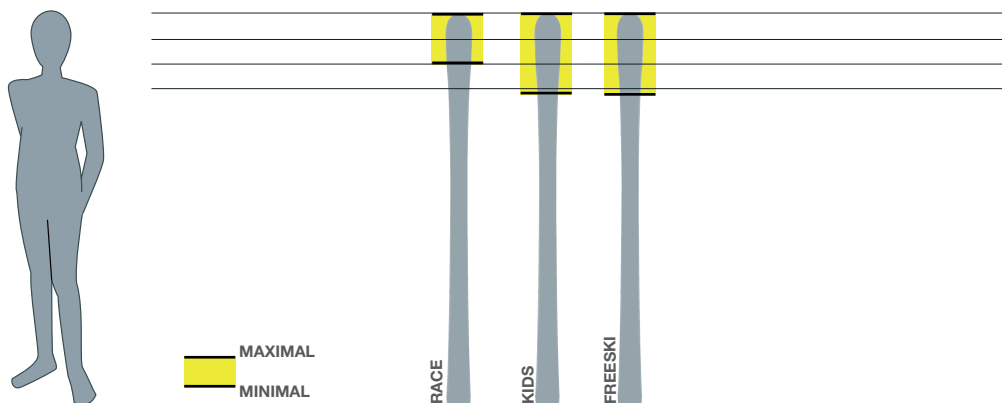

CARE AND PREPARATION

PREPARATION - FILING EDGES

1. Remove the sidewall: The sidewall ridge is filed away so the edge can be sharpened more easily.



2. Filing the edges: The idea edge angle is 87 – 88° for perfect edge grip. Filing jigs can be obtained in specialist sports shops. Step 1 rough file, Step 2 fine finish using diamond file.



PREPARATION - WAXING

1. Clean the base: Dirt, dust and wax remnants can be removed using a cleaning solvent obtainable from specialist sports shops.

IMPORTANT: Before moving on to the next steps, air the ski well (leave it outside for at least 15 minutes). An alternative is hot waxing (iron on wax and immediately scrape off soft gliding wax).



2. Apply wax: The wax is melted using a waxing iron and dripped onto the base of the ski.

NOTE: The waxing iron is at the correct temperature when the wax melts uniformly without forming smoke.



3. Iron on wax: The temperature needs to be set to between 110 and 130 °C. The waxing iron is drawn across the base at a constant speed in the skiing direction.

NOTE: Do not iron backwards and forwards or concentrate on one spot because there is a risk of the base overheating.



4. Allow the ski to cool for 5 to 10 minutes before removing excess wax. Use a sharp perspex edge to remove the wax by applying a constant, light pressure in the direction of skiing.



5. Brush the running surface with a nylon and/or combined brush in the direction of skiing. For the best possible gliding results, the structure of the base must be brushed thoroughly to remove any residual wax.



MOUNTING FLOWFLEX BINDINGS

FLOWFLEX SYSTEM

All FISCHER Flowflex System bindings can be used with skis of group 1 and 2 (page 22)

MODELS:C-Line Z13 Flowflex 2.0, C-Line Z9 Flowflex 2.0, XTR 13 Pro Plus, XTR 12 Pro Plus, Pro Z 13 Flowflex 2.0

Make sure that the boot is satisfying the international standards and has no functional damage. Check the ski boot sole length using the boot measuring jig. Now place the Flowflex binding according to the mounting position indicated on the Flowflex system (fig. 1) and tighten the screws.

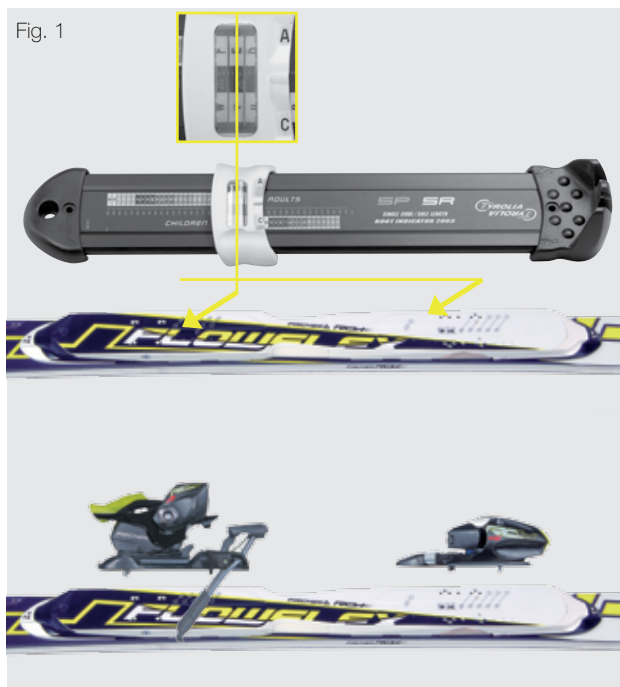

IMPORTANT: the predrilled mounting holes as of the 10I11 line are covered with a decorative film. This film simply has to be pierced through with the binding screws when mounting the binding which means that predrilling is no longer necessary! A standard stipulates that long screws have to be used when fixing the Flowflex binding on this new plastic plate. These long screws are premounted on Flowflex bindings as of the 10I11 season. When mounting older Flowflex bindings on this new plate the old short Flowflex screws have to be replaced with longer ones. If this is the case use the T 162 831 conversion set. If the reverse is the case (new Flowflex binding with premounted long screws on old aluminium plate) use the T 162 832 conversion set.

CAUTION WITH XTR 13 PRO PLUS AND XTR 12 PRO: As of the 10I11 season only long screws are premounted on these models. When using them on old aluminium

Flowflex plates these screws have to be replaced with short ones.

NOTE FOR MOUNTING RC4 Z17, Z13 and X17 FREE-FLEX BINDINGS: These bindings with the premounted screws can be used with the new plastic plate. The following rule still applies when mounting these bindings on the old aluminium Flowflex plate:

The screws have to be replaced with the following screw conversion sets – T162 752 for Freeflex bindings up to the 08I09 season, T162 829 for Freeflex bindings as of the 08I09 season.

FORWARD PRESSURE

Check to make sure the boot meets international standards and is not damaged. Place the boot in the binding and close it. The indicating pointer should rest within the scribed area (fig. 2) if not, you have to adjust the forward pressure.

IMPORTANT: Don't open the length adjustment lock as long as a ski boot is fixed in the binding.



Place the ski boot in the open binding and rest the boot heel on the brake treadle. Lift the length adjustment lock (2) with a screwdriver and slide the heel until the heel cup just touches the boot. Lock the length adjustment by pushing it down. Latch the boot in the binding and check forward pressure again. The toe pincers should not be pressed open and the indicating pointer should rest within the scribed area (fig. 2).

Adjusting the release values: The release values of the toe and heel should be determined by height and body weight (ISO/ASTM) method. Set the binding accordingly with the adjustment screws. We recommend the use of a calibrated testing device and that you keep a written record of whether the system passes or fails (requirement in the US).

MOUNTING FLOWFLEX BINDINGS

NOTE: Release/retention settings above a release moment of 100 Nm at the toe and 400 Nm at the heel are higher than the international standards recommend and are used solely at the skier's own risk!

FUNCTION CHECK

Entry/exit: Check to make sure that the boot does not catch on the heel hold down lug.

Brake: Press the brake treadle (1) down by hand (fig. 3). The brake arms (2) must automatically return to the braking position when the treadle is released.

Lateral elasticity of the toe: Press the boot laterally outward. The binding must re-center the boot easily and quickly from a 15 mm lateral displacement.

FINAL CHECK

- Has the proper mounting point been selected?
- Functional brake test passed?
- Have all screws been fastened tightly?
- Has the forward pressure been properly set?
- Are the release values of the toe and heel properly determined and set?
- Is the instruction for use booklet ready to be handed over to the consumer?



MOUNTING POWERRAIL/RACETRACK BINDINGS

POWERRAIL/RACETRACK

The Powerrail/RACETRACK system meets the demands of adult skiers, while being perfectly suited for both retail and rental sectors! Fischer offers two types of bases, the Powerrail/RACETRACK base and the Powerrail/RACETRACK PRO base, which are suited for boot-sole length of 260 all the way up to 380 mm. All Powerrail/RACETRACK bindings can be combined with both types of bases.

MODELS: RC4 Z17 RACETRACK, RSX Z13 RACETRACK, RSX 12 Powerrail, RC4 Z12 Powerrail, RSX Z12 Powerrail, RSX12 Powerrail Wide 88, RC4 Z11 Powerrail, RS 10 Powerrail, RS 11 Powerrail.

NOTE: Fischer offers different types of brakes for Powerrail/RACETRACK bindings.

MOUNTING

Make sure that the boot meets the international standards and is free of any functional damage. Take the binding parts out of the box and follow the steps on the instruction leaflet. Determine the boot sole length with the rental caliper (art. no. T162 617).

First you have to open the toe-lever and slide the toe on the rail from the front (fig. 2).

Lock at the appropriate boot sole length and close the lever (fig. 2).

Now hook the brake into the heel housing (fig. 3).

Then you can open the lever (fig. 2) and slide the heel on the rail from the back. Simply lock it at the appropriate boot sole marking by closing the lever - and you are ready to go (fig. 4).

Finally, check the forward pressure, by placing a boot into the binding. If you have followed all steps correctly, the indicator should rest in the marked area (fig. 5).

If you have too much or not enough forward pressure, check the settings at first. If necessary, adjust slightly at the heel and the toe (fig. 6). Then check the forward pressure again. Now it should be okay.



MOUNTING RAILFLEX MY STYLE/JR. RAIL

Mounting and adjusting the LR bindings is extremely simple and can be done without any additional tool. Make sure that the boot meets the international standards and is free of any functional damage. Take the binding parts out of the box and follow the steps on the instruction leaflet. Determine the boot sole length with the rental caliper (art. no. T162 617).

First you have to open the toe-lever and slide the toe on the rail from the front (fig. 8).

Lock at the appropriate boot sole length and close the lever (fig. 10).

Now hook the brake into the heel housing (fig. 9).

Then you can open the lever and slide the heel on the rail from the back. Simply lock it at the appropriate boot sole marking by closing the lever - and you are ready to go.



Finally, check the forward pressure, by placing a boot into the binding. If you have followed all steps correctly, the indicator should rest in the marked area (fig. 11).



If you have too much or not enough forward pressure, check the settings at first. If necessary, adjust slightly at the heel and the toe (fig. 12). Then check the forward pressure again. Now it should be okay.

FORWARD PRESSURE

FORWARD PRESSURE

Place the boot in the binding and close it. The indicating pointer should rest within the scribed area. If not lift the tooth lock with a screwdriver (fig. 13 - 4), adjust the forward pressure and lock the tooth lock again. The adjustment range is +/- 4 mm, the last position to the front and the rear is reached if the indicating pointer (1) or (2) is aligned with the rearend of the steel base plate (3) (see fig. 13).

In the case of bindings without tooth lock adjustment the indicator must lie within the marked area (Fig. 14, 15). If the contact pressure is too little or too much, check the setting and, if necessary, adjust the heel and jaw setting and check the contact pressure again.

NOTE: Always remove the boot before opening the toothed lock. Check the forward pressure again.

ADJUSTMENT OF THE RELEASE VALUES

The adjustment value of toe and heel should be determined by height and body weight (ISO/ ASTM) method. Set the bindings accordingly to the individual parameters of the skier. We recommend the use of a calibrated testing device, and that you keep a written record of whether the system passes or fails (this is a requirement in the US).

NOTE: Release/retention settings above a release moment of 100 Nm at the toe and 400 Nm at the heel are higher than the international standards recommend and are used solely at the skier's own risk!

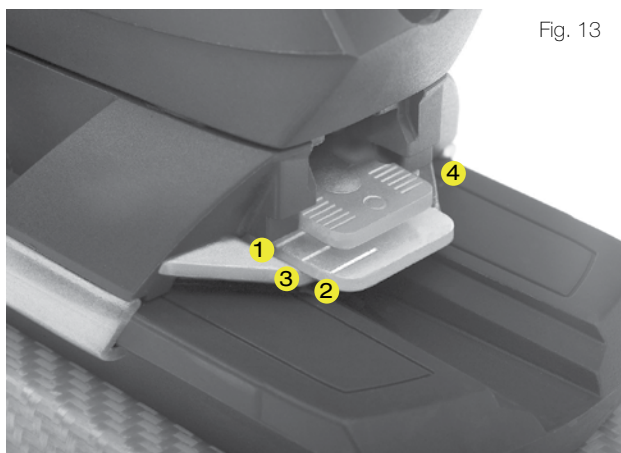

Fig. 13



Fig. 14



Fig. 15



Fig. 16



Fig. 17



Fig. 18

FORWARD PRESSURE

4. FUNCTIONS CHECK

Entry/exit: Check to make sure that the boot does not catch on the heel hold down lug (fig. 19).

Brake: Press the brake treadle (1) down by hand (fig. 20). The brake arms (2) must automatically return to the braking position when the treadle is released.



Fig. 19



Fig. 20

5. FINAL CHECK

- Is the proper mounting point selected?
- Functional brake test passed?
- Are all screws fastened tightly?
- Is the forward pressure properly adjusted?
- Are the release values of toe and heel properly determined and set?
- Is the Instruction for use booklet ready to be handed over to the customer?

SAFETY

HIGH QUALITY MARK

The unique positioning of FISCHER bindings in terms of safety, has also been recognized by the independent TÜV Product Service Institute: Following amazing results in safety tests, due to the friction minimizing release using ABS, FISCHER was awarded the title High Quality Mark for particularly high standards in safety. Now, nothing stands in the way of unrestricted skiing enjoyment.

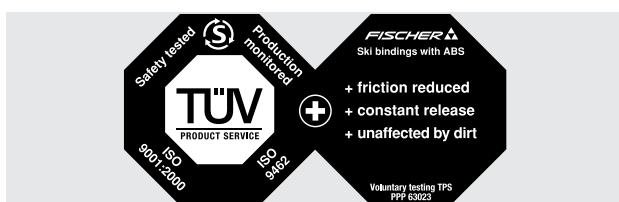

DIAGONAL

The FISCHER diagonal heel has a release arc of 150°. The impact on the skier is reduced especially in dangerous forward twisting falls.



FRP

Four rollers and glide plates optimize the retention and release characteristics of the binding. This system provides 30% higher reset and hold power and 30% less play for direct power transmission to the edge of the ski. Short, hard impact is absorbed more effectively.



FULL DIAGONAL

The FISCHER full-diagonal toe piece ensures 180° release and reacts especially to backward and backward twisting falls. This technology can reduce impact on the knees and ligaments during a fall.



ABS

Thanks to the ABS system the boot is able to exit the binding virtually friction-free. This ensures that the triggering pressure remains constant to provide the highest degree of safety, even if the soles of the ski boots are worn or dirty.



FREEFLEX-PRO

The patented system with free-moving heel section. The ski can flex unrestricted and maintains its dynamic properties. The result is optimum ski control and best possible edge grip. Two springs in the middle section of the ski respond to counterflexing by stabilizing the resonance of the ski.



DRILL TEMPLATE SELECTION

Drill Template	Line 12 I13	Line 11 I12	Line 10 I11
92 W (T 162 760)	RC4 Z 17 Freeflex	RC4 Z 17 Freeflex-Pro	RC4 Z 17 Freeflex-Pro
	RC4 Z 13 Freeflex	RC4 Z 13 Freeflex-Pro	RC4 Z 13 Freeflex-Pro
	RC4 Z 11 Freeflex	RC4 Z 11 Freeflex-Pro	RC4 Z 11 Freeflex-Pro
	RS 10 / RS 11	FS 10 / FS 11	FS 10 / FS 11
	RC4 Z 9	RC4 Z 9	RC4 Z 9
	FJ 7 AC	FJ 7	FJ 7
	X 17 w/o brake	X 17	X 17
	X 13 w/o brake	X 13 (wb)	X 13 (wb)
	X 11 wide 90	X 11	X 11
	X 9 wide 90	X 9	X 9
	X 7 AC wide 90	X 7	X 7
94 W (T 162 761)	FJ 4 AC AC	FJ 4 AC	FJ 4 AC
XTR Pro (T 162 826)		XTR 13 Pro Plus	XTR 13 Pro Plus
	XTR 12 Pro	XTR 12 Pro	XTR 12 Pro
	XTR 10 Pro	XTR 10 Pro	XTR 10 Pro
	XTR 9 Pro	XTR 9 Pro	XTR 9 Pro
	XTR 7 Pro	XTR 7 Pro	XTR 7 Pro
	XTR 4 AC Pro	XTR 4 AC Pro	XTR 4 AC Pro
XTR RENT (T 162 827)	XTR 10 Rent	XTR 10 Rent	XTR 10 Rent
	XTR 4 AC Rent	XTR 4 AC Rent	XTR 4 AC Rent

DRILL TEMPLATE 92 W

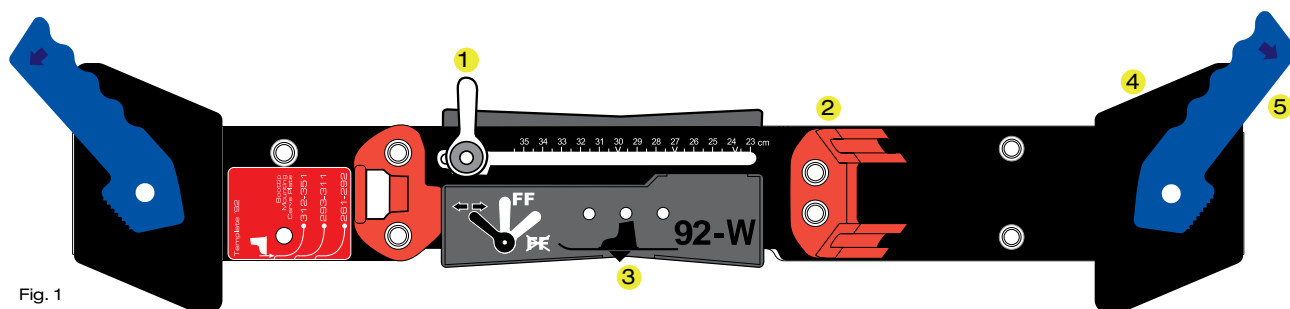

Fig. 1

1. COMPATIBILITY

Presently the drill template 92 W is valid for:

MODELS: RC4 Z 17 Freeflex, RC4 Z 13 Freeflex, RC4 Z 11 Freeflex, RS 10, RS 11, RC4 Z 9, FJ 7 AC, X 17, X 13, X 11 wide 90, X 9 wide 90, X7 AC wide 90.

All adult-bindings and RC4 Z9 can be used with skis of group 1 and 2. The junior bindings FJ 7 and FJ4 are delivered with screws for skis shorter than 140 cm. If they are mounted on skis of group 1 and 2, replace them with longer screws. Drill template 92 W can be used for ski widths from 59 mm to 108 mm. For other skis use the template adapter set (art. no. T 162 569). With this adapter set, skis from 45 to 132 mm can be mounted.

NOTE: FISCHER offers two different types of brakes for adult bindings – the Power Brake and the FS Brake. Refer to the brake overview on page 40 for brake and binding compatibility.

Power Brake LD 78: The standard brake, the Power Brake LD 78 (art. no. T 162 578), can be used for skis up to 78 mm. For ski widths from 78 to 97 mm use Power Brake LD wide 97 (art. no. T 162 874) and from 94 to 115 mm use Power Brake LD fat 115 (art. no. T 162 603). For skis up to 130 mm the Power Brake LD XFat (art. no. T 162 710) must be used: for RC4 Z13 Flowflex, RC4 Z 13 FF, RC4 Z11 FF, Pro Z 13 Flowflex, RC4 Z 12 Flowflex, RSX 12 Flowflex, XTR 13 Pro plus, XTR 12 Pro, XTR 10 Pro, XTR 9 Pro, XTR 7 Pro, XTR 10 Rent.

SL Brake (for FS 10 and FS 11 bindings): The FS Brake 78 (art. no. T 162 642) is for skis up to 78 mm, for wider skis use the FS Brake wide 90 (art. no. T 162 755), which is for skis ranging from 78 mm to 90 mm.

Junior Brake: The FJ Junior Brake 72 (art. no. T 162 764) can be used for ski widths up to 72 mm for wider skis, from 72 to 90 mm, use also SL Brake wide 90 (art. no. T 162 776). There have to be used other types of brakes for Jr. Rail: SL-Brake LR 78 (art. no. T 162 942) für Z9 und Z7; SL Brake LR 74 (art. no. T 162 941) für Z4.

ATTENTION: The description of the brakes always includes a number like 72, 78, 90, 93, 115. This number stands for the maximum ski width in the brake area and not in the ski center!

2. ADJUSTING THE DRILL TEMPLATE

To adjust the template unlock the locking lever (1) by rotating it counter-clockwise to the far left position.

Freeflex: Due to the center piece these bindings are limited to ski boots with sole lengths from 257 to 362 mm. Place the ski boot in the template and push the template together until the stops (2) come against the ski boot sole. Take the boot out of the template. Position the locking lever (1) in the mid position, then open or close the template to the nearest centimeter mark.

For other bindings: Place the ski boot in the template and push the template together until the stops (2) come against the ski boot sole. Lock the lever to the far right position to prevent length change, then take the boot out of the template.

DRILL TEMPLATE 92 W

3. POSITIONING OF THE DRILL TEMPLATE

Open the clamping jaws (4) of the template by rotating the clamping handles (5) and then place template correctly on the ski, with the boot midsole indicator (3) aligned with the mounting mark on the ski. Be sure the template is evenly seated against the ski's top surface. Release clamping handles thus attaching the template to the ski.

NOTE: Keep in mind that some ski manufacturers do not use the center of boot sole location method, always follow their instructions.

4. DRILLING THE HOLES

Standard groups are to be introduced for the 09/10 season. The info box on the ski shows you which standard group it is.

Group	Length of binding mounting point section	Drill hole depth	Screw strength
STANDARD GROUP SPECIFICATION			
1	285 mm	9.5 mm	2600 N
2	240 mm	9.5 mm	2600 N
3	210 mm	7.5 mm	1600 N
4	190 mm	7.5 mm	1300 N

If not otherwise specified by the ski manufacturer, use a 4,1 Ø x 9,0 mm drill bit for skis of group 1 and 2. Use a 4,1 Ø x 7,0 mm drill bit for skis of group 3 and 4. Drill the holes using the appropriate drill bit. If required by the ski manufacturer, tap the hole with a 12 AB tab. After drilling place a drop of glue in each hole. It lubricates the screws and seals the holes (fig. 2).



5. MOUNTING

For Freeflex Pro: Place the pre-assembled heel over the prepared holes and tighten the screws in a cross pattern (fig. 3).



Then attach the AFD to the toe and place it together with the base plate over the front holes. Check if the AFD has snapped in, in its specific position (fig. 4). Then you have to place the pre-assembled toe over the holes (fig. 5).

ATTENTION: First you have to tighten the screw in the center - the number has to correspond to the centimetre mark from the template (fig. 6).

To fix it you have to hold the bands together and tighten the screw carefully. After this align the toe over the holes and fasten the screws.

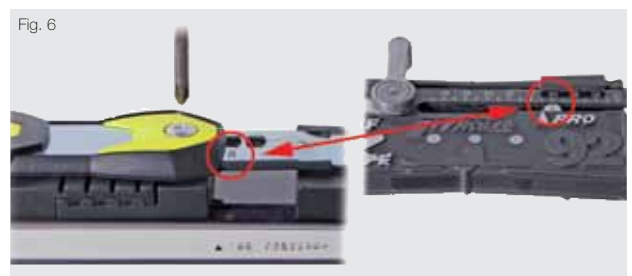
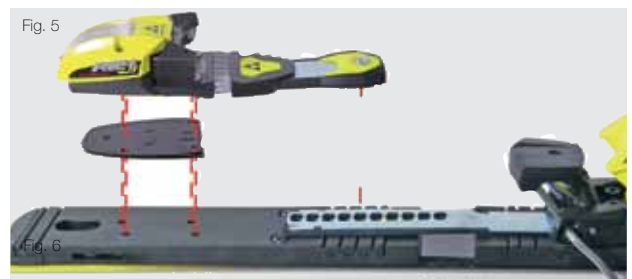



Fig. 7

6. FORWARD PRESSURE

Check to make sure the boot meets international standards and is not damaged. Place the boot in the binding and close it. The indicating pointer should rest within the scribed area (fig. 8/9) if not, you have to adjust the forward pressure.

IMPORTANT: Don't open the length adjustment lock as long as a ski boot is fixed in the binding.

Place the ski boot in the open binding and rest the boot heel on the brake treadle. Lift the length adjustment lock (2) with a screwdriver and slide the heel until the heel cup just touches the boot. Lock the length adjustment by pushing it down. Latch the boot in the binding and check forward pressure again. The toe pincers should not be pressed open and the indicating pointer should rest within the scribed area (fig. 8/9).

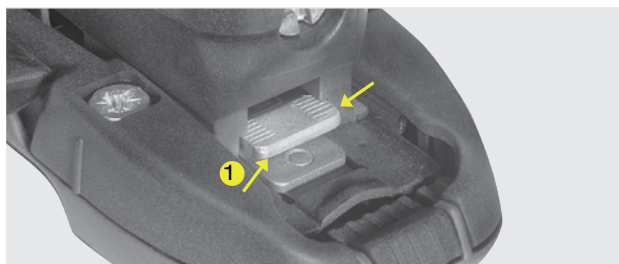

7. ADJUSTING THE RELEASE VALUES

The release values of the toe and heel should be determined by height and body weight (ISO/ASTM) method. Set the binding accordingly with the adjustment screws. We recommend the use of a calibrated testing device and that you keep a written record of whether the system passes or fails (requirement in the US).

NOTE: Release/retention settings above a release moment of 100 Nm at the toe and 400 Nm at the heel are higher than the international standards recommend and are used solely at the skier's own risk!



Fig. 9

8. FUNCTION CHECK

Entry/exit: Check to make sure that the boot does not catch on the heel hold down lug.

Brake: Press the brake treadle (1) down by hand (fig. 10 and 11). The brake arms (2) must automatically return to the braking position when the treadle is released.

Lateral elasticity of the toe: Press the boot laterally outward. The binding must re-center the boot easily and quickly from a 15 mm lateral displacement (model FJ 7 – 10 mm).



Fig. 10



Fig. 11

DRILL TEMPLATE 92 W

9. FINAL CHECK

- Has the proper mounting point been selected?
- Functional brake test passed?
- Have all screws been fastened tightly?
- Has the forward pressure been properly set?
- Are the release values of the toe and heel properly determined and set?
- Is the instruction for use booklet ready to be handed over to the consumer?

DRILL TEMPLATE 94 W

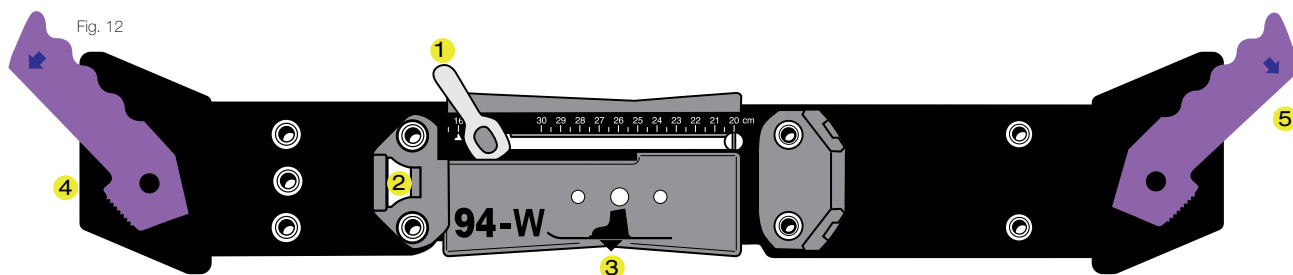

1. COMPATIBILITY

Presently the drill template 94 W is valid for:
MODEL: FJ 4 AC AC

This binding can be used for children's skis shorter than 140 cm. The standard brake, the SL Kid Brake 74 (art. no. T 162 399), can be used for skis up to 74 mm, for wider skis use the SL Kid Brake wide 84 (art. no. T 162 658), which is for skis from 75 to 84 mm.

ATTENTION: The description of the brakes always include a number like 72 or 84. This number stands for the maximum ski width in the brake area and not in the ski center!

2. ADJUSTING THE DRILL TEMPLATE

Unlock the locking lever (1) by rotating it counterclockwise. Place the template on the ski. Place the ski boot in the template. Push the template together until the stops are against the sole (2). Lock the lever (1) to prevent length change and take the boot out of the template.

3. POSITIONING OF THE DRILL TEMPLATE

Align the boot midsole indicator (3) with the midsole mounting mark on the ski. Be sure the template is evenly seated against the ski's top surface. Check the boot midsole mark with template mark. If they are not the same use the boot midsole mark to align the template with the ski mounting mark.

NOTE: Some ski manufacturers do not use the center of boot sole location method. Always follow the ski manufacturer's instructions.

4. DRILLING THE HOLES

If not otherwise specified by the ski manufacturer, use a 4,1 Ø x 7,0 mm drill bit. Drill the holes using appropriate drill. If required by the ski manufacturer, tap the hole. Place a drop of glue into the holes. It lubricates the screws and seals the ski (fig. 13).

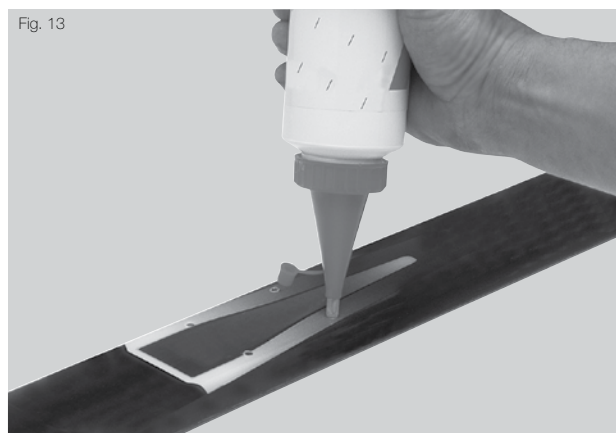

5. MOUNTING

Mounting the toe: Place toe unit over the holes and fasten the screws.

Mounting the heel: Place the heel over the holes. Drive the front screws first, then the rear ones.

6. FORWARD PRESSURE

See page 17.

DRILL TEMPLATE 94 W

7. ADJUSTMENT

Check to make sure that the boot meets international standards and has no damage (fig. 16)

Fig. 16



AFS JUNIOR: The SX Junior Line is suitable for both adult (type A) and children (type C) boots: the innovative mechanical Anti Friction Slider (AFS) automatically adjusts to the boot sole height, compensating A/C standards as well as height differences due to icing up, dirt or boot wear (fig. 17).

Fig. 17



If you want to increase the stability of your junior binding in combination with children (type C) boots, you can replace the standard AFS with a vertically blocked AFS (Art. No.T162962), which is for children (type C) boots ONLY. All you have to do is to separate the standard slider from the base plate (fig. 18).

Fig. 18



Afterwards you can simply click in the spare slider.



ADJUSTING THE RELEASE VALUES:

The release values at toe and heel should be determined by height and body weight (ISO/ASTM) method. Set the binding accordingly with the adjustment screws. We recommend the use of a calibrated testing device and that you keep a written record of whether the system passes or fails (requirement in the US).

8. FUNCTION CHECK

Entry/exit: Check to make sure that the boot does not catch on the heel hold down lug.

Brake: Press the brake treadle (1) down by hand. The brake arms (2) must automatically return to the braking position when the treadle is released (fig. 19).

Lateral elasticity of the toe: Press the boot laterally outward. The binding must re-center the boot easily and quickly from a 10 mm lateral displacement.

Fig. 19



9. FINAL CHECK

See page 24.

DRILL TEMPLATE ADRENALIN



1. COMPATIBILITY

Presently the drill template ADRENALIN can be used for: Adrenalin 16, Adrenalin 13

All ADRENALIN bindings come with 8mm penetration screws (except the screws for the locking mechanism, which have only 6 mm penetration) and can be used with skis of groups N1 & N2.

Drill template ADRENALIN can be used for ski widths from 75 to 125 mm. For other skis use the template adapter set (art. no. T162 569). With this adapter set skis from 61 to 149 mm can be mounted.

NOTE: Fischer offers different types of brakes. The Description of the brakes always includes a number like 88, 97, 115, 130. This number stands for the maximum ski width in the brake area and not in the ski center!!!

2. POSITIONING OF THE TEMPLATE

There are two ways to mount ADRENALIN bindings. Either with the solid jig (art. no. T162976) or with the paper template, which is included in the packaging of each binding.

We will show both procedures. First of all make sure that the boot is satisfying the international standards and has no functional damage. Determine the boot sole length with the Fischer rental caliper (art. no. T162 617).

2.1. DRILL TEMPLATE

Open the clamping jaws (2) by rotating the clamping handles (1) and then place the template on the ski. Align the boot midsole indicator (3) for the appropriate boot sole length with the midsole mounting mark on the ski. Release the handles and ensure that the template is evenly seated against the ski's top surface.

The front holes are identical for both versions (gold bushings). You just have to select the right bushings for the rear holes: ADRENALIN short 270-330 mm (silver), ADRENALIN long 300-360 mm (black).

2.2. PAPER TEMPLATE

Align the boot midsole indicator for the appropriate boot sole length with the midsole mounting mark on the ski. Fix it with a sticky tape and ensure that the template is centered and evenly seated against the ski's top surface.

After that you can mark the correct indicators with a punch. The front holes are identical for both versions. You just have to select the right indicator for the rear holes: ADRENALIN Short 270-330 mm (Symbol ○), ADRENALIN Long 300-360 mm (Symbol □).

NOTE: Keep in mind that some ski manufacturers do not use the center of boot sole location method. Always follow the ski manufacturer's instructions.

3. DRILLING THE HOLES

If not otherwise specified by the ski manufacturer use a 4.1 Ø x 9mm drill bit for the holes for the toe and the heel track and a 4.1 Ø x 7mm drill bit for the holes for the locking mechanism. After drilling place a drop of Fischer glue into the holes. It lubricates the screws and seals the holes.



4. MOUNTING

Place the heel track assembly over the holes and fasten all screws in a cross pattern. Then you can place the toe

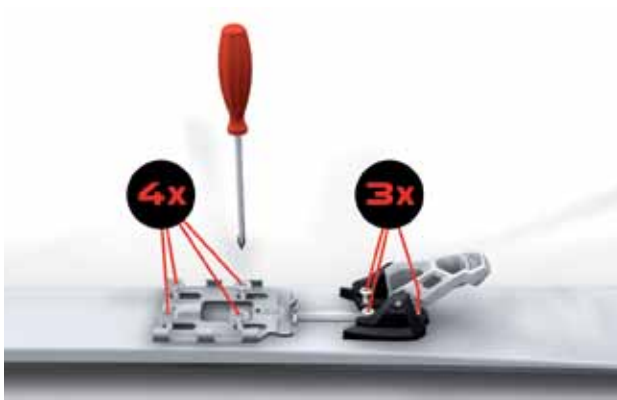

assembly over the holes and fasten the two front screws lightly. After that you have to close the platform with the ascender lock and then tighten fast the front screws. Open the lock again and tighten the other two screws of the toe piece. Now you can mount the heel. Therefore hook the brake into the heel housing, slide the heel on the platform from the back and lock it at the appropriate boot sole marking. After that you can close the ascender lock and you are ready for the final adjustments.

4. SOLE HEIGHT ADJUSTMENT

The ADRENALIN is designed to accommodate both type of boots - ALPINE SKI BOOTS (according to DIN/ISO 5355) and TOURING BOOTS (according to DIN/ISO 9523). For proper function the height of the AFS must be adjusted to the height of the boot sole. Fischer recommends to use the "AAA boot height adjustment tester" (art. no. T162983) to get the ideal distance of 0.5 mm between boot and AFS. Turning the adjustment screw at the toe moves the AFS up or down.



Place the tester on the AFS and enter the boot in the binding. Lift the tip of the boot to take out the play of the toe. Adjust the AFS with the adjustment screw so that you can pull out the tester with a slight resistance.

6. FORWARD PRESSURE

Check the forward pressure, by placing a boot into the binding. If you have followed all mounting steps correctly, the indicator should rest in the marked area- and you are ready to go. If you have too much or not enough forward pressure, check the settings and if necessary re-adjust the heel. Then close the lever and check the forward pressure again. Now it should be okay.



7. ADJUSTMENT OF THE RELEASE VALUES

The release values at toe and heel should be determined by height and body weight (ISO/ASTM) method. Set the binding accordingly with the adjustment screws. We recommend the use of a calibrated testing device and that you keep a written record of whether the system passes or fails (requirement in the US).

NOTE: Release/ Retention settings above a release moment of 100 NM at the toe and 400 NM at the heel are higher than the international standards recommend and are used solely at the skier's own risk!

8. FUNCTION CHECK

Check the function of the heel. Make sure that the boot does not catch on the heel during entry and exit. Check the brake function by pressing down the brake pedal (1) by hand. The brake arms (2) must open to the braking position when the brake pedal is released. Check the elasticity and retention of the toe by pushing the boot inward and outward. The binding must recenter the boot easily and quickly from a 15 mm lateral displacement.

9. FINAL CHECK

- Is the proper mounting point selected?
- Functional brake test passed?
- Are all screws fastened tightly?
- Is the forward pressure properly adjusted?
- Are the release values of the toe and heel properly determined and set?
- Is the instruction for use booklet ready to be handed over to the consumer?

DRILL TEMPLATE XTR PRO

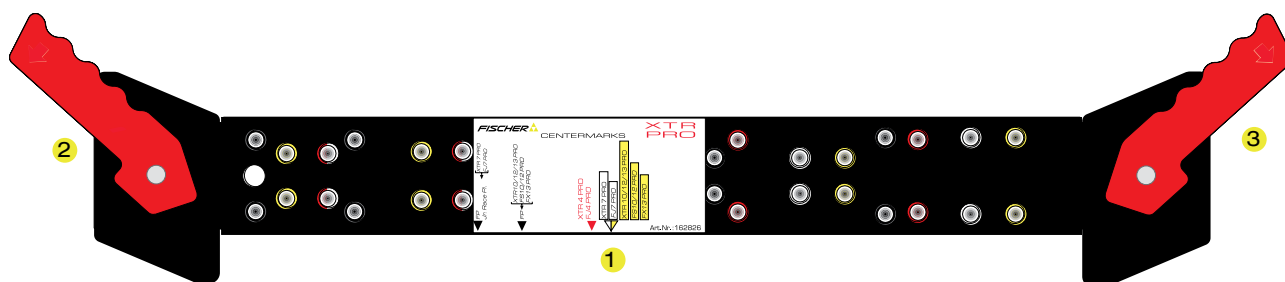

1. COMPATIBILITY

The drill template XTR PRO is used for:

MODELS: XTR 13 Pro Plus, XTR 12 Pro, XTR 10 Pro, XTR 9 Pro, XTR 7 Pro, XTR 4 AC Pro

All FISCHER adult bindings can be used with skis of group 1 and 2. The junior binding XTR 7 Pro is delivered with screws for skis of group 3 and 4. If it is mounted on skis of group 1 and 2, replace them with longer screws. XTR 4 AC Pro is only for skis of group 3 and 4. Drill template XTR Pro can be used for ski widths from 59 to 108 mm. For other skis use the template adapter set (art. no. T 162 569). With this adapter set skis from 45 to 132 mm can be mounted.

NOTE: The standard brake for XTR 13/12 Pro is the Power Brake LD 85 (art. no. T 162 805). The standard brake for XTR 10/9/7 Pro bindings is the Power Brake LD 78 (art. no. T 162 578), which can be used for skis up to 78 mm. For ski widths from 85 to 97 mm use Power Brake LD wide 97 (art. no. T 162 874) and from 97 to 115 mm use Power Brake LD fat 115 (art. no. T 162 603). The standard brake for the XTR 4 AC Pro is the SL Kid Brake Sympro 74 (art. no. T 162 559), which can be used for skis up to 74 mm, for wider skis use the SL Kid Brake wide 84 (art. no. T 162 658), which is for skis from 75 to 84 mm.

ATTENTION: The description of the brakes always include a number like 74, 78, 82, 93 or 115. This number stands for the maximum ski width in the brake area and not in the ski center!

See OMS System page 40:

<http://spareparts.fischersports.com>

User: spare_fischer

Password: omsnew

2. POSITIONING THE DRILL TEMPLATE

Open the clamping jaws (4) by rotating the clamping handles (5) and then place template correctly on the ski. Align the boot midsole indicator (3) for the appropriate binding model with the midsole mounting mark on the ski. Be sure the template is evenly seated against the ski's top surface. Release clamping handles (5) and attach the template firmly to the ski.

NOTE: Some ski manufactures do not use the center of boot sole location method. Always follow the ski manufacturer's instructions.

3. DRILLING THE HOLES

If not otherwise specified by the ski manufacturer, for all Pro adult models use a 4.1 Ø x 9.0 mm - drill bit for skis of group 1 and 2. For XTR 7 Pro and XTR 4 AC Pro use a 4.1 Ø x 7.0 mm - drill bit for skis of group 3 and 4. If XTR 7 Pro is mounted on skis of group 1 and 2 use a 4.1 Ø x 9.0 mm drill bit and replace the screws with longer ones. Drill through the appropriate bushings (see table).

Model	Colour of bushing
XTR 13 Pro Plus	yellow
XTR 12 Pro	yellow
XTR 10 Pro	yellow
XTR 9 Pro	white
XTR 7 Pro	white
XTR 4 AC Pro	red

DRILL TEMPLATE XTR PRO

If required by the ski manufacturer, tap the hole. After drilling place a drop of glue into the holes. It lubricates the screws and seals the holes (fig. 21).

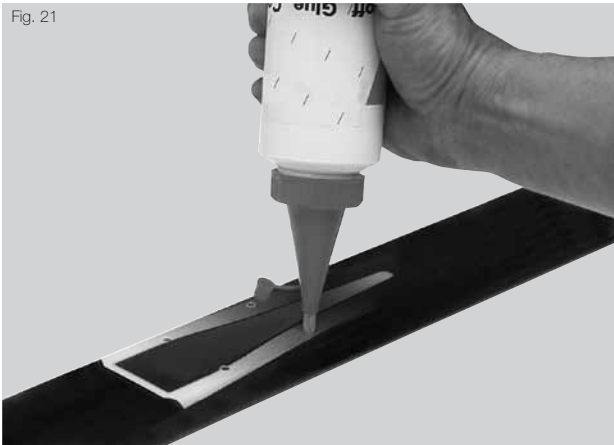

4. MOUNTING

Mounting the toe: Connect the plastic mid section (3) with the metal toe track (1). Place the assembled toe track (1) over the holes and drive the 4 (four) screws. Open the hand lever (2) and slide the toe piece on from the front. Adjust the toe piece to the desired Single Code position and close the hand lever (2) (fig. 22). Make sure that the lever snaps in place completely (it may be necessary to slide the toe forwards and backwards slightly).

Mounting the heel: Place the heel unit with its brake, guide and track over the holes. Drive the rear screws first, then the front screws.

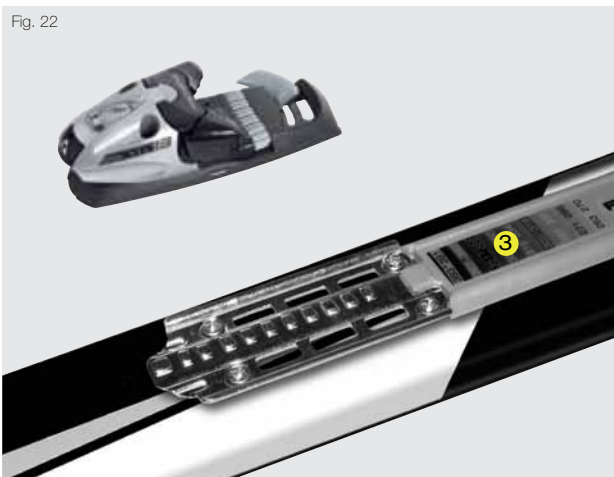

5. FORWARD PRESSURE CONTROLL

Place a suitable reference boot in the binding using the Single Code for length adjustment and close it. Then check the indicator (see fig. 23) located at the rear end of the heel piece. With boot inserted the pointer should rest in the middle of the scribed area. If necessary, readjust the boot sole length, check the Single Code.

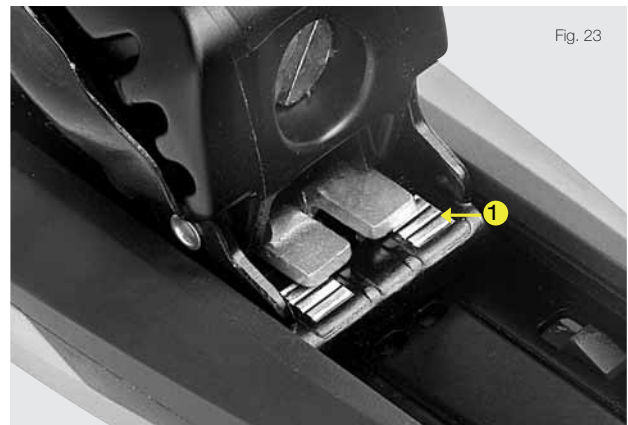

6. ADJUSTMENT

FOR ALL MODELS:

Find adjustment ranges and some handling hints in the section "Rent" of the Technical Manual. Take at least one reference boot satisfying all standards and free of functional damages to perform test adjustments with the binding.

Using the Single Code: Adjust toe and heel to the corresponding alpha-setting (Single Code) of the ski boot (fig. 24).



If a boot of unknown size is used proceed as follows: Place the boot in the toe cup. Slide the heel piece forward until it just touches the boot. Close the binding and check the forward pressure.

Adjusting the release values: The release indicator at toe and heel should be determined by height and body weight (ISO/ ASTM) method. Set the binding accordingly with the adjustment screws. We recommend the use of a calibrated testing device and that you keep a written record of whether the system passes or fails (requirement in the US).

NOTE: Release/retention settings above a release moment of 100 Nm at the toe and 400 Nm at the heel are higher than the international standards recommend and are used solely at the skiers own risk!

7. FUNCTION CHECK

Before the newly mounted ski equipment is rented perform a complete functional check.

NOTE: In some countries (USA) rental equipment has to pass a Pre-Season Test (see the Rental section of this manual). The boot should not catch on the sole hold-down of the heel as it opens and closes.

Brake: Press the step-on plate (1) down by hand. The brake arms (2) must close and open automatically to the braking position when the step-on plate is released (fig. 25).



Lateral elasticity of the toe: Press the boot laterally outward (by hand). The binding must re-center the boot easily and quickly from a 15 mm lateral displacement. (XTR 7 Pro, XTR 4 AC Pro - 10 mm).

8. FINAL CHECK

- Has the proper mounting point been selected?
- Have all screws been fastened tightly?
- Has the forward pressure setting been controlled?
- Has at least one full adjustment been made using a representative reference boot including release/ retention setting and momentum test?
- Has the functional check been passed successfully?
- Functional brake test passed?

DRILL TEMPLATE XTR RENT

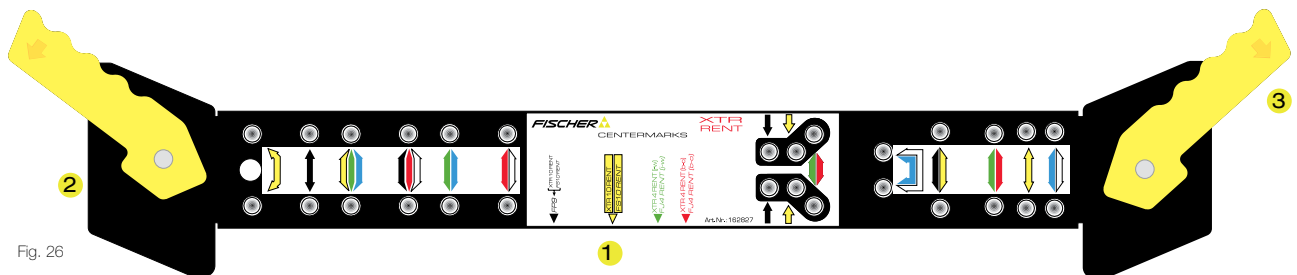

Fig. 26

1. COMPATIBILITY

The drill template XTR Rent is used for: Rent models.

MODELS: XTR 10 Rent, XTR 4 AC Rent

XTR 10 Rent can be used with skis of group 1 and 2. XTR 4 AC Rent is only for skis of group 3 and 4. Drill template XTR Rent can be used for ski widths from 59 to 108 mm. For other skis use the template adapter set (art. no. T 162 569). With this adapter set skis from 45 to 132 mm can be mounted.

NOTE: The standard brake for all Rent bindings, except the XTR 4 AC Rent, is the Power Brake LD 78 (art. no. T 162 578), which can be used for skis up to 78 mm. For ski widths from 78 to 97 mm use Power Brake LD wide 97 (art. no. T 162 874) and from 97 to 115 mm use Power Brake LD fat 115 (art. no. T 162 603). The standard brake for the XTR 4 AC Rent/Pro is the SL Kid Brake 74 (art. no. T 162 399), which can be used for skis up to 74 mm, for wider skis use the SL Kid Brake wide 84 (art. no. T 162 658), which is for skis from 74 to 84 mm. Following brakes fit to XTR 10: T 162 578 Power Brake LD 78, T 162 805 Power Brake LD Wide 85, T 162 874 Power Brake LD Wide 97, T 162 603 Power LD Fat 115.

ATTENTION: The description of the brakes always includes a number like 74, 78, 97 or 115. This number stands for the maximum ski width in the brake area and not in the ski center!

2. POSITIONING THE DRILL TEMPLATE

Open the clamping jaws (2) by rotating the clamping handles (3) and then place template correctly on the ski. Align the boot midsole indicator (1) for the appropriate binding model with the midsole mounting mark on the ski. Be sure the template is evenly seated against the ski's top surface. Release clamping handles and attach the template firmly to the ski.

NOTE: Some ski manufactures do not use the center of boot sole location method. Always follow the ski manufacturer's instructions.

Model	Colour of indicator
XTR 10 Rent	yellow
XTR 4 AC Rent	red (b-o)
XTR 4 AC Rent	green (j-w/F)

3. DRILLING THE HOLES

If not otherwise specified by the ski manufacturer, for all Rent adult models use a 4.1 Ø x 9.0 mm - drill bit for skis of group 1 and 2. For skis of group 3 and 4 use a 4.1 Ø x 7.0 mm drill bit. Drill through the appropriate bushings (see table). If required by the ski manufacturer, tap the hole. After drilling place a drop of glue into the holes. It lubricates the screws and seals the holes (fig. 27).



Fig. 27

4. MONTAGE

Mounting the toe: Place toe piece on the prepared holes and drive the screws (fig. 28).

Mounting the heel: Place the heel unit with its brake, guide and track over the holes. Drive the rear screws first, then the front screws.

Fig. 28



5. FORWARD PRESSURE CONTROL

Place a suitable reference boot in the binding using the Single Code for length adjustment and latch it. Then check the indicator (see fig. 29) located at the rear end of the heel piece. With boot inserted the pointer should rest in the middle of the scribed area.

Fig. 29

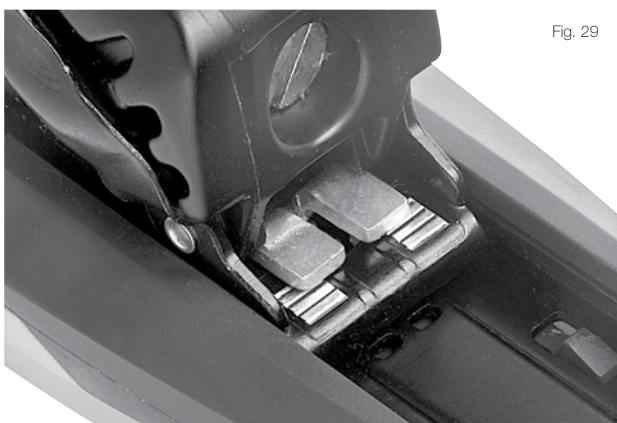

NOTE: If the forward pressure is not correct, readjust the boot sole length and check the Single Code. Please make sure that no boot is placed in the binding during adjusting!

6. ADJUSTMENT

FOR ALL MODELS: Find adjustment ranges and some handling hints in the section "Rent" of the Technical Manual. Take at least one reference boot satisfying all standards and free of functional damages to perform test adjustments with the binding.



Fig. 30

Using the Single Code: Adjust toe and heel to the corresponding alpha-setting (Single Code) of the ski boot (fig. 30).

If a boot of unknown size is used proceed as follows: Place the boot in the toe cup. Slide the heel piece forward until it just touches the boot. Close the binding and check the forward pressure.

Adjusting the release values: The release values at toe and heel should be determined by height and body weight (ISO/ASTM) method. Set the binding accordingly with the adjustment screws. We recommend the use of a calibrated testing device and that you keep a written record of whether the system passes or fails (requirement in the US).

NOTE: Release/retention settings above a release moment of 100 Nm at the toe and 400 Nm at the heel are higher than the international standards recommend and are used solely at the skiers own risk!

7. FUNCTION CHECK

Before the newly mounted ski equipment is rented perform a complete functional check.

DRILL TEMPLATE XTR RENT

NOTE: In some countries (USA) rental equipment has to pass a Pre-Season Test (See the Rental section of this manual). The boot should not catch on the sole hold-down of the heel as it opens and closes.



Brake: Press the step-on plate (1) down by hand. The brake arms (2) must close and open automatically to the braking position when the step-on plate is released (fig. 31).

Lateral elasticity of the toe: Press the boot laterally outward (by hand). The binding must re-center the boot easily and quickly from a 15 mm lateral displacement (XTR 4 AC Rent - 10 mm).

8. FINAL CHECK

- Has the proper mounting point been selected?
- Have all screws been fastened tightly?
- Has the forward pressure setting correct?
- Has at least one full adjustment been made using a representative reference boot including release/retention setting and momentum test?
- Has the functional check been passed successfully?
- Functional brake test passed?

MOUNTING PROCEDURE CARVE PLATES

1. GENERAL

For proper mounting of FP 13, FP 9 (up to line 07 108) use drill template 92 W. For mounting these plates beginning with line 08 109 use new drill template „Template Base & Plates (T 162 865). For the new Junior Racing Plate (Race Plate jr.) use T 162 902.

The compatible binding-plate combinations can be found in the compatibility chart. All Carve Plates can be used for skis of group 1 and 2. If mounted on skis of group 3 and 4 the screws have to be replaced by shorter ones. For mounting FJ7 or XTR7 Pro on Fischer Carve Plates you have to replace the pre-mounted screws by screws with 8 mm penetration depth. Only with these screws can we guarantee the right pullout strength (see table page 37).

2. ADJUSTING THE DRILL TEMPLATE 92 W

Unlock the adjustment lever (fig. 1, 1) by rotating it counterclockwise and push the template together as far as possible (23 cm). Fix the position by rotating the adjustment lever (fig. 1, 1) clockwise until it stops (see template 92 W on page 23).

3. POSITIONING THE DRILL TEMPLATE

Open the jaws (fig. 1, 4) of the template by rotating the handles (fig. 1, 5) and place it on the ski with the boot midpoint indicator aligned with the mounting mark of the ski. For skiboot tip mounting align the corresponding sole length mark on the sticker (fig. 32) with the boot tip mounting mark on the ski.

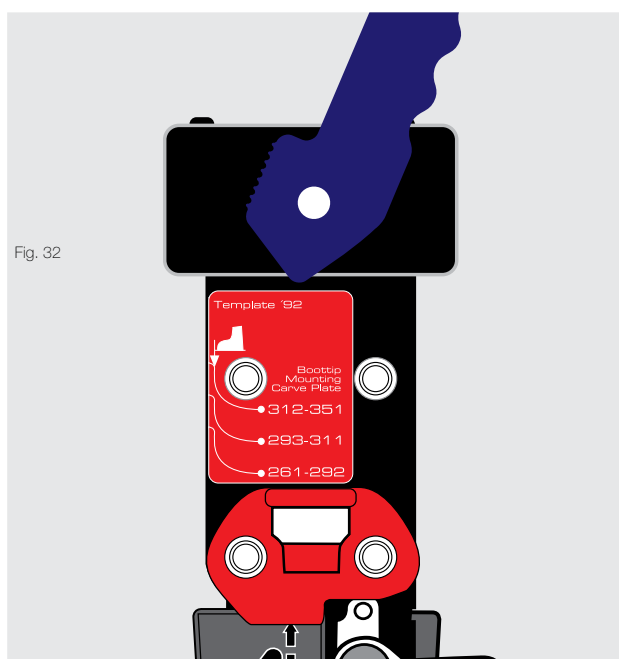

Fig. 32

IMPORTANT: When mounting Rental bindings the boot midpoint indicator should be behind the mounting mark. For older drill templates stickers can be ordered from your local distributor: Sticker Boot tip – art. no. T 159 03 83.

4. DRILLING THE HOLES

Open if not otherwise specified by the ski manufacturer, use a 4.1 Ø x 9.0 mm drill bit for skis of group 1 and 2. For skis of group 3 and 4 use a 4.1 Ø x 7.0 mm drill. Drill the holes using the appropriate drill bit. After drilling, drop some glue into the clean holes. This lubricates the screws and seals the hole.

5. MOUNTING

Place the front part of the plate over the holes and fasten the screws. Then place the back part over the holes and fasten the screws. Determine the bootsole length with the boot measuring device and place the binding on the Carve Plate corresponding with the appropriate printed length markings. Mount the binding in accordance with the procedures in the Tech Manual.

MOUNTING OF JUNIOR BINDINGS ON CARVE PLATES OR ON SKIS

For mounting these junior bindings on plates or on skis, group 1 and 2, replace the pre-mounted screws by 8 mm

penetration depth screws. Only with these screws can we guarantee the right pullout strength (see figure).

FJ 7	 T 162 401 5.5 x 15.5	 T 162 376 5.5 x 13.4	 T 160 018 5.5 x 18.5	 T 160 031 5.5 x 20.5		
X 7	 T 162 401 5.5 x 15.5	 T 162 376 5.5 x 13.4	 T 160 018 5.5 x 18.5	 T 160 031 5.5 x 20.5		
XTR 7 PRO	 T 162 639 5.5 x 9.0	 T 162 639 5.5 x 9.0	 T 162 458 5.5 x 25.0	 T 162 461 5.5 x 32.5		

FISCHER

MOUNTING OF BINDINGS ON PLATES

For mounting these bindings on skis, group 3 and 4, replace the pre-mounted screws by 6 mm penetration depth screw (see figure).

RC 4 Z	<p>T 162 488 5.5 x 19.5</p>	<p>T 162 426 5.5 x 16.9</p>	<p>T 162 426 5.5 x 16.9</p>	<p>T 160 018 5.5 x 18.5</p>		
X 9	<p>T 162 488 5.5 x 19.5</p>	<p>T 162 426 5.5 x 16.9</p>	<p>T 162 426 5.5 x 16.9</p>	<p>T 160 018 5.5 x 18.5</p>		
XTR 9 PRO	<p>T 162 640 5.5 x 7.0</p>	<p>T 162 640 5.5 x 7.0</p>	<p>T 162 417 5.5 x 26.5</p>	<p>T 162 460 5.5 x 30.5</p>		

FISCHER

MOUNTING ON RAISED PLATFORMS

MOUNTING FISCHER BINDINGS ON RAISED PLATFORMS

- Replacing the Power Brake is not necessary when you mount FISCHER bindings with the FISCHER Carve Plate 13 SLR or Carve Plate 9 SLR on skis which do not have integrated platforms.
- The Dragon Brake has extended brake arms and increased braking power replace the Standard Power Brake. Unscrew and remove both front heel screws and pull the Power Brake off the heel.
- Then slide on the Dragon Brake (see fig. 34) and screw it on.

CAUTION: If you use FISCHER bindings on plates from other manufacturers, check the Brake Matrix to see if the desired combination of ski-plate-binding is possible.



FOLLOW THE PROCEDURE BELOW:

1. Add together the weight of the components you want to mount ski + plate + binding.
2. Add together the thickness of the components you want to mount ski + plate + binding.
3. Using the list below, determine which brakes are standard on the bindings delivered.
4. Find the value on the vertical axis which corresponds to the sum of the addition for the standheight.
5. Follow the horizontal axis on the matrix to the right until you find the value which corresponds to the total weight on the horizontal axis.
6. If the point of intersection of the weight and standheight lies below the respective curve, the brake will function properly.
7. If the point of intersection lies above the curve for the Power Brake short or Power Brake/long, the brake must be replaced with the next stronger one.
8. If the point of intersection lies above the curve for the Dragon Brake, using this combination of ski + binding + plate is not possible. In this case, you have the following possibilities to come within the permitted range:
 - a) Reduce the total thickness through:
 - a thinner plate
 - a FISCHER binding with less standheight
 - b) Reduce the total weight to
 - a lighter plate, e.g. a FISCHER Carve Plate FP9
 - a FISCHER binding with less weight
 - a lighter ski
 - c) Use a combination of a) + b)

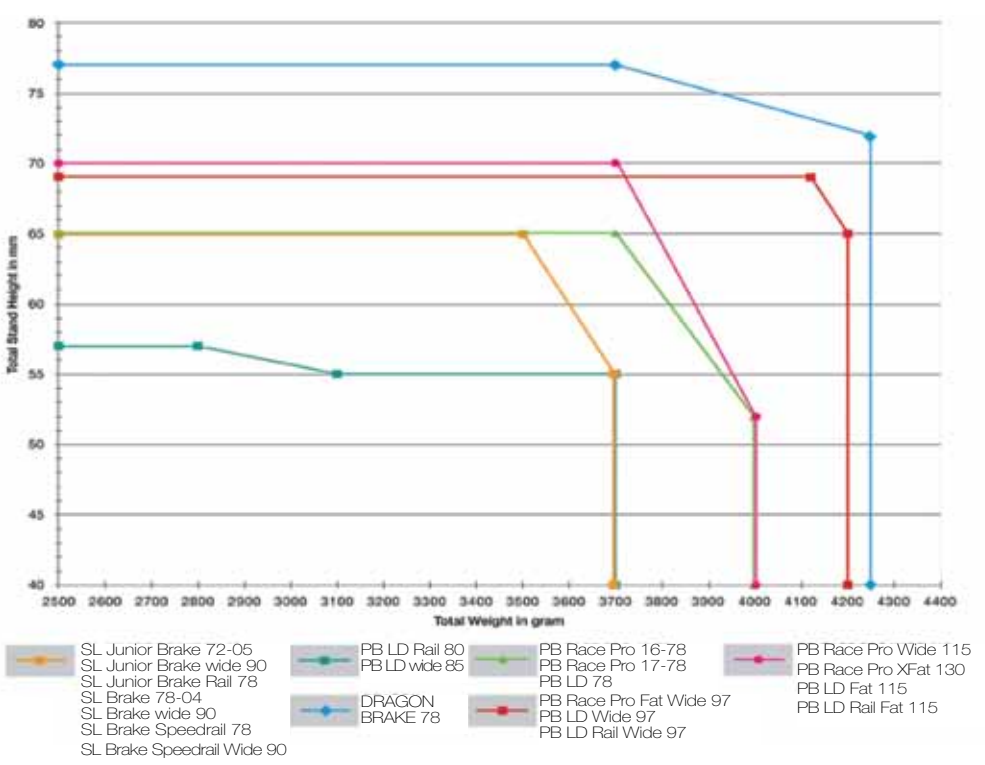

SKI-BINDING-PLATE-COORDINATION

Ski-binding stand height	Max. allowed stand height (mm)	RC4 Worldcup/ C-Line/Progressor + Flowflex Plate/ RACETRACK	RC4 Race + Powerrail	Motive, + Powerrail	Viron + FP9 Plate	RC4 Worldcup Junior + JWC Plate low	Women My Style + Women My Style Rail	Freestyl/Slopestyle without Plate
C-Line Z13 Flowflex 2.0	65	53	·	·	·	·	·	·
C-Line Z9 Flowflex 2.0	65	53	·	·	·	·	·	·
RC4 Z 13 RACETRACK	65	49	·	·	·	·	·	·
RC4 Z 17 Freeflex	65	49	·	·	·	·	·	36,5
RC4 Z 13 Freeflex	65	53	·	·	·	49,5	·	35
RC4 Z 12 Powerrail	65	·	·	·	·	·	·	·
RC4 Z 11 Freeflex	65	·	·	·	·	49,5	·	35
RSX Z 13 RACETRACK	65	53	·	·	·	·	·	·
RSX 12 Powerrail	65	·	54	53	·	·	·	·
RC4 Z12 Powerrail								
RSX 12 Powerrail wide 88	65	·	·	·	·	·	·	36,5
RS 11 Powerrail	65	·	52	51	·	·	·	·
RC4 Z11 Powerrail	65							
RS 10 Powerrail	65	·	52	51	·	·	·	36,5
RS 11	65	·	·	·	46	46	46	·
RS 10	65	·	·	·	46	46	·	·
V 9 My Style	65	·	·	·	·	·	46	36,5
RC4 Z 9	65	·	·	·	46	46	·	36,5
FJ 7 AC wide brake	65	·	·	·	·	·	·	36,5
FJ 4 AC	·	·	·	·	·	46	·	·
X 17 w/o brake	65	·	·	·	·	·	·	36,5
X 13 w/o brake	65	·	·	·	·	·	·	36,5
X 11 wide 90	65	·	·	·	·	·	·	36,5
X 9 wide 90	65	·	·	·	·	·	·	36,5
X7 AC wide 90	65	·	·	·	·	·	·	36,5
XTR 9 Pro C-Line	65	63	·	·	·	·	·	·
XTR 13 Pro	65	63	·	·	·	56	·	46,5
XTR 12 Pro w/o brake	65	63	·	·	·	56	·	46,5
XTR 10 Pro premount	65	·	·	·	·	56	·	·
XTR 10 Pro	65	·	·	·	·	56	·	46,5
XTR 9 Pro	65	·	·	·	·	56	·	46,5
XTR 7 Pro	65	·	·	·	·	56	·	46,5
XTR 4 AC Pro	·	·	·	·	·	·	·	·
XTR 10 Rent	65	·	·	·	46,5	56,5	·	37
XTR 4 AC Rent	·	·	·	·	·	·	·	·

· Not compatible

The screws on the Flowflex binding 2.0 as of the 1011 line comply with the requirements of the ski standard group N1/ N2. This means that if these bindings are used with an old Flowflex (aluminium), the pre-inserted screws must be replaced with shorter ones. See page 13 of the guide.

BRAKE LINE 12113

See OMS System:

<http://spareparts.fischersports.com>

User: spare_fischer

Password: omsnew

The new Fischer OMS Spare Part Management offers all relevant information about ski bindings, technical data and their (spare) parts at a glance - and just one click away. Extensive information is available via the new OMS spare part system: Starting with the appropriate drill template right up to screws and spare parts related to a specific binding model; for example different brake types - plus, all parts can be directly identified by model. Pictures and coloured marks provide simple navigation tools and easy recognition of selected parts.

LOGIN

Type in <http://spareparts.fischersports.com>

User: spare_fischer

Password: omsnew

You may navigate through the Spare Parts OMS via two different modes:

1. Material mode
2. Spare part mode

With the material mode, all existing parts related to a specific binding model can be identified. With the spare part mode, all spare parts are listed with their designated use.



SPAREPART VIEWER

The Spare Part Viewer explains all spare parts in detail (text and pictures) and shows the appropriate article number, description and order quantity. Coloured bars and marks of the requested part make navigation extremely simple and easy.

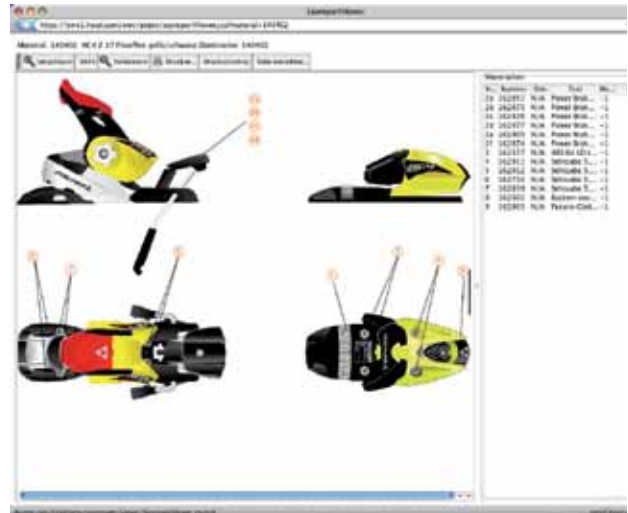

TECHNICAL DATA

One simple click and you will get all relevant data for each specific model. Just click on the spanner icon next to the requested model and the datasheet including photo will pop up.



ONLINE HELP

A HELP document is also available online. You will find it in the OMS in the top right corner.



PRO-RENT SYSTEM 12|13

Performance, for a rental binding, is not only what happens on the hill. A key measure of a product's quality is the ease with which a system can be adjusted and maintained throughout the course of many seasons. The mechanic-friendly rental design, however, deserves special attention here:

- Easy mounting: This means fewer mistakes and reduced setup time.
- Easy pre-season testing, low drop-out rate. The automatic sole lug design and the precise centering of the toe pincer system mean: fewer correction factors will be needed and less time spent testing.
- The Single Code system gives you a super fast option for binding-to-boot adjustment: set the heel length using the special sole length scale. Forward pressure will be right on, first time, every time.
- All models have automatic lug height adjustment which accommodate standard differences in boot sole-height.
- Easy, hand-levered "One Touch"-set up. One tool adjustment, easy to turn adjustment screw.
- Almost maintenance-free, easy to change the AFD, clean and lubricate the heel track.

FISCHER made the commitment to offer a comprehensive product and service program.

The Rental Bindings: No single rental binding can ever fulfill all the needs of all types of shops. We therefore offer the following lineup of rental/demo models.

MODELS: XTR 13 Pro Plus, XTR 12 Pro, XTR 10 Pro, XTR 9 Pro, XTR 7 Pro, XTR 4 AC Pro

THE BINDINGS THAT HELP YOUR HIGH PERFORMANCE SKIS SET UP:

- Handlever-adjusted heel (60 mm) and toe (64 mm).
- 7-toe positions (see fig. 35).
- DIN-ranges from 2.5 up to 13 that accommodate even high level skiers.
- Short, lightweight heel track, despite wide adjustment range.
- Power Brake.
- Single Code: "A-6" for ski boots from 263 - 391 mm sole length.
- Replaceable brake.
- Diagonale toe.
- Optimal for carving skis, minimized deviation between ski and boot mounting point.

Fig. 35



MODEL: XTR 9 Pro

- High performing model for adult boot sole dimensions.
- "One Touch" handlever adjustment for toe (40 mm) and heel (36 mm).
- Single Code: "A-T" for ski boots from 263 - 343 mm sole length.
- DIN range 2.5 up to 9.
- Diagonale toe.

MODEL: XTR 7 Pro

- High performing model for adult boot sole dimensions.
- "One Touch" handlever adjustment for toe (40 mm) and heel (36 mm).
- Single Code: "A-T" for ski boots from 263 - 343 mm sole length.
- DIN range 1.5 up to 7,5.
- Diagonale toe.

PRO-RENT SYSTEM 12|13

MODEL: XTR 4 AC Pro

A child and junior model, super convenient, “parent-free” operation.

- Automatic toe and heel pieces accept child and adult boot sole dimensions, giving you full utilization of your child/junior ski inventory.
- Single Code: “a-w/F” for ski boots from 191 - 287 mm sole length.
- “One Touch” handlever adjustment for toe and heel.
- Replaceable brake.
- Diagonal toe.
- For skis of group 3 and 4.
- DIN range 0.75 up to 4.5.

RENT

MODEL: XTR 10 AC Rent

A technically proven workhorse for the discerning skier who rents.

- Retail cosmetics enhance the value of the binding to the skier.
- Single Code: “A-V”.
- Large 84 mm heel adjustment range.
- Automatic toe and heel height adjustment.
- “One Touch” - handlever adjustment for the heel.
- Replaceable brake.
- Diagonal toe.
- DIN range 2.5 up to 10.

MODEL: XTR 4 AC Rent

A child and junior model, super convenient, “parent-free” operation.

- Automatic toe and heel pieces accept child and adult boot sole dimensions, giving you full utilization of your child/junior ski inventory.
- Single Code: “b-o” (199 - 255 mm) standard, or “j-w/F” (231 - 287 mm) with spare part: (T 162 538).
- “One Touch”- handlever heel adjustment.
- Replaceable brake.
- For skis of group 3 and 4.
- DIN range 0.75 up to 4.5.

PRO-RENT - DATA OVERVIEW

Model	Din	Toe	Single Code	Mondopoint	Sole length L=mm	Drill template	Drill template- adjustment
XTR 13 Pro Plus	4 - 13	Aero OT*	A-6	22,5 - 36	263 - 391	XTR Pro	yellow bushings
XTR 12 Pro	4 - 12	FX OT*	A-6	22,5 - 36	263 - 391	XTR Pro	yellow bushings
XTR 10 Pro	2,5 - 10	FS OT*	A-6	22,5 - 36	263 - 391	XTR Pro	yellow bushings
XTR 9 Pro	2,5 - 9	FS-Junior OT*	A-T	22,5 - 30	263 - 343	XTR Pro	white bushings
XTR 7 Pro	2 - 7,5	FS-Junior OT*	A-T	22,5 - 30	263 - 343	XTR Pro	white bushings
XTR 4 AC Pro	0,75 - 4,5	SL-Kid OT*	a-w/F	15,0 - 24,5	191 - 286	XTR Pro	red bushings
XTR 10 Rent	2,5 - 10	FS OT*	A-V	22,5 - 31	263 - 351	XTR Rent	yellow arrow
XTR 4 AC Rent	0,75 - 4,5	SL-Kid	b-o	15,5 - 21,5	199 - 255	XTR Rent	b-o red arrow

* OT = One Touch

PRO-RENT ON THE SHOP FLOOR

PREPARING AND CHECKING RENTAL SYSTEMS

Customers usually don't treat rental equipment as gently and carefully as they would handle their private property. In order to keep your rental fleet as functional and appealing as possible, a systematic maintenance program is a must. The best results are obtained with an ongoing program which constantly checks boots, bindings and skis. To keep the equipment in good condition while minimizing liability we recommend the following program (this is a requirement in the U.S.). In order to produce a truly efficient rental inventory some pre-season setup is required.

Single Coding: This enables a quick boot and binding coordination even during the rush hours of rental business. Simply check the boot's Single Code and adjust the binding accordingly. In order to gain the efficiencies of FS, all you need to do is follow our simple procedure.

1. Mount all bindings accordingly to the FISCHER FS procedures. Pick a mounted sample binding of each model.
2. Place a boot of each size in the binding and adjust forward pressure until correct.
3. Open the heel and remove boot.
4. Record the Single Code from the track that corresponds to the mark on the side of the heel housing (the boot must not be in the binding when you read the code).
5. Check each code again before marking all boots of this size with their Single Code (fig. 36)! For this procedure the FISCHER Rental Boot Indicator (art. no. T 9043) can be used.



Fig. 36

RENTAL INSPECTION SUMMARY

Since it is impractical to perform a full inspection each time a system is rented, a routine of pre-season and in-season inspections has been developed to verify release indicator accuracy, confirm correct equipment function, and assure proper assembly and adjustment procedures by the rental shop staff. Fully implemented, the procedures that follow provide rental shop customers a standard of care equivalent to that provided retail shop customers under current ISO and ASTM standards. The program is based on the existing standards: ISO 13993 and ASTM F1064.

PRE-SEASON INSPECTION

Pre-season inspections are performed on components of the release system: bindings and boots. All rental bindings, new and used, are visually inspected, and then tested using specially selected Reference Boots. Bindings that fail go through a trouble - shooting procedure to identify and correct the deviation or malfunction. If this procedure does not correct the problem, the binding is removed from inventory. All rental boots, new and used, are visually inspected for damage, wear, contamination, broken or missing parts, or inferior materials at contact points with the binding. In addition, one boot per "cell" is tested for boots that are new to the rental inventory. A cell is all boots of the same make, model, age, and shell size. A random selection of 5% of all boots, previously accepted into inventory, is also tested. Tests are performed with a test device and a pair of specially selected reference bindings. If a boot fails, all boots from that cell are then tested. Boots that fail and cannot be repaired are removed from inventory.

IN-SEASON INSPECTION

In-season inspection are performed on complete rental systems to ensure that the equipment is adjusted appropriately and continues to function correctly. Typically 5% of the rental inventory is tested during each two weeks sampling period. The random sample is equally divided between equipment that is available for rental and equipment that has just been rented. The equipment in the "as rented" category is from real skiers in the condition in which it is either dispatched or returned, while the "available for rental" equipment may be set up for fictitious skiers. Only single skis, not pairs, are tested, and testing at the toe is only required in one direction. A count is maintained of test results which exceed allowable limits. The magnitude and frequency of these deviations determines the frequency of future inspections. Shops which fail an inspection must sample daily until source of the problem is found and corrected. Then, as inspection results improve, the frequency of sampling and inspection is relaxed.

INSPECTION PROCEDURES IMPORTANT TERMS

Correction Factor: The value that must be added or subtracted from the initial visual indicator setting to bring the result within the Inspection Tolerance (or Inspection Range).

Directions of Release: Unless otherwise specified (see Inseason Inspection), the directions of release to be tested are forward lean in clockwise and counter clockwise in twist.

Test Device: A device which meets ISO standard 11110 or ASTM standard F1061 and has been checked and maintained in the manner specified by the device manufacturer.

Test Result or Release Torque: The middle quantitative value of three tests made in the same direction.

PRE-SEASON TEST

Reference Boot Selection: The Reference Boot is a boot of a designated sole length which is otherwise typical of the boot inventory. Use the procedure below if the boot inventory includes several models and a representative boot can not easily be identified.

1. Select five single boots with sole lengths as specified in Table A for the binding type to be tested: adult, junior, or child.
2. Clean all five boots with a mild detergent and water.
3. Adjust a rental binding to the release indicator setting specified in Table A for the binding type.
4. Fit the binding to the boot and determine the Release Torque in all three directions of release (forward lean and both directions in twist—three releases in each direction).
5. Average the Release Torque for CW (clockwise) and CCW (counter clockwise) twist release.
6. Reject and replace any boot with a CW to CCW difference of more than 6 Nm for adult boots or 4 Nm when testing child boot types.
7. Rank the five twist results and select as the Reference Boot for twist, the middle boot.
8. Rank the five forward lean results and select as the Reference Boot for forward lean, the middle boot.

PRE-SEASON BINDING INSPECTION

The procedure that follows is an integral part of pre-season maintenance. It is also a good way to determine if maintenance and which units have outlived their usefulness and must be removed from inventory.

1. Clean areas of the bindings that contact the boot and perform all pre-season binding maintenance.
2. Visually or manually check:
 1. Clean areas of the bindings that contact the boot and

perform all pre-season binding maintenance.

2. Visually or manually check:
 - a) AFD condition.
 - b) Brakes' function.
 - c) Release indicator readability and travel.
 - d) Screw tightness.
3. Check that the heel track and toe track Single Code agrees with the sole length Single Code of the Reference Boot.
4. With the Reference Boot in the binding, verify elastic travel of the toe piece by striking the boot toe with a mallet or dead hammer and checking that the toe piece returns the boot quickly and completely to center.
5. Verify elastic travel of the heel piece by lifting the boot while depressing the heel piece cocking lever and checking that the heel piece returns the boot quickly and completely to the latched position.
6. Manually release the binding 3 times in each direction.
7. Lubricate all boot/binding interfaces with a mild liquid detergent and water solution.
8. With the Ski Binding Test Device determine the Release Torque for each direction of release (forward lean and both directions in twist).
9. Record "Pass" in the bindings's maintenance record if Test Results are within the Inspection Range provided in Table A.
10. Set the ski aside if the Test result in any directions of release is outside the Inspection Range in Table A.
11. Follow Troubleshooting Procedure on page 58 for units which have been set aside and retest if changes in the unit's condition or adjustment are made.
12. Record "Fail" in the binding's maintenance record if, after troubleshooting, test results in any direction of release are outside the In-Use Range. Replace the "failed" unit and retest before returning the ski to service.
13. If after troubleshooting, Test Results are outside the Inspection Range, but within the In-Use Range, apply a Correction Factor to the unit and note the Correction Factor for that unit in the binding's maintenance record.
14. If many bindings fail, check the test device and re-inspect the Reference Boot. If necessary, select another boot and retest the bindings.

PRO-RENT ON THE SHOP FLOOR

Skicode	Binding type	Sole length mm	Release Indicator setting	Reference Indicator twist Nm	Reference torque forward Nm	Twist inspection range Nm	Forward inspection range Nm	Twist in-use range Nm	Forward in-use range Nm
TABLE A: PRE-SEASON BINDING INSPECTION									
F	Children	270	2,5	25	94	21 - 29	80 - 108	17,5 - 33	66 - 122
J	Junior	306	4,5	45	175	38 - 52	149 - 201	31 - 59	122 - 228
L	Adult	327	6,0	60	239	51 - 69	203 - 275	42 - 78	167 - 311
		Min.							Max.

TABLE B										
Inventory Size - Pairs	50	100	200	300	400	500	600	700	800	900
Inventory Size - Units (half pairs)	100	200	400	600	800	1000	1200	1400	1600	1800
Sample Size - Pairs	16	16	20	30	40	50	60	70	80	90
Max. Class I dev.	3	3	4	6	8	10	12	14	16	16

PRE-SEASON BINDING PREPARATION

The procedure that follows is an integral part of pre-season maintenance.

1. Clean all boots with a mild detergent and water, and repair or replace damaged or missing parts.
2. Visually check:
 - a) Conformance with ISO and other applicable standards-ISO 5355. If the boot contacts the binding, brake, or AFD in areas other than the designated contact points, it may be incompatible with the binding.
 - b) Boot material. If the sole at the contact points with the binding or AFD can be scratched with a finger nail, the boot may be of inferior quality and incompatible with the binding.
 - c) Boot sole condition. If the boot sole is damaged, worn, or contaminated at contact points with the binding or AFD in a manner which can not be corrected, the boot may be incompatible with the binding, "Verify boot sole dimensions".
 - d) Brake compatibility with sole.
 - e) Rubber and/or metal sole protectors. If such materials contact the binding or AFD the boot may be incompatible with the binding.
 - f) Mold flashings. Flashing which can be seen or felt at

contact points with the binding, brake, or AFD must be carefully removed.

3. Remove from inventory all boots that have failed the visual check.

PRE-SEASON BOOT SAMPLING

Although sampling eliminates the need to test every boot before the season starts, the sample chosen must be representative of the inventory.

1. For boots that are new to inventory or have 1. never been inspected, take a single boot from each cell (a cell is all boots of the same make, model, year, and shell size).
2. For used boots, take a 5% (but not less than 16 or more than 80) random sample of the entire inventory, see Table B.

Make sure that there is at least one boot from each cell in the sample.

PRE-SEASON BOOT INSPECTION

The procedure that follows helps to assure boot/binding compatibility and boot interchangeability.

NOTE: When using Table A, in the Boot Inspection pro-

cedures that follow, the Sole Length and release Indicator Setting columns should be ignored.

1. Randomly select a pair of bindings that have passed the pre-season inspection from each binding type; adult, junior, child.
2. Lubricate all boot/binding contact points with a mild liquid detergent.
3. Without regard to whether the boot is new or used, sort the sample by sole type and length according to the 20 mm Sole Length Categories defined by the Release/Retention Adjustment Chart.
4. In each Sole Length Category rank the boots by sole length and select the middle boot.
5. In each Sole Length Category fit the appropriate reference bindings to this “typical” boot and adjust the two bindings to release as close as practical to the Reference Torque in Table A. Use the Reference Torque corresponding to Skicode L for the Adult binding, J for Junior binding, and F for the Child binding.
6. Rinse the lubricant from one binding and mark it “clean”. Mark the other “lubricated”.
7. Test each boot in the Sole Length Category with the clean Reference Binding and then the lubricated Reference Binding in both twist and forward lean (only one direction in twist is required for the clean binding).
8. Set aside any boots for which the lubricated Test Result is more than 20% less than the clean Test Result in the same direction of release or the lubricated Test Result in any direction of release is outside of the Inspection Range provided in Table A for Skicode used to set up the Reference Binding (L, J, or F).
9. Repeat the Visual check on all boots that have been set aside, correct any defects noted, and retest. Remove from inventory boots that fail the retest.
10. Check all other boots from the same cell (make, model, year and shell size) as those that failed.

NOTE: On completion of the pre-season inspection, clean the liquid detergent from equipment and lubricate the binding before returning it to service.

IN-SEASON SAMPLING AND INSPECTION

The In-season Inspection is a test of complete systems and all the procedures used by the rental staff to assemble and adjust the system. The program uses random samples of rental inventory taken at routine intervals. Any sampling program that gives every unit of inventory the same chance as every other of being picked is valid.

Sample Frequency: Random sampling is conducted throughout the entire season. Frequency is as follows:

1. After 7 days of operation.
2. If the sample passes the next sampling is taken after another 7 days operation.

3. If two consecutive samples pass, sampling frequency is increased to 14 days.

4. If a sample fails at any time, daily sampling is instituted until two consecutive samples pass, at which point weekly sampling resumes.

Sample Size: Sample size is 5% of inventory but not less than 16 nor more than 80 units as noted in Table B. Sample size is based on average daily output. If rental output drops below 50% of capacity over the sampling period, the sample size can be reduced proportionately.

IN-SEASON INSPECTION

1. Take a random sample of the rental inventory as determined by Table B. Take half the sample from inventory as it is either rented or returned and the remainder from inventory available for rental.
2. The returned samples are tested with the last customer's data, the other samples adjust to randomly selected skier data. Consider already applied Correction Factors.
3. Wipe the boot clean and cycle the boot/binding systems at least once in each direction.
4. Test sample units in Twist (one direction only) and Forward Lean.
5. Compare the Test Results with the Inspection Range for the appropriate Skicode, see ISO 11088 Release/Retention Adjustment Chart (page 63).
6. If the results are within the Inspection Range, one value above to one value below the reference value, the unit passes.
7. If the results are outside Inspection Range 07. but within the In-Use Range, two values 07. above to two values below the reference 07. value, count the unit as a Class I Deviation.
8. If the results are outside the In-Use Range, count the unit as a Class II Deviation.
9. Check elastic travel and visually inspect the ski brake function, interface areas between boot and binding, including AFD, lug height adjustment (if appropriate), and forward pressure. Count any deficiencies as Class I Deviations.
10. If more than the maximum number of Class I Deviations given in Table B are found in the sample, or a single Class II Deviation is detected the sample fails and daily sampling must be conducted until the problem which led to the failed sample is found and corrected. See page 58 for Trouble - shooting Procedures following a Failed In-season Inspection.
11. Record the date the sample was tested, the number of units tested the number of Class I and Class II Deviations, whether the sample passed or failed and any actions taken.
12. There is not need to record the identity of units tested or actual Test Results.

PRO-RENT ON THE SHOP FLOOR

RENTAL / DEMO OF PARTIAL SYSTEM

Many shops rent their customers partial ski equipment systems. Boots only if customers own their own skis with bindings, or skis and bindings if the customers own their own boots. Additionally some shops utilize on-hill "demo days" as a means by which new products can be tested and evaluated by potential buyers. In order to offer these skiers the same level of care as that afforded under the preceding procedures, the following guidelines should be used:

Rental of skis / Binding only:

Customer-owned boots: Although the retail test procedure may be applied in this case, it is often impractical to require actual system testing, especially in on-hill situations. In lieu of retail testing, the following procedures may be employed:

1. The ski/binding system to be rented or demoed should be tested "pre-season" using a boot which passes the FISCHER Boot Visual Inspection.
2. The skier's boot should also pass the Visual Inspection. If any questions exist regarding the quality of the boot, retail-type testing should be used.
3. The binding should be adjusted and its indicators set per current FISCHER recommendation.
4. A full record noting appropriate customer information and binding settings should be kept by the individual or organization responsible for the adjustment.
5. After seven days of use, the ski/binding system should be tested according to the In-Season Inspection Procedures previously described.

NOTE FOR US AND CANADA: Signatures by both the customer and FISCHER Certified Mechanic are required on all shop forms to qualify for the FISCHER Dealer Indemnity Program.

BOOT HANDLING AND TESTING

VISUAL INSPECTION OF SKIBOOTS

In assembling a system for the skier, it is the responsibility of the shop to inspect and evaluate each equipment component. This inspection checklist should be followed before any mounting or adjusting is performed. Ideally, they should be posted and used on the sales floor while the customer is still in the shop so that any deficiencies can be explained on the spot. In retail, boots must pass all four points of this inspection before being accepted for use. In rental, this inspection is the first step in the “pre-season boot test procedure”.

1. CHECK TYPE, SIZE AND OVERALL CONDITIONS

- Is the performance level appropriate for the skier?
- Is the size correct (Single Code, bootsole length)?
- Is all hardware intact and in working order?
- Is the boot free of excessive or asymmetric wear?
- Is the boot free of dirt or sole warp?

2. CHECK MATERIAL

- Binding contact surfaces require a high quality hard, lowfriction material. Check both lower shell and any separately attached inserts.
- If you can easily scratch the surface of the sole with your fingernail, that’s an indication of extremely soft material that can degrade system performance.

3. CHECK CONDITION OF BINDING CONTACT SURFACES, TOE AND HEEL

- Any scratches or other roughness should not be deeper than 1 mm.
- Check for any rocks, gum, or other foreign matter stuck to the sole.

4. VERY BOOT SOLE DIMENSIONS

- Skiboos must meet international standard specifications.
- Use the Boot Rental Indicator to determine whether wear is excessive. The most critical dimension for FISCHER bindings is the front surface and height of the boot toe. Any boots worn past the indicated amounts should be repaired or not used with FISCHER bindings.

THE FISCHER RENTAL BOOT INDICATOR

Art. no. T 9043

This rental boot device is a multifunction-tool (fig. 37):

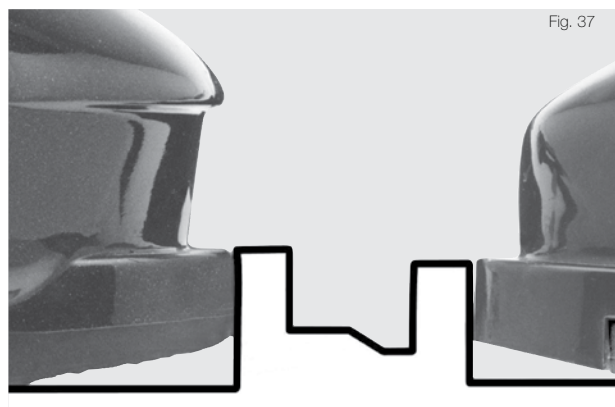

1. Sole length: Put the boot in the device and slide the toe stop up to the boot toe. Read sole length in the window, used for FISCHER rental bindings: the Single Code (fig. 38).

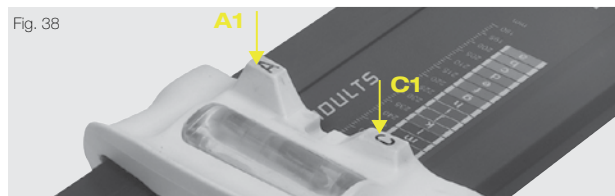

2. Boot sole wear: The standardized inter faces (contact bootsole with solelugs) are important in the functioning of FISCHER bindings.

3. Boot toe bottom: Excessive wear is indicated if the lower edge of the front surface is at or above the bottom step on the appropriate child (C2) or adult (A2) post (fig. 39).

BOOT HANDLING AND TEST

4. Boot toe ledge height: With the toe stop against the boot toe, the level of the toe ledge should be at or above the top of the appropriate post, “Child” (C1) or “Adult” (A1) (fig. 39). Replace toe pads if worn.

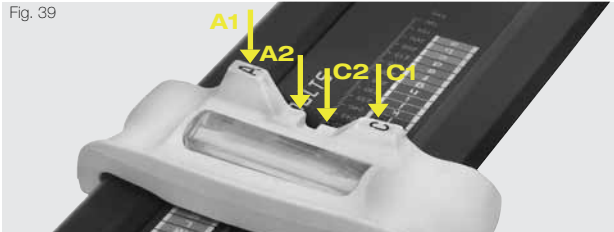

5. Heel height and wear: Check this boot standard with the same procedure used for the toe. The heel posts (A3 + C3) are located at the rear of the device (fig. 40).
 6. The marks “A/C” help to select a “Child” boot from an “Adult” by indicating the standardized sole width.

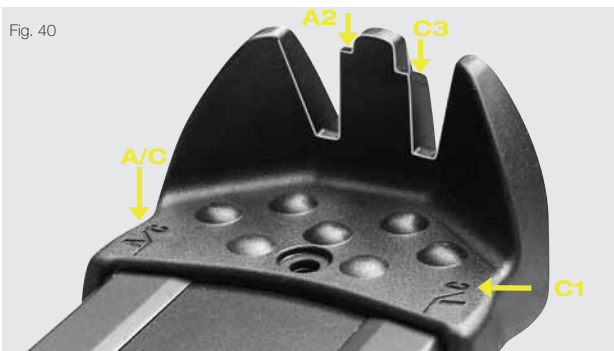

NOTE: Any boot which passes points 3, 4 and 5, as well as conforming to the Visual Inspection Checklist, may be accepted for use with FISCHER bindings. Boots which fail any point should be repaired or replaced. These checks apply only to boots used with FISCHER bindings. Consult other binding manufacturers for their used boot specifications.

CLEAN VS. LUBRICATED SKI BOOT TEST

This test is designed to determine the influence of a given boot on the release characteristic of a binding. It should be performed on boots not meeting all the points of the FISCHER boot visual inspection criteria, or if measured release values fall outside the system “inspection” tolerance. It is seen as the “last chance” for a boot to qualify before getting eliminated from inventory.

1. Clean the boot(s) to be tested with soap and water. Allow to dry.
2. Select an appropriate FISCHER “reference” binding that has displayed release values within the inspection tolerance on the FISCHER Adjustment Chart. Clean the binding’s boot contact surfaces with soap and water and allow to dry.
3. Test the binding and boot in Twist and Forward Lean at a mid-scale indicator value (only one direction of twist is required).
4. In a further test run lubricate all boot/binding contact areas with soapy water. Retest in Twist and Forward Lean.
5. Results of each lubricated test should be within 20% of the corresponding results when tested clean. Any boot which fails this test should not be used with a FISCHER binding.

MAINTENANCE & SERVICE

VISUAL INSPECTION OF BINDING

In assembling a system for the skier, it is the responsibility of the shop to inspect and evaluate each equipment component. This inspection checklist should be followed before any mounting or adjusting is performed. Ideally, they should be posted and used on the sales floor while the customer is still in the shop so that any deficiencies can be explained on the spot.

Check suitability:

- Is the binding model appropriate for the skier's ability?
- The binding must be compatible with the customer's boot/ski.
- The skier's release/retention setting should fall within the binding's adjustment range. Additionally, we recommend that the skier's setting not be closer than one number from the minimum or maximum settings on the binding in order to allow for future readjustment.
- Are the mounting screw lengths appropriate for the ski being used?

Check the condition of binding:

- Are all parts present and in working order?
- Is the AFD surface smooth and secure? If not, it should be replaced.
- Are all mounting screws present or tight?
- Does the binding show signs of contamination?
- Has proper periodic lubrication been performed? Dried out or corroded bindings can function improperly.

RETAIL TESTING

Completion and documentation of the following Retail Test Procedures is recommended for U.S.: required under the terms of the FISCHER Dealer Indemnity Program. These tests should be conducted any time work is performed on a ski/boot/binding system that may affect its release values. The procedure applies to all FISCHER alpine bindings, new as well as used.

1. Follow FISCHER procedures for inspection, mounting, adjustment, and maintenance as appropriate.
2. Confirm that toe and heel indicator values match those specified on the actual FISCHER Adjustment Chart.
3. Using a calibrated testing device, according to its instructions for use, "exercise" the binding by releasing it at least once in each direction (clockwise and counter clockwise at the toe, vertically at the heel). Then measure Twist and Forward Lean Torque Values. The middle quantitative value of 3 releases in each direction should be used as the test result.

4. Compare Twist and Forward Lean test results with the System Inspection Ranges on the actual FISCHER Adjustment Chart.

5. If any test results fall outside the System Inspection Range, consult FISCHER Troubleshooting Procedures which follow this section.

6. With testing complete, the FISCHER Certified Mechanic must complete and sign the workshop ticket. Be sure the Final Indicator Settings are correctly shown there.

The workshop ticket should simply reflect that the system has "passed all tests" or that "all manufacturer's procedures have been completed".

Replacing the brake: If the brake feels too hard or blocked during the hand test, if the brake arms are damaged, if the pedal is worn out or if a wider brake is necessary then the brake should be replaced immediately.

- The "Power Brake Standard" for all adult and junior binding models.
- The replaceable Kid Brake for the models XTR 4 AC Rent and XTR 4, skis shorter 140 cm.
- The Power Brake LD Rail for all FISCHER Rail bindings.

To change the brake, all you have to do is to unscrew the old brake and replace it with the proper brake previously selected for the binding. In order to fix the brake, tighten the screws. On most Railflex Vision and FS bindings the brake is hooked into the heel housing and not fixed with screws. Slide the heel off from the rails and replace the brake (fig. 41).



Fig. 41

MAINTENANCE & SERVICE

On Railflex My Style bindings the heel lever has to be opened and the brake pedal has to be in its top position to do this (fig. 42).



REPLACING THE HEEL GLIDE INSERTS FOR DIAGONAL HEEL

For RC4 Z 18 Freeflex, RC4 Z 17 Freeflex, RC4 Z 17 Flowflex 2.0, RC4 Z 13 Freeflex, RC4 Z 13 Flowflex 2.0, RX Z 13 Freeflex, PRO Z 13 Flowflex 2.0 and X 17: Unscrew the brake and take it off. Open the heel locking lever and pull off the heel backwards. Remove the inserts and mount the new ones (fig. 43).

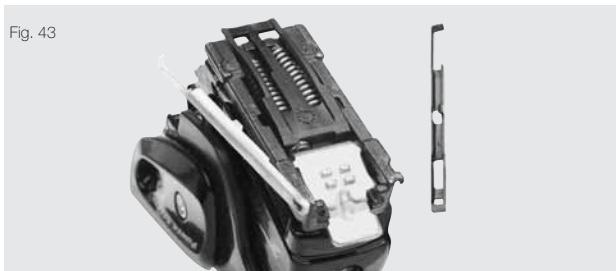

COLORS OF THE HEEL GLIDE INSERTS:

blue/grey: art. no. T 162 803: RC4 Z18 Freeflex, RC4 Z17 Freeflex, X 17

red/yellow: art. no. T 162 510: RC4 Z13 Freeflex, RC4 Z13 Flowflex 2.0, PRO Z13 Flowflex 2.0

Lubricate the new inserts with grease, clean the heel track, and slide the heel back into the track. Lock the locking lever into the same position it was before, remount the brake and tighten the screws. For remounting the brake it is necessary that the cross-bolt of the brake is located under the hooks of the heel track. The brake has to be in the upright-braking position (fig. 44).



REPLACING THE GLIDE INSERTS

Powerrail Bindings: To provide unaffected long-term performance of the new POWER binding models, the toe and heel guides can be exchanged or retrofitted. These features ensure that steady function is guaranteed, even after massive use in rental.

Art.No. – 162950 Play compensator Powerrail TOE
Art.No. – 162951 Play compensator Powerrail HEEL

Heel insert for Race Pro heel: Open the heel-locking lever and pull off the heel backwards. Remove the inserts and mount the new ones - Art. no. 162 803. Lubricate the new inserts with grease, clean the heel track, and slide the heel back into the track. Lock the locking lever into the same position it was before.



Long and short screws: FJ7, FJ4 and XTR 7/4 Pro are delivered with screws for skis of group 3 and 4 (penetration depth 6 cm). If they are mounted on skis of group 1 and 2, the screws have to be replaced with longer screws (penetration depth 8 mm). RC4 Z9 has long screws. If the skis are of group 3 and 4, the screws have to be replaced with shorter screws.

Tapping: FISCHER recommends tapping the drilled binding holes of any ski before mounting. Of course, there is a never-ending discussion among the mechanics if this is really necessary. But the pros are convincing:

- smooth and easy mounting
- reduced risk of stripping a screw
- same momentum adjustment of the screwdriver regardless of the ski material
- increased mounting quality/precision
- fewer pull outs

TEMPLATE "ADAPTER"-SET:

(art. no. T 162 569) Compatible to all FISCHER Template.

WARNING: Avoid dropping the template. The clamping jaws could be damaged.

For skis with integrated mounted plates.

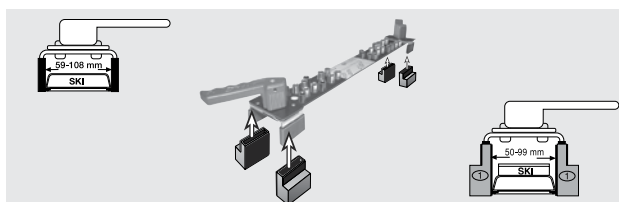

For wide skis.

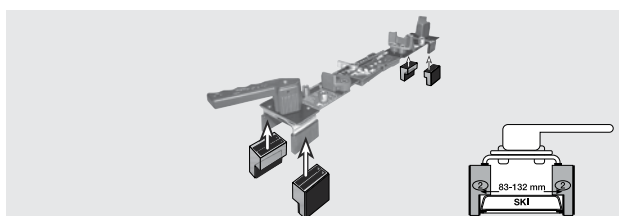

For children skis.

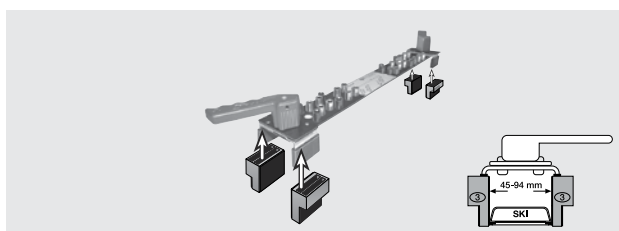

RACING BINDINGS

Certain binding models are produced by FISCHER each year for the exclusive use of qualified competitors under the supervision of FISCHER Technical Specialists. These bindings are not covered by either the FISCHER Warranty or any Dealer Indemnity Program. We recommend you decline to service them, and warn against their use. DIN settings 10 do not satisfy the standard. Protection assertions are not applicable. Adjustments exceeding this range are made on one's own risk.

CLEANING AND LUBRICATING

Ski bindings need regular maintenance. Proper function is no longer insured if this procedure is not followed periodically.

- Please use only FISCHER recommended lubrication: Grease art. no.: T 160 052, Service-Grease-Spray art. no.: T 162 779. Both have the same content, but the grease tube is more precise lubrication and the spray is suited for spots which are hard to reach with the tube.
- Clean the surfaces with a dry rag or warm water and soft soap.
- Avoid any contact with aggressive solvents or degreasers.
- Do not use cleansers and solvents!
- High pressure cleaning is not recommended. It might have the negative side effect of washing away the lubricating films.

Aero toes: Toe release indicator adjustment screw, guides of the main spring in the housing (with ServiSpray).

All Pro/XTR toes:

- In case of friction in the track system: Mark the toe position, open the FS hand lever and slide the toe piece off (see fig. 46).
- Dry-clean the track and the toe guide base gently using a plastic brush.
- Then lubricate the locking mechanism at both sides of the toe guide base.



- Lubricate also both sides of the track guide over the entire length.

MAINTENANCE & SERVICE

LUBRICATING THE HEEL

All Rental bindings: Mark heel position, open the guide lock with screwdriver, press hand lever and pull off the heel piece backwards (fig. 47).



Lubricate:

- Edge of the release cam under the heel lug as shown white in the fig. below (use grease, see fig. 48).
- Both sides of the heel track (inside), entire length (use grease).



- The bearings of the opened hand lever, bottom side (use grease, see fig. 49).
- The guiding channel of the release setting adjustment screw (use ServiSpray).

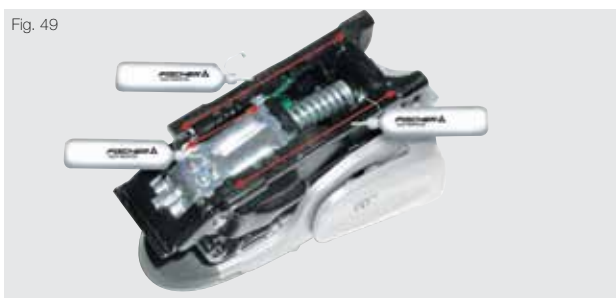

After finishing the heel lubrication slide on the heel and lock it in its original position.

FJ 4 AC AND XTR 4 AC Rent

Lubricate:

- both sides of the heel track (inside) over the entire length.
- the contact areas between housing and the release cam on the frontside and the backside as shown in fig. 50 and 51.
- the guiding channel of the release setting adjustment screw (fig. 51).

After finishing the heel lubrication slide on the heel and lock it in its original position.



ATTENTION: Not to be lubricated: The locking element and the corresponding holes in the heel track should be cleaned, but not lubricated. This could prevent dirt accumulation in this area, which could interfere with the ease of handling.

TEST YOUR DRILL TEMPLATE

A worn or damaged drill template could create a lot of trouble. Please check your templates periodically:

1. Position the fully extended drill template on a discarded ski.
2. Turn the clamping lever to open the clamping jaws of the mounting template.
3. Position the template properly on the ski so that the boot center marking is aligned with the mounting point described on the ski.
4. Let go of the clamping lever. The template clamps automatically.

5. Drill all the holes.
6. Remove the mounting template and clean the ski.
7. Measure the holes with a slide gauge.
8. The distance of the screw holes to the edge of the ski must be equal for each pair of related holes. The deviation must not be more than 1mm.
9. The mounting template must be discarded if greater deviations occur!

REPAIR OF DAMAGED MOUNTING HOLES OR BROKEN SCREWS

For repairing damaged holes, we suggest our special "Repair Set" – art. no. T 162 127. It consists of a hollow



Fig. 52

drill bit and plastic inserts (fig. 52). You can extract broken screws too. Remove the binding from the ski.

Drill with the hollow drill through the bushing of the appropriate drill template and drive in the plastic insert. Mount the binding again (fig. 53).

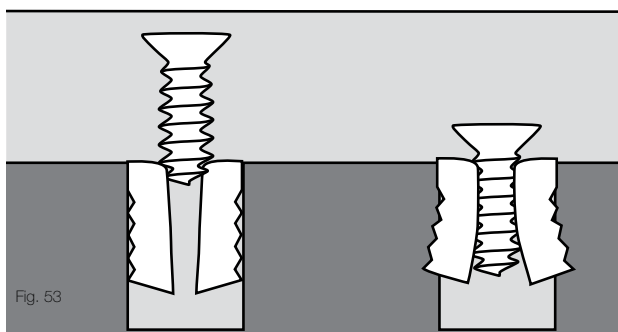











Fig. 53

SEALING OLD MOUNTING HOLES

For sealing old holes you can use wood plugs or plastic plugs (art. no. T 160 857), if not otherwise specified by the ski manufacturer.

LINE UP SCREWS RENTAL 11/12

Spare Part No.	Screw	XTR 13 PRO PLUS XTR 12 PRO XTR PRO 12 C-LINE XTR 10 PRO XTR 9 PRO XTR PRO 9 C-LINE XTR 7 PRO (Ski >=140 cm)	XTR 9 PRO XTR PRO 9 C-LINE XTR 7 PRO (Ski <140 cm)	XTR 4 AC Pro	XTR 10 RENT	XTR 4 AC Rent
T 160 018	5,5x18,5					
T 160 030	5,5x15,5					
T 162 332	5,5x10,3					
T 162 376	5,5x13,4					
T 162 401	5,5x15,5					
T 162 417	5,5x26,5					
T 162 423	5,5x21,4					
T 162 426	5,5x16,9					
T 162 429	5,5x24,5					
T 162 455	5,7x10,7					
T 162 458	5,5x29,0					
T 162 460	5,5x30,5					
T 162 461	5,5x32,5					
T 162 488	5,5x19,5					
T 162 639	5,5x9,0					
T 162 640	5,5x7					

BRAKES

See OMS System:

<http://spareparts.fischersports.com>

User: spare_fischer
Password: omsnew

The new Fischer OMS Spare Part Management offers all relevant information about ski bindings, technical data and their (spare) parts at a glance - and just one click away. Extensive information is available via the new OMS spare part system: Starting with the appropriate drill template right up to screws and spare parts related to a specific binding model; for example different brake types - plus, all parts can be directly identified by model. Pictures and coloured marks provide simple navigation tools and easy recognition of selected parts.

LOGIN

Type in <http://spareparts.fischersports.com>
User: spare_fischer
Password: omsnew

You may navigate through the Spare Parts OMS via two different modes:

1. Material mode
2. Spare part mode

With the material mode, all existing parts related to a specific binding model can be identified. With the spare part mode, all spare parts are listed with their designated use.



SPAREPART VIEWER

The Spare Part Viewer explains all spare parts in detail (text and pictures) and shows the appropriate article number, description and order quantity. Coloured bars and marks of the requested part make navigation extremely simple and easy.

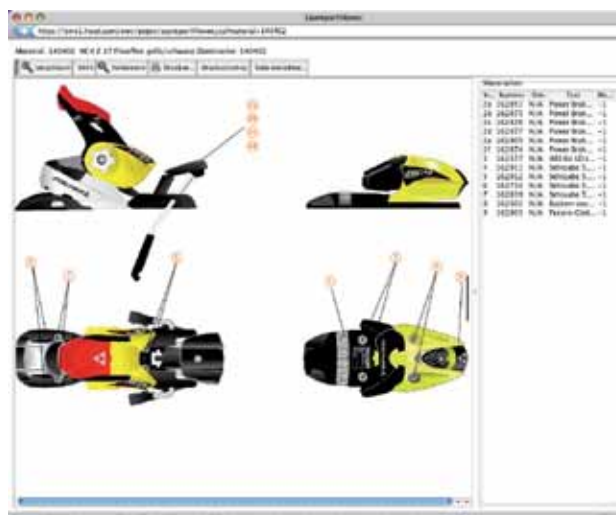

TECHNICAL DATA

One simple click and you will get all relevant data for each specific model. Just click on the spanner icon next to the requested model and the datasheet including photo will pop up.



ONLINE HELP

A HELP document is also available online. You will find it in the OMS in the top right corner.



TROUBLESHOOTING (INCLUDING RENTAL)

Problem	Possible Reason	Solution
Difficulty when stepping in	Non-standard bootssole	Test and select a new boot
	Forward pressure too high	Readjust according to instructions
	Brake jams	Clean & lubricate; replace
Brake does not retract	Obstruction under the brake	Remove, clean, lubricate
	Brake arm bent	Replace brake
	Ski obstructs brake	Replace standard brake with wider brake, accordingly to ski width
Boot fails pre-season test	Low-quality boot material	Replace boot
	Excessive wear or contamination	Clean, repair or replace boot
	Reference binding worn	Recheck reference binding with a boot that has passed
	Boot does not meet ISO 5355	Replace boot
	Improper use of testing device	Check calibration and operating technique
Excessive in-season class I or class II deviations	Excessive boot sole wear or contamination	Clean, repair or replace boot
	Inadequate binding service	Conduct recommended maintenance every 15-20 days of use
	Improper use of testing device	Check calibration and operating technique
	Indicator correction factor needed	Test system according to pre-season testing
		Define indicator correction factor for subsequent adjustments
Single Code on binding interferes Single Code on boot	Incorrect template adjustment used when mounting	Set template to proper length and remount heel
	Incorrect track guide scale chosen mounting position	Choose binding according to given for given mounting position
Pro toe wobbles in this track	Toe locking lever not properly engaged in locking holes	Remove toe, clean track. Be sure toe piece locks into place
Freeflex-drill pattern not fitting	Toe / equalizing bridge in wrong position	Unmount, place toe in correct position
	Drill template not locked	Readjust, drill new holes
Heel slides backwards when customer steps in	Rear locking lever not fully closed or boot length exceed adjustment range	Lever shutt fully engage locking teeth inslots on track or boot sole length exceeds binding range
Binding fails pre-season test: release values too high or too low	Reference boot contaminated or worn	Clean or replace boot as indicated Indicated by clean vs. lube test result
	Forward pressure set incorrectly	Readjust to FISCHER recommendations
	Incorrect or off-center-mounting	Check the template. Remount using template correctly
	Improper use of testing device	Check calibration and operating technique
Adult bootssole does not fit into Junior toe lug	Boot sole exceeds the standard tolerance	Clean ADF and bootssole, check standard tolerance
Diagonal heel wobbles in the track	Heel glide inserts worn	Remove heel and replace plastic heel guides

RELEASE/RETENTION ADJUSTMENT TABLE

		1	2	3	4	5	6	7	8	Mz (Nm)	My (Nm)	
		SINGLE CODE										
		SKIER CODE	a-i	j-n	o-s/B	t/C-G	H-L	M-Q	R-V	V-6		
kg (lbs)	cm (ft'in")		≤230	231-250	251-270	271-290	291-310	311-330	331-350	≥351		
10-13 kg (22-29 lbs)		A	0,75	0,75	0,75						5	18
14-17 kg (30-38 lbs)		B	1,00	0,75	0,75	0,75					8	29
18-21 kg (39-47 lbs)		C	1,50	1,25	1,25	1,00					11	40
22-25 kg (48-56 lbs)		D	2,00	1,75	1,50	1,50	1,25				14	52
26-30 kg (57-66 lbs)		E	2,50	2,25	2,00	1,75	1,50	1,50			17	64
31-35 kg (67-78 lbs)		F	3,00	2,75	2,50	2,25	2,00	1,75	1,75		20	75
36-41 kg (79-91 lbs)		G		3,50	3,00	2,75	2,50	2,25	2,00		23	87
42-48 kg (92-107 lbs)	≤148 cm (≤4'10")	H			3,50	3,00	3,00	2,75	2,50		27	102
49-57 kg (108-125 lbs)	149-157cm (4'11" - 5'1")	I			4,50	4,00	3,50	3,50	3,00		31	120
58-66 kg (126-147 lbs)	158-166 cm (5'2" - 5'5")	J			5,50	5,00	4,50	4,00	3,50	3,00	37	141
67-78 kg (148-174 lbs)	167-178 cm (5'6" - 5'10")	K			6,50	6,00	5,50	5,00	4,50	4,00	43	165
79-94 kg (175-209 lbs)	179-194 cm (5'11" - 6'4")	L			7,50	7,00	6,50	6,00	5,50	5,00	50	194
≥95 kg (≥210 lbs)	≥195 cm (≥6'5")	M				8,50	8,00	7,00	6,50	6,00	58	229
		N				10,00	9,50	8,50	8,00	7,50	67	271
		O				11,50	11,00	10,00	9,50	9,00	78	320
		P						12,00	11,00	10,50	91	380
											105	452
											121	520
											137	588

Issued in accordance to ASTM and ISO 11088. Note: for proper adjustment, please look up the annual technical manuals of the binding manufacturer.
Use calibrated ski bindings test equipment!

RELEASE/RETENTION ADJUSTMENT TABLE

HOW TO USE THE RELEASE/RETENTION ADJUSTMENT TABLE

1. Determine the Skicode by locating the skier's weight in the first column and the skier's height in the second column. If the height and weight are not on the same line select the Skicode closer to the top of the chart.
2. The Skicode found in step 1 is for Type I skiers. For Type II skiers move down the chart toward the bottom one Skicode. For Type III skiers move down two Skicodes. If the skier is age 50 or older or under 10 move up the chart one Skicode toward the top. For skiers 13 kg/29 lbs and under, no further correction is required.
3. Find the column that corresponds to the skier's boot sole measurement in milli meters.
4. The value where the Skicode and the bootsole measurement intersect is the initial indicator setting for the skier. If the intersection of the row and column falls in a blank box, do not move up or down the chart. Move sideways on the same row to the nearest box showing a visual indicator setting.
5. This value should be recorded on the work shop form under Initial Indicator Settings.

MECHANICAL SYSTEM TESTING

1. Adjust the bindings toe and heel indicators to the Initial Indicator Setting.
2. Use a calibrated torque measuring device according to the instructions provided by the supplier.
3. Exercise that binding by release it at least once in all direction.
4. Three tests are required in each direction. The middle quantitative value of the three releases should be used as the test result.
5. Using the previously determined Skicode slide across the chart to the column representing twist torque reference values.
6. If the test result is within one torque value above to one torque value below the reference value, it is in the Inspection Range. These results are acceptable and no further adjustment is necessary.
7. If the test result is within two torque values above to two torque values below the reference value, it is in the In-Use Range. The indicator value should be readjusted and the system retested so that it falls in the Inspection Range. Record the corrected indicator value in the box for final release/retention settings.
8. If the test result value falls out of the In-Use Range the system should be thoroughly inspected for the following:
 1. Correct forward pressure.
 2. Correct sole-hold down adjustment.
 3. Worn or contaminated AFD's.
 4. Out of standard boot soles. No work can be performed on the system until these problems are corrected.
9. Check the heel for forward lean the same way, determining the middle quantitative value of three vertical releases. Adjust if necessary.

10. Record final indicator settings on the workshop form in the area for final release/retention settings.

TYPE I SKIERS

- Cautious skiing on smooth slopes of gentle to moderate pitch.
- Skiers who designate themselves as Type I receive lower than average release/retention settings. This corresponds to an increased risk of inadvertent binding release in order to gain releaseability in a fall. This type also applies to entry-level skiers uncertain of their classification.

TYPE II SKIERS

- Skiers not classified as Type I or Type III.
- Skiers who designate themselves as Type II receive average release/retention settings appropriate for most recreational skiing.

TYPE III SKIERS

- Fast skiing on slopes of moderate to steep pitch.
- Type III settings should not be used by skiers of less than 22 kg/48 lbs. Skiers who designate themselves as Type III receive higher than average release/retention settings. This corresponds to decreased releasability in a fall in order gain a decreased risk of inadvertent binding release.

NOTE: If the skier reports release/retention problems see the chapter "troubleshooting release/retention problems", page 127 in the manual. Skiers who desire release/retention settings lower than Type I may designate themselves (I-). Type I- is inappropriate for skiers 17 kg/38 lbs or less. Type I- move down the table three skier codes. Skiers who desire release/retention settings higher than Type III may designate themselves (III+). Type III+ move down the table three skier codes. Skiers may select skier type designations that are different for twist and forward lean. In such a case, the selection shall be indicated by a slash separating twist and forward lean selections, in that order (for example, K/L, K for the toe and L for the heel).

THE REVOLUTION KEEPS ON FASCINATING!

VACUUM FIT
FITS. GUARANTEED.



Soma VACUUM FC4 Pro 150/130



Soma VACUUM FC4 130



Soma VACUUM T30/110



Soma VACUUM Renard 12



Soma VACUUM Hybrid 12 Plus



CAN YOU IMPROVE ON A SENSATION? YES YOU CAN: WITH EVEN MORE INDIVIDUALISATION.

Fischer's VACUUM FIT technology was a worldwide sensation last year: the Fischer VACU-PLAST material enables for the first time a completely anatomical adjustment of the boot with a quality never reached before. And all that in 20 minutes. The 100% guaranteed fit you can achieve as a result was awesome for both the skiers and Fischer's selected retail partners. A good reason to step up another gear this year!

This year the VACUUM FIT concept has been enhanced even further to exactly match the individual requirements in the different skiing disciplines. Fischer creates the perfect boot with an optimised fit through a variety of last widths and a wider range of models for skiers who are looking for the ultimate in performance.



VACUUM FIT Station

THREE STEPS TO THE RIGHT FIT



1

WARM-UP

- Heat up the shell to 80 degrees Celsius in the oven



2

PRE-FIT

- Insert foot into preheated shell
- Put on Cooling Pad and Compression Pad
- Adjust the stand position on the VACUUM FIT Station

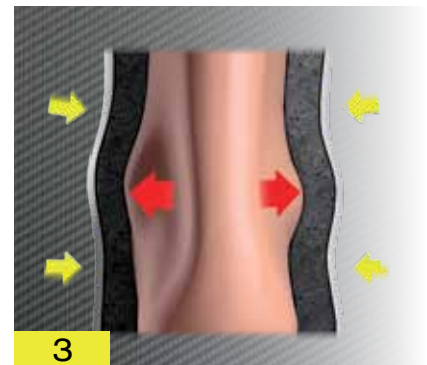

3

PERFECT FIT AND COOL DOWN

- Adjust the entire boot to the anatomy of the foot using compressed air
- Use the Cooling Pad to cool it down

Soma VACUUM Hybrid 9 Plus



Soma VACUUM Trinity 110



Soma VACUUM Hybrid W10



Soma VACUUM Hybrid W8 Plus



Soma VACUUM RC4 100 Jr.



THE BIGGER PICTURE OF PERFECTION

TOP PERFORMANCE ON AND AWAY FROM THE SLOPES: FISCHER HYBRID

The hybrid trend is not where it should be until there is the perfect interplay of the combined technologies of Fischer and all their technical prowess: the peak of skiing enjoyment for skiers who yearn for breathtaking performance!

With a choice of three settings and just one movement of the hand the boot is perfectly adjusted to the respective requirements within a matter of a second: LOCK MODE with optimum performance for racing, RIDE MODE for cool turns in powder and HIKE MODE if you need to walk one stretch once in a while.

HYBRID

TECHNOLOGY





SOMATEC®

POWER. GRIP. CONTROL.

MAXIMUM POWER TRANSFER



SOMA-TEC harnesses all power exactly in the skiing direction.

- Perfect power transfer
- Maximum acceleration
- Less effort required



ON CENTER POSITION



The stand position lies exactly on the centre of the ski.

- Perfect edge grip
- Faster and easier edge switches

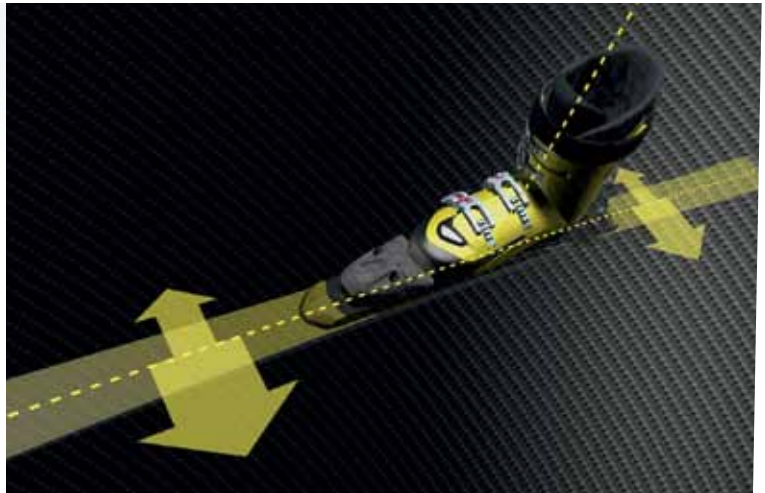

ORIGINAL V-POSITION



The natural V-position of the feet is retained inside the boot.

- Better control
- Less strain on joints
- The natural motion sequence is retained

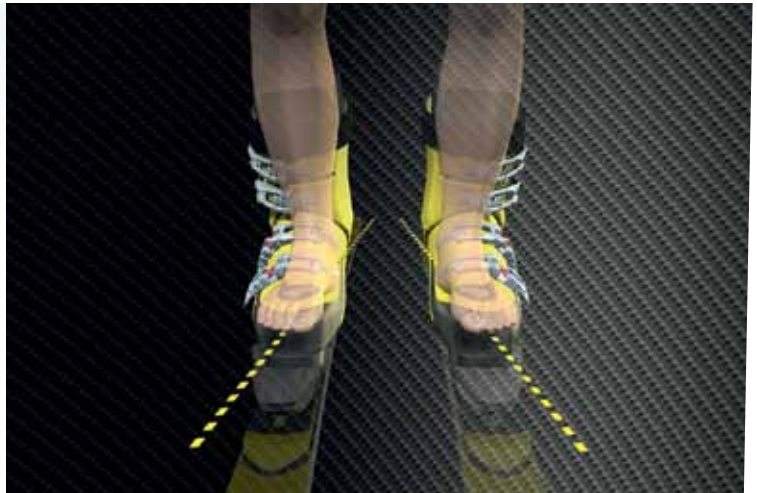

RACE



ADJUSTABLE SPOILER



The spoiler is fixed to the boot liner by a Velcro strap and can be adjusted individually. Higher spoiler for more support, lower spoiler for lower calf position, spoiler removed for less forward lean.

HEEL & TOE PLATES



Replaceable sole plates that do not affect power transfer to the ski.

H.I.P.E.



High Insulation PolyEthylene: maximum warmth insulation through the 3-layer principle (mesh, aluminium coating, polyethylene). The material also gives you a more homogeneous fit.

VACU-PLAST



Perfect fitting at 80°C for the anatomy of the foot for direct control impulses and more rebound through greater elasticity. Greater temperature stability and 15% less weight.

HYBRID



HIKE / RIDE / LOCK MODE



HIKE MODE: maximum freedom of motion for the cuff so you can walk easily.
RIDE MODE: the cuff is blocked at the back, the flex at the front stays smooth – for perfect turns in powder.
LOCK MODE: the cuff is blocked as on racing boots for maximum performance on the piste.

ON/OFF PISTE MODE

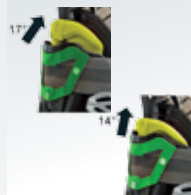

The boot can be adapted according to the respective snow conditions. Removed spoiler for more forward lean (17°, X-Series 17°) and hard piste conditions (On Piste Mode). Lowered spoiler for less forward lean (14°, X-Series removable spoiler with 12° forward lean) for deep snow and soft piste conditions.

HEAT SYSTEM READY



Cuff and boot liner are prepared for heating systems to be added. All you have to do is thread in the cable of the heated insole and connect the powerpack to the cuff. Fischer recommends:



H.I.P.E.



High Insulation PolyEthylene: maximum warmth insulation through the 3-layer principle (mesh, aluminium coating, polyethylene). The material also gives you a more homogeneous fit.

WOMEN MY STYLE



FREESKI



HIKE / RIDE / LOCK MODE

HIKE MODE: maximum freedom of motion for the cuff so you can walk easily.
RIDE MODE: the cuff is blocked at the back, the flex at the front stays smooth – for perfect turns in powder.
LOCK MODE: the cuff is blocked as on racing boots for maximum performance on the piste.



HEAT SYSTEM READY

Cuff and boot liner are prepared for heating systems to be added. All you have to do is thread in the cable of the heated insole and connect the powerpack to the cuff. Fischer recommends:



WOMEN SPECIFIC FIT

Concave, arched back boot liner construction for added space in the calf area and a comfortable fit.



H.I.P.E.

High Insulation PolyEthylene: maximum warmth insulation through the 3-layer principle (mesh, aluminium coating, polyethylene). The material also gives you a more homogeneous fit.



HIKE / RIDE / LOCK MODE

HIKE MODE: maximum freedom of motion for the cuff so you can walk easily.
RIDE MODE: the cuff is blocked at the back, the flex at the front stays smooth – for perfect turns in powder.
LOCK MODE: the cuff is blocked as on racing boots for maximum performance on the piste.



VIBRAM SOLE



Vibram rubber sole made of two components with different hardnesses for perfect grip on steep rock terrain. Using the hard component at the points where the boot comes into contact with the binding means the rubber sole fulfils the DIN standard for Alpine boots and bindings.



VACU-PLAST

Perfect fitting at 80°C for the anatomy of the foot for direct control impulses and more rebound through greater elasticity. Greater temperature stability and 15% less weight.



MOTION SUPPORT LINER

A pivot point on the liner cuff where the ankle is increases freedom of movement when required backwards and forwards for easier walking, on ski tours and also on slopes.

FFS - FISCHER FIT SYSTEM

WHAT IS FFS?

No two skiers are the same. Whether it's a novice or an enthusiastic recreational skier. Each one has his or her own requirements in terms of performance, material and comfort. With the Fischer Fit System we have developed a variable inner boot design which, combined with the various materials, is perfectly tuned to the individual requirements of our customers. The six different Fit Systems differ in terms of features, boot liner lasts, outer material, cushioning, lining material and insole, and are easily identifiable thanks to well placed logos on the edge of the boot.



A boot liner fully tuned for racing with perfect, direct power transfer and maximum performance.



Race standard, thermoformable, direct shell contact, ideal power transfer.



For regular skiers, robust, durable, narrow fit, thermoformable.



Athletic, thermoformable, good heel fit, combines good performance and comfort.



Soft cushioning material, comfortable heel and ankle fit, thermal insulation, thermoformable.



Soft cushioning material, comfortable with thermal insulation, heat-prepared.

FULL THERMO FIT

Thermally formable boot liner with excellent thermal insulation enables perfect individual adjustment to the anatomic shape of the foot.



SEAMLESS SLIDER

Smooth Lycra upper material in entry area, eases entry and exit.



WORLD CUP INSOLE

Anatomically-shaped and thermoformable insole for optimum heel hold.



SENSITIVE TOEBOX

Elastic neoprene ensures optimum fit in toe section and also provides excellent thermal insulation.



GEL FLOW PAD

An ankle cushion also used in the World Cup and made of a gel/cork mixture ensures a perfect fit and excellent heel cradling.



HEAT SYSTEM READY

The boot liner is prepared for the use of heatable insoles – all you have to do is thread in the heating system cable.



FISCHER FIT SYSTEM



FULL THERMO FIT

SEAMLESS SLIDER

SENSITIVE TOEBOX

GEL FLOW PAD

WORLD CUP INSOLE

HEAT SYSTEM READY

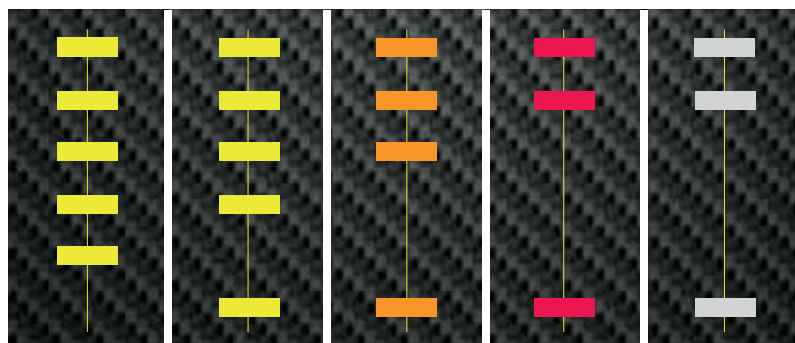

FOAM BOOT LINER

A Foaming Kit (boot liner + foam) is also available for all RC4, Progressor, My Style 100 and X models. Please refer to the foam section for a description of fitting Foam Boot Liners.

THERMOFIT

Heating up the boot liners before the skier puts them on allows the liner to adapt to the individual shape of the skier's feet. Method: heat the boot liner for 10 minutes at 80°C (ideally in the special oven supplied for this purpose), put on the ski boots, close the buckles and wear the ski boots for 10 minutes. It is important that as little movement as possible is made in the ski boots. FISCHER ski boots offer a wide range of Thermofit options. Please refer to the product description for more details.

BENEFIT TO THE CUSTOMER

The technical features of the boot liners improve the fit and increase the performance of FISCHER ski boots.

NEOPRENE TOE BOX: Optimised heat insulation in toe section.

FOAM BOOT LINER: Foaming process for perfect individual adjustment to match the customer's feet.

FULL THERMOFIT: Foaming process for perfect individual adjustment to match the customer's feet.

HEAT SYTEM READY: The boot liner is prepared for the use of heatable insoles.

GEL FLOW PAD: Perfect fit and excellent heel cradling

SENSITIVE TOEBOX: Optimised heat insulation in toe section.

SEAMLESS SLIDER: Makes putting on the boot more comfortable.

TROUBLE SHOOTING RELEASE/RETENT. PROBL.

IF THE SKIER REPORTS A RELEASE OR RETENTION PROBLEM

- Re-inspect the equipment to make sure that all components are in good condition and function properly.
- Test the system to make sure that it is calibrated properly.
- Have the skier use the “Classify Yourself” materials to make certain that the correct Skier Type has been selected.

If component inspections and a calibration check do not reveal a problem the skier may request discretionary settings.

INFORMATION FOR SKIERS REQUESTING DISCRETIONARY SETTINGS

1. Your normal release/retention settings comply with ISO/ASTM standards. Although these guidelines may be inappropriate for some types of competitive skiing or competition training, they are believed to provide an effective compromise between the release and retention needs of most recreational skiers.

2. Adhering to these guidelines may help to reduce the risk of injuries resulting from improper release/retention setting selection. However, skiing involves inherent risks. Injury can result from simply falling down, impact with an object, or from many other actions. Many injuries are unrelated to the function of the release system. Furthermore, even a properly adjusted binding cannot protect the skier in all situations.

3. Difficulties with release or retention may be unrelated to release/retention settings and can result from your skiing style, the incompatibility of your boots and bindings, or wear, damage, or contamination of a component of the release system. Be sure to describe your circumstances to the shop technician and to authorize recommended inspections and repairs before proceeding.

4. If you have been dissatisfied with the release/retention settings that result from your normal skier classification, you may wish to consider changing your skier classification, designating skier type classifications that are different for twist and forward lean, or request discretionary release/retention settings that are higher or lower than the normal range. Lower settings correspond to an increase in the risk of inadvertent binding release in order to gain increased releasability in a fall. Higher settings correspond to a decrease in releasability in a fall in order to gain a decreased risk of inadvertent binding release.

5. Although the shop technician may help you to record your choice on the appropriate form, the final decision on your release/retention settings is yours.

FISCHER CERTIFICATION REQUIREMENTS

This section must be read, and thoroughly understood, prior to completion of FISCHER's Employee Training Documentation Form and viewing the 12113 FISCHER Certification Video.

At FISCHER we realize that the quality added to our products in your shop is every bit as important as the quality we build in at the factory. The FISCHER Retailer Indemnity Program, which includes indepth technical training, is a key element of maintaining consistent quality.

TECHNICAL INFORMATION

Procedures for installation, release/retention adjustment, testing, troubleshooting and record keeping should always be taken from the current season's FISCHER Technical Manual.

EMPLOYEE TRAINING

This manual provides a depth of information unprecedented in the industry, it is here to help you fulfill the shop's responsibility to bring new employees to a basic level of competence. It also addresses our desire to provide information specific to selling, installing, function checking, and maintaining FISCHER products. Last but perhaps most important, we produced it to help you understand why FISCHER represents the state of the art in bindings. We hope you will use it as part of a well planned and professional employee training program which goes far beyond properly installing bindings. Done well it will translate into consistent quality and the high level of satisfaction your customers deserve. Look at it as one of the first steps in your Total Quality Management program.

NOTE: Hands on training is the best training, an ideal task that can be incorporated into the training is pre-season testing. This will give your trainees hands on experience operating a testing device and adjusting ski/boot/ binding systems. Other tasks, such as routine rental maintenance, can also be done during the training period.

SHOP REQUIREMENTS

Each retail location must have:

- A current FISCHER Authorized Retailer Agreement on file with FISCHER Skis US LLC, Auburn, NH, USA/ Raymond Lanctot LTD., Can.
- A current FISCHER Binding Indemnification Agreement on file with FISCHER Skis US LLC, Auburn, NH, USA/Raymond Lanctot LTD., Can.
- At least one FISCHER Certified Technician employed per location.
- The required equipment for installing and testing FISCHER bindings. All Agreements and Certifications must be valid for the current season.

REQUIRED SERVICE SHOP TOOLS

This list is the bare minimum a shop can survive with.

- Tape Measure
- FISCHER Templates
 - #92 (Blue)
 - #94 (Violet)
 - #XTR PRO (Red)
 - #XTR RENT (Yellow)
- Variable speed, reversible electric drill
- Step Drill Bits (or equivalent)
 - 4.1 Ø x 9 mm
 - 4.1 Ø x 7 mm
 - 3.5 Ø x 9 mm
 - 3.5 Ø x 7 mm
- Tap, Tap Brace and Tap Guide
- Pozidrive No. 3 screwdriver
- FISCHER Large slot screwdriver
- Current FISCHER retention/release adjustment table
- Approved mechanical testing device
- Screw extractor
- Tap extractor
- Hole plugs, plastic & wood
- FISCHER threaded plastic ski inserts
- Chisel
- Hammer

FISCHER CERTIFICATION REQUIREMENTS

CREATING AN INFORMED CONSUMER

Customers, whether rental or retail, come to your shop with all levels of knowledge. The range extends from true experts who really know the sport and their equipment needs, to never-ever skiers who know they must rely totally on your expertise. A key role played by a good shop, and a requirement in the US and Canada under the "FISCHER Retailer Indemnity Program", is providing information, guidance and instruction to all customers.

Specifically this means:

- Providing product and suitability information to help customers make an informed choice of which equipment models are right for them. The amount and type of advice given will naturally be different for each customer.
- The shop's responsibility is to be sure that each product sold or serviced is appropriate for the needs of its user.
- The shop must provide accurate information about the nature of the sport, and what equipment can and cannot do. Inform customers that there are risks inherent in the sport of skiing that no binding can protect against. It is imperative that each customer be informed there are limitations to the protection their equipment can afford and that injuries can and do occur in the normal course of skiing.
- Under no circumstances should you make any warranties or assertions about the customers safety on the hill. Speaking simply, no binding is "absolutely safe". Well designed shop record forms address the disclosure and agreement subject very directly and professionally. Use them to your advantage by making sure customers read and understand the form before signing it. The following points must be explained to all customers (rental or retail) before they leave the shop with their equipment (consumer awareness checklist):
- Go through your workshop ticket and fully explain each task that has been performed by the shop.
- Explain how to use bindings and equipment. Let customers put on their boots and step in and out of the binding if need be.
- Remind skiers to clean their boots and bindings each time before stepping in. Tell them that they should always walk through clean snow before entering the bindings.
- Deliver the "Instructions For Use" booklet to retail customers. It is an important document and is essential for warranty service.
- Advise the customers to return to your shop periodically for maintenance and a system inspection. The service interval is once each 15 - 20 days of skiing, or annually, whichever comes first. Failure to adhere to this service interval will void the FISCHER Limited Warranty.
- Recommend care in transport: heels closed, bindings covered.
- Recommend care in storage: dry, moderate temperature, heels closed, boots not in bindings.
- Explain that bindings and boots must be kept clean for optimal function.
- Skiers should make a visual inspection of their system before each use, including the AFD pad which should be checked for wear, damage or loss. It is also wise to visually verify the release indicator value.

NOTE:

- The workshop ticket must be read, initialed and signed by the customer. If the customer is a minor, his or her signature should be obtained, along with that of the parent or guardian. If a parent or guardian is not available, the equipment should only be released if the proper signatures have been obtained.
- Remember, the customer's signature is required in two places under the terms of the FISCHER Retailer Indemnity Program. In order to avoid misunderstandings with the customer, please inform them of this requirement when equipment is taken in for service.
- If the customer is not the end user, every attempt should be made to make certain all aspects of the system are explained to the user, and to obtain his/her signature on the workshop ticket.

ABOUT TESTING

Testing is required for all FISCHER retail and rental systems as specified in this manual. Many consumers view system testing as a valuable service provided by professional shops. They expect their equipment will be properly tested, and are willing to pay for it. On the other hand, some customers may be reluctant to accept any additional costs. They may be especially resistant to charges made by the shop for testing and inspections of equipment which is being serviced. Following are some communication techniques that have been found to be helpful:

- Post your shop's testing policy. A clear statement, prominently displayed, will reassure customers that they're all receiving the same treatment. Consider a text similar to the following: "Industry standards have defined shop testing procedures for your ski/boot/binding system. We're proud to offer this service since it is in your best interest. While even the best ski equipment cannot eliminate all risks of injury, we strive to maximize your enjoyment of the sport by verifying the settings and function of your equipment. The extra time and expense of system testing will pay off for you in a better skiing experience."
- Make your service shop a showplace. Place your testing bench in a prominent location. Many customers like to know what kind of work you're doing for them. If you get a question, offer to let the skier watch.
- Proudly display diplomas and certificates received by your mechanics. Make their expertise known to your customers.
- Above all, don't apologize for testing. It's a valuable and necessary service well worth the cost.

ABOUT TESTING DEVICES

ASTM and ISO have defined specifications for ski equipment system testing devices. Only those devices that meet these recognized performance standards should be used to test systems that include FISCHER bindings. You should make it the responsibility of your testing device supplier to verify that their device fulfills all ASTM/ISO requirements.

Each device has its own unique features and some will fit your shop's needs better than others. Therefore, we can't recommend a single device as universally "the best". The following points, however, can be used as a guideline to getting the most out of your choice:

- Training is very important in the use of any device. Read the instructions thoroughly, and practice!
- To insure reproducibility from one technician to another a "Multiple Operator Reproducibility Test" should be performed by all users of the testing device. This simply requires that all technicians join in a "round robin" exercise where each tests the same system with the same test device. The goal is to verify that the testing techniques are the same and that all test results are comparable. Speak with your testing device supplier for the details on how to conduct this program.
- Beware of "black box" calculations that may be performed by some electronic testers, the calculations performed to arrive at an indicator value or determine an appropriate Torque Range could be based on old standards. Check the current FISCHER Adjustment Chart for applicable values.
- Periodic calibration of these devices is important, and this information should be documented in your shop records.
- Most important, never blindly trust the values given by any test device. This is just one tool to use in your evaluation of a complete release/retention system.

MAINTENANCE

Inform every customer of the simple fact that periodic maintenance is needed. If they don't bring their gear back for regular function checks, it is unreasonable to expect it to work as designed. Studies have shown that binding systems which have not been properly maintained have serious injury rates very much higher than those which have. Following this simple, logical guideline is the single most effective way to decrease serious injuries dramatically. Have the system serviced by a FISCHER certified technician once each 15 - 20 days of skiing, or annually, whichever comes first.

THE FISCHER LIMITED WARRANTY

FISCHER warrants to the initial purchaser that its 12 I13 series and newer bindings are warranted to be free from defects in materials and workmanship for a period of four years from date of purchase or five years from date of manufacture, whichever period expires earlier. For rental bindings it is 2 years from date of purchase. FISCHER disclaims all other warranties express or implied (USA and Canada). Buyer's sole remedy under the above warranty or under any implied warranty is limited to the repair or replacement, at FISCHER's sole option, of subject product or parts thereof. Buyer should return the subject product or parts to the place of purchase for warranty service. This limited warranty applies only to products that have been subject to normal use and that have been properly serviced. It excludes parts subject to wear such as AFD's, brakes, windows, plastic or metal tracks, etc. The "Instructions for Use" booklet (warranty), proof of purchase and proof of periodic service must accompany all bindings returned for replacement consideration.

LIMITATION OF LIABILITY

In no event shall FISCHER be liable for incidental, consequential statutory or exemplary damages, whether the action is in contract, warranty, negligence or strict liability, including without limitation, loss to property other than the binding, loss of use of the binding or other property, or other economic losses. FISCHER shall not be liable for contribution or indemnification, whatever the cause. Some states do not allow limitations on how long an implied warranty lasts, so the above limitation may not apply to you. Some states do not allow the exclusion of limitations of incidental or consequential damages, so the above limitation or exclusion may not apply to you. This warranty gives you specific legal rights, and you may also have other rights which vary from state to state.

SERVICE UNDER THE FISCHER WARRANTY

Products requiring service under the terms of the warranty should be dealt with as follows:

- Send the complete binding set to the authorized distributor where evaluation will be made and warranty action taken if required.
- If a clear warranty situation exists, and the shop wishes to replace the pair of bindings products out of stock for a customer, the shop may do so after the approval of the ski warranty department of your FISCHER distributor. Be sure to check suitability and mounting hole pattern before making a change of model.
- When possible, the replacement should be of the same model as the returned product.

- If the same model is not available, the shop should contact the authorized FISCHER distributor warranty department for authorization before a more expensive model is selected for replacement.
- If a replacement is made from retailer stock, the complete binding set should be returned to the authorized FISCHER distributor as soon as possible. The packing list must clearly state which model was used for replacement.
- The "Instructions for Use" booklet (warranty), and proof of purchase must accompany all products returned for consideration.
- No credits will be issued.
- The authorized FISCHER distributor reserves the right to deny replacement to the retailer if the alleged problem is not verified or if products are returned without the "Instructions for Use" booklet and proof of purchase.
- Replacement bindings are covered by the warranty stated above.
- Any bindings returned to the authorized FISCHER distributor due to inappropriate release values (i.e. values which fall outside the "In-Use" tolerance range on the current FISCHER Adjustment Chart) must be accompanied by a completed System Performance Report. The report form is printed in this manual; no warranty action will be taken on release value related claims unless this report accompanies the returned bindings.

Distributor addresses:

FISCHER Skis US LLC
60 Dartmouth Drive,
Auburn, NH 03032 USA

FISCHER Canada
Raymond Lanctot LTD.
5790 Rue Paré
Montréal, Quebec,
CANADA H4P 2M2

Phone: 603-314-7110

Phone: 800-361-5045

13|14 CERTIFICATION EXAM



1. Freeflex bindings:

- A - Maintain consistent forward pressure and release/retention value during ski flex.
- B - Reduce ski vibrations for improved edge grip and control.
- C - Have a total stand-height of 21 mm to leave room under FIS regulations for race plates.
- D - Provide all of the above.

2. The FISCHER roller-pincer system includes:

- A - 4 rollers and glide elements that minimize friction.
- B - 180° release range with programmed elasticity to reduce peak loads on the knee.
- C - Direct power transfer to the edge.
- D - All of the above.

3. FX Railflex bindings have a heel standheight of:

- A - 33.5 mm.
- B - 31 mm.
- C - 36,5 mm.
- D - 21 mm.

4. FJ 7, XTR 7 Pro bindings can accept:

- A - Adult soles only on the FJ 7.
- B - Child soles only on the FJ 7.
- C - Adult and child soles on all models.
- D - Adult and child soles on the rental bindings only.

5. When adjusting the 92 template for Freeflex models:

- A - Lock the lever in the far right position after measuring the boot.
- B - Use the number on the template that matches the sole length.
- C - Adjust the template to the boot, put the lever in the middle position and set to the nearest centimeter mark until the template locks in position.
- D - Use setting 23 for all adult boots.

6. To activate the Freeflex dampening function:

- A - Turn the eccentric screw in the middle of the band until the marks are aligned.
- B - Do not use a power screwdriver.
- C - Always deactivate when dismantling the binding.
- D - All of the above.

7. FJ 4 AC, XTR 4 AC Rent, XTR 4 AC Pro:

- A - Use a 94 W drill template for mounting.
- B - Provide consistent performance for adult and child soles.
- C - Have a toe height adjusted by sliding an adjustment wedge under the toe.
- D - All of the above.

8. The FISCHER XTR 10 Pro Rental binding:

- A - Offers a boot sole range of 263 - 391 mm.
- B - Utilizes a single letter code for quick adjustments of both heel and toe.
- C - Uses a tool-free, one-touch mechanism.
- D - All of the above.

9. The FISCHER Rental Boot Indicator (SymRent Caliper) can be used to:

- A - Measure boot sole length in millimeters and choose a Single Code.
- B - Check for excessive wear on the boot sole dimensions.
- C - Determine whether the boot sole is adult or child.
- D - All of the above.

10. For all FISCHER bindings, the release/retention settings:

- A - Must be verified with an approved calibrated testing device per industry standards.
- B - Must begin with the FISCHER Adjustment Chart for initial indicator settings and torque values.
- C - Must be clearly recorded on the workshop ticket.
- D - All of the above.

11. What are the features of FISCHER's Railflex bindings:

- A - They can be mounted without drilling any holes.
- B - Maximum ski flex and minimum tension is created by binding and boot.
- C - There are three positions to mount the FISCHER Railflex binding to adapt the system to individual skiing needs.
- D - All of the above.

12. The FISCHER ABS system:

- A - Cleans itself as it rotates.
- B - Enables the boot to exit the binding virtually friction free.
- C - A and B.
- D - Aligns the forward pressure of the binding.

12 | 13 CERTIFICATION EXAM

13. Forward Pressure on the FS 10 are measured:

- A - When the boot is not in the binding.
- B - With the boot in the binding, the pointer on the lower part of the heel should be in front of the scribed area.
- C - With the boot in the binding, the pointer should rest in the middle of the scribed area on the toothed lock.
- D - None of the above.

14. When mounting a FISCHER Railflex binding:

- A - Determine the boot sole length with the Rental boot caliper.
- B - Connect the toe and heel with the band at the closest sole length mark corresponding with the measured boot sole.
- C - Slide the binding on the Railflex base from the rear and align and fasten with the appropriate mounting position.
- D - All of the above.

15. FISCHER binding warranty covers defects in materials and workmanship:

- A - For a period of 4 years from the date of purchase.
- B - For a period of 5 years from the date of manufacture.
- C - Both A and B.
- D - For a period from when the customer's money is taken and they reach the front door.

16. If a diagonal heel housing wobbles in the heel track you should:

- A - Follow the simple procedure for replacing the worn out heel glide insert.
- B - Ignore the situation.
- C - Send the bindings to FISCHER warranty for replacement.
- D - Smack the heel piece gently but firmly against the hood of your car.

17. To complete your FISCHER certification:

- A - Review the FISCHER Technical Manual.
- B - Practice the procedures with hands on in-store training.
- C - Send in your completed Employee Certification Answer Sheet.
- D - All of the above.

Please refer to the 12 | 13 FISCHER Release/Retention Adjustment Table for the next four questions:

18. A type 2 male skier weighing 165 pounds that is 5'10" tall and 36 years old with a boot sole of 310 mm has a skier code of:

- A - L.
- B - K.
- C - J.
- D - 5.

19. The DIN and Inspection Range for twist for this skier is:

- A - 6.50 and 43-78.
- B - 5.50 and 43-58.
- C - 6.50 and 50-67.
- D - 5.50 and 37-67.

20. A type 3 skier weighing 190 lbs that is 6'1", and 35 years old with a boot sole length of 321 mm will have a DIN of:

- A - 7.0
- B - 8.5
- C - 8.0
- D - 10.0

21. The Flowflex plate can be mounted with:

- A - RC4 Z 17 Flowflex binding.
- B - RC4 Z 13 Freeflex binding.
- C - FS 10.
- D - All of the above.

Refer to the pages listed in the Technical Manual for more information.

Copies may be made for additional employees.

Only fax in Answer Sheet.

EMPLOYEE CERTIFICATION ANSWER SHEET

FISCHER

PLEASE READ CAREFULLY

- Duplicate copies of this form only will be accepted.
- Sections 1 - 4 must be completed in full before this form can be processed. Unanswered or incomplete information may result in failure of exam. Technicians with failed exam forms will be contacted by FISCHER Skis US LLC or Raymond Lanctot LTD., Can.
- Incorrect information in Sections 1 - 4 may result in denial of dealer indemnification.
- A score of at least 80% (16 correct answers) must be achieved in Section 4 to pass this exam.
- FAX # FISCHER Sports USA: 603-314-7124; Raymond Lanctot LTD., Canada: (514) 342 4059

1. TECHNICIAN INFORMATION

Today's Test Date	
Dealer (Customer) Number (six digits)	
Technician Name (please print)	
Technician Signature	Initials
Technician's City, State, Zip	E-Mail

2. DEALER MAILING ADDRESS

Dealer Name	Street/P.O. Box
City	State/Province Zip/Postal Code Country

3. SHOP ADDRESS

Shop Name	Street/P.O. Box
City	State/Province Zip/Postal Code Country
Telephone	Website/E-Mail

4. EXAM ANSWER SECTION

Indicate one correct answer for each question given.

- | | | | | | |
|--|--|---|---|---|---|
| 1. <input type="checkbox"/> a <input type="checkbox"/> b <input type="checkbox"/> c <input type="checkbox"/> d | 5. <input type="checkbox"/> a <input type="checkbox"/> b <input type="checkbox"/> c <input type="checkbox"/> d | 9. <input type="checkbox"/> a <input type="checkbox"/> b <input type="checkbox"/> c <input type="checkbox"/> d | 13. <input type="checkbox"/> a <input type="checkbox"/> b <input type="checkbox"/> c <input type="checkbox"/> d | 17. <input type="checkbox"/> a <input type="checkbox"/> b <input type="checkbox"/> c <input type="checkbox"/> d | 21. <input type="checkbox"/> a <input type="checkbox"/> b <input type="checkbox"/> c <input type="checkbox"/> d |
| 2. <input type="checkbox"/> a <input type="checkbox"/> b <input type="checkbox"/> c <input type="checkbox"/> d | 6. <input type="checkbox"/> a <input type="checkbox"/> b <input type="checkbox"/> c <input type="checkbox"/> d | 10. <input type="checkbox"/> a <input type="checkbox"/> b <input type="checkbox"/> c <input type="checkbox"/> d | 14. <input type="checkbox"/> a <input type="checkbox"/> b <input type="checkbox"/> c <input type="checkbox"/> d | 18. <input type="checkbox"/> a <input type="checkbox"/> b <input type="checkbox"/> c <input type="checkbox"/> d | |
| 3. <input type="checkbox"/> a <input type="checkbox"/> b <input type="checkbox"/> c <input type="checkbox"/> d | 7. <input type="checkbox"/> a <input type="checkbox"/> b <input type="checkbox"/> c <input type="checkbox"/> d | 11. <input type="checkbox"/> a <input type="checkbox"/> b <input type="checkbox"/> c <input type="checkbox"/> d | 15. <input type="checkbox"/> a <input type="checkbox"/> b <input type="checkbox"/> c <input type="checkbox"/> d | 19. <input type="checkbox"/> a <input type="checkbox"/> b <input type="checkbox"/> c <input type="checkbox"/> d | |
| 4. <input type="checkbox"/> a <input type="checkbox"/> b <input type="checkbox"/> c <input type="checkbox"/> d | 8. <input type="checkbox"/> a <input type="checkbox"/> b <input type="checkbox"/> c <input type="checkbox"/> d | 12. <input type="checkbox"/> a <input type="checkbox"/> b <input type="checkbox"/> c <input type="checkbox"/> d | 16. <input type="checkbox"/> a <input type="checkbox"/> b <input type="checkbox"/> c <input type="checkbox"/> d | 20. <input type="checkbox"/> a <input type="checkbox"/> b <input type="checkbox"/> c <input type="checkbox"/> d | |

FISCHER OFFICE USE ONLY

Pass	Fail
Certificate Number	Date Entered Initials

FISCHER RETAILER INDEMNITY PROGRAM

Today's equipment may help reduce certain hazards involved in the sport, but the risk of injury remains. The FISCHER Retailer Indemnity Program is designed to help formalize service procedures and minimize the risks to both you and your customer.

Under the plan, FISCHER will defend and indemnify the Authorized Retailer in bodily injury claims when certain conditions are met, including following all FISCHER required procedures. The program benefits are not without limits, indemnification is not insurance, and it does not eliminate the need for a shop to have adequate insurance of its own. But, for the shop willing to make the investment in doing a quality job as an assembler of equipment systems from components, it is a key element in their Risk Management plan.

Retailer benefits under the terms of the plan are based, in part, on the adequacy of the service work performed by the mechanic. For this reason, thorough employee training is essential. This manual, and technical seminars are presented by FISCHER to help define appropriate shop procedures. It is the responsibility of the FISCHER Authorized Retailer to see that all technical and product information materials provided by FISCHER Skis US LLC/ Raymond Lanctot LTD., Can. are ordered and available in their shop. This should be done with the aid of your FISCHER Representative while placing your FISCHER pre-season binding order.

RETAILER AGREEMENTS AND INDEMNIFICATION AGREEMENTS

Both Agreements must be completed annually. This year's Retailer and Indemnification Agreements should already be completed, if not please contact customer service or your sales rep.

Agreements and Certification Exams should be received at FISCHER Skis US LLC/ Raymond Lanctot LTD., Can. no later than December 31, 2012. If a retailer loses his only FISCHER certified mechanic, he must notify FISCHER Skis US LLC/ Raymond Lanctot LTD., Can. in writing within 48 hours.

SUMMARY OF REQUIREMENTS

These basic requirements help assure that the end product which is delivered to the customer is appropriate.

- Signed, current copies of the FISCHER Authorized Retailer Agreement and the FISCHER Bindings Indemnification Agreement must be on file with FISCHER Skis US LLC/ Raymond Lanctot LTD., Can.
- The shop must adhere to 12 | 13 FISCHER procedures for selection, mounting, adjusting, testing and/ or servicing of system components as detailed in this manual.
- The actual FISCHER retention/release adjustment, or its equivalent, must be used.
- A FISCHER Certified Mechanic must properly mount, inspect, adjust and/ or service system components and/ or check to make sure all service, adjustments, testing and record keeping were properly completed.
- Mechanics must receive full training, including hands-on practice in the use of system testing devices, as provided by the testing device supplier. A multiple operator reproducibility test should be completed and results documented by the shop each season.
- The shop must maintain records of all retail/ rental testing and/ or service work for 5 years or for the length of the statute of limitations in the state where your business resides, which - ever is longer. Bear in mind that the statute of limitations for minors begins only when they come of legal age.

PAPERWORK REQUIREMENTS

FISCHER Retail/Rental Workshop tickets have demonstrated their usefulness in the legal system, and we strongly recommend their use.

At the very minimum, records must contain the following information:

- Identification of shop and customer: name, address, phone.
- Date of transaction or work.
- Information on which binding settings are based: skier height, weight, skier type, age, boot sole length.
- A full description of the equipment being serviced or rented (skis/boots/bindings), including but not limited to brand, model, size and serial numbers.
- Skier code, "Initial" binding release/retention settings, and final settings.
- Signed, dated statement from the FISCHER Certified Mechanic that all manufacturer's procedures have been completed, and the signature of the mechanic who performed the service (if they are different individuals).
- An agreement dated and signed by the customer, the language of which is substantially similar to the current FISCHER form.

This agreement must include the following points:

- User verification of skier information.
- WARNING that there are risks of injury inherent in the sport of skiing and that the customer accepts those risks.
- DISCLOSURE of the equipment's limitations, that it will not release, retain or prevent injury under all circumstances, and is no guarantee of the user's safety.
- RELEASE language whereby the user releases the retailer, manufacturer and distributor from liability and damages, to the fullest extent allowed by law.
- STATEMENT that no warranties of any kind are offered by the shop beyond those offered by FISCHER.
- AGREEMENT that instruction in the use of the equipment has been received, that the skier height, weight, skier type, age, boot sole length, as well as the settings on the binding match those on the record form, and that the skier will inspect the system, including the binding's AFD, before each use.

NOTE:

- Any changes in documentation requirements must be authorized in writing by FISCHER Skis US LLC/Raymond Lanctot LTD., Can.
- Signatures by both the customer and FISCHER Certified Mechanic are required by for the FISCHER Retailer Indemnify Program. Post Accident Report (see sample in appendix).
- In addition to the above information on the system's performance, fill out a Post Accident Report when you become aware that an injury has occurred. Keep this document for 5 years or the duration of the statute of limitations for minors, whichever is longer.

IN THE EVENT OF AN INJURY CLAIM

- Notification to FISCHER Skis US LLC/Raymond Lanctot LTD., Can. by retailer, of any bodily injury claim, must be made in writing on or before the tenth calendar day from the date on which the retailer first received notice of any such claim. In the event of a lawsuit the retailer must notify his/her own attorney and must cooperate with FISCHER Skis US LLC/Raymond Lanctot LTD., Can. and respond to requests as required.
- In a rental situation, from the time that any injury claim is made to the retailer, the retailer must maintain possession of any equipment that may have been involved in the accident (equipment may be returned to service upon passing a postaccident investigation).

- In the event of an injury, a Post Accident Report must be completed and retained if the shop is in possession of all components of the system. If the entire system is not available for test it should be noted and all pertinent information such as equipment condition, visual indicator settings, and any equipment abnormalities should be recorded.

NOTE: FISCHER reserves the right to deny indemnity if FISCHER requirements are not fulfilled. Strict compliance by the dealer with all requirements, as stated in the FISCHER Binding Indemnification Agreement, is a condition precedent to favorable consideration of a request for indemnity.

This is only a summary. The precise requirements of the FISCHER Binding Indemnification Program are contained in your FISCHER Binding Indemnification Agreement, Indemnification, Insurance, and your liabilities.

RISK MANAGEMENT

INDEMNIFICATION

Indemnification simply means that someone agrees to reimburse you for certain costs. In the ski industry it normally means that provided you fully follow the manufacturer's requirements and install and adjust the binding system correctly, the manufacturer or distributor will provide a defense and pay any judgment which may be entered against you if you are the subject of a claim or suit by a customer who claims to have suffered bodily injury as a result of using certain equipment. The key here is you must be able to prove that you did your job properly in order to qualify. If you do not, you will not be entitled to a defense or indemnification in the event of a claim.

YOUR PERSONAL LIABILITY

It's simple: If you make a mistake which causes harm to another, you can be held liable for it. Be very careful not to make verbal warranties that extend beyond those made by FISCHER. Read the manufacturer's literature and warranties carefully. If a feature or benefit is not mentioned there, don't mention it to the customer.

SHOP LIABILITY INSURANCE

No indemnification program is a substitute for liability insurance. Common sense dictates that you should have an insurance policy that covers your shop and employees for commercial general liability and completed operations. Check with your insurance broker.

SHOP PROCEDURES TO REDUCE LEGAL EXPOSURE

Risk Management has become a very important area in virtually every industry. In today's world it is more important than ever to do as much as possible to recognize how and where we might be exposing ourselves to a potentially serious problem. FISCHER has been the leader in molding valuable risk management concepts into a program that virtually the entire ski industry follows today. FISCHER has defined proper shop practices and how shop personnel and customers need to interact in order to maximize skiing enjoyment while lowering the risks of liability. If these procedures are followed properly, both the skier and the industry are well served. In the event of a mishap, the programs documentation and record keeping system will provide strong evidence of work performed.

YOUR OBLIGATIONS UNDER THE FISCHER RETAILER INDEMNITY PROGRAM

Selecting equipment for your customer.

- Make sure the products are suitable for the skier's height, weight, ability, shoe size and level of ability.
- Always make sure your recommendations are consistent with the manufacturer's.

BINDING SELECTION

Generally, the idea that top of the line products offer the greatest margins for safety as well as performance and durability is correct - provided the skier fits the weight range of the product. Combine this knowledge with our weight and ability recommendations for the skier when selecting a binding. Avoid selling a product with the idea that the customer will grow into it. If a product is not suitable for their current requirements make another choice. Avoid the temptation to do the customer a favor by re-writing the rules. More often than not, all you will do is cause problems. At the time of delivery to the customer, the bindings must be accompanied by all the informational materials supplied by the manufacturer, i.e., pamphlets, forms, etc.

The product must be fully demonstrated to either the intended user or their parent or legal guardian if the child is a minor. This includes instructions on inspecting the low friction surfaces, cleaning the boot sole, entry of the binding, re-entry after releasing on the hill and exiting the system.

You must also explain what care and maintenance the skier is responsible for, as well as when to return the equipment to your shop for a thorough function check. Routine maintenance is the most cost effective thing a skier can do to protect their well being.

BOOT SELECTION

Make sure the customer's boot choice is consistent with their level of skiing and that the boots meet all current DIN or ISO standards.

SKI SELECTION

Take care to ensure that the skier's intended use of the chosen equipment is consistent with the manufacturer's recommendation for the skier's weight and level of skiing. This is another area where regular maintenance is critical. It is only logical that skis which help keep your customer upright reduce their overall chance of injury.

RACING BINDINGS

Certain binding models are produced by FISCHER each year for the exclusive use of qualified competitors under the supervision of FISCHER Technical Specialists. These bindings are not covered by either the FISCHER Warranty or any Dealer Indemnity Program. We recommend you decline to service them, and warn against their use. In a similar vein some skiers may wish to use retention settings which are excessive. DIN settings over 10 do not satisfy current industry standards and should not be used. Adjustments exceeding this range are made on one's own risk.

COMPLETING THE WORK ORDER WITH THE CUSTOMER

It is critical that certain basic information be included on all shop work orders. While we do not require it, the easiest way to make sure the form you use fits FISCHER's requirements is to use ours.

Once the customer has selected equipment or described the repair or service to be performed, the technician must ask the customer to complete a portion of the Work Order Form which includes their Name, Address, Phone number, Weight, Height, Age, Sex, and Skiing ability. There are few things more embarrassing than having a customer come in to pick up a pair of skis that could not be serviced due to an improperly filled out form, or an unforeseen technical problem.

The best way to avoid this is to have a FISCHER Certified Technician thoroughly inspect all incoming work, and check the paperwork. The skier must then sign indicating that they have read, understood, and agreed to the terms of your Rental/Repair agreement (this agreement must comply with FISCHER Dealer Indemnity Program requirements). It is also important that the customer be informed that they will be expected to verify in writing that the indicator settings agree with what is written on the form, and that they have been instructed in the use and maintenance of their equipment, and fully understand it. This procedure must be completed before the transaction is consummated. Remember, the customer has the option of going to another store if the terms of the contract are not acceptable to them, and under no circumstances should the transaction go any further without their signature. The end user, or their agent, must sign the incoming work order.

SHOP PROCEDURES SUMMARY

For in depth details, see the "Binding Installation" section of this manual.

- Follow FISCHER procedures for inspection, mounting, adjustment and maintenance as appropriate.
- Confirm that toe and heel indicator values match those specified on the actual FISCHER Adjustment Chart.
- Using a calibrated testing device, according to the manufacturer's instructions for use, "exercise" the binding by releasing it at least once in each direction (clockwise and counter-clockwise at the toe, vertically at the heel). Then measures Twist and Forward Lean Torque Values. The middle quantitative value of 3 releases in each direction should be used as the test result.
- Compare Twist and Forward Lean test, results with the System Inspection Ranges on the actual FISCHER Adjustment Chart.
- After the equipment is adjusted to the skier's needs according to the manufacturer's standards, the certified technician signs the form indicating that the work has been completed according to the manufacturer's specifications.
- With testing complete, the FISCHER Certified Technician must complete and sign the workshop ticket. Be sure the Final Indicator Settings are correctly shown there. The workshop ticket should simply reflect that the system has "passed all tests" or that "all manufacturer's procedures have been completed".

PROCEDURES FOR RETAIL CUSTOMER PICK-UP

When the Retail Customer or his representative comes in to pickup the equipment, the store employee has a fantastic opportunity to improve the skier's safety and enjoyment, while minimizing the risk of a law suit later on. All that's involved is properly informing the skier about the realities of skiing and ski equipment.

- Explain the function and operation of the binding, including a review of the manufacturer's pamphlet.
- Explain the settings that show in the release setting windows and how they were derived by referring to the manufacturer's release adjustment charts.
- Explain how much proper maintenance of the entire system (boots, bindings and skis) can improve their enjoyment and margins for safety. Also make it clear that skiing, like any sport, has its risks, and equipment can not eliminate them.
- Have the customer sign the form again indicating that they have been instructed on the use of the equipment and that they verified that the visual release indicators on the bindings correspond to the manufacturer's recommended settings shown on the work order ticket.

RISK MANAGEMENT

ARCHIVING RECORDS

Should you become one of the few that must defend against a law suit you will soon find out that the very best defense is made of paper. For this reason we recommend that you start out each ski season with a huge, brand new, manila envelope.

Over the course of the sea son you should fill it with the following items:

- Collect a copy of the Technical Manual for each and every binding, boot and ski on the market. Be especially diligent with those you carry or work on regularly.
- Copies of the manufacturer's customer instruction booklets.
- Technician employment applications. Make sure they have the address of someone who will always know where they can be found, and is likely to stay put – Moms are good. This can be invaluable if you need the technician as a witness.
- A listing of all technician certifications and their dates. Keep all certification records as well.
- Copies of any pertinent wall charts, customer information posters etc.
- A copy of your shop procedures, including training materials, rental and repair shop practices, and binding setting charts.
- Copies of rental fleet test data.
- This type of supporting documentation can be tremendously useful for your lawyer.

STORAGE OF FORMS

All forms containing the customer's signature must be kept for a minimum of five years or the term of the statute of limitations in the state where the injury occurs, or your state, whichever is longer. As a practical matter you have no idea where or when your customer may sustain an injury on this equipment. Naturally, should an injury occur to either an adult or a child, keep the original form in a safe place until the case is completely resolved.

Risk Management is really just common sense. Do your job well, have integrity, keep your customers well informed, and keep proper records. Follow these simple rules and you will have very few problems.

USE OF NON-RECOMMENDED SETTINGS

SKIERS REQUESTING SETTINGS NOT RECOMMENDED BY FISCHER

The 12113 FISCHER Release/Retention Adjustment Table is the only adjustment chart recommended for use by FISCHER dealers during the 12113 season.

Some skiers may request settings different from those in the FISCHER Release/Retention Adjustment Table. Most of these concerns can be addressed by following the procedures for reclassifying skier type and for troubleshooting which follow the instructions for using the FISCHER Release/Retention Adjustment Table.

FISCHER and the ISO/ASTM standards organizations do not recommend the use of release/retention settings outside of these tolerances, but skiers occasionally may request such settings. FISCHER recognizes a skier's right to choose other settings, but if the skier requests settings outside of those derived from the normal procedures for re-classifying skier type and for trouble - shooting, the shop may either:

1. Adjust the system to the setting derived from FISCHER Release/Retention Adjustment Table and instruct the skier on how to change the setting (if this done, make a note to this effect on the workshop or rental form), or
2. Adjust the system to the skier's individual request, but only if the technician notes on the workshop or rental form the reason the higher or lower setting was requested. Do not in any case adjust the system to a release/retention value higher than the maximum acceptable setting at the bottom of the FISCHER Release/Retention Adjustment Table. The customer must verify the request for the higher or lower settings by signing and dating the workshop or rental form by the reason noted next to the setting request. The skier must also read and sign a warning, release and indemnity agreement identical to the one printed on this page. In such cases, the system will only be indemnified if all other conditions of indemnification are met and the signed warning, release and indemnity agreement are attached to the completed workshop or rental form.

WARNING, RELEASE AND INDEMNITY AGREEMENT

I, _____, hereby acknowledge that I have been advised by the _____ (rental shop, sales department, etc.) that settings which I have requested for my bindings (Model _____) is not the setting recommended by the manufacturer of the bindings for a skier of my height, weight, age and skier type. I understand and acknowledge that there may be an increased risk of injury or death to me as a result of my own personal preference for these binding settings.

To the fullest extent allowed by law, I hereby waive and release all claims arising from the use of the bindings and release from all liability the shop, the distributor and the manufacturer, their agents and employees, and I further agree to indemnify them from any and all liability or harm or damage of any kind whatever which may result from the use of these bindings by myself or anyone I allow to use the bindings.

I, the undersigned, have read and understand this liability release agreement, and agree that it is binding upon me, my heirs, guardians, administrators, assigns, and legal representatives. If any part of this agreement is held to be invalid or unenforceable, the remainder shall be given full force and effect.

 Skier's Signature
 (or that of the skier's parent or guardian)

 Shop Manager's Signature

POST ACCIDENT INSPECTION REPORT



Date of Accident	Workshop Ticket #
Skier Name	Skier Phone
Address	Witness Name
City, State, Zip	Witness Phone

SKIER'S DESCRIPTION OF ACCIDENT AND INJURY

(Use Back For Additional Comments)

DESCRIPTION OF SYSTEM

		RENTED	PURCHASED
Ski Brand	Model	Size	
	Serial #	Inv. #	
Boot Brand	Model	Size	
Binding Brand	Model	Size	

CONDITION OF SYSTEM

Are the boot soles within industry standards?	Yes	No	
Are all buckles, boot adjustments functioning correctly?	Yes	No	
Are the A.F.D.'s intact?	Yes	No	
What are the Visual Indicator Settings?	Toe	Heel	
Is the Forward Pressure set correctly?	Yes	No	
Is the Toe Height set correctly?	Yes	No	NA
Do the brakes function smoothly?	Yes	No	
Is the ski bent delaminated or damaged?	Yes	No	
Describe:			
Was the equipment returned to service post-accident?	Yes	No	

MECHANICAL SYSTEM TESTING

Testing Device	Last Calibration date	/	/
	Clockwise	Ctr. Clockwise	Clockwise
	Toe L		R
	Heel L	R	

BACKGROUND

Shop Name	
Inspected By	Inspector Signature
Checked By	Checker Signature

3D FLOW PADDING MATERIAL

Pliable and displaceable cushion material used in RC4 World Cup Pro boot liners for perfect power transmission due to perfect fit around the skier's foot.

A

ADJUSTABLE SPOILER

Height-adjustable spoiler that allows the ski boot to be adjusted around the calf area.

AIR CHANNEL

Air channels in the fibreglass/wood core reduce the weight of the ski enormously for the highest possible strength and optimised surface pressure distribution.

AIR POWER

The injection ski design for harmonious, energy-saving enjoyment.

B

BASE, SINTERED BASE (GRAPHITE), TRANSPARENT BASE, EXTRUDED BASE, CUT BASE

The ski's gliding surface. The type of base is decisive regarding the ski's gliding properties.

BRUSHING

Excess wax is brushed away from the base. This is essential to give the ski optimum gliding properties.

C

CANTING TOOL

Clamping device to ensure optimum setting and checking of the canting angle.

CANTING, RACING CANTING

Shifting the canting angle of the shaft inwards or outwards adapts the position of the cuff to the skier's leg stance.

COMFORT INSTEP COMPONENT

Soft plastic components in the instep area for easy entry into the ski boot.

COMPOSITE COMPONENTS, COMPOSITE TECHNOLOGY

Composite materials used in the aerospace and automotive industries, and in FISCHER skis.

D

DIAGONAL

This binding heel has a release arc of 150°. Low release pressure, particularly on forward twisting falls.

E**EMBOSSING**

During a special process a pattern is “printed”, or embossed, onto the base of the ski.

EDGE ANGLE

The edges are ground on the base and the side. The finish is defined by the edge angle.

F**FFS – FISCHER FIT SYSTEM**

A variable boot liner system which, combined with a wide variety of technologies is perfectly tuned for the requirements of the various target groups.

FLEX, FLEXING, ANATOMIC FLEX

The ski boot’s movement when the knee bends forwards. With anatomic flex the motion axis of the ski boot matches the natural motion axis of the ankle.

FLEX INDEX

The Flex Index shows the force necessary to make the boot flex.

FLOWFLEX

The first Skifahrwerk™ (ski suspension system) in the world for increased edge grip, control and ease of turning, completely free flexing and 100% power transmission.

FOAM BOOT LINER

Foam boot liner for the perfect fit of ski boot.

FOAMING KIT

Foam boot liner and foam for retrofitting to RC4 and X series ski boots.

FORWARD LEAN ADJUST

Individually adjustable shaft. Provides additional lift for a more aggressive skiing style.

G**GRINDING**

The structure of the base is achieved using grinding discs and belts.

H**HEAT SYSTEM READY**

The boot liner is prepared for heatable insoles to be added later.

L**LAST WIDTH**

Dimension specifying the width of the shell in the forefoot area.

LIFT

Standard height difference between toe and heel within the ski boot.

LEXIKON

M

MASKING

Problem areas on the skier's feet are covered up with adhesive masking pads prior to fitting foam ski boot liners to prevent pressure points inside the boot liner.

N

NATURAL V POSITION, ORIGINAL V POSITION, SO-MATIC STAND POSITION

The feet remain in their natural V stance inside the ski boots.

O

OPTIMIZED EDGE REINFORCEMENT

A layer of Titanal in the binding area of Slope Style Skis prevents damage to the edge when landing on rails.

P

PERFORMANCE TONGUE

A reinforced anatomically-shaped tongue with high density foam gives optimum power transfer to the ski.

R

REMOVABLE TOE & HEEL PLATE

Sole plate can be replaced if worn. Ensures high degree of safety for triggering binding.

REMOVING EXCESS WAX

After waxing excess wax is removed using a perspex edge.

S

SANDWICH SIDEWALL CONSTRUCTION

An intelligent laminated construction with a wooden core and glassfiber shell. This design ensures highest stability, strength and durability.

SENSITIVE TOEBOX

Elastic neoprene ensures optimum fit in toe section and also provides excellent thermal insulation.

SIDEWALLS

Component along sides of skis on sandwich constructions.

SHAFT TUNING

Width adjustment in shaft area thanks to variable position of the adjustment ratchet.

SLIDER

Large areas of Lycra make boot entry even easier.

SOMA-TEC

Ski boot technology from FISCHER with promoting the natural V position of the feet.

STRUCTURE

Ski base structure for optimum gliding properties. Achieved using embossing or grinding.

T

THERMO FIT INSOLE

Insole for that controls the temperature of the feet.

THERMO FIT

Boot liner that adapts to the shape of the foot due to thermoplastic formation of the cushion material.

TPU ETHER, TPU ESTER, POLYPROPYLENE

High-quality injection-moulding plastics from which ski boot shells and cuffs are manufactured.



© 2012

W4432.ENGL
A-TECHNICAL MANUAL



9 002971 584405

fischersports.com