

## Section 09. Wiring Diagrams - industrial engines

### 09.1 GENERAL NOTES

These instructions apply to all the industrial wiring diagrams shown unless shown otherwise on individual diagrams.

The wiring diagrams contained within this section are given with our best intentions and are believed to be correct at the time of going to press.

Should difficulties be encountered or enlargements be required please contact Lister Petter.

1. All cables must be 32/0.020 or 19/0.26, unless otherwise stated, PVC insulated thin wall space saving automobile cable.
2. The cable sizes given relate to the cables between the control panel, or loose components, and the engine being a maximum length of 2.0 metres, and the cables between the battery and engine being a maximum length of 0.94 metres.
3. The cable colour code relates to the first colour being the main colour and the second colour the tracer.
4. Items 6 and 12 are only applicable when gauges are fitted.
5. Item 10 is only applicable to LPWS engines.  
10A and 10B - LPWS2  
10A, 10B and 10C - LPWS3  
10A, 10B, 10C and 10D - LPWS4
6. Items 15B and 16B are only applicable when extension looms are fitted.

### 09.2 DIAGRAM IDENTIFICATION CODES

#### 09.2.1 Component Codes

For clarity, components on the following wiring diagrams have been given an identification code number as shown below. For engines fitted with a Mitsubishi alternator refer to the relevant drawing.

Components, and their associated wiring, shown dotted are optional accessories or are only fitted on some engines as shown.

1. Alternator
2. Belt breakage shutdown relay
3. Control keyswitch
4. Not used
5. Excitation resistance
6. Engine temperature gauge sender
7. Engine temperature switch
8. Fuel control solenoid circuit breaker
9. Fuel control solenoid
10. Glowplugs - LPWS
11. Glowplug relay - LPWS
12. Oil pressure gauge sender
13. Oil pressure switch
14. Protection override push-button
15. Plug and socket - 9 way
16. Plug and socket - 7 way
17. Protection switch relay
18. Starter battery
19. Starter motor
20. No charge warning lamp
21. Alternator suppression ferrites
22. Manifold heater plug - LPWT

#### 09.2.2 Cable Colour Codes

For clarity, cables shown on the following wiring diagrams have been given the international colour identification code as shown below. For engines fitted with a Mitsubishi alternator refer to the relevant drawing.

The first code letter denotes the main colour and the second the tracer colour.

- B Black
- N Brown
- W White
- G Green
- U Blue
- R Red
- N/B Brown/Black
- B/U Black/Blue
- W/R White/Red
- W/N White/Brown
- N/G Brown/Green
- N/U Brown/Blue
- N/W Brown/White
- G/R Green/Red
- U/W Blue/White
- U/Y Blue/Yellow

### 9.3 Plug and Socket Terminals

Plugs and sockets are only applicable when loom extensions are fitted and are shown as looking on the cable entry face. For engines fitted with a Mitsubishi alternator refer to the relevant drawing.

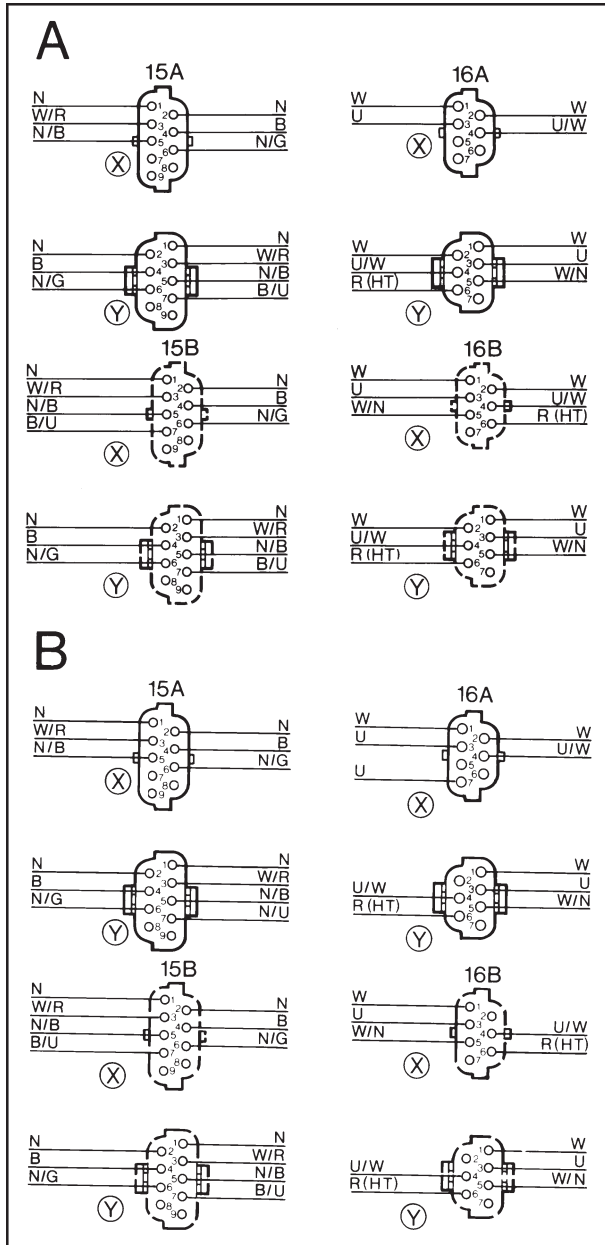

Figure 9.3.1 Plugs and Sockets  
 A - Lucas Starter  
 B - Denso Starter  
 X - Plug  
 Y - Socket



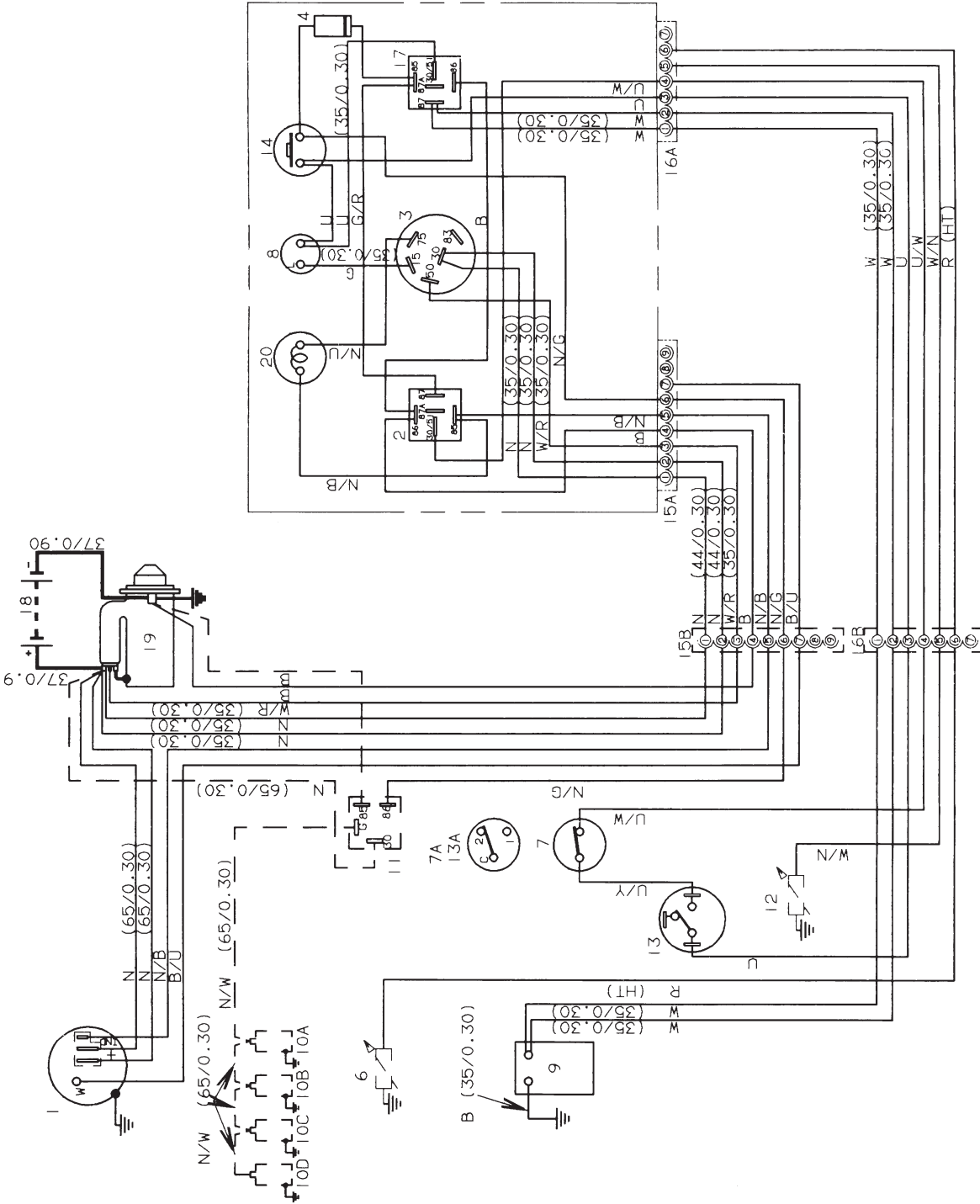

Figure 9.4.2 Industrial Start Panel with Shutdown Protection and Lucas Starter

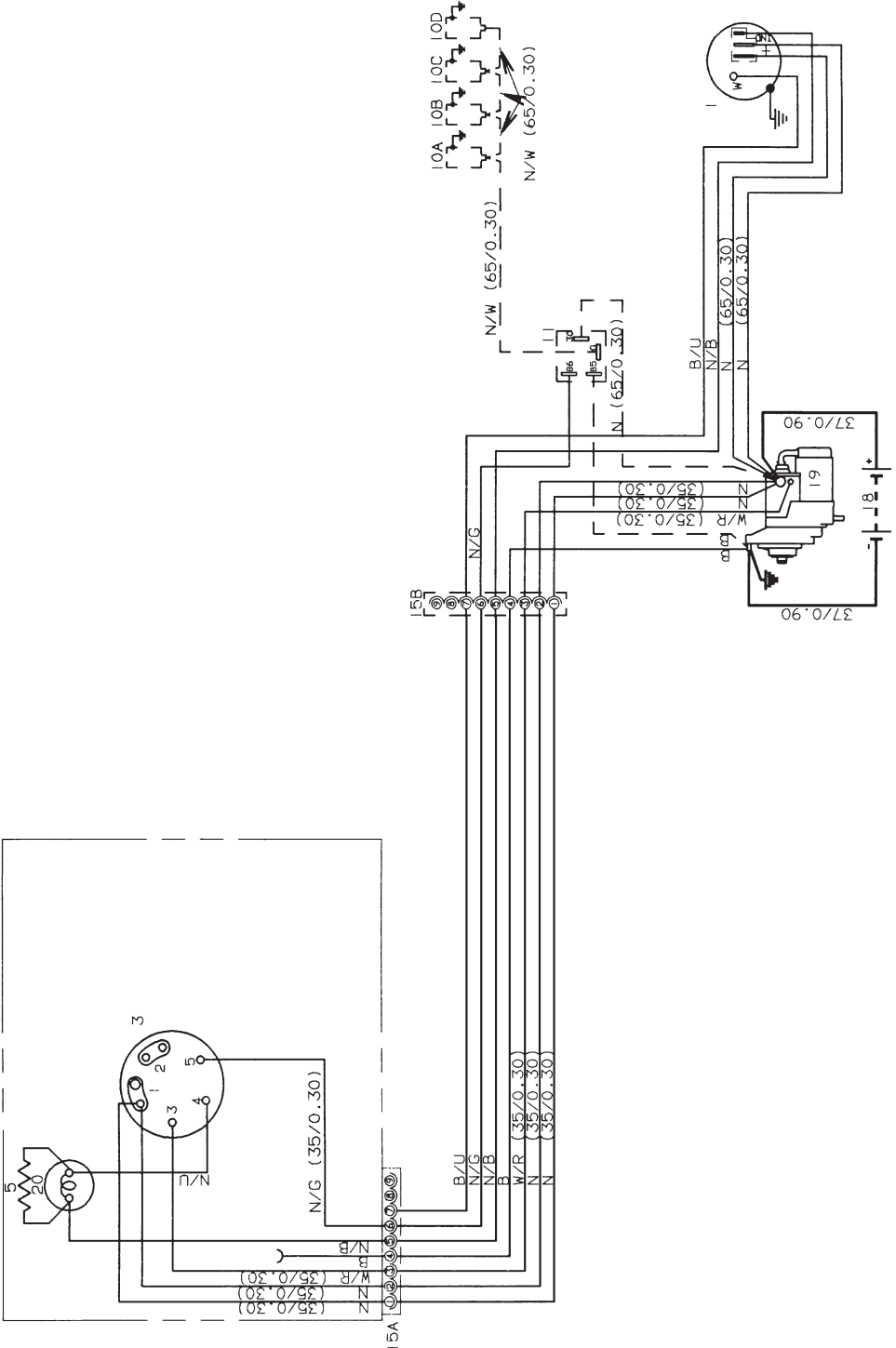

Figure 9.4.3 Industrial Start Panel with Denso Starter

For identification of the components and cables refer to "9.2 Diagram Identification Codes".

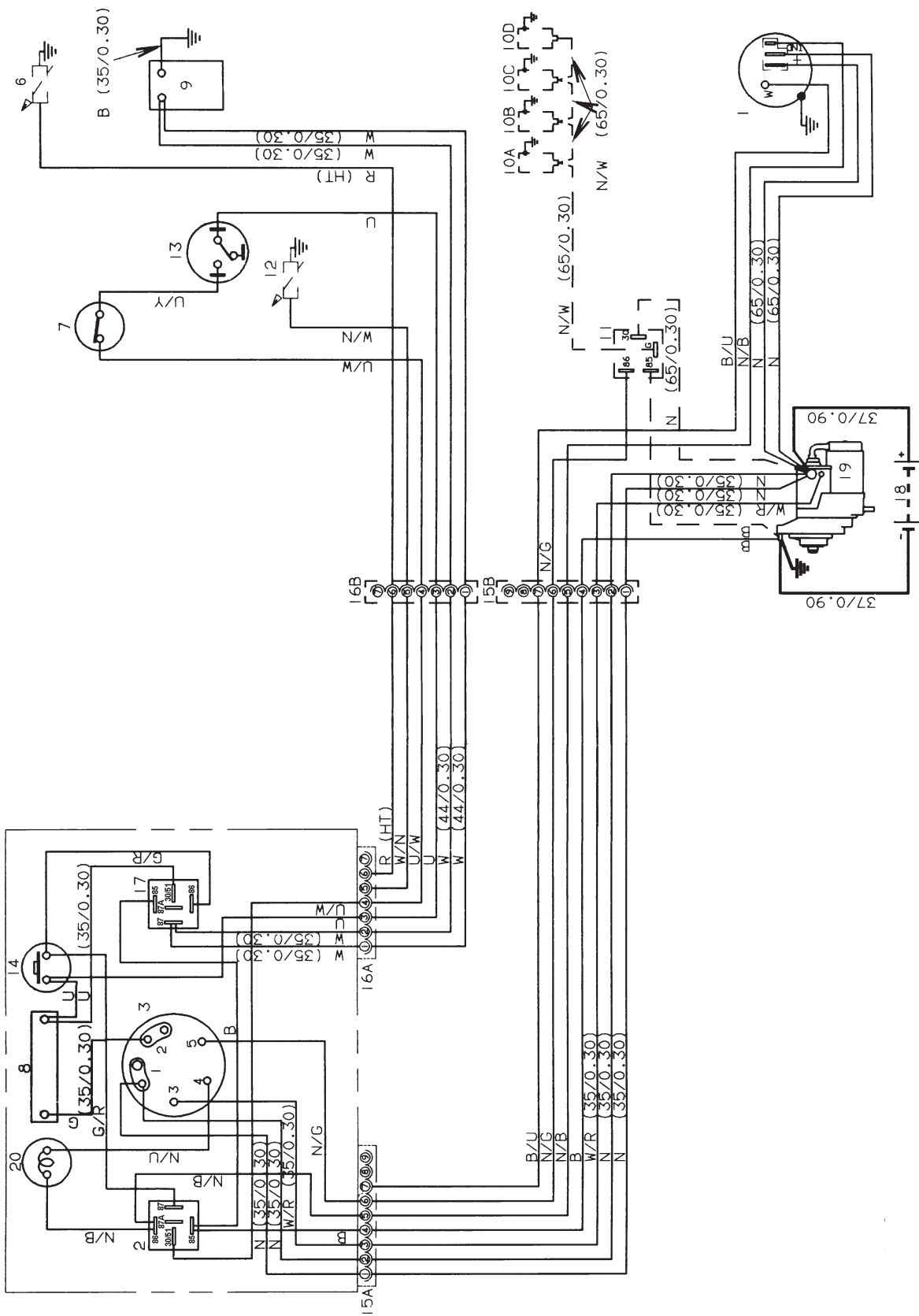

Figure 9.4.4 Industrial Start Panel with Shutdown Protection and Denso Starter

For identification of the components and cables refer to "09.2 Diagram Identification Codes".

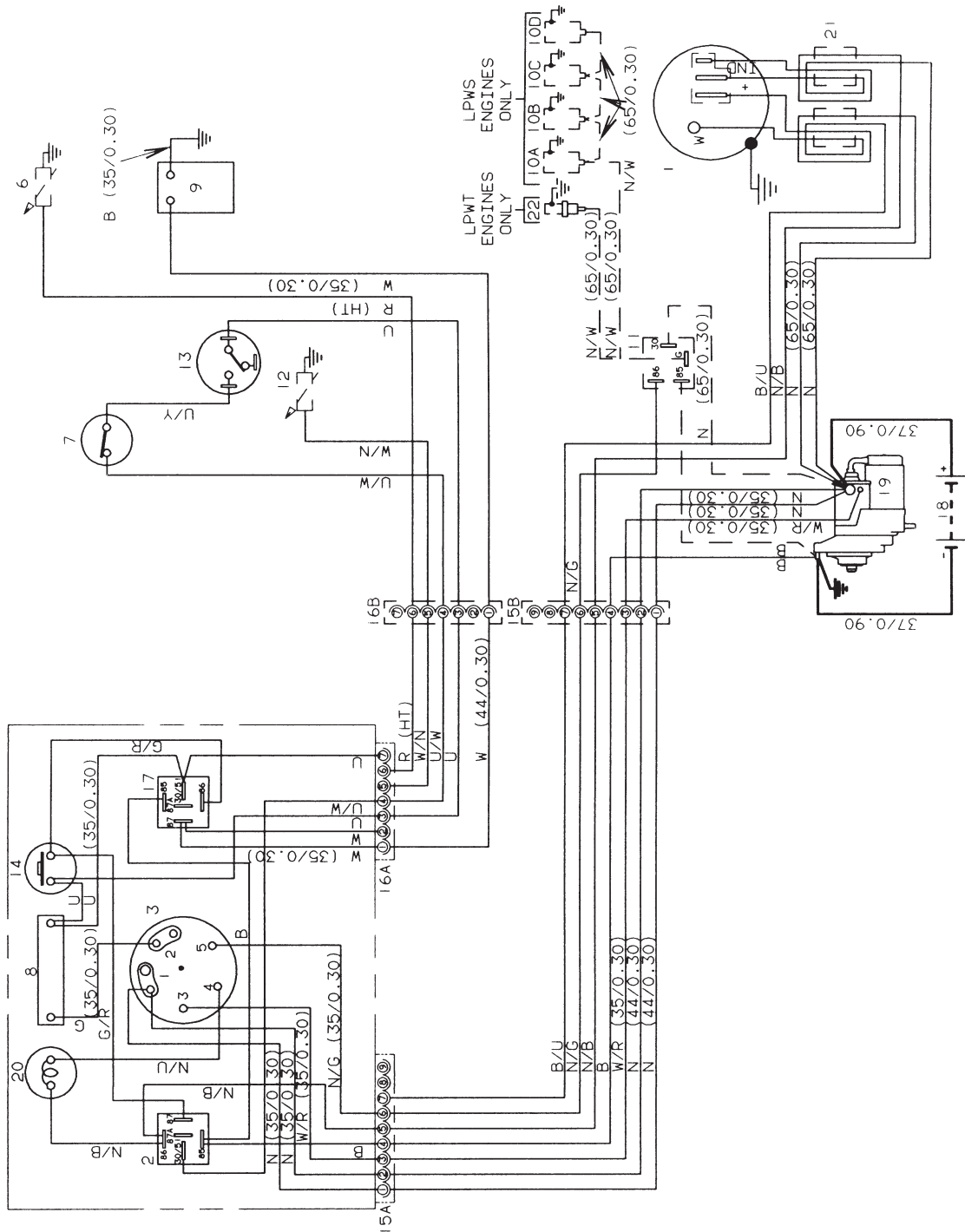

Figure 9.4.5 Industrial Start Panel with Shutdown Protection and Denso Starter

For identification of the components and cables refer to "09.2 Diagram Identification Codes".







**Component Codes**

- AL Alternator
- BSR Belt breakage shutdown relay
- CS Control keyswitch
- ETGS Engine temperature gauge sender
- FCB Engine temperature switch
- FCS Fuel control solenoid circuit breaker
- GP1-4 Fuel control solenoid
- GPR Glowplugs - LPWS only
- HP Heaterplug - LPWT only
- OPGS Oil pressure gauge sender
- OPS Oil pressure switch
- POB Protection override pushbutton
- PS1,3 Plugs and socket (9 way)
- PS2,4 Plugs and socket (7 way)
- PSR Protective switch relay
- SB Starter battery
- SM Starter motor
- WL No charge warning lamp

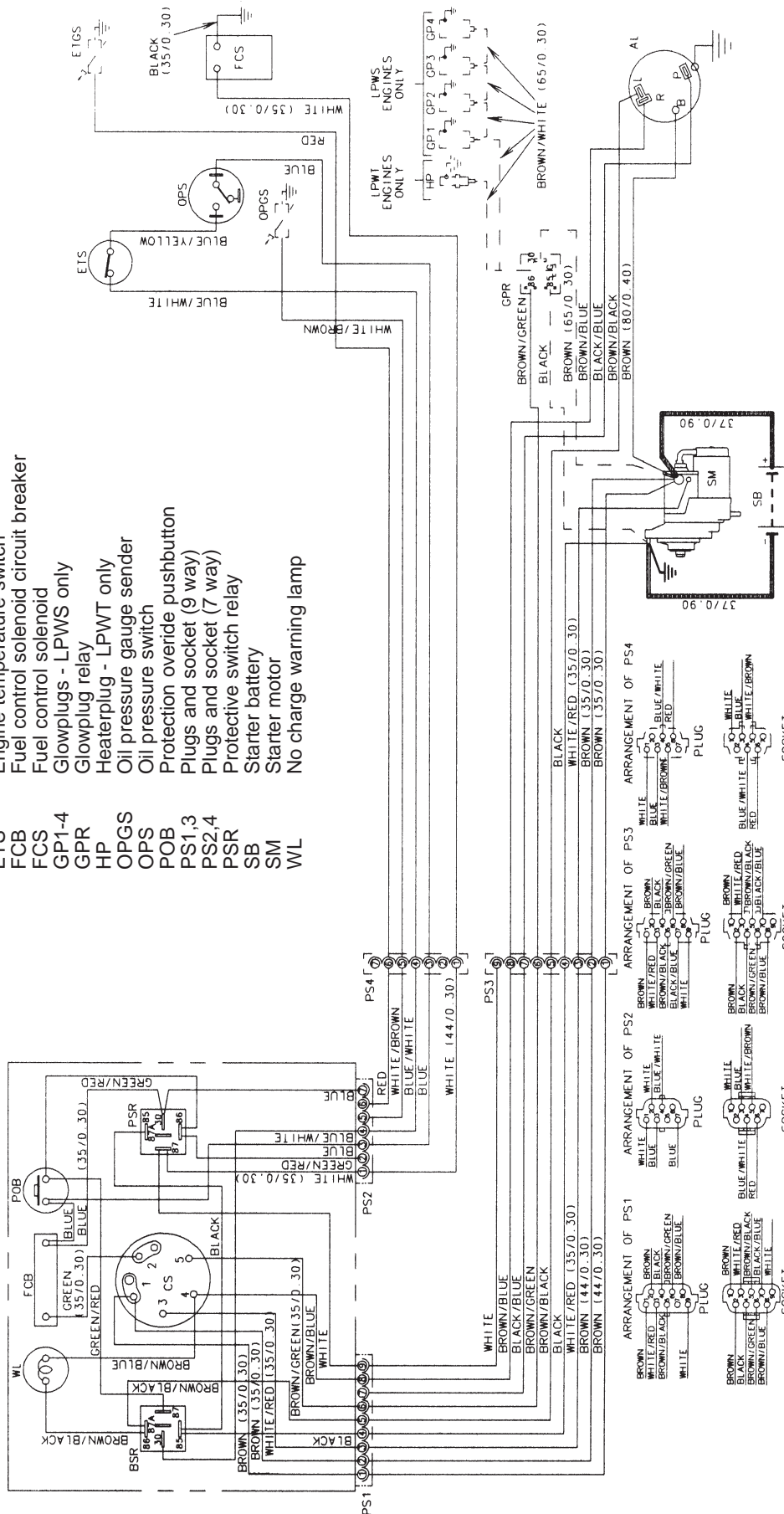

Figure 9.4.8 Industrial Start Panel with Shutdown Protection, Denso Starter and Mitsubishi Alternator

## Section 10. Wiring Diagrams - marine engines

### 10.1 WIRING DIAGRAMS

The following instructions and information only applies to the marine wiring diagrams from Figures 10.3.2' to '10.3.6' inclusive.

The wiring diagrams contained within this section are given with our best intentions and are believed to be correct at the time of going to press.

Should difficulties be encountered or enlargements be required please contact Lister Petter.

#### 10.1.1 General Notes

1. All cables must be 32/0.20 or 19/0.26, unless otherwise stated, PVC insulated thin wall space saving automobile cable.
2. The cable sizes given relate to the cables between the control panel and the engine being a maximum length of 12.0 metres, and the cables between the battery and engine being a maximum length of 0.94 metres.
3. The cable colour code relates to the first colour being the main colour and the second colour the tracer.
4. Items shown dotted are optional accessories.

### 10.2 DIAGRAM IDENTIFICATION CODES

#### 10.2.1 Component Codes

For clarity, components on the following wiring diagrams have been given an identification code number as shown below.

Components, and their associated wiring, shown dotted are optional accessories or are only fitted on some engines as shown.

1. Auxiliaries circuit breaker
2. Alternator
3. Alternator suppression ferrites
4. Earthing solenoid
5. Engine temperature gauge sender
6. Engine temperature switch
7. Fuel control solenoid circuit breaker
8. Fuel control solenoid relay
9. Fuel control solenoid
10. Glowplugs - LPWS
11. Glowplug controller - LPWS
12. Glowplug isolating relay - LPWS
13. Manifold heater plug - LPWT
14. Oil pressure switch
15. Oil pressure switch and sender
16. Starter battery
17. 16 way socket
18. Starter motor
19. Starter motor relay

#### 10.2.2 Cable Colour Codes

For clarity, cables shown on the following wiring diagrams have been given the international colour identification code as shown below.

The first code letter denotes the main colour and the second the tracer colour.

B	Black
N	Brown
W	White
G	Green
K	Pink
O	Orange
N/B	Brown/Black
B/U	Black/Blue
W/R	White/Red
W/N	White/Brown
W/G	White/Green
G/R	Green/Red
U/W	Blue/White
U/Y	Blue/Yellow

### 10.3 WIRING LOOM PLUG ASSEMBLY

16 way AMP CPC Series 1 plug assembly (arrangement 17-16) for sockets with cable clamp. The plug is shown as looking on the cable entry face.

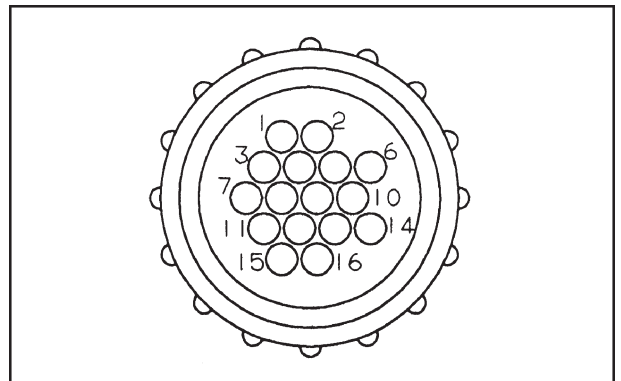

Figure 10.3.1 Plug Assembly

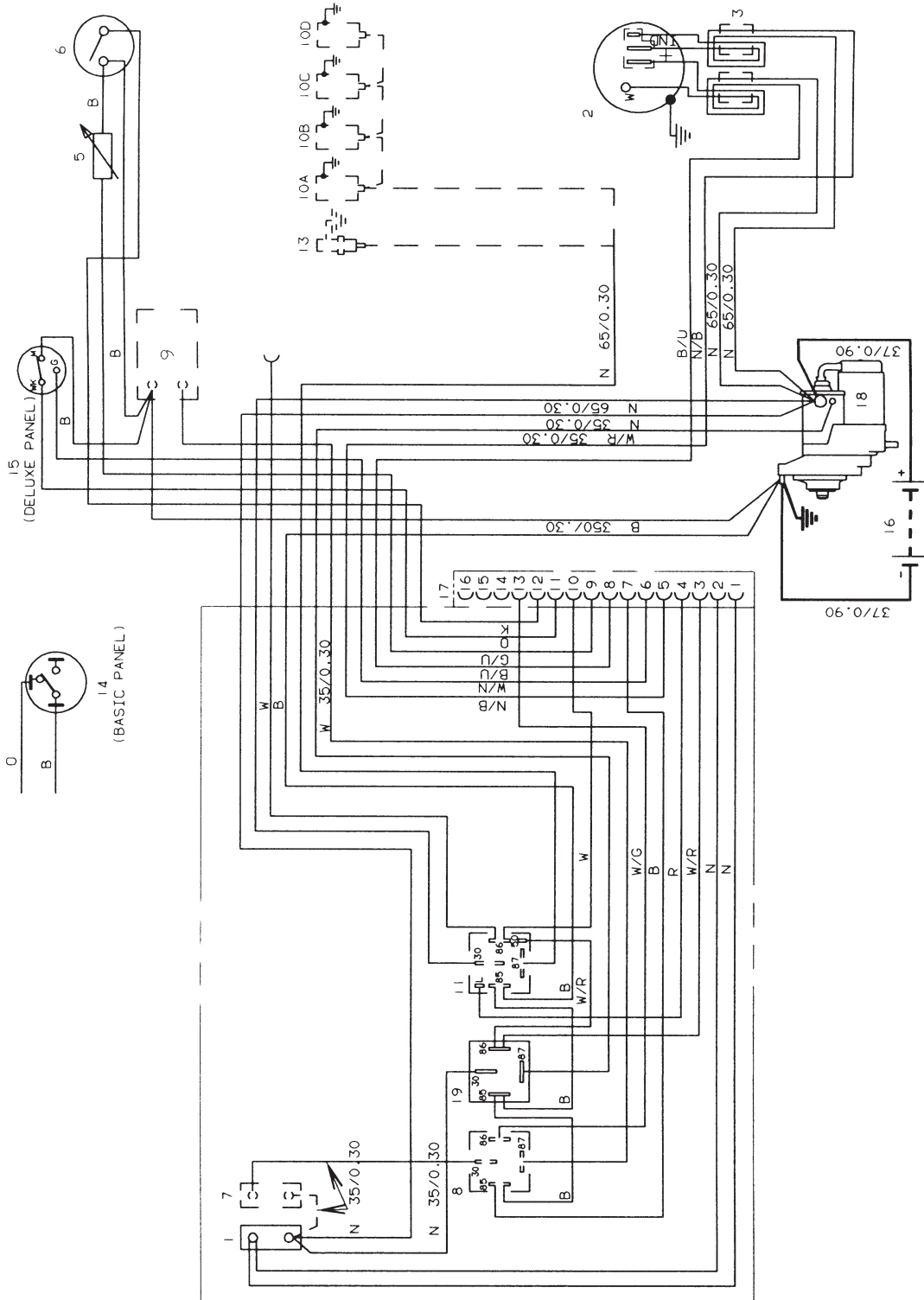

Figure 10.3.2 Marine Earth Return Start Panel

For identification of the components and cables refer to "10.2 Diagram Identification Codes".

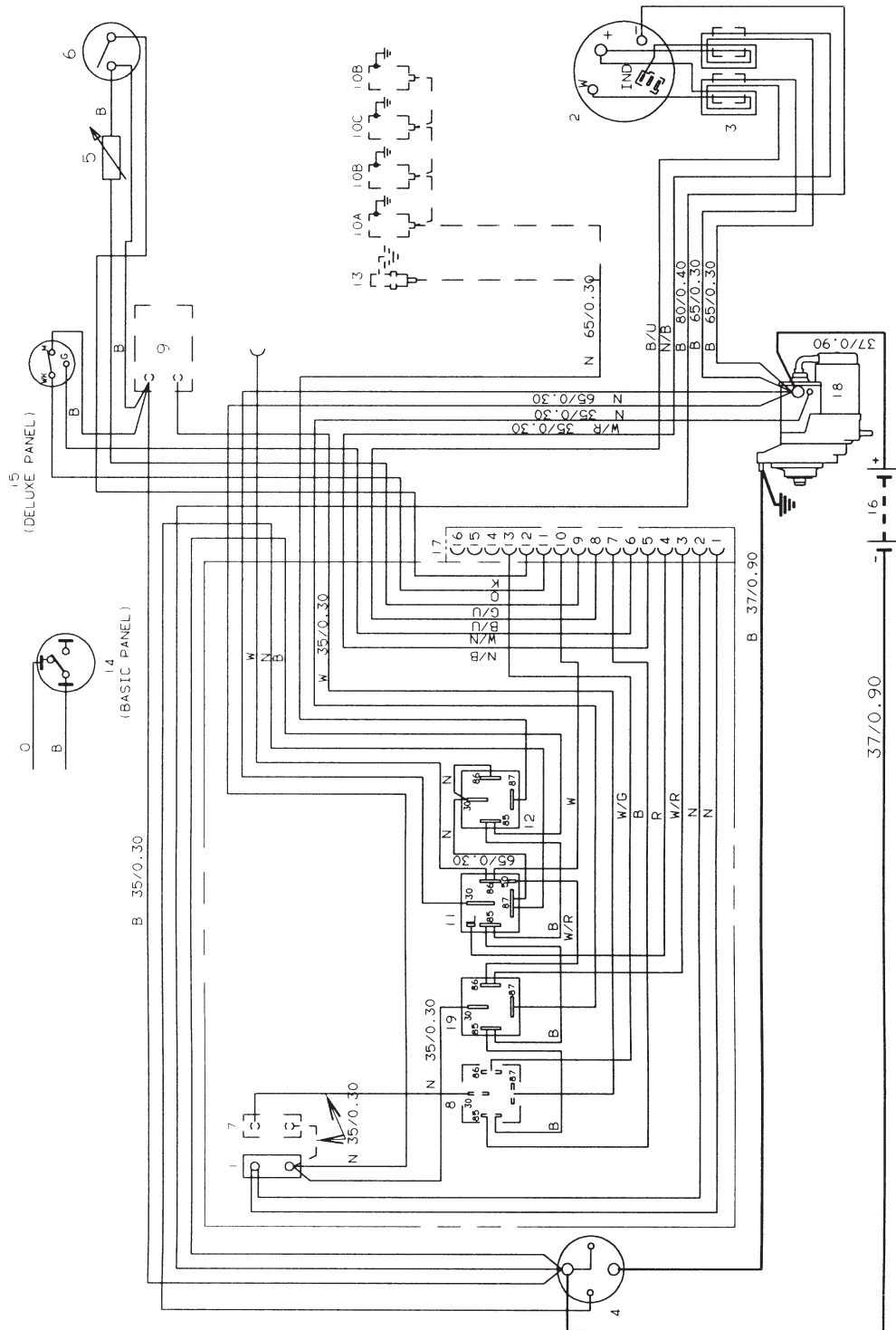

Figure 10.3.3 Marine Insulated Return Start Panel

For identification of the components and cables refer to "10.2 Diagram Identification Codes".

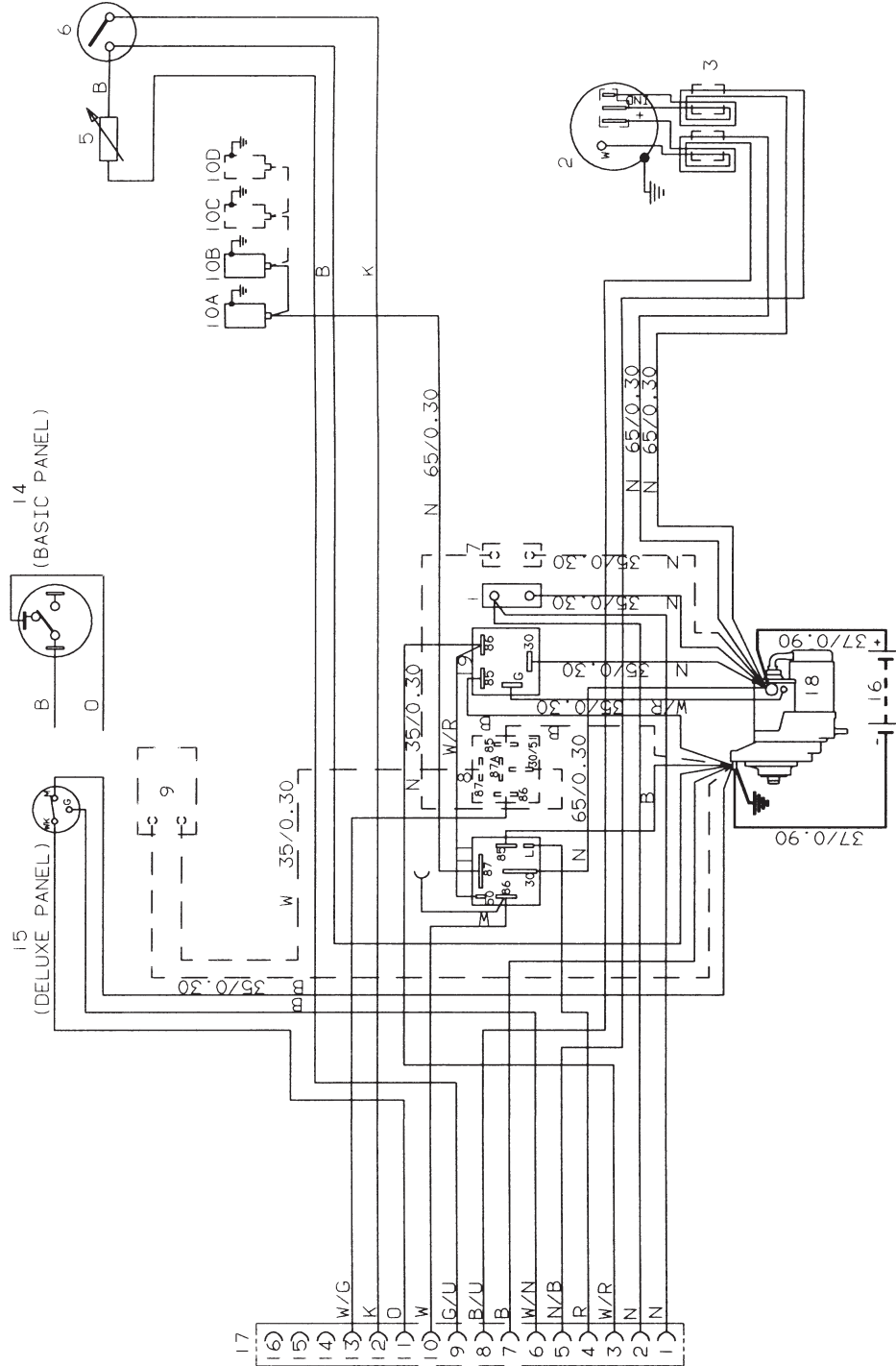

Figure 10.3.4 Marine Earth Return Start Panel - LPWS

For identification of the components and cables refer to "10.2 Diagram Identification Codes".

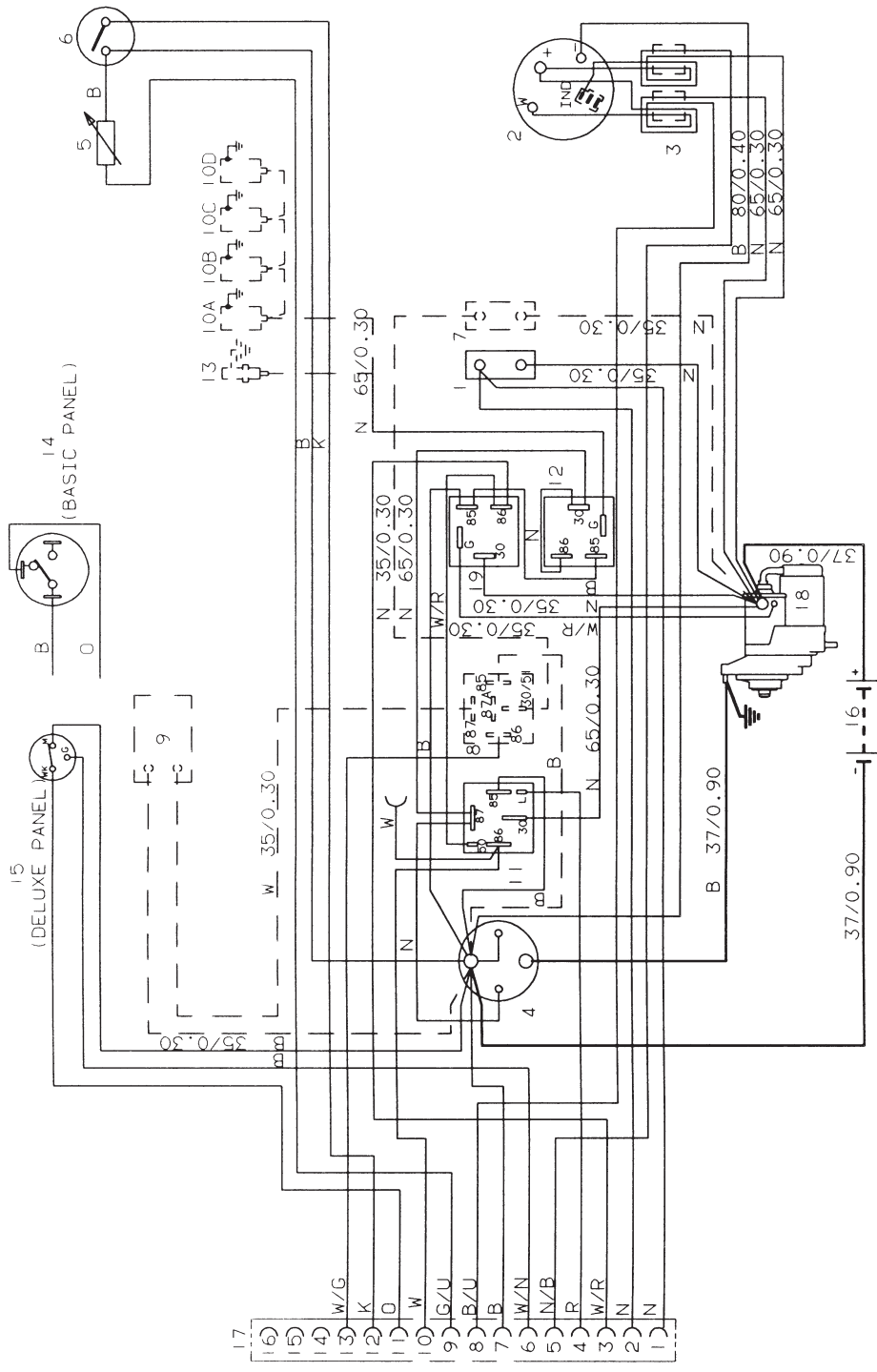

Figure 10.3.5 Marine Insulated Return Start Panel

For identification of the components and cables refer to "10.2 Diagram Identification Codes".

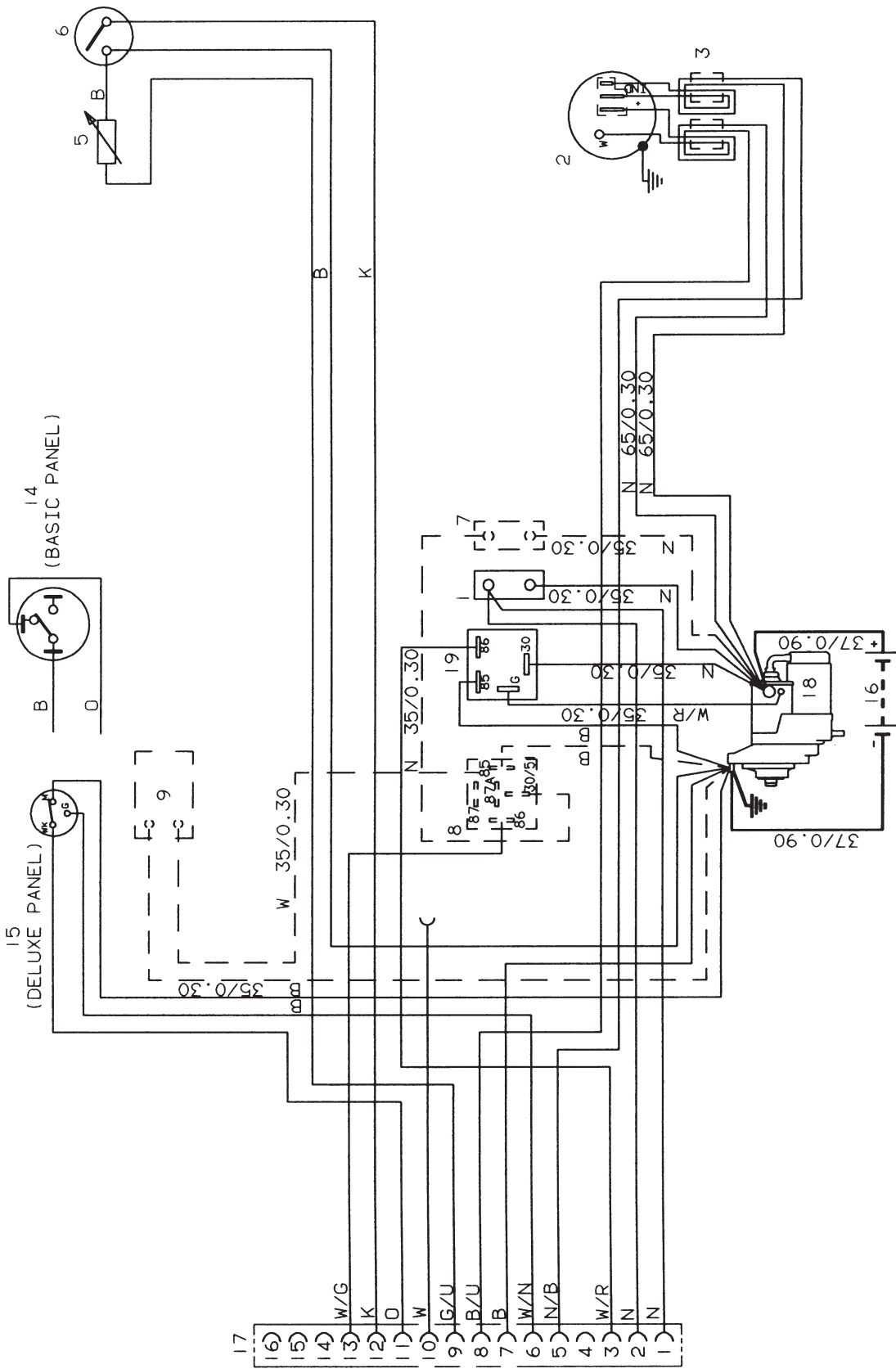

Figure 10.3.6 Marine Earth Return Start Panel - LPA and LPW

For identification of the components and cables refer to "10.2 Diagram Identification Codes".



## 10.4 WIRING DIAGRAMS

The following instructions and information only applies to the marine wiring diagrams from Figures 10.6.2' to '10.6.4' inclusive.

The wiring diagrams contained within this section are given with our best intentions and are believed to be correct at the time of going to press.

Should difficulties be encountered, or enlargements be required, please contact Lister-Petter.

### 10.4.1 General Notes

1. All cables must be 19/0.26 PVC insulated thin wall space saving automobile cable.
2. The cable colour code relates to the first colour being the main colour and the second colour the tracer.
3. All connections are to be tin plated.

## 10.5 DIAGRAM IDENTIFICATION CODES

### 10.5.1 Component Codes

For clarity, components on the following wiring diagrams have been given an identification code number as shown below.

1. Audible alarm
2. Connector assembly
3. Control keyswitch
4. Diodes
5. Excitation resistance
6. Engine temperature gauge
7. Engine temperature lamp
8. Switch for gauge lights
9. Oil pressure gauge
10. Oil pressure lamp
11. Preheat lamp
12. Tachometer/Running hour recorder
13. Tachometer plug
14. Voltmeter
15. Warning lamp
16. Running hour recorder

### 10.5.2 Cable Colour Codes

For clarity, cables shown on the following wiring diagrams have been given the international colour identification code as shown below.

The first code letter denotes the main colour and the second the tracer colour.

R	Red
B	Black
N	Brown
W	White
K	Pink
O	Orange
N/B	Brown/Black
B/U	Black/Blue
W/R	White/Red
W/N	White/Brown
W/G	White/Green
W/B	White/Black
G/U	Green/Blue

## 10.6 WIRING LOOM PLUG ASSEMBLY

AMP CPC Series 1 16 way free hanging receptacle (arrangement 17-16) for pins with peripheral seal and cable clamp. Shown as looking on the cable entry face.

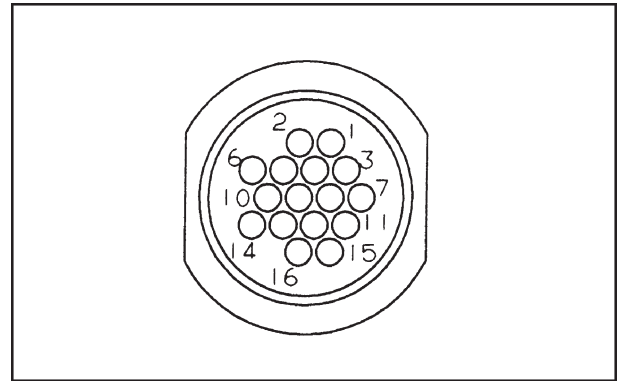

Figure 10.6.1 Plug Assembly

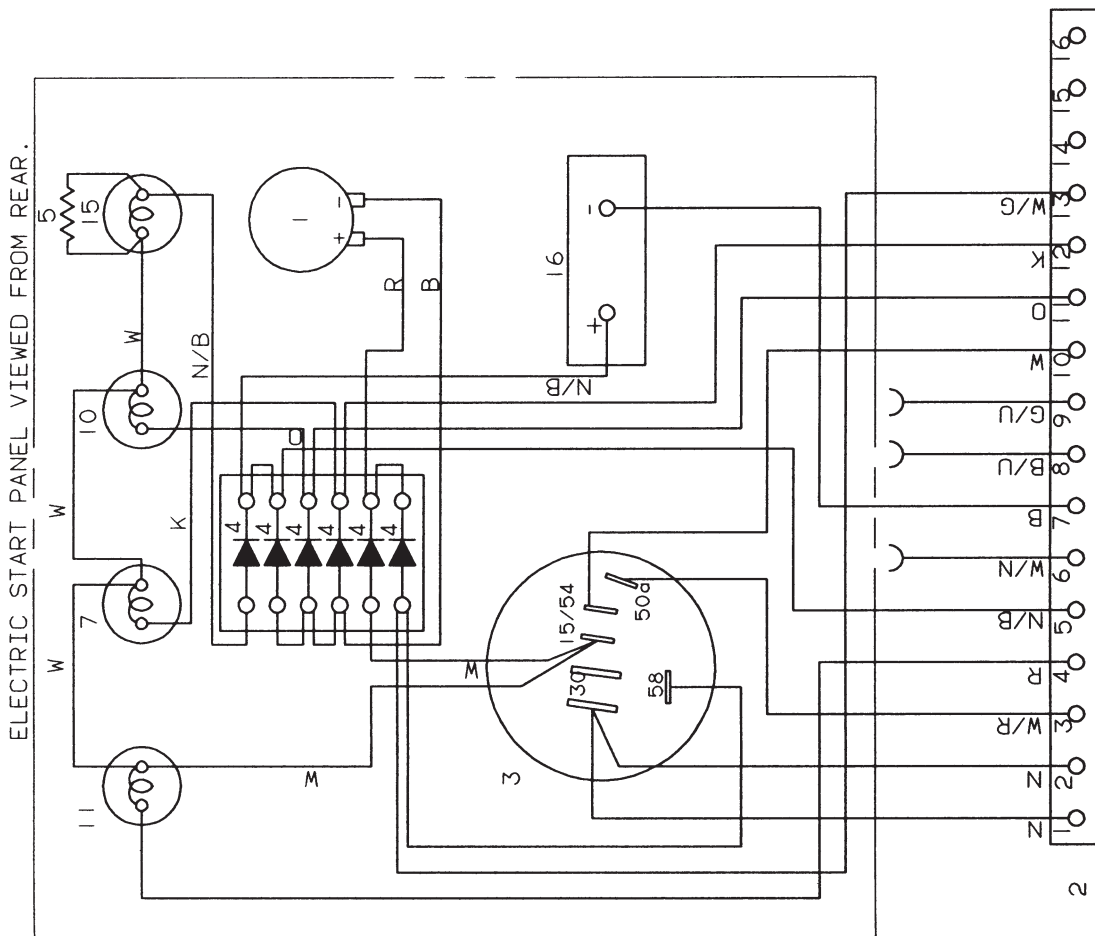

Figure 10.6.2 Marine Basic Electric Start Panel

For identification of the components and cables refer to "10.5 Diagram Identification Codes".

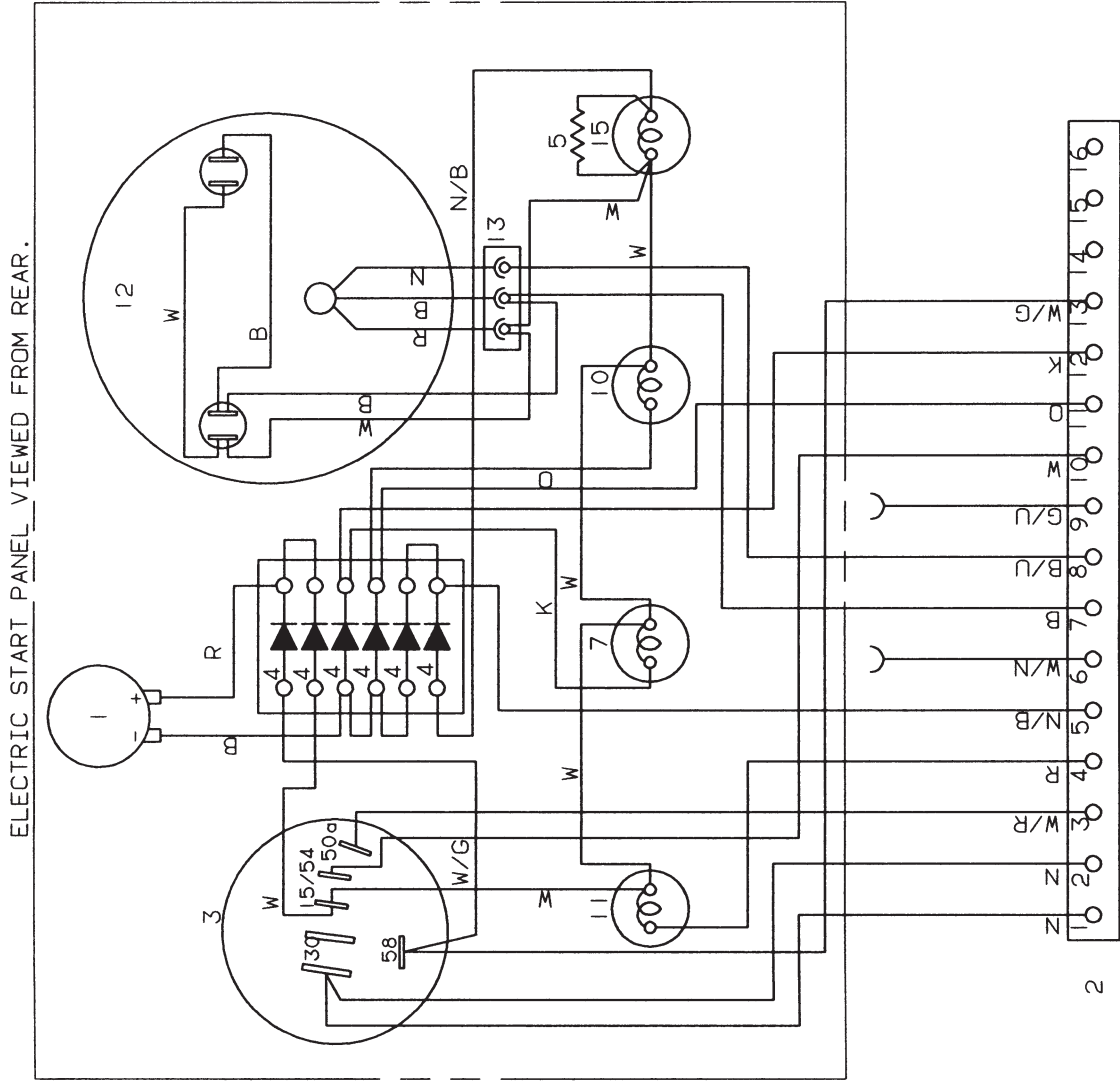
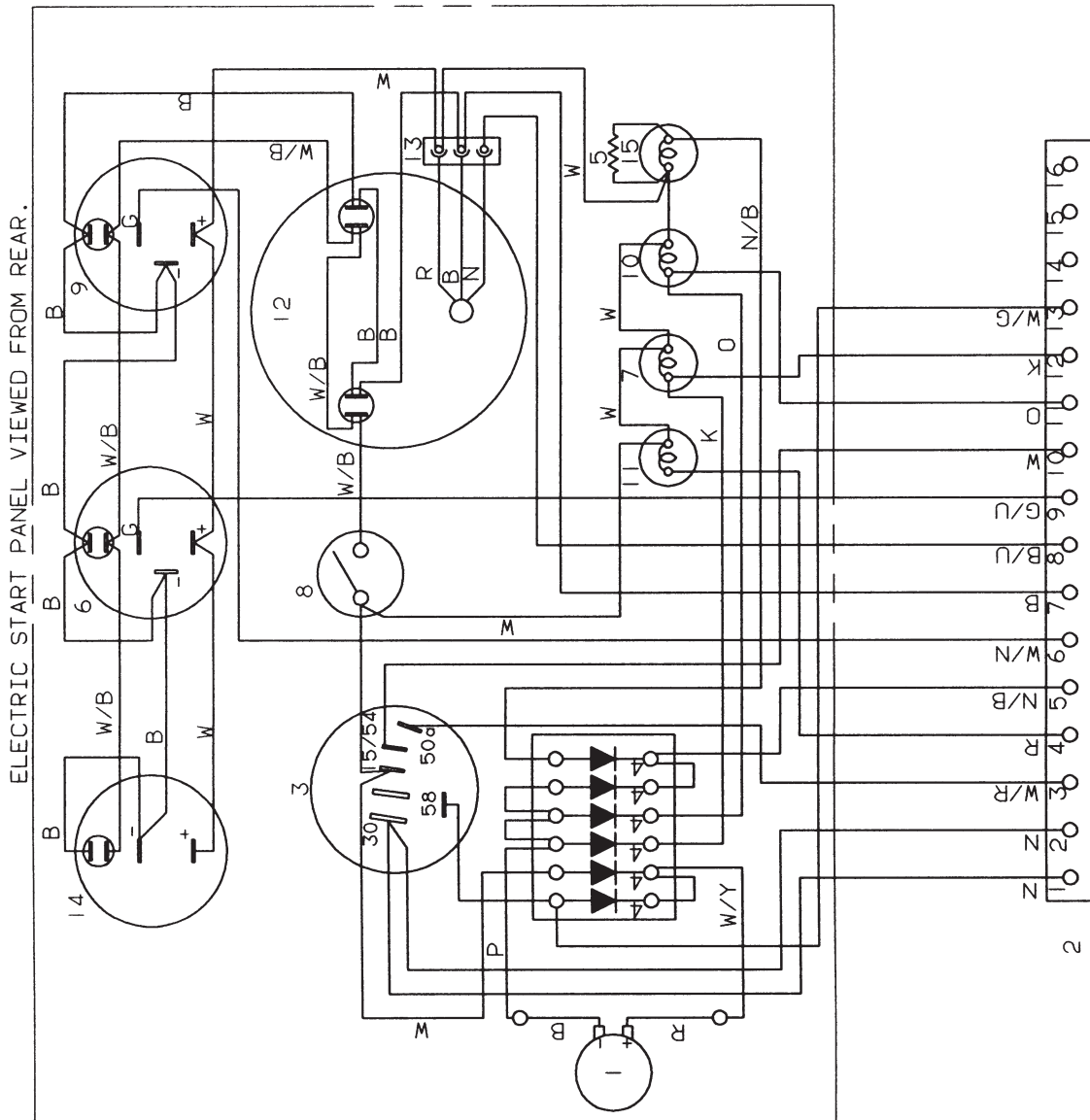

Figure 10.6.3 Marine Standard Electric Start Panel

For identification of the components and cables refer to "10.5 Diagram Identification Codes".



For identification of the components and cables refer to "10.5 Diagram Identification Codes".

Figure 10.6.4 Marine Delux Electric Start Panel

## Section 11. Wiring Diagrams - LPWG engines

### 11.1 ELECTRICAL WIRING DIAGRAMS

#### 11.1.1 General Notes

These instructions apply to all the LPWG wiring diagrams shown unless shown otherwise on individual diagrams.

The wiring diagrams contained within this section are given with our best intentions and are believed to be correct at the time of going to press.

Should difficulties be encountered or enlargements be required please contact Lister-Petter.

1. All cables must be 32/0.20 or 19/0.26, unless otherwise stated, PVC insulated thin wall space saving automobile cable.  
Alternative cable sizes for 35/0.30 and 44/0.30 cable are 19/0.41 and 37/0.32 respectively.
2. The cable sizes given relate to the cables between the control panel, or loose components, and the engine being a maximum length of 2.0 metres, and the cables between the battery and engine being a maximum length of 0.94 metres.
3. The cable colour code relates to the first colour being the main colour and the second colour the tracer.
4. The engine temperature gauge sender ETGS and oil pressure gauge sender OPGS are shown dotted and are only applicable when gauges are fitted.
5. Plugs and sockets PS3 and PS4 are shown dotted and are only applicable when extension looms are fitted.

#### 11.1.2 Component Codes

For clarity, components on the following wiring diagrams have been given an identification code as shown below.

Components, and their associated wiring, shown dotted are optional accessories.

A	Actuator for electronic governor
AL	Alternator
ASF	Alternator suppression ferrites
BI	Battery isolator
BSR	Belt breakage shutdown relay
CS	Control keyswitch
EGC	Electronic governor controller
EGP	Electronic governor magnetic pick-up
ETGS	Engine temperature gauge sender
ETS	Engine temperature switch
F	Fuse
GV	Gas valve
IC	Ignition coil
ICS	Ignition coil sensor
OPGS	Oil pressure gauge sender
OPS	Oil pressure switch
PCB	Protection circuit breaker
POB	Protection override pushbutton
PS1, 3	Plug and socket - 9 way
PS2, 4	Plug and socket - 7 way
PSR	Protection switch relay
RR	Run relay
SB	Starter battery
SM	Starter motor
SP	Spark plugs
WL	No charge warning lamp

#### 11.1.3 Plugs and Sockets

Viewed on cable entry face

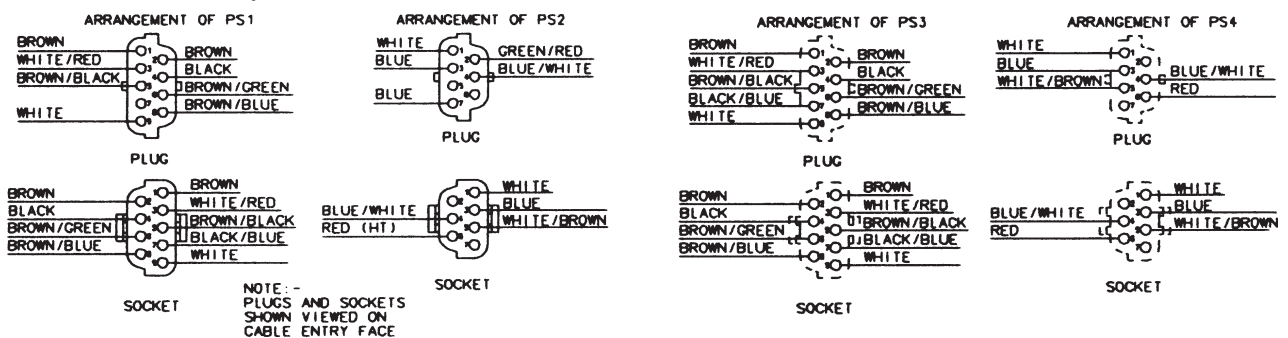

Figure 11.1.1 Plug and Socket Wiring Diagrams

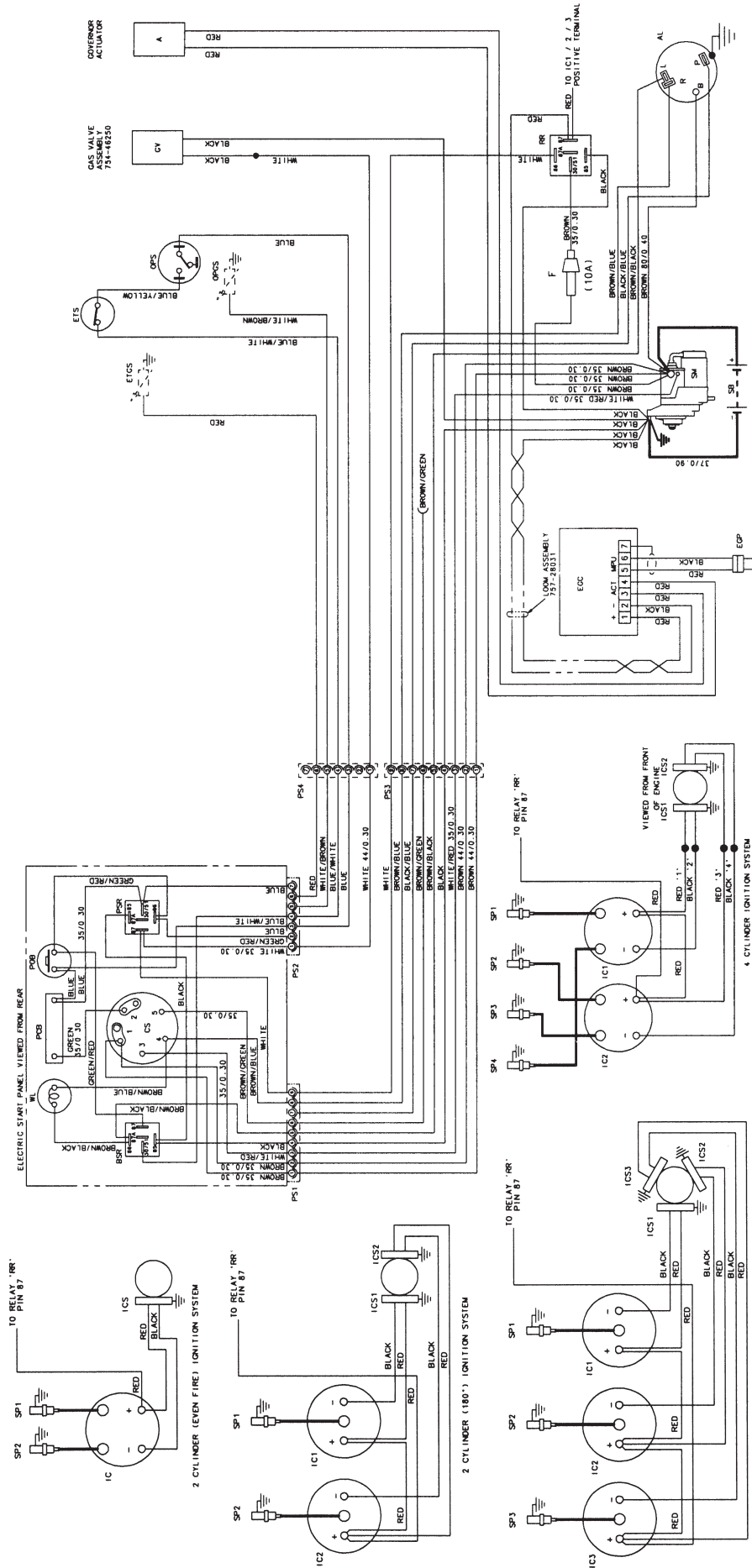

Figure 11.1.2 LPWG Wiring Diagram

For identification of the components and cables refer to "11.1 Electrical Wiring Diagrams".

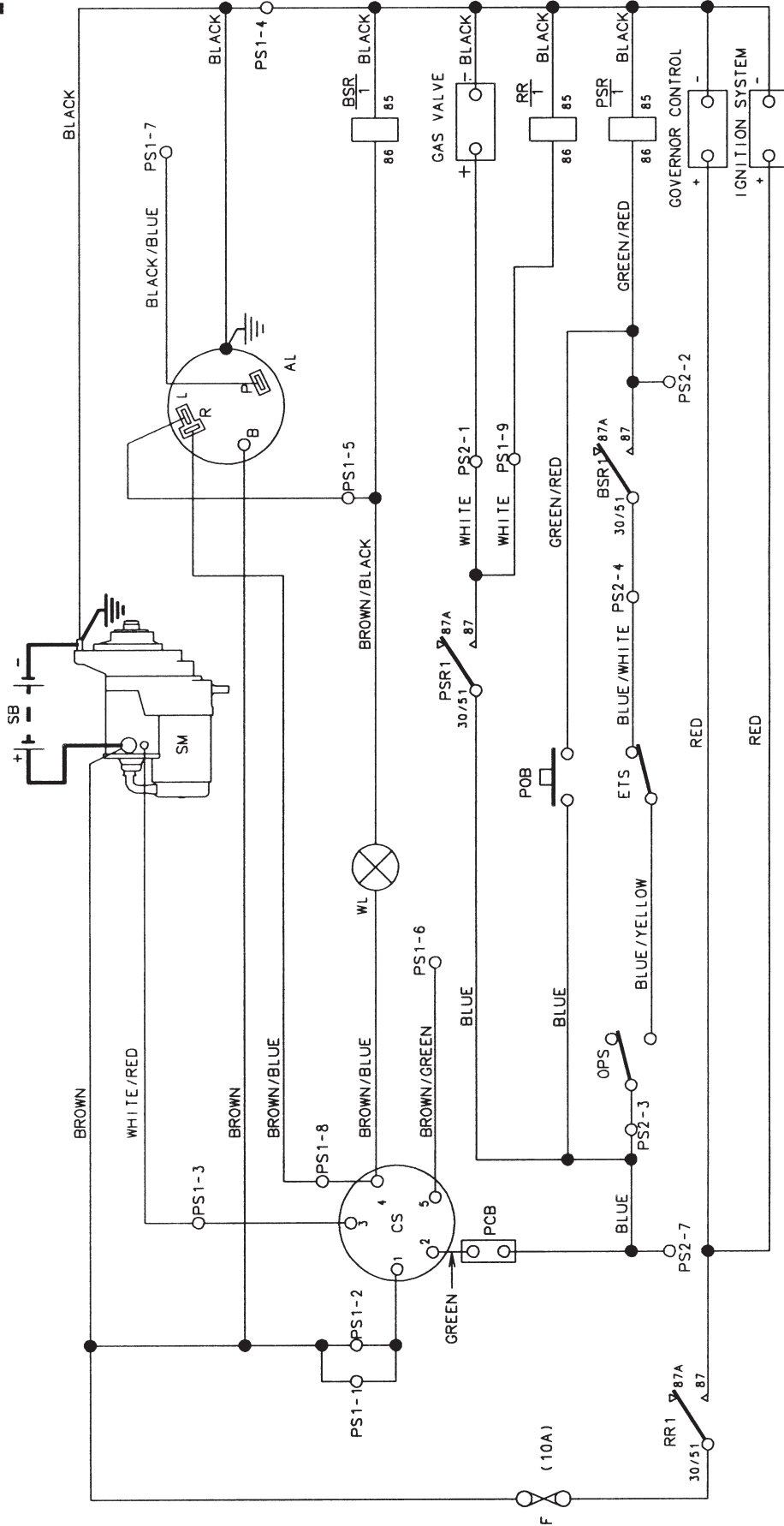

Figure 11.1.3 LPWG Schematic Wiring Diagram

For identification of the components and cables refer to "11.1 Electrical Wiring Diagrams".





## Section 12. Engine Build Details

### 12.1 GENERAL INFORMATION

Where the build number is preceded by a 9 this indicates that the engine is either of a non-standard configuration, or contains non-standard parts or accessories.

When new parts are required for such a build it is suggested that reference be made to Lister Petter to determine the exact engine specification and which parts are non-standard.

### 12.2 Emissions Certification

For details of emissions certification for these engines please refer to Lister Petter or your local Lister Petter Distributor.

### 12.3 Build Details (excluding LPWG)

Build and Details		LPA		LPW				LPWS		
		2	3	2	3	4	T4	2	3	4
01	Variable speed 850-3000r/min 100% load. Class B1	☐	☐	☐	☐	☐	☐	☐		
02	Variable speed 850-3000r/min 110% load. Class B1	☐	☐	☐	☐	☐	☐	☐		
03	Variable speed 850-3000r/min 90% load. ECE R24.03	☐	☐				☐	☐	☐	
04	Variable speed 850-3000r/min 90% load. ECE R24.03		☐				☐			
07	Constant speed 1500r/min 110% load. Class A1						☐		☐	
08	Constant speed 1800r/min 110% load. Class A1						☐			
09	Constant speed 3000r/min 110% load. Class A1	☐	☐	☐	☐	☐		☐		
10	Constant speed 3600r/min 110% load. Class A1	☐		☐	☐	☐				
11	Variable speed 850-3000r/min. High torque								☐	☐
12	Variable speed 850-2800r/min 110% load. Class B1 CARB rating								☐	
13	Variable speed 850-3000r/min 100% load. CARB rating							☐	☐	☐
14	Variable speed 850-3000r/min 100% load. ECE R24.03				☐	☐				
16	Variable speed 850-3000r/min 110% load. Tractor rating 77/537 EEC				☐	☐				
18	Constant speed 1800r/min 110% load. Class A1 CARB rating			☐	☐	☐		☐	☐	☐
27	Dual speed set at 1500r/min			☐	☐	☐				
28	Dual speed set at 1500r/min. Deep sump			☐	☐	☐				
40	Variable speed 850-3000r/min. Marine work boat rating				☐	☐				
41	Dual speed set at 1500r/min. Marine auxiliary			☐	☐	☐				
	Constant speed 1500r/min 110% load. Class A1 marine auxiliary						☐		☐	
42	Variable speed 850-3000r/min. Marine pleasure boat rating			☐	☐	☐	☐	☐	☐	
44	Constant speed 3000r/min 110% load. Class A1 marine auxiliary			☐	☐	☐		☐		☐
45	Variable speed 850-2600r/min. Marine pleasure boat rating			☐						
46	Variable speed 850-3000r/min 110% load. Class B1 marine auxiliary			☐	☐	☐	☐			☐
47	Variable speed 850-3000r/min. Marine pleasure boat rating			☐	☐	☐		☐	☐	☐
48	Variable speed 850-3000r/min 100% load. Class B1				☐	☐				
49	Variable speed 850-3000r/min					☐				
51	Variable speed 850-3000r/min 100% load	☐		☐	☐	☐	☐			
52	Variable speed 850-3000r/min 110% load. Class B1	☐		☐						
57	Constant speed 1500r/min 110% load. Class A1		☐	☐		☐	☐		☐	☐

continued....

## Section 12

### Engine Build Details

- LPA, LPW, LPWS, LPWG engines

Build and Details		LPA		LPW				LPWS		
		2	3	2	3	4	T4	2	3	4
58	Constant speed 1800r/min 110% load. Class A1	<input type="checkbox"/>		<input type="checkbox"/>			<input type="checkbox"/>			
59	Constant speed 3000r/min 110% load. Class A1	<input type="checkbox"/>	<input type="checkbox"/>	<input type="checkbox"/>	<input type="checkbox"/>	<input type="checkbox"/>				
70	Dual speed 1500/1800r/min - Lister Genset Build			<input type="checkbox"/>	<input type="checkbox"/>	<input type="checkbox"/>				
71	Constant speed 2000r/min 100% load. Class A1					<input type="checkbox"/>				
72	Constant speed 1800r/min 100% load. Class A1			<input type="checkbox"/>		<input type="checkbox"/>				
74	Dual speed, set at 1800r/min		<input type="checkbox"/>	<input type="checkbox"/>	<input type="checkbox"/>	<input type="checkbox"/>				
	Dual speed 1500/1800r/min - Onan Genset Build			<input type="checkbox"/>	<input type="checkbox"/>	<input type="checkbox"/>				
75	Variable speed 850-2650r/min 110% load. Class B1. LPA2 as Build 02	<input type="checkbox"/>	<input type="checkbox"/>							
76	Variable speed 1025-3000r/min. High torque							<input type="checkbox"/>	<input type="checkbox"/>	
78	Constant speed 1800r/min 110% load. Class A1						<input type="checkbox"/>			
79	Constant speed 1800r/min 110% load. Class A1	<input type="checkbox"/>	<input type="checkbox"/>	<input type="checkbox"/>	<input type="checkbox"/>	<input type="checkbox"/>				
81	Dual speed, set at 1500r/min	<input type="checkbox"/>	<input type="checkbox"/>	<input type="checkbox"/>	<input type="checkbox"/>	<input type="checkbox"/>				
82	Constant speed 3000r/min 110% load. Class A1	<input type="checkbox"/>	<input type="checkbox"/>	<input type="checkbox"/>	<input type="checkbox"/>	<input type="checkbox"/>				
83	Constant speed 3600r/min 110% load. Class A1	<input type="checkbox"/>	<input type="checkbox"/>	<input type="checkbox"/>	<input type="checkbox"/>	<input type="checkbox"/>				
84	Variable speed 950-2895r/min					<input type="checkbox"/>				
	Variable speed 1250-2750r/min						<input type="checkbox"/>			
85	Constant speed 3000r/min 110% load. Class A1	<input type="checkbox"/>	<input type="checkbox"/>							
86	Variable speed 1200-3000r/min 110% load. Class B1	<input type="checkbox"/>								
89	Constant speed 3000r/min 10% load, as Build 09. 74° thermostat			<input type="checkbox"/>	<input type="checkbox"/>	<input type="checkbox"/>	<input type="checkbox"/>			
102	Constant speed 3000r/min 100% load. Class A1			<input type="checkbox"/>						
104	Variable speed 2200-3600r/min 100% load. Class B1	<input type="checkbox"/>								
105	Constant speed 2800r/min 100% load	<input type="checkbox"/>								
108	Variable speed 900-3000r/min. High torque								<input type="checkbox"/>	
109	Constant speed 3000r/min 110% load. Class A1					<input type="checkbox"/>				
113	Constant speed 1800r/min 110% load. Class A1		<input type="checkbox"/>		<input type="checkbox"/>					
173	Constant speed 2000r/min 110% load. Class A1 CARB rating			<input type="checkbox"/>		<input type="checkbox"/>				
174	Constant speed 1800r/min 110% load. Class A1 CARB rating			<input type="checkbox"/>		<input type="checkbox"/>				
177	Constant speed 1800r/min 110% load Class A1 CARB rating			<input type="checkbox"/>	<input type="checkbox"/>					
227	Dual speed, set at 1800r/min					<input type="checkbox"/>				
274	Dual speed, set at 1800r/min					<input type="checkbox"/>				
279	Dual speed, set at 1800r/min					<input type="checkbox"/>				
301	Variable speed 850-3000r/min 100% load. Class B1						<input type="checkbox"/>	<input type="checkbox"/>	<input type="checkbox"/>	
302	Variable speed 850-3000r/min 110% load. Class B1						<input type="checkbox"/>	<input type="checkbox"/>	<input type="checkbox"/>	
311	Variable speed 900-2800r/min									<input type="checkbox"/>
351	Variable speed 850-3000r/min 100% load. Class B1. Deep sump						<input type="checkbox"/>	<input type="checkbox"/>	<input type="checkbox"/>	
376	Variable speed 1025-2800r/min							<input type="checkbox"/>	<input type="checkbox"/>	
384	Variable speed 1250-2750r/min						<input type="checkbox"/>			
	Variable speed 950-2895r/min									<input type="checkbox"/>

#### 12.4 LPWG Build Details

Build and Details		LPWG		
		2	3	4
27	Dual speed 1500/1800r/min	<input type="checkbox"/>	<input type="checkbox"/>	<input type="checkbox"/>
28	Dual speed 1500/1800r/min	<input type="checkbox"/>	<input type="checkbox"/>	<input type="checkbox"/>
70	Dual speed 1500/1800r/min	<input type="checkbox"/>	<input type="checkbox"/>	<input type="checkbox"/>
74	Dual speed 1500/1800r/min	<input type="checkbox"/>	<input type="checkbox"/>	<input type="checkbox"/>

## Section 13. Technical Data

### 13.1 Technical Data - LPA

		LPA2	LPA3
Type of fuel injection		Direct	Direct
Number of cylinders		2	3
Direction of rotation - looking on flywheel		Anti-clockwise	Anti-clockwise
Nominal cylinder bore - refer to "07.7Dimensions of Wearing Parts" for machining tolerances	mm	76.0	76.0
	in	2.99	2.99
Stroke	mm	80.0	80.0
	in	3.15	3.15
Cylinder capacity - total	litre	0.726	1.089
	in <sup>3</sup>	44.30	66.45
Compression ratio		18.5:1	18.5:1
Mean piston speed at 3000r/min	m/sec	9.6	9.6
	ft/min	1890	1890
Firing order - (number 1 cylinder is at the gear end)		1 - 2	1 - 2 - 3
Lubricating oil pressure at 3000r/min and with the oil at 110°C (230°F)	bar	2.0	2.0
	lbf/in <sup>2</sup>	29.0	29.0
Lubricating oil pressure at idle	bar	0.7	0.7
	lbf/in <sup>2</sup>	10.2	10.2
Oil pressure relief valve setting	bar	3.4 - 4.1	3.4 - 4.1
	lbf/in <sup>2</sup>	48.0 - 60.00	48.0 - 60.00
Number of flywheel ring gear teeth		96	96
Idling speed	r/min	850 - 900	850 - 900
Minimum full load speed	r/min	1500	1500
Fuel lift pump maximum lift	mm	3048	3048
	in	120	120
Fuel lift pump maximum head	mm	600	600
	in	23.6	23.6
Axial fan ratio (except LPA2 Build 10)		180	2.79:1
Maximum continuous crankshaft end thrust	kgf	180	180
	lbf	400	400
Dry engine weight - approximate and based on Build 01. Refer to Lister Petter for actual figures	kg	104	132
	lb	229	291
Maximum permissible intake restriction at full load	mm H <sub>2</sub> O	254	254
	in H <sub>2</sub> O	10.0	10.0
Maximum permissible exhaust backpressure	mm H <sub>2</sub> O	762	762
	in H <sub>2</sub> O	30.0	30.0
Fuel filter nominal rating	micron	5 - 7	5 - 7

Section 13  
 Technical Data  
 - LPW

13.2 Technical Data - LPW

		LPW2	LPW3	LPW4	LPWT4
Type of fuel injection		Direct	Direct	Direct	Direct
Number of cylinders		2	3	4	4
Direction of rotation - looking on flywheel		Anti-clockwise			
Nominal cylinder bore - refer to "07.7 Dimensions of Wearing Parts" for machining tolerances	mm	86.0	86.0	86.0	86.0
	in	3.38	80.0	3.38	3.38
Stroke	mm	80.0	80.0	80.0	80.0
	in	3.15	3.15	3.15	3.15
Cylinder capacity - total	litre	0.930	1.395	1.860	1.860
	in <sup>3</sup>	56.75	85.13	113.50	113.50
Compression ratio		18.5:1	18.5:1	18.5:1	16.2:1
Mean piston speed at 3000r/min	m/sec	7.99	7.99	7.99	7.99
	ft/min	1575	1575	1575	1575
Firing order - (number 1 cylinder is at the gear end)		1 - 2	1 - 2 - 3	1 - 3 - 4 - 2	
Lubricating oil pressure at 3000r/min and with the oil at 110°C (230°F)	bar	2.0	2.0	2.0	2.5
	lbf/in <sup>2</sup>	29.0	29.0	29.0	36.3
Lubricating oil pressure at idle	bar	1.0	1.0	1.0	1.0
	lbf/in <sup>2</sup>	14.5	14.5	14.5	14.5
Oil pressure relief valve setting	bar	2.6 - 3.2	2.6 - 3.2	2.6 - 3.2	2.6 - 3.2
	lbf/in <sup>2</sup>	37.7-46.4	37.7-46.4	37.7-46.4	37.7-46.4
Number of flywheel ring gear teeth		96	96	96	96
Idling speed:					
Build 73	r/min	800 - 850			
Build 76	r/min	1025 - 1050			
LPW4 Build 84	r/min	950 - 1000			
All other Builds	r/min	850 - 900			
Minimum full load speed	r/min	1500			
Fuel lift pump maximum lift	mm	3048	3048	3048	3048
	in	120	120	120	120
Fuel lift pump maximum head	mm	600	600	600	600
	in	23.6	23.6	23.6	23.6
Radiator fan ratio		1.4:1	1.4:1	1.4:1	1.4:1
Maximum continuous crankshaft end thrust	kgf	180	180	180	180
	lbf	400	400	400	400
Dry engine weight - approximate and based on Build 01. Refer to Lister Petter for actual figures	kg	112	150	180	180
	lb	247	330	396	396
Maximum permissible intake restriction at full load	mm H <sub>2</sub> O	254	254	254	254
	in H <sub>2</sub> O	10.0	10.0	10.0	10.0
Maximum permissible exhaust backpressure	mm H <sub>2</sub> O	760	760	760	508
	in H <sub>2</sub> O	30.0	30.0	30.0	20.0
Maximum top hose temperature	°C	103°	103°	103°	103°
	°F	217°	217°	217°	217°
Fuel filter nominal rating	micron	5 - 7	5 - 7	5 - 7	5 - 7

### 13.3 Technical Data - LPWS

		LPWS2	LPWS3	LPWS4
Type of fuel injection		Indirect		
Number of cylinders		2	3	4
Direction of rotation - looking on flywheel		Anti-clockwise		
Nominal cylinder bore - refer to "07.7Dimensions of Wearing Parts" for machining tolerances	mm	86.0	86.0	86.0
	in	3.86	3.86	3.86
Stroke	mm	80.0	80.0	80.0
	in	3.15	3.15	3.15
Cylinder capacity - total	litre	0.930	1.395	1.860
	in <sup>3</sup>	56.75	85.13	113.50
Compression ratio		22.0:1	22.0:1	22.0:1
Mean piston speed at 3000r/min	m/sec	7.99	7.99	7.99
	ft/min	1575	1575	1575
Firing order - (number 1 cylinder is at the gear end)		1 - 2	1 - 2 - 3	1 - 3 - 4 - 2
Lubricating oil pressure at 3000r/min and with the oil at 110°C (230°F)	bar	2.0	2.0	2.0
	lbf/in <sup>2</sup>	29.0	29.0	29.0
Lubricating oil pressure at idle	bar	1.0	1.0	1.0
	lbf/in <sup>2</sup>	14.5	14.5	14.5
Oil pressure relief valve setting	bar	3.4 - 4.1	3.4 - 4.1	3.4 - 4.1
	lbf/in <sup>2</sup>	48.0 - 60.0	48.0 - 60.0	48.0 - 60.0
Number of flywheel ring gear teeth		96	96	96
Idling speed:				
Build 73	r/min	800 - 850		
Build 76	r/min	1025 - 1050		
Build 84	r/min	950 - 1000		
All other Builds	r/min	850 - 900		
Minimum full load speed	r/min	1500		
Fuel lift pump maximum lift	mm	3048	3048	3048
	in	120	120	120
Fuel lift pump maximum head	mm	600	600	600
	in	23.6	23.6	23.6
Radiator fan ratio		1:1	1:1	1:1
Maximum continuous crankshaft end thrust	kgf	180	180	180
	lbf	400	400	400
Dry engine weight - approximate and based on Build 01. Refer to Lister-Petter for actual figures	kg	112	150	180
	lb	247	330	396
Maximum permissible intake restriction at full load	mm H <sub>2</sub> O	254	254	254
	in H <sub>2</sub> O	10.0	10.0	10.0
Maximum permissible exhaust backpressure	mm H <sub>2</sub> O	762	762	762
	in H <sub>2</sub> O	30.0	30.0	30.0
Maximum top hose temperature	°C	103°	103°	103°
	°F	217°	217°	217°
Fuel filter nominal rating	micron	5 - 7	5 - 7	5 - 7

Section 13  
 Technical Data  
 - LPWG

13.4 Technical Data - LPWG

		LPWG2	LPWG3	LPWG4
Aspiration		Naturally aspirated		
Number of cylinders		2	3	4
Direction of rotation - looking on flywheel		Anti-clockwise		
Nominal cylinder bore - refer to "07.7 Dimensions of Wearing Parts" for machining tolerances (use LPW figures)	mm	86.0	86.0	86.0
	in	3.38	3.38	3.38
Stroke	mm	80.0	80.0	80.0
	in	3.15	3.15	3.15
Cylinder capacity - total	litre	0.930	1.395	1.860
	in <sup>3</sup>	56.75	85.13	113.50
Compression ratio		9.5:1	9.5:1	9.5:1
Mean piston speed at 1800r/min	m/sec	4.82	4.82	4.82
	ft/min	945	945	945
Mean piston speed at 1500r/min	m/sec	4.01	4.01	4.01
	ft/min	787	787	787
Firing order - (number 1 cylinder is at the gear end)		1 - 2	1 - 2 - 3	1 - 3 - 4 - 2
Lubricating oil pressure at 1800r/min and with the oil at 110°C (230°F)	bar	2.0	2.0	2.0
	lbf/in <sup>2</sup>	29.0	29.0	29.0
Oil pressure relief valve setting	bar	3.4 - 4.1	3.4 - 4.1	3.4 - 4.1
	lbf/in <sup>2</sup>	48.0 - 60.0	48.0 - 60.0	48.0 - 60.0
Number of flywheel ring gear teeth		96	96	96
Minimum full load speed	r/min	1500	1500	1500
Cooling fan load at 1800r/min	kW	0.31	0.31	0.31
	bhp	0.42	0.42	0.42
Cooling fan load at 1500r/min	kW	0.21	0.21	0.21
	bhp	0.28	0.28	0.28
Maximum continuous crankshaft end thrust	kgf	180	180	180
	lbf	400	400	400
Maximum permissible intake restriction at full load	mm H <sub>2</sub> O	254	254	254
	in H <sub>2</sub> O	10.0	10.0	10.0
Maximum permissible exhaust backpressure	mm H <sub>2</sub> O	381	381	381
	in H <sub>2</sub> O	15.0	15.0	15.0

### 13.5 Power and Torque Output - LPA

r/min		Power						Torque		
		Variable Speed				Fixed Speed		Variable Speed		
		Continuous		Intermittent		Continuous		Intermittent Power		
		LPA2	LPA3	LPA2	LPA3	LPA2	LPA3	LPA2	LPA3	
3600	kW	-	-	-	-	10.5	15.8	Nm	-	-
	hp	-	-	-	-	14.1	21.2	lbf ft	-	-
3000	kW	10.4	15.6	11.4	17.2	10.4	15.6	Nm	36.3	54.7
	hp	13.9	20.9	15.3	23.1	13.9	20.9	lbf ft	26.8	40.3
2500	kW	9.2	13.8	10.1	15.2	-	-	Nm	38.6	58.1
	hp	12.3	18.5	13.5	20.4	-	-	lbf ft	28.5	42.9
2000	kW	7.5	11.2	8.2	12.3	-	-	Nm	39.2	58.7
	hp	10.1	15.9	11.0	16.5	-	-	lbf ft	28.9	43.3
1800	kW	6.5	9.8	7.2	10.8	6.0	9.0	Nm	38.2	57.3
	hp	8.7	13.1	9.7	14.5	8.0	12.1	lbf ft	28.2	42.3
1500	kW	5.2	7.8	5.7	8.6	4.7	7.1	Nm	36.3	54.7
	hp	7.0	10.5	7.6	11.5	6.3	9.5	lbf ft	26.8	40.3

**Rating: BS5514/ISO3046/DIN6271/SAE1995**  
 Note that output ratings apply only to fully run in engines without power absorbing accessories.  
**Derating: BS5514/ISO3046/DIN6271/SAE1995**  
 Altitude - Approx. 4% for every 300m (1000ft) higher than 100m (330ft) above sea level.  
 Temperature - Approx. 2.0% for every 5°C (10°F) above 25°C (77°F).

### 13.6 Power and Torque Output - LPW

		Power						Torque			
		Fixed Speed Continuous (ICXN)			Variable Speed Fuel Stop (IOFN)			Variable Speed Fuel Stop (IOFN)			
		LPW2	LPW3	LPW4	LPW2	LPW3	LPW4	LPW2	LPW3	LPW4	
3600	kW	14.0	21.0	28.0	-	-	-	Nm	-	-	-
	hp	18.8	28.2	37.5	-	-	-	lbf ft	-	-	-
3000	kW	13.4	20.1	26.8	14.7	22.1	29.5	Nm	46.8	70.4	93.9
	hp	18.0	26.9	35.9	19.7	29.6	39.5	lbf ft	34.5	51.9	69.3
2500	kW	-	-	-	13.0	19.5	26.0	Nm	49.7	74.5	99.3
	hp	-	-	-	17.4	26.1	34.9	lbf ft	36.7	54.9	73.2
2000	kW	-	-	-	10.6	15.9	21.2	Nm	50.6	75.9	101.2
	hp	-	-	-	14.2	21.3	28.4	lbf ft	37.3	56.0	74.6
1800	kW	9.3	13.9	18.6	9.4	14.1	18.7	Nm	49.8	74.9	99.2
	hp	12.5	18.6	24.9	12.6	18.9	25.1	lbf ft	36.7	55.2	73.2
1500	kW	7.5	11.3	15.0	7.5	11.3	15.0	Nm	47.7	71.9	95.5
	hp	10.1	15.2	20.1	10.0	15.1	20.1	lbf ft	35.2	53.0	70.4

**Rating: BS5514/ISO3046/DIN6271/SAE1995**  
 The output ratings apply only to fully run in engines without radiator, fan or power absorbing accessories, however DIN 70020 includes radiator and fan loss.  
**Derating: BS5514/ISO3046/DIN6271/SAE1995**  
 Altitude - Approximately 4% for every 300m (1000ft) higher than 100m (330ft) above sea level.  
 Temperature - Approximately 2.0% for every 5°C (10°F) above 25°C (77°F).

## Section 13

### Technical Data

#### - LPWT and LPWS power

#### 13.6 Power and Torque Output - LPWT4

r/min		Power			Torque	
		Variable Speed		Fixed Speed		
		Continuous	Intermittent	Continuous		
3000	kW	37.5	40.2	37.5	Nm	128.0
	hp	50.3	53.9	50.3		lbf ft
2500	kW	34.3	36.7	-	Nm	140.2
	hp	46.0	49.2	-		lbf ft
2000	kW	28.7	31.0	-	Nm	148.0
	hp	38.5	41.6	-		lbf ft
1800	kW	26.4	28.5	23.8	Nm	151.2
	hp	35.4	38.2	31.9		lbf ft
1500	kW	20.7	22.3	19.1	Nm	142.0
	hp	27.8	29.9	256		lbf ft

**Rating: BS5514/ISO3046/DIN6271/SAE1995**  
The output ratings apply only to fully run-in engines without radiator, fan or power absorbing accessories.  
**Derating: BS5514/ISO3046/DIN6271/SAE1995**  
Altitude - Approx. 1.2% for every 300m (1000 ft) higher than 100m (330 ft.) above sea level.  
Temperature - Approx. 1.0% for every 5°C (10°F) above 25°C (77°F).

#### 13.7 Power and Torque Output - LPWS

		Power									Torque			
		Variable Speed						Fixed Speed			Variable Speed			
		Continuous			Intermittent			Continuous			Intermittent Power			
		LPWS 2	LPWS 3	LPWS 4	LPWS 2	LPWS 3	LPWS 4	LPWS 2	LPWS 3	LPWS 4	LPWS 2	LPWS 3	LPWS 4	LPWS 2
3000	kW	13.4	20.1	26.8	14.7	22.1	29.5	13.4	20.1	26.8	Nm	46.8	70.3	93.9
	hp	18.0	26.9	35.9	19.7	29.6	39.5	18.0	26.9	35.9		lbf ft	34.5	51.9
2500	kW	12.2	17.5	23.3	13.4	19.2	25.6	-	-	-	Nm	51.2	73.4	97.8
	hp	16.4	23.5	31.2	18.0	25.7	34.3	-	-	-		lbf ft	37.8	54.1
2000	kW	10.1	14.0	18.7	11.1	15.4	20.5	-	-	-	Nm	53.0	73.5	98.0
	hp	13.5	18.8	25.1	14.9	20.6	27.5	-	-	-		lbf ft	39.0	54.2
1800	kW	9.1	12.4	16.6	10.0	13.6	18.2	8.2	12.3	16.4	Nm	53.1	72.2	96.6
	hp	12.2	16.6	22.3	13.4	18.2	24.4	11.0	16.5	22.0		lbf ft	39.2	53.3
1500	kW	7.4	9.9	13.2	8.1	10.9	14.5	6.6	9.9	13.2	Nm	51.6	69.4	92.3
	hp	9.9	13.3	17.7	10.9	14.6	19.4	8.8	13.3	17.7		lbf ft	38.0	51.2

**Rating: BS5514/ISO3046/DIN6271/SAE1995**  
The output ratings apply only to fully run in engines without radiator, fan or power absorbing accessories.  
**Derating: BS5514/ISO3046/DIN6271/SAE1995**  
Altitude - Approx. 4% for every 300m (1000ft) higher than 100m (330ft) above sea level.  
Temperature - Approx. 2.0% for every 5°C (10°F) above 25°C (77°F).



### 13.8 Power and Torque Output - LPWG

r/min		Power											
		Natural Gas						Propane Vapour					
		Continuous			Intermittent			Continuous			Intermittent		
		LPWG2	LPWG3	LPWG4	LPWG2	LPWG3	LPWG4	LPWG2	LPWG3	LPWG4	LPWG2	LPWG3	LPWG4
1500	kW	5.3	9.9	13.2	5.8	10.9	14.5	6.2	11.3	15.0	6.8	12.4	16.5
	hp	7.1	13.3	17.7	7.8	14.6	19.5	8.3	15.1	20.1	9.1	16.6	22.1
1800	kW	6.8	12.3	16.4	7.5	13.6	18.1	7.9	14.0	18.6	8.7	15.4	20.5
	hp	9.1	16.5	22.0	10.0	18.2	24.2	10.6	18.7	25.0	11.7	20.6	27.5

**Rating: BS5514/ISO3046/DIN6271**  
 The output ratings apply only to fully run in engines without radiator, fan or power absorbing accessories.  
**Derating: BS5514/ISO3046/DIN6271.**  
 Altitude - Approx. 4% for every 300m (1,000 ft.) higher than 100m (330 ft.) above sea level.  
 Temperature - Approx. 2% for every 5°C (10°F) above 25°C (77°F).



## Section 14. Dismantle and Rebuild

### 14.1 DISMANTLING AN ENGINE

#### WARNING

*Maintenance must be performed by qualified persons who are conversant with the hazards of fuels, electricity and machinery.*

*Read the Safety Precautions and observe all instructions and precautions in this publication.*

#### CAUTION

*These notes, based on an LPW engine, are of a general nature and are included as an aide memoire and in no way are they intended as instructions.*

#### 14.1.1 Preliminary Instructions

- a. Disconnect or isolate any non-electric starting systems.
- b. Disconnect and remove the battery.
- c. Drain the diesel fuel and lubricating oil.
- d. Drain the water.
- e. Disconnect all services.
- f. Remove any accessories or components that may be susceptible to damage when the engine is turned out of its normal plane.
- g. On LPWG engines remove any gas components that may be susceptible to damage when the engine is turned out of its normal plane.

#### WARNING

*These engines are fitted with hydraulic tappets therefore it is important to follow the procedures given.*

1. Remove the radiator hoses.
2. Remove the radiator after disconnecting the top and bottom mountings.
3. Remove the starter motor.
4. Slacken the alternator or jockey pulley.
5. Remove the radiator fan drive belt.
6. Remove the alternator or belt tensioner.
7. Remove the radiator fan (left hand thread).
8. Remove the inlet and exhaust manifolds.
9. Remove the fuel pump to injector pipes.
10. Remove the injectors; LPW have clamps, LPWS are screwed in.
11. Remove the cylinder head covers.
12. Remove the lifting eye(s).
13. Remove the valve rockers and push rods.
14. Remove the water pump.
15. Remove the cylinder head and gasket.
16. Lift out the push rod tubes, rubber seals and washers.
17. Remove the remaining fuel pipes and the fuel filter.
18. Remove the radiator support bracket.

19. Remove the oil filter.
20. Remove the dipstick and crankcase door.
21. Remove the oil pressure relief valve and the oil strainer.
22. Remove the connecting rod caps.
23. Carefully remove the carbon build-up from the top of the cylinder bore.
24. Turn the crankshaft until the piston is at TDC.
25. Lift out the piston and connecting rod.
26. Fit the flywheel locking tool.
27. Remove the front pulley (left hand thread).
28. Move the engine control to the stop position.
29. Remove each fuel pump; take care to retain the shim pack with each pump.
30. Remove the gear end cover.
31. Release the speeder spring from the governor lever assembly.
32. Remove the governor lever assembly and the governor rack.
33. Remove the governor sleeve.
34. Remove the governor weights.
35. Use a suitable magnet to remove the hydraulic tappets and the fuel pump tappets.
36. Rotate the engine until the governor weight slots in the camshaft are vertical.
37. Remove the two camshaft thrust plate screws and the control lever tension spring.
38. Carefully withdraw the camshaft.
39. Remove the oil pump.
40. Remove the crankshaft pinion.
41. Remove the flywheel.
42. Remove the flywheel housing.
43. Remove the flywheel end main bearing housing.
44. Use a manifold bolt to remove the centre main bearing locating dowel.
45. Gently withdraw the crankshaft.
46. Remove all the main and the camshaft bearing shells.

## 14.2 REBUILDING AN ENGINE

Tables showing torque values and recommended jointing compounds can be found in "Section 07 Routine Maintenance"

When assembling the engine, use normal engine lubricating oil to spray all moving parts during assembly. All bearing surfaces must be well lubricated including the valve stems and the cups of the push rods.

The pistons with rings and connecting rods assembled, must be submerged in oil just before fitting into the cylinder. After submersion drain both ways so that no oil is left in the combustion chamber or inside the piston.

Replace all joints and gaskets.

1. Replace the main bearing shells.
2. Replace the camshaft bearing.
3. Fit the gear end thrust bearings.
4. Replace the crankshaft; ensure the centre bearing dowel hole is correctly aligned.
5. Fit the centre main bearing locating dowel.
6. Fit the flywheel end thrust bearings.
7. Fit the main bearing housing.
8. Check the crankshaft end float.
9. Fit the flywheel housing.
10. Replace the flywheel.
11. Heat the crankshaft pinion and fit it with the timing marks outwards.
12. Replace the oil pump.
13. Replace the engine control and speeder spring.
14. Replace the camshaft aligning the timing marks and ensure the thrust plate is located correctly.
15. Replace the fuel pump tappets.
16. Replace the hydraulic tappets.
17. Replace the governor weights and governor sleeve.
18. Replace the governor lever assembly and springs.
19. Set the governor.
20. Replace the fuel pumps.
21. Replace the gear end cover.
22. Adjust the engine control.
23. Fit the crankshaft pulley (left hand thread).
24. Replace the piston and connecting rod.
25. Replace the oil pump relief valve and strainer.
26. Replace the crankcase door and dipstick.
27. Replace the oil filter.
28. Replace the radiator support bracket.
29. Replace the push rod tube seals, washers and the push rod tubes.
30. Replace the cylinder head and gasket.
31. Replace the push rods and the valve rockers.
32. Replace the cylinder head covers.
33. Replace the fuel injector pipes.
34. Replace the fuel injectors.
35. Replace the water pump.
36. Replace the manifolds.
37. Replace the radiator fan (left hand thread).
38. Replace the alternator or tensioner.
39. Replace the starter motor.
40. Fit the fan drive belt and tension it.
41. Replace the radiator and hoses.
42. Replace the fuel filter and all other fuel pipes.

## Section 15. Conversion Factors

### 15.1 FORMULAE

#### BMEP

$$\text{Bar} = \frac{\text{kW} \times 60000 \times 20000}{\text{Cylinders} \times \text{r/min} \times \text{bore area (mm}^2\text{)} \times \text{stroke (mm)}}$$

$$\text{lbf/in}^2 = \frac{\text{bhp} \times 792000}{\text{Cylinders} \times \text{r/min} \times \text{bore area (in}^2\text{)} \times \text{stroke (in)}}$$

#### Torque

$$\text{Nm} = \frac{\text{kW} \times 9549}{\text{r/min}} \times \text{load factor}$$

$$\text{lbf ft} = \frac{\text{bhp} \times 5252}{\text{r/min}} \times \text{load factor}$$

Load factor:  
No overload = 1,0  
10% overload = 1,1

#### Fuel Consumption

A Specific Gravity of 0.84 is assumed

$$\text{l/h} = \frac{\text{g/kWh} \times \text{kW} \times \text{load factor}}{840}$$

$$\text{pt/h} = \frac{\text{lb/bhp h} \times \text{bhp} \times \text{load factor}}{1.05}$$

Load Factor - Naturally aspirated engines

$$\begin{array}{ll} 100\% = 1.0 & 50\% = 0.58 \\ 75\% = 0.78 & 25\% = 0.40 \end{array}$$

Load Factor - Turbocharged engines

$$\begin{array}{ll} 100\% = 1.0 & 50\% = 0.55 \\ 75\% = 0.76 & 5\% = 0.38 \end{array}$$

#### Oil Consumption

A Specific Gravity of 0.886 is assumed

$$\text{litres/24hours} = \frac{\text{g/kWh} \times \text{kW}}{4922}$$

$$\text{pints/24hours} = \frac{\text{lb/bhp h} \times \text{bhp}}{0.15}$$

#### Piston Speed

$$\text{metres/second} = \frac{\text{stroke (mm)} \times \text{r/min}}{30000}$$

$$\text{feet/minute} = \frac{\text{stroke (in)} \times \text{r/min}}{6}$$

#### Mechanical Efficiency

$$\% = \frac{\text{bhp} \times 100}{\text{ihp}}$$

#### Cyclic Irregularity

$$\frac{\text{max flywheel speed} - \text{min flywheel speed}}{\text{mean flywheel speed}}$$

#### Power

$$\text{kW} = \frac{\text{r/min} \times \text{torque(Nm)}}{9549}$$

$$\text{bhp} = \frac{\text{r/min} \times \text{torque(lb ft)}}{5252}$$

## Section 15

### Conversion Factors

- length, liquid, volume, linear velocity, rate of flow

#### 15.2 CONVERSION FACTORS

The conversion tables in this section have been derived from BS350

To use the tables the left hand base unit is multiplied by the relevant conversion factor given in one of the right hand columns.

For example:

To convert 6.28 metres to inches using the 'Length' Table  
 $6.28 \times 39.3701$  (factor from third column) = 247.244 inches.

It is not good practice to round-up the conversion factors given

#### Length

	metre m	inch in	foot ft	yard yd
1 metre		39.3701	3.2808	1.0936
1 inch	0.0254		0.0833	0.0278
1 foot	3.038	12.0000		0.3333
1 yard	0.9144	36.0000	3.0000	

1in = 25.4mm

1mm = 0.03937in

#### Liquid Capacity

	litre l	UK pint <sup>1</sup> pt	UK gallon <sup>2</sup> gal	US pint US pt
1 litre		1.7598	0.2199	2.1134
1 UK pint	0.5683		0.1250	1.2009
1 UK gallon	4.5464	8.0000		9.6076
1 US pint	0.4732	0.8327	0.1041	

<sup>1</sup> Also known as the imperial pint

<sup>2</sup> Also known as the imperial gallon

1 UK gallon = 1.2009 US gallon

1 US gallon = 0.8325UK gallon

#### Volume

	cubic metre m <sup>3</sup>	litre l	cubic inch in <sup>3</sup>	cubic foot ft <sup>3</sup>
1 cubic metre		1000.0	61023.8	35.3147
1 litre	0.0010		61,0238	0.0353
1 cubic inch	$1.6387 \times 10^{-5}$	0.0164		$5.7870 \times 10^{-4}$
1 cubic foot	0.0283	28.3168	1728.0	

1 dm<sup>3</sup> = 1litre

1 in<sup>3</sup> = 16.3871cm<sup>3</sup>

#### Linear Velocity

	metre per second m/sec	foot per second ft/sec	foot per minute ft/min	inch per second in/sec
1 metre per second		3.2808	196.850	39.3701
1 foot per second	0.3048		60.0000	12.0000
1 foot per minute	0.0051	0.0167		0.2000
1 inch per second	0.0254	0.0833	5.0000	

#### Rate of Flow - Mass

	kilogram per second	kilogram per hour	pound per second	pound per hour
1 kilogram/second		3600.0	2.2046	7936.6
1 kilogram/hour	$2.7777 \times 10^{-4}$		$6.1239 \times 10^{-4}$	2.2046
1 pound/second	0.4535	1632.9		3600.0
1 pound/hour	$1.2599 \times 10^{-4}$	0.4535	$2.777 \times 10^{-4}$	

Section 15  
Conversion Factors  
- rate of flow, pressure, torque, force

**Rate of Flow - Volume**

	cubic metre per second - m <sup>3</sup> /sec	litre per second l/sec	cubic foot per second - ft <sup>3</sup> /sec	UK gallon per second - gal/sec
1 m <sup>3</sup> /sec		1000.0	35.3147	219.969
1 l/sec	0.0010		0.0353	0.2200
1 ft <sup>3</sup> /sec	0.0263	28.3168		6.2288
1 UK gal/sec	4.5460 x 10 <sup>-3</sup>	4.5461	0.1605	

1 UK gallon = 1.2009 US gallon

**Pressure - Table 1**

	newton per square millimetre N/mm <sup>2</sup>	kilogram-force per square centimetre kgf/cm <sup>2</sup>	pound-force per square inch lbf/in <sup>2</sup>	pound-force per square foot lbf/ft <sup>2</sup>
1 N/mm <sup>2</sup>		10.1972	145.038	20885.4
1 kgf/cm <sup>2</sup>	9.8066 x 10 <sup>-2</sup>		14.2233	2048.16
1 lbf/in <sup>2</sup>	6.8947 x 10 <sup>-3</sup>	0.0703		144.000
1 lbf/ft <sup>2</sup>	4.7880 x 10 <sup>-5</sup>	4.8824 x 10 <sup>-4</sup>	6.9444 x 10 <sup>-3</sup>	

**Pressure - Table 2**

	bar	atmosphere atm	kilogram-force per square centimetre kgf/cm <sup>2</sup>	pound-force per square inch lbf/in <sup>2</sup>
1 bar		0.9869	1.0197	14.5038
1 atm	1.0132		1.0332	14.6959
1 kgf/cm <sup>2</sup>	0.9807	0.9678		14.2233
1 lbf/in <sup>2</sup>	0.0689	0.0680	0.073	

**Pressure - Table 3**

	inch of water in H <sub>2</sub> O	foot of water ft H <sub>2</sub> O	millimetre of mercury - mm Hg	inch of mercury in Hg
1 in H <sub>2</sub> O		0.0833	1.8683	0.0735
1 ft H <sub>2</sub> O	12.000		22.4198	0.8827
1 mm Hg	0.5352	0.0446		0.0394
1 in Hg	13.5951	1.1329	25.400	

1 in H<sub>2</sub>O = 0.00248 bar

**Torque (Moment of Force)**

	newton metre Nm	kilogram-force metre - kgf m	pound-force foot lbf ft	pound-force inch lbf in
1 Nm		0.1020	0.7376	8.8507
1 kgf m	9.8066		7.230	86.8507
1 lbf ft	1.3558	0.1382		12.000
1 lbf in	0.1130	0.0115	0.0833	

The kilogram is known as the kilopond (kp) in Germany. 1 kgf m = 1 kp m

**Force (Mass x Acceleration)**

	newton N	kilogram-force kgf	pound-force lbf	poundal pdl
1 newton		0.1019	0.2248	7.2230
1 kilogram-force	9.8066		2.2046	70.9316
1 pound-force	4.4482	0.4536		32.1740
1 poundal	0.1382	0.0141	0.0311	

The kilogram is known as the kilopond (kp) in Germany. 1 kgf m = 1 kp m

1 pdl = 1 lb ft/s<sup>2</sup>

1 N = 1 kg m/s<sup>2</sup>

## Section 15

### Conversion Factors

- energy, power, fuel consumption

**Energy - Table 1**

	kilowatt hour kWh	kilogram-force metre - kgf m	foot-pound force ft lbf	horsepower hour hp h
1 kWh		$3.6709 \times 10^5$	$2.6552 \times 10^6$	1,3410
1 kgf m	$2.7240 \times 10^{-6}$		7.2330	$3.6530 \times 10^{-6}$
1 ft lbf	$3.7661 \times 10^{-7}$	0.1382		5.0505
1 hp h	0.7457	$2.7373 \times 10^6$	$1.98 \times 10^6$	

**Energy - Table 2**

	joule J	horsepower hour hp h	calorie cal	British thermal unit Btu
1 joule		$3.7250 \times 10^{-7}$	0.2388	$9.4781 \times 10^{-4}$
1 hp h	$2.6846 \times 10^6$		641186	2544.43
1 cal	4.1868	$1.5596 \times 10^{-6}$		$3.9683 \times 10^{-3}$
1 Btu	1055.06	$3.9301 \times 10^{-4}$	251.996	

**Power - Table 1**

	kilowatt kW	metric horsepower CV	brake horsepower bhp	British thermal unit per hour Btu h
1 kW		1.3596	1.3410	3412.14
1 CV	0.7355		0.9863	2509.63
1 bhp	0.7457	1.0139		2544.43
1 Btu h	0.00029	$3.9846 \times 10^{-4}$	$3.9301 \times 10^{-4}$	

**Power - Table 2**

	watt W	kilo calorie per hour k cal/h	British thermal unit Btu
1 watt		0.08598	3.4121
1 k cal/h	1.1630		3.9683
1 Btu	0.2930	0.2519	

### Specific Fuel Consumption

	pounds per horsepower hour lb/hp h	pounds per Cheval Vapeur hour lb/CV h	grams per kilowatt hour g/kW h	grams per Cheval Vapeur hour g/CV h
1 lb/hp h		0.9862	608.27	447.33
1 lb/CV h	1.0140		616.80	453.59
1 g/kW h	$1.6440 \times 10^{-3}$	$1.621 \times 10^{-3}$		0.7354
1 g/CV h	$2.235 \times 10^{-3}$	$2.205 \times 10^{-3}$	1.3600	

The Cheval Vapeur (CV) is also known as the metric horsepower (1CV = 1CH = 1PS)

1 lb = 453.592 grams



## Section 16. Index

<b>A</b>	
Agglomerator .....	21
Air	
- baffles .....	33
- cleaner .....	14
- cowling .....	33
Alternator .....	18
Anode .....	64
Antifreeze .....	59
Associated Publications .....	4
<b>B</b>	
Battery	
- cold cranking .....	12
- details .....	11
- requirement .....	12
- type .....	12
Bearing	
- clearance .....	51
- housing .....	53
Belt tension .....	19
Breather .....	16
Builds .....	10, 133
<b>C</b>	
Camshaft .....	45
- bush .....	47
- endfloat .....	46
Carburettor .....	80
Cold cranking .....	12
Cold start aid .....	15
Cold starting - performance .....	12
Connecting rod .....	51
Coolant	
- capacity .....	59
- concentrate .....	59, 78
Crankcase	
- door .....	42
- vacuum .....	74
Crankshaft .....	55
- endfloat .....	56
- main bearings .....	57
- pulley .....	55
Cyclonic air cleaner .....	14
Cylinder head .....	34
- clearance .....	38
- covers .....	34
- gaskets .....	38
<b>D</b>	
Decarbonising .....	101
Dimensions of wearing parts .....	101, 102
Dismantling - aide memoir .....	143
Dismantling and rebuilding .....	13
Drive belt tension .....	19
<b>E</b>	
Electrical wiring diagrams	
- industrial .....	109
- LPWG .....	129
- marine .....	119
Electronic governor - LPWG .....	81
End cover .....	43
Engine	
- builds .....	10
- fluids .....	75
- serial number .....	10, 96
- speed adjustment .....	71
Exhaust backpressure .....	15
Exhaust silencer .....	15
Expansion tank - marine .....	62
<b>F</b>	
Fault finding .....	105
Flywheel and flywheel housing .....	52
Formulae .....	145
Fuel	
- agglomerator .....	21
- filter .....	21
- injection pump .....	22
- Injector .....	26
- lift pump .....	20
- pump .....	22
- pump timing .....	24
- specification .....	77
- tank .....	19
<b>G</b>	
Gas	
- pressure regulator .....	80
- specification .....	79
Gear end cover .....	43
Gearbox	
- Hurth .....	93
- Newage .....	91
Glow plug .....	15
Governor .....	65
- electronic, LPWG .....	81
- linkage, LPWG .....	81
- settings .....	70
- weights and springs .....	67
<b>H</b>	
Head	
- clearance .....	38
- covers .....	35
- gaskets .....	38
Heat exchanger .....	63
Heater plug .....	15
High tension leads - LPWG .....	83
Hurth gearbox .....	93
Hydraulic tappets .....	37

## Section 16

### Index

---

<b>I</b>	
Ignition system - LPWG	82, 83
Industrial wiring diagrams	111
Injection pump	22
Injector	26
- back leakage	26
Inlet manifold restrictor	15
Intake restriction	14
Interim maintenance	95
<b>J</b>	
Jointing compounds	99
<b>L</b>	
Laying-up procedure	64
Lift pump	20
Long term storage	104
Lubricating oil	75
- oil and filter change periods	96
<b>M</b>	
Main bearings	57
Main bearing housing	53
Maintenance schedule hours	97
Manifolds	15
Marine	
- expansion tank	62
- heat exchanger	63
- raw water pump	63
- zinc anode	64
<b>N</b>	
Newage gearbox	91
Nomenclature	10
<b>O</b>	
Oil	75
- dipstick	28
- filter	30
- jets	50
- oil and filter change periods	96
- pump	58
- specification	75
- strainer	58
- sump, capacity	29
- sump, draining	29
- system	28
- viscosity	75
Operating instructions	
- industrial	85, 87
- LPWG	87
- marine	88
Other publications	4
Oversize and undersize items	101
<b>P</b>	
Piston	48
- oil jets	50
- ring wear	101
Polarity	11
Power and torque output	
- LPA	139
- LPW	139
- LPWG	141
- LPWS	140
- LPWT4	140
Precautions and safe working practices	5
- gas	79
- oil, filters	95
- waste disposal	95
Primary ignition system - LPWG	82
Priming the fuel system	21
Problems	4
Publications	4
Pump timing	24
<b>R</b>	
Radiator	61
- fan	61
Raw water pump	63
Rebuilding - aide memoir	144
Routine maintenance	95
- schedule hours	97
<b>S</b>	
Safe working practices	5
Safety precautions	5
- gas	79
- oil filters	95
- symbols	7
- waste disposal	95
Sealing compounds	99
Secondary ignition system - LPWG	83
Setting the Governor	70
Silencer	15
Spanner torque settings	100
Spark plug - LPWG	83
Speed adjustment	71
- LPWG	82
Start aid	15
Starter battery requirement	12
Starter motor	17
Starting performance	12
<b>T</b>	
Technical data	
- LPA	135
- LPW	136
- LPWG	138
- LPWS	137
Thermostat	60
Timing	24
Torque spanner settings	100
Troubleshooting	105
Turbocharger	16

**U** \_\_\_\_\_

Undersize and Oversize Items ..... 101

Using this Workshop Manual ..... 4

**V** \_\_\_\_\_

Vacuum ..... 74

Valves ..... 39

- guides ..... 41

- seats ..... 40

**W** \_\_\_\_\_

Water

- circulating pump ..... 62

- cooling system ..... 59

Wearing parts - dimensions ..... 101, 102

Weights and springs ..... 67

Wiring diagrams

- industrial ..... 109

- LPWG ..... 129

- marine ..... 119

**Z** \_\_\_\_\_

Zinc Anode ..... 64



CALIFORNIA

Proposition 65 Warning

Engine exhaust and some of its constituents are known to the State of California to cause cancer, birth defects, and other reproductive harm.



**UK**

Lister Petter UK Limited, Dursley, Gloucestershire GL11 4HS England  
Tel: +44 (0)1453 544141; Fax: +44 (0)1453 546732  
E-mail: [sales@lister-petter.co.uk](mailto:sales@lister-petter.co.uk) <http://www.lister-petter.co.uk>

**USA**

Lister Petter Americas Inc. 815 E. 56 Highway, Olathe, Kansas 66061 USA  
Tel: +1 913 764-3512; Fax: +1 913 764-5493  
E-mail: [info@lister-petter.com](mailto:info@lister-petter.com); <http://www.lister-petter.com>

**FRANCE**

Lister Petter France, 17 Avenue de L'escouvrier, Zone d'Activites, 95842 Sarcelles, Cedex France  
Tel: +33 (0)1 39330420; Fax: +33 (0)1 34195760  
E-mail: [commercial@lister-petter-france.fr](mailto:commercial@lister-petter-france.fr)

**INDIA**

Lister Petter Private Limited, 102 Beaver Gradeur, Baner, Pune 411045 India  
Tel: +91 20 729 3284/85/86; Fax: +91 20 729 3287