



INSTALLATION INSTRUCTIONS

Accessory

HARDTOP

Application

2008 S2000

Publications No.

All 38253

Issue Date

OCT 2007

PARTS LIST

Hardtop

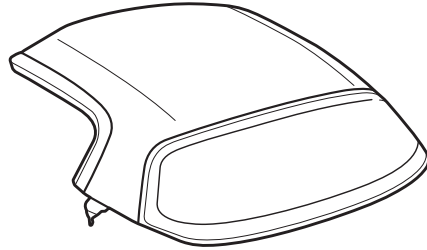

Left rear roof pillar trim



Right rear roof pillar trim

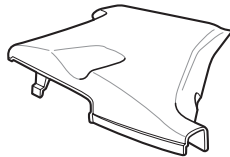

Left body side catcher
(Not included with Rio Yellow Pearl hardtop)

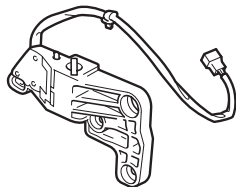

Right body side catcher

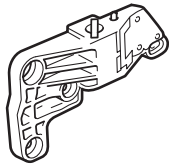

Left side trim brush



Right side trim brush

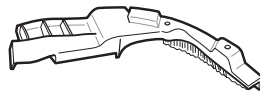

2 Front strikers
(Not used)



Rear defroster switch
(If equipped, not used)



3-Pin subharness

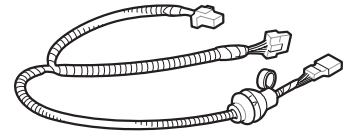

4-Pin subharness
(If equipped, not used)

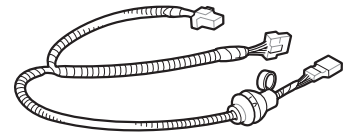

Switch cover
(If equipped, not used)

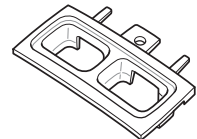

Plastic cover
(Not used)



4 Bolts, 6 x 18 mm



4 Bolts, 8 x 20 mm



2 Rubber spacers

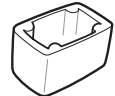

4 Cushion spacers
(Not used)



Rear defroster relay
(If equipped, not used)

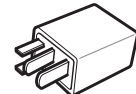

4 Cushion tapes

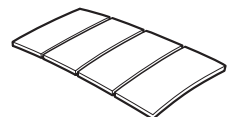

Information label



TOOLS AND SUPPLIES REQUIRED

Small flat-tip screwdriver
#2 Phillips screwdriver
Center punch
Hammer
Eye protection (face shield, safety goggles, etc.)
Tape measure
Felt-tip pen
Ratchet
10 mm, 12 mm, and 14 mm Sockets
14 mm Wrench
Piece of wire
Isopropyl alcohol
Shop towel
3M Weatherstrip adhesive

INSTALLATION

Customer Information: The information in this installation instruction is intended for use only by skilled technicians who have the proper tools, equipment, and training to correctly and safely add equipment to your vehicle. These procedures should not be attempted by "do-it-yourselfers."

1. Unlatch the convertible top, and lower it just past the halfway point.

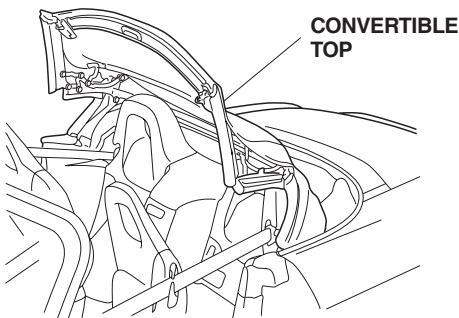

2. Locate the link stopper. Apply weatherstrip adhesive to the inside of the rubber spacer, and attach it over the link stopper. Repeat on the other side, then lower the convertible top completely.

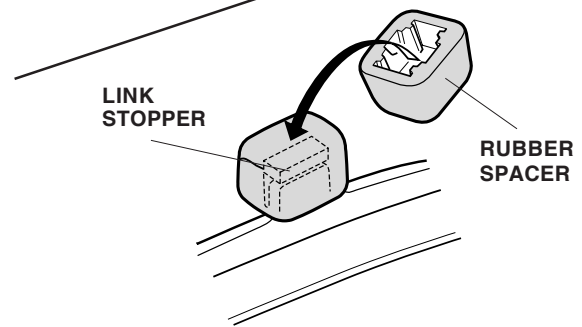
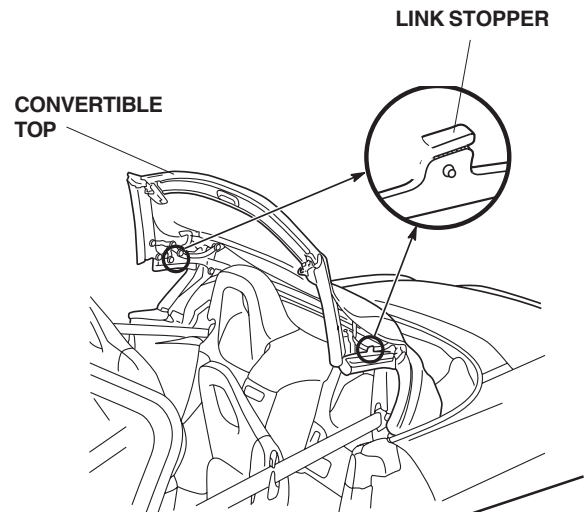

3. Remove the left and right door sill trims (three retaining clips).

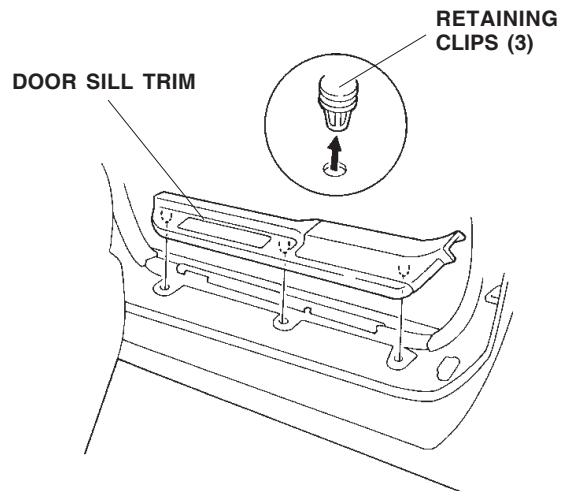

- On each side of the vehicle, remove the roll bar lower trim from the roll bar (two hooks and five retaining tabs).

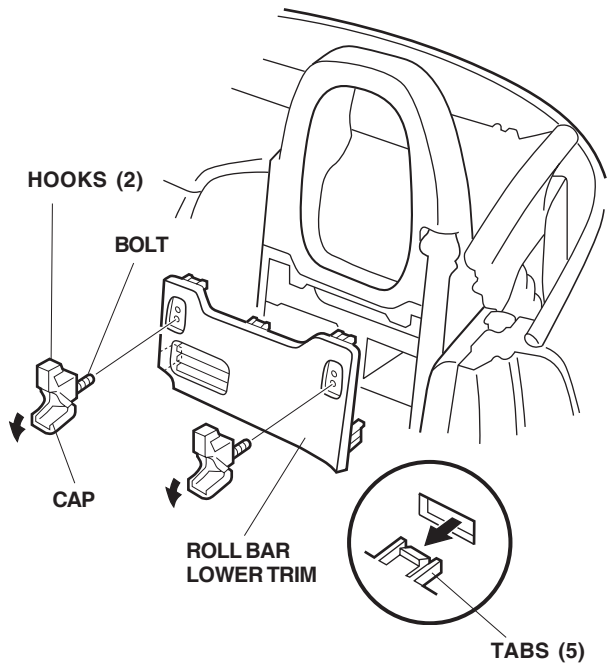

- Remove the left and right rear side trims (one self-tapping screw and one retaining clip for each trim).

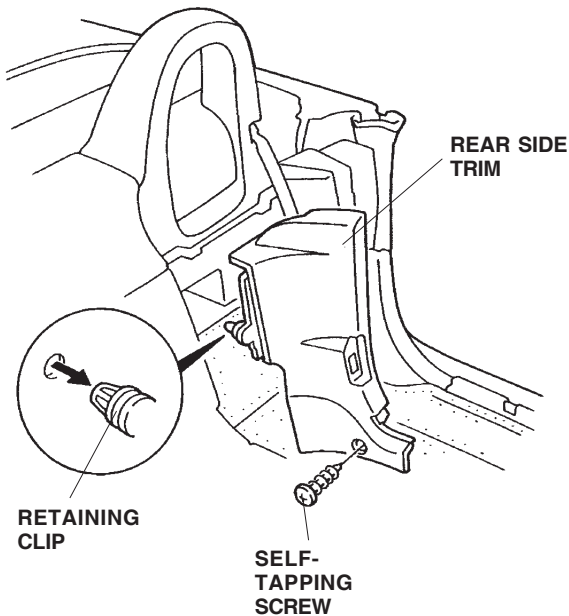

Installing the Subharness

- Behind the driver's seat, locate the 3-pin connector taped to the vehicle harness. Plug the 3-pin subharness connector into the vehicle 3-pin connector.

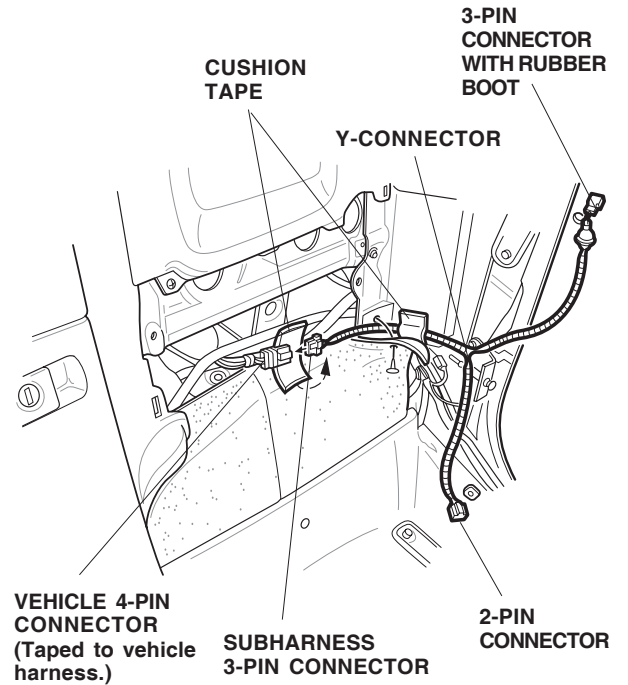

- Route the other end of the subharness along the vehicle harness toward the driver's door. At the Y-connector, route the 2-pin connector downward and the 3-pin with rubber boot upward. These connectors will be plugged in later.
- Wrap one cushion tape around the 3-pin connector, and use an additional cushion tape to secure the subharness to the vehicle body in the area shown.

9. Install the left body side catcher:

- Locate the area where the convertible top frame and the corner gusset meet. Using a hammer and a center punch, bend the corner gusset outward until it follows the contour of the convertible top frame.

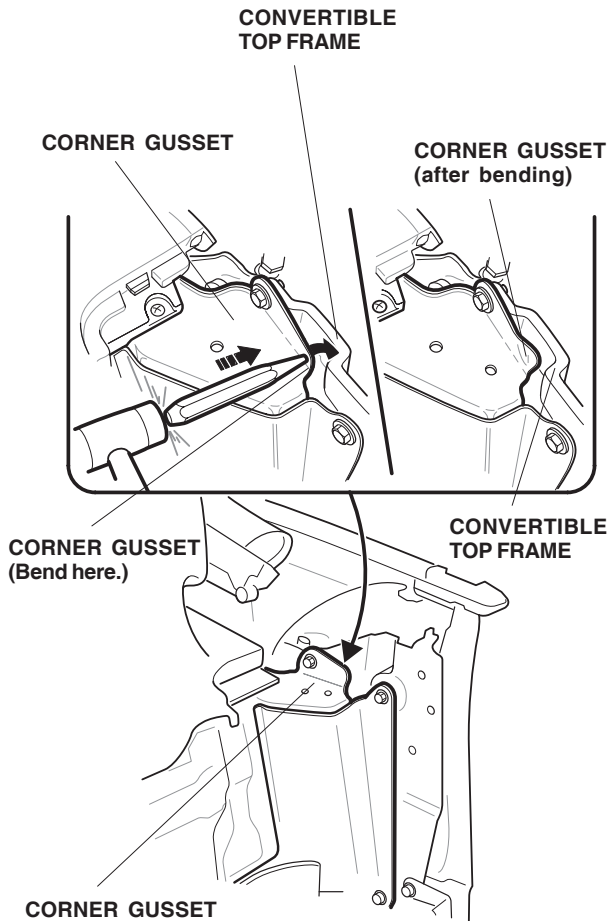

- Install the body side catcher into position over the corner gusset, and install two 6 x 18 mm and two 8 x 20 mm bolts. Torque the 6 mm bolts to 10 N·m (7 lb-ft), and torque the 8 mm bolts to 30 N·m (22 lb-ft).

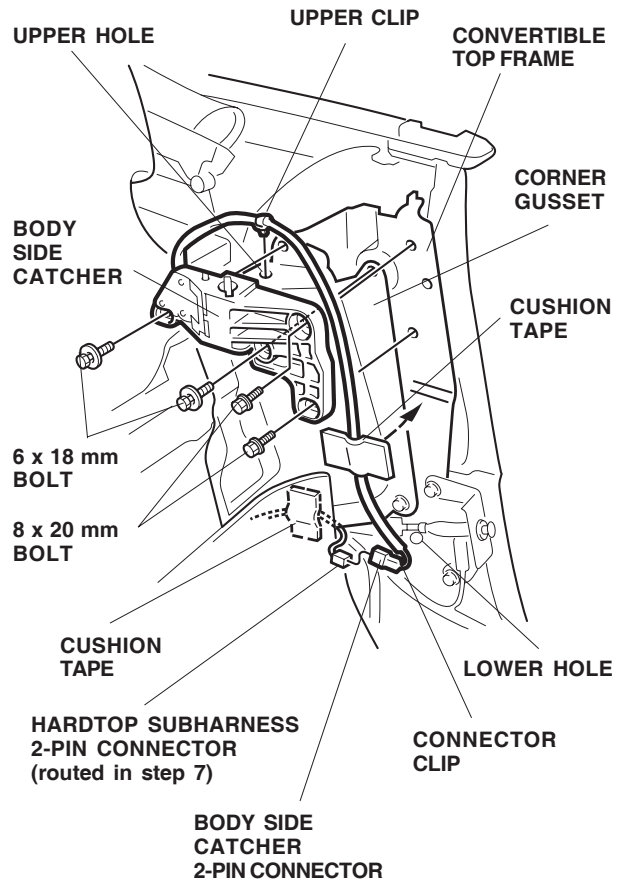

- Route the 2-pin connector from the body side catcher down in front of the catcher, and plug it into the hardtop subharness 2-pin connector (routed in step 7).
- Attach the upper clip on the wire to the upper hole in the body, and attach the connector clip to the lower hole in the body. Tuck the harness under the carpet.
- Secure the subharness with two cushion tapes in the areas shown.

10. Repeat step 9 to install the right body side catcher, but note that there are no wires to connect on the right side of the vehicle.

11. Get the left rear side trim removed in step 5. Remove and discard the side trim brush (three screws). Install the new left side trim brush to the rear side trim using the two screws. Remove and discard the plastic cap from the left rear side trim.

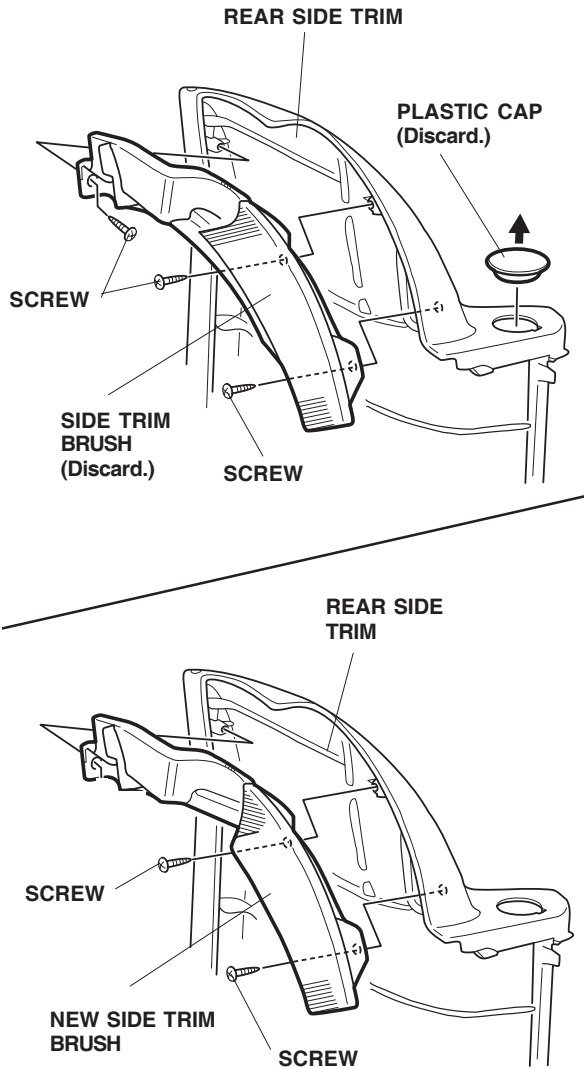

12. Get the right rear side trim removed in step 5. Repeat step 11 to install the new right side trim brush to the right rear side trim.

Installing the Hardtop

13. Install the hardtop:
 - Check that the rear lock pin handles on the hardtop are in the forward (**unlocked**) position and the bolts that secure the handle assembly are loose.

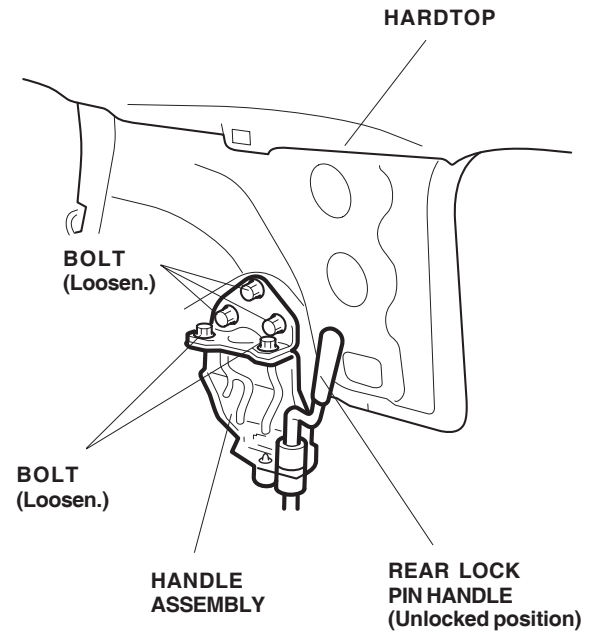

- Open the front lock handles. With the help of an assistant, gently set the front of the hardtop on the windshield frame, and align the front lock handles with the front strikers. At the rear of the hardtop, fit the roof lock pins through the holes in the body side catchers.

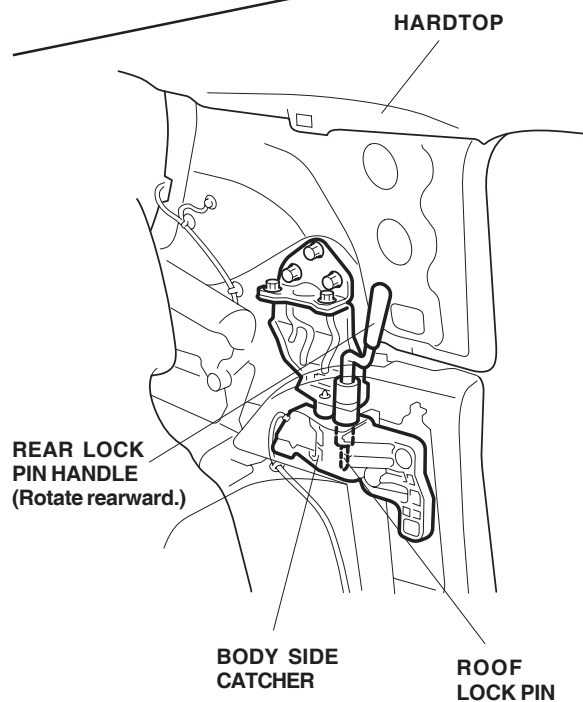
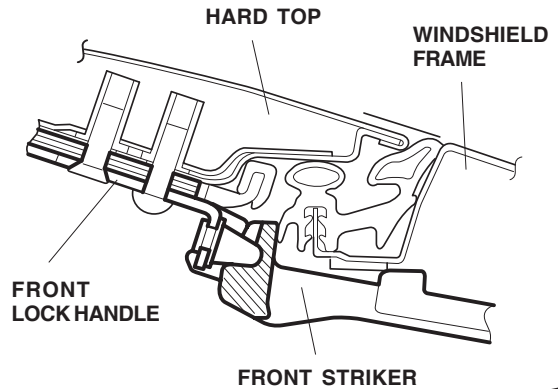

- Lock the front of the hardtop into position with the front lock handles, and lock the rear of the hardtop by rotating the rear lock pin handles rearward into the **locked** position.

Adjusting the Weatherstrip Gap

- At the rear of the hardtop, measure the gap between the hardtop and the body at the location shown. If the gap is incorrect, adjust the weatherstrip gap:
 - Unlock the front lock handles.
 - Make sure the rear lock pin handles are in the **unlocked** position (handles forward).
 - Lift up the hardtop, and reposition it back on the vehicle.
 - Lock the front lock handles.
 - With the hardtop resting in position with the lock pins in the catchers, but **not** locked, tighten the holder plate mounting bolts.
 - Rotate the rear handles to the **locked** position, and recheck the gap. Repeat the entire adjustment procedure until the proper gap is obtained. If necessary, rotate the rear handles slightly to increase or decrease the gap.

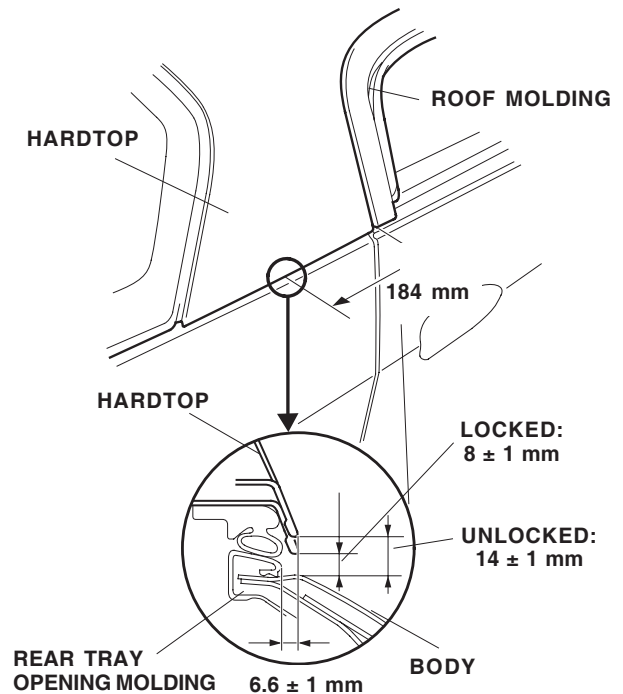

15. Check the door glass weatherstrip at the top and side to make sure that it contacts the glass evenly. If necessary, adjust the roof retainer. If window glass adjustment is required, refer to the service manual. Repeat for the other window.

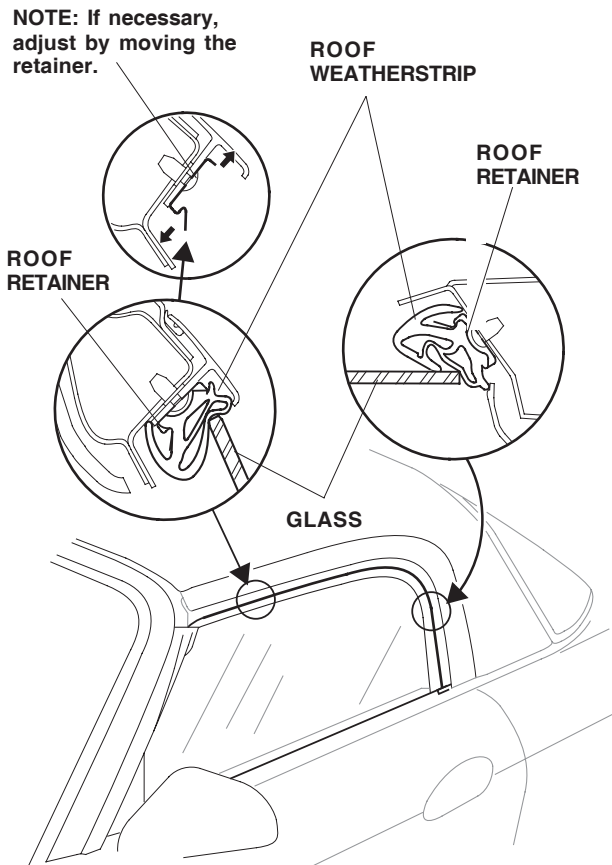

16. Check for water leaks.

17. Install the rear roof pillar trims:

- *On the left side only*, route the wire harness through the hole in the left rear pillar trim, and attach the wire harness clip.
- Peel back part of the hardtop side trim.
- Fit the rear roof pillar trim in place, and make sure the tabs fit into the holes in the hardtop.
- Snap the rear roof pillar trim into place, and reinstall the side trim over the rear roof pillar trim.
- Remove the backing from the adhesive inside the trim end cap, and attach the trim to the rear pillar.
- Repeat on the other side of the vehicle.

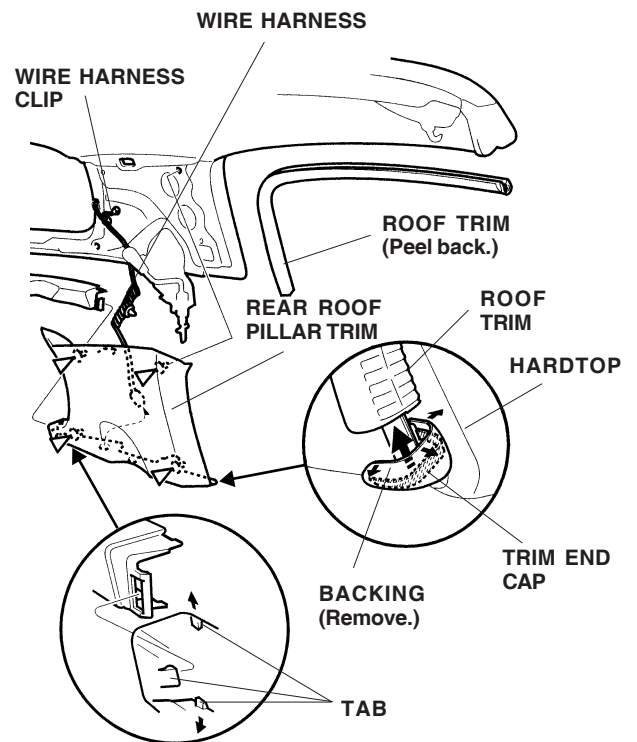

18. Route the 3-pin connector with the rubber boot (routed in step 7) through the empty hole in the left rear side trim, and seat the rubber grommet in the hole. Reinstall the left rear side trim.

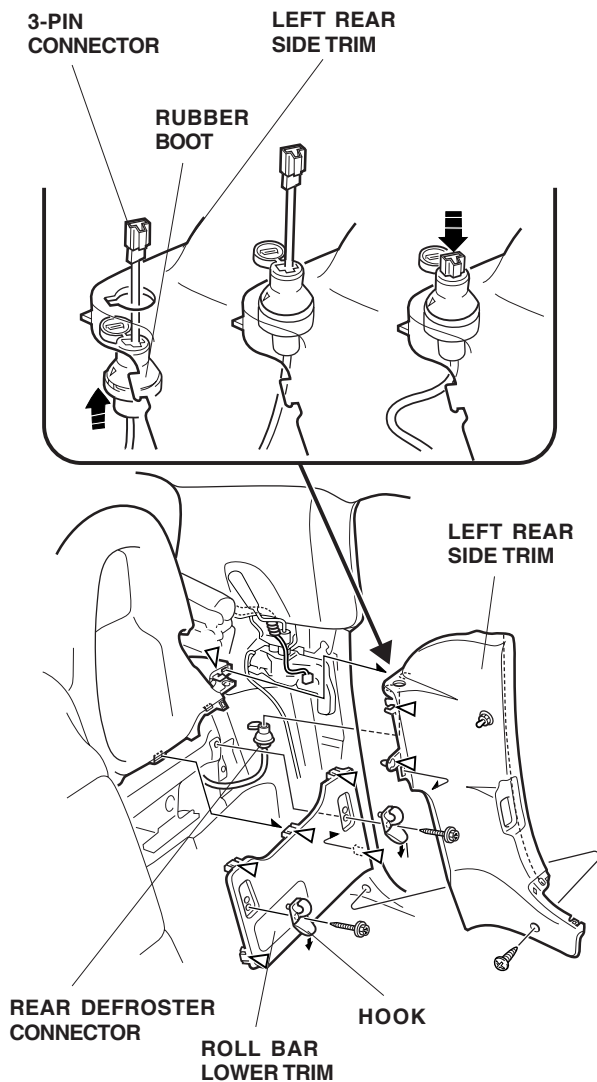

19. Reinstall the right rear side trim.
20. Reinstall the right roll bar lower trim and hook.
21. Reinstall the left and right door sill trims and the left kick panel.
22. Plug the rear defroster harness into the 3-pin connector on the left rear side trim. Place the clip on the defroster harness into the hole in the left rear side trim. Check that the harness is not pinched by the hardtop.

23. Attach the information label to the left rear side trim:

- Using isopropyl alcohol on a shop towel, clean the area where the information label will be attached.
- Remove the backing from the information label, and attach it to the left rear side trim in the area shown.

