

TT TOOLSTECHNIC

“KESİCİ TAKIMLARI”

Sektörün Lider Firması





www.toolstechnic.com

ELMAS KARBÜR FREZE BİÇAKLARI

Diamond Carbide Profile Router Cutters



KARBÜR FREZE PRESSDOWN NEGATİF Z-1

ÜRÜN KODU	ÇAP	KESİM BOYU	TAM BOY	Z1 AGIZ SAYISI
TTN1001	1,5	6	50	1
TTN1002	2	8	50	1
TTN1003	3	15	50	1
TTN1004	3	22	50	1
TTN1005	4	15	50	1
TTN1006	4	22	50	1
TTN1007	5	22	50	1
TTN1008	6	22	57	1
TTN1009	6	32	63	1
TTN1010	8	22	63	1
TTN1011	8	32	63	1
TTN1012	8	42	75	1
TTN1013	8	60	100	1
TTN1014	10	22	72	1
TTN1015	10	32	72	1
TTN1016	10	45	90	1
TTN1017	10	55	100	1
TTN1018	10	65	110	1
TTN1019	12	22	75	1
TTN1020	12	36	83	1
TTN1021	12	45	100	1
TTN1022	12	55	110	1
TTN1023	12	65	120	1

NOT:KESİM YAPARKEN TALAŞI AŞAĞI TABLAYA DOĞRU BASTIRIR, VAKUM OLMAYAN CNC MAKİNALARDA KESİLEN PARÇALARIN HAREKET ETMEMESİNİ SAĞLAR, HASSAS BİR ÜST KESİM ELDE EDİLİR.

ELMAS KARBÜR FREZE BİÇAKLARI

Diamond Carbide Profile Router Cutters



KARBÜR POZİTİF FREZE Z-1

ÜRÜN KODU	ÇAP	KESİM BOYU	TAM BOY	Z1 AGIZ SAYISI
TTP1101	3	15	50	1
TTP1102	3	22	62	1
TTP1103	4	15	50	1
TTP1104	4	22	62	1
TTP1105	5	22	62	1
TTP1106	6	22	62	1
TTP1107	6	32	75	1
TTP1108	8	22	62	1
TTP1109	8	32	75	1
TTP1110	8	42	90	1
TTP1111	8	60	120	1
TTP1112	10	22	72	1
TTP1113	10	32	72	1
TTP1114	10	45	100	1
TTP1115	10	55	110	1
TTP1116	10	65	120	1
TTP1117	12	22	83	1
TTP1118	12	36	83	1
TTP1119	12	45	100	1
TTP1120	12	55	110	1
TTP1121	12	65	120	1
TTP1122	14	65	120	1
TTP1123	14	100	150	1
TTP1124	16	65	120	1
TTP1125	16	100	150	1
TTP1126	18	65	120	1
TTP1127	18	100	150	1
TTP1128	20	65	120	1
TTP1129	20	100	150	1

ELMAS KARBÜR FREZE BİÇAKLARI

Diamond Carbide Profile Router Cutters



KARBÜR ALÜ KOMPOZİT FREZE Z-1

ÜRÜN KODU	ÇAP	KESİM BOYU	TAM BOY	Z1 AGIZ SAYISI
TTA2001	1,5	6	50	1
TTA2002	2	8	50	1
TTA2003	3	15	50	1
TTA2004	3	22	50	1
TTA2005	4	15	50	1
TTA2006	4	22	50	1
TTA2007	5	22	50	1
TTA2008	6	22	57	1
TTA2009	6	32	63	1
TTA2010	8	22	63	1
TTA2011	8	32	63	1
TTA2012	8	42	75	1
TTA2013	8	60	100	1
TTA2014	10	22	72	1
TTA2015	10	32	72	1
TTA2016	10	45	90	1
TTA2017	10	55	100	1
TTA2018	10	65	110	1
TTA2019	12	22	75	1
TTA2020	12	36	83	1
TTA2021	12	45	100	1
TTA2022	12	55	110	1
TTA2023	12	65	120	1

ELMAS KARBÜR FREZE BİÇAKLARI

Diamond Carbide Profile Router Cutters



KARBÜR DÜZ KANAL FREZE Z-2

ÜRÜN KODU	ÇAP	KESİM BOYU	TAM BOY	Z2 AGIZ SAYISI
TTD2001	3	15	50	2
TTD2002	3	22	62	2
TTD2003	4	15	50	2
TTD2004	4	22	62	2
TTD2005	5	22	62	2
TTD2006	6	22	62	2
TTD2007	6	32	75	2
TTD2008	8	22	62	2
TTD2009	8	32	75	2
TTD2010	8	42	90	2
TTD2011	8	60	120	2
TTD2012	10	22	72	2
TTD2013	10	32	72	2
TTD2014	10	45	100	2
TTD2015	10	55	110	2
TTD2016	10	65	120	2
TTD2017	12	22	83	2
TTD2018	12	36	83	2
TTD2019	12	45	100	2
TTD2020	12	55	110	2
TTD2021	12	65	120	2
TTD2022	14	65	120	2
TTD2023	14	100	150	2
TTD2024	16	65	120	2
TTD2025	16	100	150	2
TTD2026	18	65	120	2
TTD2027	18	100	150	2
TTD2028	20	65	120	2
TTD2029	20	100	150	2

ELMAS KARBÜR FREZE BİÇAKLARI

KARBÜR POZİTİF NEGATİF FREZE Z-2+2

Diamond Carbide Profile Router Cutters



ÜRÜN KODU	SAP ÇAPI	KESİM BOYU	TOPLAM BOY	Z
TTPN2150	3	22	62	2+2
TTPN2151	4	22	62	2+2
TTPN2152	5	22	62	2+2
TTPN2153	6	22	62	2+2
TTPN2154	6	32	85	2+2
TTPN2155	8	22	85	2+2
TTPN2156	8	32	85	2+2
TTPN2157	8	42	100	2+2
TTPN2158	10	32	85	2+2
TTPN2159	10	45	95	2+2
TTPN2160	12	32	85	2+2
TTPN2161	12	45	95	2+2

NOT:LAM YÜZEYLER İÇİN POZİTİF ÜSTE ÇEKER, NEGATİF AŞAĞI İTER.
KESİM YAPARKEN TALAŞI ORTAYA BOĞAR. İKİ LAM YÜZEY TEMİZ VE KIRIKSIZ ÇIKAR. SERT AĞAÇ VE
LAMLI YÜZEYLER İÇİN KULLANILIR.

ELMAS KARBÜR FREZE BİÇAKLARI

Z3 ELMAS KARBÜR FREZE

Diamond Carbide Profile Router Cutters



ÜRÜN KODU	ÇAP	KESİM BOYU	TAM BOY	Z2 AGIZ	SAYISI
TTE2207	6	32	75	3	3
TTE2208	8	22	62	3	3
TTE2209	8	32	75	3	3
TTE2210	8	42	90	3	3
TTE2211	8	60	120	3	3
TTE2212	10	22	72	3	3
TTE2213	10	32	72	3	3
TTE2214	10	45	100	3	3
TTE2215	10	55	110	3	3
TTE2216	10	65	120	3	3
TTE2217	12	22	83	3	3
TTE2218	12	36	83	3	3
TTE2219	12	45	100	3	3
TTE2220	12	55	110	3	3
TTE2221	12	65	120	3	3
TTE2222	14	65	120	3	3
TTE2223	14	100	150	3	3
TTE2224	16	65	120	3	3
TTE2225	16	100	150	3	3
TTE2226	18	65	120	3	3
TTE2227	18	100	150	3	3
TTE2228	20	65	120	3	3
TTE2229	20	100	150	3	3

ELMAS KARBÜR FREZE BİÇAKLARI

Z2 ELMAS KARBÜR FREZE

Diamond Carbide Profile Router Cutters



ÜRÜN KODU	ÇAP	KESİM BOYU	TAM BOY	Z2 AGIZ SAYISI
TTD2501	3	15	50	2
TTD2502	3	22	62	2
TTD2503	4	15	50	2
TTD2504	4	22	62	2
TTD2505	5	22	62	2
TTD2506	6	22	62	2
TTD2507	6	32	75	2
TTD2508	8	22	62	2
TTD2509	8	32	75	2
TTD2510	8	42	90	2
TTD2511	8	60	120	2
TTD2512	10	22	72	2
TTD2513	10	32	72	2
TTD2514	10	45	100	2
TTD2515	10	55	110	2
TTD2516	10	65	120	2
TTD2517	12	22	83	2
TTD2518	12	36	83	2
TTD2519	12	45	100	2
TTD2520	12	55	110	2
TTD2521	12	65	120	2
TTD2522	14	65	120	2
TTD2523	14	100	150	2
TTD2524	16	65	120	2
TTD2525	16	100	150	2
TTD2526	18	65	120	2
TTD2527	18	100	150	2
TTD2528	20	65	120	2
TTD2529	20	100	150	2

ELMAS KARBÜR FREZE BİÇAKLARI

KABATALAŞ FREZE

Diamond Carbide Profile Router Cutters



ÜRÜN KODU	ÇAP	KESİM BOYU	TAM BOY	Z2 AGIZ SAYISI
TTD3007	6	32	75	2
TTD3008	8	22	62	2
TTD3009	8	32	75	2
TTD3010	8	42	90	2
TTD3011	8	60	120	2
TTD3012	10	22	72	2
TTD3013	10	32	72	2
TTD3014	10	45	100	2
TTD3015	10	55	110	2
TTD3016	10	65	120	2
TTD3017	12	22	83	2
TTD3018	12	36	83	2
TTD3019	12	45	100	2
TTD3020	12	55	110	2
TTD3021	12	65	120	2
TTD3022	14	65	120	2
TTD3023	14	100	150	2
TTD3024	16	65	120	2
TTD3025	16	100	150	2
TTD3026	18	65	120	2
TTD3027	18	100	150	2
TTD3028	20	65	120	2
TTD3029	20	100	150	2

ELMAS KARBÜR FREZE BİÇAKLARI

YAZI DESEN RESİM

Diamond Carbide Profile Router Cutters



ÜRÜN KODU	ÇAP	KESİM BOYU	TAM BOY	Z2 AGIZ SAYISI
TTYA3055	30	55	6	
TTYA3056	45	55	6	
TTYA3057	60	55	6	
TTYA3058	30	55	8	
TTYA3059	45	55	8	
TTYA3060	60	55	8	
TTYA3061	30	55	10	
TTYA3062	45	55	10	
TTYA3063	60	55	12	

ELMAS KARBÜR FREZE BİÇAKLARI

ÜÇ BOYUTLU İŞLEME KONİK KÜRE FREZE

Diamond Carbide Profile Router Cutters



ÜRÜN KODU	ÇAP	KESİM BOYU	TAM BOY	Z2 AGIZ SAYISI
TT3D3055	2	35	65	6
TT3D3056	3	35	65	6
TT3D3057	2	35	82	8
TT3D3058	3	35	100	8
TT3D3059	2	55	100	10
TT3D3060	3	55	100	10
TT3D3061	2	65	100	12
TT3D3062	3	65	100	12

ELMAS KARBÜR FREZE BİÇAKLARI

Z2 KÜRE ELMAS KARBÜR FREZE

Diamond Carbide Profile Router Cutters



ÜRÜN KODU	ÇAP	KESİM BOYU	TAM BOY	Z2 AGIZ SAYISI
TTK4001	6	32	75	2
TTK4002	8	22	62	2
TTK4003	8	32	75	2
TTK4004	8	42	90	2
TTK4005	8	60	120	2
TTK4006	10	22	72	2
TTK4007	10	32	72	2
TTK4008	10	45	100	2
TTK4009	10	55	110	2
TTK4010	10	65	120	2
TTK4011	12	22	83	2
TTK4012	12	36	83	2
TTK4013	12	45	100	2
TTK4014	12	55	110	2
TTK4015	12	65	120	2
TTK4016	14	65	120	2
TTK4017	14	100	150	2
TTK4018	16	65	120	2
TTK4019	16	100	150	2
TTK4020	18	65	120	2
TTK4021	18	100	150	2
TTK4022	20	65	120	2
TTK4023	20	100	150	2

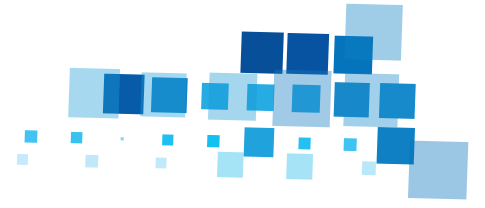

ELMAS KARBÜR FREZE BIÇAKLARI

Diamond Carbide Profile Router Cutters

PENS GRUBU



PENS GRUBU

ÜRÜN KODU	KESİM BOYU
TTER11	1 mm <> 7 mm
TTER16	3 mm <> 10 mm
TTER20	3 mm <> 13 mm
TTER25	3 mm <> 16 mm
TTER32	3 mm <> 20 mm
TTER40	3 mm <> 26 mm
DIN6388-462E	3 mm <> 25 mm

ELMAS KARBÜR FREZE BIÇAKLARI

Diamond Carbide Profile Router Cutters

IMS-ITALY TUTUCU FİYAT LİSTESİ



POS. KOD ÖLÇÜ FİYAT EURO

1	WF208	HSK 63 -F ER 32
2	WF224	HSK 63 -F ER 40
3	W503	ISO 30 - ER 32
4	W524	ISO 30 - ER 40
5	W408	ISO 30 - ER 32 MORBİDELLİ
6	W424	ISO 30 - ER 40 MORBİDELLİ

ETP/İSVEÇ HİDRO TUTUCU FİYAT LİSTESİ

1	G31	ETP HYDRO-GRIP G3-12/HSK63F
2	G32	ETP HYDRO-GRIP G3-20/HSK63F
3	G21	ETP HYDRO-GRIP G2-12/HSK63F
4	G22	ETP HYDRO-GRIP G2-20/HSK63F

MATKAP TUTUCU

1	A434.218.110.00	42X18X10 VİTAP
2	A434.220.110.00	42X19,25X10 MORBİDELLİ YENİ
3	A434.219.110.00	40X20X10 MAGGI
4	A434.320.042.51	45X20X10 M10 MORBİDELLİ - LH
5	A434.320.142.51	45X20X10 M10 MORBİDELLİ - RH

FREZİTE/IMS TAKIM TUTUCU SÖKME APARATI

POS. KOD ÖLÇÜ FİYAT EURO

1	A431.300.049.00	ISO 30 49 100x160 - FREZİTE
2	A431.300.050.00	SK30 50 100x160 - FREZİTE
3	A431.300.053.00	BT35 53 100x160 - FREZİTE
4	A431.300.063.00	SK40 / HSK63F 63 100x160 - FREZİTE
5	D-50 VE330	ISO30 SK30 - HSK50 - CAPTO5 - IMS
6	D-63 VE340 ISO 40	SK40-BT40-HSK63-KM63-CAPTO6-IM

PART NO: 01 MENTEŞE VE KİLİT YERİ MATKABI / HINGE BORING BIT

KOD	S (mm)	D (mm)
TTMK2101	10	15
TTMK2102	10	18
TTMK2103	10	19
TTMK2104	10	20
TTMK2105	10	22
TTMK2106	10	25
TTMK2107	10	26
TTMK2108	10	28
TTMK2109	10	30
TTMK2110	10	33
TTMK2111	10	35
TTMK2112	12	40
TTMK2113	12	45
TTMK2114	12	50
TTMK2115	12	54
TTMK2116	12	55
TTMK2117	12	60
TTMK2118	12	65
TTMK2119	12	70
TTMK2120	12	75
TTMK2121	12	80
TTMK2122	12	90
TTMK2123	12	100



PART NO: 02 CAM YERİ BIÇAĞI / "T" TYPE BIT WITH BEARING

KOD	S (mm)	D (mm)	H (mm)	B(mm)	Z
TTMK2201	12	33	3	10,50	2
TTMK2202	12	33	3	10,50	3
TTMK2203	12	33	4	10,50	2
TTMK2204	12	33	4	10,50	3
TTMK2205	12	33	5	10,50	2
TTMK2206	12	33	5	10,50	3
TTMK2207	12	33	6	10,50	2
TTMK2208	12	33	6	10,50	3
TTMK2209	12	33	8	10,50	3
TTMK2210	12	33	10	10,50	3

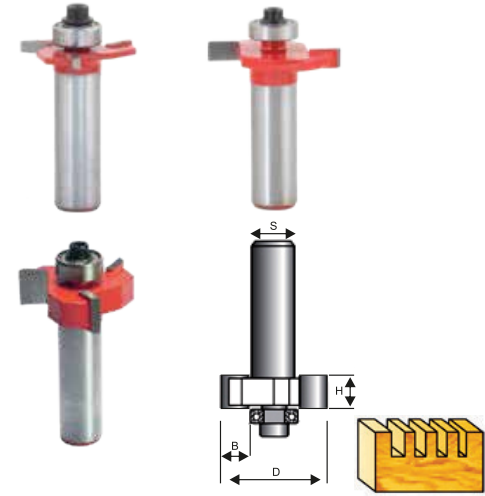

PART NO: 03 LAMBA BIÇAĞI / RABBETING BIT

KOD	S (mm)	D (mm)	H (mm)	B(mm)	Z
TTMK2301	12	33	12	10,50	3
TTMK2302	12	33	14	10,50	3
TTMK2303	12	33	16	10,50	3
TTMK2304	12	33	18	10,50	3
TTMK2305	12	33	20	10,50	3
TTMK2306	12	35	25	10,50	2
TTMK2307	12	35	25	10,50	3
TTMK2308	12	39	25	13	3
TTMK2309	12	35	30	10,50	3

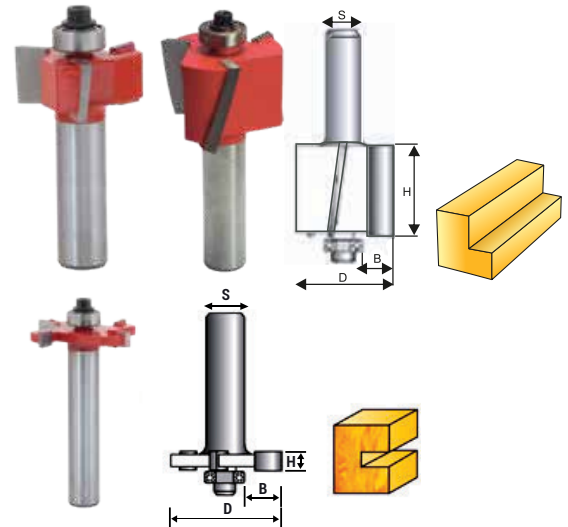

PART NO: 04 CAM YERİ BIÇAĞI (16mm DALMALI) / "T" TYPE BIT WITH BEARING AND Z4

KOD	S (mm)	D (mm)	H (mm)	B(mm)	Z
TTMK2401	12	46	6	16	4

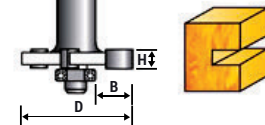

PART NO: 05 HAVŞA BIÇAĞI / T.C.T ADJUSTABLE COUNTERSINK BIT

KOD	S (mm)	d (mm)	D (mm)	H (mm)
TTMK2501	10	3	10	10
TTMK2502	10	3	8	10
TTMK2503	10	3,50	10	10
TTMK2504	10	4	10	10
TTMK2505	10	5	10	10

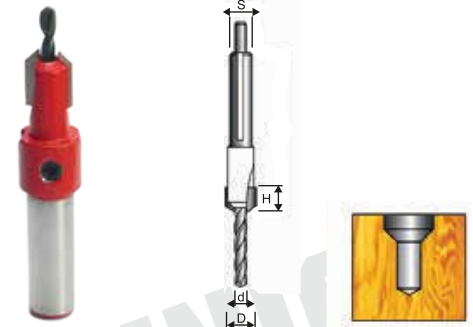

PART NO: 06 BALIK SIRTI RADÜS BIÇAĞI / CORNER ROUND BIT

KOD	S (mm)	D (mm)	R (mm)
TTMK2601	12	18,70	3
TTMK2602	12	22,70	5
TTMK2603	12	25,20	6
TTMK2604	12	28,70	8
TTMK2605	12	32,50	10
TTMK2606	12	36,70	12
TTMK2607	12	42,70	15
TTMK2608	12	52,40	20
TTMK2609	12	62,40	25
TTMK2610	12	72,70	30

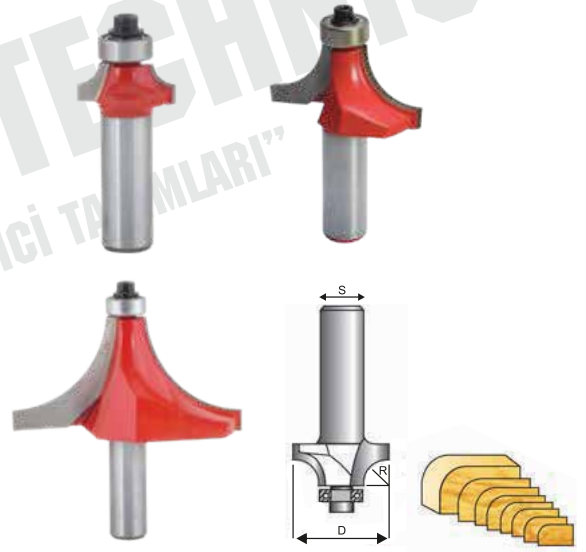

PART NO: 07 KANAL AÇMA BIÇAĞI TEK AĞIZLI / ONE FLUTE STRAIGHT BIT

KOD	S (mm)	D (mm)	H (mm)
TTMK2701	6	3	10
TTMK2702	6	4	15
TTMK2703	6	5	15

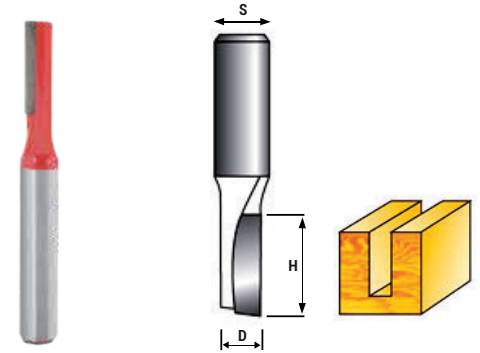

PART NO: 08 KANAL AÇMA BIÇAĞI-TEPE ELMASI AYRI / STRAIGHT BIT

KOD	S (mm)	D (mm)	H (mm)
TTMK2801	6	6	20
TTMK2802	6	8	25
TTMK2803	6	10	25
TTMK2804	8	8	25
TTMK2805	8	10	25
TTMK2806	12	8	20
TTMK2807	12	10	25
TTMK2808	12	12	25
TTMK2809	12	12	40
TTMK2810	12	24	24

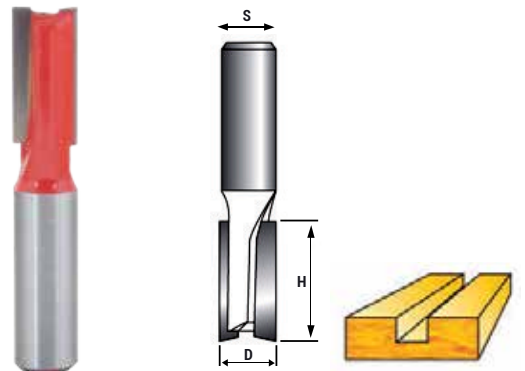

PART NO: 09 KANAL AÇMA BIÇAĞI-TEPE ELMASI BİRLEŞİK
CLEANING BOTTOM BIT

KOD	S (mm)	D (mm)	H (mm)
TTMK2901	6	6	25
TTMK2902	12	6	25
TTMK2903	12	8	25
TTMK2904	12	9	25
TTMK2905	12	10	25
TTMK2906	12	12	25
TTMK2907	12	14	25
TTMK2908	12	16	25
TTMK2909	12	18	25
TTMK2910	12	20	25
TTMK2911	12	25	30
TTMK2912	12	30	30
TTMK2913	12	35	30

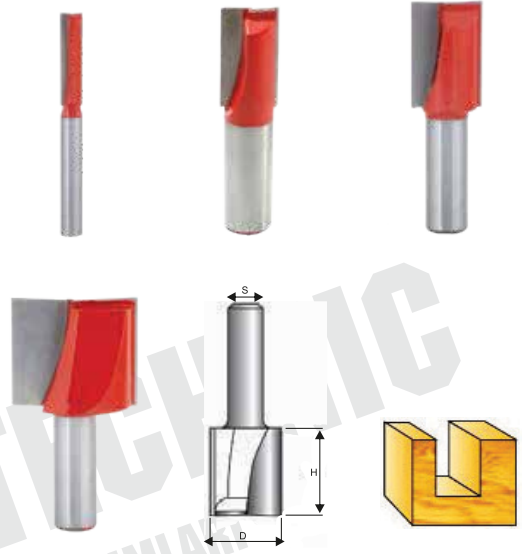

PART NO: 10 TEMİZLEME BIÇAĞI / FLUSH TRIM BIT

KOD	S (mm)	D (mm)	H (mm)	Z
TTMK3001	6	6	30	2
TTMK3002	6	10	50	2
TTMK3003	8	8	30	2
TTMK3004	8	13	30	2
TTMK3005	10	13	30	2
TTMK3006	12	8	30	2
TTMK3007	12	13	30	2
TTMK3008	12	13	30	3
TTMK3009	12	13	50	2

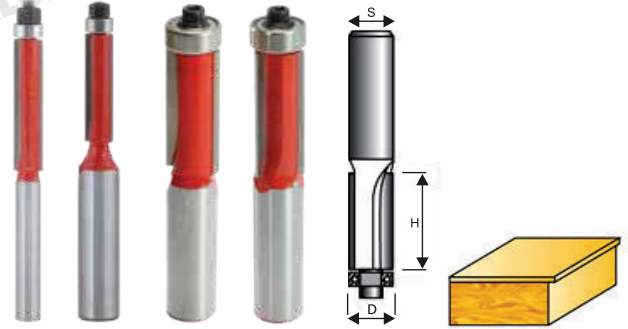

PART NO: 11 ALTTAN RULMANLI TEMİZLEME BIÇAĞI / PATTERN BIT

KOD	S (mm)	D (mm)	H (mm)
TTMK3101	6	13	25

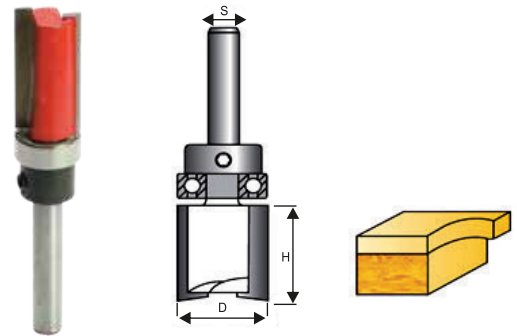

PART NO: 12 PVC TEMİZLEME BIÇAĞI
CORNER ROUND BIT WITH TWO BEARING

KOD	S (mm)	D (mm)	R (mm)
TTMK3201	6	16,70	2
TTMK3202	6	18,80	3
TTMK3203	6	20,70	4
TTMK3204	6	22,60	5

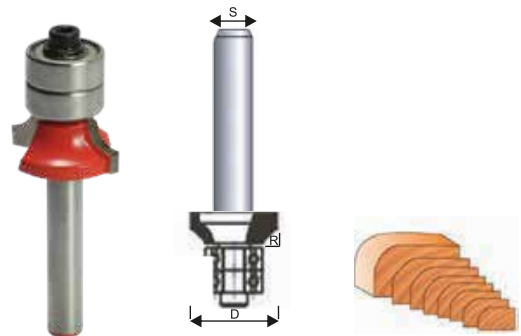

PART NO: 13 STAND KANAL YERİ AÇMA BIÇAĞI / BEVEL SLOTTING BIT

KOD	S (mm)	D (mm)	H (mm)
TTMK3301	12	28	17
TTMK3302	12	30	17
TTMK3303	12	32	17

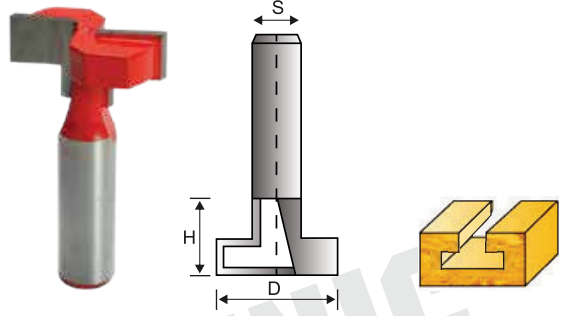

PART NO: 14 "U" DERZ BIÇAĞI / COVE BOX BIT

KOD	S (mm)	D (mm)	H (mm)
TTMK3401	12	6	6
TTMK3402	12	8	7
TTMK3403	12	10	8
TTMK3404	12	15	10
TTMK3405	12	20	15
TTMK3406	12	25	16
TTMK3407	12	30	19
TTMK3408	12	40	24
TTMK3409	12	50	29

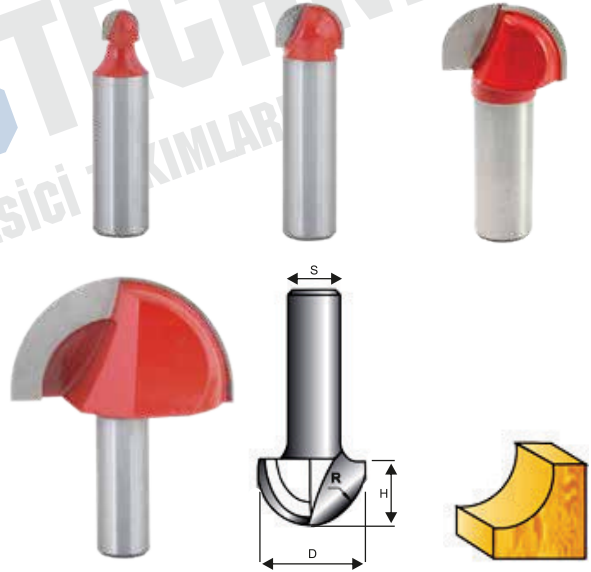

PART NO: 15 TERS BALIK SIRTI BIÇAĞI / COVE BIT WITH BEARING

KOD	S (mm)	D (mm)	H (mm)
TTMK3501	12	30	14

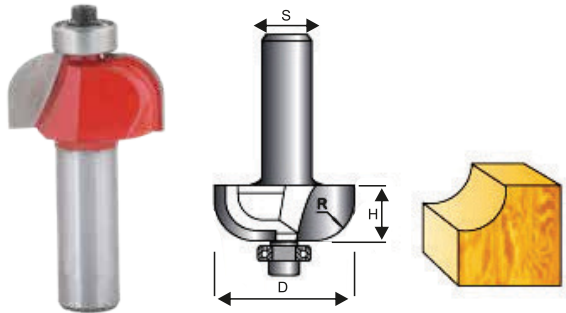

PART NO: 16 "S" MOTİF BIÇAĞI / CURVED LINE BIT

KOD	S (mm)	D (mm)	H (mm)
TTMK3601	12	35	19

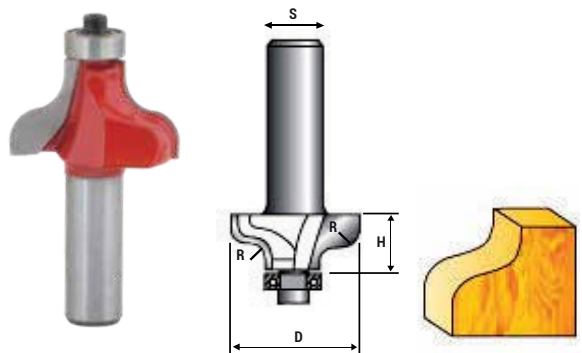

PART NO: 17 45° PAH BIÇAĞI / 45° CHAMFER BIT

KOD	S (mm)	D (mm)	H (mm)
TTMB3701	12	30	9
TTMB3702	12	45	17
TTMB3703	12	53	22

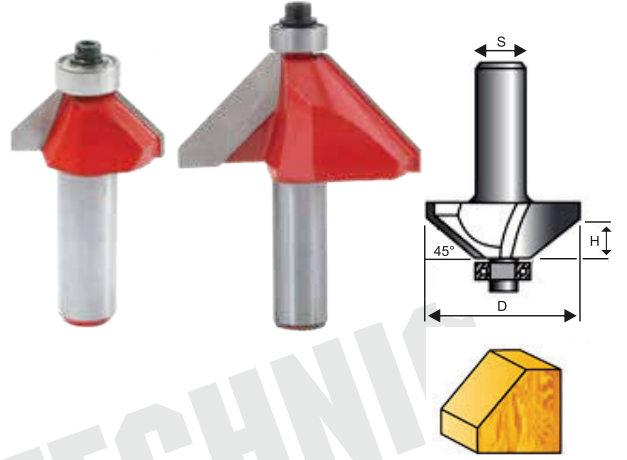

PART NO: 18 45° "V" KANAL AÇMA BIÇAĞI / 45° "V" GROOVING BIT

KOD	S (mm)	D (mm)	H (mm)
TTMB3801	6	15	7,50
TTMB3802	12	25	13
TTMB3803	12	32	16
TTMB3804	12	40	20

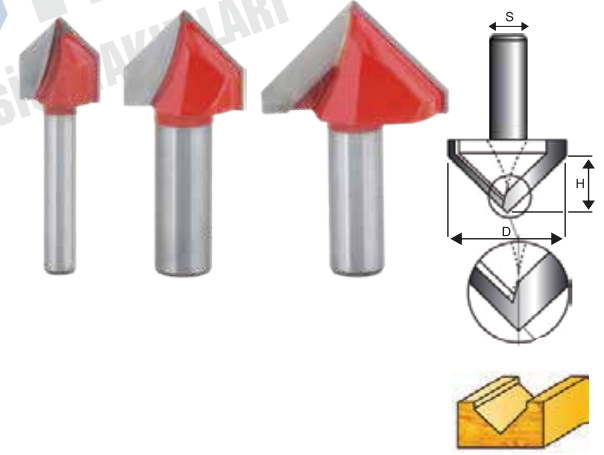

PART NO: 19 60° "V" KANAL AÇMA BIÇAĞI / 60° "V" GROOVING BIT

KOD	S (mm)	D (mm)	H (mm)
TTMB3901	12	16	14

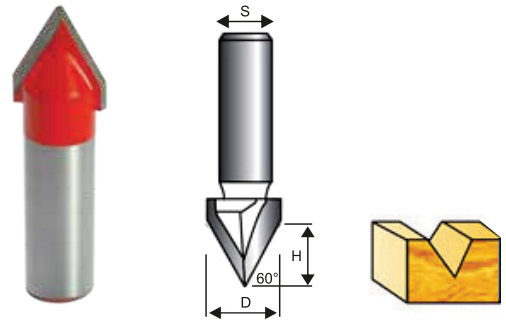

PART NO: 20 KULP BIÇAĞI / FINGER GRIP BIT

KOD	S (mm)	D (mm)	H (mm)	Z
TTMB4001	12	45	25	2

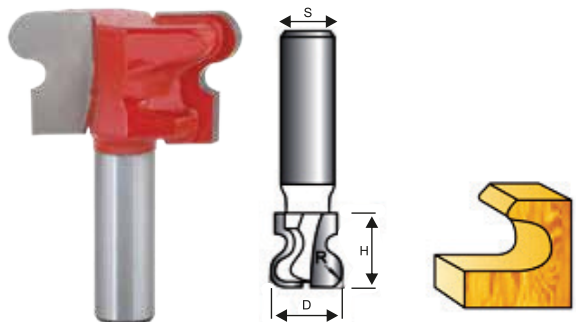

PART NO: 21 EKLEME BİÇAĞI / JOINT BIT

KOD	S (mm)	D (mm)	H (mm)	B (mm)
TTMB4101	12	35	38	8

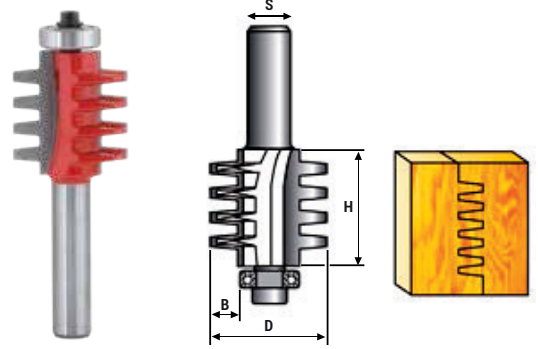

PART NO: 22 KUTU BİRLEŞTİRME BİÇAĞI / 45° LOCK MITER BIT

KOD	S (mm)	D (mm)	H (mm)
TTMB4201	12	38	17

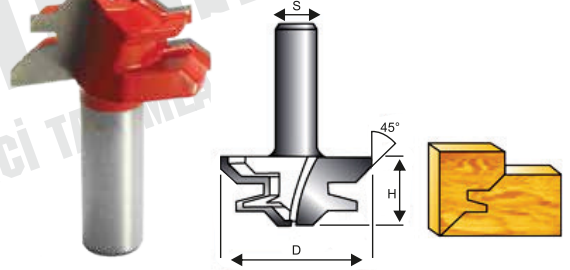

PART NO: 23 MOTİF BİÇAĞI / OPEN END CARVING BIT

KOD	S (mm)	D (mm)	H (mm)
TTMB4301	12	25	7,50
TTMB4302	12	40	10,50

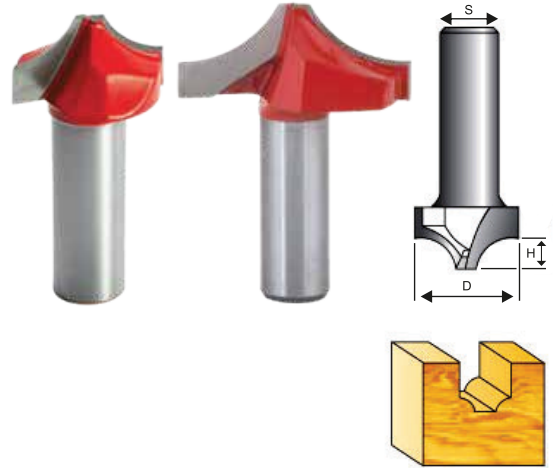

PART NO: 24 MOTİF BİÇAĞI / VARIOUS SHAPE BIT

KOD	S (mm)	D (mm)	H (mm)
TTMB4401	12	40	8

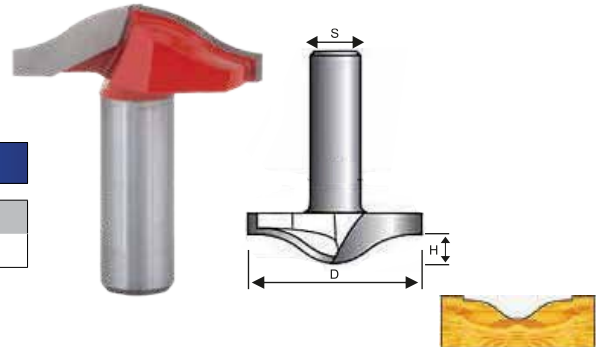

PART NO: 25 MOTİF BIÇAĞI / RAISED PANEL PLUNGE BIT

KOD	S (mm)	D (mm)	H (mm)
TTMB4501	12	40	8

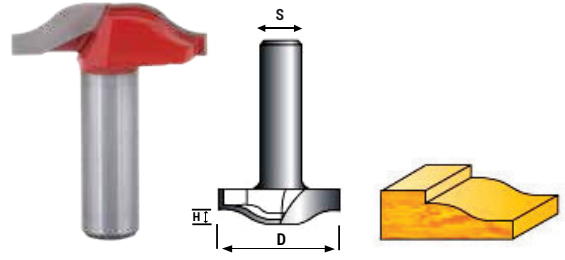

PART NO: 26 MOTİF BIÇAĞI / CARVING BIT

KOD	S (mm)	D (mm)	H (mm)
TTMB4601	12	12,70	4
TTMB4602	12	20	6,50
TTMB4603	12	25	9,50
TTMB4604	12	32	12,50

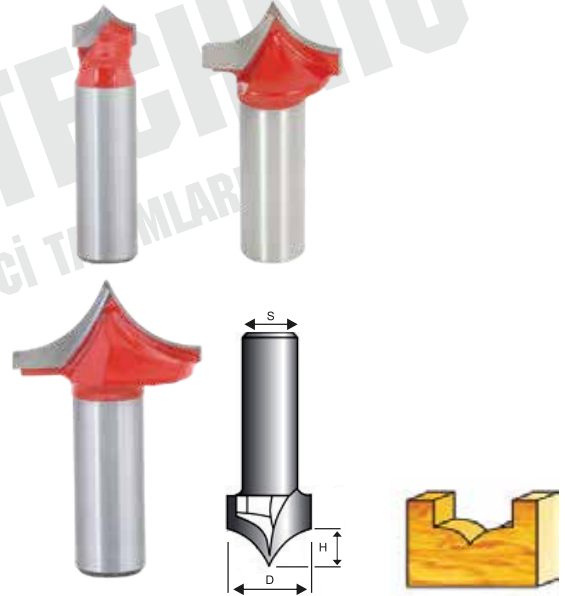

PART NO: 27 MOTİF BIÇAĞI / CLASSICAL MOUNDLING BIT WITHOUT BEARING

KOD	S (mm)	D (mm)	H (mm)
TTMB4701	12	33,60	15

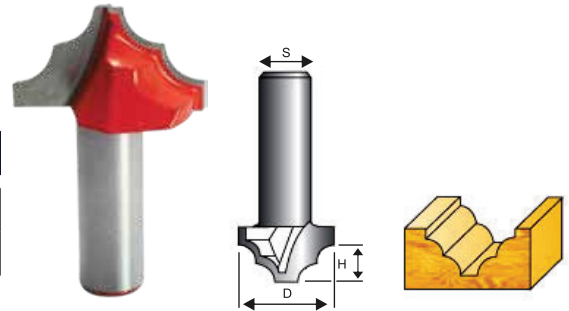

PART NO: 28 MOTİF BIÇAĞI / CLASSICAL PLUNGE BIT

KOD	S (mm)	D (mm)	H (mm)
TTMB4801	12	40	6

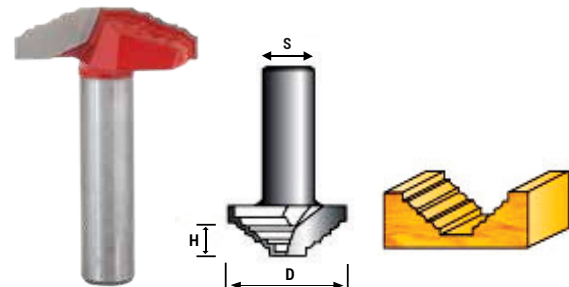

PART NO: 29 MOTİF BIÇAĞI / CLASSICAL PLUNGE BIT

KOD	S (mm)	D (mm)	H (mm)
TTMB4901	12	40	6

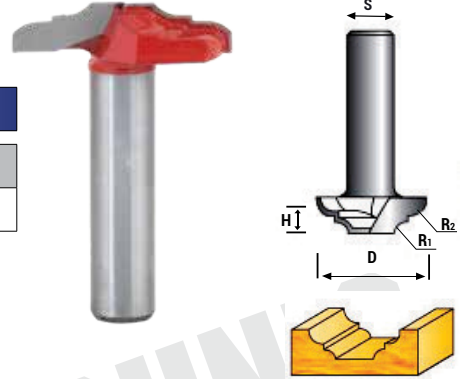

PART NO: 30 MOTİF BIÇAĞI / RAISED PANEL BIT

KOD	S (mm)	D (mm)	H (mm)
TTMB5001	12	40	7

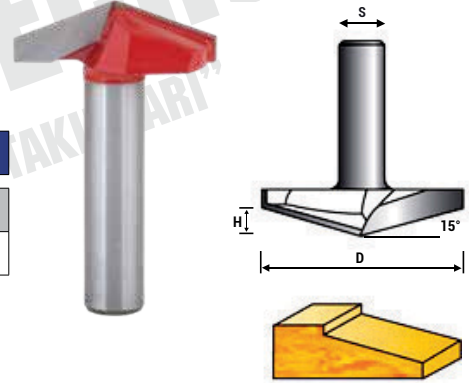

PART NO: 31 MOTİF BIÇAĞI / CLASSICAL PLUNGE BIT

KOD	S (mm)	D (mm)	H (mm)
TTMB5101	12	40	6

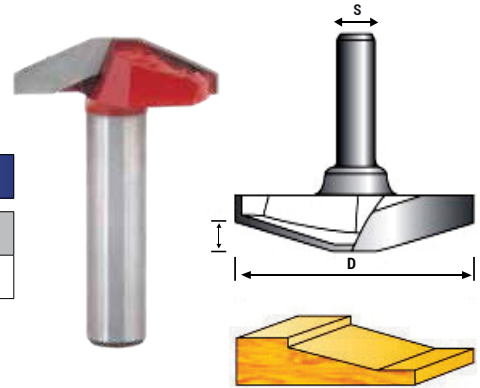

PART NO: 32 MOTİF BIÇAĞI / CLASSICAL PLUNGE BIT

KOD	S (mm)	D (mm)	H (mm)
TTMB5201	12	40	6

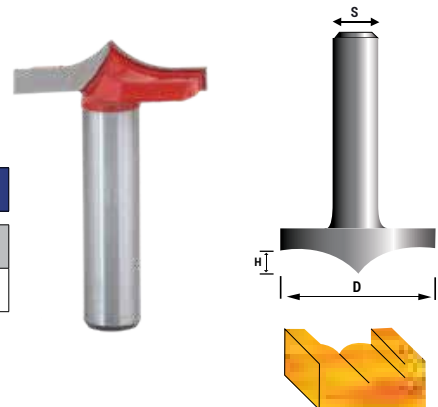

PART NO: 33 MOTİF BİÇAĞI / RAISED PANEL PLUNGE BIT

KOD	S (mm)	D (mm)	H (mm)
TTMB5301	12	40	6

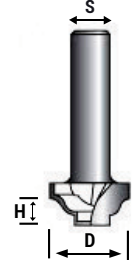

PART NO: 34 MOTİF BİÇAĞI / RAISED PANEL PLUNGE BIT

KOD	S (mm)	D (mm)	H (mm)
TTMB5401	12	35	5

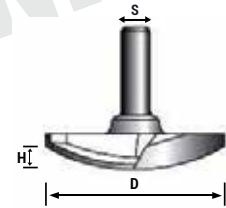

PART NO: 35 MOTİF BİÇAĞI / RAISED PANEL PLUNGE BIT

KOD	S (mm)	D (mm)	H (mm)
TTMB5501	12	45	7

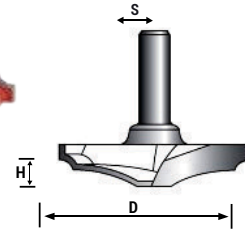

PART NO: 36 R3 EBATLAMA BİÇAĞI / PLUNGING ROUND-OVER BIT

KOD	S (mm)	D (mm)	H (mm)
TTMB5601	12	22	19



PART NO: 37 ÇOKLU DELİK MATKABI-YARIM DELİK / T.C.T. BITS FOR MULTIPLE DRILLING MACHINES

KOD	S (mm)	D (mm)	H (mm)
TTMB570101	10	4	57,50
TTMB570201	10	5	57,50
TTMB570301	10	6	57,50
TTMB570401	10	7	57,50
TTMB570501	10	8	57,50
TTMB570601	10	9	57,50
TTMB570701	10	10	57,50

TTMB570102	10	4	70
TTMB570202	10	5	70
TTMB570302	10	6	70
TTMB570402	10	7	70
TTMB570502	10	8	70
TTMB570602	10	9	70
TTMB570702	10	10	70

PART NO: 39 ÇOKLU DELİK MENTEŞE MATKABI T.C.T. DRILL BITS FOR HINGES

KOD	S (mm)	D (mm)	H (mm)
TTMB590101	10	15	57,50
TTMB590201	10	20	57,50
TTMB590301	10	25	57,50
TTMB590401	10	35	57,50

TTMB590102	10	15	70
TTMB590202	10	20	70
TTMB590302	10	25	70
TTMB590402	10	35	70

PART NO: 38 ÇOKLU DELİK MATKABI-TAM DELİK T.C.T. BITS FOR MULTIPLE DRILLING MACHINES

KOD	S (mm)	D (mm)	H (mm)
TTMB580101	10	4	57,50
TTMB580201	10	5	57,50
TTMB580301	10	6	57,50
TTMB580401	10	7	57,50
TTMB580501	10	8	57,50
TTMB580601	10	9	57,50
TTMB580701	10	10	57,50

TTMB580102	10	4	70
TTMB580202	10	5	70
TTMB580302	10	6	70
TTMB580402	10	7	70
TTMB580502	10	8	70
TTMB580602	10	9	70
TTMB580702	10	10	70

PART NO: 40 ÇOKLU DELİK MATKABI İÇİN HAVŞA T.C.T. COUNTER SINK

KOD	d (mm)	D (mm)
TTM6001	4	16
TTM6002	5	16
TTM6003	6	16
TTM6004	7	16
TTM6005	8	18
TTM6006	9	20
TTM6007	10	20
TTM6008	12	20

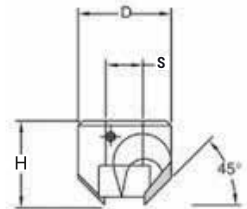
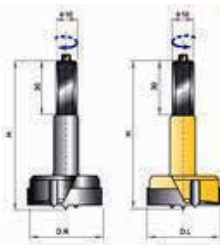
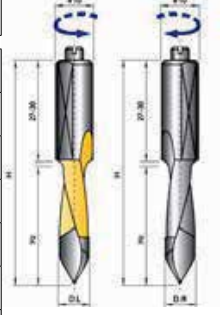
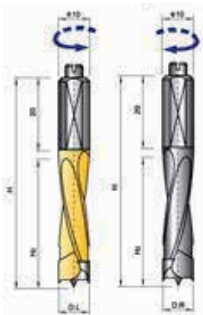

PART NO: 54 PLANYA BIÇAĞI CRV / PLANER KNİFE CRV

KOD	L (mm)	W (mm)	T (mm)
TTMB7401	300	35	3
TTMB7402	400	35	3
TTMB7403	500	35	3
TTMB7404	600	35	3

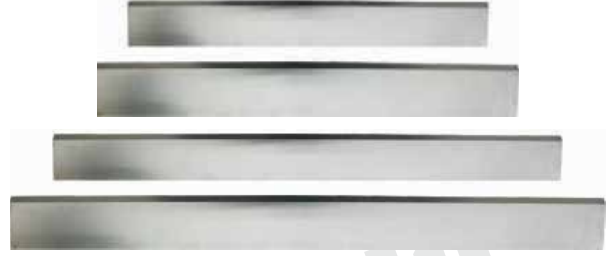

PART NO: 55 PLANYA BIÇAĞI %18 HSS / PLANER KNİFE %18 HSS

KOD	L (mm)	W (mm)	T (mm)
TTMB7501	300	35	3
TTMB7502	400	35	3
TTMB7503	500	35	3
TTMB7504	600	35	3

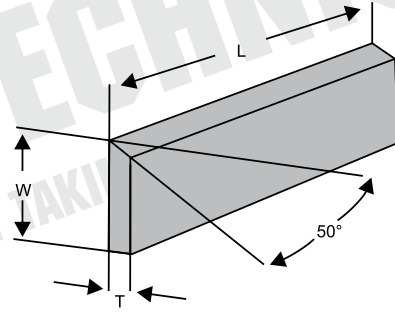

PART NO: 56 PLANYA BIÇAĞI TAKMA APARATI

KOD	ÖZELLİK (SPECIALITY)	AÇIKLAMA (EXPLAIN)
TTMB7601	MIKNATISLI	ÇİFT



PART NO: 57 EL PLANYA BIÇAĞI / HAND PLANER KNİFE

KOD	L (mm)	W (mm)	T (mm)
TTMB7701	82	5,50	1,10
TTMB7702	82	29	3
TTMB7703	82	29	3

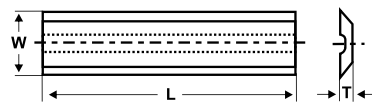
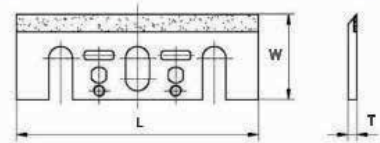

PART NO: 58 ALÜMİNYUM FREZE TOPU VE RULMANI
CUTTER HEAD FOR RABBETS AND BEARING

KOD	d (mm)	D (mm)	H (mm)	Z
TTMB7801	30	85	50	4
TTMB7802	30	85	50	4
TTMB7803	30	85	60	4
TTMB7804	30	85	60	4
TTMB7805	30	85	100	4
TTMB7806	30	85	-	-



PART NO: 59 RULMAN VE ADAPTÖR / BEARING AND SHAFT SLEEVE

KOD	d(mm)	D (mm)
TTMB7901	4	13
TTMB7902	5	13
TTMB7903	5	16
TTMB7904	6	8
TTMB7905	6	12
TTMB7906	8	12
TTMB7907	10	12
TTMB7908	12	14



PART NO: 60 KAPI KİLİT YERİ MATKABI

KOD	Matkap Kalınlığı (mm)	Kilit Yeri (mm)
DRB8001	17	23



PART NO: 61 BUDAK ÇIKARTMA MATKABI / PLUG CUTTERS BIT

KOD	Ölçü (DIMENSION) (mm)
DRB8101	8
DRB8102	10
DRB8103	12
DRB8104	15
DRB8105	20
DRB8106	25
DRB8107	30
DRB8108	35
DRB8109	40



PART NO: 62 Bİ METAL PANÇ / BI METAL HOLE SAW

KOD	ÇAP (DIAMETER) (mm)
TTMB8201	14
TTMB8202	16
TTMB8203	17
TTMB8204	19
TTMB8205	20
TTMB8206	21
TTMB8207	22
TTMB8208	24
TTMB8209	25
TTMB8210	27
TTMB8211	28
TTMB8212	29
TTMB8213	30
TTMB8214	32
TTMB8215	35
TTMB8216	38
TTMB8217	40
TTMB8218	41
TTMB8219	44
TTMB8220	46
TTMB8221	48
TTMB8222	51
TTMB8223	52
TTMB8224	54
TTMB8225	57
TTMB8226	60
TTMB8227	65
TTMB8228	68
TTMB8229	70
TTMB8230	73
TTMB8231	76
TTMB8232	79
TTMB8233	83
TTMB8234	86
TTMB8235	89
TTMB8236	92
TTMB8237	95
TTMB8238	98
TTMB8239	102
TTMB8240	105
TTMB8241	108
TTMB8242	111
TTMB8243	114
TTMB8244	121
TTMB8245	127
TTMB8246	133
TTMB8247	140
TTMB8248	146
TTMB8249	152
TTMB8250	160
TTMB8251	165
TTMB8252	168
TTMB8253	178
TTMB8254	200
TTMB8255	210



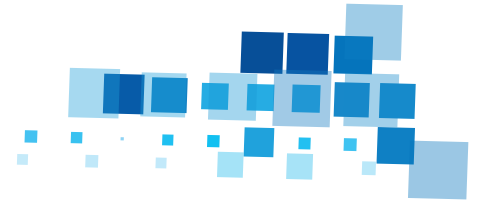

PART NO: 63 ELMAS PANÇ / DIAMOND HOLE SAW

KOD	ÇAP (DIAMETER) (mm)	FİYAT (PRICE)
TTMB8301	54	32,00 \$
TTMB8302	55	33,00 \$
TTMB8303	60	37,00 \$
TTMB8304	62	40,00 \$
TTMB8305	65	42,00 \$
TTMB8306	70	44,00 \$
TTMB8307	130	78,00 \$
TTMB8308	140	82,00 \$

PART NO: 64 PANÇ ADAPTÖRÜ / PUNCH ADAPTER

KOD	ÖLÇÜ (DIMENSION)	FİYAT (PRICE)
TTMB8401	14-30	4,50 \$
TTMB8402	14-30 (SDS)	5,50 \$
TTMB8403	32-210	7,50 \$
TTMB8404	32-210 (SDS)	9,50 \$



PART NO: 66 PVC BANTLAMA MAKİNALARININ BIÇAKLARI

KOD	AÇIKLAMA (EXPLAIN)
DRB6601	ÖZ KONYALI, KLK, GÜMÜŞ, HASDEM, AYZA MIZRAK
DRB6602	MIZRAK, ÖZ BAŞKENT
DRB6603	ÖZ ANADOLU
DRB6604	ANADOLU

PART NO: 67 KAPI KİLİT MAKİNALARININ BIÇAKLARI

KOD	AÇIKLAMA (EXPLAIN)
DRB6701	KOL YERİ BIÇAĞI
DRB6702	KİLİT YERİ BIÇAĞI
DRB6703	AYNA YERİ BIÇAĞI

PART NO: 68 ÖZEL PROFİL, KAZIMA VE BANTLAMA MAKİNASI JİLETLERİ

KOD	AÇIKLAMA
039045	16*14*2*4 R3 - SCM GRUP KAZIMA
037922	12,70*12,70*3,20 R3
033311	20*16*2*3 R3 - TURANLAR PVC SAĞ
033315	20*16*2*3 R3 - TURANLAR PVC SOL
016511	16*17,50*2*4,40 R3
016511	16*17,50*2*4,40 R2
035041	12,70*12,70*3,20 R2 - HOLZER/BRANT/SCM
032984	20*12*2*4 R1 - HOLZER/BRANT/SCM
016419	20*12*2*4 R2 - HOLZER/BRANT/SCM
020990	12*13*2 D:4 R2 - BRANT
033963	19,60*15,20*2 D:4 R2 SAĞ - BRANT
033966	19,60*15,20*2 D:4 R2 SOL - BRANT
X1617L5	16*17*5 KAZIMA JİLETİ SAĞ
X1617M5	16*17*5 KAZIMA JİLETİ SOL
1411R3R	14*11*2 R3 KAZIMA JİLETİ SAĞ
1411R3L	14*11*2 R3 KAZIMA JİLETİ SOL
032297	16*22*5 R3 KELEBEK JİLET
013278	34*16*3 3MM KANAL JİLET
013271	22*19*2 30° PANTOGRAF JİLETİ

PART NO: 69 PVC KENAR BANTLAMA MAKİNALARI BAŞ SON KESME TESTERELERİ

KOD	D (mm)	B (mm)	d (mm)	Z
DRB6901	80	3,20	20V	20
DRB6902	90	3,20	24	20
DRB6903	100	3,20	20	30
DRB6904	100	3,20	30	30
DRB6905	100	2,80	32	30

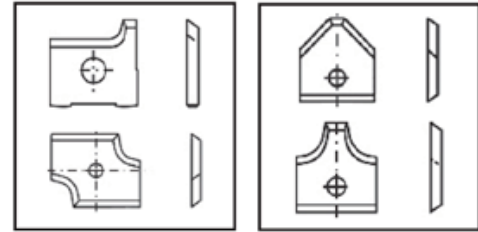

BU GRUP İÇİN LÜTFEN FİYAT SORUNUZ.

PART NO: 78 SERT METAL PLAKETLİ KENAR TEMİZLEME FREZE BİÇAĞI / REBATING CUTTERS BLOCK T.C.T.

KOD	D (mm)	b (mm)	d (mm)	Z
TTS7801	85	40	30	4
TTS7802	85	45	30	4
TTS7803	85	50	30	4
TTS7804	85	55	30	4
TTS7805	85	60	30	4
TTS7806	85	65	30	4



PART NO: 79 SERT METAL PLAKETLİ YARIM DAİRE BİÇAĞI / HALF ROUND PROFILE CUTTERS BLOCK T.C.T.

KOD	D (mm)	b (mm)	r1 (mm)	d (mm)	Z
TTS7901	120	24	5	30	3
TTS7902	120	26	6	30	3
TTS7903	120	30	8	30	3
TTS7904	120	34	10	30	3
TTS7905	120	39	12,50	30	3
TTS7906	120	44	15	30	3
TTS7907	120	49	17,50	30	3
TTS7908	120	54	20	30	3

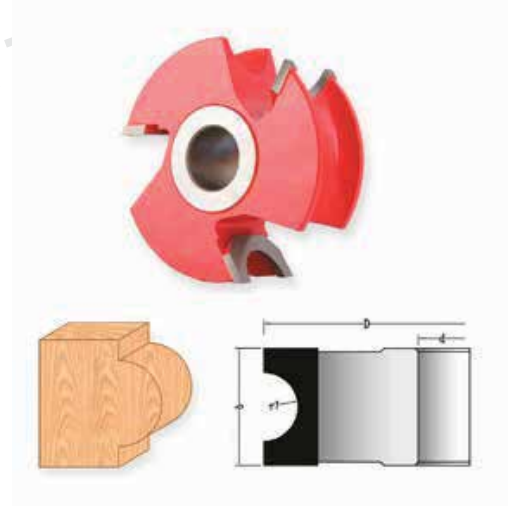

PART NO: 80 SERT METAL PLAKETLİ 1/4 DAİRE KENAR YUVARLAMA FREZE BİÇAĞI / 1/4 RADIUS PROFILE CUTTERS BLOCK T.C.T.

KOD	D (mm)	b (mm)	r1 (mm)	d (mm)	Z
TTS8001	90	13	5	30	3
TTS8002	92	14	6	30	3
TTS8003	96	16	8	30	3
TTS8004	100	18	10	30	3
TTS8005	105	20,50	12,50	30	3
TTS8006	110	23	15	30	3
TTS8007	120	28	20	30	3
TTS8008	130	33	25	30	3
TTS8009	140	38	30	30	3
TTS8010	150	45	35	30	3
TTS8011	160	50	40	30	3
TTS8012	170	55	45	30	3
TTS8013	180	60	50	30	3

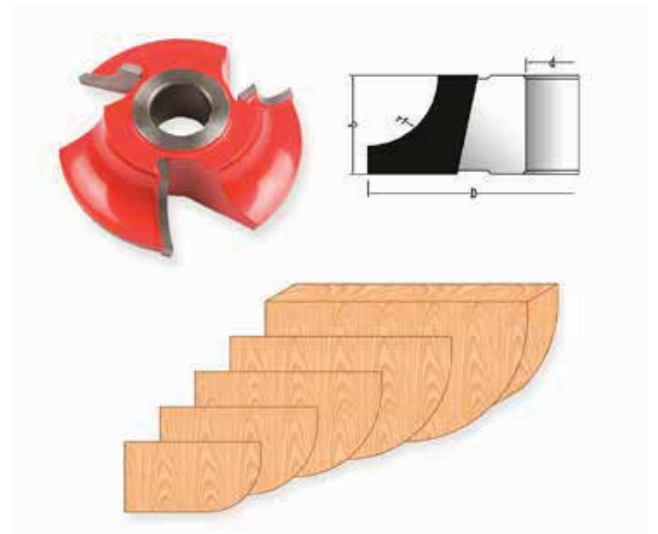

PART NO: 81 SERT METAL PLAKETLİ RUSTİK ÇERÇEVE BİRLEŞTİRME FREZE BIÇAK GRUBU / TONGUE AND GROOVE CUTTER SET T.C.T.

KOD	D (mm)	b (mm)	r1 (mm)	d (mm)	Z
TTS8101	109	13	7	30	4
TTS8102	109	5	-	30	4
TTS8103	85	7	-	30	4

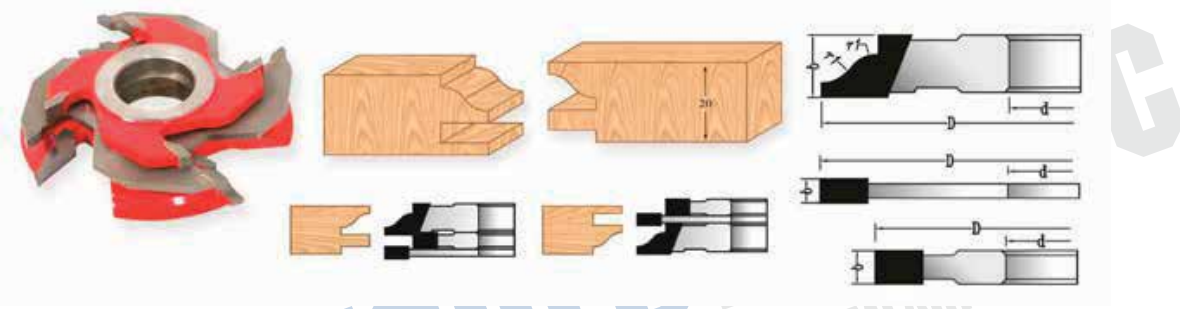

PART NO: 82 SERT METAL PLAKETLİ RUSTİK ÇERÇEVE BİRLEŞTİRME FREZE BIÇAK GRUBU / TONGUE AND GROOVE CUTTER SET T.C.T.

KOD	D (mm)	b (mm)	r1 (mm)	d (mm)	Z
TTS8201	109	13	27	30	4
TTS8202	109	5	-	30	4
TTS8203	85	7	-	30	4

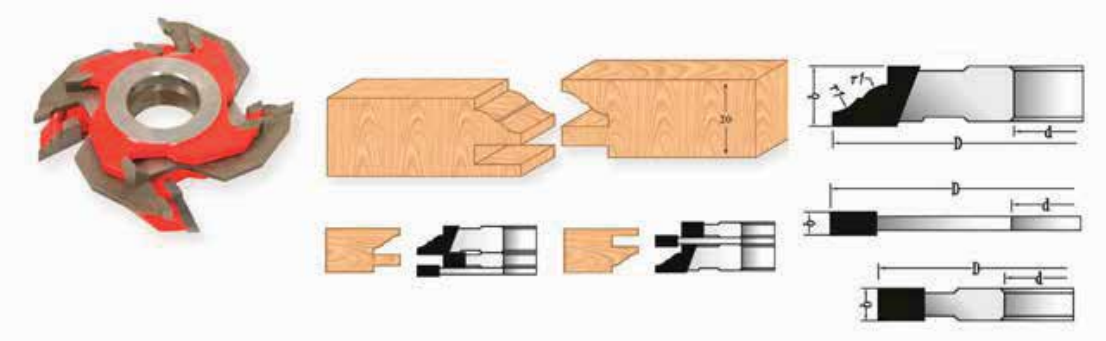

PART NO: 83 SERT METAL PLAKETLİ RUSTİK KAPI PROFİL FREZE BIÇAK GRUBU / TONGUE AND GROOVE CUTTER SET FOR THE DOORS T.C.T.

KOD	D (mm)	b (mm)	a°	d (mm)	Z
TTS8301	150	18	25	30	4
TTS8302	160	12	-	30	4
TTS8303	110	13	-	30	4
TTS8304	150	18	25	30	4

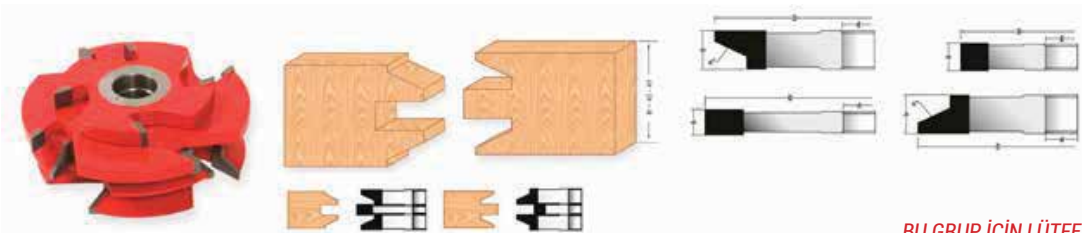

BU GRUP İÇİN LÜTFEN FİYAT SORUNUZ.

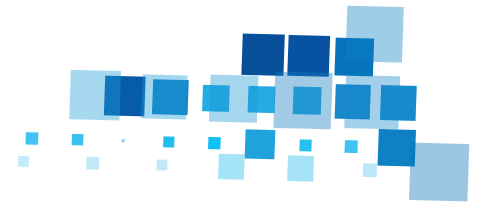
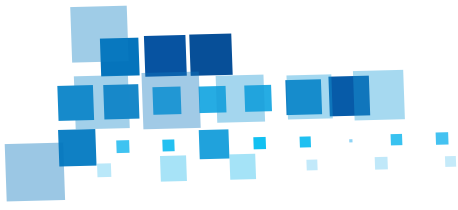

PART NO: 84 SERT METAL PLAKETLİ KAPI KASASI PROFİL FREZE BIÇAK GRUBU / PROFILE REUTER CUTTERS T.C.T.

KOD	D1 (mm)	D2 (mm)	d (mm)	Z
TTS8401	200	150	30	4+8+12

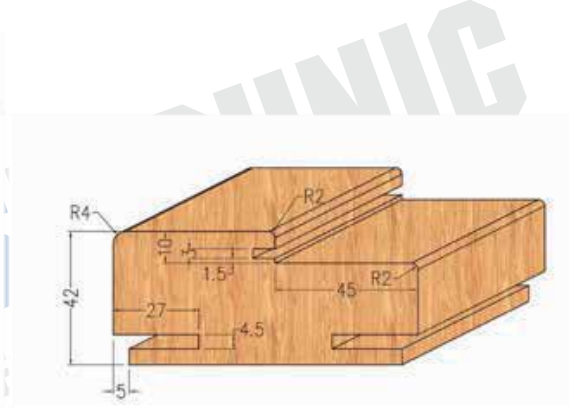
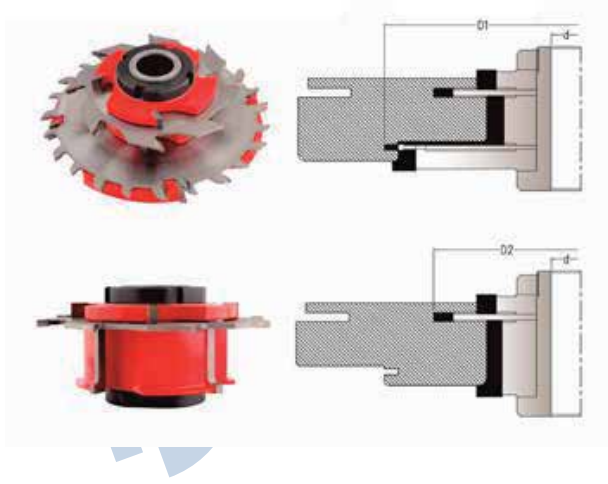

PART NO: 85 SERT METAL PLAKETLİ KAPI KASASI PROFİL FREZE BIÇAK GRUBU / PROFILE REUTER CUTTERS T.C.T.

KOD	D1 (mm)	D2 (mm)	d (mm)	Z
TTS8501	200	158	30	4+8+12

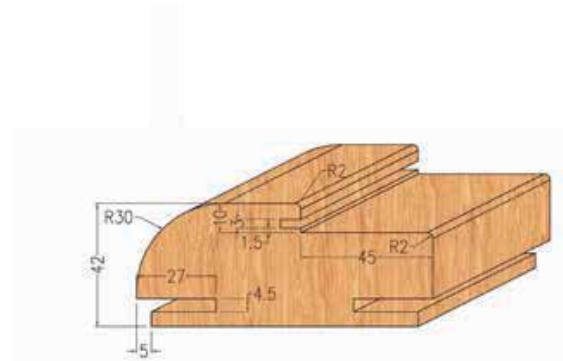
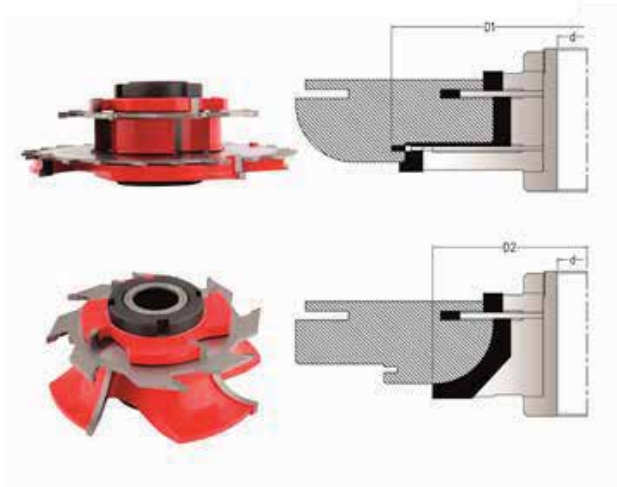

PART NO: 86 SERT METAL PLAKETLİ FREZE GÖBEK BIÇAĞI / PANEL RASING CUTTER T.C.T.

KOD	D (mm)	b (mm)	r1 (mm)	d (mm)	Z
TTS8601	180	16	6	30	3
TTS8602	180	16	6	30	3
TTS8603	180	16	6	30	3
TTS8604	180	19	5	30	3

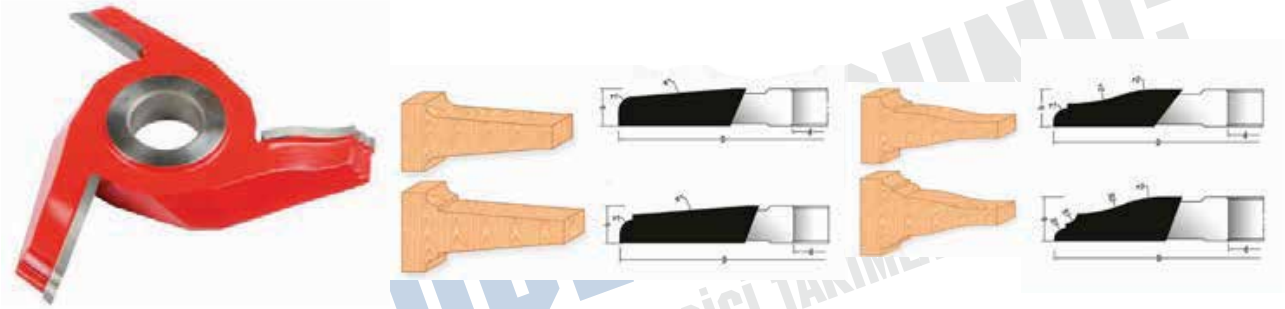

PART NO: 87 SERT METAL PLAKETLİ 45° FREZE PAH BIÇAĞI / PROFILE REUTER CUTTERS T.C.T.

KOD	D (mm)	b (mm)	a°	d (mm)	Z
TTS8701	120	30	45	30	3
TTS8702	140	40	45°	30	3
TTS8703	160	50	45°	30	3

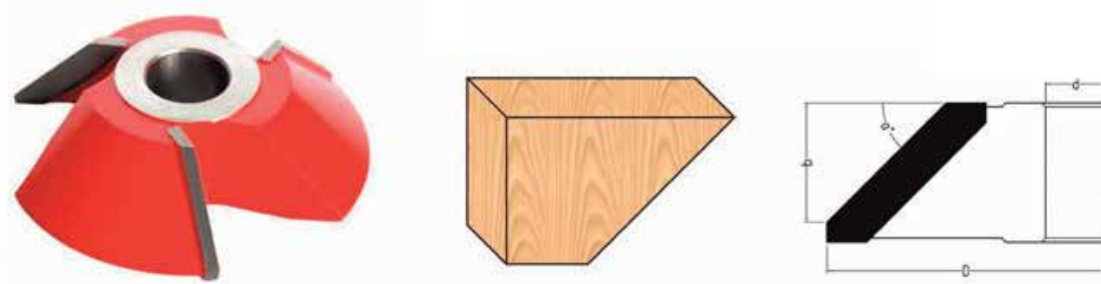

PART NO: 88 SERT METAL PLAKETLİ FREZE TAÇ BIÇAĞI / PROFILE CUTTER BLOCK T.C.T.

KOD	D (mm)	b (mm)	r1 (mm)	r2 (mm)	r3 (mm)	d (mm)	Z
TTS8801	130	48	6	10,50	7	30	3

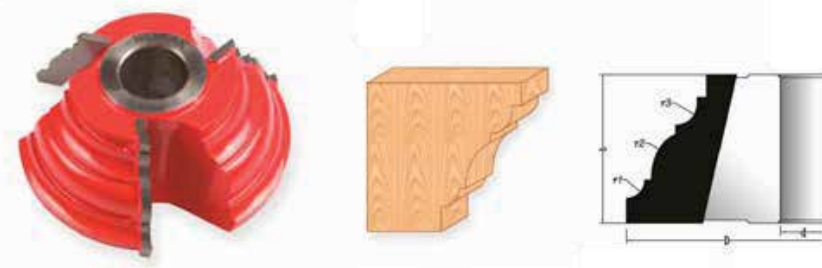

BU GRUP İÇİN LÜTFEN FİYAT SORUNUZ.

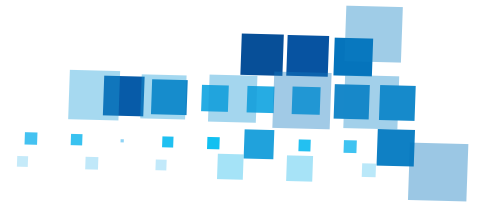
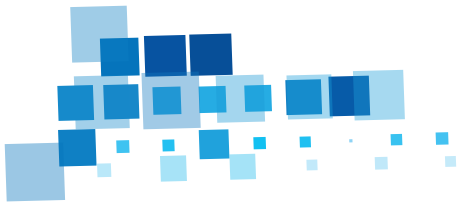

PART NO: 89 SERT METAL PLAKETLİ FREZE TAÇ BIÇAĞI / PROFILE CUTTER BLOCK T.C.T.

KOD	D (mm)	b (mm)	r1 (mm)	r2 (mm)	d (mm)	Z
TTS8901	130	45	7	11	30	3



PART NO: 90 SERT METAL PLAKETLİ FREZE TAÇ BIÇAĞI / PROFILE CUTTER BLOCK T.C.T.

KOD	D (mm)	b (mm)	r1 (mm)	r2 (mm)	d (mm)	Z
TTS9001	140	50	6	14	30	3

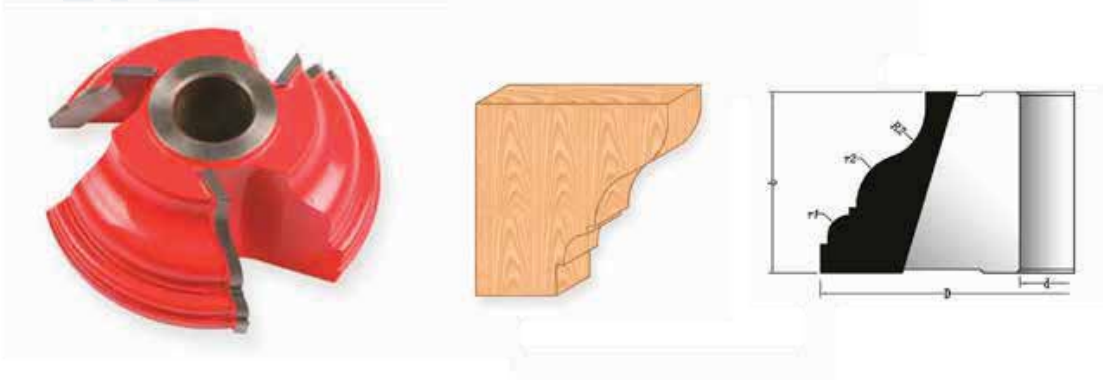

PART NO: 91 SERT METAL PLAKETLİ FREZE TAÇ BIÇAĞI / PROFILE CUTTER BLOCK T.C.T.

KOD	D (mm)	b (mm)	r1 (mm)	r2 (mm)	d (mm)	Z
TTS9101	140	46	8	16	30	3



PART NO: 92 SERT METAL PLAKETLİ TERS YARIMAY FREZE BİÇAĞI / PROFILE CUTTER BLOCK T.C.T.

KOD	D (mm)	b (mm)	R1 (mm)	d (mm)	Z
TTS9201	120	18	15	30	3
TTS9202	120	23	20	30	3
TTS9203	130	28	25	30	3
TTS9204	130	32,50	30	30	3



PART NO: 93 SERT METAL PLAKETLİ ÇİTA FREZE BİÇAĞI / PROFILE CUTTER BLOCK T.C.T.

KOD	D (mm)	b (mm)	d (mm)	Z
TTS9301	120	25	30	3
TTS9302	120	30	30	3
TTS9303	120	26	30	3

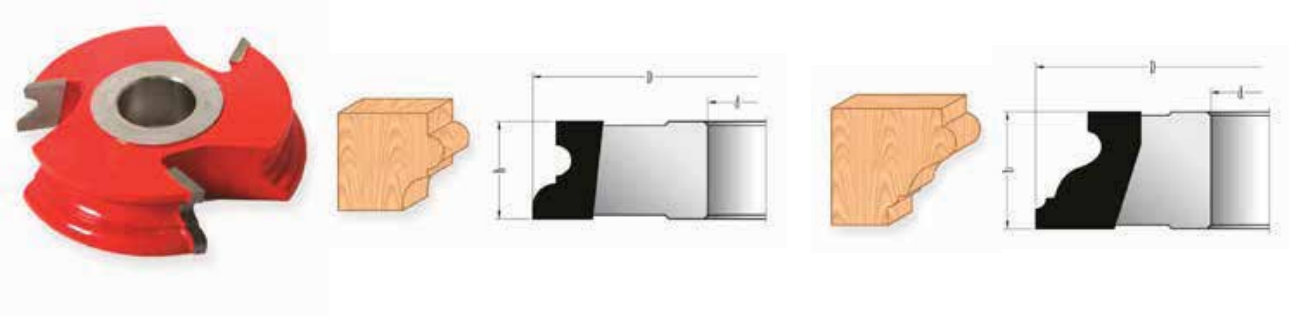

PART NO: 94 SERT METAL PLAKETLİ ÇİTA FREZE BİÇAĞI / PROFILE CUTTER BLOCK T.C.T.

KOD	D (mm)	b (mm)	d (mm)	Z
TTS9401	120	30	30	3
TTS9402	120	27	30	3

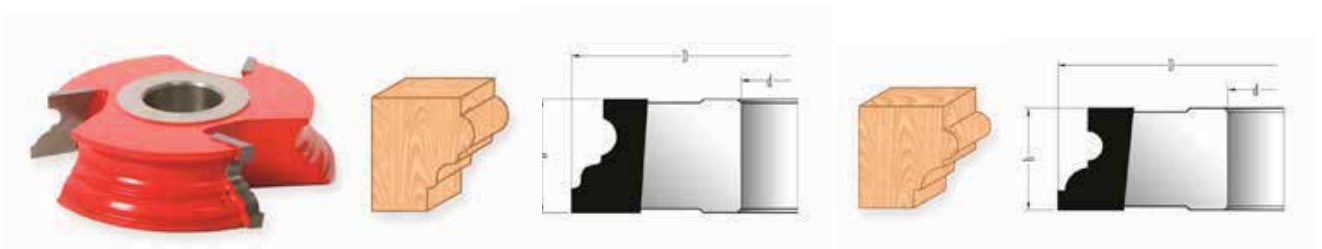

PART NO: 95 SERT METAL PLAKETLİ KIRICI DİŞLİ TEMİZLEME BIÇAĞI / COPYING - JOINING CUTTERS T.C.T.

KOD	D (mm)	b (mm)	d (mm)	Z
TTS9501	62	80	30	8
TTS9502	80	80	30	8
TTS9503	80	100	30	8
TTS9504	100	100	30	10
TTS9505	120	100	30	12

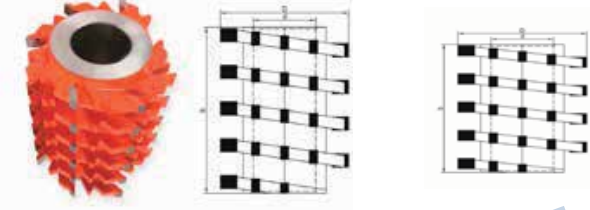

PART NO: 96 SERT METAL PLAKETLİ KÜPEŞTE BIÇAĞI / PROFILE CUTTER BLOCK T.C.T.

KOD	D (mm)	b (mm)	r1 (mm)	r2 (mm)	r3 (mm)	d (mm)	Z
TTS9601	150	42	36	11,80	6,80	30	3
TTS9602	150	40,70	57	8,25	12,30	30	3

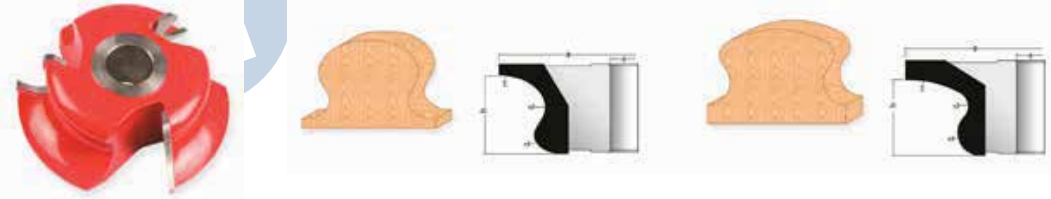

PART NO: 97 SERT METAL PLAKETLİ EN EKLEME BIÇAĞI / GLUE JOINT CUTTER BLOCK T.C.T.

KOD	D (mm)	b1 (mm)	b2 (mm)	d (mm)	Z
TTS9701	120	36	16	30	3
TTS9702	120	44	24	30	3

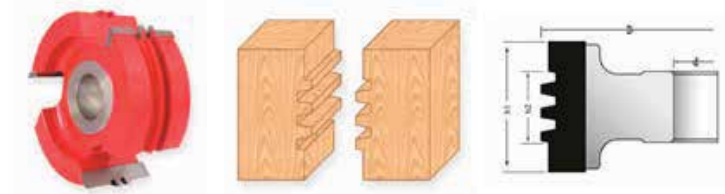

PART NO: 98 SERT METAL PLAKETLİ BOY EKLEME BIÇAĞI / GLUE JOINT CUTTER BLOCK T.C.T.

KOD	D (mm)	b1 (mm)	b2 (mm)	d (mm)	Z
TTS9801	120	40	24	30	3
TTS9802	120	48	32	30	3
TTS9803	120	56	40	30	3
TTS9804	120	64	48	30	3

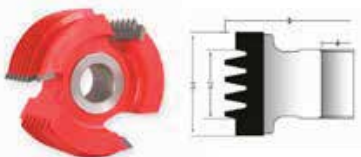

BU GRUP İÇİN LÜTFEN FİYAT SORUNUZ.

PART NO: 99 İÇ BİLEME TAŞI / DISH GRINDING WHEELS

KOD	D (mm)	T (mm)	W (mm)	X (mm)	H (mm)
5-0041	50	6	2	1,50	20
5-0042	75	10	2	1,50	20-25
5-1031	100	10	3	2	25-32
5-1041	125	13	3	2	25-32
5-1051	150	16	5	3	20-32
9-3261	160	14	3	2	20-32
3-3047	200	12	4	2	20-32

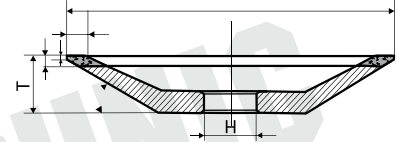

PART NO: 100 TEPE BİLEME TAŞI / RECESSED FLAT GRINDING WHEELS

KOD	D (mm)	T (mm)	W (mm)	X (mm)	H (mm)
3K2671 Standart	100	24	5(2,5+2,5)	10	25
3-0088 Standart	125	24	5(2,5+2,5)	10	32
3K2671 Premium	100	24	5(2,5+2,5)	10	25
3-0088 Premium	125	24	5(2,5+2,5)	10	32

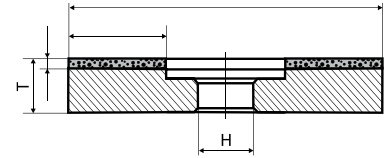
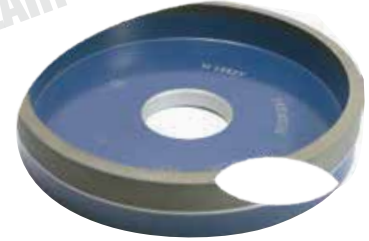

PART NO: 101 TAKIM BİLEME TAŞI / DISH GRINDING WHEELS

KOD	D (mm)	T (mm)	W (mm)	X (mm)	H (mm)
5-0006	75	10	6	2	16
5-0008	100	12	6	2	20
5-0010	125	16	6	2	20-32
5-0011	125	16	10	2	20-32
5-0013	150	18	6	2	20-32
5-0014	150	18	10	2	20-32
9-5016	175	21	10	2	20-32
5-0018	200	22	10	2	20-32

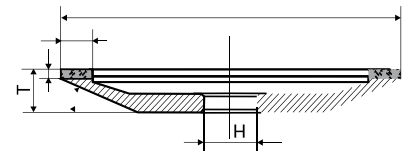

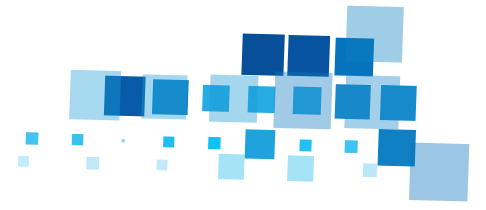
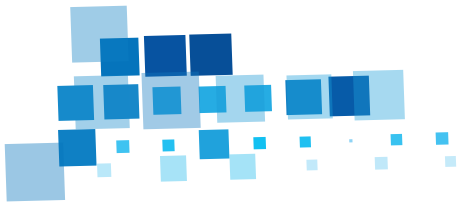

DIA PROFİL FEREZE BIÇAKLARI

PCD (DIA) Profile Router Cutters



Kod / Art Number	Ölçüler / Dimensions							
Kod No:	D	B	b	r1	r2	L	d	Z
TTD020	24	12	5	10	2	75	16	2

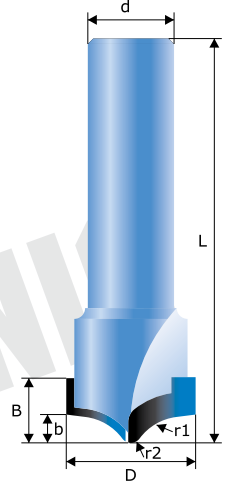

DIA PROFİL FEREZE BIÇAKLARI

PCD (DIA) Profile Router Cutters



Kod / Art Number	Ölçüler / Dimensions							
Kod No:	D	B	b	r1	a°	L	d	Z
TTD040	25	16	10,5	-	50°	75	16	2

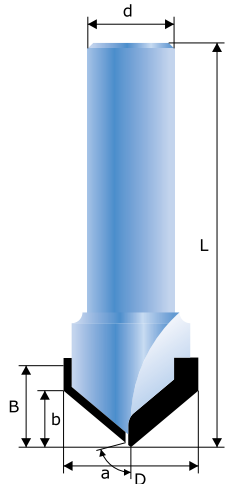

DIA PROFİL FEREZE BIÇAKLARI

PCD (DIA) Profile Router Cutters



Kod / Art Number	Ölçüler / Dimensions								
Kod No:	D	B	b	r1	r2	a°	L	d	Z
TTD060	30	15	8	5	10	-	75	16	2

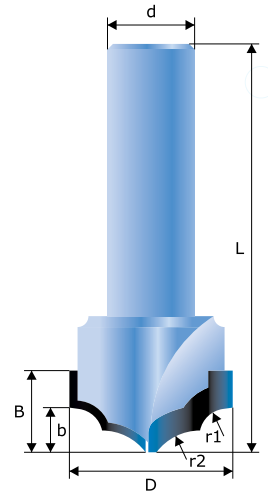

DIA PROFİL FEREZE BIÇAKLARI

PCD (DIA) Profile Router Cutters



Kod / Art Number Ölçüler / Dimensions

Kod No:	D	B	b	r1	r2	a°	L	d	Z
TTD080	16	14	8	8	-	-	71	16	2
TTD081	20	16	10	10	-	-	73	16	2
TTD082	24	18	12	12	-	-	75	16	2
TTD083	28	20	14	14	-	-	79	16	2
TTD084	32	22	16	16	-	-	83	16	2
TTD085	36	24	18	18	-	-	87	16	2
TTD086	40	26	20	20	-	-	91	16	2

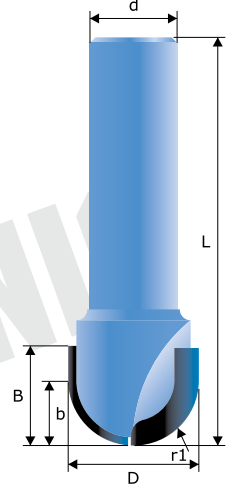

DIA PROFİL FEREZE BIÇAKLARI

PCD (DIA) Profile Router Cutters



Kod / Art Number Ölçüler / Dimensions

Kod No:	D	b	r1	r2	a°	L	d	Z
TTD100	69	7	-	-	-	77	20	2

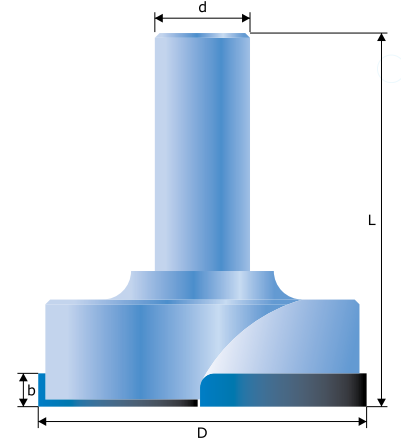

DIA PROFİL FEREZE BIÇAKLARI

PCD (DIA) Profile Router Cutters



Kod / Art Number Ölçüler / Dimensions

Kod No:	D	B	b	r1	r2	L	d	Z
TTD120	69	13	6	82	-	75	20	2

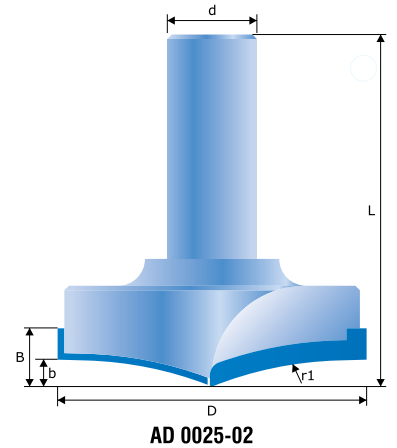

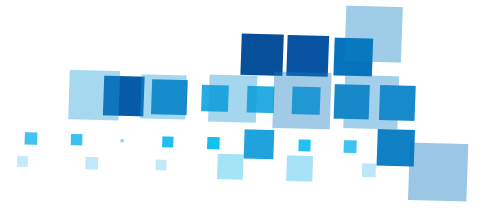
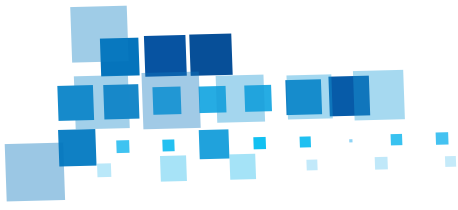

DIA PROFİL FEREZE BIÇAKLARI

PCD (DIA) Profile Router Cutters



Kod / Art Number		Ölçüler / Dimensions						
Kod No:	D	B	b	r1	a°	L	d	Z
TTD140	69	20	7,5	-	78°	77	20	2

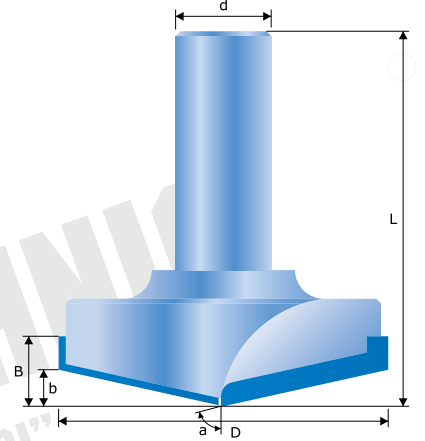

AD 0025-03

DIA PROFİL FEREZE BIÇAKLARI

PCD (DIA) Profile Router Cutters

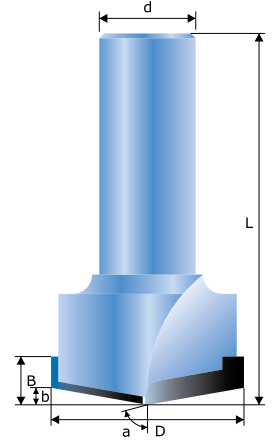

Kod / Art Number		Ölçüler / Dimensions						
Kod No:	D	B	b	r1	a°	L	d	Z
TTD160	40	10	3,5	-	10°	77	20	2
TTD161	43	12	5	50	-	77	20	2

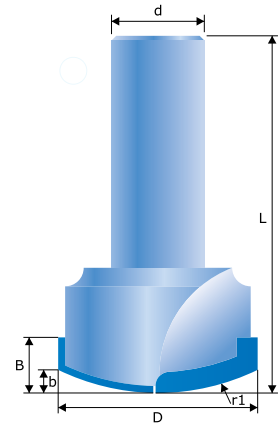

DIA PROFİL FEREZE BIÇAKLARI

PCD (DIA) Profile Router Cutters

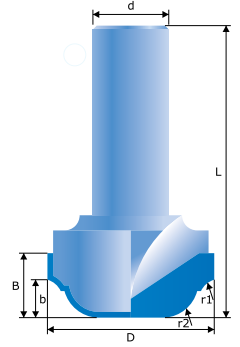
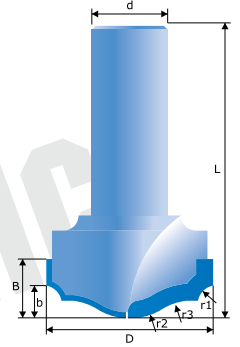

Kod / Art Number	Ölçüler / Dimensions								
Kod No:	D	B	b	r1	r2	r3	L	d	Z
TTD180	44	15	8,5	5	15	15	77	20	2
TTD181	44	17	10	5,5	9,5	-	77	20	2

DIA PROFİL FEREZE BIÇAKLARI

PCD (DIA) Profile Router Cutters

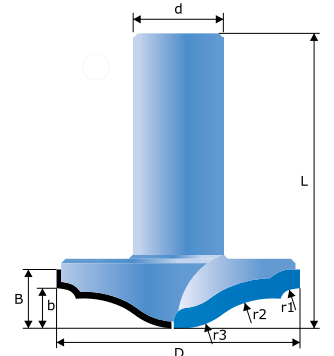
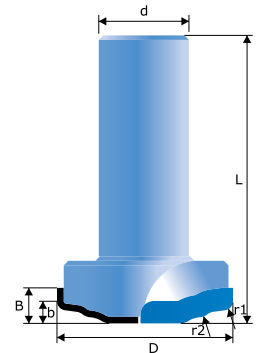

Kod / Art Number	Ölçüler / Dimensions								
Kod No:	D	B	b	r1	r2	r3	L	d	Z
TTD200	39	8	5	2	3	-	64	20	2
0030-06	54	13	9	3	20	14,5	65	20	2

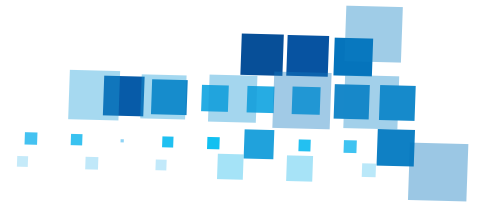
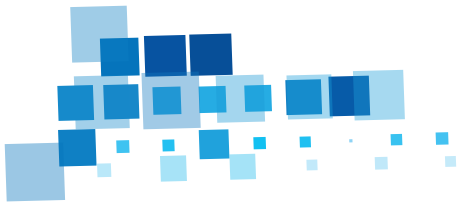

DIA PROFİL FEREZE BIÇAKLARI

PCD (DIA) Profile Router Cutters

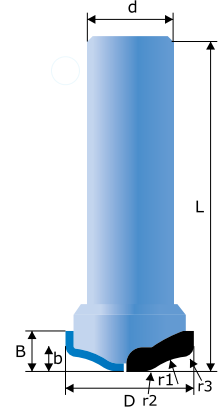
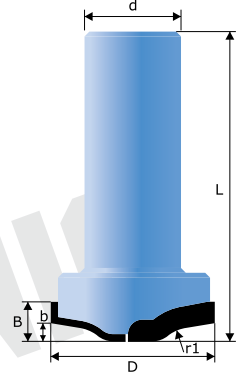

Kod / Art Number	Ölçüler / Dimensions								
Kod No:	D	B	b	r1	r2	r3	L	d	Z
TTD220	34	8	4	8	-	-	64	20	2
TTD221	12,5	14,5	12	11,5	5,5	2	65	12	2

DIA PROFİL FEREZE BIÇAKLARI

PCD (DIA) Profile Router Cutters

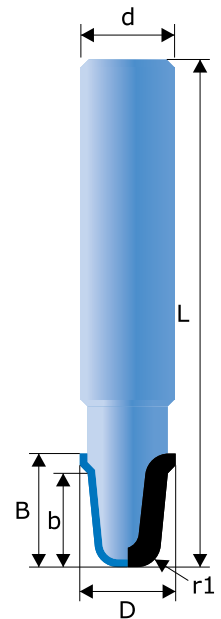

Kod / Art Number	Ölçüler / Dimensions								
Kod No:	D	B	b	r1	r2	r3	L	d	Z
TTD240	12,5	14,5	12	3	-	-	65	12	2
TTD241	37	9	5	-	-	-	62	14	2

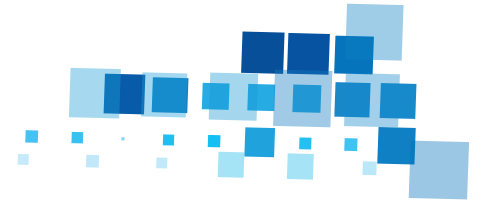

DIA PROFİL FEREZE BIÇAKLARI

PCD (DIA) Profile Router Cutters

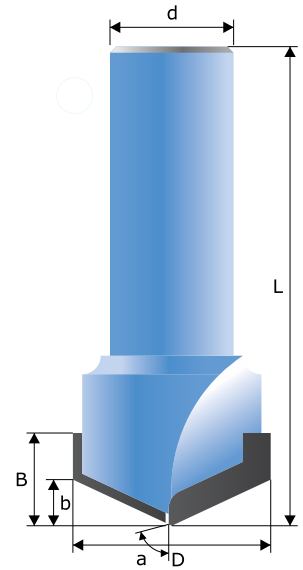
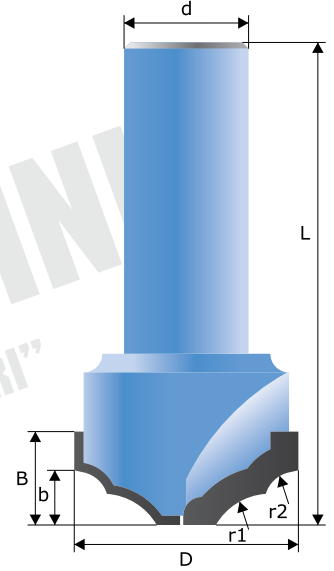

Kod / Art Number	Ölçüler / Dimensions								
Kod No:	D	B	b	r1	r2	a°	L	d	Z
TTD260	36	15	8,5	10	5	-	77	20	2
TTD261	32	15	7,5	-	-	65°	77	20	2

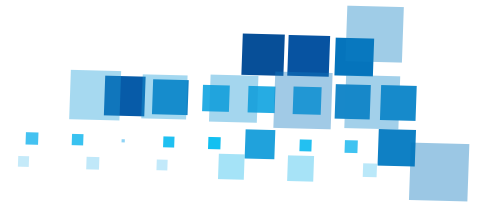
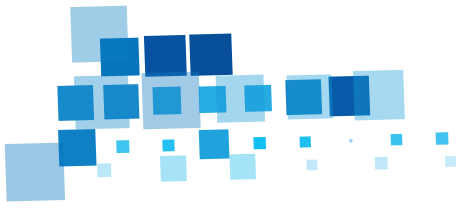

DIA PROFİL FERZE BİÇAKLARI

PCD (DIA) Profile Router Cutters

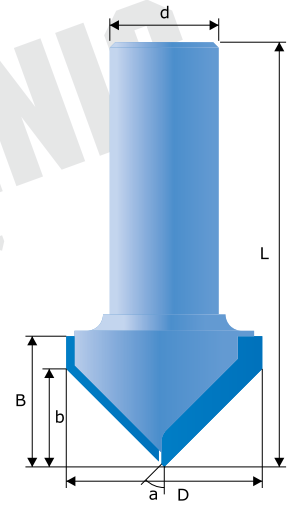

Kod / Art Number Ölçüler / Dimensions

Kod No:	D	B	b	r1	a°	L	d	Z
TTD280	32	24	18	-	45°	77	20	2

DIA PROFİL FERZE BİÇAKLARI

PCD (DIA) Profile Router Cutters

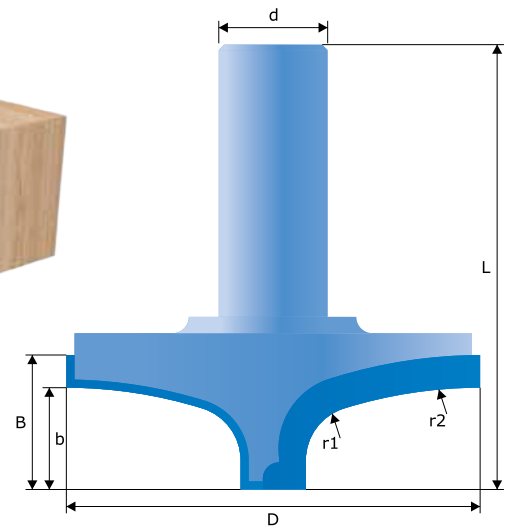

Kod / Art Number Ölçüler / Dimensions

Kod No:	D	B	b	r1	r2	L	d	Z
TTD300	76	25	19	10	85	80	20	2+2

DIA PROFİL FERZE BİÇAKLARI

PCD (DIA) Profile Router Cutters

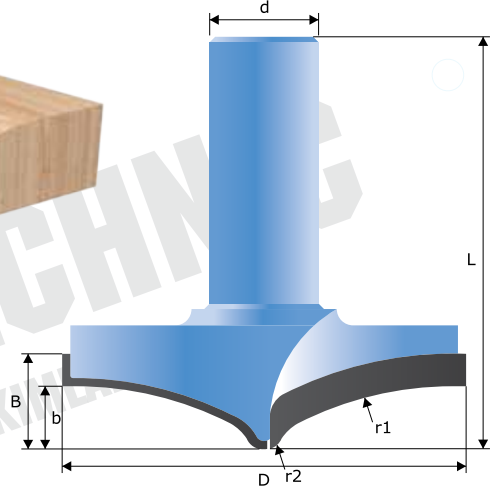

Kod / Art Number	Ölçüler / Dimensions								
Kod No:	D	B	b	r1	r2	a°	L	d	Z
TTD320	75	25	11,5	62	3	-	75	20	2

DIA RADÜS EBATLAMA FERZE BİÇAKLARI

PCD (DIA) Radius Profile Router Bits

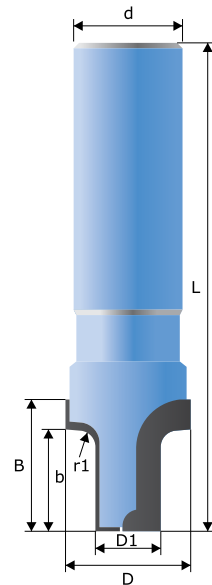

Kod / Art Number	Ölçüler / Dimensions								
Kod No:	D	D1	B	b	r1	L	d	Z	
TTD340	23	12	24	18,7	2	90	20	2	
TTD341	25	12	23	18,7	3	90	20	2	
TTD342	27	12	23	18,7	4	90	20	2	
TTD343	35	12	23	18,7	5	90	20	2	
TTD344	35	12	23	18,7	6	90	20	2	

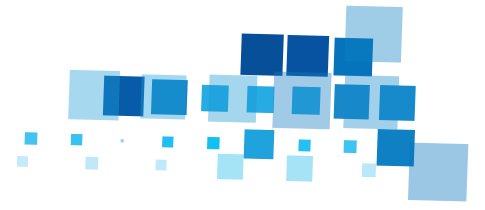
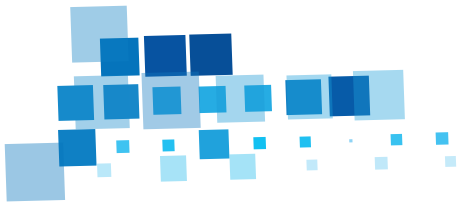

DIA 45° EBATLAMA PARMAK FERZE BİÇAKLARI

PCD (DIA) Profile Bits

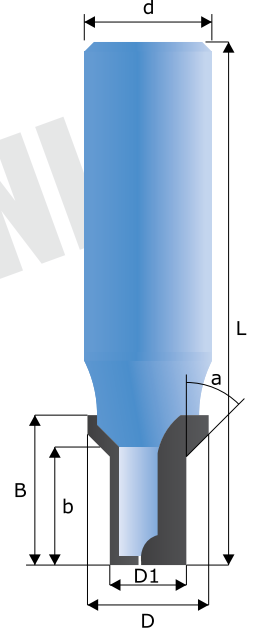

Kod / Art Number Ölçüler / Dimensions

Kod No:	D	D1	B	b	a°	L	d	Z
TTD360	19	12	24	18,5	45°	82	20	2

DIA PROFİL FERZE BİÇAKLARI

PCD (DIA) Profile Router Cutters

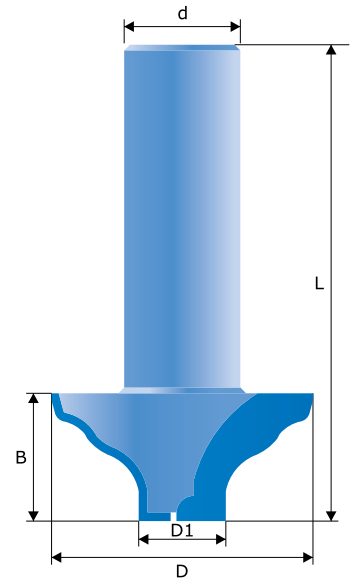

Cam Yeri Açma

Kod / Art Number Ölçüler / Dimensions

Kod No:	D	D1	B	b	a°	L	d	Z
TTD380	45	25	22	-	-	82	20	2

DIA PARMAK FEREZE BIÇAKLARI

PCD (DIA) End Mills



Parmak Freze 1+1

Kod / Art Number	Ölçüler / Dimensions				
Kod No:	D	b	L	d	Z
TTD400	8	15	70	10-12	2
TTD401	9	20	70	10-12	2
TTD402	10	20	70	10-12	2
TTD403	12	25	75	12-14	2

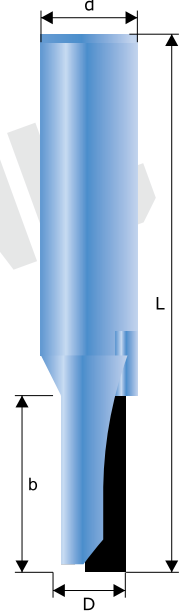

DIA PARMAK FEREZE BIÇAKLARI

PCD (DIA) End Mills



Parmak Freze 1+1

Kod / Art Number	Ölçüler / Dimensions				
Kod No:	D	b	L	d	Z
TTD420	8	20	65	10	1+1
TTD421	8	25	70	10	1+1
TTD422	10	20	70	10	1+1
TTD423	10	25	70	10	1+1
TTD424	12	27	70	12	1+1
TTD425	12	35	70	12	1+1
TTD426	16	25	95	16-20	1+1
TTD427	16	33	95	16-20	1+1
TTD428	18	25	95	20	1+1
TTD429	18	33	95	20	1+1
TTD430	18	42	105	20	1+1
TTD431	20	25	95	20	1+1
TTD432	20	33	95	20	1+1
TTD433	20	42	105	20	1+1

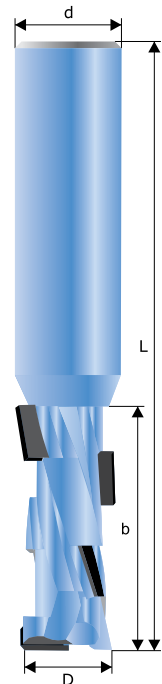

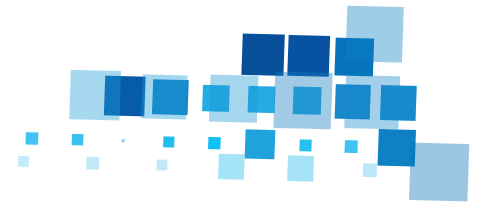
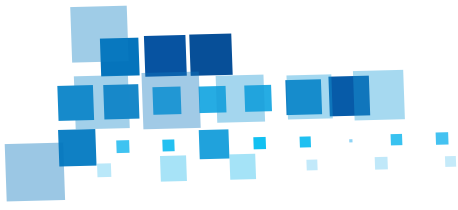

DIA PARMAK FEREZE BİÇAKLARI

PCD (DIA) End Mills



Parmak Freze 2+2
Kod / Art Number Ölçüler / Dimensions

Kod No:	D	b	L	d	Z
TTD440	14	38	101	14-16	2+2
TTD441	14	38	101	14-16	2+2
TTD442	16	42	105	16-18	2+2
TTD443	16	51	110	16-18	2+2
TTD444	18	42	105	18-20	2+2
TTD445	18	51	110	18-20	2+2
TTD446	20	25	95	18-20	2+2
TTD447	20	33	95	18-20	2+2
TTD448	20	42	105	18-20	2+2
TTD449	20	51	110	18-20	2+2

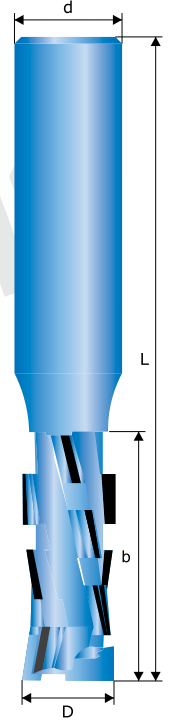

DIA ÖN FREZE TEMİZLME BİÇAKLARI

DIA (PCD) Jointing Cutters

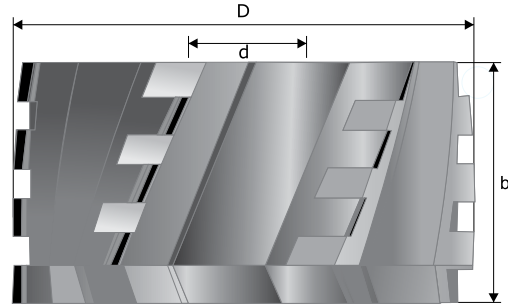
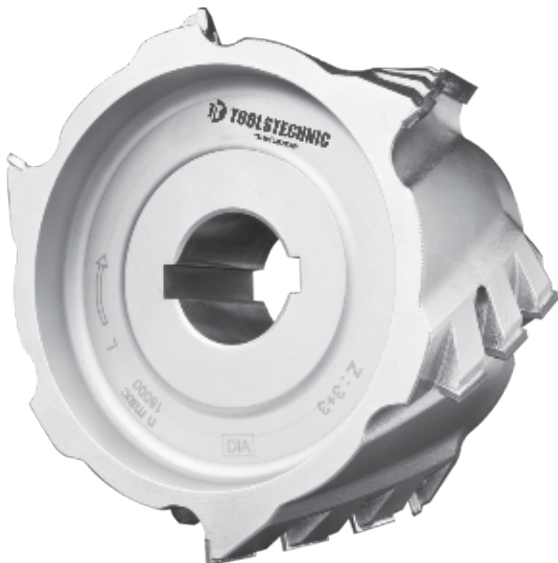

Temizleme 3+3 (Sağ - Sol)

Kod / Art Number	Ölçüler / Dimensions			
Kod No:	D	b	d	Z
TTD460	70	50	20	3+3
TTD461	80	64	30	3+3
TTD462	85	48	30	3+3
TTD463	100	50	30	3+3
TTD464	125	30	30	3+3
TTD465	125	44	30	3+3
TTD466	125	55	30	3+3
TTD467	125	63	30	3+3

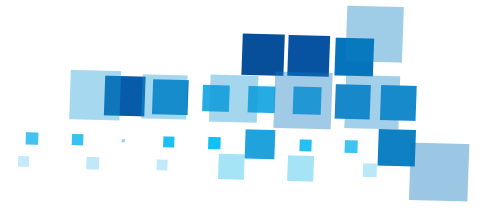
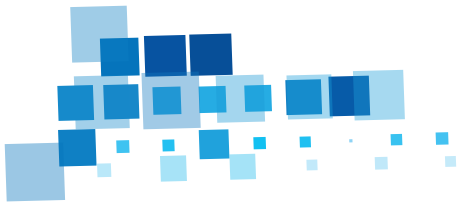

DIA PERVAZ BIÇAKLARI

PCD (DIA) Profile Cutter

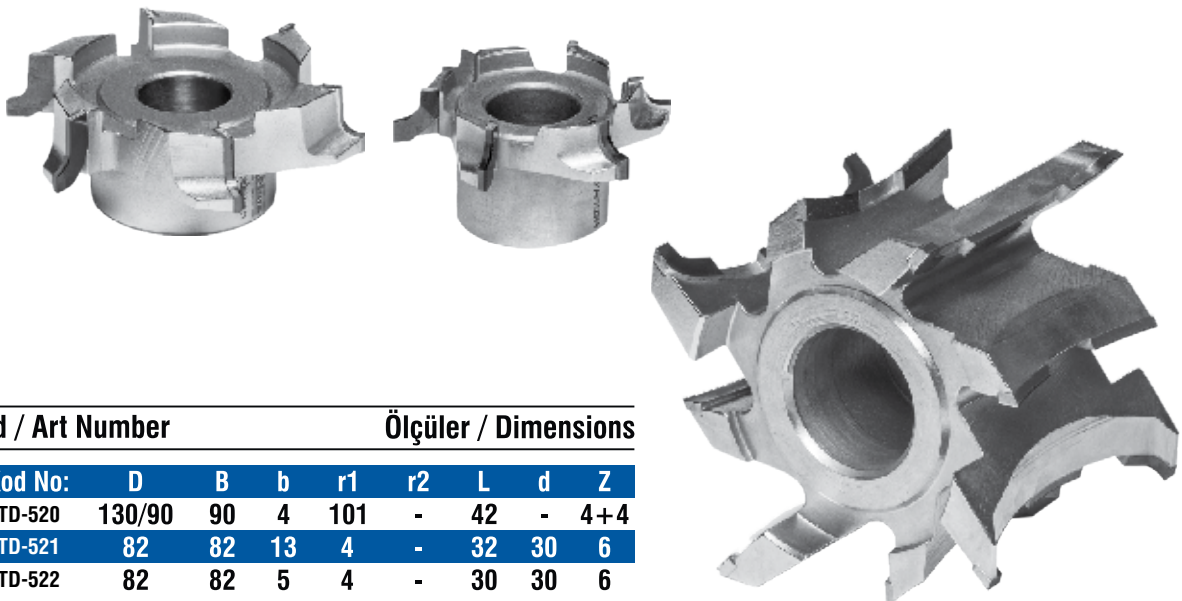
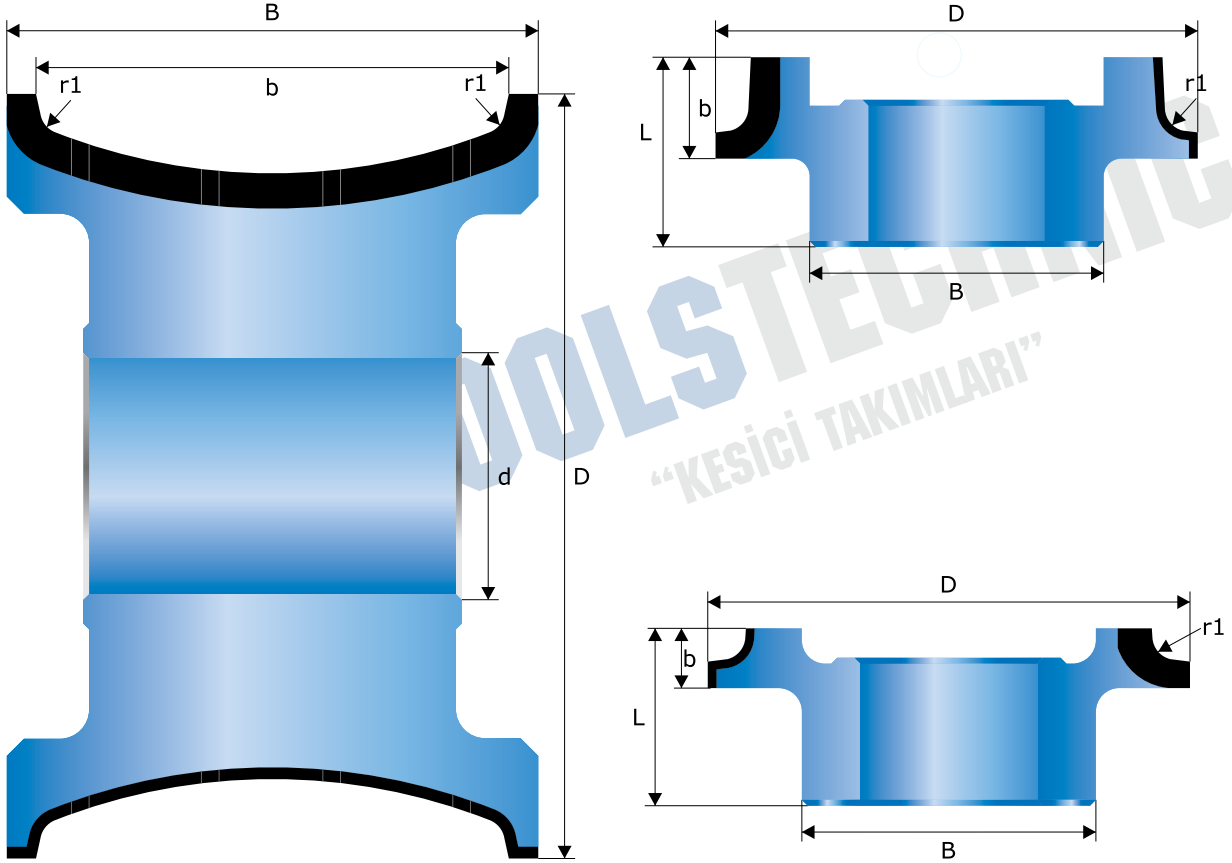

Kod / Art Number	Ölçüler / Dimensions							
Kod No:	D	B	b	r1	r2	L	d	Z
TTD-520	130/90	90	4	101	-	42	-	4+4
TTD-521	82	82	13	4	-	32	30	6
TTD-522	82	82	5	4	-	30	30	6

DEĞİŞTİRİLEBİLİR JİLETLER

Changeable Blades

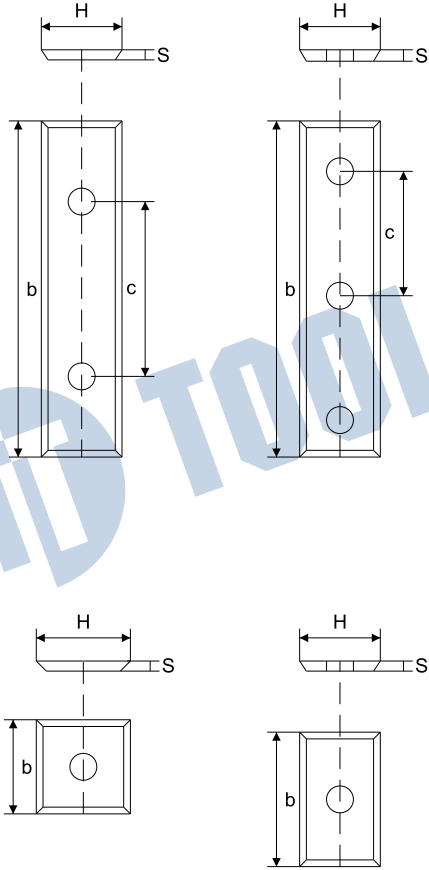

Kod / Art Number	Ölçüler / Dimensions			
Kod No:	b	H	S	C
TTJ-580	7,5	12	1,5	-
TTJ-581	9,6	12	1,5	-
TTJ-582	10,5	12	1,5	-
TTJ-583	11,6	12	1,5	-
TTJ-584	15	12	1,5	-
TTJ-585	20	12	1,5	-
TTJ-586	30	12	1,5	14
TTJ-587	40	12	1,5	26
TTJ-588	50	12	1,5	26
TTJ-589	60	12	1,5	26
TTJ-590	80	13	2,2	60
TTJ-591	100	13	2,2	60
TTJ-592	120	13	2,2	60
TTJ-593	12	12	1,5	-
TTJ-594	14	14	2	-
TTJ-595	29,5	9	1,5	14
TTJ-596	50	12	1,7	18,5
TTJ-597	49,5	9	1,5	26
TTJ-598	20	4,1	1,1	-
TTJ-599	19,5	12	1,5	-
TTJ-600	29,5	12	1,5	14
TTJ-601	39,5	12	1,5	26
TTJ-602	49,5	12	1,5	26
TTJ-603	59,5	12	1,5	26
TTJ-604	29,5	9	1,5	14
TTJ-605	49,5	9	1,5	26
TTJ-606	59,5	9	1,5	26
TTJ-607	14	14	1,2	-
TTJ-608	17	17	2,0	-

DEĞİŞTİRİLEBİLİR JİLETLER

Changeable Blades

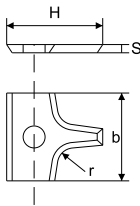

Kod / Art Number	Ölçüler / Dimensions			
Kod No:	b	H	S	r
TTJ-620	16	17,5	2	2
TTJ-621	16	17,5	2	3

DEĞİŞTİRİLEBİLİR JİLETLER

Changeable Blades

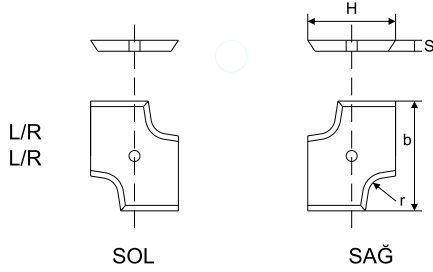

Kod / Art Number Ölçüler / Dimensions

Kod No:	b	H	S	r
TTJ-620	20	16	2	2
TTJ-621	20	16	2	3

Kod / Art Number Ölçüler / Dimensions

Kod No:	b	H	S	r
TTJ-640	13	16	2	2
TTJ-641	13	16	2	3
TTJ-642	13	16	2	4
TTJ-643	20	21	2	5
TTJ-644	20	21	2	6
TTJ-645	20	21	2	7
TTJ-646	20	21	2	8
TTJ-647	26	24	2	9
TTJ-648	26	24	2	10
TTJ-649	26	24	2	11
TTJ-650	26	24	2	12
TTJ-651	26	24	2	13
TTJ-652	30	25	2	14
TTJ-653	30	25	2	15
TTJ-654	30	25	2	16

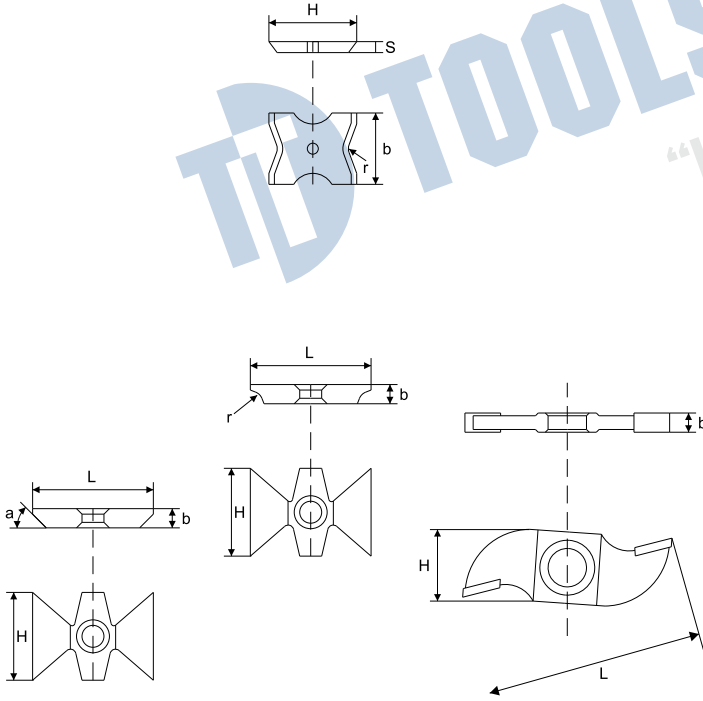

Kod / Art Number Ölçüler / Dimensions

Kod No:	L	H	b	r	a°
TTJ-660	22	16	3,5	2	-
TTJ-661	22	16	3,5	3	-
TTJ-662	22	16	3,5	-	45°
TTJ-663	38	13	3,5	-	-
TTJ-664	41,5	13	5,5	-	-

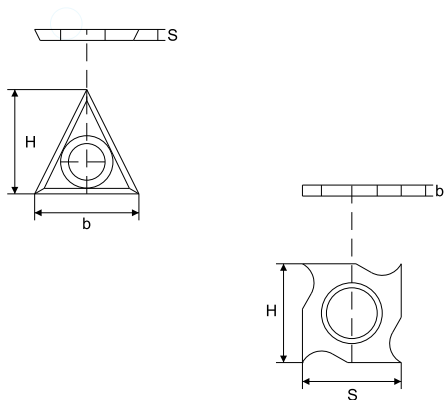

Kod / Art Number Ölçüler / Dimensions

Kod No:	b	H	S
TTJ-680	1,95	18	18
TTJ-681	2,5	18	18
TTJ-682	2,95	18	18
TTJ-683	3,7	18	18



TABLA TEMİZLEME (TARAMA) ÇEVİR KULLAN

Changeable Blades



Kod / Art Number	Ölçüler / Dimensions			
Kod No:	D	B	L	b
TTJ-3000	25	12	85	20
TTJ-3001	40	12	85	20
TTJ-3002	60	12	85	20
TTJ-3003	80	12	85	20
TTJ-3004	100	12	85	20

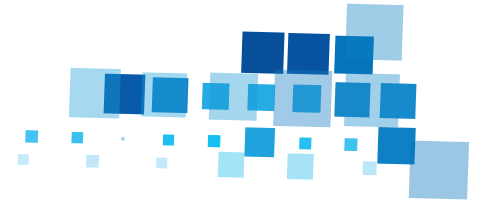
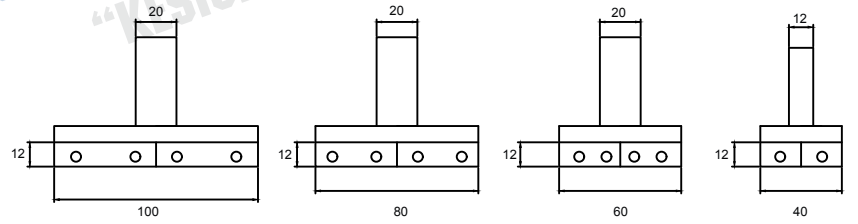

DEĞİŞTİRİLEBİLİR JİLETLİ PROFİL BİÇAKLARI

Changeable Blade Profile Rout

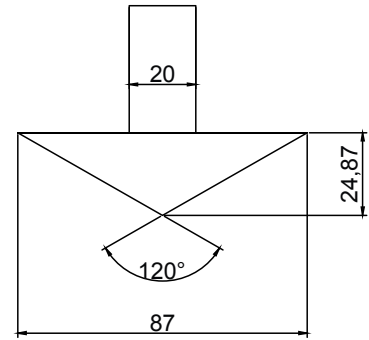

Kod / Art Number	Ölçüler / Dimensions							
Kod No:	D	B	b	r1	r2	a°	L	Z
TTJ-3020	87	24,87	-	-	-	120	20	2



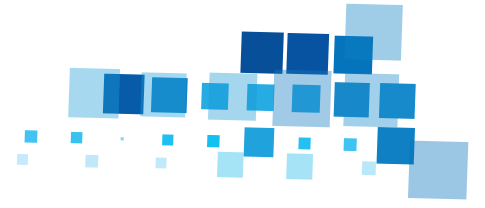

DEĞİŞTİRİLEBİLİR JİLETLİ PROFİL BİÇAKLARI

Changeable Blade Profile Rout

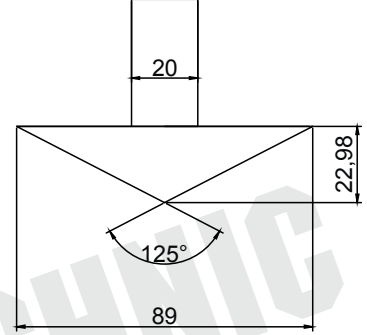

Kod / Art Number		Ölçüler / Dimensions							
Kod No:	D	B	b	r1	r2	a°	L	Z	
TTJ-3040	89	22,98	-	-	-	125	20	2	

DEĞİŞTİRİLEBİLİR JİLETLİ PROFİL BİÇAKLARI

Changeable Blade Profile Rout

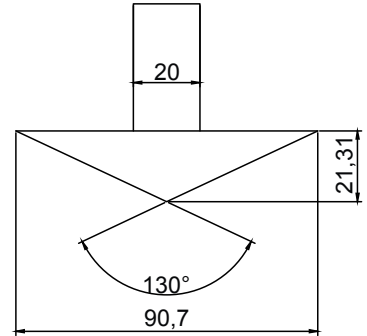

Kod / Art Number		Ölçüler / Dimensions							
Kod No:	D	B	b	r1	r2	a°	L	Z	
TTJ-3060	90,7	21,31	-	-	-	130	20	2	

DEĞİŞTİRİLEBİLİR JİLETLİ PROFİL BİÇAKLARI

Changeable Blade Profile Rout

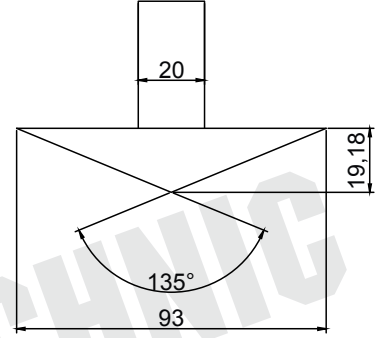

Kod / Art Number		Ölçüler / Dimensions						
Kod No:	D	B	b	r1	r2	a°	L	Z
TTJ-3080	93	19,18	-	-	-	135	20	2

DEĞİŞTİRİLEBİLİR JİLETLİ PROFİL BİÇAKLARI

Changeable Blade Profile Rout

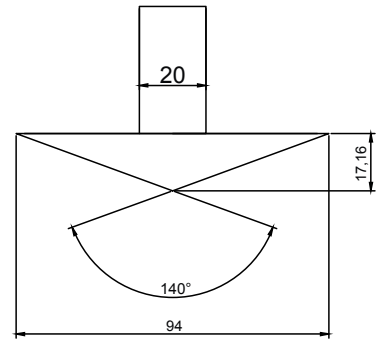

Kod / Art Number		Ölçüler / Dimensions						
Kod No:	D	B	b	r1	r2	a°	L	Z
TTJ-3100	94	17,16	-	-	-	140	20	2

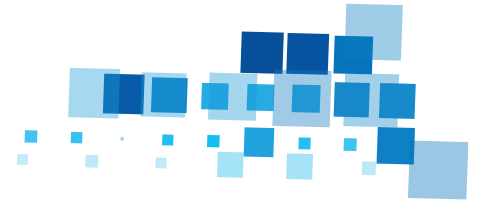

DEĞİŞTİRİLEBİLİR JİLETLİ PROFİL BİÇAKLARI

Changeable Blade Profile Rout

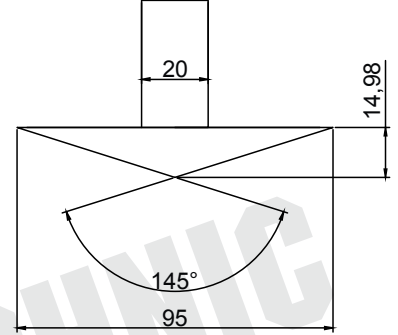

Kod / Art Number	Ölçüler / Dimensions								
Kod No:	D	B	b	r1	r2	a°	L	Z	
TTJ-3120	95	14,98	-	-	-	145	20	2	

DEĞİŞTİRİLEBİLİR JİLETLİ PROFİL BİÇAKLARI

Changeable Blade Profile Rout

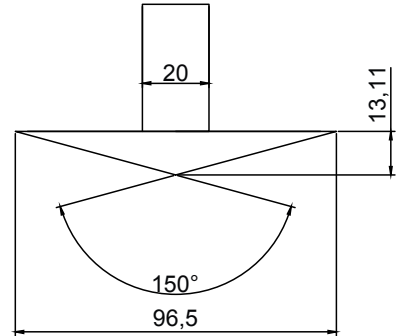

Kod / Art Number	Ölçüler / Dimensions								
Kod No:	D	B	b	r1	r2	a°	L	Z	
TTJ-3120	96,5	13,11	-	-	-	150	20	2	

DEĞİŞTİRİLEBİLİR JİLETLİ PROFİL BİÇAKLARI

Changeable Blade Profile Router Bit

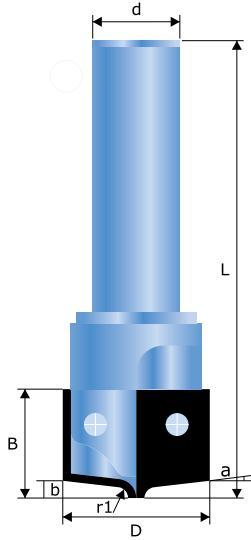

**AYNI TUTUCUYA 14 ADET FARKLI
PROFİL JİLET TAKILABİLİR.**

Kod / Art Number	Ölçüler / Dimensions								
Kod No:	D	B	b	r1	r2	a°	L	d	Z
TTJ-700	30	20	8	10	5	-	85	16	2
TTJ-701	27	20	3	2	-	7°	85	16	2

Takım Tutuculara uygun, profiller sipariş edilebilir.



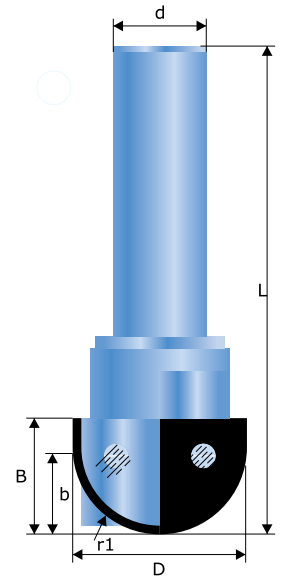
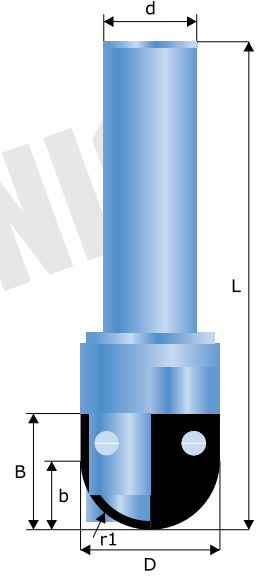
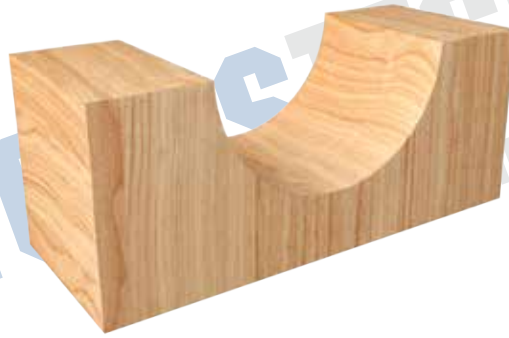
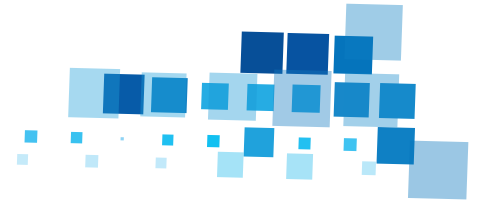

Kod / Art Number		Ölçüler / Dimensions							
Kod No:	D	B	b	r1	r2	a°	L	d	Z
TTJ-720	27	20	12	12	-	-	85	16	2
TTJ-721	30	20	15	15	-	-	85	16	2
TTJ-722	40	20	12	12	-	-	85	16	2
TTJ-723	50	20	15	15	-	-	85	16	2
TTJ-724	60	20	12	12	-	-	85	16	2

Takım Tutuculara uygun, profiller sipariş edilebilir.

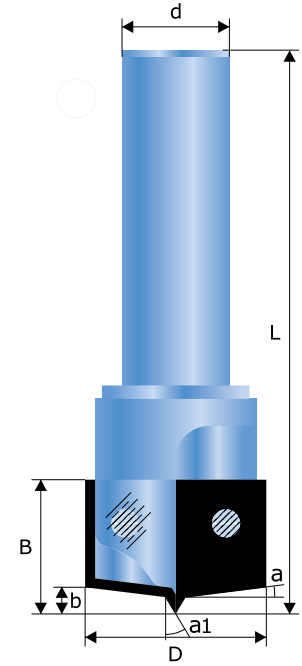
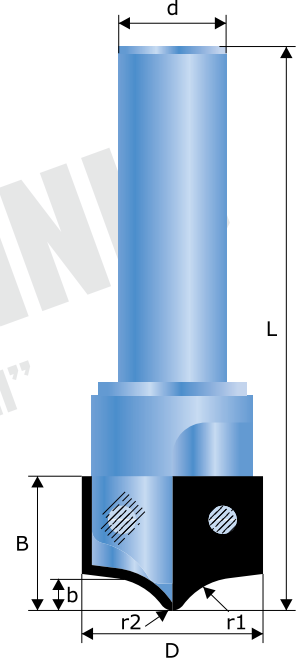

Kod / Art Number	Ölçüler / Dimensions									
Kod No:	D	B	b	r1	r2	a°	a1	L	d	Z
TTJ-740	24	20	5,5	10	3	-	-	85	16	2
TTJ-741	24	20	4	-	-	7°	31	85	16	2

Takım Tutuculara uygun, profiller sipariş edilebilir.

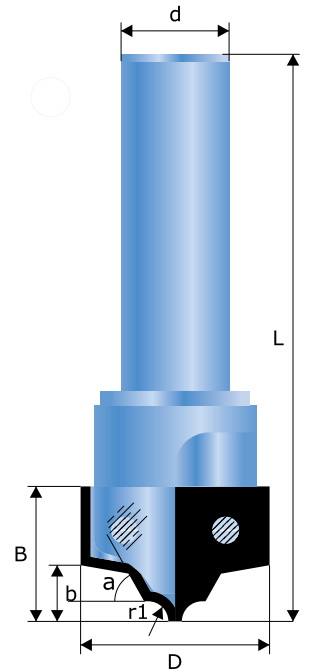
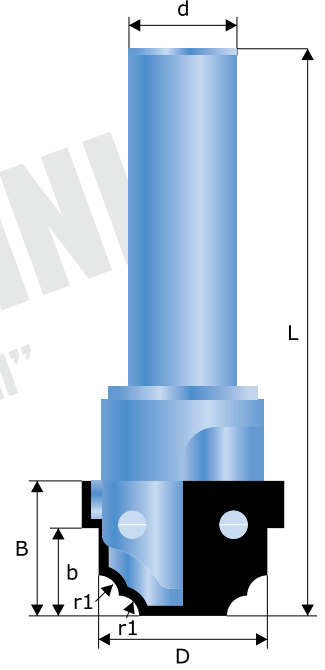
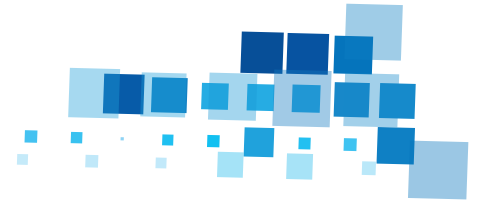

Kod / Art Number **Ölçüler / Dimensions**

Kod No:	D	B	b	r1	r2	a°	L	d	Z
TTJ-760	30	20	13	3	-	-	85	16	2
TTJ-761	28	20	8	3	-	60°	85	16	2

Takım Tutuculara uygun, profiller sipariş edilebilir.

DEĞİŞTİRİLEBİLİR JİLETLİ PROFİL BİÇAKLARI

Changeable Blade Profile Rout

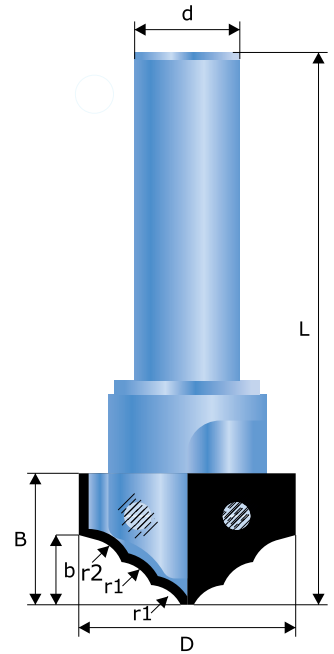
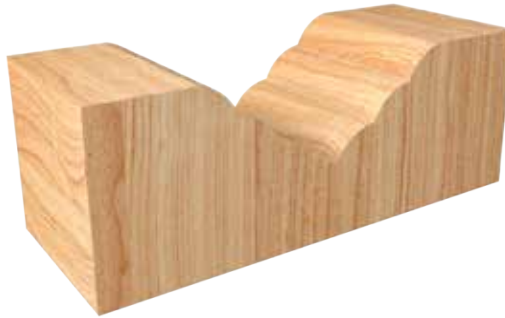
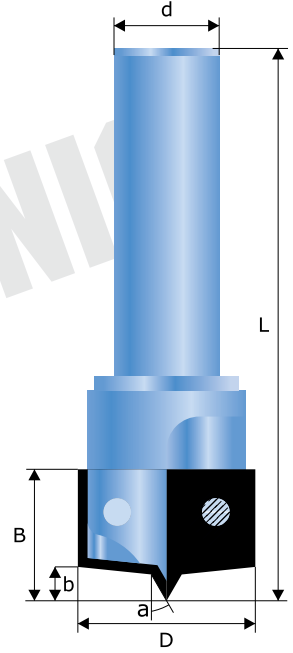

Kod / Art Number **Ölçüler / Dimensions**

Kod No:	D	B	b	r1	r2	a°	L	d	Z
TTJ-780	24	20	5	-	-	30°	85	16	2
TTJ-781	30	20	10	5,5	5,5	-	-	16	2

Takım Tutuculara uygun, profiller sipariş edilebilir.

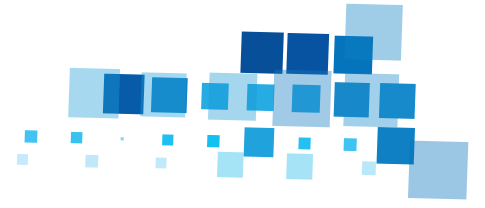

DEĞİŞTİRİLEBİLİR JİLETLİ PROFİL BİÇAKLARI

Changeable Blade Profile Rout

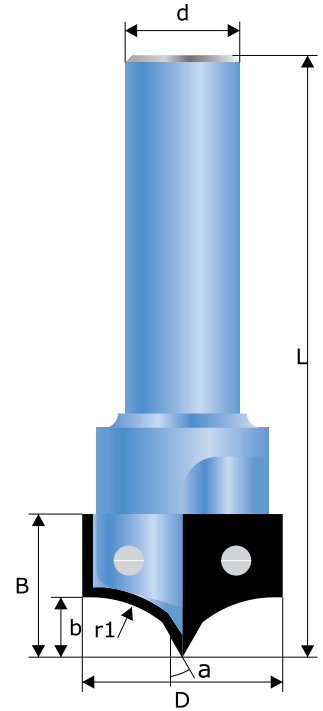
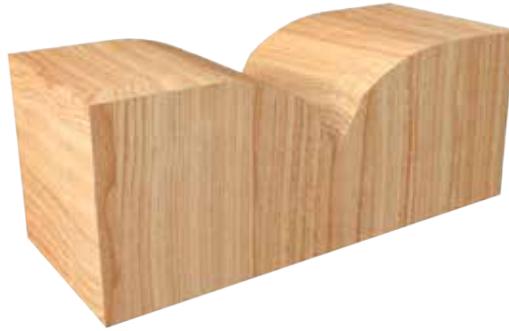

Kod / Art Number Ölçüler / Dimensions

Kod No:	D	B	b	r1	r2	a°	L	d
TTJ-800	27	20	5	2,5	-	30°	85	16
TTJ-801	28	20	8,5	16	-	30°	85	16

Takım Tutuculara uygun, profiller sipariş edilebilir.

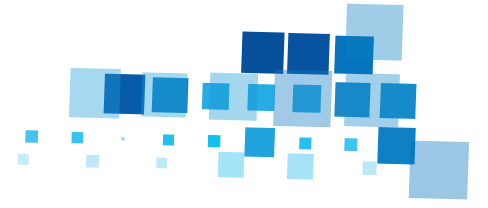

DEĞİŞTİRİLEBİLİR JİLETLİ PROFİL BİÇAKLARI

Changeable Blade Profile Rout

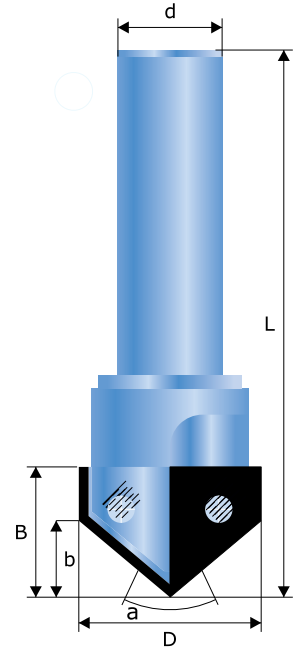
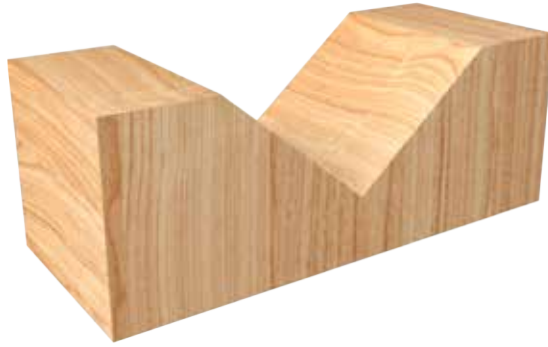
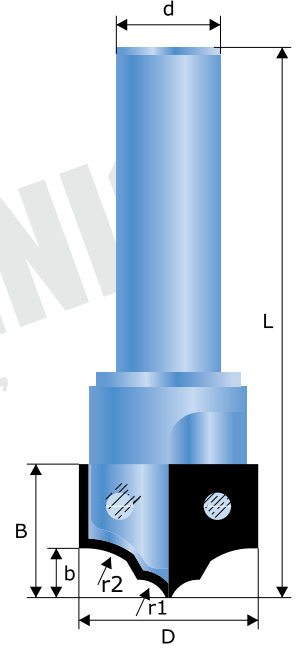

Kod / Art Number

Ölçüler / Dimensions

Kod No:	D	B	b	r1	r2	a°	L	d	Z
TTJ-820	28	20	7,5	5	11	30°	85	16	2
TTJ-821	25	12	-	-	-	50°	85	16	2

Takım Tutuculara uygun, profiller sipariş edilebilir.

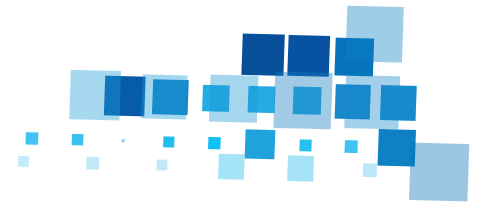
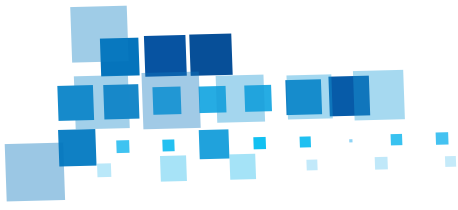

DEĞİŞTİRİLEBİLİR JİLETLİ PROFİL BİÇAKLARI

Changeable Blade Profile Router Bit

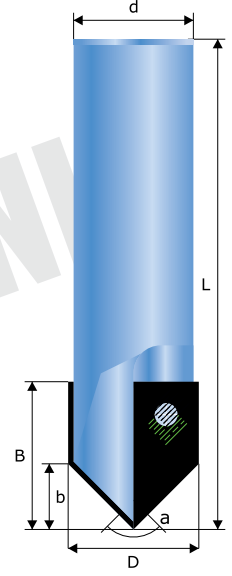

Kod / Art Number

Ölçüler / Dimensions

Kod No:	D	D1	b	B	r1	r2	a°	L	d	Z
TTJ-840	24	-	12	27	-	-	90°	90	20	2

Takım Tutuculara uygun, profiller sipariş edilebilir.

DEĞİŞTİRİLEBİLİR JİLETLİ PROFİL BİÇAKLARI

Changeable Blade Profile Router Bit

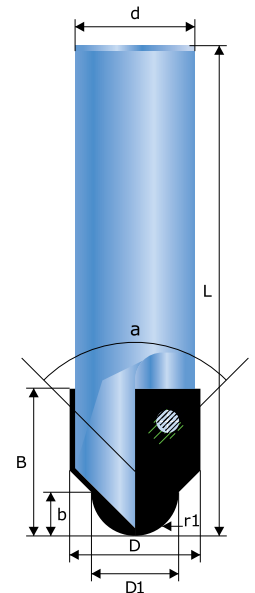

Kod / Art Number

Ölçüler / Dimensions

Kod No:	D	D1	b	B	r1	r2	a°	L	d	Z
TTJ-860	24	15	8	27	7	-	90°	90	20	2

Takım Tutuculara uygun, profiller sipariş edilebilir.

AJ 0012 - 02

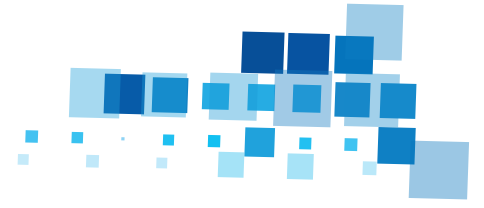

DEĞİŞTİRİLEBİLİR JİLETLİ PROFİL BİÇAKLARI

Changeable Blade Profile Router Bit

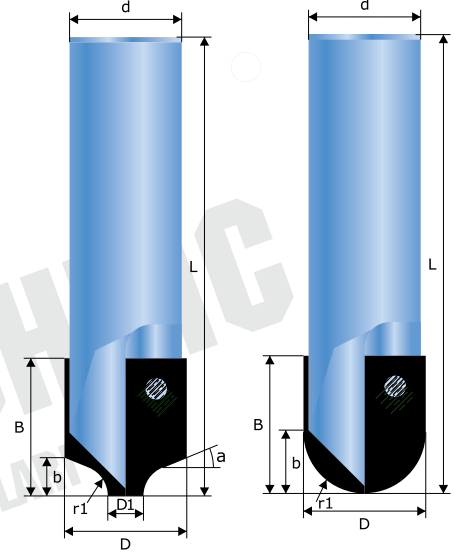

Kod / Art Number	Ölçüler / Dimensions									
Kod No:	D	D1	b	B	r1	r2	a°	L	d	Z
TTJ-880	24	7	7,5	27	6	-	22°	90	20	2
TTJ-881	24	-	12	27	12	-	-	90	20	2

Takım Tutuculara uygun, profiller sipariş edilebilir.

DEĞİŞTİRİLEBİLİR JİLETLİ PROFİL BİÇAKLARI

Changeable Blade Profile Router Bit

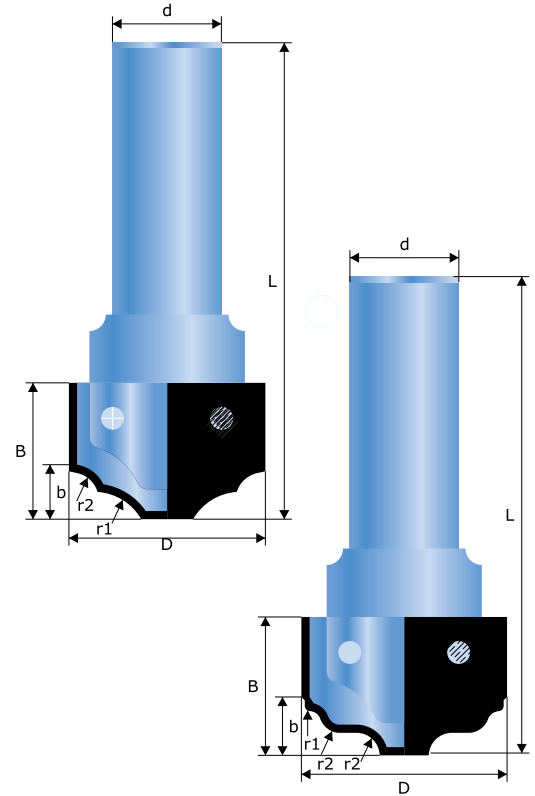
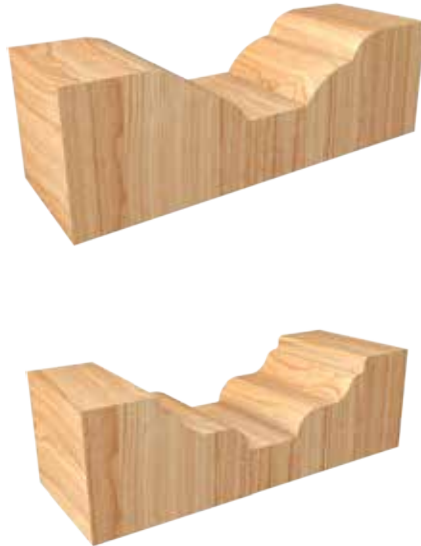

Kod / Art Number	Ölçüler / Dimensions									
Kod No:	D	B	b	r1	r2	a°	L	d	Z	
TTJ-900	36	25	8,5	12	5	-	85	16	2	
TTJ-901	27	25	10,5	1	4	-	87	20	2	

Takım Tutuculara uygun, profiller sipariş edilebilir.

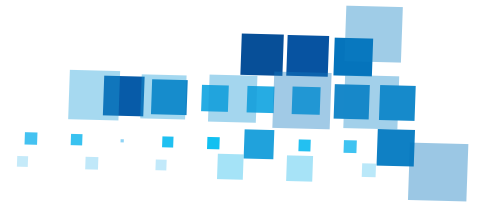
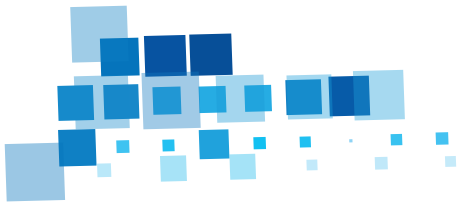

DEĞİŞTİRİLEBİLİR JİLETLİ PROFİL BİÇAKLARI

Changeable Blade Profile Router Bit

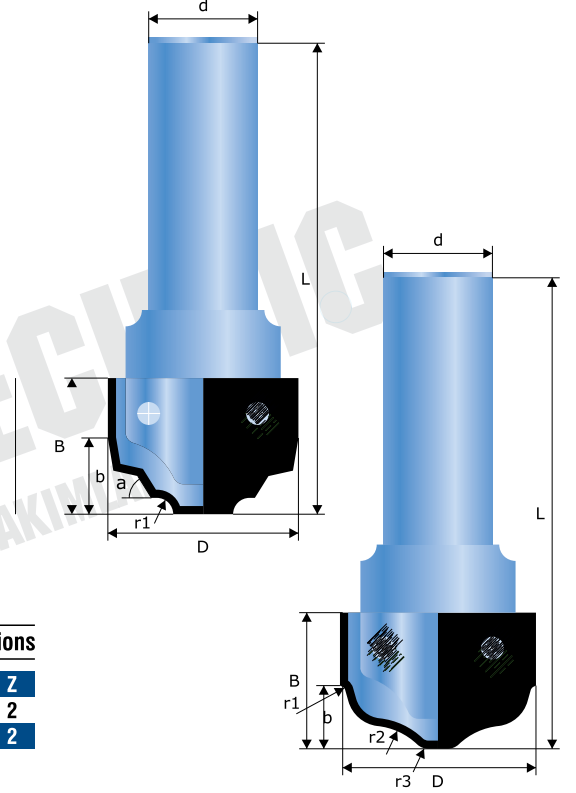

Kod / Art Number	Ölçüler / Dimensions									
Kod No:	D	B	b	r1	r2	r3	a°	L	d	Z
TTJ-920	35	25	14	3	-	-	60°	87	20	2
TTJ-921	36	25	11,5	3	12,5	3	-	87	20	2

Takım Tutuculara uygun, profiller sipariş edilebilir.

DEĞİŞTİRİLEBİLİR JİLETLİ PROFİL BİÇAKLARI

Changeable Blade Profile Router Bit

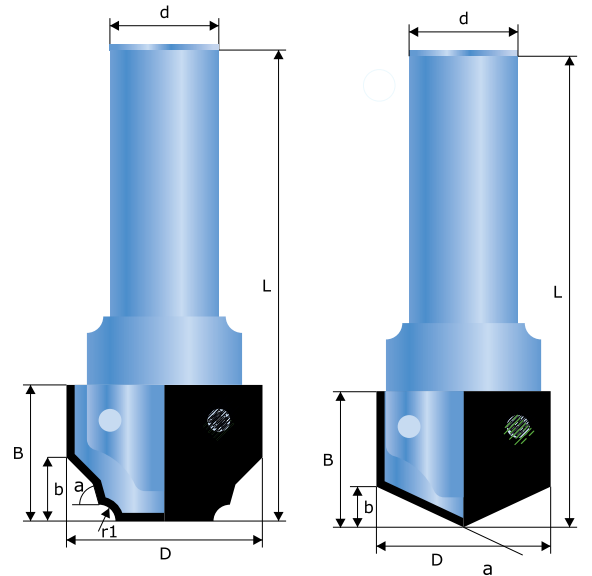

Kod / Art Number	Ölçüler / Dimensions									
Kod No:	D	B	b	r1	r2	a°	L	d	Z	
TTJ-940	36	25	12	3	-	74°	87	20	2	
TTJ-941	32	25	7,5	-	-	65°	87	20	2	

Takım Tutuculara uygun, profiller sipariş edilebilir.

DEĞİŞTİRİLEBİLİR JİLETLİ PROFİL BİÇAKLARI

Changeable Blade Profile Router Bit

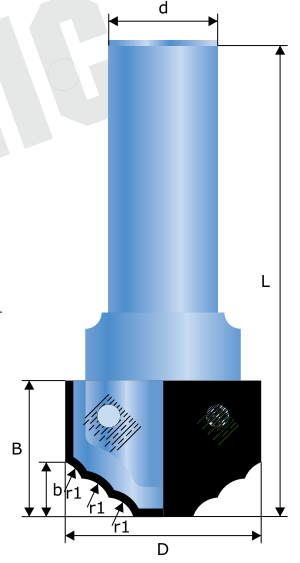
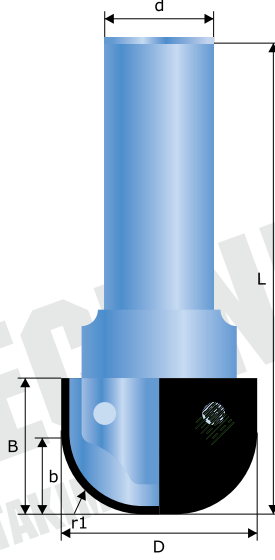
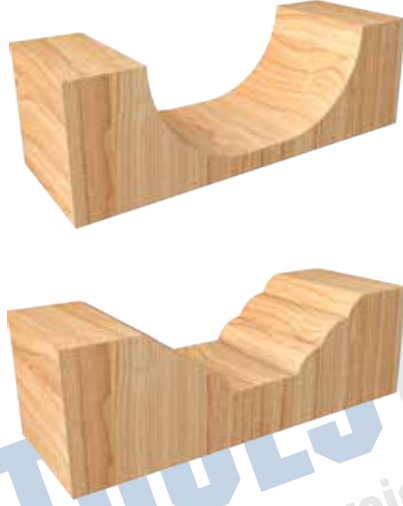

Kod / Art Number	Ölçüler / Dimensions								
Kod No:	D	B	b	r1	r2	a°	L	d	Z
TTJ-960	36	25	13	15	-	-	87	20	2
TTJ-961	36	25	12	5	5	-	87	20	2

Takım Tutuculara uygun, profiller sipariş edilebilir.

DEĞİŞTİRİLEBİLİR JİLETLİ PROFİL BİÇAKLARI

Changeable Blade Profile Router Bit

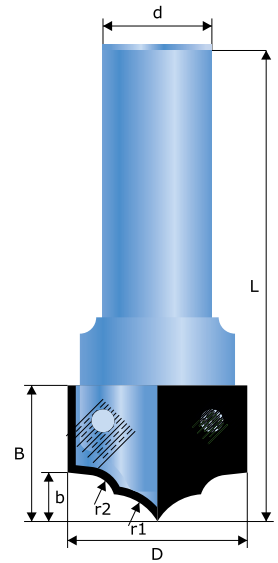

Kod / Art Number	Ölçüler / Dimensions								
Kod No:	D	B	b	r1	r2	a°	L	d	Z
TTJ-980	33	25	9	10	5	-	87	16	2

Takım Tutuculara uygun, profiller sipariş edilebilir.

AJ 0015 - 09

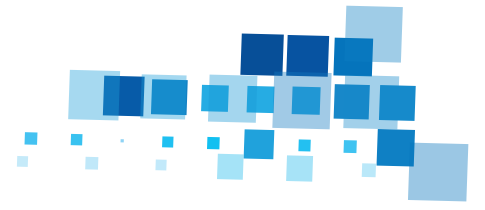
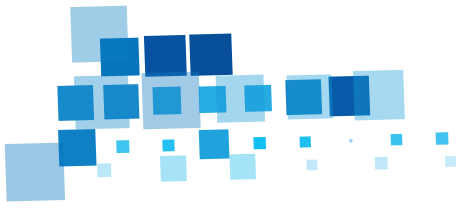

DEĞİŞTİRİLEBİLİR JİLETLİ PROFİL BİÇAKLARI

Changeable Blade Profile Router Bit

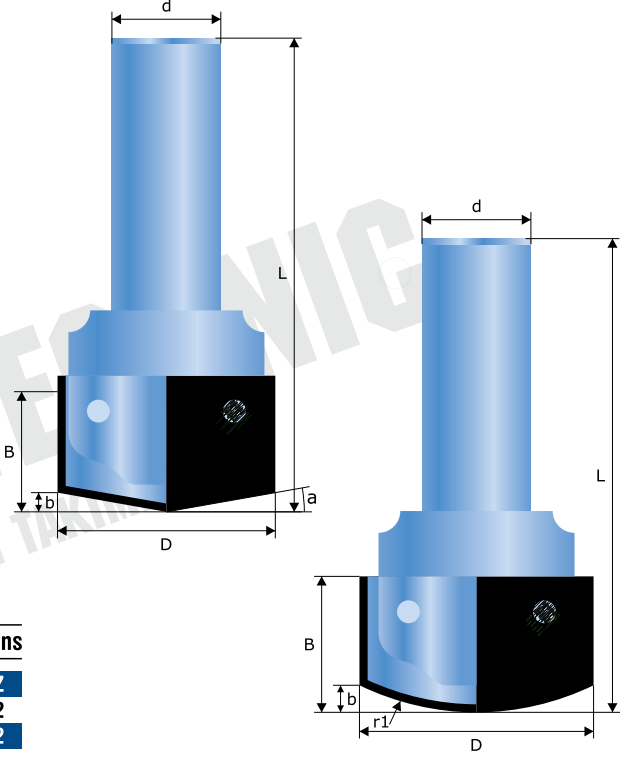

Kod / Art Number	Ölçüler / Dimensions									
Kod No:	D	B	b	r1	r2	a°	L	d	Z	
TTJ-1040	40	25	-	-	-	10°	87	20	2	
TTJ-1041	43	20	5	50	-	-	87	20	2	

Takım Tutuculara uygun, profiller sipariş edilebilir.

DEĞİŞTİRİLEBİLİR JİLETLİ PROFİL BİÇAKLARI

Changeable Blade Profile Router Bit

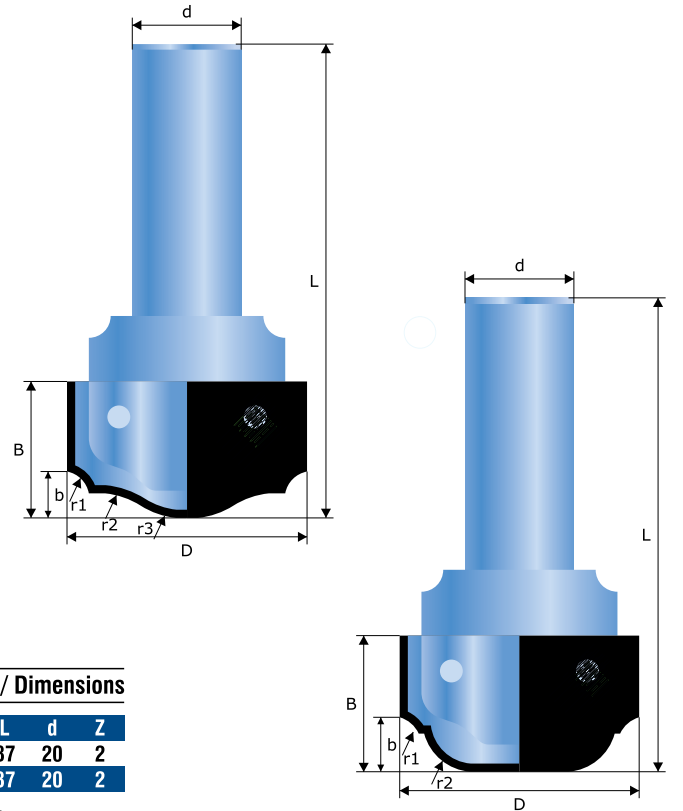

Kod / Art Number	Ölçüler / Dimensions									
Kod No:	D	B	b	r1	r2	r3	a°	L	d	Z
TTJ-1060	44	25	8,5	5	15	15	-	87	20	2
TTJ-1061	44	25	10	5,5	9,5	-	-	87	20	2

Takım Tutuculara uygun, profiller sipariş edilebilir.

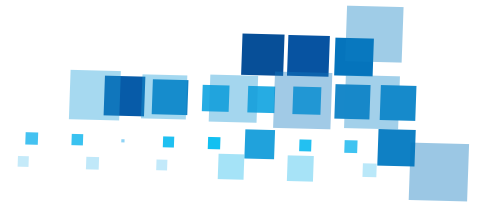
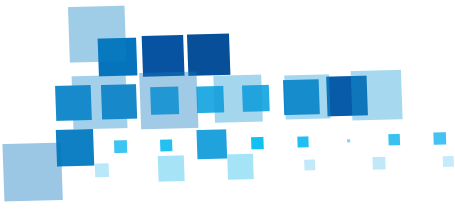

DEĞİŞTİRİLEBİLİR JİLETLİ PROFİL BİÇAKLARI

Changeable Blade Profile Router Bit

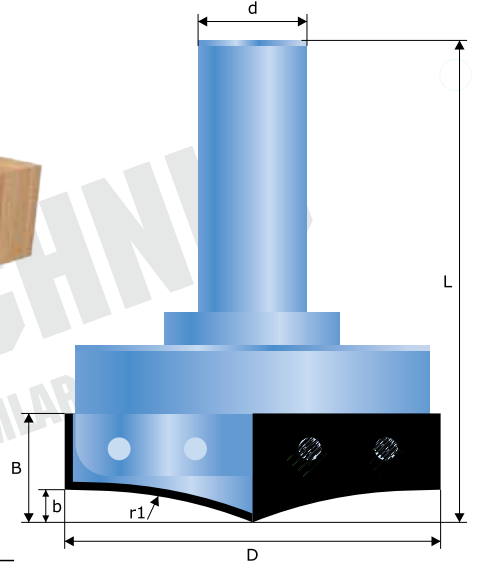

Kod / Art Number

Ölçüler / Dimensions

Kod No:	D	B	b	r1	r2	a°	L	d	Z
TTJ-1080	69	20	6	88	-	-	88	20	2

Takım Tutuculara uygun, profiller sipariş edilebilir.

DEĞİŞTİRİLEBİLİR JİLETLİ PROFİL BİÇAKLARI

Changeable Blade Profile Router Bit

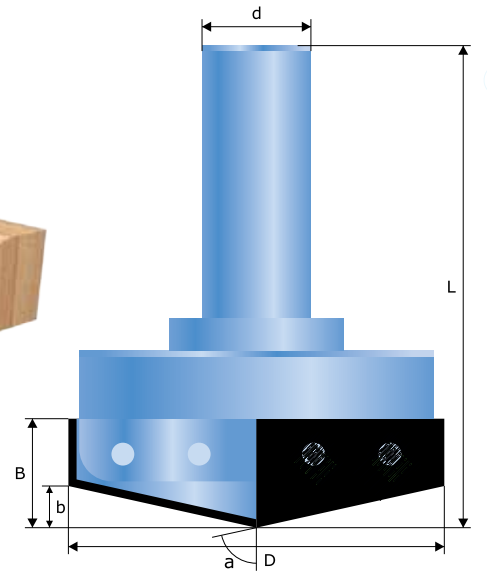

Kod / Art Number

Ölçüler / Dimensions

Kod No:	D	B	b	r1	r2	a°	L	d	Z
TTJ-1100	92	20	7,5	-	-	78°	88	20	2

Takım Tutuculara uygun, profiller sipariş edilebilir.

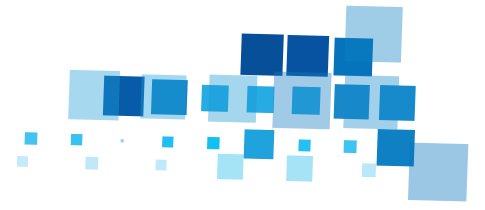
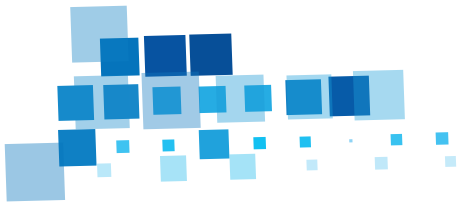

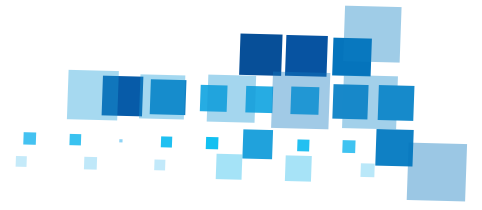
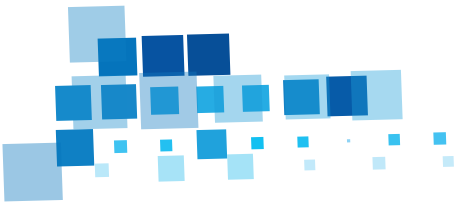

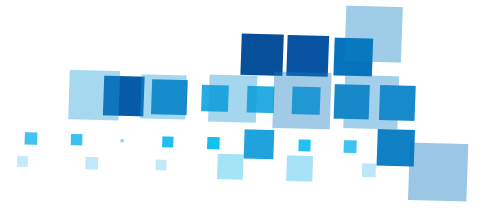
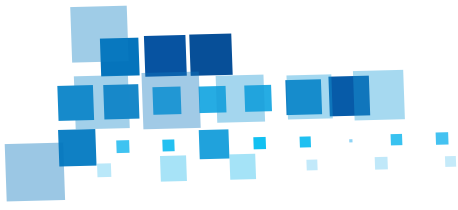

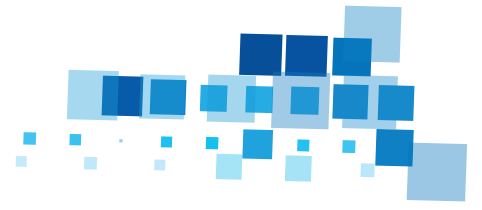
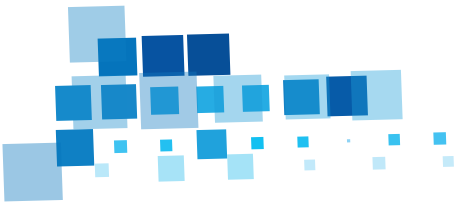

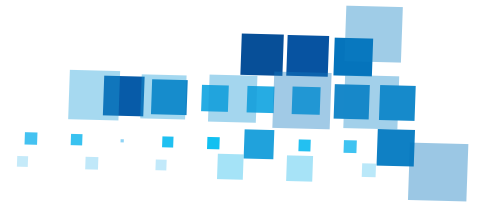
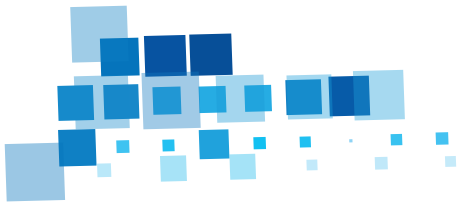

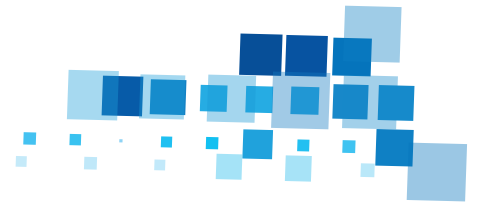

ELEKTROLİZE KÜRE FREZE



	ÇAP	KESİM BOYU	TOPLAM BOYU
TTE3001	3	20	80
TTE3002	4	20	80
TTE3003	5	20	80
TTE3004	6	30	100
TTE3005	6	60	100
TTE3006	8	40	120
TTE3007	8	60	120
TTE3008	10	60	120
TTE3009	10	40	120
TTE3010	12	45	120
TTE3011	12	60	120
TTE3012	14	40	120
TTE3013	16	40	120
TTE3014	18	40	120
TTE3015	20	50	200
TTE3016	25	50	200
TTE3017	30	45	190

ELEKTROLİZE KONİK KÜRE FREZE



	ÇAP	KESİM BOYU	TOPLAM BOYU
TTE3021	3	20	80
TTE3022	4	20	80
TTE3023	6	30	100
TTE3024	8	40	120
TTE3025	10	40	120
TTE3026	12	50	120
TTE3027	14	50	150
TTE3028	16	70	170
TTE3029	18	80	170
TTE3030	20	100	200

ELEKTROLİZE DÜZ FREZE



	ÇAP	KESİM BOYU	TOPLAM BOYU
TTE3031	3	20	80
TTE3032	4	20	80
TTE3033	5	20	80
TTE3034	6	30	100
TTE3035	6	60	100
TTE3036	8	40	120
TTE3037	8	60	120
TTE3038	10	40	120
TTE3039	10	60	120
TTE3040	12	45	120
TTE3041	12	60	120
TTE3042	14	40	120
TTE3043	16	40	120
TTE3044	18	40	120
TTE3045	20	50	200
TTE3046	25	50	200
TTE3047	30	45	190

ELEKTROLİZE YAZI FREZE



	SIKMA ÇAPI	YAZI ÇAPI	KESİM BOYU	TOPLAM BOYU
TTE3048	8	4	5	60

**ELEKTROLİZE SİRİRAL ÇANAK
(MEZAR SULUĐU)**



TTE3050

ÇAP
100

**ELEKTROLİZE SİRİRAL EVYE
BOŐALTMA**



TTE3051

ÇAP
100

ELEKTROLİZE EVYE KESİM PROFİL AÇMA



TTE3052

ÇAP
30

ELEKTROLİZE PAH AÇMA 45'LİK



TTE3053

ÇAP
50

ELEKTROLİZE KAROT



TTE3061
TTE3062
TTE3063
TTE3064
TTE3065
TTE3066
TTE3067

	ÇAP	KESİM BOYU	TOPLAM BOYU
TTE3061	17	10	80
TTE3062	22	10	80
TTE3063	32	10	80
TTE3064	34	10	80
TTE3065	40	10	80
TTE3066	50	10	80
TTE3067	60	10	80

**ELEKTROLİZE STOPLU SİRİRAL
PROFİL**



TTE3071
TTE3072
TTE3073
TTE3074

	ÇAP	PROFİL
TTE3071	100	2'LİK
TTE3072	100	3'LİK
TTE3073	100	4'LİK
TTE3074	100	5'LİK

ELEKTROLİZE TARAMA FREZELERİ



	ÇAP	KESİM BOYU	TOPLAM BOYU
TTE3071	8	30	120
TTE3072	10	30	120
TTE3073	12	30	120
TTE3074	14	40	150
TTE3075	16	40	150
TTE3076	18	40	150
TTE3077	20	40	200
TTE3078	25	40	200
TTE3079	30	40	200

ELEKTROLİZE R15 VİDALI CNC PROFİL FREZE



	ÇAP	TOPLAM BOYU
TTE3080	50	70

MERMER YAZI FREZE

KESİLECEK MALZEMELER: MERMER , DOĞALTAŞ HIZ : 12000



	ÇAP	SAP ÇAPI	2A
TTE3090	1	8	70'
TTE3091	1	8	90'

MERMER - SERAMİK YAZI FREZE



	ÇAP	TOPLAM BOYU
TTE4001	3	70
TTE4002	4	70
TTE4003	5	70
TTE4004	6	80
TTE4005	7	80
TTE4006	8	80
TTE4007	10	90
TTE4008	12	90
TTE4009	14	90
TTE4010	16	90

BETOPAN KARBÜR FREZE

KESİLECEK MALZEMELER: BETOPAN HIZ : 12000



	ÇAP	KESİM BOYU	SAP ÇAPI	TOPLAM BOY	Z
TTE4021	8	28	8	64	2
TTE4022	10	32	10	74	2
TTE4023	12	32	12	85	2

TT TOOLSTECHNIC

“KESİCİ TAKIMLARI”

Yukarı Dudullu Mah. Kıbrıs Cad.
No:19 / 1A Ümraniye / İSTANBUL
Tel: 0544 462 32 65
Mail: tools_technic@hotmail.com
Web: www.toolstechnic.com

