

DRILLS



Contents

Page

Introduction.....	270
Pistol grip drills	272
Straight drills.....	276
Angle drills.....	278
Modular drills	282
Micro stop drills.....	285
Tappers.....	287
Screw-feed drills.....	289
Positive feed drills.....	290

Reliable, productive and comfortable to work with



The handheld drills in Atlas Copco's wide range are of the highest quality and built to provide consistent reliability and performance in a wide range of applications. Their advanced ergonomic designs make your job easier, safer and more efficient.

From the time our first drill was produced in 1901, Atlas Copco has demonstrated a genuine understanding of customer needs. Our drills have evolved to meet changing customer demands over the years. Whatever the job, Atlas Copco has a drill to match your exact requirements.

RELIABLE

When you pick up an Atlas Copco drill, you can be confident that it will do the job over and over again.

POWERFULLY PRODUCTIVE

Despite their compact designs, our drills consistently deliver all the power you need. Their high power-to-weight ratio ensures maximum material removal in the shortest possible time.

ERGONOMIC

Thanks to 50 years of focusing on ergonomics, Atlas Copco drills fit comfortably in your hand. Grips are anatomically shaped to keep your arm and wrist straight, reducing the risk of injury during

long-term use. The light weight and perfect balance of each drill enables you to guide it smoothly and easily. Low noise and vibration levels make the tools comfortable to work with all day long.

DURABLE, LOW MAINTENANCE

The rugged, lubrication-free designs of our drills can withstand the toughest industrial situations and go on working day in, day out. Maintenance requirements are low.

QUALITY THROUGHOUT THE TOOLS' LIFE-CYCLE

Atlas Copco stands for quality, from the manufacture of critical drill components, through production and sales, to service and support throughout the tools' long life-cycle.



Regardless of which model you choose, you'll get a product with superior ergonomics and productivity.

- Quiet – Very low noise level.
- Comfortable grip – For high precision.
- Two-hand grip available – Gives even greater flexibility.
- Lubrication-free – For clean working environment and operator comfort.



Model	Free speed r/min	Chuck capacity mm	Weight with chuck		Air consumption at free speed		Hose size		Air inlet thread BSP	Power		Stall torque Nm	With chuck Ordering No.	Without chuck	
			kg	lb	l/s	cfm	mm	in		W	hp			Model	Ordering No.
Non-reversible drills with air supply through handle															
LBB16 EP-003 ^b	300	10	0.7	1.5	8.0	17.0	6.3	1/4	1/4	290	0.4	-	8421 0108 01	003-U	8421 0108 02
LBB16 EP-005 ^b	500	10	0.7	1.5	8.0	17.0	6.3	1/4	1/4	290	0.4	21.6	8421 0108 06	005-U	8421 0108 07
LBB16 EP-010	1000	10	0.7	1.5	8.0	17.0	6.3	1/4	1/4	290	0.4	7.8	8421 0108 10	010-U	8421 0108 11
LBB16 EP-024 ^a	2400	6.5	0.6	1.2	8.0	17.0	6.3	1/4	1/4	290	0.4	4.2	8421 0108 20	024-U	8421 0108 21
LBB16 EP-033 ^a	3300	6.5	0.6	1.2	8.0	17.0	6.3	1/4	1/4	290	0.4	3.4	8421 0108 30	033-U	8421 0108 31
LBB16 EP-045 ^a	4500	6.5	0.6	1.2	8.0	17.0	6.3	1/4	1/4	290	0.4	2.0	8421 0108 40	045-U	8421 0108 41
LBB16 EP-060 ^a	6000	6.5	0.6	1.2	8.0	17.0	6.3	1/4	1/4	290	0.4	1.7	8421 0108 50	060-U	8421 0108 51
LBB16 EP-200 ^a	20000	6.5	0.6	1.2	8.0	17.0	6.3	1/4	1/4	290	0.4	0.5	8421 0108 60	200-U	8421 0108 61
LBB16 EPX-005 ^b	500	13	0.7	1.5	9.5	20.0	6.3	1/4	1/4	340	0.45	25.2	8421 0108 08	005-U	8421 0108 09
LBB16 EPX-010 ^b	1000	10	0.7	1.5	9.5	20	6.3	1/4	1/4	340	0.45	12.3	8421 0108 12	010-U	8421 0108 03
LBB16 EPX-024 ^a	2400	6.5	0.6	1.2	9.5	20.0	6.3	1/4	1/4	340	0.45	4.9	8421 0108 22	024-U	8421 0108 23
LBB16 EPX-033 ^a	3300	6.5	0.6	1.2	9.5	20.0	6.3	1/4	1/4	340	0.45	3.7	8421 0108 32	033-U	8421 0108 33
LBB16 EPX-045 ^a	4500	6.5	0.6	1.2	9.5	20.0	6.3	1/4	1/4	340	0.45	3.0	8421 0108 42	045-U	8421 0108 43
LBB16 EPX-060 ^a	6000	6.5	0.6	1.2	9.5	20.0	6.3	1/4	1/4	340	0.45	2.3	8421 0108 52	060-U	8421 0108 53
LBB16 EPX-200 ^a	20000	6.5	0.6	1.2	9.5	20	6.3	1/4	1/4	340	0.45	0.6	8421 0108 82	200-U	8421 0108 63
LBB26 EPX-003 ^b	300	13	0.82	1.8	14.5	31.8	10.0	3/8	1/4	500	0.7	53.5	8421 0500 00	003-U	8421 0500 01
LBB26 EPX-005 ^b	500	13	0.82	1.8	14.5	31.8	10.0	3/8	1/4	500	0.7	31.6	8421 0500 02	005-U	8421 0500 03
LBB26 EPX-007 ^b	700	13	0.82	1.8	14.5	31.8	10.0	3/8	1/4	500	0.7	24.6	8421 0500 04	007-U	8421 0500 05
LBB26 EPX-013 ^{ab}	1300	10	0.79	1.7	14.5	31.8	10.0	3/8	1/4	500	0.7	14.7	8421 0500 06	013-U	8421 0500 07
LBB26 EPX-019 ^a	1900	10	0.79	1.7	14.5	31.8	10.0	3/8	1/4	500	0.7	9.9	8421 0500 24	019-U	8421 0500 25
LBB26 EPX-026 ^a	2600	8	0.79	1.7	14.5	31.8	10.0	3/8	1/4	500	0.7	7.7	8421 0500 08	026-U	8421 0500 09
LBB26 EPX-033 ^a	3300	8	0.69	1.5	14.5	31.8	10.0	3/8	1/4	500	0.7	5.7	8421 0500 10	033-U	8421 0500 11
LBB26 EPX-045 ^a	4500	8	0.69	1.5	14.5	31.8	10.0	3/8	1/4	500	0.7	4.1	8421 0500 12	045-U	8421 0500 13
LBB26 EPX-060 ^a	6000	8	0.69	1.5	14.5	31.8	10.0	3/8	1/4	500	0.7	3.3	8421 0500 14	060-U	8421 0500 15
LBB26 EPX-200 ^a	20000	6.5	0.69	1.5	14.5	31.8	10.0	3/8	1/4	500	0.7	0.8	8421 0500 28	200-U	8421 0500 29
LBB36 H005 ^b	500	-	1.2	3.3	16.5	34.9	10	3/8	3/8	700	0.9	43.8	-	-H005U	8421 0408 03
LBB36 H007 ^b	700	13	1.6	3.5	16.5	34.9	10	3/8	3/8	700	0.9	37.2	8421 0408 07	-H007U	8421 0408 05
LBB36 H013 ^a	1300	10	1.5	3.3	16.5	34.9	10.0	3/8	3/8	700	0.9	19.5	8421 0408 15	-H013U	8421 0408 13
LBB36 H026 ^a	2600	10	1.2	2.5	16.5	34.9	10.0	3/8	3/8	700	0.9	10.3	8421 0408 33	-H026U	8421 0408 31
LBB36 H033 ^a	3300	10	1.2	2.5	16.5	34.9	10.0	3/8	3/8	700	0.9	8.6	8421 0408 41	-H033U	8421 0408 39
LBB36 H060 ^a	6000	6.5	1.2	2.5	16.5	34.9	10.0	3/8	3/8	700	0.9	5.0	8421 0408 49	-H060U	8421 0408 47
LBB36 H200 ^a	20000	6.5	1.0	2.2	16.5	34.9	10.0	3/8	3/8	700	0.9	1.3	8421 0408 55	-H200U	8421 0408 53
LBB37 H006	600	13	1.2	2.5	20.5	44.0	10.0	3/8	3/8	820	1.1	48.0	8421 0608 06	-H006U	8421 0608 14
LBB37 H015	1500	10	1.5	3.3	20.5	44.0	10.0	3/8	3/8	820	1.1	22.5	8421 0608 05	-H015U	8421 0608 15
LBB37 H037	3700	10	1.2	2.5	20.5	44.0	10.0	3/8	3/8	820	1.1	9.2	8421 0608 13	-H037U	8421 0608 16
LBB37 H065	6500	6.5	1.2	2.5	20.5	44.0	10.0	3/8	3/8	820	1.1	5.0	8421 0608 11	-H065U	8421 0608 17
LBB37 H230	23000	6.5	1.0	2.2	20.5	44.0	10.0	3/8	3/8	820	1.1	1.3	8421 0608 03	-H230U	8421 0608 18
LBB45 H004 ^b	400	16	4.3	9.3	10.0	21.0	10.0	3/8	1/4	700	0.9	-	8421 0501 16	-	-
LBB45 H006 ^b	600	16	4.3	9.3	10.0	21.0	10.0	3/8	1/4	700	0.9	-	8421 0501 24	-H006U	8421 0501 40
LBB45 H017 ^b	1700	16	4.2	9.3	10.0	21.0	10.0	3/8	1/4	700	0.9	-	8421 0501 32	-	-
ATEX certified models															
LBB26 EPX005-ATEX	500	13	0.82	1.8	14.5	31.8	10	3/8	1/4	500	0.7	-	8421 0500 22	-	-
LBB26 EPX007-ATEX	700	13	0.82	1.8	14.5	31.8	10	3/8	1/4	500	0.7	-	8421 0500 21	-	-
LBB26 EPX013-ATEX	1300	10	0.79	1.7	14.5	31.8	10	3/8	1/4	500	0.7	-	8421 0500 20	-	-
LBB26 EPX026-ATEX	2600	8	0.79	1.7	14.5	31.8	10	3/8	1/4	500	0.7	-	8421 0500 19	-	-

^a Including chuck guard.

^b Including support handle.

Dimensions

LBB EP/EPX/H

Model	L mm	H mm	C mm	D mm	E mm
LBB16 EP/EPX-200	177	131	16.5	31.4	13.8
LBB16 EP/EPX-060	177	131	16.5	31.4	13.8
LBB16 EP/EPX-045	177	131	16.5	31.4	13.8
LBB16 EP/EPX-033	177	131	16.5	31.4	13.8
LBB16 EP/EPX-024	177	131	16.5	31.4	13.8
LBB16 EP/EPX-010	190	131	16.5	31.4	27.0
LBB16 EP/EPX-005	190	131	16.5	31.4	27.0
LBB16 EP-003	190	131	16.5	31.4	27.0
LBB26 EPX-060	180	147	21	39	-
LBB26 EPX-045	180	147	21	39	-
LBB26 EPX-033	180	147	21	39	-
LBB26 EPX-026	180	147	21	39	-
LBB26 EPX-019	196	147	21	39	-
LBB26 EPX-013	196	147	21	39	-
LBB26 EPX-007	196	147	21	39	-
LBB26 EPX-005	196	147	21	39	-
LBB26 EPX-003	196	147	21	39	-
LBB36 H200	217	157	23	41.5	16.5
LBB36 H060	217	157	23	41.5	16.5
LBB36 H033	217	157	23	41.5	16.5
LBB36 H026	217	157	23	41.5	16.5
LBB36 H013	256	157	23	41.5	64.0
LBB36 H007	256	157	23	41.5	64.0
LBB36 H005	256	157	23	41.5	64.0
LBB37 H230	217	157	23	41.5	16.5
LBB37 H065	217	157	23	41.5	16.5
LBB37 H037	217	157	23	41.5	16.5
LBB37 H015	256	157	23	41.5	64.0
LBB37 H006	256	157	23	41.5	64.0
LBB45 H006	360	185	33	60	113
LBB45 H017	360	185	33	60	113
LBB45 H004	360	185	33	60	113

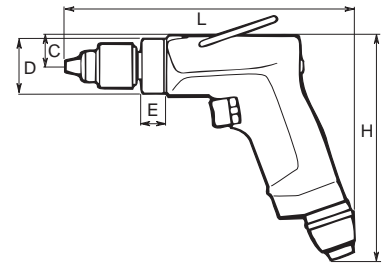

Accessories Included

Chuck, chuck key, hose nipple.

LBB16 and -36/37 with suspension yoke and with chuck guard where possible.

LBB16 and -36/37 have a 3/8" -24 UNF spindle thread.

LBB36 H005 and LBB37 H006 have a 1/2" -20 UNF thread.

LBB45 has a JT3 taper mount.

Optional Accessories

KEY CHUCKS

Mount	Body diameter mm	Chuck capacity mm	Ordering No.		
			Chuck (key incl)	Key only	Key designation
1/2-20UNF	43	2.0-13.0	4021 0289 01	4021 0465 00	S2
3/8-24UNF	30	0.0- 6.5	4021 0283 00	4021 0293 00	S1
3/8-24UNF	30	0.5- 8.0	4021 0495 00	4021 0293 00	S1
3/8-24UNF	36	2.0-10.0	4021 0416 00	4021 0449 00	S8
3/8-24UNF	46	2.0-13.0	4021 0289 00	4021 0465 00	S2
JT3	59	3.0-16.0	4021 0423 00	4021 0301 00	S3



Key chuck

QUICK CHUCKS

Mount	Chuck dia mm	Chuck capacity mm	Ordering No.
3/8-24UNF	34	0.0- 6.5	4021 0400 00
3/8-24UNF	34	0.0- 8.0	4021 0401 00
3/8-24UNF	36	0.0-10.0	4021 0402 00
3/8-24UNF	36	2.0-13.0	4021 0403 00



Quick chuck

Optional Accessories

COLLET CHUCK AND COLLETS

Designation	Capacity		Ordering No.	
	mm	in		
Collet	3		4150 0081 00	
	6		4150 0075 00	
	8	5/16		4150 0074 00
		1/8		4150 0082 00
		5/32		4150 0648 00
		3/16		4150 0649 00
		1/4		4150 0076 00
Collet holder			4110 0844 90	
Collet nut			4150 0760 00	



Collet chuck and collets

CHUCK GUARDS

For model	Max chuck dia mm	Ordering No.
LBB16 ^a	30	4110 1619 04
LBB26	36	4110 1728 02
LBB26	30	4110 1728 03
LBB36 ^b	36	4110 1415 00
LBB37 ^b	36	4110 1415 00

^aThe guards do not fit 1000 r/min models, 500 r/min and 300 r/min models.

^bThe chuck guards do not fit the 500 r/min, 600 r/min or 700 r/min models.



Chuck guard

FLEX CONNECT

For model	Ordering No.
LBB16	4110 1601 80



Flex connect

SPOT SUCTION ATTACHMENT

For model	Hose size in	Spot suction kit ^a	Hose kit
		Ordering No.	Ordering No.
LBB16	1 1/4	4110 1715 80	4112 1227 00
LBB26	1 1/4	4110 1715 84	4112 1227 00
LBB36/37	1 1/4	4110 1716 80	4112 1227 00

^a Spare part, nose piece kit, Ordering No. 4110 1700 90.

Other standard sizes of front nozzle available.



Spot suction attachment

POWER FEED ARM FOR EXTRA FEED FORCE – LBB36 H005 AND LBB37 H006

	Ordering No.
Adapter piece (SR295), lever arm (SR201), chain (SR202) and No. 2 Morse socket (SR206)	4110 1416 80
Two extension pieces (SR204-1 and SR204-2), 370 and 750 mm long	4110 1417 80
No. 2 Morse socket	4110 1416 01



Power feed arm

Optional Accessories

SUPPORT HANDLES

For model	Ordering No.
LBB16	4110 1355 92
LBB26	4110 1355 95
LBB36/37	4110 1355 82
LBB45	4110 1355 84



Support handle

OPTIONAL ACCESSORIES – LBB45

Designation	Ordering No.
Feed screw	4110 0976 80
No. 2 Morse socket	4130 1080 00

Productivity Kits

Model	Max air flow	Hose, 5 m	Coupling	Lubrication	Ordering No.
For small drills with 1/8" BSP air inlet					
MIDI Optimizer F/RD EQ08-C06-1/8	6 l/s	Cablair 6 mm	ErgoQIC 08	Yes	8202 0850 10
MIDI Optimizer F/R EQ08-C06-1/8	6 l/s	Cablair 6 mm	ErgoQIC 08	No	8202 0850 19
For small drills with 1/4" BSP air inlet					
MIDI Optimizer F/RD EQ08-C06	6 l/s	Cablair 6 mm	ErgoQIC 08	Yes	8202 0850 06
For drills with 1/4" BSP air inlet					
MIDI Optimizer F/RD EQ08-C08	9 l/s	Cablair 8 mm	ErgoQIC 08	Yes	8202 0850 00
MIDI Optimizer F/R EQ08-C08	9 l/s	Cablair 8 mm	ErgoQIC 08	No	8202 0850 01
For drills with 3/8" BSP air inlet					
MIDI Optimizer F/RD EQ08-C10	16 l/s	Cablair 10 mm	ErgoQIC 08	Yes	8202 0850 07
For drills with 3/8" BSP air inlet					
MIDI Optimizer F/RD EQ10-C13	23 l/s	Cablair 13 mm	ErgoQIC 10	Yes	8202 0850 02
For drills with 1/4" BSP air inlet					
MIDI Optimizer F/RD EQ10-C13-1/4	23 l/s	Cablair 13 mm	ErgoQIC 10	Yes	8202 0850 11



Service Kits

LBB16	4081 0271 90
LBB26	4081 2028 90
LGB/LBV34	4081 0035 90
LBB36/37	4081 0194 90
LBB45	4081 0139 90

Atlas Copco straight drills are primarily intended for vertical drilling operations and for drilling in cramped spaces.

- Quiet – Very low noise level.
- Very high power to weight ratio.
- Adjustable exhaust – The exhaust air is directed away from the operator.
- Lubrication-free – LBB16 drills are lubrication-free for clean working environment and operator comfort.



LBB16

Model	Free speed ^a r/min	Chuck capacity mm	Weight		Air consumption at free speed		Hose size		Air inlet thread BSP	Power		With chuck Ordering No.	Without chuck	
			kg	lb	l/s	cfm	mm	in		W	hp		Model	Ordering No.
Drills with rear exhaust														
LBB16 S260	26000	6.5	0.55	1.1	8.0	17	6.3	1/4	1/4	350	0.47	8421 0210 00	S260-U	8421 0210 10
LBB16 S064	6400	6.5	0.55	1.1	8.0	17	6.3	1/4	1/4	350	0.47	8421 0210 01	S064-U	8421 0210 11
LBB16 S045	4500	6.5	0.55	1.1	8.0	17	6.3	1/4	1/4	350	0.47	8421 0210 02	S045-U	8421 0210 12
LBB16 S038	3800	6.5	0.55	1.1	8.0	17	6.3	1/4	1/4	350	0.47	8421 0210 03	S038-U	8421 0210 13
LBB16 S029	2900	8	0.60	1.2	8.0	17	6.3	1/4	1/4	350	0.47	8421 0210 04	S029-U	8421 0210 14
LBB16 S022	2200	10	0.70	1.5	8.0	17	6.3	1/4	1/4	350	0.47	8421 0210 05	S022-U	8421 0210 15
LBB16 S012	1200	10	0.70	1.5	8.0	17	6.3	1/4	1/4	350	0.47	8421 0210 06	S012-U	8421 0210 16

^a The free speed can be reduced to 50% of the maximum speed using the trim valve.

Dimensions

Model	L	H	A
LBB16 S260	196	39	146
LBB16 S064	196	39	146
LBB16 S045	196	39	146
LBB16 S038	196	39	146
LBB16 S029	196	39	146
LBB16 S022	219	39	159
LBB16 S012	219	39	159

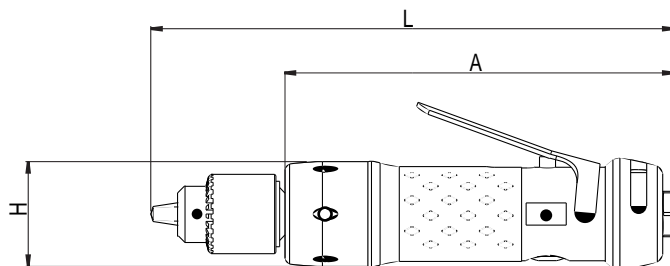

Accessories Included

Chuck, chuck key
Suspension yoke and chuck guard

Optional Accessories

KEY CHUCKS

Mount	Body diameter mm	Chuck capacity mm	Ordering No.		
			Chuck (key incl)	Key only	Key designation
1/2-20UNF	43	2.0-13.0	4021 0289 01	4021 0465 00	S2
3/8-24UNF	30	0.0- 6.5	4021 0283 00	4021 0293 00	S1
3/8-24UNF	30	0.5- 8.0	4021 0495 00	4021 0293 00	S1
3/8-24UNF	36	2.0-10.0	4021 0416 00	4021 0449 00	S8
3/8-24UNF	46	2.0-13.0	4021 0289 00	4021 0465 00	S2
JT3	59	3.0-16.0	4021 0423 00	4021 0301 00	S3



Key chuck

QUICK CHUCKS

Mount	Chuck dia mm	Chuck capacity mm	Ordering No.
3/8-24UNF	34	0.0- 6.5	4021 0400 00
3/8-24UNF	34	0.0- 8.0	4021 0401 00
3/8-24UNF	36	0.0-10.0	4021 0402 00
3/8-24UNF	36	2.0-13.0	4021 0403 00



Quick chuck

COLLET CHUCK AND COLLETS

Designation	Capacity		Ordering No.
	mm	in	
Collet	3		4150 0081 00
	6		4150 0075 00
	8	5/16	4150 0074 00
		1/8	4150 0082 00
		5/32	4150 0648 00
		3/16	4150 0649 00
		1/4	4150 0076 00
Collet holder			4110 0844 90
Collet nut			4150 0760 00



Collet chuck and collets

SAFETY LEVER

For model	Ordering No.
LBB16S	4110 1787 90



Safety lever



Service Kits

LBB16 4081 0438 90

- Quiet – Very low noise level.
- Low air consumption – Good operating economy.
- Side exhaust – The air can be directed to suit the operator.
- Rear exhaust – The air is piped away through a pliant hose.
- Lubrication-free – For clean working environment and operator comfort.
- Collet chuck or threaded spindle.
- Multiple lever options.



Model	Free speed r/min	Setting range rpm	Collet or chuck capacity mm	Weight		Air consumption at free speed		Hose dimension mm	Air inlet thread		Power		Ordering No.
				kg	lb	l/s	cfm		in	BSP	W	hp	
30° angle head													
LBV11 S029-S30	2900	–	5	0.5	1.1	4.0	8.5	5.0	1/8	1/8	110	0.16	8421 0108 70
LBV16 032-30	3200	1500-3200	5	0.5	1.1	8.7	18.4	6.3	1/4	1/4	300	0.4	8421 0110 05
LBV16 032-S30	3200	1500-3200	5	0.45	1.0	8.7	18.4	6.3	1/4	1/4	300	0.4	8421 0110 04
LBV16 032-32	3200	1500-3200	°	0.5	1.1	8.7	18.4	6.3	1/4	1/4	300	0.4	8421 0110 07
LBV16 032-S32	3200	1500-3200	°	0.45	1.0	8.7	18.4	6.3	1/4	1/4	300	0.4	8421 0110 06
LBV16 045-30	4500	3200-4500	5	0.5	1.1	8.7	18.4	6.3	1/4	1/4	300	0.4	8421 0110 71
LBV36 S030-30 ^e	3000	–	5	1.0	2.2	17.0	36.0	10.0	3/8	1/4	510	0.73	8421 0414 70
45° angle head													
LBV16 032-45	3200	1500-3200	5	0.5	1.1	8.7	18.4	6.3	1/4	1/4	300	0.4	8421 0110 59
LBV16 032-46	3200	1500-3200	°	0.5	1.1	8.7	18.4	6.3	1/4	1/4	300	0.4	8421 0110 60
90° angle head													
LBV11 S029-S90	2900	–	5	0.5	1.1	4.0	8.5	5.0	1/8	1/8	110	0.16	8421 0109 79
LBV16 032-90	3200	1500-3200	5	0.5	1.1	8.7	18.4	6.3	1/4	1/4	300	0.4	8421 0110 00
LBV16 032-S90	3200	1500-3200	5	0.45	1.0	8.7	18.4	6.3	1/4	1/4	300	0.4	8421 0110 01
LBV16 032-92	3200	1500-3200	°	0.5	1.1	8.7	18.4	6.3	1/4	1/4	300	0.4	8421 0110 03
LBV16 032-S92	3200	1500-3200	°	0.45	1.0	8.7	18.4	6.3	1/4	1/4	300	0.4	8421 0110 02
LBV16 045-90	4500	3200-4500	5	0.5	1.1	8.7	18.4	6.3	1/4	1/4	300	0.4	8421 0110 20
LBV16 045-92	4500	3200-4500	°	0.5	1.1	8.7	18.4	6.3	1/4	1/4	300	0.4	8421 0110 21
LBV16 055-90	5500	4500-5500	5	0.5	1.1	8.7	18.4	6.3	1/4	1/4	300	0.4	8421 0110 23
LBV16 055-S92	5500	4500-5500	°	0.45	1.0	8.7	18.4	6.3	1/4	1/4	300	0.4	8421 0110 58
LBV36 S030-90 ^e	3000	–	5	1.0	2.2	17.0	36.0	10.0	3/8	1/4	510	0.73	8421 0414 60
LBV36 S030-92 ^e	3000	–	°	1.0	2.2	17.0	36.0	10.0	3/8	1/4	510	0.73	8421 0414 64
LBV36 S045-90 ^e	4500	–	5	1.0	2.2	17.0	36.0	10.0	3/8	1/4	510	0.73	8421 0414 62
360° angle head													
LBV16 032-90Z	3200	1500-3200	5	0.5	1.1	8.7	18.4	6.3	1/4	1/4	300	0.4	8421 0110 64
LBV16 032-92Z	3200	1500-3200	°	0.5	1.1	8.7	18.4	6.3	1/4	1/4	300	0.4	8421 0110 68
90° angle head – large angle head													
LBV16 005-91	500	200-500	6.6	0.6	1.2	8.7	18.4	6.3	1/4	1/4	300	0.4	8421 0110 11
LBV16 005-93	500	200-500	°	0.6	1.2	8.7	18.4	6.3	1/4	1/4	300	0.4	8421 0110 12
LBV16 010-91	1000	500-1000	6.6	0.6	1.2	8.7	18.4	6.3	1/4	1/4	300	0.4	8421 0110 16
LBV16 010-93	1000	500-1000	°	0.6	1.2	8.7	18.4	6.3	1/4	1/4	300	0.4	8421 0110 17
LBV16 018-91	1800	800-1800	6.6	0.55	1.2	8.7	18.4	6.3	1/4	1/4	300	0.4	8421 0110 18
LBV16 018-93	1800	800-1800	°	0.55	1.2	8.7	18.4	6.3	1/4	1/4	300	0.4	8421 0110 19
LBV16 032-91	3200	1500-3200	6.6	0.55	1.2	8.7	18.4	6.3	1/4	1/4	300	0.4	8421 0110 09
LBV16 032-93	3200	1500-3200	°	0.55	1.2	8.7	18.4	6.3	1/4	1/4	300	0.4	8421 0110 10
LBV16 032-S93	3200	1500-3200	°	0.45	1.2	8.7	18.4	6.3	1/4	1/4	300	0.4	8421 0110 39
LBV16 045-91	4500	3200-4500	6.6	0.55	1.2	8.7	18.4	6.3	1/4	1/4	300	0.4	8421 0110 38
LBV36 S030-91 ^e	3000	–	6.6	1.0	2.2	17.0	36.0	10.0	3/8	1/4	510	0.73	8421 0414 50
LBV36 S060-91 ^e	6000	–	6.6	1.0	2.2	17.0	36.0	10.0	3/8	1/4	510	0.73	8421 0414 51
LBV36 S030-93 ^e	3000	–	°	1.0	2.2	17.0	36.0	10.0	3/8	1/4	510	0.73	8421 0414 52
LBV36 S060-93 ^e	6000	–	°	1.0	2.2	17.0	36.0	10.0	3/8	1/4	510	0.73	8421 0414 53
90° angle head – Key chuck models													
LBV16 018-11	1800	800-1800	8 ^a	0.8	1.7	8.7	18.4	6.3	1/4	1/4	300	0.4	8421 0110 22
LBV34 S005 ^b	500	–	13 ^a	2.1	4.6	7.5	15.9	10.0	3/8	1/4	400	0.6	8421 0309 04
LBV34 S010 ^b	1000	–	10 ^a	2.0	4.4	7.5	15.9	10.0	3/8	1/4	400	0.6	8421 0309 12
LBV34 S040 ^b	4000	–	6.5 ^a	1.5	3.3	7.5	15.9	10.0	3/8	1/4	400	0.6	8421 0309 46

Continued...

Model	Free speed r/min	Setting range rpm	Collet or chuck capacity mm	Weight		Air consumption at free speed		Hose dimension mm	Air inlet thread		Power		Ordering No.
				kg	lb	l/s	cfm		in	BSP	W	hp	
90° angle head – heavy-duty													
LBV37 030	3000	–	c	1.1	2.4	22	46	10.0	3/8	3/8	820	1.1	8421 0414 54
LBV37 HD030	3000	–	d	1.1	2.4	22	46	10.0	3/8	3/8	820	1.1	8421 0414 56

^a Spindle thread, male 3/8"-24 UNF.

^b Side exhaust.

^c Internal thread 1/4"-28.

^d Internal thread 5/16".

^e Short lever as standard.

Dimensions

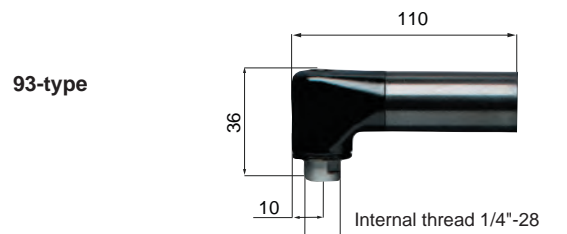
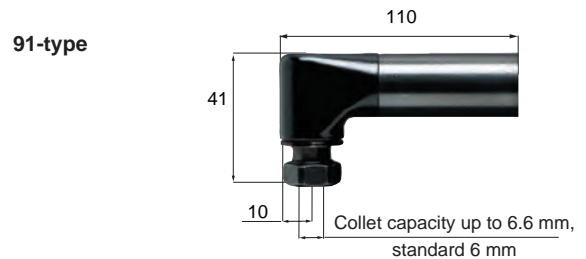
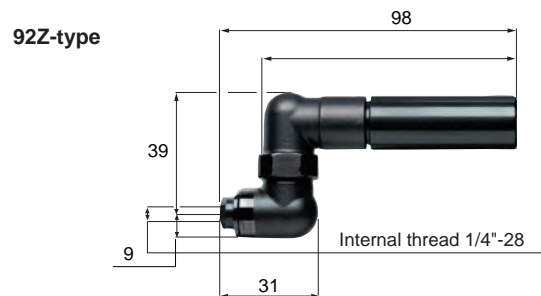
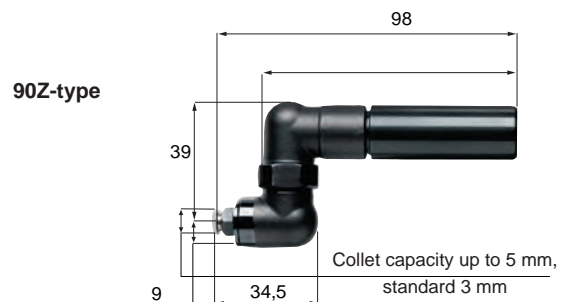
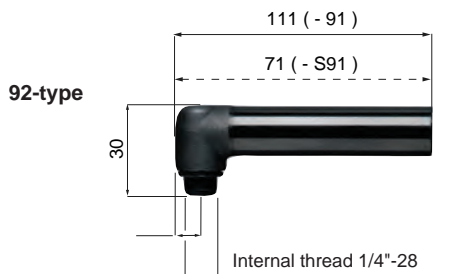
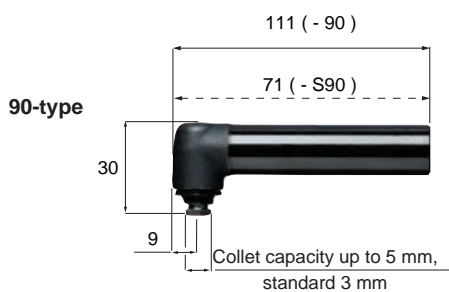
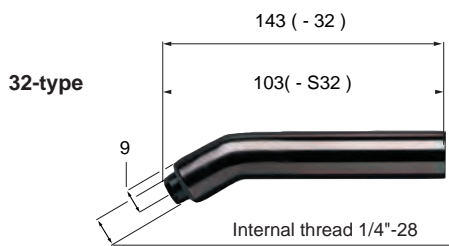
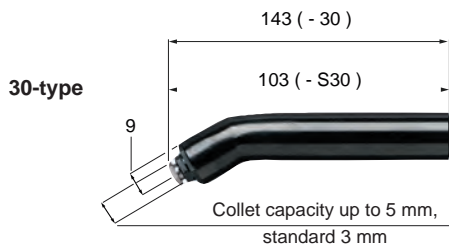

Dimensions

DRILLING CAPACITY

Model	Angle head mm				
	A	B	C	L	H
LBV11 S027-S30	59	25	18	224	30
LBV11 S025-S90	44	30	18	204	30
LBV16 032-S30	103	25	17	241	42
LBV16 032-30	143	25	17	281	42
LBV16 032-S32	103	25	17	241	42
LBV16 032-32	143	25	17	281	42
LBV16 032-90	111	30	17	248	42
LBV16 032-S90	71	30	17	209	42
LBV16 032-S92	71	30	17	209	42
LBV16 032-92	111	30	17	249	42
LBV16 032-90Z	145	48	17	283	42
LBV16 032-91	110	39	20	248	42
LBV16 032-93	110	36	20	248	42
LBV16 005-91	110	39	20	248	42
LBV16 005-93	110	36	20	248	42
LBV16 010-91	110	39	20	248	42
LBV16 010-93	110	36	20	248	42
LBV16 018-91	110	39	20	248	42
LBV16 018-93	110	36	20	248	42
LBV34 S040	92	97	20	255	43
LBV34 S010	92	114	20	290	43
LBV34 S005	92	120	20	290	43
LBV36 S030-91	92	41	20	252	43
LBV36 S060-91	92	41	20	252	43
LBV36 S030-93	92	36	20	252	43
LBV36 S060-93	92	36	20	252	43
LBV36 S030-30	122	26	18	281	43
LBV36 S045-30	122	26	18	281	43
LBV36 S030-90	112	30	18	272	43
LBV36 S045-90	112	30	18	272	43
LBV36 S030-92	112	30	18	272	43
LBV37 030	55	39	23	262	43
LBV37 HD030	55	39	23	262	43

LBV11, -16, -36
30°

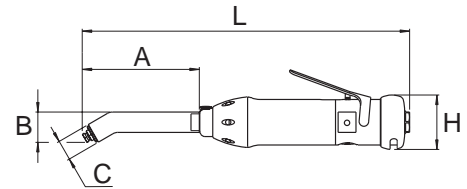

LBV11, -16, -36
90°

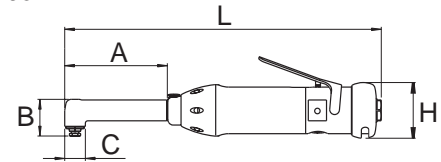

LBV16, -25
360°

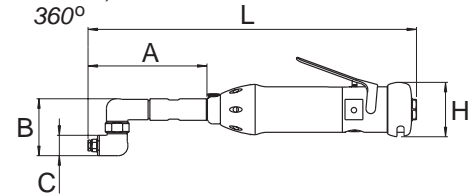

LBV34
90°

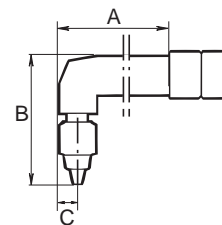

LBV37
90°

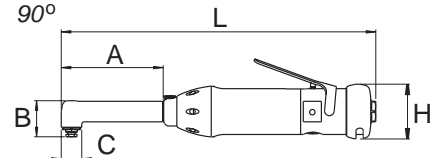

Accessories Included

KEY WRENCHES

Collet or chuck with key
3 mm collet (5.0 collet capacity head)
6 mm collet (6.6 collet capacity head)

Optional Accessories

SAFETY LEVERS

For model	Ordering No.
LBV16	4110 1787 90
LBV36/37	4150 1594 97



Safety lever

SHORT LEVERS

For model	Ordering No.
LBV16	4210 2306 04



Short lever

COLLETS FOR 5.0 MM CAPACITY HEAD LBV11, LBV16 – (-30, -90, -90Z) AND LBV36 (-30, -90)

Capacity mm	Ordering No.	Capacity mm	Ordering No.	Capacity in	Ordering No.
1.0	4110 0438 01	3.4	4110 0438 33	1/16	4110 0438 19
1.5	4110 0438 02	3.5	4110 0438 13	3/32	4110 0438 20
1.8	4110 0438 28	3.6	4110 0438 24	1/8	4110 0438 21
2.0	4110 0438 03	3.7	4110 0438 34	5/32	4110 0438 22
2.1	4110 0438 29	3.8	4110 0438 14	3/16	4110 0438 23
2.2	4110 0438 04	3.9	4110 0438 35		
2.3	4110 0438 30	4.0	4110 0438 15		
2.4	4110 0438 05	4.1	4110 0438 25		
2.5	4110 0438 06	4.2	4110 0438 26		
2.6	4110 0438 07	4.3	4110 0438 36		
2.7	4110 0438 31	4.4	4110 0438 37		
2.8	4110 0438 32	4.5	4110 0438 16		
2.9	4110 0438 08	4.6	4110 0438 38		
3.0	4110 0438 09	4.7	4110 0438 39		
3.1	4110 0438 10	4.8	4110 0438 18		
3.2	4110 0438 11	4.9	4110 0438 40		
3.3	4110 0438 12	5.0	4110 0438 27		

Collets for 5.0 mm (Thread BSF 9/32 -40)

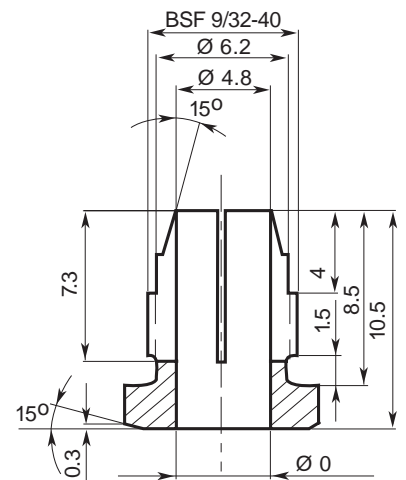

COLLETS FOR 6.6 MM CAPACITY HEAD LBV16 (-91) AND LBV36 (-91)

Capacity mm	Ordering No.	Capacity mm	Ordering No.
1.6	4110 1411 01	4.2	4110 1411 14
1.8	4110 1411 02	4.4	4110 1411 15
2.0	4110 1411 03	4.6	4110 1411 16
2.2	4110 1411 04	4.8	4110 1411 17
2.4	4110 1411 05	5.0	4110 1411 18
2.6	4110 1411 06	5.2	4110 1411 19
2.8	4110 1411 07	5.4	4110 1411 20
3.0	4110 1411 08	5.6	4110 1411 21
3.2	4110 1411 09	5.8	4110 1411 22
3.4	4110 1411 10	6.0	4110 1411 23
3.6	4110 1411 11	6.2	4110 1411 24
3.8	4110 1411 12	6.4	4110 1411 25
4.0	4110 1411 13	6.6	4110 1411 26

Collets for 6.6 mm

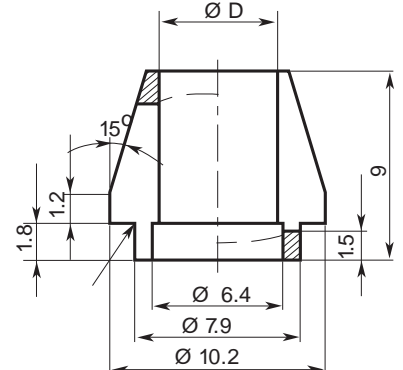

Collet nut 4110 1410 00, to be ordered separately.



Service Kits

LBV16	4081 0322 90
LBV24	4081 0005 90
LBV25	4081 0272 90
LGB/LBV34	4081 0035 90
LBV36 (30, 90/92)	4081 0263 90
LBV36 (91/93)	4081 0251 90
LBV37	4081 0431 90

Modular Drills

The LBD16M and LBP16M are designed with the operator in focus. A lightweight tool with a powerful air motor combined with interchangeable angle heads equals excellent flexibility in any handheld drilling operation. Swap to a new head in a matter of seconds with the easy-to-use quick change mechanism. With the LBD16M and LBP16M, you are always ready to take on any job in ever changing drilling applications.

- Quick change system – Easy-to-use and robust quick change design for high durability.
- Indexable head – The head can be positioned in any direction for maximum accessibility.
- High power lubrication free motor – No more oil aerosols, for a safer and cleaner working environment.



LBP16M

LBD16M

Model	Free speed ^a rpm	Motor speed ^b	Weight		Air consumption		Hose size		Air inlet thread BSP	Power		Ordering No.
			kg	lb	l/s	cfm	mm	in		W	hp	
Straight motor units												
LBD16M-005	500	600	0.57	1.25	8.7	18.4	6.3	1/4	1/4	300	0.4	8421 0122 05
LBD16M-010	1000	1200	0.57	1.25	8.7	18.4	6.3	1/4	1/4	300	0.4	8421 0122 10
LBD16M-018	1800	2100	0.57	1.25	8.7	18.4	6.3	1/4	1/4	300	0.4	8421 0122 18
LBD16M-032	3200	3600	0.45	1	8.7	18.4	6.3	1/4	1/4	300	0.4	8421 0122 32
LBD16M-045	4500	5100	0.45	1	8.7	18.4	6.3	1/4	1/4	300	0.4	8421 0122 45
LBD16M-055	5500	6200	0.45	1	8.7	18.4	6.3	1/4	1/4	300	0.4	8421 0122 55
Pistol motor units												
LBP16M-005	500	600	0.55	1.2	9.5	20.0	6.3	1/4	1/4	340	0.45	8421 0124 05
LBP16M-010	1000	1100	0.55	1.2	9.5	20.0	6.3	1/4	1/4	340	0.45	8421 0124 10
LBP16M-018	1800	2100	0.55	1.2	9.5	20.0	6.3	1/4	1/4	340	0.45	8421 0124 18
LBP16M-033	3300	3700	0.5	1.1	9.5	20.0	6.3	1/4	1/4	340	0.45	8421 0124 33
LBP16M-045	4500	5100	0.5	1.1	9.5	20.0	6.3	1/4	1/4	340	0.45	8421 0124 45
LBP16M-060	6000	6800	0.5	1.1	9.5	20.0	6.3	1/4	1/4	340	0.45	8421 0124 60

^a The free speed is given when used with a 90° angle head. ^b Multiply this value with the Speed ratio to get the free speed of each angle head.

ANGLE HEADS

Model	Angle head	Weight		Collet capacity	Thread in	Speed ratio	Length		Ordering No.
		kg	lb				mm	in	
Angle heads with collet – Short									
BHM90SC-5-0	90°	0.2	0.5	5.0	–	14:16	65.5	2.58	8421 0123 02
Angle heads with collet – Standard									
BHM90C-5-0	90°	0.17	0.36	5.0	–	14:16	88.5	3.48	8421 0123 00
BHM90C-6-6	90°	0.24	0.55	6.6	–	14:16	89.6	3.53	8421 0123 05
BHM90C-8-0	90°	0.24	0.55	8.0	–	14:17	89.7	3.54	8421 0123 80
BHM45C-5-0	45°	0.20	0.44	5.0	–	14:15	117.3	4.62	8421 0123 10
BHM30C-5-0	30°	0.20	0.44	5.0	–	14:15	120.4	4.74	8421 0123 20
BHM30C-6-6	30°	0.20	0.44	6.6	–	14:15	127	5	8421 0123 15
BHM90ZC-5-0	360°	0.21	0.47	5.0	–	7:9	100.8	3.97	8421 0123 30
BHM90ZC-6-6	360°	0.21	0.47	6.6	–	7:9	108	4.25	8421 0123 40
Angle heads with collet – Extended									
BHM90EC-5-0	90°	0.26	0.58	5.0	–	14:16	128.5	5.06	8421 0123 08
BHM45EC-5-0	45°	0.29	0.64	5.0	–	14:15	157.3	6.19	8421 0123 18
BHM30EC-5-0	30°	0.29	0.64	5.0	–	14:15	160.4	6.31	8421 0123 28
BHM90EZC-5-0	360°	0.30	0.67	5.0	–	7:9	140.8	5.54	8421 0123 38
Angle head with internal thread – Standard									
BHM90T-1-4	90°	0.17	0.36	–	1/4"-28	14:16	88.5	3.48	8421 0123 01
BHM90LT-1-4	90°	0.23	0.52	–	1/4"-28	14:16	89.6	3.53	8421 0123 06
BHM45T-1-4	45°	0.20	0.44	–	1/4"-28	14:15	118.2	4.65	8421 0123 11
BHM30T-1-4	30°	0.20	0.44	–	1/4"-28	14:15	121.1	4.77	8421 0123 21
BHM90ZT-1-4	360°	0.21	0.47	–	1/4"-28	7:9	101	3.98	8421 0123 31
Angle head with internal thread – Extended									
BHM90ET-1-4	90°	0.26	0.58	–	1/4"-28	14:16	128.5	5.06	8421 0123 09
BHM45ET-1-4	45°	0.29	0.64	–	1/4"-28	14:15	157.9	6.22	8421 0123 19
BHM30ET-1-4	30°	0.29	0.64	–	1/4"-28	14:15	161.1	6.34	8421 0123 29
BHM90EZT-1-4	360°	0.30	0.67	–	1/4"-28	7:9	141	5.55	8421 0123 39
Straight short angle head									
BHM0C-5-0	0°	0.14	0.31	5.0	–	1:1	78	3.07	8421 0123 43
BHM0T-1-4	0°	0.14	0.31	–	1/4"-28	1:1	78	3.07	8421 0123 44

Angle heads Standard/Extended (pictures shows extended versions)



Dimensions

ANGLE HEAD DIMENSIONS

Model	A mm	B mm	C mm	L mm	H mm	Ordering No.
90° heads						
BHM90SC-5-0	65.5	29.8	17	106.2	19.8	8421 0123 02
BHM90C-5-0	88.5	29.8	17	129.2	19.8	8421 0123 00
BHM90C-6-6	90	39.3	20	130.3	20	8421 0123 05
BHM90C-8-0	90	41.1	20	130.3	20	8421 0123 80
BHM90EC-5-0	128.5	29.8	17	169.2	19.8	8421 0123 08
BHM90T-1-4	88.5	30	17	129.2	19.8	8421 0123 01
BHM90LT-1-4	90	36	20	130.3	20	8421 0123 06
BHM90ET-1-4	128.5	30	14	169.2	19.8	8421 0123 09
30° heads						
BHM30C-5-0	120.4	25	17	161	19.8	8421 0123 20
BHM30C-6-6	127.3	32.3	17	168	19.8	8421 0123 15
BHM30EC-5-0	160.4	25.2	17	201	19.8	8421 0123 28
BHM30T-1-4	121.1	26.4	17	161.6	19.8	8421 0123 21
BHM30ET-1-4	161.1	26.4	17	201.8	19.8	8421 0123 29
45° heads						
BHM45C-5-0	117.3	30.5	17	158	19.8	8421 0123 10
BHM45EC-5-0	157.3	30.5	17	198	19.8	8421 0123 18
BHM45T-1-4	118.2	31.4	17	159	19.8	8421 0123 11
BHM45ET-1-4	158.2	31.4	17	199	19.8	8421 0123 19
360° heads						
BHM90ZC-5-0	100.8	45.9	17	141.5	19.8	8421 0123 30
BHM90ZC-6-6	107.3	45.9	17	148	19.8	8421 0123 40
BHM90EZC-5-0	140.8	45.9	17	181.5	19.8	8421 0123 38
BHM90ZT-1-4	101	45.9	17	141.5	19.8	8421 0123 31
BHM90EZT-1-4	141	45.9	17	181.5	19.8	8421 0123 39
Straight heads						
BHM0C-5-0	78	-	17	119	19.8	8421 0123 43
BHM0T-1-4	78	-	17	119	19.8	8421 0123 44
Extension - for chuck						
EXTENSION	35	-	17.5	76	28.5	4110 1692 90

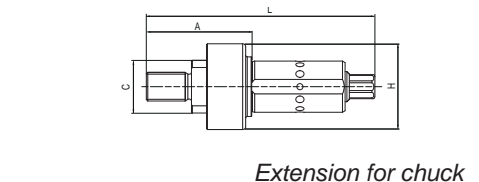
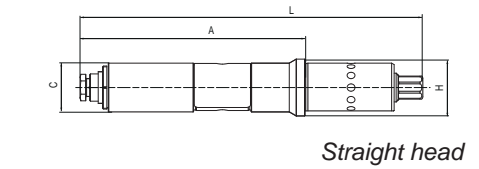
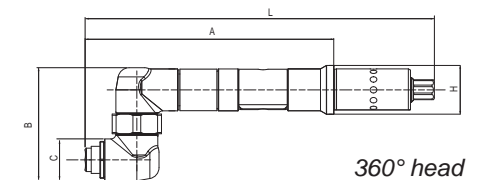
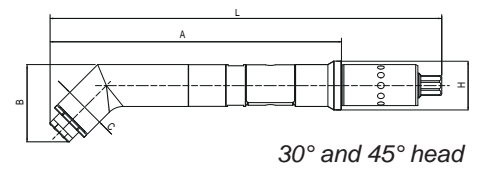
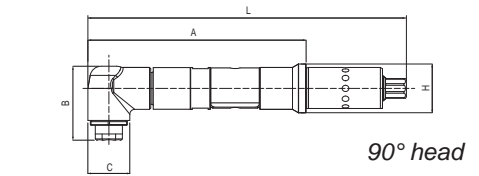

Optional Accessories



STRAIGHT DRILL HEAD FOR CHUCK

For model	Ordering No.
LBD16M, LBP16M	4110 1692 90



SAFETY LEVERS

For model	Ordering No.
LBD16M	4110 1787 80



SHORT LEVERS

For model	Ordering No.
LBD16M	4210 2306 04

COLLETS FOR 5.0 MM CAPACITY ANGLE HEAD BHMC-5-0 (-30, -45, -90, -90Z)

Capacity mm	Ordering No.	Capacity mm	Ordering No.	Capacity in	Ordering No.
1.0	4110 0438 01	3.4	4110 0438 33	1/16	4110 0438 19
1.5	4110 0438 02	3.5	4110 0438 13	3/32	4110 0438 20
1.8	4110 0438 28	3.6	4110 0438 24	1/8	4110 0438 21
2.0	4110 0438 03	3.7	4110 0438 34	5/32	4110 0438 22
2.1	4110 0438 29	3.8	4110 0438 14	3/16	4110 0438 23
2.2	4110 0438 04	3.9	4110 0438 35		
2.3	4110 0438 30	4.0	4110 0438 15		
2.4	4110 0438 05	4.1	4110 0438 25		
2.5	4110 0438 06	4.2	4110 0438 26		
2.6	4110 0438 07	4.3	4110 0438 36		
2.7	4110 0438 31	4.4	4110 0438 37		
2.8	4110 0438 32	4.5	4110 0438 16		
2.9	4110 0438 08	4.6	4110 0438 38		
3.0	4110 0438 09	4.7	4110 0438 39		
3.1	4110 0438 10	4.8	4110 0438 18		
3.2	4110 0438 11	4.9	4110 0438 40		
3.3	4110 0438 12	5.0	4110 0438 27		

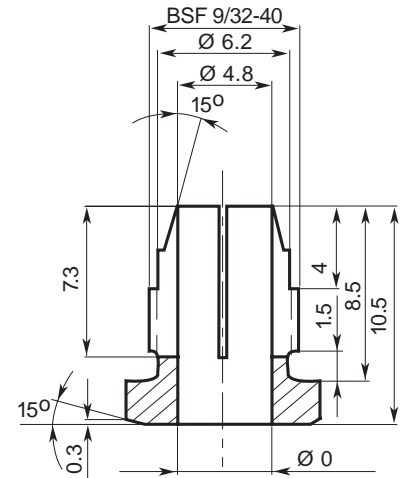

Collets for 5.0 mm (Thread BSF 9/32 -40)

COLLETS FOR 6.6 MM CAPACITY ANGLE HEAD BHMC-6-6 (-30, -90, -90Z)

Capacity mm	Ordering No.	Capacity mm	Ordering No.
1.6	4110 1411 01	4.2	4110 1411 14
1.8	4110 1411 02	4.4	4110 1411 15
2.0	4110 1411 03	4.6	4110 1411 16
2.2	4110 1411 04	4.8	4110 1411 17
2.4	4110 1411 05	5.0	4110 1411 18
2.6	4110 1411 06	5.2	4110 1411 19
2.8	4110 1411 07	5.4	4110 1411 20
3.0	4110 1411 08	5.6	4110 1411 21
3.2	4110 1411 09	5.8	4110 1411 22
3.4	4110 1411 10	6.0	4110 1411 23
3.6	4110 1411 11	6.2	4110 1411 24
3.8	4110 1411 12	6.4	4110 1411 25
4.0	4110 1411 13	6.6	4110 1411 26

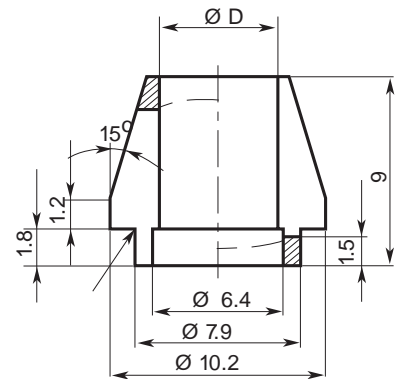

Collets for 6.6 mm

Collet nut 4110 1410 00, to be ordered separately.

COLLETS FOR 8.0 MM CAPACITY ANGLE HEAD BHMC-8-0 (-90)

Capacity mm	Ordering No.	Capacity mm	Ordering No.
6.8	4110 1812 01	7.6	4110 1812 05
7.0	4110 1812 02	7.8	4110 1812 06
7.2	4110 1812 03	8.0	4110 1812 07
7.4	4110 1812 04		

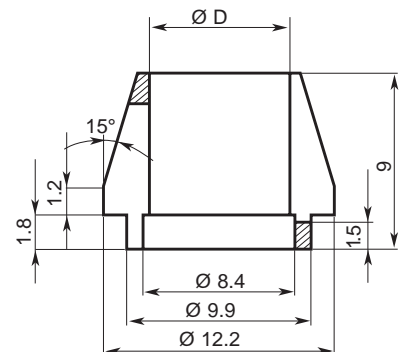

Collets for 8.0 mm



Service Kits

LBD16M 4081 0322 90

LBP16M 4081 0271 90

The Atlas Copco LBS36 drill is equipped with an integrated micro stop. It is designed for the aerospace industry where the focus is on high-precision drilling, reaming and countersinking.

- Accurate – The integrated micro stop function makes the LBS36 unique for high-precision drilling of rivet holes and other fasteners. Minimized spindle run-out is achieved by eliminating standard drill chuck.
- Ergonomic handle design – The integrated micro stop function makes the tool shorter and lighter in weight.
- Flexible – Can be used for drilling, reaming, countersinking and, in certain applications, a combined operation using a form bit.
- Dust extraction – Equipped with a specially designed spot suction system for working in composite materials.
- Lubrication-free – For clean working environment and operator comfort.



Model	Free speed r/min	Spindle thread in/mm	Stroke		Setting range ±		Weight		Hose size		Air consumption		Air inlet thread BSP	Ordering No.
			mm	in	mm	in	kg	lb	mm	in	l/s	cfm		
LBS26 H033-40	3300	1/4"-28	40	1.6	6	1/4	0.9	2.0	10	3/8	14.5	31.8	3/8	8421 0220 40
LBS26 H013-40	1300	1/4"-28	40	1.6	6	1/4	1.2	2.6	10	3/8	14.5	31.8	3/8	8421 0220 45
LBS36 H033-40	3300	1/4"-28	40	1.6	6	1/4	1.2	2.6	10	3/8	16.5	34.9	3/8	8421 0220 80
LBS36 H013-40	1300	1/4"-28	40	1.6	6	1/4	1.5	3.3	10	3/8	16.5	34.9	3/8	8421 0220 90

Dimensions

Model	L mm	H mm	C mm
LBS26 H033-40	253	146	21
LBS26 H013-40	285	146	21
LBS36 H033-40	281	157	21
LBS36 H013-40	314	157	21

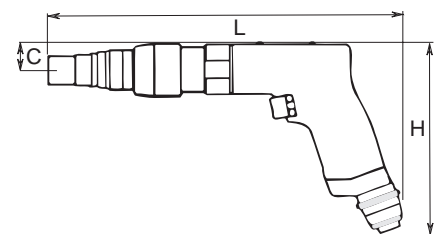

Accessories Included

Hose nipple
2x2 mm Allen wrenches

Optional Accessories

Designation		Attachment	Ordering No.
Plain base, dia 24 mm	Fig 1	M 20x1	4110 1521 00
Plain base for nylon ring (attached with thread M35x1)	Fig 2	M 20x1	4110 1522 00
Separate nylon ring for above base, outer dia 40 mm, thread M35x1	Fig 3	M 20x1	4110 1523 00
Plain base, dia 14.5 mm	Fig 4	M 20x1	4110 1520 00
Tripod, nylon supported	Fig 5	Dia 22 mm	4110 1524 00

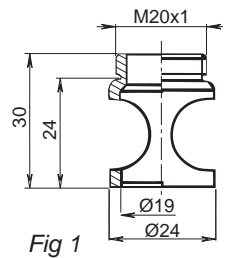

Fig 1



Fig 3

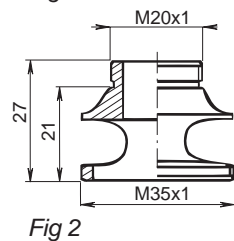

Fig 2

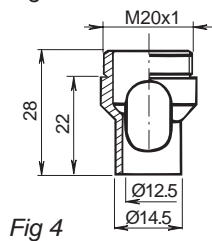

Fig 4

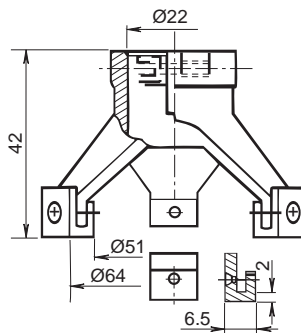

Fig 5



Service Kits

LBS26 4081 0507 90
LBS36 4081 0005 90

Atlas Copco tappers are designed for tapping and thread-cleaning operations with thread taps. The tools are fitted with a tap chuck as standard.

- Comfortable and effective – The ergonomically designed handle gives a comfortable grip and maximum performance.
- Higher productivity – Double speed when you withdraw the machine.
- Low noise level – Rear-directed exhaust gives a lower noise level.
- Lubrication-free – For a clean working environment and operator comfort.
- Quick change system – Upgrade your old tool, or order a new one with this system. Various tap holders can be used to change a broken tap or to change to a different tap size.
- Lower cost – The efficient air motor, together with interchangeable components from our standard drills, cut your costs.



Model	Free speed		Tapping capacity mm	Weight		Hose dimension		Air inlet thread BSP	Air consumption		With chuck Ordering No.	Without chuck	
	Forward r/min	Reverse r/min		kg	lb	mm	in		l/s	cfm		Model	Ordering No.
Pistol-grip tappers with air supply through handle													
LGB34 H007	700	1400	10	1.8	4.0	10.0	3/8	1/4	7.5	15.9	8421 0311 66	-U	8421 0311 68
LGB34 H007Q ^a	700	1400	10	1.8	4.0	10.0	3/8	1/4	7.5	15.9	8421 0311 76	-	-
LGB36 H007Q ^a	700	1400	12	2.0	4.4	10.0	3/8	3/8	16.5	34.9	8421 0411 00	-	-
Straight tappers													
LGB34 S007	700	1400	10	1.8	4.0	10.0	3/8	1/4	7.5	15.9	8421 0311 72	-	-

^a Quick change system.

Taper: Jacob 1

Dimensions

Model	L mm	H mm	C mm
LGB34 H007	300	156	20
LGB34 S007	293	43	21
LGB36 H007	335	157	20

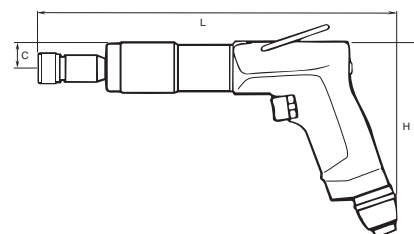

Accessories Included

Non Quick change system

LGB34 Chuck complete with collet 6.4-10 mm 4021 0469 00

Quick change system

Chuck plus one tap holder with collet for M6 shank Ø 6.3 mm.

Optional Accessories

COLLETS FOR NON QUICK CHANGE SYSTEM

Model	Capacity		Ordering No.
	mm	inch	
LGB34	3.5 - 6.5	0.139 - 0.257	4021 0337 00
	4.5 - 8.1	0.176 - 0.320	4021 0336 00
	6.4 - 9.7	0.253 - 0.383	4021 0456 00

COLLETS FOR QUICK CHANGE SYSTEM

Collets for tap size mm	Shank dia		Ordering No.
	mm	in	
M2.2/M2.5	2.8		4021 0414 01
M3	3.15	1/8	4021 0414 02
M3.5	3.5		4021 0414 03
M4	4.0		4021 0414 04
M4.5	4.5		4021 0414 05
M5	5.0	3/16	4021 0414 06
M5.5	5.6	7/32	4021 0414 07
M6	6.4	1/4	4021 0414 08
M6 (DIN)	6.0		4021 0414 13
M7	7.1	9/32	4021 0414 09
M8/M11	8.0	5/16 & 7/16	4021 0414 10
M9/M12	9.0	1/2	4021 0414 11
M10	10.0	3/8	4021 0414 12

COMPLETING EXISTING EQUIPMENT WITH QUICK CHANGE SYSTEM

Accessories	Length mm	Ordering No.
Quick change chuck	47	4021 0406 90
Tap holder	58	4021 0408 00



Service Kits

LGB34 4081 0035 90
LGB36 4081 0194 90

Atlas Copco screw-feed drills are ideal for heavy-duty drilling operations requiring high feed forces. They can also be used for reaming and tube-rolling.

- Reliable – Simple, reliable design.
- Constant speed – The speed governor keeps the drilling speed constant and reduces air consumption as power is reduced.
- Safer – The safety catch prevents accidental starting. The throttle is also self-closing.



Model	Forward	Reverse
RAB9	0.85 kW (1.14 hp)	0.55 kW (0.74 hp)
RAB12	1.5 kW (2.0 hp)	1.1 kW (1.5 hp)

Model	Free speed r/min	Capacity				Morse taper No.	Length feed mm	Height		Weight		Hose dimension		Air consumption max output		Distance centre to side mm	Air inlet thread BSP	Ordering No.
		Drill- ing mm	Ream- ing mm	Tapp- ing mm	mm			in	kg	lb	mm	in	l/s	cfm				
RAB9 VR003	300	23	23	16	2	75	265	10.4	9.5	20.9	13	1/2	22	47	40	1/2	8421 5109 37	
RAB9 VR006	600	23	23	12	2	75	265	10.4	9.5	20.9	13	1/2	23	49	40	1/2	8421 5109 45	
RAB12 L150	140	51	40	32	4	90	385	15.2	14.9	32.8	16	5/8	30	64	50	1/2	8421 5112 08	
RAB12 L250	240	51	40	30	4	90	385	13.2	14.9	32.8	16	5/8	33	70	50	1/2	8421 5112 16	
RAB12 L450	475	32	32	24	3	90	340	13.4	12.9	28.4	16	5/8	32	68	50	1/2	8421 5112 24	

Accessories Included

Hose nipple

Optional Accessories

SQUARE DRIVE ADAPTER

Morse taper No.	Square drive in	Ordering No.
3	1	4021 0394 00
4	1	4021 0395 00



Square drive adapter

Robust and versatile, the PFD-drills are your best choice for holemaking

PRODUCTIVITY

With this platform you have all you need for hole preparation. Reduce cycle time and increase output with a powerful turbine motor. This robust tool is well suited for factory environment and the long service intervals maximizes uptime of your investments.

HOLE QUALITY

Keep your workplace clean with Atlas Copco's ChipLet® feature which makes chips easy to evacuate. With ChipLet® during countersinking, you have a one-step process. Giving process improvements in terms of both productivity and quality.

ERGONOMICS

My operators will really appreciate how all the controls on the tool are grouped in one and the same place. This reduces the risk of operator errors. The tool is also very well balanced which makes it easy to move around.

SAFE OPERATION

The modular design means fewer back-up tools. You can also save on service as the platform is based on standard, reusable components.

SUPPORT

The modular approach means quick deliveries when needed, and makes it easy to re-work your existing products when urgent applications come up. With our technical documentation and support you will quickly put new tools to work on your assembly line.





PFD 1500

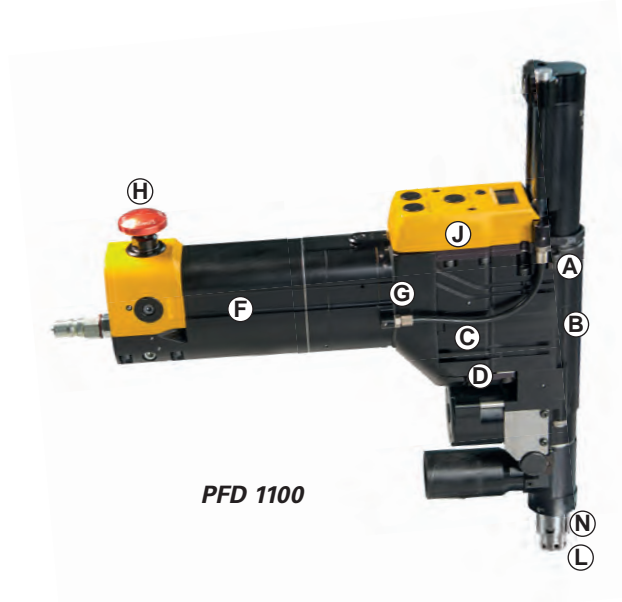

PFD 1100

PFD 1500

Item	Ordering No.
PFD1500RA-200-R	8440 1500 39
Indexer-1-9-16	4141 0306 90
PFD1500-IPR2	4141 0034 92
Spindle-1500-12-9-6	4141 0004 91
Guard-1500-12	4141 0323 91
Nose-8IN-1-1-2	4141 0245 90

Example: Twistlock model with rapid advance and indexer. Spindle with 9/16"-18" interface, speed of 200 rpm and feed of 0.05 mm/r (0.002 IPR). Suitable for drilling of 19 mm holes (3/4") in Ti or Ti/CFRP stacks.

PFD 1100

Item	Ordering No.
PFD1100RA-IFB110B	8440 1110 66
Spindle-CC-1100-2	4141 0742 90
Guard-1100-2in-p	4141 0826 92
Guide-CC-R-1100-M6	4141 0743 91
Bush-CC-1100-53	4141 0707 92
Foot-CC-1100-MINI	4141 0764 90
Mandrel-CC-25.4-A	4141 0806 28
Collet-CC-1	4141 0813 28

Example: Concentric collet model with inboard lubricator, counter and ChipLet®. Spindle with M6 interface, speed of 2600 rpm and feed of 0.07 mm/r (0.003 IPR). Suitable for drill and countersink of Ø 6.35 (1/4") holes in Al or Al/CFRP stacks.

- (A) Optional ChipLet® module which effectively breaks chips while drilling for improved chip evacuation and hole quality.
- (B) Angle head with superior durability with double needle bearings for both feed and drive gear.
- (C) Overload clutch protects the angle head and drive train from overthrust.
- (D) The replaceable feed cassette system enables quick and easy change of feed rate.
- (E) Optional indexer which allows the tool to be locked in the jig also when free space is compromised.
- (F) High torque, high power governed air motor maintains cutting speed while drilling.
- (G) Easy-to-change split gearbox for quick adjustment of rpm.
- (H) Emergency stop fully compliant with the European machinery directive for a high level of safety.
- (J) Rapid advance of spindle reduces cycle time and makes setup a quick and safe task.
- (K) Reliable and user-friendly tool controls with optional cycle counter.
- (L) Best in class spindle power and thrust capabilities. A wide range of speeds and feeds.
- (M) A large selection of tool noses with or without vacuum port makes the tool fit existing drill jigs.
- (N) Concentric collet foot which allows clamp force for countersinking up to diameter 22 mm (7/8"). Debris protection and efficient vacuum exhaust of chips. Foot is modular and easily removed for drill bit change.

Specifications

Feature	PFD1100		PFD1500	
	Metric	Imperial	Metric	Imperial
Motor	Turbine	Turbine	Vane	Vane
Drill and ream	yes	yes	yes	yes
Countersinking	yes	yes	no	no
Sound level	78 dB(A)	78 dB(A)	83 dB(A)	83 dB(A)
Spindle power	1.7 kW	2.3 hp	1.5 kW	2.0 hp
Max hole	15.9 mm	5/8"	32 mm	1 1/4"
Max countersink	22 mm	7/8"	N/A	N/A
Max speed	7300 rpm	7300 rpm	2360 rpm	2360 rpm
Min speed	350 rpm	350 rpm	38 rpm	38 rpm
Max thrust	2000 N	450 lbf	4000 N	900 lbf
Max clamp force (cc)	1800 N	400 lbf	N/A	N/A
Max feed	0.17 mm/rev	0.007 IPR	0.25 mm/rev	0.010 IPR
Tool weight (base)	3.0 kg	6.6 lb	5.5 kg	12.0 lb
Max air consumption	30 l/s	60 cfm	35 l/s	70 cfm
Air inlet	1/2" BSP	1/2" NPT	1/2" BSP	1/2" NPT
Operating pressure	5.5–7.5 bar	80–110 psi	5.5–7.5 bar	80–110 psi
Angle head radius	16.0 mm	5/8"	17.8 mm	0.7"
Air hose	13 mm	1/2"	16 mm	5/8"

Collet



Mandrel



Counter sink stop nut



Optional Equipment

Item	PFD1100	PFD1500
Chiplet®	yes	yes
Rapid advance	no	yes (with J-Clutch)
Lubrication pump	inboard, 30 ml	onboard, 55 ml
Counter	yes	yes
Indexer	yes	yes
Tool handle	no	yes
Nose sizes	21k–23k	23k–25k
Concentric collet	yes	no
Max collet outer diameter	1 3/8"	N/A

Tool nose with vacuum port



Tool nose



Tool nose indexer



Concentric collet unit



Air Installation

Item	PFD1100 Light to Medium Duty Cycle	PFD1500 / PFD1100 Heavy Duty Cycle
Swivel	MultiFlex with 1/2	MultiFlex with 1/2
Coupling	ErgoQIC 08 with H13	ErgoQIC 10 with H16
Air fitting	ErgoNIP 08 with 1/2	ErgoNIP 10 with 1/2
Hose	PVC 13, 30 m coil	PVC 16, 30 m coil
Clamp	clamp for PVC 13	clamp for PVC 13
Air preparation unit	MIDI Optimizer F/R A with 1/2	Optimizer F/R A with 1/2
Ball valve	BAL-1A with 1/2	BAL-1A with 1/2
Connection	Double with two 1/2	Double with two 1/2