

Rear End Spoiler Package Installation (Instruction ID: 23243056)

Installation Instructions Part Number

23243056

[Kit Contents](#)

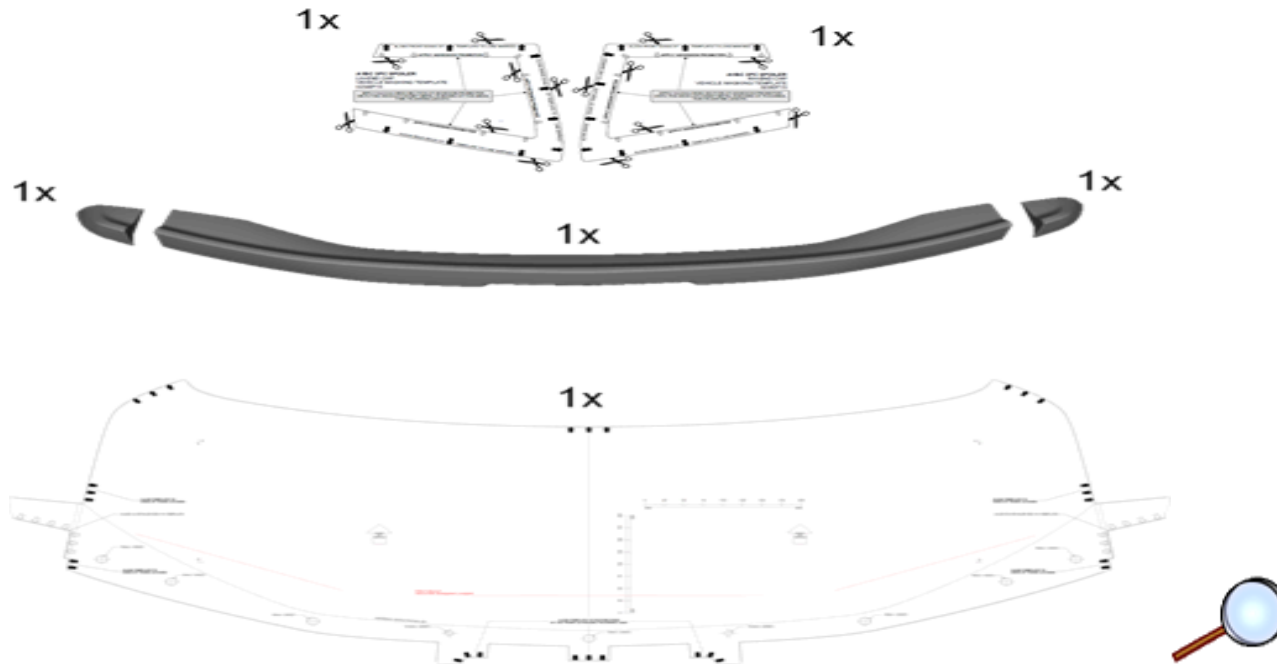

[Tools Required](#)



Procedure

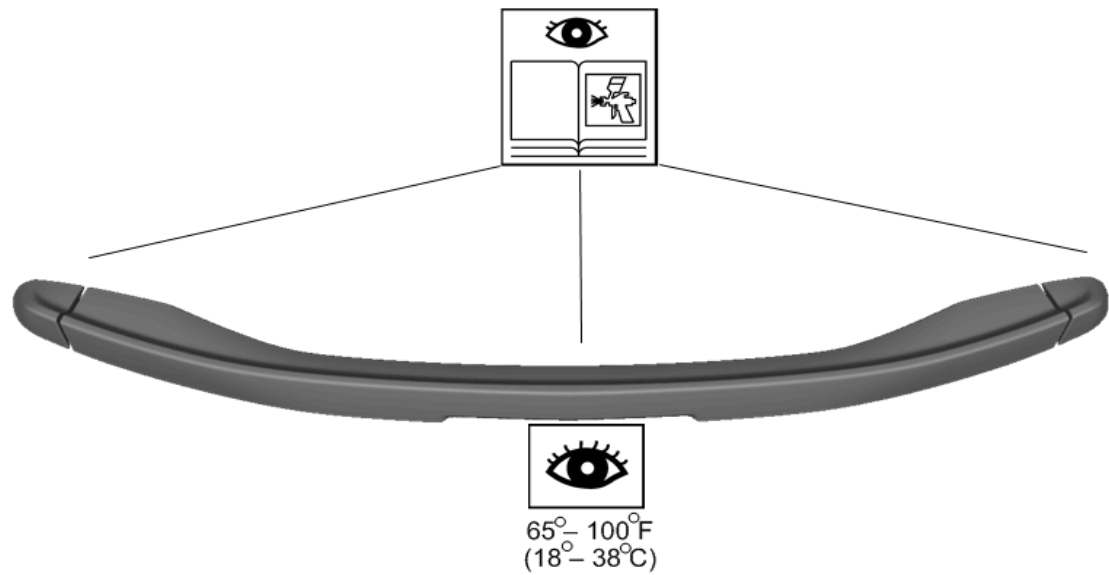

1. Refinish surface...



2. Wash and dry rear compartment lid and quarter panel areas where spoiler is to be mounted.

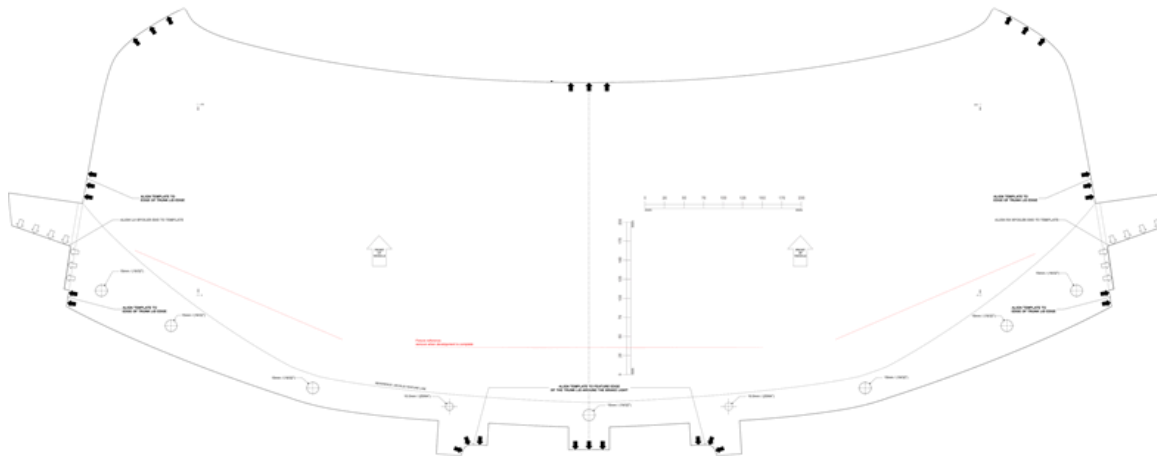

3. Locate template spoiler.

Note: The template is a die cut template, there will be not cutting required in spoiler installation layout procedure.

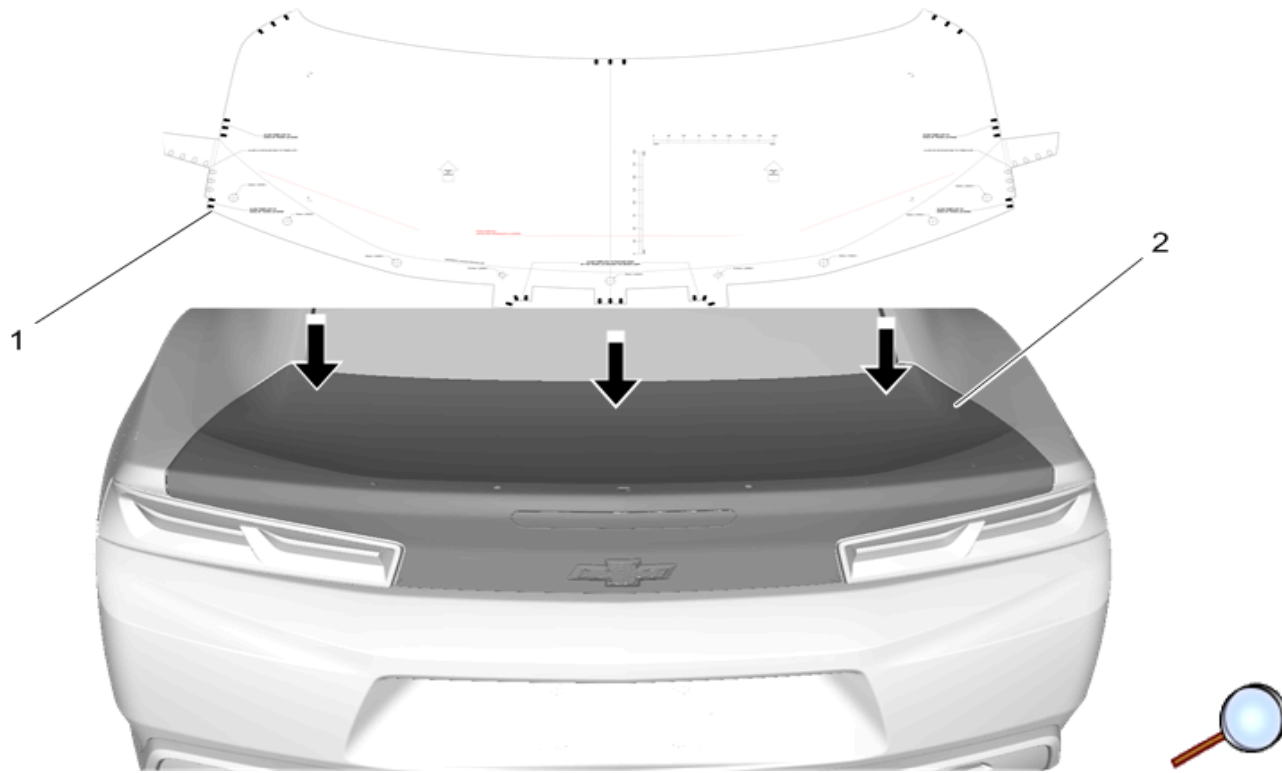

4. Position template (1) on rear compartment lid (2). Follow the instruction on the template for layout procedure.

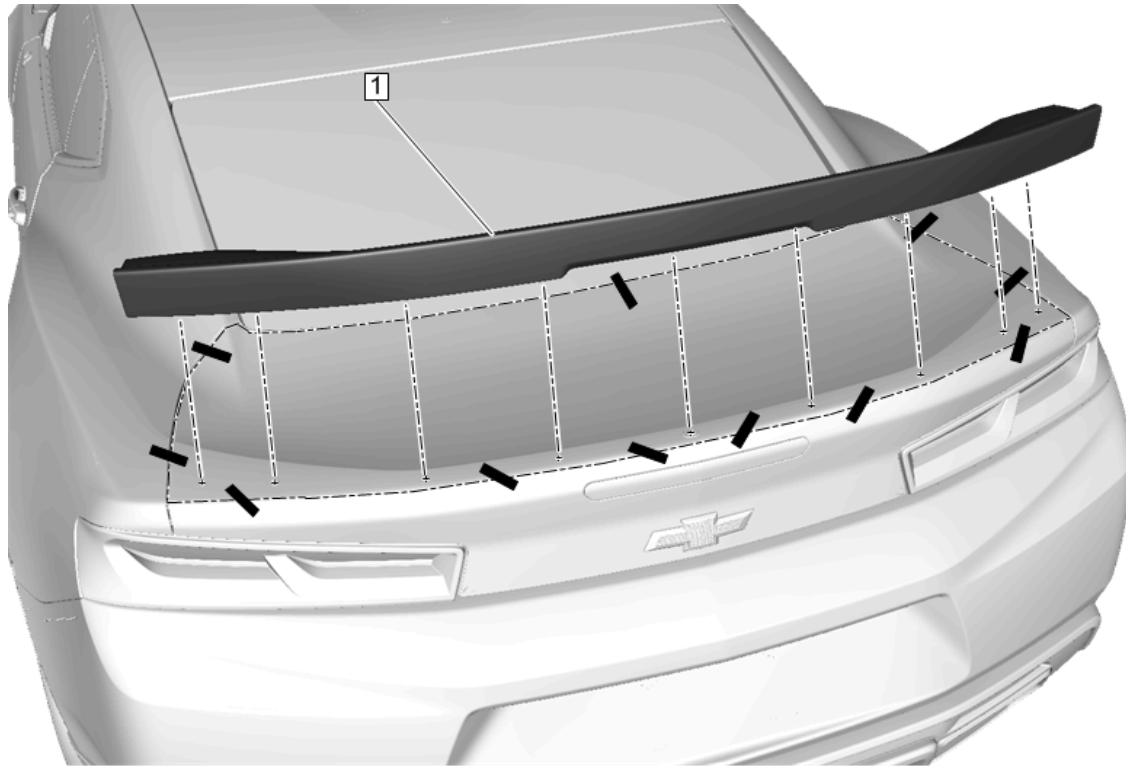

5. Verify spoiler (1) layout.

6. Remove spoiler and set aside.

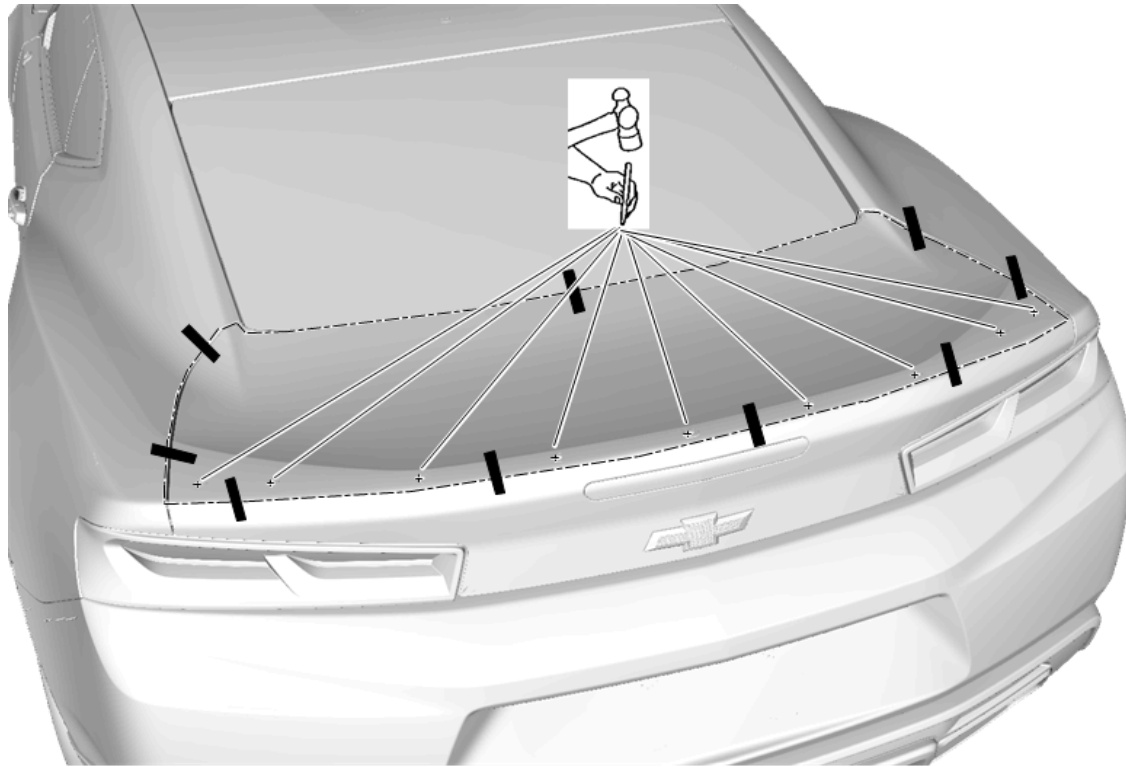

7. Punch center of each hole.

Note: If the deck lid has the RS holes and installation is a Production Spoiler replace with Accessory Spoiler, please skip to Step 11.

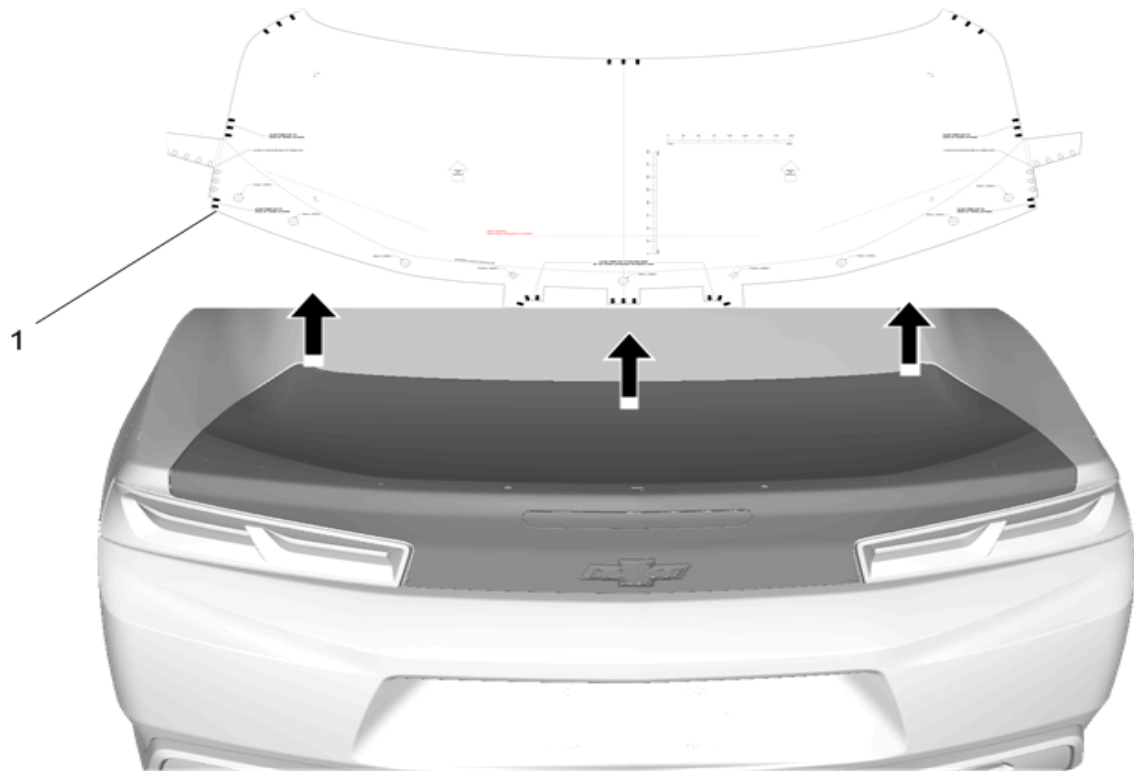

8. Fold the template (1) upwards and secure for later use. Use tape to keep template clear of work area for drilling.

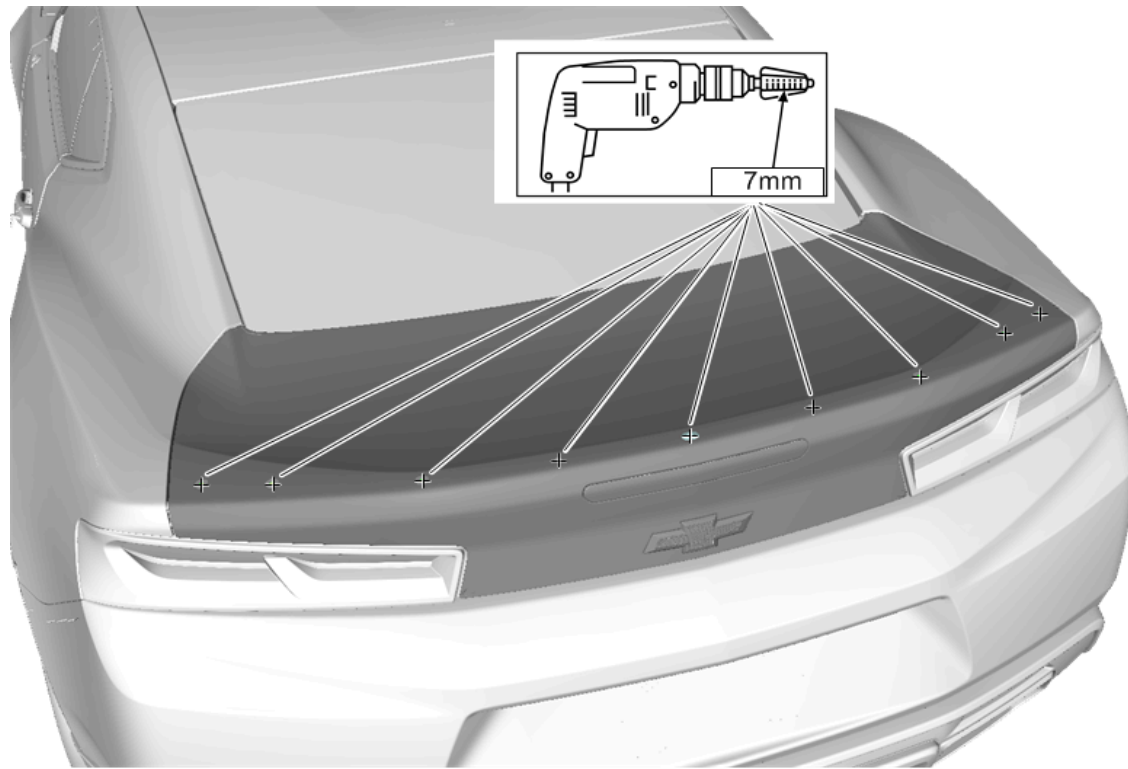

9. Drill a 7mm hole at all the punched center for each hole.

Note: Use a 3 step down drill process to prevent dimpling. This will ensure clip engagement.

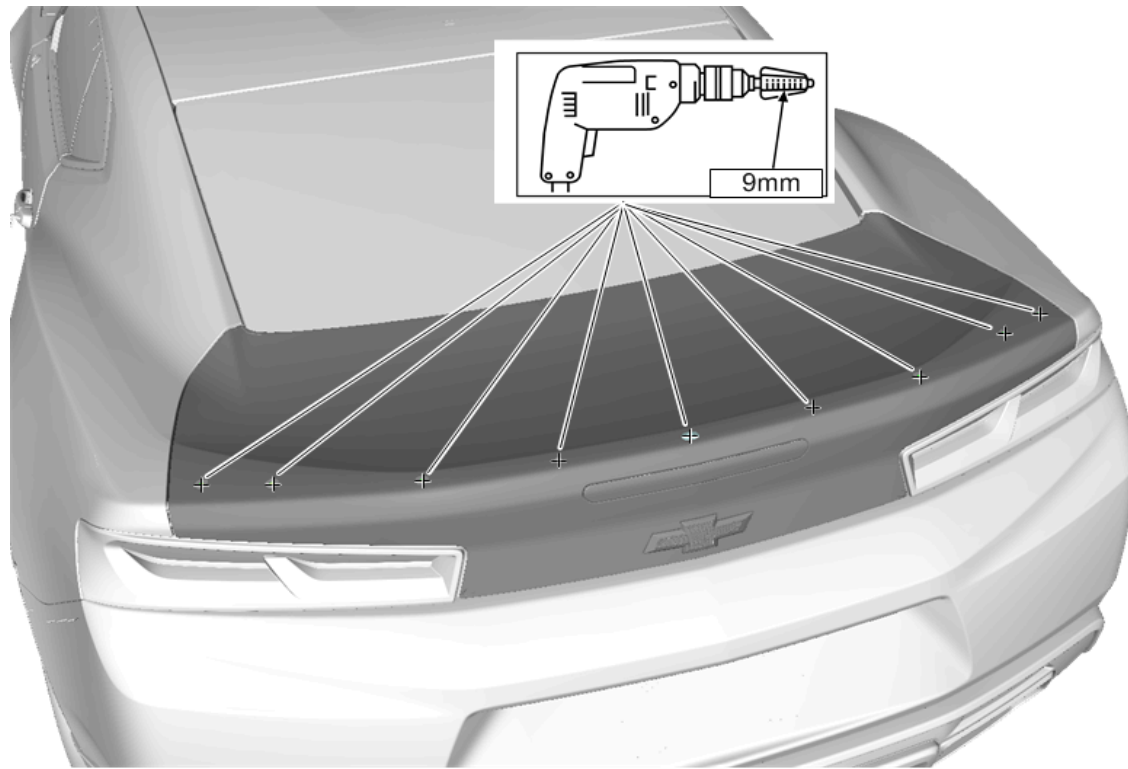

10. Drill 9mm holes according to locations specified.

Note: Use a 3 step down drill process to prevent dimpling. This will ensure clip engagement.

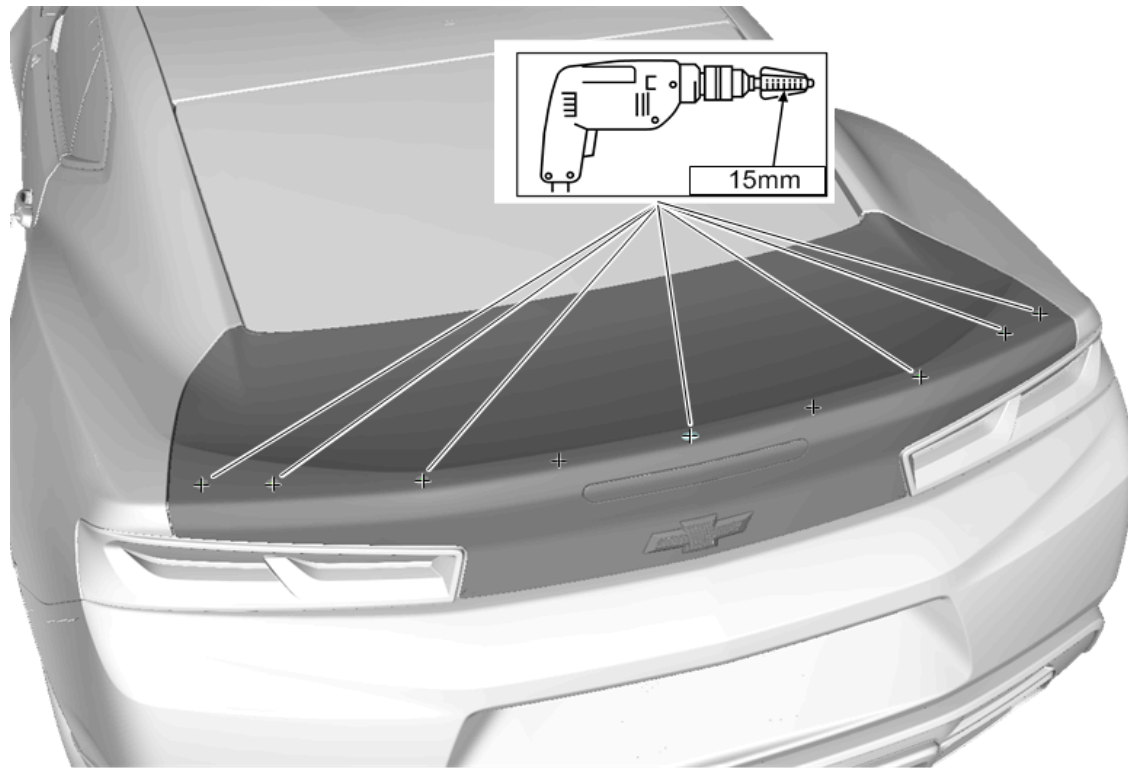

11. Drill 15mm holes according to locations specified.

Note: Use a 3 step down drill process to prevent dimpling. This will ensure clip engagement.

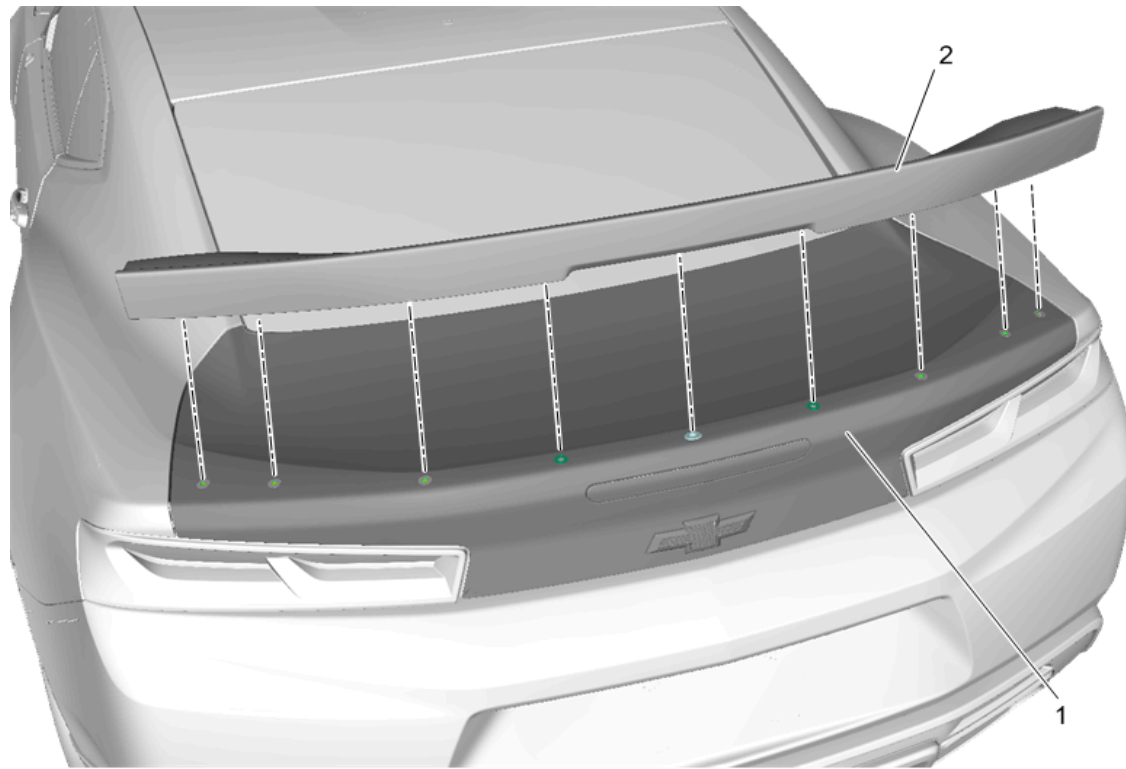

12. Verify spoiler (2) fits rear compartment lid (1).

Note: Do not push down on spoiler or clips will engage and cannot be removed without breaking.

13. Remove spoiler and set aside.

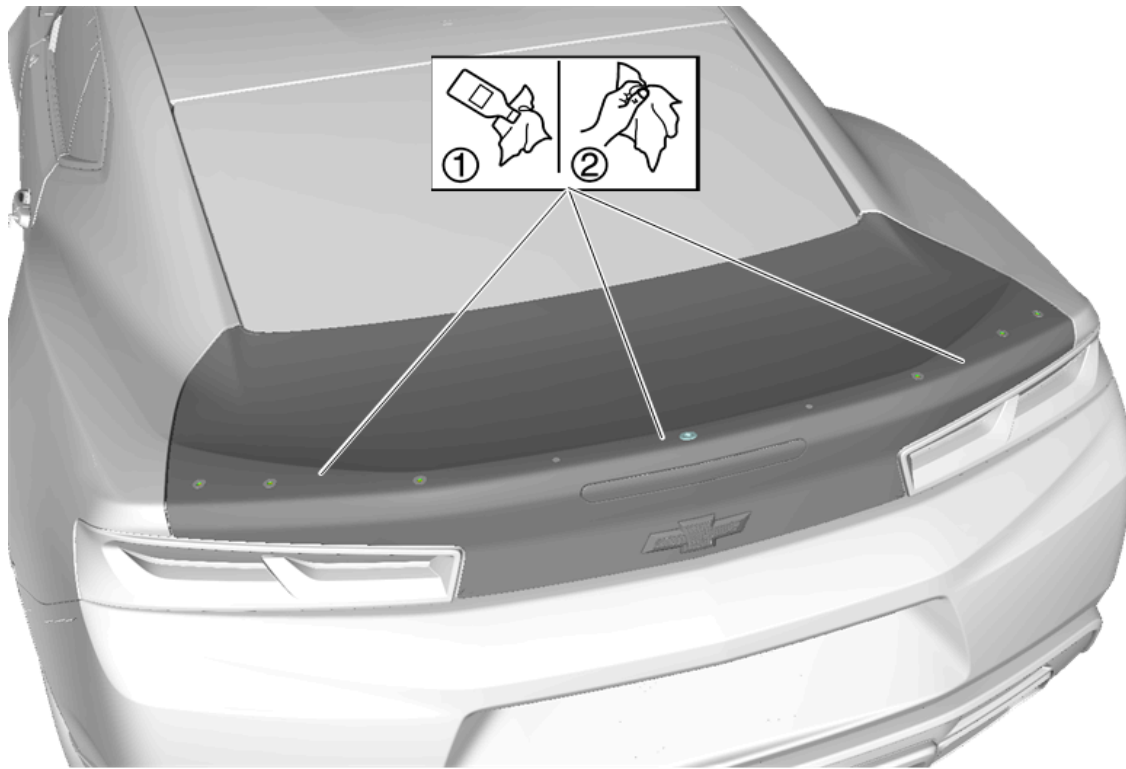

14. Clean rear compartment lid with solvent pack.

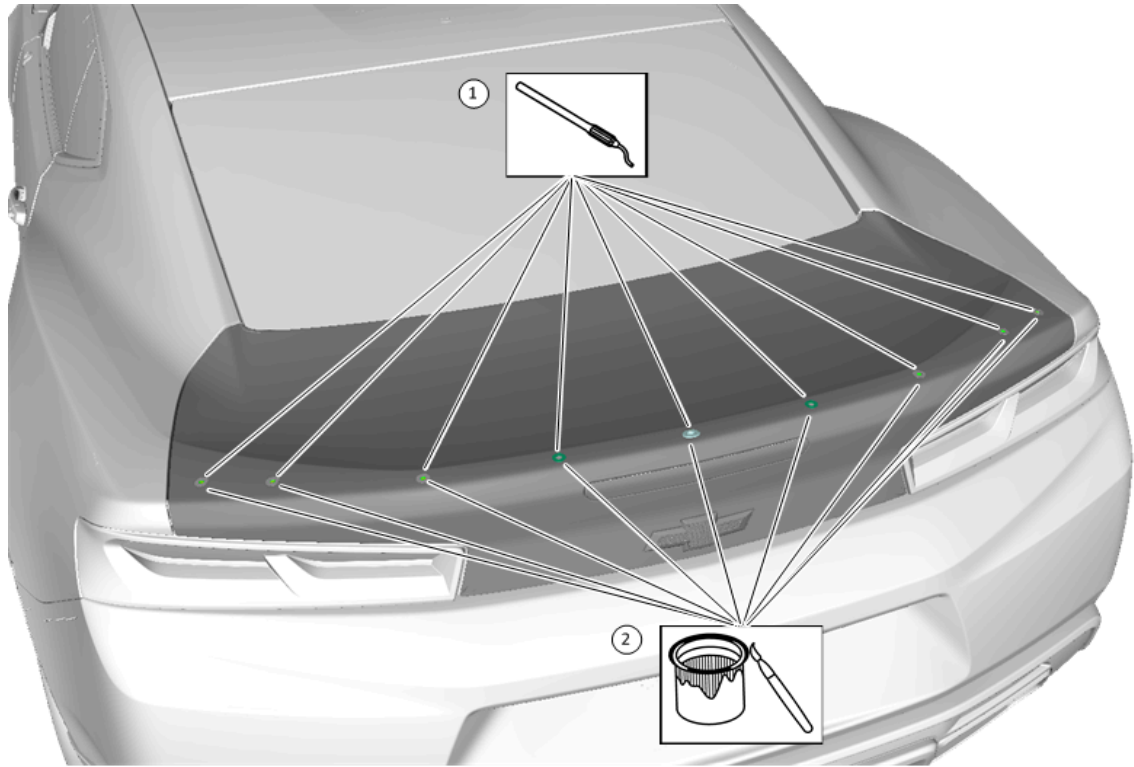

15. De-burr drilled holes and apply P/N 12346225 to all holes.

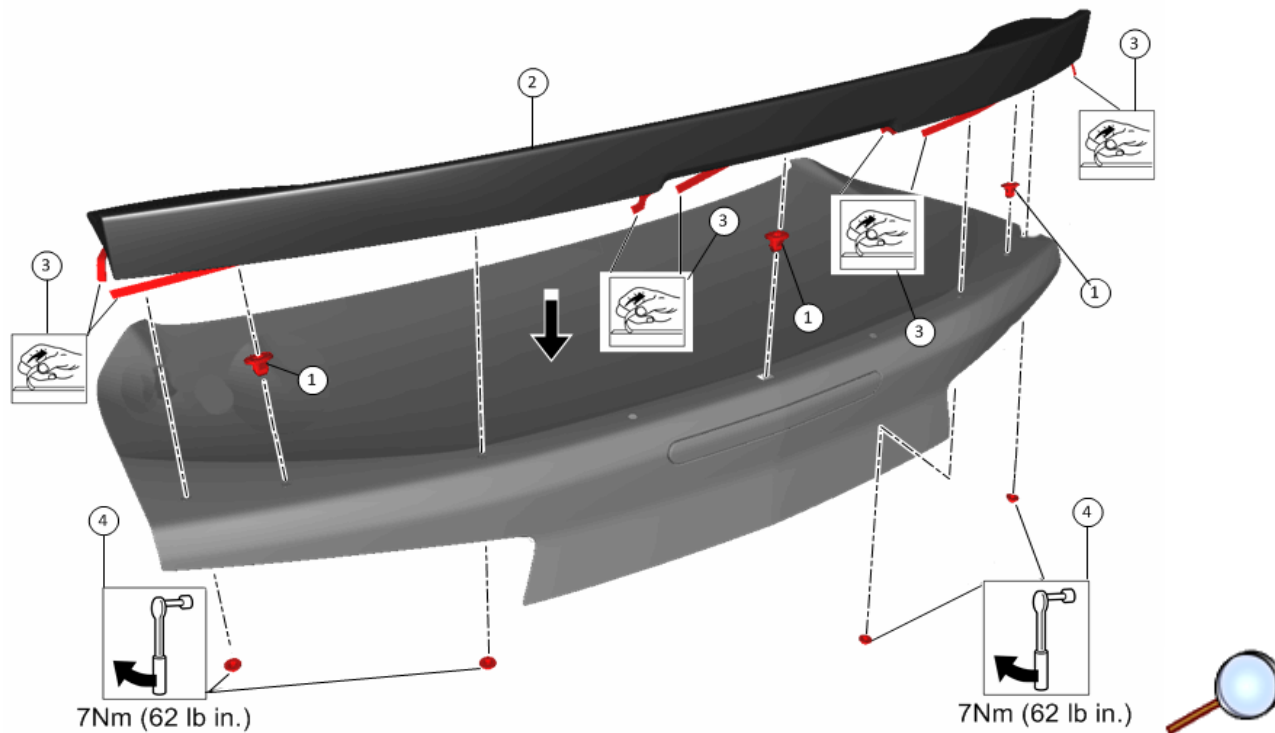

16. Insert the stud retainer into the center and the second out-board hole on each side. Start the tape and set the spoiler to rear compartment lid. Ensure the studs engage into the retainers. Pull the tape tabs. Install the nuts and tighten to 8 N.m (71 lb in.).

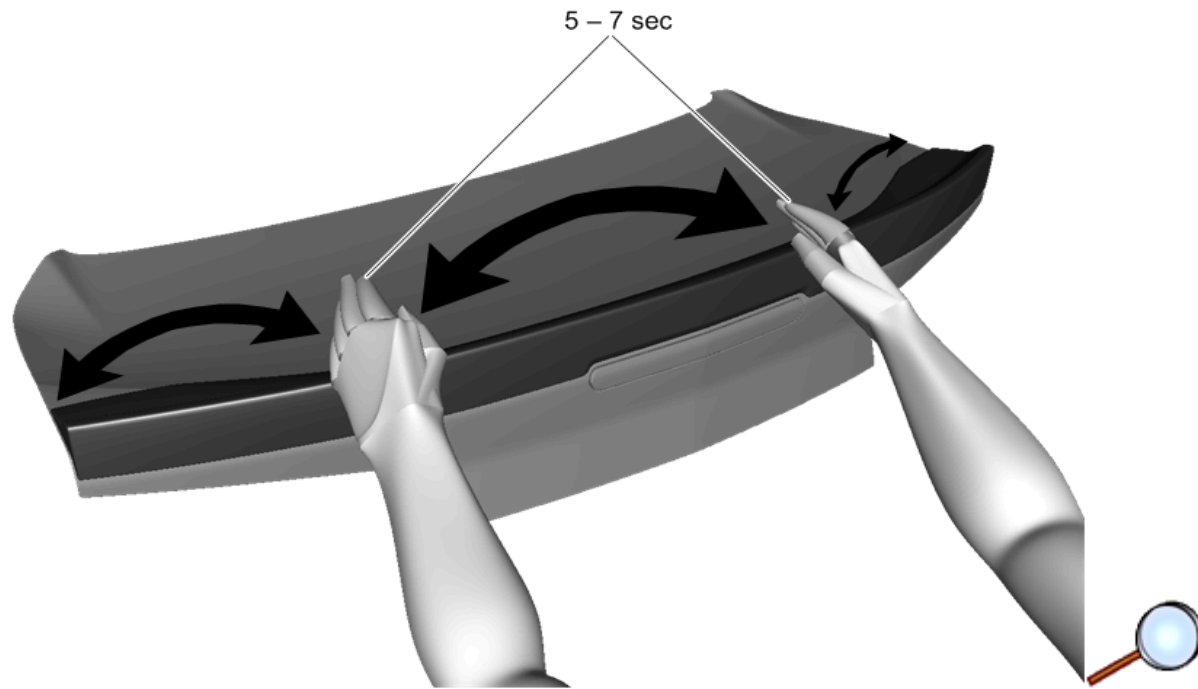

17. Apply pressure to entire spoiler surface. Ensure that all clips are engaged.



Note: ADHESIVE SYSTEM TO BE DOW K1, DOW U400HV, OR EQUIVALENT THAT MEETS PERFORMANCE PER GMW3041. PLEASE CHECK THE EXPIRATION DATE ON THE ADHESIVE IN KIT PRIOR TO STARTING INSTALLATION OF END CAPS.

18. Unfold the template and re-position the template over the spoiler to the quarter panels.
19. Verify end cap (1) layout onto quarter panels.
20. Remove end caps (1) and set aside.

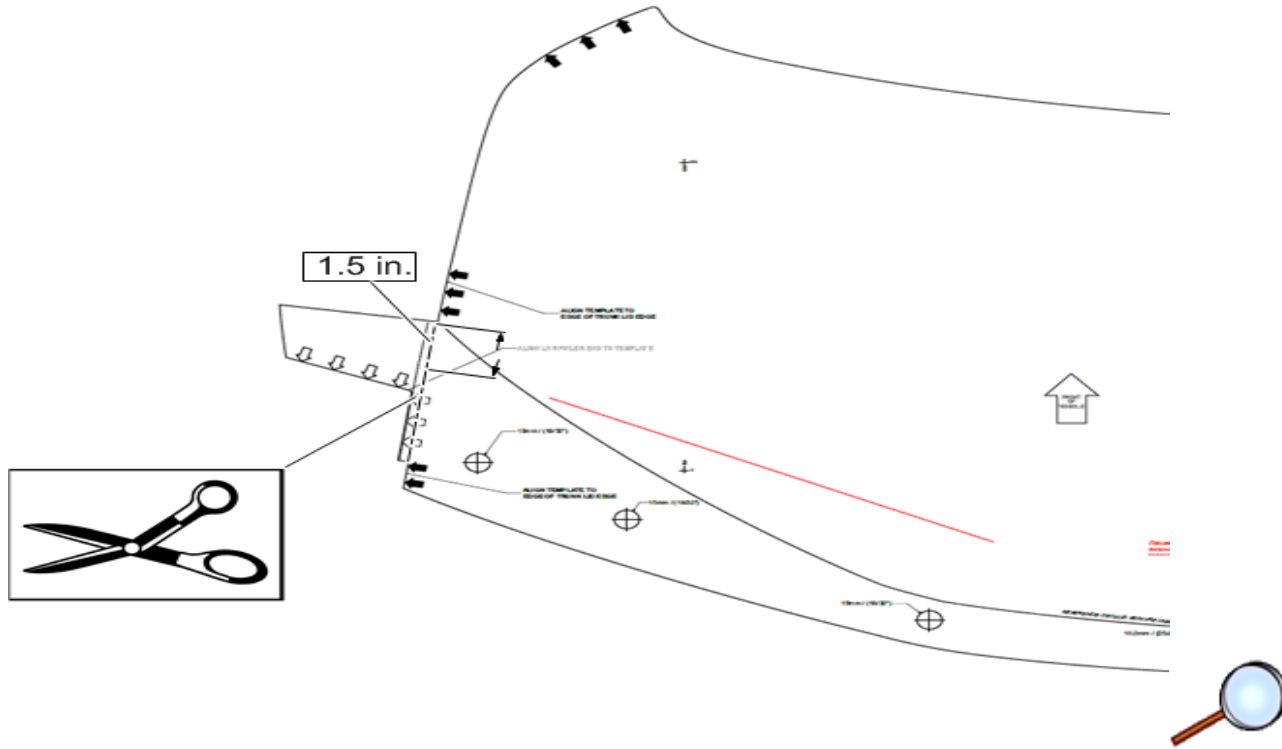

21. Cut on the inner dotted-line at the shown location so the section of template is flush with the deck-lid to ensure the 6mm (min.) gap. Cut approx.1.5 in. to remain attached to the template.

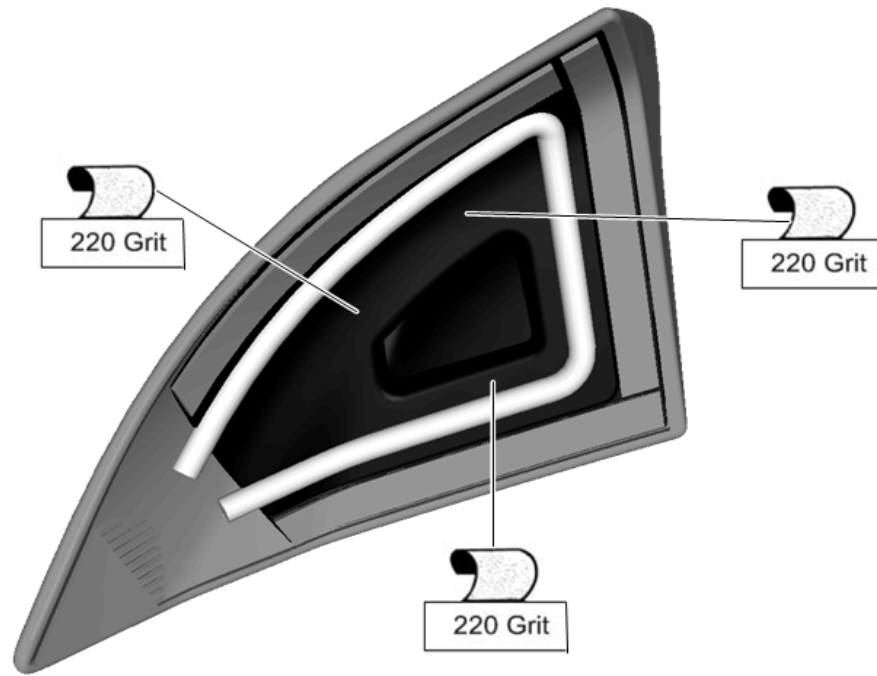

22. Scuff and sand with 220 grit sand paper to remove all gloss from inner surface of end cap (LH & RH).

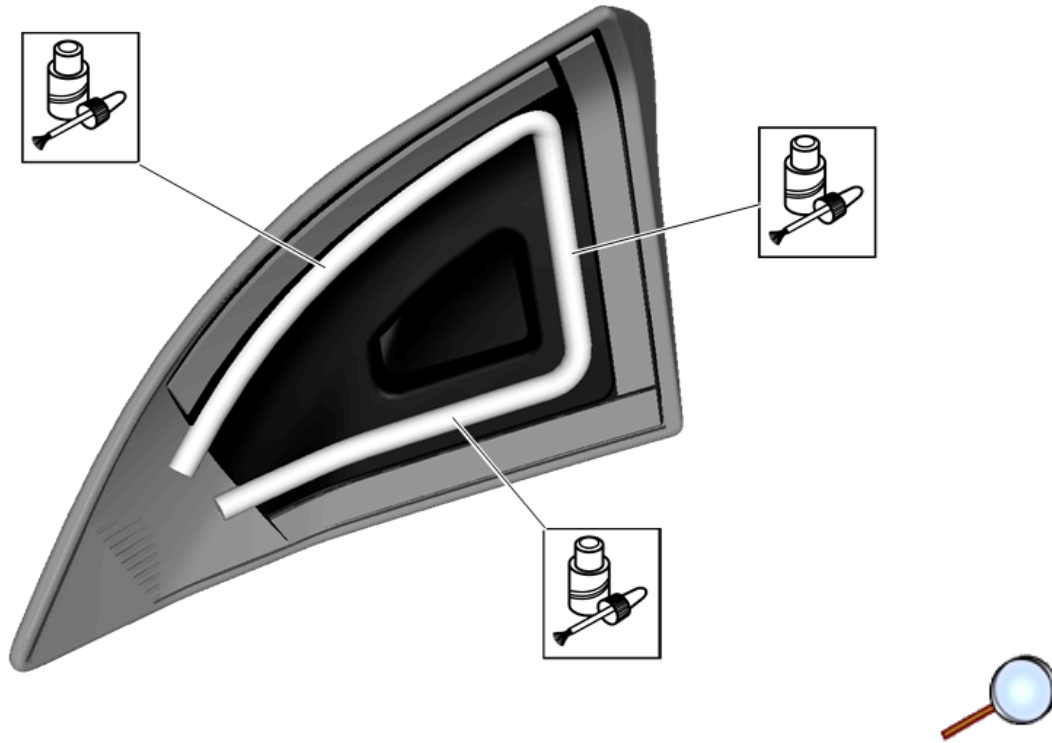

23. The bonding surface on the inner surface of the end caps to be primed with 3 applications in interval of 5 minutes between each application with Primer.

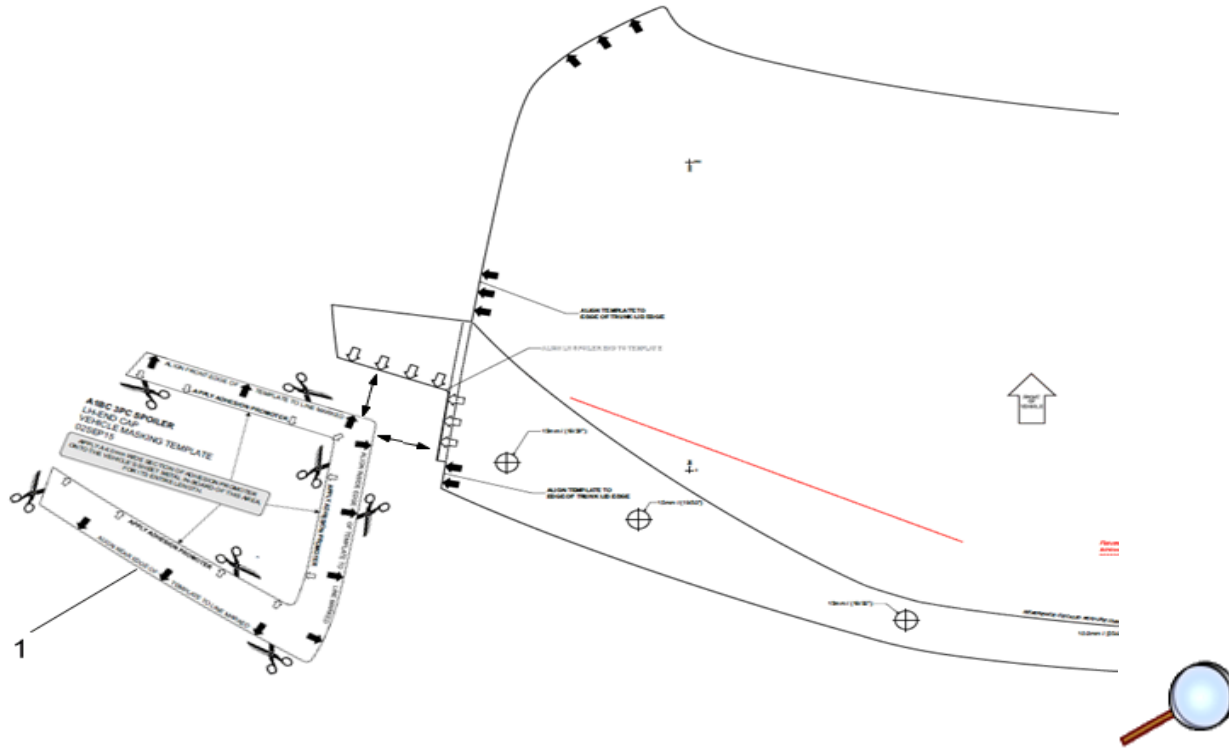

24. The Primer template (1) should be positioned as shown above.

Note: Please use the cut-out template provided for appropriate priming area on quarter panel.



25. The bonding surface on the quarter panel surface to be primed with 3 applications in intervals of 5 minutes between each application. Remove Primer Template after last application.

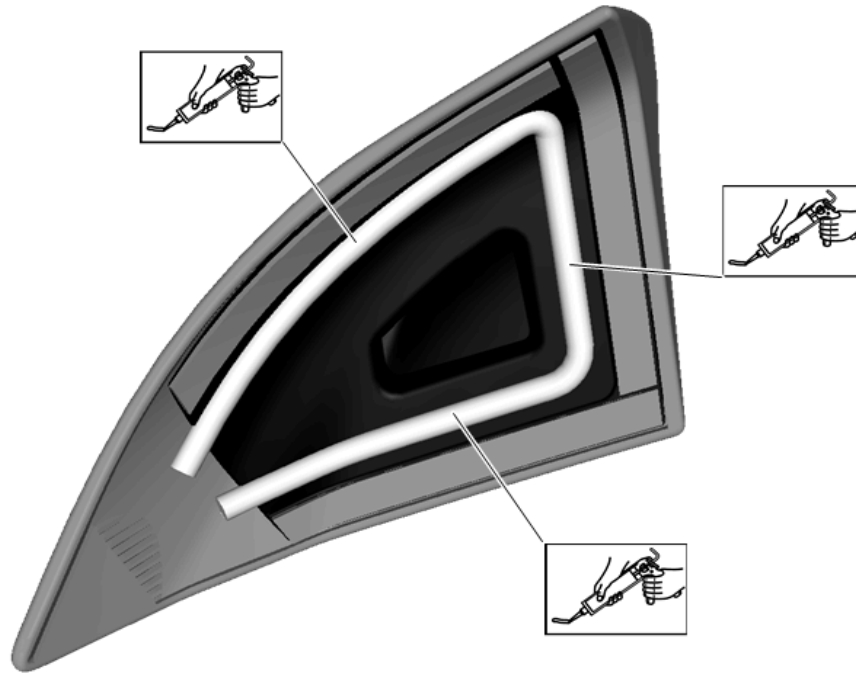

26. Apply the adhesive system using a caulking gun on the inner surface of the end caps on 3-sides using the glue guideline on end caps. Ensure the glue bead is an even 6mm diameter or consistent bead amount.

Note: Recommended to work with both end caps (LH & RH) since adhesive has medium usage time once opened.

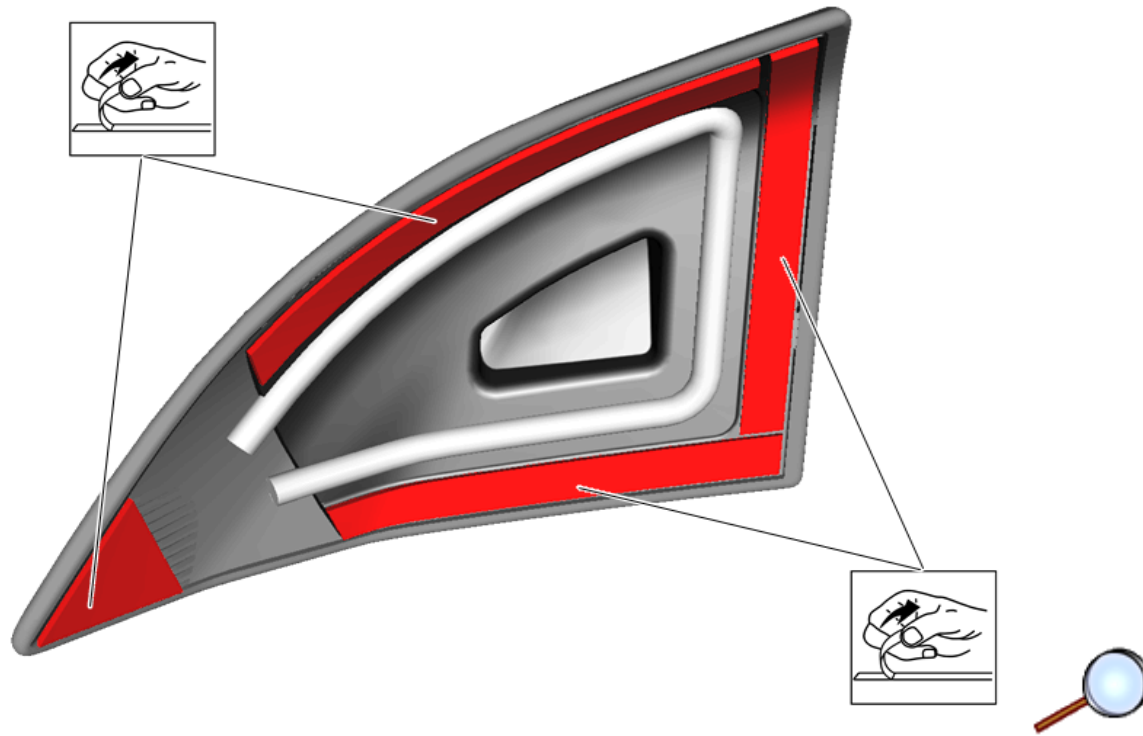

27. Start the pull the tape tabs from end caps ensuring not to smudge the adhesive bead.

Note: Recommended to work with both end caps (LH & RH) since adhesive has medium usage time once opened.



28. Using the aligned template, carefully place LH end cap on the quarter panel. Ensure that all contact points of the end cap line up with the template prior to applying even pressure. Repeat for RH end cap.



29. Ensure the gap between the end of the spoiler (1) and the start of end cap (2) is 6mm using the template, this should already be 6mm.

30. Remove template. Allow 72 hours for full cure of primer/adhesive/tape wet out.

Vehicle Masking Templates

Note: Templates are for reference only.

