

# INVERTER GENERATOR Owner's Manual

3500io

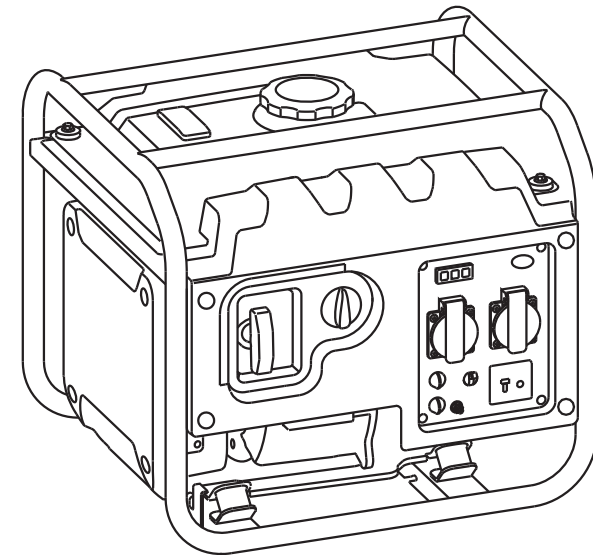

Tips—read this manual carefully before operating this generator.

Save this operating manual properly and carry it with the generator for the convenience of emergency query in the future. This manual constitutes one permanent element of the generator. This manual shall be provided along with the generator set when you lend or resell it.

Relevant information and technical specifications defined in this manual take effect when printing is approved, with the contents based on the equipment in production at time of publication. Manufacturer reserves the rights to modify and improve any parts described in the text without prior notice.

# Contents

1	Foreward	01
2	Safety Information	02-05
3	Control Function	06-12
4	Pre-operation	13-14
5	Operation	15-21
6	Application Range	22-28
7	Storage	29
8	Troubleshooting	30
9	Parameters	31
10	Electrical Schematic Diagram	32-34

## Foreward

Thank you for purchasing a generator. We recommend that the operator read this manual carefully before use this generator, and fully comprehend all requirements and operating procedure concerning the generator. In case of any questions about this manual, contact the recent authorized dealer for startup, operation, maintenance program and so on. The technician will teach you how to use the generator in a correct and safe manner. We also recommend that the operator consult startup and operating procedure of this generator when buying it.

### Safety precautions

This generator will work in a safe, effective and reliable way only when it is kept, operated and maintained properly. Before operation or maintenance of the generator, the operator should:

- Know well and strictly observe local laws and regulations.
- Read and observe all safety warnings in this manual and on the device.
- Let your family get familiar with all safety warnings in this manual.

It is impossible for manufacturers to predict all hazardous circumstances that may occur, for this reason, warnings in this manual and caution signs on the generator set may not cover all hazardous circumstances. If we do not give extra cautions for operating procedures, methods or techniques, operate the generator in such ways that helps guarantee personal safety, make sure no damage to generator set arises there from.

To make sure safe operation, Please read carefully three vital safety warnings in this manual and on the generator, preceded by a safety alert symbol  including:

** DANGER** You WILL be KILLED or SERIOUSLY HURT if you don't follow instructions.

** WARNING** You CAN be KILLED or SERIOUSLY HURT if you don't follow instructions.

** CAUTION** You CAN be HURT if you don't follow instructions.

**NOTICE** Your generator or other property could be damaged if you don't follow instructions.

### Safety Information

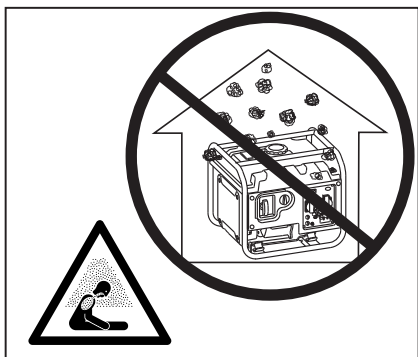

#### ⚠ DANGER

Do not use it indoors.



#### ⚠ DANGER

Keep the machine clean and avoid spilt combustibles including gasoline on it.



#### ⚠ WARNING

Do not use it in a wet condition.



#### ⚠ WARNING

Turn the generator "OFF" when add fuel.

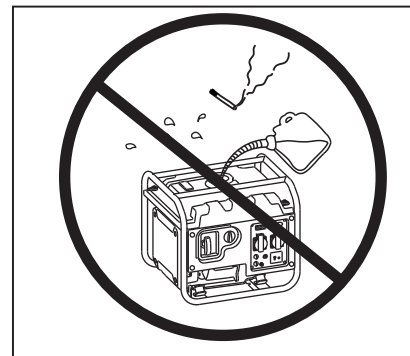

#### ⚠ WARNING

Don't add fuel near the flammable thing or cigarette.

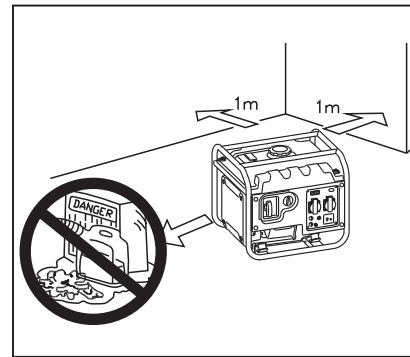

#### ⚠ WARNING

Keep children and pets away from the area of operation. Do not place flammable objects close to the outlet valve when generator operation. Keep it at least 1m away from inflammables.



### ⚠ WARNING

Do not connect to a home power system.

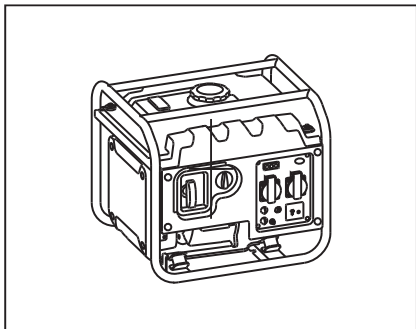

### ⚠ WARNING

It must realize safe grounding.

#### NOTICE

Use the ground wire with enough electric flux.

Ground wire diameter : 0.12mm/A  
EX:10A-1.2mm

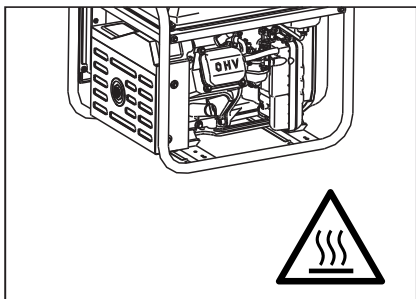

### ⚠ WARNING

The generator surface has high temperature, avoid scalding.  
Pay attention to the warnings on the generating set.

### ⚠ WARNING

- A warning reminding the user that he shall conform to regulations of electrical safety applicable to the place where the generating sets are used.
- A warning on the requirements and the precautions to be respected by the user in the case of re-supply by generating sets of an installation, depending on existing protective measures in this installation and applicable regulations.

### Connection to a home power supply

If the generator is to be connected to a home power supply as a standby, connection shall be performed by a professional electrician or by another person with proficient electrical skill.

When the loads are connected to the generator, please carefully check whether electrical connections are safe and reliable. Any improper connection may cause damage to the generator, or cause a fire.

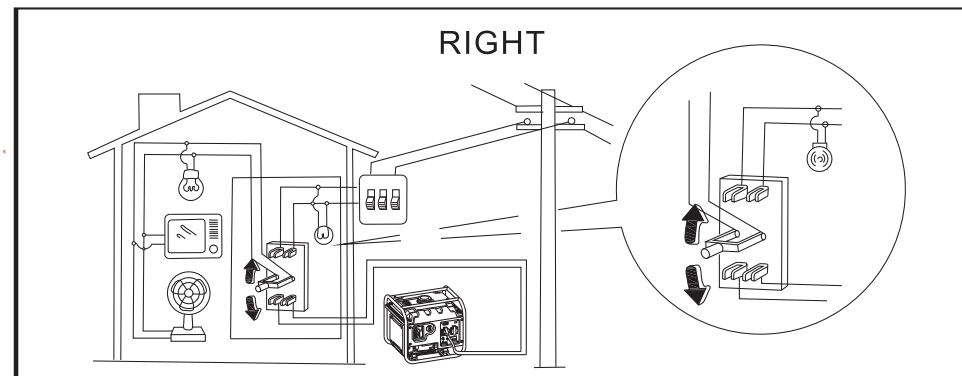
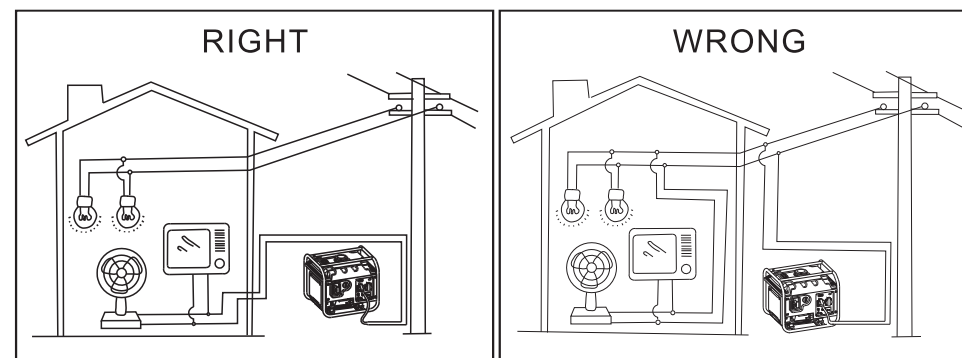

### Others

Make sure Inverter ducted fan, muffler louver and the inverter bottom side cooling well and without chips, mud and water come in. it may damage the generator, inverter or alternator if the cooling vent blocked. Do not mix the generator with other stuff if moving, storing or running the unit, It may cause generator damage or bring property safety issue when the inverter in leakage.

### Control Function

#### DESCRIPTION

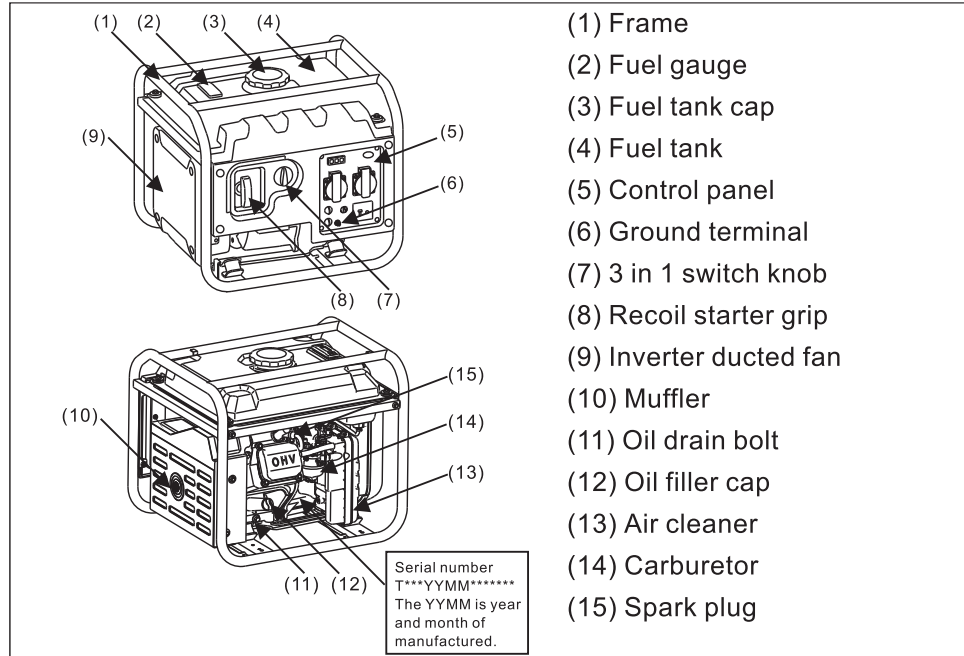

#### CONTROL PANEL

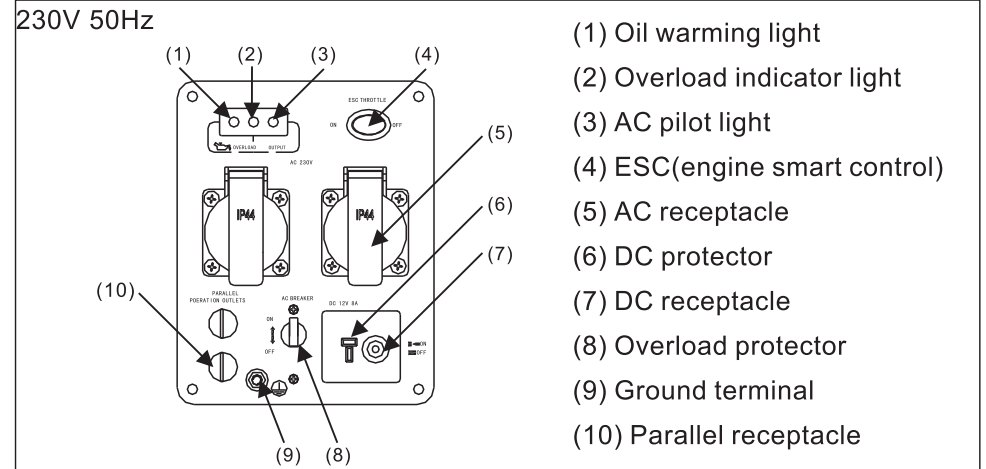
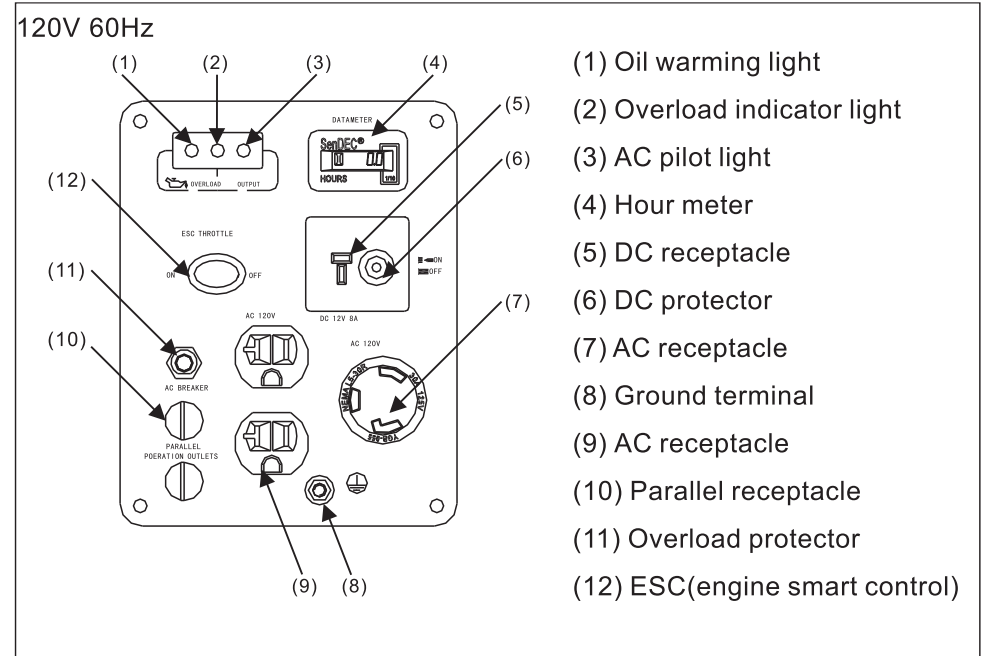
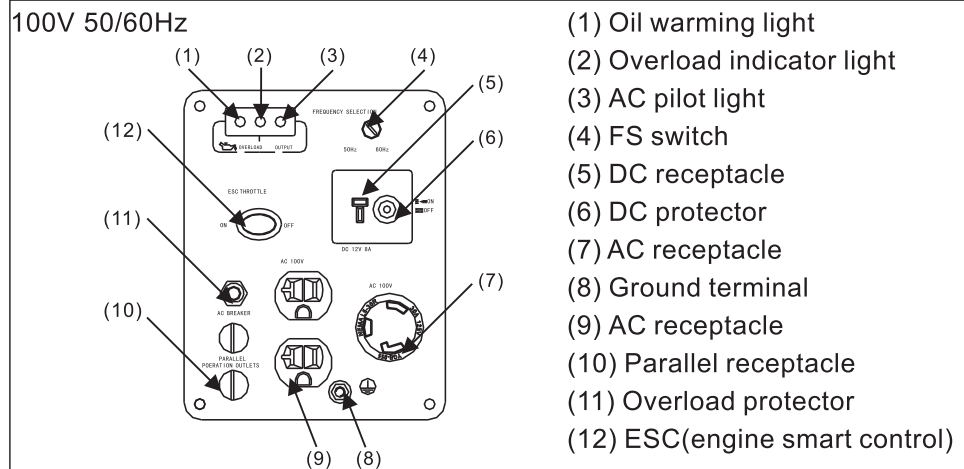

### CONTROL FUNCTION

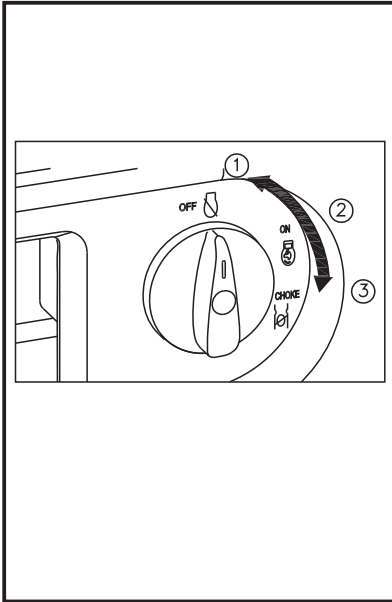

#### 3 in 1 switch knob

- ① Engine/fuel valve "OFF"; Ignition circuit is switched off. Fuel is switched off. The engine will not run.
- ② Engine switch \fuel valve \chock. "ON" Ignition circuit is switched on. Fuel is switched on. Chock is switched on. The engine can be running.
- ③ Engine switch \fuel valve \chock. "ON" Ignition circuit is switched on. Fuel is switched on. Chock is switched on. The engine can be start.

TIP: The chock is not required to start a warm engine.

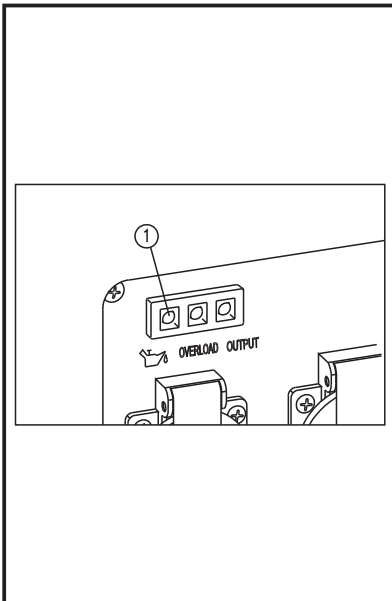

#### Oil warning light

When the oil level falls below the lower level, the oil warning light comes on and then the engine stops automatically. Unless you refill with oil, the engine will not start again.

Tip: If the engine stalls or does not start, turn the engine switch to "ON" and then pull the recoil starter. If the oil warning light flickers for a few seconds, the engine oil is insufficient. Add oil and restart.

#### Overload indicator light (Red)

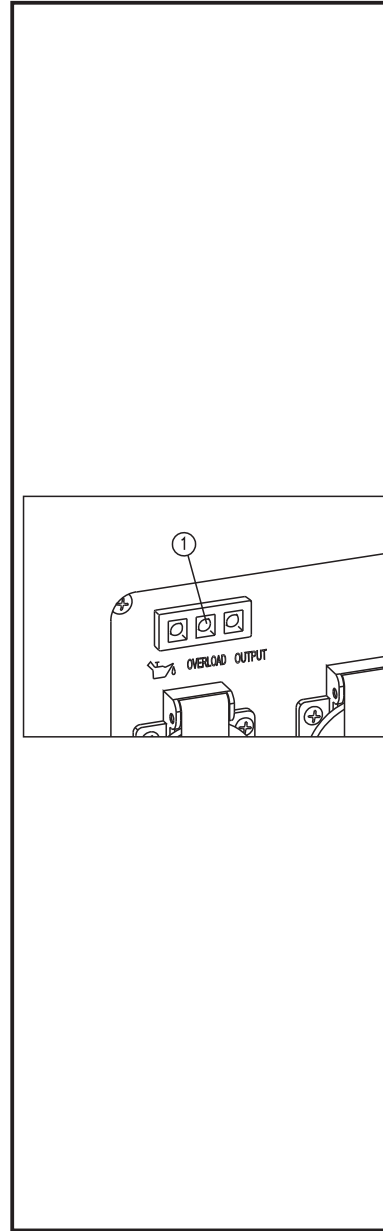

The overload indicator light comes on when an overload of a connected electrical device is detected, the inverter control unit overheats, or the AC output voltage rises. Then, the AC protector will trip, stopping power generation in order to protect the generator and any connected electric devices. The AC pilot light (Green) will go off and the overload indicator light (Red) will stay on, but the engine will not stop running.

When the overload indicator light comes on and power generation stops, proceed as follows:

1. Turn off any connected electric devices and stop the engine.
2. Reduce the total wattage of connected electric devices within the rated output.
3. Check for blockages in the cooling air Inlet and around the control unit. If any blockages are found remove.
4. After checking, restart the engine.

TIP : The overload indicator light may come on for a few seconds at first when using electric devices that require a large starting current, such as a compressor or a submersible pump. However, this is not a malfunction.



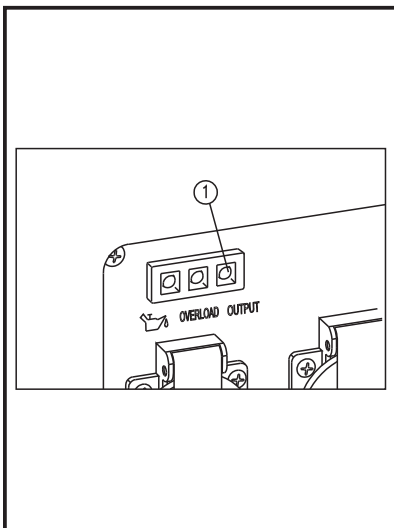

### AC pilot light (Green)

The AC pilot light comes on when the engine starts and produces power.

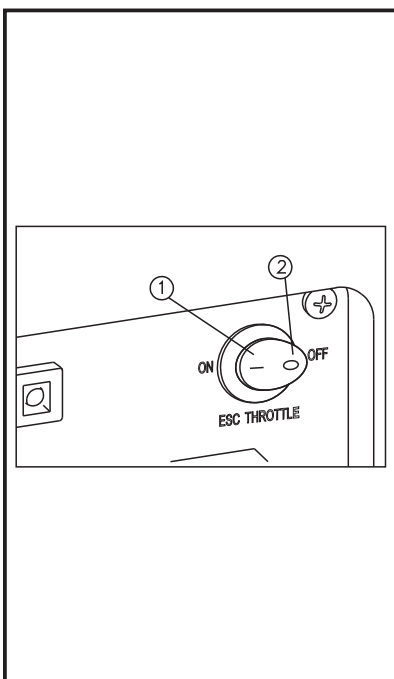

### Engine smart control

- ① "ON"  
When the ESC switch is turned to "ON", the economy control unit controls the engine speed according to the connected load. The results are better fuel consumption and less noise.
- ② "OFF"  
When the ESC switch is turned to "OFF", the engine runs at the rated (3100r/min) regardless of whether a load is connected or not.

**Tip:** The ESC must be turned to "OFF" when using electric devices that require a large starting current, such as a compressor or a submersible pump.

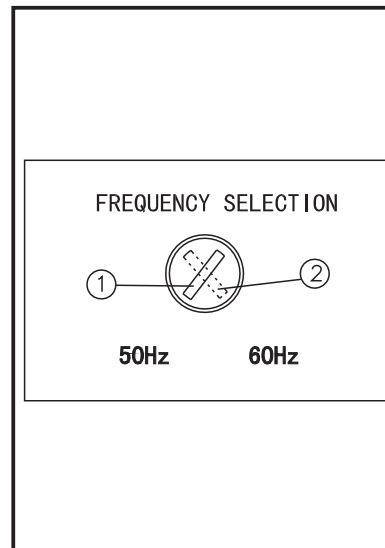

### Frequency selection (FS) switch

- ① 50Hz
- ② 60Hz

If you need to change the machine output frequency, please stop the generating set first, then adjust the position of the frequency switch with a screwdriver. Then restart it.

**NOTICE** Frequency switch can change frequency only when the generator setting stops. The generator setting output frequency can't change if it operates.

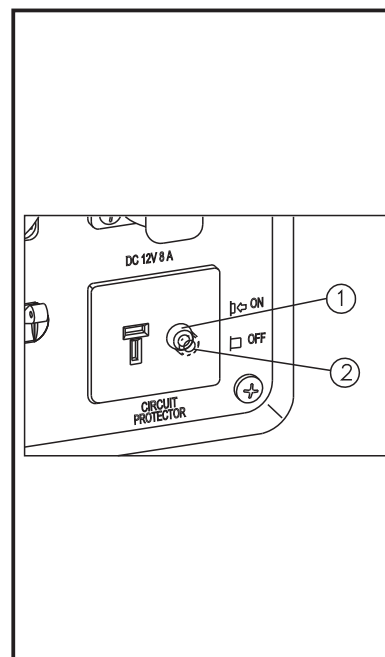

### DC protector

The DC protector turns to "OFF" automatically when an electric device connected to the generator is operating and the current is above the rated flow. To use this equipment again, turn on the DC protector by pressing its button to "ON".

- ① "ON" Direct current is output.
- ② "OFF" Direct current is not output.

**NOTICE** Reduce the load of the connected electric device below the specified rated output of the generator if the DC protector turns off. If the DC protector turns off again, stop using the device immediately and consult your generator dealer.



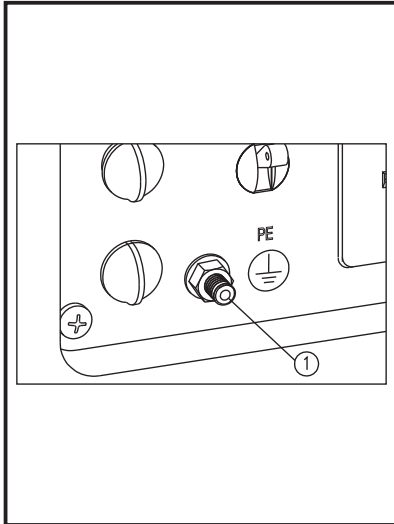

### Ground (Earth) terminal

Ground (Earth) terminal ① connects the earth line for prevention of electric shock. When the electric device is earthed, always the generator must be earthed.

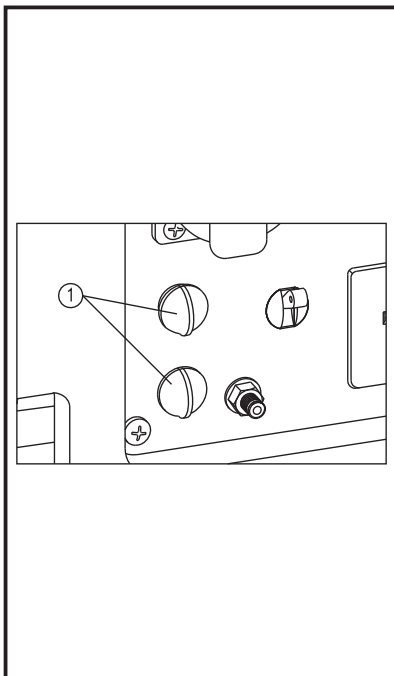

### Parallel Operation Outlets

This is the terminal ① for connecting special cables for parallel running of two 3500io. The parallel running requires two 3500io and the special cables. (The rated output in parallel running is 5.6Kva and the rated current is 56A/100V;46.7A/120V;24.3A/230V.)

The handing, operation procedure and the notes on usage are described in the PARALLEL RUNNING KIT OWNER'S MANUAL included in the Parallel.

### Pre-operation

#### NOTICE

Pre-operation checks should be made each time operation.

#### ⚠ WARNING

The engine and muffler will be very hot after the engine has been run. Avoid touching the engine and muffler while they are still hot with any part of your body or clothing during inspection or repair.

#### Fuel

#### ⚠ WARNING

- Fuel is highly flammable and poisonous. Check "SAFETY INFORMATION"(See page 2-5) carefully before filling.
- Do not overfill the fuel tank, otherwise it may overflow when the fuel warms up and expands. After fill the fuel, make sure the fuel tank cap is tightened securely.
- Immediately wipe off spilled fuel with a clean.
- Use only unleaded gasoline. The use of leaded gasoline will cause severe damage to internal engine parts.

Make sure enough gasoline in fuel tank.

Recommended fuel: Unleaded gasoline  
Fuel tank capacity: Total: 9.0L

- ① Fuel level gauge  
F (FULL)  
E (EMPTY)

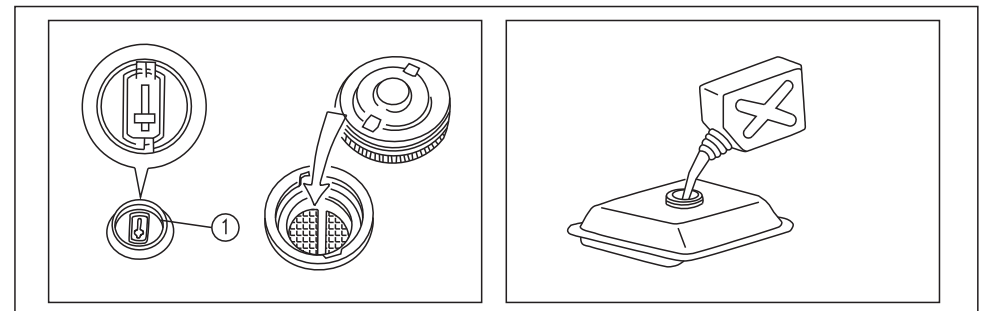

### Engine Oil

The generator has been shipped without engine oil. Do not start the engine till fill with the sufficient engine oil.

Do not tilt the generator when adding engine. This could result in overfilling and damage to the engine.

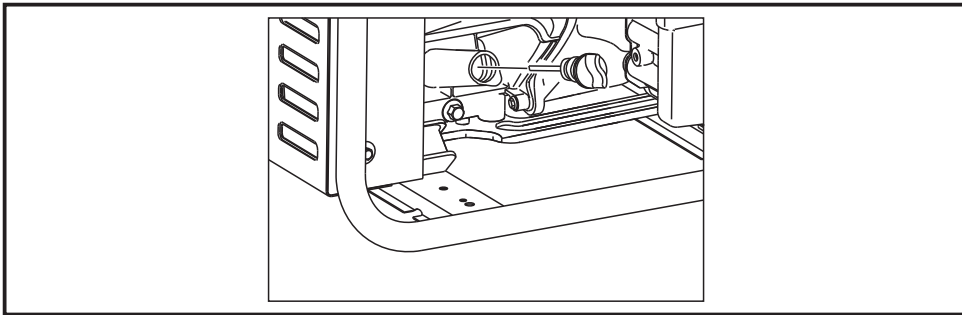

### Oil level

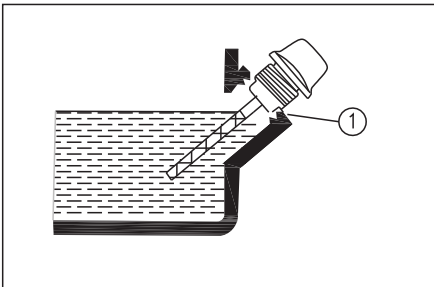

Recommended engine oil:  
SAE 10W -30  
Recommended engine oil grade:  
API Service SE type or higher  
Engine oil quantity:  
0.6 L

### Operation

#### NOTICE

Never operate the engine in a closed area or it may cause unconsciousness and death within a short time. Operate the engine in a well ventilated area. The generator has been shipped without engine oil. Do not start the engine till fill with the sufficient engine oil.

#### TIP:

- The generator can be used with the rated output load at standard atmospheric conditions.
- “Standard atmospheric conditions ”; Ambient temperature 25°C.
- Barometric pressure 100kPa; Relative humidity 30%
- The output of the generator varies due to change temperature, altitude (lower air pressure at higher altitude) and humidity.
- The output of the generator is reduced when the temperature, the humidity and the altitude are higher than standard atmospheric conditions.
- Additionally, the load must be reduced when using in confined areas, as generator cooling is affected.

### STARTING THE ENGINE

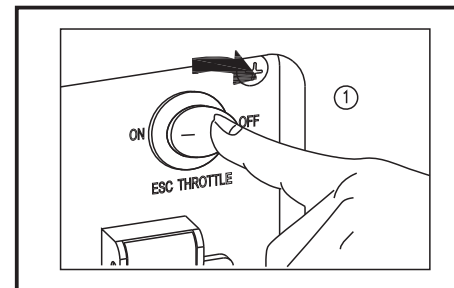

Before starting the engine, do not connect any electric devices.

Turn the ESC switch to “OFF” ①

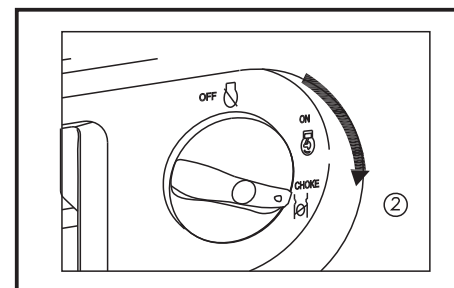

Turn the 3 in 1 switch to “CHOKE” ②  
a. Ignition circuit is switched on.  
b. Fuel is switched on.  
c. Choke is switched off.

TIP: The choke is not required to start a warm engine. Push the choke knob in to the position “ON”.

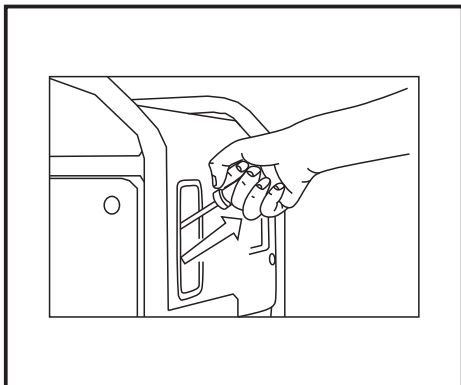

Grasp the carrying handle firmly to prevent the generator from falling over when pulling the recoil starter.

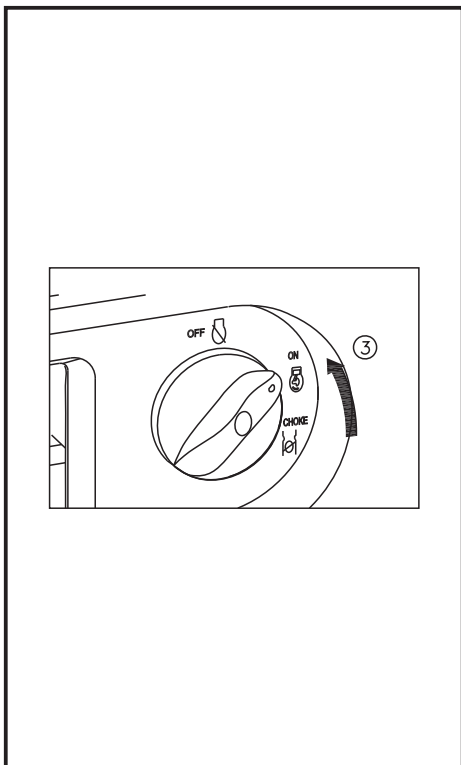

After the engine starts, warm up the engine until the engine does not stop when the choke knob is returned to the "ON" position ③.

#### TIP:

When starting the engine, with the ESC "ON" and there is no load on the generator:  
 In ambient temperature below 0°C (32°F), the engine will run at the rated (3600r/min) for 5 minutes to warm up the engine.  
 In ambient temperature below 5°C (41°F), the engine will run at the rated r/min (3600r/min) for 3 minutes to warm up the engine.  
 The ESC unit operates normally after the above time period, while the ESC is "ON".

## STOP THE ENGINE

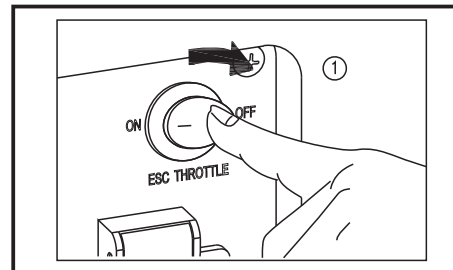

TIP: Turn off any electric devices.

1. Turn the ESC to "OFF" ①.
2. Disconnect any electric devices.

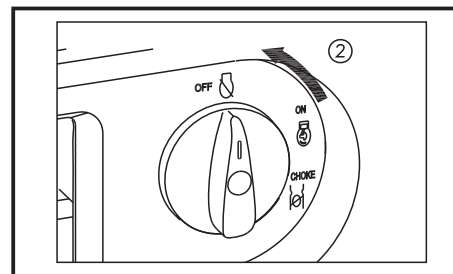

Turn the 3 in 1 switch to "OFF" ②.

- a. Ignition circuit is switched off.
- b. Fuel valve is switched off.

## ALTERNATING CURRENT (AC) CONNECTION

### ⚠ WARNING

Be sure any electric devices are turned off before plugging them in.

### NOTICE

- Be sure all electric devices including the lines and plug connections are in good condition before connection to the generator.
- Be sure the total load is within generator rated output.
- Be sure the receptacle load current is within receptacle rated current.

TIP: Make sure to ground (Earth) the generator. When the electric device is earthed, always the generator must be earthed.

1. Start the engine.
2. Turn the ESC to "ON".
3. Plug in to AC receptacle.
4. Make sure the AC pilot light is on.
5. Turn on any electric devices.

**TIP:** The ESC must be turned to “OFF” before increasing engine speed to rated rpm.

- Most motorized appliances require more than their electrical rating for startup. When an electrical motor is started, the overload indicator (red) may come on. This is normal if the overload indicator (red) goes off within 4 seconds. If the overload indicator (red) stays on, consult your generator dealer.
- If the generator is connected to multiple loads or electricity consumers, please remember to first connect the one with the highest starting current. And last connect the one with the lowest starting current.
- If the generator is overload, or if there is a short circuit in a connected appliance, the overload indicator (red) will go ON. The overload indicator (red) will stay ON, and after about 4 seconds, current to the connected appliance(s) will shut off, and the output indicator (green) will go OFF. Stop both engines and investigate the problem. Determine if the cause is a short circuit in a connected appliance or an overload, correct the problem and restart the generator.

## BATTERY CHARGING

**TIP:**

- The generator DC rated voltage is 12V.
- Start the engine first, and then connect the generator to the battery for charging.
- Before starting to charge the battery, make sure that the DC protector is turned on.

1. Start the engine.
2. Connect the red battery charger lead to the positive (+) battery terminal.
3. Connect the black battery charger lead to the negative (-) battery terminal.
4. Turn the ESC “OFF” to start battery charging.

### NOTICE

- Be sure the ESC is turned off while charging the battery.
- Be sure to connect the red battery charger lead to the positive (+) battery terminal, and connect the black lead to the negative (-) battery terminal. Do not reverse these positions.
- Connect the battery charger leads to the battery terminals securely so that they are not disconnected due to engine vibration or other disturbances.
- Charge the battery in the correct procedure by following instructions in the owner's manual for the battery.
- The DC protector turns off automatically if current above the rated flows during battery haring. To restart charging the battery, turn he DC protector on by pressing its button to “ON”. If the DC protector turns off again, top charging the battery immediately and consult your generator dealer.

**TIP:**

- Follow instructions in the owner are manual for the battery to determine the end of battery charging.
- Measure the specific gravity of electrolyte to determine if the battery is fully charged. At full charge, the electrolyte specific gravity is between 1.26 and 1.28.
- It is advisable to check the specific gravity of the electrolyte at least once every hour to prevent overcharging the battery.

### ⚠ WARNING

- Never smoke or make and break connections at the battery while charging. Sparks may ignite the battery gas.
- Battery electrolyte is poisonous and dangerous, causing severe burns, etc. contains sulfuric (sulphuric) acid. Avoid contact with skin, eyes or clothing.

**Antidote:**

External- Flush with water.

INTERNAL- Drink large quantities of water or milk. Follow with milk of magnesia, beaten egg or vegetable oil.

Call physician immediately.



**EYES:** Flush with water for 15 minutes and get prompt medical attention. Batteries produce explosive gases. Keep sparks, flame, cigarettes, etc., away. Ventilate when charging or using in closed space. Always cover eyes when working near batteries.

## KEEP OUT OF REACH OF CHILDREN

### AC parallel operation

Before connection an appliance to either generator, make sure that it is in good working order and that its electrical rating does not exceed that of the receptacle.

During parallel operation, the ESC switch should be in the same position on both generators.

1. Connect the parallel operation cable between the 3500io to either an 3500io or companion generator following the instructions supplied with the cable kit.
2. Start the engines and make sure the output indicator (green) on each generator comes on.
3. Plug an appliance into the AC receptacle.
4. Turn on the appliance.

### AC Parallel Operation Applications

#### TIP:



- Make sure that it is in good working order. A faulty appliance or power cord can create a potential for electrical shock.
- If an appliance begins to operate abnormally, becomes sluggish, or stops suddenly, turn it off immediately. Disconnect the appliance and determine whether the problem is the appliance, and determine whether the problem is the appliance or the rated load capacity of the generator has been exceeded.
- Make sure that the combined electrical rating of the tools or appliance do not exceed that of the generator. Never exceed the maximum may be used for no more than 30 minutes.
- Never connect different generator models.
- Don't remove the parallel operation cable when the generator operation.
- For single generator operation, the parallel operation cable must be removed.



#### **⚠ WARNING**

- Substantial overloading that continuously lights the overload indicator (red) may damage the generator
- Marginal overloading that temporarily light the overload indicator (red) may shorten the service life of the generator.
- Limit operation requiring maximum power to 30 minutes.
- Maximum power in parallel operation is; 6.0kVA.
- For continuous operation, do not exceed the rated power.
- Rated power in parallel operation is: 5.6kVA.

When using the generator, make sure the total load is within rated output of a generator. Otherwise, generator damage may occur.

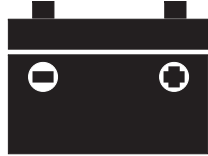
				DC 
AC	1	0.8-0.95	0.4-0.75 (Efficiency 0.85)	
Power factor	1	0.8-0.95	0.4-0.75 (Efficiency 0.85)	
3500io	~3000W	~2400W	~1200W	Rated voltage 12v Rated current 8A

**TIP:**

- “~” means below.
- Application wattage indicates when each device is used by itself.
- The simultaneous usage of AC and DC power is possible but total wattage should not exceed the rated output.

**EX:**

Generator rated output		3000VA
Frequency	Power factor	
AC	1.0	~3000W
	0.8	~2400W
DC	--	96W(12V/8A)

The overload indicator light comes on when total wattage exceeds the application range. (See page 12 for more details.)

**NOTICE**

- Do not overload. The total load of all electrical appliances must not exceed the supply range of the generator. Overloading will damage the generator.
- When supplying precision equipment, electronic controllers, PCs, electronic computers, microcomputer based equipment or battery chargers, keep the generator a sufficient distance away to prevent electrical interference from the engine. Also ensure that electrical noise from the engine does not interfere with any other electrical devices located near the generator.

**NOTICE**

- If the generator is to supply medical equipment, advice should first be obtained from the manufacturer, a medical professional or hospital.
- Some electrical appliances or general-purpose electric motors have high starting currents, and cannot therefore be used, even if they lie within the supply ranges given in the above table. Consult the equipment manufacturer for further advice.

### Periodic maintenance

Safety is an obligation of the owner. Periodic inspection, adjustment and lubrication will keep your generator in the safest and most efficient condition possible. The most important points of generator inspection and lubrication are explained on the following pages.

**⚠ WARNING**

If you are not familiar with maintenance work, have a generator dealer do it for safety.

### Maintenance chart

**⚠ WARNING**

Stop the engine before starting maintenance work.

Use only your generator dealer specified genuine parts for replacement. Ask an authorized your generator dealer for further attention.

Item	Routine	Pre-operation check(daily)	6 months or 100 Hr	12 months or 300 Hr
Spark plug	Check condition. Clean and replace if necessary.	○		
Fuel	Check fuel level and leakage.	○		
Fuel hose	Check fuel hose for cracks or damage, Replace if necessary.	○		
Oil	Check oil level in engine.	○		
	Replace		○ (1)	



Item	Routine	Pre-operation check(daily)	6 months or 100 Hr	12 months or 300 Hr
Air filter	Check condition. Clean.		○ (2)	
Muffler screen	Check condition. Clean and replace if necessary.		○	
Spark arrester	Check condition. Clean and replace if necessary.		○	
Fuel filter	Clean and replace if necessary.			○
Crankcase breather hose	Check hose weather for cracks or damage. Replace if necessary.			○
Cylinder head	Decarbonizes cylinder head More frequently if necessary			★
Valve clearance	Check and adjust when engine is cold			★
Fittings/ fasteners	Check all fittings and fasteners. Correct if necessary.			★
The point where abnormality was recognized by use		○		

- (1) Initial replacement of the engine oil is after before one month or after 20 hours of operation.
  - (2) The air filter needs to be cleaned more frequently when using in unusually wet or dusty areas.
- ★ Since these items require tools, date and technical skills have a dealer perform the service.

### SPARK PLUG INSPECTION

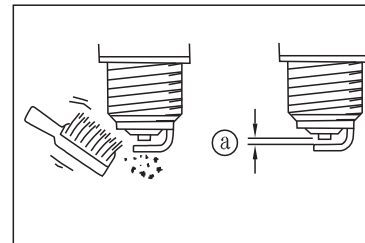
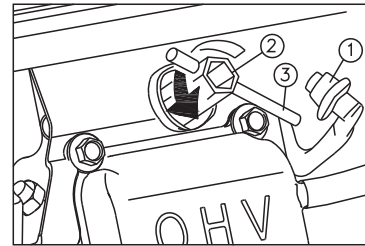

The spark plug is important engine components, which should be checked periodically.

1. Noise suppressor cap assy ① , install spark plug wrench box ② on the spark plug appropriately.
2. Insert the handlebar③ into the tool and turn it counterclockwise to remove the spark plug.
3. Check for discoloration and remove the carbon. The porcelain insulator around the center electrode of spark plug should be a medium-to- light tan color.
4. Check the spark plug type and gap.

Standard spark plug:  
BPR6ES/BP6ES (NGK)  
F7RTC/F7TC  
Spark plug gap: 0.6-0.7mm

5. Install the spark plug.

#### TIP:

If a torque wrench is not available when installing a spark plug, a good estimate of the correct torque is 1/4-1/2 turn past finger tight. However, the spark plug should be tightened to the specified torque as soon as possible.

6. Install the spark plug cap and spark plug cover.



### CARBURETOR ADJUSTMENT

The carburetor is a vital part of the engine. Adjusting should be left to a dealer with the professional knowledge, specialized date, and equipment to do so properly.

### CLEAN FUEL FILTER

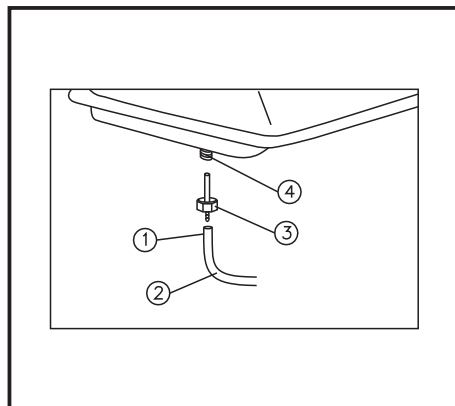

1. Drain the fuel in the fuel tank. Hold the tube clip ① toward downward and pull out the fuel tube ② which connect on the fuel tank, then disassemble fuel filter.
2. Put the fuel filter ③ into non-combustible or higher flash point solvent and clean it.
3. Assemble fuel filter to the main jet ④ on the fuel tank, then assemble fuel tube to main jet on the fuel tank and install tube clip.

### ENGINE OIL REPLACEMENT

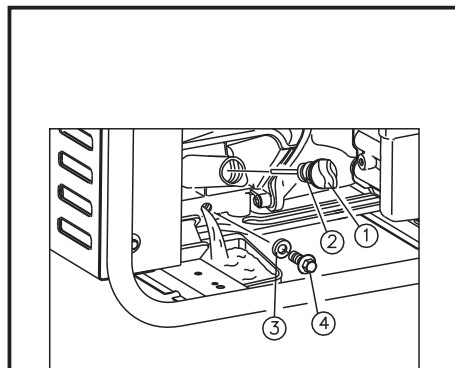

- ① Oil cap
- ② O-ring
- ③ Oil filler cap packing
- ④ Oil drain bolt

Avoid draining the engine oil immediately after stopping the engine. The oil is hot and should be handled with care to avoid burns.

1. Place the generator on a level surface and warm up the engine for several minutes.
2. Remove the oil filler cap.
3. Place an oil pan under the engine, remove the oil drain bolt, drain the oil from the oil tank.
4. Check oil filler cap, O-ring, Oil drain bolt, Oil filler cap packing. Replace immediately new one if it damages.
5. Assemble oil drain bolt and oil filler cap packing.
6. Add oil till to a suitable level, tighten oil filler cap.

### NOTICE

Do not tilt the generator when adding engine oil. This could result in overfilling and damage to the engine. Don't make foreign body fall into engine.

### AIR FILTER

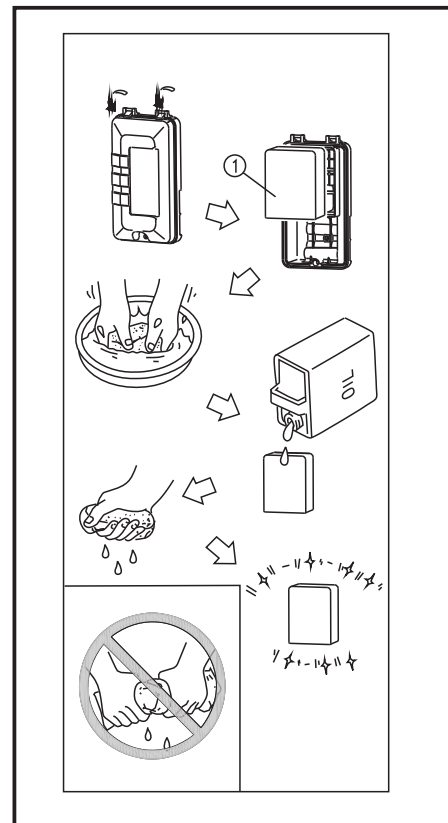

1. Remove the air filter cover and foam element ①.
2. Wash the foam element in solvent and dry it..
3. Add oil for the foam element and squeeze out excess oil. The foam element should be wet but not dripping, avoid be damage.
4. Insert the foam element into the air filter case.

#### TIP:

- Be sure the foam element sealing surface matcher the air filter so there is no air leak.
  - The engine should never run without the air filter; excessive poisonous gas will lead to piston and cylinder wear.
5. Install the air filter case cover in its original position.

### MUFFLER SCREEN

#### ⚠ WARNING

The engine and muffler will be very hot after the engine has been run. Avoid touching the engine and muffler while they are still hot with any part of your body or clothing during inspection or repair.

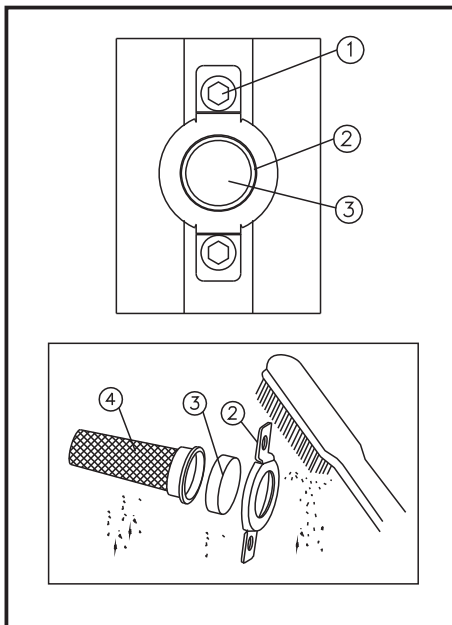

1. Remove the bolt ① , Remove the muffler cap ② , Remove the muffler screen ③ , Remove the spark arrester ④ .
2. Clean the carbon on the muffler screen by wire brush.
3. Check the muffler screen and spark arrester, replace if it damage.
4. Install spark arrester.

#### ⚠ WARNING

Never use an engine without an appropriate spark arrester in the forest areas! Doing so may cause a fire!

### Storage

Long term storage of your machine will require some preventive procedures to guard against deterioration.

#### DRAIN THE FUEL

1. Turn the 3 in 1 switch to "OFF".
2. Remove the fuel tank cap, remove the filter. Extract the fuel from the fuel tank into an approved gasoline container using a commercially available hand siphon. Then, install the fuel tank cap.
3. Fuel is highly flammable and poisonous. Check "SAFETY INFORMATION" (See page 1) carefully immediately wipe off spilled fuel with a clean, dry, soft cloth, since fuel may deteriorate painted surfaces or plastic parts.
4. Start the engine and leave it run until it stops. The engine stops in approx. 20 mins. Time by running out of fuel.

#### TIP:

- Do not connect with any electrical devices. (Unloaded operation).
- Duration of the running engine depends on the amount of the fuel left in the tank.

5. Drain the fuel from the carburetor by loosening the drain screw on the carburetor float chamber.
6. Turn the 3 in 1 switch to "OFF".
7. Tighten the drain screw.

#### ENGINE

Perform the following steps to protect the cylinder, piston ring, etc. from corrosion.

1. Remove the spark plug; pour about one table-spoon of SAE 10W-30 into the spark plug hole and reinstall the spark plug.
2. Recoil start the engine by turning over several times (with 3 in 1 switch knob off) to coat the cylinder walls with oil.
3. Pull the recoil starter until you feel compression. (This prevents the cylinder and valves from rusting).
4. Then stop pulling.
5. Clean the outside of engine and spay antirust additive.
6. Store the generator in a dry, well-ventilated place, with the cover placed over it.
7. Lay the engine vertically.

## Troubleshooting

### ENGINE CAN'T START

#### 1. Fuel systems

- No gasoline in the fire chamber.
- No fuel in the fuel tank...add fuel.
- Fuel in tank.
- Clogged fuel filter .... Clean fuel filter.
- Clogged carburetor.... Clean carburetor.

#### 2. Engine oil system

- Oil level is low.... Add engine oil.

#### 3. Electrical systems

- Put the 1 in 3 switch to “CHOKE” and pull the recoil starter...Poor spark.
- Spark plug dirty with carbon or wet.... Remove carbon or wipe spark plug dry.
- Faulty ignition system.... Consult your generator dealer.

### GENERATOR WON'T PRODUCE POWER

- Safety device (DC protector) to “OFF”.... Press the DC protector to “ON”.
- The AC pilot light (Green) go off .... Stop the engine, and then restart.

## Parameters

Model No.		3500io
Generator	Type	Inverter
	Rated frequency /Hz	50/60/50&60
	Rated voltage /V	100/120/230
	Max. output power /KVA	3.3
	Rated output power /KVA	3.0
	Power factor	1.0
	AC output quality	ISO8528 G2
	THD/%	≤5
	Noise Level dB/LPA (3/4 load) (3/4 load)dB	68.5
	DC Output/ V-A	12-8
	Overload Protect	DC
AC		Control by inverter overload protect program
Engine	Engine	170F-3
	Engine type	Single cylinder, 4-Stroke, forced air cooling, OHV
	Displacement/cc	212
	Fuel type	Unleaded Gasoline
	Fuel capacity/L	9
	Continue Running Time (at rated power)	6
	Fuel Tank Capacity/L	0.6
	Spark Model No.	BPR6ES/BP6ES(NGK) F7RTC/F7TC
	Starting mode	Recoil starter
Generator	Length×Width×Height/mm	484×420×417
	Net weight/kg	34

### Electrical Schematic Diagram

#### ● A 100V 50/60Hz

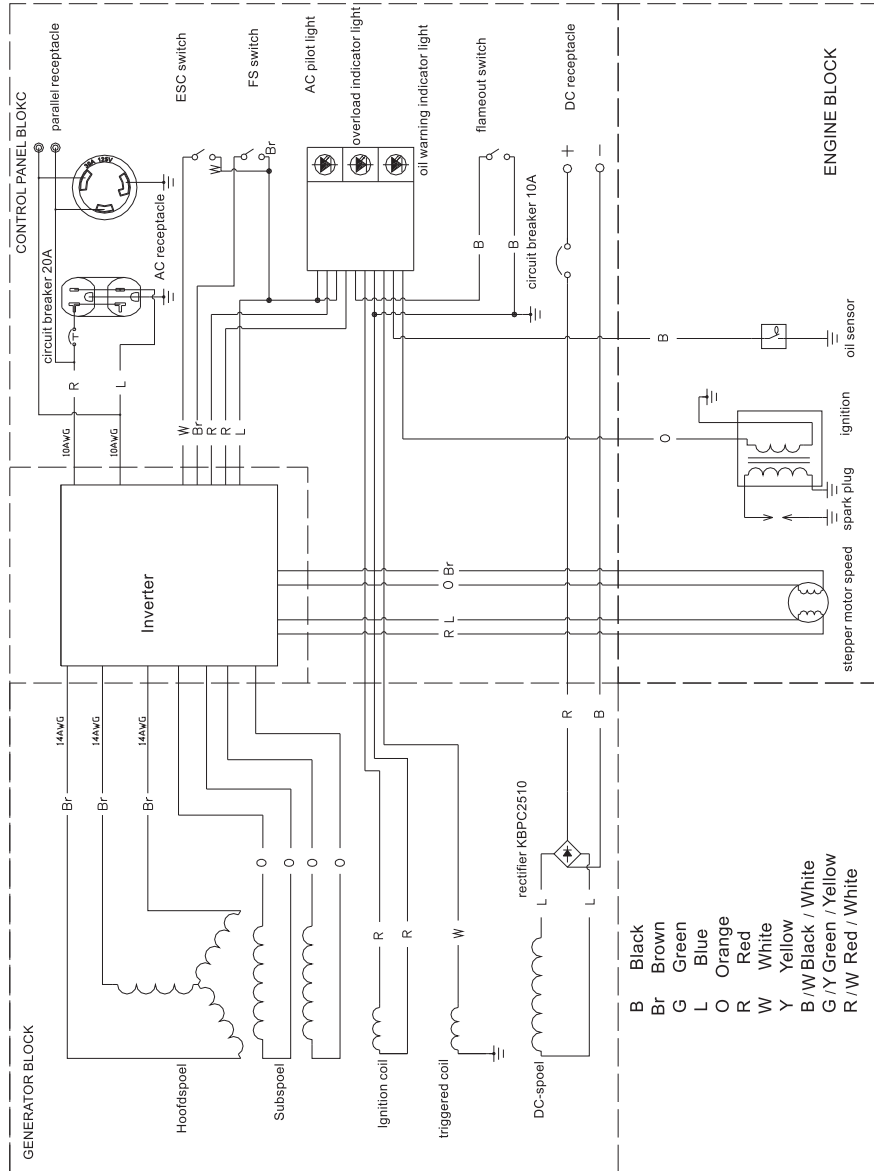

#### ● B 120V 60Hz

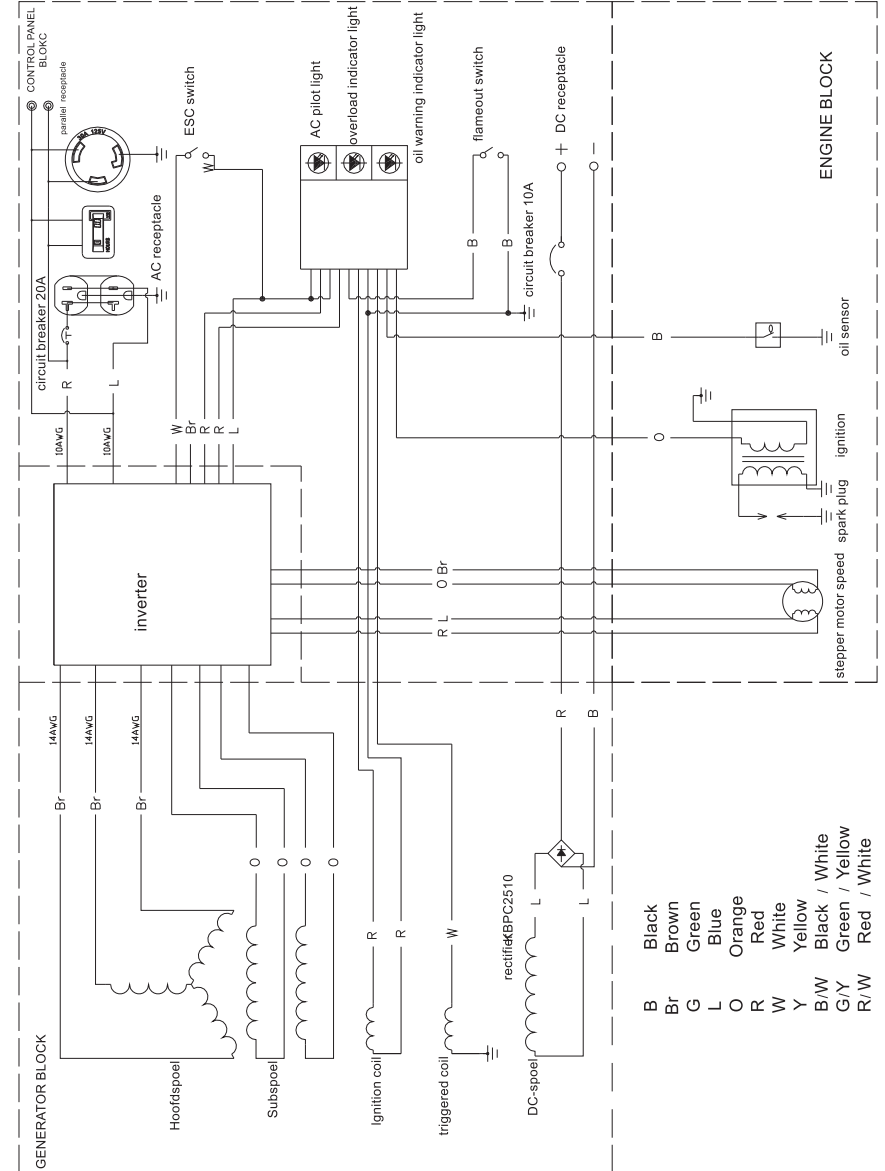

● C 230V 50Hz

