

SCHROTH RACING CHAMPIONS CHOICE

SCHROTH[®]
RACING



**NEW FIA Standard 8853-2016
available right now**



**XLT
CARBON**

Wide Range of HANS Devices, Harness Belts & Racing Nets

Visit www.schroth.com/racing to learn more about our products.



Follow us on Facebook
www.facebook.com/schrothracing

MONACO GP AND INDY 500 SPECIAL



AUTOSPORT

BRITAIN'S BEST MOTORSPORT WEEKLY

30 MAY 2019

LEWIS THIS ONE'S FOR NIKI

How Hamilton took Monaco win despite Mercedes tyre error

NIGEL ROEBUCK ON LAUDA

LAUDA'S GREATEST F1 RACES



PLUS
PAGENAUD
PIPS ROSSI
IN INDY 500

'That was a victory worthy of Niki'

TOTO WOLFF

BOTB
WIN YOUR DREAM CAR

**GUARANTEED WINNER
EVERY WEEK.**

ARIEH BITTON WINS ASTON MARTIN DB11 V8 + £20K CASH



WIN YOUR DREAM CAR!

**£29 MILLION WORTH OF PRIZES WON SO FAR
TICKETS FROM JUST 85p**

ENTER NOW AT [BOTB.COM](https://www.botb.com)



PAUL GERRATY
MERCEDES A35 AMG + £20K



JACOB WALTON
AUDI ABT RS3 + £20K



DEREK HASTIE
NISSAN GT-R RECARO + £20K



PHILIP BODYCOTE
BENTLEY C. GT W12 + £20K



Hamilton and F1 provide fitting tributes to one of the sport's greats

Was that one of Lewis Hamilton's hardest victories, as the Mercedes star suggested? On the one hand, if you're going to have the wrong tyres on and need to defend position, Monaco is probably the place to be (though a more open circuit might have made a second stop more likely). On the other, staying off the walls with one of Formula 1's best overtakers applying pressure means it would certainly have been a challenging day in the cockpit.

Either way, Hamilton's victory – and indeed the F1 paddock's reaction to Niki Lauda's death last week – was a fitting way to pay tribute to the legendary Austrian, who was always impressive on the world's most famous street circuit.

The news of Lauda's passing came too late for us to do him justice in last week's magazine, so this week Nigel Roebuck looks back at the sort of remarkable man Lauda was and the impact he had on racing (see page 32). We also pick out Lauda's greatest drives (p36), to underline that he was much more than 'just' one of F1's most outspoken characters. He was one of the best drivers ever.

Arriving in the F1 paddock in 1969, just before Lauda, was legendary illustrator Giorgio Piola, who marks his half-century milestone in this week's issue by picking out his favourite F1 designs (p42). Fittingly, he picks several cars that Lauda drove. Perhaps most important of all was Mauro Forghieri's Ferrari 312T, with which Lauda secured his first world title.

Lauda and Forghieri were key parts of the 1970s Ferrari superteam that finally delivered the sort of success the Italian squad should be capable of. While Lauda was a Mercedes man in the final years of his life, he always had an emotional connection to Ferrari. He will be missed by both teams – and a great many more people besides.



Kevin Turner
Editor

kevin.turner@autosport.com

**NEXT WEEK
6 JUNE**

A tech focus on F1's big three teams plus our all-encompassing Le Mans preview



COVER IMAGES

Motorsport Images/Etherington; Miller

PIT & PADDOCK

- 4 IndyCar to introduce aeroscreen for 2020
- 6 Macau GP wants FIA's new F3 cars
- 9 F1 technical focus
- 13 Opinion: Edd Straw
- 14 Opinion: David Evans
- 15 Feedback: your letters

FORMULA 1

- 16 Monaco GP report and analysis
- 32 Nigel Roebuck on Niki Lauda
- 36 Lauda's top 10 drives
- 42 Giorgio Piola's greatest F1 cars

RACE CENTRE

- 48 Pagnaud wins dramatic Indy 500
- 54 How di Grassi won again in Formula E
- 60 World of Sport: Formula 2; Formula Renault Eurocup; Super GT; Euroformula Open; World Rallycross; Australian Supercars; NASCAR Cup

CLUB AUTOSPORT

- 76 BTCC ace Ingram stars in historics
- 78 Merc driver Buhk for British GT4
- 80 Opinion: Stephen Lickorish
- 81 National reports: Castle Combe; Brands Hatch; Lydden Hill; Oulton Park; Anglesey; Kirkistown

FINISHING STRAIGHT

- 88 What's on this week
- 90 Pit your wits against our quiz

SUBSCRIPTION OFFER

- 12 Free Brabham BT52 book worth £25

VISIT AUTOSPORT.COM

For other ways to read Britain's best motorsport weekly





Aeroscreen blends lessons of the halo and Red Bull's F1 concept, which was rejected by the FIA



INDYCAR ADOPTS RED BULL

INDYCAR

Red Bull Advanced Technologies has partnered with IndyCar to develop the aeroscreen, which will be installed on all Dallara IR18s cars for all races from next year's opening round.

In shape, the titanium framework of the screen is not dissimilar to the Formula 1 halo. But the horseshoe-shaped hoop at the top, rather than dip downwards, stays almost level to sweep round and anchor at the base of the rollhoop, so the driver's helmet is protected from side on.

The height of the hoop also ensures it is out of the distant sightline of the driver on banked ovals – previously one of the major concerns of drivers when considering the next generation of cockpit protection, since they need to be looking a long way around turns at 200mph-plus.

The front anchor-point for the framework is the Advanced Frontal Protection device that IndyCar introduced for the IndyCar Grand Prix on the Indianapolis Motor Speedway road course in mid-May, and which will be retained for the remainder of this season.

For the screen, Red Bull Advanced Technologies has applied what it learned from the aeroscreen that it developed for Formula 1 three years ago. That was rejected by the FIA in favour of the halo. For IndyCar, it will employ a laminated polycarbonate screen that includes an anti-reflective coating, an anti-fogging device through an integral heating element

RECENT SCREEN CONCEPT TESTS



Renault engine issue went undiagnosed

FORMULA 1

Renault's start to the Formula 1 season was compromised by an engine reliability issue that was only found after the Bahrain Grand Prix.

The manufacturer, which remains eighth in the constructors' table after last weekend's Monaco GP, was known to have suffered MGU-K issues this year but a more fundamental problem with its engine had not been publicised.

Renault boss Cyril Abiteboul revealed that a conrod issue, which came to light when Nico Hulkenberg retired in Bahrain, had forced the team to adopt "containment measures" that reduced performance in China and Azerbaijan.

The issue with the conrod – the component that connects the crankshaft to the piston – was addressed when all four Renault-powered cars took new V6s for the Spanish GP. The engines were initially run in a conservative mode, but Renault had enough confidence to turn the engines up in Monaco.

"This winter we were given the opportunity to properly focus on power gain, and competitiveness gain," said Abiteboul. "What it meant was we consciously decided to focus on performance, to the detriment of reliability. It means that a number of engines that should have been used on the dyno to secure reliability were actually used to develop performance."

"What it meant was a very good start in terms of engine power, but reliability that was below standard."

"Two reasons, one which you know was the MGU-K, and one which you don't know, which was that Nico's failure in Bahrain was actually a conrod failure."

ADAM COOPER

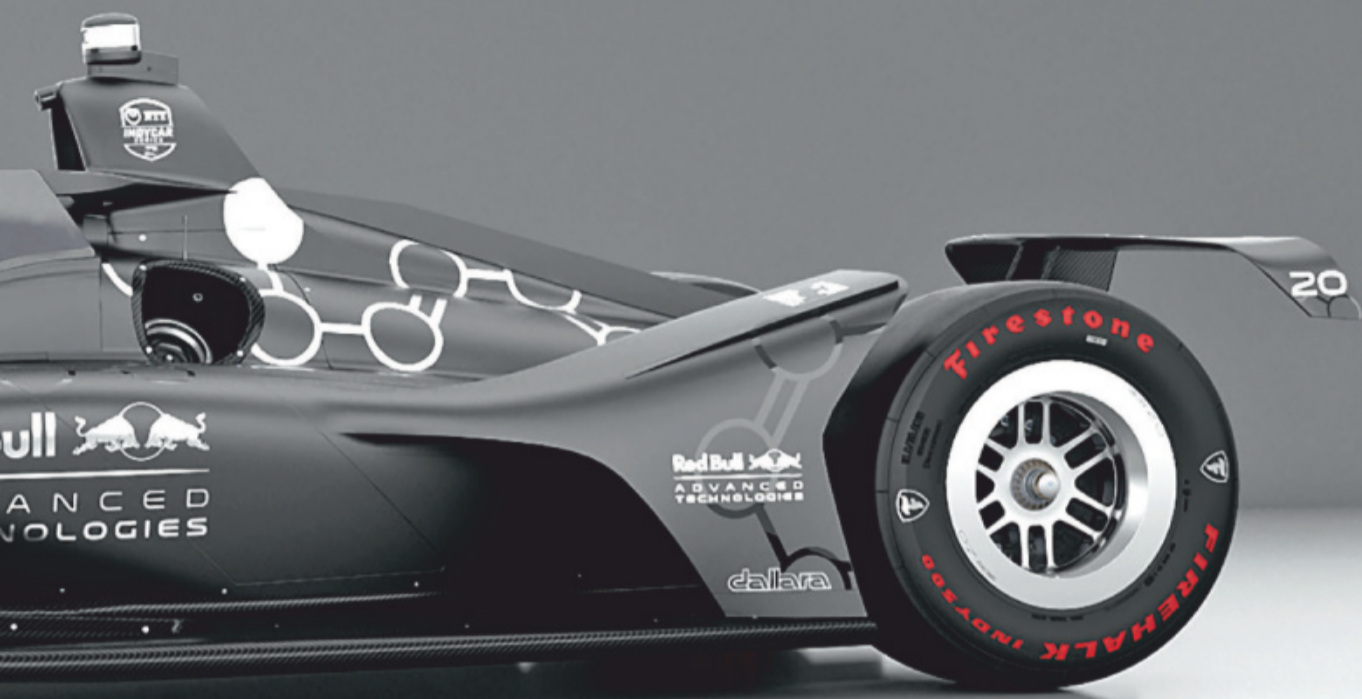

INDYCAR

AEROSCREEN FOR 2020

and possibly tear-offs, all to be produced by integrated third-party companies.

Red Bull also examined IndyCar's first windscreen concept, which was developed in conjunction with PPG Aerospace and was tested by Scott Dixon at Phoenix and Josef Newgarden at Indianapolis last year. According to IndyCar, "additional comprehensive testing at PPG's facility in Huntsville, AL, revealed additional work was needed before any implementation".

The aeroscreen's load-bearing ability is expected to be 150 kilonewtons (kN), the same requirements for the halo.

One of the other original concerns from drivers – besides potential vision distortion and the hoop device being in their sightline – was the heat build-up in the cockpit, given the lack of airflow and being surrounded by glazing. This has been answered by vents faired into the panel just ahead of the aeroscreen that feed air into the cockpit and can be adjusted by the driver, but this design has not yet been finalised.

IndyCar aims to have the prototype fitted to a car this summer for select drivers to begin testing, and for each team to take delivery of at least one approved screen per 2020 entry by November.

Christian Horner, CEO of Red Bull Advanced Technologies, said: "Since the first prototypes were developed and demonstrated in 2016, the potential of [the] aeroscreen to improve safety for drivers in the event of frontal impacts in the cockpit area of cars has been clear.

"This new partnership with IndyCar gives us at Red Bull Advanced Technologies the go-ahead to fully explore that potential, and to deliver a protection system that will help prevent serious injuries and potentially save lives in the US's premier single-seater series.

"Over the coming months, we'll be working closely with IndyCar and its drivers to refine and perfect aeroscreen, and we're looking forward to seeing the results race in 2020."

Ed Collings, head of composites and structures at Red Bull, added: "Talking to IndyCar at the beginning of this project, [the halo] does also remove some of the protection from smaller debris, which is something that IndyCar felt was essential for their series. So we think this is the right solution, more comprehensive solution, more fitting for IndyCar."

Collings also explained that the height of the screen and hoop, as well as being given two secure anchor points with the rollhoop, was also defined "to help prevent a driver's crash helmet making contact with the any part of the design".

"In order to deliver that, we've created an exclusion zone where this device doesn't enter that zone where it would impede the driver's head," he said.

The aeroscreen – and, if necessary, any subsequent modifications – will be included from the outset in the design of Dallara's next-gen IndyCar, currently set for introduction in 2022.

DAVID MALSHER

Macau favours new Formula 3 cars for 2019 Grand Prix



motorsport
IMAGES

MACAU GRAND PRIX

The FIA Formula 3 concept looks favourite to head to Macau this year, after Macau Grand Prix organisers stated their intent to run the classic race for the new F3 cars.

Macau Grand Prix Organising Committee sporting coordinator Chong Coc Veng confirmed “the intention to introduce the FIA Formula 3 Championship car to the Guia Circuit” in an announcement about the November race’s title sponsorship last week.

Such a move would still need to be ratified by the FIA, which grants the event FIA F3 World Cup status, but if approved it would end a 36-year period where the race

was run to the previous FIA F3 concept.

The event will not be part of the FIA F3 Championship promoted by Formula 2/FIA F3 chief Bruno Michel’s company, although the F3 calendar was left free for Macau as the series’ final round will support the Russian Grand Prix at the end of September.

The Guia circuit’s homologation as a Grade 3 track was an obstacle, as power-to-weight rules guiding what is eligible to compete on different circuit grades meant Macau was not homologated to allow the new FIA F3 cars. Macau’s last period of homologation ran out after the 2018 race, and the circuit did not appear under any category in the FIA’s latest updated list.

Autosport understands the late Charlie Whiting indicated only minor changes would be required to move the circuit homologation to the Grade 2 level required to host FIA F3 machinery.

Sources in Macau have indicated that such changes could be centred on trackside furniture around the Lisboa bend, where Sophia Florsch had her horrific 2018 shunt.

That accident was a major influence in the race-organising AAMC favouring the retention of the older F3 cars, which are homologated until the end of 2019, for this year’s race. Other parties were also lobbying for a switch to the FIA’s Regional F3 set-up.

MARCUS SIMMONS

Dovizioso tests Audi ahead of DTM debut



DTM

MotoGP rider Andrea Dovizioso completed a two-day test at Misano to prepare for his DTM debut at the circuit next month.

Assisted by two-time DTM champion Mattias Ekstrom, the Ducati rider impressed in the Audi RS5 DTM. On day two he was making set-up changes to suit his driving style.

“It was really important

for me to test here at Misano, because the level is extremely high in the DTM and there are many things to manage while you’re at the wheel,” said Dovizioso.

Had DTM boss Gerhard Berger’s plan prevailed, Dovizioso’s test would have been the precursor to a DTM battle with fellow MotoGP star Valentino Rossi, but a plan to place Rossi in a BMW as a guest driver fell through due to his

watertight Yamaha contract – which prevents him from racing in other series.

Sources suggest the DTM may try for Rossi again next year, and that BMW is working on its 2019 guest driver plans.

The series is understood to have opened up its guest driver rules for 2019, which will now allow each marque to field multiple star drivers in any given year.

TOM ERRINGTON



BMW pulls plug on WEC

WORLD ENDURANCE

BMW is calling time on its participation in the World Endurance Championship after just one season. Next month's Le Mans 24 Hours, the 2018/19 superseason finale, will be the last WEC outing for the M8 GTEs fielded by the MTEK squad.

The pull-out, announced last week after the closing date for entries for the 2019/20 season, follows comments by BMW Motorsport boss Jens Marquardt on the lack of marketing value presented by the WEC. In the statement confirming BMW's withdrawal from GTE Pro, he said that "continuing our WEC involvement in the coming years does not fit with our direction".

"The global presence of BMW M Motorsport is safeguarded by customer racing and the DTM in Asia and Europe, as well as the IMSA series in North America, even without competing in a world championship," he explained.

BMW stressed its participation in the



IMSA SportsCar Championship, where the M8 races with the Rahal team, would continue. Marquardt said the series "plays a central role" in the most important market for BMW M cars.

BMW reaffirmed its commitment to the DTM and the new Class One rules that have finally brought the German series and Super GT in Japan in line, Formula E and its customer racing programmes with the M6 GT3 and M4 GT4 cars. It also announced an increased involvement in Esports.

Ford, meanwhile, will celebrate the final factory participation of its GT with the Ganassi WEC and IMSA teams with a series of retro liveries. Three of the cars will run at Le Mans in schemes paying homage to the marque's MkII and MkIV racers of the 1960s (below).

The #66 WEC entry will race in a livery based on that of the 1966 Le Mans-winning Shelby American MkII driven by Bruce McLaren and Chris Amon, while the sister #67 will invoke the 1967 MkIV in which Dan Gurney and AJ Foyt won.

The #69 IMSA car takes its design cues from the second-placed car at Le Mans in 1966. The #68 car will race in the same livery in which it won the GTE Pro class at Le Mans in 2016.

- Ginetta has lodged two 2019/20 WEC entries for its AER-engined G60-LT-P1 privateer contender under the Team LNT banner. It hopes the cars will be fielded by a customer team, but hasn't ruled out running at least one itself.

GARY WATKINS

IN THE HEADLINES

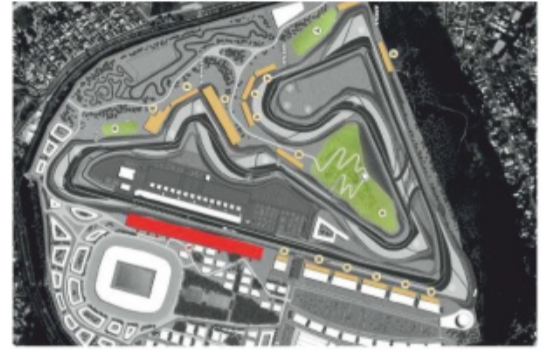

NEW RIO GP LAYOUT REVEALED

A definitive layout (above) has been revealed for the planned Rio de Janeiro circuit that wants to take over Formula 1's Brazilian Grand Prix slot, but only once Interlagos's deal expires. US consortium Rio Motorsports claims it won a tender to build the new track, and says it has been awarded a 35-year concession to build on military land. Interlagos is expected to host the race again next year, which is the final event under the terms of its current contract.

F1 BOSSES WANT KYALAMI RETURN

A South African Grand Prix at Kyalami could rejoin the Formula 1 calendar amid interest from championship bosses and a desire from the redeveloped circuit to host F1 again. Since the circuit's new owners took hold in 2014, it has been substantially redeveloped to FIA Grade 2 standard. Last week F1 commercial boss Sean Bratches referenced it while confirming "very productive conversations" about hosting a race in the country after 2020.

LORANDI GETS RENAULT F1 NOD

Italian Formula 4 runner-up Leonardo Lorandi has secured a tie-in with Renault's Formula 1 junior programme as an affiliate driver. The position is similar to that occupied by Anthoine Hubert last year before he joined the junior programme as a fully fledged member in 2019.

HAAS RETAINS STAG LOGO

The Haas Formula 1 team has no plans to change its livery or use of title sponsor Rich Energy's stag logo, after the sponsor's court defeat to Whyte Bikes. The cycling company won a copyright infringement claim. The matter is set to return to court next month.

MIKKELSEN IS BENCHED... AGAIN

World Rally Championship driver Andreas Mikkelsen has been benched by Hyundai for the second time in four rallies to be replaced by Sebastien Loeb. The nine-time champion will return for Rally Portugal after Mikkelsen finished Rally Chile 4m39s behind winner Ott Tanak (Toyota). Portugal will be Loeb's fifth start of the season, and his contract with the team is to contest only six events in 2019.

Surface Engineering

Coatings

Decorative Finishing

Engineering Consultancy



Specialist surface engineering solutions

Sandwell are world leaders in surface engineering, offering a wide range of innovative solutions to help you meet your engineering challenges. Whether it involves specialist shot peening, bead blasting, specialised coatings or even decorative finishing, our team of experts can provide the right solution for you.

Contact us today to see how we can help improve performance and durability of your components.

Sandwell UK Ltd, 2 Foundry Place, Towcester, Northamptonshire NN12 6FP

Telephone: +44 (0) 1327 350205 Email: sales@sandwell-uk.com

www.sandwell-uk.com

Sandwell 
shot peening & specialist coatings

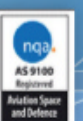
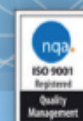

DRAWING BOARD

GIORGIO PIOLA

RED BULL'S NOSE JOB

Monaco is completely unlike any other circuit on the Formula 1 calendar, which means it's especially hard to introduce new parts around the streets of the principality.

It puts such a focus on downforce that teams like to bring a few specialist parts to find as much grip as they possibly can – getting the front-end to turn into the ever-tightening corners is vital. Anything to alleviate the

symptoms of understeer is readily welcomed.

The snorkel nose (inset) has been a concept that Red Bull has stood by for the last couple of seasons. It's quite a novel way to sidestep the low crash structure regulations, picking up some clean air and using it to trim any high-pressure air produced by the underside, where it may begin to separate and develop a small pocket of lift.

But Monaco is a different kettle of fish, and you don't need to worry quite so much about the minutiae of boundary layer mechanics and such. You need downforce, and lots of it.

By changing the nose crash structure to something more conventional (main) –

similar to what Red Bull had run prior to the 2018 season – it allowed the team to redefine the pressure distribution at the front to create more front-end downforce. Sure, it might not have been a low-drag solution, but that's rarely a consideration in Monte Carlo.

This gave Max Verstappen the tools to stay close to Lewis Hamilton throughout the race, and he looked far more assured in the corners – albeit as Hamilton's tyres continued to show signs of wear.

It remains to be seen whether Red Bull's new-old nose will continue to be used throughout the year – we'll only really know in Canada next month.

JAKE BOXALL-LEGGE

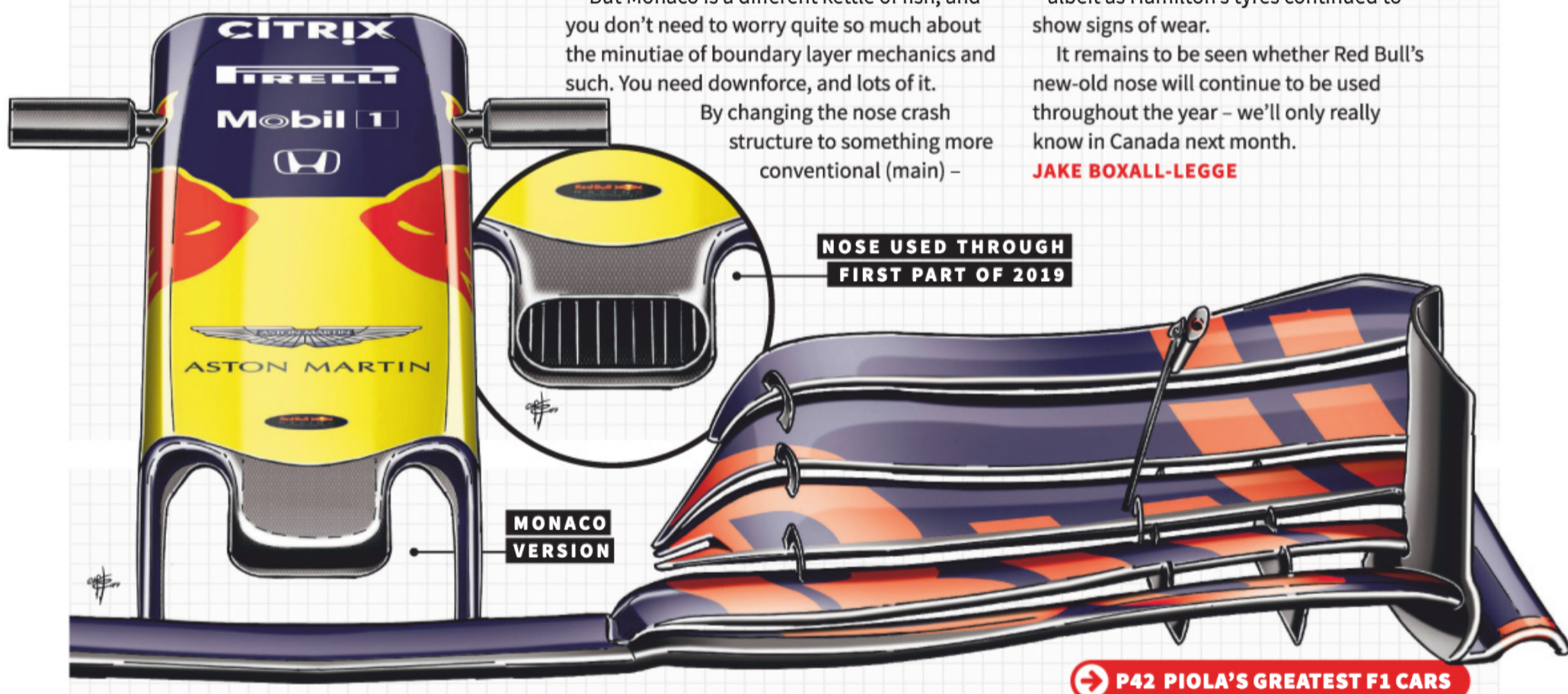

P42 PIOLA'S GREATEST F1 CARS

RENAULT CHANGES PAY OFF

So far, the 2019 season has been something of a nightmare for Renault. The TV feed's sporadic shots of a pensive-looking Alain Prost harks back to the early 2000s. But there were signs of a recovery in Monaco – although it might not have been entirely reflected on the scoreboard.

Externally, not too many changes were made. The upgrades brought to the Spanish GP reappeared on the car, but were augmented with a pair of deflectors on top of the chassis bulkhead, either side of the S-duct.

These help to direct airflow over the top of the suspension components, building small tip vortices that can be used further down the car. There's also the opportunity to use them to increase the suction at the outlet of the S-duct, pulling the airflow through from the front of the car to keep it attached over the top side.

The team also benefited from redesigned engine components; having traced the

unreliability that had forced the team to run lower power modes down to a connecting rod in the engine. It was revised and brought in for Monaco.

While power is never really a factor at the venue, it has certainly renewed Renault's hopes. Daniel Ricciardo managed an excellent sixth in qualifying, but was one of the drivers who had made their pitstop during the safety car – which turned out to be the wrong call.

Nico Hulkenberg sustained a puncture after his incident with Charles Leclerc's Ferrari, and endured a tough day.

JAKE BOXALL-LEGGE

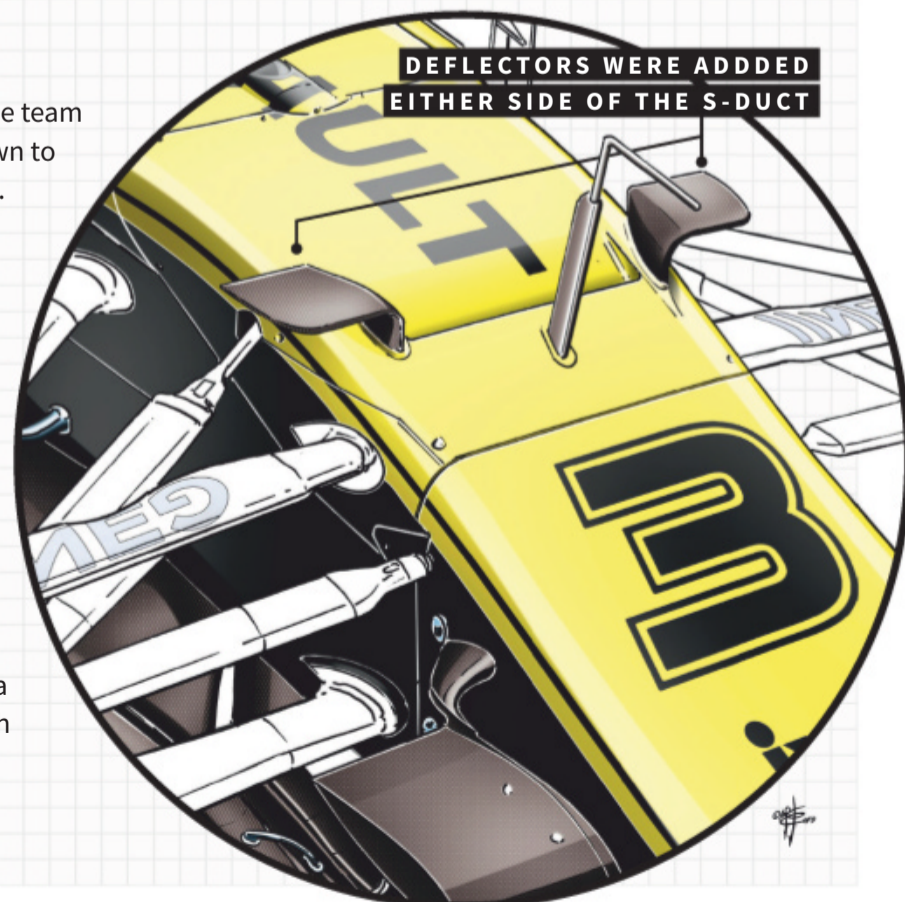

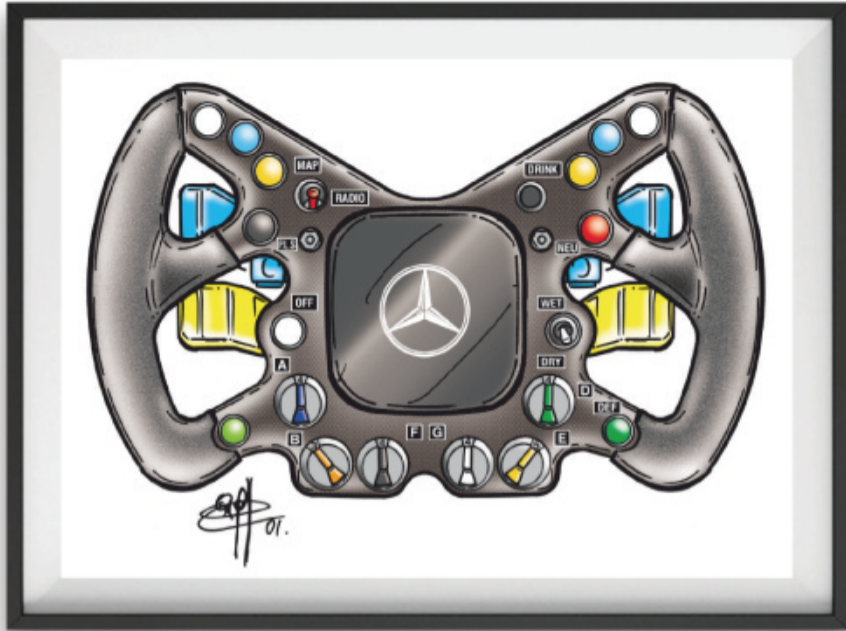

McLAREN MP4/16 - 2001

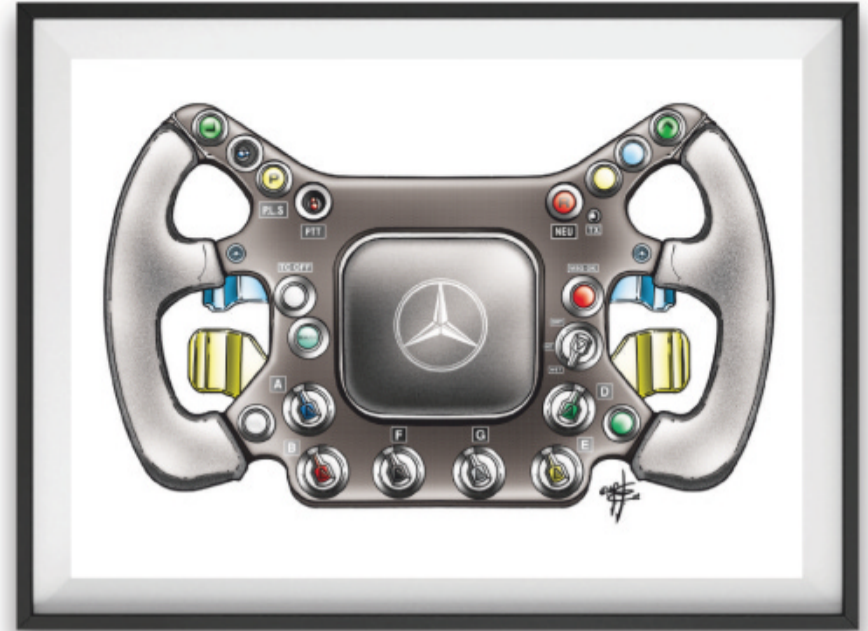

McLAREN MP4/17 - 2002

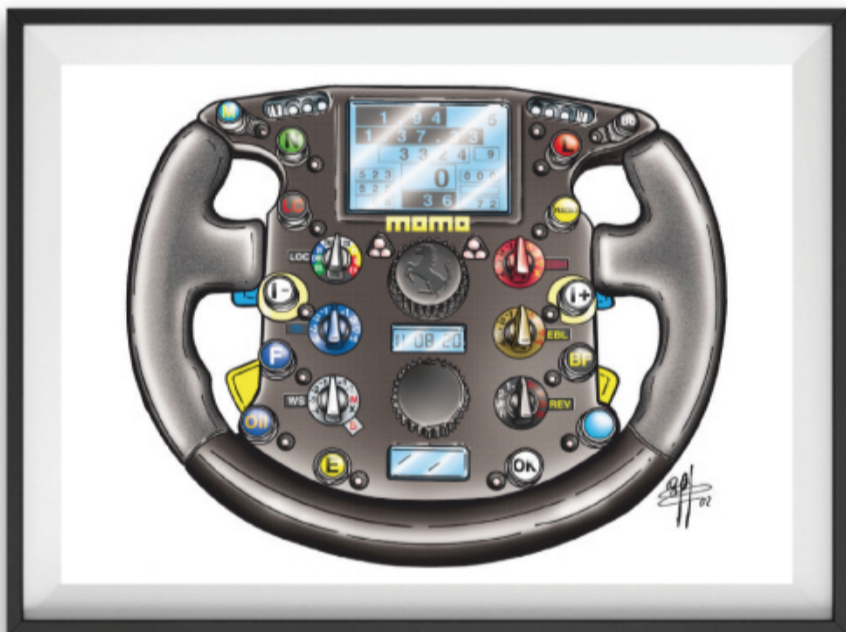

FERRARI F2002 - 2002



WILLIAMS FW26 - 2004



MERCEDES F1W04 - 2013

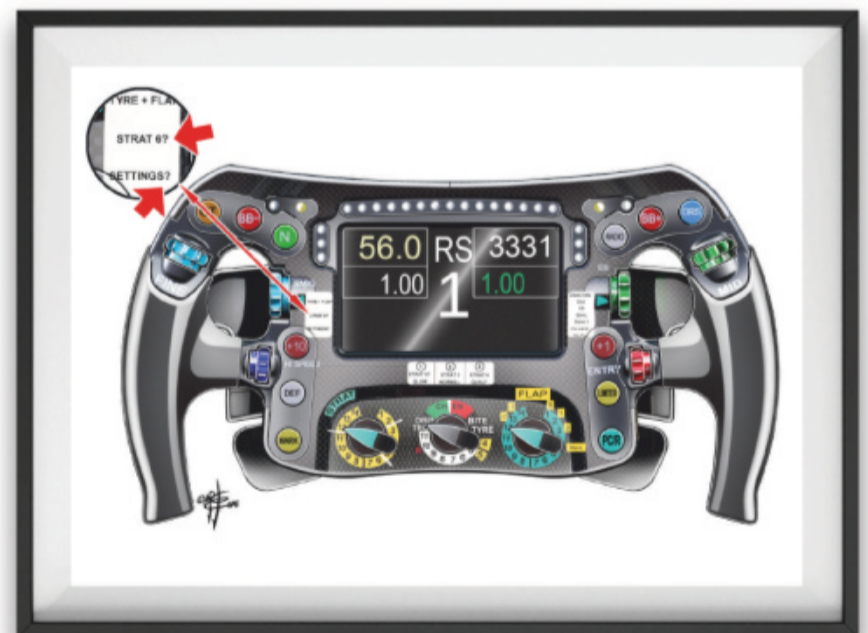

MERCEDES F1W07 - 2016



FERRARI SF70H

THE ART OF



RACING

SUBSCRIPTION OFFER

SAVE UP TO 68%

JUST IN TIME FOR FATHER'S DAY

TRY 6 ISSUES OF AUTOSPORT FOR £6



PLUS FREE GIFT WORTH £25

SUBSCRIBE ONLINE www.autosportmedia.com/offer/ASP19FD

OR CALL 0344 848 8817 QUOTE PROMO CODE **PASP19FD**

FOR OVERSEAS RATES CALL +44 (0) 1604 251 451

WHY SUBSCRIBE?

SAVE UP TO 68%
on the cover price

ON THE MOVE
read on your iPhone or iPad

FREE DELIVERY
direct to your door



IN EVERY ISSUE

LATEST NEWS
from across a range of series

UNRIVALLED STORIES
from our award-winning journalists

EXTENSIVE ANALYSIS
of everything Formula 1

Terms and conditions: Offer valid for new UK subscriptions by Direct Debit only. After your first 6 weeks, your subscription will continue at £30.99 every 13 issues for the print and digital bundle. Digital magazines only available on iPhone and iPad. Direct Debit rates are valid for one year after which they are subject to change. Should you wish to cancel your subscription it will be cancelled on expiry of the current term. The gift will be sent separately from the magazine and will not be dispatched until your first payment has cleared. Should we run out of gifts, you will be offered an alternative gift. You will be emailed instructions on how to gain access to your digital subscription. Savings based on the standard UK cover price. Offer ends 23 June 2019.



Long may Monaco reign

Its tight nature might thwart overtaking, but the street circuit still presents a unique and daunting challenge to F1 that wholly earns it a place on the calendar

EDD STRAW

There were only two passes for position during the Monaco Grand Prix after the opening lap. Both were by Charles Leclerc, and even they were followed closely by the failed attempt to overtake Nico Hulkenberg that ultimately led to the Ferrari driver's retirement. Cue the usual complaints – that Monaco should not be on the world championship calendar – that are almost as old as the hills the city state clings to.

But it's a race that should never be left behind by GP racing, it's too important for that. And its sporting value sits apart from the supposed glitz and glamour, the ostentatious displays of wealth around the Monaco harbour, the myriad celebrities and the old world faded grandiosity of the place. Instead it's about something far purer – driving.

Last Sunday even proved that Monaco can be a *race* too. So what if there was precious little overtaking, the slow-burn tension of Max Verstappen's chase of Lewis Hamilton made for a gripping race that will live long in the memory. Even in this era of pace-management thanks to tyre and engine regulations, the utter supremacy of track position at Monaco still doesn't prevent Sunday being a tense race even if a genuine thriller is impossible.

But even if Sunday's race is flat, as it often will be, Monaco is worth its place. Does it matter if the race is defined by qualifying, with a little bit of the start thrown in for good measure? What

“So many groan about a lack of ‘classic’ tracks. Let's appreciate one that hasn't fallen by the wayside”

Monaco offers is a unique test of those behind the wheel, one of no margin for error, that showcases the brilliance of these drivers and the poise of the cars.

While the Monaco track has changed over the years, it would still be familiar to the 16 drivers who participated in the first grand prix there back in 1929. Why, when so many gripe and groan about the lack of 'classic' tracks, do we take so little time to appreciate one that hasn't fallen by the wayside? It hasn't been immune to the march of progress and there are areas of the track where it is slightly more forgiving than it once was. But in an era of expansive runoff areas it remains precipitous.

“It's not the same Monaco as I drove the first time,” said the current driver whose Monaco GP history stretches back the furthest – Kimi Raikkonen. “It was much more tricky when there

was Armco inside Turn 1, the Swimming Pool was a lot tighter, the last part was a lot tighter. In the past, you could make more of a difference. But good cars still go fast here. Bad cars, it doesn't matter who drives it, aren't going to go suddenly fastest.”

Raikkonen's first visit was back in 2001 for Sauber, when he set some stunning times in the wet conditions despite the failure of a wheel-speed sensor forcing the team to turn off traction control. He's right that the challenge has been eased a little, but it remains the most challenging circuit on the calendar simply to drive.

The problems of Monaco are also not unique to it. While the overtaking problem is inherent to the circuit, the fact the cars spend so little time near the limit is down to the regulations.

Thanks to Pierre Gasly's stunning save in FP1 (see page 24), the only F1 driver we saw have a proper crash last weekend was Sebastian Vettel in FP3. These moments are a reminder of how Monaco can bite, and if drivers had to push harder more often then we would see more of these kinds of mistakes. That, in turn, would make for more memorable races.

The closest Monaco has come to a race for the ages in the past 10 years was probably 2011, when Vettel's Red Bull led Fernando Alonso's Ferrari and Jenson Button's McLaren with all three on different tyre strategies. Vettel was on the oldest rubber, Alonso in the middle and Button the freshest – meaning there was real hope that there would be a genuine fight in the closing stages. Unfortunately, Vitaly Petrov crashed, the red flag flew and they were allowed to change tyres before the resumption. Frustrating.

What Monaco now lacks that it once offered is the truly chaotic race, such as the events of 1982, when a plethora of drivers could have won after Alain Prost crashed, before Riccardo Patrese came through despite seemingly having spun away victory on the approach to the Loews Hairpin. Or 1996, when Olivier Panis took a shock win for Ligier. These sorts of races are less likely nowadays. If the 2021 regulations deliver on expectations – and that's a big 'if' given the politics influencing the final form of the rules – then perhaps we will see the chances for a mad Monaco race boosted.

But whether that happens or not, it's an essential driving challenge that should never be removed from F1. Drivers must be tested in a wide range of conditions and losing this unique track in favour of one that is no longer an outlier would not enrich F1. Populating the calendar with identikit, made-for-overtaking circuits would rob GP racing of the variety it has always thrived on.

This isn't an argument for more Monaco-style circuits. It should continue to stand alone as a one-off. It's an impossibility of a circuit, which still exists only because it is effectively grandfathered by its unique status. Long may it remain so. ✎

➔ P16 HOW HAMILTON WON DESPITE MERC ERROR



Rally GB requires urgent attention

Britain's round of the World Rally Championship is under threat, but not everyone seems to realise quite how serious the situation has become

DAVID EVANS

Anybody who doesn't understand the considerable threat to Britain's future in the World Rally Championship is, I'm afraid, delusional.

The lack of clarity about the rally's direction is matched only by the ambivalence to where it is right now. And, as the powers that be ponder and pontificate, new events circle, ready to pounce and pilfer Britain's slot on the calendar.

Since 2000, Rally GB has been rooted in Wales, with continued backing from the Welsh Government. Continued, that is, apart from in early 2009 when Cardiff tried to break its deal with Rally GB to punt an extra £2.2million in the direction of the following year's Ryder Cup, which was also happening in Wales. The upshot of that? The event took legal action against the Welsh Government.

Everybody made friends again and the government was delighted with former event chief Ben Taylor's management and execution of the move to north Wales.

Last year Wales agreed a new deal, with investment on a downward sliding scale, reportedly dropping below a million for the first time next year. Part of that agreement is an opportunity to trigger a clause to pause investment and take the rally elsewhere in the UK. That's where Northern Ireland comes in. There's significant interest and desire to take Britain's round of the world championship across the Irish Sea. Politically and financially, such a move is favourable to both sides, but the continued absence

“When we're counting every penny, is now the time to spend thousands on a new font?”

of a Northern Irish government leaves the process in limbo.

We're assured things are starting to move in Belfast, but Motorsport UK chief executive Hugh Chambers questions whether they will move quickly enough for next season.

Britain has a slot on the 2020 calendar, but naturally WRC Promoter is keen to know where it's going in the UK.

This is where I'm struggling to square the circle. WRC Promoter managing director Oliver Ciesla said in the clearest terms the key to Britain's future on the calendar involved a move away from Wales.

Ask Chambers and Northern Ireland is possible for next season, with a move back to Wales in 2021 “the most likely scenario”.

How's that? By his own admission, Chambers is looking for between £3million and £3.5million to run Britain's WRC round and, with Wales chipping in less than a million and no title sponsor,

how long will Motorsport UK be prepared to prop up Rally GB for?

Chambers does talk about a couple of potential title sponsors for this year – but admits six months' lead time is potentially too short to bring them home. This situation was obvious 12 months ago.

Asked about the budget shortfall and Chambers talks of his hopes of “urgently needed” repackaging of the event making it a more successful commercial proposition. Before adding: “I can't see a situation where you wouldn't need some sort of government funding [to run the event].”

But the government funding we've got is not enough. So how can we stay in Wales? Regardless of the promoter's view, the simple economics of the job means, in its current form, the contract with Wales will simply drain Motorsport UK.

Of equal concern is the message sent to other potentially interested UK regions if the Northern Ireland deal falls through. Belfast wants the rally, the infrastructure, the roads, the fans, Kris Meeke and Craig Breen... everything and everybody is in place. And, what's more, the maths more than works on this one.

If it fails, surely that would take the wind out of the sails of negotiation. Negotiations that, depending on who you believe, are ‘developing very nicely’ or ‘pretty much non-existent’.

Just to jump back to Chambers' desire to repackage Rally GB. You might have seen the result of this. Rally GB is no longer ‘Rally of Legends’ but is now ‘A World Apart’. Again, I'm lost here. Firstly, if we're on the verge of moving the rally, wouldn't it be better to wait until the move is confirmed and then look to rebrand? And secondly, what does ‘A World Apart’ actually mean?

Chambers defends his tag line telling me, like all tag lines, it needs “populating with some meaning”. When I venture ‘Rally of Legends’ didn't need populating with meaning, he replied: “We didn't feel it particularly meant anything to a non-motorsport audience. The whole proposition of ‘A World Apart’ is that rallying comes out of a different universe. It's the antithesis to stadium sport, the sanitised homogenised world of professional football players with their personal coaches, blah, blah, blah. Rallying is a world apart and Wales is a world apart. It is just over the border, but it's a completely different type of place full of castles, legends and dragons and stuff like that.”

Fair enough. But when we're counting every penny, is now the time to be spending thousands on three words and a new font?

I sympathise with Chambers. As well as being the new Taylor – a difficult job in itself, given the way the sport warmed to the ex-managing director – he's running the governing body too.

Now more than ever, we need Chambers to follow the lead of Motorsport UK chairman David Richards and show himself as a man of the people capable of finding and illuminating the right path for Rally GB. ✎

YOUR SAY

Lauda showed more bravery by getting out of the car at Fuji. He had the courage to stand up for what he believed was right, and sacrificed the chance to win a world title

BEN HALL

Lauda's most courageous act came at Fuji

I have always had tremendous respect and admiration for Niki Lauda. Many tributes have said that the most courageous thing he did was to get back in the car at Monza in 1976 so soon after his horrific accident.

I disagree. For me, he showed more bravery by getting out of the car at Fuji (right). He had the courage to stand up for what he believed was right, and sacrificed the opportunity to win a world title – can you imagine Ayrton Senna, Michael Schumacher or Lewis Hamilton doing that?

At that moment he put a career on the line, which had already nearly cost him his life – extraordinary. He will be missed.

Ben Hall
By Email

A Monaco battle that Niki would have appreciated

What an absolutely thrilling race the Monaco Grand Prix was. We have long heard detractors complain that the place is no longer worth its place on the Formula 1 calendar, that cars have outgrown the circuit and that passing is no longer possible.

Monaco, however, remains the jewel in F1's crown – the only place where drivers are really tested to the limit and where they make the difference.

Yes, fans love seeing overtakes but they also like the tactical element of racing – the potential that something might happen rather than it actually doing so – and that is what Monaco gives us.

How fitting, therefore, that the latest instalment and the fascinating battle between Lewis Hamilton and Max Verstappen – the best since Nigel Mansell and Ayrton Senna – took place in the same week as the passing of the greatest gladiator of all.

No one can doubt Niki Lauda's contribution to the sport – his accident and recovery is the greatest comeback of all time.



Above all else, Niki was a real racer and master tactician and he would surely have appreciated the battle that raged on the streets of the principality.

Niki and Monaco, we doff our caps in appreciation.

Michael Brierley
Stalybridge, Cheshire

What McLaren needs to learn from Porsche

The contrast between Autosport's 'McLaren at Indy' article (23 May issue, page 14) and the immediately following Porsche Formula E project piece (p22) says it all.

The infinite care and humility with which Porsche are approaching their entry into Formula E when compared with the approach of Zak Brown is clear for all to see.

The man who failed to give Fernando Alonso a decent car for Formula 1 and has now done the same for him at Indianapolis – this will not be an occasion when Alonso hangs his steering wheel on the wall.

Peter Stevens
By email

HAVE YOUR SAY, GET IN TOUCH

Autosport editorial
Autosport Media UK Ltd
1 Eton Street
Richmond
TW9 1AG

@
E-mail
autosport@
autosport.com

Visit our website
autosport.com

Twitter
twitter.com/
autosport

Facebook
facebook.com/
autosport

Instagram
instagram.com/
autosport

YouTube
youtube.com/
AUTOSPORTdotcom



Verstappen had one crack at Hamilton... and it didn't come off



HAMILTON WINS FOR LAUDA DESPITE MERC TYRE ERROR

After an emotional week Mercedes made things tough for Hamilton, but he rose to the challenge to hold off Max Verstappen's charging Red Bull

EDD STRAW

PHOTOGRAPHY  motorsport
IMAGES



The
RENNSPORT
COLLECTIVE

Some of the finest motorsport-inspired Porsches, curated for a public event at Donington Hall in Leicestershire. From GT1 to GT3; Carrera 6 to Carrera GT; R to RS to RSR; S/T to T/R. Cars coming from all over Europe and beyond. Adults: £25. Under 14's go free. Dedicated Porsche Parkplatz parking available. Purchase tickets from the website:

DONINGTON HALL. SATURDAY 20 JULY.

www.rennsportcollective.com



Photography: Raul Martires



@RennsportCollective



ETHERINGTON

Lewis Hamilton's Monaco Grand Prix record is patchy for a driver of his virtuosity. He's always been fast on the tortuously twisty streets, all the way back to Formula 3 days when he won here, but his under-pressure victory in the 2019 race was only the third of his 77 F1 wins to come in Monte Carlo. If there was any doubt about how desperately Hamilton wants to build a legacy here that could stand with that of his hero Ayrton Senna, you only had to witness his joyous fence-climbing reaction to bagging what was somehow only his second pole position here in 13 attempts.

This was a highly charged weekend for Hamilton for many reasons. The loss of Niki Lauda, three-time world champion and a driving force of Hamilton's Mercedes team in his role as non-executive chairman, cast a long shadow over the paddock. Hamilton is a man who wears his heart on his sleeve and there can be no questioning the authenticity of his grief. After taking pole position on Saturday, Hamilton went as far as to suggest he would still have just the 2008 world championship to his name without Lauda, who played a key role in convincing him to sign on the dotted line with Mercedes.

Lauda, a driver with two wins and three poles to his name at Monaco, would have been thrilled by Hamilton's crucial pole position lap. Mercedes was in a class of its own despite Max Verstappen's best efforts to hassle the silver cars – aided by Ferrari carelessly letting Charles Leclerc be eliminated in Q1 after misjudging the cutoff point – but Hamilton had to dig deep to beat team-mate Valtteri Bottas.

Bottas was on top after the first Q3 runs but unable to improve thanks to traffic compromising his tyre prep, so the stage was Hamilton's at the end of qualifying. His lap was a study in commitment, turn-in confidence and precise mid-corner connections.

"I was just throwing the car around," said Hamilton. "I'm pretty sure

I touched a couple of barriers along the way but there's no better way of doing it around Monaco. I've not had a huge amount of success here over the years. It's always been a track that I've been quick at but never quite got that perfect lap. Today was about as close as I could get to it, so this one is for Niki."

The race echoed one featuring an entirely different three-time world champion – Ayrton Senna. In 1992, Nigel Mansell dominated the race for Williams but a late puncture put him on Senna's tail. Mansell's frenetic, fruitless chase is the stuff of legend and Hamilton's battle to hold off Verstappen was the hyper-tense, drawn out version. What lasted three frenzied laps in 1992 was played out as a calmer, 64-lap slow burner in 2019, only Verstappen did what Mansell couldn't and at least was able to attempt a move in what was, oddly, a do-or-die one that would make the difference between winning and fourth place.

That the race came down to this was down to Leclerc, whose attempt to scythe through the field after being eliminated in Q1 ended in retirement. Starting 15th, he passed Kimi Raikkonen at the start, then Lando Norris at the hairpin before ambushing Romain Grosjean at Rascasse. Unfortunately, an attempt to repeat the move on Nico Hulkenberg for 11th led to Leclerc clipping the inside barrier in the final part of the corner and spinning – sustaining a puncture that gave him extensive floor damage that soon led to his retirement. Crucially, it also led to the safety being deployed on lap 11.

Usually, pole means job done in Monaco. But this safety car meant Hamilton, sporting a Lauda helmet design for the race, had far more than just the traditional 10% of the job to complete in the rest of the race. The early stages had played out entirely as anticipated for him as he held the lead from Bottas, who had robustly seen off the threat of Verstappen on the inside line through Ste Devote. >>



Bottas broke a wheel rim during pitlane contact with Verstappen

“ALL VERSTAPPEN HAD TO DO WAS OVERTAKE HAMILTON AND PULL FIVE SECONDS ON HIM. EVEN AT MONACO THIS WAS A REALISTIC TARGET”

“There was nothing else I could do really,” said Verstappen of his failure to take second place. “I was boxed in. I could run into the side of him but then you have the risk of a puncture or penalty, so I was just doing my line. I tried to brake deep into the corner to get ahead, but in Monaco it’s very hard.”

The top 10 on the grid all started on Pirelli’s soft compound, so it was a question of when the pitstops would happen, and with the threat of rain in the air the leaders opted to push a little harder than they would have in dry conditions. The safety car ultimately dictated the timing and the top four, rounded out by Ferrari’s Sebastian Vettel, all dived into the pits.

Two decisions at this point shaped the race. The first was Mercedes sending Hamilton back out still in the lead on medium Pirellis compared with the hards taken by Verstappen and Vettel. Since Mercedes would have to double-stack, Bottas’s second place was always in jeopardy and he drove out of his pitbox moments before Red Bull made the crucial decision to release Verstappen into his path.

Verstappen pulled out slightly ahead, but overlapping with Bottas, who grazed the wall after contact with the Red Bull. This led to damage to his front-right wheelrim, forcing him to come in for another stop and drop to fourth place, now on hard Pirellis because he only had a choice of that or used softs.

“We were side-by-side, I kept my line and he kept drifting to the right,” said Bottas. “We touched and I also touched the wall because there was

no more space. I got a puncture for that. Honestly, I thought when I had the puncture and had to stop again that I would go to the back of the grid but luckily I only lost one more place. Unlucky but lucky at the same time. It could have been a lot worse.”

Verstappen said that he couldn’t see Bottas. But it was no surprise that he was subsequently hit with a five-second penalty for the unsafe release, which he was always likely to have added to his race time given a second stop was not expected. But he still had a realistic shot of victory since Hamilton was the only leading car on mediums and was having to take it very easy once the race went green at the end of lap 14.

When Verstappen was advised of his penalty, it was suggested that all he had to do was to overtake Hamilton and pull five seconds on him. It was said partly flippantly, but even at Monaco this was a realistic target. Hamilton’s strategy meant he had to manage the pace to the end of the race with Verstappen breathing down his neck, something his increasingly irritated comments over the radio confirmed put him out of his comfort zone. At one stage, he suggested it would need “a miracle” for them to hang on. So it was entirely possible Verstappen might find a way past and then benefit from Hamilton holding up Vettel and Bottas.

Hamilton was struggling badly with graining but it was very clear he was tightly controlling his pace. For the final 53 laps of the race all but two were in the 1m17s bracket (Pierre Gasly’s fastest lap was 1m14.279s, pole 1m10.166s) and Verstappen was unable to get close enough to make



a move either into Ste Devote or the chicane. But as Hamilton grew increasingly sceptical about his chances, the tension continued to build as the race pushed into its closing stages.

On lap 70, Hamilton's vulnerability started to show as he defended into the hairpin, with Verstappen gingerly looking around the outside. At this stage the Red Bull driver was told he had 'mode seven' available, meaning he could go to all-out attack. Hamilton was warned about this but told he had the overtake button available to defend with, an instruction to which he responded witheringly.

It was clear that Verstappen's best chance was to get tight in behind Hamilton's rear wing out of the Portier right-hander leading to the tunnel. Each lap he inched closer, and on lap 76 – realistically the last time he could get past and expect to build the cushion he needed to win post-penalty – he was closer than ever. He jinked to the left late and pointed his Red Bull up the inside of Hamilton into the chicane.

It was a late move but if Hamilton was initially surprised, he responded brilliantly. Verstappen went in too deep, but Hamilton had straightened up ready to cut the chicane if required. This ensured that the angle of impact as Hamilton turned in was more benign than it could have been. Verstappen's front-right hit Hamilton's rear-left, but both survived.

Verstappen's challenge was broken, Hamilton simply had to stroke the car home for two laps and both Vettel and Bottas knew they would pick up a place apiece when Verstappen slipped to fourth at the flag. >>

QUALIFYING



The battle for pole position at Monaco was always likely to be an all-Mercedes affair. Although Max Verstappen raised hopes by topping Q2, it was clear from the moment the first sector times came in during the top 10 shootout that Mercedes was out front.

Valtteri Bottas took first blood, lapping 0.231 seconds quicker than Hamilton on the first runs thanks to his pace through the first two sectors. He knew he needed to find time on the second run but, while Hamilton did just that to snatch pole position, Bottas's tyres weren't up to temperature for the start of the lap and he peeled into the pits without finishing it.

"I felt there were two or three tenths I could still improve by, so I should have done a better job on the first run," said Bottas. "On the second run, I had quite a bit of traffic on the out-laps so had to go off the line in a few places and the tyres just didn't work on the second run. So disappointing."

Hamilton hustled the car to a lap 0.086s quicker than Bottas. His advantage through the final sector ultimately proved decisive to take his second Monaco GP pole.

Verstappen also had tyre warm-up troubles on his second run and didn't improve so was third, 0.475s down, while Sebastian Vettel kissed the wall on his final attempt and also had to rely on his first-run time for fourth. Pierre Gasly's Red Bull was next, but he was hit with a three-place grid penalty for impeding in Q2. As for the

second Ferrari of Charles Leclerc, he had long since exited qualifying after the team misjudged the cutoff time in Q1 and allowed him to be shuffled down to 16th in the closing stages.

That left the way clear for Kevin Magnussen to put in a brilliant lap to go sixth quickest in the Haas, benefiting from being the only midfielder to have two fresh sets of tyres thanks to the strong pace he demonstrated on his first run in Q1. That meant he pipped Daniel Ricciardo to best-of-the rest.

Behind them, Carlos Sainz Jr split the Toro Rossos of Daniil Kvyat and Alex Albon, the latter making his first Q3 appearance despite struggling with the car under braking and in corner entry.

Renault's Nico Hulkenberg missed Q3 by just 0.062s, while Romain Grosjean was a furious 13th after being baulked by Gasly, who was penalised for the incident.

"VETTEL KISSED THE WALL ON HIS FINAL ATTEMPT AND HAD TO RELY ON HIS FIRST-RUN LAP TIME"

SGS RACING TRANSMISSIONS



SGS is a Motorsport Transmission Design and Manufacturer, producing Innovative Sequential Racing gearboxes, 4WD Systems and Limited Slip Differentials.

Brackwell Farm, Winchendon Road,
Nether Winchendon, Aylesbury HP18 0DS

Tel 01844 299565

www.sgsracing.co.uk

m maier



Charles Maier launches soft carbon fibre watch bands for the Apple Watches, 38, 40, 42 & 44mm. A 60 year old family business stitches these bands together in Italy using our American woven & laminated carbon fibre coupled with the finest European leather.

charlesmaier.com | +1 510 581 7602 | California
sales@charlesmaier.com

Le Mans 1980 to 2018: Official Reviews on DVD and Download from £4.99

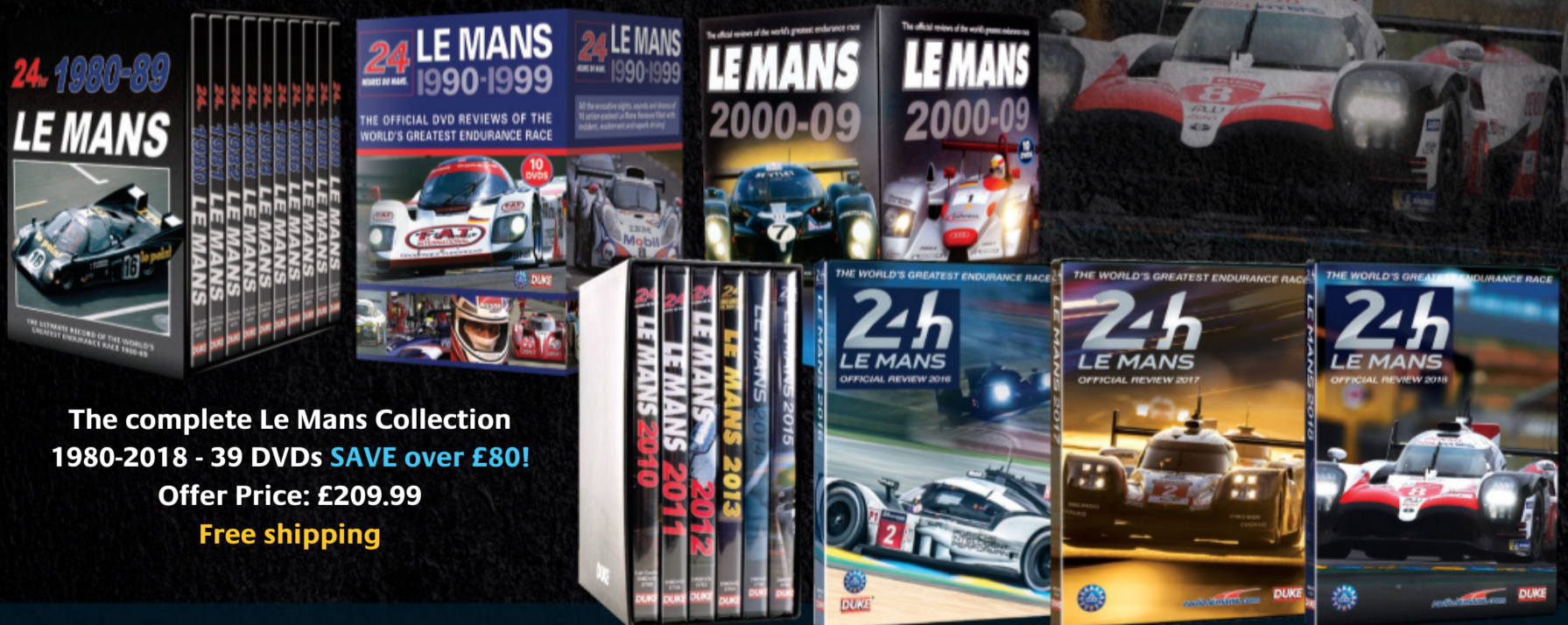

The complete Le Mans Collection
1980-2018 - 39 DVDs **SAVE over £80!**
Offer Price: £209.99
Free shipping

Buy now at dukevideo.com or call +44 (0)1 624 640 011

DUKE
VIDEO

“It was a bit of a late dive,” said Hamilton. “Luckily I saw him last minute. I think his front wing was alongside my rear wheel, so he was not fully past. It was a light touch and move on.”

Verstappen had to give himself at least one chance of passing, and although he suggested over the radio that Hamilton had turned in on him his position softened in the cold light of day after the race.

“I couldn’t really plan because I was always so close in the hairpin but all the time out of Turn 8 we just lost that momentum,” he said. “At one point I just said, ‘OK, let’s have a go and see what happens’. And then we had this little touch. But anyway, under braking you don’t normally look

“THE TONE OF THE MERCEDES RADIO CHATTER CHANGED A LITTLE ON THE SLOWDOWN LAP, AFTER TEAM BOSS TOTO WOLFF DECLARED THE DRIVE A VICTORY WORTHY OF NIKI LAUDA”

in your mirrors, and they’re difficult to see through, so I think there was no one to blame. And we didn’t have any real damage.”

Both deserve huge credit. Hamilton for seeing the move coming, but also Verstappen for making what amounted to a do-or-die move but without straying into it becoming a suicide mission. Whether the driver of 12 months ago would have had the restraint to tread that fine line is a moot point, but today’s driver was, as team principal Christian Horner later pointed out, a model of patience.

Verstappen also had to deal with the problem of being in the ‘launch’ torque setting, which he forgot to reset before leaving the pits, but he adapted to the resulting lag in power delivery well. The stewards rightly took no action on the dramatic denouement of the race. It was just unfortunate that Verstappen’s penalty cost him a podium: Vettel moved up to second ahead of Bottas and the Dutchman was fourth ahead of team-mate Gasly, who had taken the point for fastest lap thanks to being at the back of the leading drivers and making an extra pitstop.

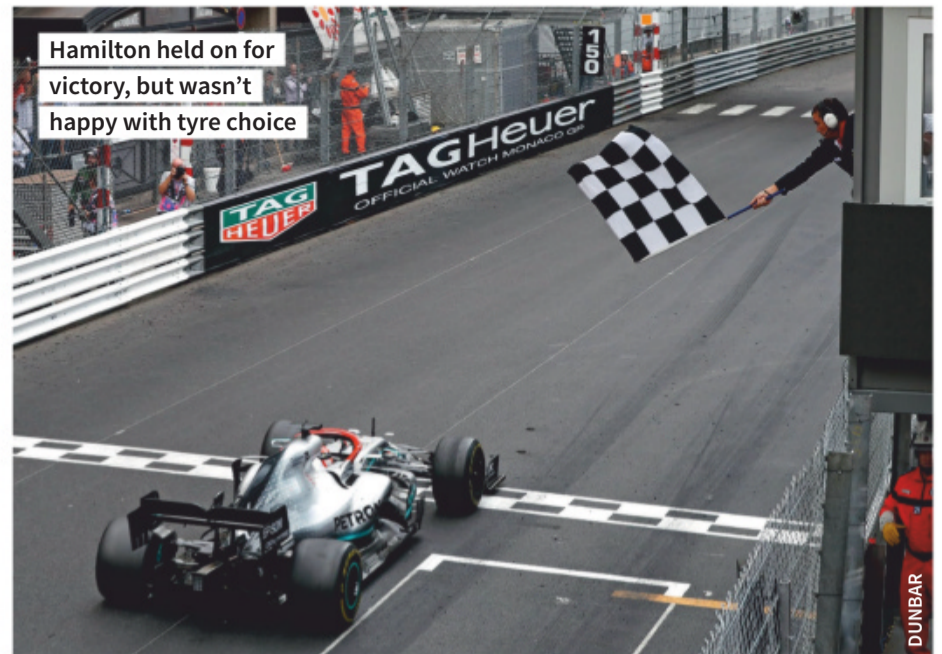

The tone of the Mercedes radio chatter changed a little on the slowdown lap, after team boss Toto Wolff declared the drive a victory worthy of Lauda. But having spent much of the race seething about the decision to send him out on mediums, which were never in any real danger of falling off a cliff but were graining, Hamilton wasn’t ready to celebrate over the radio.

After the race, Hamilton likened it to the infamous 2007 Chinese GP when the McLaren team left him out on shot wets and he went off entering the pits after being called in too late. The “empty tyres” comparison was a pointed one, given that the ’07 error cost Hamilton the world championship, and chief strategist James Vowles admitted after the race that going to mediums was a mistake. When he returned to the engineers’ room after the race, Hamilton doused Vowles, and chief race engineer Andrew Shovlin, in champagne in retribution for the decision. But what mattered was that, once again, collectively they had made the best of it and won. Wolff suggested Hamilton saved the team >>





TRACKSIDE VIEW

Monaco is an absurd, audacious anachronism of a grand prix circuit. Those who call for it to be consigned to the past should be careful what they wish for, because every year it is the scene of the most astonishing display of driver skill and the supernatural capabilities of the modern F1 car. Who cares if the race is usually a processional one of pace management and the result dictated by qualifying, what every single driver does on a quick lap around here is enough to justify the Monaco Grand Prix's permanent place on the calendar.

Heading to the Swimming Pool to watch the first practice session from the outside of the track at the exit of the fast left/right flick forces you to recalibrate your brain to absorb what a grand prix car can do in seemingly impossibly tight confines. Even for someone fortunate enough to watch from up close at every race, it's mind blowing. As for those who must head out and hurl their cars between the barriers at impossible speeds, even for them it must take a lap or two to tune into it.

When things go wrong at Monaco, there's precious little time or space to sort it out. Pierre Gasly flashes past in the Red Bull, but doesn't get the nose into the



corner. He hits the kerb on the right-hand side, unsettling the rear, which snaps out of line. He's heading for the barrier, surely? But a lightning-fast reaction, a full 180 degrees of opposite lock, and the rear corrects from its extreme angle and he's on his way.

Mercedes driver Valtteri Bottas has a similar moment with the kerb, albeit without such dramatic consequences. But debris does fly off his front wing. It's later shoved

up against the barrier at the exit of the corner by an enterprising marshal with a broom at a quiet moment. Yet still, near the end of the session, the Racing Point of Lance Stroll comes so close to the wall that he flicks it high in the air and over the fence. You also get mortared by the odd tyre marble.

The Mercedes stands out. On the kerb there's a single slab with a yellow raised part, which launches every car and brings it crashing

down. But no car can hit it with the same enthusiasm as the Mercedes, which absorbs it effortlessly and grips on landing. For Ferrari, it's harder work and both Sebastian Vettel and Charles Leclerc are visibly stressing the left-rear more.

Just a snapshot, both of the unique, unmissable challenge of Monaco – and of the difference between a fast car and the fastest one. Who'd want F1 to lose that?

EDD STRAW

Pierre Gasly couldn't match team-mate Max Verstappen's confidence



ROMNEY



Vettel and Hamilton both sported special helmets as tributes to Niki Lauda

HONE

with the brilliance of his drive, while Hamilton believed it was among his most challenging victories.

“I think it was the hardest race I’ve had,” he said. “With the tyres, with the strategy, with the circumstances with Max behind – it was the biggest challenge I’ve had. I’m really grateful that I was able to pull it off.

“There were multiple things coming into my thought process. I’ve got 38 laps to go and I’ve got no tyres left and I’m thinking that ‘there is no way that with the feeling that I have and with the pace that I have to do at the moment that I’m going to make it’. It’s a horrible feeling.

“I’ve been there before. A few years ago I was leading this race by 20 seconds, the safety car came out, I pitted, came out third, and your heart just sinks, so I was like: ‘I’m not coming in, whatever. I’m just going to drive around with no tyres until they blow up.’ With sheer will I just kept pushing. I really, really tried my best to stay focused and not crack under pressure, because Max was doing a great job behind on a much better tyre.

“I was able to get out of the last corner and pull a bit of a gap. I was super slow through Turn 1 but Turn 3 my right-side tyres were OK and once you got downforce on they would work. But then once I got to Turn 4, 5, 6, 7, 8, I had nothing. [I was] moving the brake balance rearwards, engine braking, opening up diffs, trying to get this car turned.

“I kept thinking Turn 6 is probably where he’s going to try to dive up the inside, because I was just waiting to get the car turned. So I was just trying to cover that whole area, tip-toeing and positioning myself so I could get a good exit. It was one of the most strategic drives that I think I have ever had to do in terms of finding that balance around

the track to try and keep that gap. I’m sure we touched multiple times and I definitely touched the barrier a lot of times throughout the laps but luckily kept the car in one piece.

“This has been such a hard week, emotionally, for us as a team and for me personally, I just really, really wanted to do the job. I really wanted to deliver on the word of Niki, and imagining him taking the hat off in support. When I was driving I was like, ‘what would Niki do?’ so I just kept going.”

Some might suggest that Lauda would have spent less time complaining over the radio, but given the many tributes to his forthrightness and the stories from his career he, too, was a driver not afraid to take the team to task when appropriate. But, like Hamilton in Monaco, he also delivered.

That’s what the great champions do: they produce under the most intense pressure. Hamilton could afford no mistakes, with one of the most incisive wheel-to-wheel racers in the business on his tail. And when the final attack came, he responded to it perfectly. Lauda would have been proud. 🏆

NEXT F1 REPORT

CANADIAN GRAND PRIX 13 JUNE ISSUE

Montreal’s fast and dramatic Circuit Gilles Villeneuve offers Ferrari another chance to shine. Can the Scuderia turn its season around?



Sainz stars on way to 'Class B' win

Carlos Sainz finished sixth in the race, with a double-pass on the Toro Rossos of Alex Albon and Daniil Kvyat on the first lap the key to his success.

Sainz started ninth but was passed around the outside of Ste Devote by Albon. He was alongside Albon on the run up the hill and completed that pass into Massenet before then going around Kvyat to run eighth.

"I managed to gain a position around the outside of Albon and Kvyat at Turn 3," said Sainz. "That was a really good move and I thought I had done one of the best starts of my career. And from then on, I just put together the right pace when it counted before and after the pitstops."

From eighth place, he didn't stop under the safety car and was able to get ahead of both Daniel Ricciardo and Kevin Magnussen. Team-mate Lando Norris, who finished 11th, was able to act as a roadblock to ensure those who had stopped early were backed up, allowing Sainz and the Toro Rossos drivers – as well as Romain Grosjean – to gain track position.



Q1 'misjudgement' ruins Leclerc's week

Charles Leclerc retired from the Monaco Grand Prix to complete a miserable weekend that was wrecked by a mistake Ferrari made in qualifying while chasing a risk it recognised was "not worthwhile".

Leclerc topped final practice for his home grand prix but started the race from 15th on the grid after being knocked out in Q1 when Ferrari failed to send him back out for a second run as rivals improved.

It was enough for Ferrari team principal Mattia Binotto to arrange an unscheduled media briefing after qualifying to explain a "misjudgement" with the cutoff time to make it through to Q2, and the decision not to react despite Leclerc questioning whether he was safe.

Ferrari had not factored in such significant track improvement or the gains drivers would make as they built their confidence through Q1. Binotto said that the "margin" Ferrari establishes on top of its cutoff time needs to be bigger for future races in Monaco and admitted the team needed to take responsibility because as well as the "tools" being used, it has "people managing the tools, people responsible for deciding the threshold [and] responsible for deciding to overrule, eventually, any decisions".

Ferrari wanted to avoid sending Leclerc out for a second run to save a set of tyres, because

it felt that was its best opportunity to challenge Mercedes and Red Bull.

"But no doubt that when you look at the implication of not entering Q2, it is even bigger than trying to challenge them on the final part of quali," Binotto acknowledged.

Leclerc himself questioned Ferrari's tactics during the session but Binotto explained that the team told him "we've got the data, and we believe that's good enough" – but it wasn't.

"When you've got tools and simulations you should somehow trust what you're doing," said Binotto. "We were fully conscious that it would have been tight, but our tools were telling us it would have been good enough."

"We were taking risks, too many risks, [that were] not worthwhile in such a situation. It's a misjudgement. And a misjudgement is a mistake."

Leclerc passed Romain Grosjean for 12th with an audacious move down the inside of Rascasse before attacking Nico Hulkenberg at the same place a lap later, but ran out of space, clipped the wall on the right-hand side and half-spun. Both carried on but Leclerc retired with damage a couple of laps later, while Hulkenberg was forced into the pits with a puncture.

"I had to take a lot of risks, which I did" said Leclerc. "It was fun at the beginning. Unfortunately it ended in disaster."

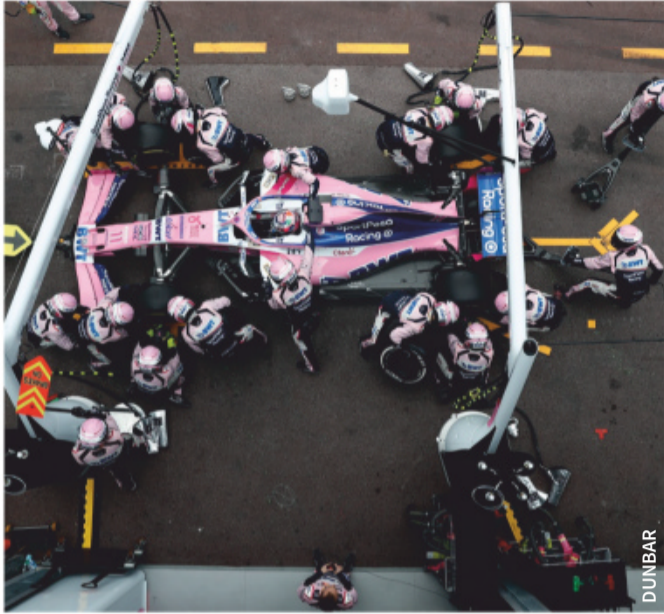

Perez narrowly misses marshals

Sergio Perez says he was “very lucky” to avoid hitting two marshals during the Monaco Grand Prix when they ran in front of his Racing Point car during his run to 12th.

The incident occurred at the pitlane exit during the early safety car period. Perez had emerged from a tyre change and was accelerating out of the pits when he encountered two marshals running across the track before Ste Devote.

One marshal managed to get across in front of his car to the inside barriers, while a second managed to stop – and fortunately Perez was able to get between them without incident.

Speaking on his team radio immediately after the incident, a shocked Perez said: “What was wrong with those marshals? I nearly killed him.”

Following the race, Perez suggested it was pure good fortune that he had not struck either marshal.

“I don’t know if you saw but in the safety car I had a marshal running and I nearly ran over him – coming out of the pits in Turn 1,” said Perez. “They were running back and I was coming out of the pits. I had to brake and was very lucky – they were lucky I avoided them.”

“They’re usually very good, but it’s safety at the end of the day – and most important is safety for the marshals and drivers.”



Q & A

GUNTHER STEINER HAAS TEAM PRINCIPAL

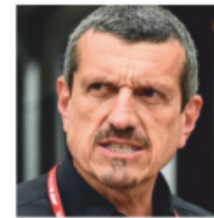

they got to their advantage. I don’t think we did anything completely wrong today, just a few things went wrong.

Haas had a disappointing weekend, with Kevin Magnussen running sixth early on but finishing 14th after getting stuck in the queue behind Lando Norris when he stopped under the safety car. Romain Grosjean was impeded by Pierre Gasly in qualifying and finished ninth on the road, but slipped behind Daniel Ricciardo in the results thanks to a five-second penalty for crossing the pit exit line.

Given the pace of the car, are you disappointed with the way the race panned out?

A tough race, everything went wrong that could go wrong. It started with Kevin at the start losing a position and getting stuck behind Ricciardo then we know he can’t get by. We never seem to get any points thrown at us, everything goes against us! My positive is that the car is quicker and this race it was circumstances. We followed Ricciardo [to the pits under the safety car] then with McLaren blocking [with Norris], which is part of racing and they used the luck

In hindsight, would you have done it differently with Magnussen?

Yes, you stay out. If we knew how long the softs would last we would have done.

Were you surprised others stayed out?

Yes, a little bit, but when they saw us and Ricciardo coming in it created an opportunity for them. If we stayed out, maybe they would have come in. We had to cover Daniel but we didn’t expect the soft tyres would last this long.

Do you accept the Grosjean penalty?

Yes. He crossed the line and we finished 10th instead of ninth. He also got caught behind the others, it wasn’t his pace. Every time, we have something in our way.

So a silly error from Romain?

Yes. The engineer said Sainz is coming and maybe that was a little bit of a distraction. There are so many things that went against us, we were unlucky with everything.

Giovinazzi penalised for Kubica clash



Alfa Romeo driver Antonio Giovinazzi finished last in the Monaco Grand Prix after being penalised for booting Williams driver Robert Kubica into a spin.

The Italian attempted to pass Kubica at Rascasse shortly after the restart, pushing the Williams round and blocking the track. He was given a 10-second penalty for causing the collision, which he served at his later

pitstop but would have struggled to have beaten Kubica even without the time loss.

“I was behind the Williams for too long and I was trying everywhere,” said Giovinazzi. “I tried at Rascasse but there was not enough space and we touched.”

“It’s a track where it’s impossible to overtake and I tried because my pace was better than them.”



FREE PRACTICE 1

POS	DRIVER	TIME
1	Hamilton	1m12.106s
2	Verstappen	1m12.165s
3	Bottas	1m12.178s
4	Leclerc	1m12.467s
5	Vettel	1m12.823s
6	Gasly	1m13.170s
7	Hulkenberg	1m13.227s
8	Magnussen	1m13.232s
9	Raikkonen	1m13.363s
10	Grosjean	1m13.379s
11	Ricciardo	1m13.413s
12	Giovinazzi	1m13.437s
13	Kvyat	1m13.731s
14	Albon	1m13.827s
15	Norris	1m14.278s
16	Perez	1m14.566s
17	Russell	1m15.115s
18	Kubica	1m15.514s
19	Stroll	1m16.135s
20	Sainz	2m00.670s

WEATHER 19C, sunny

FREE PRACTICE 2

POS	DRIVER	TIME
1	Hamilton	1m11.118s
2	Bottas	1m11.199s
3	Vettel	1m11.881s
4	Gasly	1m11.938s
5	Albon	1m12.031s
6	Verstappen	1m12.052s
7	Magnussen	1m12.174s
8	Giovinazzi	1m12.239s
9	Raikkonen	1m12.342s
10	Leclerc	1m12.350s
11	Grosjean	1m12.392s
12	Norris	1m12.393s
13	Sainz	1m12.419s
14	Kvyat	1m12.577s
15	Perez	1m12.752s
16	Hulkenberg	1m12.872s
17	Ricciardo	1m12.888s
18	Stroll	1m14.558s
19	Russell	1m15.052s
20	Kubica	1m15.146s

WEATHER 20C, sunny

FREE PRACTICE 3

POS	DRIVER	TIME
1	Leclerc	1m11.265s
2	Bottas	1m11.318s
3	Hamilton	1m11.478s
4	Verstappen	1m11.539s
5	Gasly	1m11.738s
6	Giovinazzi	1m12.170s
7	Kvyat	1m12.194s
8	Magnussen	1m12.270s
9	Raikkonen	1m12.308s
10	Albon	1m12.338s
11	Hulkenberg	1m12.489s
12	Ricciardo	1m12.519s
13	Grosjean	1m12.566s
14	Vettel	1m12.583s
15	Sainz	1m12.862s
16	Norris	1m12.914s
17	Perez	1m13.232s
18	Stroll	1m13.622s
19	Kubica	1m14.086s
20	Russell	1m14.305s

WEATHER 21C, cloudy

SEASON STATS

DRIVERS' CHAMPIONSHIP	PTS	BEST FINISH	BEST QUAL
1 Hamilton	137	1	1
2 Bottas	120	1	1
3 Vettel	82	2	2
4 Verstappen	78	3	3
5 Leclerc	57	3	1
6 Gasly	32	5	5
7 Sainz	18	6	7
8 Magnussen	14	6	6
9 Perez	13	6	5
10 Raikkonen	13	7	9
11 Norris	12	6	7
12 Kvyat	9	7	6
13 Ricciardo	8	7	7
14 Albon	7	8	10
15 Hulkenberg	6	7	8
16 Stroll	4	9	15
17 Grosjean	2	10	6
18 Giovinazzi	0	11	8
19 Russell	0	15	17
20 Kubica	0	16	18

CONSTRUCTORS' CHAMPIONSHIP

1 Mercedes	257
2 Ferrari	139
3 Red Bull	110
4 McLaren	30
5 Racing Point	17
6 Haas	16
7 Toro Rosso	16
8 Renault	14
9 Alfa Romeo	13
10 Williams	0

QUALIFYING BATTLE

Hamilton	3	3	Bottas
Vettel	5	1	Leclerc
Gasly	0	5	Verstappen
Ricciardo	4	1	Hulkenberg
Grosjean	2	4	Magnussen
Norris	3	3	Sainz
Perez	6	0	Stroll
Raikkonen	4	1	Giovinazzi
Albon	1	3	Kvyat
Russell	6	0	Kubica

Scores ignore sessions if a driver didn't participate in qualifying or had a serious technical problem

WINS

Hamilton	4
Bottas	2

FASTEST LAPS

Gasly	2
Leclerc	2
Bottas	1
Hamilton	1

POLE POSITIONS

Bottas	3
Hamilton	2
Leclerc	1

SPEED TRAP (QUALIFYING)

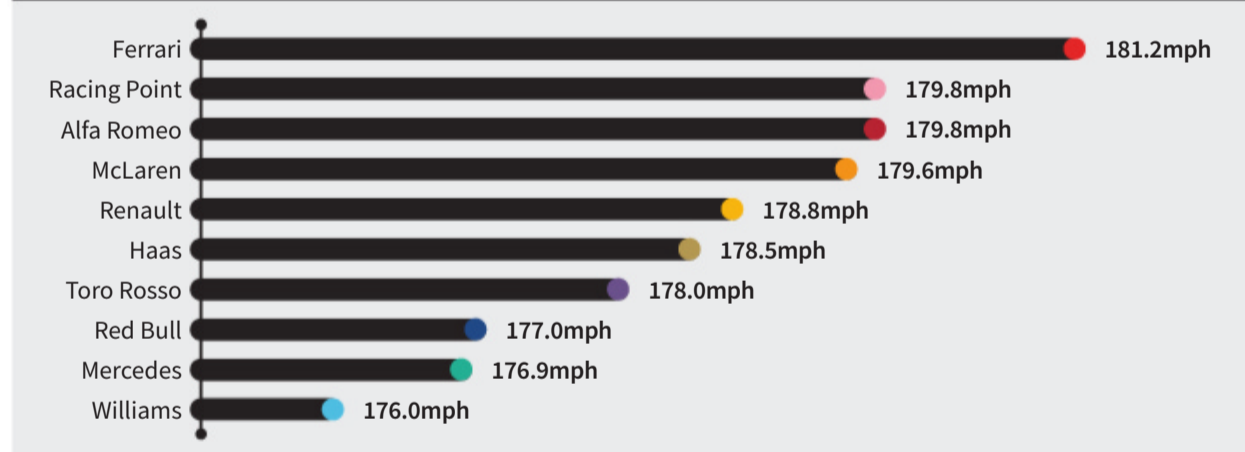

QUALIFYING 1

POS	DRIVER	TIME
1	Vettel	1m11.434s
2	Hamilton	1m11.542s
3	Bottas	1m11.562s
4	Verstappen	1m11.597s
5	Kvyat	1m11.602s
6	Gasly	1m11.740s
7	Ricciardo	1m11.767s
8	Grosjean	1m11.837s
9	Norris	1m11.845s
10	Magnussen	1m11.865s
11	Sainz	1m11.872s
12	Giovinazzi	1m11.976s
13	Raikkonen	1m11.993s
14	Albon	1m12.007s
15	Hulkenberg	1m12.097s
16	Leclerc	1m12.149s
17	Perez	1m12.233s
18	Stroll	1m12.846s
19	Russell	1m13.477s
20	Kubica	1m13.751s

QUALIFYING 2

POS	DRIVER	TIME
1	Verstappen	1m10.618s
2	Bottas	1m10.701s
3	Hamilton	1m10.835s
4	Vettel	1m11.227s
5	Magnussen	1m11.363s
6	Kvyat	1m11.412s
7	Albon	1m11.429s
8	Gasly	1m11.457s
9	Ricciardo	1m11.543s
10	Sainz	1m11.608s
11	Hulkenberg	1m11.670s
12	Norris	1m11.724s
13	Grosjean	1m12.027s
14	Raikkonen	1m12.115s
15	Giovinazzi	1m12.185s

QUALIFYING 3

POS	DRIVER	TIME
1	Hamilton	1m10.166s
2	Bottas	1m10.252s
3	Verstappen	1m10.641s
4	Vettel	1m10.947s
5	Gasly	1m11.041s
6	Magnussen	1m11.109s
7	Ricciardo	1m11.218s
8	Kvyat	1m11.271s
9	Sainz	1m11.417s
10	Albon	1m11.653s

WEATHER 20C, cloudy



STARTING GRID

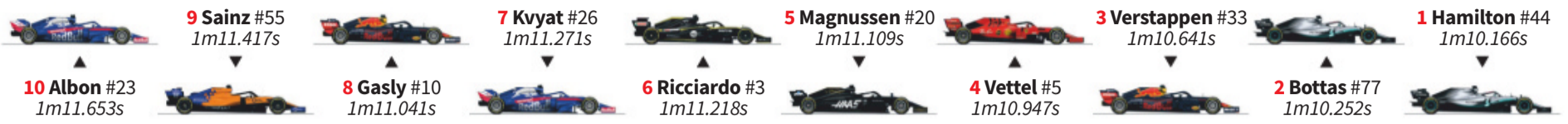

RACE RESULTS ROUND 6/21 (78 LAPS - 161.74 MILES)

POS	DRIVER	TEAM	FINISHTIME	LED	TYRES
1	Lewis Hamilton (GBR)	Mercedes	1h43m28.437s	78	Su, Mn
2	Sebastian Vettel (DEU)	Ferrari	+2.602s		Su, Hn
3	Valtteri Bottas (FIN)	Mercedes	+3.162s		Su, Mn, Hn
4	Max Verstappen (NLD)	Red Bull-Honda	+5.537s		Su, Hn
5	Pierre Gasly (FRA)	Red Bull-Honda	+9.946s		Su, Mn, Su
6	Carlos Sainz Jr (ESP)	McLaren-Renault	+53.454s		Su, Mn
7	Daniil Kvyat (RUS)	Toro Rosso-Honda	+54.574s		Su, Mn
8	Alexander Albon (THA)	Toro Rosso-Honda	+55.200s		Su, Mn
9	Daniel Ricciardo (AUS)	Renault	+1m00.894s		Su, Mn
10	Romain Grosjean (FRA)	Haas-Ferrari	+1m01.034s		Sn, Mn
11	Lando Norris (GBR)	McLaren-Renault	+1m06.801s		Mn, Sn
12	Sergio Perez (MEX)	RacingPoint-Mercedes	-1 lap		Su, Mn
13	Nico Hulkenberg (DEU)	Renault	-1 lap		Mn, Hn
14	Kevin Magnussen (DNK)	Haas-Ferrari	-1 lap		Mn, Hn
15	George Russell (GBR)	Williams-Mercedes	-1 lap		Mn, Hn
16	Lance Stroll (CAN)	RacingPoint-Mercedes	-1 lap		Mn, Hn
17	Kimi Raikkonen (FIN)	Alfa Romeo-Ferrari	-1 lap		Sn, Mn
18	Robert Kubica (POL)	Williams-Mercedes	-1 lap		Mn, Hn
19	Antonio Giovinazzi (ITA)	Alfa Romeo-Ferrari	-2 laps		Sn, Mn
R	Charles Leclerc (MCO)	Ferrari	16 laps-accident damage		Mn, Hn, Sn

FASTEST LAPS

POS	DRIVER	TIME	GAP	LAP
1	Gasly	1m14.279s	-	72
2	Bottas	1m15.163s	+0.884s	65
3	Albon	1m15.607s	+1.328s	43
4	Ricciardo	1m15.697s	+1.418s	78
5	Sainz	1m15.891s	+1.612s	32
6	Hamilton	1m16.167s	+1.888s	9
7	Verstappen	1m16.229s	+1.950s	9
8	Hulkenberg	1m16.276s	+1.997s	65
9	Vettel	1m16.277s	+1.998s	9
10	Kvyat	1m16.288s	+2.009s	31
11	Giovinazzi	1m16.299s	+2.020s	46
12	Stroll	1m16.379s	+2.100s	45
13	Norris	1m16.413s	+2.134s	61
14	Raikkonen	1m16.436s	+2.157s	50
15	Perez	1m16.613s	+2.334s	67
16	Grosjean	1m16.746s	+2.467s	41
17	Magnussen	1m16.992s	+2.713s	61
18	Russell	1m17.038s	+2.759s	76
19	Kubica	1m17.388s	+3.109s	32
20	Leclerc	1m19.151s	+4.872s	6

WEATHER 22C, cloudy/spots of rain

WINNER'S AVERAGE SPEED 93.79mph FASTEST LAP AVERAGE SPEED 100.50mph

TYRES



RACE BRIEFING

GRID PENALTIES

GIOVINAZZI Three-place penalty and one licence point for impeding Hulkenberg in qualifying
GASLY Three-place penalty and one licence point for impeding Grosjean in qualifying

RACE PENALTIES

GIOVINAZZI 10-second penalty and two licence points for causing a collision with Kubica
STROLL Five-second penalty and one licence point for leaving the track and gaining an advantage
GROSJEAN Five-second

penalty and one licence point for crossing the pit exit line
VERSTAPPEN Five-second penalty and two licence points for unsafe release from pitstop
MAGNUSSEN Five-second penalty and one licence point for leaving the track and gaining an advantage

LAP CHART What happened, when

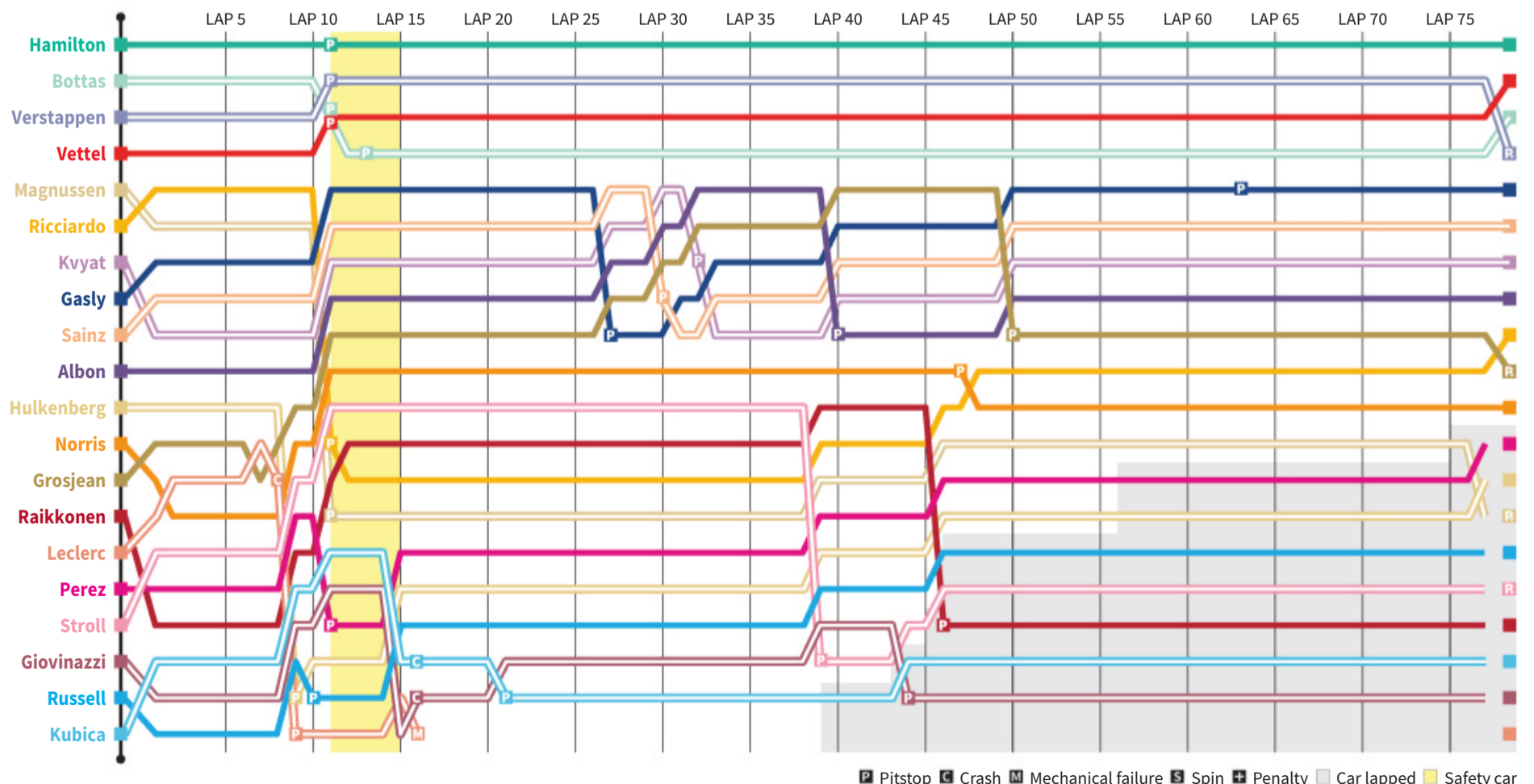

TWO DRIVERS SCORE FULL MARKS IN MONACO

Hamilton recorded one of his best victories in Formula 1 last weekend, but he's not the only star performer in our traditional post-GP ratings

EDD STRAW

MERCEDES



LEWIS HAMILTON

10 Hamilton's pole lap was as close to perfection as you can get at Monaco he reckoned, and he had to work very hard to hold the advantage. He spent most of the race trying to get his head around the tyre choice, but didn't miss a beat and was equal to Verstappen's attack when it finally came.

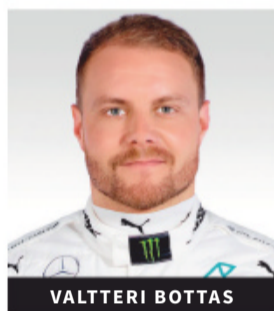

VALTTERI BOTTAS

8 Had provisional pole after the first runs in Q3 but couldn't improve thanks to compromised tyre preparation. In the race, he wasn't to blame for slipping from second to fourth on the road (which became third after Verstappen's penalty) although never looked like threatening Vettel.

FERRARI



SEBASTIAN VETTEL

8 Touched the wall on final Q3 lap, failed to improve after losing most of FP3 to a crash, but lined up fourth then picked up positions thanks to Bottas's double stop and Verstappen's penalty to take his best result of the season. Given the Ferrari wasn't competitive, it was a strong performance.



CHARLES LECLERC

6 Leclerc raised hopes of a dash for pole when he topped FP3 but after a scruffy Q1 run, when he flatspotted his fronts, he didn't make Q2 as Ferrari did not send him out. He did a great job to get from 15th to 12th but got too aggressive with Hulkenberg at Rascasse and ruined his race.

RED BULL

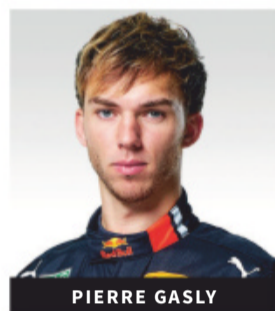

PIERRE GASLY

6 Gasly was unlucky to get a grid penalty for impeding, as the pitwall did not warn him of Grosjean's approach. But he was still 0.4 seconds off Verstappen, which left him firmly at the back of the battle of the big three at the front. Cleared the midfield, had a free stop and got the fastest lap point.

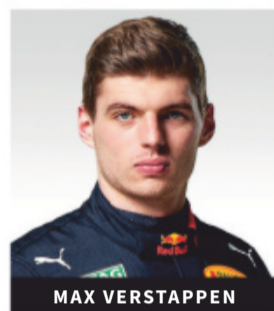

MAX VERSTAPPEN

9 Was the driver most likely to take the fight to Merc in quali, but ultimately the Red Bull didn't have the pace required. The penalty for the unsafe release was the team's error, but perhaps he could have tried harder to avoid the contact with Bottas. He was patient in the race, credit for at least trying a move.

RENAULT



DANIEL RICCIARDO

9 Last year's winner proved he could deliver in a midfield car on the twisty streets with a strong quali performance. Ran fifth early on, albeit not at a strong pace, but the decision to pit under the SC ruined his race. He did a great job to pip the penalised Grosjean to ninth with a late charge.

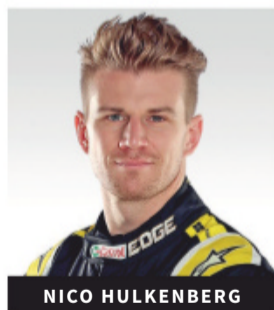

NICO HULKENBERG

7 Just missed out on Q3 and perhaps could blame some light floor damage that led to an overnight change. His race was compromised by the clash with Leclerc and the Giovinazzi-triggered traffic jam. With the resulting strategy issue he was never a points threat given his position.

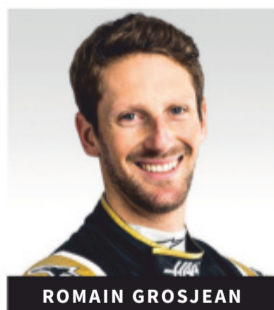

ROMAIN GROSJEAN

7 Grosjean was justifiably furious at being impeded in Q2, which explained his absence from the top 10 shootout. From there, he capitalised on the right strategy to get into the points but lost ninth by just over a tenth to a charging Ricciardo thanks to a 5s penalty for crossing the pit exit line.

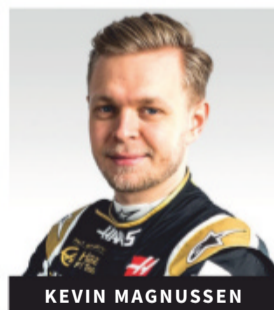

KEVIN MAGNUSSEN

8 Magnussen was superb in quali to take 'Class B' pole, shaving the wall a few times on his Q3 lap and delivering arguably one of his best F1 qualifying performances. Losing a place to Ricciardo at the start was a blow and, after following the Renault into the pits, was then buried back in the pack.

MCLAREN

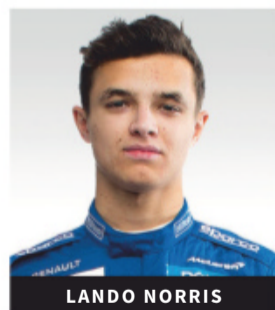

LANDO NORRIS

6 A small mistake on his key Q2 lap ensured Norris didn't make Q3 after slightly losing his way on set-up. He slipped to 14th over the first two laps and was never really a points threat despite spending much of the race holding 10th after staying out, but did help Sainz prevail in the midfield.

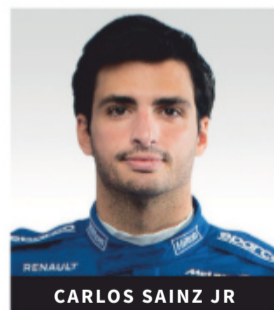

CARLOS SAINZ JR

10 Strung together a great lap to secure ninth on the grid. He briefly slipped behind Albon at the start, but swooped past both Toro Rossos through Massenet. Not stopping under the safety car paid off and his pace on fresh rubber ensured he didn't get overcut.



RACING POINT



SERGIO PEREZ



LANCE STROLL

7 The Racing Point perhaps could have slipped into Q2 with a perfect run in qualifying, but Perez was still 0.6s quicker than his team-mate. Slipped behind Stroll and then made a stop under the safety car, getting caught in the Norris traffic jam, and wasn't able to emerge as a points threat.

6 Stroll looked ill-at-ease during Thursday practice and ended up qualifying six tenths slower than Perez after struggling with traffic in Q1. He gained a couple of places at the start and ran ahead of Perez, but was left out under the safety car and got caught in the queue behind Norris.

ALFA ROMEO



KIMI RAIKKONEN



ANTONIO GIOVINAZZI

6 Kimi's weekend deteriorated along with that of Alfa Romeo, with the car struggling to pick up pace as the track gripped up. After qualifying reasonably, a poor first lap – in which he was shuffled back by the Racing Points – meant he got buried in the midfield in a battered car.

5 Qualifying wasn't bad in the circumstances, lapping just 0.07s off Raikkonen, but stewards deemed he was partly responsible for impeding Hulkenberg, which earned him a three-place grid penalty. His race didn't go well, slipping behind Russell and then clattering Kubica.

TORO ROSSO



ALEXANDER ALBON



DANIIL KVYAT

8 Despite making Q3 for the first time, Albon wasn't happy with the car and struggled with the brakes. That led to a 0.382s deficit to Kvyat. Briefly got ahead of Sainz at the start before being repassed under the SC, drove a good race to a career-best eighth place.

9 Qualified strongly to earn seventh on the grid but lost the place he gained to Gasly's grid penalty thanks to being boxed in on the inside of the first corner, then was passed by Sainz. Kvyat ran ninth in the first stint but, thanks to staying out under the safety car, jumped to seventh.

WILLIAMS

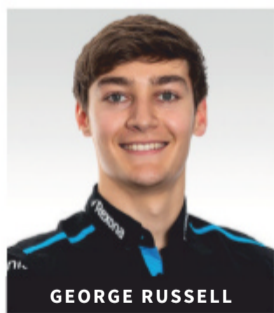

GEORGE RUSSELL

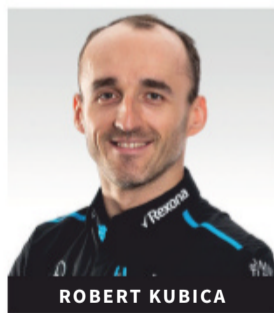

ROBERT KUBICA

9 Russell delivered an excellent qualifying lap, including an unorthodox brush of the wall before turn-in at Tabac. He lost a spot to Kubica at the start but, after pitting under the safety car, he was able to jump Stroll and Raikkonen when they stopped. Luck helped, but he still beat three cars he shouldn't have.

7 The 0.274s gap to Russell in qualifying was about right despite traffic hurting Kubica's tyre prep. Got ahead of Giovinazzi and Russell at the start but stayed out under the safety car then was clattered by Giovinazzi. That forced a pitstop, but he jumped the Alfa when Giovinazzi stopped.

TOP 10 AVERAGE RATINGS

AUTOSPORT'S RATING AFTER ROUND 6

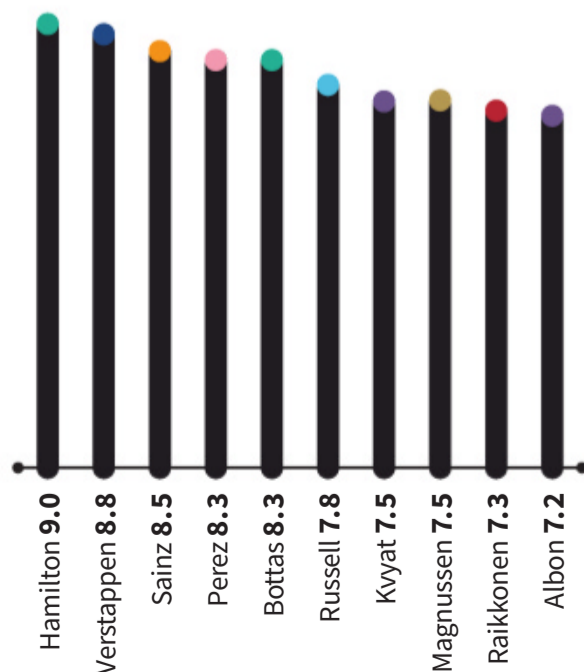

READERS' RATING AFTER ROUND 6

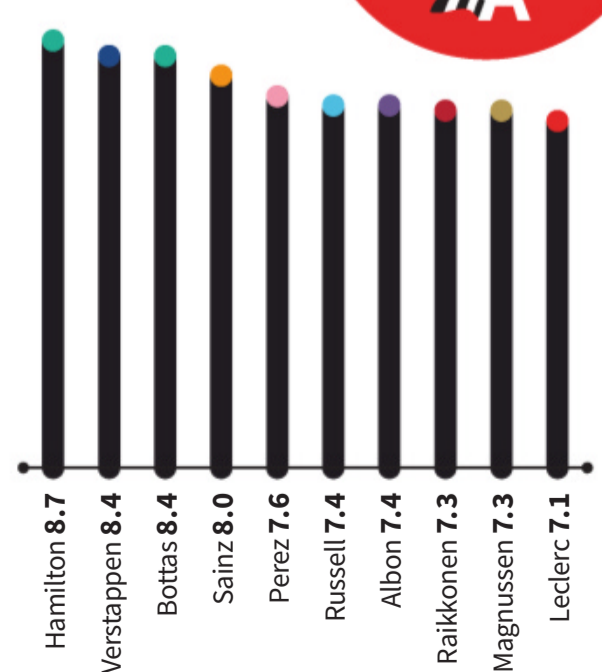

GIVE YOUR DRIVER RATINGS
[AUTOSPORT.COM/F1/DRIVER-RATINGS](https://www.autosport.com/f1/driver-ratings)

NIKI
LAUDA
1949-2019

ROEBUCK ON LAUDA

The veteran Formula 1 journalist recalls the special personality that was his friend and three-time world champion Niki Lauda

NIGEL ROEBUCK

PHOTOGRAPHY  motorsport
IMAGES

“C an I speak freely?” Niki Lauda said to the Mercedes PR man as we sat down to talk in Montreal last year, “or is it the usual PR bullshit?”

Now Niki is gone, and with him so much else, not least – in this regimented age – the last politically incorrect voice in Formula 1.

Looking back on all the time I spent with him over the years, perhaps the single moment that most crystallised Lauda came at Jarama in the spring of 1977. We were chatting in the paddock when up came an American lady seeking an interview for her news magazine. Niki agreed, and she sat down. Clearly she knew little of motor racing, and all the questions were banal until the last one. “Finally,” she said, “I have to ask you this: how much of a problem is it to face the world – looking the way you do now?”

If, like me, Lauda was taken aback by the woman’s breathtaking insensitivity, he didn’t show it, or hesitate: “I guess you’re saying it’s difficult for you to look at me, but for me it’s no problem – I can’t see me...”

This was Lauda pure, the blend of directness, pragmatism and black humour that was the trademark of the man, further amplified by his accident at the Nurburgring in 1976. Another memory... someone talking about that afternoon at the 'Ring, suggesting that as the red flag had been shown, and the German Grand Prix later restarted as a new event, in effect the first race had never happened. “In that case,” Niki said, in that deep growl, “what happened to my f*****g ear?”

For the rest of his life Lauda would come out with lines like that, making light of a catastrophic happening. I can remember that day, and those that followed, with some clarity: the red flag, and the gathering news that it was Lauda involved, that he had been badly burned, mainly about the face. We hung around desolately for a while before setting off to drive to Zeebrugge, then slept on the

boat, expecting in the morning to learn that Niki had died.

As it was, within a few days there was confirmation that he was through the worst of it, and would survive; a few days after that, reports suggested that already he was thinking in terms of a return to racing, and although he necessarily missed Zeltweg and Zandvoort, barely credible stories began to surface that maybe he would race at Monza.

And he did. Not surprisingly tentative on the first day of practice, he was fastest of the three Ferrari drivers on the second, and in the race finished fourth. I left the press room a few laps from the finish because I wanted to be in the Ferrari pit – no security goons in

**“I GUESS YOU’RE SAYING IT’S
DIFFICULT FOR YOU TO LOOK AT ME,
BUT FOR ME IT’S NO PROBLEM”**

those days – when he came in, and what I saw when he took off his helmet stays with me to this day. Gingerly Lauda started to peel off his balaclava, which was stuck by dried blood to his head and face, then – typical Niki – gave up on it, and simply ripped it off, as one would a plaster on a cut finger. All around him looked in wonder at this bloodied warrior, lost in admiration for what he had achieved.

“It was the most courageous thing I have ever seen in sport,” said Jackie Stewart at the time, and he reiterated it when we talked about it again not long ago. “It was only six weeks after the accident, and even now I find it hard to believe what happened. Niki was nowhere near healed, and shouldn’t have been anywhere near a racing car >>



Miraculous to have survived this, let alone to race again



Immense bravery shown on his return just six weeks later





No excuses needed,
Lauda retired himself
from Fuji conditions

at Monza — in today’s world it wouldn’t be countenanced. As it was, he actually increased his championship points lead.”

In Lauda’s mind, though, what he took was a reasoned decision: he hoped he could do it, and resolved to try, but suggestions from some that he was operating on emotion were firmly dispelled when he withdrew from the championship-decider in Fuji after only a couple of laps. For the sake of appearances, designer Mauro Forghieri suggested inventing a problem with the car, but Niki would have none of it: he had withdrawn because he believed the appalling conditions were beyond what was acceptable, and his life was worth more than any world championship. Niki pure again: if you don’t like it, too bad. Astonishingly, there were elements in the Italian press who called him a coward.

Time was when free spirits, not least Gilles Villeneuve, abounded in Formula 1. PR took its time to infiltrate the paddock, but even when it did, even when its tentacles began squeezing the lifeblood out of press conferences and the like, Lauda remained resolutely his own man. Like so many of my colleagues, I loved to talk to him, because you knew that when you asked a question you wouldn’t get a banal answer. How, I asked him at the beginning of 1977, do you see Carlos Reutemann? As a team-mate — or a threat? The response was succinct and withering: “Neither...”

I watched him win the championship again that year, watched him at Monaco in 1978, storming back to second after a puncture, lapping faster than he had gone in qualifying. I watched him practice at Montreal the following season, then abruptly announce that he was done with ‘driving round in circles’, and was retiring forthwith. Typically, when he departed for the airport, he left behind his helmet and overalls: well, he would have no use for them any more.

This, after all, was one who did a deal with his local garage owner, trading trophies for car washes; others were employed as feeding bowls for his beloved dog. Winning the battle was what mattered to Lauda: trimmings and mementos were of little account.

Away he went to concentrate on his new life, on founding and building up his airline, Lauda Air. Austrian Airlines, who operated a virtual monopoly in Niki’s homeland, used every trick to squeeze him out of business, and he fought them with considerable relish.

For two years he was completely off the scene, but then rumours began that a comeback might be on the cards, and ultimately it was announced he would race for McLaren in 1982. While those who knew Lauda, and also knew Ron Dennis, surmised that this looked like a marriage of nitro and glycerine, the results were not long in coming: at Long Beach, only his third race, Niki won. True, he had his enthusiasm for Ron well under control, and that never changed,

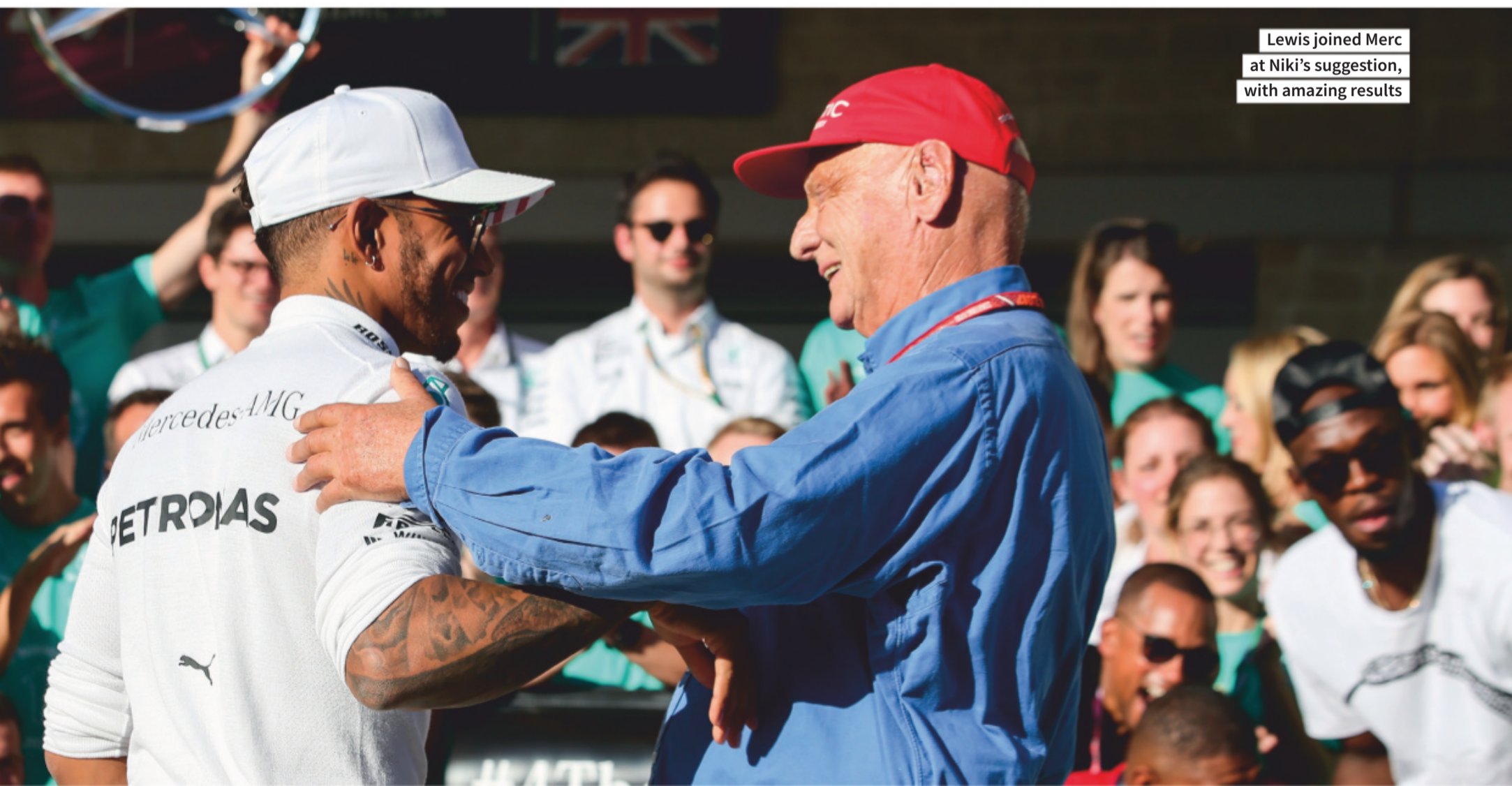

Lewis joined Merc
at Niki’s suggestion,
with amazing results



Lauda left Ferrari and took the #1 to Brabham in 1978



Huge respect, but little love between Lauda and Dennis

but he recognised his strengths as a manager, and in 1984 won his third title, beating team-mate Alain Prost by half a point.

There was a final victory, at Zandvoort, the following year, after which, at the Osterreichring, Lauda called a press conference, announcing his retirement at season's end. This time, he said, it was definitive, and then Dennis came to the microphone. In the circumstances we might have expected him to pay tribute to the man who had done so much for McLaren, but instead Ron talked about the team's focus on winning and how, for 1986, it would again have two drivers capable of doing that. It was crass beyond belief, and I never, before or after, saw Lauda as angry as he was that day.

After retiring as a driver, Niki nevertheless remained involved in Formula 1 to the end of his life, working at different times for such as Ford and Ferrari – and for many years also he was a TV commentator, always willing to speak his mind. Probably because we were of the same vintage, invariably we shared the same 'old school' values: no one loathed the Nanny State more than Lauda, and that was always refreshing in what Martin Brundle calls, "These plain vanilla, health and safety days".

On traction control, long gone now, mercifully, but once allowed back into F1 purely because the FIA couldn't police the ban on it: "It took away all the efforts of the drivers. I mean, I could drive the

"HE WAS DONE 'DRIVING AROUND IN CIRCLES' AND WAS RETIRING. HE LEFT HIS HELMET AND OVERALLS"

car like that – anyone could. Even in the wet, you just pushed the throttle to the floor. A complete joke."

On tyre-warmers: "Why do we need to heat up the tyres? They say, 'We can't do without it'. I say, 'Why – are your drivers idiots? Send them out on cold tyres, and after three spins – or 10 – they'll find out what to do...'"

On DRS: "Why do we need this ridiculous opening wing to help you overtake? Are we driving these cars, or are we computers who overtake only when the FIA tells us we are allowed to? If you manipulate everything, it's false – and to be false is no good. This is Formula 1, not touring cars or something."

Going on from this, Lauda, as you might expect, considered the halo a complete abomination: "I hate the look of it, and also what it represents. I think we're going to destroy the DNA of Formula 1 if we keep on introducing what are, for me, too many safety issues. How far do we want to go? In the end the attraction of any sport, like downhill skiing, which is the same as Formula 1 – think of the

Hahnenkamm in Kitzbuhel – is how far can we go on safety issues without losing the interest of the people. Do I think we've made Formula 1 too safe? Yes, absolutely, 100%."

I remember, too, Lauda's reaction to the decision to introduce 1.6-litre hybrid engines in 2014. "This is the biggest joke ever, and most of all I criticise the stupid teams who agreed to this engine in the first place," he said. "I mean, what were they thinking about? Why do you want to spend hundreds of millions developing this bloody engine that no one will want to listen to? The engines should be left alone, but of course when Jean Todt took over at the FIA, everything had to be different."

His opinion about the hybrids looked a touch ironic later on, given that their introduction transformed the fortunes of the Mercedes team, with which Lauda was deeply involved for the last six years of his life. Come to that, time was – during the McLaren years – that he was distinctly equivocal about Lewis Hamilton.

"I look at Sebastian Vettel," he said to me in 2012, "and see a normal grown-up kid, in the way he looks and behaves, but for me Hamilton is the opposite, with his endless changes of hairstyle, all the jewelry, the tattoos... OK, Hamilton's Hamilton, like Beckham's Beckham, and I don't care about that stuff, but I was always one who wanted to stay in his own personality, which was 'feet on the ground'. I didn't change my personality because I was suddenly famous – I'm not that type. I didn't want to show off like Hamilton or Beckham, I always wanted to be as I am."

Lauda thought then that Hamilton made too many mistakes, although he acknowledged that often, "He performs like hell...". And when it became clear that Michael Schumacher's ill-starred comeback was over after three years, that Mercedes would need a new team-mate for Nico Rosberg, Niki suggested he talk to Lewis.

"The first meeting we had was in his hotel room at two o'clock in the morning – I have to say I'd never before been with a man in a hotel room at two in the morning – and I didn't know him at all. From the beginning, though, we had a good understanding of each other. I told him I was convinced that in this hybrid era Mercedes would have the best engine, and he could be world champion in a factory team – could he imagine what that would do for his image? 'Look at me, I said: why am I known? Because I burned my ear off, and drove Ferraris, and won championships, right?'"

Lewis took Niki at his word, handed in his notice to McLaren, and the rest we know.

Of course, Niki Lauda was a great driver, and, more unusually, a great man. These things are self-evident. More than that, though, perhaps the greatest compliment I can pay a man of whom I was immensely fond is that never have I met anyone who reminded me of him. He was in all ways a true original. ✨

NIKI
LAUDA

1949-2019

NIKI LAUDA'S GREATEST FORMULA 1 RACES

We pick out the legendary Austrian's best drives

KEVIN TURNER

PHOTOGRAPHY  **motorsport
IMAGES**

1973 MONACO GP MONTE CARLO BRM P160E (RETIRED)

10

By 1973 Lauda was in considerable debt thanks to the loans he had taken out to pursue a motorsport career, and was paying for

a BRM F1 drive via instalments. Some financial jiggery-pokery had sorted the first one but, just before the Monaco Grand Prix, the second was due and Lauda had no way of paying it. He realised he had to make his mark so that he would be kept on for his driving merits rather than the money he could (or could not) bring.

The BRM P160E's main issue was a lack of power from its V12, but the chassis was decent and Lauda qualified sixth – ahead of team 'leader' Clay Regazzoni. Helped by some hiccups ahead, Lauda reached third in the race and held off Jacky Ickx's Ferrari until the BRM's gearbox failed.

"That evening [BRM boss] Louis Stanley suggested that we forget the instalment payments," wrote Lauda in his 1986 autobiography *To Hell and Back*.

Even more importantly, the race was key in getting an approach from Ferrari for 1974. "It appears that I had caught the attention of Enzo Ferrari, who had watched the Monaco GP on television," added Lauda.



1977 SOUTH AFRICAN GP KYLAMI FERRARI 312T2 (1ST)

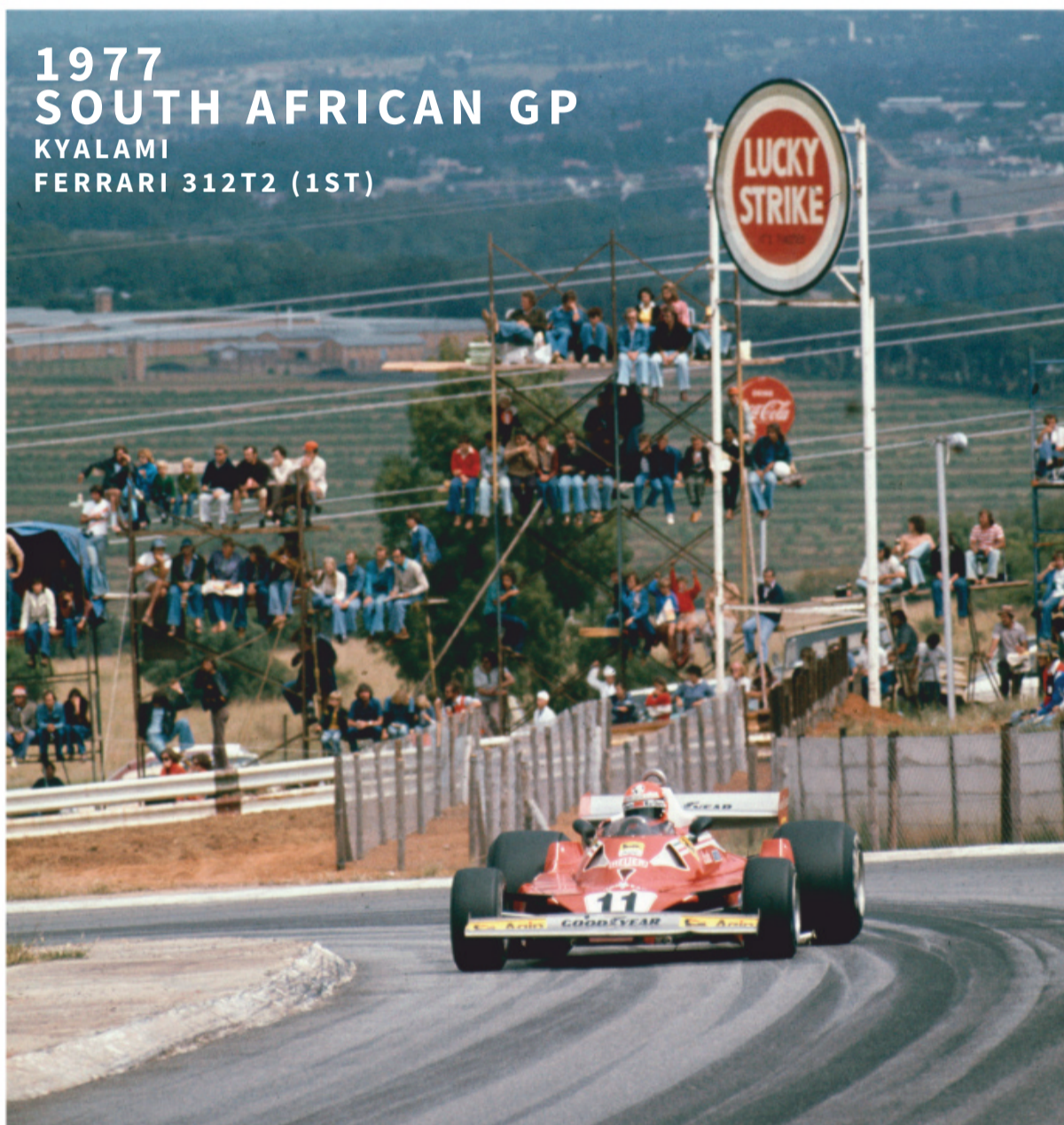

9

This race is mainly remembered for the horrific crash that killed Tom Pryce and a marshal. That should always remain the case, but it should *also* be

remembered as a milestone in Lauda's recovery.

The comeback from his Nurburgring crash had been remarkable but, heading to round three of 1977, Lauda had not won since the accident.

Reigning world champion and poleman James Hunt led at the start, with Lauda slotting in behind. The Ferrari tracked the McLaren and, at the start of lap seven, Lauda slipstreamed into the lead. While Hunt turned his attentions to

defending second, Lauda pulled clear.

He led the rest of the race and won by 5.2 seconds, but Lauda was closer to failure than it looked. "He described the car as 'completely gone,'" wrote Autosport's reporter Jeff Hutchinson. "By that he meant oil pressure and water temperature, which had been flashing their warning at him for the last 25 laps.

"His Ferrari had picked up part of the wreckage of Pryce's accident and damaged the water system. He ended up with only one third of the usual 12 litres of water. The engine would have blown up during the next lap or two."

But Hutchinson added: "It was a brilliantly judged victory. Watch out – Lauda's back!"



1982
US GP (WEST)
 LONG BEACH
 MCLAREN MP4/1B (1ST)

8

A Donington Park test with McLaren persuaded Lauda he could be competitive if he made an F1 return in 1982, and he proved it to everyone else in just his third race back.

Beaten to Long Beach pole by a last-gasp lap by Andrea de Cesaris, Lauda followed the Alfa Romeo in the early stages of the race. The gap grew to as much as 5.4s, but Lauda soon closed in.

On lap 15, de Cesaris gave Lauda the chance he needed. "Through the chicane at the start of Shoreline Drive, de Cesaris was held up by Raul

Boesel, and at the exit chose to vent his feelings, shaking his right fist when he should have been using it to change gear," reported Nigel Roebuck.

"I saw him raise his hand in a threatening gesture and I said to myself: he should be changing gear *now*," said Lauda in *To Hell and Back*. "I pulled out past him, giving him a wide berth. After all, you have to watch yourself when you pass someone who is so busy shaking his fist that he forgets he has to change gear."

Lauda completed the move at the first corner and started to edge away. When de Cesaris retired shortly before half distance, Lauda was left with a

lead of almost 50 seconds over Keke Rosberg's Williams. "He made the matter of lapping Long Beach quickly seem deceptively undramatic and simple," wrote Roebuck, who likened the drive to Lauda's Ferrari performances in the mid-1970s.

Although he outranked himself at one point as the track surface broke up, Lauda cruised home. In his first career, Lauda reckoned he'd always been afraid that the car would break in that position, but this time he felt euphoric. "I have never felt like that before," he said. "It was beautiful. Coming back and winning the third race of the season – I liked it."

1983
SOUTH AFRICAN GP
 KYALAMI
 MCLAREN MP4/1E (11TH)

7

Lauda argued with designer John Barnard that McLaren's new Porsche turbo car should run before the end of the 1983 season, to iron out

the bugs. "John wouldn't give an inch, so I had no option other than to go through the back door and do some lobbying and scheming at [main sponsor] Marlboro," recounted Lauda in *To Hell and Back*. "Marlboro promptly put pressure on Ron Dennis."

As Lauda had feared, the MP4/1E did reveal some problems in the McLaren-Porsche combination but, by the season finale at Kyalami, they had largely been resolved and Lauda's machine had revised intercoolers.

Lauda started only 12th, but swiftly moved through the field. He was 10th at the end of lap one, and gained another spot when Jacques Laffite's Williams went off after a contretemps with Eddie Cheever. Lauda passed the misfiring Lotus of Elio de Angelis on lap three and two tours later overtook Rene Arnoux's Ferrari for seventh. Keke Rosberg was Lauda's victim on



lap six, and on lap nine the McLaren went by poleman Patrick Tambay (Ferrari). The Alfa Romeo of Andrea de Cesaris and championship contender Alain Prost's Renault were next.

"This was Niki driving with an aggression we have not seen for a long time, and doing it, as ever, with perfect line and judgement," reported Autosport's Nigel Roebuck. After just 18 of the 77 laps, Lauda was behind just the dominant Brabhams and had set a fastest lap beaten only by the lightly fuelled and charging Nelson Piquet.

The leading Brabham-BMW built up such a big advantage that Piquet was able to pit and emerge still in the lead, while Lauda pitted shortly

afterwards from third. A sticking right-rear wheel meant a long stop and the McLaren rejoined in seventh. Lauda had to charge again.

When Prost retired his Renault just before half distance, Piquet only needed fourth to be sure of his second world title. The Brazilian backed off and eventually team-mate Riccardo Patrese, then Lauda – having again risen to third – went by.

With eight laps to go Lauda was just 2.9s behind Patrese, but then the Brabham responded and looked safe when the Porsche turbo broke. "Lauda will be faster in 1984," prophesied Roebuck...



1984 FRENCH GP

DIJON

MCLAREN MP4/2 (1ST)

6

For much of the 1984 season, Lauda struggled to match team-mate Alain Prost in qualifying and often needed a bit of luck to beat him in the races.

One of the exceptions was at Prost's home race. Prost suffered wheel problems, but Lauda felt he could have beaten him anyway.

Two engine failures and rain in qualifying meant Lauda started ninth. He immediately went on the offensive, rising to third after 21 of 79 laps, behind Patrick Tambay's Renault and Prost.

"I had to drive harder and more brutally than I really wanted to in case the leading group got away," said Lauda in *To Hell and Back*. "I was driving like a madman, pushing beyond what the tyres would take. I had to. There was no point in wait-and-see tactics: all I could see were those two ahead of me."

"Just as I pulled up on Prost, he turned into the pitlane, one wheel loose. Pity he's gone, I thought to myself, because he hadn't a hope today."

Lauda applied pressure to leader Tambay, his attack being more urgent than usual – "I was prepared to risk everything," he added. "My habitual calm had deserted me."

Eventually, Tambay made a mistake and Lauda moved into the lead, but then there was confusion. He had planned to make a tyre stop at half distance, but had seen no signal and had lost track of how far into the race he was.

"They hadn't signalled because Ron Dennis had persuaded himself that it perhaps wasn't necessary," recounted Lauda.

Thanks to his earlier charge, Lauda's tyres were finished so he came in with a third of the race to go and the stop was not swift. Tambay swept by and Lauda drove "like a maniac" to reel him in and retake the lead.

"I was really angry with Ron," wrote Lauda, "because he hadn't respected our halfway agreement. It makes me angry when you have to drive harder to win than absolutely necessary. Taking unnecessary risks is always stupid."

But this time they paid off. Lauda had scored a vital victory that kept him in sight of Prost in the championship fight.



1975 MONACO GP

MONTE CARLO

FERRARI 312T (1ST)

5

Lauda's dominant 1976 performance around the streets of Monte Carlo almost made this list – he took pole and led every lap – but his 1975 win stands

out because it was a more challenging event.

Lauda arrived having not won for nearly a year, but took pole by 0.69s. A fast-starting Jean-Pierre Jarier attacked at Mirabeau but only succeeded in damaging his Shadow, and he crashed later around the first lap. That left Ronnie Peterson's Lotus and the



second Shadow of Tom Pryce chasing the Ferrari as they pulled clear of the rest in wet conditions.

As the track dried, Pryce was the first of the trio to dive in for slick tyres, and a change of nose. Lauda came in next, leaving Peterson to lead a lap, but a slow Lotus stop (thanks to a dropped wheelnut) put the Swede out of contention.

Lauda moved back to the front, now chased by reigning world champion Emerson Fittipaldi's McLaren. Fittipaldi put on a mighty charge, but the gap came down slowly until the Ferrari flat-12's oil pressure began to fall and the cushion started coming down more quickly.

Fortunately for Lauda, the early slow running meant the two-hour rule kicked in and the chequered flag was waved after 75 laps instead of 78. But given his performance, that was a little bit of luck he probably deserved.

"He always had pressure on him, for whether in the rainy conditions of the start or the dry of the finish he had either Peterson or Fittipaldi ready to profit from the slightest falter," reported Pete Lyons in Autosport.

Lauda's victory was also the first one in a hat-trick that took him into a lead of the world championship he never lost.



1978 MONACO GP

MONTE CARLO
BRABHAM BT46 (2ND)

4

After the politics of Ferrari, Lauda enjoyed working with Brabham boss Bernie Ecclestone and designer Gordon Murray. His time in

Brabham-Alfa Romeo machinery was, however, hampered by poor reliability.

There were highlights and perhaps Lauda's best performance came at Monaco, a venue he didn't like but at which he invariably excelled.

Lauda qualified third, behind team-mate John Watson, and ran third in the early stages behind Watson and Patrick Depailler's Tyrrell. Watson led until lap 38 of 75, when worsening brake problems sent him down the chicane escape road. Shortly after that, Lauda pitted from second to take on fresh rear tyres following a puncture.

Now came "as great a drive as we have seen for years", according to Autosport's Nigel Roebuck. "We were about to see why this man is world champion.

"In the past 18 months, we have seen him triumph so often on caniness and consistency. But that policy went out of the window after his pitstop. This was Lauda at his best, and you could not help but think of Jochen Rindt's drive in 1970."

Lauda rejoined sixth, which became fifth when Ronnie Peterson's Lotus retired. He then caught Gilles Villeneuve's Ferrari and was attacking when the 312T3 suffered a puncture and crashed.

Watson waved his team-mate through for third, allowing Lauda to chase after Jody Scheckter's Wolf. He forced his way into second with less than three laps to go. During his charge he lapped faster than he had in practice – and 1.9 seconds faster than anyone else managed in the whole GP.

"It is a long time since we have seen a drive like this one," reckoned Roebuck. "It was a storming and majestic performance."



**1984
PORTUGUESE GP**
ESTORIL
MCLAREN MP4/2 (2ND)

3

A race in which a driver finishes 13 seconds behind his team-mate would not normally feature strongly on a list like this, but Lauda selected the 1984 Portuguese GP as the race of his life when asked by Autosport.

Largely that's because Lauda did what he had to do to take the title at the end of what he believed was his toughest season, alongside the upcoming great Alain Prost at McLaren. If Prost won, Lauda had to finish second to take the crown.

Things did not start well. Lauda's chances weren't helped by electrical and engine issues, despite a change of his TAG Porsche powerplant. He also made a rare error and could only qualify

11th, nine spots and 1.4s behind Prost. Despite topping the warm-up session, Lauda also suffered a water leak, which meant another engine change, and the pressure was on. "Psychologically, this turn of events must have been hard to deal with," opined our reporter Nigel Roebuck.

Lauda also had to bide his time early on because he had a problem with his left-hand turbo. "I was stuck in traffic for half the race," Lauda told Autosport. "I couldn't pass anybody because my turbo broke. I couldn't develop the power, so I couldn't pass anybody. I was handicapped. It was a very difficult race."

On lap nine Prost took the lead and thereafter controlled the GP. At this point Lauda was only ninth and still had a lot of work to do. He gained

one place when Derek Warwick's Renault spun on lap 13 and another when he overtook the Lotus of Elio de Angelis on lap 19.

Prost and Nigel Mansell were now well clear of the five-car gaggle, led by Ayrton Senna's Toleman, that Lauda was at the back of. But then things started to go his way. He overtook Stefan Johansson – escaping damage from minor contact – and moved into fifth when Michele Alboreto made a mistake. Lauda then picked off Keke Rosberg on lap 31 and Senna on lap 33, but Mansell – who held the second place the Austrian needed – was 37.5s ahead.

The gap came down for a while, but was still 26.3s at the end of lap 43 and thereafter started to creep up again in traffic. Lauda believed he would have caught Mansell, but that is far from certain. "All things being equal, Niki was not going to catch Mansell," reckoned Roebuck.

Then came Lauda's piece of good fortune. Just after two thirds distance, Mansell started suffering from brake trouble and on lap 51 he spun. Lauda moved into second as the Lotus toured into the pits to retire.

Prost took victory, but it wasn't enough. Lauda crossed the line 13.4 seconds later to secure his third world title by half a point.

"This championship means more than the others," said Lauda. "I liked my win in 1977, coming back after the accident, but this was much harder. When you win the title against a man like Prost – and the equipment is the same – you can't relax for a single race. There has been pressure all the way."

**1985
DUTCH GP**
ZANDVOORT
MCLAREN MP4/2B (1ST)

2

If Lauda was fortunate at times during the 1984 campaign, all that evaporated the following year as he struggled to finish races. He started

to lose interest and decided to retire, but there was still one more great victory.

Lauda was down on power in the quickest practice session and found himself only 10th on the grid at Zandvoort, but – as usual – the McLaren-Porsches were impressive in race trim.

Poleman Nelson Piquet failed to move at the start and so did Thierry Boutsen's Arrows, and Lauda completed the first lap in a remarkable fifth place. He soon dispensed with the Toleman of Teo Fabi and on lap 14 he overtook the Lotus of Ayrton Senna. Only Keke Rosberg's Williams and team-mate Alain Prost were now ahead, and on lap 20 of 70 the Finn suffered an engine failure.

Lauda was suffering with oversteer, thanks to choosing a harder-compound tyre for the left-rear, and pitted for new rubber. He later admitted that he felt the change had been



too soon, but it was better than Prost's later stop on lap 33 that dropped him to third, a quarter of a minute behind leader Lauda.

Contrary to what Lauda believed had been planned, the team had fitted the same combination of three softs and one hard as he'd had before. He still had oversteer.

"Now the real race began," wrote Autosport's Nigel Roebuck. Just as in the Austrian GP a week before, Prost started closing on his team-mate. That finely poised battle had been ruined when Lauda's turbo failed, but this time the two McLarens raced to the end.

On lap 47, Prost – with softs all round – went by Senna. The gap to Lauda was 10.7s with 23 laps to go.

"With a supreme effort on lap 57 Alain closed the gap to 2.6s, setting another record lap, but on lap 60 Niki actually pulled out a quarter of

a second," enthused Roebuck. "Yes, indeed, this was a race."

With seven laps to go they were together. "I was absolutely flat out, on the limit," admitted Lauda. "The classic place to take me was at the end of the long straight. I had to concentrate particularly hard on driving the corner before so cleanly that I could drive flat out away as early as possible."

There was one other place Prost could try, and he did – right at the end of the race.

"He tried to force through on the inside into the chicane," recounted Lauda. "I'd been expecting this and I held the middle line. Prost was forced onto the grass verge with his two nearside wheels."

Lauda held on to take his 25th and final F1 win by 0.232s from the man that would take his mantle as champion by season's end.

**LAUDA'S
F1 STATS**
STARTS 171
WINS 25
POLES 24
FASTEST LAPS 24
1976 ITALIAN GP
MONZA
FERRARI 312T2 (4TH)
1

"I said that I had conquered my fear quickly and cleanly. That was a lie, but it would have been foolish to tell the truth and play into the hands of my rivals by confirming

my weakness. At Monza I was rigid with fear. Training in the rain on Friday before the race was so terrifying that I got out of the car at the first available opportunity."

Lauda's own words, from *To Hell and Back*, help explain why this is number one. It might not technically have been his best race but, just six weeks after he was nearly killed in the fiery Nurburgring crash, surely this was his *greatest*. It's almost certainly the greatest sporting comeback.

Having scared himself on the first day of practice, Lauda regrouped on Saturday: "What I had done wrong was attempt to drive as fast I had done before the shunt, quite irrespective of my weakened condition and the rain. I hadn't held the car in check as I usually would have done."

Lauda started slowly and gradually got quicker and quicker. Unimpressed by Ferrari's mixed response internally to the accident, Lauda outqualified both his team-mates, regular colleague Clay Regazzoni and Carlos Reutemann, brought in to 'replace' Lauda.

He was, however, caught out by the seemingly



premature start and briefly fell to 12th. The Ferrari worked its way up the field and coped with intermittent rain. When both Tyrrells started losing power, the remarkable Lauda moved into fourth. With three laps to go the oil pressure started to fall, but he kept going and held off Jody Scheckter's Tyrrell by 0.1s to secure fourth. His pain and discomfort after an hour and a half of averaging over 120mph can scarcely be imagined.

"Hero of the meeting was Niki Lauda who never

relaxed from racing speed right the way through," wrote Autosport's reporter Pete Lyons. "When he took off his helmet his balaclava was soaked in blood where his healing burns had opened up."

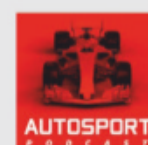

For more on Lauda's brilliant career, listen to a special edition of the Autosport podcast
[autosport.com/podcast](https://www.autosport.com/podcast)

GIORGIO PIOLA'S GREATEST FORMULA 1 CARS

The legendary technical illustrator celebrated 50 years of attending F1 races at Monaco last weekend. Here he picks out his favourite machines



For my favourite cars, I've chosen the ones that were the most innovative – the milestones of Formula 1 cars. There are two examples that I chose just because of a particular feeling but, mainly, they're the most innovative cars that I saw in my career.

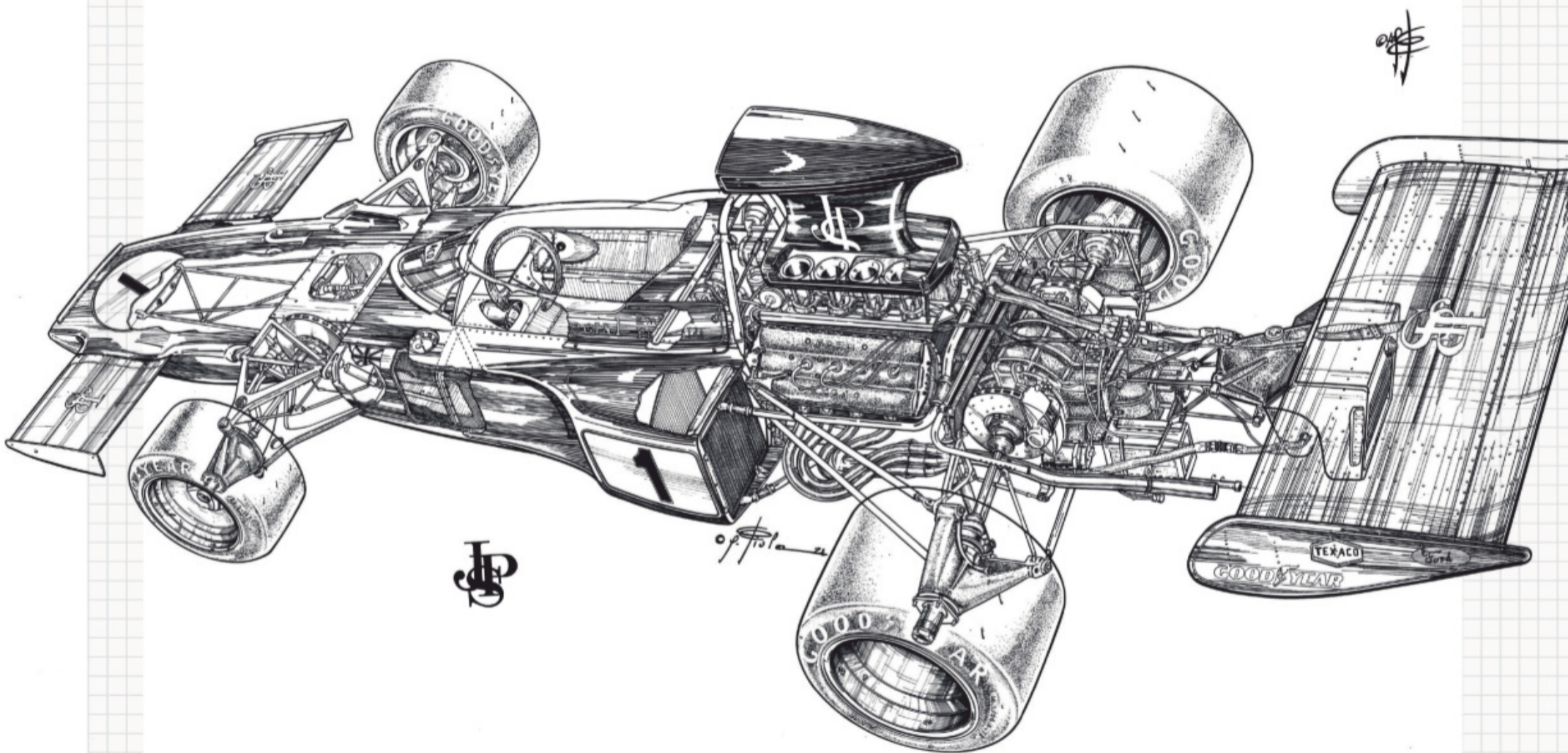

1970-75 LOTUS 72

It completely changed the shape of a Formula 1 car, with a wedge nose. If you remember, the previous Lotus was the 49, still with a big radiator in the front with a traditional nose. That was the traditional shape of an F1 car – they were called 'cigars', and were very slim.

The 72 had the wedge nose and a thin, rear aerodynamic shape. The inboard brakes at the front and rear were a dangerous solution but it was, for sure, a milestone car.

Colin Chapman was a genius in those years, and made a very important car – in

fact, when he did the Lotus 25 and the 49, and after the 72 he did the 78 and 79, they were the most important cars in all of those years.

I have to say, that was best time of F1, and it was not difficult at all to get to see the cars very, very close.

1973-74 FERRARI 312B3

The B3 was the mother of the Ferrari 312T, which won the championship in 1975 with Niki Lauda. They changed, again, the shape of F1 at that time. There was a big delta wing in the front and the sidepods were completely different – very round, oval shape from the top, and long radiators along the side. After that, there were no more radiators under the rear wing, and all of the other competitors developed this solution.

“IT WAS PROBABLY THE BEST WORK OF MY CAREER”

It was made by Mauro Forghieri. He started a big revolution at the 1973 Austrian Grand Prix, with only one car driven by Arturo Merzario. Working with Autosport, I made a very big story on the B3 – more than 40 drawings – and it was probably the best work of my career.

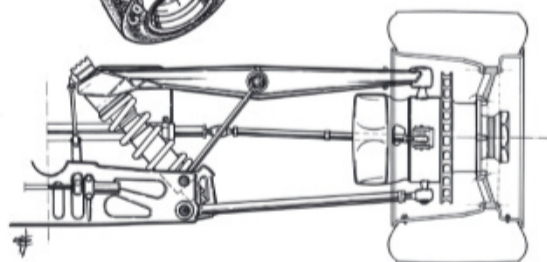
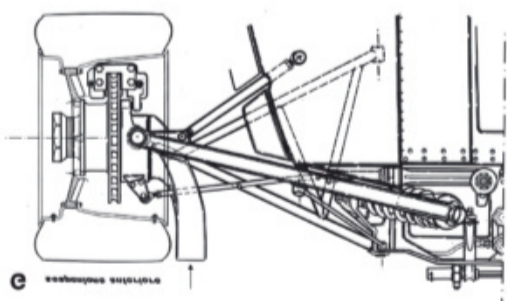
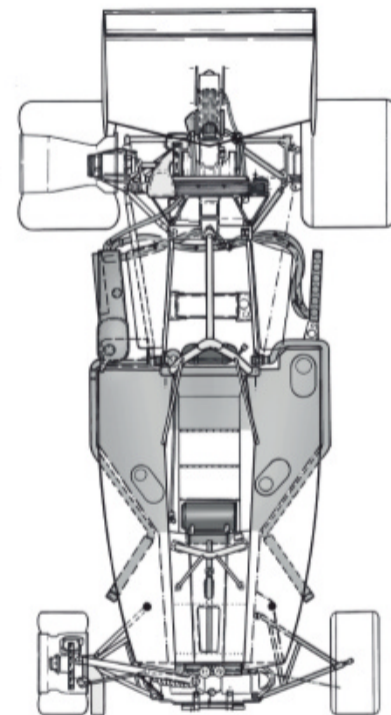
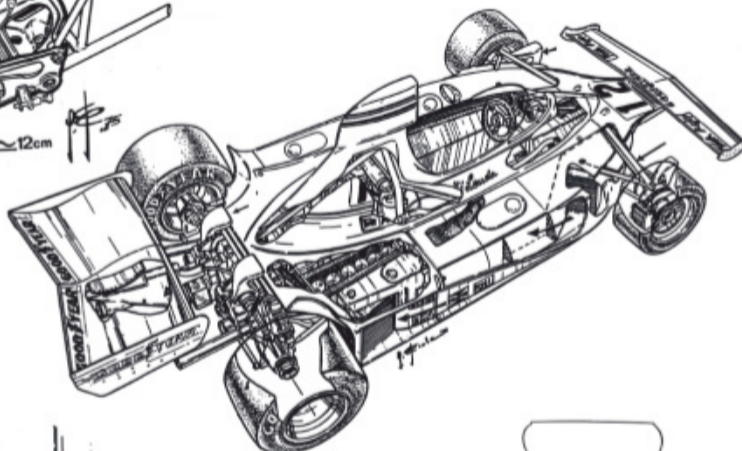
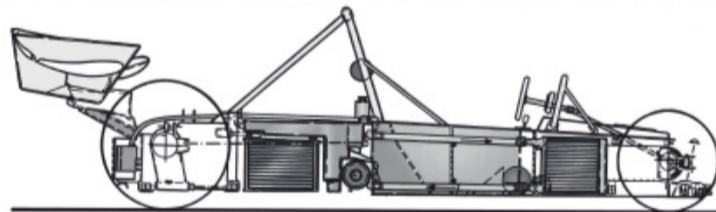
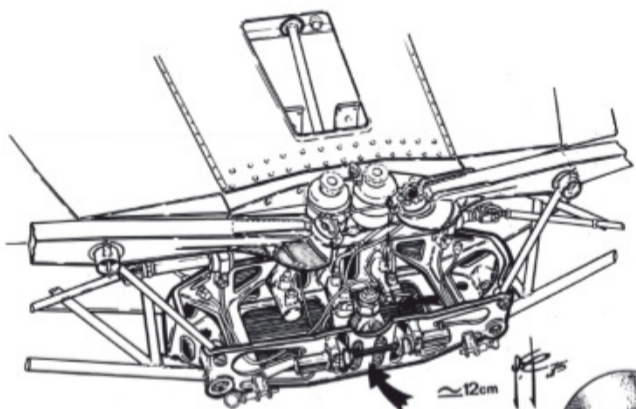
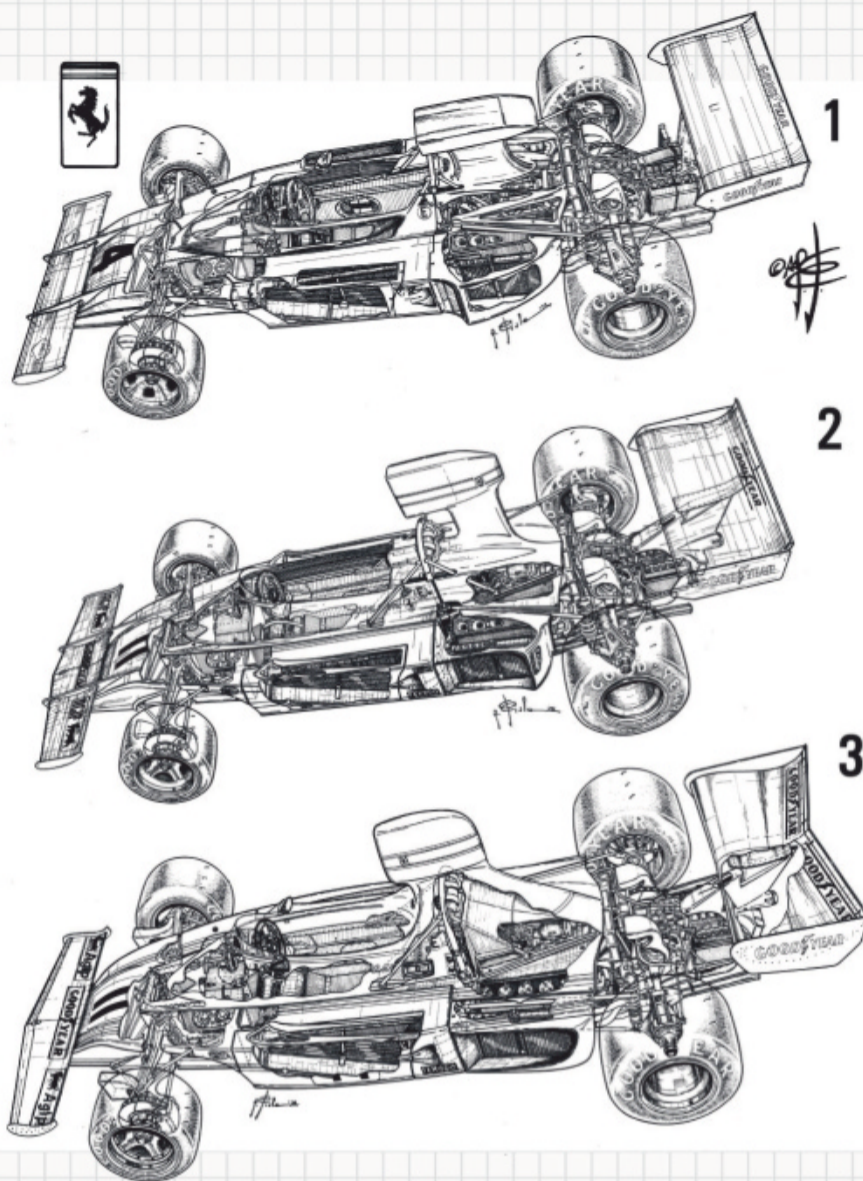

1975 FERRARI 312T / 1979 312T4

Forghieri made some fantastic cars, and the 'T' was the daughter of the B3 – the only major difference was the transverse gearbox, and it was a fantastic car. He was a big genius, for me, and must be considered in the same group as the biggest geniuses in F1.

It was an iconic car, very successful. For

the B3, I made a very big cutaway – it took 30 days of work and was very detailed – but I had to do the Ferrari 312T (above) in a hurry, maybe in three or four days! I made a table with the suspension, and it was some of my best work. But I'm not happy with the cutaway – I'd like to do it again

when I retire from going to races.

The T4 was again a championship car, and those cars – such as the Lotus 72, the Ferrari 312B3 and the McLaren MP4 – they're cars that last a long time. They don't just win for one season, and they start philosophies that last for several years.

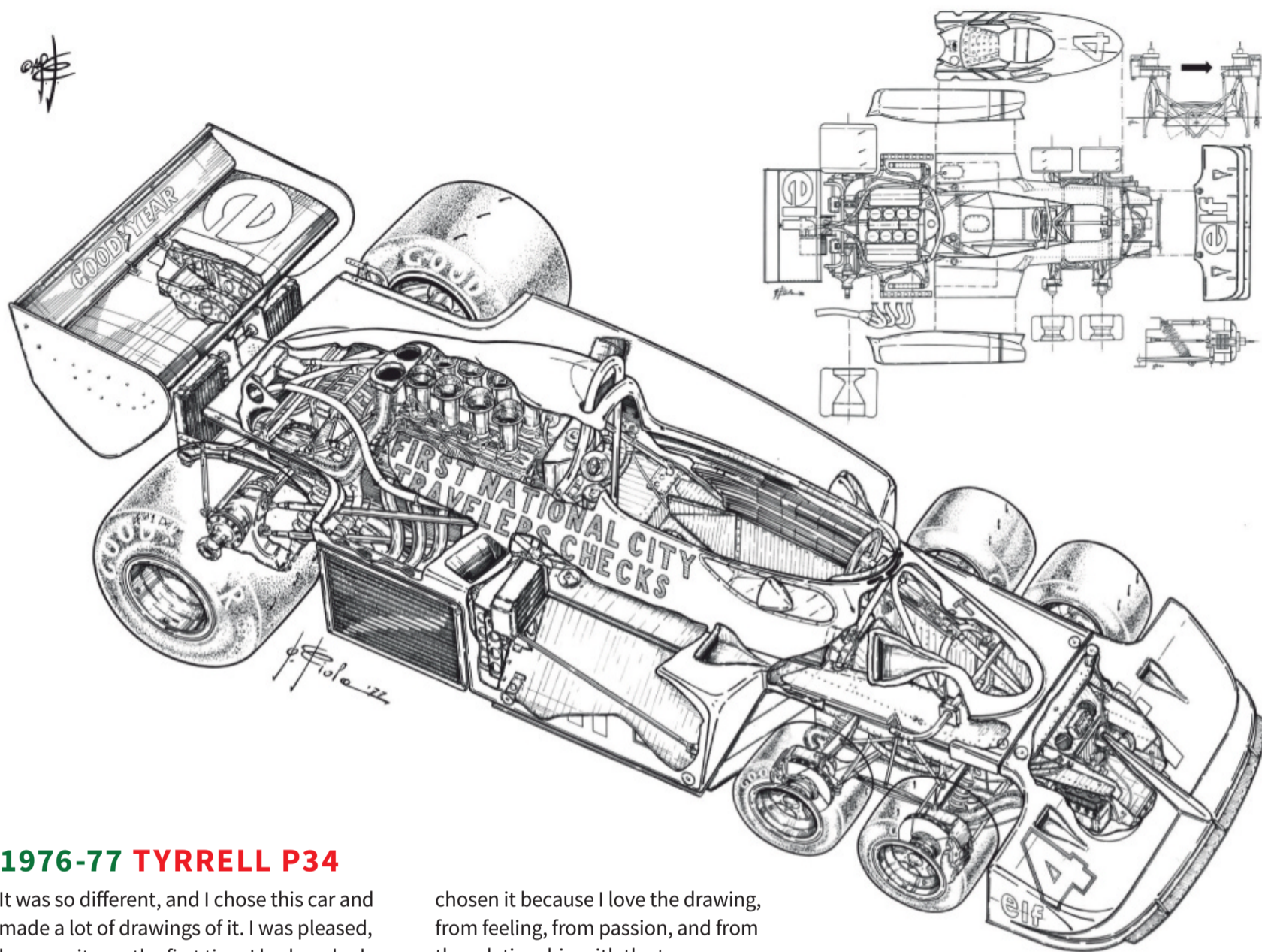

1976-77 TYRRELL P34

It was so different, and I chose this car and made a lot of drawings of it. I was pleased, because it was the first time I had worked for a team. I was sitting beside Ken Tyrrell on a flight going to Rio de Janeiro, and he asked me to do the brochure for the car.

When I did the drawings, Derek Gardner, the designer of the car, was very helpful. He was a wonderful personality. So more than the technical side of the car, I've

chosen it because I love the drawing, from feeling, from passion, and from the relationship with the team.

The biggest problem was not to do with the car. Goodyear made a big evolution with the rear tyre in 1977. It was too expensive and not very logical to build an evolution of the small front tyre. So it was handicapped by the fact that the development of the front tyre didn't match that in the back.

1977-78 LOTUS 78 / 1978-79 LOTUS 79

Everyone talks about the 79, because it was so successful – Mario Andretti and Ronnie Peterson were really playing, rather than driving, because the car was so fantastic they were using about 80% of the potential. But the Lotus 79 couldn't exist without the 78 before, which was the first one with the wing in the sidepods and had the miniskirt.

The reason why that car was creating ground-effect was because of the seal of the miniskirt to the ground. Without that, there was only a wing with no venturi effect, so the gain of downforce would be quite negligible. All the work was done to make the seal work properly.

The Williams FW07 was, I don't want to say a copy, but it followed the principle of the 79 and was built in a wonderful way. The chassis was much stiffer, the suspension was working much better, and the brakes were stronger. Because the 79's aerodynamic advantage was so big, it compensated with the lack of stiffness because the two drivers were playing. If they competed in the same year, there would be no history from the 79 because the Williams was a better car, but it was the 79 that started ground-effects.

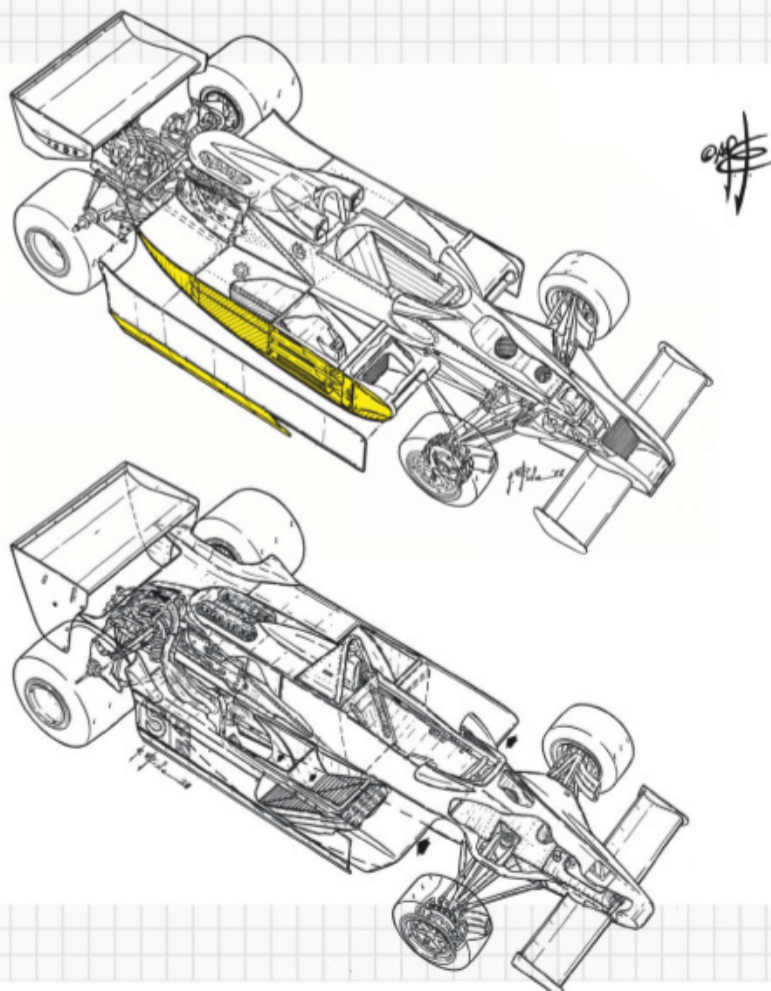

1979-80 LIGIER JS11

I picked the Ligier because it was the typical example of the interesting work that I was connected to with my technical stuff. What was the secret that the team was trying to hide? That car was particularly fast on the straights, because there was an illegal system in the sidepods – in French, they called it the 'clapet'. It was a window that under a certain pressure was opening, and allowed them to have a better straightline speed and less drag.

To cover this, the mechanics were always putting a towel on top of the radiator. I remember at Hockenheim, they were hiding so much, and I was standing there because I wanted to do the picture. They let the car go out with the towel and it overheated, so they had to stop.

At Watkins Glen, Jacques Laffite had a crash. At that time, the pitlane was down the hill and the big garage up the hill was for fabricating stuff. I went there, and thank God – I was so lucky the accident destroyed the bodywork just at the point where the 'clapet' was. So I could do the picture, and coming down the hill designer Gerard Ducarouge saw me. I made a sign with my finger to say, "OK, done", and he hated me! It's funny – he never admitted even 20 years later that the system was illegal. But they had to take it off and were immediately slower down the straight.

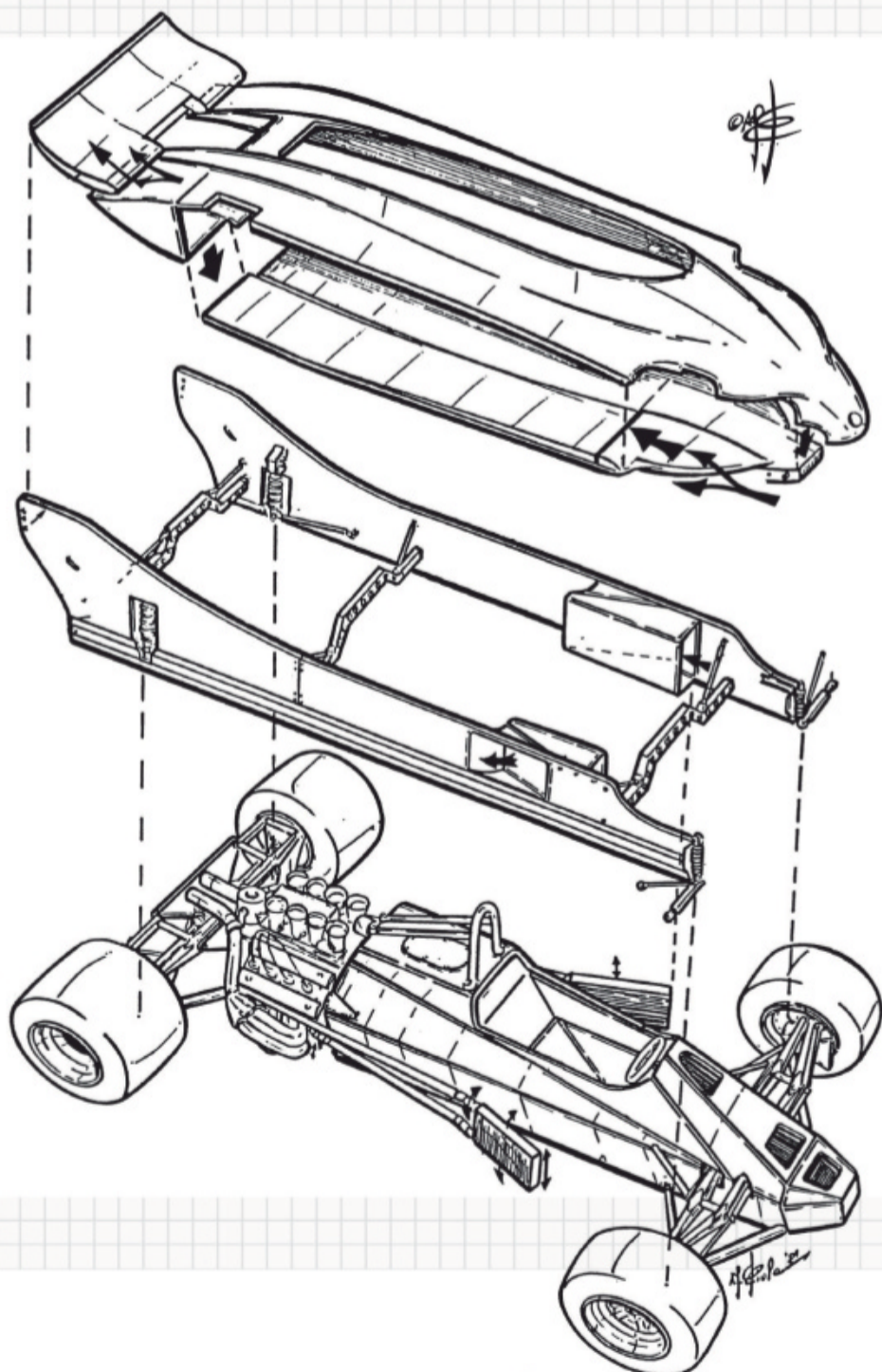
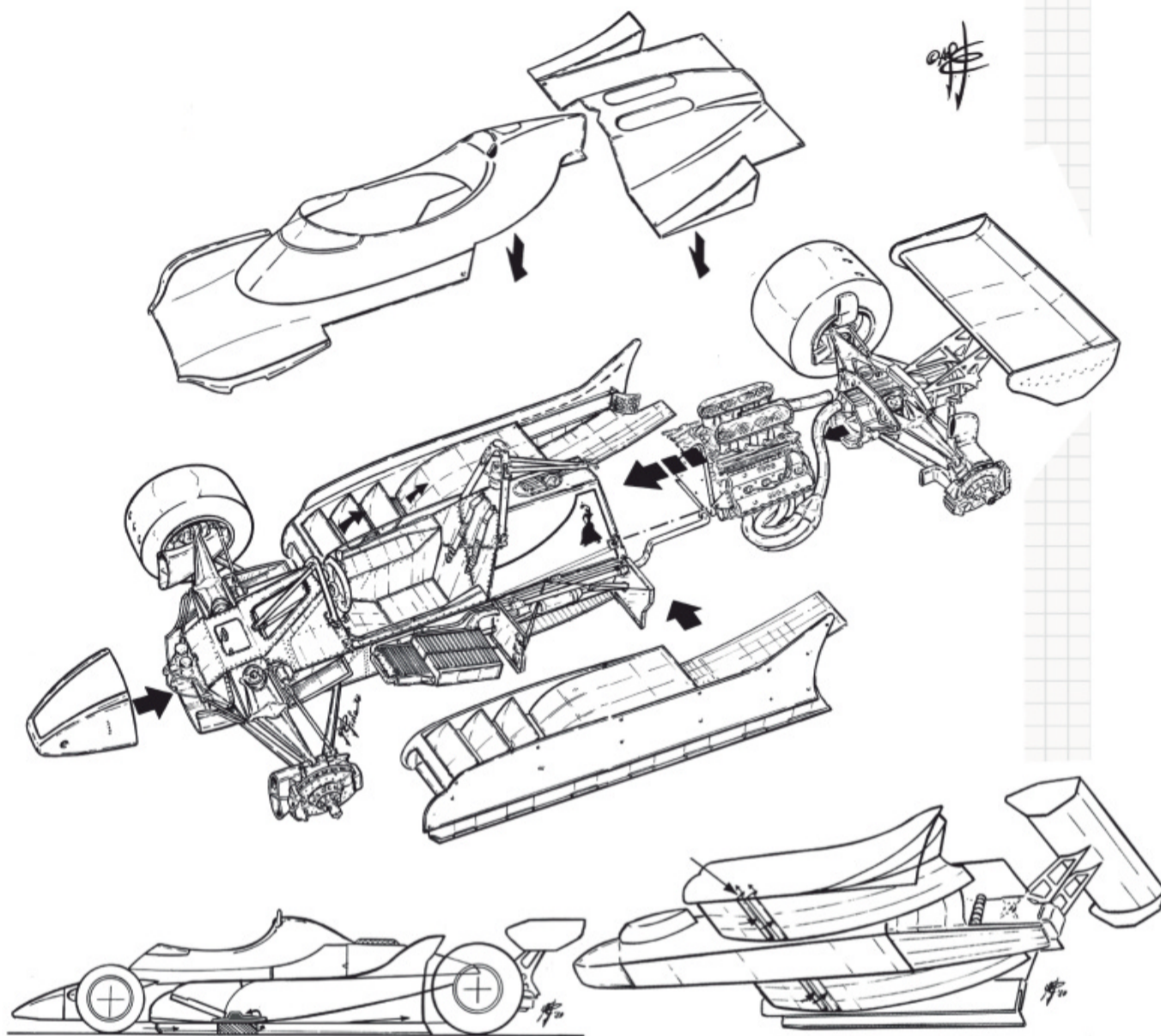

1981 LOTUS 88

Colin Chapman sometimes was able to open a new era. But sometimes he wanted to do something new, and it would be impossible. The Lotus 88 was an example of the latter. His principle and his idea was fantastic – to have two separate chassis to help the handling

“IT WAS DANGEROUS. ELIO DE ANGELIS WAS VERY HAPPY THE DAY THEY BANNED IT”

problem with the aerodynamics.

Sometimes on the 88, the downforce was massive, but sometimes the air was going inside the bodywork and creating lift. It was unpredictable, very dangerous, and I know that Elio de Angelis was very happy the day they banned it.

It happened very often that a very sophisticated car worked well in the windtunnel, but had a very narrow window and they could become unpredictable and difficult to drive.

1981-83 McLAREN MP4/1 / 1984-86 MP4/2

John Barnard was another design genius. He pushed to have all the car in carbonfibre, and his cars were often very beautiful. This technology changed the way cars were made in F1, and the MP4/1 was the mother of a series of cars that were very successful.

For example, the MP4/2 won consecutive championships with Niki Lauda and Alain Prost, with the

Porsche engine. The chassis was exactly the same as the MP4, and this concept was evolved through the years. They had the Coca-Cola-bottle shape at the rear – it was the first one, so it was a big milestone too.

Barnard gave Porsche the shape and size of what the engine should be. That level of integration between chassis and engine had never been seen before.

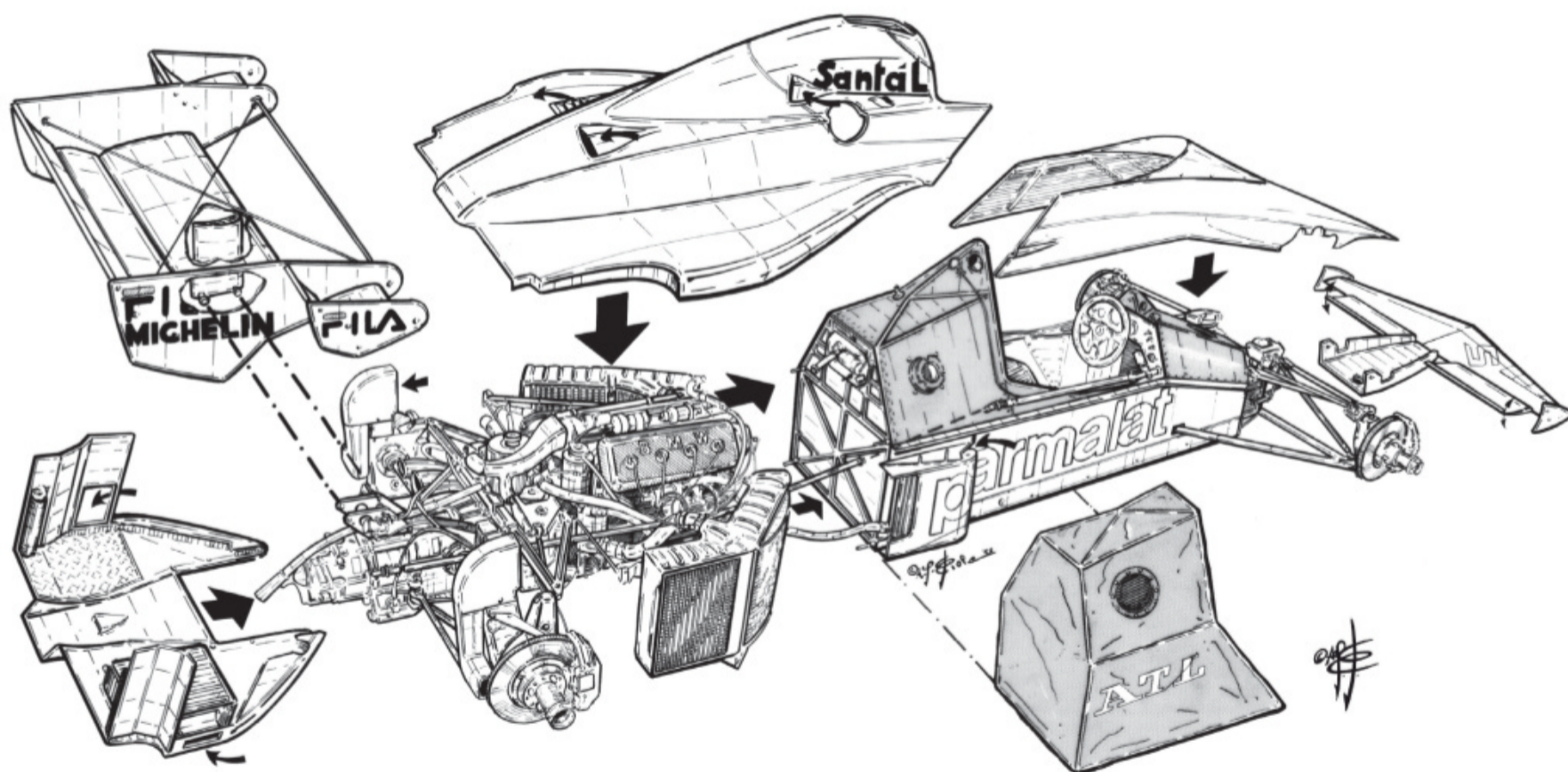
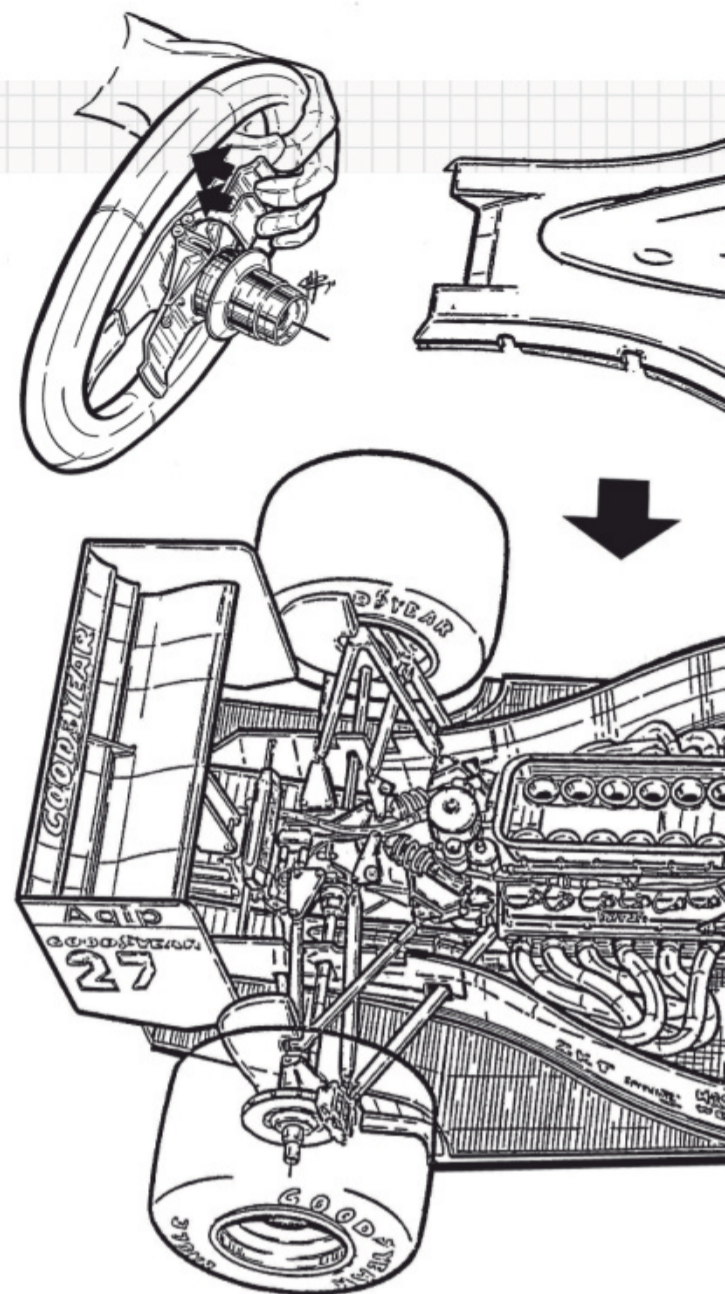
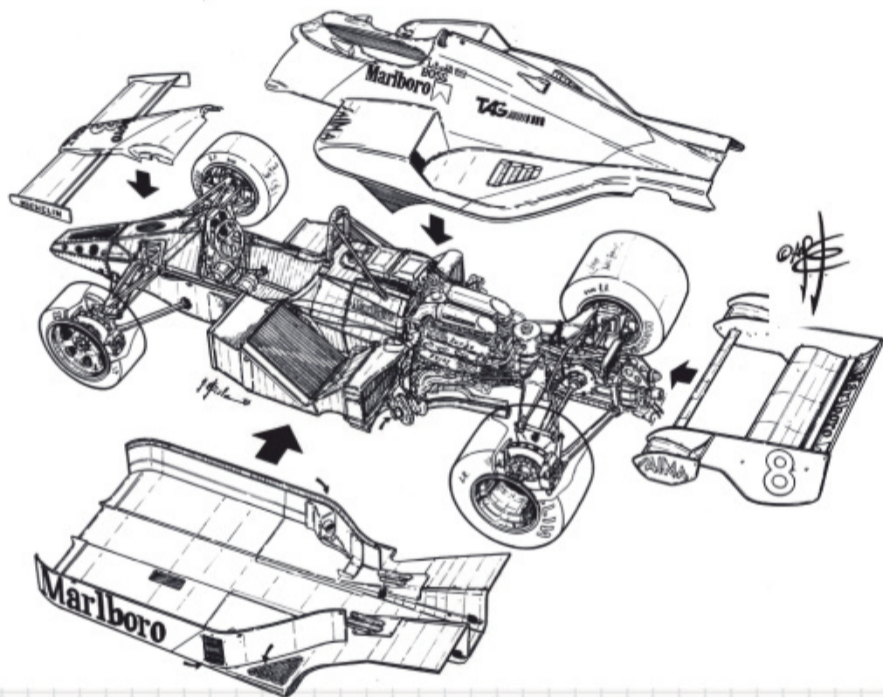

1983 BRABHAM BT52

If you talk about Gordon Murray's BT52, you also have to talk about the BT42 and the BT44 - this triangular chassis shape was distinctive to his designs. The BT52 was different from everything else, but didn't create a trend. It was just unique – narrow in the front with a big weight distribution towards the back; a big, heavy, four-cylinder BMW engine. It was the most powerful – in qualifying it had over 1000bhp.

I loved the shape – it was very beautiful. Look at all the details – Murray, like John Barnard, is very keen on detail. For example, the suspension arms were made by machined solid pieces instead of being fabricated, and were beautiful pieces. I say often that F1 pieces like that could be in a modern art museum because they are wonderful – so clean, efficient and pure, and for me they're fascinating.

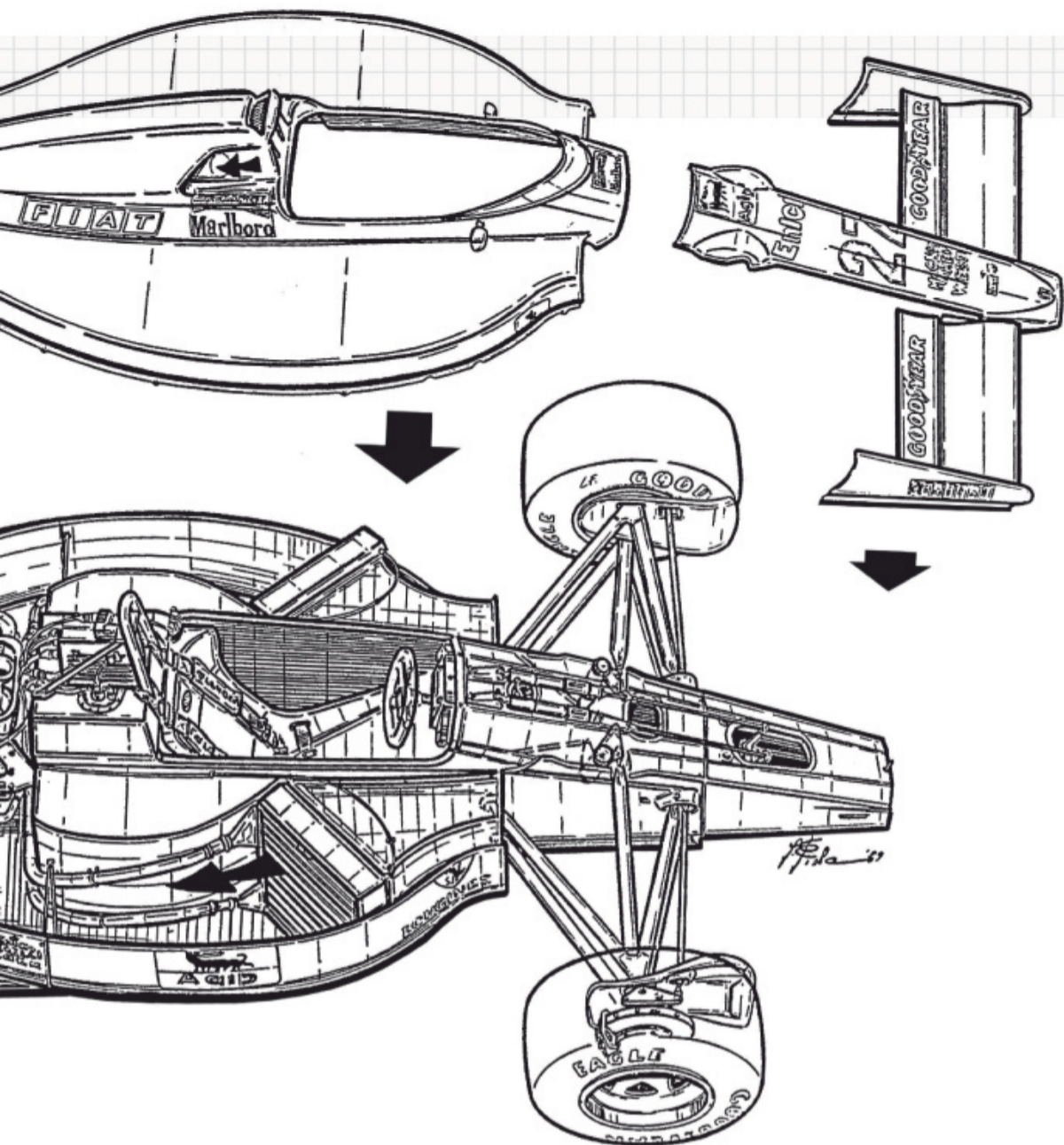

1989 FERRARI 640

The mother of the modern car. Even a city car has a paddleshift gearbox now, but at that time everyone was using a simple, longitudinal gearbox with a hydraulic actuator. I remember from a practical point of view, I liked that car, because when I made the drawing of the steering wheel with the paddle, it was published by all magazines and TV in the world. It was an easy drawing, 45 minutes in total, but the most successful!

Not only is it the mother because of the semi-automatic gearbox, but also because of the torsion-bar suspension, and the shape was completely different. John Barnard was very good, and he didn't trust the Italians and designed the chassis in a way so it was impossible to fit a gear lever!

He was right, because the car won, though nobody knows how it held together to win at the first race in 1989, in Brazil. They even changed the steering wheel during the race. It was completely unpredictable and, after that win, it was rarely reliable. The alternator was not able to charge enough of the power required by the electronic management for the gearbox. It finally became successful – Alain Prost nearly won the championship in 1990 (in the 641) – and it made a huge step forward.

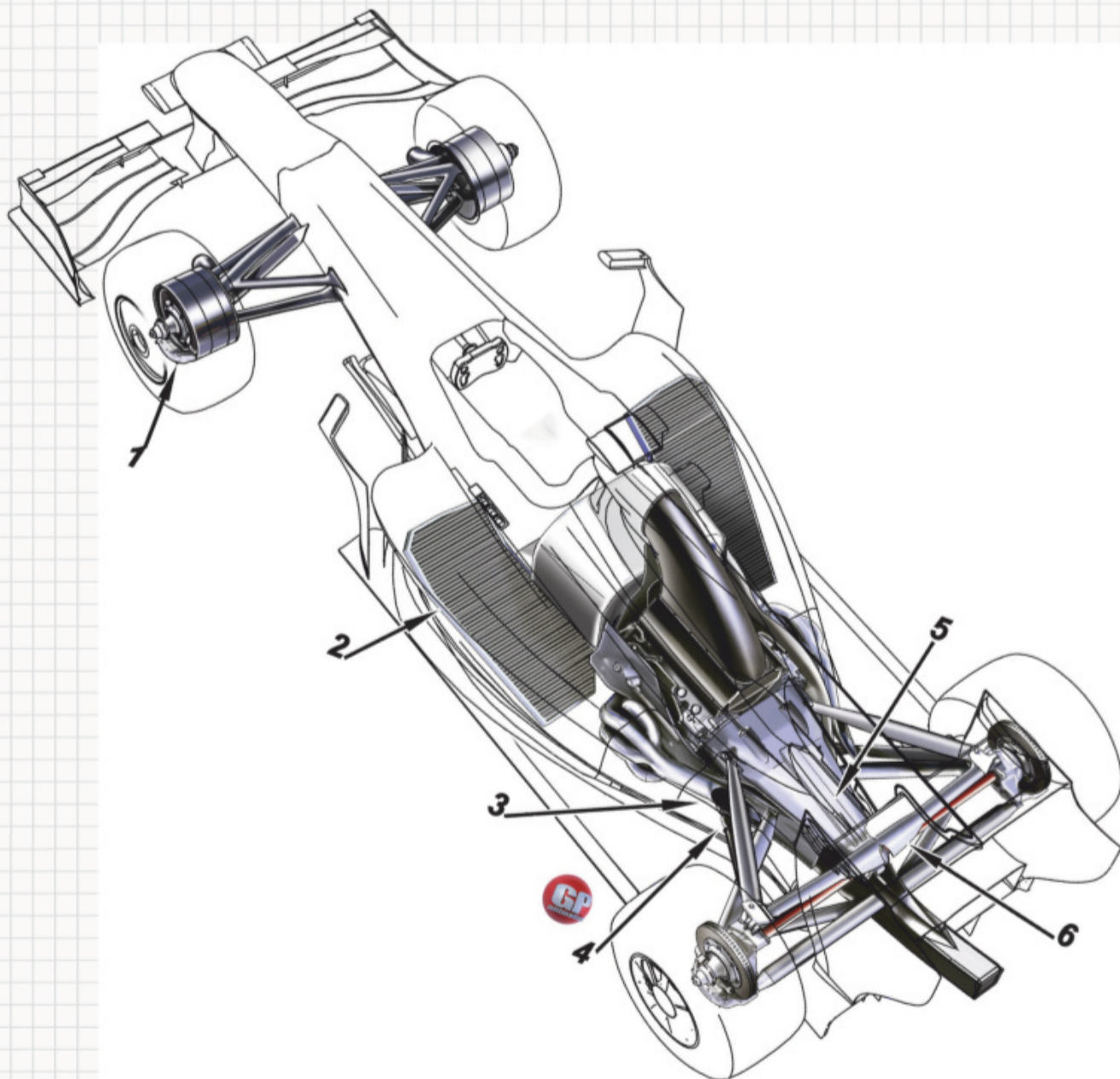

2009 RED BULL RB5

It was a car 10 years ahead of everybody. The shape was incredible. When I first saw it I was astonished. I said to designer Adrian Newey "thank you", because I had such a big emotion when I saw the car and it was completely different from everything else. What took my attention was the suspension – a pullrod with exhausts nearly blowing on the suspension arm. And nobody could believe it would be reliable!

If the Brawn GP car hadn't had the double diffuser, the RB5 would have dominated the season. Unfortunately for Red Bull, the Brawn dominated the first part, but when Red Bull put the double diffuser on there was no more history made by the Brawn. If I have to pick the car of the year, I am sorry – and I hope Ross Brawn doesn't get upset – but I'll have to pick the RB5.

Red Bull went with a completely new direction of sidepods, with less undercut in the low section, and we have to say that everybody else has tried to make a similar shape, so they're still creating another trend.

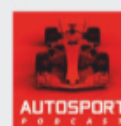

To hear more from Giorgio Piola's remarkable career go to autosport.com/podcast

RACE CENTRE

INDIANAPOLIS 500 • FORMULA E BERLIN • WORLD OF SPORT



Pagenaud's aggressive attack pays off

Simon Pagenaud took his 13th IndyCar win, and Team Penske's 18th Indy 500 triumph, in a fantastic display of strategy and determination

DAVID MALSHER

PHOTOGRAPHY  motorsport
IMAGES



LEVITT

Any lingering questions about whether the 'old' Simon Pagenaud is back have been all but dispelled by his showing over the past couple of weeks. Yes, you could argue that his finesse in the wet brought forth his best qualities in the IndyCar Grand Prix on the Indianapolis Motor Speedway road course, that it was a victory against the run of play. But his performance in the 103rd running of the Indianapolis 500 was simply impeccable, which meant that when his five or six most likely challengers all encountered various issues, they simply ran out of bullets to bring down the combined efforts of Pagenaud, his race engineer Ben Bretzman and his strategist Kyle Moyer.

Pagenaud recorded his 13th IndyCar victory, Roger Penske's 206th, Team Penske's 18th triumph in the Indy 500, and, thanks to this being a double-points race, put himself in the lead of the championship. He also became the first French winner of the race since Gaston Chevrolet in 1920, and it seems appropriate that the younger brother of marque founder Louis Chevrolet should be invoked. Chevy's power advantage proved the decisive factor in that final duel with 2016 Indy winner Alexander Rossi.

Which is to take nothing away from Pagenaud's flawless performance, nor the fact that his steady and increasingly assured decisions throughout practice turned the #22 Penske into a dayglo bullet. By contrast, team-mates Will Power and Josef Newgarden endured up-and-down performances through the practice days and qualifying and still weren't entirely happy with the handling of their cars come race day. Trying to find a set-up that kept the nose pinned so it wasn't washing out and degrading the front tyres on the turns while also not rendering the car too loose and edgy proved difficult, particularly in traffic.

Also not looking entirely convincing in practice had been Ed Carpenter >>

Racing's trio, comprising team owner Carpenter, Spencer Pigot and Ed Jones, starting 2-3-4. They were super-fast in clean air, hence their qualifying pace, but appeared to struggle to make passes in traffic, without the full cooperation of the driver being overtaken.

The car that did look extremely (relatively speaking) comfortable to drive was the Honda-powered Andretti Autosport machine of Rossi – although even he seemed to lose his mojo in Monday post-qualifying practice – before regaining his confidence in Carb Day's 90-minute session. Most days, he was the driver who could run closest to the car in front, faithfully tracking very close through the corner, and then slingshot out of the draft and pass down the next straight. He cautiously murmured that the team thought they had “found something”.

He continued: “Who knows what kind of race we're going to have though, right? It's Indiana, it's May, the forecast looks pretty bad... The race could get broken up by weather, it could be ending early once we've gone past halfway and they can call the race. The one thing we know – or think we know – is that it's going to be pretty warm.”

Thankfully for all concerned, it was a warm day but not boiling or sun-scorched and, despite gloomy predictions as late as 10am on race day morning, the race that started at 12.45pm would run uninterrupted. Well, uninterrupted by weather, that is.

The Honda cars' high card was going to be the fact that the HPD unit is easier on fuel, allowing its drivers to either run a little richer to help reduce the power deficit to Chevrolet, or in one notable and extreme case – Scott Dixon of Chip Ganassi Racing – to run fully lean the majority of the way and perhaps even eliminate the need for a sixth fuel stop.

That was not going to be an option for a Chevrolet runner, and so Pagnaud and his



engineers had a quandary how to tackle the race – run up front and exacerbate their fuel consumption issues, and make a late splash-and-dash seventh stop – or drop back behind another car or two and save fuel in the draft? They went for the former option.

“Today was about attacking,” explained the winner. “We had our strategy meeting this morning, and we decided we were going to attack, we were going to control the day, and we were going to take our fate in our

own hands. Destiny is what we decided to control. It was pretty cool. Obviously everything played for us really well. The stars, like I've been saying, have aligned this month, incredibly, but especially today.”

The decision to make a late splash and dash is always easier knowing that the Penske crews are at least a match for – usually superior to – any of their rivals, but it was going to leave Pagnaud having to slice his way past several cars. That was something he hadn't needed to do, having dominated the first three quarters of the race, so he wasn't certain how his car would behave in dirty air. Even then he had a contingency plan that had a double effect. On lap 151, after slowing the pace to around 217mph in order to save fuel and get back inside the same fuel window as his opposition, Pagnaud let team-mate Josef Newgarden ahead of him and sat in his draft to improve his fuel mileage and also learn how his car handled in disturbed air.

“Obviously I led most of the race, so I didn't have – except when I was passing back markers – big knowledge of my car in traffic,” he commented. “We ran so much up front we didn't save enough fuel. When I let Josef by the car was phenomenal, and it was really easy to follow. So we had adjusted the car really well during the race.

“Kyle and Ben were giving me the perfect information. I think we had the perfect amount of downforce on the car, all the



Fighting to the end:
Pagnaud and Rossi
after the final green flag

LEPAGE



right decisions were made. The car was just fantastic, and I realised that I could run second as long as I wanted and pass people when I wanted.”

Pagenaud zipped past his team-mate down the back straight on lap 167 before turning left and into the pits off Turn 4 for what he could only pray would be the final time. Shortly after, however, Moyer was warning his driver that he was using too much fuel to make it to the end.

By contrast Rossi, who stopped on lap 169, was told by his strategist and Andretti Autosport COO Rob Edwards that he could go flat out to the finish.

Rossi, who had started ninth, had been scintillatingly brave throughout the race, pulling off great passes on the inside and outside of drivers at Turn 1 and Turn 3. Rossi is a cool customer – more befitting of the ‘Iceman’ image than Dixon – but he looked frantic on lap 137 when, during a pitstop, some of the gains he had bravely made on track disappeared in the haze of a refueling stop that went wrong, the hose not locking into the buckeye. On this occasion, the damage was somewhat restricted by a caution period: Marcus Ericsson, who had enjoyed a near exemplary oval racing debut and had been running in the top 10, locked his brakes and spun as he braked hard to get down to the pitlane speed limit and wound up stalled and broadside. Race director Kyle Novak had no option >>

RAHAL SLAMS BOURDAIS FOR INDY SHUNT



Graham Rahal was left furious with Sebastien Bourdais after their collision on lap 177 of the 200 caused a five-car wreck that brought out the red flags in the Indianapolis 500.

The pair were fighting for eighth place when the Rahal Letterman Lanigan driver drafted the Frenchman’s Dale Coyne Racing with Vasser-Sullivan machine and started drawing alongside on the back straight.

Bourdais squeezed his rival towards the grass on the inside as they approached Turn 3, so that the rear of Bourdais’ left sidepod and front of his left-rear tyre made contact with Rahal’s front-right tyre,

“HE DROVE INTO ME. YOU JUST DON’T DO THAT ON AN OVAL. HE’S ALWAYS THE ONE WHO WANTS TO GET UPSET ABOUT BLOCKING”



knocking him toward the grass, pivoting the RLLR machine... but not before its nose made secondary light contact with the DCR car.

That, combined with Bourdais having compromised his line into Turn 3 so that he now had to add more steering lock, was enough to also spin the Coyne car into the wall. The subsequent melee wrecked Zach Veach, Charlie Kimball and Felix Rosenqvist, and damaged the car of Scott Dixon.

Bourdais’ explanation – “I didn’t think he had as much of the car as he did inside” – cut no ice with Rahal.

“He drove into me,” Rahal told Autosport while standing alongside Robert Wickens, who is still recuperating after a shunt at over 200mph at Pocono Raceway last August. “I was on the inside and he turned into me and created contact. It’s dangerous. You just don’t do that, especially on an oval, particularly if someone is that far alongside you. But he obviously doesn’t care, doesn’t get it.

“But it’s a surprise from him because [in driver meetings] he’s always the one who wants to get upset about things like that and make a scene about blocking. But that was beyond blocking; that was driving into somebody.”

Bourdais was issued with a 30-second penalty for avoidable contact, moving him down to 30th in the finishing order – last of the five cars that were wrecked.

“Big deal,” shrugged Rahal. “That doesn’t change anything for me or the rest of the guys whose day he ended, does it?”

but to throw the yellow.

That slowed everyone down, so Rossi's pit troubles cost him 'only' two spots, to Newgarden whom he had worked so hard to pass, and the Dale Coyne Racing with Vasser-Sullivan car of Sebastien Bourdais.

But Rossi's troubles weren't over. The atypically obstructive and lapped Oriol Servia had his Team Stange Racing with Arrow SPM car in the top-six mix on the lap 148 restart, and baulked Rossi so badly that it not only halted the Andretti driver's run on Bourdais, but also forced him to cede position to one-off team-mate Conor Daly. A furious Rossi had the wherewithal and car control to shake his fist at Servia as they pitched into Turn 1, and then he wasted little time in regaining lost ground. On lap 158 he was past Bourdais, on lap 162 he was ahead of Daly; as through the majority of practice, he had the handling to carry extraordinary momentum through the turns. He also nailed his out-lap following his green light from Edwards to go flat out, and easily swept around and past Newgarden, who had stopped two laps later.

Rossi was onto the fuel-wary Pagnaud within two laps and Simon put up little resistance as Rossi swept past, as drafting the Andretti car would further aid his fuel mileage. Pigot was leading when the yellows came on for the big crash (see page 51) that would become a red flag that saw the surviving cars head down pitlane and switch off, but the ECR driver was yet to stop; Rossi was the man in control... theoretically.

The stoppage was only 18 minutes, but there were then six more laps of yellow as the backmarkers at the front of the field got the wavearound to the back of the pack, and with each passing caution lap, Pagnaud's fuel worries eased, and Rossi's advantage was neutralised. It was a straight-up fight, and Pagnaud had the decided edge.

At the wave of the green, a push of Chevy power took the Penske car past the Andretti-Honda by Turn 1, but somehow Rossi got back past the following



Sato blitzed his way from 14th to third

lap. On lap 189, the Frenchman returned the favour and, for the next eight laps, Rossi applied pressure but could only jink around in the leader's mirrors rather than make a serious attempt at a pass.

Exiting Turn 4 on lap 197, Rossi had enough momentum on Pagnaud to draft past and take the lead into Turn 1, but the following lap, down to Turn 3, Pagnaud retaliated again. While Rossi tried everything to retaliate on the final lap, he simply didn't have the juice to earn the milk, and Pagnaud crossed the

line 0.2086 seconds ahead.

Third went to RLLR's Takuma Sato who, thanks to an early electrical issue, ran a lap down for most of the race, but who got back onto the lead lap during the caution period just before half-distance, and then simply charged forward at the two remaining restarts, and zapped Newgarden around the outside of Turn 1 on lap 191.

Pagnaud's strongest might-have-been opponents were all knobbed by circumstances. Ed Carpenter was prominent all day, but his handling tailed off in the final



Multi-car crash ruined Dixon's fuel strategy



RESULTS ROUND 6/16, INDIANAPOLIS (USA), 26 MAY (200 LAPS – 500.000 MILES)

POS	DRIVER	TEAM/CAR	TIME	GRID
1	Simon Pagenaud (FRA)	Team Penske / Dallara-Chevrolet	2h50m39.2797s	1
2	Alexander Rossi (USA)	Andretti Autosport / Dallara-Honda	+0.2086s	9
3	Takuma Sato (JPN)	Rahal Letterman Lanigan Racing / Dallara-Honda	+0.3413s	14
4	Josef Newgarden (USA)	Team Penske / Dallara-Chevrolet	+0.8979s	8
5	Will Power (AUS)	Team Penske / Dallara-Chevrolet	+1.6173s	6
6	Ed Carpenter (USA)	Ed Carpenter Racing / Dallara-Chevrolet	+1.9790s	2
7	Santino Ferrucci (USA)	Dale Coyne Racing / Dallara-Honda	+2.8055s	23
8	Ryan Hunter-Reay (USA)	Andretti Autosport / Dallara-Honda	+4.0198s	22
9	Tony Kanaan (BRA)	AJ Foyt Enterprises / Dallara-Chevrolet	+4.7708s	16
10	Conor Daly (USA)	Andretti Autosport / Dallara-Honda	+5.3459s	11
11	James Hinchcliffe (CAN)	Arrow Schmidt Peterson Motorsports / Dallara-Honda	+5.4821s	32
12	James Davison (AUS)	Dale Coyne Racing with Byrd and Belardi / Dallara-Honda	+6.2250s	15
13	Ed Jones (GBR)	Ed Carpenter Racing / Dallara-Chevrolet	+7.5500s	4
14	Spencer Pigot (USA)	Ed Carpenter Racing / Dallara-Chevrolet	+8.5566s	3
15	Matheus Leist (BRA)	AJ Foyt Enterprises / Dallara-Chevrolet	+10.4153s	24
16	Pippa Mann (GBR)	Clauson-Marshall Racing / Dallara-Chevrolet	+12.9803s	30
17	Scott Dixon (NZL)	Chip Ganassi Racing / Dallara-Honda	+14.7595s	18
18	Helio Castroneves (BRA)	Team Penske / Dallara-Chevrolet	-1 lap	12
19	Sage Karam (USA)	Dreyer & Reinbold Racing / Dallara-Chevrolet	-1 lap	31
20	J.R. Hildebrand (USA)	Dreyer & Reinbold Racing / Dallara-Chevrolet	-1 lap	21
21	Jack Harvey (GBR)	Meyer Shank Racing with Arrow SPM / Dallara-Honda	-1 lap	25
22	Oriol Servia (ESP)	Team Stange Racing with Arrow Schmidt Peterson / Dallara-Honda	-1 lap	19
23	Marcus Ericsson (SWE)	Arrow Schmidt Peterson Motorsports / Dallara-Honda	-2 laps	13
24	Jordan King (GBR)	Rahal Letterman Lanigan Racing / Dallara-Honda	-2 laps	26
25	Charlie Kimball (USA)	Carlin / Dallara-Chevrolet	-4 laps	20
26	Marco Andretti (USA)	Andretti Herta Autosport with Marco & Curb-Agajanian / Dallara-Honda	-5 laps	10
27	Graham Rahal (USA)	Rahal Letterman Lanigan Racing / Dallara-Honda	176 laps-accident	17
28	Felix Rosenqvist (SWE)	Chip Ganassi Racing / Dallara-Honda	176 laps-accident	29
29	Zach Veach (USA)	Andretti Autosport / Dallara-Honda	176 laps-accident	28
30	Sebastien Bourdais (FRA)	Dale Coyne Racing with Vasser-Sullivan / Dallara-Honda	176 laps-accident	7
31	Kyle Kaiser (USA)	Juncos Racing / Dallara-Chevrolet	71 laps-accident	33
32	Ben Hanley (GBR)	DragonSpeed / Dallara-Chevrolet	54 laps-mechanical	27
33	Colton Herta (USA)	Harding Steinbrenner Racing / Dallara-Honda	3 laps-mechanical	5

Winner's average speed 175.794mph. **Fastest lap** Dixon 39.8220s, 226.006mph.

CHAMPIONSHIP

1 Pagenaud 250; 2 Newgarden 249; 3 Rossi 228; 4 Sato 203; 5 Dixon 203; 6 Power 184; 7 Hunter-Reay 157; 8 Hinchcliffe 145; 9 Pigot 133; 10 Ferrucci 129.

quarter of the race, and he drifted back to sixth, passed on lap 196 by defending race winner Will Power. The #12 Penske had charged from sixth into third at the start, then demoted Carpenter for second on lap 11, and then sat contentedly in Pagenaud's wake. However, at his second stop, he slid slightly long, and refueller Quinton Washington sidestepped and stumbled making it look like Power had hit a member of his personnel. Race Control made him restart from the back of the field, and he spent two stints stuck in the lower reaches of the top 20. However, following the race stoppage he moved up from ninth to fifth, left to rue what might have been.

Dixon felt the same way. "We kept extending our pit windows, I think we were probably going to eliminate a stop, which was going to put us in a great position. And then that yellow flag just hosed us."

Pagenaud was perfect, each of his best rivals had something awry, they paid dearly, he won deservedly. 🏆

NEXT REPORT

DETROIT GRAND PRIX
6 JUNE ISSUE

Can Pagenaud triumph again at the very different street track double-header?

How di Grassi triumphed at Formula E's playground track

The open expanses of the disused Tempelhof Airport are like a blank canvas for FE, and it should consider a refresh to shake up the Berlin order

ALEX KALINAUCKAS

PHOTOGRAPHY  motorsport
IMAGES





RACE CENTRE FORMULA E BERLIN

There was a very familiar feel to the ABB FIA Formula E round in Berlin last weekend. The German capital has hosted a race in each of the championship's first five seasons, with the disused Tempelhof Airport staging four of those events. But the venue was not the sole element that felt similar to last year's race – the main protagonists were largely the same as well.

Last year, Daniel Abt gave Audi a memorable victory, leading his team-mate Lucas di Grassi to the manufacturer's first FE 1-2, which came on home ground in Audi's first season as a works FE entrant. This year, it was di Grassi who secured the win – one that led to BMW's head of brands and marketing, Jens Thiemer, handing the winning constructor's trophy to Audi motorsport boss Dieter Gass, as the Munich marque was the race's title sponsor.

Behind di Grassi came Sebastien Buemi and Jean-Eric Vergne – the duo that had fought a tight scrap at Tempelhof in 2018 that ended with Vergne following the Audi drivers home. He took third in 2019, but had a similar battling drive to the podium.

Tempelhof is something of a playground for FE. As the track is located on the vast concrete apron that juts out from the even larger, fascist-era-designed terminal building, it is not a 'traditional' circuit for the electric championship. There are no buildings to wind around – setting up typical strings of 90-degree turns – and is also wide throughout its 1.4-mile course.

The original layout for the race – used just a single time in FE's inaugural season – came much closer to the terminal, was nearly 100 metres longer and had seven more corners. When the series returned to Tempelhof following a one-year hiatus in season two – a result of the venue being used to house refugees and the event subsequently moving to a street-course near Berlin's Alexanderplatz square – the current layout was adopted. The E-Village fan area now resides in the terminal area,



which, as well as being larger and featuring impressive stands showcasing the technology of FE's current and future manufacturers, was joined for 2019 by 2016 Formula 1 world champion Nico Rosberg's Greentech Festival. The day after the event, FE also used the circuit for media demo runs – and Mercedes held a charity track run in the hours after this year's race. The timetable for the 2019 event was also a new one for the series, with practice sessions on Friday, followed by qualifying on Saturday morning with the race at 1300hrs – all to avoid a clash with the build-up to the German football cup final, which also took place in Berlin last Saturday (and was won 3-0 by Bayern Munich over RB Leipzig).

The current layout was designed around a large tent that FE used to house its Emotion club hospitality area. Previously, the track travelled through the tent in a tunnelled

stretch, which brought the cars close to the championship's guests and created a unique element for watching on TV. But the tent was owned by Tempelhof and when the venue decided to get rid of it, FE moved its hospitality – positioning it above the pits – while keeping the track layout the same.

All of this serves to highlight the uniqueness of the Tempelhof track. So, with no buildings to bother with, why not change the layout every year to keep the teams and drivers on their toes? Audi, after all, has now dominated the two most recent races – so why not introduce a new track to challenge its home-soil supremacy? The race winner is not against it.

"I'm totally in favour, as far as the layout is exciting," said di Grassi. "I was saying during my track walk – 'If I was supposed to design a track like this with all this open space, I would have designed a very different track'. [I'd have made it] much more crazy, much more technically interesting.

"So yes, we could come up with a new track every time. It would just cost more for simulator work – because you'd have to redo it every time – but otherwise it could be very interesting."

In addition to the added cost, the reason why FE itself isn't in favour of changing the track for each Berlin E-Prix is because it is trying to build the race's 'equity' factor. By keeping the same layout, a similar date and position on the calendar, it aims to build recognition with fans – along the lines of famous F1 venues, such as Monaco, Suzuka and Monza. The same layout also showcases the electric technology advances the teams are making – and the fastest lap time (set at 1m07.295s in superpole by Buemi) was better by 2.143 seconds than last year's.



FE wants to retain the layout for fan familiarity

SBLOXHAM



Wide open Tempelhof gives FE the chance to fiddle with the layout each season

Those are very sensible reasons why the track hasn't changed in the last three years. But if FE fancied getting experimental – a joker corner for attack mode could easily be fitted in – for next year's race, its Tempelhof playground is the place to do it.

The timetable change had somewhat split the drivers ahead of the on-track action getting underway. Di Grassi, in particular, was concerned by the lack of running – not even a Jaguar I-PACE eTrophy session – between the end of FP2 on Friday and qualifying on Saturday. His gripe related to the group one runners – and championship leaders – effectively sweeping the track.

In the end, di Grassi was the only group one runner to make it through to superpole, something that left him “very surprised”. He lined up third on the grid, behind polesitter Buemi and HWA's Stoffel Vandoorne. But, after a quiet opening phase, di Grassi began his rise up the order.

In very similar fashion to FE races in late 2018 – where Audi showed off the efficiency advantage its package had last season – he caught and passed his prey with relative ease. Vandoorne was dispatched at the obtuse-angle left-hander of Turn 6 on lap three of what would be a 37-lap race, with Buemi passed in the same way three laps later. From there, di Grassi marched clear – opening a significant lead as his rivals fought each other in his wake.

A full course yellow interruption – caused by Alex Lynn stopping on the pitstraight as a result of his rear axle locking, ending what had been an impressive weekend performance from the Briton – with a third of the race remaining was negotiated with ease. Di Grassi came home 1.856s clear to win for the second >>

JAGUAR I-PACE ETROPHY



The early stages of the first Jaguar I-PACE eTrophy season looked to have set up the Rahal Letterman Lanigan Racing squad for an intra-team title battle between Katherine Legge and Bryan Sellers.

But with two races left, the momentum is firmly with Jaguar Brazil Racing, as Sergio Jimenez tops the standings after finishing second behind team-mate Caca Bueno in Berlin.

RLLR had a disappointing time last weekend. It began with Legge being unable to put together a clean lap in qualifying, ending up inside the Pro-Am field in eighth, with Sellers lining up behind the two Jaguar Brazil drivers and Simon Evans.

With RLLR on the back foot, Jaguar Brazil seized the initiative with polesitter Bueno leading every lap on his way to victory. Jimenez mounted several attacks and came closest to taking the lead when he dived around Bueno at the Turn 9 hairpin late-on. But Bueno cruised across

the line to win by half a second and take back-to-back wins.

“This was one of the toughest races we've had this season,” he said. “I had good pace throughout, but the wide circuit offered opportunities to overtake, meaning I had to hold off Sergio.”

Jimenez now heads to New York with a six-point lead over Sellers, who could only muster fourth place after failing to pass Evans in the early laps.

Adam Carroll replaced Stefan Radzinski at the TWR Techeetah team for Berlin and managed a solid fifth place following a spectacular four-wheel drift around the Turn 1 bend that allowed Sellers by into fourth. It is unclear if Carroll will return for the New York finale.

Legge took sixth despite tipping Pro-Am title leader Bandar Alesayi into a spin.

Alesayi's Pro-Am title rival Yaqi Zhang took his third class win of the campaign once he cleared a battle with Celia Martin.

TOM ERRINGTON



Back-to-back wins for Bueno only takes him to third in the points

IN THE HEADLINES

HOT BATTERY HALTS CHARGE

Andre Lotterer endured a difficult race day. He just missed the cut to start a 250kW flying lap in qualifying, which left him 21st on the grid. In the race, he charged to 11th, but climbing battery temperatures – caused by an improper connection in his car’s battery cooling circuit – forced him to retire.

LYNN’S LOCKED AXLE

Alex Lynn retired after a locked axle left him stranded on the pitstraight. “We lost a lot of coolant [before that],” he later explained. It had been a strong drive from the Jaguar racer – although he did receive a warning for a clash with Gary Paffett at the Turn 9 hairpin.

HWA THROWS PUNCHES

Both HWA drivers shone in qualifying, with Paffett taking fourth on the grid and Stoffel Vandoorne second. Both fell away in the race, with Paffett finishing 16th after getting edged along the wall on the outside of Turn 9 by Lynn, which he suspected cost him performance. Vandoorne ended up fifth but was still pleased to “fight with the big boys”.

PENALTY-FREE FORMULA E

Remarkably, given the number dished out at the other races so far this season, there were no penalties or reprimands issued in Berlin. The only investigation involved Audi’s Daniel Abt, with a team member suspected of working on his car after the five-minute pre-qualifying cut off had passed. Abt escaped sanction as the car was not touched.

DOUBLE SCORING BMW

Alexander Sims (below) returned to the points for the first time in seven races with seventh in Berlin for BMW Andretti. He made superpole for the third time this season, but had to drop five thanks to his grid penalty earned for a clash with di Grassi in Monaco. He climbed well from 11th at the start, and helped to give BMW its first double points finish of the season as a result.



SBLOXHAM



Buemi was back on the podium, but the next round marks two years since his last FE triumph

time during the 2018/19 campaign.

Behind him came Buemi. After losing the lead to di Grassi, his main competition for second place came from BMW Andretti’s Antonio Felix da Costa – whose aggressive approach and opportunity-seizing use of his first attack mode (he was the first of the leaders to activate the system) had helped him climb from seventh on the grid.

When Buemi took his first attack mode on lap 19 he fell behind da Costa, who had, at the same moment, made a lunge at the Turn 6 left-hander. Buemi could not make his higher power mode pay, but did deploy his fanboost activation – a largely forgotten tactical factor this season due to attack mode’s effectiveness – to get alongside da Costa at the near-circular Turn 1 on lap 24. Buemi edged da Costa wider as the corner went on, with the pair making contact on the approach to Turn 2, sealing the position.

The end result gave Buemi his first podium of the season, but confirms that two whole calendar years will have passed since his last FE win by the time of the Bern race.

Vergne’s race was the most swashbuckling. From eighth on the grid, he put in a series of passes to clinch the final podium place. Turn 6 was his favourite spot to force a move, and a late dive to the inside was his method. Lynn, Abt, and da Costa were his main victims, with the last pass featuring a bump between the cars at the apex. The DS Techeetah driver was pleased with his progress from lowly practice positions, but slightly frustrated about the FCY as he felt it cost him an energy advantage that he had built in the initial phase of the race.

“It was the maximum achieved today, and I like to leave the track knowing I got the best result possible,” he reflected later after extending his championship lead to six points, now over di Grassi.

Da Costa came home fourth, probably deserving more for his efforts, ahead of Vandoorne and Abt, who could not repeat his win from 2018, which he felt was a result of starting in the pack.

The wider, purpose-built nature of the



Lynn and Paffett came to blows at Turn 9

STALEY



Vergne hauled himself onto the podium and holds a six-point lead over di Grassi

Tempelhof track suggested this would be a rare occasion where the powertrain package pecking order of 2018/19 would be seen. Indeed, Audi, Nissan, DS and BMW (not necessarily in that order) are clearly among the frontrunners, but the FCY turned the race from an energy efficiency test into a flatout run to the flag. It also led to all the leaders taking their second attack mode activation while the race was neutralised, removing the chance of final strategy divergence. Plus, as di Grassi pointed out afterwards, just one driver from each team finished in the top five positions – so no clear powertrain pattern emerged in Berlin.

But Audi can at least reflect positively on yet another home win as the outfit aims to improve on last seasons teams' championship-only triumph.

“We know that this is a battle in the war, it is not the end of the war,” said team boss Allan McNish. “We’ve got to be very aware that there is more coming up. But in terms of our positioning, it’s a lot better than where we were last year and where we were [ahead of Berlin].”

In the end, FE’s playground provided more clues about the best packages of the first season of the championship’s Gen2 era, but no definite answers. One thing is clear though – with just three races remaining, the destination of both titles is far from certain. ❄️

RESULTS ROUND 10/12, TEMPELHOF (DEU), 25 MAY (37 LAPS – 54.649 MILES)

POS	DRIVER	TEAM/CAR	TIME
1	Lucas di Grassi (BRA)	Audi Sport Abt / Audi e-tron FE05	47m02.477s
2	Sebastien Buemi (CHE)	Nissan e.Dams / Nissan IM01	+1.856s
3	Jean-Eric Vergne (FRA)	DS Techeetah / DSE-Tense FE19	+2.522s
4	Antonio Felix da Costa (PRT)	BMW / BMW iFE.18	+5.845s
5	Stoffel Vandoorne (BEL)	HWA / Venturi VFE-05	+6.336s
6	Daniel Abt (DEU)	Audi Sport Abt / Audi e-tron FE05	+6.551s
7	Alexander Sims (GBR)	BMW / BMW iFE.18	+8.235s
8	Oliver Rowland (GBR)	Nissan e.Dams / Nissan IM01	+10.781s
9	Sam Bird (GBR)	Virgin Racing / Audi e-tron FE05	+13.153s
10	Pascal Wehrlein (DEU)	Mahindra Racing / Mahindra M5Electro	+14.846s
11	Edoardo Mortara (CHE)	Venturi / Venturi VFE-05	+15.377s
12	Mitch Evans (NZL)	Jaguar / Jaguar I-TYPE3	+17.688s
13	Robin Frijns (NLD)	Virgin Racing / Audi e-tron FE05	+21.197s
14	Maximilian Gunther (DEU)	Dragon Racing / Penske EV-3	+26.154s
15	Felipe Massa (BRA)	Venturi / Venturi VFE-05	+26.684s
16	Gary Paffett (GBR)	HWA / Venturi VFE-05	+27.718s
17	Jerome d'Ambrosio (BEL)	Mahindra Racing / Mahindra M5Electro	+27.729s
18	Oliver Turvey (GBR)	NIO / NIO004	+32.117s
19	Tom Dillmann (FRA)	NIO / NIO004	+33.706s
20	Jose Maria Lopez (ARG)	Dragon Racing / Penske EV-3	+46.895s
R	Andre Lotterer (DEU)	DS Techeetah / DSE-Tense FE19	28 laps - battery cooling circuit connection
R	Alex Lynn (GBR)	Jaguar / Jaguar I-TYPE3	23 laps - locked axle

Winner's average speed 69.703mph. **Fastest lap** di Grassi 1m09.357s, 76.664mph.

SUPERPOLE 1 Buemi 1m07.295s; 2 Vandoorne 1m07.693s; 3 di Grassi 1m07.719s; 4 Paffett 1m07.783s; 5 Lynn 1m07.849s; 6 Sims 1m08.017s*. * = Five-place penalty for causing a collision in previous race.

QUALIFYING 1 Vandoorne 1m07.619s; 2 Buemi 1m07.625s; 3 Sims 1m07.728s; 4 Paffett 1m07.877s; 5 Lynn 1m07.920s; 6 di Grassi 1m07.926s; 7 Abt 1m07.953s; 8 da Costa 1m08.013s; 9 Vergne 1m08.046s; 10 d'Ambrosio 1m08.065s; 11 Wehrlein 1m08.086s; 12 Rowland 1m08.119s; 13 Bird 1m08.182s; 14 Turvey 1m08.203s; 15 Gunther 1m08.218s; 16 Mortara 1m08.223s; 17 Dillmann 1m08.263s; 18 Evans 1m08.314s; 19 Massa 1m08.348s; 20 Lopez 1m08.720s; 21 Frijns 1m08.919s*; 22 Lotterer 1m12.568s. * = Five-place penalty for causing a collision in previous race.

CHAMPIONSHIP 1 Vergne 102; 2 di Grassi 96; 3 Lotterer 86; 4 da Costa 82; 5 Frijns 81; 6 Evans 69; 7 Abt 67; 8 d'Ambrosio 65; 9 Rowland 63; 10 Buemi 61.

NEXT REPORT

BERN
27 JUNE ISSUE

In the penultimate round of the season, before a double-header New York finale, can anyone assert a clear championship lead in Switzerland?



Street circuit slicker
de Vries slashed his
deficit in the points

PORTLOCK

De Vries dominates feature race as F2 commits red flag

FORMULA 2
MONACO (MCO)
24-25 MAY
ROUND 4/12

Rarely does an incorrect decision as bad as the one that befell the Monaco Formula 2 feature race happen in modern times, but with drivers paying millions to compete in the series it seemed almost farcical.

The only real winner from the weekend was Nyck de Vries, who dominated the feature race and reduced a 30-point championship deficit to a solitary point with seventh in the sprint race as his rivals hit trouble.

Polesitter de Vries, Luca Ghiotto and

Sergio Sette Camara scarpers away at the start of the feature race. Then, 19 laps in, Mick Schumacher punted ninth-placed Tatiana Calderon into a spin at Rascasse.

The red flag was waved when the track was blocked. Although the cars were reordered in the pitlane, those that had been halted by the blockage were not allowed to regain the lap they had lost.

An F2-issued document acknowledged that the regulation wasn't followed and added: "While this procedure negatively impacted the remainder of the race by putting significantly more cars down a lap than would otherwise have been the case, the Stewards find no equitable method to resolve this error and accordingly leave the

results from race one as they stand."

'Sorry, it's a bit of a farce, but there's nothing we can do after the race', is how the message felt, five hours after the race had finished. The final result was posted just after 1600 the next day...

Rewind to the red flag and the front eight drivers panicked as they were yet to stop. If the regulations were followed, they would be at the front for the restart. But drivers from ninth down had already completed their mandatory tyre change, so no doubt had a chance at victory because those in front had to pit. De Vries and many of his seven followers used an extra set of tyres as they believed they would have to build a gap over the field, so compromised their Sunday races by eating into their tyre allocation. But, in the end, it wasn't necessary because all those from ninth back were a lap down.

The only justice was that de Vries was streets ahead of the competition and rewarded for his brilliant driving in qualifying and the race.

There was further joy for de Vries. Ghiotto was excluded post-race because the rack stops on his steering column were irregular. No performance gain but a big penalty, which promoted Nobuharu Matsushita into second and Sette Camara onto the podium after a run of bad luck. Matsushita pulled off an incredible move on Sette Camara at Mirabeau while the latter was still warming his tyres after his pitstop.

De Vries's other main rival, erstwhile points leader Nicholas Latifi, was docked



Rascasse blockage was only
the start of F2's issues...

DUNBAR



RESULTS ROUND 4/12, MONTE CARLO, 24-25 MAY RACE 1 (37 LAPS - 106.944 MILES)

POS	DRIVER	TEAM	TIME
1	Nyck de Vries (NLD)	ART Grand Prix	1h30m56.153s
2	Nobuharu Matsushita (JPN)	Carlin	+4.046s
3	Sergio Sette Camara (BRA)	DAMS	+5.470s
4	Dorian Boccia (FRA)	Campos Racing	+9.120s
5	Guan Yu Zhou (CHN)	Virtuosi Racing	+1m02.548s
6	Artem Markelov (RUS)	MP Motorsport	-1 lap
7	Louis Deletraz (CHE)	Carlin	-1 lap
8	Anthoine Hubert (FRA)	Arden	-1 lap
9	Ralph Boschung (CHE)	Trident	-1 lap
10	Nikita Mazepin (RUS)	ART Grand Prix	-1 lap
11	Giuliano Alesi (FRA)	Trident	-1 lap
12	Nicholas Latifi (CAN)	DAMS	-1 lap
13	Mick Schumacher (DEU)	Prema Racing	-1 lap
14	Tatiana Calderon (COL)	Arden	-2 laps
15	Mahaveer Raghunathan (IND)	MP Motorsport	-2 laps
16	Juan Manuel Correa (USA)	Sauber Junior Team by Charouz	37 laps-not running
17	Jack Aitken (GBR)	Campos Racing	36 laps-not running
EX	Luca Ghiotto (ITA)	Virtuosi Racing	+3.049s- excluded, rack stop infringement
R	Sean Gelael (IDN)	Prema Racing	32 laps-incident
NS	Callum Irott (GBR)	Sauber Junior Team by Charouz	electrical fire

Winner's average speed 56.092mph. **Fastest lap** Matsushita 1m22.243s, 90.763mph.

QUALIFYING - GROUP 2 Irott 1m21.462s; 4 Schumacher 1m21.469s; 6 Camara 1m21.537s; 8 Hubert 1m21.675s; 10 Deletraz 1m21.936s; 12 Mazepin 1m22.089s; 14 Boschung 1m22.233s; 16 Zhou 1m22.772s; 18 Aitken 1m22.877s; 20 Raghunathan 1m26.522s. **QUALIFYING - GROUP B** 1 de Vries 1m20.676s; 3 Ghiotto 1m20.924s; 5 Latifi 1m21.130s*; 7 Gelael 1m21.598s; 9 Matsushita 1m21.807s; 11 Markelov 1m22.086s; 13 Boccia 1m22.290s; 15 Correa 1m22.437s; 17 Alesi 1m22.785s; 19 Calderon 1m24.791s. * = Three-place penalty for exiting pitlane under reds.

RACE 2 (30 LAPS - 62.205 MILES)

GRID FOR RACE 2 Decided by result of Race 1, with top eight finishers reversed.

1 Hubert 44m23.388s; **2** Deletraz +0.059s; **3** Zhou +0.922s; **4** Markelov +2.459s; **5** Boccia +13.689s; **6** Camara +16.322s; **7** de Vries +16.952s; **8** Mazepin +17.337s; **9** Matsushita +18.770s; **10** Latifi +19.335s; **11** Schumacher +21.559s; **12** Correa +22.639s; **13** Aitken +23.284s; **14** Irott +24.813s; **15** Gelael -1 lap; R Alesi 17 laps-spin; R Boschung 9 laps-no power; R Raghunathan 6 laps-incident; R Ghiotto 6 laps-incident; R Calderon 2 laps-incident.

Winner's average speed 84.080mph. **Fastest lap** Gelael 1m23.318s, 89.592mph.

CHAMPIONSHIP 1 Latifi 95; 2 de Vries 94; 3 Ghiotto 67; 4 Aitken 62; 5 Zhou 54; 6 Camara 52; 7 Hubert 46; 8 Deletraz 34; 9 Boccia 30; 10 Matsushita 26.



blockage blunder

three places on the starting grid for breaching a pitlane red light in practice. He tried an alternate strategy in the race, so he was one of the drivers a lap down.

Reigning GP3 champion Anthoine Hubert had ran as high as fourth as his impressive rookie campaign for Arden continues, but a slow pitstop and brake issues meant a lowly finish. After Ghiotto's exclusion, he was awarded eighth and the reversed-grid pole for the sprint race.

He led from lights to flag, showing Arden's work with HWA has helped to improve the qualifying pace as well as maintain its strong race performance.

Louis Deletraz attacked and got within a half a car's length, but had to take second for the second year in a row in a Monaco sprint race. Another successful F2 rookie, Guan Yu Zhou, held off the returning Artem Markelov for the final podium spot having driven from 16th to fifth the previous day. Markelov was entertaining as ever in his return to F2 to replace for the Indianapolis 500-bound Jordan King at MP Motorsport, and hinted it might not be his last outing.

Despite throwing his overalls in the bin in Baku and using Formula 3 driver David Beckmann's suit, and narrowly avoiding a serious knee injury in a charity football game, everything else went perfectly for de Vries. Like last year's champion George Russell, an ART driver is excelling - only, de Vries is doing it earlier than Russell did and against weaker competition.

JACK BENYON



FORMULA RENAULT EURO CUP
MONACO (MCO)
25-26 MAY
ROUND 3/10

Nobody in Monaco knows what it means to have to fight off much faster cars to score a podium in Monte Carlo more than Daniel Ricciardo. So, 12 months after his heroic drive to victory having lost the power of his MGU-K, the Renault Formula 1 driver-turned-Eurocup chequered flag waver must have been impressed by the resilience shown by Joao Vieira last Sunday.

Vieira was only 18th fastest in free practice but capitalised on wet conditions in qualifying to steal a second-row starting position for both races by staying on wet tyres and improving late on as others switched to slicks and suffered for it.

He was a distant fifth-place finisher in race one (and sixth on the road),

35 seconds behind the race winner in a 21-lap race. Come Sunday, though, he managed to fend off Renault protege Caio Collet to complete the podium. Anywhere else and Vieira would likely have been a sitting duck: but credit goes to where it is due, and he did not put a foot wrong in his defence despite often lapping two seconds off the pace thanks to a broken flap on his front wing.

Vieira grabbed attention in the grand prix-supporting Sunday showpiece race because of the multi-car train that formed behind him and the rate at which he fell away from the leaders. In fairness, the true headline performers all weekend were Victor Martins and Alexander Smolyar.

The duo shared pole positions after topping their respective groups, Martins in the wetter first session and Smolyar in Group B despite the mistaken decision to switch to slicks and subsequent failure to improve. Unsurprisingly, given this is

Monaco, they turned those grid positions into victory: Renault academy driver Martins leading from start to finish in the opening race before SMP Racing-affiliated Smolyar repaid the favour in race two.

Their results launched them to the top of the pile in the championship. Martins, the only driver to score a point in every race this season, leads the way on 89 points with Smolyar up to second and just three points behind.

Both overhauled erstwhile points leader Oscar Piastrì, the double Silverstone winner who had a podium-less trip to Monaco. Piastrì was fourth in the first race but only fifth in the second, when he was stuck in the Vieira train behind Collet. French Formula 4 champion Collet is now finding his feet in the Eurocup. But for Vieira's stern defence, Collet would have followed up his maiden podium finish on Saturday with another in race two.

SCOTT MITCHELL

Ammermuller takes his chance

PORSCHE SUPERCUP
MONACO (MCO)
26 MAY
ROUND 2/9

Qualifying is nine-tenths of the battle in Monaco, so Larry ten Voorde was on the brink of a first Porsche Supercup win after setting the pace. But his best lap was run under yellow flags, meaning he was bumped to third and defending champion Michael Ammermuller promoted to pole.

With his Lechner Racing entry carrying the words "you're more than a memory, you'll never be forgotten" in tribute to

Niki Lauda, Ammermuller held the lead at the start and was never headed. He inched away from Mikkel Overgaard Pedersen to build a lead that stabilised at around the 0.9-second mark. Until, that is, seventh-placed Dylan Pereira lost the rear at Ste Devote and tagged the barrier on the exit of the right-hander. The car then speared across the track and slapped the inside wall. He limped on but parked before Massenet and triggered a safety car.

Pedersen pressured Ammermuller in the four-lap sprint to the flag that followed (and set fastest lap), but the German held on.



Ten Voorde took his first podium finish in third in a processional race, with Florian Latorre fourth ahead of leading rookie Ayhan Guven and 2015 Monaco Supercup race winner Jaap van Lagen. Julien Andlauer was seventh, losing the points lead to Ammermuller and Guven.

EDD STRAW

Lexus strength paves way for internal fight

SUPER GT
SUZUKA (JPN)
26 MAY
ROUND 3/8

Team TOM'S converted its qualifying dominance into victory at Suzuka to claim back-to-back Super GT wins for both the squad and the Lexus LC 500.

Kazuki Nakajima was back in his regular Lexus seat, returning from the World Endurance Championship round at Spa, to share with most recent Super Formula winner Yuhi Sekiguchi.

They faced Nick Cassidy and Ryo Hirakawa, sharing the sister car, in the fight for pole, with Sekiguchi running clear by just 0.013s to score his first pole since switching to TOM'S.

Both Nakajima and Hirakawa took control for the race start, and it was Nakajima who pulled out an early gap.



MOTORSPORT IMAGES/SHIHARA

Kazuya Oshima and Kenta Yamashita, also in an LC 500, rose from fifth to third, behind the leading TOM'S duo – coming at the expense of Tomoki Nojiri/Takuya Izawa's Honda NSX and the Nissan GT-R of Daiki Sasaki/James Rossiter.

Ronnie Quintarelli, in the NISMO-run Nissan GT-R, suffered a high-speed off at the infamous 130R corner. A break on the front-right corner meant the Italian couldn't get his car to turn, and so the lap 17 incident resulted in a safety car.

Nakajima responded by pitting for a driver change, and Hirakawa followed suit one tour later. That brought the Team LeMans car back into play, with Cassidy and Oshima swapping positions in their

dice for second. But with four laps to run, Cassidy pulled off a pass to consolidate second as Sekiguchi stretched 8.1s clear to his first TOM'S victory.

First round winner Tomoki Nojiri and Takuya Izawa finished fourth in their NSX, with Heikki Kovalainen fifth for Lexus. An engine problem dropped Rossiter to 10th, but he was still three places clear of defending champions Naoki Yamamoto and Jenson Button – the latter had to manage a puncture after tangling with a GT300 runner while in fifth.

JIRO TAKAHASHI

motorsport.tv

Relive this race at Motorsport.tv

Experienced Motopark wins on home turf

EUROFORMULA OPEN
HOCKENHEIM (DEU)
25-26 MAY
ROUND 3/9

It was a good weekend for Japan during Euroformula Open's first ever visit to Hockenheim, where the circuit experience of former European Formula 3 Championship team Motopark was evident.

The German outfit managed to lockout the top four spots in qualifying for race two, with well-timed laps putting Taki Inoue protege and experienced European F3 racer Marino Sato on pole for both races.

Sato turned pole into a 'grand slam' by adding victory, fastest lap and all laps led in race one, as Double R Racing's Jack Doohan and Linus Lundqvist provided a useful early buffer from team-mate Liam Lawson.

Although Lawson was able to clear both, he finished behind Doohan after a high-speed spin at Turn 1 late on. It turned out that the leg rest in the New Zealander's car had detached itself, making it "undriveable" for Lawson as his legs were pinned down.

A poor start left Lawson's Motopark



team-mate and fellow Red Bull junior Yuki Tsunoda in fourth. He only just missed out on pole for race two to fellow Japanese driver Sato by 0.047s.

New championship leader Sato didn't defend hard when Tsunoda made a move for the lead early in the race, and he was demoted to third by Lawson not long after. Once again Lawson made a late mistake, this time dropping to fifth, and Sato reclaimed a distant second place.

The fourth Motopark car of Julian Hanes completed the podium, while Pau Grand Prix winner Billy Monger struggled to 12th and 13th places for Carlin.

ELLIOT WOOD

WEEKEND WINNERS

FORMULA RENAULT EURO CUP

MONACO (MCO)

Race 1 Victor Martins
MP Motorsport

Race 2 Alexander Smolyar
R-ace GP

PORSCHE SUPERCUP

MONACO (MCO)

Michael Ammermuller
Lechner Racing

SUPER GT

SUZUKA (JPN)

Kazuki Nakajima/Yuhi Sekiguchi
Team au TOM'S (Lexus LC 500)

EUROFORMULA OPEN

HOCKENHEIM (DEU)

Race 1 Marino Sato
Motopark

Race 2 Yuki Tsunoda
Motopark

INTERNATIONAL GT OPEN

HOCKENHEIM (DEU)

Race 1 Fran Rueda/Andres Saravia
Teo Martin (McLaren 720S GT3)

Race 2 Norbert Siedler/Mikael Grenier
Emil Frey Racing (Lamborghini Huracan GT3 Evo)

POWERED BY
 motorsport
STATS

For full results visit motorsportstats.com

Sibling rivalry:
Timmy Hansen leads
brother Kevin to
deprive him of the
points lead



Timmy Hansen rediscovers lost luck

WORLD RALLYCROSS
SILVERSTONE (GBR)
26 MAY
ROUND 4/10

Timmy Hansen's 2018 World Rallycross Championship campaign was bedevilled with poor fortune. So often when he had a clear opportunity to put a dent in Johan Kristoffersson's incredible run of dominance, he would miss the chance.

In Spain, for example, he led his semi-final with ease until his works Peugeot 208 WRX ground to a halt with an electric fault; in Portugal, glancing a barrier cost him the chance of a podium finish. At Silverstone, having set a fastest qualifying time on Saturday afternoon, he broke a wheel in the semi-finals and retired.

Putting the first round of the current season in Abu Dhabi aside – where Hansen

was removed from the event by substantial contact with Andreas Bakkerud's Audi during Q3 – Hansen has been enjoying significantly better luck this term.

In the fourth round at Silverstone last weekend, the second World RX event to be held on the Stowe Circuit layout, Hansen netted a pole position start for Q1 from the random draw. He was matched into Turn 1 from the outside of the grid by his teammate and brother Kevin, who started faster, but the pair gave each other racing room.

Fastest in Q1 and Q2, Timmy Hansen was beaten to the best time in Q3 by Bakkerud, which dropped the Swede to second on the grid for Q4. In the final qualifier, on another day contract with Cyril Raymond's GCK Academy Renault Clio might well have resulted in at least a puncture, but Hansen survived relatively unscathed and qualified top in the Intermediate Classification.

A win in the semis secured Hansen pole for the final. But fellow front-row starter Bakkerud, who was fastest again in Q4, made a better launch into the right-hand first corner and Hansen was squeezed into the tyre wall on the inside. Several drivers had fallen foul of that Turn 1 barrier over the weekend, but the Hansen MJP 208 WRX didn't get sucked in, and a subsequent nudge with Bakkerud forced the Audi wide.

Hansen's car then hesitated on the apex. But he was given a helping hand by a push in the rear from a fast-starting Timo Scheider as Bakkerud took the lead. Hansen ran second, but closed significantly through the loose-surface Turn 7 hairpin in the early stages. Taking his joker on the third tour, Hansen set the fastest lap of the day in clear air in a bid to leapfrog Bakkerud's Audi, which he did, just, when Bakkerud took his joker at the penultimate opportunity.

Hansen maintained the advantage to the finish, while Bakkerud was second. Later Bakkerud revealed he'd had an issue with his handbrake not releasing drive to the rear wheels from the second lap of the semis.

During 2018, any of those incidents would probably have cost Hansen the win. But 12 months on he rode his fortune, claimed a second win of the year and moved into the points lead.

Compatriot Anton Marklund scored a maiden podium for the GCK team with its Renault Megane in third, as Scheider and Krisztian Szabo were fourth and fifth. Liam Doran didn't make the finish and was sixth. Pre-event points leader Kevin Hansen spun in the semis and failed to progress.

HAL RIDGE

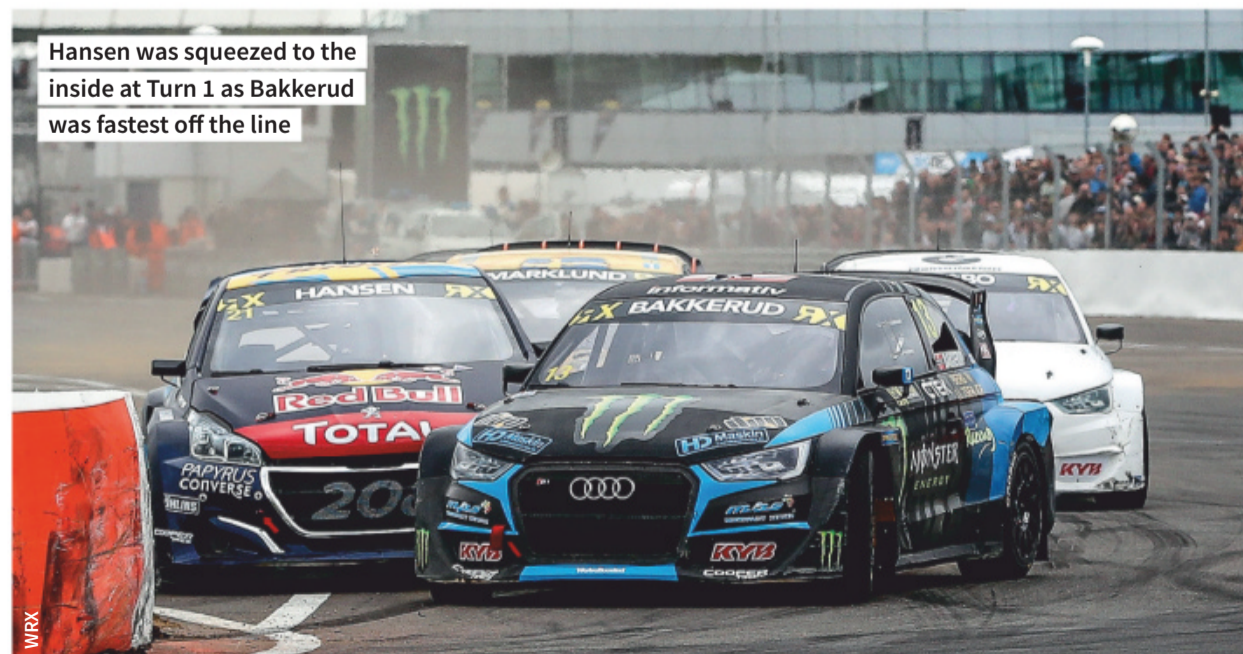

Hansen was squeezed to the inside at Turn 1 as Bakkerud was fastest off the line

McLaughlin nets imperfect 10 amid controversy

AUSTRALIAN SUPERCARS

WINTON (AUS)

25-26 MAY

ROUND 6/15

Scott McLaughlin continued his domination of the 2019 Supercars season with another pair of wins at Winton.

Saturday's victory was a controversial one for the defending champion, who clashed with DJR Team Penske team-mate Fabian Coulthard on the opening lap. The pair made contact on the way into Turn 5, and

both of the Ford Mustangs took to the infield. However, while Coulthard rejoined at the back of the field, McLaughlin opted to shortcut his way to Turn 8 and carried on in third place.

Questions were asked over the legality of the shortcut, but since the briefing notes only called for cars to re-enter the circuit before the Turn 9 flag post, it was deemed above board. He went on to the triumph ahead of Chaz Mostert and David Reynolds.

On Sunday it was significantly more clear-cut for McLaughlin, who qualified on

pole by a staggering half-second margin. From there he could cruise to a lights-to-flag victory (aside from pitstops) ahead of Coulthard, with Jamie Whincup beating Reynolds to what would have been a distant third had it not been for a late safety car.

McLaughlin now has 10 wins from the 14 races so far this year, one more than he took during his title-winning 2018 season.

He's a whopping 244 points clear of Coulthard in the standings too, with Shane van Gisbergen in third, 415 points shy.

ANDREW VAN LEEUWEN



Truex denies Penske double

NASCAR CUP

CHARLOTTE (USA)

26 MAY

ROUND 13/36

At various points during the NASCAR Cup's visit to Charlotte for the 600-mile race, Team Penske was in the hot seat to become the first squad to score a Memorial Day clean sweep.

Hours after Simon Pagenaud had claimed Roger Penske's 18th win at Indianapolis, the boss's hopes of a unique double rested on reigning champion Joey

Logano and team-mate Ryan Blaney.

There was just one problem: Martin Truex Jr. The 2017 champion's Joe Gibbs Toyota Camry is a potent weapon on 1.5-mile layouts, having won three of the last five races on such configurations.

But in the first half of the race, Truex's drive nearly came to a premature end when he hit the wall. He suffered a right-front tyre failure, a widespread phenomenon among the Toyota runners.

Steady progress through stage two allowed Truex to pip Alex Bowman for victory in the third stage, before he comfortably defended from Logano in a five-lap sprint following the 17th restart of an incident-filled event.

That final caution was caused by Logano's team-mate Brad Keselowski spinning into the pitlane with just over 10 laps of the 400 to run. Keselowski, who had looked serene out front in dominant stage one and two victories, was hampered by scrubbed tyres at the beginning of stage three and barely factored thereafter.

JAKE NICHOL

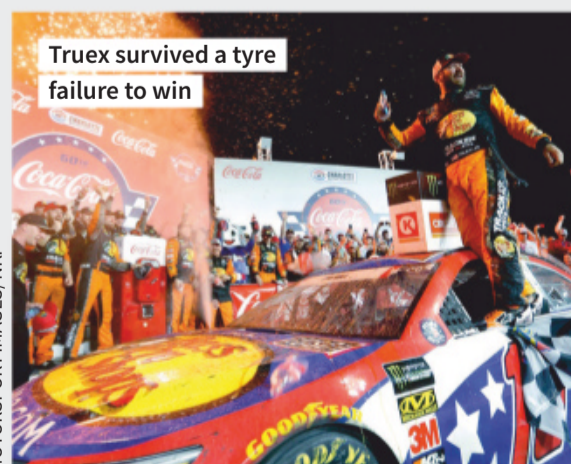

WEEKEND WINNERS

WORLD RALLYCROSS

SILVERSTONE (GBR)

Timmy Hansen

Team Hansen MJP (Peugeot 208 WRX)

AUSTRALIAN SUPERCARS

WINTON (AUS)

Race 1 Scott McLaughlin

DJR Team Penske (Ford Mustang)

Race 2 Scott McLaughlin

DJR Team Penske (Ford Mustang)

NASCAR CUP

CHARLOTTE (USA)

Martin Truex Jr

Joe Gibbs Racing (Toyota Camry)

NASCAR XFINITY SERIES

CHARLOTTE (USA)

Tyler Reddick

Richard Childress Racing (Chevrolet Camaro)

EUROPEAN RALLY CHAMPIONSHIP

LIEPAJA (LVA)

Oliver Solberg/Aaron Johnston

SRT (Volkswagen Polo GTI R5)

POWERED BY



For full results visit motorsportstats.com

AWNINGS



No1 for Inflatable Structures.
With you from the Paddock to the Podium.
www.aireshelta.com

EXHAUSTS

Inconel & Stainless Steel Specialists
SIMPSON
Race Exhausts
Tel: 01753 532222
www.simpsonraceexhausts.com

GEARBOXES

Gearboxman.com
COMPETITION TRANSMISSION SERVICES
Gearboxes & Axles for Road, Race, Rally and more
Telephone: 01582 840008 Fax: 01582 840007

HELMET GRAPHICS

Mike Fairholme Designs
Sole approved painter of Arai helmets.
Silver Birches, Corby Birkholme, Nr Grantham, Lincs NG33 4LE.
Tel: 01476 550630. Fax: 01476 550029.
email: fairholmedesigns@btconnect.com
www.fairholmedesigns.co.uk

MEMORABILIA



FINAL LAP
For Everything Formula One
www.finallap.net **WE BUY AND SELL**
+44 (0) 1245 287588 / 07771 920345

MOTORSPORT LEGAL ADVICE

Motor Sport Legal Advice
Tudor Alexander, L.I.B Solicitor
07887 713512

RACE PARTS

Autoparts and Hydraulics

sales@LMAautoparts.com

Passionate About Motorsport

www.jjcraceandrally.com

ARE DRY SUMP SYSTEMS
ARMSTRONG RACE ENGINEERING INC.
WWW.DRYSUMP.COM (916) 652-5282

RACE RADIO

Pit to Car Autotel
Radio solutions **Digital Race Radio**
0044(0)1508 528837
www.raceradio.co.uk

RACING

MARDI GRAS MOTORSPORT

www.mardigras.co.uk

www.mcracecars.co.uk
phone. 07771 762145
MCR's for sale
arrive & drive packages

RACING

PORSCHESHOP
10% off with website
voucher code AUTOTEN
Or Call: 0121 585 6088

demon-tweaks.com

AUTHORISED DISTRIBUTOR
OMP YBRACING
MOTORSPORT & PERFORMANCE
WWW.YBRACING.COM

RACING

CARTEK
MOTORSPORT ELECTRONICS

info@cartekmotorsport.com
023 80 457747
www.CARTEKMOTORSPORT.com

RACEWEAR

GPR Grand Prix Racewear
Silverstone
The best of racewear & kartwear
www.gprdirect.com

TRACK PREPARATION

KENDALL DEVELOPMENTS
3D SCAN - REVERSE ENGINEERING
Tel: 01480 718117 • Track Support • 3D Design
• Track Preparation • Restoration
www.kendall-developments.com

TRAILERS & TRANSPORTERS

Signature RV.co.uk
RV SALES AND SERVICE

BRIAN JAMES TRAILERS
» Connected to you
www.brianjames.co.uk

www.EMPIRE RV.co.uk
Living the high life
Tel: +44 (0) 1761 300 489
www.EmpireRV.co.uk ■ info@EmpireRV.co.uk



TO ADVERTISE IN THE WEB DIRECTORY
PLEASE CALL +44 (0) 20 3405 8109
OR EMAIL ads@autosport.com

BRIAN JAMES TRAILERS

»» Connected to you

www.brianjames.co.uk

Style and Substance

Introducing the new Race Transporter 6 by Brian James Trailers. An even more stylish and capable enclosed trailer specifically suited to car transportation.

New features include a standard automatic tilt-operation, invaluable for all professional motorsport or transport operations. An extra side access hatch door provides the ability to easily reach in for securing the standard equipment 'over wheel' strap system.

In addition, many new optional features are now available, all designed to offer the latest technology and improved convenience to all operators.

Race Transporter trailers are available from £ 7,699 + vat

Race Transporters are available ex-stock at many UK dealers. Please visit our website or call us for further details.

**RACE TRANSPORTER 6****T +44 (0)1327 308 833**

For more information and details on the Brian James Trailers range, please contact our head office



HIGH QUALITY TRAILERS
FOR CLUB, PRIVATE AND
PRO MOTORSPORTS

Woodford covered trailers **Superior in design, quality and finish**

TRAILERS & TRANSPORTERS



Woodford Trailers Limited | 14 Great Central Way, Daventry, Woodford Halse, Northants, NN11 3PZ | Telephone 01327 263384



THE RACER

Pit talk from the HRDC



VOL NO.
09 113
MAY 20

LAST OF THE SUMMER WINE! HRDC RACES AT DONINGTON



**LAST HRDC SUMMER RACE
BEFORE AUTUMN!** **29th
JUNE**

HRDC 'COYS 100 TROPHY' for Touring Cars 1958 – 1966

HRDC 'ALLSTARS' for pre-'66 Sports, GT & Touring Cars

COMPETITION ENQUIRIES: JULIUS THURGOOD 07850 361159 • direct@juliusthurgood.co.uk • www.hrdc.eu

JOIN THE BEST TEAM IN HISTORIC RACING



MARKETPLACE

WANTED

WANTED

RACE USE
FORMULA 1
SINGLE HELMETS
OR COMPLETE
COLLECTIONS

CONTACT ROB:
07771 920 345
ROB@FINALLAP.NET

RACE PRODUCTS

Co-ordsport
DEALERS

PartBOX
Performance and Tuning Parts

Leading performance brands online

Whether you are a trader, a rally team or a performance car enthusiast, we have the technical knowledge and parts to meet your needs

www.part-box.com

demon tweeks

EXPERT ADVICE • MASSIVE STOCK • RAPID DELIVERY



LOW RATE 0844 375 2196 demon-tweeks.com
CALLS MAY BE RECORDED FOR TRAINING PURPOSES

MARKETPLACE

MEMORABILIA

F1 COLLECTORS .COM



#1 FOR F1 MEMORABILIA & AUTOGRAPHS

We buy and sell F1 items
AYRTON SENNA specialists

Call CHRIS GRINT

01763 274448

email: - sales@f1collectors.com

AUTOSPORT

If you wish to advertise your products and services with Autosport in print and online please contact

Ben.kavanagh@motorsport.com

or call

+44 (0) 20 3405 8109

CARS FOR SALE



2001 PORSCHE 911-996 GT3 RS
£90,000



2000 PORSCHE 911-996 GT3 R
£140,000



1982 FORD MUSTANG 'FOX BODY' GROUP A
€200,000

MARK DONALDSON
SPORTS & COMPETITION CARS OF ALL ERAS

MARK DONALDSON
01252 759009
WWW.MARKDONALDSON.COM

RACE PREPARATION



Malpassi **GLENCOE**
U.K. Concessionaires

FILTER KING

Used professionally in:

- Off Roothing Sports
- Historic Racing
- Historic Rallying

BENEFITS

- Fuel Filtering
- Fuel Pressure Control
- High Flow (optional)
- Cleanable Chamber
- Clear or Metal Bowl
- Robust Design
- Proven High Quality

FULL RANGE OF MODELS

ALWAYS BUY ORIGINAL EQUIPMENT

Historically original equipment with
ALFA ROMEO • BENTLEY • BRITISH LEYLAND • LOTUS

RETAIL & TRADE ENQUIRIES WELCOME
TEL: 01784 493 555
Email: sales@glencoeltd.co.uk
www.glencoeltd.co.uk



Facet
FUEL PUMPS

Glencoeltd - Facet UK Concessionaire

Military standard: MIL-STD-461F
Test life cycle: 6,000 hrs

Made in the USA

Tel: 01784 493 555
Email: sales@glencoeltd.co.uk
www.glencoeltd.co.uk



MARDI GRAS MOTORSPORT

2A Brunel Close
Drayton Fields Industrial Est
Daventry NN11 8RB

tel: 01327 858006 fax: 01327 858800
email: info@mardigras.co.uk
web: www.performanceclutch.co.uk

Distributors and agents for:

K&N THE WORLD'S BEST AIR FILTER | **HELIX** AUTOSPORT | **VDO** Performance Instruments

RACELOGIC | **AP RACING** | **LifeLine** Fire & Safety Systems Ltd.

Eibach SPRINGS | **PFC** BRAKES | **KW**

VARLEY RED TOP™ THE ORIGINAL RACING BATTERIES | **FERODO RACING**

FIRE SERVICES Extinguisher Refills on Site | **Castrol** | **SCHRICK**

SPA DESIGN | **VP RACING** FUELS

10%
DISCOUNT OFF YOUR ORDER! QUOTE AD 10%



CBR

CRAIG BECK RACING

Historic Engine Specialists

Ford Cosworth BDA/BDG,
Lotus Twin Cam, BMW M10



Craig Beck Racing Ltd
T: 07876 221 932
E: craig@craigbeckracing.co.uk
www.craigbeckracing.co.uk



THE RACER

Pit talk from the HRDC



VOL NO.
09 113
MAY 20

LAST OF THE SUMMER WINE! HRDC RACES AT DONINGTON



**LAST HRDC SUMMER RACE
BEFORE AUTUMN!** **29th
JUNE**

HRDC 'COYS 100 TROPHY' for Touring Cars 1958 – 1966

HRDC 'ALLSTARS' for pre-'66 Sports, GT & Touring Cars

COMPETITION ENQUIRIES: JULIUS THURGOOD 07850 361159 • direct@juliusthurgood.co.uk • www.hrdc.eu

JOIN THE BEST TEAM IN HISTORIC RACING





LONDON CONCOURS
HONOURABLE ARTILLERY COMPANY
5-6 JUNE 2019

Photograph by Tim Scott - fluidimages.co.uk



LAMBORGHINI MIURA: TOTAL OUTPUT OF 355 PS; 350 HP (261)KW. A TOP SPEED OF 163 MPH, 0-60 MPH IN 6.3 SECONDS.

DID IT REDEFINE THE
CONCEPT OF A SPORTS CAR?

MARKETPLACE

On 5th – 6th June, the gardens of the Honourable Artillery Company, in the heart of the City, will host a selection of the rarest and fastest cars from 1912 to the present day, each an icon of its era.

A unique automotive garden party with the perfect combination of concours cars from the UK's leading private collectors, luxury retailers, fine watches, art, gourmet food and champagne; an occasion of pure indulgence.

TICKETS AT LONDONCONCOURS.CO.UK

Hospitality and general enquiries 020 3142 8542

SUPPORTED BY **Octane**

2 FOR 1 TICKET OFFER
USING THE CODE
AUTOSPORTVIP

PRESENTED BY





RECRUITMENT
DRIVEN BY
PASSION



MOTORSPORT JOBS

Find your dream job

Here at Autosport we've been helping people find great jobs in motorsport for over 60 years. Today we're launching a new global motorsport jobs site, where you can:

- Find the latest jobs in motorsport
- Apply for a job with just one click
- Upload your CV and let recruiters find you
- Set up job alerts - don't miss out on your dream move

Register at motorsportjobs.com today 🔍

motorsport
NETWORK

Motorsport Jobs
- A Motorsport
Network Company



Supervisor 911 GT3 Cup Race Support

Technical customer service management for the 911 GT3 Cup (Porsche Carrera Cup Asia).

All year-long:

- Consultant for customers regarding entire technical preparation/performance setup of race car, including analyzing and solving of technical issues
- Acquisition and coordination of technical customer orders
- Organization and execution of technical trainings for customers

Event period:

- Preparation and planning of all technical aspects of test or race weekends in cooperation with the relevant parties within the Porsche Carrera Cup Asia Organization
- Complete technical documentation and reporting
- Coordination of warranty claims in close cooperation with Porsche Motorsport
- Supervision of spare parts provision and management

To apply now visit www.motorsportjobs.com



ROKIT WILLIAMS RACING

HPC Engineer - Aerodynamics

The HPC systems at Williams are right at the heart of our aerodynamic design process and critical to the race car performance.

Reporting to the lead HPC engineer, in this role you will be ensuring we develop and maintain state-of-the art HPC capability to support our fast-paced CFD program. You will have a strong focus on performance and reliability and be motivated by working in a challenging and high technology environment.

Key operational duties:

- Develop monitoring tools to identify opportunities for performance improvement as well as potential issues.
- Develop strategies to maximise performance of the hardware, software and workflow.
- Contribute to a long term HPC strategy including collaboration with hardware and software vendors.
- Assist in day-to-day support of HPC systems (including some out of hours support of critical systems).
- Work alongside aerodynamicists to understand their use of the systems and provide technical guidance.

The Williams Group are based in Grove, Oxfordshire. We offer free onsite parking and large open green spaces to unwind during breaks. We are a short 5 minutes' from Wantage, our closest town center.

To apply now visit www.motorsportjobs.com



motorsport JOBS

Want to advertise a motorsport job?

If you are recruiting in motorsport and wish to advertise with Autosport in print and online please contact

James.robinson@motorsport.com

or call

+44 (0) 020 3405 8105

**For all current vacancies advertised
please visit our website**

Motorsportjobs.com



Ingram took fourth in Chevrolet Corvette he shared with Attard

BTCC ACE INGRAM MAKES MASTERS HISTORIC DEBUT

HISTORICS

British Touring Car Championship Independents Trophy holder Tom Ingram made his Masters Historic debut last weekend, when he shared both a Chevrolet Corvette Stingray and a Lotus Cortina with 2014 British GT champion Marco Attard at Brands Hatch.

Aside from one race at the Goodwood Revival back in 2016 in an Austin A35, it was Ingram's maiden outings in historics.

The Team Toyota GB ace qualified the mighty Chevrolet seventh and brought it through to a spectacular third, behind fellow touring car hotshoe Jake Hill (Lotus Elan) and Julian Thomas (Shelby Cobra Daytona Coupe replica), before relaying Attard at the stops. Attard kept the place until he was ambushed on the finish line by Andrew Smith in Mark Donnor's Jaguar E-type, finishing fourth.

Undeterred by starting the Cortina 18th, Ingram made light work of screaming through to eighth as drizzle fell before putting Attard in during a safety car interlude. Attard found

himself third in the queue once everybody had stopped but slipped back to seventh, under constant pressure from Marcus Jewell, as the V8s of Hill and Craig Davies (Ford Mustangs) and Calum Lockie (Ford Falcon) bellowed past as conditions improved.

Ingram, 25, said: "I had a call from Marco a few weeks ago and he asked if I would be up for doing some races, so I jumped at it.

"I'd had a pre-event test at Silverstone but it was raining and the Chevy had a misfire, so that didn't run at all. There was a lot to learn in qualifying.

"The Chevrolet was a delight to drive. It looks like a monster from the outside, but the handling was actually very good. It has a lot of weight and it was a question of making the most of its straightline power. With the Lotus Cortina, you know you are in an iconic touring car, and it was brilliant to race one of those machines.

"We will team up and race again, and we now know we have some work to do to the cars to be even more competitive next time we race. I loved it."

MATT JAMES AND MARCUS PYE



Ingram had only raced in historics once before

MOTORSPORT IMAGES/JEP

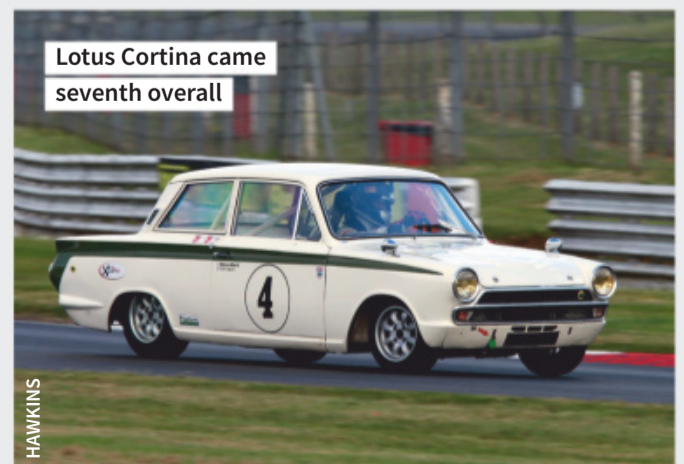

Lotus Cortina came seventh overall

HAWKINS

Mega Bertha deemed too noisy to race

CLASSIC SPORTS CAR CLUB

Ric Wood withdrew his ex-Gerry Marshall Mega Bertha Vauxhall Cavalier from last weekend's Classic Sports Car Club Special Saloons races at Oulton Park after scrutineers deemed it to be too noisy.

The 8500cc Dealer Team Vauxhall car has had very little running time since it first appeared at the 2018 Goodwood Festival of Speed.

Wood was left unhappy with the noise test procedures at Oulton, rather than the rules themselves.

"I did the qualification, came in to check the tyre pressures, and then was told I had to do a noise test before they let me back out," he said, after failing the test by 1.5 decibels.

"I know it'll pass the noise test when [the car's] a bit cooler, but if I go out they'll black flag me on the first lap."

Wood believes Mega Bertha's exhaust configuration puts it at a disadvantage compared to other Special Saloons.



"The problem is, on this car, the sound comes out of the side, not the back, so I suppose it's just firing it straight at the noise meter," said Wood.

CSCC director David Smitheram refuted Wood's claim that the noise test was not carried out correctly. He says the noise scrutineer was very experienced and followed procedures correctly, adding that Wood was given the option of modifying the exhaust and returning for a retest, but declined.

Smitheram agreed Mega Bertha's engine was pleasant to hear, but says the CSCC had to abide by external rules and avoid aggravating residents.

RACHEL HARRIS-GARDINER

Classic Ford moves under HSCC banner

HISTORIC SPORTS CAR CLUB

There will be a new look to period Formula Ford racing next season when the Classic Formula 1600 Championship moves to the Historic Sports Car Club to run alongside the Historic FF1600 Championship.

To date, the Classics, for cars built and raced before 1982, have run with the British Automobile Racing Club but will now switch to the HSCC and run in parallel to the HSCC's successful Historic Championship for cars from up to 1971.

The twin championships will mean that racing for the first 25 years of Formula Ford history will be managed and organised by the HSCC.

Stuart Kestenbaum, who represents Classic Formula Ford, said: "We think it is a fantastic move. The HSCC paddock is a great place for Classic Formula Ford to be and there is good sense in having the older Formula Fords racing at the same events."

The cars in the Classic FF1600 Championship represent a golden era of Formula Ford racing. Manufacturers like Van Diemen, Royale, Lola and Crossle set the standard when British Formula Ford was the ultimate proving ground for young talent.

Andy Dee-Crowne of the HSCC said: "This move will strengthen our portfolio and the Classics will sit nicely alongside our Historics. We are excited to have the championship coming on board. This move is one of the key elements of our plans for 2020 and beyond."

PAUL LAWRENCE



Lyons suffers heavy Brands crash

MASTERS HISTORIC F1

Michael Lyons escaped with bruising and abrasions when he crashed his Longhorn Indycar-based Williams FW07B at Brands Hatch's Paddock Hill Bend while challenging for the lead of last Saturday's FIA Masters Historic F1 championship race.

"It's always exciting in a Formula 1 car round here but we had a technical issue [thought to be a sticking throttle] approaching paddock in fifth gear," said the former Historic F1 champion. "I felt the engine pushing on as I braked and changed down. I'm not sure what speed I was pulling, but managed to turn the

car a little for a side impact. Hitting the wall in fourth gear going pretty fast [around 100mph] is not great, but I'm absolutely fine. I have a few minor scrapes, that's all."

Observers from Colin Bennett's CGA team in a neighbouring pit said they saw something unusual about Lyons' left front tyre.

"We had a similar thing when a tyre deflated and the chassis dropped on a Williams, pulling the throttle cable at the front," said the vastly experienced Bennett.

Lyons' weekend did not improve on Sunday when engine failure halted his replacement Hesketh 308E.

MARCUS PYE





Mercedes factory driver Buhk to make GT4 debut in British GT

BRITISH GT

Blancpain GT Series champion and Mercedes factory driver Maximilian Buhk headlines a cluster of wildcard British GT entries for next weekend's Silverstone 500, which is set to swell the field to a 40-car grid for the first time since the equivalent round in 2013.

Buhk has a glittering CV in international GT racing, having won the Blancpain Endurance Cup and the Spa 24 Hours in 2013, the Sprint Cup in 2015 and the FIA GT3 European Championship in 2012, as well as the overall Blancpain GT championship for combined Sprint and Endurance points in 2016.

The 26-year-old German will team up with 2011 British GT4 champion Peter Belshaw, returning to the championship for the first time since 2014, at Silverstone and Spa in a Mercedes-AMG GT4 run by ERC Sport.



Buhk has a fine record in GT3

"I know British GT's GT4 class is very competitive – there are a lot of good Pros who are used to working with their Ams," said Buhk, who will be making his GT4 debut. "Peter's won the title before and ERC have recent experience of the championship, too, so we should be on the pace."

Meanwhile GT Cup regulars John Seale and Jamie Stanley will step up to British GT in a new Lamborghini Huracan EVO GT3 run by JMH Automotive, ahead of a planned full-time graduation in 2020. They will compete at Silverstone and the first of the series' two trips to Donington Park in June.

"[Seale's] been very competitive so far this year and we've seen how well the new Lamborghini has performed in British GT during the opening two rounds, so we have the tools to do a good job," said Stanley, the 2010 British GT4 champion.

Stewart Proctor, father of Snetterton winner Lewis and Mia Flewitt will pair up in a second Balfe Motorsport McLaren 570S GT4. Flewitt, a former TWR engineer, beat Proctor to win the inaugural Pure McLaren GT Series last season.

Finally, Superdry founder James Holder and Matt George will race a new Aston Martin Vantage GT4 run by the same David Appleby Engineering outfit that campaigns the Invictus Games Racing Jaguar F-Type SVR at Silverstone. George is expected therefore to do 'double-duty' for the second year in a row, across two different brands.

JAMES NEWBOLD

Gamble to partner Haigh in Le Mans support race

ROAD TO LE MANS

McLaren Autosport BRDC Award winner Tom Gamble will join British GT champion Flick Haigh in a TF Sport Aston Martin Vantage GT3 at the Road to Le Mans race supporting the Le Mans 24 Hours next month.

Gamble, who races an Audi R8 LMS GT3 in the Blancpain World Challenge Europe, completed a successful test with TF at Anglesey, which led to an impressive British GT cameo at Snetterton earlier this month filling in for Adrian Willmott at Century Motorsport.

As reported by Autosport (18 April), Haigh will return to the event for the first time since 2017, when she drove an Optimum Motorsport-run Audi.

TF Sport won both races with Ahmad Al Harthy and Tom Jackson in 2017.

Gamble said: "We don't know the pecking order yet as we've not taken part in the other Michelin Le Mans Cup rounds, but we're very much going there with the expectations of a strong result."

JAMES NEWBOLD

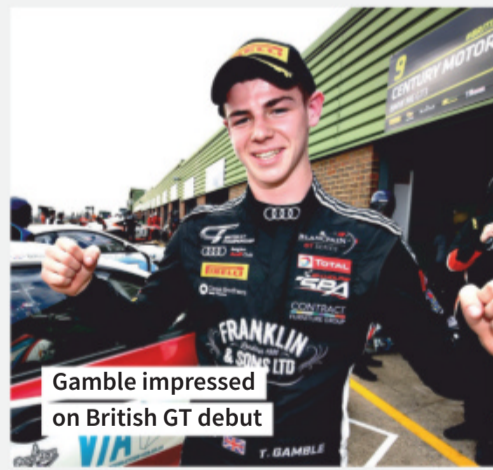

MOTORSPORT IMAGES/JEP

Comprehensive motorsport insurance products to keep you on track;

- ✓ Accident damage On Track
- ✓ Rally damage On Event
- ✓ Storage and Transit
- ✓ Liability
- ✓ Personal Accident
- ✓ Track day

Log on to www.ryanmi.com to obtain your online quote
Email – info@ryanmi.com Tel – +44 (0)1799 524202

Ryan Motorsport Insurance Limited is an appointed representative (557405) of Independent Broking Solutions Limited who are authorised and regulated by the Financial Conduct Authority. Its Financial Services Register number is 312026

RYAN
MOTORSPORT INSURANCE



Combe's GT Challenge prize money event set to continue

GT CHALLENGE

The £1000 prize money GT Challenge contest at Castle Combe is set to become an annual race, following its inaugural running at the Combe bank holiday meeting.

The GT Challenge is a half-hour race run to CCRC GT Championship regulations, with an unusual feature of a £1000 prize for the overall winner as well as £250 for each of the four class winners.

The race is the brainchild of Jordan Billinton, who competed in a Lamborghini Gallardo GT3. He is founder of building services consultancy firm ME7 and put up the prize money.

"I really hope we can make this a yearly

event," Billinton said. "I started racing under two years ago and I've already wanted to give back to the sport. I saw an opportunity, particularly for Castle Combe, because the GT Championship is great but it lacks some of the real top-class cars. So I spoke to the circuit and they really kindly offered a slot this year."

Ten cars entered the GT Challenge, which included a GT3 McLaren driven by Lucky Khera, Keith Butcher in his ex-Team Rosberg Audi R8 LMS GT3 and Tim Woodman in a Caterham 7.

"The entries in the GT3 class are some fantastic cars," Billinton added. "[I'm a] little bit disappointed with the overall numbers but next year it's something to build on."

GRAHAM KEILLOH

ROGER ANDREASON 1944-2019

OBITUARY

Roger Andreason, managing director of Chevron Cars since 1983, succumbed to cancer on 21 May.

A gifted driver and fine engineer, he first raced an MGA in 1966, progressing to Clubmans and a Modsports Marcos GT. But it was driving a ZA Magnette – of which four nicknamed examples were built in Andreason Racing and Tuning's Eastleigh workshops – that he won Classic Saloon championships and enjoyed rallying success.

Andreason was at home in the slick-shod Druid he created, and which he raced in Formula 3 and FAtlantic, as he was skittering skinny-tyred tin-tops round tracks or on mountain passes. Who else

could leap from Magnette or Jaguar to Cosworth DFL-powered Lola T610 in world sportscar championship events?

Having bought the remnants of the late Derek Bennett's hallowed empire with long-time acolyte and co-driver Tim Colman, Andreason serviced the needs of Chevron owners and added new models, from Sports 2000s to the Group C2 B62. There were flirtations with karts and FF1600 too.

A patient and insightful teacher and mentor, he developed the early talent of world sportscar C2 champion Ray Bellm, whose cars his team prepared and ran. He even jumped into Bellm's Williams FWo8C and bettered Silverstone's club circuit record inside a few laps.

MARCUS PYE

IN THE HEADLINES

LAMBO YOUNGSTERS PICKED

Five British drivers have been selected for the Lamborghini Youngster Programme. Bonaldi Motorsport team-mates Jack Bartholomew and Stuart Middleton have been picked for the Young Driver Programme. Barwell Motorsport's Blancpain GT Series stablemates Sandy Mitchell and ex-BRDC British F3 racer James Pull, plus FFF Racing's Taylor Proto, made it into the GT3 Junior Programme.

HALSTEAD TO DO TCT RACES

Ginetta GT5 Challenge Am champion Nick Halstead will contest the next round of the Touring Car Trophy at Donington Park next month, alongside racing his GT5 car the same weekend. Halstead will drive a Fox Motorsport Honda Civic TCR in three 2019 TCT events.

ALPINE DEBUT FOR EATON

The *Grand Tour* driver and 2014 Mazda MX-5 Supercup champion Abbie Eaton took a best result of fifth from the two Alpine Europa Cup races at Hockenheim last weekend. Eaton, who has also competed in the Australian Supercars Super2 support series this year, was making her debut in the Alpine category with the Racing Technology squad. She was ninth in the opening race.

MAURICE REEVES 1930-2019

Rallycrosser and former committee member of the British Rallycross Drivers' Association Maurice Reeves (below) has passed away aged 88. He also competed in road rallying, hillclimbing, sprints and autocross. He was best known among the rallycross paddock for team-managing son Trevor's competition career in the UK during the 1970s, before the team moved up to competing in Europe in the '80s.





Time for clubs to get ruthless

Do we really need two-car races and two-day meetings with only 10 contests? Worrying marshal numbers suggest things need to change soon in UK club racing

STEPHEN LICKORISH

It's a very old cliché that it only takes two cars to make a race but that literally rang true at Brands Hatch earlier this month. A pathetic entry for a Tin Tops Championship race dropped from three after qualifying to two for the 16-lap race.

And it just raises the question of 'why?'. That championship replaced the old British Automobile Racing Club South Eastern centre category, following the club's decision to shut down the centre. But was it needed? Especially when the club already had a poorly supported BARC Saloons series?

It wasn't the only shambles at that early May Brands Hatch meeting. The new Series Elite category, featuring Jaguars driven by those over 40 years of age, was not ready to launch so its races were replaced by a number of two-car demonstration runs.

In total, there were just 10 races across the two days of the meeting – and one of those was the two-car Tin Tops farce. All of that content could have been squeezed into a single day rather than being dragged out over two.

And it's not been the only meeting with very questionable value this month. Last weekend the British Racing and Sports Car Club organised a one-day event at Mallory Park. All sounds fair enough but the trouble was just one BRSCC championship attended.

The club had intended to run catch-all Allcomers races with both sprint and a mini-enduro contest but there was insufficient

“All of that could have been squeezed into a single day rather than dragged out over two”

interest in the longer race and the Saloon/Sportscar Trophy encounters attracted just six drivers. That left the BRSCC Northern Formula Ford 1600 Championship and three club-level Superkart races (not the main British series) as the rest of the meeting's content and again leaves you wondering why the club booked the track in the first place.

Last year, following the demise of Rockingham, clubs reported it was much trickier than usual to book circuits and put together their calendars. Is that any wonder, when some clubs are booking dates that they simply don't need?

And this has knock-on consequences. Take this weekend's Britcar meeting at Donington Park. Last week we reported that it may have to switch from being held on the Grand Prix layout to the shorter National circuit because of a shortage of marshals as there

is so much motorsport this coming weekend. If there were fewer meetings lacking content, it would help to reduce this problem.

The issue of marshals is an important one. Without the men and women in orange, we simply wouldn't have any motorsport. However, why should people give up their weekends to go and marshal at an event where there are just 10 races over two days and one of those has two cars?

One possible solution would be for entry fees to rise by a tiny amount – say £5 – and this could be distributed among the marshals attending so they receive at least something in return. But if the number of race meetings doesn't reduce and events continue to struggle to attract marshals, we may get to a point where marshalling at a few meetings could become a requirement of getting a racing licence.

With all of this in mind, it's now more than ever that clubs need to look at what they are offering. So far this year eight series have had at least one meeting where their entry has been in single figures. And this encompasses a wide range of categories from the BRSCC Porsche Championship to the Division 1 British Truck Racing Championship contests. Others to struggle include the BARC's Max5 Championship, the new-for-2019 Touring Car Trophy and Fiesta Junior.

Some of those are perennial strugglers that, despite the hard work of the championship organisers, are never likely to flourish, while others are well-established categories going through a blip. As well as the economic uncertainty surrounding Brexit, another factor that has been suggested to Autosport for the number of small grids is the impact series such as the Citroen C1 Challenge are having. This has proved enormously popular, with a relatively small budget required for the huge amount of track time you receive – some feel it may also be tempting competitors away from some of the traditional club championships where the costs are higher.

It's important to point out that it's not all doom and gloom. The 750 Motor Club's Club Enduro and Toyota MR2s, BRSCC Mazda MX-5 and Compact Cup championships, Caterham Roadsport, Classic Sports Car Club's Swinging Sixties and New Millennium, and the Equipe GTS series have all boasted grids of over 40 cars so far this season – some considerably more than that. Clearly some championships are thriving and it's noticeable how endurance series across the board have been doing well, with the likes of Britcar enjoying record grids too.

But for all the success stories, sadly there's no shortage of the seven, six or even two-car grids. Given the congested nature of club calendars and concern over the number of officials to go around, perhaps now is the time when clubs really do need to act and seriously look at culling their number of categories and events. ❄

Kerry's BMW 1 Series (leading) got through nine fuel pumps in two months



Kerry's BMW finally number one

**CASTLE COMBE
CCRC
27 MAY**

Ex-British Touring Car Championship driver Rick Kerry took his first BMW Car Club Racing victories in his V8-powered 1 Series, triumphing in both Castle Combe bank holiday races.

It was Kerry's first time racing at the circuit and in the opening stanza, starting from second, he used his V8's strong torque to move clear of polesitter Gary Hufford's M3 and win by 4.6 seconds.

Race two followed a similar path. Kerry got the jump off the line, this time with Mike Cutt's M3 as runner-up, 4.8s adrift. Cutt won both Donington Park season-opening races but felt his ballast impeded him more here. He was another Combe freshman, having only circulated the track on his bike prior to qualifying!

"Unexpected really, but great," said Kerry of his double success. "I really like the circuit, and it suited my car. I got a good start in both races and she's got good legs down the straight."

Kerry also hoped the performance spelled the end of his concept car's technical woes.

"We've had nine fuel pumps in two months, and we think we've tracked it

down to a wiring issue," he added. "With a car that's a relatively new concept – we're probably the first to put in a V8 and make it work in the 1 Series – you can't look at somebody else's car and find out. So to have a good test session and two cracking results today – I was thinking of retiring but I think I'll carry on a bit longer now."

Reigning Combe Formula Ford champion Luke Cooper ended the Fisher brothers' 2019 dominance in the single-seater category by taking a double victory and top spot in the standings. In race one, Cooper passed Felix then Josh Fisher in the first half of the race to move into a lead he didn't lose. In race two, he passed early leader Neil MacLennan – Kevin Mills Racing's National regular – before breaking clear as MacLennan held off the Fishers for second.

Adam Prebble continued his Combe Saloons domination, winning his third 2019 race from three in his Vauxhall Astra, holding off a strong challenge from brother Gary in a SEAT Leon Cupra.

Gary Prebble had the compensation of a 750MC Hot Hatch double victory in a Peugeot 205 GTI. In the intensifying rain of race one, Prebble prevailed with a spectacular pass of Chris Southcott's 205 at Camp late on after a long battle. In the dry second race, reigning champion

WEEKEND WINNERS

750MC BMW CAR CLUB RACING

Races 1 & 2 Rick Kerry (BMW 1 Series V8)

CCRC FORMULA FORD

Races 1 & 2 Luke Cooper (Swift SC16)

CCRC SALOON CAR

Adam Prebble (Vauxhall Astra)

750MC HOT HATCH

Races 1 & 2 Gary Prebble (Peugeot 205 GTI)

CCRC HOT HATCH CHALLENGE

Chris Southcott (Peugeot 205)

CCRC GT CHAMPIONSHIP

Lucky Khera (McLaren GT3)

GT CHALLENGE

Craig Dolby (Nissan GTR)

750MC SPORT SPECIALS

Races 1 & 2 Martin Gambling (Eclipse SM1)

For full results visit: tsl-timing.com

Ben Rushworth took the lead from Prebble with his own magnificent move on the outside of Camp early on. However, Rushworth and Southcott touched while disputing the lead on the penultimate lap, putting Southcott off and allowing Prebble to go through and win. Southcott, however, cruised to the Combe Hot Hatch win, 39s ahead of Joe Dorrington's similar 205.

Lucky Khera took his McLaren GT3 to the CCRC GT victory. He shadowed long-time leader Kevin Jones's Noble M12 and passed at two-thirds distance after Jones outbraked himself. Jones then immediately spun exiting Bobbies and retired a lap later because grass had filled his air intakes.

Craig Dolby's Nissan GTR cruised to victory in the inaugural GT Challenge, winning the wet-but-drying race by a lap, ahead of Khera and Jones.

Martin Gambling claimed both 750MC Sport Specials wins in his Eclipse SM1, while reigning Class B champion Lee Emm took both class victories.

GRAHAM KEILLOH



Cooper ended the Fisher brothers' run of FFord wins

ALL PICS: READ



Hartley took first Historic F1 win in his ex-Watson McLaren MP4/1B

Hartley's sweet success as Historic F1 thrills

BRANDS HATCH MASTERS HISTORIC FESTIVAL 25-26 MAY

Thirty-five years after the European Formula 2 Championship era ended at Brands Hatch, the Historic Sports Car Club-badged Historic F2 competition for pre-1979 cars' unprecedented strength forced FIA Historic F1 contenders to dig deep to justify the three-litre category's place at the sport's pinnacle.

The annual Masters Festival showcased both genres superbly, but Steve Hartley's first victory in his ex-John Watson McLaren MP4/1B on Sunday – following a poignant Niki Lauda tribute – wowed spectators as Cosworth DFV power

reigned on the magical Grand Prix circuit.

A scintillating three-way fight for Saturday honours between champions Martin Stretton (Tyrrell 012), Michael Lyons (Longhorn-born 'Williams FW07B') and Matteo Ferrer-Aza (Ligier JS11) ended abruptly when Lyons, hounding Stretton in fifth gear, ploughed-off at Paddock when his throttle jammed. Relieved to escape with cuts and bruises, Lyons was still classified second under FIA rules, ahead of Ferrer-Aza, Mike Cantillon (Williams FW07C) and Hartley's McLaren.

Playing catch-up since quillshaft failure halted his Tyrrell 011 in qualifying, Jamie Constable led Sunday's reversed top eight sequel in which Lyons's substitute Hesketh 308E's engine blew on lap two.

Hartley and Stretton jinked to the top but, when Cantillon crashed at Clearways on lap 12, scrapping with Christophe d'Ansembourg (FW07C) and Ferrer-Aza, the Aston Martin safety car was despatched. The race finished under caution, with invitee Hartley delighted to win in his second event with the gorgeous McLaren, from Stretton and Constable.

Wave after wave of F2 cars made a fantastic spectacle. Clubmans king Mark Charteris (March 742) stunned rivals by seizing pole and led Miles Griffiths (Ralt RT1) and Martin Stretton (March-BMW 782) brilliantly on Saturday until he lost second gear. He kept third, aided by a red flag after fourth-placed Mike Bletsoe-Brown (Chevron B27) rode over Peter Brennan's Brabham BT40 at Stirlings. New to F2, Griffiths was ecstatic with victory over Stretton. Chevron drivers Matt Wrigley (ex-Giacomo Agostini B42) and, from the back after fuel pressure issues, Martin O'Connell (B40) were fourth and fifth.

O'Connell scorched to victory in Sunday's race from which Stretton pitted immediately when his tacho went haywire. Griffiths and Mark Dwyer (782) didn't stint in their pursuit as Glenn Eagling (ex-Reine Wisell GRD 273) claimed a superb fourth. Alsacian Robert Simac, champion of the past six years, was again invincible in the 1600cc division.



Griffiths (r) and O'Connell enjoy Historic F2 scrap

ALL PICS: HAWKINS

WEEKEND WINNERS

FIA MASTERS HISTORIC F1

Race 1 Martin Stretton (Tyrrell 012)

Race 2 Steve Hartley (McLaren MP4/1B-5)

HISTORIC F2

Race 1 Miles Griffiths (Ralt-BDG RT1)

Race 2 Martin O'Connell (Chevron-BDG B40)

FIA MASTERS HISTORIC SPORTS CARS

Robert Beebee/Martin O'Connell
(Lola-Chevrolet T70 Mk3B)

GENTLEMAN DRIVERS

Julian Thomas/Calum Lockie
(Shelby Daytona Cobra Coupe)

MASTERS PRE-1966 TOURING CARS

Rob Fenn/Jake Hill (Ford Mustang)

YOUNGTIMER TOURING CAR CHALLENGE

Races 1 & 2 Daniel Brown (Ford Escort RS Mk2)

EQUIPE GTS

Lee Atkins (TVR Grantura MkIII, below)



For full results visit: tsl-timing.com



Brown took two
Youngtimer wins



O'Connell and Beebee
scored sportscar spoils



BTCC ace Hill powered
Mustang to top of Pre-1966
race alongside Fenn

FIA Masters Historic Sports Cars turned the clocks back to a golden era of sportscar racing as gruff V8s and nimble two-litre prototypes went head-to-head. Henry Fletcher (Chevron B26) had it won before full-course cautions twice expunged his lead, and Martin O'Connell forged Rob Beebee's Lola T70 ahead before the race was red-flagged with Nick Allen's Lola T212 off at Paddock seconds after the last green.

Helped by these hiatuses, T70-mounted Andy Wolfe (in for spinner Jason Wright) and Stretton (after Nick Sleep's first lap stop to secure a door) were third and fifth, split by Joaquin Folch/Nick Padmore (Chevron B19).

British Touring Car racers Jake Hill (Lotus Elan) and Tom Ingram (starting Marco Attard's Chevrolet Corvette) made their presence felt in Saturday's 90-minute Gentlemen Drivers Pre-1966 GT thriller. Polesitter Steve Soper, debuting his Elan, and Hill went ahead at the start with Julian Thomas's Shelby Daytona Cobra replica, Andrew Haddon (Elan) and Ingram next up.

Safety car interludes kept the pack tight, but Hill steamed away from Thomas, Soper and Ingram's lairy beast to the mandatory stops. Soper stayed in his Elan as Hill and Thomas relayed Rob Fenn and Calum Lockie, and Attard took the Stingray's helm. Soper's scrape with Mark Martin's Elan as he and Lockie tried to pass

Fenn in heavy traffic behind the pits ended his run, leaving Lockie to bag gold. Fenn finished 52.6 seconds adrift.

A lap down, Andrew Smith (finishing Mark Donnor's Jaguar E-type) snatched third from Attard on the line. Rapid Classic Sports Car Club racer Eddie Powell, flying in dad Nick's Elan, took fifth surviving a gravelly excursion having boldly outraked Smith into Paddock on the penultimate lap.

Hill starred in Sunday's fabulous Masters Touring Car race too, converting Ford Mustang owner Rob Fenn's conservative start to victory. Craig Davies (Mustang) and Julian Thomas (Ford Falcon) were pursued initially by a Lotus-Cortina squadron comprising Steve Soper, Ambrogio Perfetti, Mark Sumpter and Geoff Letts.

Letts worked his way to the top of the Cortina quartet as drizzle swayed the balance of power, nonchalantly passed Thomas and went after Davies.

A safety car – with William Ward's Mini on its side in the Clearways gravel – led to Soper, Sumpter and Fenn stopping before the scramble with the window just open.

Sumpter went top as the pit stagger unwound, but Hill eagerly outgrunted him. Displaced by the caution period, Davies recovered to third, two seconds behind Sumpter. Lockie hauled Thomas's ochre 'taxi' from 12th to fourth, chased by Perfetti and Joe Ferguson in Tom Bell's Mini.

"Smile, it makes you go faster," is the mantra of the Dutch-promoted Youngtimer Touring Car Challenge, back with a staggeringly diverse and cosmopolitan 46-car field. All manner of rumbustious V8 growlers – from Roger Bolliger's Jerry Titus Pontiac Firebird Trans Am and Christian Nowak's bewinged Cobra clone to Urs Steffen's bizarre 5.7-litre Chevrolet-engined Triumph Spitfire GT8 – through spectacular Porsches, BMW and Fords to East German Trabants filled the track.

As last May, Daniel Brown aced both races in his 2.5-litre Ford/Holbay YB-motivated Escort. Nowak's sinister-looking Chevrolet LS3-powered 'Cobra' blasted past Brown in the second outing, forcing Dan to raise his game for a breathless 0.838s victory over the German. Tjarco Jilesen (Porsche 964) and Christian Marx (Group 44-built IMSA Triumph TR8) bagged a third apiece.

Equipe GTS's hordes were back but, with the Ashworth family's TVR Grantura – April's triple winner – sidelined in qualifying, Lee Atkins won in another Blackpool bomber.

A safety car in the pit window defused his lead battle with Mark Holme (Austin-Healey) and Tom Smith (MGB), who battled back from 20th to fourth. After a cautious start, Martin Brewer's gorgeous Aston Martin DP214 clone was a strong third.

MARCUS PYE



Watts leads Swift in titanic battle for Mini victory

Inaugural Historics On The Hill event proves a hit

LYDDEN HILL
HRDC
27 MAY

Established stars Andrew Jordan, his father Mike and local tuning ace Nick Swift all shone during their ascendancy at the inaugural Historics On The Hill event.

Mike Jordan has a wealth of experience at Lydden from his Eurocar era, but Andrew's only effort on the full Tarmac circuit was a single trackday in 2006.

And Swift had raced at Lydden only twice before – the last time 10 years ago.

But the Swiftune boss had another problem: during a short practice session his UPU2 Mini wore its nearside front tyre right through the carcass. "I just don't have enough tyres here today," he said.

Andrew Jordan put his Austin A40 on pole for the Touring Greats race, but the spectacular James Dorlin, who drove a similar car, was less than one-tenth adrift.

Jordan made a good start though,

and led away from Dorlin, Ding Boston's Riley and James Colburn's A40. As the race developed, Jordan inexorably eased away to win, his neat, economic steering inputs contrasting strongly with his rival's all arms and elbows, hang-it-out style. Boston pulled onto the infield at half-distance, leaving Colburn to finish third behind Dorlin, well clear of Marc Gordon's Jaguar XK 150.

During qualifying for the Coys 100 Trophy, for pre 1958-66 touring cars, another established ace, Patrick Watts,

Watkinson dazzles in Swinging Sixties battle at Oulton Park

OULTON PARK
CSCC
25 & 27 MAY

The cars and drivers of the Swinging Sixties series provided the greatest dramas on the first day of the Classic Sports Car Club's Cheshire Challenge event at Oulton Park.

Chris Watkinson's Mini was a well-received winner in the Group 1 race. Starting from second, Watkinson pushed hard after an influx of early pitstops and capitalised on previous leaders Nik Aveyard and Rob Sinclair's MG Midget getting caught in traffic. The Midget finished second.

Another Mini driven by Anthony Lucas and Chris Hoy was third after the retirement of Tim Cairns's Midget and some very fast laps from Hoy. The

polesitting Alfa of Tim Parsons and Richard Mitchell spun off early on, necessitating a safety car and triggering the pitstops.

Group 2 was won by Malcolm Johnson's Lotus Europa, which inherited the lead from the Ginetta G4 of Mark Halstead and Stuart McPherson. The Ginetta crew had fought back from a spin and a delay in the pits, regaining the lead each time, but the car lost drive and retired late on.

Nicholas King was second in his Aston Martin DB4 and the TVR Tuscan of Jon Wolfe/David Thompson was third, having battled with the Aston in the latter part of the race.

There was a relatively small Special Saloons & Modsports entry. Paul Sibley won both races in his Lotus Elan, climbing from last to fourth during the first lap of race two after a 10-place success penalty.

Future Classics featured another



Watkinson came through to win in Swinging Sixties

JONES

dominant win for Tim Bates in his Porsche 911. He was 18 seconds ahead of the Triumph TR7 of Martyn Adams and a minute ahead of the rest of the field. The battle for sixth place was the closest part of the race, with Alex Taylor (Mazda RX-7) prevailing over Paul Dingle's Porsche after coming back from 22nd.

A partially wet track and oil dropped by Chris Earle's Honda Civic made for tricky conditions in Tin Tops, particularly around Cascades. Nigel Ainge handled it best in his Honda Integra as erstwhile leaders Steve and Colin Simpson (Peugeot 206) slipped to ninth. Ainge handed the Integra over to Danny Cassar, who



Watts (left) went to apologise to Swift after light contact



Andrew Jordan took victory in Touring Greats contest

was pipped to pole by Swift. But when the race started the former British Touring Car driver seized the lead and then held on to head Swift into the first corner by inches, chased by Mike Jordan and Ollie Streek.

At half-distance the Swiftune Cooper S drew alongside the leader's similar car for half a lap before Watts slipped ahead again as they tackled the hairpin.

Swift had been shaping up to dive down the inside at Chesson's Drift, but with a lap to go he switched his line

and swept around the outside of Watts in one glorious move.

Once in front, Swift held on to win by a length, with Streek and Jordan third and fourth. Afterwards it transpired that Swift had been given a five-second penalty for exceeding track limits, which placed him second in the official results.

"I couldn't see anything except Patrick's boot lid," he declared. In the paddock, Watts met up with Swift to apologise for light contact on the last lap. They both smiled, shook hands and then Watts said: "After all, what's a little love-nudge between mates!"

The HRDC Allstars event was led from pole to the chequered flag by James Colburn's Lenham GT, which pulled away steadily from the Lotus Elans of Richard Bateman and Paul Auston.

Matthew Moore's pretty Austin Healey 3000 Jamaican was in the leading group, but he fell back and so Ben Colburn finished fourth in the ex-works Midget formerly raced by Roger Enever.

Dorlin briefly held the lead in the A-Series Challenge contest until Swift swept past at the Devil's Elbow on the second lap. Thereafter, Dorlin and Streek squabbled over second place until Watts, who had started from the back, passed them both. Then the red flags flew for a beached car in a dangerous place.

Watts got the jump on Swift at the restart and did the double when he went on to win by a couple of lengths. Dorlin was a distant third.

KERRY DUNLOP



The Turbo Tin Tops head down Cascades at the start of the race

powered to a huge lead, in front of the resurgent Simpsons.

Polesitter Andrew Windmill (Honda Civic) lost out on a podium as his car developed a misfire and, unsure which lap he was on, he pulled into the pits in an attempt to finish. Simpson passed him on the line and Windmill was awarded a DNF. Tom Mensley was third in his Renault Clio.

Disputed finishes were the order of the day. Vicky Brooks was dropped from second to fifth in Turbo Tin Tops for loosening her belts too early in the pits, handing second place to Sean and Daniel Woodard, also in a BMW Mini. The Renault Megane of John Hammersley

and Nigel Tongue won comfortably.

Jason Holyhead's BMW crashed during lap three of the New Millennium encounter, bringing out a red flag. Confusion reigned after the restart as half of the field did not make their mandatory pitstop during the shortened race, but on-track winner Michael Vitulli (BMW M3 E46) kept his win, ahead of the similar car of Mark Smith and Ainge/Cassar in another Integra.

Heavy rain arrived during the Modern Classics race, which was won by Richard Ellis's Porsche 993, and this led to the cancellation of the Open Series contest.

RACHEL HARRIS-GARDINER

WEEKEND WINNERS



LYDDEN HILL TOURING GREATS

Andrew Jordan (Austin A40)

COYS 100 TROPHY

Patrick Watts (Mini Cooper S)

ALLSTARS

James Colburn (Lenham Sprite GT, above)

A-SERIES CHALLENGE

Patrick Watts (Mini Cooper S)

STARS OF LYDDEN

Ding Boston (Riley 1.5)

OULTON PARK SWINGING SIXTIES

Group 1 Chris Watkinson (British Leyland Mini)

Group 2 Malcolm Johnson (Lotus Europa)

SPECIAL SALOONS & MODSPORTS

Races 1 & 2 Paul Sibley (Lotus Elan Modsports)

FUTURE CLASSICS

Tim Bates (Porsche 911 SC)

TIN TOPS

Nigel Ainge/Danny Cassar (Honda Integra Type R)

TURBO TIN TOPS

Nigel Tongue/John Hammersley (Renault Megane F1 R26)

NEW MILLENNIUM

Michael Vitulli (BMW M3 E46)

MODERN CLASSICS

Richard Ellis (Porsche 993 C2, below)

MAGNIFICENT SEVENS

Stephen Nuttall (Caterham Supersport)

CLASSIC K

Paul Tooms (Lotus Elan GTS)

JAGUAR SALOON & GT CHAMPIONSHIP

Races 1 & 2 James Ramm (XJS)



For full results visit: tsl-timing.com

Harraway moves into Legends points lead after brace

**ANGLESEY
BARC
25-26 MAY**

Consistency was key in the UK Legends Championship's visit to Anglesey last weekend. Although finals went the way of Sean Smith and Marcus Pett, a Sy Harraway brace vaulted him into the points lead as bad luck was attracted to former leader Connor Mills.

"I've never won here – it doesn't like me," said Mills after engine troubles on Saturday and driveshaft problems the following day. Fourth in the opening heat of the weekend proved his best result.

Similarly, Pett's Sunday threatened to unravel after a solid first day, which included a comfortable heat two win that was sandwiched by third and fourth place finishes. A mistake in

the damp third heat cost him points, and engine fitting issues in the following contest put him out with a trail of oil in his wake.

"It was a £1 fitting that went wrong, but we saved the engine," said Pett, who recovered with a fine victory in the second final ahead of Harraway, who charged to second from a pitlane start. Harraway started strongly by winning a four-car opening heat dice, adding another win in Sunday's second contest. Trailing Miles Rudman on wets in heat three, Harraway – wearing an Ayrton Senna replica helmet – miraculously saved a sideways moment on the pit straight, where Robert King and Paul Simkiss met the pitwall.

"I'm thinking championship points now," admitted Harraway, as reigning champion John Mickel endured a quiet weekend – second in heat two his highlight. Smith fought hard for the opening final win,



BOURNE

batting off Jack Parker's late attack.

John Paterson was the class of the Scottish & Irish Legends races. The Scot took both finals, grabbing four wins in six outings in north Wales. A dominant second final win came after a hard-fought last-lap triumph the previous day. Part of a six-car squabble, Paterson climbed the order and outfoxed battling leaders Steve Whitelegg and David Newall, sneaking by the latter at School for the final time.

It wasn't plain sailing as a suspension-related technicality resulted in Paterson's heat two exclusion, a race that was won by Whitelegg. Steven McGill revelled in Sunday morning's wet conditions



Thrills and spills in Mini Cooper Cup encounters

**KIRKISTOWN
500MRCI
25 MAY**

The Mini Cooper Cup has been one of the success stories of Scottish racing, and its appearances at Knockhill are much anticipated events that rarely disappoint.

The drivers travel well too, as their visit to Kirkistown last weekend proved. In the first of their three races, all 21 got through the very fast left-hander at Debtors without mishap, with poleman Joshua Hislop leading

the train. But, when they arrived at Colonial, the expected mayhem broke out and, while Hislop emerged unscathed, a number of others didn't, including front-row starter Michael Weddell and several others.

Unsurprisingly, when the survivors reappeared at the start/finish straight they were greeted by the safety car, which was replaced by a display of red flags. Further dramas on the restart brought another appearance of the safety car and, when it went back to its lair for the final time, there was just one lap left to run. After a

hectic 1.5 miles, during which everybody set their fastest lap, the wily Robbie Dagleish took the chequered flag by a bumper from Mark Geraghty with Hislop third.

Race two proved less stressful despite another safety car interlude, as Dagleish repeated his win, this time with Vic Covey Jr looming large in his mirrors and Michael Weddell a strong third. The safety car remained tucked away for race three, which started from a partially reversed grid, but nonetheless went to Weddell from Covey, with Hislop and Dagleish next in line.



C1s had four-hour race at Anglesey, won by PrepTech UK

to also grab a heat win.

Danny Bird enjoyed a CNC Sports & Saloons hat-trick in his Spire GTR. A fast-starting David Harvey set the narrative by grabbing the initial lead in all three races in his Locosaki, but polesitter Bird usurped him each time with a better run through Church. Bird's final win required a recovery in drying conditions, passing Luke Armiger's Vauxhall Tigra before overpowering Harvey once more.

Paul Dobson recovered from a mechanically-induced race two retirement to grab a final race podium, despite pirouetting across the line after passing Armiger. Understeer prevented

Andrew Southcott's MG Modsport from challenging Bird in race one.

The four-hour Citroen C1 Challenge race was held on the International circuit, and was won by PrepTech UK from 10th on the grid thanks to Nicole Drought's mammoth late stint in the car she shared with Colin Lewis.

Silverstone victor McAttack Motorsport slipped from pole to 15th but fought back through a spirited Declan McDonnell charge, dropping out of the top three in the final hour behind Team Davies and early pacesetter, Majestic Motorsport.

DAN MASON



McGlade () and Stewart shared the Fiesta Zetec honours



Both Irish Ginetta Junior races were won by Nicholl

Perhaps inspired by this, the local Formula Ford 1600 brigade went into battle in a very determined mood. David McCullough powered away from pole, but found himself looking back at second row starter Will Herron while usual rival Alan Davidson was in third with Scott Finlay on his case. However, he set about getting past Herron, which he did briefly on the inside at Debtors in a brave move that ultimately left him spinning back to fourth.

Undeterred, the Mondiale driver set about playing catch up, which Davidson did several laps later to pass Herron at the same place, but stayed on the road this time. He almost got McCullough too, finishing just 0.098s adrift, with Herron third.

The trio were at it again in race two, but this time Herron looked much racier, grabbing the lead at the hairpin on lap five of 16 before being demoted moments later by both McCullough and Davidson. An even more determined effort a lap later at Colonial led to the inevitable contact and, while Herron continued to finish second to McCullough, Davidson retired

with a very modified rear corner.

The first of two combined races involving the NI Saloons and Scottish Mini Cooper S and Ford Fiesta ST players was won by Donal O'Neill's SEAT after the Cooper S of Oly Mortimer stopped, while second-placed Jock Borthwick topped the Mini brigade. Top Fiesta ST man was Jack Davidson. Mortimer took Cooper S and overall honours in race two from Paul Wilson and O'Neill. Davidson was again the best of the Fiestas.

In another combined affair for NI Mazda MX-5s and Fiestas, Rob Kennedy took the laurels ahead of Eorann O'Neill and David Cousins among the Mazdas – a result they repeated later in the day. Fiesta Zetec honours were shared by Desi McGlade and Mark Stewart.

Matthew Nicholl took two close wins in Irish Ginetta Junior although Sean McGovern ran him very close in race one and might have done the same in the second contest but for a spin, which dropped him behind Christopher Grimes.

RICHARD YOUNG

WEEKEND WINNERS



BOURNE

ANGLESEY

UK LEGENDS CHAMPIONSHIP

Heat 1 Sy Harraway

Heat 2 Marcus Pett

Final 1 Sean Smith

Heat 3 Miles Rudman

Heat 4 Sy Harraway

Final 2 Marcus Pett

SCOTTISH & IRISH LEGENDS

Heat 1 John Paterson

Heat 2 Steve Whitelegg

Final 1 John Paterson

Heat 3 Steven McGill

Heat 4 John Paterson

Final 2 John Paterson

CNC SPORTS & SALOONS

Races 1, 2 & 3 Danny Bird (Spire GTR, above)

CITROEN C1 CHALLENGE

PrepTech UK (Nicole Drought/Colin Lewis)

For full results visit: tsl-timing.com

KIRKISTOWN

SCOTTISH MINI COOPER CUP

Races 1 & 2 Robbie Dalgleish

Race 3 Michael Weddell

NORTHERN IRELAND

FORMULA FORD 1600

Races 1 & 2 David McCullough

(Van Diemen RF01, below)

NORTHERN IRELAND SALOONS

Race 1 Donal O'Neill (SEAT Cupra)

Race 2 Oly Mortimer (Mini Cooper S)

NORTHERN IRELAND FIESTAS/MX-5s

Races 1 & 2 Rob Kennedy (Mazda MX-5)

IRISH GINETTA JUNIOR CHAMPIONSHIP

Races 1 & 2 Matthew Nicholl



DEMPSTER

For full results visit: speedhive.mylaps.com

Mercedes retirements brought the Italians to the fore in 1955



A PEPPERED MONACO PAST



BOOK REVIEW
THE LIFE
MONACO GRAND PRIX
 RRP £19.99

Phrases such as “the jewel in Formula 1’s crown” and “a sunny place for shady people”, and images of superyachts lining the marina

with casual onlookers toasting champagne as grand prix cars navigate the streets have become inexorably tied to the Monaco Grand Prix.

But behind the veil, the diminutive principality has an engrossing and not always pleasant history. The death of Lorenzo Bandini in the 1967 edition of the race, an economy that crippled its local community prior to the Second World War, and royal sleaze – look beyond appearances and Monaco is by no means above reproach.

Stuart Codling explores the origins of the most famous race on the F1 calendar with his latest title *The Life Monaco Grand Prix...* as if being Autosport and F1 Racing’s executive editor didn’t pay enough.

To the author’s credit, *The Life* has carved out an impressive and largely unoccupied niche in motorsport literature by offering a comprehensive historical narrative that homes in on one locale. Naturally, most venues on the F1 calendar don’t lend themselves to such a detailed story – with the possible exceptions of Silverstone, Monza and Spa.

It’s fascinating to learn the backstory of grand prix founder Antony Noghes. He and Louis Chiron are the stars of the cast for how they enshrined the grand prix’s reputation.

Codling explores the race’s roots, why the circuit follows the layout it does today (largely unchanged over the decades) and how the first race was

decided after a farcical pistop that included Rudolf Caracciola’s car jack falling down a tramway rail gully – impressively, he fought back to third.

It then tracks through to Olivier Panis’s extraordinary 1996 victory, and Michael Schumacher’s Rascasse antics before a look at the steps made in safety and the Jaguar team’s ability to (supposedly) lose a couple of diamonds.

Where the book is strongest – and this is Autosport’s personal preference when it comes to particular eras of history – is in how it debunks the myth of Mercedes earning its ‘Silver Arrows’ nickname, and the fascist money backing the rise of the German juggernauts of the 1930s.

Autosport can only imagine how much it pains the author to see his prose rendered in American spelling, given the rigour with which he presides over the house style of the magazine each week.

Another slight grievance is how *The Life* can feel like an interrupted read in areas. The images accompanying many pages have their captions listed separately at the back. You can find yourself too often flicking between pages. The upshot is the photos are uncluttered, but it does slow the pace.

One of the biggest takeaways is something that also became clear when Autosport ran its poll to find F1’s greatest era. For those who bemoan that grand prix racing was ‘better back then’, it’s staggering to read just how many pole positions in the early days were won by massive margins, and how Juan Manuel Fangio could navigate the circuit some half a minute faster than his rivals over a race.

Monaco is the perfect case study for a deeper historical exploration, and it’s the characters that absolutely star in this well-sorted book.

We relish the author’s smugness in the office on Monday morning.

MATT KEW



motorsport
NETWORK

WATCH THE TRAILER NOW
[youtube.com/AUTOSPORTdotcom](https://www.youtube.com/AUTOSPORTdotcom)



Heroes, a new feature-length film focusing on the lives of five motor racing legends, will be unveiled in July in the week leading up to the British Grand Prix. Commissioned by Motorsport Network, it has been written and directed by Manish Pandey – the person behind the screenplay for the award-winning *Senna*. *Heroes* brings together Mika Hakkinen, Felipe Massa, Tom Kristensen and Michele Mouton to tell their love of four wheels, their big breaks, successes and personal struggles, all accompanied by footage from the archive. To view the trailer, go to bit.ly/HeroesFilm

WHAT'S ON

INTERNATIONAL MOTORSPORT

Rally Portugal

World Rally Championship
Round 7/14

Matosinhos, Portugal

31 May–2 June

TV Live BT Sport 2, Fri 1900. BT Sport 3, Sat 0830, 1500. BT Sport 1, Sun 0900, 1200. Red Bull TV, Sat 1450.

TV Highlights BT Sport 2, Fri 2200, Sun 0030, 2230. Red Bull TV, Fri 2200, Sat 2200, Sun 2200. Spike Mon 1900.

Live coverage on wrc.com

All live service via WRC+

IndyCar Series

Round 7/16

Detroit, USA

1 June

TV Live Sky Sports F1, Sat 2000, Sun 2000

IMSA Sportscar

Round 5/12

Detroit, USA

1 June

Blancpain Endurance Series

Round 3/5

Paul Ricard, France

1 June

Live Motorsport.tv, Sat 1200

Formula Renault Eurocup

Round 4/10

Paul Ricard, France

1-2 June

NASCAR Cup

Round 14/36

Pocono, USA

2 June

TV Live Premier Sports, Sun 1830

TV Highlights Premier Sports, Mon 2000

NASCAR Xfinity Series

12/33

Pocono, USA

1 June

MotoGP

Round 6/19

Mugello, Italy

2 June

TV Live BT Sport 2, Sun 1230

UK MOTORSPORT

Snetterton HSCC

1 June

Road Sports, Historic FF1600, Historic Touring Cars, Classic Clubmans, Classic F3/Classic FF2000

Oulton Park BRSCC

1 June

Caterham Seven 420R, Caterham Seven 310R, Caterham Seven 270R, Caterham Roadsport, Caterham Academy

Donington Park BARC

1-2 June

Dunlop Endurance, Clubmans, Caterham Graduates, MGOC, Karts

Thruxton BARC

1-2 June

Sports 2000, Formula Junior, Historic Touring Cars, U2TC,

Woodcote Trophy/Moss Trophy, Classic Alfas, Coys Trophy, HRDC Allstars

Silverstone BARC

1-2 June

Jaguar Series Elite, Mighty Minis, Junior Saloons, Kumho BMW, Pre-'66 Touring Cars, Pre-'83 Group 1 Touring Cars, Pre-'93 Touring Cars, Pre-'03 Touring Cars, Pre-'05 Production Saloon Cars, Blue Oval Saloon Series, Classic and Historic Thunder Saloons, Tin Tops, Porsches

Brands Hatch MSVR

1-2 June

American Speedfest: NASCAR Euro Series, Legends, Bernie's V8s, Formula 5000s, Silhouettes, Pickups

Croft 750MC

1-2 June

Club Enduro, 116 Trophy, Formula 1000, Locost, Toyota MR2, Roadsports, 750 Formula



QUIZ

WHO, WHAT, WHERE, WHEN?



WHO IS THIS?

From serving time beneath the waves to rubbing shoulders with the best, this lost talent left an enduring legacy.

He caught the bug at home at an unusually old age, but quickly rose through the ranks before leaving for the traditional centre of motorsport where he became a national champion. This led to him flying the flag in the big pond where he caught the eye of the future president and a chunk of influential thinkers.

When a flower failed to bloom it led to two established stars abandoning ship, creating an opportunity he couldn't refuse.

Things started badly, but from rock bottom when it found effective ground it was transformational, which he took full advantage of in tricky conditions. He was part of a roc group that had plenty of big hits, but his dreams were cut short in tragic fashion when he should have been all of a quiver.

LAST WEEK'S ANSWERS Who, what, where, when? Kurt Busch, Andretti Autosport Dallara, Indianapolis 500, May 2014. **Who is this?** Kyle Busch. **On this day** 1) Jarno Trulli. 2) Didier Pironi. 3) Fernando Alonso, Michael Schumacher and Jenson Button. 4) Team Rahal. 5) Jarno Trulli. **Name the helmet** Danny Sullivan.

ON THIS DAY

1 Which driver claimed his only fastest lap in Formula 1 on this day in the 2010 Turkish Grand Prix?

2 Who claimed his only F1 front row start on this day in the 2004 European GP?

3 Which future champion made his F1 world championship debut on this day in the 1965 Monaco GP?

4 It's Dieter Quester's birthday. Where and when did he make his single world championship F1 start?

5 The first Indianapolis 500 took place on this day in 1911. Ray Harroun won, who was second?

NAME THE HELMET



IN NEXT WEEK'S ISSUE

LE MANS 24 HOURS PREVIEW

LE MANS 2019



Our 52-page guide to the world's greatest enduro

MOTORSPORT IMAGES/LePAGE

AUTOSPORT

Autosport Media UK Ltd, 1 Eton Street, Richmond, TW9 1AG
Tel +44 (0) 20 3405 8100 **Email** autosport@autosport.com
Individual email firstname.surname@motorsport.com
Website www.autosport.com **Twitter** @autosport

EDITORIAL

Editor **Kevin Turner**
 Deputy Editor **Marcus Simmons**
 Grand Prix Editor **Edd Straw**
 F1 Correspondent **Scott Mitchell**
 Technical Editor **Jake Boxall-Legge**
 Chief Sub-Editor **Peter Hodges**
 Executive Editor **Stuart Codling**
 Performance and Engineering Editor **James Newbold**
 Rallies Editor **David Evans**
 BTCC Correspondent **Matt James**
 Editorial Assistant **Matt Kew**
 Art Editor **Lynsey Elliott**
 Senior Designer **Michael Cavalli**
 Origination/Repro **David Sternberg**
 Office Manager **Joanne Grove**



Photography

Steven Tee
 Glenn Dunbar
 Sam Bloxham
 Zack Mauger
 Jakob Ebrey
 Mark Sutton

Special Contributors

Ben Anderson
 Gary Anderson
 Alan Eldridge
 Tom Errington
 Stephen Lickorish
 Stefan Mackley
 David Malsher
 Jonathan Noble
 Marcus Pye
 Nigel Roebuck
 Jim Utter
 Gary Watkins

AUTOSPORT.COM

Video Content Editor **Glenn Freeman**
 Editor **Matt Beer**
 Autosport Plus Editor **Alex Kalinauckas**
 News Editor **Jack Cozens**
 International Editor **Jack Benyon**
 Social Media Editor **Joshua Folks**
 Technical Team Leader **Geoff Creighton**
 Lead UX Designer **Prad Patel**

CORRESPONDENTS

Argentina Tony Watson **Australia** Andrew van Leeuwen **Austria** Gerhard Kuntschik **Belgium** Gordon McKay **Brazil** Lito Cavalcanti **Finland** Esa Illoinen **Germany** Rene de Boer **Greece** Dimitris Papadopoulos **Italy** Roberto Chinchero **Japan** Jiro Takahashi **New Zealand** Bernard Carpinter **Russia** Gregory Golyshev **Spain** Raimon Duran **Sweden** Tege Tornvall **USA** Jeremy Shaw **UK & Ireland** Stephen Brunsdon, Dom D'Angelillo, Kerry Dunlop, Graham Keilloh, Mark Libbeter, Dan Mason, Lucy Morson, Jason Noble, Mark Paulson, Brian Phillips, Hal Ridge, Peter Scherer, Ian Sowman, Chris Stevens, Ian Titchmarsh, Richard Young

ADVERTISING

Tel +44 (0) 20 3405 8106 **Email** autosport.ads@motorsport.com
 Sales Director **James Robinson**
 Display Advertising **Jamie Brooker, Nick Gavigan, Karen Reilly**
 Creative Solutions **Don Rupal**
 Classified Advertising **Matt Buxton, Ben Kavanagh, Balvin McKenzie**
 Online and Agency Sales **Chris Hermitage**

ADVERTISING PRODUCTION

Production Controller **Ben Webster**
Tel +44 (0) 20 3405 8131 **Email** ben.webster@motorsport.com

SUBSCRIPTIONS

UK +44 (0) 344 848 8817 **Overseas** +44 (0) 1604 251451
Email help@asm.secureorder.co.uk **Back issues** 0344 8488817
Main office +44 (0) 20 3405 8100

Autosport, ISSN number 0269946X, is published weekly by Autosport Media UK Ltd, 1 Eton Street, Richmond, TW9 1AG, United Kingdom. Airfreight and mailing in the USA by agent named Air Business Ltd, c/o Worldnet Shipping Inc., 156-15, 146th Avenue, 2nd Floor, Jamaica, NY 11434, USA. Periodicals postage paid at Jamaica NY 11431. Subscription records are maintained at Autosport Media UK Ltd, 1 Eton Street, Richmond, TW9 1AG. Air Business Ltd is acting as our mailing agent.



CIRCULATION TRADE ENQUIRIES

Seymour Distribution Ltd, 2 East Poultry Avenue, London, EC1A 9PT. **Tel:** +44 (0) 20 7429 4000. Printed by William Gibbons & Sons Ltd, 28 Planetary Road, Willenhall, Wolverhampton WV13 3XT. ISSN 0269-946X. Autosport is published weekly by Autosport Media UK Ltd, 1 Eton Street, Richmond, TW9 1AG.

MANAGEMENT

President, Motorsport Network
James Allen
 Editor-in-Chief, Autosport Media UK
Andrew van de Burgt
 Group Publishing Manager **Sunita Davies**
 Special Events Manager **Laura Coppin**

We abide by the Editors' Code of Practice and are committed to upholding the highest standards of journalism. If you think we haven't met those standards and want to make a complaint, contact 0203 405 8100.



©2019, AUTOSPORT MEDIA UK LTD

Trading as Autosport Media UK. Publishing, trade and further subscription details on www.autosport.com. While due care is taken to ensure the contents of Autosport are accurate, the publishers and printers cannot accept liability for errors and omissions. Advertisements are accepted for publication in Autosport only upon Autosport Media UK's Standard Terms of Acceptance of Advertising, which are available from the Advertising Department.

LA FRENCH COURSE!



21-23 JUNE
CIRCUIT PAUL RICARD
LE CASTELLET



EXPERIENCE IT LIVE



WWW.MOTORSPORTLIVE.COM