

Seminar Objectives

- Goals
 - Educate
 - Eliminate
 - Communicate
- Headache Overview
- The latest research
- Atlas Orthogonal - “State of the Art Chiropractic”
- Questions/Wrap-up

Chronic Headaches & Migraines

New Findings – New Treatment

- What your doctor doesn't know.
- What the pharmaceutical industry hopes you don't find out.
- What have they recently discovered ?
- Why don't we know about this ?

Headaches are not “NORMAL”

- To accept that you must be reliant upon numbing pain medications on a regular basis for your headaches is not justified if you know about the latest research and treatments that are available.
- Empower yourself with knowledge your family doctor does not have!

Types of Headaches

- Migraine Headaches
- Tension Headaches
- Hormonal Headaches
- Cluster Headaches
- Sinus Headaches
- ****Cervicogenic Headaches****

Migraine details

- Can last 8 hours to 3 days
- 10% men & 20% women suffer at some period in their life.
- Can be a dull ache or “ice pick” pain – may begin behind one eye or temple.
- Cost individuals and families lost quality of life and lost production to industry.
- Attributed to nerve irritation and blood vessel constriction. Example – caffeine.

More migraine details

- Studies show blood levels to the brain decrease during migraine attacks.
- The blood travels to the outer blood vessels.
- Low levels of Magnesium are noted with migraines. Mg is a mineral involved with nerve function.

TENSION HEADACHES

- ~75% Of all Headache sufferers fall into this category
 - Two Types:
 - Acute – temporary and alleviated with rest, relaxation, and over the counter meds.
 - Chronic – frequent, even daily, don't respond as readily as acute. – More aggressive measures are needed. Most analgesics have become useless.
 - *All “Tension Headaches” have a muscular component!*

HORMONAL HEADACHES

- Headaches can clearly be triggered by changes in body chemistry.
- Factors that can change chemistry include:
 - Stress
 - Diet fluctuations – additions / subtractions
 - Menstruation
 - Medications

SINUS HEADACHES

- Most often misdiagnosed
- Must be accompanied with nasal drainage, runny nose, and fever.
- Usually referred pain from fifth cranial nerve – can cause pain around face, forehead, behind the eyes, and sinuses.

CLUSTER HEADACHES

- Most painful type of headache.
- Vascular in origin
- Occur in less than 1% of true headache patients.
- Occur in men 5:1 to women.
- Pain so intense, can become suicidal.

Medical Approach

- Medications
- Injections
- Nasal Sprays
 - All address the symptoms.
 - All address the chemical component.
 - *Underlying cause of many not addressed!*

Dr. Gary Golembiewski
D.C., F.A.S.B.E., B.C.A.O.
Board Certified Atlas Orthogonal &
Biomechanical Engineering

Our Goal Is To Address The Cause!

Release ~ Re-educate ~ Rebuild

A TEAM APPROACH !

What is the common connection
between all these types of
headaches?

Atlas Neuro-Vascular
Syndrome! - ANVS

Atlas Neurovascular Syndrome

- Compromises the integrity between the brain and the body.
- Medication can never correct this.
- Traditional chiropractic does not address this condition.
- Massage therapy and biofeedback can compliment treatment – after correction process begins.



No New Muscles have been
discovered since the 16th Century

- Discovery was a result of dissecting a cadaver from the side of the neck to view muscles of mastication while conventional dissection is from the back of the neck.
- Discovered a connective tissue bridge that attaches the rectus capitus posterior minor muscle (from the base of the skull to the atlas) to the dura at the atlanto – occipital junction. (present in all 10 cadavers)

Spine 1995;20:2484-2486

TMJ Research Leads to Discovery

- Led by assistant professor Gary Hack DDS, scientists at the University of Maryland discovered a physical connection between the muscular system and the central nervous system.

1998 Encyclopedia Britannica Medical and Health Annual

Cadaver

**Spinal
Cord**

Dura

**The
Connection**

Occiput

C₁ T.P.

C₂



Occiput

Dura

**Rectus Capitus
Posterior
(RCPM)
Muscle**

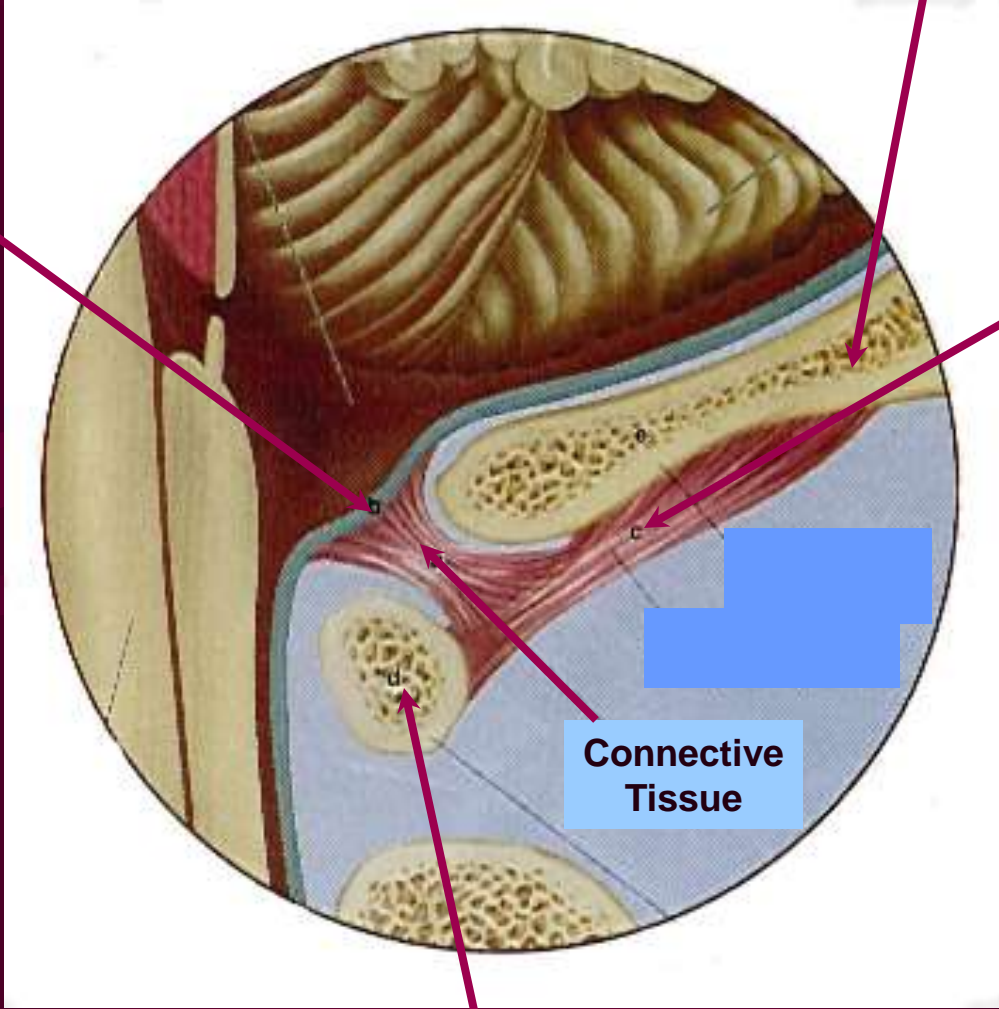

**Connective
Tissue**

C₁ Transverse Process

Stained Slide

Dura

The Connection

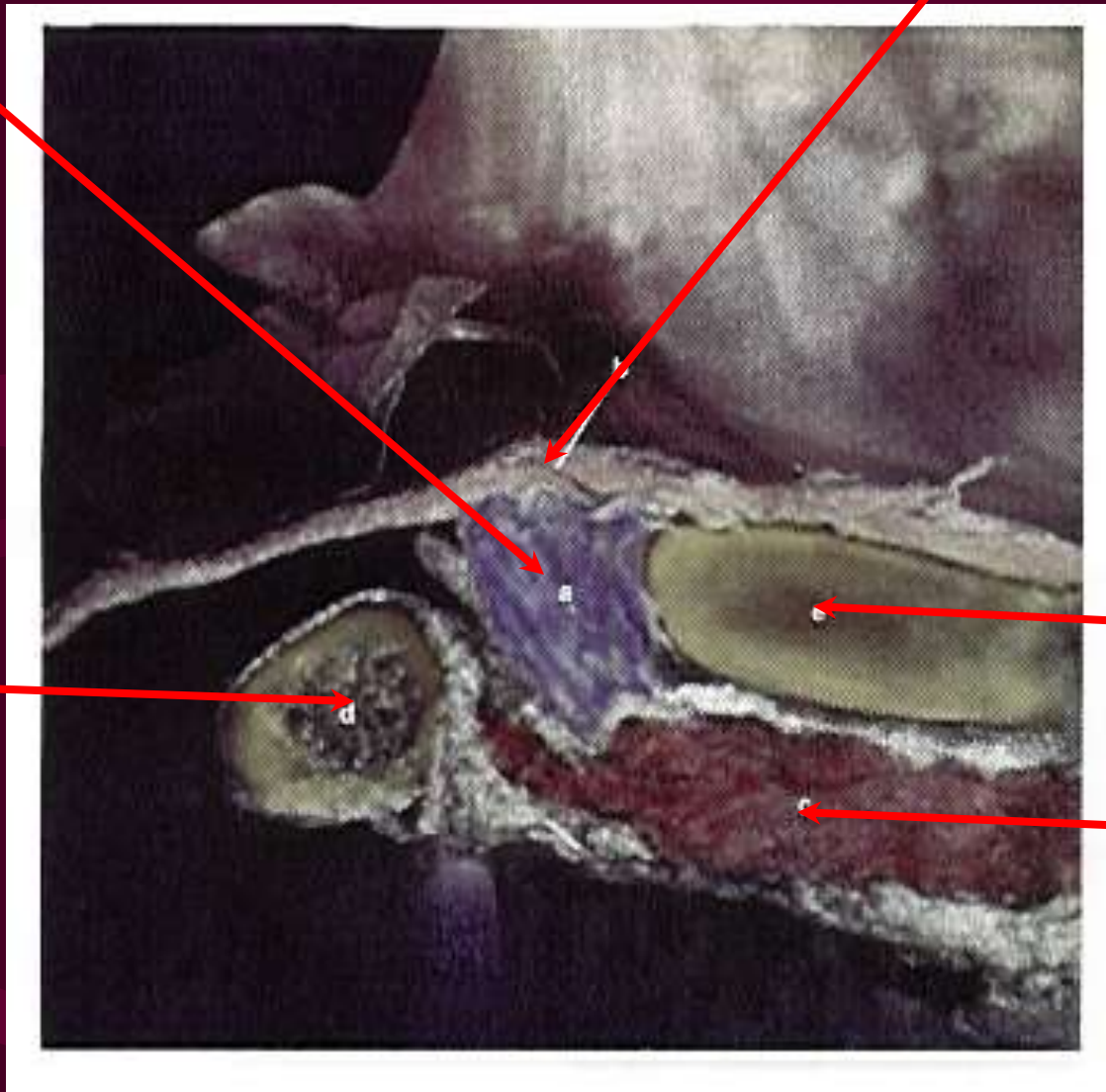

Atlas

Occiput

Rectus Capitus Posterior Minor

5th Muscle of Mastication

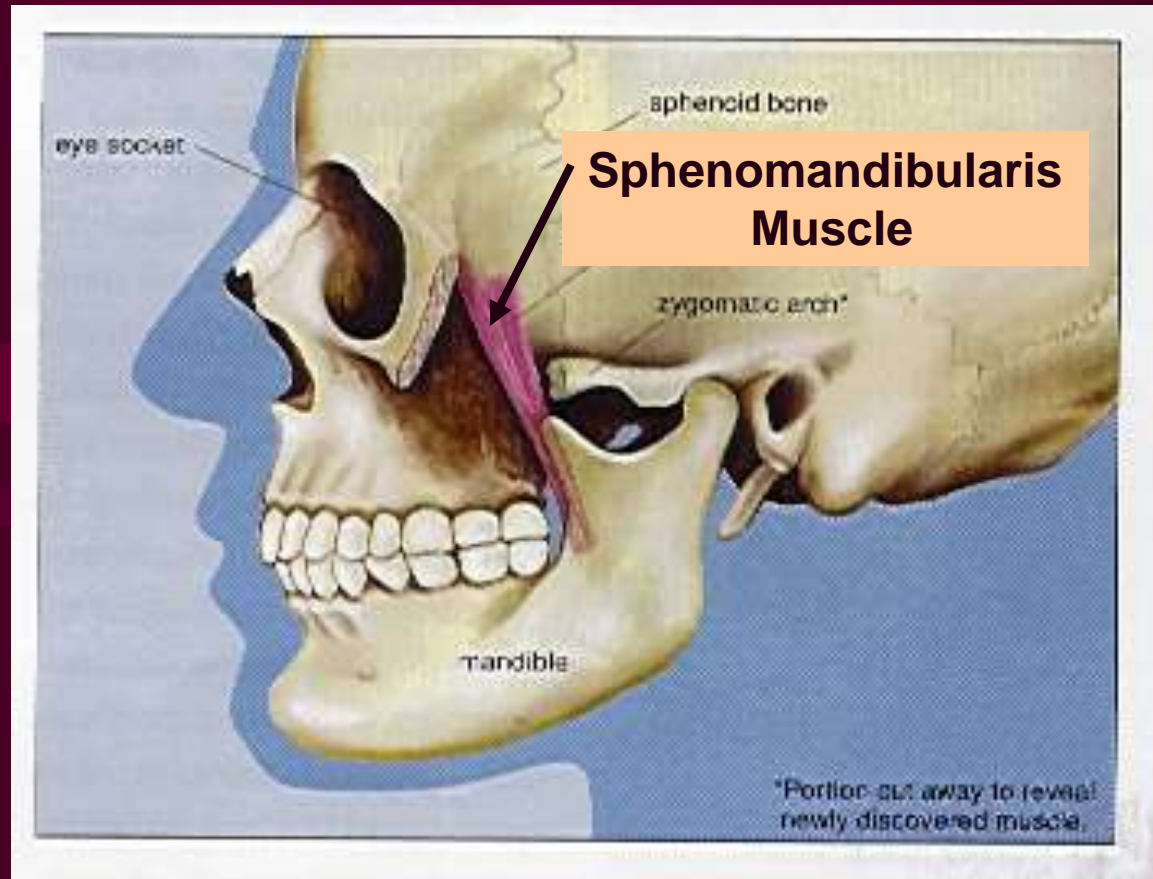

Connects the Sphenoid to the TMJ to the 2nd cervical vertebra

The Neuromuscular Connection

- Dr. Hack stated:
 - Maryland Scientists speculate that the newly described muscle – dura connection may transmit forces from the neck muscles to the pain sensitive dura.

Why Cervicogenic Headache Occurs

- Generally due to trauma to the neck.
- Macrotrauma
 - Motor vehicle accident
 - Traumatic birth – “Normal Birth”
 - Childhood falls (without obvious injury)
 - “Old sports injury”
- Microtrauma
 - Sustained forward flexion of head
 - Occupational positioning (posture)
 - Arthritic degeneration
 - Muscle fatigue – chronic muscular compensation!

Muscle or Joint Injury?

- Muscles do not play a significant role during the injury-causing phase.
- “The worst crash may be over before the muscles can become fully effective.”

Foust et al. Cervical ROM and dynamic response & strength of cervical muscles. Warrendale, PA: Society of Automotive Engineers Inc., 1993; 1023-35

Spine Vol. 23 Number 6 Pg. 649 - 1998

Anatomic Considerations of C2 Nerve Root Ganglion

- Sjaastad, Evans, Pikus, and Phillips noted that cervicogenic headache is associated with neck whiplash injuries.
- Keith points out that trauma with extreme rotation and hyperextension (whiplash) at the atlantoaxial joint has the potential to injure the C2 ganglion – thought to be of pathological significance in cervicogenic headache.

Cervicogenic Referred Pain

**Trigeminal
Nucleus**

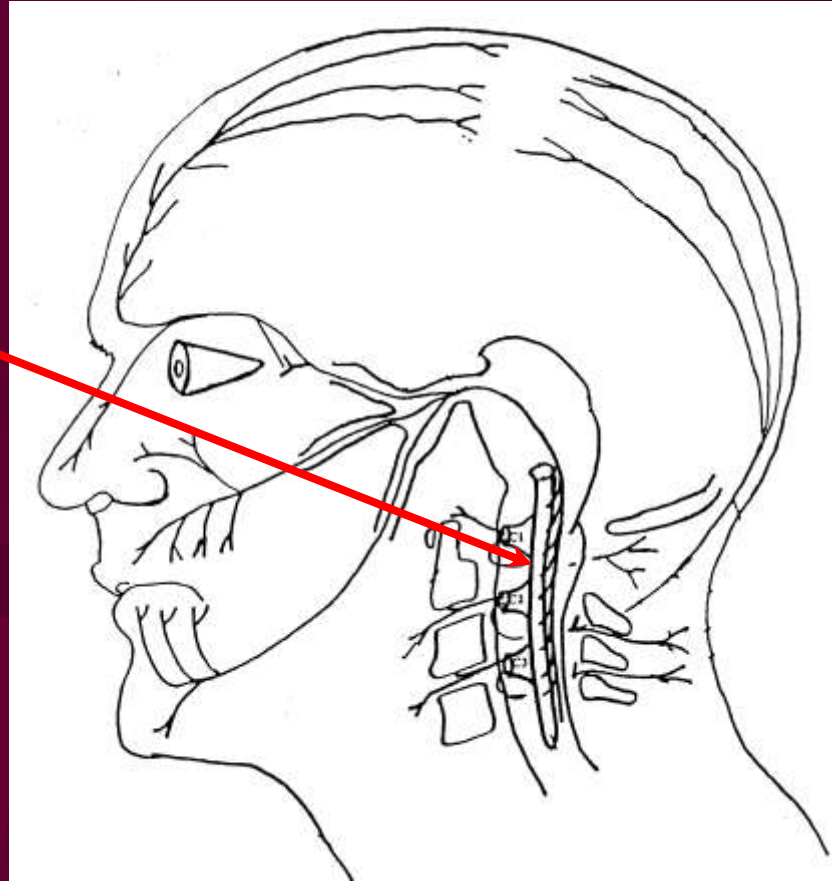

Any incoming nociception through C1, C2 & C3 (Facets, discs, ligaments, muscles, vertebral & dura arteries) can cause the Neurologic phenomenon of “pain” - Bogduk 1992

Explanation of Cervicogenic Headache – Peter Rothbart M.D.

- - “has its origin in the area of the neck. The source of pain is found in structures around the neck which have been damaged. These structures can include joints, ligaments, muscles, and cervical discs, all of which have complex nerve endings. When these nerve endings are damaged, they send pain signals from the upper nerves of the neck to the brain and intermingle with nerves of the trigeminal nerve.”

Chiropractic for headaches?

- Spinal Manipulation as a treatment for tension headache is predicated upon the assumption that the dysfunction in the neck muscles contributes to the head pain.
- The muscle dura connection may represent – at least in part – the underlying anatomical basis for the effectiveness of this treatment.

1998 Encyclopedia Britannica Medical and Health Annual

How would chiropractic help?

- Such treatment, as performed by a chiropractor, would decrease muscle tension and thereby reduce or eliminate pain by reducing the potential force exerted on the dura via muscle dura connection.
- 1998 Encyclopedia Britannica Medical and Health Annual

- “We’ve been able to put together a scientific explanation for how neck structure causes headaches...not all headaches”.
- “Chiropractors have been saying that for years. Unfortunately, many (medical) Doctors tend to have a jaundiced view of Chiropractors, but (Chiropractors) were right about headaches.”

Peter Rothbart, MD, FRCPC. President North America
Cervicogenic Headache Society

If this is your idea of chiropractic care...

CLOSE TO HOME JOHN McPHERSON

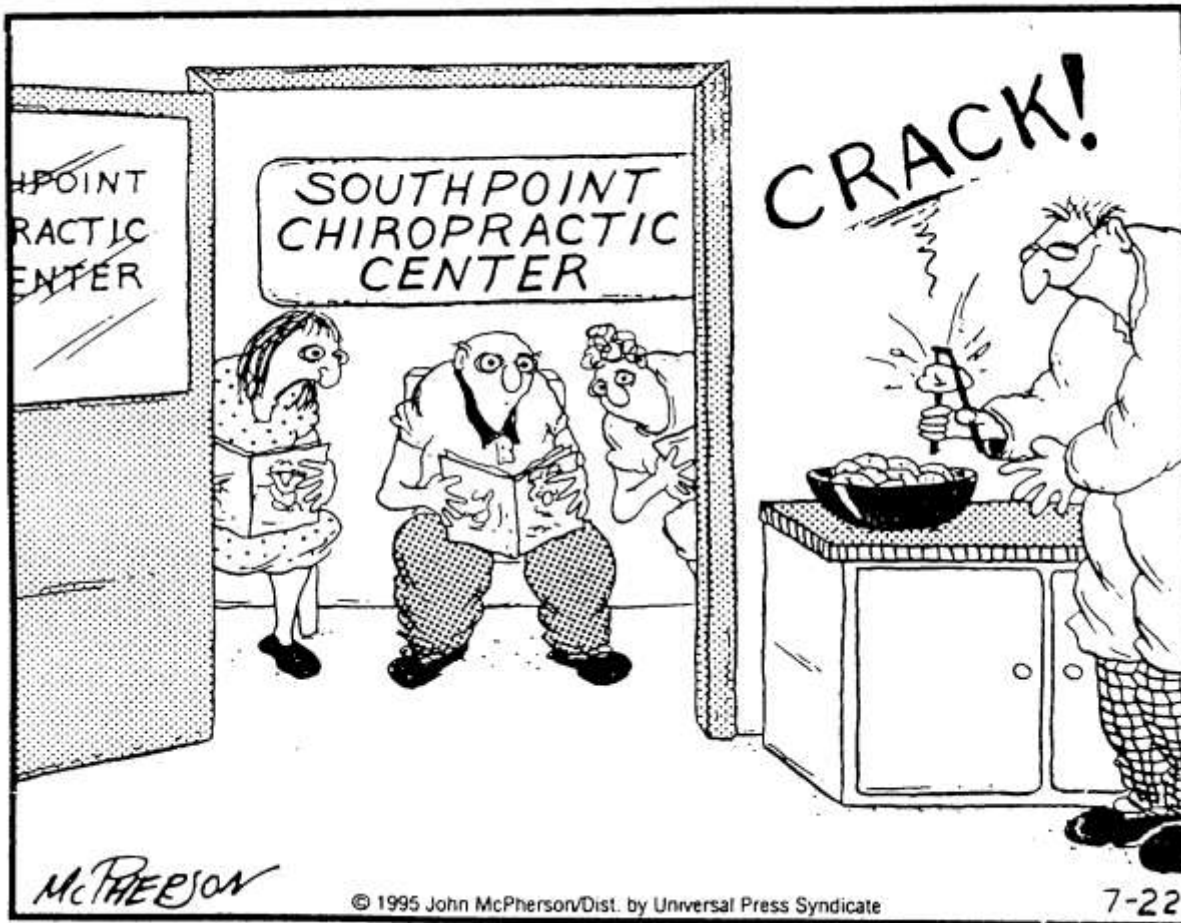

**THINK
AGAIN !!**

Not Just Any Chiropractor!

- Board Certified Atlas Orthogonist
- Post Graduate certification to detect, analyze and correct the C₀/C₁/C₂ vertebral Subluxation complex. Board certification includes:
 - Specialized radiographic position
 - Radiograph template or digital analysis
 - Use of Atlas Orthogonal Percussion Adjusting Instrument
 - Post corrective radiographic & spinal analysis
- 200 hours of post graduate education
- 3-9 month internship

Atlas Orthogonal Technique

- Designed by 1995 Scientific Achievement Award winner Roy Sweat, D.C. – Atlanta, GA

Architectural blueprint demonstrating mutual perpendicular balance of the 1st cervical vertebra between the skull and the center of the lower cervical spine.

- Measure to millimeters and degrees.
- Use speed and precision as a substitute for “forceful manipulation”.
- Math & physics based – Reproducible!

Atlas

- The 1st cervical vertebra articulating with the skull onto the neck.
- The Greek titan known to support the weight of the world upon his shoulders.

Orthogonal

- Right angles
- Intersecting at right angles
- Mutually perpendicular

Atlas Subluxation Patterns

All patterns are described with reference to being actually deviant from a perpendicular, 90° , or Orthogonal position

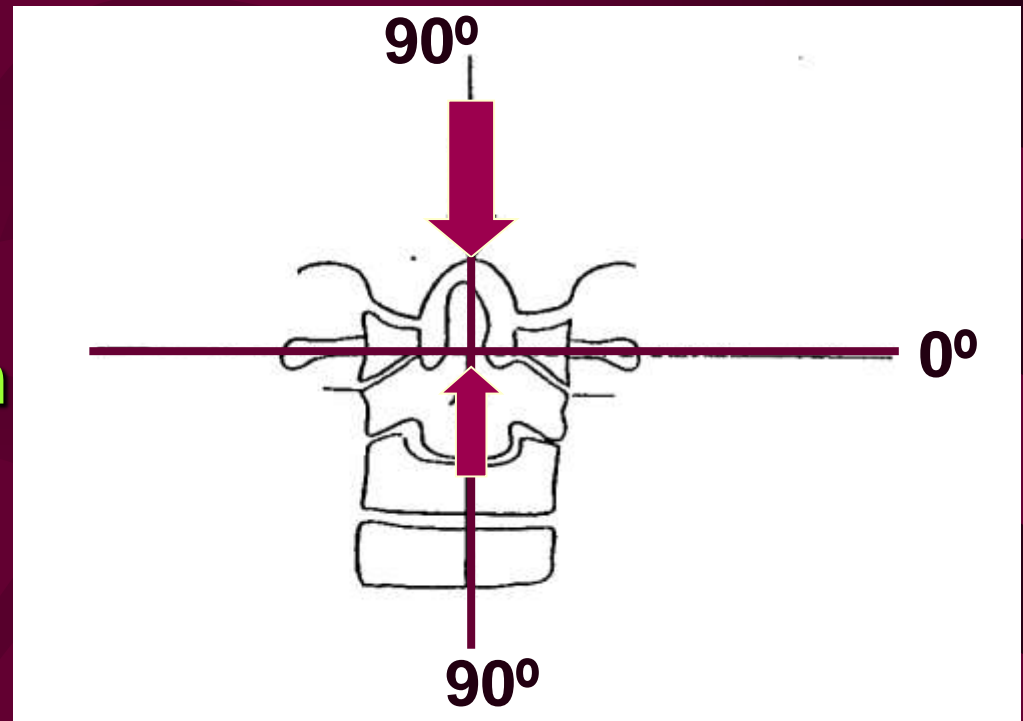

Neutral Orthogonal Position

Radiographic Positioning

**Special X-Ray
Training &
Equipment
Minimize
Radiographic
Distortion.**

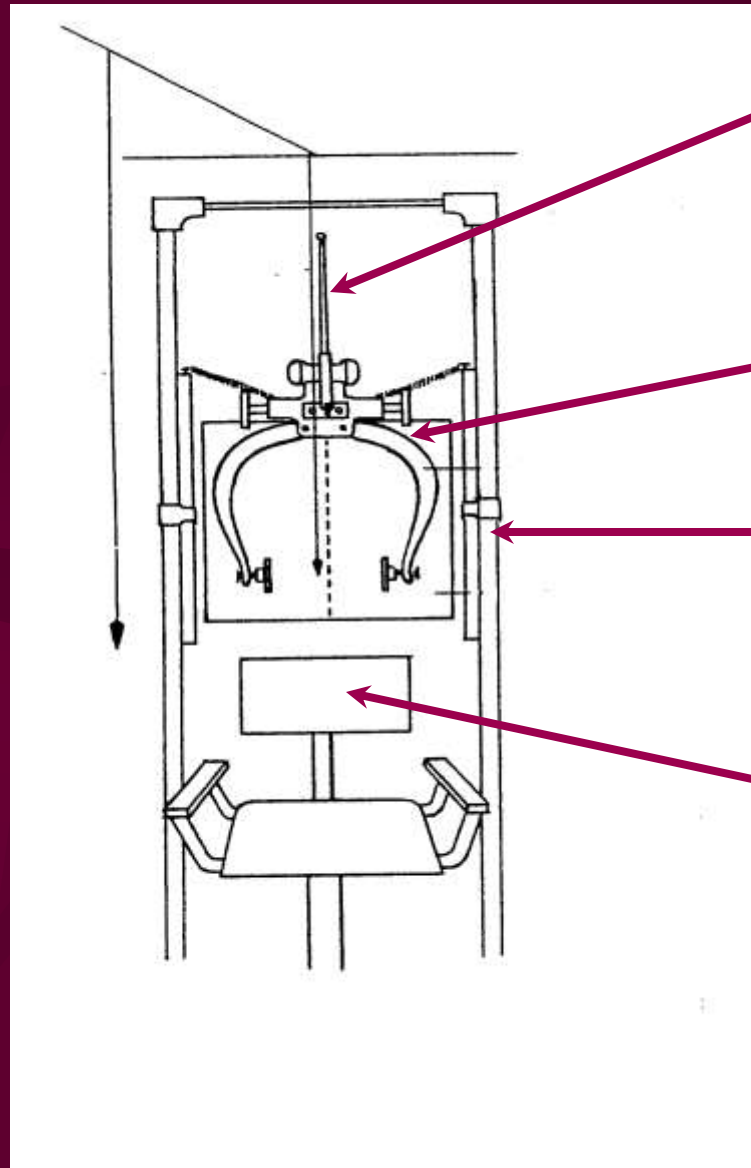

**Alignment
Rod
(Globella Bar)**

Head Clamps

**Special L- or
C-Frame**

**Gliding
Positioning
Chair**

Typical Frontal/Nasium View of Head & Neck

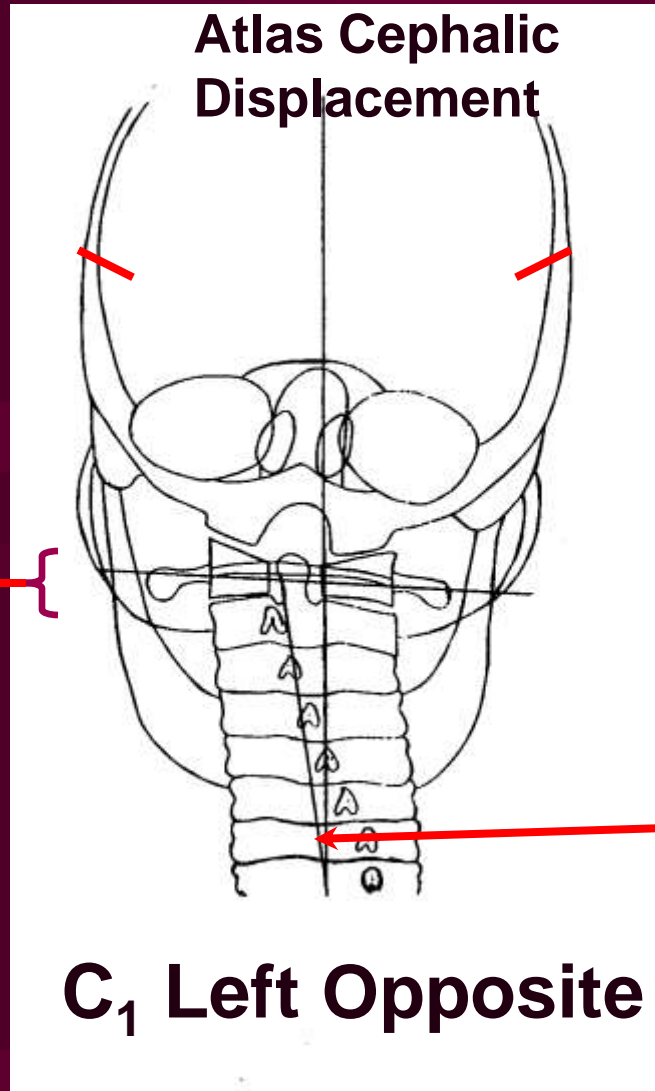

Occipital-Parietal Sutures

Lower Cervical Spine





White & Panjabi
Kinematics of the Spine
Page 66

- “Axial rotation of the Atlas can cause symptoms of vertigo, nausea, tinnitus, and visual disturbances.”
- Augustus A. White III, MD and Manchar M. Panjabi, PhD.

Pre X-Ray





Show Me Some Research

- Spinal adjustments compared to Amitriptyline (the most commonly used drug for tension headache). Compare their effectiveness for Chronic tension-type Headaches
- 150 Patients randomized into 2 groups:
 - Chiropractic Care
 - Care managed with Amitriptyline by a medical physician
- 2 week baseline; 6 week Treatment; 4 week follow-up

Boline et al. Spinal Manipulation vs. Amitriptyline for the Treatment of Chronic Tension-type Headaches: A RCT. JMPT 1995; 18(3): 148-54.

- “During the treatment period both groups improved at similar rates, but after 4 weeks of cessation of treatment, the manipulation group continued to show a sustained therapeutic benefit of improvement in all major outcomes.”
- “In contrast, the Amitriptyline group showed no improvement or a slight worsening from the baseline values in the same outcomes.”

Boline et al. Spinal Manipulation vs. Amitriptyline for the Treatment of Chronic Tension-type Headaches: A RCT. JMPT 1995; 18(3): 148-54.

The Ontario Ministry of Health: The Effectiveness of Chiropractic

- “Based on a review of international evidence and Canadian health care statistics estimates that an increase in the proportion of the public using chiropractic services of 10-20% in the province of Ontario (pop. 11.5 million) would save the government \$348 million per year in direct health care costs.”
- Reference:-Prof. Pran Manga, Ph.d., 1998

Spinal Adjustments Vs. Other Types of Conservative Care

- “In comparing the effectiveness of manipulative therapy, physiotherapy, general practitioner care, and placebo in 256 patients with back and neck complaints, improvement was largest with manipulative therapy and the difference was maintained at a 1 year follow-up.”
- Koes et al. British Medical Journal, 1992

Spinal Adjustments Vs. Other Types of Conservative Care

- “In the terms of return to normal function and patient satisfaction chiropractic seems to be of value.”
- Family physicians should refer to chiropractors.

Curtis P, Bove G. Family Physicians, Chiropractors, and Back Pain. The J Fam Practice 1992;35(5):551-555.

Conclusion

- Questions / Answers
- Headache Survey
- Thank You !

Gary V. Golembiewski, D.C.,

Doctor of Chiropractic
Board Certified Atlas Orthogonist

*If you have a spine, it should be
in line!”*