

**F1 TV REVOLUTION** How Sky & BBC will vie for your attention

FORMULA 1 • SPORTSCARS • TOURING CARS • NASCAR • INDYCAR • RALLYING • NATIONAL RACING & MORE

# AUTOSPORT

DECEMBER 1 2011 • £3.30 • AUTOSPORT.COM

**IT'S OFFICIAL**

# Kimi is back!

**THE CRUCIAL QUESTION**  
Can former world champion be a winner again with new-look Lotus?

**PLUS**  
Brazilian GP analysis  
**WEBBER**  
gets one over Vettel



haymarket



# Two classic WRC seasons on DVD - save £20



RRP £44.98  
**OFFER PRICE**  
£24.98

The 2011 World Rally Championship Review is more than 7 hours of action, analysis, interviews and bonus features on 2 discs, charting every round of the down-to-the-wire title battle. Order it with the 2001 WRC review, celebrating the 10th anniversary of Richard Burns's victory, and **save a massive £20!**

Code: WRC0111

Available separately:

**WRC 2011** Code: 4974 RRP: £24.99 **Offer Price: £19.99**

**WRC 2001** Code: 4751 RRP: £19.99 **Offer Price: £16.99**

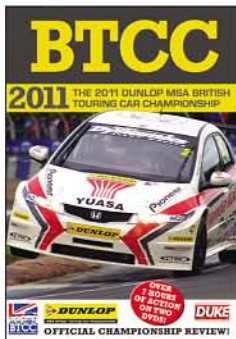

Code: 3938 RRP: £24.99  
**OFFER PRICE £14.99**

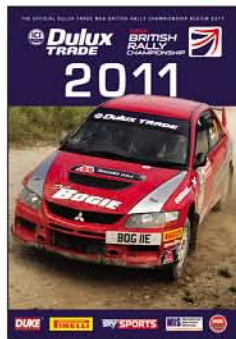

Code: 4975 RRP: £24.99  
**OFFER PRICE £14.99**



Code: 3757 RRP: £24.99  
**OFFER PRICE £19.99**  
DVD Code: 3756 RRP: £19.99  
**OFFER PRICE £14.99**

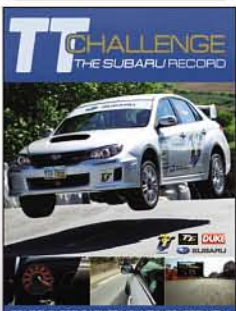

Code: 4973 RRP: £17.99  
**OFFER PRICE £12.99**

## THE HEROES OF GRAND PRIX **NEW**

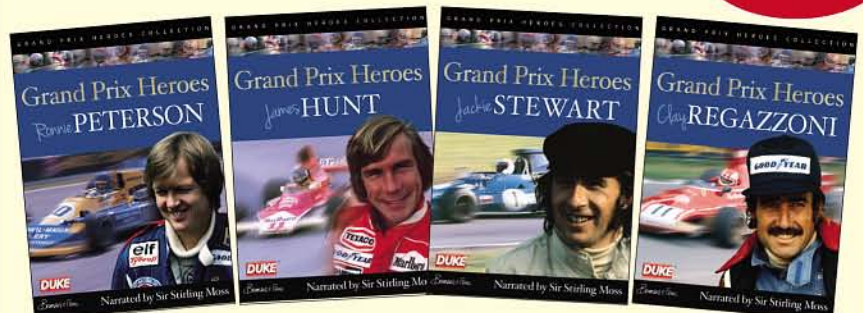

Grand Prix Heroes is a new series profiling 11 of Formula One's most popular characters. Produced by Brunswick Films, each features mouthwatering archive race action, rarely-heard period interviews and narration by Sir Stirling Moss O.B.E. Each DVD is packed with important career highlights and fascinating 'behind-the-scenes' footage.

**Each DVD is just £16.99** - for the full range visit [www.DukeVideo.com/Autosport](http://www.DukeVideo.com/Autosport)



Scan with your Smart phone to find out more

Shop online

[www.DukeVideo.com/Autosport](http://www.DukeVideo.com/Autosport)

or call

**+44 (0)1624 640 000**

Media code: Auto11

Duke and the Duke logo are registered trademarks of Duke Marketing Limited. All rights reserved.

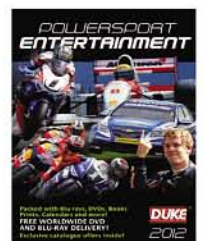

**FREE 2012 catalogue**  
out now!

# CONTENTS

December 1 2011 – vol 206 no 9



## AUTOSPORT.COM

Up-to-the-minute news and reports from F1, WRC and more. Subscribe for must-read opinion, stats and images

COVER IMAGE:  
LOTUS RENAULT  
GRAND PRIX  
INSET:  
COATES/LAT



**“I can’t deny the fact that my hunger for F1 has recently become overwhelming”**

**A HIGHLY MOTIVATED KIMI RAIKKONEN AFTER SECURING A LOTUS-RENAULT SEAT FOR 2012. WONDER HOW LONG IT’LL LAST?**

# 392

The highest-ever single-season points tally by a driver in Formula 1 World Championship history, accumulated by 2011 world champ Sebastian Vettel

**SUBSCRIBE...**  
to AUTOSPORT and get a free pair of Cebe Spider sunglasses **P84**

## NEWS



COVER STORY

Raikkonen settles into his new F1 outfit, p8

### 8 Renault’s Raikkonen plan

How squad plans to get new signing Kimi Raikkonen up to speed before the 2012 season

### 10 Mansell v Vettel

Comparing F1’s pole record breakers from 1992 and 2011

### 13 F1 ’12 TV scheduled ratified

All you need to know about F1 on the box next season

### 15 Charting F1’s performance

Measuring 20 years’ development pace at unmolested Interlagos

### 18 Priaulx: nowhere to hide

The pressure’s on at BMW now Tomczyk’s on board, says Brit

### 20 Jim Rathmann 1928-2011

Remembering the US racing ace and former Indy 500 winner

### 22 Sportscars back to Brands

FIA World GT series commits to Kent venue for 2012 event

### 25 Tweets, polls, top-fives

We won’t win the title in our first season, says VW Motorsport

supremo Kris Nissen

## REPORTS



Red Bull duo dominate F1 finale, p28

### 28 Brazilian Grand Prix

Red Bull takes another one-two,

but this time Webber beats hobbled team-mate Vettel

## REGULARS

### 5 From the editor

### 6 Snapshot

### 17 Mark Hughes column

### 84 Subscribe for a free gift

### 88 Final drive

Letters and Latest Gear

### 90 On track/on screen

The best action in the next week

### 93 From the archive

Tony Brise, British F3 1972

### 94 Race of my life

Ricardo Zunino, Canadian GP ’79

## FEATURES

### 42 Search for a star

McLaren AUTOSPORT BRDC Award shootout at Silverstone

Six young men go into battle, p42



### 46 Christmas gift guide

### 52 Dan Wheldon tribute

Amusing anecdotes and classic capers involving the fallen hero

### 58 Wheldon back to his roots

In September, Dan tested three American junior racers for us

### 64 House of Stewart

NASCAR king reflects on 2011

### 66 The Bottas empire

GP3 champ on his “vital” win

## SPORTS EXTRA

### 81 Brands to re-profile corner

Graham Hill Bend set for a future overhaul to increase overtaking

### 82 Juno makes F4 switch

British squad adapts Duratec Formula Ford for F4 assault

### 85 Short wins Baxter Trophy

Anglesey FFord memorial win for Van Diemen RFOO racer

### 86 National focus

Full season review of Ginetta GT Supercup and Ginetta Junior series



Graham Hill Bend will change

# FIA WORLD RALLY CHAMPIONSHIP. YOU CAN'T CONTROL THE ELEMENTS, BUT YOU CAN WIN THE CHAMPIONSHIP.



Congratulations to Sébastien Loeb and Daniel Elena, winners of the 2011 FIA World Rally Championship.\*



In off road rallying, driving conditions could suddenly change at any stage of the race, so Sébastien Loeb and Daniel Elena both had to have confidence in their tyres' ability to adapt. MICHELIN tyres, with their excellent grip, gave them that confidence, whatever the weather or terrain.

You could also benefit, on road and off road, from the expertise Michelin has derived from motorsport with the MICHELIN Latitude Cross.

Experience the performance at [www.michelin.co.uk/experience-the-performance](http://www.michelin.co.uk/experience-the-performance)

\*Subject to the publication of the official results by FIA.



## EDITOR-IN-CHIEF

Andrew van de Burt  
andrew.vandeburg@haymarket.com ext.5974

## EDITOR

Charles Bradley  
charles.bradley@haymarket.com ext.5889

## AUTOSPORT.COM EDITOR

Simon Strang ext.5093  
simon.strang@haymarket.com

## GROUP F1 EDITOR

Jonathan Noble ext.5810  
jonathan.noble@haymarket.com

## F1 EDITOR

Edd Straw ext.5887  
edd.straw@haymarket.com

## FEATURES EDITOR

Kevin Turner ext.5432  
kevin.turner@haymarket.com

## NEWS EDITOR

Glenn Freeman ext.5309  
glenn.freeman@haymarket.com

## SOCIAL MEDIA EDITOR

Mark Glendenning ext.5801  
mark.glendenning@haymarket.com

## REPORTS EDITOR

Jamie O'Leary ext.5811  
jamie.oleary@haymarket.com

## MANAGING EDITOR

Peter Hodges ext.8617  
peter.hodges@haymarket.com

## WEB MANAGING EDITOR

Pablo Elizalde  
pablo.elizalde@haynet.com

## GRAND PRIX EDITOR

Mark Hughes  
autosport.editorial@haynet.com

## F1 COLUMNIST

David Coulthard

## RALLIES EDITOR

David Evans  
david.evans@haymarket.com

## INTERNATIONAL EDITOR-AT-LARGE

Gary Watkins

## ART EDITOR

Aubrey Smith ext.5914  
aubrey.smith@haymarket.com

## PRESENTER/SUB-EDITOR

Henry Hope-Frost ext.5835  
henry.hope-frost@haymarket.com

## CHIEF SUB-EDITOR

Marcus Simmons ext.5807  
marcus.simmons@haymarket.com

## NATIONAL EDITOR

Ben Anderson ext.5425  
ben.anderson@haymarket.com

## NATIONAL EDITOR-AT-LARGE

Marcus Pye

## SENIOR DESIGNER

Matthew Dungate

## DESIGNER

Will Clarke

## PICTURE EDITOR

Peter Mills ext.5918  
peter.mills@haymarket.com

## AUTOSPORT.COM

TECHNICAL TEAM LEADER  
Geoff Creighton  
geoff.creighton@haymarket.com

## AUTOSPORT.COM USER

INTERFACE DEVELOPER  
Pete Holmes  
peter.holmes@haymarket.com

## AUTOSPORT.COM

PICTURE EDITOR  
Chris Bird  
chris.bird@haymarket.com

## SECRETARY

Julie Bower  
julie.bower@haymarket.com ext.5804

## PHOTOGRAPHS

LAT Photographic

## SPECIAL CORRESPONDENT

Adam Cooper

## TECHNICAL CONSULTANT

Gary Anderson

## TECHNICAL EDITOR

Giorgio Piola

## NEWS GRAPHICS

Alan Eldridge

## CARTOONIST

Jim Bamber

## CORRESPONDENTS

### ARGENTINA

Tony Watson

### AUSTRALIA

Phil Branagan

### AUSTRIA

Gerhard Kuntzsch

### BELGIUM

Gordon McKay

### BRAZIL

Lito Cavalcanti

### FINLAND

Esa Iiloinen

### GERMANY

Rene de Boer

### GREECE

Dimitris Papadopoulos

### ITALY

Roberto Chinchero

### JAPAN

Jiro Takahashi, Len Clarke

### NEW ZEALAND

Bernard Garpenter

### RUSSIA

Gregory Golyshv

### SOUTH AFRICA

Richard Asher

### SPAIN

Raimon Duran

### SWEDEN

Teze Tornvall

### USA

Jonathan Ingram, Bruce

### Martin, David Phillips,

Diego Mesa, Robin Miller, Jeff Olson, Jeremy Shaw,

### UK & EIRE

David Addison, Ben Bostock, Duff Candier, Jonathan Crawford,

Kerry Dunlop, Leanne Fahy, Paul Jurd, Linda Keen, Paul Lawrence,

Marc Orme, Graham Read, Peter Scherer, Ian

Sowman, Oliver Timson, Ian Titchmarsh, Matt

Upton, Eddie Walder, Tim Whittington, Richard Young

## ADVERTISING

Tel: +44 (0) 20 8267 5858  
Fax: +44 (0) 20 8267 5850

E-mail: autosport.ads@haymarket.com

## SALES MANAGER

Rachel Brock,  
ext: 5820  
rachel.brock@haymarket.com

## DISPLAY ADVERTISING

Andrew Barclay,  
ext: 5027  
andrew.barclay@haymarket.com

Peter De Vries,  
ext: 5961  
peter.devries@haymarket.com

Karen Reilly,  
ext: 5576  
karen.reilly@haymarket.com

## CLASSIFIED ADVERTISING

LeAnne Foley,  
ext: 5836  
leanne.foley@haymarket.com

## AD PRODUCTION

Tel: +44 (0) 20 8267 5740 Fax: +44 (0) 20 8267 5320

## ADVERTISING DIRECTOR

Matthew Witham

## SPECIAL PROJECTS DIRECTOR

Derek Redfern

## LICENSING DIRECTOR

Tim Bulley

## PRODUCTION MANAGER

Carrie McNally,  
ext: 5814  
carrie.mcnally@haymarket.com

## SENIOR DISPLAY PRODUCTION CONTROLLER

Saba Bonser, ext: 5740  
saba.bonser@haymarket.com

## PRODUCTION CONTROLLER

Lee Brister, ext: 5823  
lee.brister@haymarket.com

## SUBSCRIPTIONS

UK 0844 8488817  
OVERSEAS +44 (0)1795 592 974

## EMAIL

autosport@servicehelpline.co.uk  
US & CANADA 1-866-918-1446  
US & CANADA EMAIL

haymarket@imsnews.com  
AUTOSPORT (USPS #54230) is published weekly by Haymarket Magazines Ltd, c/o Mercury International Ltd of 365 Blair Road, Avenel, New Jersey 07001. For subscription rates please contact:

Tel: 1-866-918-1446, Email: haymarket@imsnews.com

Periodicals paid at Railway, NJ. Postmaster please send address correction changes to AUTOSPORT, c/o Mercury International at above address.

## BACK ISSUES

Tel: 0844 8488817

## DIRECT MARKETING EXECUTIVE

Karen McCarthy, ext: 5658  
karen.mccarthy@haymarket.com

## MANAGEMENT

PUBLISHING DIRECTOR  
Peter Higham

## PUBLISHER

Rob Allame

## PUBLICATIONS MANAGER

Samantha Jemson

## DIGITAL PRODUCT MANAGER

Jim Foster

## SPECIAL EVENTS MANAGER

Laura Coppin

## SYNDICATION SALES MANAGER

Roshini Sethi, +44 208 267 5396  
roshini.sethi@haymarket.com

## © HAYMARKET CONSUMER MEDIA

Publishing, trade and further subscription details on www.autosport.com. While due care is taken to ensure the contents of AUTOSPORT are accurate, the publishers and printers cannot accept liability for errors and omissions. Advertisements are accepted for publication in AUTOSPORT only upon Haymarket Consumer Media's Standard Terms of Acceptance of Advertising, copies of which are available from the Advertising Sales Department of AUTOSPORT.

## CIRCULATION TRADE ENQUIRIES

Frontline Ltd, Park House, 117 Park Road, Peterborough, Cambs, PE21 2TS. Tel: +44 (0)1773 355161. Printed in England by Wyndeham Heron Ltd. Cover and centre sections printed by CSM Impact, Basingstoke. Colour origination: Colour Systems, 90-92 Pentonville Road, London N1 9HS (editorial and advertising). ISSN 0269-946X. AUTOSPORT, incorporating Autoclassic, is published weekly by Haymarket Consumer Media, Teddington Studios, Broom Road, Teddington, TW11 9BE, UK.

## EDITORIAL DIRECTOR

Mark Payton

## DESIGN DIRECTOR

Paul Hargin

## STRATEGY AND PLANNING DIRECTOR

Bob McDowell

## MANAGING DIRECTOR

David Prasher

## CHIEF EXECUTIVE

Kevin Costello



PEFC Certified

This product is from sustainably managed forests and controlled sources

www.pefc.co.uk



Haymarket is certified by BSI to environmental standard ISO14001

## POLE POSITION

# Can Kimi and Lotus relive the glory days?



## MOTIVATION IS A STRANGE ANIMAL.

For Kimi Raikkonen, it's clear that his "overwhelming" hunger to return to Formula 1 proves its ability to intoxicate him. Yet it's been so long since his last 'hit' of this drug, what does new-look Lotus (nee Renault, Benetton, Toleman) get out of it?

Publicity for starters, as one of our sport's most exciting talents of his generation returns. A genuine top-line name too, as the ill-timed loss of Robert Kubica (Ferrari-bound for 2013?) risks its recent slump into the midfield becoming a permanent one. Let's cut to the chase: has Kimi still got it? Can the 2007 world champion and 18-time grand prix winner harness his raw driving skills and lead this faded championship-winning team to new glory? Next year we will have six world champions on the grid – that's a lot of reputations on the line, and you have to admit that the other five will all start from far more promising positions.

They say the only time you mustn't fail is the last time you try. Over to you, Kimi. Good luck...

Charles Bradley, editor

## BAMBER'S WEEK

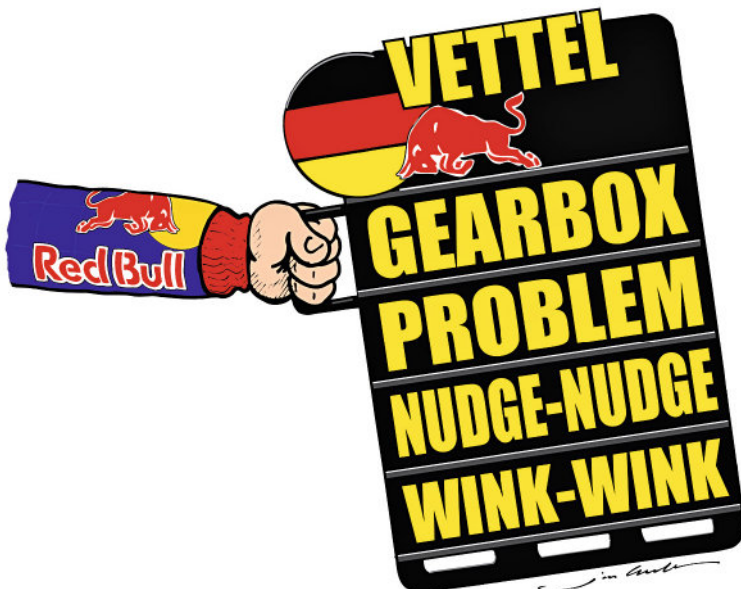



THE AUTOSPORT APP -  
NOW ON ANDROID/iPHONE



**McLAREN AUTOSPORT BRDC AWARD**

## Britain's brightest shine at Silverstone

The six finalists in the 23rd McLaren AUTOSPORT BRDC Award evaluation were put through their paces in a Formula 2 single-seater, a Mercedes C-class DTM monster and the all-new McLaren MP4-12C GT3 racer at a sodden Silverstone. Find out what they all thought of the high-pressure shootout on page 42.

Pic: Gibson/LAT

# Track-time plan for Raikkonen

Revealed: Renault's plans to get returning world champion back up to speed in a Formula 1 car. By EDD STRAW

Renault is set to give Kimi Raikkonen test mileage in a 2009-specification car to ensure that he is fully prepared for his return to Formula 1.

The former world champion has not driven a Formula 1 car since his final grand prix for Ferrari in Abu Dhabi in 2009. Pre-season testing is limited to 11 days per team, with a further four-day in-season test at Mugello in May, meaning that the 32-year-old is likely to have only six days in the team's 2012 car next February before the season-opening Australian Grand Prix.

The Finn is due at the team's Enstone base tomorrow (Friday) to begin preparation for his F1 return. As his deal, which was agreed with team owners Genii Capital, was concluded so quickly, a definitive programme has yet to be decided. But a plan for testing dates is on the

agenda for discussion tomorrow.

Team principal Eric Boullier is confident that with a little track time, Raikkonen will be back to his best – making testing in an old car the natural step.

“We have discussed some possibilities, but nothing is confirmed,” Boullier told AUTOSPORT.

“It would be logical to give him a run. Maybe for test days, you give him some more mileage to get his feeling back. Track time will allow him to get back all of his old reflexes. It will also be good for him to use our new simulator.”



We broke Kimi's plans in August

## KIMI, NO SCHUMACHER

Raikkonen has been absent from single-seaters since November 2009, during which he has competed in the World Rally Championship with limited success and competed in two NASCAR-sanctioned events.

The comparison with Michael

Schumacher, who by his own admission took a year to re-acclimatise to F1, is obvious. Boullier is certain that Raikkonen's motivation is sufficient to go through this process, but he added that the age difference and Schumacher's longer, three-year, absence means that the pair's situations are not the same.

“The difference between Michael and Kimi was the time they were out,” said Boullier. “And he is not the same age. Kimi will not need so long to be back and I think he will be able to be at 100 per cent quickly.”

Boullier confirmed that this signing was triggered in part by confirmation that Robert Kubica would not be available for the start of 2012. He sees the Finn as having the potential to establish himself as a team leader and is not concerned that one of the motivations for Ferrari dropping him at the end of 2009 was that he was not able to spur on the team as hoped.

“We need experience,” said Boullier. “The fact he won many races, and was at a team like McLaren, means he definitely can position himself as a team leader. It's obvious and logical.”

## MARQUEE SIGNING

It is clear that Raikkonen's signing was driven by team owners Genii Capital, who were determined to lure a big name to make clear the team's ambitions after a difficult season.

AUTOSPORT understands that there was some scepticism within the team about Raikkonen's level of commitment, particularly after discussions about a possible return with the team in 2011 fell apart acrimoniously. However, the maximum effort will now be put into ensuring that a driver whose ability is not in question, but whose motivation has sometimes been cast into doubt, lives up to expectations.

Boullier, who last year admitted that he needed to be convinced of Raikkonen's motivation, is now certain that there will be no problem.

“It was an easy fit with easy discussions,” he said of the deal. “Both parties had the same level of interest and Kimi clearly showed his motivation.”

The team had yet to finalise its second driver as AUTOSPORT closed for press, with Vitaly Petrov's place at the team in doubt. Adrian Sutil, Romain Grosjean and Bruno Senna are among the leading contenders.

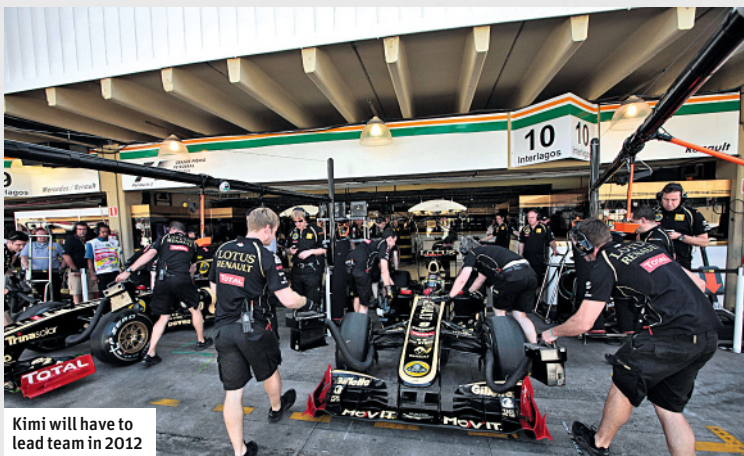

Kimi will have to lead team in 2012

## DRIVER MARKET STILL WIDE OPEN IN PLACES

As many as six seats could still be available for the 2012 Formula 1 season, with Renault's signing of Kimi Raikkonen just the first in a salvo of deals expected to be completed by the end of the year.

While the identity of the Finn's team-mate has not yet been confirmed, with Adrian Sutil, Romain Grosjean and Bruno Senna all strong contenders, Williams is on the verge of deciding whether or not to retain Rubens Barrichello. The Brazilian had appeared to be on his way out of the team a month ago, but the collapse of its bid to sign Raikkonen and the positive

impression that Barrichello has made on the team's new technical management, Mike Coughlan and Mark Gillan, means that a 20th year in F1 remains possible. Reserve driver Valtteri Bottas is also a contender to partner Pastor Maldonado.

Sutil is also known to have held advanced talks with Williams, and Heikki Kovalainen has interested both Renault and Williams. But the Finn is unwilling to turn his back on Lotus for anything other than a race-winning team.

Force India is expected to confirm that Nico Hulkenberg will

join Paul di Resta next season, while Scuderia Toro Rosso will make its decision by December 27. Current drivers Jaime Alguersuari and Sebastien Buemi could both stay on if a deal to place Daniel Ricciardo at Caterham (currently Team Lotus) succeeds. This would leave Jean-Eric Vergne as STR's third driver.

HRT's second seat alongside Pedro de la Rosa remains unclear, despite Vitantonio Liuzzi having a long-term deal. Narain Karthikeyan could return, but the owners most likely want an all-Spanish line-up. GP2 racer Dani Clos is in the frame.



Sutil and Barrichello are chasing drives



**AUTOSPORT SAYS...**

**DAVID EVANS**  
**RALLIES EDITOR**

david.evans  
@haymarket.com



**M**elbourne might have Albert Park, but it doesn't have a Royal Welsh Showground. Kimi Raikkonen's final – for now – memory of the World Rally Championship probably won't be a lasting one.

The rally love affair fell apart this season



Trudging out of the cowsheds, the Finn left his Citroen DS3 WRC sat in service looking tatty, used and sorry for itself. Raikkonen's departure from Rally GB was premature. He could have come back and raced through the woods for one more day. He'll be back but, for the next two years at least, the fact is – he's done with the WRC.

And, in all honesty, the WRC's done with him.

Rallying had loved, *loved*, the Raikkonen story last year. But this year, the novelty had worn off. He wasn't going to be the modern-day Jim Clark we'd all shamelessly touted him as. Instead, he was a bloke battling with Federico Villagra for lower-order points. When he didn't crash.

Raikkonen's a world-beater on a circuit, and the spark when he talked of a possible Le Mans entry in a Peugeot 908 testified to a lasting love of wheel-to-wheel action.

When he skipped Rally Australia, citing the alarming distance between his front door and Coffs Harbour, his WRC interest was on the wane. When he walked out of Wales early, the writing was on the wall.

**QUOTE OF THE WEEK**

“I never lost the passion for racing in F1, but maybe all the things around it. This year I missed the racing more and more”



Raikkonen admits that the thrill of wheel-to-wheel competition outweighed the excitement of competing against the clock in the World Rally Championship

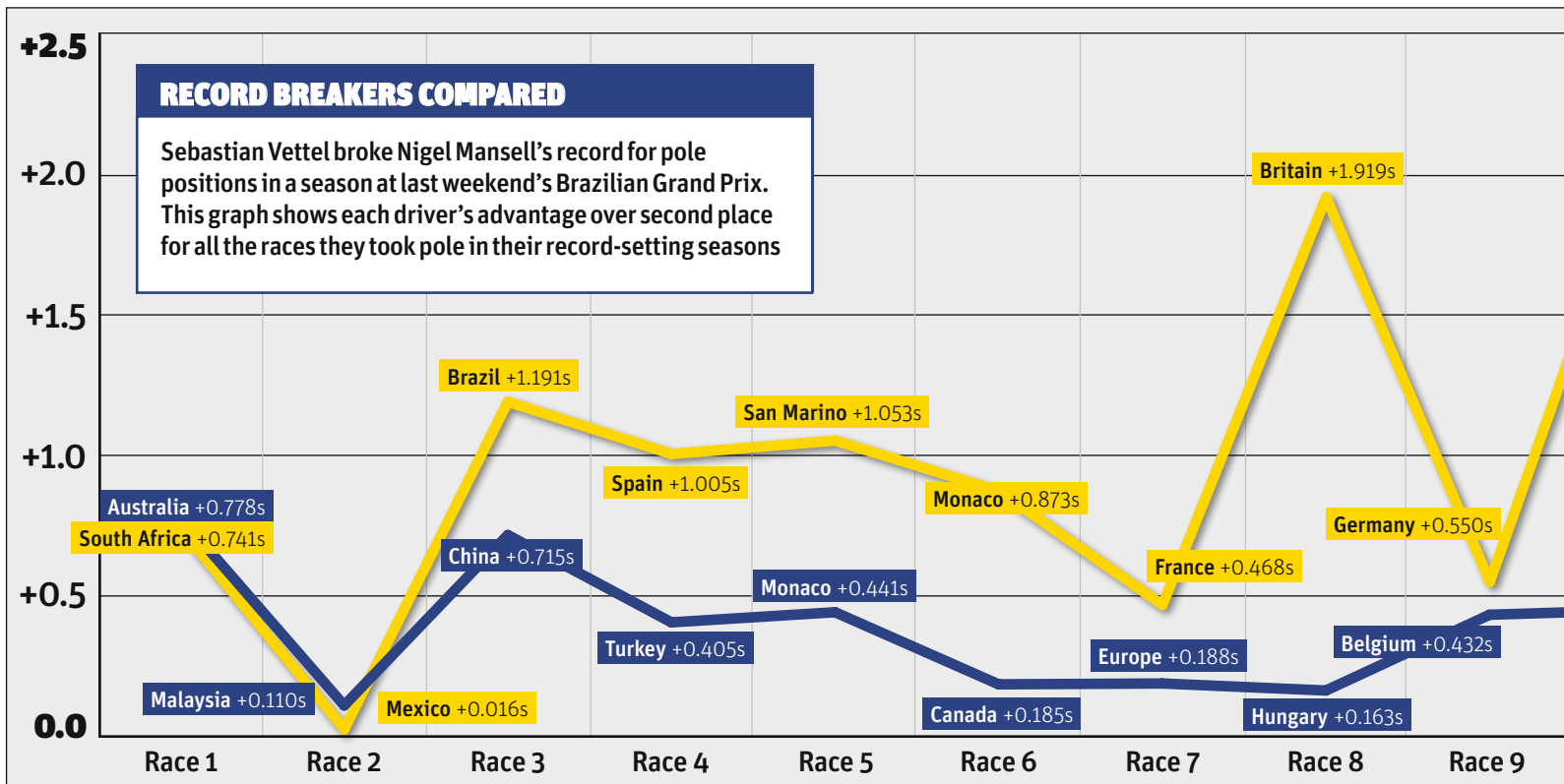

# Vettel/Mansell: which year was better?

The current world champion needed more races to beat Brit's record from 1992, but he had tougher opposition



Mansell pushed to get the most out of FW14B

Did Vettel make RB7 look even better than it was?



Sebastian Vettel's 15th pole position of the season might not have eclipsed Nigel Mansell's long-standing record of 14 out of 16 in percentage terms, but the Red Bull driver had a more competitive field to battle against.

This season, Vettel has missed out on four pole positions and has been, on average, 0.325s clear of the field in qualifying. By comparison, in 1992, Mansell took his Williams-Renault FW14B to 14 out of 16 poles with an average advantage of 0.898s. While comparisons of the two are difficult, it is clear that Vettel has had to be on his toes

Patrick Head, technical director at Williams when Mansell set the record, paid tribute to Vettel's efforts, insisting that without him the car might not have been perceived as dominant.

"Sebastian has done stunningly well and you'd have to say that although Mark Webber is a high-level driver, there were quite a lot of races where he finished behind the McLarens or a Ferrari," Head told AUTOSPORT. "If the Red Bull performance level was set by Mark, the championship might have been a lot closer, so Seb has certainly got the best out of it. Mark has been to Sebastian this year what Riccardo Patrese was to Nigel in '92."

Head refused to be drawn on which achievement was the greater, pointing out that Mansell did extract the best from the machinery even when he didn't have to.

"He had a good car, but it wasn't necessarily the easiest to drive," he said. "Riccardo was very close on speed with Nigel in the FW14 in 1991 and was a significant threat, but when the active suspension came along, Nigel took to the characteristics better."

"The active system that we had didn't give great feedback as to how much grip there was in the corner as you turn in. Then, when you

**"Webber has been to Seb what Patrese was to Nigel in '92"**

Patrick Head

throughout the year at a time when smaller margins made the difference between qualifying success and failure than in 1992, when the spread of the field was larger.

"Obviously it took the master in that discipline [qualifying], Nigel Mansell, a couple of races less," admitted Vettel. "These sorts of numbers are made forever and it would be ridiculous going into a season thinking you might be anywhere close at the end of it."

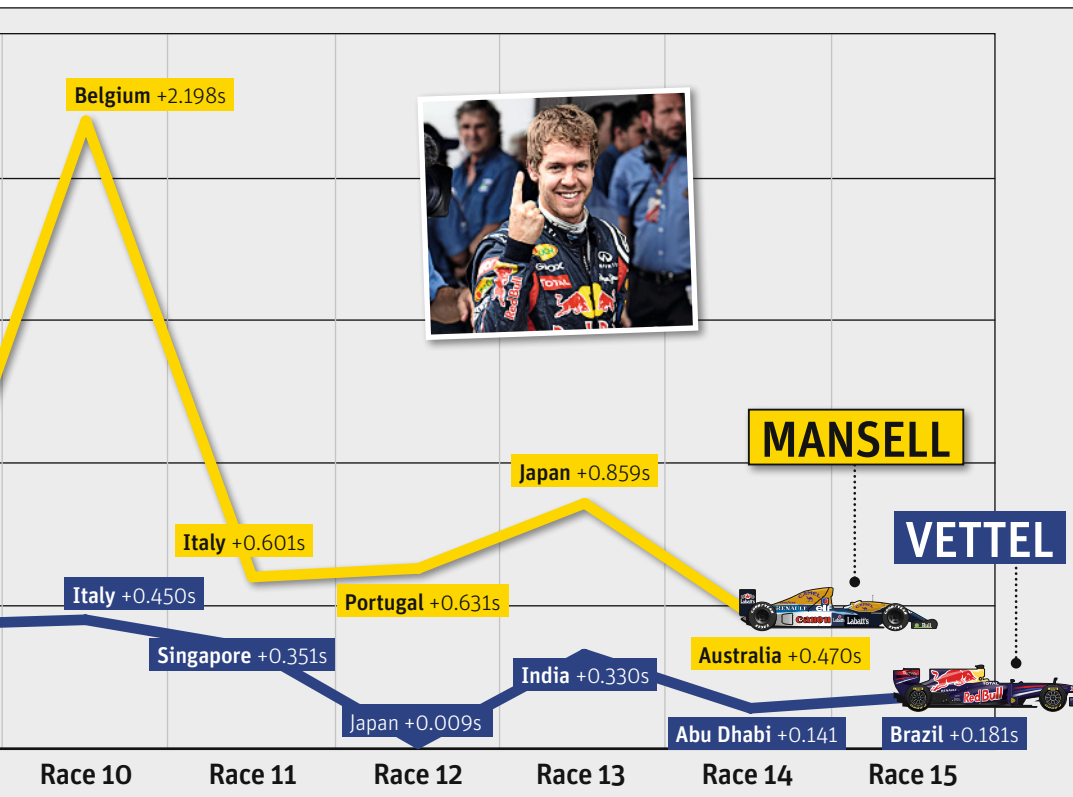

**MANSELL**

**VETTEL**

Head: Mansell used equipment to best level



**THE CASE FOR MANSELL**

**PETER WINDSOR**  
WILLIAMS TEAM MANAGER IN 1992

It's a cliché to say that Nigel Mansell was gifted the 1992 title. Yes, the Williams-Renault FW14B is probably the most sophisticated F1 car ever built (the 1993 FW15C aside!). No, it wasn't an easy car to drive. Ask Riccardo Patrese after qualifying in South Africa – or Silverstone, where he was 19mph slower than Nigel into Copse Corner.

The only two occasions when Nigel did *not* take the pole in 1992 were Canada and Hungary. In Montreal, Ayrton Senna's speed in the McLaren-Honda confirmed what many of us had been saying all year: the Honda engine had more power than the Renault. We had some handling problems with the FW14B on Friday (to the point where Nigel wanted to switch

off the traction control!) and then on Saturday it rained. Nigel qualified third but I'm sure he'd have got pole if dry.

In Hungary, we had a fire on Nigel's race car and then some electronic problems on the spare. Nigel qualified on old tyres and was still only 0.2s away from Riccardo.

Otherwise, Nigel was on pole every race. He had the best car; no doubt about it. But he also *maximised* the best car.

Now let's look at Sebastian Vettel. He failed to take pole in Spain, Silverstone, Nurburgring and Korea. In Spain, he had no KERS and in Korea, both Red Bulls made compromises on their tyre choices, so it comes down to Seb's Silverstone and Nurburgring laps, which were beaten by Webber, versus Nigel's Montreal and Hungary laps. Nigel wins the "Canada/Silverstone" comparison (one dry session followed by a wet one is always tough) and the Hungary/Nurburgring battle is also weighted slightly in Nigel's favour: he qualified second despite all his problems whereas Seb relinquished an extra place to Lewis Hamilton.



NM missed pole only twice in '92

**TOP SIX DOMINANT QUALIFIERS**

**Sebastian Vettel's 2011 qualifying record is only the sixth most dominant in Formula 1 history**

**NIGEL MANSELL 1992 - 87.2%**

Bagged 14 out of 16 poles in 1992 driving for Williams, setting a record that stood until last Saturday. Only missed out on pole position in Canada (to Ayrton Senna) and Hungary (to team-mate Riccardo Patrese).



**JUAN MANUEL FANGIO 1956 - 85.7%**

With Mercedes pulling out of F1, the Argentinian switched to the Lancia Ferrari D50 and bagged six out of seven poles. Stirling Moss, driving a Maserati 250F, denied him a 100 per cent record at Silverstone.



**AYRTON SENNA 1988 - 81.25%**

The combination of the great Brazilian and the lowline McLaren-Honda MP4/4 was almost unstoppable during the 1988 season. Alain Prost took the car to pole twice, with Ferrari's Gerhard Berger taking another.



**AYRTON SENNA 1989 - 81.25%**

Once again, Senna struck 13 times in 16 races to match his record of a year earlier. Aside from another two for Alain Prost, only Williams driver Riccardo Patrese was able to break the great Brazilian's dominance.



**ALAIN PROST 1993 - 81.25%**

Prost cantered to the 1993 title in the Williams FW15 after Nigel Mansell left for Indycar racing. Williams was utterly dominant, with Damon Hill adding two poles and Ayrton Senna nicking one for McLaren in Australia.



**SEBASTIAN VETTEL 2011 - 78.9%**

Put it on pole position a record 15 times this year as Red Bull claimed 18 out of 19 pole positions. Denied pole by Mark Webber in Spain, Britain and Germany, while the only non-Red Bull driver to beat him to the top spot was McLaren's Lewis Hamilton in Korea.



**P28 VETTEL'S RACE PROBLEMS EXPLAINED**

SHIFT\_the way you move



# ADVANTAGE NISSAN

NISSAN JUKE FROM  
£13,395 – £20,295



**3 YEARS 0% APR  
REPRESENTATIVE**



**3 YEARS  
LOW COST SERVICING**



**3 YEARS NISSAN  
ROADSIDE ASSISTANCE**



**ADVANCED FEATURES  
AS STANDARD**

JUKE 1.6 ACENTA PREMIUM £15,495



17" Sport alloy wheels



Nissan Connect with  
touch-screen navigation



Colour reversing camera



Climate control



Bluetooth® and USB connectivity



Rear privacy glass

DISCOVER THE  
ADVANTAGE AT  
[nissan.co.uk/offers](http://nissan.co.uk/offers)

Juke Range: URBAN 27.7-47.9mpg (10.2-5.9L/100km), EXTRA URBAN 47.1-65.7mpg (6.0-4.3L/100km), COMBINED 37.2-57.6mpg (7.6-4.9L/100km), CO<sub>2</sub> emissions 175-129g/km.

Offers valid until 31 December 2011 at participating dealers only. Finance is available subject to status on eligible new vehicles in the UK. 0% Offer available on Hire Purchase only. Guarantees and Indemnities may be required. Finance provided by RCI Financial Services Limited, PO Box 149, Watford WD17 1FJ. You must be at least 18 and a UK resident (excluding Isle of Man and Channel Islands) to apply. Not available in conjunction with any schemes or other offers, please visit [www.nissan.co.uk/offers](http://www.nissan.co.uk/offers) or your local dealer for information. Breakdown services provided by RAC Motoring Services and/or RAC Insurance Ltd. All prices include first registration fee and road fund licence. Juke shown has metallic paint at £455 inc. VAT. Information correct at time of going to print. Model shot shown is for illustration purposes only and subject to availability. Nissan Motor (GB) Ltd, The Rivers Office Park, Denham Way, Rickmansworth, Hertfordshire WD3 9YS.

102212/A



BBC will show 10 live races; Sky all of them

**THIS WEEK IN F1**



**RED BULL** Mark Webber was awarded the DHL Fastest Lap Award during the Brazilian Grand Prix weekend. The Australian has secured seven fastest laps this year.



**McLAREN** Lewis Hamilton attempted to end his season-long rift with Felipe Massa, visiting the Brazilian after Sunday's Grand Prix. "It was good to have a nice chat with Felipe after the race," he said.



**FERRARI** Felipe Massa became the first driver to complete a full season for Ferrari without a podium finish since Didier Pironi in 1981. The Brazilian has not finished in the top three since last year's Korean Grand Prix.



**MERCEDES** Ross Brawn blamed Bruno Senna for the clash with Michael Schumacher that ruined the seven-times world champion's Brazilian Grand Prix. "Senna showed his inexperience trying to defend a position that he had already lost," said the Mercedes team principal.



**RENAULT** Former McLaren sporting director Dave Ryan, who resigned in the wake of the 2009 Australian Grand Prix controversy surrounding lying to the stewards, could return to Formula 1 with Renault in a similar role. Ryan, nominally a consultant to team owners Genii Capital, attended the Brazilian GP.



**WILLIAMS** Chief operations engineer Mark Gillan has confirmed that Williams will run its own in-house KERS system next season. There was the possibility that the team could have taken Renault's system, but it is happy with the performance of its own.



**FORCE INDIA** Paul di Resta has no doubts that Force India can build on its sixth place finish in the constructors' championship. "We can maintain where we are, absolutely, but we need to go on an upward slope again and hopefully I'll be part of that," he told AUTOSPORT.



**TORO ROSSO** Sebastien Buemi believes that being outscored by team-mate Jaime Alguersuari by 26 points to 15 will not jeopardise his chances of staying at the team next year. "If you look into the details, I should have a lot more points but the team is aware of that," he told AUTOSPORT.



**LOTUS** Aerodynamics ace John Iley will join the team in June. Iley, who rejoined McLaren from Ferrari at the start of last year, is currently on gardening leave but Lotus has asked his former employer if he can be released earlier.



**HRT** Jan Charouz made his grand prix weekend debut driving for HRT in Brazil. He completed 37 laps during Friday morning practice, lapping six-tenths off team-mate Daniel Ricciardo.



**VIRGIN** The team has confirmed that Charles Pic will replace Jerome d'Ambrosio next season. Pic, who finished fourth in GP2 last year, tested for the team in Abu Dhabi two weeks ago.

# TV picture becomes clearer

**S**ky plans to use its recently-launched dedicated Formula 1 HD channel to provide what Sky Sports managing director Barney Francis describes as "a wealth of F1 programming" on top of its live broadcasts.

Martin Brundle revealed last Sunday that he would be leaving his BBC lead commentator role to join Sky in 2012. Brundle, who has commented on F1 since joining ITV in 1997, has long been targeted by Sky as the face of its F1 coverage.

He is expected to provide expert analysis alongside ex-BBC Radio 5 Live anchor David Croft, but Brundle's job is expected to entail significantly more than his previous role, with Sky promising additional content, including news and magazine programmes, outside of GP weekends.

Brundle, who will continue to perform his pre-race grid walks, has stated that one of his prime motivations for the move is the potential to do a

greater number of technical features, which is also an aspect that Sky is keen on.

Sky has yet to announce full details of its HD channel, but it will show full coverage of every race, practice and qualifying session live with no advert breaks interrupting the on-track action. The BBC will share the coverage and it announced last weekend the 10 races that it would broadcast live. The BBC has also confirmed that Jake Humphrey, Lee McKenzie and David Coulthard will remain a part of its coverage, although pitlane reporter Ted Kravitz is in line for a switch to Sky.

For the races that it does not show live, the BBC will broadcast either 90 minutes or two hours of highlights. For races in the Asian region, these will start at 1400, with European race highlights starting at 1730.

Initial plans to make complete races available on the BBC's red button have not been realised.

## F1 SCHEDULE '12

Sky will show full live coverage of every race, including practice and qualifying. The BBC will show 10 races live (including practice and qualifying), with extended highlights of the rest. Plans for full race re-runs fell by the wayside.

### LIVE COVERAGE IN 2012

- March 18: Australia Sky
- March 25: Malaysia Sky
- April 15: China Sky/BBC**
- April 22: Bahrain Sky
- May 13: Barcelona Sky/BBC**
- May 27: Monaco Sky/BBC**
- June 10: Canada Sky
- June 24: Europe Sky/BBC**
- July 8 Britain Sky/BBC**
- July 22: Germany Sky
- July 29: Hungary Sky
- September 2 Belgium Sky/BBC**
- September 9: Italy Sky
- September 23: Singapore Sky/BBC**
- October 7: Japan Sky
- October 14: Korea Sky/BBC**
- October 28: India Sky
- November 4: Abu Dhabi Sky/BBC**
- November 18: USA Sky\*
- 25 November Brazil Sky/BBC**
- \*Race likely to be cancelled

# No replacement for Austin race

**NEXT YEAR'S CALENDAR IS EXPECTED** to feature only 19 races after Bernie Ecclestone scotched suggestions that the Turkish Grand Prix could replace the mooted United States Grand Prix in Austin, Texas.

Organisers of the Austin race are still keen to stage their first grand prix in 2013, but work has stalled on the Circuit of the Americas and the FIA World



Motorsport Council is expected to remove it from the calendar when it meets next week. It is hoped that the funding will be found for work to be restarted

on the track, but it appears to be too late for the planned 2012 race, which would have created a late-season back-to-back with the Brazilian Grand Prix.

Ecclestone is adamant that the Bahrain Grand Prix will go ahead, although there remains scepticism among the teams amid fears that unrest could flare up there again during next year's race weekend.

**Dunlop Tyres - Equipped with Motorsport Technology.**  
Experience real grip and high performance braking.



BMW Motorsport 

Technical Partner



**DUNLOP TYRES**  
with Motorsport Technology

When it comes to winning on the track, teamwork and technology are everything. At Dunlop we work closely with leading vehicle manufacturers such as BMW, both on the track and on the road. Through these strong working relationships we're able to consistently develop cars with superb grip and excellent braking.

Dunlop tyres are tested under extreme motorsport conditions during some of the worlds most iconic endurance races such as Le Mans, Nürburgring and Silverstone 24 Hours.

Visit [www.dunloptyres.co.uk](http://www.dunloptyres.co.uk) to find out more.

 **DUNLOP**  
DRIVE WITH CONFIDENCE

# The pace of development in F1

Home of the Brazilian GP offers best comparison of the pace of F1 cars over the past two decades

Barrichello first raced at home in '93



**I**nterlagos has remained largely unchanged since it rejoined the Formula 1 calendar in 1990, and despite constant efforts to slow cars, the trend is for faster lap times.

In 1990, Ayrton Senna's pole position time was a 1m17.277s compared with Sebastian Vettel's 2011 lap, a 1m11.918s. That represents a reduction of seven per cent, a remarkable improvement given that engine capacity has been reduced from 3.5 litres to 2.4, aerodynamics have been heavily

restricted, driver aids have been outlawed, cars have been narrowed and long-life engines with rev limits have been introduced.

Rubens Barrichello, who started the Brazilian Grand Prix for the 19th time last weekend, first raced at Interlagos in 1993.

"When I drove the 1993 Jordan it felt like I had two elephants on my back because of the crowd pressure," recalls Barrichello. "The steering wheel felt heavier because of that, but also because we didn't

have the power steering then. The grip level of cars has just increased so much over the years. I still have the qualifying record from 2004 with the Ferrari, which was a mega car.

"F1 always goes on at a great rate. I had a Brawn here that was phenomenal a few years ago, but the Williams today is faster and still off the pace! But although each car has its own tendencies to oversteer or understeer, if you go faster, it always feels the same."

## INTERLAGOS LAP TIMES

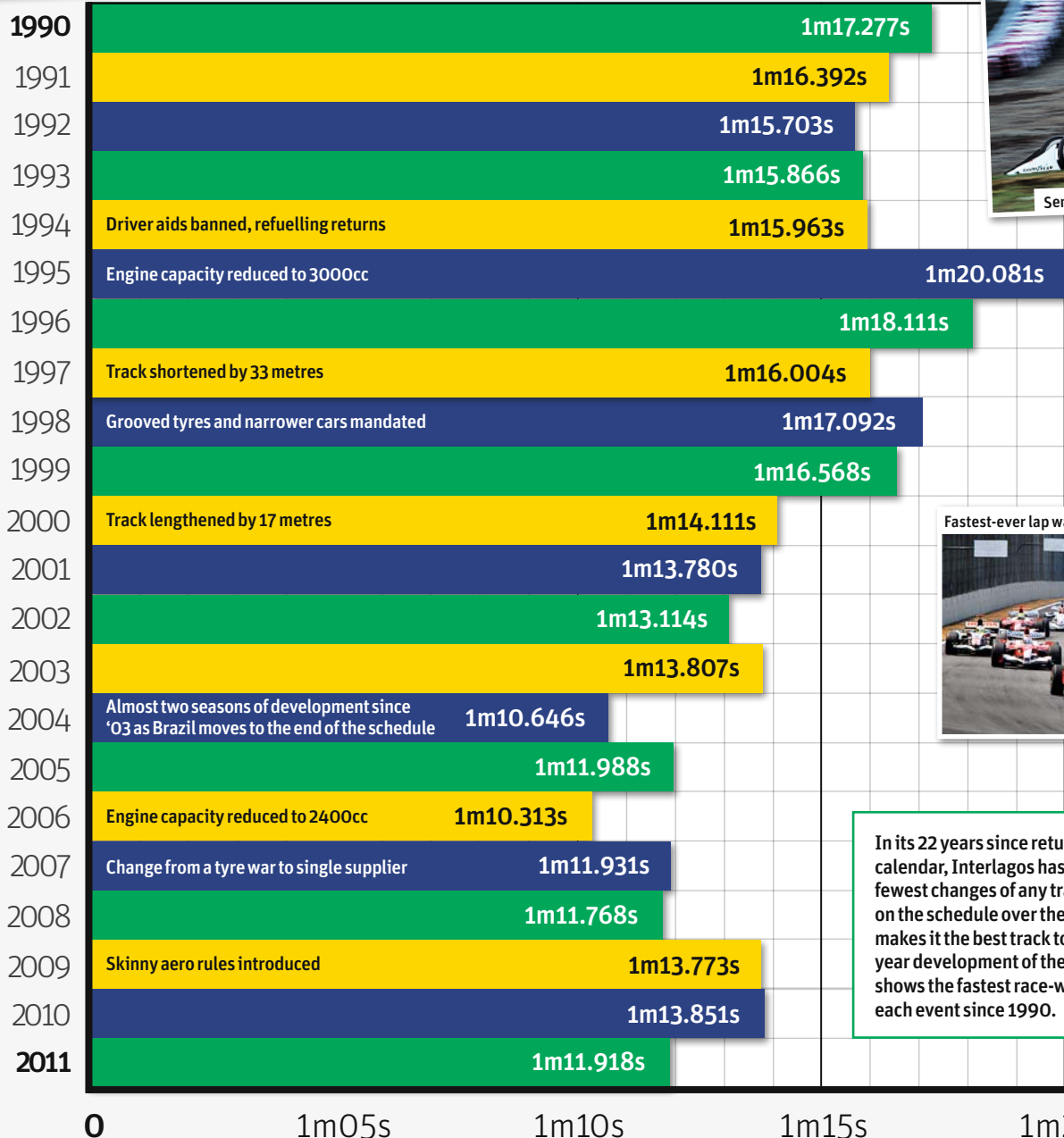

In its 22 years since returning to the Formula 1 calendar, Interlagos has undergone the fewest changes of any track that has stayed on the schedule over the same period. This makes it the best track to measure the year-to-year development of the sport. This graph shows the fastest race-weekend lap from each event since 1990.



# The Finest Collection of Motor Sports Holidays Worldwide

INCLUDING: F1, MOTOGP, WORLD SUPERBIKE, DAYTONA 500, MONACO HISTORIC, LE MANS 24 HOURS & LE MANS CLASSIC.



We offer flexible arrangements with a choice of airports, hotels and race tickets.

## Call us now to discuss your plans for 2012!

Book with the team you can trust - your experience will exceed your expectations

# 0845 375 0300

or visit [www.grandstandmotorsports.co.uk](http://www.grandstandmotorsports.co.uk)



W8164 / Y1735

A00465 -GS



Europe's leader in American motorhome rental & sales

We are currently taking bookings for all British and European Motorsport events for 2011 & 2012

FOR SALE FINANCE AVAILABLE



**2004 34' Damon Daybreak 3270**  
Single slide, 33,000 miles, 2 TVs+DVD+ Satellite, sleeps 6 in 4 beds. **£44,995**

**2008 36' Monaco Monarch**  
Full wall slide, cream leather, sleeps 4 in 2 beds, 8,000 miles. **REDUCED TO £75,000**

**2009 32' Four Winds Chateau Citation**  
Super slide, SKY TV, DVD, CD, air con, sleeps 5 in 3 beds, 9,000 miles. **REDUCED TO £55,000**

For more information email [simon@stingrayRV.com](mailto:simon@stingrayRV.com) or call **0870 241 5614**

## [www.stingrayRV.com](http://www.stingrayRV.com)



# MPH Mark Hughes

AUTOSPORT grand prix editor

There's a crop of young, gifted drivers out there ready for F1. But teams are favouring the older racer to suit their needs. If this trend continues, will we lose a generation of talent?

**W**ith 40-year-old Pedro de la Rosa's announcement of his 'comeback' drive for 2012, there is the possibility that there will be three drivers in their 40s on the grid next year. This would depend on Rubens Barrichello – who will turn 40 in May – being able to continue, as he very much wants to do. Michael Schumacher (43 in January) is contracted to the end of 2012.

Coming on the back of the young driver tests in Abu Dhabi, this prospect has created a mini-backlash along the lines of why is F1 retaining these senior citizens when there is a whole generation of exciting quick new guys bursting to be given the opportunity – and ready to go, right now.

Well first of all let's acknowledge that F1 does not act as a group on such matters. In the case of these 'old' guys, Rubens does not yet have a seat, Pedro is deemed the perfect fit for the specific situation of the HRT team which needs experience

and someone of high profile in Spain as it attempts to brand and finance itself that way, while Mercedes is satisfied with Schuey's performances. All that aside, on a broader basis the question remains: is F1 best served this way?

I'd propose turning the question around. Yes, there are several exciting prospects bubbling just under F1 and it would be wrong if they didn't get an opportunity. We've had lost generations in the past, before the young driver programmes were properly established and it did not serve the sport well, for example, during the post-Senna era when beyond Schumacher and Mika Hakkinen the depth of talent was not great, certainly nothing like as good as now. But what if, instead of using age as the parameter by which we create room, we use ability instead? Taking Barrichello as an example, there's nothing to suggest his personal performance has dropped off since two years ago when he was

winning races and in contention for the championship. His terrific drive in Abu Dhabi suggested as much. In the past he wasn't, over the balance of the season, quite as good as Button in a good car, nor as Schumacher at his peak. But there were days when he was flat quicker than either of them. That's a good enough level to be earning your place in F1.

If we took a group of four young guys we'd ideally like to see join the F1 grid – say, for example Esteban Gutierrez, Jean-Eric Vergne, Robert Wickens and Roberto Mehri – and we made way for them by moving onto pasture Felipe Massa (30), Sebastien Buemi (23), Jaime Alguersuari (21) and Vitaly Petrov (27) what would the sport lose? They are the guys who, if we are being brutal, are not justifying their place here on raw performance and who have had good opportunity to do so. Their average age is 25.

Meanwhile, Rubens is prepared to let destiny take its course: "I think it would be sad to be worried about the future," he says. "I had 19 lovely seasons... I've been wanted for such a long time here, so I feel good. I feel that I still have a lot of youth on me, and it's not like I'm asking 'please, give me the drive'. If somebody wants me to drive on a competitive basis it's because they believe I can do a good job – that's why I'm here. Yes, Abu Dhabi was good but I don't think right now the results would make a change in what people think I could do. It's based on different parameters."

Wonder in which team's motorhome we might celebrate his 40th next year? ☼

40+, de la Rosa and Schumacher, but will Rubens be there too in '12?



PICS: ETHERINGTON/LAT

**“De la Rosa is what HRT needs and Merc is happy with Schuey”**



Priaulx is motivated by BMW line-up

# 'Nowhere to hide' for Priaulx

Triple WTCC champ says that recent signings of Spengler and Tomczyk puts pressure on. By JAMIE O'LEARY

**A**ndy Priaulx says he's been left with "nowhere to hide" following the signings of DTM champion Martin Tomczyk and race winner Bruno Spengler to BMW's line-up for next year.

The 37-year-old Briton, a three-time WTCC champion with the manufacturer, was one of the first drivers to commit to the series in 2012; Priaulx being announced

last June alongside Augusto Farfus in the line-up.

However, neither he nor Farfus have DTM race experience, whereas reigning champion Tomczyk, who has moved over from Audi, and Spengler – third in the points for Mercedes this year – have made 184 starts in the series between them, winning 16 times.

"Bruno and Martin are seriously

**"If Bruno and Martin are at the front and I'm further back then I'm not doing a good enough job"**

BMW DTM driver Andy Priaulx

good drivers," Priaulx told AUTOSPORT. "So the pressure is on me and Augusto to really make sure we're on the same level. If we're all at the back of the grid, then we can put it down to the car, but if Bruno and Martin are at the front and I'm further back, it will be obvious to everyone that I'm not doing a good enough job. I have nowhere to hide, but I actually like being in that situation."

Priaulx has had a relative lack of mileage in the new M3 DTM compared to some of BMW's other factory drivers, having missed the car's initial test while he recovered

from a thyroid operation, and then skipped the recent three days at Montblanco as he was racing in the ILMC at Zhuhai. But he is delighted with the progress made over the past three months.

"You can see how seriously everyone's taking it," he added. "It's an altogether higher level than the WTCC programme was, because it's BMW's number one project."

BMW motorsport director Jens Marquardt said that the programme is now "right on track," with more than 15,000km having been chalked up by 10 drivers.

"We should be well prepared for 2012," he said. "We have created an extremely solid foundation and now it's about squeezing the maximum performance out of the car before the development will be frozen in March."

● Tomczyk will test the M3 for the first time at Montblanco on December 6.



WTCC champ was an early BMW DTM signing



Hollamby believes small teams will benefit

BTCC

## Thumbs-up for new points system

**BTCC COMPETITORS HAVE GIVEN A positive reaction to a new points system that will be introduced next year.**

Series boss Alan Gow confirmed this week that the points system, which will reward drivers down to 15th place, will be implemented. Only the top 10 finishers have scored points in recent seasons.

AmD Milltek team boss Shaun Hollamby, whose lone VW Golf finished between 10th and 15th on 10 occasions during the season with himself, Martin Byford and

Tom Onslow-Cole at the wheel, said that the move was positive for smaller teams.

“What you could have had before was us finishing 11th every race and scoring no points, and another guy finishing 20th all the time, then lucking into a 10th in a wet race and getting a point,” said Hollamby. “Then it looks like he’s done a better job than us and maybe that causes sponsors to walk, so this will change that.”

Twenty points will now be awarded for a race win, with the

spread of points between the top three finishers unaffected by the changes. Bonus points, such as those for fastest laps, will remain.

Two-time title-winner Jason Plato told AUTOSPORT that he does not believe the new system will have a bearing on the outcome of the championship.

“I’m always aiming to win,” Plato said. “But if we have a shunt and start at the back, P15 makes a difference, especially with the grid being around 30 cars now, rather than 20 a year or two ago.”

FORMULA 2

## Ford champ targeting F2

**BRITISH FORMULA FORD CHAMPION**

Scott Malvern is targeting a move to Formula 2 for 2012.

The 22-year-old dominated Formula Ford in Europe this season, driving a Jamun Racing Mygale. Now he is looking to step up to F2 after driving the car in the McLaren AUTOSPORT BRDC Award tests for the last two years.

“I really like the car,” said Malvern. “They’re a brilliant bit of kit – there’s lots of things you can adjust in the cockpit.”

Malvern had hoped to graduate to Formula Renault 2.0 this year, but was hampered by budget problems. He believes that F2 is now the place to progress his career.

“I think it’s the right move,” he added. “If I’m going to learn aero I might as well do it on grand prix tracks.”



Malvern is ready to step up



Previous HPD was strong at Sebring

ALMS

## New HPD set for ALMS in 2012

**A NEW HPD ARX-03A WILL BE RACED in the American Le Mans Series by the US Muscle Milk squad next season.**

Greg Pickett’s team, which fielded a Lola-Aston Martin coupe in the ALMS this year, has yet to announce its plans for 2012, but it is known that it has purchased one of the new Wirth-designed LMP1s.

It will become the second team to sign up to run an ARX-03a, which is an improved version of the ARX-01e that finished second at last year’s

Sebring 12 Hours built around a new monocoque.

HPD vice-president Steve Eriksen confirmed that another ARX-03a had been sold.

“We’re particularly excited to get another one out there, but it is up to the team to announce its plans,” he said.

“One car is already announced for the FIA World Endurance Championship [for Strakka Racing] and we hope that the second will be representing us in the ALMS.”

## AUTOSPORT SAYS...

**GLENN FREEMAN**  
NEWS EDITOR

glenn.freeman  
@haymarket.com



**C**redit where its due to Andy Priaulx for not trying to hide behind his lack of DTM experience as he prepares to race in the series for the first time when BMW returns next year. As far as he’s concerned, he’s shown the ability to compete at the top level in other forms of racing that if he can’t get on terms with the stars poached from Audi and Merc next year then he’ll have to dig even deeper.

But what is just as interesting is that last weekend’s BMW end of year awards ceremony appeared to mark the first public declaration from its motorsport boss Jens Marquardt that his troops are in good shape for next year. I remember dealing with the early exchanges between BMW, Audi and Mercedes over how much of a disadvantage the new boys would face by coming up against the manufacturers that have stood by the DTM for so long. BMW didn’t miss a chance to talk up its lack of experience, but its rivals were having none of it.

Marquardt still dropped in a mention of “our competitors enjoy a clear advantage” at the weekend, but by finally talking up BMW’s chances, he joins Priaulx in having nowhere to hide next year.

BMW is becoming less of a dark horse



## BIG NUMBER

6.799m

Peak ratings on ESPN in the US for the NASCAR season-finale at Homestead. It was ESPN’s biggest-ever audience for a NASCAR race



The shiny Ken-Paul took Jim to his 1960 Indy win

## Jim Rathmann 1928-2011

**JIM RATHMANN, WINNER OF THE sensational 1960 Indianapolis 500, died last week. He was 83.**

Actually, Jim was Dick, and Dick – pole-sitter at the Brickyard in 1958 – was Jim. Born Royal Richard Rathmann on 16 July 1928, he assumed elder brother James' name so that he could go racing illegally at just 16 – and never gave it back.

Raised in Alhambra, a down-at-heel area of western LA, the brothers were part of the burgeoning hotrod scene that would provide a heap of Indy hotshoes and several winners.

A tyro on the track and a smart cookie off it, his career blossomed when Andy Granatelli, promoter of the Hurricane Racing Association, took him under his wing in the late 1940s. Rathmann starred in Mid-West stock cars, and was third in the 1955 AAA National Championship – by which time he had already finished second at Indy.

Beaten to the punch on that occasion by fellow young gun and friend Troy Ruttman, he was the

runner-up in 1957 and 1959 too.

His big chance arrived in 1960. Freewheeling millionaire Texan Ken Rich and wealthy commodities broker Paul Lacy decided to enter Indy on a whim. The 500 would be the first race that Lacy had ever attended.

Rathmann, given free rein on the project, ordered an Offy roadster from AJ Watson, the best in the business, and assembled a crack squad that included tuning guru Chickie Hirashima and renegade crew chief and top race strategist Smokey Yunick.

The snazzy team's metallic-blue Watson, christened the Ken-Paul, was the most expensive and lightest yet produced. Rathmann qualified it in the middle of the front row alongside Eddie Sachs and Ward, his conqueror of the previous year.

All three men had to walk to the circuit on race morning because of traffic jams, although Ward did eventually cadge a lift from a friend driving a mortuary ambulance.

There were a record 29 changes of lead, 14 of which were between Rathmann and Ward, the pair of them passing and re-passing on individual laps too. They ran the second half of the race wheel-to-wheel, pitstop-to-pitstop, and crossed the line in a virtual dead-heat with just three to go.

The pace had been increasing as both men tweaked their weight-jackers to provide more grip and cornering speed. This, though, also increased tyre wear, and Ward backed off when the breaker strip – warning of an imminent puncture – showed through on his right-front Firestone. His rival's right-rear followed suit about 30 seconds later. By then, however, the pressure off, and Rathmann, who later admitted that he would have risked all to win, prevailed by 12.67 seconds.

He scored other USAC roadster victories, including the 1958 Race of Two Worlds at Monza and on their only visit to Daytona, in 1959, but that Indy success defined

Rathmann's legacy – and an era.

He retired in 1964, drove the Pace Car at Indy on six occasions, and became richer selling Caddys and Chevys in Florida while partying with NASA's astronauts. It is alleged that a Rathmann dealership decal was affixed to the Lunar Rover.

He was also a go-kart innovator, cable TV entrepreneur and real estate developer. He even searched for and found sunken Spanish galleons. Quite a guy.

After suffering a seizure, he was taken to a hospice in Melbourne, Florida, where he passed away on the night of November 23.

Paul Fearnley



Dick became Jim and it stuck



Webb got a Lights podium in Edmonton

INDY LIGHTS

# Webb sets sights on Indy Lights crown

**FORMER BRITISH F3 FRONTRUNNER**

Oliver Webb believes that he can fight for next year's Indy Lights title after securing a ride with reigning champion team Sam Schmidt Motorsports for next year.

Webb contested three Lights races in 2011 alongside his full season in Formula Renault 3.5, and said that the Indianapolis-based team's pedigree has made him confident that he can be a contender in his rookie season.

"I'm confident that if everything goes well I can win the title, and that's the aim," Webb told AUTOSPORT.

The 20-year-old admitted that racing in

the US full-time had not been on his radar until recently, but he says that he is now approaching this new direction in his career as a long-term plan.

"The US was never an expected route, which makes it a bit more exciting," he said. "It was going to be more of the typical, World Series for two years, then GP2, but it's the usual story for most people – funding. We saw the opportunity for the US, and how there's quite a direct ladder to top-tier motorsport."

Webb scored a podium on his Lights debut in Edmonton, and also had his first taste of ovals at the Las Vegas season finale.

Although he was hampered by an engine problem at the latter race, he says that having some oval miles under his belt ahead of next season will stand him in good stead.

"We had an engine failure at Vegas, which wasn't great, but the engine did last the whole race, and I got to do all of the practice. So it definitely helped," he said. "It means I can go into testing feeling pretty confident with the street and road tracks, and then with the ovals, at least I've got some experience."

Webb will be joined at Schmidt's team by Star Mazda champion Tristan Vautier, who signed with the squad last week.

IN BRIEF



Pagenaud is Schmidt-bound

**PAGENAUD FOR SCHMIDT**

Sam Schmidt Motorsports is expected to confirm shortly that it has signed Simon Pagenaud for next year's IndyCar season. The Frenchman will replace Alex Tagliani at the team, which will use Honda engines.

**DALY FOR ART TEST**

Conor Daly is scheduled to test with ART in the opening day of this week's GP3 test at Jerez today (Thursday). Daly was seventh quickest with Carlin at last week's Valencia test, which was topped by F3 Euro Series racer Daniel Abt for ART.

**BTCC TEAM TARGETS WTCC**

BTCC race-winning team Special Tuning Racing is planning to expand into the WTCC next season. Team principal John Boardman has confirmed that the squad will continue to run SEATs, but no driver has yet been confirmed.

**GODDARD GRADUATES**

Richard 'Spike' Goddard will step up from British Formula Ford to the British Formula 3 National Class with T-Sport next season. The 19-year-old Australian finished 10th in this year's Formula Ford campaign with Jamun Racing.

**AUTO GP RACE FORMAT TWEAK**

Auto GP will tweak its race two format next season. The second race of each weekend will now be lengthened, and have a mandatory pitstop added.

**SHARP'S TEAM EXPANDS**

Scott Sharp's Extreme Speed Motorsports ALMS squad is expanding into Grand-Am next season. ESM will run a Grand-Am specification Ferrari 458 Italia in the Triple Crown endurance events at Daytona, Watkins Glen and Indianapolis.

**GP2 TEAM RENAMED**

GP2 squad Team AirAsia will be officially renamed Caterham Racing next season. The move follows the planned rebranding of affiliated Formula 1 team Lotus.



New name for AirAsia

INDYCAR

# Scheckter wants DW12



Scheckter wants to try new car

**THOMAS SCHECKTER BELIEVES THAT** the new DW12 IndyCar could revitalise his career – if he is able to find a drive.

The 31-year-old has not had a full-time seat since 2007, and while he has a good track record on ovals, his history on road courses is less distinguished. The South African admitted that he had never come to terms with the older IndyCar.

"I've never gotten used to that car on road courses," he said. "Dan [Wheldon] said that the new car is lighter and easier to drive, and that's why I'm looking forward to it."

Scheckter said that his hopes of finding a full-time seat are dependent upon funding, but admitted that he could not continue with part-time deals for much longer.



Tag frustration led to Schmidt fall-out

INDYCAR

# Tag slams Schmidt's Wheldon decision

**ALEX TAGLIANI HAS FIRED A PARTING** shot at Sam Schmidt Motorsports after confirming that he will not race with the team in 2012.

Tagliani enjoyed some strong results with the squad, including poles at Indianapolis and Texas, and fastest lap at Iowa. But he told a French-Canadian publication that this good work was undermined by the decision to run Dan Wheldon at Las Vegas.

"With two races to go, we could

have finished seventh in the title with good results," said Tagliani, who eventually finished 15th in the points.

"But instead of fighting, Sam decided to place Dan Wheldon in my car to give it a try at Las Vegas to win five million dollars. It was a fiasco if you ask me. It's hard to throw out several months of hard work to make a big deal of money."

Tagliani is yet to confirm a deal for next year but has been linked to Bryan Herta Autosport.



WORLD GT

# Sportscars back at Brands

Planned FIA GT1 visit puts Brands Hatch back on international sportscar map after 16 years

Sportscars last raced at Brands in 1996

**T**op-flight sportscar racing is set to return to Brands Hatch for the first time in 16 years with a round of the FIA GT1 World Championship next year.

Brands, which hosted a BPR-run Global Endurance GT Series event in 1996, is one of six European races on the 2012 draft calendar. The precise schedule, which will go before the FIA World Council next week, remained confidential

as AUTOSPORT went to press but it is expected that the British round will take place in June or July.

Jonathan Palmer, whose MotorSport Vision organisation owns Brands, said: "We expressed our interest in having a race and have had talks with [series boss] Stephane Ratel. If the championship happens, we expect to be part of it."

Ratel refused to confirm that Brands was a certainty for next

season, although he admitted that a move from Silverstone to Brands would be consistent with his strategy to go to intimate venues in 2012.

"We want more visible crowds," he said. "We had a good crowd at Silverstone this year, but it got lost on such a long circuit."

The third season of the GT1 world championship will begin at Nogaro. The other European races

are likely to be at Zolder, Navarra, the Sachsenring and Algarve ahead of the four-race flyaway tour made up of events in Russia and Argentina and two in China.

Ratel's world championship will retain its GT1 tagline next season despite a switch to GT3 regulations. He explained that the title would help distinguish it from other championships running to GT3 rules.

WORLD GT

## GT1 considers Euro GT3 tie-in

**THE FIA GT1 WORLD CHAMPIONSHIP** could be combined with the European GT3 series next season.

Series boss Stephane Ratel has revealed that he has hatched the plan as a back-up in an attempt to end speculation that either the world series or the FIA GT3 European Championship will fail to happen in 2012. He has so far been unable to put together the 10 teams he is seeking for GT1 World, while the European GT3 championship looks likely to be hit by the success of his new-for-2011 Blancpain Endurance Series.

"I am working flat-out to have enough

cars for two separate championships," said Ratel, "but if there are less than 20 cars in each, there is a possibility that we will run them together. I need to stop people saying that either series won't happen. Now we can say with certainty that both series will take place."

The move has been made possible by switching the world championship to GT3 regulations. The minor adjustments he plans, which include greater freedom of springs and dampers, would also be adopted by the European series to help distinguish it from national championships running to GT3 rules.



GT1 could merge with Euro GT3

EVERY type of insurance that ANY person involved in Motorsport may require

**MIS** MOTORSPORT  
INSURANCE  
SERVICES

**ON TRACK - PERSONAL ACCIDENT - MOTORTRADE -  
COMMERCIAL - LIABILITY**

**www.raceinsurance.co.uk or call 01943 884555**

Motorsport Insurance Services Limited is Authorised and Regulated by the Financial Services Authority

NASCAR

# Penske to act over Busch rant

**KURT BUSCH COULD FACE INTERNAL sanctions** from Penske Racing in addition to the \$50,000 fine that he was issued by NASCAR for being verbally abusive to a TV reporter at the season finale at Homestead two weeks ago.

The incident happened when Busch's car was having a transmission problem repaired during the race. ESPN reporter Dr Jerry Punch was waiting to speak to him when Busch lashed out at a cameraman, telling Punch to "get this motherf\*\*ker out of my face". Busch then reacted angrily to Punch saying the interview had to be recorded live rather than pre-recorded, saying "Why can't we tape this shit? I'd like to do it



Apologies all round from Kurt recently

live too, f\*\*king 10 minutes ago."

The exchange was recorded on a video phone by a fan, who uploaded it to YouTube, and came after Busch's in-car camera also filmed him making an obscene gesture as another car got in his way while he was returning to the garage.

Busch and Penske issued separate apologies in the days that followed.

"In my frustration with the loss of my transmission early in the race, I let my emotions get the better of me," Busch said. "I regret having done this and apologise to the sponsors of Penske Racing, to NASCAR, its fans, to the media, and Dr Jerry Punch."

Penske's statement included a confirmation that the matter would be looked at internally.

Busch's sponsor Shell/Pennzoil also issued a statement, saying that "[Busch's] actions are in no way consistent with the way we want our brands represented and we have expressed our disappointment and concerns directly to Penske Racing."

The outburst comes three weeks after Busch's brother Kyle was parked for the weekend in Texas for wrecking Ron Hornaday in the Truck race, putting his place at Joe Gibbs Racing under scrutiny following complaints from sponsor M&M's.

NASCAR NATIONWIDE

# Stenhouse applauds new rules

**NEWLY-CROWNED NASCAR**

Nationwide champion Ricky Stenhouse Jr has thrown his support behind the overhauled NASCAR points system, where drivers are prevented from scoring points in more than one series.

The rule was introduced for the start of the 2011 season to prevent Cup drivers from dominating the second-tier championship and Stenhouse is the first full-time Nationwide runner to benefit, claiming the title despite winning just two races compared to Cup runners Brad Keselowski's five and Carl Edwards' eight.

"It means just as much," Stenhouse said. "We race week-in and week-out with

those guys, and we give them a run for their money.

"Obviously they changed the points system, and we still weren't in sight to [win the championship] from everybody's perspective. But we felt like as a race team, we could do it.

"I felt that as a driver, I was just as good as anybody else out there. We beat Carl, we beat Brad, we passed those guys. We raced Kyle Busch. Racing up there and beating them definitely makes this championship worth it."

Prior to this season, full-time Cup runners won the Nationwide/Busch Series title for five straight years courtesy



Stenhouse won Nationwide title

of Kevin Harvick (2006), Edwards ('07), Clint Bowyer ('08), Kyle Busch ('09), and Keselowski ('10). The last full-time second-tier champion was Martin Truex Jr in 2005, when it was the Busch Series.

NASCAR

# Vickers keeping his options open



Vickers had mixed results at Red Bull

**BRIAN VICKERS IS OPTIMISTIC THAT he will find a new drive in 2012 following the withdrawal of Red Bull Racing from NASCAR.**

The 27-year-old endured a disappointing season that included only three top-five finishes, and missed almost all of 2010 due to a health problem. Nevertheless, he is confident that he will be on next year's grid.

"I'm working on several options in

the Cup series, but until they're done, they're not done," said Vickers, who has managed two wins in his five-year stint at the top level. "I'm looking forward to hopefully continuing a strong career here. I love this racing, and I love what I do."

Vickers' Red Bull team-mate Kasey Kahne is moving to Hendrick Motorsports, where he will replace NASCAR veteran Mark Martin.

## IN BRIEF

Grand-Am is next for Nasr



**NASR TO TEST GRAND-AM**

British F3 champion Felipe Nasr will get his first taste of Grand-Am when he tests a Daytona prototype for 2009 24 Hours victors Action Express (nee Brumos Racing) at Daytona next week. The Brazilian will race in next January's edition of the enduro as his prize for winning this year's Sunoco Challenge.

**DYSON CONSIDERS LE MANS**

Dyson Racing is evaluating racing at the Le Mans 24 Hours for the first time next season. Dyson will continue with Lola-Mazda coupes next year and could run up to three cars in the American Le Mans Series.

**FIRST GRAND-AM AUDI SORTED**

The first team to sign up to run Audi's new Grand-Am specification R8 LMS is APR Motorsport. The team is graduating from the Continental Tire Sports Car Challenge to run an R8 in the full Grand-Am series.

**LALLY BACK IN GRAND-AM**

NASCAR Sprint Cup rookie of the year Andy Lally will return to Grand-Am next season. The three-time Daytona 24 Hours winner, who will team up with owner/driver John Potter, still hopes to run selected NASCAR events in the future.

**ROSSI WINS TC2000 TITLE**

Toyota driver Matias Rossi became Argentinian TC2000 champion for the third time with victory at the season finale at Parana last weekend. Leonardo Pernia and Mariano Werner, first and second in the championship with a race to go, collided at mid-distance.

**NO BMW AT LE MANS**

BMW will not be taking up its guaranteed entries for the Le Mans 24 Hours with Rahal Letterman Lanigan Racing, which will defend its ALMS titles in 2012 with a pair GT class M3s. There will also be no BMW campaign in the FIA WEC as the German manufacturer focuses on its return to the DTM.



BMW will focus on DTM

 **AUTOSPORT**

INTERNATIONAL

# The Racing Car Show

14 - 15 January 2012 NEC Birmingham, UK



**CARS : STARS : ACTION!**  
**A GREAT DAY OUT!**

INCLUDES ACCESS TO

**THE  
PERFORMANCE  
CAR SHOW**

Powered by **PistonHeads.com**

**BOOK YOUR TICKETS TODAY**

VISIT: **[www.autosportinternational.com](http://www.autosportinternational.com)**

CALL: **0844 581 1370**

**SEE YOUR FAVOURITE MOTORSPORT  
STARS AT THE WEEKEND!**



JAKE HUMPHREY

DAVID COULTHARD



PAUL DI RESTA

ALLAN McNISH

# PIT BITS

Facts and stats plus a readers' poll

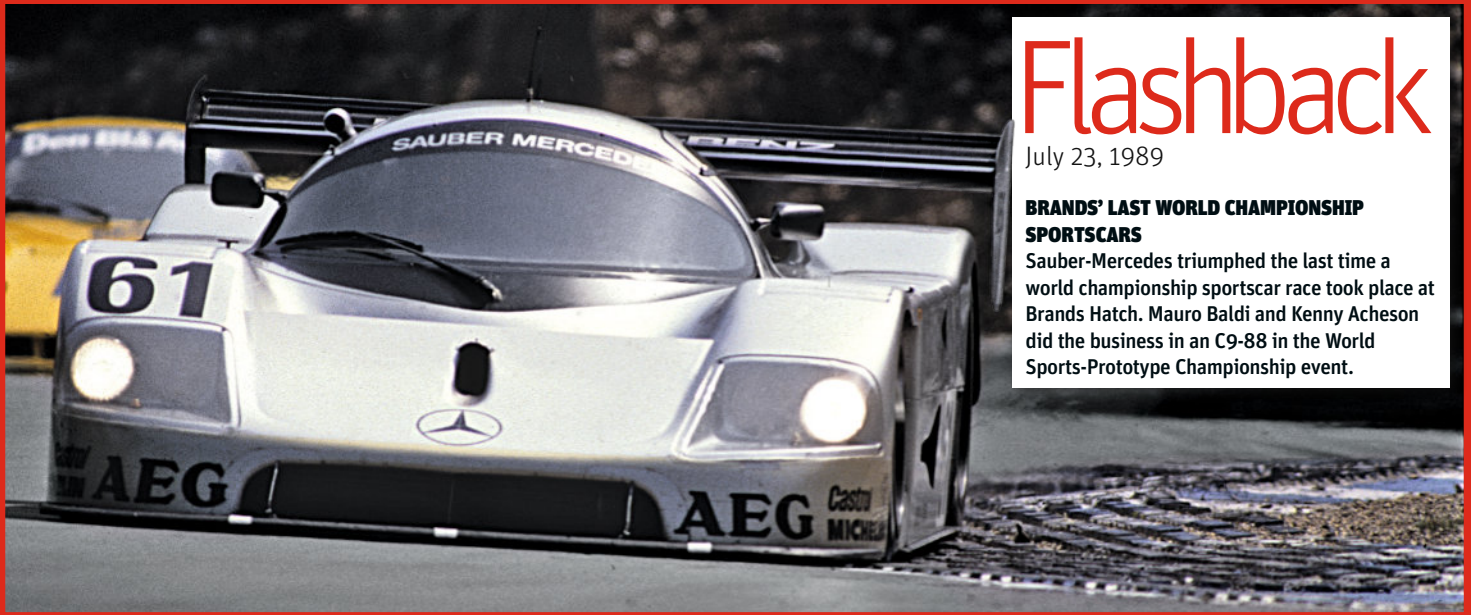

## Flashback

July 23, 1989

### BRANDS' LAST WORLD CHAMPIONSHIP SPORTSCARS

Sauber-Mercedes triumphed the last time a world championship sportscar race took place at Brands Hatch. Mauro Baldi and Kenny Acheson did the business in an C9-88 in the World Sports-Prototype Championship event.

## TOP FIVE

Pole positions in F1



Schuey took eight '04 poles

### 1 Michael Schumacher

It's been a while since his last one, but the German has the all-time record of 68 poles.

### 2 Ayrton Senna

Many thought the Brazilian's tally of 65 would never be beaten.

### 3 Jim Clark

Triple champion's count of 33 poles from 73 starts gave him a 45 per cent strike rate.

### 4 Alain Prost

Like Clark, the brilliant Frenchman was a polesitter 33 times during his career.

### 5 Nigel Mansell

With 32 poles, Mansell just edges out Sebastian Vettel, who scored his 30th pole last weekend in Brazil.

## Force India's 2012 line-up

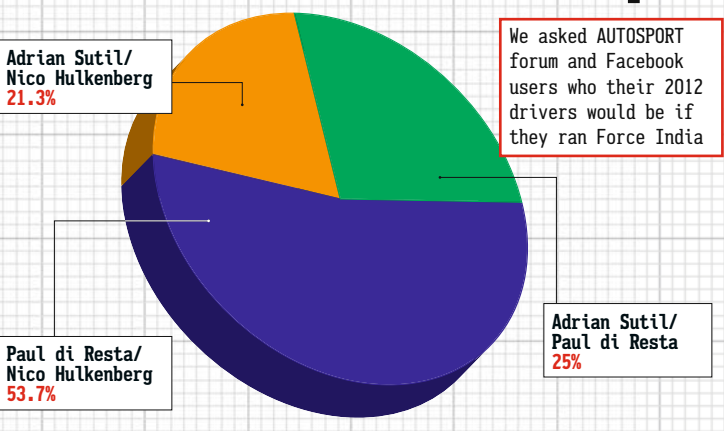

We asked AUTOSPORT forum and Facebook users who their 2012 drivers would be if they ran Force India

## top tweets



**@JamesCourtney01**  
that's something i haven't before when I get my haircut..! Would you like your Mo trimmed James? Yes as a matter a fact I would.



**@mikeconwayindy**  
Heading back stateside ...meetings, training and sun! Sorry to uk followers for sun comment..know its cold this am!



**@jimmiejohnson**  
I'm thankful we don't have a race this weekend... I'm not sure I would fit into my driving suit



**@emmofittipaldi**  
Tried to see Bernie and Tamas at track, but was blocked by a lady named Roseli, thank u #f1br. Better received last weekend at #NASCAR.



**@tomasscheckter**  
Picking up lil sister from school. The one that likes to listen to dr dre.



**@jimmyvasser**  
Sitting in airport and just noticed knee high leather boots are in fashion this winter (female).

## NEXT WEEK



### GROUP B RALLY RETROSPECTIVE

Looking back on a tumultuous era of WRC action in a 14-page special to mark 25 years since its demise

### AWARDS 2011

We dish out the prizes at motorsport's night of stars in London



## PLUS

Fernando Alonso interview; Robert Wickens reflects on his FRenault 3.5 title; full international/national news

# ON SALE DECEMBER 8

HISTORIC

## WALDEGAARD WINS SAFARI

Bjorn Waldegaard recovered from a minor road-accident delay to win the East African Safari Classic in his Tuthill Porsche 911. The 1979 world rally champion was co-driven by son Mathias. Stig Blomqvist took third.



WRC

# VW boss: Give us time

We won't win the title in our first season in 2013, admits motorsport chief Kris Nissen

Volkswagen motorsport boss Kris Nissen has played down the chances of star signing Sebastien Ogier being able to fight Sebastien Loeb for the World Rally Championship in the marque's first full season in 2013.

Loeb claimed his eighth world title on Wales Rally GB earlier this month, and is due to decide midway through next year whether to take up an option to embark on a final season with Citroen in 2013.

That's when Volkswagen's Polo R WRC competes in the world championship for the first time with seven-time world rally event winner Ogier behind the wheel.

### CHANGING TARGETS

While Volkswagen had initially pledged its challenger would be a winner from the outset, Nissen told AUTOSPORT that he's not expecting a world-title push until 2014, when Loeb is expected to defect to sportscar racing.

"We must be very realistic [about beating Loeb]," said Nissen. "First of all, Loeb is still a fantastic driver. Second, we are very proud of what we have done in Dakar [winning the past three events] but this is a new car and a different world. We ask for understanding, we have one of the best drivers in the team and we need to adapt to

this championship. I believe the team and the driver will be ready in 2013 for a very, very good performance. But we must be realistic and say 2014 is the time we will be fighting and in a good position for the championship."

### LEADING THE WAY

Volkswagen struck gold last week when it signed Ogier on a long-term deal to lead its WRC assault for the 2013 season.

Nissen expects the new addition to the German squad to step up to the role of team leader with ease.

"It won't be an easy job, but this is a milestone in the right direction," said Nissen. "Ogier is a good driver who has stepped out of a modern World Rally Car in a fantastic situation for us and for him. He is in a new family. He is the team leader for 2012, he has a lot of responsibility, it's a lot for his young shoulders, but I think he can do it. Look at F1: You have Sebastian Vettel who has won the world title two years in a row with Red Bull."

### LOEB GIVES NOTHING AWAY

Loeb will start 2012 having effectively engineered Ogier's exit from Citroen. But the 37-year-old's WRC career could only have 13 more events to run.

"In the middle of the season I will say if I stop or carry on," he said.

## Q&A

### SEBASTIEN OGIER

#### NEW VOLKSWAGEN WRC SIGNING

How busy will you be in 2012?

I will do 20 weeks of development testing with the Polo and normally the plan is to do all [13] WRC events in a Skoda Fabia Super 2000.



That's quite a comedown from a Citroen DS3 WRC...

It was the one negative knowing I won't be able to fight for the world title but I have to think beyond that and the future. But experience of all the events is still very important.

What are your test and development skills like?

Firstly I am really motivated to do this. Secondly I have good experience with the DS3 working with Sebastien [Loeb] when we often had the same conclusions about what needed to change.

How will you cope in a new team?

I don't speak German, but English is spoken in the team and there are some French people like Francois-Xavier Demaison, the head of the engineers, who I can talk to about my precise feeling with the Polo. For the German cuisine, I have not thought about it!



VW's Polo R WRC has 20-week test schedule

IRC

# Long-term IRC aim for Irish event

## CIRCUIT OF IRELAND RALLY CHIEF

Bobby Willis wants his event to be a long-term fixture on the Intercontinental Rally Challenge calendar following its inclusion on next year's schedule.

The all-asphalt event, first run in 1931, will form the third round of the expanded 13-rally series from April 6-7 2012. It has attracted backing from car retailer Donnelly Group.

Asked if the IRC would be the limit of the rally's ambitions or whether there would be a bid to bring the WRC back to Ireland in the future, Willis said: "When you've got a team of 700-800 volunteers behind you with big ambitions you never say never but the IRC is pretty damn



Willis reveals IRC slot for Irish event

big and it delivers all we could want in terms of television coverage. We'd like this to be a long-term commitment to the IRC."

Willis said full details of the route would be disclosed within a fortnight and would build on the success of this year's Superspecial stage through the streets of Lisburn, where 15,000 spectators attended. He also

said the event would be unlike all other IRC asphalt rounds.

"It's not going to be an easy rally," said Willis. "The surface here can be bumpy and slippery and whoever wins will be made to work for it. We're expecting this to be Ireland's biggest sporting event of 2012 based on the number of visitors that are likely to be in attendance."

## AUTOSPORT SAYS...

**DAVID EVANS**  
RALLIES EDITOR

david.evans  
@haymarket.com



Last week I was finally presented with a copy of the IRC calendar for 2012. While it's a series I'm not able to cover as extensively as I do the WRC, I still follow it closely, particularly to keep an eye on the emerging talent it produces.

Waiting until the penultimate week of November was bad enough, although I'm told organisers were keen to issue a concrete set of dates rather than produce a calendar that would change almost immediately, which has been the case in the past.

However, the delay paled into insignificance when it emerged that the final rounds of the WRC and IRC seasons in Spain and Cyprus respectively take place on the same weekend.

Complaining about fixtures is a tiresome process but this situation is unforgivable. The IRC and Cypriot organisers need to address pronto as it's entirely of their making.

The date of Spain's WRC round has been known for months. Regardless of whether November 3/4 is the weekend of choice for Cyprus, or that Eurosport's schedulers will struggle to accommodate the IRC finale's live television coverage, clashing with the WRC closer is a massive own goal.

Not only will the clash impact on entries, there will be a dearth of coverage and an absence of overseas visitors to the island.

But IRC 2012 is not all bad. Tour de Corse and Sanremo remain, Ypres is always a highlight and the new Circuit of Ireland will be a big success.

Cyprus: clouded in controversy



## IN BRIEF



Nasser has Qatar backing

### NASSER IN CITROEN LINK

Nasser Al-Attiyah continues to be linked to a full WRC campaign with Citroen next season with backing from Visit Qatar. It is understood the support will be extended to the cars of factory drivers Mikko Hirvonen and Sebastien Loeb.

### CSI IN ADMINISTRATION

The company which owns the commercial rights to the WRC, Convers Sports Initiatives, went into administration as AUTOSPORT closed for press. This came shortly after CSI boss Vladimir Antonov was bailed following his arrest in London last weekend in the aftermath of the collapse of Bankas Snoras in Lithuania.

### NIGHT RUNS FOR PORTUGAL

Portugal's world championship round will include three night stages, organisers have confirmed. The runs will take place following the Lisbon Superspecial on Thursday March 29. Several leading WRC drivers have slammed the inclusion of night stages on gravel events due to the visibility problems

created by dust clouds.

### PEDERSOLI TO GET DS3

Italian Luca Pedersoli is in talks with Citroen over an eight-event world championship campaign in a DS3 WRC. The 40-year-old, who shared a test with Kimi Raikkonen earlier this month, hasn't competed at global level since 2000.

### RALLY CLASS REVEALED

PWRC champion Hayden Paddon's Symtech Racing team has revealed plans for a new competition to run on six rounds of next year's WRC. Rally Class will pitch drivers together in identical Subaru Impreza STR12s. The series is being run in conjunction with WRC promoter North One Sport and will carry a five-event rally programme in 2013 as its top prize.

### PIRELLI STARS FOR ITALY

Pirelli UK Star Driver Jukka Korhonen will take part in the Pirelli Star Driver Challenge during the Bologna Motor Show in Italy on December 8. The Finn will take on his predecessor Elfyn Evans, and four of the six Pirelli Star Drivers from this year's FIA WRC Academy.

### MIKKELSEN HONOURED

Andreas Mikkelsen received a special award for his IRC title success during last Friday's Norwegian motorsport federation prize giving ceremony in Oslo.

WRC

# Rossi stars at Monza in Fiesta

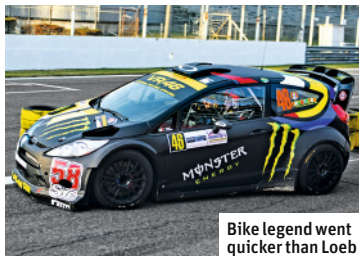

Bike legend went quicker than Loeb

**MOTOGP LEGEND VALENTINO ROSSI'S** performance at the Monza Rally Show has been described as "outstanding" after he went faster than Sebastien Loeb on two stages at the Italian GP venue.

Rossi, who drove a Ford Fiesta RS WRC alongside experienced co-driver Carlo Cassina, was quicker than Loeb on both runs of the 20.2-mile stage. He finished the event second overall, 24s behind Loeb, whose Citroen DS3 WRC was co-driven by his wife Severine.

John Steele, car builder M-Sport's commercial director who oversaw Rossi's participation in the event, said: "He was outstanding and I can't praise him enough. He'd not driven a rally car for two years and the last time was in a Focus, and in the wet. OK, it's an event he loves and he knows what's required but he was sensational."

Steele hopes the Italian will return to the event next year in an M-Sport car but added it was too early to discuss plans.

## REMEMBER WHEN...



...Bjorn Waldegaard last won the Safari? The Swedish world rally top name took 16 WRC wins between 1975 and 1990 – four of them in the Safari. The last came in the Toyota Celica GT-Four in April 1990.



## BRAZILIAN GP

Interlagos,  
November 27

**ROUND** 19/19

**LAPS** 71

## WINNER

Mark Webber  
1h32m17.464s

## POLE POSITION

Sebastian Vettel  
1m11.918s

## FASTEST LAP

Mark Webber  
1m15.324s

## RACE RATING

★★★★★

Continued the pattern  
of disappointing  
end-of-year races

## DRIVERS STANDINGS

Vettel	392pts
Button	270pts
Webber	258pts

## MILESTONES

- The 43rd podium for Button - which puts him equal with Jackie Stewart
- Massa's 100th start in a Ferrari



# WEBBER BOXES CLEVER

Sebastian Vettel's surprise gearbox problem means it's Mark Webber's turn to head a season-closing Red Bull one-two in Brazil. By MARK HUGHES



# QUALIFYING

Vettel supreme to go one up on 'Our Nige' for poles in a season

So here was the delivery, the record-breaking 15th pole in a season. Sebastian Vettel never looked like not taking it, building up the pieces of the jigsaw through the weekend as effectively as ever, totally confident it was all in his hands. "I love the moment when you go out for that final run," he said. "You are so excited, nervous – and then the lap itself is like a rush." He's become a master at it, and he shaved 0.3s off his first Q3 run (which had been quickest at the time) to put it out of the reach of everyone, including Red Bull team-mate Mark Webber, who nonetheless was providing a strong challenge to end up just 0.1s shy.

"Well I tried to help old Nigel [Mansell, previous holder of the pole record] today, but couldn't quite do it," said Webber. "You're always in for a pretty tough arm wrestle trying to get pole off Seb." The Red Bulls had been set up in the expectation of rain, with plenty of wing and shortish seventh-gear ratios.

The McLarens were maxed in downforce too, but with longer top-gear ratios in a vain effort to snatch grid position from the RB7s. But even with full wing they were still substantially quicker at the end of the straights than the blue cars, a reflection of just how much more downforce the Red Bull has.

Jenson Button, third quickest and 0.3s adrift of Vettel, reckoned there was no more lap time in the McLaren the way it was. "It was a slightly scrappy lap," he said, "pretty aggressive on the throttle, which you have to do to be fast around here. That's not normally my style, but it was definitely quick and we'd tweaked the set-up into Q3 as I hadn't been totally happy with its soft-tyre balance in Q2, and I don't think we could have got any more from the set-up. So it was quite satisfying." It was also his best qualifying performance at Interlagos for the past six seasons. Lewis Hamilton was a couple of tenths behind in fourth place. "I made no mistakes on my lap; I thought it was pretty good. Jenson was just massively fast today," he said.

Ferrari had split its strategy, putting



Vettel was a blur again in qualify

Fernando Alonso on less-than-maximum rear wing, one down from Felipe Massa who was dragging a barn door behind by comparison. As the wind picked up into qualifying, this didn't help Felipe's cause. Alonso was in his habitual fifth position, 0.5s and two places ahead of Massa, who had been able to do only one new-tyre Q3 run on account of using two sets in Q2.

Nestling between the Ferraris was Nico Rosberg's Mercedes. Had he repeated his superb Q2 effort (0.6s faster through sector 2 than any other lap all weekend, astonishing the engineers!) he'd have been fourth on the grid, but on his sole new-soft-tyre Q3 run he locked up badly at Turn 8, this costing him 0.5s. It all traced back to his out-lap, where he'd got the tyres slightly hotter than ideal. That car had a very narrow window of tyre temperature for an ideal lap here. There was another new set of softs he chose to

save for the race. The Mercedes was working well here though, consistently the fastest in the long climb up the hill, representing a strong engine/KERS in combination with an effective wing when in DRS mode. Michael Schumacher only just scraped into Q3 and didn't complete a lap there, leaving him 10th but free for the race to fit the new set of softs he'd saved. A full 1s off Rosberg in Q2, he was mystified as to why he couldn't repeat his lap times from that morning's practice.

Adrian Sutil was in strong form and was the Force India's only representative in Q3, where he put the car eighth just a couple of tenths shy of Massa – but unlike the Mercs he'd used up all his softs. Renault's Bruno Senna, not for the first time, delivered a great high-pressure qualifying lap just as it looked like he was set to be shaded by his team-mate. He'd added camber and front wing since the morning to give him the front end he felt he'd been lacking. As it was he was 0.7s faster than Vitaly Petrov, enough to get him through to Q3, where he was ninth on a used set of softs.

Paul di Resta just failed to take his Force India through to Q3, lining up 11th. His car was significantly down on top speed compared to Sutil's despite the same wing settings, and the team was at a loss to understand the problem. Without that, di Resta would likely have joined his team-mate in Q3.

Rubens Barrichello, in what may or may not have been his final F1 qualifying

session, did a great job to put the Williams 12th fastest, working on fine-tuning the balance to great effect and shading the Toro Rosso pair, a bare 0.003s faster than Sebastien Buemi. This was a good effort from Buemi, given that he'd been forced to sit out FP3 with hydraulics failure and that the set-up direction the team had followed during that session left him going into qualifying in a car that behaved differently to what he'd driven on Friday. But he was running with a much higher wing setting than team-mate Jaime Alguersuari, this being of benefit in qualifying.

Petrov was back in 15th in the second Renault, having been unable to match his Q1 time after feeling a deterioration of grip into Q2. The Saubers were again unable to generate tyre temperature, leaving Kamui Kobayashi and Sergio Perez a very busy 16th and 17th, 0.6s away from Q3. Pastor Maldonado failed to find a good balance in his Williams and was further delayed by traffic, leaving him out of Q2. In the Q1 part of the grid both HRTs outqualified both Virgins, the faster of them just 0.7s adrift of the Lotuses.

Rosberg got tyres just right in Q2 and flew



**P40 RESULTS**  
Interlagos  
intelligence





Vettel leads as Hamilton is swamped by Ferraris



**RACE CONDITIONS**

The threatened rain stayed away and the race was held in bright and occasionally cloudy conditions.

**I**t wasn't the gloves-off fight with Sebastian Vettel that Mark Webber would have preferred. But neither was Webber's victory the conspiracy some suspected. The gearbox oil leak on Vettel's car was real — as proved by a post-race look at the telemetry traces of rising temperature and falling pressure. If you wished to manufacture a result between your cars, there are far more straightforward ways of doing it.

Webber recounted smelling the oil as he came upon Vettel's tail on lap 28 — and no way on this earth would Mark Webber, of all people, have played along with being a Vettel charity recipient. This was just one of those racing things; a slow gearbox leak from a car with a phenomenal reliability record that was due a problem one day — and Webber was close enough to take full advantage when that day came.

Had there been a McLaren or Ferrari fast enough to have raced

Webber, then Vettel's problems could have given us a closer contest than we got. Or had the promised rain ever arrived, then maybe the way in which the McLaren generates tyre temperature more quickly would have given it the edge.

But for whatever reason McLaren just did not have its usual 2011 pace. It often happens this way for the team at Interlagos, and the guys don't understand it. "We've looked at all sorts of theories," said technical director Paddy Lowe, "and tried to simulate them to see if they stand up, but they don't. We've considered things like, 'Is the engine more affected by the altitude than other engines and does that change the balance adversely?'; but we've ruled them all out. It's a pretty normal track with straights and corners, kerbs and bumps, things we don't normally have a problem with. I've no idea." When Jenson Button is suffering more tyre degradation than those around him and is forced to change his strategy, then something's not quite as it should be.

So Red Bull sailed off into the sun, a sun that stayed resolutely visible, confounding every single team's forecast. Vettel led Webber away from the lights, with Jenson Button retaining his third grid place in the



Oops! Senna runs into Schumacher

McLaren. Fernando Alonso's Ferrari outaccelerated Lewis Hamilton for fourth off the line and had a look around the outside of Button, but then tucked back in between the two McLarens as they began the descent of the Senna Esses.

Vettel was his usual spellbinding best on the opening couple of laps, leaving Webber somewhat breathless but already pulling away from Button, who had Alonso breathing down his neck. Into the Esses for the second time, Michael Schumacher made a clean pass down the inside of Paul di Resta for 10th and set off after the Renault of Bruno Senna.

By the time the DRS zone down to

Turn 4 was enabled on the third lap, Vettel had pulled himself well out of reach, but Alonso was immediately using it in trying to pass Button, initially to no effect.

But Jenson knew that he was in for a tough afternoon. "I couldn't look after the tyre," he said of the soft that everyone had started on, supposedly faster than the medium by around 0.5s per lap in the race. "I really struggled with degradation, especially at the rear end, which was a little bit of a shock. The problem was made worse in the first stint by Fernando. He pushed me very hard, and when someone's doing that, you have to drive a little ▶

◀ bit harder, so I was pushing the tyres pretty hard – and it was all just sort of escalating.”

Unbeknown to Vettel as he worked at maintaining the gap over Webber at around 3s, Red Bull was beginning to see unwelcome messages on the telemetry. Seb’s gearbox was losing oil pressure and the temperature was beginning to rise, sure signs of an oil leak. The unit – new for Brazil – had been giving trouble through the weekend, not giving the smoothest of shifts. Repairs and tweaks to it had been carried out in *parc ferme* – and the KERS was replaced too. For the moment, as the signs were monitored, there was no need to alert Vettel, who continued to increase his lead.

Hamilton had fallen slightly off the back of the Button/Alonso dice, just concentrating on staying out of reach of the second Ferrari of Felipe Massa. McLaren didn’t know at this stage, but Massa was committed to a two-stop race rather than the three stops favoured by most others. He’d suffered a puncture during qualifying and therefore did not have a third set of softs available for the race. Given how the Ferrari is invariably slow on the harder tyre, this was the preferred strategy. It all left him rather hamstrung.

Hamilton/Massa were, in turn, still pulling away from the Mercedes-powered struggle between Nico Rosberg and Adrian Sutil. The Mercedes chassis’s narrow window of tyre usage was making things very difficult for Nico. “The high track temperature gave us problems, basically,” he said. “The rears began overheating from very early and I was having to nurse them very carefully.”

Just behind this pair were the duelling Senna and Schumacher, but this didn’t end well. On the 10th lap Michael tried for the outside as they flashed down the pit straight towards the Esses and was slightly ahead as

“The beautiful rhythm of Vettel’s day was interrupted by his engineer’s voice crackling into life”

they reached the braking point. Senna stayed firm and they banged wheels, Schumacher remaining ahead as they headed down the Esses, but with Bruno still trying to fight the place. In doing this he mashed his right-front endplate into the Merc’s left-rear tyre, giving it an instant puncture. As Michael limped slowly around for a replacement, Bruno continued but would later fall out of contention with the loss of fourth gear and a drive-through penalty for the Schuey incident. The Merc and Renault would finish 15th and 17th respectively.

Their incident would have a bearing on the Button/Alonso fight the following lap. Button was a little slow out of Turn 5 on his overheating rears, Fernando got better momentum out of there and was catching fast as they headed for

the blind exit uphill of Laranjinha. This isn’t a passing place and Button was quite relaxed as the Ferrari moved to his outside. “It’s an easy place to block,” he said, “but I looked at where he was and then when I looked forward again there was lots of debris on the inside. I think it was Michael’s tyre and a bit of front wing. As soon as I saw that I didn’t want to drive through it. I couldn’t pull to the left because Fernando was already there, so I had to back out of it and just pull in behind him.” It made Alonso’s pass for third look sensational but actually it was handed to him. Once past, Fernando pulled quickly away and, although he was now 6s adrift of Webber, he was lapping only a few tenths slower.

By now, Red Bull team boss Christian Horner had decided Vettel needed to know about the gearbox problem. “We’d kept a watch on it for a few laps,” he said, “and it then became clear the problem was significant. At that point we had to tell Seb to manage it. The early prediction was that it wouldn’t last much beyond half-distance.” The beautiful rhythm of Vettel’s day was interrupted by engineer Guillaume



Over and out for Maldonado...



...and over and out for Barrichello?

## DRIVER BY DRIVER by Edd Straw

**1**  **9/10**  
Event rating

**SEBASTIAN VETTEL**

Red Bull-Renault RB7-5

Start: 1st. Finish: 2nd

Bagged his customary pole under pressure from his team-mate. As usual, held the lead at the start and pulled away, but was losing gearbox oil and had to take it easy with the 'box to manage rising temperatures and preserve the fluid. Did well to hang onto second.

**2**  **9/10**  
Event rating

**MARK WEBBER**

Red Bull-Renault RB7-4

Start: 2nd. Finish: 1st

Looked to be a potential threat to Vettel in practice, although was missing the last tenth or two that he needed to claim a fourth pole position of the season. Did well to hold second at the start after a slow getaway and capitalised on Vettel’s problems to win.

**3**  **7/10**  
Event rating

**LEWIS HAMILTON**

McLaren-Mercedes MP4-26-04

Start: 4th. DNF

After the highs of Abu Dhabi, Hamilton had a low-key end to the season. He qualified behind team-mate Jenson Button and stayed there in the race until gearbox problems began to manifest themselves. Initially slowed by them, he eventually retired.

**4**  **8/10**  
Event rating

**JENSON BUTTON**

McLaren-Mercedes MP4-26-03

Start: 3rd. Finish: 3rd

Rounded off the season well, taking third place in a car that didn’t have the legs to challenge Red Bull in dry conditions. Had to give best to Alonso early in the race, but an unorthodox three-stopper with two prime stints allowed him to breeze back past using the DRS.

**5**  **9/10**  
Event rating

**FERNANDO ALONSO**

Ferrari 150° Italia-291

Start: 5th. Finish: 4th

Alonso’s Brazilian Grand Prix weekend fitted his template for the season. Qualified fifth, then extracted good pace from the machinery during the race, pulling a great move around the outside to pass Button. Didn’t have the pace to stay there, unfortunately.

**6**  **6/10**  
Event rating

**FELIPE MASSA**

Ferrari 150° Italia-290

Start: 7th. Finish: 5th

Came into his home grand prix facing the ignominy of becoming the first Ferrari driver to complete a full season without a podium in three decades, and came nowhere near avoiding it. Half a second off Alonso in qualifying, he continued to be so in the race.



Button leads McLaren/  
Ferrari battle early on



Sutil won Rosberg scrap

Rocquelin's voice crackling into life on the radio, telling him he would need to short-shift in second and third. "The message sounded pretty strong, pretty severe," related Vettel, "so I turned down the engine and then immediately started to short-shift, but it just kept getting worse. Obviously, short-shifting really hurts you as you accelerate up that long, steep hill at the end of the lap and I just tried to concentrate on going fast in the parts where the gearbox wasn't affected – in the corners basically." His times initially fell away by around 0.5s, enough for Webber to begin closing.

"I thought he was either in tyre trouble way earlier than he should be or had no KERS or something," said Webber. "Something was going on, because one thing Seb doesn't do is forget how to drive from one lap to the other. When I started to take a pretty big chunk out of him each lap, I thought something might have been going down and then Ciaron [Pilbeam, Webber's engineer] informed me about Seb's gearbox problem."

Remarkably, a very similar situation was playing out in the McLaren pits. Just as Vettel was being informed of his problem, they were seeing Hamilton's gearbox temperatures and pressures heading in opposite directions. Apparently this was a more serious leak than Vettel's; Lewis was notified immediately and shortly thereafter he began experiencing difficulties in selecting second. He remained ahead of Massa but was falling away even from Button's tyre-compromised pace.

At the end of lap 15 Button peeled off into the pitlane, a couple of laps earlier than planned, in order to get rid of this set of softs, which were replaced by another. It triggered Ferrari into bringing in Alonso to defend his place a lap later, and he

was followed down the pitlane by Hamilton and – some way further back – by Rosberg. Nico's struggle with both his tyres and Sutil was a losing one, as Force India had brought its man in two laps earlier and his new-tyre pace in those two laps catapulted him in front of the Mercedes. He would pull easily away from it.

Red Bull brought in Vettel at the end of lap 17, with his lead over the gradually-closing Webber at around 2.5s. Webber was brought in next lap, putting two-stopping Massa into a temporary lead. After the Red Bulls had rejoined, Seb's advantage was back out to 4.2s, yet their in-laps and pitstop times had been almost the same. The loss was incurred as Webber had caught and lapped the delayed Schumacher during Vettel's in-lap at an awkward place. With Alonso having pitted two laps earlier, this enabled the Ferrari to get within 3.5s, but the Red Bull was immediately lapping 0.5s faster. More significantly, it was lapping around 0.4s faster than the sister car ahead of it.

Vettel was coping remarkably well in adapting, pushing like crazy through the twisty middle section to overcome the enforced lack of engine performance. But still Webber closed relentlessly. "As I got closer I could smell the oil," he related, "and there was some fluid too."

Vettel had already radioed the team that when Webber caught him he would move aside – and he duly did so as they approached the Esses on the 29th lap. Webber quickly pulled away, alternately pushing and setting new fastest laps, then easing off to let the tyres breathe. Vettel's brilliantly-adaptive driving was allowing him to keep around 8.5-9s ahead of Alonso and within about 5s of Webber. At one point he radioed in: "I feel like Senna here in '91," in reference to Ayrton's Interlagos ▶

**7**  **7/10**  
Event rating

**MICHAEL SCHUMACHER**  
Mercedes MGP W02-09  
Start: 10th. Finish: 15th  
As usual, lacked a little pace in qualifying but was on course for his standard strong race performance. Passed di Resta to regain 10th early on but clashed with Bruno Senna, suffering a puncture. Recovered well to 15th after losing a lap.

**8**  **8/10**  
Event rating

**NICO ROSBERG**  
Mercedes MGP W02-07  
Start: 6th. Finish: 7th  
Qualified extremely well, picking off the Ferrari of Massa, but couldn't quite maintain that level of form in the race. Struggled a little with tyre degradation and, on a two-stopper compared to Sutil's three stopper, slipped behind his compatriot.

**9**  **7/10**  
Event rating

**BRUNO SENNA**  
Renault R31-05  
Start: 9th. Finish: 17th  
Most accomplished qualifying performance yet and ran well early in the race, but while drive-through penalty for clipping Schumacher was harsh, he has to accept some blame for leaving his nose in and suffering damage. Then had gearbox problems.

**10**  **7/10**  
Event rating

**VITALY PETROV**  
Renault R31-06  
Start: 15th. Finish: 10th  
The Russian didn't deliver in qualifying through a combination of changing track conditions and positioning himself in Hamilton's wake on his best Q2 lap. But he made up for it in the race with a consistent drive to score a rare point.

**11**  **8/10**  
Event rating

**RUBENS BARRICHELLO**  
Williams-Cosworth FW33-04  
Start: 12th. Finish: 14th  
Qualified exceptionally well, hauling the Williams around to a time that wasn't far off Q3 pace. Terrible start undid his good work, although he gave the crowd something to cheer with a decent drive to finish 14th. Car didn't have the pace for points though.

**12**  **4/10**  
Event rating

**PASTOR MALDONADO**  
Williams-Cosworth FW33-02  
Start: 18th. DNF  
A weekend to forget for Maldonado, who qualified poorly and struggled to make an impact in the race before spinning out while battling oversteer. In his defence, did struggle with the set-up throughout the weekend and never found a satisfactory balance.

◀ victory despite gearbox problems. That just says everything about that fantastic mind, hungry and interested enough to know the sport's history, with enough spare capacity during a troubled race to start quoting it. Just remarkable.

Approaching the second stops it was again Button who was in first, on lap 31, his second set of soft tyres having proved no more durable than the first. He was at this point switched to the mediums, a compound on which he had been happier on Saturday, even though it was supposedly slower. "We were reluctant to put his third set of softs on anyway," explained Paddy Lowe, "because they'd done a lot of laps on Saturday."

Hamilton – who'd been within a couple of seconds of Button despite his worsening gearbox problems – pitted a couple of laps later and had another set of softs fitted. Next it was Alonso and, in turn, the Red Bulls, all going for fresh sets of softs.

The out-of-sequence Massa lay a temporary fourth but was soon DRS-ed aside by Button, who was finding the car much-better-balanced on the harder tyres. The hobbled Hamilton though could make no headway on the Ferrari and he was brought in early – on lap 44 – in an effort to spring him past on strategy. Ferrari responded by bringing Massa in on the next lap for his final stop and Felipe remained narrowly ahead. Two laps later, Hamilton pulled off the track on the run down to Turn 4. Seventh gear had gone, followed soon after by the others.

Those early duellists Sutil and Rosberg had parted company and strategy once Adrian had got past. But his three-stop had lost him track position to Rosberg's two-stop, requiring him to pass once more if he wanted that sixth place. On the



The world champions sing their song

48th lap he slipstreamed the Merc down the pit straight, flicked right and passed, but Rosberg simply braked late on the inside to retake the place. On the next lap, Sutil was able to make the same move stick. Once again he pulled easily away from the silver car. Di Resta – who was generally matching Sutil's times despite the continued mysterious straight-line-speed deficit – looked like he would soon be upon Rosberg's tail too. But towards the end he would lose his KERS and suffer a gearbox glitch, letting Nico off the hook for seventh.

Fourth-placed Button made his third and final stop on the 52nd lap, with 19 to go, and had another set of mediums fitted. Alonso stopped

Button gives Webber a nice drenching



## DRIVER BY DRIVER by Edd Straw

**14**  **10/10**  
Event rating

### ADRIAN SUTIL

Force India-Merc VJM04-04  
Start: 8th. Finish: 6th  
Impeccable drive from the German, who is fighting to stay in Formula 1 next season. Qualified strongly after being quick throughout practice and carried this form over into the race, beating Rosberg's Mercedes comfortably and not being far off Massa.

**15**  **7/10**  
Event rating

### PAUL DI RESTA

Force India-Merc VJM04-02  
Start: 11th. Finish: 8th  
On paper, not as strong a weekend as Sutil's. But, given that he was battling an unexplained top-speed problem and then KERS and gearbox problems in the race, the fact that he ended up with four points represented a good weekend's work.

**16**  **9/10**  
Event rating

### KAMUI KOBAYASHI

Sauber-Ferrari C30-04  
Start: 16th. Finish: 9th  
After a difficult second half of the season, Kobayashi delivered when Sauber most needed it, passing Buemi early on and bagging two points to make sure of seventh in the constructors' championship for Sauber. Outqualified Perez as well to crown a strong weekend.

**17**  **6/10**  
Event rating

### SERGIO PEREZ

Sauber-Ferrari C30-03  
Start: 17th. Finish: 13th  
The Mexican rookie had a quiet weekend during which he never quite managed to get in among the Toro Rossos as Sauber fought with the Italian team for championship position. Survived a quick spin in the race, but other than that was solid on Sunday.

**18**  **5/10**  
Event rating

### SEBASTIEN BUEMI

Toro Rosso-Ferrari STR6-03  
Start: 14th. Finish: 12th  
With Toro Rosso splitting its set-ups in case of wet weather, Buemi ended up with the higher downforce levels of the team's two cars. Was passed, crucially, by Kobayashi early on and couldn't quite drag himself into points contention.

**19**  **5/10**  
Event rating

### JAIME ALGUERSUARI

Toro Rosso-Ferrari STR6-02  
Start: 13th. Finish: 11th  
Ended up with the right set-up for the race with the expected rain not coming, but when push came to shove he couldn't get ahead of Petrov and Kobayashi, which he needed to do to deliver seventh in the constructors' for Toro Rosso. Wouldn't have taken much though.



**“Webber ignored the radio request and his last lap of the season was the fastest of the race. He surely then sighed with relief”**

from third a couple of laps later. The earlier stop had bought Jenson two of the seven seconds by which he had been trailing the Ferrari, but there was the prospect of more to come. The Ferrari invariably hates the harder tyre – and McLaren was more than aware of this. “These tyres are good for qualifying laps to the end of the race,” Jenson was told in the way of encouragement.

Sure enough, Button was soon taking huge chunks – up to 1s per lap – out of Alonso’s advantage and, while the Red Bulls made routine stops from first and second, the attention switched to the battle for third.

With 11 laps remaining Button slipstreamed Alonso up the long hill and onto the pit straight, opting for the outside, forcing Alonso to brake late into the Esses to keep the place, the Ferrari giving a menacing little wiggle as he did so. With Button still hard on his tail and approaching the DRS zone as they exited Turn 3, Alonso was forced to use up his KERS defensively. Button chose not to use his, and stayed behind. It was a masterstroke. There is not enough braking at this track for KERS to be fully recharged in one lap – it’s a minimum of two laps’-worth of harvesting. So, going into the next lap, Alonso had only around half the KERS storage of Button – and Jenson knew this. Again, he went by Alonso’s outside up to the Esses, again Fernando defended. But this time, as they screamed out of Turn 3, Button had DRS and KERS,

and Fernando had no DRS and only a little KERS. Alonso knew he was scuppered, but defended brilliantly anyway, pulling across to the pit-exit road in his determination not to let the inside line open. But it made no difference as Jenson sailed effortlessly by on the outside approach.

As Vettel was informed that Button was now P3, he got a feeling of dread. “A couple of times this year I’ve heard that message that Jenson was catching at the end of the race,” he said. Seb had actually been off the road as he exited Turn 4 on his new medium tyres. “Yes, they took a bit longer to get up to temperature than I thought and I got caught out lapping some backmarkers,” he explained. He simply let the car run out wide over the grass and the drama was contained as he rejoined exiting Turn 5 at the bottom of the hill. But Button wasn’t about to catch him. There were not enough laps left, and it was Vettel’s payback for the brilliance of his adaptation to the gearbox problem.

Webber’s penultimate lap was the fastest of the race so far, a fact he was informed of, along with a discouragement of trying to improve upon it further. He ignored the request and his last lap of the season was the fastest of the race. He surely then breathed a sigh of relief: a victory at last. It had been too long.

“I’ll take it the way it comes,” he said. “It’s impossible to say how the rest of the race would have gone had Seb not had the problem. He was very strong in qualifying and very strong at the start of the stints, and I felt I was a bit more comfortable at the end of the stints, which was probably one of the first times this year, to be honest. Difficult to say, but it would have been a very tough race to challenge Seb hard – but we never know.”



Vettel let Webber through for victory

**20**  **7/10**  
Event rating

**HEIKKI KOVALAINEN**  
Lotus-Renault T128-04  
Start: 19th. Finish: 16th  
Like no other driver, Kovalainen has ended up in a Groundhog Day loop on race weekends. He outqualified the on-form Trulli, made a great start, bothered the midfield and picked off the hobbled Renault of Senna. Now we need to see him in a stronger car.

**21**  **6/10**  
Event rating

**JARNO TRULLI**  
Lotus-Renault T128-01  
Start: 20th. Finish: 18th  
Looked to have the beating of Kovalainen at times, but lost out in qualifying and turned in his usual race performance. Ended up well behind the Finn, but at least brought the car home – with 10th in the constructors’ championship at stake – to end a poor season.

**22**  **6/10**  
Event rating

**DANIEL RICCIARDO**  
HRT-Cosworth F111-03  
Start: 22nd. Finish: 20th  
Wasn’t particularly happy with qualifying, struggling with understeer that set in during his final run of Q1 and left him behind teammate Liuzzi. Did a decent job in the race, although didn’t have the pace to take the fight to the Virgin of d’Ambrosio.

**23**  **7/10**  
Event rating

**VITANTONIO LIUZZI**  
HRT-Cosworth F111-01  
Start: 21st. DNF  
A change of chassis appeared to bring to an end Liuzzi’s recent run of struggles as he outqualified and outraced newboy Ricciardo. Unfortunately for the Italian, an alternator problem forced him out of the race in the closing stages.

**24**  **6/10**  
Event rating

**TIMO GLOCK**  
Virgin-Cosworth MVR-02-02  
Start: 24th. DNF  
Car was all over the place during qualifying and Glock wasn’t particularly happy after being outqualified by d’Ambrosio. Had a quiet start to the race, and went no further than his first pitstop after a blunder led to him being released with the right-rear wheel not attached.

**25**  **8/10**  
Event rating

**JEROME D’AMBROSIO**  
Virgin-Cosworth MVR-02-03  
Start: 23rd. Finish: 19th  
Finished the season well, outqualifying and outracing Glock in the knowledge that Charles Pic will be taking his seat next season. His future looks uncertain, but his unflustered performance was a reminder that he’s not been out of his depth in his rookie year.



**FREEZE  
FRAME**

# Charouz control

**Czech Republic driver Jan Charouz made his F1-weekend debut for HRT in Brazil. The 24-year-old tells MARK HUGHES how he got on**

Jan Charouz locks up the inner front into the Senna Esses during his Friday morning run in the HRT, one week after testing for the team in Abu Dhabi. "It was fantastic just to be on the track with people like Schumacher, Vettel and Alonso. It's a bit different to testing because there are a lot more cars on the track so you have to make space for others and not cause traffic. I think I did quite a good job as I was pretty close to Daniel [Ricciardo] which was the main goal. I don't think five tenths is too much. The car is very easy to drive but I would have liked to have had more tyres because by the time I learned the track they weren't at their best – but that's the same for everyone." Unlike most cars, in this throttle-off phase of the corner, there is no exhaust blowing of the HRT's diffuser, either cold or hot.



# Drawing board

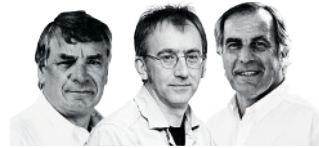

Gary Anderson, Mark Hughes and Giorgio Piola summarise final updates for 2011 - and some for 2012 - from Mercedes, Ferrari and Force India

## INTERLAGOS

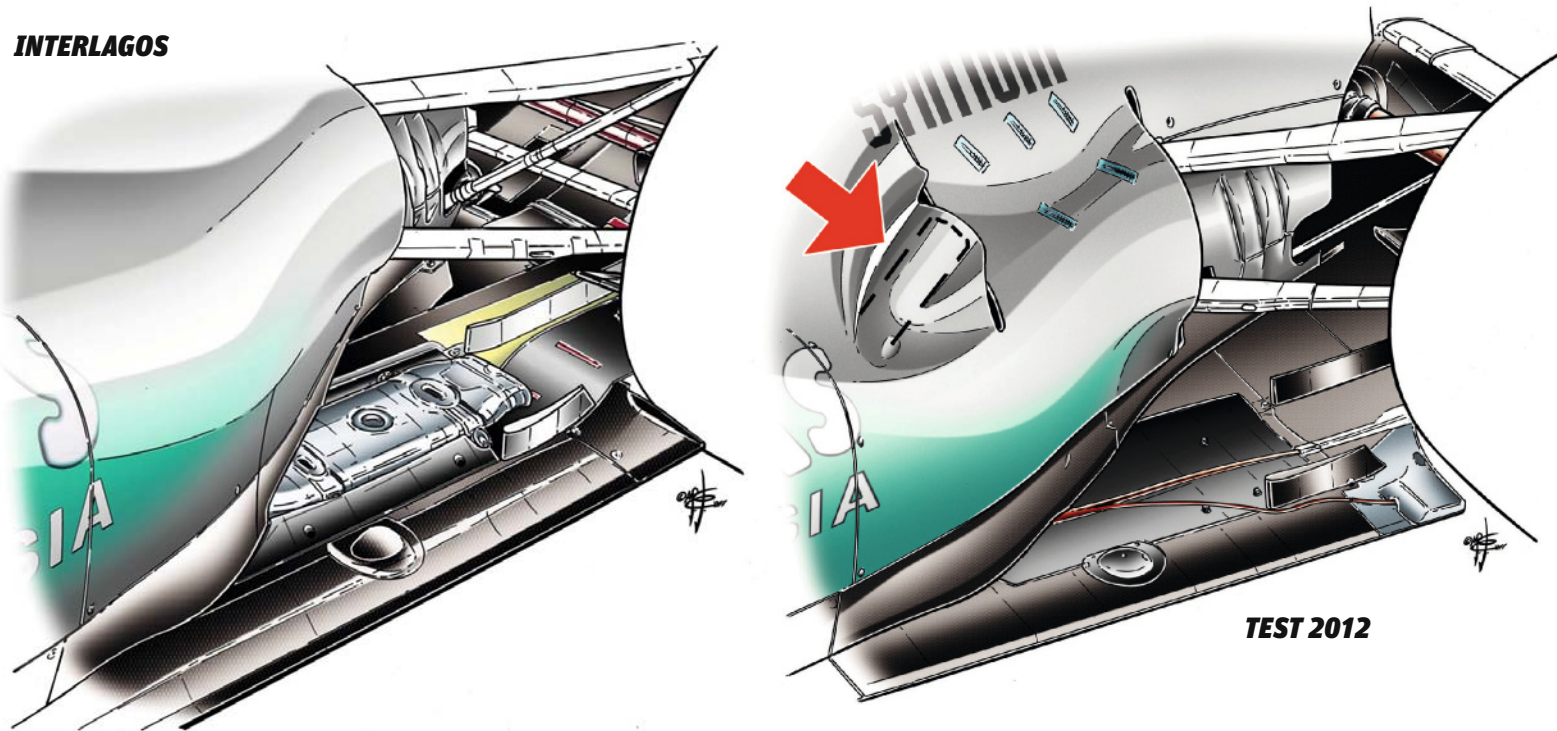

## MERCEDES 2012 EXHAUSTS

➔ In this month's Abu Dhabi young driver tests Mercedes ran with this exhaust arrangement, complying with the 2012 rules limiting exhaust-blown diffusers. The 2011 arrangement (above left) compares with the 2012 experiment (above right). To the right is the new arrangement from the rear.

**GARY ANDERSON:** With the regulations regarding the exhaust-exit location changing for next year to eliminate what are called 'blown diffusers', Mercedes and some of the other teams took the opportunity to run with this new configuration at the Abu Dhabi young driver test. In reality, the new location goes back to what most teams were running prior to Red Bull's introduction of the blown diffuser, so there shouldn't have been any big surprises in store from anyone, but what surprised me is that Mercedes has just left the diffuser alone. If - and this is a big 'if' - the exhaust-blowing system was working with a positive effect, then the same-specification diffuser should suffer some airflow-separation problems causing instability under braking. I don't really think this is a car characteristic that you want to hand over to a young driver, but on the other hand the exhaust-blown diffuser system on this car may just have been a lot of hot air.

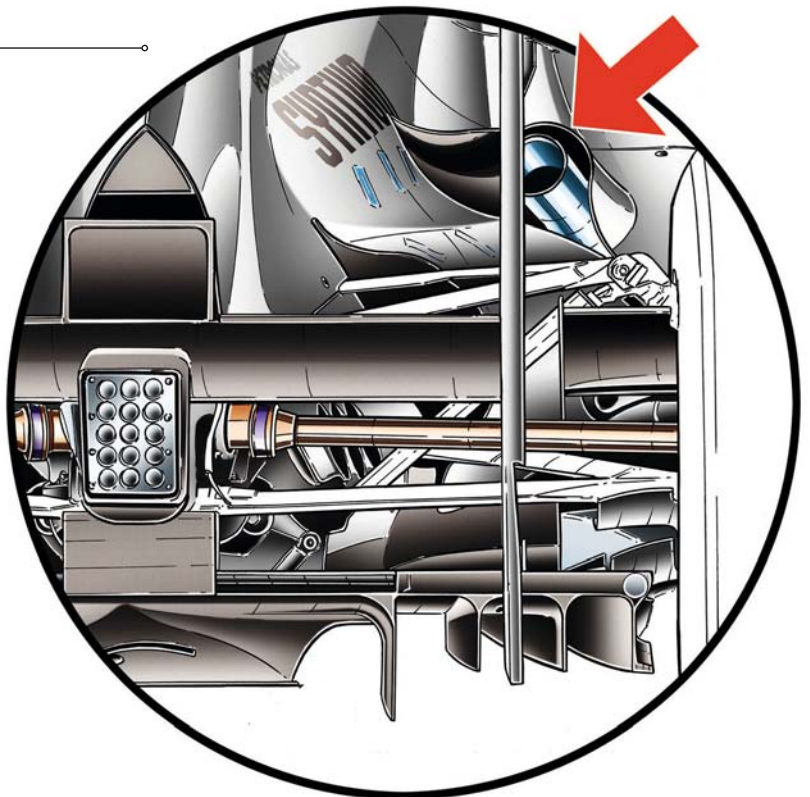

**FORCE INDIA DIFFUSER**

➔ Since Abu Dhabi, the Force India has run with this modified diffuser, featuring a flap on its trailing edge (1), middle plates that are very low, like McLaren's (2), a double flap on top of the deformable structure (3) and an oval shape of exhaust into the diffuser (4).

**GARY ANDERSON:** The regulations require that the undersurface of the diffuser is at a maximum height of 175mm and that the top surface is at a maximum of 200mm, allowing for material thickness and, if required, something along the trailing edge to help its performance. On this version

of diffuser Force India now has a small separated aero-section strip, allowing the airflow on top of the diffuser to help the airflow on the undersurface stay attached. The right-angle gurney flap around the outer corners does the same, but as can be seen from the varying heights some areas require more help than others. Of more interest to me is the wing cascade mounted on the inner face of the rear brake duct. This is the area that the high-energy exhaust flow is concentrated on, creating downforce directly onto the upright/wheel assembly. This, plus that bit of help for the diffuser, really help stability under braking.

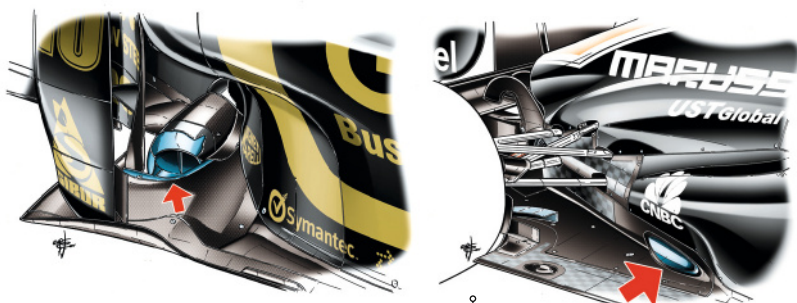
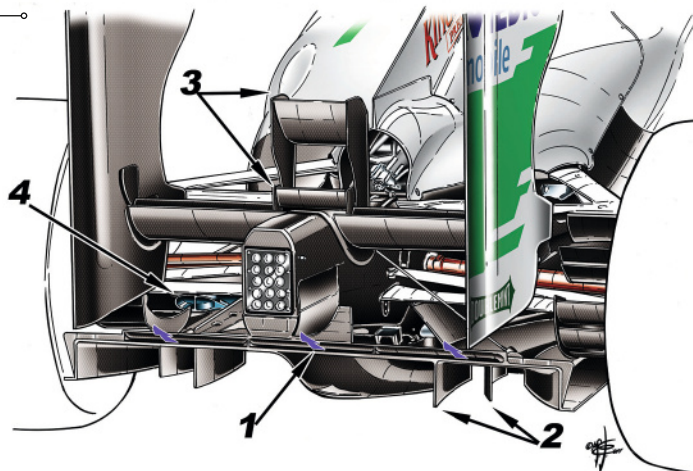

**RENAULT EXHAUST/VIRGIN EXHAUST**

➔ Neither the internally-split tail pipe (above left on the Renault) and the 'salami-cut' tail pipe (above right on the Virgin) will be legal in 2012.

**GARY ANDERSON:** As we have become accustomed to, the final details for next year's exhaust rules are still being pondered, but as far as I'm aware the exhaust outlet needs to be a round section and its exit position higher, in line with what Mercedes tested in Abu Dhabi.

**FERRARI EXHAUST**

➔ More detail on the distinctive Ferrari exhaust chamber (as revealed in news, November 17 issue), showing inset its split exit channels. In the metal, heat discolouration can be observed around halfway up the chamber's height.

**GARY ANDERSON:** I believe this is an engine-tuning device and that it works in conjunction with the exhaust-tailpipe exit detail (inset, below left). With the end of the pipe reduced in area, the exit speed of the exhaust gases will be increased, which will help the diffuser and rear brake ducts work more efficiently. But this will create a restriction, which could affect the engine performance, and this extension with the end of it closed off will act like a damper, giving the tailpipe more volume and the engine pulses somewhere to dissipate while maintaining a more-constant exhaust exit-gas velocity. All in all, this is a win-win situation; better engine performance and more-consistent diffuser performance.

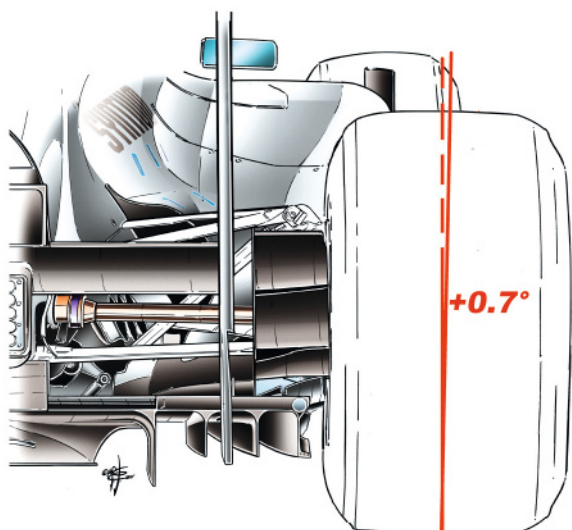
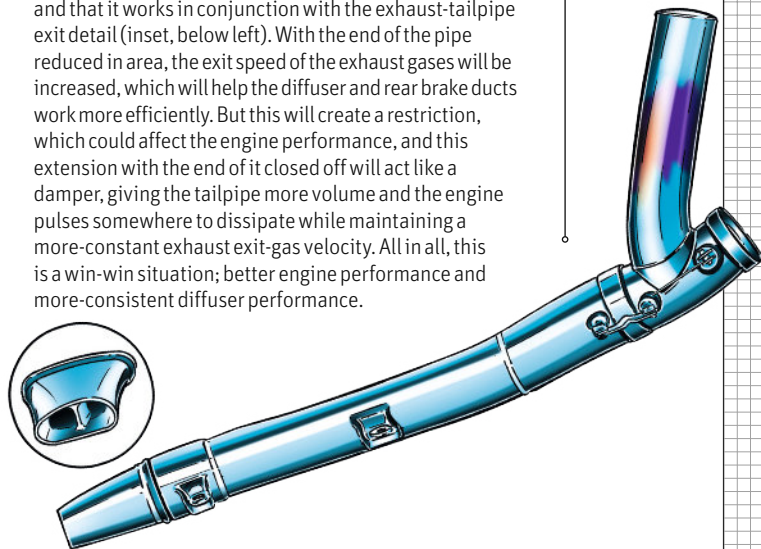

**MERCEDES REAR-WHEEL CAMBER**

➔ The Mercedes has been running recently with almost zero camber on its rear wheels, in contrast to most other teams, which run around 0.7deg of negative camber.

**GARY ANDERSON:** One of Mercedes' biggest problems at the start of the season was tyre degradation, but as the year progressed the team was able to get on top of this problem. Part of this has been in adapting the suspension geometry to the Pirelli tyres. As can be seen from this picture, the Mercs use very little rear camber and the area of tread usage looks perfect. Camber, and the requirement for it, depend a lot on the suspension geometry

itself and ultimately the circuit characteristics. A circuit with high-speed corners that induce high lateral forces, such as Suzuka or Silverstone, will require more negative camber; a circuit with more in-line acceleration such as Abu Dhabi requires less camber. This increases the tyre contact-patch area, which in turn helps traction. The rear-suspension geometry on the Mercedes looks like it has a reasonable amount of camber change as it goes into bump; this will reduce the amount of static camber required, offering good traction off slow-speed corners while still inducing the extra camber required for the high-speed turns.

# BRAZILIAN GP RESULTS



## PRACTICE 1 - Friday

POS	DRIVER	TIME
1	WEBBER	1m13.811s
2	BUTTON	1m13.825s
3	HAMILTON	1m13.961s
4	VETTEL	1m14.025s
5	MASSA	1m14.507s
6	ALONSO	1m14.541s
7	SCHUMACHER	1m15.162s
8	HULKENBERG	1m15.178s
9	DI RESTA	1m15.241s
10	ROSBERG	1m15.321s
11	ALGUERSUARI	1m15.468s
12	GROSJEAN	1m15.547s
13	BARRICHELLO	1m15.663s
14	SENNA	1m15.732s
15	KOBAYASHI	1m15.747s
16	MALDONADO	1m15.836s
17	PEREZ	1m15.979s
18	VERGNE	1m16.052s
19	KOVALAINEN	1m16.514s
20	RAZIA	1m17.595s
21	GLOCK	1m18.140s
22	D'AMBROSIO	1m18.653s
23	RICCIARDO	1m18.952s
24	CHAROUZ	1m19.577s

Weather: dry

## PRACTICE 2 - Friday

POS	DRIVER	TIME
1	HAMILTON	1m13.392s
2	VETTEL	1m13.559s
3	WEBBER	1m13.587s
4	ALONSO	1m13.598s
5	SCHUMACHER	1m13.723s
6	MASSA	1m13.750s
7	BUTTON	1m13.787s
8	ROSBERG	1m13.872s
9	SUTIL	1m14.144s
10	DI RESTA	1m14.807s
11	PETROV	1m14.856s
12	SENNA	1m14.931s
13	PEREZ	1m14.970s
14	KOBAYASHI	1m15.019s
15	BUEMI	1m15.264s
16	ALGUERSUARI	1m15.388s
17	MALDONADO	1m15.679s
18	BARRICHELLO	1m15.903s
19	TRULLI	1m16.298s
20	KOVALAINEN	1m16.338s
21	D'AMBROSIO	1m18.031s
22	GLOCK	1m18.051s
23	RICCIARDO	1m18.367s
24	LIUZZI	1m18.476s

Weather: dry

## PRACTICE 3 - Saturday

POS	DRIVER	TIME
1	VETTEL	1m12.460s
2	BUTTON	1m12.547s
3	WEBBER	1m12.597s
4	HAMILTON	1m12.622s
5	ALONSO	1m12.765s
6	SUTIL	1m13.113s
7	ROSBERG	1m13.286s
8	SCHUMACHER	1m13.393s
9	DI RESTA	1m13.419s
10	MASSA	1m13.583s
11	PETROV	1m13.838s
12	BARRICHELLO	1m14.283s
13	ALGUERSUARI	1m14.286s
14	KOBAYASHI	1m14.311s
15	MALDONADO	1m14.454s
16	PEREZ	1m14.547s
17	SENNA	1m14.551s
18	TRULLI	1m15.843s
19	KOVALAINEN	1m16.026s
20	D'AMBROSIO	1m16.616s
21	LIUZZI	1m17.143s
22	RICCIARDO	1m17.296s
23	GLOCK	1m17.984s
24	BUEMI	no time

Weather: dry



## QUALIFYING

POS	DRIVER	QUALIFYING 1	QUALIFYING 2	QUALIFYING 3
1	VETTEL	1m13.664s (5)	1m12.446s (1)	1m11.918s
2	WEBBER	1m13.467s (3)	1m12.658s (3)	1m12.099s
3	BUTTON	1m13.281s (1)	1m12.820s (5)	1m12.283s
4	HAMILTON	1m13.361s (2)	1m12.811s (4)	1m12.480s
5	ALONSO	1m13.969s (9)	1m12.870s (6)	1m12.591s
6	ROSBERG	1m14.083s (10)	1m12.569s (2)	1m13.050s
7	MASSA	1m14.269s (13)	1m13.291s (8)	1m13.068s
8	SUTIL	1m13.480s (4)	1m13.261s (7)	1m13.298s
9	SENNA	1m14.453s (15)	1m13.300s (9)	1m13.761s
10	SCHUMACHER	1m13.694s (6)	1m13.571s (10)	no time
11	DI RESTA	1m13.733s (7)	1m13.584s	-
12	BARRICHELLO	1m14.117s (11)	1m13.801s	-
13	ALGUERSUARI	1m14.225s (12)	1m13.804s	-
14	BUEMI	1m14.500s (16)	1m13.919s	-
15	PETROV	1m13.859s (8)	1m14.053s	-
16	KOBAYASHI	1m14.571s (17)	1m14.129s	-
17	PEREZ	1m14.430s (14)	1m14.182s	-
18	MALDONADO	1m14.625s	-	-
19	KOVALAINEN	1m15.068s	-	-
20	TRULLI	1m15.358s	-	-
21	LIUZZI	1m16.631s	-	-
22	RICCIARDO	1m16.890s	-	-
23	D'AMBROSIO	1m17.019s	-	-
24	GLOCK	1m17.060s	-	-

Weather: dry

## QUALIFYING

	Head to head	
VETTEL	16	3 WEBBER
HAMILTON	13	6 BUTTON
ALONSO	15	4 MASSA
SCHUMACHER	3	16 ROSBERG
HEIDFELD/SENNA	7	12 PETROV
BARRICHELLO	11	8 MALDONADO
SUTIL	10	9 DI RESTA
KOBAYASHI	8	11 PEREZ/DE LA ROSA
BUEMI	13	6 ALGUERSUARI
KOVALAINEN	17	2 TRULLI/CHANDHOK
KAR'KEYAN/RICCIARDO	5	13 LIUZZI/KARTHIKEYAN
GLOCK	14	5 D'AMBROSIO



## THE GRID

2 <b>WEBBER</b> RED BULL 1m12.099s Soft	1 <b>VETTEL</b> RED BULL 1m11.918s Soft
4 <b>HAMILTON</b> McLAREN 1m12.480s Soft	3 <b>BUTTON</b> McLAREN 1m12.283s Soft
6 <b>ROSBERG</b> MERCEDES 1m13.050s Soft	5 <b>ALONSO</b> FERRARI 1m12.591s Soft
8 <b>SUTIL</b> FORCE INDIA 1m13.298s Soft	7 <b>MASSA</b> FERRARI 1m13.068s Soft
10 <b>SCHUMACHER</b> MERCEDES no time Soft	9 <b>SENNA</b> RENAULT 1m13.761s Soft
12 <b>BARRICHELLO</b> WILLIAMS 1m13.801s Soft	11 <b>DI RESTA</b> FORCE INDIA 1m13.584s Soft
14 <b>BUEMI</b> TORO ROSSO 1m13.919s Soft	13 <b>ALGUERSUARI</b> TORO ROSSO 1m13.804s Soft
16 <b>KOBAYASHI</b> SAUBER 1m14.129s Soft	15 <b>PETROV</b> RENAULT 1m14.053s Soft
18 <b>MALDONADO</b> WILLIAMS 1m14.625s Soft	17 <b>PEREZ</b> SAUBER 1m14.182s Soft
20 <b>TRULLI</b> LOTUS 1m15.358s Soft	19 <b>KOVALAINEN</b> LOTUS 1m15.068s Soft
22 <b>RICCIARDO</b> HRT 1m16.890s Soft	21 <b>LIUZZI</b> HRT 1m16.631s Soft
24 <b>GLOCK</b> VIRGIN 1m17.060s Soft	23 <b>D'AMBROSIO</b> VIRGIN 1m17.019s Soft

PICS: FERRARO, TEE/LAT, GILHAM, THOMPSON/GETTY

THE RACE: 71 LAPS, 190.092 MILES

POS	DRIVER	TEAM	LAPS	TOTAL TIME	FASTEST LAP	PISTOP	TIME IN PIT	TYRE CHOICE	STINT 1	STINT 2	STINT 3	STINT 4
1	WEBBER	RED BULL-RENAULT	71	1h32m17.464s	1m15.324s	3	62.5s	Soft	Soft	Soft	Medium	
2	VETTEL	RED BULL-RENAULT	71	+16.655s	1m16.076s	3	63.7s	Soft	Soft	Soft	Medium	
3	BUTTON	McLAREN-MERCEDES	71	+27.638s	1m15.580s	3	64.6s	Soft	Soft	Medium	Medium	
4	ALONSO	FERRARI	71	+35.048s	1m16.181s	3	62.2s	Soft	Soft	Soft	Medium	
5	MASSA	FERRARI	71	+1m06.733s	1m17.271s	2	42.7s	Soft	Soft	Medium		
6	SUTIL	FORCE INDIA-MERCEDES	70	-1 lap	1m17.161s	3	63.1s	Soft	Soft	Soft	Medium	
7	ROSBERG	MERCEDES	70	-1 lap	1m17.207s	2	67.6s	Soft	Soft	Medium		
8	DI RESTA	FORCE INDIA-MERCEDES	70	-1 lap	1m17.452s	2	42.5s	Soft	Soft	Medium		
9	KOBAYASHI	SAUBER-FERRARI	70	-1 lap	1m17.644s	2	46.3s	Soft	Soft	Medium		
10	PETROV	RENAULT	70	-1 lap	1m17.011s	3	66.1s	Soft	Soft	Soft	Medium	
11	ALGUERSUARI	TORO ROSSO-FERRARI	70	-1 lap	1m17.162s	2	44.6s	Soft	Soft	Medium		
12	BUEMI	TORO ROSSO-FERRARI	70	-1 lap	1m17.428s	2	44.9s	Soft	Soft	Medium		
13	PEREZ	SAUBER-FERRARI	70	-1 lap	1m17.780s	2	43.6s	Soft	Soft	Medium		
14	BARRICHELLO	WILLIAMS-COSWORTH	70	-1 lap	1m16.684s	3	65.8s	Soft	Soft	Medium	Soft	
15	SCHUMACHER	MERCEDES	70	-1 lap	1m16.681s	3	67.6s	Soft	Soft	Soft	Medium	
16	KOVALAINEN	LOTUS-RENAULT	69	-2 laps	1m18.023s	3	66.3s	Soft	Soft	Soft	Medium	
17	SENNA	RENAULT	69	-2 laps	1m18.274s	3	81.3s	Soft	Soft	Medium	Soft	
18	TRULLI	LOTUS-RENAULT	69	-2 laps	1m18.596s	2	44.2s	Soft	Soft	Medium		
19	D'AMBROSIO	VIRGIN-COSWORTH	68	-3 laps	1m19.902s	2	45.4s	Soft	Soft	Medium		
20	RICCIARDO	HRT-COSWORTH	68	-3 laps	1m19.649s	2	46.4s	Soft	Soft	Medium		
R	LIUZZI	HRT-COSWORTH	61	electrics	1m20.648s	2	45.7s	Soft	Soft	Medium		
R	HAMILTON	McLAREN-MERCEDES	46	gearbox	1m17.209s	3	62.2s	Soft	Soft	Soft	Medium	
R	MALDONADO	WILLIAMS-COSWORTH	26	accident	1m19.706s	1	21.6s	Soft	Medium	dnf		
R	GLOCK	VIRGIN-COSWORTH	21	lost wheel	1m21.773s	1	22.5s	Soft	Soft	dnf		

Weather: dry. Fastest lap: Mark WEBBER 1m15.324s (127.972mph) on lap 71.  
Lap leaders: 1-16 Vettel; 17-18 Webber; 19-20 Massa; 21-29 Vettel; 30-37 Webber;  
38-39 Vettel; 40-58 Webber; 59 Vettel; 60-71 Webber.

Option tyre in bold; new set in red, used set in black

FINAL STANDINGS - Points and positions

POS	DRIVER	PTS	AUS	MAL	PRC	TR	E	MC	CDN	EU	GB	D	H	B	I	SGP	J	ROK	IND	UAE	BR
1	VETTEL	392	1st	1st	2nd	1st	1st	1st	2nd	1st	2nd	4th	2nd	1st	1st	1st	3rd	1st	1st	ret	2nd
2	BUTTON	270	6th	2nd	4th	6th	3rd	3rd	1st	6th	ret	ret	1st	3rd	2nd	2nd	1st	4th	2nd	3rd	3rd
3	WEBBER	258	5th	4th	3rd	2nd	4th	4th	3rd	3rd	3rd	3rd	5th	2nd	ret	3rd	4th	3rd	4th	4th	1st
4	ALONSO	257	4th	6th	7th	3rd	5th	2nd	ret	2nd	1st	2nd	3rd	4th	2nd	3rd	4th	2nd	3rd	2nd	4th
5	HAMILTON	227	2nd	8th	1st	4th	2nd	6th	ret	4th	4th	1st	4th	ret	4th	5th	5th	2nd	7th	1st	ret
6	MASSA	118	7th	5th	6th	11th	ret	ret	6th	5th	5th	5th	6th	8th	6th	9th	7th	6th	ret	5th	5th
7	ROSBERG	89	ret	12th	5th	5th	7th	11th	11th	7th	6th	7th	9th	6th	ret	7th	10th	8th	6th	6th	7th
8	SCHUMACHER	76	ret	9th	8th	12th	6th	ret	4th	17th	9th	8th	ret	5th	5th	ret	6th	ret	5th	7th	15th
9	SUTIL	42	9th	11th	15th	13th	13th	7th	ret	9th	11th	6th	14th	7th	ret	8th	11th	11th	9th	8th	6th
10	PETROV	37	3rd	17th	9th	8th	11th	ret	5th	15th	12th	10th	12th	9th	ret	17th	9th	ret	11th	13th	10th
11	HEIDFELD	34	12th	3rd	12th	7th	8th	8th	ret	10th	8th	ret	ret	-	-	-	-	-	-	-	-
12	KOBAYASHI	30	dsq	7th	10th	10th	10th	5th	7th	16th	ret	9th	11th	12th	ret	14th	13th	16th	ret	10th	9th
13	DI RESTA	27	10th	10th	11th	ret	12th	12th	ret	14th	15th	13th	7th	11th	8th	6th	12th	10th	13th	9th	8th
14	ALGUERSUARI	26	11th	11th	ret	16th	16th	ret	8th	8th	10th	12th	10th	ret	7th	21st	15th	7th	8th	15th	11th
15	BUEMI	15	8th	13th	14th	9th	14th	10th	10th	13th	ret	15th	8th	ret	10th	12th	ret	9th	ret	ret	12th
16	PEREZ	14	dsq	ret	17th	14th	9th	ns	ns	11th	7th	11th	15th	ret	ret	10th	8th	12th	10th	11th	13th
17	BARRICHELLO	4	ret	ret	13th	15th	17th	9th	9th	12th	13th	ret	13th	16th	12th	13th	17th	13th	15th	12th	14th
18	SENNA	2	-	-	-	-	-	-	-	-	-	-	-	-	13th	9th	15th	16th	14th	12th	16th
19	MALDONADO	1	ret	ret	18th	17th	15th	18th	ret	18th	14th	14th	16th	10th	11th	11th	14th	ret	ret	14th	ret
20	DE LA ROSA	0	-	-	-	-	-	-	12th	-	-	-	-	-	-	-	-	-	-	-	-
21	TRULLI	0	13th	ret	19th	18th	18th	13th	16th	20th	ret	-	ret	14th	14th	ret	19th	17th	19th	18th	18th
22	KOVALAINEN	0	ret	15th	16th	19th	ret	14th	ret	19th	ret	16th	ret	15th	13th	16th	18th	15th	14th	17th	16th
23	LIUZZI	0	dnq	ret	22nd	22nd	ret	16th	13th	23rd	18th	ret	20th	19th	ret	20th	23rd	21st	-	20th	ret
24	D'AMBROSIO	0	14th	ret	20th	20th	20th	15th	14th	22nd	17th	15th	19th	17th	ret	18th	21st	20th	16th	ret	19th
25	GLOCK	0	nc	16th	21st	dns	19th	ret	15th	21st	16th	17th	18th	15th	ret	20th	18th	ret	19th	ret	ret
26	KARTHIKEYAN	0	dnq	ret	23rd	21st	21st	17th	17th	24th	-	-	-	-	-	-	-	-	17th	-	-
27	RICCIARDO	0	-	-	-	-	-	-	-	-	-	19th	19th	18th	ret	nc	19th	22nd	19th	18th	ret
28	CHANDHOK	0	-	-	-	-	-	-	-	-	-	20th	-	-	-	-	-	-	-	-	-

FINAL STANDINGS - Points and positions

POS	TEAM	PTS	AUS	MAL	PRC	TR	E	MC	CDN	EU	GB	D	H	B	I	SGP	J	ROK	IND	UAE	BR
1	RED BULL	650	35	37	33	43	37	37	33	40	33	27	28	43	25	40	27	40	37	12	43
2	McLAREN	497	26	22	37	20	33	23	25	20	12	25	37	15	30	28	35	30	24	40	15
3	FERRARI	375	18	18	14	15	10	18	8	28	35	28	23	16	23	14	24	18	15	28	22
4	MERCEDES	165	0	2	14	10	14	0	12	6	10	10	2	18	10	6	9	4	18	14	6
5	RENAULT	73	15	15	2	10	4	4	10	1	4	1	0	2	2	0	2	0	0	0	1
6	FORCE INDIA	69	3	1	0	0	0	6	0	2	0	8	6	6	4	12	0	1	2	6	12
7	SAUBER	44	0	6	1	1	3	10	6	0	6	2	0	0	0	1	4	0	1	1	2
8	TORO ROSSO	41	4	0	0	2	0	1	5	4	1	0	5	0	7	0	0	8	4	0	0
9	WILLIAMS	5	0	0	0	0	0	2	2	0	0	0	0	1	0	0	0	0	0	0	0
10	LOTUS	0	0	0	0	0	0	0	0	0	0	0	0	0	0	0	0	0	0	0	0
11	HRT	0	-	0	0	0	0	0	0	0	0	0	0	0	0	0	0	0	0	0	0
12	VIRGIN	0	0	0	0	0	0	0	0	0	0	0	0	0	0	0	0	0	0	0	0

TRACKSIDE VIEW

Mark Hughes  
Grand prix editor

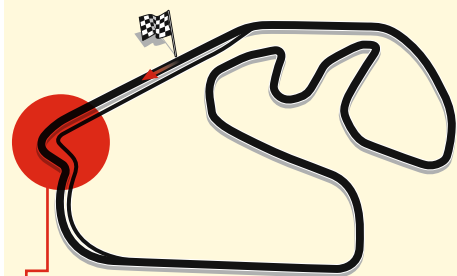

The lack of title drama, the gorgeous weather and the end of term conspire to give this race a different feel from recent years, one of appreciation rather than raw combat. At least that's how it feels from the outside, but maybe occasionally on the inside too. In the early minutes of Friday morning the two Mercedes are circulating alone, Schumacher very energised, throwing the car sideways between the Senna Esses kerbs, living in the moment as team-mate Rosberg just circulates, beginning to build up the data upon which his weekend will be based. It's as if Michael, knowing from experience that it all ends some day, that this amazing drug can be withdrawn from you, is just immersing himself in this wonderful, privileged existence, realising that one day he will have to return to the normal world. Bruno Senna is fighting to stay in here too and here he is attacking the corners named after his uncle, neat and contained by the time he gets to that first apex, able then to be very early on the gas for the rest of the downhill adventure ride. Move back to the braking area and his lateness and control on

**“Schuey knows that one day he'll have to return to the normal world”**

those brakes is the best bit of his game. In the gap between where he determines his entry speed and the apex, you sense there's lap time there still to be found. If he can marry that braking control with a little more audacity of entry speed – and that's a huge if, one that strikes at the very core of a racing driver's skill – then good things will really start happening for him. In that little blink-brief moment of each corner is where all his opportunity lies, the opportunities that will quite possibly determine his whole destiny, that will give him long-term access to this drug.



Schumacher snakes through Senna Esses



The six finalists with their shootout steeds

# A PRIZE MOMENT



Warwick, Green and Plato discuss the drivers

Each year the McLaren AUTOSPORT BRDC Award searches for the cream of British junior racing talent. *KEVIN TURNER* looks at how the process worked in 2011



Turner (left) gave simulator advice

**T**he McLaren AUTOSPORT BRDC Award is a well-known and prestigious accolade, but how does it actually work?

Every year a young driver is chosen from six finalists to walk away with a McLaren Formula 1 test and a cash prize, and yet very little is usually said about the process used to select the winner.

Some elements are well-known. Every year the finalists are put through their paces in a variety of powerful cars, but there's more to it than that.

Before the six finalists are even chosen, the judges meet to discuss the candidates. This year's panel included ex-F1 racer Derek Warwick, double BTCC champion Jason Plato, and DTM star Jamie Green. Journalists Marcus Pye and yours truly, and leading commentator Ian Titchmarsh provided insights into the British motorsport scene, while McLaren's head of vehicle engineering Mark Williams looked after the data from the test days.

As well as the judges' personal experiences, career records and – on

THANKS TO

Aspire  
Hospitality



Base Performance  
SIMULATORS



## CAR INFO



## WILLIAMS JPH1B F2

Engine: 1800cc four-cylinder turbo  
Power: 425bhp (480bhp with overboost)



## MERCEDES C-CLASS DTM

Engine: four-litre normally-aspirated V8  
Power: 476bhp



## McLAREN MP4-12C GT3

Engine: 3.8-litre V8 twin-turbo  
Power: 500bhp approx

occasion – the opinions of people who have worked with the drivers, are also used to finalise the six.

This year's finalists – Emil Bernstorff, Tom Blomqvist, Alex Lynn, Scott Malvern, Oliver Rowland, and Dino Zamparelli – were assessed on former winner and sportscar star Darren Turner's Base Performance Simulator. They had F2 runs around the Silverstone Grand Prix track on the simulator to prepare them for the test days, and Turner compiled a report on the strengths and weaknesses of each for the judges.

There was a similar process at Porsche's Human Performance Centre, which tested the fitness of the finalists and then reported back.

The two test days of driving provided the core of the assessment. Each finalist had access to his own F2 car and engineer, as well as outings in one of two DTM Mercedes run by Persson Motorsport, and McLaren's new MP4-12C GT3 car.

Having six single-seaters, rather than two as in the past, meant changing weather conditions

(a common hazard in the UK in November) were less of a problem: all the drivers had to deal with the same issues at the same time.

Benchmark drivers – F2 champion Mirko Bortolotti, DTM star Jamie Green and GT ace Andrew Kirkaldy – showed what the cars were capable of, and provided data for the finalists. The six were not, however, given access to each others' times or data.

Once all the running was completed, all the teams gave feedback, including telemetry traces where required, to the judges and answered any questions. The finalists themselves were then interviewed at the track and later at McLaren's Technology Centre.

After much discussion and debate each year – sometimes for several hours – the judges choose a winner.

BRDC President Warwick is the chairman of the judges and his view of the Award has changed now he has seen the process. "Before getting involved I questioned how the test was carried out, how they got to the final decision, and whether it was fixed," he admits.

"I think a lot of people within our industry have at times questioned the Award, mainly because they didn't understand how it was run, and some people didn't agree with the winners. I have been involved for two years now and it has completely changed my mind."

Given the difficult conditions – there was no dry running – at the tests this year, Warwick was also pleased with the finalists and the teams that worked with them.

"I was very impressed with the quality, professionalism and focus from all the drivers," he says. "I had to keep reminding myself that some of them were only 17 or 18.

"Jonathan Palmer and his F2 team were fantastic, the cars looked good and ran without problems. Every one of the drivers got out of the DTM car with the biggest smile I have ever seen, and the addition of the McLaren gave them another discipline to cope with."

Winning the Award doesn't guarantee success, but the list of previous luminaries is impressive. The rigorous process means the 2011 victor really will have earned their distinction. ▶

## WHAT'S AT STAKE?

This year's McLaren AUTOSPORT BRDC Award winner will receive £100,000, a test in a McLaren Formula 1 car, BRDC membership, a supply of Puma racewear for the 2012 season, and a TW Steel watch.

## McLAREN AUTOSPORT BRDC AWARD DIARY

## SEPTEMBER 15

AUTOSPORT calls on readers to put their nominations forward.

## SEPTEMBER 27

Judges meet at McLaren Technology Centre to pick the six finalists.

## OCTOBER 6

After the finalists have been informed, AUTOSPORT magazine and AUTOSPORT.COM publicly announce the six.

## BEFORE TEST DAYS

Each finalist has three hours in Darren Turner's Base Performance Simulator and a fitness test at Porsche's Human Performance Centre.

## THE SILVERSTONE TEST DAYS

## NOVEMBER 7

- 0800 Briefing for the finalists, and introductions.
- 0900 After being introduced to the F2 car, all six finalists head out for their first F2 familiarisation run on Silverstone's International Circuit.
- 1000 After a debrief, finalists get another F2 run, this time they can tweak limited set-up aspects of the car.
- 1100 After a further debrief, all six head out for a six-lap qualifying run (without overboost).
- 1200 Over lunch, 2010 Award winner Lewis Williamson has his McLaren F1 prize drive on the Grand Prix circuit.
- 1240 After more briefings, two finalists go out for their DTM runs, while one drives the McLaren GT, all on the International track. Each gets three runs, before the next set of finalists goes out. By the end of the afternoon all have driven one of the two DTM Mercedes, and three have driven the GT.
- 1630 Judges meeting to discuss day one.

## NOVEMBER 8

- 1000 F2 familiarisation run on the GP circuit for all finalists.
- 1100 Six-lap F2 qualifying run, with two turbo overboosts allowed per lap.
- 1140 F2 Pursuit run. Again, all six are out on the GP track at the same time, but this time the goal is to set the best overall time over a six-lap run.
- 1300 After lunch, the three finalists who did not drive the McLaren GT on day one have their runs on the International layout.
- 1600 Engineers and team representatives from F2, DTM and McLaren give their feedback on the finalists to the judges and supply them with data.
- 1800 Each finalist has a brief interview with the judges.
- 1900 Judges meeting to discuss finalists' performances.

## NOVEMBER 23

Judges interview each finalist at MTC for a more in-depth look at their tests and approach to racing. The finalists are also given a McLaren tour, and the judges don't leave until a winner is chosen.

## DECEMBER 4

The finalists will not know the result when they arrive at the AUTOSPORT Awards on Sunday, when the 23rd McLaren AUTOSPORT BRDC Award winner will be publicly revealed.



## Emil Bernstorff, 18

Third in ADAC Formel Masters with Motopark Academy

"I did an F3 test beforehand because we thought it would be good to get some experience with wings and downforce. I think it went quite well and obviously it was cool to drive all the cars – it was different to anything I've tried before.

"I enjoyed the McLaren the most. Maybe it's because it felt more like the cars I've driven before, but it felt like I could really throw it around and attack the racetrack.

"They didn't really have a seat that fitted me for the DTM car so I didn't do quite as well in that as I could have. I was trying to focus on the driving, but without really thinking about it I was battling to keep my head up!

"I hadn't driven anything with as much power as the F2 car before. I think I did well considering my experience and I hope it's enough to get the judges to vote for me!"



## Tom Blomqvist, 18

Sixth in German Formula 3 Cup with Performance Racing

"This year I knew what to expect, so I felt there was a little less pressure and I was able to relax a bit more. Last year I didn't manage to pull it off, but this year my mindset was a lot better.

"Breaking my back wasn't great preparation for the Award. I was rushing my recovery to be allowed to do it and I didn't have much time in a car or in training, but it was wet so that helped a huge amount physically.

"The McLaren was a new experience for me – it was relatively easy to drive at a certain pace but quite difficult to get the most out of.

"I'm happy with my overall performance. I think I did well in the single-seater stuff, but there was still time to come with the DTM and sportscar."



## Alex Lynn, 18

Formula Renault UK champion with Fortec Motorsport

"I approached it with the attitude of just going and pushing as hard as I could. I don't think there's any other way you can approach it. It's one of those things where you have to go flat out, because you're not going to win it if you were only quite fast!

"I really enjoyed the DTM car and the McLaren. I'd never driven a tin-top before and when you've only driven single-seaters you think the tin-tops look a real handful. But when you get inside it's probably easier because they're so much more forgiving. I loved it – especially the DTM car; that car is just incredible!

"Personally, I know I did a good job. I know I drove well. We all had a good time and if I don't win, I'm happy knowing it won't be because I didn't do my best."

THANKS TO

Aspire  
Hospitality

GP

Base Performance  
SIMULATORS

FF  
FIA FORMULA TWO  
CHAMPIONSHIP

GPR  
Grand Prix  
Racewear

McLaren  
AUTOMOTIVE



## Scott Malvern, 22

British Formula Ford champion with Jamun Racing

"I absolutely loved it – even more than last time! I tried to be methodical and drive as fast as I could without being reckless. I knew I had to push really hard to stand out, but at the same time it's not really my style to be flamboyant, so I just tried to be quietly quick.

"To be honest, the thing I struggled with was the same as last year because I haven't driven much with aero. I didn't get much quality running in the GP3 test I did because the tyres don't last. On the last lap of qualifying in the F2 car it all clicked for me and in the race run I started to trust the aero. I just needed a few more sessions.

"I had higher expectations of myself this year and I'm happy with what I did. I was closer to the pace, I didn't do anything silly and I was pretty consistent."



## Oliver Rowland, 19

Formula Renault UK runner-up with Fortec Motorsport

"I was a newcomer to the Award, so I didn't want to put too much pressure on myself – I just wanted to enjoy it.

"I had a great time, but driving the F2 car was quite difficult to start with, because of the power. I had never driven anything but a Formula Renault with paddleshift, so the DTM was quite a shock, but I felt comfortable.

"I tried to be straight into attack mode on the first day because I wanted to impress, but it was quite difficult and a few people came with a bit more experience. It was good to have a night to think about it; the second day was a massive improvement.

"I think I've got a good chance – I didn't make any big mistakes or make myself look stupid. I think I impressed the judges, but we'll see what happens on Awards night."



## Dino Zamparelli, 19

Formula Renault BARC champion with Antel Motorsport

"It was great. I wanted to go in with no pressure and learn as much as I could and, with the limited experience I've had in the last couple of years, show what I'm about.

"Inevitably for England at this time of year, it was wet; the Award has been wet for the last 20 years or something! And the only unfortunate thing for me was that I hadn't driven in the wet since May 2010. It took a bit more time than I hoped to get comfortable. In the DTM and GT3 car it was fine – I got quicker and got there in the end, but I needed more time in the F2 car to adapt to the aero.

"If I could have wished for something it would have been more time in the cars. We only had three five-lap runs in the DTM. When you're leading a race, the laps can't go quickly enough, but in this they went too quickly!"

# CHRISTMAS GIFT GUIDE

A selection of the best motorsport-related goodies to brighten up any fan's festive fortnight

## SIMULATOR SESSIONS

£250 (2h15m)  
baseperformance.net



## OFFICIAL F1 REVIEW 2011

£30 (978 0857 3310 8 3)  
haynes.co.uk



## STEVE McQUEEN LIFESIZE CUTOUT

£160 plus p+p (includes free 30cm desktop cutout worth £30)  
excitingfigures.co.uk



## AYRTON SENNA McLAREN MP4-8 1993 1:18 MODEL

£119.99  
autosport.com/shop



## MARK WEBBER 2010 RED BULL RB6 1:18 MODEL

£144.99 (250-run signed by Webber)  
autosport.com/shop



## SILVERSTONE DRIVING EXPERIENCES

From £79  
silverstone.co.uk (0844 3728 270)

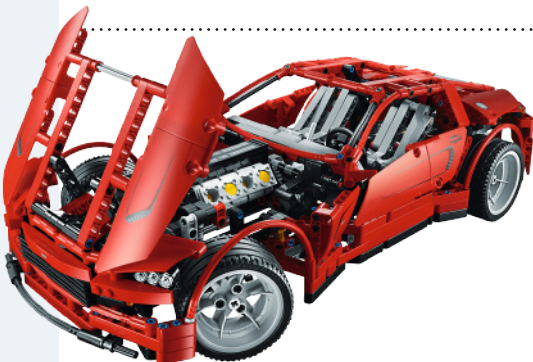

## LEGO TECHNIC SUPERCAR

£99.99 (45cm x 20cm)  
legoshop.com

## SENNA BLU-RAY DVD

£26.99  
autosport.com/shop

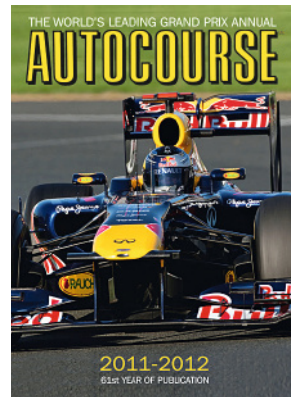

## AUTOCOURSE 2011

£42.46 (includes free 1971 Autocourse eBook, worth 19.99)  
autocourse.com



**Free eBook  
WORTH £19.99**

# AUTOCOURSE 2011

THE WORLD'S LEADING GRAND PRIX ANNUAL



Receive a **FREE Autocourse 1971 eBook worth £19.99, ONLY** when buying this year's Autocourse annual from [www.autocourse.com](http://www.autocourse.com)

This year's Autocourse Annual is packed with the usual stunning imagery from the world's leading photographers, the very best in reporting from Formula One, GP2, GP3, F2, F3, Sports Cars, Touring Cars, Karting and the US Racing scene. Also contains team reviews, features and all the stats you'll ever need in fine detail.

**Only £42.46 with 15% discount and free UK postage!**

Visit: [www.autocourse.com](http://www.autocourse.com)  
or call: **+44 (0) 1753 689693**

To buy Autocourse 2011 and receive your free eBook worth £19.99.

## speedsport gallery

A unique collection of original motor racing paintings, posters, photographs and autographed items for sale.\*



**Artist:** Dexter Brown  
**Subject:** Gulf GT40  
Signed and numbered  
limited edition print [detail]



**Photographer:** Mike O'Brien  
**Subject:** Cadwell Park, International  
Formula 3 Race 28 September 1969.  
Limited edition print from original  
Kodachrome transparency [detail]



**Artist:** Dexter Brown  
**Medium:** Gouache on board –  
original painting [detail]  
**Subject:** Olivier Gendebien driving the  
Ferrari 250 GT SWB in the 1960 Tour de  
France at Spa Francorchamps



**Artist:** Simon Ward  
**Medium:** Acrylic on canvas –  
original painting [detail]  
**Subject:** A celebration of Jenson  
Button's success in the Formula 1  
season of 2009 with Brawn GP

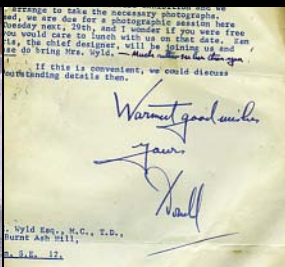

**Autograph:** Donald Campbell  
**Subject:** Private correspondence  
clearly signed by Donald Campbell,  
1966 [detail].

\*Open 9am to 5pm Monday to Friday and also at weekends by appointment Unit 43, Silverstone Circuit, Nr Towcester, Northamptonshire, NN12 8TN

T: 01327 858 167 | E: [info@speedsport.co.uk](mailto:info@speedsport.co.uk) | [www.speedsportgallery.co.uk](http://www.speedsportgallery.co.uk)

# 019

SWEATER SHOP



“If you like our racewear, then you’ll love our fashion range too...”

Fashion for ladies, men and children. Available online:



- |  |  |   |  |
|--|--|---|--|
| Childrens Eco Cotton Crew Neck Sweater - Plain           | Childrens Eco Cotton V Neck Sweater with badge embroidery                | Childrens Acrylic Snowflake Crew Neck Sweater | Childrens Eco Cotton Crew Neck Sweater - with Car embroidery |
|  |  |   |  |
| Childrens Acrylic Snowflake Crew Neck Sweater with SKIER | Childrens Eco Cotton Tipped Crew Neck Sweater with Colour Box embroidery |   |  |
|  |  |   |  |

019 Sweater Shop is brought to you by the founder of the original Sweater Shop.



# NEW SHOP NOW OPEN

Come and see us: First floor, Queensgate, Peterborough  
(opposite M&S Home Furnishings)



Online: [www.019clothing.com](http://www.019clothing.com)

# Precision Hub Plate Scale Systems

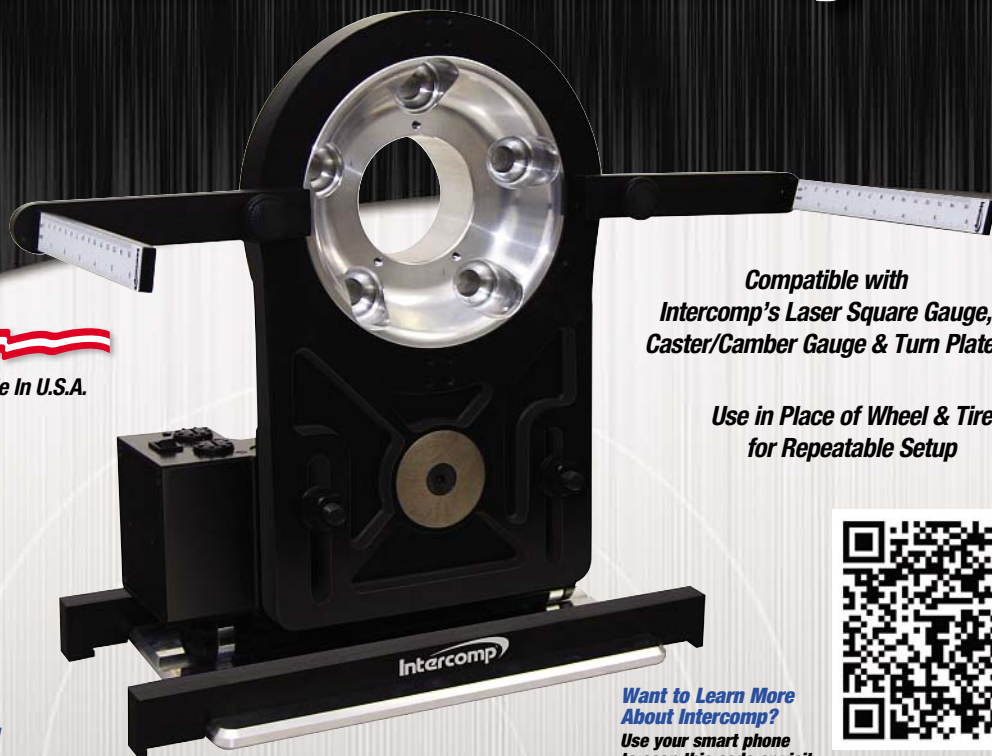

  
Made In U.S.A.



Includes RaceWeigh™ Software for PC & Handheld  
Wireless Professional (PC not included)

Compatible with  
Intercomp's Laser Square Gauge,  
Caster/Camber Gauge & Turn Plates

Use in Place of Wheel & Tire  
for Repeatable Setup



Want to Learn More  
About Intercomp?  
Use your smart phone  
to scan this code or visit  
[www.intercompracing.com](http://www.intercompracing.com)

## Precision Hub Plate Wireless Scale System (Set of Four)

- Part # 170210 - RFX - Low Profile Precision Hub Plate Scale System  
Tire Diameter 19.63" (499mm) to 25.63" (644mm)
- Part # 170211 - RFX - Precision Hub Plate Scale System  
Tire Diameter 23.25" (591mm) to 29" (736mm)

## Precision Hub Plate System (Set of Four)

- Part # 170212 - Precision Low Profile Hub Plate System  
Tire diameter 19.63" (499mm) to 25.63" (644mm)
- Part # 170213 - Precision Hub Plate System  
Tire diameter 23.25" (591mm) to 29" (736mm)

## Intercomp offers you the most comprehensive line of indicator options

Intercomp's industry leading, RFX™ Wireless Weighing Technology is the most widely used advanced weighing technology of its kind and is used by champions in all forms of motorsports.

### Euro Cross Weights Shown!



**SW787RFX™**  
PC Wireless Scale System  
Part # 170154-PC  
(PC not included)



**SW650RFX™**  
Wireless Scale System  
Part # 170126-W

Now Includes:  
RaceWeigh™ Software & Wireless Node!



**SW777RFX™**  
Wireless Scale System  
Part # 170127-WPC



**SW500™**  
Cabled Scale System  
Part # 170125



Call to request our 2012 Racing Products Catalog or log on to:



**NEW!**  
Intercomp  
Scale Systems  
App for iPhone™

+44 (0) 118 932 0578 EUROPE

[intercompracing.com](http://intercompracing.com)

+1 763-476-2531 USA

## European Sales & Service

**DEMON TWEEDS**  
Wrexham, Clwyd  
Tel: 44(0) 1978 664466  
Fax: 44(0) 1978 664467

**ROLLCENTRE RACING**  
St. Ives, Cambs  
Tel: 44(0) 1480 464052  
Fax: 44(0) 1480 461454

**RACE HARDWARE**  
The Netherlands  
Tel: 31(0)36-5370689  
Fax: 31(0)36-5371794

**DANIELSON**  
Magny-Cours, France  
Tel: 33(0) 3 86 21 22 55  
Fax: 33(0) 3 86 21 22 65

**GIEFFE SRL**  
Castelceriolo, (AL), Italia  
Tel: 39(0) 131 216505  
Fax: 39(0) 131 216506

**ISA RACING**  
Kottenheim, Germany  
Tel: 49(0) 2651 96250  
Fax: 49(0) 2651 962510

**NIMEX**  
Monheim, Germany  
Tel: 49(0) 2173 54253  
Fax: 49(0) 2173 51089



**CARRERA COULTHARD MERC DTM SLOT CAR**  
£30  
hobbyco.net

**DEXTER BROWN ORIGINAL ARTWORK**

£2750  
speedsportgallery.co.uk



**REVELL R/C HELICOPTER**  
£34.99  
revell.eu



**TOP GEAR XMAS ANNUAL**  
£12.99 (RRP)  
amazon.co.uk



**PORSCHE 956 T-SHIRT**  
£20  
slickattire.com

**LOTUS F1 HOODIE**

£39.99  
autosport.com/shop

**RED BULL SOFTSHELL TOP**

£134.99  
autosport.com/shop



**MECCANO TURBO RC PRO KIT**

£59.99  
meccanouk.co.uk

**ROCKINGHAM 'THRILLAX' EXPERIENCE**

£399.99  
rockingham.co.uk or 01536 500 500



**McLAREN SCALEXTRIC**

£134.99  
scalextric.com

**BTCC 00-09 DVD BOXSET**

£99.98 (cover 47 hours)  
dukevideo.com

**McLAREN - THE WINS**

£49.99 (978 1902 351 445)  
autosport.com/shop



# REST IN PEACE, LIONHEART

CHARLES BRADLEY remembers two-time Indy 500 winner and IndyCar champion Dan Wheldon with the people who knew him best

## THE STORY BEHIND THE PHOTO

By Andy Hallbery, former AUTOSPORT editor

We came up with the idea of 'The Running Man' about Dan for a story in *Racer* magazine in 2008. It was Spring Training at Homestead; photographer Laurence Baker and I found this location: the idea was to shoot Dan running through the tunnel in his trademark white boots.

Dan was two hours late, and apologised. Usually we get about 10 minutes with drivers for photo shoots before they get bored. Not Dan. He was fascinated by our concept. He did everything we asked of him, and looked at our test shots, making suggestions: "What about if I do this, or that? What if I jump rather than run?"

He became our 'art director', and the end product was absolutely perfect and looked great in the magazine. However, my favourite shot – never published before – is this one. It was totally his idea.

When we finished the shoot, Dan thanked *us* for *our* time. That says it all.



**E**ven now, six weeks after his death, it feels quite unreal that I witnessed Dan Wheldon's first-ever car race, a Formula Vauxhall Junior bout at Donington in 1996, and his last: the tragic IndyCar Series finale at Las Vegas. In between, there were many magic moments of exhilaration, melodrama, championship glory, meticulousness, tomfoolery, huge paydays, eloquence, against-the-odds glory, dental enhancement, charm, tantrums, finger-tip precision, fan interaction, milk-drinking, yard-of-bricks kissing, love and laughter.

He might have been just 33 when he passed away, but Dee-Dub packed three times as much into those years as most of us do in a lifetime. His success on the track over the years has been pretty well documented by this magazine, but it's the man behind the 'Lionheart' helmet who was as fascinating as any of his illustrious racing achievements.

### **THE RACER**

Wheldon found fame and fortune after emigrating to the US in 1999, but his first major rivalries came in karting in the late '80s and early '90s, part of a golden generation including future Formula 1 world champion Jenson Button.

"I raced against him since I was eight years old," says Button. "He was one of the people who, when you woke up in the morning, you were excited to fight, but you were worried you might not beat. And when you actually beat Dan, it was a triumph."

After being let down by the European route to Formula 1, due to a lack of funding and opportunity, it was in the US that Wheldon would find fame and fortune. His prowess on the oval tracks became his calling card thanks to his silky-smooth driving style.

"You could race him unbelievably closely," says four-time IndyCar champion Dario Franchitti. "To me, on those big oval tracks, he was probably the best I've ever seen. At Indy, Dan took some beating. Look at his finishing record there; he knew how to get it done."

### **THE KARTING YEARS**

From the age of five, young Master Wheldon was behind the wheel and tearing around the racetrack.

"Reg Deavin suggested to me that we should build a kart for Daniel, because he was so very small, to go around at the interval after the heats and before the finals," says Dan's father, Clive. "We started off with this purpose-built kart, and before long he was just flat-out in it. He was too bloody quick for it, so we adapted a proper kart with a 100cc engine, and soon his lap times were quicker than the Junior Britain guys!"

In 1987, Dan's race debut beckoned ▶

# PETTER SOLBERG WORLD RALLY TEAM JACKET AND CAPS

[www.pscollection.no/en](http://www.pscollection.no/en)



**Knockhill**  
Racing Circuit

**CARISTMAS SORTED**

Amazing Driving Experience Gifts!  
**Knockhill.com**

ALL NEW ASTON MARTIN DRIVING EXPERIENCES - ONLINE NOW!

2012 SEASON PASSES ARE ON SALE NOW!  
**\*\*SPECIAL OFFER\*\***

If you buy your pass in December you can save £20 on the 2012 price!

**From £109**  
BOOK NOW

FROM ONLY £109 FOR A GOLD SEASON PASS!

# colinmcraevision

Officially Branded Merchandise

**CLOTHING | MODELS | BOOKS | DVD's**

**PRE CHRISTMAS SALE  
UP TO 50% OFF!**

Plus FREE Colin McRae Biography (usually £15)  
With all orders over £25.00 (ex postage)

**FORD FOCUS WRCMONTE  
CARLO RALLY 2001  
£19.99 (+ p&p)**

Free "Flat Out Club"  
Beanie Hat with all  
Model orders

On-line Store  
**COLINMCRAE.COM**

Telephone  
**0141 585 6484**

Registered Charity: SC039506

**GAMERACER**

THE PERFECT GIFT FOR CHRISTMAS

## The virtual racing experience of your dreams

"Sturdily built, ingeniously designed & fully adjustable. The driving position feels faultless."  
The Independent

Buy online now at **GameRacer.co.uk**  
or call **02380 471117**

PS3 PC XBOX360 Wii logitech

F1 2010 FORMULA 1 GEAR FORCE 5

◀ as the RAC introduced its new Cadet category.

“Dan was the man in Cadets,” says Marino Franchitti, a rival in his first-ever race. “He was just unbelievable, always at the front, winning loads. He was the man to beat, and that was true for his entire karting career.”

Ex-F1 racer and current sportscar ace Anthony Davidson adds: “We were fierce competitors, even at the age of nine and 10. He was braver on the track than I was as a kid. He would go for moves that you wouldn’t even think about, and he would always come out on top because he would make last-minute lunges down the inside work. He was always on the attack, always fully lit. He was aggressive.”

Future IndyCar rival Justin Wilson believes it was Wheldon’s supreme confidence at such an early age that truly marked him out.

“He had this cheeky attitude and he carried that on to the track, which defined his style,” says Wilson, who also raced against him in Cadets. “He would give the kart a flick going into corners and try things other people just weren’t doing. It was pretty unique. You could always see his confidence from the outside.”

John Button, who ran his son’s karts in those days, says: “Dan and Jenson got on really well, and I think Jense learned

quite a lot from him at that stage. Dan was the target for Jenson. His was such a professional outfit; Jense would give everything to beat him.”

### THE UPEAVAL TO THE UNITED STATES

Despite a strong debut season in cars in Formula Vauxhall Junior in 1996, and taking many race wins in Formula Ford (he also featured in an epic Festival duel with Button in ’98 that Jenson admits he won by “half a foot”), Wheldon’s career stalled in the UK. A planned deal with Paul Stewart Racing for European Formula Opel fell through and he didn’t have the money for F3. Instead, he turned to the American junior single-seater ladder. He won the US FF2000 title in his rookie year – but he almost came home before he’d even started.

“It was a big, mad rush,” says Clive Wheldon of his son’s move. “He went out to the States in January, but Ralph [Firman, Van Diemen boss] couldn’t get any cars to them until the end of February, so Dan was phoning me up every night, saying, ‘Dad, I’m lonely, I want to come home’ – he wasn’t enjoying it. I told him, ‘We’ve got to stick at it son; testing will start soon’ and I told [team owner Jon] Baytos to get his backside in gear or he wouldn’t have a driver!”

Once settled, Wheldon progressed

from FF2000 via race-winning campaigns in Toyota Atlantic and Indy Lights. Adrian Sussmann was tasked with managing Wheldon’s career in the summer of 2000, when he was racing in Atlantics.

“It had been a big move for him, even for a typically cocky 21-year-old racecar driver,” says Sussmann. “He was brilliant at how he got a team to work with him. Yes, he did have that sort of arrogant streak – not that I mean that in a bad way – but people loved that; they fell in love with him. He was so confident, and he demanded the best out of everyone around him, and it made everyone deliver.”

Eventually, after spending much of 2002 on the sidelines due to the harsh economics of post-9/11 America, Wheldon was offered a test-and-two-race deal by top IndyCar Series squad Panther Racing. It would lead to Honda and Andretti Green Racing – who were switching over from CART – signing him up. It was the springboard for his glittering IndyCar career, including two 500 wins and a championship title, but away from the track...

### THE PARTY ANIMAL

Always ultra-professional on race weekends, and a stickler for perfect preparation, Wheldon was also renowned for his ringleader status when it came to nights on the town. ▶

DW’s first Indy 500 win, for Michael Andretti, in 2005



◀ “He was always a blast to go out with,” lauds Dario Franchitti. But boozy nights hadn’t always gone to plan...

“When we were quite young I remember me, him and Kristian Kolby having our first drink together,” says Marino Franchitti. “We each sneaked some beer out of Kristian’s mum and dad’s place.” Kolby takes up the story: “We destroyed my dad’s karting motorhome that night. We were young kids who thought we could drink, and we weren’t able to handle it. Very messy!”

Dario recalls: “I was indoors at the house when they did that. The next morning, when I saw the scene, I was like, ‘What have you guys done?’ Those three got into all kinds of bother together! It was fun to watch these tearaway teenagers.”

Wheldon continued to demonstrate his fondness for a party, as his long-time right-hand man Mickey Ryan remembers: “After his first IndyCar win at Motegi in 2004 we were

trying to put him to bed, and we were having to slap him in the face because he was that passed out! What I liked about Dan was, it was kinda like college – when he got his homework done and got good grades, it was time to party. Shit man, we had a lot of fun together.”

### THE METICULOUS WORK ETHIC

Dario Franchitti says that Wheldon was “like a sponge” when it came to information, right from his early days as his team-mate, and his fastidious nature rubbed off on those around him.

Mike Hull, the team manager at Chip Ganassi Racing, recalls Wheldon’s first Daytona 24 Hours with the team, in which he appeared at the pitstand at 4am, hours before he was next scheduled to drive, asking if there was anything he could do to help. It was typical of his appetite for learning.

“Dan would often move to wherever his race team was based,” says Sussmann. “He wanted to almost

camp out in the raceshop and get to know all the engineers and mechanics. He probably drove them absolutely mad – that was all part of the Dan experience!”

Ryan adds: “We got used to spending hours and hours at the racetrack waiting for Dan because he’d spend so long with the engineers. People would have gone home for the day, while Dan was still working and trying to figure out the car for the next session. He was a really hard worker.”

### THE ‘NEAT FREAK’

Dan suffered from obsessive-compulsive disorder. It’s claimed that he once put the dishwasher on to clean a single fork and, when challenged about whether that was strictly necessary, Dan responded: “If it hadn’t been for that dirty fork, I’d have put the dishwasher on to clean the insides anyway.”

Pat Caporali, his PR rep at Ganassi, remembers her visits to his

Wheldon en route to victory in 2011 Indy 500



St Petersburg residence: “The reason he didn’t invite people over to his place much was you couldn’t sit on his couch and move his cushions – as soon as you went to the washroom, he’d rearrange the couch and cushions from where you’d displaced them, then he’d go check the washroom and make sure the towel was put back and there wasn’t a drop of water in the sink.”

Kolby, who used to spend much of his school holidays at the Wheldon family home in Emberton, adds: “I’d sneak into his bathroom and swap one can of deodorant on his shelf for another, and he’d walk in and say, ‘Something’s not right!’ He’d spend the next hour stressing about it.”

“His magazines were stacked in order of size, and everything was either in alphabetical order or arranged numerically. It was unbelievable how tidy one person can be. You’ve never seen a cleaner go-kart than his. He’d buff up the stainless with baby oil. It would be gleaming.”



With pal Dario Franchitti at Goodwood Festival



Time with his favourite people, the race fans

**THE PRANKS**

There are many Wheldon wind-up stories, too numerous to mention them all. His favourite trick to play on anyone unwise enough to leave their mobile phone in his vicinity was to send lascivious text messages to their entire contacts book. But it was the pranks played on him, and his reaction to them, that were truly the stuff of legend.

Motegi, Japan, 2004: Bryan Herta has sent Wheldon on a sight-seeing tour of the Honda museum (“It’s a must-see – take your time,” he insists) while Tony Kanaan has obtained Dan’s room key from reception. Together with their remaining team-mate Dario Franchitti, they enter Wheldon’s room and are amazed to find his shoes lined up (it’s estimated that Dan owned at least 200 pairs of trainers at any one time) on his bed.

The left shoe of each pair – including race boots, trainers and dress shoes – are removed from their bags and FedEx-ed back to the US.

“When he found out what we’d done, he shouted a lot, I remember that,” says Dario, who was hiding with his giggling team-mates in an adjoining room. “There was an explosion of rage. That just made it worse; that just egged us on! He went into a little bit of a huff, but then he won the race the next day. And then he just laughed! He was merciless with that cellphone prank, though.”

Kolby recalls an earlier revenge caper of his own that didn’t go down well...

“Dan had a thing for putting washing-up liquid into my windscreen-wiper bottle, and got me on numerous occasions,” he says. “When we were in America, he had this white 4x4, a Ford Explorer, and he’d just done me again after a race in Mid-Ohio. So I decided to get him back by putting engine oil in his. Now, anybody who knows Dan will realise he didn’t like his gleaming car getting messy. I don’t think he spoke to me for about a week.”

**THE NEW-FOUND MATURITY**

Plenty of people butted heads with Wheldon over the years, as his sparky nature and demanding standards were prone to conflict. But his marriage to Susie, his personal assistant, in 2008 and subsequent birth of their two boys Sebastian and Oliver, seemed to give him a new calmness.

“There were times where he could be difficult,” admits Dario. “But it was interesting to talk to Bryan Herta [who ran Dan’s winning car] before Indy this year and hear him say, ‘You can’t believe the change in Dan.’

“Out of the car, he changed a massive amount. He still had that kinda swagger about him, but he was very much at peace with himself – he

was so happy. Happy being married, happy having the boys. A lot of it was down to Susie, and the boys, definitely, were the final piece in the puzzle. But Dan himself, he just got it. I guess everyone changes throughout life, but Dan just clicked.”

Sussmann says: “Dan and Susie were just a great team together. A big part of Dan’s success was knowing that everything was taken care of. He was so detail-oriented and specific, he wanted everything to be just perfect. I think having Susie there actually helped him on the racetrack, because he had to get into that car with a completely clear mind.”

**THE FAN FAVOURITE**

As all the success and adulation came his way, there was one group of people Wheldon never forgot: the fans.

“I couldn’t believe how good he was with the fans,” says his dad. “A lot of drivers make it, but they forget how they got there along the way, but Dan never, ever forgot that. He was forever signing autographs, having his photo taken. Just look at Goodwood this year – he loved that.”

Dario was also in awe of his relationship with the spectators.

“He was a one-off with fans, that boy,” he says. “Even in the early years, when he was quite brash, or whatever word you might wish to call it – maybe fiery is the best word to describe him – but throughout anytime I saw him, at a track, away from it, wherever, any interaction he had with a fan – he would always make time. We don’t all do that. Dan was unbelievably good at making time for people he’d maybe never even met before.”

Wilson adds: “I’ll always remember that smile, and pre-race when he was about to go out, he was always talking and being great with the fans; being perfect in every way.”

**THE UNWRITTEN CHAPTER**

The huge outpouring of sadness after the Vegas tragedy was tinged even more by the news that his future had appeared so bright. After a year without a fulltime drive, his return to Michael Andretti’s team for the 2012 season was a done deal.

“Before it happened, on that Sunday, everything was perfect,” says Sussmann. “Dan had signed his 2012 contract with Andretti Autosport, he had his beautiful family, he’d won the Indy 500 and silenced all his critics. He was excited to be going back to a top team. To be honest, I think his best years were still ahead, you know... but it just was not to be.”

His father concludes: “Dan had a great life in the short time he had. And he really did love his racing.” ❧

# The day Dan went back to his roots

**Dan Wheldon made his name in the American open-wheel ladder system. In September, he tried out the current breed of cars for us. By JEREMY SHAW**

**T**he premise for this story when it was conceived over the summer was straightforward: to ask two-time Indianapolis 500 winner Dan Wheldon to assess the opportunities that exist in North America for aspiring open-wheel stars to progress from the grassroots of the sport to the IndyCar Series; and to compare the now clearly-defined Mazda 'Road to Indy' ladder system with the bewildering proliferation of Formula 1 feeder series in Europe.

The basic tenet remains, although the tragic accident on October 16 in Las Vegas, which claimed the popular Englishman's life, has revealed a parallel purpose: to focus on his passion and eagerness to embrace the concept of helping others reach the pinnacle of the sport.

When asked whether he would like to track-test cars at each level of the Road to Indy ladder – at the Indianapolis Motor Speedway road course – Wheldon's answer was brief and to the point: "Hell, yeah!"

Wheldon never forgot the circumstances that transformed him from a struggling young racer in his homeland to an IndyCar Series

champion. After a stellar career in karting and an extremely promising first few steps on the open-wheel ladder in the UK, Wheldon realised he faced an uphill battle to finance his progression into Formula 3 and beyond. So he began to research his options. Did his homework, in other words. He soon discovered another potential avenue to pursue his ambition of becoming a top-level racecar driver – in North America.

The notion of chasing success across the Atlantic was nothing new. Countless other Europeans before him had established themselves in the IndyCar or sportscar ranks. Wheldon set out to do the same. He signed up to race in the USF2000 National Championship, won it as a rookie in 1999, and parlayed that success into impressive campaigns in Toyota Atlantic and Indy Lights, where he was hired, as a professional, by the PacWest team, and thence into Indycars.

Throughout his career Wheldon remained close to his roots. He continued to use karting as part of his fitness regimen, was a frequent visitor – and competitor – at karting events, and was always on hand to support any youngsters who sought his advice.



**INDYCAR**



Wheldon was all smiles after trying out three cars



**INDY LIGHTS**

**STAR MAZDA**

**USF2000**

“After a stellar karting career and promising first few steps on the open-wheel ladder, Wheldon faced an uphill battle to progress”

Wheldon juggled his intensive schedule of testing the prototype 2012 Dallara IndyCar to ensure he would be available to sample the current breed of junior racers – USF2000, Star Mazda and Indy Lights – and was genuinely excited when he arrived at the Speedway, bright-eyed and bushy-tailed, on a cool morning in September. The familiar toothy smile remained permanently on display all day. ▶

PICS: McQUEENEY/IMS

**HOW THE MACHINERY MATCHES UP**

SERIES	IndyCar (2012)	Indy Lights	Star Mazda	USF2000
CHASSIS	Dallara	Dallara	Star Race Cars	Van Diemen
CONSTRUCTION	Composite	Composite	Composite	Spaceframe
ENGINE TYPE	2.2-litre V6 turbo	3.5-litre V8	1.3-litre rotary	2.0-litre, 4-cyl
ENGINE MAKE	Honda, Chevy or Lotus	Infiniti	Mazda (Renesis)	Mazda (MZR)
HORSEPOWER	590-700 bhp	420 bhp	260 bhp	170 bhp
WEIGHT	680kg (oval) 703 kg (road)	676 kg (oval) 690 kg (road)	485 kg	470 kg
GEARBOX	6-speed sequential	6-speed sequential	6-speed sequential	4-speed H-pattern
SEASON BUDGET	\$5-8 million	\$800,000	\$400,000	\$250,000
NO. RACES 2011	17	14	11	12
NO. RACES 2012	17	12	16	14
CHAMPION'S PRIZE	\$1 million	\$1 million	\$565,000	\$375,000
LAP TIME AT IMS	-	1m25.38s	1m29.19s	1m31.49s

Note 1: USF2000 also will host a six-race WinterFest series over two race weekends in February  
 Note 2: The season budgets are estimated Note 3: All of the 2012 schedules are still being finalised



Wheldon prepares to get his toe down

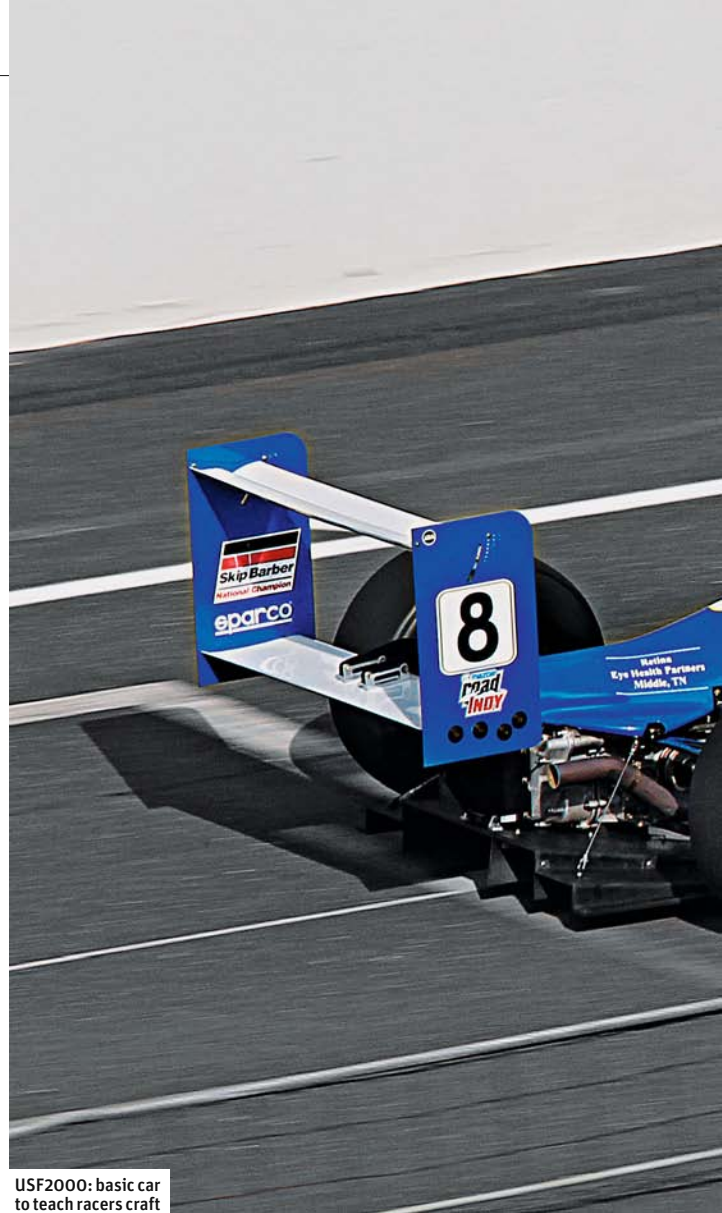

USF2000: basic car to teach racers craft



Star Mazda: thin power band means max attack



Indy Lights: good prep for next step to IndyCar

◀ “That was a lot of fun,” said Wheldon after turning some laps aboard the Andretti Autosport Van Diemen-Mazda with which MAZDASPEED development driver Spencer Pigot had finished second in this year’s Cooper Tires USF2000 National Championship Powered by Mazda – the first official rung on the Mazda Road to Indy: “I wanted to carry on but they threw the red flag so I thought I’d better come on in!

“When I first came to America, I started off in USF2000,” he added. “That’s how my IndyCar career started and it was great to be back. I always felt these cars were a really good training ground for moving up the ladder system. I’ve been driving the 2012 IndyCar a ton lately, and it has a hand clutch and basically does everything for you. When you get in this, it has the standard H-pattern, four-speed gearbox and clutch. These are the basics that you need to learn as a racecar driver, and driving these cars is a part of the process. You don’t want to give the young drivers who want to try to make it to IndyCar all the toys, gadgets and gizmos too soon. They need to learn their craft.”

After excitedly recounting his time in the Van Diemen, Wheldon clambered aboard the Team Pelfrey Star Mazda car which took Connor de Phillippi to four race wins in 2011 and narrowly missed out on the championship – and the consequent \$600,000-plus prize toward a season in Indy Lights – to the more-experienced Frenchman Tristan Vautier.

Once again, Wheldon emerged with a broad grin, despite not being particularly comfortable in the cockpit, with his knees regularly making contact with the steering wheel as he negotiated the turns.

“You can tell you’ve moved up a rung of the ladder because you’ve got more power and a little more sophistication

with the sequential, six-speed gearbox and traction control,” he related. “The rotary engine has a thin power band that you really have to stay within, so you gotta make sure that you attack the corners, but by the same token you can’t just really load on the brakes – you’ve really got to try and carry that momentum.

“Typically, through the high-speed stuff, you might not need the traction control, but if you’re going from that, braking into a hairpin, you might want some, especially as the tyres start to wear at the end of the race. So it gives the driver a start of being able to adjust some of the cockpit controls. It’s a very good progression.”

His final ‘task’ for the day was a run in Norwegian Anders Krohn’s Belardi Auto Racing Firestone Indy Lights car. Incorrect gearing left its 420bhp V8 bouncing off the rev limiter well before Turn 1 on the F1 road course, but still Wheldon was impressed.

“I like that – I like that a lot,” he declared. “It gives you tons of confidence to drive fast, but you can tell it’s another step forward. The F2000 and the Star Mazda, they feel small, they feel light, comfortable to drive, but now you can start to feel the weight. It’s a big, kind of heavy car and you can see why this is that last rung before the big time, so to speak. But it’s very nice to drive.

“It has very similar characteristics, I would say, to an IndyCar. I mean, it doesn’t quite have the power but you have to muscle it around and it teaches drivers the physical aspect of it – you know, getting on top of the wheel, as they say in America – but it’s still got that refined feeling to it. The gearbox is a six-speed sequential. It feels nice but, again, you could definitely break the gearbox if you started downshifting too soon, which I think is important because being easy on equipment is very, very important as you move up the ladder.



“I think that’s why you’re seeing a lot of successful Indy Lights drivers doing well now when they get into the IZOD IndyCar Series, because it is relevant.”

Aside from relishing his opportunity to drive cars from each rung of the Road to Indy ladder, Wheldon already had become a staunch supporter of the initiative – especially the scholarship prize structure, which allows drivers to graduate from one step to the next.

“When I left Europe, the ladder system had gone crazy; there were so many different formulas,” he said. “When I first came over here, that was one of the most, if not the

“You have to muscle the Indy Lights car around and it teaches you to ‘get on top of the wheel’”

**Wheldon enjoyed the power**

most attractive part of American open-wheel racing. We lost that to some degree [in the intervening years], and now it’s back and we’ve got to embrace that concept.

“I mean, that’s why Michael [Andretti] has all these ladder-system teams [Andretti Autosport fields entries in each of the series], because he can hand-pick the talent and move

them to his IndyCar team. Michael will probably pick ‘em up cheap – but he picked me up cheap! That’s good for them. That’s good for the team owners and it’s great for these guys because they get that opportunity.”

In addition to praising the benefits of the Mazda Road to Indy programme after driving the cars, Wheldon contributed willingly during the ladder system’s Oval Clinic in May, when he enraptured his young audience with information and anecdotes in advance of their own oval-racing debuts.

It was a true measure of the man. A class act. His contributions to the sport, at all levels, will not be forgotten. ❄

**FOLLOWING IN DAN’S FOOTSTEPS**

**NORTHERN IRISHMAN WAYNE**

Boyd was heralded as a potential future star after dominating the 2008 British Formula Ford Championship. Unfortunately, his career faltered after a disappointing ‘09 British Formula 3 season, which yielded a solitary victory in treacherous conditions at Donington, and he

raced only sporadically in ‘10.

So, aged 20, he regrouped, focused on what opportunities were available, researched the Mazda Road to Indy and concluded a very late deal to join Belardi Auto Racing’s USF2000 team just five days before the opening race of the 2011 season at Sebring.

“It was all a bit last-minute with

no pre-season testing or anything, but it’s been awesome,” he says.

“It’s a very, very good thing for young drivers, especially the tier programme, being able to move up through the ladder each year with full scholarships.

“It’s a lot more defined over here [in the US]. There is no real official ladder system back home. There are so many different classes that you can do. The one they sort of have in Europe is



Boyd raced in USF2000 this year

GP3, GP2 then F1, in theory, but they’re also a lot more expensive – and there’s a lot more politics involved as well!”

# Save up to 32% on great Christmas gifts



**Stuff**  
12 issues for £38.00  
**SAVE 27%**



**FourFourTwo**  
12 issues £39.99  
**SAVE 26%**



**F1 Racing**  
12 issues £46.25  
**SAVE 18%**



**Classic & Sports Car**  
12 issues £44.50  
**SAVE 18%**



**What Car?**  
13 issues for £44.00  
**SAVE 32%**



**Autosport**  
26 issues £72.00  
51 issues £141.25  
**SAVE 16%**



**Classic FM**  
12 issues £45.50  
**SAVE 22%**



**Champions**  
6 issues £19.99  
**SAVE 16%**



**Practical Motorhome**  
13 issues £39.99  
**SAVE 23%**



**What Hi-Fi?**  
13 issues £48.00  
**SAVE 21%**



**Motorsport News**  
26 issues £57.00  
51 issues £111.80  
**SAVE UP TO 23%**



**Practical Caravan**  
13 issues £41.65  
**SAVE 22%**



**The Official England Programme**  
6 issues £29.99  
**SAVE 17%**

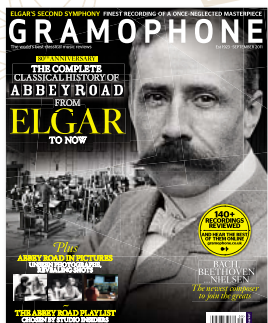

**Gramophone**  
13 issues £48.35  
**SAVE 22%**



**Autocar**  
26 issues £59.50  
51 issues £115.00  
**SAVE UP TO 22%**

Call 0845 124 7040 now or order online at [www.themagazineshop.com/XPA11](http://www.themagazineshop.com/XPA11)

**SAVE AN  
EXTRA £10\*\***  
when you buy  
two or more  
subscriptions



## Subscriber benefits

- Save up to 32% on the shop price
- Save up to an extra 5% when you pay by Direct Debit\*
- Free gift card for you to send to your friend or relative
- Spread the cost of Christmas when you pay by Direct Debit\*
- Give the gift that lasts all year

\*Call **0845 124 7040** or visit [www.themagazineshop.com/XPA11](http://www.themagazineshop.com/XPA11) for details on how to save more when you choose to pay by Direct Debit. \*\*For details of multi-buy savings call **0845 124 7040** and quote XPA11.



# ORDER FORM

To be sure your gift starts promptly after Christmas, fill in the form below and return your order to us by 16th December, 2011 at:

**Haymarket Magazines - Christmas,  
FREEPOST RSBZ-GBES-RRKB, PO Box 326,  
Sittingbourne, ME9 8FA or call the Order Hotline on  
0845 124 7040 (quote XPA11) or visit us at  
[www.themagazineshop.com/XPA11](http://www.themagazineshop.com/XPA11)**

### How to order:

- 1 Please complete the order form in BLOCK CAPITALS.
- 2 Complete the section headed 'Your Details'
- 3 Enter the name, postcode and telephone number of the person who will receive a magazine subscription as a gift.
- 4 Enter the names of the magazines in the space provided.
- 5 This form can be photocopied for further orders.

### YOUR DETAILS (BLOCK CAPITALS PLEASE - MUST BE COMPLETED)

This subscription is: A GIFT  OR FOR ME

Magazine title\* \_\_\_\_\_ (\*if subscribing for yourself)

Title \_\_\_\_\_ Name \_\_\_\_\_ Surname \_\_\_\_\_

Address \_\_\_\_\_

\_\_\_\_\_ Postcode \_\_\_\_\_

Telephone \_\_\_\_\_

Email \_\_\_\_\_

Mobile \_\_\_\_\_

I wish to pay for a total of \_\_\_\_\_ subscriptions.

ORDER TOTAL (please complete) £ \_\_\_\_\_

### GIFT SUBSCRIPTION DETAILS (BLOCK CAPITALS PLEASE)

Magazine title\* \_\_\_\_\_ No. of issues \_\_\_\_\_

Title \_\_\_\_\_ Name \_\_\_\_\_ Surname \_\_\_\_\_

Address \_\_\_\_\_

\_\_\_\_\_ Postcode \_\_\_\_\_

Telephone \_\_\_\_\_

### PAYMENT DETAILS

I enclose a cheque made payable to Haymarket Media Group for £ \_\_\_\_\_

Please debit my: **Mastercard/VISA/Amex/Maestro/Diners** for the amount £ \_\_\_\_\_

Card No.

Valid from     Expiry date     Issue no. (Maestro only)

Signature \_\_\_\_\_ Date \_\_\_\_\_

**TERMS & CONDITIONS** This is a UK only offer – for overseas offers please visit [www.themagazineshop.com](http://www.themagazineshop.com) or call +44 (0) 1795 418 660. For all gift orders received by 16th December 2011, we will post a special gift card for you to send on to the recipient letting them know about their gift subscription. Subscription orders received after 16th December will still receive a gift card but we cannot guarantee that it will arrive before Christmas. The gift subscription will begin with the first available issue on-sale in 2012. Final closing date for orders is 31st January 2012. Multi-order offers are not available online or by coupon – please call for details of available offers. All savings are based on the UK cover price and are correct as of 1st August 2011. **Haymarket Media Group Ltd** uses a best-practice layered Privacy Policy to provide you with details about how we would like to use your personal information. To read the full privacy policy please visit our website [www.haymarket.com/privacy](http://www.haymarket.com/privacy) or call us on 08456 777 800. Please ask if you have any questions as submitting your personal information indicates your consent, for the time being, that we and our partners may contact you about products and services that will be of interest to you via post, phone, e-mail and SMS. You can opt-out at ANY time by emailing the [datacontroller@haymarket.com](mailto:datacontroller@haymarket.com) or by calling 08456 777 800.

**Promo code: XPA11**

When ordering quote  
promo code **XPA11**

# THREE'S COMPANY

Owner/drivers are a rare breed in NASCAR these days, but Tony Stewart broke the mould in 2011 to secure his third title.

By ANDREW VAN DE BURGT

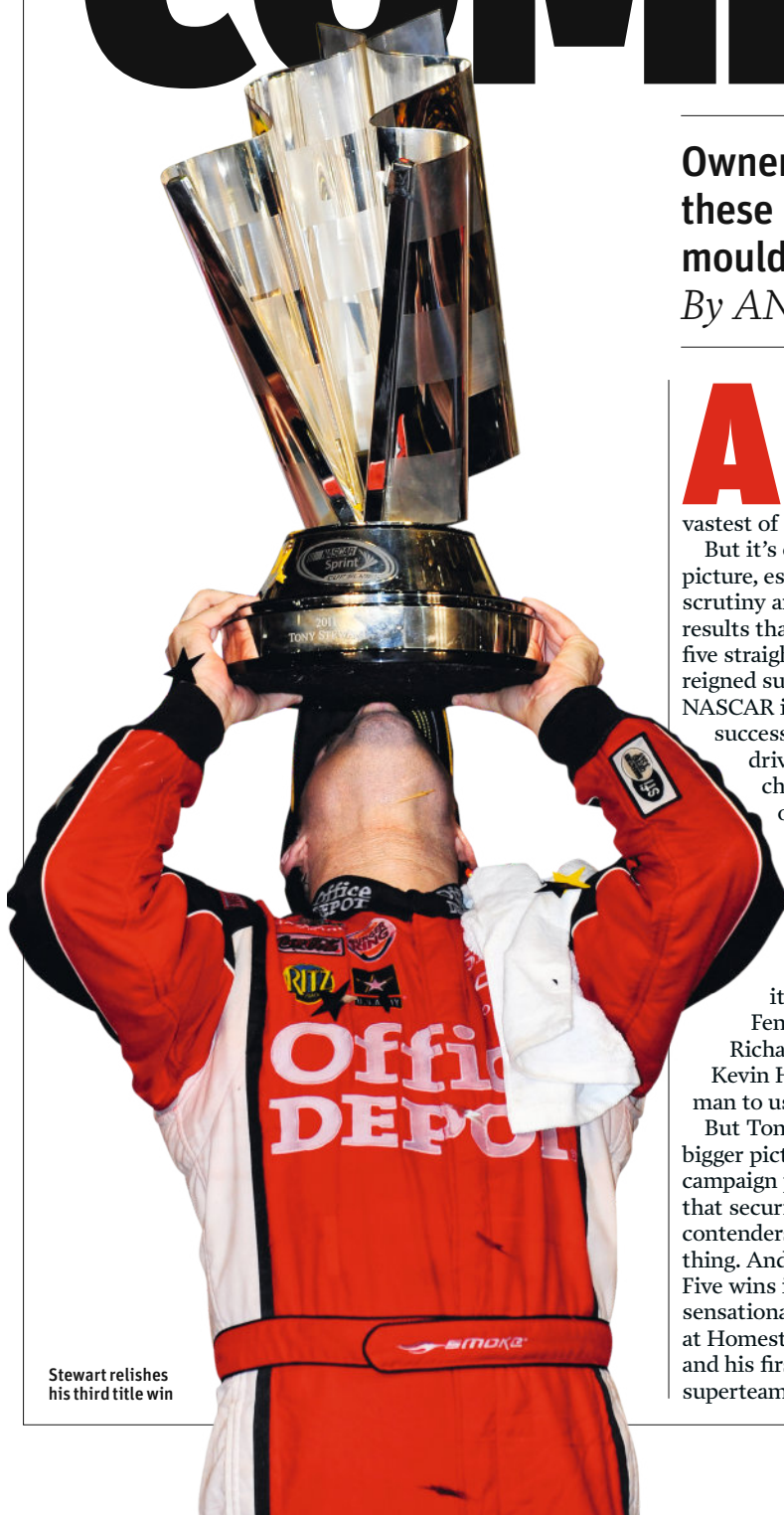

Stewart relishes his third title win

All empires eventually fall. No matter what their size, strength or pre-eminence, nothing on this world – even the mightiest of mountains or vastest of oceans – will last forever.

But it's often hard to see the bigger picture, especially under the intense scrutiny and pressure for immediate results that motor racing creates. For five straight seasons Jimmie Johnson reigned supreme over the world of NASCAR in an unprecedented run of success. The combination of his driving, the tactical nous of crew chief Chad Knaus and quality of the Hendrick Motorsports Chevrolet Impalas was literally unbeatable.

But that run was always destined to come to an end. Before this year's 'Chase' 10-race play-off, it looked like either Roush Fenway's Carl Edwards, or Richard Childress Racing's Kevin Harvick would be the man to usurp the king.

But Tony Stewart had seen the bigger picture. Despite a winless campaign prior to the Chase, he knew that securing a place among the 12 contenders was the most important thing. And how he proved that theory. Five wins in 10 races, including a sensational victory in the season finale at Homestead, delivered his third Cup, and his first since he left the Joe Gibbs superteam to go into business with

Gene Haas's struggling organisation.

It may have seemed like a bold gamble at the time, but it's one in which Stewart had complete faith.

"The thing that gave me that little bit of the push over the top that I needed came from Rick Hendrick," he says. "Rick had a relationship with Gene and Rick called me and said, 'Hey, this may be an opportunity for you.' It just seemed like every challenge that we took we were able to find some sort of success with it, and Rick talked to me on the phone one night and said, 'I'm not going to let this fail.' They are words that I have never forgot."

A restructuring of the management set-up at Stewart-Haas allowed Stewart to spend more time on his driving and less on the day-to-day running of the business operation this season, although Haas says Stewart still has a pretty hands-on approach to running his empire.

"What we've tried to do in the past year or so was make sure that Tony just concentrated on the driving part," Haas says. "Tony works really hard at driving. He also works really hard with sponsors. I've never seen a guy that spends every single day either driving the car or going to sponsors or dealing with his other businesses."

Quite where the turning point of Stewart's title charge occurred differs within the team. Crew chief Darian Grubb, who parted company with the organisation following the Homestead success, is adamant it was the Atlanta

**HAAS TEAM HISTORY HOW STEWART HAS MADE SQUAD A WINNER**

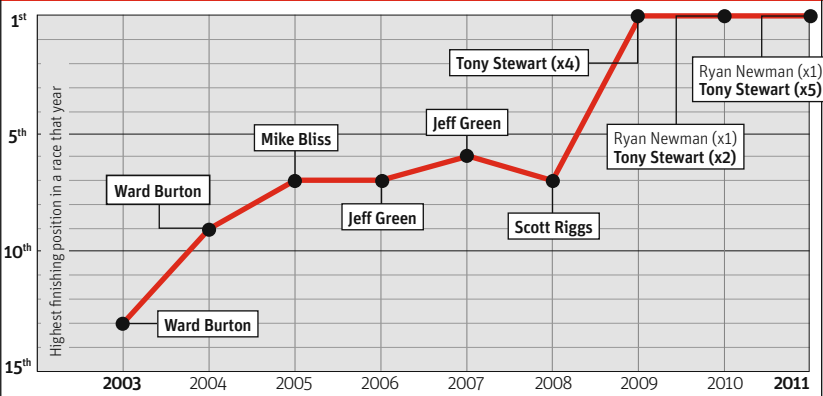

Stewart focuses more on driving duties



Rival Edwards congratulates new champ



The #14 Chevrolet won five times – all in the Chase

**NASCAR'S TRIPLE CHAMPIONS**

**LEE PETTY**

1954, '58, '59

One of the first NASCAR superstars, Petty ran his own team, taking the first of his three titles in a Hudson Hornet popularised in the Disney Pixar *Cars* movie. Father of NASCAR legend Richard Petty, with whom he ran Petty Enterprises in his later years.



**DAVID PEARSON**

1966, '68, '69

Won his three titles in a golden period in the mid-to-late 1960s, but Pearson was a contender for over 20 years at the highest level, racking up 105 wins despite only part-time programmes for much of his career. Enjoyed an amazing rivalry with 'The King' Richard Petty, with the pair finishing 1-2 in races a phenomenal 63 times.

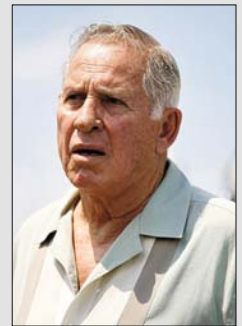

**CALE YARBOROUGH**

1976, '77, '78

Before Jimmie Johnson's five-in-a-row, William Caleb Yarborough was the only man to win three straight NASCAR Cups. All of his titles came behind the wheel of cars run by the legendary Junior Johnson. Also competed in four Indianapolis 500s and appeared alongside Burt Reynolds in his 1983 flick *Stroker Ace*.



**DARRELL WALTRIP**

1981, '82, '85

Waltrip succeed Yarborough as Johnson's lead driver, but fell one short of the 'three-peat' after suffering a huge crash in the season-opening Daytona 500. His third title was also the last for Johnson. Won plenty more races following a move to Hendrick Motorsports in 1987, but a fourth title eluded him. Now an instantly recognisable voice behind the commentary mic.



**TONY STEWART**

2002, '05, '11

The first star of Tony George's Indy Racing League, Stewart left single-seaters for a drive with Joe Gibbs Racing in 1999. Was an immediate frontrunner, but lacked consistency until the arrival of crew chief Greg Zipadelli in 2001. Beat Mark Martin to the 2002 title and became the first driver to win Cups under the old points system and 'new' Chase format when he headed Jeff Gordon in 2005.

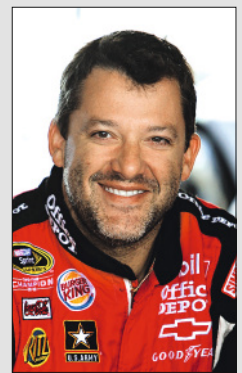

**“Rick Hendrick said to me one night, ‘I’m not going to let this fail.’ They are words I have never forgotten”**

race in September, while Stewart feels it took place much later, in the Chase encounter at Martinsville.

“If you look back to Atlanta, he was talking about how good we had the car there,” recalls Grubb. “And he drove from 20th to third and we didn’t tell him until after the race that we didn’t make a single change to the car for the last three stops, just four tyres and go. He went out there and did that, and I think that’s one of those true moments that we realised we can do it.”

“I honestly think the turning point for us was Martinsville,” counters Stewart, recalling a fine performance

during which he fought hard just to stay on the lead lap before producing a stunning end to the race that concluded with a pass around the outside of Johnson for the win.

“To leave there doing something remarkable, I feel that was the turning point in the Chase for us. And we backed it up a week later by winning Texas, and not only winning Texas but by beating the guy [Edwards] that we were racing for points, leading the most laps and really making a statement that, hey, don’t make the mistake of counting us out of this.”

All of that set up the thrilling finale at Homestead, where Stewart twice battled back from last, making 118 overtaking moves on his way to a famous win. It ended Johnson’s reign, but, it ought to be noted, it extended the winning streak for Hendrick-built cars to six years. For now, that empire still stands tall. ❁

# Risk business

The 2011 season was crucial for Valtteri Bottas, but his gamble to race in GP3 paid off. By *GLENN FREEMAN*



Bottas raced hard with Lotus-liveried ART squad

A Finn on the booze: VB celebrates GP3 success



All records are made to be broken, and unfortunately for Valtteri Bottas he will forever be the man who was on board when Formula 3 powerhouse ART Grand Prix's run of consecutive Euro Series titles came to an end in 2010. It was the first time since '03 that the French team had been defeated, and it was potentially a mortal blow for the Finn's career.

The problem was down to perception. Those on the outside – in other words, the Formula 1 paddock – wouldn't know the real story behind the 2010 campaign, and of the money spent by Volkswagen to help the Signature team defeat Mercedes-powered ART. As far as they were concerned, Bottas had failed where Jamie Green, Lewis Hamilton, Paul di Resta, Romain Grosjean, Nico Hulkenberg and Jules Bianchi had all delivered. It meant the Williams F1 test driver needed a big 2011.

"We had some different options for this year: there was GP2, World Series by Renault," he says. "But then we saw GP3 was going to be really competitive. It's still on the F1 weekends, and it's much cheaper. In the end, I think money was a big part of the decision."

For a driver who had already spent two years in F3, it was a brave decision. It was a sideways step rather than a climb up the ladder, and Bottas knew that if this year didn't go to plan he was going to be in big trouble.

"Of course there was a risk," he says.

"The plan was to go there for one year and win it. If I hadn't won it... Well, let's just say that was not the plan. Even if I'd finished second or third things would have been very difficult for me."

Those are some pretty high stakes, but Bottas had been here before. He went into 2010 with heaps of expectation on his shoulders, and when the pace of Edoardo Mortara's Signature-Volkswagen package came to the fore he struggled to deal with it. History seemed to be repeating itself in 2011, as he once again climbed into an ART car that had won the championship the year before (with Esteban Gutierrez) and found that it was no longer the fastest one out there.

"The first half of the season was a nightmare," he says, pointing to the fact that he was languishing in 10th place after eight of 16 races. "There is always pressure, but I wasn't putting any pressure on myself because I knew it wouldn't help anything. I made that mistake in 2010; I put a bit too much pressure on myself because I knew I had to win the championship, and when you do that it's easy to make mistakes. This time, I didn't change anything about my approach, even when things didn't go well."

Save for a podium finish in a wheel-banging reversed-grid thriller in Valencia, Bottas had been unable to trouble the leaders on a regular basis. Even when he hauled the green-and-yellow car into a competitive position, he could rarely sustain it over the

course of a race. With total faith in his own ability, he was convinced these struggles weren't of his own making.

"At first I thought we were just being unlucky and I was sure everything would come together," he says now. "But after the third race weekend [Valencia] I was sure something was wrong with the car. You know when you can't find any more than one or two tenths in your driving, and sometimes we were more than half a second behind."

This was the Finn's third year with ART, meaning that not only did he have the balls to tell the team it was coming up short, but the French squad knew it had a driver it could trust. Together with team-mate James Calado, Bottas worked with the team to solve the problems, which were traced back to a change of tyre compound and reduced rear-wing levels for this year.

"ART did well in the first year of GP3, winning the title with Gutierrez," says Bottas. "So we used the same set-up from 2010 for quite a long time, but then we saw there was a big problem. We worked to get back to the top, and we changed the set-up quite a lot to get it working. That was the key."

The turning point came at the Nurburgring, where rain-affected races disguised the performance jump that ART had made. Bottas got his first win of the season in race two, but he and Calado laid a real marker down next time out in Hungary by locking out the front row. After winning race one, Bottas had gone from 10th to first in the standings in just three races, and from there he would keep Calado at arm's reach to seal a crown that was so essential for his career.

Following an impressive first proper F1 test with Williams at Abu Dhabi recently, he's even being linked to a drive with the team next year. Naturally, he says "everything is open and nothing is decided", but the hype surrounding Bottas this winter is in stark contrast to 12 months ago. ❖



Strong impression in Williams Abu Dhabi test

# WEB DIRECTORY

## AWNINGS

**HAMILTON Motorsport LTD**  
 Suppliers of: Race & Rally Shelters, Minilite, Piloti, Moto-lita, Car Covers etc  
[www.hamiltongrouponline.com](http://www.hamiltongrouponline.com)

## BOOKS & DVDS

**www.chaters.co.uk**  
 Probably the World's LARGEST selection of Motoring Books & DVD's  
 Tel: 01276 686639 - Fax: 01276 686538

## EXHAUSTS

Inconel & Stainless Steel Specialists  
**SIMPSON**  
 Race Exhausts  
 Tel: 01753 532222  
[www.simpsonraceexhausts.com](http://www.simpsonraceexhausts.com)

## GEARBOXES

**eLITE** racing transmissions  
 Rally & Race Gearboxes, GearKits, LSD's and Driveshafts  
 Tel: 01782 280136 Fax: 01782 269913  
 Email: sales@eliteracingtransmissions.com  
[www.eliteracingtransmissions.com](http://www.eliteracingtransmissions.com)

## GEARBOXES

**Gearboxman.com**  
 COMPETITION TRANSMISSION SERVICES  
 Gearboxes and Axles for Road, Race, Rally, and more  
 Telephone: 01582 840008, Fax: 01582 840007

## HELMET GRAPHICS

**Mike Fairholme Designs**  
 Sole approved painter of Arai helmets.  
 Silver Birches, Corby Birkholme, Nr Grantham, Lincs NG33 4LE.  
 Tel: 01476 550630. Fax: 01476 550029.  
 email: fairholmedesigns@btconnect.com  
[www.fairholmedesigns.co.uk](http://www.fairholmedesigns.co.uk)

## MEMORABILIA

**Speed King.cc**  
 EXCLUSIVE MOTORSPORT MEMORABILIA  
 EST. 1996  
 We Buy Your Teamgear!

**FINAL LAP**  
 For Everything Formula One  
[www.finallap.net](http://www.finallap.net) - WE BUY AND SELL  
 +44 (0)1245 287588 / 01771 920345

## MEMORABILIA

**JMJ AUTOMOBILIA** America's #1 supplier of CART and Formula One Racing memorabilia. Large selection of signed original collectables. See our ad under marketplace Memorabilia. Call or fax or a mail listing at (609) 575 1143 or visit our website @ [www.JMJAuto.com](http://www.JMJAuto.com)

## MODELS

**HISTORIC SPORTS RACERS**  
 For a new range of 1/43 scale hand built 1950's Sports Racing Models visit [www.modelgarage.co.uk](http://www.modelgarage.co.uk) and follow the Online Shop link.

## MOTORHOMES & TRAILERS

**BRIAN JAMES TRAILERS CLUBMAN**  
 Tel. 01327 308833  
 Web. [www.brianjames.co.uk](http://www.brianjames.co.uk)

**JW Green Trailers** for BRIAN JAMES TRAILERS  
 Stock ready for delivery before Christmas  
 Tel: 0333 456 0222 Mob: 07785 230560  
[www.jwgreen.co.uk](http://www.jwgreen.co.uk)

## RACE PARTS

**ARE DRY SUMP SYSTEMS**  
 ARMSTRONG RACE ENGINEERING INC.  
[WWW.DRYSUMP.COM](http://WWW.DRYSUMP.COM) (916) 652-5282

**CARTEK** Electronic Battery Isolators  
 Don't compromise on Safety or Reliability  
[www.CartekMotorsport.com](http://www.CartekMotorsport.com)

**PIPER**  
[www.pipercams.co.uk](http://www.pipercams.co.uk)

**Pit to Car Radio**  
 0044(0)1508 528837  
**AUTOTEL RACE RADIO**  
[www.raceradio.co.uk](http://www.raceradio.co.uk)

## RACE PRODUCTS

## RACE PRODUCTS

**demon tweeks** MOTORSPORT Direct  
[www.demon-tweeks.co.uk](http://www.demon-tweeks.co.uk)

**Position Sensors Ltd**  
 Motorsport Specialist  
[www.position-sensors.co.uk](http://www.position-sensors.co.uk)

**TEKNOFIBRA**  
 HEAT RESISTANT MATERIAL  
 Protection to 1000°C  
 web: [www.walkersgarage.com](http://www.walkersgarage.com)  
 tel: 0044 (0) 1609 777221

**msar** LONDON MOTORSPORT SHOWROOM  
[www.msar.co.uk](http://www.msar.co.uk)

## RACE PRODUCTS

[www.porscheshop.co.uk](http://www.porscheshop.co.uk)  
**PORSCHESHOP**  
 +44 (0) 121 585 6088

RACEWEAR MANUFACTURER  
**AWS**  
[awsracewear.com](http://awsracewear.com)

**JJC** race and rally  
 PASSIONATE ABOUT MOTORSPORT  
[www.jjcraceandrally.com](http://www.jjcraceandrally.com)

**CROYDON RACE & RALLY CENTRE**  
[www.croydonraceandrally.co.uk](http://www.croydonraceandrally.co.uk)  
 220-222 Portland Road South Norwood London SE25 4QB  
 For Racewear & Motorsport equipment  
 FORECOURT PARKING Tel: 020 8656 7031

## RACEWEAR

## RACEWEAR

**GPR Grand Prix Racewear**  
 THE RACEWEAR EMPORIUM  
[www.gprdirect.com](http://www.gprdirect.com)

ALL OMP RACEWEAR AVAILABLE NOW  
[www.ybracing.co.uk](http://www.ybracing.co.uk) **OMP**

**RACING CARS FOR SALE**  
 ALAN CORNOCK FCS  
 BUYING - SELLING - BROKERAGE  
[www.racingcarsforsale.co.uk](http://www.racingcarsforsale.co.uk)  
 TEL: 01480 891212

**WWW.ROYALPURPLE.CO.UK**  
**ROYAL PURPLE** SYNTHETIC RACE OILS  
 01209 216 666

## RACING OILS

## STORAGE

## WEB DESIGN

## WHEELS

**OLD HALL PERFORMANCE LTD**  
**RED LINE** SYNTHETIC OIL  
 Tel: +44 24 7671 7100  
 Fax: +44 24 7671 7400  
[sales@redlineoil-europe.com](mailto:sales@redlineoil-europe.com) [www.redlineoil-europe.com](http://www.redlineoil-europe.com)

**LISTA**  
[www.listacabinets.co.uk](http://www.listacabinets.co.uk)  
 Tel: 01228560911 / 07733157911

**MSPORTSTARS**  
 Motorsport Specialist Web Design  
 +44 (0) 20 8289 1621  
 info@msportstars.com  
[www.msportstars.com](http://www.msportstars.com)

**Image** Manufacturers of bespoke split rim alloy wheels  
[www.imagewheels.co.uk](http://www.imagewheels.co.uk)  
 IMAGE WHEELS INTERNATIONAL LTD

# PRODUCT SHOWCASE



- World leaders in safety fuel bladder technology for over 40 years
- From rally to track, sprint to endurance, club racing to F1
- For more information visit our website [www.atfltd.com](http://www.atfltd.com) or call us on 01908 351700



Exhibiting at the Autosport Engineering Show

Birmingham NEC  
12-13 January 2012  
Stand E253

## Coolant Level Alarm



from **CARTEK**

The Coolant Level Alarm from **CARTEK** offers drivers an early warning system should their engine cooling system develop a leak, such as a punctured radiator, loose hose or gasket failure before overheating and engine damage occurs.

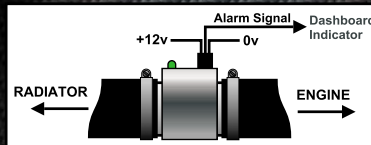

Fits into the top radiator hose.  
Alarm output for dashboard indicator.  
Integrated status LEDs.

**CARTEK AUTOMOTIVE ELECTRONICS Ltd**  
[www.CARTEKMOTORSPORT.com](http://www.CARTEKMOTORSPORT.com)

## THE WINNING CHOICE

Suppliers to F1 & all Groups of Motorsport  
All products Homologated & Fully approved for all Formulas

FX G-TEC (gas) systems from 1.5kg up to 3.0kg

AFFF (foam) systems from 2.25ltr up to 4.0ltr

Products for all budgets & Classes

**FEV**  
**MOTORSPORT**

FIRE EXTINGUISHER  
VALVE COMPANY LTD

Tel: +44 (0) 1243 55 55 66  
[www.fe-v.co.uk](http://www.fe-v.co.uk) | Email: [sales@fe-v.co.uk](mailto:sales@fe-v.co.uk)



[WWW.100COOL.CO.UK](http://WWW.100COOL.CO.UK)

- 100% waterless coolant
- Never boils over
- Prevents detonation
- Prevents cavitation
- Race proven winning formulation
- Low hose pressure
- Zero engine corrosion

**RUSTBUSTER LTD**  
**SPALDING ENGLAND**  
**01775 630 958**



SOLE UK IMPORTER & DISTRIBUTOR



2210 Silverstone Technology Park  
Silverstone Circuit, Northants NN12 8TN  
[www.modeperformance.co.uk](http://www.modeperformance.co.uk)  
[steve@modeperformance.co.uk](mailto:steve@modeperformance.co.uk)

Call 01327 855 999 for more details

## Champions of Safety

Award-winning  
Fire and Safety Solutions  
from the market leader



NOT ONLY FIRE EXTINGUISHERS BUT ALSO  
QUICK RELEASE STEERING BOSSSES • RAIN LIGHTS  
RACING MIRRORS • ROLL CAGE PADDING

Coventry UK  
Tel +44 (0)24 7671 2999

[www.lifeline-fire.co.uk](http://www.lifeline-fire.co.uk)



In a laboratory test a 100mm solid sphere of mild steel was heated to 1000°C. A sheet of Teknofibra "Contact" adhered to a 2mm piece of fibreglass to represent body work was put in direct contact with the 1000 degree heat source. The temperature of the sample bodywork protected with the Teknofibra heat resistant material PEAKED at 57°C !!

For more information about the range of Teknofibra please contact the Teknofibra UK distributor at Walkers Northallerton. North Yorkshire DL7 9HT Phone 0044 (0) 1609 777221 or email [info@walkersgarage.com](mailto:info@walkersgarage.com)



World Champion  
Electrical Connectors

Visit [www.deutsch.net](http://www.deutsch.net) for more information, a list of our worldwide distributors or to download a technical datasheet.  
Alternatively call +44 (0) 1424 852722 or email [autosport@deutsch.net](mailto:autosport@deutsch.net)



ECU/Exchange Loom/Throttle Body Packages available

## Complex modern engine? No problem

Our ECU's are capable of dealing with the most complex of modern engines without the need to change sensors or sacrifice key features such as variable camshafts.

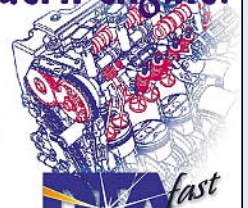

ECU solutions for:  
Honda S2000 and K20A  
Ford ST170 and Duratec  
Toyota ZZZ  
BMW Single  
BMW Twin VANOS  
Audi 1.8T and 5 cylinder  
Chevrolet LS7.



S series

Get the very best from  
any engine and from only £495.00 + VAT.

DTAfast, 10 Boston Court, Kansas Ave, Salford M50 2GN  
Tel: +44 (0)161 877 1419 Fax: +44 (0)161 877 7086  
Email: [office@dtafast.co.uk](mailto:office@dtafast.co.uk) Website: [www.dtafast.co.uk](http://www.dtafast.co.uk)

# TRAILERS & TRANSPORTERS



The ultimate in race transportation



New orders now being taken for 2012 season



[www.brooklandspeed.com](http://www.brooklandspeed.com)  
Vehicle sales: +44 (0) 1454 315522  
+44 (0) 7891 291562

## Shifting less Kilos, Costs less.

Improving efficiency takes many forms and we all depend on it to provide better for less into the future.

Brian James Trailers are designed with pure efficiency in use. And so they become lighter, stronger, more durable, offering market leading value, continuing the lineage for future generations of British Club Motorsport competitors.

### Clubman & Clubman Tilt-bed

The brand new Clubman range has new versions offering longer, wider bed space and more efficient loading. New high strength, light weight chassis manufactured using the latest CNC controlled machinery is easy to handle and operate.

Clubman models feature three hydraulic operation tilt-beds and ten loading ramp trailers. Something in the range for any Club motorsport competitor.



**Clubman - Tiltbed model 100-0510**  
 4.3 m (14ft) Long, 1.90m (6ft 3) wide  
 2000 Kg gross capacity  
 Range from £ 1,759 plus vat

### Motor Shuttle



### A-max range



### TT Tilt-bed range



**Race Shuttle RS5**

Visit the new Brian James Trailers web site at [www.brianjames.co.uk](http://www.brianjames.co.uk) for full pricing details of the product range and our extensive national dealer network.

Models shown may feature optional equipment

**BRIAN JAMES TRAILERS**

[www.brianjames.co.uk](http://www.brianjames.co.uk)

Tel. 01327 308833

ref.11/10

# TRAILERS & TRANSPORTERS



Call Us Now! tel. 01327 263 384

www.woodfordtrailers.com sales@woodfordtrailers.com



**RL 2000**  
£4,900 + vat



**RL 3000**  
£5,950 + vat

SPECIALISTS IN CAR SHIPPING  
AND TRANSPORTATION  
Worldwide export and import services



• Customs clearance • UK & European collection & delivery  
• SAFE • SECURE • COMPETITIVE  
t: 01394 695566 f: 01394 673031

www.rjjfreight.co.uk

kevin.lewis@rjjfreight.co.uk chinita@rjjfreight.co.uk Jeff.parslow@rjjfreight.co.uk



**Look Beyond**



optional colour finishes shown

PRG Trailers | Cheshire | UK | Tel: +44 (0) 1270 812402  
Web: www.prgtrailers.co.uk | Email: info@prgtrailers.co.uk

# RACE & RALLY CARS

## DRIVES AVAILABLE



**2012 BTCC DRIVE AVAILABLE  
BMW E90 TURBO**



THE UK'S FIRST COMPETITIVE BMW NGTC BRITISH TOURING CAR.  
SCHNITZER BUILT CAR SPECIFICALLY MODIFIED TO THE EXACT 2012 BTCC REGULATIONS. NO EXPENSE SPARED.  
CAR IS PREPARED AND READY FOR IMMEDIATE TESTING PROGRAM TO COMMENCE.  
Please contact Geoff Steel at [racing@gsteel.co.uk](mailto:racing@gsteel.co.uk) / 00441652 648429 for more details.  
[www.geoffsteelracing.co.uk](http://www.geoffsteelracing.co.uk)

## GINETTA

**Ginetta G22 S2000**



1978 Historic sports racing car. One of only two manufactured with a total rebuild in 2010/11. Connaught 2 Ltr Pinto, rebuilt Hewland Mk8. No expense spared, many new parts. Slicks/wets. Very rare quick pretty car. Test miles only.

**£19,950.00** ovno.  
Call **01202 761433** or  
for tech spec **07966 264876**

## HISTORIC RACING



TVR Grantura 1800 s. FIA spec, with 'proper' 1840cc engine, built regardless of cost to very high standards with Spa 6 Hrs in mind. Only done 3 races and finished 2nd in class each time, HTP papers, spare wheels and tyres, plus spares, £45,000 will consider P/X - see website.



MG 1100 saloon, well known car (Madge) prepared regardless of cost, and campaigned successfully by various different drivers, class podiums in last three outings, has to be the cheapest FIA/HTP car around at £8500, and eligible for many Europe wide events. Always attracts attention, and has her own following!  
[www.hewittsracing.co.uk](http://www.hewittsracing.co.uk)  
Mobile 07831104020 Eve 01782720422

## RACING IN THE USA!

WANT TO? BUT LOST ON A WAY TO DO IT?



Usf2000, Star Mazda, Indy Lights, Grand Am, Prototypes, Sports Cars, Pro Am, Single Make Racing,.....

Full Time Dedicated Agency Based In The USA Offering:

Advise And Management - Team And Formula Negotiations - Legal & Contracts - Accommodation And Fitness - Race Licence And Visa's

Why?

Real Prize Funds - Proper Attendance Figures For Sponsors- Proven Routes To Pro Racing - Road To Indy

Email: [motorsport-usa@hotmail.com](mailto:motorsport-usa@hotmail.com) Office: (001) 609 807 8421

**TO ADVERTISE IN  
THIS SECTION OF**

**AUTOSPORT**

**PLEASE CALL  
0208 267 5367**

## LOTUS

1997 Lotus XI Replica Called a ALBA Automotive. This a Very Rare Car Fitted With a RaceLine 2.0 Zetec 200 BHP on Throttle Bodies. Duck Egg Blue With Black Race Seats. Period Wheels With Toyo 888, 5 Speed Quaife Gear Box. Ford Live Axle. Twin Alloy Fuel Tanks. MOT July 2012. This is a Well Sorted Track or Road Car. Comes With Lots & Lots of Paper Work & Bills. **£24,995.** Tel: **07831 240733**  
[www.woodcotesportscars.com](http://www.woodcotesportscars.com)



## VEHICLES FOR SALE

CRS are selling their race stock to concentrate on manufacturing activities:

### CRS (ex BAR) Frasers Pop-Up Trailer

Built in 2002 for BAR F1, this Communications and storage truck has two levels. The upper-deck has a large office, kitchen area and separate workshop space, while the lower deck features more workshop space and externally there are many belly lockers providing extensive amounts of storage. With 2 large antennas reaching almost 60m and racking for radio repeater, this is ideal for radio communications set-up, Single car Formula team or Bike team. Sale price **£80,000**

#### Features include:

Large generator - Hydrovane compressor - 2x Compressed air antenna masts fitted - Oyster vision satellite system - Air conditioning throughout - Kitchen area with fridge, sink, microwave, and storage - Engineers office/ debrief room with TV, 2 monitors, under seat storage and cupboards - Rear top deck workshop, with storage and radio racking - Rear lower deck workshop with Lister style storage - Various sized external belly lockers, including bodywork storage.

#### Measurements:

Length: 15m /16.6 with tractor unit - Width: 2.6m - Height: 4m when travelling /5.8m inc. pop-up

### CRS Brookland Speed Race Trailer with Awning

Built in 2008 to CRS specification. Capacity to carry 4 cars or 2 cars and equipment, twin deck with storage above, and storage hatch to gain access once parked. Comes with 5 metre awning that is modular, and therefore can be used at its full length or increments per bays. Build cost new was **£245,000**, Offered at **£155,000**

#### Features include:

Generator - Air-conditioning throughout - Compressor - Kitchen area with fridge, freezer, washer, sink and TV - Overhead and bench lockers - 4x External rear belly lockers - Compressed air antenna mast fitted - Electronic keypad door entry - AV equipment to the drivers area - Data storm satellite system for data access - Pop out driver lounge.

#### Measurements:

Length: 16m / 17.5 with tractor unit - Width 2.6m / 4.4 with side pods open, each side pod 1m x Height: 4m.

### Ferrari F430 GT2 2010 Wide body Specification

Built by Michelotto, chassis 2618 Prepared to the highest standard and raced in 2010, 2011 LMS Championship. Fastest GT2 car around Spa-Francorchamps 2:19.402 (2010 LMS, FP3, A Kirkaldy). Step 7 Engine - Dynamics DSSV dampers.

Car is on the button as it finished on the podium at Estoril LMS.

Price **£190,000**

We also have a comprehensive stock of BBS wheels & car spares available upon request.

### Ferrari F430 GT2 2009 Specification

Built by Michelotto, chassis 2414, 2010 GT Open standard body specification.

Fully rebuilt early 2010, and used by the team in the International GT Open Championship.

Race winner at Spa during 2010

Price **£120,000**

We also have a comprehensive selection of spares available upon request.

### Formula Renault

2010 latest specification car with Capparo chassis, 2 litre engine.

A selection of 4 cars to choose from. The cars have only raced for 1 season.

Price **£37,000**

We also have a comprehensive stock of car spares, wheels and tyres available on request.

### Formula Master

Suitable for track learning, a selection of two 2009 specification cars, one with 3 races, one with 2 races. Ideal circuit learning cars for all categories.

Price **£30,000**

We also have some spare parts, gear ratios, 6 sets of wheels available on request.

Please contact:

Mark Busfield on +44 (0) 1530 830924 Email: [mark.busfield@crsracing.com](mailto:mark.busfield@crsracing.com)



FRASERS POP-UP TRAILER



CRS BROOKLAND TRAILER



2009 FERRARI F430 GT2



2010 FERRARI F430 GT2



2010 FORMULA RENAULT



FORMULA MASTER

# RACE & RALLY CARS

## MCLAREN



**1979 McLaren M28-2**

McLaren team car for John Watson & Patrick Tambay. Direct from McLaren to current owner. Expertly restored by ex-McLaren F1 chief mechanic Gary Anderson. Recent Historic Grand Prix winner at Mosport.

Race history includes:

- 1979 Argentine Grand Prix — 3<sup>rd</sup>
- 1979 Belgian Grand Prix — 6<sup>th</sup>

(+001) 858-459-3500 (USA)

www.grandprixclassics.com info@grandprixclassics.com

## PORSCHE

### 2008 Porsche 997 GT3 Cup



Call or email for further details  
graeme@mundy-building.com or 07768 256357

## NISSAN



**Nismo Competition / Sumo Power  
Nissan S15 Race Car**



### JRM Group / Sumo Power offer a unique opportunity to purchase one of its race cars

Nissan Silvia S15 race car, previously HKS works car (Japan) recently used for drifting events in Nismo livery (European Drift Championship winning car in 2011). Absolutely stunning condition, maintained as a JRM works car, no expense spared and can be used for race or drift competition with minor changes (setup only). 2.2 litre SR20DET engine with 430bhp ATW, 6 sp sequential gearbox (less than 100kms since rebuild at JRM), AP air-jacks, Endless brakes, RAYS wheels etc etc - extensive new and used spare parts and wheels package, ready to race in 2012. Eligible for various championships in UK/Europe/Middle East, very fast, reliable car with credible history and level of preparation that you would expect from JRM.

Price: £47,500 plus vat.

Contact: Andy Barnes, MD, JRM Group.  
+44 (0)1797 222281 or abarnes@jrm-group.com



## RACING CARS

### Why not Join Group C at Le Mans 2012?

**Spice SE90c, the Obermaier car, for Group C Revival.**  
Fresh 3.5 DFR Cosworth, Fresh 6 Speed Gear Box, New Crown Wheel, In Car Adjust Roll Bars. Some Spares: Nose, Exhaust and Wheels. The car had very little running in period and is in original condition.  
[http://en.wikipedia.org/wiki/Spice\\_Engineering](http://en.wikipedia.org/wiki/Spice_Engineering)

Price on Application

Ian Stinton - Tel: 07973 815 824 - Email: [Ian.Stinton@thesolution.co.uk](mailto:Ian.Stinton@thesolution.co.uk)



## RAGE

### FOR SALE

**AWESOME 2 SEAT ON ROAD/OFF ROAD RAGE WITH PRIVATE PLATE 'R200 AGE'.**  
Built November 2009 first road registered January 2010, only 830 miles and no track use.  
Kawasaki 1352cc (ZZR1400) engine, six speed sequential manual, circa 475kg.  
Extras include off road wheels, tyres and springs, extra child seat, fly off handbrake etc.  
0-60 circa 3.5 seconds & 120mph top speed.



Circa £36,000 new - will sell for £21,500  
For further information call Alasdair on 07887 781 298



**Alfa Romeo 156** Complete car ready to race with stack dash and logger, lot of spares.  
Price: 10,000.00 Euros



**Formula X** Complete race ready car can be single seater or sports car, 2000 duratec engine.  
Price: 20,000.00 Euros

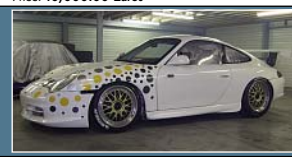

**Porsche 996GT3 Cup** Perfect condition. Engine and gearbox 0 hours. Price: 50,000.00 Euros



**Artic** Can take up to 4 cars, awning, tail lift, sleeping 4 persons. Price: 35,000.00 Euros

For any informations about the above items do not hesitates to contact John Svensson on +32 475 350538 or by Email: [info@johnracing.be](mailto:info@johnracing.be)

# MARKETPLACE

## AWNINGS

**E-Z UP® Instant Shelters**

**Grumpygrip Ltd**  
 Sales  
 Spares  
 Accessories  
 Custom Graphics

**Tel: 0800 055 6785**

E-Z UP® shelters since 1983  
 1.5m x 1.5m to 6.0m x 6.0m  
 Set up in 60 Seconds!  
 UK Next Day Delivery

[www.grumpygrip.co.uk](http://www.grumpygrip.co.uk)  
 Email: [info@grumpygrip.co.uk](mailto:info@grumpygrip.co.uk)

## FLOORING

**Kiwi Tiles**

Interlocking Plastic Floor Tiles, as used by leading race teams throughout Europe.

- ◆ Easy installation & removal
- ◆ Many colours
- ◆ Lightweight
- ◆ Strong & durable
- ◆ Self draining
- ◆ Compact & easy to store
- ◆ Top quality
- ◆ Value for money

Stock Colours:  
 Red, Blue, Green, Yellow,  
 Silver, Orange, Grey,  
 Black, White, Dayglo Red

Ralt Engineering  
 Tel: 01865 883354 Fax: 01865 883789  
 E-mail: [enquiries@kiwitiles.com](mailto:enquiries@kiwitiles.com)  
 Web: [www.kiwitiles.com](http://www.kiwitiles.com)

## BOOKS

**Paul Skilleter BOOKS**

[www.paulskilleterbooks.co.uk](http://www.paulskilleterbooks.co.uk)

**XJ13**  
 The definitive story of the Jaguar Le Mans car and the V12 engine that powered it

The story of the legendary one-off Le Mans prototype and its four cam V12 engine. Elegantly related by Peter Wilson (formerly of Jaguar's Competition Dept.) using first-hand accounts, period pictures and technical drawings including new revelations of GT40 and Lotus connections.

Price: £75, or £150 for a leather slip-cased limited edition.

We also publish: Norman Dewis of Jaguar, Mike Hawthorn Golden Boy, Ecurie Ecosse, A Passion for Speed, All About E-types etc.  
 e-mail [jagworld1@aol.com](mailto:jagworld1@aol.com) or phone 01425 612669

## GENERATORS

**Hyundai Generators**

Ideal for motorsport or home/office/business standby.  
 Don't be left in the dark this winter...

Tel: 01646 66 38 48  
[www.genpoweruk.co.uk](http://www.genpoweruk.co.uk)

## ENGINES

**Xtec ENGINEERING**  
 Championship winning engine rebuilding and preparation

Modern and Historic  
 Contact Paul Knapton  
 01922 454 858  
[paul@xtecengineering.com](mailto:paul@xtecengineering.com)

## MEMORABILIA

**F1 COLLECTORS .COM**

**#1 FOR F1 MEMORABILIA**  
 We buy and sell F1 items  
 AYRTON SENNA specialists  
 Call CHRIS GRINT 01763 274448  
 email: [sales@f1collectors.com](mailto:sales@f1collectors.com)

**JMJ Automobilia**  
 SUPPLIERS OF RACE MEMORIBILIA SINCE 1992  
 Florida, USA (609) 575-1143  
 email: [JM@JMJAUTO.COM](mailto:JM@JMJAUTO.COM)  
[WWW.JMJAUTO.COM](http://WWW.JMJAUTO.COM)

## INSURANCE



**Serious about car insurance**

With an [elephant.co.uk](http://elephant.co.uk) comprehensive policy you get loads of great features and benefits as standard.

Courtesy Car, £100,000 Legal Cover, 90 Days European Cover, up to £1,250 Stereo Cover, Windscreen Repair and Personal Injury Cover

**Plus!** you could even save yourself £150 just like the 14% of respondents who gave a best alternative price saved £150 (Dec '10 – May '11).

**elephant.co.uk** 0800 118 1644  
 Seriously good car insurance

WEB DIRECTORY

TRAILERS & TRANSPORTERS

RACE & RALLY CARS

MARKETPLACE

APPOINTMENTS

# MARKETPLACE

## MOTORSPORT EQUIPMENT



### MARDI GRAS MOTORSPORT

Saloon Car Preparation

Unit 45, Silverstone Circuit  
Towcester  
Northampton NN12 8TL

tel: 01327 858006 fax: 01327 858800  
email: info@mardigras.co.uk  
web: www.performanceclutch.co.uk

#### Distributors and agents for:



## MOTORSPORT WHEELS

FOR ALL YOUR



RACING TYRES  
Inc. ACB 10 Formula Ford  
Contact

### BMTR LTD

Tel: 0121 331 1122  
Fax: 0121 331 1144  
email: sales@bmtr.co.uk  
see our new web site at www.bmtr.co.uk

## NUMBER PLATES

### F1 VMM

Ultimate F1 number plate for  
Vodafone McLaren Mercedes

Ideal for Team, Fan, SLR or MP4-12C.  
Perfect Christmas Present!

Number plate held on retention. Sensible offer  
will secure. Call Ian: 07943 107107

## PARTS

### Lamborghini Gallardo 5.0L V10 engine for sale

Complete Engines available for sale in various configurations and options.

- Standard used long
- Rebuilt long using new components
- Race spec long using custom forged race connecting rods, forged pistons, balanced crank assembly, new valves and valve springs, ported heads and manifolds.
- Race spec as above, but complete including inlet manifolds, valve covers, oil pump, throttle bodies, exhaust manifolds, and water pump.

Prices from \$37,000.00 Australian

Contact Develo\_Pro for info  
matt@developro.com.au  
Ph +61 437 485 216



LAMBORGHINI & AUDI V10 DEVELOPMENTS



## PAINT



### Silverstone Paint Technology



- Lightweight motorsport paintwork
- Pattern block coating



- Composite repairs
- Airbrushing

[silverstonepaint.co.uk](http://silverstonepaint.co.uk)

01327 831577

[info@silverstonepaint.co.uk](mailto:info@silverstonepaint.co.uk)

# MARKETPLACE

## RACE PRODUCTS

### PORSCHESHOP

24-HR • WORLD-WIDE • PARTS-DIRECT

**SERVICES:** • RESTORATION • MAINTENANCE & DEVELOPMENT

• FULL CHASSIS-UP REBUILDS • TECHNICAL & DIAGNOSTIC

**PARTS:** • BOXSTER • CAYMAN • TURBO • HISTORIC

• 911 • 968 • 944 • GT3 • RSR • CUP-CAR



Call Adam or Kevin on: **0121 585 6088**

### TYRE BLANKETS

For Sale: 23 Sets of Ex-F1 Tyre Blankets.

Each Set includes: Control Box, 4 Discs and 4 Holdalls.

Completely Serviced and Ready to Race!

P.O.A.

Tel: 01604 859012 or 07801 859086

Circuit 2 Circuit

**+44 (0) 1604 859 012**  
Take advantage of our experience

## FREE NEW 2012 Motorsport Catalogue



Get Your Copy Now!

Calls to 0906 numbers cost 50p per minute at all times.  
(Calls should last no longer than 11/2 minutes).

**demon tweeks**  
MOTORSPORT *Direct*

**HAVE YOU GOT YOURS YET!**

[www.demon-tweeks.co.uk](http://www.demon-tweeks.co.uk) Tel: 0906 250 1516

## RACEWEAR

**Grand Prix Racewear**

DRIVEN BY PASSION

[www.gprdirect.com](http://www.gprdirect.com)

### New Product !

**BT-Q1000eX  
GPS Lap Timer**

GPR would like to introduce the new GPS lap timer from QSTARS

This is the latest GPS lap timer to hit the market, no messing around with wires, no complicated set-up just switch it on and go! Easy to use software supplied with each timer, Logs 5 times per second so you never miss a moment.

SOLE UK DISTRIBUTOR



**Tel: 01327 855585**

Unit 1 Silverstone Tech Park,  
Silverstone Circuit  
Towcester, NN12 8TN



## ARE DRY SUMP SYSTEMS



Mitsubishi EVO 8

Over 60  
Varieties  
Cast Alloy CNC  
Machined  
Dry Sumps &  
Systems



Toyota 4AGE



Subaru



Formula Ford 2000

"Products Engineered With A Passion"  
[www.DRYSUMP.com](http://www.DRYSUMP.com) 1.916.652.5282

## London Motorsport Showroom

[www.msar.co.uk](http://www.msar.co.uk)



**msar** UK agent for **SCHROTH RACING**  
ORDER HOTLINE: 020 8655 7877

WEB DIRECTORY

TRAILERS & TRANSPORTERS

RACE & RALLY CARS

MARKETPLACE

APPOINTMENTS

# AUTOSPORT

## APPOINTMENTS

**PUBLICATION DATE EVERY THURSDAY**

**CALL 020 8267 5820**

FOR ALL AVAILABLE VACANCIES PLEASE GO TO THE JOBS SECTION OF AUTOSPORT.COM

**BOOKING DEADLINE** MIDDAY MONDAY PRIOR TO PUBLICATION  
**COPY DEADLINE** MONDAY 5PM PRIOR TO PUBLICATION  
 ALL ADVERTS PLACED FEATURE IN THE APPOINTMENTS SECTION OF AUTOSPORT.COM FOR ONE WEEK

**RACHEL.BROCK@HAYMARKET.COM**

autosport.ads@haymarket.com

### Tekdata interconnect systems

#### Wiring Harness Technicians

Tekdata Interconnections have received an unprecedented demand in their Autosport division and require Wiring Harness Technicians to work at their 40,000sq.ft facility in Staffordshire.

The role will involve the manufacture of 'standard round' and Tekdata's innovative 'Flatloom' electrical wiring harness assemblies to very short lead times whilst also meeting our very high production standards. The ability to be flexible with working hours is a necessity to meet customer demand.

Candidates will be able to work to circuit diagrams and have a knowledge of contra-helically manufacturing System 25 harnesses for a variety of Autosport applications including Formula One, WRC, LMP, GT Sports cars etc.

Tekdata exclusive technology manufacturing training will be provided and candidates will also have the opportunity to manufacture assemblies within our Aerospace and Cryoconnect Space divisions.

To apply for these positions, please send your CV and covering letter detailing why you feel you would be suitable for this position to michael.tickner@tekdata-interconnect.com

*Tekdata Interconnections Limited is an equal opportunities employer*

**Tekdata Interconnections Limited, Innovation House, Festival Way, Etruria, Stoke-on-Trent. ST1 5SQ  
 Tel: 01782 254700 www.tekdata-interconnect.com www.connecting-autosport.com**

### AUTOSPORT

**LOOKING TO RECRUIT FOR 2011?  
 THE LATEST SELECTION OF MOTORSPORT JOB  
 VACANCIES UPDATED EVERY WEEK.**

- The appointment page of the website receives on average 200,000 page impressions per month
- The magazine you are looking at has a readership of 139,000 (Source: NRS Survey Q3)
- All appointment adverts placed in Autosport magazine are listed on the website.

Company	Job Title	Application Deadline
Lotus Renault GP	R&D Engineer - Ref:LRGP_RB07	1 December 2011
Red Bull Technology	COMPOSITE DESIGN ENGINEER	1 December 2011
Roush Fenway	Lead Aerodynamicist	1 December 2011
Swinson Engines	Design Engineer	1 December 2011
Team Lotus	No.1 & No.2 Race Mechanics	1 December 2011
Toyota Racing Development	Trackside Support Engineer	1 December 2011
Williams F1	Garage Technician & Toolpath Programmer, Machine Shop	1 December 2011

**WHERE ARE YOU ADVERTISING YOUR MOTORSPORT JOB VACANCIES?**



## COME AND WORK WITH THE WORLD CHAMPIONS!

With our recent success there has never been a more exciting time to join our team.

### HR842 - AERODYNAMICS PERFORMANCE ENGINEER

An opportunity exists within our Aerodynamics Performance Group for an Aerodynamics Performance Engineer.

The successful candidate should have a very strong knowledge in Matlab 7 and will play an instrumental role in the development of the group's tools as well as developing new techniques and new methods for understanding car behaviour.

The successful candidate should have an Engineering/Mathematical background with preferably some experience in mathematical modelling.

To apply for the above role please send or email a covering letter and your CV, quoting the relevant reference number, where you have seen the role advertised and your current remuneration details to:

**Email:** recruitment@redbullracing.com

**Address:** Human Resources, Red Bull Technology Ltd, Building 1, Bradbourne Drive, Tilbrook, Milton Keynes, MK7 8BJ

**CLOSING DATE FOR APPLICATIONS - 15TH DECEMBER 2011**

PLEASE NOTE: Red Bull Technology does not accept any unsolicited resumes from personnel agencies. Red Bull Technology is not responsible for any fees related to unsolicited resumes.

If you are interested in applying for this role, you will need a valid work permit or have the right to live and work in the United Kingdom.



### MERCEDES GP PETRONAS FORMULA ONE TEAM



MERCEDES GP PETRONAS Formula One Team has a true passion for motor racing excellence. As one of the leading F1 teams, we are looking for the following individuals to actively contribute to achieving the Team's goals:

COMPOSITE FITTERS (VARIOUS SHIFTS)	REF: 2997
COMPOSITE LAMINATORS (VARIOUS SHIFTS)	REF: 2998
KIT CUTTER (VARIOUS SHIFTS)	REF: 6532
AUTOCLAVE OPERATOR (VARIOUS SHIFTS)	REF: 6531
CMM & MANUAL INSPECTOR (WEEKEND SHIFT)	REF: 1063

Flexibility in hours and approach is required, along with a 'can do', 'team playing' attitude with the ability to work under minimal supervision to strict deadlines in an extremely high pressure environment.

In return for your work and commitment, we offer a competitive package including bonus, life assurance, private medical cover, car lease scheme, 25 days holiday, on-site gym, subsidised restaurant facilities together with the chance to work in a truly unique environment.

For full details on these vacancies please visit the recruitment page on our website: [www.mercedes-gp.com](http://www.mercedes-gp.com)

To apply for any of these positions please email your CV, letter of application and current remuneration details, quoting the job title and relevant job reference number of the vacancy to: [recruitment@mercedes-gp.com](mailto:recruitment@mercedes-gp.com)

Closing date: 16th December 2011.

NO AGENCIES PLEASE

[www.mercedes-gp.com](http://www.mercedes-gp.com)



## Aerodynamics DO Manager

**REF: LRGP-AER84**

We have an exciting new position within the Aerodynamics department, managing the activities of the Design Office. This is an important role, with a number of high level responsibilities:

- Managing overall department planning to ensure successful delivery of parts for the wind tunnel testing program.
- Developing systems and tools to allow all groups within the department to plan effectively.
- Managing large scale projects including major upgrades.
- Liaison with full size production to ensure agreed delivery of Aerodynamic car definition.
- Developing communication through project life cycles to ensure efficient tunnel testing.

The successful candidate will have a proven track record of effective planning and management. They will be self-driven with a positive outlook, and will be able to develop good working relationships to achieve the goals of the team.

Experience within F1 or a similar motorsport environment is expected, as well as a minimum qualification of a HND/degree level (or equivalent) in a mechanical engineering discipline.

## Graduate Aerodynamics Modelling and Software Engineer

**Ref: LRGP-AER83**

A new position has developed for a graduate engineer to join our Aerodynamics Team. The position will involve the following:

- Develop and utilise software to analyse aerodynamic data from track data at tests and races.
- Develop and utilise software to model the aerodynamics of the car in our in-house simulator.
- Developing wind tunnel software to analyse data from our 60% model. This will also involve developing and utilising methodology for wind tunnel map creation.

The successful candidate must have the following skills:

- A good grasp of Matlab and preferably Simulink
- A natural ability for software programming
- Excellent mathematical knowledge and ability
- Excellent engineering skills, preferably with aerodynamic/fluids knowledge
- Self motivated and able to develop ideas and concepts independently once given a brief.

This position is an ideal place for a recent graduate to develop their engineering skills in a fast moving and competitive environment.

Candidates for the above positions will need to be self motivated, capable of working with minimal supervision to tight deadlines, and be confident in communicating in a team environment.

Please apply in writing with current CV, salary expectations, details of your notice period and quoting job reference number to:

**Human Resources**  
**Lotus Renault GP Ltd**  
**Enstone**  
**Oxfordshire OX7 4EE**

Email [hr@lotusrenaultgp.com](mailto:hr@lotusrenaultgp.com)

Closing date **15<sup>th</sup> December 2011**



The Secretary General for Sport in Geneva is seeking to fill the position of :

## SPORTING COORDINATOR

The successful candidate will be in charge of the management of the secretariat of sporting commissions which involves planning meetings (Commissions, Committees, Working Groups...) and preparing agendas, preparing proposals for the World Motor Sport Council, writing material for publication and taking part in studies on the evolution of the disciplines concerned.

She or he will also be responsible for the monitoring of several championships, monitoring the calendars and the budgets for the championships, appointing the officials and coordinating their missions and coordinating and communicating with the National Sporting Authorities and Promoters.

Relevant experience in motor sport and if possible in administration of motor sport activities is essential.

Occasional travel to participate in meeting might be required.  
Native level in English, good knowledge of French is strongly desirable.

You are a positive person who is precise and flexible, able to adapt, and your versatility and capacity to cope with stress enable you to carry out to the very best of your ability, and within the deadlines, all the tasks that you have been given.  
You perform your duties meticulously and are skilled in organising and prioritising.  
Please apply by email : [recruitment@fia.com](mailto:recruitment@fia.com)

For more details or for apply to another position, please consult our website : [www.fia.com](http://www.fia.com)



## MERCEDES GP PETRONAS FORMULA ONE TEAM



MERCEDES GP PETRONAS Formula One Team has a true passion for motor racing excellence. As one of the leading F1 teams, we are looking for the following individuals to actively contribute to achieving the Team's goals:

<b>SENIOR MECHANICAL DESIGNER</b>	REF: 1094
<b>MECHANICAL DESIGN ENGINEER</b>	REF: 1096
<b>COMPOSITE &amp; MECHANICAL DESIGN ENGINEER</b>	REF: 1057
<b>REAL TIME CONTROL SYSTEMS ENGINEER</b>	REF: 1101

Flexibility in hours and approach is required, along with a 'can do', 'team playing' attitude with the ability to work under minimal supervision to strict deadlines in an extremely high pressure environment.

In return for your work and commitment, we offer a competitive package including bonus, life assurance, private medical cover, car lease scheme, 25 days holiday, on-site gym, subsidised restaurant facilities together with the chance to work in a truly unique environment.

For full details on these vacancies please visit the recruitment page on our website: [www.mercedes-gp.com](http://www.mercedes-gp.com)

To apply for any of these positions please email your CV, letter of application and current remuneration details, quoting the job title and relevant job reference number of the vacancy to: [recruitment@mercedes-gp.com](mailto:recruitment@mercedes-gp.com)

Closing date: 16th December 2011.

NO AGENCIES PLEASE

[www.mercedes-gp.com](http://www.mercedes-gp.com)

## GRAND PRIX CHRISTMAS CARDS



Reproduced from original paintings by

**MICHAEL JURNER**

Highlights of the 2011 Grand Prix season are captured in this set of five cards and envelopes, containing one each of the following subjects -

Sebastian Vettel - Red Bull - Italian G.P.  
 Jenson Button - McLaren - Canadian G.P.  
 Fernando Alonso - Ferrari - British G.P.  
 Paul Di Resta - Force India - Singapore G.P.  
 Kamui Kobayashi - Sauber - Monaco G.P.

Card size 187 x 124mm  
**£6.50 per set** (plus p&p) Product code **CMS-2011**

Available with or without Christmas Greeting

### HOW TO ORDER

By Phone, Fax, Post or On-Line, giving full details of your requirements. We accept payment by cheque (payable to Studio 88 Ltd.), Mastercard, Visa, or Maestro/Switch. Overseas payments by credit/debit card only.

### POSTAL CHARGES

Orders of £17 or under -  
 UK £2, Europe £5, Rest of the World £5.50  
 Orders over £17 -  
 UK £4, Europe £7, Rest of the World £8.50

[www.studio88.co.uk](http://www.studio88.co.uk)



### PRINTS

'BRILLIANT BUTTON', showing Jenson Button's inspired win in Canada, is also available as a print, size 53 x 43cm (21" x 17") £28 (plus p&p) Product code BB-28

Visit the Studio 88 website or ask for a copy of our **FREE COLOUR CATALOGUE** for details of our complete range.

**Studio 88**  
LIMITED

P.O. Box 568, Aylesbury,  
 Bucks. HP17 8ZX

01296 338504



# CLUB100

**SIMPLY, 2-STROKE KARTING AT IT'S BEST...**

With over 15 years of growth, development and race management experience, **CLUB100** boasts an unrivalled status.

**"The highest level of 2-stroke 'arrive & drive' championship kart racing in the UK and Europe."**

**CLUB100** has brought powerful arrive-and-drive karting within reach of everyone. Whichever of our 2-stroke events you choose - Test Days, Sprint or Endurance, all the karts are prepared to an identical standard.

For more information on our various formats, circuits we visit and all of our upcoming events visit our website.

**CLUB100** Racing Limited

Bon Accord House, Castle Road, Eurolink Commercial Park, Sittingbourne, Kent ME10 3SJ

Tel: +44 (0)1795 422455 Fax: +44 (0)1795 427606 Email: [racing@club100.co.uk](mailto:racing@club100.co.uk)

[www.CLUB100.co.uk](http://www.CLUB100.co.uk)

# BOOK YOUR AD

## DON'T MISS OUT

To book your ad into the 2012 Directory, email:  
[leanne.foley@haymarket.com](mailto:leanne.foley@haymarket.com)

To update your entry, email  
[asdir@haymarket.com](mailto:asdir@haymarket.com)

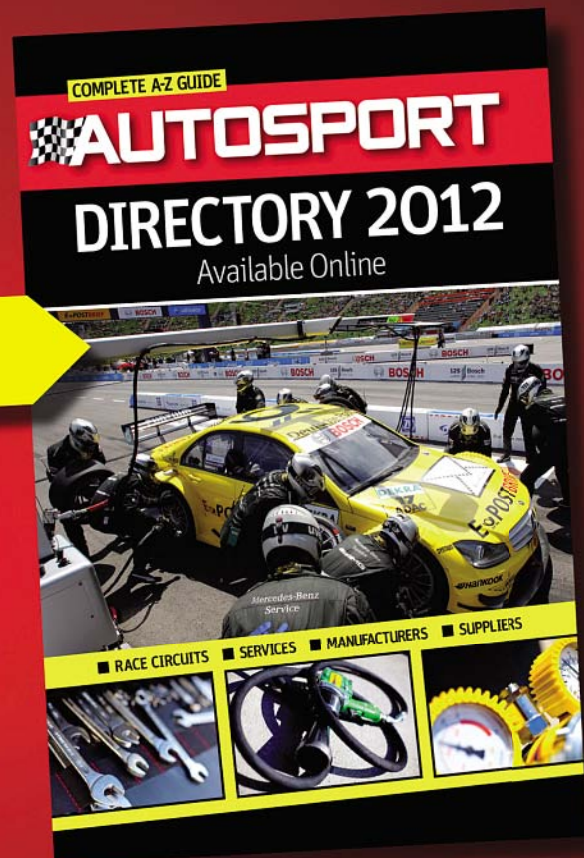

or call on **+44 (0)20 8267 5836**

# Sports Extra

NATIONAL RACING • HISTORICS • CLUB • RALLY • RALLYCROSS • HILLCLIMB

## Graham Hill Bend revamp

Brands Hatch owner plots future circuit mods to promote overtaking

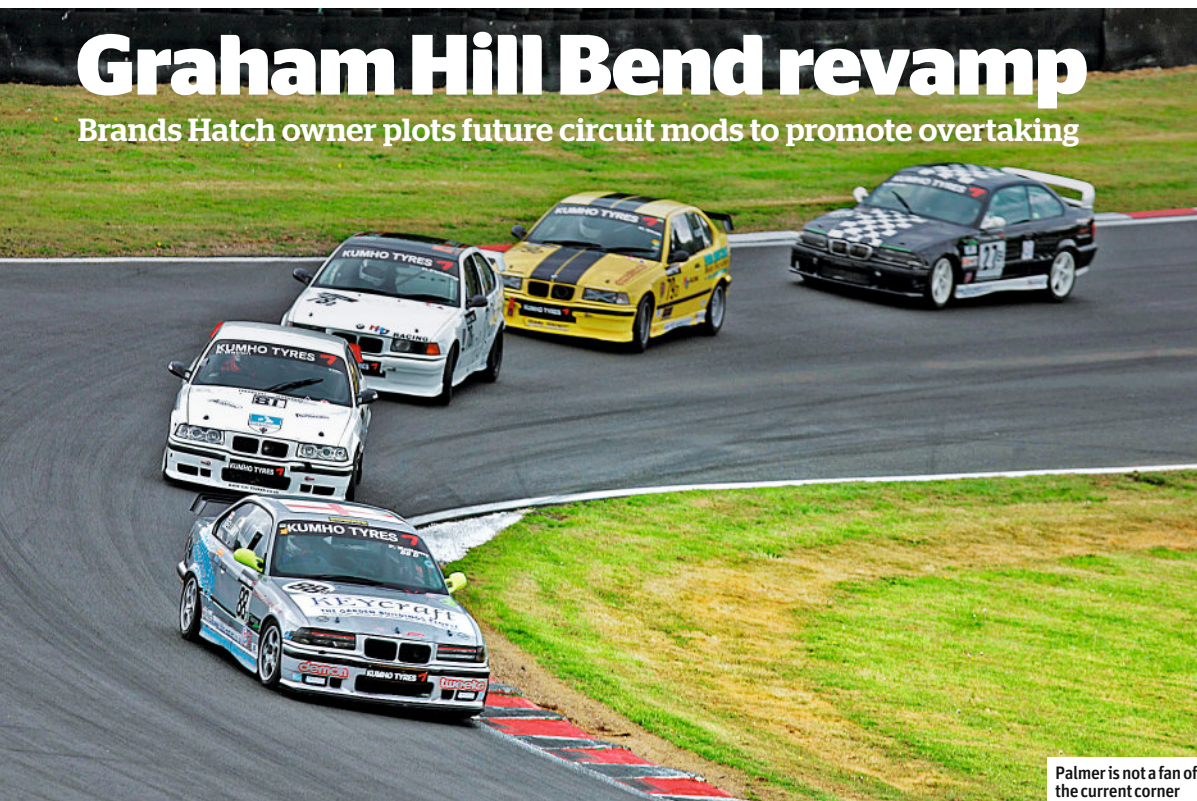

Palmer is not a fan of the current corner

» **GRAHAM HILL BEND AT** Brands Hatch will undergo a major revision in the next 18 months in an attempt to spice up racing on the Kent venue's Indy Circuit.

Jonathan Palmer, whose MotorSport Vision organisation owns Brands, has decided that the configuration in place since 1999 needs a revamp to create an overtaking spot. MSV has already lodged a planning application for a change, but is unlikely to revise the left-hander until the winter of 2012/13.

Palmer said: "MSV is intending to modify Graham Hill Bend and will do so some time in the next 18 months. That's definite.

"All the corners at Brands are classics, with the exception of Graham Hill Bend. It has been modified several times over the years, and I am not a fan of the current configuration."

Palmer explained that the motivation for the change is to increase overtaking opportunities at Brands.

"At the moment, the corner is neither fast enough to be a high-speed challenge or slow enough to be a genuine overtaking spot," he said. "We want to maximise overtaking on the Indy Circuit, which will obviously affect the Grand Prix Circuit as well, and make it better for both spectators and competitors."

Brands specialist Robbie Kerr, a race

winner at the circuit in A1GP, Formula 3, Formula Renault and Formula Palmer Audi, said: "I've always thought of Graham Hill as a bit of a nothing corner. It is difficult to get inside someone if you are racing cleanly and a good exit only turns Surtees into an overtaking spot if you are on the Grand Prix Circuit.

"It's good that the Brands people are having a close look at the corner, and it will be interesting to see what they come up with."

Palmer explained that the plans lodged with the local authority's planning department are unlikely to be definitive.

"It is important that we get it right, so we are giving ourselves time to mull over what we are going to do," he added. "That's why we are probably going to wait until next winter."

Palmer would not discuss the details of the likely revisions, but he hinted that the left-hand kink on the short straight between the Druids hairpin and Graham Hill would be removed.

The current layout of Graham Hill Bend has been in place since the start of the 1999 season. The more flowing configuration that preceded it was replaced to make the corner safer for motorcycle racing.

The corner was originally called Bottom Bend and was re-christened after two-time Formula 1 world champion Hill when Brands underwent a major overhaul prior to the start of the 1976 season.

### AUTOSPORT SAYS...

**BEN ANDERSON**  
NATIONAL  
EDITOR

ben.anderson  
@haymarket.com



**SO, THE WINDS OF CHANGE ARE** coming. For the first time in more than a decade, the profile of Graham Hill Bend at Brands Hatch is to alter.

I watched my old man race on the former, faster layout - a more sweeping left-hander that allowed drivers to carry more speed onto the Cooper Straight and made Surtees a real voyage into the unknown.

I've only raced on the current configuration, which I generally find enjoyable. Overtaking is difficult though - especially now there is mesh covering the grassy run-off on the exit, which makes it possible to stay nailed on the throttle with all four wheels off the circuit.

My recent battle with former touring car racer Eugene O'Brien at the Vee Festival proved as much, with O'Brien able to hold the outside line while under attack, go off the circuit, and yet not lose much speed on the run up to Surtees.

Plans for the first major revision to Graham Hill since 1999 are still at a formative stage, but circuit owner Jonathan Palmer is not a fan of its current form and hopes to promote overtaking by slowing it further.

The safety considerations that underlie the way Graham Hill is now militate against the possibility of going back to a faster corner, which is what most racers would probably prefer, but the short run from Druids may also limit the potential of a slower profile to create more passes.

But I'm getting ahead of myself here. JP has sensibly given himself a year to mull over the options before committing to a shift. But it is coming. So let's hope it turns out to be a change for the better.

### Extra contact details

**Kevin Turner**, features editor  
kevin.turner@haymarket.com



Faster former profile lasted until 1999

## CONTENTS

**p86** SEASON REVIEW  
GINETTA GT SUPERCUP

**p87** SEASON REVIEW  
GINETTA JUNIORS



Formula 4

# Latest Juno set to join Formula 4

British sportscar and Formula Ford builder adapts Duratec design for 750 Motor Club category

**BRITISH CONSTRUCTOR**  
 Juno is looking to expand into slicks-and-wings single-seaters after testing a Formula 4-specification machine last week.

Juno, which has campaigned cars in the SPEED EuroSeries and British Formula Ford in recent years, ran one of its Duratec-engined Formula Fords with wings and a sportscar diffuser at Donington Park last Thursday.

The car was tested by the experienced Lee Cunningham, who has driven Juno's sportscars and competes in the 750 Motor Club's F4 championship, in back-to-back runs with Edgington Racing's category-spec Van Diemen.

Juno boss Ewan Baldry confirmed he is looking at producing a number of examples. "With Formula Ford rules changing I was looking for other avenues for the car," he said. "It was Edgington's

suggestion to look at it and the likelihood is that they will look after it in F4. We want to market it in F4 and Monoposto."

Although the car ran on SPEED rubber and was powered by a different engine to the Van Diemen, Baldry was happy with its first run.

"It's hard to draw conclusions, but we were 1.4 seconds quicker and there must be quite a bit to come so we're pleased," he added.

Baldry confirmed he was considering running Duratec cars in British Formula Ford's secondary class in 2012, but building a new EcoBoost-engined model was unlikely. "We'll keep an eye on it, but we can't afford to start a new car from scratch at the moment," he said.

SPEED frontrunner Darren Burke has already been confirmed for Juno's 2012 sportscar attack, and will be joined by gentleman driver Duncan Williams.

## Castle Combe FF1600

### Ward to race new Spectrum

**CASTLE COMBE FORMULA FORD** frontrunner Nathan Ward hopes to graduate to the top class of the circuit's resident championship, after testing a Kevin Mills Racing Spectrum at Silverstone recently.

Motorsport engineering student Ward, 22, finished fifth overall and second in Class B of Castle Combe FF1600 for the second season in a row this year, driving a Swift SC95K.

Ward now hopes to raise sufficient backing to drive for KMR in the top class of the series (for newer Kent-engined cars), after setting competitive lap times in a car similar to that used by

Adrian Campfield to win the recent Walter Hayes Trophy for KMR.

KMR boss Kevin Mills, who also plans to run Combe regulars Roger Orgee Jr, Nick Jones and Steven Jensen again next season, said: "I've had my eye on Nathan all year as he's been very fast in the Castle Combe championship -

pushing hard against the Class A leaders in an older class B car.

"He was straight on the pace. If he gets the last bit of finance he will be a championship contender for 2012."

Ward added: "The team has offered to build me a new car for 2012 so now the race is on to find sponsorship."



Ward (leading) has shone in old Swift

## British GT

### Nurburgring 24 slot for Brit GT

**NEXT YEAR'S BRITISH GT** championship will support the Nurburgring 24 Hours.

British GT will join the bill for the 2012 edition of the classic, twice-round-the-clock endurance, but will race on the Grand Prix circuit rather than the legendary Nordschleife.

The event will be round two of next year's championship, on May 17-19, while the following round at Rockingham has now been pushed back from its original late-May date to the weekend of June 9-10.

EVERY type of insurance that ANY person involved in Motorsport may require

**MIS** MOTORSPORT  
INSURANCE  
SERVICES

ON EVENT - PERSONAL ACCIDENT -  
MOTORTRADE - COMMERCIAL - LIABILITY

www.rallyinsurance.co.uk or call 01943 884555

Motorsport Insurance Services Limited is Authorised and Regulated by the Financial Services Authority

HRDC

## Fledgling historic club to run new series and its own events in 2012

### THE HISTORIC RACING DRIVERS

Club will introduce another new series and run its own meetings in 2012.

The HRDC kicked off with Grand Touring Greats and Touring Car Greats at the start of this season and has since added TC63 Touring Car Greats. The club recently announced an MGB50 series to celebrate the Golden Jubilee of the MGB in 2012, and has now launched GTS65.

Catering for pre-1966 GTs of over 1500cc, running to Appendix K specification, the new initiative will have

races at Castle Combe, Donington Park and Mallory Park.

Club supremo Julius Thurgood does not believe it will hurt the Masters Gentleman Drivers series, which also runs races for pre-'66 GTs.

"I don't think we'll impinge on them at all," he said. "They're doing very well, but there seem to be a load of people who don't race with them and have cars. We've got customers already racing with us who have eligible cars."

The HRDC will join forces with the BRSCC to run meetings at Donington Park, Mallory and Lydden.

"We've got too much content to go on other people's meetings and if we are taking on our own race days we have to fill them," added Thurgood.



Early 1960s GTs will have more races

### Pearson tries out Porsche 936 at Donington Park

Historic racer Gary Pearson tested this 1977 Le Mans 24 Hours winner (in 1981 LM livery), ahead of a likely Le Mans Classic appearance in 2012.

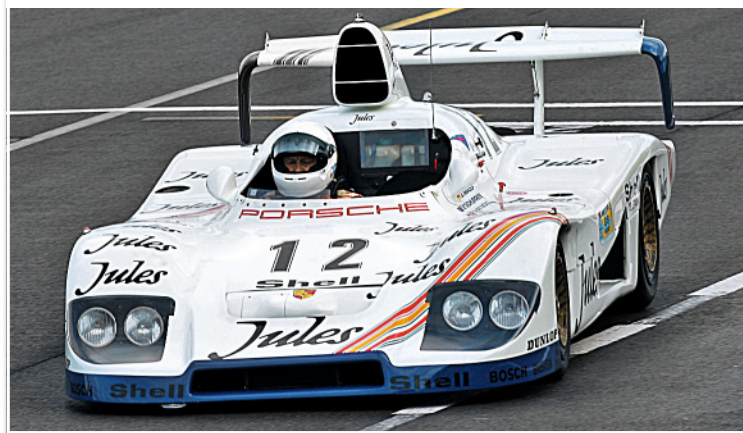

Porsche Carrera Cup

## O'Brien targets sportscar switch

### FORMULA VEE RACER

Fraser O'Brien plans to graduate to the Porsche Carrera Cup GB next season with leading squad Redline Racing.

The car racing rookie scored a win and finished 11th in 750 Motor Club Formula Vee this season. His proposed 2012 campaign will include the Porsche GT3 Cup Challenge Middle East.

The Welshman, 17, who has backing from the Welsh business community, tested his new mount for the first

time at Donington Park last Thursday, with reigning Carrera Cup GB champion James Sutton on hand to advise.

O'Brien said: "We thought about [continuing in] single-seaters and spoke to Fortec and Manor about

Formula Renault, but I want to become a professional driver in sportscars and we decided that there would be more publicity from Porsches.

"The test went well. I had a few moments, but enjoyed it."



O'Brien is moving away from FVee

## MARCUS PYE

# HUMBLE PYE

The voice of club motor racing



Palmer drove FW08C in 1983 European GP

Saturday's outstanding Historic Sports Car Club awards dinner at Whittlebury Hall, near Silverstone, attracted a record attendance of 260 - equivalent to a quarter of its unprecedented membership. They saw passions rewarded, as top racers from its dozen championships and series were lauded by their peers.

From Donington in March to Silverstone's National Circuit in October, the HSCC hordes visited Cadwell Park, Silverstone's GP track, Snetterton's new 300, both Brands Hatch layouts, Croft and Oulton Park on the home front. Plus Hockenheim, Monza, Nurburgring and Dijon for continental players.

Guest of honour was MotorSport Vision CEO Jonathan Palmer, whose love of club racing is reflected in the depth of events across his group's venues. He acknowledged that the HSCC - under Grahame White, a friend since Richard Lloyd's Canon Porsche team days in the 1980s - has become a major customer. In fact it enjoyed 14 MSV circuit days this year, delighting in their facilities and customer service.

Jonathan spoke entertainingly about his early racing exploits as a penniless teenaged medical student in Modsports 'frog-eye' Sprite, then Marcos 3-litre in the mid-'70s - I remember them well - and his hand-to-mouth graduation to FF1600. His driving ability, dogged determination and persuasive powers propelled him to

Formula 1 via British F3 and European F2 titles.

Twenty-one years after his F1 debut at Brands Hatch in '83, JP took control of its then loss-making circuit group following Octagon's faceless era. But it is no surprise that he invited Williams, whose FW08C he raced in that European GP breakthrough, to mastermind the car that brought F2 back in 2009, a quarter of a century after it was stifled by Bernie Ecclestone's F3000. Loyalty clearly means a lot.

As a promoter, Jonathan had proven the cost-effective, centrally-run, single-make championship model (pioneered by US race school guru Skip Barber from 1986 with Saab-powered Mondiales) on a grand scale with his Formula Palmer Audi initiative from '98, yet he recalls multi-marque single-seater racing's heights with a special fondness.

Indeed, entrepreneurial businessman JP remains well grounded in all aspects of motorsport, as he must with his commercial base. Amid his high-pressure helicopter-hopping lifestyle, he drove a bunch of historic racing cars on a recent Snetterton test day and loved every second. Now he can't wait to drive his beloved (and newly-restored by West Surrey Racing) Ralt RT3 - which is eligible for an expanded Classic F3 championship from 2012.

Jonathan spoke entertainingly about his early exploits as a penniless teenaged medical student"

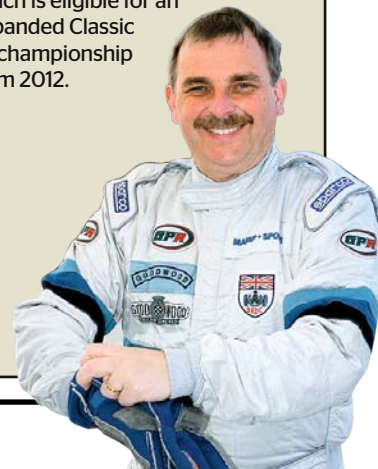

**AUTOSPORT**

**CEBE**  
PURE PERFORMANCE



**SAVE 21%**  
ON THE  
COVER PRICE

# FREE CEBE SPIDER SUNGLASSES

**WHEN YOU SUBSCRIBE TO AUTOSPORT**

**JUST**  
~~£3.30~~  
**£2.61**  
**PER**  
**ISSUE**



## 5 GREAT REASONS TO SUBSCRIBE:

- **FREE** pair of Cebe Spider sunglasses worth £50
- **Spread the cost** with easy direct debit instalments
- **SAVE 21%** - pay just £33.95 every 13 issues
- **FREE P&P** - every issue direct to your door
- **PLUS** - all AUTOSPORT subscribers get a **FREE AUTOSPORT digital edition** subscription AND unlimited access to AUTOSPORT.com (worth £158)

Subscribe online at:

themagazineshop.com

**www.themagazineshop.com/ASPO/M1211P**

Or call our hotline and quote offer code M1211P:



+



+

**FREE**  
DELIVERY

# 08448 488 817

Offer closes January 5, 2012. Please have your bank details ready

Terms and conditions: This is a direct debit offer open to readers in the UK only. Overseas rates are available by calling +44 (0) 1795 592 974 or for US rates call +1 866 978 1446. Offer closes on January 5, 2012. Direct debit prices are valid for one year, after which they are subject to change. Should prices change you will be informed in writing. Please allow 35 days for delivery of your first issue and gift. Gift will be sent under separate cover. Should we run out of gifts you will be offered an alternative - there is no cash alternative.

## IN BRIEF



Pittard impressed

**SPORTS 2000 RACER DAVID**

Pittard tested a Formula Renault UK car with Manor Competition on Silverstone's Stowe circuit last week, as his prize for finishing third in the recent Henry Surtees Trophy kart race at Buckmore Park. Team boss Tony Shaw described Pittard's performance as "astounding".

**CLUB F3 IS SET TO REGAIN**

championship status next season. The governing body the MSA has granted outline approval for the MSV F3 Cup to become a championship in 2012 - one year after MotorSport Vision Racing took over the running of the category from the British Racing and Sports Car Club.

**BRITON NICK PADMORE AND**

co-driver Jean-Lou Rihon slumped to third in the recent French VdeV title decider at Estoril. A catalogue of delays and issues meant the Norma pair could only finish seventh, while second-placed duo Philippe Mondolot and David Zollinger took the title.

**STOCK HATCH RACER RORY**

Cooper plans to switch to the Ginetta Challenge for 2012. The Sussex-based racer, who finished sixth in the 750MC championship this year in his Saxo, will test a Collards G40 shortly.

**EX-BRITISH F3000, TVR TUSCAN**

driver and Glebe gearbox boss Nick Cresswell is planning to return to racing next season with a Caterham R400. "I tried the car at Donington for the first time. It's got a Hellier 1800cc engine and [it's] doing the North West Sports/Saloons again," he said.

**LOTUS CORTINA TIN-TOP RACER**

and veteran engine builder Neil Brown has won the HSCC's Opposite Lock Trophy for best novice of 2011.

**STEFANO ROSINA GAVE HIS**

ex-Chris Craft Ecurie Evergreen McLaren M8C a run at Donington Park last week, with former driver Craft in attendance.



Rosina tested McLaren



Carter's Radical fought Winstanley Porsche 993

## BRSCC

# Short claims Baxter Trophy

Formula Fordster tops final Anglesey races of 2011 in memory of fallen racer

**MARTIN SHORT WON THE FIRST**

Bernard Baxter Memorial Trophy for Formula Ford 1600, as the BRSCC rounded out its 2011 season with a low-key winter race meeting at Anglesey last weekend.

Short's Van Diemen RFOO comfortably out-qualified the 13-car field on the International layout. He dominated race one, eventually winning by more than five seconds from Jamie Jardine's newer Ray GR11.

David McArthur (Van Diemen DPO8) recovered from an early spin to beat John Farrell (Reynard 89FF) and Daniel Headlam (Van Diemen) to the final podium spot.

Historic ace Simon Hadfield was also

involved in this fight, but he retired his Van Diemen RF85 on the final lap with steering issues.

With his car repaired, Hadfield finished a lonely fifth in the sequel. Short again led from start to finish, but only just held off a charging McArthur, who crossed the line less than a tenth adrift. Jardine and Farrell were well detached in third and fourth.

Local racer Paul Hodgson (Chevron GR8) won the 45-minute winter enduro by a lap, after the Porsche 993 of brothers Brett and Danny Winstanley broke its gearbox shortly before half-distance.

Brett had earlier claimed victory in the first of the well-supported Sports/

Saloons races, after beating Doug Carter's overheating Radical PR6.

Having finished fifth in that race, behind Cam Forbes' Westfield and James McAllister's BMW M3, novice Joe Spencer starred in race two.

He carried his father's Stuart Taylor Locosaki to the bottom step of the podium after a great fight with CNC Heads Sports/Saloons ace Cam Forbes. With Winstanley's broken Porsche and McAllister's BMW both absent, Carter's Radical won this one at a canter.

A trio of Irish Global Lights races all featured small grids but close finishes. Peter Drennan, Ivor Miller and Mark Twomey shared the wins, after a series of seesawing battles.

## Lotus Cup UK

## Lotus Cup UK set to split grids

**THE LOTUS CUP UK WILL BE split into two championships next year ahead of a plan to run separate grids in 2013.**

The Lotus on Track Racing Drivers Club, which also runs the successful Elise Trophy, launched Lotus Cup UK in 2011, based on its Lotus Cup Europe category.

An average of around 40 starters competed in the eight-round series and now the LoTRDC has decided to split it into the Lotus Cup UK Production and SuperSport championships.

SuperSport will cater for the high-performance Exige, 2-Elven and Evora models, while Production will be for Elises and lower-specification Exiges.

The two will run together for most



Lotus grids are strong

of 2012, but LoTRDC is aiming to run separate races at two meetings in preparation for a full split in 2013.

LoTRDC's Paul Golding said: "With even more entries expected in 2012 it makes perfect sense to split into two championships. This will also help to encourage even more new drivers as we build towards separate grids in 2013."

## Saxmax

## Club seeks to boost Saxmax

**THE 750 MOTOR CLUB WILL**

continue to run its Saxmax championship in 2012, despite only attracting a small field in 2011.

The club's directors have re-affirmed commitment to the category, for 14-17-year-olds in identical 1.6-litre Citroen Saxos, and will promote it as "750 Junior Formula - Saxmax".

Junior TKM karter Matt Hayes, who is looking to switch to car racing, welcomed the news. "It is a good stepping stone from karting, maybe into GT cars in the future," said the 15-year-old. "It is the only junior racing series that is accessible and the driving standards look very good."

The 750MC will organise a taster day, Saxmax Live!, on January 22 at North Weald, where prospective drivers will be able to sample a car for £100.



# Morgan's finest hour

Unfancied runner in family-run team wins the inaugural GT Supercup. *By MARC ORME*

Snetterton was scene of one of three Morgan wins

Whatever the eventual outcome of the inaugural Ginetta GT Supercup title battle, the sensational champion's prize of a fully-funded season in the British Touring Car Championship in 2012 was always going to take centre stage.

Fittingly for one of the biggest prizes in British motorsport, the title race wasn't decided until the final round of the year, when Adam Morgan pipped Carl Breeze by a mere five points and realised his dream of securing a seat in the BTCC.

Undoubtedly a deserving champion, after a superbly consistent campaign in one of the new Ginetta G55s (which superseded the older G50 Cup cars at the front of the field), Morgan went into the last race of the season at Silverstone four points behind Breeze. But, much to the veteran's chagrin, his arch-nemesis Nathan Freke was able to have a say in the outcome.

Breeze ran ahead of Morgan at the beginning of the final round, but after a lengthy safety-car period the Ciceley Racing driver was able to successfully attack his title rival for third. Breeze hit back at Luffield, but then came up against some stern defence from 2009 G50 Cup champion Freke.

GINETTA GT SUPERCUP FINAL STANDINGS		
Driver (Team)	Pts	Wins
1 Adam Morgan (Ciceley)	694	3
2 Carl Breeze (TCR)	689	6
3 Tom Sharp (IDL)	683	9
4 Nathan Freke (Century)	638	6
5 Colin White (CWS)	443	0
6 George Murrells (Optimum)	411	1

Stefan Hodgetts (JHR) and Tim Harvey (TCR) also won a race each.

Try as he might to find a way past, the TCR man only ever found the door slammed shut in his face, backing him up into Morgan once more. At Luffield Morgan stuffed his car up the inside to take third, and a few laps later he was able to easily take second as Freke offered little defence at Brooklands – the title was won.

Tom Sharp won the final two races of the season to show what might have been had a mid-year run of issues with set-up not hampered his title challenge. After starting the season with an impeccable run of six straight victories from the first two race weekends, it took the IDL driver until Knockhill in September to return to the top step of the podium. Even so, he was only 11 points shy of the crown in the end.

Although Morgan only won three races – at Thruxton, Snetterton and on the Brands Hatch GP Circuit – the ex-Escort Mk1 rally driver consistently racked up big scores. Other than a couple of unfortunate non-finishes, his lowest result was a sixth at Croft.

For Breeze, the 2011 season was yet another where he came incredibly close to winning his first car racing championship since his Formula Renault UK title success a decade ago. Six wins and a total of 17 podiums tell their own story, but as in 2010 he had to settle for the runner-up spot.

Other than Morgan, Breeze and Sharp, the winner's circle also included Freke, who scored six victories during a particularly strong second half to his campaign. Ginetta Challenge graduate

George Murrells (who achieved his maiden success at Rockingham), Stefan Hodgetts (who starred at Oulton Park in the first of two outings) and 'guest-car' driver Tim Harvey (who came across after quitting the Porsche Carrera Cup) also topped the podium.

The G50 Cup class, for the previous-generation Ginetta, was hotly contested. Tom Ingram overcame mid-year misfortune to claim the title a couple of rounds early, making it two successes in as many years for the 2010 Ginetta Junior champion.

In fact, the bulk of the G50 field comprised Junior graduates, perfectly showcasing the ladder the Leeds manufacturer provides for aspiring sportscar and saloon racers. ❖

## AUTOSPORT DRIVER RATINGS



### 1. TOM SHARP

Obliterated everyone during the first six races and showed outstanding pace all year. Clawed his way back into title contention, despite losing substantial early points lead due to set-up woes.



### 2. ADAM MORGAN

Quietly racked up big points to emerge as a serious contender for the title. Although he only took three wins, his consistency was superb. Prize BTCC drive for 2012 was well deserved.



### 3. CARL BREEZE

Always a contender and quicker than anyone on his day. Title bid gathered momentum in the second half of the year, but bitter rivalry with Nathan Freke scuppered him in the final round.

# Top Junior Morris wins it for Wales

Wrexham kid continues Hillspeed's unbeaten record in the new G40 era. *By MARC ORME*

**S**uch was Seb Morris's dominance of the majority of the 2011 Ginetta Junior season that there wasn't really any doubt over the eventual outcome. But the task did get more challenging for the 15-year-old Wrexham lad during an action-packed second half of the year.

George Gamble, Charlie Robertson and, through the latter part of the season, Niall Murray each upped their pace as the year progressed, and the trio all took the fight to Morris. But even though the wins and podiums didn't flow as easily from the mid-point of the year, Morris's record of 11 victories from 20 races, 16 podiums in total and a winning margin of 125 points proved he was the class of the field.

His title, added to the 2010 Ginetta Junior Winter Series crown, was also the second main-season championship win in succession for his Hillspeed team.

During the first event on the Brands Hatch Indy Circuit, Morris got the year off to a great start with a double win, but it was Jake Giddings who secured the first pole of the year, while 14-year-old Robertson brilliantly set the fastest lap in both encounters on his first-ever race weekend.

His maiden podium would only be a matter of time, and was achieved next time out at Donington, where Murray also celebrated his first visit to the rostrum. Morris, though, was head and shoulders above the rest, scoring two poles, two wins and a fastest lap.

Morris's stranglehold on the top step of the podium came to an end during the first Thruxton race, where an incredibly tight battle with Gamble was decided in the Englishman's favour by a mere 0.036 seconds.

Not happy to see his winning streak ended, Morris duly bounced back with his fifth win from six starts in the second encounter and added two more successes at Oulton Park.

The category's mid-season visit to Croft marked something of a turning point, the first glimpse of a chink in the

runaway points leader's previously impervious armour. After making a bad call on tyre choice in a wet-but-drying qualifying session, he was relegated to 11th and 14th on the grid for the two races. Undeterred, he salvaged fourth and fifth-place finishes after superbly carving his way through the order.

Gamble won the first race, before Robertson made history by becoming the youngest-ever winner of an MSA-sanctioned circuit race in the UK.

Normal service was resumed at Snetterton, with Morris bagging two more wins. He won again in the first race of the weekend at both Knockhill and Rockingham, as Gamble and Robertson made their own respective returns to the top step of the podium.

Going into the penultimate event of the year on the Brands Hatch GP circuit, Morris's points lead stood at 105 with the double 'dropped-score'

## AUTOSPORT DRIVER RATINGS

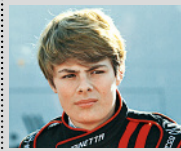

### 1. SEB MORRIS

Untouchable early on, Morris's pace, wins and podiums speak for themselves. One or two incidents later in the year did threaten to take the gloss off an otherwise remarkable campaign.



### 2. CHARLIE ROBERTSON

Outstanding debut season for the 14-year-old, who made history as the youngest winner of a UK circuit race. Consistently quick, he will be a favourite for the 2012 title.

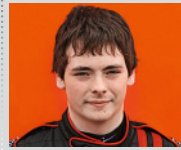

### 3. NIALL MURRAY

Very close to call between Murray and George Gamble, as both possess terrific pace and delivered some fantastic performances. Murray's late-season form made the difference.

ruling applied, and he made sure of the title with a pair of seconds – behind maiden victor Murray in race one and Robertson in race two.

More wins eluded Morris in the season finale at Silverstone. Instead, Ginetta scholar Sennan Fielding – who had taken his first podiums at Rockingham a month earlier – earned a popular win in the penultimate race of the season, while Irish youngster Murray capped off an increasingly strong campaign with a victory in the final round of a fantastic year. ❁

Morris often led the way in 2011



GINETTA JUNIOR FINAL STANDINGS		
Driver (Team)	Pts	Wins
1 Seb Morris (Hillspeed)	562	11
2 Charlie Robertson (HHC)	437	3
3 George Gamble (TJ)	383	3
4 Niall Murray (Beacon)	356	2
5 William Foster (Tollbar)	310	0
6 Max Coates (privateer)	309	0

Sennan Fielding (TJ) also won a race.

## YOUR SAY

What you think of the motorsport news of the past week



The DC & MB show: fun while it lasted

### A hard double act to follow

As the dust settles on F1, 2011-vintage, and we look ahead to 2012, I would just like to say thanks to Martin Brundle and David Coulthard for their excellent commentaries throughout the season, which have very much added to my enjoyment of the races this year. They've made a fantastic double act and it's a great shame that with Martin's departure to Sky, theirs would appear to be a 'for one year only' partnership.

Great job guys, watching next season won't quite be the same without your informed observations and friendly banter!

**James Rollin**, Belper, Derbyshire

EDITORIAL CONTACT [mail@autosport.com](mailto:mail@autosport.com)

**F1 has improved** its spectacle in 2011 – DRS and KERS have increased overtaking but also attracted criticism of the unnatural way they've enhanced the racing.

My proposal would be to assemble the grid based on points order race-by-race, with the lowest scorers at the front and the highest at the back.

F1 has strong frontrunners, great midfield racers and the new teams at the back. The performance differential is perfect for such a grid.

**Sean Garnham**  
Essex

**I think if** I was a driver in GP2 or GP3 (dream on!) I'd give up trying to get to F1.

Too many drives are going to old boys past their sell-by date. Pedro de la Rosa strikes you as a nice man and decent test driver, but he's never proved himself at the top level.

I've always thought the smaller teams were a good feeder system for young drivers, but it doesn't seem to be the case any more.

It's about time some drivers realised that they've had their chances and it's time to step aside.

**Richard Hargrave**  
Hitchin, Herts

**I enjoyed your** article on Richard Burns (November 24) – a fascinating insight.

My wife and I had the pleasure of a chance meeting with him in February 2002. We were on a last-minute skiing holiday in Andorra and bumped into him in a tiny grocery shop in a mountain village.

When he saw us discussing cheap wines he approached us with some suggestions based on his own experience. We were flabbergasted to meet him like this (the coincidence was heightened by the fact that back in my hotel room was my copy of that week's

AUTOSPORT with his picture on the front cover).

He was delighted to hear we were rally fans and spent 15 minutes discussing rallying, skiing, wine and holidays with us. A wonderful memory to have.

**Brian Hunt**  
Dublin

**I have no** problem with Sky and BBC both covering F1 next year, 'cos it means I can choose to watch whichever one doesn't feature Eddie Jordan and his non sequiturs ad infinitum (that's yer actual Latin).

**Tazio von Brauchitsch**  
By email

AUTOSPORT.COM

### TOP FIVE ON OUR WEBSITE

1. MASSA ADVISES BARRICHELLO TO RETIRE
2. DE LA ROSA JOINS HRT FROM 2012
3. KUBICA TO MISS START OF 2012 F1 SEASON
4. BBC REVEALS 2012 F1 COVERAGE PLANS
5. BRUNDLE MOVES TO SKY FROM 2012

AUTOSPORT.COM PLUS

### TOP STORY ONLINE

COMING OUT IN DEFENCE OF RENAULT

To read this exclusive feature and many others like it, log on to [autosport.com/plus](http://autosport.com/plus) and choose which package you'd like. A month will cost £5.50, a year £46. Includes access to Forix – the ultimate stats website.

WIN!



### ROAD ANGEL VANTAGE

This week's star letter will receive a Road Angel Vantage – a dedicated safety camera and blackspot locator that displays the legal speed limit of every road you drive, automatically and wirelessly updating its database every few minutes as you drive. For more details on Road Angel visit [www.roadangelgroup.com](http://www.roadangelgroup.com) Please ensure that your full address is included on all correspondence.

### CORRECTIONS AND CLARIFICATIONS

● Our Britcar season review (Nov 24, p87) did not account for dropped scores in the class championships. Thus, Class 1 GT champions are Paul White/Calum Lockie, not Javier Morcillo/Manuel Cintrano, and Class 3 runners-up are Rod Barrett/Jay Persson/Jay Shepherd, not Paul Bailey/Andy Schulz. Our report of the final Britcar race of 2011 (p83) also mixed up Porsche drivers Jay Shepherd and Rod Barrett. It was Barrett, rather than co-driver Shepherd, who drove the second part of the race and spun trying to catch the winning Topcats Marcos Mantis.

# THE LATEST GEAR

The most desirable new releases for motor racing fans: books, DVDs, models, art and gifts



**MICHAEL TURNER CHRISTMAS CARDS**  
£6.50 plus P+P (set of five)  
[studio88.co.uk](http://studio88.co.uk) or 01296 338504

For donkey's years celebrated motorsport artist Michael Turner has produced a set of Christmas cards for race fans. And it's almost as much of a tradition

for AUTOSPORT to announce their arrival. Well, here they are. The 2011 set comprises (clockwise from above) Jenson Button winning the Canadian GP for McLaren (also available as a print for £28), Paul di Resta charging to sixth place in Singapore, Fernando Alonso winning the British GP at Silverstone, Kamui

Kobayashi passing Adrian Sutil for fifth at Monaco and Sebastian Vettel squeezing past Alonso on the grass to win at Monza. The cards come on heavyweight paper and with matching envelopes.

For more details and the full range of prints, cards and original artwork, check the website or give them a call.



**CMC 1:18-SCALE FERRARI TRANSPORTER**  
£639.99  
[autosport.com/shop](http://autosport.com/shop)

CMC's 1:18-scale Ferrari 642 RN2 Bartoletti transporter is a staggering model, with 3115 parts and measuring almost 50cm. The detail, down to the leaf-spring suspension and driveshafts, to the polished metal grille, is scary. About as serious as collectors' models get...



**LEGO STAR WARS ADVENT CALENDAR**  
£24.99  
[legoshop.com](http://legoshop.com)

This advent calendar's got nothing whatsoever to do with motorsport, but Lego and Star Wars are cool enough to get on these pages. Collect 24 items of intergalactic-inspired goodies during December, including mini figures, vehicles and accessories from the full range.



**TROY LEE DESIGNS STEVE McQUEEN HELMET**  
£449.99  
[autosport.com/shop](http://autosport.com/shop)

This Troy Lee Designs helmet harks back to the days of Steve McQueen and the classic *Le Mans* flick of the early '70s. It comes with all the trick bits to make it safe and comfortable (impact-absorbing liner and an integral ventilation system) and those fab Gulf colours.

## HOT ON THE WEB THIS WEEK

**YOUTUBE: NASCAR COMES TO MONZA**



**SEARCH FOR:** Monza Rally – Cameracar Max Papis – Alex Zanardi (4:47) Max Papis, sporting a Marco Simoncelli tribute lid, ferries fellow Italian ace Alex Zanardi around Monza in a Toyota Camry NASCAR stocker. And he's not hanging around, as his Parabolica off proves. *Molto bene!*

# WHAT'S ON...

Your guide to the best events taking place in the UK and around the world this week – plus TV and online

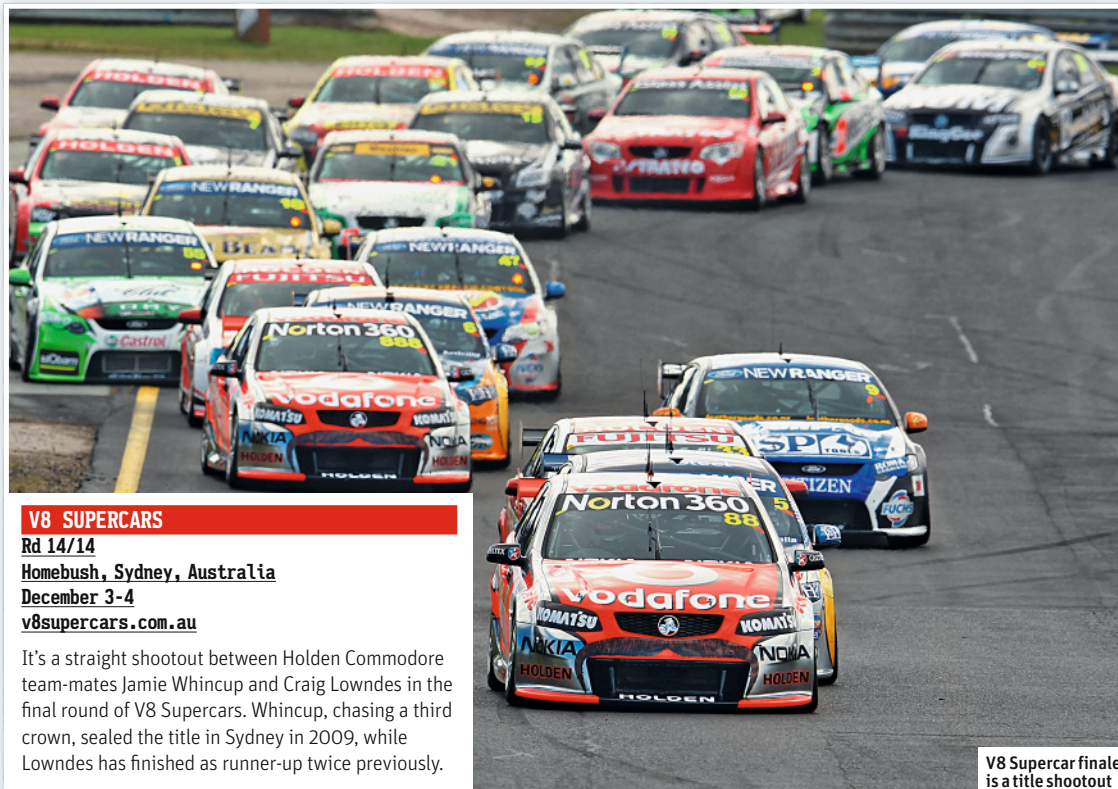

## V8 SUPERCARS

Rd 14/14

Homebush, Sydney, Australia

December 3-4

[v8supercars.com.au](http://v8supercars.com.au)

It's a straight shootout between Holden Commodore team-mates Jamie Whincup and Craig Lowndes in the final round of V8 Supercars. Whincup, chasing a third crown, sealed the title in Sydney in 2009, while Lowndes has finished as runner-up twice previously.

V8 Supercar finale is a title shootout



Prost pere et fils tackle ice racing

## ANDROS TROPHY

Rd 1/8

Val Thorens, France

December 3-4

[tropheeandros.com](http://tropheeandros.com)

The French-based Andros Trophy ice racing series gets underway at Val Thorens. Four-time F1 world champion Alain Prost and sportscar-racing son Nicolas are among those competing.

## PORSCHE CARRERA CUP AUSTRALIA

Rd 7/7

Homebush, Sydney, Australia

December 3-4

[carreracup.com.au](http://carreracup.com.au)

ACCESS  
ALL  
AREAS

Our guide on how to keep the motorsport flame burning through the cold winter months

## GERMAN MOTOR MUSEUMS

If there is one country that shares Britain's passion for the motor car, then it's Germany – and its vast array of museums is amazing.

In 1886, Carl Benz patented his design for the very first car and you can visit the Benz home in Mannheim, where there's a replica of that remarkable machine, and tour the Carl Benz museum on the site of his original factory.

The palatial new exhibition centre also houses the annual Retro Classics Fair. This year more than 60,000 enthusiasts attended the show and three of the

13 halls were devoted to motorsport. Highlights included a dozen Dino Ferraris next to a couple of pristine Alitalia Lancia Stratos rally cars, a Mercedes W196 'streamliner', and an Eggenberger Ford RS500.

Then travel across the city to the magnificent Mercedes museum, where you can trace its story through the iconic SSK sportscar and the pre-war grand prix cars, right up to the latest F1 machinery.

Why not stay at the V8 Hotel, an amazing place adapted from the terminal buildings of the old Stuttgart airport so that each room has

There are a huge amount of classics to see in Germany



a motorsport theme. Better still, there are dozens of privately-owned classic cars, each one stored in its own sealed, see-through polycarbonate 'garage'.

Next up is the Meilenwerk, which features classic cars from 1920-70, Karlsruhe's ZKM (Centre for Art and Media), and then head to the fabulous Hockenheimring for a tour of the circuit and the museum.

The Auto & Technik Museum at Sinsheim is not easily missed because it has an Air France Concorde and a Tupolev mounted on the roof. From there, you can move on to Neckarsulm for a visit to the Audi Forum, and then the fabulous Porsche museum at Stuttgart Zuffenhausen.

For more details, check out [www.germany-tourism.co.uk](http://www.germany-tourism.co.uk) and [www.tourismus-bw.de](http://www.tourismus-bw.de).  
Kerry Dunlop

## Television

### THURSDAY DECEMBER 1

0010-0315, 1210-1515 [Motors TV](#)  
FIA GT3: Season Review  
0315-0600 [Motors TV](#)  
British F3: Season Review

### FRIDAY DECEMBER 2

0500-0530 [ESPN](#)  
Planet Speed  
1445-1650, 2205-0010 [Motors TV](#)  
V8 Supercars: Sandown Highlights

### SATURDAY DECEMBER 3

0015-0115 [ESPN](#)  
WRC: 2011 Academy Review  
0915-1020 [ITV 4](#)  
Motorsport UK  
1340-1750 [Motors TV](#)  
Formula 2: Season Review  
1600-1630 [ESPN Classic](#)  
F1 British GP 1980  
1800-2105 [Motors TV LIVE](#)  
Race of Champions: Nations Cup  
2105-0010 [Motors TV](#)  
FIA GT3: Season Review

### SUNDAY DECEMBER 4

0335-0405 [ESPN Classic](#)  
F1 British GP 1980  
0415-0515 [ESPN](#)  
WRC: 2011 Academy Review  
0955-1300 [Motors TV](#)  
Race of Champions: Nations Cup Replay  
1000-1100 [Sky Sports 4](#)  
Racemax  
1300-1605 [Motors TV LIVE](#)  
Race of Champions  
1530-1630 [ITV 4](#)  
Goodwood Festival of Speed 2011  
1630-1700 [ESPN Classic](#)  
F1 British GP 1974  
1700-1730 [ESPN Classic](#)  
F1 British GP 1975

### MONDAY DECEMBER 5

0315-0600 [Motors TV](#)  
British GT: Season Review  
0500-0600 [ESPN](#)  
WRC: 2011 Academy Review  
1445-1750 [Motors TV](#)  
Race of Champions: Highlights



## Online

# AUTOSPORT.COM

Coming up on the web this week

### MARTIN BRUNDLE INTERVIEW

Find out why new Sky Sports Formula 1 commentator Martin Brundle just couldn't keep away from the cockpit in Sam Tremayne's exclusive interview with the former Le Mans winner about his return to the French classic next year. Read AUTOSPORT.com's in-depth tin-top season reviews, with the BTCC, DTM and WTCC all under scrutiny.

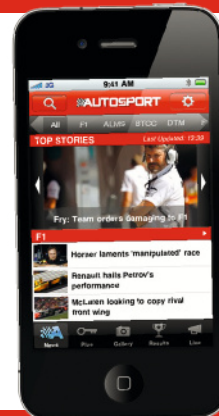

Read AUTOSPORT.com on your phone to keep up to date

### AUTOSPORT.COM ANDROID APP OUT NOW

The AUTOSPORT app is now available for Android. Dial up AUTOSPORT.com on your smart phone for instant access to news, feature articles, image galleries and live text race commentary for a one-off fee of only £2.99 (there is no renewal cost). For more info, visit [www.autosport.com/app](http://www.autosport.com/app)

## REVVED UP OVER WHAT'S ON THE BOX

We cast a critical eye over the best and worst of this week's TV shows



IF THIS column had a theme tune, this week's one would be The Byrds' *Turn! Turn! Turn!*

The Californian stoner-scene classic encapsulated the spirit of a time when the ideas and actions of the previous generation were being overturned by new, fresh ideas and ideals.

Now, it's hard to imagine anything that's connected to Rupert Murdoch having much in common with the peace-and-love hippy movement of the 1960s, but the departure of live F1 coverage (of every race) from free-to-air television is a seismic shift in the way the

customers – or fans as they were once known – engage with the sport.

So how did the Beeb acknowledge this? Er, well they didn't. There was no send-off for Martin Brundle, who's heading to Sky to team up with DC (that's David Croft, not Coulthard) for a full 19-race campaign. In fact, aside from Jake Humphrey introducing an advert for next year's coverage, you could have been forgiven for thinking that nothing much was happening.

There was certainly an end-of-term feeling about some of the coverage, with Brundle calling Ted Kravitz "Lenny" at one stage

during the race, while the 2011 F1 Awards appeared to be an afterthought. At least Jenson Button reacted in the only acceptable way: "I'm glad you haven't spent too much tax payers' money on this," as he received his tiny Perspex trophy.

As has always been the case, there were many high points. Eddie Jordan's interview with Rubens Barrichello being a case in point. Actually, when he's recording stuff to camera, EJ can be very

good, it's when he's live that his brain turns to jelly and he asks 'questions' like "your justification for signing Mark has been justified" as he did to Christian Horner.

It will be a hard act for Sky, which will have a dedicated channel for F1 next year, to top, but not an impossible one by any means. So thank you BBC. You raised the bar and for that I'll always be grateful.

"To everything (turn, turn, turn)" etc.  
*Revved Up*

"It will be a hard act for Sky Sports to top the BBC's F1 coverage - but not an impossible task by any means"

# THE WEEK IN PICTURES

Our lensmen pounding the beat around Interlagos

## WEBBER CLIMBS OFF AS HE JUMPS UP

Brazilian GP winner Mark Webber does his best falling-off-a-motorbike impression during celebrations on the Interlagos podium

PETROBRAS



## GLOCK'S WHEEL OF MISFORTUNE

Timo Glock's left-rear wheel parted company with his Virgin during the Brazilian GP, leaving him stranded on the circuit



**JESSIE J EARNS HER FORMULA 1 STRIPES**  
Jessica Ellen Cornish, better known as popstar Jessie J, brightened up the Brazilian paddock



**HAMILTON HELMET HONOURS HERO**  
Lewis Hamilton sported Ayrton Senna's helmet colours on his lid at his hero's home circuit

# FROM THE ARCHIVE

Tony Brise, F3 finale 1972

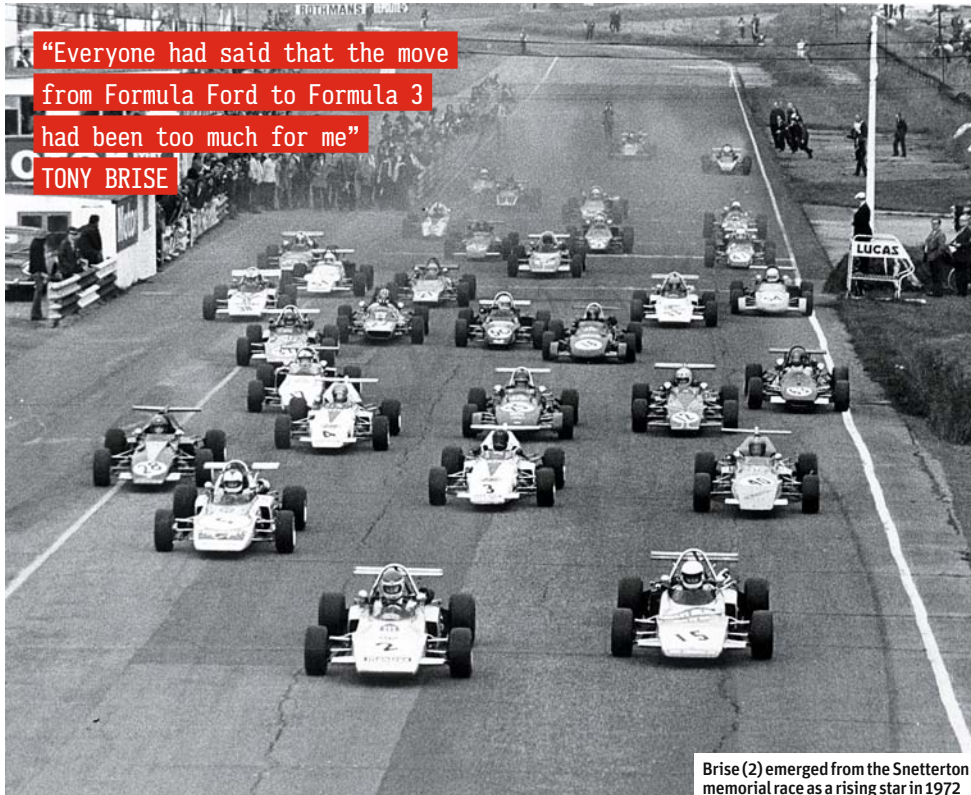

“Everyone had said that the move from Formula Ford to Formula 3 had been too much for me”  
TONY BRISE

Brise (2) emerged from the Snetterton memorial race as a rising star in 1972

**BRITAIN MOURNED THE LOSS OF ONE OF ITS** bright young stars this week in 1975, when Tony Brise was killed in a plane crash. Just seven months previously Brise had been handed his Formula 1 debut by Williams, while a subsequent move to Graham Hill's Embassy racing team yielded his maiden points in the Swedish Grand Prix at Anderstorp. Hill had re-signed Brise for the 1976 season, but the deal was never realised: flying back from a test at Paul Ricard, Hill – piloting the plane – crashed in thick fog at Arkley golf course, killing all on board. Brise was just 23.

Brise began karting at the age of eight, and over the subsequent years his career path offered many highlights – he was crowned British national kart champion in 1969, won the F3 John Player Championship in 1973 and dominated in Formula Atlantics before receiving an F1 call to replace Jacques Laffite for Williams at the Spanish Grand Prix.

Among such accolades, one of his most significant races came amidst a difficult maiden season in Formula 3 in 1972. Brise's father John had done a deal with Bernie Ecclestone to run the new Brabham BT 38 over the season, but it was quickly realised the car was lacking, as Brise confessed to AUTOSPORT. “It was just

a bad car, I'm afraid,” he reported. “Very unpredictable round corners, and very slow in a straight line.”

Brise had still tasted success in the Brabham despite its deficiencies, but with his reputation fading the decision was taken to switch chassis to the GRD 372. Podiums and then victories followed, but perhaps his most impressive performance came in finishing second to Roger Williamson at the Archie Scott-Brown memorial race at Snetterton.

Both drivers won their heats and started an enthralling final from the front row. They remained locked together 30 laps later, finishing millimetres apart and with the same race time. After a troubled year, matching the formula's established yardstick did much to mark Brise out as a future star.

“Everybody had said the transformation from Formula Ford to Formula 3 had been too much for me,” he told AUTOSPORT. “There was a great deal at stake.” There was also a great deal to be gained: in proving Williamson's equal, Brise was chosen to succeed him as a GRD factory driver when Williamson graduated into F1 a year later. Two years later and he too progressed into F1, only for his life – like Roger's before him – to be cut tragically short. ❄

## THIS WEEK IN...



DECEMBER 3, 2009

**THE FACE OF FORMULA 1 CHANGED** dramatically at the start of December 2009 as the Lotus name returned, while 2007 world champion Kimi Raikkonen neared a switch to the WRC.

The rebirth of Team Lotus – which preceded the tedium and confusion of the Lotus/Lotus squabble – came at the hands of AirAsia boss Tony Fernandes and was headed by technical director Mike Gascoyne, both of whom remain at the helm. Amid early scepticism about the return of such an iconic name there was an open recognition of Lotus' proud heritage, an attitude which earned the team a new legion of fans.

As a new team arrived, one of F1's most popular drivers left. Raikkonen, who won the final race of '07 to claim his only title, had already competed in the WRC at his home Rally Finland in 2009. He made the switch permanently however for 2010, joining the Citroen Junior Team alongside Sebastien Ogier.



PICS: LAT ARCHIVE



DID YOU BEAT THE  
GRAND PRIX PREDICTOR?

Castrol **EDGE**  
Rankings

Visit [castroledgerankings.com/predictor](http://castroledgerankings.com/predictor)

# RICARDO ZUNINO

■ Canadian GP, Montreal ■ September 30, 1979 ■ Brabham-Cosworth BT49 ■ Last-minute F1 debut yields P7



Zunino leads Shadow duo Lammers and de Angelis

**I CAN RECALL MANY RACES** but undoubtedly the race I most remember and the most important one for me was my Formula 1 debut in Canada in 1979. I had arrived as a simple spectator, invited by Brabham boss Bernie Ecclestone, to share the activity of the team.

While the first practice session was taking place on Friday, I was wandering about the pits.

I was hoping to have a place in the team some day. Mr Ecclestone had guided me in motor racing, but all things indicated that Niki Lauda would remain in the team, so I'd have to keep on waiting. My plans were to stay in New York for three days after the race and later return to London. The only problem was that at the airport, when I left England, I didn't have time to have a visa stamped on my passport at the American consulate, so I had to have it done on Friday in Montreal, because the consulate was closed at the weekend. So I left the circuit, to return in an hour's time and watch the rest of the action.

When I had done the visa, I went past the hotel on the way back and, while in the lobby, noticed Lauda walking in. He looked at me from afar but didn't say anything. I was astonished, and left for the circuit.

**"Bernie Ecclestone said, 'I've got the car ready for you. In the motorhome you'll find Lauda's kit.' I did the last five or six laps of the day's session"**

When I arrived Mr Ecclestone asked me, 'Where have you been? I've got the car ready for you.' I didn't have my race suit, helmet or boots with me. Mr Ecclestone looked me in the eye and said something like, 'Well, there are only 15 minutes remaining and there's not enough time left.' I realised I needed to climb aboard that car, because there were other drivers

interested in sitting in that car. I felt certain that Mr Ecclestone wanted me, so I answered, 'Yes, we have time!' He responded with, 'OK, in the motorhome you'll find Lauda's kit.' So I went and got changed, climbed into the car and managed to do the last five or six laps of the day's session.

That afternoon, with the team's personnel I adapted the seat, the

pedals and the steering wheel to my liking. Also that afternoon, Gilles Villeneuve sent me a pair of his boots and Jacques Laffite lent me a pair of gloves. And also, I must say that I really appreciated Niki leaving his kit behind.

On Saturday I was able to qualify 19th, and in the race I had trouble with the gear linkage and had to pit. I finished 7th, having set the fourth-fastest lap time among the Cosworth-engined cars. The international media awarded me the Candy trophy, which used to be handed out to the driver who had shown well in each grand prix.

Those were the three most wonderful days in my life as a racing driver. My thanks to my friend Bernie Ecclestone for giving me the support that allowed me to make my Formula 1 debut. ✪ *Ricardo Zunino was talking to Tony Watson*

## IN PROFILE

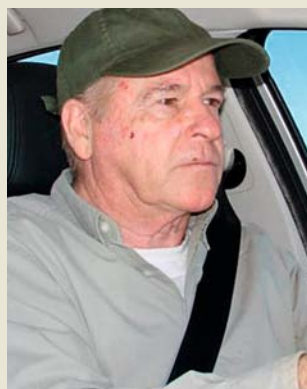

**ARGENTINIAN RICARDO ZUNINO** began racing in his domestic touring car championship, before graduating to single-seaters. He reached European F2 level in 1977 and was a racewinner in the British Aurora AFX F1 series in '79. He made a sudden world championship debut in Canada later that year when Niki Lauda quit the Brabham team. He made seven further starts for the team and raced twice for Tyrrell in '81. Zunino, now 62, runs a lodging house in the Andes mountains.

**NEXT WEEK**

**Ari VATANEN**



# FASTEN YOUR SEATBELTS THIS CHRISTMAS!

Ever wanted to drive a mega BMW M3 or a single seater on a world-famous race track, or slip and slide on a purpose-built rally stage? MSV can make your dreams come true with a brilliant range of driving experiences!

**GIFT VOUCHERS  
FROM ONLY £99  
VALID FOR 12 MONTHS**



#### Available at:

- Brands Hatch in Kent
- Oulton Park in Cheshire
- Bedford Autodrome

## Young Drive!

Get a head-start on your classmates with our unique YoungDrive! experience. Anyone aged 11 and over and taller than 4'8" can learn basic driving skills in a fabulous MINI.

**GIFT VOUCHERS AVAILABLE FOR £79**

**WWW.MSVDIVINGGIFTS.COM**  
**0843 453 1000**

**MSV** 

# ISN'T THE BEST ALWAYS SAVED FOR LAST?



## THE LEON FR.

With awe-inspiring looks, state-of-the-art TDI and TSI engines, and optional DSG-auto with paddle shift, you can't do better than the Leon FR. Unless we're talking about the 211PS FR+. After all, this version comes with striking 18" alloy wheels and dual-zone climate control. Not to mention a media system with satellite navigation and Bluetooth®. But naturally we've saved the best news for last: the FR is available with 3 years free servicing\* and low rate **8.9% APR** representative finance.

---

### LEON FR

- XDS AND ESP
- 17" ALBEA ALLOY WHEELS
- DUAL-ZONE CLIMATE CONTROL

### LEON FR+

- BI-XENON HEADLIGHTS WITH AFS
- 18" IBERA ALLOY WHEELS
- TOUCH SCREEN SAT-NAV AND BLUETOOTH®

---

Visit [seat.co.uk](http://seat.co.uk) to find your local dealer and arrange a test-drive.

**MEMBER OF THE VOLKSWAGEN GROUP**

Offer applies to Leon FR range models sold and registered between 5th October and 31st December 2011. Retail Sales only. Subject to vehicle availability. \*Up to 3 years or 30,000 miles (whichever comes sooner). Indemnities may be required. Subject to status. Available to over 18's in the UK only. At participating dealers only. SEAT Finance, Freepost SEAT Finance. Offer may be varied or withdrawn at any time.

Official fuel consumption for the SEAT Leon FR range in mpg (litres per 100km); urban 28.2 (10.0) - 46.3 (6.1); extra-urban 47.1 (6.0) - 68.9 (4.1); combined 37.7 (7.5) - 58.9 (4.8). CO2 emissions 174 - 125 g/km.