

**GUEST EDITOR DARIO FRANCHITTI**



FORMULA 1 • SPORTSCARS • TOURING CARS • NASCAR • INDYCAR • RALLYING • NATIONAL RACING & MORE

# AUTOSPORT

JANUARY 12 2012 • £3.30 • AUTOSPORT.COM

 **AUTOSPORT  
LEGEND  
JIM CLARK**

**PLUS**  
  
**KIMI  
GEARS UP FOR  
F1 RETURN**



haymarket  
9 770269 946227  
0 21  
C\$8.95

**THE GENIUS THAT WAS...**

# JIM CLARK

**INCLUDING**

**THE STORY OF HIS PRE-CHAPMAN YEARS  
WHAT HE WAS REALLY LIKE TO WORK WITH  
UNDER THE SKIN OF THE LOTUS 49**

**SEE NEW MERC DTM CAR**

**AUTOSPORT**  
INTERNATIONAL  
The Racing Car Show

**20-PAGE PREVIEW**  
THE WORLD'S BIGGEST MOTORSPORT SHOW



# NEED RACE OR RALLY INSURANCE?

Visit us at the  
Autosport Show  
**STAND  
2405**  
to discuss your 2012  
requirements



## MIS HAVE THE WINNING FORMULA

/ ON TRACK / ON EVENT / MOTOR TRADE / STORAGE & TRANSIT /  
PERSONAL ACCIDENT/REPATRIATION / PROPERTY / LIABILITY /  
INDIVIDUAL EVENTS OR FULL SEASON RACING / WORLDWIDE COVER

/ Call us today **and remember** we guarantee  
to beat any genuine reasonable quotation  
**offered by our competitors**

Call +44 (0)1943 884 555,  
email [info@mismotorsport.com](mailto:info@mismotorsport.com)  
or visit [www.mismotorsport.com](http://www.mismotorsport.com)



# MIS

MOTORSPORT

# CONTENTS

January 12 2012 – vol 207 no 2



## AUTOSPORT.COM

Up-to-the-minute news and reports from F1, WRC and more. Subscribe for must-read opinion, stats and images

COVER IMAGES:  
LAT ARCHIVE  
INSETS:  
FERRARO,  
LEVITT/LAT



**“I don’t think it’d be good for Go Daddy’s marketing if they put me into a bikini”**

**INDYCAR RACER JAMES HINCHCLIFFE PONDERES TO WHAT EXTENT HE HAS TO ‘STEP INTO DANICA PATRICK’S HEELS’ AT ANDRETTI AUTOSPORT**

# 117

Cars participating in this week’s three-day pre-Daytona 24 Hours test, ahead of the big event on January 28-29

**SUBSCRIBE...**  
to AUTOSPORT and get a free pair of Cebe Spider sunglasses **P84**

## FEATURES/REPORTS



Clark blasts off at 1963 Mexican GP

### 24 Jim Clark Special

A series of features celebrates the career of the Scot, winner of two world championships

### 47 AUTOSPORT International

All you need to know for this week’s NEC extravaganza

### 74 Sebastien Loeb interview

How do you motivate yourself if you’ve already won eight WRC titles? Simple: aim for a ninth

### 77 Looking ahead to the WRC

After a tumultuous off-season, it’s Monte Carlo Rally time

### 81 Gronholm on the Monte

Ex-champion looks back at his ‘love-hate’ event

### 85 Monte runners and riders

Who will battle it out in France?

### 88 World of Sport

Dakar Rally update

## NEWS



It’s rough going in the world of rallying

### 8 World Rally in chaos

Championship survives... just, as series scrambles for promoter in the wake of disastrous week

### 10 Trio in Williams frame

Beleaguered F1 squad chooses between Senna, Barrichello, Sutil

### 13 This week in Formula 1

Round-up of the latest stories – from Buemi to James Allen

### 16 Minassian leaves Peugeot

French make’s stalwart quits Le Mans effort in bid for more racing

### 19 Bottas: no racing in 2012

Finn to focus on Williams third-driver role – for now

### 21 Sims to race McLaren

Brit falls off single-seater ladder but picks up enduro race deal

### 23 Citroen battle is on

Loeb says Hirvonen will be able to catch him – if he can

## REGULARS

### 5 From the editor

### 6 Snapshot

### 15 Mark Hughes column

### 84 Subscribe for a free gift

### 116 Final drive

Letters and Latest Gear

### 118 On track/on screen

The best action in the next week

### 121 From the archive

Jim Clark wins in the BTCC

### 122 Race of my life

Ray Mallock, ShellSport Snet, ’76

## SPORTS EXTRA

### 107 Van Diemen pulls out

Legendary constructor won’t build EcoBoost Ford; Sinter steps in

### 108 Harvey returns to Brit GT

Ex-BTCC champ to lead Trackspeed Porsche line-up in 2012

### 112 Track test

Garrie Whittaker, winner of more races in the UK than anyone else in 2011, heads to Valencia and swaps his regular M3 for GT3 and GT4 BMW machinery



New Sinter FFord, p107

**SINCE  
NOW** HIGH PERFORMANCE  
IS AN AFFORDABLE LUXURY



Infiniti FX30d GT: 3.0-litre V6 Diesel engine, 238 PS, 550 Nm, 52 premium features as standard.

INSPIRED OFFER:

£ 499  
PER MONTH\*

- Electric glass sunroof
- Leather upholstery
- 20", 5-spoke alloy wheels
- Intelligent four-wheel drive (AWD – All-Wheel-Drive)
- Rear view camera with front and rear parking sensors with display



INFINITI

Inspired Performance

BOOK YOUR TEST DRIVE NOW AT [WWW.INFINITI.CO.UK/DISCOVERFX](http://WWW.INFINITI.CO.UK/DISCOVERFX)

\*Offer available on the Infiniti FX30d GT. Rental stated is for Infiniti Lease. Same rentals on Infiniti Selectivity PCP finance product are also available. If you choose Infiniti Lease then you will not own the car. When you have paid the final rental at the end of the contract, you can keep using the car and pay an annual rental amount of £50+VAT. Advance customer rental £8,500 followed by 35 monthly rentals of £499, final rental £16,664.90, all figures inclusive of VAT. Guarantees and indemnities may be required. Finance is available subject to status on eligible new vehicles registered between 01/01/12 and 31/03/12. You must be at least 18 and a UK resident (excluding Isle of Man and Channel Islands) to apply. Finance provided by Infiniti Financial Services Limited, PO Box 149, Watford WD17 1FJ. At participating dealers only. Not available in conjunction with any schemes or other offers, please visit your local dealer for information. All prices include first registration fee and road fund licence. Information correct at time of going to print. Model shot is for illustration purposes only. Models subject to availability. Infiniti Europe, a division of Nissan International SA, ZA La Pièce 12, 1180 Rolle, Switzerland. Model displayed: FX30d S Premium. Official fuel economy figures for the Infiniti FX30d in mpg (l/100 km): urban 25.2 (11.2), extra urban 36.2 (7.8), combined 31.4 (9.0). CO<sub>2</sub> emission: 238 g/km.

**EDITOR-IN-CHIEF**

Andrew van de Burgt  
andrew.vandeburgt@haymarket.com ext.5974

**EDITOR**

Charles Bradley  
charles.bradley@haymarket.com ext.5889

**AUTOSPORT.COM EDITOR**

Simon Strang ext.5093  
simon.strang@haymarket.com

**GROUP F1 EDITOR**

Jonathan Noble ext.5810  
jonathan.noble@haymarket.com

**F1 EDITOR**

Edd Straw ext.5887  
edd.straw@haymarket.com

**FEATURES EDITOR**

Kevin Turner ext.5432  
kevin.turner@haymarket.com

**NEWS EDITOR**

Glenn Freeman ext.5309  
glenn.freeman@haymarket.com

**SOCIAL MEDIA EDITOR**

Mark Glendenning ext.5801  
mark.glendenning@haymarket.com

**REPORTS EDITOR**

Jamie O'Leary ext.5811  
jamie.oleary@haymarket.com

**MANAGING EDITOR**

Peter Hodges ext.8617  
peter.hodges@haymarket.com

**WEB MANAGING EDITOR**

Pablo Elizalde

**GRAND PRIX EDITOR**

Mark Hughes  
autosport.editorial@haynet.com

**F1 COLUMNIST**

David Coulthard

**RALLIES EDITOR**

David Evans  
david.evans@haymarket.com

**INTERNATIONAL EDITOR-AT-LARGE**

Gary Watkins

**ART EDITOR**

Aubrey Smith ext.5914  
aubrey.smith@haymarket.com

**PRESENTER/SUB-EDITOR**

Henry Hope-Frost ext.5835  
henry.hope-frost@haymarket.com

**CHIEF SUB-EDITOR**

Marcus Simmons ext.5807  
marcus.simmons@haymarket.com

**NATIONAL EDITOR**

Ben Anderson ext.5425  
ben.anderson@haymarket.com

**NATIONAL EDITOR-AT-LARGE**

Marcus Pye

**SENIOR DESIGNER**

Matthew Dungate

**DESIGNER**

Will Clarke

**PICTURE EDITOR**

Peter Mills ext.5918  
peter.mills@haymarket.com

**AUTOSPORT.COM**

**TECHNICAL TEAM LEADER**

Geoff Creighton  
geoff.creighton@haymarket.com

**AUTOSPORT.COM USER**

**INTERFACE DEVELOPER**

Pete Holmes  
pete.holmes@haymarket.com

**AUTOSPORT.COM**

**PICTURE EDITOR**

Chris Bird  
chris.bird@haymarket.com

**SECRETARY**

Julie Bower  
julie.bower@haymarket.com ext.5804

**PHOTOGRAPHS**

LAT Photographic

**SPECIAL CORRESPONDENT**

Adam Cooper

**TECHNICAL CONSULTANT**

Gary Anderson

**TECHNICAL EDITOR**

Giorgio Piola

**NEWS GRAPHICS**

Alan Eldridge

**CARTOONIST**

Jim Bamber

**CORRESPONDENTS**

**ARGENTINA**

Tim Watson

**AUSTRALIA**

Phil Branagan

**AUSTRIA**

Gerhard Kuntzschik

**BELGIUM**

Gordon McKay

**BRAZIL**

Luis Cavalcanti

**FINLAND**

Esa Iiloinen

**GERMANY**

Rene de Boer

**GREECE**

Dimitris Papadopoulos

**ITALY**

Roberto Chinchero

**JAPAN**

Jiro Takahashi, Len Clarke

**NEW ZEALAND**

Bernard Garpinter

**RUSSIA**

Gregory Golyshev

**SOUTH AFRICA**

Richard Asher

**SPAIN**

Raimon Duran

**SWEDEN**

Tese Tornvall

**USA**

Jonathan Ingram, Bruce

Martin, David Phillips,

Diego Mejia, Robin Miller,

Jeff Olson, Jeremy Shaw,

**UK & EIRE**

David Addison, Ben

Boston, Duid Candier,

Jonathan Crawford,

Kerry Dunlop, Leanne

Fahy, Paul Jurd, Linda

Keen, Paul Lawrence,

Marc Orme, Graham

Read, Peter Scherer, Ian

Sowman, Oliver Timson,

Ian Titchmarsh, Matt

Upton, Eddie Walder, Tim

Whittington, Richard Young

**ADVERTISING**

Tel: +44 (0) 20 8267 5858

Fax: +44 (0) 20 8267 5850

E-mail: autosport.ads@haymarket.com

**SALES MANAGER**

Rachel Brock,  
ext: 5820  
rachel.brock@haymarket.com

**DISPLAY ADVERTISING**

Andrew Barclay,  
ext: 5244  
andrew.barclay@haymarket.com

**Peter De Vries,**

ext: 5961  
peter.devries@haymarket.com

**Karen Reilly,**

ext: 5576  
karen.reilly@haymarket.com

**CLASSIFIED ADVERTISING**

Victoria Townsend,  
ext: 5367  
victoria.townsend@haymarket.com

**William Putt,**

ext: 5992  
william.putt@haymarket.com

**Alex Newberry,**

ext: 5865  
alex.newberry@haymarket.com

**ONLINE SALES MANAGER**

Luciano Candilio,  
ext: 5179  
luciano.candilio@haymarket.com

**ONLINE ADVERTISING**

Adam Fennell,  
ext: 5946  
adam.fennell@haymarket.com

**ADVERTISING DIRECTOR**

Matthew Witham

**AD PRODUCTION**

Tel: +44 (0) 20 8267 5740

Fax: +44 (0) 20 8267 5320

**SPECIAL PROJECTS DIRECTOR**

Derek Redfern

**LICENSING DIRECTOR**

Tim Bulley

**PRODUCTION MANAGER**

Carrie McNally,  
ext: 5814  
carrie.mcnally@haymarket.com

**SENIOR DISPLAY PRODUCTION CONTROLLER**

Saba Bonser, ext: 5740  
saba.bonser@haymarket.com

**PRODUCTION CONTROLLER**

Lee Brister, ext: 5823  
lee.brister@haymarket.com

## POLE POSITION

# World rallying heads off down a rocky road



THE GOOD NEWS IS THAT THE MONTE Carlo Rally kicks off the World Rally Championship next Wednesday, as it

always should. The bad news is about 60 people were laid off this week from the championship's former global promoter North One Sport and its TV arm, as the FIA terminated its contract.

Since North One Sport's parent company Convers Sports Initiatives went into administration after the arrest of its principal backer Vladimir Antonov following an investigation into alleged asset-stripping in Lithuania, one always feared for the future of the WRC. And here we are, days before the season-opener, with no firm news on TV deals or who will promote the WRC this year.

The fallout is bound to reverberate over the coming weeks – trust me, the allegations are flying – with the spotlight falling on FIA president Jean Todt's role in proceedings in particular. After all, the buck stops with him, whether he was on holiday or not. But, like I said, the good news is that we have a rally to watch at all.

Charles Bradley, editor

**SUBSCRIPTIONS**

UK 0844 8488817

OVERSEAS +44 (0)1795 592 974

**EMAIL**

autosport@servicehelpline.co.uk

**US & CANADA 1-866-918-1446**

**US & CANADA EMAIL**

haymarket@imsnews.com

AUTOSPORT (USPS #54230) is published weekly by Haymarket Magazines Ltd, c/o Mercury International Ltd of 365 Blair Road, Avenel, New Jersey 07001. For subscription rates please contact:

Tel: 1-866-918-1446, Email: haymarket@imsnews.com

Periodicals paid at Rahway, NJ.

Postmaster please send address correction changes to AUTOSPORT, c/o Mercury International at above address.

**BACK ISSUES**

Tel: 0844 8488817

**DIRECT MARKETING EXECUTIVE**

Karen McCarthy, ext: 5658  
karen.mccarthy@haymarket.com

**MANAGEMENT**

**PUBLISHING DIRECTOR**

Peter Higham

**PUBLISHER**

Rob Altherne

**PUBLICATIONS MANAGER**

Samantha Jempson

**DIGITAL PRODUCT MANAGER**

Jim Foster

**SPECIAL EVENTS MANAGER**

Laura Coppin

**SYNDICATION SALES MANAGER**

Roshini Sethi, +44 208 267 5396  
roshini.sethi@haymarket.com

**HAYMARKET CONSUMER MEDIA**

Publishing, trade and further subscription details on www.autosport.com. While due care is taken to ensure the contents of AUTOSPORT are accurate, the publishers and printers cannot accept liability for errors and omissions. Advertisements are accepted for publication in AUTOSPORT only upon Haymarket Consumer Media's Standard Terms of Acceptance of Advertising, copies of which are available from the Advertising Sales Department of AUTOSPORT.

**CIRCULATION TRADE ENQUIRIES**

Frontline Ltd, Park House, 117 Park Road, Peterborough, Cambs, PE21 2TS. Tel: +44 (0)1753 555161. Printed in England by Wyndeham Heron Ltd. Cover and centre sections printed by CSM Impact, Basingstoke. Colour origination: Colour Systems, 20 St Penrose Road, London N19 5HS (editorial and advertising). ISSN 0269 946X. AUTOSPORT, incorporating Autoclassic, is published weekly by Haymarket Consumer Media, Teddington Studios, Broom Road, Teddington, TW11 9BE, UK.

**EDITORIAL DIRECTOR**

Mark Payton

**DESIGN DIRECTOR**

Paul Hargrin

**STRATEGY AND PLANNING DIRECTOR**

Bob McDowell

**MANAGING DIRECTOR**

David Prasher

**CHIEF EXECUTIVE**

Kevin Costello



PEFC Certified  
This product is from sustainably managed forests and controlled sources  
www.pefc.co.uk



Haymarket is certified by BSI to environmental standard ISO14001

## BAMBER'S WEEK

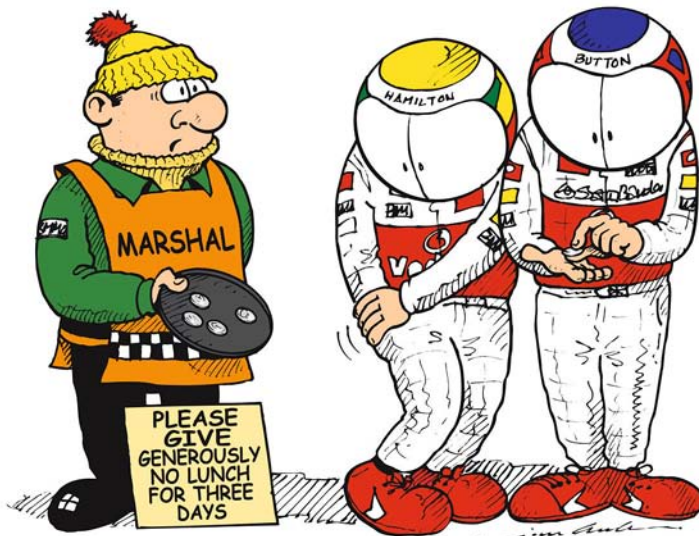

SPARE A THOUGHT FOR THE MARSHALS THIS YEAR, BECAUSE NOBODY ELSE WILL .....UNTIL THEY'RE NEEDED!

DAKAR RALLY

## Peterhansel continues his Mini adventure

Nine-time Dakar winner Stephane Peterhansel held on to his lead of the 2012 event as we closed for press earlier this week. The French Mini ace held an eight-minute advantage over team-mate Nani Roma and the Hummer of American racer Robby Gordon after a trek across the Atacama desert. Dakar report p88.

Pic: Lennon/Getty



THE AUTOSPORT APP -  
NOW ON ANDROID/iPHONE





# Rallying back from the brink after chaotic week

The WRC is on course to survive after a huge scare on the eve of the 2012 season. By DAVID EVANS

**T**he World Rally Championship has emerged from the most turbulent week in its history, but a possible £100m investment has been lost and the FIA has been left to foot the bill.

The astonishing chain of events began just under a week ago, when the FIA terminated its global promoter North One Sport's contract after the London-based

firm was found in breach of the agreement. As AUTOSPORT closed for press this week, Eurosport was expected to step in and film and distribute the WRC's TV coverage, starting from next week's opening round, the Monte Carlo Rally.

WRC Commission president Jarmo Mahonen spent Monday locked in meetings with Eurosport officials in a bid to hammer out

the agreement that will deliver television coverage and promotion for the sport in 2012 and beyond.

## WHAT WENT WRONG?

North One Sport's problems began in November when its parent company Convers Sports Initiatives went into administration, following the arrest of CSI's principal backer Vladimir Antonov.

NOS was forced to seek a buyer for the firm to continue to service the FIA's contract. First contact with a Qatari investment bank was made by NOS on December 23 and, after NOS staff worked through the holidays, the deal was planned for it to be bought out. Contracts had been expected to be signed for the purchase of NOS today (Thursday), before the deal fell apart.

A combative statement, issued by the FIA on Sunday night, said: "No firm offer to purchase NOS has been presented to the FIA. Not only has NOS failed to perform

in accordance with its contract, it has also been unable to secure the investment required to enable it to deliver the championship."

Speaking exclusively to AUTOSPORT, NOS chief executive officer Simon Long said: "The facts of the matter are that a formal offer was forthcoming and documentation was produced in support of a very significant plan to transform the WRC. It was communicated to the FIA that there was this opportunity and this offer on the table. But, for reasons best known to them, it was not deemed acceptable."

When the FIA terminated NOS's global-promoter agreement, set to run until 2020, there was nothing for the potential investor to buy and the deal, believed to be worth in excess of £100 million, collapsed.

## WHAT NOW?

While it is believed to be unhappy at the short-notice period before



## THE HISTORY OF NORTH ONE SPORT

The WRC's outgoing global promoter has existed in some form since the early 1980s.

### 1982

International Sportsworld Communicators is formed by Bernie Ecclestone to produce and distribute motorsport footage.

### 1996

ISC signs a 14-year deal for broadcasting 18 FIA championships, this is reduced to the WRC and the FIA's Regional series.

### 2000

ISC is sold to David Richards.



### 2007

Richards sells ISC to North One Television, allowing him to focus on the purchase of Aston Martin from Ford.

### 2009

ISC signs 10-year deal to become the WRC's global promoter, and later is re-named North One Sports.



The WRC has had to take a few leaps of faith

**“There was an offer on the table but it was not deemed acceptable by the FIA”**

NOS CEO Simon Long



Eurosport will take over TV

the Monte Carlo Rally, which starts on Wednesday (January 18), Eurosport is expected to film and distribute footage from the stages. The Paris-based company will likely do this for the remainder of the season, financed by the FIA.

Sources within the governing body have confirmed they hope to service all NOS agreements, while screening more action on Eurosport.

NOS had lined up new deals with ITV4 in Britain and for between 15 and 20 hours of live coverage from all 13 rounds on the championship's official website. It remains to be seen whether the FIA can deliver on those at such short notice.

Stage One Technology, the firm that runs timing and tracking in the WRC, is trying to resolve a legal battle aimed at preventing the equipment being used on round one. The Automobile Club de Monaco has its own kit that can be used on its event, which returns to the WRC for the first time since 2008.

**THE FALLOUT...**

While the reverberations were still being felt throughout the sport, the termination of NOS's contract hit home on Monday when around 60 full-time and part-time staff were laid off from NOS and NOTV.

Along with the loss of the staff, there is the loss of expertise from within the series, with many of the employees having worked in the WRC for more than a decade.

At this late stage, there will not be any calendar or sporting-regulation changes this year, but the Powerstage will not be filmed live from Monte Carlo. AUTOSPORT's sources in the governing body have confirmed the extra points will remain for the Powerstage, but funding the live footage from the final-stage shoot-out is likely to be left to the individual events.

Beyond this season, once a new global-promoter deal is in place, virtually everything will be under review.

**AUTOSPORT SAYS...**

**DAVID EVANS**  
RALLIES EDITOR

david.evans  
@haymarket.com



**W**hat next? Whatever next? The telephone conversations just kept getting more ridiculous last weekend.

“Have you heard?” demanded one caller, “Monte’s cancelled. It’s off. All off. And I hear the whole championship might be on its way as well.”

Mass hysteria ruled the World Rally Championship throughout last weekend. Fortunately, commonsense has prevailed and Valence followed by the Principality beckon. For some...

Not for North One Sport. After a decade of diligence, it's destination dole queue for far too many of the WRC's good people. It's easy to get caught up in the emotion of the moment and forget the failings of North One Sport, and there were some – ESPN springs to mind as a British consumer of WRC...

Then there were the unkept promises of mass investment and delivering the dream. And then, just as that dream and cash were on the horizon, the plug was pulled.

The FIA insists no offer was made by the Qatari contingent, while NOS insists it never got the chance to make an offer to a president who was on holiday in Bali.

Last time I checked, Bali was still on planet earth and serviceable via a conference call. So, did NOS not try hard enough or were they given the wrong number? It depends who you talk to.

The upshot of all this madness is, once again, letdown. When it might just have been liftoff.

NOS has spent a decade in WRC



**QUOTE OF THE WEEK**



The events are bigger than the promoter. We can be sure the 2012 WRC will run as planned”



FIA vice-president Morrie Chandler moved to quell fears from the organisers of rallies over the 2012 calendar after the recent disruption

**MARCH 2011**

Convers Sports Initiatives buys North One Sports.



**NOVEMBER 2011**

Arrest warrant issued for CSI backer Vladimir Antonov, and CSI goes into administration a week later.

**DECEMBER 2011**

North One Sports seeks a buyer or investor for the firm following the demise of CSI and Antonov's arrest.

**JANUARY 6 2012**

FIA terminates its contract with North One Sports, forcing it to close its doors just days later.



**RUBENS BARRICHELLO**

**PROS**  
 Vast experience  
 Technical knowledge  
 Established at Williams

**CONS**  
 Short-term option  
 Modest budget  
 Part of old regime

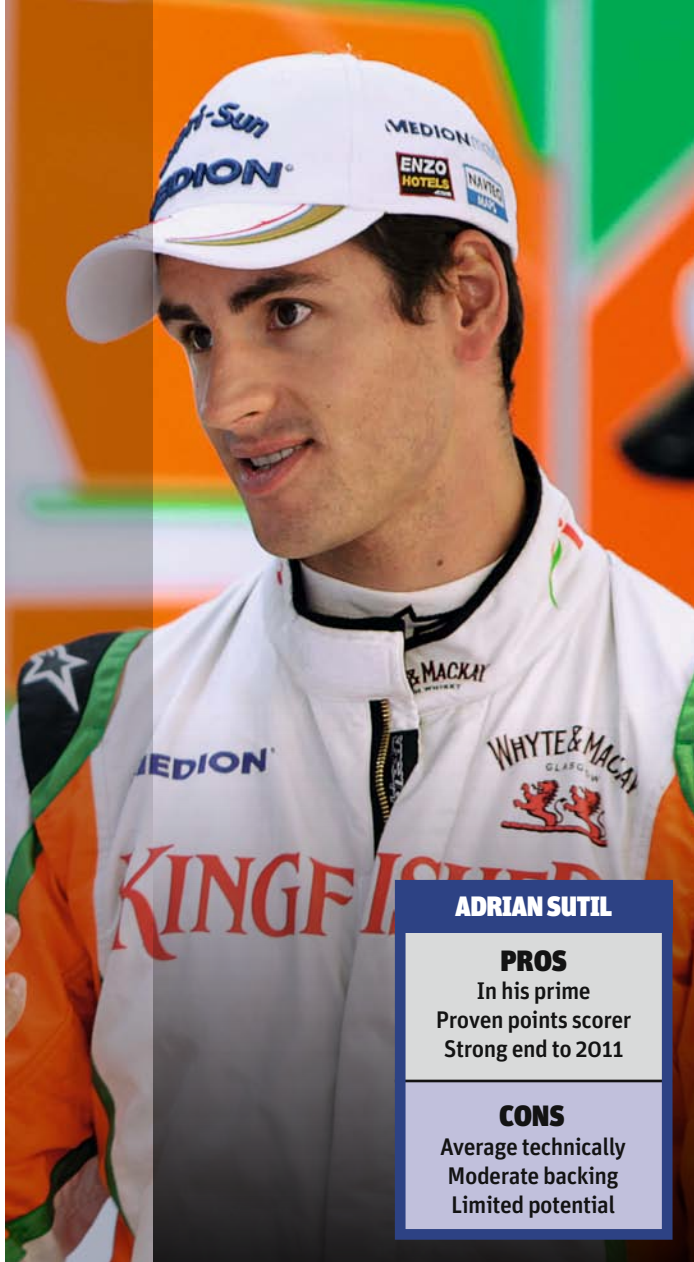

**ADRIAN SUTIL**

**PROS**  
 In his prime  
 Proven points scorer  
 Strong end to 2011

**CONS**  
 Average technically  
 Moderate backing  
 Limited potential



# Williams closing on driver decision

Off-season saga drawing to an end as legendary team ponders vital choice to complete its 2012 line-up

Williams is on the brink of making a final decision on its second driver for 2012, a choice that could make or break its season.

The team endured its worst Formula 1 campaign since it became a constructor last year, prompting a technical restructure. Ex-McLaren man Mike Coughlan succeeded Sam Michael as technical director, with former Toyota staffer Mark Gillan joining as chief operations engineer. Resources were then focused on ensuring that this year's FW34 is a significant step forward.

Gillan suggested late last season that Williams could realistically aim to move to the front of the midfield in 2012 – but the driver chosen to partner second-year pilot Pastor Maldonado will be crucial in developing the car and unleashing its full potential on the track.

Team sources indicate that Renault refugee Bruno Senna potentially has the strongest

commercial package, with a portfolio of backers in Brazil keen to bankroll him into a seat. The Brazilian, 28, showed good speed during his eight-race stint last year, but he lacks experience in F1.

Many at Williams favour the retention of veteran Rubens Barrichello. The 39-year-old has worked hard to raise sponsorship money in Brazil and is willing to race for a very low wage.

Barrichello impressed the



Maldonado is already signed up at Williams

**“Barrichello’s ability with engine maps furthers his cause as the team switches to Renault”**

incoming technical team – Gillan in particular – in the second half of last season and would provide the technical feedback to allow Williams to quickly develop a very different car to its 2011 machine.

Barrichello’s ability to work with engine maps, highlighted by his former team boss Ross Brawn, will further his cause. Williams switches from Cosworth to Renault powerplants this year and will spend the early stages of testing adapting to the engine.

Force India reject Adrian Sutil is neither the strongest contender on finance nor technical ability. Despite having proved himself as an accomplished driver, the German is

reckoned by some who have worked with him to be lacking in technical understanding. Even so, his five full seasons of race experience in F1 give him an advantage over Senna.

It is unclear how much budget Sutil, 28, has been able to offer Williams, and there is also the problem of how long he is willing to commit to the team. Williams would be looking for a one-year deal with options for the future, but Sutil’s management is aspiring to a switch to a top team in 2013, and could opt for a third-driver role with a squad such as Ferrari with the bold aim of stepping up in 2013.

Given the importance of starting the season strongly after a dismal 2011 season, Barrichello appears to be the strongest contender on merit. But financial concerns could put Senna, a driver who appears to have the potential to emerge as a good competitor at grand prix level, on pole position.



**BRUNO SENNA**

**PROS**

Big backing  
Untapped potential  
Intelligence

**CONS**

Inexperience  
Error-prone in 2011  
Unproven

Tonio Liuzzi seems unlikely to stay on



**HRT holds last empty seat**

**HRT IS THE ONLY OTHER** team yet to finalise its line-up for 2012, although Jarno Trulli's Caterham future remains in doubt.

Spanish squad HRT is close to a final decision, which could be made at the end of this week. GP2 race winner Giedo van der Garde, 2011 HRT driver Narain Karthikeyan and 18-year-old Auto GP champion Kevin Ceccon are among the contenders. The backmarker team requires a budget of more

than €5 million for the seat.

Several of the unemployed drivers from the 2011 season are out of contention for the HRT seat, with Vitaly Petrov, Jaime Alguersuari and Bruno Senna all not interested in joining.

Caterham appears increasingly likely to run Trulli, having previously come close to a deal with Red Bull to run new Toro Rosso recruit Daniel Ricciardo in his place. But a driver with a budget could still take the drive.

**AUTOSPORT SAYS...**

**EDD STRAW**  
**F1 EDITOR**

edd.straw  
@haymarket.com



**S**omehow, Rubens Barrichello never goes out of fashion. A few months ago, his 19-season grand prix career seemed dead and buried. Now, setting any financial considerations aside, he is surely the best choice for Williams as it ponders its 2012 driver line-up.

It's impossible not to admire Rubens. His enthusiasm remains boundless and, even with the temptation to treat last year's Brazilian Grand Prix as a valedictory outing, he never publically allowed himself to accept that it would be his last grand prix. He calls himself a man of the people, and proved it with his willingness to stop his car while leaving the track and spend a little quality time with those fans who had waited hours for him to appear.

Barrichello has never lost the conviction that he is a future world champion. Even now, with doubts over whether he will even be on the grid in 2012, his self-confidence will remain unshakable. Some may dismiss that as fantasy, but what it reflects is a determination to succeed that has remained undimmed over all his years in F1. There are some drivers a decade or more his junior who could learn a lot from his attitude.

If Williams does opt for Barrichello, it will be impossible to begrudge him a 20th F1 season. If it doesn't, then it will be time to celebrate the career of a driver who, although not quite world champion calibre, has earned huge respect in the grand prix paddock.



Still no farewell wave?

**ARRESTING THE DECLINE**

Williams hasn't won a grand prix since October 2004, and last season was its worst since the team was formed in 1977

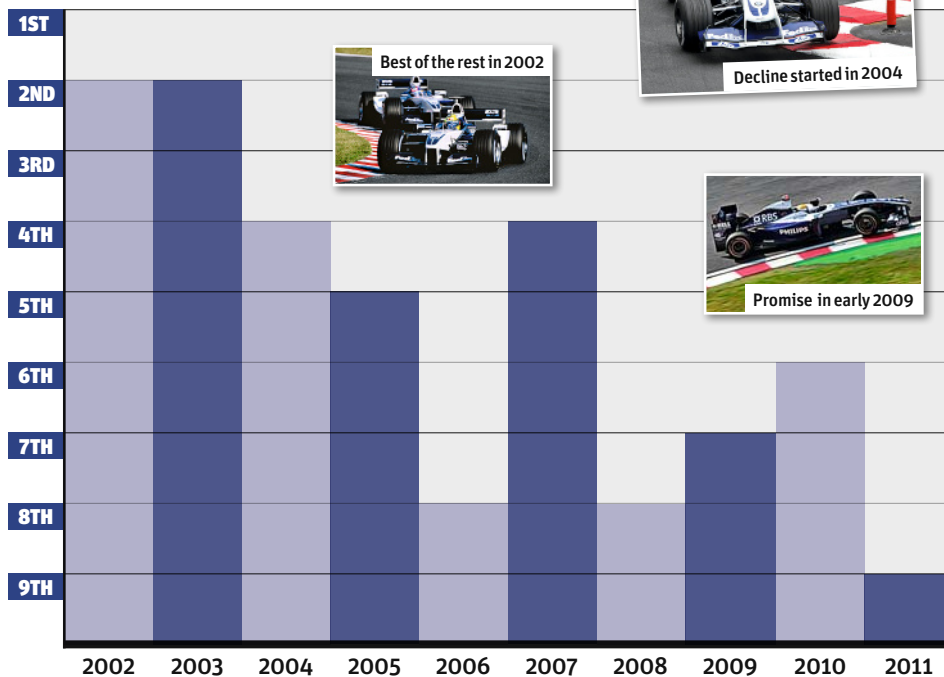

**READERS' POLL**

Who should Williams sign for 2012?

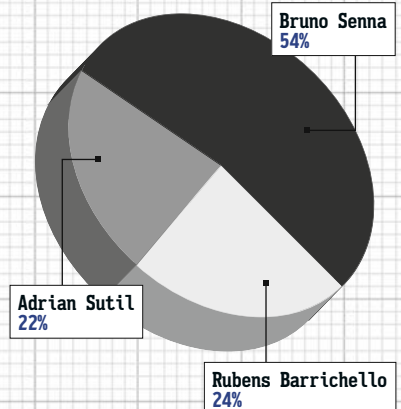

BE PART OF

# GINETTA

## 2012 CHAMPIONSHIPS

### GINETTA JUNIORS

G40 JUNIOR CAR FROM £26,950 + VAT

- // BTCC Support
- // Live TV coverage
- // 10 rounds
- // Highest profile Junior Championship
- // Full season from £16,000

### GINETTA CHALLENGE

G40 CHALLENGE CAR FROM £27,500 + VAT

- // British GT/F3 Support
- // TV coverage
- // 7 rounds
- // Class A - G40 / Class B - G20
- // Full season from £9,500

### GINETTA GT SUPERCUP

G55 CAR FROM £75,000 + VAT

- // BTCC Support
- // Live TV coverage
- // 10 rounds
- // Class A - G55 / Class B - G50
- // Full season from £31,000



TO FIND OUT MORE VISIT US AT  
THE AUTOSPORT SHOW (Jan 12/13/14/15)

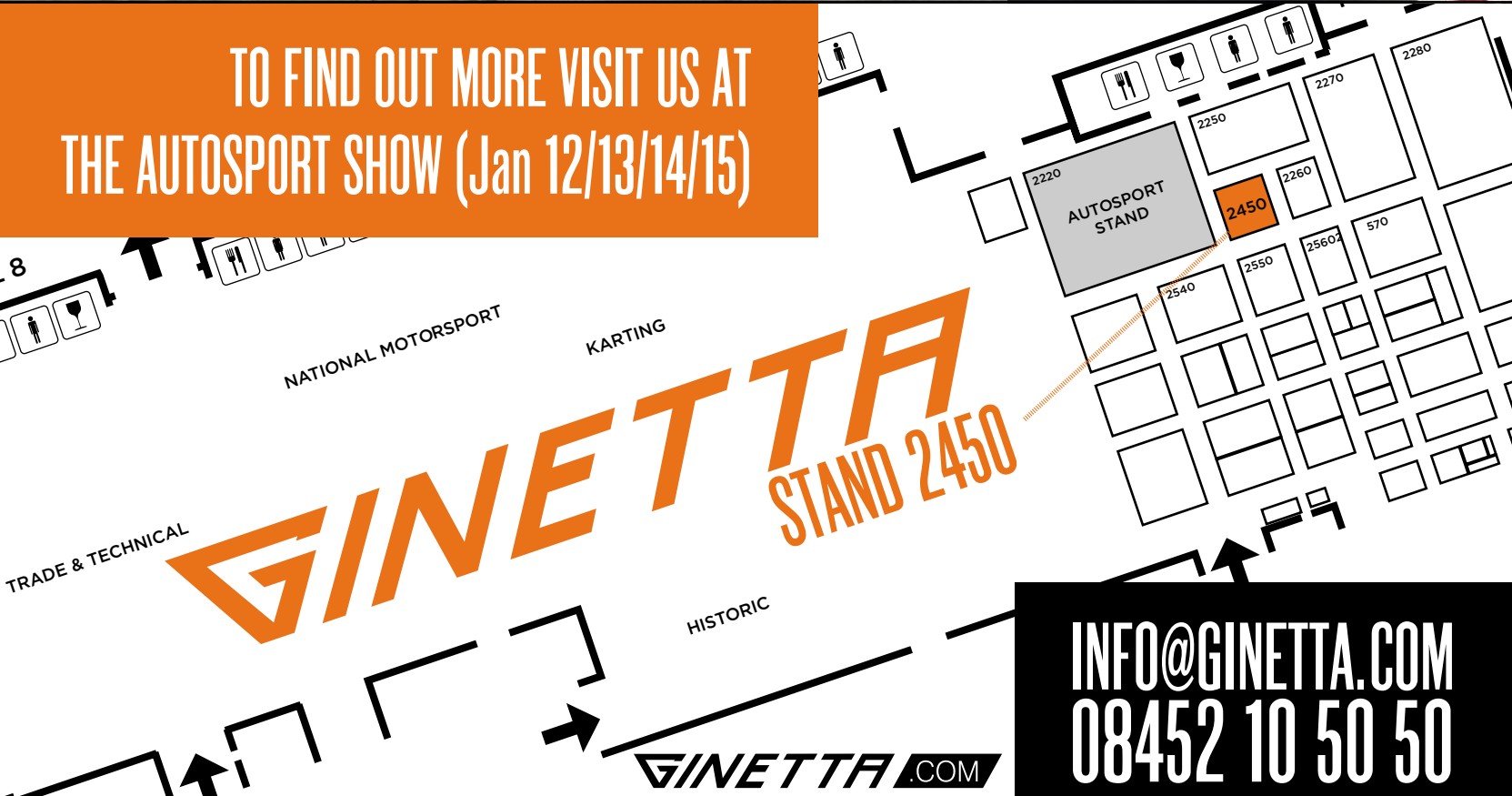

INFO@GINETTA.COM  
08452 10 50 50

# THIS WEEK IN F1

## OUSTED BUEMI LANDS RED BULL RESERVE ROLE

Toro Rosso refugee Sebastien Buemi will remain on Red Bull's books as the main team's third driver in 2012. Buemi will attend all races for Red Bull Racing and is also expected to drive in the simulator between events. He will also be available to fill in at Toro Rosso should either race driver, Daniel Ricciardo or Jean-Eric Vergne, not be able to compete.

BUEMI'S BEST F1 RESULTS

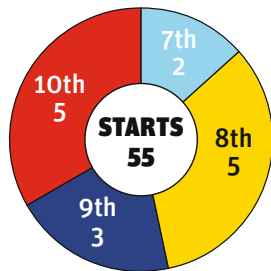

## BAHRAIN WARNING

Bahrain Center for Human Rights vice-president Nabeel Rajab has called on F1 teams to boycott April's Bahrain GP. "If they come, they are helping the government to say [the situation is normal]," he said. Race organisers have cited an independent report commissioned by the King of Bahrain that has tackled human-rights violations.

## DOUBTS OVER SPAIN'S RACES

Vice-president of the Valenciana region Jose Ciscar has revealed that he is seeking a reduction in the race-hosting fee paid to F1 boss Bernie Ecclestone to stage the European Grand Prix. The regional government is under financial stress and looking to save

money on the loss-making street-circuit event. The Spanish Grand Prix, which has been held at the Circuit de Catalunya since 1991, is also under threat after the local government expressed doubts over the affordability of hosting a race long-term.



Raikkonen at seat fitting

## RAIKKONEN TEST CONFIRMED

Lotus confirmed this week that 2007 world champion Kimi Raikkonen will test a 2010 Renault R30 to reacclimatise to Formula 1. The Finn, who visited the Lotus base at Enstone for his seat fitting last week, will drive at Valencia on January 23-24. "It felt a bit odd at first because the cockpit seems a bit small, but that's normal," said Raikkonen of his seat fitting.

795

Number of days between Kimi's seat fitting and the last time he properly sat in a Formula 1 car.

**"Toro Rosso was created to give young drivers a chance. Alguersuari and Buemi had it for three years and after this time it's possible to evaluate a driver's development. We haven't seen in them any possibility of growth. Both are worthy of grand prix racing, but for us that's not enough. We need winners"**

Red Bull's Helmut Marko explains Toro Rosso's axing of Jaime Alguersuari and Sebastien Buemi



## ALLEN JOINS 5 LIVE CREW

Former ITV F1 commentator, and sometime AUTOSPORT man, James Allen has been confirmed on BBC Radio 5 Live's F1 team for 2012. He will act as lead commentator, as well as providing news content for the station.



Blocking tweaks for 2012

## OVERTAKING RULES

The FIA released its regulations for the 2012 Formula 1 season last week. Among the new rules is one developing the "one-move" regulation on defensive driving, insisting that drivers must leave a car's width to the edge of the track once they have moved to block a rival.

## WILLIAMS LOOKS TO QATAR FOR NEW BACKER

The Williams team is hoping to tie up a new title-sponsorship agreement with Qatar's Qtel for the 2012 season. Its previous naming-rights deal, with AT&T, concluded at the end of 2011.

## FORCE INDIA ON COURSE

Force India's 2012 car is on schedule to appear at the first pre-season test on February 7 at Jerez. Technical director Andrew Green revealed that the VJM05 passed its mandatory crash tests before Christmas, even though the team kept up development of its 2011 car to the end of last season.



Covers will come off on time

# RADICAL RACES INTO 2012



**NOW FEATURING  
MOTORS TV COVERAGE**

JOIN THE 2011 RADICAL CHAMPIONS FOR ANOTHER SEASON OF THRILLING RACING IN THE RADICAL MASTERS EURO SERIES, RADICAL UK CUP OR RADICAL CLUBMAN'S CUP. RADICAL OFFERS EUROPE'S BEST ENDURANCE AND SPRINT SPORTSCAR CHAMPIONSHIPS WITH CHALLENGING, DRIVER-FOCUSED CALENDARS, RADICAL'S FAMOUS TRACKSIDE SPARES AND TECHNICAL SUPPORT, AND UNPRECEDENTED TRACK TIME OFFERING OUTSTANDING VALUE-FOR-MONEY.

**BOOK BEFORE 31 JANUARY 2012 AND RECEIVE AN ADDITIONAL 10% DISCOUNT OFF YOUR FULL SEASON ENTRY ON EACH SERIES.**

RACING THROUGH 2012 WITH RADICAL	RADICAL MASTERS EURO SERIES	RADICAL UK CUP	RADICAL CLUBMAN'S CUP
> 10 March: Snetterton 300			
> 14/15 April: Silverstone Grand Prix			
> 28 April: Donington Park			
> 03/05 May: Spa-Francorchamps (Belgium)			
> 12 May: Silverstone National			
> 26/27 May: Zandvoort (Holland)			
> 16/17 June: Brands Hatch Indy			
> 21/22 July: Paul Ricard HTTT (France)			
> 28 July: Oulton Park International			
> 25/26 August: Red Bull Ring (Austria)			
> 01 September: Cadwell Park			
> 15/16 September: Brands Hatch Grand Prix			
> 06/07 October: Donington Park International			
> 27/28 October: Snetterton 300			
> 02/04 November: Barcelona (Spain)			

**AUTOSPORT SHOW OFFER ENTRY: ONLY €10,683 ONLY €10,400 ONLY €3,374 +VAT**

**VISIT US AT AUTOSPORT INTERNATIONAL, STAND 2620, HALL 20. FOR MORE DETAILS OR TO SECURE YOUR ENTRY, CONTACT:**

**> AMANDA ABBOTT, RADICAL SPORTSCARS > +44 (0)1733 331616 > AMANDA@RADICALSPORTSCARS.COM > WWW.RADICALSPORTSCARS.COM**



# MPH Mark Hughes

AUTOSPORT grand prix editor

Perception is all: if you're not regarded as one of F1's finest, or the latest rising star, there's no place for you on the grid. Just ask Sebastien Buemi and Jaime Alguersuari...

**W**hen Toro Rosso announced a few weeks ago that it would be dispensing with both Jaime Alguersuari and Sebastien Buemi, there was a general reaction of surprise. But there really shouldn't have been. If the news underlined anything, it was that in F1 a driver has to be perceived to be either one of the very best or of showing potential to be. You're either moving up or moving out.

Being good enough to be on the F1 grid – as both the Toro Rosso guys were – doesn't justify your staying there. If you're treading water as a solid middle-of-the-pack competitor with no indication of being able to threaten the top guys were you to get in an equal car, then you're adding nothing either to the show or to the competitive aspirations of a team.

Alguersuari showed a useful, consistent ability to garner points even from unpromising grid positions, Buemi was on balance a faster qualifier, but within the

team – from the engineers looking at the data traces of tyre loadings and driver input – there was the belief that neither was accessing the full potential of the car. Neither liked the feeling of the car on the softer tyres, the way all cars squirm on the compound, and therefore was unable to squeeze out the last couple of tenths. That isn't the signature of a future champion and they had each been in the team for three seasons. They had stagnated.

Daniel Ricciardo and Jean-Eric Vergne now get the opportunity instead. If they stagnate they too will be out, but it just might be that one or both of them is a future ace. There are a few others still on the grid that really need to do more in 2012 than they have done so far to justify their continued place there.

Standing trackside at every venue, your eye becomes attuned to a car being driven at or close to its limits. Regardless of driving style, the body language of a car close to the edge is always evident. There were a few occasions when the Toro Rosso guys were visibly at that edge – Alguersuari at Singapore 2010 comes to mind – but it was the exception rather than the norm. When you then discuss driver performances with the engineers, they invariably tally reasonably well with what your eyes have told you.

So for all that F1 cars are easier to drive than they were, say, 15 years ago, they are still challenging enough that the great drivers can visibly separate themselves from the good ones. As F1 is considering the future, in particular its adoption of further green technology, it needs to ensure that this remains

the case. One of the keystones of the post-2013 'green' turbo formula will be enhanced KERS power and over the years there have regularly been requests from engineers to have the harnessing of braking energy from both axles rather than just the rear which we have at present. In efficiency terms, this makes obvious sense; because of weight transfer the front brakes are doing more than the rears.

But having KERS both front and rear opens the way for electronic stability control. Electronically programmed variation of torque loads on each end of the car will allow it to always be cornered to its maximum potential, with the inherent instability at these speeds taken care of by the computer rather than the driver. The margin where a great driver does his stuff would be wiped out. This was pointed out in this column some years ago when the original intention in F1 was to have KERS on both axles and Max Mosley, upon reading it and making further enquiries with, among others, Michael Schumacher, decreed that it would be on the rear wheels only.

But things like that tend to be forgotten over time – and if you think it sounds unlikely that the technology can be used in this way, you need to know that it's already making waves in sportscars. Last year Audi is believed to have evaluated recuperation devices on both axles. Apparently Peugeot found out and campaigned to the rulemakers to have two-axle KERS banned. The 2012 rules have indeed been tweaked to have it on the front or rear, not both. ❧

PIC: COATES/LAT



P45s for Buemi and Alguersuari

**“In Formula 1 you're either moving up or moving out”**



Minassian wants a change of scene

SPORTSCARS

# Minassian quits Peugeot

Frenchman walks away from sportscar giant because he wants more racing. By GARY WATKINS

**S**portscar stalwart Nicolas Minassian has quit Peugeot's Le Mans 24 Hours squad in order to seek a full-time drive for the coming season.

Minassian revealed that he has turned down the chance to remain with the in-house Peugeot Sport squad for a sixth season in 2012. The British-based Frenchman would not discuss exact details of the deal offered to him, but it is understood that he would have been given one or two additional races around Le Mans.

"The proposition I got from them wasn't what I was hoping for," said the 38-year-old. "I need to do more races and be fully involved in a programme.

"Two or three races a year isn't enough. The other problem is that the contract would have restricted me from racing elsewhere."

Minassian, who continued to test for Peugeot into December, became a free agent at the end of last month and has now started looking for another drive in earnest. He explained that his preference was to remain in the prototype ranks but that he was exploring all options.

He said he had no regrets about his time with Peugeot

"I had five good years with them and am leaving with my head held high," he said. "I had a difficult year in 2011 because of my crash [in testing at Paul Ricard

prior to the season], but I know I am still competitive."

Minassian's departure creates another vacancy at Peugeot, which revealed in November that it was expecting to make only two changes to its Le Mans line-up in 2012. It said it would only replace Toyota-bound Alex Wurz and Pedro Lamy, who has been released after a disappointing 2011 season.

It tested a number of drivers at the back end of the year. Ex-Formula 1 racer Lucas di Grassi, who is believed to have agreed a deal for the coming season, and prototype regulars Franck Mailleux, Olivier Pla, Loic Duval and Marino Franchitti are all known to have sampled a 2011-spec Peugeot 908 turbodiesel.

Multiple FIA GT1 World Championship race winner Frederic Makowiecki and 2009 Formula Renault 3.5 champion Bertrand Baguette were also tested by Peugeot. Nico Hulkenberg was also given a chance in a 908 prior to sealing a return to the F1 grid with Force India.

No comment was available from Peugeot about its 2012 driver line-up or speculation that it could run four cars. Peugeot traditionally announces its programme at the end of January or early in February.

Minassian has won for Peugeot



MINASSIAN'S SPORTSCAR STATS

**12** LE MANS 24 HOURS STARTS

TOP-SIX FINISHES AT LE MANS

**5**

**7** LE MANS SERIES VICTORIES FOR PEUGEOT

LAPS TO GO IN THE 2008 LMS FINALE AT SILVERSTONE WHEN HE CRASHED OUT AND HANDED AUDI THE TITLE

**2ND** BEST RESULT AT LE MANS

**150**

MARGIN OF HIS FASTEST LAP AT LE MANS 2009

**0.492s**



Artist's view of Delta's ORECA

WORLD ENDURANCE

# UK squad aims for manufacturer deal

**DELTA MOTORSPORT IS TO** become an entrant for the first time in this year's new FIA World Endurance Championship as part of a multi-year plan to land a manufacturer LMP1 deal. Delta, which designed and built the Grand Prix Masters single-seater racer of 2005-06, will field at least one ORECA-Nissan O3 LMP2 in the championship. It has joined forces with Alan Docking Racing, with which it previously worked

in Superleague Formula, to help run its operation. Delta managing director Simon Dowson said: "We are already working on hybrid projects in the automotive sector and our ambition is to work with a manufacturer in LMP1. To get to that point, we recognise that we have to showcase ourselves as a winning team. "Our goal is to win the LMP2 championship this year and move into P1 in 2013 as a privateer, but

using hybrid technology. The aim is to be working with a manufacturer by 2014 and be designing and building a car for them by 2015." The lead car will be driven by John Martin, who won last year's truncated Superleague series with the Docking squad, ex-British Formula 3 champion Robbie Kerr and Tor Graves, who will be the mandatory amateur driver in the line-up. The team is working on putting together a deal for a second WEC entry.

## IN BRIEF



KC looks set to race an HPD

Maserati in 2010 will run a pair of Z4 GT3s.

### NEW LOLAS FOR DYSON

Dyson Racing has purchased two new Lola LMP1 coupes in a bid to win the American Le Mans Series for the second year running. The cars will replace its 2008-vintage LMP2-based Lolas.

### NEWSHAM JOINS TEAM ES

British Touring Car Championship racer Dave Newsham has joined Team ES. The ex-Clio champ made his debut last year and scored his best result – fourth – with a Special Tuning SEAT. ES will announce its choice of car later this month.

### REBODIED RILEY DEBUTS

The rebodied Riley DPG3 MkXXVI made its public debut at last weekend's official Daytona test. The two Ganassi machines and solo Shank car ran so-called 'Standard' Riley aerodynamics, while the Bob Stallings/GAINSCO racers used the Corvette-styled bodyspace. Max Angelelli was fastest in the SunTrust Racing Corvette-bodied Dallara.



Shank car: 'Standard' aero

BLANCPAIN SERIES

# Full-time comeback for Blundell



Blundell back in a McLaren

### FORMER GRAND PRIX DRIVER

Mark Blundell will undertake his first full season of racing in 12 years at the wheel of a McLaren.

The former McLaren F1 driver, who also raced a McLaren F1 GTR at the 1995 Le Mans 24 Hours, will drive one of the British organisation's MP4-12C GT3s for the Anglo-American United Autosports team in the Blancpain Endurance Series. The move follows sporadic race appearances over the past two seasons, including two starts in the Spa 24 Hours and one in the Daytona 24 Hours.

Blundell, whose last full season was his final in Champ Car in 2000, said: "Doing those races last year, especially Daytona, made me start to think about a full season. Daytona proved the speed was still there, but also that the enjoyment was still there."

The 45-year-old Briton will share the United McLaren with team boss Zak Brown and Mark Patterson.

## AUTOSPORT SAYS...

**GARY WATKINS**  
INTERNATIONAL  
EDITOR-AT-LARGE



Of course Nicolas Minassian doesn't want to do just a couple of races a year – he's a professional racing driver and a successful one at that. But it wouldn't have been a problem for Peugeot if he had. It knew it could strap him into the car at Le Mans and that he would do the job.

There's a band of drivers from which Peugeot can choose to take his place. Just look at the list of names it has tested. But that situation could be different a couple of years down the line. There's going to be an inevitable changing of the guard as the current stars of sportscar racing near the end of their careers, which will be combined with an increase in demand as new manufacturer squads bolster the grid over the next few years.

There will, of course, be a pool of quick single-seater drivers looking to make the transition to long-distance racing, but the problem for Peugeot, Audi, Toyota and Porsche is going to be finding drivers with the experience necessary to win the Le Mans 24 Hours. They're not going to get that by doing two or three races a season.



Minassian has stepped out

## REMEMBER WHEN...

JUNE 19/20 1994



... Minassian made his Le Mans debut? He was racing in French Formula Renault for Alfa, who reworked a Sauber into this Alfa-Ford LM. He shared with Patrick Bourdais (Sebastien's dad) and Olivier Couvreur.

**Melbourne - 18 March**

**AUSTRALIAN GRAND PRIX**

5 Nights Melbourne  
Melbourne & Sydney  
2-Centre Holiday

**June 16/17**

**LE MANS 24 HOURS**

Self-Drive Packages with  
Hotel or Camping  
Coach Tours & Paris Stop-Overs



**Sepang - 25 March**

**MALAYSIAN GRAND PRIX**

5 Nights Kuala Lumpur  
Australia & Malaysia  
2 Grands Prix Holiday

**Valencia - 24 June**

**EUROPEAN GRAND PRIX**

Stay in Valencia  
Weekends & Longer Tours

**Budapest - 29 July**

**HUNGARIAN GRAND PRIX**

Weekend By Air  
Budapest & Vienna  
2-Centre Holiday

**Shanghai - 15 April**

**CHINESE GRAND PRIX**

Direct Flights with 5 nights  
in Shanghai

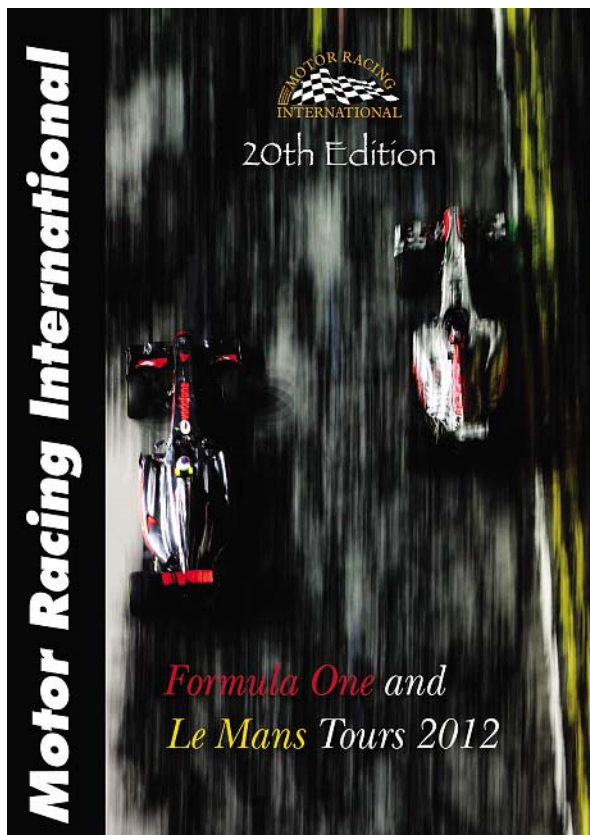

**Spa - 2 September**

**BELGIAN GRAND PRIX**

Selection of Tours by  
Coach, Air or Eurostar  
Self-Drive Packages

**Barcelona - 13 May**

**SPANISH GRAND PRIX**

Wide Selection of Weekend  
and  
Longer Tours by Air

**Monza - 9 September**

**ITALIAN GRAND PRIX**

Weekends and Longer  
Tours  
Based in Como

**Monte Carlo - 27 May**

**MONACO GRAND PRIX**

Full Programme of  
Arrangements  
including Flights and Hotels

**Singapore - 23 September**

**SINGAPORE GRAND PRIX**

Spectacular Night Race  
Direct Flights  
5 nights in Singapore

**Montreal - 10 June**

**CANADIAN GRAND PRIX**

4 Nights in Montreal  
Montreal & Niagara Holiday

**Hockenheim - 22 July**

**GERMAN GRAND PRIX**

Heidelberg based Tours by Coach or Air  
Self-Drive Packages

**Austin - 18 November**

**UNITED STATES GRAND PRIX**

Texas Hosts F1's  
Return to America

[www.motorracinginternational.uk.com](http://www.motorracinginternational.uk.com)

The 20th edition of the MRI Tour Collection is now available. Visit our website for full details. As ever, we will be featuring each and every round of the F1 World Championship and the Le Mans 24 Hour Race. A small selection of our vast choice of travel arrangements is outlined above.

Put your trust in the UK's only fully bonded, independent motorsport travel specialist.



Apply NOW for your FREE brochure Ring our 24 hour dial-a-brochure service quoting reference AS5  
TEL. 01304 612424 | [info@motorracinginternational.uk.com](mailto:info@motorracinginternational.uk.com)



Bottas will focus solely on F1 role

FORMULA RENAULT 3.5

# Single focus for Bottas

No dual Formula 1/World Series campaign for Williams Friday driver in 2012

**R**eigning GP3 champion Valtteri Bottas has decided against combining a Formula Renault 3.5 campaign with his third-driver role for Williams in Formula 1.

The 22-year-old will drive in the first free practice session of the weekend at 15 grands prix this year for Williams, and he had been looking at options to enable him to dovetail that experience with race outings. AUTOSPORT understands that Williams has not mandated

that the Finn cannot race this year, but it recommended that he focused on his test driver duties.

"We decided it would be quite difficult to do another series and really focus," Bottas told AUTOSPORT. "It would involve quite a lot of jumping from one car to another and that wouldn't help. So we decided the best solution was to focus completely on the F1 side.

"World Series was an option, and I think it was the main option. But

if the F1 is the only thing I am driving this year then I can try to learn as much as I can and do it properly."

Bottas added that he is not worried about losing his race sharpness by spending a year out of competition.

"We thought about that, but I think one year out of racing will not do any harm," he said. "I've been racing since I was six years old so it will not go away in one year."

FORMULA 2

# Tyre change promises more speed

**FORMULA 2 ORGANISERS BELIEVE** that their car will be quicker by as much as two seconds per lap due to the tweaks being introduced for the new season.

Chief among the changes, which were scheduled to be announced at AUTOSPORT International today (Thursday), is the switch in tyre supplier from Avon to Yokohama, while carbon brakes will also be introduced to reduce weight and improve performance. The new package was recently tested by reigning series champion Mirko Bortolotti at Barcelona.

F2 chief executive Jonathan Palmer said: "We're confident our new tyres will deliver



Bortolotti gave the new F2 package a thumbs up

enhanced performance both in terms of pace and also consistency. This forms a significant part of an upgrade package that will see the car lap around two seconds faster than its 2011 equivalent."

Bortolotti reported that his initial impression of the changes were positive. "The new tyres suit the car perfectly, and

combined well with the new brakes, which are 12 kilos lighter and allowed me to brake harder and later," he said.

AUTOSPORT understands that further upgrades, including revisions to the way overboost is used during a race weekend, may be introduced in time for the season-opener at Silverstone in April.

## IN BRIEF



Coletti has joined Coloni

### COLONI LINE-UP SORTED

Scuderia Coloni has confirmed its GP2 line-up for 2012, with series regular Stefano Coletti set to return alongside rookie Fabio Onidi, who is a racewinner in Auto GP and Euroseries 3000. "We are heading towards the season with a promising and competitive line-up," said team boss Paolo Coloni.

### ARIC REPLACES AJ

Aric Almirola has been confirmed as AJ Allmendinger's replacement at Richard Petty Motorsports. The 27-year-old, who finished fourth in the NASCAR Nationwide Series last year, has been signed on for one season.

### REUTIMANN FINDS A DRIVE

David Reutimann will remain in the NASCAR Sprint Cup this year after securing a deal to race alongside Dave Blaney at Tommy Baldwin Racing. Reutimann was left without a drive when Michael Waltrip Racing replaced him with Mark Martin late last year.

### STENHOUSE FOR DAYTONA

NASCAR Nationwide Series champion Ricky Stenhouse Jr will race at the Daytona 500 after being picked up by Roush Fenway to drive its #6 car, previously used by David Ragan.

### WHITT GETS JR CHANCE

Cole Whitt will graduate to the NASCAR Nationwide Series with JR Motorsports this year. The 20-year-old Craftsman Truck frontrunner will drive the #88 entry formerly steered by Brad Keselowski and Aric Almirola.

### BARNHART REPLACEMENT NAMED

IndyCar has named former ALMS race director Beau Barfield as its replacement for the oft-criticised Brian Barnhart. Barfield, who has also been tasked with rewriting the rule book, has promised better communication and more consistent decisions.



Barfield replaces Barnhart



# The Finest Collection of Motor Sports Holidays Worldwide

INCLUDING: F1, MOTOGP, WORLD SUPERBIKE, DAYTONA 500, MONACO HISTORIC, LE MANS 24 HOURS & LE MANS CLASSIC.



We offer flexible arrangements with a choice of airports, hotels and race tickets.

## Call us now to discuss your plans for 2012!

Book with the team you can trust - your experience will exceed your expectations

We are exhibiting at Autosport International - come and visit us, we are on stand 6932



# 0845 375 0300

Please quote AS1201

or visit [www.grandstandmotorsports.co.uk](http://www.grandstandmotorsports.co.uk)



W8164 / Y1735

A00465 -GS

See the full range at  
Autosport Engineering  
Show - Stand E662



web: [www.stand21uk.com](http://www.stand21uk.com) email: [sales@stand21uk.com](mailto:sales@stand21uk.com) tel: 01474-855319

## Stand 21 Club Series HANS Device

Serious Protection,

Sensible Price

Now from £299\*

Weight: 950g



Winged shoulders:  
Superior harness location

Reduced rear panel height:  
Improved helmet and seat clearance

Ergonomic yokes:  
Latest design to aid comfort

\*excluding VAT

weights include tether and padding, remove 130g for raw part weight

Weight: 610g



Stand 21 Hi-Tec  
HANS Device

Lightweight Aerospace  
Carbon Construction  
Now from £762.50\*

Weight: 850g



Stand 21 RS2  
HANS Device

Unique Compressed  
Carbon Construction  
Now from £482.50\*

WE STAND FOR SAFETY AND QUALITY!



GT

# Sims lands McLaren chance

McLaren AUTOSPORT BRDC Award winner joins up to race a McLaren MP4-12C GT3

Sims switches to sportscars

**G**P3 race winner Alexander Sims has put his single-seater career on hold to race a McLaren MP4-12C GT3 in 2012.

The 2008 McLaren AUTOSPORT BRDC Award winner has been signed up by the McLaren Group as one of its development drivers for the coming season. As part of the deal, the 22-year-old will be placed at one of McLaren's customer teams.

Sims said that he explored moving into sportscars after being

dropped by Gravity Sports Management, which funded his GP3 season last year with Status. McLaren was his first port of call because of his links with the company through the Award.

"With everything at Gravity coming to an end, I wasn't going to be in a position to move up to GP2 or Formula Renault 3.5," he said. "The focus was then on how I could continue racing, although I'm not closing the door on single-seaters."

His deal was secured with McLaren after a successful test in one of the development MP4-12Cs at Jerez prior to Christmas.



McLaren is building up its driver roster

Two-time Le Mans Series GT2 champion Rob Bell has also joined McLaren's roster of drivers for 2012.

"It was a wrench to leave Jim McWhirter [whose Ferraris and Aston Martin he raced at the JMW and Virgo teams in 2007-11], but the holy grail of any professional driver is a factory deal," he said.

Alvaro Parente has extended his deal with McLaren into 2012 and Oliver Turvey is expected to do the same.

INDYCAR

## Hinchcliffe becomes Wheldon replacement at Andretti

### LAST YEAR'S INDYCAR SERIES ROOKIE

of the Year James Hinchcliffe has been confirmed as the late Dan Wheldon's replacement in the GoDaddy-backed Andretti Autosport entry for this season.

Wheldon had signed on at last year's Las Vegas finale to take the seat being vacated by NASCAR-bound Danica Patrick, just hours before his fatal accident.

Hinchcliffe said that he felt privileged to be filling Wheldon's position.

"It's pretty common knowledge that Dan was a shoe-in with GoDaddy and Andretti," said the 25-year-old Canadian.

"I look at Dan Wheldon as a tremendous race car driver and a champion, but also as a tremendous person. I'm going to think him about every time I get in that car."

Hinchcliffe finished 12th in his debut season with Newman/Haas last year, with best results of fourth at Long Beach, New Hampshire and Kentucky.

## IN BRIEF

### INDYCAR CALENDAR UPDATE

A street race in Fort Lauderdale, Florida has emerged as the likeliest contender to replace Las Vegas as the final round on this year's IndyCar calendar. There are also talks about a possible return to Milwaukee, despite the track originally being dropped for 2012 due to poor attendances.

### 'TAG' SIGNS WITH HERTA

Canadian IndyCar veteran Alex Tagliani has been confirmed as driver for Bryan Herta Autosport for the team's first full IndyCar season. Tagliani will also help with the initial development runs for the new Lotus engine this month before official testing in February.

### WILSON RETURNS TO COYNE

Briton Justin Wilson has reportedly joined Dale Coyne Racing for the upcoming IndyCar season. The 33-year-old, who missed six races last year with a back injury, gave Coyne's team its maiden victory in 2009 before switching to Dreyer & Reinbold.

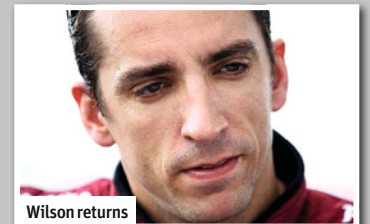

Wilson returns

MIS Motorsport - setting the standards in motorsport insurance

ON TRACK / ON EVENT / MOTOR TRADE /  
PERSONAL ACCIDENT / COMMERCIAL / LIABILITY

www.mismotorsport.com or call 01943 884 555

M.I.S. Motorsport Ltd is authorised and regulated by the Financial Services Authority.

**MIS**  
MOTORSPORT

**Dunlop Tyres - Equipped with Motorsport Technology.**  
Experience real grip and high performance braking.



**BMW Motorsport** 

**Technical Partner**



**DUNLOP TYRES**  
with Motorsport Technology

When it comes to winning on the track, teamwork and technology are everything. At Dunlop we work closely with leading vehicle manufacturers such as BMW, both on the track and on the road. Through these strong working relationships we're able to consistently develop cars with superb grip and excellent braking.

Dunlop tyres are tested under extreme motorsport conditions during some of the worlds most iconic endurance races such as Le Mans, Nürburgring and Silverstone 24 Hours.

Visit [www.dunloptyres.co.uk](http://www.dunloptyres.co.uk) to find out more.

 **DUNLOP**  
**DRIVE WITH CONFIDENCE**



New-for-2012 Fiesta has internal tweaks

WRC

## Ford makes cockpit tweaks to Fiesta

**FORD'S FACTORY DRIVERS WILL SIT** lower and further back than ever in their cars in 2012 following changes made to the Fiesta RS WRC that will challenge Citroen.

While regulations preclude significant technical changes to the current World

Rally Cars, Ford has sought to further lower the centre of gravity of the car ahead of the Valence-based season opener.

Jari-Matti Latvala said: "I am sitting 10cm lower and further back. Sometimes I have to lift my head a little bit when we are

coming to the crest, but I will get used to it."

The car Latvala and Petter Solberg will drive was unveiled at AUTOSPORT International today (Thursday). The new colour scheme shows Solberg's personal sponsors on the front spoiler.

### IN BRIEF



Ostberg gets 11-round deal

#### OSTBERG STAYS AT FORD

Mads Ostberg will remain in a Ford Fiesta RS WRC for an 11-round programme in this year's world championship. Ostberg, who twice finished on the podium in WRC rounds last year, will not contest next week's Monte Carlo Rally and is also likely to miss Rally New Zealand.

#### TOP TEAMS WRAP UP TESTING

Ford, Citroen and Mini will all be concluding their Monte Carlo Rally tests in the south of France this week. Ford and Citroen have so far run on dry and wet asphalt, but nobody has run on snow in the Alps yet. The long-range forecast for next week's season-opening WRC round is largely dry, with the possibility of snow falling for the Saturday night (January 21) run over the Col de Turini.

WRC

## Loeb: Hirvonen can fight

World champion rubbishes rumours of number-two status for new Citroen team-mate

**S**ebastien Loeb has scotched suggestions that his new Citroen team-mate Mikko Hirvonen will not be allowed to fight him for the World Rally Championship this year.

It has been rumoured that Hirvonen has been signed as Loeb's number two for 2012, but the eight-time world champion is adamant that the pair will be allowed to fight each other for the first half of the season.

Loeb said: "Mikko is the number two, but if the number two is beating the number one then he will be the number one – it's not really a number two. If he beats me in Monte Carlo and Sweden, then he is in front. At the moment, I consider that Mikko will be quite an interesting rival in the season and I think he has some good feeling with the car."

Hirvonen moved to Citroen after Loeb's 2011 team-mate Sebastien Ogier departed for Volkswagen. The two Frenchmen struggled to work together in the Versailles-based team and the relationship ended with an acrimonious split.

Loeb admitted he and Hirvonen



Loeb hopes for happier time than with Ogier

would be starting on a better footing. While the new Citroen team-mates haven't yet worked together at a test, they have shared set-up data and information with each other via their engineers.

"Mikko and I are friends. I hope it will be different from last year," he added. "I hope we can do a good and friendly job, but also we have to fight together. If he is faster, he is number one."

In previous seasons, Citroen has made it plain that its two drivers start the season on equal footing

before making a strategic decision halfway through the year. Loeb said he expects that to continue.

He said: "If Mikko is leading the championship after the first half then for sure we will not tell him to go behind [me]."

Loeb said he also welcomed news of Yves Matton's return to the Citroen fold, in place of outgoing team principal Olivier Quesnel.

He said: "I know him [Matton] quite well from the past. I have a strong relationship with him, so it will be good."

Ford has tested on dry asphalt



#### SKODA PAIR TOP JANNER

Skoda factory pair Jan Kopecky and Juho Hanninen overcame heavy snow to take a one-two finish on last weekend's Janner Rallye in Austria. The event was running as a European Rally Championship round for the first time. Former world rally champion Stig Blomqvist finished 15th in a Group N Mitsubishi.

#### MOUTON HONOURED IN FRANCE

WRC rally winner Michele Mouton was honoured by French president Nicolas Sarkozy with the Chevalier of the Legion d'Honneur in Paris late last month. Mouton dedicated the French equivalent of a knighthood to her late father: "He did everything for me," said Mouton, "including making the decision I should become a driver rather than a co-driver."

#### RALLYDAY NOW IN AUGUST

This year's Rallyday has moved forward due to Rally GB's September date. The Castle Combe event runs on August 18.



GUEST EDITOR: DARIO FRANCHITTI

# Honouring my hero: Jim Clark



Jim Clark is my hero, the driver I most admire. I was thinking hard about this the other day, preparing for my guest-editor role, because Jackie

Stewart is obviously a huge hero of mine too. So, I asked myself, what's the fundamental difference between the two? After all, anyone who's into motor racing in Scotland is immensely proud of both of them.

The big difference is that Jackie is still here, and he's always been here for me. In fact, I can pick up the phone right now and call him. I raced for his team for three fantastic years. But Jimmy...

He died five years before I was born, so I never had that chance to know him. That's a big part of it, that lack of connection, and the rest is obviously the way Jimmy went racing, his exploits on and off the track, and his great achievements.

In fact, my true obsession with Jim Clark began when Jackie called me in 1993 and invited me to a dinner to commemorate 25 years since Jimmy's passing. I was sitting next to people who'd grown up with Jimmy, his friends and colleagues, and the stories I heard that night were simply amazing about how he would charge around the back lanes of the Borders in racing cars. That flicked a switch in me.

Like me, Jimmy went to school in Edinburgh – but it sounds like he enjoyed it about as much as I did! But when Ian Scott Watson put him in that first racing car, the fuse was lit and there was no stopping him. He moved from a local racer to a national racer – in D-types and other serious stuff! – to an international superstar so quickly. He hooked up with Colin Chapman, and from there, with Colin's brains and Jimmy's skills, it took off.

Clark and Chapman were a force that dominated the racing world. Twenty-five grand prix

wins, 33 poles, 28 fastest laps and success across Indycars, F2, sportscars and touring cars. In a period where cars were very fragile, that's a very impressive strike rate. On many days, they were simply unbeatable.

You can marvel about the variety of cars he drove in his career – but often he was driving that vast array on a single weekend! That was what made him incredible to me, how he could jump from one car to another – a completely different machine – and deliver the same, top-notch performance week-in, week-out.

I've been lucky enough to drive the Lotus 25, a 1.5-litre F1 car, and then jump into the Lotus 38 Indycar with 500bhp – and the difference between the two is massive. To be that adaptable, to win a grand prix in the 25, then win the Indy 500 in the 38 and then go back to wrap up the F1 world championship... Incredible!

When I drove the Lotus 38 around Indy it was amazing, a fantastic experience, but it was a relatively big car compared with the 25. It felt so small and fragile, and gave me a huge appreciation of what those guys did back then.

You sit there, look at the fuel tanks that surround you – over the tops of your leg and down the sides of you – and you think, 'my God!' You can't really move your arms, because of the size of the cockpit, so you're driving from your wrists. Anybody who jumped in those cars at the time was incredibly brave, and you could see why not all of them that did survived.

Obviously something that's very apparent to me is the way Jimmy adapted to the intricacies of oval racing from his road-course racing background. He'd been there in 1963 and '64 before he won there in '65, but adapting to the tyres, the huge fuel-loads, the pitstops – it didn't take him long to get it all figured out.

For me, winning my first Indy 500 in 2007 to emulate what Jimmy had done 42 years earlier



**“He jumped from car to car and delivered a top-notch performance week-in, week-out”**



Franchitti emulated hero Clark in 2007

made it extra special. Following in his footsteps, having my name on the same page of the history books and my face on that same Borg Warner Trophy – that is really, really cool.

What would Jimmy have gone on to achieve had we not lost him in that Hockenheim F2 race? I was at Father David Leslie's funeral recently, having lunch with guys from the Scottish Motor Racing Club, and Sandy Denham was talking about that exact 'what if?'. And it was fascinating to hear his thoughts and ideas on what might have been. Lotus still had lots of life in the 49 and the 72 was just around the corner. How long would Jimmy have carried on racing for? It was such a dangerous period. While it's interesting to speculate, it's also kinda sad to reflect that we'll never know.

I tell you what would have been amazing to watch: Jim Clark versus Jackie Stewart. Jimmy was a few years ahead of Jackie, but when Jackie was breathtakingly quick too, and really got into his stride with Tyrrell. Both of them racing head to head at the top of their game... How awesome would that have been to see? ❧



Franchitti sampled Clark's 1965 Indy 500-winning Lotus 38 at Indianapolis in 2010



Trademark dark helmet and goggles: unmistakably Jim Clark

## Contents

### 26 Boy from the Borders

AUTOSPORT's profile from early 1960 on the hotly-tipped Clark



### 30 Cedric Selzer

Looking back at the 1960s with Clark's Team Lotus mechanic



### 36 His final chapters

The successes continued as Clark the businessman grew tougher



### 40 Great car: Lotus 49

DFV-powered jewel that moved the F1 goalposts as a debut winner in '67



## Next week



### JACKIE STEWART

Britain's only three-time Formula 1 world champion gets the AUTOSPORT Legend treatment

# From humble beginnings a superstar emerges

Jim Clark was profiled in AUTOSPORT in 1960. He was a man with his feet on the ground, and who was pessimistic about his chances in the 1500cc F1...





After 1959 AUTOSPORT 3 Hours win at Snet

When a famous works team like Aston Martin gives a young man, with only three years' club racing experience, a trial in a grand prix car, it must mean that the young man in question is possessed of the latent qualities that many, many people would like to possess themselves, but very, very few in fact do – ie those of a brilliant racing driver.

Recently Aston Martin invited Jimmy Clark down to Goodwood for testing, and Jimmy, who had only sat in a single-seater twice before in his life, covered about 50 tours, lapping between 1m30s and 1m31s, his fastest being 1m29.8s, and all this on a damp track. From this you will appreciate that Jim obviously has what it takes to become a grand prix driver. All he lacks is experience with really fast machinery.

It was in June 1956 that Jim first set wheel to track at Crimond, where he drove a DKW. Three months later he drove the DKW and a Mk2 Sunbeam at Brunton Beadnell High Speed Trials. That was the sum total of his '56 racing. The next year, he used the DKW again at Charterhall in June, and then in the October meeting he won three races in one day, this time in a Porsche. He also did a few rallies and sprints in the DKW and the Sunbeam.

In 1958 Jim joined Border Reivers. It was through Ian Scott Watson that Jim got his first taste of racing, for they met in '55 and quickly struck up a friendship. Jim used to go along as Ian's mechanic when the latter went racing. When Jim joined the Reivers they had just purchased the ex-Murkett Brothers D-type Jaguar and it was in this machine that he started out on the '58 season.

His first race was at Full Sutton in April where he gained two firsts with the Jaguar and a sixth with the Porsche. At Winfield a few days later he claimed a first and a second with the Porsche. Then came his first continental race: the Sports Car Grand Prix of Spa, where he came home a very creditable eighth in the D-type. He didn't like Spa very much – "it was too fast for me then!"

His final race that year, a second at Boxing Day Brands in a Lotus Elite, was his first in the Hornsey-built car. Jim and Ian Scott Watson caught the night train to London from Scotland, picked up the car at Green Park and drove it straight down to Brands. There they stuck some numbers on it and Jim went racing. For eight out of the 10 laps

he led but then a Sprite lost it and hit the side of the Elite. Because of this Jim lost the lead to Colin Chapman but nevertheless managed to come second.

His final score at the end of the season was 20 wins, eight seconds and three thirds, from 33 races, an almost-incredible total that won him the 1958 Scottish Speed Championship.

In March 1959, Border Reivers purchased Bruce Halford's Lister-Jaguar and on the 30th of the same month Jim had his first race in the big car at Mallory Park. In fact he had three races in it and won them all! He also won the 1000-1600cc class in the GT race with the Elite, making the day's total four wins in four races.

His next appearance was at Oulton Park for the British Empire Trophy Race meeting.

### **"He went to work on his father's farm as a shepherd, then graduated to look after the farm"**

Here he didn't do so well, coming 10th in the up to 1500cc race in the Elite and eighth in the over 1500cc race with the Lister.

This latter race provided an amusing incident for Jim. It was pouring with rain, so much so that he could hardly see where he was going. In fact, he missed the chequered flag and went blindly to complete another lap. The next time round he noticed a couple of cranes pulling Bruce Halford's Lister out of the lake at Cascades. Then on the back straight he passed a Continental Bentley, which bothered him a little, for, as far as he could recall, Bentley hadn't returned to racing.

Finally he came up behind John Bekaert and noticed that John had taken his crash hat off. Suddenly it dawned on Jim that the race must be over, so he came into the pits to investigate, much to the relief of Ian Scott Watson, who could foresee his driver continuing well into the night!

His first continental event of the year was at Le Mans, where he drove the Elite with John Whitmore. These two made a very good partnership, both being able to lap fast and consistently,



for from a driving viewpoint they were pretty evenly matched. In the race they were plagued with starter-motor bothers, but they managed to finish second in class, 10th overall and 11th on index.

Jim moved on to Zandvoort for the AUTOSPORT World Cup race, where he was forced to retire when in the lead. At the British GP meeting at Aintree he came second in the over 2000cc sports car race after a very fine drive in the wet. He followed this up with two firsts and a second at the Winfield sprint.

At Brands Hatch for the second part of the AUTOSPORT World Cup, Jim came first in the first heat and second in the second. He also won the over 3000cc class in the sports car race with the Lister. At Mallory Park a fortnight later he gained two firsts, a third and an eighth. At Oulton Park he won the up to 1600cc race for GT cars.

The next day he went to Charterhall and collected a first and a fifth, then at another Charterhall meeting a couple of weeks later he gained three firsts and a fourth. Finally, he won the AUTOSPORT Three Hours Race at Snetterton in the Elite.

So that was the end of another year, which had been even more successful than the previous one. Jim had gained 23 wins, nine seconds and two thirds. In addition to no fewer than five Championship awards: the Scottish National Speed Championship, the over 3000cc class of the BRSCC Sports Car Championship, the 1300cc class of the AUTOSPORT Production Sports Car Championship, the over 1200cc class of the Mallory Park Sports Car Championship.

Jim was educated at Clifton Hall prep school and then went to Loretto public school in Edinburgh. He left Loretto in 1952 and then went to work on his father's farm as a shepherd for 18 months, after which he graduated to looking after the farm.

He is now in partnership with his father running the 1250-acre arable farm in Duns, ▶

SHIFT\_the way you move



# 360° AROUND VIEW MONITOR ISN'T THE ONLY ADVANTAGE



ADVANTAGE NISSAN GIVES YOU A NISSAN QASHQAI 1.6 N-TEC+ FOR £249 PER MONTH\* WITH:



**£700** ADVANCED RENTAL DEALER CONTRIBUTION



**3 YEARS** LOW COST SERVICING AT £249



**3 YEARS** NISSAN ROADSIDE ASSISTANCE



ADVANCED FEATURES AS STANDARD



360° Around View Monitor  
parking assist



Nissan Connect with  
touch-screen navigation system



18" 'Onyx' alloy wheels



Panoramic glass roof



Dual zone climate control

Discover the advantage at [nissan-offers.co.uk](http://nissan-offers.co.uk)

QASHQAI 1.6: URBAN 35.8mpg (7.9L/100km), EXTRA URBAN 54.3mpg (5.2L/100km), COMBINED 45.6mpg (6.2L/100km), CO<sub>2</sub> emissions 144g/km.

Offers valid until 31 March 2012 at participating dealers only. \*Rental stated is for Nissan Finance Lease. Comparable payments are available on our personal contract purchase product - ask your dealer for details. **Advance rental £5,031 followed by 41 monthly rentals of £249 and a final rental of £6,998.** All figures are inclusive of VAT. Once you have paid the final rental you can keep using the car by paying an annual rental of £60; if you choose Nissan Finance Lease then you will never own the car. Finance quote includes £700 Nissan Advance Rental Contribution and this is only available on Acenta grade and higher grades only, excludes Visia. Offer is not available in conjunction with any schemes or other offers. A guarantee and indemnity may be required. Finance, subject to age and status, to be provided by RCI Financial Services Limited, PO Box 149, Watford, WD17 1FJ. Terms and conditions apply to all offers in this advert, please visit [www.nissan-offers.co.uk](http://www.nissan-offers.co.uk) or your local dealer for further information. Breakdown services are provided by RAC Motoring Services and/or RAC Insurance Limited. All vehicles are delivered with the first registration fee and road fund licence paid. Information correct at time of going to print. Model shot is for illustration purposes only. QASHQAI shown has metallic paint at £495 inc. VAT. Nissan Motor (GB) Limited, The Rivers Office Park, Denham Way, Rickmansworth, Hertfordshire WD3 9YS. 200510/C

►► Berwickshire. He also has his own farm of about the same size 20 miles away. The Clark family are notable stockmen of the district, having three different pedigree breed flocks of sheep at Edington Mains. He is a very keen farmer and has not yet made up his mind whether he can devote his time to a really full season of continental racing, should that happy situation arise.

In his spare time he likes to go shooting and is a pretty good shot. He is also quite a good hockey player and a fine sprint athlete.

He is a committee member of the Berwick and DMC and is assistant secretary to Ian Scott Watson in the Border MRC. Photography is also one of his hobbies and he likes listening to music: Louis Armstrong, Frank Sinatra and Ella Fitzgerald being among his favourite artists.

Ian himself is, of course, a very capable team manager for Border Reivers. Apart from this, he has known Jim for longer than most people and so is well qualified to talk about him.

"As his best friend – we've been mistaken for brothers before now, much to his chagrin – and 'tame Ken Gregory' [Scott Watson is referring here to Stirling Moss's manager at the time], I probably know him as well as anyone outside his family circle. As anyone who meets him must realise, he really is one of the nicest chaps one could wish to know and is absolutely free of any tendency to show off or get conceited. He knows his own limitations and underrates his own driving ability.

"One of the most remarkable things – which I think marks him out as a potential champion – is his wonderful consideration for the car he's driving. He can always come in from a race and tell me exactly what every gauge and dial has been reading, how many revs he has used at what point, whether there are any queer noises, etc. He has only spun a car once this year – the Porsche – when trying to keep up with the much faster Shepherd-Barron Alfa at Charterhall.

"He keeps an incredibly cool head when driving and is just about the only fast driver I can sit beside without having any qualms, but he himself is a very bad passenger. I think he has exceptionally fast reactions and coordination between eyes and limbs, and his eyesight at both day and night is quite exceptional.



Leading the way in Lister-Jaguar at Aintree in 1959, chased by Graham Whitehead's Aston

**"His style is very reminiscent of Tony Brooks; he sits well back and drives calmly and without fuss. His cornering is very neat and he gives the impression that he could become very good indeed"**



Clark and John Whitmore claimed class runner-up with Lotus Elite at 1959 Le Mans 24 Hours



Clark (left of pic) in first single-seater race in Formula Junior Gemini, Boxing Day Brands '59

"As one who watches him in every race, and I've done a little bit of club racing myself, I know something of what is involved, and I've come to the conclusion that he can drive much nearer the limit of a car than almost anyone, without using anything like the revs that others would or losing control of the car. For instance, for half the season we had a faulty rev counter on the Elite and discovered that Jim had been doing his fantastic lap times without going over 7000, whereas everyone else was using 7500 and even 7800. This did not apply to Le Mans, where our rev counter was slow, not fast.

"His weak points? Girls, perhaps! Drinks little – not that he can't – and is always particular not to the night before a race. He does not smoke. He works very hard at home, literally. No London Chelsea playboy stuff or anything like that."

So there you are. That's Jim Clark, as seen by his best friend and constant companion!

Jim very much wants to drive single-seaters this year if he can, for he is not very interested in the new formula (for 1961). "I don't think it will help me at all," he says. "It will certainly be no safer, and a lot more expensive than the current formula, which, I think, should be continued."

Reg Parnell, who watched Jim's handling of the Formula 1 Aston with a very critical eye, is considerably impressed by the young Scotsman's driving. "He does, of course, lack experience," says Reg, "but nevertheless he put up a very fine performance. His style is very reminiscent of Tony Brooks; he sits well back and drives calmly and without fuss. His cornering is very neat and he gives the impression that, given time, he could become very good indeed."

Encouraging words from one of the shrewdest judges of driving ability there are, and it is worth bearing in mind what Roy Salvadori said in an earlier 'Profile', which was to the effect that what is needed is a team or teams willing to give a place to somebody like Clark to enable him to gain the necessary experience. This, Roy felt, would surely pay dividends in the end.

However, whatever Jim drives this season, his relaxed and precise style is bound to reap reward. Watch him, for he is definitely, as our French friends say, a "coming man". ❖

# Building the stage for Clark's genius

Cedric Selzer is the mechanic who bolted together the Lotus machinery in which Jim Clark danced to glory. He looks back at a magic era



Selzer (left) joins the crowd in applauding Clark's success in the 1963 British Grand Prix



Clark and Chapman were very different, but a successful double act

Nigh on 44 years have passed since that dark April day in 1968 when the world of motor racing lost its greatest driver. Jim Clark's legend lives on, but when his Lotus 48 plunged off the track in that infamous Formula 2 race at Hockenheim, the next generations of racing fans lost the chance to get to know the Scot. The colourful Graham Hill, who was lost only seven years later, still looms in the public conscience, while compatriot Jackie Stewart remains on the racing scene to this day, but by contrast Clark is a far harder character to pin down.

The statistics are well-known. Three months before his death, Clark broke Juan Manuel Fangio's record for world championship grand prix victories in his final start at that level, and he would surely have added to his two titles had he lived on. But while his achievements speak for themselves, the loss of Clark and the relative paucity of audio-visual materials of this quiet man outside the car mean that he seems far-deeper buried in the mists of time than many of his contemporaries.

Fortunately, some of those who

**“Jimmy and Colin Chapman came from different worlds. Colin was very pushy and Jimmy was far more sophisticated. But they worked very well together”**

played their part in Clark's success are still going strong. One of those is South African Cedric Selzer, who was in charge of Clark's Lotus 25 during the all-conquering 1963 season. Selzer joined Team Lotus after the '61 Monaco Grand Prix, thanks to heading to the legendary Tip Top bar in search of a job. There, a chance meeting with Colin Chapman's right-hand man Jim Endruweit led to him being given a one-month trial that led to over four years with the team. After looking after Trevor Taylor's car in '62, he was switched to take charge of Clark's for the following season.

Selzer paints a picture of a great driver who was very professional to work with, but not easy to get close to. Even Lotus boss Colin Chapman, who Clark famously had a remarkable working relationship

with, was never that close outside a motor-racing context.

“Jimmy was very, very quiet and it was difficult to get to know him,” says Selzer. “He had his own circle of friends, which was pretty limited – people like Ian Scott Watson, Jackie Stewart and John Whitmore. Even people like Graham Hill, they got on well, but he was never really a great mate of Jimmy's. He was a type of recluse.

“He and Colin Chapman were always in a huddle chatting. There was a bond, but it was around motor racing, not around friendship as far as I'm concerned. They came from different worlds. Colin was very pushy but Jimmy was far more sophisticated than him. They were completely different, but worked very well together.

“In the beginning, Jimmy would

go out and say the car is doing this and that and Colin would come up with something to try. I also did quite a few trips when Colin wasn't around and had to interpret what Jimmy said. But we also had the problem that if Jimmy found something wrong with the car, he would quickly find a way to drive around it, which made it very difficult to fix the problem. He would get in a car and ask for two pounds more in the rear tyres and a thicker rear rollbar, then go half a second quicker, but I never knew if that was him or if the car had really improved!

“He was obviously intelligent, but being the quiet man he was you wouldn't know if what you were saying actually sunk in at the time. If he saw things in a slightly different light, you just couldn't tell.”

It's difficult to peer through the fog of time and comprehend exactly where Chapman stopped and Clark began. There are varying accounts of Clark's technical ability and how he figured in the successful equation relative to the Lotus boss. Hill once said of Clark and Chapman that “you just cannot divorce ▶



**3000 MILES OF FREE  
FUEL ACROSS THE  
RENAULT RANGE\***  
[renault.co.uk](http://renault.co.uk)

**RENAULT MEGANE  
I-MUSIC  
FROM £229 DEPOSIT  
£229 PER MONTH\*\***

-  Bluetooth and iPod Connectivity
-  Hands Free Keycard (entry & start)
-  Sports Alloy Wheels
-  100,000 Mile Warranty†



Renault TV on Sky Guide 883

**RENAULT**  
QUALITY MADE

The official fuel consumption figures in mpg (l/100km) for the Mégane Hatch I-Music 1.6 100 are: Urban 31.0 (9.1), Extra Urban 51.4 (5.5), Combined 41.5 (6.8). The official CO<sub>2</sub> emission figure is 159g/km.



\*\*Rental stated is for Renault Lease. Renault Selections PCP finance product also available. If you choose Renault Lease then you will not own the car. When you have paid the final rental at the end of the contract you can keep using the car and pay an annual rental equivalent to one monthly rental. Typical example for Mégane Hatch I-Music 1.6 100: Advance rental £229 followed by 43 monthly rentals of £229, final rental £4,090. A finance facility fee of £149 will be payable with the advance rental. Guarantees and indemnities may be required. You must be at least 18 and a UK resident (excluding the Isle of Man and Channel Islands) to apply. Finance provided by RCI Financial Services Limited, PO Box 149, Watford WD17 1FJ. Authorised and regulated by the Financial Services Authority for the conduct of general insurance business. Not available in conjunction with any schemes or other offers, please see your local dealer for details. \*The Free Fuel offer applies to new retail and local business sales (excluding Pzaz and Renaultsport range, Master RWD, Motability and Contract Hire offers - including offers with own terms). The Free Fuel calculation is based on the official manufacturer combined fuel consumption figure and UK average fuel cost (source: AA fuel price report - August 2011) for each vehicle and engine applicable to the offer. For a full listing of the free fuel calculations visit [renault.co.uk/freefuel](http://renault.co.uk/freefuel) A free fuel card will be sent to the registered keeper within 5 working days of vehicle registration. Offer cannot be used as a discount off the final invoice. †Warranty applies to new vehicles up to a period of 3 years or 100,000 miles, whichever comes first. All offers available at participating dealers only on new cars ordered between 4 October 2011 and 31 January 2012, unless otherwise stated. Car shown with optional metallic paint available at an additional £455. All figures correct at time of going to print. We reserve the right to withdraw offers without prior notice.

▶▶ the two; it was a parallel success story". Fellow racing giants Stirling Moss and John Surtees both suggested that Clark's technical ability was limited, although according to Selzer the Scot's capabilities on that score evolved dramatically during the first half of his grand prix career.

"By 1964, he knew exactly what he wanted from the car and how to achieve it," says Selzer. "He improved a lot in that area. I can remember one time at Spa in 1963 when Trevor Taylor went out and couldn't do a time but didn't know why. In desperation, Colin said to Jimmy to get in the car and see what was wrong with it. He went out and knew instantly that the car

wasn't getting full throttle. That ability evolved in him. I think it's right to say that Chapman did tailor Clark in that regard."

Certainly, there's no question that Clark was the finished article by 1963. Having won three world championship races and gone to the finale with a shot at the title in '62, Clark and the Lotus 25 dominated the following season. Inevitably, it's difficult to judge how much was car and how much was the man in the cockpit, especially as the driver in the other Lotus, Trevor Taylor, fell firmly into the good-but-not-great category.

But while the Lotus 25, which Selzer describes as the "grandfather" of the modern F1



Clark (left) took seventh win of 1963 in South Africa. Brabham and Gurney are alongside

car – it was the first monocoque grand prix machine – was the best of its time, it took a great driver to get the best out of it.

"You had to drive it on tippy-toes," says Selzer. "You had to have a light touch and set it up

you said something to him about it he wouldn't know what you were talking about. He did it automatically."

And Clark used that natural speed to extremely good effect. Very often, he would take off at the start and the rest of the field wouldn't see him again, even if he started down the grid. For example, at Spa in 1963 he lined up down in eighth but moved into the lead very rapidly. It was a clear strategy, and one that led to Clark claiming a record for 'grand slams' – leading every lap from pole position and setting fastest lap – with eight. That's a record that stands to this day despite half a dozen drivers now having eclipsed his record of 25 wins.

But this inevitably led to suggestions that he wasn't such a formidable competitor in wheel-to-wheel battle. Surtees, for example, reckoned that this was an area of weakness.

"On the pure driving side, the combination of Jimmy Clark and a car he had faith in was a very formidable one, because when he had faith in the car and the confidence he had the edge, then he drove his very best," Surtees is quoted as saying in Paul Hamlyn's *Portrait of a racing driver*.

"Jimmy was not a mixer – he didn't like to mix it – and if he didn't feel he had a slight edge somewhere I feel he got very agitated. I don't agree with the general view that he was invariably a tiger. He was a tiger, yes, when he knew ▶

**"Jimmy did pass cars, but I never saw him actually fighting. But he didn't need to"**

for the corners, and once you had done that right it was absolutely brilliant. It wasn't like a Cooper that you could throw into the corners. Stirling Moss said to me a couple of years ago that Jimmy had the lightest touch in that car.

"It was an underpowered car with about 200bhp so you absolutely had not to scrub off the speed. Jimmy had a natural ability to do that. There's a famous story about when we went testing at Silverstone with an F1 and the Lotus Cortina. Chapman sat in the back of the Cortina with Clark driving to put some more weight in the car and asked Jimmy what line he was using as it was unusual. Later, I read Mark Donohue's book where he talks about the friction circle – that's what Jimmy was doing subconsciously. He didn't know any other way but if



Selzer is working on a book about his time in racing, due out in 2013

**TIMELINE CLARK'S PATH TO THE 1963 WORLD CHAMPIONSHIP**

**MONACO**

*8th (not running at finish)  
 Leading when gearbox broke with 22 laps to go*



**BELGIUM**

*1st  
 Wins by nearly five minutes from Bruce McLaren in wet*



**HOLLAND**

*1st  
 Wins from pole position, setting fastest lap as well*



**FRANCE**

*1st  
 Despite two broken valve springs, holds on to win*



**BRITAIN**

*1st  
 Passes Jack Brabham early on to win by 26 seconds*



PICS: LAT ARCHIVE; DUNBAR/LAT

# Evolution of the species

Since introducing our innovative Zero 360 fire suppression system back in 2006, with its unique compression discharge method of deploying a highly effective gaseous extinguishant, it has become the industry standard for fire protection at every level of motorsport.

## FIRE SUPPRESSION AT ITS MOST ADVANCED

But now, through our ongoing research and development programme, we have taken the best a step further. More rigid in mounting, more flexible in use and more efficient in operation. More reason for specifying Zero 360 – the future of motorsport fire safety.

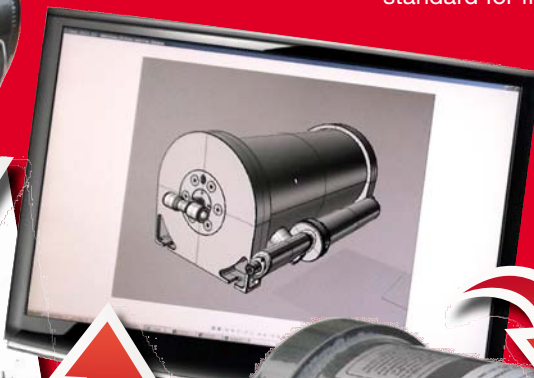
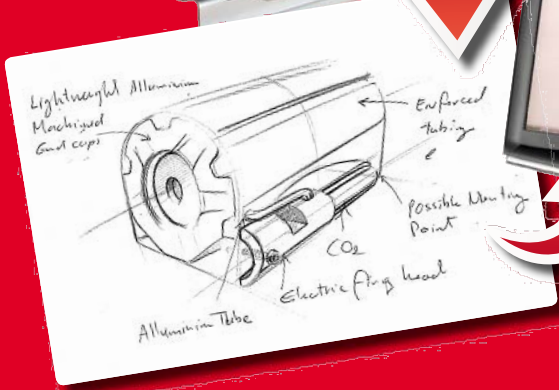

## NEW zero 360

- No separate mounting bracket – bottle mounts directly to the vehicle.
- Interchangeable operating heads from mechanical to electrical.
- Simplified electrical wiring connections – plug and play.
- Optimum discharge in any orientation.
- Available in 2.25Kg and 3.0Kg variants.

### PLUS A GROWING RANGE OF SAFETY PRODUCTS



#### RACE MIRRORS

Formula, Touring, Sports and GT. Conform to FIA and MSA requirements.

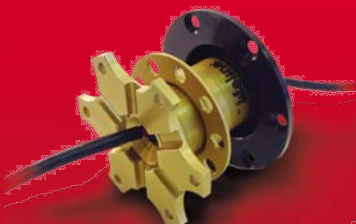

#### QUICK RELEASE STEERING BOSS

Formula, Touring, Rally. Available with pre-wired 8-way electrical connector.



#### RAIN LIGHTS

Homologated by FIA and MSA.



#### ROLLCAGE PADDING

Available in 5 different tube sizes. Exceeds latest FIA standard.

### THE AWARD WINNING



Our latest, award winning system - equally effective on unleaded, diesel and bio-ethanol fuel fires – designed for single seaters and sports prototypes. FIA homologated.



## zero 2000

Foam-based extinguisher system meeting the requirements of FIA, MSA and SCCA.

SEE US AT  
AUTOSPORT  
INTERNATIONAL  
Stand No. E256



[www.lifeline-fire.co.uk](http://www.lifeline-fire.co.uk)

# Champions of Safety



Clark chases Surtees en route to his only second place in a world championship GP



Chapman celebrates 1963 Italian GP – and two world titles – on the back of Clark’s car

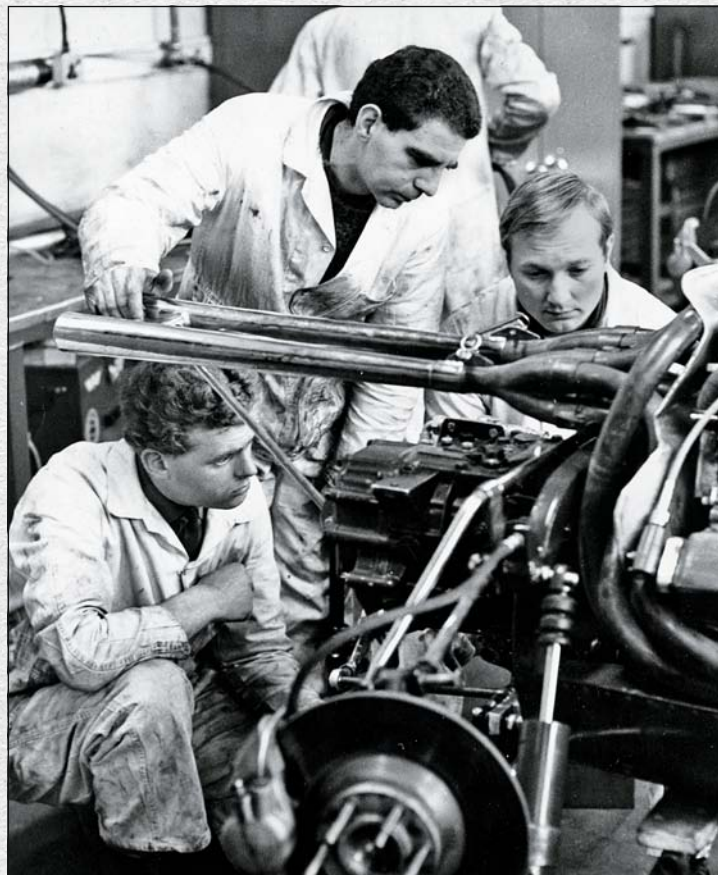

Selzer (standing up) worked hard with Lotus crew

▶▶ nobody had any sharper teeth.”

Selzer thinks there is some validity in Surtees’s opinion, with the proviso that Clark’s strengths in other areas meant that mixing it was very often unnecessary.

“He liked to get out in front and control the race,” he says. “He did that so often. There is a little bit in what John Surtees said because he wasn’t a fighter. It just wasn’t in his character. He was a fast racing driver. He did pass cars, but I never saw him actually fighting. But he just didn’t need to.”

It’s a fair point – for Clark was that good. And when he really needed to, he was more than capable of coming through the field. The 1967 Italian Grand Prix, when he came from a lap down to lead, springs to mind, as does the Aintree 200 F1 race in ’63, when his car wouldn’t get away but he

recovered to third in Taylor’s car. But don’t mistake a lack of fight for any kind of cowardice, for Clark was as bold as anyone in the cockpit in adversity. Take that Spa victory in ’63, when he won by almost five minutes in some of the worst rain ever to have hit a world championship race, or his remarkable drive to second (his only runner-up spot in a world championship GP) at the Nurburgring that year, when he ran on just seven cylinders for most of the race courtesy of a faulty spark plug.

“It was raining so heavily at Spa that it looked as if the cars were doing only 50mph past the pits,” recalls Selzer. “There was no grip at all and they were just aquaplaning. Chapman was jumping up and down telling them to stop the race because Jimmy was in the lead, but the organisers

**“Fangio said Jimmy was the greatest racing driver ever. Coming from him, that was fantastic”**

wouldn’t. Jimmy just kept going and devastated everybody.

“At the Nurburgring, he drove very well. We always put new spark plugs in after practice but for this race one of them was faulty out of the box. So he did most of the race on seven cylinders. If I hadn’t installed the faulty spark plug, he would have won.”

Clark himself agreed on that last point. The sheer confidence that Selzer had in the Scot is

perhaps the best testimony that can be given, for the true measure of a great driver is often the faith his crew has in him.

“We expected to win,” he says. “Our motto was that if we came second, we lost! We did expect to win every race with Jimmy. It was a great privilege to work with him.”

“I remember that I went to a cocktail party for Juan Manuel Fangio in Angouleme and I was introduced to him. He was a very wise interpreter of racing. He said two things to me; that Jimmy crashed [at Hockenheim in 1968] because something broke at the rear, because if something brakes at the front you can get out of it. The other thing he said was that Jimmy was the greatest racing driver ever. Coming from Fangio, that was fantastic.

You can’t get a better recommendation than that.” ❖

**GERMANY**

*2nd*  
 Faulty spark plug leaves him on seven cylinders



**ITALY**

*1st*  
 Clinches the drivers’ title, and constructors’ crown for Lotus



**UNITED STATES**

*3rd*  
 Battery failure at start costs him a lap, but charges back



**MEXICO**

*1st*  
 Takes his third ‘grand slam’ victory of the season



**SOUTH AFRICA**

*1st*  
 Breaks record for wins in a season with seventh triumph



PICS: LAT ARCHIVE

# A winner, right until near the end

The Lotus 49's bugs were being ironed out, auguring well for 1968, but off-track things were less harmonious

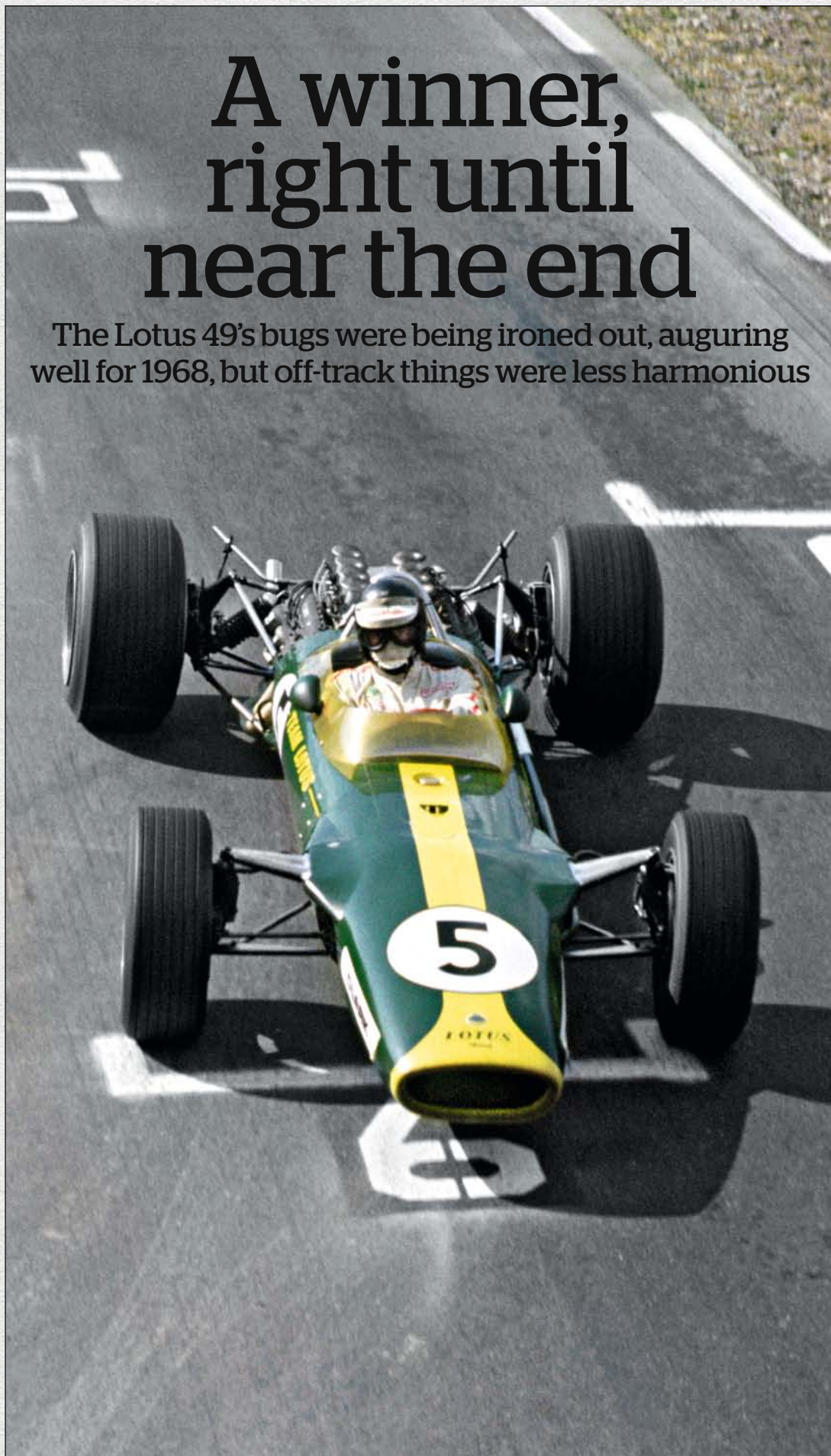

Clark nursed his car to 1967 United States GP victory



Clark and Hayes (centre) share a podium smile

Jim Clark, that most mechanically sympathetic of racing drivers, nursed his Lotus 49, its right-rear Firestone canted drunkenly because of a snapped suspension weld, across the line to secure a crucial victory at Watkins Glen. Ford UK's Walter Hayes, straining – and unusually snappy – under the weight of expectation in FoMoCo's backyard, was relieved and happy. The engineering genius that had delivered him his £100,000 V8 wonder, embossed 'FORD' twinkling on its cam covers, was unimpressed, however.

Cosworth's Keith Duckworth possessed the stereotypical Lancastrian emotional hotchpotch: tough exterior, with a small-but-soft sentimental centre. He idolised Clark and passionately believed that he deserved better treatment than Lotus's win-or-bust mentality allowed. Its 49, for crying out loud, was suffering similar failures to those flagged up at its Snetterton shakedown in May – a few months prior. Not good enough. No, he would build a car for Jim – and Jim would come.

Clark was beginning to wonder too. His relationship with Lotus boss Colin Chapman, despite its length, depth and genuine warmth, was exhibiting cracks. The fretting that had scarred Clark's early career had been redrawn sharply into focus by the extra power and speed of the new three-litre Formula 1: the cars' fragility; the trees' proximity.

The 49, the fastest thing in the joint, was not a sinecure. Neither its brakes nor 'box were up to it. And Duckworth's first-iteration DFV was not without fault either, its snorting horses bolting at 6500rpm, the precise point where Clark liked to squeeze and lean on his supernatural balance and feel.

He was suspicious of it. All of it. He respected the abilities of Chapman and Duckworth, trusted them to put matters right – but it was taking an awful long time. Until then, he was the guy putting his neck on the block. Faith was being tested.

So Clark the driver adapted – in and out of the cockpit. Gone were his quick-draw starts and bulleting first laps, to be replaced

by a more measured, conciliatory approach to winning. Gone too was his acquiescence. Spooked by a vibration on his first outing with the car, at Zandvoort for June's Dutch Grand Prix, he refused to drive it until the source was traced. (Mechanics eventually discovered a disintegrating ball-race in the right-rear hub.)

Clark the man changed too. Not fundamentally, but sufficient to be noticeable. The 'racing shepherd' had always been a media myth, but the odds on his making a return to the family's Borders farm upon his retirement from racing, once short, were lengthening – and not just because of the Inland Revenue's beady eye. Initially an unwilling tax exile, since April 1966, Clark had warmed to it, spells in a Paris flat in particular opening new avenues and lines of inquiry and interest. That he and long-time girlfriend Sally Stokes separated at about this time was not unconnected.

Clark's busiest season had been 1965, but suddenly he had time to ponder. Finalising decisions was still problematical, but new conclusions were beginning to distill: accountants were not to be averred to just because they were Scottish; and posh moneymen in swanky London offices perhaps did know a thing or two. His tight, trusted circle had broken.

He missed the racing of course. Driving fast remained an obsession, and he admitted to jealous pangs whenever he saw

a saloon with its inside-front cocked. The fun bit was shrinking. Which is why his 1966 RAC Rally in a works Lotus Cortina was a tonic. More than a showcase for his stupendous skills, it was a homecoming, a reaffirmation. He stayed with the team even after he had crashed out, and bought it a slap-up feed near London Airport, an unusual splash from a canny, if financially naive, man.

Lotus, in contrast, was becoming a bit of a chore. Therefore, when the phone at Clark's spartan Bermuda condo rang with offers of alternative drives, he accepted

a Lotus since that so-so Gemini at Boxing Day Brands, in 1959. Oregon innovator Rolla Vollstedt's design featured nose tabs balanced by a large plate curved at its trailing edge and sited over the quad-cam Ford V8's tailpipes. Clark was impressed by the stability they imbued.

The 49 had sported a nose-bib spoiler at Spa in June, but it was discarded because it generated too much oversteer. Hmm. Another conclusion distilling: either Chapman wasn't the infallible technical guru that everybody assumed, or he had been keeping

**“Clark persuaded his mechanics to fashion a wing from a chopped helicopter blade. When Chapman, half a world away, heard of this he demanded that it be removed – forthwith”**

eagerly. Chapman was most definitely not part of this loop.

The week after winning the Mexican GP, final round of the 1967 F1 world championship, Clark was bombing Rockingham's D-shaped oval in a Holman-Moody NASCAR Ford. The week after that he was strafing Riverside in a Vollstedt Indycar.

The Vollstedt was an eye-opener for him – and a worry for Chapman – this being his first single-seater race in anything but

his aero powder dry for 1968, preferring to rely on Clark for success until then.

And that was hardly a risk, because Clark was at the peak of his powers. He won the non-points November F1 race at Jarama, and on New Year's Day succeeded Juan Fangio as the most-successful GP driver with a consummate victory, his 25th, at Kyalami. Already he was a clear favourite to secure the world title, his third.

Next he won the eight-race

Tasman Series in New Zealand and Australia. This too was no easy ride. The shortening of the DFV's stroke to fit the 2.5-litre rules caused more problems than anticipated, and Chris Amon's lighter, more-compact V6 Ferrari was a genuine threat to his 49T. But Clark's responses to a schoolmasterly Chapman reproach and a hair-raising crash at Teretonga were more telling than his being on top Down Under.

Intrigued by wings' influence, he had persuaded his mechanics to fashion one from a chopped helicopter blade, which they attached to the gearbox casing at a guesstimated height and angle. When Chapman, half a world away, heard of this, he demanded that it be removed. Forthwith.

Yes, this was Chapman's area. Man-management, clearly, was not. Rather than become increasingly testy – as though a spurned lover – he might have been better advised to allow the world's best driver, his greatest asset, to use his judgement and expertise to remotely assess a new aspect of their sport. That Clark complied with the directive – he probably didn't want to land his mechanics in deeper trouble – proved Chapman still held the whip hand. But it wasn't healthy.

Clark, his wing clipped, led the race in any case, until water in the electrics, as had happened in Canada in September, caused a misfire. He was attempting to clear it with stabs of throttle ▶



Outing on 1966 RAC Rally in Lotus Cortina had been hugely enjoyable



Our January 5 issue reported on his last GP win



Racing NASCAR Ford (left) at Rockingham



Clark in winning style in the Tasman Cup

PICS: LAT ARCHIVE

# Formula Le Mans



**ORECA**  
the motorsport company

# The unmissable next step toward Le Mans

**Formula LE MANS**

5 races of 6 Hours & Le Mans Test Day

**EUROPEAN LE MANS SERIES**

45,000 € & LMP2 test to Drivers Champions

**&**

**AN INVITATION TO THE 2013 LE MANS 24 HOURS FOR THE TEAMS CHAMPION**

**24 HEURES DU MANS**

**WILL YOU BE PART OF LE MANS IN 2013?**



**SAVE THE DATE**

**1<sup>ST</sup> & 2<sup>ND</sup> FEBRUARY**

**Paul Ricard circuit**

**TEST THE FORMULA LE MANS !**

**Discover the world of Endurance racing at Paul Ricard HTTT**



Contact : **M. Mac Burnie** (mmacburnie@oreca.fr - +33 (0) 494 885 304) - Visit **Oreca-Manufacturer.com**



Ushering in commercial era during 1968 Tasman series

▶▶ when all eight chimed over a bump on the fastest part of the circuit. He spun like a top, vaulted a ditch, flattened a fence and nerfed a tree in an orchard. He reckoned himself lucky not to be coming home in a box. And told people so. Dark thoughts, long bottled, were being aired.

His manoeuvrings, if that's what they were, took another turn when he declined to blow a precious UK weekend racing a Lotus at Brands Hatch's Race of Champions yet agreed to drive Ford's new F3L sports car at the same track three weeks later. Chapman's mood can be imagined.

Alan Mann, whose team built and ran the F3L, is adamant that Chapman peevishly extracted

Clark and Hill from that equation with a late, and fateful, decision to contest the F2 Deutschland Trophy at Hockenheim, a belief confirmed by an irritated phone call from Hill. Sources close to Clark tell a different story: that he hadn't heard "a dicky bird" from Mann during the Tasman Series and so had agreed to race in Germany. Lotus was still his bread and butter after all.

Clark had reasons to be hopeful: plans for the 49B would address the original's shortcomings; the Series 8 DFV that he used at Kyalami was more user-friendly; and he was convinced that he had driven the next Indy 500 winner, cruising stealthily around the Brickyard in March aboard the 56 turbine so as not to alert twitchy

USAC officials to its ultimate performance. Dollar-laden paydays beckoned.

The taxman's cold, clinical calculations had hardened Clark's attitude towards money, had wised him up. Obviously closer to the (natural) end of his career than its beginning, he was determined to place a higher value on his exceptional talent. He himself had unveiled F1's commercial age, in New Zealand, posing tanned but hassled in a cockpit, its paint still wet after its Gold Leaf respray in a Christchurch Ford dealer. Chapman, in turn, was soon to become very rich by floating Lotus Cars Ltd on the stock market. Clark, though neither needy nor greedy, wanted a fairer share. He was making plans. What if he should die? he asked a taken-aback Stokes not long before the fateful day.

On April 7 1968 Clark paid that price, at Hockenheim, slamming into trees that had loomed ever larger in his subconscious.

Chapman battled his public grief – until the death of Mike Spence while testing a 56 at Indy in May tipped him over the edge. That his friendship with Clark had been at its most fractious, that he had been on a skiing holiday at the time of the crash, no doubt made Clark's loss even more difficult to bear. He considered quitting the sport, and vanished without trace – only to return, unannounced, in Monaco, barking orders as if nothing had happened.

Full-on pretence was the only workable option in the face of this hideous reality check. Clark probably would have done the same had he gathered that slide, shaved that tree. Any recoverable injuries, the first of his career, might have allowed both men to reflect and start afresh. Only when it's taken away do you realise what you had. Plus it's impossible to imagine Clark racing in F1 for any other team. Chapman would have had to allow him more wriggle room, but they'd have patched it up, got on with it at worst.

Duckworth's well-intentioned and superbly constructed 'Jim car' had rushed up F1's four-wheel-drive cul-de-sac, and it was to be the 1970 Lotus 72 that ushered in the next generation of F1 winners. Clark would have seamlessly blended with its new demands of fatter tyres and bigger wings – been rejuvenated by them, indeed – and won another title, a third or a fourth, before handing the baton to compatriot Jackie Stewart. By which time the taxman's UK-visiting constraints on him would have been less onerous.

Maybe a stalwart steward would have been found to run the farm day-to-day while Clark mulled his future. Any decisions would not have been quick in coming – no surprise there – but he'd have found a happy niche somewhere, albeit who knows where. For, as even those closest to him had been discovering, this new Clark was full of surprises. ❖



Clark and Chapman check out the Ferrari. Can you imagine Vettel and Newey doing that today?

**“Clark had cruised the 56 turbine around Indy. Dollar-laden paydays beckoned”**



In his F2 Lotus at Hockenheim, April 1968



A light moment with Chapman (left) and Jack Brabham (centre)

# Great Car: Lotus 49

Jim Clark had a 50 per cent win rate in the Lotus 49 in his final 10 world championship races. He would surely have won the 1968 world title in it - and appreciated the significance of the Colin Chapman/Maurice Philippe masterpiece

## LONGEVITY

The Lotus 49 and its successors - the B, introduced during 1968, and the C, brought in for 1970 - had a long, competitive life. It was due to be replaced in 1969 by the Lotus 63, an evolutionary concept that influenced the 1970 Lotus 72 and featuring four-wheel drive. John Miles raced it five times in '69, but the experimental car was abandoned because of handling problems that made it unpredictable and hated by those who drove it.

## HANDLING

The Lotus 49 had two fundamental strengths that gave it an edge over the competition. It was lighter than the rest and had a powerful engine. Despite several key changes - specifically the DFV engine, the use of the motor as a stressed member and the later addition of wings - the car was very much an evolution of the type 43 that preceded it. This meant that, once the initial teething problems that required work to be done to strengthen the suspension had been completed, the car was relatively easy to drive - certainly requiring less early-corner precision than with the Lotus machines of earlier in the decade.

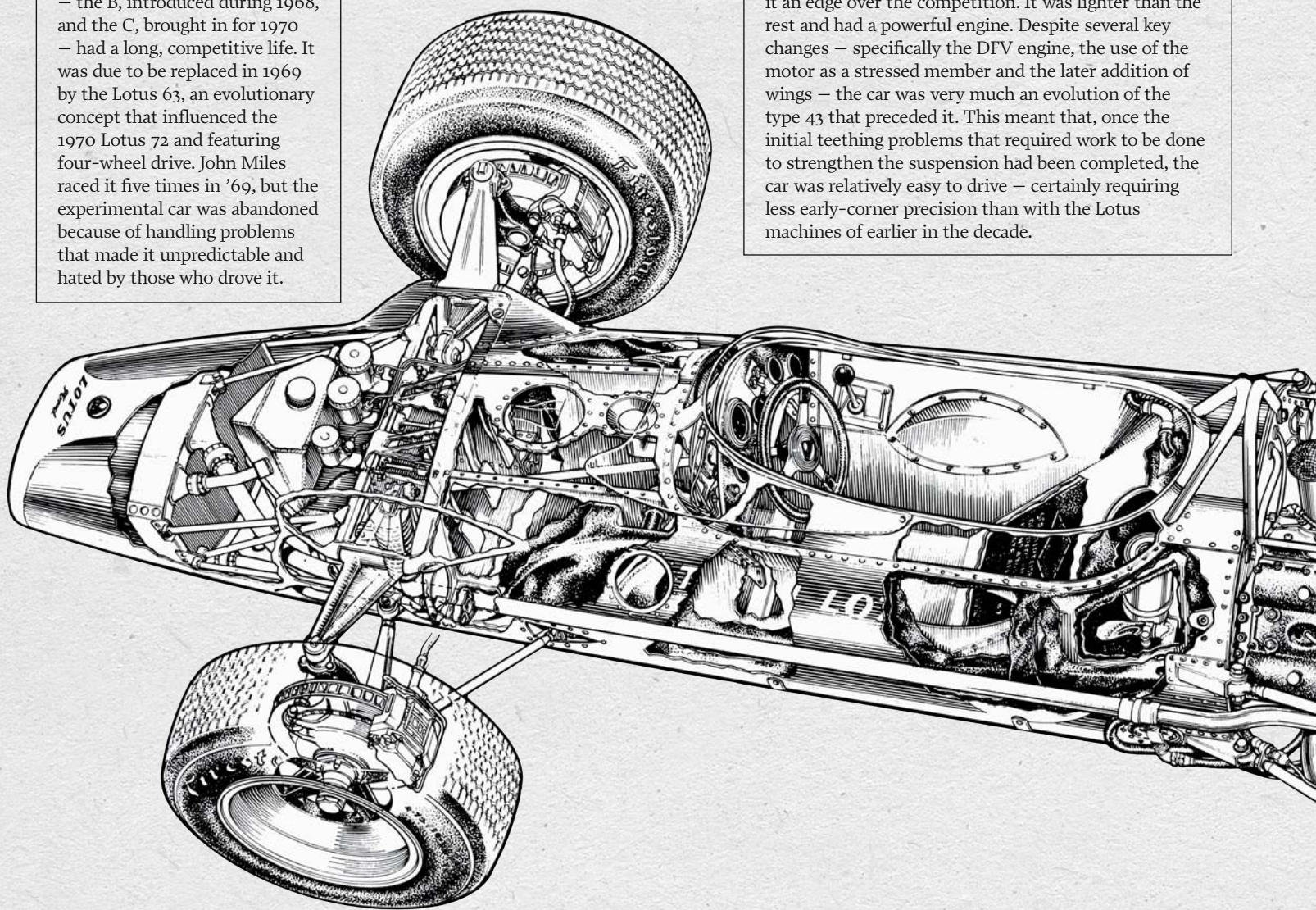

## WINGS

Initially, Chapman added a small wing to the rear bodywork, but at the 1968 French GP the Lotus 49B ran with a high rear wing mounted to the suspension. They proved dangerous and, after a few serious accidents, were outlawed after the 1969 Spanish GP.

## FORD COSWORTH DFV

Ford invested heavily in its Cosworth-developed Formula 1 engine that was introduced in 1967, with the stipulation that Lotus run equal number-one drivers from that season onwards, leading to Graham Hill being recruited from BRM to partner Clark. The DFV V8 featured four-valve heads with double overhead camshafts that produced around 410bhp at 9000rpm.

The powerplant made its debut at Zandvoort,

with Clark winning after Hill had taken pole position. Chapman had exclusive use of the engine in 1967, although it was made widely available from 1968 and soon became near-ubiquitous in F1. While initially the engine was a little 'peaky', it was soon tweaked to give smoother power delivery and, by the end of its long competitive life in F1, was putting out well over 500bhp.

## CARRYING THE LOAD

While the Lotus 49 is often remembered for heralding the wing era and the start of DFV dominance, there was one crucial design feature that created a new paradigm in F1. While the Lotus 49 was not the first car that attempted to use the engine as a stressed member (both Lotus and BRM, for example, had previously experimented with this) the 49 redefined the genre. The DFV engine, which produced little vibration compared with the units of a few years earlier, made this development possible. With the

suspension mounted on the gearbox, itself mounted to the rest of the car via the engine, which bolted onto the aluminium monocoque, a far more coherent and stiff package was possible. Rivals were soon forced to follow suit and dispense with the more orthodox rear-subframe configuration. Chapman also insisted that the engine packaging was conceived to allow rapid engine changes, requiring re-routing of pipes and cables, while brake pipes were secured to the suspension radius arms.

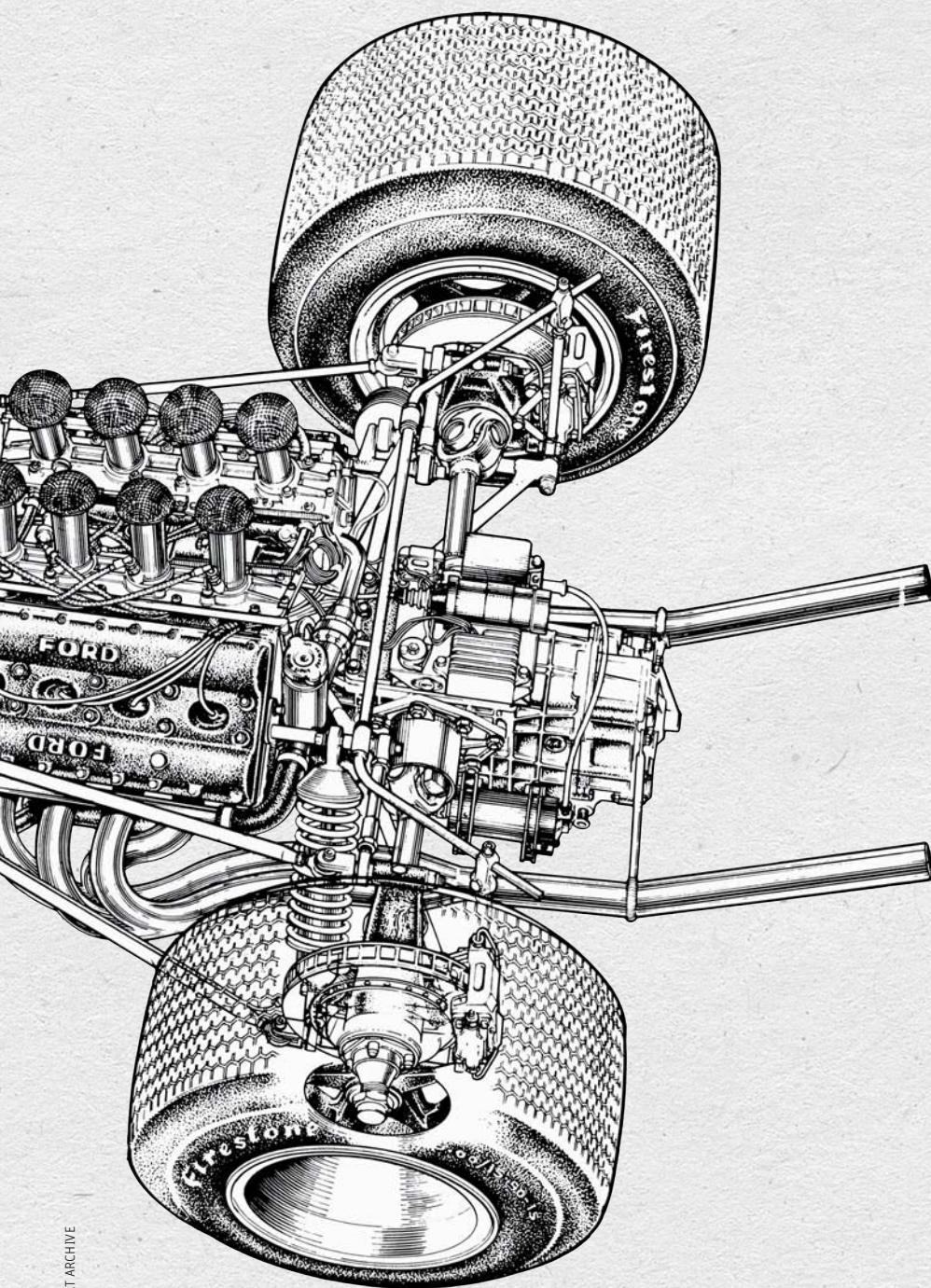

## LOTUS 49 1967-70 STATISTICS

RACES ENTERED:	41
WINS:	12
POLES:	19
FASTEST LAPS:	14
TITLES:	1968* -
DRIVERS' AND CONSTRUCTORS' CHAMPIONSHIPS	

\*Jochen Rindt raced the Lotus 49C three times in 1970, winning the Monaco Grand Prix, although mostly used the new Lotus 72 in his world championship year.



Clark wrestles the 49 to pole position at the 1967 German Grand Prix

## CLARK ALSO STARRED IN...



### JAGUAR D-TYPE

Caught the eye driving a D-type for the Border Reivers equipe in 1958, winning races at a number of UK venues.



### LOTUS 25

Won the 1963 world championship in the Lotus 25 and racked up 14 world championship grand prix wins between 1962 and '65.



### LOTUS CORTINA

Won the Snetterton 3 Hours on his first outing in the car in September 1963 and claimed the 1964 British Saloon Car Championship crown.



### LOTUS 33

Won five races during 1965 to seal the drivers' world championship title — as well as the 1967 Tasman Series.



### LOTUS 38

Clark won the 1965 Indianapolis 500 in the 38, and it is claimed that only a lap-scoring mistake cost him victory in '66 too.

CASIO®

# CONGRATULATIONS SEBASTIAN VETTEL & RED BULL RACING

Casio are proud to support Sebastian & Red Bull Racing in their outstanding achievement – 2011 FIA Formula One Drivers' & Constructors' World Champions™



**EQW-M1100DB**

**TOUGH SOLAR**  
SOLAR POWERED

**WAVE CEPTOR**  
RADIO CONTROLLED

The solar powered Edifice EQW-M1100DB offers a lifetime of use without a change of battery, a 3D chronograph and is equipped with Wave Ceptor multi-band 6 radio-controlled technology for perfect timing wherever you are. Available at H. Samuel, F. Hinds and other quality jewellers.

[www.casioracing.co.uk](http://www.casioracing.co.uk)



**EDIFICE**  
Speed & Intelligence

# Clark of the courses

From Formula 1 to Indycars, via touring cars, Jim Clark scored successes in a wide range of machinery. Here, we take a look at some of the most significant

## WORLD CHAMPIONSHIP GRANDS PRIX

**STARTS** 72

**WINS** 25

**1962 Belgian GP**

(Lotus 25)

**1962 British GP**

(Lotus 25)

**1962 United States GP**

(Lotus 25)

**1963 Belgian GP**

(Lotus 25)

**1963 Dutch GP**

(Lotus 25)

**1963 French GP**

(Lotus 25)

**1963 British GP**

(Lotus 25)

**1963 Italian GP**

(Lotus 25)

**1963 Mexican GP**

(Lotus 25)

**1963 South African GP**

(Lotus 25)

**1964 Dutch GP**

(Lotus 25)

**1964 Belgian GP**

(Lotus 25)

**1964 British GP**

(Lotus 25)

**1965 South African GP**

(Lotus 33)

**1965 Belgian GP**

(Lotus 33)

**1965 French GP**

(Lotus 25)

**1965 British GP**

(Lotus 33)

**1965 Dutch GP**

(Lotus 33)

**1965 German GP**

(Lotus 33)

**1966 United States GP**

(Lotus 43)

**1967 Dutch GP**

(Lotus 49)

**1967 British GP**

(Lotus 49)

**1967 United States GP**

(Lotus 49)

**1967 Mexican GP**

(Lotus 49)

**1968 South African GP**

(Lotus 49)

**PODIUMS** 32

**POLES** 33

**FASTEST LAPS** 28

**POINTS** 274



Silverstone in 1967 was scene of Clark's fifth British GP victory



Only Jackie Stewart finished on the same lap as Clark at Spa in '65

## CLARK'S RECORD IN THE F1 WORLD CHAMPIONSHIP

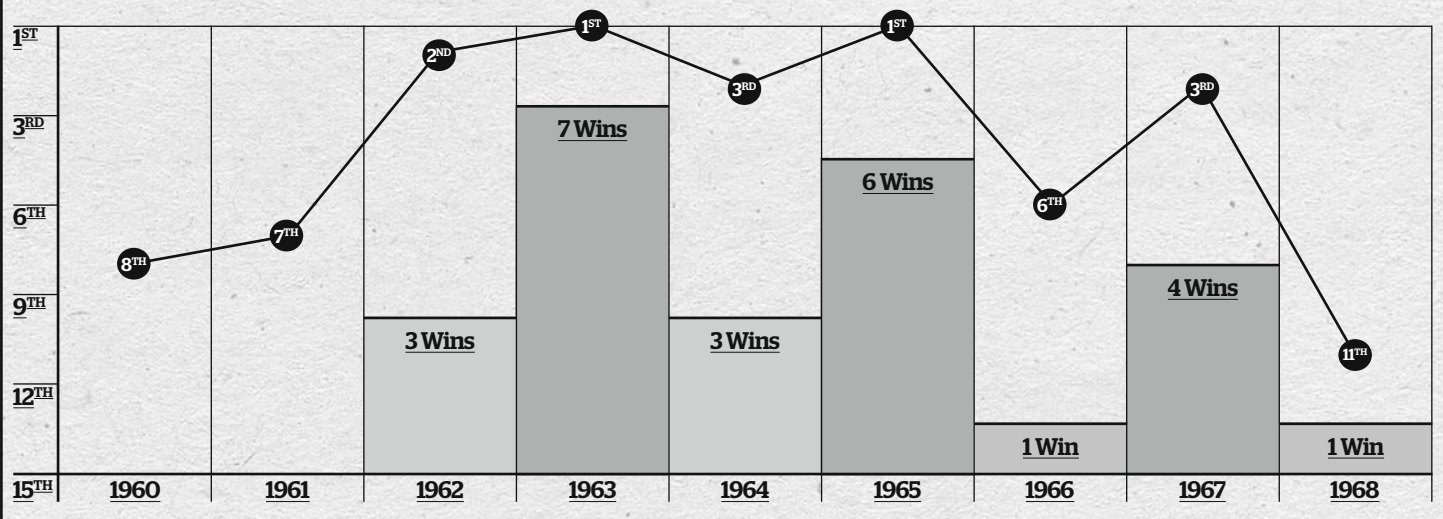

International Motorsport Events: Race Tickets, Hospitality & Travel

# SelectMotorRacing.com

● Formula One ● Le Mans 24hr ● WRC ● MotoGP ● Superbikes ● Historic

## Run by Fans for Fans

Come and see us at  
**Autosport International  
The Racing Car Show**  
12-15 January 2012  
NEC Birmingham  
**STAND 6959**

### FORMULA ONE GRAND PRIX

- ▶ Race Tickets & Hospitality packages
- ▶ Choice of Hotels
- ▶ Airport Transfers
- ▶ Circuit Transfers
- ▶ UK Travel Team to look after you

**FREE 2012  
BROCHURE**

### LE MANS 24HR & HISTORIC TOURS

- ▶ Le Mans 24hr
- ▶ Monaco Historic
- ▶ Le Mans Classic
- ▶ Goodwood Festival Of Speed
- ▶ Silverstone Classic
- ▶ Rallye Monte-Carlo Historic
- ▶ Mille Miglia
- ▶ Goodwood Revival
- ▶ Pau & Pyrenees
- ▶ Nurburgring Old Timer

### MOTO GP WORLD SUPERBIKES

- ▶ Race Ticket & Travel Packages

### WRC

- ▶ Fully Escorted Tour Packages

contact us on **+44 (0) 1451 833 721** or email [enquiry@selectmotorracing.com](mailto:enquiry@selectmotorracing.com)



[www.selectmotorracing.com](http://www.selectmotorracing.com)

**OTHER MAJOR SUCCESSES**

**INDYCAR WINS 2**

**1963 Milwaukee** (Lotus 29)

**1965 Indy 500** (Lotus 38)

**TASMAN TITLES 3**

(1965, 1967 and 1968)

**TASMAN WINS 14**

**1965 Levin** (Lotus 32B)

**1965 Wigram** (32B)

**1965 Teretonga** (32B)

**1965 Warwick Farm** (32B)

**1966 Warwick Farm** (39)

**1967 Levin** (33)

**1967 Wigram** (33)

**1967 Teretonga** (33)

**1967 Lakeside** (33)

**1967 Sandown Park** (33)

**1968 Wigram** (49T)

**1968 Surfers Paradise** (49T)

**1968 Warwick Farm** (49T)

**1968 Sandown Park** (49T)

**1964 BRITISH TOURING CAR CHAMPION**

**BTCC WINS 8**

**1963 Brands** (Ford Galaxie)

**1964 Oulton 1** (Lotus Cortina)

**1964 Crystal Palace** (Cortina)

**1964 Oulton 2** (Cortina)

**1965 Goodwood** (Cortina)

**1965 Oulton 2** (Cortina)

**1966 Brands** (Cortina)

**1966 Oulton** (Cortina)

**1965 British and French F2 champion**

**1960 Formula Junior champion**

**LE MANS RECORD**

**1 third (1960 - Aston Martin DBR1)**

**NASCAR**

Clark made one NASCAR start, at Rockingham in 1967. Driving a Holman Moody Ford he ran as high as 12th before the engine blew

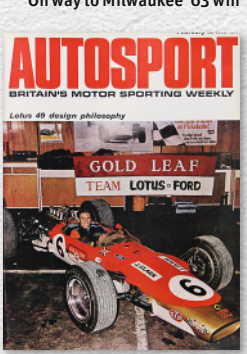
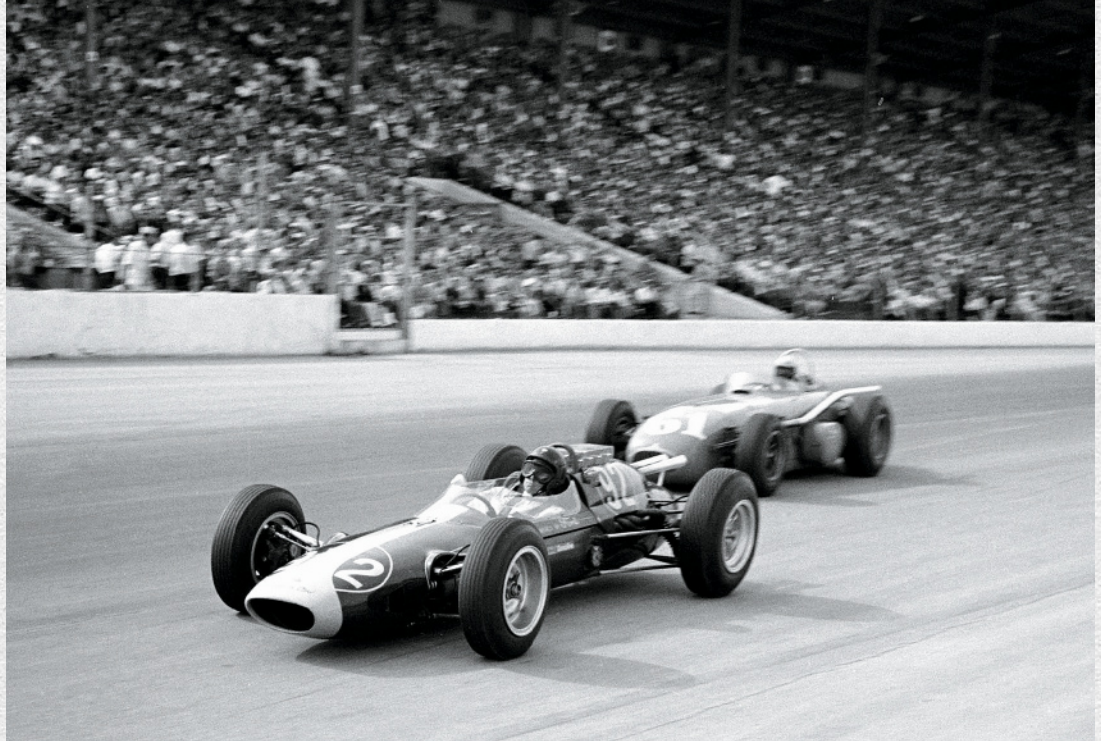

On way to Milwaukee '63 win



Clark and Roy Salvadori took ageing Aston to third in 1960 Le Mans 24 Hours

First of three Tasman titles came in 1965



Leading the V8 tin-tops in Lotus Cortina at Snetterton in 1966



PICS: LAT ARCHIVE





youtube.com/FordUKTV



twitter.com/formulafordGB



## Formula Ford 2012



### BE PART OF THE NEXT GENERATION

- New 2012 car with FIA approved chassis
- Powered by Ford EcoBoost 1.6L direct injection turbo
- More races than rival series and free testing
- Come find us at Autosport International on the BRSCC stand (7050 in Hall 7)

[britishformulaford.co.uk](http://britishformulaford.co.uk)



08456 805077 RacingLine, Championship Organisers

**AUTOSPORT**

INTERNATIONAL

The Racing Car Show

12 - 15 January 2012 NEC Birmingham, UK

The season  
starts right here

2012

Team, driver and series launches, top names interviewed, indoor action, celebrity karting, historic displays and trade exhibitors – all under one roof!





VISIT US AT  
**AUTOSPORT INTERNATIONAL**  
**STAND NO 2850, HALL 20**



**BRITISH GT  
CHAMPIONSHIP  
WINNER 2011\***



\*GTC CLASS



**CARS AVAILABLE NOW FOR  
TRACK DAY TO GT**



**E: [info@chevronracing.com](mailto:info@chevronracing.com) | W: [www.chevronracing.com](http://www.chevronracing.com)**  
**T: 01565 777 395**

# 58 SENNA OUT IN FRONT

Tribute to Ayrton Senna is a must-see display, from his kart to F1 title winner

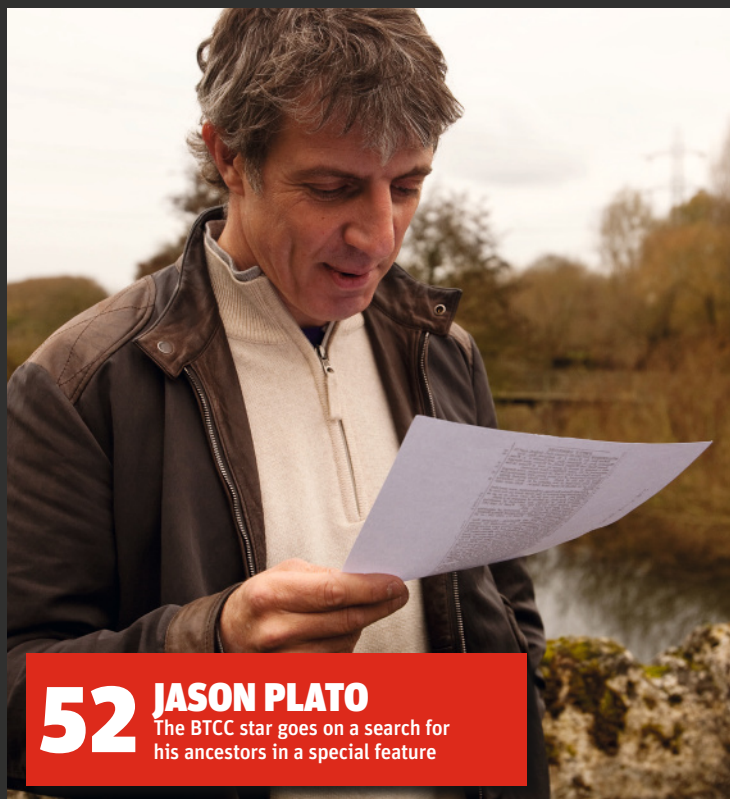

# 52 JASON PLATO

The BTCC star goes on a search for his ancestors in a special feature

# 60 INDOOR RACING

All the thrills of the NEC's Live Action



# 62 SUPERCARS

What to see at Performance Car Show: Powered by PistonHeads.com



# 65 F3 JUBILEE

HSCC celebrates 60 years of F3 to head a busy national cast





# The NEC's the place to be for AUTOSPORT International 2012

AUTOSPORT International has been an early highlight of the motorsport season for many years now, and the 22nd edition should be no exception.

The great Ayrton Senna has made a resurgence in the public eye recently thanks to the much-heralded film, and a fine display will be one of the show's highlights. Six of the Brazilian's key machines, from early kart to grand prix-winning McLarens, will chart the triple world champion's rise to prominence.

But that's only the start of the exotica that will be in Birmingham. The *F1 Racing* grid, led by Red Bull's superb RB7, will celebrate one of the best GP seasons for many years, while rallying and Group C greats of the past will add extra dimensions.

For those who want to get an early taste of racing cars in action after the winter break, there's the Live Action arena. The new-and-spectacular McLaren MP4-12C GT3 machine of United Autosports will impress, as will the Formula 2 car driven by the latest McLaren AUTOSPORT BRDC Award winner Oliver Rowland. There will also be appearances from Formula Jedi, Time Attack, drifting and the short-oval racing scenes.

Of course, one of the finest elements of any AUTOSPORT International is the Central Stage, on which our own Henry Hope-Frost will interview some of the luminaries of the sport. Paul di Resta, David Coulthard, Alan Jones, Christian Horner and John Watson are among those representing the world of F1, and there'll be stars from sportscars, touring cars, GTs and karting too. Among them will be double BTCC champion Jason Plato, who discovers a lot more about his past in this very issue.

Underpinning all the higher echelons of the sport, of course, is the grassroots competition of club and national racing. They always provide the meat of much of the show and this year a gathering of cars and drivers from the history of Formula 3 should provide a highlight. The successful Historic Sports Car Club is putting that together, but almost every other race-organising club in the UK will be on hand to show off its latest developments and attract more competitors and fans.

So, here's our guide, which should help you get the best out of AUTOSPORT International 2012. We hope you enjoy it.

**Kevin Turner**  
Features editor

My picks

**PAUL DI RESTA**



**DAVID COULTHARD**

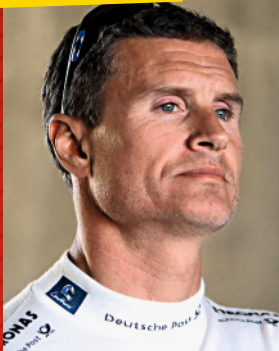

**JAKE HUMPHREY**



**ALAN JONES**



“If it moves and makes a noise it gets my vote, so it suits me just fine”

Forgive my annual pre-AUTOSPORT International main-stage interview marathon reminder: if it moves and makes a noise it gets my vote. In fact, that pretty much sums up my *raison d'être*, so chatting to ex-Formula 1 world champions, Le Mans legends, world rally warriors, touring-car doorbangers and youngsters ready to impress suits me just fine, thanks.

This year's four-day, all-day extravaganza has a line-up to match the best of them, so pop along to Hall 20 and enjoy hearing from this little lot:

**Paul di Resta** Force India F1 ace  
**David Coulthard** Ex-F1 racer-turned BBC F1 pundit  
**Alan Jones** 1980 world champion  
**Christian Horner** Red Bull F1 boss  
**John Watson** 1981 Brit GP winner  
**Jake Humphrey** BBC F1 frontman  
**Ben Edwards** New voice of BBC F1  
**Pat Symonds** Top F1 engineer  
**Anthony Davidson** Peugeot sportscar ace and Sky F1 pundit  
**Allan McNish** Audi sportscar star and two-time Le Mans winner  
**Tom Kristensen** Eight-time Le Mans winner  
**Terry Fullerton** Karting legend and Ayrton Senna's biggest rival

**Andy Priaulx** BMW DTM racer  
**Rob Huff** Chevrolet World Touring Car top-name  
**Gary Paffett** McLaren F1 tester and Mercedes DTM racer  
**Jason Plato** Most successful British Touring Car racer ever  
**Gordon Shedden** Honda BTCC ace  
**Darren Turner** Factory Aston Martin sportscar driver  
**Steve Rider** Sky F1 presenter  
 I hope you're looking forward to it as much as I am. And who knows, you may even find yourself winning tickets to the British Grand Prix at Silverstone...  
**Henry Hope-Frost**

**1970s AND '80s F1 ACE WATSON**



**RACER/PUNDIT DAVIDSON**



**AUTOSPORT MAIN STAGE**



**KART LEGEND FULLERTON**



**AUDI LE MANS STAR McNISH**



# Who does Jason Plato think he is?

We thought it would be fun to find a victim to recreate the BBC's *Who Do You Think You Are?* Step forward two-time BTCC champ Jason Plato. *MARCUS SIMMONS* plays genealogist

*John Plato*

*Henry Plato*

*Henry Plato*

*Edna Plato*

*Raymond Plato*

*Timothy Plato*

***Jason Plato***

**See Jason Plato** on the AUTOSPORT Stage

**O**n a cold December afternoon, the man who holds the records for race wins, pole positions and fastest laps in the 54-year history of the British Touring Car Championship is chasing his ancestors. As Jason Plato makes swift-but-sure progress around Oxfordshire's rural lanes, he muses: "It's funny – when I go to different parts of the country I often try to find a phone book to see if there are any Platos."

It's a theme that Jason, presenter of Live Action at this week's AUTOSPORT International, immediately picked up on when we started this project a few months earlier. Relaxing in his office – the nerve centre for all his numerous activities, including his Brand Pilot marketing company – he'd remarked: "Any time we ever meet an unrelated Plato, and it's only happened about three times, we're always intrigued as to where the name comes from."

As it happens, Jason's grandmother Elsie Plato (nee Holmes), who worked at Oxford University, befriended a don who tried to investigate her married surname, and

who concluded that it could have been an affectation adopted by Italian or French immigrants. In the absence of any evidence, it's as good a theory as any...

Jason was born in Oxford but, before he started infant school, his father Tim's motor-trade job took the family to Newcastle-upon-Tyne. After Jason had left school, just at the point when he was looking to convert a promising karting career into fledgling steps in car racing, the family went south again, this time to Suffolk. During his single-seater days Jason moved to Northampton, where he shared a flat with fellow racer Simon Harrison. After this it was a few hops – BTCC superstar, *Driven/Fifth Gear* presenter, four years living in Monaco, marriage to Sophie, the births of two lasses (Platelettes?) – to the current Plato pad: a magnificent converted barn on the outskirts of Oxford, and only about three miles from...

**PLATO TRAVELS FULL CIRCLE**

...Abingdon, better known as the home town of MG and Radiohead. Where, unbeknown to Jason and Tim, the Platos lived a harsh existence in the 19th and early 20th centuries, when to survive from day to day was as big a battle as JP has ever faced on the track.

**"In 1920, Jason's great-grandmother Edna Plato married a Chinese laundry proprietor"**

The key figure in Jason Plato being who he is today, the person who battled successfully to escape adversity in early life, is his great-grandmother Edna. She was born Edith Plato on October 3 1883 in Ock Street, Abingdon and died in the summer of 1979 – at the age of 95. Jason doesn't remember her, but Tim recalls: "She used to frighten me. We would all troop in to visit her in bed, me and my brother and sisters. A lovely old lady, but she had this incredibly white skin. Very much a matriarch – and I heard she was known as a bit of a girl!"

By the time of the 1911 census, Edith had become Edna – name-changing to something more 'glamorous' was not uncommon at the time – and was working as a domestic servant in a 16-room mansion in nearby Sutton Courtenay. Jason is intrigued, and we make the short trip to the village; the property we believe his great-grandmother to have served

in is next door to his 1997-98 team-mate Alain Menu's old house!

In December 1914 Edna, living now in Headington on the outskirts of Oxford, gave birth to twin boys: Raymond (Jason's grandfather) and Ernest. While Ernest died in infancy, Raymond became an engineer and motorcycle trials rider, married Elsie and had a family of four.

Intriguingly, the birth certificates of Ray and his twin list no father, meaning the Plato name was passed down the maternal line for this generation. Bearing in mind their birth date of late 1914, the illegitimacy could have been caused by Jason's great-grandfather being an early casualty of the First World War, and family whispers do suggest the involvement of an Australian soldier.

Even so, the discovery is a revelation to Jason, who had assumed the Plato name had always passed down the male line and, remembering the Australian-soldier story, had even borne that in mind on trips down under for the Bathurst 1000. The news that his great-grandmother Edna was born a Plato also reinforces his ideal for the future. He is a very proud dad to his two girls, but he and Sophie may not have a third. "Because of that, I really want the girls to keep the Plato name to give to their ▶



JP learns the names of 100-odd direct ancestors



Abingdon War Memorial...

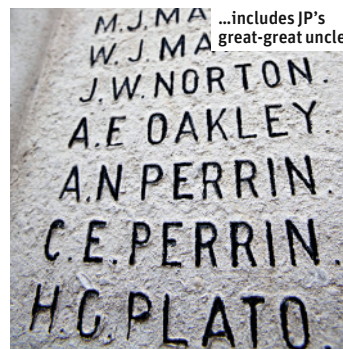

...includes JP's great-great uncle

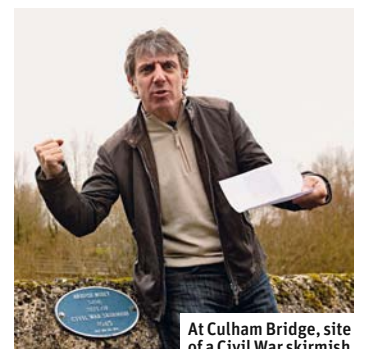

At Culham Bridge, site of a Civil War skirmish

**pankl**  
RACING SYSTEMS



High Tech | High Speed | High Quality



Pankl Engine Systems GmbH & Co KG

A member of Pankl Racing Systems

A-8600 Bruck/Mur, Kaltschmidstrasse 2-6

Phone: +43(0)3862 51 250-0

FAX: +43(0)3862 51 250-290

e-mail: [engine@pankl.com](mailto:engine@pankl.com)



[www.pankl.com](http://www.pankl.com)



Jason, and mum and dad, meet the ancestors



Abingdon Cemetery, next to MG Car Club HQ, is resting place of Henry Plato (1800-83)



◀ children when they grow up," he says. "Otherwise there'll be no Plato descendants of mine. Now I've discovered that already happened – through Edna!"

In 1920 Edna married Chow Coon, a Chinese laundry proprietor whose business was built upon washing the gowns and starching the collars of Oxford University undergraduates. Together Edna and Chow had a son – a half-brother to Ray called Francis Neville Coon. Chow died in 1941, but Jason fondly remembers his great-uncle Neville, and Tim adds: "He had spina bifida but looked after my grandmother until she died – everyone loved him."

The stabilising influence of Chow was much-needed for Edna. He gave his stepson Ray Plato a steady childhood, a platform to acquire the skills he would need to set his family off on the right foot, something Edna had certainly not enjoyed...

**A PUNCH-UP IN 1862**

Edna was one of four children born to Henry and Emily Plato. Big sister Alice was in and out of Abingdon Workhouse, while younger brother Ernest suffered severe illness from birth and died of a seizure in the Fairmile Asylum at the age of 13.

Life was tough for the family long before these incidents, perhaps explaining some of the scrapes they became embroiled in and making Edna's life journey to her own family stability so remarkable. For instance in 1862, Henry (Jason's 2 x great-grandfather), his brother George, and Henry Sr (his 3 x great-grandfather) were involved in an altercation that was reported in the *Oxford Journal*.

'A fight took place between John Leech and George Plato, by Culham Bridge,' reads the write-up, 'and Henry Plato, the father of George, had threatened to thrash his own boy if he did not give the other a good thrashing. Henry Plato the younger was charged with aiding and abetting, but was dismissed. Plato, the father, was ordered to pay a fine of 30 shillings or go to prison to hard labour for 10 days. George Plato was fined sixpence.' Jason and Tim both laugh, before concluding: "We bet the missus made him do the time instead of paying the fine!"

Edna's other sibling was her youngest brother, Henry George, and here is the kindred spirit for Jason. Remarkably, he appears on the 1911 census with his occupation listed as driver (car), beating JP by at least 85 years as a professional driver, but was killed in the Battle of the Somme in 1916. Jason reflects: "He was probably a chauffeur. Maybe he got Edna to help get him the job..."

"Had my mystery great-grandfather been around, the name Plato would have stopped, because my great-grandmother Edna's brothers and sister all died without any surviving children."

A visit to the National Archives in Kew, in search of the relevant war diary for Henry George Plato, fails to unearth any specific details of Jason's great-great uncle. We know he belonged to the 120th Siege Battery of the Royal Garrison Artillery and fell on August 7 1916; the war diary reports that they were at Carnoy. It makes no mention of the fatality, but brings to life the boisterous spirits of the troops as they named their trenches Pint Trench, Beer Trench, Ale Alley and Lager Lane. As a war hero, Henry is commemorated at the Thiepval Memorial in France and on Abingdon War Memorial.

Henry George Plato would have been proud to know that his big sister Edna Plato would become a great-grandmother to not one, ▶

Time stretches back from JP



# ÖHLINS®

By AUROK



We are the only UK distributor specifically for Design, Development and Service of Ohlins Car Product. We have been designing, building and developing the Ohlins automotive range since 1996. In conjunction with our extensive network of agents we provide a full service from idea to the podium for some of the World's major racing teams in GT, Formula, Touring, Off Road, Rally and Truck racing.



**Aurok Ltd**  
**Hermitage Farm,**  
**Colemore,**  
**Alton, Hants,**  
**GU34 3PU**  
**Tel: 01420 588191**  
**Fax: 01420 588190**  
**WWW.AUROK.COM**

rgmmc.com

**“Advancement  
in Motorsport”**



Over the past few years a gentle whisper of hope and promise has resonated into a mighty roar... the roar of adrenaline and high octane engines competing for pole position; a position made possible through the passion and expertise of the RGMMC team.

Motorsport starts in karting and karting starts with RGMMC.

RGMMC can also provide the following equipment alongside the trained personal needed to work it:

- Electronic Flag Marshals
- Unipro Clutch control
- Race / Start control with 6 cameras
- Communication systems
- Petrol testing equipment
- ID card printing
- Timing systems for events

We can also provide you with event consultancy, organisation and preparation.

If you are interested in any of our services dont hesitate to contact us.



**KARTWORLD TV**

**KOBE**  
High Performance kart tyres

RGMMC Establishment  
An der Halde 3  
9495 Triesen  
Liechtenstein  
Fax: +423 230 21 52  
Tel: +423 230 21 50  
Email: info@rgmmc.com

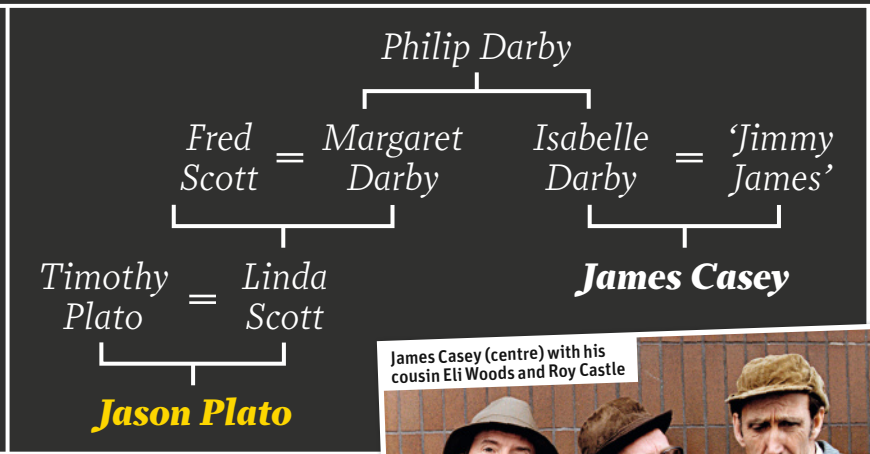
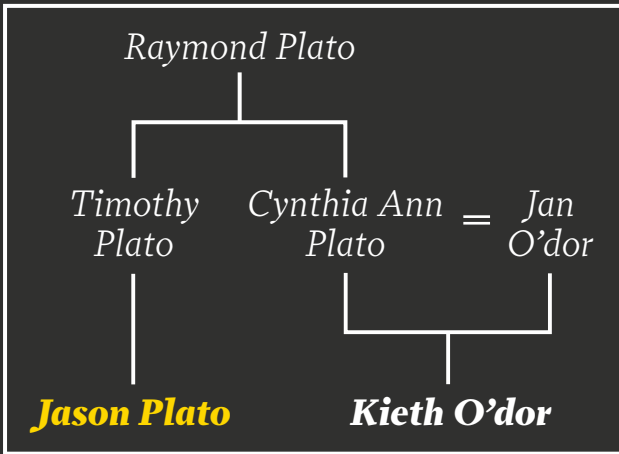

James Casey (centre) with his cousin Eli Woods and Roy Castle

◀ but two Touring Car stars, for Jason's aunt Cynthia Ann Plato (Tim's sister) married Hungarian refugee and motorsport engineer Jan O'dor. Their son Kieth, Jason's cousin, would drive for Janspeed Nissan before his death in a crash at Avus in Berlin in 1995.

**KEN DODD... AND THE INDUSTRIAL REVOLUTION**

Jason's mother Linda is the daughter of Middlesbrough's Fred and Margaret Scott, who moved south to Oxford with Fred's parents, Wilfred and Mabel. "Mabel used to ride a motorbike and my grandad would be in the sidecar," says Linda. "They were pawnbrokers, and they came to Oxford so my grandfather could become director of Charles Geddes antiques."

Jason grew up very close to the Scotts, and it was Fred who gave the future racer the controls of a car for the first time, letting five-year-old grandson Jason sit on his lap to drive up Shotover Hill in Oxford en route to Fred's favourite place to enjoy a crafty cigarette!

"My mum's maiden name was Darby," continues Linda. "She was once a Tiller girl and her sister [Isabelle] married Jimmy James." Real name James Casey, Jimmy James was a hugely popular comedian, a star of stage, screen and radio until the 1960s – a man famous for playing drunks, even though he was teetotal. Their son, James Casey Jr, was Linda's cousin and another comic. Casey Jr, who died last April, rose to a high position in the BBC's light-entertainment department. He gave that scourge of mothers-in-law Les Dawson his big break, discovered Ken Dodd, Tommy Steel and ventriloquist Peter Brough, and performed with Roy Castle.

**"The Les Dawson connection - he could have got me on Blankety Blank!"**

As a leading scriptwriter, he was responsible for the hugely popular *Clitheroe Kid* and early episodes of TV/radio show *Educating Archie*. In other words, he was a true giant of northern comedy.

"I'd absolutely love to have met him," enthuses Jason. "I've been doing telly for 12 years and if only I'd known... And the Les Dawson connection: it doesn't get any better than Les – if I'd been born earlier he could have got me on *Blankety Blank!*"

Tracing Jason's Darby ancestors further back, by the 1860s we found ourselves in Sedgley in the West Midlands. We then discover that Jason's 5 x great-grandfather is Abraham Darby. Is this the Abraham Darby whose iron-smelting techniques kick-started the Industrial Revolution? No, too young, but the famous one also hailed from Sedgley. There must be a connection... Back and back we go until we find that Edward Darby, Jason's 9 x great-grandfather, was the brother of John Darby, whose

son Abraham, born in 1678, pretty much did more to change the world we live in than anyone else.

**NAPOLEONIC FLAWS**

Jason's Scott ancestors spent most of the 19th century in the picturesque North Pennines town of Middleton-in-Teesdale, proper Escort Mk1 rally country not far from Hamsterley forest. While most of the town's men worked as miners for the London Lead Company, the Scotts were the local blacksmiths. A little further back we find John Scott, who was born just over the border in Alston, Cumberland in 1789 and got to Middleton via the Battle of Waterloo...

We look up the service record of Private John Scott, Jason's 4 x great-grandfather. Over six feet tall, he served in the First Life Guards regiment under the Earl of Harrington. His discharge, with good conduct, was due to 'repeated ulceration of the inside of the knee incurred by riding and occasional ophthalmia'. In other words, he needed glasses – and didn't need saddle sores.

Until the 13th century, Alston alternated back and forth between England and Scotland, so the

Scotts were, in all likelihood, Scots. (We can almost hear John Cleland laughing at this point.)

**SO WHO IS JASON PLATO?**

We've now found 40 different surnames of direct ancestors, from Alder and Almond to Wilkinson and Wilson. Plato is a microscopic proportion of his make-up, but it's his identity, hence the keen interest in where the name came from. We've got to John Plato, Jason's 4 x great-grandfather, who died in Abingdon in 1825 at the age of 70. But no further... yet. Little clues keep disappearing into clouds of doubt, and there's a connection to Portsmouth. So did the Platons really come from Italy or France, or is there just a long line of rural English strugglers?

"Looking at your own family makes history engaging," concludes Jason. "Just to live and breathe on a daily basis was so hard for these people."

"I'd now really love to dig back in Sophie's history so that my girls get the full picture of who they are, but that will be a bit difficult considering her dad is the youngest of a family of 14 siblings who hail from the Middle-East!"

"On my side, we've not found any millionaires, but we've met some interesting characters, and we've met people who've contributed to the world we live in, whether that be through the Industrial Revolution, or whether that be through just making us laugh." ❄



Kieth O'dor: Plato's cousin

SOON ON AUTOSPORT.COM HOW WE TRACED PLATO'S ANCESTORS - AND MORE OF THEIR STORIES FROM THE PAST

# Sennasational display of the legend's cars

You've seen the documentary and our special Ayrton Senna edition. Now, at AUTOSPORT International this weekend, you can get up close to the cars, when a special tribute to Senna gives fans a rare chance to see some of the machinery that he raced during his career.

Set your internal GPS for Hall 20 and get up close to the DAP/Parilla kart the Brazilian used in the 1980 world kart championship, and his title-winning Formula Ford 2000 from 1982.

Senna moved into Formula 1 in 1984 with Toleman. You'll be able to see the TG183B he raced that year, as well as the Lotus 99T he used to capitalise on a turbo problem on Nigel Mansell's car and take an emphatic win at

Monaco in 1987 – the first victory for a car with active suspension.

One of the greatest races of Senna's career was at Donington in 1993, when his sublime touch in wet conditions helped him to go from fifth to first on the opening lap. The clip of those first few minutes of the race has been watched more than a quarter of a million times on YouTube, and the McLaren MP4/8 that he deployed to such incredible effect on that afternoon will be on display.

A Senna display wouldn't be complete without one of the cars that took him to the world championship, and you'll be able to see the MP4/4 that helped him earn his first crown in 1988.

Make sure you've got your camera batteries charged...



McLAREN-FORD MP4/8



McLAREN-HONDA MP4/4

## F1 RACING GRID

The 2011 Formula 1 field is probably sick of the sight of the Red Bull RB7, but they'll line up alongside it one last time at ASI on the *F1 Racing Grid*, while foot-tapping team boss Christian Horner will also be on hand. At the time of writing, the line-up was also set to include the Force India VJM04 driven by main-stage guest Paul di Resta, the Mercedes MGP W02, and cars from Williams, Lotus Renault, Virgin Racing (now Marussia) and Lotus (now Caterham). The first of 2012's cars are only weeks away, so take advantage of the chance to see their predecessors one last time.



RED BULL-RENAULT RB7



## BRITISH RALLY HEROES

As usual, rally fans will be well catered for at the show, with our sister publication *Motorsport News* showcasing a collection of British rallying's most important cars.

Pretty much every legendary rally driver from the British Isles is represented. Among the favourites has to be the Mini that Paddy Hopkirk used on the Monte Carlo Rally in the 1960s, with an ex-Roger Clark Escort following quickly behind from the '70s.

Moving more up to date, you'll find Malcolm Wilson's Michelin

Pilot-liveried Ford Escort Cosworth from his British Rally Championship-winning season in 1994. Staying with Ford, the stand is graced by the Focus RS WRC in which Colin McRae edged out Richard Burns in a classic Brit-fight on the 2001 Cyprus Rally.

Burnsie's in there as well, with Prodrive supplying an Impreza WRC driven by the first and only English world champion. For the contemporary fans, there's a 2012-specification Fiesta RS WRC. Away from the *Motorsport News*



**FORD FOCUS RS WRC**

gathering, the place to be is the RS Owners Club stand, which houses Stig Blomqvist's Ford RS200, resplendent in the decals in which it retired from the final ever Group B round of the WRC, the 1986 Lombard RAC Rally.

## GROUP C

Fans of the great Group C era of sportscar racing should make a beeline for the Ohlins stand, where the display will include the Peugeot 905 that won the Le Mans 24 Hours in both 1992 and '93. Also on show will be the Porsche 962, the giant of Group C racing in the '80s.



**PEUGEOT 905**

# Don't miss all the live action



TERRY GRANT IN ACTION

## BriSCA STOCK CARS



FORMULA 2

The Live Action Arena is a popular mainstay of AUTOSPORT International, giving the public a first chance to see, hear and smell cars on track – with no threat of the January weather intervening.

Single-seaters, sportscars, rallying, short-oval racing and even motocross will be represented in the hour-long shows, which will be extended to 90 minutes on Saturday and Sunday evenings. Double British Touring Car champion Jason Plato and TV presenter Louise Goodman

will talk the 4700-strong crowd through the action.

Anglo-American sportscar team United Autosports will show off the mega McLaren MP4-12C GT3 car in the show, and also perform pitstops to add an extra bit of spice to its demonstration.

International motorsport will be represented again when McLaren AUTOSPORT BRDC Award winner Oliver Rowland takes to the track in a 500bhp, Williams F1-designed Formula 2 car.

National competition will take

centre stage when championships including cars from Formula Jedi, Time Attack and autograss take to the arena. Stunt-driving superstar Terry Grant will be up to his usual tricks as well, while the two-wheeled action will come courtesy of freestyle stunt performers UK FMX. There will also be a drifting performance, including the Nissan Silvia S15 driven by former Boyzone singer Shane Lynch.

The UK's popular short-oval racing scene will put on plenty of action with a field of BriSCA F2 cars, which will reappear to have

their own races to form the basis of the extended shows at the end of Saturday and Sunday.

### PERFORMANCE TIMES

Thursday January 12 1400

Friday January 13 1400

Saturday January 14

0930, 1100, 1230,  
1400, 1530

Sunday January 15

0930, 1100, 1230,  
1400, 1530

# Put the kart before the course

The world of karting will be well represented at this year's AUTOSPORT International, with plenty of on-track action complementing the various displays that will be on show.

A regular highlight of the annual trip to Birmingham is the Ginetta Celebrity Karting Challenge, which takes place on Thursday January

12 and is put together by the pairing of racing4charity founder Bill Williams and former Le Mans 24 Hours winner David Brabham.

As always, there will be a 90-minute endurance race featuring teams of six drivers, each made up of four 'celebrities' and two paying members of the public, whose money is donated to charity.

This year the causes backed by the race are The Royal British Legion, Help for Heroes and Combat Stress. In relation to that theme, there will be an additional 30-minute race for wounded military personnel in specially-adapted karts.

Stars on hand to race include Brabham, GP2 race winner Sam Bird, ex-World Touring Car champ

Andy Priaulx, sportscar star Darren Turner and GP3 race winner Alexander Sims. Expect chaos!

The more serious side of karting is always well covered too, with the sport's top clubs, several big teams and suppliers all on hand to help newcomers and seasoned competitors prepare for the 2012 season.



**PRO/AM KART LINE-UPS**



**KARTS READY FOR OFF...**

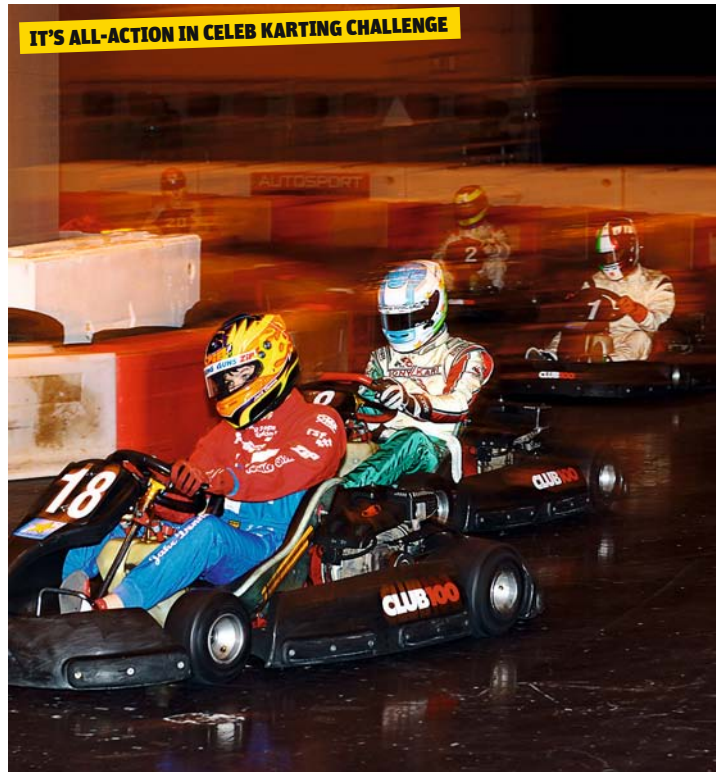

**IT'S ALL-ACTION IN CELEB KARTING CHALLENGE**

## CATERHAM EXPERIENCE

If you get tired of being on your feet while walking around Birmingham's NEC, you can always take a seat at the Live Action Arena. And if you get tired of being on the outside looking in, head to the Caterham Driving Experience.

There, you can get a passenger ride in a Caterham Seven for just £10, where you will witness first-hand the capabilities of the legendary little machines. To add to the experience this year, Caterham will be offering on-board video footage for passengers to take away with them.



**TRY THIS FOR A TENNER**

## THE PERFORMANCE CAR SHOW

Powered by **PistonHeads.com**

14 & 15 January 2012 NEC Birmingham



NOBLE M600



McLAREN MP4-12C



LAMBORGHINI GALLARDO LP560-4

# Marvelling at mega metal

If you're as serious about driving as you are about racing, then The Performance Car Show: Powered by PistonHeads.com is an absolute must. Alongside an array of exotic supercar muscle, the show will host the launch of Noble's carbon version of its flagship M600 and BMW's diesel 3 Series Saloon, plus a spectacular display of UK engineering and ingenuity in the Hand Built British Sports Car Pavilion.

In addition to the Noble M600, which boasts a top speed of 225mph, visitors will be able to get up close to McLaren's MP4-12C, the Ferrari 458 Italia and the Lamborghini Gallardo LP560-4 – and plenty of other exotic models – in the Supercar Paddock. Porsche Club Great Britain is just one of a

number of owners' clubs contributing to the exhibition, as it brings a range of iconic models from past and present.

Two kit-car launches will cater for those with a passion for all things mechanical, with R-Tec Motorsports unveiling its mid-engine, rear-wheel-drive La Bala, and SDR Sportscars pulling the covers off the latest model of the successful V-Storm.

Meanwhile, if you're looking to freshen up your road car, car care product manufacturer Dodo Juice will be on hand with its award-winning products – including the popular 'Home Brew' wax kits – while the *Autocar* road test team will be conducting live Q&A sessions at 1200, 1400 and 1600 on Saturday and Sunday.

## COYS AUCTION LINE-UP

Following record-breaking success in 2011, Coys auction house returns in 2012 with an impressive array of competition machinery, including a 1985 Austin Metro 6R4 Group B driven in a Welsh test by Ayrton Senna.

Other highlights include the 2001 Ford Focus WRC that the late, great Colin McRae drove in Rally Great Britain and Rally New Zealand, and took to victory in Argentina.

From the F1 world the March 811 used by Derek Daly in the 1981 Formula 1 world championship will

go under the hammer, as will a BMW M1 Group 4 Rally Car, veteran of several French events in 1984 and 1985.

Last year's Coys auction proved a landmark success, grossing over £1.4 million in sales. The record purchase was an extremely rare 1968 Bizzarrini 5300GT which went to a Spanish bidder for a record £242,600. This year's auction will take place on Saturday from 1500, although visitors will be able to view the lots throughout the weekend.

NISSAN GT-R



## INDUSTRY SHOW

Alongside the main show, AUTOSPORT International also plays host to Europe's largest trade-only motorsport exhibition, dedicated to performance engineering and specialist motorsport suppliers.

AUTOSPORT Engineering is a two-day exhibition (Thursday/Friday in Hall 9) and offers an opportunity to meet some of the industry's leading buyers, decision makers and suppliers. Around 200 exhibitors will be showcasing their expertise – be it cross-over technology from other industries, new suppliers or new expertise and techniques – creating an array of networking opportunities.

Highlights will include displays from leading vehicle transmission specialist Xtrac, and Alcon – a firm that has provided brakes and clutches for teams competing in F1, NASCAR and the WRC for over 25 years – and a display from this year's crack FIA GT1 Nissan team, James Rumsey Motorsport.

### OVAL RACING

● The Oval Racing section of the show covers all aspects of autograss, rallying, oval racing, drag racing and off-road racing. Located in Halls 9 and 10, it will be open on the weekend public days of the show (Saturday and Sunday) only.

AUTOCAR MAGAZINE STAND



FERRARI 458 ITALIA



RANGE ROVER EVOQUE

## AUTOSPORT INTERNATIONAL Engineering Show



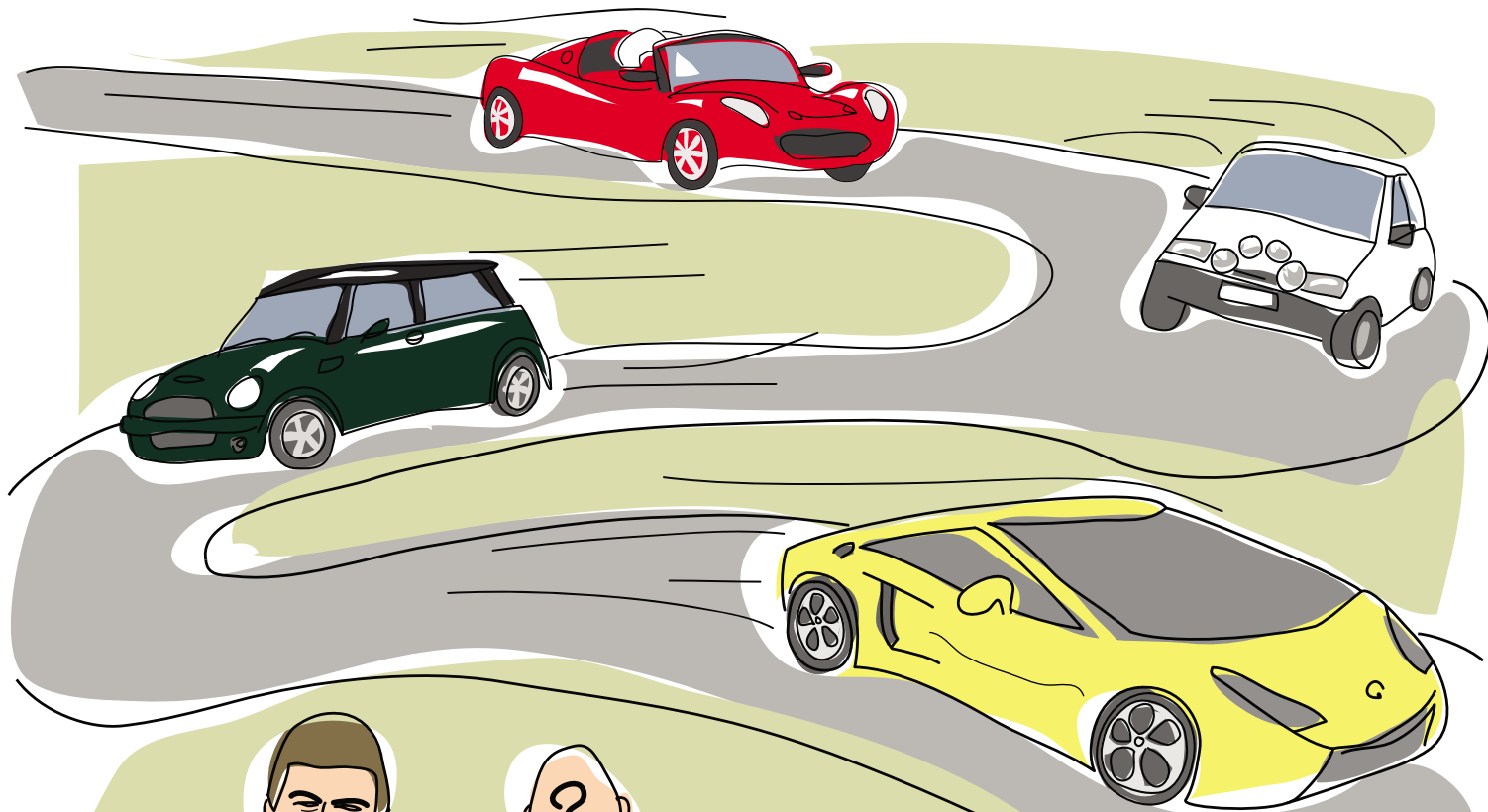

# This petrolhead could be YOU!

Auto Windscreens and Team Aon are offering eight lucky car fans the chance to win a driving day with Tom Onslow-Cole at Donington Park!

The day includes technical briefing with Tom Onslow-Cole, hot laps in a Ford Focus RS, Lamborghini Gallardo, Lotus Elise and Mini Cooper S or Fiat Abarth, as well as a gravel rally session and awards presentation, all courtesy of Auto Windscreens.

Visit [www.facebook.com/autowindscreens](http://www.facebook.com/autowindscreens) and 'Like' the Auto Windscreens page. 

#### HOW TO ENTER

Visit our Facebook page, watch the video, filmed backstage at the 2011 British Touring Car Championship and answer the question based on the film – good luck!

Terms and Conditions apply.  
See [www.facebook.com/autowindscreens](http://www.facebook.com/autowindscreens) for full details.

**Auto  
Windscreens™**

CLEARLY GOING PLACES

# Celebrating a slice of motorsport heritage



**KIEFT 500CC F3 WILL APPEAR**



**SATO DOMINATED IN DALLARA**



**BRABHAM WON IN '89**



**DE FERRAN REYNARD IS ON SHOW**

They say it's impossible to know where you're going unless you appreciate where you've come from. If that philosophy applies to motorsport, then there's no better place to find it than the UK's vibrant historic racing scene.

The Historic Sports Car Club is one of AUTOSPORT International's most-loyal partners and always puts on a fantastic show. Following on from wonderful Formula 5000 and historic two-litre sportscar themed displays of recent times, this year it will host a special offering to commemorate the 60th anniversary of Formula 3 racing in Britain.

From the early 500cc Mk5 Cooper and Kieft of the 1950s, right through to the latest Dallara F312 homologated for the coming season, this display on stand 6700 in Hall 6 will showcase some of the category's most iconic designs.

The HSCC has managed to gain

loans of 13 different F3 cars, including British Racing Drivers' Club president Derek Warwick's 1977 Chevron B38, an example of the Ralt RT3 that dominated the category in the early '80s, IndyCar legend Gil de Ferran's '91 Reynard 913, and the Dallara F301 in which Japanese racer Takuma Sato dominated the 2001 British F3 Championship with Carlin Motorsport.

HSCC executive director Grahame White has also thumbed the pages of his little black book to organise a gathering of past stars of the category on Friday morning. Make your way to the ▶



**WARWICK CHEVRON B38**

# Precision Hub Plate Scale Systems

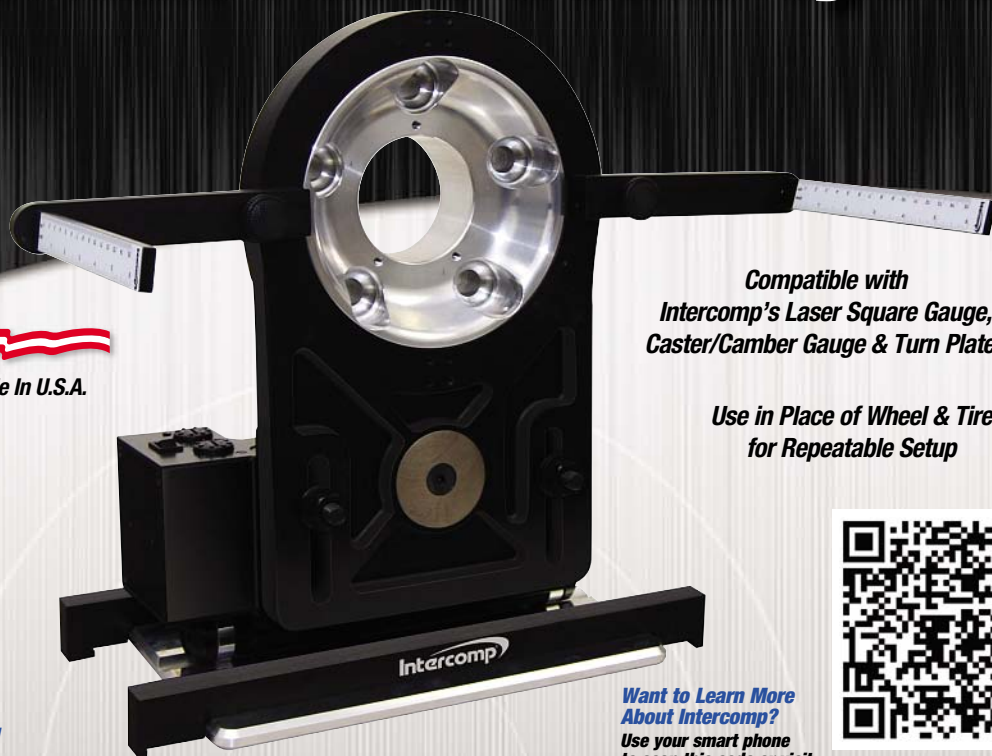

Includes RaceWeigh™ Software for PC & Handheld  
Wireless Professional (PC not included)

Compatible with  
Intercomp's Laser Square Gauge,  
Caster/Camber Gauge & Turn Plates

Use in Place of Wheel & Tire  
for Repeatable Setup



Want to Learn More  
About Intercomp?  
Use your smart phone  
to scan this code or visit  
[www.intercompracing.com](http://www.intercompracing.com)

## Precision Hub Plate Wireless Scale System (Set of Four)

- Part # 170210 - RFX - Low Profile Precision Hub Plate Scale System  
Tire Diameter 19.63" (499mm) to 25.63" (644mm)
- Part # 170211 - RFX - Precision Hub Plate Scale System  
Tire Diameter 23.25" (591mm) to 29" (736mm)

## Precision Hub Plate System (Set of Four)

- Part # 170212 - Precision Low Profile Hub Plate System  
Tire diameter 19.63" (499mm) to 25.63" (644mm)
- Part # 170213 - Precision Hub Plate System  
Tire diameter 23.25" (591mm) to 29" (736mm)

## Intercomp offers you the most comprehensive line of indicator options

Intercomp's industry leading, RFX™ Wireless Weighing Technology is the most widely used advanced weighing technology of its kind and is used by champions in all forms of motorsports.

### Euro Cross Weights Shown!



**SW787RFX™**  
PC Wireless Scale System  
Part # 170154-PC  
(PC not included)



**SW650RFX™**  
Wireless Scale System  
Part # 170126-W

Now Includes:  
RaceWeigh™ Software & Wireless Node!



**SW777RFX™**  
Wireless Scale System  
Part # 170127-WPC



**SW500™**  
Cabled Scale System  
Part # 170125



Call to request our 2012 Racing Products Catalog or log on to:

**NEW!**  
Intercomp  
Scale Systems  
App for iPhone



+44 (0) 118 932 0578 EUROPE

[intercompracing.com](http://intercompracing.com)

+1 763-476-2531 USA

## European Sales & Service

**DEMON TWEEDS**  
Wrexham, Clwyd  
Tel: 44(0) 1978 664466  
Fax: 44(0) 1978 664467

**ROLLCENTRE RACING**  
St. Ives, Cambs  
Tel: 44(0) 1480 464052  
Fax: 44(0) 1480 461454

**RACE HARDWARE**  
The Netherlands  
Tel: 31(0)36-5370689  
Fax: 31(0)36-5371794

**DANIELSON**  
Magny-Cours, France  
Tel: 33(0) 3 86 21 22 55  
Fax: 33(0) 3 86 21 22 65

**GIEFFE SRL**  
Castelceriolo, (AL), Italia  
Tel: 39(0) 131 216505  
Fax: 39(0) 131 216506

**ISA RACING**  
Kottenheim, Germany  
Tel: 49(0) 2651 96250  
Fax: 49(0) 2651 962510

**NIMEX**  
Monheim, Germany  
Tel: 49(0) 2173 54253  
Fax: 49(0) 2173 51089

◀ HSCC stand for 1130 to see mid-1970s Formula 5000 ace Ian Ashley, 1981 British F3 champion Jonathan Palmer and '89 title winner David Brabham (among others) reminiscing about the glory days.

The rich diversity of national motorsport underpins the more glamorous and professional tiers of the sport, and so it is at ASI, as some of the UK's best-loved racing clubs come out in force to launch their new seasons.

Organisations such as the British Racing and Sports Car Club, British Automobile Racing Club and the 750 Motor Club will all be on hand to advise showgoers what they can expect to see at circuits up and down the UK in 2012.

Meanwhile, our governing body the Motor Sports Association will showcase thousands of other grassroots racing organisations through its Go Motorsport initiative, which will be on display in Hall 7, stand 7450, and celebrated club-racing manufacturer Caterham is planning to launch its own brand-new grass-roots initiative during the show.

Club motorsport is a great place for engineering students to get

their hands dirty and learn their craft before setting sights on more glamorous things. Glyndwr University students will put their skills into practice by race preparing a Golf Mk2 GTI during the show, in partnership with racing-component manufacturer Polybush. They will aim to fit a collection of race parts to a standard Golf in four days, in order to have the car ready to race in this year's Production Golf GTI series.

Speaking of club tin-tops, French motor-lubricants company Motul always has a strong presence at the show, and this year will show off a 20-year-old Nissan Skyline R32 GTR that will compete in the 2012 Classic Thunder championship.

As ever, there will be various other manufacturers and suppliers on display at ASI, showcasing the latest cars and products they hope will take the motorsport scene by storm in 2012. So whether you're a newcomer looking to get involved in motorsport for the first time, or a hardened veteran searching for the latest trick to make your racing car go faster, the National Motorsport section of ASI should be the place for you this weekend.



BRITCAR IS ASI REGULAR

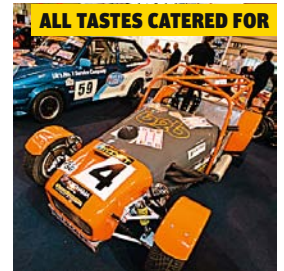

ALL TASTES CATERED FOR



BRSCC WILL BE ON HAND AT ASI



CATERHAM RETURNS



BARC IS ALWAYS WELL REPRESENTED

# Plot a path around the exhibitionists

It can be a bit bewildering trying to make your way around the labyrinthine NEC, so take a look at our map to guide yourself to some of the headline attractions of AUTOSPORT International



LIVE ACTION ARENA



MN RALLY HEROES STAND

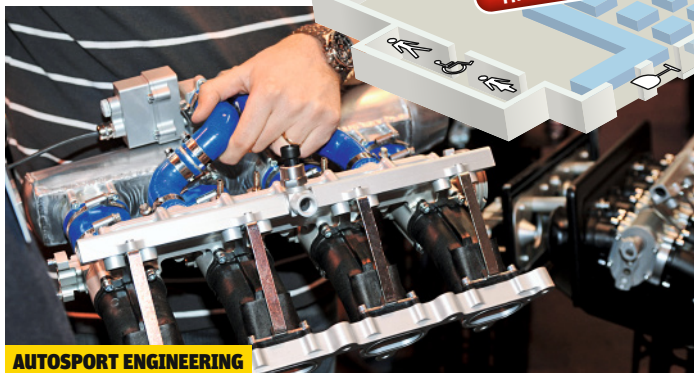

AUTOSPORT ENGINEERING

(THURS/FRI ONLY)





**AYRTON SENNA DISPLAY**



**AUTOSPORT MAIN STAGE**

**SHOW INFORMATION**

**OPENING TIMES**

9am to 6pm each day (January 12-13 are Trade Days only)

**TICKET PRICES (SATURDAY AND SUNDAY)**

Ticket type	Advanced price	Door price
Adult	£30	£32
Child (5-15)	£19.50	£21.50
Paddock Pass	£37	£39
Child Paddock Pass (5-15)	£26.50	£28.50
VIP Club	£100	£100

All tickets include a free seat in the Live Action Arena and free entry into The Performance Car Show. Children under five get free access to the show.

**TO BOOK TICKETS CALL 0844 581 1420  
OR VISIT AUTOSPORTINTERNATIONAL.COM**



the **magazineshop.com**

The Magazine Shop stand will be selling AUTOSPORT, F1 Racing, Motorsport News and Autocar, and offer discounted subscription rates including a choice of gifts – such as the Senna DVD and Autoglym car cleaning kit.

**THE PERFORMANCE CAR SHOW**  
Powered by **PistonHeads.com**  
14 & 15 January 2012 NEC Birmingham



**ROUTE FINDER**

**BY CAR**

The NEC is easily accessible from junctions 6 and 7 of the M42, which connects to the M6, M40 and M5. The A45 also passes the NEC. Alternatively, you can type B40 1NT into your sat nav.

**BY TRAIN**

The NEC is a few minutes' walk from Birmingham International Station. Connections from Birmingham New Street run regularly and take 10 minutes. New Street has excellent links to all major UK cities.

**BY PLANE**

The NEC is a few minutes' drive from Birmingham International Airport. The easiest way to reach the venue is by the Rail Air Link, a free shuttle service running every two minutes between 0515 and 0200. For scheduling call 08445 766000 or log on to [www.bhx.co.uk](http://www.bhx.co.uk).

**BY COACH**

National Express runs regular services to the NEC. For information, call 08705 808080 or log on to [www.nationalexpress.com](http://www.nationalexpress.com).

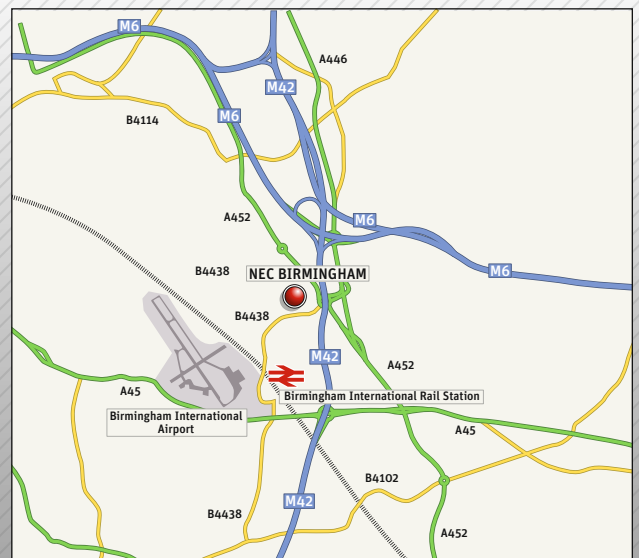

# Scott Malvern Record Breaker!

Most Successful Single Seater Driver of 2011

26 Wins from 33 Races

Dunlop MSA Formula Ford Champion

Winner of all 4 Formula Ford Euro Cup Series Events

BRSCC Formula Ford Festival Winner

BRDC Henry Surtees Award Winner

McLaren AUTOSPORT BRDC Award Finalist 2010 & 2011

Seeking Support & Opportunities for the 2012 Season



## A Proven Winner!

Please contact 07940 204985 or  
scottmalvern@googlemail.com | www.scottmalvern.com

# PERFORMANCE UNLIMITED

Distributors of some of the most  
respected racing components  
manufacturers in the United States.

Distributors of:



And many other leading manufacturers



We are very proud of our machine shop  
which is equipped with the finest  
machinery available. A number of Europe's  
leading engine builders utilize our facility  
due to our extensive equipment  
capabilities and reputation for accuracy.

3 Chessingham Park, Dunnington, York, North Yorkshire, England YO19 5SE  
tel: +44 (0) 1904 489332 • fax: +44 (0) 1904 488355

email: [info@performanceunlimited.co.uk](mailto:info@performanceunlimited.co.uk) • website: [www.performanceunlimited.co.uk](http://www.performanceunlimited.co.uk)

# A-Z of exhibitors

EXHIBITOR NAME	STAND	HALL									
3M United Kingdom	2400	20	Delphi Automotive	8705	8	Lohen Limited	7140	7	Revolution Wheels International Ltd	6466	6
600 Racing	7440	7	Demon Tweaks	6540	6	Lotus Cars Ltd	2500	20	Richbrook International	6772	6
750 Motor Club Limited	7430	7	DEN Motorsport	6850	6	Lotus on Track Racing Drivers Club	6570	6	Rip Raw	2916	20
A.R.C. Clothing	6610	6	DimSport - Dimensio Sport srl	8550	8	LP Tent	6100	6	Robert Bosch Ltd	7300	7
Active Simulators	4010	4	Drayson Racing Technologies	6240	6	Lucas Oil Products (UK) Ltd	6505	6	Rustbuster	6926	6
Advanced Wear and Safety (1996) Ltd			Drenth Motorsport Gearboxes	8405	8	Mac Tools	2860	20	Ryan Motorsport Insurance	6770	6
	6120	6	Duke	6456	6	Magic of Motoring	6845	6	RZR Racing	7230	7
AET Motorsport	8450	8	Dynapak	6251	6	Manchester Metropolitan University	7010	7	Sadev	8620	8
Aford Awards Ltd	6131	6	EBC Brakes	8240	8	Maxxis Tyres	2250	20	Saenz Transmission Europe	6805	6
AH Video Concept	6950	6	EJM Preparation	7026	7	McGard Deutschland GmbH	8640	8	Saker Sports Cars	6400	6
Aireshelta	6721	6	EJM Preparation	7340	7	McGill Motorsports	7228	7	Samco Sport	7552	7
Alutight	6920	6	Elite Racing Transmissions	8615	8	MCR Race Cars Limited	7445	7	SBD Motorsport	8315	8
Anglo American Oil Company Ltd	6565	6	E-Lites Electronic Cigarettes	2880	20	MCR Race Cars Limited	6405	6	Scorpion Exhausts Ltd	6650	6
AP Racing	7500	7	enclosed-trailers.co.uk	6450	6	Mechanix Wear	6255	6	Select Motor Racing	6959	6
Association des Entreprises Pole de la			Exact Engineering (Hose & Fittings) Co Ltd			Mercedes-AMG GmbH	2765	20	Selkin	6928	6
Performance de Nevers Magny-Cours	6500	6				Millers Oils	8650	8	Showtrax	6460	6
ATS Motorsport	6755	6	F1 Model Helmets	6895	6	Milltek Sport Ltd	8555	8	Silverstone Autosport	2402	20
Aurora Bearing Company	8330	8	Fast Films	6515	6	Miracle Shammy	6938	6	Silverstone Classic and Classic & Sports Car		
Australian Clutch Services	8205	8	Ferret Photographics	6826	6	MIS	2405	20		6720	6
Auto Concepts (Aust) Pty Ltd	6550	6	Fire Extinguisher Valve Company Ltd	7215	7	Mode Racewear	8320	8	Simply the Ticket	6855	6
Autoglym	6520	6	Flameproof Technics Ltd	2664	20	Motor Sports Association	2840	20	Sparco SpA	2550	20
AUTOSPORT International Show Research			FlatOutArt.com	6822	6	MotorSport	6922	6	Sparco UK	6435	6
	9050 Linkway		Forge Motorsport	8210	8	MotorSport News: British Rally Heroes			Spax	6630	6
Autotel Race Radio	7325	7	Forge Motorsport	8230	8		8435	8	SpeedKing.cc	6905	6
Avitas Motorsport	7120	7	Formula Kart Stars	6000	6	MotorSport Safety Fund	7232	7	Spencer Elton	6816	6
Bailey Morris Ltd	8216	8	FreeM	6132	6	MotorSport Vision	2720	20	Staffordshire University	8050	8
Baines Engineering	8730	8	Fuchs Lubricants (UK) PLC	6865	6	MotorSport UK - High Speed Television			Stingray RV Rentals	2780	20
BARC	7250	7	Galuppo Racewear	6954	6		6765	6	Stingray RV Rentals	8000	8
Barkers Marquees	7755	7	Garage Tek	2945	20	Motul	7610	7	Subaru	2460	20
Base Performance Simulators	6476	6	Gaz Shocks Ltd	7665	7	Mountune Racing	8540	8	Suixtil	6800	6
BB Engineering Services	6835	6	GB Motorsports Ltd	2870	20	MP Motorsport	6934	6	Super B	8745	8
BHP UK Limited	8246	8	Ginetta	2450	20	Muc Off	6253	6	Super One Karting Championship	6410	6
Birchills Automotive	6620	6	Glyndwr University	7100	7	NGK Spark Plugs (UK) Ltd	2650	20	SuperPro Europe Ltd	8325	8
BMW GB Ltd	2520	20	Go Motorsport	7450	7	Nicky Grist Motorsports	6470	6	SuperPro Europe Ltd	7132	7
BR Racing	7216	7	Grand Prix Racewear	6220	6	Nimbus Motorsport	8250	8	System Store Solutions	8740	7
Braid Wheels	6660	6	Grandstand Merchandise	2772	20	Ningbo Easence Int'l Trade Co Ltd	7712	7	TAG Heuer Professional Timing	6250	6
Brembo SpA	8520	8	Grandstand Motorsports Holidays	6932	6	Nitron Racing Systems Ltd	7525	7	Team Dynamics	2640	20
Bremsten Technik UK Ltd	8245	8	Greenpower	9070 Linkway		Ohlins Racing AB	7600	7	Team FJ - Racecar Euro Series	2760	20
Brian James Trailers	7410	7	GreyCar	6821	6	Owen Developments (UK) Ltd	7630	7	Tecalemit Garage Equipment Co Ltd	8200	8
Britcar	2700	20	Group C Racing/GTP Racing Ltd	6705	6	Oxford & Chervell Valley College	7115	7	The AUTOSPORT Stage	2220	20
British Motorsport Marshals Club	7020	7	GRP4 Fabrications	7530	7	Oxford Brookes University	8150	8	The College of West Anglia	7022	7
British Radio Car Association	7246	7	Grumpy Grip	6202	6	Oxford Products	7560	7	The F1 Racing Grid	6020	6
British Superkart Association	6200	6	Hafix	7562	7	Paddock Solutions	7222	7	The F1 Shop Ltd - Meadowhall	2900	20
Brookland Speed International	6050	6	Hamilton Classic	6606	6	Partsworld Performance	7620	7	The Simulator.co.uk & The Raceroom Bedford Ltd		
Brookland Speed International	6445	6	Haymarket Research	6102	6	Peltor AB	2400A	20		7714	7
Brooklands College	7105	7	Hedtec	6615	6	Pencil Gallery	6820	6	Thorney Motorsport	7040	7
BRSCC	7050	7	HEL Performance	6510	6	Peter Lloyd Rallying	6406	6	Tillett Racing Seats	7320	7
Brunel University	7210	7	Hickleys Limited	8455	8	Piers Dowell	6900	6	Time Attack Series	7030	7
Burning2Learn	7012	7	Hill Rally & Marches 4x4	7150	7	Piper Cams	8605	8	Track Driver Magazine	6860	6
Burton Power	8440	8	HiSpec Motorsport	8600	8	Pipercross	6760	6	Travel Destinations	6640	6
BWRDC	8154	8	Historic & Classic Kart Club for Great Britain			Pirelli Tyres Ltd	6260	6	Vodafone McLaren Mercedes	2672	20
Caracalla - Bath	6842	6		6101	6	Pitbitz	7710	7	Vortex Performance Exhausts	7400	7
Castle Combe Racing Club Ltd	7240	7	Historic Sports Car Club (HSCC)	6700	6	Plays Kool Motorsport	7027	7	WD-40	2671	20
Caterham Cars Ltd	2641	20	Historica Ltd	6824	6	Porsche Cars GB Ltd	2540	20	WDE Motorsport	7310	7
Charters Booksellers	2920	20	Hofmann Megaplan	8344	8	Powerboat P1 Management Ltd	6245	6	Wesbrook Engineering Limited	6133	6
Chevron Racing Cars	2850	20	Hortons Books	2940	20	Powerflex	7545	7	Westfield Sportscars Ltd	6575	6
Civic Racing Cup	7130	7	Image Wheels International Ltd	6600	6	Powervamp Ltd	7747	7	Whizzstitch Embroidery	6616	6
CJ Autos	6830	6	Industrias Lahoz 2004 SL	7200	7	Practical Performance Car	6750	6	Wiltshire College	7013	7
Classic Sports Car Club	7330	7	In-Excess UK Ltd/RC Distribution	7640	7	Praga Racing Holding	6150	6	Woodford Trailers	2770	20
Classic Team Lotus	6730	6	Instant Awnings	7510	7	Premier Power & Race Performance			Wright's Auto Supplies	6812	6
Club 100 Racing Ltd		4	Intercomp	8300	8		8220	8	www.themagazineshop.com	2655	20
CNC Heads	8340	8	International Dongchuan Debris Off-Road & Perfect (Beijing) Culture Spreading Co Ltd	8247	8	PRG Trailers Ltd	7570	7	XYZ Racing	8709	8
Cobra Seats	6645	6	iracing.com	7245	7	Pro-Bolt Ltd	8305	8	Yokohama HPT Ltd	2740	20
Colway Tyres	8711	8	jjcraceandrally.com	7342	7	Quaife Engineering	8500	8			
Commercial Express	7405	7	John Monkman	6909	6	Quantum Tuning	7520	7			
Corbeau Seats Ltd	6464	6	JR Motorsports Limited	2200	20	Race Tech	8618	8			
Corby Motorsport	7740	7	K&N Filters	6870	6	Race Technology	7315	7			
Core Motorsport	7750	7	Karcher	6555	6	Race to the Finish	2910	20			
Courtenay Sport Racing	7540	7	Karting Pavilion	6210	6	Race-Keeper	8708	8			
Coys	2270	20	Kent Performance Cams Ltd	8400	8	Racelogic Ltd	7535	7			
Coys	2280	20	Knight Motorsport - WS2 Coatings	7029	7	Raceshirt	6856	6			
Craybell Ltd	6810	6	Koni Suspension	7650	7	Raceworld	6951	6			
Croydon Race & Rally	7752	7	KW Automotive UK Ltd	2750	20	Radical	2620	20			
Cruden BV	6670	6	L'Anneau Du Rhin	6455	6	Radtec Racing Radiators Ltd	7550	7			
CSMA	6430	6	LAT Photographic	6814	6	Rally Design	8345	8			
David Bailey Developments Ltd	6907	6	Light Commercial Motorsport Models			Randstad Ltd	8202	8			
				6956	6	Rapid Racking	2665	20			
						Reverie Ltd	8610	8			

**PistonHeads Performance Car Show exhibitors**

1st Tickets	19612	19
360 Racing	19710	19
Active Simulators	19070	19
Adamesh Limited	19511	19
Adrian Flux Insurance	19706	19
ALIVE	19611	19

# The new B-Class. Looks smart. Is.

Never before has a new Mercedes arrived with so many intelligent features and developments. Like Collision Prevention Assist, a radar-based system that helps the driver avoid a collision with the vehicle ahead. Or the sleek contours that make this the most aerodynamic car in its class. Looks can sometimes be deceiving. Here they're not.

Discover more at [newbclass.co.uk](http://newbclass.co.uk)



**Mercedes-Benz**  
The best or nothing.

Official government fuel consumption figures in MPG (Litres per 100 km) for the new B-Class Range: Urban 34.0 (8.3)-52.3 (5.4), Extra Urban 56.5 (5.0)-74.3 (3.8), Combined 45.6 (6.2)-64.2 (4.4). CO<sub>2</sub> Emissions: 145-115 g/km. Model featured is a Mercedes-Benz B180 CDI Sport at £25,775.00 on-the-road including optional panoramic sliding roof at £1,195.00, Active Park Assist at £705.00 and metallic paint at £515.00 (price includes VAT, delivery, 12 months Road Fund Licence, number plates, new vehicle registration fee and fuel). Prices correct at time of going to print.



# Loeb: I'll fight for title number nine

Sebastien Loeb made it through a tumultuous 2011 WRC season with an eighth title. Now he's ready to try for a ninth, says *DAVID EVANS*

**G**roundhog day. The same phone call around the same time on very much the same subject for the eighth consecutive year.

Except this year was different. Sebastien Loeb was different. Sure, he's always relaxed – the first time I made this call, in 2005, he was so relaxed he put me on speakerphone and started doing handstands. This time around, as far as I know, there were no handstands.

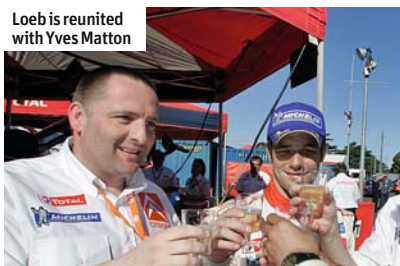

Loeb is reunited with Yves Matton

And no fluff.

Talking to the world's most successful rally driver is not a difficult job, he's a disarmingly decent bloke. But, on occasion, he'll bat off a question with a quick answer. Not this time.

The obvious place to start is his motivation. With, brace yourself... 67 rally wins, eight titles, 103 podiums, 808 stage wins and 1281 points scored in a professional career spanning 137 starts, where does he find inspiration for another season on the stages?

"I like to drive," he says. In previous years, he has talked of his motivation always being the same. Just as strong as it ever was. Psychologists might say this was born of the insecurity of fearing that somebody was going to topple him. Maybe it was.

If it was, that fear has gone now.

"My motivation has changed. It's not the same as it was in 2003, when I was

fighting for the first title. How can it be? The pressure was different in those days. Then, and even, five or six years ago I was still trying to prove that I was able to do something. Now, I have nothing to prove. I just don't want to be beaten by anybody. The motivation is that I like what I do. But, I only enjoy it when I am in the fight."

Didn't enjoy it much last year, though did he?

There were fears that last year changed Loeb more than any other. For season after season, the 37-year-old enjoyed an entirely compliant teammate in Dani Sordo, the line-toeing Spaniard who became Versailles's perennial whipping boy. Then, along came Sebastien Ogier. Ogier was Loeb's polar opposite: confident to the point of arrogance, impatient, impudent and almost disrespectful of the records that surrounded him along Citroen's corridors of power.



Loeb took his second Finland win in 2011



Ford foe Hirvonen has joined Loeb at Citroën

It wasn't long before civil war broke out within the team and it wasn't much longer before Ogier's exit was planned. Outwardly, there was a feeling that Loeb might have stamped his feet and, understandably, finally demanded the respect he commanded anyway.

For a while, Loeb's trademark nonchalance appeared to have deserted him and, for a while, he actually looked like the baddie.

Twelve months ago, Loeb faced a team-mate he didn't really want or like in a squad governed by Olivier Quesnel, a man with whom he never found the same bond as the previous team principal, Guy Frequelin – whom he describes as a spiritual father.

And now, he has good friend Mikko Hirvonen sitting in Citroën #2 and Yves Matton, Freq's general in the good old days, steering the ship. For a man never really seen as a political animal, Loeb appears to have played the game exceptionally well.

And he has. But, and here's the rub, he was forced to.

Loeb's actions weren't born out of petulance, more of a frustration at the unfairness of a situation. Ogier was beating him, but only when the dice was loaded in his favour. Added to that, Loeb couldn't bear the way the situation was undoing all the good work he and Frequelin had done in the early days.

**“The motivation is that I like what I do, but I only enjoy it when I am in the middle of a fight”**

All of this becomes clear when the conversation moves, inevitably, to last season. Loeb bristles at the subject change, but deals with it professionally, while making it clear this is the last time he's going to talk about it.

“We had team orders at the time which I was not happy with,” he says. “I'm not going into the stories again. That's it. Now, Mikko is here and I hope it will be different from last year. I feel okay about Quesnel going, I have no problem with that. We have a new team manager in Yves Matton. I know him quite well from the past, when he was working in the Citroën team. I have a strong relationship with him, so it will be good. I think everything has been done in the team to try to have a good atmosphere. It will be good.”

With Ogier dispatched to a car without a turbo and zero chance of challenging for the title this year and Hirvonen, the driver who finished runner-up for three of the past four years, in the team with him, surely he can win title number nine standing on

his head?

Loeb can't really see this point. And it's here that you realise that Loeb's the same, decent and honest competitor he ever was.

“Yes,” he says, “you are right Mikko is in the car #2. But if the #2 is faster than the #1, then he becomes the number one, right?”

Yeah, right...

Seriously? What about Sordo? He never got a shot at being number one.

“I was always in front of Sordo,” says Loeb. “Okay, on some Tarmac rallies we were fighting together and he was asked not to fight. But this was logical. We were one minute ahead of everybody else in the rally, I was leading the championship and it was stupid to fight against each other. Of course, this worked in my favour, but at the same time it was logic. But, right now, I am not leading the championship and Mikko is another interesting rival for me.”

Loeb wants a fair fight, nothing more and nothing less.

He continues: “Mikko is my team-mate and I hope we can do a good and friendly job together, but also we have to fight together, because if he is faster, he is number one.”

Loeb's other concern is Jari-Matti Latvala: “He showed he can be very dangerous with his speed at the end of last year...”

Right now, though, the danger man must be Loeb. He's genuinely more relaxed and contented than ever before. Further evidence of this comes from the return of Monte Carlo – usually a season-opening slam-dunk for the champion. Loeb admits he's pleased at the chance to race through the French Alps again, but he's not so pleased about the fact that he's got to be on duty from Wednesday until the following Sunday. Talking more deeply about the route for round one is, however, pointless.

“I'm not sure where we are going,” he says, with a mildly embarrassed laugh. “I have to check what is the route. All I know is that it goes on for a long time!”

Returning to that motivation, Loeb delivers the perfect pay-off.

“I will fight for title number nine,” he says. “When you already have eight, what else can you do?”

WRC rivals: you have been warned... ▶



Some reckon Loeb could win it like this

**Autosport Show Stand 7630**

*Just come and talk to us!*



**OWEN DEVELOPMENTS**

*championship winning performance turbochargers & motorsport engine management*



[www.owendevelopments.co.uk](http://www.owendevelopments.co.uk) +44 (0)1865 821062

**Stunning Motorsport Canvas Art**

web [www.imagespeed.co.uk](http://www.imagespeed.co.uk) // tel 0844 870 8278



**THE BIGGEST VODAFONE DMAX CHAMPIONSHIPS YET!**

**BIGGER THAN EVER, NEW WEIGHT CLASSES, NEW CIRCUITS  
EVEN BETTER VALUE - LESS THAN £1500 FOR A SEASONS RACING**



The Championships will race over ten rounds on 9 different circuits:

Rnd	Date	Venue	Circuit
1	19th February	Daytona Milton Keynes	International
2	18th March	Wilton Mill, Northants	International
3	15th April	Daytona Sandown Park	Grand Prix
4	20th May	Lydd, Kent	Clubman
5	17th June	Wilton Mill, Northants	National Circuit
6	8th July	Daytona Milton Keynes	International Extra
7	19th August	PF International, Lincs	Extended Circuit
8	16th September	Daytona Milton Keynes	International
9	21st October	Rye House, Herts	Raceway Circuit
10	18th November	Daytona Sandown Park	Alternate

**Tel: 0845 644 5504**  
[www.daytonamax.co.uk](http://www.daytonamax.co.uk)



# WRC 2012: what's in store?

The return of the most famous rally in the world, top drivers switching teams, and a few tweaks to the regulations. *DAVID EVANS* runs through the key changes

**F**orget about Russians wanted in Lithuania. Forget the squabbles over Mini seats or the concern over Ford's commitment to the World Rally Championship. Focus on the here and the now. Here is the start of the new season and now is the return of the Monte Carlo Rally.

After a shocking winter of uncertainty, the WRC is back. And back where it should be: the French Alps. Lovely place that Karlstad is, it was never really right as a curtain-raiser for the globe's most glorious competition. And next week's Monte Carlo Rally is going to be a great way to blow away the cobwebs. There's competition spanning six days (including qualifying on Tuesday) and a route including the best

mountain roads in the world. The classics are back.

And so is Sebastien Loeb.

For a while it looked like he might be done with us. But he's not. And, after a troubled year with a fellow Frenchman sharing his team, it's all change. In comes a Finn. And not just any Finn, the one who has come closer than most to beating Loeb in recent years: Mikko Hirvonen. There's been plenty of seat shuffling during the closed season.

But the drives are set now and it should be standing room only for a great year ahead.

## WHO'S GONE WHERE?

But will it really be a great year of competition? How can it be when Loeb's chief rival from last year, Sebastien Ogier, is now with a Volkswagen team running a Skoda without a turbo. And Hirvonen is sitting next to Loeb, gratefully accepting crumbs from the eight-time champion's table. And he's not about to challenge Loeb's seniority in a Citroen team around which the world's most successful rally driver has moulded perfectly his own needs.

Hmm. It's a tough one. Until you remember three words:

Jari-Matti Latvala.

Latvala is the Ford man charged with

getting up in the face of the French. He has the full backing of Malcolm Wilson's team and the pace to fight with Loeb across the spread of a season. Any lingering questions over Latvala's asphalt ability were shot with a great showing in Spain last autumn, while the 26-year-old's pace across a loose surface is incontrovertible.

There's going to be a fascinating dynamic at Ford this year. Latvala will have a wingman few ever expected to see darken Dovenby Hall's front door again: Petter Solberg. The Norwegian and Wilson have put the past firmly in

“Jari-Matti Latvala is the man charged with getting up in the face of the French and has Ford's full backing”

the past (Solberg walked out on him for Subaru in 2000) and this time around the 2003 world champion knows his place in a subservient relationship that mirrors that in the red corner across the service park.

At least Loeb and Latvala have got pukka team-mates. Mini driver Dani Sordo hasn't. The cash-strapped Mini World Rally Team has been forced to take paying drivers for Kris Meeke's John Cooper Works WRC, leaving ▶

Argentina becomes a marathon event



Latvala hopes to make the Citroen boys dizzy





# AUTOSPORT

INTERNATIONAL

## The Racing Car Show

14 - 15 January 2012 NEC Birmingham, UK



# CARS : STARS : ACTION!

## A GREAT DAY OUT!

INCLUDES ACCESS TO

THE  
PERFORMANCE  
CAR SHOW  
Powered by [PistonHeads.com](http://PistonHeads.com)

### BOOK YOUR TICKETS TODAY

VISIT: [www.autosportinternational.com](http://www.autosportinternational.com)

CALL: 0844 581 1370

### SEE YOUR FAVOURITE MOTORSPORT STARS AT THE WEEKEND!



JAKE HUMPHREY

DAVID COULTHARD



PAUL DI RESTA

ALLAN McNISH



Ogier (r) and Ingrassia have jumped ship to VW



Ford has welcomed back Solberg after 11-year gap



Mini's financial woes may have ended Meeke's dream

◀ the former IRC champion all dressed up with nowhere to go. Meeke has been promised more testing this season, but what's the point of building the toys if you don't get a chance to play with them? The fiscal dire straits the team finds itself in are also likely to reflect in the development of one of the most talked about and promising World Rally Cars in the sport's history.

Instead of basking in the memory of Paddy Hopkirk's glorious 1964 victory, Mini will be found hiding its light under a bushel at the quieter end of Monaco's seafront next week.

Ogier is another driver we won't be seeing at the cutting edge this year. He won't win again until at least next year, when VW's Polo R WRC arrives. But, that's not to say we won't see some superpersonal stage times from his Fabia S2000 in 2012.

Ogier's not registered for Super 2000 WRC, which is a shame – with only half a dozen names in the hat, the feeder series could have done with a boost and a benchmark. Still it could be worse, it could be five... like the entry in Production Car WRC. Fortunately, the WRC Academy looks slightly healthier.

**AND WHERE ARE WE GOING?**

In a numerically unchanged 13-round calendar, the Middle East has made way



Ott Tanak (l) gets big break, thanks to Ford boss Wilson

for Monte Carlo in 2012.

Not that it was a straight swap: for a while, it was hoped we would start in Monaco and end in Abu Dhabi, until politics, agendas and apparent incompetence got in the way. So, unfortunately, we're staying out of the sand this year – Jordan had always made it clear it would be taking a break after another fine WRC round in 2011.

**“The running order for every day after the opening leg will be reversed - the leader will be the last to tackle stages”**

The championship does return to New Zealand, which takes the place of Australia. And, once again, we head to Auckland with a sense that this could be the last time that trip is made. Despite being blessed with some of the best gravel roads in the world, it seems the day it takes to get there is a day too long for the sport's rulemakers in these straitened times.

We are, however, going to Wales again. But it won't be the title decider following the shift from November to September, which comes in an attempt to show Wales in a meteorologically better light. Because it never rains in Wales in September...

Which leaves Catalunya to close the curtains on the second weekend in November. Oh, yes, I almost forgot, Italy's back – despite forgetting about its commitment to taking its WRC round back to the mainland. Oddly enough, soon after former president Silvio Berlusconi reportedly committed us to the mainland, news broke of Rally d'Italia's departure for Sicily...

**NEW RULES**

The biggest regulatory change for the year ahead comes on the eve of each round. Shakedown switches from being

a last-minute systems check to something meaningful with the potential for an impact on the end result of a WRC round: it's now the qualifying stage.

After two practice runs around the stage, the drivers will take one qualifying run. The fastest driver then gets to choose his place on the road for the opening leg of the event. The slowest driver is last to choose. This is aimed at getting rid of the near-constant tactical jockeying for position at the end of days one and two on hot gravel rallies, where the lead driver is forced to sweep the loose surface clear for those following.

In another related regulation change, the running order for every day after the opening leg of a WRC round, will be reversed – the leader will be the last of the FIA-seeded priority drivers.

The tactics debate is one which rages in car clubs around the world: part of the game or the ruination of the sport's simple philosophy of driving from point A to B as fast as you can?

One thing that did seem to unite spectators across the world against the sport's governing body was the SupeRally regulation, allowing crews who had – in the traditional sense – retired from an event to return and be classified as a finisher. SupeRally has been here since the 2004 Acropolis Rally until now, but for next year it's up to the events if they want to run it. And those purists at the Automobile Club de Monaco have said “Non!”

WRC rookies and relative rookies like Ken Block are appalled at the prospect of paying all that money and coming all that way to start a rally and not have the chance to retire and carry on. Welcome to the way it was. And, dare I say it, the way it should be. To finish first, first you must...

Sermon over. Enjoy the season. ▶

speedsport

## SPONSORSHIP SEMINAR



Friday 3<sup>rd</sup> February 2012  
10.00 a.m. - 4.00 p.m.  
at Speedsport Gallery, Unit 43  
Silverstone Circuit. NN12 8TL

Our seminar is aimed at all racing drivers, teams and even those currently sitting on the sidelines dreaming of a motor racing career.

Heading up the seminar is experienced racing driver, successful team owner and proven sponsorship procurer MIKE O'BRIEN. Mike has over 30 year's experience in the sport and has funded his own racing career, and more recently those of Darren Manning, Callum MacLeod and Stefan Hodgetts entirely through commercial sponsorship and/or investment partnerships.

The full day seminar will cover all aspects of sponsorship, ranging from how to identify your targets through to detailed presentations and most importantly 'closing the deal'.

You'll also hear from Steve Plastow, Managing Director of Tesa, a long term sponsor and now, through Mike, a major supplier to Formula 1; Phil Harris, an experienced chartered accountant with a passion for motorsport with the knowledge and experience to advise how to structure your motorsport activities, and finally TV Presenter Diana Binks on 'being media savvy'. Q & A sessions and the opportunity to talk one to one with Mike and the other speakers make this an opportunity not to be missed!

**VISIT US AT STAND  
6855 IN HALL 6 AT THE  
AUTOSPORT/NEC SHOW.**

Price is **£195 per person**  
Lunch & light refreshments will be provided

Speakers will include:

**MIKE O'BRIEN**  
Managing Director, Speedsport  
**'The Art of Sponsorship'**

**STEVE PLASTOW**  
Managing Director, Tesa UK  
**'A Satisfied Sponsor'**

**PHIL HARRIS**  
Chartered Accountant  
**'Structuring your Finances for Racing'**

**DIANA BINKS**  
TV Presenter and Media expert  
**'Being Media Savvy'**

Call **01327 858 167**  
or email:  
**info@speedsport.co.uk**  
to reserve your place  
**Strictly limited to 25 attendees**

01327 858 167 • info@speedsport.co.uk • www.speedsport.co.uk

+44(0)1280 704 525 / sales@atecautotechnic.com

www.atecautotechnic.com

# ATEC

Fluid Systems

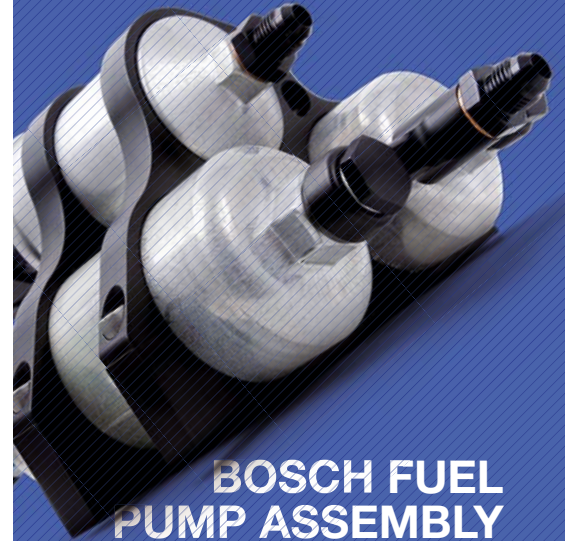

**BOSCH FUEL  
PUMP ASSEMBLY**

**VIEW MORE**

# PRECISION FLOW ANALYSIS

*At last, a solid-state, highly accurate Fuel Flow Sensor  
designed specifically for use on a race car*

NO MOVING PARTS

COMPACT & LIGHTWEIGHT

ULTRASONIC TECHNOLOGY

MINIMAL PRESSURE DROP



For more information visit  
[gillsensors.com/flow](http://gillsensors.com/flow)

+44 (0)1590 613400 • info@gillsensors.com

**AUTOSPORT**  
INTERNATIONAL  
**Engineering Show**  
STAND E928

**GILL**  
SENSORS



Gronholm climbs a Monte mountain pass in 2006

# Marcus's magic Monte memories

**M**arcus Gronholm pauses, thinks, takes a deep breath. "I hate it," he says. He stops. Thinks again. Another pause. "Hey, no," he smiles, "I love it."

Now that he's a long way away from it, he really does love it. And he loves it even more because he beat the master, the Monte master.

Sebastien Loeb has won the Monte Carlo Rally five times. In his head he's won it six times. Had Gronholm not got in the way in 2006, that number would have been seven.

Six?

Yes, six. Loeb: "I won the rally in

2002, but got a penalty after the finish which made me second. In my mind, this was my first win. I count this one as a half win..."

So, we'll settle for five and half.

Fact is, Loeb's love for the Monte is the real deal. Which is why Gronholm's 2006 win hurts so much.

And means so much to the Finn.

"This is a classic rally," says Gronholm. "Of course everybody wants to win it."

Given that the two-time world champion was the last man to beat Loeb, we thought he'd be a good guide to winning next week.

"But nobody can beat Loeb next week," says Gronholm. "Okay, maybe Mikko [Hirvonen] can get close in the same car, but really, nobody else can get close to him."

Gronholm did, though. Admittedly, Loeb did go off the road. I know: *Loeb off the road...*

He out-braked himself in the second part of an icy right-into-left on the D428 just outside the village of Pierlas. The Citroën Xsara WRC gently slid down the bank and came to rest a couple of metres below the road. Loeb was staggered, the car undamaged, but going nowhere.

"I was not so far from him when he



Loeb's off handed Ford rival the lead

went off," says Gronholm. Granted, he had taken time out of the defending world champion on one of the morning's stages, but heading into the opening leg's final test, Loeb had just about a minute on everybody.

Gronholm continues: "I had lost some time myself. I was sliding the car around too much. I'd made the wrong tyre choice and I was pushing quite hard, we were really sliding... But Loeb made the mistake, maybe he made the mistake because he was fighting. I don't know, but we were leading then."

Suddenly, a dream debut was on the cards for Ford's new Finn.

But Gronholm had been here before on the Monte Carlo Rally.

"You can't play with the Monte," he says, "it bites you. I remember when I was driving with the [Peugeot] 307 for the first time. I was pushing like hell, much too hard. Crazy. I wanted to show that this car was good. Corrado [Provera, Peugeot team principal] wanted to show this was the best car. I was trying to do that by driving like mad. We were fastest on the first stage, but you can't keep pushing like that."

A year after that Peugeot debut, the Monte did bite Gronholm. Having crossed the Col de Turini, the Finn was threading his 307 down the other ▶



Gronholm and Loeb fought for 2006 win

**CLUB100**

It's *just* racing!

[www.CLUB100.co.uk](http://www.CLUB100.co.uk)

Loeb's expression on '06 podium said it all



The Finn broke French hearts for a Ford win



Ford's flying Finn kept the Focus on the road...



... and was delighted to finally master the Monte

◀ side of the mountain, when it got away from him and clattered a wall. "We lost a wheel," recalls Gronholm, before adding with pride: "But we got out of the stage and drove on three wheels back to service in Monaco. You know, we were actually overtaking other cars on the motorway to get to service on time. The police waved us in, but they must have thought we were crazy. Maybe the people on the motorway thought the same..." But in 2006 the champagne flowed. "It was an incredible moment," says Gronholm. "You know this is a nice rally. When you are up there in the mountains, it's really nice, it's beautiful. And then, when you have the stage which is full snow, it's fantastic;

you can really attack. And then you have the stage which is full Tarmac, all of the time dry, and this is okay. "But then, you get to the startline of the stage and the co-driver says, 'Here we have ice, black ice, some snow and slush and dry road.' Oy-oy, that I don't like at all. That I really don't miss," he concludes with a shudder. "The feeling is the same. You drive your car down the road in the winter, you turn to the corner and the ice is there. You feel the car slide, you hate it. It's the same sometimes in Monte, just the same. The feeling is terrible." This is hardly going to inspire confidence in those squaring up to Loeb next week. But it's not all bad, the last man to beat Loeb in the

mountains does have some tips. "Confidence," says Gronholm. "You must have confidence in what your ice-note crew tells you." These are the crews who go through the stage an hour or so before the start of the stage to mark where the ice is. In the worst case scenario, four days will have passed between the crews' recon and the time they see the stage at full speed. Four days is a lifetime in a place where the weather can change by the minute. And then there are the Monte intricacies; the Burzet stage, for

**"The police waved us in but they must have thought we were crazy"**

example, will run in dusk on Wednesday night. The sun's still up when the ice-note crew find a damp patch. Fast forward that hour, the sun's down and it's starting to freeze. When does damp turn to black ice. Think about it... make the call. Get it wrong and your man could be in the boonies. "Don't listen to any of the blah, blah, blah about the weather," adds Gronholm. "Just listen to the ice-note crew and trust them. Drive fast, do your job and believe you can win.

"Oh yes, and pick the right tyres." Will that be enough for anybody to beat a man who knows these streets, has a Monegasque co-driver and a team that appears to have a meteorological inside line from the Big Fella upstairs? Probably not. Loeb might not have competed on this event for three years, but he cut his teeth on this terrain. He won his French Championship title down these lanes. Almost as much as Alsace or Trier, the switchback passes dissecting the Alpes Maritimes are home to the man who has spent eight years on top of the world. Good luck to anybody standing in the way of Loeb and Monte win number six. Or should that be seven? Or seven and a half? ❄

**AUTOSPORT**

**CEBE**  
PURE PERFORMANCE



**SAVE 21%**  
ON THE  
COVER PRICE

# FREE CEBE SPIDER SUNGLASSES

**WHEN YOU SUBSCRIBE TO AUTOSPORT**

**JUST**  
~~£3.30~~  
**£2.61**  
**PER**  
**ISSUE**



## 5 GREAT REASONS TO SUBSCRIBE:

- **FREE** pair of Cebe Spider sunglasses worth £50
- **Spread the cost** with easy direct debit instalments
- **SAVE 21%** - pay just £33.95 every 13 issues
- **FREE P&P** - every issue direct to your door
- **PLUS** - all AUTOSPORT subscribers get a **FREE AUTOSPORT digital edition** subscription AND unlimited access to AUTOSPORT.com (worth £158)

Subscribe online at:

themagazineshop.com

**www.themagazineshop.com/ASPO/M0112P**

Or call our hotline and quote offer code M0112P:



**FREE**  
DELIVERY

# 08448 488 817

Offer closes January 19, 2012. Please have your bank details ready

Terms and conditions: This is a direct debit offer open to readers in the UK only. Overseas rates are available by calling +44 (0) 1795 592 974 or for US rates call +1 866 978 1446. Offer closes on January 19, 2012. Direct debit prices are valid for one year, after which they are subject to change. Should prices change you will be informed in writing. Please allow 35 days for delivery of your first issue and gift. Gift will be sent under separate cover. Should we run out of gifts you will be offered an alternative - there is no cash alternative.



There's only one way worth going...



Bouffier won IRC qualifier last year



Icy hairpins in the dark: classic Monte

**2012 MONTE CARLO RALLY ITINERARY**

**Wednesday January 18**

- Start Valence** 0800
- SS1 Le Moulinon-Antraigues (22.91m)** 0903
- SS2 Burzet-St Martial (18.94m)** 1021
- Service Valence** 1246
- SS3 Le Moulinon-Antraigues (22.91m)** 1421
- SS4 Burzet-St Martial (18.94m)** 1539
- Service Valence** 1749

**Thursday January 19**

- SS5 Labatie d'Andaure-Lalouvesc (11.80m)** 0933
- SS6 St Bonnet-St Julien Molhesabate-St Bonnet (15.67m)** 1014
- SS7 Lamastre-Gilhoc-Albousiere (13.45m)** 1137
- Service Valence** 1257
- SS8 Labatie d'Andaure-Lalouvesc (11.80m)** 1450
- SS9 St Bonnet-St Julien Molhesabate-St Bonnet (15.67m)** 1528
- SS10 Lamastre-Gilhoc-Albousiere (13.45m)** 1654
- Service Valence** 1802

**Friday January 20**

- SS11 St Jean en Royans-Font d'Urle (14.46m)** 1002
- SS12 Cimetièrre de Vassieux-Col de Gaudissart (14.99m)** 1043
- Service Valence** 1218
- SS13 Montauban-Eygalayes (18.57m)** 1511
- Parc Ferme Monaco** 1956

**Saturday January 21**

- Service Monaco** 1315
- SS14 Moulinet-La Bollene Vesubie (14.54m)** 1508
- SS15 Lantosque-Luceram (11.68m)** 1554
- Service Monaco** 1753
- SS16 Moulinet-La Bollene Vesubie (14.54m)** 1934
- SS17 Lantosque-Luceram (11.68m)** 2017
- Service Monaco** 2132

**Sunday January 22**

- SS18 Ste Agnes-Col de la Madone (3.20m)** 1011
- Finish Monaco** 1117

# Monte Carlo: it's snow business

**A**fter three years on the naughty chair, the World Rally Championship has been allowed to return to Monte Carlo. Sounds bizarre doesn't it? But that's the size of this tail-wagging-dog relationship.

But it's the Monte and it's back. And that's all that matters.

That's not to deride the Intercontinental Rally Challenge in any way. The IRC served the event superbly and helped to deliver the challenging and interesting route we'll follow next week. It's worth registering the point, however, that for all its foot-stamping about central service and cloverleaf routes, the Automobile Club de Monaco still hasn't truly broken free from that mould.

What we've got now is a cloverleaf still attached to the stalk.

Like I said, the main thing is that the world's fastest drivers and rally cars will be racing through the Alps to celebrate in the sunshine once again.

Just like the old days. And the really old days: this is the 80th running of this Med-bound dash.

The master of the modern-day Monte is Sebastien Loeb and the defending champion will be very, very difficult to beat. There are drivers, such as Loeb's own Citroen team-mate Mikko Hirvonen and Ford's new signing

**“Defending champion Sebastien Loeb will be very, very hard to beat”**

Petter Solberg, who have more recent experience of a route running through the Ardeche, Drome, Haute Loire and Alpes Maritimes, but none who can match his five-from-six record.

Or his instinctive ability to find grip where others fear to tread.

Ford's team leader Jari-Matti Latvala is not a man known for throwing in the towel, but he openly admits a trouble-free run for the number-one Citroen will make it impossible to catch.

But this is Monte Carlo. Impossible means nothing. Here, if the weather does its thing, everything is possible. Remember last year? Bryan Bouffier and Francois Delecour were down and out one minute. Then the snow came and they were one-two.

It's been a long time since we had a truly wintry Monte to open the WRC, so snow would be more than welcome. And if not, let's have some hardcore frosts, forcing the even harder-core spectators to throw another log on the stage-side fire during the day and pack another sleeping bag for sundown.

This is one for the brave; crest the Col, tighten the belts and take on the black ice of a north-facing downhill. Do that faster than Loeb, and you'll be spraying the champagne outside the Grimaldi gaff a week on Sunday. ☼

**TOP 20 MONTE CARLO RALLY ENTRIES**

Sebastien Loeb/Daniel Elena	Citroen DS3 WRC
Mikko Hirvonen/Jarmo Lehtinen	Citroen DS3 WRC
Jari-Matti Latvala/Miikka Anttila	Ford Fiesta RS WRC
Petter Solberg/Chris Patterson	Ford Fiesta RS WRC
Henning Solberg/Ilka Minor	Ford Fiesta RS WRC
Matthew Wilson/Scott Martin	Ford Fiesta RS WRC
Ott Tanak/Kuldar Sikk	Ford Fiesta RS WRC
Evgeny Novikov/Denis Giraudet	Ford Fiesta RS WRC
Thierry Neuville/Nicolas Gilsoul	Citroen DS3 WRC
Martin Prokop/Jan Tomaneck	Ford Fiesta RS WRC
Dani Sordo/Carlos del Barrio	Mini John Cooper WRC
Pierre Campana/Sabrina de Castelli	Mini John Cooper WRC
Francois Delecour/Dominique Savignoni	Ford Fiesta RS WRC
Armando Araujo/TBA	Mini John Cooper WRC
Bryan Bouffier/Xavier Panseri	Peugeot 207 S2000
Sebastien Ogier/Julien Ingrassia	Volkswagen Polo S2000
Kevin Abbring/Lara Vanneste	Volkswagen Polo S2000
Per-Gunnar Andersson/Emil Axelsson	Proton Satria S2000
Giandomenico Basso/Mitia Dotta	Proton Satria S2000
Craig Breen/Gareth Roberts	Ford Fiesta S2000



*europa's leader in american  
motorhome rental & sales*



# Redefining American Motorhome Sales and Rental Across Europe



*uk*



*france*



*sweden*



*germany*



*holland*



*norway*

**coming soon...**

A stylized map of Europe is shown in white against a grey background. The map is overlaid with several blue shapes representing different countries. Each blue shape contains a white oval with the text 'stingray RV' followed by a country code. The country codes shown are .no, .se, .nl, and .de. The text 'coming soon...' is written along the outline of Italy.

stingray *RV*.no

stingray *RV*.se

stingray *RV*.nl

stingray *RV*.de

coming soon...

- Europe's Largest RV Retailer
- Largest Rental Fleet Outside the USA
- Full Europe-Wide Warranty
- Unrivalled Service And Support
- The Best Range of RVs at Great Value
- Largest Stockist of RVs in Europe

For more information or to hire a 'home from home':  
visit [www.stingrayRV.com](http://www.stingrayRV.com), call **0870 241 5614**  
or email [simon@stingrayRV.com](mailto:simon@stingrayRV.com)

[www.stingrayRV.com](http://www.stingrayRV.com)

**INTERNATIONAL RACES & RESULTS**  
**DAKAR RALLY**  
San Rafael (RA) - Copiapo (RCH)

**LEADERS AFTER STAGE SEVEN**  
→ Cars **Stephane Peterhansel**  
→ Trucks **Gerard de Rooy**  
→ Quads **Alejandro Patronelli**  
→ Bikes **Cyril Despres**

**RACE RATING**  
★★★★☆  
Peterhansel edging away, but plenty of punctures keep you guessing

DAKAR RALLY STAGES 3-7, SAN RAFAEL (RA) - COPIAPO (RCH), JANUARY 3-7

# Peterhansel zones in on 10th Dakar win



Peterhansel has run largely trouble-free

## X-RAID TEAM DIRECTOR

Sven Quandt edged ever closer to his dream of winning the Dakar Rally as 123 cars began the final seven stages, starting with the Atacama desert, on Monday.

Quandt's Mini All4 Racings were beginning to tighten their grip on proceedings, with Stephane Peterhansel 11m22s ahead of his Polish team-mate Krzysztof Holowczyc. But American Robby Gordon was still within striking distance of upsetting the Mini party over the stages to come in Chile and Peru.

Gordon and 2011 winner Nasser Al-Attiyah had

set the pace on the Copiapo loop stage before Sunday's rest day, and that performance had pushed Gordon's third-placed Hummer to within 1m47s of second spot. "We have changed a lot of things on the Hummer, including the transmission, and we're in a great position for the rest of the rally," said Gordon.

Al-Attiyah's chance of defending his Dakar title hung by a thread. The convincing Copiapo stage victory had improved his case, but engine-cooling problems, delays in a muddy hole and the cancellation of the stage between Fiambala

and Copiapo had all worked against the Qatari. Despite his troubles, Al-Attiyah had climbed back into sixth, albeit 42m54s behind Peterhansel.

"Attack and push hard is the only option now," said Al-Attiyah. "I need to take around 7m on every stage. That is the reality."

Quandt's army of Minis had enjoyed a relatively trouble-free run through Argentina and into Chile. Peterhansel – chasing an unprecedented 10th Dakar title and his fourth in a car – had taken the lead for the first time on stage two, regained the initiative on stage four and held the lead for four days with the help of one fastest stage time.

Holowczyc set the quickest time on the fifth stage into Fiambala and held the lead for one day. "It was a nice feeling to lead the rally and take my first fastest time," said the Pole. "There are no team orders with us so this final week will be exciting."

As we went to press

Spaniard 'Nani' Roma held fourth in the third Mini and had set the quickest time on stage three. But Roma – a Dakar winner on two wheels in 2004 – began the second half of the rally trailing Peterhansel by over 18 minutes.

The relatively untested South African-built Toyota Hilux, driven by 2009 winner Giniel de Villiers, had been a revelation over the opening seven stages. De Villiers held fifth out of Copiapo and had been as high as second in Chilecito.

Reigning FIA World Cup holder Leonid Novitskiy held seventh position in the fourth Mini, and Portugal's Carlos Sousa was running in eighth with the Chinese-built, diesel-engined Great Wall Haval. Argentina's Lucio Alvarez (Toyota) and Dutchman Erik van Loon (Mitsubishi) rounded off the top 10.

Japan's Jun Mitsuhashi held a comfortable 23-minute lead over Spaniard Xavier Foj (Toyota) in the showroom T2

category. Abdullah Al-Herai was third.

● Neil Perkins

## STANDINGS AFTER STAGE SEVEN

**1 Stephane Peterhansel/Jean-Paul Cottret (Mini All4 Racing),**

15h32m53s; 2 Krzysztof Holowczyc/Jean-Marc Fortin (Mini), +11m22s;

3 Robby Gordon/Johnny Campbell (Hummer H3); 4 'Nani' Roma/

Michel Perin (Mini); 5 Giniel de Villiers/Dirk von Zitzewitz (Toyota Hilux Pickup); 6 Nasser Al-Attiyah/Lucas Cruz (Hummer).

## IN BRIEF

Riviere won twice



## ANDROS TROPHY

Jean-Philippe Dayraut moved level with Alain Prost at the head of the points as the Mini driver beat his Dacia rival on each day at Isola 2000. Benjamin Riviere (Skoda) won both days, closing in on the series lead as a result.



Al-Attiyah was fast, but made errors

# New Year's efficiency revolution

Get your new race season off to a quick and efficient start with a safe and reliable brand new Brian James Trailer.

The A-max is at the leading edge of trailer efficiency. Every detail is honed through many years of experience and know how.

## A-max range

*Robust commercial quality components, a 33 year long understanding of race car transportation and dedication to providing the most efficient trailers on the market. This is what it takes to create an A-max.*

*The super efficient, super fast loading ramp system is what makes this such a popular trailer. A low, wide loading platform is another highly attractive feature.*



## Clubman & Clubman Tilt-bed



**Clubman - Tiltbed model 100-0510**  
 4.3 m (14ft) Long, 1.90m (6ft 3) wide  
 2000 Kg gross capacity  
 Range from £ 1,809 plus vat

## TT Tilt-bed range



**Race Shuttle RS5**

Visit the new Brian James Trailers web site at [www.brianjames.co.uk](http://www.brianjames.co.uk) for full pricing details of the product range and our extensive national dealer network.

Models shown may feature optional equipment

**BRIAN JAMES TRAILERS**

[www.brianjames.co.uk](http://www.brianjames.co.uk)

Tel. 01327 308833

ref. 12/01

# TRAILERS & TRANSPORTERS



Built in 2002 for BAR F1, this Communications and storage truck has two levels. The upper-deck has a large office, kitchen area and separate workshop space, while the lower deck features more workshop space and externally there are many belly lockers providing extensive amounts of storage. With 2 large antennas reaching almost 60m and racking for radio repeater, this is ideal for radio communications set-up. Also Large 415V generator, Hydrovane compressor, 2 x Compressed air antenna masts, Oyster vision satellite system, Air-conditioning throughout, Dhollandia Tail lift.

The transporter would now suit World GP Bikes, 2 car Formula Team, or as a high end Formula Management/Data transporter with additional storage to support a car carrying transporter.

Sale price £129,000+vat



Year 2009 HMS Race Transporter, Complete new build in 2009 with 13.5m x 8m awning Co awining, 2,500kg Dhollandia Tail lift, capacity for 5 cars with drivers changing area.

Top deck height: 1470mm,  
Lower deck height: 1880mm.



## THE RACE TRANSPORTER SPECIALISTS

SALES - BUILD - UPGRADES REFURBISHMENT - RENTAL



Double deck 4 car race transporter with office on goose neck, 2,000kg Dhollandia lift, Awning, Air con, etc.  
**£44,000+vat**



Double deck 4 / 5 car transporter, 4m high, Dhollandia Tail Lift, Awning, Externally refurbished including: Chassis shot blasted and painted, New brakes etc, fresh paintwork.  
**£38,000+vat**



Year 2010 chassis and conversion by SDC, 1 car rally transporter, Dhollandia Tail lift, 9kw diesel generator, living, basic workshop.  
**£55,000+vat**



We have 1x freshly converted transporter in stock finished externally only as per the photos attached, internally the trailer is empty except for the original middle deck. Specification: chassis shot blasted and painted, new brakes shoes, drums, air bag etc, Dhollandia 2,000kg Tail lift, internal heights 2080mm lower 1440mm top deck. The trailer can be finished in any colour. Our order books are now full so the trailer will be sold part built.  
**£45,550+vat**



Year 2004 Man support truck with workshop & generator, 110,000km from new, (this does not having a racing spec tail lift)  
**£12,000+vat**



3 x Formula car transporter with awning.  
**£24,750+vat**



For more information please view our website

**[www.hopkinsmotorsport.com](http://www.hopkinsmotorsport.com)**

or call **01179 509294**

# TRAILERS & TRANSPORTERS



Call Us Now! tel. 01327 263 384

www.woodfordtrailers.com sales@woodfordtrailers.com



**RL 5000**  
£7,300 + vat



**RL 6000**  
£9,500 + vat

**For Sale**

Hi Specification Aloy panelled BTCC 45ft Race Trailer & Scania V8 530 Unit



Total cost New £240,000  
For Sale @ **£85,000** inc Tractor Unit  
Call David Pinkney on **07970 829293**



**Look Beyond**



optional colour finishes shown

PRG Trailers | Cheshire | UK | Tel: +44 (0) 1270 812402  
Web: www.prgtrailers.co.uk | Email: info@prgtrailers.co.uk

**Currently in production.  
Tri-axle, step frame race transporter**

- Will carry 4 cars
- Front living area with 2 pod
- Hydrovane compressor
- Honda generator



Unit D16, Backfield Farm  
Business Park, Wotton Road,  
Iron Acton, Bristol, BS37 9XD



Bespoke race transporters  
designed, built and refurbished  
to your requirements



For further information, please contact Ian Green  
Tel/Fax: 044 (0) 1454 227 191 Mob: 07766108873

www.gbmotorsports.co.uk

## The brand new Race Transporter. Contains racing DNA

Paddocks and race meetings are no strangers to a Brian James Trailer. Literally tens of thousands of competitors over the years have chosen the quality, design integrity and value-for-money to which there is no equal.

2012 and the arrival of a brand new, very special and exciting race trailer range for professional and private teams alike. The Race Transporter.

Provides race transportation and race weekend workshop accommodation, within an affordable and capable format. Your exact requirements can be met with the Race Transporter being configured from a vast array of sizes and optional specification.

see the new  
Race Transporter  
at Autoport Int.  
our stand 7410



Visit the new Brian James Trailers web site at [www.brianjames.co.uk](http://www.brianjames.co.uk) for full pricing details of the product range and our extensive national dealer network.

**BRIAN JAMES TRAILERS**

[www.brianjames.co.uk](http://www.brianjames.co.uk)

Tel. 01327 308833

ref. 12/02

# WEB DIRECTORY

## AWNINGS

**HAMILTON Motorsport LTD**  
 Suppliers of: Race & Rally Shelters, Minilite, Piloti, Moto-lita, Car Covers etc  
[www.hamiltongrouponline.com](http://www.hamiltongrouponline.com)

## BOOKS & DVDS

**www.chaters.co.uk**  
 Probably the World's LARGEST selection of Motoring Books & DVD's  
 Tel: 01276 686639 - Fax: 01276 686538  

## EXHAUSTS

**Inconel & Stainless Steel Specialists**  
**SIMPSON**  
 Race Exhausts  
 Tel: 01753 532222  
[www.simpsonraceexhausts.com](http://www.simpsonraceexhausts.com)

## GEARBOXES

**Gearboxman.com**  
 COMPETITION TRANSMISSION SERVICES  
 Gearboxes and Axles for Road, Race, Rally, and more  
 Telephone: 01582 840008, Fax: 01582 840007

## GEARBOXES

**eLITE**  
 Rally & Race Gearboxes, GearKits, LSD's and Driveshafts  
 Tel: 01782 280136 Fax: 01782 269913  
 Email: sales@eliteracingtransmissions.com  
[www.eliteracingtransmissions.com](http://www.eliteracingtransmissions.com)

## HELMET GRAPHICS

**Mike Fairholme Designs**  
 Sole approved painter of Arai helmets.  
 Silver Birches, Corby Birkholme, Nr Grantham, Lincs NG33 4LE.  
 Tel: 01476 550630, Fax: 01476 550029.  
 email: fairholmedesigns@btconnect.com  
[www.fairholmedesigns.co.uk](http://www.fairholmedesigns.co.uk)

## MEMORABILIA

**JMJ AUTOMOBILIA** America's #1 supplier of CART and Formula One Racing memorabilia. Large selection of signed original collectables. See our ad under marketplace Memorabilia. Call or fax or a mail listing at (609) 575 1143 or visit our website @ [www.JMJAuto.com](http://www.JMJAuto.com)

**Speed King.cc**  
 EXCLUSIVE MOTORSPORT MEMORABILIA  
 EST. 1996  
*We Buy Your Teamgear!*

## MEMORABILIA

**FINAL LAP**  
 For Everything Formula One  
[www.finalap.net](http://www.finalap.net) WE BUY AND SELL  
 +44 (0)1245 287588 / 07771 920345

## MODELS

**HISTORIC SPORTS RACERS**  
 For a new range of 1/43 scale hand built 1950's Sports Racing Models visit  
[www.modelgarage.co.uk](http://www.modelgarage.co.uk)  
 and follow the Online Shop link.

## MOTORHOMES & TRAILERS

**BRIAN JAMES TRAILERS**  
**CLUBMAN**  
 Tel. 01327 308833  
 Web. [www.brianjames.co.uk](http://www.brianjames.co.uk)

**JW Green Trailers**  
 for BRIAN JAMES TRAILERS  
 Stock Ready For Delivery  
 Tel: 0333 456 0222 Mob: 07785 230560  
[www.jwgreen.co.uk](http://www.jwgreen.co.uk)

## RACE PARTS

**CARTEK**  
 Electronic Battery Isolators  
 Don't compromise on Safety or Reliability  
[www.CartekMotorsport.com](http://www.CartekMotorsport.com)

**PIPER**  
[www.pipercams.co.uk](http://www.pipercams.co.uk)

**ARE DRY SUMP SYSTEMS**  
 ARMSTRONG RACE ENGINEERING INC.  
[WWW.DRYSUMP.COM](http://WWW.DRYSUMP.COM) (916) 652-5282

**Pit to Car Radio**  
 0044(0)1508 528837  
**AUTOTEL RACE RADIO**  
[www.raceradio.co.uk](http://www.raceradio.co.uk)

## RACE PRODUCTS

**Position Sensors Ltd**  
 Motorsport Specialist  
[www.position-sensors.co.uk](http://www.position-sensors.co.uk)

[www.porscheshop.co.uk](http://www.porscheshop.co.uk)  
**PORSCHESHOP**  
 Come and see us - Hall 19, Stand 19232  
 +44 (0) 121 585 6088

**demon-tweeks**  
 MOTORSPORT Direct  
[www.demon-tweeks.co.uk](http://www.demon-tweeks.co.uk)

**msar** LONDON MOTORSPORT SHOWROOM  
[www.msar.co.uk](http://www.msar.co.uk)

## RACE PRODUCTS

ALL OMP RACEWEAR AVAILABLE NOW  
[www.ybracing.co.uk](http://www.ybracing.co.uk) **OMP**

**GPR Grand Prix Racewear**  
**THE RACEWEAR EMPORIUM**  
[www.gprdirect.com](http://www.gprdirect.com)

**JJC** race and rally  
 PASSIONATE ABOUT MOTORSPORT  
[www.jjcraceandrally.com](http://www.jjcraceandrally.com)

**RACING CARS FOR SALE**  
 ALAN CORNOCK FCS  
 BUYING - SELLING - BROKERAGE  
[www.racingcarsforsale.co.uk](http://www.racingcarsforsale.co.uk)  
 TEL: 01480 891212

## RACING OILS

**OLD HALL PERFORMANCE LTD**  
**RED LINE** SYNTHETIC OIL  
 Tel: +44 24 7671 7100  
 Fax: +44 24 7671 7400  
[sales@redlineoil-europe.com](mailto:sales@redlineoil-europe.com) [www.redlineoil-europe.com](http://www.redlineoil-europe.com)

**S&B**  
 • [www.stevens-bolton.co.uk](http://www.stevens-bolton.co.uk)  
 • [tudor.alexander@stevens-bolton.co.uk](mailto:tudor.alexander@stevens-bolton.co.uk)  
 • Tel: 01483 734210 / 07887 713512  
 We are solicitors acting for racing teams, drivers, sponsors and manufacturers.  
 Contact Tudor Alexander.

**LISTA**  
[www.listacabinets.co.uk](http://www.listacabinets.co.uk)  
 Tel: 01228560911 / 07733157911

**Image** Manufacturers of bespoke split rim alloy wheels  
[www.imagewheels.co.uk](http://www.imagewheels.co.uk)  
**IMAGE WHEELS INTERNATIONAL LTD**

## RACEWEAR

## RACING

## RACING OILS

## SOLICITORS

## STORAGE

## WHEELS

**AUTOSPORT.COM**

TO ADVERTISE IN THE WEB DIRECTORY PLEASE CALL  
 020 8267 5367 OR E-MAIL [autosport.ads@haymarket.com](mailto:autosport.ads@haymarket.com)

# DRIVE FEATURE



## MATT BLYTH MOTORSPORT

Championship winning team has drives available for the 2012 Season.

- Ginetta GT Supercup G55 & G50
- Ginetta Junior
- Ginetta Challenge
- British GT
- Britcar Endurance Series
- Immediate Testing Programme Available
- Full Paddock Support
- Excellent Preparation and Presentation
- Hospitality Packages
- Driver Development and Coaching
- Capacity for Owner Drivers
- Car Preparation and Set Up

Full Preparation, Race Services, Rebuild & Restoration available for current and historic race cars. **Contact us now to arrange a meeting at the Autosport International Show.**

Email: [enquiries@mattblythmotorsport.co.uk](mailto:enquiries@mattblythmotorsport.co.uk)

or contact **Matt 07808 318494** or **Andy 07900 800648** to discuss your requirements.



## DRIVES AVAILABLE!



### DRIVES AVAILABLE IN:

- 2012 Porsche Carrera Cup GB Championship
- 2012 MSA British Endurance Car Championship
- 2012 Dutch Supercar Series
- 2012 Nurburgring VLN Championship

### For further information please contact:

Shaun  
[shaun@kg-motorsport.co.uk](mailto:shaun@kg-motorsport.co.uk)  
 07805 618991  
[www.kg-motorsport.co.uk](http://www.kg-motorsport.co.uk)

## Top sports car team Century Motorsport are offering drives for 2012 in multiple prestigious series.

### Drives available in 2012

- Ginetta GT supercup
- Ginetta Challenge
- Ginetta Junior
- British GT3
- British GT4
- European GT4
- Britcar endurance series
- GTcup
- GT trophy
- V de V
- Speed series

### Professional services for all classes:

- Best in paddock support
- Proven Driver development program
- Owner drivers welcome
- First class hospitality packages
- Full preparation and storage facilities



### Multi National Championship Winners.



For test days and enquiries contact us:

Clive Freke 07710 232 813 or Nathan Freke 07947 883 103 or [mail@centurymotorsport.com](mailto:mail@centurymotorsport.com)  
 7 The Barn, Manor Farm, Northend Road, Fenny Compton, CV47 2YY



## Race with the Champions in 2012!

### Ginetta British GT3

- Drives available in new Ginetta G55 GT3
- Testing from February 2012
- Full test programme available
- Factory supported racing programme

### Ginetta Challenge

- Drives available in a Ginetta G40
- 2011 Champions
- 2011 Team Champions
- British F3/GT support
- Free Ginetta G55 test at end of season

### Ginetta GT SuperCup

- 2011 Race Winners
- G50 Cup Drives
- G55 Cup Drives
- Free GT3 test at end of season



For more information, or to drive, contact Optimum Motorsport:  
 Phone: 07876 655575  
 Email: [enquiries@optimum-motorsport.com](mailto:enquiries@optimum-motorsport.com)

## Drivers Wanted



### Taking your racing seriously?

- Drives available with RLR Msport in Le Mans support series championships
- Full driver development programme to enhance both race and media skills
- Sponsor focused team - delivering on your promises
- Experienced in delivering manufacturer backed programmes
- All levels of ability catered for - from new racers to the experienced campaigners

RLR Msport Ltd  
 Tel. + 44 (0)1254 777029  
 Web. [www.rlrmsportltd.com](http://www.rlrmsportltd.com)  
 email: [info@rlrmsportltd.com](mailto:info@rlrmsportltd.com)



# RACE & RALLY CARS

## FERRARI



**Ferrari F430 Challenge GTC (2008)** with all GT cup modifications, low mileage, new pads and discs, GTC aero pack, race suspension, track exhaust and passenger seat.

This car has had many race wins and is in first class condition ready to go out and win again this season. Car maintained by FF Corse for the past 5 years.

Priced to sell **£85,000**  
For further information please call **Glynn Geddie on 07763304895**

## HONDA



### Team Dynamics offer for sale



## 2011 specification Honda S2000 BTCC Civic

Complete rolling chassis with engines available from Neil Brown Engineering.

Comprehensive spares package available.  
Price on application.

For further information, please contact Peter Crolla / **01386 556122** / [pcrolla@rimstock.com](mailto:pcrolla@rimstock.com)

## HISTORIC



**Ashley GT, 1963**  
Perfect.  
£12,500 ono

Tel 07795 244 322.  
[www.classiccars.eu](http://www.classiccars.eu)

## SUNBEAM

### For Sale: 1967 Sunbeam Alpine



Professionally prepared and maintained.  
Brand new unraced 1725cc engine by Coltec Racing and Power Engineering.  
Eligible for CSCC Swinging Sixties and HSCC/HRSR.  
This well-known and reliable car has many class wins including Eifelrennen and Spa Summer Classic.

**P.O.A.**  
Contact Piers on **01753 885399**

## MASERATI

# MASERATI 250 F. TIPO 1954 G.P. CAR DRIVER JUAN MANUEL FANGIO

Home: 0044 (0) 1462 230 282

Mobile: 0044 (0) 7860 264932



A UNIQUE OPPORTUNITY EXISTS TO PURCHASE THE "GREATEST GRAND PRIX CAR" IN THE WORLD. SHE COMES WITH FULL F.I.A. PAPERS NAMING FANGIO AS THE WINNER OF THE 1954 ARGENTINE AND BELGIAN GRAND PRIX'S. A MATCHING NUMBERS CAR PURCHASED FROM THE MASERATI FACTORY AND THE FOURTH CAR REBUILT AND RESTORED BY CAMERON MILLAR. FROM A PRIVATE COLLECTION SHE IS FULLY RUNNING AND READY TO DRIVE. HUGE INVESTMENT POTENTIAL AND A GREAT ENTRY INTO HISTORIC GRAND PRIX RACING.  
LUST OVER HER OR DRIVE HER IT'S YOUR CHOICE. **£995,000**

# RACE & RALLY CARS

MINI

## Mini Challenge winning JCW car

Fresh engine, KW Shocks, PI Data logger, maintained regardless of cost.

Can be seen at the Autosport International Show



E: [leeallen1@hotmail.co.uk](mailto:leeallen1@hotmail.co.uk) or T: 07802496988

RACING CARS

### Group C C2 Tiga 287 chassis # 351



Ex Tim Harvey Chris Hodgetts C2 winning car. Full rebuilt & 'turnkey' ready to go. Fantastic value, reliable and cost effective car. Good spares package. £110,000

### Group C C2 Tiga 286 Chassis #336



Ex 'Pink Panther' car, excellent history. Fully rebuilt with 0 mile Cosworth DFL. Good spares package. £155,000

Contact [bob@chamberlainsynergy.com](mailto:bob@chamberlainsynergy.com) for further details



## 2011 Built R56 JCW Class Mini Challenge Car

Would also suit a variety of Saloon championships. Fast & Reliable Car, Immaculate Condition - Ready to race. Extensive Spares package included in price.

**£20,833.00 + VAT**

Contact Finlay Crocker

Tel: 07836 529439 Email: [finlay@corecut.co.uk](mailto:finlay@corecut.co.uk)



RACING CARS



## RACE CARS FOR SALE

CRS are selling their race cars to concentrate on manufacturing activities:

### Ferrari F430 GT2 2010 Wide body Specification

Built by Michelotto, chassis 2618 Prepared to the highest standard and raced in 2010, 2011 LMS Championship. Fastest GT2 car around Spa-Francorchamps 2:19.402 (2010 LMS, FP3, A Kirkaldy). Step 7 Engine - Dynamics DSSV dampers. Car is on the button as it finished on the podium at Estoril LMS 2011. Price **£175,000**

We also have a comprehensive stock of BBS wheels & car spares available upon request.

### Ferrari F430 GT2 2009 Specification

Built by Michelotto, chassis 2414, 2010 GT Open standard body specification. Fully rebuilt early 2010, and used by the team in the International GT Open Championship. Race winner at Spa during 2010. Price **£110,000**

We also have a comprehensive selection of spares available upon request.

### Formula Renault

2010 latest specification car with Capparo chassis, 2 litre engine.

A selection of 3 cars to choose from. The cars have only raced for 1 season.

Price **£37,000**

We also have a comprehensive stock of car spares, wheels and tyres available on request.

Please contact:

Mark Busfield on +44 (0) 1530 830924 or Email: [mark.busfield@crsracing.com](mailto:mark.busfield@crsracing.com)



CRS Racing Ltd. Unit A, Bardon Hill Business Park, Bardon Hill, Leicestershire LE67 1PG, United Kingdom  
Telephone: +44 (0)1530 830 924 / Fax +44(0) 1530 830 910 / Email: [www.crsracing.com](http://www.crsracing.com)

TRAILERS & TRANSPORTERS

WEB DIRECTORY

RACE & RALLY CARS

MARKETPLACE

APPOINTMENTS

# RACE & RALLY CARS

## RACING CARS

### HPD ARX-03B



**FOR SALE OR LEASE**

2012 COST CAPPED specification, including new tub.  
Full spares package included.  
Also available: Ex-RML Saleen S7R.

For full details contact:

Phil Barker : +44 7768397661 or Mike Newton : +44 7798927111  
[www.rml-adgroup.com](http://www.rml-adgroup.com)



**Dallara F396** race-ready. Mugen Honda engine, 2 extra sets of wheels, numerous spares including wishbone pull rods, complete front wing and nose box, etc. Eligible for MSVR F3 championship (New Trophy Class/Masters Class/Monoposto Class).  
Sale price **£13,000.00** ONO.  
Tel: 07766-465201/07766-465208. 01244-834100 for Jon Gray



**Speads RS08** fitted with hi spec Hyabusa Powertec 1300 drysump, programmable ecu, Racetec dash with logger, ATS f3 wheels 2 sets, new suspension arms front and rear, new uprights front and rear, new brake discs, callipers, pads and bells front and rear, new drive shafts with inner and outer joints, all new outer rod ends, 3 way adjustable shocks with remote gas tanks, price to include spare front and rear body work +spares. **£19,995**  
Contact details Tel: 01553 768376 Mobile: 07720 719515

## MARKETPLACE

### AWNINGS

**Grumpygrip Ltd**  
Sales Spares Accessories Custom Printing  
Tel: 0800 055 6785

**E-Z UP® Instant Shelters**  
E-Z UP® shelters since 1983  
1.5m x 1.5m to 6.0m x 6.0m  
UK Next Day Delivery

Indoor/Outdoor Heating solutions from Chillchaser

[www.grumpygrip.co.uk](http://www.grumpygrip.co.uk)  
Email: info@grumpygrip.co.uk

**TO ADVERTISE IN THIS SECTION OF**

**AUTOSPORT**

**PLEASE CALL 0208 267 5367**



info@nicholasmee.co.uk  
[www.nicholasmee.co.uk](http://www.nicholasmee.co.uk)  
+44 (0) 208 741 8822



**V8 Vantage GT4 - £110,000**  
Prepared and raced by NMR for 3 seasons. 2011 AM GT4 Challenge winner and 2nd overall in 2011 Silverstone 24 Hrs. Manual gearbox car features full 2011 upgrade specn including 4.7litre engine, endurance Brembo brake package, Bosch motorsport ABS and traction control system and 2011 aero upgrade. For sale with an extensive spare parts package worth £30,000+. Available now.



**V8 Vantage GT4 - £75,000**  
V8 Vantage GT4, built by AML in 2007. Rebuilt with a 4.7l engine and 2011 aerodynamic kit in 2011. 'Alec' was raced in the 2011 AM GT4 Challenge, driven by a number of high profile automotive journalists including Andrew Frankel, Jethro Bovingdon and BBC's Chris Partridge securing a number of podium finishes along the way. Supplied in special 'Works' livery as designed by Autocar readers and in very good condition with racing mileage left on both the gearbox and engine.



**NMR 2 car race transporter and equipment - £60,000**  
Mercedes Benz Axor tractor unit and 2 car transporter. The tractor unit was first registered in 2004, has now covered just 88k kilometres from new, and is in excellent order. The transporter, fully equipped with tail lift, benching and cabinets, generator etc; was refurbished by Hopkins Transporters in 2009. Both tractor and transporter are finished in white. Used for 3 seasons by NMR to transport 2 x V8 Vantage GT4 race cars and equipment. For sale with a list of motorsport team equipment including garage flooring and walling, air equipment etc.

### COMPETITION DIFFERENTIALS

## GRIPPER DIFFERENTIALS LIMITED

### Multi plate LSD's

- Peugeot 205-£625.00. Peugeot 106 inc c/wheel £700.00. F/drive pinion £245.00.
- Renault Clio £750.00. Clio CWP 14/60, 13/59 & 12/63 £450.00.
- VW Polo £625.00. VW 02A/J £625.00. VW 02Q/M £785.00. VW 020 £625.00.
- Astra F20 £625.00. BMW 188 £850.00. BMW 210 £850.00.
- Ford Atlas £745.00. English Ford £625.00. Cosworth 7.5" £750.00. Cosworth 7.0" £625.00.
- Honda Y21 £625.00. Honda R type £625.00.
- Jaguar 4HA&HU £850.00 Alloy body £950.00.

We have a full range of Historic Race and Rally car Lsd units. We specialise in the manufacture of one off units from £900.00. If we cannot make it, no one else can.

These prices do not include VAT. Fitting and installation service available.

### LIFETIME GUARANTEE

Phone: **024 7663 8564**  
Fax: **024 7658 1852**  
[sales@gripperlsd.com](mailto:sales@gripperlsd.com)

For more information please visit [www.gripperlsd.com](http://www.gripperlsd.com)

## The Original and Best Selling Instant Shelter in the World! E-Z UP INSTANT SHELTERS



- Celebrating 21 years supplying to Motor Sport
- Next day delivery on standard colours
- Sets up in 60 Seconds or less
- 10 sizes & 23 colours available
- Durable all-steel double truss design
- Aluminium frames available
- Optional sidewalls & accessories
- For offers and pricing visit our website:



[www.e-z-up.co.uk](http://www.e-z-up.co.uk)

E-Z UP SHELTERS ARE PERFECT FOR:

Race Pit • Sign In Booth • Control & First Aid Point • Equipment Cover & More!



Authorised Distributor  
**MAYFLOWER MARQUEES**



Unit 6, Penn Street Works, Penn Street, Near Amersham, Bucks HP7 0PU  
Tel: 01494 718800 Fax: 01494 718111

# MARKETPLACE

## ENGINES



Championship winning engine rebuilding and preparation

Modern and Historic

Contact Paul Knaption

01922 454 858

paul@xtecengineering.com

## FLOORING

### Kiwi Tiles

Interlocking Plastic Floor Tiles, as used by leading race teams throughout Europe.

◆ Easy installation & removal

◆ Many colours

◆ Lightweight

◆ Strong & durable

◆ Self draining

◆ Compact & easy to store

◆ Top quality

◆ Value for money

Stock Colours:

Red, Blue, Green, Yellow,

Silver, Orange, Grey,

Black, White, Dayglo Red

Raft Engineering

Tel: 01865 883354 Fax: 01865 883789

E-mail: enquiries@kiwitiles.com

Web: www.kiwitiles.com



## MEMORABILIA

### JMJ Automobilia

SUPPLIERS OF RACE MEMORABILIA SINCE 1992

Florida, USA (609) 575-1143

email: [JMJAUTO.COM](mailto:JMJAUTO.COM)  
[WWW.JMJAUTO.COM](http://WWW.JMJAUTO.COM)

### F1 COLLECTORS .COM



### #1 FOR F1 MEMORABILIA

We buy and sell F1 items

AYRTON SENNA specialists

Call CHRIS GRINT 01763 274448

email: sales@f1collectors.com

### AUTOSPORT

MISSED AN ISSUE?

THEN CALL OUR  
BACK ISSUE HOTLINE

0844 848 8817

## MOTORSPORT EQUIPMENT



### MARDI GRAS MOTORSPORT

Saloon Car Preparation

Unit 45, Silverstone Circuit  
Towcester  
Northampton NN12 8TL

tel: 01327 858006 fax: 01327 858800  
email: info@mardigras.co.uk  
web: www.performanceclutch.co.uk

Distributors and agents for:



## HOSPITALITY

# SPIRES OF OXFORD

SUPPLIERS OF LUXURY HOSPITALITY MOTORHOMES  
ON EVENT COMMUNICATION & MEDIA CENTERS  
PROMOTIONAL ROADSHOWS

INTERNATIONAL RACE CHAMPIONSHIP HOSPITALITY UNITS  
EXCLUSIVE CORPORATE HOSPITALITY & TEAM CATERING  
LOGISTICS & SECURE STORAGE

As specialists in the field of international motorsport, with vast experience in all levels of sports hospitality, promotional roadshows & corporate events, we can supply for hire or sale an exclusive purpose built, fully self contained event facility, ideal for all on circuit hospitality, championship/media centers, marketing, merchandising conferences product launches & roadshows, at any sporting event world-wide. Units vary in specification, and can include luxury lounges, office facilities, Commercial Kitchens, showers and full awning size options.

### F1 SPEC MOTORHOMES & AWNINGS



### GENERAL SERVICES

- International race centers, VIP hospitality & team catering specialists
- Hospitality & shared team catering service at SF, Le Mans, LMS & FIA GTs
- Exclusive hospitality packages at all major events including, F1, WRC, Touring Cars & Le Mans
- Sponsor/partner co-ordination, travel, accommodation, ticketing & VIP transfers to circuit
- Logistics on track marketing, merchandising, product sampling plus event support
- Management, logistics & operation of clients own units also undertaken
- Comprehensive world-wide insurance



Exclusive VIP Hospitality



Race & Test Team Motorhomes



Shared Team Catering

FOR UP TO DATE INFORMATION ON OUR SERVICES, UNITS AND EVENTS VISIT [www.spiresoxford.co.uk](http://www.spiresoxford.co.uk)

TEL: +44 (0)1865 875539 • FAX: +44 (0)1865 875510 • MOBILE: +44 (0)7836 767619 • E-MAIL: [info@spiresoxford.co.uk](mailto:info@spiresoxford.co.uk)

# MARKETPLACE

## INSURANCE

The cost of our car insurance has come down with 12 months for the price of 10



### 12 months for the price of 10

To help new customers save on their car insurance, we're offering 12 months of cover for the price of just 10. This is applied as an introductory discount and is subject to minimum premium. Offer ends 31st March 2012.

Chat to Churchill  
**0800 404 8719**  
**churchill.com**



Underwritten by U K Insurance Limited.

## RACE PRODUCTS



ADVANCED SUSPENSION TECHNOLOGY

OHLINS HAVE WON OVER 200 WORLD CHAMPIONSHIPS

## MICK GARDNER RACING

OFFICIAL DISTRIBUTION FOR ALL OHLINS PRODUCTS

- Official Sales and Service Centre • Large Stocks of Shocks, Springs and Parts • Factory Trained Technicians
- Fast Turnaround on Servicing, Revalving, etc.
- Bespoke Shock Absorbers Built to Customer Spec

CONTACT RUSS WALTON  
 @ MICK GARDNER  
 RACING NOW

TELEPHONE 01226 240 099  
 WEBSITE [www.mickgardnerracing.com](http://www.mickgardnerracing.com)  
 E-MAIL [russwalton@mickgardnerracing.com](mailto:russwalton@mickgardnerracing.com)



## Admiral MultiCar More than just a second car discount

Some insurers give MultiCar discounts - but only for the second car. With Admiral MultiCar each car receives a discount - guaranteed!

**admiral.com**  
**0800 600 880**



# MARKETPLACE

## RACE PRODUCTS

• EXPERT ADVICE • MASSIVE STOCKS • RAPID DELIVERY

[www.demon-tweaks.co.uk](http://www.demon-tweaks.co.uk)



**DON'T DELAY, CALL TODAY** **demon tweaks**  
0844 375 2196 **MOTORSPORT Direct**

LOW CALL RATE CALLS MAY BE RECORDED FOR TRAINING PURPOSES

## ARE DRY SUMP SYSTEMS



Mitsubishi EVO 8

**STAND E363**  
Over 60  
Varieties  
Cast Alloy CNC  
Machined  
Dry Sumps &  
Systems



Toyota 4AGE



Subaru

UK Distributor- RaceParts



Formula Ford 2000

"Products Engineered With A Passion"  
[www.DRYSUMP.com](http://www.DRYSUMP.com) 1.916.652.5282

## TEKNOFIBRA®

In a laboratory test a 100mm solid sphere of mild steel was heated to 1000°C. A sheet of Teknofibra "Contact" adhered to a 2mm piece of fibreglass to represent body work was put in direct contact with the 1000°C heat source. The temperature of the sample bodywork protected with the Teknofibra heat resistant material PEAKED at

"Come and see us at Autosport International"  
Engineering, Hall 9, Stand E554



For more information of Teknofibra heat resistant materials please contact the Teknofibra UK distributor at Walkers Northallerton, North Yorkshire DL7 9HT  
Phone 0044 (0) 1609 777221 or email [info@walkersgarage.com](mailto:info@walkersgarage.com)

COME AND SEE US ON  
STAND 7325 AT THE SHOW

**Autotel**  
**Digital Race Radio**  
MOTORSPORT COMMUNICATION  
SPECIALISTS

**DIGITAL RACE CAR  
RADIO**

**CUSTOM FIT EARPIECES  
FOR DRIVERS & CREW**



Tel: +44(0)1508 528837  
Email: [sales@autotel.co.uk](mailto:sales@autotel.co.uk)

## KARTING

Race at the  
circuit where Lewis  
Hamilton was discovered

**BUCKMORE  
PARK**



## New Year Karting

for individuals and teams

Discounted hire practice  
sessions available  
on selected dates  
– contact the  
sales team  
for details.



Bambino and  
Junior Club karting  
available for children  
aged 6-16 years.

## Forthcoming Events

note: all events include timed qualifying

### Features

- Online booking.
- Sprints and enduros.
- Competitive racing.
- Electronic scoreboards.
- Helmet, gloves and suits provided.
- Excellent facilities.
- Superb trophies.

### 2hr Team Enduro

● 14th January (Saturday)  
5:30pm - 8:45pm. 2 hour team  
endurance race. £199 per team.

### Man of Steel

● 15th January (Sunday)  
5:45pm - 7:45pm. 1 hour  
individual enduro. Two weight  
classes. £125 per driver.

### National Sprint

● 16th January (Monday)  
6:15pm - 9:45pm. Practice, 3  
heats and final. 600m National  
Circuit. £49 per driver.

### 30 Solo Enduro

● 23rd January (Monday)  
7:30pm - 9:45pm. 30min  
individual endurance race.  
£59 per driver.

### International Sprint

● 25th January  
(Wed) 6:15pm -  
9:45pm. Practice,  
3 heats and final.  
International  
Circuit. £83 per  
driver.

Super fast  
RX390 karts



Tel: 01634 661613  
[www.buckmore.co.uk](http://www.buckmore.co.uk)

# MARKETPLACE

## RACE PRODUCTS

**Race bred performance and optic tuning packages for the Ferrari 458 Challenge and 458 Italia**



**Ferrari 458 Challenge Trofeo Sportivo Upgrade from Evolution 2 Motorsport developed by racing in 2011 with multiple pole positions, wins and fastest laps.**



A 458 Italia Emozione Aero kit is also available, stunning style and 602 BHP.

See the Evolution 2 Motorsport 458 Challenge on Stand 19535 Autosport International



Trofeo Sportivo Aero Kit is a complete 'bolt on' all carbon, track proven aero kit, comprising of full 80mm front splitter and aero floor, single set dive planes, and new for 2012 anhedral, fully adjustable rear wing with billet alloy uprights is now available.

Suspension damper upgrades and engine remapping to 618 BHP and 585ft/Lbs torque plus a larger air-box, and free flow exhaust also available to 645 bhp.

**Email info@evolution2motorsport.com Telephone +44 (0) 1753 885 453  
www.evolution2motorsport.com**

CARBS • EXHAUSTS • FASTENERS • CLUTCHES • MIRRORS • STEERING WHEELS  
• CANT FIND WHAT YOUR AFTER - CALL OR EMAIL! • EXHAUSTS • BRAKES • WHEELS • TYRES

**JJC) race and rally**

See us at the Autosport show  
12th to 15th January 2012, Hall 7, Stand 7342

Call for individual product prices Email: sales@jjraceandrally.com Tel: 0843 208 2203



RSS FFC  
FIA APPROVED  
SNELL



RSS FFR  
FIA APPROVED  
SNELL



STAND 21  
HANS®  
FIA APPROVED

All prices are subject to VAT

SRP £481.50

£430.00

SAVE £51.50

**SUPER OFFER 1** RSS FFC or RSS FFR + STAND 21 CLUB SERIES HANS® = £430.00!



RSS JET  
FIA APPROVED  
SNELL



STAND 21  
HANS®  
FIA APPROVED

All prices are subject to VAT

SRP £448.16

£400.00

SAVE £48.16

FREE UK Delivery on all orders!

**SUPER OFFER 2** RSS JET + STAND 21 CLUB SERIES HANS® = £400.00!

**www.jjraceandrally.com**

P.O. BOX 2333, Kencourt T/A JJC Race and Rally, Wrexham, LL11 0HB. Lines are open Monday to Friday 8.30am to 5.30pm.



**SURPRISE**

SAVE UP TO 60%



- F1-R Race Rally High Boots from £29.16
- F1-T Race Rally Low Boots from £29.16
- Tech 1-T (2011) FIA Race Rally Boots £131.29
- Tech 1-Z (2011) FIA Race Rally Boots £164.96
- GP Tech (2011) FIA Race Rally Suit £712.46
- GP-T (2011) FIA Race Rally Suit £374.96
- SP (2011) FIA Race Rally Suit £284.96
- Tech 1-Z (2011) FIA Race Rally Gloves £74.96
- Tech 1-ZX (2011) FIA Race Rally Gloves £86.21

HURRY! WHILE STOCKS LAST!  
Please call now for more amazing deals including Kartwear and Mechanics wear!

**SALE**

# MARKETPLACE

## RACEWEAR

**Grand Prix Racewear**

DRIVEN BY PASSION

[www.gprdirect.com](http://www.gprdirect.com)

### New Product!

#### BT-Q1000eX GPS Lap Timer

GPR would like to introduce the new GPS lap timer from QSTARS

This is the latest GPS lap timer to hit the market, no messing around with wires, no complicated set-up just switch it on and go! Easy to use software supplied with each timer, Logs 5 times per second so you never miss a moment.



SOLE UK DISTRIBUTOR



**Tel: 01327 855585**

Unit 1 Silverstone Tech Park,  
Silverstone Circuit  
Towcester, NN12 8TN



## RACE PRODUCTS

**London Motorsport Showroom**

[www.msar.co.uk](http://www.msar.co.uk)



**UK agent for SCHRÖTH RACING**

ORDER HOTLINE: 020 8655 7877

## WHEELS & TYRES

FOR ALL YOUR

**AVON**  
TYRES  
MOTORSPORT

RACING TYRES  
Inc. ACB 10 Formula Ford  
Contact

**BMTR LTD**

Tel: 0121 331 1122

Fax: 0121 331 1144

email: [sales@bmtr.co.uk](mailto:sales@bmtr.co.uk)

see our new web site at [www.bmtr.co.uk](http://www.bmtr.co.uk)

TO ADVERTISE IN  
THIS SECTION OF

**AUTOSPORT**

PLEASE CALL  
**0208 267 5367**

# APPOINTMENTS

**CATERHAM**  
F1 TEAM

### RACE TEAM ELECTRICIAN

Due to continued expansion within Caterham F1 Team we are looking to recruit a Race Team Electrician to join the team.

As part of the race team you will be responsible for all of the garage and on car wiring systems as well as the lifing of electrical parts.

You should have experience of Raychem and MIL spec wiring systems as well as a good understanding of sensor installations on racing cars. It is essential that you are trained in mains electrical installations; ideally you will hold a 17th edition IEE wiring regulations certificate.

The ideal candidate must have good communication skills and be able to work to tight timescales in a team environment.

If you wish to be considered for this post, please email [hr@caterhamf1.com](mailto:hr@caterhamf1.com) quoting CF1/RE/055/12, attaching an up to date CV and covering letter.

Closing date for applications: 20th January 2012.

**marcvds**  
racing team

The Marc VDS Racing will continue in the Blancpain Endurance Series and VLN with 2 BMW Z4 GT3 and is looking to recruit:

- Car Chief Mechanic
- Race Engineer

Successful candidates must have previous relevant working experience.

Application should be received before the 18th January.

[bas@marcvds-group.com](mailto:bas@marcvds-group.com) • [www.marcvds.com](http://www.marcvds.com)



## COME AND WORK WITH THE WORLD CHAMPIONS!

With our recent success there has never been a more exciting time to join our team.

### HR919 SENIOR COMPOSITE DESIGN ENGINEER

Working in our Composite Design Group, you will be responsible for the design & project management of a variety of composite design projects. You will work closely with fellow composite & laminate booklet designers; you will liaise confidently with the Aerodynamics group, other Design groups, Planning & Operations groups, as well as the various Manufacturing departments.

As a Senior Composite Design Engineer you will be responsible for overall scheming and oversight of detailed design work, all pattern work and tooling, detailed component design, assemblies and associated jigs. You will also have involvement in drawing sign off, structural sign off, provision of supporting documentation and resolution of operational issues.

You will be involved in managing designer's workload, defining & monitoring plans & reporting regularly on project progress.

You will be involved in the composite design of the chassis, impact structures, wings, bodywork & gearbox as well as potential involvement in a wide range of composite R&D projects.

The successful applicant should ideally have:

- An Engineering Degree or similar Engineering Qualification.
- At least three years relevant experience of composite design in a Formula 1/motorsport environment.
- People & project management experience.
- Intimate knowledge of current composite material technologies, their associated tooling, production techniques and processes.
- Experience of 3D CAD (NX7.5)
- An organised and methodical approach to your work.

Applicants will be self-motivated and proactive, with excellent communication skills and the ability to work to very tight deadlines within a team environment, often with minimum supervision.

TO APPLY, PLEASE EMAIL OR SEND A COVERING LETTER AND YOUR CV, QUOTING THE ABOVE REFERENCE NUMBER, WHERE YOU HAVE SEEN THE ROLE ADVERTISED AND YOUR CURRENT SALARY DETAILS TO:

Email: [recruitment@redbullracing.com](mailto:recruitment@redbullracing.com)

Address: Human Resources, Red Bull Racing Limited, Broadbourne Drive, Tilbrook, Milton Keynes, MK7 8BJ

CLOSING DATE FOR APPLICATIONS: 26TH JANUARY 2012

PLEASE NOTE: Red Bull Technology does not accept any unsolicited resumes from headhunters, executive recruiters, or other staffing or personnel agencies. Red Bull Technology is not responsible for any fees related to unsolicited resumes.



# APPOINTMENTS



West Surrey Racing is looking for the following experienced people to join its Championship winning team.

- Race Engineer
- No 1 Mechanic
- No 2 Mechanic
- Data Engineer
- Race Team Truckie
- Hospitality Truckie

Please forward your CV with a covering letter to:

**Human Resources**  
**West Surrey Racing Ltd**  
**Longwood Business Park**  
**Fordbridge Road**  
**Sunbury-on-Thames**  
**TW16 6AZ**

Or email: [admin@wsr-racing.com](mailto:admin@wsr-racing.com)

## CATERHAM



### Development Engineer - Caterham Cars Ltd - Dartford, UK

A position is available for an experienced Automotive or Mechanical Engineer with a relevant degree to join the enthusiastic and dynamic engineering team at Caterham Cars. This job will expose the successful applicant to a wide varied range of vehicle development, test and design aspects. The role will involve development of existing parts, designing of new parts and products through prototyping into production. The candidate should be highly motivated have current extensive experience of Solidworks, ability to create cost effect designs for varying manufacturing methods and flexible approach to working hours.

Applicants CV and cover letter should be submitted to [opportunities@caterham.co.uk](mailto:opportunities@caterham.co.uk)  
[www.caterham.co.uk](http://www.caterham.co.uk)

### Motorsport Tyre Engineer - Trackside UK Based

Pirelli Tyre, one of the leading international tyre manufactures, with more than 100 years of success in Motorsport, is currently looking for an experienced Tyre Engineer.

You will provide trackside support to our Motorsport Activities to enable correct operation and utilisation of our product. You will also provide the link back into the design department with analysis of performance data and operating conditions.

A strong background in either tyre engineering, race car engineering, or vehicle dynamics is required. You must also possess a high level of fluency in both spoken and written English and be highly computer literate.

The role will require extensive travel.

Successful applicants will be enthusiastic, capable of working with minimal supervision to tight deadlines and be confident in communicating in a team environment. Candidates with previous similar experience will be preferred.

If you believe you possess the appropriate qualifications and experience for this position, please send a cover letter and C.V. to the following email address:

[recruiting.motorsport@pirelli.com](mailto:recruiting.motorsport@pirelli.com)



POWER IS NOTHING WITHOUT CONTROL

## COSWORTH

# Formula One Opportunities at Cosworth

Cosworth are seeking the following positions for its 2012 F1 program

### Calibration Engineer

#### Specific Responsibilities:

- Develop engine calibrations and associated tools to maximise on-track performance
- Work within a team environment liaising directly with chassis engineers and drivers
- Be the central point of contact for all team dialogue, including team briefs, installation issues, development tests etc
- Proven track record in race engine calibration, strategy development and track support, including liaison with race engineers and team principals

#### Essential Skills:

- Team player, promoting good customer relations
- Strong relevant engineering degree
- Common, consistent and rigorous approach to documentation and engine running procedures
- Highly computer literate, including an interest in developing Matlab, Simulink and other software capability

### Analysis Engineer

#### Specific Responsibilities:

- To attend all F1 race and test events as well as attending dedicated team events when required
- To work within a dedicated Cosworth F1 team environment where you will be responsible for the performance, analysis and health-checking of the engines at the circuit
- To assist the team by identifying potential performance & reliability issues and either suggesting and/or performing fixes as required
- To compile detailed technical event reports in line with the current Track Support Group's working practices
- To continually work to improve the Cosworth Track Support Group's analysis software tools
- To support related engineering activities to the above whilst back in the factory

#### Essential Skills:

- Hold a relevant engineering degree with an strong interest in race engines
- Be highly computer literate with essential experience with all current MES software applications
- Be familiar with VB.NET, VBA, Matlab and Simulink as well as the ability to quickly grasp other related technical computing software
- Be able to work within a team environment as a key player, promoting good customer relations and helping colleagues achieve their work objectives in a methodical, time efficient manner
- Apply a common, consistent and rigorous approach to technical documentation and engine running procedures and protocols
- Demonstrate a professional approach to Formula 1 track support by promoting the Cosworth brand whilst exhibiting good self-discipline, time management and a professional visual appearance
- Exercise good communication skills (oral & written), management and interpersonal skills
- A willingness to travel worldwide with extended periods away from home

If you are interested in applying for either of these positions, please send your CV and a covering letter to [clrecruit@cosworth.com](mailto:clrecruit@cosworth.com)

[www.cosworth.com](http://www.cosworth.com)



In its plans to continuously develop its Team, **Scuderia Toro Rosso** has a number of exciting opportunities within its Aerodynamics Department, based at the Wind Tunnel facility in Bicester (UK).

**Aerodynamics Project Leader - ref. "HR APL 49"**

This is a high level position within the Aerodynamics group, with the responsibility for the leadership of a number of Wind Tunnel programmes. The ideal person will coordinate the definition phase and will follow the day to day procedures within the design and testing preparation process. The applicant will be accountable for a number of aerodynamic teams, playing a key role in aero development and working close cooperation with the Head of Aerodynamics. Extensive F1 aerodynamic experience is essential. Technical knowledge in conjunction with quick decision making and problem solving constitute an integral part of the profile.

**Junior Aerodynamicist(s) - ref. "HR JA 50"**

Working as part of a team within the Aerodynamics group, the successful candidates will support the Senior Aerodynamicists in Wind Tunnel testing and designing of model parts with the drawing office. The ability to demonstrate innovative and creative design solutions is essential. You will have a degree in Aeronautical Engineering (or equivalent), and ideally some previous experience of working on Formula 1 aerodynamic development. Flexibility and the ability to work under pressure to meet strict deadlines are essential. We are seeking multiple positions, some of which will require some day shift work, while some positions will require some night shift work.

**Model Design Engineer(s) and Junior Model Design Engineer(s) - ref. "HR MDE 51" and - ref. "HR JMDE 52"**

Working within the Aerodynamic Design group, we are seeking highly capable solid model, surface and mechanical Design Engineers, from graduates to experienced designers, to support our aerodynamic development programme. The successful candidates will possess good communication skills, be self-motivated and have a flexible approach to working hours. You will be able to demonstrate experience in solid modelling and/or free form surface definition (ideally using NX7), and have a proven ability to work to a high level of accuracy and tight deadlines. A relevant qualification in Mechanical, Automotive or other appropriate discipline is necessary, and design experience within motorsport is preferred, but not essential. Positions will be assessed according to experience and skill level.

**Model Maker(s) and Junior Model Maker(s) - ref. "HR MM 53" and ref. "HR JMM 54"**

Working within the Aerodynamics Model Shop, you will assist in model preparation and model changes in support of wind tunnel testing sessions, and occasionally assist wind tunnel system and instrumentation maintenance. A number of years of experience as a model maker in a high level of motorsport is desirable, but not essential for a junior role. Knowledge of Microsoft Windows applications and some experience using CAD software are an advantage. Flexibility, problem solving and good organisational skills are essential. We are seeking multiple positions, some of which will require some day shift work, while some positions will require some night shift work. Positions will be assessed according to experience and skill level.

**SLA Technician(s) - ref. "HR SLAT 55"**

We are seeking highly capable and motivated Technicians to be responsible for the preparation of rapid prototype parts. Working closely with the model makers, you will manually clean, prepare and paint the rapid prototype parts for the wind tunnel model. Responsible for the quality and finish of the components, you will report to the Model shop Supervisor to ensure all aspects are covered. The ideal candidate will have experience in part finishing, ideally with previous experience with Rapid Prototype parts. Candidates will be enthusiastic with a flexible approach to working hours and be able to work under the minimum of supervision to deadlines in high pressure situations without compromising quality.

**Aerodynamic Support Technician - ref. "HR AST 56"**

The main responsibility for chosen candidates will be to guarantee the correct, accurate and safe running of the wind tunnel and associated equipment. This involves running systems to maintain control of the wind tunnel, the model and the data acquisition, and support the model makers with model changes. The role includes regular checks and maintenance of all wind tunnel subsystems, assembly, installation and testing of wind tunnel and model electronic equipment. You will have a professional qualification in electronics or equivalent, and have a good understanding of electronic and mechanical systems of a modern F1 Wind Tunnel. This role requires working on a shift system including some night shifts and weekends.

**Aerodynamics R&D Engineer - ref. "HR ARDE 57"**

Working as part of a team within the Aerodynamic Operations group, you will work on wind tunnel, model and instrumentation R&D projects. The work is varied including some support to the day to day operation of the wind tunnel and required maintenance. A professional qualification in electronic or mechanical engineering is essential, and you will possess excellent problem solving skills, a practical hands-on approach, and a flexible attitude to working hours. This role requires some shift work, including night shift and weekends, and some on-call support.

To apply please send a covering letter and your CV, quoting the relevant reference number and your current salary details to:

**HR Department, Scuderia Toro Rosso Spa**  
Via Spallanzani 21 – 48018 Faenza (RA) – Italy  
Or upload your CV in our website: [www.tororosso.com->jobs](http://www.tororosso.com->jobs)  
**Closing date:** 03<sup>rd</sup> February 2012





## Senior Mechanical Design Engineer

**REF: LRGP-DES39**

You will be working in the Mechanical Section of our Design Office at Enstone. Your primary responsibilities will be to undertake the scheming and detailing of mechanical systems and components (such as suspension, steering, hydraulic, fuel, engine installation & cooling, driver controls, electrical packaging etc). In addition, while it is not required that you should be a composites specialist you should be confident to design non structural composite material components (such as oil tanks, fuel collectors, brake drums, cooling ducts etc). Your duties will also include specifying and detailing any necessary tooling, jigs or testing fixtures.

The ideal candidate for this position will have:

- A Mechanical Engineering degree or similar qualification
- Substantial level of mechanical or composite design experience in high level motorsport
- Catia V5 CAD system usage experience
- Knowledge and experience of current manufacturing techniques
- Some project management skills

## Reliability Section Head

**Ref: LRGP-RELI**

You will be based in the Design Office at Enstone and your primary responsibility will be to manage the Reliability Section. You will lead a small team of engineers dedicated to fault rectification actions both within the factory and trackside. In addition, the section carries responsibility for managing the lifing system and organising all activity associated with the mock-up car. Your section will be required both to enable the speedy rectification of identified faults and also to operate proactively to prevent faults occurring at the design stage.

The successful candidate will be required to develop our Fault and Lifting systems in support of this goal and will be expected to manage, develop and publish appropriate reliability KPIs to the design staff. This important role requires an engineer with an unusual blend of experience, leadership, initiative, innovation and, above all, a demonstrated ability to interact effectively with company personnel at all levels.

The ideal candidate for this position will have:

- A Mechanical Engineering degree or similar qualification
- Substantial level of mechanical or composite design experience in high level motorsport
- Catia V5 CAD system usage experience
- Knowledge and experience of current manufacturing techniques
- Some project management skills

## Software Validation Engineer

**REF: LRGP-ELE19**

As part of the Electronics Department you will be involved in the development of tools and processes to ensure the highest quality software/systems are delivered to the track. This will require design of enhancements to our current hardware-in-the-loop simulators, and development of automated data analysis systems to continually improve the speed and accuracy of our test systems.

The role requires in-depth experience with design and development of software controlled test equipment, and use of graphical modelling techniques. Familiarity with Matlab, Simulink, C# and DSpace is preferred, as is a working knowledge of electronic control systems.

The successful candidate will have demonstrated technical competence as well as a collaborative, creative and proactive approach. Previous experience in motor-sport is desirable in this position but not essential.

## Composite Laminators/Fitters – Dayshift/Nightshift

**REF: LRGP-COM8**

We are currently looking for Laminators / Fitters to work in our Composites Department.

The roles will involve the manufacture of composite race car components whilst maintaining high levels of quality and output. Self-motivated and enthusiastic, the successful candidates will have had extensive experience within the F1 composite environment and will have demonstrated a high degree of competency in associated disciplines.

All candidates must be self motivated, capable of working with minimal supervision to tight deadlines, and be confident in communicating in a team environment.

In return we offer a team with a strong commitment to return to the highest level of achievement, a unique and friendly working environment, competitive remuneration and a flexible benefit package.

Please apply in writing with current CV, salary expectations, details of your notice period and quoting job reference number to:

**Human Resources**  
**Lotus Renault GP Ltd**  
**Enstone**  
**Oxfordshire OX7 4EE**

Email [hr@lotusrenaultgp.com](mailto:hr@lotusrenaultgp.com)

Closing date **26<sup>th</sup> January 2012**

# Sports Extra

NATIONAL RACING • HISTORICS • CLUB • RALLY • RALLYCROSS • HILLCLIMB



Van Diemen was FFord powerhouse in 1990s

## AUTOSPORT SAYS...

**BEN ANDERSON**  
NATIONAL EDITOR

ben.anderson@haymarket.com



### IF THERE'S ONE NAME PEOPLE

associate with Formula Ford above all others it's surely Van Diemen.

Named after the initial identity of Tasmania, from where co-founder Ross Ambrose (father of NASCAR racer Marcos) hailed, this Norfolk marque has won more races in British Formula Ford than any other.

Some would say Van Diemen hasn't been the same since Ralph Firman Sr sold up in 1999, and a Van Diemen car hasn't claimed the British Formula Ford title since Valle Makela topped the field in 2004.

More recently, Fluid Motorsport boss Lindsay Allen has taken up the Van Diemen mantle. Despite taking a stunning Brands Festival win in 2010, he has not enjoyed the success of the glory years - as six race wins during the past four Mygale-dominated seasons of Duratec FFord attest.

Not everyone is convinced that Formula Ford's bold new EcoBoost boat is the right one to set sail on, and current Van Diemen owner Elan Motorsports Technologies doesn't see the value in building a car to the new rules.

That's a shame, because it means Van Diemen will not be represented in the top class of the category for the first time since it started winning races in the mid-1970s.

Allen clearly loves Formula Ford though, and good on him for going it alone and building a brand new car (dubbed the Sinter) to 2012 rules.

It would be handy if his new design could give Mygale some serious trouble in the battle for British Formula Ford supremacy too. Multi-make racing is part of the essence of Formula Ford, so it would be a shame if more Mygale dominance turned it into a *de facto* single-make series.

### Extra contact details

**Kevin Turner**, features editor  
kevin.turner@haymarket.com

## Van Diemen out of FFord

Legendary constructor will not build EcoBoost car for category's new era

» VAN DIEMEN WILL NOT build a car for the British Formula Ford EcoBoost regulations in 2012, but will be replaced by a new manufacturer.

Southern International, run by experienced category team boss Lindsay Allen, is building the Sinter chassis for this year's championship. Allen's Fluid Motorsport concern, which has run the works Van Diemen team in the category since 2008, hopes to field up to three examples in British Formula Ford.

Allen took over the Van Diemen factory and car construction in Europe ahead of the 2009 season. But, when American parent company Elan Motorsports Technologies decided not to build an EcoBoost car, the race-winning team boss decided to go it alone.

"They didn't want to continue with Formula Ford due to cost, and they didn't

see a market at this stage," said Allen. "At that point I decided I wanted to build a car, so I had to loosen my ties with Elan/Van Diemen."

The car has been designed by Sam Owen and will be developed by Fluid. It also has bodywork design input from Caterham F1.

"This is totally new from the ground up," said Allen. "We've been working on it for the past 18 months and I wouldn't have invested in the project if I thought the new rules weren't going to work. The overall concept, with FIA regulations, allows the car to be sold further afield."

Allen also believes the new rules, which include a sequential gearbox and chassis/body changes, as well as the new turbocharged engine, provide a chance for Mygale's run of seven consecutive drivers' titles to come to an end.

"It's more of an even playing field," he said. "Mygale has had to start again. They're ahead of the game because people have been out testing already, but with our experience I believe we can compete.

"We hope to run three cars and I'd like to think other teams will take it too."

Allen could still run some Duratec-engined Van Diemens in the secondary

class of British Formula Ford this year, but the company is unlikely to produce any new cars for Europe in the near future as it focuses on the American market.

The move means that Van Diemen, which was founded by Ralph Firman Sr and Ross Ambrose, will not be represented at the top level of British Formula Ford for the first time since the firm started winning in the category in the mid-1970s.

Van Diemen has also built successful FF2000 and Sports 2000 cars, but is most famous for its Formula Ford 1600 machines, which have scored over 700 national-level race wins in the UK alone.

The manufacturer also helped launch the careers of Ayrton Senna, Roberto Moreno, Mauricio Gugelmin, Eddie Irvine, Mark Blundell, David Coulthard and Mark Webber.

VAN DIEMEN'S UK Formula Ford record	
National titles	33*
National junior titles	18**
Frontline Festival wins	21
Championship race wins with Fluid	6

\* Includes RAC, BARC, BRDC and MCD/BRSCC titles \*\* Includes BARC Junior, Star of Tomorrow and Zetec Junior titles



Artist's impression of the new Sinter Formula Ford

PIC: LAT

## CONTENTS

**p112** TRACK TEST  
BMW M3 & Z4 GT



British GT

# Harvey in British GT comeback

Former Carrera Cup champion to join historic ace Jon Minshaw in Trackspeed Porsche

Trackspeed will run three 997s

**EX-BRITISH TOURING**  
Car champion Tim Harvey will return to British GT this season, after being drafted in by celebrated historic racer Jon Minshaw to share a Trackspeed Porsche.

Demon Tweaks boss Minshaw has recruited double Porsche Carrera Cup champ Harvey to aid his progression into modern motorsport following a successful 2011 season in

the HSCC's Jaguar E-type Challenge. Minshaw said: "For my first foray into a professional championship I felt I needed somebody with a wealth of experience in Porsches and Tim gives me that. After such a terrific year in historics I needed a bit of a challenge and always fancied doing a proper championship like British GT.

"Now I've been fortunate to find a budget, I didn't want to look back in

10 years and think, 'why didn't I do that when I had the opportunity?'"

Harvey, who last raced in British GT in a one-off for RPM in a Dodge Viper in 2007, added: "Jon is a competitive driver and serious racer. I wanted to be in a Porsche and Trackspeed has done a good job with the car."

Group C and Lola T70 racer Steve Tandy will also move into British GT with Trackspeed, partnering 2009

European GT4 champion Joe Osborne.

Osborne, who drove an Audi R8 in FIA GT3 in 2011, said: "Steve's done well in historics. I know him from '08 when I raced a Ginetta G50 for RPM in GT4. We've always got on well. I want to get into historics, so to move in his circles should help."

Trackspeed is also expected to run a third upgraded 997 GT3-R for 2010 British GT3 champion David Ashburn.

Formula Renault

## Red Bull's Albon gets Renault seat

**RED BULL-BACKED BRITISH KARTER**  
Alexander Albon will graduate to car racing this season in the Formula Renault Eurocup.

The former European and World KF3 karting champion will also compete in the Italian/Swiss ALPS series with Spanish squad Epic Racing.

Albon, 15, who will turn 16 on the day of his first race in March, was one of three drivers chosen to join the Red Bull Junior programme following a test at Estoril at the end of last year.

Albon, who finished second in the CIK FIA World Karting Championship for KF1 this year, said: "Red Bull originally decided that I should go to BMW, but I always wanted to do



Albon is targeting 2013 Eurocup title

Formula Renault and asked [Red Bull Junior programme manager] Dr [Helmut] Marko and he gave me the opportunity.

"This is the biggest step I've made in my career - it's like starting from zero again - so this year will be about experience and learning the tracks for 2013, that's when I'll

be competing with the top boys."

German Stefan Wackerbauer, 16, won the 2011 Formula BMW Talent Cup and has also earned a Eurocup race berth, alongside Russian racer Daniil Kvyat.

This year's British Junior karting champion Callan O'Keeffe also appeared at the Estoril test and will now compete in the 2012 Talent Cup.

Formula Abarth

## Scottish karter goes for Italian

**FORMER SCOTTISH KARTING**  
champion Gregor Ramsay will graduate full time to the European and Italian Formula Abarth series in 2012 with Swiss team Jenzer Motorsport.

Ramsay, 15, son of 1992 Scottish Junior Formula Ford 1600 and '95 BRC British FF1600 champ Scott, has joined FABarth on the advice of Ferrari Driver Academy manager Luca Baldisserri.

Englishman Andy Welch, who helped guide the early careers of the late Dan Wheldon and Danica Patrick in British Formula Ford, will engineer Ramsay at Jenzer.

MIS Motorsport - setting the standards in motorsport insurance

ON TRACK / ON EVENT / MOTOR TRADE /  
PERSONAL ACCIDENT / COMMERCIAL / LIABILITY

www.mismotorsport.com or call 01943 884 555

M.I.S. Motorsport Ltd is authorised and regulated by the Financial Services Authority.

MIS  
MOTORSPORT



Optimum will run new G55 in 2012

British GT

## Optimum steps up to British GT

### SUCCESSFUL GINETTA SQUAD

Optimum Motorsport will enter this year's British GT3 championship with the latest-specification Ginetta G55.

Shaun Goff and Ron Linn's squad, which has won five Ginetta Challenge titles and ran George Murrells to a race win in last year's inaugural GT Supercup, is looking to expand further into endurance racing.

The line-up for the G55 in British GT has yet to be confirmed, but Optimum will take delivery of its 540bhp Ginetta G55 at the end of February and team principle Goff said he was already

in discussions with several drivers.

"We learnt a great deal in 2011 and are very confident we can hit the ground running in 2012," he said.

"The new Ginetta G55 GT3 is the perfect addition to our stable and enables us to offer a route to the pinnacle of British GT racing.

"In the right hands, we expect the GT3 car to be a potential winner."

Murrells and G40 Challenge racer Lee Mowle have already competed with Optimum in Britcar and GT Trophy races in a Ginetta G50 and are expected to pair up again for Britcar in 2012.

Ginetta GT Supercup

## Sharp to return for Ginetta title tilt

**GINETTA GT SUPERCUP** frontrunner Tom Sharp plans to dovetail a return to the TOCA-support category in 2012 with selected outings in British GT.

Sharp, 20, won nine races - including the first six - and finished third in the inaugural title race last year with his family-run IDL team.

He also appeared in the final two rounds of British GT, finishing 10th in the three-hour Donington Park enduro in a works-blessed Rollcentre-run G55 and also driving in the Silverstone finale.

Sharp is plotting a title assault in the GT Supercup, which will feature upgraded cars in 2012. Engine modifications to the top-spec G55s will hike power to 380bhp.

Sharp said: "There's no better



Sharp and G55 were a strong combo in 2011

way to improve your driving than in a closely matched one-make series, but I'm keen to get some more GT experience as well.

"I enjoyed competing in the last two races in British GT with Ginetta and it's definitely something I want to do more of."

Ginetta's Junior championship (for 14-17-year-olds) has also been revised for 2012, with the introduction of slick tyres and a new rookie title.

Porsche Carrera Cup

## Plant plots a fresh Porsche charge

**FORMER FORMULA PALMER AUDI** champion Richard Plant will return to the Porsche Carrera Cup for a second season in 2012.

The 21-year-old Derbyshire racer, who took the 2009 Formula Palmer

Plant was top Carrera Cup rookie in 2011



Audi title, finished fifth in last year's Carrera Cup. He has re-signed with top squad Team Parker Racing for an assault on the drivers' championship.

Plant said: "Last year definitely exceeded my expectations. To be top rookie was a great achievement and the experience I gained and the relationships I built with everyone at the team made it the perfect fit for a title challenge in 2012.

"Everything about the Parker squad is first class and I believe we have what it takes to really have a go at winning the series."

MARCUS PYE

# HUMBLE PYE

The voice of club motor racing



The HRDC was a 2011 success story

Five-starred in AUTOSPORT's review of virgin race series (last week), the Historic Racing Drivers Club's Touring Greats and Grand Touring series clearly won the hearts of racers and enthusiasts last season. Big grids, top value and plenty of harum-scarum, tail-out track action are hallmarks of Julius Thurgood's initiatives down the years, so why should anybody be surprised?

There's poetic licence in his Pre-'60 tin-top rules, where vehicle specs mirroring those of the celebrated Goodwood Revival's '50s 'flashbacks' encourage unlikely bolides. Purists may look elsewhere, but, with entertainment value king on both sides of the barrier, total authenticity matters not when motorsport and theatre are conjoined. This is clubbie fun by design, not a fastidious reincarnation of the period.

While we are accustomed to 'red hot' 1430cc Austin A35s (which come at a serious cost) duffing-up big bangers at Goodwood, interest in the Touring Greats 'nipper' class is running high. Darryl Davis of Moto-build Racing has thus evolved a budget A35 for those wishing to have a hoot battling Morris Minors and Abarth replica Fiats.

The £15,000 Ashley A35R features a professionally prepared and caged shell with an MB-R 1140cc engine specced using inexpensive standard parts and

breathing through a Weber 45DCOE carburettor. MG Midget disc/drum brakes and sorted suspension makes an accessible entry-level racer to share with pals or fly solo, with six 45-minute events in 2012.

The 1500cc GT series follows the same calendar - Castle Combe, Snetterton, Spa, Donington, Lydden and Mallory Park - and eligibility format, although the single-driver races are over half an hour.

For those demanding historic accuracy, the HRDC's 'TC63' races (for Pre-'64 touring cars prepared to period FIA Appendix J Group 2 regs), 'GTS65' (Pre-'66 sports cars in GT trim) and 'MGB50' series (Pre-'66 FIA Appendix K cars and non-FIA MGBs of historical interest) are gathering momentum, too. No fewer than 72 owners have already registered for the B competition in the model's Golden Jubilee year!

Whichever HRDC series appeals, you can be certain it has been conceived from a competitor's standpoint. But Thurgood's strengths are also in brilliant branding and clever marketing.

You won't find an HRDC stand at AUTOSPORT International, alas, but catch up with Julius on the Coys auction enclave, where you might even pick up a car to join the fun that starts at Castle Combe on Easter Monday. See you at both.

“The HRDC offers big grids, top value and plenty of harum-scarum, tail-out track action”

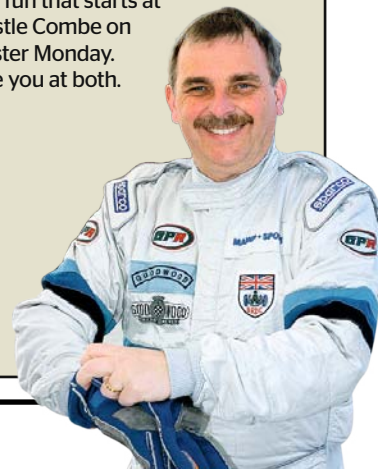

**LAST CHANCE - BOOK  
YOUR SAXMAX TEST NOW!**



Great racing for 14 - 16 year olds  
Look no further than the 750 Motor Club SAXMAX series

22<sup>nd</sup> January  
**2012**  
at North Weald  
in Essex



For more information call:  
**01379 741641**  
or visit [www.750mc.co.uk](http://www.750mc.co.uk)

**WANT IRONMONGERY  
DELIVERED NEXT DAY?  
CALL THE  
MASTERS.**

**UK'S  
BIGGEST RANGE  
NEXT DAY DELIVERY  
AWARD WINNING  
SERVICE  
MONEY BACK  
GUARANTEE**



**CALL NOW FOR YOUR  
FREE CATALOGUE**

**0808 168 28 28**  
**IronmongeryDirect.com**

Or TEXT **RBA16** to 62244 FREE! (With name, address and email).

**IronmongeryDirect**

**MASTERS OF OUR TRADE**

DOOR FURNITURE • WINDOW & JOINERY HARDWARE • SLIDING DOOR HARDWARE • HINGES • DOOR CLOSERS • FIRE CONTROL • SIGNS  
LOCKS, LATCHES & SECURITY • CABINET FURNITURE • SHELVING & STORAGE • BOLTS & STOPS • SEALANTS & ADHESIVES • SCREWS & FIXINGS

**IN BRIEF**



Belcher to Clios

**LEGENDS RACER SIMON BELCHER**

will graduate to the Clio Cup full time this year with multiple title-winning squad Team Pyro. The former British and European Jet Ski champion appeared at last year's Brands finale in a self-run car and finished 15th and 16th in two races.

**FORMULA RENAULT BARC SQUAD**

Antel Motorsport has signed four drivers for its assault on the 2012 championship. British racer Raoul Owens and Russian Ivan Taranov will both return to FR BARC after switching to the team that ran Dino Zamparelli to the 2011 crown, while Formula Vee racer Henry Chart and karter Tom Oliphant will both step up.

**BRITCAR RACER JENSEN LUNN HAS**

reformed his Jensen Motorsport outfit for an assault on the 2012 British Endurance Championship with a Chevron GR8. The team competed in FF1600, FVauxhall, Frenault and British GT between 1999 and 2005 before Lunn stopped to focus on his driving career.

**THE PORSCHE GT3 CUP CHALLENGE**

will join Formula Renault BARC as part of the guest support package for the BTCC's Silverstone finale in 2012. The move is the result of closer ties between the lower-level Porsche category and the premier Carrera Cup GB for this season.

**FORMULA FORD RACER NEIL**

Alberico will return to his native US this year to contest USF2000 with JDC MotorSports. Alberico, 19, was ninth in British Formula Ford in a CDR Ray in 2011.

**THE CLASSIC SPORTS CAR CLUB**

will run a series of races for Modsports and Special Saloons in 2012. The four-round series will include double-headers at Silverstone, Castle Combe, Mallory Park and Donington Park.

**THE FLEDGLING JD CLASSICS**

saloon car series will allow earlier cars into its ranks in 2012. The eligibility start date has been pushed back from 1972 to '66 in an effort to encourage Ford Anglias and Escorts onto the MRL-run grid for pre-'85 BTCC and ETCC racers.



Older cars will be eligible for JD Classics



Cecotto drove BMW 320i Super Tourer in Germany

**Classic Thunder**

# Super Tourer for Whittaker

**Kumho BMW champ is building Cecotto 320i replica for Classic Thunder**

**KUMHO BMW CHAMPION**

Garrie Whittaker is building a Super Touring replica for an assault on Classic Thunder this season.

Whittaker dominated the BMW series in 2011 and scored Classic Thunder successes in his E36 M3. He is now building a faster version for Classic Touring Racing Car Club events.

"I didn't have enough opposition in Kumho, so I'm doing Classic Thunder to get a good race," he said.

"When you're allowed to modify your car, if you're not as quick as someone you'll change it until you are. In Classic Thunder anything can happen."

The car will run a 390bhp E46 engine built by Gee-Sport and will appear in a livery based on Johnny Cecotto's 1998 German Super Tourenwagen Meisterschaft BMW 320i.

Other successful club tin-top racers are also expected to race in Classic Thunder this season. Former Classic

Group 1 champion Stacy Vickers is developing a Mazda RX7, while Joss Ronchetti is planning to enter his recently acquired Holden Monaro.

Whittaker has not ruled out Kumho BMW appearances in his old car and is also considering outings in Euro Saloons and GT Cup, as well as a Britcar race with BMW rival Colin Wells.



**Historics**

## Shuckburgh to race replica Cunningham

**BEN SHUCKBURGH'S REPLICA OF a 1955-spec Cunningham C4R, which appeared briefly in practice at last year's Goodwood Revival, will be raced this season.**

Shuckburgh is targeting the Le Mans Classic alongside RAC Woodcote Trophy and new FISCAR



C4R will race this season

(1950s sportscars) events.

Shuckburgh, who will share the car with Ludovic Lindsay, said: "Fifties sports-racing cars have always, in my view, been the absolute pinnacle, but the best were also out of reach

financially. Both original C4Rs are in museums, so, having found a '52 C3 project, I started to create one."

The Collier Motor Museum in Florida (which has an original) and builder Jim Stokes's workshop in Hampshire have aided the project.

"I've run it in on the road," added Shuckburgh. "The Chrysler engine seems to make plenty of power, but the drum brakes are pretty useless so it's going to take some taming."

"I'm testing at Donington next month and plan to debut it there in the Historic Festival in May."

**Group C/GTP**

## Rare Toyotas to join Group C revival series

**TOYOTA IS SET TO JOIN THE GROUP C/GTP grid for the first time in 2012 thanks to historic ace Kent Abrahamsson buying two of the Japanese marque's cars from the late 1980s.**

Abrahamsson, who is a Group C regular at the wheel of a Nissan R90C, has acquired a Group C Toyota 87C and an IMSA GTP Eagle-Toyota HF89.

The Group C car, chassis 003, raced

at Le Mans in 1987 with a roster of drivers including ex-F1 world champion Alan Jones. The Eagle, chassis AAR 06, raced in IMSA in 1989-90.

Abrahamsson said: "These cars have great history. The 87C is ready to go. I'll test it, see how it goes and then decide when to race it. The Eagle is as it finished its final race in 1990."

Series boss Bob Berridge added:

"We've never had a Toyota before; they are like hen's teeth."



Rare Toyota will race again

# Works driver for a day

When Garrie Whittaker racked up over 20 club wins in 2011, he had no idea it could lead to a test with BMW. *By KEVIN TURNER*

**M**ost club drivers toil away with their own machines for years and, however successful they are, don't get the chance to drive a factory-prepared racer. Happily, thanks to BMW, Garrie Whittaker is no longer in that category.

Whittaker took his own BMW E36 M3 to AUTOSPORT's 2011 Golden Helmet for scoring the most race wins in the British Isles and we were able to reward him with a trip to Valencia before Christmas. There, he got to drive two of the Munich marque's latest GTs: the GT4 E90 M3 and the GT3 Z4.

"I didn't sleep for a week after I found out I was doing it," he admits. "I was thinking the plane would break down, I'd miss the flight, or I'd fall over in a lift and break something. I

couldn't believe it, especially after we looked up the Z4 and realised it's worth something like €300,000."

When Whittaker does arrive at the Spanish circuit he's met with another unfamiliar sight: a paddock that is empty and lifeless but for the BMW Motorsport truck. He is to share the day with four other drivers, but otherwise has the circuit to himself. They quickly get started on the briefings and all the drivers are taken around the track in a 5-series Bimmer.

Then it's time to get acquainted with the slick-shod GT4 M3 and GT3 Z4. "I can't believe they're going to let me out in their cars," says Whittaker.

First up is the M3. The GT4-spec car, which took both the drivers' and teams' titles in the 2011 GT4 European Cup, is relatively close to the road car on which it is based. Whittaker's normal steed is a Group N-style BMW E36 M3, so it's perhaps not surprising that he quickly finds his feet.

"It doesn't feel any different to my E36, which has 291bhp at the wheels," he says after his 10-lap run. "The shocking thing is that the M3 has 420bhp and I was expecting to put my foot down and really have to catch it, but it's also quite heavy so it was fine."

With the starter rapidly consumed, attention swiftly turns to the main course. Launched in 2010, the GT3 Z4 has racked up wins in the competitive FIA GT3 and Blancpain Endurance championships, as well as taking victory in the 2011 Dubai 24 Hours.

Works driver Dirk Adorf is on hand to offer advice, and takes the car out on new tyres to make sure everything is doing what it should.

Other drivers get their runs before Whittaker, so the tyres are well past their best when he climbs in, but that's not his first worry: "It's got paddleshift and I've never driven with that before."

It's also got traction control and dynamic stability control, and Whittaker is told not to change the settings. "They are there to look after you," says the engineer.

The Kumho BMW champion is not



Whittaker drove M3 GT4 (left), then fierce Z4 GT3



M3 felt little different to Whittaker's club racer

tall, so he needs cushions to enable him to see past the long bonnet that contains the 4.4-litre engine, producing over 500bhp. It's intimidating, but Whittaker is allowed as many laps as he can cope with.

There's one last warning before he goes out. "There's a new kerb out the back. The front splitter is €5000 so don't hit that because it will rip it off."

Whittaker heads out, trying to remember what each of the myriad buttons and knobs do. He seems to do so pretty well and stays out for nearly 30 laps. Not only that, but he outpaces the other guests, and gets within around four seconds of Adorf's benchmark.

"It was even more different than I expected," he says afterwards. "It was getting to about 160mph on the start-finish straight and goes through the gears so quickly – it wants the next one straight away. Everything happens a couple of seconds before you think it's going to, but after about five laps I was thinking, "This is all right, I like this!"

The braking also takes some getting used to. "I didn't get the ABS to kick in once," he says.

"I pressed the pedal harder and harder and it just stops quicker."

After an extensive debrief, Whittaker speaks to Adorf over lunch. Being a competitive club driver, Whittaker wants to know how to go quicker on his second run. "The pressure is all coming from me," he says. "They are all about making sure I have a good time."

Once again the tyres are pretty worn by the time he gets in, but Whittaker is determined to press on and make the most of his chance. Only when he comes in is it noticed that the traction control has been turned off.

Whittaker maintains his innocence, which the crew are able to confirm when they check the data

logging. It must have been knocked during the driver change...

"A bit lairy," is Whittaker's response when asked how it was without TC, and there are black lines out of the hairpins to prove it. "I had one moment on full opposite lock, but it came back."

But he hasn't gone any quicker than in the morning and wants to look at the data to see where he is losing out to Adorf. He's never driven an aero car before and isn't trusting it to turn in on the brakes enough at Valencia's fast first corner. The engineer goes through the rest of the lap, pointing out that much of the deficit is due to the worn tyres. "But I reckon I'm still two seconds off," says Whittaker, who is clearly in full ▶



**BMW M3 GT4**

Engine	4.0-litre V8
Power	420bhp
Weight	1380kg
Price	€123,500 (exc VAT)

**BMW Z4 GT3**

Engine	4.4-litre V8
Power	515bhp
Weight	1190kg
Price	€315,000 (exc VAT)

# The one in the middle wins races



## DS1.11® & DS2.11®

SILOXANE TECHNOLOGY

BRAKE PADS





RACING

FEDERAL MOGUL

The best brands in the business

Relative Performance Characteristics of Ferodo Racing Range Under Heavy-Duty Conditions

	Pad Life	Disk Life	Average mu	Fade	Pedal Travel	Release
DS 2500	Excellent	Moderate	Moderate	Moderate	Moderate	Moderate
DS 3000	Excellent	Moderate	Moderate	Moderate	Moderate	Moderate
DS 3000+03	Excellent	Moderate	Moderate	Moderate	Moderate	Moderate
DS 3000E	Excellent	Moderate	Moderate	Moderate	Moderate	Moderate
FER 4003	Excellent	Moderate	Moderate	Moderate	Moderate	Excellent
DS 1.11	Excellent	Excellent	Excellent	Excellent	Excellent	Excellent
DS 2.11	Excellent	Excellent	Excellent	Excellent	Excellent	Excellent

Excellent   
 Good   
 Moderate 

www.federal-mogul.com/ferodoracing

### Race Proven

- DS1.11 - suffix "W"
- A1GP
  - FIA FT
  - Touring Cars
  - Formula Cars
  - Group N
  - Stock Cars
- DS2.11 - suffix "X"
- WRC
  - Rally Group N
  - Touring Cars



Circuit Supplies (UK) Ltd

Unit 8, Eden Court, Eden Way

Leighton Buzzard, Beds LU7 4FY

Tel: 01525 385 888 Fax: 01525 385 898

info@circuitsupplies.com www.circuitsupplies.com



BMW Z4 has been successful in GT3

◀ want-to-go-faster mode. “As a racer you want to know how quick you are.

“What are the chances of putting on a new set of tyres and letting me have another go?”

The engineer’s answer is courteous but unbending: “The problem with an aero car is you’ve got grip, grip, grip, and then you go off. We don’t want you to go off today.”

Whittaker then has his eye on a set of the BMW Motorsport overalls. “You can have them, but you have to buy the car first,” is the response.

That’s not an option, but Whittaker is clearly impressed with the Z4. “The only reason I came in on the second run was because it ran out of fuel!” he says. “It was such good fun.

“I’m always thinking what to do next and I’d never thought of British GT [for which both cars are eligible] until I drove the Z4.”

It’s also fair to say that Whittaker has done himself and British club racers proud with his performance, even if he is frustrated to be off the pace of the established pro. And he already has a plan to improve: “Now I’m determined to get some aero on my E36 so I can get some downforce experience.”



Whittaker listens to BMW instructions

## BMW BLITZER

**GARRIE WHITTAKER IS THE** second tin-top driver to win the AUTOSPORT Golden Helmet since we revived it in 2008. The BMW ace joined Rod Birley as the most-successful pilot in the UK in a given year by taking 22 wins in his E36 M3.

To achieve that he dominated the Kumho BMW Championship – finally taking the overall title after years of trying – as well as scoring successes in Classic Thunder and the Classic Sports Car Club’s new Deutsche Marque series.

“I didn’t realise the Golden Helmet existed at the start of the year,” he admits.

“I was always going to do Kumho, and I did a Classic Thunder race in 2010 and quite liked it. At the start of the year I persuaded [rival BMW driver] Dan Stringfellow to do the Classic Thunder round at Oulton Park and he beat me. If I hadn’t badgered him I’d have won that championship too.”

Apart from some Jim Russell Racing School events in the late 1990s, the 45-year-old didn’t do any competitive driving until he entered an E30 M3 in the Kumho championship in 2006. “I only did it because I wanted to drive an E30 and learn the circuits,” he says.

After several near-misses and numerous wins with the E30,

Whittaker finally landed Kumho title



Whittaker moved to the E36 and won 17 Kumho races in 2011, despite running most of the year with 45kg of success ballast. More of a challenge was Classic Thunder, in which he took four wins, but it is a race he lost that stands out.

“My favourite race of the year was coming fifth at Brands Hatch,” says Whittaker. “We’d just put slicks on for Classic Thunder and didn’t even add any more rear camber. I had a massive spin at Paddock on the first lap. Nobody touched me and I got going, but I’d ripped a front brake duct off so at

about half-distance I’d overheated the front brakes.

“I was having such a good time I thought I’d be all right. My best overtake was on Keith Butcher’s Super Touring Nissan. We both braked for Paddock at the same place but nothing happened so I went straight past him on the inside! It was my worst result of the year and best race.”

The result is that although Whittaker will keep his current E36 for occasional Kumho outings, his focus is now on a Super Touring E36 replica for Classic Thunder.

POS	DRIVER (CAR/CARS)	O/ALL	CL.	TOT.
1	Garrie Whittaker (BMW E36 M3)	22	0	22
2	Scott Malvern (Miygale SJI1)	19	0	19
3	Mark Burton (Jade Trackstar)	18	0	18
4	Ross Marshall (Ford Coupe/Ford Escort)	16	2	18
5	Tom Roche (Mazda MX5 Mk1/Mk3/Alfa Romeo GTV)	16	1	17
6	Kenneth Thirtwall (Van Diemen RF92)	16	1	17
7	John Marshall (Ford Escort Mk1/Ford Coupe)	12	5	17
8	Nic Grindrod (SHP Pickup)	15	0	15
9	Paul Bellamy (BMW 318is)	1	14	15
10	Stephen Treherne (Ford Coupe)	14	0	14
11	Mark Coleing (Caterham CSR 260)	14	0	14
12	Garry Watson (Westfield SE1W)	12	2	14

Repechage consolation, overflow entry and handicap races not included. Races classes must have minimum six starters, and be scheduled for a minimum distance of 10 miles. Overall wins take precedence in the event of a tie, followed by average grid size. For any queries, email us at [autosporteditorial@haynet.com](mailto:autosporteditorial@haynet.com)

## YOUR SAY

What you think of the motorsport news of the past week

Curtains for Buemi and Alguersuari



### Chances run out at Toro Rosso

I agree with Red Bull's Helmut Marko that Sebastien Buemi and Jaime Alguersuari were given enough chances to demonstrate that they are 'winners'. The Toro Rosso was certainly quick in some of the races, but Buemi and Alguersuari didn't seem to be extracting the best out of their machinery.

Toro Rosso has become a test bed for future world champions. But sadly these two have failed to inspire like Sebastian Vettel did when he was there. It's only right to bring on the next generation of drivers in order to seek out that 'Vettel magic'.

**Luciane Sabiston**, Didcot, Oxon

EDITORIAL CONTACT [mail@autosport.com](mailto:mail@autosport.com)

**I was disappointed to** read of Kris Meeke's omission from the Mini WRC team due to lack of funding.

I had hoped that maybe this was a British driver in a British car that could have kickstarted interest in the sport – much needed at present – that was previously generated when Richard Burns and Colin McRae competed.

But cash rules, and if necessary in these times funded drivers will get the drives, but it's a shame.

**Andy Maclean**  
Churchill, Oxon

**Just a word on Patrick** Head as he leaves F1. He has done as much for our sport as any driver, owner or engineer/designer. His innovation and solid engineering spoke for itself.

I became a Williams supporter from the days that the white and green cars started to beat the black and gold cars. Patrick in particular got my attention and I hung on every word of interviews either in print or audio.

Often preceded by "I have to say...", you knew what was coming was pure gold – a profound

statement of common sense said with forthright opinion.

**David Metcalf**  
By email

**In response to Jacob** Hanerman's letter on how F1 can crack the States (January 5), I have a suggestion: make May the teams' break, and allow F1 drivers to compete in the Indy 500 for a regular IndyCar team.

Having F1 drivers take part in the great American race would help capture the US imagination.

**Benjamin Middlewood**  
By email

**Bernie Ecclestone is** complaining that the US will not take to F1. It has embraced F1 in the past and has quite a large fan base. And the teams need a presence over there for their sponsors.

But times have changed and it is questionable whether huge amounts of money can be put into circuits which may never turn a profit.

Perhaps Bernie should be more realistic about the viability of these races before asking them to sign up.

**Brendan Budgen**  
Woodley, Berks

**AUTOSPORT.COM**

### TOP FIVE ON OUR WEBSITE

1. **SENNA DOWNPLAYS WILLIAMS RUMOURS**
2. **FIA CLARIFIES DEFENSIVE DRIVING RULES**
3. **WILLIAMS LOOKING FOR NEW TITLE SPONSOR**
4. **ROSBERG: MISSING TEST NO PROBLEM**
5. **RAIKKONEN: COMEBACK FANFARE NO WORRY**

**AUTOSPORT.COM PLUS**

### TOP STORY ONLINE

**NICO ROSBERG: A FUTURE F1 CHAMPION?**

To read this exclusive feature and many others like it, log on to [autosport.com/plus](http://autosport.com/plus) and choose which package you'd like. A month will cost £5.50, a year £46. Includes access to Forix – the ultimate stats website.

**WIN!**



### ROAD ANGEL VANTAGE

This week's star letter will receive a Road Angel Vantage – a dedicated safety camera and blackspot locator that displays the legal speed limit of every road you drive, automatically and wirelessly updating its database every few minutes as you drive. For more details on Road Angel visit [www.roadangelgroup.com](http://www.roadangelgroup.com) Please ensure that your full address is included on all correspondence.

### CORRECTIONS AND CLARIFICATIONS

● Marijn van Kalmthout's Donington Park National lap record was set in a race for the fledgling BOSS GP series, not EuroBOSS as reported in our 'Fastest laps in the British Isles' feature (January 5, page 64).

It is the policy of AUTOSPORT to correct significant errors as soon as possible. Please note the issue date and page number when contacting us on [autosport.editorial@haynet.com](mailto:autosport.editorial@haynet.com)

# THE LATEST GEAR

The most desirable new releases for motor racing fans: books, DVDs, models, art and gifts



**UVEX CARBON HELMET**

£POA  
gprdirect.com

Grand Prix Racewear has become the sole UK distributor for Uvex helmets and the all-carbon, futuristic model is soon going to be available to budding racers for the 2012 season.

If the helmet's good enough for 2011 DTM champion Martin Tomczyk (the picture shows his Red Bull Audi-liveried example from last season), then it's good enough for you.

No prices have been released yet, but keep an eye on the website for details.

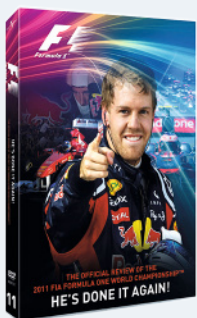

**OFFICIAL F1 2011 SEASON REVIEW DVD**

£16.99  
autosport.com/shop

This year's official review runs to more than five hours of footage. A highlight is the amount of unheard radio banter from each race, featuring a lot of (bleeped out) language!

Lowlights? Glossing over stories such as Renault's driver changes, and too many Vettel interviews.



**FUJIMI FERRARI F10 1:20 PLASTIC KIT**

£59.80  
grandprixmodels.com

Fujimi's 1:20-scale plastic kit of Ferrari's 2010 Formula 1 challenger, the F10, is incredibly detailed, with 130 parts.

It's officially licensed by the Scuderia, too, so accuracy is guaranteed.

The kit comes with decals to make up either the Alonso or Massa car.



**WRC: WORLD RALLY CHAMPIONSHIP 2 GAME**

£14.99 (PS3/Xbox 360/PC)  
play.com

The second instalment of the official WRC series doesn't take things on much from its predecessor, but it does have more cars (now 20 in WRC class), the 2011 field in full and the new-spec pocket rockets. It can't be expected to match the big-budget DIRT series, but it remains too far off.

## HOT ON THE WEB THIS WEEK

**YOUTUBE: FRANCHITTI DRIVES HERO CLARK'S INDYCAR**



**SEARCH FOR:** Exclusive: Dario Franchitti Drives Jim Clark's Indy-Winning Lotus 38 Ford (5:51)

As you'll have read in Dario Franchitti's intro to our Jim Clark tribute, he realised a dream driving the Lotus 38. Here, you can watch how he got on.

# WHAT'S ON...

Your guide to the best events taking place in the UK and around the world this week – plus TV and online

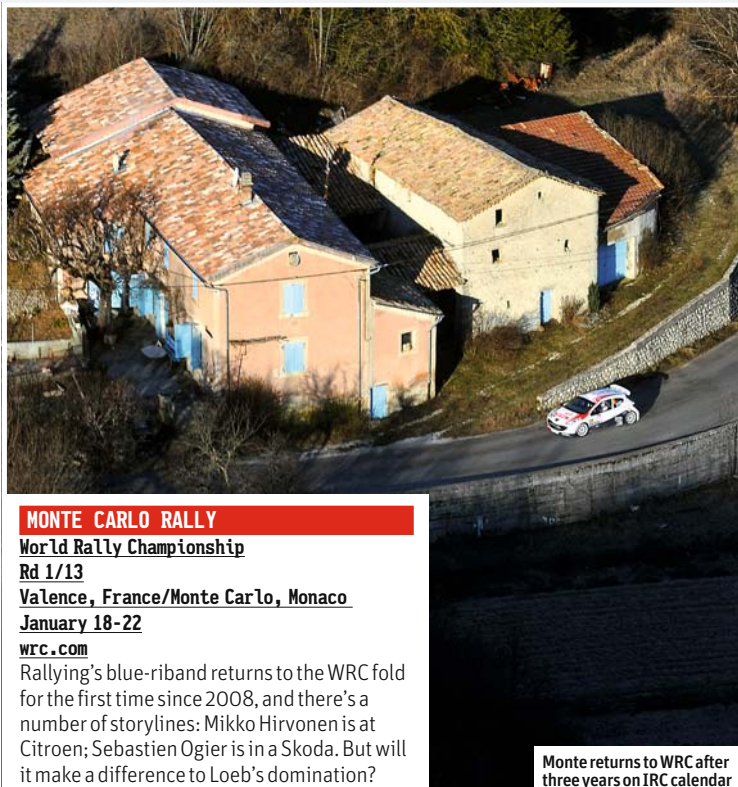

## MONTE CARLO RALLY

World Rally Championship

Rd 1/13

Valence, France/Monte Carlo, Monaco

January 18-22

wrc.com

Rallying's blue-riband returns to the WRC fold for the first time since 2008, and there's a number of storylines: Mikko Hirvonen is at Citroen; Sebastien Ogier is in a Skoda. But will it make a difference to Loeb's domination?

Monte returns to WRC after three years on IRC calendar

## AUTOSPORT INTERNATIONAL

January 12-15

Birmingham NEC

The annual AUTOSPORT International show returns to Birmingham's NEC, bringing together teams, drivers and a host of specialist engineering and supply companies – from karting right up to Formula 1 – under one roof.

## DAKAR RALLY

Stages 11-14

Arica, Chile - Lima, Peru

January 12-15

dakar.com

The 2012 Dakar Rally heads into the majestic dunes of Peru for the final four days. After seven stages Nasser Al-Attiyah's bid to repeat his 2011 win is under pressure from Mini's Stephane Peterhansel and Krzysztof Holowczyc, the Qatari driver trailing by just over 40 minutes. Can he recover the deficit before reaching Lima?

## ANDROS TROPHY

Rd 5/7

Lans-en-Vercors, France

January 13-14

tropheeandros.com

Jean-Philippe Dayraut overhauled Alain Prost at the summit of the championship in the previous round, but the four-time F1 champion remains in the hunt.

## 24 HOURS OF DUBAI

Dubai, United Arab Emirates

January 13-14

24hdubai.com

## NEW ZEALAND V8 TOURING CARS

Rd 3/6

Teretonga, New Zealand

January 15

nzv8s.co.nz

## TOYOTA RACING SERIES

Rd 1/5

Teretonga, New Zealand

January 14-15

toyotaracing.co.nz

## COMPETITION

# WIN TWO TICKETS TO ATTEND THE LAUNCH OF A NEW GRAND PRIX CAR



HILTON  
HHONORS

Hilton HHonors™, the guest loyalty programme for the Hilton Worldwide portfolio of hotels, are pleased to offer you and a guest the chance to attend the official launch of the Vodafone McLaren Mercedes MP4-27. The event, which is not open to the public, is due to take place at the McLaren Technology Centre in Woking, Surrey on February 1 and will involve Lewis Hamilton and Jenson Button revealing their car for the 2012 grand prix season. In addition, each winner and guest will receive a year of free access to AUTOSPORT.com PLUS. Everyone who enters will receive one month's free access to AUTOSPORT.com PLUS.

To win, answer this question. Which of the current Vodafone McLaren Mercedes drivers most recently won the world championship?  A: Jenson Button  B: Lewis Hamilton

To enter scan the QR code, visit [www.autosport.com/competition](http://www.autosport.com/competition) or visit us at the AUTOSPORT, *F1 Racing*, *Motorsport News* or [magazineshop.com](http://magazineshop.com) stands at AUTOSPORT International.

**Essential terms and conditions:** 1. To enter: visit AUTOSPORT, *F1 Racing*, *Motorsport News* or [magazineshop.com](http://magazineshop.com) stands at AUTOSPORT International or via [AUTOSPORT.com/competition](http://AUTOSPORT.com/competition). 2. Entries close: 11.59pm January 24, 2012. 3. Prize(s) are: as stated above, two winners and guest to attend the official 2012 Vodafone McLaren Mercedes launch at the McLaren Technology Centre. Transportation, subsistence or other costs incurred are at the winner's own expense. The location of the launch is subject to change and is at the sole decision of McLaren. 4. Open to UK residents aged 18 or over. 5. Approval will be necessary of the winner/guests (ie if the winners or their guests work for/in the motorsport industry as an employee of or as a supplier to an F1 team, an engine supplier of a competitive team or in the media, be it general or F1 media, they could be subject to rejection). There can be no late substitution of prior supplied names. 6. Dress code will be obligatory. No communication of the launch via any digital channel will be permitted during the day (no image capture or recording, live blogging or tweets). 7. There will be no direct meeting with the Vodafone McLaren Mercedes drivers. 8. No cash alternative. Prizes are non-transferable. 9. Only one entry per person. 10. For full terms and conditions see: [AUTOSPORT.com](http://AUTOSPORT.com). The Promoter: Haymarket Media Group, Teddington, Middlesex, TW11 9BE.



[www.autosport.com/competition](http://www.autosport.com/competition)

## Television

### THURSDAY JANUARY 12

0505-0600, 1620-1720 [Motors TV](#)

Andros Trophy: Isola 2000

0730-0815, 1130-1215,

1725-1815 [Eurosport](#)

Dakar Rally: Day 10

1815-1845 [Eurosport LIVE](#)

Dakar Rally: Day 11

1900-2000 [Sky Sports 4](#)

Racemax

2045-2200 [Eurosport](#)

Dakar Rally: Day 11

2100-2305 [Motors TV](#)

Dubai 24 Hours: Qualifying Highlights

### FRIDAY JANUARY 13

0000-0045 [Eurosport](#)

Dakar Rally: Day 11

0900-1210, 1700-2000,

2135-2205 [Motors TV LIVE](#)

Dubai 24 Hours

1210-1310 [Motors TV](#)

Andros Trophy: Isola 2000

1300-1400 [Sky Sports 3](#)

Racemax

1800-1830, 1915-1945 [Eurosport LIVE](#)

Dakar Rally: Day 12

2245-2330 [Eurosport](#)

Dakar Rally: Day 12

### SATURDAY JANUARY 14

0030-0115, 0730-0815 [Eurosport](#)

Dakar Rally: Day 12

0400-0425 [Channel 5](#)

Motorsport Mundial

0600-0700 [Sky Sports 4](#)

Racemax

0700-0800 [Sky Sports 4](#)

Max Power

2100-0010 [Motors TV](#)

Dubai 24 Hours: Highlights

2200-2245, 2345-0030 [Eurosport](#)

Dakar Rally: Day 13

### SUNDAY JANUARY 15

1415-1515 [Motors TV](#)

Andros Trophy: Isola 2000

1545-1855 [Motors TV](#)

Dubai 24 Hours: Highlights

2245-2325 [Eurosport](#)

Dakar Rally: Day 14

### MONDAY JANUARY 16

0315-0600, 1005-1310 [Motors TV](#)

Dubai 24 Hours: Highlights

1230-1300, 1900-1930 [ESPN Classic](#)

F1 British GP 1973

1500-1600 [Sky Sports 2](#)

Max Power

1830-1900 [ESPN Classic](#)

F1 British GP 1969



Silverstone, 1969:  
Piers Courage in action

## Online

# AUTOSPORT.COM

Coming up on the web this week

### AUTOSPORT INTERNATIONAL

AUTOSPORT International, the world's best racing car show, takes place from January 12-15, so where better than AUTOSPORT.com to keep you up to date with all the breaking news from Birmingham's NEC? Plus, find out whether Stephane Peterhansel takes his 10th Dakar Rally win as the enduro concludes in Peru, or whether Krzysztof Holowczyc or Robby Gordon can defeat him.

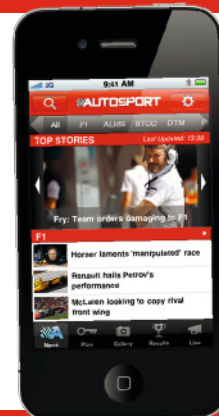

Read AUTOSPORT.com on your phone to keep up to date

### AUTOSPORT.COM ANDROID APP OUT NOW

The AUTOSPORT app is now available for Android. Dial up AUTOSPORT.com on your smart phone for instant access to news, feature articles, image galleries and live text race commentary for a one-off fee of only £2.99 (there is no renewal cost). For more info, visit [www.autosport.com/app](http://www.autosport.com/app)

## REVVED UP OVER WHAT'S ON THE BOX

We cast a critical eye over the best and worst of this week's TV shows

MUCH AS PUMPKIN sales peak around the end of October, Quality Street tins are conspicuous by their absence outside of December and Brits are only seen playing tennis around Wimbledon time, casual interest in the sport of rally-raiding reaches its pinnacle right about now.

Of course, I mean the Dakar, or the Paris-Dakar as it was when I was a lad – but given that it neither starts in France nor finishes in Senegal, what it's called doesn't really seem to matter these days.

Eurosport is the custodian of the rights,

which means that live coverage starts whenever they can be bothered. Setting the Sky Plus to record any of the said action is a lesson in abject futility. Still, half a live stage is better than nothing, if only just.

On Monday evening, it was the Copiato-Antafagasto trek that was beamed into our living rooms. And it was dusty. And windy. So dusty and windy, in fact, that a huge patch of soggy mud had been rendered invisible, which caught almost all the intrepid motorcycle entrants out, resulting in some comical footage as they were plunged head over heels into what was

bordering on quicksand.

The 'live' action was restricted to showing the cars roll into the finish, but did provide some unexpected treats, not least Nani Roma having a massive pop at Nasser Al-Attiyah's co-driver for failing to warn them when they made a pass mid-stage.

Al-Attiyah had already given rise to a gem from this column's favourite (ahem) commentator Carlton Kirby, who speculated that Robby

Gordon's reaction to driving by his Hummer team-mate – temporarily sidelined with an alternator problem – was... "I bet it was hand signals only, if you get my drift, ha ha ha."

Infuriating as Kirby can be, his bizarre asides somehow suit an event that's named after a place that it doesn't visit and pushes its entrants to the limit of human endurance, but only if the weather's right. *Revved Up*

"The Dakar was the Paris-Dakar when I was a lad, but it neither starts in France nor finishes in Senegal"



Only on the Dakar can bikes be more practical than cars

# THE WEEK IN PICTURES

Our lensmen pounding the beat, from Australia to South America

## UPHILL TASK FOR NASSER IN HIS HUMMER

Last year's Dakar Rally winner Nasser Al-Attiyah won stage seven to close on the leaders but then fell back on the next test after problems. He's now 45 minutes in arrears



## TIN-TOP RACERS PAY TRIBUTE TO RICHARDS

Aussie V8 stars Andrew Jones, Jason Bright and Paul Dumbrell honour fallen colleague Jason Richards at a Melbourne memorial



## SIX WHEELS ON THE THEIR WAGONS

The annual 'Wroom' press skiing event in Madonna di Campiglio gave Fernando Alonso and Valentino Rossi a chance to share secrets



## NASTY NOSEDIVE FOR SPANISH RACER

Lucio Alvarez performs an unwanted 'stoppie' in his Toyota truck during SS7 of the Dakar

# FROM THE ARCHIVE

Formula 1 star proves adept at racing and rallying Cortina tin-top

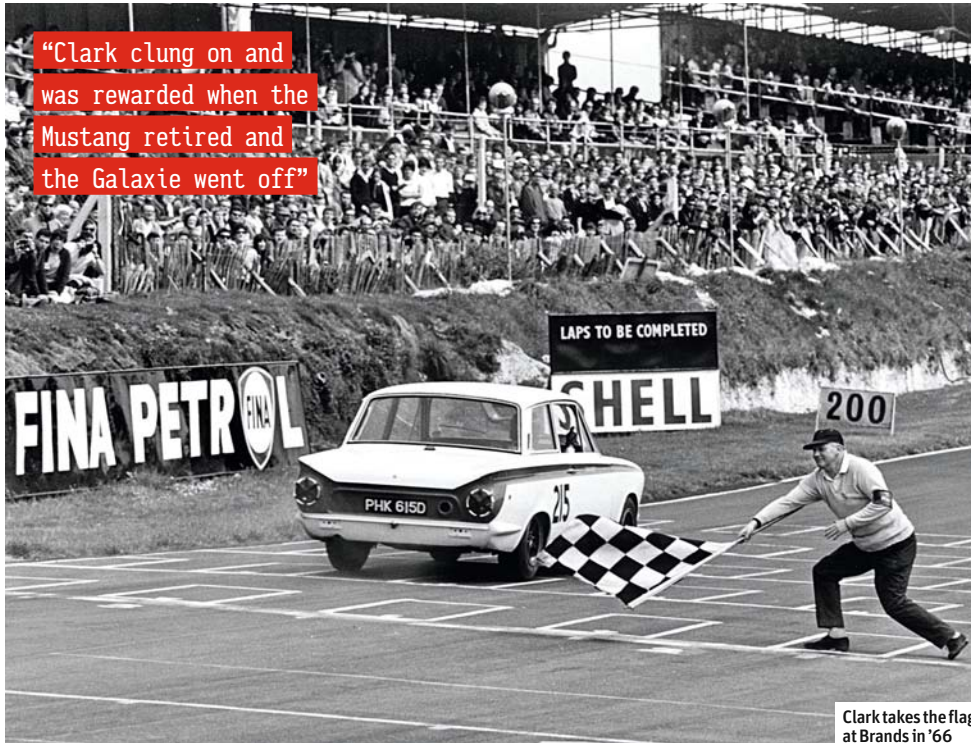

“Clark clung on and was rewarded when the Mustang retired and the Galaxie went off”

Clark takes the flag at Brands in '66

**JIM CLARK IS FAMOUS FOR MANY MOTORSPORT** achievements, but outside his single-seater career many people remember his three-wheeled antics in Ford Lotus Cortinas.

The Scot had already taken his first British Touring Car victory in a Ford Galaxie when he went into 1964 with the 1600cc Lotus-tuned tin-top. He scored the first of his seven Cortina BTCC wins pretty quickly, but it took a bit of luck to beat the quickest of the American V8s at April's Oulton Park round.

The Galaxie of Jack Sears took command and was pulling away from Clark when a defective oil seal sent him off at Lodge. Clark was left to take an easy win.

There were similar stories at Crystal Palace in May and Oulton in September. Sears led both, only to suffer a blown tyre in London and ignition failure in Cheshire. Clark took the wins, which, along with class successes throughout the year, gave the reigning F1 world champion the BTCC title.

Clark needed no such good fortune at Goodwood in 1965. Now Sears was in a Cortina and, when rain hit, the duo left the bigger cars behind, with Clark winning by 11 seconds.

Four rounds later, Clark's fine Oulton Park luck returned. He and Sears streaked away as Roy Pierpoint's Ford Mustang triggered a multi-car shunt

behind. Jack Brabham's Mustang emerged from the melee to catch the Cortinas and win on the road, but was then disqualified. Clark was again the beneficiary.

Perhaps his best BTCC performance was his next victory, at Brands Hatch on August Bank Holiday 1966. By now Jackie Oliver led the V8 onslaught in his 4.7-litre Mustang, but a brief downpour levelled the playing field. Clark shot into the lead from the off and was never headed as the track dried.

Clark's eighth and final BTCC win was once again due to a tenacious drive spliced with some good fortune. After a good start at Oulton in September '66, Clark was soon overpowered by Oliver's Mustang and Brian Muir's seven-litre Galaxie. He clung on and was rewarded when Oliver's stub axle broke and Muir went off thanks to his brake pedal going to the floor.

Just two months later, Clark showed he could handle the Cortina on the rough as well. Tackling the RAC Rally with Brian Melia, Clark was fifth quickest on the first stage and ran in the top 10 early on. Despite the odd puncture, Clark was "consistently fast and was going as quickly and smoothly as ever" according to our report.

The duo spectacularly retired when the Cortina got airborne over some humps and flipped into some trees, but not before Clark had set three fastest stage times and added another dimension to his versatility. ❧

## THIS WEEK IN...



JANUARY 11 1990

**IT WAS A BUSY SEVEN DAYS FOR** AUTOSPORT in 1990, with the annual AUTOSPORT Awards show at Cafe Royal and the Racing Car Show in Olympia to attend. It also proved a historic week with the unveiling of David Coulthard as the first winner of the newly created McLaren/AUTOSPORT Young Driver of the Year Award.

As part of his prize for winning the Award, which has since been claimed by Jenson Button, Dario Franchitti and Paul di Resta, Coulthard received the opportunity to drive a McLaren F1 car. He would go on to join the team for 1996, taking 12 of his 13 grand prix wins there and finishing runner-up in the 2001 world championship.

Across in Olympia, the 1990 Racing Car Show proved a massive draw, with an array of race machinery, including the Cooper T53 in which Jack Brabham won the 1960 F1 world title.



PIC: LAT ARCHIVE



## DID YOU BEAT THE GRAND PRIX PREDICTOR?

Castrol **EDGE** Rankings

Visit [castroledgerankings.com/predictor](http://castroledgerankings.com/predictor)

# RAY MALLOCK

■ Shellsport Formula 5000 ■ Snetterton ■ August 1, 1976 ■ March-Ford 752 ■ Victory in underdog F2 car



Mallock (14) stays out of trouble at the busy start

**THE BACKGROUND TO MY** favourite race was that I'd gone into 1976 expecting to run the latest Lola Formula 2 car, the T460. It was basically a Formula Atlantic car with an F2 engine and I'd tested at the end of '75 at Snetterton. It was a fabulous car – I lapped in under a minute – so I ordered one!

Well, since my test and the car's arrival it had had endless tweaks to the wheelbase, the tracking and the aero which meant it now handled like a pig!

Because it was so far off the pace (three seconds at Snetterton) we decided to sell it and make the best of the season with what we could get together. John Wingfield kindly loaned us his Ralt RT1 for a couple of races which was a super little car and I got good results at Rouen and Hockenheim with it.

By mid-season we had wheeled out the '75 March Formula Atlantic car but fitted with a two-litre Swindon BDX motor. It had a good steady chassis, designed by Harvey Postlethwaite. Using some of the lessons learned from the RT1 we converted the March to full width nose (off a Mallock), front radiator and we stiffened the chassis considerably with

**"Mike and I were running one-two, but I realised the only way I was going to beat him was if I could pass him in two places on the same lap. And it worked!"**

an engine-bay cross-brace.

When we arrived at Snetterton for the August 1 meeting we had done no testing with the car in that configuration. It was OK but not as well balanced as I would've liked and I qualified seventh.

We made some set-up changes for the race and off we went! I made a good start and got into the thick

of a scrap at the front. One of the changes we had made was fitting a cockpit-adjustable anti-roll bar for the first time. The mods we'd made nailed the front end, but the rear was too nervous, so for the first time ever I used the cockpit-adjustable ARB and that dialled it in. Now the car was flying!

David Purley and Keith Holland

had made a lot of the running at the front but they collided with two laps to go after early-spinner David had caught Keith. I had got up to fourth and eased up to Mike Wilds in the Shadow DN3 F1 car.

After the leaders had gone off, Mike and I were running one-two, but I realised the only way I was going to beat him was if I could pass him in two places on the same lap. Firstly into Sear, the corner just prior to the back straight, then I'd have to hold my inside line while Mike inevitably drove back past me on the straight. I'd then have to outbrake him into the Esses at the end of the straight. And it worked!

It was the first and only time that an F2 car had won a F5000/Group 8 race – and it was my biggest single-seater win. A real thriller! ✪ *Ray Mallock was talking to Henry Hope-Frost*

## IN PROFILE



### RENOWNED RACER AND ENGINEER

Ray Mallock began building clubmans cars with father Major Arthur Mallock before turning to driving. He raced extensively in single-seaters and sportscars, winning titles in Formula Atlantic and Group C. His RML concern, which he started in the early 1980s, has recorded championship success for numerous global manufacturers. In 2011, RML masterminded Chevrolet's dominance of the World Touring Car Championship.

NEXT  
WEEK

David  
COULTHARD





## Porsche Carrera Cup GB

The Porsche Carrera Cup Great Britain is at the very pinnacle of British motor racing. Stunning cars, top teams, talented drivers and superb grids, with unrivalled back up from Porsche Cars GB, make the Carrera Cup GB the obvious choice for ambitious drivers in 2012.

In 2012 the Carrera Cup GB will again be a key support race to the MSA British Touring Car Championship, thus ensuring the biggest crowds, best atmosphere and greatest media coverage available in British motor racing.

The new season will be the tenth year of Carrera Cup in Britain, modeled on the long-established Porsche Carrera Cup concept. Equal cars, close and exciting racing and first-class facilities for teams, drivers and sponsors all add to the strength of the championship. Pro, Pro-Am1 and Pro-Am2 categories deliver fierce competition all the way down the field and ensure that all drivers are chasing success in their particular category.

The Carrera Cup GB has proved to be the premier springboard for drivers aiming to graduate into the Porsche Mobil1 Supercup. Richard Westbrook, Damien Faulkner, James Sutton and Tim Bridgman have all graduated into the international series after winning the Porsche Carrera Cup GB.

For more information on the Porsche Carrera Cup GB visit [www.porsche.com](http://www.porsche.com) or email [carreracupgb@porsche.co.uk](mailto:carreracupgb@porsche.co.uk)

**PORSCHE**

**CARRERA  
CUP**  
GREAT BRITAIN





## Porsche Carrera Cup GB 2012

### JANUARY

S	M	T	W	T	F	S
1	2	3	4	5	6	7
8	9	10	11	12	13	14
15	16	17	18	19	20	21
22	23	24	25	26	27	28
29	30	31				

### FEBRUARY

S	M	T	W	T	F	S
			1	2	3	4
5	6	7	8	9	10	11
12	13	14	15	16	17	18
19	20	21	22	23	24	25
26	27	28	29			

### MARCH

S	M	T	W	T	F	S
				1	2	3
4	5	6	7	8	9	10
11	12	13	14	15	16	17
18	19	20	21	22	23	24
25	26	27	28	29	30	31

### APRIL

S	M	T	W	T	F	S
1	2	3	4	5	6	7
8	9	10	11	12	13	14
15	16	17	18	19	20	21
22	23	24	25	26	27	28
29	30					

Rounds 1 & 2  
March 31-April 1  
Brands Hatch (Indy)

GT3 Cup Challenge  
April 7-8  
Snetterton

Rounds 3 & 4  
April 14-15  
Donington

Rounds 5 & 6  
April 28-29  
Thruxton

### MAY

S	M	T	W	T	F	S
		1	2	3	4	5
6	7	8	9	10	11	12
13	14	15	16	17	18	19
20	21	22	23	24	25	26
27	28	29	30	31		

GT3 Cup Challenge  
May 19-20  
Rockingham

### JUNE

S	M	T	W	T	F	S
					1	2
3	4	5	6	7	8	9
10	11	12	13	14	15	16
17	18	19	20	21	22	23
24	25	26	27	28	29	30

Rounds 7 & 8  
June 9-10  
Oulton Park (Island)

GT3 Cup Challenge  
June 17  
Thruxton

Rounds 9 & 10  
June 23-24  
Croft

For more information on the 2012 Porsche Carrera Cup Great Britain visit [www.porsche.com](http://www.porsche.com)

**PORSCHE**

**GT3 CUP  
CHALLENGE**  
GREAT BRITAIN

**PORSCHE**

**CARRERA  
CUP**  
GREAT BRITAIN





**JULY**

S	M	T	W	T	F	S
1	2	3	4	5	6	7
8	9	10	11	12	13	14
15	16	17	18	19	20	21
22	23	24	25	26	27	28
29	30	31				

GT3 Cup Challenge  
July 21-22  
Croft

**AUGUST**

S	M	T	W	T	F	S
			1	2	3	4
5	6	7	8	9	10	11
12	13	14	15	16	17	18
19	20	21	22	23	24	25
26	27	28	29	30	31	

Rounds 11 & 12  
August 11-12  
Snetterton

GT3 Cup Challenge  
August 18-19  
Donington

Rounds 13 & 14  
August 25-26  
Knockhill

**SEPTEMBER**

S	M	T	W	T	F	S
30						1
2	3	4	5	6	7	8
9	10	11	12	13	14	15
16	17	18	19	20	21	22
23	24	25	26	27	28	29

Rounds 15 & 16  
September 22-23  
Rockingham

**OCTOBER**

S	M	T	W	T	F	S
	1	2	3	4	5	6
7	8	9	10	11	12	13
14	15	16	17	18	19	20
21	22	23	24	25	26	27
28	29	30	31			

Rounds 17 & 18  
October 6-7  
Silverstone

GT3 Cup Challenge  
October 6-7  
Silverstone

Rounds 19 & 20  
October 20-21  
Brands Hatch (GP)

**NOVEMBER**

S	M	T	W	T	F	S
				1	2	3
4	5	6	7	8	9	10
11	12	13	14	15	16	17
18	19	20	21	22	23	24
25	26	27	28	29	30	

**DECEMBER**

S	M	T	W	T	F	S
30	31					1
2	3	4	5	6	7	8
9	10	11	12	13	14	15
16	17	18	19	20	21	22
23	24	25	26	27	28	29



## Porsche GT3 Cup Challenge GB

The Porsche GT3 Cup Challenge is poised for an excellent season in 2012. Following development seasons in 2010 and 2011, the series is gathering strength and promises to deliver excellent value for money racing in 2012 when it will be managed directly by Porsche Cars GB, alongside the hugely successful Porsche Carrera Cup GB.

The series is open to any 911GT3 Cup car from 2009 or earlier. The series sits comfortably beneath the Carrera Cup GB, which will, as usual, be open to the latest model 911GT3 Cup car. There will be close links between the Carrera Cup GB and the new GT3 Cup Challenge and the series will share a race weekend at Silverstone in October when the GT3 Cup Challenge steps up to join the BTCC support programme for the first time.

The GT3 Cup Challenge, which is an established concept across the world, will have a six weekend, 12-race calendar and is designed to be perfect stepping stone for drivers aiming to graduate from track days as well as an ideal learning platform for drivers planning to move up to the Carrera Cup GB in subsequent seasons.

For more information on the launch of the GT3 Cup Challenge, please call 0118 916 5012 or email [gt3cupchallengegb@porsche.co.uk](mailto:gt3cupchallengegb@porsche.co.uk)

**PORSCHE**

**GT3 CUP  
CHALLENGE**  
GREAT BRITAIN