

**RUUKKI**

**Finnera™ roofing system**

**Installation instructions**







### The most intelligent roof ever seen.

Finnera's new and innovative design makes your steel roof not only beautiful but also extremely durable and practical. The revolutionary front-edge folding within the product maximizes weather resilience and enables an admirable seamless roof finish, even with modular sheet format. This means you get top quality in a fully standardized stock-ready package, making your whole roofing project as easy and fluent as possible. You have less to worry about, that is.

Finnera suits all kinds of roof construction needs. It is sold in installation-ready components straight from the warehouse, which makes your roofing project easier and faster. Finnera adapts to all roof shapes and sizes.



### Designed for demanding climates.

Our roofs are designed for demanding climates and withstand years of fluctuating conditions, from summer heat and autumn rains to ice-cold winter. By choosing Ruukki, the building will have a beautiful roof that lasts for decades.

A key advantage is our unique surface treatment, i.e. the color coating. The coating gives the surface unparalleled durability, effectively protecting it from corrosion due to humidity, and also ensures that the color will not fade due to the sun's UV radiation. We do not just say this; instead we openly assign a generous product warranty for aesthetic and functional performance.

### Contents

Finnera roofing system .....	4
Finnera technical specification .....	4
Finnera roofing system components .....	5
Delivery reception .....	6
Unloading and handling the delivery .....	6
Dimensioning .....	6
Work safety .....	6
Ordering the roof .....	7
Preparing the understructure .....	7
Lifting and laying out the sheets .....	8
Installation method and direction .....	9
Screwing .....	9
Planning the installation .....	10
Installing the sheets .....	10
Building roof valley .....	12
Flashings .....	14
Roof maintenance .....	15
Detailed drawings .....	16

The installation methods presented in the installation instructions are for guideline purposes. The required method of installation may vary slightly depending on the roof type or country of installation. For special instructions, updates and more installation tips visit our web site at [www.ruukkihome.com/finnera](http://www.ruukkihome.com/finnera).

For general installation instructions and guidance, follow the structural designer's instructions or contact our technical support department.





## Finnera roofing system



## Finnera technical specifications

### Product

Name	Finnera™
e-code	TS52-330-1140
Total height	52 mm
Length of pattern	330 mm
Total width	1190 mm
Total length	725 mm
Thickness	0.50 mm
Weight per piece	3.90 kg
Sales unit	pieces

Weight on roof	5.20 kg/m <sup>2</sup>
Area on roof	0.75 m <sup>2</sup> /pcs
Effective width	1140 mm
Effective length	660 mm

### Material

Hot galvanized steel sheet	SFS-EN 10326
Minimum zinc amount	275g/m <sup>2</sup>
Coated steel flat products	SFS-EN 10169-1 SFS-EN 10169-2

### Tolerances

Product	SFS-EN 508-1
Material	SFS-EN 10143

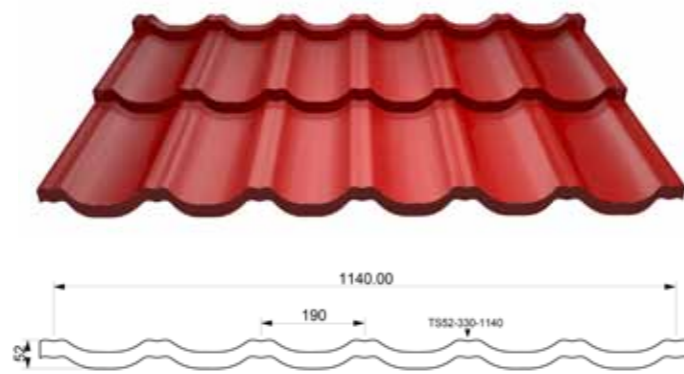

### Colours

	Red (RR29)
	Dark brown (RR32)
	Black (RR33)



## Finnera roofing system components

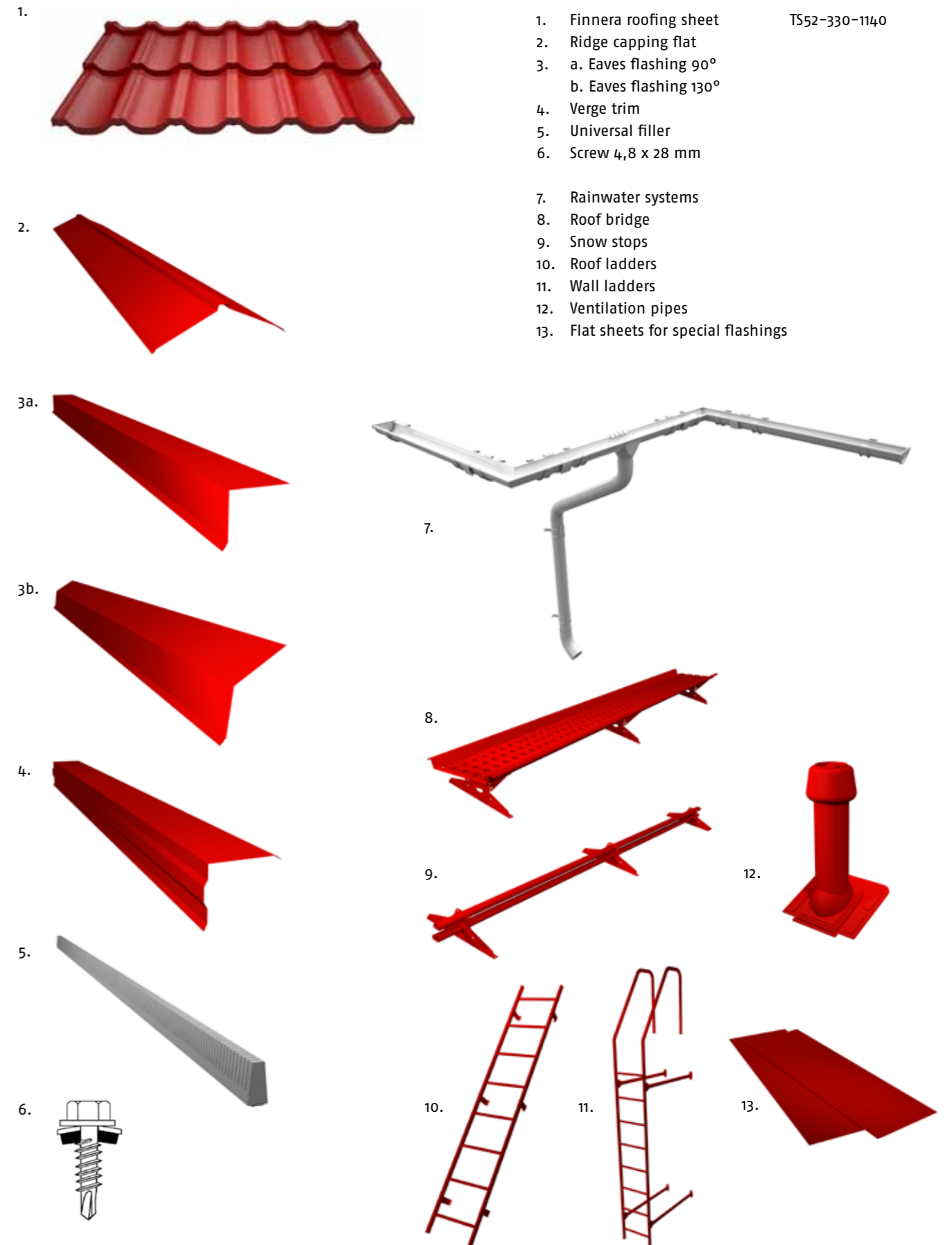

## Delivery reception

Ensure that the goods delivery is as ordered and features all the goods listed on the dispatch note. Any deficiencies, errors or transport damage must be recorded in the consignment note and reported immediately to Ruukki or the retailer.

Any claims regarding the delivery must be made within 8 days of the delivery. Ruukki accepts no liability for costs arising from the replacement of products installed in a manner other than that described in these instructions.

## Unloading and handling the delivery

Unload the roofing sheets from the delivery vehicle onto Euro pallets set on level ground. If Euro pallets are not available, place the sheets onto a supporting structure covered with plywood board or a similar level surface that is roughly equal in size to the roofing sheets.

When handling individual sheets, ensure that the sheets do not rub against each other, ideally by hanging them from their folded edge. Lift the sheets in stacks of three (N.B. three sheets weigh approx. 13 kg) when using scaffolds or ladders. Calculate the number of sheets needed for the roof pane you are installing and stack the sheets in piles on the roof pane. A hoist can also be used to lift the required sheets up to the roof pane.

In normal conditions, the roofing sheet stacks can be stored either packaged or unwrapped for about one month. For longer storage periods the stacks must be protected and placed on a sloping surface to allow any water between them to evaporate or drain off.

## Dimensioning

The roofing sheets come in standard sizes. For ridges, roof valleys, hipped roofs and lead-ins etc., the sheets need to be cut on site. Roofing sheets can be cut with a handheld circular saw suitable for cutting steel sheets, shears, nibbling machine, jigsaw or any other non-heat generating cutting device. Use of an angle grinder and cut-off disc for sheet cutting is strictly forbidden (doing so automatically voids the product warranty).

In addition to a hand-held circular saw with suitable blade and shears or nibbling machine, you will need at least one screw gun and a measuring tape. Protect the sheets before starting cutting work, as the sharp cuttings can damage the sheet surface. Any debris created by drilling or cutting during installation must be carefully brushed off. It is recommended that any scratches on the coating and any visible cut surfaces are painted with suitable touch-up paint.

## Work safety

Always wear work gloves and protective clothing when working on the sheets. Avoid contact with sharp cut edges and corners. Use the folded front edge of the sheet to get a good grip.

Do not walk beneath raised sheets or sheet packages. Ensure that the hoisting lines are in proper working order and suitable for the sheets' weight and that they are appropriately attached. Avoid handling the sheets during high winds. Observe utmost caution when moving and working on the roof. Use a safety rope and soft soled footwear and observe all valid safety regulations.

## Checking the roof measurements

Roofing sheets are installed at right angle (90 degrees) to the eaves. Before the installation, check how level the roof is, its cross-measure, and the straightness of the ridge and eaves. In problem situations, contact our technical support department.

## Ordering the roof

Finnera roofing comes in standard-sized pieces, which makes the material calculation, purchasing, transportation and installation processes easier compared to a cut-to-length system.

The number of sheets needed can be easily calculated using the three-step formula below. Alternatively, you can request your sales person to calculate the required amount for you based on the measurements taken from your structural drawings, or based on a simplified drawing showing the relevant key measurements. For automatic calculator, see [www.ruukkihome.com/finnera](http://www.ruukkihome.com/finnera)

Required number of Finnera pieces horizontally (X)  
1.  $(\text{Width} - 50 \text{ mm}) / 1140 \text{ mm} = X$  pieces horizontally (round up to the nearest whole number - use this figure in step 3 of the formula)

Required number of Finnera pieces vertically (Y)  
2.  $\text{Length} / 658 \text{ mm} = Y$  pieces vertically (round up to the nearest whole number - use this figure in step 3 of the formula)

3.  $X \times Y = \text{Total number of Finnera pieces for the roof pane}$

N.B. Extra sheet pieces may be left over due to rounding up.

For the required amounts of flashing and other accessories, contact your sales person. To make the calculations the sales person will need the basic measurements, primarily the ridge/eave (W) and verge (L) lengths.

## Preparing the understructure

### Roofing underlay

Begin installing the underlay horizontally from the eaves, over the roof trusses. The underlay should extend at least 200 mm beyond the wall at the eaves and the verge. Staple the underlay onto the roof trusses, and then finish the fixing by nailing wooden strips, e.g. 22 x 50 mm (needed to ensure ventilation), on top of the underlay in the direction of the roof trusses. Leave the roofing underlay hanging loose between the roof trusses.

At the ridge, install the underlay according to the installation instructions specified in the detailed drawings. In case of problems, contact the structural designer regarding the specific ridge design.

The underlay sheets should overlap by about 150 mm at the horizontal joint. If the underlay must be extended lengthways, this must be done at the roof trusses with a minimum overlap of 100 mm.

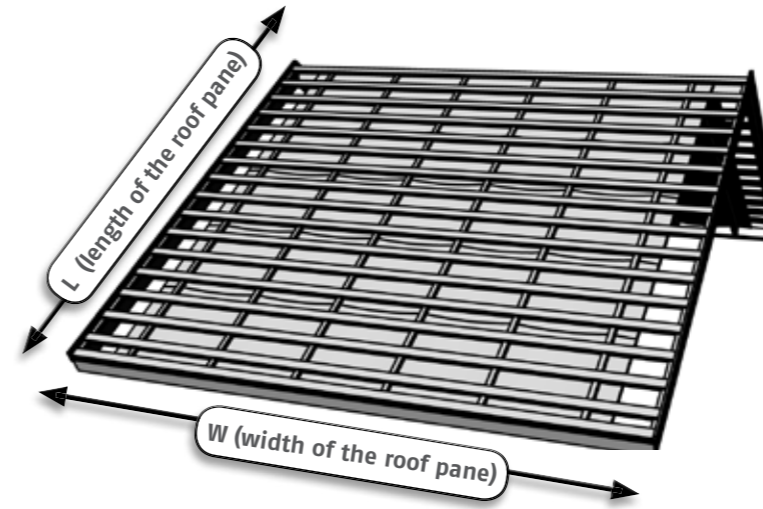

### Needed Finnera pieces - Example calculation:

W (width of the roof pane) = 10 000 mm

L (length of the roof pane) = 4 500 mm

1.  $(10\,000 \text{ mm} - 50 \text{ mm}) / 1140 \text{ mm} = 8,728 = 9$  pieces after rounding up
2.  $4500 \text{ mm} / 658 \text{ mm} = 6,838 = 7$  pieces after rounding up
3.  $9 \times 7 = 63$  pieces of Finnera for the roof pane

### Formula:

1.  $(\text{Width} - 50 \text{ mm}) / 1140 \text{ mm} = X$

2.  $\text{Length} / 658 \text{ mm} = Y$

3.  $X \times Y = \text{Total number of Finnera pieces for the roof pane}$

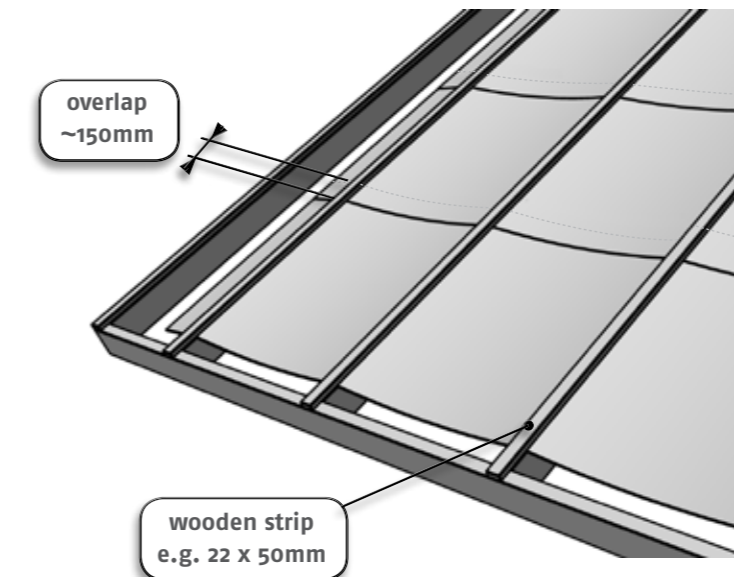



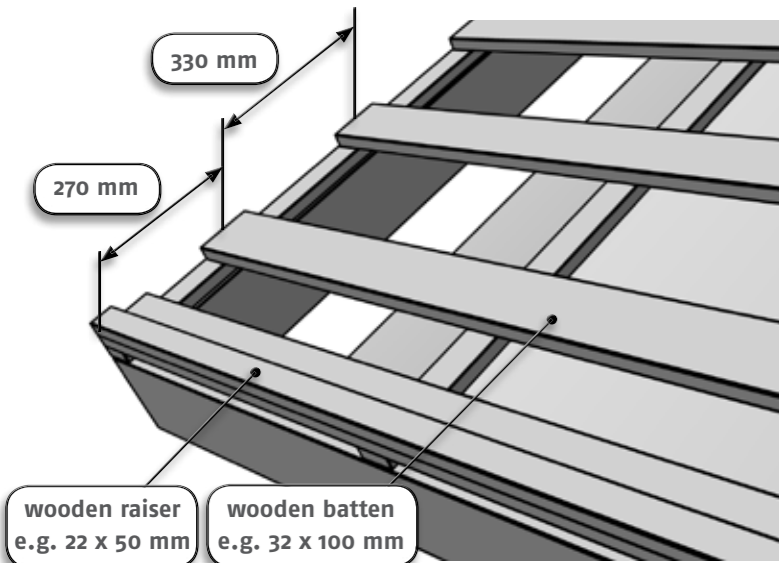

#### Battening and wooden raiser

With a roof truss spacing of 900 or 1200 mm, 32 x 100 mm wooden battens will suffice. To verify the correct batten thickness, contact your structural designer.

When using Finnera roofing sheets, install a wooden raiser (e.g. 22 x 50 mm) above the lowest roofing batten. Correct alignment of the raiser can be ensured, e.g., by marking a straight line along the eaves using a stringline.

Begin installing the roofing sheet battens on the eave where the roofing is to be installed first. This is important if the eaves are staggered and pattern adjustment must be taken into consideration.

The distance from the outer edge of the fascia boards to the centre of the second batten is 270 mm. The distance between the remaining battening boards is c/c 330 mm.

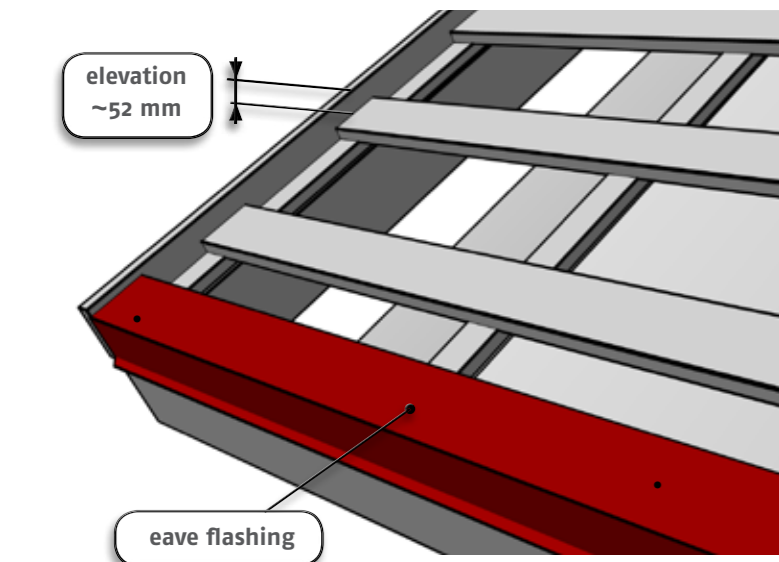

#### Installation of fascia boards

With Finnera roofing sheets, the bargeboards should be positioned level with the height of the profile above the roofing battens. The verge trims will be fastened to the bargeboards.

Bargeboard top edge elevation above the roofing battens: approx. 52 mm

#### Installation - Eave flashing

Install the eave flashings before installing the roofing sheets. Align the flashing with the eave line and fix it to the first battening board with galvanised nails. Install the eave flashing end-to-end, not overlapped.

#### Lifting and laying out the sheets

Use the folded front edge of the sheet to get a good grip and avoid sharp corners. Lift the sheets in stacks of three (N.B. three sheets weigh approx. 13 kg) when using scaffolds or ladders. Calculate the number of sheets needed for the roof pane you are installing and stack the sheets in piles on the roof pane. A hoist can also be used to lift the required sheets up to the roof pane.

N.B. Secure the sheets when piling on the roof pane. Unsecured sheets are major work safety risk. Falling sheets may cause serious damage.

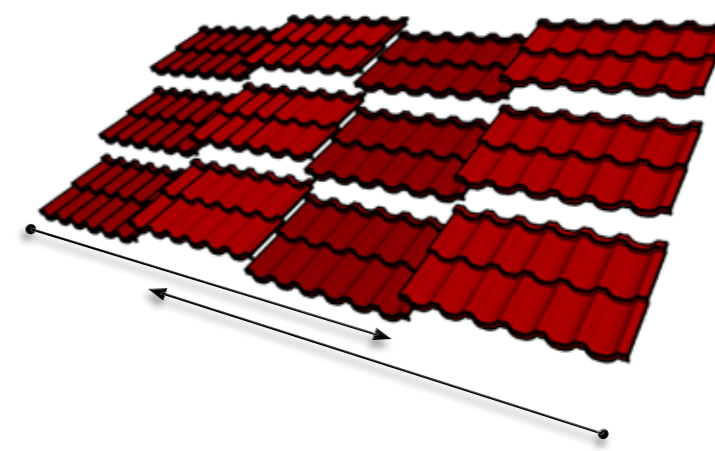

#### Installation method and direction

Starting from the eaves and working towards the ridge, lay the sheets row-by-row, overlapping the sheets alternately above and below each other (above-below-above-below).

The sheets can be laid horizontally either left-to-right or right-to-left. Wherever possible, installation should start from the eaves and proceed towards the ridge.

#### Screwing

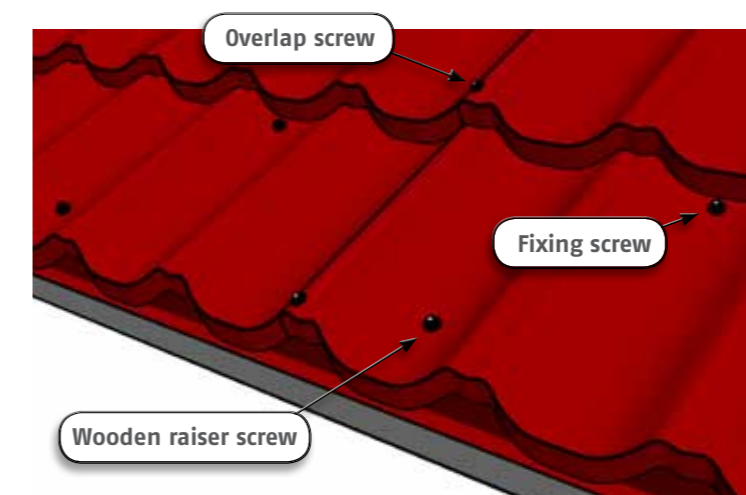

#### Fixing the sheets

Screw the Finnera sheets to the battening at the lowest point of the wave profile, just below the lateral raised edges of the sheet. With wooden battening, use 4.8 x 28 mm self-drilling screws.

At the overlap joint, fix the sheets together with the same self-drilling screws at the highest point of the profile, just above the raised lateral edges of the sheet. Then fasten an additional overlap screw in the middle of the sheet, just above the raised lateral edge. Alternatively, the overlap screws can be fastened at an angle through the raised lateral edge to conceal the screw heads and achieve a more pleasant visual appearance.

Fasten the first row of sheets through eaves flashing to the wooden raiser on the eaves.

The instructions for laying and fixing the sheets take into account possible wind uplift on the sheet edges, thermal movement, and the tightness and appearance of the sheet joints.

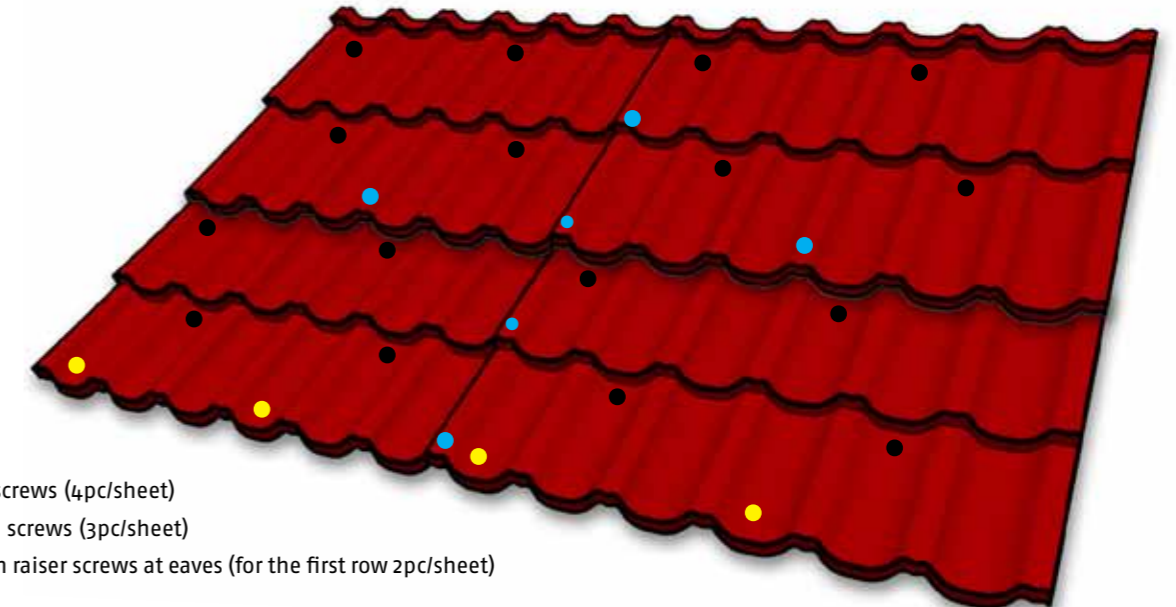

- Fixing screws (4pc/sheet)
- Overlap screws (3pc/sheet)
- Wooden raiser screws at eaves (for the first row 2pc/sheet)



## Planning the installation

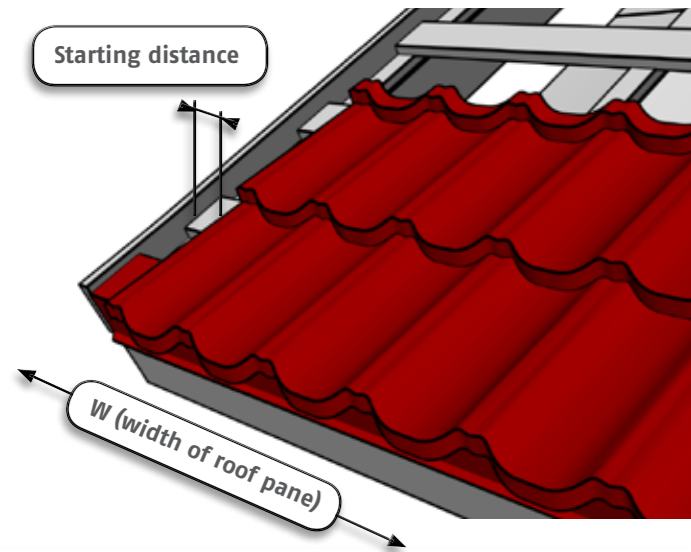

Before starting the sheet installation, calculate the exact starting point for the first sheet using the two-step formula below. This eliminates the need to trim the last sheet in the row. The formula gives the distance from the verge at which the first sheet of the row should be installed. The last sheet at the end of the row is then overlapped by the necessary number of waves to achieve a correct fit. N.B. When starting the installation, leave some free space beneath the verge trim. For automatic calculator, see [www.ruukkihome.com/finnera](http://www.ruukkihome.com/finnera)

1.  $(\text{Width} - 50 \text{ mm}) / 190 \text{ mm} = A$   
(Round down to the nearest whole number - use this figure in step 2 of the formula)
2.  $((\text{Width} - 50 \text{ mm}) / 190 \text{ mm} - A) \times 95 \text{ mm} = B$   
(B=Starting distance from the verge)  
(N.B. Same distance also at the end of the pane)

The sheets are symmetrical and can be overlapped above and below each other by one or more wave pattern lengths.

### Starting distance from verge - example calculation: W (width of the roof pane) = 10 000 mm

1.  $(10\,000 \text{ mm} - 50 \text{ mm}) / 190 \text{ mm} = 52,368 = 52$  after rounding down
2.  $((10\,000 \text{ mm} - 50 \text{ mm}) / 190 \text{ mm} - 52) \times 95 \text{ mm} = 35 \text{ mm}$   
Start installation 35 mm distance from verge.

### Formula:

1.  $(\text{Width} - 50 \text{ mm}) / 190 \text{ mm} = A$
2.  $((\text{Width} - 50 \text{ mm}) / 190 \text{ mm} - A) \times 95 \text{ mm} = B = \text{Starting distance from the verge}$

## Installing the sheets

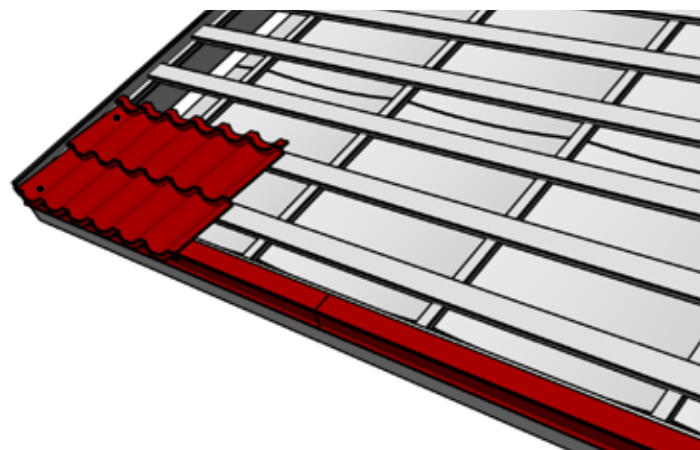

At the side where you are starting the roofing, fasten the first sheet in place, leaving a sufficient overhang over the eave (approx. 40-45 mm).

Fix the sheet through eaves flashing onto the wooden raiser and temporarily fasten the top left-hand corner with a single screw.

N.B. Install the first sheet at the starting point, i.e. the distance from the verge determined by the starting distance formula.

Lay the second sheet alongside the first so that the sheets overlap by one wave pattern length. Fasten the overlapping edge of the second sheet in place with screws at the top of the wave, just above the two raised lateral edges of the sheet.

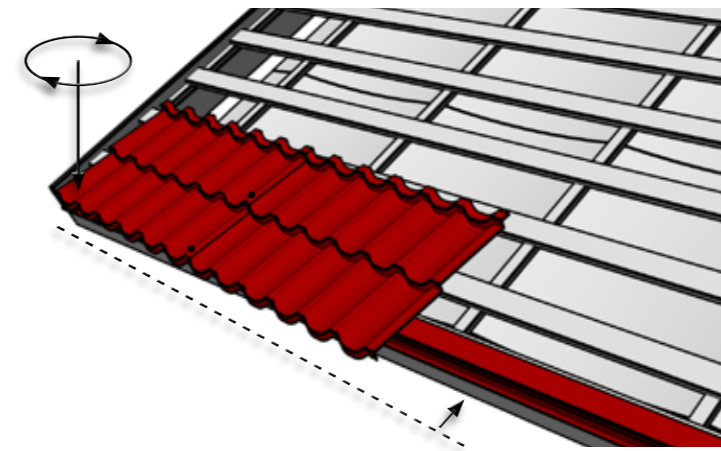
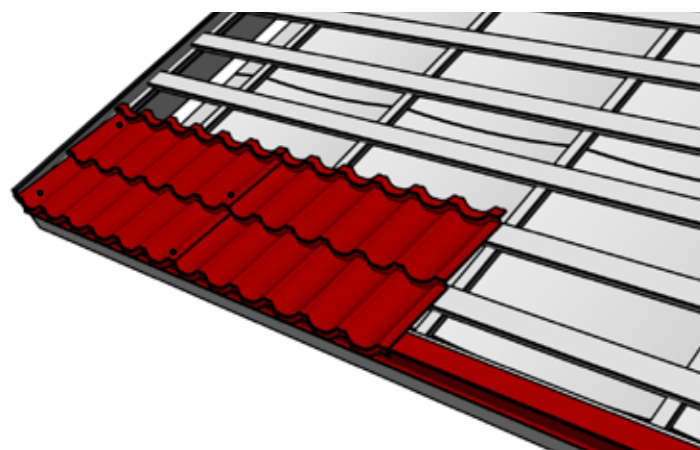

Remove the screw from the top left-hand corner and align the sheets with the eave. The length over the eave should be equal (approx. 40-45 mm).

Fix the first sheet according to the screwing instructions (p.9).

Lift the other side of the second sheet up slightly and slide the third sheet into place so that the second sheet overlaps the third sheet by one wave pattern.

Fix the second overlapping edge at the top of the wave, above the sheet's two lateral raised edges.

Continue the row installation as described (above-below-above-below).

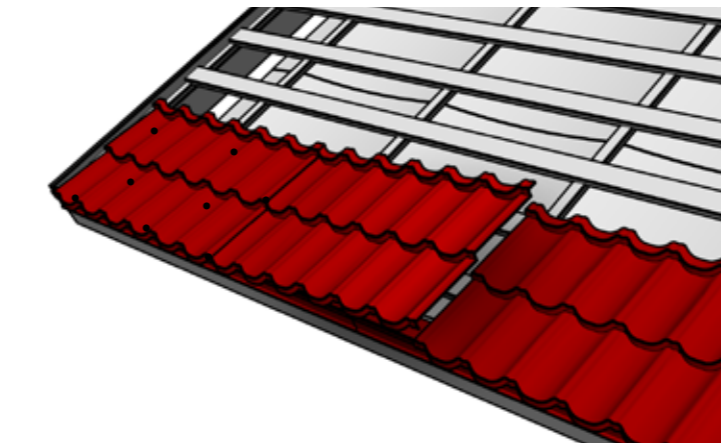

At the end of the row, overlap the last sheet by the number of wave patterns needed to make the verge. If you used the starting distance formula, the distance from the last sheet to the verge is the same as the starting distance for the first sheet at the beginning of the row.

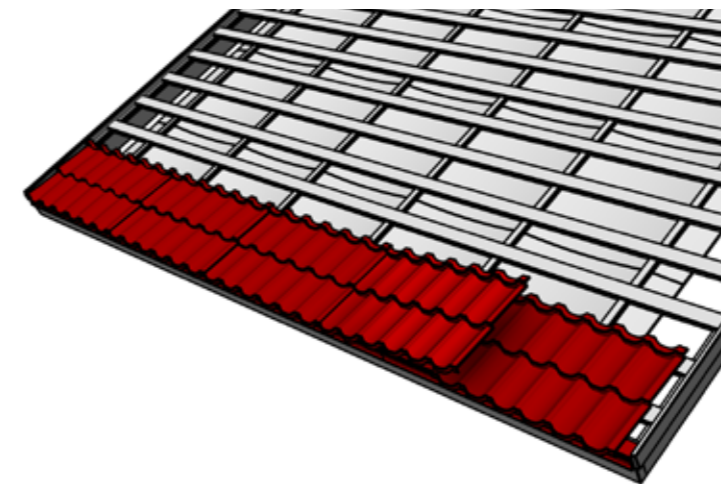

Continue the installation as described (above-below-above-below) row-by-row, working upwards from the eaves to the ridge.

Brush off any cutting and drilling debris from the finished roof pane using a soft brush. Carry out touch-up painting as necessary.

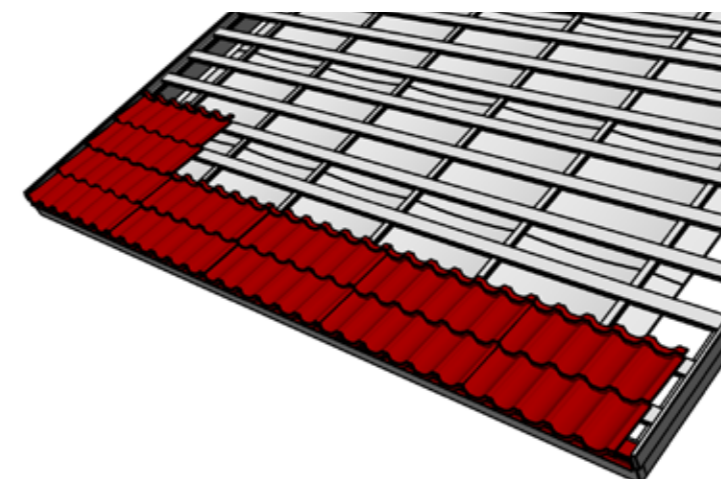



## Building roof valley

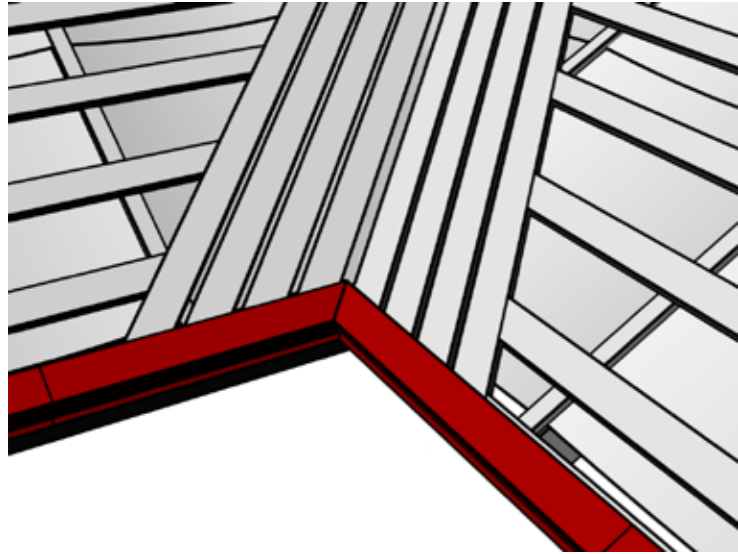

Lay the base boards for roof valleys level with the roof pane battening. Leave ventilation gaps of approx. 20 mm between the roof valley boards.

Install a wooden raiser on top of the first batten and valley boards at the eaves.

Cut the eave flashing to shape and install it in the corner of the roof valley.

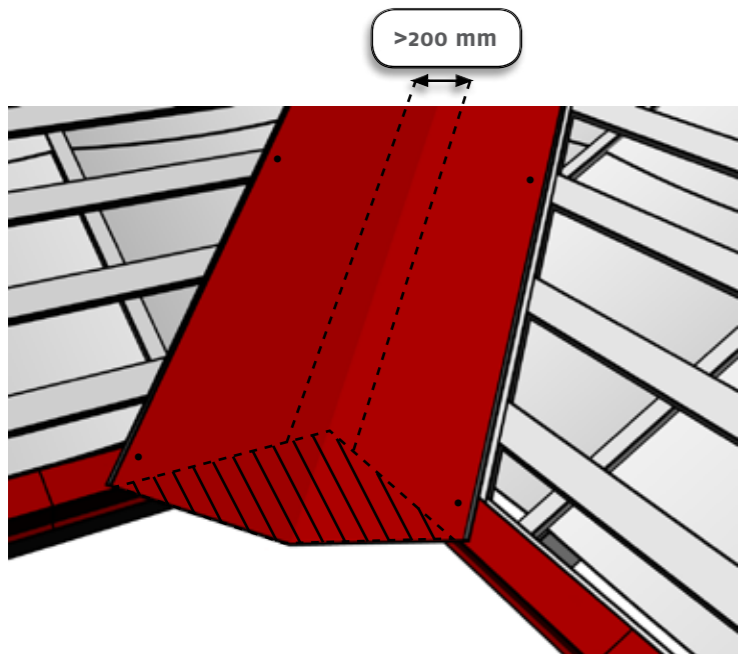

Fit the angled roof valley sheet in place. Fasten the sheet in place with galvanised nails. The angled roof valley sheet should have an overlap of at least 200 mm at the joints. The use of sealing compound to seal the overlap is recommended.

Cut and shape the bottom end of the roof valley sheet according to the alignment of the eaves.

Draw guide lines on the roof valley sheet to show the alignment of the sheets along the roof valley.

The minimum distance between the guide lines (indicating the position of the roofing sheets) must be at least 200 mm. The angled roof valley sheet must extend at least 250 mm beneath the roofing sheets.

Apply universal filler to the roof valley sheet: remove the cover tape from the universal filler and apply it about 30 mm from the guide lines in the edge direction of the valley sheet.

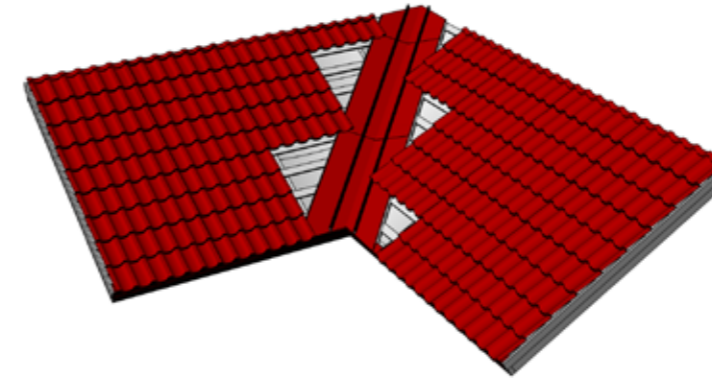
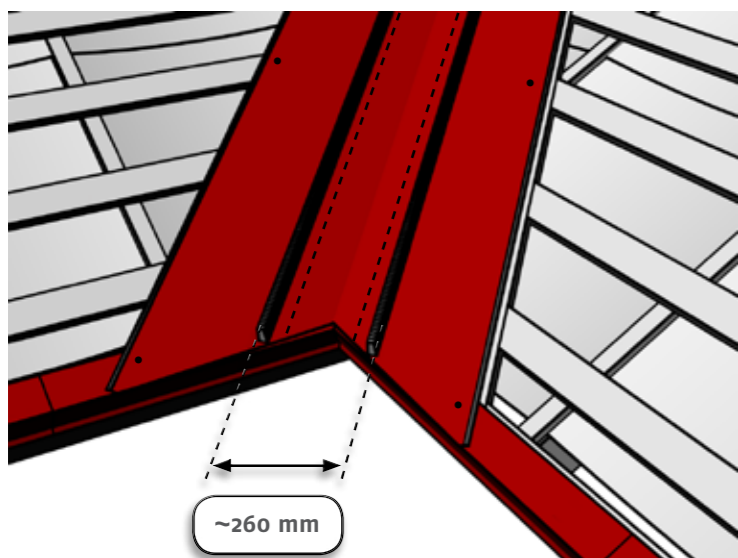

Lay the full-size roofing sheets. Leave the sheets that require cutting uninstalled at this stage.

N.B. Do not fully fasten the roofing sheets along the valley yet. Fasten the sheets fully in place only after the cut sheets have been installed along the valley.

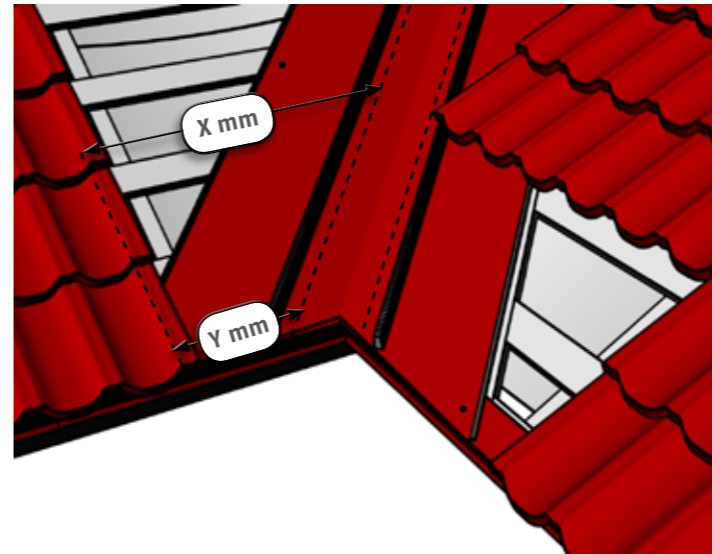

Measure the space for the roofing sheet. Measure from the guide line to where the roofing sheet overlap ends.

Measure the widths from two points: from lowest point of the sheet (Y) and the highest point of the sheet (X).

Draw the measured cutting line onto the roofing sheet.

Cut the sheet.

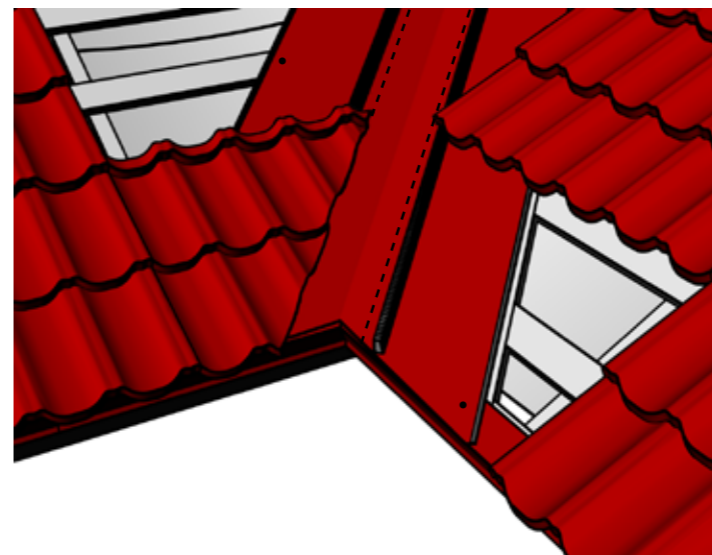

Install the cut roofing sheets up to the top of the roof valley, making sure as you proceed that the angle of the roof valley follows the drawn guide line.

Fix the roofing sheets installed along the roof valley in place with self drilling screws.

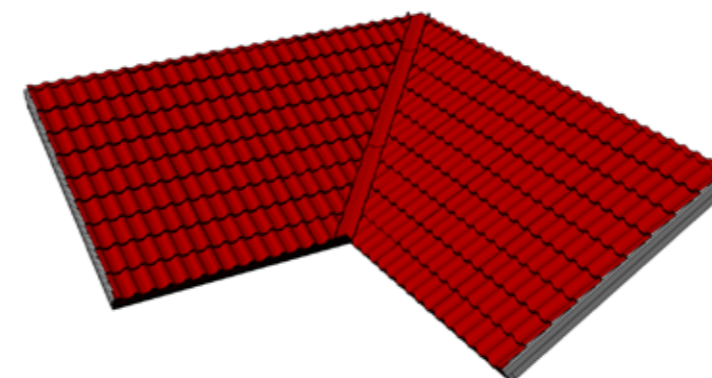

Brush off any cutting and drilling debris from the finished roof pane using a soft brush. Carry out touch-up painting as necessary.

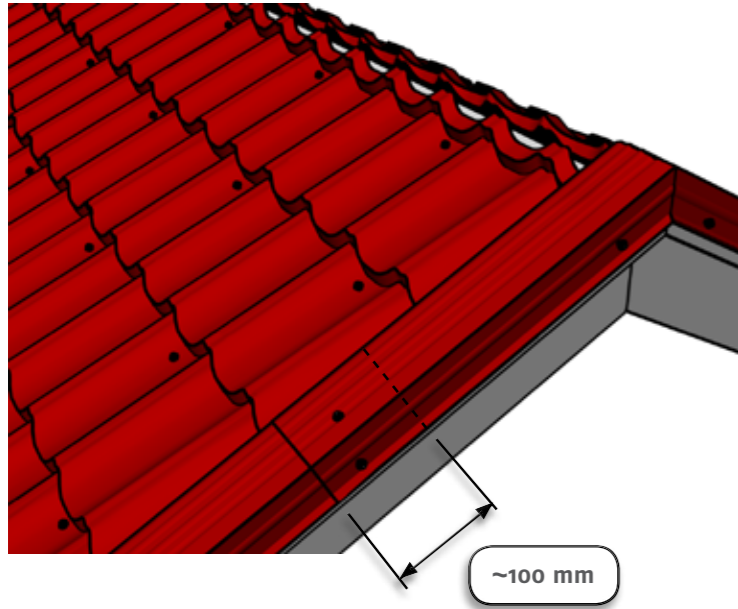

#### Verge trim

Install the verge trims from the eaves upwards. Trim off any extra length at the ridge. Fix the trims to the fascia boards and from above to the roofing sheets with self-drilling screws at approx. 1000 mm screw spacing. Overlap the verge trims by at least 100 mm.

N.B. The verge trim must extend over the first pattern profile of the roofing sheet. Use the formula to calculate the starting distance at the beginning of the installation.

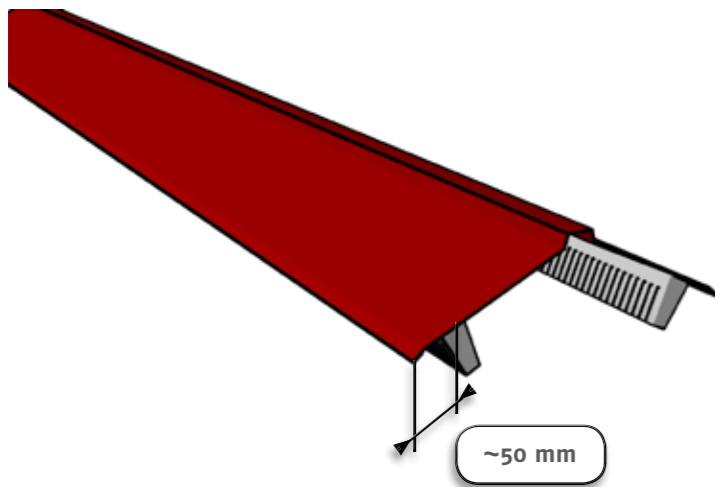

#### Ridge filler

Apply universal filler to the ridge capping before fixing the capping to the roof. Remove the cover tape from the universal filler and apply the filler under the ridge capping about 50 mm from the edge in the ridge direction.

N.B. It is not recommended to fix screws through the filler.

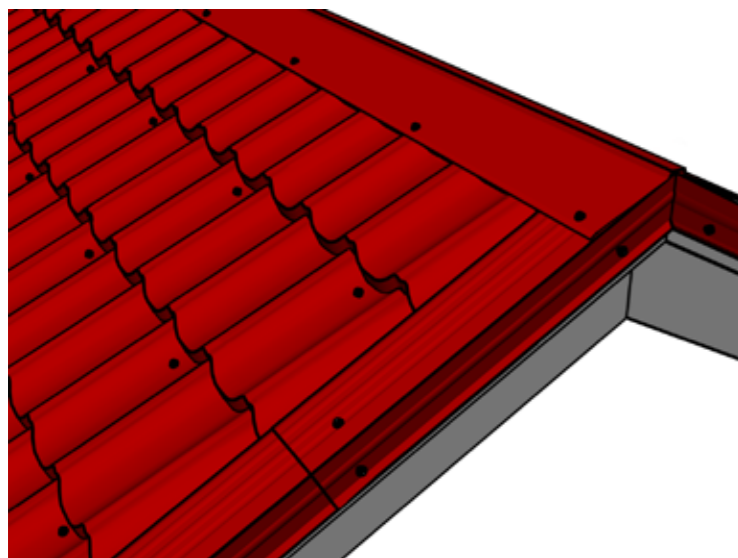

#### Ridge capping

Fix the ridge capping to the roofing sheets at every third wave with self-drilling screws. The ridge cap overlap must be at least 100 mm.

#### Annual maintenance

To ensure optimal condition and a long service life, the roof condition should be inspected regularly. Under normal conditions the surface will be kept sufficiently clean by rainfall, although any fallen leaves, twigs etc. not washed away by rainwater should be cleared from the roof on an annual basis. Roof valleys and rainwater systems also require annual cleaning.

#### Cleaning

Dirt and stains can be washed off with a soft brush and water. Pressure washers (up to 50 bar) may also be used. More persistent dirt can be cleaned using a detergent intended for cleaning painted surfaces. Follow the detergent's usage instructions or contact the product manufacturer to verify its suitability. Persistent localised stains can be rubbed off with a cloth dipped in white spirit. The paint coating should be rinsed from the top down to ensure all detergent is removed. Finally, flush the rainwater systems through with water.

#### Removal of snow

Snow will not typically accumulate on the painted roof or exceed the roof's structural load capacity. However, if snow removal is required, a layer of snow (~100 mm) is recommended to be left on the roof to protect the coating during snow removal.

- **Check the following annually**

The ventilation of roof structures still works  
 Condition and fixings of rainwater systems  
 Condition and fixings of roof safety products  
 Condition, tightness and fixings of lead-ins  
 Condition of seals  
 Condition and fixing of screws  
 Condition of paintwork on roofing sheets and flashing

- **When necessary**

Clean the roof  
 Remove snow  
 Remove leaves, twigs etc



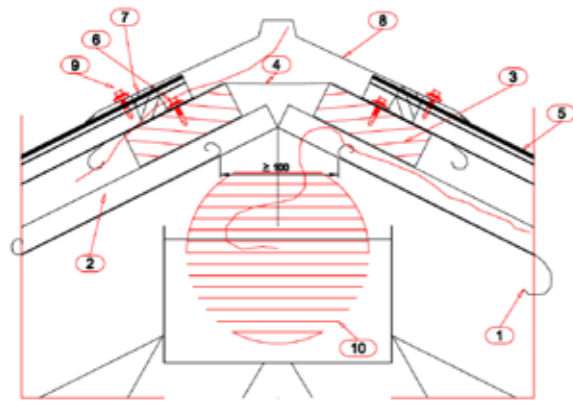

## Ridge

1. Roofing underlay (ventilation gap at ridge  $\geq 100$  mm)
2. Wooden strip, e.g. 22 x 50 mm
3. Batten, e.g. 32 x 100 mm
4. Roofing underlay strip, width  $\sim 400$  mm
5. Finnera roofing sheet
6. Screw
7. Universal filler
8. Ridge capping flat
9. Screw (to every third wave)
10. Ventilation (if needed)

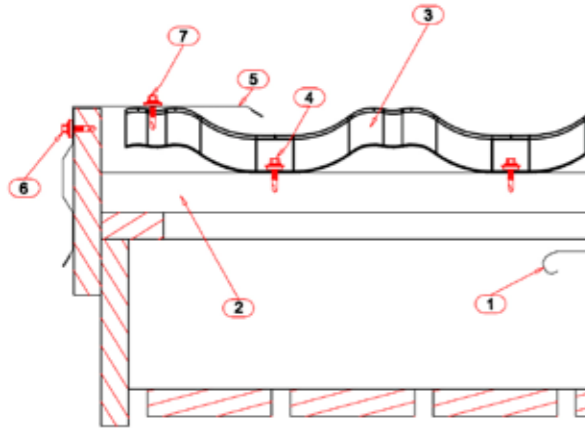

## Verge

1. Roofing underlay
2. Batten, e.g. 32 x 100 mm
3. Finnera roofing sheet
4. Screw
5. Verge trim
6. Screw (to every  $\sim 1000$  mm)
7. Screw (to every  $\sim 300 - 800$  mm)

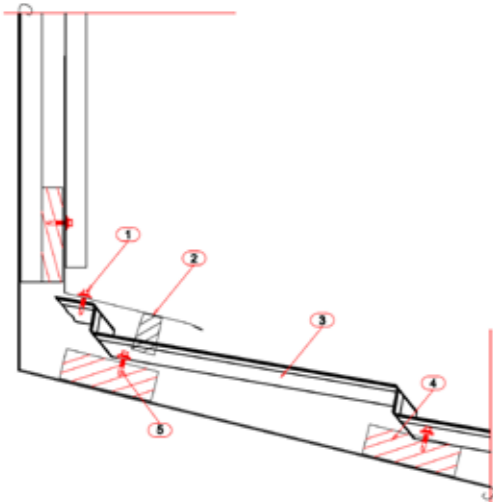

## Roof-to-wall intersection, end wall

1. Joint flashing
2. Universal filler
3. Finnera roofing sheet
4. Batten, e.g. 32 x 100 mm
5. Screw
6. Roofing underlay

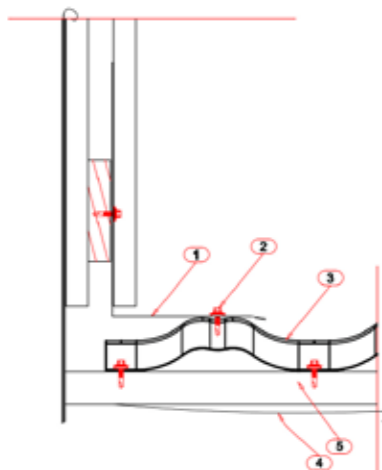

## Roof-to-wall intersection, sidewall

1. Joint flashing
2. Screw
3. Finnera roofing sheet
4. Roofing underlay
5. Batten, e.g. 32 x 100 mm

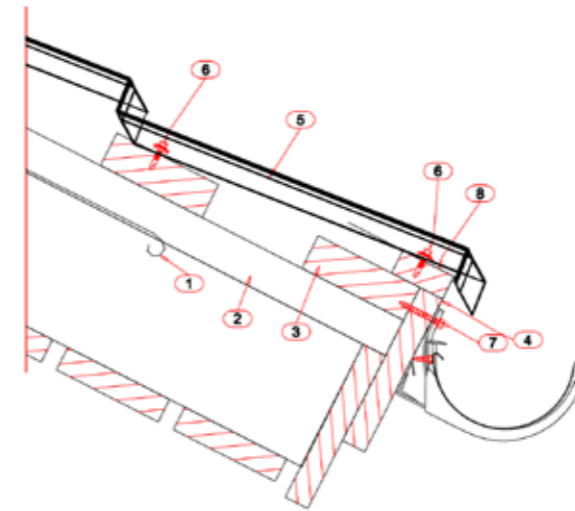

## Eaves

1. Roofing underlay
2. Wooden strip, e.g. 22 x 50 mm
3. Batten, e.g. 32 x 100 mm
4. Eaves flashing
5. Finnera roofing sheet
6. Screw (for Finnera)
7. Screw (for gutter bracket)
8. Wooden raiser, e.g. 22 x 50 mm

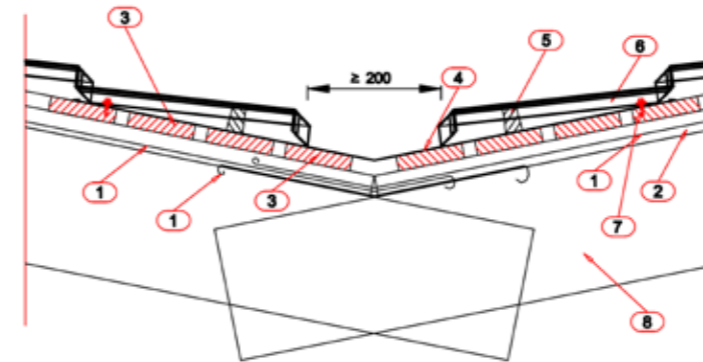

## Roof valley

1. Roofing underlay (Lowest strip of underlay parallel with roof valley, underlays from pane of roof over it overlapped)
2. Wooden strip, e.g. 22 x 50 mm
3. Roof valley boarding, e.g. 32 x 100 mm
4. Valley flashing
5. Universal filler
6. Finnera roofing sheet
7. Screw
8. Roof rails

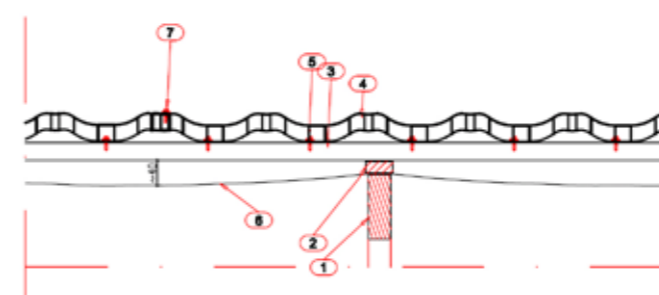

## Intersection, vertical detail

1. Roof rail
2. Wooden strip, e.g. 22 x 50 mm
3. Batten, e.g. 32 x 100 mm
4. Finnera roofing sheet
5. Screw
6. Roofing underlay
7. Overlap screw

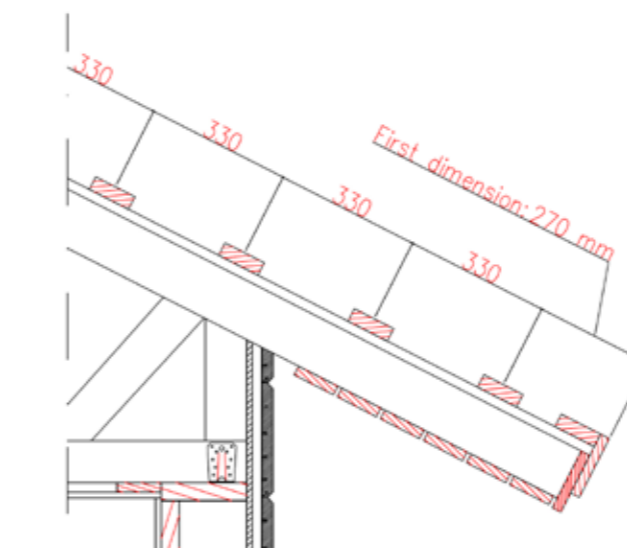

## Battening

- The distance from fascia boards outer surface to the middle of second batten is 270 mm.
- The distance between rest of the battening boards is c/c 330 mm



