



PEUGEOT

NOT : 2867

Réf. : 16 118 643 80

308 Berline
(T91)

308 SW
(T92)

FR NOTICE DE POSE A USAGE PROFESSIONNEL / LES PHOTOS ET LES DESSINS NE SONT PAS CONTRACTUELS
 GB FITTING INSTRUCTIONS FOR PROFESSIONAL FITTERS / THE PHOTOGRAPHS AND THE DRAWINGS ARE NOT CONTRACTUAL
 ES INSTRUCCIONES DE MONTAJE PARA USO PROFESIONAL / LAS FOTOGRAFÍAS Y LOS DIBUJOS NO SON CONTRACTUALES
 P MANUAL DE MONTAGEM PARA UTILIZAÇÃO PROFISSIONAL / AS FOTOGRAFIAS E OS DESENHOS NÃO SÃO CONTRATUAIS
 DE MONTAGEANLEITUNG FÜR PROFESSIONNELLEN EINSATZ / DIE FOTOS UND DIE ZEICHNUNGEN SIND NICHT VERTRAGLICH
 IT ISTRUZIONI DI POSA AD USO PROFESSIONALE / LE FOTOGRAFIE ED I DISEGNI NON SONO CONTRATTUALI
 NL MONTAGEHANDLEIDING VOOR PROFESSIONEEL GEBRUIK / DE FOTO'S EN DE TEKENINGEN ZIJN NIET CONTRACTUEEL

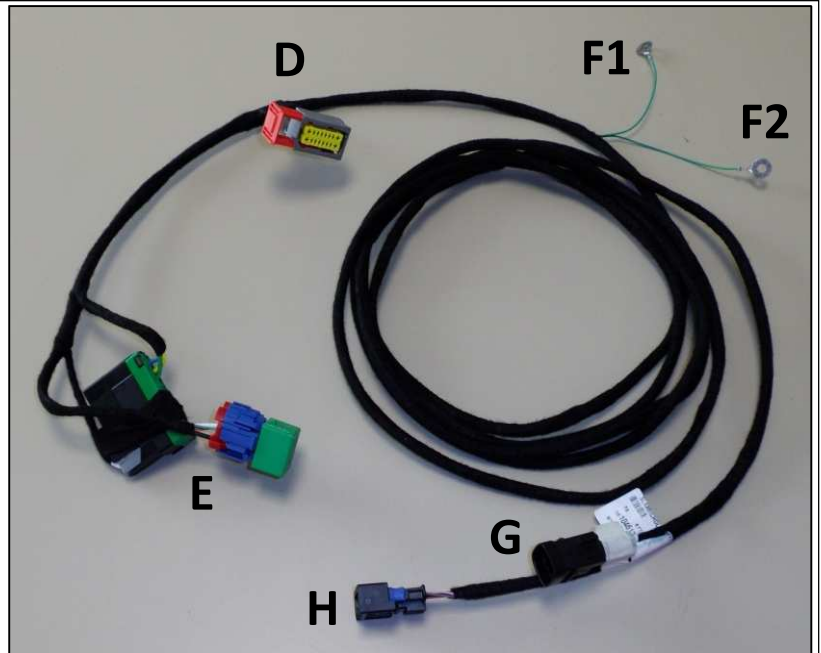

K: 9665524180

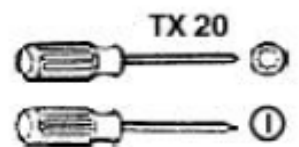
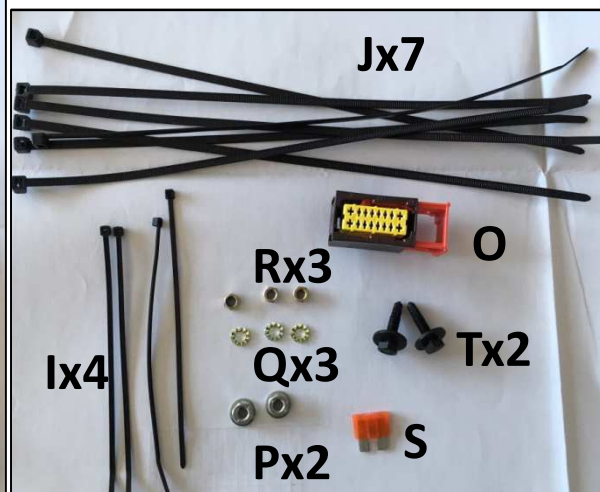
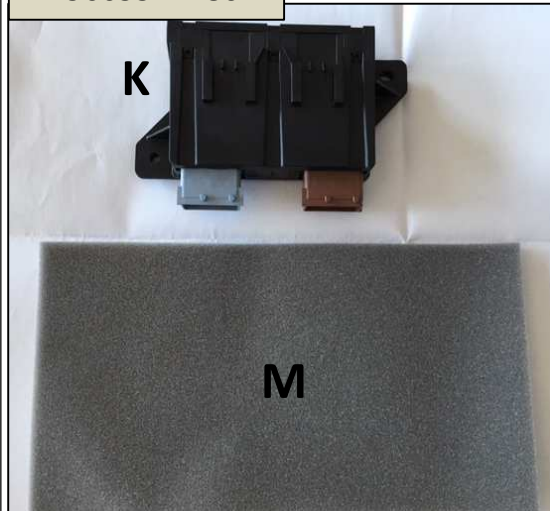



T91 – T92

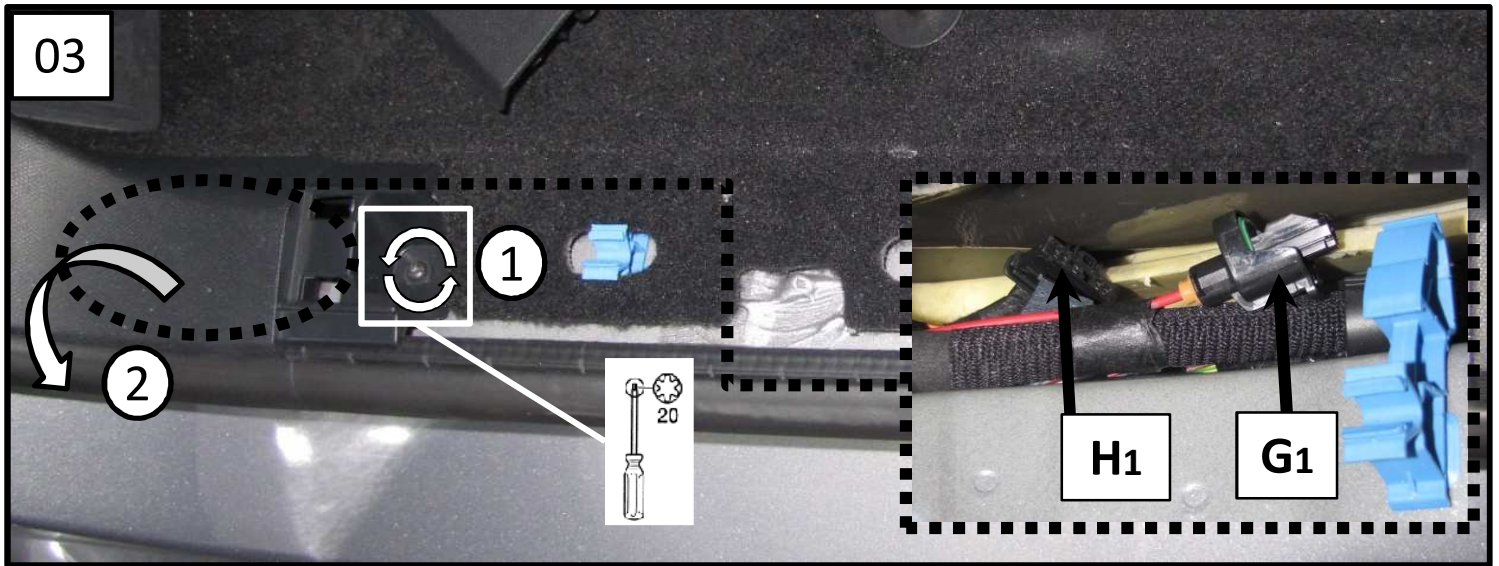
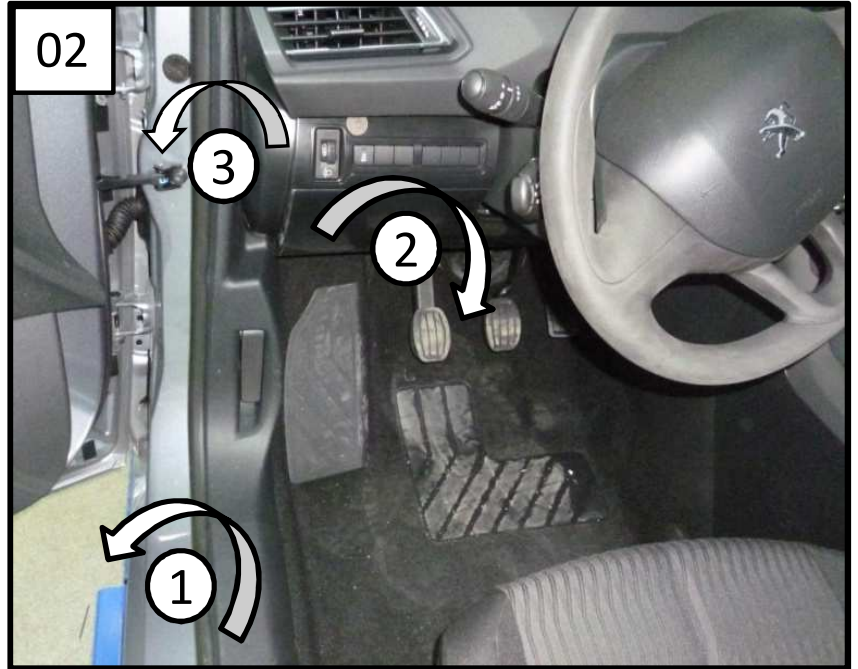
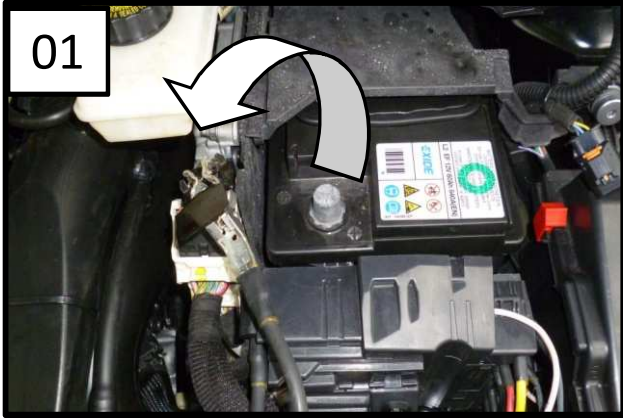

T91 – T92

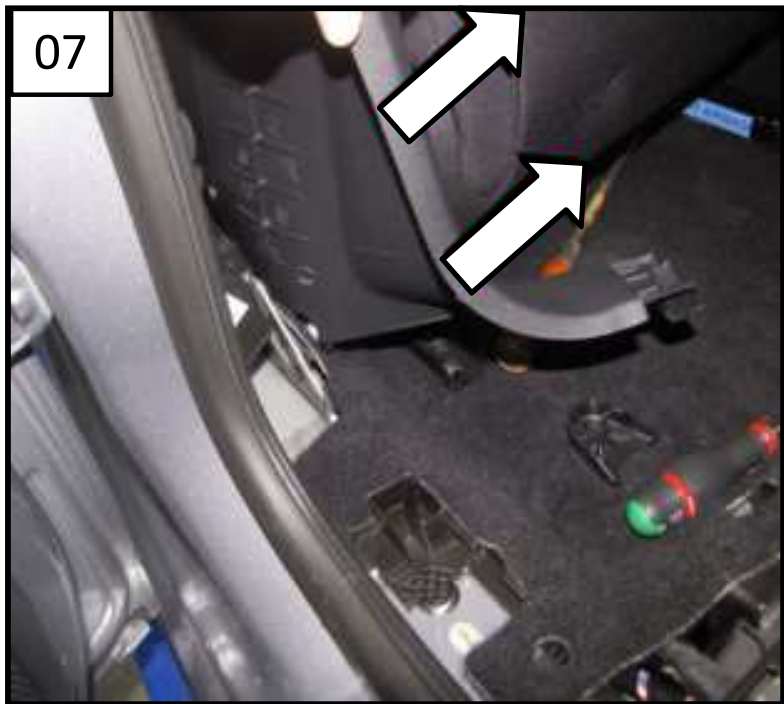
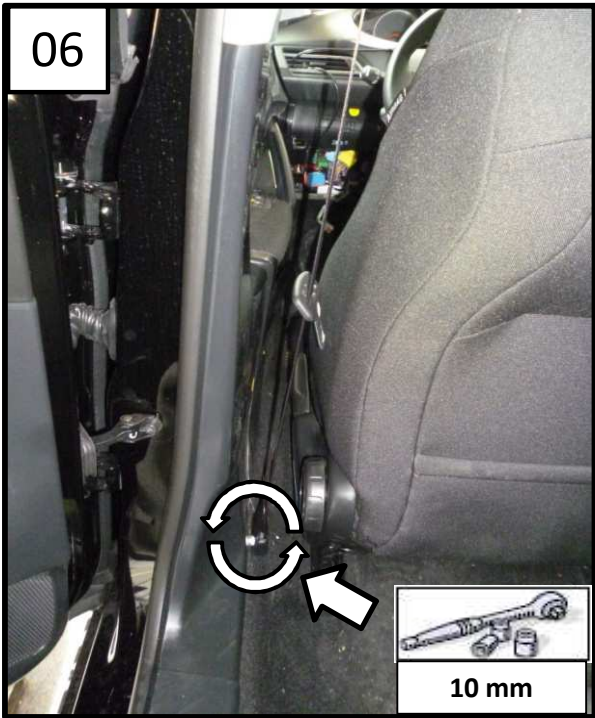

T91

T92   p26 08a

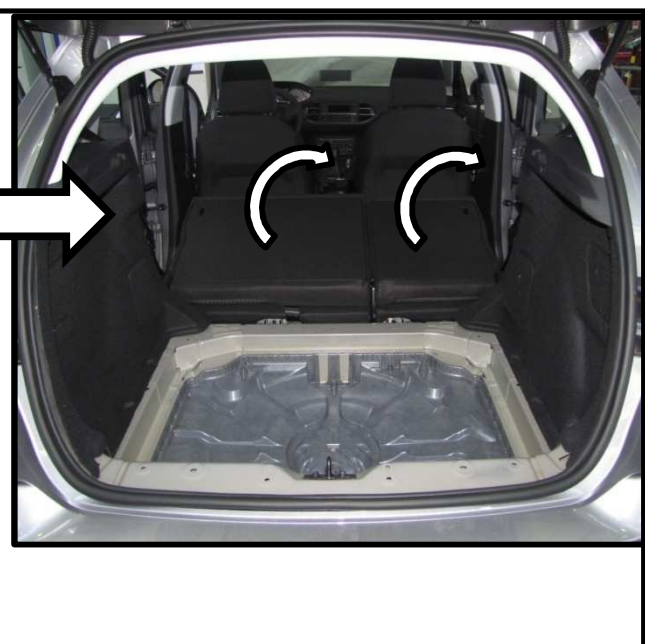
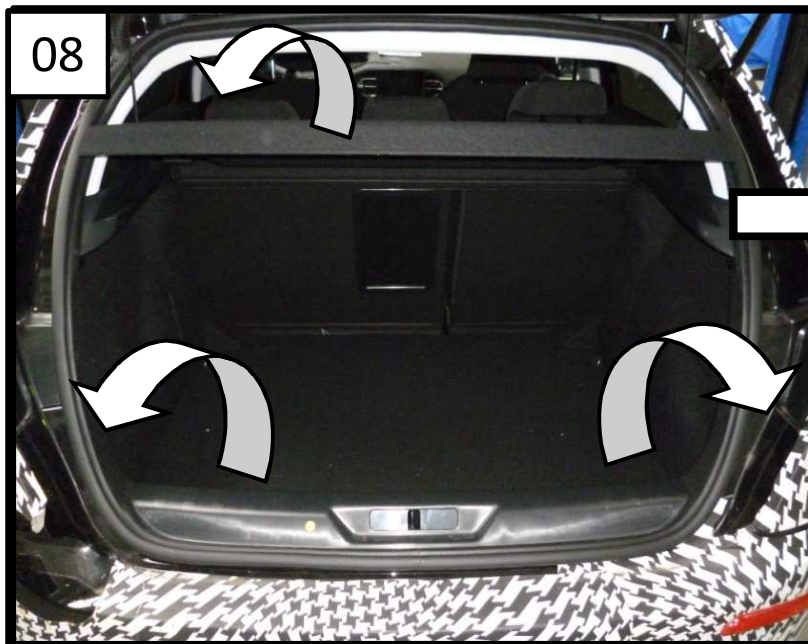

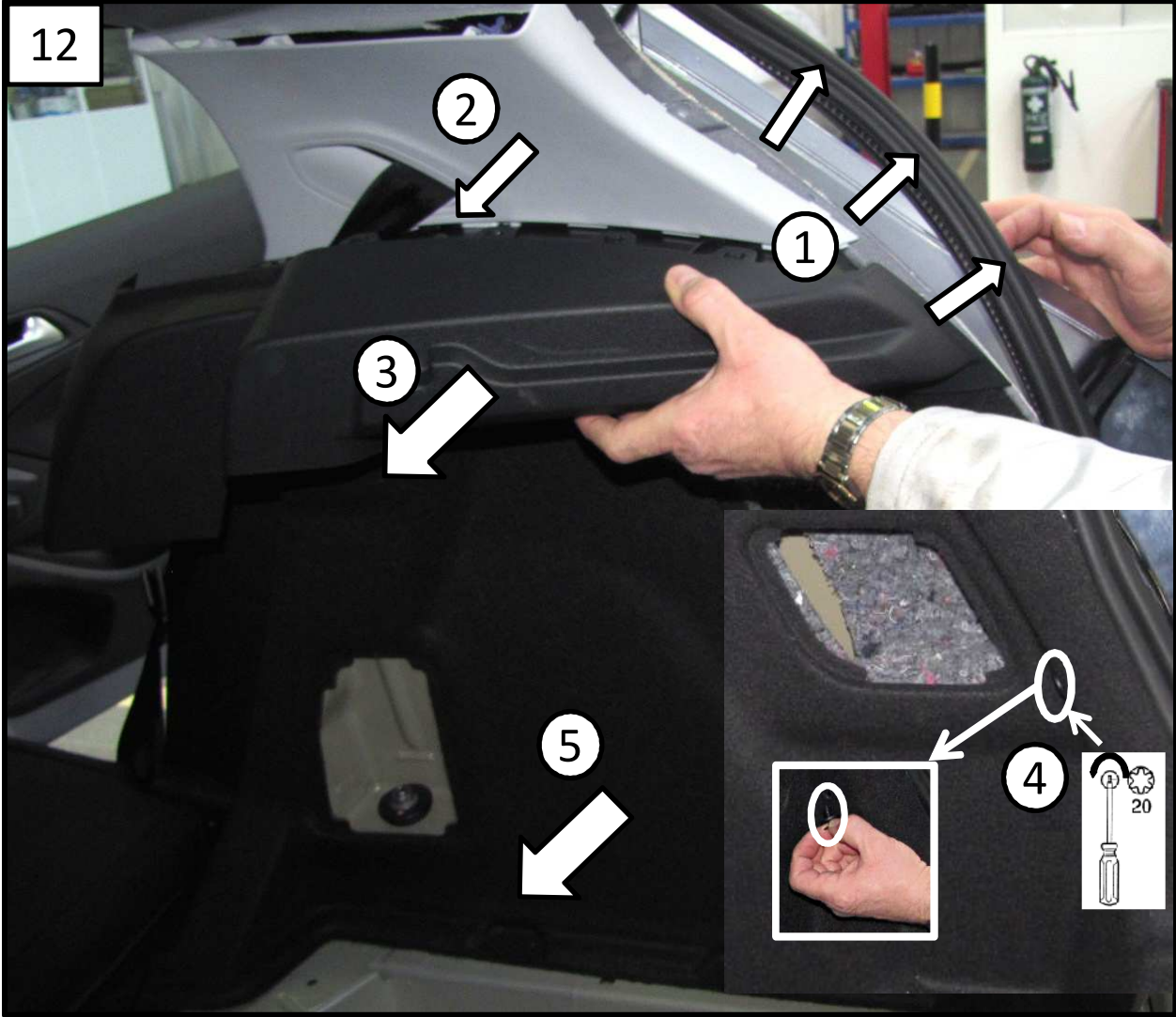
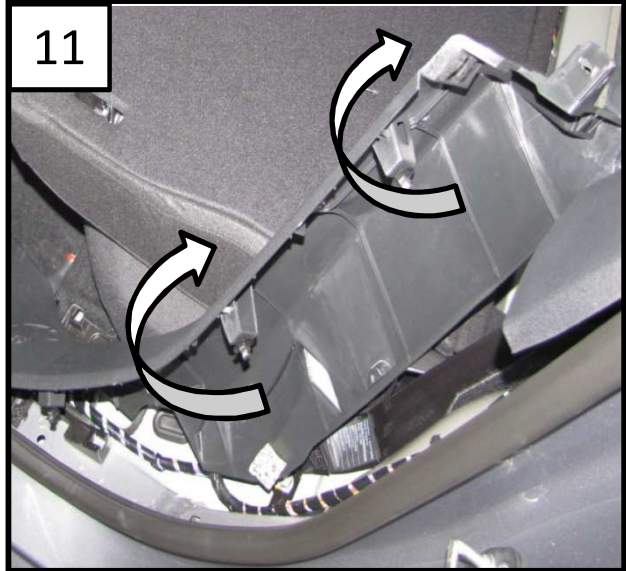
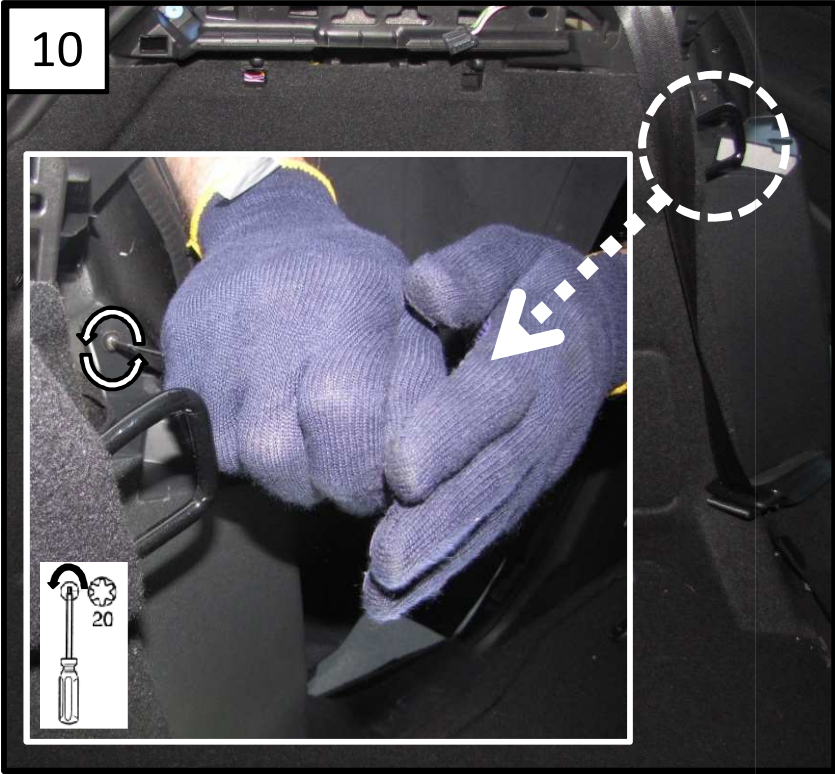

T91

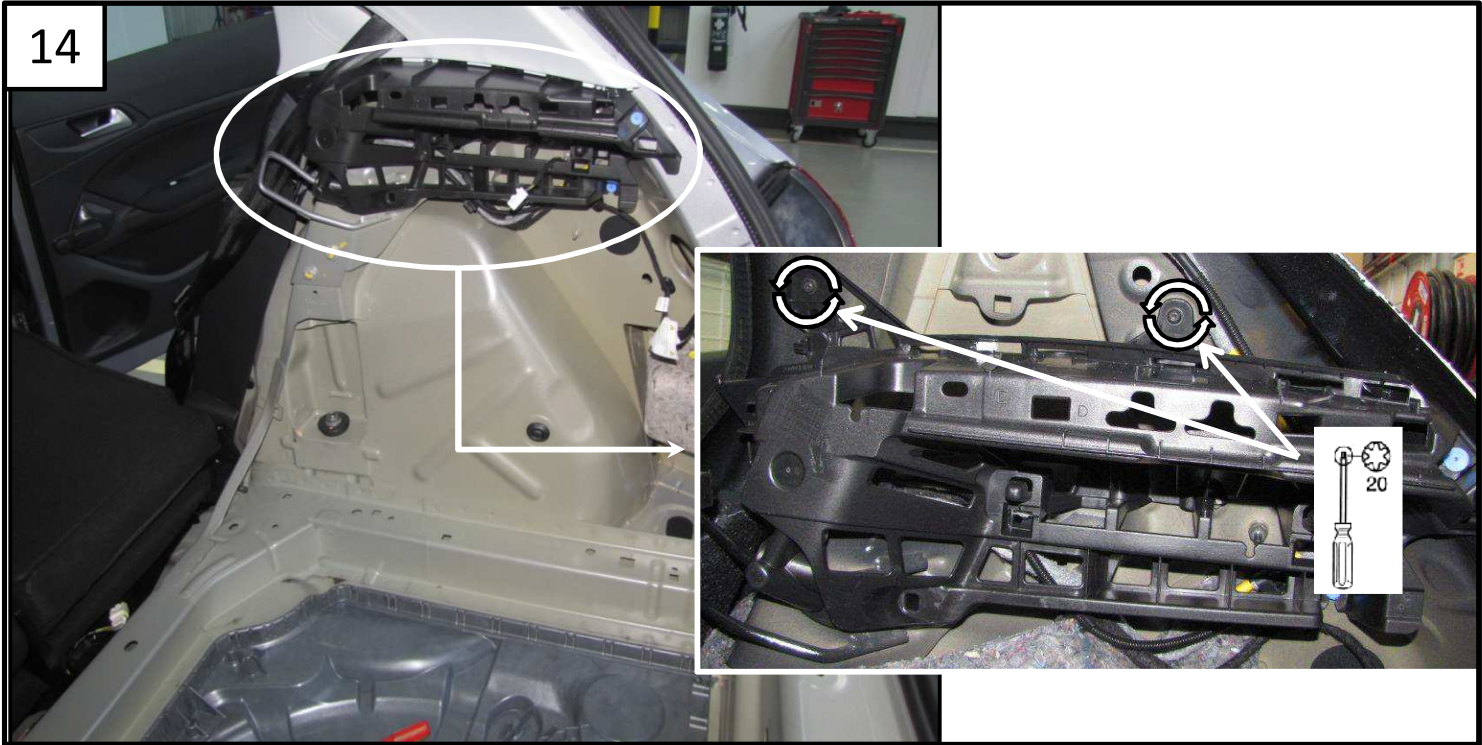
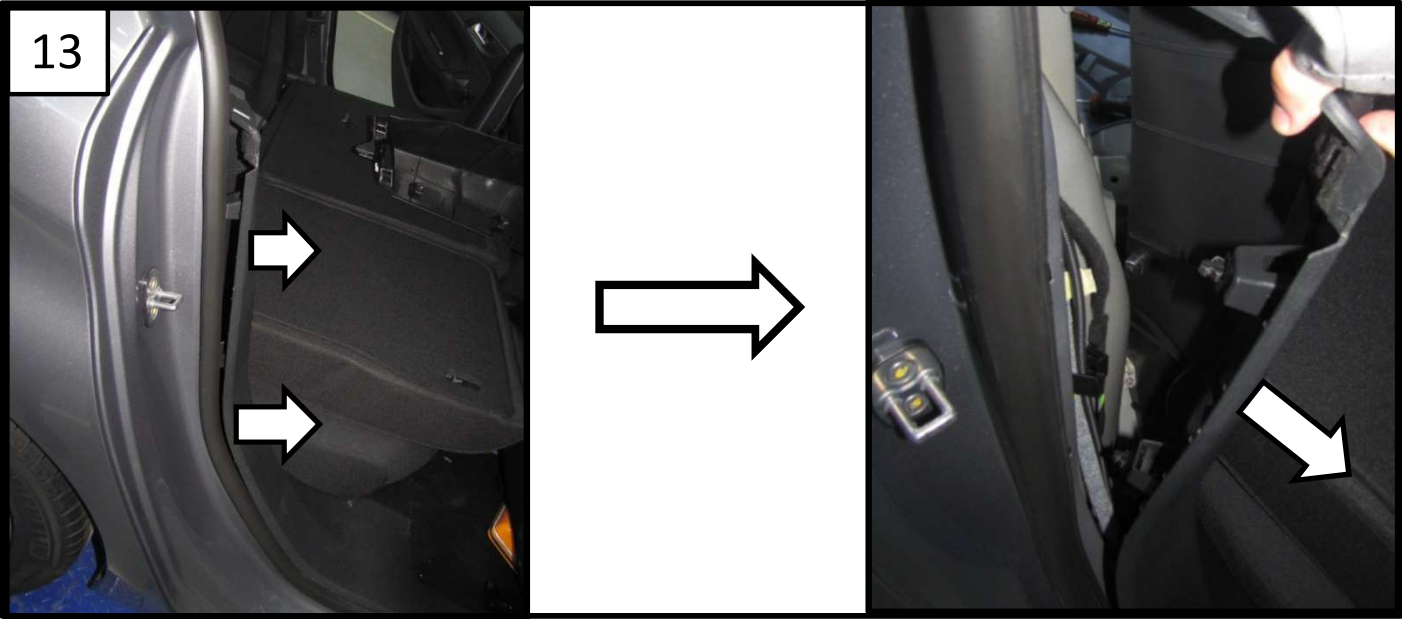

T91 – T92

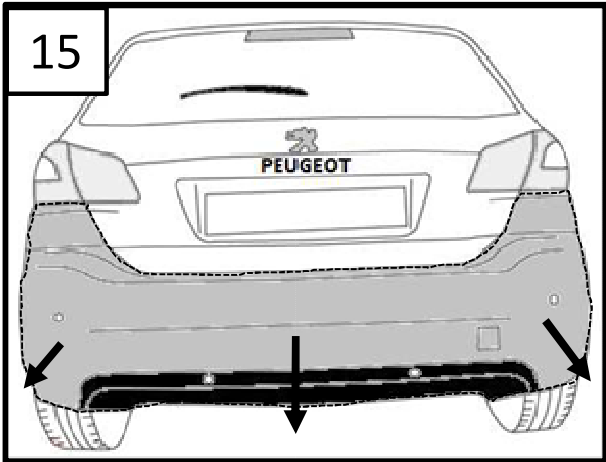

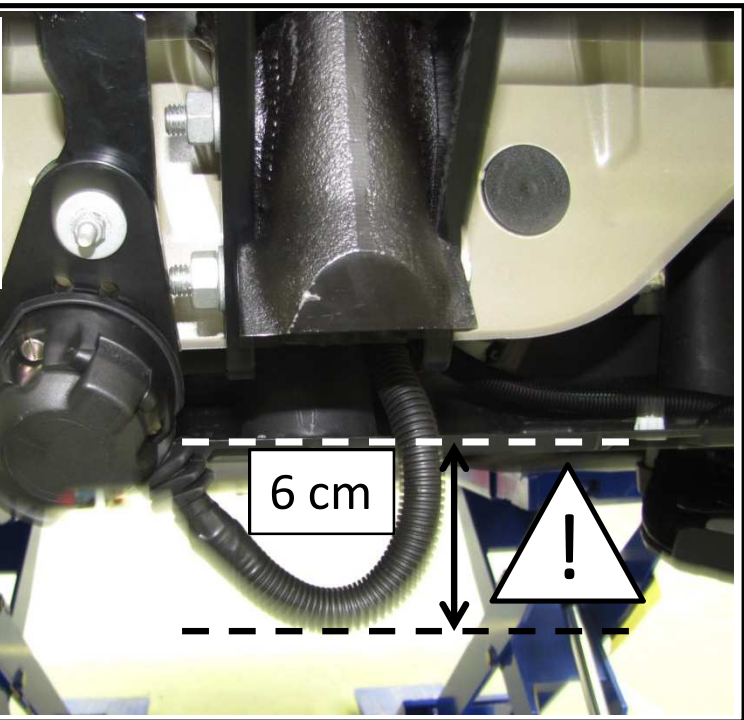
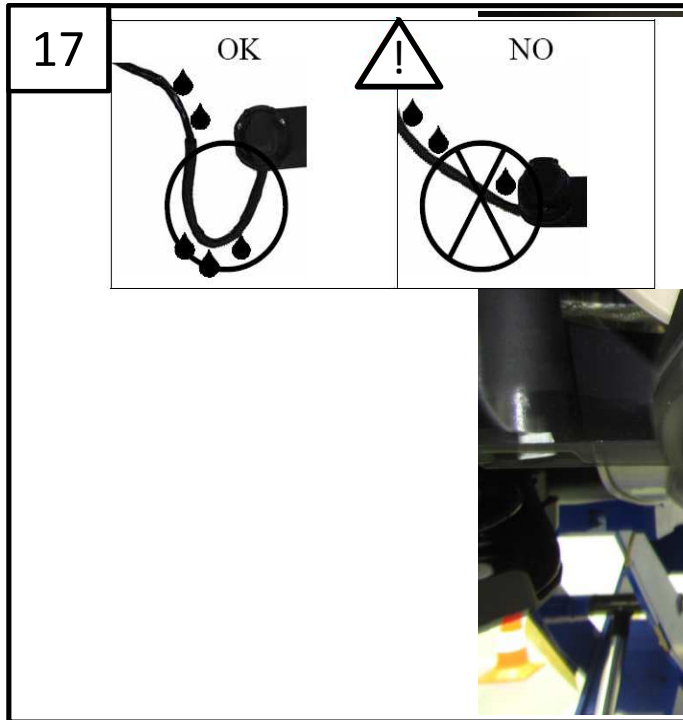
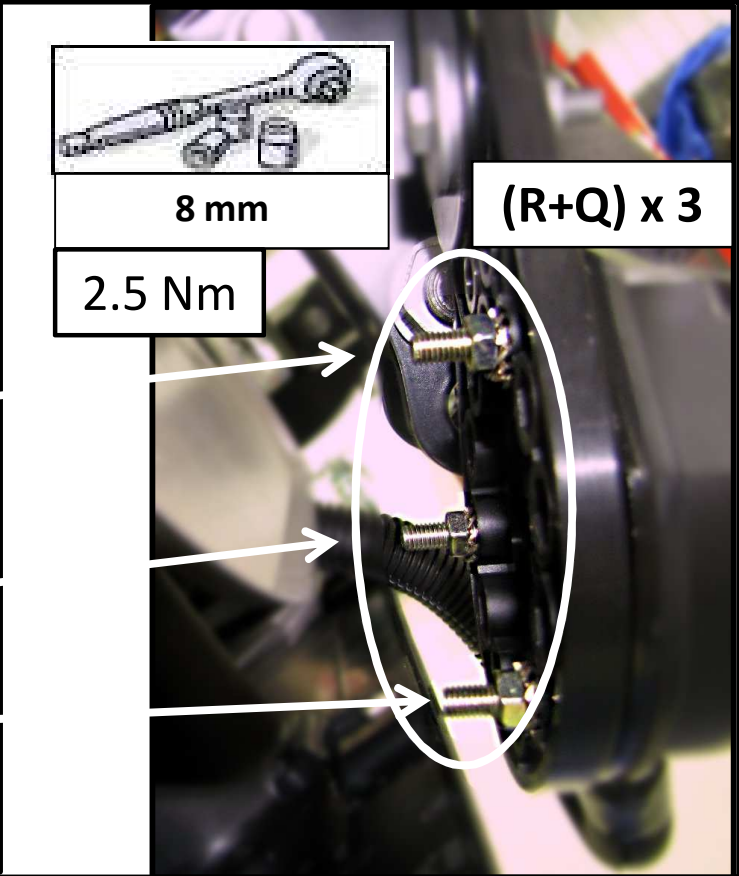
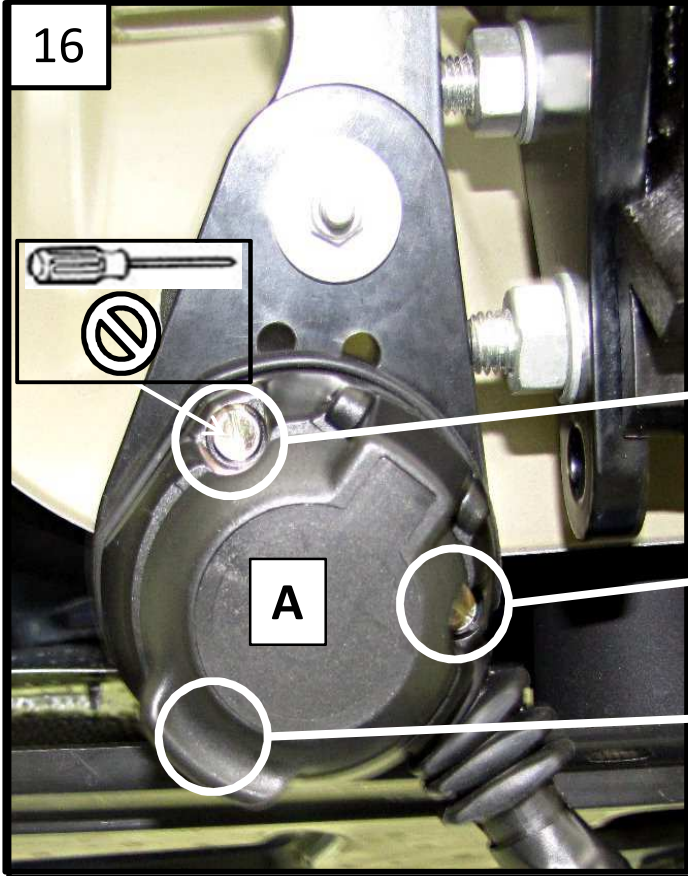

18-19-20

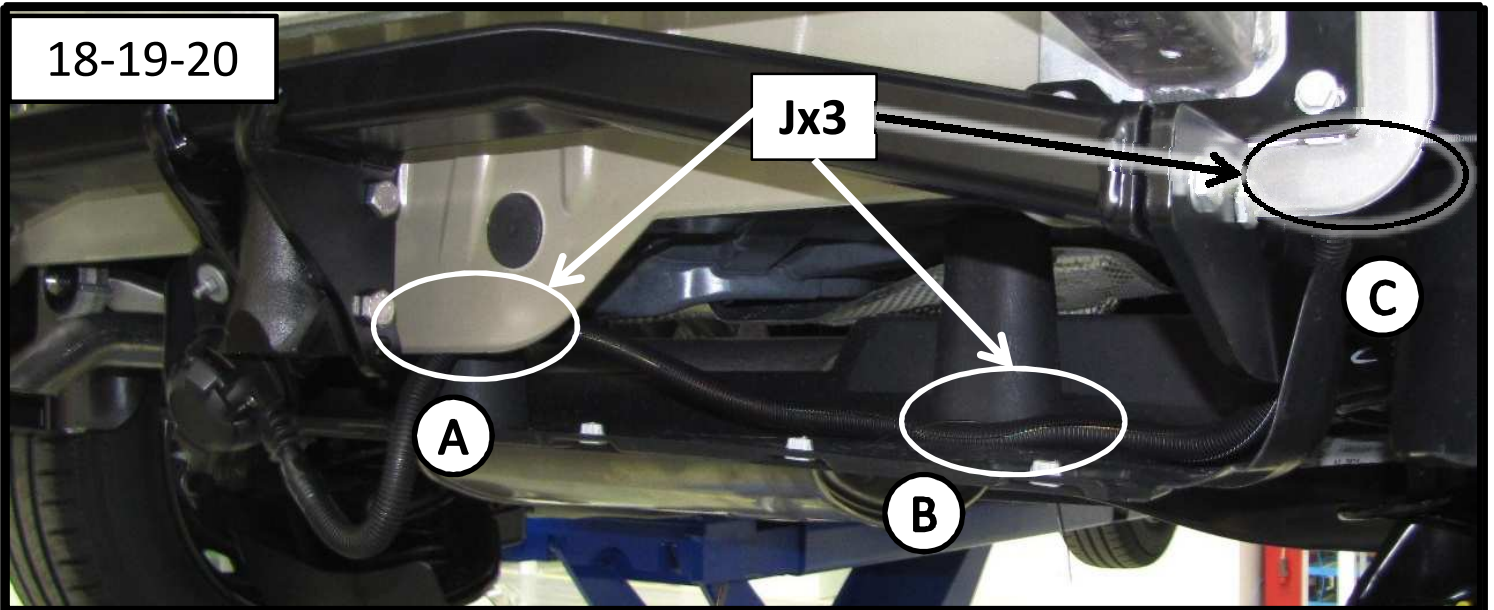

18

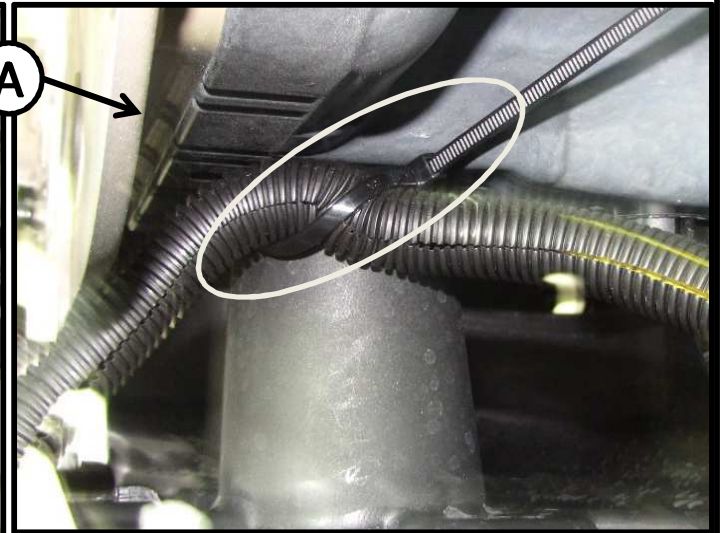

19

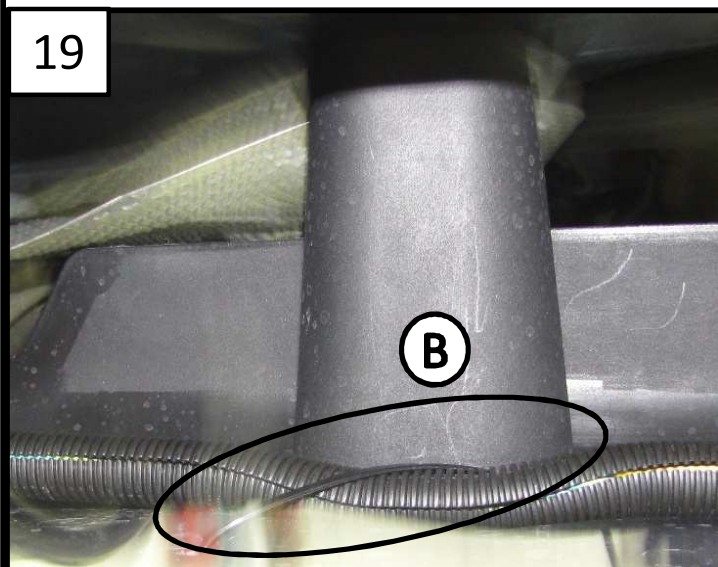

20

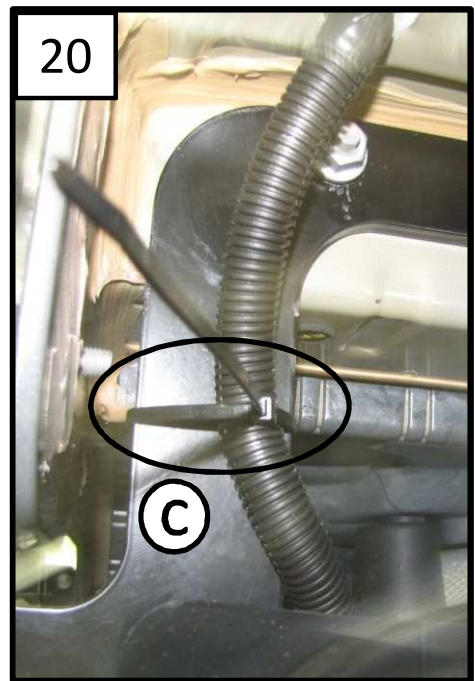

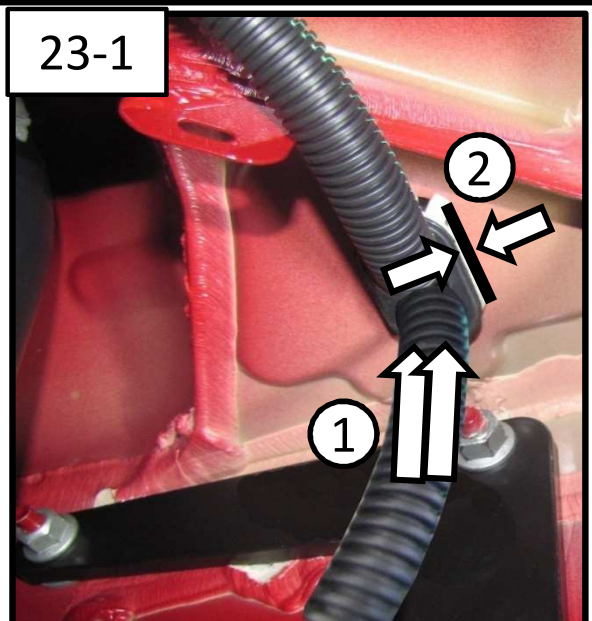
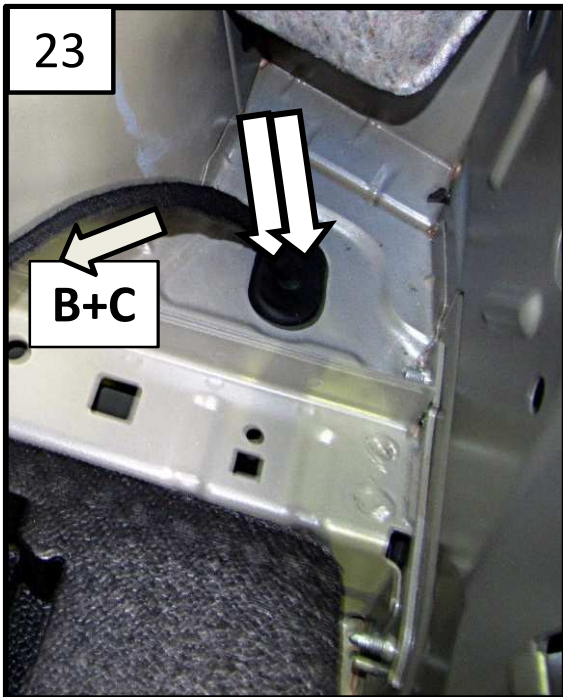
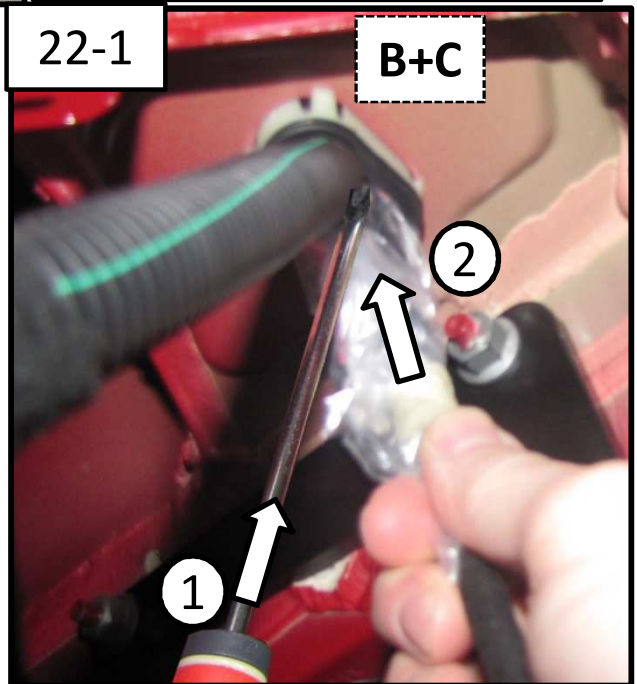
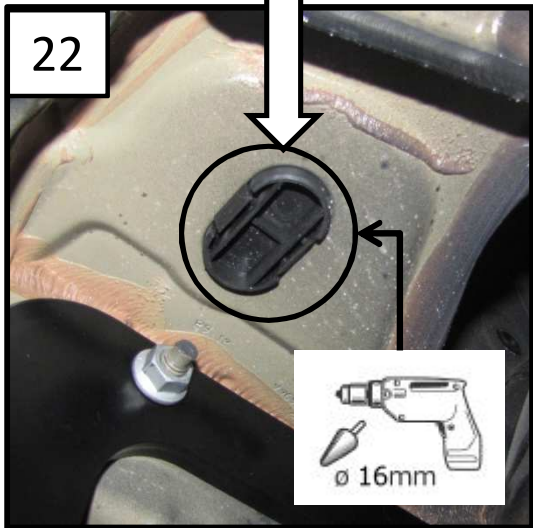
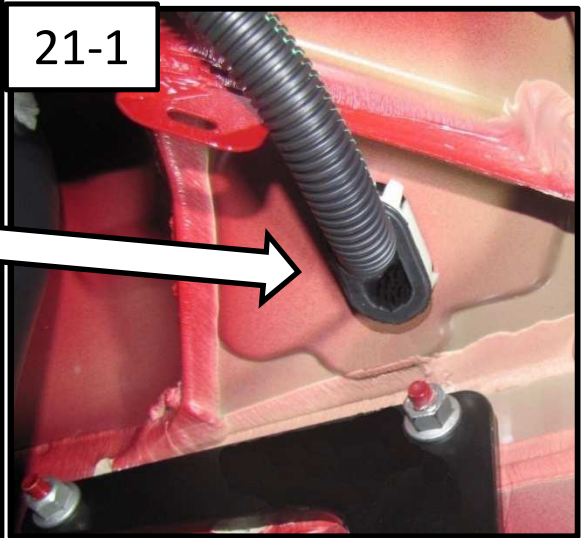

24

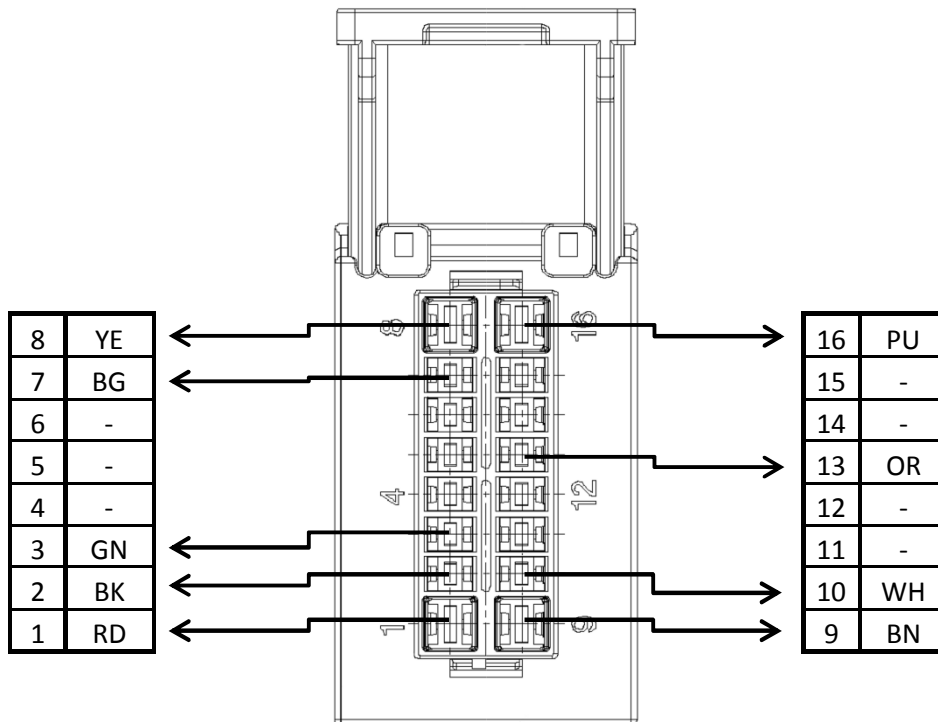
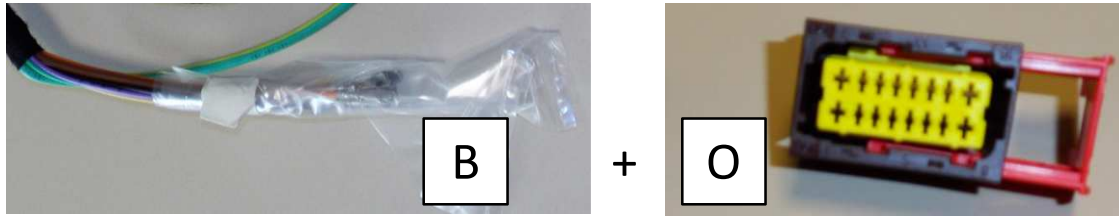

	BK	WH	GN	RD	YE	BN	PU	OR	BG
FR	Noir	Blanc	Vert	Rouge	Jaune	Marron	Violet	Orange	Beige
GB	Black	White	Green	Red	Yellow	Brown	Purple	Orange	Beige
ES	Negro	Blanco	Verde	Rojo	Amarillo	Marrón	Violeta	Anaranjado	Beige
P	Preto	Branco	Verde	Vermelho	Amarelo	Castanho	Violeta	Laranja	Bege
DE	Schwarz	Wei	Grn	Rot	Gelb	Braun	Violett	Orange	Beige
IT	Nero	Bianco	Verde	Rosso	Giallo	Marrone	Viola	Arancione	Beige
NL	Zwart	Wit	Groen	Rood	Geel	Bruin	Violet	Oranje	Beige

T91 – T92

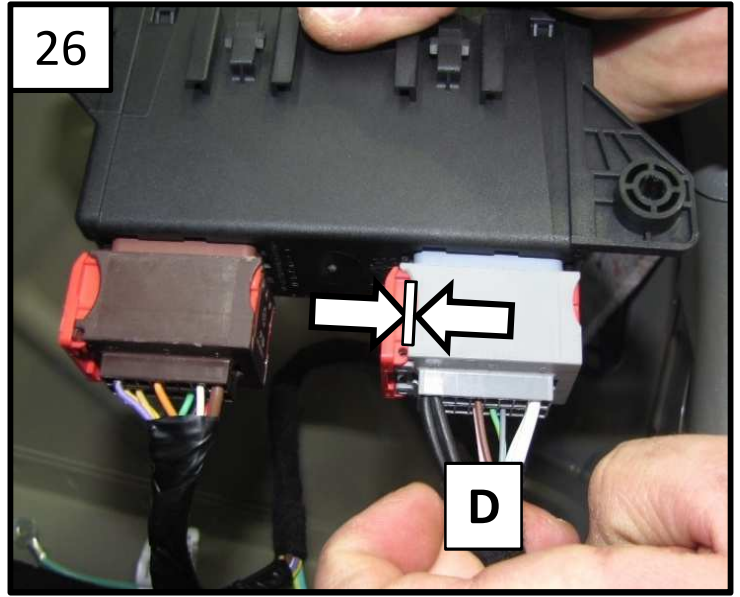
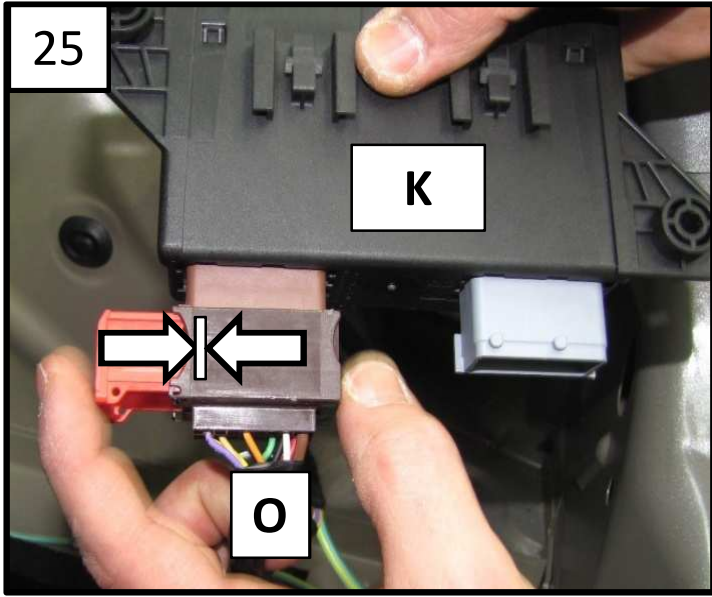

T91

T92   p29 27a

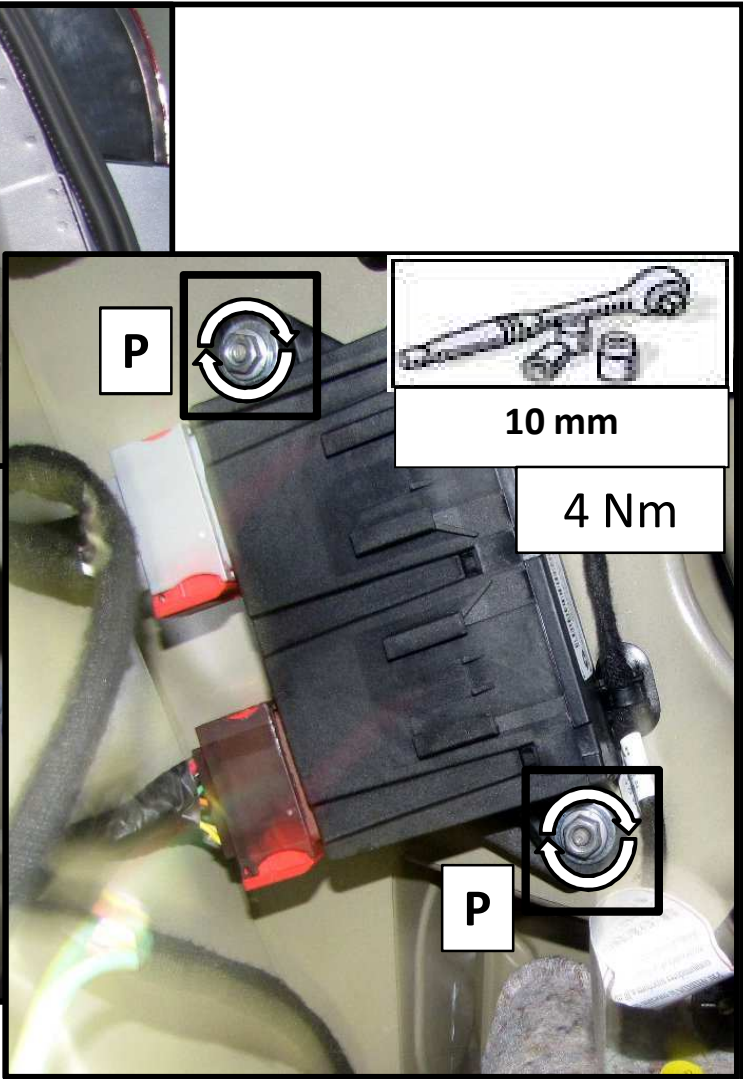
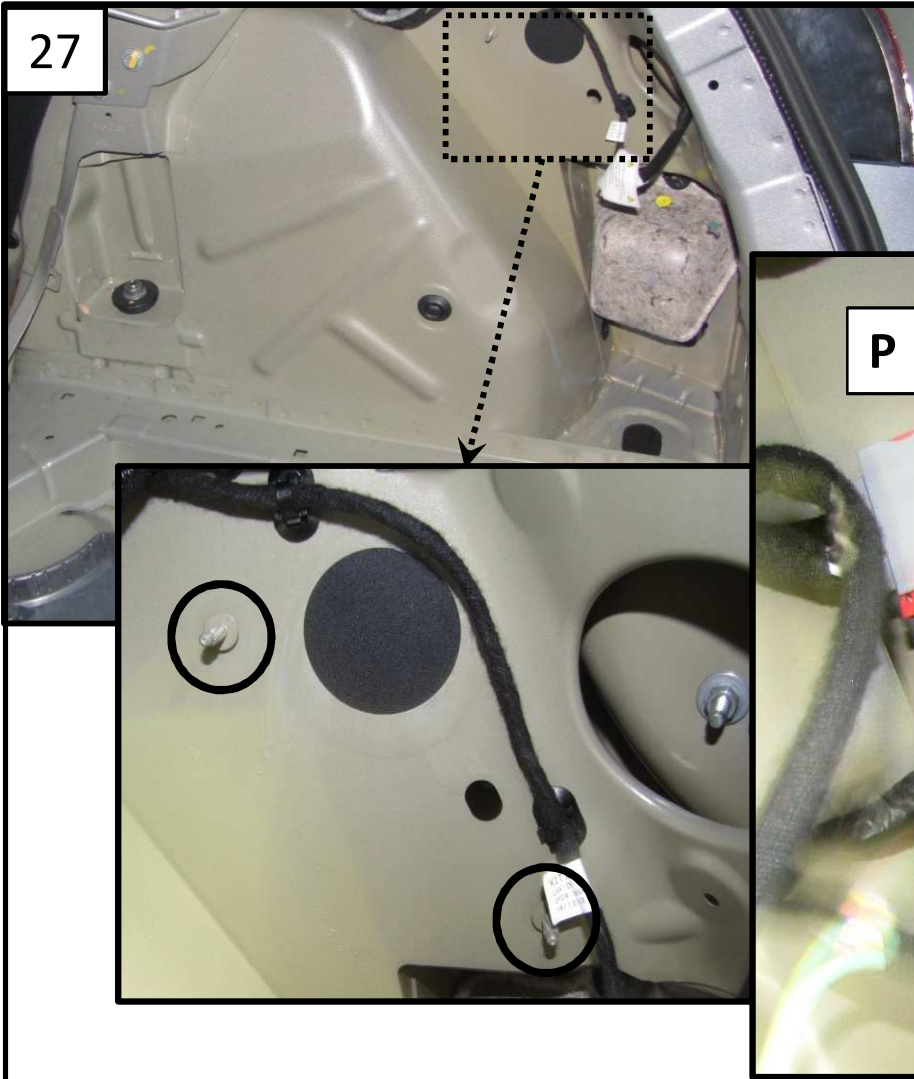

28

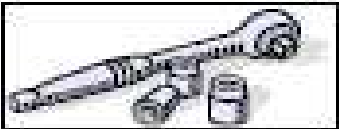

10 mm

10 Nm

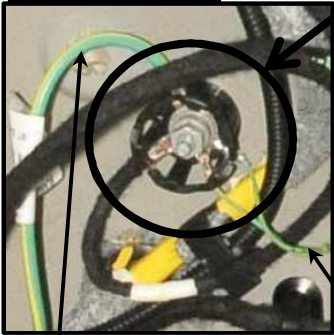

C

F1+F2

T91 – T92

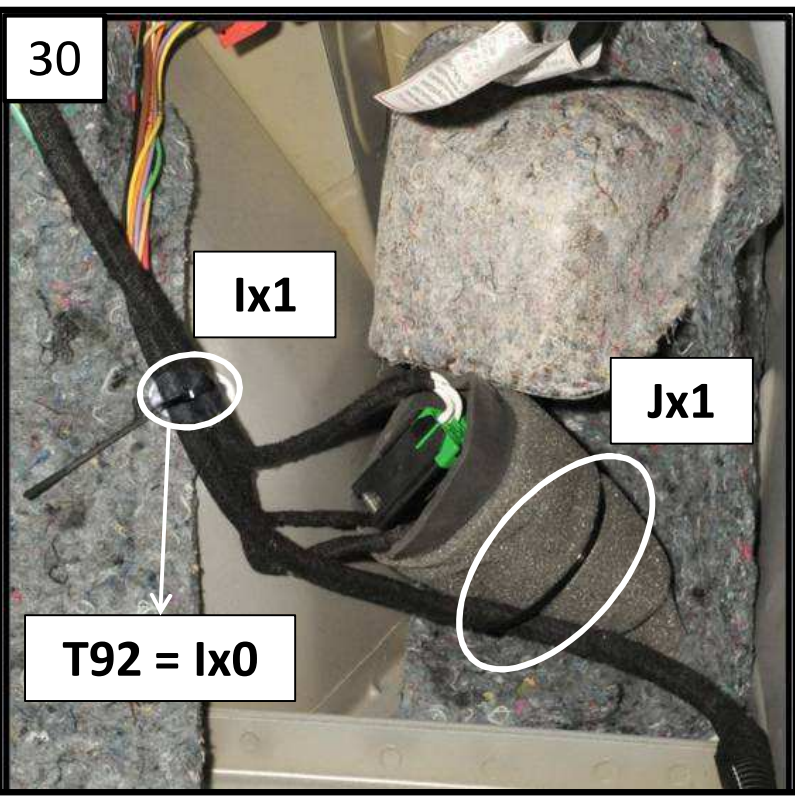
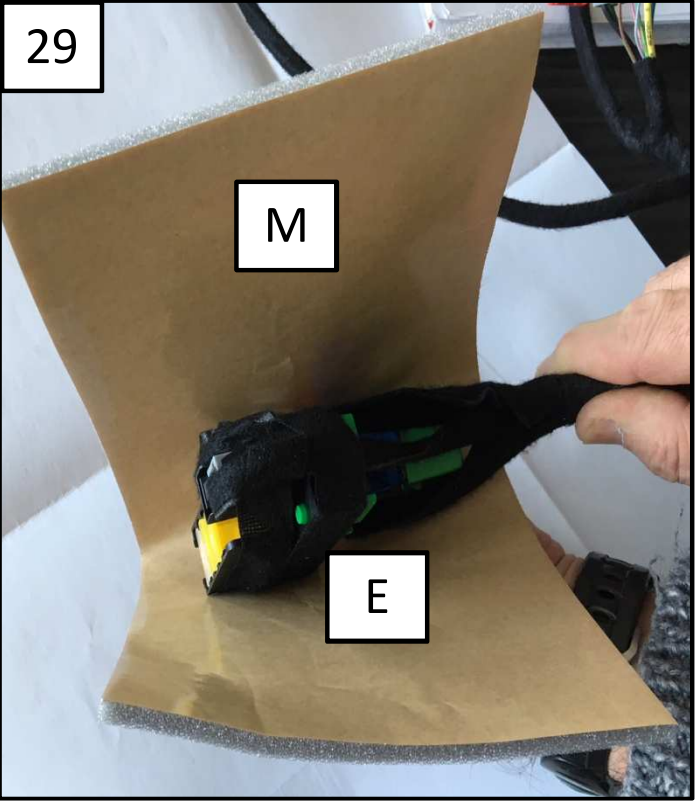

T91

T92   p30 31a

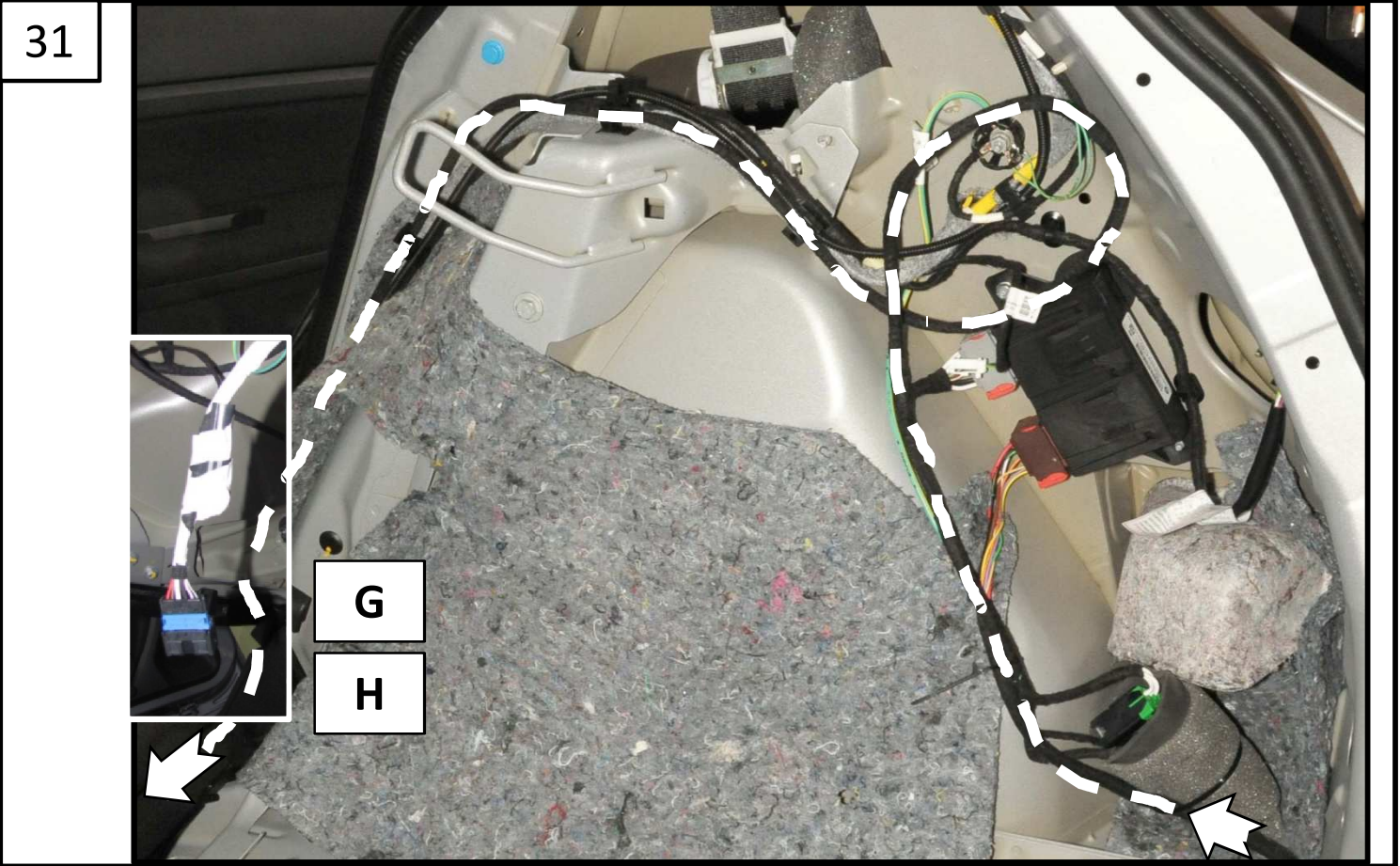

32

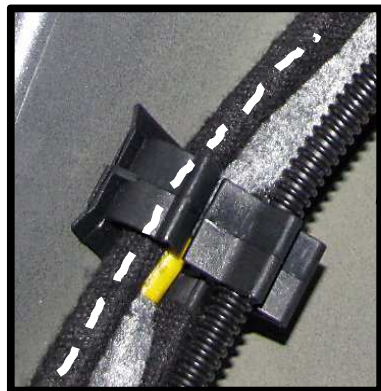

33

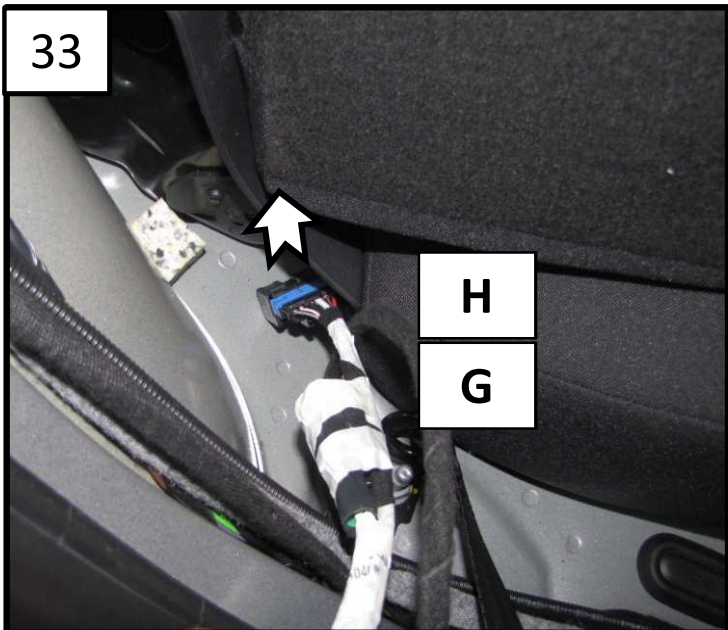

34

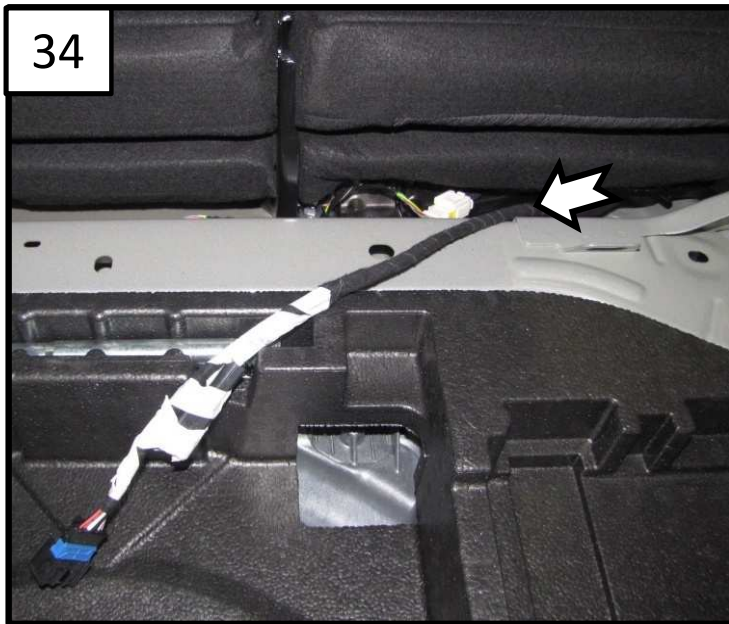

35



36

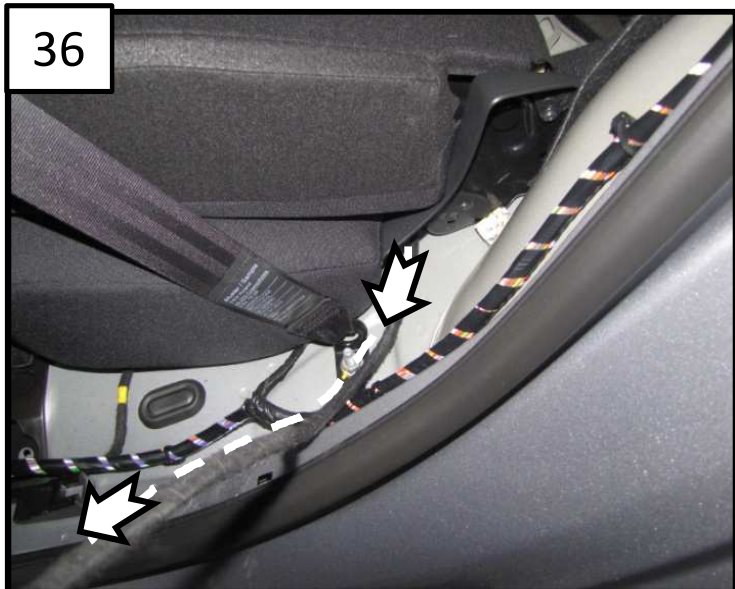

37



T91

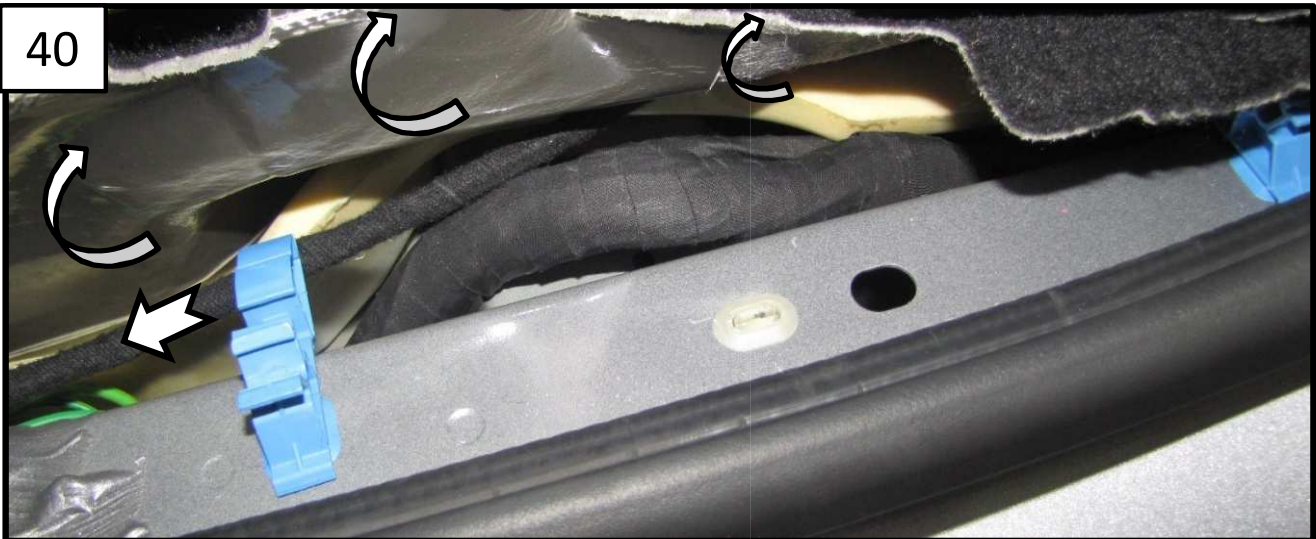
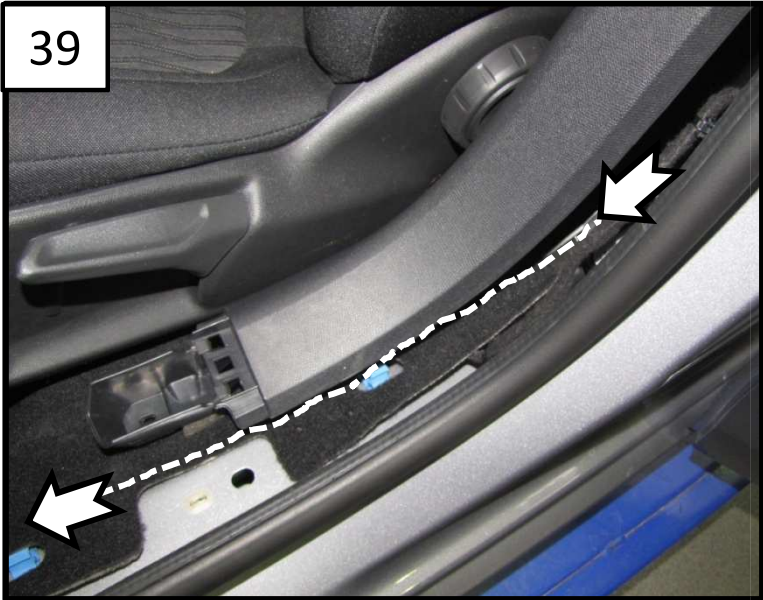
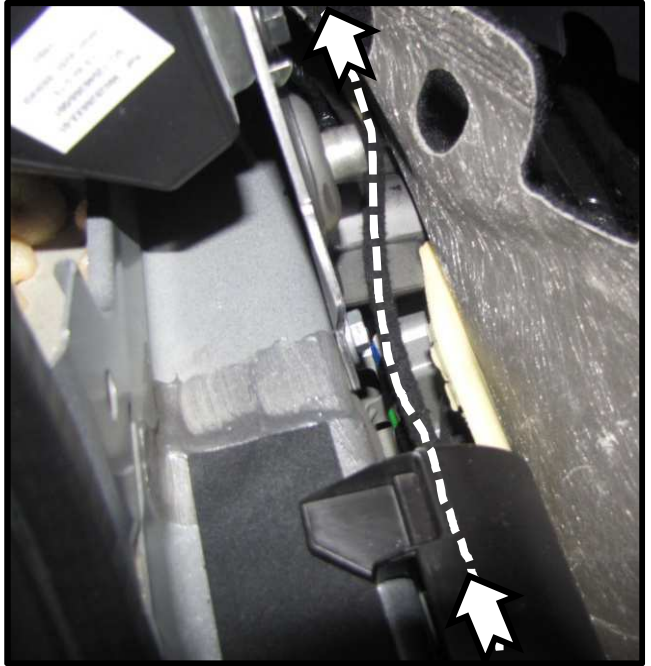

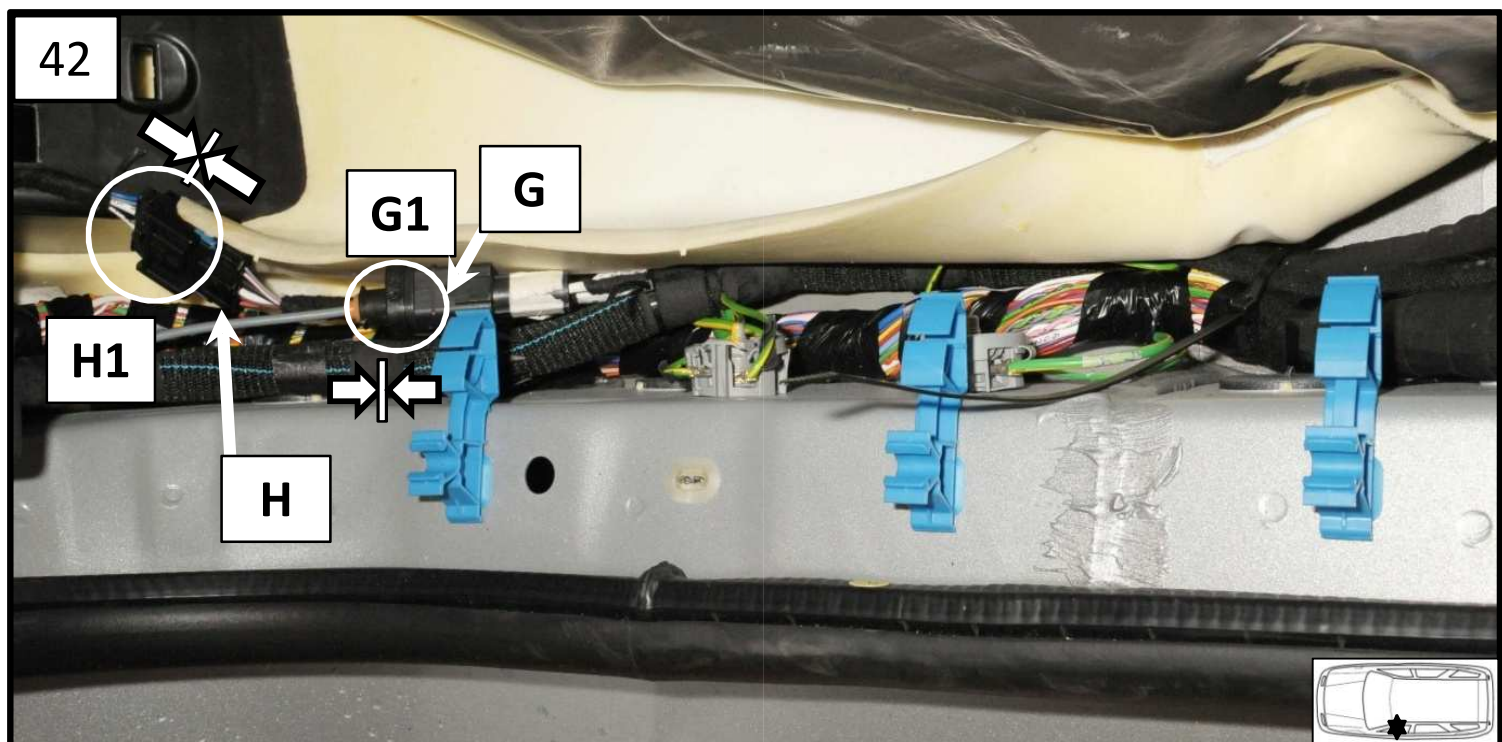
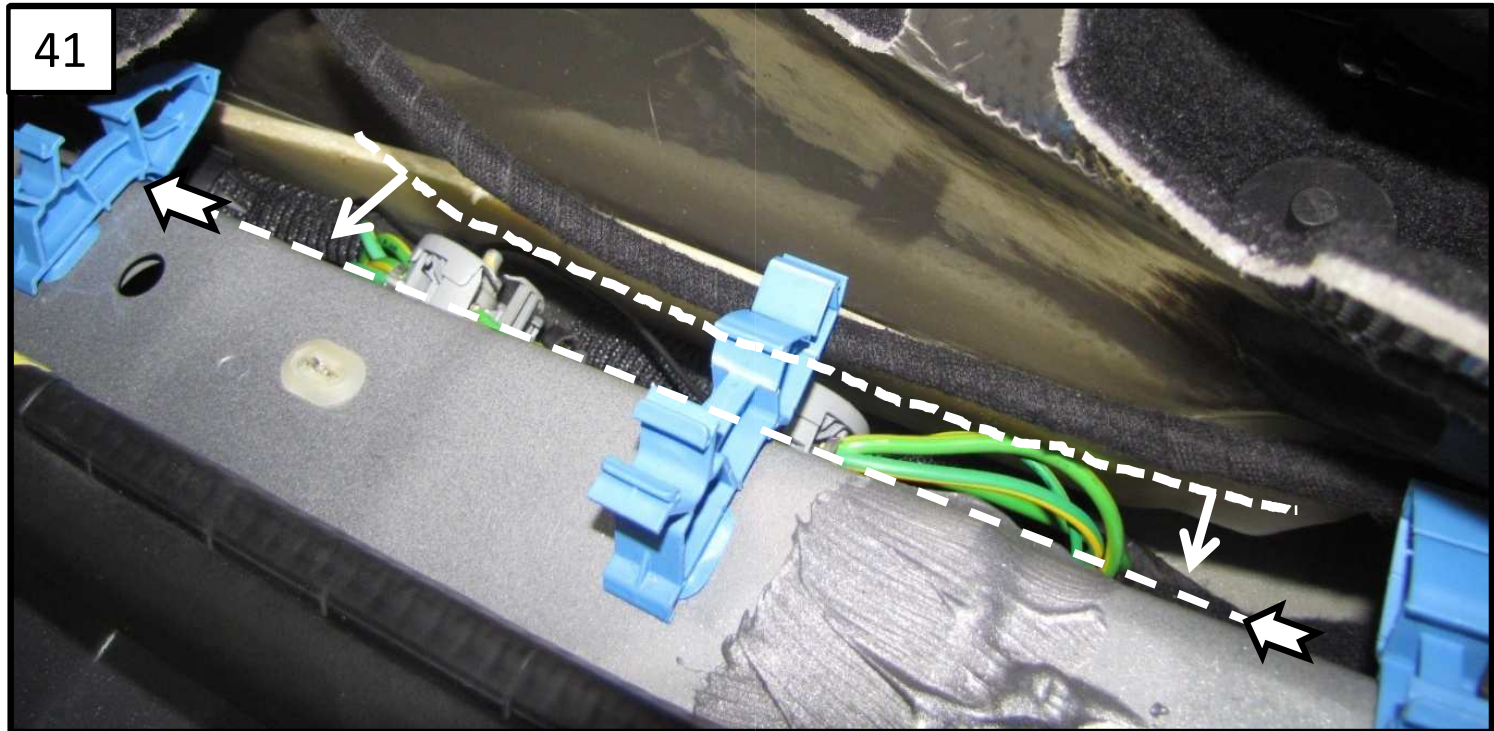

T91 – T92

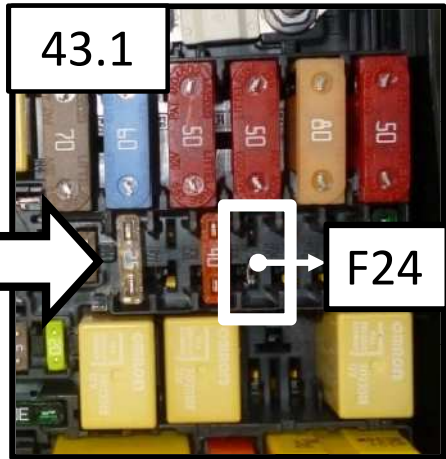
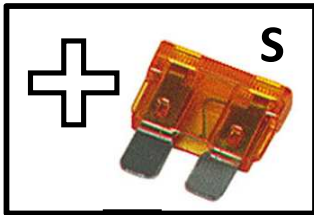
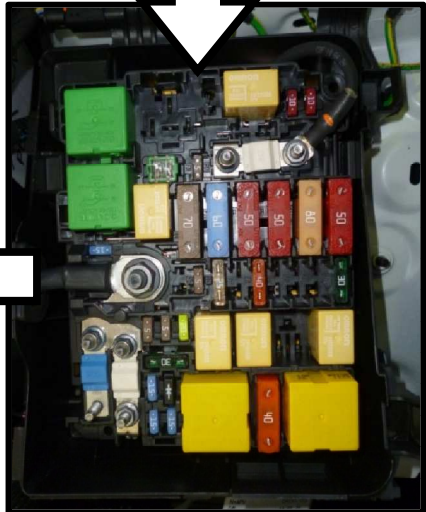
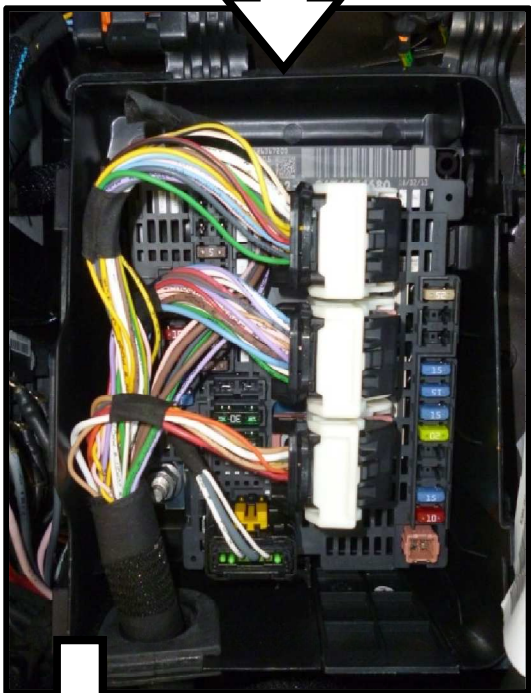
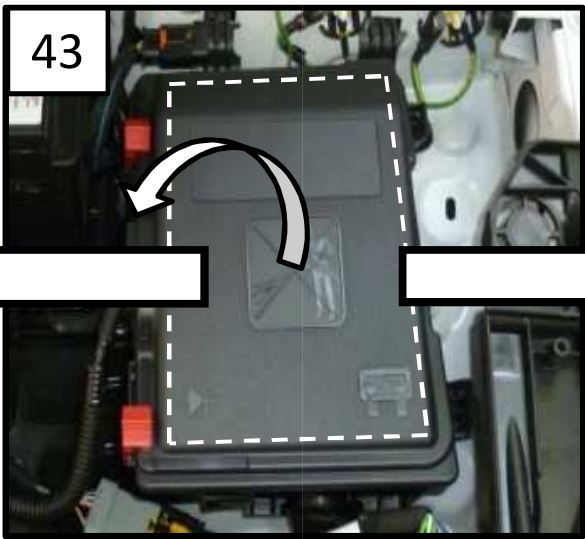



DIAGBOX

- A l'aide de l'outil DIAGNOSTIQUE PEUGEOT : déclarer la présence du BSR dans la BSI. Après montage du faisceau, vérifier l'absence de tout code défaut de fonctionnement.
- By means of the tool DIAGNOSTIQUE PEUGEOT : indicate the presence of the BSR (trailer control module) in the BSI. After fitting the wiring loom, check that there are no operating faults.
- Mit Hilfe des Werkzeugs DIAGNOSTIQUE PEUGEOT : Vorhandensein der Anhänger-Schalteneinheit (BSR) in der Zentralschalteneinheit BSI angeben. Nach Montage des Kabelstrangs dass kein Funktionsfehlercode vorliegt.
- Con la herramienta DIAGNOSTIQUE PEUGEOT : declarar la presencia de la BSR (Caja Servicio Remolque) en la BSI. Después del montaje del haz, comprobar que no hay ningún código de fallo de funcionamiento.
- Con lo strumento DIAGNOSTIQUE PEUGEOT : notifica la presenza della BSR (Scatola Servitù Rimorchio) nella BSI. Dopo montaggio del fascio, verificare l'assenza di qualsiasi codice difetto di funzionamento.
- Meld met met van het werktuig DIAGNOSTIQUE PEUGEOT : de aanwezigheid van BSR (Boîtier Servitude Remorque– processor aanhanwagenorganen) in de BSI. Controleer na montage of er geen storingscodes worden gemeld.
- Meld hjälp av verktyget DIAGNOSTIQUE PEUGEOT : uppge närvaron av BSR (Anslutningslada för släp) i BSI. Efter monteringen av kabelsatserna, kontrollera att det inte finns några funktionsfelkoder.
- Utilizando a ferramenta DIAGNOSTIQUE PEUGEOT : declarar a presença do BSR (Boîtier Servitude Remorque = caixa de controlo do reboque) no BSI. Após a montagem da cablagem, verificar se não existe qualquer código de avaria.

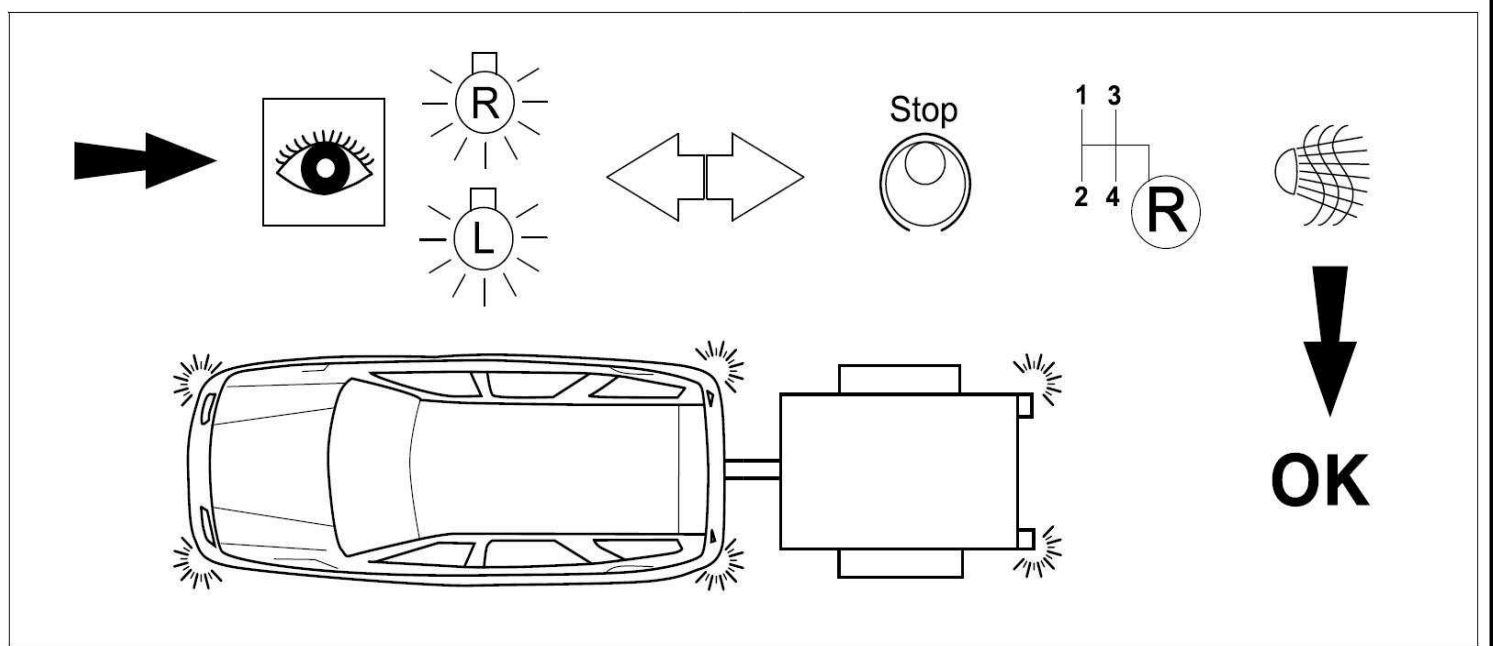

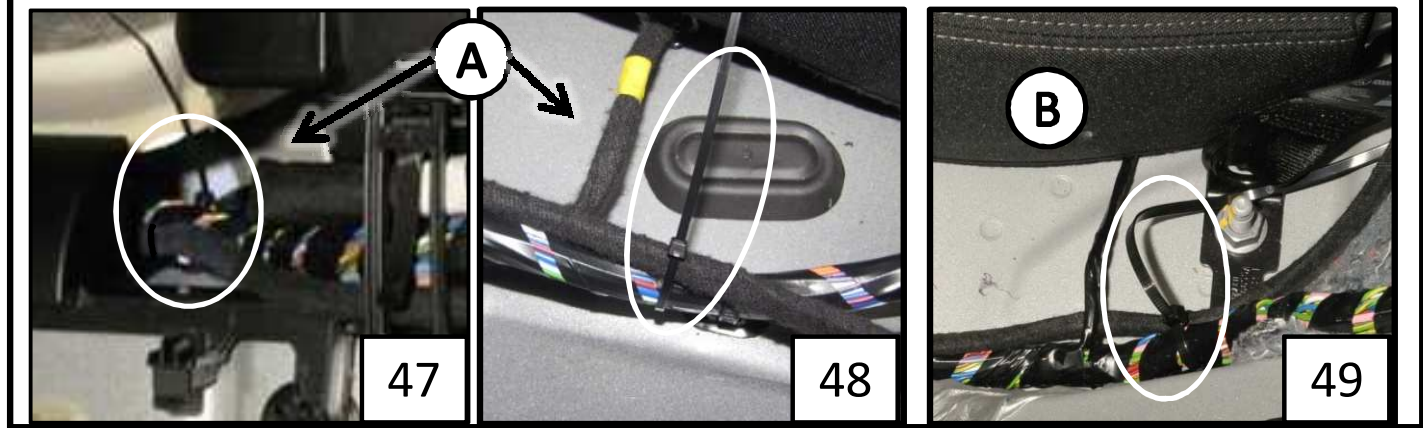
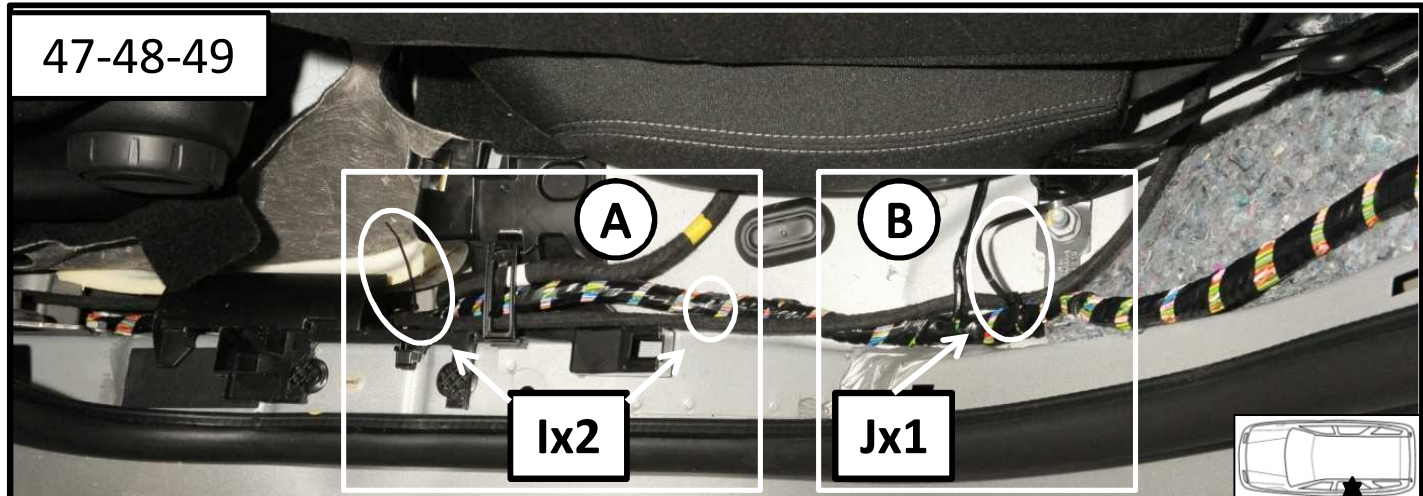
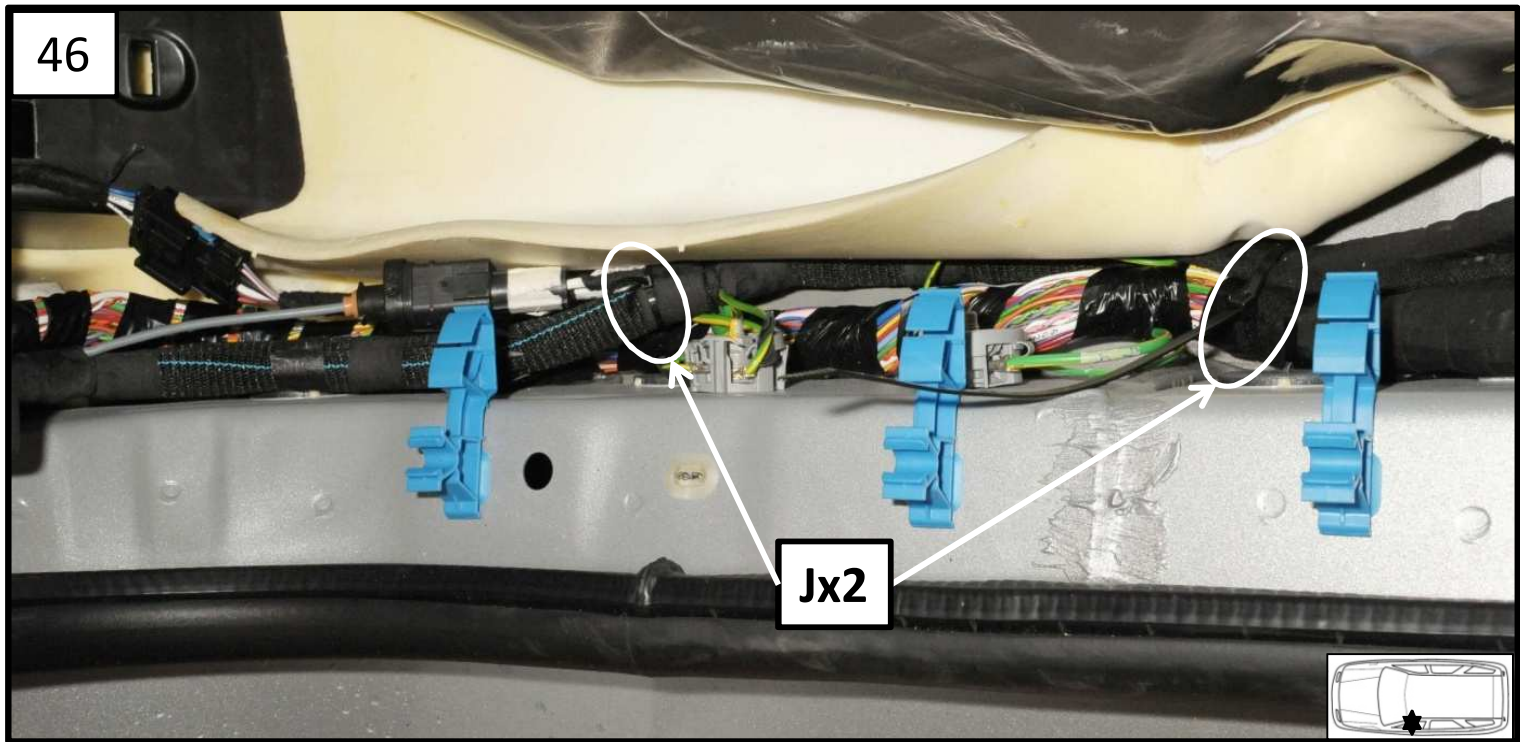

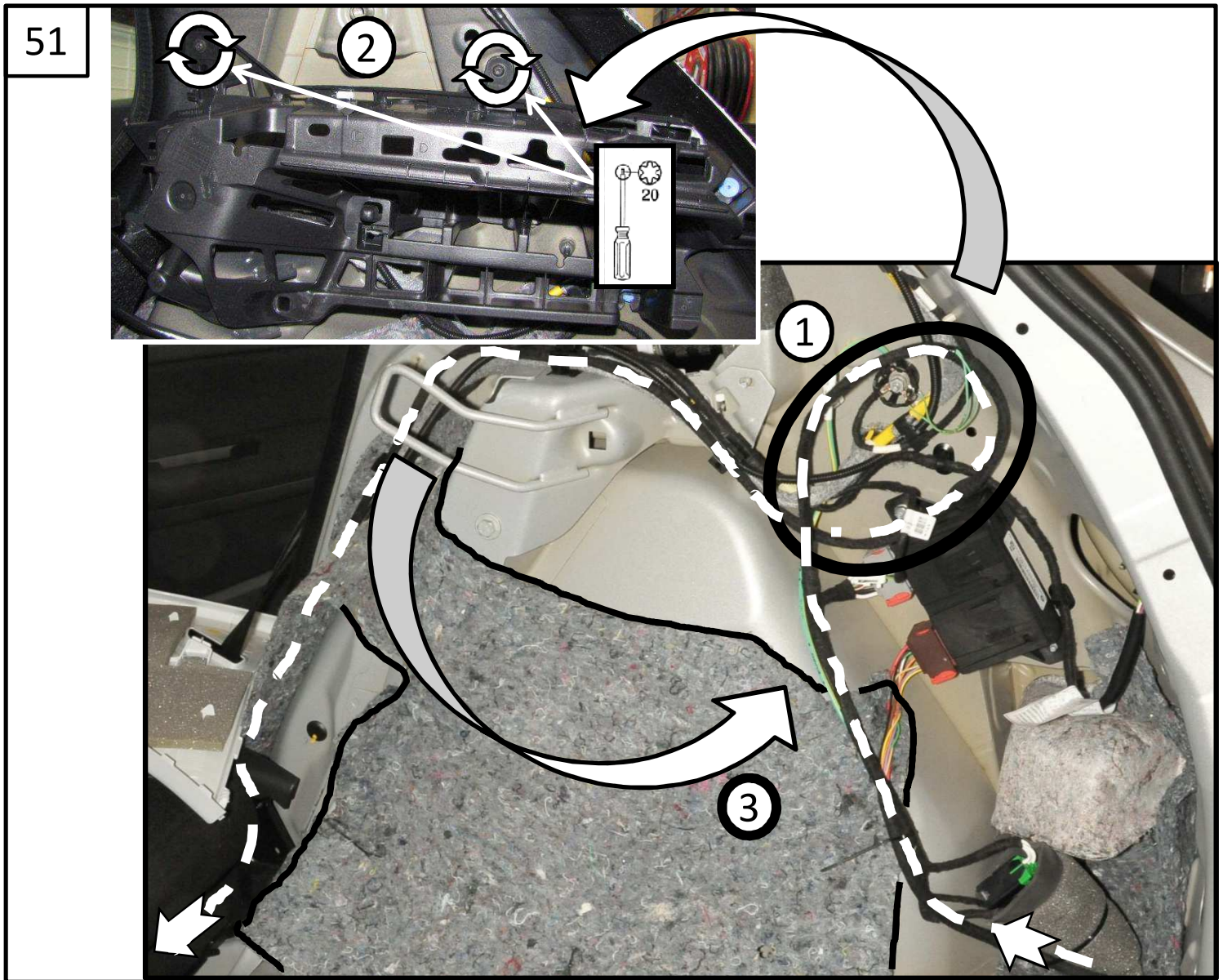
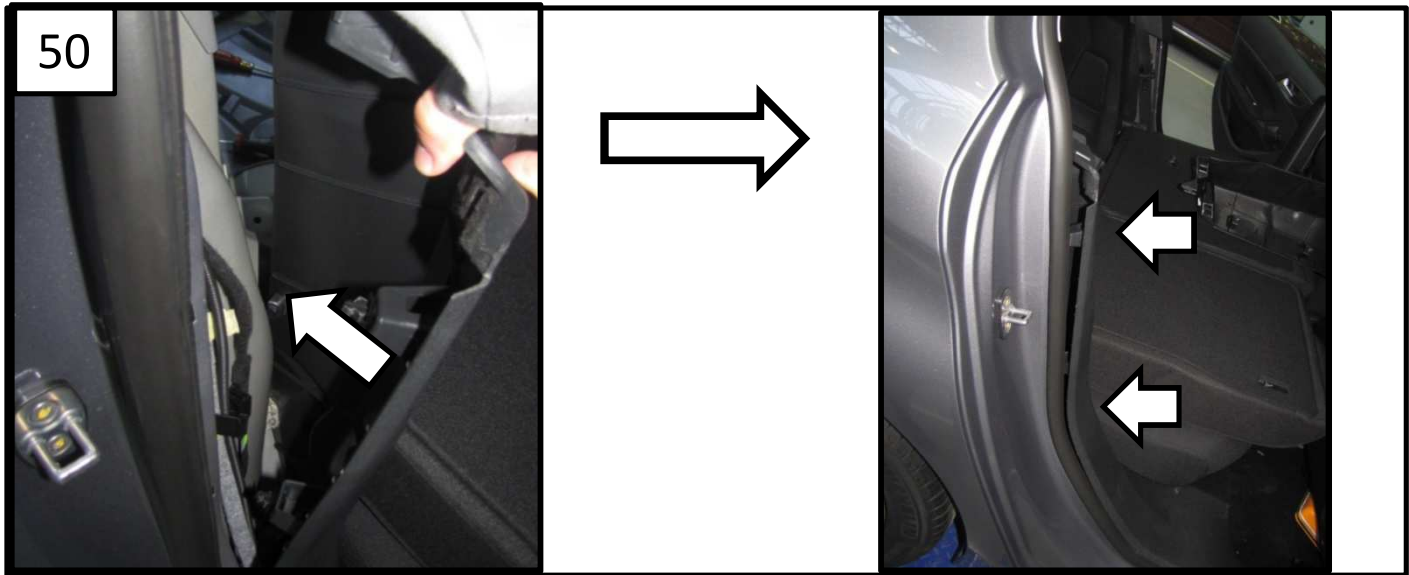

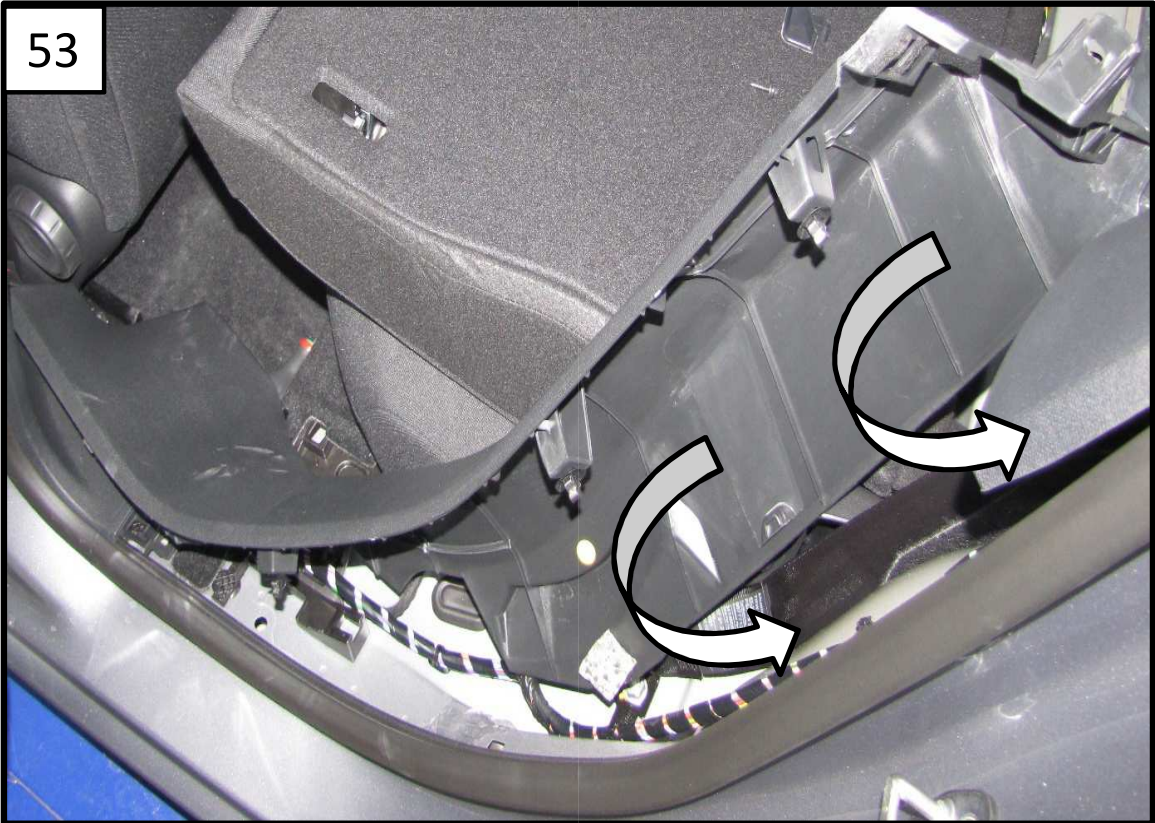
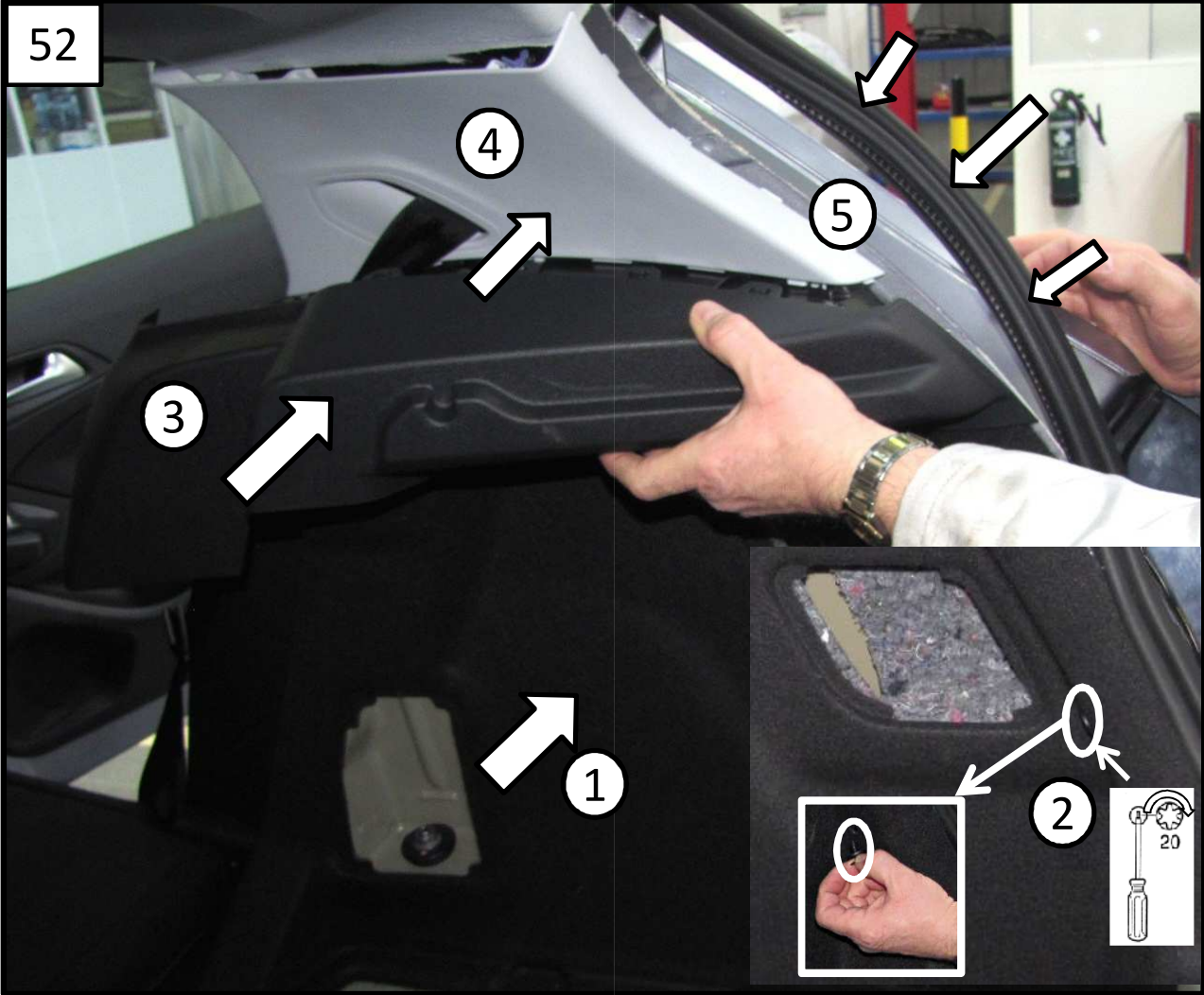

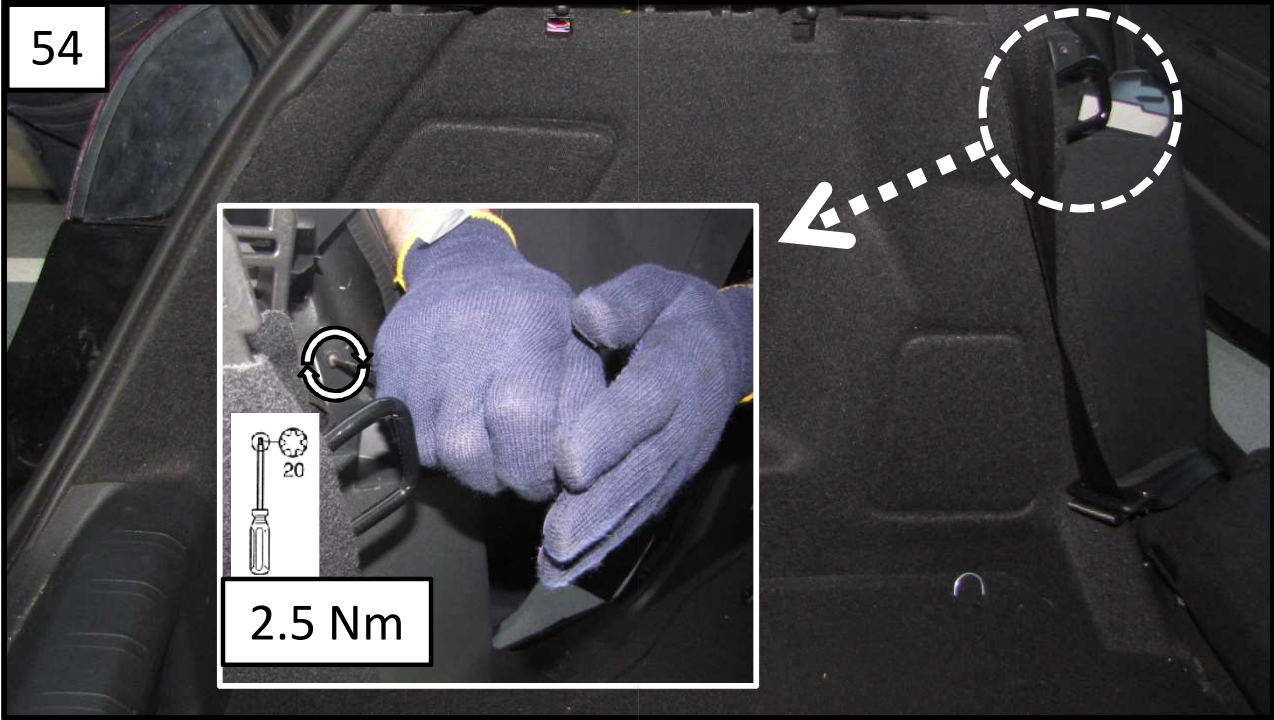

T91

56

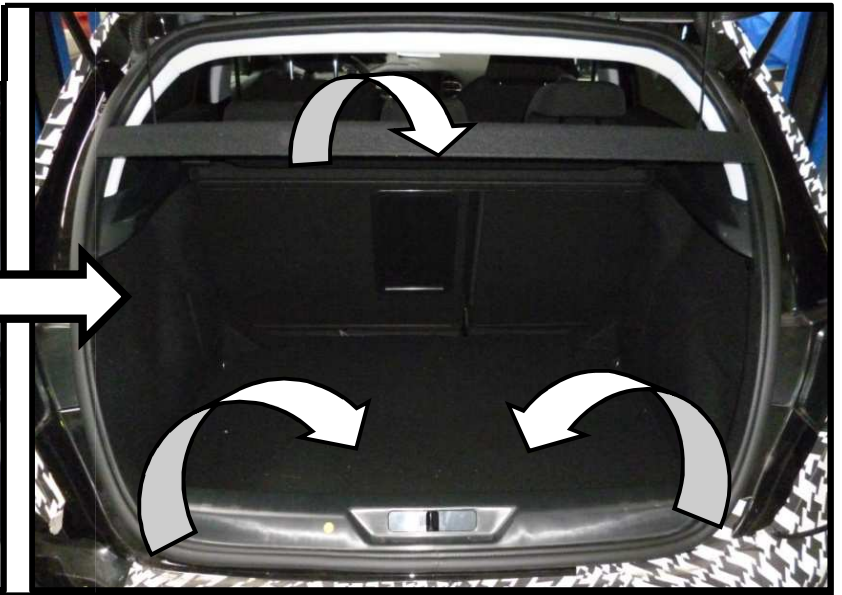

T91 – T92

57



58

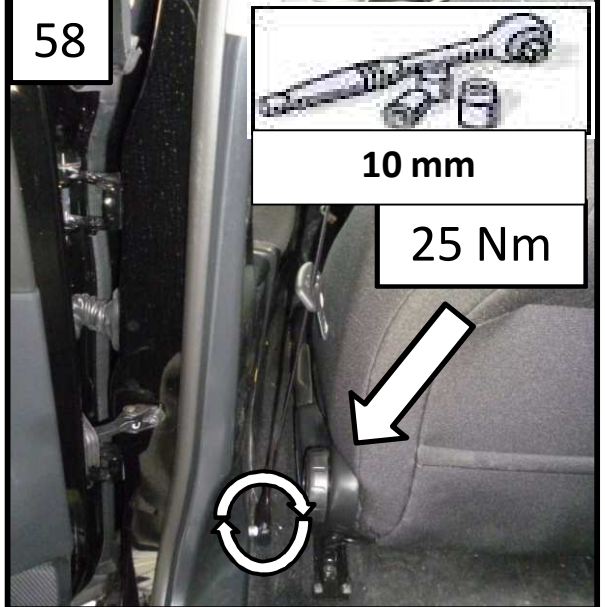

59

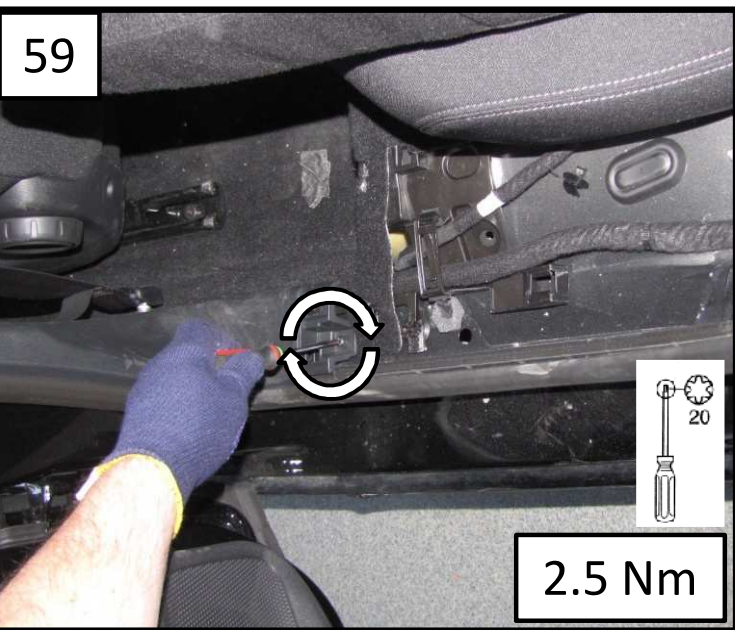

60

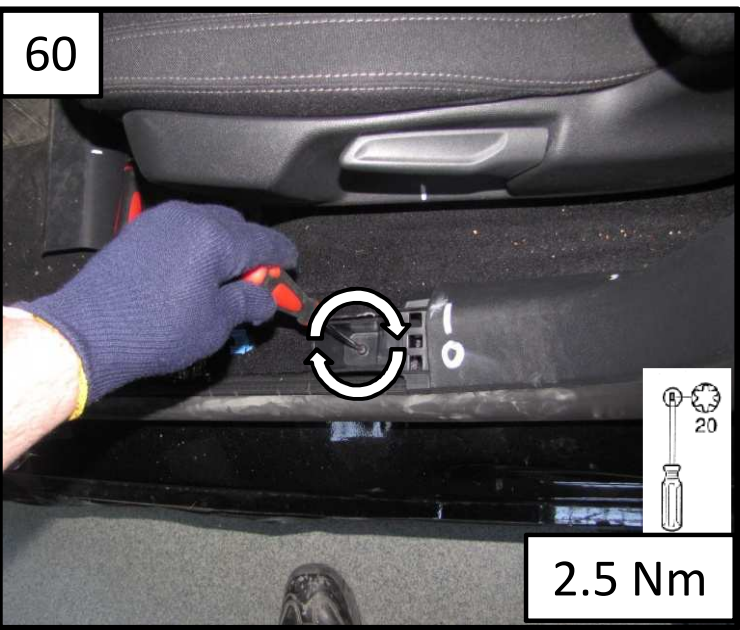

T91 – T92

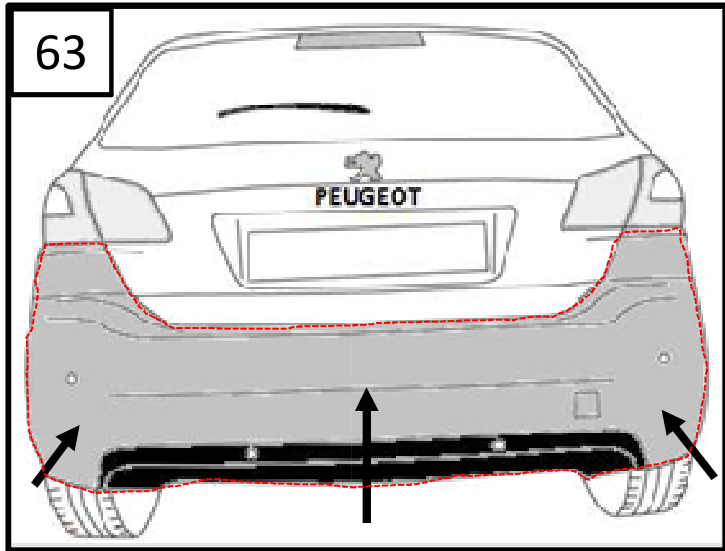
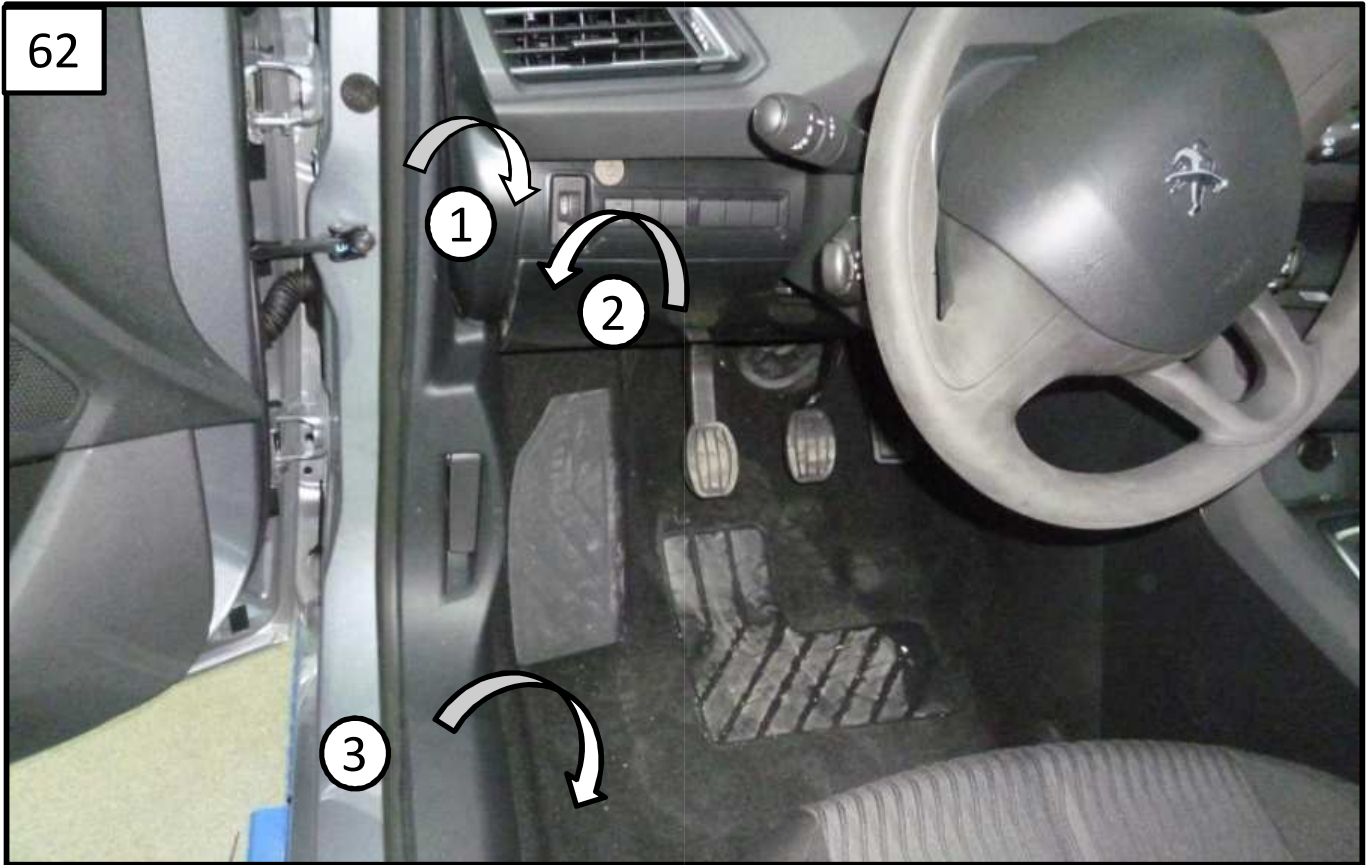
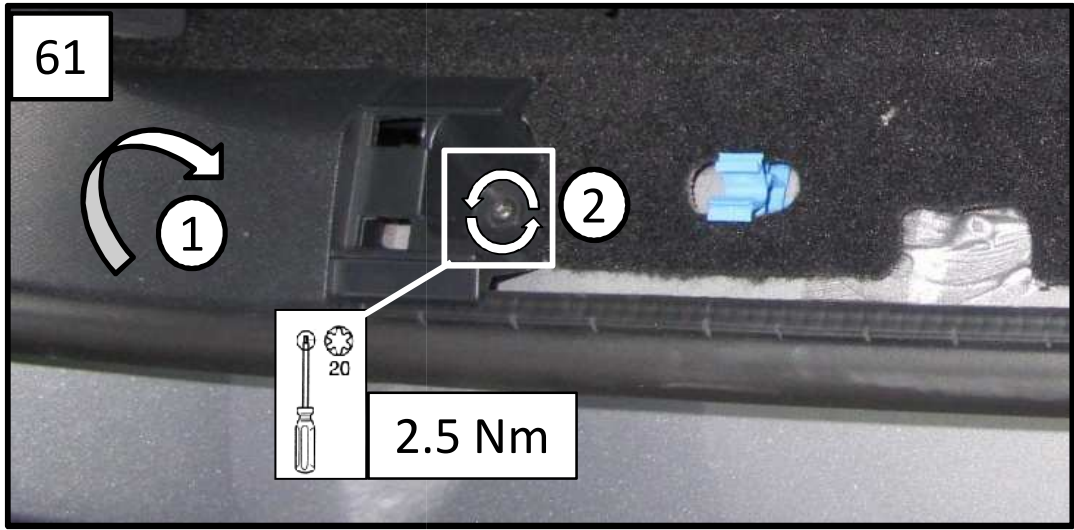



308 SW (T92)



308 (T91)

p2

01

-->

07

08a

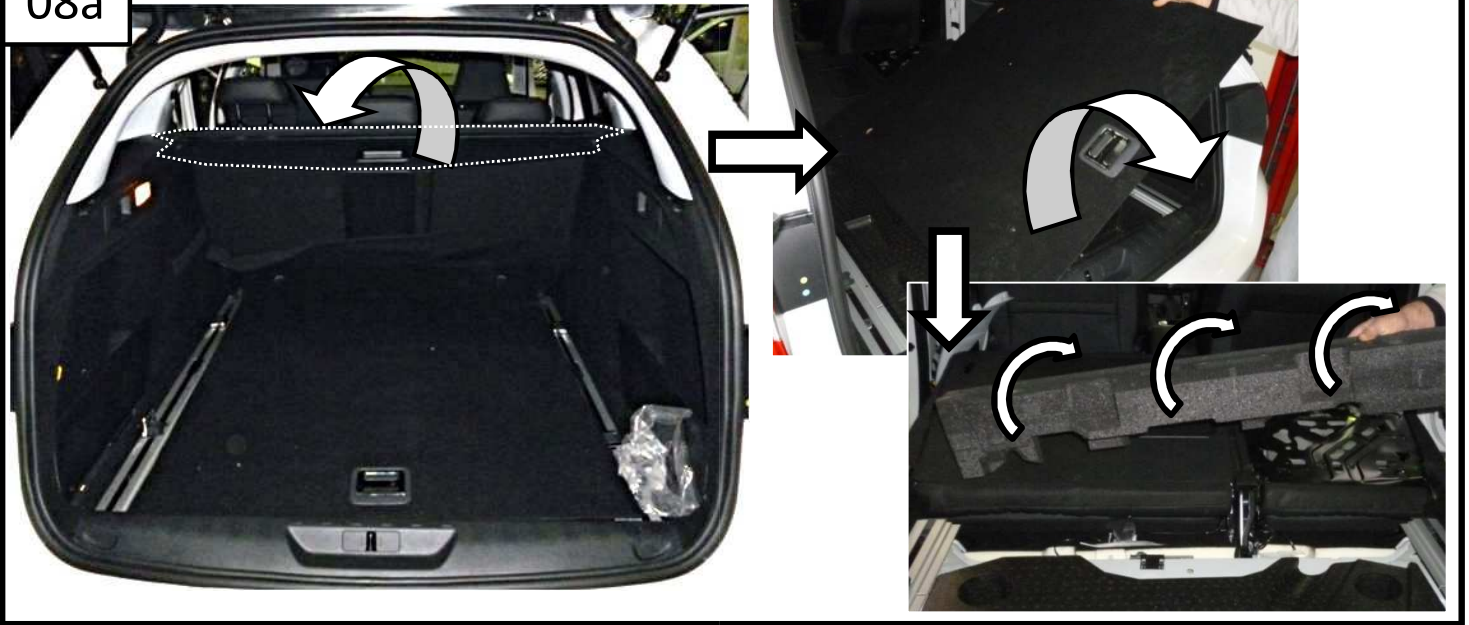

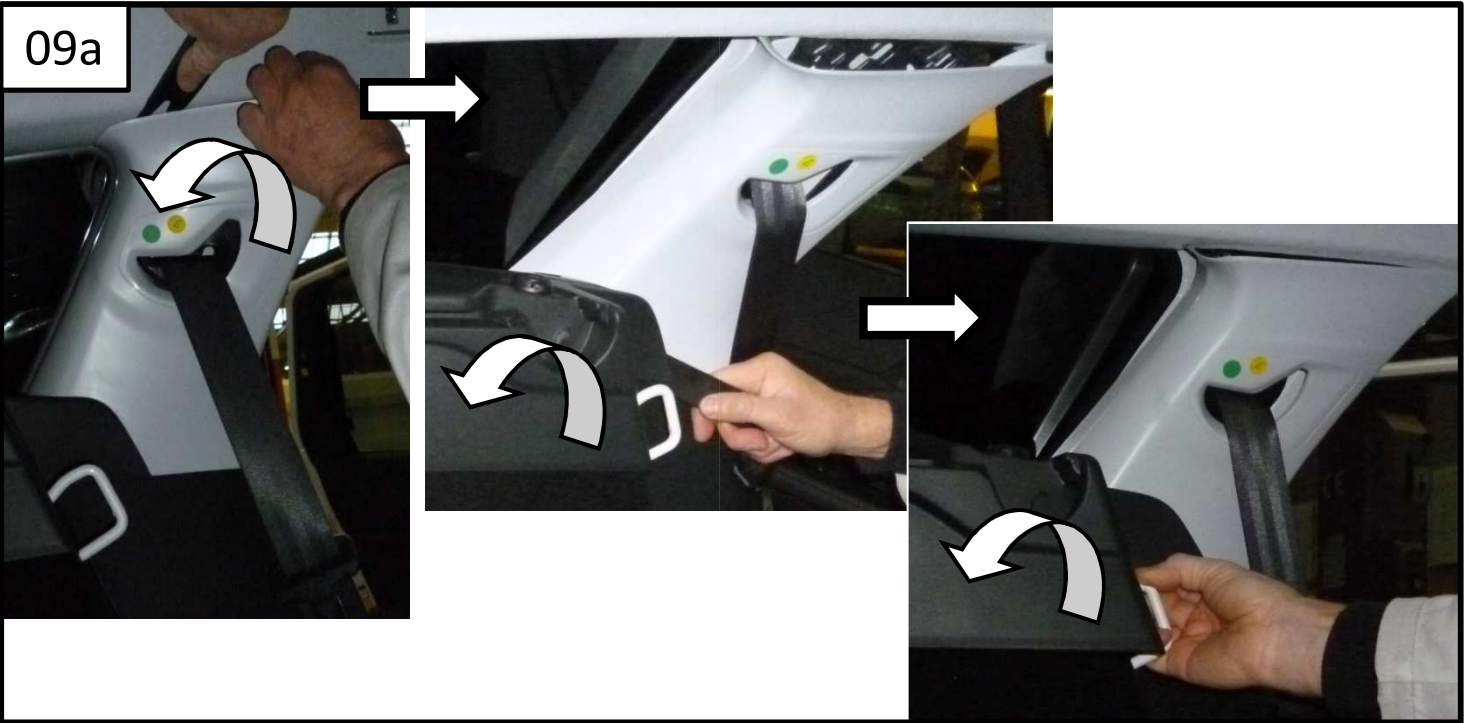

09a

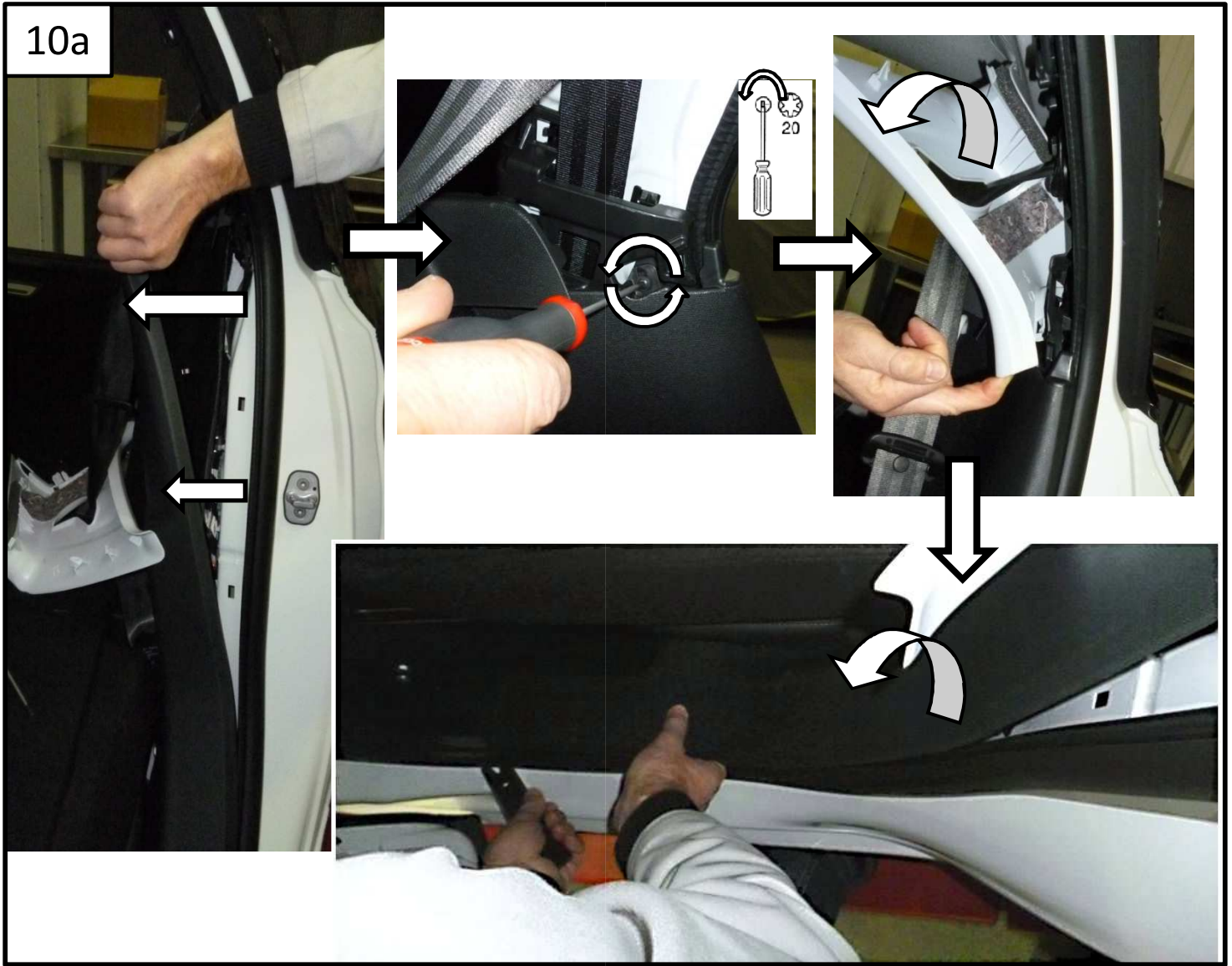

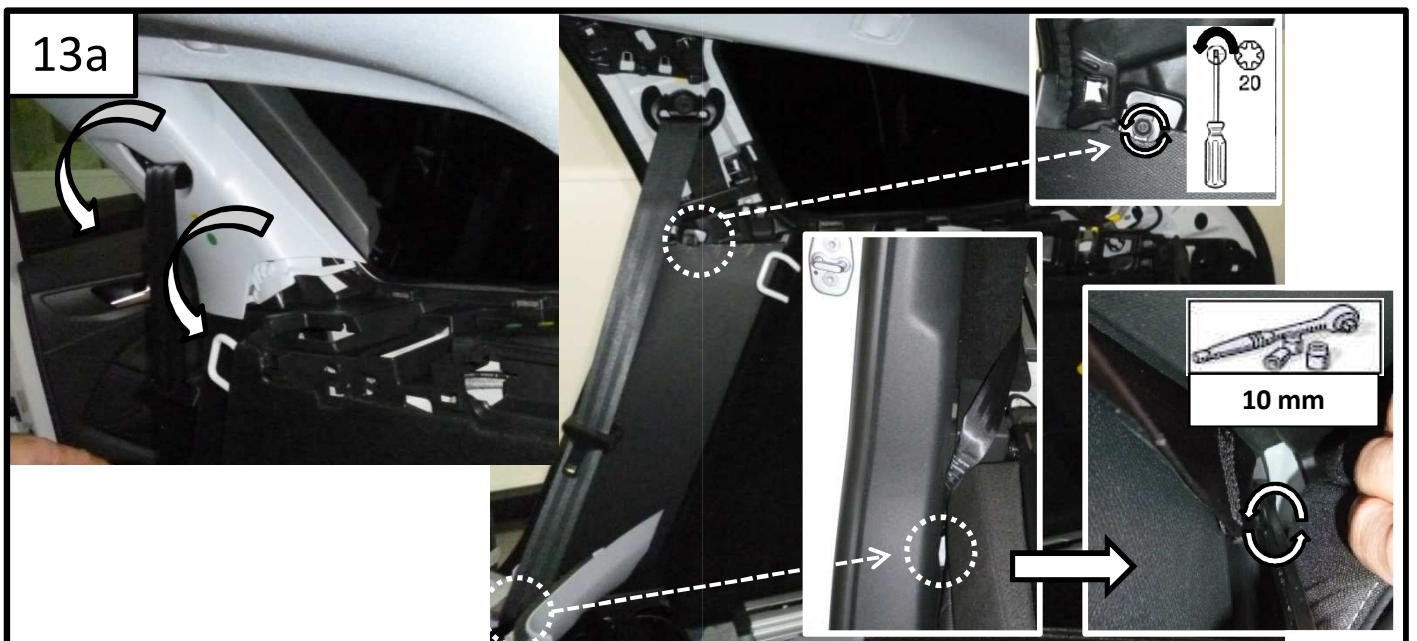
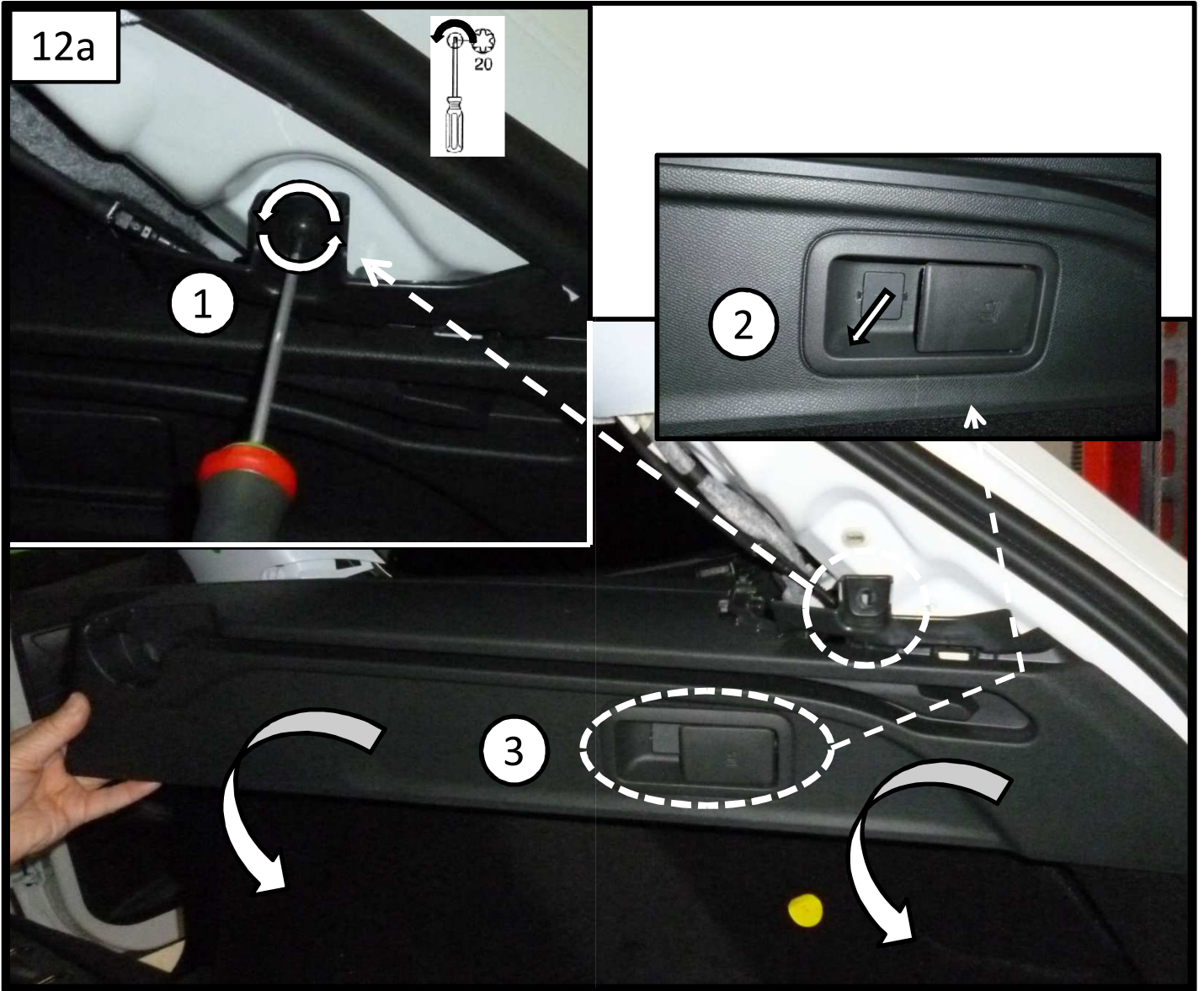

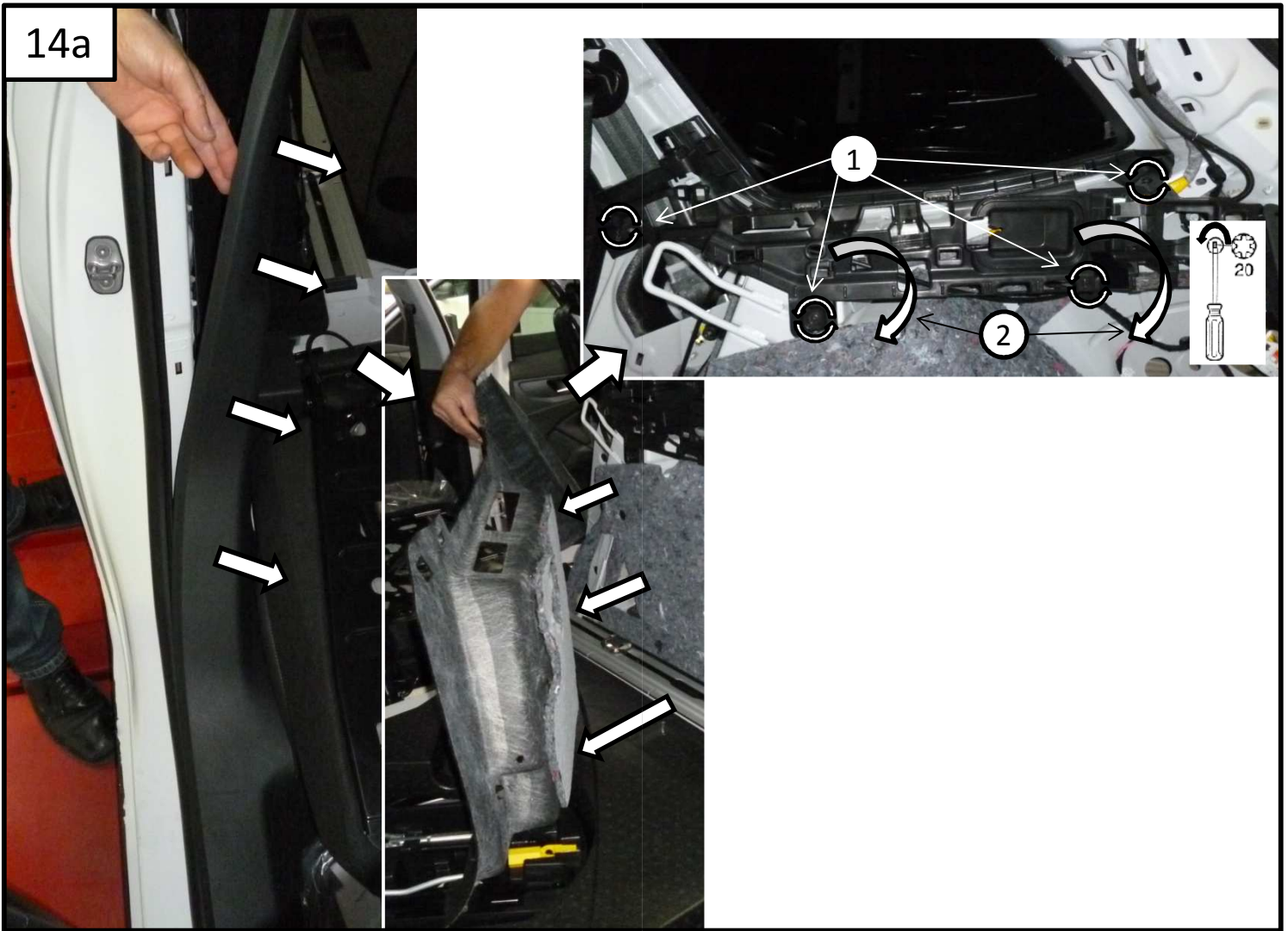



	308 (T91) p5	15
---	--------------	----

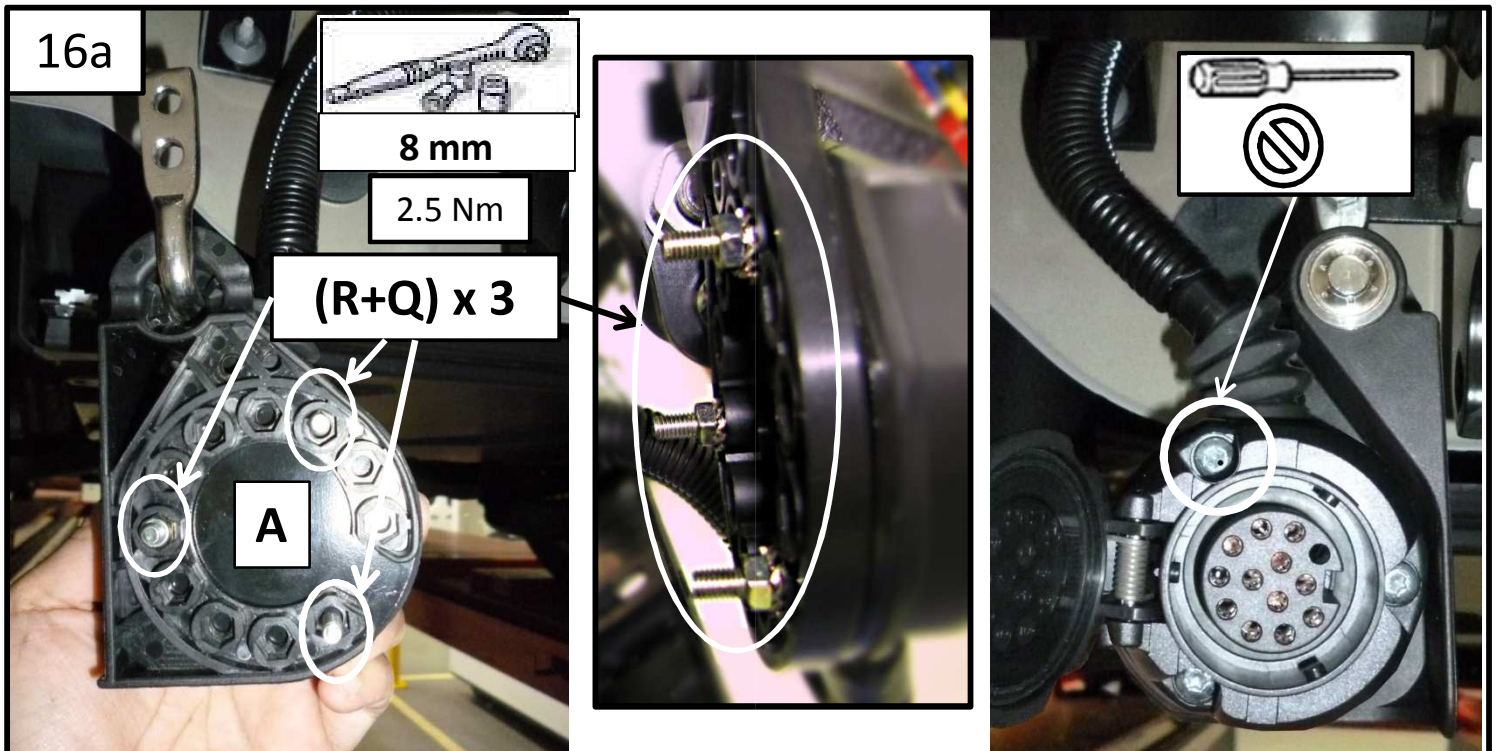

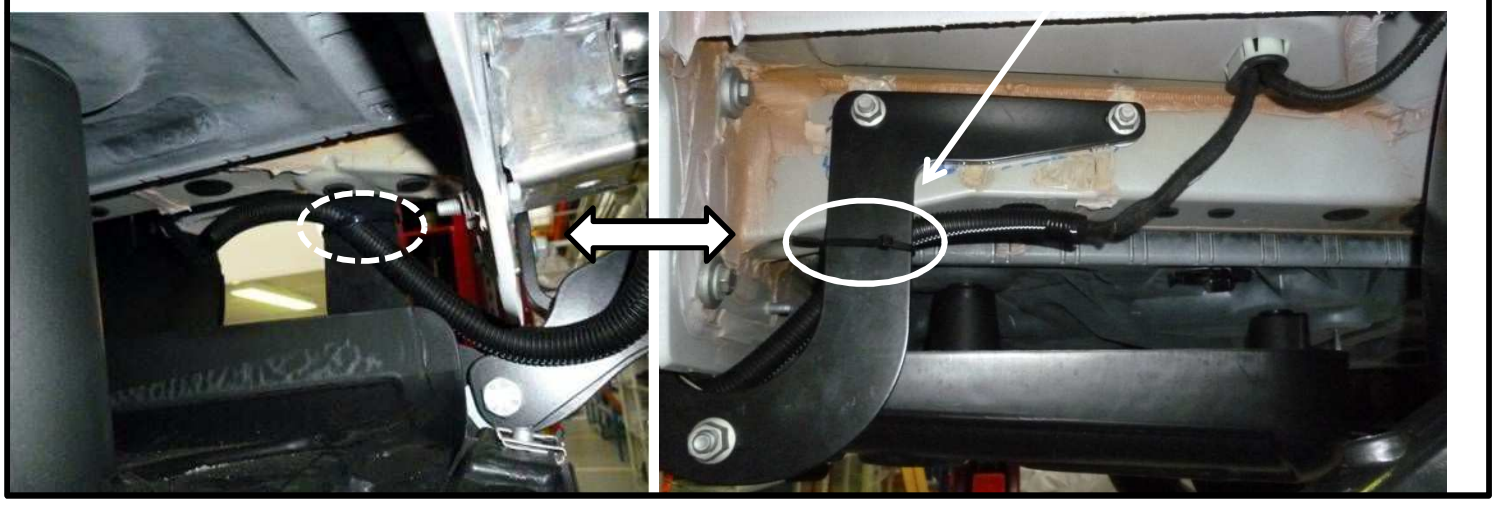
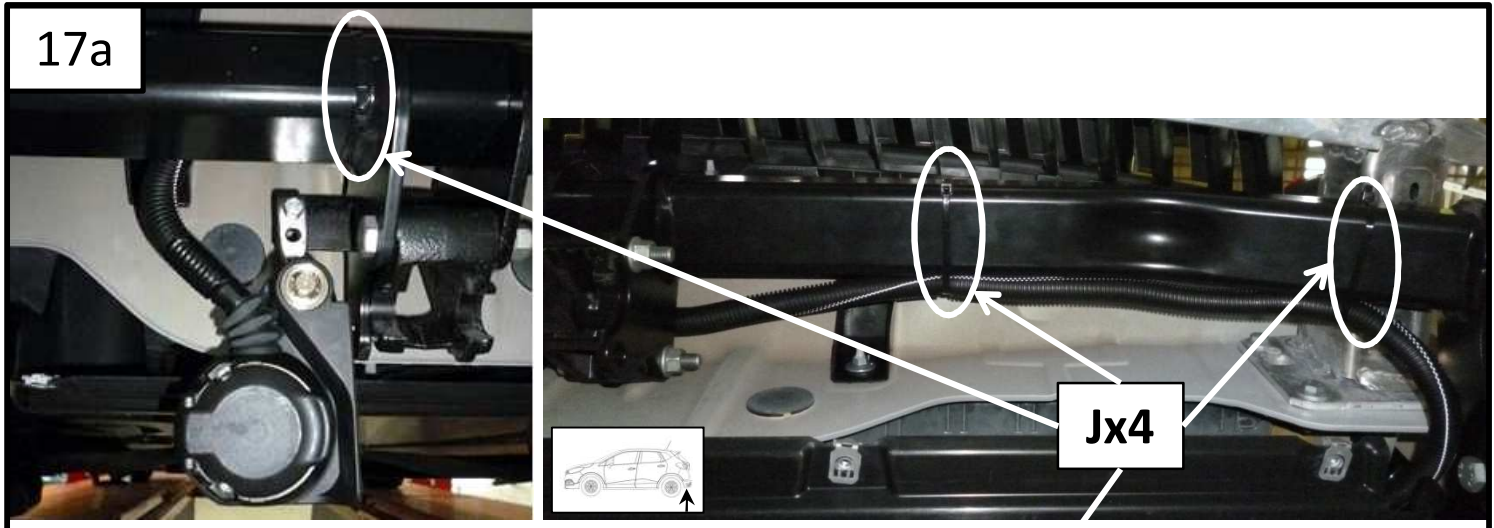

	308 (T91) p10	21	-->	26
--	---------------	----	-----	----

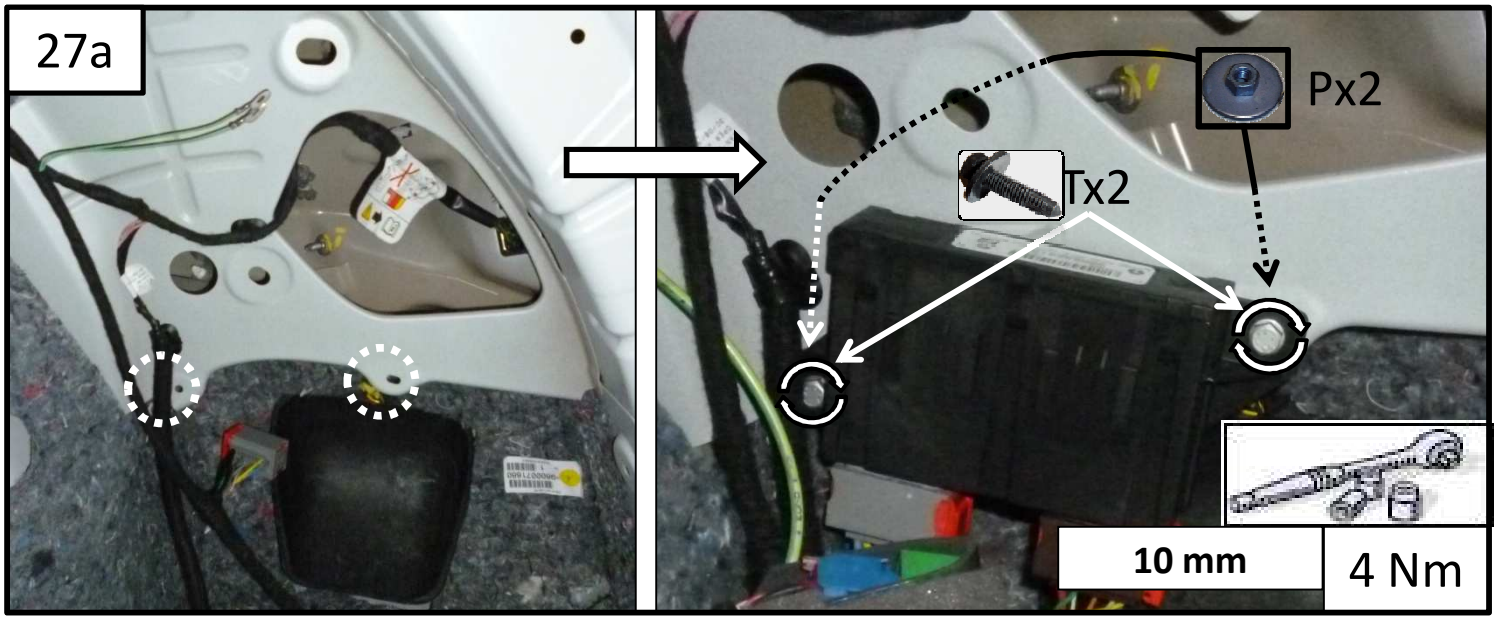

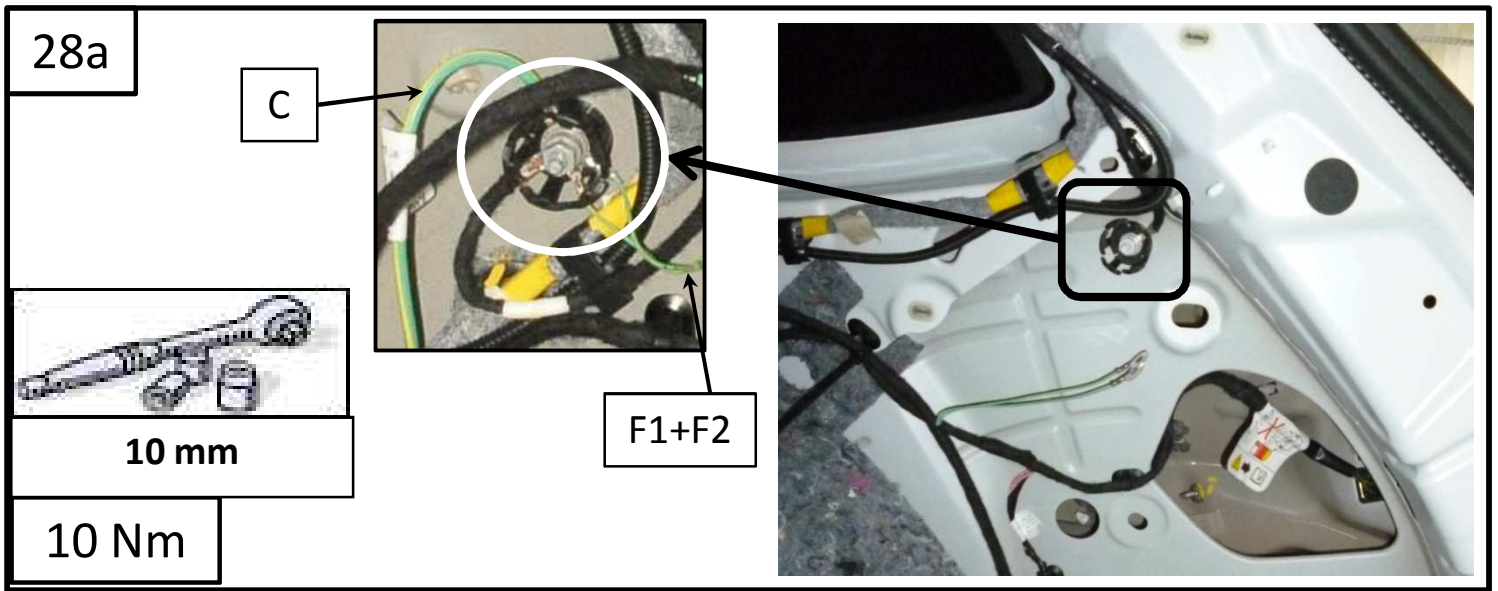

308 (T91) p12 29 ---> 30



308 (T91) p13 32 ---> 34

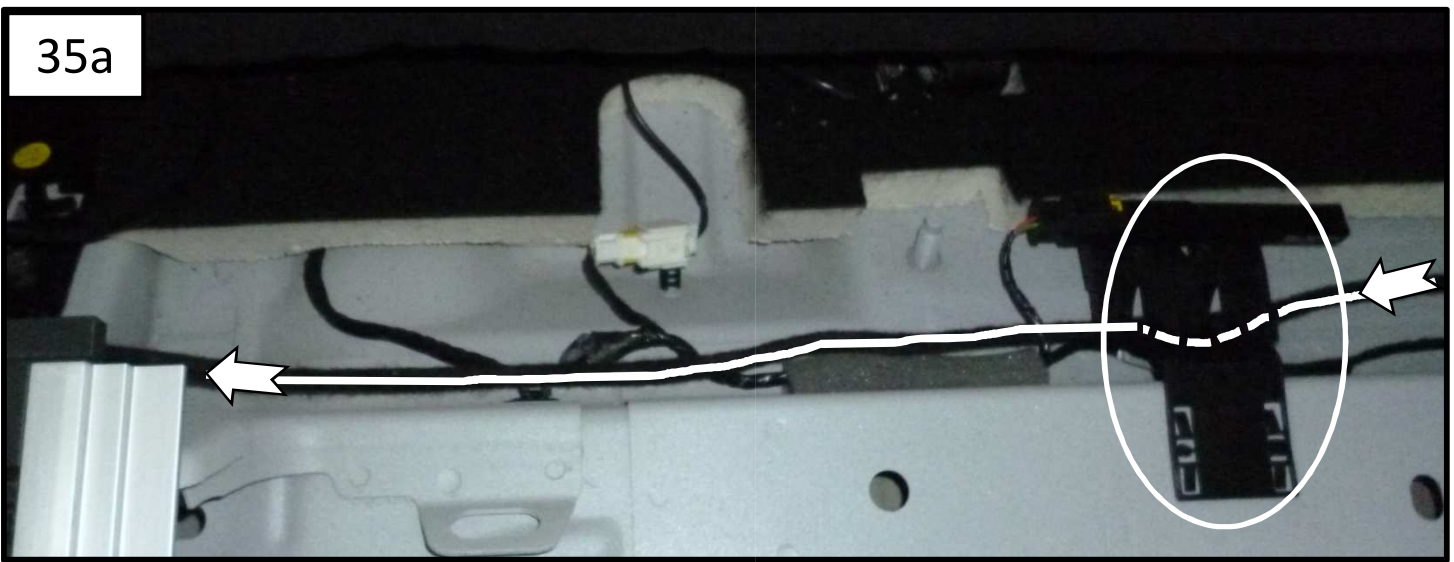

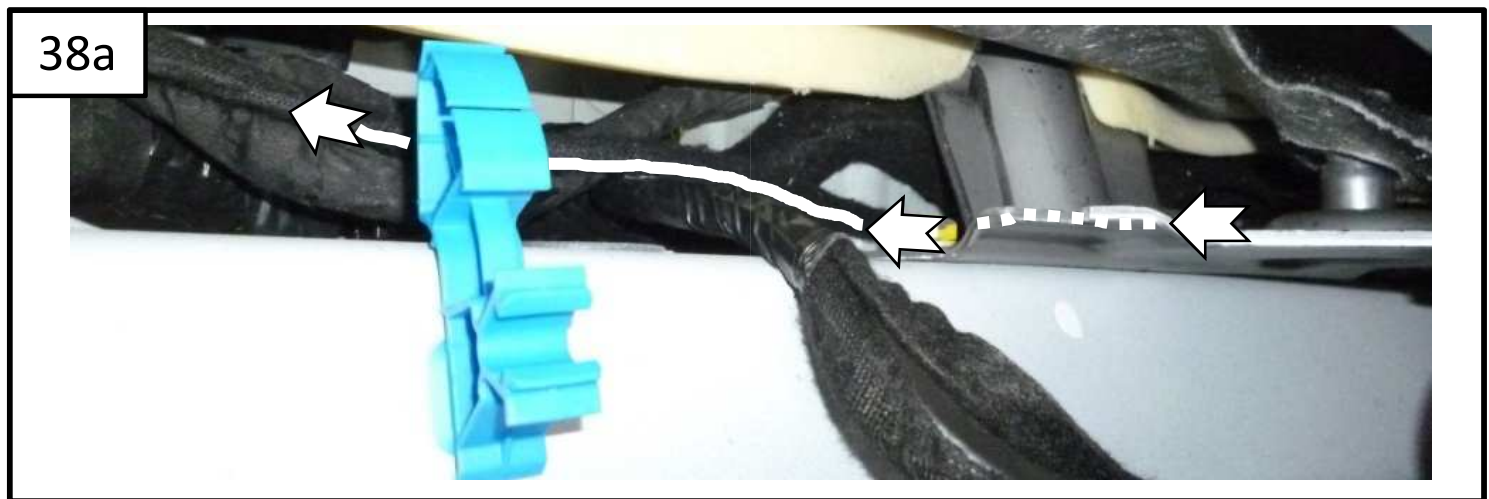
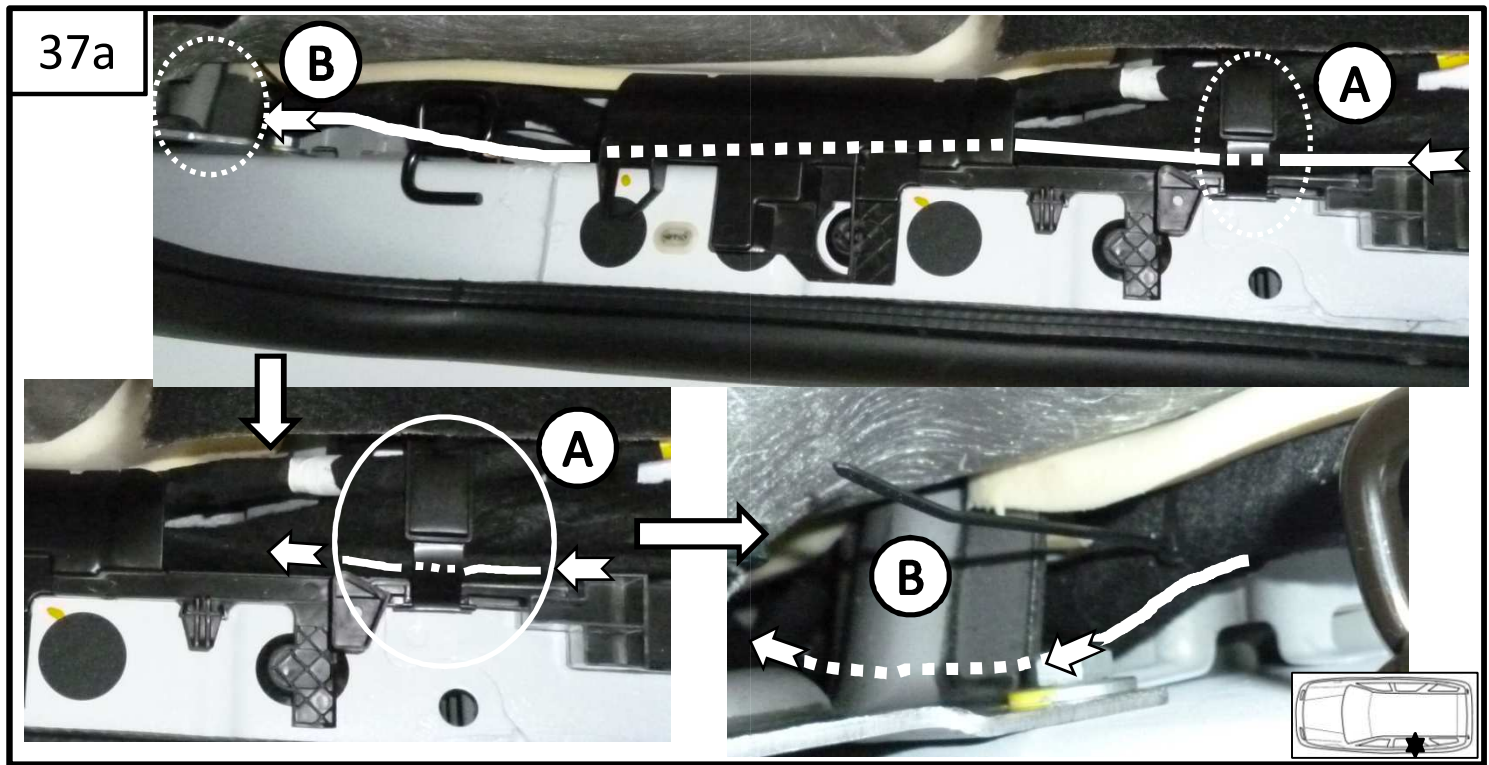
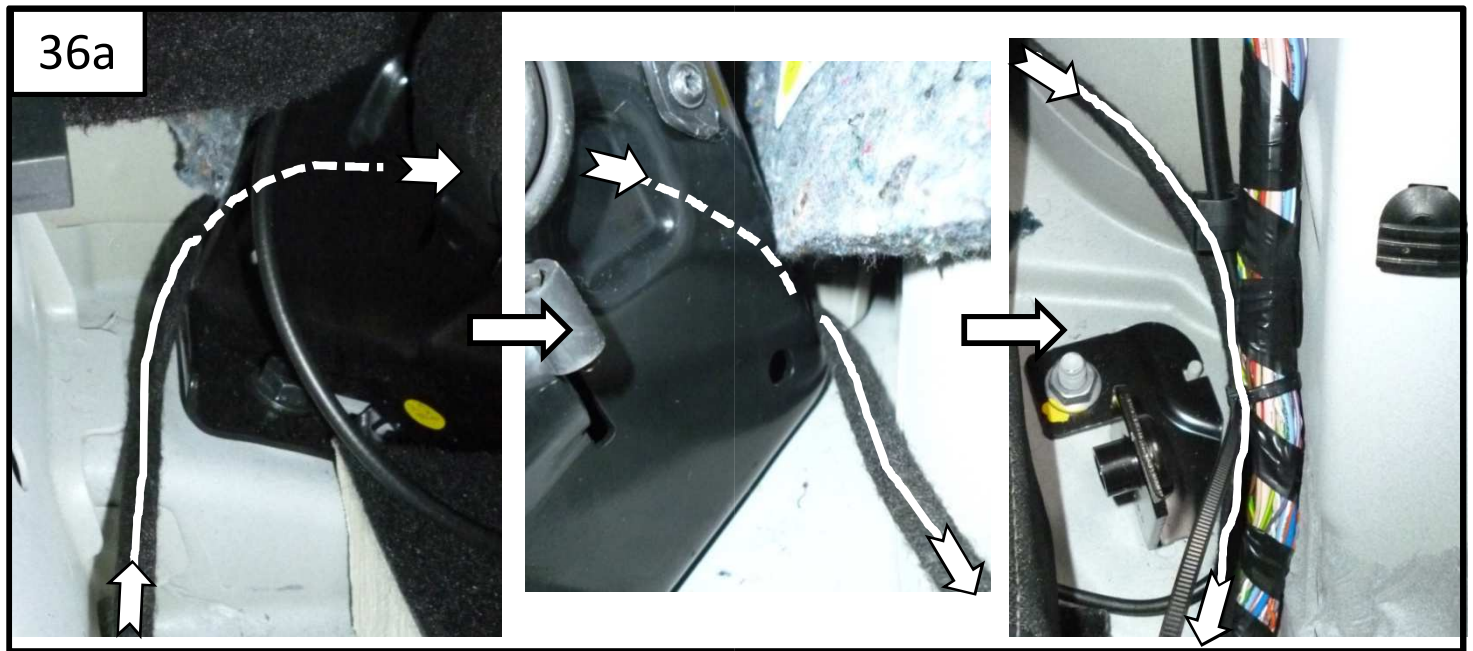

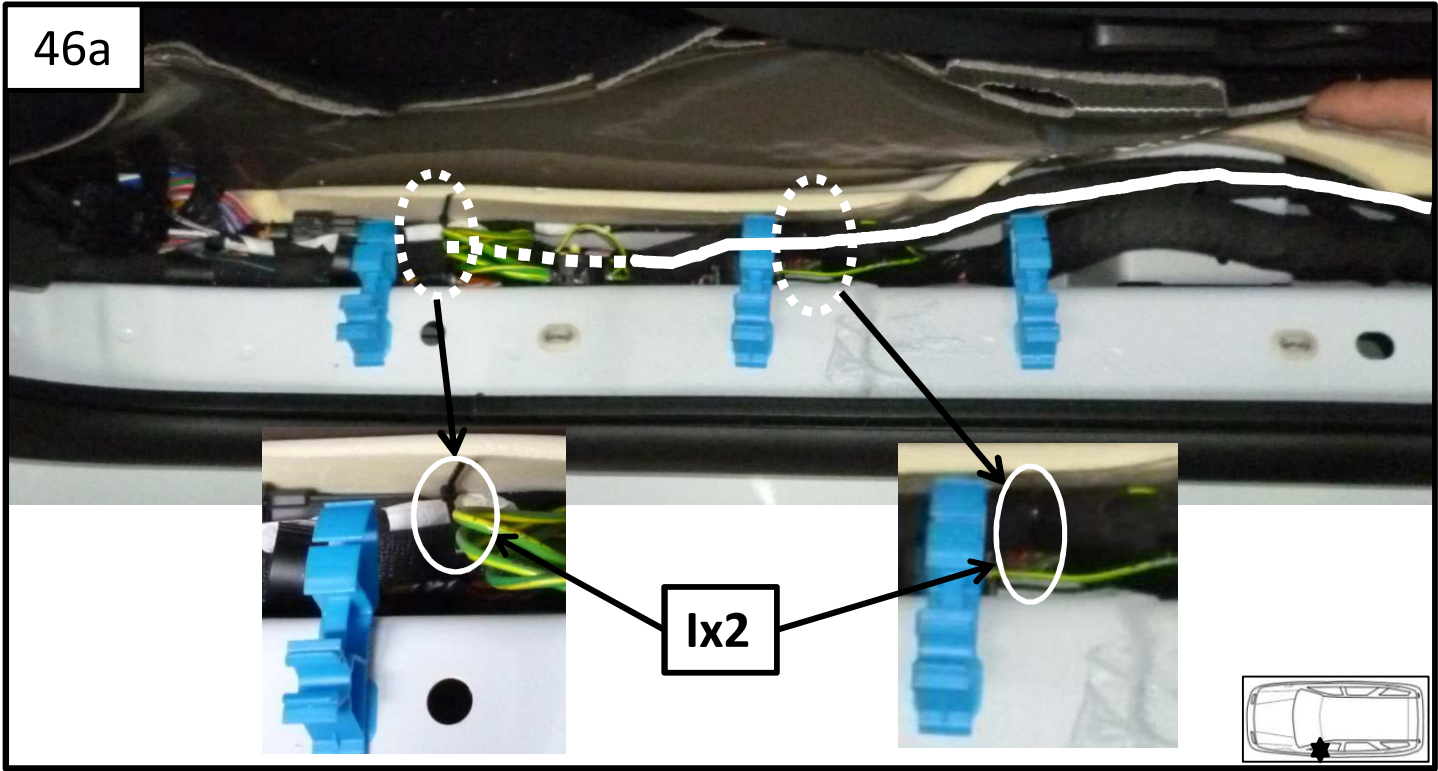

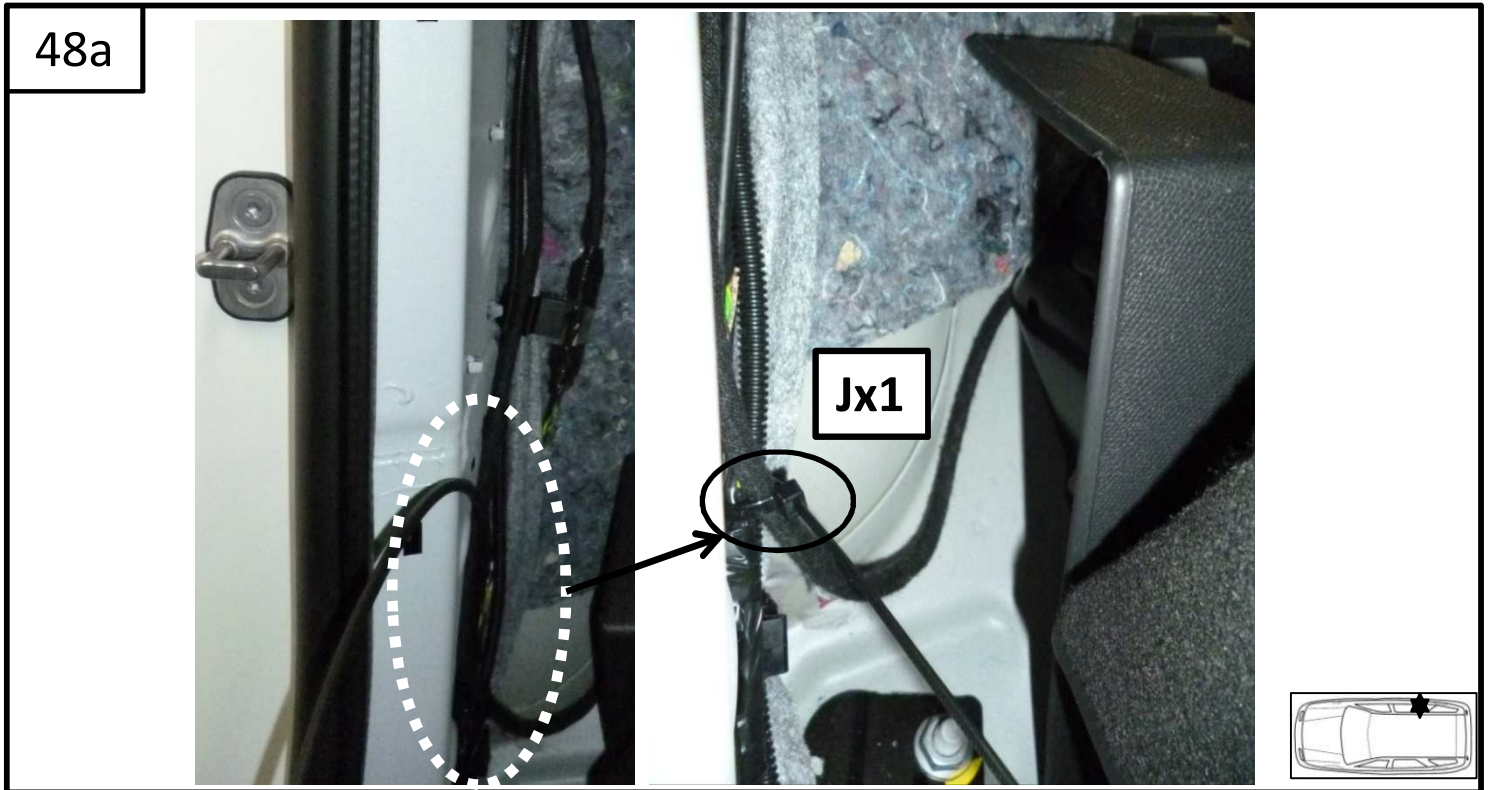
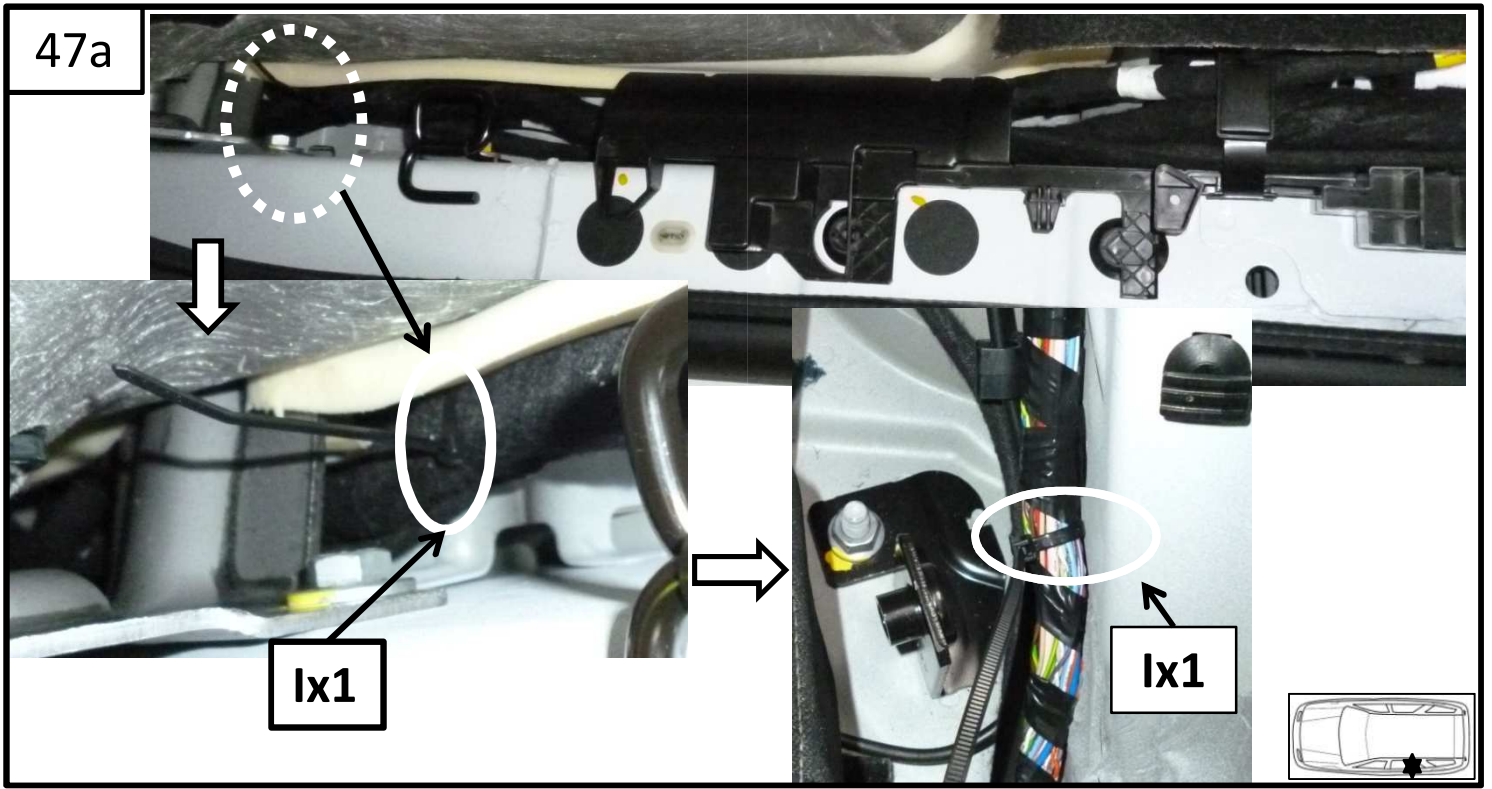

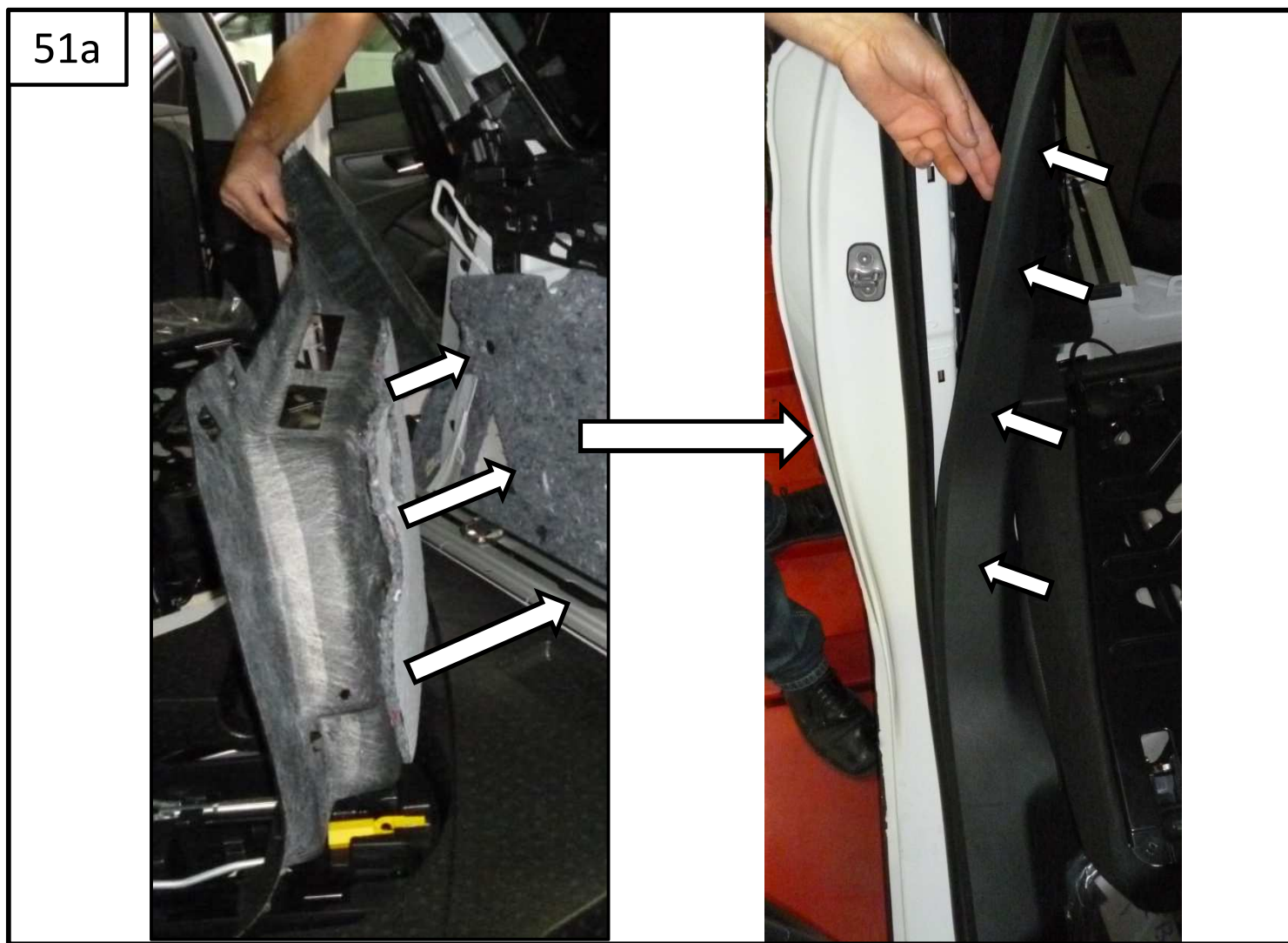
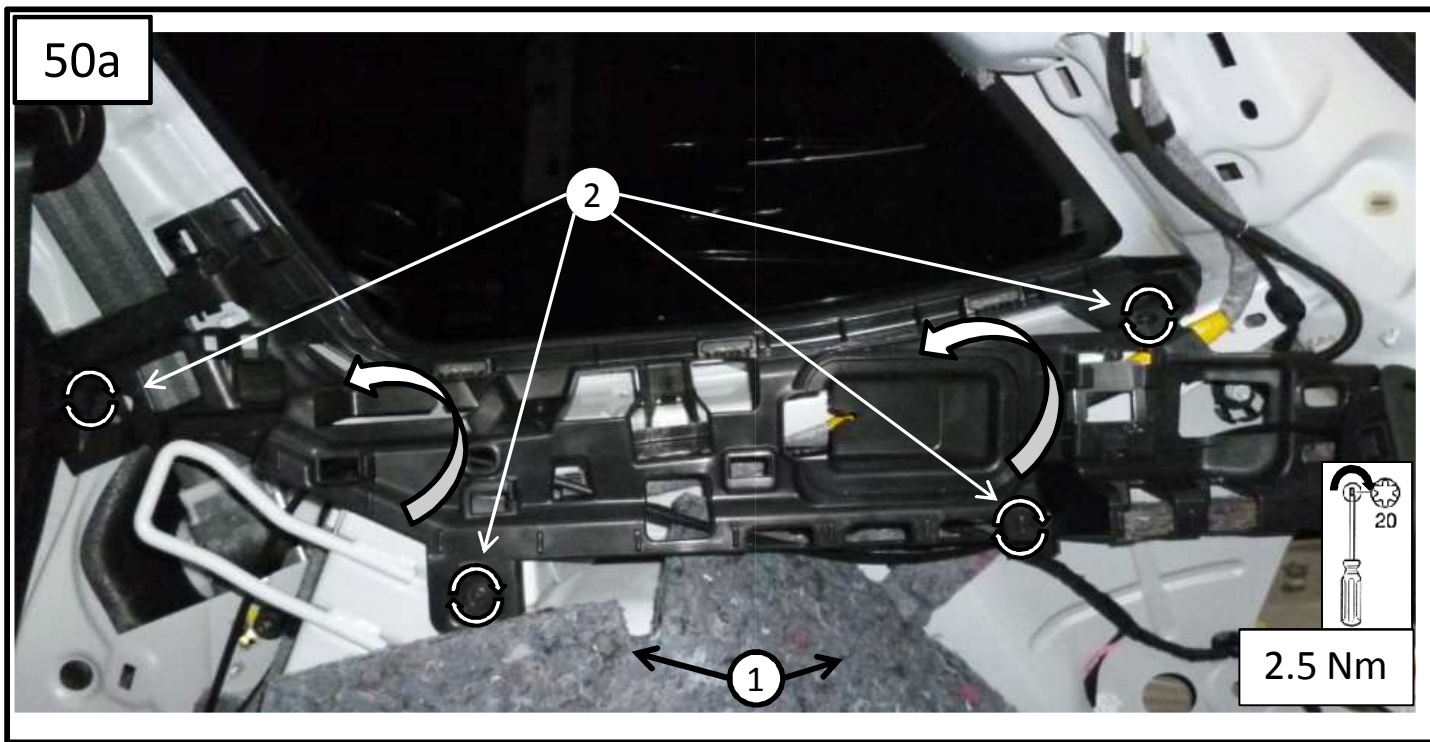

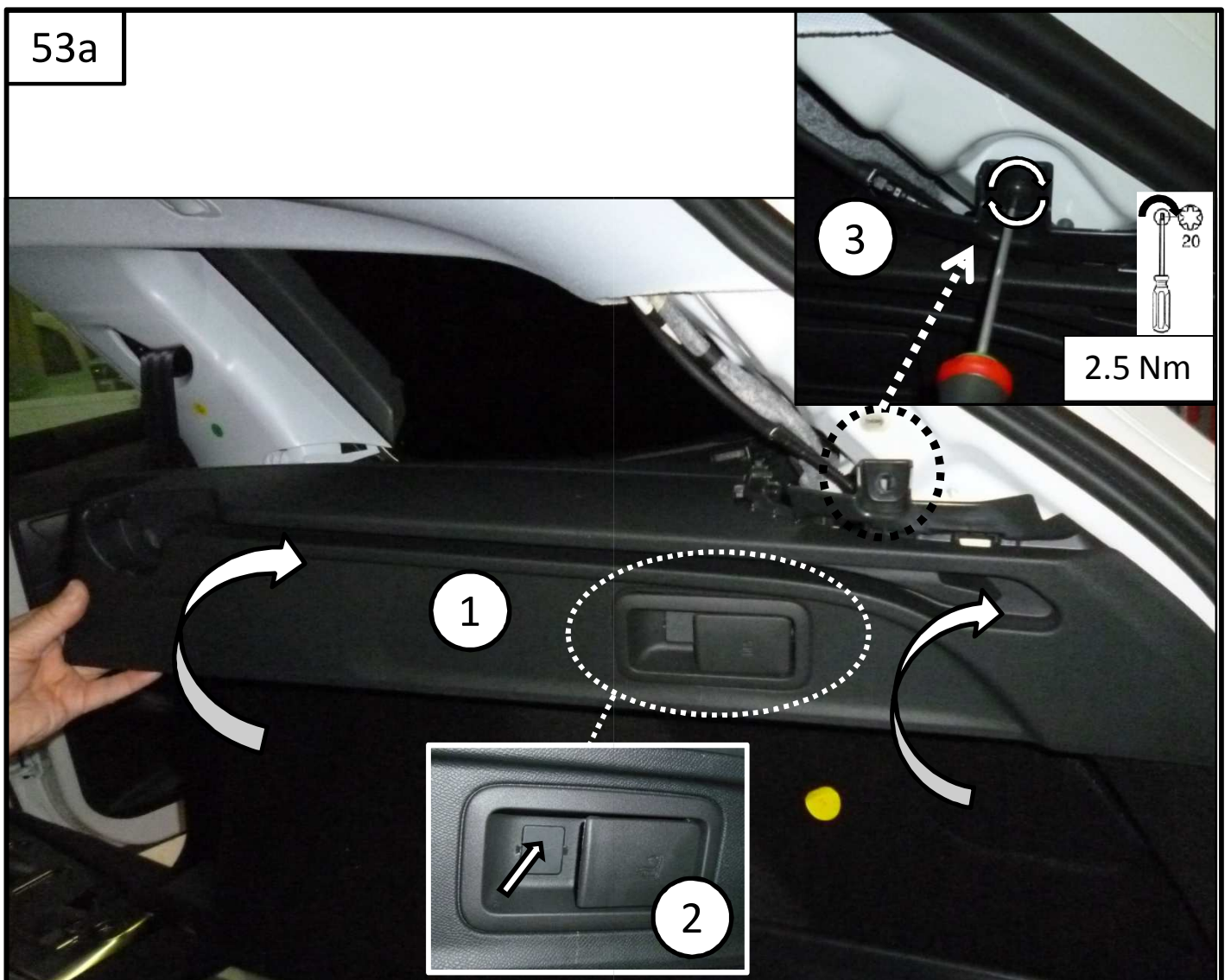
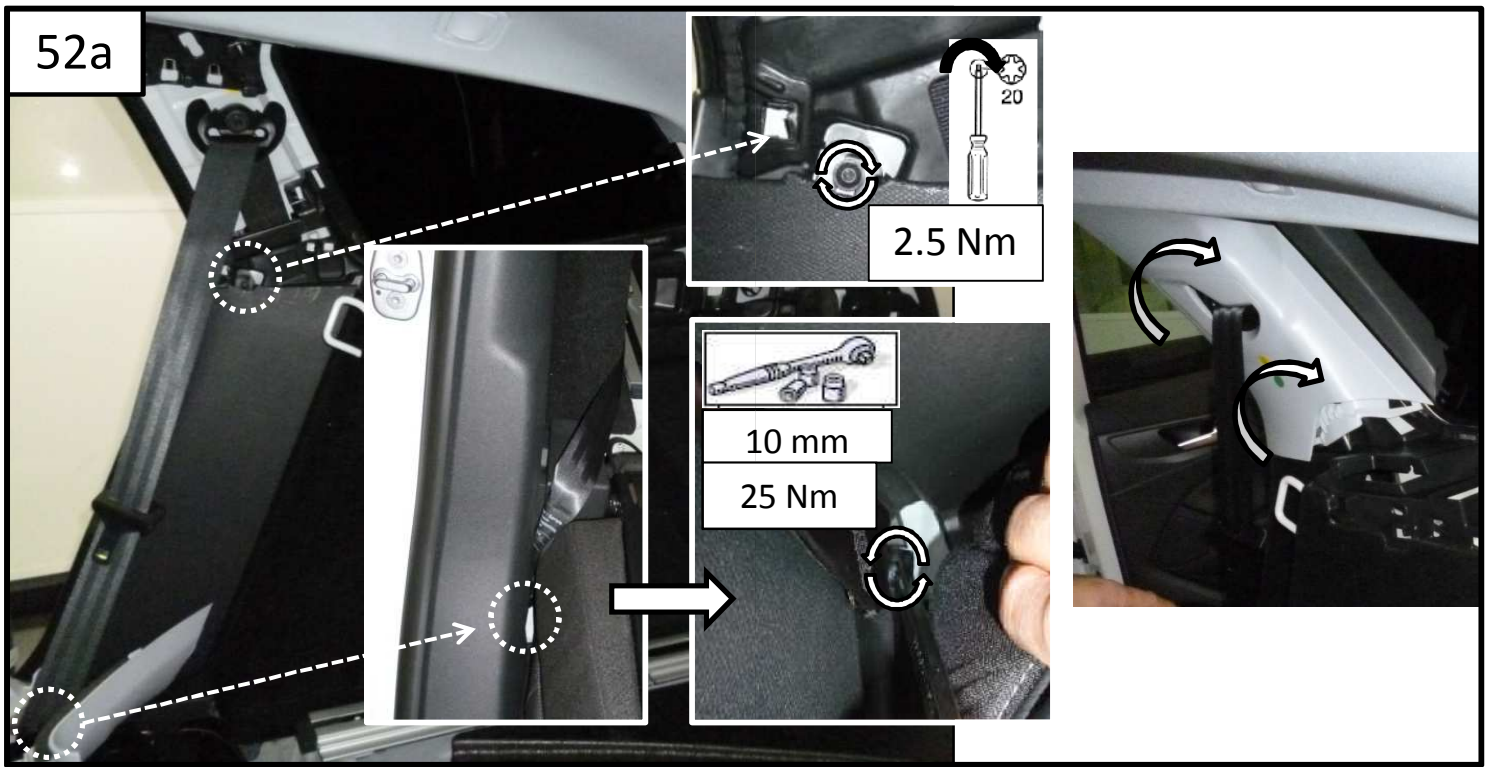



54a

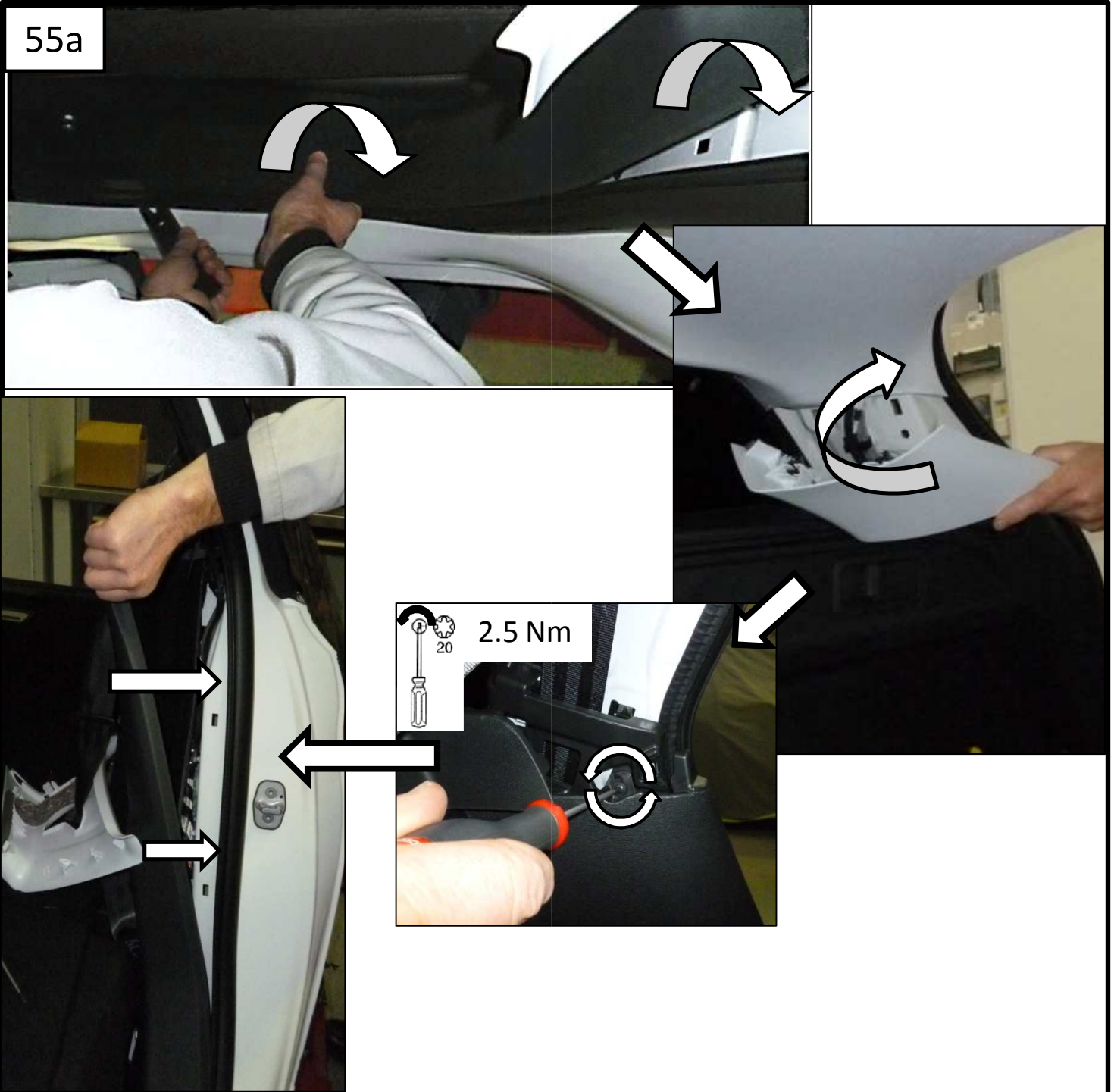

55a

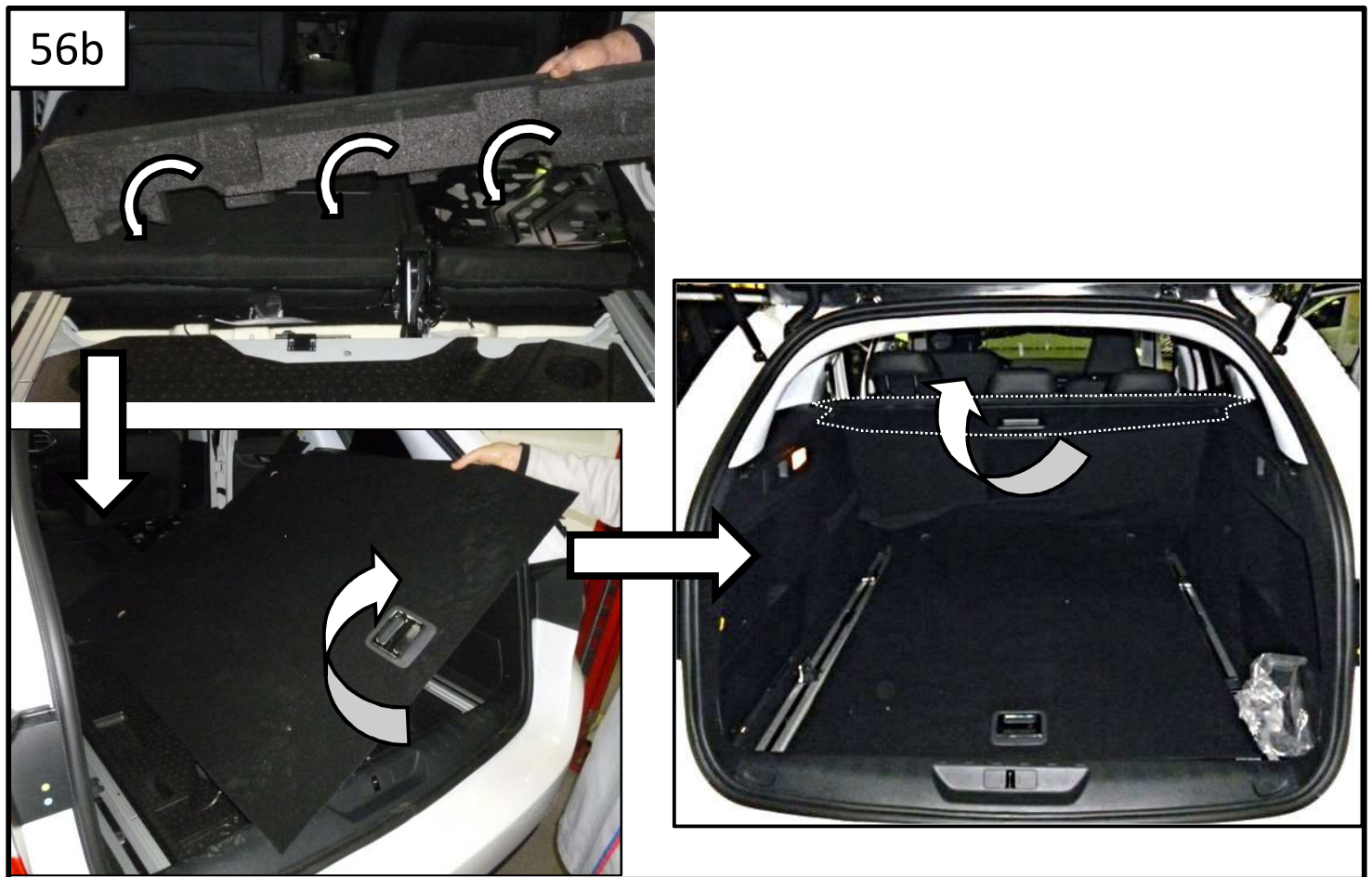
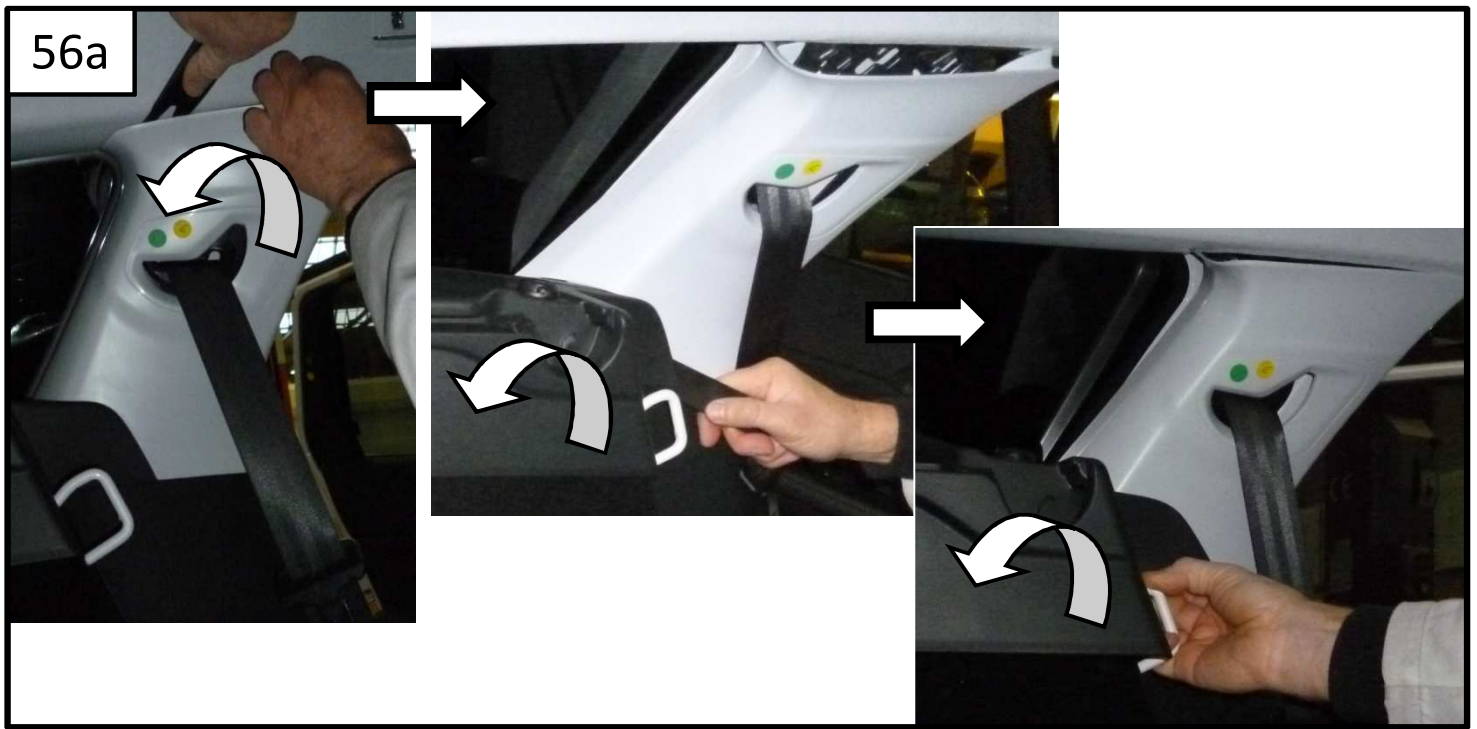



	308 (T91) p23	57	---	63
---	---------------	----	-----	----