

Parts to be installed.

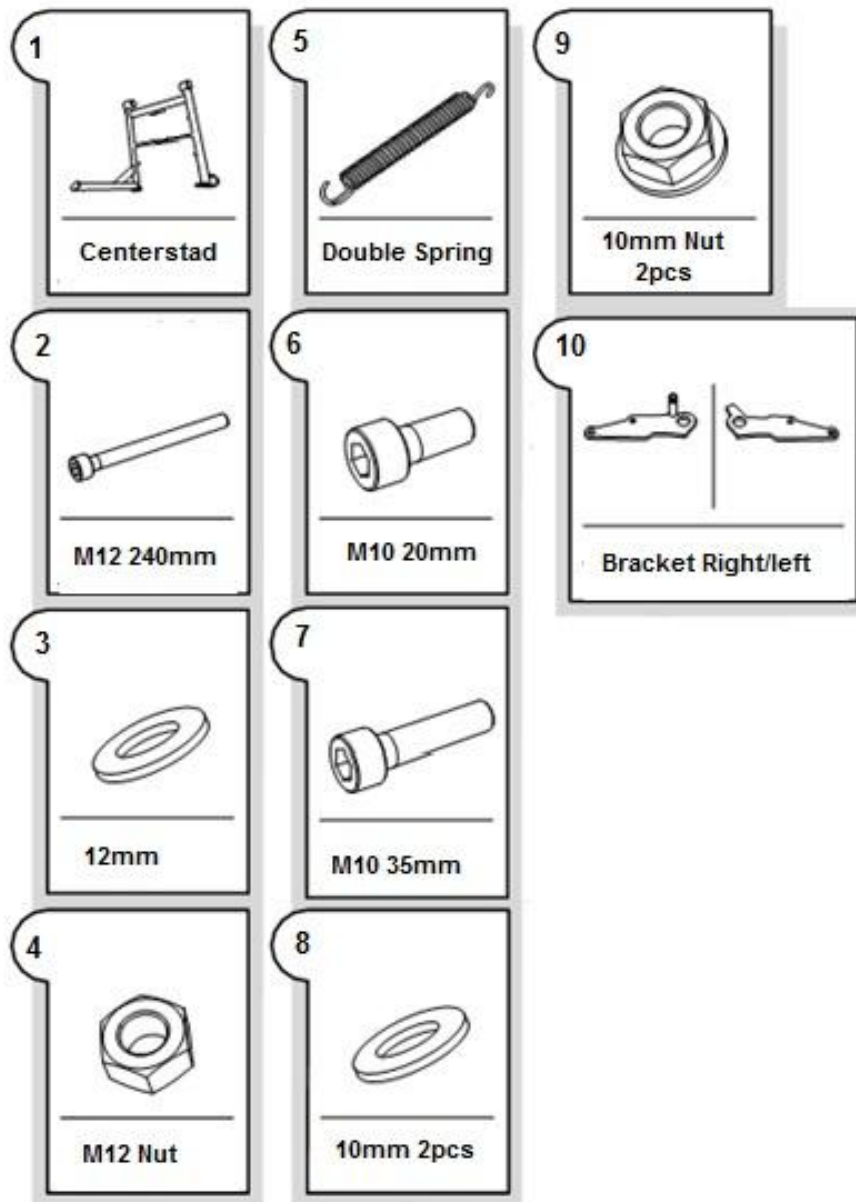

Photo 1

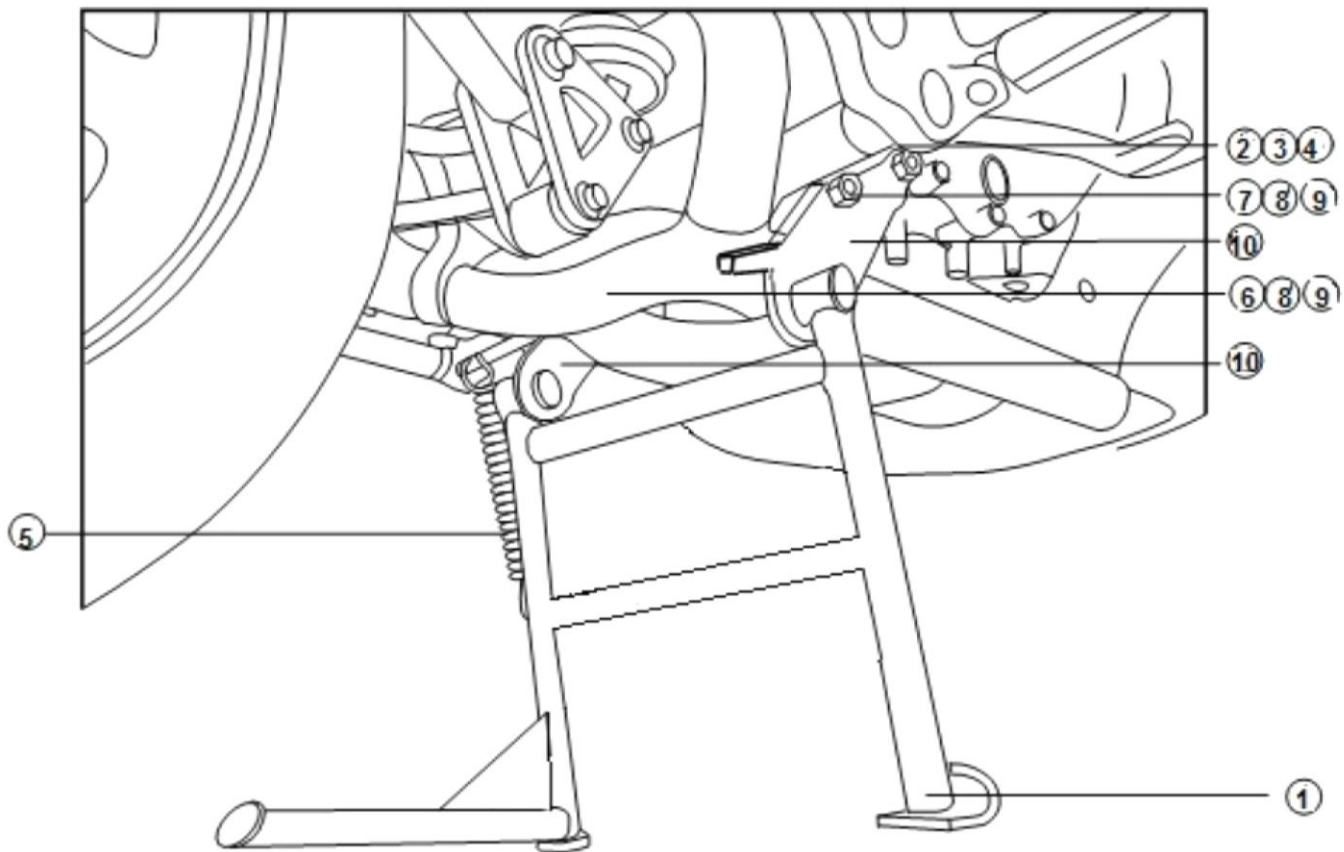

Photo 2

Step 1: Have the bike on the side stand.

Step 2: Remove the engine bolt.

Step 3: Install the left bracket (10) using the items (6),(8),(9) and do not have the nut fully tighten.

Step 4: Insert the bolt (2) with washer (3) from the left side. You will have to hold up the gear lever in order to insert the bolt. Do not push the bolt all the way through.

Step 5: Attach the centerstand (1) on the left bracket (10).

Step 6: Attach the right bracket (10) to the centerstand.

Step 7: Insert bolt (7) and the nut (8) with washer (9) and do not tighten the bolt.

Step 8: Push the bolt (2) all the way and do not tighten the nut and washer (3) and (4).

Step 9: Have the bike standing on the centerstand and tighten all bolts.

Step 10: Set the bike on the side stand and use a flat screwdriver to install the double spring. To make the installation easier have the centerstand on it's folded position.

Tips

Apply grease to the brackets (10) at the hole where the centerstand will be attached.

The first couple of times you will use the centerstand it might not fold on it's own.

From 2016 the double spring has been moved to the right side of the motorcycle.