

INSIDE! BUMPER 14-PAGE BTCC SEASON REVIEW

AUTOSPORT

OCTOBER 30 2014 • £3.60

With two teams on the brink of collapse...

F1 CASH CRISIS

Full story How total spend tops £1.5 billion

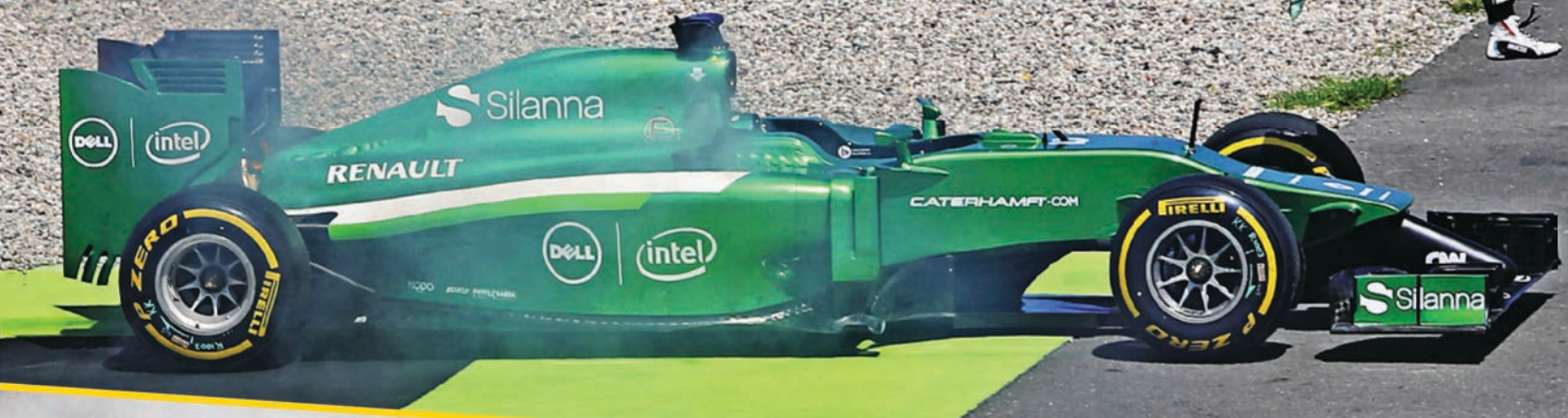

Marussia & Caterham on sidelines means smallest F1 grid since 2005



OGIER'S WRC TITLE MARCH

Second crown for VW superstar



haymarket

9 770269 946258



£3.60



Define yourself in three letters.

GTS. One name that declares the concentrated essence of Porsche.

Cars with increased power, enhanced specification and an amplified link to our motorsports roots.

Cars driven by individuals who always desire more.

The new 911 Carrera GTS models.

All that matters.

Find out more at porsche.co.uk/911CarreraGTS

Fuel consumption for the 911 Carrera GTS in l/100km (mpg): urban 13.7-12.2 (20.6-23.2), extra urban 7.5-6.7 (37.7-42.2), combined 9.5-8.7 (29.7-32.5); CO₂ emissions: 202-223 g/km. The mpg and CO₂ figures quoted are sourced from official EU-regulated test results, are provided for comparability purposes and may not reflect your actual driving experience.



PORSCHE



Innovation
that excites



THE ALL NEW NISSAN NOTE DRIVE SMARTER

Introducing the All New Nissan Note Style.
With an aerodynamic profile, unique diamond
cut alloy wheels and engine Stop/Start
system as standard across the range,
it's time to drive the smarter super-mini.
Now also available with interest free credit.

nissan.co.uk/offers

0% APR : £159
REPRESENTATIVE : PER MONTH



New Note Range £9,995 - £17,830. URBAN 45.6-67.3mpg (6.2-4.1L/100km), EXTRA URBAN 62.8-88.3mpg (4.5-3.2L/100km), COMBINED 55.4-80.7mpg (5.1-3.5 L/100km), CO₂ emissions 119-90g/km.

Offer valid until 31 December 2014 at participating dealers only. Note 1.2 Acenta Premium Style DEPOSIT REQUIRED OF £3,537.97, FOLLOWED BY 24 PAYMENTS OF £159 AND OPTIONAL FINAL PAYMENT OF £7,571.03, please visit www.nissan-offers.co.uk or your local dealer for full details. This offer is not available on Visia Limited Edition. Offer based on 8,000 miles pa, excess mileage 8p per mile. Offers not available in conjunction with any schemes or other offers and at participating dealers only. Finance provided by RCI Financial Services Limited, PO Box 149, Watford WD17 1FJ. Subject to status. Guarantees and indemnities may be required. You must be at least 18 and a UK resident (excluding the Isle of Man and Channel Islands). Terms and conditions apply. All prices include first registration fee and 12 months road fund licence. Information correct at time of going to print. Model shots shown are for illustration purposes only. Models subject to availability. Breakdown services provided by RAC Motoring Services and/or RAC Insurance Ltd. Model shown has metallic paint at £500 inc VAT. Nissan Motor (GB) Ltd, The Rivers Office Park, Denham Way, Rickmansworth, Hertfordshire WD3 9YS. MPG figures are obtained from laboratory testing, in accordance with 2004/3/EC and intended for comparisons between vehicles and may not reflect real driving results. (Optional equipment, maintenance, driving behaviour, road and weather conditions may affect the official results.)

POLE POSITION

F1 needs to act now to protect its smaller teams

THE LAMENT “YOU’LL MISS US WHEN WE’RE GONE” rings true for Caterham and Marussia. It’s all too easy to dismiss them falling into administration as a case of the weak dying out to leave the strongest to survive – who cares about the cars that lap 3-4s off the pace, anyway? But you should, because next in the firing line will be Sauber. Then Lotus. They will likely be at the back at Austin this weekend, and suddenly their investors will be asking, “Why are we paying all this money for that?”

Third cars, run by the top teams, that’s the answer. Really? Sure, the mouthwatering prospect of the opportunity for Fernando Alonso to leap into a third Mercedes next year to take on Lewis Hamilton and Nico Rosberg appeals. But at what cost? And what do we do if Sauber and Lotus disappear? Four-car teams? Imagine that, surely consigning the mid-sized teams (we’re now talking Force India and even Williams) to their back-of-grid doom.

This week we revisit our *True Cost of F1* feature we first ran last year. Dieter Rencken toils hard to compile and produce it, since the teams really don’t want you to know what they spend and receive, and I get a decent amount of bleating (and the odd snide Tweet) about it. But it’s worth it, because at least I know we’re doing something to highlight the sheer unsustainability of the current spending levels. May I suggest that they save their breath this year, sit down around a table with Bernie and come to some decisions that benefit the sport rather than their own interests for once?



Bradley

CHARLES BRADLEY EDITOR

charles.bradley@haymarket.com

@Autosport_Ed

COVER STORY



“We must speak about reducing [F1] costs by 30-40 per cent”

FIA president Jean Todt, p23

COATES/LAT

FIND US ON



Cover images: Thompson/Getty, Tee/LAT, Bettiol/Getty

PIT & PADDOCK

8 THIS WEEK IN F1

11 JONATHAN NOBLE: F1 NEWSHOUND

12 THIS WEEK IN MOTORSPORT

24 US GP PREVIEW

SPECIAL REPORT & DEBRIEFS

14 CASH CRISIS: THE TRUE COST OF F1

We investigate the teams’ accounts to find out what they’re *really* spending – as well as what they’re actually earning. The numbers will shock you

20 BREAKING POINT FOR SMALL F1 TEAMS

What the troubles for cash-strapped Caterham and Marussia mean for the future of Formula 1

26 LMP3: A NEW PATH IN SPORTSCARS?

Assessing the new ‘baby’ prototype division

BTCC REVIEW

30 HOW TURKINGTON TOOK THE CROWN

There was plenty of debate about his rear-wheel-drive car, but Colin Turkington deserved his second title

34 AUTOSPORT’S TOP 10 DRIVERS

We rank the star performers of the BTCC year

35 COLIN TURKINGTON: INSIDE LINE

The BMW ace writes exclusively for AUTOSPORT

36 THE CHAMPIONS RETURN

Tin-top legends Alain Menu and Fabrizio Giovanardi tell all about their difficult comeback season

40 PLATO AND MG: SUCCESS OR FAILURE?

Jason Plato’s three-year deal with MG has come to an end with plenty of wins but no drivers’ title

RACE CENTRE

47 V8 SUPERCARS; TC2000; FRENCH GT

48 WRC SPAIN

Ogier recaptures mojo for second championship

53 ERC; NASCAR

54 WTCC SUZUKA

Jose Maria Lopez lifts the crown with one round to run

CLUB AUTOSPORT

65 YOUNG DRIVER EVALUATION

The contenders for this year’s McLaren AUTOSPORT BRDC Award get put through their paces

66 COVENTRY SPRINT EVENT PLANS

City council involved in plans to host sprint event on Coventry ring road as part of racing festival

70 NATIONAL REPORTS

Brands Hatch Formula Ford Festival and supports; Silverstone 750MC Birkett Six Hour Relay; Snetterton MSVR; Oulton Park MSVR

SUBSCRIPTION OFFER

78 FREE McLAREN MEDIA BAG

Subscribe for a great free gift and digital package

THE BACK STRAIGHT

82 THIS WEEK

Readers’ letters; best pictures; product reviews

84 WHAT’S ON

The best track and TV action in the coming week

86 RACE OF MY LIFE: SCOTT MAXWELL



THE BIG PICTURE

Jamie Whincup took a big step towards a sixth V8 Supercars title with first and second places in the two races at Surfers Paradise in his Triple Eight Holden shared with Paul Dumbrell





GIVES YOU WINGS

INSILVON



CALTEX
MAVERICK



Red Bull

CALTEX
HOLDEN

class

805

805

805

This week in F1

Parry gets prize McLaren test

McLaren AUTOSPORT BRDC Award winner Matt Parry undertook his chance-of-a-lifetime test on Monday in the Formula 1 McLaren MP4-26 that Jenson Button steered to victory in the 2011 Canadian Grand Prix. "It's hard to describe how fast it is; I've never driven anything remotely close to the speed," said Parry, 20, who drove at Silverstone. "Every gear is just another power band."

➔ P65 CLASS OF 2014 IN ACTION AT SILVERSTONE



Customer teams can't win titles, says Dennis

McLaren chief Ron Dennis believes customer teams will never be able to win a world championship under the current engine regulations.

McLaren will switch to Honda power next year, and Dennis reckons works teams have a huge advantage in getting the most out of the new hybrid systems.

"The one thing that jumps at you, if you look at all the qualifying sessions this year, is the time difference between the Mercedes works team and other teams," Dennis said. "My opinion, and it is an opinion held by many people within our organisation, is that you have no chance of winning the championship if you are not receiving the best engines from whoever is manufacturing yours."

REMEMBER WHEN



The last time McLaren won a constructors' title without a 'works' engine supply. It beat Ferrari to the crown by eight points using the Ford DFV engine that powered the majority of the grid.

88



PROST: MERC MAY BE BEATABLE IN 2015

Former world champion Alain Prost has warned Mercedes that its domination of Formula 1 could end as early as next year.

When asked by AUTOSPORT if, despite its strong form, Mercedes could be beaten as early as next year, Prost said: "It can. When you have this kind of domination, it's going to be difficult [to beat it], but not impossible. The way you can make things different on the chassis is limited, but altogether – team and engine – they [Mercedes' rivals] can do a better job."

Hopefully the power units should converge into next season, and we should be able to give them a much bigger fight.



Red Bull boss Christian Horner

BIG NUMBER

31

The number of times over the 56-year history of the world championship for constructors that a team hasn't managed to retain its title the following season.

For all the breaking news, visit AUTOSPORT.COM

FERRARI DEFENDS RAIKKONEN FORM

Ferrari insists Kimi Raikkonen's performance is improving, despite a season-long podium drought since rejoining the Scuderia.

Raikkonen has struggled with the handling of his Ferrari for most of the 2014 season and his best result remains fourth in August's Belgian Grand Prix.

However, Ferrari team principal Marco Mattiacci insists that the

2007 world champion is driving more competitively, despite his driver's best results since Belgium being a pair of eighths.

"Definitely we see the pace of Kimi improving," Mattiacci said. "Does it translate immediately into more points in the races? Evidently not, but there have been a series of events that didn't allow this. But he's increasing the speed."

It is not easy to be his [Alonso's] team-mate, and for sure the problem Kimi is having [this year] is in his head.



Felipe Massa reckons Alonso is out-psychoing Raikkonen at Ferrari



Michael to leave McLaren

McLaren sporting director Sam Michael is to depart from the team at the end of the season.

Michael said Michael was leaving "on extremely good terms", having handed in his notice in March as part of a long-term plan to move back to his native Australia.

Michael joined the team at the end of 2011, having previously been technical director at Williams.

While confirming Michael's departure, McLaren denied reports it is set to part with chief operating officer and acting CEO Jonathan Neale and technical director Tim Goss.



Lotus Junior Ocon makes F1 test debut

FIA Formula 3 European champion Esteban Ocon tested a 2012 Lotus F1 car at Valencia last week. The French teenager completed more than 150 laps over two days and drove "exceptionally well", according to the team's trackside operations director Alan Permane. Adderly Fong and Roy Nissany also had F1 runs at Valencia, both driving for Sauber.



Kvyat will not change style

Daniil Kvyat says he will not alter his approach to Formula 1 when he graduates from Toro Rosso to Red Bull next season.

"My approach since I have come to F1 hasn't changed a lot from when I was in GP3 or Formula 3," Kvyat said. "Red Bull picked me up because they like my approach, so I'm not planning to change anything, because this is probably why they decided [to go] with me."

Lotus expects to keep Grosjean



Lotus believes that Romain Grosjean will remain with the squad in 2015, although a new deal has not yet been finalised.

The team's poor results mean Grosjean is free to leave at the end of the current campaign, but he hinted during the recent Russian Grand Prix that Lotus' 2015 Mercedes engine deal would make him more likely to stick with the Enstone squad.

Team owner Gerard Lopez confirmed he now expects to retain his current driver line-up for 2015. "I don't expect any changes," Lopez told AUTOSPORT. "I've known Romain long enough to know that if he were to go it would be to a team that can fight for wins."

"I think at this stage he's well advised to stay here, given the changes we're doing for next year."

GROSJEAN AND LOTUS IN NUMBERS

61 STARTS

236 POINTS

0 WINS (BEST FINISH 2ND)

BEST CHAMPIONSHIP FINISH: 7TH (2013)

9 PODIUMS

0 POLES (BEST GRID 2ND)

1 FASTEST LAP



BE ONE WITH IT

Be one with your tyres, and the road will be one with you.



ventus F200

Top-notch performance slick tyre with consistency and high mileage in dry conditions



For all your motorsport tyre requirements contact Hankook's official motorsport distributors:
UK: MR TYRE MOTORSPORT on +44 (0)121 551 4589
IRELAND: DOC SPORT on +353 (0)87 2638951

hankooktyres.co.uk

Hankook Tyre UK Ltd, Fawsley Drive, Heartlands Business Park, Daventry NN11 8UG



Jonathan Noble

F1's newshound

With two teams in administration and the possibility of more to follow, F1's powers that be must act now to halt ever-spiralling costs

If it had been unforeseen, and warning bells hadn't been ringing for months, then the troubles of Caterham and Marussia this week could have been accepted as just another chapter in the long history of teams coming and going in Formula 1.

After all, since the F1 World Championship came into being in 1950, 164 teams have participated. Only nine will be on the grid in Austin. The potential end of another two in joining the 153 who are now historical footnotes may not be statistically of huge importance, but because of where F1 stands right now, it matters so much more.

After months of discussion about teams collapsing if costs in F1 were not brought under control, the events of the past week are much harder to stomach. It's one thing to be caught on the hop by circumstance. It's quite another to be given warning after warning and fail to react.

When the smaller teams shouted out earlier this year that F1 was heading for financial crisis if nothing was done about expenditure, no one wanted to listen. The big teams marched on regardless, scuppering an original agreement for a cost cap and putting in place money-saving measures that will barely have an impact on their catering budgets.

The sport's chiefs didn't respond either. FIA president Jean Todt realised that the governing processes of F1 meant there was nothing he could do to force the issue if others wanted to block him, so he reluctantly gave up. Nor did Bernie Ecclestone particularly want to be involved. He was more worried about his own legal



building expensive engines just for themselves. Financially that's not sustainable.

A potential move to introduce third cars for teams in 2015 to fill the gaps would also trigger potential disaster. Who pays for the extra car? What impact will it have on the smaller teams? How does it protect the sport from further trouble? It's not a long-term solution.

The best way forward has always been to keep at least 10 independent teams alive with enough income to cover their costs. And for a sport that generates more than £1 billion a year in revenue to not be able to sustain that number of cars is illogical. However, that's the legacy of

“When the smaller teams shouted out about F1’s potential financial crisis no one wanted to listen”

entanglements in Munich and keeping alive the income streams from tracks and television companies that his paymasters CVC are so desperate to suck out of the sport. Time and again he said it would be better if the grid was trimmed a bit. The approach of the big teams, the FIA and Ecclestone has culminated in not just F1's smallest field for years, but it has opened up a very real prospect of there being even more trouble ahead.

In sporting terms, the absence of Caterham and Marussia means teams that were previously labelled as 'midfield', such as Sauber, Lotus and Toro Rosso, will now be relegated to fighting at the back of the pack. That's not going to help them to go chasing the big sponsors they so need to stay afloat.

There will also be knock-on effects for manufacturers. Ferrari and Renault may each now lose a customer engine deal, costing them income during a time of increased expenditure. Should one of their customers defect to Honda in 2016, as is possible, then suddenly they are

the selfish game we are in right now. There has been a land-grab of the money by the bigger teams, and no push back from the paymasters to tell them to get a grip on themselves and think of the bigger picture.

Former FIA president Max Mosley suggested to me earlier this year that having uneven finances up and down the grid should be no more acceptable than teams enjoying bigger engines or better tyres.

“The big, rich teams don't want everybody to have the same money,” he said. “They've got an advantage because they've got more money. It's a simple fact that if you've got three times as much money as I have, you might just as well have a bigger engine. A bigger engine alone doesn't guarantee wins, but everything else being equal, it does. So if you want sporting fairness, you've got to give everybody the same money.”

The answer seems obvious. But is anyone listening and do those who can make a difference really care? I fear we all know the answer to that. ❧

This week in motorsport

HAWKSWORTH JOINS FOYT FOR 2015

AJ Foyt Racing was expected to announce this week that it has snapped up Briton Jack Hawksworth to run alongside Takuma Sato in IndyCar next year.

The deal, scheduled to be made public yesterday (Wednesday), marks the realisation of the team's long-held ambition to add a second car. It means that 23-year-old rising star Hawksworth will have the benefit of a vastly experienced team-mate for his second IndyCar season.

"This is a great opportunity for me," said Hawksworth, who will drive the team's #41 entry. "Ultimately I want to win races, and I feel that this is a place I can do that."

Sato embraced Hawksworth's arrival. "I welcome Jack in joining us," he said. "We've had some good weekends but need more improvement, and having two cars should boost things massively."



CLEAR/LAT



CUNHA/DPPI

Vaxiviere heads Renault 3.5 test

Lotus junior Matthieu Vaxiviere topped the two-day test last week as the Formula Renault 3.5 teams stayed on at Jerez after their season finale.

Frenchman Vaxiviere's Charouz-run car topped both sessions on the second day of the test, with all of the overall fastest times set during the second morning.

Series regular Pietro Fantin was fastest on the first morning with Draco Racing, before GP3 title contender Dean Stoneman set the pace in the afternoon with Arden Motorsport.

Zeta Corse, which took Roberto Merhi to the brink of the crown, missed the test, but aims to be back for the next sessions at Motorland Aragon next month. Comtec returned to action after missing the race weekend.

LEADING TIMES

1	Matthieu Vaxiviere	Lotus	1m27.074s
2	Nicholas Latifi	Lotus	1m27.456s
3	Pietro Fantin	Draco	1m27.502s
4	Jazeman Jaafar	Fortec	1m27.560s
5	Nyck de Vries	DAMS	1m27.792s
6	Jordan King	Arden	1m27.811s

KEEN GETS GT OPEN FERRARI

British GT star Phil Keen will contest this weekend's International GT Open finale at Barcelona.

Keen, 30, will race a Balfe Motorsport Ferrari 458 Italia with Shaun Balfe, a race winner in the club-level GT Cup series in 2015.

Meanwhile, international race veteran Jerome Policand will return to the wheel in the same event, the Frenchman driving a Ferrari run by his own Sofrev ASP squad.

Westbrook joins Baku ringers

Chevrolet-contracted Richard Westbrook is among a raft of factory racers to join the entry for this weekend's Baku World Challenge Blancpain Sprint Series finale.

Westbrook will renew his relationship with the Trackspeed Porsche squad with which he was a regular in the British GT Championship in 2012-13 (right). The Briton will share the 911 GT3-R with Porsche Supercup frontrunner Norbert Siedler in the two one-hour races on the Azerbaijan street circuit.

McLaren has loaned its complete roster of factory drivers out to teams fielding the MP4-12C in Baku: Rob Bell and Kevin Estre will team up in a Boutsen



EBREY/LAT

entry, renewing their successful partnership at Hexis from last year, while Alvaro Parente joins the Italian Bhaitech squad, sharing with Sten Pentus.

Porsche factory driver Marco Holzer

has been placed with the Schutz Motorsport squad, a frontrunning team in the ADAC GT Masters series in Germany, to drive a 911 GT3-R together with Martin Ragginger.

For all the breaking news, visit AUTOSPORT.COM

Ambrose goes home early

V8 Supercars' returning prodigal son Marcos Ambrose will make an early comeback by contesting this year's finale at the Homebush street track in Sydney in December.

Ambrose, who won the 2003 and '04 V8 titles before switching to NASCAR in '06, will race a third Dick Johnson Racing Ford Falcon with support from Team Penske.

Personnel from Penske's IndyCar team will be in attendance as the US motorsport giant gears up for its new Australian presence as DJR Team Penske in 2015.

Team boss Dick Johnson said: "This is a great opportunity to give Marcos a good hit out in one of the DJR Falcons before next year and give him real race miles."



NASCAR steps in to end race riot

NASCAR had to step in to end a series of deliberate contact between Kasey Kahne and Brian Vickers in last weekend's Sprint Cup round at Martinsville.

By lap 279 of 500, Vickers said over the radio: "All right, we owe him

another. We can do this all day long."

But NASCAR event director David Hoots intervened, radioing: "Tell the 5 [Kahne] and 55 [Vickers] it's over. It's done."

Vickers was classified 27th, with Kahne a non-finisher in 40th.



Tandy in LMP1 Porsche trial

Three more Porsche factory GT drivers have been given a try-out in the German manufacturer's LMP1 World Endurance Championship contender.

Nick Tandy (above), Patrick Pilet and Richard Lietz all drove the 919 Hybrid during Porsche's final in-season WEC test at Motorland Aragon last week. They followed fellow GT drivers Frederic Makowiecki and Michael Christensen, who sampled the P1 car at Magny-Cours in September.

Porsche has given its GT drivers a chance in the 919 because it is evaluating an expansion of its P1 squad from two to three cars for next year's Le Mans 24 Hours. Porsche LMP1 team principal Andreas Seidl said that "internal promotion is important".

LAPIERRE OUT FOR SEASON

Nicolas Lapierre will be absent from Toyota's World Endurance Championship squad for this weekend's Shanghai round and the remainder of the season, the Japanese manufacturer has confirmed.

The latest decision follows the Frenchman's absence from the line-up of the #8 Toyota TSO40 HYBRID at the Fuji event by what was described as "mutual agreement". His regular team-mates Anthony Davidson and Sebastien Buemi went on to win Toyota's home event.

A statement from Toyota read: "Based on its experience in Fuji, the team



considers it is the best option to continue with a two-driver line-up of Anthony and Sebastien in Shanghai and for the remaining races of the season."

Toyota has confirmed that Briton Mike Conway will again sub for Kazuki Nakajima in the #7 TSO40 in Bahrain on November 15.



Management switch at United

United Autosports boss Zak Brown plans to sell his share of the team's British Touring Car Championship operation.

American Brown cited increased business pressures as the reason for stepping back from the squad, which he has jointly run with successful racer Richard Dean.

Dean says he is now looking for a new investor for the squad, whose brace of Toyota Avensis cars took a best result of 12th this season with Glynn Geddie.

Brown added: "United will continue to prepare and maintain my collection of historic cars. I simply don't have enough time to dedicate to the BTCC."

● BTCC racer Aiden Moffat has traded in his Chevrolet Cruze for a Mercedes A-Class for 2015. Moffat's Laser Tools Racing team has worked increasingly closely this season with Ciceley Racing, which developed the Merc into a race winner with Adam Morgan.

Piquet #3 set for European F3



Runaway Brazilian Formula 3 champion Pedro Piquet looks set to graduate to the F3 European Championship in 2015.

The 16-year-old son of three-time world champion Nelson Piquet tested at Silverstone for two days last week with top team Carlin, which ran him alongside its five Macau Grand Prix contenders. Piquet is also due to test at some point with Van Amersfoort Racing.

Carlin also ran Italian Michele Beretta, who has competed this year with EuroInternational.

Meanwhile, Fortec Motorsport tested Matt Parry, a podium finisher with the team in the Formula Renault Eurocup this season.

REMEMBER WHEN



Pedro Piquet won't be the first member of his family to race F3 in Europe, or even the second. Father Nelson competed in the European championship in 1977 and won a British title in '78, while half-brother Nelson Jr was British champion in 2004.





TORO ROSSO £90m

MARUSSIA £70m

CATERHAM £60m

FORCE INDIA £100m

**FERRARI £275m
(including engines)**

LOTUS £130m

Currencies converted from Euro (Ferrari/Toro Rosso), Swiss Francs (Sauber) and US Dollars (FOM) to Sterling for ease of comparison

THE TRUE COST OF FORMULA 1

As well as being a world-class sport, Formula 1 is a £1.5 billion business. Who spends what? Where do their revenue streams come from? Who's in profit or making a loss? **DIETER RENCKEN** investigates the numbers some teams don't want you to know

Since AUTOSPORT first published *The true cost of Formula 1* a year ago, the financial squeeze on teams has tightened. Few race weekends passed without some tale of money woes sweeping through the paddock, and as this issue of AUTOSPORT closed for press both Caterham and Marussia were set to miss the US GP.

More than one team has had to resort to pay drivers and shareholder loans to stay afloat as the global economic crisis continues to bite. F1 lost a major sponsor in Vodafone at the end of 2013, and other sponsors are said to be negotiating downwards off the back of dwindling live attendances and falling TV audiences. Introduction of F1's impressively efficient but markedly dearer power units further skewed budgets after engine bills doubled, while an ill-planned expanded calendar (to 20 rounds in 2015) compounded financial pressures.

Since budget and performance have a symbiotic relationship, disparities in finances are evident in the performance spread, with the best-funded teams racing at the sharp end and budget operations bringing up the rear. The middle class survives – just.

Beginning 2013, the Big Five – Ferrari, Red Bull, Mercedes, McLaren and Williams – receive varying bonuses from commercial rights holder Formula One Management, further widening the divide between rich and poor. These have been identified accordingly in our figures (FOM monies are disbursed a year in arrears).

With eight (of 11) teams – including Red Bull Racing, McLaren and Mercedes – based in Britain, direct comparisons are facilitated by Companies House filings. The accounts are, though, at least nine months in arrears. We requested interviews with all teams and their level of co-operation is noted in the key below.

Where teams refused to divulge information, we have arrived at educated estimates. Various sources were consulted and cross-referenced, including filings, known variables, informed assumptions and inside information.

Key:
 *** Full co-operation/input
 ** Input provided
 * Zero co-operation/input

RED BULL RACING

Milton Keynes, Britain (Austrian-owned) ***

Budget: £240m (estimated)

Income: £265m
 Profit: £15m (2013)



Red Bull's operation consists of two intertwined companies: Red Bull Technology, which produces cars for Racing Bull Racing, and the race team management entity. RBT also provides gearbox and hydraulics technology to Scuderia Toro Rosso and Caterham, so the purified budget is RBT (including RBR), less 'Other', less profit.

RBT's 2013 turnover was £258m, on which a profit of £15m (RBR £1m) was turned, with customer income running to £30m. This year the operation will spend marginally more, with engine cost increases absorbed by Infiniti.

This season RBR drops to second in the classification, precipitating a £10m loss (for 2015) ▶

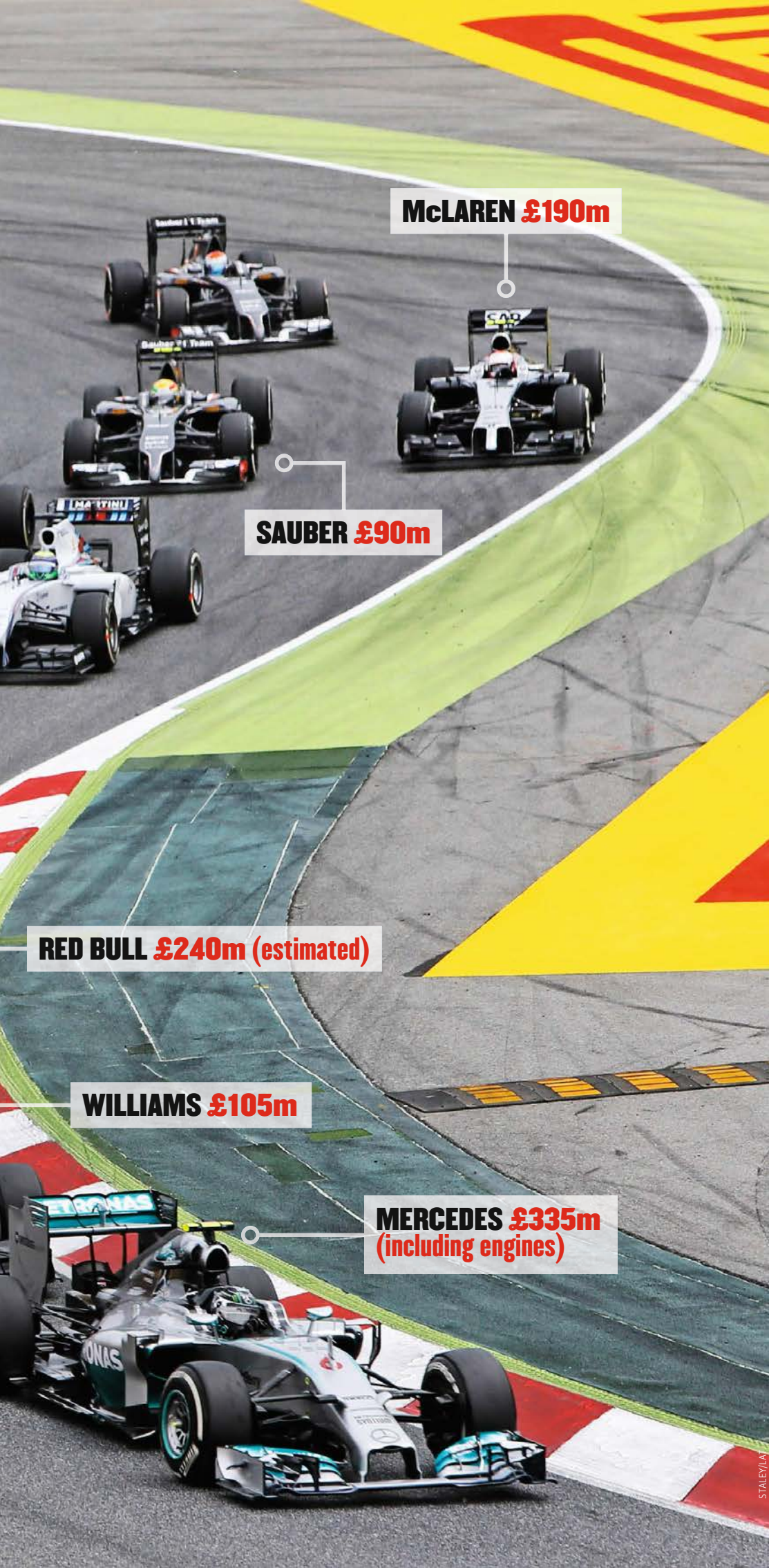

McLAREN £190m

SAUBER £90m

RED BULL £240m (estimated)

WILLIAMS £105m

MERCEDES £335m (including engines)

THE SIZE OF FORMULA 1'S TEAMS

The number of people employed by the teams varies hugely across the different operations. These graphics show the current number of employees per team

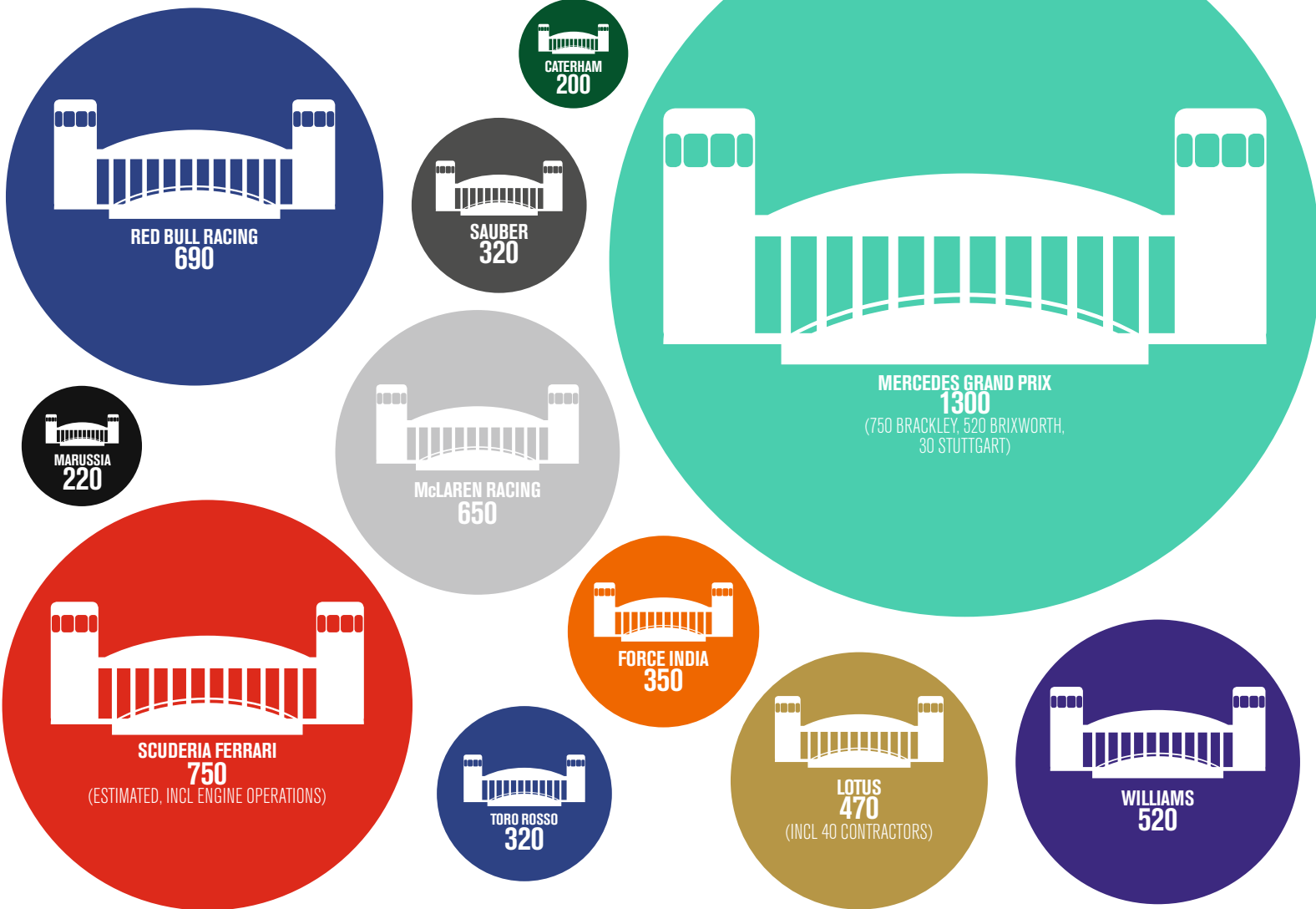

► in FOM revenue, while bonuses reduce to £25m after a one-time payment falls away.

The objective is to reduce dependence on Red Bull while generating global brand exposure. However, since the FOM revenues will reduce, Adrian Newey is stepping back from F1 design, and some key technical personnel (plus Sebastian Vettel) have left, there are challenges ahead.

Team principal Christian Horner: "We've had significant influx of sponsorship revenue, together with renewals from [variety of sponsors]... Red Bull Racing has posted a healthy performance."

Note 2013 accounts have not been published at the time of closing for press, thus calculations have been based on data provided.

SCUDERIA FERRARI

Maranello, Italy*

Budget: £275m including engines



Profit: £200m (group) 2013

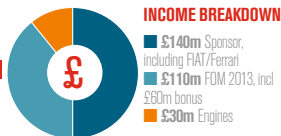

Ferrari is the only team producing an entire car in one location, doing so by sharing mainframe facilities with its road car division, which supports the *Gestione Sportiva* racing department in lieu of global advertising. This, though,

complicates matters, for internal policies make it impossible to split revenues and profits, although 2013 parameters improved over the previous year by an average of 10 per cent – with similar growth expected again.

Already on preferential FOM terms through heritage, the Scuderia additionally benefits from being one of the Constructors' Championship Bonus (CCB) teams. Having achieved profits in 2013 of £200m, it has a huge war chest, bolstered this year by £110m in (2013) FOM payments.

Engines are supplied to two customers teams, enabling costs to be further defrayed; we have extracted these to provide a purified base. While overall costs have been well contained, engine costs have risen, boosting the budget by 10 per cent, yet still allowing a modest internal profit.

Ferrari's brand provides a powerful commercial pedestal for its partners, but the signs are that tobacco company Philip Morris is scaling back, and whether the departure of Fernando Alonso calls into question Santander's long-term support is a moot point. Whether Ferrari will dip into profits in that case or find replacements is the burning question.

Ferrari Press Office statement: "These matters remain confidential, and no guidance can be offered as to the accuracy of these estimates."



TEAM SPENDING

This is how the total estimated £1685m budget spent by the F1 teams per season breaks down

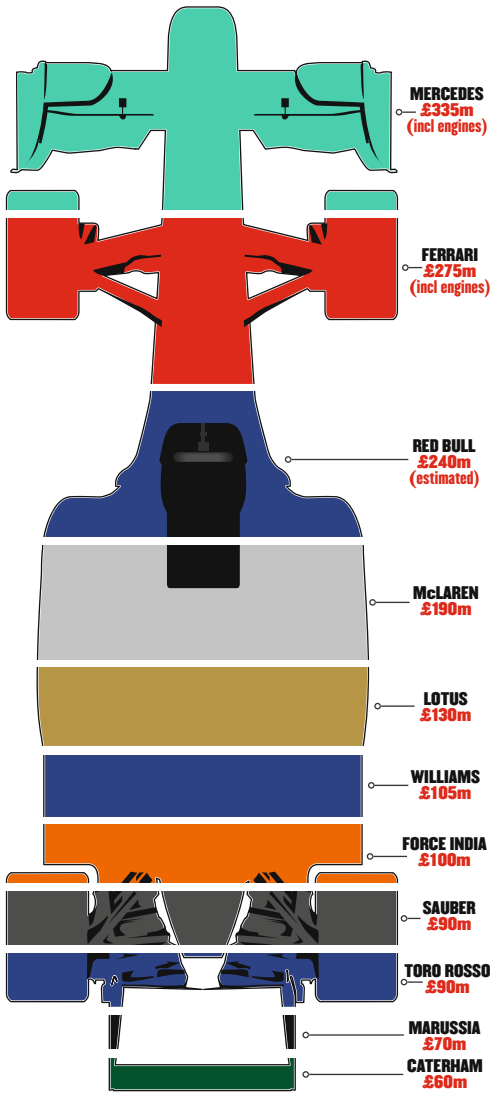

McLAREN RACING

Woking, Britain **

Budget: £190m

Income: £180m

Profit: £22m (2013)

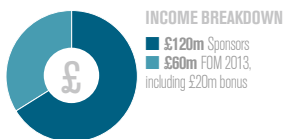

McLaren Racing's finances are tough to call on account of its position as part of a wider structure, the McLaren Group. This encompasses the Applied Technologies division and caterer Absolute Taste, as well as Marketing — all formally separate



entities. In the absence of formal breakdowns, informed assumptions are made.

Although associate company McLaren Automotive contributes directly and indirectly, Racing is profitable in its own right — posting the largest attributable profit on the grid (£22m, 2013). This, though, is likely to have been consumed this year in the absence of a replacement for Vodafone. Sharing facilities reduces costs, but complicates accounting and headcount allocations.

McLaren's strength has long been the length, breadth and depth of its partnerships, and a 10-year commercial and technical deal with Honda (commencing 2015) provides for a bright future. However, the continued absence of a title sponsor remains a worry, as does McLaren's serial lack of championship success in recent years, which impacts on FOM revenues.

Chairman Ron Dennis: "McLaren has a proud and victorious record at the pinnacle of Formula 1, and I am confident the actions we are taking will enable the team to regain competitiveness in time."

MERCEDES GRAND PRIX

Brackley/Brixworth, Britain (German-owned) ***

Budget: MGP £195m excluding engines; HPP £140m

Income: £195m

Loss: MGP £50m (2013)

Profit: HPP £6m

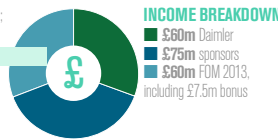

Mercedes F1's activities are split: Mercedes Grand Prix (the Brackley-based race operation) and engine builder High Performance Powertrains are separate, albeit integrated, entities, with HPP supplying Mercedes GP and others.

Brackley recruited upwards of 100 heads over the past year. This is reflected in 2013 losses — which remain a worry, being underwritten by parent company Daimler and potentially causing the board to reconsider its engagement over time.

HPP offsets its costs via income from MGP, Daimler R&D projects and F1 customer engine deals, last year recording modest profits.

Combined Mercedes constitutes F1's largest global spend — with commensurate headcounts — yet MGP is arguably the most effective bang-for-buck operation, delivering the constructors' title for around £50m direct cost. The operation is financed by a combination of Daimler funding, sponsorship, customer activities and FOM revenues.

Although a member of F1's Strategy Group, MGP is not a full CCB operation, qualifying for annual incremental payouts of £8m until 2015, increasing to £10m through to 2020.

Motorsport director Toto Wolff: "If you see it from Daimler's perspective it's not a large contribution for what they get. And it's a very important message, because you hear all those crazy numbers..."



WILLIAMS GRAND PRIX ENGINEERING

Wantage, Britain (Frankfurt SE listed) ***

Budget: £105m

Income: £110m

Loss: £5m Accounting anomaly

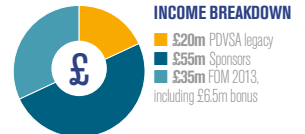

Williams moved back to the sharp end after totally reinventing itself — in the process snaring Mercedes power — and it certainly paid off on scoreboard and balance sheet. WGPE has a unique business model, being F1's only listed team: 50 per cent held by founder Frank Williams and 9 per cent by business partner Patrick Head, Toto Wolff (Mercedes) controls 10 per cent, a US investor 5 per cent, employees own 4 per cent, with 22 per cent publicly traded.

Williams has three revenue streams: team-sourced sponsors, driver-related contributions and FOM revenues, although for 2014 it benefits from a pay-off courtesy of Venezuela's state oil fund PDVSA after Pastor Maldonado broke contract. This resulted in an accounting anomaly, and an on-paper loss for the year.

Deputy team principal Claire Williams: "I think the team's been very lucky; all the work we put in last year is paying off, and obviously that has a knock-on effect on future commercial discussions."

LOTUS

Witney, Britain (Luxembourg-owned) ***

Budget: £130m

Income: £120m

Loss: £10m

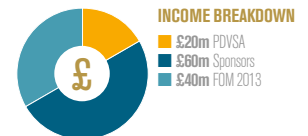

Neither fish nor fowl, Lotus floats in that middle ground between majors and independents, carrying large-team overheads on modest income, yet without the safety net of CCB payments.

The team has restructured and downsized, reducing headcount by 100. Although the directors are hopeful of breaking even, a modest loss is projected — a far cry from the £90m headline deficit of a year ago, most of which was driver-related.

The challenge lies in retaining blue-chip sponsors such as Microsoft, Rexona and Burn (Coca-Cola) against a backdrop of disappointing results, which also impacts on FOM revenues. However, Mercedes power in 2015 should redress the performance deficit.

CEO Matthew Carter: "We've turned it from a huge loss to hopefully getting somewhere near break-even, the idea being that we secure things financially first, then look at making improvements on track."

WHO'S GETTING THEIR MONEY'S WORTH?

It's difficult to estimate exactly which team in F1 should be considered the best value for money. After all, in terms of pounds per point, the higher

scoring rate of the top teams makes them look far better value than outfits spending a fifth of the budget. However, taking a glance at the

constructors' championship, when seen alongside the budgets of each team, gives a much better indication of the over- and underachievers.

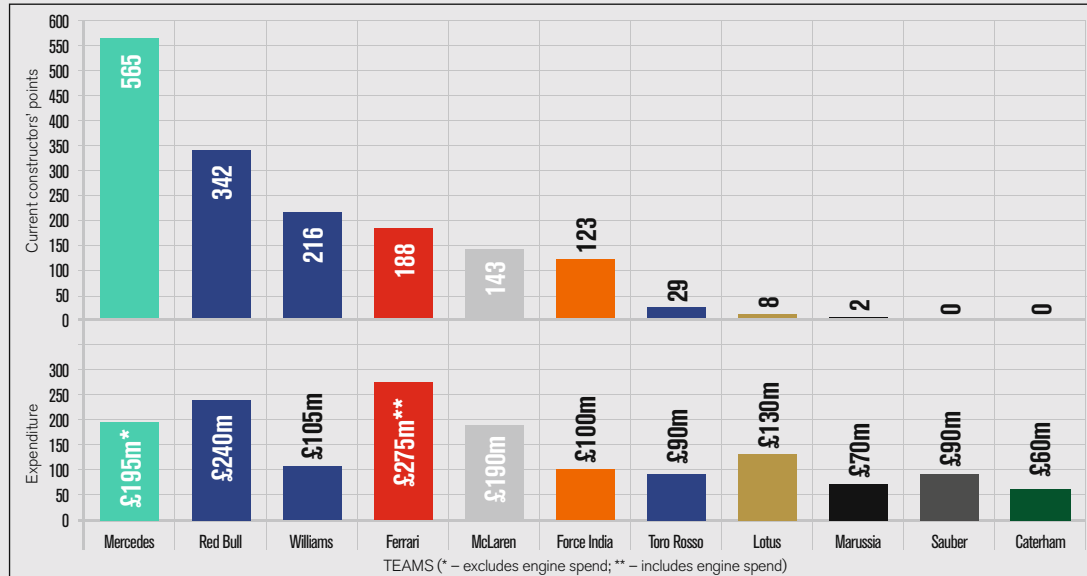

A straight comparison of the teams' expenditure is not always a case of comparing like with like: for example, because of the company structures the figure here for Ferrari includes its engine operations, whereas the Mercedes figure does not.

But the figures do show that there is a relationship between expenditure and achievement for the most part. One

dramatic exception is Williams, sixth in the expenditure rankings but third in the constructors' championship. Lotus, which is one place above Williams in terms of expenditure, is ranked three places lower on achievement after its terrible 2014 season.

Overall, Mercedes, Williams, Force India, Marussia and Toro Rosso have been punching above their weight in

this comparison, with Ferrari, McLaren, Lotus and Sauber underachieving.

Red Bull and Caterham are arguably performing where you would expect, although the inflation of the Ferrari figure because of engine operations means there is a case for saying Red Bull should still be winning the constructors' race given the magnitude of its expenditure.



SAUBER

Hinwil, Switzerland ***

Budget: £90m

Income: £85m

Loss: £5m

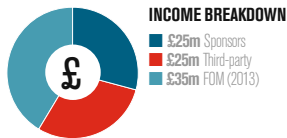

Sauber swims mid-stream; unlike its peers, it is disadvantaged by invoicing in US Dollars, but trading in buoyant Swiss Francs. This disparity, compounded by FOM's inequitable revenue structure, lies at the root of its travails.

Sauber's state-of-art facilities (particularly its windtunnel) are its salvation, for it can rent them out to supplement budgets. The balance of funding is made up of a mix of team sponsorship, driver contributions and FOM monies.

Team principal Monisha Kaltenborn: "We are hopeful of acquiring an investor, but aim to increase third-party business to compensate for reduced FOM income. It's not easy."



FORCE INDIA

Silverstone, Britain (Indian-owned) ***

Budget: £100m

Income: £90m

Loss: £10m

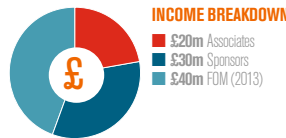

Despite similar headline numbers to Sauber, Force India's business model could not be more different, being funded by a mix of shareholder loans, group companies, driver-linked contributions and FOM revenues.

A portion of Force India's funding flows from associate companies, many of them under pressure in India - creating cause for concern.

Upgrades are planned for its Silverstone base, and new sponsors have been signed. For 2014 Force India entered into a technical partnership with Mercedes GP, which paid off handsomely: it trades blows with McLaren using the same power unit, yet on half the budget.

Deputy team principal

Robert Fernley: "We outsource significant amounts of our production, and try to get a balance between production running full time, and outsourcing of major items."



SCUDERIA TORO ROSSO

Faenza, Italy (Austrian-owned) *

Budget: £90m

Income: £90m

Profit/loss: Even (2013)

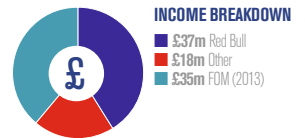

STR exists as a finishing school for Red Bull's cadre of development drivers, and came of age with the successive elevations of Daniel Ricciardo and Daniil Kvyat to RBR.

The team is on the up budget-wise, having doubled the size of its Faenza base, while recruitment for staff to service its Bicester (UK) windtunnel is on-going. Being a 'school', STR operates on a break-even basis, being funded by an expanding portfolio of external sponsors, with the budget underwritten by Red Bull. STR receives substantial support from RBT, and runs similar rear-end technology to RBR, although it does design and produce its own gearbox casing.





Mercedes is Formula 1's biggest spender, but it's reaped great rewards

19
COATES/LAT



CATERHAM

Leaffield, Britain (Malaysian-owned)**

Budget: £60m

Income: £50m

Loss: £30m (2013)



INCOME BREAKDOWN
 £15m Sponsors
 £15m Driver contributions
 £20m FOM (2013)

A mess: After a mysterious Swiss-Arabian consortium “bought” the team, management downsized to 200 staff operating on a £60m budget – made up of sponsorship, driver (race, test, development) contributions and (decreasing) FOM revenue. Associate supply company CSL is now in administration, and as AUTOSPORT went to press the race team was also under the control of administrators – who are seeking buyers for its assets. The issue of who owns what is still confused, and if the team skips rounds it will lose out on FOM revenue.

MARUSSIA

Banbury, Britain (Russian-owned)*

Budget: £70m

Income: £50m

Loss: £25m (2013)

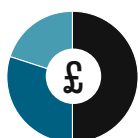

INCOME BREAKDOWN
 £25m Shareholders
 £15m Driver/sponsors
 £10m FOM (2013)

Potentially in the most precarious position of all because the oligarch who has injected upwards of £100m since 2011 seems to have lost interest, just when the team's future seemed brighter than ever owing to increased FOM monies for 2015.

The team had been seeking buyers, but administration was confirmed on Monday and it will not participate in the US GP.

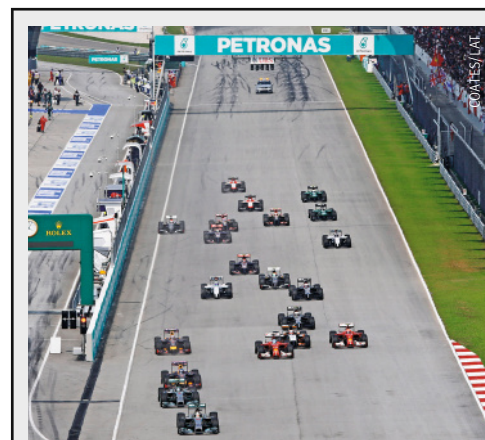

CONCLUSION

The total cost of Formula 1 in 2014 amounts to £1.5 billion – excluding engine costs incurred by Mercedes, Renault and Ferrari (and Honda in 2015), which are deemed R&D – yet the teams received just one third (£530m) of that figure from FOM, which in turn banked around £300m from the sport's many revenue streams. The recent implosion of Caterham and Marussia is a timely demonstration that F1's current revenue model is unsustainable. It's time to think again about how the money is shared out.

Caterham's finances have been in the gravel for quite some time

F1 ROCKED AS SMALL TEAMS HIT CRISIS POINT

Caterham and Marussia enter administration as Formula 1's cash crisis hits home ahead of the final flyaway races. **JONATHAN NOBLE** and **BEN ANDERSON** explain what's next

20

Formula 1 is facing fresh concern about its long-term future after the Caterham and Marussia teams were forced out of this weekend's United States Grand Prix because of their respective financial difficulties.

Speculation about their precarious situations has intensified over recent months. Matters reached a head when, within days of each other, both teams were forced to appoint administrators in a last-ditch effort to stay afloat.

Their absence from Austin means that F1 will have just 18 cars on the grid – the first time that has happened since the 2005 Monaco Grand Prix, when BAR was banned because of a rules breach. But of greater concern than the grid number is that, after season-long warnings that too little was being done to contain rising costs, the loss of Caterham and Marussia could be just the start of a wave of

other team failures that would leave F1 in a serious crisis.

Here, AUTOSPORT explains what the Caterham and Marussia troubles really mean for F1.

IS IT THE END FOR BOTH TEAMS?

Not yet. Although Caterham and Marussia will be absent from the US Grand Prix, it does not mean that they cannot return later in the season. There was a time when teams would lose all commercial rights income if they did not compete in every event. Now the situation is slightly more relaxed.

It is understood that clauses in the bi-lateral agreements between teams and Formula One Management gives leeway for them to miss three races in a single season without sanction.

That means as long as the companies that own the Marussia and Caterham entries remain in business, and an official entry for



Marussia's position
in the points is a
good selling point



GIL HAN/GETTY

21

'\$45 million sounds generous, but is only part of the expenditure now needed to compete'

the 2015 championship is lodged in time, then they could return next year if there is the money to do so.

However, much will depend on whether or not the administrators can find suitable purchasers in time for all the preparations to be ready for 2015.

Marussia's administrators should certainly have an easier time trying to entice buyers – because the team's current ninth place in the constructors' championship means it is on course to land valuable commercial rights income at the end of the year.

That could be worth up to \$45 million if it is not overhauled by Sauber and Caterham – and would become a regular payment if the team could maintain at least 10th place in the constructors' standings again next season. Such a place would be guaranteed if Caterham did not return.

But while \$45 million sounds

generous on face value, the problem is that it only represents part of the expenditure now needed to compete in F1. Since plans for a cost cap have been abandoned and the top teams have failed to agree any form of meaningful cost-saving rules for 2015, this situation is unlikely to change in the near future.

That is why there are serious doubts about whether anyone will be interested in finding the funding needed to save either team. For such a large investment, the risk of failure is significant.

THIRD CARS NOW A REALITY

The prospect of Caterham and/or Marussia falling off the grid before the end of the season brings the oft-mooted idea of teams running third cars back into focus.

If neither team returns, then grid numbers at the start of 2015 will fall below 20 – the line at which the FIA and Formula One Management

can enact a request for some teams to run a third car. First option for making the demand is believed to go to Ferrari, Red Bull and McLaren.

The FIA has ruled out asking top F1 teams to fill the grid for the remaining races of 2014 – but it is unlikely to be so lenient if Caterham and Marussia are absent next year. Agreements with teams are believed to state that they will get 60 days' notice to run a third car.

But there remains uncertainty over what livery such cars should run, which drivers would race them, who runs the extra cars and whether they should be eligible to score championship points.

F1 commercial boss Bernie Ecclestone is a fan of the third-car concept anyway, saying ahead of September's Singapore Grand Prix that he would like to see teams running extra cars in 2015 even if all the present squads survive. But the sport's top outfits are still

not convinced this is a realistic proposition, regardless of whether they have all winter to get their houses in order.

Mercedes motorsport boss Toto Wolff reckons there are too many issues to resolve in too short an amount of time.

"First of all," he argues, "you need to set up and do the logistics, the infrastructure and the resources to run a third car. Then you need intelligent rules around who runs a third car: Where is it being run? Who is going to drive it? Is it going to score points? And which livery will it be running?"

"There is so much to be sorted out before we can run it and I don't see it happening."

In simple terms, third cars seems like an easy option to re-grow the F1 grid – replacing uncompetitive and underfunded cars with better ones, and offering fans the chance to see more ▶

► drivers in capable machinery.

With enough willpower behind it, third cars could still appear on the grid. But the move will need to be executed with caution to ensure the financial woes plaguing the back of the grid are not merely displaced further up the order.

“I’m not a big fan of it; I don’t think it’s good for the sport,” says Wolff, who estimates additional expenditure of £20-25million to run a third car. “It means additional costs; the way you can refinance it is not enough, so even for smaller teams it wouldn’t be a profitable business case.

“We don’t want to harm F1 by the top teams suddenly fielding three cars. The midfield teams would really struggle – it could bite them.”

The situation in F1 becomes even more complicated should other teams join Caterham and Marussia on the sidelines. Under clauses in commercial deals, if grid numbers fall even further then the FIA is empowered to change the rules to ensure there is a grid of at least 16 cars. It is this number that FOM has agreed to deliver at each race.

CALL TO ARMS

Whether or not third cars happen, and irrespective of the success of the administrators overseeing Marussia and Caterham, the current crisis will prompt much soul-searching within the sport. Ever since the FIA gave up on a push for a cost cap in F1, the smaller teams have warned of big problems – especially because there has been a widespread failure to agree on any effective cost-saving measures.

Concerns are now mounting that other outfits are in similar financial difficulties to Caterham and Marussia, and could fall off the grid as well. Earlier this year, FIA president Jean Todt expressed frustration at the way big teams did not want to reduce costs – and made no bones about how big a cut was needed in expenditure to make F1 sustainable.

“We know the budgets are between \$100 million and \$400m,” he said. “The proposals that they seem happy with are to reduce budgets by \$2 million, which is ridiculous. When we speak about costs we must speak about reducing it by 30-40 per cent. Then we can feel comfortable.”

Achieving such dramatic cuts may be hugely difficult to achieve, but the magnitude of the problem now facing the sport may be enough to convince those who have previously resisted change to alter their stance. ❧



The troubled teams usually occupied the back of the grid

Caterham’s highly public spat grabs the headlines

Less than four months after Swiss company Engavest took over at Caterham, the team’s troubles were blown into the public domain after dramatic developments at its Leaffield factory last week. The end of the road for the team’s new owner came after a bizarre series of accusations and counter-claims between the current management team and former boss Tony Fernandes.

When Engavest took control on July 1, it accepted there would be an uphill struggle to keep the team alive, let alone move it forward. Indeed, within a few hours of the

management team arriving, the problems began to manifest themselves. Engavest’s main representative, Colin Kolles, likened it to walking in to a “hurricane”.

Despite having completed due diligence of Caterham’s companies, the new buyer admitted to being surprised by a number of debts, financial arrangements and other liabilities it had not been expecting.

BAILIFFS AND ADMINISTRATORS

The growing troubles bubbled to the surface after the Singapore GP, when bailiffs seized items from Caterham’s Leaffield factory in a bid

to recover debts from Caterham Sports Limited (CSL), claimed to be a supplier to the F1 company ‘1 Malaysia Racing Team’ (1MRT).

That triggered a dispute over who owned what assets at Leaffield – a situation that got much more complicated when administrators were appointed on behalf of the Malaysian Exim bank to oversee CSL. Although Kolles was adamant in the first hours after the administrators moved in that the F1 team should be unaffected, his hopes were dashed when the legal representatives took a hardline approach.

Rather than let Caterham F1



Tony Fernandes (right) accused buyer of not honouring its bills



Grid could drop below contractual obligation of 16 cars



Colin Kolles (left) and Christijan Albers acted for new owner



Ecclestone (left) has allowed Caterham to skip next two races

F1'S UNEVEN SHARE OF WEALTH

The troubles that F1's minnow teams are facing has highlighted how the sport's prize-money structure is so heavily skewed towards the bigger teams. Here is AUTOSPORT's estimates of how F1's 2013 money was distributed.

F1's biggest earner Ferrari's accounts were boosted by a

\$32million bonus payment – as well as the \$62million it earns as a deal it has to take 2.5 per cent of F1's profits – on top of its earnings for where it finishes in the constructors' championship.

For Caterham and Marussia, their income is well below the costs of competing.

- Caterham 31
- Marussia 10

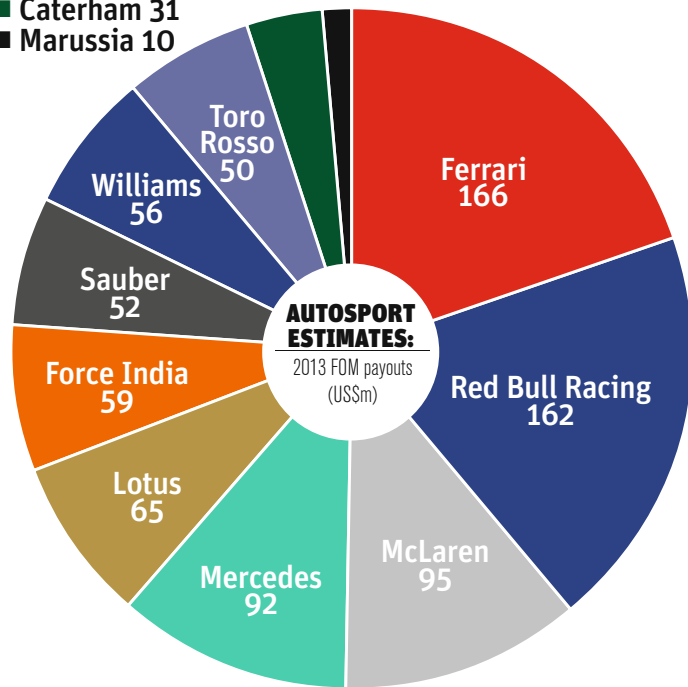

continue to operate as normal, administrators Smith & Williamson locked down all the assets that it believed belonged to CSL, including the race cars, equipment and the factory itself. By last Thursday, the gates to Leafield were locked.

Following a stand-off between Engavest and the administrators about a deal to keep the team going, talks eventually collapsed last Friday as the management handed over control of the team. Within hours, administrators had reached a deal with Bernie Ecclestone to skip the next two races.

PUBLIC WAR OF WORDS

During the collapse of talks, there was an unprecedented series of statements between the Engavest camp and Fernandes over who was to blame for what had happened. Fernandes was adamant that Caterham's new buyers had not fulfilled their part of the deal in paying off debts – which is why he had never transferred his ownership of the team to them.

"If you agree to buy a business,

"The car became probably 1.5 seconds quicker overnight. If we are allowed to continue, it will be a hugely respectable team"

IAN PHILLIPS, COMMERCIAL DIRECTOR

you must pay its bills," he said.

"They have breached that promise and now, sadly, it is others such as the employees and the fans of the Caterham F1 team that will suffer if the team ceases to race."

Fernandes' camp also mocked the fact that a cleaner at the F1 team, former professional footballer Constantin Cojocar, had been appointed as a director of CSL shortly before it hit trouble. But Engavest was adamant it had fulfilled all its obligations.

"Incidents such as a Caterham Group representative breaking into a filing cabinet containing our private and confidential documents,

and the continued refusal to deal with the outstanding loan of Exim Bank and complete the agreement, has culminated in Engavest's total contempt of Mr Fernandes and his Group executives, with whom we entered a deal in good faith," read a statement.

THE REAL VICTIMS

While the only winners in the Caterham affair will be the lawyers, the biggest losers from the saga will be the staff who now face an

uncertain future. Commercial director Ian Phillips reckoned that if the team had carried on there was a chance for it to show its potential.

"The nucleus of the design and race team – there are fantastic people in there," he said. "You can see the way they were liberated by Colin when he came in.

"The car became probably 1.5 seconds quicker overnight. If we are allowed to continue, in time I promise you it will be a hugely respectable team in F1."



UNITED STATES GP PREVIEW

Unravelling F1's complex electronics

The electronics systems of a Formula 1 car have become even more sophisticated due to hybrid power units this year. CRAIG SCARBOROUGH reveals how an F1 car is wired up

There is no more influential and complex system on a Formula 1 car than the electronics that govern its operation. So much so that the 18 cars on the grid in Austin this weekend can only be steered and braked without electronics. And even then, both those functions are assisted by electrical systems.

Although there are nearly 100 sensors, many kilometres of wiring and around 50 control units on each car, the teams have surprisingly little freedom in the hardware they select. Every control unit and sensor must be FIA-homologated, even the tail light.

Packaging all of this hardware into the tight bodywork is a tough task, so a lot of the smaller control units are mounted inside the cockpit. Larger

units are placed in the sidepods where they can receive air or water cooling, and the Energy Recovery System hardware is under the fuel tank area.

Linking these components together within a small wiring loom is achieved with what's known as "CAN Bus" architecture. This is a multiplex system more akin to a network than point-to-point wiring as used in older road cars.

The most critical unit is the standard ECU. Since 2006, this has been supplied by McLaren Electronic Systems (now amalgamated with McLaren Applied Technologies). This provides the control for both chassis and powertrain functions. Before this, teams often had an ECU from their engine supplier and managed their own chassis ECU. The distinctive triangular

SECU was updated in 2013 to allow for more throughput and to accommodate the needs of the complex new power units introduced this year. Every sensor and control unit links back to the SECU.

The SECU does provide some data-logging function, but a separate logger can be fitted. Another form of data logging is the Safety Data Recorder (SDR). This is the equivalent of a black box flight recorder. As well as linking to the main loom, it also carries its own accelerometer for crash investigations.

The driver can view and control most systems through the steering wheel. There are homologated dash displays and interface units to be used.

The electrical supply to the car is managed by the power box, a unit that takes its main electrical feed from the

ERS. This then provides the main 12v supply and higher voltage feeds for the ignition coils and direct fuel injectors.

Since 2009, and increasingly this year, the Energy Recovery System places greater demands on the electronics. Separate units manage the ERS-K and ERS-H, and there's also a unit for battery management.

Away from the operation of the car, other systems are required by the FIA. These include the onboard cameras and microphones, plus the driver radio.

Other aerials fitted to the car are for GPS, telemetry, and a small local aerial for the tyre pressure monitoring system commonly fitted in the mirror pod. The timing system requires receivers and a transponder for the actuation of the lap trigger, timing and jump starts.

KEY FOR IMAGE

- 1 Hub interface unit (on each upright)
- 2 TV antenna
- 3 Steering wheel and display
- 4 Tyre temperature/pressure monitoring system
- 5 Lap timing receiver
- 6 Data logger
- 7 Battery management system
- 8 Control electronics – ERS-H
- 9 Powertrain hydraulics manifold
- 10 Tail light
- 11 Rear junction box
- 12 Engine junction box
- 13 Control electronics – ERS-K
- 14 Power box
- 15 Driver radio
- 16 SECU
- 17 Sensor interface unit
- 18 FOM camera unit
- 19 Telemetry aerial
- 20 GPS antenna

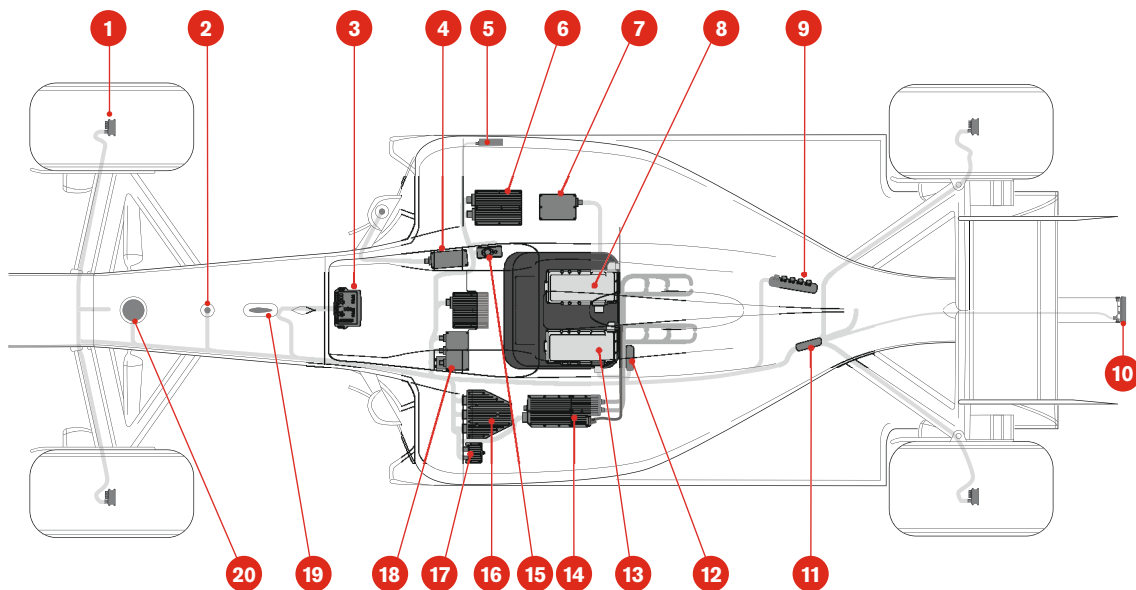

WHAT TO WATCH OUT FOR

Vettel taking a grid penalty

Renault and Red Bull have been doing their best to hold back the inevitable tide, but it looks likely four-time world champion Vettel will finally be forced to break rules that limit the number of engines and associated components a driver can use during a single season. If it happens, expect Vettel to start from the pits on Sunday.



Lotus running without twin tusks

Changes to the rules for next season will effectively outlaw some of the more outlandish nose designs seen on F1 cars this year. Having already written off a disastrous campaign, Lotus will run an experimental 2015-spec nose during free practice at Austin.

Smallest Formula 1 grid for a decade

The ongoing legal battle at Caterham has raised fresh doubts about that team's future, while fellow minnow Marussia is now under administration. Neither will be at Austin – the question now is whether any other teams will fail before the season is out...



UNITED STATES

Austin



KEY INFO

2013 winner
Sebastian Vettel (Red Bull)

2013 pole
Sebastian Vettel (Red Bull)

UK Start times
FP1: 1500
FP2: 1900
FP3: 1500
Qualifying: 1800
Race: 2000

Live TV
Sky Sports F1

Tyre allocation

Soft Medium

CLASSIC RACE: 1959

AUTOSPORT declared it "one of the most dramatic finishes ever witnessed at a motor race". Bruce McLaren (right) won the first post-war grand prix to be held in the US by less than a second from a charging Maurice Trintignant.

McLaren claimed his maiden Formula 1 victory at the Sebring event when fellow New Zealander and Cooper pilot Jack Brabham ran short of fuel on the final lap. Brabham, who led most of the race, nevertheless claimed the world title

with a fourth placed finish. In a prelude to a famous Nigel Mansell moment at the 1984 Dallas GP, Brabham pushed his car across the finish line to secure the championship, then promptly collapsed from exhaustion.

Third place behind Trintignant was not enough to crown Ferrari's Tony Brooks, who finished four points shy of Brabham in the table. Stirling Moss also came into the race with a shot at the title, but he retired from the lead when his car's transmission failed.

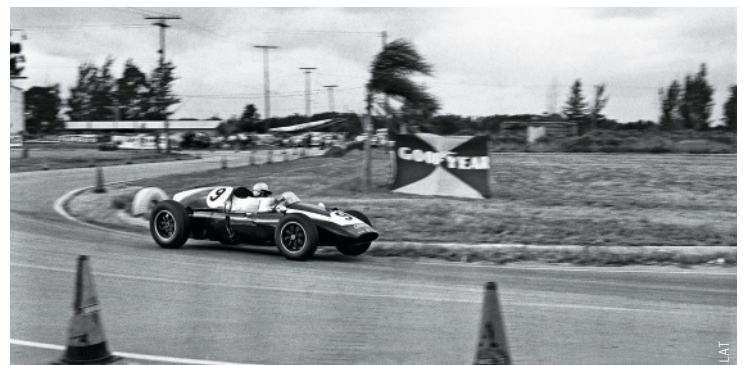

Ginetta believes LMP3 is a "perfect fit" for its design philosophy



26

LMP3 aims to endure where LMPC failed

It's being pitched as a cost-effective and value-for-money introduction to prototype endurance racing, but can it succeed in Europe, or will it go the way of its predecessor, asks **GARY WATKINS**

The Automobile Club de l'Ouest likes to talk about a "pyramid of endurance" with the Le Mans 24 Hours at its pinnacle. A ladder would be a better term, and in 2014 it will have a new bottom rung, called LMP3.

The new class, which was announced in November 2013, has been devised as an entry point into the world of prototype endurance racing, not only for teams and drivers but also for aspiring constructors. It is that which distinguishes it from its predecessor in Europe, the one-make LMPC class of the Le Mans Series that started life as the Formula Le Mans series for ORECA's Chevrolet-engined FLM09 in 2009.

That category was conceived with similar if slightly narrower aims, but ultimately failed in

Europe. Which begs the question, can LMP3 succeed and offer a cost-effective first step on the road to the Le Mans 24 Hours in the European Le Mans Series and beyond?

The ACO is pitching P3 at a lower level than LMPC. The price of one

of the turn-key coupes will be significantly less than that of its predecessor: €195,000 compared to €280,000. The budget required to run an LMP3 in the five four-hour ELMS races will be around €350-400,000 – a reduction of

something in the region of €175,000 over LMPC.

The ACO is working hard to ensure that its target can be met. The life between rebuilds of the five-litre Nissan V8 engine and Xtrac gearbox, which like all the

New car prices will be capped at €195,000



car's electronic systems will be managed by ORECA, is 10,000km.

The ACO also wants the cars to be run by minimal crews. It initially envisaged that refuelling would be handled centrally to allow a team of just four people to run a car, although this is bound to rise now that the organising body has decided that two cars will share a fuel rig in the first season.

There is definite interest in the concept from the teams – Sam Hignett, boss of ELMS LMP2 frontrunner Jota Sport, believes that it could work.

“If you can keep the budget to €400,000, you will be in Blancpain Endurance Series territory and might attract a few people who are competing there,” he says. “It is definitely an interesting concept.”

The category appears to have captured the imagination of the constructors. There are six who are actively working on cars for next season, according to the ACO.

LMP3 might have been tailor-made for British sportscar manufacturer Ginetta, reckons boss Lawrence Tomlinson.

“Ginetta is all about a career ladder, offering the best value in any category, so LMP3 is naturally a perfect fit for us,” says Tomlinson, whose organisation has just expanded its range by purchasing Group CN constructor Juno, a company with a P3 design on the stocks.

Riley Technologies in the USA is also at an advanced stage with a design. Crucially, though, it is working on a deal for that design to be built by another constructor.

“It will be tight to do it for the cost cap,” says company boss Bill Riley. “That’s why we are working with a smaller organisation with lower overheads that would have a

better chance of making it work.”

That is one of the big challenges of racing LMP3 right now. The constructors need to be convinced that they can make a proper business case for the category with such a tight budget.

Tomlinson estimates that a run of 20 cars would be needed for a project to go into profit, but the ACO has modest aspirations for the category. It envisages only “two to four” cars out in year one in the ELMS and possibly a similar number in the struggling Asian Le Mans Series.

ACO sporting manager Vincent Beaumesnil suggests the market will grow. There are discussions with the United SportsCar Championship about the future of its highly-successful Prototype Challenge class using the ORECA-Chevrolet, he says, while he also suggests there is interest from promoters to run national LMP3 series.

The introduction of LMP3 into the USC is likely to face resistance from the teams running in PC. Paul Gentilozzi, whose RSR Racing team (formerly Rocketsports) has regrouped in the PC division since the end of its factory-supported Jaguar GT programme, says that when the subject of LMP3 comes up with USC sanctioning body “we express our concern”.

“We already have a great car with an engine that is relevant to North America. The only thing the class needs is a relationship with a manufacturer, who can put a bit of money into marketing,” he says, while conceding that such support is unlikely to come from Chevrolet given its involvement in both the Prototype and GT Le Mans divisions of the USC.

Riley suggests the category



LMP3'S DIFFERING FORTUNES

There appears to be a consensus on why LMP3, nee Formula Le Mans, didn't take off in Europe. And it is the corollary of why the category has been an undoubted success in North America.

When Formula Le Mans went from being a one-make series of two one-hour races a weekend to a class within the Le Mans Series for 2010, it didn't offer its competitors the chance of taking part in the jewel in the crown of endurance racing in Europe, the Le Mans 24 Hours.

Conversely, when FLM cars were introduced into the American Le Mans Series as the Prototype Challenge division in 2010, teams could take part in the two most important races under its governance, the Sebring 12 Hours and Petit Le Mans. The creation of the United SportsCar

Championship for 2014 now offers PC teams the chance to race at the Daytona 24 Hours as well.

RSR boss Paul Gentilozzi reckons it is as simple as that. “The strength of PC in the US is that it enables you to do all the major races,” he says. “In Europe, it died because it had a credibility problem — you couldn't do Le Mans and you couldn't be part of the World Endurance Championship.”

Hugues de Chaunac, whose ORECA organisation launched Formula Le Mans together with the Automobile Club de l'Ouest, has a similar opinion. “The problem was that competing in LMP3 came at a relatively high cost in comparison to running in LMP2 and it didn't give the chance to race at Le Mans,” he says. “That's why we have to make LMP3 significantly cheaper.”

wouldn't be able to support six manufacturers in the long term should that number actually build cars, although both his company and Ginetta are aiming to amortise development costs by producing trackday versions of their P3 designs. Riley sees a similarity with the

early days of Grand-Am's Daytona Prototypes: “We started with seven constructors and it eventually dropped to three, yet more than 100 DPs have been built since 2003. LMP3 isn't going to support five or six manufacturers, but it could be a success for two or three.”

LMP3 SPECIFICATIONS

BODY

Coupe bodyspace, complete with a shark fin, chosen to mimic look of LMP1 and, from 2017, all P2 machinery

ENGINE

Power comes from a lightly-tuned Nissan V8 with 420bhp, which will drive through an Xtrac gearbox

CHASSIS

Carbon monocoques are mandated, but a one-piece tub with an integral composite roof is not allowed

PERFORMANCE

The target performance for an LMP3 is two seconds a lap quicker than a current GTE car



**NEW DAYS FOR
2014, NOW THURSDAY,
FRIDAY AND SATURDAY!**

FREE TO ATTEND REGISTER ONLINE NOW!

25crmo

**BOOK YOUR STAND
NOW FOR 2014
BUCHEN SICH
SCHON JETZT
FÜR 2014**

**15 NOVEMBER
2014
COLOGNE
GERMANY**

**BOOK YOUR
STAND NOW**

**YOUR SPACE
NOW**

FROM CLUBSPORT TO F1

NO ENTRY TO THE GENERAL PUBLIC



230+
EXHIBITORS
SEE WEBSITE
FOR DETAILS



Professional **MotorSport**

WORLD EXPO 2014
13, 14, 15 NOVEMBER 2014
COLOGNE, GERMANY



European Launch of Toyota
GT86 CS-R3 Rally Car

TECHNOLOGIES ON SHOW

- Race Engine and Component Manufacturers
- Data loggers, timing and video equipment
- Performance equipment
- Everything for Race Cars
- Testing and development
- Racewear and safety devices
- Paddock equipment
- Transportation and logistics
- Race simulators (buy or rent)

BOOK YOUR FLIGHT!

Many low-cost airlines fly to Cologne, with cheap flights available from almost all UK airports. Cologne-Bonn airport is about 15 minutes by taxi from the exhibition centre. A good alternative, which expands low-cost flight options, is Düsseldorf Airport, about 40 minutes by car from the exhibition centre. All the major car rental companies have desks at the arrivals zone.

PROFESSIONAL MOTORSPORT WORLD EXPO 2014

CONTACT: Phil White Tel: +44 1306 743744 Email: philip.white@ukipme.com

www.pmw-expo.com

2014 BTCC REVIEW

FULL STORY OF A DRAMATIC TIN-TOP TITLE FIGHT



ALL THE ACTION AS TURKINGTON TOOK SECOND CROWN

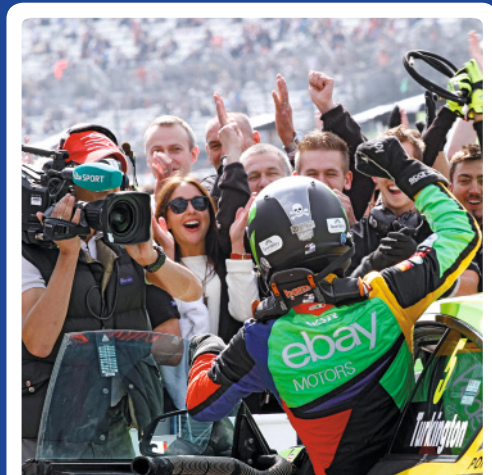



MCDONALD/GETTY

CHAMPIONSHIP POSITIONS

1	COLIN TURKINGTON (GB) WSR BMW 125i M Sport	434
2	JASON PLATO (GB) MG (Triple Eight) MG6	399
3	GORDON SHEDDEN (GB) Honda (Dynamics) Honda Civic Tourer	349
4	MAT JACKSON (GB) Motorbase Ford Focus ST	316
5	ANDREW JORDAN (GB) Eurotech Honda Civic	310
6	ROB COLLARD (GB) WSR BMW 125i M Sport	277
7	SAM TORDOFF (GB) MG (Triple Eight) MG6	255
8	MATT NEAL (GB) Honda (Dynamics) Honda Civic Tourer	207
9	ARON SMITH (IRL) BMR Volkswagen CC	201
10	ADAM MORGAN (GB) Ciceley Mercedes A-class	185
11	ALAIN MENU (CH) BMR Volkswagen CC	176
12	ROB AUSTIN (GB) Rob Austin Audi A4	147
13	FABRIZIO GIOVANARDI (I) Motorbase Ford Focus ST	138
14	TOM INGRAM (GB) Speedworks Toyota Avensis	121
15	JACK GOFF (GB) BMR Vauxhall Insignia/Volkswagen CC	119
16	NICK FOSTER (GB) WSR BMW 125i M Sport	101
17	DAVE NEWSHAM (GB) AmD Ford Focus ST	70
18	MARC HYNES (GB) MG (Triple Eight) MG6	54
19	JACK CLARKE (GB) Motorbase Ford Focus ST	50
20	HUNTER ABBOTT (GB) Rob Austin Audi A4	20

MANUFACTURERS/CONSTRUCTORS CHAMPION

MG/TRIPLE EIGHT

TEAMS CHAMPION

WSR

INDEPENDENTS TROPHY

COLIN TURKINGTON (GB) WSR BMW 125i M SPORT

INDEPENDENTS TEAM TROPHY

WSR

JACK SEARS TROPHY

DAVE NEWSHAM (GB) AMD FORD FOCUS ST

WINS

TURKINGTON	8
PLATO	6
JORDAN	4
SHEDDEN	3
M JACKSON	2
SMITH	2
AUSTIN	1
COLLARD	1
MORGAN	1
NEAL	1
TORDOFF	1

POLES

PLATO	4
TURKINGTON	*3
JORDAN	2
TORDOFF	*1

* Turkington is awarded pole for Knockhill, instead of Tordoff, as he topped qualifying prior to a non-technical grid penalty.

FASTEST LAPS

TURKINGTON	11
JORDAN	4
SHEDDEN	3
NEAL	3
PLATO	2
SMITH	2
AUSTIN	1
JAMES COLE	1
GOFF	1
MORGAN	1
TORDOFF	1

POINTS SYSTEM EXPLAINED

In each race: 20-17-15-13-11-10-9-8-7-6-5-4-3-2-1 to top 15 finishers. Additional point for starting from R1 pole, setting fastest lap, and leading a lap.

FOR IN-DEPTH RESULTS
forix.autosport.com



TURKINGTON TAKES TWO

The 2009 champion was in superb form with his developed WSR BMW 125i M Sport and swept to his second British Touring Car crown. By KEVIN TURNER

Despite all the debate about rear-wheel drive, pretty much the entire British Touring Car paddock agreed that the right man won the 2014 title. Colin Turkington was a star last season and, with a better BMW 125i M Sport at his disposal, became the dominant force this term. Turkington took the crown in the first race at the Brands Hatch finale and his final winning margin – 35 points – was the biggest in the championship since 2008. And it could easily have been even more had it not been for a dubious grid penalty and two clashes with Jason Plato's MG along the way.

Apart from the odd misdemeanour, Plato also performed superbly. Triple Eight worked hard on the MG6 and it finally ended Honda's run of consecutive manufacturers' titles at four, while Plato won what he described as the 'front-wheel-drive class' by a massive 50 points. But Turkington, WSR and BMW were well down the road.

HOW IT WAS WON

All the pre-season excitement was about the seven champions on the grid, but in truth returnees Alain Menu and Fabrizio Giovanardi were never in the fight (see page 36). It was always about the top

contenders from last season: reigning champion Andrew Jordan, Plato, Turkington and the works Honda squad of Matt Neal and Gordon Shedden.

Turkington's season did not start in a way that suggested dominance was on the horizon. A rollbar issue hampered him in the first race of the year, he struggled with the set-up early on at Donington Park (where he also had a controversial last-corner clash with Shedden in the third race) and initially struggled at Thruxton, a circuit RWD BMWs have never really enjoyed.

In the meantime, Jordan's Eurotech Honda Civic and Plato looked the top contenders. Jordan set the



Shedden's new Civic Tourer races Jordan's hatchback at Brands



EBREV/LAT

pace at Brands Indy and Thruxton. Plato quickly bounced back from his TOCA engine going into safety mode at Brands and would have scored a double at Donington had he not accidentally hit the speed-limiter button briefly at the start of race two, allowing team-mate Sam Tordoff through.

Turkington had still been picking up points, scoring two reversed-grid victories, and at Oulton Park the WSR BMWs really came alive. Turkington took pole and a double, leading home team-mate Rob Collard in the opener. A mandated longer first gear arrived for Croft, but still Turkington won twice on another circuit that has always suited RWD. Only a clutch failure in the final encounter prevented him opening up a bigger points lead.

Ironically, a more useful meeting from Turkington's championship point of view was Snetterton. Three podiums, twice behind pacesetter Plato, opened out a margin and the BMW's performance – on a circuit not traditionally one of its best – underlined the fact that WSR now had the best package.

The 125i M Sport's advantage was not so much over a single lap, it was as a racecar it had two main advantages. The first was its traction off the line; Turkington's superb qualifying efforts usually meant he started high enough up the grid to have a shout of leading into the first corner. ▶

Triple Eight MGs were class of FWD



MCDONALD/GETTY

TALKING POINT

How much of the BMW 125i M Sport's advantage was down to WSR, Colin Turkington and the regulations was the topic of much debate. Nobody doubted the abilities of Dick Bennetts' squad and its lead driver, but there was a feeling that the rear-wheel-drive machines had an edge under the NGTC rules.

As well as the usual traction boost, many argued that the weight distribution and rules tweaks allowed to make RWD cars work under the NGTC regs gave them an inherent advantage. It just took a team of WSR's experience, after a year learning the car, and a driver of Turkington's calibre to reveal it. On raw pace – as our graph

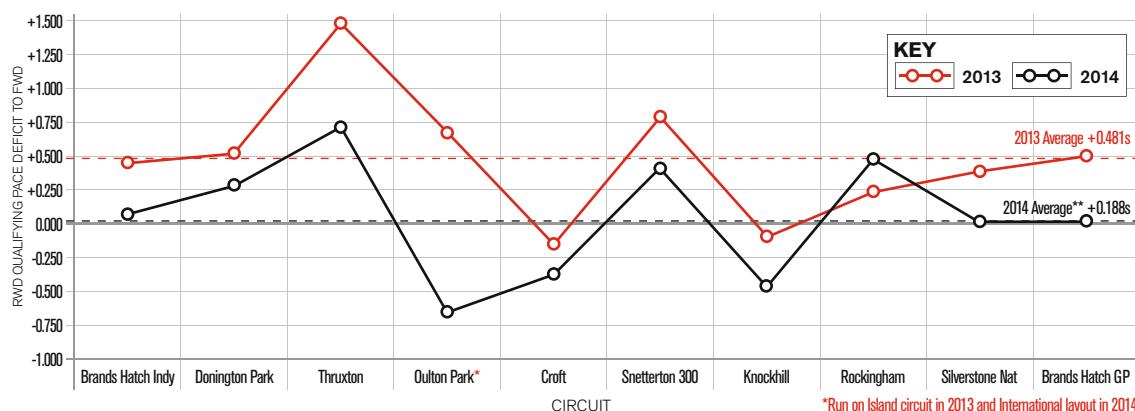

showing the gap between the best RWD car against the quickest FWD performer in qualifying over the past two years illustrates – there wasn't a lot in it. But when Turkington was able

to contest victory at Snetterton and Silverstone, two circuits on which the BMW was expected to struggle, it did indicate there was a RWD advantage to be had in the races.

Whatever the reason, it is not in the interests of series boss Alan Gow to have anyone running away with the championship, so expect some rule changes ahead of 2015.

HOW IT WAS LOST

Early on in the season Honda – with both Jordan's hatchback-bodied Civic, and works drivers Shedden and Neal with the new estate Civic Tourer – were in contention.

Jordan's first minor setback came at Oulton Park, when he was one of those to be caught out by a late red flag in qualifying and had to line up 13th. On the International track that proved tough to overtake on, progress was limited, but the real blow came after the summer break, at Snetterton.

A mistake at Riches in free practice sent Jordan into the barriers. It was a big crash and the 25-year-old was forced to miss qualifying. He still wasn't quite right on race day, on which he only scored a single point. Being collected by a spinning Shedden in the first race at Knockhill ended his chances for good.

Team Dynamics initially found the switch to the Civic Tourer and VTEC engine more tricky than they first anticipated, and the car was certainly not as agile as the hatchback, but Shedden was usually in the mix. During the first half of the season he put together a canny run of consistent finishes and, despite only two wins and the usual Honda problem of being held back on turbo boost, was still second in the points with three meetings to go.

Rockingham was a disaster, an off in race one being followed by contact with Hunter Abbott in the finale, and the Hondas were always going to struggle around the straightline-speed-dependent Silverstone National. Shedden was also a bit too aggressive at times, but his sublime wet-weather drive at the Brands finale ended his year on a high.

That was more than could be said of team-mate Neal, who finished his campaign with a trip to



Austin won at Rockingham

hospital after being the innocent victim of a multi-car crash in the first Brands GP race. Neal's final championship position of eighth did not reflect his efforts behind the wheel. He outqualified Shedden three times and was rarely far from the pace, but a wide range of bad luck derailed his bid.

Neal lost a podium at Croft when his Civic failed the rideheight test, there were numerous on-track clashes – of which few were his fault – and a drivethrough penalty for jumping the start in the second Knockhill race. To cap it all, he then suffered the wrath of TOCA thanks to comments made to AUTOSPORT at Rockingham...

STANDOUT PERFORMERS

After a troubled 2013, Mat Jackson and Motorbase bounced back. Jackson even started qualifying well (!) and completely dominated team-mate Giovanardi. He also showed admirable restraint when battling the title rivals in the closing stages of the season, though it was a surprise to see him throw away a victory in race two at Brands GP.

Tordoff and Collard both had their moments, but were overshadowed by their team leaders. Once he gave up on left-foot braking after the Brands opener, Tordoff was rarely too far off Plato and added to his win tally. He was hit by a few technical issues, though Triple Eight wasn't entirely convinced some of them weren't self-inflicted.

Like Jackson, Aron Smith also beat a more illustrious colleague, but his fight with Menu was much tighter. The slippery BMR Volkswagen CCs – of which there were four by season's end – were rapid on occasion. Smith took his two reversed-grid chances well, inbetween the odd drama, and beat Menu by 15 points and two spots in the standings.



Neal suffered an awful season

Menu had his troubles while getting to grips with NGTC, but his pace was often strong. He was especially rapid on the soft tyre, with some fine charges bringing him into contention for the Jack Sears Trophy, this year awarded for most places gained over grid position across the season. That ultimately went to AmD's Dave Newsham, while Menu got into too many scrapes for someone of his experience. The double champ criticised driving standards, but he was as often to blame as he was the victim.

Tom Ingram was comfortably the top rookie, the Speedworks Toyota driver being held back by a combination of tin-top battling inexperience and the odd car problem, which usually seemed to strike on Sunday. Rob Austin also occasionally starred – good defence against Plato at Oulton, a second career win at Rockingham – during another inconsistent and action-packed season.

SOMETHING TO REMEMBER

The reversed-grid Silverstone bout involving Turkington, Giovanardi, Menu and Plato included some classic touring car battling, but perhaps the feel-good result was Morgan's first BTCC win in the second Brands GP race.

The Ciceley Mercedes came on strong late in the year and would have been on the podium sooner had it not been for a radiator issue at Rockingham and alternator failure at Silverstone. Morgan battled Tordoff, Plato and Collard brilliantly at Brands – showing how far he has come in wheel-to-wheel battle with the top drivers – only to make a mistake at Sheene and let Plato back by. He might have been fortunate to get the win after the MG driver's penalty for hitting Turkington, but it was no less than team and driver deserved after a promising first year with the A-class.

SOMETHING TO FORGET

The arguments about RWD. And the first race at Knockhill. Apart from Neal's well-judged drive to victory, it was not right to see Turkington and Jordan – two of the BTCC's cleanest drivers – punted out at Scotsman. At least it set up Turkington's stellar drive in race two, after which the BMW came back unscathed, despite making its way past more than 20 cars around the tight confines of the Scottish circuit. As was said about the new double champion many times throughout the year: class. ☞

AUTOSPORT'S TOP 10 DRIVERS

With 31 entries and seven BTCC champions, it took a lot to stand out in 2014. **KEVIN TURNER** picks out the best drivers

34

1 COLIN TURKINGTON

Championship 1st (434 points)

Wins 8 Poles 3 Fastest laps 11

Took more wins and fastest laps than anyone else, and invariably delivered in qualifying. Didn't make mistakes and showed breathtaking racecraft at times. Knockhill race-two charge and Silverstone race-three defence were two of the drives of 2014.

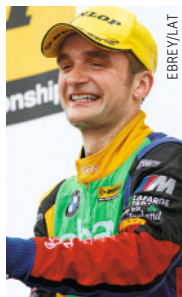

EBREY/LAT

2 JASON PLATO

Championship 2nd (399)

Wins 6 Poles 4 Fastest laps 2

One of his finest seasons. Aside from unfortunate clashes with Turkington at Knockhill and Brands GP, he was on top form. Once the WSR BMW was in its stride, Plato looked like the only man to stop it, and brilliantly did so at Snetterton and Silverstone.

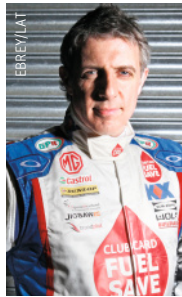

EBREY/LAT

3 ANDREW JORDAN

Championship 5th (310)

Wins 4 Poles 2 Fastest laps 4

The reigning champ was the only driver outside the top two to be a pacesetter across a weekend, at Brands Indy and Thruxton. Snetterton free-practice crash was his fault; he was unfortunate to have to miss qualifying, which prematurely ended his title hopes.



MCKLEIN/LAT

4 GORDON SHEDDEN

Championship 3rd (349)

Wins 3 Poles 0 Fastest laps 3

Rarely a pacesetter since team got to grips with the new Civic, but he put together a consistent campaign to stay in contention until the Rockingham disaster. Too often a little too robust in combat, though low straightline speed was a mitigating factor.

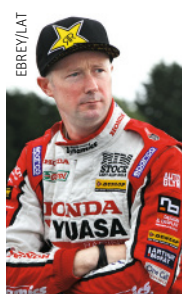

EBREY/LAT

5 MAT JACKSON

Championship 4th (316)

Wins 2 Poles 0 Fastest laps 0

Overshadowed returning double champion team-mate Fabrizio Giovanardi. Always raced well, showing admirable restraint in several battles with Turkington during the title run-in. Loses marks for Oulton/Brands GP errors that cost possible wins.



EBREY/LAT

6 SAM TORDOFF

Championship 7th (255)

Wins 1 Poles 1 Fastest laps 1

When things went well, Tordoff could match – and beat – team-mate Plato, such as at Donington and Rockingham. The difference came when things weren't so easy, like making soft tyres last a race. He also suffered more than his fair share of bad luck.

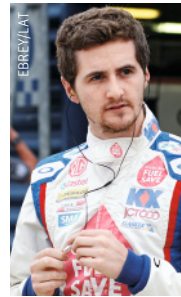

EBREY/LAT

7 MATT NEAL

Championship 8th (207)

Wins 1 Poles 0 Fastest laps 3

The results indicate a terrible year for the triple champion, but it wasn't his efforts that let him down. There often wasn't a lot in it between him and Shedden on pace and many of Neal's issues – rideheight dsq at Croft and a few clashes – were not his fault.

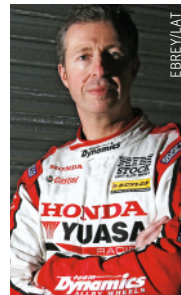

EBREY/LAT

Honourable mentions

Rob Collard put in some exciting charges, but too often didn't do the job in qualifying and was usually well behind team-mate Turkington. Standout rookie **Tom Ingram** was a top-10 challenger in qualifying from his debut. Bad luck and being elbowed back in races meant he didn't get the results he deserved. The return of **Menu** and **Giovanardi** grabbed attention, but both were beaten by team-mates. Menu showed good pace, but found too many things to hit. Ex-British F3 champion **Marc Hynes** got faster, but found tin-top racing a tough challenge.

8 ARON SMITH

Championship 9th (201)

Wins 2 Poles 0 Fastest laps 2

BMR became a major player in 2014 and Smith held his own against star signing Alain Menu. There were a few wild moments – hitting Jackson at Brands, free-practice off at Thruxton – but he took two reversed-grid wins with aplomb, and under big pressure.

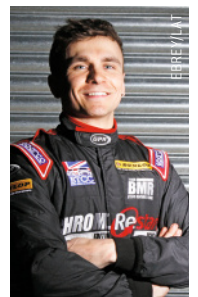

EBREY/LAT

9 ADAM MORGAN

Championship 10th (185)

Wins 1 Poles 0 Fastest laps 1

Once again a thorn in the side of the multi-car teams. Made the odd error, including Oulton qualify crash, but usually had strong race pace. Showed great racecraft at Brands GP, though it would have been nice to win without an off and Plato's penalty.



EBREY/LAT

10 ROB AUSTIN

Championship 12th (147)

Wins 1 Poles 0 Fastest laps 1

Austin put in what's now a fairly typical BTCC season for him: big highs punctuated by technical problems and a few too many on-track skirmishes, though not all were his fault (see Knockhill). Managed a second win, but this time in a reversed-grid race.



EBREY/LAT



Ingram was a star rookie

EBREY/LAT



THE INSIDE LINE

COLIN TURKINGTON

The BTCC's most recent two-time champion on what went into his second successful title campaign with WSR & BMW

The BTCC doesn't start at the first round in March or April. I started working on this campaign in February. You eat, sleep and drink motor racing and you let it consume your life, with the one focus of winning the championship. You have one goal. You immerse yourself in it, but the trouble is that you are not the only person doing that – everyone else does too.

But I was very determined this year. It was the year that people were building up because there were seven champions on the grid, so to win it this year was more important than ever. If you wanted to win it, then this was the year to do it.

It took a day or two to sink in but I have just been enjoying it. I have had a great response back home in Northern Ireland.

I was always destined to go into the sport. Motorsport has been in my heritage for a long time. Northern Ireland is steeped in motorsport history, both on two wheels and four. My granddad was always very passionate about motorbikes, and still is at 96 years old. My dad was a rally driver and my mum was his co-driver and I have two brothers who are also racing drivers. When I was a wee boy, I didn't think I had much choice. Instead of a football, I was given a steering wheel!

I am just a small cog in what has happened this season. It is incredible that we have won every title going – we have the main championship, the teams', the independents' and the independents' team trophies. There has been a tremendous



Eight wins helped seal Turkington's second title

EBREY/LAT

“We are the champions and that is a great feeling. I don't want to lose that feeling and I am able to come back in 2015 carrying the number one”

effort from the boys in the factory to make sure the car is strong, and we have had some fantastic backing from eBay. What you see at the weekend is only a fraction of the effort we put in. It has been a lot of hard work that has stretched over two years since we first introduced the car in 2013.

Winning this title is just as special as my first one. When I won it in 2009, I was 27 years old. When you haven't won it before, you would give anything to get your name on that trophy alongside the great names that are already there. When you read the names that are already on the trophy, then you know that you are joining the elite. Back then, there was lot of pressure, because I had never won it before and I wanted it so badly. I was up against Jason Plato and Fabrizio Giovanardi. They were massive names and formidable opponents and it was all new ground for me. It was a new experience and I was a complete nervous wreck going in to the showdown at Brands Hatch at the end of the season.

I was pretty confident all year, but the pressure was really ramped up on that last day. The difference this year is that I was able to stay much more relaxed, and I was in control of what was going on and my feelings. I knew what to expect. That isn't to

say it was any easier, but to win twice and to join that next elite group of those who have won it twice is extra special.

There were frustrations in the season. There were the arguments about the rear-wheel-drive cars. I was disappointed with other people's reactions to that: it's not like we finished one-two-three in the championship, was it? It was annoying that people thought we had an advantage. Yes, we were quick off the startline, but we had our problems too. It is harder to get temperature into the tyres and you are very vulnerable in the heat of battle. We didn't dominate at every track. We had to work as hard as the front-wheel-drive cars, and it was down to the work of a good team that we prevailed.

I have been with WSR for every year apart from one. Whenever a team gives you a car that is capable of winning week in, week out, that's what you want. And that formula isn't going to change in the future. We are the champions and that is a great feeling. I don't want to lose that feeling and I am able to come back in 2015 carrying the number one, which I wasn't able to do in 2010. So that means next year is going to be as important to me as any other. I can't wait until Brands Hatch on April 5. 🏆

RETURN OF

Alain Menu and Fabrizio Giovanardi conquered the BTCC on four occasions between Motorbase Ford Focus respectively didn't add to their mighty tally of race victories.

“I still love racing. The day I feel like I'm making up the numbers I'll retire”

ALAIN MENU

The return of two-time champions Alain Menu and Fabrizio Giovanardi to the British Touring Car Championship was one of the biggest pre-season storylines of 2014. But their status as bit-part players this season, rather than title contenders, reflects how difficult this series has become to master without recent experience. There were flashes of form by both, and podium finishes too, but the fact that neither ended the season in the top 10 in the points is something of a surprise for drivers of their undoubted calibre.

Their routes back into the series were quite different. Menu's eight-year association with Chevrolet in the World Touring Car Championship had ended and, following a fruitless brief stint in the Porsche Supercup last year, he found the full-time opportunity he was looking for in Warren Scott's ambitious BMR team and its sleek Volkswagen CC for 2014.

Giovanardi had ventured much further into the wilderness, with random starts in the Nurburgring 24 Hours, V8 Supercars, Superstars and Scandinavian Touring Cars his only real activity since his amazing record of tin-top distinction across Europe in the late-90s and noughties. With seven titles to his name, coupled with Menu's two BTCC crowns and 36 race wins, how was it that their returns weren't more successful?

MENU'S STORY

Now 51, Menu is one of the true stars of the BTCC from its Super Touring heyday. After winning his first title in a Williams-run Renault Laguna, his second came in a Prodrive-run Ford Mondeo. But how would he handle his comeback with BMR, a team only set-up in 2013 and one that was expanding rapidly to a four-car set-up?

“I did see it as a big challenge,” admits Menu, who finished 11th in points but had been in the top 10 until a disastrous final round, “but an achievable challenge. When I first met Warren I was impressed, both with him and his vision.

“The way he was going about it was impressive for someone new to motorsport, his superbike racing aside. He had [engineer] Geoff Kingston, who I worked with in my first year of the BTCC in '92, and Alan [Cole] as team manager. We were all experienced guys, and had the basis to achieve something. I've been there before, so knew it would take time.”

THE KINGS

them, but their comebacks to the series in the BMR Volkswagen CC and **CHARLES BRADLEY** asks them both why they think things have been so tough

Menu returned with a bang, qualifying eighth at the Brands opener, but a poor start and first-corner tankslapper sent him into recovery mode for the rest of the day. It ended with a promising fifth in race three, but also with a big clash with rookie Tom Ingram. "When we started the season, I wasn't ready," he admits. "Stupid things like starts – we didn't have time to practise or everything we needed to do proper standing starts. Even though I qualified well at Brands, shit starts mean you're in the middle of the pack and from then... pffffffft.

"I said my goal was to enjoy myself, well I did not enjoy myself to start with. Some of the driving is too aggressive; completely unnecessary – I just don't understand why some of the guys do it. It's like banger racing, heavy side-to-side contact. Touring car racing should be leaning on each other, respecting the other guy to give him room when he needs it – unless it's the last lap! Why push somebody completely wide when you overtake and cause him to lose another place? I was not impressed with that."

A dispute with series chief Alan Gow over driving standards occurred behind the scenes, but eventually resolved itself: "We go back a long time, and respect each other. We haven't always seen eye to eye, but there's a deep respect for each other. We made up and it's all fine now."

While he wasn't perfectly happy on the track, off it Menu found everything he was looking for in BMR. "I still love racing, and I wanted to enjoy myself here," he says. "Obviously that means winning. I'm not here to make up the numbers – the day I feel like that I'll retire. What we were up against was the TOCA rules on testing, so very few test days during the season. The cars were ready later than planned, so we did not do as much testing as we should have done.

"Warren has done everything he told me he was going to do. He is true to his word, which is fairly rare in motor racing. And that's the way I like to work, so in that sense it's been a very good year."

And results-wise?

"Not as good as I expected," he replies. "Rockingham [round eight] was my first race weekend where it was clean. I did not get pushed off, or a drivethrough like at Thruxton, or throttle issue like at Knockhill. Without some bad luck, I would have had quite a few more podiums this year, I'm sure.

"We are not quite there yet to win races on merit. The potential is there, I'm pretty sure. I'm quite happy with my driving. The team needs a proper winter of testing and development. A few things will get changed on the car – this team and that car should hit the ground running at Easter next year. Whether ▶

"I didn't expect it to be so tough. People have been expecting different results..."

FABRIZIO GIOVANARDI

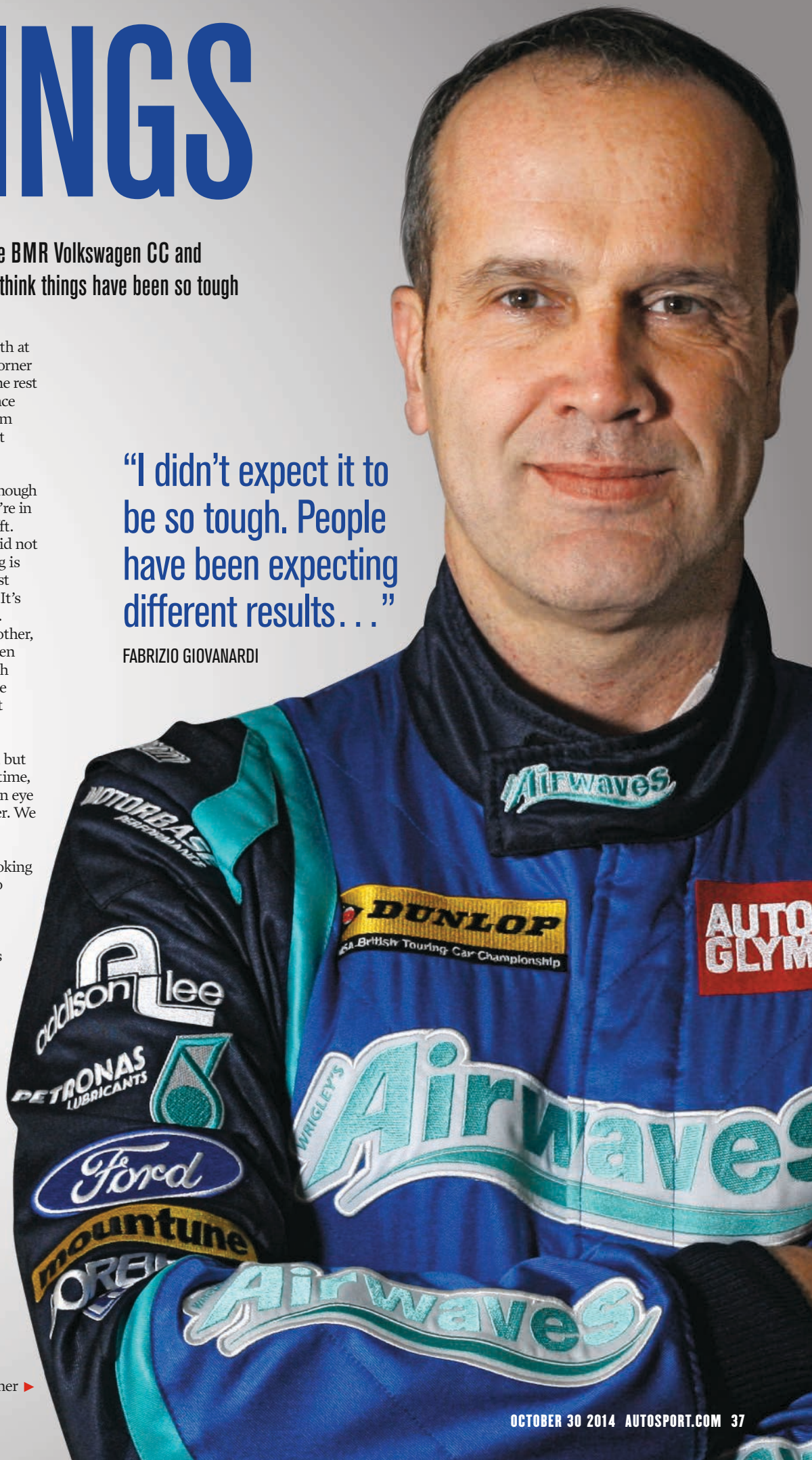



Giovanardi goes rallycross in a Focus he didn't gel with

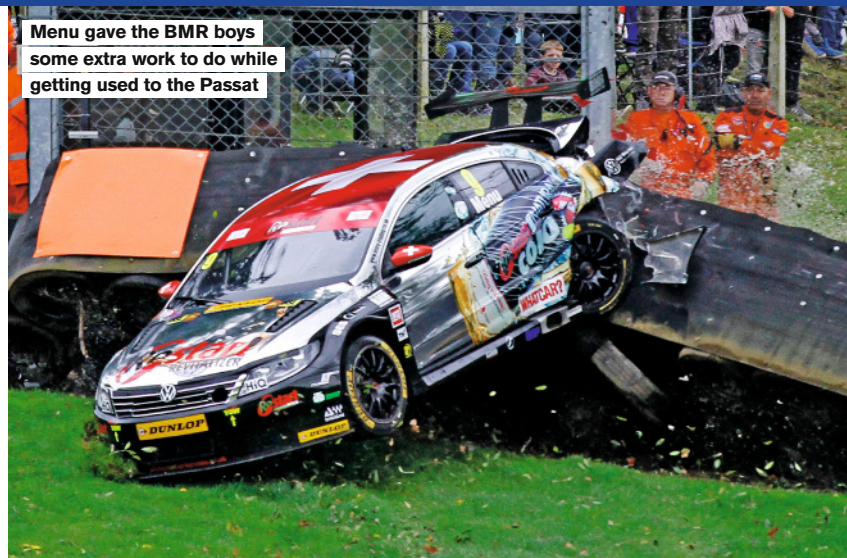

Menu gave the BMR boys some extra work to do while getting used to the Passat

► it's right at the top, like a Honda or MG, I don't know. But potentially it will be."

That clean weekend at Rockingham produced Menu's first (of two) podiums. Hardly a stranger to the experience, how did that feel?

"It's nice, because that's where you want to be, ideally winning races," he says. "It meant less to me than it did to most observers. OK, the last time was 2000, and some people said, 'Oh it must be a relief after 14 years' – but I had been doing something else you know! I hadn't been doing nothing and waiting 14 years for a podium!

"The past is the past, and the best thing about that podium was it was for the boys. It was their podium, the joy was for them, and we should have got one earlier actually. Hopefully, one day, that podium will be a win. Maybe it's next year..."

Ah, it's a Menu wink. How the BTCC has missed that. And will we be seeing Menu, wink and all, back in the BTCC next year with BMR?

"There's a good chance," he allows. "But if you'd asked me that in the first half of the season I'd have said no.

"I don't think I've lost much, if any, speed. If I was in one of the top cars I would have been fighting for the championship this year, no question. Racing is still my life, you know? The championship is different from what it used to be, so with one year's experience, in a way it would be a shame to go and do something else. Watch this space, as they say."

GIOVANARDI'S STORY

While Menu's opportunity was with an unproven team, 47-year-old Giovanardi's was with one of the BTCC's top five teams in the Airwaves-backed



"I don't think I've lost much, if any, speed. Racing is still my life, you know" ALAIN MENU

Motorbase squad. David Bartrum's operation was a proven winner and, with his Italian stallion teaming up with vastly experienced race winner Mat Jackson, the future looked rosy at the start of the season, even after the Focus had proved a tad recalcitrant in 2013. Don't forget, Giovanardi's success in this series was far more recent than Menu's, his titles coming in 2007 and '08 with Triple Eight-run Vauxhalls.

"I felt good about coming back and driving these

cars in this championship because I was always looking to come back for some real competition," says Giovanardi. "All my life I've loved driving touring cars and having fun, having contact, having fights. But in the past few years I twice raced in the Nurburgring 24 Hours with GT cars... it's just not the same, it's just driving along through the middle of nowhere!

"When David asked me to come over, I was really happy to do that. But what happened since then, I didn't expect it to be so tough. Everyone was expecting different results from me, and it just hasn't happened."

Giovanardi has always been a very realistic driver, always open and honest about his situation. And this year turned out to be an uncomfortable one behind the wheel – he ended the season 13th in the standings with less than half the points of Jackson.

"I've had tough seasons before, like 2006 in the Vauxhall, but that was for a different reason, different rules. When the manufacturers were in the championship it was a case of always developing the cars. Now, with the NGTC, it's more closed for a driver like me. You know, it's like being in a small room. That is the car you have to drive. You only have a small box to work inside.

"I don't want to find excuses, I had difficulties to find confidence immediately. I was scared about the car – it was that tough to drive. But once you've started, you want to keep going and find out why something is wrong."

And you can't fault Gio for trying. He and the team plugged away at getting the Ford Focus to his liking, but its handling continued to plague him.

"In some way, as a team, we had an improvement



Menu was surprised by some of the driving standards in the BTCC

Giovanardi leads team-mate Jackson at Thruxton, where he took a podium

Early spin at Brands opener was a wake-up call for returnee Menu



this year," he says, searching for that elusive silver lining. "From what I know about last year, Mat's results weren't as good as they are now. This is maybe because they were pushing a lot, but even when the room is small, you have to find a comfortable space inside.

"I've always been looking for something better with the car this season, and when you go looking you make mistakes – you can sometimes jump out of the room!"

Like Menu, Giovanardi felt he made a breakthrough at Rockingham but it turned out to be something of a false dawn. Much like his podium finish in race three at Thruxton in May.

"At Rockingham, I had a good feeling with the car, I had a good race for a short time. So the car could be good for me, but then I came to Silverstone and it was like a punch! Woah.

"They made a test at Snetterton between the races and tried for something more, looking for improvements, and then I lost first practice at Silverstone and only found in the second practice that I had real problems driving the car with what they'd found. They expected an improvement, but for me it wasn't.

"This championship is so close that if you miss one or two tenths, your weekend won't go in a good way. Maybe it's half fault of the car, and maybe it's half fault of me. I don't want to blame either, but I'm not yet joined with the car. My attitude is not to find an excuse; it's not in my character."

Giovanardi doesn't want to blame the lack of testing for his poor season, but admits the lateness of his deal didn't help his cause. He felt rushed.

"We did four tests in winter, twice at Brands



"When I'm driving it's always fun, but outside the car it has been tough" FABRIZIO GIOVANARDI

then Oulton and Snetterton, but it rained a lot. Then we started the championship, and I wasn't ready. I wasn't understanding the car at all there. I was just seeing what I had to drive, and then you get into the season and you have no time. When you go looking for results, you push more – pushing, pushing – and then you make more mistakes than normal.

"If you are in a good position, the results just come. If you are randomly up and down,

then you're struggling. Look at Valentino Rossi: last year he was almost disappearing from view, this year he's been winning races and is strong again. You need everything, yourself to have a comfortable mind and the team understanding what you want and going in the right way. But it's OK."

He's certainly not blaming Motorbase for all its work this year: "They are a good team, they put in all the effort and I'm happy with that, but I didn't have enough time – maybe I need more than one season."

And what chance of that? It seems unlikely.

"I can understand if they don't choose to keep me, because obviously as a name they expect to have a miracle, but I'm not doing that miracle," he says. "But I can do the miracle if I'm in the right way. When people are expecting something that doesn't come they instantly ask: what? Why? You know, and I'm the only person who knows exactly what's going on, you know what I mean?"

"I know my history, I know my difficulties in the past, I've been up and down before. You just have to try within yourself; don't forget what happened in the past.

"Sometimes I have had fun this year. When I'm driving it's always fun, but outside the car has been tough. We need time during the winter, we need a small jump – it's not huge. We have to find an average set-up to be in the room, but we need testing. I need testing and time.

"If it's not coming, then it's game over. Then maybe I'm going back to those 24-hour races... [he closes his eyes and rests his head against his hands]. Zzzzzzzzz!"

A lack of testing put former double champ Gio on the back foot



PLATO AND MG: MISSED OPPORTUNITY?

Jason Plato's three-year deal with MG has come to an end. The combination won a lot of races, but not the drivers' title. **KEVIN TURNER** asks whether it was a success or failure

Since the MG6 made its British Touring Car debut at Brands Hatch in 2012, Jason Plato has scored more wins and poles than any other driver. The Triple Eight man has been in the hunt for his third crown each time in the NGTC machine, but has missed out. Plato has mixed feelings about his past three campaigns, but on balance believes he has achieved his goals, aided by the fact that MG finally ended Honda's four-year run of manufacturers' crowns in 2014.

"Where I am at the moment – what's truly important to me – is anything we do we do it with style and with the sponsors and our obligations to them at the forefront of our mind," says the double champion. "From that perspective, starting from nothing we're very proud of what we've achieved.

"We've turned this car into the fastest front-wheel-drive car. From that perspective, it's incredibly rewarding.

"If I win another BTCC championship, is it going to change my life? No, it's not. So long as I am competitive every year, that's what matters, that I can race and be in with a shout. I wish I had more than two championships, but winning races and being competitive is what it's all about."

Triple Eight team boss Ian Harrison is more blunt. "We're not happy with it," he says. "We could have won a couple of titles.

"We've had good speed. We were inconsistent in damp and wet conditions and it's taken us longer than we would have liked to get on top of that."

Harrison is sure, however, that his outgoing 47-year-old lead driver has been as good as ever: "JP's been the class of the grid the last couple of years and he drove better than ever this season. He's been more circumspect."

So, with such pace and experience – not to mention team pedigree – what has stopped the potent Triple Eight and Plato combination from lifting more end-of-season silverware?

2012: A YEAR TOO SOON

Going for the title in year one – the first season the majority of the field ran NGTC machinery – was always going to be a tough task.

"Four days before Christmas [2011] there was no deal and we had no shell until February," recalls Plato. "We started too late and lost ground at the beginning of the year."

Chief engineer Carl Faux concedes that compromises were made to get the MG6s of Plato and Andy Neate onto the grid for the Brands Hatch opener.

"The first challenge was that we started in January," says Faux. "We were really pleased with being able to win on the car's debut with a car that



Wet-weather handling was 2012 bugbear

was nowhere near what we've got now. It's a completely different car."

While the chassis and cooling package (which has also been used by some other teams) have changed little since, the aerodynamics on the 2012 car were a compromise.

"It was done quite quickly – that was the necessity of it, to get it on the grid," adds Faux. "The NGTC suspension was also a primary focus through the first season and going into 2013 we did a big damper-development programme and that continued this year."

One obvious weakness was the car's performance in wet conditions, which was certainly inferior to the Honda Civic during that first season. Faux concedes some of that was in the suspension department, but most was in simply trying to understand the idiosyncrasies of NGTC.

"It was about understanding how to get the best out of the package – the engine, diff, tyres," he explains. "We were struggling with that in 2012 because our first test was Brands, the first round, whereas other teams – specifically Honda – had three cars pounding round in winter weather."

There was also the odd clash – with Dave Newsham at Brands and Rob Collard at Donington Park – and reliability issues in that first season.

"It was a development year," adds Faux. "We had a couple of on-track incidents with other cars, and some reliability issues, like the subframe failure at Oulton Park and an engine failure when we were leading the race at Silverstone."

Although the MG6 was quick by the end of the year, with three poles in the season's second half, the result was that Plato finished third in the points, albeit top non-Honda by a long margin.

2013: THE ONE THAT GOT AWAY

"We should have won it last year and would have done had we not had so many issues with breakdowns and DNFs" – that is Plato's concise take on 2013. "Reliability and team mistakes cost us the championship."

Faux agrees: "It's the one that got away. We should have won it. We had the quickest car and we didn't capitalise on it."

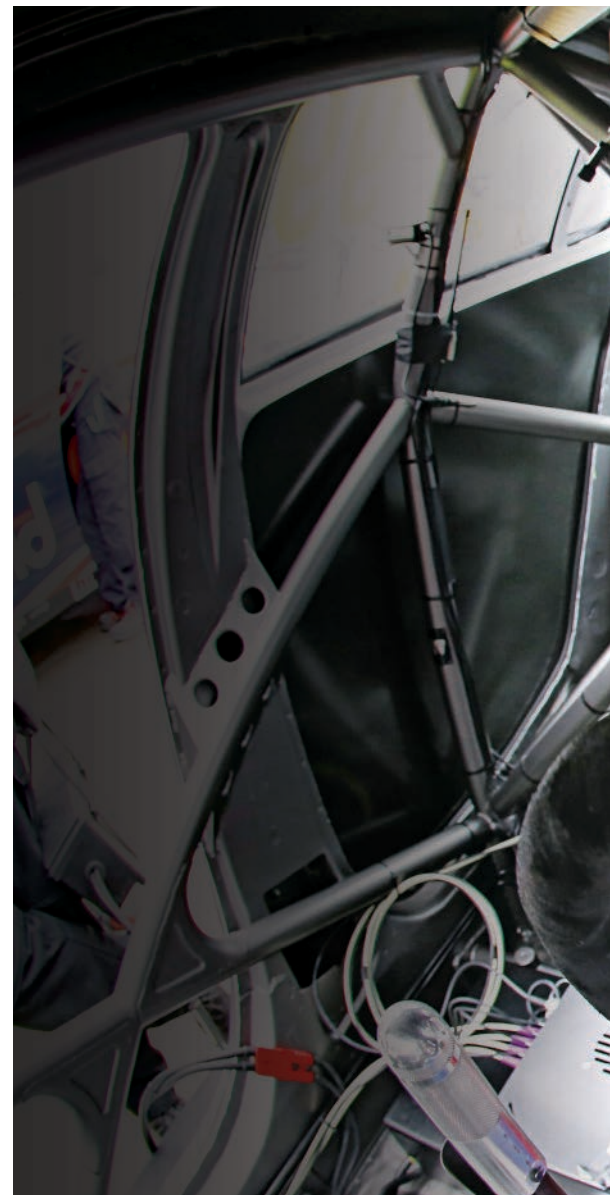

Oulton fire one of many 2013 failures

Plato took more wins and twice as many poles as champion Andrew Jordan, but suffered a lot more drama along the way. Snetterton was perhaps the key. The MG6 was the car to have in Norfolk and the success-ballast-laden Plato followed teammate Sam Tordoff home in race one. A win in the second encounter looked likely, only for Plato to run out of fuel. That then put him to the back for the third race, in which he crashed out.

There were still positives. Consistency in wet (if not changeable) conditions improved and the MG6 was usually one of the quicker cars in a straight line. Most put that down to the turbo-boost level of the car's TOCA engine and while that was a factor, Faux points to another explanation.

"We went for a low-drag philosophy," he argues. "That's really shown in the speed traps and also in the tyre wear.

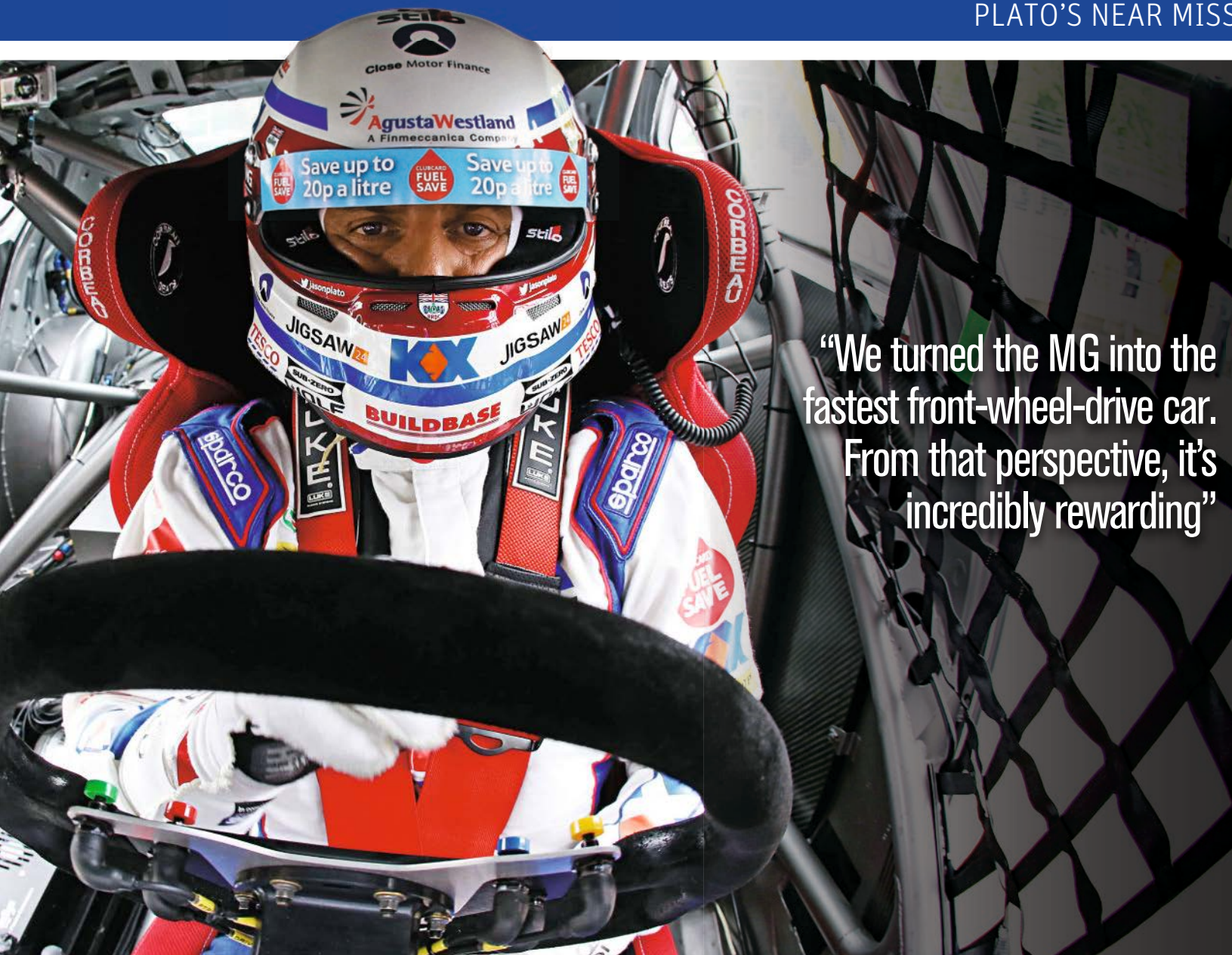

“We turned the MG into the fastest front-wheel-drive car. From that perspective, it’s incredibly rewarding”

“We built a slippery car, Honda built a draggy car; they built a car with more downforce, we didn’t so it can look like they’re slow in a straight line.”

Nevertheless, another third in the drivers’ table – again behind two Honda pilots – and second in the teams’ championship was poor reward.

2014: BEATEN BY RWD

More aerodynamic work was done over the winter of 2013-2014. Indeed, there was even a radical design on the drawing board (or CFD screen) that Triple Eight calculated would have given an average gain of 0.2 seconds per lap.

“We found a solution that was a bit quicker than what we’ve got, but it was a complete bodywork change,” explains Faux, who does his design work with CFD rather than in the windtunnel. “It would have required completely retooling. What we’ve got ▶



THE TITLE CHASERS

TOP BTCC WINNERS 2012-2014



TOP BTCC POLESITTERS* 2012-2014

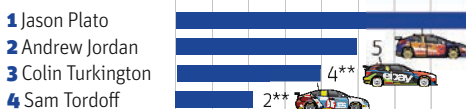

* Only qualifying sessions for race-one grids counted.
 ** Turkington is awarded pole for Knockhill 2014, instead of Tordoff, as he topped qualifying prior to a non-technical grid penalty.



FASTEST LAPS TOP FIVE 2012-2014



► on the car is the best economical option.”

The 2014 kit that did hit the track was thus less radical, though it was estimated to provide a boost of around 0.1s over the previous car, as well as improving cooling by 20 per cent.

“The focus was to add more front-end [grip] on the car and we achieved that,” adds Faux. “Another area we struggled with before was in traffic – because we went for a low-downforce, low-drag car – with the front-end and brake cooling. Our cooling ducts moved to a lower-pressure area, which has also given us downforce.”

There were still some setbacks, most notably the engine going into safety mode at the start of the second race at Brands Indy and Plato being a victim of someone else’s clash at Thruxton. But, for the first time, he beat all the Honda drivers in the title race. It was just that both marques were jumped by the WSR BMW of Colin Turkington.

The debate about the advantages of rear-wheel-drive under the NGTC regulations raged on and on, but Triple Eight remained convinced the squad was fighting with a disadvantage in 2014. “Had the RWD situation not developed this year, we’d have won it,” says Plato, who finished 50 points clear of Honda’s Gordon Shedden. “Over the winter the [Dunlop] tyre changed and we had to learn that. We did that well. Take the RWD out of the equation and I’ve blitzed it.”

“I’ve given everything and I’ve performed when I’ve needed to. If you don’t win because another team has got a march on the regulations, you can look at that and be happy.”

Faux adds: “Gordon [Shedden] had a non-score [at Rockingham] and we jumped him in the championship, which shows once again we’ve got the best front-wheel-drive car on the grid. We just couldn’t compete with the BMW.”

DESIGN LIMITATIONS

Across the whole programme, one of the things the team has had to overcome is the limitation of the base car, which is bigger and older than most rivals. That, combined with the restrictive nature of the NGTC regulations, in which many spec parts are mandatory, has made getting the car where the

BEST MG POSITION TRACK BY TRACK 2012-2014

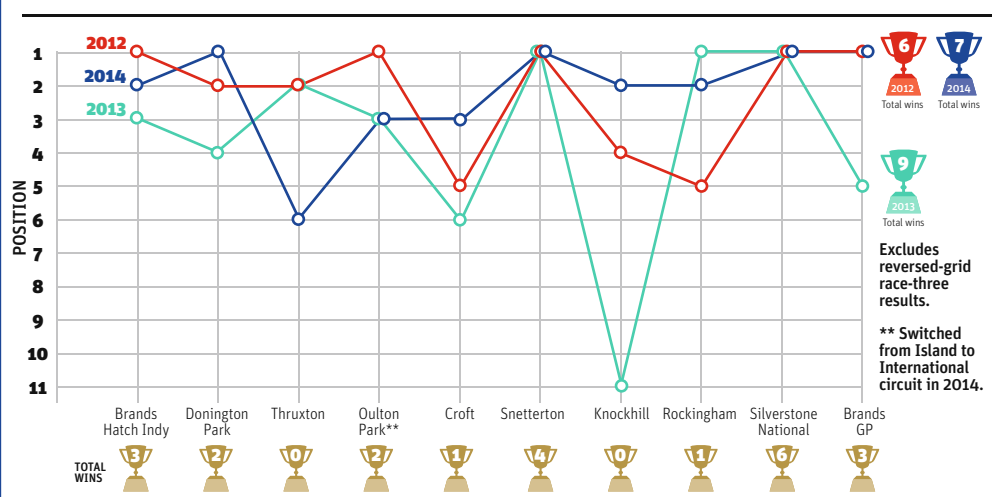

team wants it difficult. It’s a change for a squad used to building cars – and finding its own solutions – in the days of Super Touring and S2000. “It’s a new challenge,” says Harrison. “You can’t just go and redesign the front suspension.”

Faux adds: “I come from a background of working for a manufacturer, having free rein to do what we want. If you’ve got a problem you fix it. With NGTC it’s a different proposition. We are quite hard on our tyres, unless it’s wet. I put it down to the weight distribution. We don’t have any ballast to bring it up to the minimum weight. We’re fixed with what we’ve got, which is very front heavy – over 60 per cent on the front axle. It is a big road car and the road car is an older platform.”

That helps to explain why certain cars go well at some tracks and are weaker at others. After three years of NGTC it is often easy to predict who will be quick at each circuit: Honda dominates at Thruxton, BMW at Croft, MG at Snetterton.

“Everyone has their strong circuits, and everyone has their weak ones,” says Faux, who points to Thruxton, Croft and Knockhill as the most challenging tracks for the MG6. “Knockhill was a



big improvement this year. We did some specific testing for the circuit and it paid off for us.

“At some places the MG works very well. Thruxton is the biggest problem for us circuit-wise. I’ll be honest, it’s something I’ve not got my head around, bearing in mind the [old S2000] Vauxhall Vectra was the strongest car round Thruxton. Why I can’t get that to translate to the MG I don’t know.”

All things considered, the first three years of Triple Eight’s MG programme have to be considered a success, even if narrowly missing out on the drivers’ title is becoming a theme for Plato.

“We achieved a lot, it just didn’t come my way,” says the 88-time BTCC race winner. “I’ve delivered, the team has delivered, the programme has delivered.”

“We achieved a lot. I’ve delivered, the team has delivered, the programme has delivered”

MG THAT NEVER WAS

Triple Eight did explore a more radical aero package for the MG6. This design, estimated to provide a gain of around 0.2s over the 2013 car, produced less drag for the same level of downforce, thanks largely to the more rounded front wings. It was deemed too expensive, but another lower-cost option, with front flicks to produce downforce, did help the squad to find around 0.12s for 2014.

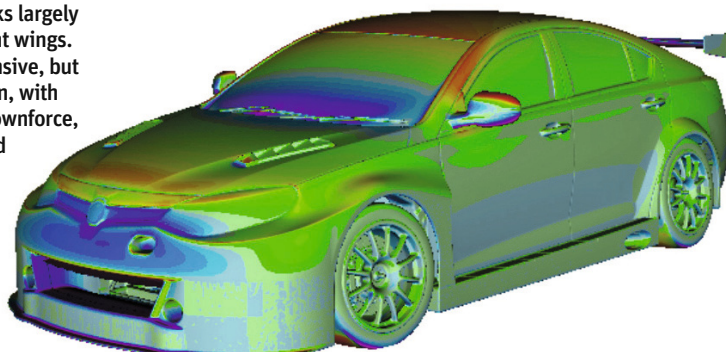
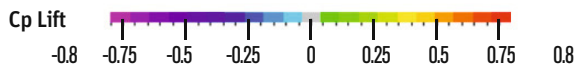

KX QUESTION TIME

We would like to thank everyone who took part in this year’s KX BTCC Question Time sessions, including the fans for their questions. Special thanks to our partners KX and Jason Plato, Dunlop for supplying prizes and host Alan Hyde.

Thank you to our guests who appeared on the panel: Hunter Abbott, David Addison, Rob Austin, Dave Bartrum, Derek Butcher, Mickey Butler, Jack Clarke, Fabrizio Giovanardi, Louise Goodman, Alan Gow, Pete Harris, Tim Harvey, Robb Holland, Marc Hynes, Tom Ingram, Jack Mitchell, Adam Morgan, Scott Stringfellow, Ian Titchmarsh, Sam Tordoff, Colin Turkington and Dorothy Uwota.



Student Profile

FACTFILE

Student's name: Lewis Wimpenny

Age: 23

Course: Motorsport Technology BSc

Year: 2nd



Q&As ■

➤ **What or who inspired you to pursue a career in motorsport?**

An interest in cars and my grandfather.

➤ **What did you want to be when you were growing up?**

A car designer or a sprinter.

➤ **What are your earliest motorsport memories?**

Watching Rally GB with my dad. Think the early Gran Turismo games are there too.

➤ **What was it about the course at the University of Bolton which made you apply?**

Experience with RLR Msport was a big factor as was Bolton's history. Before it was a university it was a higher education institute that specialised in engineering.

➤ **What's it like being a student in Bolton?**

It's great! There are good opportunities for extracurricular activities and a brilliant sports centre. The transport links into Manchester are good and the shops, bars and nightlife in town are pretty impressive too.

➤ **What prospects does the course offer after you graduate?**

The ongoing work experience is going to be an advantage in getting a career in motorsport. We're surrounded by people who have made a livelihood out of it and they know how to prepare students for the real world.

➤ **Which projects have you worked on during your studies?**

Last year we designed and manufactured a piston. We're currently doing some aero work on one of RLR Msport's cars and I'm performing some analysis work

on a DRS flap using a 3-D scanner and CFD.

➤ **Is there work experience or placement opportunities?**

With RLR Msport being on site there is always opportunity to gain experience with them. Seeing how a real racing team operates day-to-day has been invaluable to my learning.

➤ **Can you tell us about the projects you're working on this year?**

This year we're undertaking group tasks; our group have chosen to perform analysis on the side pods of a Ligier JS53 Evo with a view to redesigning them and making additions for reduced drag.

➤ **What extracurricular activities does the University offer to motorsport students?**

I've been able to attend numerous race meetings including a prototype endurance race at Catalunya. We've also been taken to Rockingham and Silverstone too.

➤ **If you could work for anyone in motorsport who would it be and why?**

Colin Chapman is a long time hero of mine so it'd have to be Lotus.



Our next Open Day is Saturday 22nd November 2014

Visit www.bolton.ac.uk/autosport for more information | @BoltonCAPE

TEN DRIVERS, ONE MSC MASTER, THE CHOICE IS YOURS!



Each weekend throughout the season a Mobil 1 Service Centre (MSC) Master was selected from the Avon Tyres British GT and Cooper Tires British Formula 3 Championships.

Awarded on merits which reflect the Mobil 1 Service Centre brand, these drivers displayed a combination of outstanding effort, significant improvement in championship standings and exceptional sportsmanship.

A Master of the Year will be announced at the SRO Motorsport Group Night of Champions and awarded with the season trophy and £5000 worth of fuel courtesy of WP Racing.

VOTING - WIN A SUPERCAR RACE EXPERIENCE

The power is in your hands – vote for your MSC Master of the Year.

To vote for your favourite driver please visit facebook.com/mobilservicecentre. All participants will go into a prize draw to win a supercar race experience.

Voting ends 14th November 2014. Winner to be announced on Facebook. Terms and conditions apply, please visit www.mobilservicecentre.co.uk/competition_terms.html



Mobil 1 Service Centre proud sponsor of the British GT and Formula 3 Championships.



BRYANT-MEISNER

GIDDINGS

MARSHALL

WELLS

PARFITT

Mobil 1™

SERVICE CENTRE

For more information please contact us at;

facebook.com/mobilservicecentre

mobilservicecentre.co.uk

0800 980 6172



Mobil 1 Service Centre is an exclusive WP Group initiative

Turn your garage into a Mobil 1 Service Centre

Reflecting excellence and long-term care, the Mobil 1 name plays amongst world championships and passenger vehicles alike. This means that your customer can be confident that they are dealing with a garage that insists on using the highest quality Mobil oil in their vehicle.

When you become an MSC, you open the doors to a complete tool kit of marketing support including;

- *A Facebook page attracting thousands of followers*
- *Extensive TV coverage*
- *Advertising through magazine publications*
- *Garage branding and signage*
- *Mobil 1 Service Centre merchandise*
- *Consumer promotions and competitions*

AUTOSPORT

INTERNATIONAL

The Racing Car Show

8-11 JANUARY 2015 **BIRMINGHAM NEC**



**CARS
STARS
ACTION**

**FASTEST SHOW
ON EARTH**



BOOK NOW! 0844 581 1372

WWW.AUTOSPORTINTERNATIONAL.COM



Whincup and Dumbrell took win and a second

V8 SUPERCARS SURFERS PARADISE (AUS), OCTOBER 25-26 RD 12/14

Towering Whincup closes on V8 crown

JAMIE WHINCUP HAS A HEADLOCK on a sixth title after two strong performances on the Gold Coast.

Aided by co-driver Paul Dumbrell, Whincup took second in the first 300km race and dominated the second, stretching his points lead to over 400 with two rounds to go.

Whincup was beaten on Saturday by Shane van Gisbergen. The Tekno Holden man put the disappointment of Bathurst behind him, taking the lead mid-race after a strong start by co-driver Jono Webb. The pair looked to be in contention to win on Sunday until van Gisbergen served a

drive-through penalty for a restart breach, dropping him to midfield before he charged back to fifth.

The first race was marked by a controversial battle for third. Tim Slade held the position, on fading tyres over the final laps, but at the final corner he was pushed wide by Mark Winterbottom's Ford, which moved past into third. But officials reversed the order change, restoring Slade and co-driver Tony D'Alberto to third. The Nissan of Michael Caruso/Dean Fiore was not far behind in fifth, and they went even better on Sunday, taking third

place, chasing home the Volvo of Scott McLaughlin/Alex Premat. The S60 had led the opening race early on before falling back to seventh.

It was a terrible weekend for Craig Lowndes and co-driver Steven Richards, who finished outside the top 10 in both races. Ditto the Holden Racing Team, whose progress was stopped by a startline crash and steering and tyre problems.

Bathurst winner Chaz Mostert dragged his Ford into the top six on Saturday but could not repeat the effort on Sunday.

● Phil Branagan

RESULTS

Race 1 1 Shane van Gisbergen/Jonathon Webb (Holden Commodore VF), 102 laps in 2h13m24.0986s; 2 Jamie Whincup/Paul Dumbrell (Holden), +2.2552s; 3 Tim Slade/Tony D'Alberto (Holden); 4 Mark Winterbottom/Steve Owen (Ford Falcon FG); 5 Michael Caruso/Dean Fiore (Nissan Altima); 6 Chaz Mostert/Paul Morris (Ford). **Race 2** 1 Whincup/Dumbrell, 100 laps in 2h13m00.3105s; 2 Scott McLaughlin/Alexandre Premat (Volvo S60), +2.8513s; 3 Caruso/Fiore; 4 Slade/D'Alberto; 5 van Gisbergen/Webb; 6 David Reynolds/Dean Canto (Ford). **Points** 1 Whincup, 2835; 2 Winterbottom, 2433; 3 van Gisbergen, 2357; 4 Craig Lowndes, 2331; 5 Fabian Coulthard, 2192; 6 Mostert, 2147.

SUPERTC2000 RIO HONDO (RA), OCTOBER 26 RD 10/12

Fluency for Renault ace

A NEW RULE OBLIGATING TYRE changes and an early safety car played into the hands of Renault driver Fabian Yannantuoni as he rose from the sixth row to win.

With track temperatures of 60C, drivers had a hard and a soft compound to use, with pitstops



Yannantuoni leads the way

any time between the first and penultimate laps. The safety car benefited Yannantuoni and reigning champion Matias Rossi, who had retired his Toyota from his heat and started from the back row.

Rossi narrowly took second from Leonel Pernia, whose Renault nearly caught him at the finish line.

Points leader Nestor Girolami held first place early on in his Peugeot, only for mechanical issues to necessitate a second stop. Norberto Fontana continued to struggle with the grid handicap system, and could rise no higher than ninth before spinning away his chances of closing on Girolami.

● Tony Watson

RESULTS

1 Fabian Yannantuoni (Renault Fluence), 21 laps in 40m05.971s; 2 Matias Rossi (Toyota Corolla), +9.705s; 3 Leonel Pernia (Renault); 4 Bernardo Llaver (Toyota); 5 Emiliano Spataro (Renault); 6 Esteban Guerrieri (Toyota). **Points** 1 Nestor Girolami, 168; 2 Norberto Fontana, 143; 3 Pernia, 134.5; 4 Facundo Arduso, 131; 5 Agustin Canapino, 129; 6 Mariano Werner, 126.

FRENCH GT PAUL RICARD (F), OCTOBER 25-26 RD 7/7

Imsa claims last-ditch title

IMSA PORSCHE DUO NICOLAS

Armindo and Raymond Narac leapfrogged from third in the points to win the title in a dramatic finale.

A win in the opening race had already allowed them to slash the gap to Sebastien Loeb Racing Audi pair Mike Parisy and Henry Hassid, who entered the weekend atop the points.

Hassid had run second in race one, behind the Sofrev ASP Ferrari of Philippe Giaouque and ahead of Narac. But after the pitstop handicaps it was Armindo in front, with Parisy forced to recover from 11th to seventh.

Olivier Panis led the second race,

with Armindo losing a fight with Morgan Moullin Traffort for second.

After the stops, Gilles Vannelet overhauled the similar Ferrari of Jean-Claude Police – which then suffered a puncture – to win in the Sport Garage-run car started by Enzo Guibbert. While Narac took fifth, Hassid lost the title thanks to a drive-through penalty for contact.

RESULTS

Race 1 1 Nicolas Armindo/Raymond Narac (Porsche 911 GT3-R), 38 laps in 1h01m00.422s; 2 Arno Santamato/Eric Cayrolle (Ferrari 458 Italia GT3), +4.318s; 3 Morgan Moullin Traffort/Philippe Giaouque (Ferrari); 4 Ludovic Badey/Jean-Luc Beaubelique (Ferrari); 5 Gregory Guilvert/David Hallyday (Audi R8 LMS ultra); 6 Olivier Panis/Eric Debard (Ferrari). **Race 2** 1 Enzo Guibbert/Gilles Vannelet (Ferrari), 43 laps in 1h01m06.690s; 2 Panis/Debard, +3.412s; 3 Guilvert/Hallyday; 4 Santamato/Cayrolle; 5 Armindo/Narac; 6 Matthieu Vaxiviere/Christian Ried (Porsche). **Points** 1 Armindo/Narac, 177; 2 Mike Parisy/Henry Hassid, 175; 3 Guilvert/Hallyday, 170; 4 Moullin Traffort/Giaouque, 140; 5 Panis/Debard, 125; 6 Santamato, 122.



Porsche beat Audi crews to crown

Rally of Spain



World Rally Championship
Salou (E), October 23-26

Round 12/13

RESULTS

17 STAGES, 231.74 MILES

1	SEBASTIEN OGIER (F)/JULIEN INGRASSIA (F)	3h46m44.6s
	VW Motorsport Volkswagen Polo R WRC #1	
2	JARI-MATTI LATVALA (FIN)/MIKKA ANTILA (FIN)	+11.3s
	VW Motorsport Volkswagen Polo R WRC #2	
3	MIKKO HIRVONEN (FIN)/JARMO LEHTINEN (FIN)	+1m42.2s
	M-Sport WRT Ford Fiesta RS WRC #5	
4	MADS OSTBERG (N)/JONAS ANDERSSON (S)	+2m13.3s
	Citroen Total Abu Dhabi Citroen DS3 WRC #4	
5	DANI SORDO (E)/MARC MARTI (E)	+2m22.2s
	Hyundai Motorsport Hyundai i20 WRC #8	
6	ANDREAS MIKKELSEN (N)/OLA FLOENE (N)	+3m52.9s
	VW Motorsport Volkswagen Polo R WRC #9	
7	THIERRY NEUVILLE (B)/NICOLAS GILSOUL (B)	+4m01.0s
	Hyundai Motorsport Hyundai i20 WRC #7	
8	MARTIN PROKOP (CZ)/JAN TOMANEK (CZ)	+8m06.8s
	Jipocar Czech National Team Ford Fiesta RS WRC #21	
9	HAYDEN PADDON (NZ)/JOHN KENNARD (NZ)	+9m12.4s
	Hyundai Motorsport Hyundai i20 WRC #20	
10	NASSER AL-ATTIYAH (Q)/GIOVANNI BERNACCHINI (I)	+12m39.8s
	Ford Fiesta RRC #32	

OTHERS

11	YURIY PROTASOV (UA)/PAVEL CHEREPIN (UA)	+12m40.4s
	M-Sport WRT Ford Fiesta RS WRC #14	
12	KEN BLOCK (USA)/ALEX GELSOMINO (I)	+13m00.9s
	M-Sport WRT Ford Fiesta RS WRC #15	
14	ELFYN EVANS (GB)/DANIEL BARRITT (GB)	+13m15.0s
	M-Sport WRT Ford Fiesta RS WRC #6	
17	ROBERT KUBICA (PL)/MACIEK SZCZEPANIAK (PL)	+21m11.9s
	M-Sport WRT Ford Fiesta RS WRC #10	
19	KRIS MEEKE (GB)/PAUL NAGLE (IRL)	+27m36.0s
	Citroen Total Abu Dhabi Citroen DS3 WRC #3	

DRIVERS' CHAMPIONSHIP

1	OGIER	242	6	NEUVILLE	89
2	LATVALA	211	7	MEEKE	84
3	MIKKELSEN	152	8	EVANS	71
4	HIRVONEN	108	9	PROKOP	42
5	OSTBERG	92	10	SORDO	40

MANUFACTURERS' CHAMPIONSHIP

1	VW MOTORSPORT	416	4	HYUNDAI WRT	175
2	CITROEN TOTAL	187	5	VW MOTORSPORT 2	133
3	M-SPORT	180	6	JIPOCAR CZECH NATIONAL	45

STAGE TIMES

SS1 BARCELONA (1.99 miles) Fastest: Mikkelsen 3m39.1s Leader: Mikkelsen	SS11 ESCALADEI 2 (31.07 miles) Fastest: Ogier 29m17.3s Leader: Ogier
SS2 GANDESA 1 (4.35 miles) Fastest: Meeke 4m26.3s Leader: Mikkelsen	SS12 COLLDEJOU 2 (16.45 miles) Fastest: Latvala 15m40.6s Leader: Ogier
SS3 PESELLS 1 (16.52 miles) Fastest: Paddon 15m26.6s Leader: Neuville	SS13 SALOU (1.39 miles) Fastest: Mikkelsen 2m36.4s Leader: Ogier
SS4 TERRA ALTA 1 (22.17 miles) Fastest: Ogier 23m26.1s Leader: Ogier	SS14 LA MUSSARA 1 (12.73 miles) Fastest: Latvala 11m08.3s Leader: Ogier
SS5 GANDESA 2 (4.35 miles) Fastest: Ogier 4m23.0s Leader: Ogier	SS15 RIUDECANYES 1 (9.66 miles) Fastest: Latvala 10m00.1s Leader: Ogier
SS6 PESELLS 2 (16.52 miles) Fastest: Neuville 14m43.3s Leader: Ogier	SS16 LA MUSSARA 2 (12.73 miles) Fastest: Latvala 11m05.6s Leader: Ogier
SS7 TERRA ALTA 2 (22.17 miles) Fastest: Ogier 22m46.1s Leader: Ogier	SS17 RIUDECANYES 2 (9.66 miles) Fastest: Latvala 10m00.1s Leader: Ogier
SS8 TIVISSA (2.46 miles) Fastest: Latvala 2m25.6s Leader: Ogier	
SS9 ESCALADEI 1 (31.07 miles) Fastest: Latvala 29m14.4s Leader: Ogier	
SS10 COLLDEJOU 1 (16.45 miles) Fastest: Latvala 15m41.6s Leader: Ogier	

Rally route The ceremonial start remained in Barcelona, but was joined by a spectator-pleaser around part of the Montjuic grand prix circuit on Thursday evening. The gravel stages were moved from Saturday to Friday, but the roads were all familiar on this tried-and-tested route.

Back on top: Ogier dominated the rally



Ogier reigns in dust-clouded Spain; his rivals mainly complain

Poor visibility prompted some drivers to fury in the opening stages, but Sebastien Ogier dug deep to secure a second world title for himself and Volkswagen. **DAVID EVANS** was there

LEAVE THE STICKERS ON. THE #1 VOLKSWAGEN

Polo R WRC will stay the same for another year. Sebastien Ogier found his mojo, his motivation and some massive speed to win in Spain last weekend. The defending world champion was simply superb. Unbeatable on the gravel and utterly in control on the asphalt, he delivered a champion's drive to seal a successful defence of his title. Team-mate Jari-Matti Latvala was the quicker of the two over the weekend, but his chance was gone when he couldn't find a Friday feeling with Polo #2.

LEG ONE (88.07 miles)

Sunny - ambient temperature range on stages 15-25C

Before the event, Andreas Mikkelsen had promised to go crazy in his attempts to take his first-ever win in the World Rally Championship. In the middle of Barcelona, last Thursday night, he delivered on that promise. In fact, he'd clearly gone a bit loopy on the road up to the crowd-pleaser around Montjuic Park. The Norwegian had managed to burn the tread completely from his gravel-spec Michelins, leaving himself a set of slicks for the two-miler. He was fastest by 1.8 seconds, but almost paid the penalty as his Polo R WRC ran curiously low on fuel. Almost as though it had been doing doughnuts or something...

When conversation veered off Mikkelsen's slicks, it invariably alighted upon Friday's gravel roads and the potential for billowing clouds of car-swallowing dust. Predictably, Ogier had no truck with any such chatter. He'd eaten dust through the final leg of last year's Rally of Spain and demolished a 46-second gap in some style to win. He would far rather be buried deep in the dust than first in, sweeping the stones.

He was only eighth fastest through Gandesa, so the road had clearly cleaned, but Ogier wasn't going to be drawn. "Everything's perfect," he said at the finish. Citroen was one-two at the top of the timesheet, with Kris Meeke quickest, despite suffering dust from not just cars, but also the telly heli. Keen to capture the DS3 at full tilt at the exit of a corner, the pilot hovered low over the road and pulled up as Meeke passed beneath. The side-effect of the downdraft was yet more dust.

One stage later and things had got a whole lot worse: Meeke was out.

"I ran wide on a fast left-hander. I arrived too fast - it wasn't a problem with dust or anything like that. There was nothing on the outside, it just dropped a wheel about a foot down off the road. I didn't lose any time, but it pushed the rear tyre off the rim. We changed the wheel and when I pulled out we had a load of understeer. We'd got a front puncture as well."

With one spare and two flats, his day was done.

One stage later and it was Hyundai's turn in the spotlight as Hayden Paddon took a brave pill, kept his foot in through the "white wall" of dust and set his first fastest time in the WRC. Third quickest for team-mate Thierry Neuville was enough for the Belgian to move into the lead, albeit by the smallest possible margin from a battling Ogier.

Like Meeke, Paddon was unable to capitalise on

his stage win and biffed a bank in the first corner of SS4, knocking two tyres off the rim. Fortunately they did have two spares on board, but the five minutes taken in changing them did little to help the overall position.

That Terra Alta test has around four miles of asphalt in the middle. Everybody was glad to get there. Ogier was delighted; for four miles he was sweeping dust rather than those second-sapping stones, and those behind were chuffed to find some clear air mid-stage.

Ogier came into his own in stage four. He powered his way past Neuville and into an 8.4-second lead. He was more than happy.

"I didn't expect this," he smiled at service. "It's been a very good morning."

Neuville was content with second, but far from

circumstances on the final stage of the day.

The Belgian was distracted in the car, slid wide, whacked a bank and knocked a tyre off the rim. He lost two minutes stopping and changing the tyre.

What had cost him his chance of leading the rally on speed and absolute merit?

"It was a fly," he said rather sheepishly. "It was in the car flying everywhere and then the screen wasn't clean. I got angry and frustrated."

Over lunch Latvala had changed suspension settings, but still he was frustrated: "I haven't had the feeling today. I couldn't get the braking right and I've been wearing the tyres too much."

The only good news for Latvala was that a late charge on the day's final test elevated him to second. He was six tenths up on Ostberg, who had a tenth in hand over Mikkelsen.



Latvala lost his last chance of the title

happy with the dusty conditions. Ostberg was in third place, 11.4s down on the i20. The Norwegian wasn't best pleased at catching the dust from his team-mate's Citroen. Meeke offered a stout and sensible defence of his own position, but the atmosphere among the reds was definitely not quite as amiable as always over lunch.

Mikko Hirvonen, Mikkelsen, Robert Kubica and Jari-Matti Latvala were all engaged in a 4.1-second squabble over fourth place. Much of the attention was on Latvala and his ever-decreasing chance of keeping the world title fight alive a few weeks longer. "I made every mistake possible this morning," he grimaced. "Everything was wrong."

Ogier set about the afternoon like a man possessed. Generally the conditions were better all round second time through; there was still cleaning to be done, but not so much and for those behind the dust wasn't hanging as badly.

Only in the Pesells test was the leader beaten as Neuville trimmed his advantage back to 4.6s. Neuville's hopes of landing the status of overnight leader going into day two went south in the oddest

All of them were half a minute down on the flying Ogier. Ostberg, Mikkelsen, Hirvonen and Kubica had all been near-faultless through the day, only a seventh-stage spin spoiling the Pole's exceptional day in the LOTOS Fiesta. Elfyn Evans admitted his day had been anything but: "We seem to have spent all day crashing!" He went off the road and stayed there in SS6.

POSITIONS AFTER DAY ONE

1 Ogier/Ingrassia	1h29m04.0s
2 Latvala/Anttila	+36.6s
3 Ostberg/Andersson	+37.2s
4 Mikkelsen/Fløene	+37.3s
5 Hirvonen/Lehtinen	+41.4s
6 Kubica/Szczepaniak	+57.0s

LEG TWO (98.90 miles)

Sunny - ambient temperature range on stages 16-27C

The two-mile Tivissa test was nothing but a loosener for the monster that was coming the way of the drivers. Escaladei hadn't been used for 12 years, and was brought back into the route and run at exactly 50 kilometres to mark the rally's 50th ▶

Hirvonen scored first podium in six months



► anniversary. This was the one the drivers feared. How would the new Michelin tyre cope?

Perfectly was the answer. And it was Latvala, not Ogier, who was making best use of them. Latvala took just under half a second per mile out of the leader in SS8 and, had he managed the same in SS9, he would have halved Ogier's lead. Unfortunately for Jari-Matti, he could only get two seconds back in the 31-miler. But he was still smiling.

And his explanation for the upturn in speed with the dirt behind him was typically honest.

"I concentrated so hard on this rally being the Tarmac rally, I forgot a little bit about the gravel," he said, with the look of a bashful youngster about to launch the well-worn dog-ate-my-homework tale on their teacher.

The second run of the long stage was the only place where Latvala lost time to Ogier. The last four miles were particularly nasty, with razor-sharp edges to one of the twistiest sections of the route. Latvala sympathised with his Michelins and eased off. Across the spread of the day, Ogier lost just short of 10 seconds, but wasn't concerned.

"I'm pushing," he said. "But where it's risky, I'm being more sensible."

Asked if he would respond to Latvala's times, he responded with a "Why?" and a smile.

Ogier was definitely back on top of the world in Spain, and he clearly knew it.

The VW pair moved clear of the chasing pack on Saturday and it was Hirvonen who was left to lead the charge for the bottom step of the podium. And M-Sport's Finn was utterly sublime – the best he's been for a long, long time. Few would have expected him to be six seconds up on Mikkelsen when the Norwegian was forced to stop and change a puncture.

Hirvonen's smile was wide. And welcome.

"I like this tyre," he said. "I've found out how to get the best out of it. I just hope the others don't learn the secret too quickly!"

The new-construction Michelin offered more movement – even in its hard-compound form used in Spain – and Hirvonen quickly acclimatised to the car moving about more at the apex and requiring more patience before getting on the throttle in the longer corners.

Ostberg was another fan of the new cover, but his confidence ebbed in the afternoon and he



Sordo's fifth was a disappointment

slipped back from the fight for third and now had fifth-placed Dani Sordo just 22.1s behind with one day to run. Kubica's hopes of securing his first WRC podium went south when he put a little bit too much effort into warming the tyres on the way to SS8 and broke a rear driveshaft. Going off the road in the afternoon ended another forgettable day for him.

POSITIONS AFTER DAY TWO

1 Ogier/Ingrassia	3h04m14.5s
2 Latvala/Anttila	+27.3s
3 Hirvonen/Lehtinen	+1m18.6s
4 Ostberg/Andersson	+1m48.3s
5 Sordo/Marti	+2m10.4s
6 Neuville/Gilsoul	+3m36.1s

LEG THREE (44.77 miles)

Sunny – ambient temperature range on stages 14-23C

Tempted as he might have been to engage in a battle for stage wins, Ogier was content to let Latvala whittle his lead away. In all honesty, Latvala drove brilliantly on the asphalt, winning eight of the 10 sealed-surface stages – and astonishingly setting precisely the same time through Riudecanyes both times. The question of how much Ogier had in reserve would remain, however.

It's not often that we talk of two Finns driving brilliantly on a largely asphalt event, but Hirvonen claimed his first podium since Portugal in April with a fantastic final-day display. If the likeable M-Sport man had been doing this more often this season, there wouldn't be nearly so many questions regarding his future.

Ostberg did enough to hold Sordo off for fourth place, securing a confidence-building result after a tough second half of the season. Sordo's result was disappointing given the speed he's shown at home in the past, and the pace Neuville has managed in the i20 WRC. Neuville's sister Hyundai was sixth – just. Mikkelsen missed out on a top six by just 1.9s.

No matter. There was plenty of celebrating to do at the opposite end of the top six. Crossing the line of the final stage, the French-flagged Polo had barely stopped before Ogier was out. Falling to his knees rather than leaping straight onto the roof, as in the past, he looked like a man offering a silent prayer of thanks. He might not have been on top of the car, but both man and machine top the world for the second year in succession. **W**

IN THE SERVICE PARK

DAVID EVANS
RALLIES EDITOR

@daviddevansrally



SEBASTIEN OGIER SMILED. HE'D HEARD THE stories of dust before. He had the perfect answer.

"Remember last year?" he asked rhetorically. Who could forget it? Ogier had hammered his way through the final day's gravel stages to take 46 seconds and the win from team-mate Jari-Matti Latvala. But you could barely see Ogier for the dust.

He didn't need reminding. But he felt he'd shown what could be done in those conditions. Last week, he escaped the dust but faced the flip side: sweeping the loose gravel from the surface, first on the road. Given the choice, he'd take the dust.

In some of the trickiest and loosest conditions of the season, Ogier showed his true colours again. Earlier this year, by own admission, his head has dropped. He'd become disillusioned with the direction from the sport's powerbrokers and, momentarily, he lost motivation. Arriving in Catalunya last week, fresh from bitter disappointment at home in France – where he missed the chance to take the title – he was rejuvenated in Salou. The spring was back in his step in Spain.

And he was exceptional. Brilliant. And perfect. His speed on Friday was sublime, but his ability to control proceedings through the weekend – while Latvala won the stages and risked all – was almost as impressive. Calculated and courageous, Ogier was a worthy winner in Spain and a very, very worthy world champion.

Ogier: calculated and courageous



BIG NUMBER

4044

That's the number of parts Volkswagen Motorsport used in switching three Polo R WRCs from gravel to asphalt specification on Friday night.

Ostberg, here on

Escaladei, was fourth



ALL PICS: MCKEIN/LAT



Ogier claimed title with one round to go

Second world title more demanding, says Ogier

SEBASTIEN OGIER CELEBRATED A second world title in Spain last weekend, and admitted that his achievement confirmed his position in rallying's elite.

Ogier took the crown with one round of the championship – next month's Rally GB – still remaining. He admitted, however, that the second one was made tougher than the first by a mid-season dip in form and by the pace of his team-mate Jari-Matti Latvala, who was the only man capable of denying him the crown in Salou.

"The target of every champion is to prove

that it is not just luck," said Ogier. "You always want to confirm that speed and that was the target for this year. I have often said that to get one title is difficult, but to conserve it is difficult also and that was the case for many reasons this year.

"The second title was more demanding, for sure," he admitted. "My team-mates were giving me a harder job and the regulations of this year, making me run first on the road many times, these parameters made my season harder. But sometimes when you have the close fights, you enjoy the victory

even more. I am very happy and very proud to get this second title – I think it's well deserved for all of the team."

A tough summer, where he was beaten in Finland by Latvala then crashed twice in Germany, put what had been a 50-point buffer in danger.

"Germany was a wake-up call for me," he said. "I realised there was danger. I couldn't lose what I had been working on from the beginning of the season. It would have been stupid to lose it like that. The main thing is that I made it back."

Kubica future under doubt

ROBERT KUBICA'S FUTURE IN the World Rally Championship has been brought into question with the news that he does not have any offers on the table for 2015.

The Polish star has suffered a tough first season in rallying's top flight, crashing on all but one of the 12 WRC rounds he has started with his Ford Fiesta RS WRC this year.

Asked about next season, Kubica said: "I will say I will be behind the wheel, but I don't know where."

M-Sport's Malcolm Wilson said: "Of course we would be interested in him staying with us, but we need to start talking about the possibilities."



Robert Kubica is short on WRC options for 2015



Friday's stages were very dusty

Drivers' fury about Spanish dust

THE FIA HAS REQUESTED THE Rally of Spain organisers to reconsider the use of some routes following forceful complaints regarding dust levels on Friday's gravel stages.

The drivers were upset at being forced to drive in what they considered dangerous conditions, with poor visibility. FIA rally manager Michele Mouton says she has spoken to the organisers about potential solutions for next season.

Hyundai's Thierry Neuville said: "For me it is too dangerous. Why should we risk our lives just because somebody doesn't want to give us another minute or more gap? It's always like this until something happens and somebody dies with a big accident in the dust.

"Then people start thinking. But before, nobody wants to listen. Every year we ask for a four-minute gap, but every year we come back and do the same stupid things."

VW CONFIRMS LINE-UP

Volkswagen confirmed before the start of Rally of Spain that its driver line-up will remain identical for next year and beyond. Nobody would comment on the length of contracts for Sebastien Ogier, Jari-Matti Latvala and Andreas Mikkelsen, but the team was glad to put an end to speculation regarding the world champion's future employment.

PARN TAKES ON WRC2

Sander Parn clinched a major prize on Sunday when victory in the Drive DMACK Fiesta Trophy landed him seven WRC2 rounds in a Ford Fiesta R5 next year. Parn, who finished fifth in Spain, was co-driven by Welshman James Morgan. Brits Tom Cave and Craig Parry were the only ones who could deny Parn, but they slid off the road while leading and eventually finished second. Nil Solans won the class.

NEW CAR FOR DMACK

Next year's Drive DMACK series will be based on a completely new, one-litre, turbocharged Ford Fiesta. The M-Sport built three-cylinder machine is expected to roll out some time next month with homologation coming early in the second quarter of next year.

AL-ATTIYAH CLOSSES IN

Nasser Al-Attiyah played himself into a 20-point lead in WRC2 with only one round remaining. The Ford Fiesta RRC driver won WRC2 after opening up a stunning two-minute gap on the gravel stages. Only Jari Ketomaa can deny him the title in Wales.

WRC3 SOLOISTS WIN

Mohamed Al Mutawaa took a lonely WRC3 victory in a Citroen DS3 R3T he shares with Northern Irishman Stephen McAuley. They had no opposition.

BAD WEEK FOR CHAMP

Recently crowned Junior WRC champion Stephane Lefebvre had a tough weekend. Before Rally of Spain even started, he was called before the stewards and told that he – and all the Junior WRC runners – were excluded from the Rally of France results due to a clerical error on the homologation papers. Then Lefebvre, driving a four-wheel-drive car for the first time, crashed his Citroen on day one.



AUTOSPORT fantasy league **GP**

**GRAB YOUR PLACE ON THE GRID!
IT'S NOT TOO LATE TO ENTER...**



\$100M TO BUILD YOUR ULTIMATE GP TEAM
AUTOSPORT.FANTASYLEAGUEGP.COM



Proud Sponsors of the
M-Sport World Rally Team

GOODRIDGE
FLUID TRANSFER SYSTEMS
www.goodridge.net





Skoda leaps to win in the Swiss Alps

ERC VALAIS RALLY (CH), OCTOBER 23-25 RD 10/11

Clean run on Valais puts Lappi on verge

ESAPEKKA LAPPI NEEDS FIVE POINTS from the last round in Corsica next week to take the title following his second win on a row on the tricky mountain roads east of Geneva.

With Peugeot drivers Kevin Abbring and Craig Breen hitting trouble early on and Lappi's Skoda team-mate Sepp Wiegand unable to maintain his strong initial pace, the Finn was out in front by stage five.

Kajetan Kajetanowicz started the final day 23s behind Lappi, having demoted Wiegand when his fellow Valais debutant struggled with a poor tyre choice for the drier-than-anticipated conditions on day two.

But the Pole was no match for the flying Breen, who clocked a sequence of stage bests as he

recovered the time lost with a puncture on stage three to overhaul Kajetanowicz for the runner-up spot on stage 16 when Kajetanowicz's Ford Fiesta R5 developed a terminal oil leak and momentarily caught fire.

But despite his heroic charge from 20th on Thursday night to second, Breen, like Kajetanowicz, is unable to catch Lappi on the Mediterranean island finale.

Abbring had led after two stages, but dropped to third with a brake issue before retiring with a clutch fault on day two. He restarted on leg three, won four stages, then bashed his 208T16s's steering on a post and stopped for good.

Andrea Crugnola bagged his maiden ERC Junior victory after

leading from the off. He is trying to raise the funds to contest the season closer, where Junior world champion Stephane Lefebvre will start with a nine-point lead. Mark Higgins led the ERC Production Car Cup before a transmission fault put him out.

● Graham Lister

RESULTS

1 Esapekka Lappi/Janne Ferm (Skoda Fabia S2000), 2h46m22.4s; 2 Craig Breen/Scott Martin (Peugeot 208T16), +42.0s; 3 Sepp Wiegand/Frank Christian (Skoda); 4 Jonathan Hirschi/Vincent Landais (Peugeot); 5 Olivier Burri/Jean-Jacques Ferrero (Ford Fiesta R5); 6 Robert Consani/Maxime Vilmot (Peugeot 207 S2000). **Points 1 Lappi, 162**; 2 Wiegand, 128; 3 Breen, 104; 4 Kajetan Kajetanowicz, 100; 5 Vaclav Pech, 63; 6 Vasily Gryazin, 53.

NASCAR SPRINT CUP MARTINSVILLE (USA), OCTOBER 26 RD 33/36

It's too late, but Earnhardt wins anyway

DALE EARNHARDT JR TRIUMPHED ON a chaotic afternoon at Martinsville to secure the win in his Hendrick Motorsports Chevy, one week after he was eliminated from the Chase.

On the 10th-anniversary weekend of the plane crash that killed 10 Hendrick crew family members and associates, Earnhardt picked his way through 15 caution periods (for a total of 105 laps under yellow) and two red flags to earn the victory.

Earnhardt was in control for much of the latter part of the race, but any hopes of an easy win were quashed when Kyle Larson crashed 10 laps from the end. A late flurry of

pitstops dropped Earnhardt to fifth for the restart, but he capitalised on the faster inside line to swiftly jump to second, and then passed Tony Stewart for the lead.

"We've tried to win here for so many years, and this place is so special to me," said Earnhardt. "This is a real emotional win."

He had to see off a late challenge from team-mate Jeff Gordon to get the job done, although Gordon might not have been behind him in the first place had he not incurred a pitlane-speeding penalty midway through the race. He recovered from the infraction to finish as the

highest-place Chase driver. "I put us in a bad position," Gordon said. "It was a silly mistake."

Gordon's pain was eased a little by the knowledge that many of his Chase rivals endured even bigger problems. Matt Kenseth spun and collected Kevin Harvick, and Brad Keselowski was sidelined with a driveline failure.

Kenseth recovered to sixth, and joins Gordon, Ryan Newman and Joey Logano among those who are currently in the top four and who qualify for the final title shootout.

● Mark Glendenning

RESULTS

1 Dale Earnhardt Jr (Chevrolet SS), 500 laps in 3h43m07s; 2 Jeff Gordon (Chevy), +0.344s; 3 Ryan Newman (Chevy); 4 Tony Stewart (Chevy); 5 Joey Logano (Ford Fusion); 6 Matt Kenseth (Toyota Camry); 7 Clint Bowyer (Toyota); 8 Denny Hamlin (Toyota); 9 AJ Allmendinger (Chevy); 10 David Ragan (Ford). **Eliminator 8 1 Gordon, 4044**; 2 Newman, 4041; 3 Logano, 4040; 4 Kenseth, 4039; 5 Hamlin, 4037; 6 Carl Edwards, 4024; 7 Brad Keselowski, 4013; 8 Kevin Harvick, 4011.



VLN

Jurgen Alzen and Dominik Schwager won the season finale on the Nurburgring Nordschleife in their Ford GT – the first overall VLN win for Ford since 1990, when Dieter Selzer/Hermann Tilke won in a Sierral The Frikadelli Porsche of Klaus Abbelen, Sabine Schmitz, Patrick Huisman and Frank Stippler finished second, with works driver Fred Makowiecki and stalwart Otto Klohs third in a Manthey Racing 911 GT3-R. Guy Smith, Steven Kane and Andy Meyrick took 13th overall in their works Bentley.

AUSSIE CARRERA CUP

Veteran Steven Richards is the 2014 champion after finishing fifth in the final race to take his first title since he won the Aussie Formula Ford crown 20 years ago. He beat Warren Luff and Craig Baird in the final-round showdown. Nick Foster won two of the three races on the Gold Coast, the other going to David Russell.

ITALIAN GT

Tomas Enge joined Solaris Motorsport's Francesco Sini as they took the squad's Chevrolet Camaro to victory in the final race of the season at Monza, but the big story was the ill-tempered title battle. Audi Sport Italia has appealed the decision to penalise Marco Mapelli and Thomas Schoffler 10 seconds, after the Scuderia Baldini 27 team claimed that Mapelli deliberately slowed at the Roggia chicane on the final lap to make contact with the Ferrari of title rival Raffaele Giammaria (co-driven by Lorenzo Case). The first race went to the Ombra Racing Ferrari of Alex Frassinetti and Stefano Costantini.

NASCAR TRUCKS

Darrell Wallace Jr grabbed the lead from Johnny Sauter in heavy traffic with 12 laps remaining to win at Martinsville in his Kyle Busch Motorsports Toyota. Timothy Peters, who bumped Sauter out of the way – sparking a near-brawl – was second from series leader Matt Crafton.

FRENCH FORMULA 4

Lasse Sorensen was already crowned champion, and the Dane emerged from some great battling at Paul Ricard with a win and two seconds. First-time winner Valentin Moineault took the final race, while Mexican Patricio O'Ward scored in the reversed-grid event.

FRENCH CARRERA CUP

Come Ledogar did his best to throw away the title at Paul Ricard, taking drive-through penalties in both races for jumped starts. Maxime Jousse pipped Tom Dillmann to victory in race one. Dillmann won the second, with Ledogar storming from 20th to seventh to deny Jousse the crown.



Earnhardt leads Gordon over line

WTCC

Suzuku (JPN)

October 26

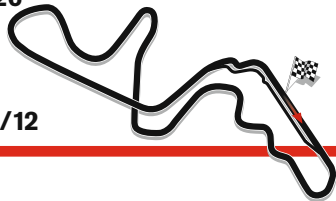

Round 11/12

RESULTS

RACE 1: 11 LAPS, 39.691 MILES

1	JOSE MARIA LOPEZ (RA)	23m54.353s	
	Citroen Total Citroen C-Elysee WTCC; Grid: 1st-2m05.439s		
2	TOM CHILTON (GB)	+8.473s	
	ROAL Motorsport Chevrolet RML Cruze TC1; Grid: 4th-2m06.321s		
3	SEBASTIEN LOEB (F)	+9.693s	
	Citroen Total Citroen C-Elysee WTCC; Grid: 3rd-2m05.590s		
4	NORBERT MICHELISZ (H)	+10.414s	
	Zengo Motorsport Honda Civic WTCC; Grid: 6th-2m06.865s		
5	HUGO VALENTE (F)	+12.153s	
	Campos Racing Chevrolet RML Cruze TC1; Grid: 5th-2m06.703s		
6	GABRIELE TARQUINI (I)	+12.707s	
	Castrol Honda Team (JAS) Honda Civic WTCC; Grid: 10th-2m07.305s		
7	TOM CORONEL (NL)	+13.514s	
	ROAL Motorsport Chevrolet RML Cruze TC1; Grid: 8th-2m06.993s		
8	DUSAN BORKOVIC (RS)	+14.340s	
	Campos Racing Chevrolet RML Cruze TC1; Grid: 9th-2m07.132s		
9	TIAGO MONTEIRO (P)	+16.507s	
	Castrol Honda Team (JAS) Honda Civic WTCC; Grid: 11th-2m07.306s		
10	GIANNI MORBIDELLI (I)	+17.846s	
	Munnich Motorsport Chevrolet RML Cruze TC1; Grid: 7th-2m06.906s		

Winner's average speed: 99.619mph. Fastest lap: Lopez 2m09.279s, 100.479mph.

RACE 2: 11 LAPS, 39.691 MILES

1	TARQUINI	23m55.783s	
	Honda; Grid: 1st		
2	BORKOVIC	+1.725s	
	Chevrolet; Grid: 2nd		
3	MICHELISZ	+4.360s	
	Honda; Grid: 5th		
4	CORONEL	+5.497s	
	Chevrolet; Grid: 3rd		
5	YVAN MULLER (F)	+6.116s	
	Citroen Total Citroen C-Elysee WTCC; Grid: 9th-2m05.514s		
6	LOPEZ	+6.346s	
	Citroen; Grid: 10th		
7	LOEB	+6.665s	
	Chevrolet; Grid: 8th		
8	MORBIDELLI	+14.062s	
	Chevrolet; Grid: 4th		
9	MONTEIRO	+14.791s	
	Honda; Grid: 11th		
10	CHILTON	+15.104s	
	Chevrolet; Grid: 7th		

Winner's average speed: 99.519mph. Fastest lap: Tarquini, 2m09.063s, 100.647mph.

DRIVERS' CHAMPIONSHIP

1	LOPEZ	422	6	TARQUINI	167
2	MULLER	305	7	CORONEL	148
3	LOEB	275	8	CHILTON	144
4	MONTEIRO	174	9	MORBIDELLI	108
5	MICHELISZ	169	10	BENNANI	85

YOKOHAMA TROPHY

1	ENGSTLER	226
2	FILIPPI	143
3	DI SABATINO	98

POINTS SYSTEM EXPLAINED

In each race: 25-18-15-12-10-8-6-4-2-1 to top 10 finishers. 5-4-3-2-1 to top 5 qualifiers.



Tarquini won from pole in race two



The Argentinian kept a steady head to win in Suzuka and secure the WTCC title

Lopez clinches crown

IT WAS PERHAPS FITTING THAT JOSE MARIA

Lopez should be crowned 2014 World Touring Car Champion at Suzuka, a venue with a fine tradition of hosting title deciders. The 93-point lead the Argentinian carried into the meeting meant there was little prospect of a tense showdown. Lopez required only 17 points, equivalent to a second place, to secure the championship.

Lopez's Citroen team-mate Yvan Muller arrived at the penultimate round as the only man who could deny him the crown, but four-time champion Muller's reputable character made it unthinkable any nefarious moves would be attempted to prolong his slim titles hopes into the Macau finale. Indeed, he insisted his focus had already shifted to 2015.

But perhaps to live by the motor-racing adage, 'If you want to avoid trouble, start at the front', Lopez qualified on pole, but he admitted to nerves after securing the coveted grid slot. "Sometimes, when I think about the title, my legs shake, but God willing, if things happen as normal, I can do it on Sunday," he said. Five points for pole meant a single fourth place from the two races would do the job.

Circuits should charge the Citroen team rent for using the top-three grid slots, such is the frequency with which the C-Elysees have occupied the top qualifying positions this year. It was the case again in Suzuka, after a thrilling qualifying session in which the trio were separated by a tenth.

The performance of customer Chevrolets caused some unease at Honda. At the manufacturer's home circuit, the Civics were comprehensively eclipsed. Beijing winner Tom Chilton joined Sebastien Loeb on the second row, ahead of Campos' hard-charger Hugo Valente. Consolation for Honda's qualifying woes came via Gabriele Tarquini's totally unintended reversed-grid pole for 10th place.

Away from the line, things went wrong for Loeb. "It was a very bad start," he explained, "there was



The C-Elysee was again the car to beat

some mistake with the start manipulation, so I was fifth behind Chilton and Valente."

As Lopez and Muller sprinted away, Chilton lost third before the opening lap was out by running wide at 130R. The ROAL driver immediately picked up Valente's tail, but had to be mindful of the threat from Loeb in his mirrors. A five-car train formed as Norbert Michelisz and Tarquini joined the group, which swiftly became a procession.

The rare sight of a suddenly slowing Citroen provided a diversion. After falling back three to four tenths a lap on Lopez, Muller was forced to retire on lap seven owing to a slow puncture. Lopez was left with a huge advantage, and would claim the title in style with his ninth win of the season.

The Valente-led bottleneck/scrap, now for second, remained static until the penultimate lap. "At Spoon 2, Hugo turned in a bit wide and missed the apex by half a car's width," explained Chilton. "I put two wheels on the grass and squeezed by."

Valente complained of a slight loss of power, and ran wide at 130R a few hundred yards later, losing out to Loeb. Wild antics continued at the chicane, where Michelisz took to the escape road. The Hungarian rejoined ahead of Loeb, but relinquished the position into Turn 1 to secure fourth.

Tarquini saved two new tyres for the reversed-grid race and elected to attack from the off. A large gap was quickly established over Dusan Borkovic, and the Italian was able to ease off in the closing laps to win by 1.7s. Borkovic became the first Serbian to stand on the podium in an FIA World Championship motorsport event, having survived an opening lap minor collision with eventual third-place finisher Michelisz.

Tom Coronel successfully fought off the Citroen brigade for fourth. Dethroned king Muller kept fifth place after being investigated by race officials for his part in an accident with Valente (see separate story).



Chilton squeezed into second in race one

FOR IN-DEPTH RESULTS
forix.autosport.com

IN THE PADDOCK

PETER MILLS
WTCC CONTRIBUTOR
@Peter_Autosport



LIKE A WELL BROUGHT-UP PRIMARY school child whose constant over-politeness manages to remain charming rather than grating, Jose Maria Lopez seemingly never fails to reel off a long 'thank you' list after each latest success.

The Argentinian has also been modest in press conferences, in part so not to rock the Citroen boat. Diplomacy has resulted in oft-repeated phrases such as, "I have great team-mates"; "I am learning from them"; "they are pushing me hard" and "we are always very closely matched".

At Suzuka, Lopez found the confidence to change the record – slightly – and was finally prepared to say out loud what his 117-point advantage in the standings and name engraved on the championship trophy had indicated to many already; that the performance of three Citroen men was not quite as evenly matched as it had been at the start of the season.

"I heard maybe Yvan said one of the things in my favour was I drove a touring car in Argentina that was similar [to the WTCC's new TC1 cars]," said Lopez. "But I have the feeling I was improving during the season. I won the first race in Morocco, but I got pole because Yvan made a mistake. Then I started to understand some things on the car with my engineer and improve."

However, as if to reassure us that deep down the title hadn't changed him, Lopez concluded. "But I think next year, given the quality of my team-mates, it won't be easy to match this year."



Lopez has the legs on his team-mates

BIG NUMBER

57

Jose Maria Lopez is the first Argentinian to win a motorsport world title for 57 years – since Juan Manuel Fangio in F1 in 1957.

Campos team boss calls for permanent stewards

CAMPOS WTCC BOSS JOAN ORUS has called on the championship to consider permanent stewards after his driver Hugo Valente was involved in a collision in race two. Valente was holding fifth when the chasing Yvan Muller made contact with the left-rear of his Cruze at the apex of the hairpin on lap five. A broken hub led to Valente's immediate retirement.

"The problem is that we have no permanent stewards to achieve consistency," said Orus. "We have seen people do similar things to Yvan in other races and get a drive-through, so I don't understand why he didn't get one today. At least Hugo had a good result in race one.

"In race two he did go into the hairpin wide, but it was his normal racing line because he was some way ahead. Also, it's impossible to overtake in that corner. I thought Yvan was driving like a very young man, or someone going for the title."

Muller survived the incident to finish fifth. The Citroen racer was given a formal



Valente (7) and Muller (1) eventually clashed

reprimand, but kept his result. "It is a weekend that reflects my season, with a chronic lack of success," said Muller. "In the second race, I made a good start before I found myself behind Hugo Valente. It was not easy to pass, I tried an attack and

it ended with an involuntary 'touchette'."

Orus also said he is working to keep his TC1 driver pairing of Valente and Dusan Borkovic for 2015. Serbian Borkovic's car is owned by the team, while Valente is the proprietor of his Chevrolet.

New Thai circuit eyes WTCC

WTCC BOSSES MET FOR introductory talks at Suzuka with officials from Thailand's Buriram United International Circuit. The Thai track hosted a Japanese Super GT round earlier this month.

WTCC consultant and former Chevrolet Europe Motorsport boss Eric Neve said, "The Thai circuit is brand new and potentially interesting to us geographically. For example, we could have stopped there this year on the return from Argentina. I'd guess they are looking into the feasibility of Formula 1, and want to put their circuit on the map. The FIA may want to see them host something else first,

but there are no plans for us to go there at the moment. We haven't even sat down and discussed anything with them yet."

Representatives from Japanese car manufacturers were also on hand at Suzuka on Sunday, having been invited to take a look at the series and meet with the promoter.



Tarquini win gives Honda a lift

GABRIELE TARQUINI HAS emphasised the critical importance of Honda's winter development programme to improve the Civic WTCC's qualifying speed.

The Italian and his team-mate Tiago Monteiro qualified in 10th and 11th places on the grid for the Suzuka round after struggling on new tyres, but Tarquini's subsequent reversed-grid win broke the team's 2014 victory duck.

"In Q2, I was pushing to keep up with Citroen, but unfortunately I made two mistakes," said Tarquini. "But the performance was not what I was expecting.

"This [Suzuka] is the right place to score a victory, though. I think our race pace has been improving since Beijing. Now we must work hard in winter testing because we don't have much time to improve the car for 2015."



Suzuka victory was Honda's first of 2014



KWONG'S SUZUKA LOW

Hong Kong driver Henry Kwong made his 2014 WTCC debut in Suzuka. An engine failure meant the Campos driver missed qualifying, but he was allowed to start at the back of the grid. He finished race one, but lengthy repairs to a damaged upright prevented him completing 75 per cent of the distance in race two.

LOPEZ TARGETS ROC

Newly crowned WTCC champion Jose Maria Lopez has expressed interest in competing in this year's Race of Champions in Barbados. "It would be really good to be asked to go there," he said "it would crown my season."

BENNANI MISSES OUT

Shanghai reversed-grid winner Mehdi Bennani failed to appear on the race two grid after a failure on a support to a shaft on his Proteam Honda. The problem became apparent with a worsening vibration in race one, where the Moroccan finished 11th.

UPGRADE FOR C-ELYSEE

Citroen technical boss Xavier Mestelan Pinon believes the C-Elysee will benefit from improvements to the design of many mechanical parts over the winter. He identified the suspension as one area for attention, but believes the aerodynamics are already very efficient.

WEB DIRECTORY

CAR BROKERAGE

RACING CARS FOR SALE

ALAN CORNOCK FCS
BUYING - SELLING - BROKERAGE
www.racingcarsforsale.co.uk
TEL: 01480 891212

ENGINES

JULIAN GODFREY ENGINEERING

visit our new online shop www.racetuners.com

EXHAUSTS

Inconel & Stainless Steel Specialists

SIMPSON Race Exhausts

Tel: 01753 532222
www.simpsonraceexhausts.com

GEARBOXES

Gearboxman.com COMPETITION TRANSMISSION SERVICES

Gearboxes & Axles for Road, Race, Rally and more

Telephone: 01582 840008 Fax: 01582 840007

HELMET GRAPHICS

Mike Fairholme Designs

Sole approved painter of Arai helmets.
Silver Birches, Corby Birkholme, Nr Grantham, Lincs NG33 4LE.
Tel: 01476 550630. Fax: 01476 550029.
email: fairholmedesigns@btconnect.com
www.fairholmedesigns.co.uk

LEGAL

eugene O'BRIEN.co.uk

DRIVER DEVELOPMENT

Tel: 0775 383 5629

MEMORABILIA



www.finallap.net WE BUY AND SELL
+44 (0) 1245 287588 / 07771 920345

MODELS



Specialists in 1:2 Scale Replica F1 Helmets

RACE PARTS



ARMSTRONG RACE ENGINEERING INC.
WWW.DRYSUMP.COM (916) 652-5282

RACE PRODUCTS

LONDON
MOTORSPORT
SHOWROOM
WWW.MSAR.CO.UK

MARDI GRAS
MOTORSPORT
www.mardigras.co.uk

call: 0208 568 1172 visit: www.thinkauto.com

RACE PRODUCTS

PORSCHE SHOP
10% off with website
voucher code AUTOTEN
Or Call: 0121 585 6088

Pit to Car Radio solutions
0044(0)1508 528837
Autotel Digital Race Radio
www.raceradio.co.uk

www.demon-tweaks.co.uk

RACEWEAR

AUTHORISED DISTRIBUTOR
OMP YBRACING
MOTORSPORT & PERFORMANCE
WWW.YBRACING.COM

JJC race and rally
PASSIONATE ABOUT MOTORSPORT
www.jjraceandrally.com

Grand Prix Racewear THE RACEWEAR EMPORIUM
WWW.GPRDIRECT.COM
08435 070 858
sparco uvex OMP Arai BELL SCHOTT horn seat

TRAILERS

www.prgtrailers.co.uk
Phone no: +44 (0) 1270 812402

BRIAN JAMES TRAILERS
» Connected to you
www.brianjames.co.uk

WORKSHOP EQUIPMENT

Image® Manufacturers of bespoke split rim alloy wheels
www.imagewheels.co.uk
IMAGE WHEELS INTERNATIONAL LTD.



TO ADVERTISE IN THE WEB DIRECTORY
PLEASE CALL 020 8267 5992
OR EMAIL: autosport.ads@haymarket.com

BRIAN JAMES TRAILERS

»» Connected to you



Photograph courtesy of Litchfield Motors.

www.brianjames.co.uk

Night shift

High performance, cutting edge technology, Race Transporter enclosed designs offer fast, safe and efficient vehicle transportation. Crossing continents, travelling through many years our trailers have served at every race or rally.

With bright LED ambient lighting, and carefully designed interior space Race Transporter trailers operate day and night.

Main photograph, Race Transporter 6 with double assistor ramps, interior LED lighting, high level tyre rack and work bench combination.

Race Transporter range from £ 6,750 (excl. VAT).



RACE TRANSPORTER

T +44 (0)1327 308 833

For more information and details of your local BJT dealer please call or visit our website.

TRAILERS & TRANSPORTERS



www.**WOODFORDTRAILERS**.com

HIGH QUALITY TRAILERS FOR CLUB, PRIVATE AND PRO MOTORSPORTS



Email: Sales@woodfordtrailers.com

CALL US NOW **01327 263 384**

TRAILERS & TRANSPORTERS

D.A.F LF 45 race truck, large rear workshop which includes compressor, generator, tool cabinet, work bench etc. Front living area with cooker, microwave, sink, couch/bed, tv, toilet. Customised metallic paint.



Phone
Neil **00353872658933**

Price
€22,950

STUNNING RACE TRAILER, REPRESENTING AN UNMISSABLE OPPORTUNITY



Pristine 4-bay awning with windows, 2-tonne tail-lift, full bespoke living space, and endless features. Exceptional condition throughout, MOT April-2015. Very reluctant retirement sale.



PRICE REDUCED

OFFERS OVER **£44,995** WILL BE CONSIDERED.

SENSIBLE PART EXCHANGE/CASH EITHER WAY OFFERS WILL ALSO BE TAKEN INTO CONSIDERATION.

Visit teamwrihtracing.com for full specification/price. To Include all equipment and Hospitality

Richard Wright - 07900681161

PRG TRAILERS

Finest Built British Trailers.



PRG Trailers | Cheshire | UK | Tel: +44 (0) 1270812402
Web: www.prgtrailers.co.uk | Email: info@prgtrailers.co.uk

RACE & RALLY CARS

ROAD CARS FOR SALE

CARBON8
Coupe Cup
with **ACTIVA CONSULTANTS**
www.coupecup.com



New Hyundai Coupe Cup Race Car Builds Available From **£4299**



Hyundai Coupe Cup 2015 Season Package From **£6499**

Season Package Includes:
New build Hyundai Coupe Cup car, a set of Toyo R888 control tyres, race entries for seven double header meetings along with club and series registration fees with the Track Attack Race Club

Arrive & Drive Race Hire Also Available

EXIT 13 Tel:- 07714 291417
Web:- www.exit13.biz
email:- sales@exit13.biz



Donington Park 1,000 km "day into night" race. 8th November 2014.

Arrive & drive packages available with JPR. Teams of 2 - 6 drivers. We can match you with team-mates, if required.

T: 01538 306921 / E: paul@funcup.co.uk / W: funcup.co.uk



AUTOSPORT

IF YOU'D LIKE TO ADVERTISE YOUR PRODUCTS AND SERVICES PLEASE CALL: 0208 267 5367

450HP, V8, 6.2 Litre, Choice of Cars



Chevrolet V8 cars. Raced in Lumina Series in Middle East, only done 6 races, multi point injection, electronic engine management, Jerico 4 speed box, ZF LSD differential unit with two ratio options, aluminium flywheel, dual plate clutch, hydraulic clutch release system, numerous spares available by negotiation

2009 cars x16 • 2006 cars x6

"There are enough cars and spares to run a whole championship!"

**www.circuit2circuit.com
email - Leigh@circuit2circuit.com**

01604 859012

MARKETPLACE

CAR RENTALS

FOR ALL YOUR
AVON
 TYRES
MOTORSPORT
 RACING TYRES
 Inc. ACB 10 Formula Ford
 Contact

BMTR LTD

Tel: 0121 331 1122
 Fax: 0121 331 1144
 email: sales@bmtr.co.uk
 see our new website at www.bmtr.co.uk

FLOORING

Kiwi Tiles

Interlocking Plastic Floor Tiles, as used by leading race teams throughout Europe.



- Easy installation & removal
 - Many colours
 - Lightweight
 - Strong and durable
 - Compact & easy to store
 - Top quality
 - Value for money
- Stock Colours:
 Red, Blue, Green,
 Yellow, Silver, Orange,
 Grey, Black, White,
 Dayglo Red

Ralt Engineering
 Tel: 01865 883354 Fax: 01865 883789
 Email: enquiries@kiwitiles.com
 www.kiwitiles.com

MEMORABILIA

F1 COLLECTORS .COM



#1 FOR F1 MEMORABILIA & AUTOGRAPHS

We buy and sell F1 items
AYRTON SENNA specialists

Call CHRIS GRINT

01763 274448

email:- sales@f1collectors.com

SPEARS & ACCESSORIES

Levelling Feet & Castors



All Goods In Stock, Next day delivery, Buy Online.

01327 312664
 www.stainless-feet.co.uk

RACE PRODUCTS

Elite Carbon Fibre

Carbon fibre race car component manufacturer

EliteCarbonFibre Ltd.
 Units 20-22 Norwich Road Ind. Est.
 Watton, Thetford, Norfolk IP25 6DR

Contact – Dave Greenwood 07809390316
 Email – davecarbonelite@googlemail.com
 Website – elitecarbonfibre.co.uk



Carbon Composite Wings, Bodywork & Repairs

MARKETPLACE

- EXPERT ADVICE
- MASSIVE STOCK
- RAPID DELIVERY

demon tweeks MOTORSPORT Direct



CALL TODAY **0844 375 2196** LOW CALL RATE CALLS MAY BE RECORDED FOR TRAINING PURPOSES
 MEDIA CODE: PZ252A

www.demon-tweeks.co.uk

CARTEK MOTORSPORT ELECTRONICS



Suppliers to:

www.CARTEKMOTORSPORT.com
CARTEK AUTOMOTIVE ELECTRONICS Ltd
 44 (0)2380 637600
 info@cartekmotorsport.com

Procar International Limited.

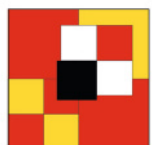

PROCAR INTERNATIONAL LIMITED

Unit B, 201 Long Lane,
 Stanwell, Middlesex,
 TW19 7AU England.
 Tel: +44 (0)1784 247407
 Fax: +44 (0)1784 244266

Have been appointed to dispose of a large quantity of Flight Cases surplus to their requirements.

These cases are manufactured to the very highest standard and afford a selection of sizes as well as access openings, split opening, all on castors etc.,

An excellent opportunity to acquire equipment of the highest quality – Viewing recommended – offers invited.

Procar International Ltd., Unit B, 201 Long Lane,
 Stanwell, Middlesex TW19 7AU.

karl.zaple@procar.co.uk

Procar International Ltd. Registered in the UK Reg No: 3255217

MARKETPLACE

RACE PRODUCTS

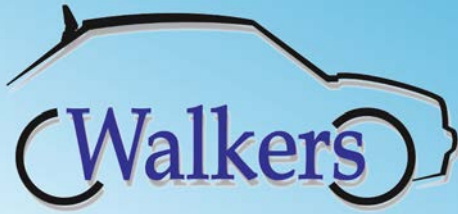

Walkers Garage Ltd.
Northallerton DL7 9HT
0044(0)1609 777221
www.walkersgarage.co.uk
www.teknofibra-racing.co.uk
www.walkers-radiators.co.uk
www.tecno2.co.uk
www.energa-batteries.co.uk

Heat resistant material
to 1000 °C



Bespoke radiator
manufacture

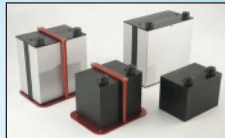

Up to 5 years life
expectancy

360 cranking amps – 1.28 kg.
600 Cranking amps – 2.25 kg.

- Importers & Manufacturers
- Teknofibra heat resistant materials
- Lightweight Lithium Batteries
- Walkers Competition Radiators
- Tecno2 Performance Products
- Competition wheel studs & nuts



Major Stockists of
Professional Quality
Motorsport Components

Free Catalogue

If you would like a copy of our catalogue then please contact us, alternatively you can download a PDF version from our website.



Over 20 years of experience in motorsport components. Conveniently located at:
Unit 40, Silverstone Circuit,
Towcester, Northants, NN12 8TN
For more information please visit our Silverstone store, website or telephone:

01327 857991

www.competitionssupplies.com

- Expert Advice
- Large Stocks
- Fast Delivery
- Competitive Prices

Stocked Brands
Include:



RACEWEAR

FIA COMPLIANT MOTORSPORT BADGES

SPONSORS LOGOS NAME BADGES NATIONALITY BADGES CHAMPIONSHIP BADGES CLUB BADGES



NO MINIMUM ORDER VALUE
FULL SEWING KIT INCLUDED
QUICK TURNAROUND
ANY IMAGE FORMAT

WWW.HOT-STITCH.COM
01559 372356

Transform your Workshop at Surprisingly Sensible Prices

NewAge Pro Series Cabinets from GaragePride

Huge Depth
610mm



Great Height
2100mm



Ideal Width
4.67 metres



Heavy Duty
1.2mm steel



Only
£2770
plus VAT
Delivered!
♥♥♥♥♥



www.GaragePride.co.uk

0800-206-2303

Or Google GP31665
to find the above!

GARAGEPRIDE
Quality Storage for Home and Industry

MOTORSPORT JOBS



JOB TITLE - Internal Sales Executive
BRAND - Autosport | **LOCATION** - Teddington

We are now seeking an internal sales executive to join our motorsport sales teams.

The Role

As an internal sales executive you will be responsible for generating revenue from existing and new clients. You will have to be inquisitive in order to engage in credible conversations with your clients and uncover new revenue streams. As such, an appreciation and understanding of motorsport is a bonus, although not required.

You will have clear objectives from day one, with a probationary review after 3 months and performance related pay reviews at 12, 18 and 24 months. As well as this you will have access to career development opportunities across sales and management.

The Candidate

Our training sets the media industry's benchmark for quality, however, to be able to hit the ground running we are looking for someone who is:

- Enthusiastic, inquisitive & hungry to succeed
- A natural conversationalist with exceptional listening skills
- Able to build on going and lasting working relationships
- Somebody that enjoys working within a fast-paced environment
- Degree educated
- Proficient in the use of Word, Excel & Powerpoint

Other Information You Will Need to Know

Haymarket's consumer brands are all based in Teddington, please be aware of this when applying for roles with us. We offer a competitive starting salary of £19k plus up to 40% commission, while those successful candidates who prove themselves will find many opportunities for development and promotion to regularly increase this salary. Haymarket offer a generous 25 days a year holiday entitlement, which increases year on year by 1 day (to a max of 30).

If you want to work in a fun, lively and engaging environment, then Haymarket will give you this opportunity.

Please include a brief covering letter and an up to date CV when making your application.

Haymarket is an equal opportunities employer and welcomes applications from all areas of the community.

If you are interested in applying for this position.

Please send applications to - recruitment@haymarket.com
Ref: 'Application - Internal Sales Executive - Autosport'



JOB TITLE - Editor | **BRAND** - Autosport
LOCATION - Teddington

Autosport is seeking to hire a new editor. This is a rare and exciting opportunity to edit the world's most respected and recognised motorsport magazine. Published weekly since its launch in 1950, Autosport is a vibrant and hugely influential title, completely dedicated to the sport on which it reports. And it is about to embark on a period of redevelopment designed to ensure that it remains relevant to its readers in a digital media age.

The editor will ensure that the brand's excellent reputation in racing circles is not only maintained, but grown over time. You will be used to working in a similar consumer publishing/ media environment - ideally at editor level. Strong motorsport knowledge is also a key requirement.

You will:

- Be an editor with a proven track record, preferably in the consumer space
- Be audience and client led
- Want to do what is best for your audiences, clients and colleagues
- Understand how to manage teams
- Have excellent verbal and written communication skills
- Ensure your editorial team are motivated and working well
- Maintain the highest possible editorial standards
- Ensure all content is produced on budget, with appropriate quality control measures in place
- Take responsibility for stylistic or legal issues arising from content
- Establish and manage effective forward planning systems for all content
- Generate and/or manage content ideas
- Set high standards of behaviour, attitude, professionalism and commitment
- Ensure this demanding weekly publication is produced on time
- Have a strong knowledge and huge passion for motorsport as a whole and not just Formula 1
- Have experience in spotting new development opportunities for the brand
- Be able to tackle unfamiliar and complex topics

Key Responsibilities include:

- Play a key role in event brand developments
- Ensure that Autosport is making the most of digital opportunities as well as remaining relevant in print
- Working with the editor of Autosport.com and the group editor to develop digital strategy, with the aim of growing our digital presence in the sector; consolidating our market leading position across all media channels including online, tablet (apps), mobile, live events and social media where necessary
- Lead from the front to increase our audience insight and inspire the team to emulate your success

The successful applicant will be rewarded with a job that offers unparalleled access to the world of motor racing and a position of considerable influence within it.

Please send applications to - recruitment@haymarket.com
Ref: 'Application - Editor - Autosport'

MOTORSPORT JOBS

Trackside Support Engineer

Toyota Racing Development (TRD USA) is looking for talented engineers with trackside engineering experience to support its exciting NASCAR Cup Series program.

Typical duties will include:

- Driver and team liaison
- Optimization of race engine performance (from analysis of logged data) and engine integration with chassis tuning.
- Pre-test planning and post-race engineering reporting
- Pre/post event race strategy analysis

This position is based in North Carolina and extensive travel to race events and tests will be required.

Applicants should have an engineering degree (or equivalent experience), a background in I.C. engine development, and at least 2 years full-time trackside engineering experience (incl. typical software such as ATLAS, MOTEC). Initiative and excellent communication skills are essential.

Please submit your cover letter, resume and salary history to

jonathan.whitehead@haymarket.com

LOOKING TO RECRUIT FOR 2014? THE LATEST SELECTION OF MOTORSPORT JOB VACANCIES UPDATED EVERY WEEK.

- The Motorsport Jobs page of the website receives on average 200,000 page impressions per month
- The magazine you are looking at has a readership of 144,000 (Source: NRS Survey Q3)
- All appointment adverts placed in Autosport magazine are listed on the website.

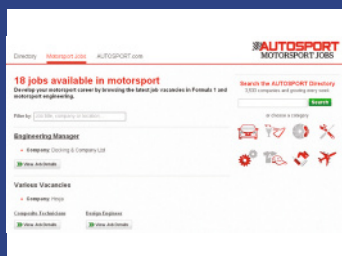

WE ARE RECRUITING AT RED BULL TECHNOLOGY:

From the moment Red Bull Racing first turned a wheel in Formula One it was always obvious that the ultimate goal of Championship victories would only be achieved by a team that invested in Formula One's most crucial assets: people and experience.

The team's Formula One adventure began in 2005. Today, a number of years into the project and with four consecutive World Championships in the locker, that is still the philosophy propelling the team forwards.

HR27101401 – Electrical Systems Engineer
HR24101401 – Additive Manufacturing Technician

As well as being part of our multi-Championship winning team, we reward our employees with a significant benefits package including Championship Bonus, Life Insurance, Private Medical Cover and a Pension Scheme.

For further information and details of how to apply please visit:
WWW.INFINITI-REDBULLRACING.COM

PLEASE NOTE: No Agencies please



MSV Media and PR Officer

This is an opportunity to join MSV's six-strong publicity team, based at Brands Hatch and reporting to the Head of Media and PR.

This role will primarily focus on Britain's strongest single-seater racing series, the BRDC F4 Championship, attending test events and race meetings, writing press releases, adding content to websites and social media channels, writing copy for event programmes, and arranging driver interviews for TV producers.

This role will also provide PR support for newly-crowned GP2 Series Champion Jolyon Palmer, writing press releases, handling

media enquiries, and seeking publicity opportunities. There will also be scope for involvement in MSV's other, widely varied PR and social media activities.

Applicants will need to be enthusiastic, hard-working and organised, with good copywriting skills and an eye for a good story.

Please apply in writing with CV, stating salary expectations and notice period, to Katie Dickens, Human Resources Department, MotorSport Vision Limited, Brands Hatch Circuit, Fawkham, Longfield, Kent, DA3 8NG
e-mail katie.dickens@msv.com

Closing date: 14 November

www.msv.com

CUSTOMER SUPPORT ENGINEER

This is an exciting opportunity to join McLaren GT as a Customer Support Engineer based at our Head Office in Woking, Surrey.

You will be able to provide a comprehensive engineering support service, on event and factory based, for McLaren GT race car customers worldwide, including the monitoring and optimisation of engine operation.

The successful candidate will be able to work alone or as part of a team and be able to travel extensively. The role requires an analytical and solution focused approach to problem solving and a proven ability to accurately interpret data. You will be an excellent communicator with customers and peers and should have previous experience of a similar role.

You will be experienced, reliable and enthusiastic and live within travelling distance of our Head Office in Woking, Surrey. Previous experience of working in motorsport is desirable.

Please email or post a covering letter, explaining why you would be the best candidate for this role, together with your CV and salary expectation to:

Human Resources, McLaren GT, Unit 22 Woking Business Park, Albert Drive, Woking GU21 5JY

E-mail: paula.karter@mcclarengt.com

Closing date: for applications is Friday, 30th November 2014



RBM runs 2 cars for BMW Motorsport in DTM.

With a focus on competitiveness we are looking for outstanding people to join us and strengthen our team filling following vacancies:

Race Engineer

The Race Engineer is in charge of one of the team's cars in the DTM. In this key position, reporting to the Chief race engineer, you will be responsible for the coordination of all technical aspects of the race car operation with the focus on extracting the maximum performance out of the available package.

Performance Engineer

The Performance Engineer works closely with the Race Engineer and driver to ensure the team is maximising the full performance of the car. He will have a significant input into optimising the car performance and provide analysis and feedback to the driver during the race weekend. The role also covers the development of race engineering models and tools as well as providing detailed analysis and reporting.

Both roles require excellent communication skills in English, a strong understanding and working knowledge of all aspects of race performance packages and an extensive track record in a high level motorsport environment.

The ideal candidates must be able to demonstrate an excellent understanding of vehicle dynamics and data analysis software (ideally Wintax), simulation tools and a programming language (preferably Matlab/Simulink).

Race Mechanic

You will be part of a group of people running 1 of our DTM cars. The successful candidate will be a fully qualified mechanic with significant experience working within a similar environment.

All candidates must have good communication and analytical skills, excellent problem-solving skills and be able to work to tight deadlines, often under pressure with a conscientious attention to detail.

Candidates must be fluent in English. The positions are factory based (Mechelen/Belgium) but also require a significant amount of international travel.

If you wish to apply for this position please forward your cv (including picture) and application letter with current remuneration details/salary expectations to hr@rbmteam.be

OUR 2014 CHAMPIONS

JEFF
WYATT
GTA
Champion



DAVID
WALLEY
GTB
Champion



JIM
GEDDIE
GTO & Overall
Champion

JOHN
SEALE
GTC
Champion



JAMIE
STANLEY
GTC
Champion



CLUB AUTOSPORT

NATIONAL RACING • HISTORICS • RALLYCROSS • HILLCLIMB • TRACK TESTS

The six finalists tried a variety of machinery



GRIFFITHS/LAT

Award assessment under way

McLaren AUTOSPORT BRDC Award finalists begin shootout process

THE TWO ASSESSMENT DAYS for the 26th McLaren AUTOSPORT BRDC Award took place at Silverstone earlier this week.

Formula Renault Eurocup frontrunner Alexander Albon, FR Northern European Cup champion Ben Barnicoat and title rival Seb Morris, British Formula Ford runner-up Harrison Scott, BRDC Formula 4 champion George Russell and series race winner Sennan Fielding took part in the two-day evaluation process.

Five of the drivers were first-time finalists, with Morris the only returnee following his place in the 2013 shootout, won by Matt Parry.

The drivers began the process, which took place on the Grand Prix circuit after being moved from the

International layout, with old- and new-tyre runs in MotorSport Vision-prepared Formula 2 machinery.

They then moved onto McLaren's latest GT3 model, the 650S, in which factory driver Rob Bell provided the benchmark, and a DTM Mercedes C-Coupe run by leading team HWA with assistance from ex-Formula 1 driver and Award winner Paul di Resta.

"There were two reasons for running on the Grand Prix circuit," said BRDC president and 1992 World Sportscar champion Derek Warwick, chairman of the judges.

"One was to give them experience of it; the feedback from everybody last year was that they wanted to run on it. The other thing we thought was there would be a bigger spread and it would be easier to pick between two or three

but that actually hasn't happened.

"We've got six very good, talented guys out there. It's surprised all us judges that they are so bloody close."

DTM frontrunner di Resta, who won the Award in 2004, believes consistent conditions over the two days – both of which were run in the dry, despite overnight rain threatening the F2-only running on Tuesday – has enabled each driver to showcase his talents to the full.

"They've had bloody good conditions," he said. "It's pushed them on a bit more to be honest. They're all full of confidence; it's amazing how well they dealt with it."

"The excellence will rise. There's a few that have stuck out, but they all deserved the opportunity."

"Whether they win it or not they've had a chance to drive some special cars and be involved."

The final stage of the process will take place at McLaren's Woking base later this month, when each driver will go through an interview process with the judging panel.

In addition to Warwick, the judges include record British Touring Car winner Jason Plato, McLaren head of vehicle engineering Mark Williams, 1997 Award winner Andrew Kirkaldy, leading circuit commentator Ian Titchmarsh and *Motorsport News* editor Kevin Turner.



Warwick and Plato are judges

GRIFFITHS/LAT

SCOTT MITCHELL
ASSISTANT
EDITOR

scott.mitchell@haymarket.com
@ScottMitchell189



MOTORSPORT IS DEFINED BY winners and losers, and how drivers handle falling into either category can shape the rest of their careers.

Title defeats can prove to be a valuable lesson: if you can't handle disappointment then a sport in which careers will always peak and trough is probably not your long-term future.

Witnessing the contentious end to the British Formula Ford title battle at Brands Hatch last month was difficult, because both Jayde Kruger and Harrison Scott were – in different ways – worthy champions. Inevitably one had to lose; the fact the loser will be decided in court is disappointing.

There was a different kind of finale at Snetterton last weekend. The BRDC Formula 4 Championship produced a superb conclusion, and for George Russell to overcome a 21-point deficit across three races – winning the finale after a superb move – made him a deserving champion.

Speaking to his team-mate Arjun Maini, also 16, afterwards was an eye-opener. Defeated by three points, he was visibly upset but carried himself impressively and vowed to use that feeling to improve for 2015.

Russell and another F4 title contender, Sennan Fielding, headed straight for Silverstone after the Snetterton decision for the McLaren AUTOSPORT BRDC Award, leaving little time for either to collect his thoughts. The two-day process is an intensive evaluation and the winner will be very deserving indeed. But as BRDC president Derek Warwick likes to say: while it will be life changing for the one winner, for the other five it can still be life enhancing.



Maini will learn from title defeat

EBREY

TWO BIG UK EVENTS PLANNED FOR 2015



Coventry Motofest

Coventry ring road could host sprint event in 2015

COVENTRY CITY CENTRE COULD host competitive motorsport next year if plans for a sprint event on the ring road come to fruition.

Fledgling motorsport festival Coventry Motofest, which is run in conjunction with Coventry City Council, hopes to incorporate competitive time trials into its 2015 event next May based on a 2.1-mile route on the A4053.

The trials are subject to the British government completing the process of enabling local authorities to suspend the Road Traffic Act without an Act of

Parliament. The Deregulation Bill, in which the Road Traffic Act change features, has not yet reached the Royal Assent, but is in the final stages of the legislative process and was discussed in the House of Lords earlier this week.

Festival director James Noble said: "This was a big part of our vision when Motofest was first developed and we are so grateful to Coventry City Council for its forward-thinking approach in enabling us to make it a reality.

"With Coventry's rich motoring heritage and history, it feels like the right

fit to be racing in Coventry and we can't wait to make it happen."

The British Automobile Racing Club, one of British motorsport's most prominent organising bodies, is assisting the organisation of the event.

It is hoping that a variety of cars from its range of club and national championships will take part in the event in some way, while a demo involving older cars from the British Touring Car Championship, as well as machinery from the Porsche Carrera Cup GB, could also take place.

It has been suggested that BTCC cars would participate in the trials, but this is not correct and there is no official championship involvement. However, festival bosses retain a bold ambition to host racing in 2016.

While some competitive motorsport events, such as the Jim Clark Rally, take place on UK roads and the British Hillclimb Championship has similar rounds in Ireland and on the Isle of Man, the last street-circuit car race held in Britain was the 1990 Birmingham Superprix.

Silverstone 24 Hour

Silverstone 24-hour endurance set to be revived for spring

SILVERSTONE IS SET TO HOST its first 24-hour race in almost three years next April, as Britcar chief James Tucker announced plans to revive the twice-around-the-clock endurance event in 2015 with backing from Dunlop.

The Britcar 24 Hours ran most years from 2005 until 2012 before being reduced to a 1000km race in 2013, and was cancelled altogether for this year following a dispute over noise levels between race organisers and the local Whittlebury Parish Council.

The rebranded 'Dunlop 24 Hour Race

at Silverstone' is set to be held on April 25-26 on Silverstone's full Grand Prix layout, departing its usual autumn slot. The new date is intended to slot in better with the global endurance calendar, coming after teams' return from the American and Middle Eastern events for the major summer European enduros.

Tucker hopes to attract up to 80 entries to compete, ranging from GT3/GTE-spec machinery and CN prototypes to production-based touring cars. Sky Sports and Motors TV will provide coverage.

After-dark racing could return to Silverstone

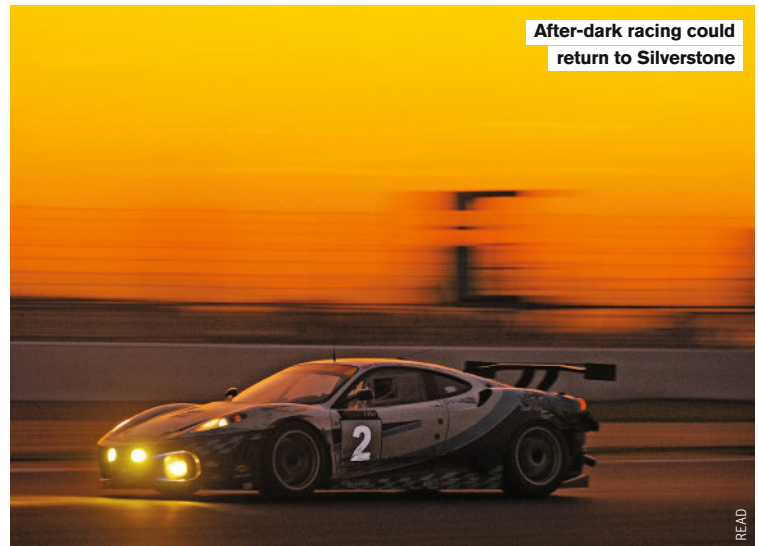

Quick and competitive Track Day Insurance

The first online "quote and buy" system solely for the track day user, supplied by established track day and motorsport insurance provider - Ryan Motorsport Insurance

INSUREMYTRACKDAY.COM

- ✓ Damage to your car on a track day, regardless of fault.
- ✓ Any circuit in Europe, including Spa and Nürburgring Nordschleife.
- ✓ Inclusive cover for barrier damage at the Nordschleife.
- ✓ Vehicle recovery available for circuits in Great Britain.
- ✓ Organisers and Clubs - promotional rates and discounts
- ✓ Storage and transit for vehicles and trailers

Log on to www.insuremytrackday.com to obtain your online quote today

Ryan Motorsport Insurance Limited is an appointed representative (557405) of Independent Broking Solutions Limited who are authorised and regulated by the Financial Conduct Authority. Its Financial Services Register number is 312026

Formula Ford Festival

Last year's winner Murray has Festival entry declined

LAST YEAR'S FORMULA FORD

Festival winner Niall Murray was prevented from taking part in the 2014 event when his entry was refused by organiser the British Racing and Sports Car Club.

Murray appealed the decision to the Motor Sports Association and took part in pre-race testing, but the governing body upheld the BRSCC's ruling.

His 2013 victory had stood despite the MSA recommending a six-month ban

after judging that Murray had withheld video evidence related to a yellow-flag dispute, a suggestion Motorsport Ireland declined to follow.

BRSCC competitions director Drew Furlong insisted that the decision to bar Murray from this year's Festival was prompted by requests by competitors and an accumulation of factors, rather than being a specific response to the 2013 controversy.

"We had been approached by other drivers who were concerned by the number of judicials he had been involved in during the year. We looked at this and then decided not to accept his entry," said Furlong.

Murray's entry for this weekend's Walter Hayes Trophy at Silverstone has been accepted by race organiser the Historic Sports Car Club.



Murray was FFord Festival victor in 2013

Birkett Relay

Birkett racer hospitalised

CHARLES HARVEY-KELLY WAS

airlifted to Coventry's Walsgrave Hospital with multiple injuries following a violent accident in the 750 Motor Club's Birkett Relay last Saturday.

The Radical SR3 driver, who was part of last year's Birkett Scratch-winning team The Third Radicals, had a heavy impact with a concrete wall at Becketts following contact with Ben Pearson's BMW M3.

Harvey-Kelly sustained a head injury in the collision along with a broken collarbone and two fractured ribs. As AUTOSPORT closed for press, he was being kept sedated in hospital while doctors monitored his progress.

750MC competitions manager Giles Groombridge said: "Naturally, our thoughts are with his wife, family and team during this time."



Harvey-Kelly (29) was driving for The Third Radicals team

Porsche Carrera Cup GB

Spa included in '15 calendar

THE 2015 PORSCHE CARRERA CUP GB

calendar will include a round at Spa-Francorchamps supporting the World Endurance Championship in May.

The Spa event replaces this year's Le Mans 24 Hours support race in the championship's overseas slot. It will be a double-header with one race of 45 minutes' duration. Whereas Le Mans was a combined grid with the French series, Spa will be purely for British championship competitors.

Next season's calendar will be reduced from 19 to 16 races, as the series skips the Donington Park, Thruxton and Rockingham BTCC events.

Porsche Cars GB product affairs manager Nick Perry said the changes aimed to "balance bringing the championship closer to the international Porsche Motorsport world, with the goal to offer an overall calendar that still presented an exciting challenge for drivers."



Carrera Cup will be at fewer BTCC rounds next year

HUMBLE PYE

The voice of club racing



V8 muscle cars shared the track with Smarts during the Birkett

Splitting the Birkett relay will not prevent accidents

The 750 Motor Club's Birkett Six Hour Team Relay race has been a fun event come rain or shine since 1951, a quintessentially British social and sporting occasion that legions of devotees will not miss. Saturday's running, in which 69 teams eventually tackled Silverstone's Historic GP circuit, was a joyous event until the clash between Charles Harvey-Kelly's Radical SR3 and Ben Pearson's BMW M3 showed us the other side of amateur competition.

While the precise catalyst of the incident (captured on the closed-circuit TV system) has not been released, pending investigation, both cars careered into the concrete wall at Maggotts with massive impacts. Pearson was out relatively quickly, but marshals and specialist rescuers painstakingly extricated poor Harvey-Kelly (one of last year's Scratch winners). He was later transferred from the medical centre to Coventry Hospital with severe head injuries. The whole operation, including the repatriation of another car off on the exit of Copse, was expedited under a 13-lap safety-car interlude of almost an hour's duration.

Nobody has yet suggested that speed differentials – always to be respected in a field containing cars as diametrically-opposed as a Smart 4Two and a Porsche 935K3 clone – were a factor in this accident. With constant overtaking from lap two and cars such as Tim Gray's fastest-lap-setting 1500cc Suzuki Hayabusa-powered Spire GT3 pulling towards 150mph on the Hangar Straight, errors of judgement are commonplace.

It's the same deal in any motor race, albeit magnified by distance, diversity and experience, but for the vast majority of the time competitors

come out unscathed. Nobody wants to see the event canned or emasculated, but inevitably there will be calls from some parties for the breadth of the field to be reduced. That would be a pity, but I don't believe that there is currently room for a second 750MC enduro (as there was one year) for purpose-built race cars alongside one for production-based machines.

"Nobody has yet suggested that speed differentials were a factor"

Many would contend, indeed, that splitting the field might be missing the point. Since thundering Bentleys went wheel-to-wheel with spindly Austin 7s in the inaugural team relay race at Silverstone 63 years ago (run in torrential rain on a rough circuit in which Copse and Stowe corners were linked by a super-long runway), steering clear of trouble has been as much a key to success as speed, consistency, reliability and beating a handicap system that presents a level playing field.

Marcus Pye

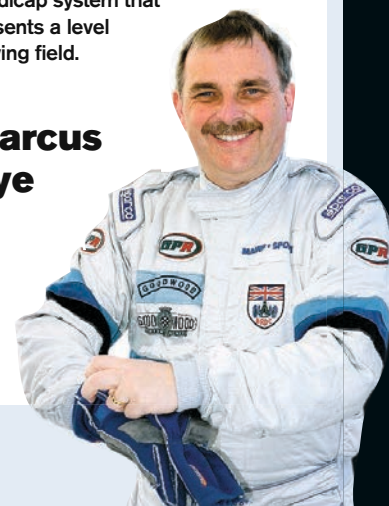



Lanan Racing congratulates
GEORGE RUSSELL on becoming
2014 BRDC
MSV F4 Champion

Supported by





Scott Malvern leads last year's WHT field away at the start

Walter Hayes Trophy

Kruger headlines WHT entry

BRITISH FORMULA FORD champion Jayde Kruger will make his Walter Hayes Trophy debut in the National College for Motorsport Van Diemen RF92, forming part of a 114-strong entry for the Formula Ford 1600 showpiece event.

Kruger was invited to drive the car by college lecturer and JTR engineer Guy McCulloch as its 2013 WHT occupant Nick Tandy – who had been keen to return – had clashing commitments at the Baku Blancpain Sprint Series finale.

"I'm not sure if it's a good or a bad

idea, but we're doing it now!" said South African Kruger, who tested the RF92 at Silverstone earlier this month.

"I knew of it because I'm friends with [FF1600 legend] Rick Morris, but I didn't understand what it was until I saw the entry list and all the three million cars..."

"The car's really different to drive to the EcoBoost. I'm getting used to having no power as opposed to loads of power."

Last year's winner Scott Malvern returns to the Kevin Mills Racing Spectrum after a year of Radical racing to aim for a second straight triumph, while

three-time victors Peter Dempsey and Joey Foster are back to bid for record fourth wins. Dempsey rejoins the family Cliff Dempsey Racing team after his 2013 outing with KMR, with Festival winner James Raven and Team USA scholars Aaron Telitz and Michai Stephens alongside him.

The Castle Combe contingent absent from the Festival joins in, led by champion Adam Higgins, while Festival podium finishers Jonathan McMullan and Stuart Gough have secured last-minute deals having previously lacked funding.

ENTRIES TO WATCH OUT FOR

Heat 1

Niall Murray
James Raven
Ben Norton

Heat 2

Adam Higgins
Oliver White
Jake Byrne

Heat 3

Ciaran Haggerty
Aaron Telitz
Joey Foster

Heat 4

Chris Middlehurst
Wayne Boyd
Jayde Kruger

Heat 5

Stephen Daly
Peter Dempsey
Freddie Hunt

Heat 6

Scott Malvern
Noel Dunne
Graham Carroll

Patch Fiestas

Turkington in Patch enduro

REIGNING BRITISH TOURING Car champion Colin Turkington will make his Patch Fiesta debut when he contests the championship's six-hour endurance event at Mondello Park.

Turkington, who initially made his name in the BTCC-supporting Fiesta series, will race on November 30 alongside brothers Gary (who formerly

raced in Formula Ford and Formula Renault) and James in the car regularly campaigned by James in Northern Ireland. "It will be the first time racing a Patch Fiesta for Gary and I," said Turkington, who will be up against fellow BTCC racer Aron Smith.

"We won't be taking it too seriously; our main aim will be just to finish."



Turkington will make his Fiesta bow

Century has run G55 in British GT this year



Nurburgring 24 Hours

Century eyes Nurburgring 24

CENTURY MOTORSPORT CHIEF Nathan Freke hopes to field a GT3 car in the 2015 Nurburgring 24 Hours after giving the Ginetta G55 its debut in the Nordschleife's VLN series last weekend.

Freke and team-mate Colin White were running second in class until a

tangle with a slower car forced them out of the race on the final lap.

"The reason we haven't done more out there is because it always clashes with UK races, but if I only ever did one more race it would be the Nurburgring 24 Hours," said Freke.



In brief

Sunoco prize to Kruger

Oskar Kruger (above) will race a Chevrolet Camaro at Daytona next January in a support event for the 24-hour race after winning the Sunoco 200 Challenge. The 19-year-old, who won the Prosport class of the Radical Clubman's Cup this year, secured the prize after F3 Cup champion Toby Sowery failed to attend last weekend's season finale at Snetterton.

Juniors eye '15 title bid

Ginetta Junior race winners Dan Zelos and Jamie Caroline are both likely to remain in the series next year to mount a title challenge. Both scored two wins apiece in their respective rookie Junior campaigns, finishing fourth and sixth in the title standings respectively, and will be considered pre-season favourites in 2015 if they return.

Massot joins Supercup

Porsche Carrera Cup GB frontrunner Pepe Massot will step up to the Formula 1-supporting Supercup for its final round at the United States Grand Prix this weekend. The 18-year-old Spaniard, a three-time podium finisher in the British series after moving from the Ginetta GT Supercup mid-season, will drive for the Momo-Megatron team.

Oliphant to try VdeV

Ginetta has drafted in GT4 Supercup and British GT Championship GT4-class race winner Tom Oliphant to replace marque chief Lawrence Tomlinson in the factory G55 GT3 car for the VdeV series' six-hour finale at Estoril on November 8-9. He will race alongside Mike Simpson and Steve Tandy.

Asch Vectra for UK

Historic racer Simon Garrad has acquired a 1998 Opel Vectra (below) to run in the 2015 Super Touring series. He intends to restore the car to the livery it wore when driven by Roland Asch in Germany's STW Cup. The car was subsequently used by Miroslav Josipovic for hillclimb and race events in Bosnia and Serbia.



Raven recovered from shunt in qualifying to come out on top in the Festival final



HAWKINS

FORMULA FORD FESTIVAL BRANDS HATCH, OCTOBER 25-26 BRSCC

Raven flies to Festival victory

SLEWING INTO THE BARRIERS AT A damp Paddock Hill after just one flying lap of qualifying is not the smoothest way to start a Formula Ford Festival.

James Raven wasn't concerned: what happens at sunset on Sunday is what history remembers, his Cliff Dempsey Racing Ray was quick enough to move up the field, and that one pre-shunt lap was good enough for 10th. His confidence proved justified, because 30 hours later Raven celebrated victory in a final he had taken absolute control of.

Until that time, the CDR man who looked the safest bet was Team USA scholar Aaron Telitz, who enjoyed an exemplary European racing debut until the moment it really counted.

On pole for heat one, Telitz lost

the lead to Noel Dunne at the start and then had his hands full with Johnny McMullan and Jake Byrne. But he swiftly shook off his aggressors before passing Dunne, who went to the grid knowing that a master cylinder problem would make his race pretty hairy. By half-distance, he was out of brakes and in the Clearways barriers.

After assertive early progress, Raven passed Noel Robinson under the yellows for Dunne's crash. The resultant penalty put him fifth, but he had given a big hint of what would follow by hacking through to second on the road and closing to within half a second of Telitz.

Telitz's semi-final one win was even more straightforward, as he pulled clear of FF1600 returnee Chris

Middlehurst in Geva's new Kent Mygale through two safety car periods. Middlehurst initially had a peaceful time as Luke Williams had surged around the outside of the pack at Druids to take third in a Ray he felt was both overweight and down on power, and then bottled up Stephen Daly, Byrne and Raven.

Daly lost ground going wide at Graham Hill Bend, moments before a slip out of Clearways from Williams let his other two pursuers past. Up to third, Raven spent the remaining green-flag laps trying every conceivable way to pass Middlehurst, who hung on for second by 0.076s with Byrne and Williams just behind.

Daly spun trying to pass Luke Cooper at Paddock on the last lap,

but caught it masterfully and salvaged a place in the final with 13th.

Semi-final two removed a man all the frontrunners feared would be hard to beat: Medina Sport's Wayne Boyd. The 2008 Duratec Festival winner had controlled a yellow-plagued heat two ahead of Middlehurst, Scottish champion Ciaran Haggarty, Daly, Stuart Gough and Williams. But Boyd's Sunday lasted just one lap of semi two before he spun out of the lead at Paddock, a broken pin on a damper mounting causing his latest FF1600 trophy race heartbreak.

The best race of the weekend followed as McMullan clung to the lead under huge pressure from Haggarty, rapid starter Neville Smyth and Gough. When Haggarty tried around the outside of McMullan at Paddock just past half-distance, Smyth got a run that took him right around the outside of Druids and into second on the inside of Graham Hill Bend. But his left-rear wheel sheared off at Paddock two laps later – a legacy, Smyth suspected, of a crash at the Martin Donnelly Trophy.

That allowed Haggarty back on to McMullan's tail, until they hit traffic on the final lap, prompting a frantic finish in which Gough got past Haggarty and came within 0.053s of beating McMullan over the line. Robinson, Pedro Matos and CDR's Team Canada scholar Chase Pelletier completed a six-car lead pack.

McMullan – in only his second event of 2014 but brilliantly advertising both his and the Souley



Team USA scholar Telitz starred before spinning off into the gravel in the final

HISTORIC/DURATEC/ZETEC FORD BRANDS HATCH, OCTOBER 26-27

Campbell defends Northern Irish honour with Historic win

WHILE THE SIZEABLE KIRKISTOWN driver contingent couldn't pull off victory in the main Festival event, Ryan Campbell did them proud with a dominant performance in the Historic final behind the wheel of his Mondiale M89S.

Campbell initially had some

opposition from Klaus-Dieter Hackel, but when the German's Van Diemen RF88 slowed and retired, he was free to control the rest of the race.

In his wake, Michael Thompson closed down Ben Tinkler for second and brought a Quest back to the Brands podium, only to get excluded



Campbell sauntered to a straightforward win in the Fford Historics

for running underweight. Conor Murphy hinted that he would have been in this fight too given his rapid progress forward from 13th on the grid before retiring.

It was Henry Campbell who ended up third in the final results, having fended off Innes Hickman, James Hagan and Paul McMorran in the race's closest battles.

To lambast the size of the Duratec and Zetec field would be a disservice to the handful of competitors, half of them from France, who did support the categories' Festival lifeline.

Duratec men John Whitbourn and Thomas Craincourt, plus Julian Hoskins in a 1993 vintage Zetec Vector did their best to entertain, with Craincourt narrowly winning from Whitbourn, who fell behind Hoskins due to a penalty for starting the shortened final out of position.

The fact that only one other car started the final rammed home the fact that both the Zetec and Duratec classes are now dispensable.

● Matt Beer



Hoskins leads a thin Duratec and Zetec class field

HISTORIC FORMULA FORD FINAL (15 LAPS)

1 Ryan Campbell (Mondiale M89S) 13m14.993s (82.04mph); 2 Ben Tinkler (Reynard 89FF) +11.207s; 3 Henry Campbell (Reynard 83FF); 4 Innes Hickman (Van Diemen RF89); 5 James Hagan (Crosle 32F); 6 Paul McMorran (Crosle 32F). CW Hagan; Matthew Wrigley (Merlyn Mk20a). FL Campbell 52.273s (83.19mph).

DURATEC AND ZETEC SEMI-FINAL (15 LAPS)

1 John Whitbourn (Ray GR10) 13m07.350s (82.84mph); 2 Julian Hoskins (Vector TF93) +1.924s; 3 Eric Heudicourt (Mygale SJ03); 4 Thomas Craincourt (Mygale SJ10); no other finishers. CW Hoskins. FL Craincourt 50.992s (85.28mph).

FINAL (10 LAPS) 1 Craincourt 8m44.929s

(82.84mph); 2 Hoskins +3.194s; 3 Whitbourn; 4 Heudicourt; no other starters. CW Hoskins. FL Craincourt 50.941s (85.36mph).

Motorsport team's potential – therefore earned pole for the final with Telitz alongside. Only sixth on the grid and with some formidable opposition in his way, Raven remained an outside bet, yet proved to be an irresistible force.

Past Haggarty off the line, he overtook Gough at Druids and Middlehurst at Clearways on lap two. Telitz then made his first mistake of a hitherto flawless weekend and dumped his Ray in the Paddock gravel while trying to line McMullan up on the outside as they began lap four.

More bonuses for Raven followed: Middlehurst's promising Mygale parked in a plume of engine smoke and Haggarty slid off at Graham Hill Bend while wheel to wheel with Raven, the Scot declaring himself surprised at how early McMullan had braked ahead. When McMullan lost momentum on Middlehurst's oil at Clearways, Raven was into the lead.

"Once I had three car lengths and saw McMullan was defending, I knew it was time to push," said Raven, who switched off all thoughts of the pack behind and took command, escaping to victory by six seconds.

McMullan was sure that without

the oil slip, victory was his. "This would've been the widest Ray in the universe," he insisted. He certainly wasn't going to relinquish second, despite the spectacular efforts of Gough, Robinson and Williams. By the end it was a six-car swarm covered by 0.9s over the line, although a track-limits penalty dropped Williams down to ninth.

Gough was delighted with third, his Oldfield team showing what was possible with an older car as Caterham GP2 data engineer Matos brought the sister Van Diemen RF92 home a jubilant fifth between Robinson and Byrne in only his second 2014 outing.

Dunne surged from the back to eighth in his semi and seventh in the final, followed by Daly, who flew from 26th to eighth. Fastest lap went to the recovering Haggarty, a notable achievement given the traffic he was dodging as he rose from 17th to 10th.

While Telitz starred until his error, Brands proved a crash course for fellow USA scholar Michai Stephens. He showed pace between incidents, and is one of many awaiting a second chance at the Walter Hayes Trophy.

● Matt Beer



Smyth's left-rear wheel went AWOL during the second semi-final



McMullen (6) took second, but Haggerty (14) slid off at Graham Hill in the final

FORMULA FORD 1600 KENT FINAL (20 LAPS)

1 James Raven (Ray GR13/14) 19m00.626s (76.24mph); 2 Jonathan McMullen (Ray GR07) +5.960s; 3 Stuart Gough (Van Diemen RF92); 4 Noel Robinson (Van Diemen JL012K); 5 Pedro Matos (Van Diemen RF92); 6 Jake Byrne (Ray GR13); 7 Noel Dunne (Van Diemen RFO0); 8 Stephen Daly (Ray GR11); 9 Luke Williams (Ray GR13); 10 Ciaran Haggerty (Ray GR14). Class winners Ryan Campbell (Mondiale M89S). Fastest lap Haggerty 50.487s (86.13mph).

HEAT 1 (12 LAPS) 1 Aaron Telitz (Ray GR09)

10m17.823s (84.46mph); 2 McMullan +2.941s; 3 Byrne; 4 Robinson; 5 Raven; 6 Neville Smyth (Ray GRS10). CW Campbell; Denis Sheehan (Crosle 45F); Matthew Wrigley (Merlyn Mk20a). FL Raven 50.290s (86.47mph).

HEAT 2 (12 LAPS) 1 Wayne Boyd (Van Diemen MS13)

13m04.728s (66.49mph); 2 Chris Middlehurst (Mygale GV14-K) +0.480s; 3 Haggerty; 4 Daly; 5 Gough; 6 Williams. CW Klaus-Dieter Hackel (Van Diemen RF88); Kevin Howell (PRS RHO1). FL Boyd 50.667s (85.82mph).

SEMI-FINAL 1 (15 LAPS) 1 Telitz 15m47.006s

(68.87mph); 2 Middlehurst +1.007s; 3 Raven; 4 Byrne; 5 Williams; 6 Geoff Richardson (Van Diemen RFO3). CW Hackel; Paul McMorran (Crosle 32F); Wrigley. FL Telitz 50.739s (85.70mph).

SEMI-FINAL 2 (15 LAPS) 1 McMullan 14m38.061s

(74.28mph); 2 Gough +0.053s; 3 Haggerty; 4 Robinson; 5 Matos; 6 Chase Pelletier (Ray GR3). CW Campbell; Hagan. FL Haggerty 50.589s (85.95mph).



Boyd (leading) was highly fancied before his car let him down



ALL PICS: STEVE JONES

BIRKETT SIX HOUR RELAY SILVERSTONE HISTORIC GP, OCTOBER 25 750MC

Six Signatures join Birkett victors

THE SIX SIGNATURES CATERHAM equipe of Britons James Needham, David Rowe and Spencer Horgan, interspersed with expat Australians Kurt Brady and John Toshack, drove a faultless race to win the 750 Motor Club's 'Holly' Birkett Six Hour Relay's handicap classification at Silverstone last Saturday.

"This was the culmination of five years of trying," beamed Needham from behind the coveted historic silver salver named after the club's founder. "We finished 51st at our first attempt in 2010 and have learned every year since!"

Sadly, a quarter of the organisers' 75th anniversary event on the Historic Grand Prix circuit was run under safety-car control, including the start – a rolling single-file release, not the usual grid formation – so no mass-start image! It took almost an hour to clear an incident on the approach to Maggotts, just before the two-hour mark, in which experienced Radical driver Charles

Harvey-Kelly (a member of last year's scratch-winning team) sustained serious head injuries having collided with a BMW, then hit the concrete wall on the left side of the track.

For the first three hours the Podium Prep squad led the way, George Wright having set the target with a stout first stint in his Porsche 993, but a fundamental error cost them dearly when they had two cars – Peter Jokinen's Ford Fiesta ST and Andrew Stacey's Mini Cooper S – circulating nose to tail simultaneously in the fourth hour. With these laps discounted, they fell to 13th in the peloton, but recovered strongly to seventh, fourth of eight teams on 144 laps with credit laps added to distance covered.

So good were the handicappers' calculations – based on competitors' previous lap times where known, drivers' performances relative to competitors in similar cars at other tracks and educated 'guesstimates' for

new combos – that the top three teams finished on the same number of laps. Indeed, 47 of the 69 were within five laps on corrected distances, with handicaps adjusted by percentage to account for full-course cautions, ensuring that nobody was disadvantaged.

Six Signatures moved up from 11th after an hour to sixth, then fourth at the midway point. Once atop the table at two-thirds duration, they resisted pressure from fellow Caterham crew Gradsports and the Turtle Wax team, anchored by Rebecca Jackson, who did a grand job, tearing round and round in her vivid green Porsche Boxster.

But the big surprise in the final reckoning was the Jagnuts team of five XJSs and an XJ40, which sneaked up under the radar. Nineteenth after one hour, they climbed as high as fifth before slipping to 12th with 60 minutes remaining. A brilliant final session saw the Coventry sextet rocket back to finish second.

"The safety cars could not have fallen more perfectly for us, matching our timings precisely," echoed the elated victors – who last year snared fifth with Needham, Toshack, Horgan, Chris Bingham, Wes Fox and Mike Hart – at the prizegiving.

Last year's winning Regency Autos/TBR Stock Hatch team morphed into Two Past Two Future, former champion Joe Ferguson being drafted into the Cambridge posse's spare Citroen Saxo alongside newly-crowned title winner Shayne Deegan, his older brother Lee and Carl Swift.

After a promising start they wound up 11th, albeit with one bent car.

Only one of the top six Scratch teams, RGBargy, permeated the top 10 on the opposite side of the equation. A class-winning fourth on Handicap, two laps and 24 places ahead of rivals Racing Sevens, represented a fine effort from the high-revving motorcycle-engined cars' throttle jockeys.

Equally delighted were the Smarts4YouRacing bunch which, but for a blip when former Formula Palmer Audi racer Natali Harris's car went into 'limp mode' on her out-lap (a simple fix), appeared to run metronomically to 24th place.

The Scratch competition was a three-horse race, between The Winning Radicals (Aaron and Lee Bailey in their SR3 and PR6 pilot Doug Carter the nucleus of last year's champions The Third Radicals, joined by Brian Murphy and John MacLeod in PR6 and SR3 respectively), 2012 victor Paul Rose's Team JPR/Saker Sportscars posse and Spire Sports Cars boss Paul Nightingale's Inspires, so narrowly denied last October.

Multiple 750MC champion Tim Gray was back to lead Spire's jousting, his unique 1500cc Suzuki Hayabusa engined single-seater Bikesport Spire GT3 a step up from the 1000cc RGB-spec original in which he recorded a stellar 105mph lap last season. Gray, on wet tyres, set off at a tremendous pace on a damp track, but his 36-second lead was wiped out by a front-suspension



The field for the Birkett was as varied as ever



David Rowe (leading) was part of the five-man Six Signatures squad that won the handicap contest

failure after seven laps.

He gathered the drama up and was still 21 seconds ahead of Aaron Bailey's red Radical when his car crawled forlornly over the timing line into the pits. Team-mates John Cutmore, Al Boulton and Richard Wise kept Inspires in the hunt with their RGB cars – Cutmore testing a 1000cc Suzuki engine for 2015's campaign rather than running the familiar Honda – while Gray's was repaired. Tim was back ahead (through the long yellow) with fastest lap when his engine bay erupted into flames, triggering another caution.

Later, having not completed his allotted 43-lap maximum in the 'hot' car, Gray drove mentor Wise's machine – which had been retrieved from The Loop on a truck – in a last-ditch bid to catch the second-placed Sakers and maybe pressure them or The Winning Radicals into an error. Again he lapped quickly before the clutch started slipping.

Taking over from Lee Bailey just before the four-hour mark, Murphy quickly closed a 10-second deficit to Rose's open Saker and passed it to restore his team to the lead it had last held in hour one when Aaron Bailey had relayed Doug Carter. Murphy had built the advantage diligently to beyond a minute before MacLeod took the final stanza. A measured 30-lapper to the chequered flag assured a second successive victory for Aaron Bailey's team.

Finished by Steve Harris in one of two identical closed RAPX models, the Subaru flat-four motivated Sakers were a lap behind the Radicals at the flag after another trouble-free run, save for slick-shod Rose "swapping ends three times, once my fault" in his slippery first stint. They were two laps clear of the Inspires,



David Dennett's 600bhp Porsche 935K3 clone – "a nut-and-bolt replica" of Bob Wollek's iconic Vaillant-backed Kremer car of the late 1970s – from the Men-O-Porsche team, theoretically capable of 185mph on Hangar Straight.



Veteran competitor David Butler – the inspirational triple amputee who assesses aspiring disabled racers for MSA licences – raced alongside daughter Natali Harris, who was watched by her three-month-old son!



Under a bizarre veil of secrecy, AC/DC frontman Brian Johnson – a popular Mini Cooper S and GRD sportscar racer at European historic events – competed in an MGB, as part of a TV programme to be shown next spring.

whose mechanics needed medals for perseverance.

The battle for fourth, fifth and sixth raged throughout. Racing Greens' Caterhams (for which long-running Pascal Green led outright after an hour) were deservedly best of the many front-engined teams. They landed fourth, Barney Prior, Bill Hailstone and Richard Green repelling everything RGBargy's miscellany – Duncan Horlor (Spire), Colin

Chapman (BDN), Dan Bromilow (Fisher Fury), Adrian Moore (AB Sabre) and Tim Hoverd (AB 'Hovercraft') – could throw.

Veteran Doug Newman's Gold Arts Caterham team and Chris Hart's Clubmans Cup perennials, the Hart Attacks, tussled mightily although both suffered late breakdowns. Gold Arts slipped to ninth behind Patrick Mortell's Rogue's Allstars, for which Fergus Walkinshaw (Ginetta G55) opened.



Shayne Deegan, last year's handicap winner, struggled

65TH BIRKETT SIX HOUR RELAY HANDICAP

1 Six Signatures: James Needham (Caterham Tracksport), Kurt Brady, David Rowe, John Toshack, Spencer Horgan (Caterham Supersports) 145 laps (131+14 credit); 2 Jagnuts: Lawrence & Charles Coppock, Chris Palmer, Sam R & Sam W Clarke (Jaguar XJs), Chris Boon (Jaguar XJ40) 145 (126+19); 3 Gradsports: Alex Gurr, Tristan Judge, Zoltan Csabat, Scott Lawrence, Tom Woodcock, Jason Gale (Caterham 7s) 145 (130+15); 4 RGBargy: Duncan Horlor (Spire GT3), Adrian Moore (AB Sabre), Colin Chapman (BDN S3), Dan Bromilow (Fisher Fury), Tim Hoverd (AB Sabre T2A Hovercraft) 144 (135+9); 5 Turtle Wax: Rebecca Jackson (Porsche Boxster), Adam Dawson, Sanjay Tallwar (Porsche 911SCs), David Gardner, Chris Mills (Ginetta G27s) 144 (127+17); 6 Anetec Automac BMW: Jason Holyhead, Kal Ezzat, Mike Cutt (M3s), Paul Travers (328i) 144 (132+12); 7 Podium Prep: George Wright (Porsche 993), Steve Atkinson (Porsche 968), Andrew Stacey, James Bird (Mini Cooper S), Peter Jokinen (Ford Fiesta ST) 144 (126+18); 8 RAF Motorsports: Ed McKean (BMW 328i), Dom Benfell (Lotus Esprit), Darren Howe (VW Golf GTi), Darren Berris (Westfield V8) 144 (126+18); 9 The Blat Pack: Nick Portlock, Peter Fortune, Stephen Nuttall, Tony Mingola, Andrew Sinclair (Caterham Tracksport), Matt Dyer (Caterham Tracksport) 144 (129+15); 10 Samsboyz: Matthew Irons (BMW 323i), André Severs (VW Vento VR6), Robert Hardy (Porsche 944), Mark Heywood (Caterham 7) 144 (122+22). **Class winners** Jagnuts; RGBargy; DLH Motorsport: Michael & Thomas Hibbert (BMW M3 Evos), James Ford (BMW 318is) 143 (128+15).

SCRATCH 1 The Winning Radicals: Aaron & Lee Bailey, John Macleod (SR3s), Doug Carter, Brian Murphy (PR6s) 141 laps in 5h59m09.43s (85.74mph); 2 Team JPR/Saker Sportscars: Paul Rose (Saker Sniper), Steve Harris, Mark Burton, Tim Wheeldon (Saker RAPXs) 140; 3 Inspires: Tim Gray, John Cutmore, Richard Wise, Alastair Boulton (Spire GT3s) 138; 4 Racing Greens: Pascal & Richard Green, Barney Prior, Bill Hailstone (Caterham C400s) 136; 5 RGBargy, 135; 6 The Free Radicals: Gary Ramsdale, Charles Harvey-Kelly, Richard Hardie, Gary Paterson (SR3s) 134; 7 The Hart Attacks: Peter Richings (Mallock Mk30PR), Barry Webb (Mallock Mk23), Howard Payne (Mallock Mk20b), Mike Evans (Mallock Mk27), Alex Champkin (Vision V84), 'Wid' Pickering (Mallock Mk27EBX) 134; 8 Rogue's Allstars: Fergus Walkinshaw, Ryan Connolly (Ginetta G55 Supercup), Patrick Mortell (Rogue Xenon), Andy Napier (Lotus Elise S1) 133; 9 Gold Arts: Doug Newman, Chris Porritt, Simon Harris, Mick Jones, Graham Booth (Caterham 7s) 133; 10 Anetec Automac BMW 132. **Fastest lap** Tim Gray (Spire GT3) 2m07.25s (102.98mph).



'Wid' Pickering's flat battery left the HAs prey to The Free Radicals who bravely carried on, grabbing sixth for their sick comrade Harvey-Kelly.

One of the best unsung performances came from the Run Baby Run Sports Specials outfit, for which Nigel Brown (Sylva Phaser) and Colin Benham (STM Phoenix) pounded round – peaking at 12th – after Anton Landon's Cyana and John Moore's FRS Arrow broke.

● Marcus Pye



Ellesley (39) took his second victory by just two tenths

ALL PICS: HAWKINS

FIESTA CHAMPIONSHIP BRANDS HATCH, OCTOBER 25-26 BRSCC

Double victory gives Ellesley second title

DAVID ELLESLEY ADDED THE 2014 title to his 2009 success with wins in both season-ending races for the hotly contested Class C of the Fiesta championship, one of which ended after just three laps.

Third on the grid for race one, Ellesley made a lightning getaway that helped him avoid first-corner mayhem that triggered an immediate stoppage.

The re-run was scheduled for 12 minutes instead of 20, but ended much sooner with red flags so that Samuel Priest's damaged car could be shifted. Ellesley passed poleman

David Grady on one of the two racing laps to take a truncated victory.

Race two went all the way, but the best action took place within the first mile when Grady nosed alongside Simon Horrobin at Clearways and both drivers lost momentum, allowing Ellesley to sweep past.

Horrobin held on for second as Grady fell to fifth behind Daniel Holland and Andrew Taylor. James Ross made a good recovery after his second slow start of the weekend from fourth on the grid to complete the top half-dozen finishers.

Edward Cockill was a double

winner in the Classes A, B & D races, with Jordan Annells a close second in both. David Abbott and Simon Roud lost 20s to the leaders trading third and fourth places in race one.

Abbott was third again in race two, but this time slipped nearly half a minute behind Annells. Next in line this time was Pete Daniels in his Class A car, giving a very hard time to Roud and Al Daly. The veteran driver and Fiesta preparation expert boasted number 61 to match his age and easily beat his class rivals. Mike Hooper completed a Class B double.

● Brian Phillips

RESULTS, CLASS C (3 LAPS) 1 David Ellesley 3m26.684s (63.11mph); 2 David Grady +0.974s; 3 Daniel Holland; 4 Scott Robertson; 5 Andrew Taylor; 6 James Ross. **Fastest lap** Taylor 56.421s (77.07mph). **RACE 2 (21 LAPS)** 1 Ellesley 19m48.786s (76.81mph); 2 Simon Horrobin +0.197s; 3 Holland; 4 Taylor; 5 Grady; 6 Ross. **FL** Ellesley 55.998s (77.65mph). **CLASSES A, B & D (BOTH 21 LAPS)** 1 Edward Cockill 20m20.580s (74.81mph); 2 Jordan Annells +1.687s; 3 David Abbott; 4 Simon Roud; 5 Peter Daniels; 6 Al Daly. **Class winners** Daniels; Mike Hooper. **FL** Cockill 57.200s (76.02mph). **RACE 2 1 Cockill 20m13.367s (75.26mph)**; 2 Annells +2.701s; 3 Abbott; 4 Daniels; 5 Roud; 6 Daly. **CW** Daniels; Hooper. **FL** Annells 57.110s (76.14mph).

SPORTS 2000 DURATEC BRANDS HATCH, OCTOBER 25-26 BRSCC

Champagne for Sherrington

THE QUICKEST CARS ON THE Festival programme didn't produce the best racing, but helped to demonstrate why Patrick Sherrington has been the man to beat in this year's Sports 2000 Duratec series with his MCR.

Though beaten to pole by Tom Stoten, Sherrington was in control of the 30-minute race, beating Stoten's Gunn off the grid and

never looking threatened thereafter.

David Houghton was in Stoten's sights once backmarker traffic became a factor. They finished more than 20s ahead of class-winning fourth man Paul Martin. Paul Streat lined up fourth but broke a driveshaft at the start. Peter Trayhurn and Mike Turner were in the group following Stoten before coming to grief, although Turner continued after a pit visit.

● Brian Phillips

RESULTS (37 LAPS) 1 Patrick Sherrington (MCR) 29m59.443s (89.41mph); 2 David Houghton (Van Diemen RFSC02) +15.022s; 3 Tom Stoten (Gunn TS11); 4 Paul Martin (MCR); 5 Peter Needham (MCR); 6 Roger Donnan (MCR). **CW** Martin; Bryan Mullarkey (Carbir CS2). **FL** Sherrington 47.774s (91.02mph).



FIESTA JUNIORS BRANDS HATCH, OCTOBER 25-26 BRSCC

Thompson caps year with pair of wins

ROMFORD'S AARON THOMPSON PLANS a full Fiesta Junior title challenge next year after ending a character-building 2014 campaign with two wins at the Brands Hatch finale.

In the absence of this year's champion Geri Nicosia, Thompson dominated race one on Saturday, leaving four drivers to spar over the minor placings. Thomas Grundy and Michael Higgs, rivals for second in the points table, narrowly headed Samuel Watkins and Jessica King.

The race for the lead was much closer at the second attempt; Higgs gave Thompson a hard time from start to finish. Watkins finished third after some paint-swapping moments



with Grundy, who later went straight on at Druids and into retirement.

From then to the end, Watkins was no threat to the leaders and faced no challenge from behind, while King successfully held onto her position despite having Connor Grady and Nathan Edwards in close attendance.

● Brian Phillips

RESULTS (BOTH 19 LAPS) 1 Aaron Thompson 20m26.404s (67.37mph); 2 Thomas Grundy +6.687s; 3 Michael Higgs; 4 Samuel Watkins; 5 Jessica King; 6 Connor Grady. **FL** Thompson 57.215s (76.00mph). **RACE 2 1 Thompson 20m19.264s (68.32mph)**; 2 Higgs +0.203s; 3 Watkins; 4 King; 5 Grady; 6 Nathan Edwards. **FL** Thompson 57.527s (75.59mph).

PATCH FIESTAS BRANDS HATCH, OCTOBER 25-26 BRSCC

Denning and Lillis share honours in Irish invasion

NEARLY 30 CARS FROM THE Mondello-based Patch Fiesta championship made the long trip to Kent for two highly entertaining races. Suggestions that most would be staying out of trouble with their upcoming Mondello Park Six Hour race in mind proved a little hard to believe, especially as in qualifying 25 cars were covered by less than 1.9s.

The wins were taken by 2013 champion John Denning and the driver who has succeeded him to the title, last year's top rookie Sean Lillis.

Lillis had pole for race one but Denning led from the start. These two, accompanied by Philip Lawless, were clear of some mad midfield moments on lap one. Lawless was helped by the leaders slowing each other as they raced side by side, and at the final corner Lawless went for the tight line and beat Lillis into second by less than a car's length. The first three were covered by 0.3s at the flag.



Denning (1) shared Patch wins with 2014 series champ Lillis

Lillis made up for this defeat with a lights-to-flag race two success, although Denning did not allow him a moment's relaxation.

"Sean drove a great race and I couldn't do any more," said Denning, while new series star Lillis was "delighted" after riding out the unrelenting pressure.

Lawless couldn't repeat his late charge but finished securely in third with Brendan Fitzgerald fourth. The most exciting action in this race was further back, up to nine cars fighting for eighth place in a pulsating bunch until Barry Barrable made a slight break to claim the place.

● Brian Phillips

RESULTS (15 LAPS) 1 John Denning 15m53.654s (68.39mph); 2 Philip Lawless +0.256s; 3 Sean Lillis; 4 Stephen Kirwan; 5 Michael Fitzgerald; 6 Barry English. **FL** Lawless 1m01.970s (70.17mph). **RACE 2 (14 LAPS) 1 Lillis 14m42.265s (69.00mph);** 2 Denning +0.395s; 3 Lawless; 4 Brendan Fitzgerald; 5 Alan Watkins; 6 Kirwan. **FL** Denning 1m02.134s (69.98mph).

SPORTS 2000 PINTO BRANDS HATCH, OCTOBER 25-26 BRSCC

Snowdon shades rivals to round off season with double

CHRIS SNOWDON OVERCAME HEAVY pressure and unlucky timing with a safety-car period, which stripped away a hard-earned advantage, in order to win both season-closing Sports 2000 Pinto races.

Michael Gibbins ran him close in both races, though he also had to beat a self-imposed handicap in the form of two slow starts.

A Historic Trophy race for pre-1983 cars on Saturday provided

more than a hint of what was to come in Sunday's championship event. Slow away from his front-row grid slot, Gibbins recovered to second by lap five and his Lola started taking chunks out of Snowdon's early lead.

Half a dozen laps from the end he was close enough for a lunge into Clearways, but the move didn't come off and in the closing stages Tiga driver Snowdon put a backmarker between them, delaying Gibbins long

enough to prevent another attack.

Gibbins had another shocker of a start on Sunday and briefly sank to sixth. Snowdon gratefully headed into the distance, leaving Clive Steeper, Colin Feyerabend and Mike Fry to delay the recovering Gibbins for as long as possible.

Snowdon was almost seven seconds ahead when Gibbins reached second place on lap 13, but this lead was immediately slashed to almost

nothing as the safety car was scrambled so that Simon Aldworth's car could be moved from the Paddock gravel trap.

From the restart Snowdon was ready for a challenge and increased his pace enough to keep the chasing Gibbins just out of range. Steeper, who had been second until Gibbins got through, completed the podium, helped by Feyerabend's firm-but-fair defence of fourth place. Feyerabend faltered just enough on the last lap for Damien Griffin, who supplanted Mike Fry, to squeeze past.

● Brian Phillips

RESULTS (27 LAPS) 1 Chris Snowdon (Tiga SC80) 24m57.832s (78.38mph); 2 Michael Gibbins (Lola T590) +0.758s; 3 Clive Steeper (Tiga SC80); 4 Damien Griffin (LolaT598); 5 Colin Feyerabend (Lola T90/90); 6 Mike Fry (Lola T86/90). **CW** Steeper; Griffin; Feyerabend. **FL** Snowdon 50.658s (85.84mph).

HISTORIC TROPHY (24 LAPS) 1 Snowdon 20m41.423s (84.07mph); 2 Gibbins +0.444s; 3 Steeper; 4 Simon Aldworth (Lola T492); 5 Mike Johns (Royale S2000M); 6 Peter Pettersson (Tiga SC77). **FL** Gibbins 50.698s (85.77mph).



Snowdon celebrates a hard-earned victory



Russell started weekend 21 points behind, but ended it three in front

EBREY

BRDC FORMULA 4 SNETTERTON, OCTOBER 25-26 MSVR

Russell overcomes odds to seal F4 title

76

THE GAP BETWEEN THE TOP TWO IN the BRDC Formula 4 Championship had never been greater heading into the Snetterton finale, but somehow George Russell overturned the deficit to emerge from a gripping three races as champion.

Trailing Lanan Racing team-mate Arjun Maini by 21 points, Russell gave himself the best possible chance of achieving a relatively unlikely triumph by taking pole for the opening race after an inspired call in qualifying to switch from slicks to wets as the damp track failed to dry quickly enough in the final sector.

But 16-year-old Russell fluffed the start first time around, allowing Mexican Diego Menchaca to surge past on the run to Riches. Gaetano di Mauro also slipped by at Agostini. Russell had barely any time to react before the red flag was required when Will Palmer and Jordan Albert collided at the Montreal hairpin, leaving their cars stranded.

That incident eliminated one of the six mathematical title protagonists (Palmer), and by the race's end it was just a quartet as fifth place was not enough to keep Struan Moore in



Race-one winner Menchaca (1) battles Eastwood at Riches

STYLES

points contention. Moore's mid-race attempt at passing di Mauro at Riches ended in both being delayed at Montreal and Moore banging wheels with Russell at Palmer, dropping the poleman to seventh and allowing Sennan Fielding past both for fourth.

Fourth became third for the HHC man as he passed di Mauro at Riches, despite an over-the-top defence from the Brazilian. But Fielding could do nothing about Menchaca and Charlie Eastwood, whose fine restart dragged him past Russell and included an around-the-outside move at Riches on di Mauro, as both claimed career-best results.

Moore, a charging Raoul Hyman (up from last on the grid), Russell and a rather anonymous Maini completed a train of five cars that ended the race nose to tail.

Russell's verdict so far? "A disastrous start to the weekend."

That put Maini on pole for the reversed-grid sequel, and he led into Riches while Russell again got away

slowly and was passed by Hyman. The Indian led the first few laps, but Hyman slipstreamed him as they began the fifth tour and forced him to defend into Riches before diving inside at Montreal. Two corners later, Russell bumped his team-mate and title rival down to third with a superb move around the outside at Agostini.

While Russell couldn't find a way past Hyman, he and Fielding — who completed the podium — did claw valuable points back on Maini when a mistake dropped the points leader from third to fifth with two laps to go.

The poor getaways in the opening two races hurt Russell's confidence — "my right foot" was his blunt answer when asked if there was anything particularly wrong — and his nervousness showed as a sluggish start to the season finale allowed Hyman and Fielding to attack from either side.

The South African eased ahead on the outside, but Fielding went to Russell's right and was squeezed onto

the grass for his troubles. That dropped him behind Eastwood, who had demoted Maini to fifth, and allowed the top two to gradually ease clear. That order would have been enough to earn Maini the crown by three points, but Russell attacked Hyman for the lead and pulled off a fine move into Hamilton after forcing his rival to defend into Agostini.

Three blistering laps handed Russell a one-second buffer over Hyman, which he held to the flag to clinch a fifth win of the season and the title with it, as Maini failed to make progress from fifth.

"I was so emotional when I came off the track," Russell confessed. "It's been such an up-and-down year."

Maini was philosophical in defeat, admitting he had played it too safe in not attacking Fielding and Eastwood ahead of him.

"It's important to be positive, but also to criticise yourself a bit to work harder for next year," the youngster admitted afterwards. "I tried to be careful and I should have made the moves earlier."

● Scott Mitchell

RESULTS

RACE 1 (6 LAPS) 1 Diego Menchaca 11m24.472s (93.69mph); 2 Charlie Eastwood +0.247s; 3 Sennan Fielding; 4 Gaetano di Mauro; 5 Struan Moore; 6 Raoul Hyman.
Fastest lap George Russell 1m51.505s (95.85mph).
RACE 2 (10 LAPS) 1 Hyman 18m44.360s (95.05mph); 2 Russell +1.525s; 3 Fielding; 4 Moore; 5 Arjun Maini; 6 di Mauro. FL Russell 1m50.715s (96.53mph).
RACE 3 (10 LAPS) 1 Russell 18m49.674s (94.61mph); 2 Hyman +0.738s; 3 Eastwood; 4 Fielding; 5 Maini; 6 Moore. FL Hyman 1m51.219s (96.09mph). **POINTS** 1 Russell, 483; 2 Maini, 480; 3 Hyman, 465; 4 Fielding, 464; 5 Moore, 412; 6 Will Palmer, 356.



Hyman leads the pack into Montreal

STYLES

Waite took BMW title with a win and a second place



STYLES

PRODUCTION BMWs SNETTERTON, OCTOBER 25-26 MSVR

A patient Waite clinches BMW crown

IN ONE OF THE CLOSEST SEASONS IN the series' history, three drivers went into the Production BMWs' decisive championship double header with a shot at the title.

Points leader Harry Goodman, whose blend of consistency and speed had yielded eight top-three finishes this year, was up against the rapid Stuart Waite, with five victories to his name already, and Donington Park winner Gary Feakins.

The momentum swung in Waite's favour in race one, as he boosted his title chances by overtaking poleman Feakins for the lead in the opening corners. Once ahead, Waite was able

to carve out a narrow lead. Although he couldn't afford to relax, the gap proved enough to secure his sixth win of the year.

Meanwhile, Feakins was ever-present in the leader's mirrors, keeping his championship hopes open with a strong second place. By contrast, Goodman was disappointed by his relative lack of pace in a distant third place, knowing that it left him with it all to do in the final race.

Sadly for Goodman, race two followed a similar pattern, with Waite and Feakins getting away at the front while he fell back in third. This time it was Waite who claimed an early

lead before being passed by the determined Feakins on lap four.

Knowing that second place would be enough for the title, Waite was content to shadow his rival to the finish and thereby secure the championship crown.

● Oliver Timson

RESULTS (BOTH 7 LAPS) 1 Stuart Waite 16m56.971s (73.56mph); 2 Gary Feakins +1.777s; 3 Harry Goodman; 4 Mark Palmer; 5 Matthew Swaffer; 6 Rob Cooper. **FL** Waite 2m23.498s (74.48mph). **RACE 2 1 Feakins 17m00.533s (73.31mph);** 2 Waite +0.884s; 3 Goodman; 4 Swaffer; 5 Palmer; 6 Cooper. **FL** Waite 2m23.642s (74.40mph).

RACING SALOONS SNETTERTON, OCTOBER 25-26 MSVR

Father-and-son duo split Saloon triumphs

THE BATTLE FOR VICTORY IN THE PAIR of Racing Saloons races proved to be a family affair, as the BMW M3s of Peter Seldon and son Matt finished one-two both times.

Having started from pole in the opening race, Seldon Jr briefly dropped a place at the start, but moved back ahead in the opening corners and pulled clear thereafter.

His dad also fell back initially before passing Dave Griffin and Richard Evans on consecutive laps to claim second. Evans held on in a three-way battle for third, while Darren Stamp

overtook Griffin for fourth after a side-by-side battle through Agostini and Hamilton a lap from home.

Karl Cattliff had looked like challenging the leaders early on, surging up the order to briefly threaten for second, only for gearbox gremlins to force him off track and down the order. The determined Cattliff made it back to sixth, despite continued gearbox issues.

Just behind him came the ever-improving Mazda RX-8 of Liam Crilly. Having spent the year getting the car sorted, a delighted Crilly reaped the

rewards with a creditable Class B win in seventh overall.

The Seldon duo overhauled fast-starting Evans to move into first and second again in the sequel. This time, it was Seldon Sr who made the running, claiming top spot along the Bentley Straight on lap two, with his son following next time around. Although he chased his dad to the finish, he couldn't find a way past.

"I just kept hoping the chequered flag would come out," admitted the relieved winner afterwards.

● Oliver Timson

RESULTS (BOTH 7 LAPS) 1 Matt Seldon (BMW E36 M3) 15m47.146s (78.99mph); 2 Peter Seldon (M3) +4.243s; 3 Richard Evans (M3); 4 Darren Stamp (M3); 5 Dave Griffin (M3); 6 Karl Cattliff (M3). **Class winners** Liam Crilly (Mazda RX-8); John Willcocks (E30 M3); Andy Gay (E30 320); Steve Allen (Honda Civic); Mark Morton (BMW Compact). **FL** M Seldon 2m12.843s (80.45mph). **RACE 2 1 P Seldon 15m31.412s (80.32mph);** 2 M Seldon +0.979s; 3 Evans; 4 Stamp; 5 Griffin; 6 Cattliff. **CW** Willcocks; Crilly; Liam Walker (BMW 325); Gay; Morton. **FL** M Seldon 2m10.864s (81.67mph).



Peter leads son Matt in all-Seldon Saloons battle

STYLES



STYLES

Snetterton in brief F3 Cup

Henry Chart (above, leading) capitalised on the absence of 2014 champion Toby Sowery and regular frontrunner Lee Morgan to secure a well-deserved double victory in the season finale. Chart headed Rockingham double winner Alice Powell both times, while Louis-Hamilton Smith took a brace of third places after holding off championship runner-up Tristan Cliffe in both races.

Atom Cup

Martin James got the better of his rivals in the season-closing triple-header, taking two wins and a third. He snatched a late victory in race one ahead of Andrew Smith after long-time leader Nick Whitehead spun off on the final lap. Although Smith dominated race two ahead of Whitehead, James rounded out the season with a flourish after sweeping past Whitehead and holding him off to win the finale by a car's length, with Smith taking third.

Trackday Trophy

Oliver Withington enjoyed an impressive race debut, partnering Guy Pettit to victory. His more experienced team-mate put their SEAT in control in the opening stint, charging from 10th place on the grid to unseat the Vauxhall VX220 of early leader Mark Penny. Once the dust had settled after the mandatory pitstops, Witherington set fastest lap as he made sure of top spot. The Peugeot of Dan and Ben Abbutt secured a distant second, ahead of Paul Ivens's Clio.

Team Trophy

Having won three of the past four races in their Ginetta G20, Richard Preece and James Reed were the in-form team going into the penultimate round. But there proved to be no stopping the SEAT Leon of brothers Adam and Ben U'Ren (below) in the hour-long race – Adam set up the win by overtaking early leader Reed, before Ben sealed the deal after the mid-race driver changes. Preece and Reed were forced to be content with second, with Darren Goes's SEAT completing the podium.



STYLES

SUBSCRIBE TO AUTOSPORT AND GET...

A FREE MCLAREN MEDIA BAG



+ PLUS +

**FREE DIGITAL EDITION
SUBSCRIPTION & UNLIMITED
ACCESS TO AUTOSPORT.COM**

FREE GIFTS

- ✓ **Free McLaren media bag**
This stylish Team McLaren media bag features an outer compartment, phone pocket and adjustable padded strap.
Dimensions: height 30cm, width 24cm, depth 8.5cm.
- ✓ **Free subscription to the AUTOSPORT Digital Edition and unlimited access to AUTOSPORT.com**

SUBSCRIBE NOW!



- ✓ Save 25% on the cover price
- ✓ Pay just £34.99 every 13 issues by Direct Debit

Visit: www.themagazineshop.com/taspo/m1014p

08448 488 817

Or call and quote **M1014P**
Please have your bank details ready.

Offer ends December 4 2014.

themagazineshop.com

THE BENEFITS OF SUBSCRIBING!

- ✓ Never miss an issue
- ✓ Free delivery direct to your door
- ✓ Unlimited access to news and views from the paddock
- ✓ Access to subscriber-only analysis and comment

This offer is open to UK residents only. If you require any assistance following the purchase of your subscription, then you can speak to a member of our customer service team on 01795 592 974, calls are charged at local rate. Overseas rates are available on +44 (0) 1795592 974. Please allow 35 days for delivery of your gift and first issue. The gift will be sent under separate cover from the magazine. Should we run out of gifts, you may be offered an alternative gift – there is no cash alternative. To activate your AUTOSPORT online account visit <https://secure.autosport.com/subs/activate.php> and enter your activation code (your personal magazine subscriber number which will be included in your welcome email/letter) along with your email address to access your extra AUTOSPORT content. Direct Debit rates are valid for one year after which they are subject to change – should prices change we will inform you in writing. We ask that you enter into a Direct Debit agreement with the intention that your subscription will continue for a minimum period of 12 months, even if the frequency of payment is for a shorter period, however, you will still have the right to cancel your Direct Debit in accordance with Direct Debit Guarantee. Should you wish to cancel your subscription it will be cancelled on expiry of the current term which will not be refundable, other than in exceptional circumstances. If a gift is included as part of the subscription offer we reserve the right to request the return of the gift. Details of the Direct Debit Guarantee are available on request. Savings are based on the standard UK cover price of £3.60. Offer ends December 4 2014. Haymarket Media Group Ltd uses a best-practice layered Privacy Policy to provide you with details about how we would like to use your personal information. To read the full privacy policy please visit our website www.haymarket.com/privacy or call us on 08448 482 800. Please ask if you have any questions as submitting your personal information indicates your consent, for the time being, that we and our partners may contact you about products and services that will be of interest to you via post, phone, e-mail and SMS. You can opt-out at ANY time by emailing the datacontroller@haymarket.com or by calling 08448 482 800.

GT CUP OULTON PARK, OCTOBER 25 MSVR

Geddie is a Clutton for punishment

JIM GEDDIE AND MARCUS CLUTTON were the big winners as the curtain fell on a superb season for the GT Cup. While Geddie won the opening race in his McLaren MP4-12C to seal the overall title, Clutton took a hard-earned victory in the season finale with the Chevron GR8.

Along with the rest of the 29-car pack, Geddie had a lucky escape at the first corner of the first race. Iain Dockerill's Porsche got out of shape under braking and pushed Richard Chamberlain's Porsche 935 replica sideways. For a moment, the 935 virtually blocked the track but it then spun onto the grass and allowed the pack through.

In the confusion, Will Plant blitzed clear in his Porsche GT3 Cup but Geddie was soon in pursuit and, after a safety-car period, reeled in the leader and went ahead to settle the title contest in the best possible way.

"I just tried to avoid the carnage on the first lap: it was still damp in places and it was tricky," said Geddie. A mighty charge from way down the grid, after being caught out by mixed conditions in qualifying, earned Clutton second from Plant and



Clutton levelled the scores with Geddie in Ginetta/McLaren fight

Darren Nelson's Ferrari 458.

The start of the second race was chaotic as eight cars tangled in the midfield even before the first corner. The race was halted for a lengthy clear-up and then restarted over 15 minutes as the light began to fade.

From pole, Clutton shot away and had Geddie chasing hard for most of the race. The McLaren was stronger on the brakes and Geddie attacked

relentlessly until a backmarker gave Clutton the slender gap he needed to make sure of a fine victory. Nelson took third after a resolute defence against the similar Ferrari of Jamie Stanley.

RESULTS (14 LAPS) 1 Jim Geddie (McLaren MP4-12C) 25m27.687s (88.81mph); 2 Marcus Clutton (Chevron GR8) +11.501s; 3 Will Plant

(Porsche 997 GT3 Cup); 4 Darren Nelson (Ferrari 458); 5 Peter Jennings (Ferrari 458); 6 Phil Burgan (Audi R8 LMS). **Class winners** Plant; Nelson; Salih Yolcu (Ginetta G50). **Fastest lap** Clutton 1m39.264s (97.63mph). **RACE 2 (9 LAPS) 1 Clutton 14m58.342s (97.09mph); 2 Geddie +2.522s; 3 Nelson; 4 Jamie Stanley (Ferrari 458); 5 Iain Dockerill (Porsche 997 RSR); 6 Jennings. CW** Nelson; Plant; Andrew Bentley (Lotus Evora). **FL** Geddie 1m37.942s (98.94mph).



Vaulkhard leads Lines and Depper into Lodge

VAG TROPHY OULTON PARK, OCTOBER 25 MSVR

Vaulkhard takes the title

A WINNING RETURN FOR BTCC RACER Martin Depper and an emotional title for Harry Vaulkhard topped the VAG Trophy's deciding double-header.

The first race was soon red-flagged, and in a 10-minute restart Scirocco pilot Depper had time to reel in and pass the fast-starting Golf of Vaulkhard. But that was still enough for Vaulkhard to clinch the title. "I just wish my dad was here to see it," said Vaulkhard of his racing father Nigel, who died earlier this year.

Later, Vaulkhard got another flying start to lead all the way, chased by Stewart Lines's Scirocco. Depper had his engine let go at Hislop's after five

laps, and the dropped oil had a big outcome on the Class B title contest.

Mike Smith's Golf slid up the escape road, and Darren Bedford's similar car shot past to take the crown.

RESULTS (5 LAPS) 1 Martin Depper (VW Scirocco) 10m21.274s (77.99mph); 2 Harry Vaulkhard (VW Golf) +5.067s; 3 Stewart Lines (Scirocco); 4 Richard Morgan (Golf); 5 Rob Allum (Golf); 6 David Fairbrother (Scirocco). CW Allum. **FL** Morgan 1m59.848s (80.86mph). **RACE 2 (8 LAPS) 1 Vaulkhard 15m43.281s (82.19mph); 2 Lines +3.065s; 3 Fairbrother; 4 Morgan; 5 Len Simpson (VW Vento VR6); 6 James Pile (Golf). CW** Allum. **FL** Fairbrother 1m56.042s (83.51mph).

Mk2 GOLFS OULTON PARK, OCTOBER 25 MSVR

Tingle has Wits about him

JASON TINGLE CLAIMED VICTORY IN the opening Mk2 Golf race, but only by the smallest of margins – 0.016s – as Tom Witts dragged up alongside on the sprint to the line.

Josh Johnson couldn't go with them, but was a secure third, well clear of the rest of the 11-car field.

The second race was cut to just a 10-minute sprint following a lengthy clear-up after the GT Cup startline shunt. With the light beginning to fade, it was a five-lap dash and for four of those laps it seemed as though Tingle was going to double up. But as they

headed for Shell, Witts slipped ahead and won by 0.4s.

Simon Tomlinson twice won Class B but just lost the class title to Alex Nuttall.

● Paul Lawrence

RESULTS (8 LAPS) 1 Jason Tingle 16m48.003s (76.91mph); 2 Tom Witts +0.164s; 3 Josh Johnson; 4 Stewart Lines; 5 Adam Hance; 6 Pete Milne. CW Simon Tomlinson. **FL** Tingle 2m04.257s (77.99mph). **RACE 2 (5 LAPS) 1 Witts 10m31.558s (76.72mph); 2 Tingle +0.409s; 3 Johnson; 4 Hance; 5 Tomlinson; 6 Matthew Petts. CW** Tomlinson. **FL** Witts 2m03.724s (78.33mph).



Tingle (left) battles it out with Johnson

WIN

A VIP EXPERIENCE AT WALES RALLY GB

THE PRIZE FOR AN AUTOSPORT READER AND THEIR GUEST:

- A pair of guest passes for all Forest stages
- Exclusive Service Park tour of M-Sport and hospitality
- Meet Elfyn Evans

The final round of the FIA World Rally Championship is Wales Rally GB (November 13-16), and with Welsh hero Elfyn Evans and Northern Irish star Kris Meeke among the frontrunners, there really could be a famous home win. Tickets are on sale via the Wales Rally GB website at walesrallygb.com.



**TO WIN ANSWER
THIS QUESTION:**

Who was the last UK driver to win Britain's round of the World Rally Championship?

- A) Roger Clark
- B) Colin McRae
- C) Richard Burns

...then go to
autosport.com/competition

Entries close at 11.59pm November 5, 2014.



TO ENTER VISIT AUTOSPORT.COM/COMPETITION

Terms and conditions 1. To enter visit autosport.com/competition. 2. Entries close 11.59pm on November 5, 2014. 3. Prize(s) are stated in the competition. 4. Open to UK residents aged 18 or over. 5. No cash alternative. Prizes are non-transferable. 6. Only one entry per person. 7. For full terms and conditions see autosport.com. 8 The Promoter is Haymarket Media Group, Teddington, Middlesex, TW11 9BE.

NATIONAL RESULTS ROUND-UP

SNETTERTON
OCTOBER 25-26, MSVR



ATOM CUP (4 LAPS) 1 Martin James 8m33.483s (83.25mph); 2 Andrew Smith +0.207s; 3 Ollie Taylor; 4 Nick Whitehead; 5 Marc Mercer; 6 Matthew Ellis.

Fastest lap Smith 2m05.724s (85.01mph).

RACE 2 (10 LAPS) 1 Smith 21m10.421s (84.13mph); 2 Whitehead +4.549s; 3 James; 4 Mercer; 5 Richard Marler; 6 Steven Endress. **FL** James 2m05.825s (84.94mph).

RACE 3 (10 LAPS) 1 James 21m11.092s (84.08mph); 2 Whitehead +0.100s; 3 Smith; 4 Mercer; 5 Taylor; 6 Marler. **FL** Whitehead 2m05.623s (85.08mph).

TRACKDAY TROPHY (19 LAPS) 1 Guy Pettit/Oliver Withington (SEAT Leon Supercopa) 46m41.278s (72.49mph); 2 Dan Abbitt/Ben Abbitt (Peugeot 306 Rallye) +14.715s; 3 Paul Ivens (Renault Clio); 4 Jeremy Hayman/Mark Penny (Vauxhall VX220); 5 Aaron Harding/David Slater (Renault Clio); 6 Gary Johnson/James Vowles (SEAT Ibiza R). **Class winners** Abbitt/Abbitt; Jason Jones/Tony Jones (Toyota MR2); Adrian Timpson/Colin Tester (Toyota MR2); Jonathan Shilcock (Ford Fiesta). **FL** Withington 2m17.511s (77.72mph).

TEAM TROPHY (26 LAPS) 1 Adam U'Ren/Ben U'Ren (SEAT Leon Cupra Cup) 1h00m22.470s (76.71mph); 2 Richard Preece/James Reed (Ginetta G20) +28.729s; 3 Darren Goes (SEAT Supercopa); 4 Chris Fryer/Chris Oakham (Mini Cooper S JCW); 5 Gerry Atkinson (SEAT Supercopa); 6 Marcos Burnett/William Burnett (BMW E36 M3). **CW** Fryer/Oakham; Burnett/Burnett; Will Jackson-Moore (Renault Clio); Simon Hogg/George Wright (Citroen Saxo). **FL** Preece 2m12.195s (80.85mph).

F3 CUP (BOTH 12 LAPS) 1 Henry Chart (Dallara F305) 21m39.554s (98.69mph); 2 Alice Powell (Dallara F307) +5.866s; 3 Louis Hamilton-Smith (Dallara F307); 4 Tristan Cliffe (Dallara F307); 5 Oliver Rae (Dallara F301); 6 Aaron Steele (Dallara F307). **CW** Rae; Geoffrey Hoodless (March 813). **FL** Chart 1m46.978s (99.90mph).

RACE 2 1 Chart 21m38.952s (98.73mph); 2 Powell +6.732s; 3 Hamilton-Smith; 4 Cliffe; 5 Rae; 6 Nick Robinson (Dallara F302). **CW** Rae; Hoodless. **FL** Cliffe 1m47.094s (99.80mph).

OULTON PARK
OCTOBER 25, MSVR

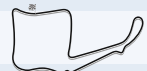

ALFA ROMEO OWNERS' CLUB (7 LAPS) 1 Tim Hayes (Alfasud Sprint) 16m28.212s (68.64mph); 2 Malcolm Jeffs (Alfasud Sprint) +8.513s; 3 Will Dick (GT TS); 4 Ron Davison (164); 5 Richard Leggett (Alfetta GTV); 6 Lukas Halusa (Giulia Sprint). **CW** Jeffs; Dick; Davison; Halusa. **FL** Dick 2m17.573s (70.44mph).

MASTERS ALLCOMERS (25 LAPS) 1 Mike Wilds/Steve Guglielmi (BMW CSL GT0) 50m02.775s (80.68mph); 2 Mark Wright/Dave Coyne (Ford Escort Mk2) +6.979s; 3 Mike Gardiner/Dan Cox (TVR Griffith); 4 Steve Dance (Ford Capri); 5 Graham Scarborough (Ford Capri); 6 Peter Ratcliff/Howard Dawson (Ford Capri). **CW** Gardiner/Cox; Nicholas King (Ford Mustang). **FL** Wright 1m52.233s (86.34mph).



Mike Wilds and Steve Guglielmi took their fire-spitting BMW to victory in the Masters allcomers

WALKER



Birkett Relay race had a few spills over six hours

JONES



As Sam Priest spins off, Jamie Going heads past at Brands in the Fiesta ST round

HAWKINS



Mark Penny's VX220 leads James Birch's Corsa early in Trackday Trophy at Snett

STYLES



Andrew Smith took a win in Atom Cup at Snetterton

STYLES

The new Sin GT Cup racer was badly damaged in this startline shunt at Oulton



WALTON



Teddington Studios, Broom Road, Teddington, Middlesex TW11 9BE, UK.
Tel: +44 (0) 20 8267 5804 Fax: +44 (0) 20 8267 5922
E-mail: autosport@haymarket.com Website: www.autosport.com

EDITOR
Charles Bradley ext.5889
charles.bradley@haymarket.com

DEPUTY EDITOR
Marcus Simmons ext.5807
marcus.simmons@haymarket.com

GROUP F1 EDITOR
Jonathan Noble ext.5810
jonathan.noble@haymarket.com

GRAND PRIX EDITOR
Edd Straw ext.5887
edd.straw@haymarket.com

F1 ASSISTANT EDITOR
Ben Anderson ext.5425
ben.anderson@haymarket.com

EDITOR AUTOSPORT.COM
Glenn Freeman ext.5309
glenn.freeman@haymarket.com

DEPUTY EDITOR AUTOSPORT.COM
Matt Beer ext.5811
matt.beer@haymarket.com

MANAGING EDITOR
Peter Hodges ext.5903
peter.hodges@haymarket.com

EXECUTIVE EDITOR
Stuart Codling ext.5835
stuart.codling@haymarket.com

RALLIES EDITOR
David Evans
david.evans@haymarket.com

ART EDITOR
Lynsey Row ext.5914
lynsey.row@haymarket.com

SENIOR DESIGNER
Michael Cavalli ext.5381
michael.cavalli@haymarket.com

PHOTOGRAPHS
LAT Photographic

ASSISTANT EDITOR
Scott Mitchell ext.5370
scott.mitchell@haymarket.com

GROUP PICTURE EDITOR
Peter Mills ext.5918
peter.mills@haymarket.com

AUTOSPORT.COM TECHNICAL TEAM LEADER
Geoff Creighton
geoff.creighton@haymarket.com

AUTOSPORT.COM DEVELOPER
Tomasz Trznadel
tomasz.trznadel@haymarket.com

OFFICE MANAGER
Joanne Grove ext.5804
joanne.grove@haymarket.com

SPECIAL CONTRIBUTORS

Gary Watkins
Henry Hope-Frost
Marcus Pye

Mark Glendenning
Dieter Rencken
Gary Anderson

Alan Eldridge
Pablo Elizaide

CORRESPONDENTS

ARGENTINA
Tony Watson

AUSTRALIA
Phil Branagan

AUSTRIA
Gerhard Kuntschik

BELGIUM
Gordon McKay

BRAZIL
Lito Cavalcanti

FINLAND
Esa Iloninen

GERMANY
Rene de Boer

GREECE
Dimitris Papadopoulos

ITALY
Roberto Chinchero

JAPAN
Jiro Takahashi, Len Clarke

NEW ZEALAND
Bernard Carpenter

RUSSIA
Gregory Golyshv

SOUTH AFRICA
Richard Asher

SPAIN
Raimon Duran

SWEDEN
Tege Torvall

USA
Jonathan Ingram,

David Phillips, Robin Miller, Jeremy Shaw

UK & EIRE
Jack Benyon, Jonathan Crawford, Dan Cross, Kerry Dunlop, Leanne Fahy, Paul Healy, Linda Keen, Jamie Klein, Mark Libbeter, Stephen Lickorish, Marc Ome, Graham Read, Hal Ridge, Peter Scherer, Ian Sowman, Oliver Tinson, Ian Trichmarsh, Matt Upton, Eddie Weider, Richard Young

ADVERTISING
Tel: +44 (0) 20 8267 5389
Fax: +44 (0) 20 8267 5850
E-mail: autosport.ads@haymarket.com

AD PRODUCTION
Tel: +44 (0) 20 8267 5588 Fax: +44 (0) 20 8267 5320

DISPLAY SALES MANAGER
Martin Lee ext.5389
martin.lee@haymarket.com

DISPLAY ADVERTISING
Gary Lee Hoebeck ext.5276
garylee.hoebeck@haymarket.com

Luke Ricketts ext.5961
luke.ricketts@haymarket.com

Don Rupal ext.5244
don.rupal@haymarket.com

CLASSIFIED SALES MANAGER
Jonathan Whitehead ext.5908
jonathan.whitehead@haymarket.com

CLASSIFIED ADVERTISING
Rachelle Francis-Dottin ext.5992 rachelle.francis-dottin@haymarket.com

James Hunter ext.5367
james.hunter@haymarket.com

Jamie Brooker ext.5271
jamie.brooker@haymarket.com

AUTOSPORT.COM SALES MANAGER
Alex Newberry ext.5551
alex.newberry@haymarket.com

ONLINE ADVERTISING
Leah Mimms ext.5846
leah.mimms@haymarket.com

Matt Simpkin ext.5820
matt.simpkin@haymarket.com

SPECIAL PROJECT SALES
James Robinson ext.5384
james.robinson@haymarket.com

ADVERTISING DIRECTOR
Matt Upton
matt.upton@haymarket.com

LICENSING DIRECTOR
Jim James

PRODUCTION MANAGER
Ailsa Donovan ext.5839
ailsa.donovan@haymarket.com

PRODUCTION CONTROLLER
Abbey Gunner
abbey.gunner@haymarket.com

SUBSCRIPTIONS
UK 0844 848887
OVERSEAS +44 (0)1795 592 974
EMAIL autosport@servicehelpline.co.uk

BACK ISSUES
Tel: 0844 848887

MARKETING MANAGER
Karen McCarthy ext.5658
karen.mccarthy@haymarket.com

LICENSING AND SYNDICATION
LICENSING MANAGER
David Ryan ext.5024

MANAGEMENT
GROUP DIRECTOR
Tim Bulley

GROUP COMMERCIAL DIRECTOR
Ben Guynan

GROUP EDITOR
Anthony Rowlinson

PUBLISHER
Stuart Williams

PUBLISHING MANAGER
Samantha Jempson

SPECIAL EVENTS MANAGER
Laura Coppin

DIGITAL SPECIAL PROJECT MANAGER
Simon Strang, ext.5093
simon.strang@haymarket.com

DIGITAL PRODUCT MANAGER
Simon Grayson, ext.5346
simon.grayson@haymarket.com

© 2014, HAYMARKET MEDIA GROUP LTD
Publishing, trade and further subscription details on www.autosport.com While due care is taken to ensure the contents of AUTOSPORT are accurate, the publishers and printers cannot accept liability for errors and omissions. Advertisements are accepted for publication in AUTOSPORT only upon Haymarket Media Group Ltd's Standard Terms of Acceptance of Advertising, copies of which are available from the Advertising Sales Department of AUTOSPORT.

EDITORIAL DIRECTOR
Mark Payton

CREATIVE DIRECTOR
Paul Harpin

STRATEGY AND PLANNING DIRECTOR
Bob McDowell

PUBLISHING DIRECTOR
Patrick Fuller

MANAGING DIRECTOR
David Prasher

CHIEF EXECUTIVE
Kevin Costello



When you have finished with this magazine please recycle it.



PEFC Certified
This product is certified by BSI to environmental standard ISO14001

haymarket BSI environmental standard ISO14001

THIS WEEK

LETTERS • BEST PICS • LATEST GEAR • ON TRACK & SCREEN • ONLINE

What you think of the motorsport news of the past week



Siffert in Rob Walker's Lotus, French GP 1969

F1 needs the privateers back

I am old enough to remember the 1969 French Grand Prix at Clermont-Ferrand, which had only 13 runners and riders following the withdrawal of BRM.

Three privateers bolstered the 13-car entry (Jo Siffert, Vic Elford and Silvio Moser), so the works teams accounted for 10 cars, Team Lotus running three of them.

Dominated by Jackie Stewart and Jean-Pierre Beltoise in Ken Tyrrell's Matras, the race was not much cop;

how could it have been?

There is obviously going to be a high degree of additional fallout further to the putting into administration of Caterham and Marussia, so the sooner a potential grid of perhaps 14 cars next year is seriously addressed the better.

Where are the likes of Rob Walker when you need them? Bring back privateers in Formula 1.

Jeremy Elliott, London

How many more series are going to rewrite their rules to attempt to prevent the best talent of the moment from dominating?

First, we saw it in NASCAR – the ultimate when it comes to the racing 'show'. Petrified of Jimmie Johnson's run of title success, they have constantly played with the rules for the Chase for the Championship play-off, which he and his team had mastered. Its most recent attempt seems to have worked in that regard, but now might produce a champion (Ryan Newman or Matt Kenseth) who hasn't won a race all season!

You'd have thought a world championship would be above such gimmicks, but the WRC seems intent on

avoiding Sebastien Ogier inheriting his namesake Loeb's title dominance. Ogier's complaints over the running-order rules, and the need for the championship leader to start stages first on the opening day of rallies, will be exacerbated next year as that will apply for the first two days of each event.

Surely the whole point of motor racing and rallying is that the best man/woman in the best-performing car wins... Or am I missing something here?

Dan Ashcroft
Norwich

What a fantastic weekend of motor racing, with great judgement among a horde of skilfully driven, low-rewing 1600cc single-seaters. No, I'm not talking

about Formula 1, but the Formula Ford Festival at Brands Hatch!

It may not be what it used to be, but the Festival still gives us brilliant sport – the perfect antithesis to the modern game.

For one can't wait for this weekend, when I'll watch an even bigger field of FF1600s at Silverstone in the Walter Hayes Trophy. Bring it on!

Thomas Curtis
London

With Carlos Sainz Jr, Alex Lynn and Pierre Gasly waiting in the wings, maybe Red Bull needs four F1 teams. Toro Rojo and Taureau Rouge, anyone? Edward Rainford
by email

In pictures

Images around the globe, from Spain to the UK via Japan and the USA



WHAT DID I GO AND DO THAT FOR? Estonian Karl Kruuda almost rolled his Fiesta end over end during Rally Spain, but crashed it into a ditch instead. Here, he calls on spectators to tow him out – they succeeded too!

BETTINO/GETTY



A GREAT SILVERSTONE SEND OFF SIR JACK Over 400 people attended a memorial service for Sir Jack Brabham at Silverstone last week, with the Brabham family joined by Sirs Stirling Moss and Jackie Stewart, plus John Surtees and Tony Brooks among others. The event raised money for Kidney Research UK – click on www.justgiving.com/SirJackBrabham

JAKOBEBREY

HAVING YOUR CAKE & EATING IT Argentina's Jose Maria Lopez wrapped up the World Touring Car Championship at Suzuka in Japan on Sunday, and then celebrated in bake-off style



IT'S OLD FATHER TIME FOR JUNIOR Dale Earnhardt Jr grew up with his dad's Martinsville trophy ticking in their front room. Now he's got his own prize example for winning at the tiny 'paperclip' oval



In the shops

Desirable new releases

250 GTO HAYNES MANUAL

£25 – haynes.co.uk

If you're one of the rare and hugely fortunate owners of a Ferrari 250 GTO this Owners' Manual in the style of the world-famous Haynes superguides will come in handy. If you're not, it serves to prove what a staggering bit of kit it is. Packed with period pics and technical illustrations, it's the best under-the-skin guide to this iconic 1960s GT car there is.

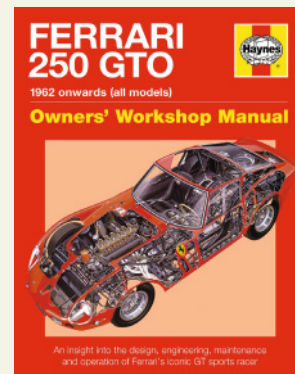

ASTON MARTIN RACING CAP

£19.95 – autosport.com/shop

The recent 10th anniversary of the Prodrive-run Aston Martin Racing squad has spawned a retro-look collection of official gear, including this baseball cap. Featuring the AMR logo and #59 branding in deference to the firm's 1959 Le Mans 24 Hours and World Sportscar title success, the cap has a curved peak and metal clasp for size adjustments.



DUNCAN HAMILTON BOOK

£8.99 – autosport.com/shop

Re-released in paperback, *Touch Wood* remains a definitive autobiography – in any sphere. Pilot/racer Duncan Hamilton was an extraordinary character and we'll leave it at that. You simply have to read this *Boy's Own* tale of adventure that's quite unlike any other. You won't get stories as juicy as this for nine quid anywhere else.

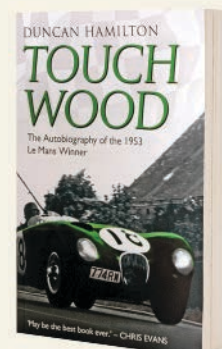

WHAT'S ON

ON TRACK IN THE UK

SILVERSTONE

November 1-2

HSCC

silverstone.co.uk

The now legendary Walter Hayes Trophy has a 114-strong entry for 2014, and it's packed with the cream of the current Formula Ford 1600 scene, along with great names from the recent and distant past. Two days of frantic heats builds up to a grand final invariably settled with a last-lap slipstreaming battle. After taking command of the Formula Ford Festival, James Raven has his sights on becoming the first man to win both trophy events in the same year. Peter Dempsey, Joey Foster, Scott Malvern, Jayde Kruger, Wayne Boyd, Stuart Gough, Jonny McMullan, Ciaran Haggerty and Niall Murray are just some of those out to stop him. A variety of allcomers races will also feature.

BRANDS HATCH

November 1-2

MSVR

brandshatch.co.uk

Brands Hatch rounds off its 2014 racing season with its annual truck racing and fireworks spectacular. Leading the supporting cast at the



There'll be fireworks on and off track at Brands' end-of-season truck spectacular

family-friendly weekend are Pickups and Legends.

SNETTERTON

November 1

MSVR

snetterton.co.uk

The Lotus Cup UK championships will be decided after the Norfolk sunset, with the double-points enduro finale running into Saturday evening. That's the showpiece of a day of Lotus festivities that also includes a demonstration of one of the marque's Formula 1 cars and a parade lap for Lotus road-car owners. Non-

Lotus variety comes from the Track Attack Race Club's Autumn Trophy for Japanese and French machinery.

DONINGTON PARK

November 1

BRSCC

donington-park.co.uk

Britcar completes its 2014 season with a 90-minute Saturday night race for its Endurance classes, which will also compete in daylight earlier on the bill. The Britcar Trophy Series has four counters as well, with a pair of Superkart thrashes providing contrast.



Walter Hayes Trophy brings together FF acers past and present

ON TRACK AROUND THE WORLD



It's F1 Texas-style this weekend

CORATE/LAT

PORSCHE SUPERCUP

Rd 9/9
Austin, Texas, USA
November 1-2
porsche.com

WORLD ENDURANCE CHAMPIONSHIP

Rd 6/8
Shanghai, China
November 2
fiawec.com

BLANCPAIN SPRINT SERIES

Rd 7/7
Baku, Azerbaijan
November 2
blanpain-gt-series.com



GT Open series concludes in Spain

FOTOSPEEDY

NASCAR SPRINT CUP

Rd 34/36
Texas Motor Speedway, USA
November 2
nascar.com

V8 STOCK CARS

Rd 10/12
Taruma, Brazil
November 2
stockcar.com.br

INTERNATIONAL GT OPEN

Rd 8/8
Barcelona, Spain
November 1-2
gtopen.net

EUROFORMULA OPEN

Rd 8/8
Barcelona, Spain
November 1-2
euroformulaopen.net

NZ SUPER TOURERS

Rd 2/7
Hampton Downs, New Zealand
November 1-2
nzsupertourers.co.nz

UNITED STATES GRAND PRIX

Formula 1 World Championship
Rd 17/19
Austin, Texas, USA
November 2
f1.com

Your guide to the best events taking place in the UK and around the world – plus TV and online

ON TELEVISION

THURSDAY OCTOBER 30

1600-1645 Sky Sports F1 LIVE
US GP: Drivers' press conference
2100-2315 Sky Sports F1
Classic F1: 2007 US GP
2235-2340 Motors TV
WRC: Spain highlights

FRIDAY OCTOBER 31

1445-1650 Sky Sports F1 LIVE
US GP: Free practice 1
1650-1845 Sky Sports F1
Classic F1: 1981 US GP Long Beach
1845-2100 Sky Sports F1 LIVE
US GP: Free practice 2
2100-2145 Sky Sports F1 LIVE
US GP: Teams' press conference
2145-2245 Sky Sports F1
1977 F1 season review

SATURDAY NOVEMBER 1

1350-1450 Motors TV LIVE
Euroformula Open: Barcelona race 1
1400-1545 BT Sport 2 LIVE
GT Open: Barcelona race 1
1450-1625 Motors TV LIVE
GT Open: Barcelona race 1
1445-1615 Sky Sports F1 LIVE
US GP: Free practice 3
1615-1700 Sky Sports F1
Classic F1: US GP Long Beach 1982
1700-1945 Sky Sports F1 LIVE
US GP: Qualifying
1930-2205 Motors TV LIVE
NASCAR Nationwide: Texas
2100-2145 Eurosport LIVE
Porsche Supercup: Austin race 1
2200-2315 BBC 2
US GP qualifying highlights

SUNDAY NOVEMBER 2

0230-0945 Motors TV LIVE
WEC: Shanghai
0500-0630 BT Sport 2 LIVE
BSS: Baku qualifying race
0730-0900 Eurosport LIVE
WEC: Shanghai
0900-1130 BT Sport 2 LIVE
BSS: Baku championship race
1050-1150 Motors TV LIVE
Euroformula Open: Barcelona race 2
1150-1325 Motors TV LIVE
GT Open: Barcelona race 2
1340-1750 Motors TV
Blancpain Endurance season review
1715-1800 Eurosport 2
Porsche Supercup: Austin race 2
1750-2100 Motors TV
British GT season review
1900-2230 Sky Sports F1 LIVE
US Grand Prix
1900-2330 Premier Sports LIVE
NASCAR: Texas
2230-0000 BBC1
US GP highlights

MONDAY NOVEMBER 3

0015-0045 Sky Sports F1
Classic F1: US GP 1990
0945-1045 Eurosport
WEC: Shanghai race
2100-2140 Sky Sports F1
Classic F1: US GP West 1983

TUESDAY NOVEMBER 4

2115-2145 Sky Sports F1
Classic F1: Monaco GP 1982
2220-2250 Eurosport
BSS: Baku highlights

ONLINE

HOT ON THE WEB THIS WEEK

YouTube **SURFERS PARADISE V8 SUPERCARS HOT LAP**

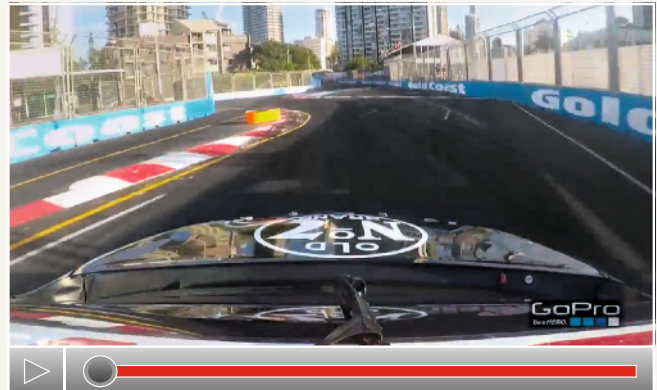

SEARCH FOR: Rick Kelly – Castrol EDGE Gold Coast 600 GoPro Hot Lap (1:40)
Nissan ace Rick Kelly talks you through a quick lap of Surfers Paradise in his Altima, as he hugs the walls and bashes the chicanes. There are cameras pointing in all directions to give you multiple perspectives of what it's like to drive.

AUTOSPORT+

Is Formula 1 in crisis? Our paddock experts have their say

With the dust yet to settle on the troubled situations faced by Caterham and Marussia, AUTOSPORT's team of journalists – plus ex-F1 technical director Gary Anderson – give their take on the financial state of the sport. We'll also be covering the US GP weekend live.

GET AUTOSPORT ON THE MOVE

IN THE IPAD ISSUE THIS WEEK

- HIGHLIGHTS FROM V8 SUPERCARS AND NASCAR, PLUS US GP PREVIEWS
- ON SALE ALL OVER THE WORLD FOR ONLY £2.99

DOWNLOAD IT NOW FROM AUTOSPORT.COM



Revved up over what's on the box

Ring, ring... Ring, ring...

"G'day!"

"Hello, stereotypical Aussie blokes from the Fosters adverts, it's Rewved Up."

"Rewol!"

"Given your strangely self-appointed role as Australian agony uncles handing out advice to Brits about trivial social conundrums on a purely altruistic basis, should I have woken up at three o'clock in the morning to watch live coverage of the V8 Supercars Gold Coast on Sunday morning on ESPN, or was I right to enjoy the vagaries of the switch from British Summer Time to GMT to enjoy an extra hour in bed to watch it delayed on Motors?"

While I'm sure the fictional surfer dudes would have dispensed their urban wisdom

with a mixture of wisecracks and Antipodean colloquialisms, I elected not to trust the ESPN/BT Sport axis after their recently tardy joining of the Bathurst 1000 (lap 16!) and instead opted for the

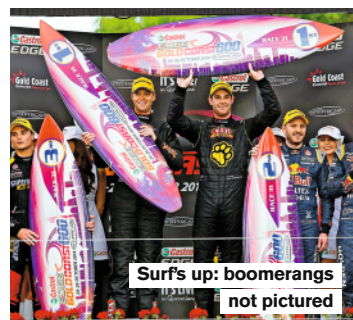

Surf's up: boomerangs not pictured

KALISZ/GETTY

snoozier option of waiting for Motors TV to replay the race at midday.

The coverage is identical: taking 7 Sport's expert broadcast along with a world-feed commentator joining the gaps for when Crompo (Neil Crompton) and Skaife (Mark Skaife) in the commentary box took a break (in my head this involves them cracking open tinnies and throwing another shrimp on the 'barbie'). While ex-racers don't always make great transitions to broadcasters, here's an example of how it can work superbly.

It's also a vagary of Australia's premier tin-top series that its race formats are almost seasonal, as the autumn brings the three long-distance events in Sandown, Bathurst and Surfers. It's quite an

investment, whether you're in the same time zone or not, to watch a pair of two-hour events – especially as the international co-driver quota has waned.

But what you are guaranteed in V8 Supercars is plenty of close racing on the track, and race strategy expertly explained by pitlane guru Mark 'Larko' Larkham, who sets new standards in poking his nose into teams' business and, unlike some pitlane reporters we could mention, knows his stuff inside out.

In terms of enthusiasm and expertise, not to mention the plethora of on-boards, kerb cams, helicopters and speed shots, is V8 Supercars the best-served motorsport series on the planet? Good call!

Revved Up

Scott Maxwell

“Donohue stormed to our pit to throttle me. He knew I’d snookered him”

■ Daytona 24 Hours ■ February 1-2 2003 ■ Multimatic MDP1-Ford ■ Debut pole position and win



Hastily built Multimatic took pole and stayed out of trouble to win the race

PHILLIPS/LAT

I’VE BEEN RACING WAY TOO long and I’ve forgotten more races than I can remember so it’s hard to pick a specific Race of My Life. So I thought I’d put a twist on what is my favourite column in AUTOSPORT. Rather than a race I’ve selected a couple of memorable pole positions, both from the 24 Hours of Daytona.

The first, in 2001, came when Toronto brothers Klaus and Harry Bytze entered two Porsche GT1 Evos to take on the factory Corvettes in GT1. I joined Canadian ‘stars’ Richard Spenard and David Empringham.

The car was one of the easiest I’ve ever driven and I got the nod to qualify. We were expected to be quick but no challenge to the factory Vettes, led by fellow Canadian Ron Fellows and Dale Earnhardt Sr and Jr.

We were happy to be P2 towards the end of the session, splitting the Corvettes. I thought I’d have one more go, ignoring my braking markers and scaring myself to death! As I crossed the line my radio came to life with the team telling me we got pole!

The Corvette group were stunned that this little team from Canada spoiled their day! So that was a great moment, but of course Corvette won the race in the end – we ran second until mid-race and gearbox failure. Sadly, that was also Earnhardt’s last finish as he was killed two weeks later.

The other one I remember fondly is from 2003. It was the debut of the Daytona Prototype, and Multimatic

had designed and built a car in under three months. Well, it ran, but it had only had a basic shakedown. And it was evil – you drove in fear, just trying to keep it on the road.

My team-mates [Empringham and David Brabham] and I tried to make it driveable, but in practice we each did a few laps, jumped out and tried to hide so that someone else had to get in! Again I was nominated to qualify

as neither Brabs or Emp wanted to – they’re both a lot smarter than me.

I went out and was in front of David Donohue, the favourite to grab pole in the Brumos Porsche DP. On our first out-lap I let him by and as we began the first flying lap I stayed about a half second behind him. I drove like mad to stay close in the infield where he was quicker, but I then drafted him all the way around the banking. On the long run down to the start/finish line, I pulled out of his draft and went past him. Pole!

David, who’s a friend, was irate. He stormed over to our pit to throttle me! He knew I’d snookered him.

We had very low expectations for the race but the car was very solid, and in the end that won us the very first DP race. We weren’t fast, we just kept out of trouble – which was the plan from the start. So Brabs, Emp and I won our Rolex watches and swore we’d never set foot in that car again – until it was sorted! *Scott Maxwell was talking to Henry Hope-Frost*

PROFILE



DOLE/LAT

CANADIAN SCOTT MAXWELL

began in single-seaters, winning titles in Formula Vee and FF1600. He moved to sportscars in the mid-1990s and has competed in Grand-Am and the American Le Mans Series. His CV boasts a class win at Le Mans in 2000 and victory in the first Daytona Prototype race at Daytona in ’03. Now 50, he still races in the US-based SportsCar Challenge in a Ford Mustang.

NEXT WEEK US GRAND PRIX REPORT
Plus: Shanghai WEC & Baku Blancpain finale

CONFERENCE CENTRE
ENGINEERED TO INSPIRE

WILLIAMS

The award-winning Williams Conference Centre is a state of the art conferencing facility that never fails to impress.

Located at the home of leading Formula One team Williams in Grove, Oxfordshire, the Williams Conference Centre offers a secure environment in which to meet, inform, discuss, educate and celebrate.

Our 10 multi-purpose event rooms can accommodate up to 200 guests and afford excellent flexibility within modern and inspiring surroundings.



T +44 (0) 1235 777900
E CONFERENCES@WILLIAMSFI.COM
W WILLIAMSCONFERENCECENTRE.COM
FACEBOOK.COM/WILLIAMSCONFERENCECENTRE
@WILLIAMSCONFCTR



WTCC 2014

CITROËN

WORLD

CHAMPION

MANUFACTURER*

TITLE

* Subject to the official publication of the results by the FIA.

**1ST SEASON AND 1ST WTCC MANUFACTURERS'
WORLD CHAMPION TITLE***

After 8 World Rally Championship titles, Citroën wins in its first ever season the Manufacturer World Touring Car Championship title. By imposing itself on the tracks the world over, the Citroën C Ellysée proved once again Citroën's technological expertise.

Discover more at www.citroen.co.uk

CRÉATIVE TECHNOLOGIE

