

F1 REVIEW AND **AUTOSPORT AWARDS SPECIAL**



AUTOSPORT

F1 2017 Review

- **Top 10 drivers**
- **How Lewis made it four**
- **Inside Ferrari's new approach**



HAMILTON AND PIQUET TOP OUR AWARDS

MARC MARQUEZ
MOTOGP WORLD CHAMPION

LEVI SHERWOOD
RED BULL X FIGHTERS CHAMPION

ELI TOMAC
AMA MOTOCROSS CHAMPION

SAM SUNDERLAND
DAKAR RALLY CHAMPION

JONATHAN REA
WORLD SUPERBIKE CHAMPION

AARON GWIN
DOWNHILL WORLD CUP CHAMPION

TIMO BERNHARD
BRENDON HARTLEY
EARL BAMBER
WORLD ENDURANCE CHAMPIONS

LUCAS DI GRASSI
FORMULA E WORLD CHAMPION

PAULS JONASS
MOTOCROSS 2 WORLD CHAMPION

JEREMY MCGRATH
LUCAS OIL OFF-ROAD CHAMPION

GEORGE RUSSELL
GP3 CHAMPION

PABLO QUINTANILLA
CROSS COUNTRY RALLY CHAMPION

SHANE BYRNE
BRITISH SUPERBIKE CHAMPION

KAILUB RUSSELL
GNCC CHAMPION

LANDO NORRIS
FIA FORMULA 3 CHAMPION

WILLIAM BYRON
XFINITY SERIES CHAMPION

TONI ELIAS
MOTOAMERICA SBK CHAMPION

SAMI TAOUFIK
CIKFIA KARTING CHAMPION

RENE RAST
DTM CHAMPION

SCOTT SPEED
GLOBAL RALLYCROSS CHAMPION

TONI BOU
TRIAL WORLD CHAMPION



ONE GOAL
ONE VISION

ALPINESTARS PROTECTS
2017 WORLD CHAMPIONS





THE BEST & LATEST TV & MOVIE MERCHANDISE



Get **15% discount*** with your
next order at emp.co.uk
with this code: **AUTOD**

*minimum order £40.

visit us at
emp.co.uk



Celebrating the best of motorsport in 2017

THERE WERE SO MANY STORIES DURING THE 2017 Formula 1 season that we've ended up with our biggest review issue for quite a few years this week.

The main storylines, of course, were Ferrari's renewed challenge to Mercedes and the beefier and faster cars, following extensive changes to the aerodynamic regulations.

A couple of Ferrari failures and moments of madness from Sebastian Vettel gave the initiative to Lewis Hamilton, who put in arguably his greatest F1 campaign yet to take his fourth world title. We delve into the detail of the contest, as well as the many successes and failures experienced up and down the field.

Beyond exploring the hows and whys of the 2017 F1 battles, we also celebrate the winners from the Autosport Awards last weekend. Stars of the sport turned out in force, including World Rally champion Sebastien Ogier, Polish hero Robert Kubica and new Sauber F1 driver Charles Leclerc. The night reached its climax with a lifetime achievement award presented to emotional triple world champion Nelson Piquet, who was joined on stage by members of his family and former Brabham men Gordon Murray and Herbie Blash.

Many of the awards were voted for by you, the readers, which really means something to those involved. As ever, we thank you for your participation, and for providing a very worthy list of 2017 winners.



KEVIN TURNER EDITOR

kevin.turner@autosport.com

@KRT917



COVER IMAGES
Dunbar/LAT,
Etherington/LAT,
Mauger/LAT,
Portlock/LAT

PIT+PADDOCK

- 6** Sauber secures Alfa Romeo deal
- 8** Button on his 2018 Super GT drive
- 10** Fifth Column: Nigel Roebuck
- 15** In the paddock: Kevin Turner
- 16** Feedback: your letters

FORMULA 1 2017 REVIEW

- 25** The fight we all wanted to see
- 36** Top 10 F1 drivers of 2017
- 43** Team bosses' top 10
- 44** Why 2017 was just the start for Ferrari
- 48** Bottas on his first year at Mercedes
- 50** Did the new tech regulations work?
- 54** Red Bull's great missed chance
- 58** The final McLaren-Honda disaster
- 60** Why Alonso is still a powerful force
- 62** Force India's civil war
- 64** The 2017 rookies speak out
- 66** Gary Anderson's technical analysis
- 76** Renault's road to recovery
- 78** Dieter Rencken's political review
- 82** Top stories on autosport.com
- 84** We rate the GPs on the 2017 calendar
- 86** Season statistics
- 90** Top five race drives of the year

REPORTS

- 92** Bird and Rosenqvist top FE openers
- 97** Volvo's Bjork snatches WTCC crown

AUTOSPORT AWARDS

- 98** All the 2017 winners you voted for
- 117** Autosport Williams Engineer of the Future
- 118** McLaren Autosport BRDC Award

CLUB AUTOSPORT

- 133** Road to Indy Shootout revamp
- 134** HHC reveals expanded GT4 line-up
- 137** Humble Pye: the voice of club racing

FINISHING STRAIGHT

- 138** What's on this week
- 140** From the archive: 1981 Monaco GP
- 142** Have-a-go hero: Martin Brundle

AUTOSPORT SUBSCRIPTION OFFER

- 116** Special Christmas deal

FORMULA 1

Leclerc promoted as Sauber links up with Alfa Romeo

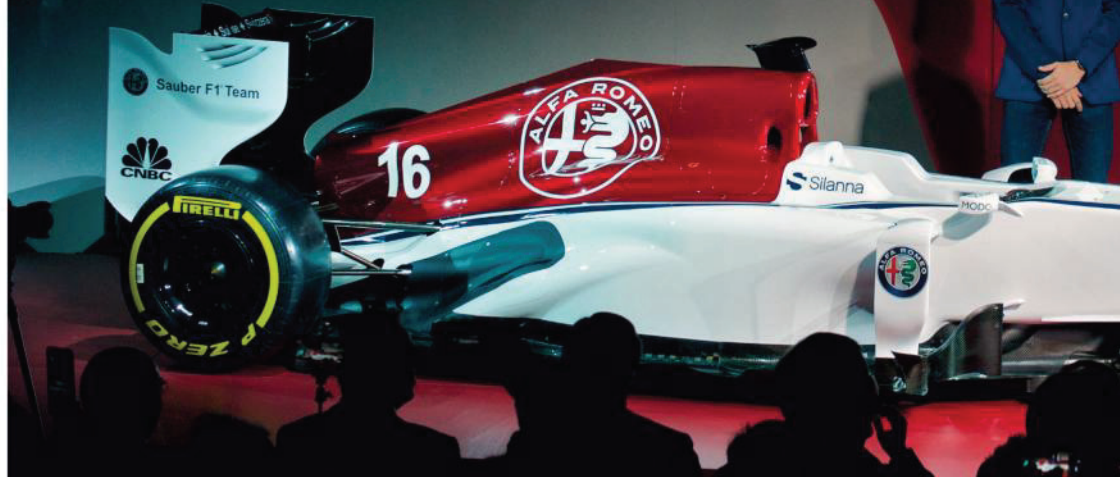

FORMULA 2 SENSATION CHARLES LECLERC will race in Formula 1 next season with Sauber, which will bring Alfa Romeo back to the pinnacle of the sport for the first time since the 1980s.

Ferrari protege Leclerc had been expected to get a seat following his domination of F2 this season. The other seat was less certain, with the incumbent Marcus Ericsson finding himself in a fight with Ferrari-supported Antonio Giovinazzi as the Prancing Horse weighed up the possibility of making Sauber its junior team.

But although Sauber announced a deal for closer ties with engine supplier Ferrari next season, through a partnership that brings back the Alfa brand to F1, Ericsson's links with Sauber's owners ensured he kept his seat for a fourth year. "Marcus is an experienced Formula 1 driver, who knows the procedures and the team well, having worked together for the past three years," said Sauber boss Fred Vasseur. "He is a team player, and has a very positive attitude.

"Charles has proven his talent in several racing series. He had the chance to drive in four FP1 sessions and two tyre tests for us this season, and convinced the team with his professionalism and charisma. I look forward to going into 2018 with this driver pairing, and I am convinced that they will complement each other very well."

Giovinazzi will be the team's reserve driver for next year, as well as fulfilling the role for Ferrari, with the Italian squad keen to find him a race seat in the future.

The Alfa deal is more than just a title-sponsorship arrangement. Sauber already had a contract in place to receive 2018-spec engines, having run year-old units this year. The deal has been expanded to include "strategic, commercial and technological cooperation" and "the exchange of engineering and technical knowhow".

Sauber chairman Pascal Picci said Alfa was an ideal partner for his team. "Alfa Romeo has a long history of success in grand prix racing, and we are very proud that this internationally

renowned company has chosen to work with us for its return to the pinnacle of motorsport," he said. "Working closely with a car manufacturer is a great opportunity for the Sauber Group to further develop its technology and engineering projects. We are confident that together we can bring the Alfa Romeo Sauber F1 Team great success, and look forward to a long and successful partnership."

Sauber had another tough season, finishing the year 10th in the constructors' championship for the third time in four years. Monisha Kaltenborn left her role as team principal, with Vasseur taking over. The plan to run Honda engines in 2018 was abandoned, with Vasseur working hard to repair the relationship with Ferrari and create a new deal that he hoped would give the team some much-needed stability, as well as improved performance and reliability. The addition of the Alfa partnership also generates credibility, while Ferrari chairman Sergio Marchionne gets an opportunity to boost awareness of one of his brands.

"This agreement with the Sauber F1 team is a significant step in the reshaping of the Alfa Romeo brand, which will return to Formula 1 after an absence of more than 30 years," said

Farina was first world champion with Alfa in 1950



LAT IMAGES



FORMULA 1

Williams in dilemma over 2018 driver line-up

WILLIAMS IS UNCERTAIN WHO IT will sign to drive alongside Lance Stroll next season after results from last week's Abu Dhabi Pirelli tyre test proved inconclusive.

The team ran Robert Kubica and ex-GP2 ace Sergey Sirotkin during the two-day test at Yas Marina, gathering data on both long and short-run pace as well as evaluating how they worked with the team.

Kubica was considered the frontrunner to get the seat and, while he still holds the edge, his performance was such that Williams remains unsure whether to take him.

Kubica says that 90% of his F1 driving ability is the same as before he suffered life-threatening injuries in a rally crash in 2011. He has undergone an intensive physical-training regime and had tests with

Renault and Williams in a bid to return to F1 next season. Williams has said there are no concerns that the Pole's injuries will affect his ability to race, but there remains questions over his performance.

Williams plans to hold a series of meetings this week, with both Kubica and Sirotkin visiting the factory for analysis of the test. The team hopes to make a decision in the coming weeks.

Kubica and Sirotkin also face competition from ex-Toro Rosso and Red Bull driver Daniil Kvyat. It is believed that the trio have very similar financial packages. Williams reserve driver Paul di Resta also has financial backing but is considered to be an outside bet for the seat.

LAWRENCE BARRETTO

Marchionne. "A storied marque that has helped make the history of this sport, Alfa Romeo will join other major automakers that participate in Formula 1. The brand itself will also benefit from the sharing of technology and strategic knowhow with a partner of the Sauber F1 team's undisputed experience."

Alfa has not been involved in F1 since its works team project of 1979-85 – although Osella continued to use its turbo engines until '88, and has not had a high-profile motorsport programme since its touring car efforts of the early 2000s. It dominated the first two years of the world championship, taking Nino Farina and Juan Manuel Fangio to the 1950 and '51 titles. It was also a race winner as an engine supplier to Brabham in the late '70s.

The Alfa Romeo Sauber announcement means Pascal Wehrlein's last remaining hope of securing a seat on next year's grid lies with Williams. But it is believed that Wehrlein is now a long-shot to get the drive. Williams is still considering its options, with Robert Kubica holding the edge (see right), ahead of Russian duo Sergey Sirotkin and Daniil Kvyat, and Williams reserve Paul di Resta.

LAWRENCE BARRETTO

Clockwise from top left: de Adamich used Alfa power in McLaren in 1970; Brabham had Alfa engines from 1976-79, here with Pace; Osella (Ghinzani pictured) used Alfa turbos in 1980s; works Alfa team, here with Giacomelli, raced from 1979-85

F1 TESTING DAY 1 YAS MARINA (UAE), NOVEMBER 28

POS	DRIVER	TEAM	TIME	GAP	LAPS
1	Kimi Raikkonen	Ferrari	1m37.768s	-	99
2	Daniel Ricciardo	Red Bull-Renault	1m38.066s	0.298s	109
3	Lewis Hamilton	Mercedes	1m38.551s	0.783s	136
4	Romain Grosjean	Haas-Ferrari	1m39.270s	1.502s	137
5	Lance Stroll	Williams-Mercedes	1m39.580s	1.812s	29
6	Fernando Alonso	McLaren-Honda	1m39.762s	1.994s	115
7	Nico Hulkenberg	Renault	1m39.803s	2.035s	85
8	Nikita Mazepin	Force India-Mercedes	1m39.959s	2.191s	90
9	Robert Kubica	Williams-Mercedes	1m41.296s	3.528s	100
10	Sean Gelael	Toro Rosso-Renault	1m41.428s	3.660s	117
11	Marcus Ericsson	Sauber-Ferrari	1m41.681s	3.913s	97
12	Oliver Turvey	McLaren-Honda	1m41.914s	4.146s	105

F1 TESTING DAY 2 YAS MARINA (UAE), NOVEMBER 29

POS	DRIVER	TEAM	TIME	GAP	LAPS
1	Sebastian Vettel	Ferrari	1m37.551s	-	118
2	Valtteri Bottas	Mercedes	1m38.490s	0.939s	141
3	Max Verstappen	Red Bull-Renault	1m38.736s	1.185s	132
4	Sergio Perez	Force India-Mercedes	1m38.818s	1.267s	52
5	Esteban Ocon	Force India-Mercedes	1m39.148s	1.597s	72
6	Carlos Sainz Jr	Renault	1m39.444s	1.893s	109
7	Robert Kubica	Williams-Mercedes	1m39.485s	1.934s	28
8	Stoffel Vandoorne	McLaren-Honda	1m39.782s	2.231s	105
9	Kevin Magnussen	Haas-Ferrari	1m39.810s	2.259s	124
10	Sergey Sirotkin	Williams-Mercedes	1m39.947s	2.396s	86
11	Charles Leclerc	Sauber-Ferrari	1m40.666s	3.115s	149
12	Lando Norris	McLaren-Honda	1m41.714s	4.163s	118
13	Brendon Hartley	Toro Rosso-Renault	1m43.345s	5.794s	61
14	Pierre Gasly	Toro Rosso-Renault	1m44.827s	7.276s	63



Q&A

JENSON BUTTON SUPER GT ROOKIE



Jenson Button confirmed at last weekend's Honda Thanks Day at Motegi that he will race an NSX full-time in Super GT next season.

How long have you wanted to race in Super GT?

It all started here [Motegi], at the end of 2006. I spoke

to Yamamoto-san from Honda and said I'd love to have a go in a Super GT car at the Thanks Day. I didn't actually drive on the day, but they gave me half a day's testing and it was a great experience. That led me to saying that I'd like to do the Suzuka 1000km, which I did [this year], and I really enjoyed it, so here we are. Towards the end of this year Yamamoto-san asked me if I'd like to do a full year of racing, and I said I'd love to do that. This year off from Formula 1 has been the best thing I possibly could have done because my love for racing is back. The race I did in August was so exciting, there was so much fighting, so much overtaking, and it was also really challenging – there's a lot of competition between the manufacturers, and a lot of talented drivers, which is what you need in a sport. That's what gets you excited, that competition.

We understand there was a possibility of you driving in IMSA with Penske and Honda. Why did you not do that as well?

We talked, but I was thinking about the endurance races, because I wanted to do Daytona. But it was tricky fitting it in with Super GT because you'd be all over the place during the season, flying between the US and Japan, and the testing schedules don't fit either. We test a lot in Super GT at the start of the year and you can't do both, really. I wanted to do one thing properly – I didn't want to come into a season and over-race. Eight races [in Super GT] isn't a lot but it's the perfect amount to get you back into racing again.

STUART CODLING



FORMULA 2/GP3

Ferrari junior Ilott joins ART for GP3

NEW FERRARI DRIVER ACADEMY recruit Callum Ilott will race for GP3 powerhouse ART Grand Prix in 2018.

Ilott, the first Briton to join the Ferrari scheme, switches from the Formula 3 European Championship, in which he finished fourth this season before winning the qualification race for last month's Macau Grand Prix.

"Together with the FDA, we made the decision to do GP3 with ART and I'm really happy with this as the first step in our partnership," said Ilott (below). "ART is a very professional team with a proven track record in GP3 and I'm hugely excited to start working with them. To be selected by ART for one of its much-coveted seats is a privilege."

ART has just secured a seventh GP3 teams' title in the championship's eight-year history, and took a 1-2-3-4 in the 2017 drivers' standings, which was topped by Mercedes Formula 1 junior George Russell, with Renault Academy member Jack Aitken and Honda protege Nirei Fukuzumi second and third. All three are expected to graduate to Formula 2 for 2018. Russell and Aitken

are tipped to form the ART line-up, and took part in all three days of last week's Abu Dhabi test with the team. Fukuzumi drove with Arden, where he looks very likely to race next season.

Alexander Albon, who drove for ART in F2 this season, topped the running at Yas Marina with DAMS, edging Norman Nato in the final session by 0.005 seconds. Louis Deletraz (MP Motorsport) and Arjun Maini (Russian Time) headed two sessions apiece, with Lando Norris (Campos Racing) topping the other period. Aitken set the fastest rookie time over the three days.

MP Motorsport, which has taken over the DAMS GP3 entry ahead of 2018, topped all three days of the third-tier category's test. Outgoing Red Bull junior Niko Kari was fastest on the opening two days, with Macau Grand Prix star Ferdinand Habsburg quickest on the last. The pair also set the fastest two times overall. ART duo Ilott and Jake Hughes, as well as Campos Racing's Leonardo Pulcini, also emerged as session toppers over the test.

ALEX KALINAUCKAS

FORMULA 2 TEST TIMES

POS	DRIVER	TEAM	TIME
1	Albon	DAMS	1m48.110s
2	Nato	Rapax	1m48.115s
3	Deletraz	MP	1m48.282s
4	deVries	Prema	1m48.380s
5	Aitken	ART	1m48.422s
6	Latifi	DAMS	1m48.452s
7	Maini	Russian Time	1m48.555s
8	Ghiotto	MP	1m48.632s
9	Makino	Russian Time	1m48.636s
10	Ferrucci	Trident	1m48.648s

GP3 TEST TIMES

POS	DRIVER	TEAM	TIME
1	Kari	MP	1m54.733s
2	Habsburg	MP	1m54.869s
3	Daruvala	MP	1m55.024s
4	Mazepin	ART	1m55.033s
5	Pulcini	Campos	1m55.120s
6	Lorandi	Trident	1m55.125s
7	Ilott	ART	1m55.277s
8	Alesi	Trident	1m55.280s
9	Defourny	MP	1m55.330s
10	Hughes	ART	1m55.331s





HONDA RACING THANKS DAY Among the highlights at Motegi last weekend was (above) a 'Triumphant Run' for Indianapolis 500 winner Takuma Sato on the oval, its first use since its earthquake damage in 2011. Only thing is, he found MotoGP champion Marc Marquez hard on his heels... Meanwhile, Marquez and team-mate Dani Pedrosa had runs in Toda Racing's Dallara Formula 3 cars. **Photographs by Honda**



BLANCPAIN GT

New team to run pro Astons

THE ARDEN AND JOTA TEAMS ARE linking up with a Swiss entrant to mount Aston Martin's first full-season pro-class attack on the Blancpain GT Series Endurance Cup in seven years.

The British single-seater and sportscar specialists are firming up a cooperation first announced in 2015 to field a pair of Aston Martin Vantage V12s in the five BGTS enduros under the banner of R-Motorsport, which has contested selected enduros using the British manufacturer's machinery over the past three years. The deal gives Aston a full-time presence in the pro division of the BGTS Endurance Cup for the first time since the inaugural season of what was then known as the Blancpain Endurance Series in 2011.

The two Astons will, for the first season of what is initially a two-year deal, be run from the Kent base of Jota Sport, which masterminded the Jackie Chan DC Racing LMP2 campaign in this year's World

Endurance Championship. The first two of the six drivers have been confirmed as Jake Dennis and Alex Brundle, who both have existing links with Arden and Jota.

Team co-owner Florian Kamelger explained that the team would be "making no compromises on drivers".

"We are going to be testing a lot of drivers and our decisions will be data-driven," he said. "We have the ambition to fight for the win of the championship and to step onto the highest step of the podium at the Spa 24 Hours [the double-points round of the BGTS] in 2018."

The deal with R-Motorsport was forged through Arden founder and Red Bull Formula 1 boss Christian Horner. The Swiss team's affiliate company, AF Racing, played a key role in the conception and funding of the Aston Martin Valkyrie hypercar, which has been designed by Red Bull Racing technical director Adrian Newey.

GARY WATKINS

IN THE HEADLINES

BUDKOWSKI RENAULT DATE DELAYED

The FIA and Renault have agreed that former F1 technical chief Marcin Budkowski will not start working at the Regie's Enstone base until April 1, after extending his period of gardening leave from three months to six. This comes after rival teams were angered that he could take privileged knowledge of developments to the team.

ASTON TAKES ON MORE F1 ENGINE MEN

Aston Martin has recruited another ex-Ferrari man as anticipation grows regarding its plans to return to F1 in 2021. Former Maranello engine chief Joerg Ross teams up with Luca Marmorini, who has already started work on the manufacturer's engine concept.

SAO PAULO FORMULA E CANCELLED

Sao Paulo's Formula E race has been postponed until 2019, leaving series chiefs needing to find an alternative venue to fill the 2017-18 calendar. The cancellation is due to city authorities taking longer than expected to sell Anhembi Park, where the race was due to be held, to a private buyer. But it is understood to be viable in '19.

HWA BRINGS ASSISTANCE TO VENTURI

Venturi has partnered with Mercedes racing specialist HWA for the 2017-18 Formula E season. The move comes ahead of Mercedes' entry to FE in 2019-20, and means HWA embeds engineering personnel within the team. Venturi driver Edoardo Mortara came close to victory on his debut FE race weekend in Hong Kong (see p92).

DUMAS AND DUVAL FOR DAYTONA

Former World Endurance champions Romain Dumas and Loic Duval have joined CORE Autosport for January's Daytona 24 Hours. The two Frenchmen will join CORE regulars Colin Braun and Jon Bennett aboard the team's LMP2 ORECA-Gibson.

WTCC SET TO PARTNER WITH TCR

The World Touring Car Championship will be rebranded as the WTCR as part of an agreement to switch to TCR rules for 2018. The WTCC and the FIA have signed a two-year licensing deal with TCR boss Marcello Lotti to use both the name and regulations. The move, which will result in the end of the TCR International Series, was due to be rubber-stamped at Wednesday's (yesterday) meeting of the FIA World Motor Sport Council.

ROWLAND VISITS JAPAN FOR TALKS

Formula 2 ace Oliver Rowland was on his way to Japan as we went to press for discussions with Super Formula squad Team LeMans. Rowland was due to meet the team, which ran Felix Rosenqvist (below) to third place this year, at the two-day Suzuka test.



NIGEL ROEBUCK

The more it changes...

It was a year in which Hamilton and Mercedes won the titles again. But beneath the surface, the world of F1 is changing

 @autosport

ON THE SURFACE, AT LEAST, IT HAS BEEN BUSINESS as usual in Formula 1 this year, with Lewis Hamilton and Mercedes taking the titles, but beneath it much has changed, for after nearly half a century in the iron control of Bernie Ecclestone, the sport passed into the hands of Liberty Media. Thus a one-man band has been replaced by a cast of thousands, and for the moment the jury is out: some in the paddock express faith in the new regime, others would have Bernie back tomorrow.

Twelve months in, it may be said that Liberty's honeymoon period is over, and not a few have anxieties about the company's future plans, mainly because – as I write – we still don't know what they are.

While Ross Brawn speaks with conviction about what needs to be done to reignite excitement on the track, to introduce an engine cheaper and louder than the current hybrid lump, to give aerodynamics an urgent revamp, and so on, little of consequence has been heard from other Liberty folk.

There has, of course, been much talk of the need to attract the young, by means of social media, digital platforms, and whatnot, Sean Bratches speaking of his wish to 'turn Formula 1 from a motorsports company to an entertainment company and brand, with Formula 1 at the centre of it'. In the coming years, Bratches and Chase Carey will do well to

remember *not*, in their pursuit of new fans, to alienate the sport's bedrock supporters, who have kept faith with F1 through what has lately been a shaky period in its history.

Niki Lauda is one with concerns, recently mentioning – with a shudder – a suggestion by Bratches that 'grid kids' be introduced to the sport. Anyone who has ever witnessed the endless build-up to a NASCAR race, which every weekend culminates – during the Stars and Stripes – in a drivers' baby show, will surely go with Niki on this.

Similarly, the elaborate 'Drivers Introduction' ceremony at Austin found little favour with worldwide fans – or, for that matter, with those being introduced.

A while ago, someone from Liberty spoke of an aspiration to turn every grand prix into a Super Bowl. Call me

old-fashioned, but I would venture that rather more crucial than any of this – even Justin Timberlake or a new F1 logo – is to put on a race that makes folk want to come back for another one.

All that said, the task before Liberty is undoubtedly a daunting one, and on more than one front, for Formula 1 is not as it was when Ecclestone took control, when most teams bought very affordable engines from Cosworth, and were entirely content to have Bernie negotiate with race organisers on their behalf. He made a lot

“The task before Liberty is a daunting one, and on more than one front”



Liberty's Brawn, Carey and Bratches (from l to r) face big challenges

TEE/LAT

HONE/LAT



Vettel gave Hamilton a closer fight



of people inordinately rich, and for more than 40 years their hearts and minds followed.

Things are very different now. One hopes down the road that the situation will change, but these days there is no DFV equivalent available to anyone who might wish to buy it: instead you need to do a ‘customer’ deal with one of the manufacturers, and if – if – they choose to sell you an engine, it can come with ancillary conditions, like leaning on you to put one of ‘their’ drivers in your car.

In this era, enormous power therefore resides with tycoon suits like Sergio Marchionne and Dieter Zetsche, as evidenced by their teams’ response to Brawn’s suggested engine changes for 2021: we don’t like them, and we might well quit. As Bernie said to me long ago, “Never rely on the manufacturers. They come and go as it suits them – always have, and always will. They’re not in Formula 1 because they love it...”

True enough: think bottom line. This is why, for example, Marchionne refused to countenance going back on the absurd ‘three engines per season’ rule, to be introduced next year. Guaranteed to produce even more of the grid penalties which, as Brawn says, ‘make a farce of Formula 1’, the Ferrari boss said he couldn’t care less: he hadn’t spent all that money on increasing engine life for nothing.

In a perfect world, as Christian Horner and Sebastian Vettel have frivolously suggested, F1’s next engine would be a V12, plain and simple. The likes of Cosworth and Mario Illien could then get in on the act, supplying whomever wished to buy from them, and – as in the 1960s and ’70s – any manufacturers wishing to compete would be very

welcome: if not, sayonara. A pipedream? Yes, of course – but does anyone doubt it would bring back the fans?

Emphatically, they have never taken to quiet, low-revving, hybrid engines, but that is only part of the problem: of arguably greater significance is the current cars’ inability to race, thanks to the joys of ‘aero’. A couple of years ago, NASCAR, facing a similar dilemma, opted to reduce downforce, and the racing greatly improved. For 2018, IndyCar is following a similar path, and – sooner rather than later – Formula 1 *must* do the same, putting an end to processions of cars, three or four seconds apart, such as we saw in Abu Dhabi.

Therefore, while there may be manifold problems at the moment, far and away the most fundamental lies with the basic *product*. As a MotoGP rider said to me a while ago, “They’ve got a thousand horsepower in Formula 1 – how the hell do they manage to make it boring?”

Much has been made this year of the world championship fight between Hamilton and Sebastian Vettel, and assuredly it was good, after three seasons of absolute Mercedes domination, to see Lewis facing opposition from other than his team-mate. The Ferrari resurgence, so long anticipated, was stronger than expected, and many a time Vettel went into a race with the quickest car.

Hamilton it was, though, who in the end won conclusively, and if he was helped by Ferrari’s operational failings, as well as Vettel’s occasionally intemperate behaviour, it must be said that – particularly in the second half of the season – Lewis himself was better in 2017 than ever before. >>



S.BLOXHAM/LAT



Interestingly, while drivers have traditionally expressed a preference for a team-mate who will push them, both Hamilton and Vettel seem to flourish best with a firm number two in the other car. Overall, Valtteri Bottas did a sound job for Mercedes, and sometimes he excelled, but routinely he was not the threat that Nico Rosberg had been, and in this changed environment a newly serene Hamilton thrived. Similarly, Vettel – not unmindful of his drubbing by Daniel Ricciardo at Red Bull in 2014 – has good reasons for keeping the fading, apolitical, Kimi Raikkonen at Ferrari.

Hamilton, always known for occasional ‘off’ weekends, duly had a pair this season, at Sochi and – more surprisingly – Monaco, but usually his driving was close to faultless, and so was his composure. Vettel, though, continued to compromise his greatness at the wheel with what these days we are pleased to call ‘anger management problems’: never far from the surface, they cost him dear at Baku, where he simply lost his rag, and Singapore, where he threw away victory on a plate with a stupidly aggressive and unnecessary move at the start.

Fundamentally, you needed a Mercedes or Ferrari this year, not least for the ability to ‘turn up’ the engine when required, be it in Q3, or – as Bottas demonstrated to Lance Stroll at Baku – blasting by a rival on the last lap. In this regard, not to say routine horsepower, Renault users remained at a disadvantage, but still Red Bull, after developing an initially disappointing car, sometimes threatened, Ricciardo and Max Verstappen both winning in 2017.

This was the year in which the scarily quick Verstappen truly bloomed. Precisely aware of how good he is, Max is in

awe of no-one, and nor should he be, but he manages his innate aggression well, saying what he thinks in words of one syllable, but without brattish arrogance. A series of Renault failures drove him to distraction this season, but took no toll of his motivation: at 20, his future looks limitless.

It says much for Verstappen’s team-mate that he didn’t allow himself to become at least a little overwhelmed. Along with Bottas, ‘Danny Ricci’ is the most well balanced driver in the paddock, and if he couldn’t equal Max in qualifying, on race day he remained a match for anyone, his incisive overtaking moves as breathtaking as ever.

The financial gulf between the big three and the rest, as we know, is immense, but Force India knows a thing or two about working with loaves and fishes, and once again excelled in 2017, making the most of a good chassis, a Mercedes engine, and a pair of drivers who really did push each other all the way. After uncertain times earlier in his career, which included being dropped by McLaren, Sergio Perez has matured into a fine grand prix driver, aggressive and opportunistic, yet better than most at looking after tyres.

Down the road, though, it is his team-mate who will go further. Although outqualified more often than not by Perez, newcomer Esteban Ocon had a startlingly impressive season, and there is about him that indefinable something that separates the special from the rest. A gentle demeanour in the paddock emphatically does not carry over to the track, and if, as expected, he shines even more in 2018, it is easy to envisage him the following year at Mercedes.

For Williams it was an up and down season, with Felipe

“This was the year in which the scarily quick Verstappen bloomed”



Main: Verstappen (leading Ricciardo here at Monaco) blossomed

Below: Ocon (l) and Hulkenberg both impressed their teams



COATES/LAT



HONE/LAT

Massa, instantly called back from retirement after Bottas's unexpected move to Mercedes, doing his usual sound job, and newcomer Stroll sometimes all at sea, occasionally – as at unforgiving Baku – brilliant.

Nico Hulkenberg, at last in a factory team, greatly impressed everyone at Renault, revelling in Pirellis that lasted long enough to let him go racing, and making the most of a car that improved significantly through the season. Too many indifferent showings, tied in with poor reliability, sadly cost Jolyon Palmer his place before season's end, and at Austin, his first drive with the team, Carlos Sainz was stunningly impressive. This is a strong pairing for 2018.

After Sainz's negotiated departure from Toro Rosso, and Daniil Kvyat's harsh dismissal, Pierre Gasly and once-dropped Red Bull man Brendon Hartley came in for the last few races, and will drive for the team next year, now with the Honda engine finally abandoned by McLaren.

Ironically, in the closing races of the season, Honda's reliability markedly improved, allowing McLaren's excellent MCL32 to score a few points, but horsepower remained in lamentably short supply – up the hill at Interlagos, Fernando

Alonso and Stoffel Vandoorne were like tethered goats – and after three years of this, enough was clearly enough. Vandoorne, while obviously a star of the future, looked unconvincing in the first half of the season, but picked up well in the second, while Alonso – still for many the best driver on earth – every weekend wrung the neck of his car because that's him: the ultimate racing warrior, he can do no other.

That leaves us with Haas and Sauber. Romain Grosjean, once – like Hulkenberg – in the frame for a Ferrari drive, continued to disappoint those of us who have believed in him, and was often outshone by the underrated and uncomplaining Kevin Magnussen, while Pascal Wehrlein invariably had the better of Marcus Ericsson, whose sponsors keep him – rather than Marchionne's choice, Antonio Giovinazzi – at Sauber in 2018.

Closing note, and one to ponder. In this, the first year of Liberty's F1 ownership, the company has spent considerably on recruitment, as well as new offices and the like, so that end-of-season monies paid to the teams are down (by \$43 million) for the first time in eight years. It has not gone down well. ❄

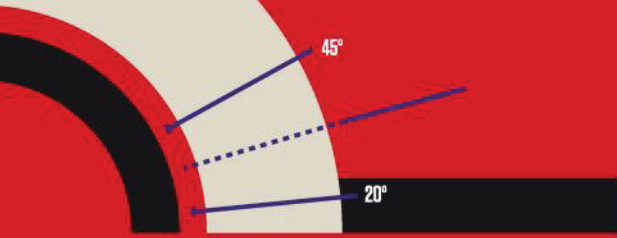

SBK MOTUL
 FIM SUPERBIKE WORLD CHAMPIONSHIP
 SUPERSPORT € SUPERSPORT300 € SUPERSTOCK 1000 €

SUPERBIKES
14-16 SEPTEMBER

**RESERVE
 YOUR SEAT.**

EUROPEAN LE MANS SERIES **26-28**
OCTOBER

**EUROPEAN
 LE MANS
 SERIES**



ACF
**ALGARVE
 CLASSIC FESTIVAL**

ALGARVE CLASSIC FESTIVAL
19-21 OCTOBER

PROMOCODE: #AIARACES18

Be one of the **first 50** to reserve a seat for these amazing racing events at aia.pt and get a special 30% discount on your tickets.



True Brit talent

McLaren Autosport BRDC Award winner Dan Ticktum deserves his chance, along with a group of exciting young British drivers

By Kevin Turner, Editor

[@KRT917](#)

IT REALLY IS TIME TO MOVE ON. YES, DAN TICKTUM was banned for driving into championship rival Ricky Collard behind the safety car in an MSA Formula race at Silverstone in 2015. Yes, it was unacceptable and deserved censure. But no, it doesn't mean he should never be allowed on a race track again.

For a start, how many 16-year-olds make stupid decisions? Lots. And most of their errors aren't broadcast live on national television.

There would also be tremendous inconsistency and hypocrisy if the Red Bull junior was to pay for his crime with anything more than his year out of the sport. In the past, we've had experienced drivers deliberately collide with rivals at *racing speed* in order to win the F1 world championship, with varying degrees of success, and none of them so much as missed a race as a result. Just this season, a 29-year-old, four-time world champion lost his rag following a perceived injustice and drove into the race leader behind a safety car. He served a 10-second penalty and finished that race fourth.

Ticktum has worked hard to get his career back on track, repay Red Bull's faith in him and show that he has learned his lesson. This year has really provided evidence of what many in the MSA Formula (now British F4) paddock already knew: that Ticktum is one of the most exciting young talents out there.

The Silverstone tests for the McLaren Autosport BRDC Award are always fascinating and every now and again produce a special moment, such as Jenson Button's run in a Super Touring Nissan Primera in 1998 or Alexander Sims's DTM performance 10 years later.

This year, it was a session on a damp-but-drying Silverstone Grand Prix circuit in the MotorSport Vision-run Formula 2 cars on slicks. Ticktum was first on the road, normally a disadvantage, but his commitment and pace were extraordinary and he ended the session well clear of the other finalists.

Ticktum's old MSA Formula rival and predecessor as Award winner Lando Norris was not surprised – it's an ability he has seen before. That run was not the only reason Ticktum won the Award, but it's a performance that will stick in the minds of those who witnessed it.

Ticktum is an intense, confident personality. He doesn't have the quiet, understated polish of McLaren protege Norris, or the easy charm of 2014 McLaren Autosport BRDC Award winner and GP3 champion George Russell. But he is an

engaging character – the sort many fans say they want – and, most importantly, he is *fast*.

The future of British representation in F1 should be safe. Russell is affiliated to Mercedes, Norris to McLaren and Ticktum to Red Bull. All three have shown the potential to not just get to F1 but make a real impact once they are there. If you're an athletics fan, it could be likened to the Steve Ovett, Sebastian Coe and Steve Cram trio of the 1980s.

There's a little bit of healthy needle between the young Brits too. Each knows the others are threats, and are a little less effusive than they might be if they weren't pretty convinced they'll be racing each other at ever-higher levels over the next few seasons. And let's not forget Ferrari Driver Academy member Callum Ilott, who will be one of the favourites in GP3 next year now that he has been confirmed at leading squad ART.

Norris and Russell will go head to head for the first time in cars in F2 next year, hoping to take on Prema's dominance of the category, while Ticktum will try to repeat Norris's successful rookie campaign in European F3. Ticktum will drive

with Motopark, which took Joel Eriksson to the runner-up spot this year. And not just because he won the Macau Grand Prix with Timo Rumpfkeil's squad last month.

"I did some testing with him when I was banned, and Timo's one of those guys who always trusted in me," said Ticktum last Sunday.

"He's seen some wonderful drivers, like Valtteri Bottas, and he was ringing me and wanted me. We'll have to assess the goals for 2018 once we've done some testing. I'll still be a rookie but right now I'd love to be winning."

Like Norris this year, Ticktum will also dovetail his F3 campaign with F1 simulator support over grand prix weekends. He'll be running in Red Bull's advanced sim, performing the same sort of role for Max Verstappen and Daniel Ricciardo as Norris did for Fernando Alonso and Stoffel Vandoorne at McLaren in 2017. That's how much trust Red Bull and Helmut Marko have placed in him.

As ever with Red Bull's drivers, Ticktum will have to deliver, but he does not seem the sort of guy to lift off the gas. Ever. As long as he continues to learn and add experience to his obvious abilities, there's no reason to think he won't continue his rise.

Ticktum has served his time and responded. Now it's time to start enjoying what he can do alongside Britain's other young motorsport stars. 🌟

“Ticktum is one of the most exciting young talents out there”

FEEDBACK

Alonso stands out as a true star



What a great end to the Formula 1 season I witnessed on 'catch-up'. But for one thing...

When you get to my age jokes about failing memory become a regular thing, but I did find myself wondering if the C4 team of Jones, Webber, Jordan, Wolff and Coulthard, all of whom I like and respect, had lost theirs. Their disdain for Fernando Alonso's ambitions outside of F1 tempted me to put my ageing foot through the television! Have they forgotten their history, and the great all-rounders like Stirling Moss, Jim Clark, Mario Andretti and Graham Hill – winner of the triple crown: F1, Le Mans and Indy?

"He shouldn't have raced at Indy," proclaimed Eddie. Yeah, right. He only led the bloody thing! Given his frustrating run at McLaren, this was for me *the* story of the year.

I'm so glad that as a lad I got to witness Clark racing and winning in F1, saloons and sports cars – all on

the same day. I am therefore delighted to see Alonso successfully reviving that tradition, and following in the wheeltracks of giants.

A racer is a racer is a racer. Maximum respect therefore to his team boss, Zak Brown, for supporting his driver, a true star in my humble opinion.

Tim Hain
Lower Kingswood, Surrey

Clip these wings

Enough, I say. I can contain myself no longer. The current front wings on Formula 1 cars have no place in motorsport. Please, please someone shout stop!

Alex Sinclair
Bray, Co Wicklow

Formula E fails to spark

So, I thought, let's give it a go and see what Formula E is about. Now I know it's about officials and organisers doing their best to turn fans away! Fastest lap

Alonso's decision to race at the Brickyard makes him a true racer in the eyes of reader Hain

removed because a car power-spiked due to touching a kerb. Race win taken away because a barcode wasn't correct. Race start delayed for some unknown reason. After a season of ridiculous F1 grid penalties, I was hopeful of something better.

Bob Bull
Byemail

Variety's the spice of life

I have been in motorsport for 50 odd years in one way or another and been watching F1 for the same time. F1 has now become a bore, there is no real excitement or drama anymore – unless you think a replay of a wheel locking or a race car with a bit of opposite lock is worth all the excitement from the commentary team.

Take off all the aero junk and open up the engines to just a cc limit and let them build what they want.

This is the grid for the 1966 Dutch Grand Prix: Ferrari V12 3.0-litre; Climax V8 2.0-litre; Climax 4-cylinder 2.7-litre; BRM V8 2.0-litre; Repco V8 3.0-litre; Serenissima V8 3.0-litre; Maserati V12 3.0-litre.

As for tyres, there were Firestone, Goodyear and Dunlop.

And you could tell what car was on the grid by just looking at it, you did not need the number. My point is you need more variety, not a grid of clones.

Richard Holmes
Holland on Sea, Essex

HAVE YOUR SAY, GET IN TOUCH

Autosport editorial
Autosport Media UK Ltd
1 Eton Street
Richmond
TW9 1AG

@
E-mail
autosport@
autosport.com

Twitter
twitter.com/
autosport

Facebook
facebook.com/
autosport

THE OFFICIAL REVIEW OF THE 2017 FIA FORMULA ONE WORLD CHAMPIONSHIP™



The best audio, the best video; the best of a great season on two discs - all in three hours. The ultimate review of the season is available to pre-order now on Blu-ray and DVD

Delivery expected from Monday 18th December. Delivery to UK addresses only. Postage free.

Order now at dukevideo.com or call + 44 (0) 1 624 640 011

© 2017 Formula One World Championship Limited, a Formula One group company. All rights reserved.
The F1 FORMULA 1 logo, F1 logo, F1 FIA FORMULA 1 WORLD CHAMPIONSHIP logo, FORMULA 1, FORMULA ONE, F1, FIA FORMULA ONE WORLD CHAMPIONSHIP, GRAND PRIX and related marks are trade marks of Formula One Licensing BV, a Formula One group company. Licensed by Formula One World Championship Limited, a Formula One group company. All rights reserved.

WORLD LEADING POWERSPORT ENTERTAINMENT FOR OVER 35 YEARS

DUKE®

COLLECTABLE DVDS ALL GRAND PRIX FANS SHOULD OWN

Classic films from a golden era of F1



Formula I 1970-1979 10 DVD Collection

Ten years that still define Formula One - a decade of phenomenal drivers, competition and change

FEATURING Rindt, Stewart, Fittipaldi, Lauda, Hunt, Andretti, Scheckter

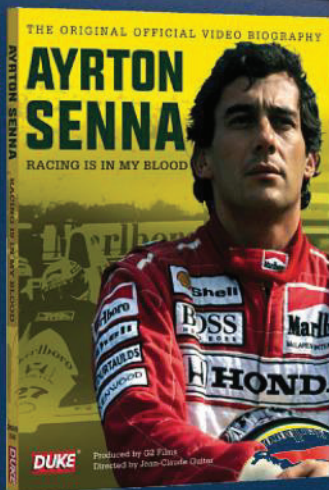

One of the all-time legends of the sport - in his own words.

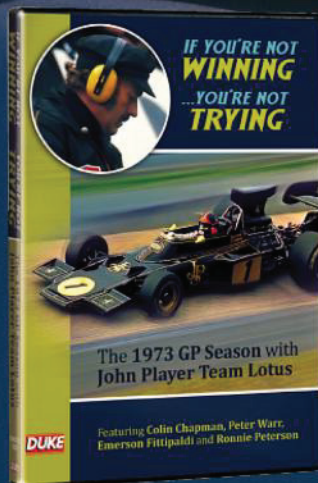

Fly-on-the-wall with Colin Chapman and Emerson Fittipaldi in 1973

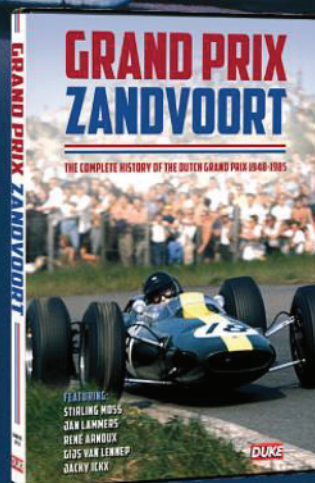

The complete story of one of the iconic "lost" Grand Prix circuits

Hundreds more classic motorsport films at dukevideo.com
Free worldwide delivery at dukevideo.com

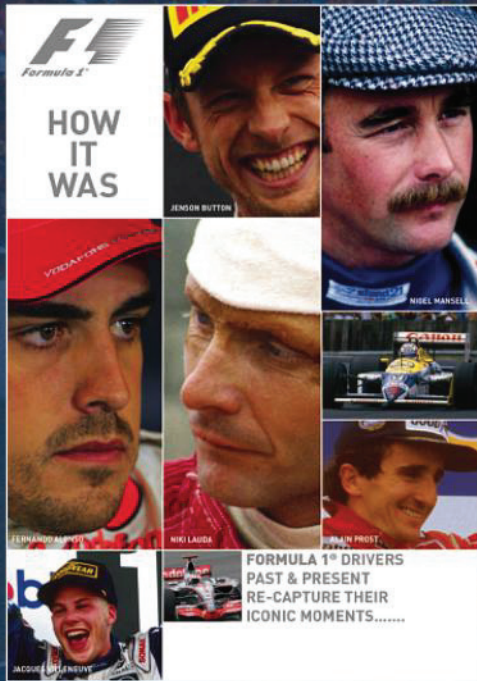

FORMULA 1® HOW IT WAS

Ten great races from the last three decades of Formula One®, seen through the eyes of the drivers

Exciting archive footage and in-depth interviews combine to paint a picture of famous races from a point of view you've never heard before

DRIVERS FEATURED

Nigel Mansell, Jenson Button, Fernando Alonso, Jacques Villeneuve, Jean Alesi, Gerhard Berger, Johnny Herbert, David Coulthard, Niki Lauda and Alain Prost

Now available on Blu-ray and DVD*

* PAL or NTSC compatible DVDs available. Please specify at time of purchase.



WILLIAMS

The incredible true story of Formula One's greatest family

The story of the incredible racing dynasty that started with Frank Williams and is being carried on by his daughter Claire. The critically acclaimed film shows how Frank's single-minded obsession with speed led him, like Bruce McLaren, to create a racing empire from virtually nothing.

Available on Blu-ray and DVD

Buy now at dukevideo.com or call + 44 (0) 1 624 640 011

© 2017 Formula One World Championship Limited, a Formula One group company. All rights reserved.
The F1 FORMULA 1 logo, F1 logo, F1 FIA FORMULA 1 WORLD CHAMPIONSHIP logo, FORMULA 1, FORMULA ONE, F1, FIA FORMULA ONE WORLD CHAMPIONSHIP, GRAND PRIX and related marks are trade marks of Formula One Licensing BV, a Formula One group company. Licensed by Formula One World Championship Limited, a Formula One group company. All rights reserved.

WORLD LEADING POWERSPORT ENTERTAINMENT FOR OVER 35 YEARS



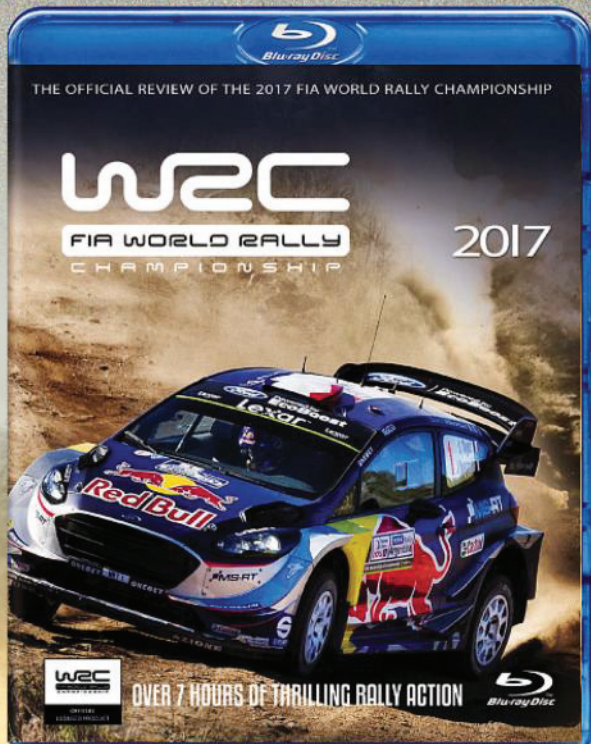

FIA WORLD RALLY CHAMPIONSHIP REVIEW 2017

For the first time ever on Blu-ray*: a sizzling season in glorious HD

Available on Blu-ray & DVD

* Blu-ray plays in NTSC territories (eg N.America) as well as PAL



OVER THREE DECADES OF WRC REVIEWS ONLINE

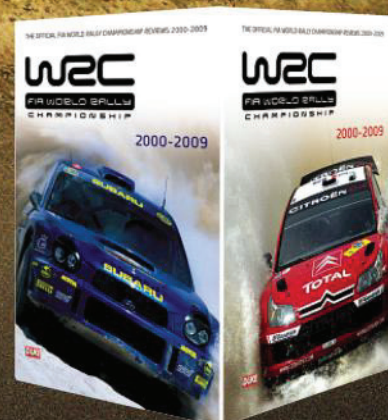

Free worldwide delivery at dukevideo.com

WORLD LEADING POWERSPORT ENTERTAINMENT FOR OVER 35 YEARS



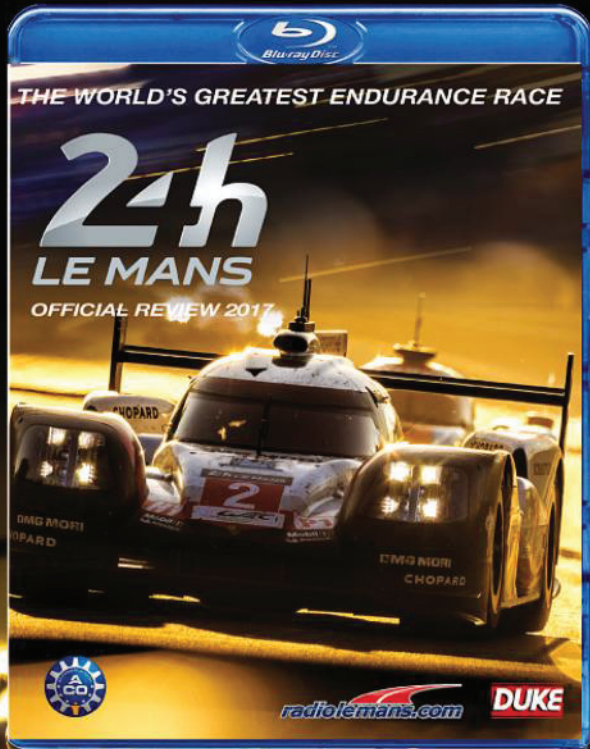

THE OFFICIAL REVIEW OF THE 2017 24 HOURS OF LE MANS

Relive one of the most
thrilling GTE races ever, and
Porsche's 19th overall win

Available on Blu-ray* and DVD

EVERY OFFICIAL REVIEW SINCE 1980 - THE ULTIMATE COLLECTION

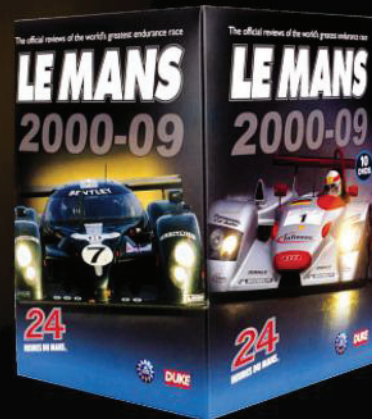
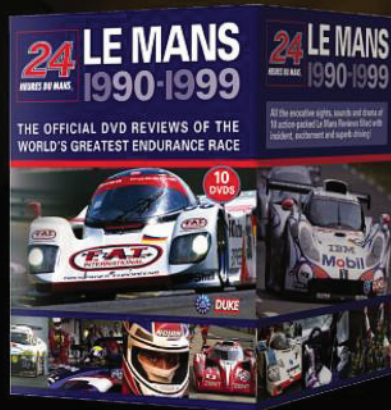
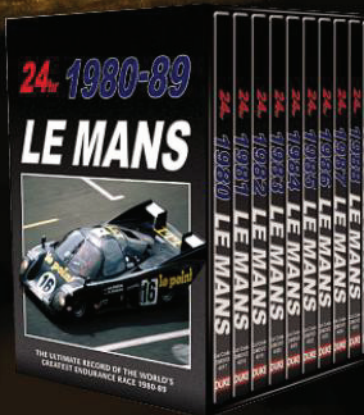

Buy now at dukevideo.com or call + 44 (0) 1 624 640 011

WORLD LEADING POWERSPORT ENTERTAINMENT FOR OVER 35 YEARS



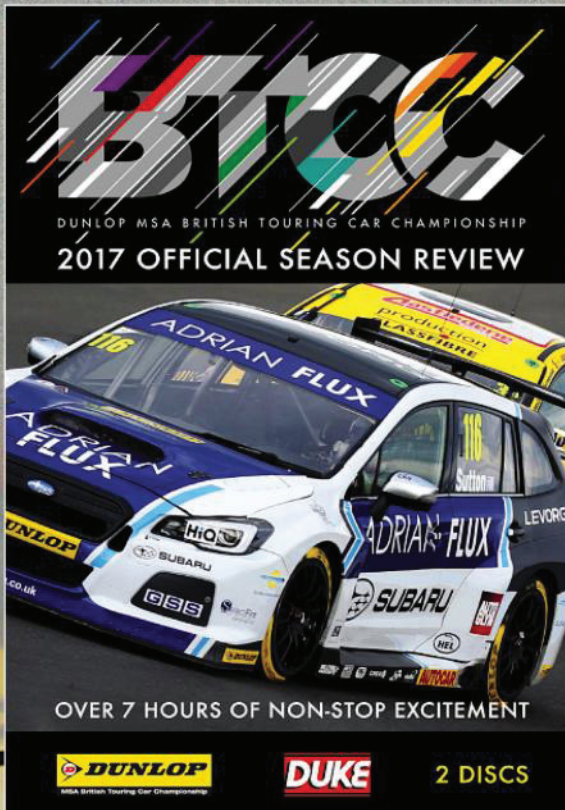

BTCC OFFICIAL REVIEW 2017

30 epic door-bashing, bumper-bending races from the World's most exciting touring car championship



EVERY OFFICIAL REVIEW SINCE 1994 NOW AVAILABLE TO OWN ON DVD



Free worldwide delivery at dukevideo.com

WORLD LEADING POWERSPORT ENTERTAINMENT FOR OVER 35 YEARS





RACING TOGETHER MotoGP™ 1949 - 2016

New official Dorna documentary! From the first World Championship race through the Honda vs MV years, the two-stroke revolution, the huge personalities of the 1980s, the reign of Rossi all the way up to today's stars, this superbly produced and edited new film captures it all

LEGENDS OF THE SPORT INCLUDE:

John Surtees • Giacomo Agostini • Phil Read
Angel Nieto • Kenny Roberts • Freddie Spencer
Wayne Gardner • Wayne Rainey • Kevin Schwantz
Mick Doohan • Valentino Rossi • Nicky Hayden
Casey Stoner • Jorge Lorenzo • Marc Marquez
Franco Uncini • Kenny Roberts Jr • Alex Criville

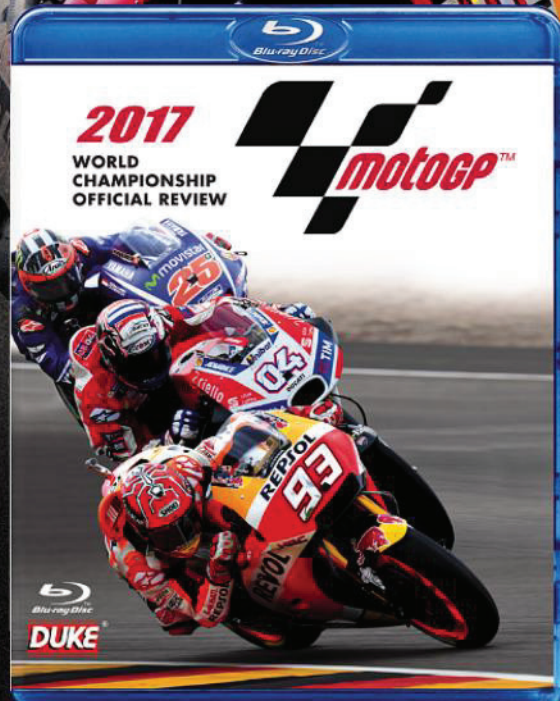

MOTOGP™ OFFICIAL REVIEW 2017

The biggest MotoGP review ever: two discs, over four hours

The Official Review of some of the most exciting racing on the planet. All the best action packed on to Blu-ray and DVD to enjoy time and again

Both titles available on Blu-ray & DVD*

* PAL or NTSC compatible DVDs available. Please specify at time of purchase.

Buy now at dukevideo.com or call + 44 (0) 1 624 640 011

WORLD LEADING POWERSPORT ENTERTAINMENT FOR OVER 35 YEARS

DUKE®

ISLE OF MAN TT 2018

EXCLUSIVE SEATS FOR THE WORLD'S ULTIMATE ROAD RACE



• VIP HOSPITALITY • GRID PASS • CLOSED ROADS CAR LAP • CELEBRITY HOST

37.73 MILES, 200 CORNERS = 1 INCREDIBLE MEMORY

VIP Platinum Experience
Limited Availability

Saturday	2nd June
Monday	4th June
Wednesday	6th June
Friday	8th June



For details see iomtt.com/travel
or call +44 (0) 1624 640 011

TT is a registered trademark of the Department for Enterprise (a department of the Isle of Man Government)

iomtt travel

AUTHORISED TRAVEL PARTNER OF THE ISLE OF MAN TT RACES

WORLD LEADING POWERSPORT ENTERTAINMENT FOR OVER 35 YEARS



Duke and the Duke logo are registered trademarks of Duke Marketing Limited. All rights reserved. Media Code: F1R17

F1
SEASON
REVIEW
2017

ETHERINGTON/COATES/LAT

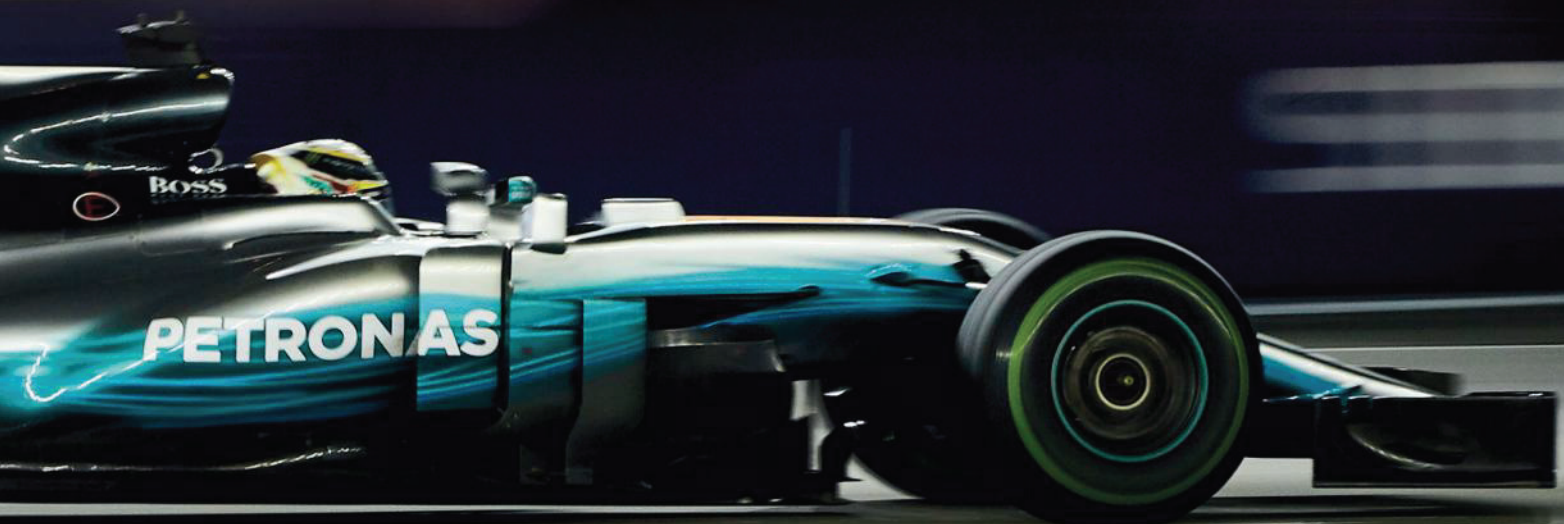

F1
SEASON
REVIEW
2017



BACK TO HOW IT SHOULD BE

Under F1's new rules, Mercedes at last had a fight on its hands — Ferrari star Vettel pushed Hamilton hard for the title, making it the crown he'd "been hoping for"

By Ben Anderson, Grand Prix Editor

HONE/LAT



 LAT IMAGES

F1 SEASON REVIEW 2017

Formula 1 in 2017 had very little in common with the previous three seasons of grand prix racing's turbocharged-hybrid-V6 era, save for the fact that Mercedes once again triumphed in both world championships.

Mercedes showed the rest the way for the fourth year in succession, claiming a Red Bull-style fourth consecutive constructors' crown, and helping Lewis Hamilton to a fourth career drivers' title – his third from the past four seasons. But the journey to that destination was utterly unlike the internal contests between Hamilton and Nico Rosberg that had defined F1 since V8 engines were scrapped at the end of 2013.

There are many reasons why this became so, a principal one being that Rosberg was absent from the grid this year, having retired unexpectedly upon achieving his life's ambition. After so much sacrifice to fulfil his dream, Rosberg saw no point trying to summon the necessary energy to run the gauntlet again, and that cleared the way for a new dynamic to emerge within Mercedes.

Rosberg's retirement played a major role in deciding the destiny of this year's world championship, beyond simply vacating his hard-earned title for someone else to lift. It removed a cloud of tension and internal division within the Mercedes camp, akin to the signing of a peace accord after years of civil war.



COATES/LAT

Peace in our time helped his former arch foe reach new heights. With Rosberg no longer around, this season became about Hamilton and his journey to equalling the championship tally of his hero Ayrton Senna's arch rival Alain Prost. Senna did not live long enough to surpass his nemesis, but Hamilton has now transcended his childhood inspiration. In becoming a four-time champion, Hamilton also broke Michael Schumacher's pole position record, and overtook Jackie Stewart to become Britain's most successful grand prix driver ever.

But this season was also about another four-time world champion – the one Hamilton vanquished to reclaim Rosberg's vacated crown. Sebastian Vettel pushed

Hamilton hard for much of the season, as Ferrari used the opportunity presented by F1's substantially revised aerodynamic regulations and beefed-up Pirelli tyres to rejuvenate itself after a troubled 2016, becoming a genuine championship contender once more. How refreshing it was to see Mercedes faced with an external threat at last. Fernando Alonso always said Ferrari should be winning every year; that it's the team's right to do so. It was wonderful to witness the great Maranello squad back in business again.

Vettel ultimately fell short in his quest to emulate his own hero Schumacher and win a championship in Ferrari red, thanks to a wretched run of races in Asia that derailed his season. That wasn't the only reason Vettel lost this championship, but

RACE BY RACE
BY LAWRENCE BARRETTO



S BLOXHAM/LAT

Australia

1 Vettel 2 Hamilton 3 Bottas

Vettel beats Hamilton to win the opening race. Hamilton bags pole, but is surprised by Vettel's ability to follow closely and better use his ultra-soft tyres, so loses out at the pitstops. Giovinazzi (above) finishes 12th on his grand prix debut for Sauber, deputising for Wehrlein, who withdraws citing lack of fitness.



COATES/LAT

China

1 Hamilton 2 Vettel 3 Verstappen

Hamilton hits back with a comfortable win, though helped by an early safety car period nullifying Vettel's strategic gamble to pit at the end of lap two. Vettel battles back to second, ahead of the two Red Bulls, while Raikkonen (above) finishes a distant fifth and is criticised by Ferrari president Sergio Marchionne.



Hamilton and Vettel went toe to toe for the world title. Here they battle in the US GP

it played a major part. That the title fight fizzled out with two races left, rather than going all the way to a final-race showdown in Abu Dhabi, was a real shame, but that shouldn't detract from the fact that F1 finally enjoyed a proper, multi-team contest for the world championship this year, for the first time in the V6 era.

The dawn of a new age

The principal aim of 2017's new rules package was to improve lap times by between four and five seconds compared to '15, following repeated complaints that hybrid F1 was too slow, as well as too quiet. The rules broadly achieved that ambition, as well as re-energising a grid of drivers who had grown weary of, as

Felipe Massa put it, "driving like a grandmother" to protect fragile tyres – even on qualifying laps.

It was heartening to hear the drivers talk about F1 in enthusiastic tones again, to hear the vociferous internal criticism of recent seasons muted by these faster, better looking, more aggressive machines. This must have been music to the ears of F1's new owner Liberty Media, as it seeks to define a suitable future for the championship post-2020.

But a familiar consequence of all major rule changes is that they inevitably spread the field out, as teams with greater resources are afforded more opportunity to add performance to their cars. After two weeks of winter testing in Spain, it

quickly became clear that F1's current big three – Mercedes, Ferrari and Red Bull – would be well clear of the rest.

"Between the top three and the other ones it is between one second and 1.5 seconds I think," said Haas team boss Gunther Steiner. "It is aero. The big teams will always have more resources to do it. There is no surprise that Mercedes and Ferrari and Red Bull came out better."

They certainly did, but a dose of overambition from Renault in the engine department created unreliability and meant Red Bull, which overhauled Ferrari for second in the 2016 championship, failed to hit the ground running. Additional problems correlating its windtunnel with Pirelli's wider tyres added further impotence to the RB13 in the early part of the season, and removed Red Bull from title contention.

So it was left to Ferrari, with its innovative sidepod/bargeboard concept and trick floor, to carry the fight to Mercedes. It became apparent through the early races that Mercedes had a slight edge in pure performance that didn't always translate over a race distance. The Wo8 set pole position for four of the first six races, and 15 of 20 overall, but Vettel assumed the championship lead thanks to a handy run of three wins from those first half-dozen grands prix. When he wasn't winning, Vettel was finishing second, which Hamilton described as a "championship-winning road".

Mercedes began to realise Ferrari had produced a more raceable car, one that seemed able to work the tyres more >>



Bahrain

1 Vettel 2 Hamilton 3 Bottas

Bottas claims his maiden F1 pole position, but struggles with incorrect tyre pressures in the race and slips back. Hamilton's bid to help Mercedes execute a double pitstop behind the safety car backfires when he takes too long entering the pitlane and gets a penalty. Vettel takes victory as Hamilton recovers to second.



Russia

1 Bottas 2 Vettel 3 Raikkonen

Ferrari locks out the front row of the grid as Mercedes struggles with the ultra-soft tyre again, but Bottas jumps both at the start and hangs on against severe pressure from Vettel to score his first grand prix victory. Hamilton trails home a distant fourth but at least keeps his scoreboard ticking over.



Spain

1 Hamilton 2 Vettel 3 Ricciardo

Hamilton and Vettel go wheel to wheel for victory, with Hamilton losing out at the start but ultimately beating Vettel thanks to an offset tyre strategy and a round-the-outside pass at Turn 1. A collision wipes out Verstappen and Raikkonen, while Bottas suffers engine failure, allowing Ricciardo onto the podium.

Ferrari started season in style, with Vettel claiming victory in the Australian GP

consistently through a race distance, particularly at the softer end of the compound range. The Wo8 was substantially longer than the SF70H in wheelbase, and started the season overweight, following problems with fragile aero components in testing.

Team boss Toto Wolff later described the Mercedes as a “capricious diva” – one that was unstoppable when everything was right in its world, but too often threw a tantrum when the track surface wasn’t rough enough and the ambient temperatures not to its liking. The car showed its capriciousness most clearly in Russia and Monaco, where Hamilton endured his worst races of the season in pure performance terms. Vettel capitalised on every mistake to assume a 25-point lead after those first six races.

“I don’t think you need to be a particular scholar of the sport to see the tracks at which Mercedes has been less dominant over the last few years, and they have figured this year as well,” says Mercedes technical director James Allison, who joined the team after leaving Ferrari in the middle of last year. “Some of it is a consequence of the approach we’ve taken. There are some things that are particular to this year, and that is a much stronger front tyre requiring a different approach than what we’ve had previously.

“Cars have been getting longer year by year, not because we like big, long, heavy things, but because you get more downforce that way. Obviously, they’re not going to be 400 miles long, even though the rules would permit it, but

there has been a general benefit for going longer because of the surface area of the floor for some years, and we’ve taken that a step forward this year.

“On average, whenever we go to a circuit that requires good aero efficiency we’re right up the front. There’s no doubt that the raw aero numbers on our car are good. The car’s reliability, across the whole piece, is very strong. But it’s too nervous at high speed, too stable at low speed. All cars on the grid will be like that, it’s just a question of extent. Often when a car has something different from everybody else – pullrods on Ferrari’s suspension; walrus noses on the Williams – the tendency if that car has a tough time in any given event is for the outside

world to go, ‘Oh, it’s because it’s different’.

“If you look at the areas Mercedes has been less dominant in previous years, and look at them this year, they’re not so different, and we’ve had short and long wheelbases in that period. I think it’s just a design compromise like any other – it puts a bit of weight on our car that we have to then manage. I built the rest of it light enough to cope with that, but we think we get more downforce from it.”

Ferrari seemed to benefit from using Allison’s sudden departure in the summer of 2016 to revamp its own technical structure. President Sergio Marchionne was said to be embarrassed by the team’s failure to deliver on his overconfident proclamations ahead of



S BLOKHAN/LAT

LAT IMAGES



ETHERINGTON/LAT

Monaco

1 Vettel 2 Raikkonen 3 Ricciardo

Raikkonen (above) claims first pole since France 2008, but is beaten to victory by Vettel in the pits. A similar strategy hands Ricciardo a podium at the expense of Verstappen. Hamilton struggles on ultra-softs again and is eliminated in Q2. He recovers to seventh in the race, and accuses Ferrari of favouring Vettel.



DUNBAR/LAT

Canada

1 Hamilton 2 Bottas 3 Ricciardo

Hamilton strolls to a third win of the season, as Vettel has his nose cut off by Verstappen at the start and is forced into damage-limitation mode. Verstappen briefly challenges Hamilton until his car breaks down. Third-placed Ricciardo fends off the Force Indias (above) before Vettel comes through to claim fourth.



HONE/LAT

Azerbaijan

1 Ricciardo 2 Bottas 3 Stroll

Ricciardo wins after Vettel is penalised for driving into Hamilton behind the safety car and Hamilton’s headrest works loose. Verstappen’s car breaks (again), the Force Indias collide (taking out Raikkonen), Massa’s suspension fails and Hulkenberg crashes, so Bottas (delayed by a clash with Kimi) pips Stroll to second.



Bottas was instantly a force with Mercedes, here winning the Russian GP

“But from there probably the biggest thing we’ve done this year is we threw away two or three races at the beginning of the year because we had not appreciated how best to adjust the car between qualifying and the race.

“So we had cars that were comfortably on pole, but then got beaten because we didn’t use the tyres well. With last year’s ones, you overstep the mark once and the tyre just ratchets down. These tyres are better but they’re still fiddly, and that’s the reason you get ridiculously different performance swings from event to event.

“There were times this year when we were absolutely in the window and we could just crack the car onto pole, and other times where we were fiddly, fiddly, tooth-and-nail finessing it, to try to get the best out of it, while probably down the road they’re sort of thinking, ‘What’s all the fuss? This is easy’.

“There isn’t a pattern. Just go and look at the competitiveness traces through the year. You’ll see there’s just as much yo-yo on a Ferrari as there is on a Mercedes. There’s never been a year where you get at every track the same percentage difference from pole to tail, with each car in its allotted slot all through the season. It’s always just chaos, and there are a ridiculous number of degrees of freedom on the car, and there’s also a human in there, who has preference from track to track, corner to corner, asphalt to asphalt, and so it wiggles up and down.

“The challenge is to try to reduce the size of that ripple as much as we can. I think you’ll struggle to remember a >>

that season, so decided to place faith in home-grown talent instead of scouring the paddock to poach another established technical star. Under the leadership of Mattia Binotto – the clever and analytical architect of the revival of Ferrari’s flagging V6 engine project in ’15 – Ferrari started work on the SF70H early and produced a tidy package, designing it in a more expressive, aggressive and, crucially, democratic fashion. It also developed well through the season, which has been a chief Ferrari weakness in the past.

Ferrari additionally pushed the FIA to issue a pre-season technical directive, outlawing particular forms of trick suspension that many believed was targeted at hampering Mercedes and Red Bull. Red Bull said the directive forced it

out of a development avenue, but didn’t adversely affect the RB13. Allison says the move had “zero” effect on Mercedes, which worked hard to recover the benefits of FRIC (front and rear interconnected) suspension after it was banned in 2014.

Instead, Allison says Mercedes’ swings in performance through the early part of 2017, which allowed Ferrari to steal a march, came down to misunderstanding how best to set up the car and use the tyres between qualifying, where Mercedes remained strong, and the race, where it proved inconsistent. “By far and away the main development was all the main bread-and-butter stuff – just making the car lighter, giving it more horsepower, letting it run at hotter temperatures, giving it more downforce,” Allison adds.



Austria

1 Bottas 2 Vettel 3 Ricciardo

Bottas claims his second win of the season thanks to a lightning-fast start from pole. Vettel hounds Bottas to the finish, while Ricciardo fends off Hamilton to complete the podium, as the Merc recovers from a gearbox penalty. Ferrari president Sergio Marchionne calls fifth-placed Raikkonen an “occasional laggard”.



Britain

1 Hamilton 2 Bottas 3 Raikkonen

Hamilton dominates, qualifying on pole by more than half a second and pulling away from Raikkonen’s Ferrari at will in the race. Bottas recovers from a gearbox grid penalty to finish second as both Ferraris suffer front-left tyre failures late on. Raikkonen scrapes home third as Vettel plummets to seventh.



Hungary

1 Vettel 2 Raikkonen 3 Bottas

Vettel rebuilds his shrunken championship lead with victory, despite struggling with bent steering. Raikkonen provides a buffer to the chasing Mercedes, led by Bottas, who temporarily moves aside for Hamilton after a team-orders discussion. Verstappen finishes fifth after taking Ricciardo out on lap one.

F1 SEASON REVIEW 2017

race after Barcelona where we just gobbled up our tyres. We might not have been quick enough, but we didn't have a car on pole that then just went shooting backwards in the race. That's the biggest single thing we worked on."

Vettel implodes part 1

After Vettel came from behind to beat team-mate Kimi Raikkonen to victory in Monaco, Hamilton suggested Ferrari was favouring Vettel in the championship fight, rather than adopting Mercedes' egalitarian approach. At this stage, Mercedes newcomer Valtteri Bottas remained firmly in title contention, thanks to winning in Russia and generally doing a better job than Hamilton initially at handling the Wo8 in its weakest moments.

But Vettel's near-perfect run ended abruptly in Canada and Azerbaijan, as Ferrari dropped points in each of those races. A touch from Max Verstappen's Red Bull after a slow start in Montreal forced Vettel into a damage-limitation run to fourth, as Hamilton raced untroubled to victory. That cost Vettel at least six points.

In Baku, Vettel completely lost his composure while following Hamilton behind the safety car. This was a rare occasion when Ferrari misjudged the tyres on Saturday and ended up way off the pace, but Vettel got up to second early on and was looking to use the opportunity presented by a restart to threaten Hamilton's superiority.

Feeling that Hamilton had deliberately



brake-tested the Ferrari as the field bunched in readiness to go racing again, Vettel inadvertently rear-ended the Mercedes. Furious at the perceived slight, Vettel drew alongside Hamilton and deliberately weaved into the side of his rival's car. The 10-second penalty Vettel received consequently relegated him to a fourth-place finish. That ultimately cost him a victory because Hamilton's headrest came loose after a subsequent red-flag restart, dropping the Mercedes man to fifth. Vettel extended his points lead by two, but would have enjoyed a 15-point swing in his favour had he managed to keep his cool.

Vettel was hauled in front of the FIA and subsequently apologised for creating

a "dangerous situation" with his actions, but the significance of yet another example of losing his equilibrium in the heat of battle – following his foul-mouthed tirade at race director Charlie Whiting in Mexico last year – was not lost on Hamilton. "We're not 20-year-olds, we're grown men now," said Hamilton, when asked to explain the dynamic with Vettel later in the season. "If you watch great tennis players, great golfers, great athletes in the world, the mind is everything.

"There's a famous saying in war: keep your friends close and your enemies closer. I watch Sebastian; I know what he's achieved; I know how consistent he's been; I know where his strengths



Belgium

1 Hamilton 2 Vettel 3 Ricciardo

Hamilton narrowly fends off Vettel to claim his fifth win of the season and cut Vettel's championship lead to seven points. Verstappen suffers another engine failure as Ricciardo beats Raikkonen and Bottas in a thrilling late battle for third. Force India (above) imposes team orders after its drivers collide again.



Italy

1 Hamilton 2 Bottas 3 Vettel

Hamilton leads a comfortable Mercedes one-two in Ferrari's backyard. Vettel recovers to third after starting sixth, helped partly by grid penalties for nine drivers. Verstappen comes unstuck battling Massa (above), but Ricciardo charges up from 16th and lunges past Raikkonen to finish fourth.



Singapore

1 Hamilton 2 Ricciardo 3 Bottas

Hamilton claims an unlikely win from fifth on the grid, after poleman Vettel collides with Verstappen and Raikkonen at the start. All three are eliminated, along with Alonso's McLaren, leaving Hamilton clear to beat Ricciardo home. Kvyat loses his Toro Rosso drive after crashing out.



LAT IMAGES



Turning point for Hamilton: British GP victory, with now-obligatory crowdsurfing

and weaknesses are; I know the strengths and weaknesses of his car. If you look at [Rafael] Nadal and [Roger] Federer, the composure they have through a game, and how they present themselves after they win or lose, I think athletes like that really set an example, and I try to follow that.”

At the time, Hamilton suggested the mutual respect between himself and Vettel remained undimmed, but he also told Vettel in no uncertain terms to tread more carefully in future. He suggested Vettel disgraced himself with his behaviour, but that’s all it looked like for the moment – an ugly but inconsequential flashpoint. The true significance of this Vettel slip-up would only manifest itself much later.

The Mercedes turnaround

For the moment, Ferrari remained in the ascendant. Vettel extended his championship advantage to 20 points by finishing second to Bottas at the next race in Austria, where Hamilton was restricted to fourth after taking a new gearbox ahead of schedule, thanks to Mercedes running overly aggressive settings in the face of Ferrari’s early-season onslaught.

But the title battle took a decisive swing in Hamilton’s favour as the season reached its midway point with July’s British Grand Prix. Hamilton destroyed his opposition, claiming pole by more than half a second – the biggest qualifying margin he enjoyed over anyone in dry conditions all season – and

waltzing away from the Ferraris in the race. Mercedes was so strong that Bottas finished second comfortably, despite taking a grid penalty for the same gearbox problem Hamilton had suffered in Austria. Ferrari was peculiarly off-colour. To make matters worse, the team also suffered front-left tyre failures on both cars, as Vettel and Raikkonen overreached while trying to keep up.

Many teams had to go slow in this race with concerns over front-tyre blistering. The aerodynamic loads at Silverstone were enormous, and so therefore was the energy going through the rubber. Ferrari got caught out and Vettel suffered badly. Instead of finishing on the podium and limiting the damage, he trailed home seventh and saw his points lead slashed to almost zero.

Ferrari got back on top with a one-two next time out in Hungary, where Vettel led home Raikkonen, despite suffering from bent steering for much of the race. Hamilton also gave up three extra points by letting Bottas back past to complete the podium, having been allowed through by his team-mate in a failed bid to unseat the Ferraris. It was another example of a difficult weekend for Mercedes while trying to extract performance from the softest tyres on a low-speed track, but it also seemed to produce the early signs of a personal breakthrough for Hamilton, who qualified four tenths off the pace but was bang on form in the final stint of the race, after experimenting with different driving lines and car settings.

Hamilton used F1’s three-week >>

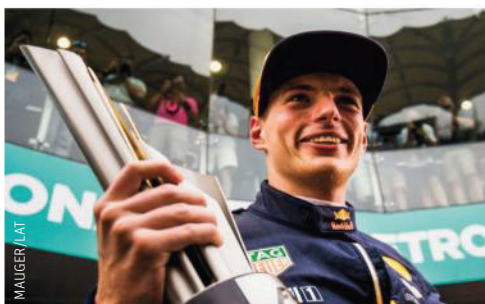

Malaysia

1 Verstappen 2 Hamilton 3 Ricciardo

Ferrari’s travails continue as Vettel suffers two engine failures, while Raikkonen fails to start the race. Hamilton bags pole after aero-package reversion, but is beaten by Verstappen’s Red Bull. Ricciardo claims another podium as Vettel charges from last to fourth before colliding with Stroll on the slowing down lap.



Japan

1 Hamilton 2 Verstappen 3 Ricciardo

Vettel’s fading title hopes evaporate as his car suffers spark plug failure and he retires after four laps. Hamilton wins narrowly from Verstappen. Ricciardo claims his third straight podium, ahead of Bottas, who recovers from a gearbox penalty. Renault says 2018 signing Sainz will replace Palmer for the final races.



United States

1 Hamilton 2 Vettel 3 Raikkonen

Vettel desperately needs victory to resuscitate his title bid, but is well beaten by Hamilton despite taking the lead at the start (above). Ricciardo’s hopes of a fourth consecutive podium are undone by engine failure, while Verstappen charges from 16th to steal third from Raikkonen, but is penalised for cutting the track.

F1 SEASON REVIEW 2017

August break to re-energise his batteries, further study the weaknesses of the Wo8, and work out a way to come out swinging over the final part of the season. He won five of the next six races, from Spa to Austin, amassing 143 points to wrest unassailable control of the championship. During that same period, Vettel scored no wins and just 63 points of his own...

"The first half of the season was maybe a little bit up and down in terms of extracting maximum performance out of the car," says Hamilton. "Ferrari seemed to be a lot more consistent in that respect. The second half of the season was really the turning point for me. The studying and the understanding of the balance, being really able to hit the nail on the head most weekends, and get the car where I was able to exploit its potential, and my potential, on a consistent basis, was really a [big] part of it."

Vettel implodes part 2

But not the only part of it. Amid Hamilton's winning run, Ferrari's season also imploded spectacularly. First, the team "screwed up" on home turf at Monza, as Vettel trailed both Mercedes home. This created added pressure to win next time out in Singapore – the sort of Monaco/Hungary-style circuit on which Ferrari had been so strong earlier in the season.

Vettel bagged pole, ahead of the resurgent Red Bulls of Verstappen and Daniel Ricciardo, helping put more space between Vettel and Hamilton, who was starting down in fifth for what recent

history would suggest is always Mercedes' worst race of the season.

Vettel knew he needed to make the most of the opportunity. If he could win this race, with the Red Bulls and Raikkonen restricting Hamilton to fifth, he stood to turn a three-point deficit into a handy 12-point cushion with six races left. But the Ferrari ace blew his big shot. He chose to start the first wet Singapore GP in second gear and made a sluggish getaway. Verstappen began to draw alongside as they sped towards the first turn, so Vettel veered across the track to block his path. What Vettel didn't count on was team-mate Raikkonen making a blistering start from the second row.

The trio collided as Verstappen became pincered between two Ferraris. The damage to Vettel's radiator caused him to spin off on his own fluid further around the lap. Verstappen and Raikkonen were out on the spot, taking Alonso's McLaren-Honda with them and forcing Ricciardo to lift off the gas to pick his way through the chaos. Sailing serenely around the outside of the mayhem, and on to an unlikely victory, was Hamilton.

Vettel resolutely believes he did nothing wrong in Singapore, that he couldn't have accounted for Raikkonen's dynamite start. But in truth he only had himself to blame – for the poor getaway that left him vulnerable in the first place, and for not conceding the lead to Verstappen and living to fight another day. Even a second-place finish in that race would have been better for Vettel than what ultimately transpired. But

that's what pressure does sometimes.

When Ferrari's engine reliability disappeared during the next two races in Malaysia and Japan, which the team put down to quality control problems with externally supplied components, Vettel's title hopes all but evaporated. When he failed to beat Hamilton to victory in the US, despite taking the lead at the start, then collided with Verstappen and Hamilton on the first lap of the following race in Mexico – recovering to fourth when a minimum of second was needed to prolong the fight – Vettel's title bid was finally ended for good. Hamilton was crowned champion for a fourth time.

"Overall, I think we had a good year," argues Vettel. "In the end Mercedes was better, they were faster – look at the amount of pole positions, of race wins. We had our chances, we used them, we had races where we probably got away with a good result even though it was on the edge. I'm thinking about races like Bahrain, where we were very close to having a failure. We won the race in Hungary, which I don't think we were supposed to win with the steering failure we had during the race.

"We finished races that could have been a DNF. On the other hand, we had other races where we didn't finish. It's obviously bitter because you're not in the fight. That's how it goes sometimes. In that regard, Mercedes has been more consistent. The issues they had, thinking about the gearbox at the beginning of the year, were less costly, but that's how it goes.



Mexico

1 Verstappen 2 Bottas 3 Raikkonen

Vettel takes pole but Verstappen grabs the lead at the start, while Vettel and Hamilton both drop back after colliding. Verstappen dominates as Vettel charges back to fourth, two places less than he needs to prolong the title fight. Hamilton is crowned champion, finishing ninth after a late scrap with Alonso.



Brazil

1 Vettel 2 Bottas 3 Raikkonen

Hamilton crashes in Q1. Bottas narrowly beats Vettel to pole, but loses the race with a poor start and overcaution into the first turn. Hamilton charges up to fourth from a pitlane start, before running out of tyres chasing Raikkonen. Massa (above) holds off Alonso to finish seventh in his final Brazilian GP.



Abu Dhabi

1 Bottas 2 Hamilton 3 Vettel

Bottas makes amends for his Brazil mistake by winning a straight fight with Hamilton, who pressurises the sister Merc for most of the race but cannot force an error. Vettel finishes a distant third as Ferrari is forced into aggressive fuel saving, which leads Raikkonen to liken F1 to endurance racing.



Turning point for Vettel: the clumsy moment that gave Hamilton honours in Singapore GP

contention himself until the summer break, but couldn't live with Hamilton through the Asian leg of the season and lost confidence. Bottas improved greatly over the final races, though, culminating in an impressive defeat of Hamilton in a straight fight in Abu Dhabi, which suggests he could be a proper title contender in 2018 if he can string a full season together.

The other teams to watch out for next year will likely be McLaren and Renault. McLaren had high hopes for the third season of its revived partnership with Honda, but that relationship blew apart following a woeful winter testing programme and a serious underlying lack of performance and reliability. Having produced a decent car under the 2016 rules, which developed well too, McLaren expected to challenge for podiums and finish at least fourth in the constructors' championship this year. Instead, the team scored only three more points than it managed in '15.

The hope is that a new engine deal with Renault will make McLaren a properly potent force again in 2018, when the Renault works team is also expected to make a big step forward. After the growing pains of '16, the Enstone-Viry combination was much more respectable this season, with Nico Hulkenberg almost single-handedly carrying the team to a top-six finish in the constructors' standings, at the expense of Toro Rosso. The aim next year will be to overtake Force India (impressively best of the rest again in 2017) and Williams.

If Renault and McLaren can somehow join Red Bull and Ferrari in challenging Mercedes next year, then F1 could be set for a truly epic fight at the front. Mercedes deserves enormous credit for remaining on top during a period of significant rules upheaval, which is a testament to the strength of its organisation, but this is the hardest it has had to fight since the V6 rules were introduced, and F1's new owner Liberty Media — as keen as the rest of us to see a worthy spectacle — will desperately hope 2017 marks the beginning of a long-overdue trend.

"This year definitely is a championship I've been hoping for — more like 2008, where you're fighting another team," says Hamilton. "To be able to battle someone else, who is a four-time world champion, who's got great skill, and a team also that knows how to win championships — to extract the most from my guys to compete with that, that's how every championship needs to be. I hope there are more championships like this one."

As do we all. ✨

"I want to emphasise the positives for us — the steps we were able to make; the way the team has grown together. I don't think you always see the full picture. Maybe we are less vocal about it than other people as well. In the end, we do our job, and that's what brought us here in the first place. If we keep doing that, I'm confident that we can be in a better place next year."

Hints of a bigger battle ahead

The championship fight might have ended with a whimper, but there were at least some signs of life elsewhere on the grid during the final races. After its troubled start to the year, Red Bull came on strong in the season's second half. Verstappen followed up that unfortunate Singapore disaster by overtaking Hamilton for victory in Malaysia, pushed him hard in Japan, then dominated in Mexico.

Problems with the performance and reliability of the Renault engine remained,

and the RB13 couldn't challenge for pole except in extreme circumstances of rain, heat or otherwise low grip. But it developed into a potent racing car, and so convinced was Verstappen by the team's progress that he opted to extend his contract until the end of 2020, taking arguably the hottest property in next year's driver market off the table.

With better reliability, both Verstappen and Ricciardo would have finished ahead of Raikkonen in the championship. Raikkonen also lost a hatful of points to incidents and problems not of his own making, but his form did not impress Ricciardo, who reckoned the 2007 world champion should have scored way more points with a car as potent as the Ferrari at his disposal.

Ultimately, Raikkonen finished 100 points behind fellow Finn Bottas, who was a far sharper weapon for Mercedes in the constructors' fight than Raikkonen was for Ferrari. Bottas was in drivers' title

TOP 10 DRIVERS

By Ben Anderson



10

Sergio Perez

NO CHANGE

PEREZ COULD MAKE A CASE TO BE HIGHER UP this list after another excellent campaign with Force India. He is now undoubtedly one of the F1 midfield's most consistent drivers.

With Nico Hulkenberg moved on to pastures new, Perez became the undisputed reference for Force India, and its new driver Esteban Ocon, and he didn't disappoint. There was no podium this season, but he amassed a three-figure points tally again and fell just one point shy of matching his 2016 peak of 101.

Perez was narrowly Force India's faster driver across the balance of the campaign too, and proved he is much more than just a good tyre manager. He has flourished into a properly fast, super-consistent, utterly dependable performer. Force India feels he is operating at his peak.

The big question then is whether Perez has reached his ceiling. Ocon began to turn the tide on familiar circuits and will only get better. If Perez cannot retain the balance of power against Mercedes' star junior, hopes of another shot at the elite end of the grid will surely never materialise.



9

Esteban Ocon

NEW ENTRY

OCON WAS NOT DEFINITELY better than Perez, but gets the nod in this ranking because of just how close he came. To be within 0.075% of Perez's qualifying pace throughout the year, and to fall just 13 points shy of Perez's points total, was a truly outstanding effort for a driver of Ocon's inexperience.

Ocon slotted in at Force India so seamlessly, and was so

accomplished, that it was easy to forget he'd started only nine grands prix before this season got under way. Remember, this was Perez's seventh year in F1, his fourth with Force India, and he's contested well over 100 races in that time.

The early part of the year was tough, as Ocon found his feet, but his progress massively impressed the team. And once back on circuits

at which he drove his part-season with Manor in 2016, Ocon evened out the qualifying battle, pretty much matched Perez point for point, and was narrowly the faster Force India driver after the August break.

If Ocon continues this rate of development, he will surely become a serious contender for a works Mercedes drive in 2019.

8

Carlos Sainz Jr

DOWN 2

THE TORO ROSSO WAS A TRICKY CAR, WHICH did not develop well and lacked power, but Sainz did extraordinary things with it, which is why he beats the Force India drivers here.

Sainz's race to seventh in China – miles faster than the other midfield runners in difficult conditions – was something special, as was beating Hamilton's Mercedes to sixth in Monaco. Fourth in Singapore, Sainz's best result yet in F1, was another example of overachieving in tough circumstances.

Sainz scored 48 of Toro Rosso's 53 points, and the team added only one more after he left, which says a lot. Finishing seventh on his Renault debut at Austin – passing Perez around the outside at high speed – was Verstappen-esque in its audacity.

Red Bull clearly ranks Sainz third in its talent pool, behind Verstappen and Ricciardo, which is fair enough, but Sainz continues to suggest he is simply too good to ignore.



COATES/LAT



HOME/LAT

7

Nico Hulkenberg

UP 2

THIS WAS HULKENBERG'S MOST IMPRESSIVE F1 season since 2013, when heroic drives for Sauber made him a contender for a Ferrari seat. The ambitious but nascent Renault works project represents his final realistic shot at the big-time, and he so far hasn't disappointed.

He was the only driver not to get outqualified by a team-mate all season – though Jolyon Palmer was on course until his Renault broke at Spa – and Hulkenberg would have scored many more points but for poor reliability.

The Renault was not definitively the fourth best on the grid, but there were occasions when Hulkenberg took it to places it did not belong. He was outstanding at Silverstone, and was pushing Bottas for a podium in Singapore before it broke down.

Crucially, it was Hulkenberg's feedback that led Renault down the development path that transformed its fortunes mid-season, proving he is a leader as well as extraordinarily fast. >>

6

Valtteri Bottas

UP 2

BOTTAS HAD ONE OF THE TOUGHEST tasks on the grid: stepping up from a midfield team late in the day, into a seat vacated by the reigning world champion – a driver so exhausted by fighting Lewis Hamilton that he decided to retire rather than defend his title.

Bottas acquitted himself superbly – pole in his third race, two wins from

the first nine, a title contender before the August break. When Mercedes most struggled with the W08 on smooth, low-speed tracks during the first half of the season, it was Bottas who looked more assured than his multiple world champion team-mate.

But Bottas's form dipped as the car improved, and Hamilton stepped up his game. Bottas started to look second rate, admitting his confidence took a battering. Arguably the most impressive aspect to Bottas's season is the fact that he found a way to turn things around.

His strong finish to the year, showcasing impressive mental resilience and capacity for self-improvement, elevates him back into the top six in this ranking.



HONE/LAT



MAUGER/LAT

5

Daniel Ricciardo

DOWN 4

LAST SEASON'S OUTSTANDING DRIVER struggled to reach the same heights this year, mainly because of the leap forward Max Verstappen made on the other side of the Red Bull garage. Ricciardo is the same super-smooth, fast and classy racer of recent seasons, it's just that Verstappen's superlative form made it tougher for him to stand out.

Whenever the RB13 was a bit loose, Ricciardo looked less comfortable than his team-mate, and there were a couple of uncharacteristic slumps and errors. When the car became a genuine victory contender at certain circuits during the final part of the year, it was Verstappen and not Ricciardo doing the winning.

There were still some brilliant performances: holding off Hamilton to finish on the podium in Austria; burns from the stern at Silverstone and Monza (including a trademark lunge pass on Kimi Raikkonen); and a brilliant weekend before the car broke in Abu Dhabi.

But although Ricciardo scored more podiums in one season than ever before, and finished fourth in the championship, he was definitely the second-best driver at Red Bull this year, which is a new experience for him.

Ricciardo remains one of the best on the grid, but now he is discovering what it's like to exist in Verstappen's shadow. Finding a way to emerge from it will be his next big test.



Irrepressible force
Alonso took his
McLaren-Honda
to places it didn't
deserve to be

4

Sebastian Vettel

UP 3

AFTER A TROUBLED 2016, FERRARI AND Vettel rediscovered their mojo this year. Having a car underneath him capable of fighting for the championship seemed to galvanise Vettel.

His qualifying form was outstanding. He made the front row 14 times in 19 attempts (discounting Malaysia, where the engine failed in Q1) – including four pole positions – which represents a superb effort in a car that was not often the fastest over one lap. Kimi Raikkonen threatened Vettel's superiority in 2016, but was pummelled into submission this year.

While Mercedes struggled to consistently unlock the full potential of the W08 early on, Vettel brilliantly capitalised to assume the championship lead.

Given their inferiority to Mercedes and Hamilton at most circuits, Ferrari and Vettel could not afford mistakes. Ferrari's bizarre unreliability in Malaysia and Japan cost Vettel a heap of points, but so did his mad moment in Azerbaijan, and that ill-advised chop on Max Verstappen at the start in Singapore.

They were needless errors, which cost Vettel his title shot. That susceptibility in moments of extreme pressure is the chief reason Vettel is not better placed.



DUNBAR/LAT



COATES/LAT

3

Fernando Alonso

UP 2

IT WILL REMAIN AN ENDURING tragedy of the ill-fated McLaren-Honda revival that Alonso's talents spent three seasons going to waste. If you factor in Ferrari's woeful 2014 campaign, at least 79 grands prix have gone by since Alonso last sat in a car worthy of his abilities.

But he is still driving like the champion he is. Enthused by 2017's enhanced aerodynamics and faster cars, plus McLaren's impressive rate of development, Alonso was consistently excellent and regularly

overachieved in a car lacking serious straightline speed.

There were some comedy moments of radio frustration, and a few petulant outbursts – including retiring an apparently healthy car at Spa – but they are far outweighed by the way he manhandled a difficult package and bent it to his iron will.

Alonso was superb over the first four races, before Honda got the engine's woeful driveability under control, and qualifying seventh in Spain was outstanding

– as were the laps that got him into Q3 in Brazil and put him fifth in Q1 in Mexico.

Amazingly, Alonso almost scored a point in Canada, and was denied a big result in Singapore by Vettel's startline crash. The way he clung to Felipe Massa in Brazil, and beat the Williams in Abu Dhabi, were classic examples of a fierce racing intellect undimmed by years of uncompetitive machinery.

Alonso remains an irrepressible force to be reckoned with. >>



Hamilton was as fast as ever, but it's his capacity for self-improvement that marks him out

2

Max Verstappen

UP 1

VERSTAPPEN WAS BRILLIANT in 2017. Sixth in the world championship, 32 points behind Red Bull team-mate Ricciardo, doesn't do justice to his season. Poor reliability ruined too many of his races, robbed him of points and tested his patience to breaking point, but that couldn't disguise how consistently excellent he was.

With more experience and a proper winter of preparation under his belt at Red Bull, Verstappen stepped up his game on Saturdays, comfortably beating Ricciardo –

renowned as one of F1's elite qualifiers, and last year's outstanding driver – across the balance of the campaign.

There is a very strong argument to be made for putting Verstappen at the top of this list. He won two races in the third-best car, and was roughly a match for Hamilton by pretty much every measure. That Verstappen misses out is down to the lower-pressure nature of his fight, plus the fact that he continues to take major risks in battle, asking other drivers to jump out of his

way or court calamity.

It undid him in Spain, almost destroyed Red Bull's race entirely in Hungary, and Verstappen was fortunate not to puncture a tyre in collisions with Vettel in Canada and Mexico. Verstappen's instincts are highly attuned, and impressive, but they will be his undoing in a title fight if they are not tempered.

This is arguably his only weakness as he continues an irrepressible rise to the summit of grand prix racing. He's not there yet, but it is surely only a matter of time.



LAT IMAGES

1

Lewis Hamilton

UP 1

HAMILTON BECAME A FOUR-TIME WORLD champion, broke Michael Schumacher's pole position record, and became Britain's most successful grand prix driver in 2017, but it was the way he achieved this success that stood out – and which elevates him to the #1 spot in these rankings.

He stayed resolutely ice-cool under pressure, in a way vanquished rival Vettel did not. Hamilton clawed back his early points deficit, and visibly raised his game as the season wore on, leaving new team-mate Valtteri Bottas trailing and Ferrari scrambling.

Hamilton won six of eight races from Silverstone to Austin – dominating when he could, defending when he needed to,



COMTRES/LAT

BELOW THE BUBBLE

Of the drivers to miss out on the top 10, **Felipe Massa** has the strongest case for inclusion. F1 2017's faster cars suited his committed driving style and he destroyed rookie Williams team-mate **Lance Stroll** in qualifying.

Without a couple of unfortunate failures, Massa would have finished ninth in the world championship. He drove well enough to deserve further postponement of his retirement in all honesty, but he can leave with his head held high.

Kimi Raikkonen enjoyed flashes of inspiration again this year – including a rare pole in Monaco – and earned yet another Ferrari contract extension. But in truth this was another underwhelming season for the 2007 world champion, who was twice called out by company president Sergio Marchionne for underperformance.

Kevin Magnussen won few friends with his uncompromising approach to battle, but managed what predecessor Esteban Gutierrez could not by scoring points frequently for Haas. Magnussen also gave qualifying specialist

Romain Grosjean the hurry-up. Grosjean dazzled on occasion again, but struggled from mid-season as the Haas picked up understeer.

Mercedes junior **Pascal Wehrlein** made Q2 three times and scored five points in the worst car. Sadly, that wasn't enough to guarantee him a seat for 2018. Sauber duo Wehrlein and occasionally error-prone **Marcus Ericsson** were the most closely matched pairing on the grid in qualifying. Ericsson was unlucky not to score at least one point during his best season yet in F1.

Of the rookies, McLaren's **Stoffel Vandoorne** was the most impressive, once Honda got its engine to run cleanly and Vandoorne found a way to adapt his driving to the car and not be overawed by his hero Fernando Alonso. Stroll endured a tough baptism at this level, struggling particularly to get up to speed in qualifying. He raced well several times, and qualifying fourth fastest in the rain at Monza suggests he is capable of special things, but there were far too many Q1 exits in a car that was consistently able to challenge for Q3.

Sophomore **Jolyon Palmer** had it worse. His car was plagued by woeful unreliability, but he struggled to score and failed to put Renault team-mate Nico Hulkenberg under any real pressure, so was dropped with four races left.

Toro Rosso's **Daniil Kvyat** finally ran out of last chances with Red Bull and was also dropped before the season finished. Kvyat was undoubtedly fast at times, but inconsistent, didn't score enough, and finally got axed after crashing out in Singapore.

Kvyat reappeared at Austin, signing off with a points finish, ironically, before making way for Super Formula graduate **Pierre Gasly** to return alongside Porsche World Endurance champion **Brendon Hartley**. Both did a solid job in difficult circumstances as Toro Rosso's season tailed off. 🏆

coming from behind if he had to, making the most of others' mistakes when they made them. This was Hamilton's little-heralded, Alain Prost-like versatility and capacity for calculation on display.

There were some wonderful performances. He was on another level at Silverstone, and his pole lap in Malaysia, despite having to revert to a dated aero package, was remarkable.

Hamilton's stunning qualifying form was the foundation of his success yet again – 11 pole positions and 13 front-row starts – and his well-established formidable skill as a racer was there whenever he needed it. What elevates this Hamilton season is the capacity he showed for self-improvement.

It wasn't a perfect campaign by any means. Ferrari was faster in race trim early on, and Hamilton struggled with the W08's initial recalcitrance more than Bottas did. But he found a way to dig himself out of trouble.

He focused on the weaknesses of his car, on his own weaknesses in driving that car, and neutralised them. He found a way to drive a car that wasn't always the best on the grid and made it look like it unquestionably was.

Hamilton was as fast and as ruthless as ever, but he was also clever, and humble enough to recognise his flaws. Finding a way to turn his season around, making himself stronger than ever, is why he's F1's most outstanding driver in 2017, as well as its deserving champion.

Flexible Travel Options

Travel the World with our Escorted Tours and UK Travel Team



ALL FORMULA ONE EVENTS

Join me for our F1 Escorted Tours; by Air - Coach options

◇ Winter & In Season Testing ◇ Team Factory Visit

2018 Book Now All Formula One Grand Prix

Extended Holiday options; China, Canada, Singapore, Japan, US Austin, Mexico



US GP ROAD TRIPS

Vegas, Route 66
Monument Valley
Grand Canyon

NASA Space Centre
New Orleans, Memphis
Nashville, Indianapolis

COMBINED TOURS

Monaco Historic with
Mille Miglia

F1 France + Austria
F1 Germany + Hungary
F1 Belgium + Italy
F1 US Austin + Mexico



LE MANS 24HR - WEC - ENDURANCE RACING

LE MANS 24HR

15 Coach Tour options

Self Drive | By Air | Train with Camping or Hotel

BLANCPAIN: Monza | Spa 24HR | Barcelona

WEC 6HR SPA | Silverstone

HISTORIC MOTORSPORT RACING EVENTS

- ◇ MONACO HISTORIQUE
- ◇ MILLE MIGLIA
- ◇ LE MANS CLASSIC
- ◇ GOODWOOD FESTIVAL OF SPEED
- ◇ GOODWOOD REVIVAL



UK TRAVEL TEAM: +44 (0) 1451 833 721

BOOK ONLINE: enquiry@selectmotorracing.com



THE BOSSES' TOP 10

By Lawrence Barretto, F1 Correspondent



TOTO WOLFF
Mercedes



MAURIZIO ARRIVABENE
Ferrari



CHRISTIAN HORNER
Red Bull



VIJAY MALLYA
Force India



CLAIRE WILLIAMS
Williams



CYRIL ABITEBOUL
Renault



FRANZ TOST
Toro Rosso



GUNTHER STEINER
Haas



ERIC BOULLIER
McLaren



FRED VASSEUR
Sauber

Lewis Hamilton has comfortably come out on top in Autosport's F1 team principals' top 10 drivers poll for 2017.

We asked all 10 teams' bosses to rank their top 10 drivers, based on on-track performances over the course of this season's 20 races.

Points are awarded using F1's scoring system (25-18-15-12-10-8-6-4-2-1) to generate an overall winner.

Votes are kept secret to ensure team bosses are willing to take part and can give their honest opinion of drivers up and down the grid.

Hamilton, who won nine races this season on his way to a fourth world title, collected an impressive total of 233 points from a possible maximum of 250 to retain top spot – one point short of last year's tally but, with the number of teams this term being reduced by one, this year's score is even more dominant.

It is Hamilton's fourth successive victory in the poll, with Red Bull's Max Verstappen, who secured two wins this year, 90 points adrift in second.

Hamilton's closest rival in the championship – Vettel – slotted into third, two points shy of Verstappen but two places higher than last year.

Mercedes protege Esteban Ocon is the highest new entry, coming in at number five, ahead of world champions Fernando Alonso and Kimi Raikkonen. *W*

HOW THE TEAM CHIEFS VOTED



1 233PTS

LEWIS HAMILTON

NO CHANGE



6 65PTS

FERNANDO ALONSO

NO CHANGE

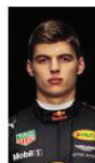

2 143PTS

MAX VERSTAPPEN

NO CHANGE



7= 49PTS

KIMI RAIKKONEN

NO CHANGE



3 141PTS

SEBASTIAN VETTEL

UP 2

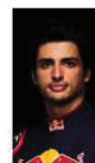

7= 49PTS

CARLOS SAINZ JR

UP 3



4 122PTS

DANIEL RICCIARDO

NO CHANGE



9 47PTS

NICO HULKENBERG

RE-ENTRY



5 73PTS

ESTEBAN OCON

NEW ENTRY



10 39PTS

VALTTERI BOTTAS

DOWN 1

PREVIOUS SEASONS



2012

- 1 Fernando Alonso
- 2 Sebastian Vettel
- 3 Lewis Hamilton
- 4 Kimi Raikkonen
- 5 Jenson Button
- 6 Mark Webber
- 7 Nico Hulkenberg
- 8 Nico Rosberg
- 9 Sergio Perez
- 10 Felipe Massa

2013

- 1 Sebastian Vettel
- 2 Fernando Alonso
- 3 Kimi Raikkonen
- 4 Lewis Hamilton
- 5 Nico Rosberg
- 6 Romain Grosjean
- 7 Nico Hulkenberg
- 8 Mark Webber
- 9 Jenson Button
- 10 Felipe Massa

2014

- 1 Lewis Hamilton
- 2 Fernando Alonso
- 3 Daniel Ricciardo
- 4 Valtteri Bottas
- 5 Nico Rosberg
- 6 Felipe Massa
- 7 Sebastian Vettel
- 8 Jules Bianchi
- 9 Jenson Button
- 10 Daniil Kvyat

2015

- 1 Lewis Hamilton
- 2 Sebastian Vettel
- 3 Nico Rosberg
- 4 Max Verstappen
- 5 Daniil Kvyat
- 6 Fernando Alonso
- 7 Valtteri Bottas
- 8 Sergio Perez
- 9 Daniel Ricciardo
- 10 Kimi Raikkonen

2016

- 1 Lewis Hamilton
- 2 Max Verstappen
- 3 Nico Rosberg
- 4 Daniel Ricciardo
- 5 Sebastian Vettel
- 6 Fernando Alonso
- 7 Kimi Raikkonen
- 8 Sergio Perez
- 9 Valtteri Bottas
- 10 Carlos Sainz Jr

Why Ferrari may not have blown its only chance

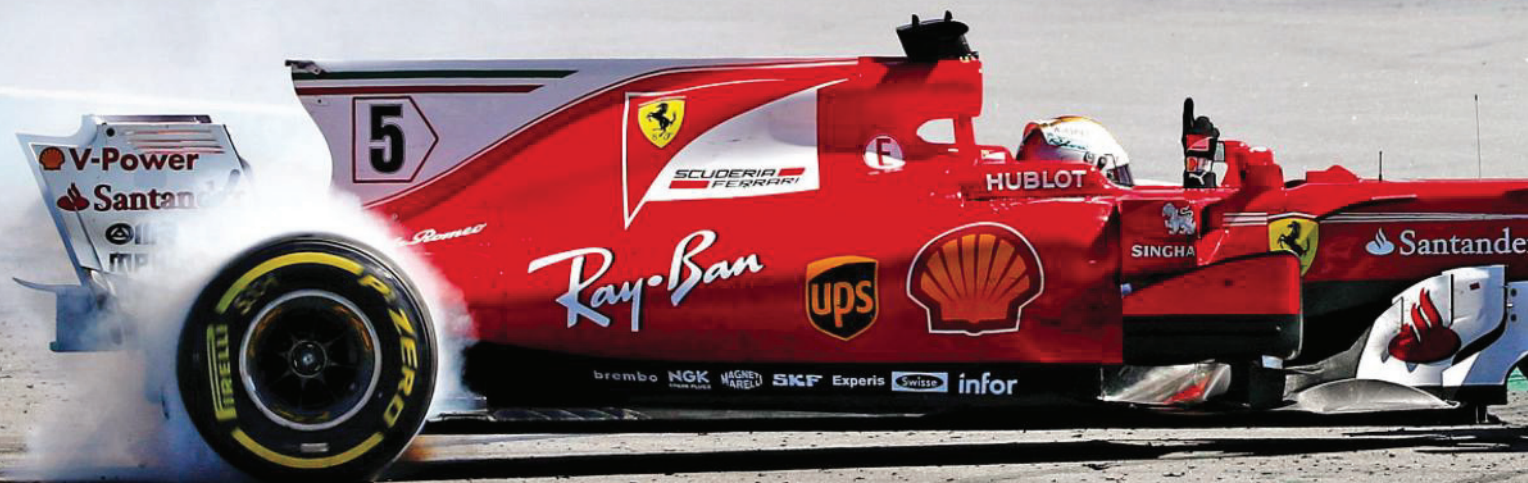

It would be easy to assume that the Prancing Horse's golden opportunity has bolted through the stable door. But that would be to ignore the team's new structure that, with refinement, could give it another shot in 2018

By Jonathan Noble, Special Contributor

Hindsight is a wonderful thing. With a chill pill for Sebastian Vettel in Azerbaijan and Singapore, plus a different spark plug in Japan, we could be sitting here now reflecting on a full-blown title resurrection for Maranello.

But top-level sport is not about ifs and buts, and Ferrari's Asian collapse – Vettel's needless crash in Singapore and the engine problems in Malaysia and Japan – effectively derailed what until then had been a nailbiter with Mercedes. The cruel and dramatic nature in which it all went wrong for Ferrari overshadowed many of the positives of a campaign where a restructuring under the guidance of chief technical officer Mattia Binotto really started to deliver performance

and results. Maranello produced its fastest and most benign racing car for years, and it matched that with a development push that kept pace with Mercedes throughout. So at some levels it was a year where Ferrari exceeded almost all expectations.

The roots to this success (and failure) can be traced back to the winter of 2014-15, when former Marlboro man Maurizio Arrivabene arrived as team principal at the start of a new era



Ferrari new broom Binotto's management style has redefined the role of tech boss

COMES/LAT



S. BLOMHA/W/LAT



Vettel won in Monaco, one of five 2017 victories, but let two more slip through his fingers

under Sergio Marchionne. The new management had inherited Vettel, an improved engine and a more competitive car, with then-technical director James Allison's influence fully unleashed after an early switch of focus to its 2015 challenger. The three wins that season should have been the launchpad for a full title assault in '16. But the tragedy that struck Allison after the Australian Grand Prix, when his wife died unexpectedly, hit the team hard.

Allison's absence – with a structure inside the team that relied so heavily on him as a focal point and leader – put it off kilter for four months as it failed to match Mercedes' impressive development rate. In the end, Allison's personal situation, and differences of opinion with Marchionne about how the team should move forward technically, led to him leaving the team in July and opening the way for a major reshuffle.

The first step was to move Binotto across from his position as head of the engine department to become chief technical officer. From the outside it seemed a strange move because, despite his vast experience in the F1 team, Binotto had never designed a racing car.

But to think like that was to not understand the different way of working that was being adopted. Binotto was not a technical chief in the old sense of being a car creator. Instead, he was more a super-manager. A championship-winning football manager does not need to know how to play in goal, how to pass a ball in midfield or how to take a penalty. But they need to understand which players can do those jobs best, how to get them all to work together and how best to get them to perform.

Ultimately, for a talented and intelligent engineer such as Binotto, the challenges of overseeing the creation of

the best car need the same skillset and processes as building the benchmark engine. After all, decisions are based on data and feedback from engineers – and, whether concepts work on dynos or windtunnels, it's about simulating, creating, testing, validating and racing.

With Binotto moving across, and with direct input from Marchionne, the team adopted a wholly different approach for its technical structure. Rather than a vertical organisation with a technical >>

F1 SEASON REVIEW 2017

director operating above department heads, Ferrari went for a more horizontal system, where talented individual staff in each area of the team had more of a say in the decision-making processes.

It helped give each department, and even individuals within them, more accountability, rather than relying on the technical director to make the final call. The well-controlled autonomy with which this empowered each department gave them more freedom for innovation and a better chance to develop themselves, rather than hitting a bottleneck with everything having to be approved from above.

As well as Arrivabene and Binotto fixing upon this system, a series of ambitious targets for the 2017 car were laid down too, very different from the approach that had been taken before. Previously, each department would have focused on producing the best it could in isolation. You would optimise the gearbox, the chassis, the aero and so on, and then bring it all together in an attempt to create what should be the ultimate car. Ferrari's approach from last summer – even though it was relatively late in the design process for the all-new 2017 regulations – was to think more holistically. The mindset from each department was more about what they could do to help as part of the overall package, rather than as an isolated element.

This helped create a unified approach to the SF70H, where each department understood where it fitted within the overall project. The result was not only a well-performing car, but one that correlated perfectly to the CFD and windtunnel – something that Red Bull and Force India struggled with at the start of the year. For Ferrari, having that baseline was essential. Correlation stayed



LAT IMAGES



Season started off on a high with Vettel's victory in Melbourne

well aligned through the year too, and each development that Ferrari brought to the track worked, proving that its new structures and process were paying off.

Ferrari made good progress on the engine front, too. It might not have totally closed the gap to Mercedes – especially in terms of 'magic' modes for qualifying – but there wasn't much in it. And the season-long controversy surrounding oil-burn might have had a small impact, but in the overall scheme of things it did not define Ferrari's success or failure rate.

What did define it were two separate elements: the reliability problems in Malaysia and Japan, plus Vettel's incidents in Azerbaijan, Singapore and Mexico. The cracked manifold pipe in Malaysia and faulty spark plug in Japan might have triggered the problems, but ultimately their existence highlighted weaknesses that remain in Ferrari's infrastructure. Although both faulty parts came from external suppliers, the team well knows that it is its own responsibility to ensure that those suppliers are up to the job, and that what they fit to the car is good enough.

It's the endless juggling act that every team goes through: balancing the push for performance against the need for reliability. It's about coping with pressure, being robust in every area. Ferrari perhaps went a step too far in this respect.

On the driving front, Vettel's questionable aggression in Azerbaijan and Singapore meant that two almost

certain victories slipped through his grasp needlessly, which ultimately proved hugely costly. Singapore in particular was a race that Ferrari was clear favourite to win, with Lewis Hamilton not looking like he had the pace for the podium. A Vettel victory, with Hamilton fourth, would have meant a 38-point swing in the championship, changing the dynamic of the year immensely. Don't forget that even the Malaysia reliability failure in qualifying only meant Vettel dropped six points on Hamilton, which is hardly a disaster if taken in isolation.

The margins were certainly close this year. Bad luck behind the safety car in China, losing out at the starts in Russia and Austria, and Mercedes' clever strategy to use Valtteri Bottas as a block in Spain, shifted what could easily have been Ferrari wins into Mercedes' hands. But those moments are part of racing, and they were all elements Ferrari had no direct control over – so can have no regrets about. It's areas within its control that must be Ferrari's focus if it is to prove that 2017 was no flash in the pan.

Ferrari has already worked on tightening up its reliability validation processes. Even before the Malaysia/Japan troubles, it was aware that this was an area of weakness, so the team had moved to pull across Fiat engineer Maria Mendoza, an expert in metals and chemicals, to help. News of her appointment only emerged after the Asian tribulations, but this was very much a planned move rather



HONEY/LAT



Arrivabene (left) has had to cope with driver indiscretions and technical hiccups



than a kneejerk response.

It's clear that the pain of this year has fired up a determination not to go through the same travails again in 2018. Its staff will be a year more experienced too, and insiders talk of Ferrari being much further forward in its processes than 12 months ago. The team can also hope that Vettel has learned his lessons.

But while there may be frustration about Azerbaijan, Singapore and Japan, the team is realistic that building a title-winning operation is not something that happens overnight. Even in Ferrari's golden era with Michael Schumacher under Jean Todt, Ross Brawn and Rory Byrne, it endured years of near-misses. Don't forget it lost the title in the final race of the season in 1997, '98 and '99.

Despite Ferrari's long history, as it heads into this winter it views itself as a young team getting used to a new structure. And for all the benefits that such youthfulness brought, as it pushed on with enthusiasm to create an innovative and brilliant design for 2017, there was a price to be paid for a lack of experience. What Ferrari needs now, more than anything, is patience. More patience on track from the star man at the wheel; and patience off it for the processes and structures that are in place now to fully blossom and deliver what the team is capable of. ❄

PARANOIA IN MARANELLO

SUCCESS IN FORMULA 1 MEANS LEAVING NO stone unturned in the quest to beat your rivals. While much of that focus revolves around the engineering job needed to make your car quicker, there are political battles to be fought and off-track wars that matter too.

One important element for every F1 team is the media battle; maximising the positives of your squad, keeping the pressure off your personnel and lobbing a few hand grenades at your rivals so they get distracted from their own efforts.

Ferrari team principal Maurizio Arrivabene did something totally baffling in 2017 when he elected to have an almost complete media lockdown: no official interviews were allowed with team personnel, as he decided that his squad's purposes were best served by cutting itself off from the F1 community.

Beyond limiting media coverage for Ferrari's own sponsors – who after all pay big bucks to get their names written about or broadcast – the approach proved both self-defeating and confusing. Primarily, it made a good story bad – the positives of the great tale of how Ferrari recovered from 2016 to deliver a championship challenger (which Autosport has managed to piece together here) were overshadowed by the negatives of the team's unhelpful attitude in not wanting to tell it. And it meant arch rival Mercedes was pretty much handed an open goal to set the media and fan agenda throughout '17 at a pace it wanted.

In the heat of a tight championship fight, throwing a few political curveballs at your rivals – just remember what Ferrari did in 2003 when Jean Todt and Ross Brawn publicly threatened to appeal the world championship over tyre rules – is hugely valuable and not something to be ignored. Added to that, Ferrari's approach

also served to leave it with a paddock full of journalists and photographers who had little sympathy when things went wrong. The backlash after its Monaco strategy call, the Azerbaijan incident or the Asian reliability dramas could have been avoided with better leadership in controlling the message.

Complaints from Arrivabene himself about the media getting things wrong – when they were trying to work out what had been happening, and the team's policy was never to explain anything properly – were laughable and showed a distinct lack of respect for journalists trying to do their job as best they could.

Quite why the media strategy took this direction was never properly explained. Was it

“Arrivabene’s almost complete lockdown on the media was totally baffling”

a Sergio Marchionne diktat? Was it nervousness from Arrivabene after setting targets too high in 2016? Was it the result of a team, or Arrivabene himself, fearful of getting it wrong and being exposed? Or was it a mixture of all of these?

Some in Ferrari tried their best to work around the confusing policy to help when they could, but in this exciting new era of greater fan access to F1 and a push to build a bigger and more informed audience, it was sad that Ferrari chose to go back to the dark ages.

Kimi Raikkonen was happy not to let the media get any closer than this





SBLOXHAM/LAT

LAT IMAGES

Q&A

Valtteri Bottas

By Ben Anderson

The Finn won three races and finished third in the championship in his first season with F1's best team, but Nico Rosberg's Mercedes replacement was well beaten by Lewis Hamilton and knows he has work to do to make sure he continues his fine Abu Dhabi GP form

AUTOSPORT In many ways, your first season with Mercedes happened in reverse – you started strongly, pole in your third race, you won two of the first nine, but everyone expected the second half would be the stronger, so how do you explain the season happening upside down?

VALTTERI BOTTAS It was a little bit weird. The beginning of the year started more or less as I hoped – I was getting closer and closer to Lewis in qualifying, got my first pole, then first win, and the results were pretty consistent. Before the summer break there was a really good period for me – I got more points from the four or five races than Sebastian [Vettel] and Lewis [Bottas outscores Vettel and Hamilton from Monaco to Hungary] – so I was expecting a very strong second half of the year. But after the August break, I had quite a bit of struggle. There were some circuits that highlighted more of the issue of my driving style with this car, as well as with the set-up. I struggled to find it. It has been a quick car, but many times it's been very difficult to set it up and drive, and you needed to drive around some issues we have, particularly with the rear of the car.

AS The first half of the year the pattern seemed to be that when the car was at its most difficult, you were at your strongest, but in the second half of the year you had real swings, whereas Lewis was basically strong all the time. So what did he do differently or what changed about the car that made it easier for him and harder for you?

VB There was no big switch with the car. There was consistent development



Breakthrough
victory came on
smooth surface at
the Russian GP

and the set-up direction moved slightly, and I struggled to drive the car with optimal set-up sometimes. Lewis managed with his driving style to drive it, and I found it very tricky.

AS Do you have different driving styles then?

VB There are definite differences, and still some things I need to do better. I've also learned from Lewis this year – some things I've been able to pick up. After struggling quite a lot for a couple of races [Singapore and Malaysia], it wasn't easy mentally, because I was quite confused – like, 'What's going on, did I just suddenly forget how to drive?!' You start to doubt what you're doing then, when you need to change some things with your driving style and adapt to many different things suddenly, you realise it's not that simple – then you easily overthink things and it becomes less natural driving. But it's going to a much better direction [now], and if there's going to be similar struggles next year I'm prepared. I've learned massively from those difficult races.

AS On tracks with a very smooth asphalt you've been really strong – Sochi, Monaco, Baku, also Mexico City, and Lewis has been up and down, and on the higher-energy tracks it's been more difficult for you. Does it basically come down to the way your driving style treats the tyres, so on the rough tracks, where they overheat more easily, you have problems managing that, and on the low-energy tracks your style helps switch the tyres on? Is that broadly what's been happening?

VB Yeah, more or less, exactly. We've

“After struggling quite a bit for a couple of races it wasn't easy mentally. I was quite confused. You start to doubt yourself”

definitely seen that pattern on the smooth surfaces. It was always better for me this year, and I haven't seen the pattern in the last years. With this car, it really highlights the differences of how we drive.

AS Your team-mate became a four-time world champion this year. What have you noticed about the level he drives at compared to your previous team-mates, and how do you plan to take the next step?

VB I always knew that he's really talented, and he's quick in any circumstances, always. But that also comes from hard work – he works hard with the team. I think this year what he's been doing better than me comes mainly from experience. He's reacting to different conditions, different situations, different set-up issues, different things with driving. Ultimately, mechanically, the [Mercedes] car hasn't changed much from the past few years, in terms of how it behaves, but it was very different from how the Williams behaved, so there have been many things for me to learn, and

I've been catching up on things all the time. Experience helps a lot, just making the most out of every single situation. With what I've learned this year, I believe I can be much more complete, a quicker driver on average next year. I also think starting the season with a team I now know is going to be different mentally.

AS Did the new contract make any difference, because you got the extension and your form dipped, so it might look like you relaxed the intensity? And do you feel the one-year extension is fair, or do you think you deserved a longer-term contract?

VB I can for sure say that it had no effect – I didn't have it on my mind at all. I was just focusing on my goal – to be quicker, and better. With the one-year [deal], I've been kind of always in a similar situation, so it's nothing new for me, and I understand the team also wants to keep all options open. I need to prove myself next year that I deserve [to be] long term with the team, and if I perform, as always in Formula 1, then everything will be good. ✨

F1
SEASON
REVIEW
2017

Were the new rules a hit or a miss?

Heading into the 2017 season, all the talk was about the new regulations. The objective was for faster, more spectacular and exciting cars, and a better kind of Formula 1. But did the changes succeed?

By Gary Anderson, Technical Editor



HOW MUCH FASTER WERE THE CARS?

The specific objective of the regulations was to make the cars four to five seconds per lap faster than they were in 2015, as it was believed that this would produce a better kind of Formula 1. To F1's credit, that objective was achieved, and if you look at the fastest single laps at each circuit the average step from '15 to '17 was 4.52 seconds – so bang on the money. The cars were faster through the corners, with a loss of speed on the straight from the increased drag, so it was in the right direction for the spectacle.

If you increase the mechanical grip, via the tyres, and increase the downforce, you will get that kind of improvement. So, from that perspective, it was job done, but faster and better are two very different things for F1.

The four-to-five seconds per lap just disappear into the undergrowth as far as the fans watching are concerned. From qualifying laps to race laps there's a gap in that region, but the armchair fans don't see any difference. And that's who F1 was trying to improve the show for.

Watching the cars during pre-season testing up close at Barcelona, you could see the drivers were able to carry a little more speed into the corners and through the long Turn 3, but that's up close and doesn't make much difference to the spectacle.

Lap records fell, and F1 cars should always be fast, but I don't think that this in itself tackles what fans didn't like about the show. So the objective was set, and credit to the rulemakers for achieving it, but to aim for lap time as the catch-all solution to F1's problems was not the right approach.

Wider tyres made for a classic, squat, 'retro' appearance



DID THE WIDER TYRES WORK?

The increase in tyre width by 25% was definitely a very positive step.

The front tyre's width increased by 60mm to 305mm and the rears by 80mm to 405mm. The result is that F1 cars just look a lot more like proper racing machines.

More rubber on the ground is always going to be better because it gives you more mechanical grip, especially at low speeds. There is a gain in the high-speed corners, although aerodynamics overpower the tyres so much there, but in the slow stuff 90% of the increase will come from the tyres. The mechanical-grip gain is always a good thing to aim for, because it's always there and doesn't get affected by turbulence, so you aren't reliant on the downforce. But this also came hand in hand with an increase in the downforce levels, which did nothing for the racing. If you had the same downforce levels as 2016 with wider tyres, then mechanical grip would have accounted for a higher percentage of the overall grip. This wouldn't have transformed the racing, but it might have made it slightly easier to follow another car.

The wider tyres also looked much more sensible on the cars and gave the cars far better proportions, so that was also an improvement. Improved compounds for next season will be another positive step.

Ultra-softs: as nicely scuffed by Magnussen on Monaco wall



WERE THE EXTRA COMPOUNDS HELPFUL?

Yes and no. Pirelli had five dry compounds available, thanks to the addition of the new

ultra-soft tyre and, by offering teams a choice of three on a race weekend rather than two, there was more potential for strategy differences. But Pirelli did not provide soft enough tyres this year.

In Pirelli's defence, it was a new type of car and it had to go conservative because there's only so much that could be learned from the high-downforce 'mule' cars used for testing last year. But the learning process seemed very slow.

We saw in pre-season testing at Barcelona that the hard tyre was never going to be used. That's a track that should require the hardest tyre, but the ultra-softs were standing up in testing. We need to get into a position where the softest tyre is more like a qualifying tyre, so you get one good lap out of it and if you make a mistake you pay the price.

Pirelli has seven compounds for next season, and has built up knowledge for next year. So if it can learn from this season and get that range right for 2018, then the racing should improve. But this year we saw very little variation. >>



Still a lot of complicated aero bits and bobs

PHOTO/FAT

WHY DIDN'T THE FIELD CLOSE UP?

Rule changes spread out the field, which is just something that always happens. The big teams have the most resources and can research and develop in the most directions, and the small teams

have to choose the right direction and exploit it well to have any chance of not losing ground.

Up at the front, we did see Ferrari close up on Mercedes and make a fight of it, although the Mercedes was more often the best car, and unfortunately Ferrari dropped away towards the end of the season.

How much of that improvement could be put down to the change of rules for 2017 is questionable, but it did create an opportunity for a team that had struggled in '15 and '16 to make up ground.

But Ferrari was one of only two teams, along with Renault, that was relatively closer to the pace in 2017 than it was the previous year. So that means eight of the teams lost ground and the gaps spread. This was completely predictable and is the norm when there are rule changes of this magnitude.

There's nothing about these regulations that should make things closer. We still see some very complex, multi-element aero components that require vast amounts of money, windtunnel and CFD work to develop them, so why should anything different happen? We do usually see things closing up, so next year that may change, but the rules aren't written to make the competition any closer. And if the aim was to deliver cars that could run close together and create exciting racing, which it should have been, this wasn't the right direction.

WERE THE CARS BETTER LOOKING?

The wider cars, with wider tyres and lower rear wing, looked much better and this was a big improvement for F1.

The previous generation of cars always looked a bit like a London bus – very narrow and very tall. This was a positive step for the spectators, because F1 cars need to look fast and these definitely do.

But there is still a lot of detail in the aero that adds nothing to the looks of the cars, and if anything makes them look more messy. I don't understand why, in conjunction with making the cars wider and better proportioned, a plan to increase the reliance on ground-effect downforce wasn't pursued.

Everything is prone to turbulence, but the fact that the ground effect is an expanding duct means that you should be able to write the regulations carefully to ensure it works without being too critical.

You can't simply have a ground-effect car, because everyone will exploit what is possible to the maximum, but address that and you will have much more stable aero from the underfloor, and you can gain overall grip by going two or three steps softer on the tyres.

You're always going to lose out in turbulence, but with decent control over implementing ground-effect rules you keep it to an acceptable minimum of a few percent. That will allow cars to follow each other, so as well as having cars that look good you will also have ones that can race well.

WHY ARE THE CARS SO HEAVY?

The minimum weight increased by 20kg to 722kg (not including fuel) this year. And for 2018, thanks to the introduction of the halo, this increases by a further 6kg. Looking back a few years

ago, the minimum weight in the regulations was 625kg, but we were able to build a car to around 550kg and ballast it up to the legal minimum. We're a long way from that now.

But, if you want to have a more complex hybrid engine package – including the battery pack, MGU-K and MGU-H – than the little engines we had a few years ago (the Cosworth was 98kg plus radiators, and today you are looking at 140kg plus radiators), you can't do anything about that. And the extra safety measures such as the monocoque and the side-impact structures also add weight. It would be wrong to set the weight low with all of that, because then the first thing teams will do is have super-light drivers.

So, on balance, this is an unpleasant necessity and the price you pay for having those things. But it does have an impact on how the cars look on track, and a heavier car will always be a lazier car.



MAUGERY/FAT

At least Kvyat tried to make his Toro Rosso a bit lighter

WHY DIDN'T THE RACING IMPROVE?

Going back to the tests at the beginning of the year, you could see exactly what was going to happen. The car is a bigger cross-section because it's wider and the wheels are wider. And the cars have more downforce, so there is a bigger wake – it's like the difference between following a Ford Fiesta and a lorry on the motorway.

The increase in downforce and bad racing go hand in hand. When you have a projectile going through the airflow and it's creating downforce, you cannot stop it creating that turbulence. It's simply a question of what components on the car are affected by the turbulence. The front wing is one that is badly affected, because it works right on its limit in free stream. So when a car is on its own on a qualifying lap and the airflow is perfect then it works very efficiently. But all of those surfaces are working so hard that one bit of turbulence or a crosswind affects it dramatically.

The airflow structure is developed around the car, and everything has an impact downstream. In the old days, you could develop things like the rear wing and front wing more or less in isolation, because the aerodynamic platform wasn't so sophisticated. Today, when you get a problem with the front wing, it affects three or four things downstream and you lose downforce from that. Until you have a car consisting of simpler aerodynamic components, you will have big problems with following in traffic.

Simpler airflow is still affected by turbulence, but you are talking about losing 5-6% of the downforce rather than 20%.

Combine this increase in downforce and complex aero with the fact that the tyre compounds weren't as soft as they should have been, and you have a recipe for racing that isn't very dramatic. Drivers can't follow closely, the gaps between different cars on pace are too big, and there's not enough strategic variety. All of this was predictable coming into the season and I'm not sure why anything different was expected.

Suzuka: perfect driver's track but tough to race on

DUNBAR/LAT



DID THE DRIVERS ENJOY IT?

Drivers always want cars to go faster, and they also enjoy pushing hard. So, from that perspective, the increased downforce and the greater grip from

the wider tyres, plus the fact that the tyre compounds were not that soft, means the drivers did enjoy it.

But, as we saw from comments from Lewis Hamilton late in the season, drivers do also like wheel-to-wheel racing and that's an area where these new regulations fall down.

LAT IMAGES

COATES/LAT



New rules almost guaranteed fewer overtaking moves

CONCLUSION

In creating these new regulations, the mistake that was made was a single-minded focus on reducing the lap time. Believing this would fix everything was always a mistake. In some ways, F1 is going round in circles because back in 2009 the new regulation for that year stripped back the aerodynamic components to improve racing; this year that was reversed because it didn't work then and it still doesn't work now.

The lesson is that F1 needs to look at how these incorrect objectives are set. There will always be a situation when you have a small number of people who set the rules, then thousands of engineers finding solutions, and this will always be overpowering. But if you set your objectives correctly, you can mitigate that.

For the 2017 rules, the single objective was to say that we wanted the cars 4-5s per lap faster than in '15. Well, that was achieved. But it did absolutely nothing to improve the racing. ❄

F1
SEASON
REVIEW
2017

How Red Bull missed its golden chance

The 2017 season should have seen Red Bull reclaim its place at the top of the F1 pack, but instead it struggled at first

By Lawrence Barretto





Ricciardo retires in Abu Dhabi (main). Horner (l) and Helmut Marko will be expecting more in 2018 (below)



LAT IMAGES

The overhaul to the 2017 Formula 1 technical regulations, leading to bigger, wider cars with chunkier tyres, should have been the tonic

Red Bull needed to haul itself back into contention with Mercedes. They presented chief technical officer Adrian Newey with the chance to get his teeth into a project that offered possibilities, having felt the previous iteration of rules was too restrictive.

beginning of the season, we undershot the target. Some issues with our tools over the winter created issues on track and it wasn't until we started running that we were able to see things weren't aligned with our simulation tools.

"Predominantly, it was the windtunnel that was leading us a little bit astray. The size of the model, the size of the tyres in the tunnel that we have, gave some spurious results, whereas previously they've been very, very reliable in specific areas. Suddenly we had this divergence between track and tunnel and CFD.

"The big issue that we had was that the car suddenly got a lot wider, a lot bigger.

"It's been a season of two halves for us. At the beginning, we undershot the target..."

But Red Bull failed to seize its chance. This became clear as early as winter testing, and was confirmed in the first two races of the season, when its cars qualified more than one second adrift of pole position. The team did recover, producing the most impressive development rate of any operation on the grid, but it was too little too late. The wait for a first title since 2013 goes on. So where did it go wrong?

"It's been a season of two halves for us," says team boss Christian Horner. "At the

There was a lot more blockage in the tunnel and our particular windtunnel was pretty sensitive to that, creating issues that we haven't seen previously. That probably cost us about two months in terms of where it put us back to. Then of course you're working flat-out to try and recoup all that time, but it's not like the others are all standing still."

Two months in F1 may as well be a lifetime. Red Bull's hopes of winning either title were over before the >>

HONE/LAT

F1 SEASON REVIEW 2017



Verstappen finished the year with strong performances, and won in Malaysia and Mexico



season proper had even started.

The team opted for a low-drag design philosophy this season, in a departure from previous car concepts that had focused on cornering strength making up for straightline deficiencies. Horner says Red Bull stuck with that concept even amid the changes it made once the correlation problems were diagnosed.

That commitment and perseverance paid off. For May's Spanish Grand Prix, it introduced a massive update, which cured some of the problems and gave it a more stable base upon which to build. Red Bull qualified within six tenths of pole for the first time in 2017, and it reduced that to just over three tenths in Monaco. Canada, as expected, was tough given the nature of the track, but the team still secured a third-straight podium with Daniel Ricciardo, while Max Verstappen ran second before retiring with a suspected battery failure on his Renault engine. But the team's rate of development was on a sharp upward curve and it continued to be relentless and consistent across the season.

Horner says Newey was "heavily" involved in the direction and development over the winter, but "he stepped things up since Barcelona testing this year". Newey's time has been split in recent years between F1 and the Valkyrie road-car project with Aston Martin. That will have had an impact on both projects as you can't be in two places at the same time. And it's not easy to switch your thought process from one to the other overnight.

With Newey's role on the Valkyrie project winding down, his input on F1 increased and, together with a ruthlessly efficient technical department, Red Bull outdeveloped its rivals. By the second half of the season, it had a car capable of winning races. Horner thinks the team now has the best chassis.

"Once we had understood the problem, we had a very clear development path," he says. "The whole team at Milton Keynes has worked incredibly well to put the amount of performance on the car that we have seen over the course of the season, to get us from being a second off at race one to winning races on merit and arguably, in the last third of the season, having the strongest chassis.

"On our analysis, if you look at the last four or five races, on race day, we've had arguably the best chassis. That's satisfying to see that progress."

Ricciardo echoes Horner's comments, but suggested getting the most of the chassis consistently remains challenging. "At the start of the year, for sure, the chassis wasn't where it needed to be," he says. "So it was both. Now our chassis has improved a lot. It's back to the scenario where it's more engine than chassis at the moment. The chassis is still quite hard to get going but when it does, it's very strong."

In the final six races of the season, Red Bull scored 138 points, compared to the 97 it managed in the first six races of the season. That compares to Ferrari scoring 149 and 196 respectively in those two



Ricciardo took his only victory of 2017 in the dramatic Azerbaijan GP

periods, and Mercedes 193 and 179, proving Red Bull closed the gap to both.

If Red Bull can continue on its current trajectory, and avoid the slow start out of the blocks that has afflicted it over the past couple of years, Ricciardo says the team should be the one to watch. "We just started off on the wrong foot this year," he says. "But the rate of development has been amazing, so I'm hoping if we can start on the right foot in 2018, you would argue we would be the favourites, if we started with Mercedes and Ferrari. Our development is pretty strong."

Having the best chassis and a strong development rate is important, but to win the championship you need the best package. While Red Bull will admit it was 50-50 at the start of the season between the engine and the chassis in terms of its



RICCIARDO VERSUS VERSTAPPEN

CHRISTIAN HORNER SAYS RED BULL'S SEASON has been a tale of two halves, and the same can apply to the drivers. While Max Verstappen had a series of unreliability problems and collisions in the first half of the season, Daniel Ricciardo had the rub of the green, finishing on the podium five times in a row from the Spanish GP, including a victory in Azerbaijan. But Verstappen emerged as the stronger in the closing part of the season, winning two races.

Ricciardo came out on top in terms of points scored, by 200 to 168. But Ricciardo knows championship positions do not always tell the story, as he was outscored by Daniil Kvyat in 2015 despite having the stronger season. When both cars finished, Verstappen came out on top five times to two. He also won the qualifying head-to-head.

Verstappen grew increasingly frustrated with the unreliability as the season wore on, raising concerns within Red Bull that he would leave. But the team's turnaround in form came at just the right time and he was convinced to commit his future to Red Bull until the end of 2020. "It's been really testing for him because it's probably the first time in his career he's had to deal with DNFs when he has been in great positions," says Horner. "We talked about approaching the final sector of the championship as a mini-championship, which he did with a renewed enthusiasm."

In the last six races of 2017, Verstappen scored 100 points to equal Lewis Hamilton's tally over the same period. To put his early woes into context, he scored just 68 in the other 14 races.

While Verstappen's season ended on a high note, Ricciardo's went the other way. Successive retirements in the US and Mexico hurt, as Verstappen gained the edge. "Daniel had a run of podiums in the summer where he could do no wrong," says Horner. "Unfortunately, he had some misfortune in later races when he was in great positions as well. It's been tough for him. But I think he's handled it incredibly well."

Horner wants to keep Ricciardo beyond 2018, but there is the potential of seats at Mercedes, Ferrari and Renault from '19. Verstappen has a long-term deal with Red Bull, and Horner says he has the chance to build the team around him.

If Ricciardo thinks he has a genuine chance to challenge for titles at Red Bull, he'll almost certainly renew. If not, another team beckons. He has a lot of thinking to do this winter.



shortfall, by the resumption of the season at Spa in August the team was comfortable in laying its performance deficit at the door of engine supplier Renault.

This season, Ricciardo and Verstappen have failed to finish three races apiece because of engine issues. Renault accumulated 310 places of grid penalties this season for engine component changes, of which 60 were accrued by Ricciardo and 35 by Verstappen.

Verstappen bore the brunt of the misfortune early in the season, scoring just one podium to Ricciardo's five (which included victory in Baku) before the summer break. But the run of form flipped in the closing stages of the season, with unreliability hitting Ricciardo, while Verstappen scored the most points of any driver between Malaysia and Mexico, scoring two wins, a second and a fourth.

"If you look at the amount of DNFs and penalties we have endured compared to our competitors, it's significantly more," says Horner. "Reliability-wise, specifically engine reliability, it's probably been the worst year we've had since 2006."

Renault chief Cyril Abiteboul admits unreliability has been "killing us slowly", with the team even having to turn units down and sacrifice performance in the closing races in a bid to avoid failures. Abiteboul adds the French manufacturer is "changing the way we are approaching management" and will "spend more time in validation and sign-off of every single component so we will be in a totally

different situation regarding reliability."

For Horner, improvements are needed quickly, particularly in qualifying, and he has demanded more from the supplier, particularly as Renault will now be entering the fifth year with this technology. "Our engine partner is working hard to address that over the winter," he says. "They need it for their own team as well. Hopefully, we can then put a campaign together to really challenge Ferrari and Mercedes, who will not be standing still either during the course of next year."

"We've seen a bit of convergence on race day but still in qualifying, with these modes and potential use of oil and so on, there is quite a differential certainly on a Saturday, and qualifying is so vital. At the end of the day, the stopwatch doesn't lie. We're now going into year five of hybrids, so one would hope by season five you do start to have convergence and they do start to understand some of the issues they have been struggling with."

With Red Bull having got to the bottom of its correlation problems and the regulations remaining relatively stable, the team should be in good shape next year, providing Renault delivers improvements both in power and reliability.

"We're going to rely heavily on our engine partner to raise their bar, particularly on reliability, next year," says Horner. "It's important to have targets. We've had a competitive car in the last few races. We'd like to see that translate into a full-year performance with both our drivers." ❄️

DIVORCE

How an oil tank helped destroy McLaren-Honda, and caused the end of a disastrous three-year alliance

By Ben Anderson



RODNEY/JAT

The humble oil tank seems such an innocuous component amid the extraordinary complexity of V6 Formula 1 engines and their hybrid parts. With all the

millions of dollars invested in trying to make a success of a works grand prix operation, combined with the expertise of two mighty racing organisations, you wouldn't expect something so basic to be the root cause of calamity.

But that's exactly what happened in 2017. The unfeted oil tank is the chief reason why the McLaren-Honda alliance is no more, dissolved in a poisonous concoction of broken promises and shattered dreams.

Having made encouraging progress in 2016, invested time in helping the FIA to draft this year's new and enhanced aero regulations, and restructured the team in readiness to make the most of them, McLaren felt ready to catch up lost ground to F1's big three teams – Mercedes, Ferrari and Red Bull.

Meanwhile, Honda planned a major revamp of its engine design, abandoning its original 'size-zero' architecture that contained the turbine and compressor within the V-bank of the engine, instead bringing them outside and adopting the Mercedes concept of attaching them

at opposite ends of the block via an elongated connecting shaft.

This would make the engine lower and lighter, helping McLaren solve a high-speed handling imbalance prevalent in the 2016 car, while Honda simultaneously developed new lean-combustion technology on its Sakura dyno that was intended to boost power significantly.

All of which was meant to lift McLaren definitively into the top four at worst, and hopefully into podium and occasional race win contention.

But things got off to the worst possible start when a problem with the oil system consigned Fernando Alonso to the garage for much of the first day of pre-season testing at Barcelona. There was barely an improvement over the remaining seven days of running, as severe vibrations from the power unit and transmission caused repeated breakdowns.

The new-and-improved Honda engine was proving anything but – it was unstable, undriveable, and less powerful than last year's unit. McLaren's patience snapped. As Ferrari and Mercedes completed hundreds upon hundreds of laps, McLaren found itself facing yet another season of severe struggle, and so began machinations behind the scenes to end this ill-fated partnership for good.

It's been an incredibly disappointing season for McLaren-Honda: ninth in the constructors' championship and only three points better than its 2015 nadir.

Sixth for Alonso in Hungary was the highlight result, and McLaren was actually further away from Mercedes' pace this season than it was last year.

Results, performance and reliability all went backwards in 2017. As Honda F1 boss Yusuke Hasegawa explains, it all had to do with a confluence of connected circumstances, with the oil tank at their epicentre. "Go back to 2015, our MGU-H energy-recovery level was very low," says Hasegawa. "It was because of the limited turbine package size. In 2016 we modified the turbine to make it much bigger. Because of that we needed to make the turbine position much higher.

"With doing that, I think the recovery level was very competitive – almost the



Honda chief Hasegawa had an unhappy year



TEEZ/JAT



Fernando Alonso endures another failure, this time in practice for the Spanish Grand Prix

same level as the top team. But because of that we were thinking the centre of gravity was one of the big issues for us – especially in Suzuka I noticed that momentum of the car was very bad.

“Of course we identified that issue from the beginning of the season, so we understood we needed to change the turbine position to much lower, but to do that we had to make the turbine/compressor split and make it a completely different package.

“The connecting-rod length is [now] much longer for the turbine. We didn’t create a problem with that connecting rod but, because of the turbine coming out of the engine, the oil-tank configuration was very different. We needed to create an oil-tank configuration that avoided the turbine package.”

Switching from a conventional oil tank to what Hasegawa describes as a “crescent shape” created a whole host of unforeseen disastrous consequences for Honda. “The previous oil tank was just straight, but this year’s oil tank was a different shape,” Hasegawa adds. “Of course, we tested that oil-tank shape on the dyno, but this is one of the most difficult items to check. We found an issue in the first Barcelona test. It was not a fundamental issue, but it hurt our testing time very much, so it was very bad.

“Of course we modified the oil tank – we updated the oil tank and the situation was solved in just two or three

days. But missing two or three days is very fatal for the winter testing.”

This problem set back McLaren-Honda’s development programme to such an extent that it took five races before the basic package was under control, never mind bettered. On top of the oil dramas, the new Honda combustion concept was also wreaking havoc with the car – something that took months to resolve without adding extra power to last year’s numbers.

“It’s fair to say the starting level was almost equivalent from last year – peak power was almost equivalent, but low-rpm power was very down,” Hasegawa concedes. “It had huge gaps from something like 9000-10,000rpm – no torque. It’s OK on the dyno, but when we used upshift and went from 10,000 to 9000, torque decreased dramatically.

“It will create a big oscillation. The dyno’s inertia is huge, so it doesn’t create a big problem, but the inertia of the car itself is much less. Such a big torque drop was creating a big oscillation.”

This made the car extremely difficult to drive (when it was running) until Honda modified the intake system for May’s Spanish Grand Prix, which helped recover the lost bottom-end power and driveability. Until then, the drivers were forced to change gear at odd points. You could hear the graunching sounds as the transmission protested the unusual upshift and clutch settings

required to avoid this torque drop.

As well as the engine being “far behind” Honda’s target at the start of the season, McLaren had to cope with woeful unreliability. Stoffel Vandoorne took just three races to run into grid-penalty trouble, and failed to even start in Bahrain thanks to recurring problems with the engine’s MGU-H, while team-mate Alonso non-started the following race in Russia, thanks to an ERS shutdown.

“Other than the target performance we very much had an issue with reliability,” admits Hasegawa. “We had so many issues with the oscillation, and also the MGU-H bearing. It also comes from the oil blowing from the oil tank. The oil came to the bearing of the turbine and the turbine bearing was seizing or about to seize – that was creating an issue.

“The bearing itself was not changed from last year, although the package is different, but last year we didn’t have such oil blowing from the oil tank because we had a conventional design. Actually, this is just an excuse – we studied very much for every area we changed – but we didn’t allow for something besides that area, like the oil-tank configuration, so we had many issues that we didn’t expect from our modification.

“We had many MGU-H issues at the beginning of the season, especially in Bahrain. We had maybe three MGU-H failures on Stoffel’s car. But we had nothing for that. We just applied a new MGU-H and failure. We spent four or five MGU-Hs there, because we didn’t understand what was happening.”

When Honda did finally understand what was going on, it modified the oil tank to stop the oil blowing, and beefed up the MGU-H bearing to make it more resilient. Things got much better after that, but McLaren still used more engine components than any other individual team this year and, when Honda missed its agreed performance target to match the estimated power output of the Mercedes customer engine in time for August’s Belgian Grand Prix, the fate of McLaren-Honda was sealed.

We’ll never know if McLaren could have been convinced to remain on board had all those reliability problems not derailed Honda’s early-season development. Without them, perhaps Honda would have made faster progress with its new combustion concept and things might have been different.

But McLaren had pretty much made its mind up before the end of pre-season testing, where that pesky new oil tank had already begun wreaking irrevocable chaos with its mighty aspirations. ❄



It's been a trying year for Alonso and McLaren; sixth place in Hungary (right) was a high point



He's had a shocking three seasons with McLaren, but the team is convinced that the two-time world champion is more than a match for anybody

By Jonathan Noble

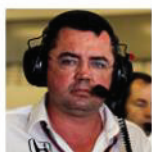

ERIC BOULLIER
McLaren
sporting chief



ZAK BROWN
McLaren
team boss



TIM GOSS
McLaren
technical director

From the depths of despair during pre-season testing (when he left the track to go and play tennis after another Honda engine failure), to retiring from the Russian Grand Prix before the start, to punching a hole in the wall of the driver's room in Singapore, it has not been the easiest of years for Fernando Alonso.

But speak to those who have worked closest to the two-time world champion and they have nothing but praise for his attitude, and the way his commitment never wavered despite the machinery he had at his disposal.

How good is he?

ERIC BOULLIER It's difficult to rank somebody, but in simple words, for me, I would say he is the complete driver. And by this, I mean the best. He is from the first lap of the weekend, and any lap after, always at 100% – and let's say capable of 90-95% of the car, which is very rare. I've never met anyone like this in my career.

On needing an arm around his shoulder in pre-season testing

ZAK BROWN He copes well himself. I tend to give him space. So when he went to play tennis in testing in Spain, it was like, OK, the alternative is make him sit in a five-by-five box, where he's got all this adrenalin ramped up – and punch a wall! Or go, get out of here, get some fresh air, get some adrenalin out. Get your mind off things.

EB As a competitor, he makes his mental preparation over the winter. And he's drawing in his head how the season should be. That even motivates him more because he tries to stick to his own goals. So turning up at Barcelona, and having gone backwards in terms of engine performance, it was a mix of sadness, humiliation and frustration. It was not good.

On what he brings to McLaren

TIM GOSS Behind the scenes, probably the most important thing is the level of commitment that we get from him. If you go back to drivers like Ayrton Senna and Alain Prost, they were very, very committed. There were other drivers who were just as quick, but they wouldn't commit to the other side of it – which is

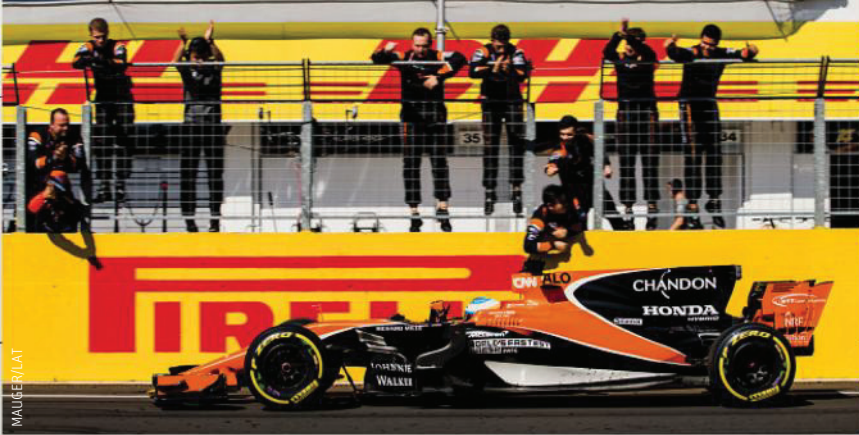

MAURER/LAT

TEE/LAT



LAT IMAGES

SATO ON ALONSO'S AMAZING INDY 500

TAKUMA SATO COULDN'T HAVE CHOSEN A better time to win the Indianapolis 500. The eyes of the world were on the Brickyard back in May, due to Fernando Alonso's decision to contest the race instead of the Monaco Grand Prix. Alonso starred, but it was his Andretti Autosport team-mate Sato who triumphed.

"There was no doubt he would learn very quickly, and indeed he did," says Sato. "He went to the simulator each morning, and then the afternoon was actual track testing. The Indy 500 is actually the best race for a rookie because, unlike the other races where you have just two 45-minute sessions and then you go straight into qualifying, at the 500 you have a week of practice from noon to 5 or 6pm, so plenty of time to learn. Fernando was smiling every single day – he looked to be enjoying it and he was enjoying it. We talked a lot – debriefs and privately – and he had great fun and showed tremendous speed immediately."

Could Alonso have won without his engine failure? Sato isn't sure: "The first and last quarter of the race are completely different animals, and the

"The Indy 500 is the best race for a rookie"

way we drive is completely different. Fernando said he wanted to lead the race, he didn't want to be sitting in traffic, but when you're leading you use so much fuel – but I understand where he was coming from.

"He went probably one of the lightest on downforce in the field, so that's why you could see him pick up speed to lead. Alexander Rossi [in one of the other Andretti cars] had very similar downforce to Fernando and he was leading at the beginning too. But in the last 10 laps, when you're in a competitive race with light downforce, following people is difficult. So I don't know. The only thing I can tell is he was a potential winner and it was great to see his determination."

MARCUS SIMMONS

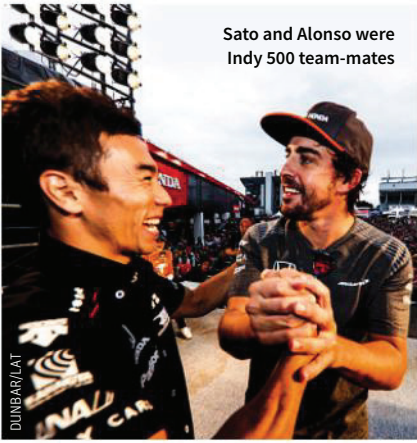

Sato and Alonso were Indy 500 team-mates

DUNBAR/LAT

more than just developing driver skills. What they have got to do is contribute to developing the car. And Fernando falls very much into the bracket of one of those drivers.

ZB What happens is when he walks into the garage, everyone stands up a little bit straighter. And he has his own expectations of himself, so he creates a really good team environment because he never blames others. Apart from Honda, I haven't heard him have a go at someone on the team. He will be demanding and if it is a millimetre off perfect, that's not good enough. He's a perfectionist in that sense. So everyone then raises their game and it's a real positive influence and environment.

On being a political animal

ZB His reputation says that, but I've found he's not political. He knows what he wants. He just wants to race. He is very smart and very business astute. The hardest part of managing him is his enthusiasm to want to do everything.

EB He is a little bit but not that much. Obviously, like every competitive driver, there is a selfishness to try to bypass

people to get what you want. That's part of the game and they're all the same. But it's more or less controllable.

TG Not at all. I think over the past three years, although they have been very challenging, we've got a lot of praise for the way it hasn't developed into a fist fight. In the debriefs, I think people would be amazed to see that we have just been tackling it in an extremely professional way and trying to identify what the issues are.

On how having a competitive car again will change him

ZB I think the raging bull is in there. And as soon as we let him out, I have no doubt in my mind that he is going to be right back to where we're used to seeing him – as one of the most difficult guys to race against. No doubt about it. He's dying for that.

EB I'm sure the level of frustration he's got is so high that he'll be like an animal – a racing animal. I always compare him to a shark. When he can sense blood, he goes straight there. And that's why, if he feels he can be on the podium or competitive enough to be there, he will not give up one inch to anyone. ❄

Force India's civil war

The conflicting ambitions of Esteban Ocon and Sergio Perez meant the imposition of team orders was deemed necessary to preserve fourth in the constructors' championship

By Lawrence Barretto

Force India faced the biggest challenge of its 10-year existence when Esteban Ocon and Sergio Perez collided not once but twice on the fast run down to Eau Rouge during this summer's Belgian Grand Prix.

Ocon said Perez "risked my life in there, at 300km/h down to Eau Rouge" before later tweeting: "We were having a good race until Perez tried to kill me two times!" Perez defended himself and pointed the finger back at Ocon.

Tensions between the duo, partnered for the first time this season, had been building all year. They had rowed in Canada in June, when Perez refused to allow Ocon through to challenge for a podium position, and then collided spectacularly and lost a probable podium in Azerbaijan. They clashed again in Hungary, with Ocon admitting he would be more careful when battling Perez wheel-to-wheel in future. And then they banged wheels again in Belgium.

That was the final straw – Force India could take it no more. The pair were hauled into a meeting with senior management and told in no uncertain terms that the kind

of behaviour shown by them in Belgium would not be tolerated.

It was made clear that the team came first, and that fourth place in the constructors' championship was the priority, with the associated prize money crucial for the squad's development. Until further notice, Ocon and Perez would no longer be free to race each other on track and would be required to abide by team orders. Both agreed to comply.

"They are both smart guys and they have learned their lesson," says chief operating officer Otmar Szafnauer. "Our philosophy here is always to maximise the team potential, and we have to do what it takes. Usually, letting them race and go as fast as they can maximises the team potential. But when they start crashing into each other a lot then it doesn't maximise the team potential, so we have to do something different."

The two drivers met at Monza one-to-one to discuss the incident and agreed to shake hands and move on. Over the subsequent races their relationship thawed, with Mercedes protege Ocon seeking and acting on advice from his boss Toto Wolff on how to deal with the situation, given that Wolff had recent experience of a similar scenario with Lewis Hamilton and Nico Rosberg.

Ocon admits that he and Perez will

never be the best of friends, but they have a level of respect for each other that should allow them to continue racing as team-mates. "It's important we have respect for each other, and it's important for the team that there is a good atmosphere and we work together to develop the car correctly," he says. "We are maybe not going to go on holidays together, but we get along well."

Perez admits his relationship with Ocon had "broken down completely" after Spa. "We hit a very low point in Belgium," he says. "But things have got



THEIR/LAT



Duo's on-track rivalry got too physical too often (above). Below: Perez and Ocon have achieved detente – but will it last?



DUNBAR/LAT



LAT IMAGES

a lot better since then. We're working professionally. We know we work for a team and we have to do the best for them, especially for next year. It's going to be a massive challenge, given the competition and threat from bigger teams that have struggled this year."

The pair were closely matched in 2017, with Ocon shading it in the second half of the season, aided by racing on tracks he was familiar with following his half-campaign with Manor in '16. They ended the season nose to tail, seventh and eighth in the drivers' championship, 13 points apart in Perez's favour. Chances are, they'll be even closer next year.

It will be interesting to see how the team deals with their rivalry in 2018. This year, Force India management gave their drivers several chances before finally reading the riot act. Some might say it took them too long.

By putting together one of the strongest and most ambitious driver line-ups on the grid, Force India created this problem. In Ocon, it has a driver who is considered to be Mercedes' answer to Max Verstappen. He is every bit as ruthless as the Dutchman and desperate to prove he has what it takes to earn a drive at the works Mercedes team and challenge for world championships.

Perez is a driver with far more

experience, but who has spent the past four years rebuilding his reputation after a damaging stint at McLaren. The Mexican knows he needs to outperform Ocon if he is to keep himself on the radar of the top teams for 2019. Both have something to prove, albeit for different reasons.

Keeping them in check next year will only get tougher. Force India is undecided as to whether it will reimpose team orders, given the success it had in helping to secure fourth in the constructors' championship for the second successive year. But it may have its hand forced.

"I hope the ban [on racing each other] is lifted," says Perez. "We have got to understand how difficult it's going to be next year. We'll have the Renaults and McLaren's pushing us hard. So we need to push freely if we are to be in the fight."

While Force India has spent most of this season on its own in fourth place, some way off the top-three teams but largely comfortable ahead of the rest of the field, next year will likely be a different story. Renault, with a far bigger budget, is on an upward trajectory and McLaren is aiming to make a leap forward after swapping Honda for Renault power. Force India will no longer have a buffer, and that will make the way it manages its internal driver rivalry even more crucial. ❄

JUNIOR CHOICE: WHILE OCON FLOURISHES, WEHRLEIN FACES AN UNCERTAIN FUTURE

ESTEBAN OCON'S FELLOW MERCEDES JUNIOR Pascal Wehrlein capped an impressive F1 debut season with Manor in 2016 by winning the Rookie of the Year prize at the Autosport Awards. Sauber was supposed to be the next step on the road to a drive at the Mercedes works team. But a difficult car with a year-old Ferrari engine made life tricky for both the German and his team-mate Marcus Ericsson this season.

Wehrlein scored all the team's points – with eighth in Spain and 10th in Azerbaijan – but he failed to comfortably outperform Ericsson in the way it was hoped. His 'supertime' – his fastest lap from any session over a grand prix weekend converted to a percentage, with 100% representing the outright fastest – was just 0.013% better than the Swede's.

Meanwhile, his former team-mate Ocon excelled at Force India, although he had a stronger package underneath him.

Wehrlein says he's happy with his performance. "I scored all the points for the team, which is the most important thing. Qualifying is good, I'm ahead of Marcus in the head-to-head. I'm happy with how the season has gone, especially as I missed two races and a lot of winter testing [because of injury], so the first few races back were a learning process for me."

But Sauber's new partnership with Ferrari/Alfa Romeo has made life more challenging for Wehrlein. Ferrari junior and Formula 2 champion Charles Leclerc and Ericsson were confirmed as 2018 Sauber drivers last weekend.

That could leave Wehrlein in the F1 wilderness. Williams is believed to be interested, but Wehrlein is not at the top of the list there. If he misses out on a place, he will likely head back to the DTM, with his future in F1 hanging in the balance.



Wehrlein could get left out in the cold

COMES/LAT

F1
SEASON
REVIEW
2017

Vandoorne and Stroll: 2017's slow-burning Formula 1 rookies

It's been a tough baptism for F1's two full-time rookies in 2017. But Stoffel Vandoorne and Lance Stroll both came through their struggles to show enough flashes of star quality to suggest they have something serious to offer

By Ben Anderson





“How’s your ageing team-mate?”
 “Annoyingly fast.”
 Stroll and Vandoorne compare notes. Far left: in action at Suzuka

Getting off on the wrong foot

The one thing you absolutely need coming into your first full Formula 1 season is a smooth passage through winter testing, but Stoffel Vandoorne and Lance Stroll enjoyed anything but.

Vandoorne lost vital track time needed to get up to speed amid McLaren-Honda’s litany of reliability woes, while Stroll suffered a couple of unfortunate off-track excursions and faced criticism of his suitability to step up to F1 straight from Formula 3, given the substantial leap in car performance under 2017’s new regulations. The Stroll family’s sizeable investment into the Williams team also raised questions about the merits of his promotion.

SV “I felt like we came to Melbourne very underprepared; definitely not an easy situation for everyone. The mechanics were tired of having to change engines. For me it was a new experience. In the junior series I was turning up to every race knowing I could fight for victory. It was the first time I was having to deal with many problems. It was not a nice situation to be in.”

LS “There will always be people that think certain things, but what matters to me are the people that work closely with me. The rest is the public and you can’t control everyone’s opinion; you can’t please everyone. I’m glad I proved what I was capable of this year, but I believe I’d done that before coming into F1, and people just didn’t see that – the championships I’ve won. People just didn’t want to see that and some people still don’t want to see what I’ve done. I can’t control that. I can just control what I’m doing. The rest is background noise.”

Difficult races pile on pressure

Things didn’t get much better for either rookie during the early races. Vandoorne was blown away by double world champion team-mate Fernando Alonso,

failing to make it out of Q1 at any of the first five races. Stroll only once made Q3 in a car Felipe Massa consistently qualified inside the top 10. The pressure was steadily piling onto both rookies.

SV “The first races were definitely not to my standards, but it’s only my first season in F1 so this relationship with the team, with my engineers, had to develop. Because we ran through so many problems it was difficult to do that. In Bahrain, I didn’t even manage to start the race! Also, when things were going wrong, when the car was a little tricky to drive, I was maybe losing a bit more time because I struggled to adapt. There were so many issues that we almost were not concentrating on the driving.”

LS “At the beginning of the year there were hard times – I wasn’t capable of doing everything right and being at the level I wanted to be at. But over the course of the year I really improved and became a better driver. I’m proud to say that. Towards the beginning it wasn’t the right time to compare [to Massa] because the experience couldn’t really be compared. But I’ve used him as a benchmark and tried to pick up what I can. Some areas, he’s been a lot stronger than me, but that’s part of the learning curve. You look at the championship points and it’s pretty close, so I’ll take that as a positive.”

Turning things around

Vandoorne began to gradually get back on track following May’s Spanish GP. He was placed into a special working group of McLaren engineers to better understand the MCL32, and his own needs, and to find a compromise between the car’s set-up and his driving style. Slowly but surely, he worked his way out of Alonso’s long and intimidating shadow.

Stroll enjoyed a breakthrough drive to ninth in his home race in Canada, followed immediately by an excellent run to the podium in Azerbaijan.

He also benefited from conducting set-up experiments in a 2014 Williams test mule and following team-mate Massa’s preferences more closely.

SV “That period around Monaco, but even Canada, Baku – those were key moments where everything started to fall together. I had more track time, spent more time in the factory, went through the data and spent more time in the simulator. It was just a matter of getting the relationship with the team and the engineers going, because my driving style was quite different to Fernando’s. I’ve never doubted myself – I knew I could get on top of the issues.”

LS “When we were in the points in Canada and on the podium in Baku, it was just a matter of time because I never doubted what we were capable of doing. Once we broke the ice, it started to become... I wouldn’t say easier because it’s always challenging, but we knew what we were capable of; it was a fact – we’ve been in the points now, so we can just carry on improving, progressing, and there’s no reason we can’t do it again. That was big for me.”

The future looks brighter

Vandoorne outqualified Alonso for the first time at July’s British Grand Prix, and from then on was much more consistently impressive. He scored a point in the next race in Hungary, and added a double haul of seventh places in Singapore and Malaysia.

Stroll scored points in four races after the August break and was stunning in wet qualifying for September’s Italian GP, emphasising that he has genuine quality, though his overall qualifying record (Stroll dropped out in Q1 12 times in 20 attempts) remained disappointing.

Nevertheless, both Vandoorne and Stroll finished the season within touching distance of their respective team-mates in the championship, so can be satisfied that they pulled their weight in the way that matters most to their teams.

SV “Lately we’ve been very competitive. Everything has been going in the right direction, feeling very confident with the car, with the team – there’s nothing we need to have doubts about. Since Austria/Silverstone we’ve been challenging very hard with Fernando, in nearly every session. The future looks promising.”

LS “For sure the results haven’t always been there in qualifying, but I believe the potential has been there. It’s my first year, I’m 19, and there’s a lot I can still improve on. [But] I’ve made a big impact. Putting the car P8, P7 [in races] multiple times has shown it’s no fluke. Those are the facts. I’m not trying to be cocky about it, I’m just pointing out facts.”

Mercedes versus Ferrari

How two different approaches produced a title fight that was compelling – until the closing stages

By Gary Anderson

After three years of dominance, the big question was whether Mercedes could stay on top in 2017 through the major aerodynamic rule changes. As for Ferrari, was this a chance to recover from a poor previous season and get back into the game? The answer to both questions was yes, with both teams fighting for the championship until Ferrari and Sebastian Vettel lost momentum, thanks to the start crash in Singapore and then failures in Malaysia and Japan.

In pre-season testing, we could see differences in approaches between the cars. Both teams tried to maximise the distance from the front wheels to the leading edge of the sidepods to allow the maximum time to control the airflow, but in very different ways. Mercedes moved the front wheels forward, hence the longer wheelbase, while Ferrari cut back the sidepods, incorporated some of the crash structures into the bargeboards and then had a complex bargeboard concept to work the airflow. We also saw that Ferrari ran with a reasonable amount of rake, although not as much as Red Bull, while Mercedes had a flatter platform for the car.

Over the course of the season, the Mercedes was the faster car over a single lap. There were only five weekends where the Ferrari set a faster overall lap time – Russia, Monaco, Hungary, Singapore and Mexico – so it was often stronger in the slower and high-downforce-configuration tracks.

The famous comment from Toto Wolff was that the Mercedes was a 'diva'. And it's clear that in the first half of the season in particular it was harder to get the best out of the Wo8. If you have a car that has peaky aero performance, you



have a battle to keep it in its optimum working window. A change of half a millimetre in front rideheight is night and day, and particularly in slower corners the cars bounce around all over the place. Mercedes had to work to make it more benign and less rideheight-critical, which it did do.

In many ways, while Mercedes didn't have the pace dominance it had from 2014-16, the team became stronger because it had to get on top of these problems. That's a worry for the competition next year. I'd expect Mercedes to move in the direction of running higher rake, but it's not just a question of jacking up the rear rideheight – it has an impact on the whole aerodynamic concept of the car.

Ferrari had the more consistent car and, in the first part of the season, looked after its tyres better. That made it stronger on race days. And Ferrari did seem to make the complex bargeboard concept work. The question here is if there is more to come in 2018, or if Ferrari has to choose a different direction. I suspect that there is still more to exploit there. And at the end of the year, Ferrari tried diffuser modifications, so there's a clear direction

there. It might also be able to take another step, with the rake being closer to how Red Bull runs its car. The main concern for Ferrari is that it appeared to lose that tyre-management advantage over the season, and unfortunately that didn't come with a gain in performance relative to Mercedes.

But overall, I'd liken the Mercedes to a jigsaw with more pieces. If you have 10,000 pieces, each optimised, that will be stronger than a jigsaw that has 1000 pieces. Ferrari needs to take a step with its aero in areas beyond the bargeboards to have the chance to jump ahead.

The positive thing is that Ferrari and Mercedes took two different approaches and were able to have a good battle. This bodes well for next season, if Ferrari can avoid the mistakes and reliability problems that put Vettel out of contention.



Mercedes was fastest car over one lap but team battled to get best out of it at start of season



Ferrari was more consistent, and may get stronger in 2018 if team can exploit its strengths

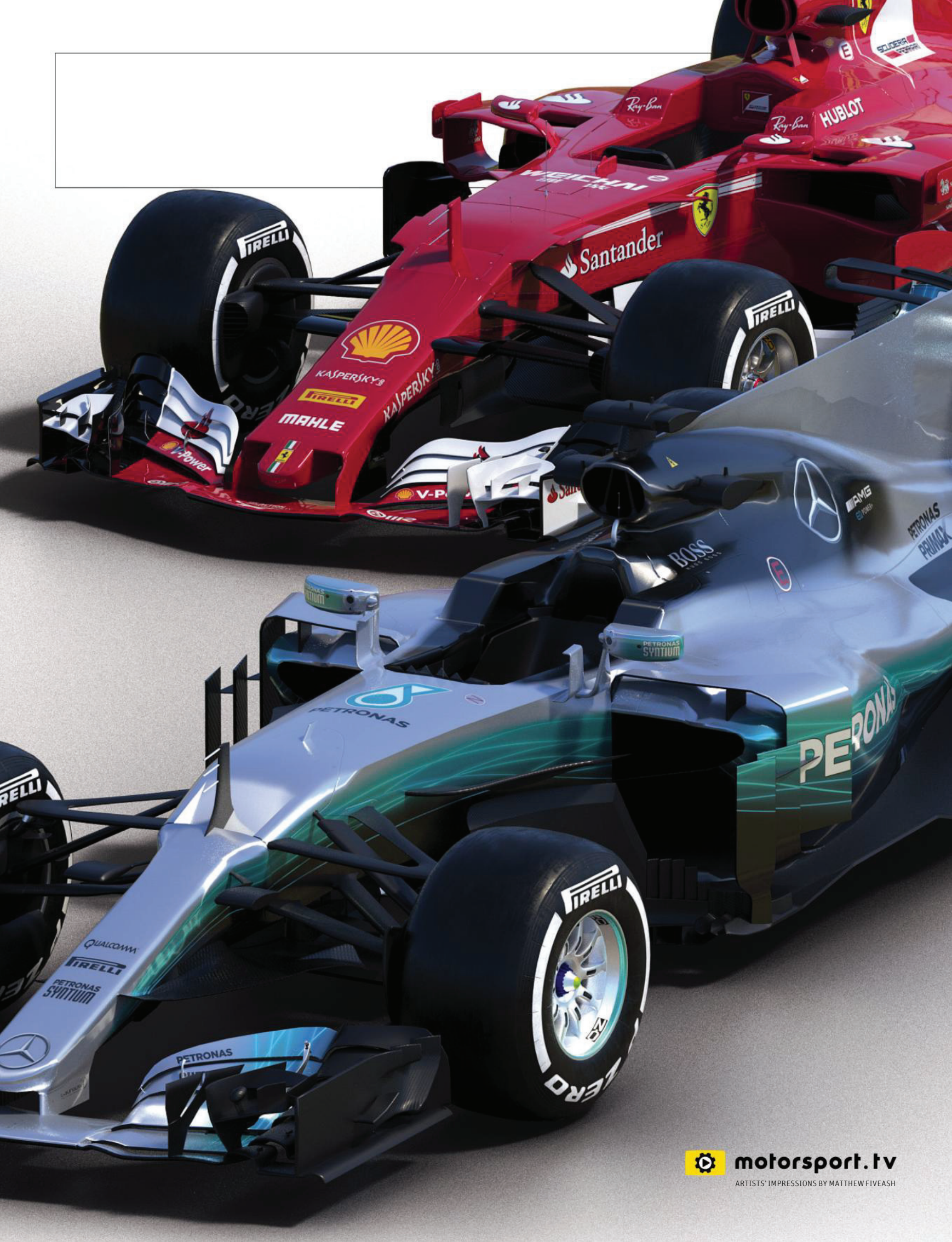



Ferrari's front-wing main plane (below right) had a longer chord than Mercedes' for more downforce in slow to medium-speed corners

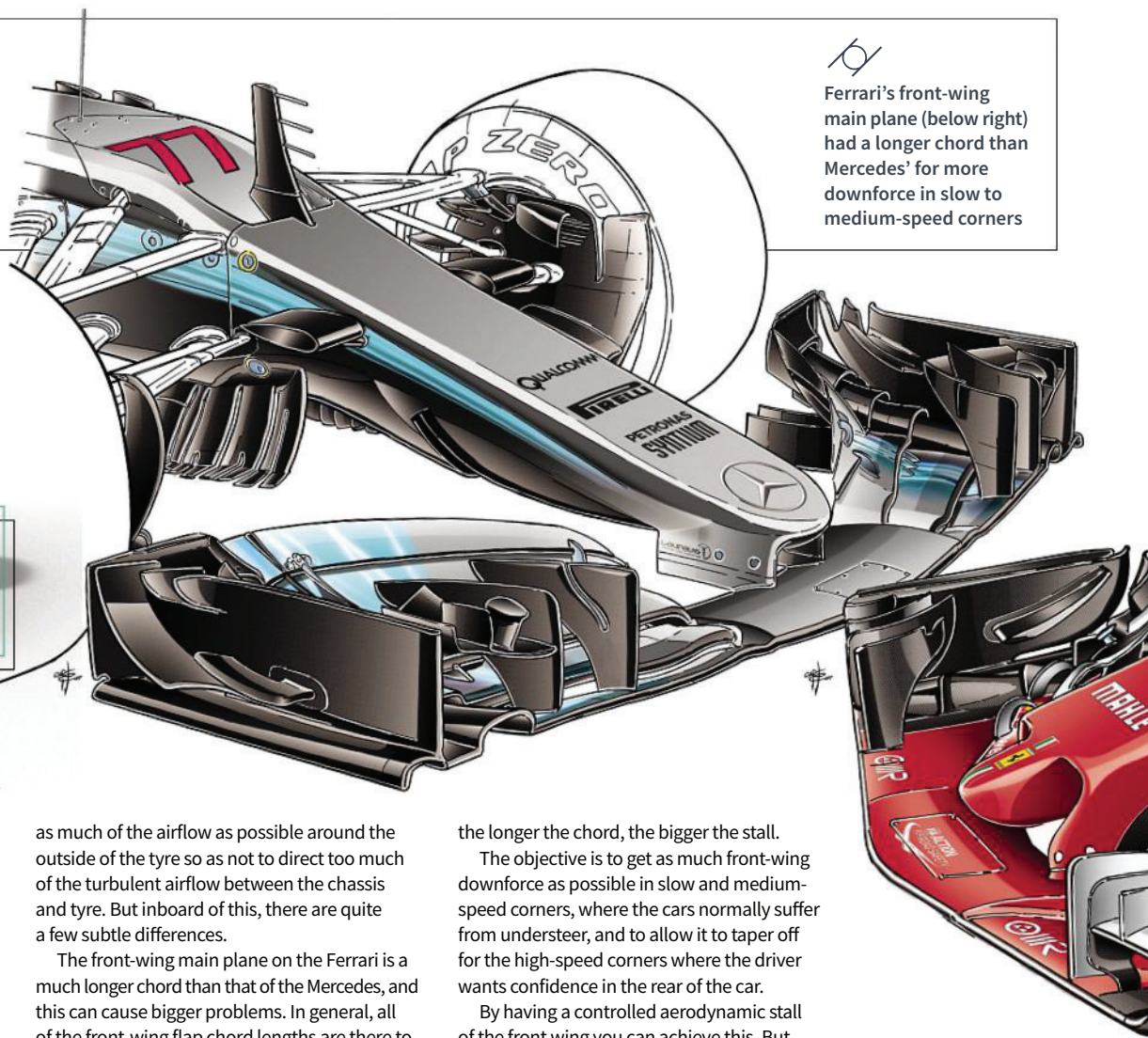
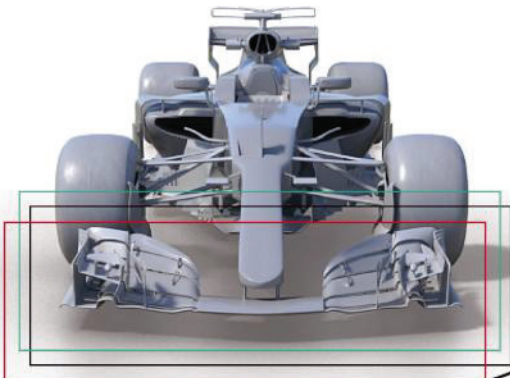

Front-wing comparison

THE FRONT WING OF A FORMULA 1 CAR IS probably the most important aerodynamic component. All the other aero components downstream have to work in its wake, so if you change the front-wing airflow characteristics everything else needs to be optimised for it.

Comparing the Mercedes to the Ferrari front wing, you can see that the general principles are the same but the detail is quite different. The outer end and endplates are designed to move

as much of the airflow as possible around the outside of the tyre so as not to direct too much of the turbulent airflow between the chassis and tyre. But inboard of this, there are quite a few subtle differences.

The front-wing main plane on the Ferrari is a much longer chord than that of the Mercedes, and this can cause bigger problems. In general, all of the front-wing flap chord lengths are there to optimise the aerodynamic stall characteristics;

the longer the chord, the bigger the stall.

The objective is to get as much front-wing downforce as possible in slow and medium-speed corners, where the cars normally suffer from understeer, and to allow it to taper off for the high-speed corners where the driver wants confidence in the rear of the car.

By having a controlled aerodynamic stall of the front wing you can achieve this. But some teams do this better than others.

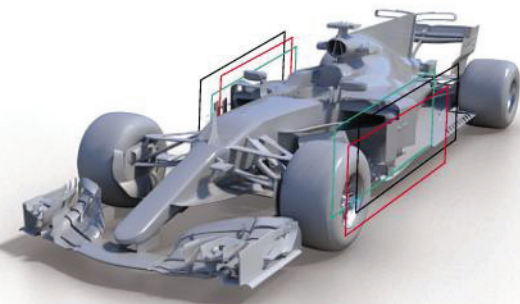

Bargeboard comparison

ONE OF THE AREAS THAT WAS OPENED UP IN the 2017 regulations was the bargeboard area. This is basically anything between the trailing edge of the front tyre and the leading edge of the sidepod/radiator-inlet area.

This is also the area that differs most between the Mercedes and the Ferrari. The bargeboard area is a very powerful package of components and, optimised, it is responsible for well in excess of 10% of the car's overall downforce. It doesn't really produce any downforce in its own right – it's about how it manipulates the airflow to improve the performance of the front wing and underfloor.

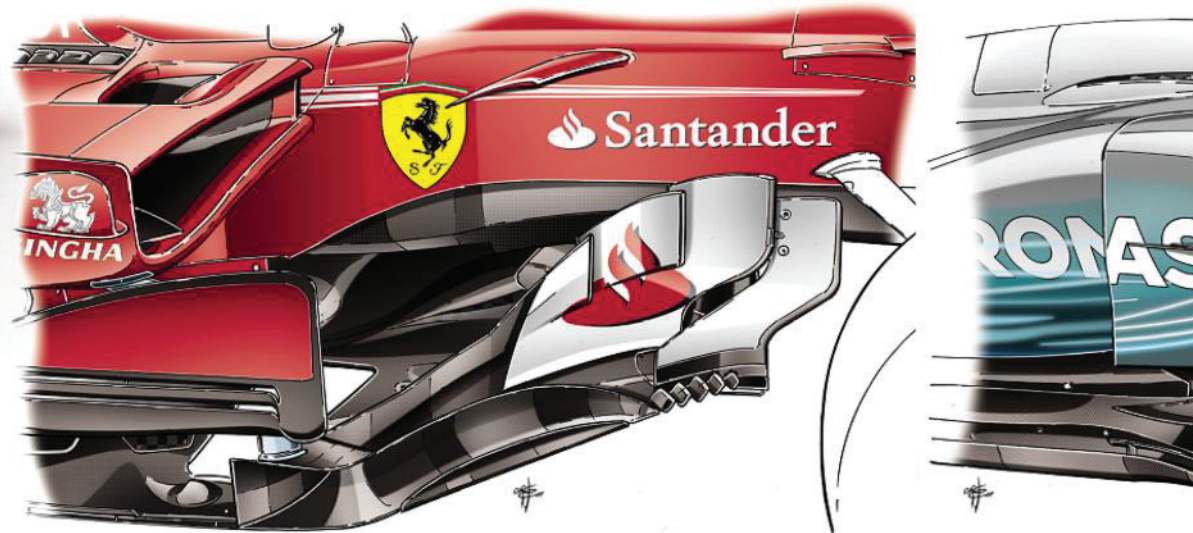

Ferrari produced sidepod with a more undercut shape than on other cars and used bargeboard mountings for side-impact structures

It also improves the sealing of the sides of the floor, making the diffuser more effective.

To give itself more opportunity to manage the turbulent airflow coming off the wider front tyre, Mercedes increased its wheelbase by moving the front wheels forward and away from the sidepod leading edge. This allowed it to introduce extra components that would

pick up that turbulent wake and realign it to best work with the front wing and underfloor.

Ferrari went the other way and found a solution that allowed it to move the leading edge of the sidepods rearward, while keeping a similar wheelbase to the 2016 car. Parts of the independent bargeboard mountings were used to house the side-impact structures and



↓ Diffuser comparison

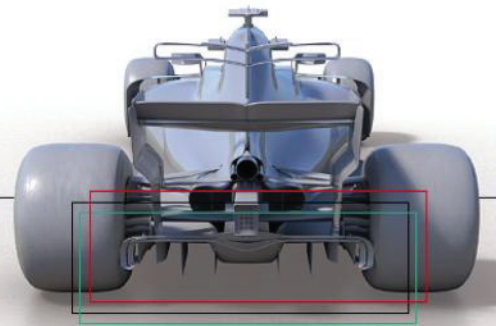

FOR 2017, THE DIFFUSER SIZE WAS INCREASED to make it 50mm higher, 50mm wider and 175mm longer. This makes the diffuser more powerful and means you can create more underfloor downforce. But as a standalone component you can only work the airflow so hard before it suffers from airflow separation. When that happens, you get a very quick loss in overall downforce, mainly at the rear.

This loss in downforce will be more pronounced at the end of a straight. Most teams play with the height relative to the ground that the diffuser will stall at, as this gives a drag reduction and leads to higher straightline speeds. But when you hit the brake pedal, you need the airflow to reattach in nanoseconds, otherwise the rear of the car will be unstable and ring alarm bells for the driver.

By getting the outside area of the diffuser to work in conjunction with the low-pressure area behind the rear tyres, the complete rear of the car works to pull the airflow through the

underfloor. In general, it gives more underbody downforce, but more importantly it will improve the airflow reattachment.

Mercedes started the season with the better package in this area, with outer vertical turning vanes helping the diffuser connect to the low-pressure area behind the rear tyre. This not only helps overall downforce, it also helps with consistency of overall downforce.

Ferrari had a more sympathetic design, which allowed airflow coming around on top of the floor's outer foot area inside the rear tyre to fill the void created by the rear tyre. This was probably more efficient (so less drag), but there are areas on the car for efficiency and there are areas where out-and-out downforce consistency has to be the primary focus. The diffuser is one of the latter.

In Abu Dhabi, Ferrari trialed a version more like the ones Mercedes and Red Bull also use. So watch this space when the 2018 Ferrari first appears.

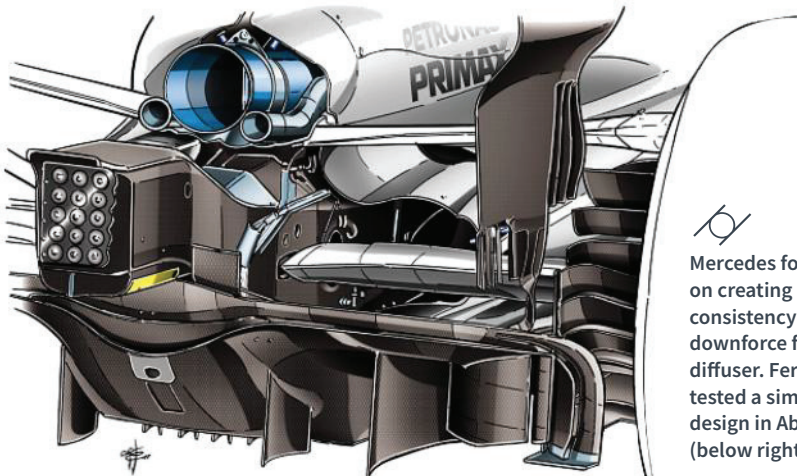
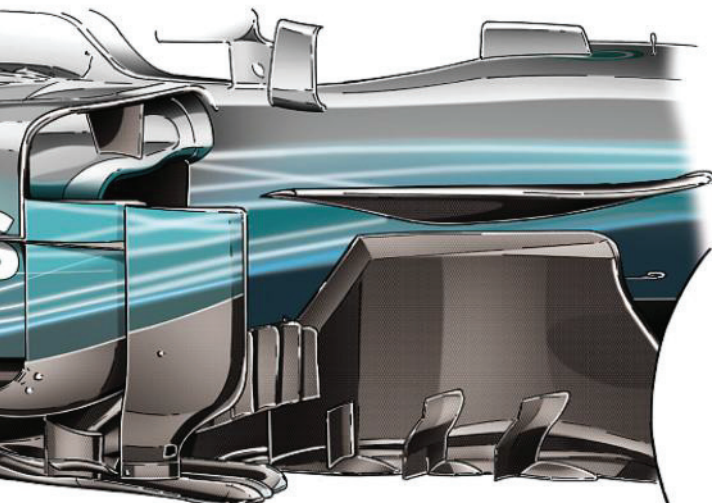
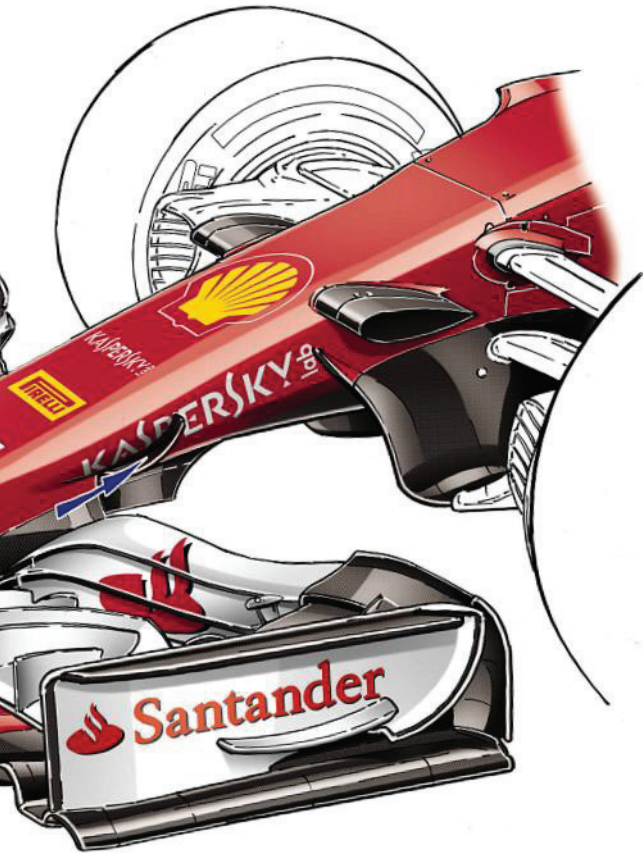

Mercedes focused on creating consistency of downforce from its diffuser. Ferrari tested a similar design in Abu Dhabi (below right)

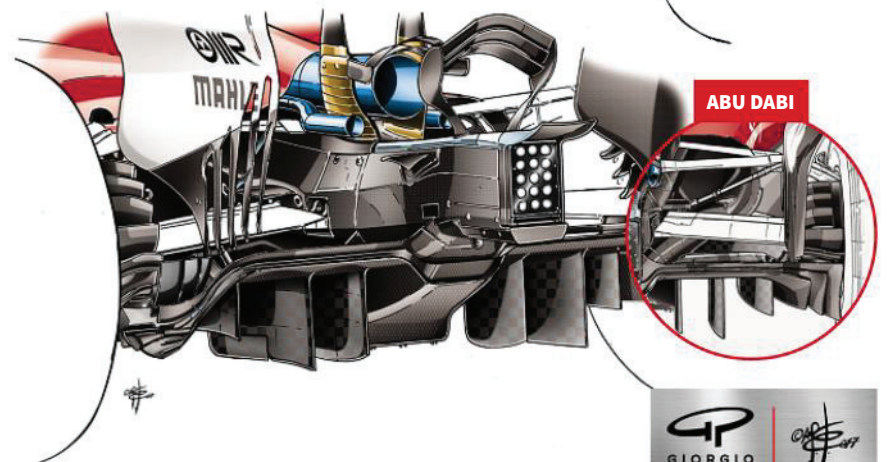

that, together with a higher and more horizontal radiator inlet, meant the undercut sidepod was much more pronounced than on any other car.

Which team was right? The jury is still out, but it will be interesting to keep a watchful eye on which direction these two teams take in this area in 2018.

Mercedes increased car's wheelbase to move front wheels away from sidepod leading edge and used space for extra aero components to manage airflow



Off the drawing board

Beyond Ferrari and Mercedes, there were plenty of developments down the field

By Gary Anderson



Red Bull front wing

ONE THING WE DID NOT SEE CHANGE IN 2017 was the complexity of the multi-element front wings. Again, Red Bull was at the forefront of this. This front wing, introduced at Silverstone, illustrates the level of complexity, with the main aim being to create stable, consistent downforce.

Force India 'stegosaurus' wings

FOR THE SINGAPORE GRAND PRIX, FORCE INDIA ran a row of winglets on the spine of its shark fin. To help the overall efficiency of the rear wing, especially in high-downforce configuration when using the triple-element shark-fin wing, the angle of attack of the airflow onto the leading edge of the main rear wing is very important. This was what Force India was trying to improve.

With the bulk of the car in front of the rear wing, it's difficult to get the airflow to turn back down onto what is called the separation point. This is where the airflow decides what flows over the top of the wing and what flows under the wing. A higher separation point effectively means a more cambered – or banana-shaped – wing, which will produce more downforce.

This small row of wings angled downwards

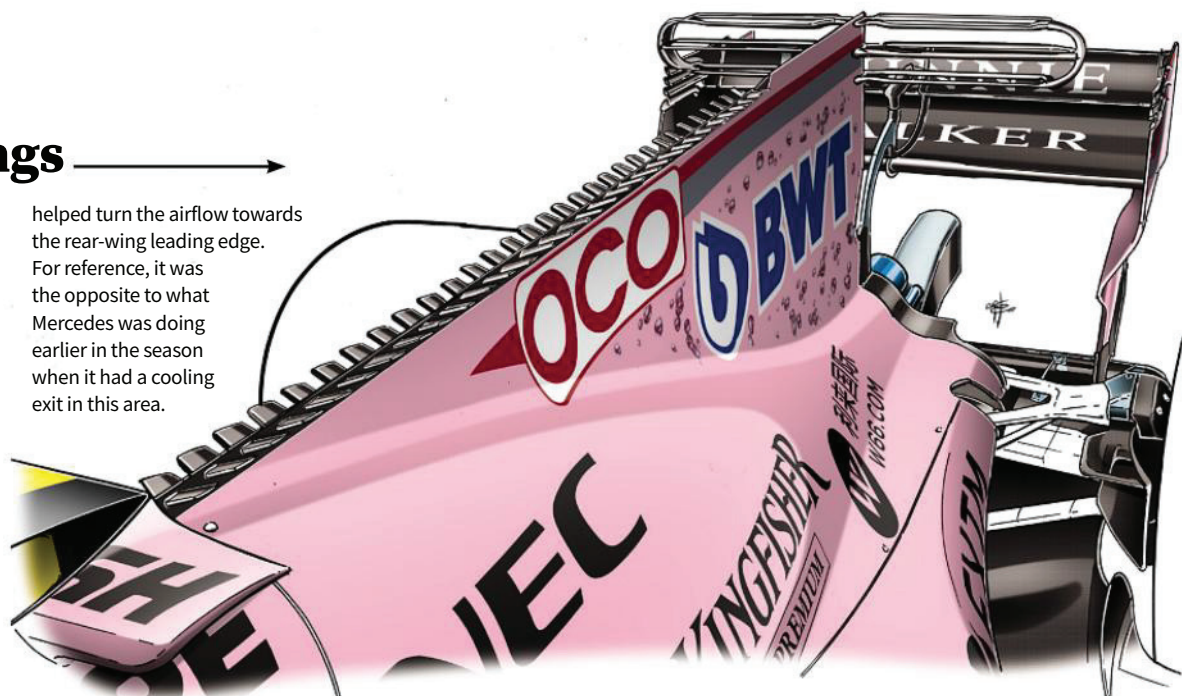

helped turn the airflow towards the rear-wing leading edge. For reference, it was the opposite to what Mercedes was doing earlier in the season when it had a cooling exit in this area.

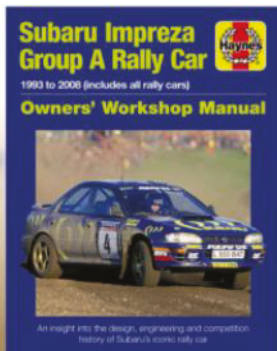

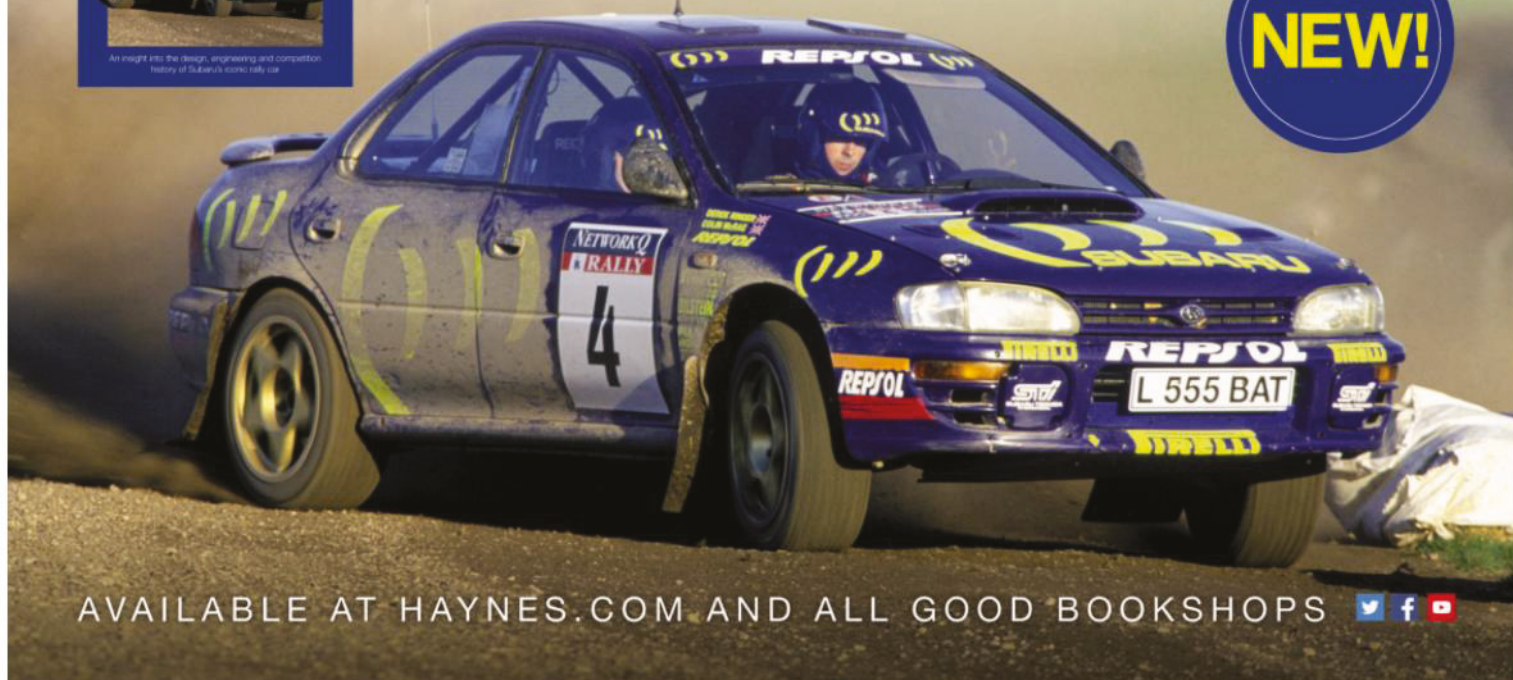

IDEAL GIFT FOR THE MOTORSPORT ENTHUSIAST



AVAILABLE AT HAYNES.COM AND ALL GOOD BOOKSHOPS   

THE ULTIMATE REVIEW OF 2017

Whilst rival F1 annuals come and go, **AUTOCOURSE** - The World's Leading Grand Prix Annual - is proud to have reached its 67th year of publication as the indisputable leader in its field.

The 20-race Formula One World Championship season is covered in its usual full depth, with hugely experienced paddock insiders Tony Dodgins and Maurice Hamilton dissecting the drama and intrigue that is always an intrinsic part of any F1 season. Their race commentaries are backed up by detailed results spreads, including lap charts and tyre strategies.

Mercedes-Benz again proved the class of the field, with Lewis Hamilton and Valtteri Bottas taking the lion's shares of the victories, however they did not have it their own way.

Sebastian Vettel and Ferrari returned to winning form in 2017, and the German driver took the title battle to Hamilton in a feisty and often controversial manner. In addition, the ever-resourceful, Red Bull Racing with Daniel Ricciardo and Max Verstappen also scored dramatic victories to deny the Silver Arrows total domination.

Renault and McLaren Honda endured a challenging year as they sought a return to past glories, whilst Sahara Force India showed the independents how to go racing as they led the race to fourth place in the constructor's championship for a second successive year.

The highly respected Mark Hughes, in his Team-by-Team review, looks at the technical development of every team, the feature is enhanced by Adrian Dean's beautiful F1 car illustrations.

As well as Formula 1, the sport's other major categories are all afforded ample coverage. The Formula 2 and GP3 championships, the key rungs on the professional single-seat ladder to the top are chronicled, as is the rise of Formula E, which is gaining big manufacturer support.

In Sports car racing, Porsche, won Le Mans once again, and then swept to a WEC title triumph over Toyota, before taking their leave from the sport. Also covered are the door-banging exploits of leading Touring Car series comprising of the WTCC, DTM and BTCC.

From the other side of the Atlantic, Gordon Kirby provides his always insightful analysis of the United States racing scene.

AUTOCOURSE traditionally wraps up the year with the most complete record of results published anywhere in a single volume.

At 408 pages, this lavish yearbook is essential reading for all fans of global motor-sport.

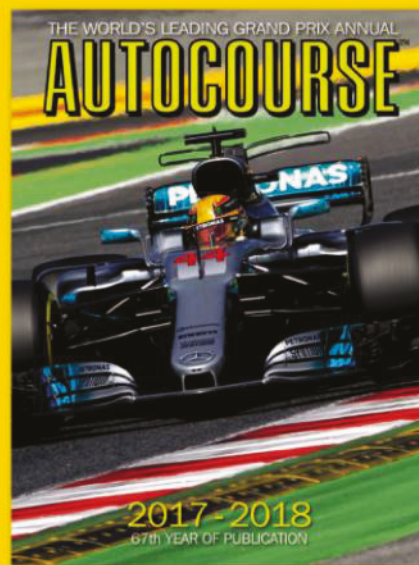

To order visit:
www.autocourse.com
 or call our hotline: +44 (0)1753 689693

FREE and SECURE
 pre-Christmas delivery!

Last UK order date:
 18th December*

*Delivery times dependent upon
 order destination - see website
 for full details

ONLY
£45.00*
 INCLUDING FREE UK
 secure post and
 packing
 *RRP £55.00



WTC

World Challenge

Evolution is a key part of global motorsport. Sit still and you'll likely get left behind in the fast-paced world of GT and touring car racing.

The racing climate constantly shifts, with new cars, teams, concepts and formulae being launched each year – and the Pirelli World Challenge is a shining example of a series evolving with the times.

This year marked another successful campaign for the World Challenge, which has become a staple of sports and touring car racing in North America since its launch in 1990.

Offering a range of racing formats and classes, the World Challenge has spread its net wide. Along with its staple GT and Touring Car series, one of its biggest successes is the developing Sprint X concept.

Through its partnership with the SRO Motorsports Group, series promoter WC Vision and its vice president of competition – Great Britain's own Marcus Hazelgrove – have worked to introduce a successful Pro-Am race format for GT3 and Cup spec cars. Sprint X allows two drivers to share a car, the race, and the budget.

"We've seen big growth in Sprint X this year,

and we're always looking at ways to streamline it and add value for the teams, drivers and fans," says WC Vision President Greg Gill.

"Grids have risen and now it's a known quantity people can plan and budget for Sprint X effectively as it's one of our most accessible formats. Drivers who have done club racing or similar can now join up with a co-driver and afford to go GT3 racing at the top level. This year we saw more people deciding to rely on a co-driver to get them where they want to be, whether that was a financial lift or simply sharing talent. That's what Sprint X offers."

The World Challenge has become a go-to place for racing enthusiasts – be they full professionals, career-driven semi-professionals, or complete amateurs. The breadth of the World Challenge is its biggest strength, and this year again reinforced that.

The GTS division – for GT4 cars – has been a big area of growth and now features cars from many global major manufacturers.

The World Challenge's core Touring Car classes continue to boast full grids too. The Touring Car categories cater for everything from





showroom-spec production cars up to modified offerings, and now also TCR-spec machinery.

"We included TCR because it was economical for people," says Gill. "With the rise in manufacturers now offering ready-to-race TCR products, we included those cars because our drivers and teams like them as an off-the-shelf option.

"Our grid drove the interest in TCR. This year the TCR cars ran toned-down, but for next year we're in talks with the TCR International organisers to run them uncorked and we think that that will be a big addition for next year."

The Pirelli World Challenge brings with it one of the most diverse fields anywhere. With a dense concentration of manufacturers present, the World Challenge has become recognised as an ideal environment for career-focused drivers.

The series offers a range of prize incentives, helping its champions climb the ladder toward their goal of becoming a professional racing driver.

"In the world no other series has the number, or the diversity, of manufacturers present that the World Challenge does, and it's something we pride ourselves upon," Gill adds.

"To earn your living in motorsport is the exception, not the rule. But the opportunity is there if you can apply yourself and find the right people to impress in the paddocks, and we do offer that environment.

"There are people who have discovered those links through us. We're thankful for being able to encourage and support people who come here to chase their dream.

"We have a slogan that says 'This is how racing should be'. It originally came from a TV commentator as throw-away line. But it's what we are.

"The World Challenge is professional yet approachable. Top-level, yet aspirational. The diversity of makes and models makes it very challenging and exciting for drivers, teams and fans. And we keep focusing on ways to delight our customers, and those can be drivers, fans, teams and sponsor partners."

BRANDS HATCH
KENT

DONINGTON PARK
LEICESTERSHIRE

OULTON PARK
CHESHIRE

SNETTERTON
NORFOLK

CADWELL PARK
LINCOLNSHIRE

BEDFORD AUTODROME
BEDFORDSHIRE

CHRISTMAS CRACKERS!

- EVENT TICKETS AND SEASON PASSES
- DRIVING EXPERIENCES
- PASSENGER RIDES
- CIRCUIT MERCHANDISE
- TRACKDAY VOUCHERS

From the
UK's biggest
motor racing
circuit operator
MSV



HIGH SPEED GIFT IDEAS FOR THE PETROLHEAD IN YOUR LIFE!

Call **0843 453 1000**
or visit **www.msv.com/christmas**

Calls will cost 7p per minute plus your telephone company's access charge.



TOTALLY MOTORSPORT BRING YOU ADVENTURES FROM -20°C TO +30°C



Ayrton Senna - The Final Picture The last recorded photograph at such close proximity of Ayrton Senna printed on toughened glass and framed to create an unrivalled finish - comes with a certificate of authenticity and a plaque reading the words.... Ayrton's Last Race Start of the San Marino GP - 1st May 1994 Ayrton Senna . Born 21st March 1960 died 1st May 1994

-Overall dimensions approx 95cm x 55cm
-Special pre Christmas offer - £250.00 inc VAT and UK postage (RRP £345.00)

Ice Driving is the Ultimate Driving Experience
Three courses available; Race Driver Training
Course Fun weekend Drive SkiPackage
Now in our tenth year and voted as the best value
Ice Driving Experience in Europe
www.icedriving.net



Feline Fields is an amazing Safari Lodge in Botswana and sponsors of one of our drivers - Ruben Del Sarte. Totally Motorsport can now offer exclusive and inclusive packages to this fabulous resort www.felinefields.com



FOR FURTHER DETAILS PLEASE CONTACT GRAEME@F1.CO.UK / 01625 427683 OR VISIT WWW.F1.CO.UK

Williams diffuser

ALTHOUGH WILLIAMS HELD ON TO FIFTH IN THE constructors' championship, it had the biggest slip back in performance from last season to '17.

But it did work to improve the car. At Monaco, it added some small detail turning vanes to the outer extremity of the diffuser. It's important to get this area of the diffuser, the rear brake-duct turning vanes and the low-pressure area behind the tyre working together.

If this is achieved, the complete rear of the car works to extract the airflow coming through from under the car to improve the performance.

Alonso's start trick

MCLAREN FOLLOWED THE TREND MERCEDES set with its clutch-paddle designs. This involved adding pockets for the driver's fingers to slot into.

These are designed to allow the driver more position feel during the start phase, perhaps helping Fernando Alonso's already-brilliant starts.

Last year, the driver could use both clutch paddles, holding one at the bite point while fully disengaging the clutch with the other. Then they

would release the fully disengaged paddle, which meant the one at the bite point would allow the clutch the correct engagement for the launch.

This year, the clutch control had to be a single paddle movement controlled by the driver. The longer the stroke, and the more feeling the driver has, the easier it is to find the bite point and control the rest of the start depending on the available traction.

Toro Rosso front suspension

LIKE MERCEDES, TORO ROSSO RAISED THE height of the outboard ends of its front wishbones to upright pickups.

This was done with the addition of an 'ear' coming off the top of the front upright around the inner edge of the front rim. The lower wishbone was also higher, above the centre of the axle.

This moved the wishbones into a position where they did less damage to the airflow coming off the front wing, as well as better preparing the airflow for hitting the sidepod leading edge and underfloor.

Renault bargeboard development

RENAULT STARTED THE YEAR WITH A CAR THAT looked a little underdeveloped, but made good progress as the season progressed and finished the year as best of the rest in Abu Dhabi.

At Silverstone, it introduced a new multi-slotted bargeboard foot, and this evolution in Hungary added a new double element to it.

These vortex generators improved sealing along the outer edge of the underfloor, added at Silverstone, and gave a major performance gain.

Haas bargeboard

AT AUSTIN, HAAS INTRODUCED ONE OF THE more elaborate bargeboard components we saw – what can best be called a 'Venetian-blind' forward-facing one. This component works in conjunction with the main bargeboard arrangement and sidepod outer vertical vane to help scavenge airflow from under the front of the chassis. This allowed the underfloor to create more downforce.

It's a complex area, and contributes to both front-wing and underfloor performance, which was why it was a key area of development for all teams in 2017.

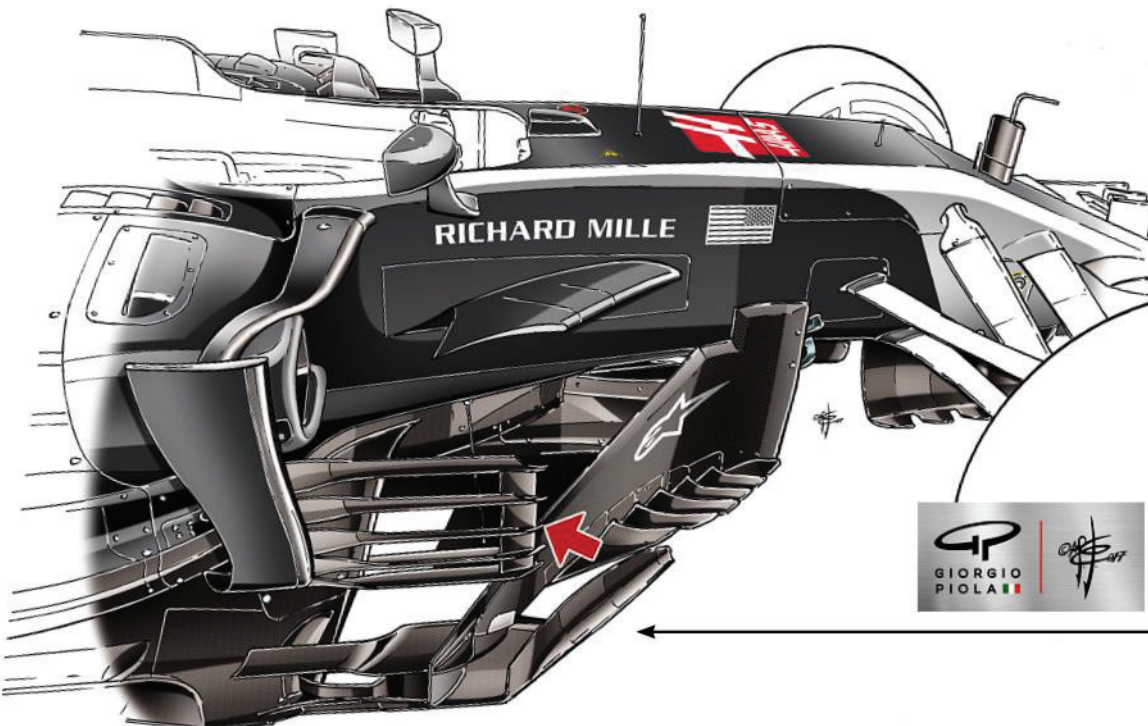
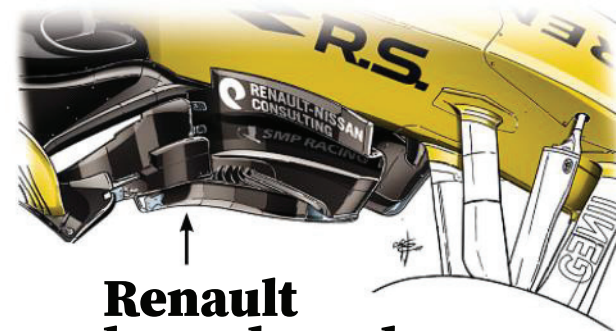
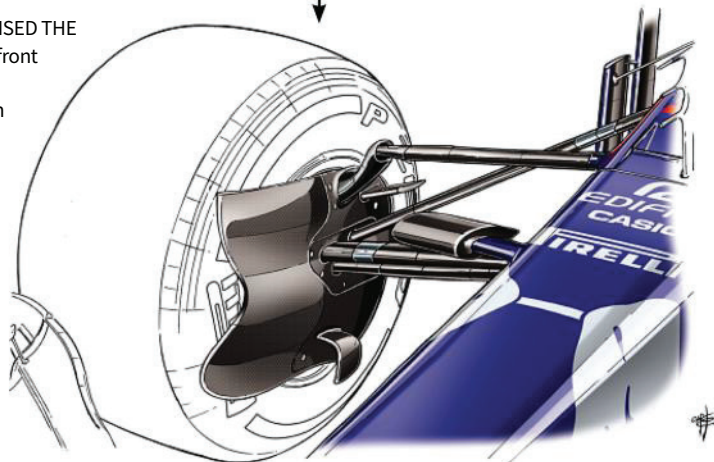
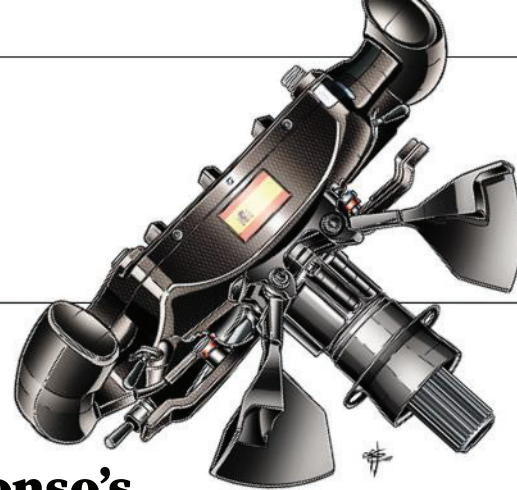
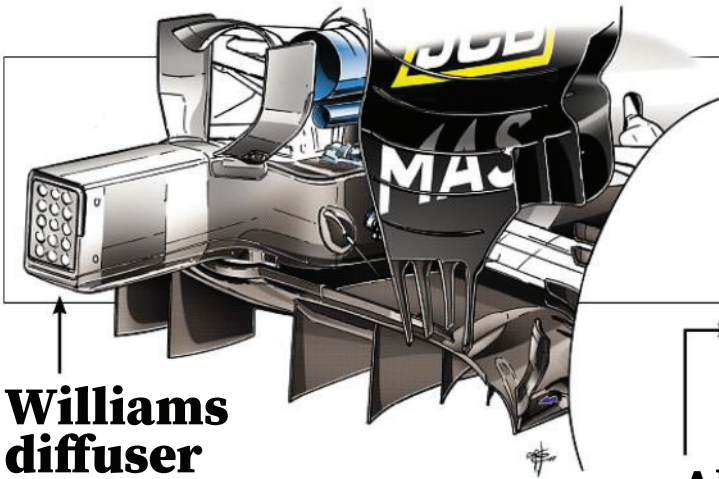

Renault knocking on the door

From the shambles of two years ago, Renault has expanded its workforce and facilities and now reckons it can challenge F1's big three

By Jonathan Noble



HONEY/LAT

It said much about the growing momentum behind Renault this year that, on the Sunday night of the season-closing Abu Dhabi Grand Prix, Mercedes boss Toto Wolff mentioned the team as a contender to join the 'big three' in the fight at the front of Formula 1 in 2018.

Indeed, the French car manufacturer's second season back as a works entrant has been one where it has found new stature in F1 – albeit with a few growing pains here and there. On the downside, Renault suffered too many reliability failures to deliver on the full potential of what was probably the fourth best chassis by the end of the campaign. But the increasing pace of the RS17, the ever-booming resources at Enstone, the recruitment of some key personnel – including the controversial coup of landing the FIA's Marcin Budkowski – and that \$6.5million bonus for capturing sixth in the constructors' championship in the final race lifted spirits.

For Renault F1 managing director Cyril Abiteboul, the high note on which the season finished – especially after the calamity of Mexico – is far more important than any extra finances the team earned from commercial rights. "F1

is all about people," he says. "You need resources, but that is not what is going to make a huge difference for next year. But people, mindsets, spirit, motivation, that is huge. I believe so much in every single employee and team member, who are going to have an extra element of motivation that will make so much more difference than a couple of million."

Change at Renault has been fast over the past two years. Since taking over a Lotus team, at the end of 2015, where competitiveness had fallen well behind and investment had stopped, there has been an aggressive push. There have been new buildings, new computers, new facilities, new machines – and a massive recruitment drive that will see staff levels jump from 400 when Renault took over to nearly 700 by the middle of next year.

Growth hasn't stopped yet, as even Nico Hulkenberg has noticed in his first year on board. "It's been a massive improvement," says Hulkenberg. "If you look at the start of the season, in terms of performance and where we were in the pecking order and where we are now, we have made a lot of big steps forward. You have to understand where the team has come from. When Renault decided to buy the team back and make it a factory team again, it was in a very bad state. So it takes the time to build it back up and,

unfortunately, even though we would like to make it in two weeks, it doesn't happen like that."

In spite of the car and team improving greatly over the past 18 months, things haven't been an easy ride at all times. Engine and car reliability failures proved too costly for the team's aim of finishing fifth in the constructors' championship this year, and this is definitely an area that has to be worked on for next season.

The causes of these problems were twofold. On the engine side, Renault's decision to go with a new concept for 2017, and push hard for performance



Jolyon Palmer had a tricky year – and some bad luck – and was out before the end of the campaign



HONEY/LAT



LAT IMAGES

gains, did not come without consequence, and it struggled all year with its MGU-K.

“We decided to take some risk in an attempt to fast-track, as we know there is little time if we want to meet our ambition, which is to fight for the championship in 2020,” says Abiteboul. “We had to take that decision to take some risk. It’s a risk that in my opinion is paying off from a performance trajectory perspective, but it did not pay off from a reliability perspective.”

On the team front, the reliability problems were a legacy of its organisation still being young and finding its feet. Technical director Nick Chester suggests that the combination of an aggressive push to make progress by a fledgling organisation, with the added complication of the upheaval of the 2017 rules revamp, triggered a perfect storm to leave unreliability in the system.

“Some of it started in the design side and some of it is a mixture of being a bit pushed when we were designing the 2017 car,” says Chester. “We had an absolutely different car to do, and we needed a lot more time to do it. So, there are some things that we probably pushed through with design too quickly.”

Poor reliability was perhaps a not unexpected growing pain for an organisation that produced a solid car

in the RS17. It made big progress over the second half of the year, especially with a floor update from the British Grand Prix, as the chassis stepped forward to end the year as best of the rest behind Mercedes, Ferrari and Red Bull.

There is little to suggest that this momentum will not be carried forward into next year, as long as the team gets on top of those reliability problems. And that is why Renault has talked of new targets for next season; of more diligent sign-off of parts and a better-structured plan to get everything checked and double-checked before it hits the track.

It is perhaps telling that, as Abiteboul left Abu Dhabi to prepare for the winter, thoughts were not on what Renault can achieve in racing in 2018, but on how far it can go in pre-season testing. “We need to focus on what matters, on what counted, this year,” he says.

“The first goal is to have a very reliable car as early as the winter tests. We want to be right up there in terms of mileage.

“We have not defined the target next year in terms of the championship, but actually the first target we have set ourselves is to be top three in terms of mileage for the winter tests. That is the top way we want to approach it. Because once you have that, you work backwards.” ❄

SAINZ: THE BIG WINNER



Sainz was on the pace as soon as he joined Renault

MAUGER/LAT

CARLOS SAINZ ENDED UP AS ONE OF THE biggest winners from the McLaren-Honda divorce, when he found himself to be an important pawn in the chess movements required to split the Woking team from its Japanese engine partner.

With Honda’s only option to remain in F1 a deal with Toro Rosso, Renault needed an incentive to end its customer deal with Red Bull’s junior team early. That came in the form of the young Spanish driver, whose switch came at the United States Grand Prix, when Jolyon Palmer accepted a deal to walk away from F1.

Sainz was immediately on the pace – even though he never outqualified new team-mate Nico Hulkenberg in a straight fight – proving that Renault’s faith in him was right.

His points-scoring first outing for the team in Austin erased any doubts about his own performance, and also showed how solid a platform Renault had with its car.

But beyond the performance this year, for Sainz the most important thing has been about getting an early eye in with the team ahead of 2018, as now he can push for things to be tweaked to better suit him for next year. “It has given me a big advantage, to have these four races to know the car, to know the systems, to know my engineers,” he says. “It has been fundamental for next year.

“It means that in testing we can start focusing on car performance and also me integrating even better with the car and the team, and that will be encouraging to know that. It’s going to give us a big advantage for next year.”

The switch was not just good news for Sainz – it’s been a boost for Renault, too. Although Sainz’s driving style differs slightly from Hulkenberg’s, having two drivers pushing the team hard is good for everyone at Enstone.

As Hulkenberg says: “Having Carlos here now, he is pushing and I am still pushing. We are pushing each other to the benefit of the team; he is giving good feedback to the team as well. Two guys instead of one pushing everything forward is really important for a team.”



Finding a balance

Liberty has arrived to blow away Bernie and CVC (hooray).
But still there are inequitable revenues as the rich get
richer (boo). Is all well in the F1 political pantomime?

By Dieter Rencken, Special Contributor

In many ways, 2017 marked a watershed in Formula 1's future: not only was its former tsar Bernie Ecclestone, who shaped the sport unto his own image for three decades, deposed and "booted upstairs" by incoming commercial rights-holder Liberty Media, but the new owners – at last – ridded F1 of its former managers at CVC Capital Partners.

Although the takeover was confirmed in September 2016, change of control was effected on January 24. When F1 decamped in Melbourne eight weeks later, it was clear that fresh winds were gusting through F1 from various directions – albeit mainly from the United States – as much on-track as within the paddock.

For starters, the atmosphere was more relaxed and less restricted, with a can-do attitude prevailing within Formula One Management, the Liberty subsidiary charged with pointing F1 towards the 21st century. Details such as freed-up social media activities and increased paddock pass allocations made the teams bullish about a future under Liberty; yet, to many, this was simply a public tummy-tickling show.

F1's root evils – its inequitable revenue structure and apartheid-like governance process – are, after all, cast in contracts through to the end of 2020, while the rich-to-poor gap is wider than at any point in recent history, and rivals divides found in most Third World countries. Forget not that Manor had recently folded, with the difference between success and failure being a single point (not) scored in the penultimate 2016 round.

At a media briefing in Melbourne, Liberty frontmen (Ross Brawn, MD Sport, and Sean Bratches, MD Marketing) presented their visions, with the legendary F1 manager talking about "getting a team within FOM together, a way of working together with teams and the FIA", while Bratches waxed about "engaging fans in new ways, creating experiences, opportunities and emotions that continue to drive this great sport".

Come the last race, the teams were irate after being hit by a third-quarter cut of 13% in FOM earnings – the first drop in over a decade, driven mainly by a raft of marketing/media recruits, plus the cost of operating Brawn's "team" – while fans raged against F1's new logo, a replacement for the iconic (to many) 'Flying F', which most saw as little more than a

(costly) attempt at expunging the last vestiges of Bernie.

Were F1's revenues equitably shared, then the reduction would not be as drastic. But the haves receive substantial bonuses, while the have-nots are, as always, worst hit. True, Liberty voluntarily offered bridging loans, but these need to be repaid when (and if?) revenues rise.

The question is, though, whether teams should be funding F1's plans in the first place – they are suppliers, not equity partners, and as such should be fairly remunerated for services they supply through entering the championship. Liberty is, by definition, F1's investor – not the teams, who are stakeholders.

But during 2017 Liberty learned a lot, not least that Ecclestone, unsurprisingly, refused to accept he had lost control of his life's work. Despite his (and his family trust) being minority shareholders in FWONK (Liberty's NASDAQ stock exchange 'ticker'), the octogenarian waged war against those who dared to 'promote' him to the position of chairman emeritus.

Among his first moves, apart from giving scathing interviews, was to permit Malaysia to cancel its contract without penalty, costing Liberty an estimated £15 million, plus, crucially, enormous loss of face. His suggestion that "we charged [promoters] too much for what we provided" further compounded the situation. Any wonder Malaysia's promoter felt ripped off,

"F1's root evils are cast in contracts through to the end of 2020"

or that Singapore pushed for reduced fees?

This cancellation of Sepang could not have come at a worse time: just when Liberty planned to grow F1 in Asia and the US, it lost its oldest 'new world' event in the most public fashion possible; by year end, talk of future 25-race calendars and three US events had been replaced by speculation about a race in Vietnam, and possibly a round in Miami – if, that is, environmental protesters don't manage to get in the way.

True, 2018 lists 21 rounds, but Hockenheim is out of contract thereafter, while Interlagos is endangered after teams were subjected to utterly unacceptable security risks, so where to then? As things stand now, '19 marks the last British Grand Prix after Silverstone gave notice, so F1 is unlikely to hit 21 again unless Liberty converts two (or three) of its "over 40 expressions of interest" for races into reality.

Then, Liberty learned that the governance process devised by CVC is stacked against the CRH for the foreseeable future. Example: no sooner had Brawn unveiled a concept for cheaper,



Liberty men Brawn (far left), Carey and Bratches (left) were in, Ecclestone (below left) was out

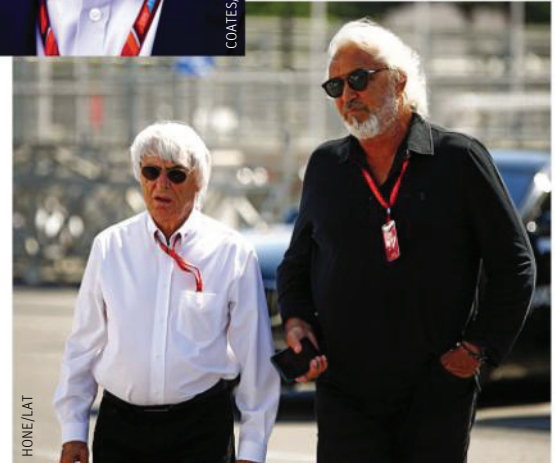

DUNBAR/LAT

LAT IMAGES

HONE/LAT



ETHERINGTON/LAT

less complex post-2020 engines attractive to independents and prospective motor manufacturers, than Renault and Mercedes vehemently opposed the concept, while Ferrari threatened to exercise its veto, or even exit F1. At that point the honeymoon period was clearly over, which visibly shocked Bratches and his boss, FOM CEO Chase Carey. To Brawn, though, it was just another day in F1.

Whether or not Ferrari eventually walks is not the point – the point is that these public spats damage the F1 brand, in turn affecting FWONK's price, which dipped almost 10% in a month. Where CVC operated behind a veil of secrecy as it milked F1, Liberty's performance is audited daily by the markets, and thus its executives seem overly obsessed with investor sentiments.

Liberty's frustrations are further illustrated by F1's daft penalty system: all realise the idiocy of imposing 35-place grid penalties (on 20-car grids...) for engine reliability infringements, yet rules are rules, and unless unanimity is

found – a commodity in short supply in arguably the most self-centred sport on earth – they are unlikely to change. Then, 2018 brings a further reduction, to three engines per season.

Talking of engines, a major mid-season bone of contention – one that possibly cost Ferrari its competitive edge from Monza onwards – was the topic of 'oil-burn'. In order to reduce pre-detonation and boost calorific energy, engine suppliers injected oil – 1.2 litres/100km – into their powerplants. In July, the FIA imposed limits of 0.9 litres on units introduced from Monza. This benefited Mercedes, running to different duty cycles. Renault and Honda were not in on such technology, and thus squealed loudly, although Honda was hardly in a position to object given its woeful performance and unreliability, triggering not only a painful divorce from McLaren, but an embarrassing split from Sauber, which intended switching to the Japanese engines for 2018.

This convoluted saga was eventually resolved in typical F1 fashion, and just in time: Toro Rosso lost Renault in favour >>



Ecclestone allowing Malaysian GP promoters to cancel their contract could not have come at a worse time as new F1 owners seek to expand in Asia

F1 SEASON REVIEW 2017



Security problems
may finally end
Brazilian GP

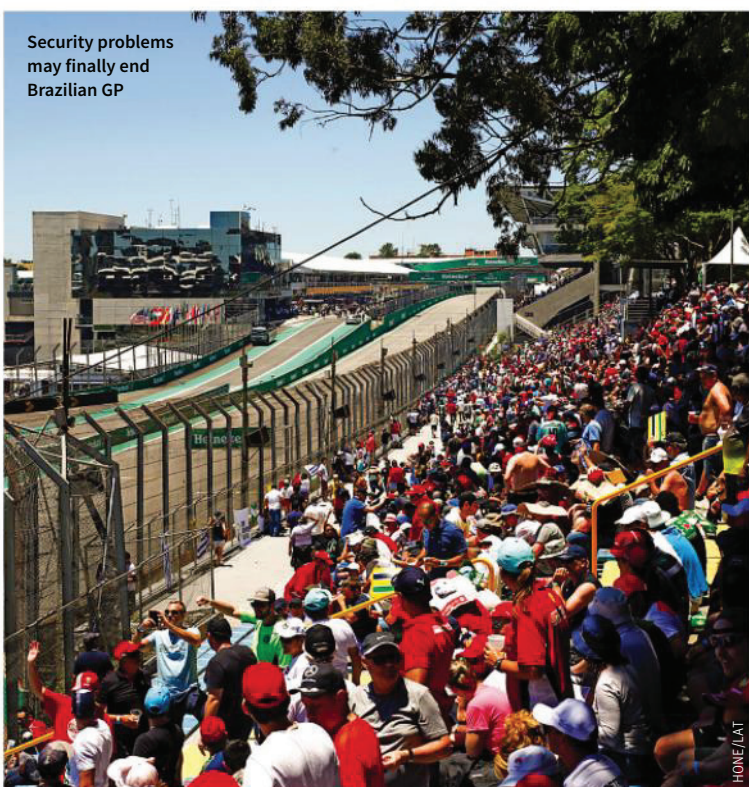

of Honda; McLaren took Renault; and Sauber remained with Ferrari (albeit partnered by Alfa Romeo) – with the ultimate winner being Carlos Sainz, released by Toro Rosso and ‘loaned’ to Renault as part of a severance package. Win, win, win, yes – but only after negotiations were conducted in the media.

If the relationship between the FIA and the ‘old’ FOM had at times been fractious, that prevailing between the governing body and new CRH could hardly be rosier, in part because Brawn was one of FIA president Jean Todt’s lieutenants during the Frenchman’s Ferrari tenure, when the Scuderia swept all before in a show of hegemony only now dreamed of by Mercedes. Such winning experiences tend to cement relationships.

The two men seem aligned on most areas of importance and, when asked whether he was afraid that Brawn’s team could usurp the federation’s regulatory powers by taking the lead on technical and sporting issues, Todt, now heading for his third presidential term unopposed, was sanguine.

“Now we have a strong team, technical, sporting, inside of Liberty Media. So, their responsibility is to give us the outcome of their research and then, as the regulator, with the governance, we will deal with that,” he explained in Abu Dhabi. One simply could not imagine such confidence being so openly expressed during the Bernie Days, with the word ‘now’ saying it all...

Possibly the hardest lesson for Liberty to take on board during 2018, though, was that there exists massive resistance to change among fans, and that their loyalty runs but one race deep, regardless of ‘fans this’ and ‘fans that’ commitments. True, the racing improved year on year, but that was hardly thanks to Liberty, which came aboard only after the current



July's F1 demo
in London
sought to bring
fans closer
to the sport



DUNBAR/LAT



TEE/LAT



“Regardless of hype, Liberty is judged by on-track action”

regulations were finalised, and Ferrari had regrouped.

Paying lip service to F1 and its fanbase does not engender loyalty, and there exist suspicions of American business methods being applied to a quintessentially European sport – consider how the boxing-style US GP build-up, complete with red carpets and announcer, was panned. Regardless of social media initiatives, activities such as the Trafalgar Square demo and ‘Super-Bowl’ hype, Liberty is judged by on-track action.

While there is no denying that in 2017 F1 was at its most harmonious for 30 years (at least), there remains much grist for the rumour mill. Until current contracts have run their course, in 2020, F1’s political undercurrents will continue to ebb and flow, driven as they are by the competitive nature of the sport’s stakeholders, whether regulator, money or media man, team boss or driver.

Politics are as vital to F1’s success as petrol or personalities; its constant power struggles keep the sport in the global spotlight and public eye, in turn attracting media attention and, crucially, feeding fans and sponsors. In 2017, F1 seems to have found its optimum balance. ❄

VIVE LE PRESIDENT (ENCORE)



TEE/LAT

BY THE TIME YOU READ THIS, Jean Todt will have been confirmed as FIA president for a third consecutive term. Significantly, the Frenchman stood unopposed in the first election not influenced by predecessor Max Mosley, Bernie Ecclestone’s friend and confidant for over 30 years. They had, of course, ruled F1 with velvet-gloved iron fists since 1980.

So, for the first time in four decades, F1 is under truly new management, commercially and administratively. Todt is free to concentrate on steering world motoring’s governing body into the 2020s and beyond, while Liberty Media drags F1 into the digital age.

It has not, though, been an easy ride for either F1 or the FIA: Ecclestone continues to attend races, where he commands

progressively less authority, and then only among the old guard. Mosley was last seen in Monaco during the early Todt years and not since.

Their piece de resistance was, of course, the Concorde Agreement (in all its iterations since 1982) and, arguably much like their styles, the document is well past its shelf life and likely to be superseded once present covenants expire at the end of 2020. Should F1 reach rare unanimity, it could be sooner.

What could replace Concorde? Bets are on a constitution containing sporting, technical, commercial and administrative ‘chapters’, updated as and when required with agreement of all parties. Crucially, it would have no expiry given that F1’s value decreases as it gets to ‘sunset’, in turn affecting share prices...



DUNBAR/LAT

Todt can now focus on running FIA



Bottas revealed his surprise at Mercedes team-mate Hamilton's strong work ethic



TOP 10 FORMULA 1 AUTOSPORT.COM STORIES*

*Accurate as of December 1 2017

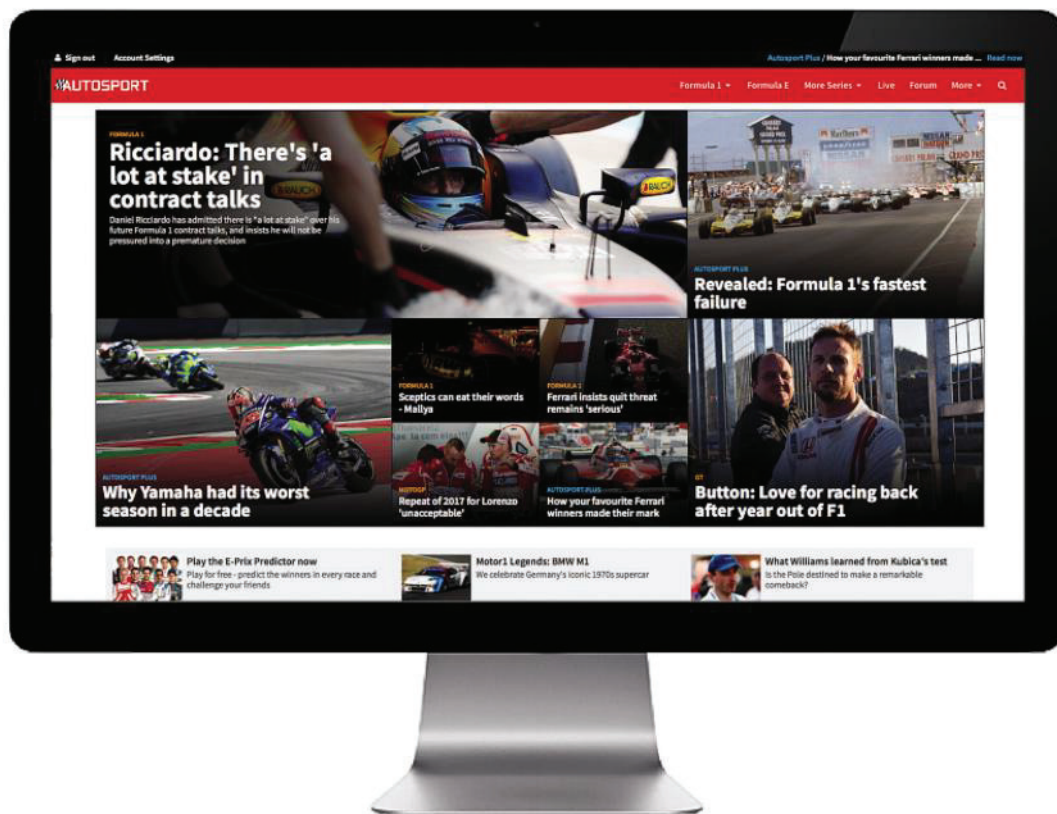

1

Revealed: first images of 2017 Williams

The first images of a Formula 1 car designed to the new-for-2017 regulations – the Williams FW40 – were released exclusively by Autosport and Motorsport.com. The rendered pictures and video were sent out a week before the car was officially launched at pre-season testing.



6

Monaco GP returns to terrestrial TV in Britain

Proving that interest runs high in stories about free-to-air F1 coverage, this piece revealed the 2017 schedules of Sky and Channel 4, with the news that the Monaco Grand Prix would be broadcast on the latter. It outscored the next story considerably in terms of page views.





Below: Villeneuve's outburst hit the headlines; right: Renault revelations piqued interest



2

Sainz Renault deal sets up McLaren changes

This story announced the first concrete suggestions that Carlos Sainz had signed a deal to join Renault, which would trigger changes that led to McLaren getting the French manufacturer's engines for 2018 and Toro Rosso switching to Honda power.



3

Force India reveals pink livery for 2017

Another popular early story was Force India revealing its pink livery – the colour scheme of its new sponsor, water technology company BWT. It was also announced that drivers Sergio Perez and Esteban Ocon would have pink helmets for the upcoming season.



4

Bottas didn't realise how hard Hamilton works

Here, via an extract from Motorsport.tv's weekly programme *The Flying Lap*, Valtteri Bottas explained how he had not realised how hard Lewis Hamilton works until he joined Mercedes and partnered the four-time world champion in F1 this year.



5

Formula 1 team payments for 2017 revealed

The annual update of F1 payments was another popular story online this year, with this piece revealing that Ferrari would receive the largest share of revenues allocated for teams in 2017 despite finishing third in the '16 constructors' championship.

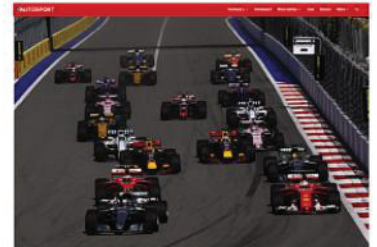

7

McLaren agrees deal to leave Honda for Renault

Following hot on the heels of the Sainz-to-Renault revelations, this story broke the news that McLaren had reached an agreement with Honda to be released from their partnership and switch to Renault power for the 2018 season.



8

Stockpiling Honda engines paid off – McLaren

McLaren racing director Eric Boullier explained how the team's strategy of taking penalty hits in preceding races by stockpiling Honda engines had paid off for Fernando Alonso in the Brazilian Grand Prix, where he finished eighth after qualifying seventh.



9

Villeneuve: Bottas was 'embarrassing' in Brazil

A slightly more controversial story online reported 1997 Formula 1 world champion Jacques Villeneuve's comments following the Interlagos race, where he labelled Valtteri Bottas's performance "embarrassing" and the level of a "number two" driver.



10

Senna family clarifies Hamilton helmet gift

This quirkier entry covered the family of Ayrton Senna clearing up confusion about the helmet presented to Lewis Hamilton for his 65th F1 pole position, which was initially and incorrectly thought to be race-worn by the Brazilian triple world champion.



THE BEST F1 TRACK

For a bit of fun, we thought we'd give our F1 hacks who trudge around the paddocks and circuits of the globe chance to have their say. Which is the best?

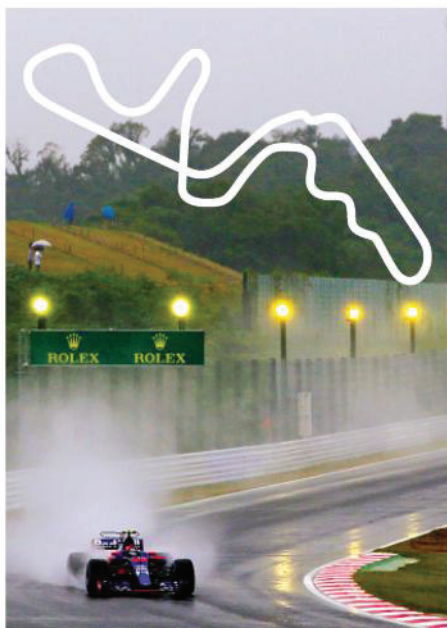

Challenge

IT'S ALL ABOUT MAN AND MACHINE, STRIVING against the odds. So which track is dastardly and which just doesn't push them to the limit?

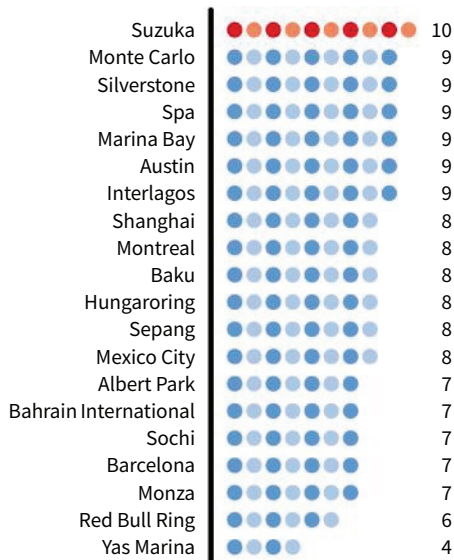

Speed

MOTOR RACING IS SUPPOSED TO BE ALL ABOUT going fast, right? Step forward, the venerated 'cathedral of speed'.

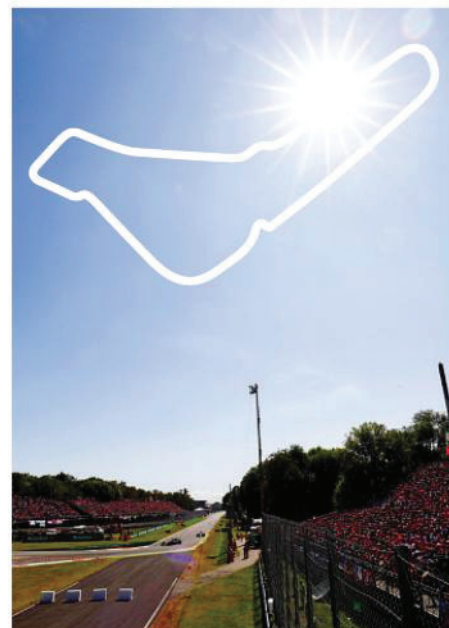
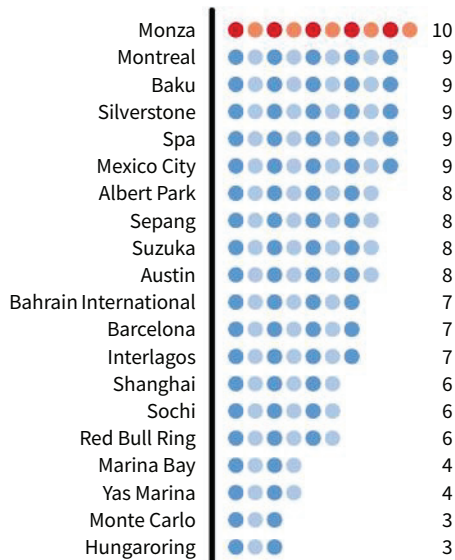

Venue

PUT SIMPLY, HOW COOL IS THE PLACE TO GO TO? Or is it some recently constructed, atmosphere-bereft place that takes a day to fly to?

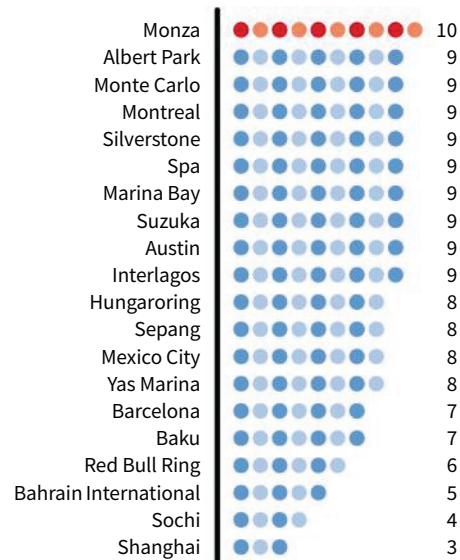



Tradition

EXACTLY WHAT IT SAYS. A COMPOSITE OF HUGELY enthusiastic fans, and the amount of times you see that overused phrase 'ghosts of the past'.

Monte Carlo	10
Silverstone	10
Monza	10
Suzuka	10
Spa	9
Interlagos	9
Barcelona	8
Montreal	8
Hungaroring	8
Albert Park	7
Red Bull Ring	7
Mexico City	7
Sepang	6
Marina Bay	4
Austin	4
Yas Marina	4
Bahrain International	2
Shanghai	2
Sochi	1
Baku	1

Competitiveness

WHEN YOU'VE GOT THROUGH TWO DAYS OF build-up, you want entertainment. So the most challenging track may not be easiest to race on...

Spa	9
Interlagos	9
Montreal	8
Baku	8
Silverstone	8
Marina Bay	8
Sepang	8
Austin	8
Bahrain International	7
Shanghai	7
Red Bull Ring	7
Monza	7
Albert Park	6
Suzuka	6
Mexico City	6
Hungaroring	5
Sochi	3
Barcelona	2
Monte Carlo	2
Yas Marina	2

AND THE WINNER IS...

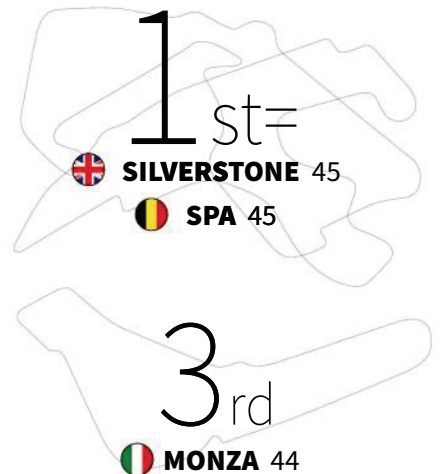

4TH	SUZUKA	43
=	INTERLAGOS	43
6TH	MONTREAL	42
7TH	SEPANG	38
=	AUSTIN	38
=	MEXICO CITY	38
10TH	ALBERT PARK	37
11TH	MARINA BAY	34
12TH	MONTE CARLO	33
=	BAKU	33
14TH	RED BULL RING	32
=	HUNGARORING	32
16TH	BARCELONA	31
17TH	BAHRAIN INTERNATIONAL	28
18TH	SHANGHAI	26
19TH	YAS MARINA	22
20TH	SOCI	21

Year in numbers

Compiled by forix.autosport.com

DRIVERS' STANDINGS

POS	DRIVER	AUS	PRC	BRN	RUS	E	MC	CDN	AZ	A	GB	H	B	I	SGP	MAL	J	USA	MEX	BR	UAE	PTS
1	Hamilton	2nd	1st	2nd	4th	1st	7th	1st	5th	4th	1st	4th	1st	1st	1st	2nd	1st	1st	9th	4th	2nd	363
2	Vettel	1st	2nd	1st	2nd	2nd	1st	4th	4th	2nd	7th	1st	2nd	3rd	R	4th	R	2nd	4th	1st	3rd	317
3	Bottas	3rd	6th	3rd	1st	R	4th	2nd	2nd	1st	2nd	3rd	5th	2nd	3rd	5th	4th	5th	2nd	2nd	1st	305
4	Raikkonen	4th	5th	4th	3rd	R	2nd	7th	14th	5th	3rd	2nd	4th	5th	R	NS	5th	3rd	3rd	3rd	4th	205
5	Ricciardo	R	4th	5th	R	3rd	3rd	3rd	1st	3rd	5th	R	3rd	4th	2nd	3rd	3rd	R	R	6th	R	200
6	Verstappen	5th	3rd	R	5th	R	5th	R	R	R	4th	5th	R	10th	R	1st	2nd	4th	1st	5th	5th	168
7	Perez	7th	9th	7th	6th	4th	13th	5th	R	7th	9th	8th	17th	9th	5th	6th	7th	8th	7th	9th	7th	100
8	Ocon	10th	10th	10th	7th	5th	12th	6th	6th	8th	8th	9th	9th	6th	10th	10th	6th	6th	5th	R	8th	87
9	Sainz	8th	7th	R	10th	7th	6th	R	8th	R	R	7th	10th	14th	4th	R	R	7th	R	11th	R	54
10	Hulkenberg	11th	12th	9th	8th	6th	R	8th	R	13th	6th	17th	6th	13th	R	16th	R	R	R	10th	6th	43
11	Massa	6th	14th	6th	9th	13th	9th	R	R	9th	10th	NS	8th	8th	11th	9th	10th	9th	11th	7th	10th	43
12	Stroll	R	R	R	11th	16th	15th	9th	3rd	10th	16th	14th	11th	7th	8th	8th	R	11th	6th	16th	18th	40
13	Grosjean	R	11th	8th	R	10th	8th	10th	13th	6th	13th	R	7th	15th	9th	13th	9th	14th	15th	15th	11th	28
14	Magnussen	R	8th	R	13th	14th	10th	12th	7th	R	12th	13th	15th	11th	R	12th	8th	16th	8th	R	13th	19
15	Alonso	R	R	14th	NS	12th	-	16th	9th	R	R	6th	R	17th	R	11th	11th	R	10th	8th	9th	17
16	Vandoorne	13th	R	NS	14th	R	R	14th	12th	12th	11th	10th	14th	R	7th	7th	14th	12th	12th	R	12th	13
17	Palmer	R	13th	13th	R	15th	11th	11th	R	11th	NS	12th	13th	R	6th	15th	12th	-	-	-	-	8
18	Wehrlein	NS	-	11th	16th	8th	R	15th	10th	14th	17th	15th	R	16th	12th	17th	15th	R	14th	14th	14th	5
19	Kvyat	9th	R	12th	12th	9th	14th	R	R	16th	15th	11th	12th	12th	R	-	-	10th	-	-	-	5
20	Ericsson	R	15th	R	15th	11th	R	13th	11th	15th	14th	16th	16th	18th	R	18th	R	15th	R	13th	17th	0
21	Gasly	-	-	-	-	-	-	-	-	-	-	-	-	-	-	14th	13th	-	13th	12th	16th	0
22	Giovinazzi	12th	R	-	-	-	-	-	-	-	-	-	-	-	-	-	-	-	-	-	-	0
23	Hartley	-	-	-	-	-	-	-	-	-	-	-	-	-	-	-	-	13th	R	R	15th	0
24	Di Resta	-	-	-	-	-	-	-	-	-	-	R	-	-	-	-	-	-	-	-	-	0
25	Button	-	-	-	-	-	R	-	-	-	-	-	-	-	-	-	-	-	-	-	-	0

CONSTRUCTORS' STANDINGS

POS	CONSTRUCTOR	AUS	PRC	BRN	RUS	E	MC	CDN	AZ	A	GB	H	B	I	SGP	MAL	J	USA	MEX	BR	UAE	PTS
1	Mercedes	33	33	33	37	25	18	43	28	37	43	27	35	43	40	28	37	35	20	30	43	668
2	Ferrari	37	28	37	33	18	43	18	12	28	21	43	30	25	0	12	10	33	27	40	27	522
3	Red Bull	10	27	10	10	15	25	15	25	15	22	10	15	13	18	40	33	12	25	18	10	368
4	Force India	7	3	7	14	22	0	18	8	10	6	6	2	10	11	9	14	12	16	2	10	187
5	Williams	8	0	8	2	0	2	2	15	3	1	0	4	10	4	6	1	2	8	6	1	83
6	Renault	0	0	2	4	8	0	4	0	0	8	0	8	0	8	0	0	6	0	1	8	57
7	Toro Rosso	6	6	0	1	8	8	0	4	0	0	6	1	0	12	0	0	1	0	0	0	53
8	Haas	0	4	4	0	1	5	1	6	8	0	0	6	0	2	0	6	0	4	0	0	47
9	McLaren	0	0	0	0	0	0	0	2	0	0	9	0	0	6	6	0	0	1	4	2	30
10	Sauber	0	0	0	0	4	0	0	1	0	0	0	0	0	0	0	0	0	0	0	0	5

SUPERGRID (AVERAGE GRID POSITION)



Vettel
3.15



Bottas
3.35



Hamilton
3.60



Raikkonen
3.85



Verstappen
6.10



Ricciardo
7.75



Perez
8.85



Ocon
9.50



Hulkenberg
9.65



Massa
10.26



Sainz
11.65



Kvyat
12.27

FIRST-LAP HEROES AND VILLAINS

WHICH DRIVERS GAINED OR LOST THE MOST POSITIONS OVER THE SEASON FROM STARTING POSITION TO THE END OF THE FIRST LAP

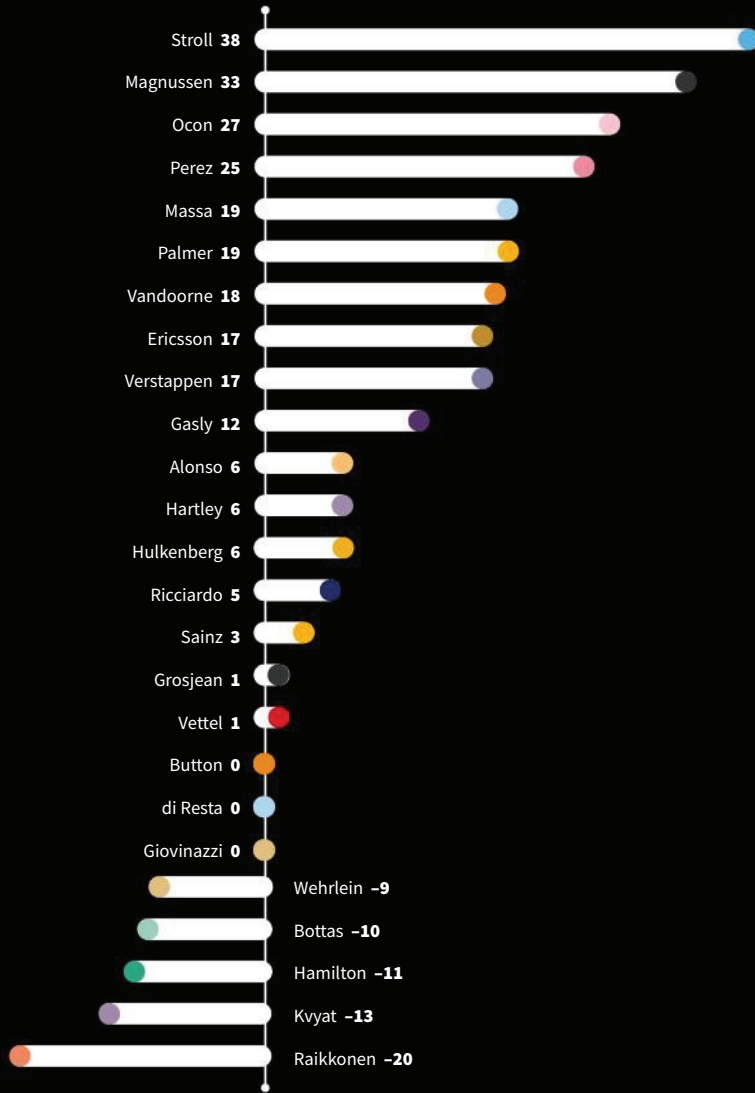

QUALIFYING PROGRESS

DRIVER	GOTT TO Q3	OUT IN Q2	OUT IN Q1
Bottas	20	0	0
Raikkonen	20	0	0
Ricciardo	19	0	1
Verstappen	19	0	1
Vettel	19	0	1
Hamilton	18	1	1
Perez	15	4	1
Ocon	13	5	2
Hulkenberg	12	8	0
Massa	11	5	3
Sainz	8	11	1
Alonso	7	11	1
Vandoorne	6	7	7
Grosjean	5	7	8
Stroll	3	5	12
Kvyat	2	11	2
Palmer	2	6	8
Button	1	0	0
Magnussen	0	10	10
Wehrlein	0	3	15
Ericsson	0	2	18
Hartley	0	2	2
Gasly	0	1	4
Giovinazzi	0	1	1
di Resta	0	0	1

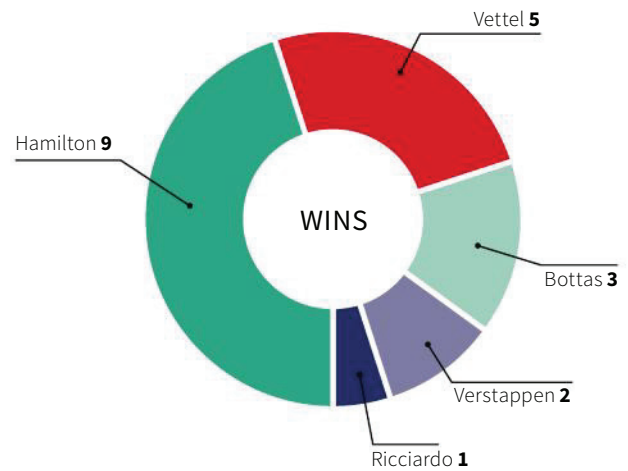
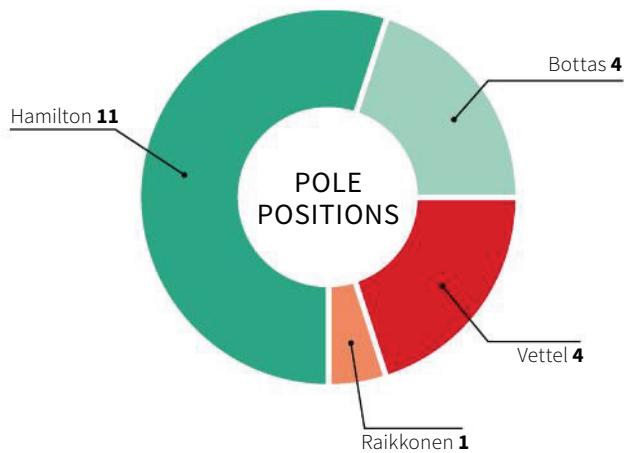

TEAM PERFORMANCE

Supertimes
(relative to 2016)

Based on taking each car's fastest single lap of each weekend, expressed as a percentage of the overall fastest time, averaged out over the 20-race season

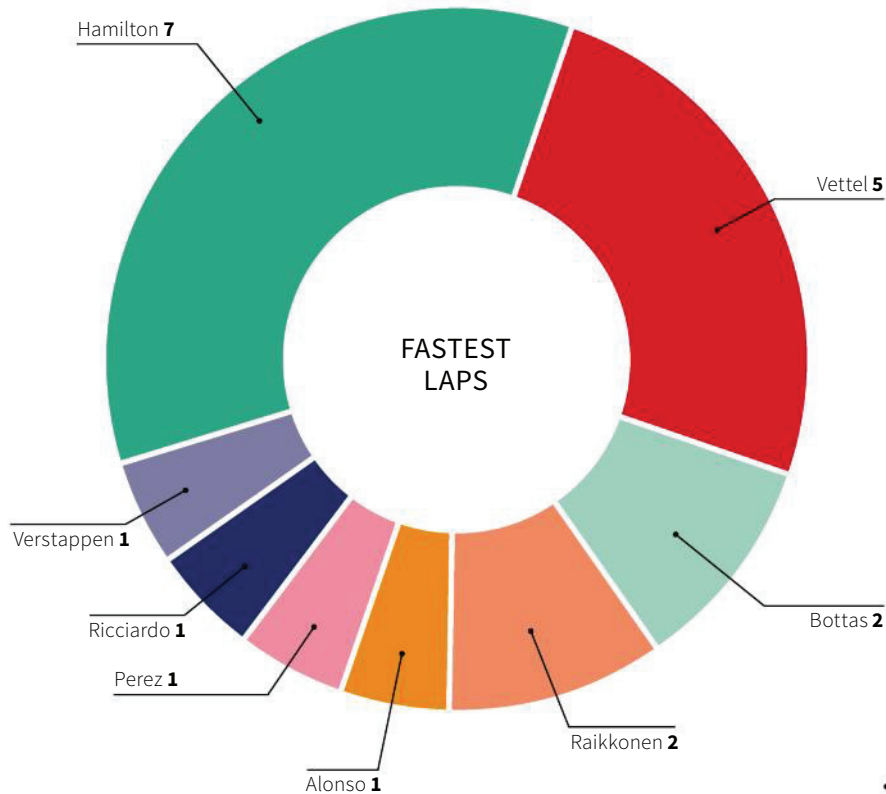
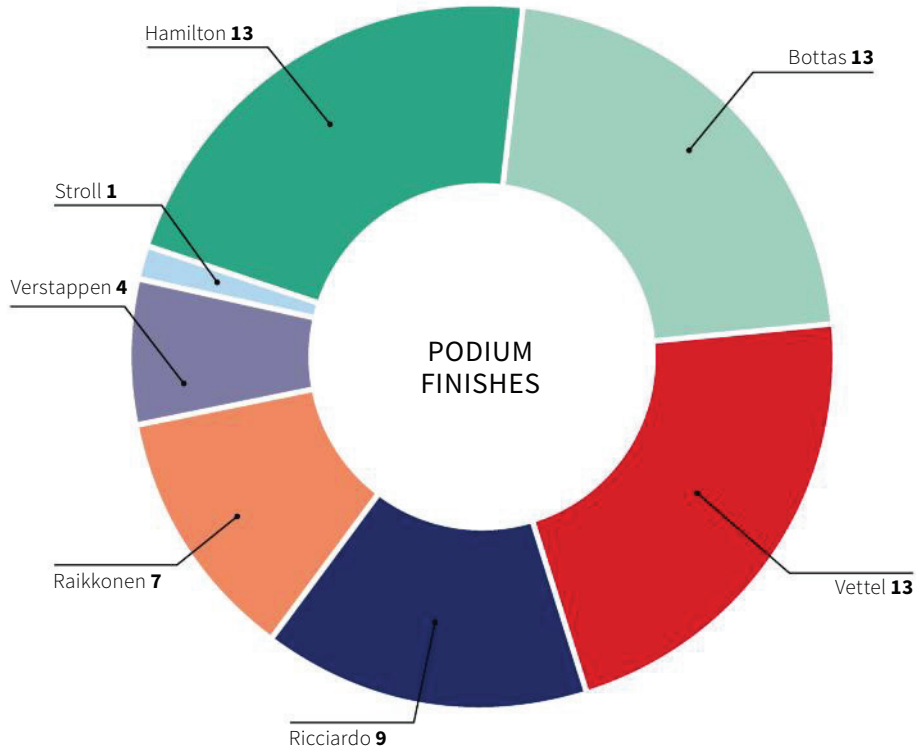
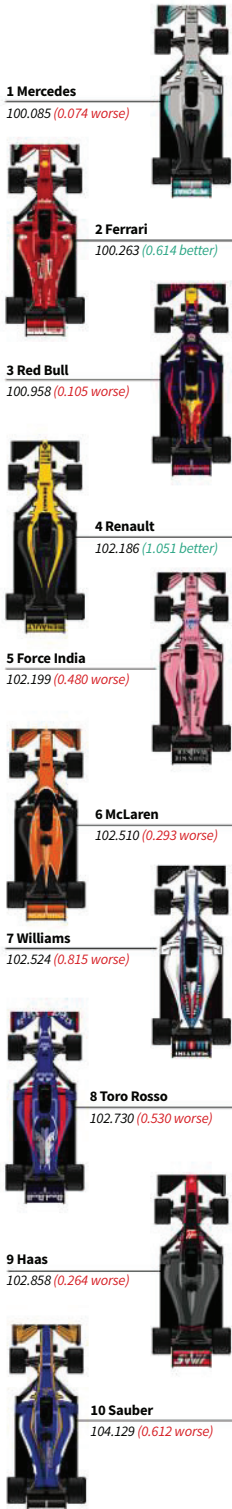

PRACTICE-ONLY APPEARANCES

Giovinazzi	7
Gelael	4
Leclerc	4
Sirotkin	4
Celis	3
Russell	2

TIMES FASTEST IN FREE PRACTICE

Hamilton	19
Vettel	14
Bottas	7
Verstappen	7
Raikkonen	6
Ricciardo	5
Massa	1

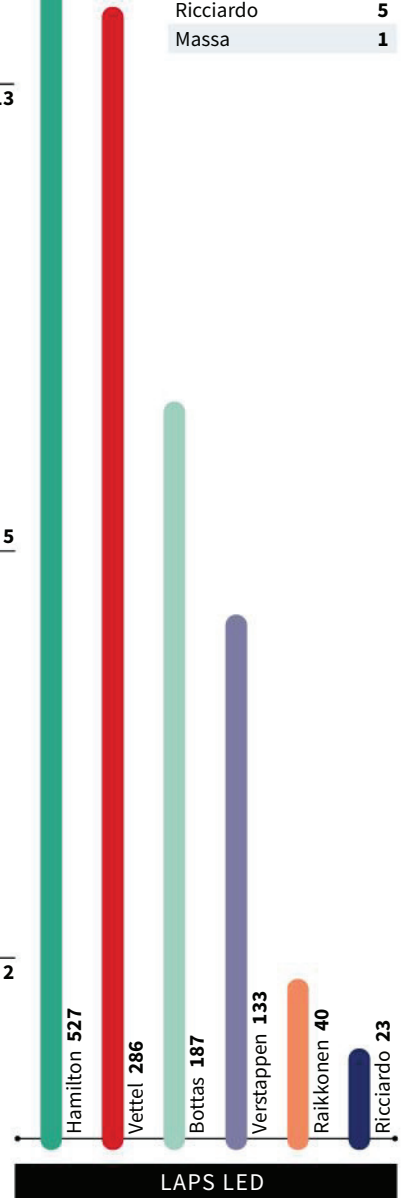

LAPS RACED

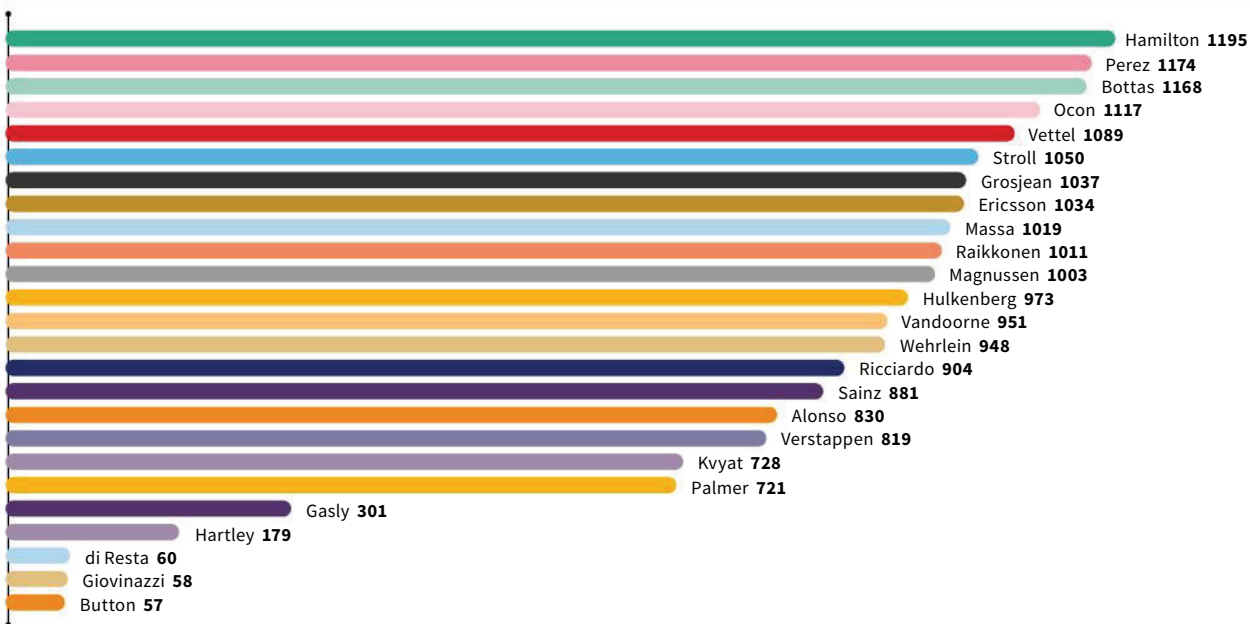

GRID PENALTIES

(TOTAL POSITIONS DROPPED)

Driver	Grid Penalties
Stoffel Vandoorne	215
Fernando Alonso	160
Daniel Ricciardo	75
Brendon Hartley	65
Pierre Gasly	45
Jolyon Palmer	40
Nico Hulkenberg	35
Max Verstappen	35
Carlos Sainz Jr	30
Marcus Ericsson	20
Daniil Kvyat	20
Sebastian Vettel	20
Jenson Button*	15
Valtteri Bottas	10
Lance Stroll	10
Pascal Wehrlein	10
Antonio Giovinazzi	5
Romain Grosjean	5
Lewis Hamilton	5
Sergio Perez	5
Kimi Raikkonen	5

*NOT SERVED

MOST COMMON RACE POSITION

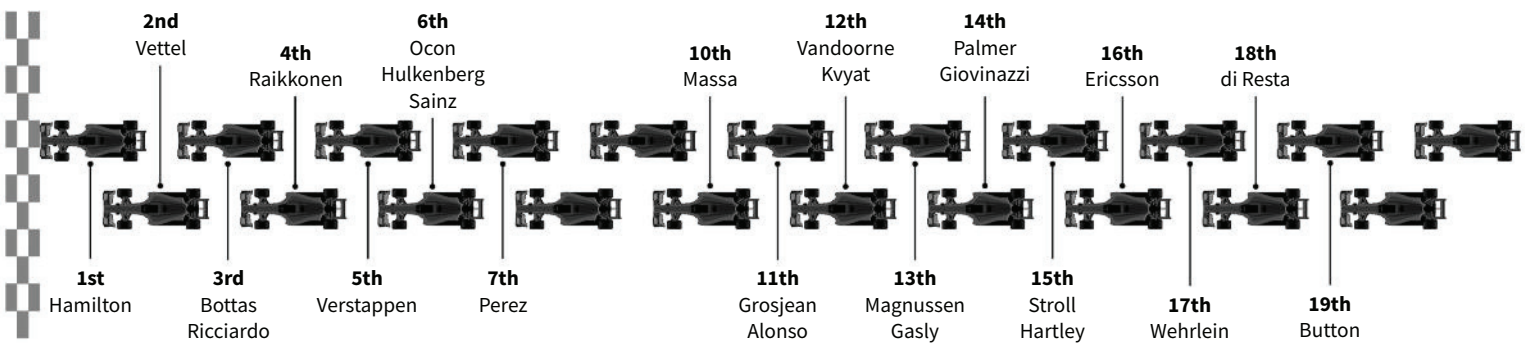

QUALIFYING HEAD-TO-HEAD

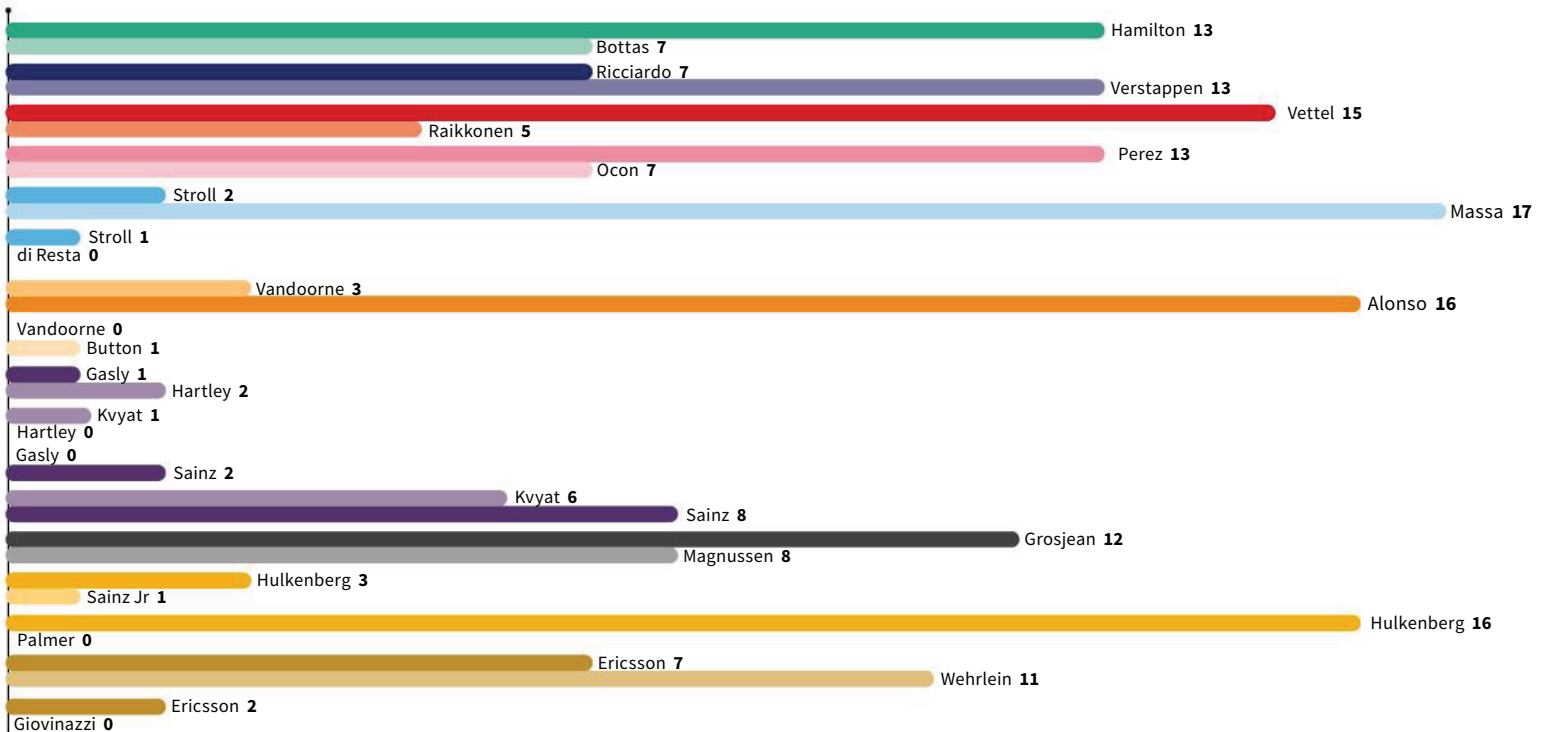

BEST RACE DRIVES

By Ben Anderson

5



Pascal Wehrlein

SPANISH GP

THIS WAS THE ARCHETYPAL HEROIC DRIVE in a poor car. Wehrlein unexpectedly made Q2 in F1's slowest steed, picking off Jolyon Palmer's Renault, Lance Stroll's Williams and Daniil Kvyat's Toro Rosso, which all should have been ahead of both Wehrlein and his Sauber team-mate Marcus Ericsson, who himself qualified only 0.005 seconds behind Wehrlein.

The Mercedes junior's performance in this race was eye-catching. He was no mere roadblock, despite being required to execute a tricky one-stop strategy to gain track position.

Of course, he gained from that strategy, as others made an extra stop, and he also benefited from the first-lap collision that took out Kimi Raikkonen and Max Verstappen. But Wehrlein held off Carlos Sainz Jr's Toro Rosso to the finish, coming home seventh on the road before a five-second penalty was applied for entering the pits the wrong side of the entry bollard, for which the team took responsibility.

"We had good pace," says Wehrlein. "I think in Barcelona you need to be more than one second faster to be able to overtake someone. Sainz was behind me for 20 laps and trying to overtake, but he couldn't because he couldn't get close enough."

Without that pit-entry mistake, Sauber's best result of the season would have been even better, but Wehrlein still executed a perfect weekend in a very difficult car.



MAUGER/LAT



COATES/LAT

4

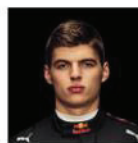

Max Verstappen

UNITED STATES GP

BY HIS OWN ADMISSION, VERSTAPPEN DID NOT PRODUCE A great performance in qualifying for October's race at Austin, and a grid penalty for an engine change made life even harder by sending him back to 16th on the grid. But Verstappen never knows when he's beaten.

The Red Bull ace got up to 13th on lap one, was into the top 10 by the end of three and climbed back to his original sixth position after just 10. He eventually assumed the lead by running a long first stint, before getting repassed by race winner Lewis Hamilton, then pitting on lap 24 of 56.

Verstappen completed his out-lap 21.754 seconds behind the leader, with a 10s deficit to Kimi Raikkonen's Ferrari. Over the remaining distance, Verstappen hunted the leading group down. He overtook Valtteri Bottas's struggling Mercedes for fourth, then chased after Raikkonen over the final four laps, before lunging inside the Ferrari on the final lap to claim a sensational podium.

But the stewards ruled Verstappen cut the inside of the track in making the move, so docked him five seconds and handed third back to Raikkonen. Verstappen was furious but, penalty or no penalty, it was still a brilliant, stirring performance from F1's most exciting young talent.



ETHERINGTON/LAT

3



Lewis Hamilton

BELGIAN GP

SO MANY OF HAMILTON'S RECENT GRAND PRIX victories with Mercedes have been achieved by taking pole position then driving off into the distance, but this season he has had to work harder than ever in the face of Sebastian Vettel's relentless onslaught and Red Bull's resurgence.

Hamilton won relatively comfortably in China, Canada, Italy and Singapore (after Vettel crashed out), and crushed the field in Britain, but had to fight to keep Max Verstappen at arm's length to win in Japan, and had to overtake Vettel to taste victory in Spain and the United States.

Hamilton's other win – in August's Belgian Grand Prix – stands out because he was pressured all the way by Vettel, and had to use all his tactical racing nous to keep the Ferrari behind, particularly during the late-race safety car restart.

Defensive skill is a relatively unheralded weapon in Hamilton's armoury, but he showed it brilliantly by delaying gunning full throttle until midway through Eau Rouge, suckering Vettel into following too closely and creating just enough extra space on the drag race to Les Combes to stay ahead.

Spa was a unique Hamilton race in that sense, and it was one of the classiest drives within a large portfolio of classy performances from the world champion in 2017.



Left: Magnussen was “perfect” in Mexico City. Below: Spin didn’t spoil Sainz’s “most special Sunday”

2



Kevin Magnussen

MEXICAN GP

HAAS CAN BE UP AND DOWN AT THE BEST OF TIMES, SUCH as the team’s inexperience and the sensitive nature of the tricky Pirelli tyres. It was nowhere in Mexico City, where both Magnussen and team-mate Romain Grosjean qualified on the back row, behind even the perennially uncompetitive Saubers.

But a host of grid penalties and various incidents and retirements early in the race propelled Magnussen up to seventh. Once Sebastian Vettel’s Ferrari came back past, Magnussen’s mission over the second half of the race was to hang on for an unlikely points finish.

He fended off the McLaren-Honda of Fernando Alonso and the Mercedes of world champion Lewis Hamilton to finish an excellent eighth in a very difficult car. The team reckoned it was the “perfect” drive from Magnussen.

“How he was able to do that I don’t know,” says team boss Gunther Steiner. “The weekend didn’t start good – we seemed to be struggling everywhere – and all of a sudden he pulls this out of the bag.

“Perfect start – it’s quite amazing how good he is on the starts – and he was confident. Every time we had an engine issue and needed some management – it’s distracting, but he stayed calm. He got in a place where sometimes in life nothing can go wrong.”

CORTES/LAT



TEE/LAT

1



Carlos Sainz Jr

CHINESE GP

THERE WERE SEVERAL OUTSTANDING PERFORMERS IN CHINA: Lewis Hamilton completely controlled things from the front; Sebastian Vettel charged impressively to second after his strategy backfired; Max Verstappen produced a mesmerising first lap to leap from 16th to seventh; and Fernando Alonso was heroic in the weedy McLaren-Honda. But Carlos Sainz Jr’s race to seventh was the pick of a brilliant bunch.

His Toro Rosso was the only non-Mercedes, Ferrari or Red Bull runner to finish on the lead lap, despite dropping to 18th on the first lap and spinning behind the safety car after starting the race on slicks on a wet track. Sainz matched the pace of the leaders at times, in tricky mixed conditions, and was miles faster than any of his midfield competitors. He has several highlights from this season, but describes China as “my most special Sunday”.

“When you have a car that gives you confidence whenever it’s damp, whenever it’s tricky conditions, you can always extract that bit more,” he says. “I was thinking I made the wrong decision on tyres, especially when I saw 99% of the field on the inter, and then spinning on the second or third lap. But, all of a sudden, I saw myself catching the leading group. Obviously, they pulled away when the track dried out, but I enjoyed that race a lot.”

LAT IMAGES



KING KONGS

Felix Rosenqvist and Sam Bird each claimed a bizarre win in Hong Kong, as Lucas di Grassi and Sebastien Buemi suffered a nightmare

By Scott Mitchell, Formula E Correspondent

[@ScottAutosport](#)

The other 18 Formula E drivers would have bitten your hand off had you offered them the chance to leave Hong Kong after the opening 2017-18 weekend with the same number of points as reigning champion Lucas di Grassi or Sebastien Buemi. Nobody would have expected both to blank in Saturday's race given Buemi has won the previous two season openers, with di Grassi second both times – and there was the insurance of a second race on Sunday. Their

combined total from Formula E's first opening-weekend double-header? One point. And that was only because of a 10th place Buemi inherited long after the second race had ended.

The previous two title winners endured what Buemi generously labelled a “nightmare” weekend, and cleared the way for Sam Bird and Felix Rosenqvist to share the first spoils. Yet even with the two best drivers over the past two seasons removed, the respective paths to victory were anything but simple. Bird won despite having to serve a drivethrough penalty for almost clattering into a group of bystanders during his car swap on Saturday.

Rosenqvist recovered from a spin to a brilliant second – and then inherited the win

Rosenqvist had that beat: his triumph in Sunday's sequel came after spinning out of the lead at the first corner, fighting back from 11th to third, taking second after debutant Edoardo Mortara looped it from a commanding lead with less than three laps to go, and then inheriting the win hours after the race when Daniel Abt was disqualified for a paperwork error.

Dramatic? Just a little. Although certainly lucky, Rosenqvist was a worthy winner on Sunday. His pace, energy management and aggression as he recovered from a foolish spin at Turn 1 constituted an amazing fightback, reminiscent of drives we've seen from Buemi several times before. The Swede



STALEY/LAT

LAT IMAGES

was still visibly irate when he finished second on the road, because he knew it would probably have been a clear path to victory without his error. As he recovered he slipped to more than 15 seconds off the lead at one stage, but effectively halved that over the second stint.

“This whole weekend has been quite scrappy for me,” admitted Mahindra ace Rosenqvist, who took pole for Sunday’s race with a wild qualifying lap. “I haven’t had the same confidence as I had with the brakes last year. I’ve been working all weekend to find the confidence in the braking zones and work with the brake bias. To actually win this race after what happened at the start, with pole and the point for fastest lap as well, it’s been a pretty amazing day.”

It made amends for a similarly eventful, but far less successful, Saturday. Rosenqvist was boxed in at the start from fifth, T-boned into a half-spin by Luca Filippi a few laps later from 11th, and eventually booted out of seventh post-race for exceeding the maximum race power output of 180kW. This angered Mahindra, which felt it only

happened because an FIA software glitch meant Rosenqvist unknowingly had illegal access to Fanboost.

Still, this was nothing compared to the “heartbreak” Abt suffered on Sunday, losing a win because of human error – the barcodes on the motor and inverter units of one of his Audi e-tron FE04s didn’t match those on the car’s technical passport. The German made a big step last season, but this was often overshadowed by misfortune in both qualifying and race situations. It continued to a lesser degree on Saturday, when he had moved himself into a comfortable podium position before his second car failed to start in the garage. He recovered to fifth, gaining eight seconds on eventual winner Bird in the process, but that seemed a paltry reward for his pace.

Luck seemed to finally swing his way 24 hours later when he inherited his maiden win in the series, and Audi’s first as a fully works FE team, in dramatic fashion following Mortara’s heartbreaking spin at Turn 2 on lap 43 of 45. Venturi newcomer Mortara had >>



JAGUAR ON THE UP

IS JAGUAR THE WORST TEAM IN FORMULA E? Autosport didn’t win many friends when that headline appeared online, alongside a detailed look at the troubled start of the British manufacturer’s much-heralded return to racing, 12 months ago. Progression over 2016-17 helped make those terrible first two races seem a distant memory, and in Hong Kong Jaguar made its first proper mark on FE.

Mitch Evans should have been fighting for pole on Saturday, but an amateur mistake from the team meant he did not start his flying lap in time. That consigned him to an almost progressionless race from the back, although new team-mate Nelson Piquet Jr matched Jaguar’s best-ever result with fourth.

A day later Evans (above) gave Jaguar its first superpole appearance and qualified second, but had to start fourth after a technical irregularity. He ran third until slipping behind Rosenqvist in the car swaps, but, when Daniel Abt was disqualified, Evans was promoted to Jaguar’s first FE podium.

The Kiwi reckons the team is now comparing itself to the leaders, “because we are really mixing it with them, if not even a little bit quicker” on one lap, which means “our expectations and goals have slightly changed”.

But there is a warning amid the positivity. Jaguar’s race pace was not so strong, and Evans and Piquet (below) were both around 0.3 seconds per lap slower than the fastest runners on average. That is still a strong step from last season, but could be a crucial weakness given Jaguar’s pure performance looks to be directly comparable with the frontrunners.

“We are trying to extract the speed for a whole race stint and there are obviously some frustrations,” said Evans. “It’s just in comparison to where we are in one-lap pace.”

SAM BLOXHAM/LAT



IN THE HEADLINES



DA COSTA ENDS POINTS DROUGHT

More than a year after his previous Formula E points finish, Antonio Felix da Costa's sixth place in race one marked his first top-10 since last year's opener in Hong Kong. The Andretti driver (above) was on course to do even better on Sunday before his second car failed to start.

BACK FOR MORE?

Ex-Formula 1 driver Kamui Kobayashi unsurprisingly had a trying debut, but could yet continue with the Andretti team. He did well to qualify 13th on Saturday, having not tested the car before morning practice, but dropped to 15th with radio issues in the race, then finished 17th on Sunday after suffering the same problem as da Costa.

LOTTERER'S CHALLENGE...

Andre Lotterer called Formula E "the most challenging thing I've ever done" after getting disqualified from the opener for leaving his car in an unsafe mode in parc ferme, and he finished 13th on Sunday. "This is completely different," he said. "There's no margin for error and it's very tricky to master the cars."

...AFTER FE'S WORST EVER RACE

Lotterer's disqualification capped what must go down as the series' worst race. He sparked the red flag on lap one, then picked up a five-second time penalty when Techeetah failed to remove a cooling device in time for the restart. Lotterer earned a drivethrough penalty for using the escape road at the Turns 3/4 chicane without coming to a complete stop before rejoining the circuit, then had 22s added to his race time in lieu of a drivethrough for doing it again.

DRAGON BAPTISM OF FIRE FOR JANI

At least Lotterer produced competitive lap times in the second race – his former Porsche LMP1 team-mate Neel Jani (below) had a debut weekend to forget. Jani's Dragon Racing team was well off the pace, and the Swiss driver finished both races in a lapped 18th, and last of those classified.



put in an astonishing performance in only his second FE start, and the ease with which he saved energy and edged clear was something very special, but ultimately his error cost him.

"I guess that at some point I wanted too much and made a stupid mistake," he conceded. "Sometimes you need to admit it. I was probably overconfident and looking for too much. I should have gone just for the win."

It was a mistake the Swiss-licensed Italian will be unlikely to repeat, but second place (eventually) was still a fine reward for Venturi, which suffered myriad gearbox problems in pre-season testing but has kicked off its new technical partnership with Mercedes specialist HWA in encouraging fashion.

Abt paid tribute to Mercedes-contracted Mortara post-race – "He did an incredible job, no matter if there was a mistake" – but left the significance of his inheritance in no doubt.

"It was not easy for Audi to stick with me coming into this season, because when your last name's the same as the team you always get looked at a bit different," said Abt, whose father Hans-Jurgen owns the team that Audi has adopted as its works entrant. "There were a lot of guys who said I didn't deserve to be here, and I think today, or this weekend, was really time to prove them wrong. I don't think the odds on me were very good, or people would have bet on me, but I think what helped me is that Audi gave me [its] trust and belief. I just felt that coming into the season that gave me extra motivation and confidence, and maybe that was why I performed the way I did this weekend."

Sadly, it came to nothing, with Abt dumped from a breakthrough race win that had secured him the championship lead and a little bit of Audi history. It also promoted Bird to the top of the points, after a quiet but effective rise from 10th to fifth to follow up his win on Saturday.

To earn that victory Bird had to pull off a beautiful pass on early leader and poleman Jean-Eric Vergne, selling him a delicious dummy into the Turn 6 hairpin. Techeetah racer Vergne thought he had the DS Virgin star covered off and edged fractionally back to the racing line on the outside – Bird reacted instantly, jinking to the right and diving down the



inside to wrest the lead. "I knew that was the area that I could exploit and I just needed to get another half a metre closer than I had been the whole stint," he said. "I got the half-metre and I took a chance."

It was a masterful move – Bird at his best – and a reminder that, when it all comes together, he deserves to be viewed in the same echelons as Buemi and di Grassi. In one regard, he is now their superior – Bird is the only driver to have won races in each of the four FE seasons. He also leads the championship for the first time with a two-point cushion over Vergne, who was very happy to finish his weekend with a second and a fifth.

The first result was earned in questionable fashion, after a fight with Nick Heidfeld's Mahindra in which Vergne's defence crossed the line at least once. Heidfeld was raging – well, as raging as the unruffled ex-Formula 1 driver can appear – after the race, calling it the most disappointing third place he's ever scored and accusing Vergne of conducting a "slalom race". Vergne, nonplussed, was simply grateful to make it to the end after claiming he'd struggled with a blend of unspecified technical problems "like never before".

What Buemi and di Grassi would have given for their woes to have ended with 33 points and second in the





RESULTS ROUND 1/11, HONG KONG (PRC), DECEMBER 2-3 (43 LAPS – 49.697 MILES)

POS	DRIVER	TEAM / CAR	TIME
1	Sam Bird (GB)	DS Virgin Racing · DS Virgin DSV-03	1h17m10.486s
2	Jean-Eric Vergne (F)	Techeetah · Renault Z.E.17	+11.575s
3	Nick Heidfeld (D)	Mahindra Racing · Mahindra M4ELECTRO	+12.465s
4	Nelson Piquet Jr (BR)	Jaguar · Jaguar I-type 2	+15.324s
5	Daniel Abt (D)	Audi Sport Abt · Audi e-tron FE04	+17.205s
6	Antonio Felix da Costa (P)	Andretti · Andretti ATEC-03	+18.083s
7	Edoardo Mortara (I)	Venturi · Venturi VM200-FE-03	+19.797s
8	Alex Lynn (GB)	DS Virgin Racing · DS Virgin DSV-03	+20.904s
9	Nicolas Prost (F)	Renault e.dams · Renault Z.E.17	+24.785s
10	Luca Filippi (I)	NIO · NextEV NIO 003	+25.500s
11	Sebastien Buemi (CH)	Renault e.dams · Renault Z.E.17	+26.202s
12	Mitch Evans (NZ)	Jaguar · Jaguar I-type 2	+34.871s
13	Maro Engel (D)	Venturi · Venturi VM200-FE-03	+35.752s
14	Felix Rosenqvist (S)	Mahindra Racing · Mahindra M4ELECTRO	+41.174s
15	Kamui Kobayashi (J)	Andretti · Andretti ATEC-03	+48.422s
16	Oliver Turvey (GB)	NIO · NextEV NIO 003	-1 lap
17	Lucas di Grassi (BR)	Audi Sport Abt · Audi e-tron FE04	-1 lap
18	Neel Jani (CH)	Dragon Racing · Penske EV-2	-1 lap
EX	Andre Lotterer (D)	Techeetah · Renault Z.E.17	+1m21.073s
NC	Jerome d'Ambrosio (B)	Dragon Racing · Penske EV-2	34 laps

Bird's Saturday win was his sixth triumph in Formula E, while Buemi (bottom left) claimed just one point and di Grassi (top right) scored none

championship... Di Grassi was not too disheartened, drawing comfort from Abt's performance as well as his own race pace – he had been in contention for top-five finishes before succumbing to right-rear suspension damage in the opening race and dropping down the order when his car lost power before the pitstops on Sunday.

“A little bit more luck will help, but the pace is there,” the champion said. “In the second stint we were quicker than Felix, quicker than Edoardo, quicker than Daniel [Abt]. It's just frustrating because of small details, which are sometimes out of our control.”

Buemi was ultra-fast in practice on Sunday but clouted the wall in qualifying later that day and made slow progress in the race to 11th on the road. It followed a battery-management-system error immediately after swapping cars on Saturday, which cost the Renault e.dams man a probable top-five finish.

“At the end it's a nightmare, it's a very bad weekend,” he said. “The car is extremely difficult to drive, and clearly in the race [on Sunday] we didn't have any pace. We know what the problem is, but we don't know why it happened. So now we need to understand why and hopefully for Marrakech we have it sorted.”

Champions in strife helped contribute to a fascinating and frenzied opening weekend of the season. The various subplots were entertaining, but also disguised the ultimate potential of several frontrunners: Renault, Audi, Mahindra, DS Virgin, Venturi, Techeetah and even Jaguar – which has made a huge step and inherited its first podium finish when Abt was disqualified – all demonstrated powerful performance, be it over one lap or in race trim. Marrakech will be a litmus test for whether it proves to be an opening-weekend anomaly, but the 2017-18 season has got off to a truly extraordinary start. ✨

Winner's average speed 38.637mph. **Fastest lap** d'Ambrosio 1m04.297s, 64.710mph.

SUPERPOLE

1 Vergne 1m03.568s; 2 Bird 1m03.595s; 3 Heidfeld 1m03.597s; 4 Abt 1m03.724s; 5 Rosenqvist 1m04.718s.

QUALIFYING

Bird 1m03.276s; Heidfeld 1m03.350s; Vergne 1m03.403s; Rosenqvist 1m03.466s; Abt 1m03.561s; 6 di Grassi 1m03.773s; 7 Turvey 1m03.881s; 8 da Costa 1m03.914s; 9 Buemi 1m03.966s; 10 Piquet 1m03.993s; 11 d'Ambrosio 1m04.405s; 12 Lotterer 1m04.423s; 13 Kobayashi 1m04.806s; 14 Engel 1m04.907s; 15 Filippi 1m05.450s; 16 Lynn 1m05.544s; 17 Prost 1m07.745s; 18 Mortara 1m12.730s; 19 Evans 1m19.616s; 20 Jani 1m05.615s*.

RACE 2 (45 LAPS - 52.009 MILES)

1 Rosenqvist 50m05.084s; 2 Mortara +7.031s; 3 Evans +10.619s; 4 Vergne +12.593s; 5 Bird +12.879s; 6 Turvey +14.199s; 7 Engel +15.676s; 8 Prost +18.905s; 9 Lynn +19.025s; 10 Buemi +22.139s; 11 da Costa +23.359s; 12 Piquet +27.904s; 13 Lotterer +28.591s; 14 di Grassi +39.137s; 15 d'Ambrosio +55.189s; 16 Heidfeld -1 lap; 17 Kobayashi -1 lap; 18 Jani -1 lap; EX Abt -5.276s; R Filippi 36 laps-gave up.

Winner's average speed 62.304mph. **Fastest lap** di Grassi 1m03.928s, 65.084mph.

SUPERPOLE

1 Rosenqvist 1m02.836s; 2 Mortara 1m03.108s; 3 Abt 1m03.715s; 4 Evans no time; 13 Bird 1m03.109s*.

QUALIFYING

Evans 1m02.577s; Abt 1m02.703s; Mortara 1m02.870s; Rosenqvist 1m02.878s; Bird 1m02.897s; 5 Lynn 1m02.929s; 6 da Costa 1m02.979s; 7 Vergne 1m02.982s; 8 Turvey 1m03.092s; 9 Filippi 1m03.210s; 10 Heidfeld 1m03.276s; 11 Piquet 1m03.310s; 12 di Grassi 1m03.346s; 14 Prost 1m03.418s; 15 Engel 1m03.446s; 16 Kobayashi 1m03.473s; 17 Lotterer 1m03.845s; 18 d'Ambrosio 1m03.849s; 19 Jani 1m04.612s; 20 Buemi 1m05.346s. * = grid penalty.

CHAMPIONSHIP

1 Bird 35; 2 Vergne 33; 3 Rosenqvist 29; 4 Mortara 24; 5 Heidfeld 15; 6 Evans 15; 7 Piquet 12; 8 Abt 11; 9 da Costa 8; 10 Turvey 8.

Keeping you On Track.....



Insurance products available

- ✓ Accident damage On Track
- ✓ Rally damage On Event
- ✓ Storage and transit
- ✓ Liability
- ✓ Personal accident
- ✓ Track day



- ✓ Competitive premiums
- ✓ A-Rated Insurers
- ✓ Fast claim payments
- ✓ Simple quote form
- ✓ Bespoke cover
- ✓ Knowledgeable staff

Complete an online quote request form at

www.ryanmi.com

Email us: info@ryanmi.com Call us: +44 (0)1799 524202

Ryan Motorsport Insurance Limited is an appointed representative (557405) of Independent Broking Solutions Limited who are authorised and regulated by the Financial Conduct Authority. Its Financial Services registration number is 312026.

RACE CENTRE

WORLD TOURING CARS • ASIAN LE MANS SERIES • ANDROS TROPHY

Bjork bags title, finale fizzles out

**WORLD TOURING CAR
CHAMPIONSHIP**
LOSAIL (Q)
DECEMBER 1
ROUND 10/10

FINALLY, ON THE WORLD Touring Car Championship's third visit to Qatar, the season finale had a purpose.

Six drivers arrived in mathematical contention for the championship, but realistically the title fight boiled down to two: Volvo's calm and consistent Thed Bjork and the form man, Norbert Michelisz, representing Honda.

Hopes were high for a proper elbows-out showdown. Michelisz had slashed Bjork's lead from 32.5 to just 6.5 points in the space of two rounds following Honda's loss of points in China for non-compliant fuel injectors, and looked like he might give the boys in blue another headache with the fastest times in both of Thursday's practice sessions. In the end, though, this was not the grand finale anyone had hoped for, but rather the dampest of squibs for the TC1 era to end on.

Fastest again in Q1 and on course to be so again in the second session, Michelisz then returned to the pits on the second of his fast laps. Perplexed Honda faces quickly turned to panicked ones when the Hungarian was bumped from the top 10 by Kevin Gleason and then failed to return to the track. It later emerged that he had suffered a master cylinder failure that locked his brakes on.

Resigned to 11th on the grid for both races, Michelisz still harboured hopes of clinching the title, but soon realised how difficult the task ahead of him was on a circuit dominated by medium and high-speed corners.

With just two places gained in the reversed-grid race, with Bjork fifth, Michelisz needed at least third in the finale to stand any shot at taking the crown. Three positions came to him on the



First-time champion Bjork took two wins during 2017 campaign

opening lap, but he spent the remaining 11 laps bottled up behind series returnee Yvan Muller, who came out of retirement to support Volvo's title bid.

Bjork, meanwhile, had climbed to third behind Honda stand-in and eventual race winner Esteban Guerrieri and Rob Huff, as team-mate Nicky Catsburg handed him the place. But, safe in the knowledge that Michelisz had not done enough, he slowed on the run to the line to allow Catsburg back through, and defeated an "exhausted" Michelisz with fourth.

For all the disappointment over the lack of finale fight, Bjork was a worthy winner. The Swede's steely approach combined with ruthless speed where necessary paid off in easily the most open title fight in recent seasons.

Third place overall looked to be the feistiest scrap over the weekend, with four drivers in contention. Tom Chilton emerged on top of that tussle, thanks in part to his victory in the opening encounter, which he described as "the race of my life". Once clear of Gleason, Chilton set about reeling in his Sebastien Loeb Racing

team-mate Mehdi Bennani and, by lap eight of 10, was tucked up in the tow of the sister C-Elysee down the main straight. An attempt to overtake through the opening section of corners failed, but Chilton had better luck at the Turn 12/13/14 sequence of right-handers towards the end of the lap to squeak past.

Third not only marks the highest overall championship position Chilton has achieved since joining the British Touring Car Championship at the tender age of 17 in 2002, but a Bennani retirement in the second race also guaranteed him the Independents' crown in what was undoubtedly his most accomplished campaign since joining the WTCC in 2012.

JACK COZENS

RESULTS

Race 1 1 Tom Chilton (Citroen) 10 laps 20m44.557s; 2 Mehdi Bennani (Citroen) +2.175s; 3 Kevin Gleason (Lada); 4 John Filippi (Citroen); 5 Thed Bjork (Volvo); 6 Yvan Muller (Volvo). **Race 2 1 Esteban Guerrieri (Honda)** 12 laps in 24m43.996s; 2 Rob Huff (Citroen) +3.708s; 3 Nicky Catsburg (Volvo); 4 Bjork; 5 Chilton; 6 Kris Richard (Chevrolet).

Points 1 Bjork 283.5; 2 Norbert Michelisz 255; 3 Chilton 248.5; 4 Guerrieri 241; 5 Catsburg 238.5; 6 Bennani 234.

IN BRIEF

ASIAN LE MANS SERIES

Stephane Richelmi, Harrison Newey and Thomas Laurent claimed victory in the Four Hours of Fuji for Jackie Chan DC Racing. Davide Rizzo, Anthony Xu and Pipo Derani were second, with David Cheng and Jazeman Jaafar third. Guy Cosmo and Patrick Byrne took the LMP3 class win, with Yu Lam, Ollie Millroy and Marco Cioci winning the GT class.

ANDROS TROPHY

Benjamin Riviere left the opening round at Val Thorens with the points lead after sharing honours with reigning champion Jean-Baptiste Dubourg. Riviere and his Peugeot 3008 led the way in qualifying, superpole and the final on Saturday. Dubourg, debuting his new Renault Captur, passed Evens Stievenart (Mazda 3) and Benoit Treluyer (Audi A1) for second, with Dubourg's brother Andrea also leapfrogging this duo for third. Dubourg headed Riviere in qualifying, superpole and the final on Sunday, while Franck Lagorce was third, with Treluyer coming home fourth.



AUTOSPORT

AWARDS 2017

Three-time F1 world champion Nelson Piquet provided the climax to the 36th Autosport Awards at Grosvenor

House on Park Lane last Sunday.

Piquet's Gregor Grant Award for lifetime achievement was one of many highlights of an evening that also included awards – many of them voted for by Autosport readers – for World Rally

champion Sebastien Ogier, newly confirmed Sauber Formula 1 driver Charles Leclerc, outgoing British Racing Drivers' Club president Derek Warwick and the Automobile Club de l'Ouest.

Replacing long-serving Autosport Awards presenter Steve Rider were 13-time F1 winner David Coulthard and Lee McKenzie in a revamped event. Star guests included Olympian Ben Ainslie, Ross Brawn, Chase

Carey, Pietro Fittipaldi, Damon Hill, Robert Kubica and World Endurance champions Earl Bamber, Timo Bernhard and Brendon Hartley.

Four-time world champions Lewis Hamilton and Marc Marquez could not be present, but accepted their awards via video presentation, while FIA president Jean Todt also made an appearance on the big screens.

Martin Brundle announced the

new Industry Leader Challenge, aimed at raising money for the Grand Prix Trust. Red Bull's Christian Horner accepted the challenge of learning to drive a car on two wheels, Terry Grant-style...

Paddy Lowe presented the third Autosport Williams Engineer of the Future Award to Martins Zalmans, while Macau Grand Prix victor Dan Ticktum was the 29th winner of the prestigious McLaren Autosport BRDC Award.

“It’s much easier to race than to see your son racing!”

NELSON PIQUET







THINKING OUTSIDE THE BOX BEGINS WITH THINKING OUTSIDE THE OFFICE

Whether you're looking for an exciting day at the track with your team or want to build the dynamic of your next conference, we have special corporate packages tailored to suit every occasion. Hire our world-class circuit and get your adrenaline pumping at your next corporate event. Or combine business with pleasure and experience bespoke hospitality by renting our state-of-the-art facilities.

**To book your next corporate event,
call +973 1745 1086 / corporate@bic.com.bh / bahraingp.com**





GREGOR GRANT AWARD

NELSON PIQUET

ON THE 30TH ANNIVERSARY OF his third Formula 1 world title, Nelson Piquet finally made his first appearance at the Autosport Awards.

With Professor Gordon Murray on stage to present him with his Gregor Grant Award, and a large contingent of his family in the room to celebrate the occasion, it was clearly an emotional moment for Piquet, who fought back the tears as he collected his prize.

"I just want to say thanks to Autosport for bringing me here after so many years and to people like Bernie [Ecclestone] and Frank Williams for giving the opportunity to race for their teams. It was a real pleasure to work with them for many years."

Murray, who designed the Brabham BT49 and BT52 with which Piquet won the 1981 and '83

titles, said: "As well as being a driver with fantastic natural talent, it was a privilege and a pleasure to work alongside Nelson for seven years. He was part of the family – and I say that with real conviction. We had more than a team, it was a family. We had a lot fun, and having fun and success is a great combination."

Alongside his award Piquet was also presented with a signed, framed photo of himself, Murray and Ecclestone taken by Rainer Schlegelmilch in 1981, which was handed over by former Brabham team manager Herbie Blash.

"Nelson was technically fabulous, which was great for Gordon, but for me he was the biggest practical joker!" said Blash. "Two world championships was something we can all be very proud of, and Nelson is a true friend."

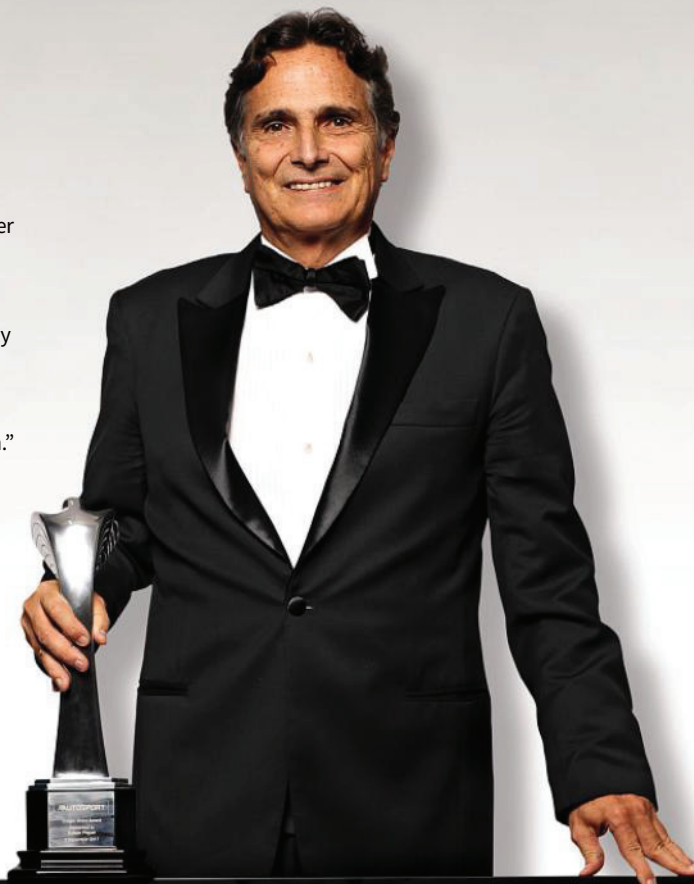

Murray with Awards
newbie Piquet



"When Brabham went to race in Brazil in 1974 I was a very young boy then and I helped them in the pit, cleaning the car. And on Saturday night I slept in the team's tent because I couldn't go outside as I didn't have a pass for the next day!"

NELSON PIQUET



Official Team Partner



AMG
PETRONAS
MOTORSPORT

You need focus to win and quiet to focus.

QUIETCOMFORT[®] 35
WIRELESS HEADPHONES II





INTERNATIONAL RACING DRIVER OF THE YEAR

PRESENTED BY



LEWIS HAMILTON

LEWIS HAMILTON WON Autosport's International Racing Driver of the Year after topping our readers' poll.

The Mercedes driver lost out to then team-mate Nico Rosberg last year. But in 2017, he fended off competition from Ferrari's Sebastian Vettel, whom he beat to the Formula 1 world championship, Red Bull's Max Verstappen, McLaren's Fernando Alonso, Formula E title-winner Lucas di Grassi, and IndyCar champion Josef Newgarden to win the award.

Four-time world champion Hamilton was unable to attend the ceremony, but sent a video message.

"I wanted to send a message to thank Autosport and thank the fans for voting for me," he said.

"I remember being at the Autosport Awards for the first time in 1995. It's great that it is still going

and still doing wonderful things.

"I want to congratulate all the nominees and all the other winners this evening."

It is the third time in four years and the fifth in total that Hamilton has clinched the prize. The Briton first won the award in 2007, when he narrowly missed out on the F1 title to Kimi Raikkonen in his rookie season.

It comes after an impressive year in which he defeated a strong challenge from Ferrari and Vettel.

A run of five wins from six races after the summer break proved crucial as Hamilton pulled ahead to seal his fourth drivers' world championship crown with two rounds to spare.

He ended the campaign with nine wins from 20 races and also broke the record during the season for the most pole positions in F1 history, going on to extend his tally to 72.

"I wanted to send a message to thank Autosport and thank the fans for voting for me"

ROLL OF HONOUR

1982	Keke Rosberg	1994	Damon Hill	2006	Fernando Alonso
1983	Nelson Piquet	1995	Michael Schumacher	2007	Lewis Hamilton
1984	Niki Lauda	1996	Damon Hill	2008	Lewis Hamilton
1985	Alain Prost	1997	Jacques Villeneuve	2009	Jenson Button
1986	Nigel Mansell	1998	Mika Hakkinen	2010	Sebastian Vettel
1987	Nigel Mansell	1999	Mika Hakkinen	2011	Sebastian Vettel
1988	Ayrton Senna	2000	Michael Schumacher	2012	Sebastian Vettel
1989	Jean Alesi	2001	Michael Schumacher	2013	Sebastian Vettel
1990	Ayrton Senna	2002	Michael Schumacher	2014	Lewis Hamilton
1991	Ayrton Senna	2003	Juan Pablo Montoya	2015	Lewis Hamilton
1992	Nigel Mansell	2004	Jenson Button	2016	Nico Rosberg
1993	Nigel Mansell	2005	Kimi Raikkonen	2017	Lewis Hamilton





Carlube[®]

The **HEARTBEAT** *of your* **ENGINE**



BRITISH
COMPETITION DRIVER
OF THE YEAR

LEWIS HAMILTON

Lewis Hamilton secured a 2017 Autosport Awards double, winning both the International Racing Driver category and the British Competition Driver accolade.

The four-time world champion beat GP3 champion George Russell, European Formula 3 champion Lando Norris, Formula 2 frontrunner Oliver Rowland and Ferrari World Endurance Championship drivers Sam Bird and James Calado to win your

vote in the British category for the fifth successive year.

“Let’s keep pushing the bar,” he said via a video message. “It’s great to see England producing such great talents.”

Hamilton secured nine wins in 2017, taking his tally to 62 – 29 shy of all-time record holder Michael Schumacher. He also moved above Alain Prost into second on the list of all-time podium finishes with 117, 38 adrift of Schumacher.



“It’s great to see England producing such great talents”

LEWIS HAMILTON

RACING CAR
OF THE YEAR

MERCEDES F1 W08



“We probably wouldn’t call our car a diva anymore”

JOHN OWEN,
CHIEF DESIGNER

PRESENTED BY



MERCEDES FACED A MAJOR challenge in Formula 1 this year: maintaining its extraordinary run of recent success through a winter of substantial regulation change.

The Silver Arrows team was pegged back by rivals Ferrari and Red Bull, enjoying its least dominant season since 2014.

As our technical journalist Giorgio Piola showed on the night, the W08 proved tricky to set up, leading team boss Toto Wolff to call it a “capricious diva”, but it still claimed 12 wins, 26 podiums, 15 poles and a fourth consecutive title double for the team.

“We seemed to do what looked like the right things and it didn’t respond the way we wanted it to,” said chief designer John Owen. “Over the year we’ve come to learn how to get the best from the car.”

MORE THAN BLACK.



PIRELLI COLOR EDITION.

CHOOSE THE COLOR, FROM ENDLESS POSSIBILITIES,
TO MAKE YOUR CAR EVEN MORE UNIQUE.

PRE-ORDER ON SHOP.PIRELLI.COM



The curved lines () and the **C** are distinctive signs of Pirelli Tyre S.p.A.
The PIRELLI COLOR EDITION tyres can be pre-ordered, in selected sizes and countries, on the website shop.pirelli.com



RICHARD MILLE ROOKIE OF THE YEAR

CHARLES LECLERC

CHARLES LECLERC PICKED UP THE Rookie of the Year award following his dominant title win in Formula 2.

Leclerc scored seven victories in the second-tier category alongside eight poles and four fastest laps. He capped his year with the award, the day after he was announced as

a 2018 driver for the Alfa Romeo-branded Sauber Formula 1 squad.

The 20-year-old's season was not easy throughout – his father Herve died days before the Baku F2 round, where Leclerc won the feature race and finished second in the sprint event after a penalty.

PRESENTED BY
RICHARD MILLE

“It’s a unique award, and I won’t be able to win it again!”

LANDO NORRIS



“This feels great, it’s such a prestigious award and ceremony with so many big people from motorsport”

CHARLES LECLERC

“It’s a great way to finish this year – that has been amazing professionally and that has

also helped me to move forward after what happened to our family,” he said.

NATIONAL DRIVER OF THE YEAR

LANDO NORRIS

AFTER EIGHT CONSECUTIVE YEARS of the reigning British Touring Car champion winning the National Driver award, European Formula 3 title winner Lando Norris thought Ash Sutton would claim that honour last Sunday night. “I said to Trev [team boss Trevor Carlin],

“It’ll probably be Ash,” said Norris.

Instead, the 18-year-old followed up his 2016 McLaren Autosport BRDC Award triumph. “I don’t know why, the Autosport Awards just seem different to the rest of the awards,” he enthused. “It’s not just winning a championship – it’s doing well against other drivers. Hopefully over the next few years I can continue and get more and more of them!”





MOTORSPORT

OFFICIAL PARTNER OF THE AUTOSPORT AWARDS 2017

RACING IN THE 2018 GT3 BLANCPAIN SERIES
STRATEGIC PARTNER IN ASTON MARTIN VALKYRIE



ASTON MARTIN
RACING



MOTORSPORT

www.r-motorsport.com





BRITISH CLUB DRIVER OF THE YEAR

ENAAM AHMED

IT WAS A BRILLIANT YEAR FOR Enaam Ahmed, recognised as Club Driver of the Year by Autosport readers after his 13 wins in the BRDC British F3 season. The fact that he wrapped up the title with a round to spare only endorses his title further.

Ahmed was quick to credit his team, single-seater juggernaut Carlin, for its role in his success.

"I just want to say thank you to everyone at Carlin," said Ahmed. "I'm really happy with the whole season."

Ahmed beat British F4 champion Jamie Caroline, who became the first driver in the championship's history to win all three races in a weekend. Renault UK Clío Cup champion Mike Bushell,

Porsche Carrera Cup GB title-winner Charlie Eastwood, Ginetta Junior champion Tom Gamble and British F3 race winner Ben Hingeley were also nominated.

"I just want to say thank you to everyone at Carlin"

ENAAM AHMED

RIDER OF THE YEAR

MARC MARQUEZ

MARC MARQUEZ WAS NAMED Rider of the Year following his fourth MotoGP world title.

The Honda rider was pushed all the way by Ducati's Andrea Dovizioso and had to recover from a 37-point deficit to then



championship leader Maverick Vinales after six races.

But, after six wins and eight pole positions – plus third place at the Valencia season finale – he became the eighth rider to win at least four premier-class grand prix motorcycle titles.

Although Marquez was not able to attend the awards in person, he was presented with his prize at the Honda racing 'Thanks Day' event at the Motegi circuit by Jenson Button.



MONGER'S LOOKING FORWARD



BILLY MONGER HAS BECOME an inspiration to everyone in motorsport following the loss of both his lower legs in a British F4 crash at Donington Park. His spirit appears unbreakable, as shown by his short interview at last Sunday's Awards. "I'm really looking forward to next year," he said. "But you'll have to wait a little longer to find out what I'll be racing!"

RICHARD MILLE

A RACING MACHINE ON THE WRIST



CALIBER RM 11-03

RICHARD MILLE BOUTIQUES LONDON

90 MOUNT STREET, MAYFAIR
0207 1234 155

HARRODS

87-135 BROMPTON RD, KNIGHTSBRIDGE
0203 036 6264

www.richardmille.com



“Le Mans is, every year, another historic race”

PIERRE FILLON,
PRESIDENT, ACO



2017 edition was the 85th running of the famous race

JOHN BOLSTER
AWARD

PIERRE FILLON

THE LE MANS 24 HOURS IS THE world's greatest single motor race, so it was fitting that the organising Automobile Club de l'Ouest should be presented with a John Bolster Award in this, the year of the 85th running of the event.

ACO president Pierre Fillon stepped onto the stage to receive the coveted gong from 2017 Le Mans winners and World Endurance champions Earl Bamber, Timo Bernhard and Brendon Hartley. “It’s a great honour to accept this award,” said Fillon. “I accept this on behalf of the Automobile Club de l'Ouest, every single member, and also the marshals and volunteers – there are 2000 almost – and the fans and all the public.”

Compere David Coulthard then moved into full double-entendre mode and, to chuckles from an

audience obviously well versed in 1970s sitcoms, enquired: “What’s your secret for staying up all night?”

“The secret is competition,” responded Fillon. “If the race is interesting you stay, if the race is not interesting you are sleeping. But in fact every year we have an interesting race. Le Mans is, every year, another historic race.”

While Hartley is now F1-bound with Toro Rosso, Bamber and Bernhard weren’t able to say much about their 2018 prospects after Porsche canned its LMP1 project. “It’s been incredible this year with Brendon, a childhood friend of mine, and Timo who was my team boss in Carrera Cup two years ago,” said Bamber. “For me I’m destined to go back to GT racing in the RSR, but which programme I can’t say yet.”



Dragon's Breath is a specialist pH neutral wheel cleaner that reacts with the iron contamination within brake dust to produce a brilliant red bleed from an otherwise colourless gel; showing you that it's working. More importantly, this chemical reaction also turns iron into a water soluble solution which makes it easy to rinse away baked on brake dust.

DRAGON'S BREATH

Valet PRO[®]

PROFESSIONAL VALETING SUPPLIES



cleaned painted and metal surfaces
 PH WHEELS
 BALANCED
 EASY TO RINSE
 SPECIALIST
 bleeds red
 500ml
 www.valetpro.co.uk
 Specialist
 Thick liquid
 Clings to
 PH NEUTRAL
 NO OVERS
 THICK LIQUID
 PREPARE
 Clear Gel
 Instant
 Easy to rinse
 safe for all wheels
 AMAZINGLY EFFECTIVE
 IT STINKS!
 reacts with iron in brake
 chromed or polished wheels
 designed for (non-poll) painted and

01323 287980
 WWW.VALETPRO.CO.UK



GREGOR GRANT AWARD

DEREK WARWICK

ONE OF THE MORE EMOTIONAL moments of the night came when Derek Warwick was presented with a Gregor Grant award.

More widely known for his Formula 1 exploits and successes at Le Mans and in the world sportscar championship, arguably Warwick's biggest contributions to the sport have come in recent years. As British Racing Drivers' Club president, a position he only stepped away from this year, he worked tirelessly on many projects, including the British Grand Prix. But it was for his efforts assisting young drivers that he received the award last Sunday.

Not only has Warwick been a driving force behind improvements to the McLaren Autosport BRDC Award, he has made himself available to many young British drivers, offering advice and support whenever he can. He has often gone beyond the call of duty, most of the time without any official or public acknowledgement.

Presenter David Coulthard explained how Warwick helped him early on in his career, when Warwick was still an active F1

driver. Fittingly, two former McLaren Autosport BRDC Award winners – GP3 champion George Russell and European F3 title winner Lando Norris – presented a surprised Warwick with his trophy.

“I’m humbled,” said the 63-year-old. “I’ve seen so many people win this award over the years and I never imagined I’d win it.”

“Being president of the BRDC has been one of the greatest moments of my life and helping young British talent come through has been really special.”

Although he has stepped down as BRDC president, Warwick plans to continue on the McLaren Autosport BRDC Award as the contest enters its 30th year in 2018.

“Helping young British talent come through has been really special”

DEREK WARWICK

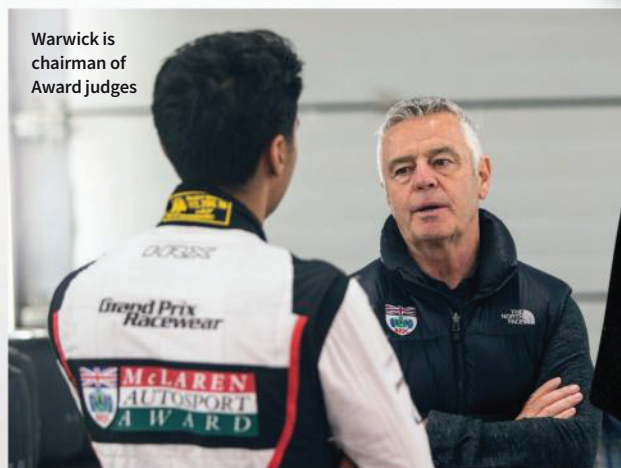

Warwick is chairman of Award judges

STREAMLINE YOUR INTERNATIONAL TRAVEL & EXPENSES MANAGEMENT

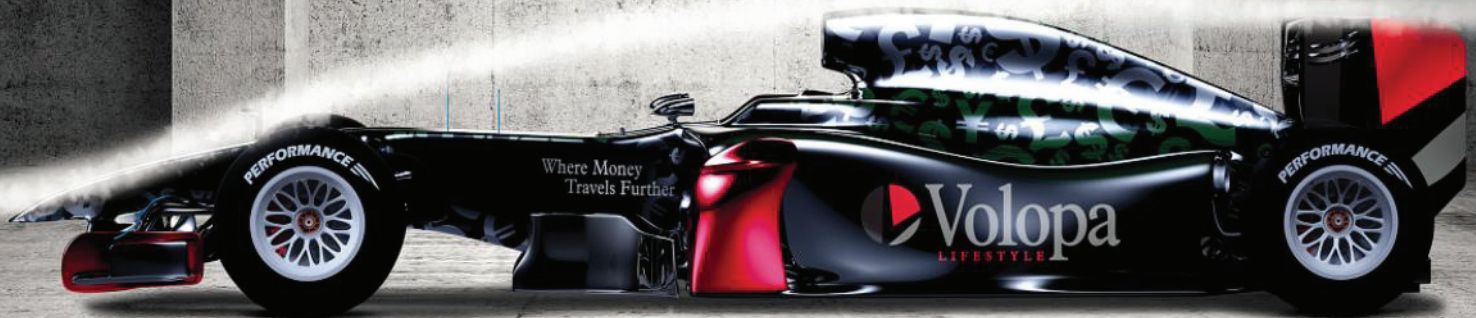

Travel effortlessly throughout the race season and beyond with local currency at your fingertips at all times.

Avoid hidden charges on your travel expense costs and empower every team member with your company branded multi-currency Mastercard.

Instantly access and exchange your money 24/7, 365 days per year online or via our mobile app.

Volopa provides you with;

- total transparency of currency exchange costs
- typical savings in excess of 70% of charges compared to our competitors
- fiscal control and expense management

Whether you are using our service as an individual, a race team or embracing and empowering your fan base, Volopa will revolutionise the way you travel and use currency.

Your Volopa card will also allow you to benefit from discounts and exclusive access to restaurants, hotels, retail stores and much more.

BE IN POLE POSITION WITH YOUR TRAVEL & EXPENSE MANAGEMENT

Contact Volopa Group today.

VISIT VOLOPA.COM

Email: sales@volopa.com Tel: +44 (0)333 400 1287
22 South Audley Street, Mayfair, London W1K 2NY



Official Foreign Exchange Partners



 **Volopa**
Where Money Travels Further



INTERNATIONAL RALLY DRIVER OF THE YEAR

SEBASTIEN OGIER

WHEN SEBASTIEN OGIER STEPPED up to collect Rally Driver of the Year, he couldn't have been happier when he saw his former world championship rival Robert Kubica waiting for him. The admiration and respect between these two is huge and it's no surprise the Frenchman's parting words were of his desire to see Kubica back at the top of the Formula 1 tree.

The mark of a true titan of the sport is the ability to keep turning points into prizes. Ogier was a deserved champion on Sunday night. And he was in good company when he collected his Award.



"Winning with the private team is something special"

SEBASTIEN OGIER

RALLY CAR OF THE YEAR

FORD FIESTA WRC

IN THE END, 20 MINUTES WAS ALL it took to crown the perfect year for Malcolm Wilson's M-Sport World Rally Team. At the penultimate round of the series in Wales, months, years of hard work came to fruition as first Ott Tanak sealed the manufacturers' championship with sixth place, then Sebastien Ogier clinched his

drivers' title in third and finally Elfyn Evans won the rally. Three Fiestas, one *fiesta*.

Fastest out of the blocks to win in Monte Carlo, the Fiesta demonstrated devastating consistency with a podium on every round of the series. It was an astonishing season for a privateer effort.



LAST CHANCE

AUTOSPORT CHRISTMAS SUBSCRIPTION SPECIAL OFFER

£70 FOR 6 MONTHS SAVE 65% ON THE COVER PRICE

Buy a subscription to Autosport for the race fan in your life and they will receive six months' access to the best motorsport content. Autosport editors have access-all-areas in the pitlanes of the world's best racing series. The recipient of your gift will be able to access this great content on the go as well as receiving the print magazine each week with our digital and print bundle.

GIVE THE GIFT THAT KEEPS ON GIVING



UNLIMITED ACCESS

- ✓ Full access to autosport.com
- ✓ Autosport iPad edition subscription
- ✓ Great saving of 65%

Subscribe today to ensure the subscription starts with the first issue in January.

www.autosportmedia.com/offer/ASPXMAS172

CALL 0344 848 8817

QUOTE THE PROMOTIONAL CODE **P1712XMAS**

CREDIT CARD ONLY OFFER. EXPIRES JANUARY 4 2018

FOR OVERSEAS OFFERS PLEASE CALL +44 (0)1604 251 451



AUTOSPORT
WILLIAMS
ENGINEER OF THE FUTURE

This year's winner of the Autosport Williams Engineer of the Future Award will be given the prize of a two-year placement with the famous Formula 1 team. They will be mentored by senior engineers at Williams and rotate through various areas of the squad before finding their specialism. There will also be the opportunity to work in the team's race operations division and gain experience at a grand prix.

ROLL OF HONOUR

- 2015 Lizzie Thompson
- 2016 Sam O'Neill
- 2017 Martins Zalmans



THE FINALISTS

(From left to right) Lottie Gilmore, Jack Simmons, Alfie Dent, Henry Fidler and Martins Zalmans

AUTOSPORT WILLIAMS
ENGINEER OF THE FUTURE
MARTINS ZALMANS

MARTINS ZALMANS BECAME the third winner of the Autosport Williams Engineer of the Future Award. He was presented with his trophy by Williams chief technical officer Paddy Lowe, who was chairman of the judging panel, after prevailing during an intensive two days of evaluations in October.

The University of Bath student stood out during the tasks, one of which involved constructing

“It’s a unique opportunity to be involved with different areas of the company. I hope to stay in F1 as long as possible”
MARTINS ZALMANS

a device to suspend a wheelnut using paper and Sellotape.

“Martins was outstanding and actually thought really out of the box,” said Lowe. “What Martins spotted was that Sellotape has very high strength in tensile direction, although not compression, and he took advantage of that creating stays made out of Sellotape.”

The award aims to select a winner who not only shows great individual attributes and skills, but who also has the potential to one day take up technical leadership of an F1 team.

The other finalists were Alfie Dent (Cambridge), Henry Fidler (Bath), Lottie Gilmore (Bath) and Jack Simmons (Loughborough).



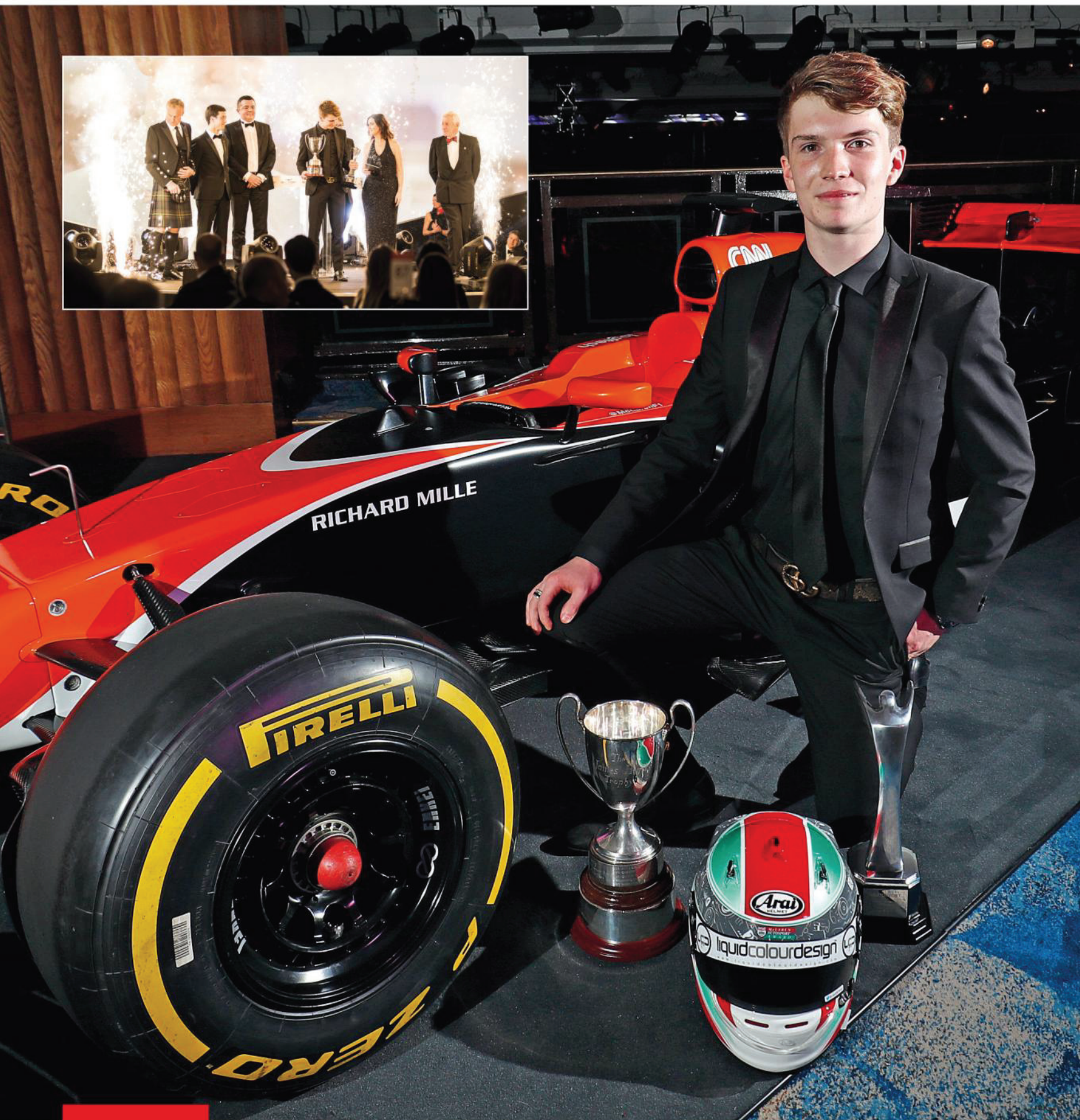

THANK YOU

McLaren, Autosport and the BRDC gratefully acknowledge the support of the following: Arai, Grand Prix Racewear, HRX, McLaren Automotive, McLaren GT, Mercedes-Benz, MotorSport Vision, Pirelli, Silverstone Circuit, Timing Solutions Ltd

The McLaren Autosport BRDC Award judging panel: Andrew Kirkaldy, Scott Mitchell, Jason Plato, Alexander Sims, Ian Titchmarsh, Kevin Turner, Mark Williams
Chairman of the judges: Derek Warwick



McLAREN AUTOSPORT BRDC AWARD

WINNER 2017

DAN TICKTUM

DAN TICKTUM COMPLETED HIS career resurrection by winning the McLaren Autosport BRDC Award and the James Hunt Trophy last Sunday. The 18-year-old has faced a lot of criticism since his ban for driving into 2015 MSA Formula rival Ricky Collard behind a safety car, but has firmly re-established his momentum during '17.

"It's been an incredible experience right from the outset"

DAN TICKTUM

Ticktum began the year by becoming a Red Bull junior. Although his Formula Renault Eurocup season with series newcomer Arden proved tricky, he impressed in three GP3 appearances with DAMS, won a dramatic Macau Grand Prix for Motopark, and has now beaten Enaam Ahmed, Max Fewtrell and Harrison Scott to become

the 29th Award winner.

"Macau and this Award are a launchpad," said a thrilled Ticktum. "I've had bad luck, some of my own making, but the monkey's off my back now. This is a firework ending to the year.

"The season in Formula Renault was average and I couldn't fulfil my potential. When I've been given the kit I've performed."

Ticktum starred in Formula 2, DTM Mercedes and McLaren GT3 machinery at Silverstone in October to take the prize, which includes the opportunity to test a McLaren F1 car, full British Racing Drivers' Club membership and an Arai crash helmet.

"A couple of weeks after the tests I was confident, but the more I dwelled on it the more I thought of the mistakes!" added Ticktum.

"I had an amazing weekend in Macau and this has exceeded that. I cannot put into words how proud I am right now to have won this award."



ROLL OF HONOUR

1989	David Coulthard	1999	Gary Paffett	2009	Dean Smith
1990	Gareth Rees	2000	Anthony Davidson	2010	Lewis Williamson
1991	Oliver Gavin	2001	Steven Kane	2011	Oliver Rowland
1992	Dario Franchitti	2002	Jamie Green	2012	Jake Dennis
1993	Ralph Firman Jr	2003	Alex Lloyd	2013	Matt Parry
1994	Jamie Davies	2004	Paul di Resta	2014	George Russell
1995	Jonny Kane	2005	Oliver Jarvis	2015	Will Palmer
1996	Darren Turner	2006	Oliver Turvey	2016	Lando Norris
1997	Andrew Kirkaldy	2007	Stefan Wilson	2017	Dan Ticktum
1998	Jenson Button	2008	Alexander Sims		

THE AWARD

Every year the McLaren Autosport BRDC Award aims to find the best of young British driving talent. The winner of the 29th edition of the Award has joined a long list of illustrious predecessors, including 2009 F1 world champion Jenson Button, 13-time grand prix victor David Coulthard and triple Indy 500 winner Dario Franchitti.

The victor will be offered the opportunity to become a paid simulator driver for McLaren, and join the marque's young-driver programme. This is in addition to the McLaren F1 test and full BRDC membership that are established prizes for the Award winner.

THE VANQUISHED FINALISTS



Enaam Ahmed Age 17
Ahmed moved from Douglas Motorsport to Carlin for his second year in BRDC Formula 3. He won the 2016 Autumn Trophy, then dominated the main championship, scoring 13 victories on his way to the '17 crown.

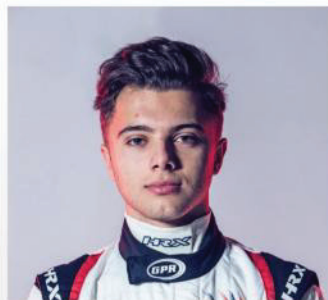

Max Fewtrell Age 18
After taking the 2016 British Formula 4 title, the Renault Sport Academy driver stepped up to the Formula Renault Eurocup. Driving for Tech 1, Fewtrell took a race victory and finished sixth in the standings.

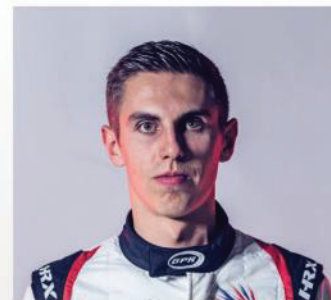

Harrison Scott Age 21
A 2014 Award finalist, Scott earned his place this year by dominating the Euroformula Open championship. Driving for RP Motorsport, he scored 12 victories and was only beaten twice during the campaign.







RICHARD MILLE



Teaching Intensive, Research Informed



PROFESSIONAL VALETING SUPPLIES



Where Money Travels Further



ENGINEER OF THE FUTURE



THANK YOU

British Racing Drivers' Club, Kevin Chapman, Grosvenor House Hotel, Highland Spring, LAT Images, Giles Burris, McLaren Group Ltd, Mercedes-Benz, David Coulthard, Lee McKenzie, SEAT UK, Silverstone Circuit, Andy Spellman, Velocity Experience, Williams Martini Racing

Award Sponsors

Bahrain International Circuit, Bose, Carlube Motor Oil, Pirelli, R-Motorsport, Richard Mille, University of Bolton, Valet Pro, Volopa, Williams Martini Racing

Video material kindly supplied by

Formula 1®, Daytona, Eurosport, FIA, Hay Fisher, IndyCar, ISC, ITV Sport, Le Mans Series, McLaren, MotorSport Vision, NASCAR, North One Television, Renault, Sky Sports, SRO, TOCA, V8 Supercars, WEC

McLaren, Autosport and the BRDC gratefully acknowledge the support of the following

Arai, Grand Prix Racewear, HRX, McLaren GT, McLaren Automotive, Mercedes-Benz, Motorsport Vision, Pirelli and Silverstone Circuit

The McLaren Autosport BRDC Award judging panel

Andrew Kirkaldy, Scott Mitchell, Jason Plato, Kevin Turner, Alexander Sims, Ian Titchmarsh, Mark Williams.

Chairman of the judges Derek Warwick

Williams and Autosport would like to thank

Jakob Andreasen, Dirk de Beer, Kat Greenfield, Chris Murray, Sophie Ogg, Oly Webb and the Williams Conference Centre

The Autosport Williams

Engineer of the Future judging panel

Richard Parry-Jones, Tony Purnell, Nicola Salter, Edd Straw. Chairman of the judges Paddy Lowe

On behalf of our charity the Grand Prix Trust

we would like to thank Nelson Piquet for signing the table centres and Amalgam for producing the limited-edition sculptures

Autosport would like to thank

Velocity Experience for the production of the 2017 Autosport Awards.

For further information visit www.velocityexperience.com

We would also like to thank Duck and Weave for filming the McLaren Autosport BRDC Award test.

www.duckandweave.co.uk

Additional videos by Make Television

www.maketelevision.co.uk and Duck and Weave



WEB DIRECTORY

AWNINGS



No1 for Inflatable Structures.
With you from the Paddock to the Podium.
www.aireshelta.com

EXHAUSTS

Inconel & Stainless Steel Specialists
SIMPSON
Race Exhausts
Tel: 01753 532222
www.simpsonraceexhausts.com

GEARBOXES

Gearboxman.com
COMPETITION TRANSMISSION SERVICES
Gearboxes & Axles for Road, Race, Rally and more
Telephone: 01582 840008 Fax: 01582 840007

HELMET GRAPHICS

Mike Fairholme Designs
Sole approved painter of Arai helmets.
Silver Birches, Corby Birkholme, Nr Grantham, Lincs NG33 4LE.
Tel: 01476 550630. Fax: 01476 550029.
email: fairholmedesigns@btconnect.com
www.fairholmedesigns.co.uk

MEMORABILIA

FINAL LAP
For Everything Formula One
www.finallap.net **WE BUY AND SELL**
+44 (0) 1245 287588 / 07771 920345

MOTORSPORT LEGAL ADVICE

Motor Sport Legal Advice
Tudor Alexander, LL.B Solicitor
tudor@fletcherday.co.uk 07887 713512
Fletcher Day 56 Conduit St
Mayfair London W1S 2YZ

MOTORSPORT LEGAL ADVICE

MOTORSPORT CONTRACTS AND LEGAL ADVICE
(NATIONAL AND INTERNATIONAL)

CALL JAMIE CHAMPKIN
07880 965001

info@champkin.uk.com - www.champkin.uk.com

RACE PARTS

JJC race and rally
PASSIONATE ABOUT MOTORSPORT
www.jjcraceandrally.com

ARE DRY SUMP SYSTEMS
ARMSTRONG RACE ENGINEERING INC.
WWW.DRYSUMP.COM (916) 652-5282

RACE RADIO

Pit to Car **Autotel**
Radio solutions **Digital Race Radio**
0044(0)1508 528837
www.raceradio.co.uk

RACING

MARDI GRAS MOTORSPORT
www.mardigras.co.uk

CARTEK
MOTORSPORT ELECTRONICS
www.cartekmotorsport.com
023 80 457747

RACING

www.mcracecars.co.uk
phone: 07771 762145
MCR's for sale
arrive & drive packages

PORSCHE SHOP
10% off with website
voucher code AUTOTEN
Or Call: 0121 585 6088

demon tweeks
www.demon-tweeks.co.uk

RACING

AUTHORISED DISTRIBUTOR
OMP **YBRACING**
MOTORSPORT & PERFORMANCE
WWW.YBRACING.COM

RACEWEAR

GPR **Grand Prix Racewear**
Silverstone
The best of racewear & kartwear
www.gprdirect.com

TRAILERS & TRANSPORTERS

HUSLIG
COLLECTIVE
Luxury designs for custom vehicles
sales@husligcollective.com

TRAILERS & TRANSPORTERS

Signature
RV.co.uk
RV SALES AND SERVICE

BRIAN JAMES TRAILERS
» Connected to you
www.brianjames.co.uk

www.EMPIRE RV.co.uk
Living the high life
Tel: +44 (0) 1761 300 489
www.EmpireRV.co.uk ■ info@EmpireRV.co.uk



TO ADVERTISE IN THE WEB DIRECTORY
PLEASE CALL **0203 405 8109**
OR EMAIL ads@autosport.com

BRIAN JAMES TRAILERS

» Connected to you



www.brianjames.co.uk

Speed is of its essence

Built to outperform, the Race Transporter 6 has been designed around your race weekend.

Light-weight materials and clever design provide strength throughout. Combined with a proven wheels under the bed chassis and advanced suspension your journey with a Race Transporter will be competent and comfortable.

In the paddock the Race Transporter 6 includes many specific race weekend orientated features providing a comfortable work environment. Tyre and equipment storage is available in several places, with enhanced options also offered. Interior lighting, remote controlled electric winch and a full set of side doors with hatches all contribute to making loading effortless and speedy.

Race Transporter trailers are available from £ 7,499 + vat

Race Transporters are available ex-stock at many UK dealers. Please visit our website or call us for further details.



T +44 (0)1327 308 833

For more information and details on the Brian James Trailers range, please contact our head office

RACE TRANSPORTER 6

QUALITY THAT WE ARE PROUD OF

Woodford GRP covered trailers - Value for money. Superior in design, quality and finish



DEALERS WANTED - All Woodford Trailers have full European Type Approval



WOODFORD TRAILERS DEALERS UK

POTHSMOUTH

BLENDWORTH TRAILER CENTRE
Tel: +44(0)2392 412731
E: sales@blendworthtrailers.co.uk
W: www.blendworthtrailers.co.uk

LONDON

VINTAGE & PRESTIGE FINE
MOTORCARS
Office ++44 (0) 1442 236711
Mobile ++44 (0) 7967 260673
E: richard@vandp.net
W: www.vandp.net

LONDON-KENT

SOUTHEAST TRAILERS
498 London Road
Ditton, Kent
me206bz.
Tel: 07933842719
E: ellisviner@btinternet.com
W: www.southeast-trailers.co.uk

SOUTH LONDON

SOUTH LONDON TRAILER CENTRE
Hackbridge Station Depot
London Road
Wallington, Surrey, SM6 7BJ
Tel: 0208 647 0110
Mob: 07836 224250
E: steve@sltc.co.uk

WINCHESTER

TRAILERTEK LTD
Warren Farm
Micheldever Station
Winchester, Hampshire
SO21 3AS
E: info@trailers.co.uk

SLOUGH

BERKSHIRE COUNTY TRAILERS
Mobile: 07853263484
Tel: 01628 559782
E: sales@berkshirecountytrailers.co.uk
W: www.berkshirecountytrailers.co.uk

ESSEX

1 STOP TRAILERS
Tel: +44 (0)1787 249737
Tel: +44 (0)7850 554776
E: 1stoptrailers@mail.com
W: www.1stoptrailers.co.uk

BRIGHTON

HALF MOON BAY (LEISURE) LTD
Smart-Trailers.co.uk
Monastery Lane
Storrington, West Sussex
RH20 4LR
Tel: 07950 968348
E: Alan@Smart-Tow.com
W: www.smart-tow.com

LEICESTER

MARSDEN BARN TRAILERS
Unit 1
Marsden Barn
Huncote Road
Stoney Stanton
Leicester
LE9 4DJ
Tel: 01455641367
Mob: 07968888624
E: marsdenbartrailers@gmail.com

NOTTINGHAM

APPLEYARD TRAILERS
The Kennels
Main St
Strelley
Nottingham
NG8 6PD
Tel: 01159293901
Mob: 0785075014

MID WALES

HUMPHREYS & FOULKES
Unit 6
Lion Works
Pool Rd,
Newtown
Powys
SY16 3AG
Tel: 01686 628144

LEEDS

ROTHWELL TRAILERS
126 Wakefield Road
Rothwell
Leeds
LS26 0SB
Tel: 01132887179
E: sales@rothwelltrailers.co.uk
W: rothwelltrailers.co.uk

READING

LOVELL TRAILERS
James Farm
James Lane
Grazeley Green
Reading
RG7 1NB
Tel: 01183240403
E: sales@lovelltrailers.co.uk
W: www.lovelltrailers.co.uk

NORTHERN IRELAND

MONTGOMERY MOTORSPORT
Tel: 0044(0)2885549851
W: www.montgomery-motorsport.co.uk



www.WOODFORDTRAILERS.com

HIGH QUALITY TRAILERS FOR CLUB, PRIVATE AND PRO MOTORSPORTS

Woodford Trailers Limited • 14 Great Central Way • Daventry • Woodford Halse • Northants • NN11 3PZ

Telephone: 01327 263384

LUXURY MOTORHOMES BY VISIBLY LOUD

**FOR SALE! 2016 FORMULA 1 WORLD CHAMPION
NICO ROSBERG'S MOTORHOME**



PRICE AND ADDITIONAL INFORMATION UPON APPLICATION
FULL SIZE IMAGES [f FACEBOOK.COM/LUXURYMOTORHOMES](https://www.facebook.com/luxurymotorhomes)

**ARTICULATED DREAM • GENERATION II
BESPOKE MANUFACTURED LUXURY MOTORHOME**



CUSTOM BUILT CHASSIS • TAILORED DESIGN & FLOORPLANS
2, 3 or 4 SLIDEOUTS • FINISHING TO THE HIGHEST OF
STANDARDS • FINEST FIXTURES & FITTINGS • PRIVACY GLASS
GAGGENAU KITCHEN APPLIANCES • WALK-IN WARDROBES
IMAGES & INTERIORS [f FACEBOOK.COM/LUXURYMOTORHOMES](https://www.facebook.com/luxurymotorhomes)

HAVE A MOTORHOME? WE PROVIDE TAILORED MOTORHOME MANAGEMENT SOLUTIONS TO RACING DRIVERS.



TEL: +44 3333 44 55 15 • WWW.LUXURY-MOTORHOMES.EU • 2017@LUXURY-MOTORHOMES.EU



TAILORMADE TRAILER FOR THE U.K.

Each trailer is tailored made to each customer's requirements, the dimensions and configuration are bespoke. We are able to create payloads up to 2500 kg – available as tarpaulin or solid construction. Moetefindt has over 35 years experience in building individual trucks & trailers.

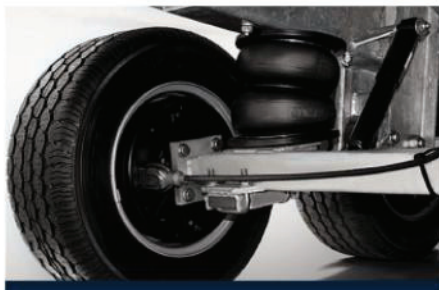

AIR SUSPENSION SYSTEM
The trailer tilts automatically and the system is maintenance-free.



ALUMINIUM CONSTRUCTION
Complete alloy chassis giving the system the lowest empty weight.

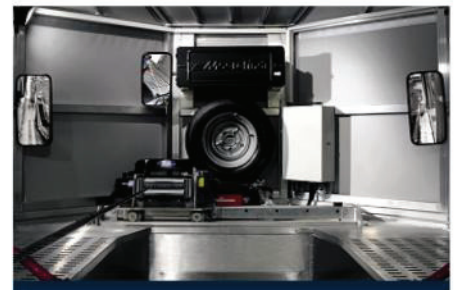

INDIVIDUALLY EQUIPPED
Extensive variety of options to build the perfect solution to meet all requirements.

www.moetefindt.co.uk
www.facebook.com/moetefindt



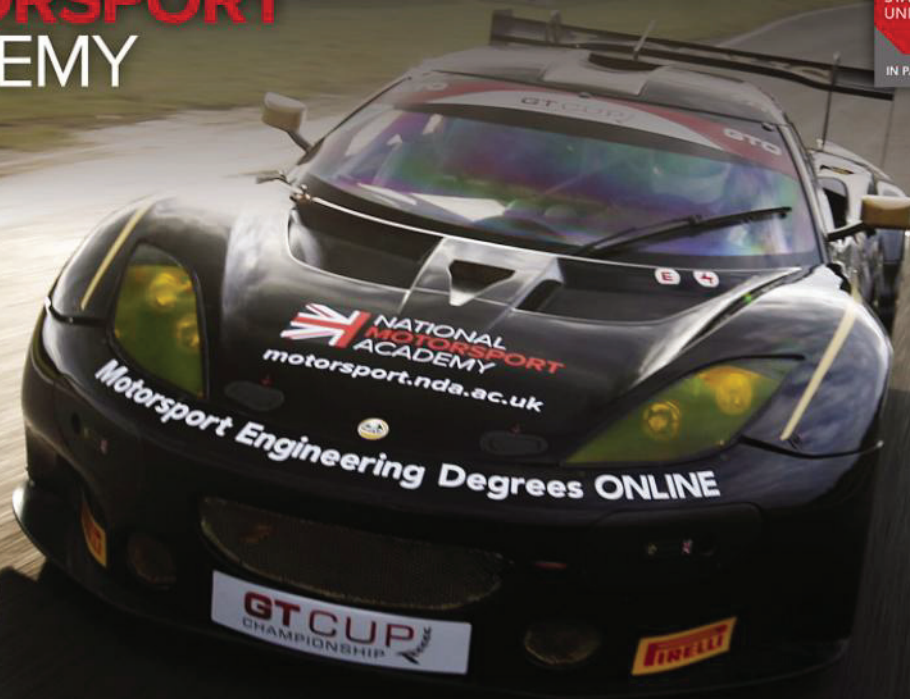

WORLD'S FIRST ONLINE Motorsport Engineering Degrees

**FdSc Motorsport Engineering - BSc (Hons) Motorsport Engineering
NEW for January 2018 - MSc Advanced Motorsport Engineering***

* MSc subject to validation. All degrees awarded by our academic partner Staffordshire University



NMA Students at Silverstone GP - NMA Mosler MT900 - GT Cup 2017

The only **TRULY FLEXIBLE** route to gaining your **Motorsport Engineering Degree**

- APPLY ONLINE, choose your own start date & study from anywhere in the world
- Earn while you learn, study flexibly around work & family commitments
- 40% lower fees than other universities
- Access to student loans for UK students
- Latest industry standard CAD & Simulation software FREE

**NMA now has students from Formula 1,
The World Endurance Championship & The World Rally Championship!**

<http://motorsport.nda.ac.uk>



+44 (0)1159 123456

MARKETPLACE

MOTORSPORT EQUIPMENT



2017 PRODUCT RANGE



NEW! POWER DISTRIBUTION PANEL

CARTEK are pleased to announce the new Power Distribution Panel is now available. This product is a full redesign of their successful but bespoke, Power Control Panels, with the main aim of allowing the user to customise and configure it themselves

The CARTEK Power Distribution Panel is a fully integrated, fully electronic solution to power distribution in race and rally cars. Designed to replace 16 Fuses, Relays and Switches as well as a variety of control systems, these units therefore greatly simplify the wiring, reducing build time, saving weight and maximising reliability.

The 140x195mm panel only weighs 625g and is enabled with short circuit and over-current protection.



2 x Multicoloured Sticker Packs Included

Key features:

- 16 User Configurable Channels (no Laptop required)
- 7 Selectable Amperage Settings: (0A, 5A, 10A, 15A, 20A, 25A, 30A)
- Choice of Functions such as: Momentary, Latching, Flashing etc
- 2 Backlight Settings
- Status LED for each Channel
- ECU and Switch Inputs available
- Dedicated Wiper Control Module

BATTERY ISOLATOR XR



The new Battery Isolator XR can output a signal to shut down the CARTEK Power Distribution Panel as well as isolate the Battery.

WIRELESS CONTROL SYSTEM



Use the Wireless Control System to communicate with the CARTEK Power Distribution Panel or ECU/Dashboard

For more information go to www.CARTEKMOTORSPORT.com

MEMORABILIA

F1 COLLECTORS .COM



#1 FOR F1 MEMORABILIA & AUTOGRAPHS

We buy and sell F1 items
AYRTON SENNA specialists

Call CHRIS GRINT

01763 274448

email:- sales@f1collectors.com

TYRES

AUTOSPORT

If you wish to advertise your products and services with Autosport in print and online please contact

Benjamin.kavanagh@motorsport.com

or call

0203 405 8109

RACE PRODUCTS



0844 375 2196 www.demon-tweaks.co.uk
LOW CALL RATE CALLS MAY BE RECORDED FOR TRAINING PURPOSES

MEDIA CODE: NZ252A **EXPERT ADVICE • MASSIVE STOCK • RAPID DELIVERY**

RACE PRODUCTS

Elite Carbon Fibre

Carbon fibre race car component manufacturer

EliteCarbonFibre Ltd.
Units 20-22 Norwich Road Ind. Est.
Watton, Thetford, Norfolk IP25 6DR

Contact – Dave Greenwood 07809390316
Email – davecarbonelite@googlemail.com
Website – elitecarbonfibre.co.uk

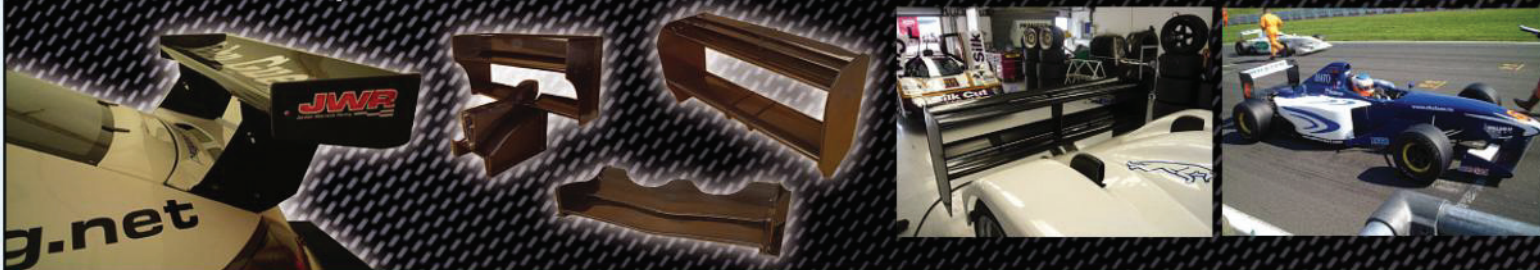

Carbon Composite Wings, Bodywork & Repairs

MARKETPLACE

DRIVERS WANTED



MARDI GRAS MOTORSPORT

Saloon Car Preparation

2A Brunel Close,
Drayton Fields Ind Estate,
Daventry, NN11 8RB

tel: 01327 858006 fax: 01327 858800
email: info@mardigras.co.uk
web: www.performanceclutch.co.uk

Distributors and agents for:



FIRE SERVICES
Extinguisher Refills on Site



DRIVERS WANTED

FOR SALE



RS500 COSWORTH SIERRA

Built by 'BBR',
Brodie Brittain Racing,
500+bhp,
offers near £60k.

Call David Brodie for info!
Phone number: 07836 22899

RACE PRODUCTS



Grand Prix Racewear

Silverstone



The best of racewear & kartwear
www.gprdirect.com



GTECHNIQ
SMART SURFACE SCIENCE

LEADING THE WAY IN
**AUTOMOTIVE
DETAILING
TECHNOLOGY**

THREE WISHES
FOR YOUR CAR:

- 1  APPLIED BY A MASTER
GTECHNIQ
ACCREDITED
DETAILER
- 2  THE BEST AVAILABLE
PRODUCT
PERFORMANCE
& FINISH
- 3  **7** YEAR **GUARANTEE**

Crystal Serum is the only ceramic coating that comes with its own **Gtechniq Accredited Detailer**.

The unique service ensures your car is detailed to unrivalled levels of perfection, with a product that offers the ultimate durability, scratch and chemical resistance. Plus, the same slick finish and candy-like gloss you can expect from the world's finest carnauba waxes.



Meet Adam
One of our Gtechniq Accredited Detailers.

GENIE
WITH A BOTTLE

service.gtechniq.com



MOTORSPORT JOBS

DAYTONA MILTON KEYNES GENERAL MANAGER

We are looking to recruit a General Manager for our award-winning flagship venue at Milton Keynes who will be responsible for the smooth and safe day-to-day running of the venue.

Main areas of responsibilities:

Staff management and training
Managing daily operations
Ensuring high standard product quality is maintained
Exceptional service delivery is achieved
Meeting financial objectives

A passionate advocate for the customer experience, you'll identify key business priorities, evaluate operational processes and implement change, inspiring and engaging your team and deliver an excellent customer experience in terms of service and product.

Essential Skills & Experience

The successful candidate will have strong organisational, motivational and communication skills at all levels. You must be able to manage, engage, train, incentivise and supervise staff whilst ensuring adequate staffing levels. Ensuring that the entire team pulls together to deliver Daytona's renowned customer service and safety level is a key element of the role. Adept financial knowledge is essential. You must maintain and develop exceptional levels of service and full responsibility for the health and safety of your staff and customers.

You must be commercially driven with a passion and flair for marketing, you will have your finger on the pulse when it comes to managing and running events.

If you would like to apply for the position, please email your CV and covering letter to: recruitment@daytona.co.uk quoting ref: GMMK17. A full job description is available on request.

DAYTONA

AUTOSPORT

If you wish to advertise your products and services with Autosport in print and online

please contact

[Benjamin.kavanagh@](mailto:Benjamin.kavanagh@motorsport.com)

motorsport.com

or call

0203 405 8109

Red Bull 
TECHNOLOGY

WE ARE CURRENTLY LOOKING TO RECRUIT THE FOLLOWING POSITIONS AT RED BULL RACING:

R0000277 – GARAGE TECHNICIAN

We have an opportunity for a highly capable and motivated Garage Technician to join our travelling race team.

You will be part of team that are responsible for the build, maintenance, reliability and safe transportation of Red Bull Racing's pit and garage equipment. This challenging role will involve working as part of a highly motivated team that supports remote events whilst setting the highest industry standards in all areas.

The successful candidate will have current F1 experience and ideally come from an excellent mechanical background. They will also be able to demonstrate excellent attention to detail. Candidates will be enthusiastic with a flexible attitude to working hours and be able to work under the minimum of supervision to meet deadlines in high pressure situations without compromising on quality. The role will require extensive global travel. A forklift licence would be an advantage.

R0000270 – AERODYNAMICS ANALYSIS ENGINEER

This is an outstanding opportunity to be part of our highly skilled Aerodynamics team working at the pinnacle of Formula One.

In this important role your focus will be the analysis of aerodynamic data from our Formula One car, ensuring our continued success on the race track.

Working from our Milton Keynes factory you will be involved in analysis of data from both our development environments (wind tunnel and CFD) and the track. This role will also include improvement of tools and methodologies to facilitate aerodynamic analysis and active involvement in accessing, integrating and developing novel aerodynamic measurement technologies.

To fulfil this position you will need:

- A high quality Engineering Degree, preferably with a specialisation in aerodynamics.
- A thorough understanding of aerodynamic principles, with experience of CFD and wind tunnel testing. Previous experience of track testing will be a distinct advantage.
- An excellent understanding of data analysis tools and techniques with proven experience of developing engineering tools and workflows.
- An engineering background with experience of mechanical design and a hands on approach to delivering projects.

You should be self-motivated, organised and proactive, with excellent communication skills and the ability to work to very tight deadlines within a dynamic team environment, often with minimal supervision.

The role may require some travel.

CLOSING DATE FOR APPLICATIONS: SUNDAY 17TH DECEMBER 2017

For details of available opportunities at Red Bull Technology and Red Bull Racing, please visit the recruitment page on our website www.redbullracing.com





TIMEPIECES

LIMITED EDITION

BY THE MAN WHO HAS SPENT A LIFETIME
ILLUSTRATING EVERY DEFINING INNOVATION IN FORMULA ONE.



G5

SWISS MOVEMENT

-Forged Carbon case -Sapphire Crystal Glass
-Carbon Fiber accents -Titanium Bezel

GIORGIOPIOLA.COM

CLUB AUTOSPORT

NATIONAL RACING • HISTORICS • HILLCLIMB • TRACK TESTS • FEATURES



White (l) and Murray (r) at last year's MRTI Shootout

ENTRIES FROM THE UK AND IRELAND

Matt Cowley
Keith Donegan
Ross Martin
Niall Murray
James Raven
Jamie Thorburn
Oliver White
Luke Williams

MAZDA ROAD TO INDY SHOOTOUT

White: We could struggle in US Shootout

FORMULA FORD 1600 RACER OLIVER White believes American drivers could have an advantage in the Mazda Road to Indy Shootout after a venue change.

This weekend's event – where a \$200,000 (£150,000) scholarship to compete in USF2000 is up for grabs – will take place at Bondurant Racing School with Formula Mazda cars.

White, who reached the final stage of the Shootout last year – when it was held at Laguna Seca – and was awarded a place for this year based on his performance in 2016 and leading the Walter Hayes Trophy last month, believes that some drivers may have experience of the circuit.

“Some of the Americans might have driven it [the track] before, which might make it harder for the foreign drivers,” he said. “I didn't manage to do any simulator work, I don't think any of the places have it [the track] on them, and that's because it's a driving school.



In the end I just had to stick to YouTube, which is not perfect.”

Kyle Kimball, manager of operations at Mazda Motorsports, said: “It offers a level playing field with cars and a circuit where no-one has a big advantage over the others. Part of what we will be judging is how well these young drivers adapt to an unfamiliar track in an unfamiliar car.”

Niall Murray competed in the shootout last year at Laguna Seca

Last year's winner Oliver Askew – who went on to take the 2017 USF2000 championship – will be on the judging panel, alongside Indycar race winner Scott Goodyear and Mazda representatives.

The original group will be narrowed down into an unspecified number of finalists, who will then be evaluated over a 30-minute race. The race winner isn't guaranteed to win the Shootout.

Of the British and Irish entrants, White and 2016 British Racing and Sports Car Club FF1600 champion Niall Murray are the only returnees to the event. This year's National champion Luke Williams joins a host of other FF1600 champions from Britain and abroad.

• Following a vote by teams, the BRSCC FF1600 National Championship has confirmed it will visit Kirkistown for its sole standalone round next year. The rest of its rounds support TCR UK.

Comprehensive motorsport insurance products to keep you on track;

- Accident damage On Track
- Rally damage On Event
- Storage and Transit
- Liability
- Personal Accident
- Track day

Log on to www.ryanmi.com to obtain your online quote
Email – info@ryanmi.com Tel – +44 (0)1799 524202

Ryan Motorsport Insurance Limited is an appointed representative (557405) of Independent Broking Solutions Limited who are authorised and regulated by the Financial Conduct Authority. Its Financial Services Register number is 312026

RYAN
MOTORSPORT INSURANCE

Tregurtha and Middleton have been replaced



BRITISHGT4

Champion GT team expands

HHC MOTORSPORT WILL PUSH FOR THE CLEAN sweep of British GT4 titles next season after expanding to field two cars in the championship.

The team won the GT4 teams' drivers' and silver/silver titles in its maiden season, running Will Tregurtha and Stuart Middleton in a single Ginetta G55 GT4 in 2017.

With that pairing expected to move on, HHC has recruited GT4 Supercup champion Callum Pointon, 23, to share alongside European GT racer Patrik Matthiesen, 19, in its silver-graded entry.

HHC has also signed British Touring Car convert Will Burns and GT regular Mike Newbould to run a Pro-Am car.

Team boss Charlie Kemp said: "We're really excited about British GT for next season and we've definitely got two driver line-ups that can impress. In Callum we have a very proven young driver, who's coming into British GT knowing the G55 inside-out, but from a sprint race format. We ran Patrik to the Ginetta Junior Rookie title in 2015

and we know his pace. He's bringing endurance racing experience, so together they should be right at the front.

"In Will and Mike we have a developing Pro-Am partnership with good experience. They won on their debut in the GT Cup [at Snetterton in October] and will be out for the Pro-Am title.

"It was natural to take our commitment a step further and run two cars. We've stuck with the Ginetta because it's a proven car that we know well and gives us a nice continuity. Winning all the titles would be a dream."

Pointon, who scored two wins on his way to the GT4 Supercup crown this year, added: "I felt I proved something with the GT4 Supercup title this year and I've improved as a driver again. Consistency is what paid for me this year and that's key in British GT – bringing the car home.

"I've still got things to learn, and the full GT4 cars have a bit more torque but less overall aero and grip, so there will be an adaptation."

MSA

Tregurtha wins MSA Young Driver of Year award



BRITISH GT4 CHAMPION Will Tregurtha won the MSA Young Driver of the Year award last week, entitling him to a winter testing programme with iZone at Silverstone.

Tregurtha, who steered an HHC Motorsport Ginetta G55 to British GT4 honours with Stuart Middleton this year, was chosen by judges at the iZone facility after excelling in a range of different simulator scenarios and a physical workout.

Tregurtha won the Ginetta Junior title in 2016 in his

second year of car racing.

"I really enjoyed it, driving cars I haven't driven in real life is really good fun," said Tregurtha. "[The prize] will be invaluable, I can use the sim, gym and work on the mental side of things through the winter to prepare for next year."

Tregurtha beat GT5 Challenge driver Angus Fender, karter Dan Seager and Renault UK Clio Cup Junior race winner Max Marzorati. The four were put forward from the MSA-endorsed AAASE course at Loughborough College.

CASTLE COMBE

PROTEST PROMPTS COMBE TRACK ALTERATIONS

CASTLE COMBE CIRCUIT bosses will make changes for 2018 in a bid to stop track limits being exploited following an end-of-season protest.

The Formula Ford 1600 Carnival race was delayed by several minutes in October as the majority of drivers got out of their cars on the dummy grid to protest track limit penalties, which were issued in an earlier race.

The Wiltshire circuit has now installed rumble strips on the entrance to the second chicane to deter drivers from attempting to gain an advantage.

A Castle Combe statement said: "In May this year,

rumble strips were installed at the Esses [first chicane] and immediately proved effective to negate any unfairly gained advantage and we will now complete the job and install similar measures at Bobbies, [allowing] self-regulating at both these complexes and removing the human element of line judgements, previously made by a driving standards observer."

Team owner Kevin Mills – whose drivers Michael Moyers and Michael Eastwell lost a one-two finish because of post-race track limit penalties – said: "This year since the National Formula Ford round they have had some sort of sleeping policemen or rumble strip at the first chicane," he said.

"They seem to be working and if they do the same sort of thing in the second chicane it will probably be a step in the right direction."



Bushell drove Pyro's Civic at Brands Hatch



HAWKINS

TCR UK

Clio champ Bushell swayed by TCR

TWO-TIME RENAULT UK CLIO CUP champion Mike Bushell says TCR UK is a "serious option" for him next season after testing a Honda Civic TCR car.

The 28-year-old had the test as part of the TCR UK taster day at Brands Hatch with the Team Pyro squad – the outfit he has won both Clio titles with – and was impressed by the car. Bushell had one season in the British Touring Car Championship in 2015 in a Ford Focus and said the TCR car

was quicker than the BTCC machine.

"I went in with an open mind – there's been a lot of talk about TCR," he said.

"To me it was straightaway easy to drive at 90%. But that 100% lap gave me such a thrill. In terms of lap time, I was actually quicker than I ever went in qualifying in 2015 with only three degrees track temperature. It's a serious option [for 2018] and the beauty of it is the car can be raced anywhere."

CSCC OPENSERIES

CSCC to race at Magny-Cours in 2018

THE CLASSIC SPORTS CAR Club will hold an event at the Magny-Cours Circuit in France next season, as well as its traditional European fixture at Spa-Francorchamps.

The club will take its Open Series to the former French Grand Prix venue on October 19-21, allowing 51 cars to take part in a series of races. It will

be the first time the CSCC has run there.

"We wanted to do something different and the fact that no other British club offers its members a race at Magny-Cours is exactly why we went for it," said the CSCC's Hugo Holder.

"You can only do so much to vary the calendar in the UK

and we got offered this chance and decided it would offer something different."

The CSCC will also be part of the Three Hours of Spa on the Summer Classic Festival on June 22-24. It will run on Snetterton 200 – instead of 300 – for its opener on April 7/8 and make a return to Mallory Park in 2018.



CSCC Open Series will go to France in 2018

READ

FORD FIESTAS

Second Mondello enduro race added

A SECOND FORD FIESTA ENDURANCE race will be held at Mondello Park next season and will run as the season-opener.

The traditional six-hour enduro is a popular fixture at the end of the Irish racing calendar and attracted 32 teams for the 2017 edition last month.

"There was an interest in doing another event," said Mondello's Ian Beatty. "After last year's race, quite a few people said they wanted to do a championship or series.

But when we put this out, the feedback was that people didn't want to do it, because if they wanted to race in the main championship, they wouldn't be able to do the endurance races too because it would be too much for the cars."

But with the extra 2018 event proposed for February 18, this would allow teams to repair any damaged cars.

"There's a gap before the season starts and there's good interest in it," added Beatty.

IN BRIEF



SCHERER

YOUNG AND TURKINGTON ROLL CLIO

Ryan Young, elder brother of the inaugural Renault UK Clio Cup Junior champion Jack, took over his title-winning MRM Racing car at a Donington test day – only to roll it alongside double BTCC champion Colin Turkington. "I touched the grass going down the Craner Curves, dug in and rolled, coming to rest upside down," said Young.

F1000: NEW RULES AND TWO TCR SLOTS

F1000 will appear on the TCR UK support bill at two rounds next season and a number of regulation changes will be made, aimed at encouraging new competitors. The one-make series, previously Formula Jedi but renamed earlier this year, will join the TCR UK support package for the Castle Combe (July) and Croft (September) events. The changes to the series' draft 2018 regulations include a new invitation class for older Jedi cars.

BROWNING TO STAY IN GINETTA JR

Ginetta Junior racer Luke Browning will remain with Richardson Racing in the series next year. The former Junior Saloon Car driver was 11th in the standings in his rookie season. "It was a late call to join Ginetta Junior this year and we knew early on it would be a season to learn the ropes and master the style of driving that was needed to be competitive," he said.

MX-5 SUPERCUP SEASON FOR SYCAMORE

Mazda MX-5 racer Jack Sycamore will contest the MX-5 SuperCup next season. Sycamore, who finished third in the Mk1 MX-5 Cup standings in 2016, had sporadic outings this year but is planning a full SuperCup campaign with the AB Motorsport squad that is run by John Miles Award winner Ali Bray.

PORTIMAO FUN CUP WINS ARE SHARED

Racelogic and MAK Racing shared the victory spoils at Fun Cup's Portimao away weekend. In race one, Racelogic's Julian Thomas, Jon Tomlinson and David Denyer had the lead from lap three, only briefly losing it during the pitstops, before taking victory by a lap. Nobody was more surprised than MAK's Michelle Hayward (below) to take the race two victory, after passing Charlie Kennedy in the last hour.



SCHERER

TAKE YOUR TEAM TO THE TOP!

MOTORSPORT MASTER

DOWNLOAD IT NOW
FREE GAME



www.motorsportgaming.com

www.motorsportnetwork.com

© 2017 MOTORSPORT NETWORK. All rights reserved.



Pounding the circuits of racing champions

By Marcus Pye, the voice of club racing

[@autosport](#)

CIRCUIT RACING OPPORTUNITIES HAVE BEEN FEW and far between in recent years. I last raced at Hampton Downs in New Zealand in 2010, since when lack of free weekends in-season, on top of financial constraints, have kept me on the sidelines.

Fortunately, I enjoy equally reporting and commentating on youngsters trying to 'make it' in the sport, or competing for fun. Watching Ben Mitchell race my Historic Formula Ford Merlyn superbly has brought a new perspective this season. Competing is a drug that has fascinated me for more than half a century.

Discovering it first hand by way of FF1600 outings in 1981 was a revelation – indeed I was fortunate to have been able to indulge in it, largely on an ad hoc basis, for as long as I did.

Imparting knowledge gained over many years to circuit virgins as an ARDS-licensed instructor was rewarding, too, but, like many of the body's number, I still hanker after another go.

Two recent sessions have re-whetted my appetite, underlining (as if I needed a reminder) that the taste for hot-lapery has not deserted me. The first came when my wife booked a Performance Track course at Goodwood for her uncles and a cousin-in-law, who insisted that I accompanied them.

The sun obligingly showed off the track at its glorious best, adding to a red-letter day for our intrepid 'racing rookies,' aged 49-70. Chief instructor David Brise – son of rally champion Tim and nephew of the late Tony, a rising F1 star in my teenage years – set the tone perfectly, introducing everybody to the historic 2.4-mile venue, track discipline basics and the high-powered BMWs (a set of M models, with i8 option) as well as Mini Cooper Ss we'd be driving.

Top ARDS instructors then guided us through the nuances of eking speed from them over several sessions. I teamed up with marquee nut Steve Markey, whose parents I'd watched racing BMWs at Thruxton in the early 1970s!

A wonderful time was had by all, and the newbies took away heightened appreciation of concentration and car control at speeds approaching double the UK road limit. A superb lunch at The Kennels on the Goodwood estate, which I'd arranged as a long-time Goodwood Road Racing Club member, completed a memorable experience.

One of Fiona's aforementioned uncles, recycling guru Mike Nicol, subsequently invited me to one of ace rallyman Dennis Moody's regular corporate karting enduros at Clay Pigeon Raceway. Situated between Dorchester and Yeovil, the venue has hosted MSA-sanctioned racing since 1963 and was the scene of F1 world champion Lewis Hamilton's first win.

The well organised one-hour team event, using twin Honda-engined prokarts, saw November temperatures soar to 5C. We heavyweights were well duffed up by Clay regulars, but for entertainment it was top value.

I'd not been to the West Country's most celebrated track since I attended the TVS Gulf Superprix with Rob Willshire in 1989 and witnessed Jenson Button win the Cadet title brilliantly.

Twenty years later, the morning after Jenson had won the F1 title, my phone rang. It was Rob – Paul Stewart Racing's truckie in the interim, and subsequently MSA Superkart championship organiser – in excited voice. "You said at Clay Pigeon that Jenson would be world champion. Now he is!"

If I'd have put £50 on it at the bookies', how much racing could I have done on the winnings? 🍀



FORMULA 5000 TO TOP MONDELLO PARK'S 50TH in 2018

The return of Formula 5000 to Ireland will create a sensational centrepiece to Mondello Park's 50th anniversary celebrations next summer when the HSCC Derek Bell Trophy series visits on August 18-19. "I'm working on getting 15-20 cars [including F2s/FAtlantics] there. It will make a fantastic spectacle and something different for competitors," said club chairman Frank Lyons, the Irishman being a longtime F5000 racer. Mondello hosted championship rounds for the V8 class – which transformed the USA's Formula A in 1968, then crossed the Atlantic in '69 – until '74. David Hobbs, Trevor Taylor, Frank Gardner, Brian Redman, Keith Holland and Bob Evans were their winners. Opened in '68, the track was extended from 0.8 to 1.2 miles for '69. Its 2.2-mile International layout debuted in '98. Martin Birrane, Mondello's owner since '87, raced the unique F5000 Brabham BT43 in '74. His ex-Clay Regazzoni/Damien Magee Lola T330 stars in the circuit's museum.

WHAT'S ON

Le Mans legends, on the go

WHEEL-TO-WHEEL ACTION, gut-wrenching retirements, the challenge of racing through the night – the Le Mans 24 Hours is one of the most eagerly anticipated events of each motorsport season.

From January 1 2018, the entire video history of the famous race will have a new home, with the massive collection of event films and video available on Motorsport Network's TV and online properties. These outlets will become the only online home where the entire history of official films can be seen.

What that means is more than 70 films of Le Mans races over the years – including every official film of the event from 1954 onwards – will become available to view on the Network's new Motorsport.tv broadband platform.

"The 24 Hours of Le Mans is the greatest race in the world with an amazingly rich history," says Zak Brown, chairman of the Network. "Our worldwide audience will be able to enjoy this exclusive content, not only on our TV network but also on Motorsport.tv on demand.

"We will become the only online home where fans can watch the entire official ACO library of Le Mans films. All our viewers will need to do is watch on their favourite device or stream it on their large TV monitor."

The long-term partnership will continue to showcase future races on Motorsport.tv, which broadcasts each round of the World Endurance Championship, as well as highlights from Le Mans each year, and attracts more than 185million page views per month across 28 global editions in 81 countries in 17 different languages.

"We are delighted to join forces with Motorsport.tv to present the amazing history of 24 Hours of Le Mans to such an incredible global audience," says ACO President Pierre Fillon. "The ACO has worked closely with Motorsport



Network and Motorsport.tv for many years and their ever-expanding reach will help us further promote the legend of Le Mans to our growing international fan base."

The archive will also be available on Motorsport.tv's upcoming over-the-top (OTT) on-demand streaming mobile app, which means the Le Mans films will be available on the go.

"Our objective is to create new and innovative user experiences around the content," explains Eric Gilbert,



READ
AUTOSPORT
ON THE
MOVE

DOWNLOAD IT
NOW FROM

 autosport.com

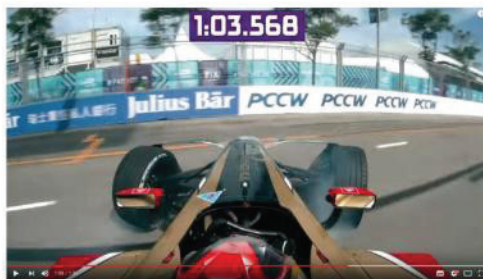

HOT ON THE WEB THIS WEEK

 GOING BACKWARDS TO THE FRONT

Search for JEV Crosses Line Backwards; Takes Pole!
2017 HKT Hong Kong E-Prix Round 1

Watch Techeetah's Jean-Eric Vergne claim pole position for the 2017/18 Formula E season-opener in Hong Kong in unconventional style, spinning on the exit of the last corner. Lends a whole new meaning to the term 'reversed grid'.

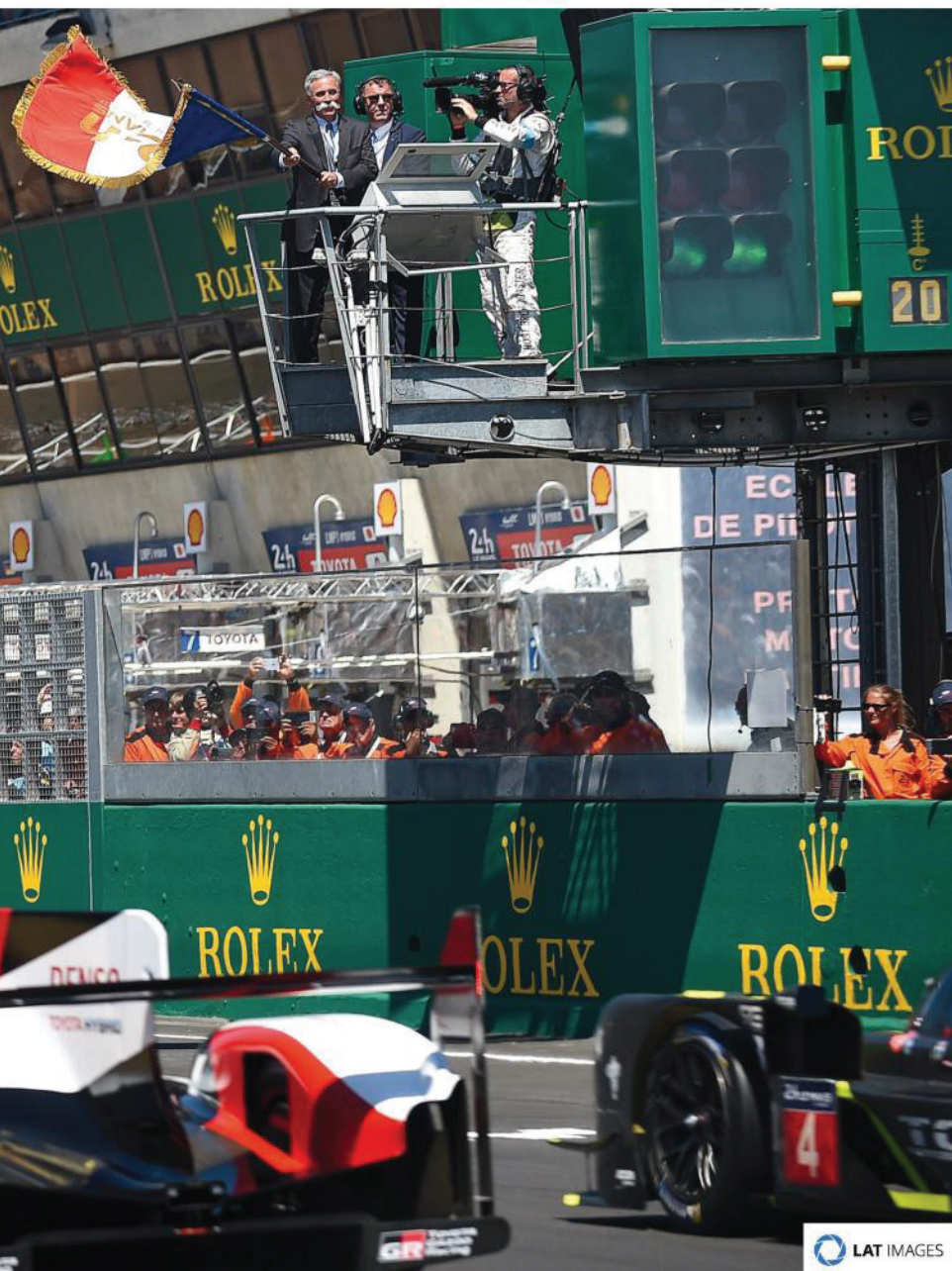

Above: Chase Carey gets the 2017 Le Mans underway (above) under the watching gaze of a TV camera

Left: The 1980 and '54 races form part of the archive

chief product officer at the Motorsport Network. "This full 24 Hours of Le Mans library of past, present and future races will be available anywhere, anytime on our ever-expanding platforms: web, iOS and Android mobile devices, Apple TV, soon to be released Roku, and much more.

"Viewers will be able to interact with this video library like never before thanks to our on-demand platform and its unique features such as timeline-based moments and comments."

NEXT WEEK

CHRISTMAS
SPECTACULAR

DOUBLE ISSUE

— FEATURING —

TOP 50 DRIVERS

PICTURES OF THE YEAR

BEST F1 NON-WINNERS

CHRISTMAS QUIZ

TOP 10 CLUB RIVALRIES

AND LOTS MORE...



COATES/LAY

INTERNATIONAL MOTORSPORT

MRF CHALLENGE

Rd 2/4

Dubai, United Arab Emirates

December 8-9

Interlagos, Brazil

December 10

ANDROS TROPHY

Rd 2/7

Alpe d'Huez, France

December 8-9

V8 STOCK CAR

Rd 12/12



CARTA
FRANCA

Marlboro

Mobil

Marlboro

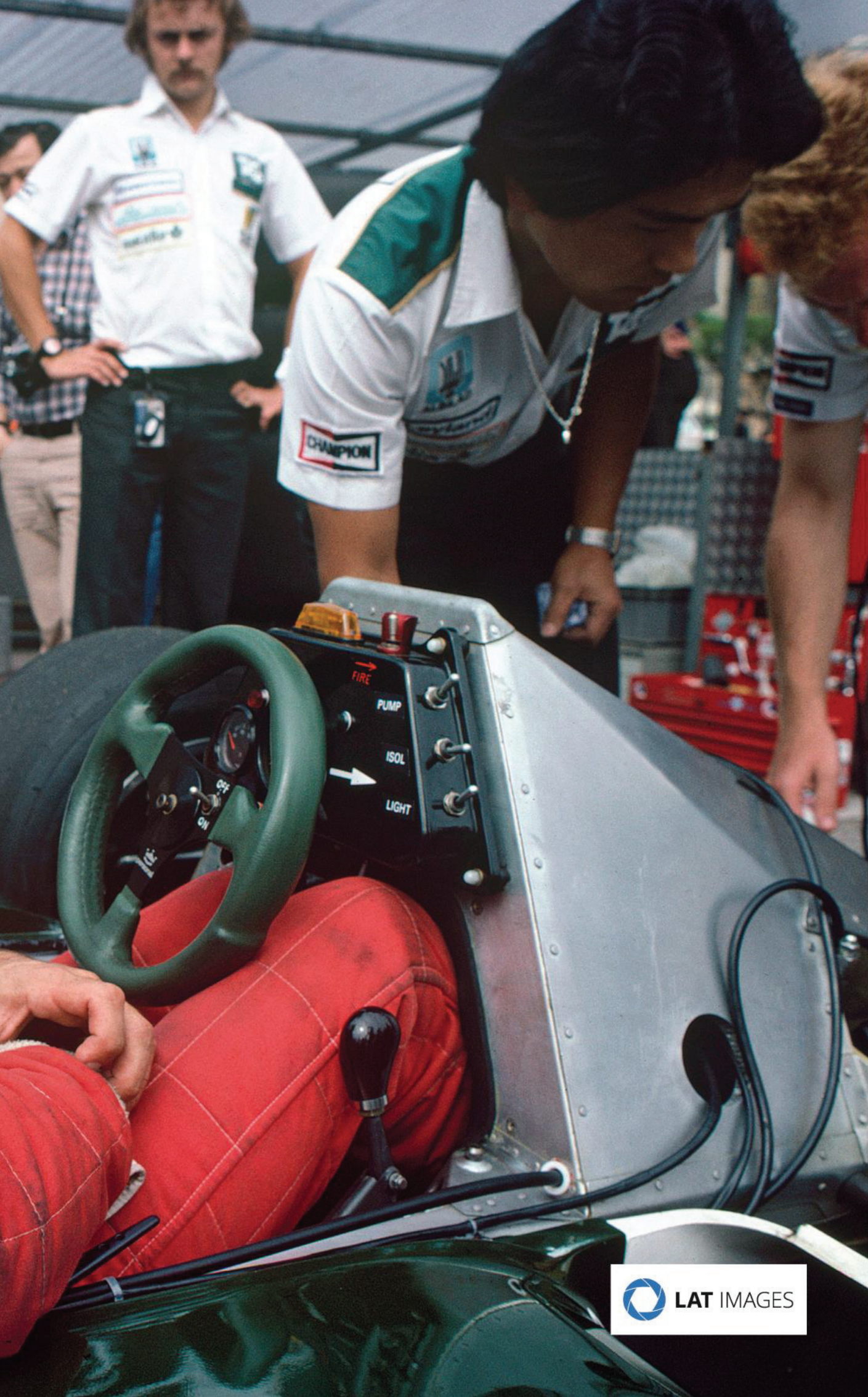

FROM THE ARCHIVE

Carlos Reutemann waits in the cockpit of his Williams-Ford FW07C at the 1981 Monaco Grand Prix. The Argentinian qualified in fourth place, but retired on lap 34 when his gearbox packed up. Although he kept his world championship lead, it brought to an end a 15-race run of points finishes.

HAVE-A-GO HERO

WHEN DRIVERS CROP UP IN UNEXPECTED PLACES

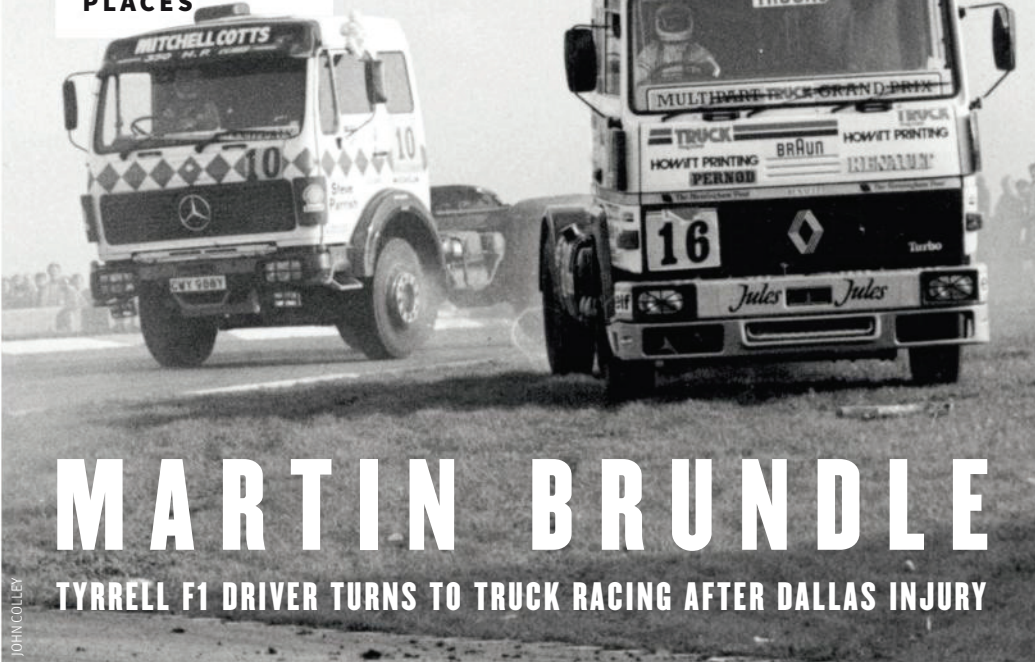

MARTIN BRUNDLE

TYRRELL F1 DRIVER TURNS TO TRUCK RACING AFTER DALLAS INJURY

JOHN COLLEY

“My brakes have just failed,” says Martin Brundle on seeing the above picture of him competing in the inaugural British Truck Grand Prix at Donington Park in late September 1984. He’s the one in the Renault on the grass, in case you were wondering.

This was the unusual location where Brundle, then in his first season of Formula 1 with Tyrrell, was making his racing comeback after breaking his ankles during a shunt in Dallas in July.

“I remember turning up in the paddock on crutches because my left ankle was still in plaster,” he says. “I had to climb up to get into the truck and the guys running it looked at me as if to say, ‘How are you going to do this then?’ It was easy enough to press the clutch with my leg in plaster anyway. And of course it had power everything – clutch and brakes – and shifting was easy enough. So off we went racing – and it was brilliant!”

“All we did was pump the tyres up to some scary number, fill the inside diesel tank – to try to stop it rolling – because it was almost all right-handers, and off we went. You can see from the picture that these are just rigs off the road with a few stickers on them. Later, racing trucks turned into monsters with water brakes and a gazillion horsepower.”

Despite scepticism about an injured F1 driver being able to lap quickly, Brundle not only made the 20-lap final, which included drivers such as Willie Green, Barry Lee and Barry Sheene, but he started from second on the grid alongside John Kent’s Leyland. He was a serious contender for victory when the brake problems began, leading to his off. The race was won by Duilio Ghisloti in a Volvo.

“I thought on the way home when I was a bit disappointed, ‘Actually, you don’t want to be the winner of the first British Truck Grand Prix’. At that stage, in my mind, I’m a guaranteed future world champion after all! [But] it was a good weekend that I really enjoyed – and I earned a few quid. I was absolutely potless then despite being an F1 driver. I think I got £5000 to do it, so it was an important weekend for my bank balance!”

EDD STRAW



LAT IMAGES

Brundle started seven races for Tyrrell in 1984 before his Dallas crash. He would lose his second place at Detroit (above) when the team was disqualified from the world championship on technical grounds

AUTOSPORT

Autosport Media UK Ltd, 1 Eton Street, Richmond, TW9 1AG
Tel +44 (0) 20 3405 8100 Email autosport@autosport.com
Individual email firstname.surname@motorsport.com
Website www.autosport.com Twitter [@autosport](https://twitter.com/autosport)

Editorial

Editor **Kevin Turner**
Deputy Editor **Marcus Simmons**
Grand Prix Editor **Ben Anderson**
F1 Correspondent **Lawrence Barretto**
Assistant Editor **Alex Kalinauckas**
Chief Sub-Editor **Peter Hodges**
Executive Editor **Stuart Codling**
Group National Editor **Jack Benyon**
Rallies Editor **David Evans**
BTCC Correspondent **Matt James**
Art Editor **Lynsey Elliott**
Senior Designer **Michael Cavalli**
Office Manager **Joanne Grove**

Autosport.com

Editor **Glenn Freeman**
Deputy Editor **Matt Beer**
Autosport Plus Editor **Scott Mitchell**
International Editor **Jack Cozens**
Social Media Editor **Fatema Chowdhury**
Technical Team Leader **Geoff Creighton**
Head of UX and Digital Design **Amar Vijay**

LAT IMAGES

Photography

Steven Tee
Glenn Dunbar
Sam Bloxham
Zack Mauger

Special Contributors

Gary Anderson
Alan Eldridge
Tom Errington
Rob Ladbrook
Stephen Lickorish
Stefan Mackley
David Malsher
Marcus Pye
Dieter Rencken
Nigel Roebuck
Caroline Stammers
Jim Utter
Gary Watkins

Correspondents

Argentina Tony Watson **Australia** Phil Branagan **Austria** Gerhard Kuntschik **Belgium** Gordon McKay **Brazil** Lito Cavalcanti **Finland** Esa Illoinen **Germany** Rene de Boer **Greece** Dimitris Papadopoulos **Italy** Roberto Chinchero **Japan** Jiro Takahashi **New Zealand** Bernard Carpinter **Russia** Gregory Golyshev **Spain** Raimon Duran **Sweden** Tege Tornvall **USA** Bruce Martin, Jeremy Shaw **UK & Ireland** Pete Allen, Lee Bonham, Stephen Brunsdon, Jonathan Crawford, Dom D’Angelillo, Kerry Dunlop, Charlie Eustice, Joe Hudson, Jake Jones, Samarth Kanal, Matt Kew, Mark Libbeter, Stefan Mackley, Dan Mason, Damian Meaden, Lucy Morson, Will Moulton, James Newbold, Jason Noble, Mark Paulson, Brian Phillips, Graham Read, Hal Ridge, Peter Scherer, Ian Sowman, Chris Stevens, Oliver Timson, Ian Titchmarsh, Eddie Walder, Rob Watts, Richard Young

Advertising

Tel +44 (0) 20 3405 8106 Email autosport.ads@motorsport.com
Sales Manager **James Robinson**
Display Advertising **Don Rupal, Karen Reilly, Jamie Brooker**
Classified Advertising **Fran Hall, Ben Kavanagh**
Autosport.com Sales Manager **Fiona Bain**
Online Advertising **Chris Hermitage**
Sales Director **Matthew Witham**

Advertising Production

Senior Production Controller **Abbey Gunner**
Tel +44 (0) 20 3405 8131 Email abbey.gunner@motorsport.com

Subscriptions

UK +44 (0) 344 848 8817 Overseas +44 (0) 1604 251451
Email help@asm.secureorder.co.uk Back issues 0344 8488817
Laura Paterson +44 (0) 20 3405 8129

Autosport, ISSN number 0269946X, is published weekly by Autosport Media UK Ltd, 1 Eton Street, Richmond, TW9 1AG, United Kingdom. Airfreight and mailing in the USA by agent named Air Business Ltd, c/o Worldnet Shipping Inc., 156-15, 146th Avenue, 2nd Floor, Jamaica, NY 11434, USA. Periodicals postage paid at Jamaica NY 11431. Subscription records are maintained at Autosport Media UK Ltd, 1 Eton Street, Richmond, TW9 1AG. Air Business Ltd is acting as our mailing agent.



CIRCULATION TRADE ENQUIRIES

Seymour Distribution Ltd, 2 East Poultry Avenue, London, EC1A 9PT. Tel: +44 (0) 20 7429 4000. Printed by William Gibbons & Sons Ltd, 28 Planetary Road, Willenhall, Wolverhampton WV13 3XT. ISSN 0269-946X. Autosport is published weekly by Autosport Media UK Ltd, 1 Eton Street, Richmond, TW9 1AG.

©2017, AUTOSPORT MEDIA UK LTD

Trading as Autosport Media UK. Publishing, trade and further subscription details on www.autosport.com. While due care is taken to ensure the contents of Autosport are accurate, the publishers and printers cannot accept liability for errors and omissions.

Advertisements are accepted for publication in Autosport only upon Autosport Media UK’s Standard Terms of Acceptance of Advertising, which are available from the Advertising Department.





Destination for all
MOTORSPORT
merchandise.



motorstore



Support your team
in style with the very best
of replica and lifestyle
Motorsport fashion!



MOTORSTORE.COM



ventus F200

Top-notch performance slick tyre with consistency and high mileage in dry conditions



Be one with innovation
Hankook Tyre and Real Madrid
Together as one

BE ONE WITH IT

Global
Partner



Hankook Tyre U.K. Ltd.
Fawsley Drive, Heartlands Business Park, Daventry,
Northamptonshire NN11 8UG, U.K.
Tel : +44 (0)121 551 4589