

**CANADIAN GRAND PRIX
FULL 16-PAGE REPORT**

**CAN TOYOTA BREAK
ITS LE MANS JINX?**

**WHAT TO EXPECT AS
F1 HEADS TO BAKU**

AUTOSPORT

HAMILTON STINGS LIKE A BEE

**AS FERRARI
THROWS IT
AWAY... AGAIN**



**NEWGARDEN
ESCAPES TEXAS
HORROR SHUNT**



Le Mans addicted



www.ycom.it

Find more issues at magazinesdownload.com



Hamilton is now the man with momentum

THERE WAS ALWAYS A CHANCE THIS COULD HAPPEN. Even when Nico Rosberg was stringing together those wins early in the season, he was at pains to point out that Lewis Hamilton would come back at him. And thanks to a couple of trying grands prix for Rosberg, his lead has already all but vanished.

Hamilton has not only gained the momentum, he has shown he's prepared to be robust with Rosberg when required. Whether or not you buy into his 'I got understeer' explanation for the Montreal bump, it's fair to say that Lewis sails close to the wind on occasion with his team-mate. Generally he has – just – kept it the right side of the line, but his approach, and Nico's increasing frustration, means more clashes between the Mercedes pair seem inevitable as the title fight heats up.

It's open to doubt whether anyone else can capitalise on that. Questionable strategy once again undid Sebastian Vettel's bid in Canada, Ferrari seemingly incapable of picking up the sort of crumbs from Mercedes' table that fed the Italian team so well in 2015. Red Bull may prove to be a bigger threat, helped by upgraded Renault engines, particularly when we get back to more aero-dependent circuits.

While we're on the subject of underachievement, Toyota's frustrating history at Le Mans is the subject of Gary Watkins' focus this week. The Japanese firm will be desperate to end its jinx as the teams get their French campaigns under way.



KEVIN TURNER EDITOR
 kevin.turner@haymarket.com
 @KRT917



COVER IMAGES
 Photo4/XPB Images;
 Levitt/LAT

COVER STORY

4 Canadian Grand Prix report and analysis

PIT+PADDOCK

- 20** What to expect from Baku
- 22** Aeroscreen fails FIA safety test
- 24** Lucky escape as IndyCar race postponed
- 26** Feedback: your letters
- 27** Dieter Rencken: political animal

FEATURES AND REPORTS

- 28** WRC: Neuville bounces back in Italy
- 34** Toyota's turbulent Le Mans history
- 38** The end of open cars in the 24 Hours

RACE CENTRE

42 NASCAR Sprint Cup; TCR Italy; Asian GT; Japanese F3; Spanish F4; WTCC

CLUB AUTOSPORT

- 61** Iconic F1 machines for Silverstone Classic
- 62** Rain stops play for GT supports
- 65** Humble Pye: the voice of club racing
- 66** National reports: Silverstone; Brands Hatch; Thruxton; Snetterton; Rockingham; Mallory Park; Mondello Park; Loton Park
- 80** Nash-Healey returns to the track

FINISHING STRAIGHT

- 82** What's on this week
- 84** From the archive: 1967 French Grand Prix
- 86** Top five driver line-ups in bad cars

AUTOSPORT SUBSCRIPTION OFFER

46 Sign up and get a FREE Ferrari cap

FIND US ON

- autosport.com
- twitter.com/autosport
- facebook.com/autosport
- instagram.com/autosportdotcom/
- youtube.com/AUTOSPORTdotcom
- the Apple App Store
- digitalmagazine.autosport.com
- Apple News



Ferrari throws it away again

By Ben Anderson, Grand Prix Editor [@BenAndersonAuto](#)



F1/CANADIAN GRAND PRIX RACE REPORT

Rosberg takes to the runoff area at Turn 1 after Hamilton-clash



FERRARI DENIED IT, OF COURSE, BUT THE SIMILARITIES IN HOW THE Australian and Canadian Grands Prix played out were almost uncanny. Mercedes had the fastest car, but lost its Montreal advantage to bad starts. Ferrari stole the initiative, but again ultimately failed to win the race after a debatable strategic call.

Oh, and the two Mercedes drivers collided at the first corner – again, just as they did in Australia. Only this time it was “pissed off” championship leader Nico Rosberg who lost out, rather than arch-rival Lewis Hamilton, who won his second Formula 1 race on the bounce.

The clutch difficulties that caught Mercedes out earlier in the season also resurfaced in Canada, as polesitter Hamilton bogged down off the line while Rosberg – though less affected – was also slow away from second on the grid.

By contrast Sebastian Vettel hooked up what Ferrari team boss Maurizio Arrivabene called “one of the greatest starts I’ve ever seen in Formula 1” to jump both and grab an unlikely lead.

“The formation start was fantastic,” said Hamilton. “I let the clutch out and it was perfect torque, no wheelspin. I came round, did exactly what they asked me, and the damn thing just slipped!

“They’re going to investigate to understand why. It’s not the first time. Having seen the data I’m happy I didn’t make any mistakes, but this clutch is definitely catching us out.”

In yet another repeat of events in Melbourne, Rosberg got a slightly better start than Hamilton and drew alongside as they reached the braking zone for Turn 1. But Rosberg’s momentum was not sufficient to carry him clean past Hamilton and they

rounded the opening left-hander side by side.

The two Wo7 Hybrids banged wheels on the exit, which forced Rosberg onto the grass on the outside. He jinked right onto the escape road that rejoins the circuit at the exit of Turn 2, but was swamped by both Red Bulls and the two Williams drivers on the run to the first chicane.

He also lost a place to Fernando Alonso’s McLaren-Honda, before Nico Hulkenberg’s Force India swept around the outside into the second chicane. Rosberg finished the first lap in 10th place, and fuming.

“I was massively pissed off in the moment,” he said. “But in the end it’s just tough racing on the edge and that’s it. I gave it a go round the outside – in Barcelona it worked out and here it didn’t.”

Hamilton suggested he picked up understeer through the first corner, perhaps because of a tailwind or following closely behind Vettel, and played down the significance of what he described as “the smallest tap” with Rosberg.

“On my side I barely felt it,” said Hamilton. “I don’t see it as something the team has to look at because you couldn’t have predicted we’d be side by side going into the first corner.

“Nico was on the outside, I was on the inside; I was on the racing line. Vettel was close in front of me, so I couldn’t have braked later



MAUGER/LAT



The moment Hamilton understeered into team-mate Rosberg...



...which resulted in the German dropping to 10th place

HONE/LAT

if I'd wanted to. Sometimes you make it around the outside, sometimes you don't..."

You wonder if Mercedes is simply powerless to prevent its two cars coming together in these marginal situations. Rosberg is desperate to win his first world championship; Hamilton is desperate to stop him. That's now three times in seven races they've collided this year, and in two out of the past three.

"From the team's perspective, starting one and two and coming out of Turn 1 two and nine is not pleasant," said Mercedes sports boss Toto Wolff, who called Hamilton's move "hard".

"The question is how much can you really manage it from the outside? Turn 1 in Canada is a difficult one. There is a concrete runoff area. If there was a wall, probably we wouldn't have the discussion.

But then if you are on the inside, you dictate the line. I guess I have déjà vu — we are having these discussions after every race."

The stewards saw no reason to investigate, and Rosberg was consigned to a difficult afternoon battling his way back through the lower points positions, while up front the stage was set perfectly for Ferrari to possibly steal an opportune win from Mercedes.

Vettel held a slender advantage of 1.3 seconds over Hamilton before Jenson Button stopped his McLaren-Honda at the side of the track on the back straight, following an engine failure on lap 10 of 70. Officials briefly deployed the virtual safety car while marshals shifted the McLaren out of harm's way. Ferrari decided to use this moment to make the first of its two planned pitstops, and the team switched both its drivers onto the super-soft tyre. >>



Vettel rejoined fourth, but made short work of closing down and passing the Red Bulls of Daniel Ricciardo and Max Verstappen, though he heavily locked his front-right wheel diving past Ricciardo at the hairpin. By the end of lap 18 he was back up to second and only 10s behind Hamilton, with a pitstop already in the bag.

The Ferrari driver whittled that gap down to less than six seconds before Mercedes brought Hamilton in for his first stop on lap 24. Here Mercedes chose to fit the soft-compound Pirelli tyres in an attempt to make the finish without stopping again.

“The two-stop strategy was the faster by a couple of seconds, but it was clear that the virtual safety car came too early for us to really commit to the best possible two-stop,” explained Wolff. “This is why we decided to stay out.

Even with a slightly hotter track we thought the one-stop was feasible and you could see most of the other teams had the same thinking.

“Interestingly, the soft was really robust. We could see that Alonso had seven laps

more on the tyre, so it was a pretty good indication of how far it would really go, and we knew we would have a warning if his tyres would suddenly fall off the cliff, and they never did.”

Hamilton’s pace on the soft tyre in the middle of the race put Ferrari on the back foot. Vettel’s tyres were softer, but 13 laps older than Hamilton’s on account of that early stop. He lost an average of 0.287s per lap to Hamilton before diving into the pits for a second time on lap 37.

By this point it was clear that Hamilton would attempt to get to the end of the race without stopping again. The similarities to Melbourne were again striking – Vettel needing to hunt down Hamilton and overtake him, having conceded the precious advantage of track position.

Vettel charged after his rival, but only took 0.017s per lap on average out of Hamilton’s lead. The reigning world champion not only nursed his 13-lap-old Pirelli tyres brilliantly, he was also fast.

“The one-stop was the team’s decision, which was a great call on strategy,” said Hamilton. “I felt there was a long way to go, but it actually went pretty quick, and I had a really nice balance with the car. There are certain corners where you can push, others where you have to lift and coast, so if you get that right balance then the tyres can go forever, and I had the perfect balance.”

But for all Hamilton’s brilliance there were also a few key moments that cost Vettel during his pursuit and gave Hamilton some extra breathing space. Vettel lost time lapping Romain Grosjean’s Haas on lap 42 and gave away more than a second by locking up and missing the final chicane on lap 56. He regrouped, but another mistake at the same spot on lap 61 while lapping

Pascal Wehrlein’s Manor looked an error too far. The gap stabilised over the final few laps. Hamilton was off the hook.

Hamilton’s pace and longevity on the soft tyre suggested Ferrari ultimately misread this race. In

Melbourne, Ferrari inexplicably failed to fit the mandated compound to both cars during the mid-race stoppage, which forced it to make an extra pitstop unnecessarily.

The call in Canada was not quite so clear-cut, but nevertheless Ferrari should know from the way it beat Mercedes to victory in Malaysia in 2015 how vital it is to retain track position at all costs.

Mercedes reckoned it enjoyed little or no straightline-speed advantage in the race in Canada, so Vettel would not have been an easy target for Hamilton even though the W07 remains a slightly faster car than the SF16-H overall.

Mercedes pitted under an early safety car in Malaysia last season and couldn’t recover; Ferrari returned the favour in Canada this year.

Ferrari claimed it couldn’t predict that the soft tyre would perform so well, or be so durable, but there are numerous examples of the Pirelli rubber lasting longer in the race when the track has rubbered in. Also, Kimi Raikkonen completed a very strong >>

Hamilton: “If you get the right balance, then the tyres can go forever”



Vettel passes Ricciardo on his way through after first stop

XPB IMAGES

QUALIFYING



Hamilton celebrates his fifth Canadian Grand Prix pole

XPB IMAGES

SEBASTIAN VETTEL CURSED LOUDLY OVER THE RADIO. HE'D come within two tenths of stealing pole position from Lewis Hamilton's Mercedes. So close!

He apologised to Ferrari for picking up some oversteer out of the hairpin on his final flying lap. But for being "maybe a bit greedy" exiting that turn, could he actually have snatched top spot away from Mercedes?

This was by far the closest a Ferrari has come to outqualifying a Mercedes in F1 this season. At the previous two races the team has lost its way with the Pirelli tyres and failed to challenge. As in Monaco, Vettel topped the final practice session here, but this time he sustained his form when it counted.

"Going into qualifying I thought pole was possible," he said. "I wanted to get below the 1m13s mark because then I knew it would be very close."

He did that, but in truth the final gap of 0.178s was closer than it should have been. Both Hamilton and Mercedes team-mate Nico Rosberg, who qualified second, made errors on their second runs in Q3, which meant they failed to make the most of an improving circuit and had to rely on earlier efforts.

"I had an oversteer moment out of Turn 8/9 [the penultimate chicane]," Hamilton explained. "I didn't hook any of the laps up, so there was definitely more time in it."

Hamilton was faster in the first and third sectors of his final lap, but ended up just under a tenth shy of his earlier best. That second lap in Q3 was still fast enough to beat Vettel, but had Hamilton hooked everything together he would have been around three tenths quicker than the Ferrari.

That failure to improve should have presented a chance for Rosberg to snatch pole himself. He was only 0.062s slower after the first runs and was giving away nearly two tenths in sector one alone, which he put down to Hamilton being "simply faster" through the first chicane.

Rosberg tried again, but a massive lock-up under braking for Turn 1 on his second run ended his hopes immediately.

Another disappointing qualifying session for Kimi Raikkonen allowed the Red Bulls of Daniel Ricciardo and Max Verstappen to qualify fourth and fifth, Ricciardo 0.248s clear of his team-mate with what he felt was a "pretty clean lap".

The 0.4s boost from the latest Renault engine helped Red Bull stay clear of Williams, which locked out row four at one of its best circuits. Raikkonen came perilously close to being outqualified by the Williams drivers, and was nearly six tenths slower than Vettel.

"We struggled a bit in Turn 10 [the hairpin]," Raikkonen explained. "We struggled to make the front turn and took a hit for that, and we lost a bit of time all the time for locking the front."

"When you have a small issue before the straights here you take a big penalty on laptime and that's how it was."

"Could Vettel have snatched top spot away from Mercedes?"



Hamilton locks up while chasing Vettel for the race lead

TEELAT

VETTEL'S FINAL PURSUIT OF HAMILTON

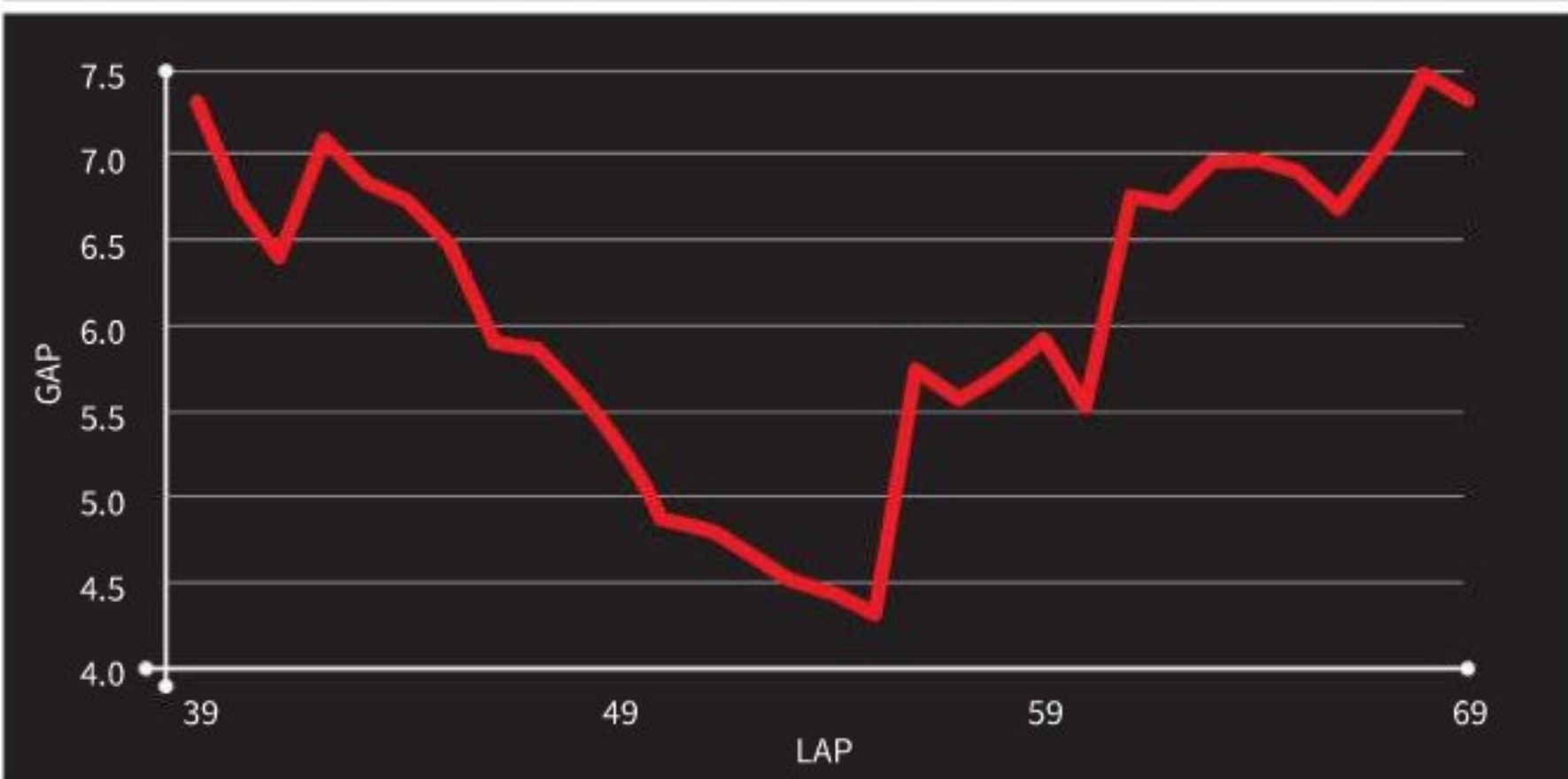

F1/CANADIAN GRAND PRIX RACE REPORT



“RICCIARDO COMES THROUGH ON OPPOSITE LOCK, WITHOUT THE HINT OF A LIFT”

WALL OF CHAMPIONS



WHEN YOU THINK OF THE Circuit Gilles Villeneuve’s ‘wall of champions’, you automatically recall the famous names who have creamed their cars against its unforgiving concrete.

Watching F1 cars from the top of the bank that overlooks that wall, as I did during the final practice session for the Canadian GP, is an awesome experience.

The wall of champions is so nicknamed because of its big-name victims, but it also deserves the accolade for highlighting the audacity that separates the better drivers from the lesser ones.

The Ferrari drivers are impressively committed on their first laps through here, both using the entire kerb on the outside, while some others took time to build up their nerve.

Kimi Raikkonen is the standout to start with. He’s rightly taking a lot of flak for his poor form at Ferrari, but the way he gets on the case so quickly shows that a proper driver still lurks within him somewhere.

Both Sebastian Vettel and Fernando Alonso flirt with disaster, flying off the kerbs and skimming the wall, displaying expertly controlled aggression.

Daniel Ricciardo and Lewis Hamilton are smoother and



Ricciardo flirts with the ‘wall of champions’

more classical with their lines, but no less committed. Ricciardo once comes through with his RB12 on opposite lock, without a hint of a lift.

Nico Rosberg takes way more kerb than anyone else, doing his best to straightline the corners. Lesser cars protest with vicious kicks of oversteer, but the way

Rosberg batters the kerbs and gets away with it highlights the superior ride quality of the W07.

The contrast between former Toro Rosso team-mates Max Verstappen and Carlos Sainz Jr is also fascinating. Verstappen is all rapid rotation and dead-straight acceleration. It’s not spectacular but it is fast. Sainz is

all flair and artistry, flinging his (admittedly lesser) car in and catching the slides, living completely on his wits.

Somehow he avoids becoming that famous wall’s next victim. Little does he know that in the next session it will finally claim him.

BEN ANDERSON



Bottas claimed his and Williams’s first podium of 2016

Vettel congratulates Hamilton for a win he should have taken



long run on the soft tyre in the early stages of Friday's second practice session, when track conditions were far less evolved.

Not only was one stop possible, but several different teams had it down as a potentially viable strategy going into the race.

Red Bull tried it, but abandoned it when it became clear that the RB12 wasn't getting on so well in the cool conditions. Alonso managed an even longer stint than Hamilton. Rosberg would have pulled off a one-stop without a late puncture, and third-placed Valtteri Bottas also delivered, as did Renault's Kevin Magnussen.

A two-stop strategy made sense for those starting behind on the grid and needing to be aggressive, but once Vettel jumped both Mercedes it seemed odd that Ferrari wasn't prepared to adjust its plan to the evolving situation.

Arrivabene admitted that Ferrari would have stuck to its guns even without the deployment of the VSC, which means it never even considered a one-stop, or simply waiting to see how Mercedes reacted to being on the back foot after the start. And by making such an early first stop under VSC conditions – which no one else other than Wehrlein did – Ferrari also compromised Vettel's tyre life for the latter part of the race, when he needed to attack.

It seems a lack of strategic flexibility cost Ferrari here, but Vettel refuted comparisons to Melbourne and backed his team after the race. "I will always defend our strategies," he said. "Others favoured two stops [too]; with hindsight maybe they'd do it differently.

"Put yourself on the pitwall – to make that decision is tricky. I wouldn't criticise the team because the guys are on the money and reacting very well."

But ultimately this is now the third time this season that Ferrari has failed to seize a real chance to score a victory. The opportunities are presenting themselves, but the team has suddenly lost the ability to grasp them.

This was not the case in 2015, when there was relatively little to lose. Now that the pressure to succeed is firmly back on, mistakes are coming frequently. The good news for Ferrari is that it endured

no repeat of the mysterious tyre problems it suffered in qualifying for the Spanish and Monaco Grands Prix. Vettel qualified within two tenths of pole in Canada, and Ferrari's latest turbo update

seemed to help it maintain serious competitiveness in the race.

"The team reacted very well and we've started to understand clearly how to find the right balance with the car," Arrivabene said. "The gap that we have from Mercedes is now short, but we need to work more to be able to win."

Winning is suddenly something Hamilton could be beginning to make a habit of again. After such a trying start to the season he's now won two grands prix on the spin, and slashed the championship gap to Rosberg from 43 points to just nine.

A title race that looked utterly under Rosberg's control suddenly seems far from a foregone conclusion. ❦

Vettel: "I'll always defend our strategies. To make that decision is tricky"

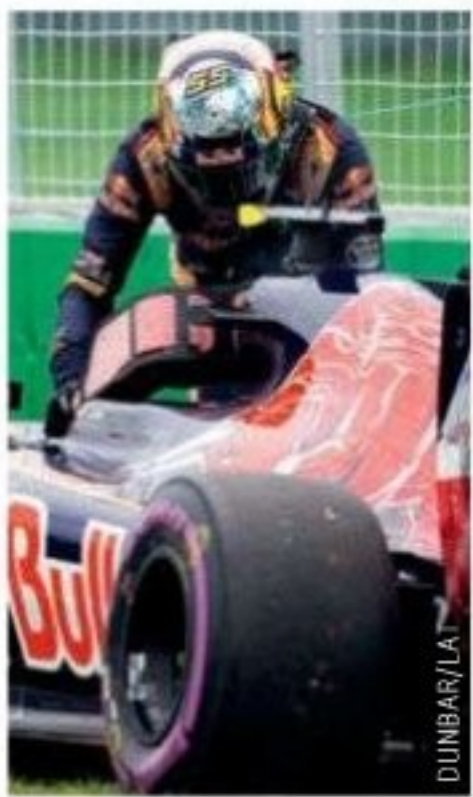

Williams podium down to tyre work

VALTTERI BOTTAS PULLED OFF a similar one-stop strategy to race winner Lewis Hamilton to claim a podium for the second successive season at the Canadian Grand Prix.

The Williams driver started the race seventh and gained a place after Hamilton and Nico Rosberg came together at Turn 1, causing Rosberg to slow on the run to the first chicane.

Bottas's strategy helped him get ahead of Kimi Raikkonen's Ferrari, but he also held off the recovering Mercedes of Rosberg and overtook Daniel Ricciardo's Red Bull midway through.

He resisted more pressure from Rosberg before the Mercedes suffered a puncture, and was also quick enough on old tyres to stay clear of Max Verstappen's Red Bull late on.

A low-downforce, high-power circuit was always likely to suit Williams, but the team's performance chief Rob

Smedley said Bottas's race showed how far Williams has come in understanding how to use the Pirelli tyres.

"The work we have done has really paid dividends in these [cool] conditions – we were able to get the fronts turned on," explained Smedley, who reckoned the cold weather prevented the soft tyre from overheating and Bottas could have got "another 10 laps out of his tyres".

"We still probably have a bit of work to do at the other end of the scale, in keeping the temperatures under control in really hot conditions."

Red Bull struggled for race pace in Canada and team boss Christian Horner felt the cool conditions made it too difficult for the benign RB12 to get the tyres into the correct temperature range.

"We just got into more trouble at the end of the stints and didn't quite have the range that Mercedes and Williams had," said Horner.



SAINZ GETS INTO POINTS AFTER QUALIFYING CRASH

CARLOS SAINZ JR recovered from a crash into Montreal's infamous 'wall of champions' in qualifying to score two points for Toro Rosso in the Canadian Grand Prix.

Sainz admitted that the crash was the result of "living too close to the edge all weekend" and "closing my eyes and going for it" in his attempt to make Q3 on his first flying lap in Q2 on Saturday.

He lost the rear of the car on the exit kerb, which then pitched the front into the concrete wall.

The crash meant he finished the session with the 16th fastest time, and also resulted in the car requiring a new gearbox, which triggered a penalty and put him back to 20th on the grid.

He recovered well in the race, rising to 16th on the first lap and beating both Haas drivers, Toro Rosso team-mate Daniil Kvyat, Fernando Alonso's McLaren-Honda and Sergio Perez's Force India to finish ninth.

"I quickly forgot about the disappointment of Saturday," said Sainz. "Even if the mistake wouldn't have existed, it wouldn't have been much better than P9 – maybe a P8."



Verstappen holds Rosberg for fourth

RED BULL'S MAX VERSTAPPEN fended off the charging Mercedes of championship leader Nico Rosberg to finish in fourth place in the Canadian Grand Prix.

After his Turn 1 collision with Mercedes team-mate Lewis Hamilton, Rosberg recovered through the field and was threatening the Williams of Valtteri Bottas for the final podium spot when he was forced to pit with a slow puncture.

Rosberg rejoined in seventh, but managed to pass Daniel Ricciardo's Red Bull and Kimi Raikkonen's Ferrari before charging onto the back of Verstappen as the race entered its

final 10 laps. Rosberg tried a pass into the final chicane on lap 63 of 70, but Verstappen defended the inside line, and again on the subsequent run to Turn 1.

The Mercedes backed off for a few laps to save fuel, before Rosberg tried again on the penultimate lap. He again went to the outside for the final chicane but spun under braking.

Verstappen held on to fourth, while Rosberg limped home fifth, running short on fuel and only just remaining ahead of Raikkonen.

"It was a massive mission to manage everything; the whole race was so complicated," said Rosberg. "I had

brake warnings, I got the puncture as well, which probably cost me the podium.

"I did a huge lift-and-coast lap on the last lap just to try and carry it over the line."

Red Bull boss Christian Horner said the battle had highlighted how much progress engine supplier Renault has made during this season.

"In previous years he [Rosberg] would have gone past no matter which side he picked," said Horner.

"Twelve months ago we were a lap behind and 1.5s off in qualifying. This year we were three tenths away. So it really is a step in the right direction."



McLaren-Honda fails to meet qualifying promise

McLAREN-HONDA MADE THE top 10 in qualifying for the third race in succession, on what was one of its worst circuits in 2015, but came away from the Canadian Grand Prix without the reward of a points finish.

Fernando Alonso finished a lapped 11th, more than 27 seconds behind the 10th-placed Force India of Sergio Perez (which started behind Alonso on the grid), while team-mate Jenson Button retired with an engine failure.

Alonso described the race as “not good fun” because of a one-stop strategy that

that required a 53-lap final stint on soft tyres, and the fact that McLaren-Honda lacked pace on the power-dependent Circuit Gilles Villeneuve.

The Spaniard asked to make a late stop for fresh rubber, but was told to stay out in case any of the cars ahead dropped out of the points.

“It was a lonely race and not lucky with no rain, no safety car, nothing that put us again in a fight,” Alonso said. “When you have to save fuel, when you are two seconds off the pace and when you have old tyres, the fun of driving is quite poor.”



Q&A

KIMI RAIKKONEN FERRARI DRIVER



You talked about difficulties with the car in qualifying. Was it better in the race?

It was pretty OK on certain points, but on the last sector always at this track it's difficult to keep the tyres working after the straights. It went through the same loop every lap, so I struggled.

When you and Sebastian Vettel pitted early on, Seb had the benefit of a clear track but you were stuck in traffic. Was it there that you lost the chance to do better?

We decided to stop and then at the last minute they tried to call me to stay out because the virtual safety car ended, but I was already braking into the pitlane, so it was too late. Would it have made a lot of difference? I don't know; there are always speculations. We tried to get the maximum after that and we managed to overtake people, but the end result isn't exactly what we want.

Does the pace of the car give you confidence in taking the fight to Mercedes?

We have had good pace in many races, not just here, but we need to make it last all the time, every session. There has been a very good feeling with the car and good lap times at certain moments on all the weekends, but then we lost it in the qualifying moments – the feeling or the speed – and go back in the race. The aim is always to be up there and competitive the whole weekend, then the results will come. For sure, the car made a step, but from my side it was a difficult weekend.

How do you rate your own performances this season so far?

Some good and not so good moments. For sure, this race and the last race weren't ideal. Hopefully, we will get things running more smoothly the next race and get back to where we should be. If we're comparing to the beginning of last year, I think it's been better, but if we cannot win races and fight at the top every weekend we cannot be happy.

Magnussen struggles after 'weird' practice crash

KEVIN MAGNUSSEN ENDURED A difficult race to 16th in the Canadian Grand Prix, having started last following a crash in final practice.

He was on an out-lap on a set of used ultra-soft Pirellis late in FP3 when he lost control of his Renault coming out of the second chicane. The resulting damage meant he missed qualifying, with the team rebuilding his car around a spare chassis used earlier in the season.

"It was really strange," said Magnussen. "We put on a set of tyres that I'd run on already and [the blankets]

didn't have time to get them warm – they were very slippery. It was weird because we've done it before and been all right, but maybe because the track temperature was so low it caught me out. I was just going out of the corner, hit a bump, then it snapped massively."

He survived contact with Felipe Nasr's Sauber at the first chicane on lap one of the race, but his one-stop strategy was not enough to beat the second Sauber of Marcus Ericsson.

"We struggled and P16 is not where we wanted to be," said Magnussen.



Massa rues engine trouble and spare-parts shortage

FELIPE MASSA FAILED to finish the Canadian Grand Prix in a Williams that was hamstrung by a shortage of spare parts after a practice crash and then suffered problems with an overheating engine in the race.

Massa crashed heavily under braking for Turn 1 in FP1 when the drag-reduction system on his car's rear wing failed to close correctly.

Williams rebuilt the car

and he went on to qualify eighth, less than a tenth behind team-mate Valtteri Bottas, but the team confirmed that a lack of parts meant his FW38 lacked "about two tenths" of laptime, according to performance chief Rob Smedley.

Williams spent part of Friday investigating the cause of the DRS fault, which Smedley said was related to the control mechanism, and

suffered no repeats.

Bottas went on to finish a strong third in the race. Massa tracked him closely initially, then had to back off and retire midway through.

"It was a water-system issue on the power unit that caused the pressure and temperature to rise," said Smedley. "We tried a number of counter measures to mitigate, including asking Felipe to lift-and-coast more, but none of them worked."



WING FAILURE HITS GROSJEAN AGAIN

ROMAIN GROSJEAN SAYS HAAS MUST SOLVE ITS recurring front-wing problems after he suffered a failure for the fourth time this season in Canada.

Grosjean had to make an unscheduled stop to replace the wing and finished 14th, one place behind team-mate Esteban Gutierrez.

The failure follows others in pre-season testing and the Bahrain and Spanish GPs. The Barcelona breakage has been traced to a manufacturing error.

"There was a touch at the start; maybe that didn't make life easier, but we need to sort it out," said Grosjean. When asked if the problem was similar to the previous ones, he replied: "I didn't check, to be fair. I lost it – I shouted on the radio, and I came in."



MORE ELABORATE MERCEDES AERO TWEAKS

There were a number of new parts for the W07 in Canada, adding yet more complexity to Mercedes' already sophisticated aero package. At the front end there were three main updates to the wing turning vanes and S-duct.

In what is a new aero solution for F1, the front wing gained six strakes. These break up the airflow off the

wing and shape it around the inside of the front tyre. Further in are new turning vanes that replace the serrated footplate. Instead, the rear two vanes extend forwards to overlap the front two vanes.

Less noticeable is the change to the S-duct outlet over the nose. The scuttle panel has been reshaped to be flatter, creating a straight-edged rectangular outlet

rather than the old curved shape. These are likely to be updates that remain on the car beyond the Canadian GP.

At the rear, the monkey-seat winglet is also revised. The old three-element winglet is replaced with a near-circular two-element design. The exhaust now flows outwards from the wing to alter the blown effect under the top rear wing.

MONACO CANADA

REVISED MONKEY-SEAT WINGLET

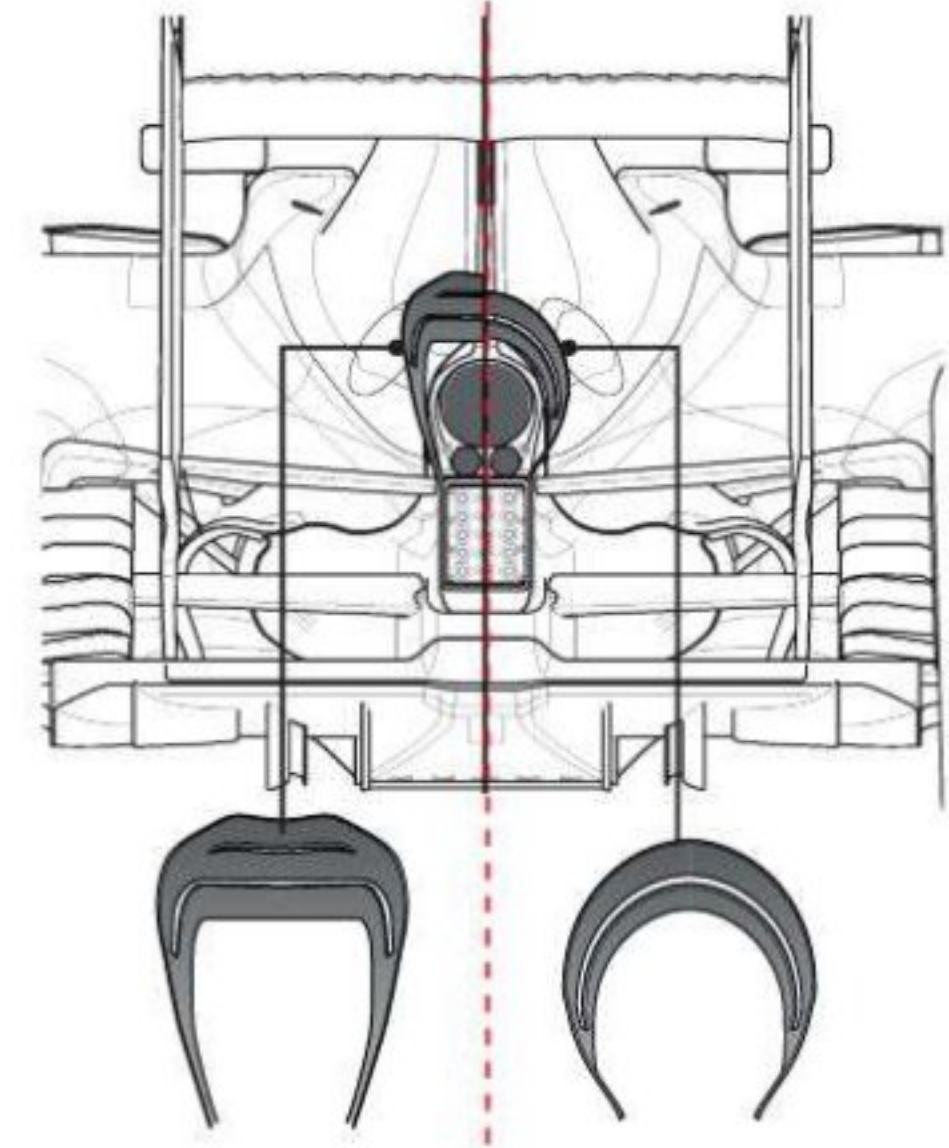

REVISED REAR-WING PROFILE

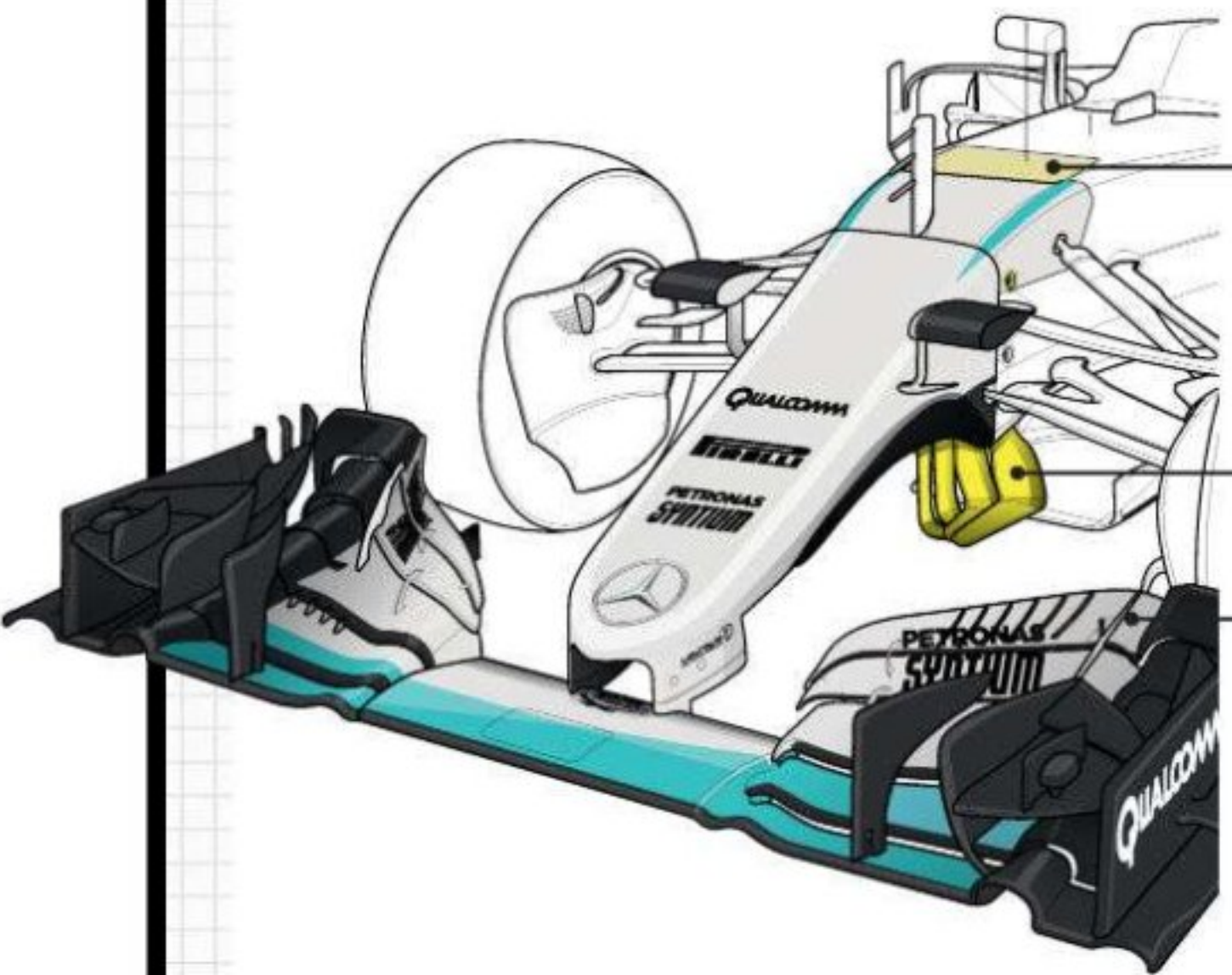
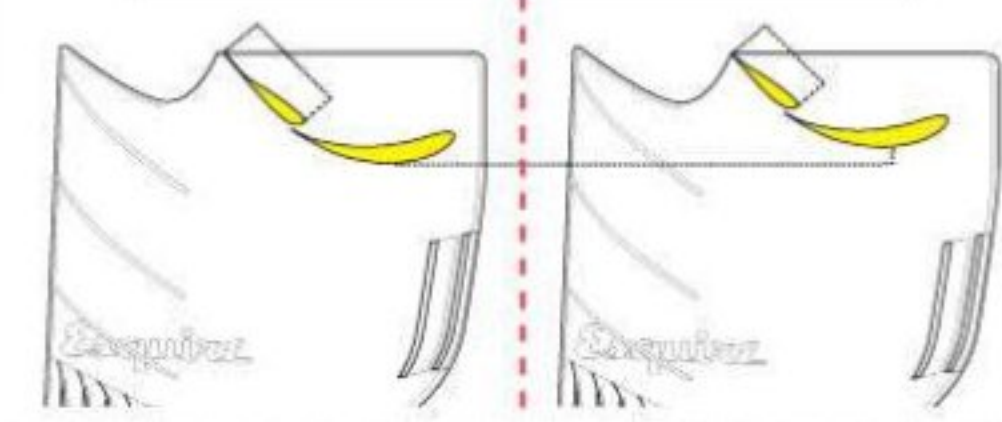

REVISED S-DUCT OUTLET

OVERLAPPING TURNING VANES

FRONT-WING STRAKES

CLIPPED WINGS FOR WILLIAMS

The Circuit Gilles Villeneuve has always demanded low drag for the long straights and lack of fast corners, so teams regularly bring slimmed wings to Canada. For this year Williams had a revised rear

wing, with a shorter chord flap. This has the effect of lifting the wing's main plane and making the two-element wing assembly much shallower, thereby reducing its angle of attack.



FERRARI TRIMS SIDEPODS TO CUT DRAG



Ferrari cut back the sidepods to reduce drag along Montreal's straights. A large section was removed, which serves to both shorten and lower the top surface. Rather than leaving a hole, Ferrari fitted a stepped panel inside the gap to merge the outer airflow with the hot air escaping the sidepod.

F1/CANADIAN GRAND PRIX RESULTS



Race results / 70 laps – 189.686 miles

POS	DRIVER	TEAM	FINISH TIME	LED	TYRES	TIME IN PITS
1	Lewis Hamilton	Mercedes	1h31m05.296s	47	●●●	22.243s
2	Sebastian Vettel	Ferrari	+5.011s	23	●●●	44.958s
3	Valtteri Bottas	Williams-Mercedes	+46.422s		●●●	22.184s
4	Max Verstappen	Red Bull-Renault	+53.020s		●●●	46.495s
5	Nico Rosberg	Mercedes	+1m02.093s		●●●	45.194s
6	Kimi Raikkonen	Ferrari	+1m03.017s		●●●	46.083s
7	Daniel Ricciardo	Red Bull-Renault	+1m03.634s		●●●	46.890s
8	Nico Hulkenberg	Force India-Mercedes	-1 lap		●●●	45.987s
9	Carlos Sainz	Toro Rosso-Ferrari	-1 lap		●●●	47.962s
10	Sergio Perez	Force India-Mercedes	-1 lap		●●●	47.313s
11	Fernando Alonso	McLaren-Honda	-1 lap		●●●	27.952s
12	Daniil Kvyat	Toro Rosso-Ferrari	-1 lap		●●●	45.627s
13	Esteban Gutierrez	Haas-Ferrari	-2 laps		●●●	47.340s
14	Romain Grosjean	Haas-Ferrari	-2 laps		●●●	1m18.849s
15	Marcus Ericsson	Sauber-Ferrari	-2 laps		●●●	46.256s
16	Kevin Magnussen	Renault	-2 laps		●●●	23.162s
17	Pascal Wehrlein	Manor-Mercedes	-2 laps		●●●	49.300s
18	Felipe Nasr	Sauber-Ferrari	-2 laps		●●●	47.595s
19	Rio Haryanto	Manor-Mercedes	-2 laps		●●●	54.801s
R	Felipe Massa	Williams-Mercedes	35 laps-overheating		●●●	22.925s
R	Jolyon Palmer	Renault	16 laps-water leak		●●●	-
R	Jenson Button	McLaren-Honda	9 laps-engine		●●●	-

Fastest laps

POS	DRIVER	TIME	GAP	LAP
1	Rosberg	1m15.599s	-	60
2	Hamilton	1m15.981s	+0.382s	68
3	Vettel	1m16.297s	+0.698s	70
4	Verstappen	1m16.319s	+0.720s	49
5	Ricciardo	1m16.506s	+0.907s	51
6	Perez	1m16.559s	+0.960s	54
7	Sainz	1m16.578s	+0.979s	54
8	Hulkenberg	1m16.604s	+1.005s	68
9	Raikkonen	1m16.919s	+1.320s	44
10	Bottas	1m16.938s	+1.339s	68
11	Kvyat	1m16.942s	+1.343s	50
12	Grosjean	1m17.281s	+1.682s	50
13	Alonso	1m17.307s	+1.708s	67
14	Massa	1m17.424s	+1.825s	32
15	Gutierrez	1m17.728s	+2.129s	48
16	Nasr	1m17.883s	+2.284s	66
17	Ericsson	1m18.100s	+2.501s	63
18	Magnussen	1m18.224s	+2.625s	42
19	Wehrlein	1m18.282s	+2.683s	48
20	Haryanto	1m18.658s	+3.059s	57
21	Button	1m19.456s	+3.857s	5
22	Palmer	1m19.879s	+4.280s	6

WEATHER Dry, cloudy. Air: 12C. Track: 23C ● New ○ Used ● Ultra Soft ● Super Soft ● Soft ● Medium ● Hard | ● Wets ● Intermediate

13 Massa has been outqualified by his team-mate on all 13 of his Canadian GP weekends	2500 Hamilton became only the fifth driver ever to notch up 2500 laps in the lead of F1 races	5 Hamilton has now won the Canadian GP five times in nine attempts	100 Perez notched up his 100th F1 start	16 Number of points scored by Rosberg in the past three grands prix	3000 Mercedes has become the sixth constructor to lead 3000 laps in F1	3 Vettel has now led three races this year without managing to win one
---	---	--	---	---	--	--

Lap chart / What happened, when

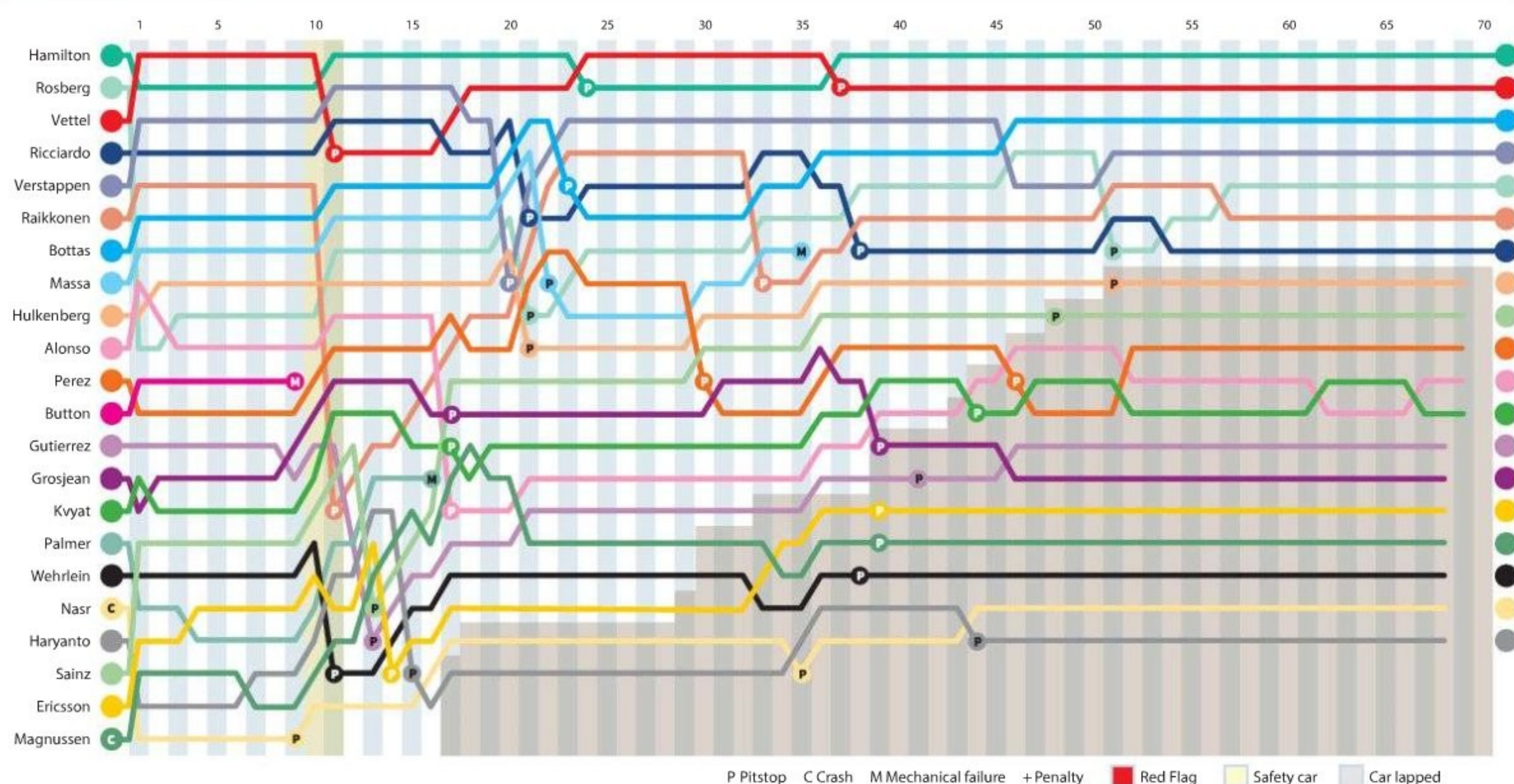



SEASON STATS

Drivers' championship

1	Rosberg	116
2	Hamilton	107
3	Vettel	78
4	Ricciardo	72
5	Raikkonen	69
6	Verstappen	50
7	Bottas	44
8	Massa	37
9	Perez	24
10	Kvyat	22
11	Grosjean	22
12	Alonso	18
13	Hulkenberg	18
14	Sainz	18
15	Magnussen	6
16	Button	5
17	Vandoorne	1
18	Gutierrez	0
19	Palmer	0
20	Ericsson	0
21	Wehrlein	0
22	Nasr	0
23	Haryanto	0

Constructors' championship

1	Mercedes	223
2	Ferrari	147
3	Red Bull	130
4	Williams	81
5	Force India	42
6	Toro Rosso	32
7	McLaren	24
8	Haas	22
9	Renault	6
10	Sauber	0
11	Manor	0

Wins

Rosberg	4
Hamilton	2
Verstappen	1

Fastest laps

Rosberg	3
Hamilton	1
Hulkenberg	1
Kvyat	1
Ricciardo	1

Pole positions

Hamilton	4
Rosberg	2
Ricciardo	1

Qualifying head-to-head

ROS	3	4	HAM
VET	5	2	RAI
MAS	1	6	BOT
RIC	3	0	VES
RIC	4	0	KVY
PER	4	3	HUL
MAG	5	2	PAL
KVY	1	2	SAI
VES	3	1	SAI
ERI	6	1	NAS
ALO	5	1	BUT
BUT	0	1	VAN
HAR	3	4	WEH
GRO	5	2	GUT

Qualifying 1

POS	DRIVER	TIME
1	Rosberg	1m13.714s
2	Vettel	1m13.925s
3	Ricciardo	1m14.030s
4	Hamilton	1m14.121s
5	Bottas	1m14.389s
6	Raikkonen	1m14.477s
7	Verstappen	1m14.601s
8	Hulkenberg	1m14.663s
9	Sainz	1m14.714s
10	Button	1m14.755s
11	Perez	1m14.814s
12	Massa	1m14.815s
13	Kvyat	1m14.829s
14	Alonso	1m15.026s
15	Gutierrez	1m15.148s
16	Grosjean	1m15.444s
17	Palmer	1m15.459s
18	Wehrlein	1m15.599s
19	Ericsson	1m15.635s
20	Nasr	1m16.663s
21	Haryanto	1m17.052s
22	Magnussen	did not run

WEATHER Mostly dry, cloudy. Air: 15C. Track: 20C

Race briefing

GRID PENALTIES

ERICSSON 3-place grid penalty for Monaco GP collision

KVYAT 3-place grid penalty for Monaco GP collision

MAGNUSSEN 5-place grid penalty for gearbox change

MAGNUSSEN starts from pits after changing chassis

SAINZ 5-place grid penalty for gearbox change

Qualifying 2

POS	DRIVER	TIME
1	Hamilton	1m13.076s
2	Rosberg	1m13.094s
3	Ricciardo	1m13.540s
4	Bottas	1m13.791s
5	Verstappen	1m13.793s
6	Raikkonen	1m13.849s
7	Vettel	1m13.857s
8	Massa	1m13.864s
9	Hulkenberg	1m14.166s
10	Alonso	1m14.260s
11	Perez	1m14.317s
12	Button	1m14.437s
13	Kvyat	1m14.457s
14	Gutierrez	1m14.571s
15	Grosjean	1m14.803s
16	Sainz	1m21.956s

WEATHER Mostly dry, cloudy. Air: 15C. Track: 20C

Qualifying 3

POS	DRIVER	TIME
1	Hamilton	1m12.812s
2	Rosberg	1m12.874s
3	Vettel	1m12.990s
4	Ricciardo	1m13.166s
5	Verstappen	1m13.414s
6	Raikkonen	1m13.579s
7	Bottas	1m13.670s
8	Massa	1m13.769s
9	Hulkenberg	1m13.952s
10	Alonso	1m14.338s

WEATHER Mostly dry, cloudy. Air: 15C. Track: 20C

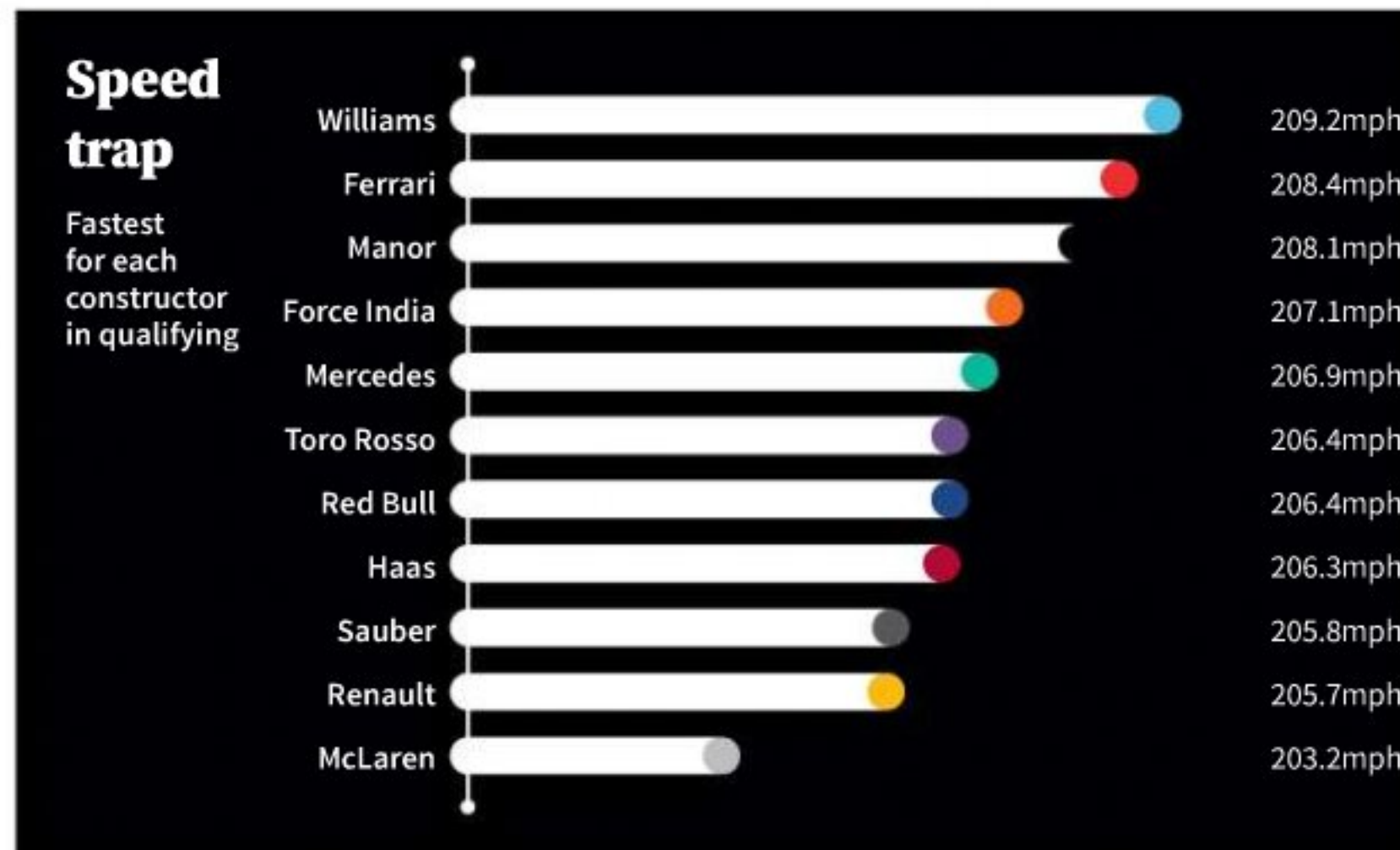

Free practice 1

POS	DRIVER	TIME
1	Hamilton	1m14.755s
2	Rosberg	1m15.086s
3	Vettel	1m15.243s
4	Verstappen	1m15.553s
5	Raikkonen	1m15.618s
6	Bottas	1m16.301s
7	Hulkenberg	1m16.464s
8	Sainz	1m16.543s
9	Perez	1m16.577s
10	Alonso	1m16.663s
11	Ricciardo	1m16.734s
12	Button	1m16.788s
13	Grosjean	1m17.008s
14	Massa	1m17.065s
15	Kvyat	1m17.310s
16	Gutierrez	1m17.319s
17	Nasr	1m17.855s
18	Haryanto	1m18.103s
19	Ericsson	1m18.129s
20	Magnussen	1m18.409s
21	Wehrlein	1m18.453s
22	Palmer	1m18.583s

WEATHER Dry, cloudy. Air: 14C. Track: 29C

Free practice 2

POS	DRIVER	TIME
1	Hamilton	1m14.212s
2	Vettel	1m14.469s
3	Rosberg	1m14.738s
4	Verstappen	1m15.156s
5	Ricciardo	1m15.168s
6	Bottas	1m15.213s
7	Button	1m15.213s
8	Raikkonen	1m15.234s
9	Hulkenberg	1m15.321s
10	Sainz	1m15.410s
11	Alonso	1m15.450s
12	Perez	1m15.493s
13	Massa	1m15.513s
14	Kvyat	1m15.559s
15	Grosjean	1m16.093s
16	Magnussen	1m16.255s
17	Nasr	1m16.582s
18	Gutierrez	1m16.591s
19	Ericsson	1m16.902s
20	Palmer	1m17.001s
21	Wehrlein	1m17.023s
22	Haryanto	1m17.423s

WEATHER Dry, sunny. Air: 17C. Track: 43C

Free practice 3

POS	DRIVER	TIME
1	Vettel	1m13.919s
2	Verstappen	1m14.158s
3	Rosberg	1m14.316s
4	Raikkonen	1m14.332s
5	Hamilton	1m14.334s
6	Ricciardo	1m14.487s
7	Sainz	1m14.655s
8	Alonso	1m14.801s
9	Perez	1m14.886s
10	Massa	1m14.890s
11	Hulkenberg	1m14.918s
12	Bottas	1m14.985s
13	Button	1m15.023s
14	Kvyat	1m15.199s
15	Gutierrez	1m15.444s
16	Palmer	1m15.656s
17	Grosjean	1m15.704s
18	Ericsson	1m16.078s
19	Magnussen	1m16.085s
20	Nasr	1m16.326s
21	Wehrlein	1m16.622s
22	Haryanto	1m16.901s

WEATHER Mostly dry, cloudy. Air: 14C. Track: 19C

F1/CANADIAN GRAND PRIX DRIVER RATINGS

A weather-beaten weekend

Each driver's Canadian Grand Prix performance, scored out of 10

By Ben Anderson, Grand Prix Editor

[@BenAndersonAuto](https://twitter.com/BenAndersonAuto)

MERCEDES



9 LEWIS HAMILTON
Hamilton's record in Montreal is formidable, so it was no surprise to see him claim a fifth pole here, though Rosberg's lock-up at the end of Q3 let him off the hook somewhat. Poor start was the only flaw in an otherwise excellent race, in which he was both fast and expert in tyre management. Firmly back in title contention.



5 NICO ROSBERG
Ultimately failed to bounce back from Monaco. Pole chance went up in a cloud of brake smoke at Turn 1 and his race unravelled at the same spot. Podium went begging to a puncture, and fourth to a spin while trying to pass Verstappen. Once looked unstoppable; now looks distinctly vulnerable.

FERRARI



8 SEBASTIAN VETTEL
Vettel is another who excels here in qualifying and can't be faulted for falling just short, even armed with Ferrari's updated turbo. His start was superb, but Ferrari's strategy was not and thus a win went begging. Is not blameless, though. Scruffy driving in the last stint made Hamilton's life easier.



4 KIMI RAIKKONEN
Followed a poor performance in Monaco with another underwhelming showing here. A lock-up at the hairpin cost him most of his qualifying deficit to Vettel, but that's become too familiar a story. Managed to beat one of the Red Bulls in the race, but burned too much fuel and finished almost a minute behind Vettel.

WILLIAMS



9 VALTTERI BOTTAS
Bottas hustled impressively around this track, but probably should have outqualified Raikkonen's Ferrari given the small gap to Massa's hobbled car. Lack of front-tyre temperature cost him in Q3. His race was superb. Problems for others helped, but his tyre management helped clinch the podium.



7 FELIPE MASSA
Williams lacked the parts to fully rebuild Massa's car after the DRS failure that caused him to crash heavily in first practice, so qualifying within a tenth of Bottas in a car two tenths slower was a strong effort. Tracked Bottas early on, but his engine overheated so he had to back off and then retire from the race.

RED BULL



7 DANIEL RICCIARDO
Cleared the air with Red Bull after his Monaco debacle and excelled in qualifying here. But his race was disappointing. Lost out to Verstappen at Turn 2 after the start and wrecked his second set of tyres with a big lock-up, which led to a compromised second stop that plunged him into traffic.



8 MAX VERSTAPPEN
Finally got his hands on the updated Renault engine – thought to be worth 0.4s around Montreal. Was beaten by Ricciardo in qualifying, and admits he's leaning on his team-mate's experience for set-up help, but delivered an excellent race. Overtook Ricciardo on lap one and defended expertly at the end.

FORCE INDIA



6 SERGIO PEREZ
Struggled with a long brake pedal in qualifying, which he felt cost him two tenths into the third chicane alone. Without that he would have made Q3. The race was not his cleanest. Struggled on the soft tyre and got stuck behind the McLarens. Stalled at his second stop, but late passes rescued a point.



7 NICO HULKENBERG
Felt he couldn't have done more in putting Force India ninth on the grid, given the VJM09 is still limited by a lack of rear grip and was no match for Mercedes, Ferrari, Red Bull or Williams here. Found the car difficult to drive in the race, but drove well enough to keep ahead of Sainz's Toro Rosso at least.

RENAULT



5 KEVIN MAGNUSSEN
Got caught out by cold tyres in final practice, and the crash severely damaged his car and compromised his weekend. Skipped qualifying while the team built up a spare. Collided with Nasr on lap one. The bright spot was executing a 31-lap stint on ultra-softs to beat Wehrlein's Manor in a largely forgettable race.



7 JOLYON PALMER
Was struggling for confidence in his car during practice, but set-up changes transformed matters and he did well to get within 0.015s of bumping Grosjean out of Q2. Lost ground on lap one after a clash with Sainz, and got overtaken by Ericsson, but repassed him before a water leak spoiled his fun.

“Sainz recovered brilliantly with an aggressive first lap, fast driving and smart strategy”



S. BLOXHAM/LAT

TORO ROSSO



6 DANIL KVIAT
Was pleased to qualify cleanly, though felt more than 13th fastest time was possible had his brakes been set-up better through practice. Grid penalty from Monaco dropped him behind both Haas drivers. Jumped them easily, but lost his chance of a point by getting stuck behind Alonso.

8 CARLOS SAINZ JR
Bounced his car off Montreal's kerbs spectacularly, but loses marks for a needless crash into the wall of champions that came from trying too hard. Started 20th thanks to grid penalty for a gearbox change, but recovered brilliantly with an aggressive first lap, fast driving and smart strategy.

SAUBER

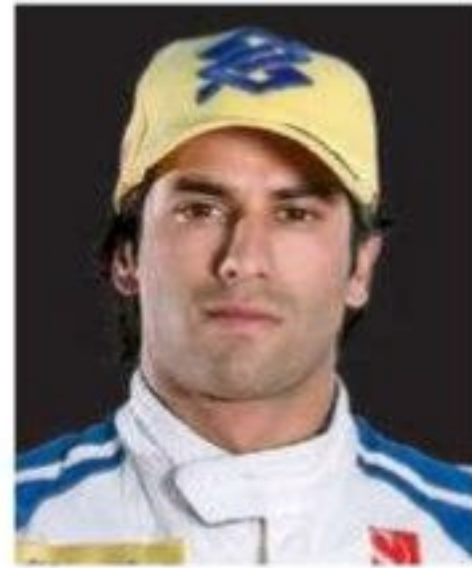

4 FELIPE NASR
Qualified well behind team-mate Ericsson, not helped by an incorrect brake set-up as he struggled for grip. The team corrected this, but Haryanto's crash cost Nasr his second chance in Q1. His race was compromised by a collision with Magnussen's Renault at the first chicane, which broke the Sauber's floor.

7 MARCUS ERICSSON
Was delighted to beat team-mate Nasr by over a second in qualifying, though perhaps should have beaten Wehrlein's Manor too. Took a grid penalty for punting Nasr in Monaco and struggled early on. But the Sauber was better on the soft tyre, and he recovered well to beat Wehrlein and Magnussen.

McLAREN



7 JENSON BUTTON
Blamed a lack of an aerodynamic tow for failing to match Alonso in qualifying, despite being quicker in two sectors. In truth he was running too far ahead to properly tow Alonso, and simply paid the price for locking up into the hairpin. Jumped Perez on the first lap and was right with Alonso when his engine failed.

8 FERNANDO ALONSO
Did a great job to put McLaren-Honda into Q3, on one of the team's worst 2015 circuits, which raised eyebrows at Force India and Toro Rosso. Jumped Hulkenberg and Rosberg on the first lap, but quickly fell back again. Attempted a one-stop strategy, but tyre and fuel saving meant he was too slow for the points.

MANOR



4 RIO HARYANTO
Given he lapped within three tenths of team-mate Wehrlein in final practice, Haryanto was rightly disappointed to be nearly 1.5s slower in qualifying, even before he crashed. Started the race quite well and overtook Magnussen, Palmer and Ericsson, but got stuck behind Nasr after a slow first pitstop.

7 PASCAL WEHRLEIN
Did a great job to outpace Kvyat, Grosjean, Palmer and both Saubers on his first run in Q1, but got bumped as faster cars improved and lost his own chance to do better when Haryanto crashed. His car was damaged on the way to the grid, costing laptime. Fought hard but couldn't hold off Magnussen.

HAAS



6 ROMAIN GROSJEAN
Grosjean is happier, but Haas is still struggling with the tyres and he was close to getting outqualified by a Manor and a Renault here. Battled with Kvyat initially and passed Gutierrez, but lost tyre temperature under the VSC, and had to make an extra stop because of front-wing failure. A disappointing weekend.

6 ESTEBAN GUTIERREZ
Gutierrez was unwell throughout the weekend, so did a good job to outqualify Grosjean. The race was tough, as he continued to fight illness and lacked grip as Haas struggled to work the tyres properly. Faded as the race wore on and only just finished ahead of Grosjean, despite his team-mate's extra stop.

TOP 10 AVERAGE RATING

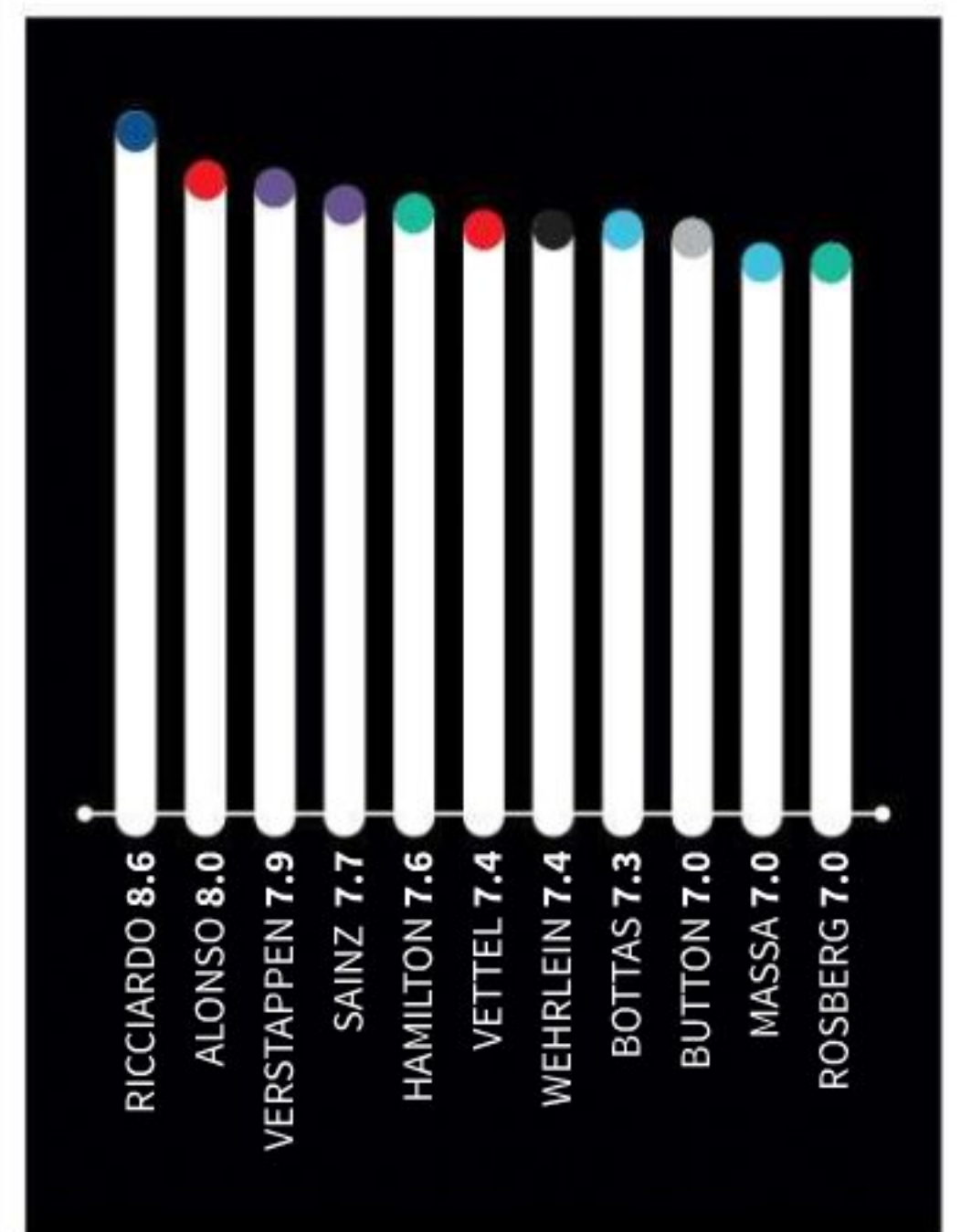



New venue has been dubbed the fastest city track in the world

FORMULA 1

Teams facing Spa-like set

FORMULA 1 TEAMS FACE A SET-UP DILEMMA for this weekend's inaugural grand prix on the streets of Azerbaijan's capital city Baku.

At 3.732 miles, the 20-turn circuit is the second longest on the calendar and has been described by its designer Hermann Tilke as the fastest city track in the world, with an estimated maximum corner speed of 126mph.

But alongside its fast, sweeping corners and long, seafront straight – where drivers will be at full throttle for around 1.4 miles – there is also a narrow, twisty section through the Old City that will give the teams a headache. Between Turns 8 and 12 the corners are just 7.6m wide, making it one of the tightest sections of track in F1.

This presents a similar scenario to Spa-Francorchamps, where teams can choose to run high downforce and be quick in the twisty middle sector, or go for low downforce and be fast in the first and final sectors.

Williams performance chief Rob Smedley says: "It's going to be quite a challenge because you've got this requirement for huge straightline speed, and then it almost goes into this Monaco-style street circuit in places.

"I've only looked at the pictures, so I can't say for sure, but it looks like it goes into some reasonably sweeping, quite quick right-handers or medium-speed right-handers. The place where I would say it's most similar to is Spa. You'll see some teams taking different choices for both qualifying and the race."

Teams are relying on CAD drawings for background research, but will have to wait until after Friday practice to see how accurate the track maps are.

Red Bull team principal Christian Horner suggested that most teams will opt for lower downforce, which could present an opportunity for his team, with its history of getting strong performance out of a car running more downforce than its rivals.

"The straight is twice as long as the longest straight in Canada, which is enormous," says Horner. "It's going to be fascinating to see what set-ups people adopt. I guess the length of that straight will push most people towards the lower end of the downforce spectrum."

A number of drivers have tried the track in the simulator, but Nico Rosberg is wary about making any comment about the layout.



Turn 8 is the start of a tight, twisty four-corner section...



...which includes the narrow, uphill Turn 10 left-hander

-up challenge on streets of Baku

"I did the track in the simulator and it wasn't great," he says. "Then I looked at pictures and it didn't look like the simulator track, so I'm hoping the simulator track was not very accurate because that was not good. There were some weird corners – just wrong – but looking at the pictures, it's fine."

Others have done very little preparation and not run in the simulator.

"I've seen nothing, I have no idea which way it goes," says Renault's Kevin Magnussen. "I've not done it in the simulator as we don't have the track. I have no expectations, I don't know the place and I don't know the track."

Red Bull's Max Verstappen has had a good first impression.

"I quite like it," he says. "I enjoyed doing my laps on the simulator. It's a bit different to Macau because it's a bit wider. You have a few corners where it's quite tight, but in Macau everything is very tight except that long straight. In general, I've quite enjoyed it so far."

Lewis Hamilton was not so complimentary,

Horner: "It'll be fascinating to see what set-ups people use"

lamenting that street tracks should be more like Monaco: "I don't have a lot to say about it. Monaco is the street circuit... why don't they just make street circuits like they used to? It's almost as wide as a motorway in some places, but hopefully it'll be fun."

Newcomer Haas believes it faces a particular challenge in Baku as it is still trying to get settled in F1 and has not been able to spend as much time as the bigger teams on its preparations.

"The good teams are good for one reason: because they can get well prepared," argues Haas boss Gunther Steiner. "Our preparation is maybe less than the big teams are doing because for us everything is new. But it should be more of a level playing field for us."

Fernando Alonso, who is an ambassador for the new circuit, is expecting a top speed of around 210mph and believes the race "will be amazing".

The McLaren driver adds: "It may be not

so good for us, in terms of how the track is for our car, but I think the people at the front will enjoy it."

The feeling in the paddock ahead of Baku is mixed. Many who have visited the city on pre-race reces rave about the country and the welcome they received.

Others are acutely aware of the human rights problems in the country, which were highlighted last week when pressure group Sports For Rights called for singers Pharrell Williams, Chris Brown and Enrique Iglesias to cancel performances scheduled for the race weekend, as well as asking F1 boss Bernie Ecclestone to speak out in defence of human rights.

US-based NGO Freedom House, which monitors human rights and democracy around the world, rates Azerbaijan as "not free".

F1 is used to races being held in countries with questionable human rights records, with the Bahrain Grand Prix in particular coming under fire during the past five years. So the focus this weekend is likely to be on how the circuit delivers for drivers and fans.

LAWRENCE BARRETTO

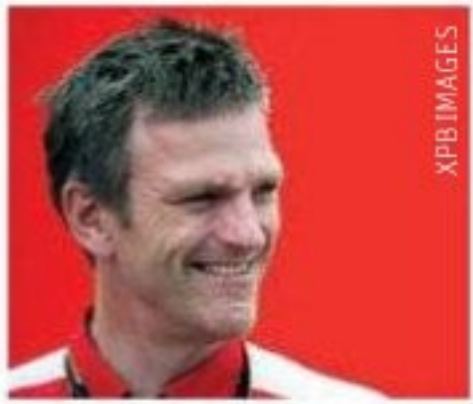

FORMULA 1

RENAULT BIDS TO RE-SIGN ALLISON

THE RENAULT TEAM HAS approached Ferrari in an attempt to re-sign James Allison as part of its recruitment drive.

Allison is currently in his second stint with Ferrari, returning to Maranello almost three years ago as the team's technical director.

Allison is seen as someone who can help Renault live up to its pre-season predictions of challenging for wins and world titles in 2018-19.

Sources have confirmed that, aside from Allison, Renault has also made approaches to other teams as it seeks to bring in the best personnel.

It is unclear whether Allison would replace or work alongside chief technical officer Bob Bell.

Racing director Frederic Vasseur's role is known to be under the spotlight, with one source suggesting he has failed to gel with the team.

One consideration for Allison are his personal circumstances, after suffering the loss of wife Rebecca to meningitis in late March.

Allison had been splitting his time between Britain and Italy to be with his wife and three children. Rejoining Renault could allow more time with his children.

Should Allison accept the position it would be his fourth spell at Enstone after starting his F1 career in 1990 with Benetton as a junior designer. The most recent was as technical director from 2009-2013.

IAN PARKES



Red Bull ran a trial aeroscreen during free practice for the Russian GP in April

FORMULA 1 SAFETY

Aeroscreen failed FIA safety test, leading to halo choice

THE FIA'S DECISION TO CHOOSE THE HALO AS ITS preferred cockpit-protection device for 2017 came after the rival aeroscreen concept failed to pass recent tests.

The halo was given the green light for introduction next year following a meeting of the technical regulations working group last month, with the time constraints of developing Red Bull's alternative aeroscreen cited as a factor.

But one day before the meeting, the FIA had conducted its own tests on the aeroscreen. Though Red Bull released a video of its own static test, in which a wheel was propelled at the aeroscreen, the FIA's evaluation was unsuccessful.

According to a source, "the most recent tests on the aeroscreen didn't go as well as expected", and showed

"further development is needed". One of the problems concerns the free air volume around a driver's helmet in relation to the rim of the aeroscreen. Should a car fitted with an aeroscreen be involved in an impact, the helmet could collide with the rim.

The halo was found to have no such problems, although the open space between the halo's loop and the cockpit is still problematic. An object smaller than this gap could pass through it and strike the driver's head.

The definitive halo will be more refined than the 'rough draft' seen in pre-season testing and made from titanium. It will be made by a third-party supplier after a tender process.

IAN PARKES

WORLD TOURING CAR CHAMPIONSHIP

Honda half-wins its appeal

HONDA HAS HAD PART OF ITS exclusion from the third and fourth rounds of the World Touring Car Championship overturned, after the International Court of Appeal decided to reinstate its Hungarian results.

Stewards at the Nurburgring last month excluded the manufacturer team and Zengo Motorsport's Honda Civics from the Hungarian and Moroccan rounds because a technical report adjudged the flat floor of the

Civics to be illegal (Autosport, June 2).

Honda announced its intention to appeal the decisions relating to its factory cars and formally lodged its appeal against the exclusions.

Its case was heard last Thursday at the ICA in Paris, and the panel found Honda's appeal to be admissible. It judged that the Hungarian results (the best being Tiago Monteiro's third in race two) would be reinstated for procedural reasons – Honda having

initially been cleared by stewards – but that its exclusion from Morocco, which it dominated, would be upheld. The floor will not be used again.

Honda has been Citroen's closest challenger this season, and its drivers sat second, third and fourth in the championship prior to the ruling. Monteiro, Norbert Michelisz and Rob Huff have dropped to fourth, sixth and eighth in the standings respectively

JACK COZENS

IN THE HEADLINES



NEW LIVERY FOR TORDOFF

British Touring Car Championship leader Sam Tordoff's WSR BMW will run with a special one-off silver livery (above) at this weekend's Croft round marking the 70th anniversary of JCT600, the Tordoff family company.

FIA TIGHTENS UP FLEXI WING TESTS

The FIA has carried out more stringent flexibility tests on rear wings in Formula 1 amid speculation that some are moving illegally at high speed, thereby reducing drag. Videos have emerged that appeared to show movement from Ferrari and Red Bull's wings. But the FIA says the items in question are fully compliant with the current regulations, even after increasing the test loads by 50%.

LECLERC TOPS AUSTRIA GP3 TEST

Ferrari junior Charles Leclerc topped last week's two-day GP3 test at the Red Bull Ring. The ART driver lapped 0.278s faster than fellow Ferrari protege Antonio Fuoco.

FINAL LE MANS SEATS FILLED

Nathanael Berthon has taken the vacant seat at the Greaves Ligier LMP2 squad for the Le Mans 24 Hours. He replaces Kuba Giermaziak. Jean-Philippe Belloc has taken the injured Paolo Ruberti's place in the Larbre GTE Am Chevrolet, while Erik Maris has replaced Olivier Lombard in the Lombard Racing Ligier.

JOHN THORNBURN 1938-2016

John Thornburn, who managed Nigel Mansell in his formative years, has died at the age of 78 after a long illness. Thornburn started out in team management with the Team Elite Lotus squad in sportscars in the early 1960s and again when it was revived later in the decade. He went on to manage the Alan McKechnie Racing Formula 5000 squad that won the Rothmans European championship with Bob Evans in 1974. Thornburn worked with a number of young drivers through the 1990s and advised Mansell's sons, Greg and Leo, when they started racing in the 2000s.

ANDRETTI FORMULA E

Andretti Autosport has completed the first on-track running of its 2016/17 Formula E powertrain. The American team had to scrap its first attempt at its own FE technology ahead of the current campaign, but has already racked up "several hundred kilometres" with its ATEC-02.



F1 PREVIEW

European Grand Prix

June 17-19



BAKU

LENGTH 3.732 miles **NUMBER OF LAPS** 51
2015 POLE POSITION N/A
QUALIFYING LAP RECORD N/A
RACE LAP RECORD N/A



Tyre allocation



UK start times

LIVE ON SKY SPORTS F1 & CHANNEL 4
FRIDAY
FP1 1000 **FP2** 1400
SATURDAY
FP3 1100 **QUALIFYING** 1400
SUNDAY
RACE 1400

RADIO COVERAGE BBC 5 LIVE
QUALIFYING SATURDAY 1400 **RACE** SUNDAY 1400

Previous winners

2012	Fernando Alonso	Ferrari
2011	Sebastian Vettel	Red Bull
2010	Sebastian Vettel	Red Bull
2009	Rubens Barrichello	Brawn
2008	Felipe Massa	Ferrari
2007	Fernando Alonso	McLaren
2006	Michael Schumacher	Ferrari
2005	Fernando Alonso	Renault
2004	Michael Schumacher	Ferrari
2003	Ralf Schumacher	Williams

Themes to watch

FERRARI'S PACE

After being in the mix for victory in Canada, but squandering that shot with poor strategy, Ferrari appears to have the speed. But is the team up to winning?

ROSBERG'S RUN

Following four wins on the bounce at the start of the year, Rosberg has scored just 16 points in the past three races. He could lose the points lead in Baku.

HONDA'S STRUGGLE

After the Canadian GP, Fernando Alonso said McLaren needs to do something on the aero side to make up for a lack of power – can it respond this quickly?

INDYCAR

Newgarden escapes Texas accident

JOSEF NEWGARDEN ESCAPED A HORROR shunt in last Sunday's abandoned IndyCar race at Texas Motor Speedway with only minor injuries.

Newgarden was running just behind Daly on lap 42 (picture 1) when the Dale Coyne Racing driver lost the rear of his car. Daly corrected, but in doing so sent the car up the banking and into the path of Ed Carpenter Racing's Newgarden.

Daly's nose hit the front-left of Newgarden's car, pushing them into the wall together. When pinched against the wall, Newgarden's car rolled onto its right side (2), before the two machines

spun back to the middle of the track and then drifted back into the wall for a second time in the kink before the start-finish line.

Newgarden's car went into the SAFER barrier for the second time top-first (3), with the rollhoop taking the initial impact. The cars eventually came to a halt after the second hit and were promptly attended to by safety crews (4).

Newgarden was able to get out of the car with assistance, although subsequently slumped to the ground and received further medical attention (5). He was transferred by air to

Parkland Memorial Hospital in Dallas. Examinations at Parkland revealed that Newgarden had sustained a fractured right clavicle and a small fracture in his right hand. He was released from hospital a few hours later.

"The car held up great and the response from the safety team was amazing," said Newgarden. "I'm banged up a little bit but I'm generally OK. I am feeling a little pain but I hope to be ready to rock and go again soon."

Daly admitted to making a rookie error, which caused the accident. "All of a sudden the



1

2



4



5



rears just totally lost grip," he said. "It felt like I floated all the way through the corner. I should have recognised it, it was just a rookie mistake.

"I was trying to stay a little bit lower because I knew Josef was coming. So maybe by just pinching it a little bit I just put too much load on the right rear, because although the car was quite good, it was on the edge in 3-4 all the time."

Lengthy barrier repairs were carried out under the safety car, but the race did not get back under way in earnest because of the heavy rain.

BRUCE MARTIN

"The car held up great and the response from the safety team was amazing"



INDYCAR

Race will resume at end of August

THE FIRESTONE 600 TEXAS IndyCar round will be completed on August 27 after being abandoned after 71 laps because of bad weather.

The race was postponed from Saturday because of rain and, when it finally got under way on Sunday, it was interrupted by the massive accident involving Josef Newgarden and Conor Daly that led to a lengthy caution period. With 177 laps left to run, the race was red-flagged because of storms.

IndyCar president of competition and operations Jay Frye said the race will pick up from where it was stopped after the two-and-a-half month delay.

"This is unique, but we look forward to coming back here," Frye said. "The Olympics will be over and we are talking to networks but we are confident the race will be televised live.

"If everything had played out we might have got to halfway but that is not our intention. We wanted a complete race."

So when IndyCar returns, it will be a one-day show with practice during the day, a full autograph session by the drivers under the main grandstand afterwards and the remainder of the race set for 7pm local time. Organisers were unwilling to try to stretch the race to half-distance, when it could have been called as a points-paying race.

"That was the best way to serve all the fans," said track boss Eddie Gossage. "We could have hung around and get it to dry tonight to get it to halfway but that's not right."

Gossage confirmed he had unanimous support from the teams to take this course of action.

Ever since Texas Motor Speedway opened with a NASCAR Sprint Cup race

in 1997 it has been plagued by a drainage problem. This is because the high banks were built into an artificial embankment, and when the ground gets saturated with moisture it seeps through the asphalt surface. The sun actually pulls moisture through the pavement, so on a sunny day the track is often too damp to allow racing.

Gossage said that the track added more French drains after last November's NASCAR Sprint Cup race to help the water issues that have seemed to plague this racetrack since it was opened in 1997. "Do you want to repave and seal it off or do you deal with it?" he said. "The answer is every race car driver says not to repave so we are being dealt a tough hand by nature."

James Hinchcliffe led at the stoppage, followed by Ryan Hunter-Reay, Mikhail Aleshin, Will Power and Ed Carpenter. But there was controversy over whether Hinchcliffe really was leading, as Hunter-Reay's Andretti Autosport team argued that its driver was first to the blend line when exiting the pits from his stop under caution, and therefore should be considered the leader. That is a debate that could continue for the next two and a half months.

Earlier in the race, Andretti driver Carlos Munoz had led from his first pole position, but the interruptions resulted in the order being mixed up prior to the stoppage, thanks to pitstops made under caution. This meant that the early-race frontrunners were outside the top six at the time of the stoppage, while those who had run longer, and had yet to pit when the crash happened, moved to the front of the field.

BRUCE MARTIN



Hinchcliffe leads field on pit road prior to 11-week interruption

FEEDBACK

What makes a great grand prix



Having just recovered from one of the coldest but best grands prix I have attended in 50 years, I wondered what made it feel that way.

In my opinion it was a true race with two exceptional drivers at the front and a couple of really good ones behind who genuinely like racing. Yes, they earn a lot of money, but they showed true racer qualities.

The fans were amazing, the grandstands were packed for both qualifying and the race, and also with a high attendance on Friday.

The Montreal city's metro transport made the queuing at many grands prix seem archaic.

Bag and ticket checks were completed with a friendly attitude, unlike the militia-style approach at some other circuits.

If I could afford it I would book next year now, but hope for slightly warmer weather.

Bob Bull
By email

Does F1 need social media?

The introduction to F1 of Heineken as a global brand partner is of course welcome in terms of helping to make the sport sustainable, especially should similar companies follow suit.

Even noises made about attempting to increase popularity via social media might be considered to be news out of the positive camp, but ultimately I'm not sure this is where the real issue that causes discontent lies.

Fans want to see close and exciting racing throughout the grid. In the main that's what we have, and any gimmicks used to falsify what should be a natural race outcome do no one any favours.

It is therefore the job of the sport to promote itself and this is easily done via good racing, with the help of broadcasters who showcase its coverage.

We didn't need social media in the gold old days to enjoy the sport and I'm not convinced we need it now.

Michael Brierley
Stalybridge, Cheshire

What made Canada special? It starts with the star drivers' "true racer qualities", says reader Bull

Ferrari's tyre 'madness'

I believe Einstein described insanity as doing the same thing over again and expecting different results.

In Australia Ferrari sacrificed track position with Vettel for tyre strategy; same in Barcelona (where everyone knows overtaking doesn't happen and track position is everything); and now in Canada track position was again sacrificed for a tyre change.

Go figure...

Tim Magness
By email

You can't stop progress

So, Nicky Samengo-Turner (Letters, June 9) wants an end to "invisible technology". Where should we have stopped? Hybrid power, V8s, V10s, multi-valve engines, variable valve-timing, turbochargers, carbonfibre, seatbelts, disc brakes, or was losing the riding mechanic a step too far?

You can't stop car makers, or racing car makers, from innovating, nor should you try. Otherwise we would still be driving around behind a bloke with a red flag.

Phil Oakes
Portishead, Bristol

HAVE YOUR SAY, GET IN TOUCH

Autosport editorial
Bridge House
69 London Road
Twickenham
TW1 3SP

@
E-mail
autosport@
haymarket.com

Twitter
twitter.com/
autosport

Facebook
facebook.com/
autosport

CORRECTION

Chris Meek was born in 1932 and not 1942, as reported in our obituary in the June 2 issue.



Sale of the century

The venture-capitalist fund that owns F1 has long wanted to cash out, but is finding itself with a product of diminishing worth to investors

By Dieter Rencken, Special Contributor

[@RacingLines](#)

A LITTLE OVER 10 YEARS HAVE PASSED SINCE private equity-fund manager CVC Capital Partners acquired majority control of Formula One Management with the intention of exploiting F1's commercial rights.

CVC's original plan was to list the sports property on Singapore's stock exchange in 2013. To that end the business was restructured, with Strategy Group status and premium payments being offered to the 'Big Five' teams in exchange for their commitments to remain in the sport through to the end of 2020. The reasoning behind this is clear: providing an incentive for the teams with the biggest box-office value to stay ought to have maximised the chances of achieving a high valuation in the initial public offering (IPO).

But a raft of factors conspired against that plan and, as a result, the planned flotation date passed with no sale. CVC found itself in charge for much longer than most venture capitalists like to stay cashed in. And worse, the contracts have come back to haunt CVC, for not only has the revenue structure they imposed left independent teams relatively worse off, some of those teams have argued that they breach EU laws and have filed official complaints.

Sources close to CVC regularly allude to potential purchasers for the rights, yet a deal appears no closer than before the planned IPO. Little wonder too. As things stand now the contracts have just 50 per cent of their original life remaining. Who would shell out billions for a business with just four years of guaranteed shelf life, and invest in an entity headed up by an 85-year-old with an obvious aversion to succession planning?

In the words of a sharp F1 numbers man: "CVC must start offering post-2020 contracts post-haste, simply because they need a long runway to make a sale fly. As things stand right now they no longer have anything long-term to offer..."

Thus the word in the Montreal paddock was that Bernie Ecclestone would soon commence negotiations with the teams. Autosport understands that when Renault acquired Lotus the company was offered a deal to 2024, but that this extension was more a function of CVC's desire to backload the contract owing to cashflow issues created by debts incurred during the original purchase, and subsequent dividend payments.

Still, this timeframe sets a precedent by providing an eight-year 'runway', while – crucially – offering commercial stability to prospective entrants, particularly if F1 can lock in its technical and sporting regulations for the same period.

The main sticking points are unlikely to be the duration of contracts, but their terms and conditions. Here Ecclestone is sure to face considerable challenges in keeping the teams sweet, for Ferrari is sure to insist on its Long Standing Team bonus, and Red Bull Racing/Mercedes will clearly demand their multiple championship bonuses – while independents complain that these are unfair.

In short, any future packages offered to teams need to eliminate the inequalities created by the current contracts, while keeping the top teams sufficiently committed in order to attract a purchaser for the rights at a price acceptable to CVC's fund holders. No easy balancing act, and a situation further complicated by the fact that Sauber and Force India have filed EU complaints against the present structure.

During the Canadian Grand Prix weekend six team principals were quizzed openly at the FIA press conference about their thoughts on fair and inequitable revenue structures going forward. As anticipated, each suggested a different solution – ranging from retention of the present system, through

Premier League-type tables to splitting the 'pot' 11 ways. One proposed a return to the 2010-12 structure, which rewarded top 10 teams on a sliding scale.

Add another five team bosses plus Bernie Ecclestone and his masters at CVC, and

the voice of the FIA, and anything up to 14 different proposals could potentially be on the negotiating table.

The same goes for discussions about F1's governance process, which Ecclestone has publicly excoriated. Somewhat predictably the six respondents proposed six variations, ranging from retention of the current (much-maligned) Strategy Group structure, through the FIA and commercial rights holder jointly devising regulations and imposing them, to all teams having equal input into the regulatory process.

The bottom line is that CVC desperately needs to negotiate extensions to existing contracts if it is to sell out of F1 any time soon. But if it offers too little, Ferrari and Red Bull could exit F1 as their presidents recently threatened; offer too much, and the bottom line invites fundholder revolt while making the company less attractive to prospective purchasers.

That, in a nutshell, summarises the immediate commercial challenges faced by CVC and Ecclestone, and, by extension, Formula 1. There is no easy solution.

The tragedy for F1 (and millions of fans) is that CVC may prove unable to find a buyer at any price, any time soon. ❄

“Anything up to 14 different proposals could be on the table”

WRC/ITALY



ALL PICS: MCKLEIN

Neuville finds his redemption

Thierry Neuville's been under a dark cloud at Hyundai, so his dominant victory in Sardinia represents a career-saving turnaround in fortune

By David Evans, Rallies Editor

[@davidevansrally](#)



WRC/ITALY

Thierry Neuville and Nicolas Gilsoul sat and stared at each other. Their Hyundai i20 WRC had coughed and died, out of

fuel. So ended their Rally Portugal. But what a difference three weeks and a day make. Once again they stopped and stared, but this time, in Sardinia, they did it as winners.

When Neuville broke his World Rally Championship duck in Germany two years ago, it had the look of a hand-me-down win. It was nice, but not necessarily earned in the fashion he would have wanted.

This time he crafted and controlled a victory against a Volkswagen Polo R WRC running in virtually identical conditions to him. By some considerable distance this was the biggest win of Neuville's career. Arguably, it was the win that saved his career.

The lack of petrol on the Marao stage of Rally Portugal was a low point, but only marginally lower than the previous low point. Which had been pretty low.

Neuville's win has to be viewed in the context of the last 15 months. In that time he has gone from being on top of the world to hitting rock bottom.

Midway through day one in Mexico last year, he was up there, talking about how he intended to follow and eclipse Sebastien Ogier. Then he went off.

From that event forward it went from bad to worse, culminating in Hyundai team manager Alain Penasse's extraordinary lambasting of his driver in Germany last season – just 12 months on from Neuville's supposed breakthrough win.

Penasse pulled no punches. He told Neuville he needed to drive faster, to sort himself and his attitude out. "We were," Penasse said at the time, "frank with him and we told him we no longer see the Thierry from the past. Now, to

finish fifth, he needs [a car ahead to have] two punctures and two people going off in front of him. He is no longer within the pace of the pack and the most annoying thing is neither he, his co-driver nor his entourage has any form of explanation. We are happy to have Hayden [Paddon], because with him driving we are making progress."

Ouch. Trouble is, things didn't get much better after that.

With hindsight, Gilsoul says his and Neuville's time at world championship-winning teams Citroen and M-Sport in 2012 and '13 raised their expectations of what the fledgling Frankfurt-based Hyundai squad could deliver.

"We came from very efficient teams with a lot of experience and worked well with them," Gilsoul says. "It became like normal for us, and to then jump in with a new team, it was a big step. It took a long time..."

Penasse adds weight to that theory: "The first year was difficult with Thierry. We were building the team and he was impatient, he wanted to be world champion in a short time. But he knew we didn't have the engine for that – everything was new. Then last year we had the delay with the new car and he was not happy with that."

Even when the new car arrived and testing got underway, things still weren't right. Neuville couldn't find the balance he wanted. Plainly it wasn't love at first sight for him and the New Generation i20.

And all the time in Neuville's periphery, team-mate Paddon's stock was rising. The Kiwi was happy with the new car and still progressing with the old one, coming within an ace of winning in Sardinia 12 months ago. The pair locked horns and it was clear all was not well in the team.

A silver lining was spotted among the clouds in Wales last year. Neuville took a wheel off in Myherin, but came back to win the Gartheiniog and Dyfi stages. Just when it looked like things were changing for the better on that filthy



Road-sweeper Ogier finished third, but still extended his championship lead

November day, he rolled in Dyfnant.

The defence was as immediate as it was staunch from his fellow drivers. Whoever went in there first was having that accident. Vindication.

Monte Carlo: new year, new car, podium. Light at the end of the tunnel.

Sweden: third early on before rear-diff failure leaves him with front-wheel drive. Mexico wasn't great: he crashed twice, but in Argentina he was blameless. The Hyundai stopped on the opening day's Santa Rosa test and six minutes passed before he could trace a loose electrical connection.

Stage one in Portugal and he looked all-in, back to his absolute worst: in 17 miles he'd dropped 32s to Kris Meeke. At the end of Ponte de Lima, he babbled about a lack confidence. He could scarcely find the words to describe what had just happened.

But he got back on it and found some confidence, clearly embarrassed by his early effort. And then, nine miles into Marao, everything went quiet. Out of petrol, out of luck and, some felt, almost out of a job.

Superficially, it would have been hard to argue with a demotion, or worse. But Neuville knew there was more to his year than this. He'd worked hard with the engineers before Portugal and had come up with a differential and suspension set-up to give him more confidence in the rear of the car.

Team principal Michel Nandan recognised the change. "I think it was coming in the last rally of last year,"



Paddon was out on day one after crashing heavily



Neuville: “I was really able to control the speed. I think we deserved this. We earned it”

Nandan said. “This year, he recognised the mistakes in Mexico were his, but he also had some technical problems. Thierry has always been fast, but maybe he’s had some problems controlling that speed. He’s worked on that, like he’s worked on his pacenotes and worked on everything.”

“It’s true the car is still not how he likes it and we are trying to make that better, but now he also knows how to drive the car fast even when he is not comfortable in it. He has come to the car and we have brought the car to him. This is coming with confidence.”

That confidence was certainly evident in Sardinia last weekend. From stage seven onwards he was never headed, and he drove like he’d been winning world championship rounds for years.

What was most impressive was the way he dealt with the pressure from Jari-Matti Latvala. After the Saturday morning loop, the VW driver had slashed the gap to 2.9s.

The thinking in the service park was simple: Neuville’s had his fun, but the Finn’s here now. Stand aside.

Latvala’s co-driver, Miikka Anttila, admitted almost as much himself.

“The first stage after lunch was perfect for us,” he said. “Everything was good, there were no big slides, everything was clean. We were happy.”

And Neuville took 10.8s out of them.

The afternoon was where the time was coming for the i20. Much as he tried, Neuville couldn’t trust the car 100% when the roads were looser and offering less grip in the morning. But, once the full field had passed and swept the line clear to offer better traction, he was away.

“I put everything into that stage,” said Neuville. “I really pushed hard and it took everything to take the time from Jari-Matti.”

Not even a downpour at the start of the 14th stage could put Neuville off his stride. The dimensions of his car, however, had been expected to be a factor: Sardinia’s tight, narrow, technical roads don’t suit the new Hyundai, which is the longest World Rally Car in the service park.

“In the twisty sections, it’s not as nimble as the old car,” said Neuville. But the engine? “Oh, that works,” he replied with a big grin, patting the bonnet that shrouds one of the strongest engines in the business.

Staring at the Alghero sunset as Saturday drew to a close, Latvala was resigned to second. Sixteen seconds off P1, clearly the team had talked through the importance of bringing points home to Hannover. With Paddon having crashed heavily on day one, this was a good opportunity to open a bigger manufacturers’ margin – especially with Ogier sitting in third, one place ahead of Hyundai’s Dani Sordo.

“Thierry isn’t scoring points for Hyundai here,” said Latvala, “so his position is very different to mine. I will give it a go, but I can’t take any risks. He can give it everything.”

Latvala wasn’t bleating. He’d given it a go and been beaten. And he, probably more than anyone, understood the position Neuville was in.

And when Sunday came, Neuville was ready. He’d shown the power – now it was about control.

“I admit I was surprised how comfortable I felt in the car here,” he said, “but on the final day I was really able to control the speed. We had more grip than normal on the first time through the stages, because we were running 12th on the road so it was a bit cleaner. But still, everything felt controlled. I think we deserved this. We earned it.”

Gilsoul agreed: “We can smile again. When you are having these [problems] – the loose wire, the fuel, the puncture – it’s like you are in a nightmare. But I never stopped believing. You have to stay strong and I feel this has brought Thierry, me, our friends and management and team all closer and tighter.”

“When we crossed the line we said, ‘Now we have to enjoy it, because we deserve it! And if there is any little bit of negativity left inside then it has to come out now. Push it away.’”

And Penasse? “I am very direct and if he does something which doesn’t please me then I will tell him,” he said. “The Belgian media made a lot out of what we had said. They said Thierry and I don’t get along – that’s not true. I am happy for him.”

“And look how things change: two rallies ago, it was all about Hayden, but now it’s two crashes and it’s not so good for him – the picture is always changing.”

It certainly is; the WRC picture in particular, courtesy of a fifth different winner in as many rallies – the first time that’s happened since 2001.

Latvala’s picture has been prone to distortion as well. He arrived in Sardinia on the back of his own difficult run of results and missed opportunities – the look on his face for much of the pre-event press conference added colour to that picture: arms folded and as close to a scowl as J-ML can muster.

As much as Neuville, Latvala needed big points in Sardinia last week. That the pair were still out front on Saturday >>



WINNING THE BATTLE...

THE TAIL STILL WAGS THE DOG. THE ITALIANS still call the shots. Nothing changes.

Italy's round of the World Rally Championship landed on Sardinia in 2004, after then-series promoter David Richards and his telly-minded whizzkids deemed asphalt rallying too dull. Sanremo had had its day.

At the time, it was impossible not to get caught up in DR's whirlwind. Things were happening, money was being spent and the championship was well and truly on the up. Then DR did one, the manufacturers weren't far behind and downhill we went.

We'd sacrificed one of the best-loved and most historically relevant rounds of the championship for an industrial town and some rocky roads on an island south of Corsica.

That's a bit harsh: Sardinia might not have Sanremo's world-championship pedigree, but the island's Costa Smeralda Rally was – at its peak – a WRC round in all but name. And the roads do that justice.

But it is an island and, soon after Richards' departure, such things were deemed the WRC's devil incarnate. WRC-types told the Italians to return to the mainland quickly if they wanted any hope of maintaining world-championship status. That was about eight years ago. In case you hadn't noticed, we're still here.

And the trouble is, I really quite like it here now. The move from Olbia to Alghero has worked and the series needs this kind of rough, rocky sporting challenge in the absence of the Acropolis.

The entrance to the service park was picture-postcard on Saturday night, with the cars set to a perfect harbourside sunset. But beneath this lovely veneer, there remains a reported rift between the organisers, the FIA and WRC Promoter.

This event still runs the longest, most drawn-out of days despite efforts to bring itself into line with FIA guidelines. But in this waiver-free era, hoops are getting harder to jump through.

Italy will feel it's won the battle to keep itself in Sardinia, but with just about every country in the known universe knocking on the promoter's door with a potential calendar counter, it might well find it loses the war.

I might have said that all before...

DAVID EVANS



Latvala kept the pressure on Neuville, but had to settle for second



night surprised more than a few onlookers, Sordo being one of them.

"It's a good fight, but normally those guys are coming hot up here and then going down here," said Sordo, moving his hand up and down to indicate 'win or bust'.

Sordo finished in fourth. The bottom step of the podium was Ogier's. Extending his championship lead for the sixth event in succession gave the #1 Polo driver something smile about – just.

"The story's the same," Ogier said midway through Saturday. "All I do is fight with those around me: Andreas [Mikkelsen] and Mads [Ostberg]. I'm beating them, so I'm happy."

The last line was delivered almost as a challenge – would anybody dare ask him about the overall position? Deep breath and give it a go...

"What?" he said. "Fight with the leaders? It's not possible. How would it be possible?"

It wasn't possible. Ogier did the best he could, which, it's fair to say, is some way clear of the best the rest could manage. There was an overshoot on the first Sunday stage and a record-breaking run through the powerstage; the world champion became the first man to take the three points after using reverse in the final stage.

Was he distracted? Possibly. But he could be forgiven – his wife Andrea is about to go into labour with their first child, and Ogier had made it plain that he'd be firing up the private jet the minute anyone mentioned the words 'broken' and 'waters' in the same sentence. As it turned out, he was able to finish the rally and make a more leisurely journey to Munich

M-Sport rising star Camilli impressed with maiden fastest stage time



ALL PICS: MCKLEIN



RESULTS ROUND 6/14, RALLY ITALY, JUNE 9-12

POS	DRIVER	CO-DRIVER	TEAM	TIME
1	Thierry Neuville (B)	Nicolas Gilsoul (B)	Hyundai Motorsport N · Hyundai i20 WRC	3h35m25.8s
2	Jari-Matti Latvala (FIN)	Miikka Anttila (FIN)	Volkswagen Motorsport · Volkswagen Polo R WRC	+24.8s
3	Sebastien Ogier (F)	Julien Ingrassia (F)	Volkswagen Motorsport · Volkswagen Polo R WRC	+1m37.8s
4	Dani Sordo (E)	Marc Marti (E)	Hyundai Motorsport · Hyundai i20 WRC	+2m54.0s
5	Ott Tanak (EST)	Raigo Molder (EST)	DMACK World Rally Team · Ford Fiesta RS WRC	+5m26.4s
6	Eric Camilli (F)	Benjamin Veillas (F)	M-Sport WRT · Ford Fiesta RS WRC	+5m59.8s
7	Henning Solberg (N)	Ilka Minor-Petrasko (A)	Ford Fiesta RS WRC	+6m22.2s
8	Teemu Suninen (FIN)	Mikko Markkula (FIN)	Team Oreca · Skoda Fabia R5	+8m57.4s
9	Jan Kopecky (CZ)	Pavel Dresler (CZ)	Skoda Motorsport · Skoda Fabia R5	+9m47.0s
10	Karl Kruuda (EST)	Martin Jarveoja (EST)	Drive DMACK Trophy Team · Ford Fiesta R5	+13m28.5s
11	Martin Prokop (CZ)	Jan Tomanek (CZ)	Jipocar Czech National Team · Ford Fiesta RS WRC	+14m02.9s
13	Andreas Mikkelsen (N)	Anders Jager Synnevaag (N)	Volkswagen Motorsport II · Volkswagen Polo R WRC	+15m53.4s
15	Kevin Abbring (NL)	Sebastian Marshall (GB)	Hyundai Motorsport N · Hyundai i20 WRC	+23m40.6s
24	Roberto Tononi (I)	Paolo Comini (I)	Ford Fiesta RS WRC	+1h00m54.3s
27	Yazeed Al-Rajhi (SA)	Michael Orr (GB)	Yazeed Racing · Ford Fiesta RS WRC	+1h07m07.1s
28	Valeriy Gorbunov (UA)	Volodymyr Korsya (UA)	Eurolamp WRT · Mini John Cooper Works WRC	+1h13m42.9s
R	Mads Ostberg (N)	Ola Floene (N)	M-Sport WRT · Ford Fiesta RS WRC	SS13-driveshaft
R	Lorenzo Bertelli (I)	Simone Scattolin (I)	FWRT · Ford Fiesta RS WRC	SS12-accident
R	Hayden Paddon (NZ)	John Kennard (NZ)	Hyundai Motorsport · Hyundai i20 WRC	SS7-accident
R	Federico Della Casa (CH)	Domenico Pozzi (I)	Ford Fiesta RS WRC	SS7-lost wheel
R	Mait Maarend (EST)	Mihkel Kapp (EST)	Eurolamp WRT · Mini John Cooper Works WRC	SS5-mechanical

than might have been the case.

What of Ogier's nearest challengers? Mikkelsen and Ostberg both fell victim to big rocks on Saturday afternoon. That was particularly frustrating for M-Sport man Ostberg, who found form with the Ford Fiesta RS WRC and had just set a blistering time through Monte Lerno before one of Sardinia's heftier boulders broke a driveshaft, which then broke the engine.

But it was anything but doom and gloom in M-Sport's Cumbria HQ, as Eric Camilli delivered the drive of his life to score his maiden fastest time. The Frenchman would have been a genuine podium contender had it not been for a broken differential on day one.

For once, there was nothing broken for Neuville; quite the opposite. Asked if there had been many moments, the winner thought long and hard (Hyundai's £40,000 fine for running a left-rear window that didn't conform to homologation papers didn't count).

"I had one big slide on Friday," he said, "but that was it." Seriously? "It's true, just one slide. I tell you, this one was under control."

Neuville has always been one of the service park's more likeable characters, which is why the cheer was so loud when he crossed the line on Sunday afternoon.

"His feet," said Penasse, dodging a jet of champagne, "are on the earth again."

Not for long. He and Gilsoul were hurled into the harbour in what has become a traditional Sardinian celebration. Rarely has seawater tasted so good. 🍷

DRIVERS' CHAMPIONSHIP

1 Ogier 132; 2 Sordo 68; 3 Mikkelsen 67; 4 Ostberg 58; 5 Paddon 57; 6 Latvala 56; 7 Neuville 48; 8 Tanak 34; 9 Kris Meeke 26; 10 Camilli 22.

MANUFACTURERS' CHAMPIONSHIP

1 Volkswagen Motorsport 178; 2 Hyundai Motorsport 108; 3 M-Sport WRT 90; 4 Hyundai Motorsport N 78; 5 Volkswagen Motorsport II 74; 6 DMACK WRT 40.



STAGE TIMES

STAGE	FASTEST	LEADER	SECOND
SS1 Ittiri Arena Show (1.24 miles)	Ogier 2m00.4s	Ogier	Latvala +0.3s
SS2 Ardara-Ozieri 1 (4.66 miles)	Latvala 4m06.4s	Latvala	Mikkelsen +2.7s
SS3 Tula 1 (9.32 miles)	Ogier 12m05.3s	Ogier	Latvala +0.6s
SS4 Castelsardo 1 (8.71 miles)	Neuville 10m29.0s	Latvala	Neuville +0.8s
SS5 Tergu-Osilo 1 (9.26 miles)	Neuville 9m47.3s	Neuville	Latvala +1.5s
SS6 Ardara-Ozieri 2 (4.66 miles)	Latvala 4m01.5s	Latvala	Neuville +0.9s
SS7 Tula 2 (9.32 miles)	Neuville 11m46.3s	Neuville	Latvala +3.5s
SS8 Castelsardo 2 (8.71 miles)	Neuville 10m07.7s	Neuville	Latvala +7.7s
SS9 Tergu-Osilo 2 (9.26 miles)	Neuville 9m31.4s	Neuville	Latvala +11.1s
SS10 Monti Di Ala' 1 (13.79 miles)	Abbring 13m34.6s	Neuville	Latvala +11.7s
SS11 Coiluna-Loelle 1 (13.91 miles)	Tanak 14m12.0s	Neuville	Latvala +9.7s
SS12 Monte Lerno 1 (27.50 miles)	Ostberg 29m34.7s	Neuville	Latvala +2.9s
SS13 Monti Di Ala' 2 (13.79 miles)	Neuville 13m11.2s	Neuville	Latvala +13.7s
SS14 Coiluna-Loelle 2 (13.91 miles)	Latvala 13m56.5s	Neuville	Latvala +12.9s
SS15 Monte Lerno 2 (27.50 miles)	Neuville 28m47.1s	Neuville	Latvala +16.1s
SS16 Cala Flumini 1 (8.74 miles)	Neuville 9m08.1s	Neuville	Latvala +19.2s
SS17 Sassari-Argentiera 1 (3.77 miles)	Camilli 4m57.2s	Neuville	Latvala +19.4s
SS18 Cala Flumini 2 (8.74 miles)	Neuville 8m53.0s	Neuville	Latvala +25.7s
SS19 Sassari-Argentiera 2 (3.77 miles)	Ogier 4m50.1s	Neuville	Latvala +24.8s

Will Toyota finally win Le Mans?

Two years after it blew its best shot yet, a revitalised Toyota is showing improved form. Is it enough to put it in contention for the great race – or has it run out of chances?

By Gary Watkins, Special Contributor

[@gazzasportscars](#)





Toyota is the great underachiever in the history of the Le Mans 24 Hours. The Japanese manufacturer has been a glitch away from victory on at least four occasions – it’s almost as if it is jinxed. But it could just be ready to break the spell and bury the disappointments of past failures.

The Toyota Motorsport squad is going into this weekend’s 24 Hours with a chance of victory. It’s not the favourite, as it arguably was in 2014. But, on the other hand, it’s not out of the frame, which was definitely the case this time last year.

It was during the disappointing 2015 campaign – at the double-points round of the World Endurance Championship in the middle of its annus horribilis – that the decision was made to produce an all-new turbocharged engine to replace the long-serving normally aspirated V8. The 2.4-litre direct-injection twin-turbo V6 in the back of this year’s TS050 HYBRID, combined with a move from the six to eight-megajoule hybrid class, has resulted in a massive step forward.

The TS050s gained 2.2 seconds in comparison to last year’s car at the Le Mans test day at a time when the P1 hybrid field is having to deal with a reduction in the per-lap fuel allowance of approximately 7.5%. It cannot be a like-for-like comparison, because the conditions were undoubtedly better at the test this year, but it’s indicative of the progress that’s been made. Engineers for each of the manufacturers agree that the reduction equates to somewhere in the region of four seconds.

Toyota Gazoo Racing, as the team is officially known, ended up behind Audi and Porsche, but not by much. Which is why Toyota technical director Pascal Vasselon felt confident enough to say “we are back in the game” after the test day at the start of this month.

“We always like to be faster, but we are within a second, apart from the #8 Audi, so it is pretty close,” he continues. “In the morning all the cars were within a second on a circuit of 8.45 miles. The manufacturers have come together.”

The best time for a Toyota, a 3m23.197s set by Anthony Davidson right at the end of the four-hour morning period,

“We are within a second so it’s close. We have seen in years before that we close the gap”

was eight tenths shy of Porsche driver Neel Jani’s session best. The Brit did his time on a fresh set of tyres, but neither he nor his team-mates ran on new rubber in the improved conditions of the afternoon.

Sebastien Buemi, who is teamed with Davidson and Kazuki Nakajima in the #5 TS050, was about to go out on a new set of Michelins when a red flag brought the test to an early conclusion. Stephane Sarrazin was due to do likewise in the #6 car he shares with Kamui Kobayashi and Mike Conway.

Vasselon believes that either or both could have dipped into the 3m22s, though he concedes that the 3m21.3s set by Audi driver Lucas di Grassi was out of range.

Toyota also didn’t have an optimised tyre selection for the cooler conditions of the test. “We were between two tyres,” says Vasselon. The tyre choice was made in anticipation of hotter conditions this week.

Vasselon makes another interesting point when he notes that Toyota has, since its return to front-line sportscar racing in 2012, reduced any deficit to its rivals between the test day and race week. Not that he offers an explanation.

“We have seen in years before that we close the gap,” he says. “That is based on statistics, not science.” >>

WEC/TOYOTA

After a miserable 2015 Toyota now has the chance to avenge its agonising 2014 loss



DOLE/LAT

WORKS TEAM: YEAR-BY-YEAR BREAKDOWN

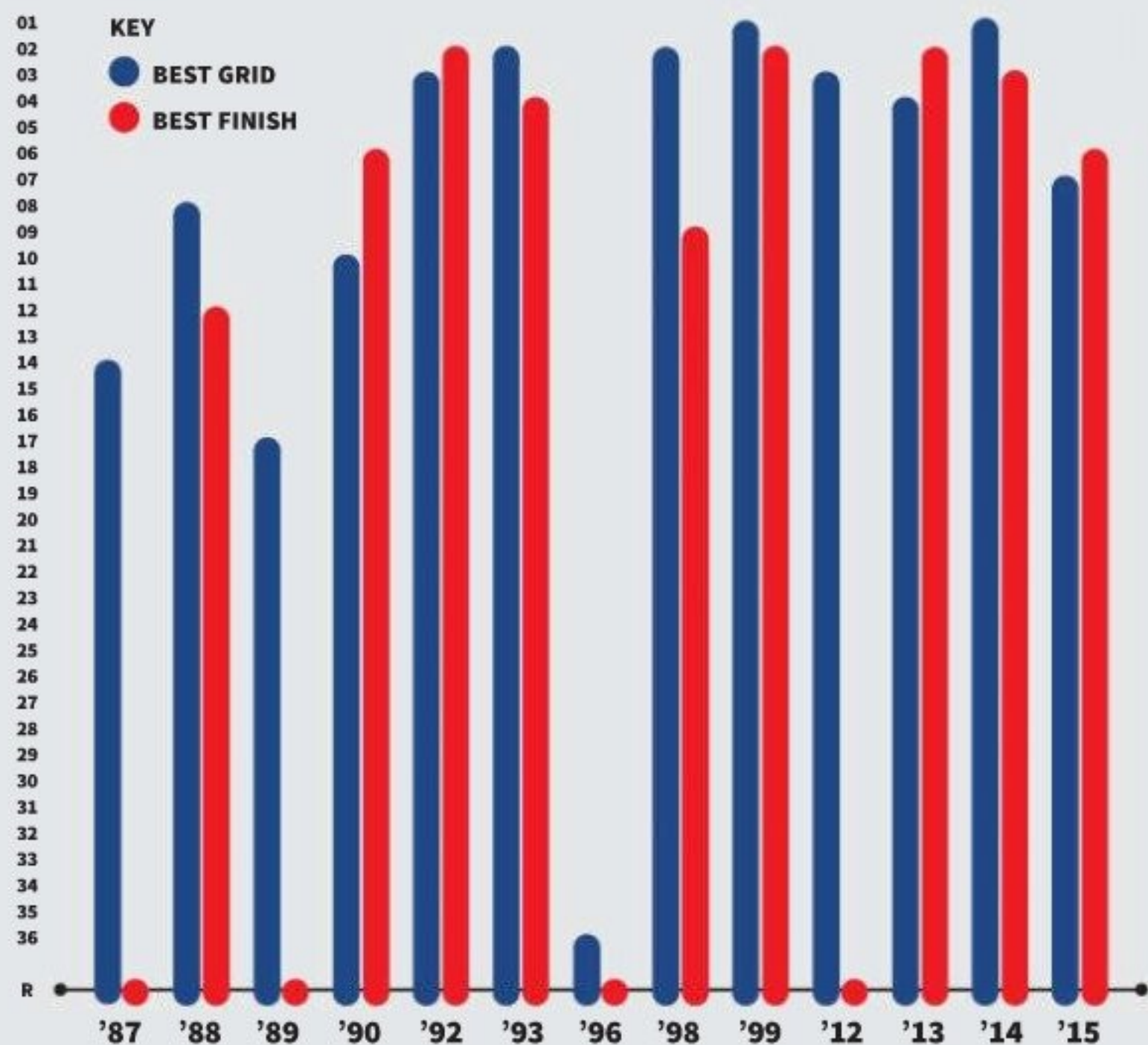

31 PARTICIPATIONS

2 FASTEST LAPS

15 FINISHES

2 POLES

4 PODIUMS

Toyota had no worries over reliability heading into the 24 Hours week, even if engine failure put both of its cars out of the Spa WEC round in May. "We have no major reliability concerns, even if it sounds a bit..." says Vasselon without finishing his sentence. "The engineering data we have doesn't suggest any component is at high risk of failure."

That's no contradiction. Toyota believes it has identified the cause of the Spa failures and is confident they will not reoccur at Le Mans. Analysis suggests that the loads encountered by the engine in compression at the bottom of Eau Rouge will not be replicated around the Circuit de la Sarthe.

That's just as well, because in the month between leaving Spa and arriving at Le Mans, it would, says Vasselon, have been "nearly impossible" to come up with a fix. The remedy will have to wait until next season.

The idea that Toyota is placing more onus on winning the 24 Hours than in previous years is countered by Vasselon. But he does admit that this season's ultra-low-downforce aero configuration is focused more on Le Mans than previous low-drag packages.

"Each circuit has its own requirements in terms of the ratio between downforce and drag," he explains. "You have the majority of the WEC tracks, and then you have Spa and Le Mans. You could decide to do a package that covers Spa and Le Mans, but this time we have a package that is more centred on the Le Mans requirements, which excluded [running it at] Spa. If you include Spa in your Le Mans package, you compromise it."

"It is not a renewed focus, because we have always mainly developed the cars for Le Mans. It is just a refinement of the way we have set the [aero] targets."

This year's Le Mans will not be the last chance for Toyota to win the race, even with its return to its traditional motorsport heartland of the World Rally Championship next season. The manufacturer is committed to the WEC programme through to the end of 2017 and the team is working as though it will continue beyond that.

"We have no end-date to our commitment," says Vasselon. "We are starting on the design of the 2017 car and evaluating the concept for '18 at the same time as discussing the regulations [with the FIA and the Automobile Club de l'Ouest]. Nothing is 100%, but it's a fact that we are starting on 2018."

Toyota's WRC comeback will have no effect on the WEC programme (its motorsport base in Cologne is also developing

Vasselon is measured in his predictions, but plans to take the fight to Porsche and Audi



the engine for the Tommi Makinen Racing-built Yaris).

“They are two disconnected programmes,” says Vasselon. “TMG has no engine resource working on the Le Mans programme [the LMP1 powerplants are developed at Toyota’s Higashi-Fuji technical centre in Japan]. It is two different groups of people, so there is no compromise.”

But Vasselon does concede that funding for the two campaigns “comes back to the same pocket” at company HQ in Japan. Toyota has not dug as deeply into that pocket as P1 rivals Porsche and Audi – that’s what Toyota believes, although at least one of the German manufacturers has begged to differ.

Vasselon talks about a “sustainable level of funding” for what is a research-and-development-led programme at Toyota. “We would like to be here for a long time and if we want to do that we have to maintain a certain level of expenditure; more than that, and we would do it for two years and go,” he says.

Vasselon admits that Toyota’s job is going to get harder as the LMP1 regulations evolve. Three rather than two hybrid systems will be permitted from 2018, which will go hand in hand with the introduction of a fifth megajoule class allowing for 10MJ to be deployed over a lap of Le Mans.

“It is getting harder because the progress rate in the WEC is incredible and we need to feed development with resources,” he says. “You can’t just be cleverer and cleverer. It is getting increasingly difficult to keep pace with the others.”

Toyota is on a par with its rivals on car count, courtesy of the decision made in the name of cost-reduction by its rivals from the Volkswagen Group to field two rather than three entries this year. A three-car team of TS050s was never on the cards for this season thanks to the late decision to switch powerplants – “We would have struggled massively to complete enough spares,” says Vasselon – and appears unlikely for the future.

“It is something we always consider, and every year we look at the budget,” explains Vasselon. “We would like to have the resources to run three cars and develop the baseline car.”

The worry for Toyota, with its limited budget, is that an expanded Le Mans assault would divert resources from car development. That’s why, he says, it “prefers to have two cars that are a bit faster rather than three that are a bit slower”.

Vasselon concedes that the Toyotas may still lag behind their rivals a little over one lap, but he approaches the 24 Hours with a certain confidence. “We expect,” he says, “to be able to race Audi and Porsche.”

1999



LAT

The missed shots

1994 THE GEAR LINKAGE

Toyota had factory representation at Le Mans every year bar one between 1987 and '93, but it finally came close to victory in '94 with a privateer. An updated version of its V8-powered design dating back to 1989 run by the SARD team was on course for victory in the hands of Eddie Irvine, Mauro Martini and Jeff Krosnoff when the gear linkage broke with 90 minutes to go. Krosnoff was able to make a quick fix to get back to the pits and the car ended up second.

1998 FINGER TROUBLE

Toyota could have won in the first year of its most concerted Le Mans campaign ever. The GT-One, developed in the same Cologne factory as today’s TS050, had a performance advantage and the car, driven by Thierry Boutsen, Ralf Kelleners and Geoff Lees, was in front by 40s when the gearbox failed with 80 minutes to go. The car had already undergone two changes of gear cluster and it appears that the sump plug had not been correctly tightened. A lack of gearbox oil did for Toyota.

1999 ERRANT BACKMARKERS

The fleet of reworked GT-Ones fought two separate battles with the ultimately triumphant BMW V12 LMR. The entry in which Allan McNish had joined Boutsen and Kelleners was battling with the leading BMW when it was punted out in the night. The subsequent retirement of the best of the BMWs turned the race into a battle between the surviving cars from BMW and Toyota. Ukyo Katayama, Toshio Suzuki and Keiichi Tsuchiya were arguably on course for a narrow victory before sustaining a puncture after being forced over the kerbs.

2014 THE MELTING SENSOR

Toyota had a narrow but stable advantage over Audi during the night when a problem with an FIA sensor stranded Kazuki Nakajima out on the track. Toyota knew it had a glitch and had just called the TS040 HYBRID, which the Japanese driver shared with Alex Wurz and Stephane Sarrazin, into the pits. The car was a few kilometres short of the garage when the sensor’s loom burnt out. The fix would have taken a couple of minutes – about the same time as the lead it had over the chasing Audi.

1994



LAT

The end of open-top cars at Le Mans

LMP1 racers have long since moved to a coupe design, but this is almost certainly the last year that the open-cockpit format so synonymous with the French enduro will be seen in the 24 Hours. Enjoy the spectacle

By Gary Watkins, Special Contributor

[@gazzasportscars](#)



Savour the moment when you see a Gibson, a Morgan or an old ORECA pass by if you're spectating at the Le Mans 24 Hours this weekend. Do the same if you catch a glimpse of one of those LMP2 machines should you be watching on TV. Squint and imagine just for a moment that you are looking at a Matra MS670, a Porsche 936, a Ferrari 333SP or maybe an Audi R8.

The long history of open-top prototypes incorporating those cars and many more, successful and unsuccessful, will effectively come to an end with this year's 84th running of the French enduro. The field that lines up on the hallowed asphalt of the Circuit de la Sarthe in the middle of June next year will, more likely than not, be made up exclusively of coupes. And quite possibly forever after.

There's a chance that there'll be the odd open P2 on the grid next year. But it's a slim one. Cars built to the existing rulebook will be able to race on for one more season in the World Endurance Championship once a new breed of faster LMP2s comes on stream. How they might be 'grandfathered' to compete on anything approaching equal terms with the new cars is anyone's guess. As one boss of a team still running an open LMP2 in this year's WEC says: "Who's going to spend

a few million quid to be uncompetitive?"

The drive to produce ever-safer cars has spelled the demise of the open format. New chassis rules that came into force in LMP1 in 2014 mandated coupes. The same monocoque regulations are the basis of the new-for-2017 P2 formula. So it's bye-bye 'roadsters'. It was inevitable that P1 would head towards a coupe hegemony – the regulations were already pushing anyone wanting to build a car down that road before the current rulebook arrived two seasons ago.

It wasn't a technical regulation that made Audi bring a line of ultra-successful open-top machinery – culminating with the R15 TDI of 2009-10 – to an end. It was a sporting rule.

The German manufacturer, and in particular its motorsport boss Wolfgang Ullrich, favoured open cars for their ease of use. There was time to be gained in pitstops on the driver changes, something Audi Sport Team Joest frequently did in its early battles with Peugeot at the end of the last decade. There were also fewer concerns about visibility in the rain and no worries about oiled windscreens.

That thinking changed for 2011 when new pitstop regulations were introduced. Limiting the number of mechanics allowed to change wheels to just two, conceived to put emphasis on tyre longevity, removed any advantage of running a roadster when it came to the pitstops. Longer tyre changes meant there was no >>



longer a chance that the drivers would still be fumbling with the belts when the car came down off its jacks.

“The last point in favour of an open car was gone,” says Ullrich. “I’m a fan of open cars, because I like to see the drivers’ helmets, but the situation was clear. A coupe was quicker, safer and more efficient. There was no discussion.”

Ullrich’s talk of efficiency is significant. The coupe shape always offered an aerodynamic advantage. Yet it was slight enough to be overcome by the ease of use of a roadster. But the aero advantage has been amplified through the current decade by an ever-increasing emphasis on efficiency. That has run through the introduction of the 2014 fuel-formula regulations and this year’s reduction in the amount of energy per lap afforded.

The roadmap laid out by the FIA and the Automobile Club de l’Ouest, the promoter of the WEC and organiser of Le Mans, for the evolution of the regulations offers no path for a return to open-top machinery. The rulemakers are committed to the coupe route. Even the ACO’s entry-level prototype class, LMP3, calls for closed cars, but they aren’t coupes in the sense of a Porsche 919 Hybrid LMP1 or a Ligier JSP2 LMP2. A P3 car’s roof isn’t a structural component of the monocoque, rather bodywork over a rollcage that sits atop the carbon tub.

But who knows what the future – the *long-term* future – might bring? Could the ‘halo’ driver protection technology due to be introduced in Formula 1 next year find its way onto a new generation of open prototype some time down the line?

“Could F1’s ‘halo’ find its way onto a new generation of open prototype?”

Or what about Red Bull’s aeroscreen? That’s a concept that is reminiscent of the bubble canopy of the Alpine-Renault A442B that won Le Mans in 1978.

There are no certainties in motorsport, especially in sportscar racing. It’s a branch that has traditionally been prone to cycles of boom and bust, as well as the shifting sands of motorsport politics. My predecessors at Autosport could have written a similar article to this more than 30 years ago when the introduction of Group C in 1982 resulted in the demise of the open-top prototype. Open cars with a capacity less than two litres were allowed to race on for a season. After that, Le Mans and the world championship was exclusively the domain of closed cars until the early years of the following decade.

Group C was at the very least influenced, and perhaps even inspired, by the GT Prototype category introduced for Le Mans in 1976. Championed by race winner and famed journalist Paul Frere, the class was devised by long-time ACO rules boss Alain Bertaut as a road-relevant category, a kind of proving ground for forthcoming GT machinery. Hence the fuel limitation of 35 litres per 100 kilometres, as well as closed bodywork.

The key tenets of the class were at the core of the FIA’s Group C division, although another former Le Mans winner disputes the importance of GTP in the inception of the category that gave us the Porsche 956 and 962. Jurgen Barth, winner of Le Mans in 1977, was head of Porsche’s customer sport division and also president of the Bureau Permanent des Constructeurs Internationale d’Automobile.

He insists that the body behind Group C opted for coupes for two reasons: safety was one and the other was an attempt to rekindle the glory days of sportscar racing of the early ’70s.

“The idea was to go back to cars that looked like the Porsche 917 and the Ferrari 512,” recounts Barth. “People were still dreaming about those cars at that time. I went into the Porsche



Peugeot’s return to Le Mans in 2007 was the first coupe top-tier LMP in years

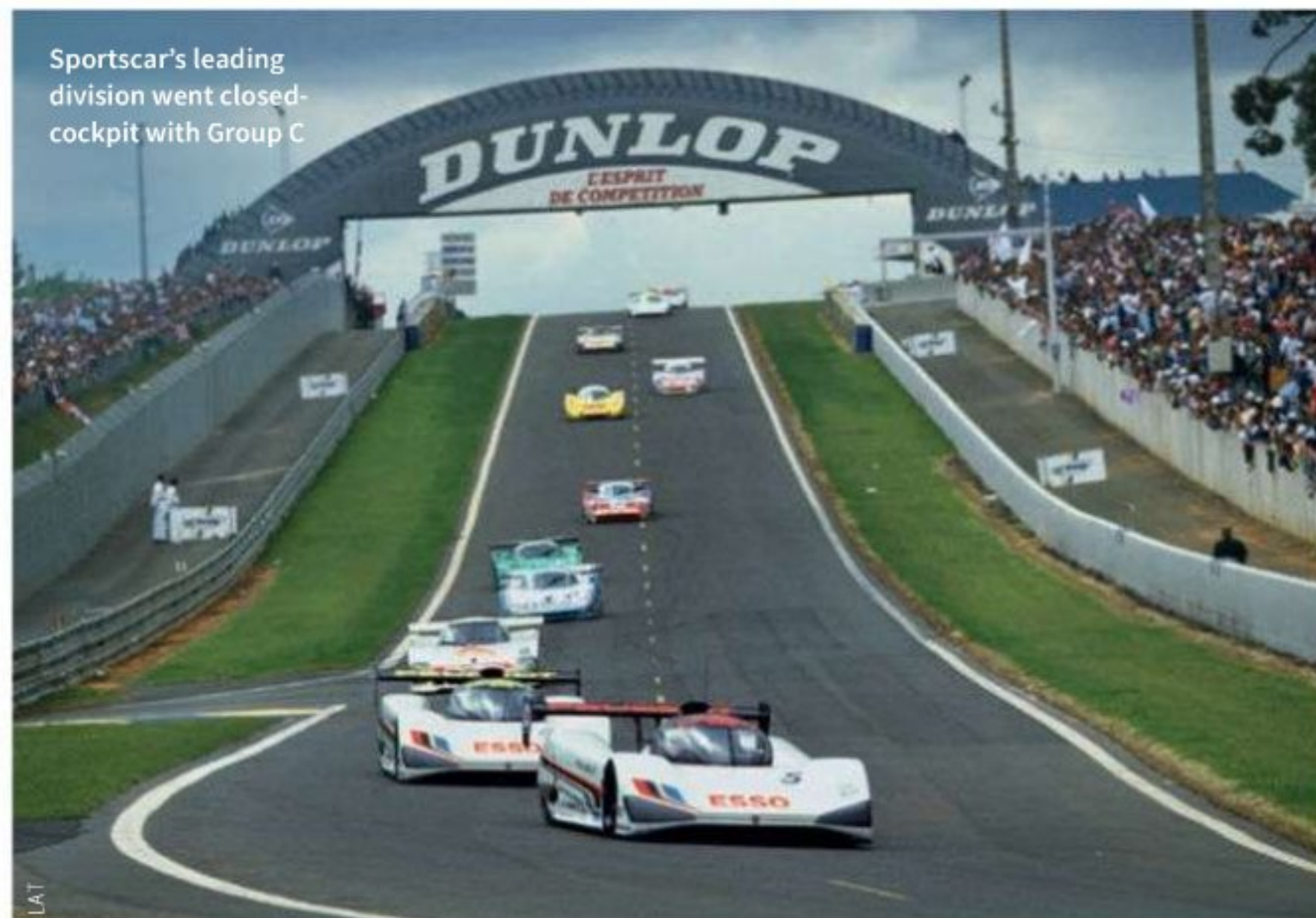

Sportscar’s leading division went closed-cockpit with Group C



museum and measured a 917 windscreen. That's how we ended up with the minimum screen width of 1200mm."

When Group C withered and died in the early '90s the ACO needed a new prototype category. It looked to North America and adopted IMSA's World Sports Car division for 1995, albeit with one or two changes. That meant the premier prototype class at Le Mans was based on a rulebook that called for open cars. IMSA had replaced its own GTP coupe class, which had its roots in the '70s Le Mans category of the same name, for 1994 for a number of reasons. GTP had admittedly been on the wane in the early '90s, but high up on the list of objectives was a reduction in speeds.

"We were going over 200mph at every track we went to except Lime Rock and Sears Point," recalls long-time IMSA man Mark Raffauf, then its president. "There was the idea that by taking the roofs off we would be making them slower because we'd be making them more draggy, which went hand in hand with making them flat-bottom."

The second factor was an impetus to change the cars at a time when the Exxon oil company had come on board as primary sponsor in place of RJ Reynolds' Camel cigarette brand in 1994. "We could have continued with GTP, but there was a desire to come up with something fresh for Exxon," explains Raffauf.

That story suggests it may not be possible to draw a line under the open prototype. History has a habit of repeating itself. "Every 20 years or so, you need a change," Barth says. "We had coupes for a long time, then we came back to open cars and now we have coupes again."

Could the rulemakers come full circle again? Not in the foreseeable future. We know what's around the corner, but you can never be sure what lies in store around the corner after that.

Never say never, but please do cherish the sight of an open car racing at Le Mans this year. You're unlikely to see one again in the 24 Hours any time soon. 🍷

The outgoing open-top LMP2s are the modern incarnation of cars like the Ferrari 333SP

FIVE OF THE BEST OPEN-TOPPERS



MATRA MS670

The MS670 prototype – the culmination of a programme dating back to 1966 – changed sportscar racing. The result of endless testing at Paul Ricard was a hat-trick of Le Mans wins from 1972-74.



PORSCHE 936

Hurriedly developed parts-bin special built to Group 6 rulebook is Porsche's forgotten victor. It won on its first two attempts in 1976 and '77, and in '81 after being pulled out of the museum.



PORSCHE WSC95

A car that started life as a coupe (a TWR Jaguar XJR-14 Group C car) was mothballed in 1995 courtesy of rule changes. Rescued by Joest for 1996, it won Le Mans that year and again in '97.



BMW V12 LMR

The second stab at an LMP by BMW partner Williams came in 1999. The Schnitzer cars took on Toyota, Mercedes, Audi and Nissan and triumphed in a classic open-versus-closed Le Mans confrontation.



AUDI R8

Audi ran both open and closed cars on its debut at Le Mans in 1999. The open route won the internal company debate (if indeed there was one) and the result was the all-new R8 for 2000. Five Le Mans wins would follow.

RACE CENTRE



Logano has made it through to the Chase

Logano beats young upstarts

NASCAR SPRINT CUP
MICHIGAN (USA)
JUNE 12
ROUND 15/36

POLESITTER JOEY LOGANO LED 139 of the 200 laps on the way to his first win of the Sprint Cup season.

Impressive performances from youngsters Chase Elliott and Kyle Larson put them within touching distance of victory, but Logano's excellent restarts meant he had the advantage at the site of his first win for Penske, back in 2013.

Runner-up Elliott came within 0.889s of becoming the first rookie winner of a Cup race in five years, while third-placed Larson's wait for his maiden victory continued.

Reminiscent of the previous Pocono race, a late caution (for contact between Danica Patrick, Casey Mears and Brian Scott) raised concerns over fuel mileage, with range expected to be somewhere around 48 laps. But two subsequent cautions negated those worries, and fuel saving was not an issue.

The 40-strong field entered

uncharted territory, with NASCAR's experimental low-downforce package used in a Cup event for the first time.

The package limits the effects of the front splitter and rear wing in an effort to facilitate easier passing and less turbulent air, and will also feature at the July Kentucky race.

It worked well for Logano, who passed Tony Stewart, Denny Hamlin and Martin Truex Jr within 10 laps after losing the lead at the start.

Kyle Busch's bad luck continued with an engine failure, his fourth race in a row outside the top 30.

RESULTS

1 Joey Logano (Ford Fusion) 200 laps in 2h58m47s; 2 Chase Elliott (Chevrolet SS) +0.889s; 3 Kyle Larson (Chevy); 4 Brad Keselowski (Ford); 5 Kevin Harvick (Chevy); 6 Carl Edwards (Toyota Camry); 7 Tony Stewart (Chevy); 8 Austin Dillon (Chevy); 9 Jamie McMurray (Chevy); 10 Kurt Busch (Chevy). **Chase grid 1 Kyle Busch**
3 wins/417 points; 2 Keselowski 2/480; 3 Edwards 2/472; 4 Jimmie Johnson 2/441; 5 Harvick 1/526; 6 Kurt Busch 1/496; 7 Logano 1/455; 8 Martin Truex Jr 1/433; 9 Matt Kenseth 1/409; 10 Denny Hamlin 1/380; 11 Elliott 0/453; 12 Dale Earnhardt Jr 0/383; 13 Dillon 0/381; 14 McMurray 0/374; 15 Ryan Newman 0/369; 16 Ryan Blaney 0/364.

Colciago's win and sin

TCR ITALY
MISANO (I)
JUNE 11-12
ROUND 2/7

THE INFANCY OF TCR ITALY continues to be all about tin-top and Formula 3 champion Roberto Colciago and his Honda Civic.

Driving for the same AGS Motorsport team that used to run his Audi A4 Quattro in the European Touring Car Championship, Colciago was chucked to the back of both grids for a technical infringement.

Colciago had forced his way up to second place in the opening race when ex-Lamborghini Super Trofeo ace Alberto Viberti retired his SEAT from the lead with transmission problems.

Viberti lasted the course in race two, and picked up the win



afterwards when Colciago was penalised for rather too robust a move to take the lead.

An entertaining scrap for third was won by Romy Dall'Antonia.

RESULTS

Race 1 1 Roberto Colciago (Honda Civic TCR) 16 laps in 28m22.425s; 2 Imerio Briagliadori (SEAT Leon Racer) +22.194s; 3 Samuele Piccin (SEAT); 4 Daniele Verrocchio (SEAT); 5 Marco Costamagna (SEAT); 6 Luigi Bamonte (SEAT).

Race 2 1 Alberto Viberti (SEAT) 16 laps in 28m18.369s; 2 Colciago +4.073s; 3 Romy Dall'Antonia (SEAT); 4 Daniele Cappellari (SEAT); 5 Vincenzo Montalbano (SEAT); 6 Costamagna. **Points 1 Colciago 81;** 2 Viberti 51; 3 Piccin/Dall'Antonia 39; 4 Montalbano 36; 5 Costamagna 27; 6 Briagliadori 23.

Ferrari loses out on double

ASIAN GT
BURIRAM (T)
JUNE 11-12
ROUND 2/6

A PENALTY PREVENTED A Ferrari double as the series visited Thailand for its second round.

Ex-Renault F1 junior Carlo van Dam had led throughout the opening stint in his 458 Italia, and co-driver Piti Bhirom Bhakdi emerged with the lead. But on his home ground Bhirom Bhakdi was given a drivethrough penalty for a breach of the minimum pitstop time limit.

Shaun Thong had suffered brake-pressure problems on his Audi early in the first stint, dropping positions. Marchy Lee took over the

car in fifth place and charged past the Bentleys — which had been started by Duncan Tappy and Adderly Fong — to take the win.

A spin for Davide Rizzo in the first race had set back the Italian and Anthony Liu in race one, but they recovered to win the second in their Ferrari. Tappy was second again, with Lamborghini pair Edoardo Liberati and Andrea Amici next.

RESULTS

Race 1 1 Marchy Lee/Shawn Thong (Audi R8 LMS) 37 laps in 1h00m46.343s; 2 Duncan Tappy/Vutthikorn Inthraphuvasak (Bentley Continental GT3) +4.234s; 3 Adderly Fong/Andrew Kim (Bentley); 4 Carlo van Dam/Piti Bhirom Bhakdi (Ferrari 458 Italia GT3); 5 Davide Rizzo/Anthony Liu (Ferrari 488 GT3); 6 Edoardo Liberati/Andrea Amici (Lamborghini Huracan GT3). **Race 2**

1 Rizzo/Liu 34 laps in 1h01m09.568s; 2 Tappy/Inthraphuvasak +0.992s; 3 Liberati/Amici; 4 van Dam/Bhirom Bhakdi; 5 Alex Yoong/Alex Au (Audi); 6 Tim Sugden/George Richardson (Porsche 911 GT3-R). **Points 1 Rizzo/Liu 55;** 2 Jonathan Venter 45; 3 Inthraphuvasak 40; 4 Lee/Thong & van Dam/Bhirom Bhakdi 39; 6 Liberati/Amici 38.



Stilo ST5 - World's Most Technically Advanced Helmet

ST5 GT ZERO



ST5 FN ZERO



- ☐ Surpasses FIA 8860 and Snell
- ☐ Worlds Lightest Race Helmet
- ☐ Incredibly Strong & Safe
- ☐ Extreme Comfort
- ☐ Smallest Shell Dimensions
- ☐ Improved Air System
- ☐ GT Model with Electronics
- ☐ FN Model with no Electronics
- ☐ Full Range of Accessories



Bespoke fitting service available
Please call for details



info@nickygrist.com
Twitter@nickygrist

Nicky Grist Motorsports

+44 (0) 1981 241 040
www.nickygrist.com

DMAX

RACE AT THE HIGHEST LEVEL





**COMPETE IN THE UK'S FASTEST
ARRIVE + DRIVE CHAMPIONSHIP**

FIND OUT MORE www.daytonamax.co.uk
OR CALL 033 033 278 70

— *Littler's* —

BIG DREAM

“This is about proving that even if you’re disabled, you can still have plenty of scope and opportunities to succeed”



PETE LITTLER

Give your support to PFL Motorsport at the next British GT round and get a signed autograph



PFL MOTORSPORT PROVING DISABILITY IS NO BARRIER

PFL Motorsport is making history in British GT this year, while defying adversity at the same time.

Team founder Pete Littler is the first disabled driver to compete within Britain's premier sportscar championship, handling a 600bhp six-litre V12 Aston Martin Vantage GT3 with rising star Jody Fannin.

A serious accident in 2004 left Littler with life-changing injuries, which included the amputation of his right leg, and multiple operations to fit a false hip and pins in his back and pelvis. Littler is classed as 40 per cent disabled.

Regardless, Littler is determined to make his mark in GT racing, and hopes to inspire other people – both able-bodied and disabled – to challenge themselves.

"This year is a dream for me to be on the grid with so many great drivers and teams, but in truth this year is about more than just racing," says former rally driver Littler.

"This is about proving that even if you're disabled, you can still have plenty of scope and opportunities to succeed.

"It's brought to my attention other people who have adversity in their lives. I've seen a lot of people in dark places, and I've been there myself as I was told I'd never walk again after my accident. I hope that through racing I can show people that you can overcome challenges and deal with the cards life has dealt you.

"I'd love to see more disabled people getting involved in motor sport. The sport's window to help people with disabilities is now wider than ever, with the technology that's available and the support from organisations like the MSA [Motor Sports Association]. For a lot of people who have suffered life-changing injuries it can be easy to think your life is over, but it's about picking yourself up and changing your mindset and reassessing what you can and can't do. You have to keep challenging yourself and pushing boundaries, and that's what racing is about for me."

Littler has worked with Fannin to adapt to the Aston Martin, which runs almost no modifications to accommodate for his false leg and restricted movement. The only change is a modified throttle heel board, which allows Littler to vary the power by sliding his leg back and forth from the thigh.

"Jody is a very talented guy," adds Littler.

"Driving with a false leg is difficult, but we've worked around the drawbacks and when I get into the car, strapped in, helmet on, I feel like anybody else on the grid. I almost forget I have a disability and I feel equal.

"I drive at 100 per cent, and Jody is doing great work bringing me on and coaching me. This is a real team effort, and we succeed together. I'd encourage anybody that faces challenges in life to come down and join us for a race weekend, come be part of it. I just want people to understand that if you're disabled, you are still capable of doing great things. We want to inspire people, and help other people to realise that this sport is about showing and proving what you can do, regardless of the circumstances."



PFL MOTORSPORT

Follow us on:



twitter.com/pflmotorsport



[facebook.com/PFL Motorsport Ltd](https://facebook.com/PFL%20Motorsport%20Ltd)

JODY FANNIN

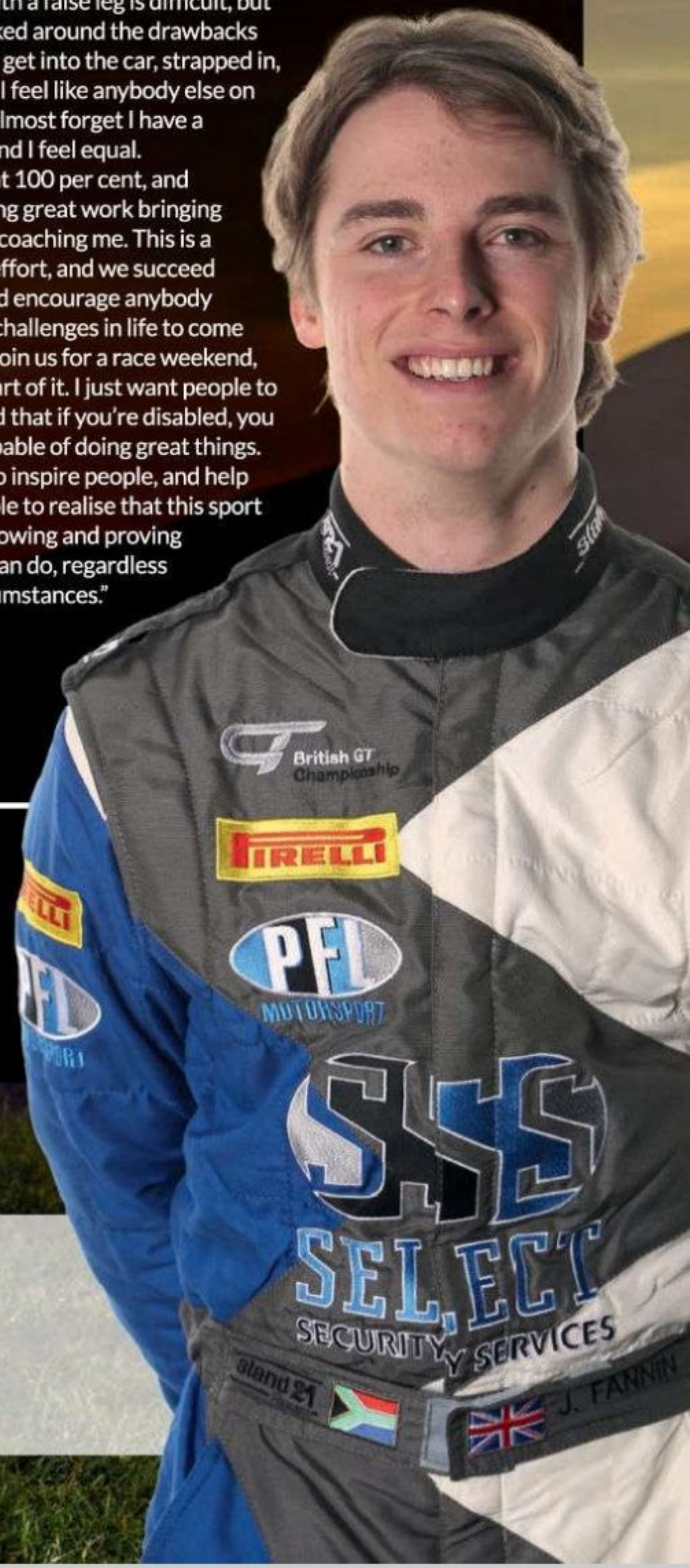

FREE

SEBASTIAN VETTEL OR KIMI RAIKKONEN FERRARI CAP

WHEN YOU SUBSCRIBE TO

AUTOSPORT

SUBSCRIBE ONLINE AT

www.themagazineshop.com/asp/as616m

QUOTE THE PROMOTIONAL CODE

AS616MP FOR PRINT ONLY OR
AS616MW FOR PRINT AND DIGITAL ACCESS.

OR CALL US ON 0344 848 8817

VETTEL

Official Ferrari 2016 Replica Vettel cap. Velcro strap closure at back with number '5' on curved peak. Puma logo and red and green stripe detail. Scuderia Ferrari patch on right side. From the new 2016 Ferrari team wear line.



RAIKKONEN

Official Ferrari 2016 Replica Raikkonen cap. Velcro strap closure at back with number '7' on flat brim. Puma logo and red and green stripe detail. Scuderia Ferrari patch on right side. From the new 2016 Ferrari team wear line.



PRINT SUBSCRIPTION ACCESS
+ FREE GIFT

UNLIMITED ACCESS FOR JUST AN EXTRA £6.25



- ✓ SPREAD THE COST – PAY JUST £34.99 EVERY 13 ISSUES BY DIRECT DEBIT
- ✓ GREAT SAVING – 29% ON THE COVER PRICE
- ✓ FREE P&P – EVERY ISSUE DELIVERED TO YOUR DOOR



- ✓ FULL ACCESS TO autosport.com PLUS SAVE UP TO 53% ON THE COVER PRICE
- ✓ AUTOSPORT iPad EDITION SUBSCRIPTION
- ✓ AUTOSPORT DIGITAL MAGAZINE SUBSCRIPTION

TERMS AND CONDITIONS This offer is open to UK residents only. Overseas rates are available on +44 (0)1604 251 451. Please allow 35 days for delivery of your first issue. Direct Debit rates are valid for one year after which they are subject to change – should prices change we will inform you in writing. Should you wish to cancel your subscription it will be cancelled on expiry of the current term which will not be refundable, other than in exceptional circumstances. If your subscription includes access to autosport.com and the Autosport digital magazine, you can set-up your Autosport online account by visiting www.autosport.com/subs/magazine.html. You'll need to enter your activation code (your subscriber number) along with your email address to access your content. You will be emailed instructions on how to gain access to your iPad edition within 24 hours of your order being processed. Details of the Direct Debit Guarantee are available on request. The gift will be sent under separate cover from the magazine and will not be dispatched until your first payment has cleared. Should we run out of gifts, you will be offered an alternative gift – there is no cash alternative. Savings are based on the standard UK cover price of £3.80 and £2.99 for the digital price. **Offer ends July 11 2016.**

Haymarket Media Group Ltd uses a best-practice layered Privacy Policy to provide you with details about how we would like to use your personal information. To read the full privacy policy please visit our website www.haymarket.com/privacy or call us on 0344 543 8035. Please ask if you have any questions as submitting your personal information indicates your consent, for the time being, that we and our partners may contact you about products and services that will be of interest to you via post, phone, e-mail and SMS. You can opt-out at ANY time by emailing the datacontroller@haymarket.com or by calling 0344 543 8035.



Takaboshi leads from Yamashita

Mardenborough loses a win

JAPANESE FORMULA 3
SUZUKA (J)
JUNE 11-12
ROUND 4/8

NISSAN'S NEW BLANCPAIN GT hopeful Mitsunori Takaboshi continued his cameo comeback in Japanese F3, as stablemate Jann Mardenborough was left to rue the loss of a win to a time penalty.

Mardenborough started the opening race from third, but his B-Max Dallara-Volkswagen soon demoted the TOM'S Dallara-Toyota of Sho Tsuboi to move up into second place. The Welshman then homed in the TOM'S team's series leader Kenta Yamashita.

Going into the chicane on the

sixth lap, Mardenborough made his move, but skipped off the inside kerb. His left-front made contact with the right-rear of the unlucky Yamashita, delaying Mardenborough only a little but putting Yamashita out of the race.

A post-race 40-second penalty gave victory to Takaboshi – who had followed Mardenborough past Tsuboi early on – with another B-Max-run Nissan charge, Katsumasa Chiyo, taking third.

Chiyo chased Yamashita for the lead in race two, before Chiyo made a mistake at the hairpin at half-distance, putting Takaboshi up to second. With the torque of the Spiess-built VW engine particularly strong against the Toyota, Takaboshi

passed Yamashita easily on the main straight for another win. Yamashita then had to fend off Mardenborough, succeeding by 0.4s.

JIRO TAKAHASHI

RESULTS

Race 1 1 Mitsunori Takaboshi (Dallara-Volkswagen F312) 12 laps in 23m08.378s; 2 Sho Tsuboi (Dallara-Toyota F314) +2.162s; 3 Katsumasa Chiyo (Dallara-Volkswagen F315); 4 Tadasuke Makino (D-Toda F314); 5 Keishi Ishikawa (D-Toda F316); 6 Hiroki Ohtsu (D-Mugen Honda F312). **Race 2 1 Takaboshi** 17 laps in 32m48.882s; 2 Kenta Yamashita (D-Toyota F312) +0.993s; 3 Jann Mardenborough (D-Volkswagen F314); 4 Chiyo; 5 Ishikawa; 6 Makino. **Points 1 Yamashita 53;** 2 Mardenborough 43; 3 Tsuboi 41; 4 Daiki Sasaki 29; 5 Takaboshi 23; 6 Chiyo 19.

Formula 4 under way in Spain

SPANISH FORMULA 4
NAVARRA (E)
JUNE 11-12
ROUND 1/7

THE LATEST ADDITION TO THE FIA's roster of F4 series got under way in Spain, with most of the 11-car field of drivers coming from the organising Koiranen GP concern's other SMP F4 contest.

Red Bull's new Dutch protege Richard Verschoor put his name in the history books as the first winner, driving away from a hectic contest for second. This was decided when Jarno Opmeer tried a move on Roope Markkanen, and Alex Vartanyan stole in to blitz them both.

An all-Dutch battle for the lead in



Verschoor: Red Bull fighter in Spain

race two between Verschoor and Opmeer culminated in both drivers running wide, allowing Finn Markkanen his first win in cars.

Verschoor led again in the finale, but suffered a puncture that allowed Tuomas Tujula into the lead. A scrap for second between Opmeer and Xavi Lloveras put the Spaniard out and dropped Opmeer to fourth. Markkanen moved up to second and takes an early series lead.

RESULTS

Race 1 1 Richard Verschoor 16 laps in 27m00.015s; 2 Alexander Vartanyan +4.145s; 3 Jarno Opmeer; 4 Roope Markkanen; 5 Xavi Lloveras; 6 Tuomas Tujula. **Race 2 1 Markkanen** 12 laps in 20m17.989s; 2 Verschoor +0.389s; 3 Opmeer; 4 Vartanyan; 5 Lloveras; 6 Nikita Volegov. **Race 3 1 Tujula** 16 laps in 27m04.647s; 2 Markkanen +2.903s; 3 Juuso Puhakka; 4 Opmeer; 5 Tuomas Haapalainen; 6 Vartanyan. **Points 1 Markkanen 45;** 2 Verschoor 37; 3 Opmeer 37; 4 Vartanyan 34; 5 Tujula 33; 6 Puhakka 18.

IN BRIEF

ITALIAN GT

The BMW Italia M6 of Alberto Cerqui and Stefano Comandini took its first win in the Misano opener when the leading Ferrari of Mirko Venturi suffered a right-rear puncture with three laps to go. Second was the Lamborghini of Mirko Bortolotti and Jeroen Mul, but a rollbar infringement meant exclusion, putting Max Mugelli and Francesco Sini up to second in their Aston. Venturi and co-driver Stefano Gai made up for their first-race heartbreak by taking the second in their Black Bull Swiss-run Ferrari 488. Filipe Albuquerque, in the Audi started by Marco Mapelli, snatched second from Alex Frassinetti's Lambo on the line.

ITALIAN CARRERA CUP

Ex-Formula 4 racer Mattia Drudi, the son of GT veteran Luca, won all three races at Misano. He beat Alessio Rovera in the first, Supercup ace Come Ledogar in the second, and Kevin Giovesi/Simone laquinta in the 'enduro' finale.

NASCAR XFINITY SERIES

Daniel Suarez made some Donald Trump-baiting history at Michigan by becoming the first Mexican-born driver to win a round of any of NASCAR's three national series. He passed the sister Toyota of team boss Kyle Busch with two laps remaining, while Paul Menard was third from Erik Jones.

NASCAR TRUCK SERIES

While the IndyCar field couldn't run its race in Texas, the Friday-night truckers got through their 167 laps, with 18-year-old William Byron (Kyle Busch Motorsports Toyota) pulling a pass on Matt Crafton with five laps to go for victory. Rico Abreu also got past multiple champion Crafton, but brushed the wall, elevating Crafton back up to second ahead of Johnny Sauter and Ben Kennedy.

TCR ASIA

The TCR-spec VW Golf GTI emulated its winning International-series form with Andy Yan taking both races at Buriram in his Team Engstler-run machine. He beat Jack Lemvard (SEAT) in race one and Kevin Tse (VW) in the second.



ALL PICS: GOODEN/DPPH

Well-stocked Lada has high-calorie

WORLD TOURING CAR CHAMPIONSHIP
MOSCOW RACEWAY (RUS)
JUNE 12
ROUND 6/12

SOMETIMES BAD THINGS HAVE TO HAPPEN before good things can.

That was certainly the case for Nicky Catsburg in Russia. On the Thursday before the race weekend at Moscow Raceway, Larbre Competition confirmed that it had picked Jean-Philippe Belloc to fill the final Le Mans 24 Hours seat in its Corvette over the sportscar-turned-touring car ace, while a day later Catsburg and Lada team-mate Hugo Valente had to stop to fix a puncture on their way to the Moscow Raceway circuit before Friday's test session.

The following day Catsburg had claimed his first WTCC pole position, and the day after he backed that up with his maiden win – and all on Lada's home ground.

The Dutchman trailed only the three factory Hondas in Friday's test, but there was better to come on Saturday. Catsburg was fastest in the morning's first practice, and saved his best for a soaking-wet qualifying session. He was imperious, topping all three sessions to claim Lada's first WTCC qualifying pole – and with team-mates Gabriele Tarquini and Valente

second and third, it capped an emphatic afternoon for the Russian marque.

"It couldn't be any better," said a shocked Catsburg. "I didn't expect this at all – to be 1-2-3 with such a gap to the others. It shows that Lada have really made some progress."

The change in weather swung fortunes very much in Lada's favour, so it was perhaps a surprise to find Catsburg just as incredulous 24 hours later after he'd sealed a triumphant win in the damp.

Starts have occasionally proved to be a problem for Catsburg – but not in Russia. He saved arguably his best of the season for the main race and, although team-mate Tarquini's getaway was slightly better, Catsburg converted pole into a Turn 1 lead before stretching his legs.

Or at least he did to start with. Catsburg's lead over Tarquini went out as far as 3.5 seconds, but from lap five he was reeled in by his older team-mate who, first gradually and then rapidly, whittled the gap down to a second with three laps to go.

But Tarquini would get no closer as Catsburg, who was celebrating a year since his debut in the series. He hung on to win, capping a dominant day for the Lada team.

That finish mirrored the pair's opening race result, as Tarquini and Catsburg sliced their way

through the field from the reversed grid in the day's earlier, wetter affair. From ninth, Tarquini made a fantastic start and had made his way into fourth by the time he and the chasing pack worked their way past polesitter Tiago Monteiro's Honda halfway round the first lap, the Portuguese struggling inexplicably in the worst of the day's conditions.

That left Tarquini on the tail of Citroen's double world champion Jose Maria Lopez, but he soon found a way past – albeit brusquely. The 54-year-old had a run on Lopez down the back straight and, while he couldn't make a move stick into Turn 15, his traction off the corner was



Privateer Ficza started with great passes in race two



weekend

far superior, Tarquini shoving Lopez's C-Elysee wide as a result as he claimed third. The move was initially investigated, although the stewards later decided no action need be taken.

He then repeated the move (with less force) successfully on Mehdi Bennani's Sebastien Loeb Racing Citroen and finally Yvan Muller's factory C-Elysee before storming away to claim his 21st WTCC win – his first since Japan in 2014 and Lada's first with its Vesta model.

Catsburg couldn't close in, having spent more time in traffic, but did secure second with a number of standout overtakes – including a sweeping pass around the outside of Monteiro at Turn 3.

Muller's leading margin at the start was enough to guarantee him third, preventing a Lada lockout, with Valente fourth and Lopez fifth.

After its early promise, the weekend was a disappointing one for Honda. Fast in the dry and the drizzle, pace deserted drivers Norbert Michelisz, Rob Huff and Monteiro in the heavier rain that took hold later in the weekend. It solved some of its problems between the two races, with Michelisz claiming third in race two ahead of Huff and Monteiro, but it failed to capitalise on the chance it has waited for all season as Citroen toiled in the midfield.

JACK COZENS



Catsburg and Tarquini know how to wash down a Vesta

RESULTS ROUND 6/12, MOSCOW RACEWAY (RUS), JUNE 12

RACE 1 (15 LAPS – 36.548 MILES)

POS	DRIVER	TEAM/CAR	TIME
1	Gabriele Tarquini (I)	Lada Sport • Lada Vesta	29m39.384s
2	Nicky Catsburg (NL)	Lada Sport • Lada Vesta	+4.782s
3	Yvan Muller (F)	Citroen Total • Citroen C-Elysee	+16.062s
4	Hugo Valente (F)	Lada Sport • Lada Vesta	+23.683s
5	Jose Maria Lopez (RA)	Citroen Total • Citroen C-Elysee	+28.092s
6	Tiago Monteiro (P)	Honda Racing Team JAS • Honda Civic	+28.803s
7	Rob Huff (GB)	Honda Racing Team JAS • Honda Civic	+29.266s
8	James Thompson (GB)	Munnich Motorsport • Chevrolet RML Cruze TC1	+30.164s
9	Mehdi Bennani (MA)	Sebastien Loeb Racing • Citroen C-Elysee	+35.037s
10	Norbert Michelisz (H)	Honda Racing Team JAS • Honda Civic	+43.985s
11	John Filippi (F)	Campos Racing • Chevrolet RML Cruze TC1	+47.000s
12	Tom Coronel (NL)	ROAL Motorsport • Chevrolet RML Cruze TC1	+51.753s
13	Fredrik Ekblom (S)	Polestar Cyan Racing • Volvo S60	+53.227s
14	Tom Chilton (GB)	Sebastien Loeb Racing • Citroen C-Elysee	+59.620s
15	Ferenc Ficzá (H)	Zengo Motorsport • Honda Civic	+1m01.302s
16	Gregoire Demoustier (F)	Sebastien Loeb Racing • Citroen C-Elysee	+1m04.878s
R	Theo Bjork (S)	Polestar Cyan Racing • Volvo S60	6 laps-electrics

Winner's average speed 73.942mph. **Fastest lap** Catsburg 1m57.084s, 75.103mph.

GRID FOR RACE 1 Monteiro; 2 Bennani; 3 Muller; 4 Coronel; 5 Lopez; 6 Michelisz; 7 Thompson; 8 Valente; 9 Tarquini; 10 Catsburg; 11 Huff; 12 Chilton; 13 Ekblom; 14 Demoustier; 15 Bjork; 16 Filippi; 17 Ficzá.

RACE 2 (17 LAPS – 41.433 MILES)

1 Catsburg 33m00.149s; **2** Tarquini +1.011s; **3** Michelisz +13.681s; **4** Huff +20.120s; **5** Monteiro +25.497s; **6** Thompson +29.838s; **7** Valente +30.611s; **8** Lopez +36.168s; **9** Ficzá +37.289s; **10** Bennani +42.772s; **11** Muller +45.498s; **12** Ekblom +54.460s; **13** Demoustier +56.782s; **14** Filippi +1m05.333s; **15** Bjork +1m19.323s; **16** Chilton -1 lap; **R** Coronel 1 lap-rear axle.

Winner's average speed 75.327mph. **Fastest lap** Ficzá 1m53.843s, 77.241mph.

QUALIFYING

Q3 1 Catsburg 1m57.722s; 2 Tarquini 1m59.160s; 3 Valente 2m00.201s; 4 Thompson 2m01.141s; 5 Michelisz 2m01.357s.

Q2 Catsburg 1m57.924s; Tarquini 1m59.093s; Valente 2m00.335s; Michelisz 2m00.336s; Thompson 2m00.401s; 6 Lopez 2m00.561s; 7 Coronel 2m00.826s; 8 Muller 2m00.882s; 9 Bennani 2m00.942s; 10 Monteiro 2m01.073s; 11 Huff 2m01.152s; 12 Chilton 2m01.722s.

Q1 Catsburg 1m59.073s; Tarquini 2m00.411s; Coronel 2m00.621s; Michelisz 2m00.830s; Valente 2m00.882s; Monteiro 2m01.075s; Thompson 2m01.296s; Lopez 2m01.306s; Muller 2m01.411s; Chilton 2m01.730s; Huff 2m01.832s; Bennani 2m02.118s; 13 Ekblom 2m02.373s; 14 Demoustier 2m02.601s; 15 Bjork 2m03.463s; 16 Filippi 2m03.618s; 17 Ficzá 2m04.134s.

CHAMPIONSHIP 1 Lopez 223; 2 Bennani 118; 3 Catsburg 118; 4 Monteiro 112; 5 Muller 109; 6 Michelisz 105; 7 Tarquini 104; 8 Huff 103; 9 Chilton 84; 10 Valente 68.

WEB DIRECTORY

AWNINGS



aireshelta
No1 for Inflatable Structures.
With you from the Paddock to the Podium.
www.aireshelta.com

EQUIPMENT

RACEWEAR & MOTORSPORT EQUIPMENT 



advantage motorsport
www.advantage-motorsport.co.uk

EXHAUSTS

Inconel & Stainless Steel Specialists
SIMPSON
Race Exhausts 
Tel: 01753 532222  
www.simpsonraceexhausts.com

GEARBOXES

Gearboxman.com
COMPETITION TRANSMISSION SERVICES
Gearboxes & Axles for Road, Race, Rally and more
Telephone: 01582 840008 Fax: 01582 840007

HELMET GRAPHICS



visit: www.liquidcolourdesign.com
Studio: +44 028 93378525
Mob: +44 0770 9442894 

liquidcolourdesign
Helmet Paint | Design | Airbrush | Custom Paint

Mike Fairholme Designs
Sole approved painter of Arai helmets.
Silver Birches, Corby Birkholme, Nr Grantham, Lincs NG33 4LE.
Tel: 01476 550630. Fax: 01476 550029.
email: fairholmedesigns@btconnect.com
www.fairholmedesigns.co.uk

MEMORABILIA



FINAL LAP
For Everything Formula One
www.finallap.net **WE BUY AND SELL**
+44 (0) 1245 287588 / 07771 920345

MOTORSPORT LEGAL ADVICE

MOTORSPORT LAWYER
JAMIE CHAMPKIN LL.B
National and International
CALL +44(0)1386 871287 ANYTIME
www@champkin.uk.com
email: info@champkin.uk.com

RACE PARTS



JJC race and rally
PASSIONATE ABOUT MOTORSPORT
www.jjcraceandrally.com

RACE PARTS



ARE DRY SUMP SYSTEMS
ARMSTRONG RACE ENGINEERING INC.
WWW.DRYSUMP.COM (916) 652-5282

RACE RADIO

Pit to Car **Autotel**
Radio solutions **Digital Race Radio**
0044(0)1508 528837 
www.raceradio.co.uk

RACING

Motor Sport Legal Advice
Tudor Alexander, LI.B Solicitor
tudor@fletcherday.co.uk 07887 713512
Fletcher Day 56 Conduit St
Mayfair London W1S 2YZ

RACING



demon tweeks
MOTORSPORT
www.demon-tweeks.co.uk

AUTHORISED DISTRIBUTOR
OMP **YBRACING**
MOTORSPORT & PERFORMANCE
WWW.YBRACING.COM

PORSCHE SHOP
10% off with website
voucher code **AUTOTEN**
Or Call: 0121 585 6088

RACING



CARTEK
MOTORSPORT ELECTRONICS
info@cartekmotorsport.com
023 80 457747
www.CARTEKMOTORSPORT.COM



MARDI GRAS MOTORSPORT
www.mardigras.co.uk



JORDAN RV
WWW.RENTAMERICANMOTORHOMES.COM
08703 008008

TRAILERS & TRANSPORTERS

BRIAN JAMES TRAILERS
» Connected to you
www.brianjames.co.uk

itchy feet
european & american motorhomes
0345 504 5550

WHEELS & TYRES

Image® Manufacturers of bespoke split rim alloy wheels
www.imagewheels.co.uk
IMAGE WHEELS INTERNATIONAL LTD.



TO ADVERTISE IN THE WEB DIRECTORY
PLEASE CALL **020 8267 5271**
OR EMAIL autosport.ads@haymarket.com

BRIAN JAMES TRAILERS

» Connected to you



www.brianjames.co.uk

Ready to Race.

For over 35 years our trailers have been used at every motorsport competition up and down the country by professionals and club racers alike.

This long standing support within racing community has enabled us to engineer the best possible products focused at every level of motorsport.

The brand new Race Sport embraces class leading features along with a class leading price to make it one of the best investments in your motorsport equipment imaginable.

Race Sport 4.5m bed length £ 6,749.00 + vat
Race Sport 5.0m bed length £ 6,999.00 + vat

BJT also offers a wide range of open trailers like the C4 BLUE shown to the right. For more information on our trailer range or to find your nearest dealer visit:

www.brianjames.co.uk/dealer

RACE SPORT



T +44 (0)1327 308 833

For more information and details on the Brian James Trailers range, please contact our head office.



www.WOODFORDTRAILERS.com

HIGH QUALITY TRAILERS FOR CLUB, PRIVATE AND PRO MOTORSPORTS

DEVELOPED BY PROFESSIONALS, FOR PROFESSIONALS



**DEALERS WANTED
IN EUROPE**

**All Woodford Trailers have full
European Type Approval**

We have been designing and building our extensive range of high-quality, adaptable vehicle trailers from our Northamptonshire home for over 20 years, selling at highly competitive prices to suit a wide range of requirements. Please get in touch with us to discuss your needs.

Tel: 01327 263384 ● Mob: 07514 954751 (24 hrs)

● E-mail: sales@woodfordtrailers.com

● Web: www.woodfordtrailers.com

TRAILERS & TRANSPORTERS

PRG TRAILERS *Finest Built British Trailers.*



PRG Trailers | Cheshire | UK | Tel: +44 (0) 1270812402
Web: www.prgtrailers.co.uk | Email: info@prgtrailers.co.uk

AUTOSPORT

IF YOU'D LIKE TO ADVERTISE
YOUR PRODUCTS AND SERVICES
PLEASE CALL

020 8267 5992

Rentamericanmotorhomes.com

Jordan RV ☎ 0870 3008008

Sales, Service, Hire, MOT's, Motorhome Management
At rentamericanmotorhomes.com we pride ourselves on being the UK's premier supplier for American RV's to the Motorsport Industry. We are official partner for Goodwood & Britcar. We are now taking bookings for Le Mans, British GP, BTCC, British GT & many more major events.

Last minute offers for Le Mans 24hrs



FIELDFARE TRAILER CENTRE

Over 100 new and used trailers in stock



Sold to Competitors by Competitors !

Fieldfare Trailer Centre, Salisbury.

With over 15 years of experience in dealing with trailers, we know a thing or two about them. Our expert and professional advice will help you find the right trailer for your requirements. People come from all over the country to see our extensive range for a number of different uses.

- * Sales
- * Trailer Hire
- * Servicing
- * Repairs
- * Parts

Selection of used Brian James Trailers for sale

1. A-Max, 5.0m x 1.96m, 2.6t GVW, £1800 + vat
2. A-Max, 4.3m x 1.96m, 2.6t GVW, £1850 + vat
3. A-Max, 4.3m x 1.96m, 2.6t GVW, £2000 + vat
4. TT Tiltbed, 5.0m x 2.02m, 3.5t GVW, £2500 + vat
5. Covered A-Max, 4.24m x 1.94 x 1.52m high, 2.0t GVW, £3,495 no vat.



BRIAN JAMES TRAILERS

Tel: 01980 611853 info@fieldfaretrailers.co.uk www.fieldfaretrailers.co.uk

The Trailer Warehouse, Ford Farm, Old Malthouse Lane, Ford, Salisbury, Wiltshire, SP4 6DR.



CARS FOR SALE



Toyota MR2 G-Limited £6995

1995 Toyota MR2 G-Limited, raced in the BARC NW Sports and Saloon Car Championship. Quick car in the right hands.

Features:

- Fully stripped out
- All plastic windows except windscreen
- 2 Sets of race tyres
- 1 Set of road tyres
- New exhaust system
- Oil + Filter change prior to last race
- Lightweight radiator
- Lauvers on front quarter panels

Race kit includes:

- Pit board & numbers
- Gazebo

For any more info please feel free to contact me
07593428159

Thanks for checking out the ad!!

Offers considered

9 Heatfield Court, Firtree Grove, Ellesmere Port CH66 2QT

VOLKSWAGEN *Racing Polska*

Only a few cars left



Original VW Golf Cup racing cars for sale. Vehicles were produced in Wolfsburg with maintenance by Volkswagen Racing Polska in cooperation with Volkswagen Motorsport. Special price offer **25 900 euro net** (included 8 extra wheel rims).

After season 2015 of VW Golf Cup all cars were reviewed, parts were changed for new. The cars are in absolutely perfect condition - ready to race! Each car has its own Sport Car Technical Passport, confirmed by Polish ASN affiliated in FIA.

Main specification:

- power 310 hp
- DSG gear box with Limited Slip Differential, steering wheel with paddles
- brakes AP Racing,
- roll cages Wiechers,
- telemetry: AIM – Memotec data logging system with GPS sensors,
- racing aero kit and many more...

More information Volkswagen Racing Polska
info@volkswagenracing.pl + 48 502 343 551 volkswagengolfcup.pl

Renault R26R Megane 2009

My car from new, just 10,000 miles and always stored in a heated garage. Never damaged nor painted, unmarked French blue body and only occasionally used in summer months. Titanium exhaust.

£21950

Call John on:

01462 232 151 or 07860264932



Ferrari 458 Challenge GTR All Carbon Upgrade AeroKit & Power Performance

Quality, precision and fastidious attention to detail



Power upgrade to 620bhp and 4-way adjustable suspension also available

www.evo2motorsport.co.uk

Email: info@evo2.biz | Tel: +44 (0) 1608 730280 | Mobile: +44 (0) 7785 330690





APPLY ONLINE
CHOOSE YOUR OWN START DATE

The WORLD'S FIRST ONLINE Motorsport Engineering Degrees

FdSc Motorsport Engineering | BSc (Hons) Motorsport Engineering



NMA Team - Lotus Evora GTE

Accelerate Your Career In Motorsport!

AFFORDABLE - FLEXIBLE - ONLINE

Who should do this course?

Do you...

- Want to improve your career prospects by becoming a highly qualified Motorsport Engineer?
- Work or volunteer in motorsport without a degree?
- Work in the automotive sector and would like a career change into motorsport?
- Want a motorsport degree but can't justify the time/travel & accommodation costs at university?
- Have work or family commitments & need to earn while you learn while studying for your motorsport qualification?

If you answered YES to any of the above, then the NMA Online BSc (Hons) Motorsport Engineering Degree is the course for you!

*Degrees are awarded by our partner Staffordshire University.



Why Study with NMA?

- 40% lower fees than other universities & access to student loans
- Choose your own start date, no term times or semesters, work at your own pace & study from anywhere in the world
- Mature students welcome - No upper age limit
- Earn while you learn
- No travel or accommodation costs
- Study Online & On-track
- Free industry standard CAD software



Race day experience for students

motorsport.nda.ac.uk

+44 (0)1159 123456

MARKETPLACE

EVENTS

Floral Events 

Bespoke Florist with both Motorsport Hospitality and Product Launch Experience. Prepared to travel throughout UK and Europe, leaving your team to do what they do best.

Contact Julie on
Mobile 07957831398 • Office 01538 308259 or
email Julie@floralevents.co.uk
www.floralevents.co.uk



RACE PRODUCTS

CARTEK
MOTORSPORT ELECTRONICS

Configure yours online now!



POWER CONTROL PANELS

- Made to Customer Requirements for a Plug-n-Play power control solution
- Power Distribution Module and switches incorporated into one unit.
- Reduces your wiring harness and easy to install
- Choice of Current Settings, Functions and Graphics
- Status LED for each channel

www.cartekmotorsport.com

MEMORABILIA

F1 COLLECTORS .COM



#1 FOR F1 MEMORABILIA & AUTOGRAPHS

We buy and sell F1 items
AYRTON SENNA specialists

Call CHRIS GRINT

01763 274448

email:- sales@f1collectors.com

TYRES

FOR ALL YOUR

AVON
TYRES
MOTORSPORT

RACING TYRES

Inc. ACB 10 Formula Ford
Contact

BMTR LTD

Tel: 0121 331 1122

Fax: 0121 331 1144

email: sales@bmtr.co.uk

see our new website at www.bmtr.co.uk

RACE PRODUCTS

Elite Carbon Fibre

Carbon fibre race car component manufacturer

EliteCarbonFibre Ltd.
Units 20-22 Norwich Road Ind. Est.
Watton, Thetford, Norfolk IP25 6DR

Contact – Dave Greenwood 07809390316
Email – davecarbonelite@googlemail.com
Website – elitecarbonfibre.co.uk

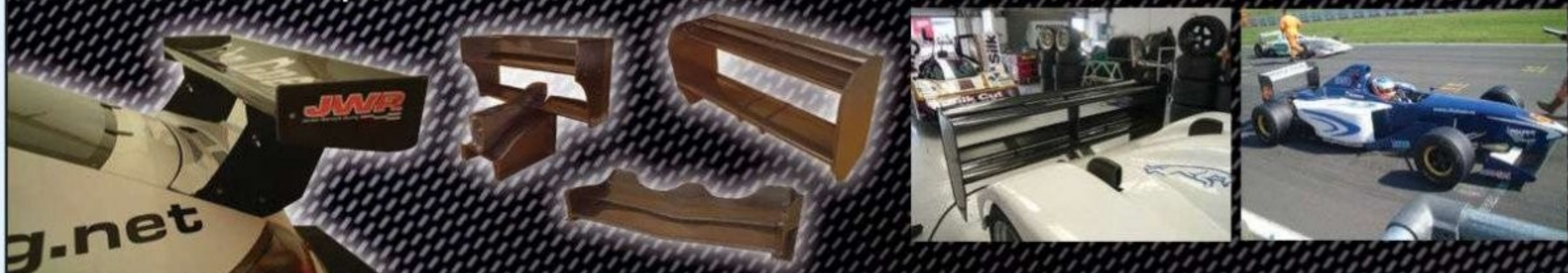

Carbon Composite Wings, Bodywork & Repairs

RACE PRODUCTS

London Motorsport Showroom

www.msar.co.uk



Order Hotline: 020 8655 7877

msar UK agent for **SCHROTH**

Visit Us At Our New Larger Showroom

RACEWEAR

EXPERT ADVICE • MASSIVE STOCK • RAPID DELIVERY

demon tweeks
MOTORSPORT



0844 375 2196
www.demon-tweeks.co.uk

MEDIA CODE:
LZ252A

LOW CALL RATE CALLS
MAY BE RECORDED FOR
TRAINING PURPOSES

MARKETPLACE

RACEWEAR

P1 *ADVANCED RACEWEAR* **MADE FOR DRIVERS**
MADE IN ITALY **BY DRIVERS**

AM *advantage motorsport*
OFFICIAL UK DISTRIBUTOR



X-PRO GT16
£598
Incl VAT



X-PRO COLOUR
£642
Incl VAT



PRO 3
£227
Incl VAT

P1 *Heritage*
PARABOLICA
£597
Incl VAT



GRIP GLOVES
ALL COLOURS STOCKED
£83
Incl VAT



FREE
UK MAINLAND
DELIVERY

www.advantage-motorsport.co.uk
01829 238268
sales@advantage-motorsport.co.uk

Externally stitched, Pre curved design for added comfort

Italian Premium Quality, Best Value For Money

Advantage Motorsport, Oulton Park Circuit, Tarporley, Cheshire, CW6 9BW

FIA COMPLIANT MOTORSPORT BADGES

SPONSORS LOGOS NAME BADGES NATIONALITY BADGES CHAMPIONSHIP BADGES CLUB BADGES



HOT-STITCH
FIA COMPLIANT EMBROIDERED NOMEX BADGES

NO MINIMUM ORDER VALUE
FULL SEWING KIT INCLUDED
QUICK TURNAROUND
ANY IMAGE FORMAT

WWW.HOT-STITCH.COM
01559 372356

MARKETPLACE

KARTING

THE FASTEST WAY TO EXPERIENCE KARTING

KKC and Vital Motorsport are proud to offer you the chance to try out some of the fastest Arive & Drive Karts in the UK for all ages from 6 in Daventry, Northampton

Our different packages are designed for people looking to try before you buy as well as people looking for a one off experience

With Rotax Max 125cc 2-stroke race Karts, that provide 75% more horse power than your standard corporate Kart, and championship winning TonyKart race chassis, this is the pinnacle of Kart racing

Prices starting from just **£125!**

More information and prices online at www.kkckart.com/rotaxexperience



☎ 01327 844320 🌐 www.kkckartshop.co.uk

@martyn@kkckartshop.co.uk 🚲 5 miles from M1 junc.16/18

📍 Whilton Mill, Whilton Locks, Daventry, Northants, NN11 2NH

NUMBER PLATES



Independent Company Providing Private Plates To Public & Trade

TEL: 01257 474746
MOB: 07904 311357

Email: karen@registrationmarks.co.uk

SPECIAL OFFERS

AM 69.....£22,000	A	474 DGM.....£3,500	GNL 74.....£4,000	KRL III.....£5,800	O	47 RMV.....£3,000	7 UNO.....£4,500
38 BB.....£10,300	999 AB.....£9,800	A12 DGD.....£1,300	37 GR.....£9,500	1000 L.....£9,500	OAK 715.....£5,500	P90 RNF.....£700	R10 UNO.....£1,200
BN 66.....£15,200	ACD 560.....£2,800	42 DM.....£23,000	G2 UMP.....£2,400	S9 LCW.....£800	7 OF.....£23,000	ROO2 ERT.....£2,400	500 UOX.....£1,300
1970 C.....£5,000	AJZ 5374.....£450	2 DOG.....£30,000	H	LEE 782.....£3,500	I6 OG.....£8,800	RTL I.....£75,000	V
600 CH.....£12,500	K99 ANA.....£1,000	98 DS.....£18,000	HAM 3R.....£12,000	400 LH.....£9,500	OKM I.....£10,500	RTL 2.....£55,000	VER 73X.....£2,000
750 DL.....£4,700	850 AT.....£6,500	400 DS.....£8,800	HEN I7.....£5,200	8 LJS.....£8,800	6 OOO.....£30,000	RUS 463.....£7,500	P21 VGB.....£1,200
32 EH.....£5,800	I68 ATP.....£1,500	A9 DSD.....£950	38 HGB.....£5,800	55 LL.....£7,000	000 IX.....£8,800	C7 RWG.....£1,800	VJ1 I50.....£950
FUN IT.....£3,000	R20 AVA.....£600	100 DVO.....£3,600	3959 HJ.....£1,300	222 LR.....£7,500	N5 OOO.....£5,000	IRX.....£78,000	VJV 306.....£1,800
20 GJS.....£5,500	AVII ARY.....£3,800	DW 21.....£35,000	R9 HJH.....£1,200	L2 LTY.....£950	F2 OOO.....£5,500	S	7 VJX.....£3,800
GIL 2.....£29,000	AXG.....£13,000	E	HJR IN.....£1,300	R11 LVE.....£950	Y7 OSH.....£1,800	7778 S.....£20,000	935 VPD.....£1,500
HX 1.....£46,000	AXT 8N.....£4,995	C4 EGC.....£7,500	HN 4626.....£1,400	LXS 40.....£2,200	I OTO.....£22,000	SAM 293.....£8,800	VSN I.....£28,000
10 HXH.....£1,750	II B.....£125,000	E10 TTT.....£2,500	II HNS.....£5,000	LYN 554Y.....£4,500	III OTX.....£1,500	MII SBB.....£700	W
JOD I7S.....£3,200	700 BA.....£7,500	ETM 800.....£3,600	AD02 HOD.....£850	M	50 OXH.....£1,500	I SBX.....£13,800	925 W.....£9,800
II JDJ.....£2,800	68 BB.....£10,500	213 EMM.....£2,800	R8 HRD.....£1,200	92 M.....£38,000	P	I2 SAC.....£5,000	WBK 588.....£2,100
24 JRC.....£4,800	M880 BBY.....£2,800	EMW 520.....£2,500	HSK 288.....£1,200	MCA 4N.....£3,500	PAM I32Y.....£1,200	T8 SCS.....£1,500	WGJ3 OXR.....£1,200
1 KX.....£68,000	I01 BH.....£9,000	G7 ENG.....£2,800	HUSICAN.....£4,500	II MCF.....£8,500	450 PAT.....£3,500	J33 SEA.....£7,000	WGS 37S.....£1,500
LOS 10.....£8,500	600 BMC.....£5,500	EP 3582.....£2,500	HU59 CAN.....£4,500	V9 MDT.....£1,200	PAT 228.....£5,500	SEZ 5692.....£150	J7 WHD.....£900
222 LP.....£5,000	190 BMW.....£3,700	EPII ATE.....£1,000	J	21 ME.....£15,000	P6 PBR.....£1,000	I3 SLK.....£5,500	WOW 69.....£15,500
MDS I7.....£5,800	BOB 984.....£8,800	ERR IK.....£12,000	JAG 8T.....£12,000	A10 MFC.....£1,300	PCY I.....£17,000	2 SLR.....£24,000	I7 WRF.....£2,800
30 OJ.....£7,800	BRI0 NEY.....£13,000	F	R100 JAG.....£5,500	MG 4.....£65,000	PE 50.....£22,000	M555 SMG.....£650	40 XKY.....£1,800
73 PS.....£17,500	333 BXS.....£1,000	19 F.....£47,000	II JCD.....£6,500	V8 MGB.....£3,500	362 PG.....£3,800	22 SMR.....£5,000	50 XWH.....£1,500
19 RMS.....£6,800	C	LA55 FAT.....£4,500	4 JCK.....£10,000	MGL 446.....£1,300	PIL 2003.....£6,800	X50UND.....£45,000	I WWW.....£95,000
40 SJX.....£1,600	345 CC.....£11,000	550 FB.....£9,800	10 JDJ.....£2,800	X7 MHB.....£950	PHC 7.....£6,800	SPD 346.....£3,500	X
I28 SM.....£7,000	M12 CFD.....£1,500	R12 FCS.....£650	W18 JEM.....£1,300	MKE I.....£75,000	P6 PBR.....£1,000	SOP 853.....£3,200	28 X.....£30,500
TSE 6.....£5,000	2 CFG.....£8,800	862 FDT.....£1,800	J655 ESE.....£5,800	MKS I.....£35,000	PIL 2003.....£6,800	150 ST.....£8,500	400 X.....£15,500
VVC 2.....£9,800	CGT 3.....£14,500	FDZ 483.....£900	624 JGC.....£1,495	S29 MLE.....£450	7584 PJ.....£1,800	507 PMY.....£2,800	I XAD.....£9,500
92 WM.....£5,500	CLS II.....£7,500	FJ I0.....£25,000	JGL 289.....£980	WI MLW.....£1,995	E10 PLA.....£900	X5 PNE.....£1,600	I XB.....£45,000
WOF 700.....£2,200	N2 CLY.....£1,800	RS54 FER.....£1,300	II JHM.....£6,000	866 MMB.....£2,800	PP I.....£55,000	PP I.....£55,000	I XBC.....£15,500
I WWW.....£90,000	COB 81E.....£8,500	FND ID.....£1,000	JOE 6E.....£5,800	M10 SES.....£3,800	X6 PPD.....£600	PRE 35E.....£2,000	I XD.....£55,000
700 X.....£14,500	COL 374.....£4,500	FP 23.....£8,500	K48 JRP.....£600	P130 MUR.....£800	1996 PS.....£5,500	78 TR.....£8,000	W444 XES.....£950
I YTA.....£5,500	S16 CPH.....£850	R555 FRY.....£1,000	F900 JRS.....£700	R	100 PXP.....£2,500	TRI3 MPH.....£5,500	94 TL.....£6,000
	CS6 289.....£2,500	FU 2.....£195,000	JW 1861.....£3,800	R80 RAK.....£1,200	R80 RAK.....£1,200	78 TR.....£8,000	50 XWH.....£1,500
	26 CTR.....£2,800	G	K	R777 LLY.....£3,000	R777 LLY.....£3,000	150 ST.....£8,500	4 XX.....£40,500
	219 CTR.....£1,500	17 G.....£52,500	K794 KAB.....£600	7 RBR.....£5,500	7 RBR.....£5,500	JJ03 SUE.....£700	XXX 4.....£18,000
		22 G.....£50,000	KCT 961.....£2,000	BI RBW.....£950	BI RBW.....£950	T	Y
		GAC 881.....£3,000	DI KDJ.....£1,200	C17 RDS.....£2,300	C17 RDS.....£2,300	T 25.....£39,000	I4 Y.....£35,500
		I20 GC.....£6,000	15 KF.....£15,000	J30 REP.....£1,300	J30 REP.....£1,300	TI TCH.....£35,000	444 Y.....£9,000
		6 GCD.....£4,800	KH 9064.....£2,800	P99 REY.....£600	P99 REY.....£600	1828 TJ.....£1,900	V10 YDS.....£2,300
		GE 4768.....£2,600	35 KL.....£9,800	RFW 9.....£9,800	RFW 9.....£9,800	TKJ 46.....£3,500	II YLP.....£3,000
		I GFX.....£8,500	660 KO.....£4,800	150 RG.....£6,000	150 RG.....£6,000	94 TL.....£6,000	YSX 88.....£2,000
		I GGY.....£9,500	3 KOR.....£5,500	RGC 943.....£1,800	RGC 943.....£1,800	78 TR.....£8,000	OFFERS
		29 GJH.....£5,000	I KRL.....£19,000	RHA 77.....£5,000	RHA 77.....£5,000	TRN I.....£29,000	CONSIDERED
		200 GM.....£8,800	8 KRL.....£6,800			TUR80G.....£18,500	
		S10 GMX.....£130				G351 TVR.....£1,000	
						TVR 653X.....£1,000	
						U	
						I UDY.....£23,000	
						I UEE.....£8,500	
						M66 UFC.....£1,800	
						UNA 332.....£3,500	

www.registrationmarks.co.uk

MARKETPLACE / MOTORSPORT JOBS

Turn your garage into a showroom



Robust interlocking floor tiles

No messy adhesives

Installation service available

Call **01676 523386** for your no obligation quotation



CHOICE OF 11 ATTRACTIVE COLOURS

DYNOTILE

Typical 20ft x 17ft garage supplied and installed with skirting for less than £1500.00. Installation service not available in all areas of the UK - contact Dynotile for details.

WWW.DYNOTILE.CO.UK

AUTOSPORT

Want to advertise a motorsport job?
If you are recruiting in motorsport and wish to advertise with Autosport in print and online please contact **Jamie.Brooker@haymarket.com** by email or call **020 8267 5271**.

For all current vacancies advertised please visit our website **www.autosport.com**

HYUNDAI Motorsport RACE ENGINEER

As Race Engineer, you will join our Rally Department and take charge of operating one of our WRC car: preparation, optimization, and development in collaboration with the driver, car mechanics and design department.

Main tasks

- Coordinate and support the car crew to prepare the race car prior to each test and race event (documents, set-up instructions, ...)
- Take responsibility of the race car during tests and race events: performance follow-up, team coordination and decision making in high pressure situations
- Ensure the legality and safety checks of the dedicated race car
- Work in close relationship with the driver, co-driver, mechanics and design office to ensure a continuous improvement of the car performances
- Prepare race and test specific documents
- Provide detailed post-events reports, listing possible issues / reasons / improvement potential

Qualifications

- Several years of working experience in competitive motorsport
- University degree in engineering or a comparable qualification
- Good and versatile technical knowledge, working according to high personal standards
- Knowledge of Wintax, Matlab and / or Catia
- Very Good English skills, both spoken and written
- Strong ability to work and take decisions under high pressure
- Proven team player and excellent communication skills

To apply, please send your CV to **jobs@hyundai-ms.com**
Further information about Hyundai Motorsport is available at **http://motorsport.hyundai.com**

Hyundai Motorsport GmbH - Carl-Zeiss Strasse 4, 63755 - Alzenau, Germany



GOODWOOD REVIVAL

"A magical step back in time"

9 • 10 • 11 SEPTEMBER

Find more issues at
magazinesdownload.com

CLUB AUTOSPORT

NATIONAL RACING • HISTORICS • HILLCLIMB • TRACK TESTS • FEATURES



Villeneuve won the 1996 British GP for Williams

EX-SHEENE SUPRA SET TO RUN AT GOODWOOD

THE EX-BARRY SHEENE Toyota Celica Supra will run at the Goodwood Festival of Speed later this month before returning to racing in the hands of new owner Nigel Garrett.

Run by the Hughes of Beaconsfield team for Sheene in the 1985 British Saloon Car Championship, the Toyota has not raced for three decades.

Garrett, who debuted the car at last weekend's Cholmondeley Power and Speed, is expected to share driving duties at Goodwood with Sheene's son Freddie. He then plans to race it.

"I came across it a couple of years ago," said Garrett, who already has several period touring cars in his stable. "I got Gordon Mayers, who was the original team manager for Toyota Motorsport GB, to check it out for me and he said it was the Sheene car.

"Bodywork-wise it was in pretty good condition, but underneath it needed a complete restoration. It's got all the original Group A stuff: brakes, suspension. It just needed a complete refurbishment."

After what proved to be Sheene's final season of racing, the Toyota was sold for rallying before being put into storage for many years. Only four such cars are thought to have been built.

British Grand Prix-winning cars on track at Silverstone Classic

TWO BRITISH GRAND PRIX-WINNING CARS, AND the winner of the 1970 Race of Champions, will be back in action at next month's Silverstone Classic.

Jacques Villeneuve's Williams-Renault FW18, which won the 1996 British GP, and the MP4-16 (right) that Mika Hakkinen drove to his penultimate Formula 1 victory five years later, will be driven in the Classic's Legends of Modern F1 demonstrations.

The cars, both designed by Adrian Newey, are now owned by United Autosports and will be driven by co-founder and owner Zak Brown, who will make his Silverstone Classic debut.

Brown will also race a third machine from United Autosports' collection, having entered a March 701 in the FIA Masters Historic Formula One Championship double-header that forms part of the event's timetable.

The chassis he will race is the same one with which Jackie Stewart claimed victory in the non-championship Race of Champions at Brands Hatch in 1970, driving for Ken Tyrrell's eponymous team. Stewart later drove the

car to second place in the BRDC International Trophy race at Silverstone that year.

"I've yet to compete in the Silverstone Classic, which I've heard is a world-class event," said Brown. "To be able to share three race cars – two of which won the British Grand Prix – with spectators and competitors is awesome. I can't think of a better track to showcase them."



Comprehensive motorsport insurance products to keep you on track;

- ✓ Accident damage On Track
- ✓ Rally damage On Event
- ✓ Storage and Transit
- ✓ Liability
- ✓ Personal Accident
- ✓ Track day

Log on to www.ryanmi.com to obtain your online quote
Email – info@ryanmi.com Tel – +44 (0)1799 524202

Ryan Motorsport Insurance Limited is an appointed representative (557405) of Independent Broking Solutions Limited who are authorised and regulated by the Financial Conduct Authority. Its Financial Services Register number is 312026

RYAN
MOTORSPORT INSURANCE

BRITISH GT

Griffin considers boycott after Silverstone exit



BRITISH GT TITLE CHALLENGER LIAM Griffin is considering sitting out the next round of the championship at Spa-Francorchamps after repeated incidents with cars racing in the combined European GT4 Series last weekend.

Barwell Lamborghini Huracan racer Griffin and co-driver Alexander Sims were taken out of the lead of the Silverstone 500 after contact at Club with a lapped Porsche running in the Euro GT4 category. The collision followed a similar accident with a different GT4 car during second

practice on Saturday, and a hit with another during testing on Friday.

Seventeen cars from SRO's European GT4 class joined the British GT grid to swell the entry to 51 cars. They are also due to share the grid at Spa for the next round on July 8-9.

Griffin said he was considering his future if that was the case: "I was hit three times in three different sessions, which was a joke, and I've ended up with a damage bill of nearly £25,000. That's not good enough.

"The European GT4 guys show no respect to GT3. They don't know how to race with the faster cars as they're used to running on their own. In the race I passed the Porsche through Stowe and was well clear and then he T-boned me like a missile at Vale. It's unbelievable.

"To be fair to SRO they realised there was an issue and called a drivers' briefing, and even highlighted Stowe/Vale as an area of danger, and it still happened. If they [Euro GT4] will be on our grid at Spa I'm considering not going because they're a liability. I'd rather pay a higher entry fee and have a standalone grid as it'll cost me less in damage."

Barwell team head Mark Lemmer, who oversees the Lamborghini Huracans, added: "Liam feels strongly about this and we did see multiple incidents over the weekend. Most GT3 drivers share the same view that they [Euro GT4s] shouldn't be racing with us."

British GT manager Benjamin Franassovici said: "I have sympathy with Liam because he was very unlucky last weekend. We excluded the car that hit him but realise that doesn't bring his race back.

"This isn't the first time we've had guest championships share our grid and we took all available steps to control any driving-standards issues. The race, aside from Liam's unfortunate accident, was largely a success on that front and incidents were minimised.

"Multi-class racing is part of GT and SRO's environment and any incidents were dealt with and punishments handed out. Having big grids with European involvement is a good thing for the strength of the championship."

BRITISH GT

Christodoulou eyeing VLN after return

FORMER BRITISH F3 RACER RIKI Christodoulou is targeting a stint in the German VLN endurance championship this year after joining the ProSport Performance Porsche team at Silverstone last weekend.

Christodoulou was drafted in to share a Cayman Clubsport GT4 with Mike Hansch for the three-hour British GT race. The pair finished seventh in the GT4 European order.

"It was a very late deal, so I had no testing," said

Christodoulou. "My cousin [Nurburgring 24 Hours winner] Adam knows the team well having raced with them, so he suggested I took the seat.

"It's nice to be back out in something as I haven't raced since a one-off in BRDC F4 last year. The Porsche was a nice little car. Despite not being a full GT4 car it handled really well and has some good pace.

"I'd like to grow this and I'll keep talking to the team and hopefully there's a chance of

doing some VLN with them later this year."

BTCC racer Michael Epps was also in action at Silverstone, making his GT4 debut. Epps was a late addition to the entry, sharing a 6.2-litre V8 Sin R1 GT4 with Hendrik Still. The pair failed to finish after Epps was forced into the gravel in his first stint while avoiding an accident in front of him, and the car later suffered a broken steering rack after Still was hit.

BRITISH GT

Mechanics hurt in paddock accident

THREE MEMBERS OF THE PFL MOTORSPORT British GT Championship team were injured in a freak accident when packing up after last weekend's Silverstone 500.

The team was loading its Aston Martin Vantage GT3 into the truck on Sunday when the tail lift failed, dropping the machine back into the garage.

Two team members suffered minor injuries while a third sustained a broken foot.

Silverstone dispatched two ambulances to the scene, one of which was involved in its own accident when it collided with a transport bus on its exit from the circuit medical centre as it responded to the emergency call.

All parties escaped major injury.

PFL team manager Paul Risbridger said: "It was a freak accident and it was very fortunate that nobody was more seriously injured.

"As soon as it happened the marshals and other teams came to help and the circuit medical staff were excellent. Everybody was thoroughly checked out.

"The car sustained quite heavy damage as a result and has been sent back to [Aston GT3 builder] Prodrive for an evaluation."



FORMULA FORD 1600

Byrne quits young-driver scheme

JAKE BYRNE HAS LEFT THE MOTORSPORT Ireland Young Driver programme after failing to find a solution to a lack of pace in the MI-run Van Diemen LA10.

Byrne won last year's Young Driver Award, granting him a fully funded campaign in the BRSCC's Formula Ford 1600 National Championship and other selected events in the UK and Ireland.

But Byrne feels his calls to improve the car have fallen on deaf ears and his pace has not

reflected the performances he produced last year in his own Ray GR13. Byrne pulled out of last weekend's rounds at Rockingham, and will revert to running his own Ray from Brands Hatch (July 9/10) onwards.

"We've been way off the pace," he said. "We tried to find a solution but they [Motorsport Ireland] couldn't find a resolution."

"There was no extra testing offered and they wouldn't let anyone else drive the car to see what the problem was."



BRITISH FORMULA 4

Jamun has no plans to continue in F4

JAMUN RACING WILL NOT contest the rest of the British Formula 4 season, leaving JTR as the only remaining team from the series' British Formula Ford days competing at Croft this weekend.

Drivers Jamie Caroline and Harry Hayek have both left Jamun, which was a British FFord powerhouse, winning seven straight drivers' titles between 2005-11.

Caroline has switched to Fortec Motorsports to fill the seat vacated by Ross Martin while Hayek left after a dispute.

Jamun boss James Mundy said the team would focus on other projects: "We're not planning to run any F4 cars. We would quite like to focus on Kent cars. We're converting a couple of [Duratec] Mygales to Kent engines and we're looking to run a couple."

Jamun's withdrawal leaves a lack of smaller teams in the F4 paddock. Since Carlin, Arden and Fortec entered the series in 2015 – when the FIA F4 Mygale car was introduced – none of the ex-Formula Ford teams has won a race.

"Managing a driver's expectations when faced with outfits like Carlin and Arden makes it a no-go for me," added Mundy.



CLIO CUP

Ciceley drivers handed BTCC test

CICELEY MOTORSPORT'S RENAULT UK Clio Cup drivers will get the chance to test the squad's race-winning British Touring Car Championship Mercedes A-Class.

Drivers Max Coates, Dan Zelos and Ollie Pidgley will all drive the touring car at the end of the current season.

The Clio Cup champion already receives a BTCC test with Motorbase.

Team boss and Ciceley BTCC driver Adam Morgan said: "We put great pride into nurturing our young drivers and really believe this adds significant value to what we can offer those joining our team in future."

IN BRIEF



HIGGINS BEATS HIS OWN TT RECORD

Three-time British Rally champion Mark Higgins beat his own Isle of Man TT course lap record for cars last week with an average speed of 128.730mph in a Prodrive-built Subaru. It was the third time Higgins had attempted the record, having set the previous best times in 2011 and '14.

JACKSON SEALS LE MANS LMP3 DEAL

Rebecca Jackson will fulfil her Project Le Mans challenge this week after securing a place in the Road to Le Mans support race aboard an LMP3 prototype. Jackson will share a Speedfactory-run Ligier JSP3 with Spaniard Jesus Fuster in the hour-long event on the undercard of the Le Mans 24 Hours.

HALL EYES TWO-CAR FORD ENTRY

Experienced Formula Ford 1600 driver Rob Hall plans to set up a two-car team in the National Championship next season and has bought a latest-specification Ray in preparation. Hall plans to race the GR16 in the Brands Hatch National round next month, having shaken it down at Castle Combe at the end of May.

HAMILTON SR TESTS MINI CHALLENGE CAR

Anthony Hamilton, father of triple Formula 1 world champion Lewis, tested a Mini Challenge car at Silverstone earlier this month. Hamilton Sr was bought the test by younger son and former Renault Clio and British Touring Car driver Nicolas as a present. Nicolas said: "It was a thank you for everything he has done for me and my life."

RAIN CURTAILS SILVERSTONE MEETING

The British Racing and Sports Car Club and MotorSport Vision Racing are evaluating ways to try to reschedule lost races after torrential rain curtailed last weekend's GT and F3 meeting at Silverstone. Heavy rainfall delayed the start of the third and final BRDC British F3 Championship race, which was abandoned after stewards deemed conditions to have deteriorated to an unsafe extent. The second Volkswagen Racing Cup and Ginetta Racing Drivers' Club races were also cancelled.



WIN ULTIMATE ACCESS AT THE 2016 FORMULA 1 BRITISH GRAND PRIX



**WIN
ACCESS
TO THE
INNER
SANCTUM
OF
FORMULA
ONE**

Silverstone is giving fans the chance to
WIN THE ULTIMATE MONEY CAN'T BUY EXPERIENCE
at next month's Formula 1 British Grand Prix.

To enter the competition, which is open to all, fans should answer the following question correctly:-

Q ON WHICH DATE IS THE 2016 FORMULA 1 BRITISH GRAND PRIX BEING HELD?

A 01 - 03 July or **B** 08 - 10 July or **C** 15 - 17 July

Text **SILVERSTONE** followed by your answer **A, B, or C** to **82344**
(texts cost £2.50 and 1 standard network message)

**WATCH THE 2016 FORMULA 1
BRITISH GRAND PRIX FROM
WITHIN THE GARAGE OF
A FORMULA 1 TEAM
ON SUNDAY 10 JULY**

**PRIZE
1**

This prize will also include:

- **FULL HOSPITALITY** in the Formula 1 Paddock Club for the day on raceday
- Access to the **FORMULA 1 PADDOCK** on Friday and Saturday of the British Grand Prix weekend.

2 WINNERS PLUS 2 GUESTS

**HOSPITALITY IN THE
FORMULA 1 PADDOCK CLUB
ON RACEDAY SUNDAY 10 JULY**

**PRIZE
2**

- Watch the race in the Silverstone Wing with full hospitality including open bar with champagne
- Four course gourmet meal and exclusive Pit Walk
- This prize will also include access to the Formula 1 Paddock on Friday and Saturday of the British Grand Prix Weekend

3 WINNERS PLUS 3 GUESTS

**ACCESS TO THE
FORMULA 1 PADDOCK
ON FRIDAY + SATURDAY OF THE
BRITISH GRAND PRIX WEEKEND**

**PRIZE
3**

PLUS+ Grandstand seats for all three days of the event.

5 WINNERS PLUS 5 GUESTS

For full terms & conditions go to:
www.silverstone.co.uk/text-win-competition/

FOR FURTHER INFORMATION, VISIT www.silverstone.co.uk or call **0844 3728 300**.

 /SilverstoneUK  /SilverstoneCircuits  /silverstoneuk

Find more issues at
magazinesdownload.com

SILVERSTONE

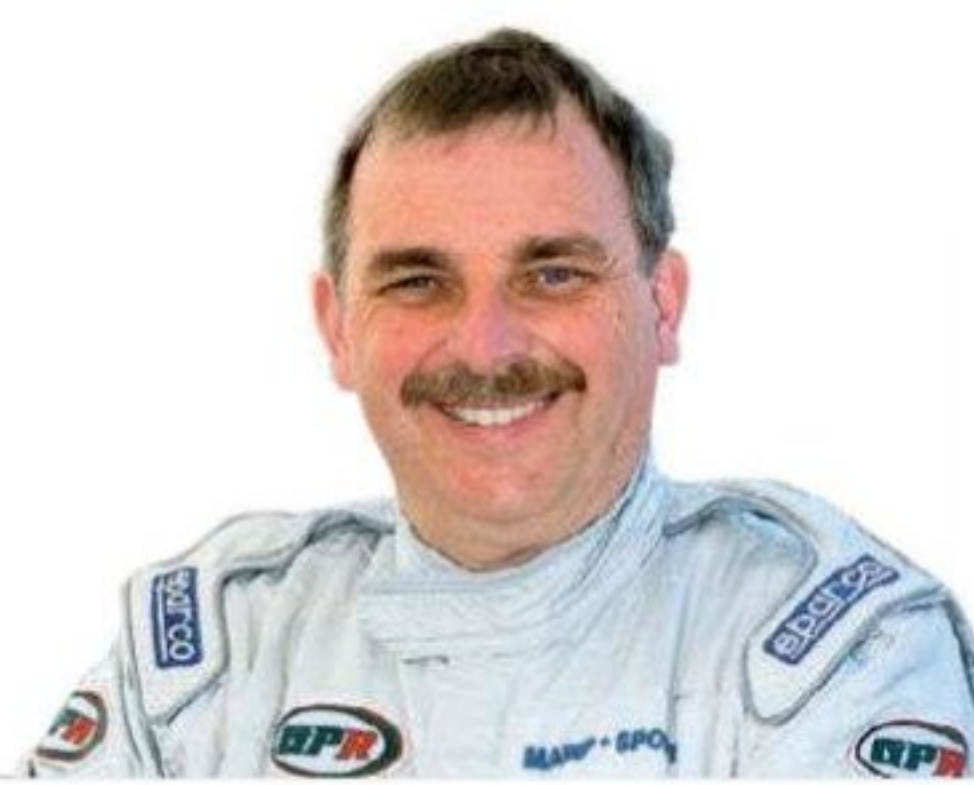

Remembering Swiss legend Jo Marquart

By Marcus Pye, the voice of club racing

[@Autosport](#)

WITH SO FEW MANUFACTURERS BUILDING CARS for one-make formulas, the days of the big-name designer may be gone. Despite many universities offering motorsport engineering degree courses, with a strong take-up for the best graduates in an ultra-professional and technical world, today it's the person who most successfully melds the input of myriad sub-teams who tends to take the credit (or carry the can) for the end product.

Back in the 1950s, when the production racing car industry was in its infancy and Cooper ruled the roost, there was no shortage of suitors to its crown. As aspirants long on ambition yet often short of finance tried to enter the marketplace, being in the right place at the right time and prepared to work all hours for a pittance often brought rewards. Bright ideas and skill at the draughtsman's board counted for a lot; nonetheless many excellent racers were only drawn post-completion. Some not at all.

When Jo Marquart arrived in Great Britain from Winterthur, Switzerland in 1964, a quiver full of technical qualifications underscored by experience with truck and bus maker Saurer was insufficient to procure the motorsport job he craved. Fortuitously, placements with the Scottish Omnibus Company – during which he designed a sports-racer for Tim Wilson (a car now with Richard Bishop-Miller, awaiting restoration) – and Hawker Siddeley ticked the remaining boxes and Jo landed work with Lotus founder Colin Chapman on Elan +2 and racing projects.

Marquart went on to pen McLaren, Huron, GRD, Modus and Argo cars. Despite an often turbulent ride, particularly when he was cash-strapped and running the show, Jo is fondly remembered for his flair, passion and majority of his designs.

I think of him often, particularly when heading to Norfolk, where he built cars for 20 years. His Formula 3 GRD 372 was a world-beater, as were FATlantic Moduses (with the great Tony Brise up), while the F3 Argo JM6 of 1980 was as good as anything in Roberto Guerrero's hands until Ron Tauranac and Rob Wilson made the Ralt RT3 'wing car' work.

Overseas, Marquart products excelled in sports-prototype racing, where Jim Downing's raucous Mazda rotary-engined JM16 and JM19s dominated IMSA's Camel Lights division in the US. A turbo evolution of the JM19 was also sensationally fast in world championship events, of course, when Norwegian rallycross ace Martin Schanche teamed up with the late Will Hoy, an enormously underrated talent taken far too soon by cancer. Jo himself passed away early, stressed but never broken by the rigours of taking on the world, succumbing to a heart attack in 1993. Renzo Zorzi's lucky Monaco F3 victory in '75 remained the race of Marquart's life, as recalled to me in Autosport, July 27 1993.

Jo had a small band of disciples, none more loyal than brilliant engineer Nick Jordan, who stuck with him through thick and thin. Jo was always immensely helpful to me, sourcing my ex-Thierry Tassin Argo JM6 in Sweden – when Tony Broster, Roy Topp and I founded Toyota (now Classic) F3 30 years ago – and repairing its ex-David Sears/Jan Thoeke successor when a suspension-joint failure triggered the biggest shunt of my life at Castle Combe in 1987.

Now, as he would have turned 80, Marquart's life's work can be reviewed on a dedicated website – jomarquart.com – put together by his compatriot Hans Treml, Jo's widow Jackie and friends as a stepping stone towards a book on one of racing's previously unsung heroes. 🍷



PACE F3 LOTUS AT CHOLMONDELEY

Fresh from restoration, Tony Wallen's ex-Carlos Pace 1000cc Formula 3 Lotus 59 was a star of last weekend's Cholmondeley Power and Speed event. Brazilian Pace contested all three British F3 championships in 1970 with the Jim Russell Racing Drivers' School team, winning several races and the BARC's Forward Trust title.



FORMER SALOON STAR GETS RADICAL

Special Saloon/GT star of the 1970s and '80s Doctor David Enderby, 74, won last Saturday's second MSV Allcomers race at Brands Hatch in his 'for-sale' Radical SR4. Son Christian, 43, had taken the opener from pole in it, but David started from the back. "The heavens opened, but it was fun coming through," he said.



MERLYN HORDES V SOLO ELDEN

Four Merlyn-mounted rivals are within a maximum score of Historic Formula Ford points leader Rob Wainwright (Elden, right) going into this weekend's Cadwell Park event. Benn Tilley and Mark Shaw are eight points adrift of Wainwright, while fifth-placed Callum Grant (left), with two wins, has two zeroes to drop.

SILVERSTONE
BRITISH GT JUNE 11-12

Barwell plays itself into title contention with strategic win

A PERFECT STRATEGY EXECUTED IN awful weather combined with expert driving from Barwell Motorsport's Phil Keen and Jon Minshaw elevated the Lamborghini pairing into title contention at Silverstone.

A dramatic three-hour race featured three safety car deployments in the thoroughly inclement conditions, but Barwell responded to the challenges and used the safety cars to its advantage.

Keen won by over 45 seconds, as Barwell made its three mandatory stops and driver changes during the caution periods.

Its first came as early as the opening lap. Torrential rain necessitated a start behind the safety car, handing Minshaw a chance to fight back from 10th on the grid after Barwell had struggled to get the Lamborghini's tyres to work in qualifying.

Bentley drivers Rick Parfitt and Seb Morris continued where they left off at Oulton Park and followed their maiden win with pole position for Silverstone.

Barwell, which had been the Team Parker-run Bentley's closest rival at Oulton, knew it had to try something different, and its first stop had Keen rejoin outside the top 30. But, having avoided losing crucial time in making the stop under yellow, it put the Lamborghini in contention.

"Going for the early stop was crucial," said Minshaw. "We knew we had to join the train of cars at the back and not be lapped to make the most of it."

Pro driver Keen set about working his way back through the order and just over 10 laps later he was into the top 10 – just before the safety car returned to the circuit, after one of the visiting



European GT4 Chevrolet Camaros shed debris onto the circuit.

Keen took the opportunity to pit again, handing back to Minshaw for a lengthy second stint. With two stops done early in the race, Minshaw was able to follow the leading cars knowing they would have to pit more times.

"It was the right call to pit, and after that conditions improved," he said. "[Ross] Gunn, Morris and [Marco] Attard went on ahead but it didn't matter; I had to run my own race."

The final safety car, required when Pete Littler's Aston Martin went off at Stowe,

Safety car pitstops gave Barwell's Keen and Minshaw unassailable lead

Mowle and Osborne were second for second year running, while Carroll (behind) finished third on 488's debut

allowed Minshaw to return the car to Keen for an untroubled run to the flag.

"I didn't have to push at all, as Jon did all the hard work for me," said Keen. "We've always had the aim of winning the championship, but we've not had the results for it. Now we've got the win here, our aim is the same."

While Keen's mirrors were largely empty, the AmD Tuning BMW Z4 of Joe Osborne – who had taken over from Lee Mowle – had to battle its way to second, repeating their result from 2015's running.

AmD planned to mimic Barwell's lap-one strategy, but Mowle had already passed the pitlane entry. After a quick rethink, it instead opted to leave Mowle out as he embarked on a stint fraught with the worst of the conditions.

That weather caught him out early on, as a spin at the exit of Chapel brought him close to hitting the wall. Mowle recovered and stayed within reach of the podium to hand the car over.

Osborne exited the pits and quickly realised their tyre selection was the wrong choice for the weather. The team had fitted slicks too early, prompting an unscheduled fourth stop.

"In the final stint we had slicks on and I told the team three quarters of the lap in that it was the wrong decision," he





said. "We had to pit again and that meant we lost about a minute."

That lost time was quickly made up as Osborne completed a stunning move on Adam Carroll's Ferrari (started by Attard) into Club before overhauling Ryan Ratcliffe's Audi for second.

Carroll's front tyres were fading and he could not respond to Osborne, and he had to be alert to hold off the rapidly advancing McLaren of Rob Bell.

An eight-lap battle between the pair proved to be the highlight of the race, with Carroll narrowly coming out on top to snatch third on the Ferrari 488's first British GT appearance, as he and Bell both passed Ratcliffe on the final lap.

While the podium trio excelled in the rain and in strategic execution, several British GT frontrunners fell victim to the race's events.

Poleman Parfitt followed his warm-up spin with another on the formation lap, and he never seemed comfortable. The team's day was compounded when Morris went off and retired.

The Silverstone 500 also claimed the TF Sport Aston Martin of series leaders Jonny Adam and Derek Johnston. Am driver Johnston caught standing water on the Hangar Straight and hit the wall, putting him out with broken suspension.



GT4 followed much the same pattern as Rob Barrable and Aaron Mason took their maiden win in dominant fashion.

A combination of well-timed stops around the safety cars and an early move to slick tyres gained them the lead. With a pace advantage over the wet-tyred runners, Barrable stroked the Ginetta G55 ahead of Century Motorsport's Nathan Freke and Anna Walewska.

The Century duo again showed their ability to work their way through the field, taking second in British GT4 as fourth GT4 machine home, while the Porsche Cayman of Peter Terting/Joerg Viebahn topped the European contingent.

TOM ERRINGTON

Team Hard duo Barrable and Mason claimed GT4 win

RESULTS

GT3 (69 LAPS) 1 Jon Minshaw/Phil Keen

(Lamborghini Huracan); 2 Lee Mowle/Joe Osborne (BMW Z4) +45.054s; 3 Marco Attard/Adam Carroll (Ferrari 488); 4 Alasdair McCaig/Rob Bell (McLaren 650S); 5 Ryan Ratcliffe/Willie Moore (Audi R8); 6 Phil Dryburgh/Ross Wylie (Aston Martin Vantage).

Fastest lap Osborne 2m04.374s (105.95mph).

Pole Rick Parfitt Jr/Seb Morris (Bentley Continental). **Starters** 18.

Points 1 Derek Johnston/Jonny Adam 97;

2 Minshaw/Keen 85.5; 3 Liam Griffin and Carroll 75.5; 4 Parfitt Jr/Morris 68.5; 5 Mowle/Osborne 68; 6 McCaig/Bell 58.

GT4 (65 LAPS) 1 Rob Barrable/Aaron Mason

(Ginetta G55); 2 Peter Terting/Joerg Viebahn (Porsche Cayman) +17.340s; 3 Nicolaj Moller Madsen/Andreas Patzelt (Cayman); 4 Anna Walewska/Nathan Freke (G55); 5 Jordan Albert/Jack Bartholomew (Aston Martin Vantage); 6 Simon Knap/Rob Severs (BMW M4).

FL Jake Giddings (Vantage) 2m15.206s (97.46mph). **S** 32. **Points** 1 Albert/

Bartholomew 91; 2 Graham Johnson/Mike Robinson 87.5; 3 Walewska/Freke 66; 4 Jordan Stilp/William Phillips 59.5; Barrable/Mason 56.5; 6 Marcus Hoggarth/Abbie Eaton 54.



SILVERSTONE
BRDC FORMULA 3 JUNE 11-12

Leist nabbed his third F3 win after restart

Lucky Leist makes the most of race-one second chance

AFTER DOMINATING AT OULTON Park, championship leader Ricky Collard struggled at Silverstone as Matheus Leist and Toby Sowery split the two wins, with the third race cancelled due to torrential rain and thunderstorms.

Leist started the weekend in excellent form, topping three of the four test sessions on the Grand Prix circuit, but he was pipped to the opening-race pole by a flying Thomas Randle.

A fine margin of just 0.034 seconds split the two in qualifying, but come the race Randle's habit of making impressive starts looked like it would prove costly to the Brazilian's victory hopes.

The Douglas Motorsport-run Aussie made a strong launch as Double R driver Leist spun his wheels and allowed his rival to hold the lead into the first corner, but the race was quickly red-flagged.

Further back at the start, Leist's team-mate Enzo Bortoletto had stalled and Krishnaraaj Mahadik hit the rear of his Tatuus-Cosworth.

On the restart, Leist exploited this second chance with aplomb. Learning from his earlier error, Leist made a far better launch as Randle instead suffered from lack of traction.



"I had wheelspin off the grid on the first start, but on the restart I made a great getaway and was able to take the lead," Leist said. "I was happy to see the red flag, but not to see my team-mate involved in an accident like that."

On the outside of Copse, Leist was able to grab the lead and the returning Lando Norris followed him through into second. That move would prove crucial, and Leist's charge to victory was made

Formula Renault Eurocup leader Norris was fast, but blundered in race one

easier when Norris made a mistake and eliminated himself from the race.

Norris misjudged Becketts, catching the kerb and damaging his car. "I went wide and bottomed out on the exit," he said. "It threw the car up and when I landed it damaged the suspension and I went straight on at the wall. Leist has had a fast weekend, and he'll be tough to catch."

Leist's race-one victory lived up to



Lall collected championship leader Collard, who dropped crucial points

that billing, but Norris returned with a vengeance in the reversed-grid encounter.

Since Formula Renault-committed Norris is out of championship contention, he admitted to being unsure as to whether to aim for the race-three pole – based on fastest laps over the first two races – or to get some practice at working his way through the field.

In the end his mind was made up, as rain made it impossible to set a good laptime. Starting 17th after his opening-race retirement, the Carlin man was scintillating as he pulled off move after move and quickly advanced to second.

Up ahead, Sowery had taken advantage of a battle for the lead between poleman Jan Jonck and Collard to move ahead of them both.

Sowery held a comfortable margin up front and might have rued losing his margin when the safety car was called out, but the full-course yellow ran to the flag. That guaranteed the Lanar Racing man a third win of the season, with all of them coming in reversed-grid races.

The safety car was called after Quinlan Lall crashed into Collard, leaving Lall beached in the gravel at Luffield as Collard continued in worsening weather. That would prove to be the low point of the Carlin driver's weekend, and he finished 13th after taking fourth in the opener.

"Lall ran into me and ruined my championship massively," he said. "Every corner links in here at Silverstone, so if you get out of the sequence it's like being punched twice."

Collard's lead in the championship was effectively halved by closest challenger Randle, who sits 19 points in arrears. Third-placed Leist could have made further ground on Collard in race three after securing pole, but instead trails by 22 points.

TOM ERRINGTON

RESULTS

RACE 1 (6 LAPS) 1 Matheus Leist; 2 Thomas Randle +4.396s; 3 Tarun Reddy; 4 Ricky Collard; 5 Enaam Ahmed; 6 Sisa Ngebulana. **Fastest lap** Leist 1m57.126s (112.50mph). **Pole** Randle. **Starters** 18.

RACE 2 (8 LAPS) 1 Toby Sowery; 2 Lando Norris +1.002s; 3 Leist; 4 Randle; 5 Ahmed; 6 Ben Hingeley. **FL** Sowery 2m10.890s (100.67mph). **P** Jan Jonck. **S** 19.

Points 1 Collard 298; 2 Randle 279; 3 Leist 276; 4 Sowery 259; 5 Ahmed 222; 6 Aleksanteri Huovinen 177.

SILVERSTONE SUPPORTS

OLLIE CHADWICK CAME TO SILVERSTONE ON A roll, having won six of the first eight Ginetta GT5 Challenge races, but he looked unlikely to add to that tally when a fuel-pump fuse blew early in qualifying, stranding him without a time.

It meant Chadwick started 39th in the 40-car field, but he produced a stunning drive to salvage a podium in race one. Chadwick's issues opened the door for Matt Chapman to take an early lead from the group of brothers Jonny and Ryan Hadfield and Matt Flowers. Chadwick managed to vault inside the top 15 within a single lap before a mid-race safety car period stunted his progress.

At the restart Chapman couldn't pull away, and the top five soon ran as one. Their squabbling allowed Chadwick to close in, and his cause was helped further when Chapman slipped down the order after a tangle at The Loop. Jonny Hadfield stole through to lead Flowers home, as Chadwick deposited Ryan Hadfield for third on the last lap.

With Chadwick near the front for the wet second race, the writing was on the wall. Chadwick was into the lead after poleman Jonny Hadfield skated off at Maggotts and then never looked back. Hadfield recovered to take second ahead of Chapman.

Chadwick made it two from three after passing early leader Jack Minshaw in the tricky third event. Jac Constable completed the podium.

Mark Halstead and Stuart McPherson crushed their opposition by lapping the entire Innes Ireland Cup field in their Ginetta G4. The Lotus Twin Cam-powered G4 qualified 11.4s clear of the pack and lapped even quicker, with Halstead stretching out a lead in excess of one minute by the time he stopped for McPherson. Martin Melling and Jason Minshaw led the chase in their Ford Falcon, beating Alex Thistlethwayte's Ford Mustang for second. Josh Sadler and Mark Henderson ran third before their Falcon was forced out with an overheating engine. Robi Bernberg won the 50s Sportscar element after finishing fourth overall in his Cooper.



Chadwick recovered from difficult start for more success

Tom Black won the AMOC Intermarque after a close fight with Christopher Kemp. The two Vantage GT4 drivers each had a spell in front, with Kemp dominating the first half of the race before Black vaulted past after the mandatory stops. Kemp lost time with a mistake, but fought back to finish just 0.6s behind his rival at the flag.

Torrential rain afflicted the Volkswagen Racing Cup, as Phil House won his second consecutive race. Amid a lack of visibility and continuing rain, House held off Bobby Thompson. "It was a real struggle at the end of that," said House.

Thompson hounded the leading Scirocco throughout the entire race, but expert defending meant the Polo driver could only take second ahead of Toby Davis. As conditions continued to worsen, the second race had to be abandoned.

The Ginetta Racing Drivers' Club was also hit by the weather, with a slow formation lap in the rain meaning there was only time for three laps.

Phil Ingram won the short sprint, but he had to work his way back into the lead after second-placed Richard Tetlow had made the superior start.

Ingram returned to the front at Abbey, holding on to take victory in what is quickly turning into a dominant season.

RESULTS

GINETTA GT5 CHALLENGE (6 LAPS) 1 Jonny Hadfield; 2 Matt Flowers +1.254s; 3 Ollie Chadwick; 4 Ryan Hadfield; 5 Ian Robinson; 6 Matt Palmer. **Class winners** Robinson; Richard Evans. **Fastest lap** Chadwick 2m27.918s (89.08mph). **Pole** J Hadfield. **Starters** 40.

RACE 2 (6 LAPS) 1 Chadwick; 2 J Hadfield +4.273s; 3 Matt Chapman; 4 R Hadfield; 5 Jac Constable; 6 Glen Broster. **CW** Broster; Evans. **FL** Chapman 2m46.003s (79.38mph). **P** J Hadfield. **S** 40.

RACE 3 (4 LAPS) 1 Chadwick; 2 Jack Minshaw +5.601s; 3 Constable; 4 Flowers; 5 Steven Wells; 6 R Hadfield. **CW** Mark Davenport; Evans. **FL** Chadwick 2m36.075s (84.43mph). **P** Flowers. **S** 39.

AMOC INNES IRELAND CUP & 50s SPORTSCARS (15 LAPS) 1 Mark Halstead/Stuart McPherson (Ginetta G4); 2 Martin Melling/Jason Minshaw (Ford Falcon Sprint) +2m40.118s; 3 Alex Thistlethwayte (Ford Mustang); 4 Robi Bernberg (Cooper Bobtail); 5 James Cochrane/David Chesney (Lotus Elan 26R); 6 Mark Donnor (Jaguar XK120 LT2). **CW** Melling/Minshaw; Bernberg; Donnor; Nigel Webb/Andy

Wallace (Jaguar Mk7 Saloon); Claire Keith-Lucas (Jaguar XK120). **FL** Halstead 2m30.755s (87.41mph). **P** Halstead/McPherson. **S** 19.

AMOC INTERMARQUE (17 LAPS) 1 Tom Black (Aston Martin Vantage GT4); 2 Christopher Kemp (Vantage GT4) +0.614s; 3 Robin Marriott (Vantage GT4); 4 Desmond Smail (Vantage GT4); 5 Mike Brown/Paul Cripps (Vantage GT4); 6 Steven Byrne/Jerry Bailey (Vantage N24). **CW** James Guess/James Hilliard (Porsche 968CS); Nigel Jenkins (Ferrari 355 Challenge); Leo Voyazides/Simon Hadfield (Ford Mustang); Neil Garnham/Robert Young (BMW M3 GT4). **FL** Kemp 2m20.303s (93.92mph). **P** Kemp. **S** 22.

VOLKSWAGEN RACING CUP (8 LAPS) 1 Phil House (Scirocco); 2 Bobby Thompson (Polo) +0.749s; 3 Toby Davis (Golf); 4 Tom Witts (Golf); 5 Rob Allum (Golf); 6 Kenan Dole (Golf). **FL** Allum 2m42.524s (71.53mph). **P** House **S** 21.

GINETTA RACING DRIVERS CLUB (3 LAPS) 1 Phil Ingram; 2 Richard Tetlow +1.089s; 3 David Holloway; 4 Richard Anderson; 5 Richard Isherwood; 6 Ray Low. **FL** Ingram 3m10.365s (69.22mph). **P** Ingram. **S** 19.

Donington



MASTERS FESTIVAL

SATURDAY 2ND - SUNDAY 3RD JULY 2016 DONINGTON PARK

FIA MASTERS HISTORIC FORMULA ONE CHAMPIONSHIP

MASTERS THREE HOURS | MASTERS PRE-66 TOURING CARS
CANAM 50 INTERSERIE CHALLENGE | 70S CELEBRATION
FIA MASTERS HISTORIC SPORTS CAR CHAMPIONSHIP

Ticket prices start at
£15.00

CHILDREN 13
AND UNDER
GO **FREE***

Book Now! Ticket Hotline
0844 873 7343

[calls cost 7p per minute plus your
company's access charge]

[Advance tickets available to purchase until
5pm Wednesday 29th June 2016]

*When accompanied by a paying adult



Or visit our website www.mastershistoricracing.com

Official Donington Park Racing @DoningtonParkUK @DoningtonPark

SUBSCRIBE TO **AUTOSPORT** FOR ONLY **£6 EVERY 6 ISSUES**



SUBSCRIBER BENEFITS...

- ✓ **JUST £6** for your first 6 issues, thereafter pay only £34.99 every 13 issues
- ✓ **NEVER** miss an issue
- ✓ **FREE** delivery direct to your door
- ✓ **ACCESS TO** subscriber-only offers and discounts

**CALL 03448 488 817 AND QUOTE ASP016 OR VISIT
www.themagazineshop.com/asp/asp016**

Terms & Conditions: This offer is open to UK residents only. Overseas rates are available on +44 (0)1604 251 451. Please allow 35 days for delivery of your first issue. Direct Debit rates are valid for one year after which they are subject to change - should prices change we will inform you in writing. Should you wish to cancel your subscription it will be cancelled on expiry of the current term which will not be refundable, other than in exceptional circumstances. Details of the Direct Debit Guarantee are available on request. Trial offers are limited to 2 trials per title within a 12 month period and we reserve the right to refuse any orders over this limit. Savings are based on the standard UK cover price of £3.70. Offer ends 31st January 2017.

A WORLD OF MOTORSPORT

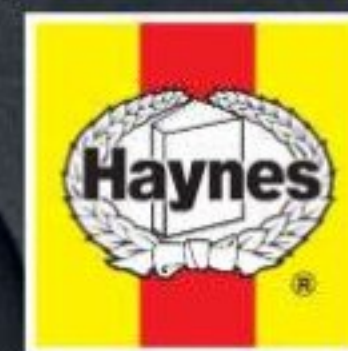

Since 1960

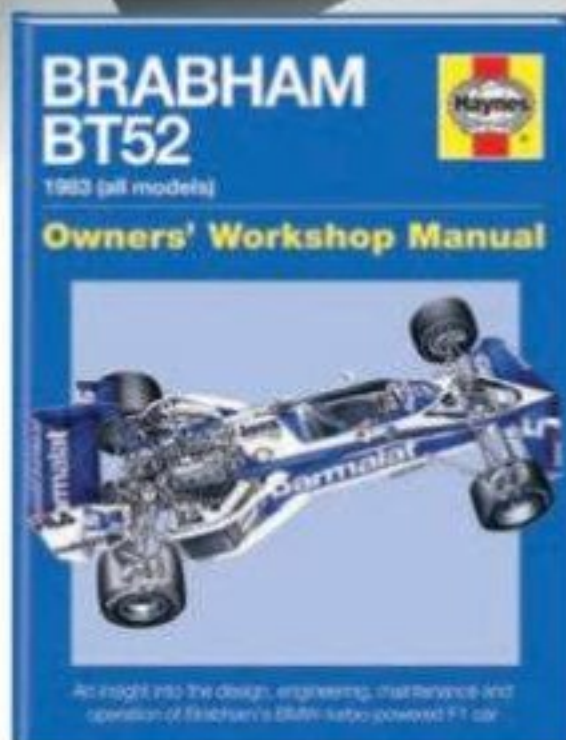

RRP: £25.00

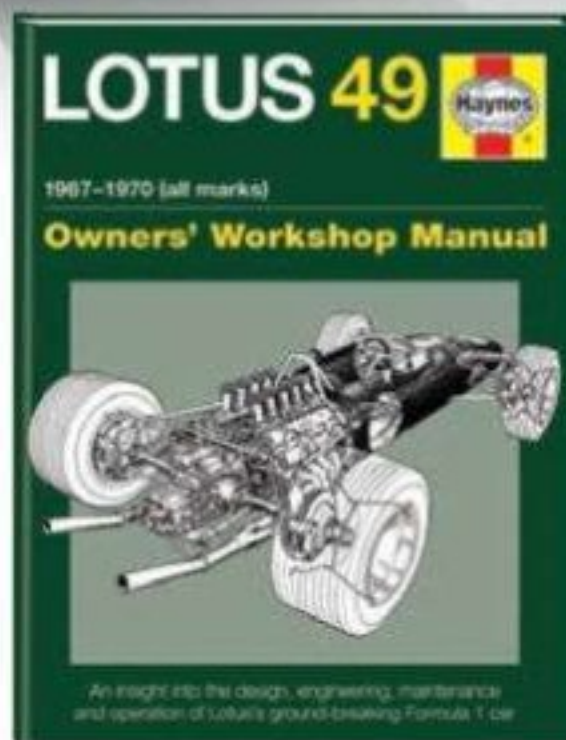

RRP: £22.99

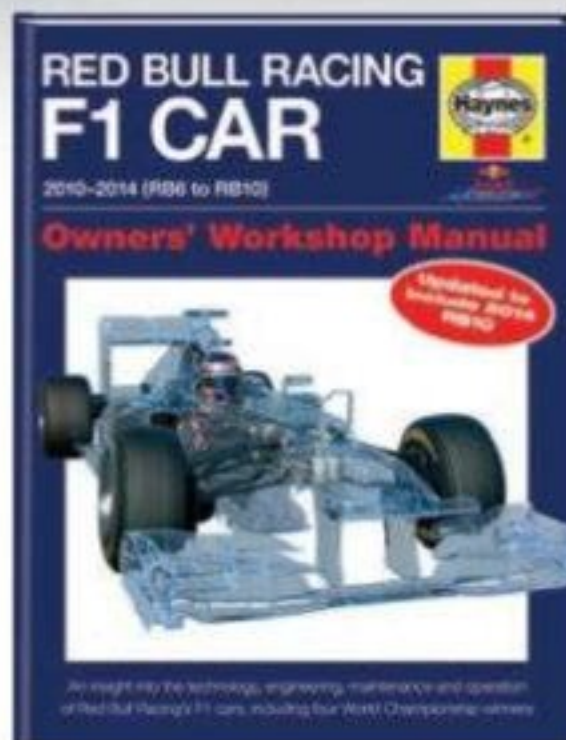

RRP: £22.99

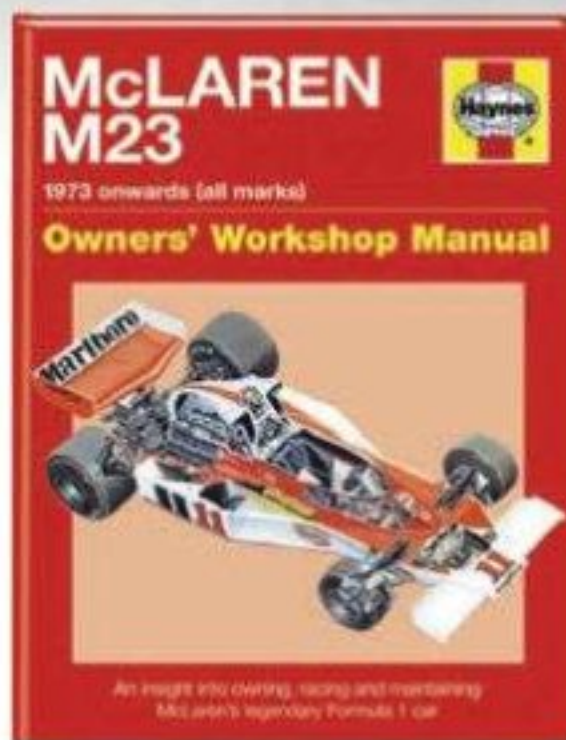

RRP: £21.99

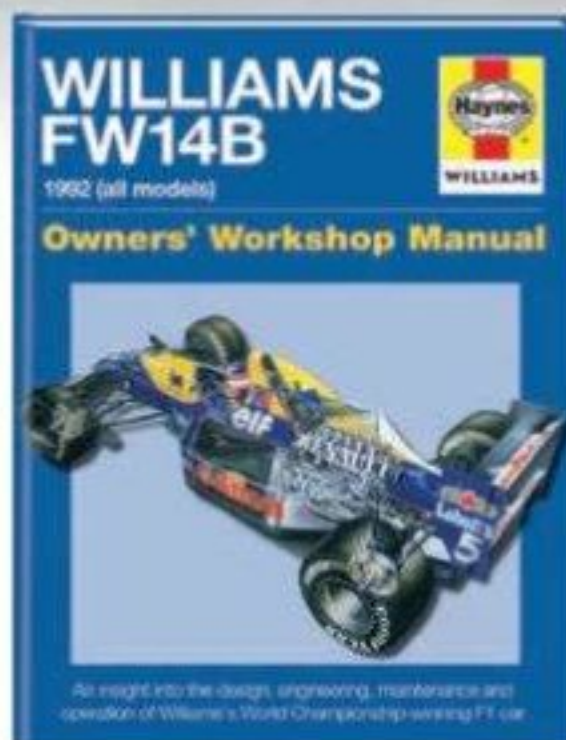

RRP: £22.99

Follow us on:



Available from all good book shops
www.haynes.co.uk
See Haynes See How

WAITING TO BE DISCOVERED



BRANDS HATCH

MSVR AMERICAN SPEEDFEST JUNE 11-12

Kumpen leads the way in American invasion

IT WAS A WEEKEND OF STRUGGLE AND success for the winner of last Saturday's NASCAR Whelen Euro Series Elite 1 race, Anthony Kumpen. Starting from pole, the 2014 champion could not shake off second-place starter Frederic Gabillon, but Kumpen maintained his edge.

His fortunes changed on Sunday, though, after a sudden rain shower at the start. Kumpen made a number of errors and dropped to 10th.

Polesitter Alon Day, who had hoped for a wet race, had Gabillon in close quarters throughout, but Day drove defensively to take his fifth victory.

"In the last four or five laps my tyres were just gone," said Day, who, now 24 points behind Kumpen, admitted that he was beginning to think about the championship. "Gabillon pushed me really hard, so I had to do a lot of blocking."

PK Carsport's Stienes Longin kept his cool in an intense battle for the lead in the first Elite 2 race, finishing clear of Thomas Ferrando and poleman Salvador Tineo Arroyo to take his fifth consecutive victory. Tineo Arroyo fought cleanly in an attempt to regain the lost ground, but was visibly disappointed as he jumped from his car.

Longin's winning streak was halted the following day by Tineo Arroyo, who defended hard from the race-one winner after several safety car restarts. Hugo Bec came home in third but was handed a 30-second penalty for exceeding track limits, handing the spot to Ferrando.

Freddie Hunt had a weekend to forget after finishing in the points at the previous round. The Brit came home a lowly 19th in race one and retired from the second when running in a solid eighth.

John Lyne stormed to victory in the MSVT Trackday Trophy in a race of high attrition. Polesitter George Wright held a comfortable lead over the field in his Porsche 944 until an engine issue forced him to retire, promoting Lyne to first and Dean Hyde into a tight fight for second.

Nick Jackson and Paul Hatton moved into second and third during the mandatory pitstops, with Hyde marooned in the pitlane owing to an uncharacteristic engine failure. Hatton's consistent pace later enabled him to take second, but it wasn't enough to stop the faultless Lyne.

Steven Wood took a hat-trick of victories in all three Bernie's V8s races. Wood dominated from pole in the first two, with the grid for the finale being decided by the organisers to spice things up.

Starting down in eighth place, Wood quickly

fought through the pack of modern and vintage muscle cars, before emerging on top from a battle with Dean Cook's TVR Sagaris for the race lead.

A last-minute overtake on Richard Tarling made it back-to-back victories for Champion of Brands winner Oliver White. Thanks to a lightning start, Andy Charsley took the lead of the race on the opening lap from polesitter White, before admitting he had "overcooked it" at Clearways, handing the lead to Tarling and allowing White through into second.

After being overtaken by White, Tarling immediately slowed on the run up to Druids and later retired the car, promoting Charsley.

Chris Enderby comfortably won the first MSVR Allcomers race in his Radical SR4. Father David Enderby took an impressive victory in the second race of the day, which began under safety car conditions due to a sudden downpour. Starting in a lowly ninth place, David scythed his way through the field, taking the two leading Caterhams of Tony Bennett and Rob Grant, who both struggled for grip in the tricky conditions.

Ex-F1 racer and 1970 British F3 champion Tony Trimmer put his victory down to experience in a very wet Anglo American 5000s race filled with spins. The circuit dried out for the second race and a close battle for the lead developed among the top four cars. After spinning on a patch of oil in the opening laps, Gregory Thornton fought back to victory in his Surtees TS11, with race-one winner Trimmer coming home a lonely fourth.

Lewis Smith looked as though he had sealed a double victory in the SpeedFest Silhouettes, until he became the first of many to retire with mechanical failures in race two. This promoted Chris Brockhurst into the lead, only for the Vauxhall Tigra driver retire with three laps to go, handing victory to Malcolm Blackman.

CAMERON TAIT



Trimmer overcame tricky conditions to win first F5000 race

RESULTS

NASCAR WHELEN EURO SERIES - ELITE 1 (BOTH 30 LAPS) 1 Anthony Kumpen; 2 Frederic Gabillon +0.342s; 3 Alon Day; 4 Marc Goossens; 5 Borja Garcia; 6 Freddy Nordstrom. **Class winners** Day; Eric De Doncker. **Fastest lap** Day 49.053s (88.65mph). **Pole** Kumpen. **Starters** 24.

RACE 2 1 Day; 2 Gabillon +0.132s; 3 Goossens; 4 Garcia; 5 Wilfred Boucenna; 6 Nicolo Rocca. **CW** Gabillon; De Doncker. **FL** Gabillon 55.147s (78.85mph). **P** Day. **S** 23.

ELITE 2 (BOTH 30 LAPS) 1 Stienes Longin; 2 Thomas Ferrando +0.734s; 3 Salvador Tineo Arroyo; 4 Guillaume Deflandre; 5 Hugo Bec; 6 De Doncker. **CW** De Doncker; Riccardo Geltrude; Erika Monforte. **FL** Arroyo 49.689s (87.50mph). **P** Arroyo. **S** 25.

RACE 2 1 Arroyo; 2 Longin +0.622s; 3 Ferrando; 4 Riccardo Geltrude; 5 De Doncker; 6 Gardel. **CW** Geltrude; De Doncker. **FL** Ferrando 49.975s (87.01mph). **P** Tineo Arroyo. **S** 24.

MSVT TRACKDAY TROPHY (45 LAPS) 1 John Lyne (VW Golf); 2 Paul Hatton (Ford Focus) +26.441; 3 Nick Jackson (Golf); 4 Oliver Owen (Renault Clio 182); 5 David Phillips/James Watson (Toyota MR2); 6 Simon Gerrard/Giles Lock (Golf). **CW** Phillips/Watson; Steven Kelly (Clio); Colin Tester (Ford Puma); Paul Hatfield/Tristan Potkins (Puma). **FL** George Wright/Jack Wright (Porsche 944) 56.548s (76.90mph). **P** G Wright/J Wright. **S** 28.

BERNIE'S V8s (13 LAPS) 1 Steven Wood (Ford Mustang); 2 William Smallridge (Sunbeam Tiger) +7.109s; 3 Simon Cripps (MGB GT V8); 4 Tim Davis (TVR Tuscan); 5 Dean Cook (TVR Sagaris); 6 Peter Samuels (MGB GT V8). **CW** Peter Samuels (MGB GT V8); William Shepherd (Mustang). **FL** Wood 59.002s (73.70mph). **P** Wood. **S** 26.

RACE 2 (15 LAPS) 1 Wood; 2 Cook +4.532s; 3 Cripps; 4 Samuels; 5 Davis; 6 Tom Frans (Dodge Challenger). **CW** Samuels; Shepherd. **FL** Cook 59.730s (72.80mph). **P** Wood. **S** 32.

RACE 3 (23 LAPS) 1 Wood; 2 Cook +1.123s; 3 Davis; 4 Cripps; 5 Alec Livesley (Jensen Healey); 6 Graham Walden (TVR Tuscan Challenge RV8). **CW** Livesley; Shepherd. **FL** Cook 51.68s (84.24mph). **P** Livesley. **S** 27.

CHAMPION OF BRANDS (14 LAPS) 1 Oliver White (Van Diemen RF01); 2 Andy Charsley (Ray GR15) +6.496s; 3 Jason Down (Getem Mygale); 4 Rory Smith (Van Diemen RF88); 5 Brian Soule (Van Diemen RF88); 6 Lucy Wardrop (Van Diemen RF01). **FL** Charsley 54.515s (79.76mph). **P** White. **S** 11.

MSVR ALLCOMERS (25 LAPS) 1 Chris Enderby (Radical SR4); 2 Gary Bate (Caterham CSR) +27.692s; 3 Richard Fearn (Radical SR8); 4 Rob Grant (Caterham C400); 5 Tony Bennett (Caterham R300); 6 Tim Davis (TVR Tuscan). **FL** Enderby 45.152s (90.30mph). **P** Enderby. **S** 18.

RACE 2 (16 LAPS) 1 David Enderby (SR4); 2 Ross Craig (Honda Civic Type R) +1.574s; 3 Bennett; 4 Grant; 5 Gus Desbarats (Ariel Atom Cup); 6 Wil Arif (Caterham Roadsport). **FL** Fearn 57.909s (75.09mph). **P** Bate. **S** 18.

ANGLO AMERICAN F5000s (12 LAPS) 1 Tony Trimmer (McRae GM1); 2 Steve Farthing (Lola T332) +7.608s; 3 Gregory Thornton (Surtees TS11); 4 Adrian Hall (Trojan T101); 5 Christopher Atkinson (Surtees TS8); 6 Michael Sidgwick (Trojan T101). **CW** Farthing. **FL** Trimmer 1m01.368s (70.86mph). **P** Thornton. **S** 8.

RACE 2 (17 LAPS) 1 Thornton; 2 Hall +2.114; 3 Neil Glover (Chevron B37); 4 Trimmer; 5 Atkinson; 6 Neil Daws (Lola T332). **CW** Hall. **FL** Thornton 50.531s (86.05mph). **P** Trimmer. **S** 8.

SPEEDFEST SILHOUETTES (14 LAPS) 1 Lewis Smith (Vauxhall Tigra); 2 Malcolm Blackman (Tigra) +3.632s; 3 Chris Brockhurst (Tigra); 4 Steve Burrows (Peugeot 206cc); 5 Keith White (BMW Z4); 6 Reuben Taylor (206cc). **CW** White. **FL** Smith 59.856s (72.65). **P** Blackman. **S** 17.

RACE 2 (18 LAPS) 1 Blackman; 2 White +2.439s; 3 Burrows; 4 Simon Smith (Z4); 5 Daniel Smith (VW Corrado); 6 Mike Thurley (Tigra). **CW** White. **FL** Blackman 49.590s (87.69mph). **P** Chris Ayling (Tigra). **S** 17.



JONES

THRUXTON
BARC JUNE 11-12

BMW honours shared in high-speed Ha

BRITISH TRUCK RACING

Championship leader Ryan Smith continued his scorching form to win three of five Thruxton battles.

Smith led race one from pole but by the Club chicane was hounded by 10-time series champion Stuart Oliver. A dive up the inside at the same corner three laps later allowed Oliver to put his Volvo into the lead, but he finished second after Smith outbraked him into the chicane.

Oliver took the race one disappointment in his stride, though, and vaulted himself up the order from 10th to second in a single lap in the reversed second affair, ultimately winning by 0.264 seconds ahead of the arguably faster David Jenkins. Oliver doubled his tally in race four with a victory from sixth.

Steve Powell had pole for the third contest, but Shane Brereton got a better run into Church for the lead. Smith had

scythed his way from the back of the pack to reach third by lap three and, having dispatched Powell, he pounced to outbrake Brereton at Campbell and Cobb to seal a second win. Victory from eighth over Mat Summerfield in race five completed an impressive weekend for the MAN TGA driver.

“This truck around Thruxton will look after its tyres – that’s what racing is all about,” he said. “I knew if I bided my time I could outbrake them into the chicane.”

The Kumho BMW battle was a two-horse race between polesitter James Card and James MacIntyre-Ure in the A1 class. A strong exit from Club allowed MacIntyre-Ure to squeeze past Card for the win, flashing his lights furiously at backmarkers who looked to threaten his lead along the way.

MacIntyre-Ure again led Cole away from pole in race two, but a power issue

at the final chicane four laps in allowed Card to stroll to victory by more than 28s.

If Mark Armstrong didn’t have bad luck, he might not have any luck at all. Hoping to put the overheating issues that plagued him at the Silverstone Formula Ford 1600 round behind him, Armstrong put his Van Diemen RF80 on pole before a sudden rear wishbone failure caused him to retire from the lead, and left him unable to race on Sunday.

“I’m not used to the Formula Ford heartache,” he joked afterwards. His woe enabled Nigel Lingwood to drink the champagne, while Charles Greenwood took a class win before passing the helmet to dad Jonathan for Sunday’s race. Lingwood won the Sunday sprint from pole with a comfortable 2.5s margin over Kevin Mansell. Ian Jeary was the Class B victor on track but was excluded for being underweight, handing the win to Kevin Howell.

Graeme Smith led on the final lap of the first Caterham Classic race, but Peter Tattersall dived up the inside at Club, and a small tag between the pair ended up with Tattersall spinning and collecting Marc Noaro and Colin Jardine. Steven McMaster avoided the carnage to win. Race two was cleaner, as McMaster sped off the line quicker than polesitter Smith to take his second victory of the day.

In the first Caterham Super and Mega duel, series-returnee Declan Dolan and Luke Cooper were dicing for the win when they touched, putting them both out of contention. Christopher Benfield made the most of a cracking start from

Bristow presses on. He was one of many Caterham winners



JONES

E46s of Card and MacIntyre-Ure had an edge over the BMW pack

mpshire

ninth and rose to second before stealing the top step of the podium.

Oliver Gibson claimed his first win of the season in a wet race two. "I love the wet conditions and I think that might have helped in the last couple of laps," he said.

Dylan Stanley defied the slipstreaming conventions in the second Caterham Sigma race, taking the lead from polesitter and race one winner Lee Bristow into Allard after getting a better start. From the front, Stanley built a 7.5s gap over Cedric Bloch and Bristow. Scott Lawrence spun out on the exit of Club on the final tour, which Bloch and Bristow narrowly avoided to take second and third respectively.

Twelve entrants lined up for Sunday's Pickup Truck Racing Championship double-header, where Carl Boardley was denied victory from pole by David O'Regan and former British Touring Car Championship driver Lea Wood. Boardley redeemed himself in the second race with victory over Wood and Mark Willis.

The sun broke through the persistent clouds just in time for the single Sports 2000 Championship race. A host of podium challengers including Paul Martin, Patrick Sherrington and Colin Peach dropped back to leave Michael Gibbins in a comfortable lead, more than 25s clear of David Houghton.

In the Hyundai Coupe Cup, Ian Goodchild made it two wins from two, with only William Taylforth seemingly able to trouble him. Taylforth finished second in both.

JASON NOBLE

SNETTERTON BRSCC JUNE 11-12

No rain pain for defiant UVio team

HEAVY RAIN, MULTIPLE SAFETY CARS and even a stop-go penalty were not enough to prevent the JPR UVio team from earning its first Fun Cup Championship win of the year.

An impressive first stint by Farquini Deott from 16th meant that, by the first driver change, Graham Roberts had a solid position to build on at the front, excelling in the wet.

But his lead of a minute was wiped out by the halfway mark when the safety car was deployed in conditions deemed unsafe for racing. Deott inherited the mammoth task of rebuilding the lead after a third stop, with Roberts having run a double stint. Despite holding off attacks from Honeywell's Neil Plimmer, Deott's lead was extinguished again when he made contact with a backmarker, the resulting stop-go penalty pushing the team down to fourth.

By the final hour, a lightning-fast driver change and some bold overtaking had put the team back in the lead, with a 57s cushion.

But with 20 minutes left, another safety car was brought out when Honeywell's Tim Wheeldon went straight off at Riches and cut the lead once again. It meant there was enough time for DespatchBay.com's James Littlejohn to carve past both Eco Racing cars into second at the restart, to score the team's second ever podium, behind Deott, who sealed the victory JPR UVio had flirted with all afternoon.

Ronan Quinn took victory from 10th on the grid in the first Fiesta Junior race ahead of Lochlan Bearman and Harry Gooding. An early charge through the field put Quinn in the best position to take advantage of

James Hillery's and leader James Waite's retirements, putting him into second. A brilliant move past Gooding through Murrays then sealed the win. He couldn't make it a clean sweep in race two, though, as an overzealous move meant Quinn retired after hitting the rear of eventual winner Gooding, who celebrated his third win of the season.

Simon Horrobin took both victories in the Fiesta Championship, leaving Snetterton as the championship leader. After leading Sam Priest to a Specialised Motorsport one-two ahead of the returning JJ Ross, Horrobin knocked Priest off the track in race two. While Priest recovered to sixth, a bold move on Ross into the Brundle chicane on the final lap handed Horrobin a clean sweep.

There were just two races in the BMW Compact Cup as the field formed a single grid for the first time this season.

Ian Jones became the seventh different winner from the first seven races after beating James 'Jiggy' Gornall off the line, and holding the 2008 British GT champion at bay. It was a different story in race two, though, where 'Jiggy' made amends, and claimed victory to become the first multiple winner of 2016.

Snetterton also played host to two HRDC grids. In the Academy race, William Lynch's Mini Cooper was victorious in a shortened affair when Richard Butterfield's Austin rolled multiple times at Brundle. Mike Jordan was victorious in the Touring Greats race, narrowly beating poleman Michael Caine.

DOM D'ANGELILLO

UVio team battled a number of setbacks to win in the rain



STYLES

CONFERENCE CENTRE

RACE DAY HOSPITALITY & PUBLIC TOURS

The Williams Conference Centre is home to the largest private collection of Formula One cars in the world. Housing more than 40 of the team's seminal race cars, the collection charts the team's 30+ years of motor racing history.

INFORMATION AND ONLINE BOOKING: WILLIAMSF1.COM

WILLIAMS
CONFERENCE CENTRE
GROVE
OXFORDSHIRE
OX12 0DQ



ROCKINGHAM
BRSCC JUNE 11-12

Cole was emphatic victor in OSS R2, despite problems either side of win



Three cheers in Open Series stanzas

AS WAS THE CASE DURING THE rounds at Silverstone, there were three different winners in the OSS races at Rockingham as Duncan Williams' Juno, Graham Cole's Jade and the Radical PR6 of Joe Stables shared the spoils.

Poleman Williams led race one from the start, with Mike Jenvey snatching second in his Jenvey-Gunn early on, as Cole gradually lost ground on old tyres. Jenvey reeled in Williams and had the lead on lap 10, only to outbrake himself a lap later. "I was right with him through the last chicane, though," he said after coming home second.

Stables grabbed third as Cole continued to lose ground, with Josh Smith's Radical PR6 and Craig Mitchell's Ligier JS49 completing the top six.

Cole fought back in race two and stormed to a lights-to-flag win, as the Smith-Stables duel for second allowed Jenvey to join them. Smith briefly challenged for the lead on lap six, but fell back as he was forced to defend from Stables. Jenvey got his braking right in race two and nipped by both of his rivals into Deene with four laps remaining, while Smith's spin handed Stables third.

"I forgot Graham was there," said Jenvey when he suddenly saw the leader.

Cole failed to start the finale when his cambelt broke in the pitlane, with Jenvey instead grabbing an early advantage over Smith, Stables and Mitchell. As the rain fell, Smith grabbed hold of the lead into Deene on lap three, with Stables following him through at the Brook Esses, only for Jenvey to regain second spot a lap later.

Stables finally made second his and was soon all over Smith, taking the lead out of Tarzan with a lap to go on his way to victory. Smith had to settle for second from Jenvey, Mitchell, Douglas Bowkett's Jade and Darcy Smith's Radical.

James Raven's Ray won both National Ford 1600 races, despite losing out to

Niall Murray's Van Diemen RF99 on both starts. In race one, Raven had regained the lead by lap three, with Chase Owen's Ray securing third from Patrik Pasma's Mygale on the same lap.

Lap three proved to be the key once more in race two as Murray again surrendered his lead to Raven. After a safety car interlude, Pasma and Owen were also able to usurp the former leader for second and third respectively. Murray finally came home fourth, from Chris Middlehurst's Mygale and Tom McArthur.

Nick Gwinnett's guesting Renault Clio beat the Nippon Challenge/Deutsche Marques Cup regulars in their first race, after James Janicki's Nissan Skyline, Nerijus Zobotka's Subaru Impreza and Richard Hockley's Honda Civic all retired from the lead on consecutive laps. James Mumbray's BMW M3 claimed second, from Craig Tomkinson's Opel Corsa.

Gwinnett led the early stages of race two until Zobotka and Janicki made it through from the back of the grid. Zobotka had the lead by lap four but was powerless to stop Janicki easing clear a lap later, as Gwinnett kept Mumbray at bay for third.

The first Caterham Academy race was a duel between poleman Tom John and Peter Spencer. Although John held the early advantage, Spencer squeezed ahead

on lap five, while Pete Walters snatched third from Steven Tozer on the last.

Jay McCormack and Ben Gillias took their duel down to the wire in the second race, with the former coming out on top.

Robert Burkinshaw's Integra led Mark Bennett's S2000 and Paul Donkin's Civic in a processional Honda VTEC Challenge opener, while Bennett headed Burkinshaw and Donkin throughout in a similarly uninspiring race two. Martyn Clatworthy and Alan Palmer shared the concurrent Smart 4Two Cup wins.

After Dan Clowes retired from the lead of the first Formula Jedi race, Andrew Dunn emerged victorious from a race-long scrap with Paul Butcher. Lee Morgan was another retiree from the lead in race two, allowing Robert Sayell to win from Dunn and Butcher.

Andrew Mitchell's Peugeot 205 GTi scooped a dominant winning double in the Tricolore Trophy. Mitchell was not headed from the Brook Esses on lap one, after Tony Hunter's Clio led initially. Ian Collins' Clio fought off Nick Gwinnett's similar car to third behind Hunter. It took until lap three for Mitchell to lead race two but in the end the top seven was identical to the first race.

Jason Clegg's Tuscan Speed Six won both TVR Challenge races, but only after Mike Luck's Chimaera exited race one from the lead with engine woes. Hugh Marshall's Tuscan was second in both affairs, with the Cerberas of Chris Ridge and Jamie Golby each taking a third place.

Having shadowed Adam Lockwood for six laps, Nathan Harrison made a decisive move in the first MR2 race as the pair turned in for Pif-Paf to secure victory. Harrison was never headed in race two, but Daniel Bryant had the legs of Lockwood for second, before Dave Hemingway and Arron Pullan demoted Lockwood further on the last lap.

Regular foes Janicki (19) and Zobotka fought back in R2 after R1 retirements



WALKER

PETER SCHERER



Smith set trend for the day with pair of Formula Vee victories

MALLORY PARK
750MC JUNE 12

Stylish Smith claims Mallory Vee double

DOUBLE WINS WERE THE FLAVOUR of the day at Mallory Park as Paul Smith continued his Formula Vee dominance to make it eight victories out of eight in 2016.

The Class B Maverick of James Harridge was his nearest challenger, and put pressure on Smith's AHS in the first race after a good start from the third row.

Harridge got by through Gerards, although his lead was shortlived when Smith, making use of his superior straightline speed, blasted ahead as the pair negotiated backmarkers on the Stebbe Straight. Their dispute was then brought to an abrupt end when Harridge's engine seized just a couple of laps before the finish.

In race two Smith was able to control the pace out in front as Martin Farmer and Graham Gant fought for second.

The pair enjoyed a close opening few laps before Gant went wide through Gerards and got his tyres dirty, forcing him to drop back. That promoted Ian Buxton to third, while fourth was settled in the closing stages when David Hughes overtook Ian Jordan coming out of the Shaw's Hairpin.

Robin Gearing was another double winner in the two 750 Formula outings in his Darvi, although his wins were overshadowed by a major shunt for Bill Cowley, which cut the second race short.

After getting into the lead at the start, Cowley was desperate to defend from Gearing, who gained advantage through the fast corners thanks to a new front wing. Cowley employed similar tactics to those he used at Donington earlier in the year by making his car as wide as possible, at one point going

three abreast with Peter Bove and Gearing into the Esses.

But as he approached backmarkers, Cowley went off the racing line and onto a patch of oil, spearing off the track and crashing heavily into the barrier at the Esses. He was conscious but taken to hospital as a precaution, with his Cowley MkIV looking the worse for wear when it was recovered.

Pip Hammond's Vauxhall Nova won the pair of Classic Stock Hatch races, taking the first from Lee Scott (Fiesta), who enjoyed a heated battle with Matt Rozier (Peugeot 205). The top four (including Fiesta driver Martin Cayzer) ran close throughout, but it was hard to pass. Rozier had one final look into the hairpin, only for Scott to firmly defend the place.

Tom Bell was the fourth double victor, claiming his brace in the Hot Hatch races. Bell's Fiesta ST controlled the pace from lights to flag on both occasions, the first from Neil Stringfellow and Alistair Camp. It wasn't an easy third place for Camp, as he had to fend off a late challenge from Matt Howarth coming out of Shaw's Hairpin to the chequered flag.

The trend was finally bucked in the 750 Trophy, as Lyndon Thruston won the first race and Christian Pedersen took the honours in the second. Pedersen was challenged by John Slatter, who braked late into the Shaw's Hairpin to briefly take the lead before Pedersen's superior straightline speed allowed him to pull away.

Peter de la Roche was another driver to take a brace of wins, as his Cooper Mk5 proved to be unstoppable in the 500cc F3 races. Darrell Woods (Cooper Mk12) was second both times.

Cowley's stout defence unravelled in 750 Formula



Barrable headed
O'Brien before
the two crashed

CHESTER



MONDELLO PARK
MEC JUNE 11-12

Barrable wins before Supercar clash

PETER BARRABLE AND SAM MOFFETT starred in the Supercar Championship Series. Points leader Andy O'Brien had qualified on pole, but an ill-advised choice of wet tyres saw him slip down the field as conditions dried out.

Reigning champion Barrable took the lead from the outside of the front row and was pretty much unchallenged on the way to the win. Moffett was second, with Graeme Colfer just holding off the charging Bob Cameron for third.

In race two, Moffett took the lead early on as Barrable and O'Brien battled in his wake. Moffett controlled it beautifully and, when the series leaders collided at Turn 2 on the final tour, he was assured of a first victory.

Jonathan Fildes qualified on pole in his SEAT Supercup Ireland debut. He led away, but a grassy moment out of Paddock handed the lead to Rob Butler, with former A1GP driver Niall Quinn also displacing Fildes by mid-race. A safety-car period changed it all, though, as Fildes cooled his tyres before diving by Quinn and charging up to challenge winner Butler at the final corner.

In race two Erik Holstein benefited from the reversed grid to ease away from the battles behind, and even a late-race charge from series debutant Dave O'Brien could not stop him taking a popular victory.

Jackie Cochrane took an unchallenged pair of HRCA wins. Bernard Foley's MGB GT V8 was the only machine to

keep the rumbling Tiger in sight.

Alan Watkins took two Irish Sportscar Championship wins, with Des Bruton his closest challenger in both races.

Sean Lillis secured a pair of Ford Fiesta ST wins, but only after former Irish Touring Car star Kev Doran retired from the lead in race one, the problem preventing him from starting race two.

Mondello's Phil Lawless won twice in Zetec Fiestas to increase his series lead, but had to work hard, Darren Lawlor even snatching the lead briefly in race two.

Grzegorz Kalinecki took yet another pair of Super Touring ITCC wins in his VW Golf, with Keith Campbell's

Kalinecki was a
double ITCC winner
in his VW Golf



CHESTER

Corrado-Honda taking two runner-up spots. Ian O'Driscoll and Robert Doherty shared the Production-class victories.

Kevin Sheane returned to winning form in Formula Sheane with two wins. Dave Parks was runner-up in race one, with Robbie Allen relegating Parks to third in race two.

Dan Polley dominated the first Formula Vee race, but in race two fellow Mondello Park instructor Kevin Grogan snatched the lead into Lola corner and held on despite Polley's best efforts.

Robbie Parks's Mitsubishi FTO took Future Classics honours after rallycross ace Patrick Donoghue was penalised for breaking the barrier time on a number of occasions. Aidan Byrne was next up in a Vauxhall Chevette, with Timmy Duggan's SEAT completing the podium.

Scottish-series visitor John Paterson took the first Legends race despite the attentions of Niki Meredith and Paul O'Brien. Meredith redressed the balance with a home win in race two and repeated it in race three, resisting the challenge of brother-in-law James Holman.

Holman reversed the order in the fourth encounter by a similarly small margin, while Paterson took another impressive win in race five, with Meredith and Holman right on his bumper. In the final race O'Brien took a great win from Paterson and Holman in what was a great weekend's racing for the fledging class.

LEO NULTY



LOTON PARK
HILLCLIMB JUNE 11-12

Willis on form
at Loton Park

Willis double does little to dent Moran's lead

TREVOR WILLIS REINFORCED HIS reputation as a rainmaster as he raced to his first double win of the season at Loton Park.

Willis's victories were emphatic, but despite his 20 points on the day he barely dented the series leader's advantage as Scott Moran was second on each occasion, exercising caution to ensure a good haul.

In third place in the points, Wallace Menzies took that position on the second climb but missed out in the first to Will Hall, who gradually overcome issues with his powertrain that have thwarted his early campaign.

Behind those four there was a satisfying scrap among the 1600cc cars and two-litre forced-induction machines. On the day it was a pair of the naturally aspirated 1600s that were best of the smaller cars, with Richard Spedding and Eynon Price trading fifth and sixth in the two rounds, Price driving solo with Sean Gould out after picking up a work-related injury.

Best of the forced-induction cars once again was Dave Uren, but seventh was his best position, as he was unable to defeat Price and Spedding on either run. Ed Hollier managed to beat Uren in the first encounter, despite lacking the advanced features of the all-carbon Gould or the small scale of the GWR.

With conditions varying throughout the day from soaking wet to slippery, there were unsurprisingly a number of delays as a result of cars skidding off. Jason Mourant was the worst affected, the Jerseyman crashing out after the finish in Q2. Mourant damaged his ex-Tom New Gould, taking the right-front corner off the car. Despite having set a run-off qualifying time, he was not able to take his place in the shootout.

Martin Jones won the 1100 class for the first time and also qualified for his maiden

run-off, managing to take a maiden British Championship point in the process.

Colin Satchell continues at the head of the Leaders chart but was comprehensively beaten in class by local specialist Steve Bailey in his immaculately prepared and elderly Ford Escort Mk1.

EDDIE WALDER

RESULTS

MSA BRITISH HILLCLIMB CHAMPIONSHIP ROUND 11

1 Trevor Willis (3.2 OMS-RPE 28) 51.94s; 2 Scott Moran (3.5 Gould-NME GR61X) 52.15s; 3 Will Hall (2.0 Force-AER/XTec WH) 52.33s; 4 Wallace Menzies (3.5 Gould-NME GR55) 52.66s; 5 Richard Spedding (1.6 GWR-Suzuki Raptor) 52.69s; 6 Eynon Price (1.6 Gould-Suzuki GR59) 53.81s; 7 Ed Hollier (1.6 Empire-Suzuki 00 Evo) 54.14s; 8 Dave Uren (1.3t Force-Suzuki PC) 56.05s; 9 Lee Griffiths (1.3s OMS-Suzuki 25) 56.13s; 10 Paul Haimes (1.3t Gould-Suzuki GR59) 56.76s; 11 Jason Mourant (4.0 Gould-Judd GR55) 57.05s; 12 Graham Wynn (3.5 Gould-Cosworth GR55) 57.07s.

ROUND 12 1 Willis 46.15s BTD; 2 Moran 46.30s; 3 Menzies 47.11s; 4 Hall 47.84s; 5 Price 48.32s; 6 Spedding 48.49s; 7 Uren 50.24s; 8 Hollier 50.58s; 9 Wynn 53.35s; 10 Martin Jones (1.0 Force-Suzuki PT) 56.01s; Haimes DNF; Mourant DNS.

Class winners Tom Barber (3.6 Porsche 996 GT3 RS) 61.61s; Richard Brant (2.0 Renault Clio 172 Sport) 69.50s; Robert Lancaster-Gaye (3.6t Porsche 997) 64.95s; Dave Wilson (2.0 Caterham-VX) 64.40s; Andrew Russell (1.1 Ginetta G15) 67.39s; Steve Bailey (2.0 Ford Escort Mk1) 63.61s; Mike Turpin (2.2s Vauxhall VX220) 64.64s; Ash Mason (1.3s Westfield-Suzuki) 63.63s; Allan McDonald (2.4t Morris Mini Evo) 61.87s; Jones 58.63s; Richard Summers (1.6 Van Diemen Formula Ford RF80) 68.44s; Spedding 56.20s; Johnathan Varley (2.0 March-Cosworth 772P) 62.06s; Haimes 56.94s; Moran 53.88s.

Points 1 Moran 117; 2 Willis 98; 3 Menzies 66; 4 Uren 53; 5 Hall 51; 6 Spedding 48; 7 Hollier 41; 8 Price 27; 9 Sean Gould 25; 10 Wynn 23.

RESULTS ROUND-UP

THRUXTON

BARC, JUNE 11-12

BRITISH TRUCKS (10 LAPS) 1 Ryan Smith (MAN TGA); 2 Stuart Oliver (Volvo RH13) +2.412s; 3 Mat Summerfield (MAN TGX); 4 David Jenkins (TGX); 5 Steven Thomas (TGX); 6 Shane Brereton (TGA Euro 6). **Fastest lap** Jenkins 1m39.519s (85.22mph). **Pole** Smith.

Starters 20. RACE 2 (10 LAPS) 1 S Oliver; 2 Jenkins +0.264s; 3 Smith; 4 Luke Taylor (Renault Premium MKR); 5 Brereton; 6 Thomas. **FL** Jenkins 1m38.965s (85.70mph). **P** Luke Garrett (Renault T Range). **S 20. RACE 3 (7 LAPS) 1 Smith**; 2 Brereton +3.558s; 3 Jenkins; 4 Summerfield; 5 Thomas; 6 S Oliver. **FL** Smith 1m39.607s (85.15mph). **P** Steve Powell (MAN). **S 19. RACE 4 (10 LAPS) 1 S Oliver**; 2 Thomas +2.556s; 3 Jenkins; 4 Smith; 5 Brereton; 6 Summerfield. **FL** Smith 1m42.319s (82.89mph). **P** S Powell. **S 19. RACE 5 (11 LAPS) 1 Smith**; 2 Summerfield +2.641s; 3 Taylor; 4 Thomas; 5 S Oliver; 6 Brereton. **FL** Smith 1m38.079s (86.47mph). **P** Michael Oliver (Scania). **S 20.**

KUMHO BMW (BOTH 15 LAPS) 1 James MacIntyre-Ure (M3 E46); 2 James Card (M3 E46) +0.291s; 3 Roger Lavender (E46); 4 Daniel Wylie (M3 E46); 5 Richard Marsh (M3); 6 Oliver Taylor (E36 M3).

Class winner Marsh; O Taylor; Alana Taylor (1 Series); Brian Anderson (E36); Max Walton (318is); Russell Dack (E46 Compact). **FL** Card 1m22.879s (102.33mph). **P** Card. **S 26. RACE 2 1 Card**; 2 Mike Hibbert (E36) +28.065s; 3 Marsh; 4 Lavender; 5 Wylie; 6 O Taylor. **CW** Hibbert; Marsh; O Taylor; Anderson; Walton; Dack. **FL** MacIntyre-Ure 1m22.723s (102.53mph). **P** MacIntyre-Ure. **S 26.**

CLASSIC FF1600 (BOTH 14 LAPS) 1 Nigel Lingwood (Van Diemen RF80); 2 Kevin Mansell (Crossle 32F) +1.770s; 3 Colin Williams (PRS RH01); 4 Roger Newman (RF80); 5 Rupert Howe (Royale RP26); 6 Charles Greenwood (Dulon MP15). **CW** Greenwood. **FL** Lingwood 1m27.090s (97.38mph). **P** Mark Armstrong (RF80). **S 17. RACE 2 1 Lingwood**; 2 Mansell +2.463s; 3 Steve Pearce (Van Diemen RF81); 4 Williams; 5 Jon Nash (RF80); 6 Newman. **CW** Kevin Howell (Elden Mk8). **FL** Lingwood 1m26.800s (97.71mph). **P** Lingwood. **S 16.**

CATERHAM CLASSIC (14 LAPS) 1 Steven McMaster; 2 Robin Webb +2.944s; 3 Marc Noaro; 4 Colin Jardine; 5 Darren Grainger; 6 Matthew Willoughby. **FL** Graeme Smith 1m36.982s (87.45mph). **P** McMaster. **S 14. RACE 2 (13 LAPS) 1 McMaster**; 2 Smith +4.630s; 3 Webb; 4 Peter Tattersall; 5 Noaro; 6 Willoughby. **FL** McMaster 1m40.596s (84.31mph). **P** Smith. **S 12. SUPER AND MEGA (BOTH 15 LAPS) 1 Christopher Benfield**; 2 Andrew Skinner +0.365s;

3 Oliver Gibson; 4 Tom Overton; 5 Edward Benson; 6 Toby Briant. **CW** Benson. **FL** Benfield 1m26.998s (97.49mph). **P** Declan Dolan. **S 25. RACE 2 1 Gibson**; 2 Glenn Burtenshaw +1.860s; 3 Luke Cooper; 4 Benfield; 5 Skinner; 6 Dolan. **CW** Briant. **FL** Benfield 1m27.901s (96.49mph). **P** Dolan. **S 25. SIGMA AND SIGMAX (13 LAPS) 1 Lee Bristow**; 2 Dylan Stanley +0.430s; 3 Cedric Bloch;

4 Scott Lawrence; 5 Gareth Cordey; 6 Tim Rowbottom. **CW** Jamie Winrow. **FL** Lawrence 1m26.597s (97.94mph). **P** Bristow. **S 31. RACE 2 (14 LAPS) 1 Stanley**; 2 Bloch +3.460s; 3 Bristow; 4 Nicholas Haryett; 5 Lawrence; 6 Simon Oliphant. **CW** David Webber. **FL** Lawrence 1m30.965s (93.24mph). **P** Bristow. **S 30.**

PICKUPS (BOTH 14 LAPS) 1 David O'Regan; 2 Lea Wood +0.100s; 3 Carl Boardley; 4 Mark Willis; 5 Freddie Lee; 6 Anthony Hawkins. **FL** Boardley 1m24.081s (100.87mph). **P** Boardley. **S 12. RACE 2 1 Boardley**; 2 Wood +0.204s; 3 Willis; 4 Lee; 5 O'Regan; 6 Paul Tompkins. **FL** Boardley 1m24.432s (100.45mph). **P** Michael Smith. **S 12.**

SPORTS 2000 (18 LAPS) 1 Michael Gibbins (MCR S2000); 2 David Houghton (MCR) +25.965s; 3 Alaric Gordon (Carbir S2000); 4 Colin Peach (Van Diemen RFSC02); 5 Nick Bacon (Gunn TS11); 6 Tom Stoten (TS11). **CW** Gordon; Mike Turner (MCR); Peter Needham (Tiga SC80); Colin Feyerabend (Lola T90/90); Mark Powell (Tiga SC84). **FL** Patrick Sherrington (MCR) 1m16.598s (110.72mph). **P** Bacon. **S 27.**

HYUNDAI COUPE CUP (10 LAPS) 1 Ian Goodchild; 2 Will Taylforth +0.321s; 3 Alex Cursley; 4 Joe McLaughlin; 5 Jon Winter; 6 Eddie O'Kane. **FL** Taylforth 1m35.840s (88.49mph). **P** Goodchild. **S 15. RACE 2 (9 LAPS) 1 Goodchild**; 2 Taylforth +3.863s; 3 O'Kane; 4 Rob Gaffney; 5 Cursley; 6 Winter. **FL** Joe McLaughlin 1m38.657s (85.97mph). **P** Goodchild. **S 15.**

SNETTERTON

BRSCC, JUNE 11-12

FUN CUP (127 LAPS) 1 JPR UVio (Graham Roberts/Farquini Deott); 2 DespatchBay.com (Andy Bicknell/James Littlejohn) +2.281s; 3 Eco Racing 61 (Alan Brown/Rory Brown/Jay Sheppard); 4 Eco Racing 209 (Paul Graham/Tom Mills/Paul Turner); 5 Team Lane Roofing (Nigel Griffiths/Christopher Weatherill/Geoff Fawcett); 6 Global Racing (Scott Mansell/John Gilbert/Sarah Reader. **FL** Roberts 2m17.871s (77.52mph). **P** MCAC Racing (Matthew Jones/Philip Jones/Gareth Jones). **S** 26.

FIESTA JUNIOR (7 LAPS) 1 Ronan Quinn; 2 Lochlan Bearman +3.166s; 3 Harry Gooding; 4 Bradley Burns; 5 Elliot Wilson; 6 Jack Davidson. **FL** James Hillery 2m22.510s (74.99mph). **P** James Waite. **S** 17. **RACE 2 (8 LAPS) 1 Gooding;** 2 Davidson +1.980s; 3 Burns; 4 Lewis Kent; 5 Wilson; 6 Waite. **FL** Burns 2m20.944s (75.83mph). **P** Quinn. **S** 16. **QUAIFE FIESTA (9 LAPS) 1 Simon Horrobin (ST);** 2 Sam Priest (ST) +2.086s; 3 JJ Ross (ST); 4 Ryan Faulconbridge (ST); 5 Alfonso Skriczka (ST); 6 Nick Sanderson (ST). **CW** Alastair Kellett (Zetec S); Peter Dendy-Sadler (Si); Derek Robinson (Zetec). **FL** Horrobin 2m16.942s (78.04mph). **P** Horrobin. **S** 31. **RACE 2 (8 LAPS) 1 Horrobin;** 2 Ross +0.147; 3 Skriczka; 4 Sanderson; 5 Faulconbridge; 6 Priest. **CW** Kellett; Tim Bennett (Si); Robinson. **FL** Horrobin 2m16.457s (78.32mph). **P** Priest. **S** 33.

BMW COMPACT CUP (BOTH 6 LAPS) 1 Ian Jones; 2 James Gornall +0.200s; 3 Joe Wiggins; 4 Ben Pearson; 5 Owen Hunter; 6 Steven Dailly. **FL** Gornall 2m22.551s (74.98mph). **P** Gornall. **S** 41. **RACE 2 1 Gornall;** 2 Jones +0.084s; 3 Hunter; 4 Jon Watt; 5 Wiggins; 6 Declan McDonnell. **FL** Jones 2m22.887s. (73.92mph). **P** Gornall. **S** 41.

HRDC ACADEMY & A-SERIES (8 LAPS) 1 William Lynch (Mini Cooper S); 2 Brian Small (Ashley MG Midget) +0.397s; 3 Thomas Grindall (MG W&P GT); 4 James Dorlin (Austin A35); 5 Tony Shirtcliffe (A35); 6 Nick Powell (A35). **CW** Dorlin. **FL** Grindall 2m31.839s (70.39mph). **P** Lynch. **S** 28.

HRDC TOURING GREATS (18 LAPS) 1 Mike Jordan (Austin A40); 2 Michael Caine (A40) +3.470s; 3 Neil Brown (A35 Speedwell); 4 Ding Boston (Riley 1.5); 5 John Yea (A40); 6 David Green/Matt Green (A35 Speedwell). **CW** Boston; Frank Slevin/Peter Mullen (A35); Nick Powell (Standard Vanguard). **FL** Jordan 2m23.347s (74.56mph). **P** Caine. **S** 28.

ROCKINGHAM

BRSCC, JUNE 11-12

OSS (14 LAPS) 1 Duncan Williams (Juno); 2 Mike Jenvey (Jenvey-Gunn TS6) +0.303s; 3 Joe Stables (Radical PR6); 4 Graham Cole (Jade Trackstar); 5 Josh Smith (Radical PR6); 6 Craig Mitchell (Ligier JS49). **CW** Stables; Cole; Darcy Smith (Radical SR4); Daniel Prendergast (Contour ZX10R); Karolis Griska (Aquila Synergy). **FL** Jenvey 1m24.121s (87.73mph). **P** Williams. **S** 22.

RACE 2 (14 LAPS) 1 Cole; 2 Jenvey +0.944s; 3 Stables; 4 Mitchell; 5 J Smith; 6 Graham Hill (Radical PR6). **CW** Jenvey; Stables; Doug Carter (PR6); Kevin Suenson (Aquila Synergy). **FL** Cole 1m23.627s (88.24mph). **P** J Smith. **S** 22. **RACE 3 (12 LAPS) 1 Stables;** 2 J Smith +2.073s; 3 Jenvey; 4 Mitchell; 5 Douglas Bowkett (Jade Chrysler 2); 6 D Smith. **CW** Jenvey; Bowkett; D Smith; Suenson. **FL** Stables 1m24.573s (87.26mph). **P** Cole. **S** 23.

NATIONAL FF1600 (12 LAPS) 1 James Raven (Ray GR15); 2 Niall Murray (Van Diemen RF99) +0.913s; 3 Chase Owen (Ray GR14/15); 4 Patrik Pasma (Mygale SJ08); 5 Tom McArthur (Van Diemen LA10); 6 David McArthur (LA10). **CW** Michael Beaver (Mondiale M89S). **FL** Pasma 1m33.949s (78.55mph). **P** Raven. **S** 24. **RACE 2 (13 LAPS) 1 Raven;** 2 Pasma +1.274s; 3 Owen; 4 Murray; 5 Chris Middlehurst (Mygale); 6 T McArthur. **CW** Beaver; Jamie Jardine (Reynard 84FF); George McDonald (Swift SC92F). **FL** Raven 1m33.948s (78.55mph). **P** Raven. **S** 22. **NIPPON CHALLENGE/DEUTSCHE MARQUES CUP/ TRICOLORE INV (BOTH 9 LAPS) 1 Nick Gwinnett (Renault Clio 172);** 2 James Mumbrey (BMW M3) +7.540s; 3 Craig Tomkinson (Opel Corsa); 4 Ash Bruneau (Clio); 5 Andrew Roberts (Honda Civic); 6 Miles Hodgson (Toyota MR2 Mk2). **CW** Mumbrey; Tomkinson; Roberts; Tony Markham (Civic Type R); Dave Hemingway (MR2 Mk3); Roger Pullan (Audi A3t); Michael Hamlett (Civic Type R). **FL** James Janicki (Nissan Skyline R32) 1m40.651s (73.32mph). **P** Janicki. **S** 25. **RACE 2 1 Janicki;** 2 Nerijus Zobotka (Subaru Impreza) +12.829s; 3 Gwinnett; 4 Mumbrey; 5 Roberts; 6 Tomkinson. **CW** Zobotka; Gwinnett; Mumbrey; Roberts; Tomkinson; Markham; Hemingway; Pullan. **FL** Janicki 1m41.060s (73.02mph). **P** Gwinnett. **S** 23.

CATERHAM ACADEMY (9 LAPS) 1 Peter Spencer; 2 Tom John +0.197s; 3 Pete Walters; 4 Steven Tozer; 5 Arnaud Graebert; 6 Marcus Rawlinson. **FL** Spencer 1m46.187s (69.50mph). **P** John. **S** 25. **RACE 2 (8 LAPS) 1 Jay McCormack;** 2 Ben Gillias +0.427s; 3 James Beardwell; 4 James Potts; 5 Caroline Everett; 6 Philip Bianchi.

FL Beardwell 1m45.583s (69.89mph). **P** Gillias. **S** 26.

HONDA VTEC/4TWO CUP (BOTH 9 LAPS) 1 Robert Burkinshaw (Integra Type R); 2 Mark Bennett (S2000) +4.639s; 3 Paul Donkin (Civic); 4 Adam Jones (Civic Type R); 5 Ryan Focht (Integra Type R); 6 James Tracey (Integra). **CW** Donkin; Jones; Martyn Clatworthy (Smart Car). **FL** Burkinshaw 1m40.826s (73.19mph). **P** Burkinshaw. **S** 16. **RACE 2 1 Bennett;** 2 Burkinshaw +3.622s; 3 Donkin; 4 Jones; 5 Focht; 6 Tracey. **CW** Donkin; Jones; Alan Palmer (Smart Car). **FL** Bennett 1m40.075s (73.74mph). **P** Burkinshaw. **S** 16.

FORMULA JEDI (BOTH 14 LAPS) 1 Andrew Dunn; 2 Paul Butcher +0.698s; 3 Robert Sayell; 4 Bradley Hobday; 5 Bryony King; 6 Jonathan Hunter. **FL** Sayell 1m25.109s (86.71mph). **P** Dan Clowes. **S** 11. **RACE 2 1 Sayell;** 2 Dunn +6.325s; 3 Butcher; 4 Hobday; 5 Jason Dixon; 6 Hunter. **FL** Lee Morgan 1m24.888s (86.93mph). **P** Morgan. **S** 11.

TRICOLORE TROPHY (8 LAPS) 1 Andrew Mitchell (Peugeot 205 GTi); 2 Tony Hunter (Renault Clio) +2.361s; 3 Ian Collins (Clio 172); 4 Nick Gwinnett (Clio 172); 5 James Breeze (Clio); 6 Ash Bruneau (Clio). **CW** Hunter; Breeze; Gerard Merriman (Citroen Saxo); Paul Clothier (Clio 197 Cup). **FL** Gwinnett 1m45.318s (70.07mph). **P** Gwinnett. **S** 13. **RACE 2 (9 LAPS) 1 Mitchell;** 2 Hunter +5.044s; 3 Collins; 4 Gwinnett; 5 Breeze; 6 Bruneau. **CW** Hunter; Breeze; Merriman; Andy Ibberson (Clio). **FL** Mitchell 1m42.859s (71.74mph). **P** Mitchell. **S** 12.

TVR CHALLENGE (BOTH 13 LAPS) 1 Jason Clegg (Tuscan Speed Six); 2 Hugh Marshall (Tuscan) +21.041s; 3 Chris Ridge (Cerbera); 4 Matt Smith (Chimaera); 5 Jamie Golby (Cerbera); 6 John Truslove (Chimaera). **CW** Ridge; Smith. **FL** Clegg 1m36.219s (76.70mph). **P** Matthew Holbin (Tuscan). **S** 9. **RACE 2 1 Clegg;** 2 Marshall +11.662s; 3 Golby; 4 Ridge; 5 Smith; 6 Rob Kerkhoven (Chimaera). **CW** Golby; Smith. **FL** Clegg 1m36.348s (76.59mph). **P** Clegg. **S** 7.

MR2 (BOTH 8 LAPS) 1 Nathan Harrison; 2 Adam Lockwood +0.321s; 3 Daniel Bryant; 4 Daniel Farmer; 5 Gareth Baxter; 6 Dave Hemingway. **FL** Hemingway 1m49.934s (67.13mph). **P** Lockwood. **S** 21. **RACE 2 1 Harrison;** 2 Bryant +0.739s; 3 Hemingway; 4 Arron Pullan; 5 Lockwood; 6 Neil Stratton. **FL** Pullan 1m49.715s (67.26mph). **P** Harrison. **S** 20.

MALLORY PARK

750MC, JUNE 12

FORMULA VEE (15 LAPS) 1 Paul Smith (AHS Dominator); 2 David Hughes (Bears GAC) +20.38s; 3 Ian Buxton (GAC Daghorn); 4 Ian Jordan (Sheane Jordan); 5 Jack Wilkinson (Sheane Mk3); 6 Adam Macaulay (Sheane). **CW** Wilkinson. **FL** Smith 54.80s (88.69mph). **P** Smith. **S** 24. **RACE 2 (16 LAPS) 1 Smith;** 2 Martin Farmer (GAC) +1.96s; 3 Buxton; 4 Hughes; 5 Jordan; 6 Macaulay. **CW** Wilkinson. **FL** Smith 51.75s (93.91mph). **P** Smith. **S** 24.

750 FORMULA (8 LAPS) 1 Robin Gearing (Darvi P88); 2 Bill Cowley (Cowley MkIV) +2.04s; 3 Peter Bove (Darvi Mk4/5); 4 Mark Glover (Racekits Falcon); 5 Bob Simpson (SS/F 750F); 6 Chris Gough (CGR2 Evo). **CW** Oliver Collett (Racekits Falcon). **FL** Cowley 52.13s (93.23mph). **P** Gearing. **S** 15. **RACE 2 (6 LAPS) 1 Gearing;** 2 Bove +0.63s; 3 Glover; 4 Gough; 5 Simpson; 6 Rod Hill (Mystic T4). **CW** Andrew Lake (Darvi 91D). **FL** Bove 51.44s (94.48mph). **P** Gearing. **S** 16.

CLASSIC STOCK HATCH (BOTH 15 LAPS) 1 Pip Hammond (Vauxhall Nova GTE); 2 Lee Scott (Ford Fiesta XR2i) +2.47s; 3 Matt Rozier (Peugeot 205 GTi); 4 Martin Cayzer (XR2i); 5 Edward Cooper (Nova GSi); 6 Andrew Thorpe (Citroen AX GTi). **FL** Hammond 56.77s (85.61mph). **P** Hammond. **S** 22. **RACE 2 1 Hammond;** 2 M Rozier +0.87s; 3 Scott; 4 Cooper; 5 Derek Rozier (205 GTi); 6 Cayzer. **FL** Scott 56.90s (85.41mph). **P** Hammond. **S** 19.

HOT HATCH (14 LAPS) 1 Tom Bell (Ford Fiesta ST); 2 Neil Stringfellow (Peugeot 205 GTi) +27.58s; 3 Alistair Camp (Fiesta ST); 4 Matthew Howarth (Vauxhall Astra GSi); 5 Phil Law (Citroen Saxo VTR); 6 Paul Jarvis (Saxo VTR). **CW** Stringfellow; Law; Mac McCarthy (Fiesta ST). **FL** Bell 1m02.00s (78.39mph). **P** Bell. **S** 24. **RACE 2 (11 LAPS) 1 Bell;** 2 Camp +5.24s; 3 Howarth; 4 Geoffrey Conner (Renault Clio 172); 5 David Allen (Fiesta ST); 6 Law. **CW** Conner; Law; McCarthy. **FL** Camp 52.71s (92.20mph). **P** Bell. **S** 23.

750 TROPHY (12 LAPS) 1 Lyndon Thruston (DNC); 2 John Slatter (Centaur Mk11) +10.39s; 3 Richard Rowe (RWR Trophy); 4 John Davies (Rapide 750T); 5 Martin Depper (Centaur Mk4); 6 Alistair Frayling-Cork (Austin 7). **CW** Frayling-Cork. **FL** Slatter 1m05.82s (73.84mph). **P** Thruston. **S** 15. **RACE 2 (14 LAPS) 1 Christian Pedersen (Austin 7);** 2 Slatter +10.54s; 3 Thruston; 4 Rowe; 5 Davies; 6 Charlie Plain-Jones (Austin 7 Cowley Special). **CW** Plain-Jones. **FL** Pedersen 1m00.32s (80.57mph). **P** Pedersen. **S** 15.

500cc F3 (10 LAPS) 1 Peter de la Roche (Cooper Mk5); 2 Darrell Woods (Cooper Mk12) +15.92s; 3 John Turner (Cooper Mk9); 4 Mike Fowler (Cooper Mk5); 5 Stuart Wright (Cooper Mk9); 6 John Jones (JLR). **FL** de la Roche 1m10.61s (68.83mph). **P** de la Roche. **S** 14.

RACE 2 (8 LAPS) 1 de la Roche; 2 Woods +15.68s; 3 Fowler; 4 Turner; 5 Wright; 6 Xavier Kingsland (Staride Mk3). **FL** de la Roche 59.32s (81.93mph). **P** de la Roche. **S** 13.

MONDELLO PARK

MEC, JUNE 11-12

SUPERCAR (8 LAPS) 1 Peter Barrable; 2 Sam Moffett +7.014s; 3 Graeme Colfer; 4 Bob Cameron; 5 Alan Dawson; 6 Andy O'Brien. **FL** Barrable 1m55.789s (67.68mph). **P** O'Brien. **S** 9. **RACE 2 (7 LAPS) 1 Moffett;** 2 Dawson +0.713s; 3 Cameron; 4 Colfer; 5 Ray Finnegan; 6 Vincent O'Reilly. **FL** Cameron 1m54.684s (68.33mph). **P** O'Brien. **S** 8.

SEAT SUPERCUP IRELAND (8 LAPS) 1 Rob Butler; 2 Jon Fildes +0.275s; 3 Niall Quinn; 4 Barry English; 5 David Kidd; 6 Rod McGovern. **FL** Fildes 1m50.439s (70.95mph). **P** Fildes. **S** 9. **RACE 2 (7 LAPS) 1 Erik Holstein;** 2 Dave O'Brien +0.307s; 3 Quinn; 4 Butler; 5 Brian Berry; 6 Fildes. **FL** O'Brien 1m51.387s (70.35mph). **P** Holstein. **S** 9.

HRCA HISTORICS (BOTH 8 LAPS) 1 Jackie Cochrane (Sunbeam Tiger); 2 Bernard Foley (MGB GT V8) +4.162s; 3 Steve Griffin (MG Midget); 4 Billy Crosbie (Lotus 7); 5 Ciaran Geoghegan (BMW 2002); 6 Wolfgang Schnittger (Midget). **CW** Foley; Schnittger; Noel Kavanagh (MGB Roadster). **FL** Cochrane 1m56.062s (67.52mph). **P** Cochrane. **S** 11. **RACE 2 1 Cochrane;** 2 Foley +11.886s; 3 Crosbie; 4 Griffin; 5 Geoghegan; 6 Schnittger. **CW** Foley; Schnittger; Kavanagh. **FL** Cochrane 1m55.123s (68.07mph). **P** Cochrane. **S** 11.

IRISH SPORTSCARS (8 LAPS) 1 Alan Watkins; 2 Des Bruton +3.596s; 3 Roger Welaratne; 4 Peter Auerbach; 5 Pat Bergin; no other finishers. **FL** Watkins 1m56.173s (67.45mph). **P** Watkins. **S** 6. **RACE 2 (7 LAPS) 1 Watkins;** 2 Bruton +14.956s; 3 Bergin; 4 Auerbach; no other finishers. **FL** Watkins 1m56.850s (67.06mph). **P** Watkins. **S** 6.

FIESTA ST (7 LAPS) 1 Sean Lillis; 2 Ulick Burke +1.060s; 3 Stephen Kirwan; 4 Brendan Fitzgerald; 5 John Denning; 6 Michael Cullen. **FL** Lillis 2m06.398s (61.99mph). **P** Lillis. **S** 15. **RACE 2 (6 LAPS) 1 Lillis;** 2 Burke +0.840s; 3 Cullen; 4 Kirwan; 5 Denning; 6 Barry Barrable. **FL** Burke 2m05.850s (62.26mph). **P** Lillis. **S** 15.

FIESTA ZETEC (7 LAPS) 1 Philip Lawless; 2 Trevor Farrar +0.373s; 3 Darragh McMullen; 4 Michael Tumulty; 5 Darren Lawler; 6 David McLean. **FL** Lawlor 2m13.501s (58.70mph). **P** Lawless. **S** 32.

RACE 2 (6 LAPS) 1 Lawless; 2 Lawler +0.773s; 3 McMullen; 4 Tumulty; 5 Peter Campbell; 6 Shane Kenny. **FL** Lawler 2m13.818s (58.56mph). **P** Lawless. **S** 31.

IRISH TOURING CARS (8 LAPS) 1 Grzegorz Kalinecki (VW Golf); 2 Keith Campbell (VW Corrado) +15.071s; 3 Eddie Kinirons (BMW M3); 4 Ian O'Driscoll (Honda Civic); 5 Jay O'Reilly (Civic); 6 David Cassidy (Nissan 200SX). **CW** O'Driscoll. **FL** Kalinecki 1m53.715s (68.91mph). **P** Kalinecki. **S** 12. **RACE 2 (7 LAPS) 1 Kalinecki;** 2 Campbell +7.774s; 3 Kinirons; 4 Robert Doherty (Civic); 5 O'Driscoll; 6 O'Reilly. **CW** Doherty. **FL** Kalinecki 1m53.430s (69.08mph). **P** Kinirons. **S** 10.

FORMULA SHEANE (BOTH 8 LAPS) 1 Kevin Sheane Jr; 2 David Parks +1.672s; 3 Robbie Allen; 4 Brian Hearty; 5 Chris McCabe; 6 Richard Kearney. **FL** Hearty 1m52.749s (69.50mph). **P** Hearty. **S** 11. **RACE 2 1 Sheane;** 2 Allen +0.299s; 3 Parks; 4 Hearty; 5 Paul McLoughlin; 6 McCabe. **FL** Hearty 1m48.454s (72.25mph). **P** Allen. **S** 11.

FORMULA VEE (8 LAPS) 1 Dan Polley (Sheane); 2 Kevin Grogan (Leystone) +2.370s; 3 Anthony Cross (Sheane); 4 Gavin Buckley (Sheane); 5 James Jones (Sheane); 6 Damian Murphy (Leystone). **FL** Polley 1m55.084s (68.09mph). **P** Polley. **S** 19. **RACE 2 (7 LAPS) 1 Grogan;** 2 Polley +0.120s; 3 Colm Blackburn (Leystone); 4 Cross; 5 Shane McBride (Sheane); 6 Mark Reade (Leystone). **FL** Polley 1m57.666s (66.60mph). **P** Polley. **S** 19.

FUTURE CLASSICS (6 LAPS) 1 Robbie Parks (Mitsubishi FTO); 2 Aidan Byrne (Vauxhall Chevette) +9.801s; 3 Timothy Duggan (SEAT Ibiza); 4 John Downey (Peugeot 206); 5 Brendan Travers (Fiat Punto); 6 Ken Byrne (MG Maestro). **FL** Patrick Donoghue (Peugeot 205) 2m07.562s (61.43mph). **P** Parks. **S** 20.

LEGENDS (5 LAPS) 1 John Paterson; 2 Niki Meredith +1.263s; 3 Paul O'Brien; 4 James Holman; 5 Des Foley; 6 Jonathan Taylor. **FL** Meredith 1m59.200s (65.74mph). **P** Paterson. **S** 13. **RACE 2 (4 LAPS) 1 Meredith;** 2 Ian Conroy +4.946s; 3 O'Brien; 4 Holman; 5 Ivor Greenwood; 6 Paterson. **FL** Conroy 2m32.539s (51.37mph). **P** Meredith. **S** 12. **RACE 3 (6 LAPS) 1 Meredith;** 2 Holman +0.180s; 3 O'Brien; 4 Paterson; 5 Conroy; 6 Taylor. **FL** Meredith 1m59.042s (65.83mph). **P** Holman. **S** 13. **RACE 4 (4 LAPS) 1 Holman;** 2 Meredith +0.184s; 3 Paterson; 4 Taylor; 5 Ross McCulloch; 6 O'Brien. **FL** Meredith 1m59.750s (65.44mph). **P** McCulloch. **S** 10. **RACE 5 (5 LAPS) 1 Paterson;** 2 Meredith +0.131s; 3 Holman; 4 O'Brien; 5 Taylor; 6 Conroy. **FL** O'Brien 2m00.595s (64.98mph). **P** Meredith. **S** 13. **RACE 6 (5 LAPS) 1 O'Brien;** 2 Paterson +4.474s; 3 Holman; 4 Meredith; 5 Ryan McLeish; 6 Gerard McCosh. **FL** Holman 2m00.419s (65.07mph). **P** McLeish. **S** 12.



Return of a forgotten Le Mans hero

A small part of British endurance racing history recently returned to UK competition after an unusual journey since success at the 24 Hours

By Kevin Turner, Editor

[@KRT917](#)

It's not often that a Le Mans podium finisher turns up to compete in a British club event. And when that car hasn't raced in its home country for more than 60 years, it's even more special.

That's what happened at the Vintage Sports-Car Club's Silverstone Spring Start meeting in April. Towards the back of the Tom Cole Trophy field for sports-racing, production sports and GT cars of the 1946-59 era was the Nash-Healey that finished third at the 24 Hours in 1952.

In one of the epic Le Mans contests, Leslie Johnson and Tommy Wisdom gradually climbed the order as others

wilted. One of two entries from Donald Healey's squad (the other being a more tweaked machine that retired), car #10 ran just inside the top 20 early on, was sixth after 14 hours and fifth after 20.

Although not the most powerful or advanced machine, the Nash-Healey did run reliably and, according to Laurence Pomeroy in *Motor* magazine, benefited from the abilities of its lead driver: "With limited engine power due to the in-line pushrod-operated valves this car owed a great deal to the skilled driving of Leslie Johnson, who was at the wheel for over 17 of the 24 hours."

In the closing stages, the consistent Nash-Healey rose to third thanks to the late failures of long-time leader

Pierre Levegh's Talbot and the top Aston Martin of Peter Collins and Lance Macklin. Johnson/Wisdom brought the 4.1-litre machine home at over 91mph, beaten only by the works Mercedes team.

It was a remarkable result for a car that had been crashed on the Mille Miglia early in May, after Donald Healey lost an argument with a bridge. An incredibly quick rebuild by Healey body maker Bill Buckingham and experimental engineer Roger Menadue got the now open racer ready in time for Le Mans.

Before its UK comeback, chassis X-6 had not been silent. After Le Mans, it toured Nash dealers in the United States before being bought by American racer Preston Gray. He ran it in Sports Car

Above: Stretton drove Nash-Healey in its first UK race for six decades at Silverstone

WHEN HEALEY MET NASH Camera fans click

SOMETIMES CHANCE encounters can have profound effects. Donald Healey was crossing the Atlantic, set for a meeting to obtain a Cadillac engine deal, when he started chatting to a fellow camera enthusiast.

That man turned out to be George Mason, president of the Nash Kelvinator Corporation. He predicted a deal with Cadillac would not be possible, but suggested Healey get in touch once he'd got his answer.

In his autobiography, *My World of Cars*, Healey said: "Having found he was right so far as the Cadillac engines were concerned, I got in touch."

Discussion then centred on Nash's Dual Jetfire 3.8-litre six-cylinder powerplant for a Healey-built sports car.

"It was one of the heaviest engines I'd ever been associated with, but it was very robust, and I knew it would never break in any

conditions it might have to face in so small a car," wrote Healey.

A bigger problem was Healey's parlous financial state, but Nash even stepped in on that front. Healey: "We eventually came to

**Healey:
"Without the help of Nash, I could not have carried on"**

a wonderful agreement, whereby they paid off my overdraft, and we were to pay them back in finished motor cars. Without them I could not have carried on."

Not only did the road-car deal save Healey, the first Nash-Healey racer took fourth at Le Mans in 1950 (below) in the hands of Tony Rolt and Duncan Hamilton.



Third place at Le Mans in 1952 was the car's finest moment



More work should boost performance for future outings



Nash-Healey has only competed in a handful of events in prestige races at Monaco and Le Mans, so is not as battle-ready as its rivals when it arrives for what's believed to be its first race on British soil since 1951.

For race organiser and FISCAR chairman John Turner, coaxing the car back out for the Tom Cole Trophy is something of a coup. "When the opportunity to bring this very special car to one of our races arose last year, but it couldn't be readied in time, perseverance was the key," he says. "Both Jose and Sam shared my desire to see it back on track, so the Tom Cole Trophy became the very appropriate target for its return. To see this wonderful old warrior appear on the grid is a truly emotional moment."

Stretton is understandably careful as he heads out onto Silverstone's National circuit for practice. Head-gasket concerns don't help, and Stretton thus lines up on row 17 in the capacity field.

A gearbox issue strikes during the race, so Stretton decides to leave it in top (third gear, though it does also have an overdrive). Fortunately, the torque of the straight-six engine means this isn't too much of a problem and Stretton makes the finish in 29th, albeit two laps down on the victorious 1954 4.5-litre Lagonda V12 of Darren McWhirter.

"The nice thing is to get the car out," says Stretton, who is well aware of the machine's history. "I was very conscious of bringing it home."

Nevertheless, he can already see why it was so at home at the 24 Hours. "It's

Club of America events and then sold the Nash to Herbert Ambler in 1955. He fitted it with a Cadillac V8 engine and, in '58, traded the car at a Ford dealership for a Ford Thunderbird!

This little piece of Le Mans history remained in the States for decades – though it did reacquire a Nash powerplant – before current owner Jose Fernandez brought the car back to Europe in 2003. It was restored in Spain and is now prepared by Capricorn in Germany, with Connaught specialist Spencer Longland running it in the UK.

And so to Silverstone. Experienced historic racer Sam Stretton is the man charged with putting the light-blue car through its paces. Since its rebuild the



got several niggles that would be great to sort out, but it's a typical Le Mans car," he says. "You could drive it all day. The engine's got lots of go, though it did start to stutter. You can see what it's built for."

"I imagine if you got it on the Mulsanne Straight it would be brilliant because it would just pull and pull and pull."

As with most successful Le Mans cars, the Nash-Healey also works with its driver rather than against him. "It's a well-balanced chassis, with a touch of understeer," says Stretton. "It slides around a bit, but there was nothing nasty at all."

First outing successfully completed, the hope now is to sort the Nash-Healey's issues and get it out on track again – finally back where it belongs. ✽

Above left: Nash-Healey has been restored to its Le Mans spec in recent years

WHAT'S ON

MARCUS SIMMONS

F1 SHOCKS IN RADIO NEWSFLASHES

Some of us are old enough to have grown up when there was hardly any motorsport on TV. In the 1970s, the only way of finding out what had happened in a grand prix before the Monday papers came out was by tuning in to Radio 2 at 6pm on a Sunday to hear the report... "from Autosport's Simon Taylor".

I was sure he had it wrong once, though. Eight-year-old me decided Jacques Laffite couldn't possibly have finished second in the '75 German GP – in a Williams! Two weeks later Taylor announced from the Osterreichring that Vittorio Brambilla had won, as dad drove us back from a Thruxton Formula 5000 race in his Ford Capri. By now I'd realised nothing was impossible in mid-'70s F1.

KEVIN TURNER

1980s BTCC VIDEO THRILLS

As a kid, I threw myself into any motorsport coverage I could find – particularly season review videos. One of the earliest was for the 1988 British Touring Car Championship.

Sponsored, like Andy Rouse's Ford RS500, by Kaliber, the video my dad bought documented a season dominated by Rouse but won by Frank Sytner's BMW M3, thanks to the era's idiosyncratic class rules.

Rouse made himself one of my childhood favourites by overpowering visiting European Touring Car Eggenberger Ford driver Steve Soper to win one of the BTCC's finest battles at Brands Hatch.

MATT BEER

FRIDAY NIGHT GERMAN EXOTICA

Top Gear Motorsport on 1990s Friday nights opened my eyes to the beyond-F1 world, and in particular the DTM/ITC – which seemed so futuristic compared to the Super Tourers I'd started enjoying on *Grandstand*. There's a whole generation of Class One drivers and tracks whose names I can only hear in my head in Tiff Needell's intonation ("silly Singen").

ALEX KALINAUCKAS

HAS A LUMP IN HIS THROAT

As a five-year-old being put to bed one Sunday in October 1996, I vividly remember asking my parents if they'd recorded the highlights of Damon Hill's

Broadcasts that got us hooked

The motorsport TV/video/radio moments that encapsulate childhood racing viewing for the Autosport and Motorsport News teams



Above: Jorg van Ommen at Singen in 1995. Heaven for young 'Matthias Bier'

Left: Alain Menu winning again (in blue-and-yellow livery, of course)

win in the Japanese Grand Prix.

I watched that VHS tape so often I memorised Murray Walker's commentary from the moment the lights went out to his famous line "and I've got to stop, because I've got a lump in my throat".

This triggered a lifelong passion for motorsport but also became a novelty my parents had me perform on demand at family functions – not that I'm bitter or anything...

SCOTT MITCHELL

SUPER TOURING WITH A FIVE-YEAR DELAY

My dad used to bring Duke VHS British Touring Car Championship season reviews home from the Autosport Show. My childhood just about predates the proliferation of the internet, and the prospect of a new video excited me so much. It never occurred to me, let alone

GET AUTOSPORT ON THE MOVE

DOWNLOAD IT NOW FROM AUTOSPORT.COM



German GP 1975: surely this car can't have finished second

bothered me, that I was watching these 'new' videos out of sync – my Super Touring consumption had a delay of about five years!

Time was irrelevant. All I cared about was whether Alain Menu would win – and being furious at the loss of the blue-and-yellow Laguna livery for 1998. Green Nescafe? He'll never win the title in that...

JACK BENYON A WRC SHOWMAN

"Going into stage 15 with a lead of 42s, Gilles decided he'd give the thousands of spectators at the bridge a little treat." I'll never forget those words from Eurosport WRC commentator Mark James in Rally Spain 2002, the first TV broadcast I truly remember. Gilles Panizzi was the showboating culprit, happy to risk his lead with a mid-stage doughnut.



HOT ON THE WEB THIS WEEK

YouTube TEXAS INDYCAR'S MASSIVE SMASH

Search for: Josef Newgarden and Conor Daly Incident

Josef Newgarden was taken to hospital with shoulder and wrist injuries after this huge crash with Conor Daly on lap 42 of the Texas Motor Speedway IndyCar race. Daly, who blamed himself for the "rookie mistake" that led to the incident, was unharmed.

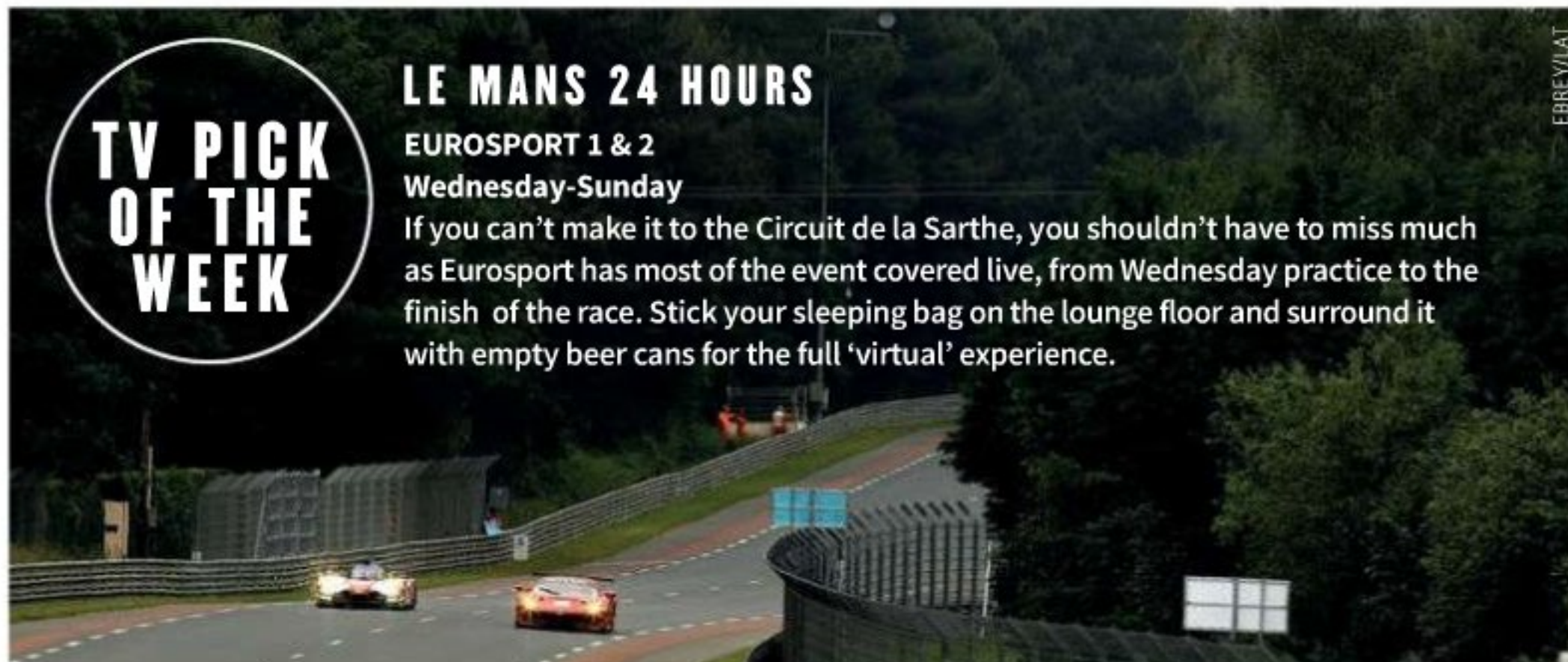

TV PICK OF THE WEEK

LE MANS 24 HOURS

EUROSPORT 1 & 2
Wednesday-Sunday

If you can't make it to the Circuit de la Sarthe, you shouldn't have to miss much as Eurosport has most of the event covered live, from Wednesday practice to the finish of the race. Stick your sleeping bag on the lounge floor and surround it with empty beer cans for the full 'virtual' experience.

INTERNATIONAL MOTORSPORT

EUROPEAN GRAND PRIX FORMULA 1 WORLD CHAMPIONSHIP

Rd 8/21
Baku, Azerbaijan
June 19
WATCH ON TV
Live: Sky Sports F1, 1330; Channel 4, 1300
Highlights: Channel 4, 2325

GP2 SERIES

Rd 3/11
Baku, Azerbaijan
June 18-19
WATCH ON TV
Live: Sky Sports F1, Saturday 0900; Sunday 1055

LE MANS 24 HOURS WORLD ENDURANCE CHAMPIONSHIP

Rd 3/9
Le Mans, France
June 18-19
WATCH ON TV
Live: Eurosport 1, Saturday 1345-Sunday 1445

GT3 LE MANS CUP

Rd 2/6
Le Mans, France
June 18

TCR INTERNATIONAL

Rd 6/11
Oschersleben, Germany
June 19
WATCH ONLINE
tcr-series.com

V8 SUPERCARS

Rd 6/14
Hidden Valley, Northern Territory, Australia
June 18-19
WATCH ON TV
Live: BT Sport 1, Saturday 0715; Sunday 0430

SCANDINAVIAN TOURING CARS

Rd 3/7
Anderstorp, Sweden
June 19

SUPER TC2000

Rd 5/12
Rio Hondo, Argentina
June 19



GP2



TCR INTERNATIONAL

UK MOTORSPORT

CROFT BTCC

June 18-19
BTCC, MSA F4, Porsche Carrera Cup, Renault Clio Cup, Ginetta Junior, Ginetta GT5 Challenge
WATCH ON TV
Live: ITV4, Sunday 1100

DONINGTON PARK BARC

June 18-19
Historic Touring/Classic Saloon Cars, Pre-1983 Touring Cars, Pre-1993 Touring Cars, Pre-2003 Saloon Cars, Pre-2005 Production

Touring Cars, Blue Oval Saloons, Thunder Saloons, Classic VWs, Historic Thunder Saloons, Scottish Minis, Porsche Club, Castle Combe Saloons, Mini Miglia, Mini Se7en, MGOC, CNC Sports/Saloons, Mighty Minis, MaX5
WATCH ON TV
Motors TV, Sunday 1800

CADWELL PARK HSCC

June 18-19
Wolds Trophy: Historic Formula 3, Historic FF2000, Historic FF1600,

Classic Racing Cars, Formula Junior, Historic Touring Cars, Classic Clubmans, Historic Road Sports, '70s Road Sports, Classic FF2000, Midgets/Sprites

ROCKINGHAM MSVR

June 18-19
GT Cup, Lotus Elise, Radical Challenge, Trackday Trophy, Monoposto, Mini Challenge, Production BMW, Racing Saloons



ARC HA

SEVA MAR CEM

DUTRAY DUTRAY

Esso toujours en tête

Esso toujours en tête

Esso

Esso

NE VABE

GARNITURES DE FREINS

Pernod

M A

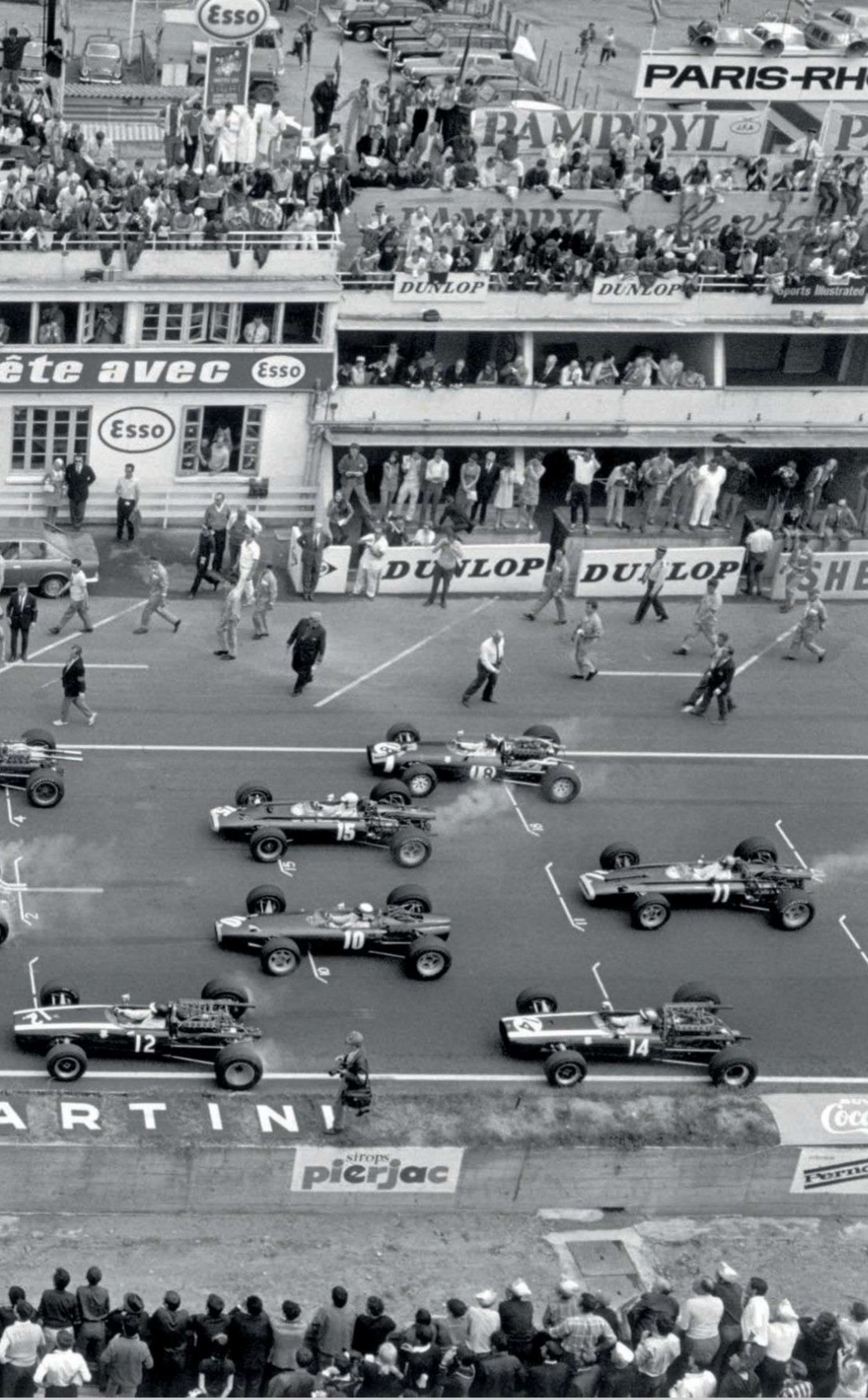

THE ARCHIVE

1967 French Grand Prix, Bugatti Circuit, Le Mans: Graham Hill (#7 Lotus 49-Ford Cosworth), Jack Brabham (#3 Brabham BT24-Repco) and Dan Gurney (#9 Eagle T1G-Weslake) lead Jim Clark (#6 Lotus 49-Ford Cosworth), Bruce McLaren (#8 Eagle T1G-Weslake), Denny Hulme (#4 Brabham BT24-Repco), Chris Amon (#2 Ferrari 312), Jochen Rindt (#12 Cooper T81B-Maserati), Chris Irwin (#15 BRM P83), Jackie Stewart (#10 BRM P261), Jo Siffert (#18 Cooper T81-Maserati), Pedro Rodriguez (#14 Cooper T81-Maserati) and Mike Spence (#11 BRM P83) at the start

www.latphoto.co.uk
[@latphotographic](https://twitter.com/latphotographic)

TOP FIVE

LINE-UPS IN BAD CARS

The trials and tribulations endured by top-class drivers in underwhelming machinery make for painful memories – but fascinating stories. When the best drivers are combined with an exceptional piece of engineering the result is astounding. But it's a fact of Formula 1 life that there are always going to be more underperforming cars than there are world-beaters – here are the best examples of driver line-ups that ended up on the wrong side of that.

STALEY/LAT



1 JENSON BUTTON AND FERNANDO ALONSO

Honda has to bear the most responsibility for a package that was simply nowhere near good enough for its world champion pedallers Jenson Button and Fernando Alonso (and Australia stand-in Kevin Magnussen) in 2015. The three suffered 15 non-starts or non-finishes from 38 attempts, scoring points in just six of 19 races. The MP4-30 is statistically the joint-worst performing full-season effort in McLaren's history, taking it to ninth in the constructors' championship.



2 JODY SCHECKTER AND GILLES VILLENEUVE

Slow and unreliable is a bad combination, especially when it's a package that succeeds a world championship winner. But the Ferrari 312T5 was awful. World champion Jody Scheckter and the mercurial Gilles Villeneuve won more races in 1979 with the 312T4 than they scored points finishes in 1980. Ferrari suffered a double retirement in the first three rounds of the campaign and toiled for the remainder.

3 JENSON BUTTON AND RUBENS BARRICHELLO

By modern Formula 1's standards, Honda's 2007 offering was a bit of a freak – draggy in a straight line but lacking sufficient downforce to be effective in corners. The result was Jenson Button and Ferrari veteran Rubens Barrichello scrapping with the tail-enders. Button scored six points and Barrichello none, making it a contender for the worst-performing F1 car pound-for-point in history.



4 NIGEL MANSELL AND RICCARDO PATRESE

The FW12's active suspension was petulant, while its Judd engine was underpowered and had a penchant for expiring. The normally aspirated 3.5-litre V8 gave up the ghost nine times in the first six races, with Nigel Mansell and Riccardo Patrese both retiring in Brazil, Mexico, Canada and the US and Mansell having another failure in San Marino. Mansell did score two podiums, though.

5 RONNIE PETERSON AND NIKI LAUDA

March's 721 failed in three varieties to live up to the promise of the previous two campaigns. Whether driving the initial version or the experimental 721X with an Alfa gearbox, Peterson and Lauda failed to make much impact. The Swede did score a podium once the team switched to the pumped-up Formula 2 car that was the 721G, but that's a paltry return between two of the 1970s' greatest drivers.



AUTOSPORT

Haymarket Consumer Media, Bridge House, 69 London Road, Twickenham TW1 3SP Tel +44 (0) 20 8267 5998
Email autosport@haymarket.com Website www.autosport.com
Individual email firstname.surname@haymarket.com

Editorial

Editor-in-Chief **Edd Straw**
Editor **Kevin Turner**
Deputy Editor **Marcus Simmons**
Chief F1 Correspondent **Ian Parkes**
Grand Prix Editor **Ben Anderson**
F1 Reporter **Lawrence Barretto**
Features Editor **Scott Mitchell**
Chief Sub-Editor **Peter Hodges**
Executive Editor **Stuart Codling**
Group National Editor **Rob Ladbrook**
Rallies Editor **David Evans**
BTCC Correspondent **Matt James**
Art Editor **Lynsey Elliott**
Senior Designer **Michael Cavalli**
Office Manager **Joanne Grove**

Autosport.com

Editor **Glenn Freeman**
Deputy Editor **Matt Beer**
International Editor **Mitchell Adam**
Technical Team Leader **Geoff Creighton**
Senior Digital Designer **Amar Vijay**

Special Contributors

Gary Anderson, Alan Eldridge, Mark Glendenning, Marcus Pye, Dieter Rencken, Gary Watkins

Correspondents

Argentina Tony Watson **Australia** Phil Branagan
Austria Gerhard Kuntschik **Belgium** Gordon McKay
Brazil Lito Cavalcanti **Finland** Esa Illoinen **Germany** Rene de Boer
Greece Dimitris Papadopoulos **Italy** Roberto Chinchero
Japan Jiro Takahashi **New Zealand** Bernard Carpenter
Russia Gregory Golyshev **Spain** Raimon Duran **Sweden** Tege Tornvall **USA** Bruce Martin, Jeremy Shaw **UK & Ireland** Pete Allen, Jack Berlyon, Jonathan Crawford, Jack Cozens, Kerry Dunlop, Tom Errington, Linda Keen, Alex Kalinauckas, Lewis Larkam, Mark Libbeter, Stephen Lickorish, Marc Orme, Dan Paddock, Graham Read, Hal Ridge, Aaron Rook, Peter Scherer, Seb Scott, Ian Sowman, Oliver Timson, Ian Titchmarsh, Eddie Walder, Richard Young

Advertising

Tel +44 (0) 20 8267 5271
Email autosport.ads@haymarket.com

Sales Manager James Robinson

Display Advertising **Don Rupal, Karen Reilly**
Classified Advertising **Jamie Brooker, Jonathan King, Joe Andrews**
Autosport.com Sales Manager **Fiona Bain**
Online Advertising **Leah Mimms**
Advertising Director **Matthew Witham**
Group Commercial Director **Ben Guynan**

Advertising Production

Tel +44 (0) 20 8267 5588 Fax +44 (0) 20 8267 5320
Production Controller **Abbey Gunner** abbey.gunner@haymarket.com

Subscriptions

UK +44 (0) 344 848 8817 **Overseas** +44 (0) 1604 251451
Email help@autosport.themagazineshop.com
Back issues 0344 8488817

Direct Marketing Executive **Maria Fernandez** +44 (0)20 8267 8254

Autosport, ISSN number 0269946X, is published weekly by Haymarket Media Group, Bridge House, 69 London Road, Twickenham TW1 3SP, United Kingdom. Airfreight and mailing in the USA by agent named Air Business Ltd, c/o Worldnet Shipping Inc., 156-15, 146th Avenue, 2nd Floor, Jamaica, NY 11434, USA. Periodicals postage paid at Jamaica NY 11434. Subscription records are maintained at Haymarket Media Group, Bridge House, 69 London Road, Twickenham TW1 3SP. Air Business Ltd is acting as our mailing agent.

Licensing and Syndication

International Director **Alastair Lewis** +44 (0)20 8267 8606
Syndication enquiries **Isla Friend** +44 (0)20 8267 5024

Management

Group Director **Tim Bulley**
Group Publisher **Stuart Williams**
Group Editor **Anthony Rowlinson**
Group Publishing Manager **Sunita Davies**
Special Events Manager **Laura Coppin**
Digital Special Project Manager **Simon Strang**
Digital Product Manager **Simon Grayson**

© 2016, HAYMARKET MEDIA GROUP LTD

Publishing, trade and further subscription details on www.autosport.com. While due care is taken to ensure the contents of Autosport are accurate, the publishers and printers cannot accept liability for errors and omissions. Advertisements are accepted for publication in Autosport only upon Haymarket Media Group Ltd's Standard Terms of Acceptance of Advertising, copies of which are available from the Advertising Sales Department of Autosport.

CIRCULATION TRADE ENQUIRIES

Frontline Ltd, Park House, 117 Park Road, Peterborough, Cambs, PE21 2TS. Tel: +44 (0) 1733 555161. Printed in England by Wyndeham Peterborough Ltd. ISSN 0269-946X. Autosport, incorporating Autoclassic, is published weekly by Haymarket Consumer Media, Bridge House, 69 London Road, Twickenham TW1 3SP.

Editorial Director **Mark Payton**
Strategy and Planning Director **Bob McDowell**
Managing Director **David Prasher**
Chief Executive **Kevin Costello**



Haymarket is certified by BSI to environmental standard ISO14001





THREE STUNNING EVENTS

ONE GREAT YEAR OF MOTORSPORT AT KNOCKHILL!



Thrilling **British Superbike** racing returns to Knockhill for three days of top-notch championship racing.

24/25/26 JUNE



British Touring Car racing makes another dramatic appearance at Knockhill... action is guaranteed.

13/14 AUGUST



Relive the glory days of **British Touring Car** racing with this iconic Super Touring event.

10/11 SEPTEMBER

TICKETS ON SALE NOW - KNOCKHILL.com

SelectMotorRacing.com

INTERNATIONAL MOTORSPORT EVENTS ▶ RACE TICKETS ▶ HOSPITALITY & TRAVEL



Run by Fans for Fans

Motorsport Travel + Tickets + Hospitality Flexible Travel Options

Escorted Tours | UK Travel Team | By Air | Coach Tours | Self Drive
Hospitality | Circuit | Yachts | Team Packages | Paddock | Amber Lounge



ALL FORMULA ONE IN 2016



WORLD ENDURANCE CHAMPIONSHIP



HOSPITALITY
BRITISH - SINGAPORE - ABU DHABI



GOODWOOD FESTIVAL OF SPEED AND
GOODWOOD REVIVAL



UK TRAVEL TEAM: +44 (0) 1451 833 721

BOOK ONLINE: enquiry@selectmotorracing.com

