

Leading-Edge Motorsport Technology Since 1990

Racecar engineering™

September 2012 • Vol22 No9 • www.racecar-engineering.com • UK £5.50 • US \$13.50



FORMULA 1

Model of efficiency The Sauber C31



Robin Herd

Legendary designer on the arrival of wings in F1



Mazda SKYACTIV-D

Controversial introduction of diesel for LMP2 in the ALMS



Formula Student

Latest innovations from universities around the world



Better Plumbing. Better Performance.



Full Swivel, Dual Angled Seats
Aerospace Style Nipple & Cutter
TITech & Other Custom Anodized
Finishes Available

Contoured
Entrances for
Excellent Flow

Braided
Stainless Steel
CPE Hose

XRP branded
aluminum hose ends
and adapters are
made in the USA

Flexible
HS-79 PTFE Hose
Aramid Fiber Braid
4-ply Construction
Tight Bend Radius.
High Hoop Strength
High Vacuum
& Temp Rated

HS-79 Hose with
Black CSM Outer Coating
to Resist Abrasion

Quick Disconnect
Couplings with Triple Latch
Finger Snap Closures

Get the ConneXion.™



Top Quality Carburetor Kits
Demon, Holley, Braswell & QFT
Forged & Swept Tube Models
Choose From Red/Blue,
Black or Super Nickel
End Fittings

Clamshell Style
Quick Disconnect Coupling
Fast. Smart. Secure.

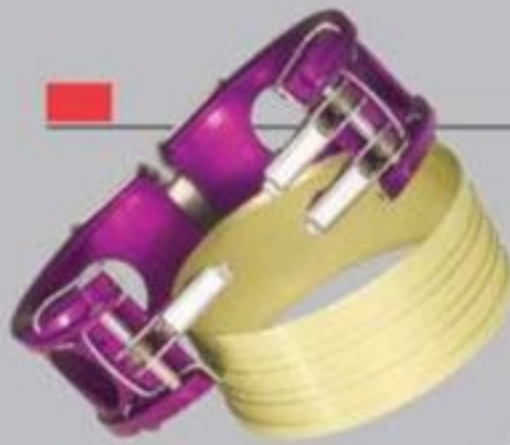

NEW In-Line Filter... Modular so changing fittings is easy
Anodized aluminum body (2.5" diameter; Max. length 11")
Use AN end fittings (-8 thru -20) or Clamshell Style
Quick Disconnect Couplings (call for sizes)
Fittings available with optional female
accessory port on the inlet side
for temp probes, etc.

Pleated
stainless element
60 sq. in. filtering area
45, 60, 75, 100 or 120
micron screens



Optional 15 psi
pressure differential
relief valve.
Heavy-duty cores
also available.



XRP®

THE XTREME IN RACECAR PLUMBING

Go to WWW.XRP.COM for
catalog downloads & new products

UNITED STATES XRP, Inc. sales@xrp.com tel 562 861 4765 fax 562 861 5503
EUROPE JLS Motorsport motorsport@lister.co.uk tel 44 (0) 121 525 5800 fax 44 (0) 121 525 4833



COVER STORY

- 8 **Sauber Formula 1**
Small and efficient, the Swiss team is quietly working towards its goal of being at the front of the grid full time

COLUMNS

- 5 **Ricardo Divila**
Our man quaffs coffee on the banks of the Loire and questions why anyone would want to be a race engineer
- 7 **Sam Collins**
Building a high specification facility is not the right way to introduce motorsport to a new market

FEATURES

- 16 **Designers: Robin Herd**
Herd talks us through his iconic designs, and tells us that ugly cars are rarely good cars
- 20 **Force India**
The team explains its new aerodynamic philosophy and the new driving style required to make the solutions work
- 26 **Toyota Yaris R1A**

TECHNICAL

- 29 **The Consultant**
Mark Ortiz describes vehicle dynamic simulation in step-by-step detail
- 33 **Databytes**
Using pitot tubes for aerodynamic data acquisition

- 37 **Aerobytes**
Examining the effects of differing rake angle and rear wing element on the Dallara F312 Formula 3 car
- 41 **Mazda SKY-ACTIV D**
A high-revving, low compression ratio, diesel race engine for LMP racing in the US and Europe
- 46 **Formula Student**
Another successful competition in the UK and the US. We look at aero, suspension and engine solutions
- 63 **Hyperco Bellows Spring**
The latest advance in carbon fibre suspension technology
- 66 **Cranfield Inertia**
How Force India uses an innovative rig in England to find its moment of inertia and c of g height
- 71 **Suspension**
We delve into the world of dampers and bearings
- 77 **Danny Nowlan**
Part two of Danny's beginners' guide to getting started in racecar simulation

BUSINESS NEWS

- 82 **Industry news**
Nürburgring close to going bust; Dennis calls for more engineering in the UK; endurance racing news
- 88 **Racecar people**
MIA launches STEM initiative; ATL's Giles Dawson under the spotlight; politicians praise UK motorsport industry
- 95 **New products**
- 98 **Bump stop**



Subscribe to *Racecar Engineering* - find the best offers online
www.racecar-engineering.com

QUALITY AND RELIABILITY



HIGHER FLOW RATES LESS FRICTION MORE POWER

With more than 40 years of experience manufacturing high performance racing valves, Supertech utilizes the finest material and design to make available the most durable, high performance racing valves on the market today. Supertech valves are forged, CNC machined, and hand polished for strength and reliability.

All Supertech parts are measured against the strictest tolerances in the industry and utilize finite element analysis, enabling us to provide a high performance product, without sacrificing durability. Regardless of your high performance needs, Supertech is the best choice for you if quality, durability and performance are vital to your needs.



3580 Charter Park Dr. San Jose, CA. 95136 USA
www.supertechperformance.com

(408) 448-2001



Experientia docet

So you want to be a motorsport engineer? Are you absolutely sure?

The most common question I get asked by aspiring young engineers is 'how do I get into motor racing?' I usually try to dissuade them, pointing out that as a career they will be better off in industry, where they will bring something to the common weal and presumably earn enough to keep body and soul together.

I will not even get into family and human intercourse, as being involved in successful racing demands a single-mindedness worthy of an Asperger syndrome sufferer, and tends to kill social life, unless you consider having drinks with the team at airport lounges a social life.

And on the rare occasions you beat the opposition roundly, it is all swiftly forgotten in the preparation for the next race, where you could conceivably be beaten. Oh, the ignominy of it all.

So you still want to go racing? First, question yourself about your reasons for doing so. The glamour and excitement of it? Not much glamour in working 18 hours a day and to be mired in a drafty pit trying to prepare a car for the forthcoming clash, with some essential ingredient missing. Then there's the endless travelling and hassle of overcrowded airports, intrusive security manned by the true descendants of concentration camp overseers, the feeling of being a jet-lagged sheep, herded down endless corridors with the great unwashed...

It was better in the halcyon days, when you loaded up the trailer with the racecar, spare wheels on the roof rack, toolbox in the boot, and cruised through Europe living off the starting fee and prize money. Excellent meals in picturesque towns, working in the sun in foreign paddocks wearing shorts, where every day brought a new adventure. It can't have been that good, but still...

The years of having the right tyre / engine / driver / finance / team / management combination are relatively rare and, as soon as

you reach the pinnacle and are winning, you can be sure Nemesis will come calling with a run of DNFs and mysteriously lacking performance.

Not dissuaded yet? What about the fact that despite all your best efforts, the ultimate result will be dependent on all the other



In a field of 26 cars, you have a 3.85 per cent chance of victory

members of the team, personal interaction and state of mind. Some of this you can influence but most of it is left to chance and circumstance, life being what it is.

On the other hand, there's the sheer pleasure of making things work, and managing to get a disparate group of people with different aims coalesce into a solid team, motivating that essential part of the car - the nut

it takes to do things. To react and improve upon what you already have can be a fraction of what it takes in normal industry. Hence the reason for several manufacturers' practice of funnelling their engineers through racing - it is a crash course in can-do ability that will stand you in good stead in

other engineering processes.

The second good point is that you are confronted with the consequences of your decisions very quickly, because you will be pitted against equally competitive people, some better skilled than yourself, which will keep you on your toes and teach respect for new ideas and solutions. As I have said before, racing is the civilised counterpart of warfare and, in

"an extremely addictive adrenaline rush, not found in other design offices"

behind the wheel - then going out and beating a similar bunch of single-minded people can be very satisfying. Akin, perhaps, to the glow a bunch of Cro-Magnons had in the European Upper Paleolithic era when bringing to the camp the day's hunt bounty.

What good I can say about racing will be mainly about learning how to overcome challenges in a difficult environment, learning about planning and structuring your working day, choosing your tactics and flexibility and, most of all, learning the amount of time

F1 for example, the input of resources, finance and individual effort is what drives technological and engineering progress. As 'the enemy' is doing the same, any advantage you acquire will soon be overtaken.

Learning to work under pressure, and the imperative of coming up with the small 'unfair advantage' needed every race to keep from being defeated gives an extremely addictive adrenaline rush, not found in other design offices. Building a bridge, a ship or being involved in the design

of a production car might carry bigger financial responsibility in the long run, but does not have the unrelenting pressure to perform, right now.

I would even go far into character building. Being resilient and having the moral strength to bounce back after being thoroughly beaten, without hiding behind 'they have better engines / tyres / driver / car' excuses. If 'they' do, knowing what resources, ideas or schemes to deploy to resolve the problem before the next race.

And do not delude yourself, you *will* be beaten, and often, for there are only three places on the podium, so in a field of 60 cars you will have a five per cent chance of being there. At best, in a classic 26-car field, the odds will be a mere 11.5 per cent. Personally, I adhere to the dictum, 'second place is the first loser', which brings victory into the 3.85 per cent range.

If anything, this is what one laments about spec formulae, where the cars are frozen and the engineer only has to work with team running and driver management. It ends up then being rather knee-jerk reactive work, with a small burst of adrenaline for the qualifying session, judging the best time to go out and some agonising over the set up, even though the possible changes are limited.

Of course, if you're not in it to win, the choice of reverting to industry is even more logical. Imagine a normal life - family, holidays, no pressure, no travelling, no late nights and lost weekends. Sounds boring...

If all this does not make you go back to industry, let me remind you of some words spoken some centuries ago: 'All, all is theft, all is unceasing and rigorous competition in nature; the desire to make off with the substance of others is the foremost - the most legitimate - passion nature has bred into us and, without doubt, the most agreeable one.' - Marquis de Sade.

we're driving success.

At epm:technology we continue to drive our clients across the finishing line, where others have failed.

A combination of industry know-how and a can-do attitude, means we constantly push the very boundaries of composite technology.

We apply this philosophy to all our customers - from motorsport right through to aerospace.

epm: technology group

ENGINEERING MOMENTUM

20 Victoria Road, Draycott, Derbyshire DE72 3PS
01332 875451

epmtechnology.com



Think small

Contrary to popular belief, bigger, or more expensive, is not always better

It frustrates me a bit more every year - the increasing number of Formula Student teams rolling out a composite monocoque chassis. Yet the rules state that the car should be designed for the weekend racer. When criticised for this, the students howl in unison (along with not a few spec series bosses) that composite monocoques are safer, stiffer and generally better. What I actually hear is, 'we want to be in F1'. I accept that carbon chassis are stiffer, safer and all of those other good things - after all, that is why they are used in F1 - but for the weekend racer? I think not. Weekend racers crash, a lot. Carbon chassis are very difficult and costly to repair. Even a small knock can do major damage and require either significant repair or replacement. That's not realistic for a weekend racer.

But that's not to say that a tubular steel chassis is the only way to go. Every year students come up with different and innovative chassis solutions, and they need to be studied, as many have concepts that can be directly utilised directly by weekend racers.

The problem is, motorsport creates an obsessive follow-my-leader attitude, where that leader is Formula 1, and a mentality of 'it must be better because that is what they do in F1'.

I guess it's true of all sports. If the top time trial rider in the Tour De France uses Zipp 808 section dimpled wheels costing \$1000 each, then you can bet in your local cycling club there will be a couple of guys running the same wheels. If it were motorsport though, the technical regulations would doubtless force all participants to use the same identical wheels (to control costs, of course).

Cycling is a developing sport in the UK, and many local cycle events are really a case of 'run what you bring', just to get

people into it before taking it too seriously. The organisers are doing whatever they can to get rid of any barriers to participation. Unfortunately, this does not seem to be a trick that motorsport has learnt.

On my travels recently I have visited a number of developing motorsport markets, and the difference in approach is striking.

Returning to the example

"You need to host events that appeal to the local market"

of cycling, the logical way to introduce the sport to an area such as Africa, which has never really seen much cycling, is to host a demonstration event at a temporary facility, followed immediately by an open event where anyone with two wheels, pedals and the will to compete can take part. Then grow it from there. If it were done in the way motorsport seems to think the

best route, an Olympic-standard velodrome would be built in the heart of the city, a race for the world's elite would be held with prohibitively high ticket prices, then afterwards other top foreign series would come to visit on occasion, with the only interest for the general public perhaps being one wealthy, but not especially gifted, local struggling to keep up. You might laugh, but

that is exactly what motorsport has done in places like Bahrain, Turkey and China.

I am working on projects to help develop motorsport in a few markets, including the Caribbean and Nigeria, and am constantly fighting off people trying to sell them top end series and FIA category 1 (F1) circuits. This is a bad idea. What they need to do is build the grass

roots of the sport, keep costs down and create a solid core of those aforementioned weekend racers. To do that, you need cars that are affordable, simple to maintain and, most importantly of all, cheap to fix! You need to host events that appeal to the local market, and that may not be Formula 1 cars, and it almost certainly is not a spec series. In Barbados, for example, they really like highly modified saloon cars (think DTM), whilst in Nigeria everyone wants to see exclusive exotica (think GT3), and South East Asia likes nothing better than watching modified sports cars (GT300).

There is a very good lesson that NASCAR can teach here - high tech and high end is not always better. Putting on a good show is more important than anything else when you are trying to build a sport from nothing, and F1 does not always get it right, as anyone who watched the Hungarian Grand Prix will tell you. 



Building cathedrals to excess is fine but, with no congregation to fill them, they have no future

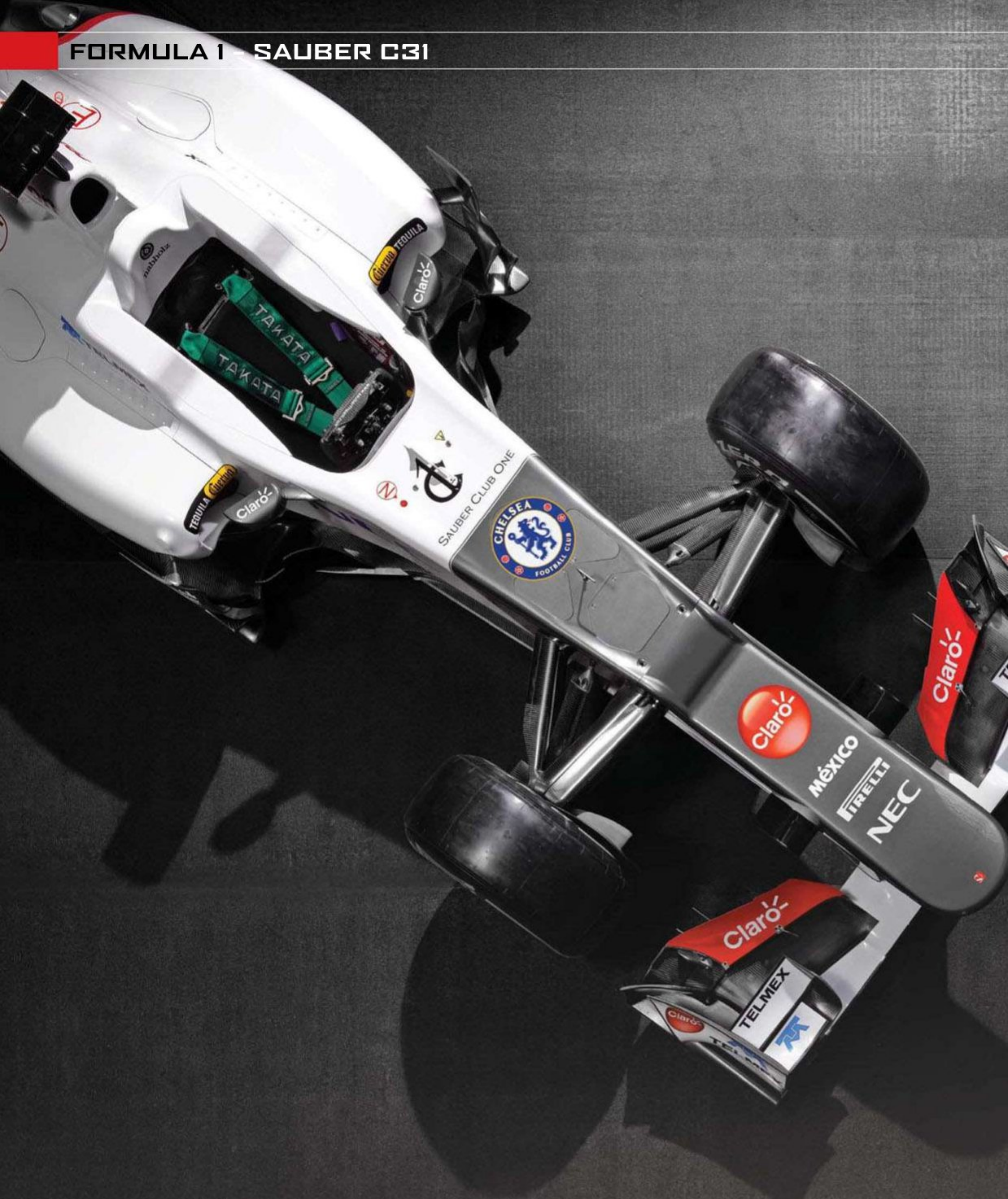

“we don't have a lot of people or a lot of money, so everything we develop has to work”

Efficiency drive

Lacking the budget of the big teams, Sauber has performed beyond expectations, and remains the only team on the Formula 1 grid to fully understand the Pirelli tyres

BY SAM COLLINS



Formula 1 has seen a record number of winners in the opening races of the 2012 season.

Some of that has been down to gained or lost performance through rule changes regarding blown floors and diffusers. However, as detailed in *Racecar Engineering* V22N8, it is understanding the Pirelli tyres, and making them work, that is key to success. Some teams find the sweet spot by accident, others, like Sauber, claim its car works perfectly with the Italian tyre compounds.

Efficiency, in all of its forms, was high on the list of design criteria for the C31. Ever since the Sauber team

parted company with BMW, it has lacked in sponsorship and, as a result, perhaps lacks the budget of the bigger teams it is often racing with.

'One of the things with this team is that we don't have a lot of people or a lot of money, so everything we develop has to work,' explains Matt Morris, the Swiss team's chief designer. 'So we can't really develop two solutions and choose which one works best. As a result, we spend a lot of time doing up-front simulation, CFD and tunnel work and, to be honest, one of the reasons we can make a competitive car and have an efficient way of working is because we have got very good correlation between CFD,

the wind tunnel and on track. If the guys working in CFD find something, it carries over to the wind tunnel and then, of course, onto the track.'

The result is, at first glance, a very conventional 2012 Formula 1 car, which borrows heavily from the 2011 C30. Its rollover structure, for example, is simply a lighter version of last year's design, but the overall design of the C31 is tidier, and a lot of time has been spent on the attention to detail. 'The wheelbase has changed very little,' Morris reveals. 'The amount we have changed it would have zero effect on the car performance. It's not a first order effect, it tends to be as a result of other

things you want to do on the car in terms of packaging. It sort of comes out in the wash whether it goes longer or shorter, at least within a window. Outside of that, you could find or lose some performance, but we are only talking a few millimetres.'

NEW DAMPING

The front suspension has been optimised for integration with the chassis and the upright. Otherwise, it's a traditional layout with a pushrod and a high level wishbone. The dampers and springs are packaged quite differently compared to the C30, in order to support a new philosophy for the front suspension set up.



Top: central 'vent' is not a vent at all, but smooths airflow around the nose. **Middle:** packaging in the sidepods is a 'nightmare', and airflow through the radiators is controlled by blocking the system (see right), depending on track temperature. **Bottom:** continual development work goes into the cooling ducts on the C31's brakes, optimising them for different tracks

One of the key things for the car was to retain the way it worked with the tyres, as the C30 was well known for being easy on the rubber. 'At the end of last year, we sat down and looked at everything and made a list of things we needed to have available. One of those was the way we use the tyres, and we designed that into the car's

architecture,' Morris continues. Sauber, it seems, is the only team on the grid that feels it has a good understanding of the 2012 tyres, as head of track engineering, Giampaolo Dall'Ara, explains: 'I don't want to sound like someone who knows everything, and sound arrogant, but when I read in the press that the teams are

struggling to understand the tyres and interaction with the car, and look at the outcome of the races, it supports that, but we do not have an issue with that, we understand it well. We have, of course, had some bad races because of others factors in the car's design, and some bad races because of incidents. But looking at the tyres alone, comparing

extract the most out of them. It is about having the tools available in terms of the mechanical car set up, and allowing us to do all the different circuits and still get the most out of the tyres. Like most things in F1, you usually have to compromise something else to achieve what you want, be it weight, or aero, or something else. But I think our balance is

"I think our balance is something that just works quite well on the tyres"

them to one year ago they are a lot easier to work with for us.'

Contrary to the belief of some in the paddock, the Sauber is not equipped with a special tyre saving solution. Indeed, Morris believes the engineering tools the team used to crack the Pirelli code are already available to most of the grid. 'There is no black magic or golden bullet. Perhaps we've developed a better understanding of how it works. Most of the work understanding it is done purely on simulation. In terms of testing, it's very difficult. The only way to test the tyre is on the track, and we don't have too much time on the track!'

LONGER STINTS

Sauber does not use its understanding of the Pirelli tyres to improve outright lap time, or to get the tyre into its working range faster. Indeed, the opposite is often true. The C30 baffled many of its rivals with its ability to run much longer on a stint without the tyres going off, which means the team make fewer pit stops and gradually move up the field as faster cars lose time on in and out laps. It can also mean that the softer - and theoretically faster - tyre can be used for a larger portion of the race. 'I think there's a lot of things you can do to make tyres last longer, but there's always that compromise between qualifying performance and race pace,' explains Morris. 'We spend a lot of time and effort understanding what the tyres actually want, in terms of making them last longer and trying to

something that just works quite well on the tyres. That really is one of our key philosophies. We've got a really good group of guys back in Hinwil that really understand [the tyres] and know what to do with them. I guess they are one of the golden bullets, especially Pierre Wache. He is an ex-Michelin engineer and is in charge of our vehicle dynamics group. He knows what the tyre needs.'

NEATLY PACKAGED

One of the major differences between the Sauber C30 and the 2012-specification C31 is at the rear end, and it has the potential to have a major impact on the car's usage of the tyres. Mounted to the now-familiar Ferrari 056 V8 engine is an all-new carbon fibre transmission, identical to the one used in the works F2012. The 'box is, according to the team, a 'very tidy and neat unit.' The entire rear of the car is much more tightly packaged as a result.

Crucially, the rear suspension is now a pull-rod design, featuring a long pull rod towards the front of the gearbox and wide angled wishbones. This allows improved packaging of the rear spring and damper elements. Despite the change from push rod to pull rod, in terms of kinematics, the engineers maintained a similar direction to the C30, and that was all to do with the tyres.

'With the Ferrari gearbox casing, we are limited on the inboard pick ups, but we are pretty much free on the other inboard suspension elements, dampers, springs and geometries,

and of course totally free outboard,' reveals Morris. 'What is not ideal is choosing the rear suspension geometry, but even with those restrictions, it's still pretty open for us. As a result, we have not really struggled with the tyres this year, apart from in Bahrain, and that's because it was really hot and there are a few things that were not available to us there.'

But, as Morris mentions, getting the maximum life out of the current breed of tyres is a compromise, which often comes at the expense of single lap performance.

'We realised last year we had done a good job on the tyre management. We found that with the Pirelli it was very easy to get them to perform and get them to work, but it was not very easy to make them last,' adds Dall'Ara. 'That is one thing we found in our car that we could do, and the car was designed around making those tyres last. But on some tracks - indeed I would say the majority of tracks with the C30 - we've had a lot of trouble trying to get the tyres up

to temperature in qualifying, and that's resulted in poor qualifying performances. Quite often that meant that in the races it was impossible for us to run at the pace we could, because someone slower would sneak through in front of us at the start or in qualifying, and it is very difficult to overtake, even with DRS.

'This season began with the big target of improving the qualifying performance, as last year our race performance wasn't necessarily down to car performance, rather that we were able to preserve the tyres throughout the race.'

HOT AIR

Making that job even harder for Dall'Ara and Morris is the fact that Sauber has adopted a very innovative exhaust layout, which appears to have inspired many others in the pit lane.

'Last season, we were not able to keep up with the development of the car, and it's no secret that we missed out on one major element of car development, which was the blown diffuser,' admits Dall'Ara. 'We introduced

our version at the Spanish Grand Prix last year, but somehow we were not good enough to make it work. After a few attempts, we decided not to pursue it any more, and the management decided to develop the car around more conventional technologies. In my view, that limited us a lot in mid-season. In 2012, we tried to use the experience with the exhausts from 2011 to learn, because the regulations this year are so much more restrictive on exhaust position. That simply re-set that area of development with all the teams back together in performance terms.'

With its focus on efficiency, developing the C31's exhausts was a major risk. 'It was a big step forward for us. But we realised that it was important to get it to work and we started the early development over the winter. It was more about understanding how it worked though, rather than designing it, which is something we didn't manage to do last year. So we took the gamble in developing it, which took a lot of effort, especially when Charlie Whiting of the FIA could have just turned to us and said actually that is not permitted. Even then we were



Hot track set up has a large cooling aperture at the rear (above), while that aperture is made significantly smaller when running at cold tracks



FORMULA 1 - SAUBER C31



Innovative exhaust design essentially acts like a blown diffuser, and has since been copied by a number of other teams on the grid

CHELSEA TIE

It started with Superleague, an ill-fated attempt to link football and motorsport, but Sauber and Chelsea have taken the concept to the next level, announcing a reciprocal link between the two teams.

At the time of writing, there was no flesh on the bones, and Monisha Kaltenborn admits Sauber jumped the gun and made the announcement early, but promises results will be seen this season.

'Chelsea approached us with the idea, and it has two areas of co-operation,' says Kaltenborn. 'On the sport side, both teams focus on developing young athletes, so have a lot of accumulated data. By exchanging that information, we can learn from each other.'

'The other side is the commercial side, and together we can reach out to a huge

fan community because they are the two most watched sports around the world. Now, if you want to become a partner of either team, you can make savings by putting both platforms together.'

A look through Chelsea FC's partners makes interesting reading. Audi is the official global automotive partner, Gazprom the global energy partner, together with Singha beer and now Sauber. It's interesting because Audi is already linked with Toro Rosso, Russian oil company, Gazprom, would make more sense with Marussia, or Caterham with Vitaly Petrov, and Singha is already a partner of Red Bull.

If Audi does seek to enter Formula 1, would it consider buying former BMW partner team, Sauber, I wonder?

Andrew Cotton



not sure we could get it to work. We did though, and Charlie saw no problem with it. Now it's very nice when other teams perhaps take a lot of inspiration from what we're doing. Of course, there is no aerodynamic advantage from the exhaust because that would be illegal!

The exhaust outlets, whilst restricted in position, are still placed in such a way that the effect of the exhaust gasses simulate a blown diffuser, as detailed in REV22N7. 'Once you know what it's capable of, like any device on the car, you can tune it with the other things. Getting balance on and off throttle with all aero components on the car is critical. If you have a huge difference the drivers don't tend to like it, and that is especially true here. It's not

philosophy to the 2011 car because, according to the team, that proved effective.

'With the engine design being pretty much frozen, you know how much heat you have to reject. It all comes down to packaging, and each year we seem to design sidepods that are more tightly packed. It's a nightmare for the electronics guys and the pipework guys.'

'We are pushing the radiator manufacturers to optimise their designs so they have to get a smaller radiator. It is something you have to work on early because it's integral to the rest of the car's design. You make sure you can put the radiators in and then put everything else in around them,' explains Morris. 'Whilst you do not necessarily fix the radiators for the season,

"the aerodynamic details of the C31 have drawn many admiring glances"

like we designed the car around the exhaust, but it does have an effect - that's one of the big things I think we have done a good job on,' Morris enthuses.

AERODYNAMIC DETAILS

Beyond the exhausts, the aerodynamic details of the C31 have drawn many admiring glances, and not a few quizzical ones, too. Especially on the car's nose, which features a mysterious duct, similar to the ones employed on the 2008 Ferrari, just behind the 'hump'. 'I could say that it is something like driver cooling, but that's clearly not the case! Everybody is interested in it, but it is something that is not actually worth much performance. When you look it is clearly not the best dynamic device on the planet, so we just use it to improve the flow in that area.'

The cooling package on the car is also of interest. Based on the C30, the shape of the sidepods play a crucial role in the car's aerodynamics. Internal packaging was optimised so the area under the sidepods is opened up for more aerodynamic development. The cooling layout itself is based around a similar

it becomes difficult to change from a cost point of view. With no testing, if we found we did need to change them because it didn't work we would be screwed.'

The Formula 1 season comprises a wide range of circuits around the globe, including predictably hot venues such as Sakhir in Bahrain, as well as unpredictable locations like Silverstone in the UK, where the track temperature can fluctuate by as much as 25degC in a single afternoon. On paper, this provides a significant challenge to the teams. 'We use the same cooler size all year round, but the engine has quite a wide operating range so the engine suppliers are not too bothered if you run a little cooler,' reveals Morris. 'What we do in order to get the most aero potential out of the car is try to have as little air flowing through the radiator as possible. So, without doing new ducts or coolers, we have to restrict that flow somehow, and we do it by restricting the air coming out of the rear of the car, essentially blocking the system all the way through. At the rear of the engine cover area, we have different options for aperture size. If you compare the car we



AT THE HEART
OF THE WORLD'S
MOST POWERFUL
ENGINES



www.arrowprecision.com

Give us your requirements and we'll find a high-performance solution,
no matter how extreme.

Call our sales team: +44 (0) 1455 234200 Email us: enquiries@arrowprecision.com

FORMULA 1 - SAUBER C31



Front suspension was re-designed from the 2011 car but retains the enviable characteristic of being kind on tyres

ran in Valencia to the car we ran at Silverstone, you'll see a big difference. We design the car to [run at] 46degC. If it hits that temperature, we need to use an option. Some people think that's a waste of time, but it hit 47degC at Valencia.'

AERO SWEEP

The C31 has been optimised aerodynamically for a particular type of track, and it seems to have an advantage at them, as was apparent early in the season. 'I think this car, like quite a few of the most recent others from Sauber, likes flowing tracks with sweeping corners.

'We saw that in Barcelona and Shanghai and we were really looking forward to Silverstone, until the red flag ruined

advantage compared to the competition in corners around the speed of 200km/h.'

One of the weaker points of the C31, however, is the braking system. It is a problem that has carried over from the C30. The issue appears to lie with the overall vehicle dynamics, as Dall'Ara explains: 'Braking performance is a bit of a limiting factor, braking stability in particular. It has improved though. Shanghai showed us that it was very satisfactory starting on the second row and making places by braking into a corner after a very long straight. In the past, this was a bit of a problem for us. These kind of corners call for a car that is stable under braking and stable in the entry. We are now okay at that, but we're not the

loses a lot of lap time. We still have some issues with the brake balance, when braking from 320km/h down to 80km/h.'

AREA FOR DEVELOPMENT

Whilst the brakes themselves are not solely to blame for the instability, they are a key area for development for the team, especially in terms of aerodynamics. 'Once you start working closely with a brake supplier, you tend to stay with them, as all the products on offer are essentially very similar. You need to get to know the guys, and they need to understand your needs, and get to know what you want. In terms of the actual design work, a lot of it is in material development, and we don't get involved in that. We tell

"We have a performance advantage compared to the competition in corners around the speed of 200km/h"

qualifying,' explained Dall'ara. 'We are looking forward to Suzuka and this kind of circuit.

'I don't really want to make out that we are necessarily slow everywhere else, but those are the circuits we are particularly strong on. The sweeping tracks make it easier for us to find the ultimate performance from the car. We have a performance

best around. For example, when Perez had a struggle with the balance at Valencia, it was to do with the brake balance as the tyre temperature built up over a run.

'it is very difficult to allow for that as the track temperature is always evolving, and he lost confidence in the braking. When that happens to a driver he

them what we want, and they go away for six months and come back and tell us they have a new material,' Morris explains. 'What we spend time on at Sauber is the cooling. As soon as you stick big brake ducts on the inside of the wheel, you get a big drag penalty. We invest a lot of time and money into that. Kim Stevens lives and breathes brake

TECH SPEC

SAUBER C31

Chassis: carbon fibre monocoque

Suspension: upper and lower wishbones front and rear; inboard springs and dampers (Sachs Race Engineering) actuated by push rods

Brakes: Brembo six-piston calipers, carbon fibre pads and discs

Transmission: longitudinally-mounted carbon fibre Ferrari seven-speed quick-shift; carbon fibre clutch

Chassis electronics: MES

KERS: Ferrari

Steering wheel: Sauber F1 Team

Tyres: Pirelli

Wheels: OZ

Dimensions:

Length: 5195mm

Width: 1800mm

Height: 1000mm

Track width, front: 1495mm

Track width, rear: 1410mm

Weight: 640kg (inc driver, tank empty)

ENGINE SPEC

Ferrari 056

Type: naturally aspirated V8; 90-degree cylinder angle; electronic injection and ignition

Engine block: sand-cast aluminium

Valves / valvetrain: 32 / pneumatic

Displacement: 2398cc

Bore: 98mm

Weight: 95kg

cooling, and spends all her time understanding how the air flows around the disc, pad and caliper. She is forever optimising it to make the cooling ducts smaller and smaller, and she is good at it.'

At the time of writing, the C31 had yet to win a race, but has twice threatened to do so, both times obtaining a podium position. At the half-way point this season, Sauber was the best of the midfield teams and, with tracks like Suzuka that should really suit the car still to come, that elusive victory could soon arrive. If it does, it is almost certain to be a race won by calculated efficiency.



CONNECTING INTELLIGENCE

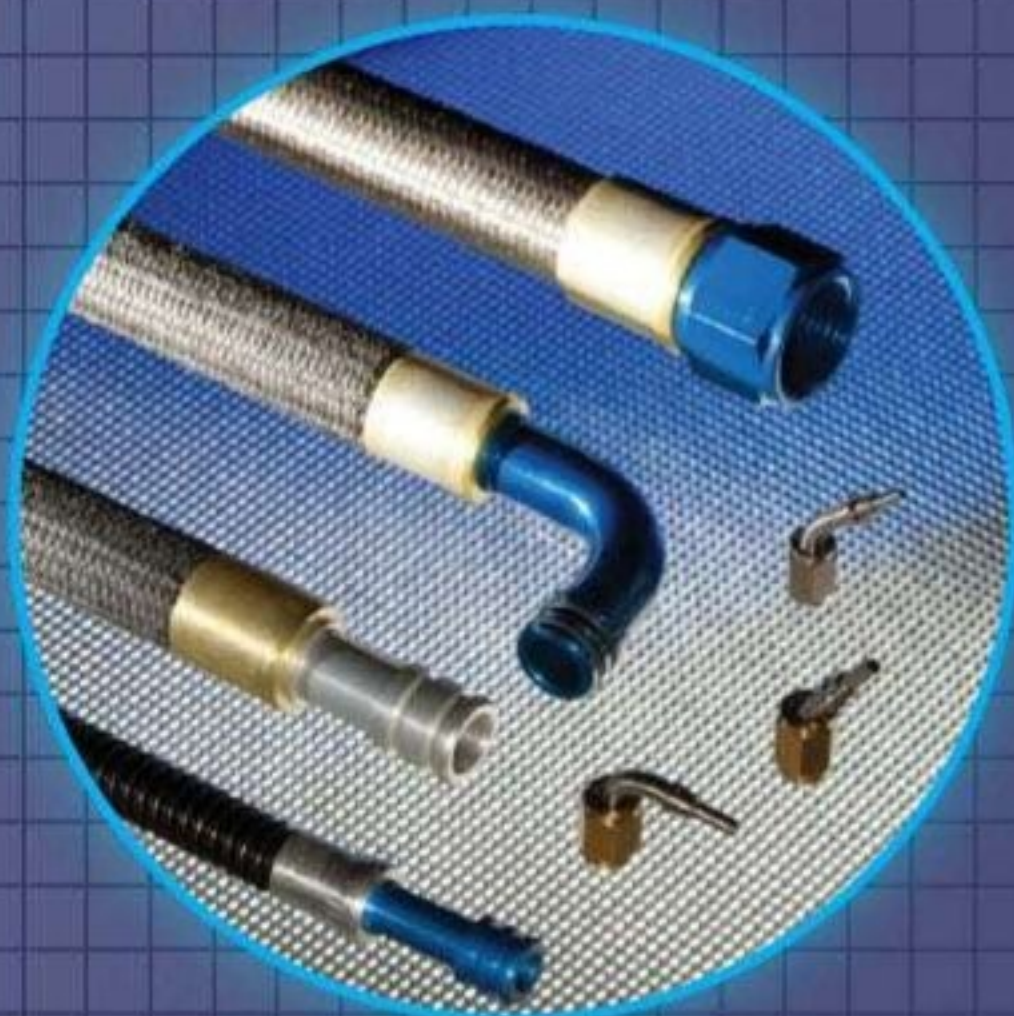

Flexible Hose and Fittings

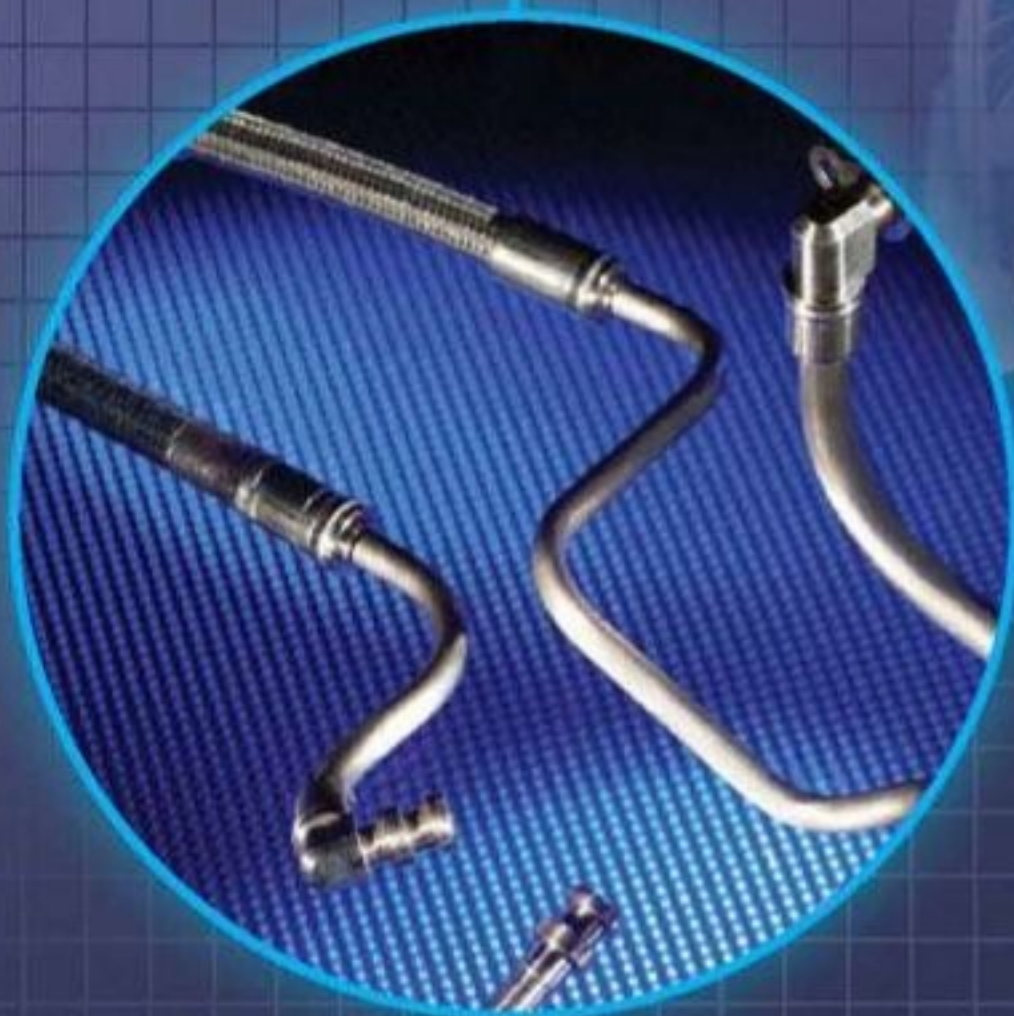

Rigid Lines and Swagetite



Filtration

Interpreting the system requirements of top level motorsport designers takes more than simply applying tried and tested formulae, it takes years of experience and intuitive thinking. Blending this with an unrivalled engineering pedigree helps us produce innovative solutions for customers in F1, endurance and WRC – in fact, every form of motorsport.

SERVICES:

- 3D cad design service
- hose assembly
- hard-line manufacture
- cnc machining
- filtration design
- laser marking

PRODUCTS:

- **Titeflex smoothbore and convoluted hose products and fittings**
- **Swagetite fittings and hard-line system solutions**
- **Pall Filtration systems**
- **Industria Solenoid valves**

FHS

M O T O R R A C I N G

Maintaining system integrity, saving weight and cutting costs. **Make the connection now.**

To find out how the quality of your own fluid transfer requirements can be improved, call our Technical Sales Team on

+44 (0) 1753 513080

Renaissance man

Robin Herd is renowned as one of the founders of March and the man who gave Adrian Newey his break in Formula 1. But that is only part of his story

The decals have disappeared from the Launton pub once frequented by the team. The mercurial March operation's influence on the region is long gone. However, it seems appropriate to meet one of the four founders, Robin Herd, at another hostelry in Bicester. The flow of conversation reflects Herd's Renaissance man nature: a double first at Oxford University; a sportsman who could have joined Worcester County Cricket Club and who, at one stage, owned Oxford United FC; a businessman, and one of motor racing's brightest and most inventive designers.

Herd is almost dismissive of his education achievements. 'I went to Oxford to read maths, but you might as well sit and do *The Times* crossword. It was just so theoretical. So they let me do physics in my first year, but that bored me brainless. However, a friend's brother was reading engineering and studying for his finals. I read his papers. I loved cars and planes - with sport they were my passions - so why I didn't do engineering straight away is beyond me.

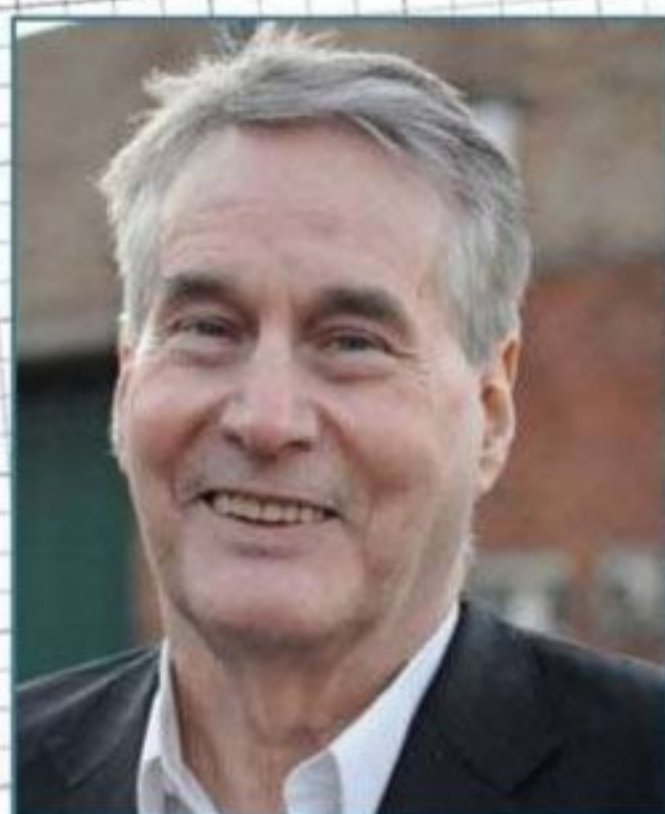

"My mistake was to bias my effort too much towards future developments, rather than perfect what then existed"

BY IAN WAGSTAFF

'They allowed me to change to engineering, so I did that, and played a lot of cricket. It was great because the old engineering labs were opposite the University Parks [scene of the OUCC's pitch]. The guy I was sharing my drawing board with was [Indian test cricketer] Abbas Ali Baig. If you were a sportsman and not very bright, you either read engineering or theology!'

Herd omits to mention his examination marks for engineering were the second highest in Oxford history.

Another simplification: 'In those days, if you had a degree in engineering you would get a job straight away. The appointments bureau sent me to [the Aircraft Research Establishment at] Farnborough. I lucked in because I was able to work on CFD for Concorde. It was very interesting because supersonic aerodynamics have linear equations.' Again, there is an omission here - he was appointed a senior scientific officer at the age of 24.

Herd reckons you should

never worry about your first job because it can simply be a way of finding what you do not want to do. It seems inevitable he would be drawn to some kind of sporting activity, and motor racing had the right synergies.

Bruce McLaren was looking for a designer for his fledgling operation. 'Owen Maddox had been very good when he was at Cooper, but his thinking was becoming outdated. Bruce wanted somebody with a more modern approach.'

Future grand prix driver, Howden Ganley, then a mechanic at McLaren, had heard through Formula 2 contender, Alan Rees, a former schoolmate with whom Herd had kept in touch, that he might be worth approaching.

'I was sitting at my desk at Farnborough realising that I did not want to work for the Civil Service and never thinking that I could be in motor racing when I had a 'phone call from Teddy Mayer asking if I was interested. And, if so, would I like to come and have dinner? We talked more about cricket [no surprise there] than we did about car design.'

Herd, who started on £30 a



Brands Hatch 1966. Bruce McLaren in the advanced monocoque McLaren M2B, with its partially Mallite, partially aluminium chassis, and powered by a Serenissima 3.0-litre V8

week, was told the team was about to set off for the Tasman Series and would be away for four months. Would he like to design its first Formula 1 car and begin the build while it was away? 'I had never worked on cars but I knew about them. It was one of those times when you have to make a decision and I said, "let's go for it."

The initial result was a 4.2-litre Oldsmobile-powered tyre test car, the advanced monocoque M2A. Herd admits that, in designing it, he erred towards, 'technical ingenuity rather than race-winning engineering. My mistake was to bias my effort too much towards future developments, rather than perfect what then existed.' The rigidity offered by Mallite, an aerospace material, appeared attractive. It was a composite laminate of 26-gauge aluminium sheets bonded over an eighth-inch sandwich filling of end-grain balsa wood.

'We put a wing on it,' recalls Herd. This rear aerofoil device was run at Zandvoort, two years before anyone else ran with a wing in grand prix racing, and immediately the car was three

seconds a lap quicker. The team took the piss, reminding me, "we race on the ground."

The chassis was quite light but the engine was 'ludicrously' heavy, so the wing was considered a low priority and quietly shelved. Herd reflects on how a modern Formula 1 team would react if it suddenly found a legal way of shaving off three

seconds per lap. 'We were so far off understanding aerodynamics, except for Jim Hall - he was a class act.'

The M2B, which resulted from the prototype, was torsionally one of the stiffest open cockpit racecars built. 'There are three essentials to chassis design,' states Herd. The before and after c of g location has to be

within the relatively narrow band dictated by the tyres. Rigidity is important, although the torsional optimum can vary. Thirdly, underbody downforce has to be as great as possible, while at the same time not being unduly sensitive to the car's current position. 'A lot of underbody downforce is going to load the tyres and get them working sensibly and quickly.'

According to Ganley, McLaren reckoned the M2A was 'phenomenal' to drive. Herd puts that down to its rigidity. After the flexible Coopers he had been driving, it was a feature the New Zealander appreciated.

Initially powered by a lined-down Ford V8 Indy engine, the M2B was tenth on the grid for its first race, Monte Carlo. 'We towed the car on a trailer behind a Ford Fairlane station wagon with me driving, accompanied by the mechanics, Howden Ganley and Johnny Muller.'

In the end, engine choice proved the downfall of the M2B, but it did win a World Championship, and it was the 'Yamura' used by James Garner's character, Pete Aron, in the 1966 film, *Grand Prix*.

"We put a wing on [the M2A]. The team took the piss, reminding me, 'we race on the ground'"



Above: South African Grand Prix, 1972. Nikki Lauda in the March 721, a car described by Herd as crap, and ugly. 'When it came to genuinely bad cars, it probably beats everything.'

This picture: French Grand Prix, Clermont Ferrand, 1970. Ronnie Peterson driving the March 701, Herd's first grand prix car for the constructor, notable for its distinctive wing-shaped, side-mounted tanks



ABNORMAL QUALITIES

Herd's first Sportscar was the McLaren M6A, which was also more rigid than its competitors. 'Jim Hall said it was a normal car built with abnormal qualities,' recalls Herd. 'It had far too much weight on the front. We worked away at taking that off and that enabled us to put a spoiler on the back. I wanted to put a wing on but Bruce would not allow it as he said we would be seen to be copying Hall. We did run a wing once. Then John Surtees rolled up and Bruce insisted that we hide it.'

Herd, and McLaren's, first winning grand prix car was the M7. 'Some people say it was the most beautiful Formula 1 car ever built. If it was, it only came about by accident.' A feature of the M7 was that it was simple to build. 'My cars were as straightforward as possible,' observes Herd.

'Then,' he says, 'I was an idiot and went off to Cosworth.'

COSWORTH CONNECTION

Although his company was known for its engine expertise, Keith Duckworth wanted to build a car. Indeed, the drawings existed for a Formula Junior.

Duckworth also wanted to tempt Jim Clark away from Lotus to drive it. 'I knew I had a lot to learn and Cosworth was so far ahead of any other organisation in motor racing,' says Herd. Much of the impetus was lost even before the car was built, though, when Clark was killed at Hockenheim. Herd was playing squash with Rees that day. 'I went into see Keith on the Monday and asked whether Jimmy's death would affect the project. He just said, "yes".'

Nevertheless, the four-wheel-drive car was built. Its unique shape was Herd's attempt to increase downforce. 'The pods between the wheels reduced drag and it just came out that shape.'

The body of the Cosworth, with its broad-set monocoque tub, was used to generate downforce that was trimmed out by wedge-section nosepieces and a small strutted rear wing. However, putting worthwhile power through the front wheels proved too much for the tyres. 'The mistake was that the



A Ford DFV-powered McLaren M7A under construction at the Woking facility in 1968

calibre at Cosworth then was engine engineering, not chassis engineering. The material for such as the brake and driveshafts was far too exotic. It was over engineered. It had a magnesium engine so we were on the weight

"My cars were as straightforward as possible"

limit, and it looked hideous.'

Herd admits it was not the only ugly car he had a hand in, believing this can be reflected in their lack of success. He cites the March 721X and 793, in particular. 'The crap cars tend to be ugly. The 721X certainly was. When it come to genuinely bad cars it probably beats everything.'

His first grand prix car at March had been the distinctive 701, with its wing-shaped, side-mounted auxiliary tanks. Herd wanted to build what eventually became the 711 for 1970, but failure to obtain any sponsorship at the outset meant fellow March founder, Max Mosley, had to sell 'replicas' of the works cars to pay for the first Formula 1 season. That meant there were just 10 weeks for the car to be designed and built in order that factory driver, Chris Amon, and Jackie Stewart, for Tyrrell, could drive it in front of the world's press. The 711 was shelved for a year and, as Herd put it, 'I just grabbed what was already available and,

preferably, built.'

Herd admits the 701 was too heavy but that, he now realises, was a result of pressure from Tyrrell, who 'hammered the safety aspect strongly'. The car was excellent in fast turns, but

wings to give it more downforce.' Despite this, the 701 led its first four races and won three of them.

The 711 was built for the following year and came second in the World Championship in the hands of Ronnie Peterson. Herd describes 'discarding a car that was as good as anything' as lunacy, admitting 'Ronnie and I had the ability to let enthusiasm overweigh realism.'

Herd liked the way Alfa Romeo's Sportscar featured a gearbox-ahead-of-final-drive transmission and Peterson was duly sent to race one at Watkins Glen. He liked what he found and Herd was encouraged into making a major mistake. 'All the weight was pushed onto the front wheels, so the weight distribution was wrong. This

it did have one major problem, that Herd admits was his fault - it had too high a moment of inertia in relation to its wheelbase, and this resulted in oversteer. By contrast, its successor, the 711, 'was fabulous, in that all the weight was inside the large wheelbase. My biggest regret was not getting around to fitting Gurney flaps to the front and rear



Riverside Raceway, California, 1968. While Herd's 1967 M6A Chevrolet-powered Sportscar was replaced by the M8A for 1968, a number of M6Bs were sold as customer cars and used in the 1968 Can-Am season



IndyCar Series, Pocono, 1984. Despite Herd's chassis design making up almost the entire grid, none of the drivers could catch the Lolas of Andretti and Sullivan

was the really big problem. The differential was also very small so we had to run it as a solid differential. It was a hell of a job getting it into the corner and then, when you wanted to put the power on, there was no weight on the rear. It was an out and out cock up!

The only answer was to ditch the 721X and replace it with a Formula 2-chassied car,

prix cars appeared to reflect a reduced commitment to the World Championship.

There is another Formula 1 March that deserves mentioning, even if it never raced in a grand prix. In 1977, Herd designed a six-wheeled car using front-size wheels and tyres all round, with the rear four all driven. Built behind closed doors by Wayne Eckersley and Martin Waters,

wanted and the finances did not come into it.

'It would have needed some effort to knock the weight off the six-wheeled car. Roy Lane proved its worth in hillclimbs. It went well in a straight line and Roy got it to go round corners, too. He said the traction was pretty good, but that was not the key purpose.'

Formula 2, and then Indianapolis, became important

Herd had designed the 1983 car, but its success meant he had to delegate much of the 1984 design. 'In an act of utter stupidity, I asked two [Adrian Newey and Ralph Bellamy] to design it in unison. At least I learnt a lesson and Adrian did the 85C and 86C alone.'

Herd remembers Newey standing out, from the moment he first did an exercise with

"I remember walking in to the track thinking that we could be the only people to have designed 29 cars on the grid and still not won"

the 721G. The G really did stand for Guinness - as in *Book of Records* - because the first was built in just nine days. For some years following this, March operated more as a production racecar manufacturer, and its usually Formula 2-based grand

Herd reckons 'it would have worked if we had been given the money to do so, but we just knocked it together. We were always compromising on money at March. We never had decent sponsors. It was different at McLaren. You could do what you

to March as a production manufacturer. 'Indianapolis became more of a technical exercise when the Europeans took over and it ceased to be what it was; phenomenal.'

For a period, March dominated the Indy 500 like no other manufacturer before or since. 'I remember walking in to the track in 1984 thinking we could be the only people to have designed 29 cars on the grid and still not won. Mario Andretti was the best driver and he was in a Lola.' That year March did win.

A car does not have to have been lacking in success for Herd to think poorly of it. The March 84C Indy car is an example: 'It was a camel, but was phenomenally successful and, based a lot on the success of the 83C, we started to win what seemed like every non-racing award under the sun.'

the constructor while still at university. However, he is at pains to credit another member of the team. 'Whenever I do an article about March, everybody asks about Adrian, but I always miss out Tim Holloway. He was so modest and unassuming. His writing was over everything. I knew that if Tim was doing the drawing, I could sleep at night.'

With five or six designs coming out of the March factory each year, people often ask how Herd could oversee so many projects. His reply is always the same, that he 'had very good people'. With Ganassi engineer, Andy Brown, and Andretti Autosport's Tino Belli passing through, as well as Newey and Holloway, perhaps Herd's legacy is not just his cars, but his ability to recognise and develop young engineering talent.



1977 saw the launch of the spectacular six-wheeled March 771. Herd stands behind in the tie, Max Mosley in the middle

A question of balance

Part 1

With more emphasis placed on track data than wind tunnel data, the VJM05's development is based on a new way of thinking

BY SAM COLLINS

The Force India VJM05 was the first 2012-specification Formula 1 car to run on track, albeit at a frozen Silverstone circuit. As the team members rolled up to see that first chassis turn its first laps, it was clear from their attitude that this was something of a new era for the team.

'The biggest change for us was the aerodynamic philosophy of the car,' reveals Andrew Green, the team's technical director. 'It took us quite a long time to wean ourselves off the old philosophy. We did some testing during the season last year, trying to move away from it, and then we used that knowledge over the winter to come up with the new concept at the front. It's delivered on the fronts we had hoped, and it continues to do so, though it has been harder to find the on-track optimum than we expected.'

Force India's approach to the car has been primarily aerodynamic. Its engine is direct from Mercedes HPE and the transmission is identical to that used in the McLaren MP4-27. 'We are using the same internals and composite casing as McLaren,' explains Green. 'We put all of our

own suspension system inside and outside of that though. The mounting pads on the casing are the same as on the McLaren, but the brackets are our design. I have no idea what they use. As a result, we are driven to a certain degree on their geometry, but it's not exactly the same,

and outboard of that it is, of course, all our own. That said, aerodynamics is the the primary source of performance for us. You have to do a lot to the suspension to get a little lap time out of it.'

COMPLETE CHANGE

The new concept used in the VJM05's aerodynamic package was not so much a set of designs, rather it was a new way of thinking. 'It was a complete change in flow around the car, and it was no longer about beating the air into submission,' explains Green, 'it was about making it do the least work possible. That was the main focus as we worked on the car over the winter. This is not a wind tunnel model championship, it is a whole car championship.'

That is one of the key elements of the new Force India philosophy - to not be overly



Sidepod, exhaust and engine bay layout shows how the aerodynamic concept carries through inside the vehicle as well as outside



reliant on the data produced in the wind tunnel using the team's scale model - something the team had apparently struggled with in the past.

'We stopped chasing ultimate load all of the time and started feeding information from the car back into the tunnel,' says Green. 'When the tunnel says a part is good, and the car says it is bad, you probably should listen to the car, not the tunnel. It is true the other way round too - if the tunnel says it is bad and the car says it good, keep it on the car. That means sometimes the numbers on the wind tunnel go down, whilst the numbers on the car actually go up, which has never happened before.'

It might sound like a problem with the team's wind tunnel in Brackley, England, but Green insists that is not the case. 'It's not a calibration issue, it's just areas of the car that are not

modelled correctly. There are lots of areas you simply cannot model correctly. It can even be the whole car that is at fault. The attitudes of the car in the tunnel cannot replicate the attitudes of the car on the track. There is no tunnel that has been designed

"The attitudes of the car in the tunnel cannot replicate the attitudes of the car on the track"

that can do that. As the car goes round a corner, the airflow that the car sees on the track is not the same as the car sees in the wind tunnel. It's impossible to mimic that, so there is always a doubt that you can pull the result from the wind tunnel model

directly onto the real car. You have to take the results with that in mind.'

Whilst clearly the team no longer place overriding

importance on the scale tunnel, Green and his aerodynamicists in England are still actively striving to improve the figures from the wind tunnel and work with them, even using another facility to tune their own. 'We only have one scale model. We use it in our

own tunnel in Brackley all of the time, and we also use the TMG tunnels in Cologne, [Germany]. We have used TMG a lot to correlate back to our tunnel. We use the data to modify our tunnel and use the numbers ours gives to match the TMG one. We believe TMG matches the real car more closely. We don't have some things that they do, such as continuous motion, but we are looking at it and are hoping to bring it online in the next 12 months.'

Many were surprised at



FORCE INDIA VJM05



Exhaust detail was deliberately conservative on the launch-spec car, the team waiting until the FIA clarified what was legal before bringing out...



...this 'blown diffuser' version at Barcelona. It works, but has caused some balance problems for the drivers

the launch of the VJM05 how conservative the car's exhaust exits were, but the rule changes and technical directives brought in over the winter had left many teams wondering what was actually legal. All of them were still trying to find a way of 'blowing' the diffuser.

'We had the launch spec exhaust on the car for the opening races,' explains Green. 'The strategy was that we had various concepts working in the

tunnel over Christmas, but we would wait to see what the FIA's view would be about blowing the diffuser area. We just waited for everyone to test the water, and then went for the solution we thought best and fitted the new system at Barcelona. It has taken some time to get to grips with it, as there are some balance implications that are proving tricky to get around.'

The regulation changes limited the teams in not only

where they could place the exhausts, but also how they can use the car's exhaust gases to drive the car's floor. In 2011, some very complex software maps were used, in very basic terms, to allow the drivers' right pedal to essentially act as a torque demand switch and the engine to run at full throttle all of the time, keeping the exhaust blowing through the diffuser.

'The mandated exhaust position is causing the balance

issue. Last year we had the engine maps to smooth it out from entry to mid-corner, and that was the big thread of development last year. When we went away from that, it became a lot harder. It is still essentially blowing the diffuser and stopping the vortex from the rear tyre from entering the diffuser area, but now we are doing it from a distance. Last year, the exit was right there, creating a vortex off a nice clean edge. This year, we have to curve it into that zone and then keep it in that zone.'

DRIVER-DRIVEN DOWNFORCE

This change in exhaust location, allied to the ongoing attempts to blow the floor, mean the car has become very different from behind the steering wheel. 'The driver now has a lot of downforce connected to his right foot. As a result, they need to understand where they lift the throttle and what it does to the car. They need to know about gear selection, as the shorter the ratio, the higher the engine rpm, and the more downforce you get. So picking a gear is crucial. Normally, you would expect a shorter ratio would give you more of a rearward loss in grip, but now it does the opposite, so you can gain rear grip simply by



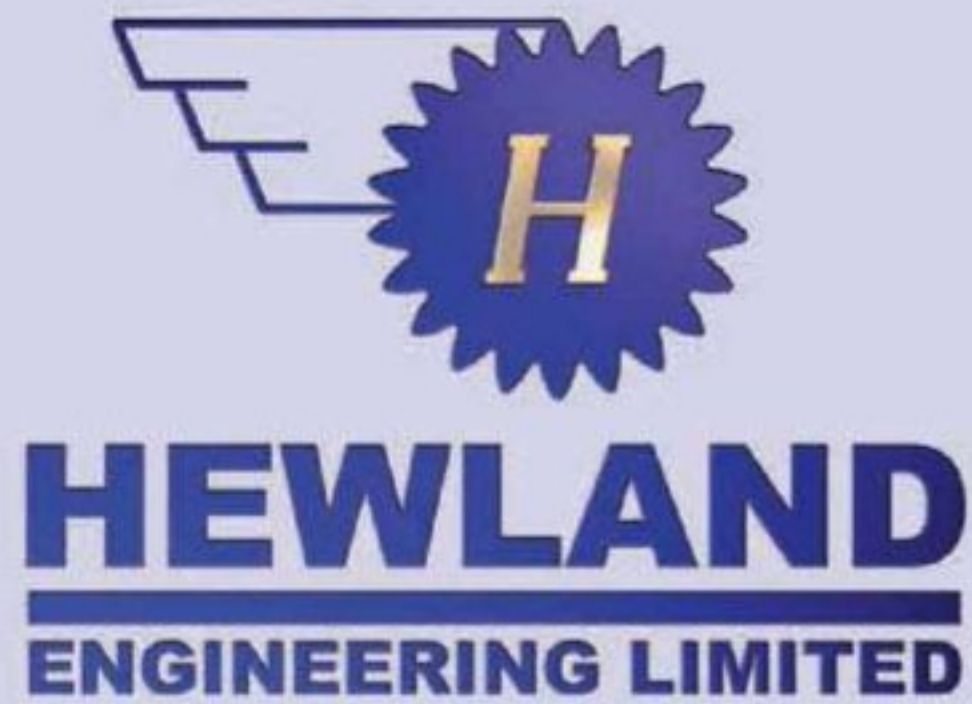

Included in our extensive 2012 range:

MLG



Designed for front engine, rear wheel drive
6 speed sequential / semi-auto option
Capacity: 320lbs.ft (435Nm/44Kg.m)
Aluminium casing

Designed for mid engine race cars
6 speed sequential / semi-auto option
Capacity: 690lbs.ft (935Nm/95Kg.m)
Magnesium or Aluminium casing

LWS



ED Differential



Heavy duty differential unit for front and/or rear drive. Choice of differential types.
Caters for all rotations.
Multiple mounting points.

Contact Hewland to learn more about what is on offer in 2012.

- **A large and varied range of gearboxes to suit most needs.**
- **High quality component manufacture, including gear grinding.**
- **Concept design and manufacture of transmissions.**

www.hewland.com

Waltham Road, White Waltham, Maidenhead, Berkshire, SL6 3LR UK
Tel: +44 (0)1628 827600; Fax: +44 (0)1628 829706; e-mail: enquiries@hewland.com

running shorter ratios. So that's an area we need to keep on top of,' explains Green. 'It certainly makes for interesting set ups and interesting driving styles. It's not just the set-up conundrum either, it's combining it with a driving style, and you do have to drive differently to get the most out of this. You also then have the factor of driving the car in sympathy with the tyres, which, as we have seen, is crucial in the races. So to combine it all together to find an optimum is a multi-dimensional puzzle, which takes a long time to solve.'

"you can gain rear grip simply by running shorter ratios"

At the season's half-distance point, Force India sits in eighth position in the constructors' championship, and that is not a position Green is happy with, despite being upbeat about the car's performance. 'It's mostly gone to plan, but what has not gone to plan is others have done better than we thought they would. We are happy with where we are with the car, but not with the championship points, so we have to claw back some of those points, which is going to be a fight. But then it always is.'

'The initial target of finishing fifth in the championship is a

long one I think now. Lotus are too strong, so realistically we have to beat Williams and Sauber. We will push until mathematically it is impossible to beat them or be beaten by them.'

As well as his clear fighting spirit for this season, Green is already actively working on the team's 2013 car, the VJM06. 'I think the car will naturally carry over to 2013, too. With no major regulation changes, you could carry over the chassis, but there are enough changes we want to make to this car that we will do a new chassis anyway. Because

it is going to be so tight next year - tighter than this year - a tenth of a second is going to be a huge amount of lap time to find. So we will need a new chassis to be able to optimise it fully, otherwise we will be running around with a handicap. The powertrain will carry over and the car will be an iteration of we have now, but it will be a new car.'

Green is planning even further ahead of that though. With major changes expected in 2014, he believes his team can create cars that are capable of fighting at the front of the pack, but is currently waiting to find

TECH SPEC

VJM05

Chassis: carbon fibre composite monocoque with Zylon legality side anti-intrusion panels

Front suspension: aluminium uprights with carbon fibre composite wishbones, track rods and push rods; inboard chassis-mounted torsion springs, dampers and anti-roll bar

Rear suspension: aluminium uprights with carbon fibre composite wishbones, track rods and pull rods; inboard gearbox-mounted torsion springs, dampers and anti-roll bar

Wheelbase: 3500mm

Front track: 1480mm

Rear track: 1440mm

Overall height: 950mm

Overall length: 5100mm

Overall weight: 640kg (with driver)

Wheels: BBS forged wheels to Sahara Force India specification

Engine supplier: Mercedes AMG High Performance Powertrain 2.4-litre V8

KERS: Mercedes AMG High Performance Powertrain

Transmission: McLaren Racing seven-speed, semi-automatic, 'e-shift'

Lubricants: Mobil 1 products

Spark plugs: NGK

Clutch: AP Racing carbon clutch

Tyres: Pirelli

Brake system: AP Racing

Brake material: Brembo

Dampers: Penske

out if he will have the chance to prove it: 'We need an indication from the shareholders on the future direction for the team. We have an effective ceiling on our relative performance, and there are some big teams with big budgets and very good facilities out there. If they get it right, we cannot compete with them. What I need from the shareholders is to know where they want to be. Are they happy with where they are now? Or do they want to be on

the podium a bit more often? The proposed cost cap would bring it back to us a little bit, but right now the cost cap is something we aspire to. It won't reduce our costs, but we would love to be able to spend up to that. It's more about facilities though. We need the best and most up-to-date tools, and we don't have that at the moment. Lots of other teams have some really good tools. We have great soldiers, we just need better guns.'



Wireless Setup Wheel Systems

Incorporating Mantracourt T24 Radio Telemetry

- ▶ License free 2.4GHz wireless connection
- ▶ High resolution data acquisition
- ▶ Secure transmission to USB powered base station
- ▶ Display and log data direct to PC/Laptop
- ▶ Retro-fit or complete setup wheel packages available from £3,100



NOVATECH

mantracourt

Novatech Measurements Ltd Tel: 01424 852744
Fax: 01424 853002 Email: info@novatechloadcells.co.uk
www.novatechloadcells.co.uk

zytek
ERS

Motorsport Energy Recovery Systems

- F1 race winning technology
- High power ERS, low weight, robust and reliable
- 30 years delivering innovations to major manufacturers, with extensive motorsport experience
- Full system design and development engineering teams, and in-house manufacturing capabilities, delivering off the shelf and custom ERS solutions
- Product testing on 4 fully transient EV dynos up to 320kW

Email: enquiries@zytek.co.uk
Tel: +44 (0)1543 412 789



zytek

zytekgroup.co.uk

Back to the roots

When Toyota withdrew from Formula 1 in 2009, Akio Toyoda declared that 'we need to go back to the grass roots of motorsport, to support customers.' The starting point is a Yaris

There are several reasons why the standard Yaris was converted to the rallying R1A. Firstly, TMG (Toyota Motorsport GmbH) wanted to 'tap into the goodwill and strong reputation [they] already have in rallying from the TTE [Toyota Team Europe] days and respond to competitor demand by offering an official Toyota rally car for the first time in many years.'

Secondly, TMG wanted to keep the costs as low as possible, and so looked at the smallest group the FIA allow, which is a car with a 1400cc engine. With the biggest Yaris engine in Europe being 1.33-litre, it was a perfect fit. 'The smallest cars before this 'R' group was established were the [Renault] Twingo and the [Ford] Fiesta, but they are 1.6-litre engines, so from that point of view we are the first to create an homologated car in that

BY GEMMA HATTON

class. That was one of our aims - to make a car that nobody else had,' explains project manager, Fredy Nowak.

Of course, the regulations played a huge role in the car's development, leaving little room for engineering innovation.

'Because the R1 group is the base group, you have to take the standard car, and you are only allowed to make small changes. We have to use the same gearbox and the same engine. We aren't even allowed to use a limited slip differential because the standard car does not have one.'

'The biggest changes were the rollcage, modifying the inside of the car, and adapting the shock absorbers for tarmac or rally.' However, as Nowak revealed, 'We were allowed to make a small change by shortening the final gear, so we reduce the top speed a little, but we have the

advantage of better acceleration through all the gears.' The R1A's final drive is now six per cent shorter than the standard model.

'We could do a little more. For instance, using the standard central ECU is difficult because it controls and monitors all the components such as ABS and airbags and when you remove these systems, such as the airbags for rallying purposes, you get an error code on the dashboard. Therefore, the regulations would allow us to have our own ECU, but it raises the development costs and we wanted to keep this car low in cost, so everything is standard.'

The future of the R1A looks bright, with the price for the base car and the kit a maximum of €22,500 (£17,550 / \$27,200). Off the back of this, TMG hopes to deliver further models with increasing levels of performance - up to Super 2000. The manufacturer also wants to

introduce rally trophies, such as a Yaris trophy. 'It was done 30 years ago with the Corolla and the Starlet in Germany,' explains Nowak. 'You had a Starlet trophy, with 30 or 40 starters in each rally. We would like to see some Yaris trophy cups in Germany, Spain, Belgium and throughout Europe.'

'We need a really basic car for this kind of motorsport, so customers can buy a Toyota and compete with it. Not like the past where Toyota was just Formula 1, and nothing below.'



TECH SPEC

TOYOTA YARIS R1A

Engine: 1.33-litre, four cylinder, 16 valve; front-wheel drive

Exhaust: 55mm racing exhaust; metallic catalytic converter designed for motorsport

Air filter: motorsport specific

Top speed: 175km/h

Max torque: 120Nm

0-100km/h: 11.7 seconds

Power: 99bhp

Transmission: six-speed standard gearbox; shorter final drive; standard differential

Suspension: motorsport shock absorbers with harder springs; adjustable ride height

Safety: OMP Fe45 steel bolt-in rollcage; OMP rally seats; OMP six-point safety harness; OMP automatic fire extinguisher, plus hand-held unit; electric power cut-off switch; sump, fuel tank and fuel line guards

Dimensions: 3885mm long; 1695mm wide; 1510mm high

Wheelbase: 2510mm

Weight: ~1000kg



The Toyota Yaris uses the same engine and gearbox as the road car, although the final gear is slightly shorter

Stockists of high performance metals to the world's most demanding markets

CR14 Titanium Alloy

- A new Generation Ti Alloy for Motorsport, Defence & Aerospace applications
- A new Titanium Alloy system is a combination of proprietary chemistry, thermo mechanical processing and heat treatment
- Ingots produced by Timet
- A unique balance of low density, high strength, ductility and stiffness, which exceeds all known production Ti Alloys
- Machining techniques such as milling, turning, gun drilling, honing and grinding applications have all been established for the material
- Density (g/cm³) 4.35
- Data for single extrusion condition
 - 0.2% PS (MPa) 940 (RT)
 - UTS (MPa) 1100 (RT)
 - EI (%) 16.3
 - E (GPa) 132
- High ductility, good strength at low temperature
- Data for the double extruded condition
 - 0.2% PS (MPa) 1350 (RT)
 - UTS (MPa) 1360 (RT)
 - EI (9%)
 - E (GPa) 135
- Good ductility, high strength at medium temperature

Motorsport applications:

- Inlet valves
- Connecting rods are proven, showing a 15% mass reduction when compared to competitive designs in Ti 64 and SP700
- Gudgeon Pins; Lower mass than hollow Steel and solid Ti Al applications
- Turbocharger impellers
- Valve train top retainers
- Quill shafts
- Developments for exhaust valves

Overall CR14 offers

- Lighter, stiffer improved component life when compared to those made in Ti 6242, Ti 6246, SP700 and Ti 64.

Smiths High Performance Unit 0, Stratton Business Park, London Road, Biggleswade, Beds SG18 8QB

Tel: +44 (0) 1767 604 708 Fax: +44 (0) 1767 312 885

www.smithshp.com

The one in the middle wins races



DS1.11 & DS2.11

SILOXANE TECHNOLOGY

BRAKE PADS



RACING

FEDERAL MOGUL
The best brands in the business

Relative Performance Characteristics of Ferodo Racing Range Under Heavy-Duty Conditions

| | Pad Life | Disk Life | Average mu | Fade | Pedal Travel | Release |
|------------|-----------|-----------|------------|------|--------------|---------|
| DS 2500 | Good | Moderate | Good | Good | Good | Good |
| DS 3000 | Good | Moderate | Good | Good | Good | Good |
| DS 3000+03 | Good | Moderate | Good | Good | Good | Good |
| DS 3000E | Excellent | Moderate | Good | Good | Good | Good |
| FER 4003 | Good | Moderate | Good | Good | Good | Good |
| DS 1.11 | Excellent | Moderate | Good | Good | Good | Good |
| DS 2.11 | Excellent | Moderate | Good | Good | Good | Good |

Excellent
Good
Moderate

- Race Proven**
- DS1.11 - suffix "W"
 - A1GP
 - FIA FT
 - Touring Cars
 - Formula Cars
 - Group N
 - Stock Cars
 - DS2.11 - suffix "X"
 - WRC
 - Rally Group N
 - Touring Cars



Circuit Supplies (UK) Ltd
Unit 8, Eden Court, Eden Way
Leighton Buzzard, Beds LU7 4FY
Tel: 01525 385 888 Fax: 01525 385 898
info@circuitsupplies.com www.circuitsupplies.com

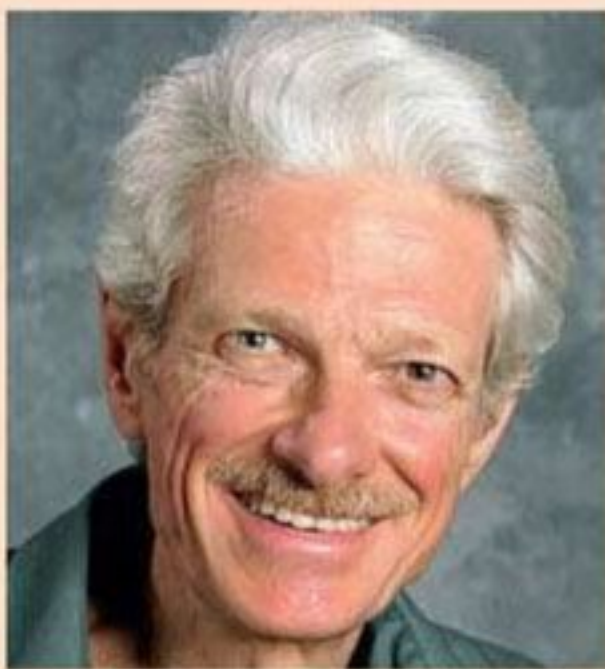

Mark Ortiz Automotive is a chassis consulting service primarily serving oval track and road racers. Here Mark answers your chassis set up and handling queries. If you have a question to put to him
Email: markortizauto@windstream.net
Tel: +1 704-933-8876
Write: Mark Ortiz
 155 Wankel Drive, Kannapolis NC 28083-8200, USA

Adjusting roll resistance distribution

Adding rear roll stiffness vs lowering front roll centre

Q My newly finished track day car, based on a Porsche 914 chassis, has a front roll centre height adjustment separate from the ride height adjustment. Track testing is showing me that the car wants a more rearward-biased roll stiffness distribution than I had

anticipated when selecting the road springs and anti-roll bars. I could add roll stiffness to the rear but am considering lowering the front roll centre as an alternative. Then I remembered you had addressed the pros and cons of that relationship in the past. Could you re-cap?

I have discussed various things that relate to this subject in the past. One in particular is the possibility of roll centre height changes having unintended or unanticipated effects in strut suspensions, especially in cars that have that type of suspension only at one end. The 914 has strut suspension at the front and semi-trailing arm in the rear.

To lower the front roll centre in such a system, without changing the ride height, one has to either raise the balljoints

or lower the inboard pick-up points for the control arm. Either of these increases the length of the front view projected swing arm, and reduces camber recovery in roll.

In general, strut suspension

balljoint or pick-up point height is useful primarily to correct for the effects of lowering the car for competition, and it does provide some limited freedom in choice of roll centre height. However, it cannot provide an escape from

the fundamental limitations of the design.

Lowering the front roll centre will also increase the amount of

“In general, strut suspension forces us to have less camber recovery in roll”

forces us to have less camber recovery in roll than we would like, just to keep roll centre height and steering axis inclination within reason. Adjustable

roll, absent other changes. If the front suspension has less camber recovery in roll than the rear, and we increase the amount of roll, the poorer cornering camber at the front will tend to dilute the understeer reduction from the change in roll resistance distribution. It may even happen that the effect from camber may outweigh the effect from load transfer distribution, and we may end up with more understeer rather than less.

A theory sometimes heard is that the geometric roll resistance distribution has a particularly large influence on entry characteristics. This is claimed to be due to the fact that the sprung mass takes time to roll, which delays the effect of elastic load transfer, whereas geometric anti-roll moments are present as soon as there is lateral ground plane force at the tyres.

Let's examine that. There are two things that make the roll displacement take some time: friction and inertia.





The friction element consists of (largely unintentional) Coulomb friction in the pivots and sliding elements of the suspension system, and (intentional) viscous friction occurs from the action of the fluid in the dampers. The friction force is anti-roll (resists roll) when roll is increasing, does not resist roll when roll velocity is zero, and is pro-roll (acts to maintain roll) when roll is decreasing. The frictional forces will add or reduce wedge according to their front / rear distribution.

The inertia is the sprung mass roll inertia. It acts in opposition to roll acceleration. It can become highly significant in tall, softly-sprung, lightly-damped vehicles subjected to abrupt inputs. If the car rolls rapidly to some angle, holds that roll angle for a time, then de-rolls, roll velocity:

1. starts at zero
2. increases to some value outward with respect to the turn
3. then decreases to zero
4. stays at zero for a time
5. then increases inward with respect to the turn
6. finally decreases again to zero

Consequently, roll acceleration:

1. starts at zero
2. is outward with respect to the turn for a while, first increasing and then decreasing
3. passes through zero and then becomes inward with respect to the turn, again increasing and then decreasing (roll velocity is outward but decreasing, so roll acceleration is inward)

“Racecars have relatively small roll displacements and velocities, and relatively stiff damping”

4. stays at zero for a time
5. is inward with respect to the turn, first increasing and then decreasing
6. passes through zero and then becomes outward with respect to the turn, again increasing and then decreasing, finally to zero at the conclusion of the manoeuvre.

During phases 2 and 3 above, the frictional forces act against roll. Since they occur within the suspension system, they must

react through the tyre contact patches, and they contribute to lateral load transfer in proportion to their front / rear distribution. More rear damping dynamically de-wedges the car and adds oversteer. The frictional forces act in parallel with the front and rear elastic and geometric anti roll components. Therefore, their influence depends on their comparative magnitude, relative

to elastic and geometric moments.

During phases 5 and 6 above, the frictional forces act against de-roll. They act to maintain the roll displacement, and are therefore pro-roll forces. More rear adds dynamic wedge and adds understeer.

During phase 2, roll inertia is anti-roll in direction. During phase 3, it's pro-roll. During phase 5, it's pro-roll (anti-de-roll). During phase 6, it's anti-roll (pro-de-roll).

The contention that geometric anti-roll has a disproportionate effect on entry behaviour is

based on the idea that the geometric forces are directly related to ground plane lateral force and therefore are not diminished by the anti-roll effect of roll inertia during phase 2.

I think that makes some sense, qualitatively. But then what about the effects of roll inertia in phases 3, 5, and 6? And how big is the effect really, in racecars as actually driven on road courses or ovals?

In a tall, softly-sprung, lightly-damped car or truck, undergoing a j-turn test at the test track, we might see the effect of roll inertia as a reduction of roll in phase 2, followed by an exaggeration of roll as the vehicle approaches steady-state cornering. There should in fact be a degree of roll overshoot and subsequent de-roll as the vehicle approaches steady state. With really light damping, the vehicle might exhibit roll oscillation as the driver tries to get the vehicle to steady-state cornering.

But do we see roll overshoot during late entry in racecars, ordinarily? Do we see noticeably higher roll velocities during late entry than during early entry? Not usually.

Racecars have relatively small roll displacements and velocities, and relatively stiff damping. The main thing that slows roll displacement during entry in is damping, not roll inertia.

So, what of the effect of lowering the front roll centre, vs adding rear anti-roll bar? For identical steady-state understeer gradient, will either option produce noticeably freer entry in a road racecar? Probably not, but the lower front roll centre will produce larger roll displacements and velocities, and will therefore make the car more responsive to damper settings than adding rear [anti-roll] bar.

And, returning to the first question, if greater front percentage is accompanied by more geometric roll resistance at the rear (eg higher Panhard bar), will the car turn in more readily? Maybe, if the rear is damped less in roll than the front, which is common with beam axle rear ends.

RACE CAR

ROAD CAR

ARMOURED VEHICLES

HISTORIC

ULTIMATE PERFORMANCE.

Giving supreme control to race teams all over the world.
Radi-CAL™ only from AP Racing



Experience, technology and innovation go into our Radi-CAL™ caliper design, resulting in reduced weight, increased strength, stiffness and improved cooling.

We apply this same approach to our whole product range as we constantly explore new materials, techniques and systems in our quest for continuous improvement and race success.

Fit AP Racing brakes and clutches for ultimate performance.

T: +44 (0) 24 7663 9595 E: racetech@apracing.co.uk

AP
RACING

The science of friction www.apracing.com



QUAIFE®

Power into motion

WORLD LEADERS IN THE
MANUFACTURE OF HIGH
PERFORMANCE DRIVELINE
AND STEERING RACK
COMPONENTS, SINCE 1965

Complete Gearboxes

5 / 6 / 7 - speed sequential, H-pattern,
heavy duty, dog engagement and
synchromesh

Motorcycle Engined Vehicles

Gear drive systems, reversing differential
units, reversing boxes

Gearkits 4 / 5 / 6 - speed synchro,
helical, semi helical, straight cut and dog

ATB Helical Gear Differentials

350 fitments – all with a life
time warranty

Complete Axles Axle kits, half shafts

Complete Steering Racks

Quick racks, rack & pinion kits

Plus Uprights, transfer units,
motorcycle gearkits and much more
for all types of vehicles

POWER into Motion

See our web site for more info and
order on line at www.quaife.co.uk
For Free brochure and in formation:
Tel 0845 1307400 / 01732 741144
or email info@quaife.co.uk



Quality Accredited
ISO 9001-2000
and ISO QS9000

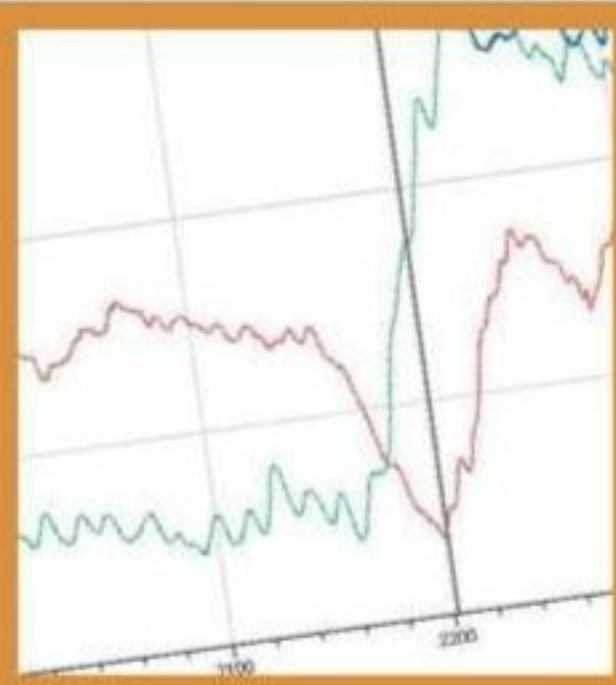

Databytes gives insights to help you improve your data analysis skills each month as Cosworth's electronics engineers share tips and tweaks learned from years of experience with data systems. Plus we test your skills with a teaser each month

To allow you to view the images at a larger size they can now be found at www.racecar-engineering.com/databytes

Tube maps

Using a pitot tube to improve your racecar engineering

Aerodynamics are a major part of any racecar development. The sensors and electronics used for measuring the various forces on a vehicle while it is running out on track are very important, too. When used skilfully, they can provide good information for making a racecar go faster.

Understanding the principles and function of the pitot tube is a key factor when measuring aerodynamic behaviour. The pitot tube provides a measurement of air pressure due to flow. A good pitot static tube will measure the air pressure in two locations - one directed at the airflow and one to measure the static pressure. This makes it possible to get a value for the actual dynamic air pressure. The two pressure tunnels in the pitot tube need to be connected to an aero pressure sensor with two pressure inputs, which then gives an electrical output into the data logger. A typical aero pressure sensor will have a pressure range of +/-2psi,

which is equivalent to a car speed of 375mph at standard atmospheric conditions.

The position of the pitot tube on a car is important in order to get an accurate reading. A moving car produces a great deal of disturbance in the air and this must be taken into account when choosing a location. The general rule is to keep it as far away from the car's body as possible, and as far forward as possible.

Aligning the pitot tube with the airflow is generally made

easy as they should be calibrated to remain accurate to +/-0.5 per cent up to around 12 degrees.

This is typically enough to compensate for car pitch, slip angle and cross wind.

Using the measured value and comparing it with an expected dynamic pressure value calculated from wheel speed using Bernoulli's equation ($P_{dynamic} = \frac{1}{2}\rho V^2$) it is possible to gauge the effects of head wind and tail wind on the grip level and performance of the car.

good areas for pitot-static tube

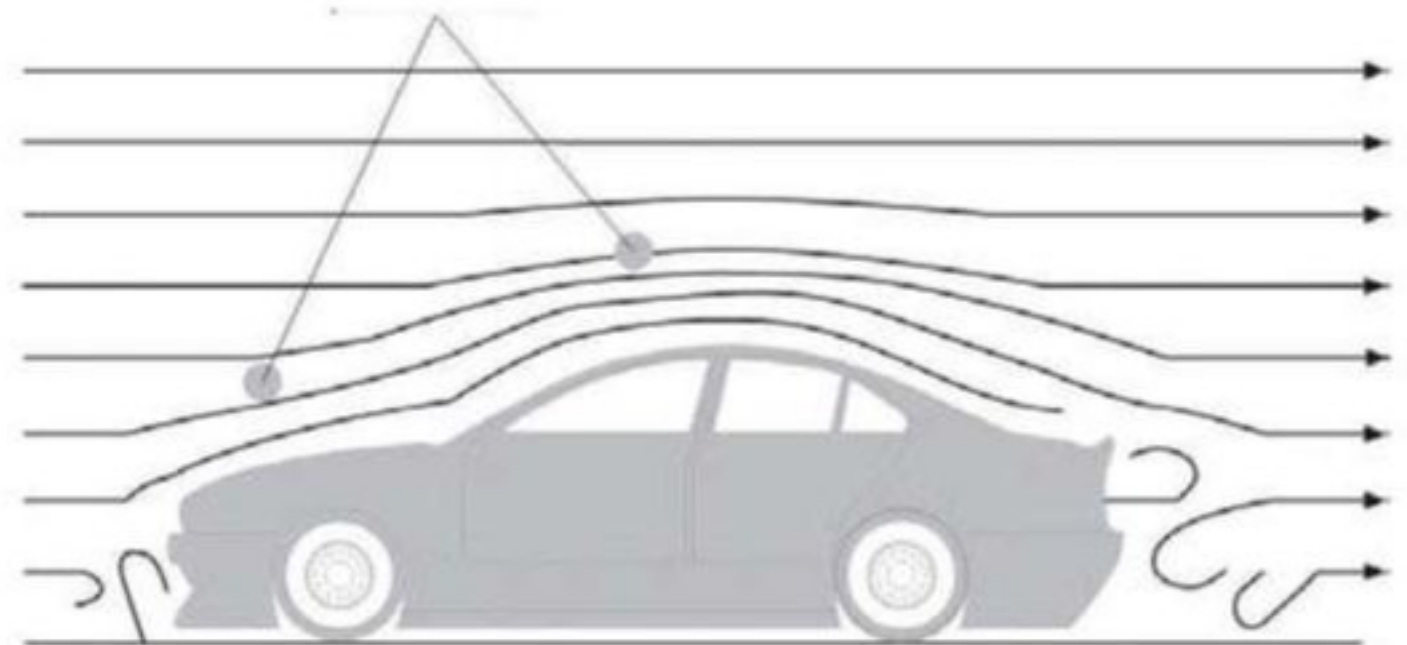

Figure 2: recommended locations for pitot tube

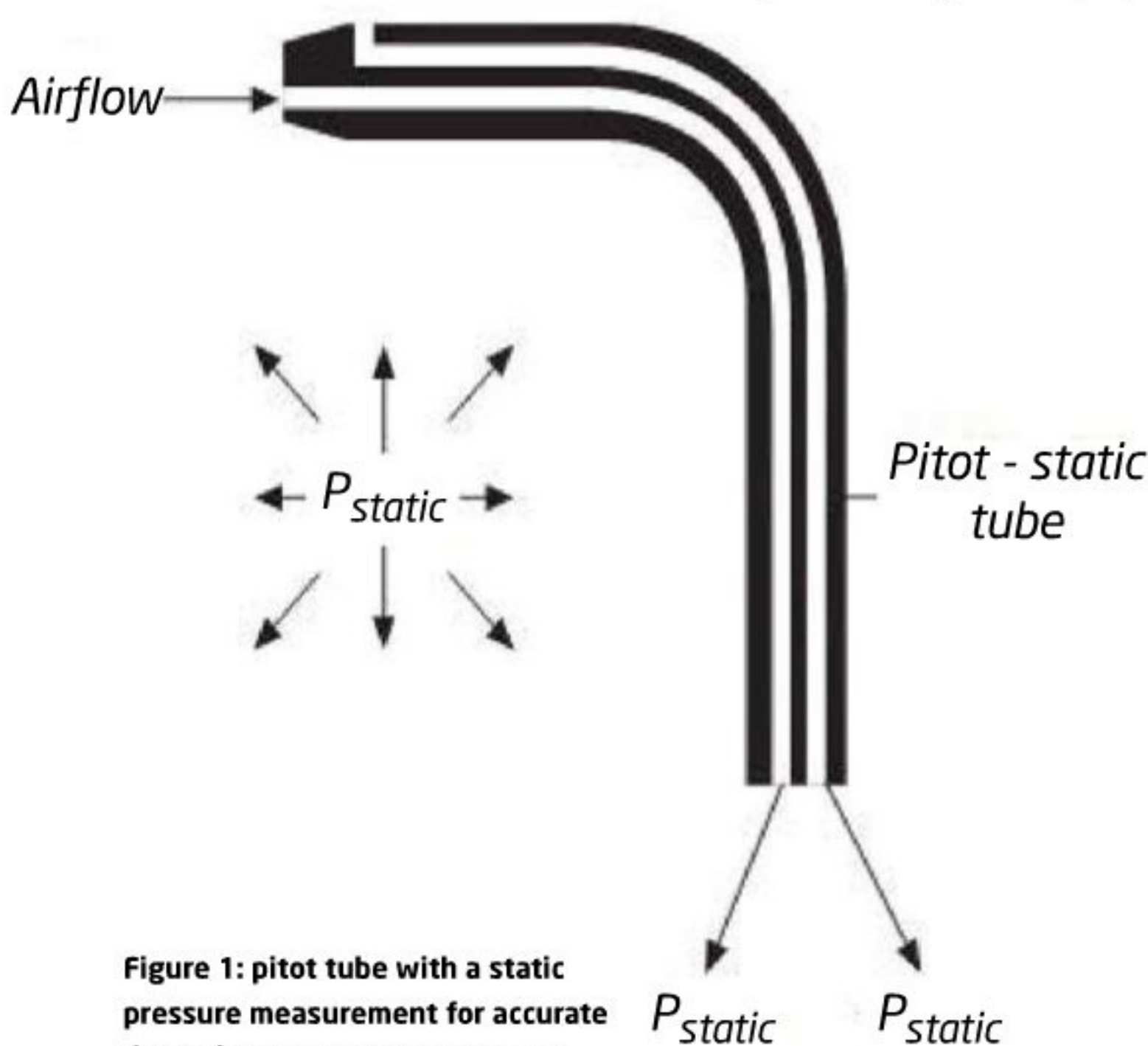

Figure 1: pitot tube with a static pressure measurement for accurate dynamic pressure measurement

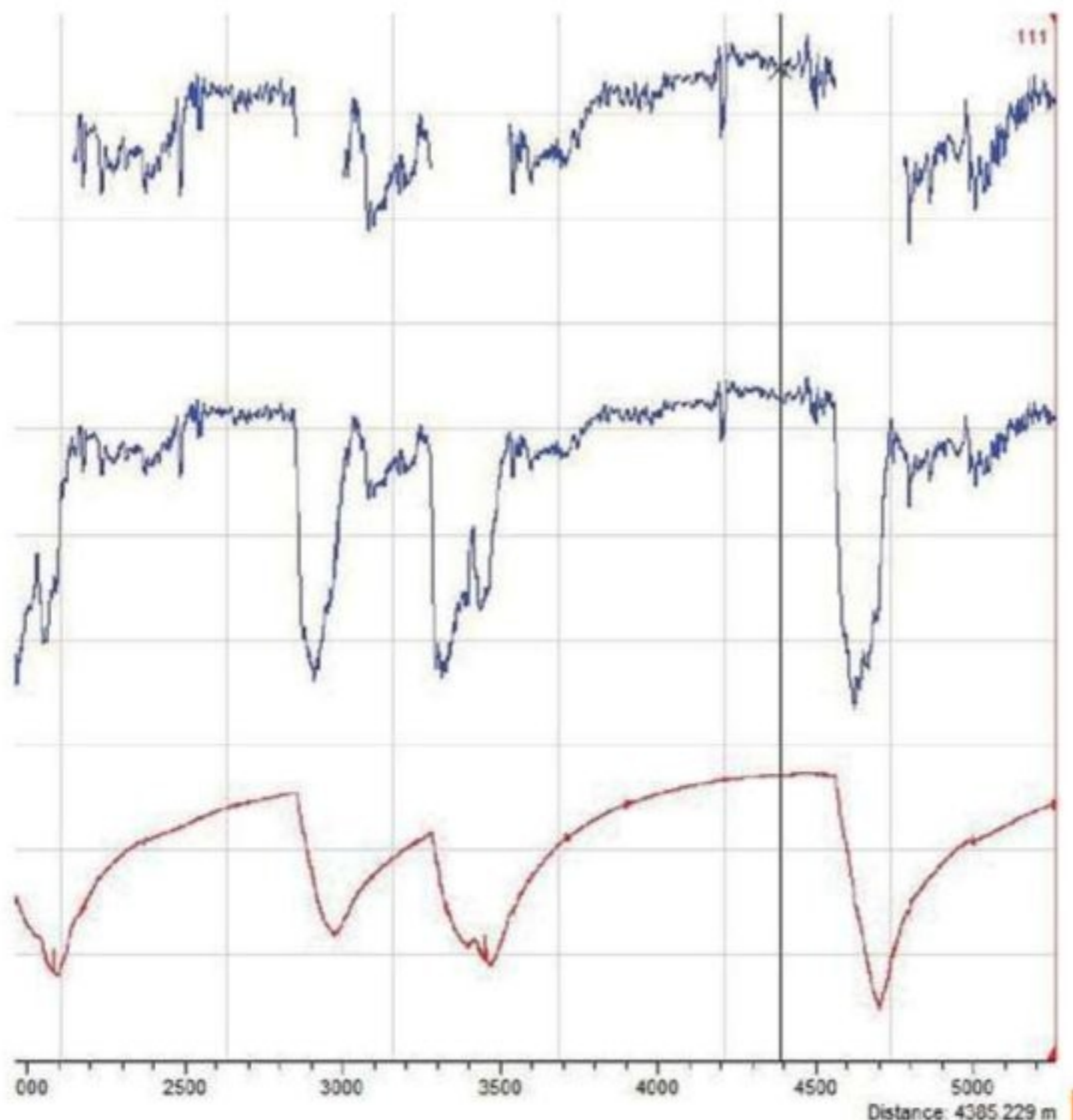

Figure 3: comparison of a normal maths channel and then that same channel filtered using the gate function. Speed is in white for reference

[TASK 1] - TABULAR OUTING REPORT

| Lap number | | 109 (out Lap) | 110 | 111 | 112 | 113 | 114 | 115 (in Lap) |
|--------------------|------|---------------|-----------|-----------|-----------|-----------|-----------|--------------|
| Lap time (min:sec) | | 02:17.870 | 01:40.340 | 01:40.250 | 01:40.710 | 01:43.260 | 01:40.460 | 02:55.220 |
| Speed (km/h) | max | 265 | 285 | 287 | 301 | 286 | 287 | 267 |
| Speed (km/h) | mean | 133 | 189 | 189 | 188 | 183 | 188 | 112 |
| Gate_Pitch | mean | 6.12 | 6.41 | 6.33 | 6.30 | 6.63 | 6.48 | 4.78 |

The dynamic pressure can also be used to determine the aerodynamic forces generated on the racecar:

$$\text{Force} = [\text{frontal area}] \times [\text{coefficient of drag (or lift)}] \times [\text{dynamic pressure}]$$

Therefore, if the coefficients of drag or lift are known, it is possible to estimate the aerodynamic forces on the car going around a circuit using the dynamic pressure readings. Using this data, along with information from inertial and suspension sensors, it is possible to start to break down the inertial and aerodynamic components of the forces working on the car. Examples of some of the corrections needed are vertical acceleration, longitudinal acceleration, anti-squat and jacking forces. In order to get all

this information, the vehicle will typically be fitted with strain gauges on the suspension, laser ride height sensors and damper position sensors. If the aero test is done in a straight line, it might not be necessary to apply all these corrections as the testing will be more or less steady state.

In order to make it easier to visualise the data and filter out the irrelevant parts, it can be useful to use some of the advanced maths functions available in good data analysis packages. For example, if the characteristics at high speed down a straight are to be investigated, it is possible to ignore data below a certain speed, and also filter based on other channels. In the example below, the pitch of the vehicle is only evaluated if the speed is above

140km/h and if the throttle angle is at or above 80 degrees.

$$\text{gate}([\text{Speed}] \geq 140 \ \&\& \ [\text{Throttle}] \geq 80, [\text{Pitch}])$$

Using this equation, it is now possible to find an average per lap to give us the pitch during high aerodynamic forces. Equally, other channels can be evaluated in the same way in order to focus on the values of interest. The lateral acceleration could, for example, also be used to filter the values further, so high-speed corners would be ignored.

A number of other interesting parameters can also be calculated using aerodynamic sensors. For example, the efficiency of a radiator can be found by measuring the air speed at the face of the radiator and comparing that with the free stream air velocity. The air pressure drop

from the front to the back of the radiator can also be determined using pitot tubes. A large pressure drop coefficient is generally required for the best cooling performance, but the aerodynamic drag of the radiator must also be considered, but is best left to wind tunnel testing.

$$K_p = \frac{\Delta P}{(\frac{1}{2} \rho V_R^2)}$$

ΔP = static pressure drop across the radiator
 V_R^2 = velocity of air at the radiator face and a large velocity ratio

$$K_v = \frac{V_R}{V_\infty}$$

V_R = velocity of air at the radiator face
 V_∞ = free stream velocity of air

CHALLENGE

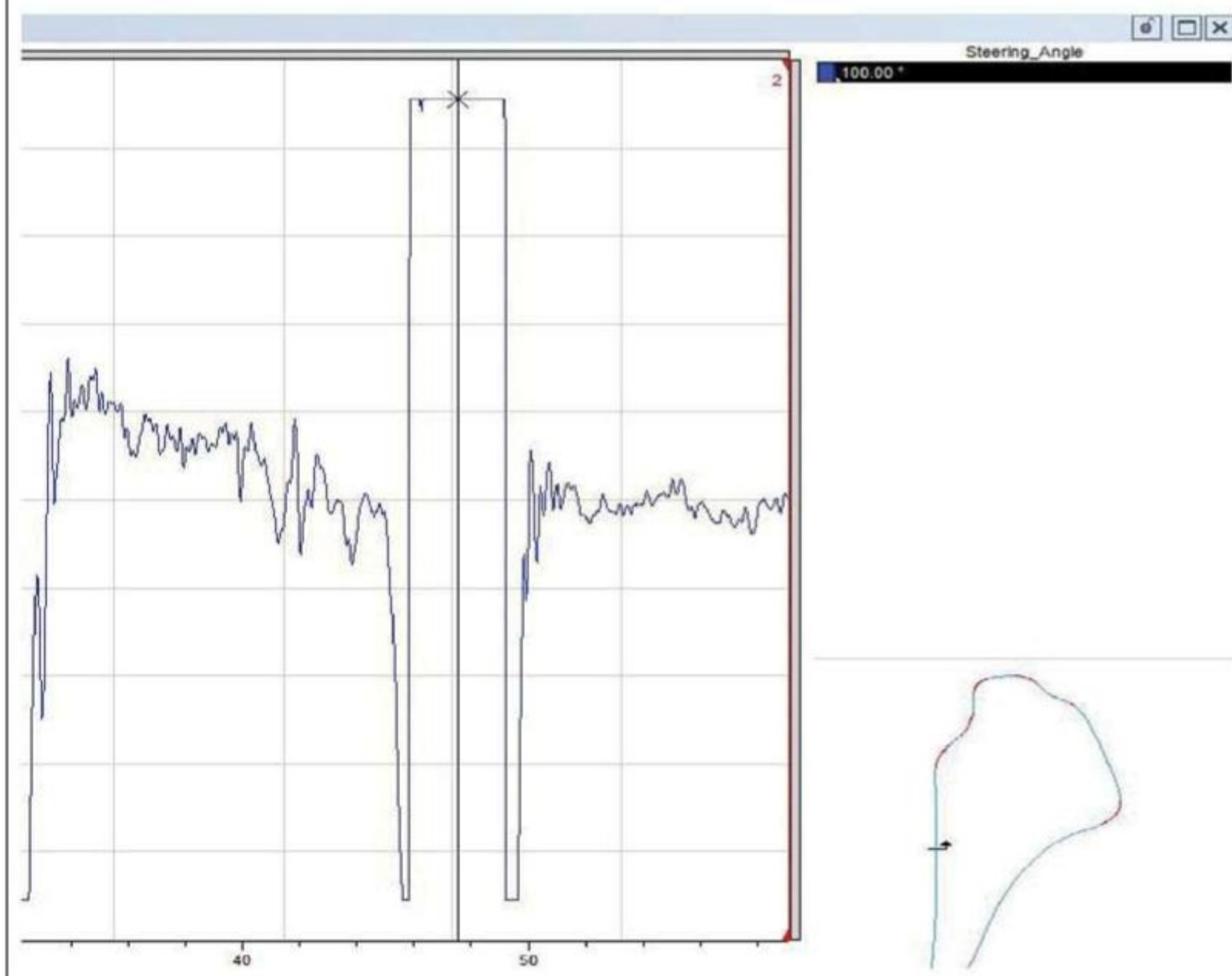

What has happened with this steering angle trace, and how could it be rectified?

Answer to last month's challenge:

B - The value being sent out is too large for an S16 value and therefore goes negative

COSWORTH

Produced in association with
Cosworth
 Tel: +44 (0)1954 253600
 Email: ceenquiries@cosworth.com
 Website:
www.cosworth.com/motorsport



Lighter.



Stiffer.



Cooler.



Quicker.

www.performancefriction.com



**PERFORMANCE
FRICTION
BRAKES**



Call us first...



**Unit 31 Silverstone Circuit Towcester Northants NN12 8TN
T: 01327 857822 F: 01327 858096 www.tridentracing.co.uk**

At last - TPMS without the "dreaded" batteries!!!

Stack's unique Tyre Pressure and Temperature Monitoring System (TPMS) has eliminated the electronics and batteries from the sensors, providing new limits of performance for TPMS, and significantly increasing sensor life to 5 seasons or more! We've reduced the first year cost, and significantly reduced on-going maintenance costs.

- Less weight – only 10g (0.35oz).
- Sampling rates up to 10Hz without reducing sensor life.
- Auto-detect wheel changes without pre-programming.
- Maintenance free - longer life, significantly lower running costs.
- Higher continuous operating temp – up to 150°C (300°F) or above.
- CAN output for connection to existing systems.
- Measures both pressures and temperatures.
- Specialist high sampling rates – up to 40Hz.



**STACK
STACK
STACK®**

...when only the best will do!



To find out more call +44 (0)1869 240404
or visit www.stackltd.com

Smart phone users can scan this code for more information from our website.



Simon McBeath offers aerodynamic advisory services under his own brand of SM Aerotechniques - www.sm-aerotechniques.co.uk. In these pages he uses data from MIRA to discuss common aerodynamic issues faced by racecar engineers

Produced in association with MIRA Ltd



Tel: +44 (0) 2476 355000
Email: enquiries@mira.co.uk
Website: www.mira.co.uk

Rake angle

Increasing downforce by altering ride height differential

Once again this month, we delve into the aerodynamic details of the new and previous generation F3 Dallaras in the MIRA full-scale wind tunnel. And for this installment we look at changes to the cars' rake angle and lower rear wing beam angle.

To briefly recap, we had at our disposal a Fortec Motorsport F308 in 2011 specification and, what at the time of our test last winter, was a very recently delivered F312. Our feature in *Racecar Engineering* V22N6 described the F312 in full but, in short, the F312 featured cleaner bodywork with less aerodynamic paraphernalia, a higher nose, a larger front wing (with no raised centre section) mounted slightly further forward, and a sharply terminated engine cover with a gearbox top shroud below.

RAKE ANGLE

As always, we have to keep in mind that MIRA's fixed floor (but with boundary layer control fence to better simulate a moving floor) and fixed wheels (but with 'trip strips' to better simulate rotating wheels) are not the same as the real world. And this is particularly relevant when looking at ride height changes on racecars with ultra-low ground clearances, which can be as low as 10mm under the front 'splitter' on F3 cars. However, we are going to take a look at some of the effects of a rake angle sweep on the F308 and the F312, knowing we can at least make qualitative comparisons between the two. Rake angle is given here as the difference between rear ride height and front ride height in mm, although the actual ride heights are not indicated. Figure 1 shows how overall lift coefficient varied with changing

rake angle on the two cars.

Clearly, both cars saw an increase in total downforce as the rake was increased by raising the rear ride height. But the key thing to notice is that the 2012 car gained relatively more overall downforce as rear ride height was increased than did the 2011 car. What we cannot see from this plot is how these downforce increases were distributed front and rear, but figures 2 and 3 create a clearer picture.

Looking at figure 2 first, we can see that front lift coefficient increased on both cars as rake angle was increased, and the 2012 car seemed to pick up slightly more front downforce with each rear ride height increase than the 2011 car. In the case of the rear lift coefficient though (figure 3), both cars started at roughly the same value at the lowest rear ride height, but clearly the new car

"both cars saw an increase in total downforce as the rake was increased"

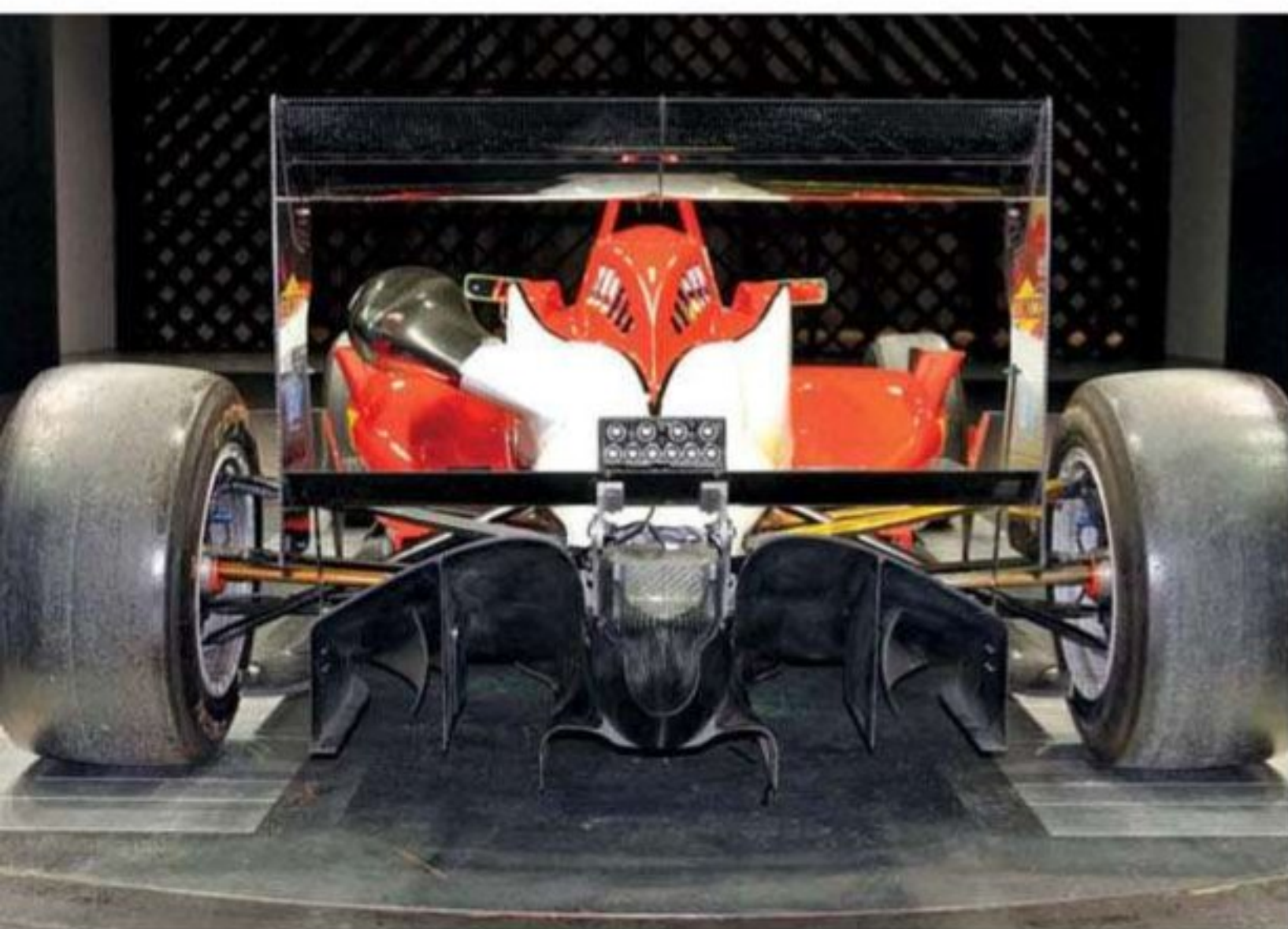

The 2011 Dallara F308 rear diffuser

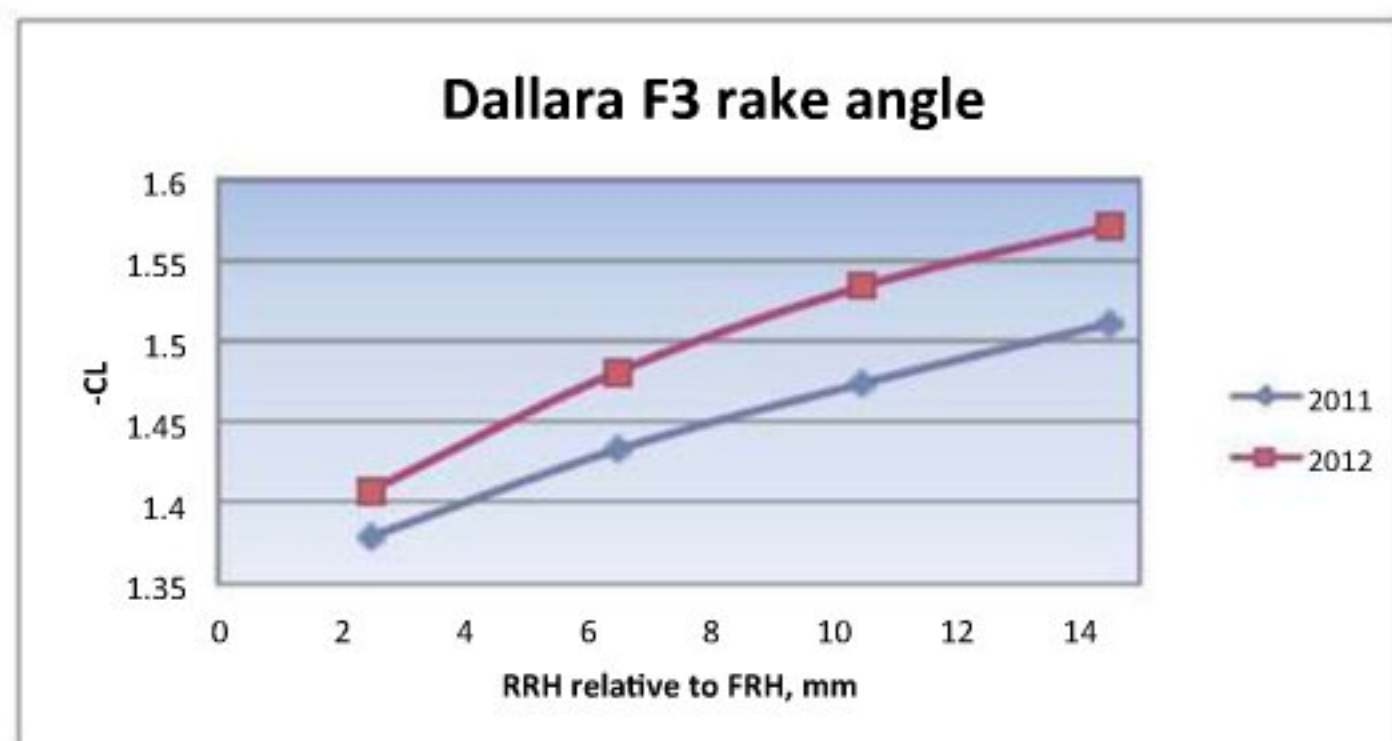

Figure 1: the effect on -CL, overall lift coefficient, of changing rake angle

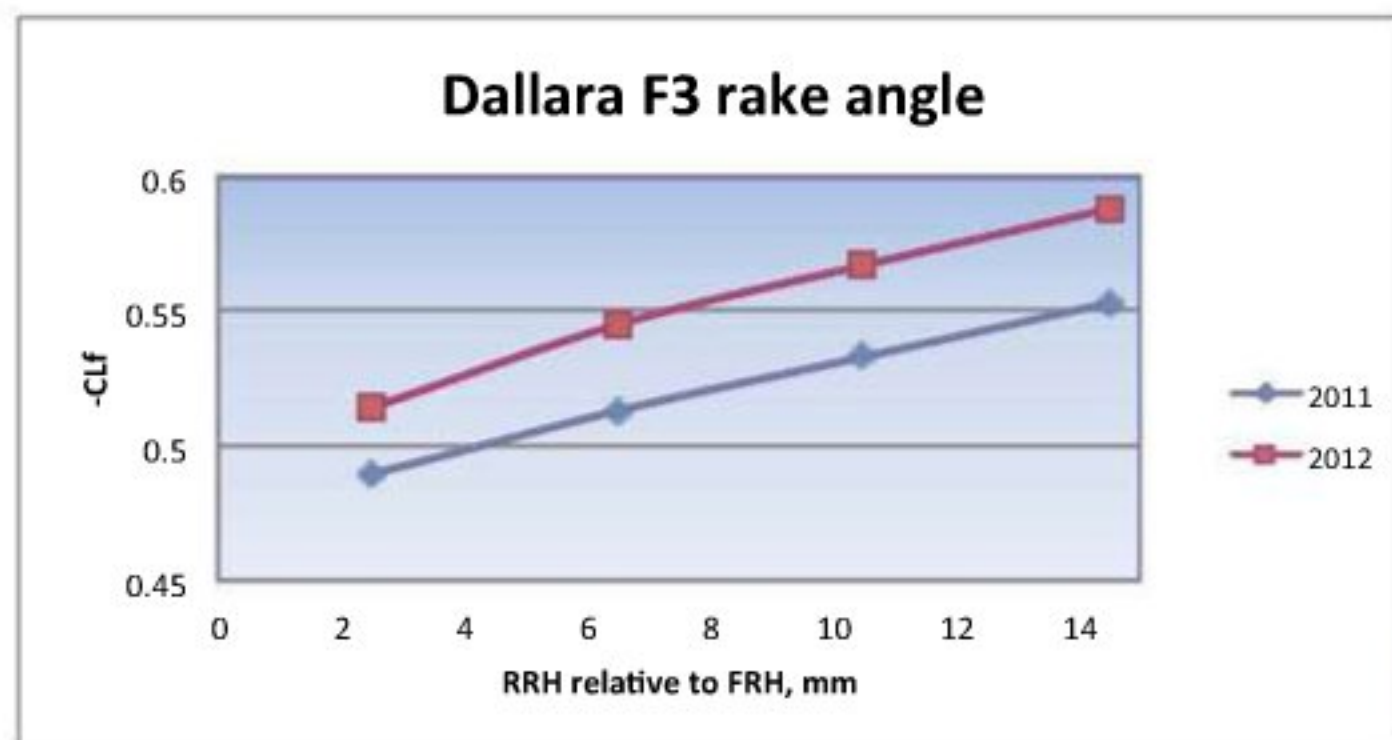

Figure 2: the effect on -CLf, front lift coefficient, of changing rake angle

picked up more rear downforce with increasing rake angle than the 2011 car.

Thinking purely in terms of the relative performance of the two cars, the overall change in actual rake angle was of the order of 0.3 degrees, which would be almost insignificant in terms of changes to the angle of the wings, so it seems as

though the new car's underbody was doing a better job as rake angle was increased. The ground clearance of the respective front wings would also have reduced slightly as rear ride height was raised, and this would have made a contribution to the increase in front lift coefficients, but the increases in rear lift coefficients had to have been

down to the floor and diffuser, hence the conclusion that the F312's underfloor works better than the F308's. This follows the conclusion in last month's Aerobytes that the F312's underfloor was also better in yaw. It isn't clear to what extent the effects we were seeing here were simply the result of lifting the underbody up from the wind

maximum available was just 8.2 degrees on this car) there was a reasonably efficient downforce gain of 62 counts for 21 counts of drag (2.952:1, better than the car's overall -L/D). With the steeper angle range tested on the 2012 car, the overall downforce gain was less at 49 counts, but the drag increase was commensurate at 16 counts

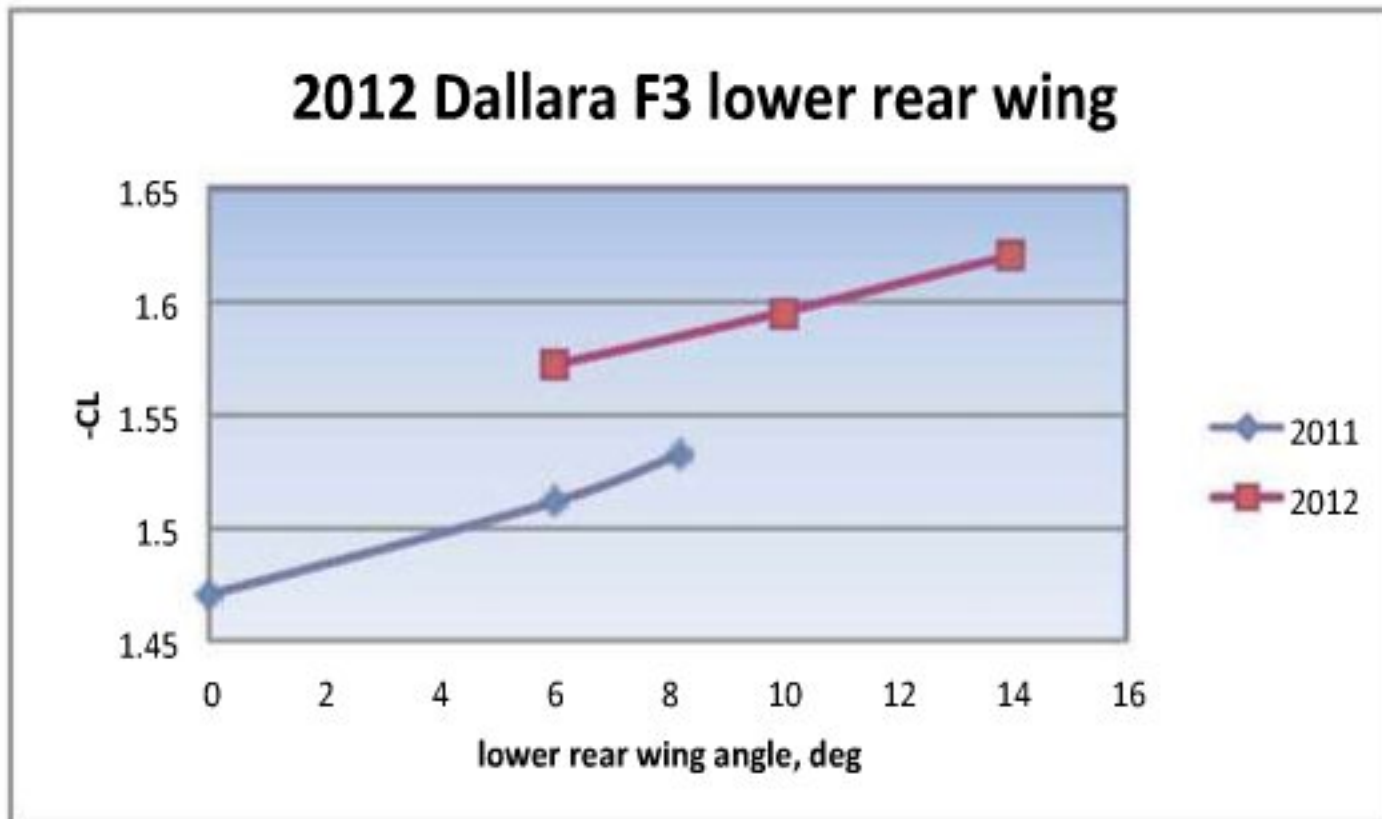

Figure 3: the effect on -CLr, rear lift coefficient, of changing rake angle



The 2012 Dallara F312 rear diffuser looks similar but the lower, centre section is narrower, the rear light has been more tidily located and it is missing one or two details visible on the earlier car's diffuser

“We might reasonably assume that the lower rear wing beam is also helping the underbody add a little more downforce”

tunnel floor's boundary layer, but it seems reasonable to think the differences we saw between the two cars across exactly the same ride height variations were real.

LOWER REAR WING BEAM

Moving (apparently) well clear of the floor's boundary layer now, we also looked at altering the angle of the lower rear wing beam, which, together with the tall end plates, also serves as the mount for the upper wing tier. The adjustment ranges available on the two cars' lower wing beams was not the same so direct comparison wasn't possible, but nevertheless the data proved illuminating. The changes to the aerodynamic coefficients are shown in tables 1 and 2 because, in this instance, it is easier to highlight points of interest.

Looking first at table 1 and the 2011 car, we can see that over the angle range tested (the

(3.063:1, also better than the car's overall -L/D).

The 2011 car showed effectively no offloading at the front for the 62 counts of extra rear downforce. This is interesting because, if we compare an adjustment to the upper rear wing tier (which we shall look at in more detail next month), it yielded 64 counts of extra rear downforce for 21 counts of drag, but -CLf reduced by seven counts. We might reasonably assume that the lower rear wing beam is also helping the underbody add a little more downforce, some of which is felt at the front end, offsetting the mechanical offloading seen with an adjustment to the upper rear wing tier. The 2012 car actually saw a small increase in -CLf despite the lower rear downforce increment from the wing beam adjustment, perhaps further emphasising that the 2012 car's underfloor is working better than the 2011 car's.

Next month, we'll end this fascinating and revealing F3 project with a look at the effects of rear wing adjustments on these relatively low-powered racecars, and also at the effects of some of the pre-2012 aerodynamic paraphernalia that has now been banned.

Racecar Engineering's thanks to Fortec Motorsport



Table 1: the change (Δ or delta) to the aerodynamic coefficients on the 2011 car resulting from lower rear wing angle adjustment, indicated in 'counts' where 100 counts = a coefficient change of 0.100 (change to %front value is absolute)

| 0 to 8.2deg | CD | -CL | -CLf | -CLr | %front | -L/D |
|-------------|-----|-----|------|------|--------|------|
| Δ | +21 | +62 | -1 | +62 | -1.6 | +18 |

Table 2: the change (Δ) to the aerodynamic coefficients on the 2012 car resulting from lower rear wing angle adjustment, indicated in 'counts' where 100 counts = a coefficient change of 0.100

| 6 to 14deg | CD | -CL | -CLf | -CLr | %front | -L/D |
|------------|-----|-----|------|------|--------|------|
| Δ | +16 | +49 | +4 | +45 | -0.9 | +12 |



IMPERIAL RANGE



METRIC RANGE



TENDER | HELPER



OFF ROAD



COIL SLEEVE



BUMP STOPS

PERFORMANCE PERFECTED

- Ultra-Lightweight for Reduced Unsprung Mass
- Maximum Travel in Combination with Smallest Block Heights
- Exceptional Block Resistance and Durability
- Precision Tolerances-The Tightest in the Industry
- Precision Parallelism and Squareness Tolerances, Maintained Under Loaded and Unloaded Conditions to +/- 1 Degree
- Lowest Side Loads and Load Centres Precisely Aligned to the Spring Axis
- Highest Linearity and Guaranteed Rate Consistency Within 2% of Advertised Rate
- Each Spring is Individually Tested and Rated

Eibach produces the finest race car springs in the world. Period. When other springs sag, or need frequent replacement, the top race teams inevitably turn to Eibach and wonder why they didn't choose us in the first place.

But don't just take our word for it, actions speak louder than words. Our springs have taken teams to 2011 championship victories and podium finishes at Le Mans, BTCC, CTCC, DTM and WRC.

Eibach: The Choice of Champions.



United Kingdom

Eibach UK | Phone: +44 14 55 - 28 58 51 | eMail: sales@eibach.co.uk

eibach.com

Find more issues at
magazinesdownload.com

Ferrea

RACING COMPONENTS

Your Complete Valvetrain Solution

Ferrea's USA based factory located in Fort Lauderdale, Florida, continues to expand manufacturing through state-of-the-art research, development and production capabilities. In 2012, we are looking to add new machinery and advanced software programs, to optimize designs, that will in turn, help meet the increasing demand for our valves, retainers and other valve train components. Pricing and lead times are available upon request for any valve train component not found in our catalog. Keep an eye out for our NEW website coming soon!

✔ Titanium, Competition Plus, Hollow Stem, 6000 Series and 5000 Series valves:

- A variety of different series valves that should be selected and used for your specific engine build
- All of these valves are manufactured from premium materials in USA



✔ Retainers:



- Fully heat treated US spec Military Titanium and Ultra-light Tool Steel retainers
- Engineered for optimum strength and weight savings

✔ Valve Springs:

- Manufactured from Ultra-clean premium wire
- Featuring new technology that increases the accuracy of spring rates in extreme racing conditions



✔ Valve Locks:

- Made from premium quality heat treated steel alloy
- Stronger than OEM. Available for most applications



✔ Valve Guides:

- Precision machined from high quality manganese bronze material
- Excellent for both Intake and Exhaust applications
- Compatible with Stainless Steel and Titanium Valves



FERREA RACING COMPONENTS

Tech Line: 954-733-2505

Toll Free: 888-733-2505

www.ferrea.com

FOLLOW US ON:



VAC

MOTORSPORTS

VAC ENGINEERED SOLUTIONS



DRY SUMP KITS - S65, S54 & MORE

RACING CRANK DAMPERS

COMPLETE ENGINE AND CYLINDER HEAD PROGRAMS AVAILABLE

ARP
automotive racing products

GT
PISTONS

ARROW
PRECISION

SCHRICK
MEMBER OF THE AVL GROUP

COMETIC
GASKET

SAMSONAS
MOTORSPORT TRANSMISSION



VISIT WWW.VACMOTORSPORTS.COM FOR 3,000+ PRODUCTS



Blue SKY thinking

Mazda announce the first production-based, four cylinder, racing diesel engine

BY ALAN LIS

In the week leading up to the 2012 Le Mans 24 Hours, Mazda Motorsport announced its intention to supply a new diesel race engine for LMP2 competitors in the 2013 event. A version of the same engine will also be raced in the new GX class of the US-based GrandAm series starting in 2013.

Both versions of the engine are based on Mazda's SKYACTIV-D power unit - a four-cylinder, 2.2-litre engine, which features a lower compression ratio than one would expect to find in a diesel engine. Dave Coleman, who has headed Mazda's R and D effort in Irvine, California on the SKYACTIV D production engine, explains: 'Lowering the compression ratio may seem counter intuitive but we've got it down to 14:1, which coincidentally is the same compression ratio used in the petrol version of the engine. The initial reason we did this was to achieve a cleaner combustion event. We were chasing an emissions target of raising the set standard without after-treatment of the exhaust. Lowering the compression ratio slows down combustion, and delays the start of combustion.'

COMBUSTION PROCESS

In a conventional diesel engine with a higher compression ratio, the combustion process starts as soon as the fuel is pouring into the combustion chamber. The result of this is a not very good mixture of oxygen and fuel molecules, which gives rise to a hot area around the edge of the fuel plume. As this area has plenty of oxygen and so burns very hot, it tends to result in a high level of NOx emissions. Alongside this, there is a rich concentration of fuel in the middle of the plume, which doesn't have enough oxygen to burn fully, so gives rise to soot.



With a low compression ratio of just 14:1, the 2.2-litre engine revs to 5200rpm and produces 450bhp and over 550lb.ft of torque in LMP2 racing spec

One of the engine's many innovative features is the use of a open deck aluminium block, unheard of in current diesel engine technology

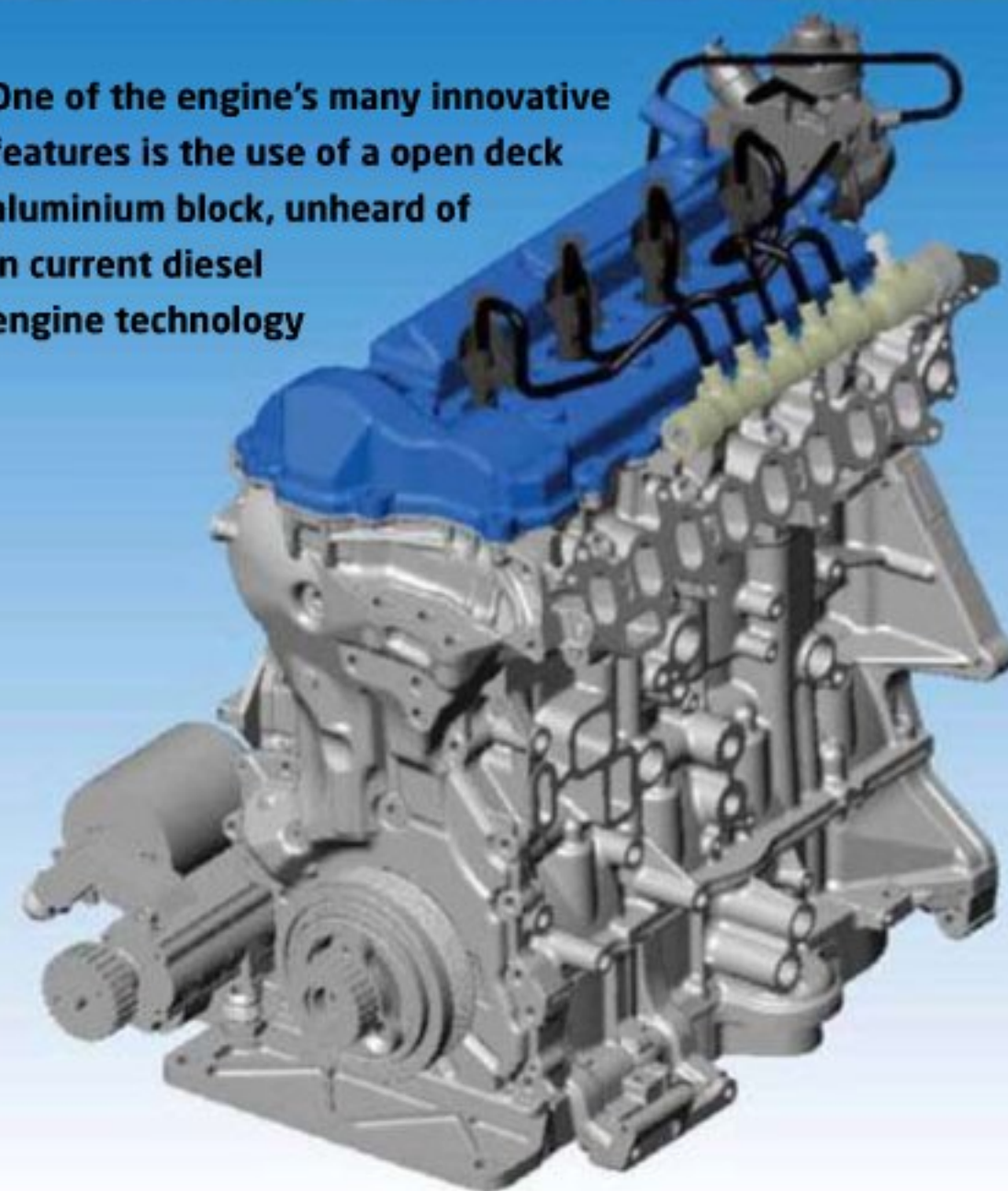

'If you try to pass the emissions standard with a high compression engine, you end up having to delay the injection of fuel until after the piston has reached top dead centre and, by doing that, you are throwing away some of your potential expansion ratio. Effectively, you are waiting until the conditions are slightly less hot, so it will take a little longer for the combustion event to begin. This allows more time for the fuel and air to mix, which results in a more homogeneous mixture.'

'If you do that in a conventional diesel engine with a 16:1 compression ratio, the expansion ratio from when you actually start burning fuel to

TECHNOLOGY - MAZDA SKYACTIV-D

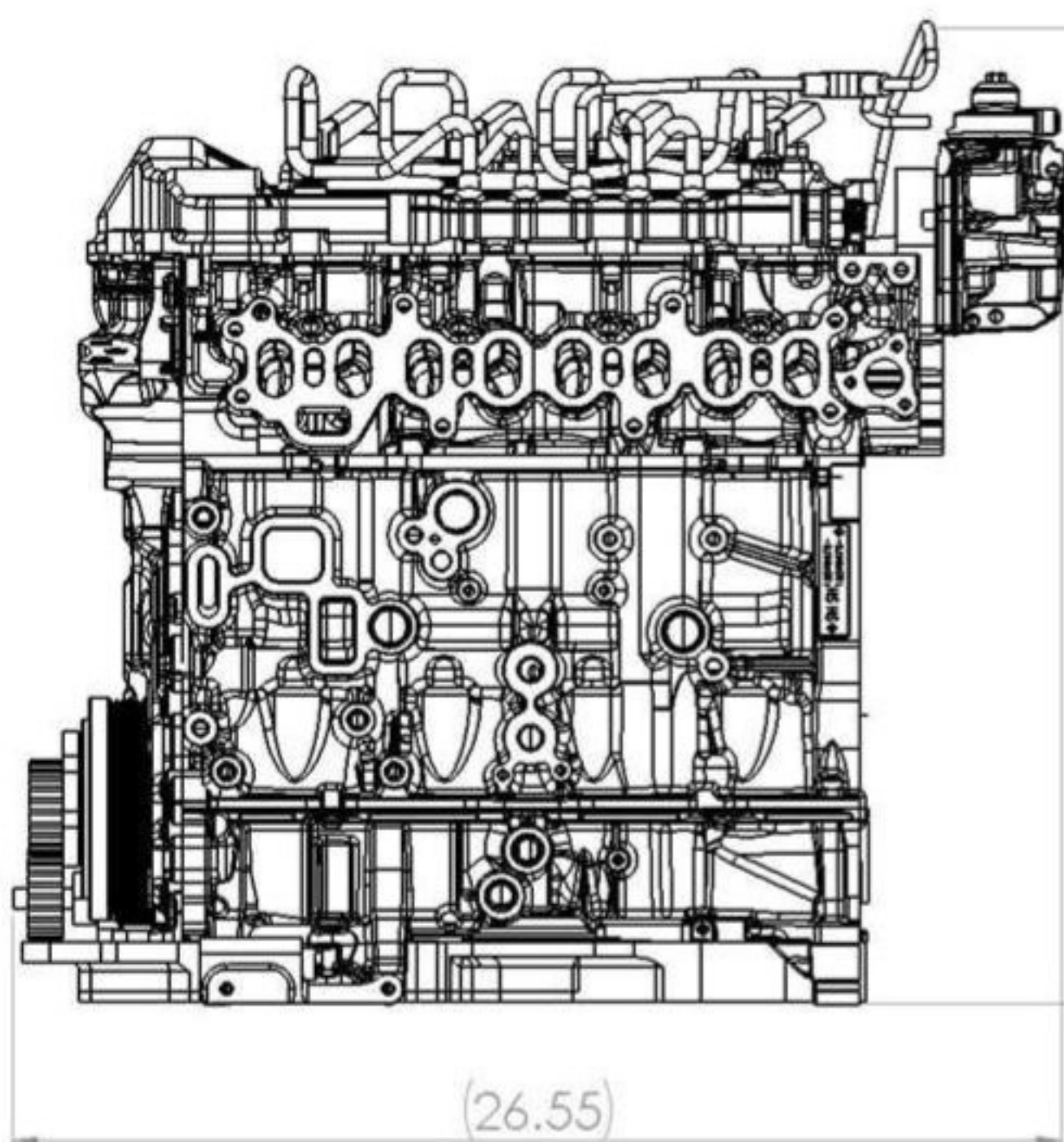

Crankshaft centreline height will be stock in the GrandAm engine, but a bespoke lower cradle will lower the crank in the block for the LMP2 version

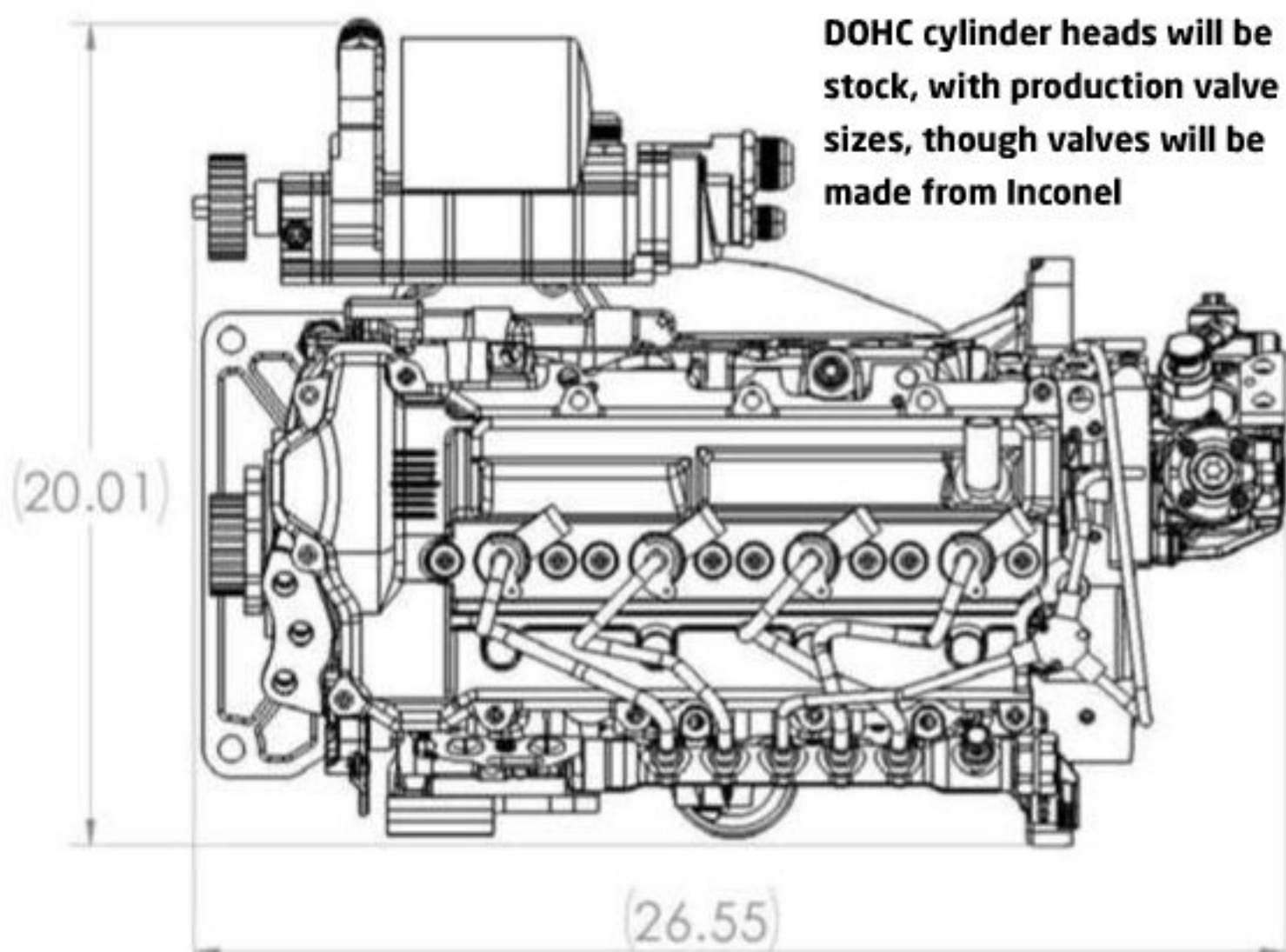
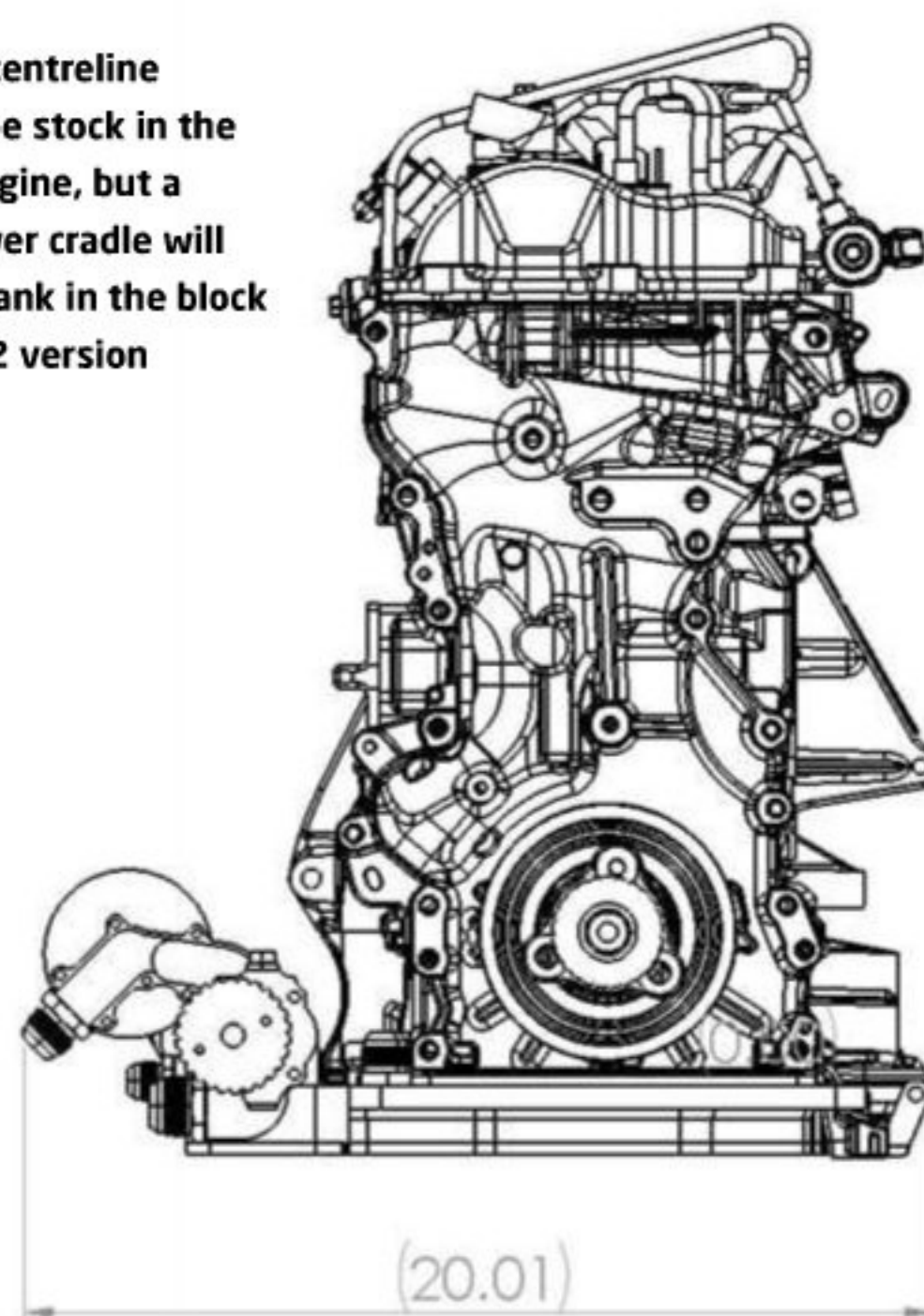

DOHC cylinder heads will be stock, with production valve sizes, though valves will be made from Inconel

the exhaust valve opening will only be around 14:1. If you just build the engine with a 14:1 compression ratio in the first place, the fuel can be injected at around TDC. The advantage of this is peak cylinder pressures are so much lower so we are able to make the cylinder block, cylinder heads, crankshaft and other parts much lighter. If you put the crank and rods of a SKYACTIV-D engine next to those of our previous diesel engine, the effect is almost comical. The old parts are so much larger and heavier by comparison.'

INTERNAL FRICTION

Coleman observes that the lightening of parts results in a snowball effect as the stresses reduce, and the end result is internal friction levels in a SKYACTIV-D engine comparable

to those of a conventional petrol engine. 'That, in turn, allows us to rev the engine quite a bit higher than a regular diesel engine,' Coleman continues. 'In production form, the SKYACTIV-D will rev to 5200rpm. With the ability to run at that level we were able to build cylinder heads and a turbocharger system that would breathe well at those speeds. All of this makes it easier to take this stock block engine and turn it into a race engine. In fact, with the SKYACTIV-D technology we are a lot closer to a racing diesel engine, in terms of the way the engine is constructed.'

Another of the engine's

big departures from a regular diesel engine is a die cast, open deck, aluminium block at the bottom end. 'That's unheard of in a conventional diesel engine, where you would typically have a closed deck, cast iron block - really heavy stuff,' says Coleman, with obvious delight. 'What we have is a block that looks like a petrol engine block in terms of construction because the forces involved are much closer, although it doesn't actually share any parts with the petrol version of the SKYACTIV engine.'

COMPOUND TURBOCHARGING

A further feature of the production engine, which is carried over to the race version is the layout of the turbochargers, though the racing application uses bespoke motorsport units.

'To achieve the driveability we were targeting for road racing, we have one turbo that does its thing in the lower rpm range and a higher pressure unit for the higher rev range,' explains Sylvain Tremblay, proprietor of SpeedSource Race Engineering, the Florida-based company that has been contracted by Mazda Motorsports to develop and build both the GrandAm GX and ACO LMP versions of the engine.

'The engineers at Mazda truly

did make it easier for us. The design of the engine has allowed us to stretch and gain in areas of development that would have been impossible to do in the relatively short time period we had for this project. The fact we have a 5200rpm stock engine means we can trust many stock components up to 5000rpm without having to sweat it in the racing world. A lot of the efficiencies needed in a racing application are already done.'

While both the GX and LMP technical regulations call for race engines to be production-based, there are nevertheless differences in their specifications. 'The biggest ones will be in packaging,' says Tremblay. 'Crankshaft centreline height is a major consideration in an LMP car, while in a GT car the production crank centreline is sufficient. So on the LMP engine, the lower cradle of the engine will have to be a bespoke part. But many of the engine internals for both the GX and LMP applications will essentially be the same.'

'We've done a lot of testing with production pieces. Currently, our plan is to have a bespoke crankshaft, simply for increased durability. We feel that while the production crank would be strong enough, it may not be cost effective because it would have to be replaced at the mandated 30-hour limit, whereas a purpose-made crankshaft would be more durable.'

'Also, because of weight and

"A lot of the efficiencies needed in a racing application have already been done"

ACCRA LITE
performance forged
pistons

A DIVISION OF



ENGINEERED TO PERFORM
world leaders in high performance pistons



MANUFACTURERS OF WORLD CHAMPIONSHIP WINNING PISTONS
FOR MOTOGP, WORLD SUPERBIKE & SPEEDWAY. WE POWER
WINNERS IN THE AMA, LE MANS, BTCC AND MANY MORE...



Omega Pistons

Oak Barn Road, Halesowen
West Midlands B62 9DW

Tel: 0121 559 6778

Fax: 0121 559 6779

info@omegapistons.com

www.omegapistons.com

“Our objective:

**to consistently satisfy motorsport’s
demand for the best connection
system, bar none.”**

- The lightest hose and fitting combination available
- Crimp and reusable hose end options
- Excellent bend radius - less hose used
- All one piece ‘billet’ fittings, no brazing
- Four exterior braid options
- Custom CNC tube bending service
- Engineering design service - part of your team

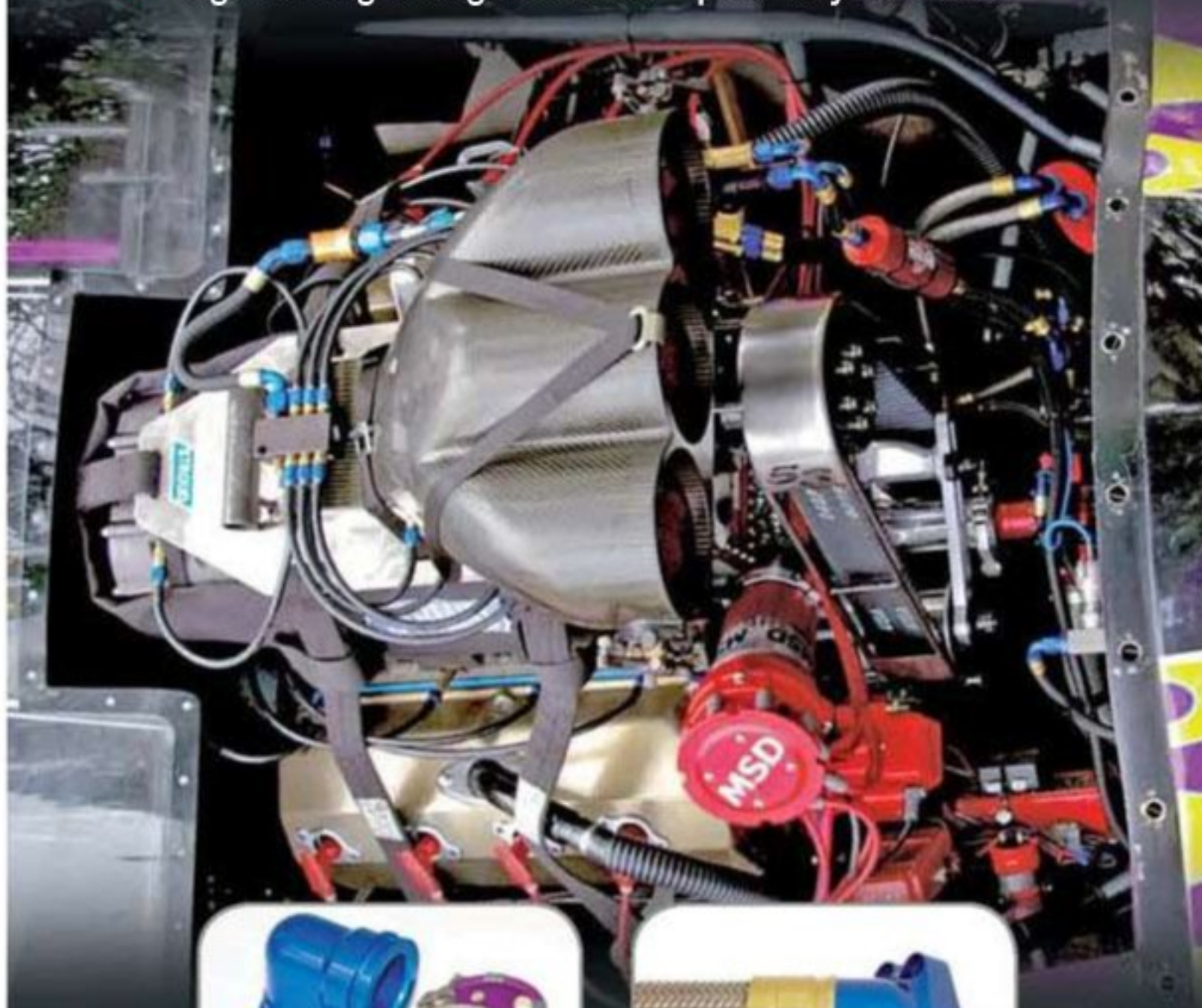

BMRS 2010 Champions in:

NASCAR Sprint Cup • NASCAR Nationwide • NASCAR Truck • NASCAR K&N East
IndyCar • ALMS LMP • ALMS GT • Grand Am Prototype • Grand Am GT
World of Outlaw Sprint Car • ARCA • USAR • USAC Midget • ASCS Sprint Car
Formula Drift • Lucas Oil Dirt Late Model • Knoxville Track • Daytona 24hr
Daytona 500 • Brickyard 400



www.bmrs.net

USA: BMRS Concord +1 (704) 793 4319

UK: BMRS Slough +44 (0)1753 545554

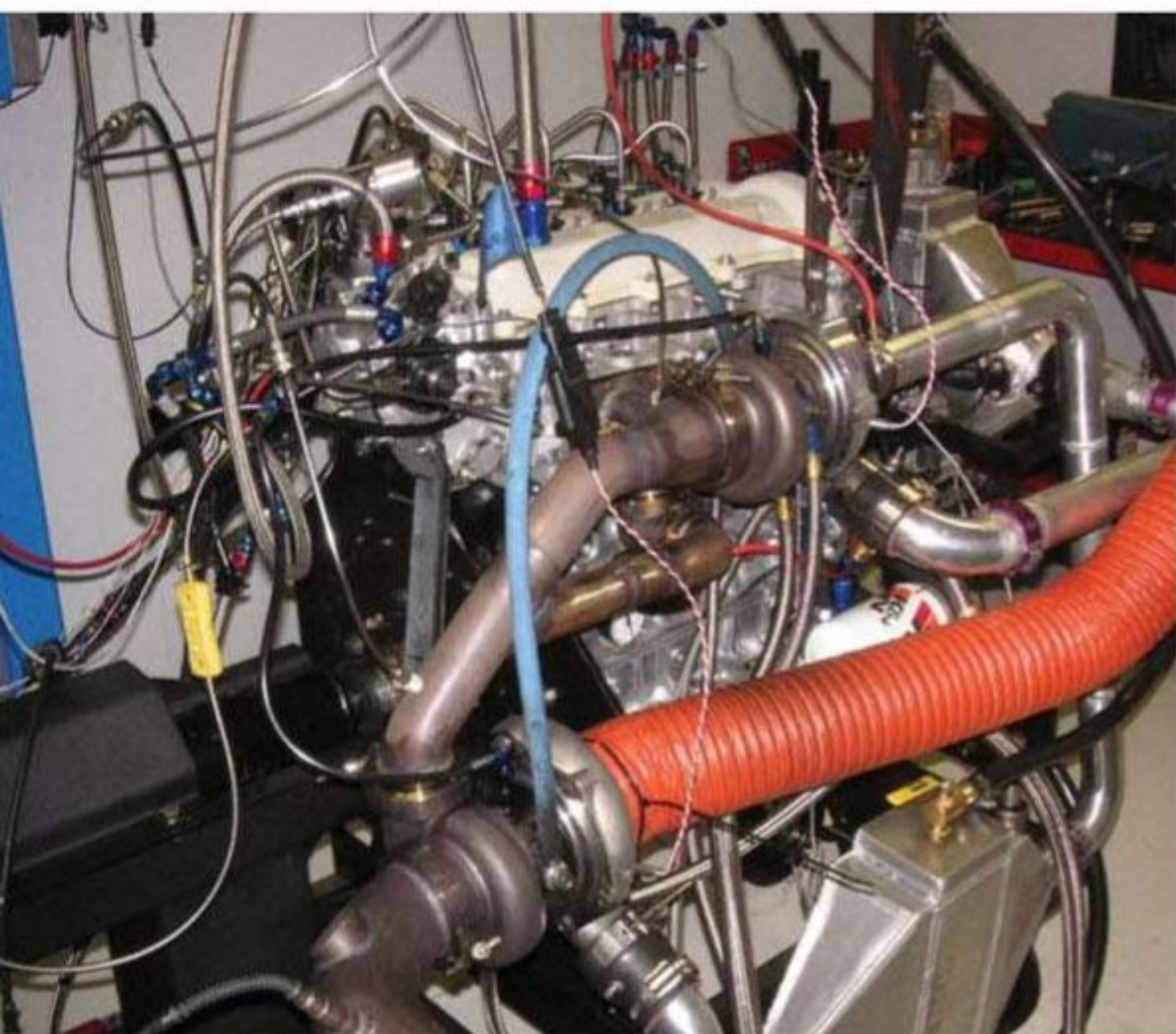

Though much of the production engine's components are up to the job in terms of strength, the race versions will use bespoke internals for improved durability

durability, the connecting rods and pistons will also be bespoke parts. For the bowl shape in the piston crown we will be using all the hard work that Mazda R and D has done in that area. The bowl shape is critical at the lower compression ratios we are using in order to have the best possible combustion.'

PRODUCTION PARTS

According to Tremblay, the DOHC cylinder heads of the race engines will be production parts, with the current plan being to keep the same valve sizes as OE, but change the material from which they are made to Inconel to

replaced with a Bosch Motorsport set up on the racing versions. 'In the racing applications we are still using the Piezo technology,' explains Tremblay, 'but with the Bosch MS15.1 ECU and Bosch Motorsport pump and injectors.

'The injectors we are currently using have eight holes but we are also experimenting with a 10-hole version. The Piezo technology essentially allows us to do pre- and post-injection of the fuel, and in all we can have as many as eight injection events in a single combustion cycle.

'To date, the lower compression ratio hasn't given us any problems in the racing

"The bowl shape is critical at the lower compression ratios we are using"

withstand the higher pressures and temperatures of racing. The camshafts will be made from production blanks with SpeedSource's own specialised grinds on them. The OE valve springs have been replaced with aftermarket parts, but the rockers are off-the-shelf production pieces. There will also be carbon fibre valve covers to save weight.

The Nippon Denso fuel injection system of the production engine has been

applications. We thought that start up might be an issue but it's not. We can use glow plugs to start the engine and keep them on to reduce smoking. Our plan is to incorporate a diesel particulate filter, but we already have a very low smoke engine because of the low compression ratio."

At Le Mans, the SKYACTIV-D engines will run on the ACO's own spec GTL (gas-to-liquid) diesel fuel - LM 24 - while in the GX class the fuel is required to

be commercially available. 'For the GX programme all of our initial testing has been done with US-grade diesel, which has a relatively low cetane number, and that has been challenging,' says Tremblay. 'With our partners we are looking at alternatives, including bio-diesel, but we can't use specially developed racing diesel. We will definitely use a fuel with a higher cetane number than the current pump fuel in the US, which is extremely low. European stock diesel is around 50-55 so it's relatively good grade fuel. American diesel historically has a low cetane number - around 40. That's not an issue at low revs, but one of the benefits of this engine is its ability to rev at a higher level and the flame front in a 40-cetane fuel is too slow. The cetane number in a diesel fuel is a determining factor for rpm.'

Despite the different fuel specs internal differences in the GX and LMP engines will be minimal. 'The biggest difference is in the spray pattern at higher revs and power levels,' explains Tremblay. 'As we look at the LMP application, which has a higher power requirement, we will need better fuel. The GrandAm GX application uses a lower power level for which standard pump fuel won't cut it, but it doesn't need to be as potent as the LMP fuel. The internals such as the piston bowl design will stay consistent for both applications. The injector pin count and angle may or may not change.'

Tremblay quotes peak power targets of around 450bhp for the LMP engine and 400bhp for the GX version, but says his preference is peak torque figures. These are above 550ft.lb in LMP form and 500ft.lb+ in GX form.

John Doonan, director of Mazda Motorsports, adds: 'The neat thing about the SKYACTIV-D race engine project was that the existing rules for GrandAm GX and ACO LMP2 allowed us to carry out parallel development. The power and torque levels we were targeting were similar. When GrandAm came to us with the GX concept it allowed us a new opportunity, but the cool thing was that we were already attempting to achieve power and performance targets at the

higher level.'

Clearly, the lack of aftermarket parts for its racing application has been a significant challenge. 'Any new internal and external parts we have needed we've had to engineer, design and build in house,' says Tremblay. 'It's been a great help to work with Bosch and Garrett, who already have extensive experience of diesel racing programmes, but the biggest single challenge has been that no one has yet built a production-based, four-cylinder, compound turbo, diesel race engine. We are breaking new ground and we've been climbing uphill throughout the programme so far.'

TECH SPEC

SKYACTIV-D

Displacement: 2191cc

Bore: 86mm

Stroke: 94.3mm

Estimated Weight: 325lb (148kg)

Horsepower: 420bhp / 336kW

Torque: 505ft.lb / 685Nm

Max engine speed: 5200rpm

Rotation: clockwise (from front)

Engine block: OEM aluminium

Camshaft : dual overhead, SpeedSource-developed

Valves: four valves per cylinder, SpeedSource-developed

Head: OEM Mazda, SpeedSource ported

Pistons: anodised aluminium alloy

Con rods: forged alloy steel

Crankshaft: alloy steel

ECU: Bosch Motorsport MS15.2

Intake manifold: SpeedSource developed

Exhaust manifold: OEM Mazda, integrated in head

Turbo and wastegate: Garrett Motorsport; air-to-air intercooler

Fuel injectors and pump: Bosch Motorsport

Fuel rail: OEM Mazda

Oiling: SpeedSource-developed

Cooling: SpeedSource-developed

Fuel: Shell LM24



THE NEW LEADER IN POWER MANAGEMENT



THE PM1 & PM2 FROM GEMS

- > CAN multiplexed power control system
- > Up to 64 outputs in a network
- > Fully programmable logic
- > Interface to keypads or switches
- > Fully customisable system



www.gems.co.uk



- THE MOST POPULAR COMPONENT IN MOTORSPORT
- COMPREHENSIVE RANGE OF COOLING ACCESSORIES
- **BRITISH** DESIGN & MANUFACTURE

FOR THE BEST IN OIL COOLING SYSTEMS...

**...MAKE IT
MOCAL!**



**WINNING RACES
SINCE 1967**

Worldwide enquiries
go to:

www.mocal.co.uk
USA enquiries go to:
www.batinc.net

0208 568 1172

World class competition

Innovative design and engineering excellence abounded at Formula Student, yet still there was a pitiful result in the Endurance event



Swedish university, Chalmers, developed their four-cylinder Yamaha-powered entry to include a full aero package for 2012. It paid off, as they were crowned overall winners

When 3000 students, with 132 cars, from 34 countries, arrived in Silverstone, UK, it was clear the 2012 Formula Student event was going to be nothing short of an engineering battle.

According to patron, Ross Brawn, Formula Student is 'one of the most innovative and exciting forms of motorsport,' and this year it certainly proved that. The overall competition is split into static and dynamic components. The static events consist of Business and Cost presentations, which challenge the teams' abilities to promote their car design as a business model for a 'weekend racer'. The Design and Sustainability of the car are scrutinised to encourage engineering excellence, all the while considering the

environment, while the dynamic events are designed to put the cars through their paces on track. This is where the real action takes place, and where all aspects of the cars are assessed, in Acceleration, Sprint, Skidpad and Endurance events.

ENDURANCE

The endurance event on the final day is the make or break part of the competition, and even though the weather was kind and the track remained dry this year, this did nothing to lessen the on-track action. In the end, less than half of the running teams made it to the finishing line, the 22km course living up to its reputation as a high-grip car breaker.

Arguably the most competitive inter-team battle was the fight for the top UK spot. Over the last few years this has been between Hertfordshire,

Bath and Oxford Brookes, and all cars looked set for promising results this year. However, in true motorsport fashion, the unexpected happened. At the driver changeover and hot re-start, Team Bath had an issue with a brake light and were disqualified from the competition. The Hertfordshire engine cooked itself, due to a fault with a cooling hose clamp, which led to a leak that resulted in red flags. On track at that point were two of the top non-UK teams, Delft and Monash, who then had to quit while the marshals cleaned up the track. Thankfully, both were able to carry on and complete the circuit.

After that, Stuttgart and Chalmers took their fight out on the track, providing some quality racing. Unfortunately, a late pit exit and an unlucky stall from Oxford Brookes left them

stranded on the track, this time causing Chalmers and Stuttgart to stop. Luckily, Brookes started relatively quickly, and all three teams finished the endurance.

The event was especially cruel to the University of Maribor, whose car expired with just one lap to go, while many other teams suffered mechanical issues that forced them to retire early. Judging by the reactions of those that survived, they may as well have finished the Le Mans 24 Hours! Ultimately, the successful teams needed a combination of reliability, pace and good driving skills to survive the most testing of all the competition's events.

In the end, Monash University set the fastest time, but fell foul of a number of time penalties for leaving the track, meaning Swedish university, Chalmers, finished the event on top, with Munich securing third place.

BEST INNOVATION: UAS AMBERG WEIDEN

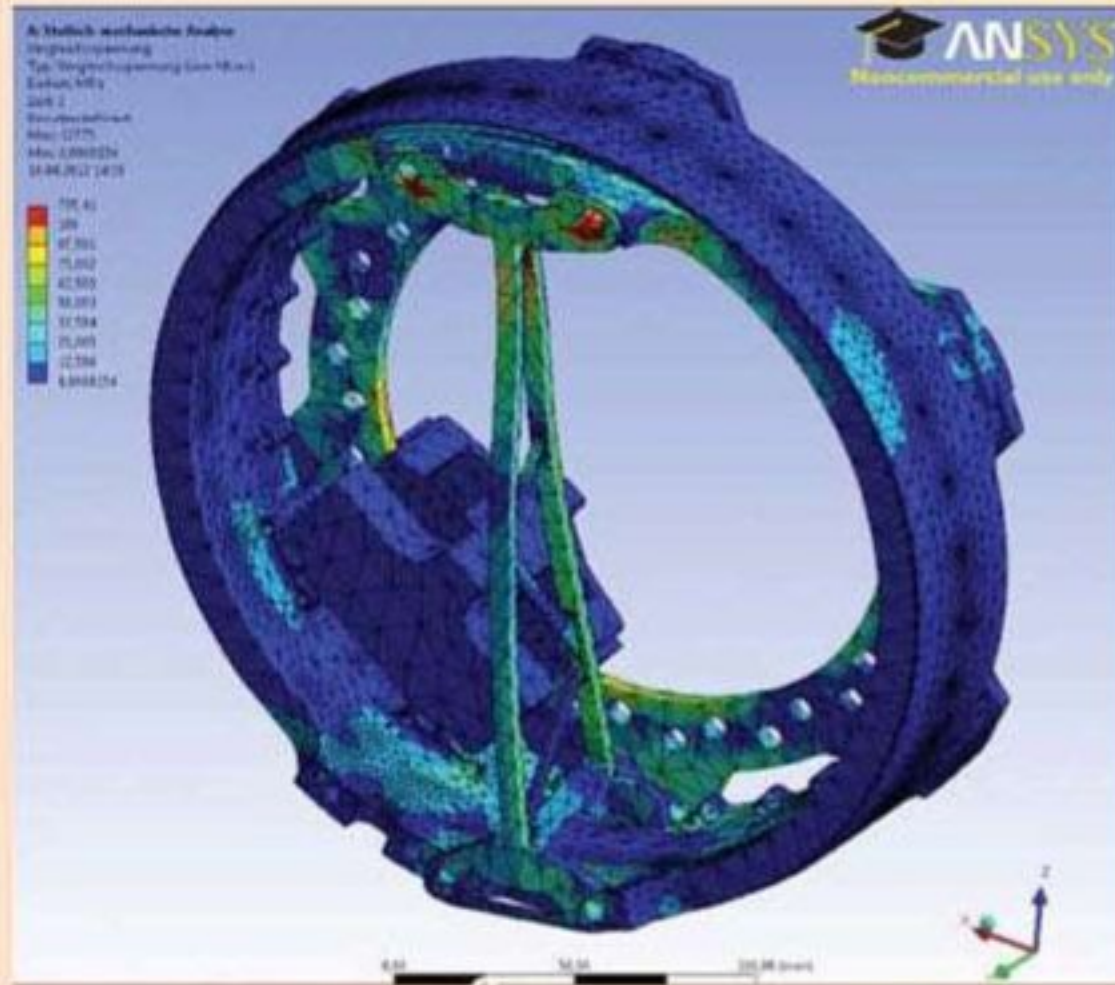

One of the most interesting design features spotted at this year's competition was the front hub / upright design on the Amberg Weiden car from Germany. It says something about the level of engineering at Formula Student that the car's carbon tub and suspension were not especially noteworthy, though their centreless wheels definitely raised some eyebrows.

The concept of centreless wheels - where the hub is almost the same diameter as the inside diameter of the wheel - was originated in the late 1980s by designer, Franco Sbarro, but the concept has never really caught on.

So why did the team opt to adapt such a design? Michael Glasser, the team's head of suspension development, explained their reasoning: 'It was to create better load paths and to reduce weight. The design provides a much shorter load path through to the wishbones than a regular hub. We also have a lightweight design philosophy of reducing the mass of parts a long way from the c of g. These hubs save 400g per side over the previous conventional design.'

The choice of such an unconventional system did not hamper the car's performance, with the team placing eighth overall in the competition.

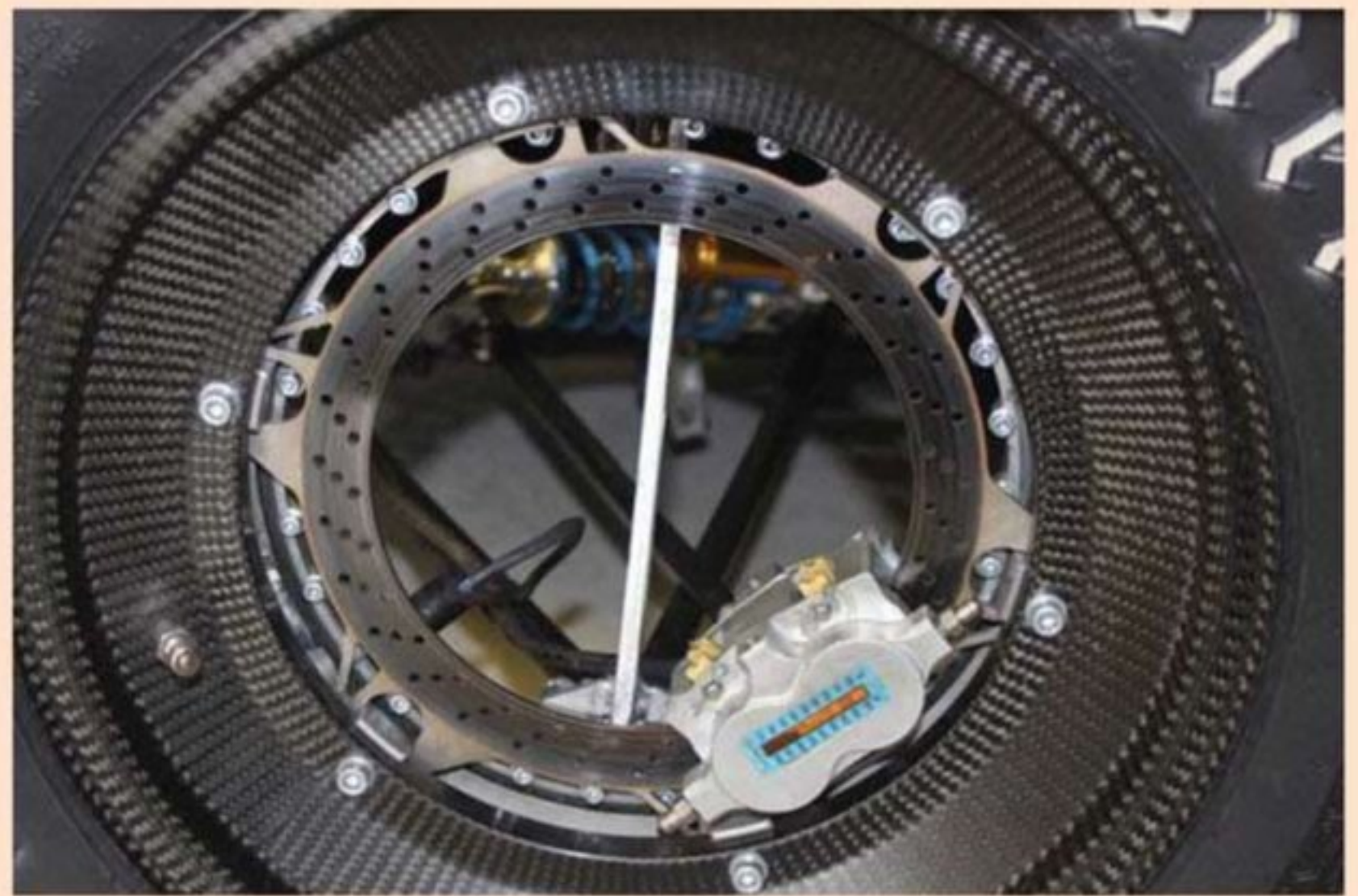

A huge 400g per hub weight saving made the centreless wheel concept worth pursuing. The team also claim a greatly decreased load path distribution through to the front wishbones

DOWN TO THE WIRE

Formula Student isn't all about the Endurance event, though, the competition has many facets, so several teams were in the running. Andrew Deakin, Formula Student vice chairman, summed it up: 'This year's competition has been truly impressive, with many of the cars displaying world class engineering that wouldn't be out of place in a Formula 1 paddock. These young engineers will mature into the motorsport team bosses and industry leaders of the future.'

After the final totting up had been done, Chalmers pipped Netherlands-based Delft by just 2.4 points, scoring 850.5 points to Delft's 848.1 points. Interestingly, the two teams' cars could not have been more different in their concepts. Chalmers' car featured a petrol engine and a

full aero package of wings and diffuser, while Delft's entry was all electric with an innovative four-wheel drive system. 'Chalmers University's car is a masterpiece of engineering that makes a worthy winner,' stated

"These young engineers will mature into the motorsport team bosses and industry leaders of the future"

Deakin. 'As well as being one of the fastest cars round the track, it also performed consistently and impressively in the static events. [But] Delft's electric car pushed it to the wire, showing that the future of motorsport needn't necessarily lie with the internal combustion engine.'

Also in the running for the overall win was Monash University - one of the first teams to run full aerodynamics on their car, which resembled a mini Sprint Car. Jonathan Rice, team leader of Chalmers

Formula Student: 'This is the biggest student engineering competition in the world. We've competed against the very best universities, not from the UK, not from Europe, but around the world. It feels amazing to have won it.'

Unfortunately, for the host

nation's national pride, it looked unlikely from early on that any of the British universities were in with a chance of a podium position, even though the quality of entries was very high. The best performance came from Oxford Brookes, coming in seventh place overall, thanks to consistently good results throughout the event. A lack of ultimate pace in the endurance was all that prevented a higher placing. Throughout the competition, their closest UK rival was the University of Hertfordshire, the highest placing UK team for the last two years, but the engine failure in the Endurance scuppered their chances. Other top 20 performers from the UK were Liverpool John Moores in 12th, University of Liverpool in 18th and Bath in 19th.

-35mm Worlds apart

Our technology centre is the most advanced in Europe.

That is how we can achieve a negative radius of up to -35mm. Extreme engineering and precision that other performance cam manufacturers in Europe cannot match. All our camshafts and ancillaries have been developed by the best to be the best.

- Nº1** Kent Cams – the best in Europe:
- No.1 for product development expertise
 - The greatest performance increase of any single modification
 - The widest range of camshaft ancillaries produced on site

- The most advanced technology:
 - Negative radius to -35mm
 - CBN wheels with constant surface speed
 - Multi-angle lobes with CNC dressing
 - Marposs 3D C and Z axis position probe
 - Microphonic wheel dressing
 - Lotus Concept Valve Train software



**HIGH PERFORMANCE
ENGINEERING**
www.kentcams.com

Cams + Pulleys, Belts & Chains :: Valves & Valve Springs :: Performance Cam Kits & Valve Spring Kits :: Followers & Tappets

Castroper Strasse 80 • 44628 Herne • Germany • Phone: +49-2323/18429
www.tennant-metall.de • e-mail: post@tennant-metall.de • Fax: +49-2323/18427

TENNANT

Metall & Technologie GmbH
Your Contact for Engineering & Aircraft Metals

We are a EN 9100 certified stockist of materials for F1/WRC/DTM applications and have been supplying various special steel grades and forms to international customers for more than 20 years. Our steel grades are designed for highest stress applications and are used for the manufacture of roll cages, motorcycle and bicycle frames, wishbones, spaceframes and axle parts.

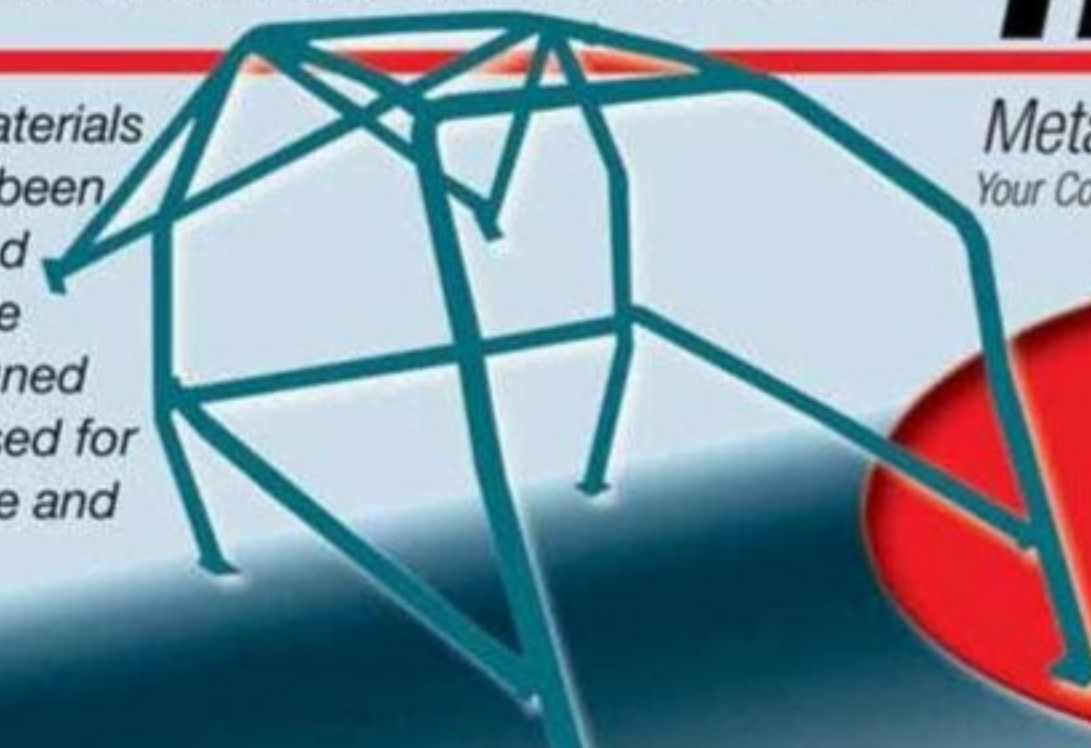

- Our strength:**
- competent advice
 - supply of small quantities
 - cutting to size

STEEL COMPETENCE

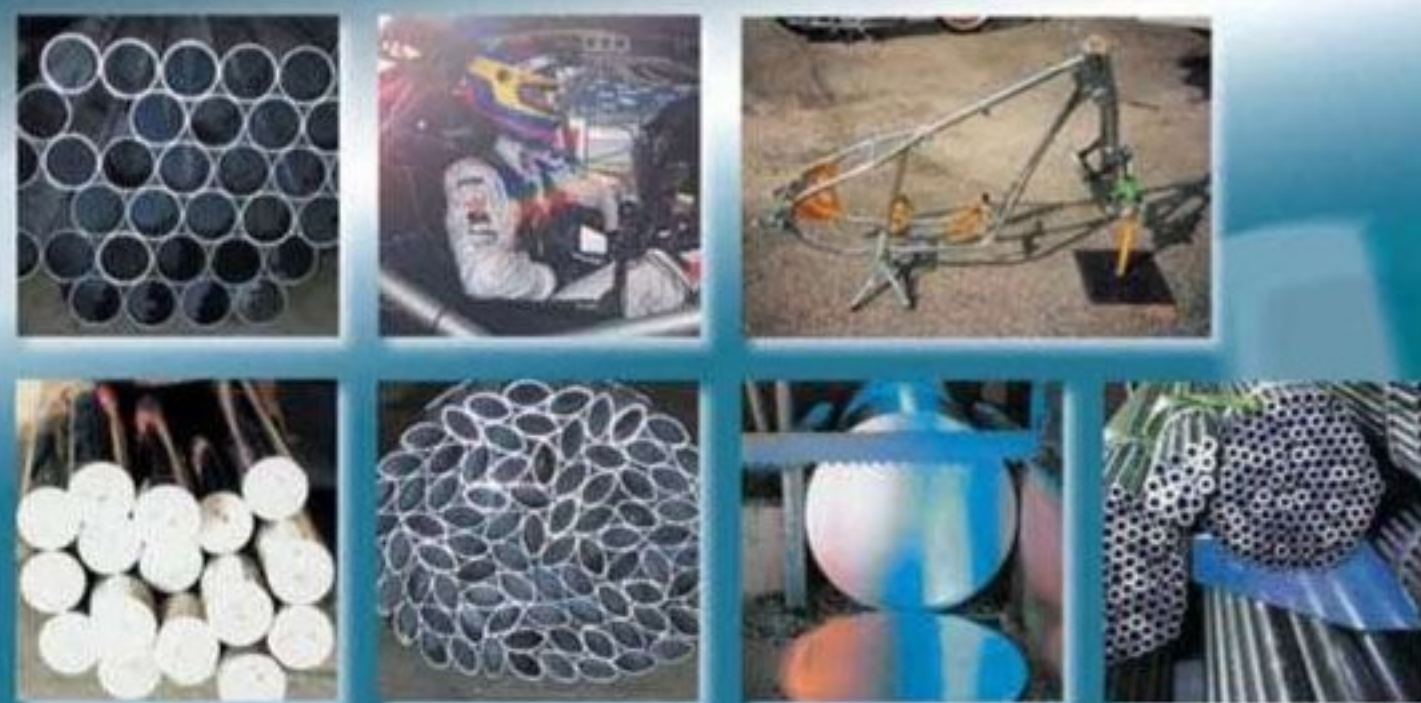

Special Steels in Material Grades 25CrMo4 and 15 CDV6 / 1.7734

available **ex stock** Herne in the following forms:

- Tube - round, oval, aeroprofile (teardrop), rectangular, square
- Bars • Flats • Sheets

We also supply **Welding Wire** in appropriate grades. All material accompanied by test certificates. We can cut to size and arrange transport at competitive prices.

THE CARS



One of the most novel solutions on display was the bamboo bodywork on the University of Warwick entry. Light, strong, sustainable and ingenious

One of the joys of Formula Student is the technical freedom competitors have. Beyond a few dimensional and safety regulations, they are given a free reign with the design. It is interesting to note how the different teams deal with this freedom. Some develop some truly innovative ideas, but fail to iron out the faults in complex concepts, some keep things simple and concentrate on good engineering practice, while a few manage to achieve a combination of both.

Ultimately, as is the case with motorsport in general, those with the biggest resources tend to have the greatest success. In the case of Formula Student, this generally means the well-resourced and financed teams from Germany and Austria, who have substantial sponsorship and technical support from major motorsport players. TU Graz, for example, is sponsored by Red



The fastest car on track was Munich, the overall dynamic winner. Look, no wings

Bull, while others have backing from major motor manufacturers. This is apparent when you take a close look at the cars' component parts - carbon monocoques are almost commonplace these days, and many sport composite wishbones and uprights machined from exotic alloys. In other words, the type of kit you

would expect to see on a top flight formula racer.

The variety on show in the paddock is refreshing for anyone jaded by countless rows of spec racers, and it's not uncommon to see a winged carbon monster next to a basic tube-framed car made out of the engineering department's scrap bin.

The paddock was full of interesting design solutions, but a couple that particularly caught our eye were the University of Warwick's novel take on composite bodywork - instead of carbon composite, they opted for laminated bamboo. The team explained that, though it was not as strong as carbon, it was just as light, considerably cheaper and far more environmentally sustainable. The Warwick car was not a one-trick pony either, and was one of the best prepared cars in the pit, with a very neat, in-house-built wiring loom and excellent attention to detail in the selection and fit of components. Staying with the concept of lightweight, yet affordable bodywork, the University of Strathclyde took things to the extreme by using corrugated plastic for its exterior panels, the regulations only specifying that the material used be non-porous. Good thinking.

FORMULA STUDENT

OVERALL WINNER - CHALMERS UNIVERSITY



Dramatic aero package added 10kg, and cost the team 0.6 litres of fuel in the Endurance event, but they gained two seconds per lap

The most dominant feature of the Chalmers' car this year was its extensive aero package, which clearly worked as not only did they win the overall competition, but they triumphed in the endurance.

'We ran a very subtle aero package last year,' says Jonathan Rice. 'We had some good CFD and a scale wind tunnel, so we used a static ground 1/3-scale model to investigate reducing drag. The most important question was for every increase in drag point, what is our increase in fuel consumption? With our aero package, we're only going to use 0.6 litres of fuel more, and yet our lap time reduces by two seconds.'

'Unfortunately, the rules committee weren't happy with how the wings were supported at the front because it hadn't been included in our impact test. So we had to pull back and raise the front wing and drop down and push forward the rear wing to maintain the aero balance. We reckon we can get another second out of this car...'

'More importantly, the drivers feel more confident in the car because it feels better on the



Weight has gone up, but so has chassis stiffness, from 800 to 3800Nm/degree

road, so for us it's worth the cost and weight penalties. Overall, the aero weighs around 10kg.

'This is our first major iteration. Next year we're going to study hard on where we can improve. Monash's package is impressive. They react their aero into the unsprung mass, but they've had some problems and the judges are talking about restricting that for next year, so they might have to take a step back, whereas we're going to take a step forward. Zurich is probably where we've got to go, as they're two seconds quicker

than us, so the challenge for next year is [to go] another two seconds faster. Until you are a team that has maximised the mechanical grip, there is no point trying to chase aero because it's going to have you running around in circles.'

'We also focused on the suspension and unsprung mass, and our main concern was stiffness. We had to change from carbon fibre rims, so we moved to aluminium and took a 9kg weight penalty. We're a 230kg car, yet we're competitive because when we were running

with carbon fibre rims we couldn't run any higher than 14psi, so the tyre wall would fold over on itself. Now we can get to 40psi and the tyre walls are extremely stiff. We have found a set up in mixed conditions where we can run super high pressures, and the more you increase the pressure, the more the lap times come down, in the wet and dry.

'It's this insistent need that people focus on weight when really they should focus on performance. Weight and power aren't everything. It's actually lateral *g*. We did a sensitivity analysis and found that if you drop the lateral *g* by 0.1, you need to increase your engine power to maintain the same lap time.'

'We made some big compromises this year with the hubs, uprights and bearings so, although we've increased weight in some places, the stiffness has increased massively. The 2010 car had a hub-to-hub stiffness of 800Nm per degree, this car runs at 3800Nm per degree.'

Chalmers' development work for 2012 clearly worked, and they've now a number of trophies to show for it.

As always, the Delft Racing Team returned to Silverstone with an even more innovative car than before. Winning a total of six awards, including Best Design, Most Efficient and Most Innovative car, the car finished in overall second place, a well-deserved result for the team from The Netherlands.

Delft are renowned for building incredibly light cars, with this year's weighing in at just 145kg, making it by far the lightest on the grid. Surprising perhaps, considering it was electric and four-wheel drive. 'The secret behind the lightweight engineering of the car is the part integration,' explains the team leader. 'For example, we've managed to integrate the small motors with the planetary gear system on the front wheels, which only weigh 6.7kg. Also, because we primarily designed this car for the overall competition, instead of focussing just on the Endurance event, we drove the Endurance with only 60 per cent power settings instead of 100 per cent, and invested some time in Efficiency and the other dynamic events. That meant we could reduce the weight of the accumulator, which is the heaviest part in an electric car.'

Also, their four-wheel drive system allows them to utilise regenerative braking. 'When you accelerate in a car, you accelerate on the rear tyres, but when you brake you actually accelerate the front tyres in the other direction, so you can regenerate your braking energy, and we regenerate about 40 per cent of our energy back.'

However, this clever design did result in some significant engineering challenges: 'The inner wheel transmission was most difficult because you have to fit something that delivers enough torque, but is still small enough to fit in a 10-inch tyre, and, of course, you want to make it as light as possible. We really designed it on the edge. For example, there is only 3mm between the start of the rim and the end of the transmission casing, which is tight.'



The lack of an aero package did not seem to hamper TU Delft's all-electric car, which also featured regenerative braking



Designing the lightweight four-wheel drive system took up a lot of resources



Careful product selection and 'part integration' kept overall weight to just 145kg

Delft Racing worked closely with AMK to design the electric motors. 'We started with an air-cooled motor by AMK and, because we wanted it as lightweight as possible, AMK suggested turning it into a water-cooled motor.

So we re-designed the casing to integrate the water cooling system. Overall, we managed to make a 4kg motor with nominal power of 6kW and a peak power of 25kW'

With approximately half of

the top 10 this year exploiting aero packages, Delft's car looked almost naked, but was still extremely successful, adding to the ongoing aero debate. 'We could try and put a lot of energy into aerodynamics, but last year we saw that it didn't make that much difference between the aero and normal cars, so that, together with the complexity of an aero concept, is why we thought we'd find something else. We always try to look at the power gains of a new concept. This year, we thought that four-wheel drive would be the best opportunity, and by making simple event simulations at the beginning of the year we could see the advantages of it.'

A second car from TU Delft, run by the Forze team, featured an in-house-built fuel cell producing 18kW and brake energy recovery. This allows for a temporary boost power of 60kW. While not the fastest car in the competition, it is still capable of a top speed of 75mph and can manage the 0-60mph dash in under five seconds.

Unfortunately, despite the drivetrain innovations, the car's chassis was compromised by last minute changes to the suspension, resulting in some exciting positive camber gain in roll, which meant its dynamic performance was lacking.

BEST UK / SKIDPAD WINNERS - OXFORD BROOKES



Oxford Brookes Racing finished as the top UK team in the 2012 event, beating their Hertfordshire and Bath rivals, and winning the Skidpad event in the process.

The distinguishing feature of this car is the aluminium monocoque that was introduced last year: 'The unique technique is the way we cut and fold the panels. Each panel is cut singularly and then bonded together and folded into shape,' explains a team member. 'This year we focussed on improving the manufacturing techniques, and then we went to weight saving. Even though this car is larger, we've dropped the weight by 19kg and improved the ergonomics. Also, to reduce weight and improve reliability we implemented launch control, and we now have a steering system that is completely designed and built in house. Manufacturing in house enables us to learn about our previous designs.'

The importance of simulation and modelling was the key to their success: 'One of our strongest points is our in house, 15 degree of freedom, mathematical model, which allows us to monitor the performance of the car when we make a change. So before

anything goes to manufacture, everything is evaluated using our software to see the performance gains.'

The team have also developed a four-post test rig which, along with track data, enables them to validate their vehicle dynamics models, improving the accuracy of their measurements, as Chris Fearby from the vehicle dynamics department explains: 'We took the track data from last year's Endurance event and input the wheel movement into the model to simulate the car and measure how the tyres' normal force

changes. Our lateral dynamics model gives us an idea of how the car handles, so we can translate that to what the tyre could potentially produce at the ground, and then we iterated the damping rates to produce as much force as possible at the ground. By validating these models with the four-post rig testing and track testing, we're confident our models accurately reflect how the car handles.'

Similar to Formula 1, the regulations determine the engineering developments. 'The rule changes this year gave more importance to sustainability in terms of fuel consumption, so we switched to a single-cylinder engine because of the better fuel consumption. We completed the Endurance using only 3.5 litres of fuel.'

Winning the Skidpad was all down to the suspension, as Fearby explains: 'We initially analysed the point contents of the competition and found that 45 per cent of the points came from Autocross and Endurance,

decreasing the yaw rate settling time, which is the turning response, so the shorter the settling time, the faster the driver turns the wheel and the quicker response. We also looked at the balance of the car using a technique called the stability effect, which measures how the yaw moment changes with respect to lateral acceleration. As the lateral acceleration increases, the car yaws more, feeling like oversteer. Neutral steer means the yaw moment doesn't change, so throughout the simulation we looked at how that yaw moment changed with respect to that lateral acceleration, and we iterated the suspension points to give us the best compromise of having a car that responds quickly but feels neutral to the driver and still has high steady-state capabilities.'

A common theme amongst competitors was the lack of time available: 'We are the only European team to get a new car in America every year, which begins in May, so you have to be ready by April. So, in six months you need to form a team, design a quick car, organise the team to get the best ideas, build and evaluate your designs and simulations, build the car, test and go to competitions.'

"we're confident our models accurately reflect how our car handles"

the majority of which is in transient cornering, which we aimed to improve first, while increasing driver confidence to make the car more neutral. We did lots of simulation work using Newton's Second Law to sum the forces and moments and we calculated how different suspension geometries affect the geometric load transfer, and therefore the performance.

'We were mostly looking at



MOTORSPORT & AUTOMOTIVE ENGINEERING

**DELIVERING
WINNING
ENGINEERING & DESIGN**

**SOLUTIONS FOR OVER
30 YEARS**



Contact us to find out more
Tel: 01480 474 402 E: sales@titan.uk.net www.titan.uk.net

DESIGN • PATTERN MAKING • CASTING • MANUFACTURING • ASSEMBLY

HEAT EXCHANGER SERVICES

Our ISO graded 'clean room' is available for complete core cleaning and particle cleanliness assessment on radiators, oil coolers and chargecoolers.

Core Cleaning

Ultrasonic, Power Flush, Pulsation, Agitation & Flow Bench

Particle Assessment

ISO 16232, Microscopic & Optical Analysis, Size & Count

Calorimetric, Flow & Pressure Testing

Radiators, Oil, Gearbox, KERs & Chargecoolers

Core Race Preparation

Cleaning, Filtration, Drying
Oil Conditioning and Sealing



www.youngcalibration.co.uk
+44 (0)1273 455572

Unit 4, Ham Business Centre, Brighton Road, Shoreham by Sea, BN43 6RE

American dreams

FSAE leaves California for Nebraska, Michigan returns to MIS, and teams from all over the world compete for overall honours

FSAE, Lincoln, Nebraska

This year's Formula SAE competition was held for the first time at Lincoln, Nebraska, having re-located from its previous site in Fontana, California.

The event site did not have the normal amenities provided at other competitions, such as electricity in the paddocks, but it does have 90 acres of asphalt,

which allowed for larger team paddock spaces and dynamic event courses (Autocross and Endurance) to be laid out and available for walking a full day prior to events. Also new this year was a short Autocross-styled practice course, in addition to the traditional practice pad.

Registrations for this year's event met the competition limit of 80 cars, plus one reserve, with teams from Brazil, Canada, Japan, Mexico and, of course, the United States.

Nine teams made it into the Design final, with University of Washington winning that event and earning the opportunity for one day of K and C testing at Goodyear's facility in Akron, Ohio.

With a slight delay to the start of the Endurance event on Saturday morning, due to the need to wait out a passing

thunderstorm, the event started with the track first declared wet, then damp. Cars that started after the lunch break, however, ran on a completely dry track. In all, 50 cars started the Endurance event, with only 24 teams finishing, and 20 of those within the allowed maximum time. Placing first was University of Kansas - Lawrence with a total time of 1328.174 seconds over 19 laps (an adjusted time for hitting one cone). Coming in second with an adjusted time of 1365.374 seconds due to hitting three cones was Texas A & M University - College Station.

Overall winner was University of Kansas - Lawrence, the Jayhawks Motorsports' team capturing its first championship in the school's programme history, after a number of previous top 10 finishes.

FSAE Michigan

Formula SAE Michigan returned to Michigan International Speedway (MIS) in 2012 for its fifth year at the venue. Located in Brooklyn, Michigan, the venue offers team paddocks on asphalt with built-in electrical hook-ups, NASCAR garages and suites for all static judging. New this year was a newly re-paved surface on the back side of the oval where the dynamic events could operate. In total, there were 120 teams registered for the competition, representing colleges and universities from Austria, Canada, Finland, Germany, Singapore, South Korea, United Kingdom, United States and Venezuela, though in the event only 106 brought working vehicles.

If Formula SAE Michigan was a continuous hockey game,

LINCOLN RESULTS

- 1st University of Kansas - Lawrence
- 2nd University of Texas - Arlington
- 3rd University of Wisconsin - Madison
- 4th University of Washington
- 5th Texas A & M University - College Station
- 6th Michigan State University
- 7th California State Poly University - Pomona
- 8th Centro Universitario Da FEI
- 9th University of South Florida
- 10th University of New Mexico



The dramatically winged University of Kansas - Lawrence entry took first place in Endurance, and secured overall honours in the Lincoln, Nebraska event

MICHIGAN RESULTS

| | |
|------|--|
| 1st | Oregon State University |
| 2nd | Karlsruhe Institute of Technology |
| 3rd | Universität Stuttgart |
| 4th | Technical University of Munich |
| 5th | University of Michigan - Ann Arbor |
| 6th | Graz University of Technology |
| 7th | Metropolia University of Applied Science |
| 8th | École de technologie supérieure |
| 9th | Friedrich Alexander University of Erlangen |
| 10th | University of Wisconsin - Madison |



A collaboration between Oregon State University and Duale Hochschule Baden-Württemberg-Ravensburg of Germany produced the winning car in Michigan, capturing the Endurance, Design and Spirit of Excellence awards in the process

Oregon State University would have itself a hat-trick, winning the championship for the third year running. Global Formula Racing (GFR), an international team collaboration consisting of students from Oregon State University and Duale Hochschule Baden-Württemberg-Ravensburg of Germany, clinched the honour when they were named first place finishers at Saturday night's award ceremony, having clinched first place in three of the most sought after awards - Design, Endurance and the SAE Spirit of Excellence, as well as three further awards.

This international collaboration originally started with the students just designing aspects of each other's vehicles but, in 2012, moved to a position where the two universities worked together to design and build an entire car to enter both US and European competitions.

Ninety one cars took the green flag in the Endurance event, with each of the two drivers completing 10 laps. Only 46 cars finished the event, with two teams finishing over the maximum time allowed. They therefore only receiving points for finishing all 20 laps.

To increase the excitement level leading up to the General Motors-sponsored awards ceremony, SAE International continued with the inverted run order that was started in 2011, running cars in order from slowest to fastest.

Lessons learned from the previous year led to a group of dedicated volunteers working extra hours on re-designing the course to allow it to be more open, longer, and to support six cars on track. They also worked closely with SCCA course designers to adopt the SCCA style of using fewer cones on the track. Oregon State University completed 20 laps of the course in 1067.060 seconds (an adjusted time score for having hit two cones). Coming in second with an adjusted time of 1124.613 seconds (seven cones and one off-course) was Karlsruhe Institute of Technology, while in third place was University of Michigan - Ann Arbor, with a clean run time of 1131.329 seconds. 

SIMULATED REALITY

Drivers for the UC Berkeley team were evaluated on simulators using the Simraceway F3 car around Infineon raceway. The Californian team is just one of a number of teams around the world turning to driver-in-the-loop simulation.

From the initial 20 or so applicants, the top eight moved up to indoor go karting for initial in-car testing. Six from this group were then chosen to undergo the karting technique training programme at the Performance Driving Centre, completing a comprehensive virtual-to-real curriculum that brought drivers up to the level needed to step into a formula car.

'In the past, the team had never paid so much attention to the drivers, and we're confident it will prove its worth in the dynamic events,' explained a team member. 'We're excited to be the first FSAE team to have a car officially integrated in a video game and the team's driver development programme will grow as we work hand-in-hand with Simraceway to accurately model our vehicles in the simulator and correlate the virtual performance with the real, using extensive on-car data acquisition.'

Watch the comparison between the real FSAE car and the virtual car online at www.racecar-engineering.com



Phone: +44 (0)1404 549940
E-mail: sales@lmcltd.net www.lmcltd.net



Vehicles
Hybrid
Marine
Industrial
Mobility
Aerospace

Standard and Bespoke Complete Drive Solutions

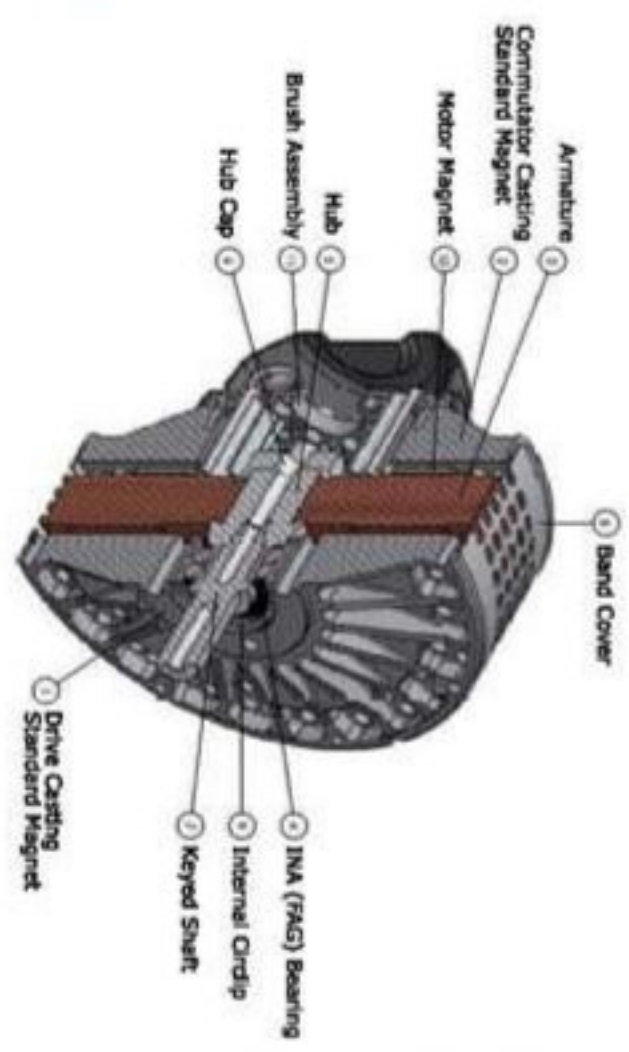

Leaders in the field of Low Voltage, High Performance DC Motors and Generators. Our motors are durable, lightweight, powerful and are suitable for all applications.



LMCLtd
Generating Movement Efficiently
www.lmcltd.net

Designed and Manufactured in the UK

Phone: +44 (0)1404 549940
E-mail: sales@lmcltd.net www.lmcltd.net

AEROCOM METALS LIMITED

Steel stockholder supporting key areas of the Aerospace & Motorsport industries

- » Titanium Alloys
- » Special Steels
- » Nickel Alloys
- » Stainless Steels
- » BS4T45 to BS5T100
- » S515
- » 4130
- » Aluminium

ENQUIRIES 02476 633355
www.aerocommetals.co.uk

Top Qualifier

Around the world or around the track, you won't find a higher quality line of bearings and rod ends with Aurora's proven 35 year track record.

Aurora Bearing Company
901 Aucutt Road
Montgomery IL. 60538

AURORA

Complete library of cad drawings and 3D models available at:
www.aurorabearing.com Ph: 630-859-2030

ECU/Exchange Loom/Throttle Body Packages available

Complex modern engine? We can manage it

ECU solutions for:
Honda S2000 and K20A
Ford ST170 and Duratec
Toyota 2ZZ
BMW Single / Twin VANOS
Audi 1.8T and 5 cylinder
Chevrolet LS7.

DTAfast Our ECU's are capable of dealing with the most complex of modern engines without the need to change sensors or sacrifice key features such as variable camshafts.

S series

Get the very best from any engine and from only £495.00 + VAT.

DTAfast, 10 Boston Court, Kansas Ave, Salford M50 2GN
Tel: +44 (0)161 877 1419 Fax: +44 (0)161 877 7086
Email: office@dtafast.co.uk Website: www.dtafast.co.uk

Engine enigmas

Opinions are increasingly divided on engine choice - four, two or one cylinder?

The deliberation between engines that has been on-going since the early 1980s, when Formula SAE began, has further split the 2012 grid. With 12 teams changing engine this year, and the majority of those downsizing, are we witnessing the beginnings of a trend?

The engine regulations only allow for four stroke, Otto cycle, piston engines, with a displacement no larger than 610cc - actively encouraging the use of high performance, yet lightweight motorcycle engines. However, teams can also run self-designed forced induction systems, such as exhaust-driven turbochargers or mechanically / electrically-driven superchargers.

FOUR CYLINDERS GOOD?

Throughout the Formula Student competition, the four-cylinder engine has been consistently dominant, with 72 per cent of the 2012 grid utilising this type. But this is down from last year as more and more teams start to convert to electric power, or smaller engines.

Reliability is the most important factor for any Formula Student team and plays a vital role in engine decisions. The four-cylinder engine still appears to be the most reliable option, as Liverpool John Moore's team explains: 'We chose the four-cylinder Honda CBR because it's bulletproof. It has done three competitions and we're still using it. We ran it last year and the water temperature was over 130degC and it still stayed together. If we move to a smaller engine, we know we would immediately lose weight, but then you compromise on reliability. Some teams spend their whole weekend just trying to get their engine running, whereas this car has never let us down. To finish first you've first got to finish.'

Of course, this reliability is

largely due to the fact that most teams have been running the same engine for a number of years and have learnt how to work with it. Formula Student Portsmouth: 'Our car has been designed around a four-cylinder engine every year, so we thought we should keep it because we know a lot more about it. Trying

think the cost of a four cylinder would be higher, and therefore a disadvantage, but oddly, the opposite is true, at least according to the Swedish champions, Chalmers: 'We've been running the Yamaha engine since 2006, and we stuck with it is because we know it quite well and it's cheap. We ran a study

"engine regulations only allow for four stroke, Otto cycle, piston engines... no larger than 610cc"

to learn about a new engine takes about a year. We haven't got the ability to produce a light enough car yet to warrant having a smaller engine.'

The obvious advantage of a four-cylinder engine lies in the smoother power and torque delivery, as more cylinders means a higher number of power strokes per crankshaft revolution.

The downside is this leads to a more complex design, and more parts, so you would

looking at choosing a different engine. We wanted the single cylinder, but it was going to cost us €6000, compared to €700 for the four cylinder. When you take into account the entire car cost €17,000, we just can't afford it.'

One major drawback, though, is the weight of a four-cylinder engine, which can be up to 30kg heavier than a single cylinder alternative. John Moore's focus on innovative engineering wasn't about to allow this to be

a problem: 'We want to engineer the weight out of the car from other areas because, in theory, to reduce weight you could just downsize the engine and make loads of parts out of carbon fibre, but it's not particularly an engineering way of doing it.'

The other disadvantage is fuel consumption, but this is seen as a small sacrifice by Rennteam Uni Stuttgart: 'Fuel consumption is half a litre higher than the single cylinder, but we have double the power and the weight-to-power ratio for the whole car is much better. It's also reliable.'

Overall then, the four cylinder appears to be reliable, available and cheap. Furthermore, with the majority of teams having a history with the four cylinder, they have built up substantial knowledge, which enables them to fine tune the engine to their specific requirements. The weight, complexity and fuel consumption penalties seem therefore to be a small price to pay for the gains in power. So why did a number of teams choose to downsize?



Herriot Watt Racing stuck with the more traditional Formula Student layout, utilising a 2006 Honda CBR four cylinder

FORMULA STUDENT - ENGINES



Swansea University Race Engineering chose a Yamaha Genesis two-cylinder



While Modena used a tiny Husqvarna single cylinder engine in their entry

TWO CYLINDERS BETTER?

The number of two-cylinder engines used in the competition remained the same between 2011 and 2012, with around 70 per cent of those teams running an Aprilia model. This implies that the teams that are downsizing are heading straight to single cylinders. Team Bath Racing explain why: 'We think the engine is one of the best to use in Formula Student because you have the weight and packaging size of a single cylinder, but 20 more horsepower. It's a high performance engine and it's really tight and light.'

The importance of weight was a key theme throughout the field. The University of Erlangen-Nuremberg commented: 'It's not so heavy and we don't need all the power from a four cylinder. The two cylinder is 56kw [75bhp], it's perfect.' The team does concede it has some issues: 'You need a lot of experience concerning maintenance, and the engine itself has small disadvantages that you have to work out and eliminate one by one. And when you start tuning it, they get heavier.'

Some two-cylinder engines

offer unique design advantages, as Swansea University Race Engineering discovered: 'We've got a new Yamaha Genesis twin and we've turbocharged it, which is quite odd as I think we're the only team to do that. We chose that engine because it's got a CVT drive, so we don't need to change gear. We have instant drive, which is good for Design points. The Honda CBR 600 [four cylinder] that we ran last year is a lot heavier and bigger, so the whole chassis had to be larger. This year, we really wanted to

get the weight down. Because we turbocharged it, though, we're still getting the same power. We think smaller is better, and getting the cylinders down is definitely the way to go.'

Unsurprisingly, weight is the key benefit for a twin, and although it appears some can be problematic, any issues can be eliminated over time.

"the one factor that all teams agreed on was the importance of reliability"

ONE CYLINDER BEST?

The percentage of one-cylinder engines on the grid doubled this year, with most running a KTM unit. The massive weight saving is clear, but the disadvantages seem to be initial cost, reliability and a reduction in power. Oxford Brookes Racing: 'There are two major ways of approaching a Formula Student car - a four cylinder or a single cylinder - and it depends on the power-to-weight ratio you want. The four cylinder weighs more than the single, but it has double the

power, so it depends on your philosophy of design - whether you want to go for power, or weight. We believe the spirit of the competition is to design a car for the weekend racer [as stated by the rules], and a single-cylinder engine is easier and cheaper to maintain than a four-cylinder engine. Plus we like the challenge of doing engineering

that is lightweight.'

Each type of engine has its benefits and its drawbacks, and the final decision depends on the targets the teams determine for their cars. However, the one factor on which all teams agree is the importance of reliability.

On closer inspection, the apparent trend toward smaller, single-cylinder engines, was amongst teams that have been competitive for several years, and have larger budgets and the ability to produce a lighter car to suit the lighter engine. As always, there are some anomalies, and some teams that embrace the challenge of engineering weight out of other areas of their design. And with Formula Student being such an innovative form of motorsport, the unexpected is never far away, as the University of Karlstad illustrate: 'We have used the four cylinder for the last few years, but our first choice was actually the 600cc Triumph Daytona three cylinder, because of its motor torque characteristics, which are closer to the regulations of 610cc.'

Only time will tell if engine downsizing yields results.

Bosch, turning all corners into the home stretch



All components in perfect harmony: Engine/data management, displays, sensors and software – everything from a single source. And all this combined with the development expertise of the world's largest automotive components supplier. We are there for you around the clock, anytime, any place.

www.bosch-motorsport.com



BOSCH

Invented for life

...one step ahead

KRONTEC
Fitting & Hose Systems

| | | |
|---|--|--|
| <p>Direct Flow Coupling Serie DFC</p>  <ul style="list-style-type: none"> • wedge segment locking • bespoke design possible • clear bore | <p>Quick Disconnect Coupler Serie HFC</p>  <ul style="list-style-type: none"> • wedge segment locking • bespoke design possible • high flow design | <p>Refuel Flow Coupling Serie RFC</p>  <ul style="list-style-type: none"> • coaxial operation • safety locking system • PTFE bellow design to avoid sliding seals |
|---|--|--|

...designed for the roughest conditions



Head office:
KRONTEC Germany • Tel.: +49-(0)9401-52 53-0

KRONTEC Design Limited • Phone: +44-(0)7824-504989

www.krontec.com

Lift vs drag vs speed

Racecar Engineering staff report on the continued trend toward aerodynamic devices in the student formula

In recent years, there has been something of a trend in FSAE towards the use of aerodynamic appendages, ranging from undertrays and diffusers to wings that would put a Sprint Car to shame. The trend was started in 2011 by Australian outfit, Monash, whose car appeared at Formula Student with sizeable wings and a rear diffuser. Many questioned whether there was any point in the weight, complexity and potential drag penalties of looking for downforce on a car that rarely sees cornering speeds

over 60km/h but, according to Marty Bett, Monash team leader, there is: 'I think generally 90kg of downforce at 60km/h is quite an advantage. Considering your car only weighs 200kg, it actually increases your cornering capacity by 1.5, which is a pretty big number.' The University of Erlangen - Nuremberg also claimed that its additions, resulting from its extensive wing package, did not unduly compromise the overall weight of their car, which came in at a very impressive 160kg, only 5kg heavier than their 2011 car.

Some teams had invested considerable effort in their aero package designs, running extensive CFD simulations and, in the case of Chalmers University, even undertaking scale model wind tunnel testing. Sven Rehnberg, responsible for aerodynamics on the Chalmers' car explained their development process: 'We ran a very subtle aero package last year, and focussed on drag reduction. We actually used our facilities, so we had some quite good CFD, and we also have a scale wind tunnel, so last year we had a static ground 1/3-scale model that we looked at to reduce drag.

'Then it suddenly dawned on me that I didn't ask the right question - for every increase in drag point, what is our increase in fuel consumption? And what we worked out with our aero

package is we're only going to use 0.6 litres more fuel, compared to running without wings, but we found that our total time on track would reduce massively. With the current package, we've seen a two-second difference over a lap.'

While it is clear aerodynamics are a beneficial factor, it is similarly clear that a good package needs resources to develop, resources some teams simply don't have. But even some of those with the capacity balked at the effort required, including TU Delft. 'At the beginning of the year we thought, 'We could put a lot of energy into aerodynamics, but we know it's a very difficult concept,' explained a spokesperson. 'We always try to look at the power gains of a new concept we're trying to make. This year, we thought about the opportunity

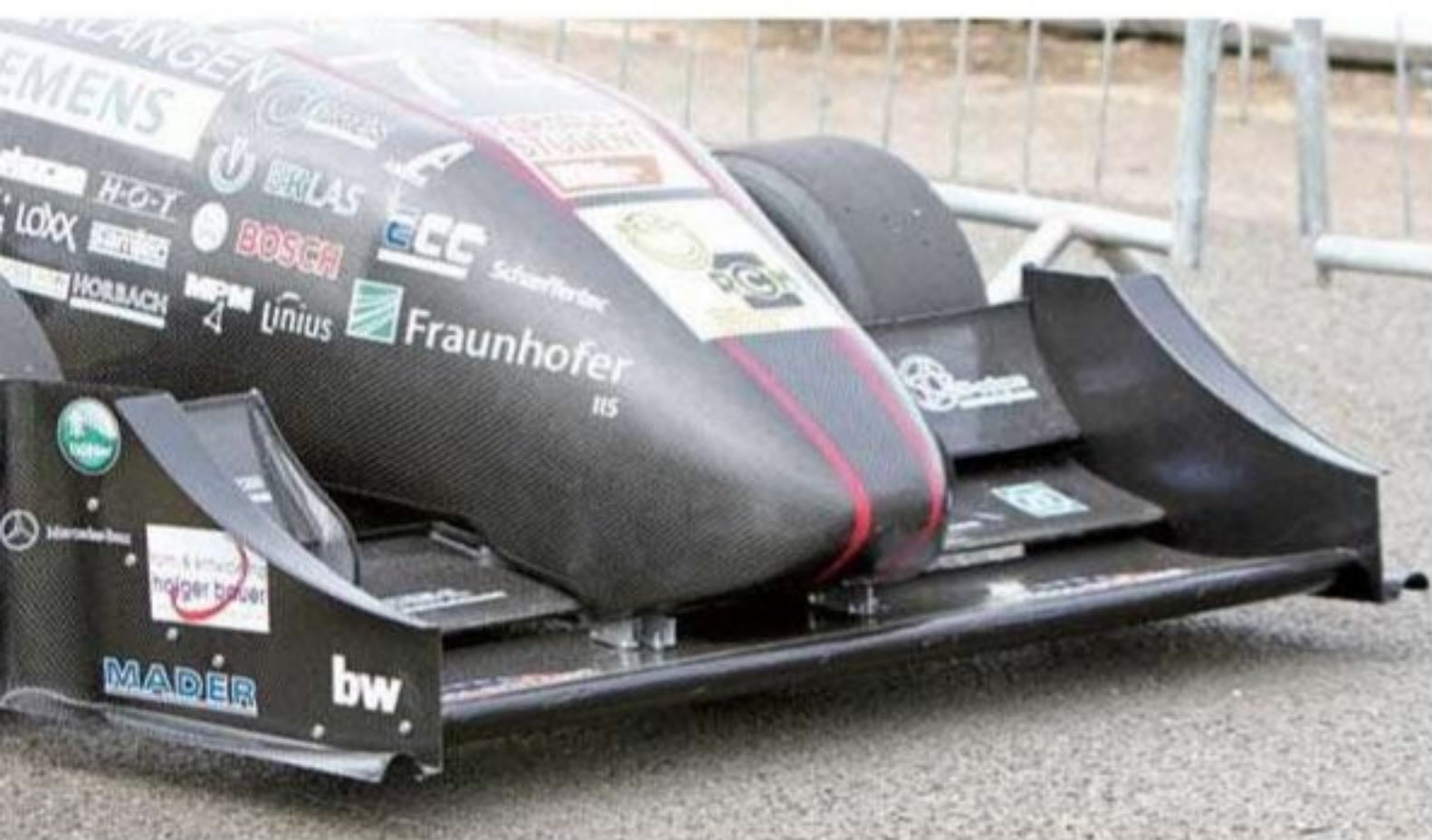

Wings are becoming increasingly complex and advanced, such as this multi-element example on the Erlangen-Nuremberg car



Karlstad University entry appeared with no wings and just an underfloor diffuser, which proved to be the quickest overall solution in the dynamic events, as shown by a similar treatment on the Munich and Stuttgart entries



By far the fastest UK car on the track was the winged car from Bath University, but on the lower speed skid pad, the wing-less Oxford Brookes' entry was quicker



With its own wind tunnel, Monash University (left) went all out to develop its double-element wing package. The solution sought by Tallinn University, Estonia (right) was less dramatic, but still placed heavy emphasis on aerodynamics

presented by electric, and we thought four-wheel drive would be the best. We abandoned the aero package pretty early on because aerodynamics devices are very complex. It doesn't mean that we could not develop it, but we prefer to take a year. We do have a group of engineers researching aerodynamics, perhaps for next year.'

Monash University is another team that has its own wind tunnel and, unsurprisingly, the wings on the Australian car in 2012 are the biggest seen. The team's aero lead designer, Marc Russouw, explains: 'This car introduced an entirely different design philosophy from an

broader programme. Furthermore, the change in rules from last year allowed the aero package to extend forward and rearwards about a foot, giving us more design freedom. We looked at efficient double-element wing configurations with a very high lift-to-drag ratio to save energy, and improve fuel efficiency, but we specifically targeted the higher coefficients of lift and downforce because we found that drag wasn't as sensitive on these sorts of tracks. So that's where the monster wings came from. We managed to design adjustability into them, so we can vary the drag and the aerodynamic balance. We can

"the changes in rules from last year allowed the aero package to extend forwards and rearwards about a foot"

aerodynamic point of view. We started off modelling basic parameters, such as power and aerodynamic loads, to assess the performance benefits from wings, which developed into a

turn out our flaps if we want less drag for acceleration, so our aero package can be manipulated to suit each event.'

Of course, aero wasn't the only thing that lead to the car's



The Monash car had adjustable wing flaps to alter the attendant drag penalty

strong on-track performance. Monash were one of the teams that switched from a four-cylinder to a single-cylinder engine this year. Russouw: 'We re-designed the chassis and suspension, and everything has got smaller. Another big step was incorporating a differential where we previously used a spool. We can take a much tighter line through the slaloms now, and in our point simulator this showed a massive increase, which we thought was worth the resources.'

For some teams, a lack of resources didn't deter the team from trying out aerodynamic ideas on their cars, with several

admitting that their undertrays and diffusers were essentially untested, and they could not quantify the difference they made. Several other teams said they had aerodynamics in development, but chose not to run them this year, pending further testing.

One thing's for sure, the aerodynamics debate in FSAE is far from over, though it was notable that the fastest cars at Silverstone this year - Munich and Stuttgart - did not carry big wings, instead relying on fairly understated underfloors for downforce. The debate will no doubt continue...

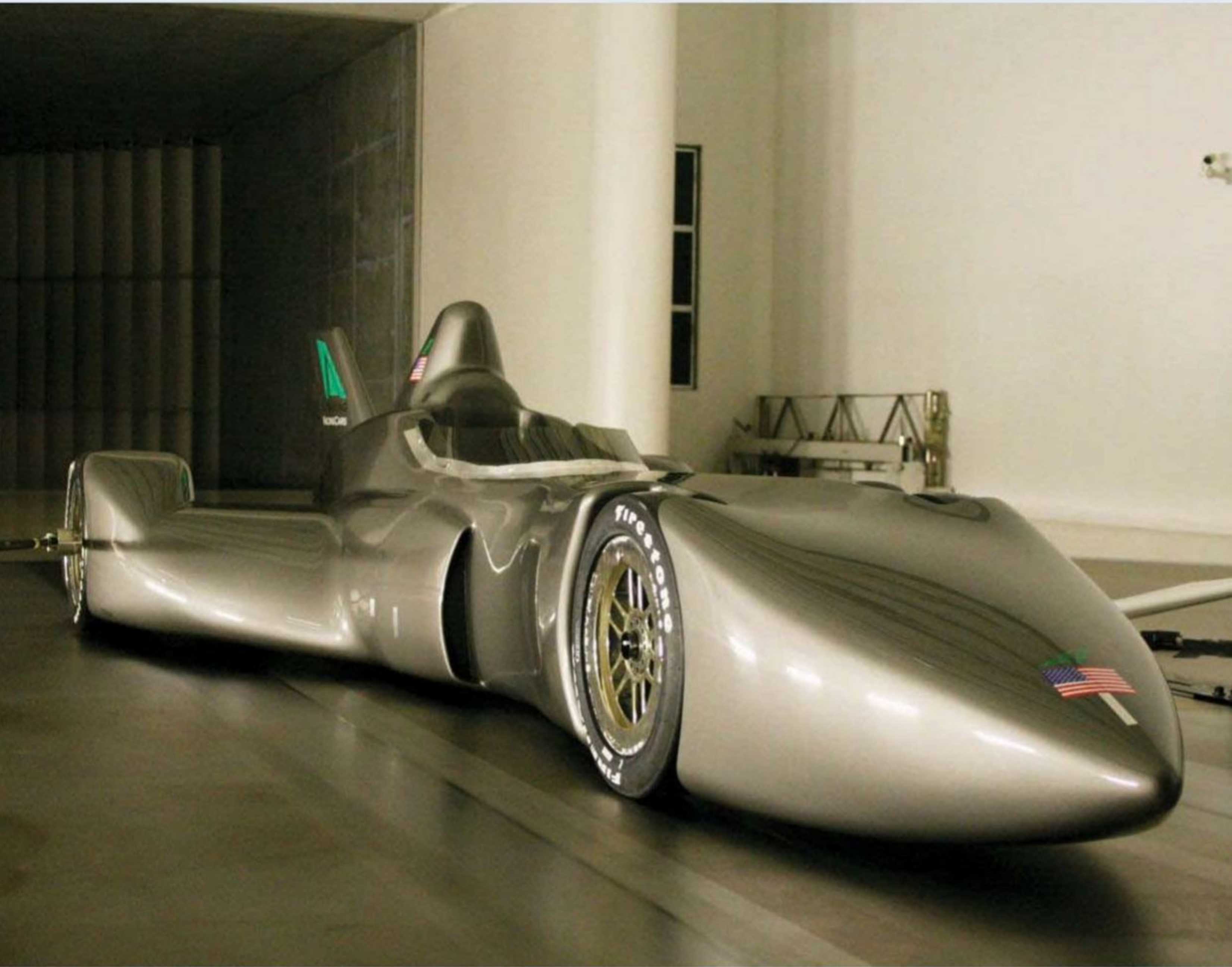

Take cutting-edge wind tunnel technology. Add a 180 mph rolling road.
And build in the best in precision data acquisition capabilities. When we
created the world's first and finest commercially available full-scale testing
environment of its kind, we did much more than create a new wind tunnel.
We created a new standard in aerodynamics.



+1 704 788 9463

INFO@WINDSHEARINC.COM

WINDSHEARINC.COM

Hypersprings

Known for its innovative suspension solutions, Indiana-based Hyperco may have just reinvented the road spring

BY CHARLES ARMSTRONG-WILSON

Carbon this, carbon that. Carbon fibre composite seems to be finding its way into every area of a racecar. Think about it for a while and you would be pushed to find a place where carbon fibre cannot be applied. Springs, though, are one of the few exceptions where metal alloys still reign supreme. That is, until now.

US suspension company, Hyperco, may just have lit the blue touch paper that could see carbon fibre springs explode into the motor racing environment.

“a carbon fibre helical compression spring would not work”

Hyperco is an Indiana-based suspension specialist with a reputation for innovative solutions. It has already been supplying composite leaf springs for some years now. Not only are they lighter than steel, but they retain their set indefinitely, while

steel leaves sag over time. They have found favour on everything from modified Corvettes to Late Model Stock Cars.

However, most racecars run coil springs, and they are a very different proposition to manufacture in carbon. That didn't stop the people at Hyperco looking into the challenge, though. Putting their heads together, general manager, Kelly Falls, manager of new product development, Mark Campbell, and engineering technician, Don Paul, soon realised a simple substitution of material was not the answer.

'It quickly became apparent that a carbon fibre helical compression spring would not work because helical compression springs operate primarily by a torsional twisting action, and carbon fibre has very little strength in torsion,' explains Campbell. 'To achieve our goal, we had to consider a spring design that worked primarily through a bending moment.'

The solution was actually based upon some very familiar and well-developed technology. 'It is a series stack of Belleville washer springs and operates under the same mathematical rate computations as a series of helical compression springs,' says Campbell. Each spring is a moulded carbon composite washer with a slightly belled profile. To create a road spring, the washers are stacked onto the damper, alternately inverted to give the bellows design.

CARBON BELLOWS

This allowed the usual rules of Belleville washers to be applied to the use of the carbon bellows. 'In any series stack of springs, the combined rate is always lower than the rate of the lowest rate spring,' explains Campbell. 'For instance, a 20-washer stack of 10,000lb/in Belleville washers will have an assembled rate of 500lb/in. Total deflection of the stack is the deflection of one washer times the number of washers in the stack. The rates can be fine tuned by changing the rates of the washers combined in a series configuration, or by adding washers in a parallel configuration to slightly increase the rates.'

If the washers are stacked against each other, that is regarded as in series and makes the overall rate softer. However, if some pairs are stacked the same way so they nest into each other, this is termed 'in parallel', and makes the overall rate harder. 'This "tuneability" factor allows us to increase or decrease spring rates in increments as low as 4lb/in!'

The (patent pending) Hyperco design concept offers significant advantages over normal steel Bellevilles. 'Because these are moulded components, we have moulded ID and OD locating flanges in the washers to allow them to be stacked without the aid of any locating components.'

So, once the design concept had been changed, was it then just a simple switch of raw material? 'Carbon fibre has generally

Using the Belleville washer principle, spring stacks are built up. Rates can then be fine tuned by altering the combination of the spring stack

been used in the development of structural components, explains Campbell. Springs are a dynamic component and that necessitated the testing of material weave / resin combinations that would provide the necessary flexibility and strength.

'As a dynamic component, we found that many of the standard performance characteristics of various material weave / resin packages were not derived from dynamic use and were often of little value. We had to start from ground zero and generate the data for the characteristics we needed. We sure learned a lot about what didn't work. Then we finally found what did work, and that is the key.'

Two of the biggest challenges in the development process were coming up with a design that reduced hysteresis and provided 'linearity of rate', as Belleville washers are well known for having high hysteresis in operation. 'Usually Bellevilles are used in low-frequency, low-grade applications, so nobody has really taken the trouble to do the development to make them more efficient,' notes Campbell. 'Typically, as they are compressed and expand they slide over each other and the friction causes hysteresis. Because we are moulding them, we could design in mating faces that have more of a rolling action. This makes them much more efficient.'

Obviously, linearity is key, as a spring rate that changes rapidly and dramatically in use is not good for suspension.

BENDING MOMENT

Changing to Bellevilles from coil springs also addresses a problem Hyperco has been very conscious of for years and made big efforts to eliminate with some of its past products. This is a non-axial load on the damper that causes a side load on the damper shaft preventing it operating properly. 'The fact that these washers work in a bending moment reduces the side loading on the damper shaft and shaft seal,' says Campbell. 'This allows the damper to operate in the manner in which it was originally designed.'

'Most people don't realise the torsional twisting action of a helical compression spring in



The benefits of carbon springs are multiple, but a less obvious one is reduced side loading on the damper shaft, improving damper efficiency

HYPERCO

The company owes its roots to one-time Indy racer, Greg Leffler. He worked with the then-dominant Indy chassis supplier, March, eventually becoming manager of the March distributor in the US.

When Lola became the more competitive chassis, he left the March distributor and started Hyperco, expanding the parts side with additional brands, including Rockwell springs. In 1990, the name was changed to Hypercoils and, around the same time, the current general manager, Kelly Falls, joined.

By 1996, its range of agencies had expanded to Dymag wheels, Alcon brakes and EMCO transmissions. However, when the company was sold to MW Industries that year, they decided to focus entirely on suspension. Now known as Hyperco, it has developed a reputation for tackling some of the most fundamental issues in suspension design with innovative solutions.

"From a set of 100 washers, you can make hundreds of different rates"

compression or expansion causes significant side loading on the shaft and / or shaft seals.' In the past, Hyperco has developed ingenious solutions to tackle this, including hydraulic spring perches that move to try and prevent the force being transmitted to the damper rod.

However, the Bellows Spring removes the problem at its source. 'In cases where side

loading is as great as 800-1000lb at full deflection, [with coil springs] we have seen side loads of less than 25lb with the Bellows Springs. This is a huge improvement and greatly reduces the internal stiction that occurs inside the damper when it is changing from compression to expansion. This side load reduction is probably the most important characteristic of this

unique spring design,' enthuses Campbell. 'The shock companies are all quite enthralled with the possibilities.'

DAMPER SUPPORT

'Most of the leading damper manufactures are very supportive because the Bellows Springs allow their product to operate in the manner they were originally designed. Many knowledgeable people in the industry have called it a game changer. Once the benefits are explained, it has been rapidly accepted.'

What about the other big factor influencing most teams' buying decisions - cost? This is where Campbell and Falls are keen to point out how different this solution is: 'If you just want a set of springs of a single rate then the price is equivalent to titanium,' says Falls. But he is quick to explain that this is not a fair comparison, and sites a D-Sports racer they worked with at an early stage of the product's development: 'A set of washers will cost around \$1125 (£725) per corner, a lot more than a set of steel springs. But the D-Sports needs a range of nine rates from 900lb/in to 1500lb/in, depending on the circuit and the conditions. The steel springs only have one rate, so you need another set of springs for each rate. The same set of washers can be configured to give you all those rates and more, so for the D-Sports it works out at \$125 per rate. Think of it in these terms and the price is much closer to steel coils.'

Falls goes on to explain the other advantages: 'For an international team to take all its springs to the races takes a lot of space, and money. But the same range of rates in washers will fit into a large briefcase. From a set of 100 washers, you can make hundreds of different rates. Also the rates are much more precisely adjustable. We can make changes as small as 4lb/in.'

For racecars that need a large range of rates and fine adjustability, it not only makes engineering sense, but financial sense, too. The product is still very new on the market but, if the benefits are as great as the company claims, we could see it spreading through the sport very fast. Watch this space. 

Heavy-duty

spherical bearings and rod ends
for motorsport

Certified as per EN 9100!

- The art of performance
- Driven by quality
- Power – Precision – Passion
- Smart way of moving

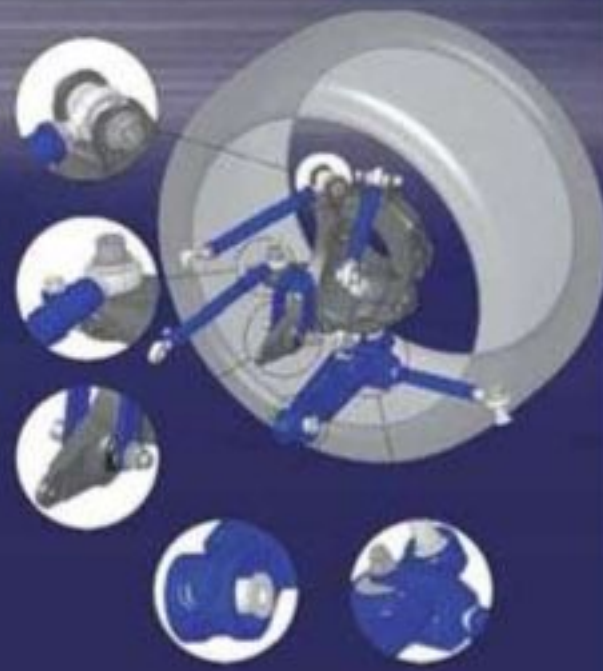

HIRSCHMANN
SPHERICAL BEARINGS

HIRSCHMANN GMBH · D-78737 Fluorn-Winzeln
Phone: +49 (0) 74 02/1 83-0 · Fax: +49 (0) 74 02/1 83-10
www.hirschmanngmbh.com · info@hirschmanngmbh.com



WHERE SIMPLICITY MEETS INNOVATION

CDL3 Dash Logger CAN TALK TO OTHERS

CDL3
TRACK LOGGING KIT
RRP £1995*



*RRP plus VAT

CDL3 TALK TO ME

Clearly displays your ECU parameters

Uses ECU data for configurable warnings system

Analysis and track mapping of ECU data with i2



CDL3 communicates with:

- OEM factory ECUs via OBDII
- Most ECUs from these and other brands



OR

OR

OR

OR

OR



CDL3 communicates
using CAN/RS232

To confirm your ECU application with MoTeC visit:

www.motec.com/cdl3/racecar



WOODWARD

CUSTOM BUILT POWER STEERING Racks and Components

SERVING MOTORSPORT WORLDWIDE
from one-off specials to entire racing series

IN USA:



woodwardsteering.com

Casper, Wyoming

phone 1 307 472 0550
fax 1 307 235 1551

IN EU:



hydroline.nl

Zeewolde, The Netherlands

phone +31 36 538 72 80
fax +31 36 522 74 59

A question of balance

How Force India and Cranfield University are using a simple rig to assess the effects of aerodynamic changes on the stability of the VJM05 **Part 2**

Behind a rather uninspiring set of wooden doors on the campus at Cranfield University lies one of the secrets of the Force India vehicle dynamics programme. The moment of inertia rig at the Cranfield Impact Centre is a remarkably simple looking device, yet its data is crucial to many aspects of the Silverstone-based team's operations.

'Measuring the moment of inertia of an object is a case of measuring the resistance to motion in a rotary fashion,' explains the man behind the rig, Dr James Watson. 'So we oscillate the vehicle in a rotary fashion to find that moment. We have tested road cars, F1 cars and even missiles - anything where an object is rotating and where you need to know the inertial properties.'

The rig itself looks deceptively simple, like a scaled-down version of a child's see-saw. Mounted on an air bed, which supports the vehicle, there is an arrangement of steel arms with two long ones running the length (or width) of the vehicle. 'The red arms have a blue arm attached with a spring,' explains Watson. 'What we are trying to do is to move the car in pitch, and oscillate it. Once it dips on one side, it moves the spring on the other. That spring then goes into tension whilst the other is in compression. That gives you the oscillation motion. What we are trying to get hold of is the time period of that oscillation. If we did not have the springs, the car would just flop onto one side. It is

very difficult to take a vehicle of this size and balance it.'

The rig is capable of being aligned for testing in pitch, roll and yaw and all three are used by Force India for its calculations. 'We can also calculate the principal moment of inertia and find out which axis the object would like to rotate about,' Watson points out. 'The c of g is not always on the car's centreline, in either x or y planes, but we assume a symmetry through the car. Certain vehicles, like Formula 1 cars, are very evenly balanced, so with them

similar factors are all crucial to the calculations though.'

The rig is linked to a computer that logs only three channels of data, including the timing pattern and force via a load cell. But the results are just what is required by racing teams' vehicle dynamicists.

'There is no point in just measuring the moment of inertia on its own though,' Watson adds, 'that would be meaningless. We have to reference it back to the c of g. You can get that in the x and y planes very easily on a flat patch with corner weights, but by

"The c of g is not always on the car's centreline, in either x or y planes"

it is usually within 2mm of the centreline, but on road cars it can be up to 10mm off.'

SHOVE OFF

Simple in appearance and seemingly simple in operation the car is levelled using a standard spirit level and the rocking motion is started by a shove of the technician's finger on one end of the car. But, as Watson explains, how hard that operative pushes is irrelevant to the results. 'What we look at is the time period from top to bottom. After a few of those have been logged, you get the oscillation time, which we average over 50 cycles. The attitude does not effect that time period, it's just like a pendulum in a clock. The arm length, spring stiffness and

using the rig for a supplementary test you can measure the height of the c of g by simply measuring the reaction force in a pitch orientation and a roll orientation. That is simply a case of tilting the vehicle to a set number of degrees and measuring the reaction force at one end. You then get two values - the c of g height and also any offset from the x or y direction.'

Certain factors need to be added to the calculations to give a realistic result. The mass and effect of the components of the rig itself need to be removed from the figures, so even the blocks of wood used to chock the car have to be precisely measured and weighed so they can be subtracted from the data. 'We can't have things on the object

moving, it has to be a rigid body, so if there are things like fuel and oil sloshing around, you can't get a proper result. We either need the fuel tank full up right to the top or empty. The suspension can also be an issue. If it moves too much during the test, again that causes problems, so it has to be set rigidly, too,' explains Watson.

MASSIVELY IMPORTANT

Force India's head of vehicle science, James Knapton, is in charge of the team's usage of the Cranfield rig, and for him one of the results it puts out is clearly the most important when developing a new model, such as the VJM05. 'We go there once a year to carry out a c of g test and an inertia test. We primarily look at the c of g height as that is massively important in F1 - change it by 10mm and





The Force India VJM05 on the Cranfield moment of inertia rig, which the team are using to test alignment in pitch, roll and yaw, as well as to measure c of g height and numerous other factors being used to develop the team's current F1 chassis

you can go about two tenths of a second faster,' he explains. 'Over time you may expect the c of g to go down as each new model is completed, but actually it has often gone up, which can scare the management. It can be heavily influenced by regulation changes, too. When car safety was improved with side panels for driver protection and bigger headrests, for example, the [c of g] height raised.

'The aerodynamicists always want to put things higher, too. The chassis has raised at the front over the years as they want to get air under the nose. In the past, there also tended to be a lot of winglets on the top of the bodywork, and we had to assess whether the gain outweighed the losses from raising the c of g height. But, if the rules don't change, you target it to



A screen grab of the rig's output when pitch measurement is being taken (left) and with the rig set up to find the c of g height and the car being oscillated in roll (right)

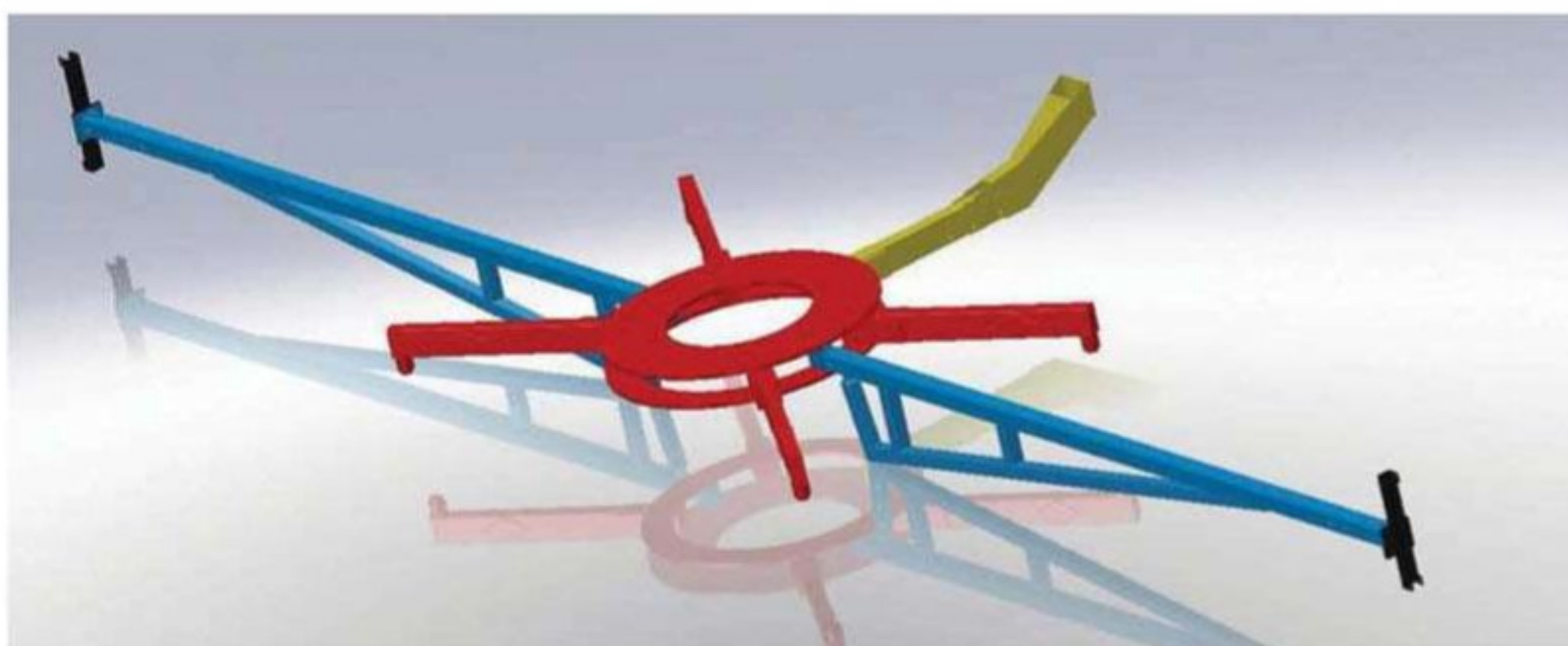

CAD model of the rig. The blue arms are attached to the red body with springs, which produce the oscillation movement

be reduced, and for us it has been between 2010 and 2012. It is usually between 200-250mm above the bottom of the car, which is fairly low. We could make it lower still, but we would have to compromise the aerodynamics, by lowering the radiators and sidepods, things like that.'

PRIMARY FUNCTION

Beyond understanding the car's c of g height, knowing the inertia of the car is also very important to the team. 'The inertia, or how much it resists turning round a corner, is of course the primary function of this rig,' Knapton continues. 'Over the years it stayed roughly the same with our cars, but in 2009 we started to make the car longer, for stability and aerodynamic reasons. And in 2010, the refueling ban made them longer still, and that changed it a lot. There is not a lot we can do about yaw inertia because the parts of the car pretty much have to be where they are, and we have regulatory

limits on weight distribution, which further limits where we can place things. The yaw inertia is usually dominated by things like the front wings and front tyres, which are right out at the corners. Our yaw inertia has gone up quite a bit recently, but strangely the drivers don't notice it. You'd imagine they would get out and say it feels very sluggish and unresponsive, but they don't really pick it up.'

In the age of digital simulation, it seems strange that such a simple looking tool is so critical, but what CAD packages output is no comparison to the real world. The data gained here is crucial to improving the team's digital version of reality. 'We use a lot of the data from this rig in our simulation models. It's very important that we have the correct c of g height and inertial properties in our vehicle model,' reveals Knapton. 'It must behave like the real thing. We use that data in dynamic models like our driver-in-the-loop simulator.

Getting the data right means it feels like the real car for the driver. We had an incident recently where we got the roll inertia wrong and the drivers were complaining that the car was very strange to drive. We didn't believe them, but later realised it was out by a factor of 100, due to user error. The car was oscillating and the drivers picked it up.'

REAL WORLD DEVELOPMENT

The data also can be used in real world car development, something technical director, Andrew Green, has placed particular emphasis on with the 2012 VJM05 (see p20).

'We work out the aerodynamic loading on the car via load cells on the pushrods. If we change an aero component, we look at those outings to see if there is any change, but when the car brakes you get a huge weight transfer forward putting load on the front. If you look at the data it then looks like there is a

massive load on the front, so we need to compensate that out, and to do that we need to know the rate of deceleration and the c of g height.

'Another way we use the data is if we do stability calculations on the car, and try to work out the yaw moment making the car turn. The front tyres will try to make the car go round the corner, whilst the rear tyres try to stop the car going round the corner. Looking at the yaw rate sensor of the car, and differentiating that from yaw acceleration, we can then divide that by the yaw inertia and get the moment acting on the car. We can then use that yaw moment to assess the stability of a change we make to the car.

'Finally, the data from the VJM05 and the forthcoming VJM06 will be fed back to the design team to allow them to optimise other parts of the car.

'We then use this when we are designing the suspension elements. The data from the c of g height helps us accurately predict the car's contact patch loads, and that feeds into other models, which give us the maximum loads for the suspension. It's especially critical as we don't use very high safety factors, perhaps 25-50 per cent.'

Force India believe in the value of the Cranfield rig, and they're almost certainly not the only F1 team using it. But with relatively affordable costs, perhaps more race teams will start to utilise it in order to develop their own models.



TeXtreme®

Spread Tow Fabrics for ultra light composites

- **20 % lighter composite products**
- **Superior surface smoothness**
- **Improved mechanical performance**

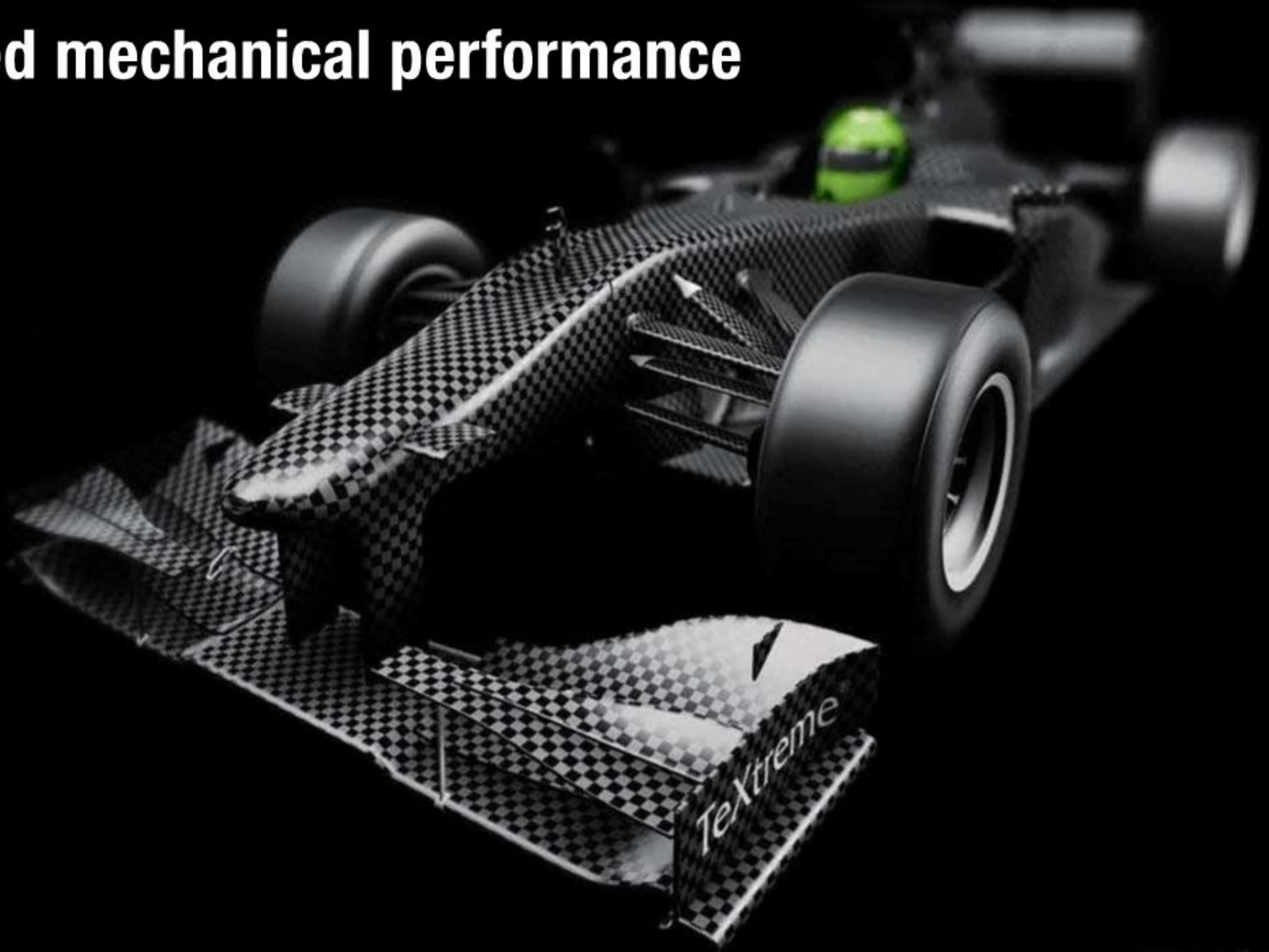

TeXtreme® is the market leader in Spread Tow carbon reinforcements. The thin Spread Tow Tapes are used to weave fabrics with virtually no crimp to realize mechanical properties similar to a cross ply of UD. Compared to use of conventional fabrics, TeXtreme® Spread Tow Fabrics enable weight reductions of 20 % of the composite without compromising the performance.

Sales contact:
Karin Widman, Application Specialist Racing, karin.widman@textreme.com

www.textreme.com

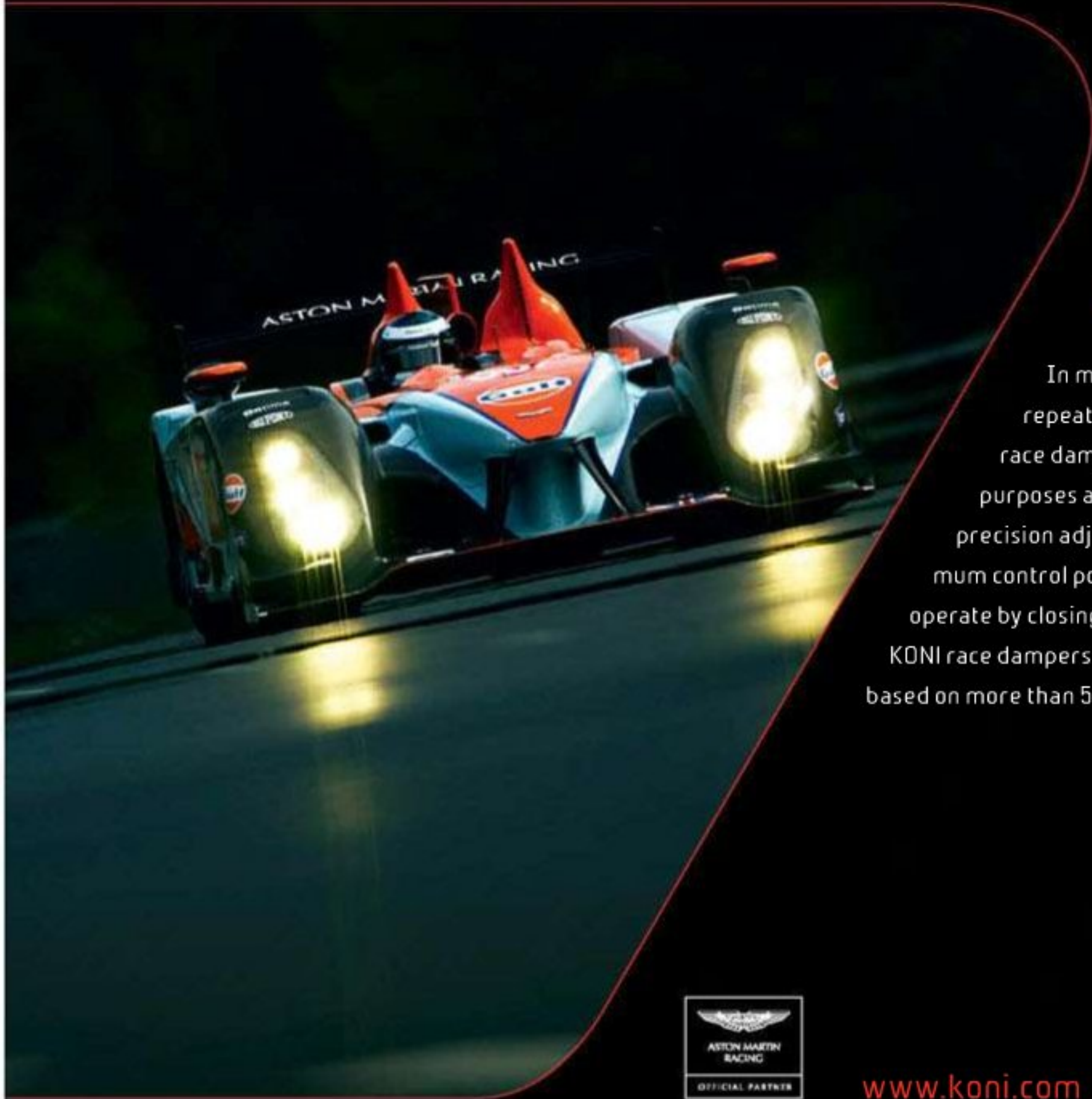

KONI Race Dampers

In modern racing applications damper sensitivity, repeatability and ease of use are a must. All KONI race dampers are specifically designed for these purposes and have a proven F1 technology. Their precision adjustment mechanisms allow for maximum control possible over the damping forces and operate by closing or opening valve-loaded ports. KONI race dampers give you best performance based on more than 50 years of F1 experience.



www.koni.com



KAMATICS RWG

Self-lubricating & rolling element technology:

- low friction
- high load
- high stiffness

Engineered bearing solutions that are proven in the most demanding aerospace & motor sport applications.

Typical applications:

- dampers
- toe links
- wishbones
- pushrods

KAMATICS RWG

Engineered Performance



EU: +49 9163 / 99 91-0 US: 860-243-9704

Email: motorsports@rwg-kamatics.com

Controlled performance

The latest advances in dampers and bearings from some of motorsport's leading manufacturers

BY GEMMA HATTON

Car performance? You may think of speed, horsepower and torque. However, the most important part of performance is utilising driver control, and this is achieved with a suspension system.

The suspension has two purposes: to isolate the driver from wheel movements due to road shocks, and to provide good handling and steering capabilities. A suspension assembly is constructed of three components - road springs, dampers and a suspension linkage. The road springs absorb road shocks by storing up kinetic energy when the spring compresses on inbound travel. Dampers absorb some energy stored in the spring, reduce vehicle bounce and dissipate kinetic energy by controlling the flow of oil through an internal piston. The suspension linkage geometry allows movement between the vehicle body and the wheels.

The majority of dampers used in the automotive industry are hydraulic, which are based on the principal of dissipating energy by pumping oil through small openings. This modern damper type offers enhanced control as the resistance increases depending on spring deflection, whereas earlier designs had constant resistance.

There are two types of hydraulic vibration dampers - lever and direct acting (otherwise known as telescopic). The latter is predominantly used in motorsport and is directly connected between the body and the suspension member that moves with the road wheel. Arguably, the most heated debate in the industry currently is the twin tube vs mono tube damper.



MONOTUBE DAMPERS

The piston works directly in the damping case and both the check and compression valves are integrated into the end of the piston rod. The main characteristic of this type is a chamber at the bottom, which contains compressed gas at approximately 25-30bar, and is sealed off by a floating separating piston that acts as a barrier between the oil and the gas. When the piston rod moves up and down due to temperature and volume changes, the separating piston is displaced by the same amount, which balances the oil expansion.

Compression phase: when the wheel moves downwards towards the road, the piston rod moves down, forcing the oil to flow upwards through the compression valve, which controls the flow and slows the piston rod. The floating separating piston moves down the same amount and the resulting pressure prevents the oil above the piston foaming.

Rebound phase: when the car wheel moves upwards, the shock absorber extends and the piston rod moves out of the damping case. The rebound valve resists the oil flowing downwards, slowing the upward motion, and therefore lifting the separating piston by the same amount.

TWIN TUBE DAMPERS

The piston works inside an inner tube and the space between the casing and the tube is used as an equalisation chamber. As the piston rod moves, the volume, and therefore the oil level, changes.

Compression phase: when the piston rod moves downwards, the displaced oil is forced into the equalisation chamber between the tubes via the base valve at the bottom of the inner tube. The oil underneath the piston flows upwards through the check valve to allow the piston to move, and can be adjusted to determine the damper characteristics.

Rebound phase: as the piston rod moves upwards, the rebound valve controls the resistance of the oil flowing downwards, slowing the upward movement of the piston. When the piston rod is pulled out of the case, its volume is balanced by the oil that flows from the equalisation chamber back into the inner tube through the compression check valve.

Therefore, the main difference between these two designs is the use of an extra tube in the twin shock and the gas chamber in the mono tube - however both work on the same principles of controlling the flow

of oil to determine the speed of the strokes.

'The most popular design for us is the twin tube because it's the standard damper that most car manufacturers use. Nearly 90 per cent of all the cars on the market have twin tubes, so when designing a sport suspension we decided to do the same,' explained Lutz Passon from KW Automotive, one of the world's leading suppliers of high performance dampers. 'The main advantage of a twin is its overall larger volume, which is better for cooling. However, it can't be used in just any situation because it has to be installed at certain angles, whereas the mono tube can be used in any position and offers more stability.'





KW Automotive has developed a unique, patented, two-way pressure valve technology, which allows the compression damping forces to be changed separately in low and high bump situations. This is achieved with two valves - one spring loaded for high speed, the other a bypass valve for low speed. 'We develop new technologies all the time, and with this valve system we can create more force at high speed and create different damping characteristics, which is why we decided to develop it. For the future, we are looking at increasing stability and stiffness, while reducing the weight in both our mono and twin tube racing dampers.'

In contrast, a representative from Koni explains why the company has found the mono tube to be a more successful solution: 'We use both but in racing, but it's mainly the mono design because it's lighter, more flexible, can be mounted horizontal or even upside down and it's gas filled. The main differences in our designs is the details of the valves and adjustments. For example, in our 28-series dampers, we use cartridges in our valves, which are pre-assembled units for each damping characteristic, each with its own set of possible adjustment steps. These cartridges make it easy to change the characteristic of a damper in a repeatable way.'

'One of our key technologies is our patented FSD (Frequency Selective Damping), which is used

in all types of vehicles, including motorsports, such as Formula 3, and in Formula 1 by Vodafone McLaren Mercedes.'

Put simply, this feature is a hydraulic amplifier that delays the build up of pressure by using a special valve that controls the oil flowing parallel to the flow through the piston rod. This parallel oil flow is closed by the FSD feature, giving a rise in damping force almost linear to the time that the piston is moving in one direction. Since it is an integrated part of the hydraulic valve system inside the

damper, there are no additional cables, sensors or any other electronic devices needed.

'Our most popular product is the 2812 series, which is a two-way adjustable damper with a cartridge valve design, which allows us to develop almost any desired damping characteristic. It's proven, cost-effective and used in many Formula racing series [F3, GP3, GP2] and also Touring and GT cars [all Aston Martin Racing cars and all HWA Mercedes Benz AMG SLS GT3s].'

This long body 2812-series race damper has a range of strokes from 114-224mm, an aluminium body and end cap and offers full adjustability on the car. As such, it is specifically

designed for competition purposes. Adjustment is achieved by a cartridge that controls the opening and closing of the valve-loaded ports, instead of the commonly used needle valves. This pair of cartridges, which are housed in the main piston, can accurately reproduce a set of eight pre-programmed damping curves, and can modify any basic valving in 64 different ways. As all the forces are generated by the piston assembly, the control of the damper is instant, precise, decisive and smooth. Furthermore, a separate bulky

reservoir is not needed, so the installation can be kept simple, compact, lightweight and clean.

On the other hand, an engineer from Reiger Suspension says it simply depends on your market: 'It is difficult to tell what our most popular product is because we are represented in many different auto and motorsport disciplines. Our core business is Rally and Rally Raid suspension, but since 2011 Gas Gas is using our suspension OEM in its trials bikes.'

Interestingly, Reiger has concentrated its developments on temperature changes, resulting in a thermostatic damper: 'We created a device that compensates the change

of viscosity of damping oil from cold to warm (start to finish). Cold oil is thicker than warm oil, which changes the damping force during the race and makes it difficult to find a good set up. With our thermostatic device, though, the damping always remains the same.'

Another patented technology is Reiger's Corner Control Valve (CCV) system, where the damper knows whether the racecar is in a corner or on a straight. 'In the corner, the CCV system creates stiffer compression damping on the outside damper so you have less roll and can therefore run a softer anti-roll bar and increase stability in a straight line. We also developed our Intelligent Compression System (ICS), which tells the damper if the compression impact is forced by the wheel going up or the chassis going down. Both have a different mass and therefore require different damping characteristics. One of the benefits is it allows us to use a soft, comfortable base damper characteristic with a lot of traction without the chance of bottoming.'

As usual with any engineering discussion, there are different solutions, different opinions and different reasons for both. Yukiko Koito from Tein UK sums it up nicely: 'When considering the twin-tube design, the advantages are that the dual chamber shell case allows the damper to function even if the outer case has damage. The longer stroke is good for comfort and control on inconsistent road surfaces and it's usually a less complex construction, which is simpler and more cost-effective to maintain.'

'The disadvantages are lower capacity can't develop as much damping force, there is less flexibility in mounting options and more risk of aeration because gas and oil are in direct contact. In conclusion, this type is usually used for street applications.'

'The advantages of the mono tube are larger capacity, resulting in more damping force (the larger piston can generate more damping force with less movement of piston shaft), which makes them excellent for restricted space. There is also

"the mono tube can be used in any position and offers more stability"



Technology & Advanced testing

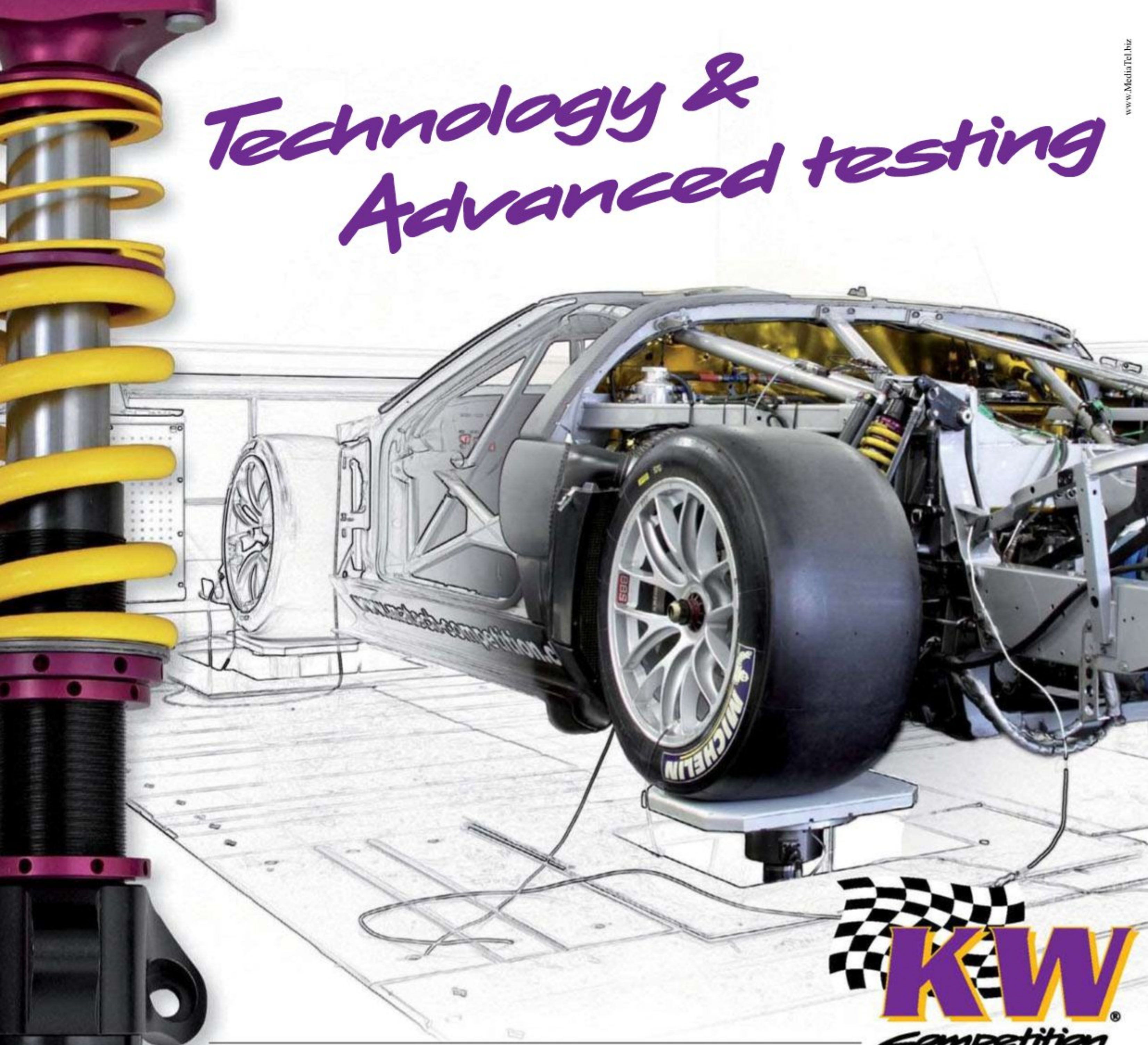

Advanced Testing KW 7post rig

- 4post sweep analysis
- 4post track replay
- Option: constant aero loads
- 7post track replay



KW 2A competition

"2-way independent adjustable"

KW 3A competition

"3-way independent adjustable"

Racing springs & top mounts



Made for Winners

Visit us at Autosports International 2012
12th-15th January @ NEC Birmingham
Stand 2750 · Hall 20



Winner 24h Nürburgring

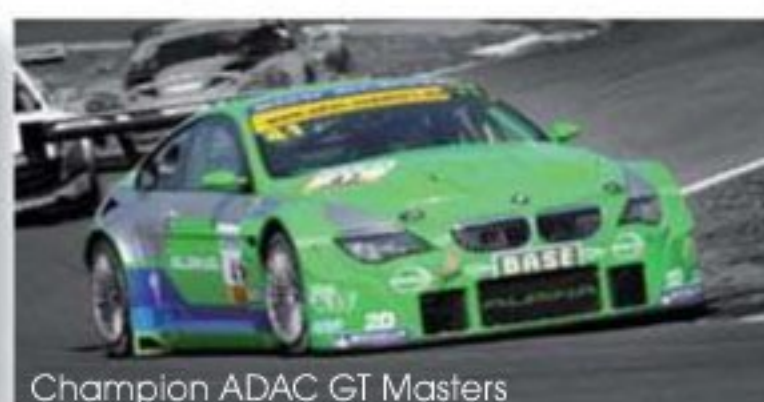

Champion ADAC GT Masters



Formula D Champion

more freedom with mounting position and less chance of aeration as gas and oil are separated. The disadvantages are higher cost of construction

and maintenance, the fact that comfort is usually sacrificed and any external damage will render the unit inoperable. We sell both types to customers, so we will

continue to supply a product that meets the needs of both.'

In conclusion, the complexity of this subject suggests the damping dilemma will continue

until a revolutionary technology is developed that combine the advantages of both types. Until then, the choice depends on specific vehicle requirements. 

BEARINGS

ABC

Autosport Bearing and Components (ABC) has been supplying a range of specialist motorsport bearings (rod end, spherical, needle, cylindrical and ball roller bearings) for 60 years - the only company in the industry to do so. The company has a unique bearing design, which has the highest specification liner currently available to the motorsport world. This bearing is used on 90 per cent of the F1 grid and 95 per cent of the LMP and WRC grid. A good design then.

'We are the world's exclusive agent of the E-Type range of NMB spherical bearings,' declares Lee Sinclair of ABC. It all started in the early 1990s, when ABC's partner, Rose Bearings (now NMB Minebea), was approached to design a bespoke bearing system that was better than the standard Mil-specification (military aerospace-specification) PTFE liners. This comprises a cloth with PTFE (Polytetrafluoroethylene composed of carbon and fluorine) molecules woven into the fabric, which is then bonded and fixed inside the bearing housing so the spherical ball runs against it.

'There was an increased demand by Formula 1 teams for a higher performance liner because they wanted to save weight. The initial brief was to achieve a bearing that could take higher loads, dynamically and statically, in each size with standard Mil-spec PTFE liners. We reduced the size of each bearing whilst retaining larger loads so the wishbone housing and fixings could be smaller. This achieved the brief, and so the E-Type liner was brought to market.'

Aside from the weight advantage, there were other benefits: 'The new liner gave less deflection under radial load (the liner didn't move

side to side as much within its housing) and when moved through its axis under load it gave less friction resistance than other PTFE-lined versions. Furthermore, there is less wear, so it lasts longer, and the unique construction of the bonding resins mean the bearings can withstand higher temperatures [+160degC (320degF) compared to the 121degC (250degF) of normal PTFE liners, so they can be used closer to the engines and exhausts. This meant the wishbones could be shorter and more extreme pick-up points can be used.'

Due to its success within F1, ABC expanded into other motorsport markets, specifically Rally and Sportscars. At that time in rallying, teams had problems with bearings 'knocking out' (where the liner wears out, breaks up and leaks out as the ball misaligns), so the bearings would have no liner, and the ball would run on the metal, resulting in welding or galling of the bearings. 'Where F1 took advantage from downsizing the bearings, the Rally industry used the same size, but in E-Type form, gaining extended life and preventing knocking out. In Sportscars, we used the Le Mans 24 Hours as the ultimate test, and the main problem competitors had was the bearings would wear and have to be replaced, or the teams would swap to a fresh wishbone, taking up valuable pit stop time. By using the E-Type this problem

was eradicated, because the bearings can complete the 24 hours without a problem.'

However, this range of bearings is currently only available in imperial sizes and ABC sees the future in bringing the E-Type liner range to market in metric sizes. 'Over the last 5-10 years we have seen an increased demand for metric bearings as most spherical and rod end bearings are imperial sizes, so spacers have to be inserted into the bore to suit a metric fastener.'

KAMATICS RWG

Another high performance bearing manufacturer is KamaticsRWG, a company that has been in the industry for over 40 years. Its self-lubricating and rolling element technology increases performance by offering low friction, high load and high stiffness solutions that are used in Formula 1, Indy, Indy Lights, DTM, NASCAR, ALMS and Grand-Am. Typical applications include damper, toe link (tie rod), front / rear wishbone and pushrod bearings.

Contrasting the reduced weight concept of ABC, KamaticsRWG has found that in many motorsport applications, because the bearings are designed to reduce weight, they are 'often undersized, resulting in locally high liner pressures, which can cause other liner systems to wear out more rapidly,' explained an engineer from the company.

So the company has developed a specific liner, the Karon BX, which 'offers high liner capacity without sacrificing its low coefficient of friction, and which is available to all high load motorsport suspension applications (as long as operating temperatures remain below 300degF (149degC)).' Although this is a lower operating temperature than the ABC E-Type, KamaticsRWG found that after 100,000 cycles at 33,000PSI the BX liner showed less than 0.003in (0.076mm) of liner wear. After 1,000,000 cycles at 33,000psi, the Karon BX liner exhibited only .0045in (0.114mm) of liner wear.

Another unique coating that KamaticsRWG offer is CBC (Carbon-Based Coating), which is currently used on open wheel racecar suspensions and steering systems. The ball material is high strength copper-nickel-tin bronze and the race material is a corrosion resistant steel with a thin layer of CBC. 'The reported performance was more than 3500 miles at racing speed without measurable wear. It provides outstanding stiffness characteristics at the lowest wear rate.'

Though the the basic goal of KamaticsRWG is to provide long wear life with high load capacity and low friction, the company also believe that weight reduction is important, if the application requirements allow for it. KamaticsRWG has significant experience incorporating lightweight materials such as titanium, aluminium and composites into its bearing designs. These materials may be combined with products such as the Karon BX liner system.

Again, although every company has developed its own technology, the choice depends on the end user's individual requirements.



ABCA

THE MOTORSPORT SPECIALISTS

the result you need . . .
where you need it . . .
on the track



From initial concept through design & development, prototype to final production, we are there to assist every step of the way



www.autosport-bearings.co.uk

Bearings, Fasteners, Adhesives,
Oils, Lubricants and much more.



Tel: +44 (0)1932 225777 • Fax: +44 (0)1932 222215
Email: abc@autosport-bearings.co.uk

WWW.REIGERSUSPENSION.COM



The best suspension for:

- Rally
- RallyCross
- AutoCross
- MotoCross
- Trial
- Quads
- Sidecar Cross
- Rallye Raid



Reiger Suspension BV
Molenenk 5a
NL-7255 AX Hengelo Gld.
Tel.: +31 (0)575-462077
info@reigersuspension.com

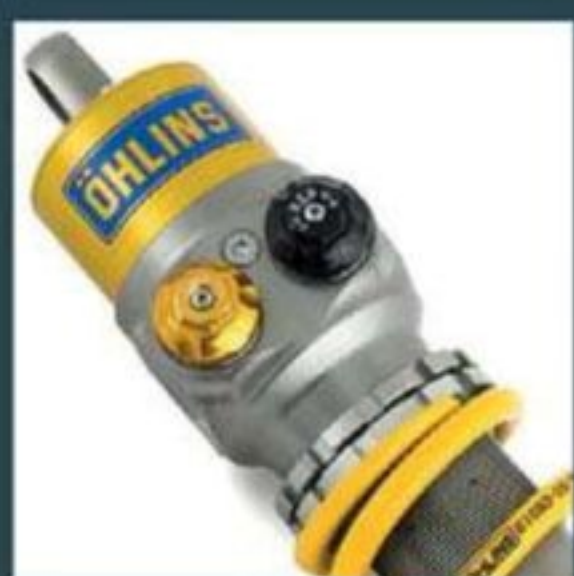

Contract manufacturing of high value, high performance components to an international clientele in formula, sports car and rally competition.

Authorized sales, service and testing of Ohlins racing dampers.

Exclusive North American agents for Farrington data acquisition systems.

413.256.0861 Amherst, Massachusetts, USA www.snapdragonms.com



inch sizes
metric sizes

INTERNATIONAL DISTRIBUTORS

AURORA® · RODOBAL® · Seals-it®
widest range in Europe

ROD ENDS ACCESSORIES:
lateral seals
protection boots,
jam-nuts
right-hand, left-hand

Getecno srl - GENOVA - Italy

fax +39 010 835.66.55
phone +39 010 835.60.16

internet: www.getecno.com
e-mail: info@getecno.com

contacts in English, Deutsch, Français, Italiano

JLS MOTORSPORT

Air Jacks

- Designed & manufactured by JLS Motorsport, bespoke strokes are available.
- Manufactured with forged alloys & high tensile steels
- Lightweight & compact in design
- Delivering maximum performance & optimum safety
- All Air Jacks are supplied with 3 location rings for positioning & alignment



Air Jack Lance



Air Jack Probe

Made in the UK
European Sales

JLS Motorsport
email: motorsport@lister.co.uk
tel: +44 (0)121 525 5800
fax: +44 (0)121 525 4833



XRP THE XTREME IN RACECAR PLUMBING

XRP Inc. email: sales@xrp.com
tel: 562 861 4765 fax: 562 861 5503



IMPROVE PERFORMANCE

Control excessive radiant heat

Clamp-On Heat Shield



T3-T4, T-5-T6
Turbo Blanket



The Original, The Best:
Exhaust Insulating Wrap

Download our catalog at

www.thermotec.com

Call for a free catalog-(Greenwich, Ohio, USA

00 1 419 962 4556

Connecting the dots

Part 2

Understanding the process of circuit modelling



In part one of our introduction to using racecar simulation last month, we showed you how to start with an initial simulation model. We discussed the fact that you need to first measure up the car, then start with a model that closely resembles your car and change it bit by bit to more accurately replicate your car. We discussed the need to interact with data, and the order in which you have to use the modelling estimation features. Once at this point, we are ready to tune.

BY DANNY NOWLAN

What we'll be discussing in this article is how you go about circuit modelling. Once again, as with the processes last month, once you see how straightforward this is, you'll be doing it yourself in no time.

What we'll be discussing here is directly related to ChassisSim for two key reasons: firstly, it's what I have the most experience with, so I can give you the most accurate information on. Secondly, ChassisSim is transient,

not pseudo static, so you'll be introduced to a wider range of parameters that I can show you short cuts on.

First things first though, let's discuss the elements you need to create a circuit model. These elements are as follows:

- **The curvature file, which is a plot of inverse corner radius vs distance**
- **The bump profile, which is a plot of all four road displacements vs distance**
- **The altitude road camber**

file, which plots altitude and road camber

- **The bump scale factor, which fine tunes the bumps**
- **The grip scale factor, which tunes in local grip**

Don't be intimidated by this. I have deliberately listed the elements in order of importance, so to construct your circuit model you need to start at the top of the list and work your way down.

Our first port of call is constructing the curvature file. This is a filtered plot of inverse

corner radius vs track distance. Effectively, it plots the trajectory we want the racecar to follow. Mathematically inverse corner radius looks like this in the following equation:

$$iR = cv_sign \cdot \frac{127.008 \cdot a_y}{V^2} \quad (1)$$

where,

iR = inverse corner radius (1/m)

cv_sign = sign for the curvature
1 if a_y is positive to the right

a_y = lateral g measured in g

V = forward car speed in km/h

When this is plotted against distance, you should have something that looks like **figure 1**.

You can create this curvature file in two ways. The first is to create a maths channel in your data analysis package and export that out. The other is to use the ChassisSim create curvature file feature. If you want a demo, visit the ChassisSim YouTube channel.

One thing I do want to touch upon, though, is the filtering you should be using for the curvature file. The two major types of filtering you can typically have a choose is low band pass frequency-based filtering or a moving average filter. If the lateral acceleration signal is coming from inside the logger box, I'll use a moving average filter. If I have a good quality lateral accelerometer being logged at 50Hz and above, I'll use the frequency-based filtering. But, as with all things, have a play with both and see what gives you the best results. Remember, the ultimate test is plotting actual curvature vs real curvature.

The next step is to create the bump profile, which is a plot of all four road displacements vs track distance. A typical bump profile for the left front input is shown in **figure 2**. There are a number of ways this can be determined. The first method is to use tools such as the ChassisSim bump profiling toolbox. The other way you can do it is to export your damper channels and scale them

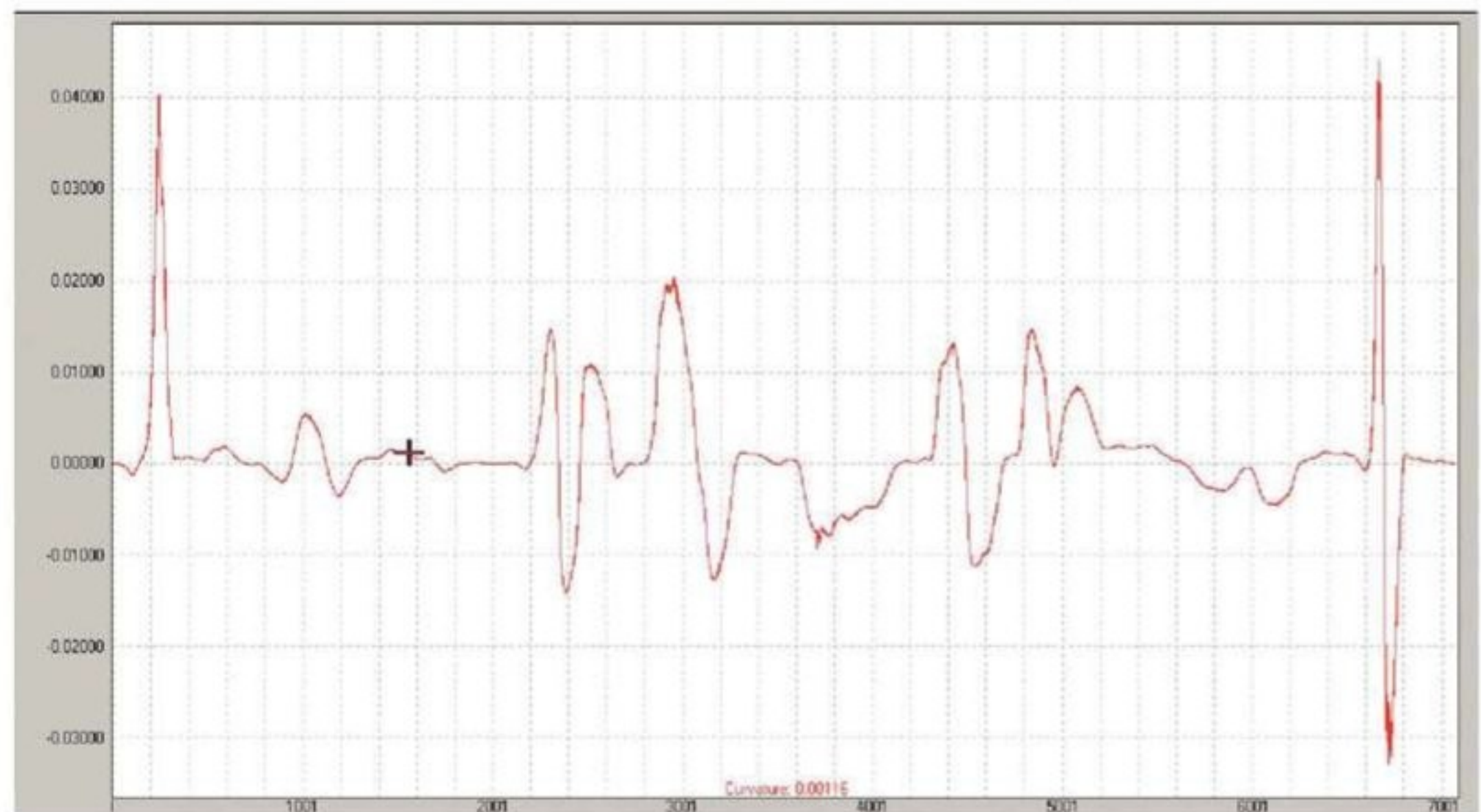

Figure 1 : plot of curvature vs distance that can be used in a curvature file

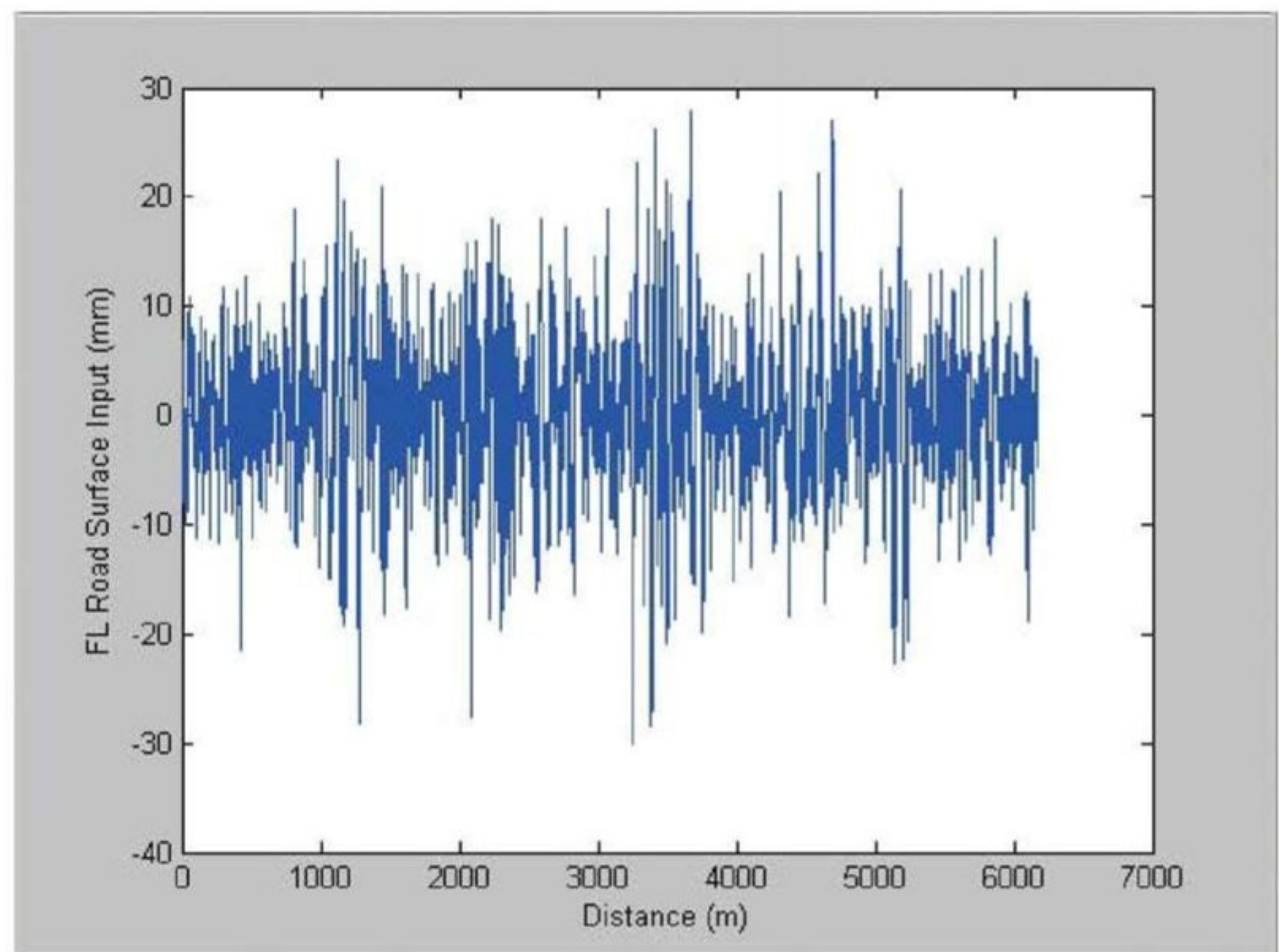

Figure 2: plot of bump input vs track distance

in the order of 20-30 per cent. Remember, you need to scale your damper channels because when you look at the dampers you are looking at an output. Our goal with the bump profile is to divine the input.

Once you are used to the mechanics of driving this, the process of generating a curvature and bump profile can be completed in minutes (the current record in the ChassisSim community is five minutes). While this might sound a bit light hearted, it illustrates how quickly this part of the process can come

Table 1

| Sector | Vact/Vsim (km/h) | Road camber | G.S.F | B.S.Ffnt/ B.S.Frear |
|-----------|------------------|-------------|-------|------------------------|
| 800-1000m | 200/190 | | | |
| 1230-1260 | 90/100 | | | |

together, and how easy it is to generate tracks you don't have.

Another point I'd like to make is that when you're creating and tuning these files, store the car data and the track data together. If you remember, in part one we discussed a suggested directory convention of C:\ChassisSim\Models\My car\My Track\Session.

This is where I suggest you store your initial files.

Now, once you have your initial curvature and bump profile, you can run your initial simulations. The first order of business is to do some basic aero, speed and damper checks to double check the speeds are within where they need to be.

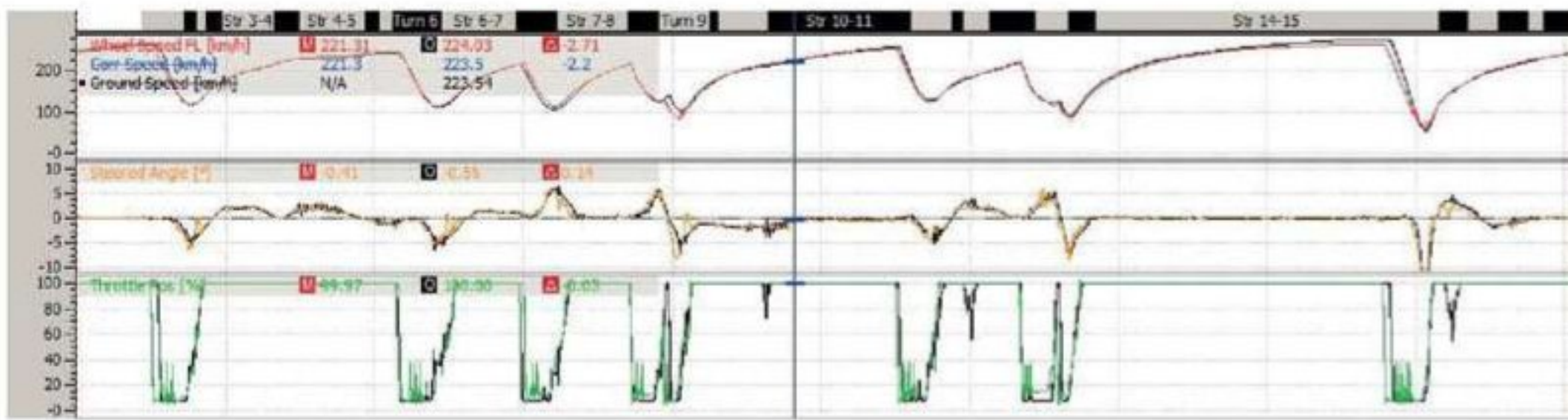

Figure 3: initial correlation

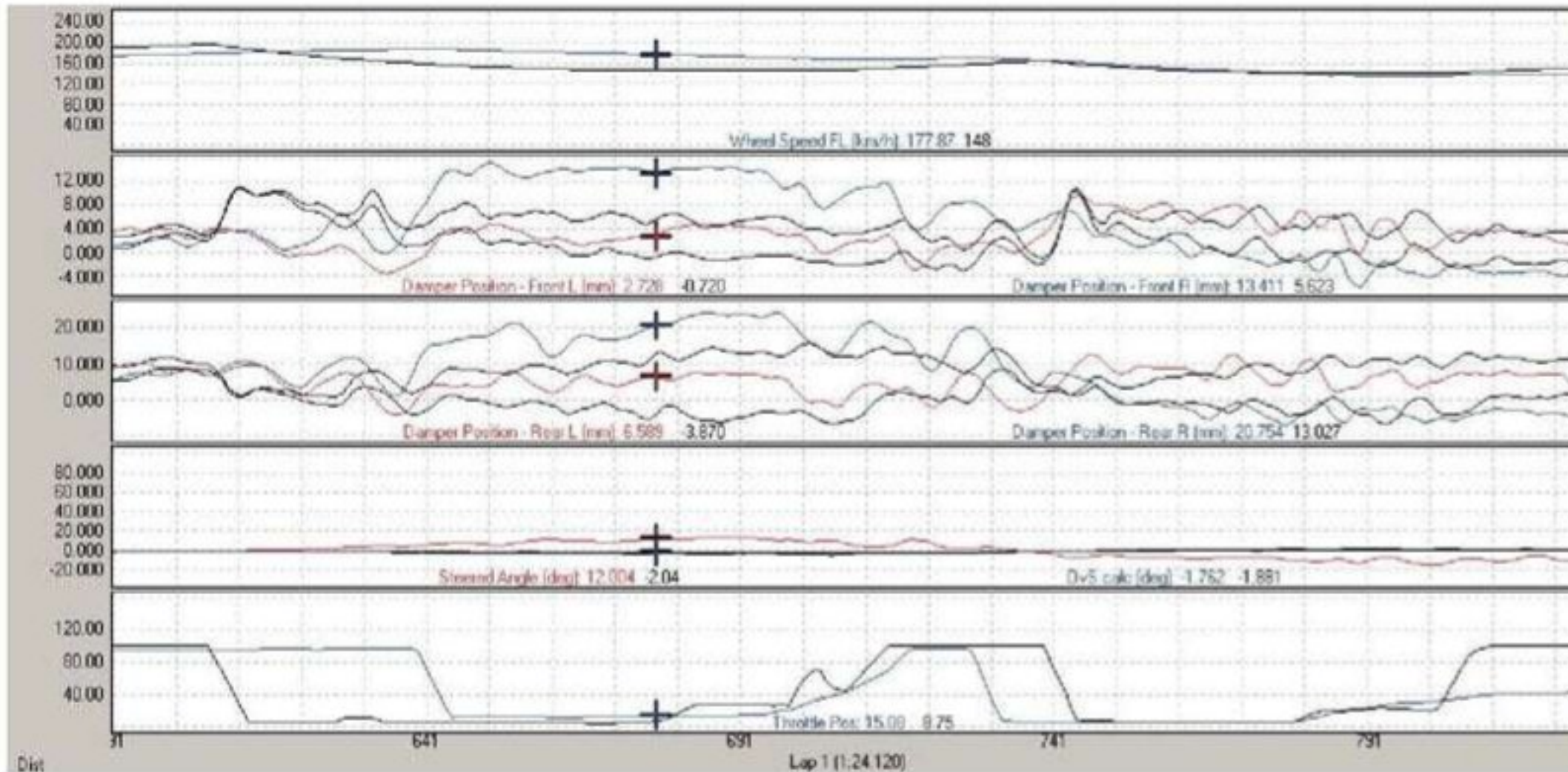

Figure 4: actual damper traces vs simulated when significant road camber or normal load is involved

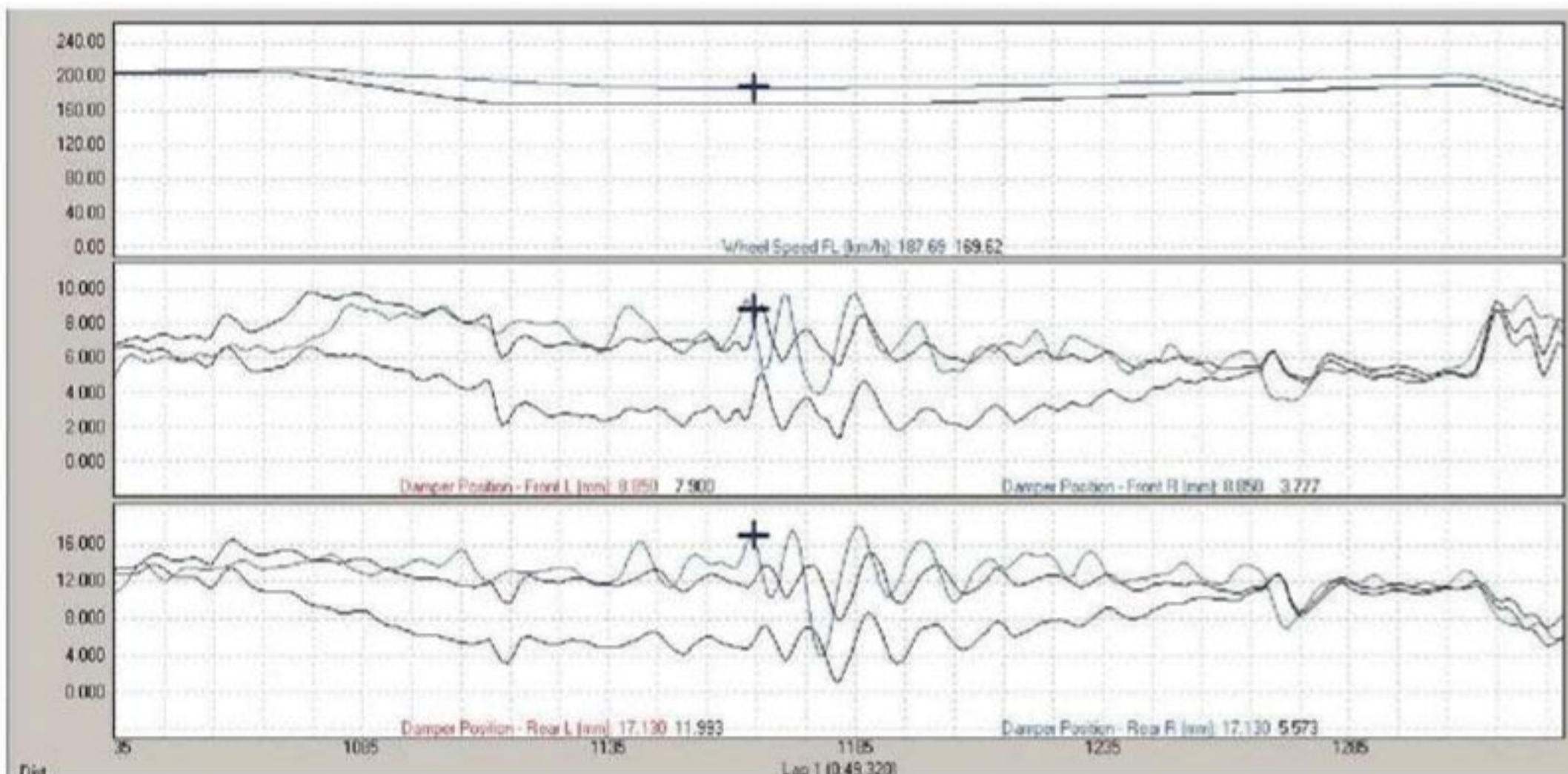

Figure 5: comparison of actual vs simulated data when bump scaling is needed

You are looking for a speed differential of 2km/h down the main straight and also to make sure the damper traces at the end of the main straight line up. This will ensure we have the correct aero loading so we don't have to chase our own tail. In ChassisSim speak you'll be playing with CLAmx and CDAmx. The other thing you are looking for is basic roll and pitch correlation. At this point in the game, your rolls and pitches should be within an error margin of about 10 per cent.

“if the speeds are down everywhere, this is your cue to adjust the tyre force scaling factors in the tyre model”

This will improve as we refine the model, but at the moment we are looking to validate that we have the correct spring rates and motion ratios entered. If you obtain something beyond this, double check your entries. When happy, you are ready to play with

tyre scaling factors.

As a rough rule of thumb, if the speeds are down everywhere, or the opposite is the case, this is your cue to adjust the tyre force scaling factors in the tyre model. A dead giveaway of this situation is

when the predicted lap time is, say, three seconds too fast, but the shape of the speed trace looks okay. This is particularly apparent if the top speeds are comparable. If this is the case, reduce the tyre scaling force factor (the opposite is also the case). In this phase, our goal is for a correlation that looks like that shown in **figure 3**.

As we can see, the general shape of the speed trace is right but there are still a few things we need to resolve.

The next step after tuning in the tyre force scaling is to list out the local speed variations. Initially, we are looking for discrepancies greater than 5km/h. What I find very helpful is to list the speed variations out in the format of **table 1**.

The area to focus on is the mid-corner because, if you get this right, the turn in and exit speeds have a funny habit of looking after themselves. You'll note I've deliberately left the road camber, grip scale factor (GSF) and bump scale factor (BSF) cells in table 1 blank. This is because it's your job to fill them in.

Our first order of business when we have a speed discrepancy is to evaluate if there is any road camber we need to deal with. Road camber has a very significant effect on tyre loads that can be approximated by the following equation:

$$F_z = m \cdot V_x^2 \cdot iR \cdot \tan(\phi_{rc}) \quad (2)$$

where,

Fz = vertical load created by the road camber

m = car mass

iR = the inverse corner radius

Vx = the forward speed in m/s

ϕ_{rc} = is the road camber

Equation 2 will tell you why IndyCars can run nearly flat out at Indianapolis, even though the speedway has a banking of 10 degrees. So ignore road camber at your peril.

There are two ways of determining if there is road camber. The first one is to watch in-car camera footage. If you don't have that logged, YouTube is your best friend. The second

way of detecting this is when the simulated damper traces are well down on the actual damper traces, as illustrated in **figure 4**.

The actual damper traces are coloured, the simulated traces are black. As can be seen, there is a significant difference here and this is where you need to add road camber. In reality, you'll be looking at both, but you'll still be surprised the effect that four degrees of on and off camber can have, so keep an open mind.

Once the road camber has been determined, our next point on the list is to look at bump scale factors. The telltale sign we need to add these in is when the simulated and actual bumps are the same, but the simulated speed is down by, say, 20km/h. This is illustrated in **figure 5**.

Again, the actual dampers are coloured and the simulated trace is black. As we can see, if we are getting the same bump magnitudes with such a large speed difference, that's a pretty clear sign we need to reduce the scaling of the bumps. What

you are looking for is to get the magnitudes the same, with about a 5km/h differential.

The last point on the list is grip scale factor. Once the road camber and bumps have been handled, grip scale should be a minor tweak. In terms of what to apply, you should find the following formula very useful:

$$G.F = \left(\frac{V_{ACT}}{V_{SIM}} \right)^2 \quad (3)$$

where,

G.F = the grip factor we need to apply

VACT = the actual speed

VSIM = the actual speed

If the grip factor is just a fine tweak, you know your model is working well.

Typically, what we have discussed here is an excellent start, but there are some things you need to be aware of. For about 90 per cent of circuits, our procedure of road camber, bump scale factor and then tweaking with grip scale factor will give you a very good circuit model. However, there will be circuits that are the exceptions to the rule. These are typically circuits that are very bumpy and have different surfaces. Street circuits, and places like Sebring in Florida are classic cases in point. In such a case, my focus is to get the bumps right and then play with grip factor.

You can also see why using auto grip scaling is not necessarily the best idea in the world. Yes, it makes you look like a hero, but, as we have just discussed, there are many things

that affect the grip in the corner, so use features like this with great caution.

Now you have a basic circuit model, you are ready to dial in the model, and this is what we'll discuss next month, in part three of connecting the dots. However, to give you a preview, this will be our game plan:

- **First, we'll go over some tyre model basics to do initial tyre modelling and to also illustrate what's going on so you get a real understanding of what you need to do**
- **Then, we'll do a quick review of aero mapping**
- **Finally, I'll show you how to employ the ChassisSim tyre force modelling tool box**

Once you're at this point, you will have a racecar model that you can really use in anger. However, as we'll discuss next month, the real benefit is what you'll learn about your racecar in the process. 

"The other thing you are looking for is basic roll and pitch correlation"

OUR COURSE IS OPEN FOR TESTING THIS WINTER

MIA Winter School of Race Engineering 2012

Course A: 1-2 December hosted by Lotus F1 Team

Course B: 8-9 December location TBC

Location partner



MIA SCHOOL OF RACE ENGINEERING



The only course of its type taught by current chief Race Engineers from GP3 and Le Mans.

Ideal for graduates, apprentices, engineers and technicians looking to progress into professional trackside race engineering.

Price includes four full days of teaching over two weekends and certificate on completion. Two dinners with special motorsport guests also included!

Priced at £650 per weekend, with discounts available for early booking.

2012 course already 50% booked - contact us now!

More info at www.the-mia.com/events-diary

CONTACT ZOE CHILTON ON +44 02476 692 600 OR EMAIL zoe.chilton@the-mia.com

DOCKING

Advanced Cooling Systems

- Water Radiators
- Intercoolers
- Oil Coolers
- Heat Exchangers
- System Design
- Ancillary Products

Manufactured to your requirements by the UK's leading supplier.

E info@dockingengineering.com
 Tel 00 44 (0) 1327 857164
 Fax 00 44 (0) 1327 858011
 Website www.dockingengineering.com
 Unit 15 Silverstone Circuit • Silverstone Northants • NN12 8TL • United Kingdom

AERODINE

COMPOSITES GROUP

ADVANCED COMPOSITE TECHNOLOGIES
 FAA CERTIFIED REPAIR STATION RDMR624X

- STRUCTURAL COMPOSITE ENGINEERING
- PRODUCT & TOOLING DESIGN
- CAD/CAM
- FINITE ELEMENT ANALYSIS
- PROTOTYPING
- MANUFACTURING
- STRUCTURAL REPAIR

Serving the Motorsports Industry Since 1989

www.AerodineComposites.com

Tel. +1 001.317.271.1207 • Fax. +1 001.317.271.4455
 8201 Indy Lane, Indianapolis, IN 46214

NEW : CAN DISPLAY

KMS

Kronenburg Management Systems

Kronenburg Management Systems (KMS) is a complete line of engine management systems, that offers you an extremely reliable and user-friendly system at a very competitive price. It gives you the possibility to manage all (turbo + n/a) petrol engines up to 12 cylinders with options such as 4mb datalogging, staged/banked injection, mapselector, odd firing, self-learning lambda control, boost control, variable launch control, idle control, traction control, powershift, rpm limiters, engine diagnostics, shift-light, water injection, cooling fan, fuel pump, etc. New KMS CAN display, UEGO CAN controller and MAP sensors now available.

For more information, free software and prices:
<http://kms.vankronenburg.nl>

KMS
 Kronenburg Management Systems

KMS Management Systems
 Spaarpot-Oost 19, 5667 KT Geldrop, The Netherlands
 T. +31(0)402854064, F. +31(0)402867765
 E. info@van-kronenburg.nl

EARL'S

PERFORMANCE PRODUCTS

CUSTOM BRAKE LINES | OIL COOLERS | HOSE | FITTINGS
 ADAPTERS | FILTERS | NOS | FUEL PUMPS & REGULATORS

FUEL LAB | NOS | Holley | EARL'S | Apex Wizzis | STÄUBLI

Visit www.earls.co.uk for the full range
Online Shop now Available

Earl's Performance Products UK Ltd
 Units 15-16 Silverstone Circuit, Northants, United Kingdom NN12 8TL

+44(0)1803 869850 | sales@earls.co.uk

QUOTE "RCE10"
 WHEN ORDERING TO
 RECEIVE 5% DISCOUNT

Nürburgring close to going bust as EC funding is refused

The historic, publicly owned Nürburgring in Germany is on the process of filing for insolvency, but says it has provisionally agreed a radical new contract with Bernie Ecclestone that would allow it to continue alternating the Formula 1 German Grand Prix with Hockenheim. Under the terms of the deal, according to unconfirmed reports, the Formula One group would effectively act as the race promoter, assuming all costs and banking all revenue.

The iconic road course in the Eifel mountains of western Germany is now 90 per cent owned by the regional government of Rhineland-Palatinate, while the local administrative district, Landkreis Ahrweiler, holds the remaining 10 per cent. The venue is operated by a purpose-formed company, Nürburgring Automotive GmbH.

The present financial problems stem from a major re-development in 2009, when projects such as a shopping and entertainment complex, and a hotel, were completed in a bid to generate revenue from non-motorsport promotions. The re-development was funded by a loan of almost \$370 million from



Excessive expenditure, crippling debts and a downgraded value have forced Nürburgring Automotive into a corner. But there's still hope for the German GP

the Bank Rhineland-Palatinate, the state's central economic development agency.

It entered into the sharing arrangement with Hockenheim that same year. The new facilities have not been as popular as hoped and, despite not having to pay out for Formula One's race hosting fees every July, the circuit management has been struggling with crippling cashflow problems.

Last week it applied to the Executive Commission of the European Union for a \$16 million loan to cover interest payments on its debt, but was informed that the Commission would not reach a decision until the end of July. Moreover, the Commission stated a preliminary view to

the effect that the request was incompatible with EU rules covering operational aid.

Consequently, state governor, Kurt Beck, has instructed the board of Nürburgring Automotive to begin a formal winding-up process. He said of the situation: 'There is a high probability of insolvency at the end of the month due to a lack of liquidity.' Selling the facility might not be an answer, as a recent assessment by Ernst & Young put a value on the site of just €126m (£98.1m / \$152.5m).

The track operator approached Formula One to find a way to remain in the alternating arrangement with Hockenheim. It has now asserted in a statement:

'Nürburgring Automotive directors, Jörg Lindner and Kai Richter, have reached agreement with Formula One chief, Bernie Ecclestone, on a project to guarantee the future of Formula 1 racing on the Nürburgring.'

It is not clear whether this new agreement has been approved by the state government. However, the majority owner has itself invested millions of Euros of public money in the form of capital and shareholder loans, and could go to almost any length to keep the venue operational.

Should the Nürburgring close its doors, Hockenheimring GmbH managing director, Georg Seiler, has indicated that, under certain conditions, he would be willing to step in so that the German Grand Prix remained an annual event. 'At present, there is no such request,' he said. 'But if there is one, I do see a possibility that Formula 1 comes back every year to Hockenheim. But everything would have to be agreed: the cost side, the contract, the policy, and much more. I don't know which of these conditions would be easy to fulfill. Basically, we would be happy if we could continue with the alternation.'

Too many GT championships to blame for recent failures, claim promoters

An overcrowded GT scene has been cited as the chief cause for the cancellation of the rest of the Le Mans Series, and also SRO's decision to stop promoting the FIA GT1 World Championship.

The remaining rounds of the European-based Le Mans Series - at Brno and Algarve - have been called off, with the organisers now saying teams can compete for double points at the American Le Mans Series' Petit Le Mans season closer instead.

This year, the LMS has excluded LMP1 cars and focussed

on LMP2 and, while that's been fairly successful, the GTE class of the championship has not proved attractive to teams, even with the opening of the regulations to allow in GT3 cars. At Donington, nine LMP2s were joined by just three GTs, while the earlier Zolder round was cancelled.

The championship's organiser says the decision to cancel the rest of the 2012 races was 'the result of the current economic climate, and a very competitive GT market with numerous championships that have led to

the dispersal of cars of this type in Europe'.

However, this should not mean the end of the LMS: 'The organisers of the European Le Mans Series are working flat out on the future of the series, which is one of the essential competitions for training teams and drivers for the top level of endurance racing...This work will result in a proposal for the coming seasons and will be announced in September,' a statement read.

Meanwhile, SRO has also

said an overcrowded Sportscar calendar is in part behind its decision to stop promoting the FIA GT1 World Championship and the FIA GT3 European Championship in 2013.

Stéphane Ratel, founder and CEO of SRO Motorsports Group, had tried to merge his two championships in an effort to save GT1, but this idea seems to have been rejected by the FIA GT Commission, and Ratel has now informed the FIA that his organisation will no longer promote the championships.

The group will continue to look after the FIA GT1 World Championship for the rest of this season, which will be run to a revised calendar.

Ban on military sports sponsorship kicked into touch by Congress

A bill amendment that could have taken millions of sponsorship dollars out of the United States professional motorsport scene has been defeated in the House of Representatives.

The amendment, which was based on the argument that defence dollars might be better spent elsewhere, was binned by a narrow margin of 14 votes - 216 to 202 - after what's been described as a vigorous debate.

Both NASCAR and IndyCar were signatories to a last minute plea to Congress days before the amendment was voted on. Other signatories were the National Football League, Major League Baseball and the National Basketball Association, but it's widely known that motorsport, and NASCAR in particular, takes the vast majority of the military sponsorship pot - estimated at \$135m - and therefore had the most to lose.

NASCAR has recently lost one

of its major military sponsors, with the US Army announcing its intention to pull out of its relationship with Stewart-Haas Racing at the end of this season, a deal worth \$8.4m a year, and proponents of the bill argued this was proof the sponsorship, which is aimed at driving recruitment, does not work.

Congresswoman Betty McCollum, one of the originators of the amendment, said the Army's decision was evidence that military sponsorship is ineffective, adding: 'Over the past few days, professional sports have come out in full force to protect their taxpayer-funded subsidy. For the purposes of the 2013 defence appropriations bill, those pro teams are military contractors, who have failed to deliver on their contract in the past, with the taxpayers, for recruits.'

At one time, the US Air Force, Navy and Coast Guard all had full-season sponsorships in one



National Guard and the US Army will continue to support NASCAR and IndyCar

or more of NASCAR's three major national series. This year, the Army and National Guard are active in NASCAR, the latter with Hendrick Motorsports, while the National Guard also supports Panther Racing in IndyCar. The National Guard's total motorsport spend is said to be \$26.5m.

In the sports series' open letter to Congress, it was argued that an amendment to the annual Defence Appropriations Bill would rob the military of one of the most efficient ways to reach young Americans interested in military service.

Panther Racing boss, John Barnes, said of the result of the vote: 'We are especially thankful that many in Congress were able to recognise the enormous tangible return professional sports provides to the recruitment, retention and overall marketing efforts of our nation's military. The magnitude of the platform provided by professional sports partnerships, and the positive message about our nation's military that is conveyed through sporting events like the Indianapolis 500 and many others, is astronomical.'



Honda plugs in to Zytek know how

Honda and Zytek have gone into partnership to develop Energy Recovery Systems for motorsport.

The aim of the partnership is to bring together the vast experience of Honda in the development and manufacture of hybrid road cars with Zytek Automotive's electronic solutions for motorsport.

Honda Motor Company is one of the world's largest manufacturers of hybrid road

cars, with over 800,000 on the road in approximately 50 countries. Since the inception of Zytek, its mission has been to develop innovative electronic solutions for both race and road cars, from the first digital engine management systems and electronic gearshifts to hybrid and EV systems, including Formula 1 KERS technology.

While the partnership has only recently been formalised, the fruits of cooperation

between the companies are already in evidence, with the roll out of the Honda CR-Z GT car at Motegi at the beginning of July.

Both English and Japanese engineers from Zytek are now on site to support their Honda colleagues in Japan, while design and development work on the next generation of systems is currently underway at Zytek's engineering facilities at Fradley and Repton, UK, and at Honda's R and D HQ in Tochigi, Japan.

Following the announcement, Zytek Automotive managing director, Neil Heslington, said: 'We are delighted and proud to have been recognised by Honda Motor Company as a world leader in hybrid race technology, and the opportunity to work together with them in partnership allows us to continue to develop our innovative solutions, keeping our products ahead of the competition.'



SOLUTIONS MADE OF PASSION

At Kaiser we manufacture the Racecar chassis, -engine and -gearbox components our customers require within the shortest possible and agreed production time. We manufacture prototypes and small batches for the top end of motorsport, aerospace and the automotive industry.



F1 RACE PARTS

- suspension wishbones and rods (incl. carbon)
- torsion bars incl. scragging and antiroll bars
- rockers, hubs, spacers, nuts
- shock absorbers (incl. rotary-dampers)
- steering housings
- steering racks and pinions
- steering columns, quick releases and paddles
- hydraulics
- brake calipers and -cylinders
- chassis parts in metal and carbon
- engine valvetrain
- conrods
- crankcases
- cylinderheads
- pump bodies, gears and shafts
- clutch components
- gearbox-cases
- gearbox-internals
- gearbox-hydraulics
- turbo components
- energy recovery system and e-motor components
- and many more ...

Kaiser Werkzeugbau GmbH

Gewerbegebiet Helferskirchen

56244 Helferskirchen · Germany

Tel. +49 2626 9243-0 · Fax +49 2626 9243-20

www.kaiser-wzb.de · kontakt@kaiser-wzb.de

KAISEER®
WERKZEUGBAU
TEAM

PEELING BACK THE STICKERS No5: YUASA

Prior to 2010, battery manufacturer, Yuasa's, UK sales arm had never considered an involvement in motor racing. That year it dipped its toe in the water with a small sponsorship deal with the Team Dynamics' Honda BTCC squad. This year it's signed up for a further three years as title sponsor to the same team. So, what went right?

Yuasa is the market leader for industrial batteries in Europe and the UK but, since 2006, it has been chasing a slice of the motoring aftermarket. It now has 30 per cent of this in the UK and, while it's difficult to quantify the efficacy of any advertising, Yuasa Battery Sales UK managing director, Andrew Taylor, feels sure its tie up with Honda in the BTCC has helped. It was the proximity of the BTCC to those operating in the aftermarket that was the clincher when it came to Team Dynamics securing the deal in the first place.

'Quantifying it is difficult,' admits Taylor. 'But one of the things with our customer base, the automotive aftermarket, is a lot of the people working in it are petrolheads. The Yuasa brand



With three years' backing from the Japanese battery manufacturer, top BTCC outfit, Team Dynamics, have re-branded as Honda Yuasa Racing Team

is a well known OEM throughout the world, but it was not so well known in the aftermarket, but this has helped lift the profile for our distributors, which was the key thing, because they are the ones selling the product for us. So it was the feedback that we had from our distributors to say that customers were now asking for the Yuasa brand, and people were starting to see the bigger exposure both on television, and in publications, that made us feel

we'd made the right move.'

The BTCC also offers great business-to-business opportunities, says Taylor: 'The other thing we found is that our customers very much enjoy the hospitality, so it enables us to let them experience the BTCC close up - which I think once you've experienced it, is a terrific sport, and it's very accessible.'

There is also the link with Honda, of course, as both companies are well known

Japanese concerns with strong links in Japan, although Taylor thinks this should not be overplayed: 'There are some strong links with Honda, which obviously helps, and it's a nice synergy to talk about. But, if we're purely focussing on the UK, it wasn't really the Honda relationship that brought this together, it was the opportunity to heighten our profile within what we felt was an applicable sport to our market.'

The good news for Team Dynamics - now known as Honda Yuasa Racing Team - is that the Yuasa name will be on the cars for at least three years, which will give it some stability in an unsure time (Taylor would not be drawn on how much the deal is worth). But the team will also be giving Yuasa far more than simple exposure, says Taylor: 'One thing we wanted to be associated with was not just the brand, but the team ethic. That's one of the things that sold it to me. The teamwork within Honda Dynamics is terrific. It's a good example, and we try and get staff to the race meetings to let them see how important teamwork can be.'

Chevrolet pulls out of WTCC

The promoter of the World Touring Car Championship insists it will still prosper, despite the withdrawal of Chevrolet.

Chevrolet announced it is to pull out of the WTCC at the end of this season, following a strategic review of its marketing and competition programmes. The American manufacturer joined the WTCC for its maiden season in 2005 with the Lacetti, switching to the Cruze in 2009. It has since won the Drivers' and Manufacturers' titles twice, in 2010 and 2011, and is also currently close to securing its third consecutive victory in both championships.

'We now say goodbye to Chevrolet, that has been a precious partner for an unusually long period for a motorsport programme, but at the same time we welcome Honda's arrival,

and are in negotiations with a few other car manufacturers interested to join,' said promoter Marcello Lotti

Chevrolet's departure came at a time when its sales figures are on the rise in the European heartland of the WTCC. European sales figures for the first six months of 2012 showed overall sales volume to be up by 11,500 vehicles, compared to the first six months of 2011, while its market share was also up, now at a record 1.43 per cent.

Susan Docherty, president and managing director of Chevrolet Europe, said that this had more to do with product pricing than success on the racetrack.

The Cruze cars will remain the property of RML, the team that has run them in the WTCC, and it is possible some will be raced on a privateer basis in 2013.



Mercedes won the annual ATL karting event at Milton Keynes following the British GP, coming out top in a 27-kart grid at the Daytona Raceway

WE MAKE, YOU RACE!

WINDFORM ADDITIVE MFG:

CAR AERODYNAMIC FEATURES
CAR BRAKE DUCTS
WIND TUNNEL PARTS
MOCKUP PARTS

WINDFORM ADDITIVE MFG:

ELECTRIC COVERS AND SPECIAL PIPES
INTAKE MANIFOLDS

MECHANICS:

UPRIGHTS/SPINDLES
ROCKER ARMS
SUSPENSIONS END FITTINGS

MECHANICS:

SPECIAL SPLINED EDM PARTS
GEARBOX
ENGINE PARTS
COMPLEX 5X CNC MACHINED PARTS

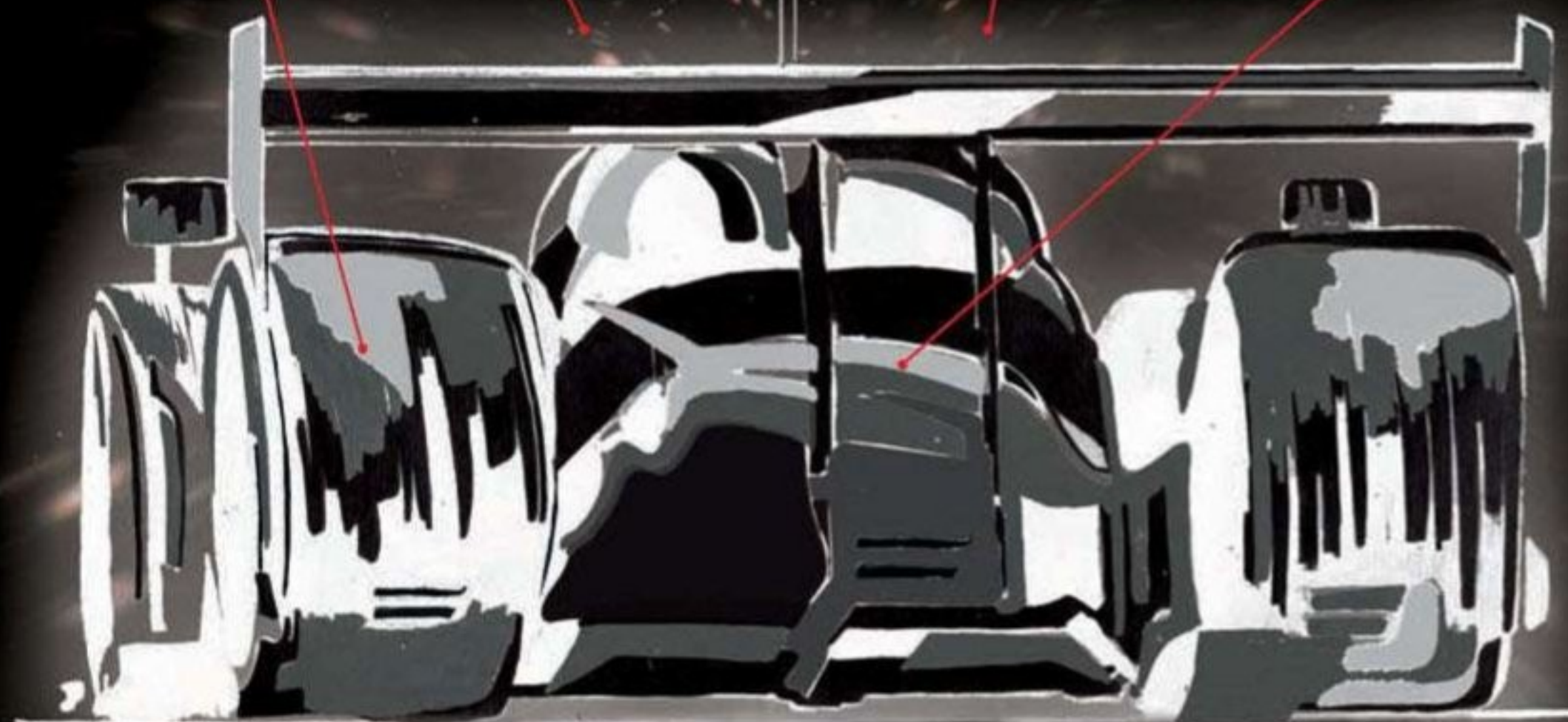

OTHER WINDFORM ADDITIVE MFG:

MOULD INSERTS
MASTER MODELS
SPECIAL JIGS

AT 300 KM/H, QUALITY ISN'T OPTIONAL, IT'S YOUR LIFE!

www.crp.eu

www.crp-usa.net



info@crp.eu

info@crp-usa.net

HS CNC MACHINING . ADDITIVE MANUFACTURING . RAPID CASTING . ENGINEERING & REVERSE ENGINEERING
C.R.P. Group · Via Cesare Della Chiesa 21 · 41126 MODENA · ITALY · Phone +39 059 821135 · Fax +39 059 822071

Dennis calls for manufacturing focus in UK

McLaren Group boss and former Formula 1 team principal, Ron Dennis, has said that the UK economy needs to continue to focus on manufacturing, and move away from a reliance on financial services.

Commenting on the announcement that the McLaren Group has been selected to exhibit at the London Science Museum's 'Make it in Great Britain' exhibition, Dennis said: 'There is absolutely no doubt in my mind that the UK's re-focus on manufacturing and engineering has not come soon enough. Moving our economy away from over-reliance on financial services makes long-term sense, and at McLaren we are fully committed to this philosophy.'

Dennis also commented



McLaren products form part of the Make it in Great Britain exhibition in London

that young people need to be encouraged to work in engineering: 'The future of our country is dependent on brain power, and industry as a whole needs to encourage young people into the engineering and technical sectors by showing them that these are evolving, progressive disciplines,' he said.

The 'Make it in Great Britain' exhibition is the culmination of

an initiative launched last year by the Department for Business, Innovation and Skills, which aims to challenge outdated opinions and transform the image of modern manufacturing.

McLaren will showcase three products that encapsulate the diversity of its activities: A McLaren F1 car, a McLaren MP4-12C Sportscar and a Specialized S-Works + McLaren Venge bicycle.

While the cars will be familiar to *Racecar Engineering* readers, the bicycle is a little different and McLaren says it's an example of how the McLaren Applied Technologies arm of the group crosses technical boundaries.

UK business minister, Mark Prisk, said of the exhibition: 'Manufacturing accounts for eight per cent of total UK employment and well over half of export goods, yet current perceptions of the industry are out of date and do not reflect that reality. We have selected a really exciting mix of exhibits, and I hope that as many people as possible visit the exhibition and see all of the great examples of British design and manufacturing - it will be spectacular.' The exhibition runs until September 9 this year.

CAUGHT

IndyCar team, AJ Foyt Enterprises, was fined and penalised at the Toronto round of the championship after a discrepancy was found in the size of the fuel tank during post-race technical checks. Foyt, the team's owner, was fined and hit with a points penalty in the entrants' standings, although driver, Mike Conway, was allowed to keep his podium finish.

FINE: \$15,000

PENALTY: 10 points

Steve Addington, the crew chief on the no14 Stewart-Haas Racing Chevrolet in the NASCAR Sprint Cup Series, has been fined and placed on suspension until August 22 after the car was found to be running with an unapproved open vent hose at Daytona. Car chief, Jeff Meendering, was also placed on probation until 22 August, while driver, Tony Stewart, and owner, Margaret Haas, have both been docked points in their respective championships.

FINE: \$25,000

PENALTY: six points

NASCAR Nationwide crew chief, Danny Stockman, who tends the Richard Childress Racing no3 Chevrolet, has been fined

\$10,000 after the car was found to be running with an unapproved open vent hose at Daytona. Both Stockman and car chief, Robert Strmiska, were suspended from NASCAR until the end of July, because they were already on probation for rules infringements at the earlier Richmond round of the championship. The penalty was all the more severe because the team was also hit with another \$10,000 fine at Kentucky Speedway at the beginning of July. The team's driver, Austin Dillon, and owner, Morgan Shepherd, were both docked points in the drivers' and owners' standings for each infringement.

FINE: \$20,000 (total)

PENALTY: 12 points

The no18 NASCAR Nationwide car was found to be outside the minimum ride height at the front at Daytona, the infringement landing crew chief, Adam Stevens, with a \$10,000 fine, while car owner, Joe Gibbs, was docked championship points. Both Stevens and car chief, Christopher Landis, have been placed on probation until August 22.

FINE: \$10,000

PENALTY: six points

BRIEFLY

F1 teams lagging

Formula 1 teams have not fared well in a list of the world's most valuable sports teams compiled by *Forbes* magazine. Ferrari, the best performing F1 team on the list, was at number 15, with an estimated value of just over \$1bn, some way behind Manchester United FC (\$2.23bn), which tops the list. The next F1 team after Ferrari is McLaren, in 40th place, with an estimated value of \$800m.

Citroën stay in WRC

Despite a huge drop off in car sales for the first half of 2012, and a resultant 8000 redundancies across the PSA Group, plus the closure of one of its factories, Citroën has said it has no plans to shelve its hugely successful WRC outfit.

PSA, which includes both Peugeot and Citroën, reported a 13 per cent fall in first-half shares, with 1.62 million vehicles sold (the company sold 1.86 million in the first half of 2011). Overall European sales fell by 15 per cent, while sales in France fell by 13 per cent.

Olympic GP

The London Legacy Development Corporation

has confirmed that a bid to host an F1 grand prix around the Olympic Park has been received. The bid is one of four and is in the name of Intelligent Transport Services, in association with Formula 1. The others are from football clubs and football-related businesses. There's little information on Intelligent Transport Services, which has only been trading for a year, but it is understood the company is bidding for use of the park rather than ownership.

Ironically, it's also been reported that the Jacarepagua circuit in Rio, which hosted the Brazilian Grand Prix on 10 occasions, is to be demolished to make way for facilities for the Olympic Games in 2016.

FANG club

The US subsidiary of motorsport engineering and automotive consultancy, Ricardo, has scooped a prestigious United States Defence Advanced Projects Agency (DARPA) contract to stage the FANG Challenge. This is a series of three competitions designed to produce the Fast, Adaptable, Next-Generation Ground (FANG) vehicle. The FANG Challenge is expected to begin in early 2013.

INTERVIEW - GILES DAWSON



Giles Dawson is the managing director of the European arm of Aero Tec Laboratories Ltd (ATL). Dawson, son of Andy Dawson of Dawson Auto Developments, has motorsport in his blood. He worked in his father's business throughout his time at school, and then while he studied mechanical engineering at Oxford Brookes University. He has also competed as a driver, worked as a race engineer, and team manager. He started off at ATL in sales, before moving on to the design team and then becoming chief designer. Dawson became MD at ATL in the UK earlier this year.

ATL has been a supplier of safety fuel bladder tanks to the motorsport market for over 40 years and has supplied virtually the entire Formula 1 grid for nearly two decades, while it also sells product into just about every other motorsport sector, too. It is now establishing itself in the defence sector.

Q. How important is experience when it comes to designing fuel tanks?

Most of it comes from experience. I think that anybody who says they can analyse fluid movement within a fuel tank via CFD is probably talking a load of rubbish. Because no two circuits are the same, you don't get the same movement in a tank at different circuits.

CFD is not something we've gone into, just because of the unique movement of fluids. It's not something we've felt the need to do, and generally, if we follow our experience, we get it right first time anyway.

Q. What would you say is the biggest challenge involved in fuel tank design?

Packaging. That's the single biggest thing. For instance, Group N classes are very restrictive -you're not allowed

to modify the bodyshell to incorporate the bladder, and that can be very challenging. It's difficult to figure out how to get everything through the holes that exist in a standard bodyshell.

Then, in Formula 1, there's the question of how do I actually fit these pumps through a hole that is no bigger than my arm, when the thing I'm trying to reach is another half metre away?

Q. What's the most important thing to get right?

It all comes down to picking up the last drop of fuel. But there's nothing else you can say about all the individual systems, all the individual categories, that's the same. The DTM tank, for instance, runs along the passenger seat, in effect, and it's nearly 1.8m long. That's a unique challenge because nothing else pulls that *g* with

a tank that runs along the centreline of the car.

Q. As a supplier to all the F1 teams, what pressures are you under in the off season?

We have to go from surface data to tank in six weeks, for all 12 teams, and generally it's all at a similar time. They're all designing at the same time, and some people leave it very, very late - last year's World Champions are very good at leaving it right to the last minute and getting it right first time! October through February is very busy.

Q. How much of an idea of just how the F1 cars will eventually look can you get from the fuel tank plans?

We can pretty much tell you what their wheelbase is going to be from the shape of the tank. The plan surface is an offset of the aero surfaces, so the

radiators and things like that, the key packaging around those, is all reflected in the tank geometry.

Q. How closely do you work with the teams?

Very close. We're just at the stage now where I've had four design reviews with different teams, and we go through that process every year. So this time of the year we'll be sitting down to review this year's tanks, and we'll talk about next year's tanks. We talk about what was good and bad manufacturability-wise, and what has been good from a performance perspective. Of course, at the moment, a big thing is insulation, because they've got this big mass of fuel that's in there for the whole race. When they were refuelling, they could dump cold fuel back into the tank, whereas now we have heat soak problems.

Q. What proportion of your business is motorsport and what other sectors are you involved in?

Motorsport is about 70 per cent of our business. But we also work in other areas, including defence. Our first major defence contract is the Foxhound, which is the Land Rover replacement.

Q. What advantages can motorsport companies bring to the defence sector?

I think it comes down to lead

Bosses with knowledge make best bosses

Drivers and mechanics make better bosses, say boffins. New academic research claims to show that Formula 1 team bosses who started out as drivers or mechanics win twice as many races as rivals with a management background.

The findings come from a study by London's Cass Business School and the University of Sheffield, where academics analysed every Formula 1 race staged in the last 60 years.

The academics found that the most successful team bosses are

more likely to have started their careers as drivers or mechanics, compared with Formula 1 leaders who are professional managers or engineers with degrees.

'Former top drivers, such as Jean Todt [actually, a former rally co-driver], consistently turn into successful Formula 1 bosses - even when we account for factors such as the resources available to each team,' said co-author of the study, Dr Amanda Goodall.

The authors suggest that former drivers make better managers because of their

deeply ingrained technical knowledge, which helps them to formulate more effective tactics and intuitive strategies.

They also suggest that 'expert leaders' command greater credibility among team mates, having worked on the floor themselves. Their reputation and track record can also help in luring other talented personnel.

Goodall: 'We can see why comparative newcomers like Red Bull (led by ex-driver, Christian Horner) and Sauber (run by former mechanic [and driver],

Peter Sauber) are doing so well in Formula 1. These teams may not have a 50-year history like Ferrari but they are led by hands-on experts with deep intuition.'

The research is important, say the authors, because it supports broader emerging ideas on so-called 'expert leaders.' It suggests that organisations perform more effectively when they are led by individuals who have a deep understanding of the core business of their organisations. Being a capable general manager is not sufficient.

time. The two major defence projects we've done are called 'urgent operation requirements', or UORs. But that's 'urgent' in their terms, and both the UORs we've worked on have taken three years. If it was a motorsport UOR, it would have taken three hours!

Q. What's the future for fuel tanks in motorsport?

We worked with the FIA to develop the standard in 1999. It's the current standard we still work to, and I don't think that will change. Ethanol has become a big problem in the industry, because a lot of our competitors don't have bladders capable of handling ethanol. But Peter Regna [ATL's CEO] has developed some new materials that can cope with it, which is fantastic and it puts us ahead of the game. So, I'd like to think we'll still be around 20 years from now.

Q. Any exciting new projects or materials on the horizon?

We've been selected for the Jaguar C-X75, which is really our first roadgoing project. We worked with McLaren on the F1 GTRs, but that was low volume. If the C-X75 happens, that's going to be reasonably large volume. We've got on to this because Peter [Regna] developed some new elastomers that are 100 per cent bio-fuel proof.

BRIEFLY

Nascar's new agency

NASCAR has selected Ogilvy & Mather to service the sport's advertising and marketing needs. The agency aims to help NASCAR engage existing fans while creating new ones, particularly in the youth, Generation Y and Hispanic sectors. Ogilvy & Mather will complete 'a comprehensive on-boarding process' this year, as the agency prepares to help NASCAR launch its new brand platform in 2013.

NASCAR switches to SapientNitro for digital future

NASCAR's much heralded new digital platform, due to come on-stream at the beginning of next year, is to be the responsibility of leading marketing and technology firm, SapientNitro.

The company, which is part of business services firm, Sapient Corporation, will supply what NASCAR describes as an 'integrated digital experience for NASCAR's fans through critical channels, including website, mobile and tablet.'

Earlier this year, NASCAR announced it was to assume business and editorial control of its interactive, digital and social media rights, including technical operations and infrastructure of NASCAR.com and all other NASCAR digital platforms, starting in January 2013.

NASCAR's website, and its other digital and social media platforms, have been managed by Turner Sports since 2001, but NASCAR and Turner Sports have now re-structured their partnership. However, Turner is to continue to support NASCAR with advertising and sponsorship sales across its digital platforms until the end of 2016.

Matthew Huser, group account director at SapientNitro, said: 'NASCAR appreciates that its target consumers are increasingly digitally centred, and sees a real strategic opportunity to evolve in a more connected fan experience - before, during and after events.'

'The proliferation of digital presents more compelling opportunities for NASCAR to attract and engage with their consumers. We're honoured that NASCAR has selected us to work alongside them in developing the sport's new digital experience.'

In addition to its work with NASCAR, SapientNitro is currently designing digital experiences for a host of other sports and entertainment clients, including WWE, Ladbrokes and LeBron James.

RACE MOVES

Marc Koretzky has resigned from his position as chief operating officer of the IndyCar series. His responsibilities will be split among current staff members until a decision is taken on a replacement. Koretzky joined IndyCar in 2011 as director of business development and was promoted to the post of COO last December. IndyCar gave no reason for his departure.

Olivier Quesnel, the former team principal at the Citroën WRC team, and the man who was also head of Peugeot's Le Mans project, has now joined the JN Holding Group - the company behind Oak Racing - as its competition activities director. Quesnel will work alongside **Sebastien Philippe**, who stays on as OAK Racing's general manager.

Well known race engineer, **Ramiro Garcia**, has joined simulator manufacturer, Cruden, as project manager. Garcia has previously worked for Sauber and HRT in F1, Ocean Racing Technology and Piquet Sports in GP2, and Hogan Racing in CART.

Martin Dewey has been appointed general manager in the UK office of motorsport electrical systems experts DC Electronics. Dewey, who has a passion for motorsport and is a timekeeper for the MSA in his spare time, has previously held top managerial positions at Warburtons and at Cambridge Assessments.

DC Electronics (see above) has also taken on four new production staff.

Darren Baker and **Fred Guynette** have secured posts in the UK while **Jon Woods** and **Jason Shady** join the US production team. The company is also currently in the process of appointing a new general manager for its Mooresville site.

Chad Norris has stepped up to become the new crew chief for Carl Edwards in Roush Fenway's NASCAR Sprint Cup team, replacing **Bob Osborne** in the position. Osborne is stepping down due to health issues but will remain with the organisation. Norris has been with Roush Fenway since 2005.

Todd Berrier has left his post as crew chief for NASCAR Sprint Cup team, JTG Dougherty Racing, and will now replace **Pete Rondeau** at



As part of the 'Make it in Great Britain' initiative - launched last year by the UK government's Department of Business - McLaren Racing engineer, Bernadette Collins, has been selected as a rising young star in the manufacturing sector.

She will now act as an ambassador for the campaign, engaging with other young people in an effort to ensure that youngsters are aware of the great career opportunities in engineering and manufacturing.

Furniture Row Racing. Berrier, a long-time crew chief at Richard Childress Racing, will work under team manager, **Joe Garone**, and director of competition, **Mark McArdle**.

Simon Long, the former chief executive of WRC promoter North One Sport, is now the commercial director of the Lawn Tennis Association. North One Sport lost its contract with the FIA after its

parent company, Convers Sports Initiatives, went into administration at the tail end of 2011.

Richard Buck, a five-time Indianapolis 500 winning crew chief, is now managing director of competition for Grand-Am. Buck also

remains in his post as director of NASCAR's touring series, overseeing the organisation's eight touring championships in the US, Canada, Mexico and Europe.

Gabriel Cadringer is now the managing director of technical regulations and development for GrandAm. Cadringer has been a technical consultant since 2011, and is a former director of the technical department of the FIA, a former technical delegate for Formula 1, and past president of the FIA Manufacturers' Commission.



Martin Dewey

EFI EURO 8

Next Generation Engine Management System.

Euro-8 is the latest generation engine management system from EFI Technology. It is one of the smallest and yet one of the most powerful ECU's specially developed for use on 6 and 8 cylinder engines. Based on a modern Power-PC processor, Euro-8 is built to conform to the latest high automotive technology standards.

The price of the ECU includes full-option software specifications. All features and strategies are available to the user at no extra cost.

System Overview

- Power PC processors
- Up to 8 cylinder engine configuration
- Drive-by-wire throttle control
- On-board data logging
- Variable camshaft timing
- Control strategy for direct injection engines
- Traction Control
- Paddle shift control strategy
- Up to 6 selectable engine maps
- Multiple CAN bus
- Small, flat, lightweight enclosures
- High density automotive connectors

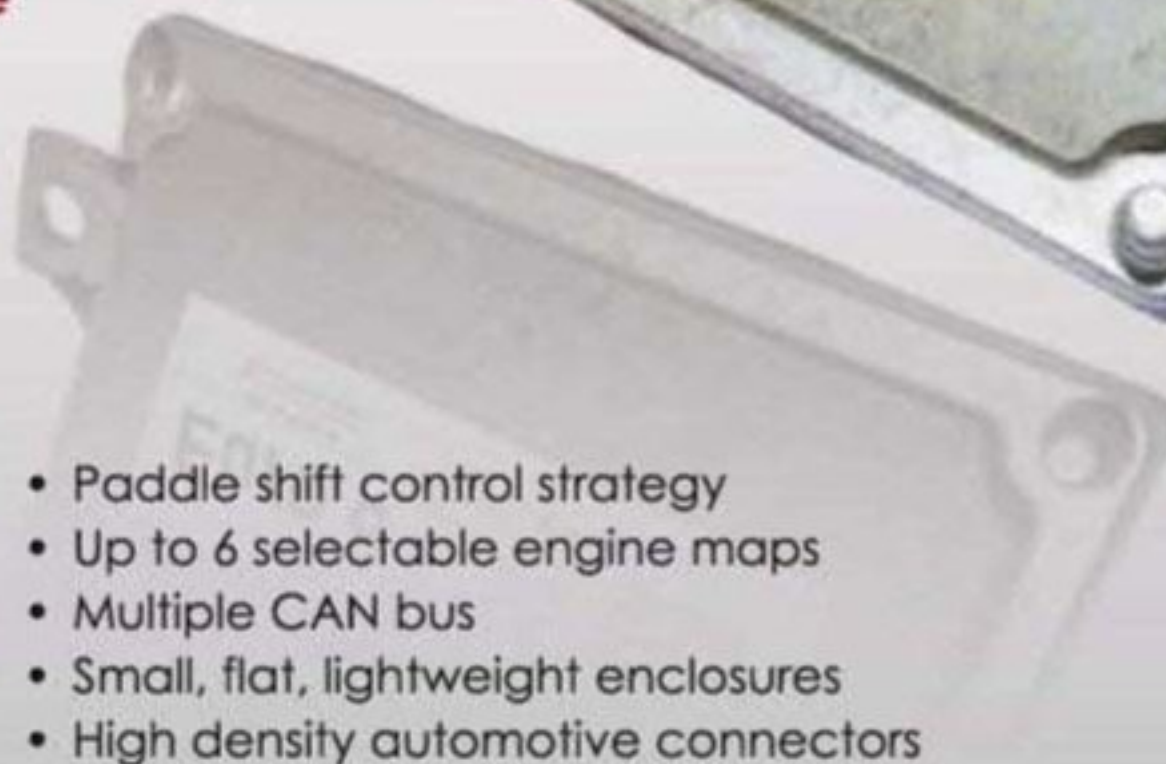

EFI EURO 4

Euro-4 is one of the smallest and yet one of the most powerful ECU's for use on competition engines.

Based on a modern production car ECU, Euro-4 is built to conform to the latest high automotive technology standards. The ECU is designed to form the centre of an integrated electronic system in a modern racing car and offers an extraordinary high level of features at an attractive price.



STEM initiative embraced by MIA

Britain's capability in high performance engineering and motorsport (HPEM) has long distinguished the UK as a world leader in Formula 1, World Rally, NASCAR and many other series. This outstanding record, the envy of many other countries, relies on a constant stream of locally available, highly talented young engineers.

The vital importance, within UK education, of the subjects - science, technology, engineering and maths (STEM) - is now widely recognised. These are critical to the highly skilled HPEM sector, which employs over 40,000 people, of which some 25,000 are 'engineers'. Members of the Motorsport Industry Association, the leading worldwide industry organisation for this sector, wish to do all they can to encourage the study of STEM subjects by young people and so attract more into engineering.

The MIA's Motorsport STEM Ambassadors initiative is being launched to encourage young people to study these four subjects, particularly if they have ambitions towards a career as an engineer in high performance engineering and / or motorsport.

This MIA initiative was open to all young people between the ages of 16 and 18, resident in the UK, and currently studying

STEM subjects. The MIA invited nominations from schools, colleges and educational initiatives across the country.

The six chosen as 'MIA Motorsport STEM Ambassadors' will take part in a number of activities, on a local and national scale, where they will use their own experience to increase STEM awareness and importance, as well as promote the enjoyment and benefits of studying STEM to inspire the UK's next generation of motorsport engineers.

The MIA received many nominations and, following a lengthy selection process, six bright and talented young engineers have been selected who have already demonstrated outstanding engineering talent and commitment to motorsport.

The six Ambassadors were invited to attend Formula Student 2012 at Silverstone on 14 July, where they received their diplomas of appointment from the MIA's Chris Aylett.

During 2012, each Ambassador will be invited to take a private tour of a leading motorsport engineering organisation, where they will gain a 'behind the scenes' insight, and have the chance to speak with motorsport engineering professionals to discuss future career prospects.

Genii set to invest in football clubs

Genii Capital, the private equity fund that owns the Lotus F1 team, is planning to branch out into the world of football.

Reports in the financial press have stated that Gerard Lopez and Eric Lux, the men behind Genii, are looking to invest some €500m in the game, spreading their spend over five 'second tier' European clubs, as well as other football-related companies.

This new venture is to be managed by Mangrove Capital Partners, a sister company to Genii, and two of FC Barcelona's

former senior executives, Ferran Soriano and Marc Ingla, have been recruited by the concern.

To bypass European football governing body, UEFA's, restrictions on investors having more than one club in their portfolio, it's believed Mangrove will buy clubs in different leagues.

Genii is not the first company within F1 to forge a connection with football. Caterham owner, Tony Fernandes, owns English Premiership club, QPR, while Sauber now has a reciprocal sponsorship deal with Chelsea.

RACE MOVES

Sabrina Macias is now director, brand and consumer marketing communications within NASCAR's Integrated Marketing Communications team, while **Chris Tropeano** has joined as senior manager, business communications. Meanwhile, **Jon Schwartz**, previously NASCAR's director of business communications, has been promoted to senior director, business and brand communications.

Anthony Hamilton is no longer **Paul di Resta's** manager. The Force India Formula1 driver confirmed the split with Lewis Hamilton's father at the British Grand Prix. Hamilton has managed di Resta since he entered F1.



Anthony Hamilton

International Olympic Committee president, **Jacques Rogge**, was an interested spectator at the British Grand Prix. While at Silverstone, Rogge ruled out any possibility of Formula 1 becoming an Olympic sport, saying the games are 'about athletes, not engines'. However, Rogge did say that the IOC could learn from the way F1 organises its events.

John Wood, the managing director of MIRA from 1991 to 2008, has been awarded an MBE for his services to mechanical engineering. Wood left the Army with the rank of Lieutenant Colonel in 1987 and then joined RAC Motoring Services as technical director before joining MIRA. On his retirement, Wood became president of the Institute of Mechanical Engineers. He also spent 10 years as chairman of Formula Student.

Famed F1 and road car designer, **Professor Gordon Murray**, CEO and technical director

at Gordon Murray Design, was part of the judging team for the Make it in Great Britain Challenge, which is an element of a national campaign to raise awareness of the importance of manufacturing within the UK economy.

David Butler MBE, chairman of the British Motorsport Association for

the Disabled, was chosen to carry the Olympic torch through his home town of Hemel Hempstead in the lead up to the London games. Butler sits on the MSA's Medical Panel where he represents disabled drivers wishing to take part in motorsport.

NASCAR's Integrated Marketing Communications team continues to go from strength to strength, with the announcement of a number of

recent additions to the staff and some promotions.

Sean Doherty joins from long-time NASCAR sponsor, Sprint, as its director, digital and content communications, while

Tracey Judd has been named director, racing operations communications.

Amanda Ellis, who has served as primary media liaison for the NASCAR Camping World Truck Series, will assume Judd's previous role with the NASCAR Nationwide Series. **Katey Hawbaker** joins NASCAR as manager, competition communications.

Further moves within the NASCAR marketing team include: **Stephanie Ackerman**, who joins as manager, stakeholder communications; **Ashley Mitchell**, who joins as coordinator, content communications, and **John Farrell**, who shifts from NASCAR licensing and publishing to content communications.

John Surtees, the former F1 team boss and the only man to be World Champion on both two

and four wheels, has scooped the MIA award for Outstanding Contribution to the Motorsport Industry. Surtees was presented with the award at the MIA's reception at the House of Lords. Adrian Newey and Ross Brawn are previous winners of the award.



John Surtees

NASCAR Digital Media has also announced a number of key hires.

The new personnel are **David Murnick**, managing director, ad services; **Philippe Dore**, senior director, digital services; **Tim Clark**, director, optimisation; **David Garlinski**, director, mobile products; and **Stu Hothem**, director, content.

■ Moving to a great new job in motorsport and want the world to know about it? Or has your motorsport company recently taken on an exciting new prospect? Then send an email with all the relevant information to Mike Breslin at bresmedia@hotmail.com



WE HELP YOU TO **Push The Envelope**



There are those who equate success in racing to the ability to "push the envelope" further than your competitors. Innovation has its rewards.

When it comes to fasteners, one firm is eminently qualified to provide you with the design, engineering and manufacturing support needed to advance your programs to the next level with complete confidentiality; ARP.[®]



For over 40 years, ARP[®] has helped race teams, engine manufacturers and professional builders in all forms of motorsports the world over to achieve race-winning performance and dependability.

And while we're best known for manufacturing engine related fastener components, ARP[®] has the expertise to design and manufacture a variety of application-specific fasteners to meet your needs. Our on time delivery record is second to none.



Our 100-page catalog contains the automotive aftermarket's largest selection of off the shelf, application specific performance fasteners. If you don't see what you need in the catalog, please contact our factory technicians for personalized assistance.

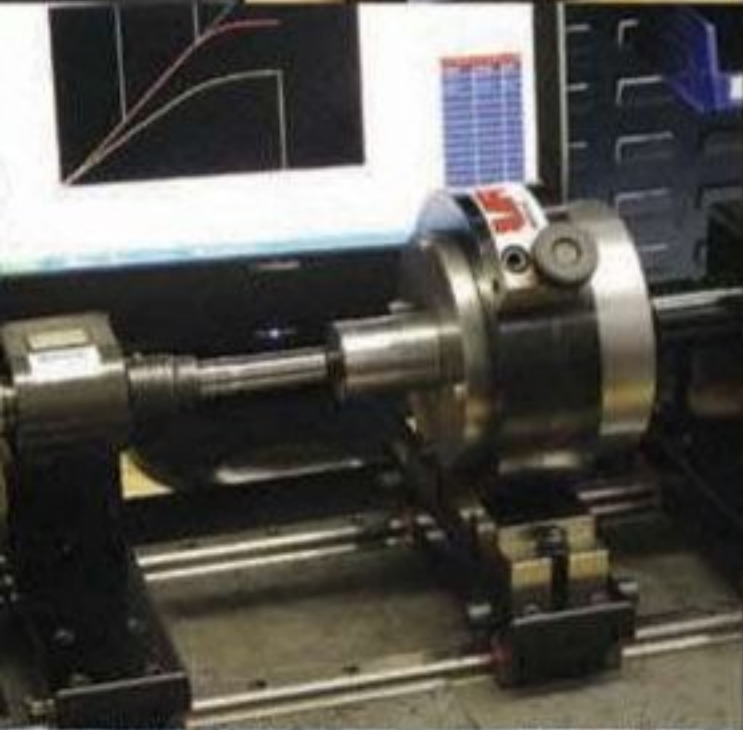

Our R&D capabilities are extensive, our factory is AS9100 and ISO-9001 certified, and we share your passion for winning.



ARP[®]

automotive Racing products



1-805-525-1497 • www.arp-bolts.com

1863 Eastman Ave., Ventura, CA 93003, USA • Local: 805-339-2200 • Fax: 805-650-0742



Car fault was not cause of crash, says team

The Marussia F1 team has said that its own investigations into Maria de Villota's testing accident did not find any fault with the car.

De Villota lost an eye and suffered facial and head injuries in the freak accident, when she crashed into the lift gate of a team truck while manoeuvring the car at low speeds following a straight-line test at Duxford.

The team's investigation was independent of the official investigation by the Health and Safety Executive (standard practice for an accident in the UK) and the team has also commissioned another separate independent investigation, which will be carried out by a company specialising in forensic research.

Marussia team principal, John Booth, said the findings of its

own report has been passed on to the Health and Safety Executive: 'We are satisfied that the findings of our internal investigation exclude the car as a factor in the accident. We have shared and discussed our findings with the HSE for their consideration as part of their ongoing investigation.

'This has been a necessarily thorough process in order to understand the cause of the accident. We have now concluded our investigatory work and can again focus on the priority, which continues to be Maria's well being. In that regard, we continue to support Maria and the De Villota family in any way we can.'

De Villota is now out of sedation in hospital and the team says she is making good progress in her recovery.



Politicians heap praise on UK motorsport industry

UK Prime Minister, David Cameron, and business secretary, Vince Cable, have gone out of their way to praise the British motorsport industry.

Speaking in a recent TV interview, Cameron said: '[It's] an extraordinary industry for Britain,' he said. '[It's] hugely important... I feel it because some of it is in my constituency; Lotus employs about 400 people about 10 minutes from where I live and I always point it out to people as we drive past: "There are 400 people who work in there, and you know how many cars they produce every year? One [sic], but it's amazing!"'

Cameron added: 'The whole of motorsport is worth something like £6bn to the UK economy. More than half of it is exported, so it's entrepreneurial, it's

high-end manufacturing, it's big technology, it's great for exports.'

Meanwhile, Vince Cable, highlighted the role of the motorsport industry during a speech at the Society of Motor Manufacturers and Traders International Automotive Summit, saying: 'In the last couple of years I've made a point of going round almost all of the volume car factories and specialist motorsport producers. It is a very good story and the industry needs a massive pat on the back.

'The UK's motorsport industry brings £6 billion to the UK economy annually. We're talking about a massive contribution. And you get a sense of real momentum. We're getting a lot of new investment, certainly over the last two years. £5.5bn of new investment by the industry.'

Top US companies flock to sponsor NASCAR

More Fortune 500 companies are involved in NASCAR now than there were before the onset of the worldwide economic downturn in 2008, according to a recent review of brands involved in the sport.

The analysis looked at companies that sponsor teams, tracks, and the sanctioning body, or are media partners. It found that there are currently 114 Fortune 500 companies involved in NASCAR, while more than 24 new brands have entered the sport in 2012.

Brian France, NASCAR chairman and CEO, said of the analysis: 'Some of the world's most profitable and successful corporations choose NASCAR to help drive their businesses. These companies bring a great amount of rigor to where they

make investments. This is especially true when it comes to marketing - and the sponsorship channel in particular - where they are looking for strong return on their investment.'

Steve Phelps, chief marketing officer for NASCAR, said that part of NASCAR's appeal to blue chip companies was its loyal fan base: 'There are more opportunities for companies to become involved as sponsors in NASCAR now than there were four years ago, when there was a different dynamic in both the economy and media and marketing landscape. We have the most brand loyal fans in all of sports. More than three out of five avid NASCAR fans agree that even in tough economic times, they will continue to support NASCAR sponsors over other brands.'

PRI 2012



Where the Global Racing Industry Gets Down to Business

- 1,100 Exhibitors
- 3,000 Booths
- 38,000 Buyers
- 72 Countries Represented
- Trade Only

Delivering Business Opportunities for 25 years!

25TH ANNUAL **Performance Racing Industry** TRADE SHOW

www.performanceracing.com

November 29–December 1, 2012 • Orlando, Florida • USA



PIT LANE EQUIPMENT

Formula car remote starter



UK-based Cambridge Motorsport Parts is offering a powerful new remote starter for use in GP2, Auto GP, Superleague, Formula Nippon, and Historic F1. The unit offers compact and efficient starting, using a 2KW motor driving through a reduction gearbox with a one-way clutch and cush drive system. It is available in clockwise and anti-clockwise rotation, and can operate on either 12V or 24V. Typically, the unit is claimed to produce 650rpm cranking speed under load, and weighs in at 11.5kg. **See www.cambridgemotorsport.com for more information**

MATERIAL TECHNOLOGY

Ferrium C64

Ferrium C64 is a new, high hardness, high strength, high temperature resistant, carburising-grade steel, designed by QuesTek Innovations LLC, which is produced and sold by Latrobe Specialty Metals.

The case of C64 can be carburised up to 62-64 Rockwell C hardness, while the core is more than 28 per cent stronger (in typical properties) than conventional premium steels such as AISI 9310 or Pyrowear 53. This combination of high case hardness and high core strength was designed

for use in transmissions, gears, integrally-gear shafts, actuators, parts, and assemblies that will better resist bending fatigue, contact fatigue and abrasive particulate exposure.

It is also claimed C64 will provide greater performance in scoring and high-temperature service (either during normal operation or emergency oil-out conditions) since the material's tempering temperature of 925degF is approximately 625degF higher than that of 9310 steel.

See www.questek.com for more information

ENGINE HARDWARE

Jenvey universal turbo plenum



Non-OEM turbo conversions are currently popular on a number of common four cylinder race engines, and to cater for this market, UK-based fuel injection specialist, Jenvey, has produced a modular plenum system to fit wide range of applications.

The plenum has been designed to feed air evenly to all four cylinders, with a diffuser and top cover that can be bolted on so the air can enter from four different positions, with efficient

sealing achieved via o-rings to make maintenance simple. There are also positions for various take-offs.

The light weight, high strength plenum is cast from aluminium in Jenvey's own foundry and is available to take 60 or 70mm throttle bodies. In tests, the 70mm version has been used successfully on cars running over 1000bhp.

See www.jenvey.co.uk for more information

HARDWARE

AP CP5898 master cylinder



AP Racing's new CP5898 design is a differential bore master cylinder, which has two mechanically attached in-line cylinders, one with a small bore, the other with a large bore. Typical differential bore designs, have two valves - a pressure relief valve that relieves the large bore at the changeover pressure, and a non-return valve that prevents the high pressure generated by the small bore from feeding back to the large bore and increasing the pedal load to an unacceptable level. The aim of AP Racing's new design was to overcome the shortcomings of the currently available differential bore cylinders. The valves are

mechanically linked as one, giving a crisp changeover as the non-return valve snaps open the relief valve and holds it open. It also exhausts the pressure in the large bore. When the large bore has done its job, it is no longer a loss to the system.

It also has the advantage that, as the driver comes off the brakes going into the corner, the valve stays open and does not cause variations in load and pressure due to the valve switching in and out. The valve is also large enough, with soft seals, that it is less prone to failing due to debris that might get into the system.

See www.apracing.com for more information



AUTOSPORT

INTERNATIONAL

Engineering Show

In association with

The International Journal of Motorsport Technology
Racecar
engineering

- **OVER 28,000 TRADE VISITORS**
- **700+ EXHIBITING SUPPLIERS**
- **5,000+ OVERSEAS VISITORS**
- **55 COUNTRIES REPRESENTED**
- **£800+ MILLION WORTH OF BUSINESS GENERATED**

Europe's largest motorsport show

10 & 11 JANUARY 2013

NEC BIRMINGHAM UK

www.autosportinternational.com/trade



AUTOSPORT.INTERNATIONAL@HAYMARKET.COM



SENSORS

Variohm PS1 level sensor



For most level sensors, industrial application boundaries are set by the resistance of the wetted parts to aggressive media. This often leads to sensors being built using special and costly materials. In some instances, the materials used can actually limit the performance of the sensitive membranes used for hydrostatic measuring sensors. To circumvent this, Variohm Eurosensor has teamed up with German sensor manufacturer, ADZ NAGANO, to produce a new series of level sensors using stainless steel casings and a PTFE coating. This combination

results in a durable sensor for use in aggressive media at a reasonable cost. ADZ's patented electron beam process deposits a PTFE layer between 0.5-1 microns, which has no adverse performance influence on the stainless steel membrane and thin-film semi-conductor diaphragm technology used for the PS1. In addition, the smooth plastic coating improves the contamination resistance of the IP68-rated sensor and significantly extends the cleaning intervals required for maintenance. **See www.variohm.com for more information**

ENGINE HARDWARE

Cosworth barrel throttle body for Ford Duratec HE I4

Cosworth has recently designed and produced a roller barrel throttle body assembly with an integrated manifold for use on the ubiquitous Ford Duratec engine. This F1-style throttle provides complete control with unrestricted flow to extract maximum flow from the engine. The body is cast from heat-treated aluminium and features

CNC-machined barrels supported by sealed bearings. It is designed to be used with Cosworth's own carbon fibre airbox and free-flow air filter element (available separately). The assembly is suitable for fitment to standard or race cylinder heads and comes complete with a fitting kit. **See www.cosworth.com for more information**



SIMULATION

Simufact modules

Germany-based simulation specialist, Simufact, has released two new modules - Simufact.forming and Simufact.welding - for its eponymously-named Simufact simulation package. Using cutting edge solver technology, Simufact.welding enables the simulation of various welding methods, effective calculation of welding sequences and a realistic prediction of component distortion, taking into account micro-structural material transformations. Simufact.forming, meanwhile,

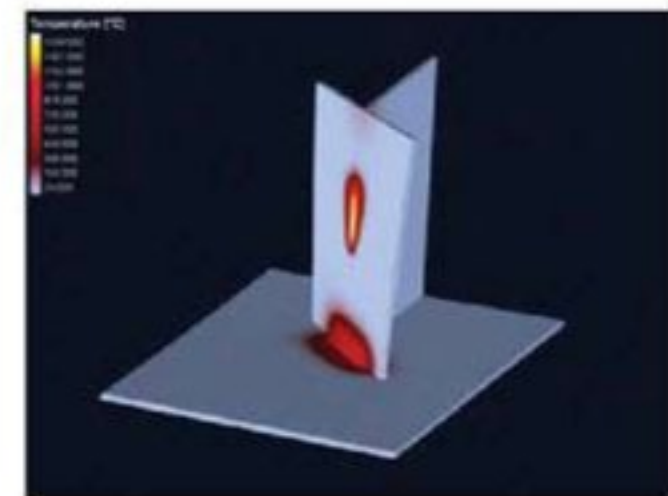

allows for accurate simulation of various joining and die forming methods, including rolling and adhesive jointing techniques. **See www.simufact.com for more information**

HARDWARE

Mojo 3D printer

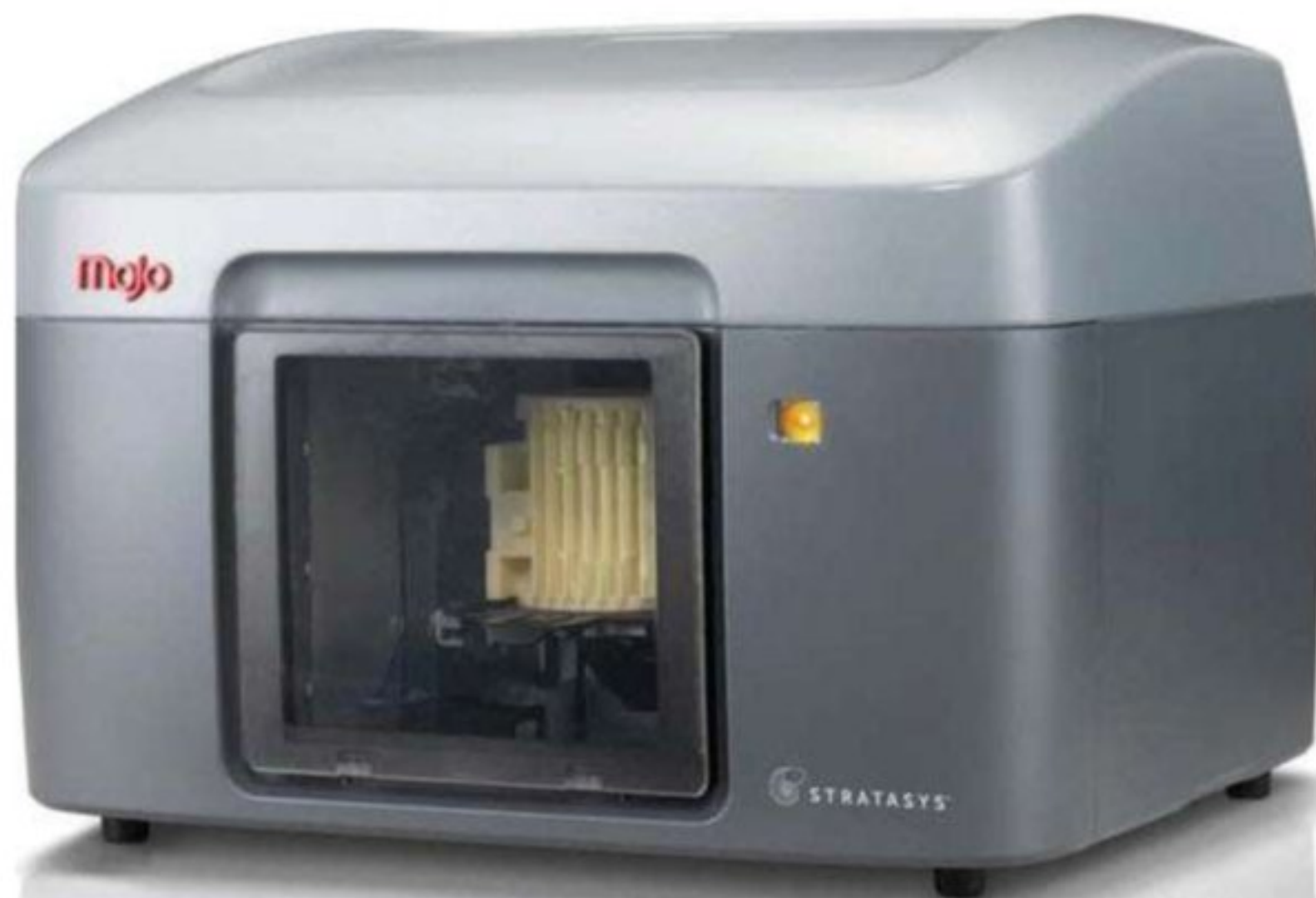

The new Mojo 3D printer delivers what UK distributor, Laser Lines, describes as 'affordable, professional 3D printing'. Powered by Stratasys FDM (Fused Deposition Modelling) technology, it works with CAD software to produce models in ABS production-grade thermoplastic. The Mojo Print Wizard software allows the user to orientate and optimise 3D print files in an easy-to-use graphic interface. Additionally, with simple colour-coded indicators on screen, Mojo Control Panel software provides real-time 3D printer status and estimated print time. Mojo also features QuickPack print engines, including easily

replaceable print heads, making it as simple to swap Mojo 3D printing materials as a standard inkjet printer cartridge. Mojo's auto-calibration and 0.007in layer resolution enables 3D models to be produced quickly and accurately, while the quiet-running compact WaveWash 55 support cleaning system, which features a stainless steel carafe, removes soluble support material. It does not require a plumbing connection and the new Ecoworks tablets make it clean and simple to run. The complete Mojo 3D Print Pack has everything the user needs to get started. **See www.laserlines.co.uk for more information**

PIT CREW

Editor

Andrew Cotton

Deputy editor

Sam Collins

News editor

Mike Breslin

Design

Dave Oswald

Chief sub editor

Mike Pye

Contributing editors

Paul Van Valkenburgh

Technical consultant

Peter Wright

Contributors

Charles Armstrong-Wilson, George Bolt jr, Lawrence Butcher Ricardo Divila, Gemma Hatton, Alan Lis, Simon McBeath, Danny Nowlan, Mark Ortiz, Ian Wagstaff

Photography

LAT, WRI2, Lawrence Butcher

Deputy managing director

Steve Ross

Tel +44 (0) 20 7901 8011

Email steve.ross@chelseamagazines.com

Head of business development

Tony Tobias

Tel +44 (0) 207 901 8026

Email tony.tobias@chelseamagazines.com

Advertisement Manager

Lauren Mills

Tel +44 (0) 207 901 8026

Email lauren.mills@chelseamagazines.com

Publisher

Simon Temlett

Managing director

Paul Dobson

Editorial

Racecar Engineering, Chelsea Magazine Company, Liscartan House, 127-131 Sloane Street, London SW1X 9AS, UK

Tel +44 (0) 207 901 8000

Advertising

Racecar Engineering, Chelsea Magazine Company, Liscartan House, 127-131 Sloane Street, London SW1X 9AS, UK

Tel +44 (0) 207 901 8000

Fax +44 (0) 207 901 8001

Worldwide subscriptions

CDS, Tower House, Sovereign Park, Market Harborough, Leics LE16 9EF UK

Tel +44 (0)1858 438749

Fax: +44 (0) 1858 434958

Subscription rates

UK £72 (12 issues)

USA \$135 (12 issues)

ROW £84 (12 issues)

News distribution

COMAG, Tavistock Road, West Drayton, Middx UB7 7QE

Printed by

Wyndeham Heron

Printed in England

ISSN No 0961-1096

USPS No 007-969



www.racecar-engineering.com

Revelling in the grass roots

Organisers of the Formula Student event at Silverstone are to be congratulated, not only for staging another incredibly successful event, but also for continued support of the brightest young engineers in the world.

From the sterile, efficient and business-like Formula 1 paddock a week earlier at Silverstone, the Formula Student paddock reminded me of my very young days walking Formula 3 and Sportscar paddocks as a child. That was why I took my son to this event, and he was hooked immediately. We, at *Racecar Engineering*, are now planning to build our own car, and my newly inspired 14-year old wants in.

While the young engineers worked on their cars in the Silverstone paddock, and bits of them were strewn around the garage as various hangers-on watched, looking vaguely baffled, it was hard to miss the technology in the cars and its outstanding value.

One team created a telemetry system for less than €200, another produced a hydrogen-powered car, while electric cars competed on a level playing field for the first time against their petrol counterparts. That was a slick move - might as well introduce engineers to the concept of performance balancing at this stage, as very few of those present will end up in a racing series that is, as F1, free of such foibles.

Teams had spent their money wisely - on the car. Catering involved filling any unused vessel with water, pasta and eventually, cheese. Others felt wealthier and headed to the paddock diner where, disappointingly for competitors, there was no student discount.

There was an element of gamesmanship in the competition, particularly on the acceleration test, which was wet. One German team arrived at the start line as 'officials' swept the start area. These 'officials' spoke not a word. Had they done so, we would have worked out that they were, in fact, German. That would have given the game away earlier than at the end of the run when they, like their car, disappeared behind the pit wall.

With time, money and manpower in short supply, teams concentrated on preparing their cars. Consequently, the business presentations were, by and large, an afterthought, although some paid full attention. Congratulations to the team from the University of Liverpool for winning the *Racecar*

Engineering-backed business prize.

Having participated in two days of presentations, there was one comment that applied in almost every case - if a team is short of staff, or short of time, use whatever is at your disposal to rope more manpower in. Invest at the student bar to woo your business and media departments to help write credible business cases, and help you put together an outstanding presentation. It really will help, not only in scoring well in the presentation, but will also expose you to the very real business end of motorsport.

There were moments of brilliance throughout the presentations. We, as racers, could not fault the Italians who, in justifying using carbon composites in their entry-level car, said they felt they would sell more fast cars than cheap ones that were easy to repair. Sadly, the scoring system didn't allow for such enthusiasm. Another team launched straight into a presentation of a business that had been running for 10 years already, neatly side-stepping the start-up cost issue that plagued so many.

One point that struck me on track is the development of one crucial element of the car - the driver. The

"continued support of the brightest young engineers in the world"

comments from UC Berkeley, who brought in a pro driver and teamed with Simraceway to simulate their car, highlighted the increased competition

and the benefits a talented pilot could bring to the party. That is not to say that teams should be replacing their drivers with anyone holding a professional racing licence, but more driver training could deliver better results, and to do that, the car needs to be finished earlier to give whoever is charged with taking the car around the track time behind the wheel. There will still be engineering issues, but spending time on the car is not the entire story. Look at how Formula 1 teams are investing in making their drivers fitter, more mentally capable and, simply, faster.

It was a fantastic event, and I am sure the others around the world were similarly well supported.

On a more sombre note, Bill Milliken has passed away at the age of 101. He was a friend of the magazine, and we will pay tribute to his work in our next edition.

EDITOR

Andrew Cotton

For subscription queries or to buy *Racecar Engineering*, go to
<http://www.subscription.co.uk/racecar/> or racecarengineering@subscription.co.uk
 telephone 0844 243 0778 +44 1858 438443 (overseas)

• *Racecar Engineering*, incorporating *Cars & Car Conversions* and *Rallysport*, is published 12 times per annum and is available on subscription. Although due care has been taken to ensure that the content of this publication is accurate and up-to-date, the publisher can accept no liability for errors and omissions. Unless otherwise stated, this publication has not tested products or services that are described herein, and their inclusion does not imply any form of endorsement. By accepting advertisements in this publication, the publisher does not warrant their accuracy, nor accept responsibility for their contents. The publisher welcomes unsolicited manuscripts and illustrations but can accept no liability for their safe return. © 2012 Chelsea Magazine Company. All rights reserved.

• Reproduction (in whole or in part) of any text, photograph or illustration contained in this publication without the written permission of the publisher is strictly prohibited. *Racecar Engineering* (USPS 007-969) is published 12 times per year by Chelsea Magazine Company in England.

Brake control from green light to chequered flag.



Pagid RS had a strong start to the 2012 racing season at the two classic US endurance races:

24 h Daytona – All of the top 6 finishers overall and 60% of the entire field used Pagid RS.

12 h Sebring – 1st and 2nd in the World Endurance Championship with AF Corse Ferrari F458 Italia followed by Team Felbermayr Porsche 911 RSR, along with 55% of the GT field used Pagid RS.

When it comes to brake modulation and control with ultimate reliance with a low wear rate, Pagid RS is your only choice. Race winners won't settle for anything less.

www.pagidracing.com · info@bremsentechnik.de
+49 6003 82 910

Pagid is a registered trademark of TMD Friction



ITS NO SECRET THE FRENCH HAVE
SOMETHING WE ENVY... (Le Mans)



CONSIDER US EVEN.



Patented continuous fiber
Carbon-Carbon Disc and
ZR43 Zero Drag Caliper
with patented pad
retraction system



Official Brake Supplier and Research
& Development Partner for



www.performancefriction.com



PERFORMANCE[®]
FRICION
BRAKES