

# AUTOSPORT

THE WORLD'S BEST MOTORSPORT WEEKLY

[www.autosport.com](http://www.autosport.com)

JULY 11 2013

**VETTEL EARNS HOME GP GLORY**

# CHARGING KIMI FALLS JUST SHORT



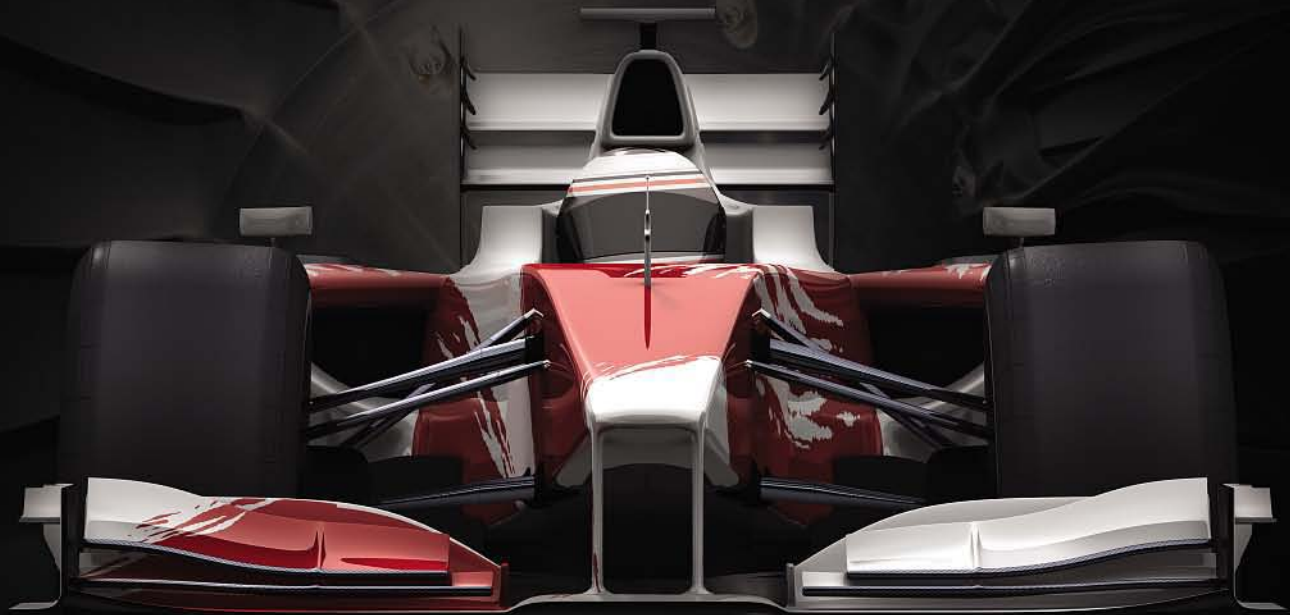

**The UK's Largest Independent Stockist  
of Titanium and Specialist Metals.**

**Aerospace metals for the most  
demanding of applications.**



E: [sales@dynamicmetalsltd.co.uk](mailto:sales@dynamicmetalsltd.co.uk)

T: +44(0) 1442 212 340

[www.dynamicmetalsltd.co.uk](http://www.dynamicmetalsltd.co.uk)

**POLE POSITION**

# Thriller rids Vettel of another 'monkey'

**HOW CLOSE WAS THAT? KIMI RAIKKONEN'S CHARGE**

after Sebastian Vettel at the Nurburgring might have been unsuccessful, but it was certainly thrilling. In the cockpit, it was plain sailing for neither driver as Vettel's KERS went briefly AWOL at a crucial stage and Raikkonen could hear – but not be heard – over his radio for the majority of the lap, the highlight being his hilarious “I told you that already!” outburst when asked whether he should make that final pitstop.

Should he have gambled by staying out? Hindsight is a wonderful thing, and the decision not to gamble was no doubt influenced by that late plunge down the order in China last year. As it was, another lap might have done it or, as team-mate Romain Grosjean found earlier in the race, perhaps the Red Bull was simply too strong in all the right places to pass.

For Vettel, his home victory is another ‘jinx race’ laid to rest, another monkey off his increasingly simian-free back. In this three-week gap before Hungary – and the subsequent factory shutdown period – his title opponents must raise their games now if they are to overwhelm him from here.



**CHARLES BRADLEY EDITOR**  
charles.bradley@haymarket.com  
@Autosport\_Ed

**BAMBER'S WEEK**

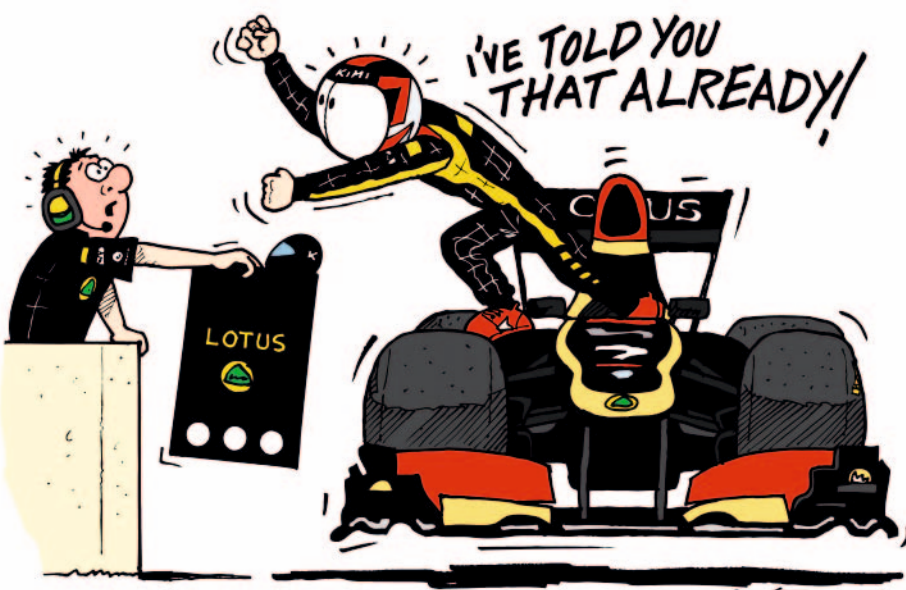

**FIND US ON**



Cover Image: Moy/XPB  
Insets: Etherington/LAT

**PIT & PADDOCK**

6 **THIS WEEK IN F1**

9 **MARK HUGHES: MPH COLUMN**

10 **THIS WEEK IN MOTORSPORT**

13 **THE SECRET DRIVER: COLUMN**

14 **GERMAN GRAND PRIX**

Full report of a dramatic, flat-out race at the Nurburgring. Vettel won, but could rivals have stopped him? Plus full results, comment, driver-by-driver analysis and all the key technical upgrades

**DEBRIEF**

32 **UPS AND DOWNS FOR LOTUS**

Trying to unravel F1's unpredictable team

34 **THE EFFECTS OF PIRELLI'S CHANGES**

Who were the winners and losers at Nurburgring?

36 **GREEN HEAVEN AT THE OTHER 'RING'**

Audi DTM squad puts faith in Norising wizard

38 **VOLVO'S V8 SUPERCAR EFFORT**

How two teams – separated by 10,000 miles – are linking up to take on Holden, Ford and Nissan

**RACE CENTRE**

44 **GP2 NURBURGRING**

Ericsson reverses horrible form in feature race

49 **GP3 NURBURGRING**

ART dons its full Regalia in Germany

50 **INDYCAR POCONO**

Ganassi's cars weren't the quickest, yet Dixon won

54 **MASTERS OF F3 ZANDVOORT**

Invincible Rosenqvist takes second Masters win

56 **FIA GT ZANDVOORT**

Text-Buhk performance for stunning Mercedes

58 **NASCAR; V8 SUPERCARS; ALMS; EUROPEAN RALLYCROSS; INDY LIGHTS**

**SUBSCRIBE FOR A FREE GIFT**

82 **FREE LEWIS HAMILTON CAP**

Subscribe for a great free gift

**CLUB AUTOSPORT**

69 **MORAN BREAKS HILLCLIMB RECORD**

Three-time champion makes it 106 wins

70 **HARVEY TO RACE SIERRA RS500**

Ex-BTCC champion to race his old RWD beast

73 **MALLORY PARK FUTURE IN BALANCE**

Council-imposed reduction could force closure

**76 REPORTS**

Brands Hatch Aston Martin Centenary; Oulton Park MSVR; Mondello Park CKMC/Vee Festival; Croft BARC; Harewood hillclimb; Lydden SEMSEC

84 **FORMULA RENAULT 1600**

Taking a look at Britain's latest junior racer

**THE BACK STRAIGHT**

86 **THIS WEEK**

Readers' letters; best pictures; product reviews

88 **WHAT'S ON**

The best track and TV action in the coming week

90 **RACE OF MY LIFE: GERARD LAROUSSE**



# THE BIG PICTURE

Mitch Evans (6) led Saturday's Nurburgring GP2 feature race for a split-second before overshooting into the run-off. He finished the opening lap in 16th





# This week in F1

## CAMERAMAN INJURED IN PITLANE INCIDENT



Webber's Red Bull sheds its wheel at the Nurburgring

PAPHOTOS

FOM cameraman Paul Allen suffered two broken ribs, a broken collarbone, concussion and bruising when he was struck by a loose wheel shed by Mark Webber's car in last Sunday's German Grand Prix.

The accident happened when Webber pitted for the first time, as he was released with the right-rear wheel unattached. As he left his pit box, the wheel struck Allen from behind. He remained conscious in the incident and was still in Koblenz Hospital under observation as AUTOSPORT closed for press. Red Bull was fined €30,000 for the unsafe release, while the FIA is to introduce measures to improve safety for non-team personnel in the pitlane as a result.

### PITLANE SAFETY MILESTONES

#### 1970 season: Pitlane barriers

Barriers separating the pits from the circuit become mandatory



#### 1981 season: Minimum width

Rules introduced mandating the pitlane must be at least 10m wide



#### 1984 season: Refuelling banned

After Brabham brings fuel stops back into F1 in 1983, they are outlawed



#### Brazil 1994: Fireproof overalls

When refuelling is reintroduced, fireproof overalls are mandatory



#### Monaco 1994: Speed limit

In the wake of an incident in the pits at Imola, pitlane speed limit comes in



ALL PICS: LAT ARCHIVE

6

## BIG NUMBER 29

Lewis Hamilton claimed his 29th F1 pole position at the German Grand Prix, matching Juan Manuel Fangio's world championship haul. Fangio's last came in a Maserati 250F in Argentina '58.

## MERCEDES LOBBYING FOR TEST

Mercedes is pushing for the FIA to allow it to complete a day of running at next week's young-driver test to allow it to try out the new-specification Pirelli tyres.

"When it is about safety it would be good if all teams are clear whether they [the tyres] work on their cars, but it is up to the FIA to decide," said Mercedes motorsport boss Toto Wolff (above).

Mercedes was banned from running at Silverstone for its illegal Barcelona tyre test.



ETHERINGTON/LAT

## Williams suffers garage KERS failure

Pastor Maldonado's Williams suffered a KERS failure in the garage two and a half hours before Saturday practice at the German Grand Prix.

Nurburgring fire marshals attended the scene and the car was undamaged, save for the need to replace the KERS unit. Williams is investigating the incident, which was a failure it had not encountered previously.



COATES/LAT

For all the breaking news, visit [AUTOSPORT.COM](http://AUTOSPORT.COM)

## F1's young driver test open to public

The Silverstone young driver test, which runs from July 17-19, will be open to the public, with tickets costing £15 per day for adults and under-16s free.

Because the new-specification Pirelli tyres – which will be introduced at the Hungarian GP – are to be used, race drivers are allowed to participate. Most teams have yet to confirm their line-ups, although as AUTOSPORT closed for press Kimi Raikkonen was set to run for Lotus on the final day.

### THE FIRST YOUNG DRIVER TEST

F1's first young driver test was held at Jerez in December 2009. Among those to run were current F1 racers Daniel Ricciardo, Paul di Resta (below), Nico Hulkenberg, Jules Bianchi and Esteban Gutierrez.



STALEV/LAT

FOR THE LATEST TESTING LINE-UP NEWS

[AUTOSPORT.COM](http://AUTOSPORT.COM)

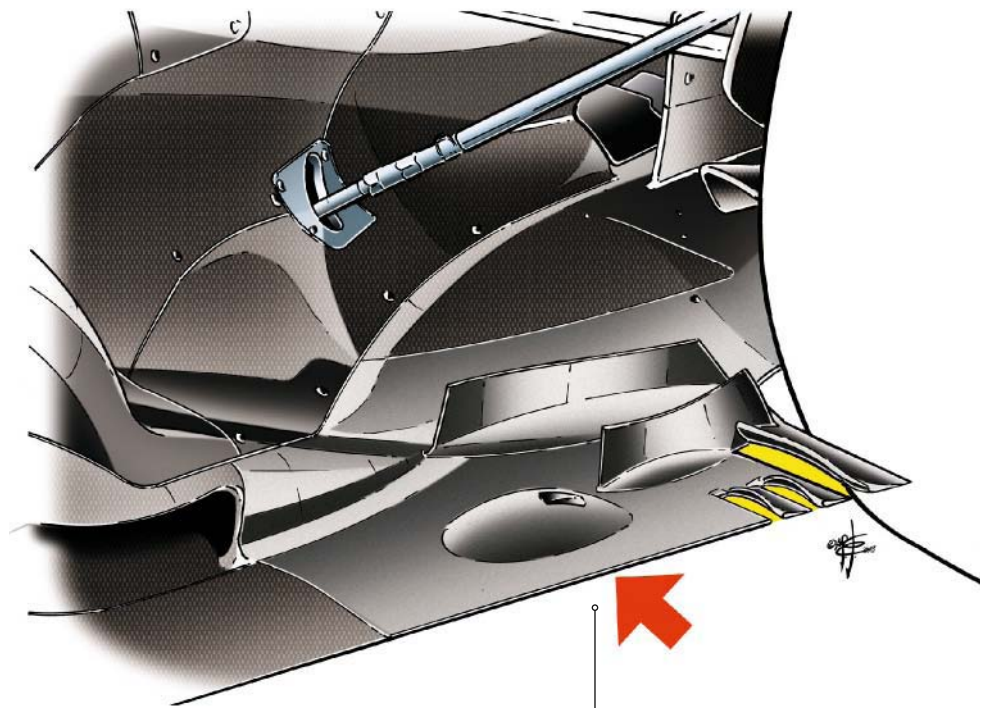

## Red Bull's floor changes

➔ Red Bull has introduced a different material to its floor to improve the consistency of its downforce-producing exhaust effect.

**GARY ANDERSON** "This part of the floor (red arrow) is very sensitive to temperature. Certain resins can only withstand certain temperatures, so the better you get at keeping the hot exhaust gases attached to the floor

surface for aerodynamic advantage, the hotter this part of the floor is going to get. The hotter it gets, the more flexible it potentially gets, which is what Red Bull is tackling with this.

"Double vanes and little wings (yellow area), both of which were introduced last month at Silverstone, clean up the airflow coming over the floor and make the whole section work more effectively."

## GPDA strike averted

The Grand Prix Drivers' Association issued a statement on the eve of the German Grand Prix weekend threatening a boycott if there was any repeat of the tyre failures that struck the British GP.

"The drivers have decided that, if similar problems should manifest themselves during the German GP, we shall immediately withdraw from the event, as this avoidable problem with the tyres endangers again the lives of drivers, marshals and fans," said a statement.

Kimi Raikkonen, one of three race drivers not a member of the GPDA along with Adrian Sutil and Valtteri Bottas, insisted he would not have joined the boycott.

"I was once involved in 2005 [US GP, right] and funnily enough there were some guys that didn't stop and they drove, so I will race whatever happens this time," he said.



Only six cars raced in the 2005 US GP

## REMEMBER WHEN



Had the drivers gone through with their Nurburgring strike threat last weekend, it would be the first time since South Africa 1982 that they took such action. The majority of the drivers sat out the start of practice at Kyalami amid a row over superlicence terms.

## Force India loses Aerolab/Fondtech appeal



Force India's Court of Appeal case against Aerolab/Fondtech was dismissed last week. Aerolab was found to have used some of the team's intellectual property in work on the Lotus T127 raced by the now-Caterham team in 2010 and made to pay €25,000 damages last year. Force India failed to have that sum increased.

## Castrol EDGE GRAND PRIX PREDICTOR

Sharvin topped this week's Castrol Edge Grand Prix Predictor scores for the German Grand Prix with a huge 175 points. The team predicted six of the top 10, including the entire podium as well as Sergio Perez gaining the most places. Play for free to compete for race-by-race prizes like the Samsung Galaxy Tab 2, by registering at [www.gppredictor.com](http://www.gppredictor.com).

V de V Endurance Series

FIA  
AUTHORISED  
INTERNATIONAL  
SERIES



MOTORLAND  
ARAGÓN



# AUGUST 30-31<sup>ST</sup> - SEPT. 1<sup>ST</sup> 2013 12-HOUR RACE

ENDURANCE SERIES



SPAIN

**CATALUNYA-BARCELONE [SPAIN]**  
March, 22-23-24  
6H GT - 6H PROTO  
FUNYO - MONOPLACE

**MOTORLAND ARAGON [SPAIN]**  
August, 30-31<sup>st</sup> - Sept. 1<sup>st</sup>  
12H GT & PROTO  
FUNYO - MONOPLACE

**MUGELLO [ITALY]**  
April, 19-20-21  
6H GT - 6H PROTO - 2H HIST.

**PAUL RICARD [FRANCE]**  
Sept., 6-7-8  
2 TOURS D'HORLOGE  
24H-HISTORIC RACE

**PAUL RICARD [FRANCE]**  
May, 31<sup>st</sup> - June, 1<sup>st</sup> - 2<sup>nd</sup>  
4H GT - 4H PROTO - 2H HIST.  
FUNYO - MONOPLACE

**MAGNY-COURS [FRANCE]**  
October, 25-26-27  
6H GT - 6H PROTO - 2H HIST.  
FUNYO - MONOPLACE

**DIJON-PRENOIS [FRANCE]**  
June, 28-29-30  
3H GT - 3H PROTO - 2H HIST.  
FUNYO - MONOPLACE

**ESTORIL [PORTUGAL]**  
November, 15-16-17  
6H GT - 6H PROTO - 2H HIST.

**INFORMATION & ENTRIES**  
www.vdev.fr | info@vdev.fr | + 33 1 69 88 05 24



Pictures © H. Laroche  
Crédit: www.graphix.fr



# Mark Hughes

## MPH

The Grand Prix Drivers' Association was right to flex its muscles after Silverstone's tyre failures. A threatened act of defiance was long overdue

**“T**he drivers of the Grand Prix Drivers' Association wish to express their deepest concerns about the events that took place at Silverstone.

*“We trust that the changes made to the tyres will have the desired results and that similar problems will not occur during the German GP weekend.*

*“We are ready to drive our cars to the limit, as we always do, and as it is expected by our teams, sponsors and fans.*

*“However, the drivers have decided that, if similar problems should manifest themselves during the German GP, we shall immediately withdraw from the event, as this avoidable problem with the tyres endangers again the lives of drivers, marshals and fans.”*

As it turned out, it was a threat that didn't need to be acted upon. But in the aftermath of the British Grand Prix tyre fiasco it was a healthy development from the GPDA and an overdue one. Tyres had been delaminating since Bahrain and while Pirelli, the teams and the governing body argued about how to solve the problem and whether the infamous Barcelona Pirelli test with Mercedes was within the regulations or not, it was the drivers who had their necks on the line as the tyres continued to give problems.

In the 1970s heyday of the GPDA, the drivers would have been calling the shots over this, something with which one of its strongest and most militant members,

Similarly, it was the GPDA that brought an end to racing on the old, horrendously dangerous, Spa circuit.

That statement last weekend was almost a throwback to those times, in response to a danger that might – if Pirelli had not finally been allowed to make the changes it had wanted to make all along – have still not been resolved by the time we got to places like Spa and Suzuka, where sudden tyre failures just do not bear thinking about.

It's long been argued that the sport, being so much safer than it was in Stewart's time, no longer needs a militant GPDA. Not so. With the Pirelli case, the political and competitive gamesmanship that delayed the solution to such a clear danger dragged on for four races after the problem became apparent. If anything, the GPDA should have been driving this action and was late in making it – after the solution had already been made.

The drivers over the years have been remiss in surrendering the power their body once had, a power that Stewart in particular had to fight hard to acquire. “I had threats,” he says. “Threats people don't even know about. People thought we were spoiling motor racing, but we weren't; we were making it better – and trying to stay alive, of course. I think the governing body have weakened [the GPDA]. They have raised the fees of the driver licences to ridiculous sums of money

**“When officialdom is obviously wrong, it is only healthy that there is rebellion”**

Jackie Stewart, agrees. “There would have been much more done about it if the GPDA had been as strong and as well represented as we were – whether it was myself, Graham Hill or Jo Bonnier,” he said at Silverstone. Back in 1970 when it was discovered, two weeks before the German Grand Prix, that not all the promised changes had been made to the Nurburgring, the GPDA calmly told the organisers they would not be showing up to race there. It wasn't the teams who were refusing, nor the governing body, but the drivers. Because it was their necks on the line.

The organisers huffed and puffed and said the drivers were being unreasonable; the GPDA responded that the organisers were being unreasonable in not having done all that had already been promised, yet still expecting them to race as if they had. The race was hastily rearranged for Hockenheim and the drivers returned to the 'Ring in '71, with all the modifications in place.

and the drivers have just paid. That wouldn't happen if the GPDA was as strong as it should be.”

Being hidebound by over-regulation got F1 into this most recent mess; testing restrictions, regulation changes requiring unanimous consent of all teams – who are obviously never going to be unanimous because they are competitive entities – regulations that don't allow a supplier to properly test a solution to a problem, etc.

The problem with formally tying everything down in regulation is that situations arise that could not have been thought of when the regulation was written – and because the regulation is there, there's a sense that it must be invoked even in situations when to do so is clearly going to be counter-productive. In situations where officialdom is obviously wrong, it is only healthy that there is rebellion. Traditionally that rebellion in F1 was led by the drivers and at the Nurburgring last weekend there was a brief flicker of that spirit. ✖

# This week in motorsport



GARY HAWKINS

10

## TANDY TESTS BTCC FORD FOCUS

Factory Porsche GT driver Nick Tandy tested an NGTC British Touring Car for the first time at Brands Hatch last week.

The 2007 McLaren AUTOSPORT BRDC Award finalist and British Formula 3 race winner drove the Motorbase Ford Focus raced by Michael Caine at Croft, with Porsche's permission.

Tandy and Caine were both scheduled to drive in the official BTCC test at Snetterton this week and team boss David Bartrum says Tandy could make his series debut this year.

"We'll throw him out there with everyone else in the Snetterton test," Bartrum told AUTOSPORT. "Several race outings are not ruled out."



GARY HAWKINS

## Quartet tests for Team Hard

British Touring Car squad Team Hard ran four drivers in its Vauxhall Insignias in Snetterton testing this week.

James Cole left the team last week and Howard Fuller, Joe Girling, Warren Scott and Robb Holland were all due to try the car. Holland is likely to race the car first, with Scott aiming to gain NGTC mileage before switching to a second Team Hard-built Volkswagen Passat for the rest of 2013.

Speedworks Motorsport ran Richard Hawken, Chris Jones and Ian Loggie in Dave Newsham's Toyota Avensis.

## CONWAY BACK TO INDYCAR

Mike Conway will return to Dale Coyne Racing for this weekend's Toronto IndyCar round and also drive for the team at Houston in October. The Brit, 29, won at Detroit on his last appearance for the squad and believes he can add more victories before the end of the year.

"Toronto is one of my best tracks so why can't we win there?" he said.

Plans to stage the event could, however, be seriously affected by severe flooding that hit the city on Monday, 127mm of rainfall disrupting transport links and leaving 30,000 people without power.



LEVITT/LAT

## Senna to race McLaren at Spa



Former grand prix driver Bruno Senna and Audi stars Andre Lotterer and Mattias Ekstrom will contest the Spa 24 Hours later this month. Senna will race a McLaren for the first time after joining the line-up in VonRyan Racing's MP4-12C alongside his manager Chris Goodwin and Rob Barff. Two-time Le Mans winner Lotterer and multiple DTM champion Ekstrom have joined WRT, which will run four Audi R8 LMS ultras, along with Marcel Fassler. Jody Fannin, last year's British GT4 champion, has joined the JRM Nissan team.

For all the breaking news, visit [AUTOSPORT.COM](http://AUTOSPORT.COM)

## FORMULA E TO BERLIN

Berlin was this week confirmed as the 10th and final host city for the inaugural Formula E season, which starts in September 2014. The race, which will form part of the championship for the electric-powered cars, will take place on a temporary circuit at the disused Tempelhof Airport, close to the city centre.

## CITROEN AIMS FOR CHAMPS

World Touring Car champions Rob Huff and Yvan Muller are on Citroen's wish list to partner Sebastien Loeb when it joins the championship next year.

Citroen Racing team principal Yves Matton also admitted that Alain Menu, who recently split with the Fach Auto Porsche Supercup team, was under consideration.



## Hanninen is Hyundai tester

Juho Hanninen will begin a rigorous Hyundai i20 WRC test schedule immediately after being announced as the Korean firm's first driver this week. While Hanninen will still drive a Ford Fiesta RS WRC on Rally Finland, he is likely to be too busy for more competition. His deal does not currently extend beyond this year.

## CASSIDY'S EURO F3 DEAL

Nick Cassidy will contest the remainder of the Formula 3 European Championship with EuroInternational. The 18-year-old Kiwi, who has won the past two Toyota Racing Series titles, will partner childhood friend Tom Blomqvist starting from this weekend's Norisring round.



## MONTE BACK TO CASINO SQUARE

One of the most iconic images in world rallying will return next year, when the Monte Carlo Rally starts from Casino Square.

The event has returned to its traditional Monaco-based format, but includes a night out of the Principality in Gap to assist in the use of such classic stages as Sisteron. The event starts on January 14 and finishes, following two runs over the Col de Turini, on January 19.



## SMP TO ENTER PROTOTYPES

The Russian SMP Racing team is entering the prototype ranks in the European Le Mans Series as part of a plan to eventually build its own LMP2 machine.

French-based SMP, which runs in the Blancpain Endurance Series and the ELMS with a fleet of Ferrari 458 Italias, will race an ORECA-Nissan O3 in the

final three rounds, starting at Spielberg on July 20. The car will be raced by sometime Minardi test driver Sergey Zlobin and Maurizio Mediani.

The team has targeted 2015 for a debut for its P2 contender, which would be designed by the engineer responsible for the Peugeot 908, Paolo Cantone.

## New event set for WRC inclusion

Next year's World Rally Championship will include a round in Brazil, China or Poland.

The calendar, likely to have 12 events, was due to be revealed at last month's FIA World Motor Sport Council meeting, but is now expected in the coming weeks.

FIA rally director Jarmo Mahonen said:

"We postponed the original announcement because I don't want it to be provisional. And I expect one of the [above] candidate rallies to be included."

A 12-round schedule including a candidate event would require two of this season's rallies to be canned.

## In brief

### BERNSTORFF F3 DEAL

Emil Bernstorff, who finished third at last weekend's Masters of Formula 3, has joined Team West Tec for this weekend's European F3 Open round at Silverstone. The Brit currently lies third in the German F3 points.

### NIKARA BACK IN MINI

Prodrive's Mini WRC will next appear on Rally Finland in August with Jarkko Nikara at the wheel. The Finn will tackle Rally Kouvolaa later this month as a warm-up.

### WILLI BERGMEISTER

Willi Bergmeister, who helped Audi win the 1980 European Touring Car title, died aged 63 this week. The father of racers Jorg and Tim also won two German hillclimb titles in the 1970s.

### WRC QUALIFYING

The qualifying stages used to decide the running order on gravel rounds of the World Rally Championship look likely to be dropped for next season, according to FIA insiders.

### MOWLEM'S ALMS DEAL

Johnny Mowlem will return to the American Le Mans Series with Dyson Racing at Virginia in October. The European LMS GTE points leader will drive in place of Chris Dyson, who has family commitments.

# Sandwell

shot peening & specialist metal coatings

## Good design sometimes needs a little help...



...that's why global race teams use Sandwell as a prime supplier of performance engineering solutions.

- Controlled Shot Peening
- Superfinishing
- Low Friction Coatings
- Kephos Coatings

Sandwell works with design and development engineers throughout the world of manufacturing to improve component performance.

- Improve component fatigue life
- Increase component strength
- Improve reliability
- Reduce component weight
- Reduce surface friction
- Apply corrosion resistant coatings

# The Secret Driver

## Hidden truths from the paddock

The death of a fellow competitor brutally brings home the realities of what every driver risks each time they climb into a racing car



**O**n June 22 the world of motorsport lost a great man and a great driver. Allan Simonsen was a gentleman on all fronts, loved deeply by all those in the motorsport community who knew him. The Dane was arguably one of the most gifted GT drivers and his passing has certainly rocked the sport. My thoughts and prayers go out to his wife, daughter and family.

Dealing with tragedy is thankfully something that we don't have to experience that often in modern-day motorsport. We are indebted to generations gone by; individuals such as Sir Jackie Stewart and Professor Sid Watkins, and all those who have sadly lost their lives.

Sir Jackie and the late Prof Watkins pioneered the development of safety using science and research. Because of the raft of improvements both to circuits and machinery, the environment we compete in today is a much safer place. Thanks to the FIA Institute, the quest to continuously improve safety continues. However, motorsport is dangerous and we will never be able

things. It was part of the sport and something you either dealt with or you hung your helmet up.

I can't imagine adopting that mindset, and it's testimony to the safety advances within the sport that I can say that. However, I can't help but feel that on the rare occasions we are exposed to the harsh realities of what can go wrong in today's world, the approach of generations gone by returns. For young drivers in today's world it's near-on impossible to block it out and just get on with things. The difference being that few drivers from my generation have never addressed the ideology that doing what you love could result in you losing your life; it's a mindset that's almost inconceivable. Admitting you are frightened to yourself is an extremely difficult process, never mind admitting you are frightened to anyone else. Fear is almost a taboo word within the sport, but when you're dealing with the harshest reality of all, I think it's more than acceptable.

What makes Allan's crash especially poignant was how such a small moment was so cruelly punished. From a driver's point of view, this makes it even harder

**“Fear is almost a taboo word, but dealing with the harshest reality of all, it's more than acceptable”**

to eliminate all risk. The tragic circumstances at Le Mans cement that notion in the harshest way.

Racing drivers deal with the dangers surrounding the sport differently. We are not robots and just like any other human being, fear is a very natural emotion. In my eyes, fear tends to be born out of imagination. Personally, I would never jump out of an airplane because I'd be frozen by fear, caused by imagining what could go wrong. In a racing car that all changes – I feel in control and the control aspect eliminates the fear. Competing in a generation where we're not exposed to mortality, drivers nowadays fear the consequences less, which I think explains some of the poor driving standards we see in some junior single-seater racing.

In previous generations, drivers experienced loss on a regular basis. It was never accepted, but it became a way of life. Drivers blocked it out and got on with

to understand. Drivers like to be able to process why an incident took place. With Allan's crash he did nothing untoward and that makes the tragedy even harder to block out in a driver's mind. The very idea that there is no logical explanation opens up a driver's imagination for the worse. Drivers seek reassurance from avoiding the unknown. Rightly or wrongly, they will look for explanations to help their peace of mind. Dealing with the unknown, within an environment where the feeling of control is essential, breeds all sorts of anxieties.

There's no correct way to react to tragedy and we are all different in our coping mechanisms. Drivers exposed to such circumstances should have a voice and the confidence to admit their thoughts should they want to do so. Having the strength to say what everyone else is thinking and feeling should be encouraged. We are only human after all. ❧

# THE RACE REPORT

QUALIFYING • TRACKSIDE VIEW • LAP CHART • DRIVER BY DRIVER • RESULTS

## Vettel towers in the Eifel at last

Lotus twins Raikkonen and Grosjean did their best to stop him, but Red Bull's champion would not be denied his first German GP win despite a brief KERS hiccup. MARK HUGHES reports

14



## AT A GLANCE



“Another lap, and Kimi might have done it. He said he would have preferred to get to the end without that pitstop”

**GERMAN GP**  
Nurburgring

**ROUND** 9/19

**LAPS** 60

**WINNER**  
Sebastian Vettel  
1h41m14.711s

**POLE POSITION**  
Lewis Hamilton  
1m29.398s

**FASTEST LAP**  
Fernando Alonso  
1m33.468s

**RACE RATING**  
★★★★★ A corking, down-to-the-wire finish, but Vettel hung on

**DRIVERS' STANDINGS**  
Vettel 157pts  
Alonso 123pts  
Raikkonen 116pts

Hamilton made it two poles in a row, his third of 2013 season



GILHAW/GETTY

16

## QUALIFYING 14.00, 6.7.2013

**7** A week is a very long time in Formula 1, and it took only a few laps of running of the Nurburgring weekend for the changeable wind and temperature to replace exploding tyres as the main story. The Kevlar-belted version of the 2013 rear Pirelli – as used in practice at Montreal and Silverstone – combined with a track that puts only around 70 per cent of the energy of Silverstone into the tyres, meant that shock loads were nowhere near the critical thresholds. Instead, practice and qualifying became all about how to adapt to a constantly moving target of track grip and wind direction.

No-one did this better than Lewis Hamilton. He revelled in the balance of the Mercedes during Friday morning, when he was conclusively fastest. “Into P2 it got worse. So we made changes and into Saturday morning it was even worse,” he explained of his struggle with wild oversteer. “I’m still finding it difficult to get a balance with this car and understanding it. I went through virtually the whole spectrum of set-up and for qualifying we took in something untried and crossed our fingers.” Remarkably, it worked beautifully.

Despite the a difference of over 1s between the medium and soft tyres, Hamilton got through Q1 without requiring the softs, and needed just one run on softs to get through to the run-



Alonso didn't bother using the softer tyres in Q3 run-off

off, leaving him two fresh sets of them for Q3. The only others able to do this were Red Bull's Sebastian Vettel and Mark Webber, and it was this trio that fought out pole.

The improvement in the track late in Q2 caught out Mercedes' Nico Rosberg, who assumed his single run – though not a great lap – was going to be enough to get him through. But that was to reckon without the track improving a lot in the last few minutes, particularly in sector three. A more powerful headwind there seemed to be responsible. Taking advantage with a good late run was McLaren's Jenson Button, who duly bumped the second Merc out of Q3, leaving Nico in a disastrous 11th. “I’d assumed I’d be qualifying behind Nico,” said Hamilton graciously later. “He seemed to have a

better handle than me on the set-up.”

Also graduating to Q3 were both Lotuses, both Ferraris, Daniel Ricciardo's Toro Rosso and the overachieving Button and Nico Hulkenberg. Of these, only the Lotuses and Ricciardo used the faster option tyres in Q3, the others preferring to focus on race day, enabling them to start on the more durable hards. The Lotuses, as usual, did not have quite the single lap pace of the Mercs and Red Bulls.

The wind was blowing from the north, giving a tailwind into T turns 1, 5 and 7, and the Red Bull seemed more adversely affected by it than the Mercedes. “The car had felt great in P3,” said Vettel, “and so we didn’t change much into qualifying, but then I struggled to bring it together, especially in the first part of the track. The trail

wind and the increase in track temperature changed the car a little. I could feel I needed to make time up in the next two sectors and I tried, but it wasn’t enough.”

With Webber struggling even more with a balance he’d been quite comfortable with in the morning, Hamilton was marginally fastest on his first Q3 run from Vettel, a trick he repeated by knocking a further 0.15s off on his final run. Vettel found a similar amount, leaving him trailing by a tenth. Webber was beaten by Vettel by a further tenth around a track where he has historically aced him. “I was actually relieved with third,” he said, “as it was very sensitive out there. We lost a little bit in the first sector and struggled to find the rhythm that we’d had there in P3, but we know there was a shift in track temp and it pulled everyone together a bit, at least for the short runs.”

Three tenths adrift of Webber came the Lotuses of Kimi Raikkonen and Romain Grosjean, separated by mere hundredths of a second. Both E21s featured the revised bodywork and brake ducts trialled on separate cars at Silverstone. Kimi rued not being able to capitalise on Webber’s problems because of struggles of his own. “I had traffic on my out-lap, which meant the front tyres were not up to temperature through the first sector.” Because the Lotus had used up all but one set of

softs in getting through to Q3, there was no further opportunity.

Having delivered a great Q2 lap in the improving Toro Rosso, Ricciardo spurned the opportunity of settling for the medium tyres in Q3 and went for it on softs. The resultant lap, though 0.6s adrift of the Lotuses, was good enough to put him sixth on the grid for the second successive race. He was the last of those in the Q3 part of the grid to set his time on the softs, with the Ferraris making the strategic choice of mediums. Felipe Massa was quicker than Fernando Alonso through all three sessions and lined up one tenth ahead on seventh. "The best we could have done on softs would have been a high 1m 29s," reasoned Fernando, "so when cars began doing mid-29s on the first Q3 runs it made no sense for us to run the softs."

Neither Button nor Hulkenberg set a time and lined up ninth and 10th, with the free choice of tyre. The McLaren was flattered by Mercedes' Rosberg

**"I assumed I'd be qualifying behind Nico," said Hamilton graciously later'**

miscalculation, but the Sauber appeared to have made a genuine competitive leap. Whether it had responded to the new-spec rear tyre better than others or to a set-up derived from that of Esteban Gutierrez's wasn't clear, but the result delighted Hulkenberg. Gutierrez acknowledged he has work to do in matching Hulkenberg in qualifying and was back in 14th, 0.8s off his team-mate.

Sauber's gain was Force India's loss, and neither Paul di Resta (12th) or Adrian Sutil (15th and with a DRS problem) could keep the car in its set-up window in the changeable conditions. Behind di Resta was the second McLaren of Sergio Perez, struggling after a problem with the rear floor was discovered, this having misled him into an unproductive direction on set-up that gave understeer.



**P28 FULL RESULTS & POINTS**

COATES/LAT

## THE GRID

	<b>1</b> HAMILTON MERCEDES 1m29.398s Softs		<b>2</b> VETTEL RED BULL 1m29.501s Softs
	<b>3</b> WEBBER RED BULL 1m29.608s Softs		<b>4</b> RAIKKONEN LOTUS 1m29.892s Softs
	<b>5</b> GROSJEAN LOTUS 1m29.959s Softs		<b>6</b> RICCIARDO TORO ROSSO 1m30.528s Softs
	<b>7</b> MASSA FERRARI 1m31.126s Mediums		<b>8</b> ALONSO FERRARI 1m31.209s Mediums
	<b>9</b> BUTTON McLAREN no time Mediums		<b>10</b> HULKENBERG SAUBER no time Mediums
	<b>11</b> ROSBERG MERCEDES 1m30.326s Mediums		<b>12</b> DI RESTA FORCE INDIA 1m30.697s Softs
	<b>13</b> PEREZ McLAREN 1m30.933s Softs		<b>14</b> GUTIERREZ SAUBER 1m31.010s Softs
	<b>15</b> SUTIL FORCE INDIA 1m31.010s Softs		<b>16</b> VERGNE TORO ROSSO 1m31.104s Softs
	<b>17</b> BOTTAS WILLIAMS 1m31.693s Mediums		<b>18</b> MALDONADO WILLIAMS 1m31.707s Mediums
	<b>19</b> BIANCHI MARUSSIA 1m33.063s Softs		<b>20</b> VAN DE GARDE CATERHAM 1m33.734s Softs
	<b>21</b> CHILTON MARUSSIA 1m34.098s Softs		<b>22</b> PIC CATERHAM 1m32.937s* Softs

\* - five-place grid penalty for gearbox change

## TRACKSIDE VIEW

**Mark Hughes**  
GRAND PRIX EDITOR

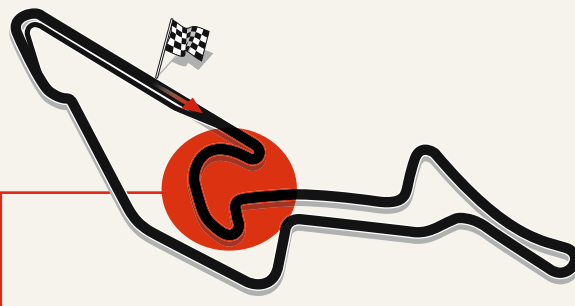

Fernando Alonso gives a wave of acknowledgement from the back of a motorcycle, his Ferrari abandoned out on track before completing a lap. The morning is cool and overcast, the track far from ready to surrender its grip to conservative-compound prime tyres. A sequence of multiple downshifts echoes off the Turn 1 grandstands and Jenson Button then pours the McLaren through the slow sequence of 2-3-4, his inputs as beautifully silky as ever, and you hear just by his throttle modulation, how his right foot moves according to the grip he feels from the front tyres and then the rears, that it's down to him. He sounds totally different to anyone else in these low-grip circumstances. Romain Grosjean is eager to get pushing but, as with Jenson, the front end of the car isn't finding grip. As he partly lifts into the entry of Turn 4, the Renault engine gurgles onto cylinder cut, the aural outcome of the lack of molecular interaction between track and front tyres as the grey cloud resolutely hides the sun. Next time, as he accelerates out of T2, red paint dust rises from the back of the Lotus as he gets onto the exit kerbs, this putting him too late back onto the track to brake enough for T3; the inner-front locks and he runs way wide. Ambition just not matched by adhesion. On his third pass through, the heat is finally beginning to seep into the rubber and the car has a semblance of a front end. As the track is cleaned by the cars and the grip builds, the fast and slightly banked left-hander of Turn 10 is a spectacular affair, especially when a Mercedes is approaching. Lewis Hamilton and Nico Rosberg are aggressively late in surrendering speed from the seventh-gear approach, the first downshift not coming until way after turn-in, which is made with right foot still flat to the floor. As the track dips and the camber comes to the aid of the car, the second downshift doesn't come until *after* the apex. It's then full throttle all the way as the car just digs into the asphalt and disappears over the crest in a fury of noise. We walk back late in the session, and the grip has built up nicely in the loop of Turns 2-3-4. Into 3, the front ends are no longer trying to ignore the steering; instead they pivot around the outer front tyre, drivers no longer needing delicate throttle modulation, the skill now being pin-sharp precision in aggressively picking the turn-in point under braking.

**'You can hear how Button's right foot moves according to the grip'**

## RACE

14.00, 7.7.2013



Five laps left. Romain Grosjean had just pulled out of Kimi Raikkonen's path, and now in the Finn's sights was the Red Bull of leader Sebastian Vettel as this thrilling, vivid race on a scorching summer day at the Nurburgring rushed towards an uncertain conclusion.

The Lotus was handling beautifully and, regardless of tyre choice, had enjoyed a wonderfully grippy front end all race. It was taking whole chunks out of even the Red Bull into the entry of slow corners, but was also brilliantly quick out of Turn 11, the fast, banked right-hander leading to the back-straight DRS zone. This was where Raikkonen had passed Nico Rosberg and Lewis Hamilton earlier in the race and, as the laps ticked down, so did the gap. From 2.5s to 2.1s, 1.6s, 1.2s and now, completing the penultimate lap, Kimi was straining to get into one of the two DRS trigger zones.

He didn't quite get to within the required one-second at the activation line between the pit-entry road and the final looping turn onto the pit straight, where the more extreme rake of the Red Bull could be clearly seen, a key part of the car's aerodynamic effectiveness. Down they went past the grandstands, the two Renault motors singing, stretched out through the gears, up to 190mph before the 5g braking for the second-gear hairpin that begins the infield loop of the Mercedes arena. This low-speed section rewards suspension suppleness, and is where Raikkonen's Lotus had been taking metres out of the Red Bull, but on this occasion Kimi got a little wide on exit, with a flick of opposite lock as the outer rear tyre found the dust and marbles.

Then the slingshot out of Turn 4 down the short back straight, the sweep through the fast downhill left of Turn 5 – Nurburg castle high up on the hill

looking down from afar upon these modern warriors – and into the long third-gear compression that funnels them down the kinking run to the lightly banked Dunlop Kehre hairpin, braking from 174mph to 60. Then they accelerated, the left-rears of both cars hard over the green paint beyond the kerbs, up the steep hill, flat-chat in sixth through the Schumacher Esses,

grabbing seventh on the exit and hurtling towards the horizon – where lies the detection point for the second DRS zone.

Raikkonen arrived there less than one second after Vettel, and would thereby have his wing-stalling device armed after they'd run through the banked fourth-gear left of Turn 10 and out through the faster downhill right

of 11. Going into the chicane for the final time, Raikkonen was going to have a DRS run at Vettel, was going to try an attempt at depriving the world champion of his first victory in his home grand prix. If Kimi succeeded, it would in turn be his first German victory in 16 attempts...

It had looked nothing like this in the two days leading up to the race: Red Bull vs Mercedes had looked to be the story, with Lotus and Ferrari vying for best of the support acts. But the combination of this previously unraced rear tyre (the solution to the Silverstone blow-ups) and glorious weather that had the track temperature at 43C and rising by 2pm Sunday completely changed the competitive picture.

The Mercedes was back to the tyre-eating beast it had been at Barcelona; the Lotus was the fastest thing in the place, but only by a small margin over the Red Bull. The Ferrari was an odd one: disappointingly slow on the medium prime tyres that were supposed to be its ace in the hole, but coming alive on the soft option rubber



Hamilton gets swamped by the Red Bulls on the run to the first corner



Massa didn't cover himself in glory, spinning out early

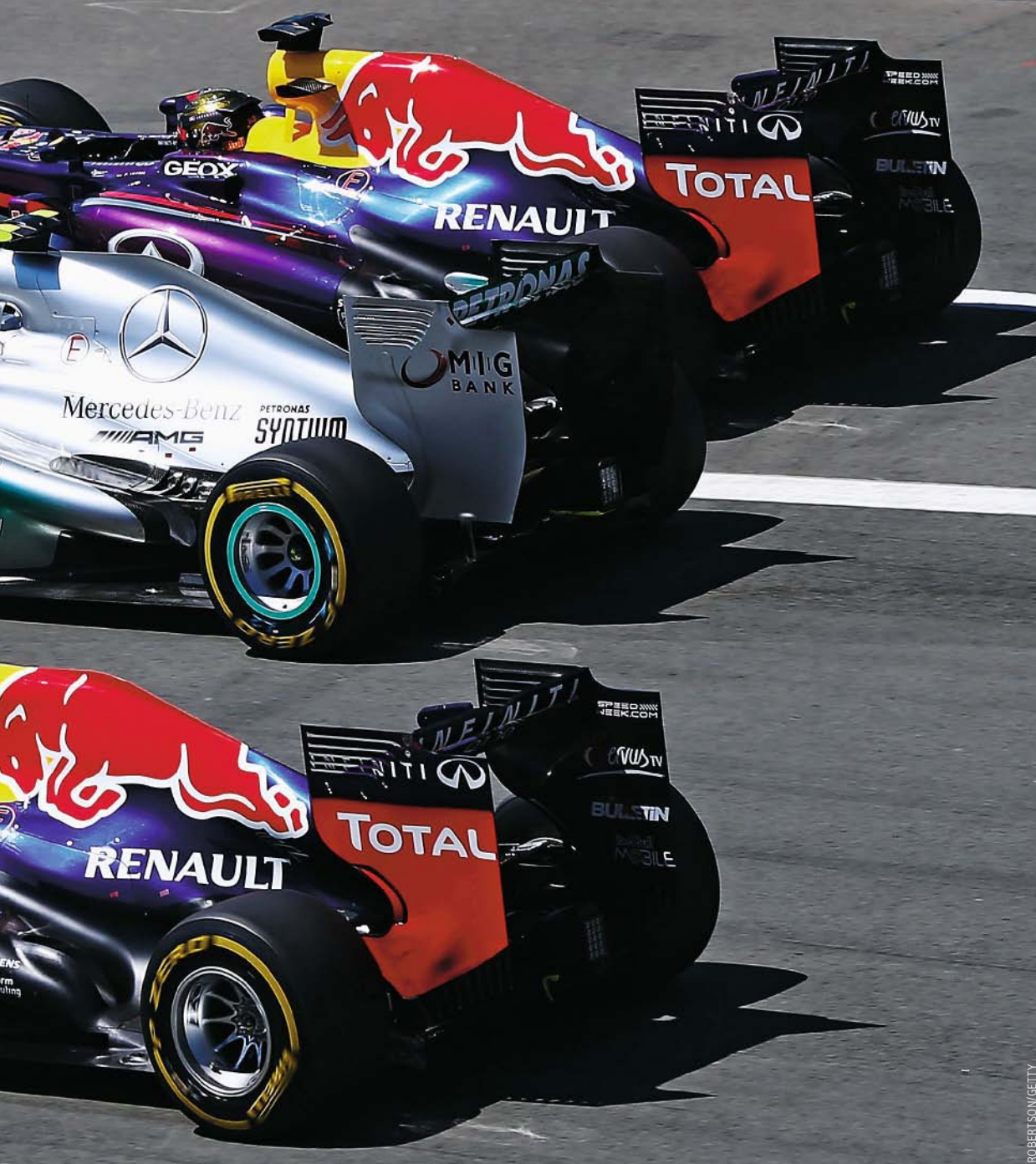

ROBERTSON/GETTY

## 'Hamilton's start from pole was just the portent of a troubled afternoon for Merc'

later on, all Fernando Alonso needed to make a nuisance of himself. The pattern of free practice had suggested the mediums were so durable that this was going to be an unambiguous two-stop race for almost everyone, even though the softs were expected to grain their fronts away in less than 10 laps. The heat and track conditions of Sunday reduced the graining of the softs and increased the thermal degradation of the mediums. That and an inconveniently-timed safety car pushed the race towards a three-stop.

Lewis Hamilton's start from pole position – he was instantly swamped by the Red Bulls, Vettel to his right into the lead; Mark Webber, on his left, slotting into second as they exited Turn



TEEL/LAT

Raikkonen passes long-running Rosberg in the early stages

1 – was just the portent of a troubled afternoon for Mercedes, a day that would suggest its improved form of late has been about conditions not pushing its tyres beyond their heat threshold rather than any fundamental breakthrough in banishing the problem. In that context, Hamilton's race to an eventual fifth place rather took the steam out of any anticipated title battle.

Lotus, on the other hand, is hoping for a long, hot summer. Raikkonen ducked in tight behind Hamilton as they rounded the Mercedes Arena, Grosjean attempting to go round Kimi's

outside at Turn 3, but locking the inside front and running slightly wide, just as he'd done in Friday practice. Felipe Massa had scorched his Ferrari off the line and was tucked behind Grosjean, but already beginning to lose touch with him, and just behind him Daniel Ricciardo had pulled off an aggressive pass on Alonso around the outside of Turn 2, Fernando having to steer suddenly left to avoid contact. It was an impressive cameo from Ricciardo who would fade badly after the stops, the Toro Rosso's pace falling off disastrously quickly. ▶

## FRIDAY



COATES/LAT

**0747** The **FIA** issues a statement confirming minimum tyre pressure and maximum camber limits have been imposed, and a ban on tyre swapping.

**1003** **Fernando Alonso's** Ferrari stops on his first run in FP1 with an ECU problem. Car is towed to pits.

**1004** **Felipe Massa** says: **"My right-hand side mirror is vibrating a bit, not 100 per cent fixed."** 

**1010** **Paul di Resta** questions why he's being told to abort an installation lap (due to a lack of telemetry) and is told: **"Do not argue with everything I say."** He argues: **"I'm not arguing with everything you say."** 

**1036** **Massa** reports that he got DRS **"in the wrong place."** **Rob Smedley** tells him: **"Don't use DRS between Turns 4 and 5, there is a problem with the DRS mask."**  

**1047** **Alonso** is in trouble again: **"Same problem, same problem, what I do? It's at the S1 timing loop, it's odd."** He's told: **"Try to go to the box. Low revs in high gears."** He does so.

**1435** **Adrian Sutil** goes off at the final corner in FP2. He reports that he's: **"OK, just a little bit of gravel."** 

**1457** **Marussia** reveals **Jules Bianchi** is feeling unwell and will take no further part in this session.

**1505** **Sebastian Vettel** is told: **"Your deg on the options is the same as everyone else. Objective is to maintain times on the primes."** 

**1506** **Mark Webber** divebombs a cruising on-his-out-lap **Romain Grosjean** at Turn 7, and waves disgust.

**1522** **Nico Rosberg** is advised on his exhaust-blowing technique in the Mercedes Arena: **"Just think about carrying a bit of throttle at Turn 2 entry, to pick up a little speed."** 

**1524** **Kimi Raikkonen** after a run on option tyres: **"I need more front wing I have so much graining."** 

**1544** **Lewis Hamilton** admits he found Thursday's GPDA meeting, which led to a boycott threat, "boring".

DUNBAR/LAT

ETHERINGTON/LAT



Recovering Hamilton passed di Resta and Maldonado late on

◀ Webber kept pace with Vettel for the first couple of laps and they were setting way too hot a pace for Hamilton's Merc. It looked positively cumbersome through the slow sections, with reluctant turn-in and twitchy rear mid-corner. The effect was exaggerated when seen from the cockpit of Raikkonen's Lotus, which was crawling all over the back of it, but unable to find a way by even after DRS was enabled on lap three. Grosjean in turn was following their every move from very close quarters. This was all full-on, proper flat-out racing, not the endurance exercises we've sometimes seen in the Pirelli era. It left Hamilton dropping away from the Red Bulls at 0.5s per lap.

Massa spun out of his sixth place beginning lap four, locking the right rear under braking for Turn 1, failing to catch the resultant moment and stalling. Two laps later Hamilton triggered the first round of stops, bringing the Merc in for a set of new mediums. Vettel by now was 0.5s off his peak pace and was brought in next time around, Webber leading for a lap before he too was in, together with Raikkonen.

The right-rear wheel on Webber's car would not locate properly and the

**'For possibly the first time since 1970, a driverless F1 car went onto the circuit'**

jackman dropped the car before the wheelman had completed his task. Raikkonen accelerated away, already ahead as the wheel departed from the Red Bull, bouncing precariously past the Lotus mechanics before hitting the camera of a fleeing FOM man and rebounding up into his unsighted colleague Paul Allen, who suffered broken ribs and collarbone. It could have been much worse. Webber had pulled up half way down the pitlane and knew nothing about the incident with the cameraman. Mechanics were dispatched to push his car back to the garage where another set was fitted. By the time he got going again he was a lap down.

Grosjean was now leading, but remarkably was showing no signs of slowing. Once Raikkonen and Vettel had pitted out of his way he upped his pace by 0.5s. He'd earlier insisted over the radio that he was much quicker than

Kimi, but at the time Raikkonen was restricted to Hamilton's speed so it was impossible to know if that was true. "The original plan had been to bring him in the lap after Kimi," recounted well-impressed Lotus engineering chief Alan Permane. "But he just took off. He was driving superbly, just as he had been all weekend, actually." So fast was he pulling away from the medium-tired Alonso in second that Ferrari brought Fernando in much earlier than planned – on lap 12. And still Grosjean circled on his options!

He'd been just over 4s behind Vettel before the Red Bull had stopped, and for a couple of laps was going quicker on his old options than Seb could manage on his fresh mediums, and also as the reigning champion passed the yet-to-stop Nico Hulkenberg and Jenson Button. Grosjean and Vettel then ran at an equally-matched pace for a couple of laps before Romain's tyres finally gave

out on the 12th lap, when he lost 0.6s to Vettel. He was never quite in a position to have overcome that earlier 4s deficit and, by the time he came in at the end of lap 13, he'd dropped a further chunk. But he'd jumped himself ahead of Raikkonen and Hamilton and was now 4s behind Vettel once more – but closing fast and with tyres that were six laps newer. Furthermore, between him and Hamilton/Raikkonen were Button's McLaren and Hulkenberg's Sauber, both of which had started on primes and would run for a time yet, thereby allowing Vettel and Grosjean to sprint away in a race of their own. And this was how it was going to pan out: a straight duel between Sebastian and Romain. Fate had other plans.

Raikkonen was getting frustrated behind Hamilton's Mercedes. He'd almost got by as they'd come up to Hamilton's yet-to-stop team-mate Rosberg. Hamilton was on the radio suggesting they move Nico on his older tyres aside, and Kimi took a look down his inside at Turn 4. Nico eventually acceded to the team's request to allow Lewis by. Raikkonen took just a couple more corners before he slammed the Lotus by Rosberg on the approach to the chicane. Within another three laps he'd made the same move on Hamilton, with Lewis complaining of no grip as his rears overheated and he came under attack from Alonso. By the time Button and Hulkenberg had pitted aside to bring Kimi up to his natural third place, Grosjean was 10s up the road and had halved his earlier deficit to Vettel.

"I don't know if we could have beaten Vettel with Romain," said Permane later. "He's a tough guy to beat. But we'd have given him a good run for his

Bianchi is usually on fire metaphorically, but at the Nurburgring it was literal



Button made his way past Perez, who ran a long stint but faded



COATES/LAT

## SATURDAY

**0830** Fire marshals are called to the Williams garage after a KERS failure on Maldonado's car. Nobody is hurt.

**1102** After completing only 10 laps on Friday because of a stomach bug, Bianchi is back on track in FP3.

**1116** Hamilton is told: "Be careful of exit Turn 4, in case of damage." He queries: "Did you say there's some damage? I haven't been wide anywhere." He's told: "We've just seen some hits on the data."

**1119** After being told Rosberg is complaining of understeer, Hamilton replies: "I have huge oversteer everywhere. I can't drive this car. It's so unstable at the rear."

**1124** Maldonado goes off the track briefly and rejoins.

**1409** Sutil in Q1: "It's really oversteery, no grip at the rear." He's told it's not the tyre temperatures or pressures that are to blame.

**1431** Rosberg has a big right-front lock up at Turn 1 in Q2 and goes on to the asphalt run-off.

**1441** Button is told after Q2 lap: "That's a really, good lap, we are P9. That was incredibly close." He slips to P10 when Raikkonen improves but makes Q3.

**1442** Sutil is knocked out in Q2 and complains on his in-lap: "That was a lap without DRS."

**1443** Rosberg is knocked out in Q2 after Raikkonen's late fast lap. He says his team misjudged the track's evolution.

**1458** Button on Q3 out-lap: "I'll be surprised if we can beat the Ferraris guys." He's told: "We're going to set a timed lap." Button reports: "There's no grip, guys."

**1501** Engineer 'Rocky' informs Vettel: "You are P1 but Hamilton is still out there, he's going to be one of the last across the line... You're P2, Hamilton did a 29.39."

**1502** Christian Horner to Vettel: "Good effort Seb." He replies: "Yeah, it wasn't the tidiest lap of the weekend. I struggled in the first sector and tried to get it back elsewhere. Sorry."



COATES/LAT



BATCHELOR/XPB

money and at the very least taken a comfortable second."

That version of the race was frustrated by the burning Marussia of Jules Bianchi, pulling off just before the chicane after 21 laps. The fire was extinguished by the car's own system even before Jules climbed out but, for possibly the first time since Jarama 1970, a driverless F1 car then careered onto the circuit, rolling down the incline back towards Turn 11. With a tractor trackside too, it was a potentially lethal moment. Even though the car then gently coasted over to the grass and stopped, the safety car was deployed.

This came at a moment in the race that effectively gave the earlier pitters their second stop for free, but probably too early in the race to then be able to complete the distance. Vettel and Grosjean pitted immediately for fresh primes and were eventually followed by Raikkonen, Alonso, Rosberg and the others who'd yet to make their second stops. This didn't include Hamilton, who'd been in for new tyres two laps earlier. This shuffled him down behind that tenacious pair Button and Hulkenberg, both delivering classy drives in maximising the opportunities of the moment. Webber's one-lap deficit had been wiped and he was soon sitting at the back of the circulating pack, ready to pick off the tiddlers.

The safety car had wiped out the 10s advantage Grosjean had held over his team-mate, and Kimi was back in the reckoning. For six laps Vettel, Grosjean, Raikkonen, Alonso, Button, Hulkenberg, Hamilton and the rest circulated, waiting for the contest to continue.



Could the gentle-on-its-tyres Lotus make a set of mediums last 36 laps? Even the team had its doubts. For most of the others, it was out of the question and there would have to be another stop before the end.

Racing got underway again at the end of lap 29. Vettel sprinted away, the Lotuses taking a lap or so to get tyre temperature. Alonso initially fell back from Raikkonen; Hamilton tried many different ways of passing Hulkenberg but was thwarted each time. For 10 laps the Red Bull and two Lotuses circulated almost as one, Romain and Kimi frequently getting to use their DRS devices but to no effective use. As has often been the case in the past couple of seasons, if only a Lotus could get past the leader it would surely have pulled away. Here was the penalty once more for that qualifying shortfall.

But Vettel was being kept on his toes. We were approaching the third stops, and Seb was desperately trying to pull out enough time over Grosjean to be

able to react to his stop a lap later without losing the lead. Complicating matters further, Vettel lost his KERS just as the vital moment was nearing! "It went for a couple of laps just before the final stop," he related. "Fortunately we did a system reset and it came back."

Grosjean was slightly scrappy on lap 39 as Vettel pulled out all the stops, extending his lead to just over 1s. Romain was called in and reminded how important it was that he leave no margin, and he responded with a beautiful in-lap. The team made a perfect 3.0s stop and he was underway on a pre-used set of mediums, exiting in sixth place but with clear track ahead of him.

Red Bull, knowing it could not get to the end on this set of tyres and stay ahead of the Lotuses, had to respond. But the team was in an invidious position because, by responding to Grosjean, it might have been surrendering the race to Raikkonen – if Kimi could stay out to the end. ▶

◀ As Grosjean was setting the fastest sector two time of the race on his out-lap, Vettel was giving it everything on his in-lap and he eclipsed even Grosjean's earlier effort by a couple of tenths. Under intense pressure the crew matched the Lotus 3.0s stop and Vettel was underway again on a new set of mediums. These were tiny margins on which the outcome of the race was pivoting – an exercise in flat-out, give-it-everything performance that F1 should always be about. Vettel exited the pits just a few car lengths ahead of the Lotus and the pair was quickly upon the back of Hamilton's about-to-pit Mercedes.

So Red Bull – and Vettel in particular – had succeeded in staying ahead of Grosjean, despite what appeared to be a slower car, through the sheer perfect relentlessness of their performance. One slightly untidy lap by Grosjean on lap 39 – to the tune of 0.4s – was the

only thing that separated them. But in meeting this challenge, Red Bull was exposed to the possibility of Raikkonen, now leading, maintaining his pace at the front to the end. Kimi led Alonso by around 4s, but the Ferrari would need to stop as it had yet to use the option tyres. Vettel and Grosjean were 14s behind. A pitstop would cost around 16.5s, so Raikkonen would definitely exit the pits down in third – if he pitted, that is.

“Do you think these tyres can get to the end?” Raikkonen was asked. He replied. But a radio problem meant they couldn't hear what he said. They repeated the question. “I've already told you!” shouted an irritated Kimi. When eventually they'd convinced him to repeat his answer, it was ambiguous enough that it led them to err on the side of caution, with Shanghai 2012 in sharp-focus memory. “If we left him out,” explained Permane, “we'd

have probably been swamped at the end. It wasn't a wear limit, just degradation; they'd just have got slower and slower. We thought 'OK, let's try him on the options.'”

Figuring the options would be good for a stint of 11–12 laps, Kimi stayed out front leading until lap 49 when, much to Red Bull's relief, he came in. Alonso pitted from second on the same lap. His options were new, Kimi's were three laps old. Vettel and Grosjean were duly promoted back to first and second; Raikkonen came out 4s off the lead, with Alonso a further 4s back.

Behind the top four, McLaren's Sergio Perez was going for the staying-out-until-the-end two-stop gamble and lay a distant and temporary fifth, being quickly closed down by the three-stopping Button and Hamilton. On lower fuel loads, the Merc was working much better, its rear-tyre temperatures under better control, and Lewis would

**'Kimi's DRS flap was open, it but wasn't enough. He needed to be on Seb's gearbox'**

pass both McLarens before the end. Paul di Resta was lying eighth, another trying to get his second set of tyres to last 36 laps, making him vulnerable to Hulkenberg, Rosberg and the recovering Webber, all of whom would pass the Force India before the end, forcing it out of the points.

Raikkonen, on his options, began closing on Vettel/Grosjean at around 0.5s per lap. But he was nowhere near as fast as Alonso. The Ferrari was loving the fresh soft tyres on a track now well rubbered-in and warmed and, for a time, was 1s faster than the leaders,

## THE RACE LAP BY LAP

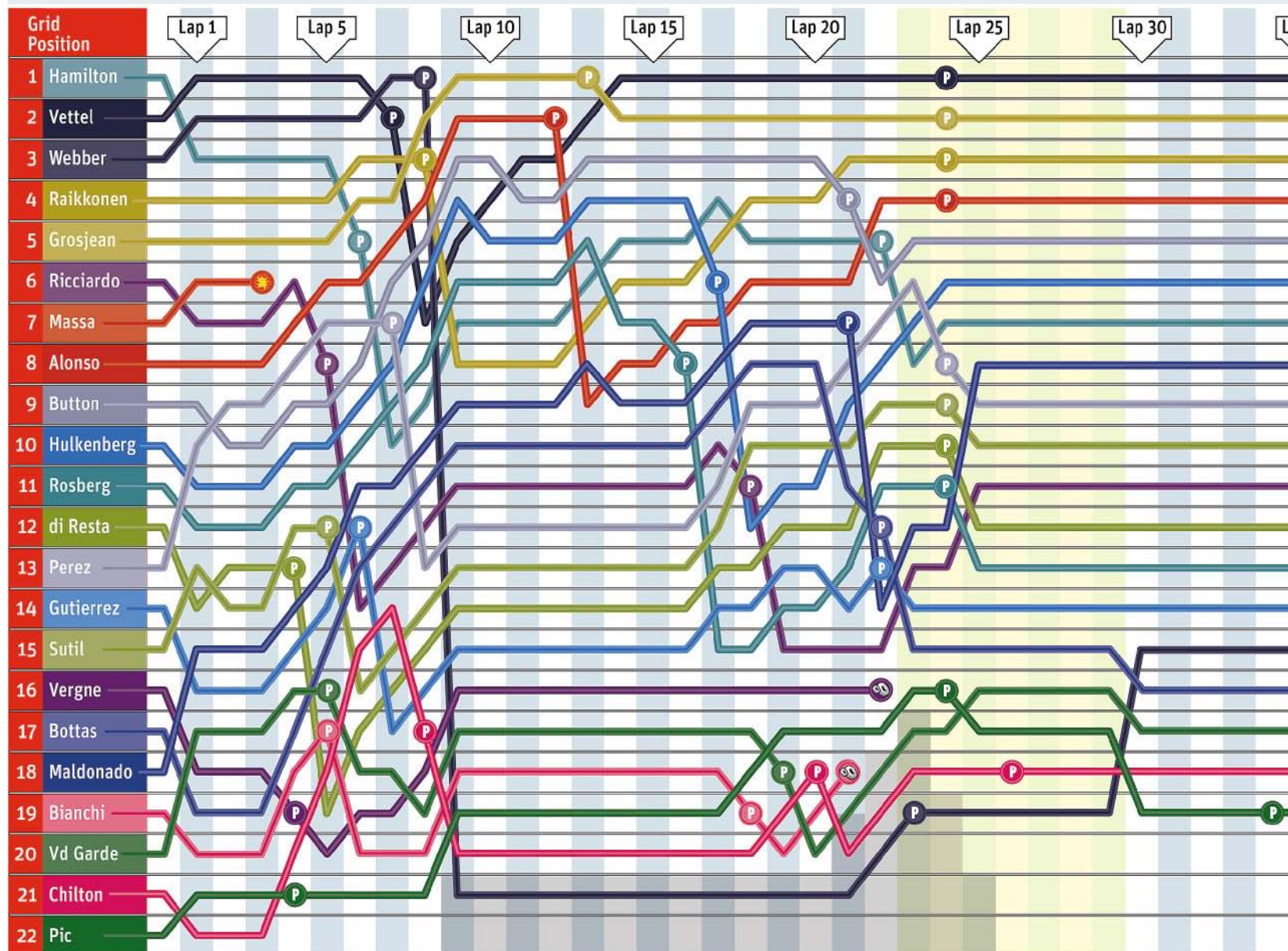



**Raikkonen ran out of time to catch Vettel at the end**

bringing itself right into podium contention. In the process Alonso set the race's fastest lap. It was another display of pummelling, relentless performance from Fernando.

If Raikkonen had been granted the same level of performance as Alonso, he'd have been onto that Red Bull sooner. He'd been allowed past Grosjean under instructions, but was only marginally faster than Vettel, who had responded like the champion he is, upping his pace by a full second with five laps to go.

...And so they rushed up to the

chicane on the final lap. Kimi's DRS flap was open, but it wasn't enough. The move needed to have started from tight up the RB9's gearbox, not a few car lengths back. Another lap might have done it. Naturally, Raikkonen was disappointed and said he would have preferred to have tried to get to the end without that final stop.

Grosjean withstood the late Alonso onslaught to hang onto a well-deserved podium place. Hamilton followed 20s behind Alonso, having passed the gripless Button on the last lap. Webber nailed Perez for seventh at the chicane

for the final time. Rosberg and Hulkenberg took the final points.

"That was a tough one," beamed Vettel, partly in exhilaration, partly relief. He'd finally won his home race. But, more significantly, he'd just extended his lead at the top of the table to 34 points over Alonso. Hamilton, coming into the weekend wondering if the Merc tyre problems had indeed been solved and whether a title tilt might be feasible, seemed to have his answer as he shook his head and said: "Nearly 60 points behind, man..."

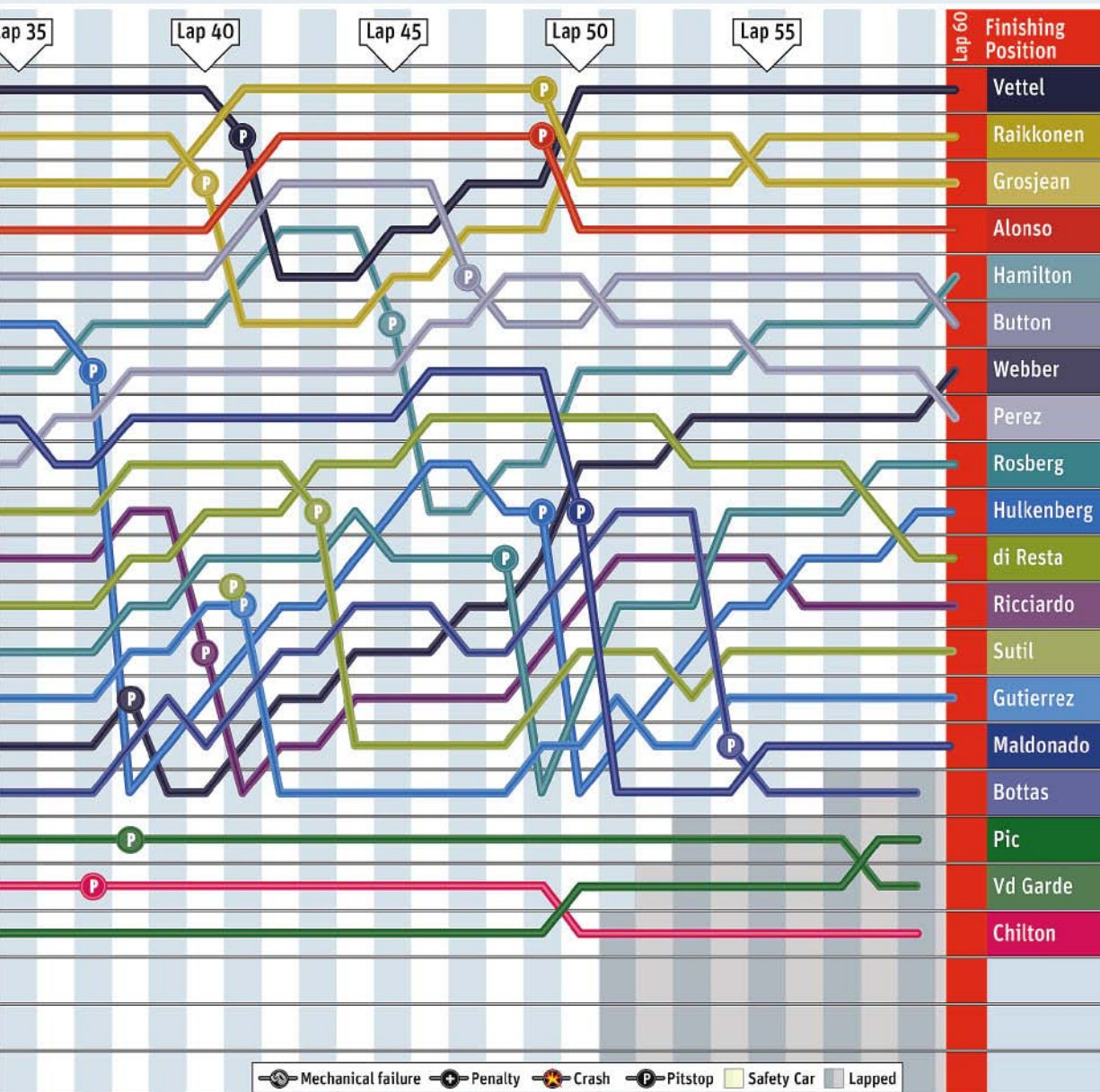

## SUNDAY



- 1211** Pic's Caterham will start from the back after a gearbox layshaft change.
- 1408** Massa locks up the rears under braking for Turn 1 and spins out of sixth place: "The gears were not going down and the engine went off."
- 1410** Force India releases di Resta's car into the path of Vergne in the pits.
- 1412** Grosjean reports that he's "much quicker than Kimi."
- 1416** Webber's right-rear wheel comes off in his pitstop and strikes cameraman Paul Allen on the back. "Stay in the car Mark... Switch off the engine." He rejoins 21 st.
- 1440** Bianchi's car blows up in front of Grosjean on the approach to the chicane. "Get out Jules, fire, get out quickly - the fire extinguisher."
- 1502** Vettel is told his KERS has failed: "Fail 1-4 fail. Brake bias three clicks rearwards."
- 1512** Grosjean can't pass Vettel: "It's really difficult to overtake."
- 1521** Kimi is told: "Vettel and Grosjean in traffic, you are quickest of anyone at the moment. Fourteen laps to go." Later: "We understood that tyres are not bad?"
- 1522** Raikkonen's radio is garbled. He's told: "Radio no good. Wait until Turn 12." Then: "Can you go to the end? Sorry radio is poor." He shouts: "I told you already!"
- 1537** Grosjean is told, after initially claiming his radio wasn't working: "Kimi behind is on the option tyre, do not hold him up." He clarifies: "So Kimi's faster than me?" He is told: "Confirm, yes."
- 1545** Vettel: "Yes, yes, yes, ja! That was a tough one! They gave me a run for the money."
- 1545** Button is livid after losing fifth: "The Caterhams absolutely screwed us. I'm glad they fought well for their 19th position."
- 1545** Grosjean admits: "A shame we couldn't take it at the end. We should have won."

COATES/LAT

# TEAM BY TEAM

## RED BULL



### Vettel exorcises home-race demons

**1**  
9/10  
Event rating

CIANFLONE/GETTY

**SEBASTIAN VETTEL**  
Red Bull-Renault RB9-03  
Start: 2nd; Finish: 1st  
Strategy: 3 stops (soft/  
medium/medium/medium)



Vettel finally filled the one glaring hole on his CV, a home grand prix victory, with a Sunday afternoon masterclass. Lotus looked to have the race in its grasp, but Vettel drove superbly, finding the pace when he needed it to ensure he never lost control of the situation. The only question-mark hanging over his weekend was whether he could have bridged the one-tenth gap to pole with a neater first sector. One mark off for that, otherwise perfect.

**2**  
8/10  
Event rating

THOMPSON/GETTY

**MARK WEBBER**  
Red Bull-Renault RB9-02  
Start: 3rd; Finish: 7th  
Strategy: 3 stops (soft/  
medium/medium/medium)



Webber pushed Vettel hard in qualifying, but his relative lack of pace in the final sector cost him. Aced the start and briefly edged ahead of his team-mate, only to be hung out to dry at the exit of the first corner. The disaster at his first pitstop (the right-rear wheel came off and struck a cameraman) cost him a lap, which was given back under the safety car. Did a decent job to climb into the points, but that was little consolation for a victory shot lost.

## FERRARI

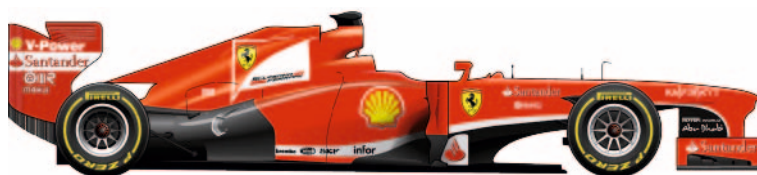

### Alonso battles up the order – again

**3**  
8/10  
Event rating

XPB/LAT

**FERNANDO ALONSO**  
Ferrari F138-299  
Start: 8th; Finish: 4th  
Strategy: 3 stops (medium/  
medium/medium/soft)



Alonso went into qualifying on medium rubber, so was on a hiding to nothing, but underachieved by ending up behind team-mate Felipe Massa. In the race, he survived his first set of tyres dropping off earlier than expected and then used the softs in the final stint to push for a podium position. Realistically, did not quite have the raw pace to challenge, so to finish so close to the front – albeit with safety car assistance – was the most he could have achieved.

**4**  
4/10  
Event rating

XPB/LAT

**FELIPE MASSA**  
Ferrari F138-298  
Start: 7th; Finish: DNF  
Strategy: retired  
(medium)



The good news is that after a spate of crashes during the previous three race weekends, Massa had a much smoother run through practice and qualifying in Germany. He even got a little more out of the medium-compound Pirellis to outqualify Alonso. The bad news is that in the race he managed to spin away sixth place, ahead of Alonso, after locking up the rears under braking for Turn 1 and stalled. One huge mistake ruined an otherwise good weekend.

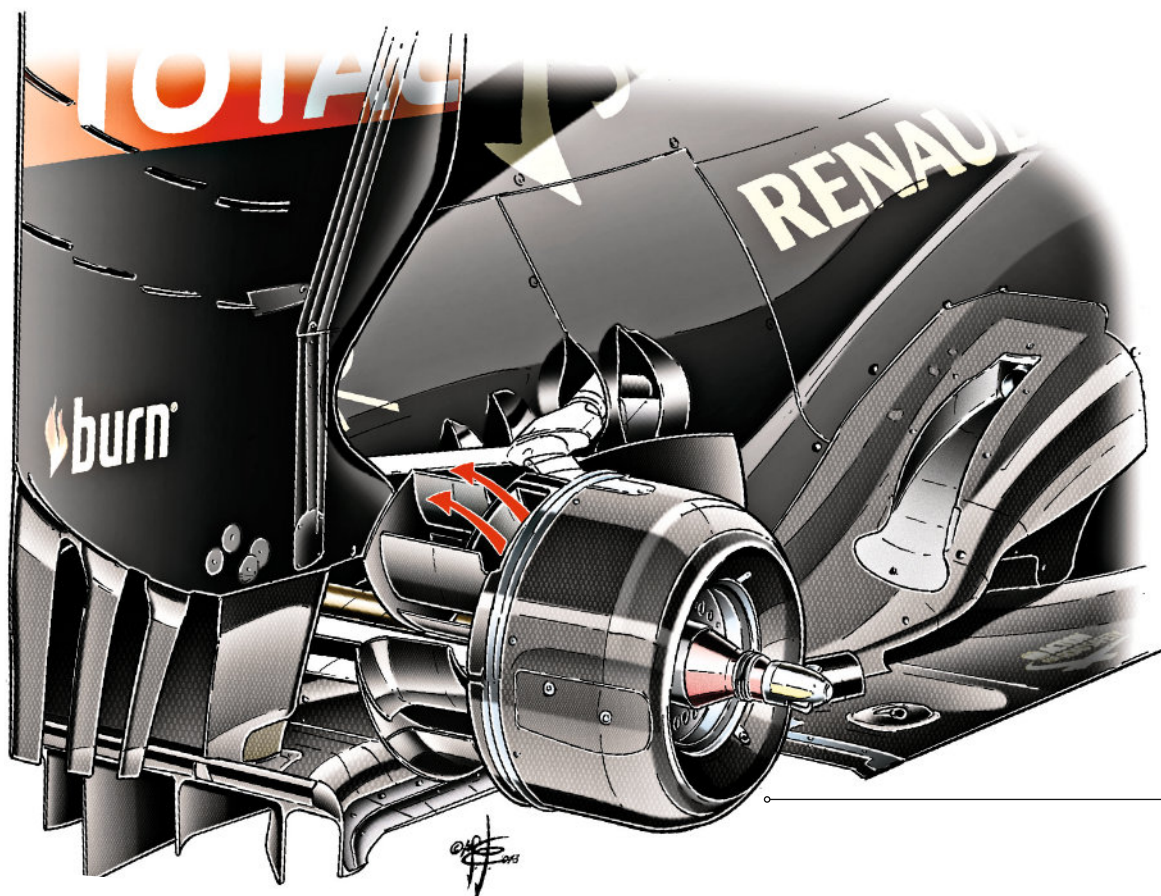

## Lotus and Mercedes keep their cool with enclosed brake discs

➔ Lotus and Mercedes have each fully enclosed their rear discs and routed the exit for the cooling air out of the top of the duct itself rather than through the centre of the wheel. The Mercedes drawing (right) illustrates the enclosing of the disc while the outlet can be seen in the Lotus drawing (left). The Mercedes outlet is in the same place as that of the Lotus.

**GARY ANDERSON** There are two significant details on these systems. One is that the disc is now completely enclosed, the other is that the cooling air is now being expelled through a hole in the duct itself rather than through the centre of the wheel. Enclosing the disc in the carbon drum so as not to put heat through the wheel rims into the tyre just wraps up the source of that heat effectively as the rear tyre temperatures are, of course, critical.

Regarding expelling the cooling air, the basic principle of rear-brake cooling up until now has been bringing cooling air into the front and expelling it out through the wheel. There's no disruption to the aerodynamic devices doing that but it does create a bit of drag because there's a

# LOTUS



## Strategy pays off for double podium

7

9/10  
Event rating

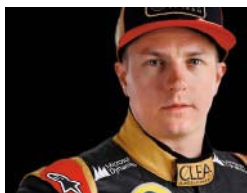

**KIMI RAIKKONEN**

Lotus-Renault E21-03  
Start: 4th; Finish: 2nd  
Strategy: 3 stops  
(soft/medium/medium/soft)



There was the feeling that Raikkonen should have done a little better in qualifying, although how much of that was in his control given that the tyres weren't up to temperature in sector 1 is open to question. But in the race, he drove typically well and pushed Vettel to the finish. In hindsight, there was a way for Raikkonen to have won this race, but after showing good pace and pulling off some decent passes, that lay more in strategy than the Finn's hands.

8

9/10  
Event rating



**ROMAIN GROSJEAN**

Lotus-Renault E21-02  
Start: 5th; Finish: 3rd  
Strategy: 3 stops (soft/  
medium/medium/medium)



Grosjean's Nurburgring weekend was a good example of a driver delivering when he needed to. With legitimate question-marks about his future, he was within 0.075s of Raikkonen in Q3 and managed to eke out his first set of softs to set up a potentially winning position that was compromised a little by the safety car. Overall, he was fast, consistent and, aside from a slightly fluffed restart and the odd ragged moment, it was a very fine performance.

# MERCEDES



## Tyre trouble blunts Arrows' race day

9

6/10  
Event rating



**NICO ROSBERG**

Mercedes F1 W04/03  
Start: 11th; Finish: 9th  
Strategy: 3 stops (medium/  
medium/medium/soft)



Came into his home grand prix on a high, but the team badly misjudged the rate of track evolution in Q2 and he failed to make the top 10 shootout. Mercedes' mistake, certainly, but had he been a tenth or two faster, as his team-mate was in similar circumstances, it wouldn't have been so costly. Drove an unremarkable race battling tyre degradation, but a final-stint charge on soft rubber allowed him to climb from 16th to ninth to salvage a couple of points.

10

8/10  
Event rating



**LEWIS HAMILTON**

Mercedes F1 W04/04  
Start: 1st; Finish: 5th  
Strategy: 3 stops (soft/  
medium/medium/medium)



The weekend started well in Friday morning practice, but as the track temperature rose Hamilton found life harder before recovering with a second successive pole position. Got an average getaway, handing Vettel the initiative, and his conservatism on the brakes into Turn 1 allowed Webber an easy pass. The team's tyre struggles made it impossible to compete and fifth, after a last-lap, around-the-outside pass on Button, was as good as it was going to get.

## Mercedes noses ahead with pillars

➔ Mercedes introduced a new higher, slimmer nose for the German GP with pillars that now sweep forwards (inset) rather than backwards (main pic).

**GARY ANDERSON** As well as holding the front wing on and joining the wing to the nose, the pillars are also used aerodynamically to guide air towards the middle of the car's width. In the old days when the central part of the front wing was allowed to be aerofoil-shaped the pillars they'd be wider at the rear because you were just trying to maximise the area to get the air through, as the aerofoil shape of the wing was taking care of the speed of the flow. But now that the central part of

the wing has to be flat, you rely on the pillars to enhance the flow – by making them wider at the front than the rear, creating some negative pressure behind – while also encouraging the air to turn inside the front tyres. I'd think this shape of nose will be a bit lighter and offer a small reduction in centre of gravity height.

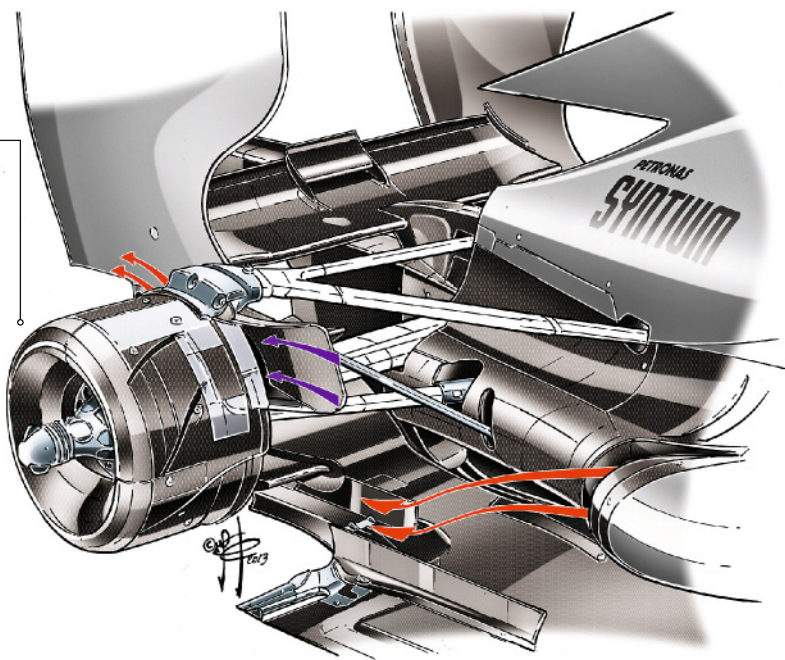

column of air coming out of the wheel centre that adds to the width of the car, in terms of what the airflow hits. But on the Lotus and Mercedes – on which all the aero devices on the bottom of the duct are working in association with the exhaust flow – there is a hole at the top of the duct to expel the hot air, keeping it from going

outside the rear wheel into the airstream but not affecting the downforce-producing devices that are all below. There's a gap between the edge of the rear wing and the inside of the rear wheel where you can direct the column of warm air. This should improve the overall aerodynamic efficiency of the car.

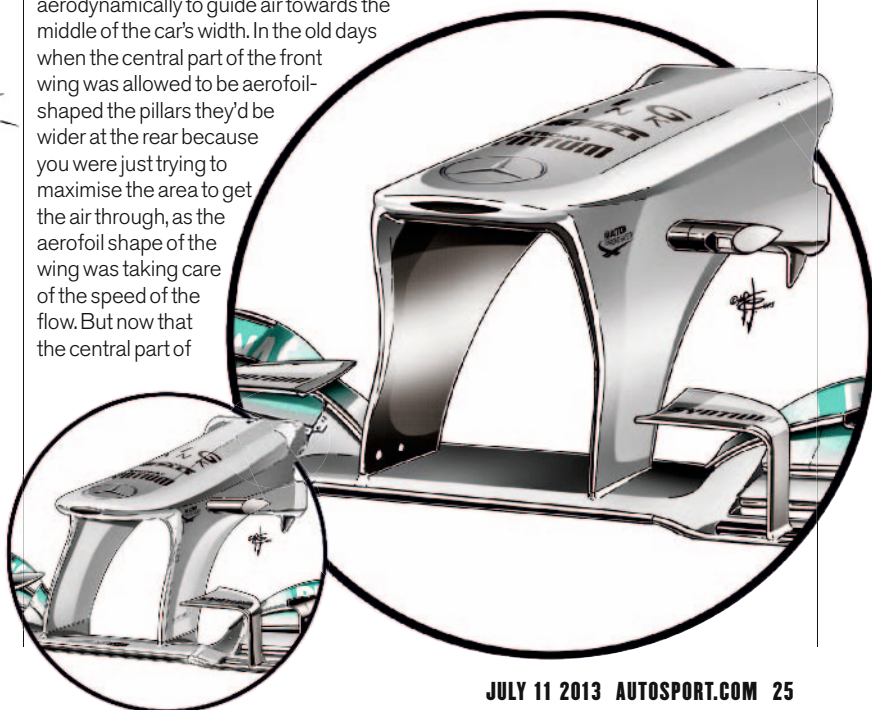

McLAREN

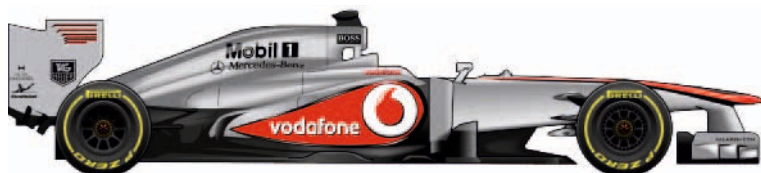

Double points finish most welcome

**5**  
8/10  
Event rating



JENSON BUTTON

McLaren-Mercedes MP4-28-01  
Start: 9th; Finish: 6th  
Strategy: 2 stops  
(medium/medium/soft)



Did a fine job to haul the tricky McLaren into Q3. In the race, it was no surprise to see him pull off a two-stop strategy, starting on medium rubber, and getting very close to claiming fifth place. Inevitably when a driver loses a position (in this case to Lewis Hamilton) on the final lap, questions are asked, and there were times in the race where Button was slightly conservative. But given the traffic and his tyre disadvantage in the dying laps, it's forgivable.

**6**  
7/10  
Event rating



SERGIO PEREZ

McLaren-Mercedes MP4-28-01  
Start: 13th; Finish: 8th  
Strategy: 2 stops  
(soft/medium/medium)



Seemed unable to cope with the handling characteristics of the McLaren as well as Button in qualifying, but was far more convincing in the race. Executed a two-stopper well, overtaking his team-mate in his first stint on softs, and had no trouble making the rubber last. Had Webber, who passed him on the last lap, not been out of position, Perez would have finished one place behind his team-mate. His race pace was certainly more impressive at times.

SAUBER



Hulkenberg takes hard-earned point

**11**  
8/10  
Event rating



NICO HULKENBERG

Sauber-Ferrari C32-03  
Start: 10th; Finish: 10th  
Strategy: 3 stops (medium/  
medium/medium/soft)



Made a set-up breakthrough after Saturday-morning practice that seemed to make the Sauber much more competitive, leading to some raised eyebrows when he made it into Q3. Rightly opted not to run and started on mediums, but didn't find the car as convincing in race trim. Seemed to spend the whole race scrapping with other midfielders, losing plenty of time, but passed di Resta with two laps remaining for one of the hardest-won points of his career.

**12**  
5/10  
Event rating



ESTEBAN GUTIERREZ

Sauber-Ferrari C32-04  
Start: 14th; Finish: 13th  
Strategy: 3 stops (soft/  
medium/medium/medium)



Had a decent run in qualifying until Hulkenberg pulled his stunning Q2 lap out of the bag, once again leaving Gutierrez looking average. He turned in a tidy race performance and fared reasonably well in battle. The trouble is, at no point during the weekend did he ever show convincingly that he had anything approaching Hulkenberg-like pace. Allowances can be made for his lack of experience, but needs to be kicking on in qualifying in particular.

FORCE INDIA



Drivers get most out of difficult car

**14**  
7/10  
Event rating



PAUL DI RESTA

Force India-Mercedes VJM06/04  
Start: 12th; Finish: 11th  
Strategy: 2 stops  
(soft/medium/medium)



Given that Force India was relatively lacklustre at the Nurburgring and didn't look like a serious Q3 contender, di Resta's performance was better than the results suggested. Having struggled for balance on Friday, he asserted himself over team-mate Adrian Sutil and came close to picking up points on a well-executed two-stopper. Sadly, tyre degradation made him a sitting duck late on. All in all a strong performance in a car that disappointed.

**15**  
6/10  
Event rating



ADRIAN SUTIL

Force India-Mercedes VJM06/03  
Start: 15th; Finish: 13th  
Strategy: 3 stops (soft/  
medium/medium/medium)



An OK weekend from Sutil, who despite qualifying and finishing behind his team-mate was usually not too far adrift. The biggest difference, aside from the three tenths of a second in qualifying, was that Sutil proved unable to pull off a two-stop strategy. A third stop was needed, which ended any possibility of points. Had been just ahead of di Resta when the call was made, but would have had no chance of making the tyres last to the end.

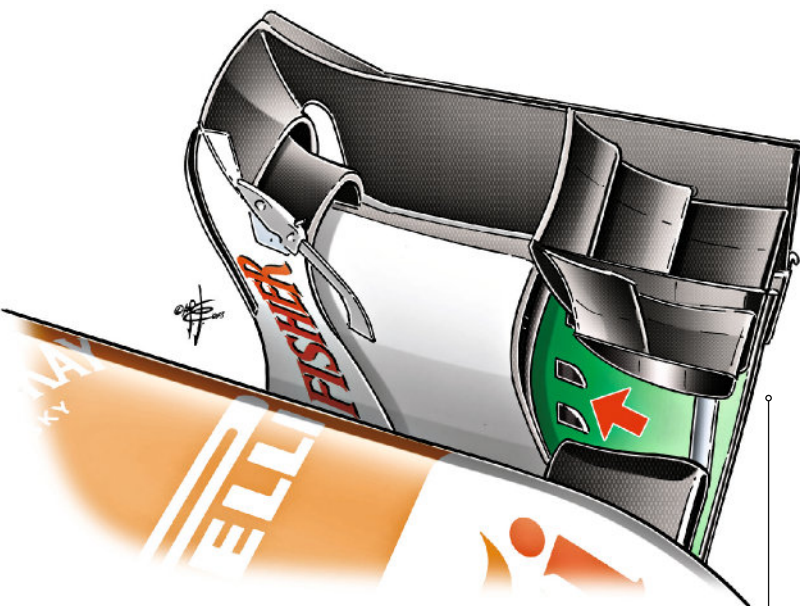

Force India's RB9-style mini-vanes

➔ Force India's front wing features miniature turning vanes similar to those introduced on the Red Bull for the Canadian GP weekend.

**GARY ANDERSON** These little turning vanes are a bit like Red Bull's. My initial belief on the Red Bull version was that they'd be good to prevent rubber debris going into the slot gaps. The air flows

through there at very high speed, so any bits of rubber tend to get sucked in – and because of the high speed it has a big effect. On the Force India they are a bit further forward than on the Red Bull and have more turning moment on them, turning the disturbed flow from the outboard stall-prone end of the wing. So the vanes seem to perform two functions.

## WILLIAMS



### Pitstop blunders prove to be costly

**16**  
Event rating



CLAM/FLORE/GETTY

**PASTOR MALDONADO**  
Williams-Renault FW35-02  
Start: 18th; Finish: 15th  
Strategy: 2 stops (medium/medium/soft)



A fuel-pump problem restricted Maldonado to a single run in Q1, meaning he was outqualified by team-mate Bottas for the sixth time this season. But come the race, he did a fine job only to lose time at his final pitstop, when there was a problem getting the wheelgun attached to the front-right wheelnut. Had he been able to go on a charge on his softs in the final stint, a point might have been possible. All things considered, a good weekend's work.

**17**  
Event rating



XPB/LAT

**VALTTERI BOTTAS**  
Williams-Renault FW35-01  
Start: 17th; Finish: 16th  
Strategy: 2 stops (medium/medium/soft)



Won the intra-Williams qualifying battle by a fraction, although it was a relatively meaningless victory given his team-mate's technical problems. As usual, drove a good, consistent race – albeit not quite as good as his team-mate's – that belied his inexperience. Ran in the points before his late final stop, which was slow thanks to a cross-threaded wheelnut that condemned him to a lowly finish. Without that, and an earlier slow stop, he might have scored.

## TORO ROSSO



### Ricciardo again proves his pace

**18**  
Event rating



XPB/LAT

**JEAN-ERIC VERGNE**  
Toro Rosso-Ferrari STR8-03  
Start: 16th; Finish: DNF  
Strategy: retired (soft/medium)



The Frenchman often has weekends like this. Struggled during practice, complaining the car was tricky to drive, and reckoned there were no mistakes in Q2 to explain the near one-second gap to his team-mate. In fairness, he didn't have much opportunity to impress during the race, save for his good awareness that prevented a crash when di Resta was released into his path in the pits. Hydraulics problems forced his retirement, but wasn't a threat for points at the time.

**19**  
Event rating



XPB/LAT

**DANIEL RICCIARDO**  
Toro Rosso-Ferrari STR8-01  
Start: 6th; Finish: 11th  
Strategy: 3 stops (soft/medium/medium/medium)



Silverstone told Red Bull very little about Ricciardo, who's regularly shown that, with a clean run, he's seriously quick and capable of scoring points. But in Germany he successfully got on top of the set-up to turn it around. His grid slot was boosted by Ferrari qualifying on mediums and Rosberg's troubles, but getting into Q3 was impressive. The car regressed to the mean in the race, leaving Ricciardo pointless as he battled low grip behind a two-stopping di Resta.

## CATERHAM



### Pic wins class war after solid charge

**20**  
Event rating



XPB/LAT

**CHARLES PIC**  
Caterham-Renault CT03-05  
Start: 22nd; Finish: 17th  
Strategy: 3 stops (soft/medium/medium/medium)



Claimed 'pole' in the Caterham/Marussia class, only to lose it again when the team had to break the seal on his gearbox to change a layshaft. That relegated him to the back, but the Frenchman took his qualifying speed into the race with a strong drive up to the point where he had to pit with a slow puncture after the safety car. To his credit he recovered well and used his tyre advantage to get ahead of Chilton's Marussia and team-mate van der Garde by the finish.

**21**  
Event rating



XPB/LAT

**GIEDO VAN DER GARDE**  
Caterham-Renault CT03-04  
Start: 20th; Finish: 18th  
Strategy: 3 stops (soft/medium/medium/medium)



Qualifying was not particularly impressive and he ended up eight tenths off his team-mate, although he reckoned there wasn't much more pace to be found in his car, particularly with a lack of tyre temperature in the first sector. But he was much more convincing in the race and looked odds-on to be the best-placed Marussia/Caterham driver. Unfortunately, his weakness in tyre management relative to Pic told, and the Frenchman was able to pass him late on.

## MARUSSIA



### Engine and tyre woes hamper team

**22**  
Event rating



XPB/LAT

**JULES BIANCHI**  
Marussia-Cosworth MR-02-02  
Start: 19th; Finish: DNF  
Strategy: retired (soft/medium/medium)



Considering he only managed 10 laps on Friday thanks to a combination of Rodolfo Gonzalez taking over his car and a stomach bug, Bianchi did a superb job to come so close to outqualifying Pic, especially as he was "not 100 per cent yet". Pic's gearbox penalty gave Bianchi a clear run in the Caterham v Marussia scrap, and he looked to have the speed to prevail, having just overtaken van der Garde when his engine let go in a smoky and fiery fashion.

**23**  
Event rating



XPB/LAT

**MAX CHILTON**  
Marussia-Cosworth MR-02-03  
Start: 21st; Finish: 19th  
Strategy: 4 stops (soft/medium/medium/medium)



Having made quietly effective progress in the first part of the season, his qualifying pace seems to have tailed off. For the second successive race he was more than a second off Bianchi thanks to "a couple of mistakes" and poor tyre temperature balance front-to-rear. The raw pace gap was perhaps between three and five tenths. His race was much stronger and he mixed it well with the Caterhams, but shot rear tyres in the final stint meant he ended up last.

# GERMAN GP RESULTS



## PRACTICE 1: Friday

POS	DRIVER	TIME
1	HAMILTON	1m31.754s
2	ROSBERG	1m31.973s
3	WEBBER	1m32.789s
4	SUTIL	1m32.822s
5	RAIKKONEN	1m32.956s
6	MASSA	1m33.065s
7	BUTTON	1m33.139s
8	VETTEL	1m33.213s
9	GROSJEAN	1m33.260s
10	PEREZ	1m33.456s
11	DI RESTA	1m33.493s
12	HULKENBERG	1m33.810s
13	RICCIARDO	1m33.901s
14	VERGNE	1m33.976s
15	MALDONADO	1m34.025s
16	BOTTAS	1m34.200s
17	GUTIERREZ	1m34.437s
18	PIC	1m35.674s
19	CHILTON	1m35.987s
20	VAN DER GARDE	1m36.078s
21	GONZALEZ	1m37.459s
22	ALONSO	no time

Weather: dry

## PRACTICE 2: Friday

POS	DRIVER	TIME
1	VETTEL	1m30.416s
2	ROSBERG	1m30.651s
3	WEBBER	1m30.683s
4	GROSJEAN	1m30.843s
5	RAIKKONEN	1m30.848s
6	ALONSO	1m31.056s
7	MASSA	1m31.059s
8	HAMILTON	1m31.304s
9	BUTTON	1m31.568s
10	DI RESTA	1m31.797s
11	SUTIL	1m31.824s
12	RICCIARDO	1m31.855s
13	VERGNE	1m32.055s
14	PEREZ	1m32.086s
15	HULKENBERG	1m32.495s
16	GUTIERREZ	1m32.762s
17	BOTTAS	1m32.879s
18	MALDONADO	1m32.880s
19	PIC	1m33.695s
20	VAN DER GARDE	1m33.804s
21	BIANCHI	1m34.017s
22	CHILTON	1m34.667s

Weather: dry

## PRACTICE 3: Saturday

POS	DRIVER	TIME
1	VETTEL	1m29.517s
2	ROSBERG	1m30.193s
3	WEBBER	1m30.211s
4	ALONSO	1m30.621s
5	MASSA	1m30.639s
6	RAIKKONEN	1m30.671s
7	HAMILTON	1m30.744s
8	GROSJEAN	1m30.781s
9	HULKENBERG	1m30.966s
10	SUTIL	1m31.009s
11	BUTTON	1m31.326s
12	GUTIERREZ	1m31.405s
13	DI RESTA	1m31.733s
14	VERGNE	1m31.855s
15	PEREZ	1m31.855s
16	RICCIARDO	1m31.898s
17	MALDONADO	1m31.969s
18	BOTTAS	1m32.036s
19	PIC	1m33.230s
20	BIANCHI	1m33.470s
21	VAN DER GARDE	1m33.964s
22	CHILTON	1m34.683s

Weather: dry

## FRIDAY TESTERS

POS	DRIVER	TIME
1	GONZALEZ	1m37.459s



ROBERTSON/GETTY



Mercedes duo got a history lesson

ETHERINGTON/LAT

## QUALIFYING TIMES

POS	DRIVER	QUALIFYING 1	QUALIFYING 2	QUALIFYING 3
1	HAMILTON	1m31.131s (1)	1m30.152s (6)	1m29.398s
2	VETTEL	1m31.269s (2)	1m29.992s (3)	1m29.501s
3	WEBBER	1m31.428s (5)	1m30.217s (1)	1m29.608s
4	RAIKKONEN	1m30.676s (6)	1m29.852s (2)	1m29.892s
5	GROSJEAN	1m31.242s (10)	1m30.005s (7)	1m29.959s
6	RICCIARDO	1m31.081s (11)	1m30.223s (5)	1m30.528s
7	MASSA	1m30.547s (9)	1m29.825s (4)	1m31.126s
8	ALONSO	1m30.709s (4)	1m29.962s (9)	1m31.209s
9	BUTTON	1m31.181s (3)	1m30.269s (10)	no time
10	HULKENBERG	1m31.132s (15)	1m30.231s (8)	no time
11	ROSBERG	1m31.322s (8)	1m30.326s	-
12	DI RESTA	1m31.322s (14)	1m30.697s	-
13	PEREZ	1m31.498s (12)	1m30.933s	-
14	GUTIERREZ	1m31.681s (7)	1m31.010s	-
15	SUTIL	1m31.320s (13)	1m31.010s	-
16	VERGNE	1m31.629s (16)	1m31.104s	-
17	BOTTAS	1m31.693s	-	-
18	MALDONADO	1m31.707s	-	-
19	PIC	1m32.937s	-	-
20	BIANCHI	1m33.063s	-	-
21	VAN DER GARDE	1m33.734s	-	-
22	CHILTON	1m34.098s	-	-

## QUALIFYING STATISTICS

	HEAD	TO	HEAD
VETTEL	9	0	WEBBER
ALONSO	6	3	MASSA
BUTTON	6	3	PEREZ
RAIKKONEN	8	1	GROSJEAN
ROSBERG	3	6	HAMILTON
HULKENBERG	9	0	GUTIERREZ
DI RESTA	6	3	SUTIL
MALDONADO	3	6	BOTTAS
VERGNE	3	6	RICCIARDO
PIC	6	3	VAN DER GARDE
BIANCHI	8	1	CHILTON



Vettel turned 26 last week

THOMPSON/GETTY

## BAD BOYS & ENGINE USAGE

	PENALTIES	FINES	ENGINES
VETTEL	0	€0	4
WEBBER	2	€35,000	4
ALONSO	0	€1000	4
MASSA	2	€1400	4
BUTTON	0	€1000	5
PEREZ	0	€600	5
RAIKKONEN	1	€1500	4
GROSJEAN	1	€0	4
ROSBERG	0	€1300	5
HAMILTON	1	€0	5
HULKENBERG	0	€1000	5
GUTIERREZ	2	€800	4
DI RESTA	0	€5000	5
SUTIL	0	€1000	5
MALDONADO	0	€0	4
BOTTAS	0	€4900	4
VERGNE	0	€10,000	4
RICCIARDO	0	€0	4
PIC	1	€0	4
VAN DER GARDE	2	€11,200	4
BIANCHI	0	€2800	4
CHILTON	1	€300	4







# MORE THAN A RACE. IT'S THE EVENT OF LEGENDS.

LEGENDARY CARS | LEGENDARY DRIVERS | LEGENDARY CIRCUIT



## Rolex Monterey Motorsports Reunion

August 16-18 in Monterey, California.

Celebrating the 60th Anniversary of the Chevrolet Corvette.



TICKETS AVAILABLE | MAZDARACEWAY.COM | 800.327.7322 | TICKETMASTER.COM

# WHY IS LOTUS SO RANDOM?

A potential winner one race, struggling for points the next, the Lotus team's form has been unpredictable over the past couple of seasons. **EDD STRAW** investigates

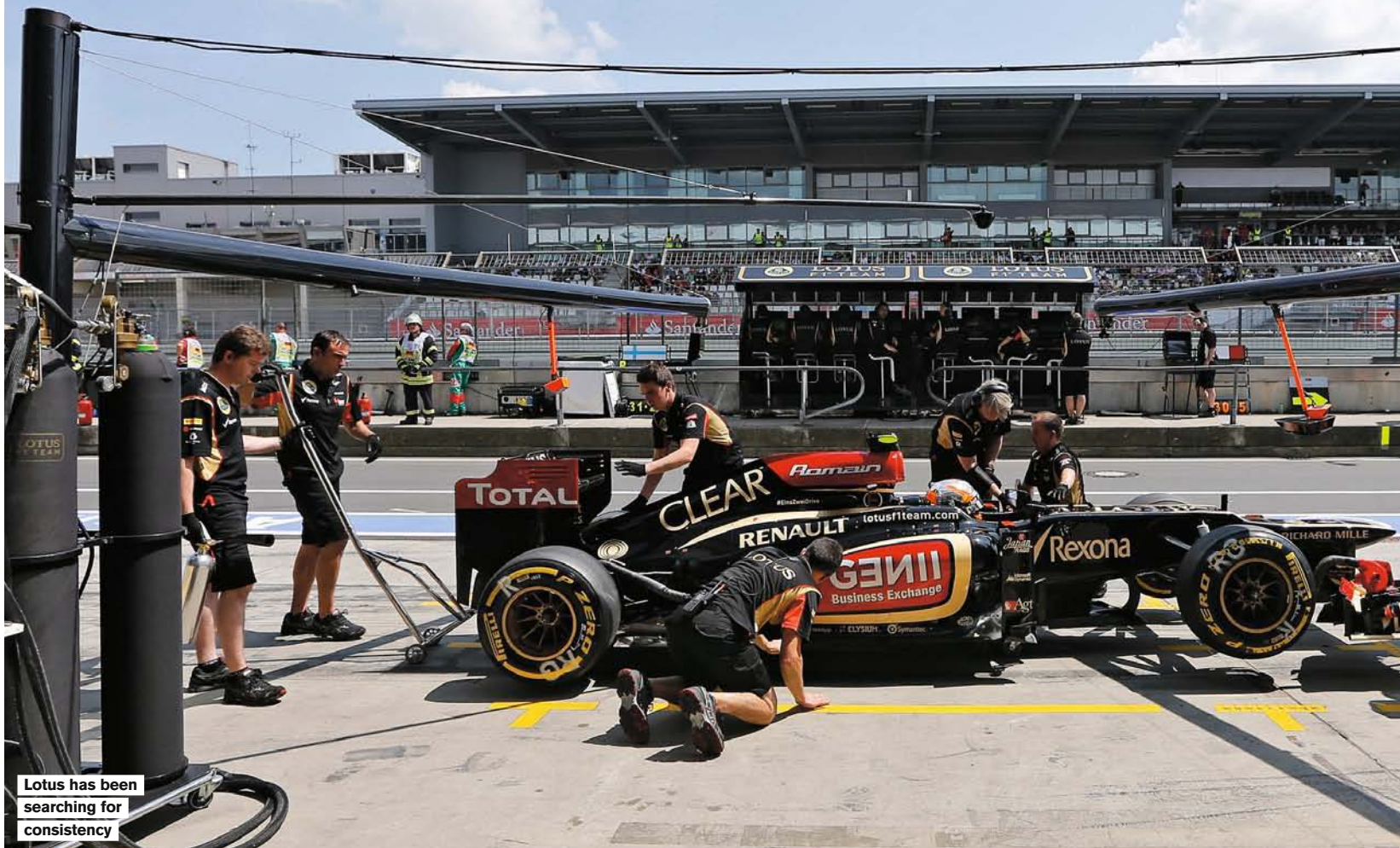

Lotus has been searching for consistency

Lotus has proved to be the most unpredictable of teams over the past 18 months. In last Sunday's German Grand Prix, arguably only the deployment of the safety car denied Romain Grosjean a maiden victory, and Kimi Raikkonen finished a close second. Heading to the Nurburgring, its aspirations of victory seemed tenuous, but for the first time since May's Spanish GP, and only the third time this season, a Lotus qualified within half-a-second of pole position.

Off all the frontrunning teams, Lotus is the most inconsistent. Twice this season it has had both its drivers on the podium, and Germany is not the only race it could have won (see sidebar), but on some weekends, most recently at the Canadian GP, it has struggled to be anything more than a minor points contender.

One factor has been the car's

relative gentleness on its tyres. This has sometimes meant Raikkonen and Grosjean have struggled to build tyre temperature quickly enough. This was less of a problem in the heat of Germany.

"It's a question of tyres," said Grosjean of Lotus's improved qualifying pace at the Nurburgring.

"It's always about that. If you get them in the right window, everything seems to be easy. If you don't get them in the right window you are nowhere. It affects the grip level."

This partly explains the fact Lotus was stronger in the race in Germany, for both drivers struggled for front-tyre temperature in Q3. Grosjean suspects this will improve when the new tyres are introduced for the next race in Hungary.

Another significant factor is that, because Lotus has not once had the quickest car in qualifying trim in the past 18 months, it is often reliant on



Grosjean and Kimi were both in the hunt in Germany

other teams struggling to come to the fore. In Australia, both drivers struggled in damp qualifying, but Raikkonen won relatively easily on a two-stop strategy while others stopped three times. This is not a situation that arises often.

There are also question marks

about the consistency of the drivers. Raikkonen is generally excellent in the race, but doesn't always appear to get the most out of the car in qualifying. How much of this is down to him and how much down to tyre temperature is hard to judge, but he is usually stronger on Sundays. As for Grosjean, he has been very inconsistent and, while he has bagged five podiums over the past 18 months, there have been weekends where mistakes or a lack of pace have held him back.

Ultimately, these struggles are to be expected. Lotus is a strong team, but by its own admission it does not have the same resources as Ferrari, Mercedes, Red Bull and McLaren. If it can attract more sponsorship, investment, it has the potential to emerge as a regular race-winning force, something that could prove key in convincing Raikkonen to stay rather than move to Red Bull.



Q&A

**ERIC BOULLIER**  
**LOTUS TEAM PRINCIPAL**



FERRAROLIAT

**Did Germany feel like a race win that got away?**

A little bit, yes. But as we finished so close to Sebastian, without the safety car and a couple of other things we could have maybe expected to win.

**Are you happy with the strategy calls made?**

Yes, but you can always improve so we will review it like we do after every race. But everything went perfectly this weekend, everyone worked hard to bring some upgrades that worked. The strategy was good, the pitstops were good and the drivers did a very good job.

**This is Lotus's most competitive weekend since the Spanish GP. What do you put that down to?**

Upgrades, weather, also a lot of work from the whole team. At Silverstone, we could have finished second without the final safety car call and in Montreal the pace was not there, but after that we are back.

**So you are confident this kind of form is going to be representative?**

I am.

**Will we see new parts in the young driver test?**

Yes, we will keep going, keep pushing.

**Do you feel like you are in this title fight?**

No, but we need to fulfil our objective, which is to finish in the top three.

**This was Romain Grosjean's best weekend of the year...**

It's more than his best weekend, it's also a weekend when he showed his class. He was there every session and in the race was fighting with guys like Vettel, Kimi, Alonso and didn't put a foot wrong. The pace was there, he was consistent. I have told him that this is his new baseline now.

**There are rumours about him being dropped, so is his seat safe for the rest of the year?**

Yes, exactly.

**THE RACE WINS THAT GOT AWAY**

Lotus has excelled in 2012 and 2013, but its victories in Abu Dhabi last year and Australia at the start of this season could – or perhaps should – have been supplemented by others:

**BAHRAIN 2012**

Romain Grosjean and Kimi Raikkonen qualified disappointingly, starting seventh and 11th, but the Finn soon emerged as a serious challenger. Still a little rusty after his F1 hiatus, Raikkonen pulled out of one attempted pass on Sebastian Vettel and finished just over three seconds down, with his team-mate third.

**SPAIN 2012**

Raikkonen was the pre-race favourite, but after a quiet first half of the race he surged into contention late on. In the final 18 laps, after pitting, Raikkonen closed the gap on leader Pastor Maldonado, who was being harried by Fernando Alonso, from almost 23 seconds to less than four.



**EUROPE 2012**

While Raikkonen finished second to Alonso, this could easily have been Grosjean's race. Running second at a safety car restart, he was mugged by Alonso at the first corner moments before leader Vettel expired. Later retired with an alternator failure while still in the hunt.

**HUNGARY 2012**

Once again, Raikkonen and Grosjean finished second and third. Had Raikkonen put the car on the front row, as his team-mate did, he would surely have beaten Lewis Hamilton rather than shadowing him home to the chequered flag.

**BAHRAIN 2013**

A near-repeat of the 2012 race, with Raikkonen (eighth) and Grosjean (11th) lining up in unremarkable positions but proving seriously quick in the race. Had Raikkonen started higher, he had a good chance of beating Vettel.

**PERFORMANCE ANALYSIS: DEFICIT TO POLE IN 2013**

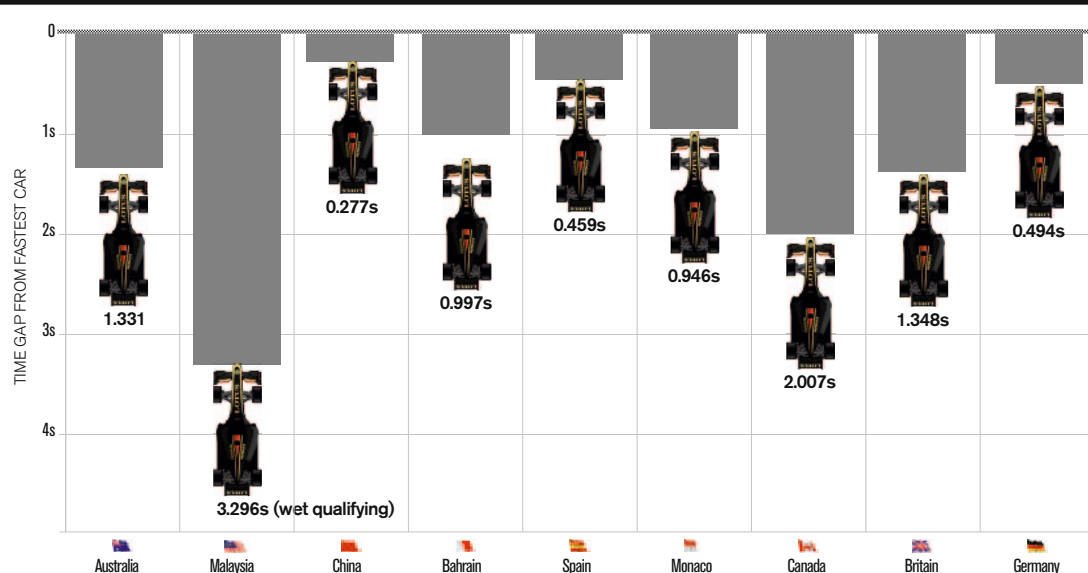

# Winners and losers of F1's tyre switch

The German GP offered some clues as to how changes to the tyres will affect the second half of the season. By **EDD STRAW**



ETHERINGTON/LAT

As many teams were about drawing such conclusions, there is little doubt that Pirelli's emergency tyre measures for last weekend's German Grand Prix did affect the competitive order. While it's difficult to draw definitive conclusions from one weekend, there were winners and losers.

After Silverstone's spate of tyre blowouts, Pirelli brought a batch of modified rear tyres in which the steel belt, introduced this year, was replaced with a Kevlar one. This was harnessed to the existing compounds, with the front tyres remaining unchanged.

The FIA also stipulated that Pirelli's recommended parameters for pressures and cambers must be complied with at all times. Additionally, the practice of 'reversing' tyres, whereby used rubber is swapped from one side of the car to the other for more

even wear, was outlawed.

At the Hungarian GP later this month, Pirelli will introduce its permanent solution. This modified rubber, which is effectively the 2013 compounds harnessed to the 2012 construction, will be tried out at next week's Silverstone 'young-driver test' at which teams can now run race drivers.

It is not clear how these new tyres will further affect the competitive order, although what happened at the Nurburgring could act as an indicator for the second half of the season.

After the race, Ferrari team principal Stefano Domenicali said: "I cannot answer yet because I don't yet have the analysis of this weekend, but some effect was there. What is going to happen from Hungary onwards, I don't know. We know what the structure is, we know the compounds of this year but we never tested them mixed together."

## LOTUS

**WINNER**

As Kimi Raikkonen pointed out after qualifying: "It helped that it was a bit more hot."

The general trend is unquestionably for Lotus to perform better when temperatures are higher. But in terms of qualifying pace, this was its strongest performance since May's Spanish Grand Prix, while its race

pace was probably better than at any previous race in 2013.

"I don't think we can know, honestly," said Lotus trackside operations director Alan Permane about whether the tyre change has helped his team. "It's like any test you do, unless you back-to-back it you don't really know. It doesn't look like it's hurt us, let's say that."



GULHAM/GETTY

## TORO ROSSO

**LOSER**

After strong performances in the previous three grands prix, Toro Rosso was very much in the midfield at the Nurburgring. Daniel Ricciardo's impressive sixth place on the grid was an overachievement thanks to others struggling and he quickly faded in the race with a general lack of grip.



COATES/LAT



There are more changes planned for the Hungarian GP

THOMPSON/GETTY

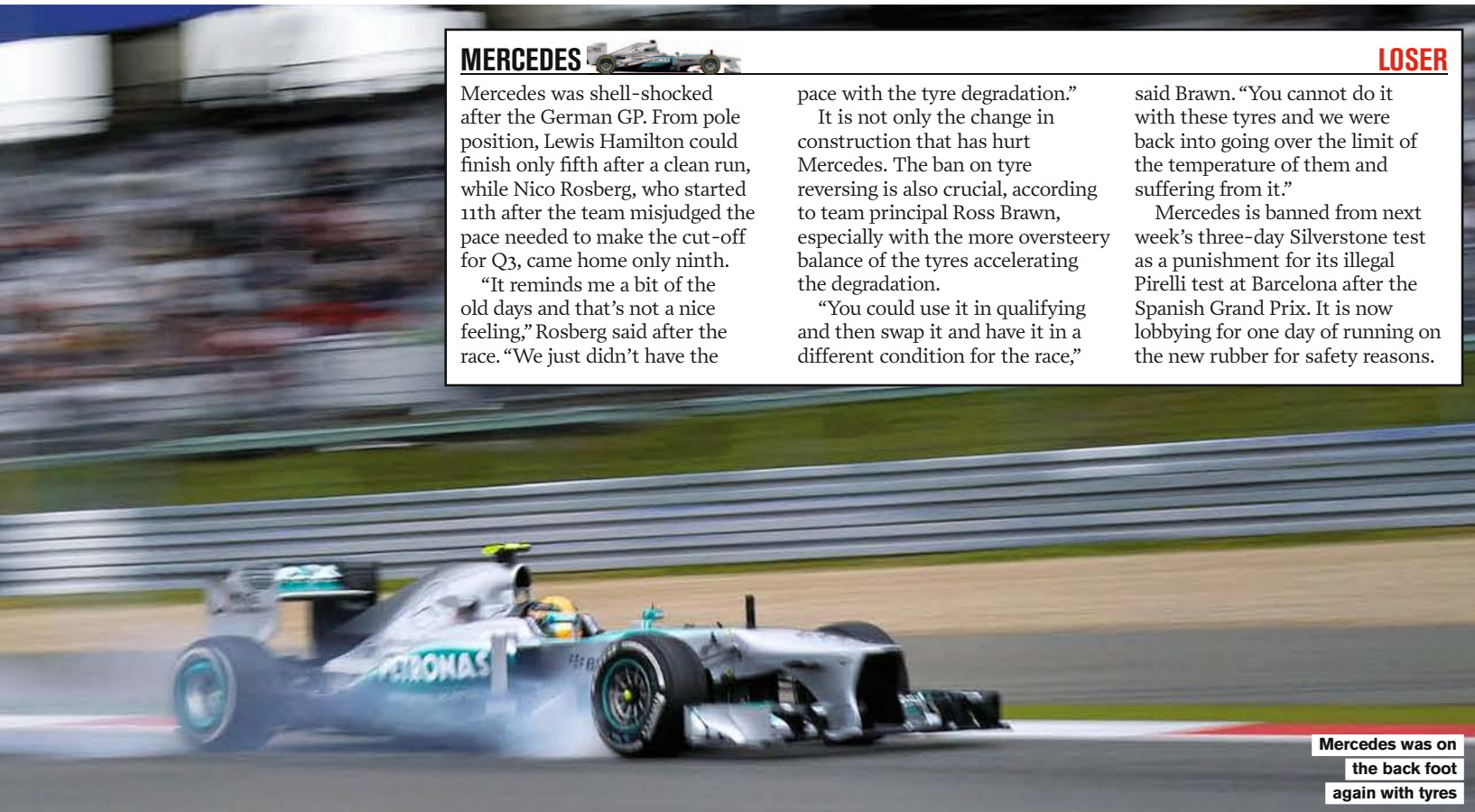

**MERCEDES** 

**LOSER**

Mercedes was shell-shocked after the German GP. From pole position, Lewis Hamilton could finish only fifth after a clean run, while Nico Rosberg, who started 11th after the team misjudged the pace needed to make the cut-off for Q3, came home only ninth.

“It reminds me a bit of the old days and that’s not a nice feeling,” Rosberg said after the race. “We just didn’t have the

pace with the tyre degradation.”

It is not only the change in construction that has hurt Mercedes. The ban on tyre reversing is also crucial, according to team principal Ross Brawn, especially with the more oversteer balance of the tyres accelerating the degradation.

“You could use it in qualifying and then swap it and have it in a different condition for the race,”

said Brawn. “You cannot do it with these tyres and we were back into going over the limit of the temperature of them and suffering from it.”

Mercedes is banned from next week’s three-day Silverstone test as a punishment for its illegal Pirelli test at Barcelona after the Spanish Grand Prix. It is now lobbying for one day of running on the new rubber for safety reasons.

**Mercedes was on the back foot again with tyres**

**McLAREN WINNER** 

McLaren had its best points haul of the year in Germany, with Jenson Button sixth and Sergio Perez eighth. While the tyres didn’t transform the car, the change appeared to edge McLaren up the competitive order, much as the team downplayed this.

When asked if the tyres had helped, McLaren team principal Martin Whitmarsh said: “I don’t think so. I don’t think there has been a change of the pecking order as a consequence of that.”



GILHAM/GETTY

**FORCE INDIA** 

**LOSER**

Force India never looked like a serious Q3 threat and its drivers suffered from oversteer in the race. This is likely down to the slightly lower level of rear grip, meaning the

rears are worked harder. As a result, Adrian Sutil had to abandon a two-stop strategy, while Paul di Resta faded in the final few laps with shot rears.

**FERRARI** 

**WINNER**

While a large part of Ferrari’s improved form at the Nurburgring was down to the move away from the ultra-high-speed sweeps of Silverstone, the team was not blighted by the graining struggles that have held it back at previous races. The Hungarian tyres should also be less prone to this problem.



GILHAM/GETTY

**AUTOSPORT SAYS**



**Gary Anderson**  
**Technical correspondent**

It’s difficult to judge exactly what role the tyres played because it is one of a number of factors that have an affect on performance, including track configuration and temperature. Certain characteristics stayed much the same: Mercedes was still quick in qualifying while the Lotus was good on its tyres in the race. But some other things did change.

The rear tyres did drop off quicker than the old ones – just look at what happened to Force India. Some drivers complained about oversteer and that adds up because the tyres were this year made with a steel belt to create a bigger contact patch, which gave more grip. That balance will change again for the Hungarian GP and probably give those cars a better balance

The rears did seem more temperature-sensitive and that, combined with the loss of rear grip, didn’t help Mercedes at the Nurburgring. It has also reduced the potential for certain teams to run longer and overachieve.

Interestingly, the Red Bull seems very much neutral, which suggests it has a good handle on the set-up balance, which will stand it in good stead for the Hungarian tyres too.

# Can king of the Norisring end Audi's drought?

This weekend the DTM hits the streets of Nuremberg for Audi's local race, and all eyes are on Jamie Green as he tries to end its 10-year wait for a victory there. By **JAMIE O'LEARY**

**A**udi is desperate to win at the Norisring. Really desperate. Not only is the annual mid-season event on the former Nazi rally ground a highlight of the DTM calendar, thanks to its party atmosphere and novel street-circuit layout on the outskirts of Nuremberg. But with Audi Sport stationed just 55 miles south in Ingolstadt, there is also a feeling of home expectation on the collective shoulders of its eight-strong driver line-up.

Add to that the fact that bitter rival Mercedes has won there for the past 10 years, and suddenly Laurent Aiello's last-gasp victory of 2002 – sealed with an aggressive move down the inside of Bernd Schneider – seems a very long time ago.

It was hardly a surprise, then, that when news of four-time Norisring winner Jamie Green's signing for the manufacturer broke late last year, the subject of a 1.4-mile piece of asphalt featuring only four corners was publicly brought up by head of Audi Sport Wolfgang Ullrich. "Maybe he can help us break our bad luck at the Norisring," he said, and it did not go unnoticed.

Green's record at the Norisring is sensational. Four wins in five years for Mercedes, in a mixture of old



**Audi DTM boss Gass wants to break losing run**

and current-spec machinery and a variety of weather conditions, make up 50 per cent of his eight career DTM victories.

And he could have had even more at the venue...

"I've had quite a good, consistent, run of races there," Green says. "And I'm not 100 per cent sure why. The 2007 race, when I was sixth, was the only time I had an average weekend. I should probably have won in 2006 too, but I got involved in a wheelbanging match with Christian Abt when I was lapping him and that ruined that one."

Green's view of why he has achieved such success on the Nuremberg street circuit is simple.

"The way I drive a racing car is all about being accurate and consistent,

and I set myself very high standards when it comes to maintaining that," he said. "On a track like the Norisring, where the walls are so close all of the time, I think that's quite an asset."

"I'm a driver who doesn't make many serious mistakes in a car. If I do make an error, it's a lock-up and a missed apex. You don't see me in the wall or the gravel very often, and that's the same even after 150 laps in a day of testing."

"What you can't ever do at the Norisring is arrive thinking you're going to win because history suggests it. Do that and you're in big trouble."

Trouble is something Audi will hope Green can avoid on Sunday, as the Brit's acclimatisation to life on the other side of the fence after eight years with Mercedes has been tough so far.

Should Green make it five Norisring wins in six years this weekend, he will become only the third driver to triumph in an Audi there and only the second in a factory machine. Aiello's



**Green has had a tricky start to life with Audi**





Schneider lost out to Aiello's Audi TT in epic 2002 race

victory for Abt came two years before Audi Sport re-entered the DTM as a works squad, meaning Ingolstadt has had to wait since Hans-Joachim Stuck took his V8 quattro evolution to a victory in 1991 to pop open the bubbly.

In that time Mattias Ekstrom, Timo Scheider, Martin Tomczyk and plenty more series heavyweights have failed to do the business, Scheider coming closest in 2009, only to be passed on the penultimate lap by Green.

Despite this sustained lack of victories at its 'home' event, Audi refuses to throw the kitchen sink at the 'other' Ring at the expense of all else. In previous years it had made bold statements based on

simulating the track on an airfield for testing purposes, but as the losing streak continues so its pre-event confidence (in public at least) has dwindled.

"It would be quite a short-sighted thing to do to sign someone like Jamie just because we want to win at the Norisring," explained Audi head of DTM Dieter Gass. "You would never jeopardise the chance to win a championship by signing a driver who can only go fast at one circuit. Jamie is much more than a one-track man and he's already started to show what he can do for us."

Regardless of this highly methodical view, Gass admits there is a feeling at Audi that it's time to

end the Norisring wait.

"It's quite a strange situation because normal race fans follow a driver, but in the DTM fans quite often follow a manufacturer, and this is the circuit for Audi fans to come to," he said.

"It's so close to Ingolstadt and it makes for a special atmosphere. It's not more noise from the fans, it's not a more colourful grandstand, but it is something you can feel in the air. It's a special place.

"Of course from a sporting point of view this race means nothing more than any other; you get the same number of points for winning. But we have to win it one day. It would be quite nice to do it this year."

## TRACKING AUDI'S NORISRING WOES

### 2004

Eventual champion Mattias Ekstrom is a distant fourth as Mercedes locks out the podium in Audi's first Norisring race since returning to the DTM as a factory team.

### 2005

Tom Kristensen takes pole, but Gary Paffett defeats a host of Audis to snatch victory in a crazy race. Audis lock out the remaining four places in the top five.

### 2006

Audi's biggest influence on a Mercedes-dominated race is when Christian Abt tangles with race leader Jamie Green's C-class while being lapped.

### 2007

Ekstrom is Audi's best hope again, but all he can do is close on the leading Mercedes pair of Bruno Spengler and Bernd Schneider in the latter stages.

### 2008

Audi narrowly misses out, as Ekstrom and Timo Scheider chase Green and Spengler home, with Scheider passing his team-mate at the final corner for third place.

### 2009

Poleman Scheider leads 44 of the 80 laps, but he is ambushed by Spengler and Green on the penultimate lap, and the Briton steals the win in thrilling fashion in an older-spec car.

### 2010

Green thwarts Audi again, sustaining serious late-race pressure from a charging Ekstrom to take a third straight Norisring victory by half a second.

### 2011

Ekstrom and soon-to-be champion Martin Tomczyk fail to interfere in a Spengler/Green battle for the win, with Tomczyk taking third for Audi in rain-shortened race.

### 2012

Audi brings one car home in the points as Mercedes and BMW fight over the top honours, with Green snatching the win from BMW's Tomczyk at the final corner.

## PERFORMANCE ANALYSIS

How far behind the winner the best-placed Audi has been at the Norisring since its return to the DTM as a factory entry in 2004

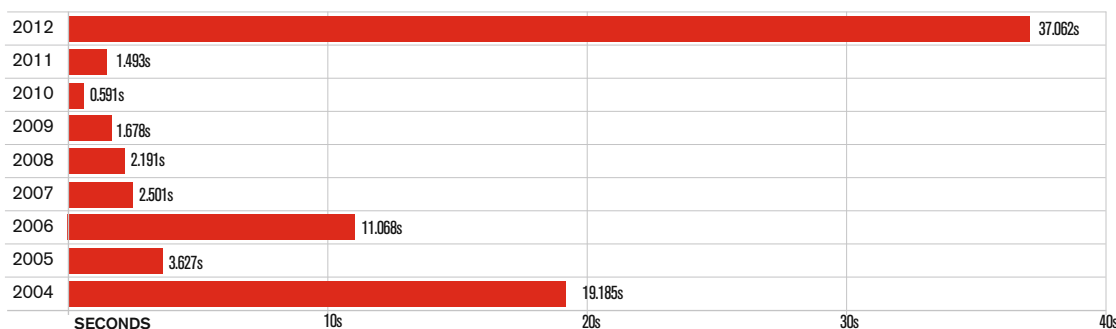

## Quick and competitive Track Day Insurance

The first online "quote and buy" system solely for the track day user, supplied by established track day and motorsport insurance provider - Ryan Motorsport Insurance

INSUREMYTRACKDAY.COM

- ✓ Damage to your car on a track day, regardless of fault.
- ✓ Any circuit in Europe, including Spa and Nürburgring Nordschleife.
- ✓ Inclusive cover for barrier damage at the Nordschleife.
- ✓ Vehicle recovery available for circuits in Great Britain.
- ✓ Organisers and Clubs - promotional rates and discounts
- ✓ Storage and transit for vehicles and trailers

Log on to [www.insuremytrackday.com](http://www.insuremytrackday.com) to obtain your online quote today.

# VOLVO V8 BUT NOT AN ESTATE



**Polestar and GRM have combined to take Volvo into V8 Supercars in 2014.**

**ANDREW VAN DE BURGT finds out more about this long-distance project**

**T**here are 9940 miles separating Gothenburg and Dandenong (that's 15,996 kilometres if you live in either of those places). Yet despite the distance between them, Polestar in Sweden and Garry Rogers Motorsport in Australia have teamed up to take Volvo into the 2014 V8 Supercar championship.

Following the arrival of Nissan and Mercedes (or rather AMG) in 2013, the two-car Volvo attack takes the number of makes in the series to five and helps vindicate its new-for-2013 rules package.

But while Nissan's return to top-flight touring car racing down under was widely predicted, the Volvo announcement last month was much more of a shock. Even more surprising was that it remained clandestine despite months of discussion between the three parties.

"I think it was September that we started to hear about it and at the end of the year we started to get really involved," admits Polestar boss Christian Dahl.

With the project finally given the green light, work started on finding a team, with race-winning Holden squad Garry Rogers Motorsport selected. With approval received to use the engine from Volvo XC90 SUV, Polestar is

undertaking its first V8 engine programme.

"If you look at it from a racing perspective you want engines without a turbo if possible, but the automotive industry and some motorsport is going in a different direction," says Dahl, "but Australia has kept the V8 – it's a fantastic engine formula if you are a motorsport guy."

Polestar, which has been closely linked to Volvo's touring car projects since 1996 (see panel, top right), will be building the engines in its Gothenburg facility in Sweden and freighting them to Australia where GRM will be preparing the cars. But the relationship will be more intertwined than this, with Polestar also having some input on the chassis development too.

"Garry has a really good set up and we looked to see if it could fit in with Polestar and they have the same ambitions, the same appetite," says Volvo's Motorsport boss Derek Crabbe.

"We will have the engine support at the race but we could also add some driving and racing strength to the team," adds Dahl. "It's quite new, so we're getting to know each other and being at as many races and tests as we can. We had some engineers over for a test last week. I think if you look at European racing and Australian racing there's quite a difference – adding a bit of European input from Polestar and the best of

Australian craft is a really good combination."

There's a burgeoning European influence in V8 Supercars with the presence of ex-Formula 1 engineers such as Steve Hallam (Walkinshaw Racing) and Adrian Burgess (Triple Eight) and junior single-seater veteran Bruce Jenkins (Tekno). But the biggest European influx came in the shape of the Triple Eight team, which made its name in the British Touring Car Championship in the 1990s and has won four of the past five drivers' championships with class benchmark Jamie Whincup.

Triple Eight team boss Roland Dane knows all about the challenges facing a European outfit making the switch to V8 Supercars.

"I think that probably everyone who has come over here from European racing would agree that there are a couple of things that would really get your attention," he says. "The biggest would be the variation in the circuits that we go to and the temperature variation of the circuits as well.

"We need to be ready to race in high 30s down to the winter in August, in northern Victoria we could be racing in 10 degrees. So there is a huge variation and they are not short races. Our shortest race is just under an hour. The regular races are 2.5 hours and, of course, Bathurst is six or seven hours. So you've got drivers in the car



JIM BAMBER

Our artist's impression of  
Volvo's V8 Supercar machine

for anything up to 250km in one hit."

GRM's current driver line-up comprises rising Aussie star Scott McLaughlin, the 20-year-old who scored a breakthrough win at Pukekohe this year, and Frenchman Alex Premat – GP2 rival of Lewis Hamilton and DTM podium finisher. But given Volvo's strong Swedish identity, there's naturally speculation that a Swede could find his way into the line-up (see panel right).

"Obviously [there's some pressure for a Swede]," confirms Crabbe, "but we have an agreement with Garry about how we select the drivers – and like we do here [in Sweden], you select them first on who delivers the most and then you have to look at how you can use them. Garry understands that we need to be able to use the drivers. Putting a Swedish driver in would help Sweden, but there are other places around

Australia that need help too, so it's not as easy as: let's take one from here and put them there. That could happen but you can't judge yet."

So far neither Nissan nor AMG has broken the Ford/Holden stranglehold on the podium places, but both have cracked the top six and are becoming increasingly competitive. With this in mind targets are high for Volvo's first season.

"I think it's possible to do a good job in the first season," says Dahl, "we're not talking about fighting for the championship but to start winning races by the end of the season."

Decked out in Volvo's 'Rebel blue' racing livery, the S60s are certainly going to add colour to a series that appears to be on the up and up.



**"It's possible to do a good job in the first season – winning races by the end of it"**



## Who is Polestar?

Founded in 1996, Polestar initially ran Jan 'Flash' Nilsson in the newly-formed STCC and has been Volvo's official race team ever since. Current owner Christian Dahl started working for Polestar in 2000 and bought the team outright in 2005. Its first purpose-built car for Volvo was the 2011 C30 that was entered in the World Touring Car Championship, and it currently runs Volvo's five-car works entry in the STCC. It has also been producing high-performance components for Volvo's road cars, including the C60 Polestar, which was launched in Australia on the week the V8 Supercar programme was announced. This is a signal of the desire to make the Polestar brand – which is 100 percent independent from Volvo in terms of ownership – as synonymous with racing and high performance as AMG is with Mercedes-Benz.

Thed Bjork is one of  
the stars of the STCC

WELANI

## Swede harmony

The ante has been upped among Volvo's legion of Swedish superstars in the STCC. For Thed Bjork, Fredrik Ekblom and Robert Dahlgren – not to mention rising young hopeful Linus Ohlsson – there's enormous incentive to prove themselves as the country's top touring car dog – a seat in a V8 Supercar. While there's no guarantee of a full-time drive, it seems highly likely that at least one of the co-driver slots for the two enduro races – Bathurst and Sandown – is up for grabs. "It's very exciting," confirms Ekblom. "Everyone is talking about it. Everyone wants to do it."

"I can tell you there's a queue of drivers wanting to go there!" says Derek Crabbe. "It's a sign of how popular the series is that I've been contacted by some really solid drivers."

**BRITISH CHAMPIONSHIP RACE SERIES**  
**RZR RACING.CO.UK**  
 ULTIMATE 4X4 OFF-ROAD MX RACING

**POLARIS** The All-Terrain Specialist  
**ACU** ASSOCIATION OF CROSS COUNTRY MOTORSPORTS  
**NORA SXS** NORTH OXFORDSHIRE CROSS COUNTRY MOTORSPORTS  
**ATV**

**RZR RACING.CO.UK**

**FIND OUT MORE:**

FOR MORE INFORMATION PLEASE CONTACT  
**FREEPHONE: 08000 147 147**

OFFICIAL TITLE SPONSOR  
**mce** insurance **BSB** BRITISH SUPERBIKES

# TEST & RACE DAY INSURANCE

Give Simon and the friendly team a call:  
**0844 338 68 67**  
**mce**motorsport.com

OPENING HOURS:  
 Monday - Friday 9.00am-5.30pm

**mce** insurance

## THE BIGGEST **VODAFONE** **DMAX** CHAMPIONSHIPS YET!

Prices are £180 per Endurance Round and £165 per Heats Round  
**£280 to enter both**

Cumulative Loyalty Discount of 2.5% for each round entered.

A full season of Heats Racing for £1476 or Enduro Racing for £1610 inc VAT

Feb 17th	Daytona MK
Mar 17th	Daytona SP
Apr 21st	PF International
May 19th	Rye House
Jun 16th	Lydd
Jul 21st	Bayford Meadows
Aug 18th	Whilton Mill
Sep 15th	Red Lodge
Oct 20th	Daytona MK
Nov 17th	Daytona SP

**Tel: 0845 644 5504**  
**www.daytonamax.co.uk**



Rydell/Richards won Bathurst in S40 in 1998

AUTOPICS

# VOLVO DOWN UNDER

41

**From a surprise performance from the 240T 'Stockholm Taxi', to one of the world's leading tin-top stars showing them how to do it in an S40... **MARCUS SIMMONS** casts his mind back**

The omens have it that, if Volvo wins a V8 Supercar title, it will be by a very narrow margin over one of the Kelly brothers' Nissan Altimas.

Why? Because the Swedish make's highlights in touring car racing in Australia – a national title in 1986 with the 240T, and Bathurst 1000 victory in '98 with the S40 – both came after narrowly beating a Nissan.

The 240T programme came almost by accident. New Zealander Mark Petch had wanted to import a Tom Walkinshaw Racing (TWR) Rover Vitesse, but got wind that one of the increasingly competitive Volvo turbo cars was on the market.

The 240T was bought from a Belgian team in 1984, and regular driver Michel Delcourt went down under to share the car in the Wellington street race. Petch stood down from driving, preferring instead for fellow Kiwi Robbie Francevic to join Delcourt. The duo won the race, and Petch made plans for his team to contest the Australian Touring Car Championship in '85.

A host of reliability problems as the team struggled to get to grips with turbo technology scuppered the '85 title challenge, but Francevic was on fire in early '86. So much so that Australia's governing body subjected this Kiwi team to a host of legality checks.

At the same time, Volvo Australia got involved

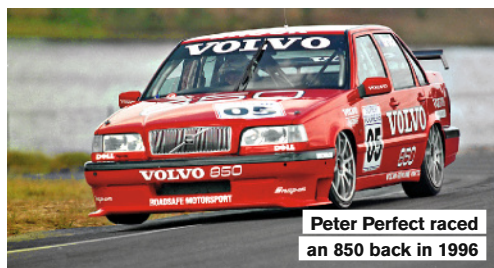

Peter Perfect raced an 850 back in 1996

AUTOPICS

and brought in long-time preparation expert John Sheppard to run the team. The relationship soon soured between Sheppard on one side, and Francevic and Petch on the other. Petch would quit the team, but Francevic – feeling that young team-mate John Bowe was being favoured – clung on to claim the title, pipping George Fury's Nissan Skyline. Even so, Francevic walked out on the team at the Sandown 500.

Nine years later, Volvo entered the Australian Super Touring Championship, and would field ex-works TWR-built BTCC cars over the next five years with a team run by George Sheppard, a multiple Australian rally champion and highly-respected technical man who had previously built Dick Johnson's Ford Falcons.

The programme kicked off in 1995 with the

ex-Jan Lammers/Rickard Rydell BTCC 850 Estate, chassis 1 no less, driven by Tony Scott. But for '96 it moved up a gear with the great Peter Brock in an 850 saloon – in very un-Volvo red livery.

With Brock concentrating on his last full V8 campaign for the factory Holden team in 1997, Jim Richards was brought in to lead the Volvo Australia line-up. For the calendar's highlight – the first Super Touring Bathurst 1000 – he was joined by BTCC star Rydell and they finished fourth in Richards's regular 850.

The S40 had been introduced to the BTCC in 1997, and Richards got one for '98. He won two races, and then the full might of TWR descended upon Mount Panorama with one of the S40s used by Rydell to win that year's BTCC title. Together with Richards, Rydell scored a thrilling win in the Bathurst 1000. The Swede was sensationally quick, setting pole by 1.5 seconds, but constant safety car periods enabled the Nissan Primera of Richards's son Steven and Matt Neal to keep them under constant pressure. This, indeed, was the first time Neal ever led a touring car race!

This S40 stayed in Australia for 1999 and Richards took the fight to BMW's Paul Morris for the Super Touring title. 'Richo' narrowly missed out on the crown and, with Super Touring fading worldwide, that was the end of the programme. ❧

# RACE CENTRE

REPORTS • NEWS • ANALYSIS • OPINION

58 **NASCAR Daytona** A 'big one' is never far away in a restrictor-plate race. This one, at the last corner, includes Kyle Busch (left), Danica Patrick (10) and David Gilliland (38)



MILLER/LAT



**44 GP2 Nurburgring**  
Lancaster makes victories a habit as Ericsson wins too



**50 IndyCar Pocono**  
Andretti drops the ball while Ganassi team nets 1-2-3

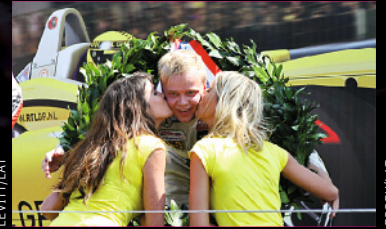

**54 Masters of F3**  
Felix Rosenqvist triumphs again in Zandvoort classic



# GP2

## Nurburgring (D)

July 5-7



Round 6/11

### RESULTS

RACE 1: 32 LAPS, 102.205 MILES

1	MARCUS ERICSSON (S)	1h00m16.988s
DAMS; Qualifying 2nd-1m38.763s		
2	JAMES CALADO (GB)	+7.860s
ART Grand Prix; Qualifying 8th-1m39.018s		
3	STEFANO COLETTI (MC)	+14.915s
Rapax; Qualifying 13th-1m39.274s		
4	FABIO LEIMER (CH)	+15.061s
Racing Engineering; Qualifying 6th-1m38.997s		
5	STEPHANE RICHELMI (MC)	+15.119s
DAMS; Qualifying 1st-1m38.467s		
6	ROBIN FRIJNS (NL)	+15.272s
Hilmer Motorsport; Qualifying 3rd-1m38.804s		
7	JON LANCASTER (GB)	+17.156s
Hilmer Motorsport; Qualifying 16th-1m39.379s		
8	TOM DILLMANN (F)	+17.323s
Russian Time; Qualifying 10th-1m39.186s		
9	FELIPE NASR (BR)	+24.265s
Carlin; Qualifying 5th-1m38.897s		
10	JOHNNY CECOTTO JR (YV)	+24.333s
Arden International; Qualifying 19th-1m39.723s		

Winner's average speed: 101.725mph. Fastest lap: Julian Leal (Racing Engineering), 1m43.041s, 111.762mph.

RACE 2: 24 LAPS, 76.614 MILES

1	LANCASTER	42m37.655s
Grid-2nd		
2	CALADO	+1.528s
Grid-7th		
3	LEIMER	+25.797s
Grid-5th		
4	NASR	+27.527s
Grid-9th		
5	CECOTTO	+32.336s
Grid-10th		
6	ALEXANDER ROSSI (USA)	+34.479s
Caterham Racing; Grid-11th		
7	MITCH EVANS (NZ)	+34.751s
Arden International; Grid-7th		
8	SAM BIRD (GB)	+36.635s
Russian Time; Grid-13th		
9	SIMON TRUMMER (CH)	+40.088s
Rapax; Grid-14th		
10	RENE BINDER (A)	+40.237s
GP Lazarus; Grid-20th		

Winners' average speed: 107.837mph. Fastest lap: Fabrizio Crestani (GP Lazarus), 1m41.626s, 113.318mph. All drivers in Dallara-Mecachrome GP2/11.

### CHAMPIONSHIP

1	COLETTI	135	6	LANCASTER	65
2	NASR	108	7	RICHELMI	47
3	BIRD	90	8	DILLMANN	47
4	LEIMER	88	9	FRIJNS	45
5	CALADO	84	10	PALMER	39

### TEAMS

1	CARLIN	147	4	HILMER MOTORSPORT	112
2	RAPAX	143	5	RACING ENGINEERING	110
3	RUSSIAN TIME	137	6	ART GRAND PRIX	87

### POINTS SYSTEM EXPLAINED

Race 1: 25-18-15-12-10-8-6-4-2-1 to top 10 finishers. Race 2: 15-12-10-8-6-4-2-1 to top eight. Pole for race one: 4. Fastest lap of top 10 finishers in each race: 2.



Ericsson (1) leads at the start of the feature

FOR IN-DEPTH RESULTS FORIX

# Lancaster flies, Ericsson atones

A second consecutive sprint-race win for Jon Lancaster, this time at the Nurburgring, was a welcome surprise. By CHARLES BRADLEY



IT SEEMS INCONGRUOUS TO SUGGEST THAT MARCUS ERICSSON and Jon Lancaster were surprise winners at the Nurburgring. Despite their recent form, and the dominance of their respective victories last weekend, these still felt like eye-opening results.

Ericsson had scored two poles this year with the champion DAMS team. But he'd only added one point in 12 races to his tally – an eighth place in the Silverstone sprint race – a staggering underachievement. The way he'd butchered other results from promising positions is as bewildering as the way he genuinely aced this feature race.

In Lancaster's case, he's a category rookie compared with veteran Ericsson. Despite winning the sprint race at Silverstone, a repeat performance seemed unlikely. But underrate him at your peril: he picked his way through the feature-race midfield from a lowly start position to a sharp-end reversed-grid spot. Groundwork laid, he converted his chance like he'd been winning GP2 races for years.

DAMS locked-out a one-two in qualifying for the feature race. Stephane Richelmi denied Ericsson

a hat-trick of poles, but his tardy start allowed the Swede ahead into Turn 1 on Saturday afternoon. The adage that you can't win a race at the first corner, but you can lose it, was proved by Mitch Evans. He lunged inside Ericsson, led momentarily, then had to U-turn out of the Turn 1 run-off into which he'd snookered himself – first to 16th in a couple of hundred yards.

Intrigue for this race had already been laid with a mixture of tyre choice: Richelmi, Ericsson and Fabio Leimer started on mediums; Robin Frijns, Felipe Nasr and James Calado on supersofts. Then there was start chaos: Kevin Ceccon got wedged between Trident team-mate Nathanael Berthon and Daniel Abt, and this pincer movement flipped him over, slamming into the stationary Adrian Quaife-Hobbs – who had stalled after qualifying sixth.

The safety car was declared as the field was mid-first sector, so it was impossible to decide if any surreptitious overtaking moves were completed before the timing loop.

At the restart, Ericsson scampered away as



Ericsson aced the feature race

PORSCHE SUPERCUP NURBURGRING (D), JULY 7, RD 4/8

## Christensen lands maiden victory

MICHAEL CHRISTENSEN TOOK HIS AND THE French DAMS team's maiden Porsche Supercup win thanks to a near-perfect weekend in round four at the Nurburgring.

The 22-year-old Dane set the pace in practice, took pole position and then led every lap on his way to victory, despite having to constantly check on the proximity of the ominous-looking blue Attempto machines of Nicki Thiim and Kevin Estre.

While Christensen's advantage ebbed and flowed between 1.7 and 0.7 seconds during most of the race, the small buffer he built up over the first three laps proved decisive.

"My only concern was the start," said the winner. "But that worked quite well and afterwards it was actually quite easy."

Christensen's day was made less difficult by Thiim and Estre having their own personal battle over second. Championship leader Sean Edwards of Tolimit Racing and VERVA Racing's Kuba Giermaziak battled right behind only for the pair to make slight contact, resulting in the Pole spinning away fifth as he tried to pass his rival.

While Giermaziak crashed out on his own a lap later, Edwards homed in on Estre – who lost second for good to Thiim with five laps left – but could not get by and settled for fourth.

Edwards' series lead is down to just four points over Thiim with Michael Ammermuller – fifth in Germany – two further back.

Impressive Briton Ben Barker took his best Supercup result with sixth for Team



Christensen beat Attempto duo

Bleekemolen – two places ahead of team-mate Sebastiaan Bleekemolen.

Klaus Bachler, who crashed in qualifying, finished ninth while Jean-Karl Vernay, fresh from his Le Mans GTE Am victory a fortnight earlier, climbed from 20th on the grid to 11th by the chequered flag.

● Dylan Jacobs

### RESULTS

**1 Michael Christensen**, 16 laps in 26m03.584s; 13 laps in 26m46.435s; 2 Nicki Thiim, +1.661s; 3 Kevin Estre; 4 Sean Edwards; 5 Michael Ammermuller; 6 Ben Barker; 7 Robert Lukas; 8 Sebastiaan Bleekemolen; 9 Klaus Bachler; 10 Richie Stanaway.  
**Points** 1 Edwards, 68; 2 Thiim, 64; 3 Ammermuller, 62; 4 Christensen, 48; 5 Kuba Giermaziak, 44; 6 Estre, 36.



Lancaster led all the way in race two...



... for a second straight sprint-race win for Hilmer

Richelmi held up a bustling queue of Nasr, Frijns and Calado. Nasr ditched his supersofts at the first opportunity, consigning him to the longest-possible run on the mediums. Frijns and Calado pitted two laps later, with Frijns suffering a slow right-rear change so Calado jumped him. Nasr was still ahead of both after the mandatory stops.

Ericsson pitted at the end of lap nine, fitting another new set of mediums. Richelmi led for another five laps before pitting, but suffered a delay when his front jackman tumbled over, dropping the front of the car. This dropped him to fifth place, behind Ericsson, Nasr, Calado and Frijns.

With Ericsson well in command, the action behind was frenetic. Calado passed Nasr just after half distance, then Frijns attacked the Brazilian relentlessly. Four times they swapped third place in the Merc Arena, and it would be another two laps before Frijns got the job done properly at Turn 1.

Points leader Stefano Coletti, who'd qualified down in 13th, now came into the equation. He'd run a 20-lap stint on his first set of mediums, so his second set was much fresher than those ahead.

He picked off Leimer, Richelmi and Nasr (who would tumble back to ninth on spent tyres).

With Ericsson and Calado long gone, the battle for third between Frijns and Coletti was electrifying. Lap after lap, Frijns repelled his attacks, until the final time into the chicane, when Coletti barged his way past. They made contact again at the final corner, as Frijns tried to repay the compliment, but this just slowed him up – so as Coletti raced away to third, Leimer and Richelmi jumped past Frijns too. "Great racing!" enthused Frijns despite coming out worst, while Coletti added: "I really wanted that podium."

Lancaster just pipped Dillmann to seventh, and outstripped him once again off the startline on Sunday morning to lead the reversed-grid sprint race. Dillmann held off a swift-starting Calado for second, ahead of Leimer and Ericsson – three of whom were on tyres they'd used the day before, whereas Lancaster and Calado were on fresh sets.

Dillmann held off Calado until lap six (two laps were lost to a safety car to recover the stranded car of Richelmi) but Calado now had 2.8s to make up on Lancaster, who had made good his escape. Calado closed to 1.7s when he was told to preserve his tyres, and the gap remained static until James was told to "go for the win" with five laps to go.

Try as he might, Calado couldn't get to within a closer margin of Lancaster than 0.8s. "He just didn't make a mistake," praised Calado. "They told me on the radio that he was one second faster than me," said Lancaster of Calado's charge. "I had a little bit left for every time he got close to one second."

Leimer took third, despite using tyres he'd run on Saturday, ahead of Nasr (who charged from ninth), Johnny Cecotto Jr, Alexander Rossi, Evans and Sam Bird, who collided with an unhappy Frijns.

Ericsson's rear tyres gave up the ghost, so he reverted to type and finished outside the points.

## IN THE COCKPIT

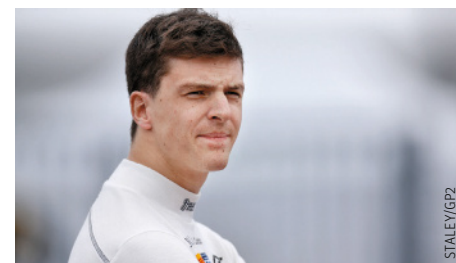

### James Calado

TWO GREAT RESULTS, JUST WHEN I NEEDED them. It's been a bit stressful recently, but the atmosphere in the team is so much more positive now and we scored 32 points across the weekend.

After the problems we'd had in the early races, it's so nice to drive a car that turns in perfectly. I was nearly 90 points off the points lead at one point, and now I'm 51 behind. It goes to show how fast things can turn around, and we're only just halfway through the season.

In race one I was quite aggressive in the early laps to gain track position, and once I was up to second my tyres went off towards the end, whereas Marcus Ericsson's stayed alive longer because he'd pitted later. In race two, I was actually faster than Jon [Lancaster], but we were quite evenly matched when I got into his dirty air, so my tyres would overheat. Two good starts were the real key to my weekend, so I'm really happy about that.

Two race wins without Coletti scoring much, and I'll be right back up at the front. If I can get my car perfect in qualifying, it's still all to play for.

# FORMULA RENAULT 2.0 ALPS

## FORMULA RENAULT 2.0 ALPS 2013 CHAMPIONSHIP // ROUNDS 7 +



Race 1. Antonio Fuoco has a great talent and at Monza's temple of speed, the Prema driver proved it once more. It was an astonishing pole position and race 1 win for the 17-year-old from Southern Italy and, along with his team mates Bruno Bonifacio and Luca Ghiotto, they seized a second season one-two-three (after Spa) for the Angelo Rosin-run team. On the prestigious Italian track, the new name up there was Egor Orudzhev. The Russian, racing for Tech1 Racing, was fastest in the first free practice session and second in qualifying. Even with a 10-place grid penalty due to an infringement at the last round, he managed fourth place, keeping at bay Estonian Hans Villemi (SMP Racing by Koiranen GP). It was a shame for the impressive Luke Chudleigh, third in Group A qualifying but soon out of the contest due to contact at the first chicane, which also caused the safety car.

Race 2. Monza provided a second win for Luca Ghiotto to follow his victory at Spa. The young Italian flew the Prema colours high after his team mates Antonio Fuoco and Bruno Bonifacio made contact on the first lap. Under the spotlight was Egor Orudzhev, who started from pole and was second under the chequered flag, although he was later penalised 25 seconds for not respecting the safety-car procedure in the early stages of the race. Big cheers for Arta Engineering, with a double podium for Joffrey De Narda and Simon Tirman who were second and third overall. Once more there were some good driving skills from SMP Racing by Koiranen GP's Estonian Hans Villemi, who was fourth just ahead of Gregor Ramsay (Euronova Racing).



NEXT RACE // Misano, Italy // 27 - 28 July 2013 // [www.renaultsportitaly.com](http://www.renaultsportitaly.com)

# FLPS 2013

8 // MONZA, ITALY



# FORMULA RENAULT 2.0 ALPS

Formula Renault 2.0 ALPS grows talents... and this is not just in the case of Antonio Fuoco, the undisputed ruler of the first half of the season and current championship leader. At Monza there were plenty of pleasant surprises. Impressive was Canadian Luke Chudleigh (Tech1 Racing), who managed a third row, and the same could be said for the Jenzer team's Singaporean Andrew Tang. It was a shame that both went out at the start of Race 1, in which Russian Egor Orudzhev, Chudleigh's team mate, left his mark by taking fourth. He improved to second place in Race 2, although was later penalised. Also worth attention were the two Arta Engineering drivers Joffrey De Narda and Simon Tirman, both on the podium on Sunday. No surprises either from the Scot Gregor Ramsay (Euronova Racing), always in the top ten on pace. It was an impressive weekend for Dario Capitano (BVM Racing), who even with a damaged front nose dueled with Tirman in Race 1, finishing eighth. Best recovery, however, was from Kevin Gilardoni who suffered technical problems in qualifying but ended tenth and seventh in the two races.

DRIVER	TEAM	PTS
Antonio Fuoco ITA	Prema Junior	141
Bruno Bonifacio BRA	Prema Powerteam	113
Luca Ghiotto ITA	Prema Powerteam	109
Pierre Gasly FRA	Tech1 Racing	57
William Vermont FRA	Arta Engineering	41
Jakub Dalewski POL	JD Motorsport	35
Guilherme Silva BRA	Koironen GP	35
Kevin Joerg SUI	Jenzer Motorsport	34
Nyck de Vries NED	Koironen GP	32
Matthieu Vaxiviere FRA	Tech1 Racing	20





# YOU CAN'T TRUST EVERYONE SELLING CARS ON THE INTERNET



You don't necessarily know who's behind selling a car when you buy online. You also need to be assured that what they say they are selling and what they are selling are the same thing. Buying from **Trusted Dealers** is the safest and most reliable way to buy a used car online. Owned by its members with hundreds of **franchised dealerships across the UK**, we can offer standards that other classified websites can't guarantee and that's why **What Car?** endorse our Ten Points of Difference.



Don't just buy from anyone. Search for trusted dealers.



**OUR TRUSTED DEALERS INCLUDE** ARNOLD CLARK · BEADLES · BRAYLEY · BRISTOL STREET MOTORS · CAFFYNS · CAMBRIA · CHAMBERS · CLEMO · COLLIERS · CO-OPERATIVE MOTOR GROUP · CURRIE MOTORS · DM KEITH · DRIVE MOTOR GROUP · EASTERN WESTERN HOLDINGS LTD · FG BARNES · FORD RETAIL · FROSTS CARS · GK GROUP · HARTWELL · HENDY · HOLDCROFT · HWM GROUP · INCHCAPE · JARDINE MOTORS · JCT600 · JOHNSONS · KINEHOLME GARAGE · LIFESTYLE EUROPE · LLOYD MOTOR GROUP · LOOKERS · MACKLIN MOTORS · MARSHALL · NIDD VALE · PENTAGON · PERRYS MOTOR SALES · PHOENIX · RIDGEWAY GROUP · RINGWAYS GARAGES · ROBINSONS · RON BROOKS · ROYCE ROBERTS SKODA · RYBROOK · SANDICLIFFE · SG SMITH · SHIELDS AUTOMOTIVE · SKY FORD · SNOWS · SPEEDWELL HONDA · STURGESS · SWANSWAY · TAGGARTS · TRIDENT · TRUST GROUP UK · WAYSIDE GROUP · WESTONS

ART driver Regalia  
took his maiden  
GP3 victory



GP3 SERIES NURBURGRING (D), JULY 6-7, RD 4/8

## Landmark wins for Regalia and McKee

**BREAKTHROUGH WINS WERE THE** order of the day as Facu Regalia delivered what he's been promising to do for the past few weeks with pole and victory in race one, while British teenager Melville McKee played his reversed-grid hand to perfection to win race two.

ART man Regalia came of age on Saturday, taking pole position in the morning and leading from lights to flag in the afternoon. He was already two seconds clear of points leader – and now title rival – Tio Ellinas by the end of the first lap.

Silverstone hero Jack Harvey outaccelerated Alex Fontana away from the grid to grab third, as the

Swiss got pushed into a spin at Turn 4 by Kevin Korjus, who received a drive-through penalty. Lewis Williamson led the chase, ahead of fellow Brit Nick Yelloly and Carlos Sainz Jr.

Early fifth-placed runner Daniil Kvyat ground to a halt with a dead battery, and his stranded machine brought out the safety car.

At the restart, Regalia left the field trailing in his wake once more having saved a fresh set of tyres for this race. Ellinas, who'd used all his fresh rubber to ensure a front-row starting position, managed to hold off a probing Harvey until the finish. Likewise, Williamson kept Yelloly at

bay for fourth, with Sainz heading McKee and comeback man Alexander Sims, making his first series start since 2011. Status GP man Sims inherited reversed-grid pole once Korjus had taken his penalty.

Regalia's Saturday joy turned to Sunday woe, as his car failed him on the dummy grid. In his absence, Sims and McKee made poor starts from the front row, so Sainz was all over them on the run to Turn 1, where he jinked left and tagged the fast-starting Harvey into a big slide – the Brit tumbled to 10th.

McKee led through the first corner, while Yelloly drove around the outside of Sims at Turn 2 to grab

second place. Williamson was fourth, ahead of Sainz and Dino Zamparelli.

Ellinas deposed Zamparelli from sixth on the exit of Turn 4, when Dino briefly ran wide. Sims made an excellent lunge past Yelloly for second at Turn 3, and chased down McKee in the closing stages. "I let him go; I thought they might battle and hold each other up but it didn't happen," mused Yelloly.

Try as Sims might, the old stager (a ripe 'old' 24) couldn't usurp the teenager. "It feels amazing to get the team's first win," said McKee of his Bamboo squad's maiden GP3 win.

Sims added: "It felt great to be back, and I felt I was able to extract more today to get on the podium."

Patric Niederhauser pressurised Conor Daly into a last-lap mistake, and nabbed the final point.

● Charles Bradley



McKee (l) beat  
polesitter Sims  
off startline

### RESULTS

**Race 1 1 Facu Regalia (ART Grand Prix)**, 15 laps in 28m27.197s; 2 Tio Ellinas (Marussia Manor Racing), +7.160s; 3 Jack Harvey (ART); 4 Lewis Williamson (Bamboo Engineering); 5 Nick Yelloly (Carlin); 6 Carlos Sainz Jr (MW Arden); 7 Melville McKee (Bamboo); 8 Alexander Sims (Status GP); 9 Dino Zamparelli (Manor); 10 Conor Daly (ART). **Race 2 1 McKee**, 15 laps in 27m23.992s; 2 Sims, +0.353s; 3 Yelloly; 4 Williamson; 5 Sainz; 6 Ellinas; 7 Zamparelli; 8 Patric Niederhauser (Jenzer Motorsport); 9 Daly; 10 Harvey. **Points** 1 Ellinas, 91; 2 Regalia, 72; 3 Korjus, 59; 4 Harvey, 57; 5 Daly, 52; 6 Yelloly, 52.

# INDYCAR

## Pocono (USA)

July 6-7

Round 10/16

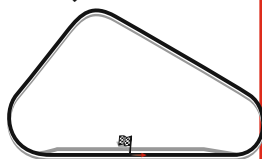

### RESULTS

160 LAPS, 400 MILES

<b>1</b>	<b>SCOTT DIXON (NZ)</b>	<b>2h04m26.4178s</b>
Chip Ganassi Racing Dallara-Honda; Grid: 17th*-219.500mph		
<b>2</b>	<b>CHARLIE KIMBALL (USA)</b>	<b>+0.4572s</b>
Chip Ganassi Racing Dallara-Honda; Grid: 12th-218.345mph		
<b>3</b>	<b>DARIO FRANCHITTI (GB)</b>	<b>+1.1989s</b>
Chip Ganassi Racing Dallara-Honda; Grid: 20th*-217.047mph		
<b>4</b>	<b>WILL POWER (AUS)</b>	<b>+5.6320s</b>
Team Penske Dallara-Chevrolet; Grid: 4th-220.286mph		
<b>5</b>	<b>JOSEF NEWGARDEN (USA)</b>	<b>+7.1949s</b>
Sarah Fisher Hartman Racing Dallara-Honda; Grid: 15th-217.832mph		
<b>6</b>	<b>SIMON PAGENAUD (F)</b>	<b>+9.4074s</b>
Schmidt Hamilton Racing Dallara-Honda; Grid: 8th-218.859mph		
<b>7</b>	<b>JUSTIN WILSON (GB)</b>	<b>+13.3012s</b>
Dale Coyne Racing Dallara-Honda; Grid: 22nd*-216.872mph		
<b>8</b>	<b>HELIO CASTRONEVES (BR)</b>	<b>+13.9376s</b>
Team Penske Dallara-Chevrolet; Grid: 6th-219.581mph		
<b>9</b>	<b>ED CARPENTER (USA)</b>	<b>+15.5500s</b>
Ed Carpenter Racing Dallara-Chevrolet; Grid: 14th-218.100mph		
<b>10</b>	<b>MARCO ANDRETTI (USA)</b>	<b>+18.4584s</b>
Andretti Autosport Dallara-Chevrolet; Grid: 1st-221.273mph		
<b>11</b>	<b>SIMONA DE SILVESTRO (CH)</b>	<b>+32.0478s</b>
KV Racing Technology Dallara-Chevrolet; Grid: 9th-218.590mph		
<b>12</b>	<b>JAMES JAKES (GB)</b>	<b>+36.2536s</b>
Rahal Letterman Lanigan Racing Dallara-Honda; Grid: 13th-218.240mph		
<b>13</b>	<b>TONY KANAAN (BR)</b>	<b>+41.5507s</b>
KV Racing Technology Dallara-Chevrolet; Grid: 5th-219.625mph		
<b>14</b>	<b>RYAN BRISCOE (AUS)</b>	<b>-1 lap</b>
Panther Racing Dallara-Chevrolet; Grid: 19th-no time		
<b>15</b>	<b>PIPPA MANN (GB)</b>	<b>-1 lap</b>
Dale Coyne Racing Dallara-Honda; Grid: 21st*-216.980mph		
<b>16</b>	<b>SEBASTIEN BOURDAIS (F)</b>	<b>-1 lap</b>
Dragon Racing Dallara-Chevrolet; Grid: 11th-218.517mph		
<b>17</b>	<b>ALEX TAGLIANI (CDN)</b>	<b>-2 laps</b>
Bryan Herta Autosport Dallara-Honda; Grid: 24th*-no time		
<b>18</b>	<b>GRAHAM RAHAL (USA)</b>	<b>-2 laps</b>
Rahal Letterman Lanigan Racing Dallara-Honda; Grid: 16th-217.457mph		
<b>19</b>	<b>TRISTAN VAUTIER (F)</b>	<b>-2 laps</b>
Schmidt-Peterson Motorsports Dallara-Honda; Grid: 10th-218.575mph		
<b>20</b>	<b>RYAN HUNTER-REAY (USA)</b>	<b>-39 laps</b>
Andretti Autosport Dallara-Chevrolet; Grid: 2nd-220.892mph		
<b>21</b>	<b>EJ VISO (VV)</b>	<b>-56 laps</b>
Andretti Autosport/HVM Dallara-Chevrolet; Grid: 23rd*-no time		
<b>22</b>	<b>TAKUMA SATO (J)</b>	61 laps - accident
AJ Foyt Racing Dallara-Honda; Grid: 7th-219.124mph		
<b>23</b>	<b>SEBASTIAN SAAVEDRA (CO)</b>	2 laps - stuck throttle
Dragon Racing Dallara-Chevrolet; Grid: 18th-215.570mph		
<b>24</b>	<b>JAMES HINCHCLIFFE (CDN)</b>	0 laps - accident
Andretti Autosport Dallara-Chevrolet; Grid: 3rd-220.431mph		

Winner's average speed: 192.86mph. Fastest lap: Sato, 41.2239s, 218.32mph. All drivers in Dallara DW12

\* - 10-place grid penalty for engine change

### CHAMPIONSHIP

<b>1</b>	<b>CASTRONEVES</b>	<b>356</b>	<b>6</b>	<b>KANAAN</b>	<b>271</b>
<b>2</b>	<b>HUNTER-REAY</b>	<b>333</b>	<b>7</b>	<b>PAGENAUD</b>	<b>269</b>
<b>3</b>	<b>ANDRETTI</b>	<b>301</b>	<b>8</b>	<b>WILSON</b>	<b>253</b>
<b>4</b>	<b>DIXON</b>	<b>291</b>	<b>9</b>	<b>POWER</b>	<b>242</b>
<b>5</b>	<b>HINCHCLIFFE</b>	<b>272</b>	<b>10</b>	<b>SATO</b>	<b>241</b>

#### POINTS SYSTEM EXPLAINED:

50-40-35-32-30-28-26-24-22-20-19-18-17-16-15-14-13-12-11-10-9-8-7-6 for the top 24, with 5 for all other starters. 2 points for leading the most laps, 1 point for leading at least one lap, 1 point for pole position.



Kanaan lost hope of Triple Crown payout

FOR IN-DEPTH RESULTS  
forix.autosport.com



# Ganassi trio ekes out the miles for podium smiles

Superior fuel mileage helped Scott Dixon lead team-mates Charlie Kimball and Dario Franchitti to a 1-2-3. By **MARK GLENDENNING**



**HISTORY TELLS US THAT THE WIDE SPACES OF Pennsylvania have not been immune to conflict: a couple of hours down the road from last weekend's IndyCar staging ground at Pocono are the fields of Gettysburg; site of the bloodiest battle of the American civil war.**

There was a bit less riding on the events of last Sunday, but it will still go down as one of the more significant encounters in a season that steadfastly refuses to stick to the script. Just as we'd become used to Andretti Autosport being the only 'big team' to have its act together, and accepted that the Honda squads were fighting with a hand behind their back on high-speed tracks, Scott Dixon led Chip Ganassi Racing to its first podium clean sweep in the team's history.

At its essence it was a race about fuel mileage, but to distil it down that far would be like describing *Stairway to Heaven* as a song about a hedge. Much was expected from IndyCar's first race at the 'Tricky Triangle' since the 1980s - indeed, the prospect of single-seaters hitting 220mph there was enough to prompt NASCAR star Jeff Gordon to turn up with his family to check things out, despite having raced on the other side of the country 18 hours earlier. The crowd was good too; with local hero Marco Andretti no doubt having prompted a late rush on tickets by putting himself on pole.

Ironically, Andretti - and his team-mates - were

probably the only people who could have left the track feeling disappointed, because what most would have enjoyed as an enthralling fight was made exciting largely at their expense.

In the opening part of the weekend Andretti Autosport looked unstoppable, with Marco leading Ryan Hunter-Reay and James Hinchcliffe to spearhead a lockout of the three-car front row. They might have had a 1-2-3-4 based on the speed of EJ Viso's first qualifying lap, but the Venezuelan crashed into the wall as he was coming out of Turn 1 for the second time.

It was an ominous sign for his rivals, although an observation from Tony Kanaan on Saturday afternoon would prove prophetic.

"I don't think you can pick a favourite yet," he said. "It's a difficult track, and we've never been here before. Obviously Andretti did a great job to put three cars in the top three. But it's a long race."

He got that last part wrong: for Hinchcliffe, the race was quite a short one. Andretti was leading the field into the first corner at the start when the Canadian lost control and looped up into the wall. The Iowa racewinner's sudden exit might have rattled the Andretti pitwall slightly, but there was more to come. Towards the end of the second stint, Hunter-Reay was running in second ahead of a surging Takuma Sato when both pitted on the same lap. The American was well down the pitlane



Dixon ended a lengthy win drought for CGR 1-2-3

and seeking out his crew when he was rammed from behind by Sato, who'd completely misjudged his own pit entry. Hunter-Reay was punted into the wall, while Sato staggered onward to his pitbox where his team retired him. Andretti managed to patch Hunter-Reay's car back up and get him back out to salvage some points, although he was 18 laps down.

"We were just coming in to pitlane, minding our own business, and we get creamed from behind," said Hunter-Reay, who aggravated a thumb injury he'd been nursing since April. "It's so frustrating when you're running top three, top two, really happy with your car, and then somebody comes from out of nowhere to take you out."

Sato was quick to take responsibility.

"I misjudged it," he said. "I was just too fast. I'm extremely sorry to Andretti Autosport and Ryan and his crew, as well as my crew. It's all my fault."

That was two of the main Andretti threats neutralised, and with Viso wobbling around somewhere at the back in an ill-handling spare car, it was left to Andretti to fly the team flag. But although he led most of the first half of the race, his afternoon was also unravelling. The initial stumble took the form of a slow first stop, a situation that the team addressed by moving Hinchcliffe's now-idle refueller onto Andretti's car.

Despite the time lost in the pits he reclaimed the

lead once the remaining stops had cycled through, but the seeds of his demise were already being sewn. Somewhere behind him, several Honda drivers — Dixon, Dario Franchitti, Charlie Kimball and Simon Pagenaud — were creeping through the pack. Dixon and Franchitti's progress was especially eye-catching considering they had started deep in the field due to penalties for engine changes. Honda might have had a power deficit, but it was stronger than Chevrolet on fuel mileage, and as Andretti slowly began to sink, it became apparent that this difference would prove crucial.

"We knew early about our fuel mileage, but not early enough," Andretti said. "I think we should have responded quicker."

Not only was Dixon able to run similar speeds to the other cars at the front, but he was able to do so while using less fuel: each of his stints was four or five laps longer than Andretti's. The latter was eventually shoehorned into making his last stop on lap 127, forcing him to run the final 33 laps on a single tank. He'd gone that far in a yellow-assisted second stint. This time he had no such help, and his efforts at fuel conservation came at the inevitable cost of his outright speed. By the end he had dropped to 10th, and was so marginal that his car ran dry on the slow-down lap.

Although all of the Andrettis were out of the picture there was still more intrigue to come



Hinchcliffe crashed out on the first lap



Hunter-Reay's car needed repairs after ramming from Sato

courtesy of KV's Tony Kanaan and Penske duo Helio Castroneves and Will Power. Kanaan had been strong right through the weekend, and immediately after the third round of stops he represented Dixon's biggest problem. There was a lot riding on the race for Kanaan — Pocono was the second race in the revived Triple Crown, and as Indianapolis 500 winner, the Brazilian was the only driver eligible for the million dollar bonus on offer for winning all three races (also including Fontana in October). He stepped out from behind Dixon in an attempt to take the lead, but misjudged it slightly and managed to brush his front wing against the rear of Dixon's car. The impact was so light that neither driver felt it, but it was enough to knock Kanaan's front wing loose and force him back to the pits for a new nose.

That still left a resurgent Penske. Castroneves was strong but probably not strong enough to threaten the cars at the front, although eighth was a further boost to his title aspirations. "It was a tough race that required a lot of thinking," he said. "And I'm terrible at thinking."

Power, on the other hand, looked like a genuine podium threat, and he admitted that he probably would have ended up in the top three had he realised that he was fighting Kimball for position late in the race. Nevertheless, after a torrid few weeks, he seemed satisfied with fourth.

But the day belonged to Ganassi, with Kimball claiming second ahead of Franchitti.

"That fuel-mileage advantage definitely helped," said the Briton. "We were very aggressive on downforce, too. We were looking around on the grid and seeing people with wickers on and all this, and there's us all trimmed out, and I think we all kind of looked at each other and went, 'it could be interesting'"

Interesting it was, but with a double-header on the bumpy streets of Toronto beckoning this weekend, there will be scant time for reflection. The 2013 season is more than half-complete, yet it's impossible to shake the sense that things are just warming up. ▶



# TECHNOLOGY SUPPLIERS BUYERS

**EUROPE'S LARGEST DEDICATED MOTORSPORT TRADE SHOW**

Covers every level of motor racing and technology.

**WINNING BUSINESS** Over £1 billion of business generated at the 2013 show. **LATEST TECHNOLOGY & PRODUCTS**

600+ exhibitors showcasing the latest technology and solutions. Plus new product launches. **NETWORKING**

28,000+ motorsport professionals, including over 5,000 overseas trade buyers from more than 50 countries.

## FOR MORE INFORMATION

**[AUTOSPORTINTERNATIONAL.COM](http://AUTOSPORTINTERNATIONAL.COM)**

**TO EXHIBIT CALL 020 8267 8300 OR EMAIL**

**[AUTOSPORT.INTERNATIONAL@HAYMARKET.COM](mailto:AUTOSPORT.INTERNATIONAL@HAYMARKET.COM)**

 **AUTOSPORT**  
INTERNATIONAL

**The Racing Car Show**

**9 - 12 January 2014 NEC**

9-10 January Trade Only Days

## IN THE PADDOCK



Briscoe finished  
14th at Pocono

## ANOTHER RACE FOR BRISCOE

Ryan Briscoe will return to the Panther Racing car this weekend in Toronto. "We should be doing all of the races that don't clash with sportscars," said the Australian, who missed qualifying at Pocono due to his American Le Mans Series commitments at Lime Rock, but still managed to finish 14th.

## PANTHER AIMS FOR EXPANSION

Panther Racing hopes to expand to two cars in 2014. Team boss John Barnes said that there are "probably six" drivers currently on his radar for next year.

## MUNOZ COULD RACE AGAIN IN '13

Carlos Munoz could make an IndyCar return at Sonoma, although he says no decision has been made by Andretti Autosport. "They do not want to tell me, because they want me to concentrate on winning the Indy Lights title," he said. "Maybe we will try to do something for Sonoma, because there is nothing happening with Lights there."

## TRIPLE-CROWN MONEY GONE

Tony Kanaan's failure to win at Pocono means that the million dollar Triple Crown prize is now off the table. However a \$250,000 bonus remains on offer for he and Scott Dixon if either driver can win the final Triple Crown event at Fontana.

## MANN WANTS MORE RACES

Pippa Mann will make another appearance with Dale Coyne Racing at Fontana, although she is uncertain whether it will be in the team's second car or a third entry. "Dale told me that he'd like me to do Fontana, so we're going to work together to try to make it happen," she said. Mann finished a career-best 15th at Pocono.

## TWO BIG MILESTONES REACHED

There were several milestones reached at Pocono last weekend. In addition to the race being Chip Ganassi Racing's first 1-2-3 finish, it was the 200th win for Honda in IndyCar-style racing. The first was scored by Andre Ribeiro at New Hampshire in Champ Car in August 1995 in a Tasman Racing Reynard.



Ribeiro took  
first Honda win

## Mark Glendenning



THERE WERE TWO VERY DIFFERENT TEAM philosophies at play at Pocono, both the product of circumstance rather than a deep-seated belief. At Ganassi, where no driver is in the title fight, it was gloves off.

"All three of us were pushing," said Dario Franchitti. "No team orders. If we had taken our team-mates out there would've been hell to pay, but we were going for the win."

Over at Andretti, where the championship is a more immediate concern, the approach was more collaborative, right down to private race simulations run during practice.

The thing they have in common is the way they benefit from being multi-car teams. Scott Dixon and Franchitti



Even Munoz  
benefits from  
Andretti data

work together at Ganassi, but after the race Charlie Kimball was also able to point to something he'd learned from Franchitti's data that had played a major part in getting him up to second.

Andretti's four cars are explicit in their on-track collaboration, but the benefit works vertically as well as horizontally: the team's Indy Lights leader Carlos Munoz said on Saturday that even he was taking set-up ideas from what the four bigger cars were doing.

Running more than two cars is difficult, and money is hard to find. But done right, the benefits of an expanded programme seem very real.

## Ganassi men see way forward

SCOTT DIXON AND DARIO FRANCHITTI ARE hoping that Chip Ganassi Racing can use the momentum from its Pocono success to reverse what has been a frustrating year for the multiple championship-winning team.

The pair came into the weekend seventh and 12th respectively in the points, with neither winning since 2012.

"I was approaching the one-year anniversary of my last win, so it was nice to get one out of the way this year," said Dixon. "More importantly, I'm super-excited for the team. Everybody has been working extremely hard and to have a glimpse of something great and some things to be positive about, hopefully we can keep this momentum rolling."

Franchitti, who was rebounding from a disastrous outing at Iowa, saluted the efforts of race engineer Chris Simmons in trying to solve the #10 car's recent problems.

"Chris and I have been working to make it close to what we need, and it's been tough," he said. "Everybody in the paddock works so hard, and when it's not going your way, it's tough. Chris and I have a similar personality – we take it very personally when it's not going well. So it's great to see him a little happier. But I know come tomorrow morning, he's going to be on the phone talking about Toronto."

Dixon's win moved him up to fourth in the standings, while Franchitti has improved to 11th.



Pocono: a CGR  
podium lock-out

## Pocono race cautiously praised

## DRIVERS WERE FULL OF PRAISE FOR

Pocono's high-speed and demanding layout following IndyCar's first race on the 2.5 mile tri-oval since 1989.

"It's a real IndyCar track," said Josef Newgarden, who equaled his career-best result by finishing fifth. "I don't know why we haven't been back here sooner. It's wide, it's fast, and I think it was a great race."

Simon Pagenaud, whom Newgarden passed late in the race, was equally enthusiastic.

"I loved it," he said. "It was very challenging; very hard on the drivers. All three corners are different and you have to adjust the tools in the car all the time. That makes it tricky."

Ryan Briscoe was also a fan of the track, but was cautious about the three-wide start procedure used.

"At the back of the pack everyone just got down and



The start featured a  
three-wide formation

rolled in and it backs up, because then everyone has gone from three to two wide," he said. "You had to be prepared for that. But it was fine. I wouldn't want to do it everywhere, but here and Indy is OK. And it looks cool when everyone's coming down the straight."

## F3 MASTERS Zandvoort (NL)

July 5-7



### RESULTS

25 LAPS, 66.91 MILES

<b>1</b>	<b>FELIX ROSENQVIST (S)</b>	<b>39m13.600s</b>
Mucke Motorsport Dallara-Mercedes F312; Qualifying: 1st-1m30.839s		
<b>2</b>	<b>ALEX LYNN (GB)</b>	<b>+5.787s</b>
Prema Powerteam Dallara-Mercedes F312; Qualifying: 3rd-1m31.154s		
<b>3</b>	<b>EMIL BERNSTORFF (GB)</b>	<b>+6.698s</b>
Prema Powerteam Dallara-Mercedes F312; Qualifying: 4th-1m31.255s		
<b>4</b>	<b>HARRY TINCKNELL (GB)</b>	<b>+12.534s</b>
Carlin Dallara-Volkswagen F312; Qualifying: 2nd-1m31.131s		
<b>5</b>	<b>JORDAN KING (GB)</b>	<b>+19.781s</b>
Carlin Dallara-Volkswagen F312; Qualifying: 9th-1m31.414s		
<b>6</b>	<b>EDDIE CHEEVER (I)</b>	<b>+29.274s</b>
Prema Powerteam Dallara-Mercedes F312; Qualifying: 11th-1m31.716s		
<b>7</b>	<b>NICHOLAS LATIFI (CDN)</b>	<b>+29.874s</b>
Carlin Dallara-Volkswagen F312; Qualifying: 8th-1m31.404s		
<b>8</b>	<b>PIPO DERANI (BR)</b>	<b>+30.536s</b>
Fortec Motorsport Dallara-Mercedes F312; Qualifying: 14th-1m31.964s		
<b>9</b>	<b>WILL BULLER (GB)</b>	<b>+31.491s</b>
Fortec Motorsport Dallara-Mercedes F312; Qualifying: 16th-1m32.001s		
<b>10</b>	<b>ANTONIO GIOVINAZZI (I)</b>	<b>+34.043s</b>
Double R Racing Dallara-Mercedes F312; Qualifying: 15th-1m31.984s		
<b>11</b>	<b>DENNIS VAN DE LAAR (NL)</b>	<b>+35.260s</b>
Van Amersfoort Racing Dallara-Volkswagen F312; Qualifying: 12th-1m31.782s		
<b>12</b>	<b>MICHAEL LEWIS (USA)</b>	<b>+36.475s</b>
Mucke Motorsport Dallara-Mercedes F312; Qualifying: 13th-1m31.916s		
<b>13</b>	<b>JANN MARDENBOROUGH (GB)</b>	<b>+36.569s</b>
Carlin Dallara-Volkswagen F312; Qualifying: 10th-1m31.572s		
<b>14</b>	<b>SPIKE GODDARD (AUS)</b>	<b>+40.224s</b>
T-Sport Dallara-Nissan F312; Qualifying: 18th-1m32.279s		
<b>15</b>	<b>JOSH HILL (GB)</b>	<b>+44.219s</b>
Fortec Motorsport Dallara-Mercedes F312; Qualifying: 17th-1m32.029s		
<b>16</b>	<b>ROY NISSANY (IL)</b>	<b>+46.776s</b>
Mucke Motorsport Dallara-Mercedes F312; Qualifying: 22nd-1m32.964s		
<b>17</b>	<b>SANDRO ZELLER (CH)</b>	<b>+54.058s</b>
Jo Zeller Racing Dallara-Mercedes F312; Qualifying: 23rd-1m33.052s		
<b>18</b>	<b>YUHI SEKIGUCHI (J)</b>	<b>+54.354s</b>
Mucke Motorsport Dallara-Mercedes F312; Qualifying: 19th-1m32.391s		
<b>19</b>	<b>ANDRE RUDERSDORF (D)</b>	<b>+54.744s</b>
Ma-con Dallara-Volkswagen F312; Qualifying: 20th-1m32.548s		
<b>20</b>	<b>TATIANA CALDERON (CO)</b>	<b>+55.142s</b>
Double R Racing Dallara-Mercedes F312; Qualifying: 24th-1m33.153s		
<b>21</b>	<b>TOM BLOMQVIST (GB)</b>	<b>22 laps-clutch</b>
EuroInternational Dallara-Mercedes F312; Qualifying: 7th-1m31.399s		
<b>R</b>	<b>SEAN GELAE (R)</b>	<b>12 laps-accident</b>
Double R Racing Dallara-Mercedes F313; Qualifying: 21st-1m32.676s		
<b>R</b>	<b>SVEN MULLER (D)</b>	<b>5 laps-accident</b>
Ma-con Dallara-Volkswagen F312; Qualifying: 6th-1m31.363s		
<b>R</b>	<b>LUCAS AUER (A)</b>	<b>4 laps-accident</b>
Prema Powerteam Dallara-Mercedes F312; Qualifying: 5th-1m31.256s		

Winner's average speed: 102.34mph. Fastest lap: Rosenqvist, 1m33.266s, 103.30mph.



Auer collided with Muller



Rosenqvist got the jump on Lynn and Bernstorff (wide)

## Dominant Rosenqvist is F3's grand master

IT'S HARD TO BELIEVE THAT FELIX ROSENQVIST wasn't too fussed about the Masters of Formula 3 during the lead-up to the event. The Mucke Motorsport driver looked like a man firmly focused on writing his name to the impressive roll of honour at Zandvoort's blue-riband race for the second time. He was always on top and didn't put a foot wrong on the way to a dominant victory in last Sunday's 25-lap race.

The Swede was fastest aboard his Dallara-Mercedes in both free practice sessions, the two qualifying periods, led every lap of the race and took fastest lap to boot. Nobody else got a look-in.

"I wasn't so much focused on this event because it's a one-off," he said, "but the car felt good from the first lap of free practice and after that there was only one target."

How and why he hit that target in some style – he was nearly six seconds ahead of nearest challenger Alex Lynn at the chequered flag – can be put down to a series of factors.

Rosenqvist was, of course, a man on a roll after winning all three races at the most recent round of the European championship at Spielberg in June. He also pointed out that he loves the 2.68-mile Circuit Park Zandvoort and reckons it suits his driving style. The same could be said of the Kumho tyres on which the cars run at the Masters.

They have quite different characteristics to the European series Hankooks. Each driver only gets three sets for the weekend and no chance to test on them beforehand. Rosenqvist was racing on the Masters Kumho for a third time and also has knowledge of the South Korean rubber, though not exactly the same tyre, from his Euro Series campaign in 2011.

"I realise that you have to change your driving style for these tyres; maybe the others don't," he said. "You need to be more cautious and more precise, and I think that suits me. I think I'm quite a calm driver."

Mucke nailed the set-up with the Kumhos at the weekend, something it had failed to do in 2012. Rosenqvist's bid for back-to-back Masters victories last year was effectively scuppered when the set-up for the tyres on the 2008-spec Dallara



Lynn (2) passed Tincknell (3) at start for second

didn't readily transfer to the latest-generation car.

Yet too much can be made of the tyre situation, according to Dutch team boss Frits van Amersfoort.

"The biggest influence here is the track," he explained. "It is like a chameleon because of the sand and the sea."

Prema Powerteam boss Rene Rosin, whose squad followed up on Daniel Juncadella's 2012 victory with second and third places for Lynn and Emil Bernstorff, called it an "old story", while conceding that experience – on the tyre and at the track – was important. He pointed out that three of his drivers, including Bernstorff, were Masters debutants.

Lynn, back at the Masters for a second time, reckoned the team was always behind the eight ball after failing to hit the sweet spot in first practice. He ended up third on the grid, but jumped ahead of front-row qualifier Harry Tincknell when his fellow Brit got too much wheelspin on the dirty side of the track.

"I went for broke at the start," said Carlin driver Tincknell, who ended up fourth. "I knew my only chance was to get ahead at the start."

Lynn led the forlorn chase of Rosenqvist and had a decent gap to Bernstorff until he started to oversteer in the closing stages. That allowed his team-mate to close to within a second.

The only black mark against Rosenqvist's victory was the absence of European series leader Raffaele Marciello, but the Swede wasn't too concerned.

"It's not my fault that he's not here," he said. "All you can do is try to beat the guys who are."

## IN THE PADDOCK

## Gary Watkins



'A SHADOW OF ITS FORMER SELF' IS THE ONLY way I can describe the 23rd running of the Masters. That's an inevitable conclusion for someone who last reported on the event 18 years ago.

When I was pounding the Formula 3 paddocks, a rite of passage for any young AUTOSPORT hack, the race was still the event it had been conceived to be – a winner-takes-all shootout between the *creme de la creme* of F3 talent from around Europe and occasionally beyond.

Just look at the top six from the race in my only year as AUTOSPORT's full-time F3 man in 1995: Norberto Fontana won from Ralf Schumacher, Helio Castro Neves (he had yet to fuse his surnames back then), Oliver Gavin, Tom Coronel and Max Angelelli. And just think of the careers they have gone on to have.

I appreciate that the landscape of motorsport has changed and I am all too aware of the plight faced by the British F3 Championship, but the *raison d'etre* of the Masters has disappeared. I'm not sure if the Masters works as a kind of non-points European F3 round with the odd ringer and stand-in here and there.

Felix Rosenqvist can now say he is only the second two-time winner of a race with an impressive pedigree. As impressive as he was last weekend, does his victory mean as much as David Coulthard's in 1991 or even Lewis Hamilton's in 2005? Of course not.



Race carried more prestige in '95

# BIG NUMBER

# 16,707

The Masters crowd. Big for an F3 meeting, but well down on the 85,000 of 1999, when tickets were given away by sponsor Marlboro.

## Event faces uncertain future

## ZANDVOORT HAS VOWED TO DO EVERYTHING

possible to maintain the Masters of Formula 3, even if the grid continues to be made up almost exclusively of European championship runners.

Track boss Eric Weijers believes the event, which was established in 1991 to bring together the top teams and drivers from the major national F3 series around Europe, is still valid in a new era of the category.

"We believe that a one-off mid-season race is good for F3," he said. "It is about performing 100 per cent over a weekend, which makes the Masters what it is.

"We believe it can remain on the calendar even if the grid is made up of just European championship cars."

Barry Bland, who puts the grid together for the event, believes it can continue even if British F3 fails to recover from its current malaise.

"We surveyed the teams at the end of last year and there was strong support for it," he explained. "The event has 20-odd years of history and is a recognised event that people consider worth winning."

There was a certain fondness for the Masters in the paddock last weekend.

"The drivers enjoy the track and the teams like being here," said T-Sport boss Russell Eacott. "It's a great



Organisers reckon there'll be a class of '14

place to come to, and this year it's good practice for the European round [with the DTM in September]."

That fixture represents a cloud on the horizon for the event. European series rules prohibit races such as the Masters at tracks it subsequently visits, meaning Zandvoort, with the help of the Dutch motorsport federation, needed a waiver to continue this year.

Weijers stressed that this waiver was for one year only, but he is hopeful that it can be extended in the future.

## Serralles pulls out injured

## FORTEC MOTORSPORT DRIVER FELIX

Serralles was a late withdrawal from the Masters.

The Puerto Rican, who lies seventh in the Formula 3 European Championship, informed the team last week that he had been advised by his doctors not to compete. The decision followed a scan on a lingering back injury in his homeland.

A trapped nerve was diagnosed and he was scheduled to have further tests this week. Surgery appeared a likely option, which will force him to miss at least some of the remaining five European weekends.

The injury was sustained in a clash in last year's penultimate round of the British series at Silverstone. Serralles finished the race after a being launched into the air on the Wellington Straight, but complained of back pain after the event and had to be removed from the car by the medical services.

Fortec team principal Richard Dutton said: "He's been carrying the injury since the winter and hasn't been the same guy that he was last year.

"They couldn't find what it was initially, but now it looks like he's going to have an operation."

Even if surgery is not scheduled, Dutton is not hopeful of his driver returning to the Dallara-Mercedes squad in time for this weekend's European F3 Championship round at the Norisring.



Serralles could be out for a while



## LOCAL MAN VAN DE LAAR GOES PINK

Dennis van de Laar, the only Dutch driver competing in the Masters this year, was faced with an usual dilemma. The corporate colours of his sponsor for the event, Sandd, were pink-and-purple and the deal was that his Van Amersfoort Racing Dallara would carry one colour and his overalls the other. Whether his decision to go for pink Nomex was the right one was hard to tell.

## ROSENQVIST'S MEDICAL-CAR SCARE

The closest thing to a hiccup in Felix Rosenqvist's relentless charge to victory came on the 16th lap when he encountered the medical car on the track. The Swede had to back off and go off line, which cut his lead from 4.5 seconds to 2.8s. It was back up over 4s in the space of four laps.

## MULLER AND AUER COLLIDE

Austrian Lucas Auer took Sven Muller out of the race on the fifth lap. The Prema driver had already made one botched attempt to snatch fifth place from the Ma-Con man when he rammed him up the rear at the Tarzan hairpin. Auer retired on the spot, while Muller made it back to the pits.

## BLOMQVIST LOSES STRONG RESULT

EuroInternational driver Tom Blomqvist moved up to fifth as a result of the Muller/Auer collision in his EuroInternational Dallara-Mercedes and looked set to finish in that position when a suspected clutch problem intervened with four laps to go.

## BRITAIN WINS NATIONS' CUP

The traditional Nations Cup competition at the Masters, based on qualifying positions, was won by Britain courtesy of the second and third-placed grid spots earned by Carlin driver Harry Tincknell and Prema Powerteam's Alex Lynn.

## FIA GT Zandvoort (NL)

July 6-7

Round 3/6

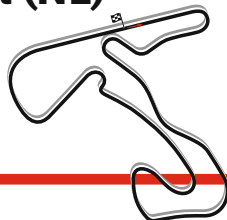

### RESULTS

MAIN RACE: 35 LAPS, 93.67 MILES

1	MAXIMILIAN BUHK (D)/ALON DAY (IL)	1h27m51.001s
HTP Gravity Charouz Mercedes-Benz SLS AMG GT3; Grid-2nd		
2	STEPHANE ORTELLI (MC)/LAURENS VANTHOOR (B)	+6.667s
WRT Audi R8 LMS ultra; Grid-1st		
3	EDWARD SANDSTROM (S)/FRANK STIPPLER (D)	+6.995s
WRT Audi R8 LMS ultra; Grid-4th		
4	KARUN CHANDHOK (IND)/JAN SEYFFARTH (D)	+33.895s
SMS Seyffarth Motorsport Mercedes-Benz SLS AMG GT3; Grid-8th		
5	HARI PROCZYK (A)/DOMINIK BAUMANN (A)	+40.127s
GRT Grasser Racing Team Lamborghini Gallardo LP560-4; Grid-10th		
6	RICARDO ZONTA (BR)/SERGIO JIMENEZ (BR)	+41.218s
BMW Team Brasil BMW Z4 GT3; Grid-16th		
7	CACA BUENO (BR)/ALLAM KHODAIR (BR)	+55.861s
BMW Team Brasil BMW Z4 GT3; Grid-5th		
8	LUCAS ORDONEZ (E)/ALEX BUNCOMBE (GB)	+58.858s
R.J.N Motorsport Nissan GT-R; Grid-13th		
9	A EBRAHIM (IND)/M HEEMSKERK (NL)	+60.473s
BMW Team India (SUNRED) BMW Z4 GT3; Grid-9th		
10	PATRICK CUNHA (BR)/MATHEUS STUMPF (BR)	+72.200s
Rodrive (Veloce) Lamborghini Gallardo LP560-4; Grid-14th		

Winners' average speed: 63.97mph. Fastest lap: Vanthoor, 1m40.041s, 96.31mph. First-named driver started race.

QUALIFYING RACE: 33 LAPS, 88.32 MILES

1	VANTHOOR/ORTELLI	1h01m01.018s
Audi; Qualifying-3rd		
2	DAY/BUHK	+0.766s
Mercedes; Qualifying-4th		
3	RENE RAST (D)/NIKI MAYR-MELNHOF (A)	+2.710s
WRT Audi R8 LMS ultra; Qualifying-5th		
4	STIPPLER/SANDSTROM	+3.129s
Audi; Qualifying-8th		
5	KHODAIR/BUENO	+6.517s
BMW; Qualifying-7th		
6	MIKE PARISY (F)/ANDREAS ZUBER (A)	+18.697s
Sebastian Loeb Racing McLaren MP4-12C GT3; Qualifying-14th		
7	ANDREAS SIMONSEN (S)/SERGEI AFANASIEV (RU)	+19.354s
HTP Gravity Charouz Mercedes SLS AMG GT3; Qualifying 8th		
8	SEYFFARTH/CHANDHOK	+28.758s
Mercedes; Qualifying-2nd		
9	HEEMSKERK/EBRAHIM	+33.387s
BMW; Qualifying-17th		
10	BAUMANN/PROCYK	+34.987s
Lamborghini; Qualifying-9th		

Winners' average speed: 86.84mph. Fastest lap: Buhk, 1m40.214s, 96.14mph. First-named driver started race.

### CHAMPIONSHIP

1	VANTHOOR/ORTELLI	70	6	KHODAIR/BUENO	28
2	SANDSTROM/STIPPLER	60	7	ZUBER/PARISY	26
3	DAY/BUHK	53	8	KUMPEN/IDE	24
4	RAST/MAYR-MELNHOF	35	9	SEYFFARTH/CHANDHOK	23
5	KOX/ROSINA	32	10	PARENTE/LOEB	22

### PRO-AM

1	BAUMANN/PROCYK	67	4	BUNCOMBE/ORDONEZ	38
2	AFANASIEV/SIMONSEN	62	5	SHULZHITSKIV/REIP	35
3	VIEIRA/CAMPANICO	58	6	STUMPF	31

### POINTS SYSTEM EXPLAINED

25-18-15-12-10-8-6-4-2-1 for top 10 finishers in main race. 8-6-4-3-2-1 for top 6 finishers in qualifying race.



Day/Buhk car wasn't always out front

FOR IN-DEPTH RESULTS FORIX



## Merc duo plays correct dune

IT DIDN'T MATTER IN THE END THAT ALON DAY, by his own admission, messed up qualifying. Such was the pace of the lead Gravity Charouz Mercedes around Zandvoort last weekend that the Israeli and Maximilian Buhk were able to come from fifth at the first corner of the opening race on Saturday to beat the might of the WRT Audi squad when it mattered in Sunday's full-points race of the FIA GT Series round in the Netherlands.

The Mercedes SLS AMG was the car to have around Circuit Park Zandvoort, or rather a Gravity Charouz one was the weapon of choice in the dunes. There were different theories as to why, but key was the German machine's excellent traction, which comes courtesy of superb electronics and the rear-suspension geometry that was key in propelling the fast-starting Munnich Mercs to last year's GT1 World title.

Buhk and Day would almost certainly have come away from Zandvoort with a double victory in the two hour-long races but for Day's failure to string a lap together in qualifying. Buhk came within a few tenths of stealing the win in the qualifying race on Saturday after battling his way through the pack of WRT Audi R8 LMS ultras.

Day, who was making only his fourth race appearance in a GT car, wasn't slow per se in qualifying, but he made mistakes on both the two laps allowed in the superpole session. Had his fastest sector times been pieced together, his theoretical best would have given him top spot.

Fourth place for Day became fifth at the start. That was where he ended the opening stint of the qualifying race, which was interrupted by a safety car period. Buhk then emerged from the pitstops in fourth behind the trio of Belgian-entered R8s.

The 21-year-old German passed Edward Sandstrom quickly, but an impressive rearguard action from Nikolaus Mayr-Melnhof, almost from the moment he'd been passed by teammate Laurens Vanthoor, probably secured victory for WRT.

Buhk was trapped behind the Audi for eight laps and only made it past with two laps to go, and by then it was too late to close down an admittedly small 1s deficit.

There was little doubt that Buhk would beat Stephane Orтели in the Vanthoor car and that he would be able to pull a gap to the Audi. The only question mark was whether the Gravity Charouz squad could turn its lead car around in the pits in time to get Day back out in the lead.

Buhk was nearly 2s up at the end of the first lap when, first, the safety car was called and, then, the race was red-flagged after Cesar Campanico crashed his Audi at Tarzan. This "annoying" intervention, as the German driver called it, didn't derail the plan and he was still 6s up on Orтели when the Audi pitted.

WRT, as usual, won the pitstop race, and that gap was more than halved. But rather than closing the gap, Vanthoor was powerless to prevent Day from edging away and by the end of the race the deficit was back up to 6s.

"I knew it would be close," said Day. "It was close for a few laps and I had to push, but by the end I was just cruising, but Max did all the hard work today."



FABRE/SRO

## IN THE PADDOCK

## Gary Watkins

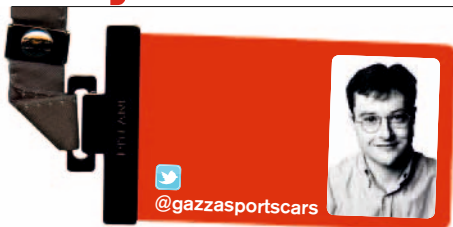

STEPHANE RATEL DOES HAVE A POINT ABOUT momentum. It, or a rather a lack of it, almost cost him his shirt in the days of the GT1 World Championship and a loss of impetus now also threatens its successor, the FIA GT Series.

The uncertainty that almost constantly surrounded GT1 World is probably the primary reason why it is not around today. Even between its two glory years in 2010 and '11 – when it really was a GT1 world series – its future hung in the balance.

GT1 World's rebirth as the FIA GT Series represents a fresh start of sorts, but the downward trend in entries is ominous and scarily reminiscent of last year's decline.

It was OK for the series to dip below 20 cars in 2011 because the quality was so deep, but now with Pro-Am and Am entries joining the 10 or so all-pro line-ups, the need for bulk is greater than ever.

Grids need to pick up and pick up soon if the latest incarnation of FIA GTs is to have a real future. It needs to finish brightly so that it bursts back into life at the beginning of 2014.

## Ratel predicts numbers to rise

## SERIES BOSS STEPHANE RATEL HAS FEW

concerns about the size of his grid despite the FIA GT entry shrinking to 20 cars for Zandvoort.

The series was hit by the withdrawal of the Blancpain-sponsored Reiter Lamborghini squad, which pulled out for reasons that included Andrea Mame's fatal accident in the Lamborghini Super Trofeo, which is also backed by the watchmaker, the previous weekend at Paul Ricard. Ratel revealed that the move had deprived the entry of the usual Gallardo raced by Peter Kox and Stefan Rosina, and a second car.

The Vita4One BMW team was a no-show, or rather a non-participant. Its trucks were in the paddock, though team boss Michael Bartels insisted that its entry of a solo Z4 was always far from confirmed.

Also absent was a second entry from the Portuguese Rodrive squad, following its swap from Ford to Lamborghini. A late entry from GT Open regular V8 Racing with its Chevrolet Corvette Z06 ensured that the grid broke the magic 20 mark, but that was still two down on the Zolder and four on the Nogaro rounds.

Ratel stated that there is genuine interest in the series and that numbers will increase for the Slovakia Ring event in August.

"We should have Reiter back and there are people telling me that they are coming to the Slovakia Ring," he explained. "On paper there are six extra cars – not including Reiter – that could come before we go to Baku."



The season finale on the streets of the Azerbaijan capital is being built around a grid of 30 cars and Ratel is insistent that he will achieve that number.

He admitted that the 10-week gap between the Zolder and Zandvoort rounds hasn't helped his cause.

"Stopping for such a long time was really not a good idea," he said. "We have lost a little bit of momentum, which we will now have to regain."



## Heemskerk makes debut

## A LATE INVITE TO DRIVE FOR TEAM BMW

India at Zandvoort meant that Dutchman Melroy Heemskerk had two jobs over the Masters weekend.

Heemskerk, 24, the Dutch Formula Ford 1600 champion in 2009, works for the successful Geva Racing team and was helping to run its cars in FF1600 on the support bill last weekend. That didn't appear to hinder the sometime Formula Palmer Audi driver's efforts behind the wheel of the SUNRED-run Z4 he shared with Armaan Ebrahim or stop him from offering to wash the thing after one session.

The opportunity came up courtesy of Gary Ayles, who coaches Ebrahim and saw Heemskerk's talents at first hand when he gave him a one-off in one of his Lotus Evora GT4s in the Dutch GT Championship last year.

"I put him in the car last year and thought, ah, he's good," said the ex-touring car driver. "He is a bit special."

The new partnership yielded a pair of ninth-place finishes overall and two Pro-Am podiums.

## RODRIVE'S NEW STRUCTURE

Rodrive has forged a partnership with fellow Portuguese squad Veloso Motorsport to continue in FIA GT after ending its relationship with the organisation behind the Ford GTs it previously run, Lambda Performance. A single Lamborghini Gallardo was run at Zandvoort for Matheus Stumpf and Patrick Cunha, regulars respectively with Rodrive and Veloso.

## SEYFFARTH MOVES FORWARDS

The Seyffarth Mercedes team picked up its best result of the season with fourth place in the main race on Sunday. Jan Seyffarth and Karun Chandhok brought their car from 16th to eighth in the first race and then up to fourth in the main event. "All we need now is to learn how to qualify the car," admitted former F1 racer Chandhok.

## RAST HIT BY MEDICAL CAR

Rene Rast's celebrations after the qualifying race on Saturday were cut short when he was tagged in the pitlane by the medical car! The German was lucky to escape serious injury and raced with a bandaged arm, although his car stopped with clutch problems shortly after the start.

## BRAZILIANS SNATCH BEST RESULT

Team BMW Brazil notched up its best result of the season with sixth for Ricardo Zonta and Sergio Jimenez in the main event. Allam Khodair and Caca Bueno finished one place behind but missed out on a shot at the podium after the former was given a drive-through penalty for overtaking Nikolaus Mayr-Melnhof under yellow flags early in the race.



## NISSAN STRONG

The RJN-run GT Academy Nissan GT-R driven by Lucas Ordóñez and Alex Buncombe fought back to eighth overall and second in pro-am in the main race after a puncture and early pitstop in the qualifying race dropped the pair back down the order.

## MILESTONE

Indy Lights graduate Alon Day become the first Israeli to win an international motor race with his FIA GT victory at Zandvoort.



In brief



CZOBAT/LAT

NASCAR NATIONWIDE

Matt Kenseth (above) took his first series win since 2011 in his Joe Gibbs Racing Toyota at Daytona, beating James Buescher's TMG Chevy and his own team-mate Elliott Sadler. Sam Hornish Jr beat Regan Smith by one place and is six points behind in the title race.

EURO NASCAR

Frenchman Frederic Gabillon won both Elite races at Tours Speedway and moved into fourth in the points as a result. Guest starter Max Papis was second in race one, with Bertrand Baguette sixth. Julien Goupy and Josh Burdon won the Open races.

V8 DEVELOPMENT

Steve Owen won twice at Townsville. He beat MW Ford team-mate Dale Wood home in each of the longer races, with Wood taking the points lead from Ashley Walsh. Veteran Paul Morris took the reversed-grid encounter. Casey Stoner's troubled debut season continued, the former biker 29th, 14th and 12th.

FRENCH GT

Fabien Barthez and Morgan Moullin Traffort took a win and a third at Val de Vienne in their Sofrev Ferrari, while Laurent Pasquali and 2012 champion Anthony Beltoise took the other race in their Sebastien Loeb McLaren. Eric Cayrolle/Arno Santamato (Sport Garage Ferrari) had a second place.

ITALIAN GT

Ferraris won both races at Mugello, Black Bull duo Tommaso Maino/Mirko Venturi and MP1 pair Giuseppe Ciro/Gabriele Lancieri each taking a victory. Stefano Comandini/Stefano Colombo (ROAL BMW) were second twice.

FRENAULT ALPS

A collision with Prema team-mate Bruno Bonifacio robbed Ferrari junior Antonio Fuoco the chance of adding to his race-one victory at Monza. Luca Ghiotto (Prema) won instead from Joffrey de Narda and Simon Tirman. Bonifacio and Ghiotto completed the race-one podium.



Ghiotto won race two



Johnson (48) beat Stewart (14)

NASCAR SPRINT CUP DAYTONA (USA), JULY 6, RD 18/36

# Johnson's Daytona double

JIMMIE JOHNSON BECAME THE FIRST man in 31 years to win both Daytona Cup races in a single season as he took last Saturday's 400-miler.

As had been the case for most of the previous event in Kentucky, it did not matter how many rivals drafted up to his tail or what tactical tricks others pulled, the Hendrick Chevrolet driver was always able to stay in front.

Unlike Kentucky, there were no late shocks this time, and Johnson led a chaotic final stint to clinch his fourth 2013 win by 0.1 seconds from Tony Stewart.

Kevin Harvick, Clint Bowyer, Michael Waltrip, Kurt Busch, Jamie McMurray and Dale Earnhardt Jr chased the leaders over the line, with a trail of smoke, debris and limping

cars in their wake as two final-lap crashes took out most of their peers.

The mayhem began when Carl Edwards was helped into a spin at Turn 2 and collected several others. The race was left green to allow the lead battle to unfold, but another multi-car crash erupted at Turn 4 when Danica Patrick was turned around mid-pack.

The worst crash had come 10 laps from the end and prompted a red flag. Denny Hamlin, who had fought back after an early tangle with Martin Truex Jr and polesitter Kyle Busch, spun up the track, sending Matt Kenseth into Jeff Gordon in avoidance. Hamlin hit the wall and rebounded into the path of AJ Allmendinger and others. All were unhurt.

A green-white-chequered finish was then required after Marcos Ambrose moved across Kasey Kahne as they battled right behind Johnson, sending Kahne violently into the inside wall.

● Connell Sanders Jr

RESULTS

1 Jimmie Johnson (Chevrolet SS), 161 laps in 2h36m30s; 2 Tony Stewart (Chevy), +0.107s; 3 Kevin Harvick (Chevy); 4 Clint Bowyer (Toyota Camry); 5 Michael Waltrip (Toyota); 6 Kurt Busch (Chevy); 7 Jamie McMurray (Chevy); 8 Dale Earnhardt Jr (Chevy); 9 Casey Mears (Ford Fusion); 10 Ryan Newman (Chevy). **Points** 1 Johnson, 658; 2 Bowyer, 609; 3 Carl Edwards, 587; 4 Harvick, 585; 5 Earnhardt, 548; 6 Matt Kenseth, 540; 7 Kyle Busch, 533; 8 Greg Biffle, 516; 9 Kurt Busch, 501; 10 Stewart, 499.

V8 SUPERCARS TOWNSVILLE (AUS), JULY 6-7, RD 7/14

# HRT breaks winless streak

THERE WAS A PAIR OF ONE-TWO finishes at Townsville, and it was two different teams that managed it.

Ford Performance Racing scored its best result of the year in race one, and a day later the Holden Racing Team took its first race win in two seasons and its first one-two since 2009.

It was a weekend decided by tyres and strategy. On Saturday, Craig Lowndes rolled the dice from mid-pack and started the race on a set of softer tyres, while the other 27 drivers began on harder rubber.

That allowed Lowndes to streak through the field and build a lead, but Will Davison chased him down, and was followed past the Triple 8 Holden of Lowndes by FPR team-mate Mark Winterbottom and Fabian Coulthard.

On Sunday, HRT duo Garth Tander and James Courtney took an even riskier route, making two stops for successive sets of the softer rubber. That allowed them to hold on ahead of the impressive Shane van Gisbergen,



Tander won race two

who recovered from last after being spun around on the first lap.

The other story of the weekend was the lack of speed from Triple 8 on the harder tyre. Jamie Whincup finished seventh and 11th in the two races, with Whincup and Lowndes struggling in qualifying.

The non-HRT Walkinshaw Racing cars ran well, Russell Ingall marking his record 226th start with fifth place ahead of privateer Tony D'Alberto.

● Phil Branagan

RESULTS

1 Will Davison (Ford Falcon FG), 70 laps in 1h28m39.597s; 2 Mark Winterbottom (Ford), +4.010s; 3 Fabian Coulthard (Holden Commodore VF); 4 Craig Lowndes (Holden); 5 Jason Bright (Holden); 6 James Courtney (Holden). **Race 2** 1 Garth Tander (Holden), 70 laps in 1h30m04.164s; 2 Courtney, +0.319s; 3 Shane van Gisbergen (Holden); 4 Winterbottom; 5 Russell Ingall (Holden); 6 Tony D'Alberto (Holden). **Points** 1 Jamie Whincup, 1591; 2 Lowndes, 1480; 3 W Davison, 1376; 4 Winterbottom, 1337; 5 van Gisbergen, 1310; 6 Tander, 1302.

AMERICAN LE MANS SERIES LIME ROCK (USA), JULY 6, RD 4/10

# Pickett pair cruises to latest victory

PICKETT RACING PAIR LUCAS LUHR and Klaus Graf cruised to victory at Lime Rock after pitstop problems for Chris Dyson and Guy Smith took their Dyson Lola-Mazda out of contention. With nearest rival Rebellion Racing missing from the event, the result further increased the HPD-driving German duo's stranglehold on the series.

While the overall battle was tame, the LMP2 contest was controversial.

Extreme Speed's Guy Cosmo went off on his out-lap after taking over Scott Sharp's class-leading HPD at its final stop, allowing Ryan Briscoe's Level 5 HPD into first place. Briscoe then tagged his rival at a late restart, sending Cosmo off and leaving him runner-up with a damaged car.

"I don't know what happened," said an apologetic Briscoe. "It hooked the cars and it spun him." An irate Cosmo replied: "Apparently Briscoe thinks we're in NASCAR and we're going to ram each other on straights."

IMSA officials waited until after the race to penalise Briscoe for avoidable contact, giving the Aussie and co-driver Scott Tucker third-place points while handing Cosmo



Pickett pair beat  
Dyson duo

and Sharp a maximum score.

John Edwards and Dirk Muller were relatively untroubled in GT as the BMW Team RLL pair won from the Jan Magnussen/Antonio Garcia Corvette. A clever pit strategy for CORE Autosport brought Patrick Long and Tom Kimber-Smith a podium finish in their Porsche.

Bruno Junqueira/Duncan Ende won for RSR in LMPC while Flying Lizard duo Nelson Canache Jr/Spencer Pumpelly won GTC.

● Jonathan Ingram

## RESULTS

1 Lucas Luhr/Klaus Graf (HPD ARX-03a), 184 laps in 2h45m41.407s; 2 Guy Smith/Chris Dyson

(Lola-Mazda B12/60), -6 laps; 3 Scott Tucker/Ryan Briscoe (HPD-Honda ARX-03b). GT 1 Dirk Muller/John Edwards (BMW Z4 GTE); 2 Jan Magnussen/Antonio Garcia (Chevrolet Corvette C6.R); 3 Pat Long/Tom Kimber-Smith (Porsche 911 GT3-RSR). Points 1 Luhr/Graf, 82; 2 Neel Jani/Nick Heidfeld, 58; 3 Nicolas Prost, 24. GT 1 Muller, 62; 2 Magnussen/Garcia, 46; 3 Edwards, 46.



Bakkerud leads  
final pack

EUROPEAN RALLYCROSS HOLJES (S), JULY 6-7, RD 6/9

# Bakkerud defeats Swedish favourites

NORWEGIAN ANDREAS BAKKERUD scored his maiden European series victory in the Supercar division at a sweltering Holjes in Sweden.

Bakkerud waited until two-thirds distance to take his joker lap and lost the lead to Timmy Hansen's Citroen as a result, but a mistake two corners later by the Swede let Bakkerud and the Marklund Volkswagen of DTM ace Mattias Ekstrom through.

Hansen was third while Petter Solberg, who had hounded Bakkerud early on, retired with an engine problem.

Timur Timerzyanov missed out on the final after finishing fourth in his

semi and now leads team-mate Hansen by only four points in the championship. Bakkerud's LD Motorsports boss and team-mate Liam Doran withdrew after suffering an engine failure in his first heat.

● Hal Ridge

## RESULTS

1 Andreas Bakkerud (Citroen DS3), 6 laps in 4m32.446s; 2 Mattias Ekstrom (Volkswagen Polo), +0.574s; 3 Timmy Hansen (Citroen); 4 Henning Solberg (Saab 93); 5 Danial Holten (Volvo C30); 6 Petter Solberg (Citroen DS3). Points 1 Timur Timerzyanov, 120; 2 Hansen, 116; 3 Davy Jeanney, 99; 4 Bakkerud, 89; 5 Liam Doran, 71; 6 Anton Marklund, 70.

INDY LIGHTS POCONO (USA), JULY 6, RD 7/12

# Munoz resumes series lead with win

CARLOS MUNOZ DEMOLISHED HIS rivals at Pocono last weekend, the Andretti Autosport driver delivering the perfect response to his poor outing in Iowa two weeks earlier.

The Colombian lost the championship lead to Sage Karam when handling problems at Iowa Speedway left him in last place, but he rebounded last Saturday by taking pole position and storming away to win more or less uncontested. His margin of victory was more than 16 seconds, and the win moved him back to the top of the standings.

Karam was left to fight Schmidt Peterson team-mate Gabby Chaves

for second in a battle that involved several changes of position and one brief moment of contact before the dispute was finally settled in Karam's favour.

Schmidt Peterson-run British charger Jack Hawksworth finished fifth behind Zach Veach.

● Mark Glendenning

## RESULTS

1 Carlos Munoz, 40 laps in 32m47.7712s; 2 Sage Karam, +16.2247s; 3 Gabby Chaves; 4 Zach Veach; 5 Jack Hawksworth; 6 Juan Pablo Garcia. Points 1 Munoz, 285; 2 Karam, 281; 3 Chaves, 246; 4 Peter Dempsey, 226; 5 Hawksworth, 221; 6 Veach, 201.



Munoz bounced  
back at Pocono

# WEB DIRECTORY

## CAR BROKERAGE

### RACING CARS FOR SALE

ALAN CORNOCK FCS  
BUYING - SELLING - BROKERAGE  
[www.racingcarsforsale.co.uk](http://www.racingcarsforsale.co.uk)  
TEL: 01480 891212

## DRIVER DEVELOPMENT

eugene **O'Brien**.co.uk

### DRIVER DEVELOPMENT

Tel: 0775 383 5629

## ENGINES

### JULIAN GODFREY ENGINEERING

visit our new online shop [www.racetuners.com](http://www.racetuners.com)

## EXHAUSTS

Stainless Steel Exhaust Specialists



Tel: 01753 532222 follow us on:

[www.simpsonraceexhausts.com](http://www.simpsonraceexhausts.com) f t

## GEARBOXES



Rally & Race  
Gearboxes, GearKits,  
LSDs and Driveshafts

Tel: 01782 280136 Fax: 01782 269913  
Email: [sales@eliteracingtransmissions.com](mailto:sales@eliteracingtransmissions.com)  
[www.eliteracingtransmissions.com](http://www.eliteracingtransmissions.com)

### Gearboxman.com

COMPETITION TRANSMISSION SERVICES

Gearboxes & Axles for Road, Race, Rally and more

Telephone: 01582 840008 Fax: 01582 840007

## HELMET GRAPHICS

### Mike Fairholme Designs

Sole approved painter of Arai helmets.  
Silver Birches, Corby Birkholme, Nr Grantham, Lincs NG33 4LE.  
Tel: 01476 550630. Fax: 01476 550029.  
email: [fairholmedesigns@btconnect.com](mailto:fairholmedesigns@btconnect.com)  
[www.fairholmedesigns.co.uk](http://www.fairholmedesigns.co.uk)



[www.finallap.net](http://www.finallap.net) WE BUY AND SELL  
+44 (0) 1245 287588 / 07771 920345

### JMJ AUTOMOBILIA

America's #1 supplier of CART and FORMULA One Racing memorabilia. Large selection of signed original collectables. See our ad under marketplace Memorabilia. Call or For a mail listing at (609) 575 1143 or visit: [www.JMJAuto.com](http://www.JMJAuto.com)

## RACE PARTS



ARMSTRONG RACE ENGINEERING INC.  
[WWW.DRYSUMP.COM](http://WWW.DRYSUMP.COM) (916) 652-5282



PASSIONATE ABOUT MOTORSPORT  
[www.jjcraceandrally.com](http://www.jjcraceandrally.com)



LONDON  
MOTORSPORT  
SHOWROOM  
[www.msar.co.uk](http://www.msar.co.uk)

## RACE PRODUCTS



[www.pipercams.co.uk](http://www.pipercams.co.uk)

## RACE RADIO



0044(0)1508 528837  
[www.raceradio.co.uk](http://www.raceradio.co.uk)

## RACEWEAR



[www.demon-tweeks.co.uk](http://www.demon-tweeks.co.uk)

## RACEWEAR



[WWW.GPRDIRECT.COM](http://WWW.GPRDIRECT.COM)  
08435 070 858



[WWW.YBRACING.COM](http://WWW.YBRACING.COM)

## RACING OILS



OLD HALL PERFORMANCE LTD T: 02476 717 100  
sales@redlineoil-europe.com [www.redlineoil-europe.com](http://www.redlineoil-europe.com)

## SPONSORSHIP

The Million Pound Touring Car™  
2013 British Touring Car Championships Contender  
Put your name/advertise your company on our front running Touring car in 2013/2014  
[www.themillionpoundtouringcar.co.uk](http://www.themillionpoundtouringcar.co.uk)

## STORAGE



Quality Storage for Home and Industry  
[www.garagestoragecabinets.co.uk](http://www.garagestoragecabinets.co.uk)  
Tel: 0800-206-2303

## TRAILERS & TRANSPORTERS



» Connected to you  
[www.brianjames.co.uk](http://www.brianjames.co.uk)

## TRAILERS & TRANSPORTERS



[www.prgtrailers.co.uk](http://www.prgtrailers.co.uk)  
Phone no: +44 (0) 1270 812402

## WHEELS



Manufacturers of bespoke split rim alloy wheels  
[www.imagewheels.co.uk](http://www.imagewheels.co.uk)  
IMAGE WHEELS INTERNATIONAL LTD.

## VIDEO PORTAL



**BRIAN JAMES TRAILERS**

»» Connected to you



[www.brianjames.co.uk](http://www.brianjames.co.uk)

## Endurance and passion for excellence

Covering long distances, travelling through many years our trailers have served at every race or rally, up and down the country.

The latest Race Transporter models are testimony to the technology and designs our dedicated engineers have developed.

The model shown is a Race Transporter 6.  
Race Transporter range from £ 7,099 (excl. VAT).

**RACE TRANSPORTER**



**T +44 (0)1327 308 833**

For more information and details of your local BJT dealer please call or visit our website.

# TRAILERS & TRANSPORTERS

## WOODFORD TRAILERS

Call Us Now! tel. 01327 263 384

www.woodfordtrailers.com sales@woodfordtrailers.com



**RL 2000**  
£4,900 + vat



**RL 3000**  
£5,950 + vat

**PRG Trailers**

All trailers now come with European COC certificate



PRG Trailers | Cheshire | UK | Tel: +44 (0) 1270 812402  
Web: www.prgtrailers.co.uk | Email: info@prgtrailers.co.uk

### WINNEBAGO SIGHTSEER MOTORHOME, 2007, 30B W

30B W series Chassis, 8L V8 petrol engine with 4 Speed Auto gearbox, Slide out saloon with awning, Full Patio awning, Genuine only 6500 miles since new. Very high specification including:- Self levelling jacks, Motor cycle rack, In-house Generator, Invertor, Rear and side view cameras Brand new high quality satellite TV and Audio system, MOT until Dec.2013 with full service and systems check certificate just completed. A rare opportunity to purchase a genuine low mileage, family owned Motorhome, in what was described as, 'In Mint condition' by a leading Winnebago Service agent. Genuine reason for sale.



**£57,950.**

**07846 017722 or kitey@fsmail.net**

## PAUL SHEARD

THE MAZDA MX5 SPECIALISTS



### RACE TRANSPORTER FOR SALE



1.5 Ton tail lift, hydraulic upperdeck, onboard generator - compressor - 12m x 6 mawning 3 years old, internal wheel racks, powersockets, lots of storage, recent white paint job, excellent tyres, long test, can carry 4 salons or 6 caterhams, very practical, ready to use Only £9695.

More Details Contact: 01260 279797 or 07717 536666  
**www.paulsheardautos.com**

For further information, contact  
Mike Tasker  
mt@msslglobal.com  
+44 (0)1420 471000

**mssl** global  
www.msslglobal.com

For Sale/Hire



A rare opportunity to acquire an extremely high specification, ex F1 hospitality unit at a very competitive price

**Quick Setup** the entire facility can be operational within six hours with a crew of two and is self contained within two trailers.

**Versatile** two hospitality areas including roof terrace, four offices, WC and industrial kitchen.

**High Spec** fully integrated multimedia system, air conditioning and on board generator.



# RACE & RALLY CARS

RACING CARS FOR SALE

**BRAND NEW Piper GTR "Le Mans" body on NEW modern space frame rolling chassis etc.**



- Very light and with considerable inherent aerodynamic advantages
- Could easily be eligible for MODERN GT RACING – Britca - GT Cup etc
- Presently fitted with Zeetec / Sigma engine, was to be used as track day car, BUT STORED AND NEVER USED

**£34,000.00 ono**

Contact Tony Claydon on 01621 851589 or piperracingcars@tiscali.co.uk

FOR SALE **458 Challenge**



Bianco Avus with Rosso Sport Cloth Interior, Forged Centre Nut Alloy Wheels, Integrated Jacking System, CCM2 Carbon Ceramic Brakes, Passenger Seat Kit, 1220kg in Weight and 570 BHP.

**NEW** £175,000<sup>+vat</sup>



OFFICIAL FERRARI DEALER

**Meridien Modena**

For further information, contact us on 02380 283 404 or email [modena@meridien.co.uk](mailto:modena@meridien.co.uk)

## AUTOSPORT

**MISSED AN ISSUE?  
THEN CALL OUR  
BACK ISSUE HOTLINE  
0844 848 8817**

## FOR SALE: 1965 Elva Mk7S BMW

Chassis no 70/046 with current HTP Papers.  
Professionally prepared car - recently finished 2nd. in the Guards Trophy at Silverstone. Fully sorted and ready to go.  
Lester Owen BMW engine.  
Only for sale due to owners change of racing plans.  
Car is available to be viewed at Silverstone Circuit and during the Silverstone Classic race meeting by appointment.

**PRICE : £125,000 negotiable.**

[www.speedsportgallery.co.uk](http://www.speedsportgallery.co.uk)



Contact Mike O'Brien TEL: 01327 858167 EMAIL: [mike@speedsport.co.uk](mailto:mike@speedsport.co.uk)

# MARKETPLACE

## AUTOMOBILIA

**JMJ Automobilia**

SUPPLIERS OF RACE  
MEMORIBLIA SINCE 1992

**Florida, USA**  
**(609) 575-1143**

email: [JMJAUTO.COM](mailto:JMJAUTO.COM)  
[WWW.JMJAUTO.COM](http://WWW.JMJAUTO.COM)

**F1 COLLECTORS .COM**



**#1 FOR F1 MEMORABILIA  
& AUTOGRAPHS**

We buy and sell F1 items  
AYRTON SENNA specialists  
Call CHRIS GRINT **01763 274448**  
email: [sales@f1collectors.com](mailto:sales@f1collectors.com)

## CAR TYRES

FOR ALL YOUR

**AVON**  
TYRES  
MOTORSPORT

RACING TYRES  
Inc. ACB 10 Formula Ford  
Contact

**BMTR LTD**

Tel: 0121 331 1122  
Fax: 0121 331 1144  
email: [sales@bmtr.co.uk](mailto:sales@bmtr.co.uk)  
see our new web site at [www.bmtr.co.uk](http://www.bmtr.co.uk)

## FOR SALE

**FOR SALE**

**F1 4 SPD**

**£2,150 ono**

**CONTACT IAN on:**  
**07833 491465 or**  
**01937 339198**

## GEARBOXES



SPECIALISING IN GEARBOX REBUILDS,  
REPAIRS AND SERVICING FOR CURRENT  
AND HISTORIC RACING CARS

**Hewland Specialist**

Call 07976 877 612 or email [jono@racing-transmissions.co.uk](mailto:jono@racing-transmissions.co.uk)  
[www.racing-transmissions.co.uk](http://www.racing-transmissions.co.uk)

**AUTOSPORT**

TO ADVERTISE YOUR PRODUCTS  
AND SERVICES HERE CALL:

**0208 267 5865**

## HAYFEVER RELIEF

# HAYFEVER?



An easier way  
to trap the pollen!

**Natural, Organic Pollen Barrier Balm**

No Drowsy Side-Effects – ideal for exams or driving  
Proven to Trap Pollen, Dust and Pet Allergens – less allergen, less sneezing  
Drug-Free – suitable for children and pregnant & breast-feeding women

**18 Awards!**



**3 for 2**

3 for the price of 2 at participating  
independent health stores, pharmacies,  
chemists, 01525 406600 & [www.haymax.biz](http://www.haymax.biz)

**Various Offers**

ASDA HOLLAND & BARRETT TESCO



Waitrose



# MARKETPLACE

## INSURANCE



# TRACK DAY INSURANCE

Give Simon and the friendly team a call:

**0844 338 68 71**

[mcemotorsport.com](http://mcemotorsport.com)



OPENING HOURS:  
Monday - Friday 9.00am-5.30pm



## RACE PREPARATION



### MARDI GRAS MOTORSPORT

Saloon Car Preparation



Unit 45, Silverstone Circuit  
Towcester  
Northampton NN12 8TL

tel: 01327 858006 fax: 01327 858800  
email: [info@mardigras.co.uk](mailto:info@mardigras.co.uk)  
Buy online at:  
[www.mardigras.co.uk](http://www.mardigras.co.uk)

Distributors and agents for:



use auto10 to get 10% discount when ordering off our website

## RACE PREPARATION



The World's leading and largest stockist of bearings, fasteners and lubricants for Motorsport



**+44 (0) 1932 225777**  
[abc@autosport-bearings.co.uk](mailto:abc@autosport-bearings.co.uk)

[www.autosport-bearings.co.uk](http://www.autosport-bearings.co.uk)



# MARKETPLACE

## RACE PRODUCTS

[www.realsteel.co.uk](http://www.realsteel.co.uk)



Denso mini race alternator. 12-16v adjustable. 50/30amp, 1 wire connection.



6425 6AL Digital Capacitive-discharge box. 530v to coil. 135mj spark for every firing!



### V8 ENGINES- parts and accessories

REAL STEEL Unit 9, Tomo Industrial Estate, Packet Boat Lane, Cowley, Middx, UB8 2JP

Tel: 01895 440505 Email: [sales@realsteel.co.uk](mailto:sales@realsteel.co.uk) E&OE.

• EXPERT ADVICE • MASSIVE STOCKS • RAPID DELIVERY



[www.demon-tweaks.co.uk](http://www.demon-tweaks.co.uk) QZ252A

DON'T DELAY, CALL TODAY

0844 375 2196

**demon**tweaks  
MOTORSPORT Direct  
LOW CALL RATE CALLS MAY BE RECORDED FOR TRAINING PURPOSES

## RACEWEAR

**Grand Prix Racewear**  
WWW.GPRDIRECT.COM



2013  
**BESPOKE** MANUAL

RACESUITS KIT BAGS  
BANNERS FLAGS  
TEAMWEAR RADIO KITS  
VEHICLE WRAPS



**08435 070 858**

RACEWEAR | KARTWEAR | SIMULATION

MARKETPLACE

## RACEWEAR

**POWER ON**  
UK Racewear Manufacturer

LIKE US ON FACEBOOK

[facebook.com/poweronracewear](https://www.facebook.com/poweronracewear)

FOLLOW US ON TWITTER

[twitter.com/poweronracewear](https://twitter.com/poweronracewear)



- ✓ Pitwear
- ✓ Teamwear
- ✓ Embroidery Service
- ✓ Tailor Made Race Suits
- ✓ Starter Packages Available
- ✓ FIA Approved Racewear: 8856-2000
- ✓ Suppliers of the Racing Team



visit: [poweronracewear.com](http://poweronracewear.com) | call: 01778 341 764 | email: [enquiries@poweronracewear.com](mailto:enquiries@poweronracewear.com)

# MOTORSPORT JOBS

# AUTOSPORT

Want to advertise a motorsport job?

If you are recruiting in motorsport and wish to advertise with Autosport in print and online please contact [Rachel.Brock@Haymarket.com](mailto:Rachel.Brock@Haymarket.com) by email or call 020 8267 5820.

For all current vacancies advertised please visit our website [www.autosport.com](http://www.autosport.com)

## Design Engineer – (Ref: HR1107-13-02) Composites

### Position requirements:

- You must demonstrate the ability to perform in a team environment and exhibit a willingness to "do what it takes" to ensure customer expectations are exceeded.
- Min 4 years of experience in a top-level motorsport environment (F1, Le Mans or Rally)
- Demonstrate a solid track record designing composite parts (structural and/or bodywork), including tooling design, using CATIA V5.
- Work independently and on own initiative to high standards with a minimum of supervision.
- Professional, strong in strategic logic, flexible with different working techniques and highly capable.
- Excellent communicational skills and a positive attitude towards problem solving.
- Polish language skills would be beneficial but not

## Composite Technicians (Ref: HR1107-13-01)

### Position requirements:

- You must demonstrate the ability to perform in a team environment and exhibit a willingness to "do what it takes" to ensure customer expectations are exceeded.
- Min 4 years of experience in a top-level motorsport environment (F1, Le Mans or Rally) using pre-preg material and/or fitting and assembly of structural and body work components.
- Understand and follow technical drawings, layout manuals (Ply-Books) and engineering work instructions.
- Work independently and on own initiative to high standards with a minimum of supervision.
- Having good English or Polish language skills would be beneficial.



To apply for either position, please send an email to [Recruitment@hexja.com](mailto:Recruitment@hexja.com) and quote the aforementioned job number.

Closing Date for Applications - 25th July 2013. NO AGENCIES PLEASE.

Please visit our website [www.hexja.com](http://www.hexja.com) to learn more about our company.

## EUROPEAN SALES ENGINEER



TE Connectivity's Deutsch Autosport range is the leading supplier of harsh environment electrical connectors to the professional motorsport market. As a result of the continued growth of our operations, we have an immediate vacancy for a highly motivated Sales Engineer to support our existing customers and establish new business based in mainland Europe. Preferred location would be Germany based. Reporting to the Central European Sales Manager, the successful candidate will be supporting our customer base in Germany, Italy and on occasion other parts of Europe. Due to the fast changing nature of the Autosport market, the ability to work to timelines and to use initiative is essential. Applicants should have a background in professional motorsport and have a passion for all levels of the motorsport market. Knowledge of Autosport connectors and associated harnessing components will be a distinct advantage together with an HNC/HND or equivalent engineering qualification. The position offers an excellent remuneration and benefits package, including company car, mobile office, life assurance and contributory pension scheme.

Applications should be made in writing together with a full CV to:

TE Connectivity  
Human Resources Department  
Finsinger Feld 1  
85521 Ottobrunn  
Tel: +49 89 6089 610  
Or by email to: [czange@te.com](mailto:czange@te.com)  
No agencies please



## LOOKING TO RECRUIT FOR 2013?

THE LATEST SELECTION OF MOTORSPORT JOB VACANCIES UPDATED EVERY WEEK.

- The Motorsport Jobs page of the website receives on average 200,000 page impressions per month
- The magazine you are looking at has a readership of 144,000 (Source: NRS Survey Q3)
- All appointment adverts placed in Autosport magazine are listed on the website.

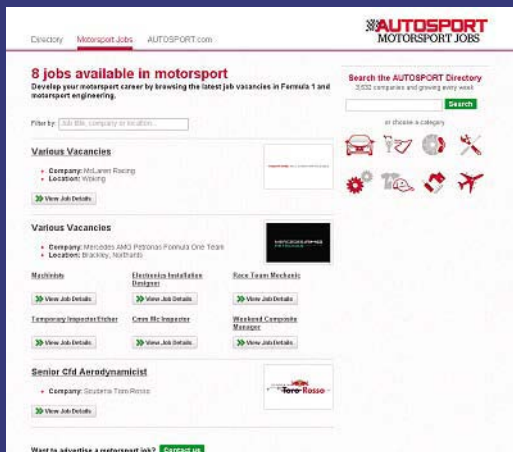

## DOCKING

### ENGINEERING MANAGER

& company Ltd

Docking Engineering, a Silverstone based company, have been supplying bespoke cooling systems and related products to the motorsport, experimental aircraft, UAV and special vehicle industries since 1984.

Due to an upcoming retirement we require a disciplined, self-motivated Engineering Manager to start in November. Reporting directly to the Company Director, the successful candidate will be responsible for:

Managing and expanding our customer base, providing quotes and technical guidance as required by our customers.  
Overseeing all areas of the engineering department.  
Liaising with the managers of associated companies.

### You will possess:

A good academic background in an engineering based discipline.  
Excellent interpersonal and organisational skills, being able to communicate both verbally and in writing effectively.

A proven history in engineering systems, including CAD  
Quality control (CMM), Bill of Materials and ISO standards.

### For full job specification contact:

Sally Dyson- Personnel Manager

E-mail: [personnel@dockingengineering.com](mailto:personnel@dockingengineering.com)

(Closing date for applications 26th July 2013)

Mercedes-Benz has been setting the standard in racing for over 100 years. The MERCEDES AMG PETRONAS Formula One™ Team continues the proud history of the legendary Silver Arrows with the clear ambition of winning the FIA Formula One™ world championships. Based in Brackley, UK, we are recruiting highly motivated, talented new members of our team. Please find further information about our current vacancies and our team in the 'join our team' area of our website [www.mercedes-amg-f1.com](http://www.mercedes-amg-f1.com)

**SENIOR MECHANICAL DESIGN ENGINEER x 2**

REF: SW568

Reporting to the Head of Mechanical Design the main responsibility is to take full ownership for a variety of complex mechanical projects and designs, taking them through from concept to assembly, specifying tests and developing improvements where possible. Taking responsibility for the design and development of mechanical car components and assemblies of the highest complexity, hand calculation and Catia FEA, R&D test specification and fault rectification.

**SOFTWARE ENGINEER**

REF: SW539

Reporting to the Head of Engineering Software, you will be responsible for supporting MESL software during race and test events, identifying improvements in the use of trackside operational tools and improving the operational software toolsets. The successful candidate will have a proven competence in developing software and ideally have experience of MESL software.

**ELECTRONICS SYSTEMS TEST SUPPORT ENGINEER**

REF: SW647

You will be responsible for the sign off and servicing of all electronic equipment. This role offers an excellent opportunity for widely varied work ranging from New Car build and in season upgrade parts sign off to individual sensor and systems calibration. A high level of experience on FIA standard ECU components and a good knowledge of current F1 sensor technologies is required.

**POWERTRAIN CUSTOMER SUPPORT ENGINEER - CHASSIS**

REF: SW674

Reporting to the Chief Engineer Control Systems (factory) & Race Team Electronics Leader (trackside), you will travel as a member of the race team supporting the team's electro-hydraulic and garage infrastructure systems. Experience of contemporary F1 gearboxes is essential. Experience of MESL systems, Matlab / Simulink, VB, Dymola & C# is advantageous.

**COMPOSITE INSPECTOR WEEKEND DAYS SHIFT**

REF: CH630

Responsible for providing first class quality control service for the composite department including management and feedback of production related quality issues, conformity to drawing, part traceability and accurate recording of information. The successful candidate will have a proven competence of composite manufacturing. Be committed, motivated and self disciplined in their work. Ideally have a working knowledge of SAP and Catia.

**COMPOSITE LAMINATORS x 8 EARLY/LATE SHIFT**

REF: CH643

Responsible for laminating and bagging of composite components and moulds to the highest standard and for maintaining good quality of components throughout its manufacture. Successful candidates for the above role must be committed, motivated and self disciplined in their work. The candidate must be able to communicate effectively with production, design and managerial staff.

We are looking for people to join the team that can be flexible in their hours and approach, have a 'can do' attitude, and are team players with great verbal and written communication skills. You will have the ability to work under minimal supervision to strict deadlines, in a professional manner.

In return for your hard work and commitment, we offer a competitive package, including bonus, life assurance, private medical cover, Mercedes-Benz company car lease scheme, 25 days holiday, an on-site gym, subsidised restaurant facilities and the opportunity to work in a truly unique environment.

To apply for a position please see our website, and then forward your CV and letter of application including the following; your current remuneration details and salary expectations, the job title and reference and where you saw the advertisement to [recruitment@mercedes-amg-f1.com](mailto:recruitment@mercedes-amg-f1.com)

CLOSING DATE: 25th JULY 2013

NO AGENCIES PLEASE

[MERCEDES-AMG-F1.COM](http://www.mercedes-amg-f1.com)

# CLUB AUTOSPORT

NATIONAL RACING • HISTORICS • RALLYCROSS • HILLCLIMB • TRACK TESTS

Moran muscled his trusty Gould to a new wins record at Harewood



## Moran takes win record

Gould driver becomes the most successful in British Hillclimb history

**TRIPLE BRITISH HILLCLIMB** champion Scott Moran became the most successful driver in the championship's history at Yorkshire course Harewood last weekend.

Moran's double victory in the 15th and 16th rounds of this year's series took his tally of run-off wins to 106, surpassing the previous record of 104 jointly held by Moran and retired former champion Martin Groves.

Moran, 36, who is bidding for a fourth British title this season in the Gould single-seater he shares with his father Roger, claimed the record at the scene of his maiden British Hillclimb success in 2003.

"You might find it difficult to believe but this has never really been on the agenda," Moran Jr told AUTOSPORT. "Some time last year,

Jerry Sturman [former AUTOSPORT and *Motorsport News* hillclimb correspondent] pointed out that I had recently matched Roy Lane's 90 wins.

"I promptly forgot about it, but after my second win at Gurston Down in May my mother pointed out that it had been my 100th career victory and it was only then I realised how significant events were about to become.

"Roy was a mentor of mine and I always listened to his guidance even if I didn't always follow it! He helped my dad in a similar way.

"Looking at the history of scorers, I'm not sure you can do a like-for-like comparison since the number of counting rounds doubled in 1999."

Under sponsor's suggestions, the British championship scoring method shifted from counting each driver's best

score from two run-offs to counting each run as separate events, which increased potential wins dramatically. The majority of Roy Lane's 90 career victories were scored before 1999 and all of five-time champion Martyn Griffiths' 67 wins came pre-'99.

Moran said he had also benefited from the retirement of four-time champion Groves at the end of 2010. "He would have certainly scored more had he continued, preventing me from taking this many wins," Moran added.

Moran's current closest rival is Trevor Willis, who claimed his first British title last year. The OMS Powertec driver paid tribute to his rival after his historic achievement.

"The way Scott took this win epitomises the man and his style," said Willis. "Under pressure after I had just taken the hill record, with his car reluctant to start, he then takes the win with a new record time. But only just, by a very fine margin, and without drama. He is always measured and so often does just enough."

### BRITISH HILLCLIMB WINNERS

POS	NAME	WINS	TITLES
1	Scott Moran	106	3
2	Martin Groves	104	4
3	Roy Lane	90	4
4	Martyn Griffiths	67	5
5	David Grace	58	5
6	Graeme Wight Jr	52	2

**BEN ANDERSON**  
NATIONAL EDITOR

ben.anderson@haymarket.com

@BenAndersonAuto



### CONGRATULATIONS TO SCOTT

Moran, who last weekend made history by becoming the most successful driver in British Hillclimbing.

Moran seems like one of the sport's nice guys and it was with admirable modesty that he played down his achievement at Yorkshire's Harewood hillclimb (fittingly the scene of the first of his 106-and-counting run-off wins in 2003).

Moran deserves great credit for a landmark tally, whatever the vagaries of the championship's scoring system since the turn of the millennium.

His new record is likely to grow much larger in the coming seasons as driver (still in his 30s) and car (still one of the most competitive on the scene) continue to be the benchmark against which the others measure themselves.

From one significant moment to another, Mallory Park was due a landmark decision on its immediate future as AUTOSPORT closed for press (see page 73).

Leicestershire's 'friendly circuit' has been embroiled in a long-running row with its surrounding community over noise and there are fears the circuit may have to close if the local council imposes a proposed 92-day limit on Mallory's annual activity.

Circuit leaseholders the BARC have already made it clear this limit, which is laid down in a pre-existing 1985 planning order, would make the circuit commercially unviable if enforced.

By the time you read this, the outcome for Mallory Park should have become clearer. We at AUTOSPORT hope a compromise can be reached and the circuit's future assured.

Previous record holder Martin Groves retired after last win in 2010



Moran will likely win many more



Harvey took two BTCC wins in Labatt's RS500 and will now race it again



Silverstone Classic

# Harvey to make RS500 race return

FORMER BRITISH TOURING CAR champion Tim Harvey will race a Ford Sierra RS500 for the first time in over 20 years in this month's Silverstone Classic.

The 1992 champ will contest the first of two Touring Trophy races at the July 26-28 event in the same RS500 he raced in the BTCC in 1989-90.

Harvey has already tested the

Labatt's-liveried machine, owned by Paul Smith, and is looking forward to the Classic. "The tests went quite well and I shall race the car on the Saturday at the Classic, and Paul will drive on the Sunday," said the 51-year-old.

"I haven't raced a Cosworth since I stepped out of the car in 1990. It's pretty much identical to how it was. For me, it's like stepping back in time."

Harvey will be up against drivers in more modern Super Touring cars, including former rivals John Cleland and Patrick Watts, who will race their Vauxhall and Peugeot respectively at this weekend's Brands Hatch Superprix.

"We'll be quick on the straights but I don't expect it to be as fast through the twisty bits," added Harvey.

"We won't run as much boost as

we did in the day, for reliability, but it's still every bit a Cossie.

"The pleasure will be for me to drive it and be on the same grid as those guys."

Smith also plans to race the RS500 in the Touring Car Trophy races at the Brands Superprix this weekend.

The top RS500 runner at the Classic last year was Craig Davies, who scored a best result of sixth.

## Formula Renault BARC

### Dempsey makes Renault return as Anttila joins grid for Croft

#### RENOWNED SINGLE-SEATER

squad Cliff Dempsey Racing made its seasonal Formula Renault BARC debut at Croft last weekend.

The team ran eventual champion Scott Malvern in the early rounds of 2012 before parting ways mid-season, but had not raced in the category since fielding Matthew Brabham in the winter series.

CDR boss Cliff Dempsey had been eyeing a return to the championship subject to finding a driver with sufficient funding (see AUTOSPORT, June 27).

Finnish Formula Ford champion Jesse Anttila secured a last-minute deal with the team to make his series debut at Croft. He claimed a best finish of 10th in the second race.

Dempsey remains cautiously optimistic



for the remainder of the campaign, but his focus is still mainly on 2014.

"We're hopeful we'll also be able to do the final two as well at Rockingham and Silverstone," he explained. "The plan is for Jesse to get experience of the car now and then hopefully secure the budget for a full season next year."

## BRDC F4

### Williams returns to BRDC F4 thanks to late Dittmann deal

#### EX-FORMULA FORD RACER LUKE

Williams returned to BRDC Formula 4 for last weekend's Oulton Park round thanks to a late deal with Chris Dittmann Racing.

Williams, who was run by the team on his F4 debut at Brands Hatch earlier in the season, had a best finish of 12th at Oulton.

Team boss Chris Dittmann is hopeful that the team will race again this season, but

says that the winter series and a full campaign in 2014 is the main focus.

"Luke is just struggling with money for the rest of the year," he told AUTOSPORT. "We have a lot of interest for the winter series and for next year as well."

"We're always ready to go. Our cars are competitive - it's just a case of confirming the drivers."



Comprehensive motorsport insurance products to keep you on track;

- Worldwide On Track
- Personal Accident
- Storage and transit
- Track day
- Liability
- Commercial



Please complete an online quote request form at - [www.ryanmi.com](http://www.ryanmi.com)

Email - [info@ryanmi.com](mailto:info@ryanmi.com) Tel - +44 (0)1799 524202

Ryan Motorsport Insurance Limited is an appointed representative (557405) of Independent Broking Solutions Limited who are authorised and regulated by the Financial Services Authority, registration number 312026

Aston Centenary

# Onslow-Cole shares GT4 Aston at Brands Centenary celebration

**BRITISH TOURING CAR RACE**

winner Tom Onslow-Cole co-drove the Mardi Gras GT4 with Julian Reddyhough in the Aston Martin Centenary meeting at Brands Hatch last weekend.

After Reddyhough retired with a broken wheel in the Indy circuit GT4 race on Saturday, the pair took 23rd in Sunday's GT Centenary race on the GP track.

"I really enjoyed this," Onslow-Cole said. "It's very different from touring cars but there was still a bit of rubbing going on! My aim is to get into GT3 and I'm close to putting a package together for rounds of British GT and the Blancpain Endurance Series, which I'll

do alongside the BTCC next year."

Aston Martin chairman David Richards also raced at Brands, sharing with chef James Martin in Sunday's Centenary race.

"It was a great celebration of Aston Martin's racing pedigree and I was particularly proud to see such a turnout of modern cars," Richards said.

"We restarted Aston Martin Racing eight years ago and if you look at what's been achieved in that short period of time, it's a great success story."

Touring car champions Rob Huff and Gordon Shedden were both scheduled to race at Brands, according to organisers, but neither appeared.



Onslow-Cole enjoyed his GT racing debut



**Famous Astons in thunderous Brands demonstrations**

Former grand prix racer Bruno Senna showed off Aston Martin's current Vantage GTE contender at the Brands Hatch Aston centenary celebrations last Sunday, and shared his demo with one of the Group C 1989 AMR1s.

Formula Ford

# Meridian joins Formula Ford with Ginetta graduate Mills

**THE BRITISH FORMULA FORD**

grid will be boosted by the addition of Ginetta Junior convert Connor Mills for the rest of the season.

Mills, who is supported by the Arden International single-seater team's Young Race Driver Academy, will drive a Mygale

run by former Ginetta GT Supercup and Clio Cup team Meridian Motorsport.

Meridian plans to enter a second Mygale by the end of the season with the intention of a full campaign in 2014.

Karting graduate Mills, who will make his debut at Snetterton in August, achieved a best finish of seventh in Ginettas but missed the most recent two rounds at Oulton Park and Croft.

"We have looked at other championships which are supposed to be affordable, but prices keep on going up and up," said the 16-year-old. "My target is to learn as much as I can so that I can go for the championship in 2014."



Mills has switched from Ginetta Junior

# HUMBLE PYE

## The voice of club racing



First FoS in '93 had atmosphere of '70s hillclimbs

# Goodwood's Festival of Speed has thrilled fans for 20 years

The Goodwood Festival of Speed comes of age this weekend, and naturally devotees – and newbies (where were you?) – can expect its 21st edition to serve up a delicious feast. Drawing its strongest influences from motorsport's past, with side dishes offering a rich flavour of current road, race and rally icons and a tantalising *amuse bouche* of tomorrow's technology, it is the petrolhead's gastrodream...

I well recall the inaugural 'FoSsy' of June 1993, when Lord March's ambition to stage a top-class racing event at Goodwood for the first time since the motor circuit closed on July 2 1966 was realised. Nobody knew what to expect – our preview was a six-paragraph *One to Watch* – but did it deliver? The "staggering" gate of 25,000, for what to me felt like a National hillclimb of the '70s, proved he was on to a winner. Competitors and socialites agreed.

Looking at the photographs today I am struck by the lack of massive straw bales, a couple of rows of spectators (some sitting on grass) behind plastic tape 'protection', a few small tents and clear sight of magnificent Goodwood House, home since 1697 of the Dukes of Lennox and Gordon. Now, the installations for a four-day extravaganza – including today's (Thursday) Moving Motor Show – are feats of civil-engineering ingenuity. But the unique atmosphere remains.

Where else can fans not blessed with grand prix corporate hospitality passes have the chance, if patient, to collect autographs or exchange a few words with Formula 1 stars Lewis Hamilton, Nico Rosberg or Jenson Button? Or world champions, grandees and innovators of previous eras?

Goodwood ticks those boxes, and more. Revealingly, rather than watch cars run 'live', many enthusiasts prefer to congregate alongside the fire-up road, where participants relax before the start, or in the finish paddock to get candid photographs of their heroes.

Highlights are shown on giant screens anyway, as the commentary team of Henry Hope-Frost, former editor Bruce Jones and yours truly keeps everybody abreast of the action as it happens.

Twenty years on from watching Willie Green set the best time of the day at 57.59s in an F1 Lotus 18, we may witness a new course record as Nick Heidfeld is reunited with the McLaren MP4/13 in which he cut an astonishing 41.6s in 1999, but do we care provided everybody has an enjoyable and safe weekend?

British hillclimb champion Scott Moran would decimate that time in his specialised Gould, if invited.

# Marcus Pye

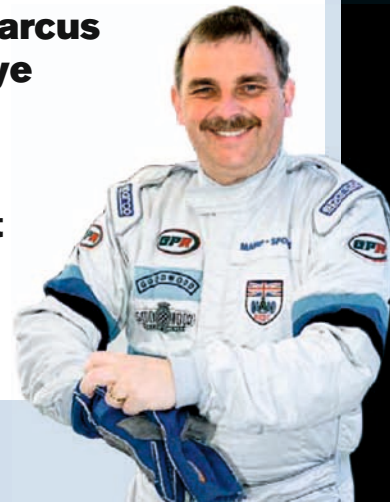

**"The staggering gate of 25,000 for what felt like a 1970s hillclimb proved Lord March was on to a winner"**

# Congratulations ROSS GUNN!

## On your BRDC F4 win from all at MOTIONSPORT!

@motionsportrace

motionsport

info@motionsport.co.uk

**“ THE MINIMUM 5 YEAR GUARANTEE GIVES ME COMPLETE CONFIDENCE IN THE PRODUCT QUALITY ”**

*...Plus the bits I get are impossible to find anywhere else!* **Stephen, Brighton**

Trustscore for IronmongeryDirect is 9.3 of 10, based on over 2000 customer reviews.

**UK'S BIGGEST RANGE  
NEXT DAY DELIVERY  
MINIMUM 5 YEAR GUARANTEE  
FREE 'NO QUIBBLE' RETURNS**

**CALL TODAY FOR YOUR FREE CATALOGUE**

**0808 168 28 28**

**IronmongeryDirect.com**

**DOWNLOAD OUR FREE APP FROM YOUR APP STORE**

**Available on the App Store**

**OR TEXT RBA16 to 62244 FREE!**

With name, address and email.

**IronmongeryDirect**

**MASTERS OF OUR TRADE**

DOOR FURNITURE • WINDOW & JOINERY HARDWARE • SLIDING DOOR HARDWARE • HINGES • DOOR CLOSERS • FIRE CONTROL • SIGNS  
 LOCKS, LATCHES & SECURITY • CABINET FURNITURE • SHELVING & STORAGE • BOLTS & STOPS • SEALANTS & ADHESIVES • SCREWS & FIXINGS



Mallory Park

## 'Decision day' for Mallory Park in local noise row

### THE FUTURE OF MALLORY PARK

was in doubt last night as Hinckley and Bosworth Borough Council met to decide whether to reduce the circuit's operations to 92 days per year.

A public council meeting was due to take place yesterday evening (Wednesday, July 10), after AUTOSPORT had closed for press. There are fears the circuit's leaseholders the BARC will have to close the circuit if such a limit were imposed, as it would render Mallory financially unviable (see AUTOSPORT, March 14).

Mallory bosses claim offers to reduce noise levels, change trackday times and reduce the number of vehicles on circuit, having already shut down motocross and drift action, have been shunned, and an independent report into the circuit's contribution to the local economy ignored.

"If they agree to reduce the days to 92 then the circuit is finished and will shut down," said circuit general manager John Ward before the meeting.

"The 145 jobs and £10m benefit to the local economy will be lost,

along with a historic motor racing circuit.

"We need them to understand we are working to reduce noise and improve life for residents, and are committed to being good neighbours. Shutting the circuit is not the right choice."

● The proposed £250m 'Circuit of Wales' project was awaiting a decision from Blaenau Gwent Council on planning permission as AUTOSPORT closed for press. The application was due to go before the council on July 10, having been delayed by months of consultations.



### Podium for Cammish

Formula Ford ace Dan Cammish made his Radical debut at Oulton Park, sharing a works car (above) with Ford rival James Abbott in the SR3 Challenge. They were second in race one and sixth in race two. "It was a bit demoralising watching Bradley Smith drive away, so now I know how the other Formula Ford drivers feel!" Cammish said.

### Fielding misses out

Ex-Ginetta Junior runner-up Sennan Fielding was absent from Wayne Douglas's BRDC F4 team at Oulton Park last Saturday. The teenager's car suffered substantial damage last time out at Snetterton and financial constraints have brought a halt to his season. Pietro Fittipaldi was also missing to contest the Formula Renault races at Croft with MGR.

### Ramsay nets ALPS best

Scottish racer Gregor Ramsay scored the best result of his maiden Formula Renault ALPS season at Monza last weekend. The 17-year-old, driving a brand new chassis after a heavy shunt at Spa, finished fifth in the second race. He failed to finish the first event after suffering accident damage on the opening lap.

### Epps makes US return

Michael Epps will return to action in USF2000 in Toronto this weekend. Epps missed the previous round at the O'Reilly oval having started the season with PRL Motorsports, but rejoins with Belardi Auto Racing. The ex-Formula Vee and Formula Renault BARC racer tested last week.

### Trackday ace to FF1600

Ex-Trackday Trophy ace Alex Read will make his single-seater debut at July's Silverstone Classic. Read will drive a Historic FF1600 Macon (below) run by Pete Alexander, who worked with former champion Darren Burke. Ex-Junior Formula Ford Zetec ace Darwin Smith has entered father John's unique Smith Special for this weekend's race at the Brands Hatch Superprix.



Go Motorsport

## Go Motorsport Live to return

**THE MSA'S FREE OPEN DAY** to encourage people to participate in motorsport will return next year after organisers hailed its debut last weekend.

Go Motorsport Live, a six-hour show that featured more than 50 displays, attracted over 2500 visitors to Silverstone last Sunday, July 7, the final day of National Motorsport Week.

A range of clubs and disciplines were represented, from circuit racing and rallying to drag racing and hillclimbing.

MSA chief executive Nick Bunting said: "We are delighted with the enthusiastic response to the inaugural event. It was a totally new concept and those displaying all reported that people attending had a genuine interest in getting involved.

"It is vital the governing body works to bring more people into the sport and, having proved the concept, I think we can look forward to a bigger and better Go Motorsport Live in 2014."

Formula Ford 1600

## Mason stars in Le Mans races

### DRIVERS FROM THE FF1600

SuperSeries joined racers from the French-based Trophee Formule Ford Kent at Le Mans last weekend.

The Van Diemen of French series regular Nicolas Belouou won both races.

Of the SuperSeries regulars, it was Paul Mason in his Swift SC94K who starred. Making his mainland European debut, Mason finished sixth in Saturday's opener before improving to third on Sunday.

Conor Murphy was another traveller to France, driving his Van Diemen RF83 to second among the SuperSeries runners.

SuperSeries boss James Beckett said: "This event offered competitors a great opportunity to race on a famous circuit. I want us to repeat this in 2014, so we will visit another of Europe's finest tracks."

Simon Jackson won both French F3 Classic rounds at Le Mans last weekend.

One of three Brits in action, Jackson dominated on the Bugatti layout in his Chevron B43.



GT Cup

## Scottish champion to GT Cup

**SCOTTISH FORMULA FORD** champion Ross McEwen will make his GT Cup debut this Saturday at Oulton Park.

The 22-year-old will drive an ex-Team Parker Porsche GT3 run by Indigo Motorsport for the remainder of the season. University commitments have prevented an earlier switch but the

Scot said it had always been the aim.

"We had three great seasons in Formula Ford but the plan was always to graduate to sportscars or GT racing," said McEwen.

"I am looking forward to gaining further experience with the Porsche, doing a full season next year and one day realising my ambition of driving at Le Mans."



**BARC LAUNCHES NEW FORMULA RENAULT  
JOINING NORDIC AND NEC JUNIOR SERIES**

**RENAULT SPORT'S NEW JUNIOR  
SINGLE-SEATER IS SET TO EXPAND  
ACROSS THE GLOBE AND ESTABLISH  
A NEW STEPPING STONE FROM  
KARTING TO CARS**



**FORMULA  
RENAULT 1.6**

**FORMULA RENAULT U KI SBACK!**

Find out more at [renaultsport.co.uk/championships/formularenaultuk](http://renaultsport.co.uk/championships/formularenaultuk)

# UK 1.6 CHAMPIONSHIP IN 2014



RENAULT *SPORT*



Ex-International GT Open  
champ Barba leads  
impressive Aston field



HAWKINS

ASTON MARTIN CENTENARY BRANDS HATCH, JULY 6-7 AMOC

# Foreign invaders are Aston stars

**THE ASTON MARTIN CENTENARY** at Brands Hatch last weekend was a fitting tribute to the historic marque. Saturday's racing took place in sweltering conditions on the Indy circuit, while on Sunday cars and drivers found the Grand Prix circuit gave them a little breathing space.

The AMR GT4 Challenge on the Indy circuit was run over 100 minutes and many drivers were feeling the heat, none more so than eventual winners, Frenchmen Olivier Bouche and Pierre Mantello.

Mark Lemmer/Jan Andersen had pole and Lemmer made the early running from BTCC racer Tom Onslow-Cole. After 40 laps, he was clear of Onslow-Cole, Bouche, Tom Black and Owen Mildenhall.

Mildenhall swapped with chef

James Martin once the pit window opened, while the leader stayed out until lap 66 of 110. When Lemmer did come in, the brakes were very hot and the radiator was crammed with grass from an excursion while lapping a backmarker. "Blue flags!" he exclaimed, "some guys don't know what they are!"

Mantello now had the lead, with Andersen a distant second as Julian Reddyhough, co-driving with Onslow-Cole, retired.

While an exhausted Mantello took victory, Andersen came under pressure from a charging Chris Kemp (in for Black), who snatched second shortly before the flag.

Bouche said: "It was a good race; a lot of traffic, so we had a lot of work in the car. I'm very proud of

my team-mate because it was his first race in nine months."

There was a moving minute's silence to remember Aston Martin racer Allan Simonsen, killed at Le Mans last month, preceding Sunday's GT Centenary race. At the start, Alvaro Barba pushed into the lead from pole, pursued by Richard Abra and Javier Morcillo. Bouche and Onslow-Cole scrapped further back, behind the GT3 frontrunners, as Barba pitted to hand over to Massimiliano Wisner. This left Stuart Hall's DBRS9 briefly in the lead.

With 30 minutes to run and most of the pitstops done – including Aston Martin boss Dave Richards handing over to James Martin – Wisner led from Morcillo's co-driver Paul White and John Gaw

(in the Vantage started by Phil Dryburgh). Various drive-through penalties were handed out, the leader included, but such was his advantage that Wisner still won from Gaw. The Abra/Mark Poole Vantage GT3 was third, just half a second ahead of the hard-charging Morcillo/White GT3.

Michael Whitaker's TVR Griffith took the initial advantage in the HRDC Allstars race as Richard Skinner nosed his Marcos GT ahead of John Davison's TVR. When Mike Youles's Rochdale Olympic expired at Graham Hill Bend the safety car was deployed, but Whitaker resumed his dominant run to the flag after the restart, ahead of Davison.

A heated dispute between Wolfgang Freidrichs (Aston Martin Project 214), Michael Squire (AC Cobra), Robert Rawe (DB4 GT Zagato) and Rae Davis (Mini Jem GT) was resolved with Squire pipping Skinner by 0.7s.

Aston Martin took a resounding victory in the Pre War Team Challenge, Heinz Stamm's win and Mark Midgley's third contributing to the 55-point total, along with placemen David Taylor, Paul Chase-Gardener and David Ozanne. James Knapp and Frederic Wakeman, in eighth and ninth, helped Frazer Nash take second.

The Equipe GTS event was red flagged when Ron Cody's MGA went off at Druids. At that point the

Bouche/Mantello  
won a hard-fought  
GT4 contest



HAWKINS



Tiger pair took a win but also got a disqualification

Intermarque

## Tiger duo win then sin, before Aston survives Mustang clash

THE FIRST OF TWO 45-MINUTE Intermarque races was immensely close at the start with Jeremy Cooke and Michael Dowd's Porsche RSR beating William Smallridge's Sunbeam Tiger off the line.

Robin North slotted into second, but after the driver changes Chris Scragg emerged leading in his Aston V8 started by Boysie Thurtle, with David Smallridge in hot pursuit. The pair swapped the lead until the Smallridge Tiger stretched its legs to the flag.

Another titanic battle for third resulted in the Michael and Ray Mallock Aston Martin DB4 coming home just ahead of North.

North's Mustang shot into the lead on the GP circuit on Sunday as the Smallridge Tiger got the better of the second-placed battle involving Stephen Byrne/Spencer Marsh's Aston Martin DB4 GT, Sean and Dan Brown's DB4 Lightweight model, and Adrian Willmott's similar car.

North lost the lead during the

pitstops and William Smallridge emerged in front. But he was given a drive-through penalty for speeding in the pitlane, which he failed to acknowledge. He was then disqualified.

North got his lead back, with Tom Alexander (in for Willmott) reeling in the Mustang until they were together on the final tour. They touched and both went off at Paddock Hill Bend, where North was beached. Alexander managed to keep going and took the laurels as the race was stopped.

**RESULTS (47 LAPS) 1 William Smallridge/David Smallridge (Sunbeam Tiger);** 2 Christopher Scragg/Boysie Thurtle (Aston Martin V8) +8.952s; 3 Michael Mallock/Ray Mallock (Aston Martin DB4); 4 Robin North (Ford Mustang); 5 Kevin Norville (Aston Martin GT4); 6 Wayne Marrs (Ferrari 355). **CW** Scragg/Thurtle; Norville; Stephen Atkinson (Porsche 968 CS), Nicholas Ruddle (Mustang). **FL** D Smallridge 53.262s (81.64mph). **RACE 2 (23 LAPS, GP CIRCUIT) 1 Tom Alexander/Adrian Willmott (Aston Martin DB4 Lightweight);** 2 Mallock/Mallock +33.754s; 3 Sean Brown/Dan Brown (DB4 Lightweight); 4 Kevin Norville/Calum Lockie (Aston Martin GT4); 5 Martin Brewer/Martin Stretton (DB4); 6 Karim Moudi (Porsche 911). **CW** Norville/Lockie, Moudi; Bob Searles/Tony Jardine (Aston Martin DBS V8), Peter Snowdon (Jaguar E-type), Nicholas King/Pete Foster (Triumph TR4). **FL** Lockie 1m40.320s (87.31mph).



Barnard, Foster and Plant had close Equipe GTS encounter

Triumph TR4s of John Andon and Pete Foster were locked in combat for the lead, but Andon drove away from the grid before the restart. He rejoined but later retired.

Peter Barnard's Elva Courier was ahead until Foster pipped him to the flag by a whisker, with William Plant also within a second of the winner in his Morgan Plus 4.

The St John Horsfall Memorial Trophy race, featuring fabulous pre-war Aston Martins, was run as a handicap. Peter Dubsy was the early leader until he retired, leaving Paul Chase-Gardener's Speed Model the winner by over 10s from Josh Sadler and Michael Dee.

Nick Naismith took the early lead in the first of two races for the '50s Sports Cars on Saturday, pursued by Paul Drayson, also in a DB4. Drayson finally negotiated his way into the lead through traffic to win, with Freidrichs a distant third.

In Sunday's GP circuit race, Naismith again made the best start as Drayson disputed second with

Les Goble's DB4. As the leaders chased through backmarkers, Goble took the lead. Drayson tried to catch Naismith but spun at Hawthorns, beaching the DB4GT in the gravel.

Goble thus took the win from Naismith and Steven Hart's Maserati 300S.

There were a few gaps on the Pre-'65 Aston Martin Centenary grid, but there were no problems for polesitter Robert Rawe, who was kept honest by Naismith and Drayson. The trio traded the lead throughout but Rawe took the flag, Naismith and Drayson finishing right on his bootlid.

It looked as if Paul de Havilland (Jaguar XK150 FHC) had the HRDC pre-'60 Touring Greats race in the bag, but on the last lap he hit trouble and retired, leaving Neil Brown's Austin A35 to take victory. Three Jaguars were next, Andrew Keith-Lucas beating the similar XK150 of Read Gomm to second, with Nigel Webb's Mk1 fourth.

● Linda Keen

**ASTON MARTIN GT4 CHALLENGE OF GB (110 LAPS)**

**1 Olivier Bouche/Pierre Mantello;** 2 Tom Black/Chris Kemp +44.056s; 3 Mark Lemmer/Jan Andersen; 4 Desmond Smail/Richard Meins; 5 Andrew Jarman/Angelos Metaxa; 6 Mike Brown/Paul Cripps. **Class winners** Chris Scragg/Boysie Thurtle (Aston Martin V8). **Fastest lap** Calum Lockie 50.713s (85.74mph).

**ASTON MARTIN GT CENTENARY RACE (63 LAPS, GP CIRCUIT) 1 Alvaro Barba/Massimiliano Wiser (Vantage GT3);** 2 Phil Dryburgh/John Gaw (Vantage GT3) +5.475s; 3 Richard Abra/Mark Poole (Vantage GT3); 4 Javier Morcillo/Paul White (Vantage GT3); 5 Andy Schulz/Paul Bailey (Vantage GT3); 6 Stuart Hall/Dan Brown (DBRS9). **CW** Dryburgh/Gaw; Kevin Norville/Calum Lockie (Vantage GT4). **FL** Barba 1m26.756s (100.97mph).

**HRDC ALLSTARS (30 LAPS) 1 Michael Whitaker (TVR Griffith);** 2 John Davison (TVR Griffith 400) +3.690s; 3 Michael Squire (AC Cobra); 4 Richard Skinner (Marcos 1800 GT); 5 Wolfgang Freidrichs (Aston Martin DP214); 6 Robert Rawe (Aston Martin DB4 Zagato). **CW** Skinner; Rae Davis (Mini Jem GT); Michael Whitaker Jr (Ford Mustang); Joe Allenby-Byrne (Ford Cortina GT Mk1); Desmond Smail (Austin A40); Louis Frankel (Alfa Romeo Giulia Super); Richard Haythornthwaite (Jaguar XK150S); Simon Merriott (Tornado Talisman); John Powis (Connaught L1). **FL** Whitaker 55.909s (77.78mph).

**PRE-WAR TEAM CHALLENGE (19 LAPS) 1 Heinz Stamm (Aston Martin 15/98 Speed Model);** 2 Paul Carter (Bentley 4½ Derby) +16.813s; 3 Mark Midgley (Aston Martin Ulster); 4 David Taylor (Speed Model); 5 Paul Chase-Gardener (Speed Model); 6 David Ozanne (Speed Model). **CW** Carter; James Knapp (Frazer Nash Sportop); Tim Greenhill (Wolseley Hornet Special); Gregan Thruston (Austin 7 Special). **FL** Frederic Wakeman (Frazer Nash Super Sports) 1m02.957s (69.07mph).

**EQUIPE GTS (6 LAPS) 1 Pete Foster (Triumph TR4);** 2 Peter Barnard (Elva Courier) +0.730s; 3 William Plant (Morgan Plus 4); 4 Colin Elstrop (TVR Grantura III);

5 Dominic Spicer (TR4); 6 Mark Hoble (Morgan Plus 4). **CW** Barnard; Plant; John Todd (Austin Healey 100M); John Davison (Lotus Elite); Anne Reed (Aston Martin DB2). **FL** Plant 59.071s (73.61mph).

**ST JOHN HORSFALL MEMORIAL TROPHY (18 LAPS)**

**1 Paul Chase-Gardener (Aston Martin Speed Model);** 2 Josh Sadler (Aston Martin Monoposto) +10.030s; 3 Michael Dee (Speed Model 'Red Dragon'); 4 David Ozanne (Aston Martin Speed); 5 David Taylor (Speed Model); 6 Mark Midgley (Aston Martin Ulster). **FL** Chase-Gardener 1m06.418s (65.47mph).

**'50S SPORTS CARS/XK150 CHALLENGE (30 LAPS) 1 Paul Drayson (Aston Martin DB4 GT);** 2 Nick Naismith (DB4)

+2.176s; 3 Wolfgang Freidrichs (DB4 GT); 4 Mark Hoble (Morgan Plus 4); 5 Mike Thorne (Austin Healey 100M); 6 Jeremy Cooke (Cooper Bobalet). **CW** Hoble; Cooke; David Reed (DB2); Robert Rawe (DB4); John Burton (Jaguar XK120); Mark Ellis (MGA). **FL** Drayson 59.438s (73.16mph). **RACE 2 (16 LAPS, GP CIRCUIT) 1 Les Goble (DB4);** 2 Naismith +6.734s; 3 Steven Hart (Maserati 300S); 4 Freidrichs; 5 Burton; 6 Andrew Moore (Jaguar XK120). **CW** Hart; Cooke; Hoble; Ellis; Reed; Ian Dalglish (Aston Martin DB4 GT). **FL** Goble 1m51.926s (78.26mph).

**ASTON MARTIN CENTENARY RACE FOR PRE-'65 CARS (16 LAPS, GP CIRCUIT) 1 Robert Rawe (DB4 Zagato);** 2 Nick Naismith (DB4) +0.394s; 3 Paul Drayson (DB4 GT);

4 Roy Stephenson (Aston Martin DB5); 5 Ian Dalglish (DB4 GT); 6 Robert MacVicar (DB4). **CW** Naismith, Anne Reed (DB2), Martin Melling (DB3), Peter Dubsy (15/98 2 Seater). **FL** Naismith 1m52.241s (78.04mph).

**HRDC TOURING GREATS (15 LAPS, GP CIRCUIT)**

**1 Neil Brown (Austin A35);** 2 Andrew Keith-Lucas (Jaguar XK150S FHC) +22.778s; 3 Read Gomm (XK150); 4 Nigel Webb (Jaguar Mk1); 5 James Turner (Ford Zodiac Mk2); 6 Rae Davis (Austin A35 'Sprint'). **CW** Keith-Lucas; Turner; Louis Frankel (Alfa Romeo Giulietta Sprint); John Page (MG1100); Mark Cross (Morris Minor 1000). **FL** Paul de Havilland (XK150 FHC) 1m58.627s (73.84mph).

# Gunn shoots to the top in finale

ONCE AGAIN THERE WERE THREE winners from three races in BRDC Formula 4, with Jack Barlow taking his second win, Matt Bell his third and Ross Gunn a maiden success.

Barlow was never headed in race one, while Jake Hughes led the pursuit after Raoul Hyman took a trip over the grass at Knickerbrook. "I knew Jake was still there mid-race, so had to push to make sure of the win," Barlow said.

Hughes closed in until a slight mistake at Lodge, while Seb Morris just held onto third after Gunn got alongside into Old Hall with a lap to go. Gunn then almost lost fourth to a recovering Hyman after a grassy moment at Cascades.

Matthew Graham completed the top six after James Fletcher and erstwhile points leader Charlie Robertson tangled at Old Hall on lap five.

Reversed-grid poleman Matt Bell held a consistent gap over Jake Dalton for the whole of race two.

They consolidated their positions when Graham and Gunn collided at Old Hall on lap four as they contested third. Graham was pitched off after contact but Gunn continued, after Hyman and Morris had gone by.

Hyman gradually eased himself clear in third, while Morris was left defending to the flag as Gunn, Hughes and Barlow shadowed him.

Fastest lap in race two allowed Robertson to line up on pole for the finale, and he held the lead as Gunn and Hughes duelled for second.

But after six laps all three had started to close up and, when Robertson ran wide at Knickerbrook on lap eight, Gunn snatched the lead.

While Gunn pushed hard and secured his maiden victory, Robertson went wide again at



Gunn, leading Hughes, became eighth winner in 12 BRDC F4 races

Knickerbrook with two laps left.

Hughes snatched second and was right on Gunn's tail as they took the chequered flag.

Robertson retained the final podium spot, well clear of the dicing Barlow, Hyman and Graham.

● Peter Scherer

**RESULTS (ALL 12 LAPS)** 1 Jack Barlow; 2 Jake Hughes +1.198s; 3 Seb Morris; 4 Ross Gunn;

5 Raoul Hyman; 6 Matthew Graham.

**Fastest lap** Gunn 1m38.631s (98.25mph).

**RACE 2** 1 Matt Bell; 2 Jake Dalton +1.399s;

3 Hyman; 4 Morris; 5 Gunn; 6 Hughes.

**FL** Charlie Robertson 1m38.526s (98.36mph).

**RACE 3** 1 Gunn; 2 Hughes +0.387s;

3 Robertson; 4 Barlow; 5 Hyman; 6 Graham.

**FL** Hughes 1m38.383s (98.50mph).

**POINTS** 1 Dalton, 212; 2 Hughes, 206;

3 Morris, 198; 4 Robertson, 191;

5 Bell, 188; 6 Barlow, 183.

## RADICAL SR1 CUP OULTON PARK, JULY 6 MSVR

# Noble thrusts to dominant double in Radical novice class



This is the closest anyone got to Noble all day in SR1 Cup

**NO ONE ELSE GOT A LOOK IN**

as Colin Noble made it four wins out of four races in the new Radical SR1 Cup.

Noble held a lead of over four seconds on the opening lap of race one, and his lights-to-flag victory by almost 33 seconds was no surprise.

With Chris Hoy spinning at Old Hall and delaying Robert Almond, Jake Bradshaw headed the chase in vain, from Brian Caudwell and the recovering Almond.

Both Daniel Vaughan and Almond began to carve their way back into contention. Almond was up to third from Old Hall on lap three and Vaughan demoted Bradshaw to fourth a couple of laps later.

Vaughan grabbed second back on

lap eight into Cascades, before Almond retook the place on the following tour. It finally went in Almond's favour after a late spin at Cascades dropped Vaughan to fourth behind Bradshaw.

Vaughan stayed considerably closer to Noble in race two, but was still over 4.5s adrift at the flag.

Almond had to fight hard for third, but managed to hold off Bradshaw.

● Peter Scherer

**RESULTS (BOTH 12 LAPS)** 1 Colin Noble Jr;

2 Robert Almond +32.926s; 3 Jake Bradshaw;

4 Daniel Vaughan; 5 Chris Hoy; 6 Brian

Caudwell. **FL** Noble 1m47.016s (90.55mph).

**RACE 2** 1 Noble; 2 Vaughan +4.510s;

3 Almond; 4 Bradshaw; 5 Caudwell; 6 Peter

Brookes. **FL** Noble 1m45.657s (91.72mph).

## RADICAL SR3 CHALLENGE OULTON PARK, JULY 6 MSVR

# Smith wins again before safety car confusion reigns

BRADLEY SMITH RETAINED HIS unbeaten record in race one, before Andy Cummings and Bradley Ellis won race two amid safety car chaos.

Smith led race one from pole and was over two seconds clear of Formula Ford points leader and Radical debutant Dan Cammish by the end of the first lap.

Both held station until the pitstop window opened, from where Smith retained his advantage despite a brake-bias problem, while James Abbott took over from Cammish

and was hounded all the way to the flag by third-placed Jeremy Ferguson.

With Smith starting from the back of the grid for race two, after being found underweight in qualifying, Ellis charged into a comfortable lead over James Littlejohn, Alex Kapadia and Phil Keen.

Cummings took over from Ellis and retained his lead, but only managed one racing lap.

The safety car was out for Jesper Westerholm's stranded car, but picked up everyone except the leader.



Cummings/Ellis broke Smith's winning run

It was four laps before the field was waved through, by which time the race time had elapsed.

● Peter Scherer

**RESULTS (24 LAPS)** 1 Bradley Smith; 2 Dan Cammish/James Abbott +18.010s; 3 Jeremy

Ferguson; 4 Tony Wells/James Littlejohn;

5 Tom Jordan/Alex Kapadia; 6 Charles Craven.

**FL** Bradley Ellis 1m37.363s (99.53mph).

**RACE 2 (21 LAPS)** 1 Ellis/Andy Cummings;

2 Littlejohn/Wells +0.484s; 3 Kapadia/Jordan;

4 Phil Keen/Peter Belshaw; 5 Ferguson; 6 Abbott/

Cammish. **FL** Ellis 1m37.368s (99.53mph).



**Delaney (third) beat the favourites in Vee Fest final**



BOURNE

**Radical Clubman's Cup**

Visiting Swede Jesper Westerholm took his PR6 (above) to a double win at Oulton. Westerholm led team-mate Oskar Kruger and SR3 class winner Lewis Plato in two professional races. Plato was considerably closer to the lead and well clear of Kruger after a determined start to race two.

**Formula Sheane**

Barry Rabbitt broke his single-seater duck with a hard fought win at Mondello, holding off experienced rivals Brian Hearty and Robbie Allen. It was a not a feat he could replicate second time out, having to settle for second behind Kevin Sheane.

**Historics**

Jackie Cochrane is used to taking victories at a saunter, due to the sheer power of his Sunbeam Tiger, but he had no answer for the nimble Crossle 9S of David Kelly. Kelly decimated the field twice, showing that it's more than just power that wins races at Mondello.

**Formula Libre**

Jonathan Fildes only had the lap record in mind at Mondello, but somebody forgot to tell Eamon Matheson. The Mission T5 thwarted Fildes until a move at Bridgestone set Fildes's Ralt RT4 free. Fildes had time to make a pitstop in race two before taking victory a lap ahead of the field, but without the lap record.

**Ford Fiesta Zetec**

Mondello's 'budget' class continues to attract large entries, to the extent that the field had to be split in two for the weekend. Philip Lawless walked away with a cash prize from series sponsor Patch 20, after beating Ian Beatty and Patrick Boland to the flag.

**Irish Touring Cars**

After defeating the BMWs last time out, Robert Butler felt confident heading to Mondello. But his Honda was relegated to a watching brief as the M3s (below) of Erik Holstein and Dave O'Brien duked it out up front. The advantage swung to and fro but Holstein (right) ultimately won twice.



CHESTER

**IRISH FORMULA VEE FESTIVAL MONDELLO PARK, JULY 6-7 CKMC**

**Delaney hangs on for Vee Festival victory**

IRISH FORMULA VEE DRIVERS DUKED it out over six races for Festival glory.

Ray Moore and Adam MacAulay traded fastest times in the qualifiers, but organisers threw a spanner in the works by reversing the top nine drivers for the final; it could not have been scripted better.

Only somebody forgot to hand Trevor Delaney a copy. Having passed both Ulick Burke and John Downey off the line, he soon took the lead and opened a gap while the pack fought among themselves.

Delaney led comfortably until a safety car pegged him. With Moore and MacAulay coming through the field, Delaney had to get the restart just right. He managed to do so with just Sean Newsome for company.

Newsome soon had to give up fighting for the lead to repel Moore, while MacAulay had a close shave with the pitwall passing Colm Blackburn for fourth. Contact between Moore and Newsome allowed MacAulay to pass both before closing on Delaney.

Moore recovered to pass Newsome on the last lap and set up a big finish, but Delaney would not be denied.

● Paul Healy

**RESULTS FINAL (13 LAPS) 1 Trevor Delaney (Sheane); 2 Adam MacAulay (Sheane FV01) +0.382s; 3 Ray Moore (Leastone JH004); 4 Sean Newsome (Sheane); 5 Colm Blackburn (Leastone JH004); 6 Morgan McCourt (Leastone). FL MacAulay 1m01.042s (67.80mph). SEMI FINAL 1 (12 LAPS)**

**1 MacAulay; 2 Delaney +20.139s; 3 Newsome; 4 John Downey (JH004); 5 Damian Murphy (Leastone JH002); 6 Brendan O'Brien (Leastone JH002). FL MacAulay 1m00.805s (68.06mph).**

**SEMI FINAL 2 (12 LAPS) 1 Moore; 2 Blackburn +16.229s; 3 David O'Brien (Sheane); 4 Gary Owens (Sheane); 5 Ulick Burke (Sheane); 6 McCourt. FL Moore 1m00.623s (68.27mph).**

**HEAT 1 (10 LAPS) 1 Moore; 2 Delaney +3.709s; 3 D O'Brien; 4 Dan Polley (Sheane); 5 Blackburn; 6 Newsome. FL Moore 1m00.820s (68.04mph).**

**HEAT 2 (10 LAPS) 1 MacAulay; 2 Stephen Morrin (Leastone) +18.371s; 3 Ger Byrne (Sheane); 4 Owens; 5 Murphy; 6 Burke. FL MacAulay 1m00.550s (68.35mph).**

**HEAT 3 (10 LAPS) 1 Downey; 2 Ger Callaghan (Sheane) +4.954s; 3 B O'Brien; 4 Steven Blanc (Leastone); 5 Gavin Beckey (Formula Vee); 6 Connaire Finn (Spyder). FL Downey 1m02.911s (65.78mph).**

**FF1600 MONDELLO PARK, JULY 6-7 CKMC**

**Daly does the double as Ray roasts rivals**

FORMULA FORD 1600 MADE A welcome return to Mondello for the Vee Festival and, although numbers were not great, the class still put on an impressive display of racing.

Stephen Daly showed the importance of getting clear air as he managed to stay clear of the kerfuffle behind him with a lights-to-flag

victory in the first outing.

The biggest battle was the one for second place between Neville Smyth and Ivor McCullough, which lasted the entire distance. As the flag fell, Smyth held on for the runner-up spot with McCullough tucked up behind his gearbox.

Smyth had the advantage early on

in the second outing as he led from pole, with the main battle being between Sean Doyle and Niall Murray for third.

That battle ended when the two drivers tangled on the exit of Ford corner with Doyle coming off the worst of the two.

Murray then came under pressure from Johnny McMullan and McCullough, both of whom would pass him late on, leaving Murray to explain himself to Doyle.

At the head of the field, a move down the inside at Dunlop corner took Daly past Smyth and clear for a double win.

● Paul Healy

**RESULTS (BOTH 16 LAPS) 1 Stephen Daly (Ray GR11); 2 Neville Smyth (Ray GR07) +3.148s; 3 Johnny McMullan (Mondiale M89S); 4 Sean Doyle (Van Diemen RF90); 5 Niall Murray (Van Diemen RFO0); 6 Ivor McCullough (Van Diemen RFO0). FL Daly 58.658s (70.55mph). RACE 2 1 Daly; 2 Smyth +4.666s; 3 McCullough; 4 McMullan; 5 Murray; 6 Doyle. FL Daly 58.488s (70.76mph).**



**Daly was the class of the field in his modern Ray GR11**

CHESTER

# Tan basks in glow of storming treble

**WEIRON TAN CONVERTED HIS OBVIOUS** pace into a perfect weekend, taking all three victories at Croft.

The Caterham F1 development driver moved up to second in the championship standings, but leader Chris Middlehurst added another two points to his huge advantage over the chasing pack.

The top six held station at the end of lap one of the opening race, with the exception of Sam MacLeod spinning out of the chicane.

When the safety car returned to the pitlane after two laps, Tan immediately challenged leader Hongwei Cao at Tower, but the Chinese driver held firm.

However, it wasn't Tan's final lunge for the lead, and his advances eventually yielded success at Tower on lap 10. He went on to pull out a 6s advantage over his Fortec team-mate.

Middlehurst (MGR) gradually dropped back from the leaders – citing tyre preservation – and into

the clutches of fourth-place man Jake Cook (Hillspeed). The Yorkshireman, on his home track, had survived a grassy moment on the way out of Sunny on lap four that caused him to briefly fall behind Wei Fung Thong.

Tan led the fast-starting MacLeod from the off in race two, with an early safety car period again required after incidents claimed Matt Rao, Pietro Fittipaldi and Tom Oliphant.

A procession followed, with Jorge Cevallos, Cao and Cook completing the top five.

Joe Ghanem went off at the chicane fighting Middlehurst for sixth, though Henrique Baptista was more successful a lap from home.

Race two proved the high point of a disastrous weekend for MacLeod, who failed to finish the finale. Battling with Rao for fourth, he ventured into a non-existent gap at the approach to the Complex, with the resulting contact spinning both cars.

After a caution period, Tan



Caterham junior Tan was unbeatable at Croft

READ

immediately set about taking the lead from Cao, and his attempt at Sunny was clumsy but successful. Cao was forced wide and tangled with Thong, picking up wing damage that cost him a lap in the pits.

Middlehurst and Ghanem gleefully inherited the final podium places as a result of the chaos in front of them, with Cevallos, Baptista and Cook again squeezing into the top six.

● Ian Sowman

**RESULTS (17 LAPS)** 1 Weiron Tan; 2 Hongwei Cao +6.046s; 3 Chris Middlehurst; 4 Jake Cook; 5 Wei Fung Thong; 6 Jorge Cevallos.

**Fastest lap** Tan 1m22.486s (92.74mph).

**RACE 2 (17 LAPS)** 1 Tan; 2 Sam MacLeod +1.669s; 3 Cevallos; 4 Cao; 5 Cook; 6 Henrique Baptista. **FL** MacLeod 1m22.519s (92.70mph).

**RACE 3 (15 LAPS)** 1 Tan; 2 Middlehurst +2.263s; 3 Joe Ghanem; 4 Cevallos; 5 Baptista; 6 Cook. **FL** Tan 1m22.943s (92.23mph). **POINTS**

1 Middlehurst, 327; 2 Tan, 229; 3 Cook, 222; 4 Cevallos, 206; 5 Cao, 170; 6 Baptista, 142.

## CLIO CUP SERIES CROFT, JULY 6-7 BARC

# Felix breaks Herbert's early Clio Series stranglehold

**LUKE HERBERT INCREASED HIS CLIO** Cup Series victory tally to three in the opening race at Croft, but Peter Felix made it a new driver on the top step with victory in the second.

Returning to the venue at which he wrapped up the Ma5da MX5 Cup last season, Sussex driver Herbert beat poleman Andy Jordan off the line, as did Rob Gaffney.

Jordan dropped to fourth when Felix passed him at the hairpin at the end of the opening lap, and retired with damage four laps later.

Herbert was untouchable, but Felix hounded Gaffney for second until he whacked a kerb and damaged a hub, leaving him lucky to finish.

Felix became the first driver other than Herbert to win a race in the series with a dominant performance on Sunday. Fastest in the separate

qualifying session, Felix led from 20-Ten team-mate Darren Wilson.

Herbert and Jordan queued up behind Wilson, before Herbert clipped the tyre stack at the chicane on lap four and retired.

Jordan was delayed, promoting his father Ian to the podium until Jordan Sr had a spin after a brush with Gaffney at the hairpin on lap nine. Gaffney came home third.

● Ian Sowman

**RESULTS (BOTH 13 LAPS)** 1 Luke Herbert;

2 Rob Gaffney +3.074s; 3 Peter Felix; 4 Darren Wilson; 5 Brett Lidsey; 6 Ian Jordan.

**CW** James Weston; Tommy Ostgaard; Sam Randon. **FL** Andy Jordan 1m35.387s (80.21mph).

**RACE 2** 1 Felix; 2 Wilson +2.205s; 3 Gaffney; 4 Lidsey; 5 Weston; 6 Jason Tarling.

**CW** Weston; Ostgaard; Randon.

**FL** Herbert 1m35.930s (79.74mph).



Felix was already on course for victory when Herbert retired

READ



Whittaker now has nine wins from 10

## KUMHO BMW CROFT, JULY 6-7 BARC

# Whittaker bags a double to extend dominant BMW run

**GARRIE WHITTAKER CONTINUED HIS** ruthless domination of the Kumho BMW championship with two more wins to make it nine from 10 races.

While Whittaker streaked clear in his E36 M3, Piers Ross scrapped with Tom Wrigley. Ross dived inside Wrigley at the hairpin on lap two for second position, but lost out two laps later and then dropped further back with two incidents on lap six. The slow-starting Colin Wells could not quite catch Wrigley for second.

Whittaker produced a repeat on Sunday, while Wrigley maintained his advantage over Ross. Wells split the pair with a move at Sunny on lap five, but struggled in the later stages and dropped back to fourth, behind Ross. Richard Bacon (M3) eventually claimed fifth after Karl Skitt's exuberant attempts came to naught.

Ian Joberns was punished for his driving standards on Saturday, handing the win in the always hard-fought Class D to Philip Grayson. Martin Whitehouse prevailed over James Ford in race two, but by barely a tenth of a second.

● Ian Sowman

**RESULTS (13 LAPS)** 1 Garrie Whittaker (E36 M3); 2 Tom Wrigley (E36 M3) +16.189s; 3 Colin Wells (M3 CSL); 4 Piers Ross (E36 M3); 5 Karl Skitt (1-series); 6 Richard Bacon (E46 M3).

**Class winners** Matthew Fielding (E36 M3); Alan Thompson (E36 328i); Philip Grayson (318is); John Cockburn (E36 318ti).

**FL** Whittaker 1m31.001s (84.06mph).

**RACE 2 (13 LAPS)** 1 Whittaker; 2 Wrigley +21.134s; 3 Ross; 4 Wells; 5 Bacon; 6 James Card (E46 M3). **CW** Ian Crisp (E36 M3); Thompson; Martin Whitehouse (318is); Cockburn. **FL** Whittaker 1m31.994s (83.15mph).

BRITISH HILLCLIMB CHAMPIONSHIP HAREWOOD, JULY 6-7

# Moran racks up record win



Harewood hosted Moran's 105th and 106th wins

SCOTT MORAN BECAME THE MOST successful driver in British Hillclimb history with two superb wins, but had to work hard to achieve them.

He broke the hill record just moments after Trevor Willis had done the same in the second run-off – both of them taking a bonus point for the first time in 2013.

After recording his record 105th victory, Moran explained: “All the booster batteries at the startline were flat, so the marshals had to bump-start the car. It took a couple of goes,

which was an anxious moment.”

Roger Moran, fifth fastest in the first run-off, split his son and Willis in the second run. This means the younger Moran has been able to forge further ahead in the standings, his championship lead now up to 12 points over Willis.

Behind, the returning Jos Goodyear also piled on the pressure with the only 1600cc entry.

Recent serious damage now repaired, he was right on the pace, qualifying second fastest to Moran

**ROUND 15** 1 Scott Moran (3.5 Gould-NME GR61X) 49.02s record & BTD; 2 Trevor Willis (3.2 OMS-Powertec 28) 49.07s; 3 Jos Goodyear (1.6 GWR Raptor Extreme-Suzuki) 49.33s; 4 Wallace Menzies (3.2 DJ-Cosworth Firestorm) 49.34s; 5 Roger Moran (3.5 Gould-NME GR61X) 49.76s; 6 Richard Spedding (1.6 Force-Suzuki PC) 50.76s; 7 Deryk Young (4.0 Gould-Judd GR51B) 50.78s; 8 David Uren (1.6 Force-Suzuki PC) 50.92s; 9 Will Hall (3.5 Force-Nissan WH) 51.72s; 10 Alastair Crawford (2.8 Gould-NME GR55) 51.83s; 11 Simon Fidoe (1.1 Empire-Suzuki 002) 53.19; Paul Haimes (1.3t Gould-Suzuki GR59) Fail.  
**ROUND 16** 1 S Moran 49.22s; 2 R Moran 49.86s; 3 Willis 49.91s; 4 Menzies 50.30s; 5 Spedding 51.04s; 6 Young 51.13s; 7 Uren 51.51s; 8 Tom New (4.0 Gould-Judd GR55) 52.04s; 9 Haimes 52.44s; 10 Crawford 52.78s; 11 Fidoe 53.20s; Goodyear Fail.  
**Class winners** Vic Lord (1.8 Lotus Elise) 66.86s; Tony Bunker (3.8t Nissan GT-R) 67.63s; Karl Jackson (2.0t Ariel Atom) 59.83s; Andrew Russell (1.1 Ginetta G15) 66.76s; Sarah Bosworth (1.8 Lotus Elise) 62.24s; Geoff Twemlow (2.1t Subaru Impreza) 65.41s; Karl Jackson (2.0t Ariel Atom) 60.00s; Graham Wynn (1.3t Force-Suzuki LM001) 54.42s; Allan McDonald (2.4t Mini-Evo) 61.60s; Fidoe 52.68s record; Goodyear 44.96s; Haimes 52.09s; S Moran 49.64s. **POINTS** 1 S Moran, 134; 2 Willis, 122; 3= Menzies & R Moran, 93; 5 Hall, 76; 6 Bradburn, 65; 7 Alex Summers, 54; 8 Young, 41; 9 Spedding, 29; 10 Uren, 24.

for the second run-off. He was forced to settle for third earlier, after the record-breaking runs of the front two, but later spun through 180 degrees at Farmhouse. The upcoming Channel Island hills should suit him.

Another driver on song was Wallace Menzies, whose team burned the midnight oil on Saturday to fix a failed fuel pump. Despite a time just three tenths off the old hill record in run-off two, he only took fourth such was the pace at the front. ● Eddie Walder



## Porsche GT3 Cup

Only five cars entered the Croft races, with Justin Sherwood (above) heading the field throughout both contests. Steve Liquorish followed him, but although he lost drive out of the final corner in the second race, he pipped actor Kelvin Fletcher for second.

## NSSCC

Reigning champion Bill Addison (Caterham) made the best start to Classes A and E race one at Croft, but an off at Clervaux on lap two allowed the Marcos of Colin Simpson through. Simpson passed Addison at Clervaux with three laps of race two remaining, before a spin dropped the Caterham out of touch. Andy Wilson took his BMW M3 to Classes B, C, D and H victory in the opener after Mike Williamson and Mike Cutt hit problems. Cutt led Williamson throughout the second contest.

## Honda V-TEC Challenge

Robert Burkinshaw made a poor start and dropped to fourth in his Integra. He was second by the end of lap two at Croft, but gave himself too much to do in his chase of winner Richard Voaden (Integra). The order was repeated in race two.

## SEMSEC Single-Seaters

Dave Connor, a regular winner at Lydden in the '80s, was clearly quicker than his rivals so he frequently let them past to make a race of it and then sportingly moved over on the last lap to give Chris Mabey his maiden win. Chris Chandler crashed his Tatuus FR97 due to wishbone failure.

## SEMSEC Sports

Triple winner Mark Burton (below) always held the upper hand over his chief SEMSEC Sports rival Charles Harvey-Kelly at Lydden, despite finishing the first race with a flat tyre. Ian Conibear swept around the outside of Bruce Wilson in both races to clinch the Kit Car category. Conibear and Wilson were promoted to the race-two podium when Harvey-Kelly spun.



SEMSEC SALOONS LYDDEN, JULY 6 SEMSEC

# Saloon victories shared after epic duels



Sibling (77) had to yield to Richards' Metro in race one

BILL RICHARDS AND PAUL SIBLEY WERE the stars of two sensational Saloon championship rounds, which featured race-long lead battles.

Sibley's sophisticated Lotus Elan started from pole position, but it was Tom Carey who seized the initiative and led the opening lap until his Honda CRX suddenly ground to a halt in the middle of the track with seized brakes, bringing out the red flags.

Richards' lightweight Metro-Duratec had inherited the lead, but then he had to restart from his original grid position. Although Sibley led away, Richards soon swept

around the outside at Chesson's Drift to seize the advantage. For the rest of the race Sibley tried every which way, but Richards held on to win by a length – then ran out of petrol as he crossed the line.

Andy Banham overhauled Robert Knox to claim the first of two thirds. Further back, Lee Bertram edged Nick Charlier in a feisty, four-car fight for 10th.

The two protagonists resumed their rivalry with renewed vigour in the second round, but this time it was Sibley who triumphed after Richards ran out of rubber.

“We were running second-hand

tyres and they were shot after the first race,” he said. “I knew I had to put the pressure on Bill and it paid off,” Sibley added.

● Kerry Dunlop

**RESULTS (BOTH 16 LAPS)** 1 Bill Richards (Rover Metro-Duratec); 2 Paul Sibley (Lotus Elan) +0.391s; 3 Andy Banham (Subaru Impreza); 4 Robert Knox (Maguire Stiletto); 5 Mary Grinham (Maguire Mini); 6 Nigel Craig (Ford Escort RS2000). **CW** Banham; Stephen Craig (Honda Integra); Nick Charlier (Citroen VTS). **FL** Richards 44.523s (80.85mph).

**RACE 2** 1 Sibley; 2 Richards +4.334s; 3 Banham; 4 Grinham; 5 Knox; 6 N Craig. **CW** Banham; S Craig; Charlier. **FL** Sibley 44.984s (80.02mph).

# FREE

## MERCEDES AMG PETRONAS LEWIS HAMILTON TEAM CAP

### WHEN YOU SUBSCRIBE TO

# AUTOSPORT

JUST ~~£3.50~~ **£2.69** AN ISSUE



RRP  
£27



SAVE  
**23%**  
ON THE COVER  
PRICE

## GREAT REASONS TO SUBSCRIBE

- **FREE MERCEDES AMG PETRONAS LEWIS HAMILTON TEAM CAP** worth £27
- **SAVE 23%** on the cover price
- **SPREAD THE COST** - just £34.99 every 13 issues with easy direct debit instalments
- **FREE P&P** - every issue delivered direct to your door

Subscribe online at:

# www.themagazineshop.com/ASPO/M0613P

Or call our hotline and quote offer code M0613P:

Offer closes August 8, 2013.

Please have your bank details ready

# 08448 488 817



## Yes

# AUTOSPORT

Yes, please start my subscription to AUTOSPORT, paying just £34.99 every 13 issues by direct debit, saving 23% on the cover price. **Please send me my FREE MERCEDES AMG PETRONAS LEWIS HAMILTON TEAM CAP**

**YOUR DETAILS** - must be completed (BLOCK CAPITALS PLEASE)

Title: \_\_\_\_\_ Name: \_\_\_\_\_

Surname: \_\_\_\_\_

Address: \_\_\_\_\_

\_\_\_\_\_

Postcode: \_\_\_\_\_

Telephone: \_\_\_\_\_

Mobile: \_\_\_\_\_

Email: \_\_\_\_\_

**DIRECT DEBIT PAYMENT (UK ONLY)**



To the manager, bank name: \_\_\_\_\_

Address: \_\_\_\_\_

\_\_\_\_\_

Postcode: \_\_\_\_\_

Name of account holder(s): \_\_\_\_\_

\_\_\_\_\_

Bank sort code   -   -

Bank/building society account number

Please pay Haymarket Media Group direct debits from the account detailed on this instruction subject to the standards assured by the Direct Debit Guarantee. I understand that this instruction may remain with Haymarket Media Group and, if so, details will be passed electronically to my bank/building society.

Signature(s): \_\_\_\_\_

Date: \_\_\_\_\_

**Please return this form to:**

**AUTOSPORT  
FREEPOST RSBY-ZLLA-SZZS  
PO Box 326  
Sittingbourne ME9 8FA**

**Terms and conditions:** This offer is open to UK residents only. Overseas rates are available on +44 (0) 1795592 974. Please allow 35 days for delivery of your gift and first issue. The gift will be sent under separate cover from the magazine. Should we run out of gifts, you may be offered an alternative gift - there is no cash alternative. Direct Debit rates are valid for one year after which they are subject to change - should prices change we will inform you in writing. We ask that you enter into a Direct Debit agreement with the intention that your subscription will continue for a minimum period of 12 months, even if the frequency of payment is for a shorter period, however, you will still have the right to cancel your Direct Debit in accordance with Direct Debit Guarantee. Should you wish to cancel your subscription it will be cancelled on expiry of the current term which will not be refundable, other than in exceptional circumstances. If a gift is included as part of the subscription offer we reserve the right to request the return of the gift. Details of the Direct Debit Guarantee are available on request. Savings are based on the standard UK cover price of £3.50. **Offer ends August 8, 2013.** Haymarket Media Group Ltd uses a best-practice layered Privacy Policy to provide you with details about how we would like to use your personal information. To read the full privacy policy please visit our website [www.haymarket.com/privacy](http://www.haymarket.com/privacy) or call us on 08448 482 800. Please ask if you have any questions as submitting your personal information indicates your consent, for the time being, that we and our partners may contact you about products and services that will be of interest to you via post, phone, e-mail and SMS. You can opt-out at ANY time by emailing the [datacontroller@haymarket.com](mailto:datacontroller@haymarket.com) or by calling 08448 482 800.

# NATIONAL RESULTS ROUND-UP

**OULTON PARK**  
MSVR, JULY 6



**RADICAL CLUBMAN'S CUP (BOTH 12 LAPS)** 1 **Jesper Westerholm (PR6)**; 2 Oskar Kruger (PR6) +3.583s; 3 Lewis Plato (SR3); 4 Tony Wells (SR3); 5 Erik Stillman (PR6); 6 Simon Hulten (PR6). **Class winner** Plato. **Fastest lap** Westerholm 1m38.071s (98.81mph). **RACE 2** 1 Westerholm; 2 Plato +1.865s; 3 Kruger; 4 Wells; 5 Stillman; 6 Paul Marsham (SR3). **CW** Plato. **FL** Westerholm 1m37.473s (99.42mph).

**MONDELLO PARK**  
CKMC, JULY 6-7



**FORMULA SHEANE (BOTH 16 LAPS)** 1 **Barry Rabbitt**; 2 Brian Hearty +0.091s; 3 Robbie Allen; 4 Kevin Sheane; 5 David Parks; 6 Gary Corcoran. **FL** Hearty 58.362s (70.91mph). **RACE 2** 1 Sheane; 2 Rabbitt +1.450s; 3 Allen; 4 Hearty; 5 Corcoran; 6 Keith Hogg. **FL** Hearty 57.896s (71.48mph). **HRC A HISTORICS (BOTH 15 LAPS)** 1 **David Kelly (Crosle 95)**; 2 Jackie Cochrane (Sunbeam Tiger) +17.444s; 3 Michael Doyle (Chevron B8); 4 Bernard Foley (MGB GT V8); 5 Clive Brandon (Lotus 47); 6 Garth Maxwell (TWR Jaguar XJS). **FL** Kelly 1m01.544s (67.25mph). **RACE 2** 1 Kelly; 2 Cochrane +28.603s; 3 Doyle; 4 Foley; 5 Brandon; 6 Maxwell. **FL** Kelly 1m00.623s (68.27mph).

**Paul Fitzpatrick won by just 0.091s in Global GT Lights**



**FORMULA LIBRE (BOTH 16 LAPS)** 1 **Jonathan Fildes (Ralt RT4)**; 2 Fergus Flaherty (Formula Renault) +19.641s; 3 Cian Carey (Formula Renault); 4 Bob Scanlon (Radical); 5 John Daly (Lola F3000); 6 Michael Larkin (Leystone F5). **FL** Fildes 51.855s (79.81mph).

**RACE 2** 1 Fildes; 2 Flaherty -1 lap; 3 Stanley Watson (Lola F3000); 4 J Daly; 5 Larkin; 6 Martin Daly (Formula Renault). **FL** Fildes 51.971s (79.63mph). **FORD FIESTA ZETEC (10 LAPS)** 1 **Barry Hallion**; 2 Owen Purcell +0.349s; 3 John Boland; 4 JJ O'Riordan; 5 Jonathan Gormley; 6 Keith Dawson. **FL** Ronan McHale 1m12.820s (56.83mph). **RACE 2** (10 LAPS) 1 **J Boland**; 2 John Denning +0.579s; 3 Dawson; 4 Daniel Clarkin; 5 David Yamamoto; 6 Sean Lillis. **FL** Lillis 1m12.382s (57.18mph). **RACE 3 (13 LAPS)** 1 **Vincent Brennan**; 2 Patrick Boland +3.941s; 3 Denning; 4 Philip Lawless; 5 Ian Beatty; 6 Hallion. **FL** Lawless 1m12.561s (57.04mph).

**RACE 4 (13 LAPS)** 1 **Lawless**; 2 P Boland +0.649s; 3 Beatty; 4 J Boland; 5 Hallion; 6 Lillis. **FL** P Boland 1m12.238s (57.29mph).

**IRISH TOURING CARS (BOTH 9 LAPS)** 1 **Erik Holstein (BMW M3)**; 2 Dave O'Brien (M3) +3.295s; 3 Robert Butler (Honda Civic); 4 Zeljko Mijatovic (Honda Integra); 5 Owain Drought (Honda Integra); 6 Norman Fawcett (Civic). **FL** Holstein 59.864s (69.13mph).

**RACE 2** 1 Holstein; 2 O'Brien +2.631s; 3 Butler; 4 Robert Savage (Honda Integra); 5 Drought; 6 Mijatovic. **FL** Holstein 1m00.158s (68.79mph).

**GLOBAL GT LIGHTS & LEGENDS (13 LAPS)** 1 **Jake Byrne (Global GT Light)**; 2 Peter Drennan (GT Light) +0.506s; 3 Paul Fitzpatrick (GT Light); 4 Mark Braden (GT Light); 5 Derek Behan (GT Light); 6 Richard Finlay (GT Light). **CW** John Holman (Legend). **FL** Byrne 58.127s (71.20mph).

**RACE 2 (15 LAPS)** 1 **Fitzpatrick**; 2 Byrne +0.091s; 3 Drennan; 4 Braden; 5 Finlay; 6 Fergus Costello (GT Light). **CW** Holman. **FL** Byrne 58.780s (70.40mph).

**CROFT**  
BARC, JULY 6-7



**PORSCHE GT3 CUP CHALLENGE GB (BOTH 18 LAPS)** 1 **Justin Sherwood**; 2 Steve Liquorish +5.663s; 3 Kelvin Fletcher; 4 Guy Riall; no other finishers. **FL** Sherwood 1m27.106s (87.82mph). **RACE 2** 1 **Sherwood**; 2 Liquorish +26.867s; 3 Fletcher; 4 Riall; 5 Peter Kyle-Henney; no other starters. **FL** Sherwood 1m26.301s (88.64mph).



**Colin Simpson's blue Marcos Mantis scored an NSSCC double win**

**NORTHERN SPORTS & SALOONS CLASSES A & E (BOTH 11 LAPS)** 1 **Colin Simpson (Marcos Mantis)**;

2 Bill Addison (Caterham R400) +13.523s; 3 Fraser Robertson (Ginetta G50); 4 Stuart Carr (Caterham 7); 5 Guy Blumer (Ford Sierra Cosworth); 6 Mark Leybourne (Westfield SEIW). **CW** Addison; Carr. **FL** Simpson 1m29.244s (85.72mph). **RACE 2** 1 **Simpson**; 2 Addison +16.094s; 3 Carr; 4 David Botterill (Porsche 944); 5 Robertson; 6 Simon Mayne (Fisher Fury).

**NORTHERN SPORTS & SALOONS CLASSES B, C, D & H (BOTH 11 LAPS)** 1 **Andy Wilson (BMW M3)**; 2 Michael Cutt (BMW M3) +3.961s; 3 Martin Lofthouse (Triumph TR8); 4 Paul Moss (Citroen Saxo); 5 Neville Anderson (Vauxhall Vectra); 6 Andy Gibson (Lotus Exige). **CW** Lofthouse; Moss; Steve Kirton (Vauxhall Astra GS). **FL** Cutt 1m34.289s (81.13mph). **RACE 2** 1 **Cutt**; 2 Mike Williamson (Mitsubishi Evo 4) +10.047s; 3 Wilson; 4 Brian Morris (Datsun 240Z); 5 Anderson; 6 Moss. **CW** Morris; Moss; Kirton. **FL** Cutt 1m33.354s (81.94mph).

**HONDA V-TEC CHALLENGE (BOTH 13 LAPS)** 1 **Richard Voaden (Integra)**; 2 Robert Burkinshaw (Integra) +1.312s; 3 Mark Chese (Civic); 4 Phil Wright (Accord); 5 Stuart King (Integra); 6 Mathew Le (Integra). **CW** Burkinshaw; Chese. **FL** Burkinshaw 1m35.856s (79.80mph).

**RACE 2** 1 **Voaden**; 2 Burkinshaw +1.629s; 3 Chese; 4 Wright; 5 King; 6 Le. **CW** Burkinshaw; Chese; Ian Redgrave (Vauxhall Astra). **FL** Burkinshaw 1m36.162s (79.55mph).

**LYDDEN**  
SEMSEC, JULY 6



**SINGLE-SEATERS (BOTH 17 LAPS)** 1 **Chris Mabey (Jedi Mk6)**; 2 Dave Connor (Jedi Mk6) +0.384s; 3 Chris Chandler (Tatuus FR97); no other finishers. **CW** Chandler. **FL** Connor 41.469s (86.81mph).

**RACE 2** 1 **Mabey**; 2 Connor +13.624s; no other finishers. **FL** Connor 40.881s (88.06mph).

**SPORTS RACING & KIT CARS (BOTH 18 LAPS)** 1 **Mark Burton (Jade Trackstar)**; 2 Charles Harvey-Kelly (Radical SR3) +20.166s; 3 Ian Conibear (Caterham Roadsport); 4 Bruce Wilson (Caterham CSR Superlight); 5 Mark Bishop (Caterham Roadsport); 6 Michael Gibbins (Lola T590). **CW** Conibear; Alastair Heys (Westfield Megabusa).

**RACE 2** 1 **Burton**; 2 Conibear +44.879s; 3 Wilson; 4 Harvey-Kelly; 5 Gibbins; 6 Heys. **CW** Conibear; Heys. **FL** Burton 40.966s (87.87mph).

**SOUTH EAST CHALLENGE (17 LAPS)** 1 **Burton**; 2 Harvey-Kelly +21.808s; 3 Wilson; no other starters. **CW** Wilson. **FL** Burton 40.527s (88.82mph).

**JOHN TAYLOR HANDICAP (12 LAPS)** 1 **Dan Williams (Ford Fiesta ST)**; 2 Nick Charlier (Citroen VTS) +1.609s; 3 Ian Conibear (Caterham Roadsport); 4 Nigel Craig (Ford Escort RS2000); 5 Michael Gibbins (Lola T590); 6 Andy Banham (Subaru Impreza). **FL** Conibear 43.362s (83.02mph).



**John Denning had two podiums and this off in Mondello Fiestas**

# RENAULT'S RETURN

Formula Renault UK died a death at the beginning of 2012, but the French are coming back to the UK with a new junior single-seater series. By BEN ANDERSON

**R**enault has a long and successful affinity with UK motorsport. Its two-litre single-seater formula launched the careers of many stars: Lewis Hamilton, Kimi Raikkonen, Paul di Resta, Daniel Ricciardo, Jean-Eric Vergne, Pastor Maldonado, Roman Grosjean, Valtteri Bottas and Jules Bianchi all passed through the French marque's junior category on their way to the top.

In fact, if a professional driver began car racing after the year 2000, it is highly likely (unless they're German) that they raced in Formula Renault 2.0 in one form or

another. But the category that launched so many careers reached a terminal decline on these shores in 2012. Organisers pulled the plug on the eve of the season after just six drivers signed up.

A combination of excessive costs and increased competition from continental Europe meant Britain went without a top-level Formula Renault championship for the first time since 1989.

But Renault was never likely

to walk away and never come back. Instead it has licked its wounds, gone back to the drawing board, and produced a plan to re-establish itself as the premier training ground for single-seater talent in this country.

Essentially, Renault hopes to revive Formula Renault 2.0 in the UK by creating a new first step into single-seater racing for teenagers, then

feeding them into a bigger formula. Ahead of the new Formula Renault 1.6 UK Championship's launch for 2014, AUTOSPORT went to Mallory Park to test the car that will form its centrepiece.

CAR PHILOSOPHY

**Lionel Chevalier,**  
general manager of  
Signatech Automobiles



"The car has already run for five years in French Formula 4. "They have developed it to have 160bhp and a paddleshift system. It is also running this year in the Junior NEC and Nordic countries. "It's a cheap, basic car; easy to handle and easy to run. You don't

need [advanced] knowledge for the mechanic or the driver. "The dampers are non-adjustable, you have only one set of springs, and there are no different rollbars and no rollbar at all on the rear. The engine and clutch are from a Twingo RS and it has no tuning. This is all to control costs. We want to make it possible for a driver with his family as mechanics to be champion."

TEAM PERSPECTIVE

**Mark Godwin,**  
MGR team boss



"It's a very simple car, which I think is good in some respects. I think it will be very cost-effective to run, because you're very limited in terms of adjustment, and it looks like it's reliable. There's not an awful lot of technology on it, which is important for novice drivers. "It's about 30-40kg heavier than a

current 2.0 Renault and has about 60bhp less, but it's not slow. We saw them at Valencia when we were testing before Christmas and they looked pretty quick for a small car. "It will be interesting to see how this compares to the old Formula BMW, which was an expensive car to run. People looked at the BMW Mygale and thought, 'That looks a bit weird', but this looks nice."

DRIVING IMPRESSIONS

**Ben Anderson,**  
National Editor  
AUTOSPORT



"The car felt almost exactly like a Formula BMW: sturdy and stable, not too powerful, with simple controls, so it should be a very accessible machine for novices. "That said, it's still possible to get out of shape using the throttle and the car does feel slightly nervous at

the rear in the high-speed corners. In this respect, it feels quite similar to the spaceframe car used in BRDC F4, though more benign. "There's not much you can do with the set-up so it will be largely down to the drivers to learn the best way to handle the car's traits. This is meant to be a cost-saving measure, though it could perversely reward those with bigger budgets to spend on testing."

EXPERT VIEW

**Stoffel Vandoorne,**  
McLaren Junior Driver



"The Formula Renault 1.6 is a good car to start your career in. I feel the step from karting to Formula Renault 2.0 is too big, and the 1.6 car is a great step in between. "It's a good car, and it helped me a lot. You don't have to worry about set-up too much; there's not a lot to change. So you can really focus on

your driving, and that's what matters in your first year when you have no experience. It prepares you very well for FR 2.0 – the basics are similar. "I don't know if I would have achieved the results I did in FR 2.0 [including winning the 2012 Eurocup] without the 1.6. It gives you a lot of confidence – something you wouldn't get if you went straight from karting to FR 2.0."

TECH SPEC

<b>CHASSIS</b>	Signatech carbon monocoque
<b>BRAKES</b>	6-piston calipers, steel discs
<b>ENGINE</b>	Renault K4MRS
<b>CAPACITY</b>	1600cc
<b>POWER</b>	140bhp
<b>GEARBOX</b>	5-speed sequential
<b>WEIGHT</b>	470kg
<b>COST</b>	€43,000



PROMOTER'S VIEW

**Simon North,**  
Renault UK promoter



"My job is to take what Lionel has done and make sure it works from a budget point of view. "The lessons we've learned from FR BARC, particularly in the last two years, give us a good understanding of the economics for the teams. "The car costs €43,000 ready to run, with new tyres, which is less than

Formula Ford 200 and about the same as BRDC F4. The budgets need to be progressive; that's exactly why we started the BARC series in 2005. You need a series for half the money so a driver can gain the track record to find the next budget. "The longer-term goal is to rebuild FR 2.0 in the UK, but we can't just bring it back as it was. We've got to rebuild the base of the pyramid."

Teddington Studios, Broom Road, Teddington, Middlesex TW11 9BE, UK.  
Tel: +44 (0) 20 8267 5804 Fax: +44 (0) 20 8267 5922  
E-mail: mail@autosport.com Website: www.autosport.com

**EDITOR-IN-CHIEF**  
Andrew van de Burgt  
andrew.vandeburgt@haymarket.com ext.5974

**EDITOR**  
Charles Bradley  
charles.bradley@haymarket.com ext.5889

**GROUP F1 EDITOR**  
Jonathan Noble ext.5810  
jonathan.noble@haymarket.com

**F1 EDITOR**  
Edd Straw ext.5887  
edd.straw@haymarket.com

**FEATURES EDITOR**  
Kevin Turner ext.5432  
kevin.turner@haymarket.com

**NEWS EDITOR**  
Glenn Freeman ext.5309  
glenn.freeman@haymarket.com

**REPORTS EDITOR**  
Jamie O'Leary ext.5811  
jamie.oleary@haymarket.com

**MANAGING EDITOR**  
Peter Hodges ext.5903  
peter.hodges@haymarket.com

**RALLIES EDITOR**  
David Evans  
david.evans@haymarket.com

**DEPUTY NEWS EDITOR**  
Sam Tremayne ext.5952  
sam.tremayne@haymarket.com

**ART EDITOR**  
Aubrey Smith ext.5914  
aubrey.smith@haymarket.com

**PRESENTER/SUB-EDITOR**  
Henry Hope-Frost ext.5835  
henry.hope-frost@haymarket.com

**CHIEF SUB-EDITOR**  
Marcus Simmons ext.5807  
marcus.simmons@haymarket.com

**NATIONAL EDITOR**  
Ben Anderson ext.5425  
ben.anderson@haymarket.com

**SENIOR DESIGNER**  
Michael Cavalli

**PICTURE EDITOR**  
Peter Mills ext.5918  
peter.mills@haymarket.com

**AUTOSPORT.COM TECHNICAL TEAM LEADER**  
Geoff Creighton  
geoff.creighton@haymarket.com

**AUTOSPORT.COM DEVELOPER**  
Tomasz Trznadel  
tomasz.trznadel@haymarket.com

**AUTOSPORT.COM USER INTERFACE DEVELOPER**  
Theo Pape  
theo.pape@haymarket.com

**OFFICE MANAGER**  
Joanne Grove  
joanne.grove@haymarket.com ext.5804

**PHOTOGRAPHS**  
LAT Photographic

**SPECIAL CONTRIBUTORS**

Mark Hughes	Dieter Rencken	Jim Bamber
Gary Watkins	Gary Anderson	Pablo Elzalde
Marcus Pye	Giorgio Piola	Matt Beer
Mark Glendenning	Alan Eldridge	

**CORRESPONDENTS**

<b>ARGENTINA</b> Tony Watson	<b>ITALY</b> Roberto Chinchero	Martin, David Phillips, Diego Mejia, Robin Miller, Jeremy Shaw.
<b>AUSTRALIA</b> Phil Branagan	<b>JAPAN</b> Jiro Takahashi, Len Clarke	<b>UK &amp; EIRE</b> David Addison, Jonathan Crawford, Bernard Carpinter
<b>AUSTRIA</b> Gerhard Kuntstschik	<b>RUSSIA</b> Bernard Carpinter	Kerry Dunlop, Leanne Fahy, Paul Healy, Paul Jurd, Paul Lawrence, Stephen Lickorish, Marc Orme, Graham Road, Hal Ridge, Peter Scherer, Ian Somman, Oliver Timson, Ian Titchmarsh, Matt Upton, Eddie Webster, Richard Young
<b>BELGIUM</b> Gordon McKay	<b>RUSSIA</b> Gregory Golyshhev	
<b>BRAZIL</b> Lito Cavalcanti	<b>SOUTH AFRICA</b> Richard Asher	
<b>FINLAND</b> Esa Iloninen	<b>SPAIN</b> Raimon Duran	
<b>GERMANY</b> Rene de Boer	<b>SWEDEN</b> Tege Tornvall	
<b>GREECE</b> Dimitris Papadopoulos	<b>USA</b> Jonathan Ingram, Bruce	

**ADVERTISING**  
Tel: +44 (0) 20 8267 5820  
Fax: +44 (0) 20 8267 5850  
E-mail: autosport.ads@haymarket.com

**COMMERCIAL MANAGER**  
Rachel Brock  
rachel.brock@haymarket.com ext.5820

**DISPLAY ADVERTISING**  
Gary-Lee Hoebeek  
garylee.hoebeek@haymarket.com ext.5576

**ALEX NEWBERRY**  
alex.newberry@haymarket.com ext.5244

**LUKE RICKETTS**  
luke.ricketts@haymarket.com ext.5961

**CLASSIFIED ADVERTISING**  
Emily Clark  
emily.clark@haymarket.com ext.5865

**Dan Hodgson**  
danielle.hodgson@haymarket.com ext.5560

**Peter Musumeci**  
peter.musumeci@haymarket.com ext.5992

**Katy Snowball**  
katsnowball@haymarket.com ext.5367

**ONLINE ADVERTISING**  
Leanne Foley  
leanne.foley@haymarket.com ext.5846

**Matt Simpkin**  
matt.simpkin@haymarket.com ext.5281

**AD PRODUCTION**  
Tel: +44 (0) 20 8267 5740 Fax: +44 (0) 20 8267 5320

**ADVERTISING DIRECTOR**  
Matthew Witham

**SPECIAL PROJECTS DIRECTOR**  
Derek Redfern

**LICENSING DIRECTOR**  
Jim James

**PRODUCTION MANAGER**  
Ailsa Donovan  
ailsa.donovan@haymarket.com ext.5639

**PRODUCTION CONTROLLERS**  
Geeta Chambers  
geeta.chambers@haymarket.com ext.5588

**Marc Baker**  
marc.baker@haymarket.com ext.5563

**SUBSCRIPTIONS**  
UK 0804 868817  
OVERSEAS +44 (0)1795 592 974

**EMAIL**  
autosport@servicehelpline.co.uk  
AUTOSPORT, ISSN number 0269946X,  
is published weekly by Haymarket Media  
Group, Teddington Studios, Broom  
Road, Teddington TW11 9BE, United  
Kingdom. The US annual subscription  
price is \$295. Airfreight and mailing in  
the USA by agent named Air Business  
Ltd, c/o Worldnet Shipping Inc., 156-15,  
146th Avenue, 2nd Floor, Jamaica, NY

**MANAGEMENT**

**GROUP PUBLISHER**  
Alastair Lewis

**PUBLISHING MANAGER**  
Samantha Jemson

**SPECIAL EVENTS MANAGER**  
Laura Coppin

**DIGITAL SPECIAL PROJECT MANAGER**  
Simon Strang, ext: 5093  
simon.strang@haymarket.com

**DIGITAL PRODUCT MANAGER**  
Simon Grayson, ext: 5346  
simon.grayson@haymarket.com

**© 2013, HAYMARKET MEDIA GROUP LTD**  
Publishing, trade and further subscription  
details on www.autosport.com While due  
care is taken to ensure the contents of  
AUTOSPORT are accurate, the publishers  
and printers cannot accept liability for  
errors and omissions. Advertisements are  
accepted for publication in AUTOSPORT  
only upon Haymarket Media Group Ltd's  
Standard Terms of Acceptance of  
Advertising, copies of which are available  
from the Advertising Sales Department  
of AUTOSPORT.

**EDITORIAL DIRECTOR**  
Mark Payton

**CREATIVE DIRECTOR**  
Paul Harpin

**STRATEGY AND PLANNING DIRECTOR**  
Bob McDowell

**PUBLISHING DIRECTOR**  
Patrick Fuller

**MANAGING DIRECTOR**  
David Prasher

**CHIEF EXECUTIVE**  
Kevin Costello

Haymarket is certified by  
BSI to environmental  
standard ISO14001

# THIS WEEK

LETTERS • BEST PICS • LATEST GEAR • ON TRACK & SCREEN • ONLINE

## What you think of the motorsport news of the past week

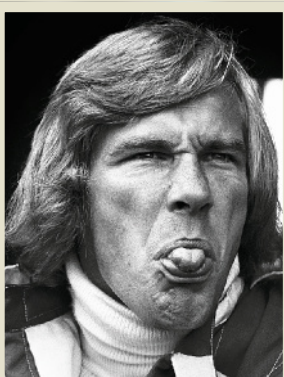

It's unfair to compare Hunt and Rosberg



ETHERINGTON/LAT; LAT ARCHIVE

## Different drivers, different eras

Sunday's *Top Gear* provided the usual highly entertaining viewing, but was marred by Jeremy Clarkson's comparison of James Hunt and Nico Rosberg.

The two drove in completely different eras. The '70s was a time when drivers were relatively free from sponsor obligations and their managers would negotiate deals over a bottle of vodka. Singling out Rosberg is poor. He was

born with a millionaire father and raised in Monte Carlo, where the sun shines as freely as money. None of it seems to have affected Rosberg, one of the most grounded drivers in the paddock.

A modern-day Hunt would have approved of Nico's lifestyle, not least his lack of fear when it comes to hair-raising pursuits such as canyoning.

**Thomas Moulton, by email**

### Having attended the British

Grand Prix, I had to write to congratulate Silverstone. Never in going to that circuit over the last 45 years have I got in and out of a major race meeting so easily.

In addition, the staff in the car parks, hospitality and merchandising were all so cheerful and helpful. A big thank you to all concerned.

**Bill Warden**  
Northampton

and helper ensured not only that the visitors had a great day, but also that we set many of them off along the road to getting involved in motorsport for the first time. Go Motorsport Live will definitely be back next year.

**Ben Taylor**  
MSA director of development and communication

### Some reports suggest that

McLaren has given up on its MP4-28 to focus on next year's car. Having lost Paddy Lowe, Pat Fry and Mike Coughlan in recent years, does it employ suitable technical strength at the highest level?

The team appears to lack the best aerodynamicists and has not seemed to have taken on board constructive suggestions made by former designer Gary Anderson (AUTOSPORT, May 16).

McLaren needs to take a leaf out of

Mercedes' book and recruit the best talent from top rival teams. As a McLaren fan, I'm concerned the team may follow Williams' downward spiral.

**Andrew Bodman**  
Northampton

### Why are F1 teams so poor at

nurturing talent? A quick look at past and present Red Bull drivers shows that with the exception of Sebastian Vettel, Red Bull's young driver scheme has been a complete failure that has deprived fans of some great talent.

Thankfully the likes of Nico Hulkenburg, Valtteri Bottas and Paul di Resta have emerged, but if F1 talent spotters were football talent spotters, we'd never have seen the likes of Messi, Ronaldo and Rooney.

**Gary Dowsett**  
By email



# In pictures

Exciting images from around the globe, from Holland to Australia via the US

**GTs AT TARZAN – IT'S THE LORD OF THE SCRAPES**

The FIA GT grid might have been down to 20 cars at Zandvoort, but they were ultra-closely matched at Tarzan on the opening lap



IMAGES/ABRE



GARDNER/GETTY

**NATIONWIDE STRIKE**

Jamie Dick (55), Travis Pastrana (60), Robert Richardson (23) and Jason White (24) show it's not just the Cup stars who can stage a 'big one' at Daytona

**ONE WAY TO SORT OUT DRIVING STANDARDS...**

Fabian Coulthard took to this Australian Army Bushmaster ahead of the V8 Supercar bash at Townsville. He piloted a Holden in the race



HITCHCOCK/GETTY

**DAD, ARE YOU SURE YOU WANT TO DO THIS?**

DTM star Mattias Ekstrom took dad Bengt – a top-level rallycrosser in the 1980s – for a spin at Holjes. Then, as you can see, they swapped over!



**In the shops**

Desirable new releases

**CRUTCHLOW MOTOGP GEAR**

From £5.99 – autosport.com/shop



Get behind Britain's best MotoGP rider Cal Crutchlow by sporting his official merchandise. After all, the last top-class win by a Brit, in 1981, was a long time ago. The 2013 range comprises everything from sticker sets (£5.99) to hoodies (£74.99), via these T-shirts (£34.99). They feature his trademark #35 and kids' versions (£20.99) are also available.

**JIM CLARK 1965 LOTUS 33 1:18**

£149.99 – autosport.com/shop

This Spark 1:18-scale resin model of Jim Clark's 1965 world championship winning Lotus 33 is a replica of the car the Scot used to win that year's German Grand Prix at the Nurburgring – his sixth victory from seven races (he missed Monaco while winning the Indy 500!). It's limited to just 500 pieces worldwide and is incredibly detailed.



**TISSOT MOTOGP WATCH**

\$925 – tissot.ch

Swiss watchmaker Tissot, who has been official timekeeper to MotoGP for many years, has launched a limited edition T-race watch. The scratch- and water-resistance Quartz timepiece, limited to 8888 pieces worldwide, features a durable silicone strap and comes in a MotoGP presentation case.



# WHAT'S ON

## ON TRACK IN THE UK

### GOODWOOD

#### Festival of Speed

July 11-14

[goodwood.co.uk](http://goodwood.co.uk)

The Festival of Speed is one of the highlights of the British motorsport calendar and this year celebrates its 20th anniversary with a gathering of the most legendary drivers and cars that have featured on the hill since 1993. A celebration of 50 years of the Porsche 911 and appearances from Jackie Stewart, Emerson Fittipaldi, Lewis Hamilton, Jenson Button, Damon Hill, Juha Kankkunen, Hannu Mikkola, Nelson Piquet, Alain Prost, John Surtees and Giacomo Agostini will get the blood pumping.

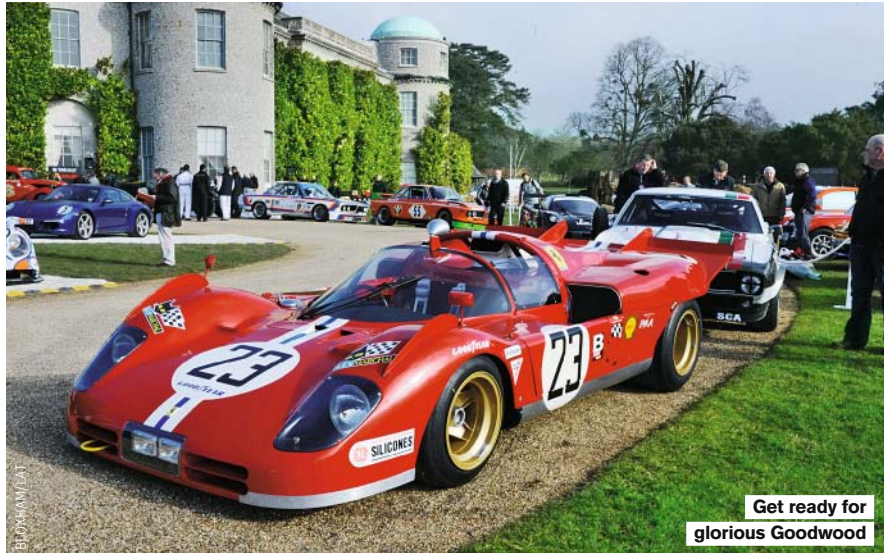

Get ready for glorious Goodwood

Sports Specials, Classic Stock Hatch, 750 Formula, BMW Compact Cup, Toyota MR2s, 750 Trophy, the Morgan Challenge, and a closed wheel Allcomers race.

### DONINGTON PARK

#### BRSCC

July 13-14

[donington-park.co.uk](http://donington-park.co.uk)

Caterham Academy, R300 Superlights, FF 1600, Sports 2000, Mazda MX5 SuperCup.

### SNETTERTON

#### BARC

July 13-14

[snetterton.co.uk](http://snetterton.co.uk)

Mini Miglias, Mini 7s, Porsches and the MGOC support the British Superkart Grand Prix.

### OULTON PARK

#### MSVR

July 13

[ouiltonpark.co.uk](http://ouiltonpark.co.uk)

Mini Challenge, GT Cup, Atom Cup and Monoposto.

### KNOCKHILL

#### SMRC

July 14

[knockhill.com](http://knockhill.com)

### BRANDS HATCH

#### HSCC

July 13-14

[brandshatch.co.uk](http://brandshatch.co.uk)

The Historic Superprix is always one of the Kent venue's season highlights. This year 18 races across two days includes Formula 5000, F2, F3, Martini Trophy, Super Touring Car Trophy, Guard's Trophy's pre-66 sportscars, Classic Racing Cars,

Road Sports, Historic Touring Cars, and Historic Formula Fords feature.

### SILVERSTONE

#### GT Open

July 12-14

[silverstone.co.uk](http://silverstone.co.uk)

International GT Open and European F3 Open come to Silverstone for their annual UK jaunt. The GT series' blend of

GT2 and GT3 should make for a great spectacle, while the F3 grid is the best-supported away from the FIA series. Radical European Masters and Maserati Trofeo support.

### CASTLE COMBE

#### CCRC

July 13-14

[castlecombecircuit.co.uk](http://castlecombecircuit.co.uk)

FF 1600, Combe Saloon,

Combe GT, CSCC Tin-Tops, Future Classics, Modern Classics, Magnificent Sevens, Swinging Sixties, Jaguar Saloons & GTs, MG Midgets, Austin Healey Sprites.

### ROCKINGHAM

#### 750MC

July 13-14

[rockingham.co.uk](http://rockingham.co.uk)

Formula Vee, Bike-Sports,

## ON TRACK AROUND THE WORLD

### INDYCAR SERIES

Rd 11/16

Toronto, Ontario, Canada

July 13-14

[indycar.com](http://indycar.com)



F3 spares bills will mount at Norisring

### INDY LIGHTS

Rd 8/12

Toronto, Ontario, Canada

July 13

[indycar.com/roadtoindy](http://indycar.com/roadtoindy)

### SUPER FORMULA

Rd 3/7

Fuji, Japan

July 14

[superformula.net](http://superformula.net)

### AUTO GP

Rd 5/8

Mugello, Italy

July 13-14

[autogp.org](http://autogp.org)

### DTM

Rd 5/10

Norisring, Germany

July 14

[dtm.com](http://dtm.com)

### FORMULA 3 EUROPEAN CHAMPIONSHIP

Rd 6/10

Norisring, Germany

July 13-14

[fiaf3europe.com](http://fiaf3europe.com)

### NASCAR SPRINT CUP

Rd 19/36

New Hampshire, USA

July 14

[nascar.com](http://nascar.com)

### SCANDINAVIAN TOURING CAR CHAMPIONSHIP

Rd 4/8

Falkenberg, Sweden

July 13

[stcc.se](http://stcc.se)



IndyCar makes its jaunt to Toronto for a double-header

### SUPER TC2000

Rd 6/12

Rio Hondo, Argentina

July 14

[super-tc2000.com.ar](http://super-tc2000.com.ar)

### JAPANESE F3

Rd 4/6

Fuji, Japan

July 13-14

[j-formula3.com](http://j-formula3.com)

Your guide to the best events taking place in the UK and around the world – plus TV and online

**ON TELEVISION**

**THURSDAY JULY 11**

0730-0745 **Eurosport**  
Silk Way Rally: Stage 5  
1245-1315 **ESPN**  
NASCAR Now  
1900-2200 **ESPN**  
IndyCar: Pocono Replay  
2335-2355 **Eurosport**  
Silk Way Rally: Stage 6

**FRIDAY JULY 12**

0730-0745 **Eurosport**  
Silk Way Rally: Stage 6  
1900-2000 **Sky Sports F1**  
Architects of F1: Gordon Murray  
1930-2000 **BBC1**  
A Question of Sport  
Three-time Le Mans 24 Hours winner Allan McNish joins this week's panel.  
2000-2100 **Sky Sports F1 LIVE**  
The F1 Show  
2235-2255 **Eurosport**  
Silk Way Rally: Stage 7

**SATURDAY JULY 13**

0355-0425 **Channel 5**  
Motorsport Mundial  
0730-0745 **Eurosport**  
Silk Way Rally: Stage 7  
0850-0950 **ITV4**  
Motorsport UK  
1005-1105 **Motors TV LIVE**  
FIA Euro F3: Norisring Race 1  
1450-1540 **Motors TV LIVE**  
Euro F3 Open: Silverstone Race 1  
1540-1710 **Motors TV LIVE**  
GT Open: Silverstone Race 1  
1710-1810 **Motors TV**  
FIA Euro F3: Norisring Race 2  
2000-2305 **Motors TV LIVE**  
NASCAR Nationwide: Loudon

**SUNDAY JULY 14**

0100-0330 **ESPN**  
IndyCar: Toronto Race 1  
0635-0730 **Channel 4**  
FIA GT: Zandvoort Highlights  
0730-0745 **Eurosport**  
Silk Way Rally: Stage 8  
0945-1015 **Eurosport**  
Auto GP: Mugello Race 1  
1015-1045 **Eurosport LIVE**  
ETCC: Pergusa Race 1  
1045-1130 **Eurosport LIVE**  
Auto GP: Mugello Race 2  
1130-1200 **Eurosport LIVE**  
ETCC: Pergusa Race 2  
1200-1300 **Motors TV**  
FIA Euro F3: Norisring Race 3  
1215-1415 **ESPN LIVE**  
DTM: Norisring  
1500-1700 **Sky Sports 4 LIVE**  
Goodwood Festival of Speed  
1500-1600 **Motors TV**  
GT Open: Silverstone Race 2  
1600-1645 **Motors TV**  
Euro F3 Open: Silverstone Race 2  
1800-2200 **Premier Sports LIVE**  
NASCAR Sprint Cup: Loudon  
2100-2200 **BBC2**  
Hunt vs Lauda:  
F1's Greatest Racing Rivals  
2015-2315 **ESPN LIVE**  
IndyCar: Toronto Race 2

**MONDAY JULY 15**

0500-0600, 2100-2200 **ESPN**  
NASCAR Sprint Cup: Loudon  
1400-1600 **Sky Sports 4**  
Goodwood Festival of Speed  
1630-1900 **ESPN**  
Global Rallycross: Loudon  
1720-1925 **Motors TV**  
NASCAR Nationwide: Loudon

**ONLINE**

**HOT ON THE WEB THIS WEEK**

**YouTube** TOYOTAS TANGLE IN SILVERSTONE BTCC BACK IN 1993



**SEARCH FOR:** A Double Collision BTCC 1993 Round 9 Silverstone (2:24)  
Twenty years ago today (Thursday) Nissan scored its first BTCC win – in the British GP support race at Silverstone. But Kieth Odor's victory came after the Toyota Carinas of Will Hoy and Julian Bailey collided. As Murray Walker says: "The car upside down is a Toyota!"

**AUTOSPORT+**

Exclusive content coming up in our premium website this week

**Russia's F1 plan, plus the stars of the future**

AUTOSPORT brings you opinion and analysis from the latest goings-on in Formula 1, while sister publication *F1 Racing* looks at how plans for the Russian GP are progressing. Plus, Marcus Simmons picks out some leading up-and-comers in his Stars of Tomorrow column.

**GET AUTOSPORT ON THE MOVE**

- IN THE IPAD ISSUE THIS WEEK...
- WATCH HIGHLIGHTS FROM LAST WEEKEND'S INDYCAR, NASCAR, AND FIA GT ACTION
- ON SALE ALL OVER THE WORLD FOR ONLY £2.99



Download it now from [autosport.com](http://autosport.com) **AUTOSPORT**

**Revved up over what's on the box**

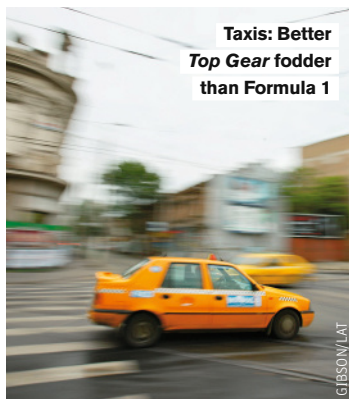

Taxis: Better *Top Gear* fodder than Formula 1

YOU CAN'T KEEP A GOOD CASH cow down. And for its 657th series, *Top Gear* is back. Even Clarkson admits that it's "last of the summer gear" but, given the format's success, why change?

The uber-blokeyness may grate the more refined palate, but there's a reason why millions tune in to Clarko, Hammy and Mayey sliding down a hill in a bathtub.

But for all the gems contained in their trips to the source of the Nile, or through the mountains of Iraq, or the utter terror of night driving in India, whenever they stray into motorsport territory the aim goes awry. Last week's episode had an especially

strong racing flavour. Showing the timeliness of the live studio segment, Pirelli's troubles in the British GP were debated. Hammond lamely suggested the introduction of a "saw zone", while the usually sensible May wondered why F1 cars aren't completely technologically unrestricted – perhaps when you make a fortune playing with big boys' toys you fail to grasp the economic crisis we're living through.

The Mono trackday special was given an entertaining appraisal before the centrepiece feature, based around finding out what's the world's best taxi, took place. The usual array of BTCC stars of past and

present was wheeled out as they took to the track at Lydden to weigh it up between a Hindustan Ambassador or a VW Beetle.

While all their races are staged, this one felt especially so, with some explosive stunts inelegantly crowbarred in. It all seemed a bit desperate, although kudos to Anthony Reid for the way he drifted a stretched limo.

A second race followed, this time between two absurdly daring freestyle runners and legendary trials rider Dougie Lampkin around Television Centre.

It all felt like I'd seen it before and lacked any suspense. And on that bombshell... **Revved Up**

# Gerard Larrousse

“The 908/3 was the best. No roof, only 480kg and perfect balance”

■ Nurburgring 1000km ■ May 30, 1971 ■ Porsche 908/3 ■ Beating the cream of the crop



Larrousse's team-mate  
Vic Elford guns the 908/3  
to victory at the 'Ring

**THERE ARE TWO REASONS** why the 1000km of the Nurburgring in 1971 is the race of my life.

Firstly it was because Vic Elford and I won and beat the best endurance drivers in the world at the time: Pedro Rodriguez and Jo Siffert in second and Helmut Marko and Gijs van Lennep in third.

The second reason is because the car – the Porsche 908/3 – was the absolute best. No roof, only 480kg, perfect balance, designed by Mr [Ferdinand] Piech. Wonderful.

I drove the open-top car on the Targa Florio first. My background was as a rally driver in France, so when Porsche came to me for what was the beginning of my second career, they told me: “Gerard, you’re a rally specialist and the Targa Florio is like a rally, so drive the car [the earlier 908/02] and see what you think of it”.

I did and it was absolutely fantastic – very comfortable, fast and easy to drive. We had a steering problem in the early days, but it was fixed very quickly and then everything was fine.

Politically that weekend in '71 was

a bit of a difficult time to be a driver at Porsche. The 917 had been around for more than a year and had won Le Mans in 1970, and the engineers in Germany were already working with computers on the car.

The computer said that the 917 was faster than the 908 on the Nurburgring. I can't remember by how much exactly, but it was fairly significant. The computers were wrong. Maybe on paper it was faster,

when you talk about putting data in a machine. But a machine can never account for the human factor, and that's why it was completely wrong. The 917 was a feral car, especially in the early days, whereas the 908, with its perfect balance, could be driven much more smoothly and easily.

You could do lots of laps at the same speed with the 908 without getting too out of shape, but to be fast in the 917 you needed to be really on

the limit all of the time. You needed a driver with a big heart like Kurt Ahrens or Rolf Stommelen to drive the 917 and some of us just said no, which made for a charged atmosphere sometimes. We didn't hate the 917 – we'd driven it in all the big races that year and won at Sebring – it just wasn't right for the Nurburgring; not if you wanted to win.

With the exception of that disagreement, my time with Porsche was fantastic, both in terms of the experience and the achievements.

The team spirit too was something special. I was very close to Vic, Mr Piech, the management and the engineers. We were just like a family. I've never known an ambience like it.

Back then I was known as a Nurburgring specialist because I was always pretty fast there, but put me in a car now and I would not remember which direction the corners go!

People have told me I should get a computer game to learn the track, but I'll leave that to the youngsters. ✘ Gerard Larrousse was talking to Jamie O'Leary

## PROFILE



### GERARD LARROUSSE MOVED

from rallying to racing in 1966 and went on to win 12 world sportscar championship races – including Sebring in '71 and Le Mans in '73-'74 – for Porsche, Matra and Alpine. He also started one GP in '74. After retiring from driving he became Renault Sport's first boss, overseeing its F1 entry and '78 Le Mans win. He ran his own F1 team from 1987-'94, which took one podium finish.

**NEXT WEEK** GOODWOOD FESTIVAL OF SPEED  
Full report on 20th anniversary event

# Driving in France?

You'll need one of these by law



From 1st July 2012 all vehicles travelling in France must carry an unused 'NF' approved alcohol breathalyser by law, like the AlcoSense NF breathalyser.

At only £5.99 for a Twin Pack AlcoSense will keep you safe and legal in France. Available now at Halfords and [www.alcosense.co.uk](http://www.alcosense.co.uk).



Scan here for more info or to order



Available Nationwide from

**that's helpful that's**  
**halfords**

# alcoSense<sup>®</sup>

ALCOHOL BREATHALYSER

Order at [www.alcosense.co.uk](http://www.alcosense.co.uk) or call **0800 195 0088**

PETRONAS  
**SYNTIUM**

**"I PUSH THE LIMITS  
AND EXCEED EXPECTATIONS.  
SO DOES MY ENGINE OIL."**

*Lewis Hamilton*



Constantly pushing the boundaries of skill, courage and driving performance, Lewis Hamilton strives to conquer every challenge. It's a passion that PETRONAS Syntium shares and enables each time he races. Developed to excel under extreme Formula One™ conditions with the MERCEDES AMG PETRONAS Formula One™ Team, it is a partnership that delivers the very best for your car.

