

Beechcraft®

STARSHIP 1®

MODEL 2000

Pilot's Operating Manual

**(NC-29 and After, NC-4 Thru NC-28 Modified By
BEECHCRAFT Kits 122-3001, 122-3002, and 122-9002)**

This Pilot's Operating Manual is incomplete without a current FAA Approved Airplane Flight Manual, P/N 122-590013-37. If any data inconsistency exists between the Pilot's Operating Manual and the FAA Approved Airplane Flight Manual, the FAA Approved Airplane Flight Manual shall be the governing authority.

COPYRIGHT © BEECH 1996

**P/N 122-590013-39
Issued: August 14, 1992**

**P/N 122-590013-39A4
Revised: October, 1996**

Published By
Commercial Publications
BEECH AIRCRAFT CORPORATION
Wichita, Kansas 67201
U.S.A.



Beechcraft®

Model 2000

Pilot's Operating Manual

P/N 122-590013-39

Log of Revisions

A1November 29, 1993

Page	Description
Title Page	Revised
Page A (A1)	
1 of 2	New
2 of 2	New
1-1 thru 1-2	Update Table of Contents
1-14	Revised NUMBER OF ENGINES, ENGINE MANUFACTURER, ENGINE MODEL NUMBER, ENGINE TYPE, COMBUSTION CHAMBER TYPE and Shifted Data
1-15	Revised ENGINE SHAFT-HORSEPOWER RATING, NUMBER OF PROPELLERS, PROPELLER MANUFACTURER, NUMBER OF BLADES, PROPELLER DIAMETER, PROPELLER TYPE and Shifted Data
1 -16	Shifted Data
1 - 17	Revised WING LOADING, POWER LOADING and Shifted Data
3-3 thru 3-4	Update Table of Contents
3-29	Revised ICE PROTECTION
3-32 thru 3-33	Shifted Data
3-34	Revised CROSS TRANSFER and Shifted Data
3-45	Revised EXTERIOR
3-49	Revised HEATING MODE
3-50	Revised BLEED AIR DISTRIBUTION DUCT OVERTEMP PROTECTION, DISTRIBUTION AIR DUCT OVERTEMP PROTECTION and Shifted Data

A1

Log of Revisions (Continued)

A1 Revision

Page	Description
3-51 thru 3-53	Shifted Data
3-54	Revised OXYGEN SYSTEM and Shifted Data
3-55	Shifted Data
3-56	Revised STALL WARNING SYSTEM and Shifted Data
3-57 thru 3-58	Shifted Data
3-58A thru 3-58B	Added GROUND ICING DETECTOR SYSTEM (OPTIONAL)
3-59 thru 3-62	Shifted Data
3-90	Revised Table
3-124	Revised WARNING
3-206	Revised BEFORE STARTING
3-247	Added WARNING
3-265	Revised RECALLING A STORED ROUTE
3-290	Revised SYSTEM REINITIALIZATION
4-108	Revised Graph

A1

Beechcraft®

Model 2000

Pilot's Operating Manual

P/N 122-590013-39

Log of Revisions

A2March 16, 1994

Page	Description
Title Page	Revised
Page A (A2) 1 of 1	New
3-205	Revised CHECKLISTS
3-206 thru 3-208	Shifted Data

A2

**STARSHIP 1 MODEL 2000
PILOT'S OPERATING MANUAL
(NC-29 AND AFTER, NC-4 THRU NC-28 MODIFIED
BY BEECHCRAFT KIT P/N 122-3001, 122-3002, AND 122-9002)
P/N 122-590013-39A3**

LOG OF REVISIONS

A3 Revision November 18, 1994

Page	Description
Title Page	Updated
Page A (A3)	New
6-1 thru 6-32	Revised Section VI, Safety Information (May, 1994)
A3	

**STARSHIP 1 MODEL 2000
PILOT'S OPERATING MANUAL
(NC-29 AND AFTER, NC-4 THRU NC-28 MODIFIED
BY BEECHCRAFT KITS P/N 122-3001, 122-3002, AND 122-9002)
P/N 122-590013-39A**

LOG OF REVISIONS

A4 RevisionOctober, 1996

Page	Description
Title Page	Updated
Page A (A4)	New
3-1	Revised Table of Contents
3-3, 3-4	Revised Table of Contents
3-17	Revised Data (ELECTRIC ELEVATOR TRIM)
3-19	Revised Data (DESCRIPTION)
3-20	Revised Data (LANDING GEAR ALTERNATE EXTENSION)
3-20A, 3-20B	Shifted Data
3-21	Revised (NOTE)
3-28, 3-29	Revised Data (PROPELLER SYNCHROPHASER)
3-38	Revised Data (FUEL PURGE SYSTEM, FUEL QUANTITY INDICATING SYSTEM)
3-39, 3-40	Shifted Data
3-42	Added Data (CIRCUIT BREAKER BUS LOADING)
3-43 thru 3-43B	Shifted Data
3-49, 3-50	Shifted Data

A4

LOG OF REVISIONS

"A4" RevisionOctober, 1996

Page	Description
3-51	Revised Data (OXYGEN SYSTEM)
3-56	Revised Data (STALL WARNING SYSTEM)

A4

SECTION I
GENERAL
TABLE OF CONTENTS

<i>SUBJECT</i>	<i>PAGE</i>
Three View	1-3
Ground Turning Clearance	1-4
Typical Illustrations	1-5
Instrument Panel	1-5
Pilot's Subpanels	1-6
Copilot's Subpanels	1-7
Center Subpanel	1-8
Overhead Light Control Panel	1-9
Left Circuit Breaker Panel	1-10
Right Circuit Breaker Panel	1-11
Auxiliary Circuit Breaker Panel	1-12
Pedestal	1-13
Descriptive Data	1-14
Engines	1-14
Number of Engines	1-14
Engine Manufacturer	1-14
Engine Model Number	1-14
Engine Type	1-14
Number of Drive Shafts	1-14
Compressor Stages and Types	1-14
Combustion Chamber Types	1-14
Turbine Stages and Types	1-14
Compressor (Gas Generator) Turbine	1-14
Power Turbine	1-14
Engine Shaft-Horsepower Rating	1-15
Compressor (Gas Generator) Shaft Rotational Speed (N ₁) Limit	1-15
Propeller Rotational Speed (N ₂) Limit	1-15
Propellers	1-15
Number of Propellers	1-15
Propeller Manufacturer	1-15
Number of Blades	1-15
Propeller Diameter	1-15
Propeller Type	1-15
Propeller Blade Angles at 30-Inch Station	1-15
Fuel	1-16
Approved Engine Fuels	1-16
Commercial Grades	1-16
Military Grades	1-16

TABLE OF CONTENTS (Cont'd)

<i>SUBJECT</i>	<i>PAGE</i>
Emergency Engine Fuels	1-16
Commercial Aviation Gasoline Grades	1-16
Military Aviation Gasoline Grades	1-16
Standard Fuel System	1-16
Approved Fuel Additives	1-16
Engine Oil	1-16
Specification	1-16
Total Oil Capacity	1-17
Drain and Refill Quantity	1-17
Oil Quantity Operating Range	1-17
Maximum Certificated Weights (Commuter Category)	1-17
Cabin and Entry Dimensions	1-17
Specific Loadings	1-17

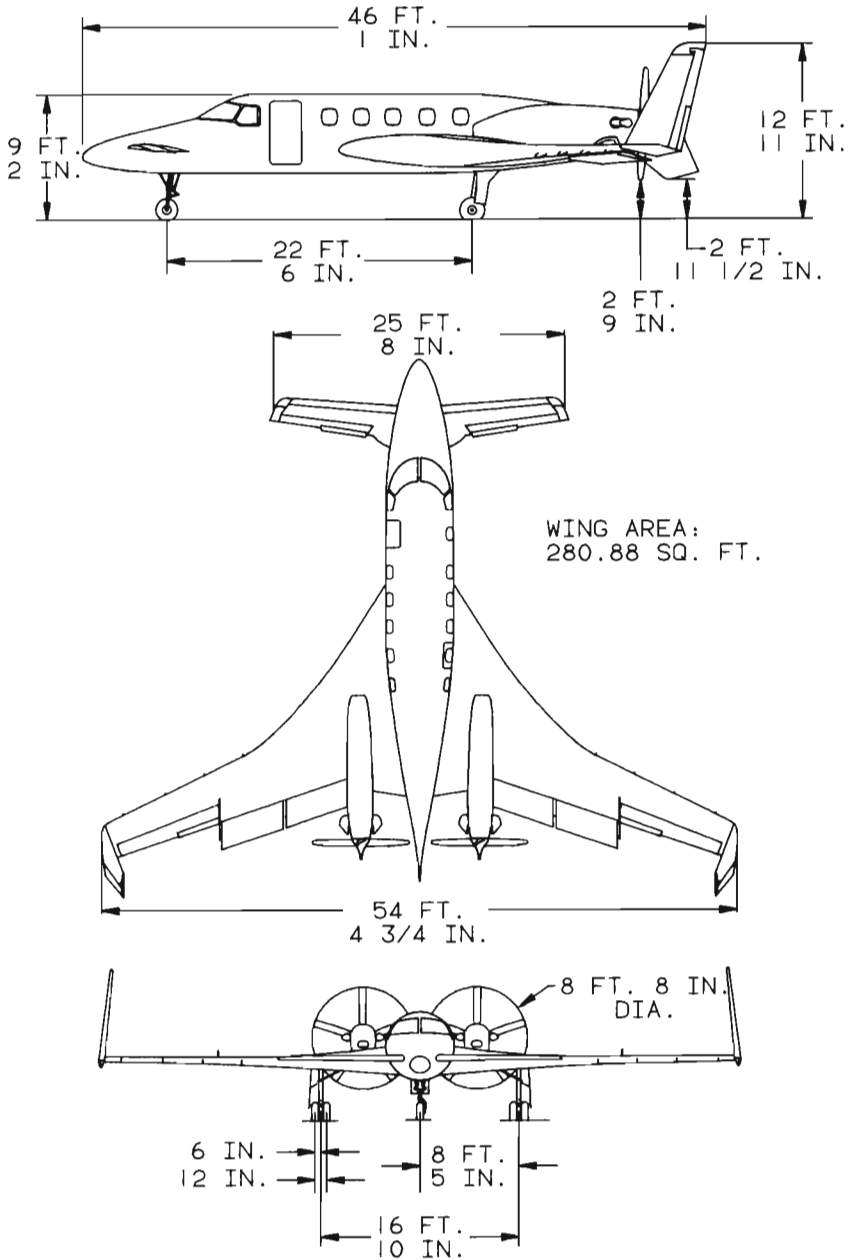

THREE-VIEW

2000-607-06

GROUND TURNING CLEARANCE

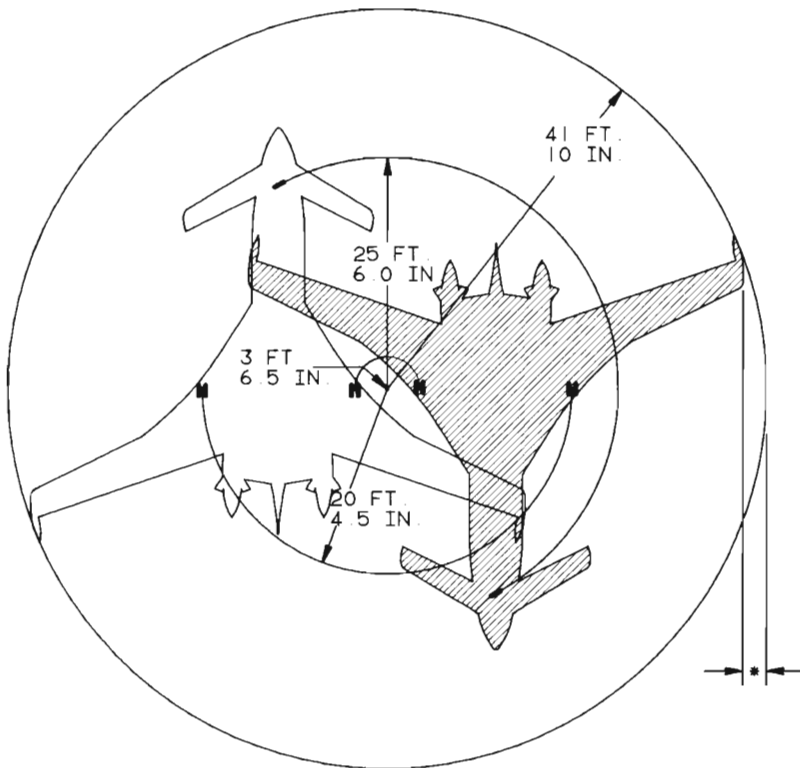

RADIUS FOR INSIDE GEAR	3 FEET 6 5 INCHES
RADIUS FOR NOSE WHEEL	25 FEET 6 0 INCHES
RADIUS FOR OUTSIDE GEAR	20 FEET 4 5 INCHES
RADIUS FOR WING TIP	41 FEET 10 INCHES
• WING TIP GROWTH (APPROXIMATELY)	2 FEET 6 INCHES

TURNING RADII ARE PREDICATED ON THE USE OF DIFFERENTIAL BRAKING ACTION AND SYMMETRICAL POWER

2000-607-07

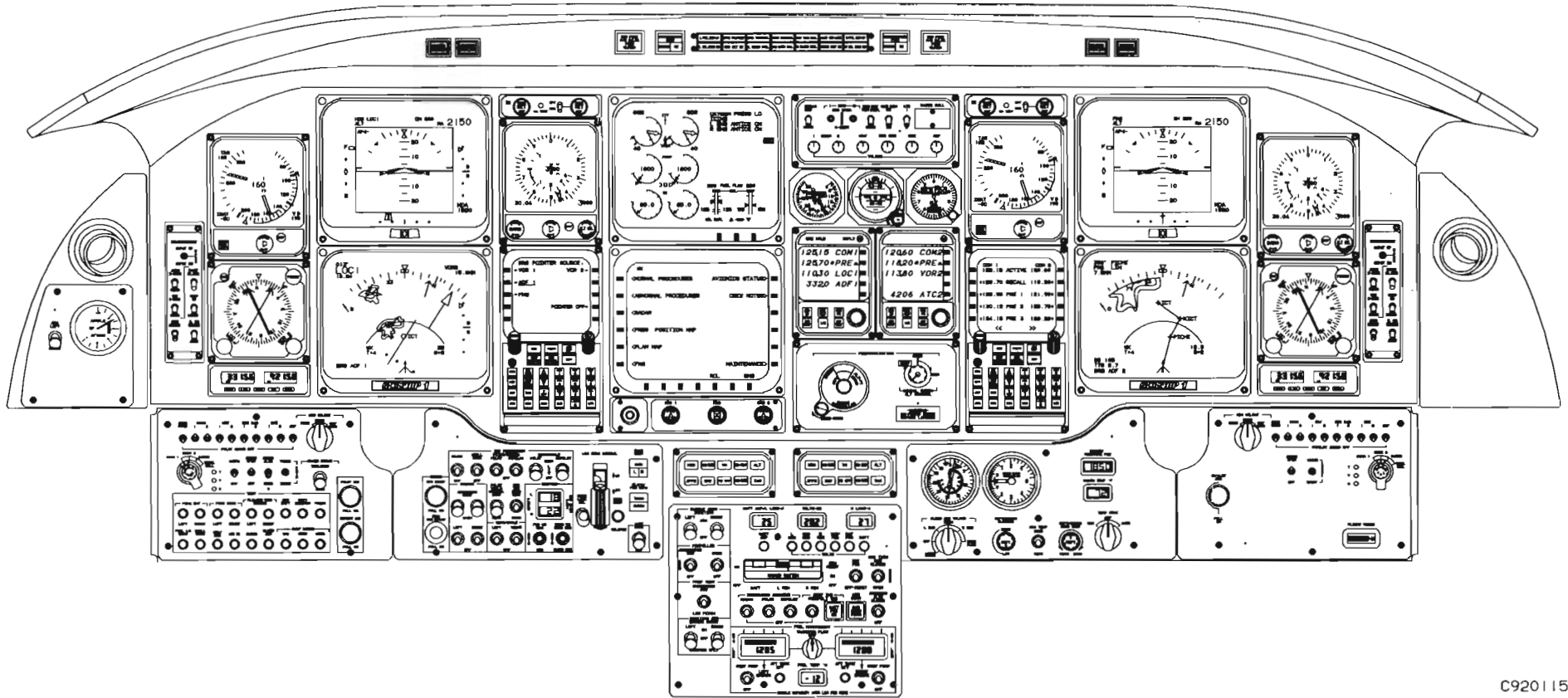

C9201155

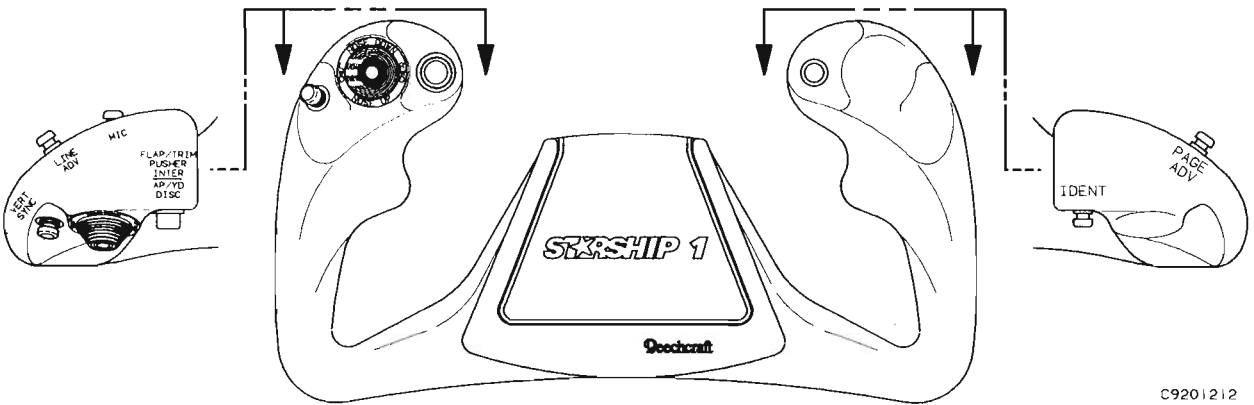
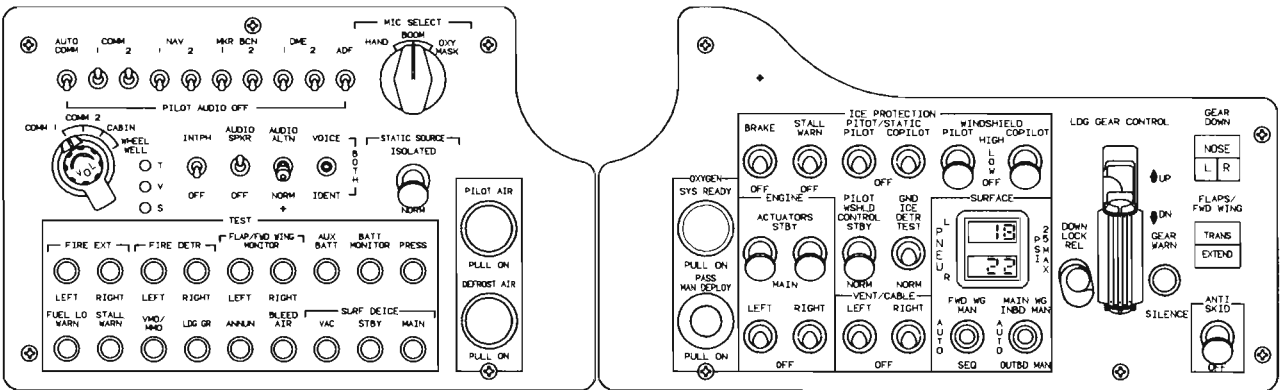

C9201212

Pilot's Subpanels

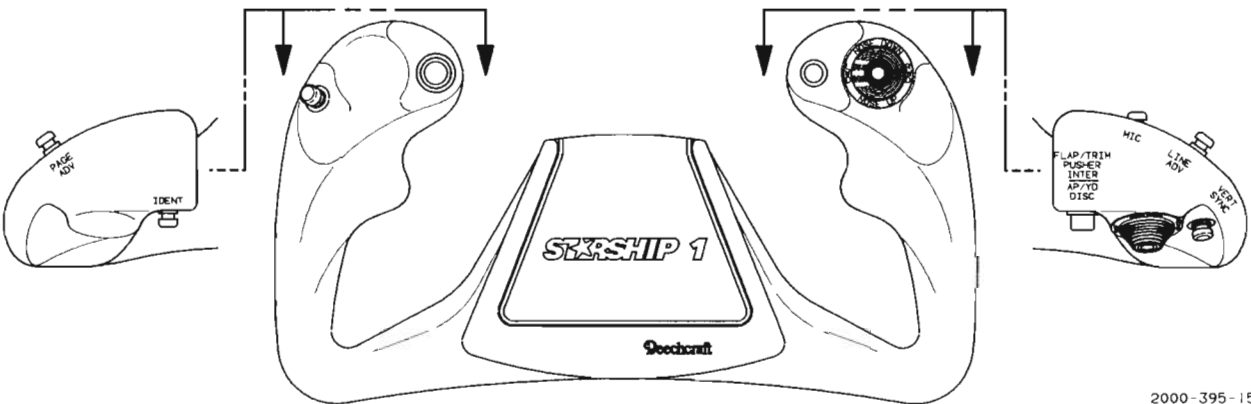
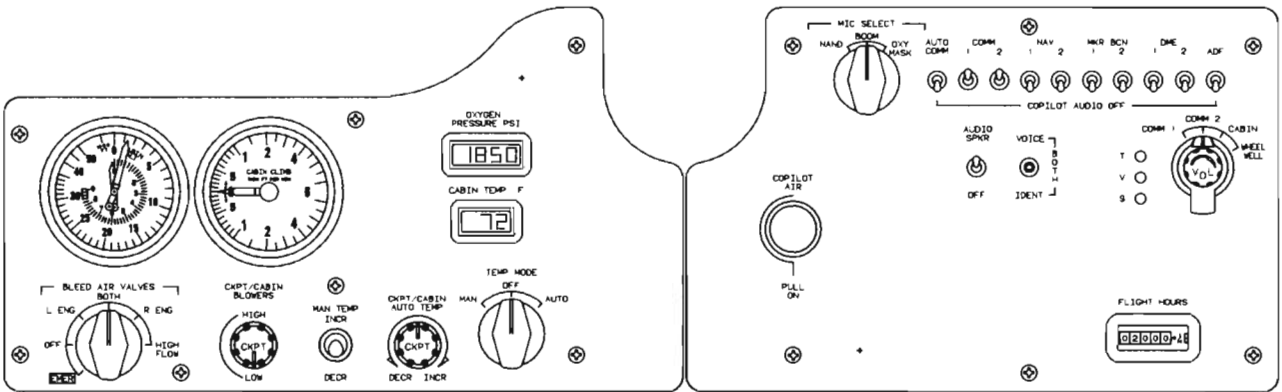

Copilot's Subpanels

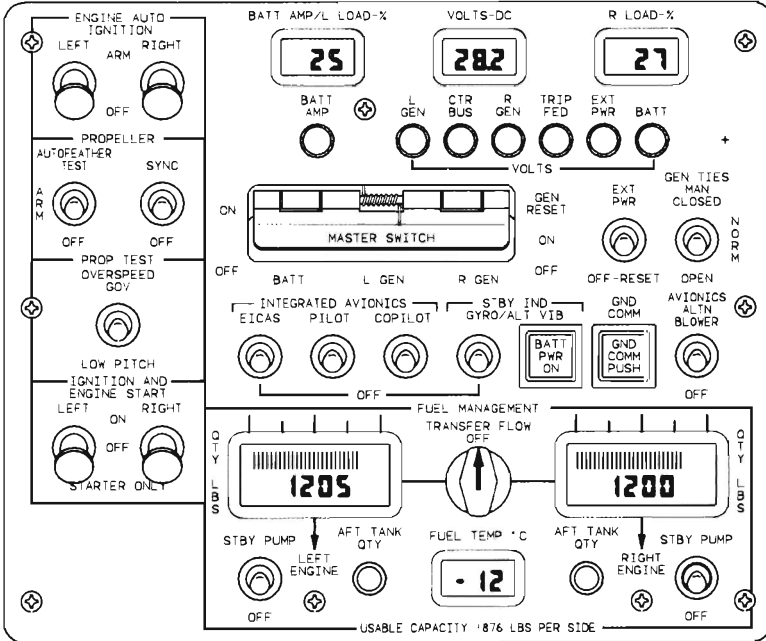

C9201210

Center Subpanel

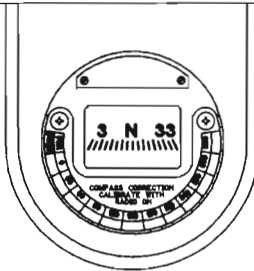
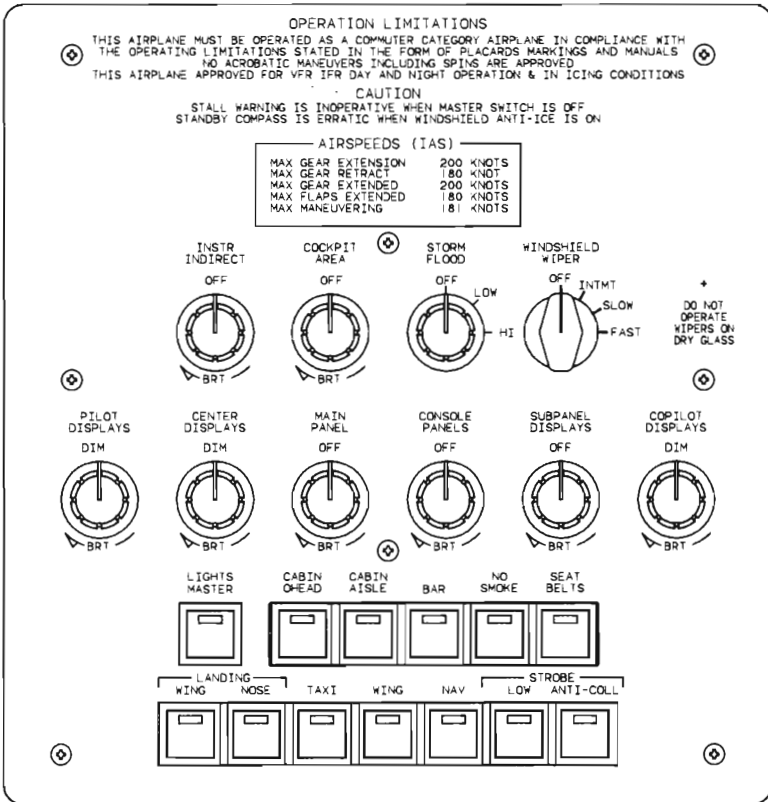

2000-368-08

Overhead Light Control Panel

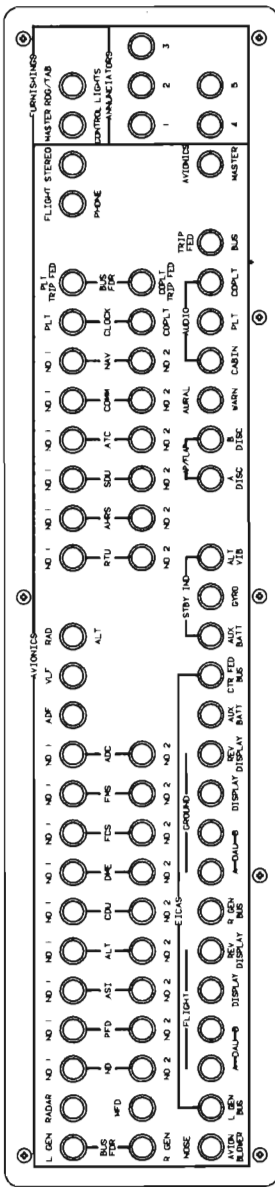

C9200519 C

Right Circuit Breaker Panel

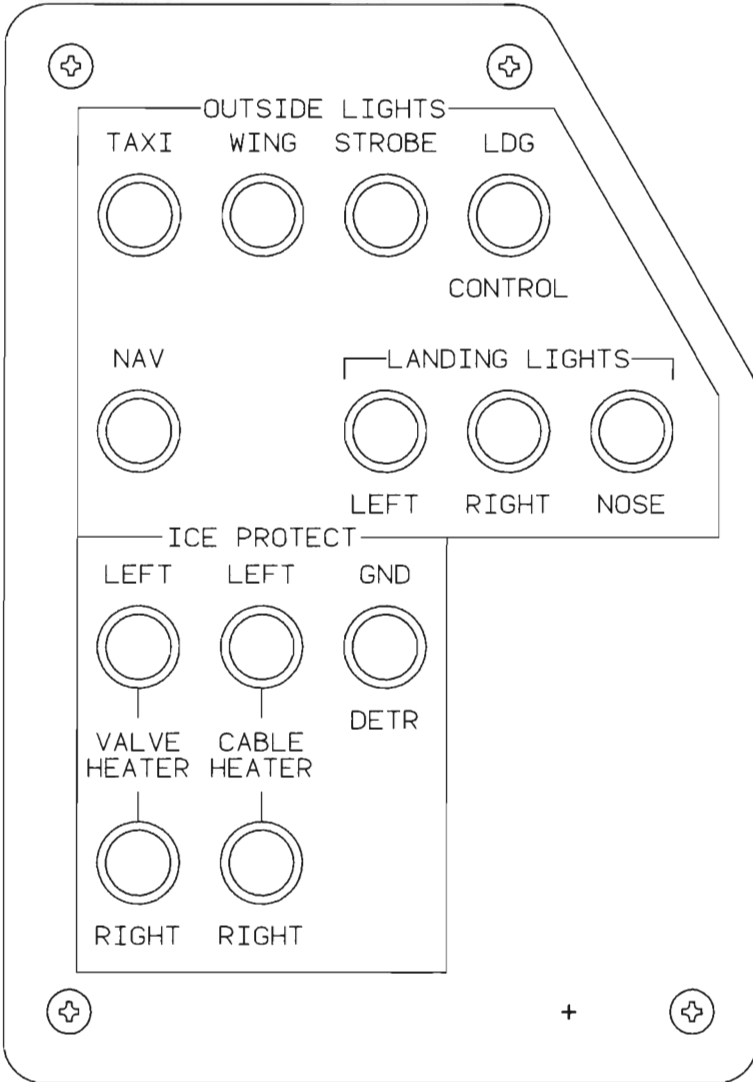

C9201211

Auxiliary Circuit Breaker Panel

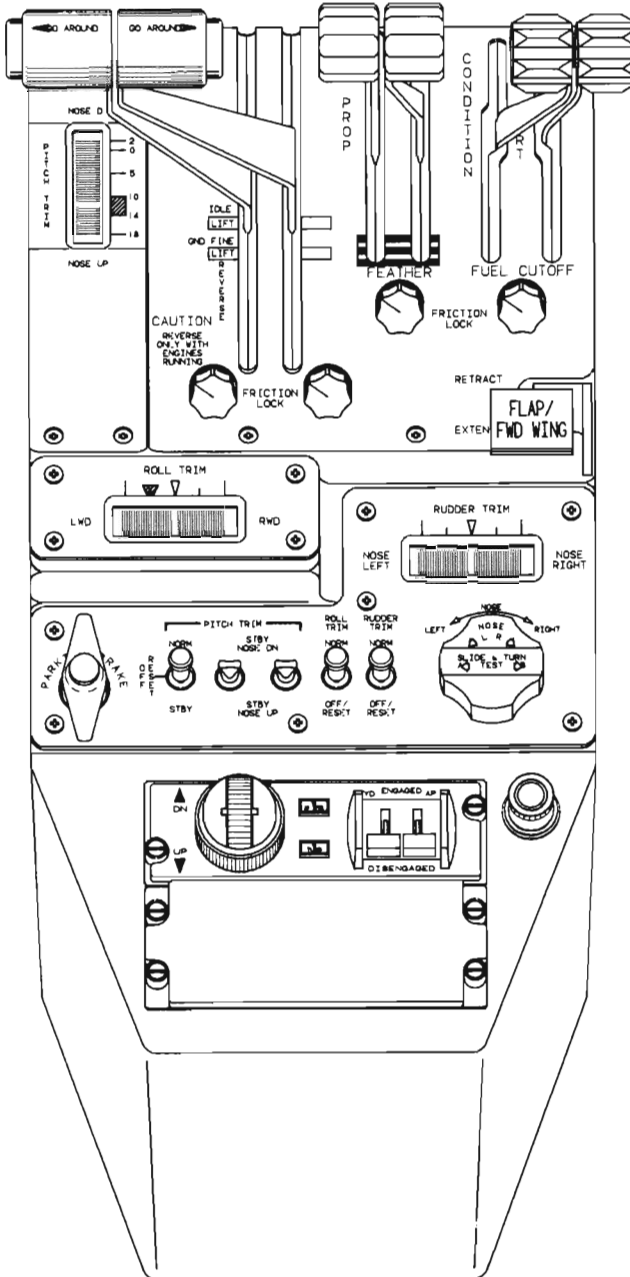

2000-396-01

Pedestal

DESCRIPTIVE DATA

ENGINES

NUMBER OF ENGINES

2

ENGINE MANUFACTURER:

Pratt & Whitney Canada Inc. Longueuil, Quebec, Canada.

ENGINE MODEL NUMBER

PT6A-67A

ENGINE TYPE

Turboprop Engine

NUMBER OF DRIVE SHAFTS

2

1 Compressor (Gas Generator) Shaft

1 Power Turbine Shaft

COMPRESSOR STAGES AND TYPES

4 Axial-flow Stages

1 Centrifugal-flow Stage

COMBUSTION CHAMBER TYPE

Annular

TURBINE STAGES AND TYPES

COMPRESSOR (GAS GENERATOR) TURBINE

Single-stage Axial-flow Reaction Turbine

POWER TURBINE

Two-stage Axial-flow Reaction Turbine

ENGINE SHAFT-HORSEPOWER RATING

1200 SHP

COMPRESSOR (GAS GENERATOR) SHAFT ROTATIONAL SPEED (N₁) LIMIT

Maximum Take-off/Maximum Continuous/Cruise Climb Power 104% N₁ (39,000 rpm)

PROPELLER ROTATIONAL SPEED (N₂) LIMIT

Maximum Take-off: 1700 rpm

Maximum Continuous: 1690 rpm

PROPELLERS:

NUMBER OF PROPELLERS

2

PROPELLER MANUFACTURER

McCauley Propeller (Vandalia, Ohio)

NUMBER OF BLADES

5

PROPELLER DIAMETER:

104.0 inches

PROPELLER TYPE

Constant-speed, Full-feathering, Reversing, Counter-weighted, Hydraulically Actuated

PROPELLER BLADE ANGLES AT 30-INCH STATION

Left Feathered: +90.9° - Reverse: -8°

Right Feathered: +91.7° - Reverse: -8°

FUEL

APPROVED ENGINE FUELS

COMMERCIAL GRADES

Jet A, Jet A-1, Jet B

MILITARY GRADES

JP-4, JP-5, JP-8

EMERGENCY ENGINE FUELS

COMMERCIAL AVIATION GASOLINE GRADES

- 80 Red
- 100 Green
- 100LL Blue

MILITARY AVIATION GASOLINE GRADES

- 80/87 Red
- 100/130 Green

STANDARD FUEL SYSTEM

Total Capacity569 gallons
Maximum Usable Fuel Quantity565 gallons

APPROVED FUEL ADDITIVES

Anti-ice Additive conforming to Specification MIL-I-27686

ENGINE OIL

SPECIFICATION

Any oil specified by brand name in the latest revision of Pratt & Whitney Service Bulletin Number 14001.

TOTAL OIL CAPACITY: 29.0 quarts

DRAIN AND REFILL QUANTITY: Approximately 13 quarts per engine

OIL QUANTITY OPERATING RANGE

MAX to 4 QUARTS LOW on dipstick, (5 quarts marked on dipstick)

MAX to 3 QUARTS LOW, green on electronic dipstick indicator

MAXIMUM CERTIFICATED WEIGHTS (COMMUTER CATEGORY)

Maximum Ramp Weight	15,010 pounds
Maximum Take-off Weight	14,900 pounds
Maximum Landing Weight	13,680 pounds
Maximum Zero Fuel Weight	12,600 pounds
Maximum Weight in Forward Baggage Compartment:	160 pounds
Maximum Weight in Aft Baggage Compartment:	525 pounds

CABIN AND ENTRY DIMENSIONS

Cabin Width (Maximum)	66.0 inches
Cabin Length (Maximum between pressure bulkheads)	26.60 feet
Cabin Height (Maximum)	63.5 inches
Cabin Entrance Door Width (Minimum)	28 inches
Cabin Entrance Door Height (Minimum)	50.39 inches
Pressure Vessel Volume	462 cubic feet

SPECIFIC LOADINGS

WING LOADING

53.05 pounds per square foot

POWER LOADING

6.21 pounds per shaft horsepower

(This Page Intentionally Left Blank)

SECTION II
OPERATING LIMITATIONS
TABLE OF CONTENTS

<i>SUBJECT</i>	<i>PAGE</i>
General	2-3

(This Page Intentionally Left Blank)

GENERAL

For operating limitations refer to the FAA Approved Airplane Flight Manual.

—

—

—

—

—

—

—

(This Page Intentionally Left Blank)

SECTION III
SYSTEMS DESCRIPTION
TABLE OF CONTENTS

<i>SUBJECT</i>	<i>PAGE</i>
Airframe	3-15
Structure	3-15
Seating Arrangements	3-15
Flight Controls	3-15
Control Surfaces	3-15
Operating Mechanisms	3-15
Control Wheel Push Buttons and Switches	3-15
VERT SYNC	3-15
LINE ADV	3-15
MIC	3-16
TRIM	3-16
FLAP/TRIM - PUSHER - INTER - AP/YD DISC	3-16
Go-around Mode	3-16
Electric Elevator Trim	3-16
Automatic Trim Operation.....	3-17
Mistrim	3-17
Flaps and Forward Wing Sweep	3-17
Ground Control	3-18
Landing Gear	3-18
Landing Gear and Nose Gear Door Lock Pins	3-18
Landing Gear Lock Pin Installation	3-18
Nose Gear Doors Lock Pin	3-19
Description	3-19
Hydraulic System.....	3-19
Landing Gear Warning System	3-20
Landing Gear Alternate Extension	3-20
Brake System	3-20A
Parking Brake.....	3-21
Tires	3-21
Baggage Compartments	3-22
Forward Baggage Compartment	3-22
Aft Baggage Compartment.....	3-22
Seats, Seatbelts, and Shoulder Harnesses	3-22

TABLE OF CONTENTS (Cont'd)

<i>SUBJECT</i>	<i>PAGE</i>
Seats	3-22
Cockpit	3-22
Cabin	3-22
Seatbelts	3-23
Shoulder Harnesses	3-23
Cockpit	3-23
Cabin	3-23
Doors, Windows, and Exits	3-24
Airstair Door	3-24
Cabin Windows	3-25
Polarized Cabin Windows	3-25
Emergency Exit	3-25
Control Lock	3-26
Engines	3-26
Propulsion System Controls	3-26
Power Levers	3-26
Propeller Levers	3-26
Condition Levers	3-28
Propeller Ground Fine Operation	3-28
Propeller Reversing	3-28
Friction Locks	3-28
Propeller Synchrophaser	3-28
Engine Lubrication System	3-29
Magnetic Chip Detector	3-29
Starting and Ignition System	3-29
Induction Air System	3-29
Ice Protection	3-29
Auto Ignition	3-30
Engine Compartment Fire Detection System	3-30
Engine Compartment Fire Extinguisher System	3-30
Propeller System	3-31
Description	3-31
Low Pitch Stops	3-31
Propeller Governors	3-31
Autofeather System	3-31

TABLE OF CONTENTS (Cont'd)

<i>SUBJECT</i>	<i>PAGE</i>
Fuel System	3-32
Fuel Tank Capacities	3-32
Forward Fuel Tank (NC-29 and After, NC-4 Thru NC-28 Modified By BEECHCRAFT KIT P/N 122-9002)	3-32
Aft Tank (Cell) (NC-29 and After, NC-4 Thru NC-28 Modified By BEECHCRAFT KIT P/N 122-9002)	3-32
Fuel Pumps	3-32
Low Fuel Quantity	3-33
Cross Transfer	3-33
Fuel Vent System	3-34
Firewall Fuel Shutoff Valves	3-36
Fuel Drains (Effectivity: NC-4 thru NC-25)	3-36
Fuel Drains (Effectivity: NC-26 and After)	3-37
Fuel Purge System	3-37
Fuel Quantity Indicating System.....	3-38
Fuel Temperature Indicator	3-38
Electrical System	3-38
Battery and Control.....	3-39
Battery Monitor System	3-39
Starter-Generator Operation and Control	3-39
External Power	3-39
Power Distribution.....	3-40
Circuit Breaker Bus Loading	3-42
Lighting Systems	3-44
Cockpit.....	3-44
Cabin	3-44
Self-Luminous Signs	3-44
Exterior.....	3-44
Environmental System	3-45
Pressurization System	3-45
Cabin Pressure Control System	3-45
Unpressurized Ventilation	3-46
Heating.....	3-46
Air Conditioning System	3-48
Environmental Controls.....	3-48
Manual Mode Control	3-48
Heating Mode	3-49
Bleed Air Control	3-49
Blower Control	3-49
Bleed Air Distribution Duct Overtemp Protection	3-49
Distribution Air Duct Overtemp Protection	3-49
Blower Failure Protection	3-50

TABLE OF CONTENTS (Cont'd)

<i>SUBJECT</i>	<i>PAGE</i>
Diagnostics	3-50
Forward Cabin	3-50
Aft Cabin	3-50
Left Wing	3-51
Right Wing	3-51
Aft Fuselage	3-51
Oxygen System	3-51
Pitot and Static Air System	3-54
Stall Warning System	3-56
Angle of Attack Transducer	3-56
Bleed Air Pneumatic System	3-57
Bleed Air Warning System	3-57
Air Distribution System	3-57
Air Return	3-57
Air Delivery System	3-57
Avionics Cooling	3-58
Ice Protection Systems	3-58A
Ground Icing Detector System (Optional)	3-58A
Stall Warning	3-59
Pitot/Static	3-59
Forward/Side Windshield/Cockpit Windows Anti-Ice/De-Ice System	3-59
Fuel Vent Heat	3-60
Engine Power Cable Heat	3-60
Engine Anti-Ice System	3-60
Ice Light	3-61
Surface Deice System	3-61
Normal (Automatic) Operation	3-61
Manual Switch Position	3-62
Vacuum Test Switch	3-62
Comfort Features	3-64
Toilet	3-64
Relief Tubes	3-64
Cabin Features	3-64
Fire Extinguishers	3-64
Windshield Wipers	3-64

TABLE OF CONTENTS (Cont'd)

<i>SUBJECT</i>	<i>PAGE</i>
Flight Instruments	3-65
Brightness and Balance	3-65
Over Temperature Warning	3-66
Altitude/Vertical Speed Indicator (ALI).....	3-66
Barometer Setting	3-66
Altitude Preselect	3-67
Altitude Alert	3-67
Flight Level 180 Alert	3-68
Reference Bug	3-68
Initialization	3-68
In-Line Monitoring	3-68
Failure Modes	3-68
Altitude Awareness Panel (AAP)	3-68
Airspeed Indicator (ASI)	3-69
Reference Bug	3-69
Display Markings	3-70
Initialization	3-70
Air Data Computer (ADC)	3-70
Standby Flight Instruments	3-70
Airspeed Indicator	3-71
Altimeter	3-71
Attitude Indicator	3-71
Clocks	3-72
Left Display	3-72
Right Display	3-72
Using and Setting the Clock	3-73
Stopwatch Timer	3-73
Downcounter Timer	3-74
Greenwich Mean Time	3-74
Local Time	3-75
Date	3-75
Total Flight Hours	3-74
Engine Instrument, Crew Alerting System (EICAS)	3-77
Engine Data Displays	3-77
ITT-TORQ	3-77
Engine Running	3-77
Engine Start	3-78
ITT Overtemp Display	3-78
Overtorque Display	3-80
Prop	3-80

TABLE OF CONTENTS (Cont'd)

<i>SUBJECT</i>	<i>PAGE</i>
N ₁	3-81
Red Line Exceedance	3-81
Synchrophaser Display	3-81
Autofeather Display	3-81
Fuel Flow	3-82
Oil	3-82
Pressure	3-82
Temperature	3-83
DSPL	3-83
Crew Alerting Displays	3-83
Failure Modes	3-84
Reversionary Modes	3-84
Test	3-84
Annunciator System	3-85
Audio System	3-93
System controls	3-93
Sensor Display Unit (SDU)	3-95
RMI	3-95
VLF	3-97
VOR	3-98
DME	3-100
Marker Beacon	3-101
Loss Of Data	3-101
Radio Tuning Unit (RTU)	3-103
Control Functions	3-103
Setting Frequencies And Codes	3-103
Mode Pages	3-105
COM	3-105
NAV	3-105
ADF	3-105
ATC (Transponder)	3-105
Reversion	3-106
Control Display Unit (CDU)	3-107
LTR (LETTER)	3-107
CLR (CLEAR)	3-107
Alphanumeric Keys	3-107
CDU Functions	3-108
Display Format	3-110
Line-Select Keys	3-110
Predesignation And Postdesignation Modes	3-110

TABLE OF CONTENTS (Cont'd)

<i>SUBJECT</i>	<i>PAGE</i>
Color Coding	3-111
Symbology	3-111
Mode	3-112
Radar And ND Controls	3-113
RANGE Knob	3-113
TILT Knob	3-113
HSI	3-113
RDR	3-113
ARC/MAP	3-113
NAV SOURCE	3-114
CRS XFER and RECALL CRS	3-114
RDR CONTROL	3-115
BRG	3-117
Radio Control	3-118
COM	3-118
NAV (VHF Navigation)	3-119
ADF (Automatic Direction Finder)	3-121
ATC (ATC Transponders)	3-122
Flight Management System	3-123
FLT PLAN (Flight Plan)	3-123
SYS CTRL (SYSTEM CONTROL)	3-135
Position Hold	3-137
Update VLF	3-138
Sensors	3-138
IDX (Index)	3-139
DIR (DIRECT)	3-142
SCROLL KEYS	3-142
V NAV (Vertical Navigation)	3-142
MSG (Message)	3-144
Action Messages	3-144
Status Messages	3-145
Erroneous Data Entries	3-146
Error Messages	3-147
Cross Side CDU Restrictions	3-148
Abort/Restart Of Navigation Data Entry.....	3-149
Primary Flight Display	3-151
Pitch Indication	3-152
Roll Indication	3-154
Attitude Failure Annunciation	3-155
Comparator Function	3-156

TABLE OF CONTENTS (Cont'd)

<i>SUBJECT</i>	<i>PAGE</i>
Reversionary Mode	3-156
Attitude Heading Reference System (AHRS)	3-157
Computer	3-157
Initialization	3-157
Failure Modes	3-158
Reversion	3-158
Internal Compensation Unit (ICU)	3-158
Failure Modes	3-158
Flux Detector Unit (FDU)	3-158
Failure Modes	3-158
AHRS Aligning Annunciation	3-158
Course Deviation	3-160
Excess Deviation	3-161
Comparator Function	3-161
Glideslope Deviation Indicator	3-161
Back Course Mode	3-163
Flight Director (FD)	3-164
Radio Altitude (2500 Feet to 1000 Feet AGL)	3-165
Radio Altitude (1000 Feet AGL To Ground Level)	3-166
Decision Height Display	3-167
DH Alert	3-168
Reporting Altitude MDA Readout	3-168
MDA Alert	3-168
Reporting Altitude	3-168
Marker Beacon	3-169
Speed Deviation	3-170
Autopilot Mode Annunciation	3-170
Autopilot Engaged/Disengaged	3-171
Armed And Capture Modes	3-172
Yaw Damper Disengage	3-174
Mistrim	3-174
Status Annunciations	3-175
Course/Glideslope Status	3-175
Flight Director (FD)	3-175
Radio Altitude (RA)	3-175
Speed Deviation	3-175
CDU Failure Annunciation	3-175
Navigation Display (ND)	3-177
Navigation Display Symbols	3-177
Readout Definitions	3-178

TABLE OF CONTENTS (Cont'd)

<i>SUBJECT</i>	<i>PAGE</i>
Navigation Signal Inputs	3-180
Control Inputs	3-180
Status Inputs	3-180
Navigation Display Formats	3-181
Horizontal Situation Indicator	3-181
ARC Display	3-182
MAP Display	3-183
With Station Symbols	3-184
Slant Range Correction	3-184
FMS Flight Plan	3-185
Waypoint Alert	3-185
Condition 1.	3-185
Condition 2.	3-185
Navigation Mode Annunciation	3-185
No Flight Plan Annunciation	3-187
Active Course	3-188
Course Pointer	3-188
Course Deviation Indicator (CDI)	3-188
TO/FROM	3-189
Heading Bug	3-189
Bearing Pointer	3-190
ILS Symbols	3-191
Color Codes	3-191
Back Course Mode	3-192
Wind Indicator	3-193
Weather Radar (RDR)	3-194
RANGE Knob	3-194
TILT Knob	3-194
Antenna Stabilization	3-194
Hold	3-194
Ground Clutter Suppression	3-194
ARC	3-194
Preset Course	3-196
Selection	3-196
MAP Display And Readout	3-197
Deviation Bar	3-197
Status Annunciations	3-198
Attitude Heading Reference System (AHRS) Failure	3-198
Cross-Side Reversion	3-199
Navigation Signal Source	3-200
NAV Source Status Annunciation	3-200
Distance Status Annunciation	3-200
DME Hold Annunciation	3-200
Bearing Pointer Status	3-200
Active Course Time-To-Go Status Annunciation	3-200

TABLE OF CONTENTS (Cont'd)

<i>SUBJECT</i>	<i>PAGE</i>
Active Station Identifier	3-200
Dead Reckoning Annunciation	3-200
Course Deviation Outputs	3-201
Radar Command Faults	3-201
Comparator Function	3-201
Excess Deviation	3-201
Multifunction Display (MFD)	3-203
MFD Initial Display	3-203
MFD Index	3-203
Line-Select And Function Keys	3-203
Checklists	3-203
Normal And Abnormal	3-203
Emergency	3-203
Function Keys	3-204
Crew Notes Display	3-207
Creating Crew Notes Checklist (USRCKLST.ASC).....	3-207
Before Starting	3-207
Formatting Diskettes (FORMAT)	3-207
Duplicating Diskettes (DISKCOPY).....	3-207
Rules For Editing	3-207
Type of Commands Allowed	3-208
Date (DA)	3-208
Title (TI).....	3-208
Line Item (IT)	3-208
Multiple Line Item (ML and MC).....	3-208
Advisory Note (AN)	3-208
Cautionary Note (CN).....	3-208
Page Advance (PA)	3-208
Creating and Converting The Crew Notes Checklist	3-209
Function Keys	3-210
Present Position Map	3-211
Map Options	3-211
Map Display	3-211
Present Position Map Joystick Operation	3-213
Function Keys.....	3-213
Range Control	3-214
Planning Map	3-215
Planning Map Menu	3-215
Function Keys And Joystick Operation	3-215
FMS	3-217

TABLE OF CONTENTS (Cont'd)

<i>SUBJECT</i>	<i>PAGE</i>
Function Keys	3-217
Performance	3-218
Function Keys	3-218
Progress	3-220
Function Keys	3-220
Route List	3-222
Function Keys	3-222
VOR/DME Status	3-223
Function Keys	3-223
VLF/OMEGA Status	3-224
Function Keys	3-224
Position Summary	3-225
Function Keys	3-225
Avionics Status Display	3-226
Function Keys	3-226
Maintenance Display	3-228
Function Keys	3-228
Weather Radar (RDR)	3-233
Display	3-233
Navigation Display	3-233
Multifunction Display	3-233
Mode/Status Display	3-234
Weather Color Code	3-235
Ground Map Color Code	3-235
Controls	3-237
Flight Management System (FMS)	3-241
System Description	3-241
Operational Summary	3-241
Nav Tuning - Aut	3-242
AutoLeg	3-242
Initialization	3-242
Normal Power Up	3-243
VLF/OMEGA	3-244
In-Line Monitoring	3-244
Accuracy	3-244
TAS And Heading Loss	3-244
Geographic Area Of Navigation	3-244
Primary Navigation Mode	3-244
Dead Reckoning Mode	3-245
Reacquisition	3-245

TABLE OF CONTENTS (Cont'd)

<i>SUBJECT</i>	<i>PAGE</i>
Synchronization	3-245
Recovery From Power Drop-Out	3-245
Clock Check	3-245
Data Base Unit (DBU)	3-245
Data Base Check	3-245
Replacing The Diskette	3-245
Updating The Data Base	3-247
Using An Expired Data Base	3-249
To Use The Expired Data Base:	3-249
Verify Present Position	3-250
Updating Present Position	3-251
LAT/LON	3-252
WPT	3-253
VOR/DME FIX	3-254
Flight Planning Functions	3-255
Creating A New Flight Plan.....	3-255
Selecting The CDU Flight Plan Menu	3-255
Erase The Existing Flight Plan	3-257
Entering Waypoints	3-258
Recalling A Stored Route	3-265
Ending The Flight Plan	3-268
RNAV Approach Waypoints	3-269
Leg Advance For RNAV Approaches	3-270
Modifying Flight Plan	3-271
Inserting A New Waypoint Into A Flight Plan	3-272
Replacing A Waypoint:.....	3-273
Deleting A Waypoint	3-273
Adding a Radial/Distance Offset to a Waypoint:.....	3-274
Inserting A Reporting Point In A Flight Plan:	3-275
Point Abeam Station	3-276
Point Of Intersection With Radial	3-277
Displaying Flight Plans	3-278
Reviewing The Flight Plan On The CDU.....	3-278
Viewing The Flight Plan On The MFD	3-279
System Control (SYS CTRL) Functions	3-281
Flying A Point-To-Point Flight Plan.....	3-281
AUTOLG/MAN LG/SELTRK	3-281
AUTOLG	3-281
MAN LG	3-281
SEL TRK	3-283
Method 1.	3-283
Method 2.	3-284
Rejoining The Original Flight Plan	3-285
Position Hold	3-286
VLF Updates.....	3-287

TABLE OF CONTENTS (Cont'd)

<i>SUBJECT</i>	<i>PAGE</i>
Sensor Control	3-288
FMS Index (IDX) Functions	3-289
Route Library	3-289
System Reinitialization	3-290
Storing A Route In The Route Library	3-291
Revising A Route	3-292
Renaming A Route	3-293
Fuel Management	3-294
Operation	3-294
Read/Write Functions	3-295
Read	3-295
Write	3-297
Inspecting Waypoints	3-298
Trip Planning	3-299
Entry Of From Waypoint Or Route Number	3-300
Entry Of Estimated Ground Speed	3-300
Direct TO (DIR) Functions	3-300
Course Heading Panel (CHP)	3-302
Course Knobs CRS 1 and CRS 2	3-302
Active Course	3-302
Preset Course	3-303
Selected Track	3-303
Heading Knob (HDG)	3-303
Joystick	3-303
Automatic Flight Control System (AFCS)	3-305
Autopilot Panel	3-305
A/P Lever	3-306
Yaw Damper Lever (YD)	3-307
Malfunction Modes	3-307
Lighting	3-307
A/P XFER Push Button	3-307
Turb Push Button	3-307
Pitch Knob	3-307
Pitch Mode	3-308
Turn Knob	3-308
Roll Mode	3-308
Mode Select Panel (MSP)	3-308
HDG	3-309
1/2 BANK	3-309
NAV	3-309

TABLE OF CONTENTS (Cont'd)

<i>SUBJECT</i>	<i>PAGE</i>
APPR	3-310
VS	3-310
IAS PROF	3-310
ALT	3-311
Altitude Preselect	3-311
Flight Director OFF.....	3-311
Descend	3-311
IAS	3-312
Malfunction Modes	3-312

AIRFRAME

STRUCTURE

The BEECHCRAFT 2000 is a composite structure of monocoque sandwich design incorporating graphite, epoxy, and NOMEX. Floorboards and keel beams are sandwich, using graphite, fiberglass, and KEVLAR.

SEATING ARRANGEMENTS

Nine passengers plus crew with approved passenger seating configuration.

FLIGHT CONTROLS

CONTROL SURFACES

The airplane has a nose mounted, variable sweep forward wing incorporating the elevators. The aft wing includes the elevons and flaps. The vertical tip sails mounted at each outboard end of the aft wing incorporate the rudders.

OPERATING MECHANISMS

The elevons and elevators operate by use of conventional dual control wheels interconnected by a T-bar. Pitch control is affected by the simultaneous operation of the elevators and the elevons.

Differential movement of the elevons provides roll control. Mechanical linkage installed in the aft wing mixes the pitch and roll inputs to the elevons. The rudder pedals interconnect and function in a conventional manner. These systems connect to the control surfaces through pushrod and cable-bellcrank systems.

CONTROL WHEEL PUSH BUTTONS AND SWITCHES

Push buttons for VERT SYNC, LINE ADV, MIC, trim, and FLAP/TRIM -PUSHER - INTER - AP/YD DISC are located on the outboard horn of each control wheel.

VERT SYNC

Actuation of the VERT SYNC push button will synchronize the flight director vertical and lateral references to those currently being flown. A yellow SYNC message will be displayed on the PFD while the button is depressed.

LINE ADV

Actuation of the LINE ADV push button when a checklist is displayed on the MFD will scroll down one line.

MIC

Actuation of the MIC button will key the COM transceiver.

TRIM

Starship is equipped with all electric trim. Pitch and roll trim are controlled by a dual-element switch with a conical cover located on the left side of the pilot's control wheel and the right side of the copilot's control wheel. Both elements of the switch must be actuated to effect the requested changes. To do this, push in on the switch to arm the system and then apply directional pressure to trim in the appropriate direction. Pushing forward trims NOSE DOWN, pushing aft trims NOSE UP, pushing left trims ROLL LEFT, pushing right trims ROLL RIGHT. Actuation of the switch with the autopilot ON disengages the autopilot but not the yaw damper. At the same time the autopilot disengage aural warning will sound. To silence the disengage warning, push in on the trim switch as if to arm the system.

Trim for any axis can be interrupted by pushing and holding the red FLAP/TRIM-PUSHER-INTER-AP/YD DISC button located next to each trim switch.

FLAP/TRIM - PUSHER - INTER - AP/YD DISC

The red push button FLAP/TRIM - PUSHER - INTER - AP/YD DISC switch functions as follows: Depressing the switch will result in the autopilot and yaw damper being disconnected. At the same time the flap, trim systems and column pusher power will be interrupted. A second actuation of the push button will cancel the aural disconnect tone and the disconnect messages.

GO-AROUND MODE

The GO AROUND push buttons are located on the outboard side of each power lever. Actuation of either of these buttons will clear all AFCS modes and at the same time disconnect the autopilot if it is engaged but will NOT disengage the yaw damper. Upon actuation of GO-AROUND, the AFCS commands a fixed pitch-up command, and simultaneously commands wings level. The GO-AROUND mode can be cancelled by engaging the autopilot, depressing the VERT SYNC push button, or by selecting another AFCS mode on the MODE SELECT PANEL.

Independent annunciation of lateral and vertical go-around modes (GA/GA) are displayed on the appropriate PFD(s). A flashing yellow A/P disengage annunciation as well as the associated aural warning resulting from selection of GO-AROUND mode may be extinguished by a second depress of the GO-AROUND push button, or by depressing the TRIM switch to the ARM position.

ELECTRIC ELEVATOR TRIM

The system is controlled by a dual-element thumb switch and a FLAP/TRIM - PUSHER - INTER - AP/YD DISC switch on each control wheel. Both elements of either dual-element thumb switch must be simultaneously actuated to achieve nose-down or nose-up trim. To accomplish this, push in on the switch and then

move the switch forward to effect nose-down trim, or aft to effect nose-up trim. No one switch element should activate the system. Any attempt to trim without first arming the system, i.e. pushing in on the switch first, could result in an induced failure of the pitch trim system as indicated by the illumination of the PITCH TRIM FAIL annunciator, and MASTER WARNING flasher on the glareshield (see ANNUNCIATOR section). Any actuation of the trim system by the copilot's thumb switch can be overridden by the pilot's thumb switch. When released, the trim switches will return to the center OFF position.

The speed of the pitch trim actuators is programmed automatically to run slower as airplane speed increases.

The PITCH TRIM circuit breaker is located in the FLAP group of the left circuit breaker panel and controls electrical power to the pitch trim system.

The pitch trim system is controlled by the PITCH TRIM - NORM - OFF - RESET - STBY switch on the lower center pedestal. The NORM position allows normal operation of the pitch trim system. The OFF position removes power from the system and no pitch trim should be available. If pitch trim is inadvertently interrupted (PITCH TRIM FAIL annunciator is illuminated), such as during an attempt to trim without first arming the system, trim can be reestablished by moving the switch to RESET and back to NORM. The STBY position allows pitch trim through the STBY NOSE DN - STBY NOSE UP switches located next to the PITCH TRIM - NORM - OFF - RESET - STBY switch in the same group.

To effect pitch trim with the STBY NOSE DN - STBY NOSE UP switches, move both switches simultaneously forward for NOSE DN trim or both switches simultaneously aft for NOSE UP trim. Neither switch by itself should activate the standby pitch trim. The pitch trim actuators run at their lowest speed during standby operation.

AUTOMATIC TRIM OPERATION

With the AFCS engaged, pitch, roll, and yaw trim is automatic. With the Yaw Damper only engaged, yaw trim is automatic. Failure of trim in any axis prior to engagement prevents A/P engagement. Failure after engagement prevents automatic trim but does not disengage the autopilot.

MISTRIM

If any autopilot servo continuously maintains more than a predetermined torque, the mistrim message for that servo (ELEV, RUD, or AIL) flashes yellow on the PFD for 10 seconds before becoming steady.

FLAPS AND FORWARD WING SWEEP

The flaps are operated by a two position FLAP/FWD WING - RETRACT -EXTEND switch located below the condition levers. Visual indication of flap position is provided by individual indicator lights TRANS (yellow) - EXTEND (white) on the pilot's right subpanel. The FLAP/FWD WING control handle must be pulled out of the detent to select the EXTEND position. The flaps cannot be stopped in an intermediate position. A safety mechanism is provided to disconnect power to the

electric flap motor in the event of a malfunction which would cause any flap to be three to six degrees out of phase with the other flaps.

The flap-motor power circuit is protected by four 5-ampere circuit breakers. Located on the left circuit breaker panel in the FLAP group. The circuit breakers are placarded IND, CONTROL, MONITOR - LEFT -RIGHT.

The test switches located in the TEST group on the pilot's left subpanel are placarded FLAP/FWD WING - MONITOR - LEFT - RIGHT. To test the system, depress the appropriate LEFT or RIGHT MONITOR push-button. This will cause the applicable L or R FLAP MON FAIL message to display on the EICAS. The test button must be held until the L or R FLAP MON FAIL message illuminates but for less than 5 seconds. If the button is held in for five seconds or more the L or R FLAP MON FAIL message will remain illuminated and the test must be performed again to clear the message. If either message fails to extinguish after the test is performed, DO NOT attempt to use the flap system, and have maintenance personnel check the monitor system before further operations.

GROUND CONTROL

Direct linkage from the rudder pedals allows for nose wheel steering.

LANDING GEAR

WARNING

Anytime the airplane is on the ground (whether on jacks or on wheels), the nose and main landing gear **MUST** be pinned in the down and locked position. The only exceptions to this would be landing gear operational checks, during the removal or installation of the landing gear components, and during taxiing operations prior to takeoff or after landing. When any work is being performed in the nose gear wheel well, the nose gear doors **MUST** be pinned in the open position.

LANDING GEAR AND NOSE GEAR DOOR LOCK PINS

The landing gear and nose gear door lock pins are identified as follows:

- The landing gear pins are the 1/4 inch diameter pins.
- The nose landing gear door pin is 7/16 inch in diameter.

LANDING GEAR LOCK PIN INSTALLATION

Install a LA4CR1500/NAS1756-24 lock pin into the lock link assembly of each landing gear. Refer to the BEECHCRAFT Starship 1 Maintenance Manual, Chapter 32-10-00 for specific instructions.

NOSE GEAR DOORS LOCK PIN

When any work is being performed in the nose wheel well the nose gear doors must be pinned in the open position. Install a LA7CR2500/NAS1756-24 lock pin (7/16 inch in diameter) according to the procedures found in the Starship 1 Maintenance Manual, Chapter 32-20-00.

DESCRIPTION

The landing gear is retracted and extended hydraulically. The retraction and extension cycles are controlled by a switch placarded LDG GEAR CONTROL - UP - DN located on the pilot's right subpanel. The landing gear control handle must be pulled out of a detent prior to moving it to the UP or DN position. The landing gear circuit breakers are located in the left circuit breaker panel under FLIGHT and WARNING.

Safety switches on the main gear open the landing gear control circuit when the strut is compressed. This prevents the landing gear control from being raised when the airplane is on the ground. The safety mechanism automatically disengages when the airplane leaves the ground, and can be overridden by pressing down on the red DOWN LOCK REL button located to the left of the landing gear control handle. Never move the landing gear control handle out of the DN detent while the airplane is on the ground. If it is, the landing gear warning horn will sound intermittently and red indicator lights located in the landing gear control handle will illuminate (provided the BATT switch is ON), warning the pilot to return the landing gear control handle to the DN position. These lights will also illuminate when the landing gear warning horn is actuated. The red landing gear control handle lights and warning horn may be checked by pressing the LDG GR or ANNUN test button located on the TEST panel.

In flight, as the landing gear moves to the full down position, the down-lock switches are actuated and interrupt current to the pump motor. When the red in-transit lights in the landing gear control handle extinguish, the landing gear are in the fully retracted or extended position. The retracted position is maintained by mechanical uplocks. The extended position is maintained by an overcenter mechanical action.

Visual indication of landing gear position is provided by individual green gear down - NOSE - L - R annunciators on the pilots right subpanel. The annunciators may be checked by pressing either the LDG GR or ANNUN test buttons located on the TEST PANEL.

HYDRAULIC SYSTEM

An electric motor-driven pump is utilized to power the system. Approximately five seconds is required to operate the landing gear to the up or down position. HYD FLUID LO will be displayed on the EICAS whenever the hydraulic fluid in the power pack is low.

LANDING GEAR WARNING SYSTEM

The landing gear warning system is provided to warn the pilot that the landing gear is not down and locked during specific flight regimes.

With the flaps and forward wing in the retracted position and airspeed below approximately 145 knots, and either or both power levers retarded below 90% N₁, the warning horn will sound intermittently and the landing gear handle lights will illuminate. Silencing of the warning horn can be accomplished by depressing the GEAR WARN - silence button adjacent to the landing gear control handle; the landing gear control handle lights cannot be extinguished. The landing gear warning system will be rearmed by sufficiently advancing the power lever(s).

With the flaps and forward wing extended and airspeed below approximately 145 knots, and either or both power levers retarded below 90% N₁, the warning horn and landing gear control handle lights will be activated and neither can be cancelled.

LANDING GEAR ALTERNATE EXTENSION

An alternate extension handle, placarded LANDING GEAR ALTERNATE EXTENSION, is located on the floor on the pilot's side of the pedestal. To engage the system, pull the LANDING GEAR CONTROL circuit breaker located on the left circuit breaker panel, and ensure that the landing gear control is in the DN position. Remove the pin from the alternate extension handle securing clip, then lift the handle from the clip. The following white EICAS messages will be displayed when the gear is up and the alternate extension handle is removed from the clip.

NS GEAR UP

L GEAR UP

R GEAR UP

The handle may be lengthened by pulling forward on it and then swiveled as required for pumping. While pumping, do not lower the handle below the level of the securing clip during the down stroke as this will allow accumulated hydraulic pressure to bleed off. When the gear unlock, the EICAS display will change to the following white messages.

NS GEAR IN TRANS

L GEAR IN TRANS

R GEAR IN TRANS

Continue the pumping action until the three green gear-down annunciators are illuminated and the GEAR IN TRANS EICAS messages are extinguished, then stow the handle in the securing clip and insert the pin. If one or more gear down annunciators do not illuminate, the alternate handle must not be stowed. Instead, leave it at the top of the up stroke. Continue to pump the handle when conditions permit until the gear is mechanically secured after the landing. Refer to LANDING GEAR ALTERNATE EXTENSION in Section IIIA, Abnormal Procedures, in the AFM. If any of the following conditions exist, it is likely that an unsafe gear indication is due to an unsafe gear and is not a false indication.

1. The inoperative gear down annunciator illuminates when tested.
2. The red light in the handle is illuminated.
3. The gear warning horn sounds when one or both power levers are retarded below 90% N₁.
4. The white GEAR UP or GEAR IN TRANS message(s) is(are) displayed on the EICAS after completing an alternate extension.

After a practice alternate extension of the landing gear, the gear may be retracted hydraulically. Refer to LANDING GEAR RETRACTION AFTER PRACTICE ALTERNATE EXTENSION in Section IV, Normal Procedures, of the AFM.

CAUTION

The landing gear will not retract or extend normally if the alternate extension handle is not properly stowed.

BRAKE SYSTEM

The main landing gear wheels are equipped with dual hydraulic power brakes. The brakes are operated by depressing the toe portion of either the pilot's or copilot's rudder pedals.

When the brake system is in the manual mode (master switch in the OFF position or ANTI-SKID circuit breaker pulled) there will be no fluid pressure from the pump at the pressure inlet port of the power brake valve. This allows the pressure generated at the master cylinders to force the shuttle valves in the power brake valve to open. The manual mode is used for braking when the airplane is being towed and no electrical power is applied to the system.

In the power brake mode (ANTI-SKID switch, located in the pilot's right subpanel, OFF and power applied to the pump), the system will operate as a power assisted brake system. This mode is used if the anti-skid portion of the system is malfunctioning or the pilot desires not to use the anti-skid mode. The system will automatically revert to this mode when taxi speed falls below approximately 10-15 knots.

The PWR BRAKE INOP message will display anytime system pressure drops below approximately 650 psi for more than 2 seconds and the landing gear is extended.

The airplane is equipped with an anti-skid system. The system detects the start of a skid condition at the wheels and automatically releases the brake pressure for all wheels in proportion to the severity of the skid. Use of the anti-skid system offers protection from skids and can generally provide shorter landing rolls for most runway conditions. The system is activated by placing the anti-skid switch

(This Page Intentionally Left Blank)

located on the pilot's right subpanel in the the ANTI SKID position. A transducer, mounted inside each main gear axle senses any change in wheel rotation speed. As a skid is detected, a signal is supplied to the system which releases hydraulic pressure from the brakes. With brake pressure released, the wheel speed will increase and hydraulic pressure will be restored to the brakes. The anti-skid system continues this cycling as long as braking pressure is sufficient to cause the skidding condition. This is not an automatic braking system. Therefore, brake pedal pressure should not be applied during touch down. The ANTI SKID system circuit breaker is located in the FLIGHT group on the left circuit breaker panel.

CAUTION

Do not land with brake pedals depressed. In addition, anti skid protection is not available below approximately 10 to 15 knots.

CAUTION

If brakes feel soft or spongy, or exhibit asymmetric or jerky operation, it is likely that air is trapped in the system. If this condition is not corrected, reduced directional control and braking response could result in a hazardous situation.

The ANTI SKID INOP message will display when the anti-skid system is inoperative and the landing gear is extended.

NOTE

When the ANTI SKID INOP message is displayed and the ANTI SKID switch is in the OFF position, complete control of braking through the normal braking system is available.

PARKING BRAKE

The PARKING BRAKE handle is located on the center pedestal. To set the parking brakes, depress the toe portion of either the pilot's or copilot's rudder pedals several times to build up pressure in the brake lines. Then pull out on the parking brake handle. The parking brakes can be released by depressing the rudder pedals briefly then pushing the parking brake handle in.

TIRES

The main gear are equipped with dual H19.5x6.75-10, 8-ply rated, tubeless tires. The nose gear is equipped with a 19.5x6.75-8, 10-ply rated tubeless tire.

BAGGAGE COMPARTMENTS

FORWARD BAGGAGE COMPARTMENT

A 14-cubic foot baggage compartment is located opposite the cabin door. The baggage capacity is 160 pounds.

AFT BAGGAGE COMPARTMENT

A 35-cubic foot baggage compartment is located at the rear of the cabin. The baggage capacity is 525 pounds. Nylon webbing is provided for the restraint of items. See Dimensional and Loading Data and Six Passenger Seating in Section VI. WEIGHT AND BALANCE/EQUIPMENT LIST of the FAA Approved Flight Manual.



Baggage and other objects must be secured by webbing in order to prevent shifting in turbulent air.

SEATS, SEATBELTS, AND SHOULDER HARNESSSES

SEATS

COCKPIT

The pilot and copilot seats are adjustable fore, aft, and vertically by the use of release levers located beneath the seats.

The armrests incorporate both angular adjustment and stowing. Stowing of the armrest can be accomplished by releasing the lever on its forward end and then rotating the armrest down until it reaches the stop location.

CABIN

Passenger seats are installed on continuous tracks mounted on the floor. All passenger seats are placarded FRONT FACING ONLY or FRONT OR AFT FACING on the horizontal leg cross-brace. Only seats placarded FRONT OR AFT FACING may be installed facing aft. All seats are equipped with adjustable headrests.

WARNING

Before takeoff and landing, the seats should be in the most outboard position with the seat back upright and the headrest adjusted as required to provide support for the head and neck when the passenger leans against the seatback.

All passenger seats can be moved fore and aft by lifting a release lever located on the front of the armrest. Seatbacks can be adjusted to any angle by depressing the button located in the inboard armrest. For reclining, depress the button and lean against the seatback. When no weight is applied to the seatback and the button is depressed, the seatback will return to its normal position. The seatbacks of all occupied seats must be in the upright position for takeoff and landing.

The inboard armrests are stowed in the straight down position by lifting the armrest slightly until it stops and then releasing the armrest.

The passenger seat is capable of moving outboard approximately 2.5 inches by lifting up on the lever located on the front of the armrest.

SEATBELTS

Each seat is equipped with a seatbelt and shoulder harness.

SHOULDER HARNESES

COCKPIT

The shoulder harnesses for the pilot and copilot seats consist of a Y-strap mounted to an inertia reel located in the lower seatback. One strap is worn over each shoulder and terminates with a fitting which inserts into a rotary buckle. The shoulder harness straps and inboard lap belt are released simultaneously by rotating the buckle release 1/8 of a turn in a clockwise direction.

CABIN

The shoulder harness is worn diagonally and runs from the shoulder to the hip area where it is secured by hooking the fastener around the securing stud on the male half of the seatbelt buckle.

DOORS, WINDOWS, AND EXITS

AIRSTAIR DOOR



Only one person should be on the airstair door stairway at any time.

The door locking mechanism is operated by rotating either the outside or the inside door handle. If the outside handle is stowed, it remains stowed when the inside handle is used. If unstowed, locking the door from inside will stow the outside handle.

To open the door from the outside, hold the release button depressed, lift the door handle out of its recessed stowed position and rotate the handle clockwise from the stowed position. The door will slowly swing downward.

To close the door from outside the airplane, lift the free end of the airstair door and push it up against the fuselage.

NOTE

Ensure all seven locking pins are retracted and the flexible handrail cables are out of the way before closing the airstair door.

Hold the door against the fuselage and rotate the handle counterclockwise until release button pops out. Next, rotate the handle clockwise and return it to the stowed position.

To close the door from inside the airplane, grasp the flexible handrail cables and pull the door up into the door frame. Hold the handrail cable and rotate the lock handle clockwise as far as possible, until the release button pops out. Verify the security of the airstair door by attempting to rotate the handle counterclockwise without depressing the release button; the handle should not move. Check the three forward, three aft and single top center latch pins. When properly latched each latch pin will display a green stripe visible through view ports in the cabin upholstery panels and headliner. If all pins are properly positioned, perform the Airstair Door Annunciator Circuitry Check found in the NORMAL PROCEDURES section prior to the first flight of the day. If any condition specified in this door-locking procedure is not met, DO NOT TAKE OFF.

WARNING

Never attempt to unlock or even check the security of the door in flight. If the cabin DOOR UNLOCKED annunciator illuminates in flight, or if the pilot has any reason to suspect that the door may not be securely locked, the cabin pressure should be reduced to the lowest practical value (considering altitude first), and all occupants should be instructed to remain seated with their seatbelts fastened. After the airplane has made a full-stop landing, only a crew member should check the security of the airstair door.

Before opening the door from the inside, ensure no one is below the entry unaware the door is opening. Hold the release button depressed and rotate the handle counterclockwise from the locked position. Do not lean on the door; it will slowly swing downward, until fully open.

CABIN WINDOWS

Cabin windows are plastic, stressed to withstand pressurization, and sealed into the fuselage, forming an integral part of the pressure vessel.

POLARIZED CABIN WINDOWS

Two dust panes are mounted inboard of the cabin window pane in each window frame. Each of these dust panes is composed of a film of polarizing material laminated between two sheets of acrylic plastic. The inboard dust pane rotates freely in the window frame and has a protruding thumb knob near the edge. Rotating the pane through an arc of 90° permits complete light regulation as desired. Rotation changes the relative alignment between the polarizing films, thus providing any degree of light transmission from full intensity to almost none.

WARNING

Do not look directly at the sun, even through polarized windows, because eye damage could result.

EMERGENCY EXIT

The emergency exit is located on the right side of the fuselage near the aft end of the cabin. Removal of the non-hinged, plug-type hatch into the cabin is accomplished by pulling down on the EXIT - PULL handle, pull in and raise the hatch from the non-connecting hinges.

From the outside, the hatch can be removed during an emergency situation. Removal of the emergency hatch is accomplished by kicking in at the upper center of the hatch. The area is located by a FOR RESCUE KICK IN THIS DOOR placard.

CONTROL LOCK

Install the control lock as follows:

1. Align the engine control levers.
2. Position the control lock with hook-end around the engine control levers and the pin-end at the hole in the control column.
3. Position the control wheel to align the holes in the control column: full forward and turned approximately 15° to the left.
4. Insert the control lock pin-end into the aligned holes in the control column. This will pull the hooked-end around the engine control levers.
5. When the pin-end is fully inserted it immobilizes both the flight and engine controls. The rudders are not locked, placing no restrictions on towing with the lock installed.

WARNING

Before starting engines, remove the control lock by reversing the above procedure.

ENGINES

The BEECHCRAFT 2000 is powered by two Pratt & Whitney of Canada Inc, PT6A-67A turboprop engines.

PROPULSION SYSTEM CONTROLS

The propulsion system is operated by three sets of controls: the power levers, propeller levers, and condition levers. The power levers control engine power. The propeller levers control the constant speed propellers through the primary governor. The condition levers control the flow of the fuel at the fuel control outlet and select FUEL CUTOFF, START, and RUN functions.

POWER LEVERS

The power levers control engine power from IDLE through take-off power by operation of the gas generator (N₁) governor in the fuel control unit. The power levers also control the detent-protected functions of ground fine and propeller reversing.

PROPELLER LEVERS

The propeller levers adjust the propeller governors which result in an increase or decrease of propeller rpm. For propeller feathering, the propeller lever releases high pressure oil from the propeller hub, allowing the counterweights and feathering spring to change the pitch. Detents at the rear of each lever travel prevent inadvertent movement into the feathering range.

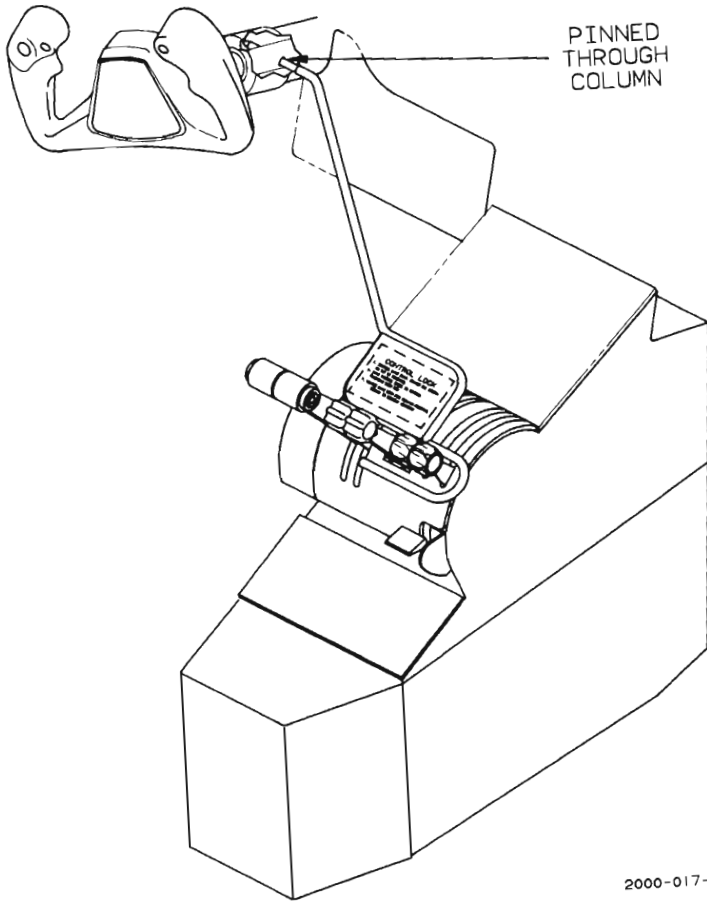

2000-017-013

Control Lock

CONDITION LEVERS

The condition levers have three positions; FUEL CUTOFF, START and RUN. Each lever controls the fuel cutoff function of the fuel control unit and limits idle speed at 65% N_1 for RUN.

PROPELLER GROUND FINE OPERATION

The propeller ground fine operation is used to provide improved deceleration on the ground during landing by taking advantage of increased propeller drag. Ground fine operation is accomplished by a detent position for the power levers. The levers are positioned in ground fine by lifting them through the IDLE detent aft to the GND FINE detent.

PROPELLER REVERSING

Engine power is controlled through the GND FINE and REVERSE ranges when the power levers are lifted over the idle detent.

CAUTION

Power levers should not be moved into the reversing range when the engines are not running as the reversing system will be damaged.

FRICTION LOCKS

Four friction locks are located on the pedestal, two below the power levers, one below the propeller levers, and one below the condition levers.

PROPELLER SYNCHROPHASER

The propeller synchrophaser system is an electronic system certified for all operations including takeoff and landing. The system automatically matches the RPM of both propellers and positions them at a preset phase relationship in order to reduce cabin noise.

Before engaging the system, manually set the RPM of each engine to within 10 RPM of each other. When the prop sync switch is turned on, engagement will automatically occur when the relative phase angle of the propellers is within 30° of the preset angle. When the system engages, both propeller speeds are increased by one-half the holding range of the system. To maintain synchronization, the system increases the RPM of the slower propeller and simultaneously reduces the RPM of the faster propeller. The system will never reduce RPM below that selected by the propeller control lever.

To change RPM with the system on, adjust both propeller controls by the same amount. If the synchrophaser is on but does not maintain synchronization, the system has reached the end of its range. Increasing the setting of the slow propeller, or reducing the setting of the fast propeller, will bring the speeds within

the limited synchrophaser range. If preferred, the synchrophaser switch may be turned off, the propellers re-synchronized manually, and the synchrophaser turned back on.

ENGINE LUBRICATION SYSTEM

Engine oil, contained in an integral tank between the engine air intake and the accessory case, cools as well as lubricates the engine. An oil radiator located inside the lower nacelle keeps the engine oil temperature within the operating limits.

The lubrication system capacity per engine is approximately 14.5 U.S. quarts or 3.6 U.S. gallons. The drain and refill quantity per engine is approximately 13.0 U.S. quarts with 5 quarts marked on the dipstick for adding purposes. Recommended oils are listed in the HANDLING, SERVICING AND MAINTENANCE Section.

MAGNETIC CHIP DETECTOR

A magnetic chip detector is installed in the bottom of each engine gearbox. This detector will activate a L CHIP DETECT or R CHIP DETECT status (white) message on the EICAS alerting the pilot to possible metal contamination in the engine oil supply.

STARTING AND IGNITION SYSTEM

Each engine is started by a three-position switch located on the center panel placarded IGNITION AND ENGINE START - LEFT - RIGHT - ON - OFF - STARTER ONLY. Moving the switch upward to the ON position activates both the starter and ignition, and the appropriate L or R IGNITION ON message will display on the EICAS. The starter drive action is stopped by placing the switch in the center OFF position. The STARTER ONLY position is used to motor the engine without ignition.

INDUCTION AIR SYSTEM

ICE PROTECTION

The L - R ENG ANTICE ON message displays when the inertial separator actuators have attained their proper position and the system is functioning properly. This message also requires that the bleed air be turned on to provide heating to the engine inlet hot lip for the respective side.

Display of either L - R ICE VANE FAIL message indicates the ice vane did not reach its proper position within approximately 30 seconds. The appropriate standby actuator should then be selected.

AUTO IGNITION

The auto ignition system, controlled by two switches located in the center panel placarded ENGINE AUTO IGNITION - LEFT - RIGHT - ARM - OFF, provides automatic ignition to prevent engine loss due to combustion failure. The system is provided to ensure ignition during turbulence, and penetration of icing or precipitation conditions.

ENGINE COMPARTMENT FIRE DETECTION SYSTEM

The fire detection system is designed to provide immediate warning in the event of a fire in the left or right engine compartments. The system consists of a temperature sensing element looped continuously around each engine, terminating in a control unit; two ENG FIRE warning lights, two test buttons on the pilot's left subpanel, and two circuit breakers placarded FIRE DETR - LEFT - RIGHT in the ENGINES group of the left circuit breaker panel. When the fire has been extinguished (if the integrity of the system has not been destroyed), the system will reset itself.

The test buttons are placarded TEST - FIRE DETR - LEFT - RIGHT. When either of the test buttons are depressed, the corresponding left ENG FIRE or right ENG FIRE annunciator and MASTER WARNING annunciators will illuminate. The system may be tested either on the ground or while in flight.

ENGINE COMPARTMENT FIRE EXTINGUISHER SYSTEM

The system is powered by the ship's battery through circuit breakers on the battery bus in the right engine nacelle.

The system incorporates a pair of annunciator/switches for each engine. The most outboard annunciator/switch has F/W VALVE PUSH etched on the lens in white lettering. The annunciator is a split lens type, with ENG FIRE shown in red on the upper portion and CLOSED shown in red on the lower portion. The ENG FIRE annunciator will illuminate when the fire detection system senses an engine fire or if the FIRE DETR test button is depressed. The CLOSED annunciator will illuminate after depressing the annunciator/switch to close the firewall fuel valve. This action will also arm the fire extinguisher and illuminate the yellow EXTINGUISHER PUSH annunciator on the annunciator/switch that is located immediately outboard of the warning annunciator panel. This annunciator/switch is normally blank and has three lens sections with EXTINGUISHER PUSH on the upper half, a yellow DISCH annunciator on the lower left and a green OK on the lower right of the left and right annunciator switches. The DISCH annunciator will illuminate after the extinguisher has been expended and will remain illuminated (regardless of the position of the battery switch) until the extinguisher cylinder has been replaced. The OK annunciator indicates that the fire extinguisher system has passed the self test when the FIRE EXT test button has been pressed.

In order to operate the fire extinguisher, the pilot must close the firewall valve and then raise the plastic cover from the face of the EXTINGUISHER PUSH annunciator/switch (this cover is safetied) and depress the switch. The fire extinguisher is usable for one activation only.

The test buttons on the pilot's subpanel are placarded TEST - FIRE EXT - LEFT - RIGHT. When either of the test buttons are depressed, the corresponding DISCH and OK annunciators should illuminate. The system may be tested either on the ground or inflight.

PROPELLER SYSTEM

DESCRIPTION

Each engine is equipped with a conventional five-blade, full-feathering, constant-speed, counter-weighted, reversing propeller mounted on the output shaft of the reduction gearbox. The propeller pitch and speed are controlled by engine oil pressure, through single-action, engine-driven propeller governors. Centrifugal counterweights, assisted by a feathering spring, move the blades towards the low rpm (high pitch) position and into the feathered position. Governor boosted engine oil pressure moves the propeller to the high rpm (low pitch) hydraulic stop and reverse position. The propellers have no low rpm (high pitch) stops; this allows the blades to feather after engine shutdown.

Propeller tie-down slings are provided for use on the moored airplane to prevent windmilling at zero oil pressure.

LOW PITCH STOPS

The propeller control systems are equipped with flight idle and ground idle low pitch stops. The flight idle low pitch stop is a mechanically actuated hydraulic stop. The ground idle low pitch stop is an electrically actuated stop controlled by a solenoid, which resets the governor beta valve to produce the desired blade angle.

PROPELLER GOVERNORS

Two governors, a constant speed governor and an overspeed governor, control the propeller rpm. The constant speed governor controls the propeller through its entire range. The propeller control lever controls the rpm of the propeller by means of this governor. If the constant speed governor should malfunction by requesting more than 1700 rpm, the overspeed governor releases oil from the propeller to keep the rpm from exceeding approximately 1768 rpm.

AUTOFEATHER SYSTEM

The automatic feathering system provides a means of immediately dumping oil from the propeller servo to enable the feathering spring and counterweights to start the feathering action of the blades in the event of an engine failure.

FUEL SYSTEM

A separate fuel system and tankage is provided for each engine. Fuel in each system is stored in two tanks. One forward tank that is an integral part of each main wing leading edge where it joins the fuselage, and a rubber bladder cell installed in the wing itself aft of the forward tank just under the leading edge of each engine nacelle. The forward tank is aerodynamically shaped to blend into the leading edge of the main wing, built of composite materials, and internally sealed against leakage.

During normal operations the fuel system is completely automatic and requires no pilot input. The system is designed to use the fuel contained in the aft tank first.

Each system of tanks is filled through a single fuel filler cap on top of each wing located near the fuselage in the forward end of the forward tank. The forward tank is filled directly through the filler opening. The aft tank is filled by gravity simultaneously via a funnel and tube arrangement which connects the two tanks.

An anti-syphon valve is installed just inside of each filler port under the cap. These metal flapper-type valves prevent excessive loss of fuel in the event of improper securing, or loss, of the filler cap.

FUEL TANK CAPACITIES

FORWARD FUEL TANK (NC-29 AND AFTER, NC-4 THRU NC-28 MODIFIED BY BEECHCRAFT KIT P/N 122-9002)

Each forward fuel tank has a capacity of approximately 194.5 gallons (1303 pounds).

In the inboard aft corner of the forward fuel tank is an integral sump or hopper tank. The hopper tank has a capacity of approximately 24 gallons. The purpose of this tank is to provide a full sump to ensure fuel is supplied to the engine.

AFT TANK (CELL) (NC-29 AND AFTER, NC-4 THRU NC-28 MODIFIED BY BEECHCRAFT KIT P/N 122-9002)

Each aft tank has a capacity of approximately 88 gallons (589.5 pounds).

FUEL PUMPS

Installed in the hopper tank is the forward tank transfer jet pump, the primary jet pump, and an electric standby boost pump. The forward tank transfer jet pump transfers fuel from the forward tank into the hopper tank. Its purpose is to keep the hopper tank full as long as there is fuel in the forward tank. If the forward tank transfer jet pump should fail, fuel will gravity feed from the forward tank to the hopper tank in level flight.

The primary jet pump transfers fuel from the hopper tank to the primary boost pump. The primary boost pump (low pressure) is engine driven and provides sufficient fuel pressure to the engine driven high pressure pump for all flight conditions. The pump also supplies motive flow to all of the jet pumps.

The electric standby boost pump provides:

- Backup in case of primary jet pump failure
- Backup in case of primary boost pump failure
- Pressure for fuel cross-transfer
- Initial pressure for engine start

The application of 28-VDC electrical power to operate the standby boost pumps is controlled by toggle switches located on the center subpanel, and through the IGNITION AND ENGINE START switches during normal engine starts. The standby boost pumps are protected by 15-amp L and R STBY PUMP circuit breakers on the left circuit breaker panel.

In the event of a failure of the primary boost pump or primary jet pump, the respective FUEL PRES LO annunciator will illuminate indicating that the fuel pressure has decreased below 5 psig. The annunciator can be extinguished by switching ON the standby boost pump for that side, thus again increasing the fuel pressure above 10 psig.

Fuel in the aft tank is transferred forward to the forward tank by the aft tank transfer jet pump and is dumped directly into the hopper tank area. If an aft tank transfer jet pump fails, most but not all of the fuel in the aft tank will gravity feed to the forward tank. The pilot should verify that fuel is being transferred from the aft tanks after cruise flight is established by checking the quantity in the aft tanks. This can be accomplished using the AFT TANK QTY push buttons below the fuel quantity gages (See FUEL QUANTITY INDICATORS).

If fuel fails to transfer forward from the aft tank, all of the fuel remaining in the aft tank at the time of the failure should be considered unusable and flight time remaining should be adjusted accordingly.

LOW FUEL QUANTITY

If a low fuel level (less than approximately 135 pounds) occurs in either hopper tank, a sensor toward the top of the tank will illuminate the L or R FUEL LEVEL LO caution message on the EICAS. If a check reveals that the fuel quantity at this time exceeds the hopper tank quantity, then the fuel is not transferring to the hopper fast enough and the standby boost pump should be turned ON in an attempt to keep the hopper tank full. If fuel quantity is equal to or less than the hopper tank quantity, then the caution message(s) indicates a low total fuel condition.

WARNING

A low total fuel condition requires immediate action on the part of the pilot to land as soon as possible.

CROSS TRANSFER

It may become necessary to transfer fuel from one side of the airplane to the other such as during single-engine cruise operations or to maintain balance within the required limit.

NOTE

Maximum allowable fuel imbalance between wing fuel systems is 150 pounds. Cross transferring of fuel is permitted only during ground and cruise flight operations.

The left and right fuel systems are connected by a cross-transfer line containing a cross-transfer valve. Fuel pressure for cross-transfer is provided by the standby boost pumps. Cross-transfer is controlled by a FUEL TRANSFER selector switch located in the FUEL group on the center pedestal.

To transfer fuel, the pilot should simply turn this selector switch so that it points toward the tank to which the fuel is to be transferred. This action accomplishes the following:

1. Opens the cross-transfer valve
2. Turns on the standby boost pump on the opposite side (the side from which the fuel is being transferred)
3. Illuminates the FUEL TRANSFER message on the EICAS

Fuel is transferred at the rate of approximately 475 pounds per hour.

FUEL VENT SYSTEM

The forward tank of each fuel system is vented to the atmosphere through a recessed vent on the underside of each wing aft and outboard of the main gear door hinge. An alternate path through this main vent is provided through a heated ram vent to insure that venting is always available for the main tank.

The aft tank is separately vented. The opening for this vent is located just aft of the center of the main gear well.

A separate vent line runs between the two tanks to insure that both tanks are always vented.

Check valves are installed in the tank end of each vent line so that fuel is not syphoned overboard through the vent lines. Flame arresters are installed at the outlet of each vent line as part of the airplanes lightning protection.

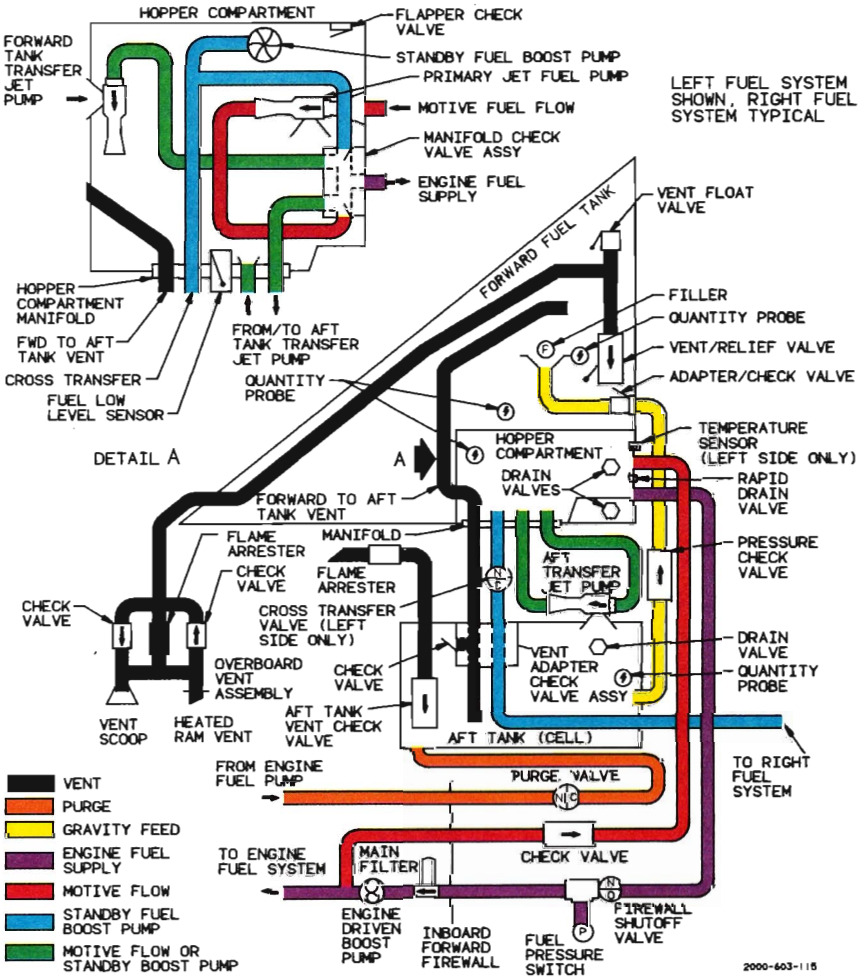

Fuel System Schematic

FIREWALL FUEL SHUTOFF VALVES

The firewall fuel shutoff valves are located in the feed line between the fuel system and the engine at the firewall. The purpose of these valves is to shut off the fuel flow to the engine compartment in the event of an engine fire. The firewall fuel shutoff valves are controlled by two alternate action push button switches located in the glareshield at both ends of the annunciator panel. Each switch is guarded with a clear plastic spring loaded cover to prevent inadvertent actuation. One push opens the firewall valve, a second closes it. These units serve as both switches and annunciators. Etched on the lens of each switch is L or R F/W VALVE PUSH in white. The annunciator is a split lens type with ENG FIRE shown in red on the upper portion and CLOSED in red on the lower half (See ENGINE COMPARTMENT FIRE EXTINGUISHER SYSTEM). The appropriate firewall valve is closed by pushing the switch on the desired side. When the firewall valve closes, the lower CLOSED portion of the switch will illuminate to indicate that the valve is in the closed position.

If the valve fails to close in approximately two seconds, the CLOSED portion of the switch will not illuminate. Instead, the yellow L or R F/W VALVE FAIL message will illuminate on the EICAS indicating that the valve is not in the selected position.

It should be noted that when the L or R F/W VALVE push button is pushed and the valve is closed, the corresponding fire extinguisher bottle is simultaneously armed as indicated by the illumination of the yellow EXTINGUISHER PUSH annunciator on the switch next to it.

FUEL DRAINS (EFFECTIVITY: NC-4 THRU NC-25)

Drains are provided at the low point in each fuel tank so that during preflight a small amount of fuel can be drained to check the fuel for water or other contamination as well as fuel draining operations. Each valve contains an internal poppet which is held in the closed position by spring pressure. To drain fuel from the left or right forward and aft fuel tanks, position a suitable container directly under the applicable fuel drain valve(s). There are two fuel drain valves located under each forward fuel tank and one located under each aft fuel tank.

Open the desired drain valve(s) by fully depressing the poppet and turning it approximately 90° in either direction with a crosspoint tool. Allow adequate time for the fuel to drain.

To close the drain valve, use a crosspoint tool to rotate the poppet approximately 90° in the opposite direction, then release. Spring pressure returns the poppet to the closed position.

Lightning protection covers are installed over all of the underwing drains and must be replaced after checking each drain location. The fuel filter drains are located in the access panel under the aft end of each nacelle just forward of the oil cooler inlet scoop.

There are four drains on each side. They are located as follows:

DRAINS	LOCATION
Forward Tank Drain	Underside of wing forward of wheel well
Hopper Tank Drain	Underside of wing forward of wheel well
Aft Tank Drain	Underside of wing aft of wheel well
Fuel Filter Drain	Aft of firewall
BT00871	

FUEL DRAINS (EFFECTIVITY: NC-26 AND AFTER)

There are two fuel drain valves located under each forward fuel tank and one located under each aft fuel tank. To drain fuel from the left or right forward and aft fuel tanks, position a suitable container directly under the applicable fuel drain valve(s). Insert an 1/8-inch allen wrench into the poppet recess and unlock the poppet by rotating it clockwise approximately 35°.

CAUTION

Use care not to apply more than 4 inch-pounds of counterclockwise torque to the drain valve poppet. The internal spring should provide enough torque to lock the poppet in the open position.

Apply upward pressure to the poppet and rotate it counterclockwise until it stops. Release upward pressure on the poppet and allow it to lock in the open position. After checking fuel for contamination, insert the allen wrench in the poppet recess and rotate it approximately 35° to 45° clockwise until the valve spring forces the poppet down. The spring should also provide enough counterclockwise torque to return the poppet to its closed and locked position. Verify the poppet is locked in the closed position by applying 3 to 5 pound upward force to the poppet. The poppet should not move. There are four drains on each side. They are located as follows:

DRAINS	LOCATION
Forward Tank Drain	Underside of wing forward of wheel well
Hopper Tank Drain	Underside of wing forward of wheel well
Aft Tank Drain	Underside of wing aft of wheel well
Fuel Filter Drain	Aft of firewall
BT00871	

FUEL PURGE SYSTEM

During normal engine operations compressor discharge air (P3 air) pressurizes a small surge tank. During engine shutdown, fuel manifold pressure decreases allowing a small poppet valve in the manifold to open. The purge tank pressure thereby pressurizes the manifold forcing any small amount of fuel left in the lines

of the manifold out through the nozzles and into the combustion chamber. At shutdown, as this fuel is burned, a momentary surge in N_1 may be observed. During cold weather a small amount of smoke may be emitted from the engines at shutdown due to this purging of fuel from the manifold. If desired, this can be eliminated by turning on the engine auto-ignition(s) just prior to shutdown; this will allow the small amount of fuel purged from the fuel manifold to be ignited and burned. The operation of the Fuel Purge System is completely automatic and requires no pilot action.

FUEL QUANTITY INDICATING SYSTEM

The fuel quantity indicating system is of the capacitance type. Fuel quantity is sensed by two sensing probes in the forward tank and one each in the hopper tank and the aft tank. The sense indications of the three probes in the forward fuel tank are averaged by a computer to obtain the fuel quantity indication. Capacitance systems automatically compensate for fuel density due to changes in temperature and are extremely accurate. A maximum indication error of 3% may be expected in the system.

The system is designed for the use of Jet A, Jet A1, JP-5 and JP-8 aviation kerosene. If other fuels are used, the system will not indicate correctly. See OTHER NORMAL PROCEDURES in Section IV of the AFM for instructions when using Jet B, JP-4, or aviation gasoline.

The LEFT ENGINE and RIGHT ENGINE liquid crystal fuel quantity indicators located on the center subpanel display total quantity in each system graphically and digitally in pounds remaining.

An AFT TANK QTY push button is provided under each fuel quantity gage to check the fuel remaining in the left or right aft fuel tanks. When these buttons are pushed the fuel remaining, in pounds, in the aft tank(s) is displayed on the quantity indicators.

FUEL TEMPERATURE INDICATOR

The fuel temperature indicator is located on the center subpanel in the FUEL MANAGEMENT group and is placarded FUEL TEMP °C. The fuel temperature sensor for this measurement is located in the left hopper fuel tank.

NOTE

Minimum operational fuel temperature is -27°C.

ELECTRICAL SYSTEM

The airplane electrical system is a 28-VDC (nominal) system with a negative lead return. Electrical DC power is provided by a single air cooled battery and one starter-generator mounted on each engine and connected in parallel. For ground operation, electrical power may be supplied from an external auxiliary power unit.

BATTERY AND CONTROL

Electrical power for engine starting and emergency airplane operation is supplied by one air-cooled nickel-cadmium battery. Battery voltage is monitored by a voltmeter located on the center subpanel. Power to the center bus from the battery is through the battery bus tie relay. It is controlled by the BATT ON - OFF switch. The battery is installed in the right hand nacelle which is fitted with an air-cooling inlet and exit which provides battery venting. The battery is protected from the cold temperatures by a thermostatic valve to reduce air intake.

BATTERY MONITOR SYSTEM

The battery monitor system notifies the pilot of an abnormal charge rate with the annunciation BATT CHG RATE on the warning annunciator panel. The system performs its own self-test whenever the battery switch is placed in the ON position. The annunciator will illuminate for 2 seconds after the battery is turned ON. The circuit will illuminate the BATT CHG RATE annunciator if the charge rate is in excess of 12 amps over a period of 15 minutes, or increasing more than 1/2 amp over a period of 30 minutes. The circuit is in parallel with the BATT AMP meter, therefore, a failure in the battery monitor circuit will be accompanied by a readout of zero on the BATT AMP meter when the BATT AMP switch is pressed. Depressing the BATT MONITOR button on the pilot's TEST subpanel will perform the same self-test as the battery switch. Depressing the button should illuminate the BATT CHG RATE annunciator for 2 seconds. The annunciator will extinguish after 2 seconds if the self-test is satisfactory.

STARTER-GENERATOR OPERATION AND CONTROL

Functioning as generators, the starter-generators are controlled by individual generator control switches (GEN RESET - ON - OFF) located with the battery switch under a single gang bar. The switches control the generators by the function of two solid-state generator control panels, one for each generator. Each control panel provides voltage regulation, generator paralleling, generator line contactor control, reverse current protection, overvoltage protection, cross-start current limiting, overexcitation protection and a generator reset function.

Functioning as starters, the starter-generators are individually powered from the center bus through a starter relay. The start cycle is controlled by two three position switches (IGNITION AND ENGINE START - LEFT - RIGHT - ON - OFF - STARTER ONLY).

During normal operation, the generators operate in parallel. Digital display indicators placarded, BATT AMP/L LOAD-%, VOLTS-DC, and R LOAD-% are provided for system monitoring.

EXTERNAL POWER

For ground operation and engine starting, 28-VDC electrical power may be supplied to the airplane from an external auxiliary power unit. The auxiliary power unit can be connected to the airplane through an external power receptacle. The receptacle is located at the forward outboard corner of the left main landing gear wheel well. The external power relay is controlled by a sensor which will allow it

to close only if the polarity of the voltage being supplied to the external power receptacle is correct. Overvoltage protection is also provided. The EXT POWER CONN message will display when an external DC power plug is connected to the airplane. Power to the airplane is controlled by the external power EXT PWR - OFF-RESET switch on the pedestal. The voltage can be monitored by the VOLTS-DC meter on the pedestal.

POWER DISTRIBUTION

The airplane electrical system is composed of a left and right generator bus, center bus, triple fed bus, and hot battery bus. The primary buses are interconnected through bus tie relays to allow the entire system to be powered by one or both generators. During manual bus tie switch operation, the battery will also power the entire system without aid from the generators for a short period of time. Power distribution control is provided by a solid-state controller. Under flight conditions with dual generator failure, both generator buses become isolated leaving the loads on the triple fed and center busses to be powered by the battery. If the current sensors (left bus tie, right bus tie or battery tie) detect a load of approximately 325 amps they will open the appropriate bus tie relay. The bus tie relay is reset by placing the GEN TIES - MAN CLOSED - NORM - OPEN switch in the OPEN position and then returning it to the NORM position. Verification of bus tie being open is provided by the EICAS caution message L - R GEN TIE OPEN.

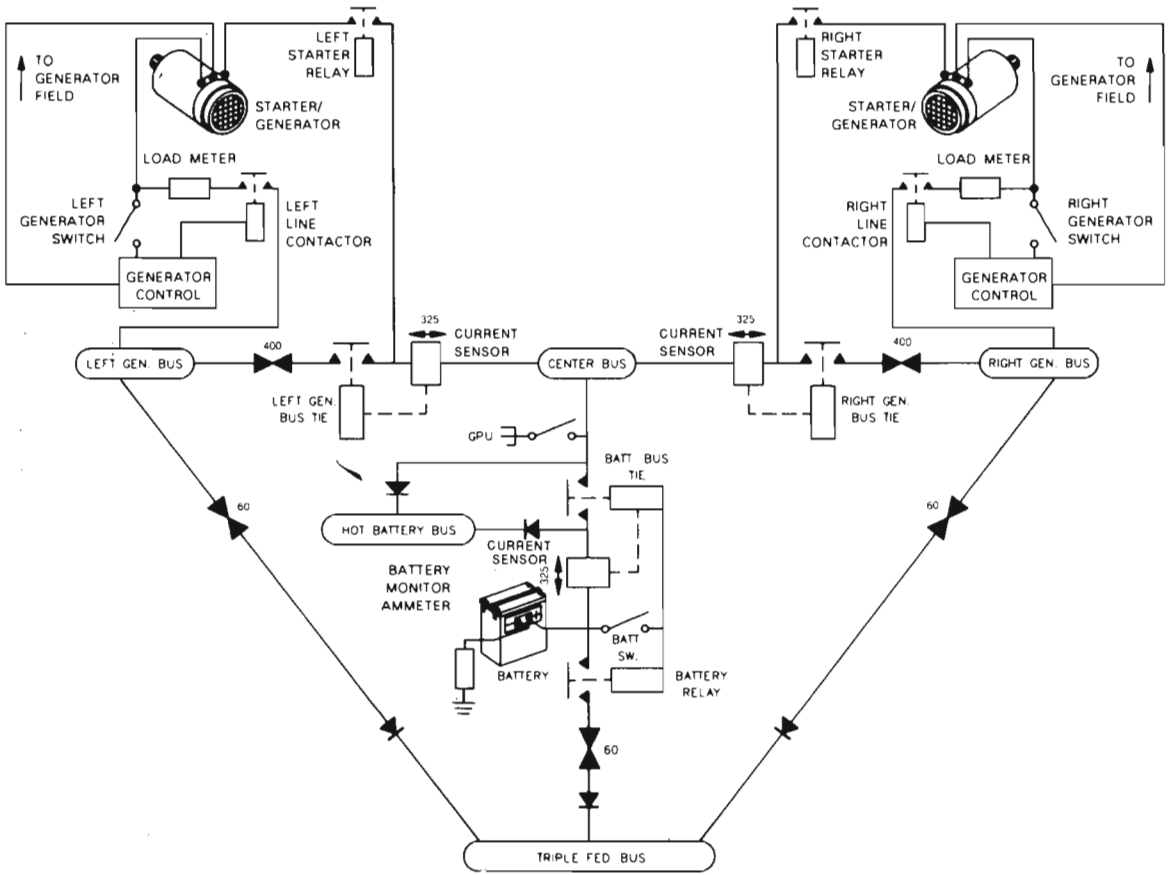

Power Distribution Schematic

CIRCUIT BREAKER BUS LOADING

HOT BATTERY BUS

CENTER BUS

LEFT ENGINE FIRE EXT
RIGHT ENGINE FIRE EXT
ELECTRIC DIPSTICK
MEMORY
SPARE
CABIN LIGHTS
BATTERY RELAY
GROUND RTU
GROUND AUDIO
GROUND COMMUNICATION
BAGGAGE COMPARTMENT LIGHTS
FLOOD LIGHTS - COCKPIT
LEFT F/W SHUTOFF VALVE
RIGHT F/W SHUTOFF VALVE
STANDBY PITCH TRIM

FWD WING ACTUATOR
WING INSPECTION LIGHT
TAXI LIGHT
STROBE -ANTI-COLLISION
LEFT PITOT STATIC HEAT
FLAP MOTOR POWER
EICAS POWER
CONDENSER BLOWER
DC TEST JACK
ALT BLOWER CONTROL
RELAY
ALTERNATE BLOWER
POWER
LANDING GEAR MOTOR

RIGHT GENERATOR BUS

AFT VENT BLOWER POWER
CO-PILOT'S WINDSHIELD ANTI-ICE
PILOT'S REDUNDANT WSHLD ANTI-ICE
RIGHT CHIP DETECTOR
RIGHT BLEED AIR CONTROL
RIGHT LANDING LIGHT
RIGHT POWER CABLE HEATER
RIGHT STANDBY ENGINE ANTI-ICE
RIGHT AOA TRANSMITTER HEAT

RIGHT PITOT STATIC
STBY ICE DETECTOR
RELAY STBY SURFACE DEICE TEST

NO. 3 AVIONICS BUS FEEDER
TRIPLE-FED BUS FEEDER
CONDENSER BLOWER
PROPELLER SYNC
NOSE LANDING LIGHT
LEFT FIREWALL FUEL VALVE
RIGHT DEICE VALVE HEATER
RIGHT FUEL VENT HEAT
RIGHT WINDSHIELD
CONTROL
LEFT STBY WINDSHIELD
CONTROL
SURFACE DEICE PCT ASSY
EICAS POWER

CIRCUIT BREAKER BUS LOADING (Cont'd)

LEFT GENERATOR BUS

FORWARD VENT BLOWER
NO. 2 AVIONICS FEEDER

TRIPLE-BUS FEEDER
LEFT CHIP DETECTOR

AUTO-FEATHER
BRAKE DEICE
RIGHT FIREWALL FUEL VALVE
NAVIGATION LIGHTS
LEFT LANDING LIGHT
LEFT STANDBY ENGINE ANTI-ICE
LEFT WINDSHIELD CONTROL
LEFT WINDSHIELD WIPER POWER
NO/SMOKING/FSB AND READING
LIGHTS
TOILET
FLOURESCENT LIGHTS
EICAS FEEDER

REFRESHMENT BAR
PILOT'S WINDSHIELD ANTI-
ICE
PROP GOVENOR TEST
WINDSHIELD WIPER
CONTROL
ICE DETECTOR
SURFACE DEICE
GROUND ICE DETECTOR
LEFT AOA TRANSMITTER
HEAT
LEFT FUEL VENT HEAT
LEFT POWER CABLE HEATER
LEFT DEICE VALVE HEATER
STORM LIGHT
CIGARETTE LIGHTER
HEATED OVERBOARD DRAIN
FWD VENT FAN CONTROL

TRIPLE FED-BUS

CABIN LIGHTS
INSTRUMENT INDIRECT LIGHTS
RIGHT EDC CHANNEL B
RIGHT SQUAT SWITCH
LDC DISPLAY LIGHTS
FLOURESCENT LIGHTS

RIGHT FUEL QUANTITY
FUEL TRANSFER VALVE
RIGHT FIRE DETECTOR
RIGHT IGNITOR POWER
LANDING GEAR CONTROL

OVERHEAD FLOOD LIGHTS
LEFT EDC CHANNEL B
LEFT SQUAT SWITCH
FLIGHT INSTRUMENT LIGHTS
AVIONICS CO-PILOT BUS
FEEDER
RIGHT STANDBY FUEL PUMP
RIGHT EDC CHANNEL A
RIGHT OIL PRESS
TRANSDUCER
RIGHT START CONTROL
RUDDER TRIM B

CIRCUIT BREAKER BUS LOADING (Cont'd)
TRIPLE FED-BUS (Cont'd)

PITCH TRIM	ROLL TRIM
FLAP CONTROL	LEFT FLAP MONITOR
COLUMN PUSHER CLUTCH	LEFT STANDBY FUEL PUMP
LEFT FUEL QUANTITY	LEFT EDC CHANNEL
FUEL TEMPERATURE	LEFT OIL PRESS
LEFT FIRE DETECTOR	TRANSDUCER
LEFT IGNITOR POWER	LEFT START CONTROL
RUDDER TRIM A	ROLL TRIM A
PITCH TRIM A	LANDING GEAR INDICATOR
COLUMN PUSHER MOTOR	LEFT OIL PRESS LO
	WARNING
LEFT FUEL PRESS LO WARNING	LEFT MAIN ENGINE ANTI-ICE
BLEED AIR FAILURE WARNING	LEFT BUS TIE CONTROL
GENERAL RESET	CABIN PRESSURE CHANNEL
	A
LEFT BLEED AIR CONTROL	CABIN PRESSURIZATION A
LEFT FUEL QTY LO WARNING	LANDING/TAXI LIGHT
L STALL WARN COMPUTER	CONTROL
RIGHT BUS TIE CONTROL	RIGHT FUEL PRESS LO
RIGHT FUEL QTY LO WARNING	WARNING
RIGHT OIL PRESS LO WARNING	CABIN ALTITUDE WARNING
STALL WARNING	LANDING GEAR WARNING
RIGHT MAIN ENGINE ANTI-ICE	HORN
STATIC SOURCE SELECT	CABIN PRESSURE CHANNEL
	B
RIGHT FLAP MONITOR	FLAP INDICATOR
R STALL WARNING COMPUTER	DEICE VALVE MANUAL MODE

BT01438

(This Page Intentionally Left Blank)

LIGHTING SYSTEMS

COCKPIT

An overhead light panel, accessible to both the pilot and copilot, controls all lights in the cockpit. With the exception of the STORM FLOOD light which is controlled by a OFF - LOW - HI switch, the cockpit, panel, and display lights are controlled by rheostat dimmers.

Refer to BRIGHTNESS AND BALANCE under FLIGHT INSTRUMENTS in this Section.

Alternate-action push button switches for the landing, taxi, wing, navigation, and strobe - anti collision lights are in the cockpit overhead panel.

The circuit breakers for the interior lights (except reading and table lights) are located in the aft electronics bay, accessible only on the ground. The reading and table lights circuit breaker is located in the cockpit where the pilot can access it if necessary.

CABIN

The cabin is lighted with perimeter lights along the sides of the cabin headliners, a table light above each table, a reading light above each seat, and aisle lights. There is also an aft baggage compartment light controlled by an automatic switch.

Reading lights are controlled by a READING LIGHT switch located on the console below each window.

Cabin overhead lights are controlled by the CABIN OVHD switch in the cockpit overhead lighting panel.

The cockpit flood and subpanel lights, aisle, entry and door lights are controlled by the switches on the cabin entry switch panel, located on the left forward partition. The switches control the lights as follows:

COCKPIT	Controls the cockpit flood and subpanel lights.
AISLE	Controls the aisle lights.
ENTRY	Controls the cabin entry lights.
DOOR	Controls the airstair door light and the light panel light.

SELF-LUMINOUS SIGNS

There are three self-luminous signs in the cabin. An EXIT sign mounted in the foyer directly above the cabin door. An EXIT sign mounted above the emergency exit and an EXIT-PULL sign on the emergency door handle.

EXTERIOR

There are three landing lights, one on each wing tip and one on the nosewheel strut. All are high intensity spotlights. The taxi light, also on the nosewheel strut, is a floodlight.

An anti-collision light assembly, is mounted on the lower outboard surface of each tipsail. The assembly consists of a forward/outboard facing colored navigation light, a protruding white strobe light and an outboard/aft facing white position light. The other aft facing white position light is mounted in the tailcone.

The lights are controlled by the NAV, STROBE - LOW - ANTI-COLL switches in the overhead light control panel. The NAV switch controls the navigation and position lights. The STROBE - LOW switch provides a low intensity strobe light. The STROBE - ANTI-COLL switch provides a high intensity strobe light.

ENVIRONMENTAL SYSTEM

The environmental system consists of pressurization, ventilation, heating and cooling systems, and their associated controls.

PRESSURIZATION SYSTEM

CABIN PRESSURE CONTROL SYSTEM

The Cabin Pressure Control System (CPCS) is designed to control cabin altitude and cabin rate-of-change. The controller is connected to the pneumatic relay, a vacuum source, and is vented to cabin ambient pressure.

The pressurization controller, mounted near the lower center instrument panel, controls modulation of the outflow valves. The outer scale (CABIN ALT-FT) of the dual-scale indicator indicates the cabin pressure altitude which the controller is set to maintain. The inner scale (ACFT) indicates the maximum ambient pressure altitude at which the airplane can fly without causing the cabin pressure altitude to exceed the value selected on the outer scale of the dial. The rate knob will control rate-of-change from a minimum of approximately 50 feet per minute up to approximately 3000 feet-per-minute.

The actual cabin pressure altitude is continuously indicated by the cabin altimeter located on the copilot's left subpanel. Just to the right of the cabin altimeter is the cabin vertical speed (CABIN CLIMB) indicator, which continuously indicates the rate at which the cabin pressure is changing.

A PRESS button located in the TEST group on the pilot's left subpanel is used to perform systems verification checks (ground only). When depressed, the cabin will pressurize to a maximum of 120 feet below airplane altitude at a cabin rate-of-descent of 400-450 feet-per-minute. Releasing the PRESS will depressurize the cabin at the same rates.

Control of the system is provided by a knob located to the right of the CABIN CONTROLLER knob and is placarded MANUAL CABIN ALT CONTROL - NORM - INCR - DUMP. The valve is connected to a vacuum source and the outflow/safety valves. Full clockwise rotation will select the DUMP position. Rotation of the knob in a clockwise direction will allow the cabin to rapidly depressurize to an altitude of 13,000 feet \pm 1500 feet if the airplane altitude is above 14,500 feet and will depressurize to zero differential if the airplane altitude is below 11,500 feet.

Prior to takeoff, the cabin altitude selector knob should be adjusted so that the ACFT ALT scale on the indicator dial indicates an altitude approximately 1000 feet

above the planned cruise pressure altitude or the CABIN ALT scale indicates an altitude at least 500 feet above the takeoff field pressure altitude. The rate control selector knob should be adjusted as desired; setting the index mark at the 10-o'clock position will provide the most comfortable cabin rate of climb. As the airplane climbs, the cabin pressure altitude climbs at the selected rate of change until the cabin reaches the selected value. If the airplane climbs to an altitude higher than the value indexed on the ACFT scale of the dial on the face of the controller, the cabin-to-ambient pressure differential will reach the pressure relief setting of either outflow/safety valve (8.4 psi cabin-to-ambient differential).

During cruise flight operation, if a new cruise altitude is required, the cabin altitude selector knob should be adjusted so that ACFT ALT scale on the indicator dial indicates an altitude approximately 1000 feet above the planned cruise pressure altitude and at least 500 feet above the landing field pressure altitude.

Should the cabin altitude exceed 10,000 feet, a red CAB ALT HI warning annunciator will illuminate. If the cabin differential exceeds 8.4 psi, a red CABIN DIFF HI warning annunciator will illuminate. Both annunciators are located in the warning annunciator panel in the glareshield.

UNPRESSURIZED VENTILATION

Fresh air ventilation is provided from the bleed air inflow system, which is available during both the pressurized and the unpressurized mode.

HEATING

Engine bleed air, through the environmental flow control valves, is utilized to heat the cabin.

Air outlets are provided for each pilot under the instrument panel. These outlets are regulated by the PILOT AIR - PULL ON knob and the COPILOT AIR - PULL ON knob located on the respective pilot's subpanel just below and outboard of the control columns. The air supply for windshield defrost is controlled by the DEFROST AIR - PULL ON knob located just below the PILOT AIR knob. If the temperature in the duct supplying the floor level outlets becomes excessive, the DUCT OVERTEMP caution message will illuminate. Refer to the ILLUMINATION OF DUCT OVERTEMP MESSAGE procedure in SECTION IIIA, ABNORMAL PROCEDURES of the AIRPLANE FLIGHT MANUAL for corrective action.

An indicator placarded CABIN TEMP °F located on the copilot's left subpanel indicates the cabin temperature in Fahrenheit and displays the ECS faults. ECS error codes 930 and 940 shown in the cabin temp display are normal and must be disregarded.

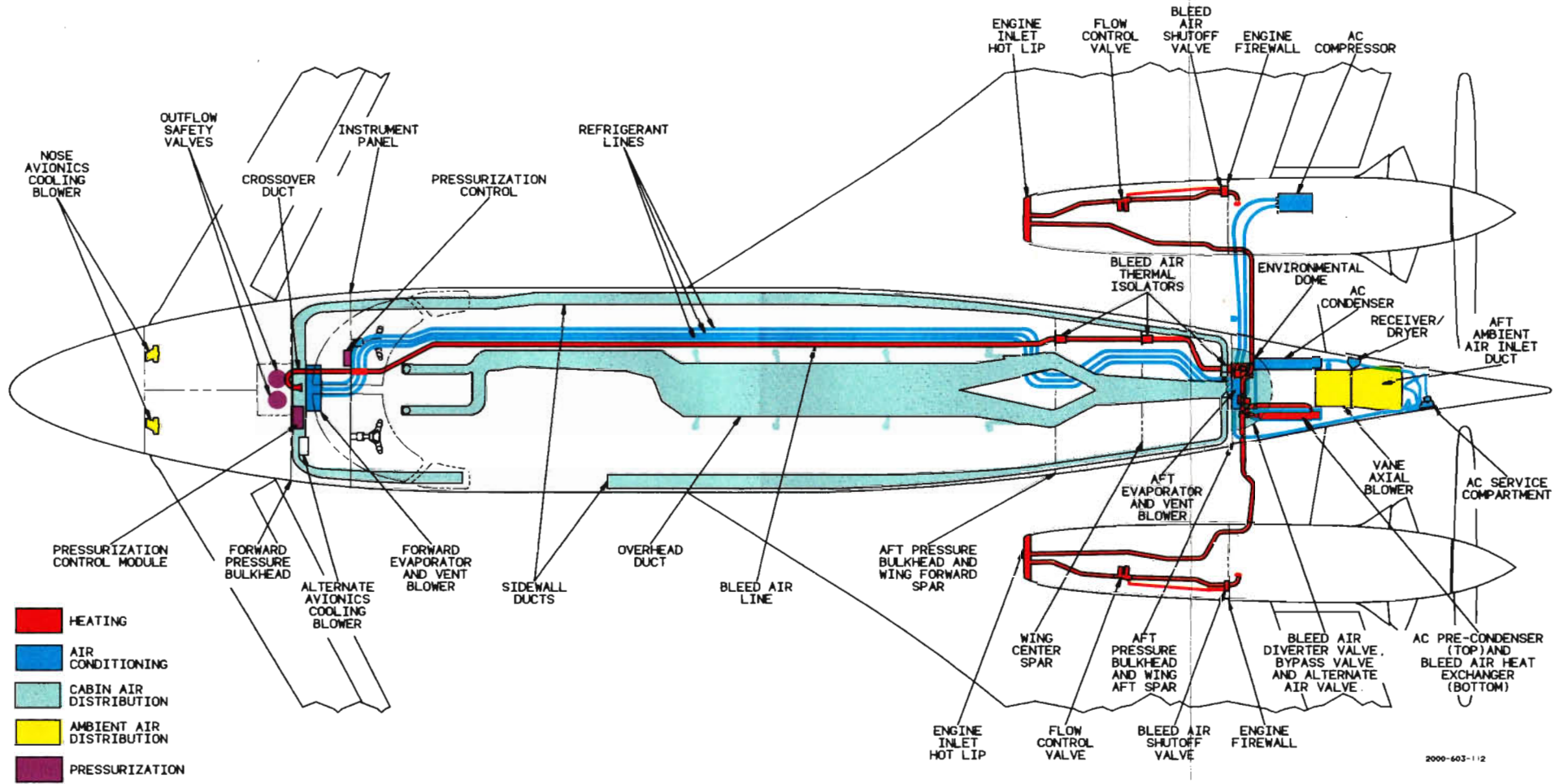

2000-603-1/2

AIR CONDITIONING SYSTEM

Cabin air conditioning is provided by a vapor-cycle refrigeration system. The engine driven compressor will operate as required in the MANUAL or AUTO TEMP MODE, provided operation is not prohibited by the system protection controls. System protection controls will prevent compressor operation if refrigerant pressure is too high or too low, or if the ambient temperature is below approximately 10°F.

The forward and aft vent blowers draw return cabin air through their respective evaporators and discharge into the cabin distribution ducts.

ENVIRONMENTAL CONTROLS

The ENVIRONMENTAL control section on the copilot's left subpanel provides for automatic or manual control of the system. Three additional manual controls on the main instrument subpanels may be utilized for partial regulation of cockpit comfort. The full out position of these controls will provide the maximum air flow to the cockpit.

When the TEMP MODE selector switch on the copilot's left subpanel is in the AUTO position, the heating and air conditioning systems operate automatically as a function of AUTO TEMP selection.

The AUTO TEMP knob provides regulation of the temperature level in the automatic mode. Temperature sensors in the cabin, in conjunction with the control setting, initiate a heat or cool command from the Environmental System Controller (ESC).

The CKPT knob is used to position the cockpit/cabin diverter valve. This valve divides the environmental air to the cockpit area or the cabin area. This knob operates independently from the AUTO TEMP knob. With the CKPT knob in the 12 o'clock position, the environmental air is split approximately 50% cockpit/50% cabin. With the CKPT knob in the full DECR position (fully CCW), the diverter valve will send virtually all environmental air to the cabin. In the full INCR position (fully CW), virtually all environmental air will be sent to the cockpit.

MANUAL MODE CONTROL

When the TEMP MODE switch is in the MAN position, regulation of the cabin temperature is accomplished by holding the MAN TEMP switch to either the INCR or DECR position as desired. When released, this switch returns to the center (no change) position. Cabin temperature response is proportional to the length of time the MANUAL TEMP switch is depressed with approximately one minute required to go from full increase to full decrease or vice versa. When the TEMP MODE selector is in the MAN position, the air conditioner system will operate when manual temperature control has reached the full decrease setting, and the cooling system protection devices are not preventing normal operation.

If the cabin temperature is comfortable but the cockpit temperature is not, the following procedures are suggested:

HEATING MODE

If the cockpit is too cold

1. Turn the CKPT/CABIN AUTO TEMP CKPT knob toward INCR.
2. PILOT AIR, COPILOT AIR and DEFROST AIR knobs - PUSHED FULLY IN, or as required.
3. Cockpit Overhead/Instrument Panel Eyeball Outlets - CLOSED, or as required.

If the cockpit is too hot

1. Turn the CKPT/CABIN AUTO TEMP CKPT knob toward DECR.
2. PILOT AIR and COPILOT AIR knobs - PULLED FULLY OUT, or as required.
3. Cockpit Overhead/Instrument Panel Eyeball Outlets - OPEN, or as required.

BLEED AIR CONTROL

Bleed air entering the cabin is controlled by a switch placarded BLEED AIR VALVES - EMER - OFF - L ENG - BOTH - R ENG - HIGH FLOW. A firewall shutoff valve is installed in each nacelle. When the bleed air valve switch is in BOTH, the left and right shutoff valves open and the flow rate is controlled to 3 lb/min by each flow control valve. When the switch is in L ENG, R ENG or HIGH FLOW, the flow rate increases to 5 lb/min from the selected side. When EMER is selected, the left firewall valve closes and the right flow control valve regulates at 5 lb/min and bypasses all plumbing in the airplanes aft section. The EMER air is routed directly to the aft ventilation blower for mixing and distribution.

BLOWER CONTROL

The forward and aft ventilation blowers are of the brushless D.C. type. The blowers use an electronic speed controller to allow for a variable selection of blower speeds. A rotary control switch on the Environmental Systems Subpanel, placarded HIGH - LOW, will enable the pilot to select blower speeds for the desired air flow rates and to minimize the sound level. The blowers are variable from 70% to 100% output.

BLEED AIR DISTRIBUTION DUCT OVERTEMP PROTECTION

The Environmental System Controller (ESC), with the bleed air duct temperature sensor, monitors bleed air temperature entering the cabin and directs the bypass to limit this temperature to 400°F. After bypass valve reposition the ESC will select condenser blower ON to improve heat exchanger capability.

DISTRIBUTION AIR DUCT OVERTEMP PROTECTION

The ESC, with the forward and aft distribution duct sensors, monitors duct air temperature. Should the duct air temperatures exceed the specified limit, the ESC will act to reduce or limit that temperature, by the following: increasing blower

speeds, repositioning the diverter valve, adjusting the bypass valve, activating the vapor cycle air conditioner and selecting the condenser blower ON.

BLOWER FAILURE PROTECTION

The ESC utilizes sensitive pressure switches to monitor the operating status of the forward and aft vent blowers. Should an inoperable blower be detected, the ESC will automatically take the following actions to avoid excessive temperatures and advise the crew of a fault.

- Override crew control of diverter valve and divert all bleed air to the remaining operable blower; upspeeding it to 100% output (only if the duct temperature exceeds the limits).
- Display on the CABIN TEMP display, alternating with CABIN TEMP the 3-digit fault code.

DIAGNOSTICS

The system has diagnostic capabilities to continuously monitor the following listed items and generate the assigned 3-digit (9XX) fault code on the cabin temperature display when that fault is detected. No pilot action is required as a result of these displayed codes.

Fault codes are displayed as long as the fault remains and are cancelled if the fault clears. The fault code is displayed for a five (5) second interval, then cabin temperature for 10 seconds - alternating. If more than one (1) fault exists, each fault is displayed for five (5) seconds in series, then the cabin temperature for the remainder of the 15 second update period. If more than three (3) codes are displayed, the cabin temperature will not be displayed.

FORWARD CABIN

910 - Fwd blower failed.

911 - Fwd Left Distribution Duct Temperature Sensor failed.

912 - Fwd Right Distribution Duct Temperature Sensor failed.

913 - Fwd Cabin Temperature Sensor failed.

AFT CABIN

920 - Aft Blower failed.

921 - Aft Left Distribution Duct Temperature Sensor failed.

922 - Aft Right Distribution Duct Temperature Sensor failed.

923 - Aft Cabin Temperature Sensor failed.

LEFT WING

930 - Normal Indication - Disregard

931 - Left Flow Control Valve Temperature Sensor failed.

RIGHT WING

940 - Normal Indication - Disregard

941 - Right Flow Control Valve Temperature Sensor failed.

AFT FUSELAGE

950 - Bypass Valve failed.

951 - Bleed Duct Temperature Sensor failed.

952 - Diverter Valve failed.

953 - Power Source to ESC failed.

955 - Processor failed.

957 - Emergency Valve failed.

Refer to the BEECHCRAFT Starship 1 Maintenance Manual for additional information.

OXYGEN SYSTEM

The oxygen system provides an emergency oxygen flow for crew and passengers at cabin pressure altitudes up to 41,000 feet. The oxygen duration chart (NORMAL PROCEDURES Section, FAA Approved Airplane Flight Manual) is based on a flow rate of 4.7 LPM per passenger mask and at an altitude schedule for the diluter demand crew masks. Before each flight, check the OXYGEN PRESSURE indicator located on the copilot's left subpanel to verify that sufficient oxygen is available for the flight.

WARNING

Adequate oxygen pressure is not provided to the passengers for sustained flight at cabin altitudes above 34,000 feet. The highest recommended cabin altitude for sustained flight is 25,000 feet.

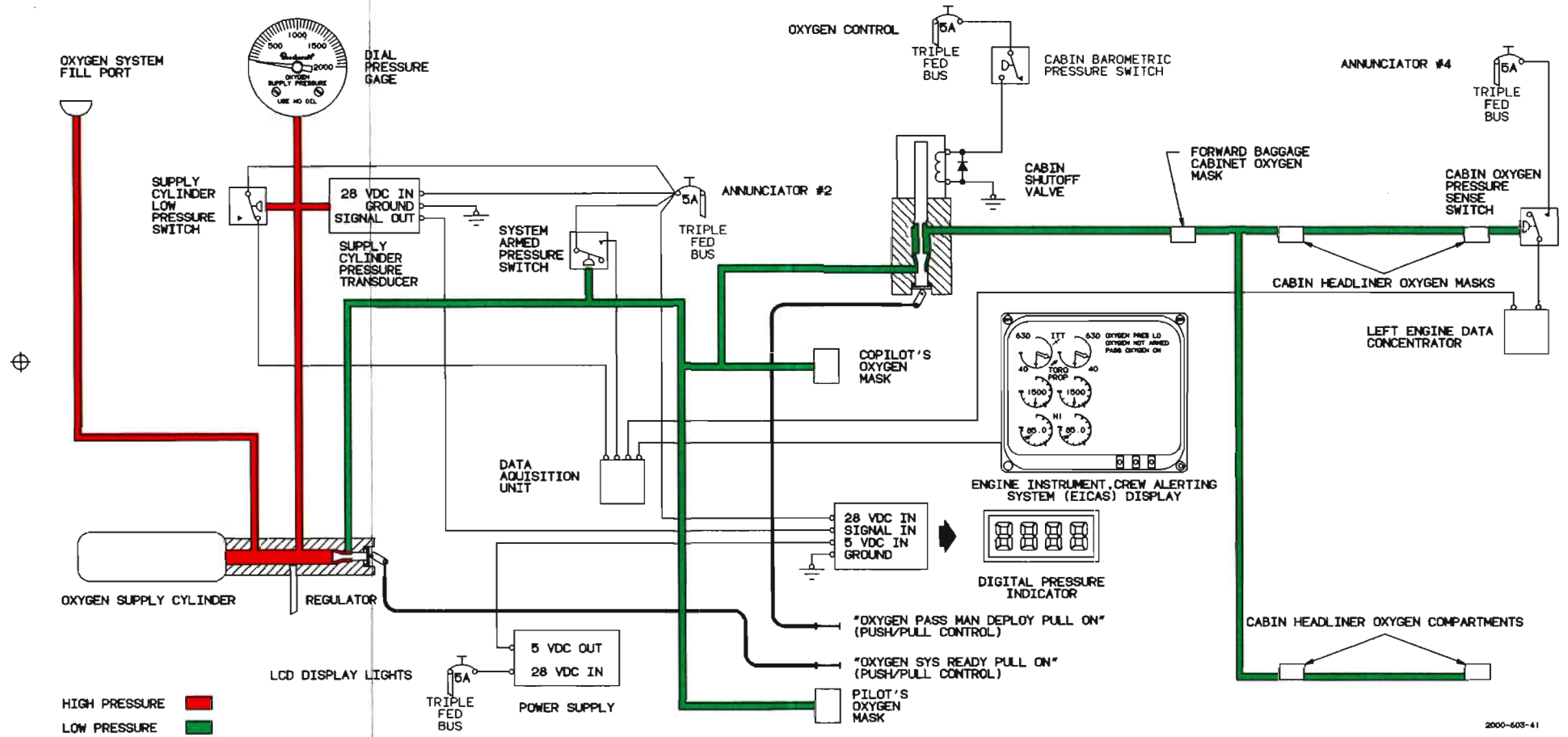

2000-603-41

Oxygen System Schematic

A standard 77-cubic foot oxygen cylinder provides oxygen for the crew and each passenger. A 115-cubic foot cylinder is offered as optional equipment. Each cylinder is of composite construction and mounted in the lower right nose compartment. Located adjacent to the cylinder and accessible through a removable cover is the cylinder fill-valve and high pressure oxygen gage. The oxygen cylinder must be filled with aviator's breathing oxygen to a pressure of 1850 \pm 50 psig at 70° F.

A SYS READY - PULL ON handle located on the pilot's right subpanel opens and closes the shut-off valve located at the oxygen supply cylinder. The primary oxygen supply line delivers oxygen at 70 \pm 10 psig to the crew and passenger oxygen outlets. Any time the primary oxygen supply line is charged, oxygen is available to the crew.

The crew is provided with EROS automatic pressure breathing diluter-demand, quick-donning oxygen masks with integral microphones. The masks are stored in the sidewalls of the cockpit just aft of the instrument panel. The crew masks should always be plugged in and stowed so that oxygen will be immediately available when required. This will not cause a loss of oxygen since demand masks deliver only upon inhalation.

To don the mask, grasp the hose at the mask and remove the mask from the storage compartment. Inflate the mask harness by squeezing the red lever on the left side of the regulator, then don the mask and release the lever.

Three modes of operation are available to the crew: NORMAL, 100% and EMERGENCY. NORMAL or 100% is selected by a lever located on the bottom right side of the mask regulator. With the mask in the NORMAL position at cabin altitudes less than 30,000 feet, the masks operate in the diluter-demand mode, delivering diluted oxygen only upon inhalation. At cabin altitudes between 30,000 and 35,000 feet, the masks operate in the 100% mode, delivering oxygen only upon inhalation. At cabin altitudes greater than 35,000 feet, the masks operate in the pressure breathing mode, delivering undiluted oxygen to the user at a positive pressure.

With 100% selected, undiluted oxygen will be supplied upon inhalation at cabin altitudes less than 35,000 feet. This position should be selected for mask stowage to ensure a maximum safety margin should a rapid cabin depressurization occur.

EMERGENCY mode is selected by turning the control knob located on the bottom of the mask regulator to the EMERGENCY position. In this position, undiluted oxygen is supplied at a positive-pressure regardless of cabin altitude. Emergency mode should be used anytime smoke or fumes are present.

After donning the mask, check the flow indicator in the oxygen supply hose to ensure oxygen is being supplied to the regulator (red-no flow; white-flow). The crew masks can be donned with the use of one hand. The masks contain microphones which allow continued communication while the masks are being worn.

The passenger-oxygen system is of the continuous flow type. Masks are provided for each passenger and deployed from overhead oxygen mask compartments. A mask is also available in the toilet area and deployed from an overhead oxygen mask compartment. These masks are automatically presented to the passengers

anytime the cabin pressure altitude exceeds 12,500 feet. The pilot can manually deploy the passenger oxygen masks by pulling out PASS MAN DEPLOY handle. Oxygen can be shutoff and the remaining oxygen isolated to the crew by pulling the oxygen control circuit breaker and pushing the PASS MAN DEPLOY handle to the OFF position.

Three messages are displayed on the EICAS to notify the crew of the status of the oxygen system along with a digital oxygen cylinder pressure display. The digital pressure display, located on the copilot's left subpanel, is driven by a pressure transducer located near the oxygen cylinder. The OXYGEN NOT ARMED message will be displayed when the OXYGEN SYST READY - PULL ON handle is in the OFF position. The OXYGEN PRES LO message will display if the pressure in the oxygen bottle is less than approximately 500 psi or as the pressure drops below that value during use. The PASS OXYGEN ON message will be displayed when the passenger oxygen supply line is charged.

PITOT AND STATIC AIR SYSTEM

Dual, electrically-heated, pitot-static probes are located on the forward nose section. Each probe is equipped with a self-limiting heating element for anti-ice/deice protection and to prevent probe overtemperature.

When the STATIC SOURCE switch on the pilot's left subpanel is in the NORM position, the system is plumbed such that pilot and copilot static sources are used together. In the case of a malfunction in either the pilot or copilot static air source, place the STATIC SOURCE switch to the ISOLATED position. This closes both solenoid valves, allowing the left and right pitot static ports to be used only for their respective sides.

The pilot's air data computer is connected to the left pitot static system. The copilot's air data computer, landing gear warning switch, standby airspeed indicator, altimeter, cabin differential pressure indicator, deice pressure indicators, and CAB ALT HI pressure switch are connected to the right pitot system.

Pitot-Static probe heater switches located in the ICE PROTECTION panel on the pilot's right subpanel are placarded PITOT/STATIC - PILOT - COPILOT.

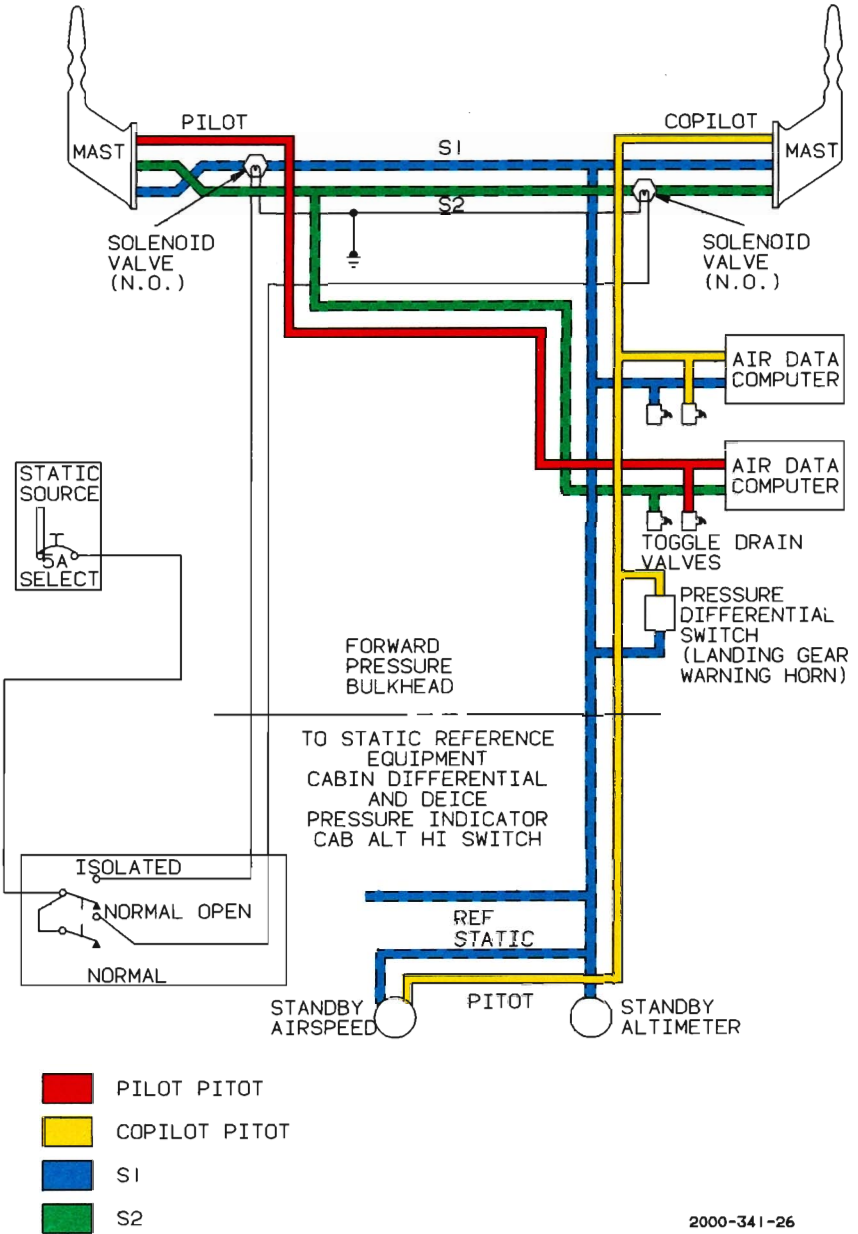

2000-341-26

Pitot and Static Air System Schematic

STALL WARNING SYSTEM

The stall warning system constantly monitors the airplane angle-of-attack and elevator position to determine airplane attitude with respect to impending stall. This determination is biased by power lever and flap position to account for configuration change as it affects stall speed. The system utilizes these inputs to signal a stall warning in the form of a column shaker, column pusher and warning horn. The system utilizes two independent stall warning computers. Each computer has its own power distribution, computation, monitoring, testing and warning functions. The computers process signals from its AOA transmitter, elevator position sensor and power lever position switch along with shared signals from the flap position sensor and squat switch (weight on wheels) sensor to provide outputs to the column shaker, column pusher and stall warning horn. Each computer will also display a STALL WRN FAIL message if it detects a failure during the test mode or during flight.

An ANGLE OF ATTACK indicator and AOA LEFT RIGHT switch are on the pilot's outboard side panel. The indicator provides a means to monitor system operation during preflight and flight operations. The LEFT RIGHT switch selects the side that provides input to the indicator.

NOTE

The angle of attack system on this airplane is installed only as a component of the stall warning system and is not designed for, nor is it usable for flying any type of angle of attack referenced maneuver.

Either computer can supply an activation signal to the control column shaker. The activation signal threshold is a predetermined value of either the elevator or AOA sensor position and is sent when either computer senses a threshold value from either sensor.

Simultaneous action by both computers is required to activate the column pusher. The computers provide a signal based on a predetermined threshold value of angle-of-attack only, which is independent of elevator position. The right computer provides power to the pusher clutch and the left computer provides power to the pusher motor. An autopilot disconnect signal is supplied by each computer when the column shaker operating threshold is reached. If any of these signals are absent, column pusher action cannot occur. The column pusher will not function if the flaps are extended. The pusher motor signal from the left computer can be interrupted by actuation of the FLAP/TRIM - PUSHER - INTER - AP/YD DISC switch. When the threshold for push is sensed by either computer, a 1.5 second internal timer is started. If the airplane angle-of-attack has not been reduced below the threshold by that time the stall warning horn is activated. A G-switch will not allow the pusher to function when less than 0.5 g is sensed.

ANGLE OF ATTACK TRANSDUCER

The angle of attack (AOA) transducers are powered through the LEFT STALL or RIGHT STALL circuit breakers located in the WARNING group on the left circuit breaker panel. A paddle vane and a potentiometer are connected inside the airstream sensing probe. Pressure differential relative to the center of the

airstream causes the paddle vane to turn and the potentiometer to output a signal to the stall warning computer.

BLEED AIR PNEUMATIC SYSTEM

High-pressure bleed air from each engine compressor, routed through the firewall shutoff valves and regulated, supplies pressure for various systems and a vacuum source.

BLEED AIR WARNING SYSTEM

A bleed air warning system is provided to warn of excessive heat caused by bleed air line rupture or leakage. A failure is indicated by the illumination of a bleed fail warning annunciator. Should an illumination occur of the L BLEED FAIL warning annunciator, place the BLEED AIR VALVES selector to the R ENG position. Likewise, to the L ENG position if the R BLEED FAIL annunciator illuminates. If the FUS BLEED FAIL warning annunciator illuminates, place the selector to the EMER position. The EMER BLEED ON status message will now appear on the EICAS.

A caution (L BLEED OFF and R BLEED OFF) message on the EICAS is provided to inform that an engine bleed air valve is not open. With the indication that the left bleed air valve is closed, place the BLEED AIR VALVES selector to the R ENG position. The illumination of the R BLEED OFF message would have the selector placed to the L ENG position.

AIR DISTRIBUTION SYSTEM

The forced air distribution system provides passenger comfort, avionics cooling, and windshield defrosting. The system incorporates both forward and aft ventilation blowers that provide air flow through a system of lightweight insulated sidewall and overhead air ducts.

AIR RETURN

Air return for the forward ventilation blower is taken from the lower portion of the cabin through openings in the floor keel structure. Once the air penetrates the keel, it is drawn under the floor towards the forward pressurized environmental box. A portion of this return air is dumped overboard by the pressurization outflow valves, the remainder of the air is filtered and redistributed by the ventilation blower.

The aft ventilation blower draws return air from the upper portion of the cabin through the aft baggage area. This air is filtered as it passes through the aft evaporator prior to redistribution.

AIR DELIVERY SYSTEM

The ventilation blowers are designed with divided blower housings and dual impeller wheels to allow for distribution of two different air temperatures when heating of the airplane is selected. This is accomplished by providing separate

duct systems to each half of the dual flow ventilation blowers and supplying engine bleed air to one inlet of the blower housing (opposite motor side) for mixing with cabin return air and redistribution to the lower duct system. The opposite inlet side (motor side) of the blower housing will deliver filtered cabin return air for avionics cooling or the cabin overhead duct system. When cabin cooling is selected, all of the cabin duct systems will be supplied refrigerated cooling air for the cabin and avionics. The overhead duct system utilizes WEMAC outlets which incorporate flow and directional adjustments. The lower duct system diffuses air from the lower consoles towards the floor for the full length of the cabin for best air distribution and temperature control.

The cockpit duct system has push/pull controlled outlets on the lower side of the avionics cooling plenum duct. Two outlets in the instrument panel and the overhead console provide additional cockpit airflow variation.

AVIONICS COOLING

The avionics equipment requires forced air cooling for proper operation. The forward vent blower is the primary source of avionics cooling and operates at the speed selected by the CKPT/CABIN BLOWERS control on the copilot's left subpanel. For the blower to operate either generator must be on line or an external power source must be in use. The blower will then function with the actuation of any one of the three INTEGRATED AVIONICS switches. Should the blower fail, an airflow sensor mounted in the ducting system will activate a yellow AVIONIC AIR FAIL message on the EICAS. The pilot should follow the appropriate procedures found in the AIRPLANE FLIGHT MANUAL, SECTION IIIA, ABNORMAL PROCEDURES.

When the airplane is operated in the air conditioner mode, the avionics will receive a portion of this conditioned air for cooling. During cold day operations when the airplane is in a heating mode, the avionics will be cooled using cabin return air. The cockpit ducting is a divided system that maintains separation of avionics air and cabin air. The portion of the avionics cooling plenum duct that supplies cooling air to the avionics has six ports that ducts air directly to the large EFIS units. The exhaust of these units is allowed to rise through the instrument panel glareshield and recirculate with the cockpit return air. The smaller EFIS units in the panel use this exhaust air for cooling. The avionics cooling plenum continues around the cockpit right side to supply air to the IAPS card cage located behind the copilot seat. The air that passes through the card cage is ventilated into the return air flow beneath the right floorboard.

ICE PROTECTION SYSTEMS

GROUND ICING DETECTOR SYSTEM (OPTIONAL)

The optional Ground Icing Detector System is composed of the following items:

1. A Rosemount Ice Detector (identical to the two ice detectors used for the surface deice system) mounted on the upper surface of the nose. The ice detector consists of a cylindrical probe mounted on an airfoil-shaped base.
2. A test switch located on the pilot's right subpanel, placarded GND ICE DETR-TEST/NORM.
3. A 15 amp circuit breaker, placarded GND DETR, located on the Aux circuit breaker panel.
4. Three messages on the EICAS display; ICING (in yellow and white), and STBY DEICE FAIL (yellow). These messages are also a part of the Surface Deice System and serve a dual purpose.

The system is designed to detect atmospheric icing conditions on the ground and to notify the pilot with a yellow or white ICING message; yellow if the icing equipment is off, and white if all icing equipment is on. The system is automatically activated after the first generator is turned on. When .020 inches of ice accumulate on the probe the heater is activated to melt the ice on the probe and the mounting base. This heat mode continues for only about 5 seconds after the ice is melted from the cylindrical probe. The duration of the heat mode is not sufficient to completely deice a probe and base that have accumulated significant amounts of ice prior to engine start. If the ice detector is not deiced prior to engine start, ice contamination at the junction of the cylindrical probe and the base may cause a system failure, denoted by the illumination of the STBY DEICE FAIL message.

During ground operations, activation of the heat mode will cause the appropriate ICING message to illuminate for a minimum of one minute. The one minute cycle begins again each time the deiced probe accumulates another .020 inches of ice. The ice detector continually performs a self test sequence and will cause the STBY DEICE FAIL message to illuminate on the ground if a fault is detected. When the left main gear squat switch is deactivated during the takeoff roll, all messages are inhibited. Thus, if a failure of the Ground Icing Detector System is detected in flight, it will not be annunciated until the squat switch is reactivated during the landing roll. In flight any ICING or STBY DEICE FAIL messages are associated with the surface deice system. On the ground, THE STBY DEICE FAIL message could be associated with either the Surface Deice system or the Ground Icing Detector System. Normal and Abnormal procedures associated with the Ground Icing Detector System are contained in the FAA Approved Flight Manual Supplement. See Section VII in the FAA Approved Airplane Flight Manual.

(This Page Intentionally Left Blank)

STALL WARNING

Each transmitter contains an internal heater. Primary power for the heaters is supplied by the LEFT STALL WARNING and RIGHT STALL WARNING circuit breakers, located in the ICE PROTECTION group on the left circuit panel, and switched through the STALL switch in the ICE PROTECTION group on the left inboard subpanel. The 157 watt probe heater is provided for deicing and anti-icing. Heater current is controlled by internal circuitry which limits the current to prevent heater burnout in still air, but still provides sufficient power for on-ground deicing. An output from the transmitter to the stall warning computer monitors the probe heater current. If a fault occurs, or if heater power is absent, either computer will output a failure signal, which will be displayed on the EICAS as L STALL WARN FAIL or R STALL WARN FAIL.

Secondary heating power is supplied directly to the transmitters from the LEFT STALL WARNING and RIGHT STALL WARNING circuit breakers to power the 50-watt case heater which is thermostatically controlled to supply additional heat when needed.

PITOT/STATIC

Heating elements are installed in the pitot masts located on the nose. Each heating element is controlled by an individual circuit breaker switch placarded LEFT - PITOT STATIC - RIGHT located in the left circuit breaker panel in the ICE PROTECTION group. The system is activated by a switch placarded PITOT/STATIC - PILOT - COPILOT located on the pilot's right subpanel.

Actuation of these switches results in the powering of the electric heaters in the pilot's and copilot's pitot/static air masts. The heater power comes from the LEFT PITOT STATIC and RIGHT PITOT STATIC circuit breakers in the ICE PROTECTION area of the left circuit breaker panel.

FORWARD/SIDE WINDSHIELD/COCKPIT WINDOWS ANTI-ICE/DE-ICE SYSTEM

The pilot's and copilot's forward/side windshields are heated. The system incorporates a controller, temperature sensing element, wiring and power source. The pilot's side has a redundant controller.

The pilot's windshield is electrically heated by either of the two controllers. Both controllers have individual temperature sensors for overtemperature protection. In the event of a controller failure, the other controller may be selected by the PILOT WSHLD CONTROL - STBY -NORM lever-lock switch located in the ICE PROTECTION panel of the pilot's right subpanel.

The heating elements are controlled by the WINDSHIELD PILOT COPILOT - HIGH - LOW - OFF lever-lock switches located in the ICE PROTECTION panel of the pilot's right subpanel. The LOW setting heats all the windows and should be adequate for most conditions. For severe conditions, HIGH concentrates the heat to the windshield centers and more than doubles the heat to that area. The heat is thermostatically controlled to maintain a glass temperature between 88°F and 110°F.

There is no announcement of windshield heat system status. For preflight and inflight checks, the pilot may verify system operation by an increase (approximately 14% for HIGH and 12% for LOW) on the loadmeter.

To preflight-check the windshield heat, ensure the glass is cool enough for the thermostat to demand heat, then observe the loadmeters while switching the windshield heat to ON.

The controllers, temperature sensing elements, wiring, and power source are redundant for the pilot's side only. A separate PILOT WSHLD CONTROL switch with NORM and STBY positions is used in the event of a controller failure.

NOTE

Standby compass is erratic when windshield anti-ice is on.

FUEL VENT HEAT

Electrically heated fuel vents consist of a resistive heating element wrapped around the fuel vent tube which protrudes through the lower surface of the main (aft) wing. The fuel vent heaters are controlled by two switches located in the ICE PROTECTION panel of the pilot's right subpanel placarded VENT/CABLE - LEFT - RIGHT - OFF.

ENGINE POWER CABLE HEAT

The engine power cables are electrically heated from the fuselage outboard to the engine nacelles. Power cable heat is controlled by the fuel vent/power cable heat switches located in the ICE PROTECTION panel of the pilot's right subpanel and placarded VENT/CABLE - LEFT - RIGHT - OFF.

ENGINE ANTI-ICE SYSTEM

The induction air inlet separators consist of two movable vanes actuated by a single actuator with redundant motors. The first vane reduces the inlet area and increases the airstream velocity. The heavier moisture and ice particles concentrate in the outside portion of the turning air mass due to centrifugal force. The second vane opens a bypass air duct which ejects the air containing the high concentration of moisture or ice particles overboard.

Engine ice protection controls, consist of two sets of switches on the pilot's right subpanel placarded ENGINE ACTUATORS - STBY - MAIN - LEFT - RIGHT - OFF.

ICE LIGHT

An ice light is provided to illuminate the outboard portion of the left main (aft) wing. A second (optional) light is available for the right wing.

SURFACE DEICE SYSTEM

The surface deice system is fully operational upon completion of the preflight test. The system is self monitoring and has the capability of displaying system messages on the EICAS unit. Component redundancy is provided up to the boot control valves. The system also incorporates a manual back-up system. The system will shut down for 40 seconds any time the Flap/Fwd wing is cycled to prevent the forward wing boots from being damaged while the wing is in motion.

The system controls are located on the ICE CONTROL panel on the pilot's right subpanel. The FWD WG MAN - AUTO - SEQ and MAIN WG INBD MAN - AUTO - OUTBD MAN switches are spring loaded to the AUTO position for normal (automatic) operation. The L - R PNEU indicator provides a digital display of system pressure.

NORMAL (AUTOMATIC) OPERATION

An ice detector is installed on each side of the lower forward area of the nose. The ice detectors sense an ice accretion of 0.020 inches and send a signal to the counter within the main and standby system controllers. The counter then monitors for eight ice detector cycles before starting normal surface deice operation. The surface deice system cycles the forward wing, main outboard wing, and main inboard wing for eleven seconds each. The counter is then reset and again monitors for eight ice detector cycles.

If the main ice detector (left side) fails, or has lost power, or the main controller fails, the system automatically switches to the standby system. The system completes the automatic cycle and resets the counter. The system will continue to operate on the standby system.

MANUAL SWITCH POSITION

Selecting the momentary manual position (FWD WG or MAIN WG) will cause the boots to pressurize for as long as the switch is held in the MAN position. The MAIN WG switch has MAN (momentary) positions for both the INBD and OUTBD boots. The FWD WG has one MAN position.

The SEQ position of the FWD WG switch will cycle the complete boot system as if the ice detector had signaled for a normal cycle. The SEQ switch does not have to be held in the activated position to complete the cycle.

NOTE

Refer to the AIRPLANE FLIGHT MANUAL SECTION II LIMITATIONS, SECTION IIIA ABNORMAL PROCEDURES or SECTION IV NORMAL PROCEDURES for specific procedures.

VACUUM TEST SWITCH

A push button switch, placarded SURFACE DEICE - VAC and located on the TEST PANEL on the pilot's left subpanel, provides for testing of the vacuum system used for boot deflation. Refer to ICING FLIGHT in SECTION IV of the AIRPLANE FLIGHT MANUAL NORMAL PROCEDURES for specific procedures.

- ▣ CROSSFEED VALVE
- Ⓟ PRESSURE SENSING SWITCH
- Ⓥ VACUUM SENSING SWITCH
- ▭ FLOW CONTROL VALVE
- HEATED DEICE VALVE
- ▽ ENGINE BLEED AIR PORT
- ⬠ PRESSURE REGULATOR
- ⊠ CHECK VALVE PLUS ORIFICE
- SEPARATOR
- ⊠ EJECTOR
- ▽ FIREWALL SHUTOFF VALVE

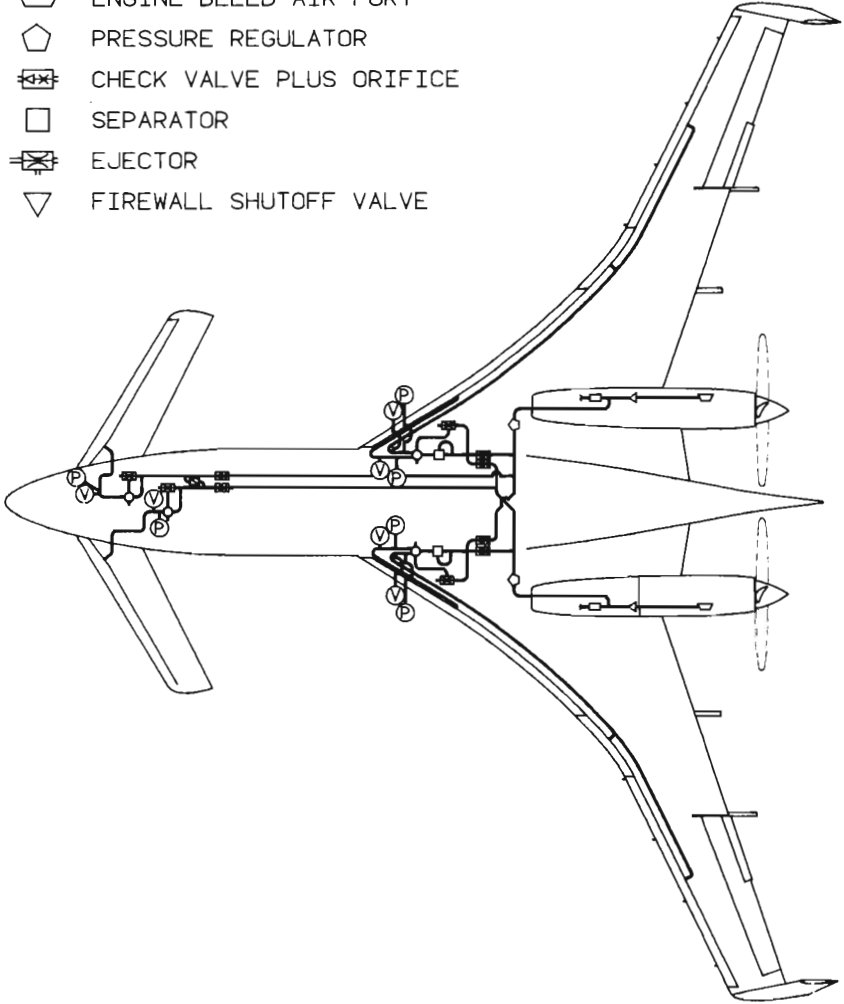

2000-603-124

Surface Deice System Schematic

COMFORT FEATURES

TOILET

The toilet is located forward of the aft baggage compartment in a separate partitioned area with two sliding doors. The toilet is positioned sideways, facing inward on the aft right corner of the airplane. Access is gained to the toilet by raising the hinged lid.

RELIEF TUBES

A relief tube is provided in the aft baggage compartment. A relief tube is also installed in the cockpit and stowed under the pilot's seat.

A valve lever is located on the side of the relief tube horn. This valve lever must be depressed at all times while the relief tube is in use.

NOTE

The relief tubes are for use during flight only.

CABIN FEATURES

FIRE EXTINGUISHERS

Two fire extinguishers are installed as standard equipment, one on top of the chart storage shelf behind the copilot's seat, and one on the floor beside the forward baggage compartment in the cabin area.

WINDSHIELD WIPERS

The dual windshield wipers have two speeds, plus a delay mode. The wipers are controlled by a WINDSHIELD WIPER - OFF - INTMT - SLOW - FAST switch located on the overhead control panel.



Do not operate windshield wipers on dry glass.

SUNVISORS

Two sunvisors, one for the pilot and one for the copilot, are provided. Each sunvisor is universally adjustable to prevent glare and glare-caused washout of the CRT displays.

FLIGHT INSTRUMENTS

All CRT display units except the Sensor Display Unit (SDU) use high resolution, high contrast color displays. The SDU uses a monochrome display.

The CRT displays replace the traditional flight instruments as follows:

Electronic Display	Features
Primary Flight Display (PFD)	Attitude Indicator, Marker Beacon Lights, and Autopilot Mode Annunciator. Also reversionary source for ND.
Navigation Display (ND)	Choice of formats; HSI, Radar, or ARC/MAP. Also reversionary source for PFD.
Airspeed Indicator (ASI)	Airspeed Indicator, Airspeed Trend Indicator, TAS Display, Air Temperature Indicator, and IAS bug.
Altitude Indicator (ALI)	Altimeter, Vertical Speed Indicator, Altitude Select Panel and V/S Set Bug.
Sensor Display Unit (SDU)	Choice of formats, RMI, VLF, VOR, and DME. When received the marker beacon identification is also displayed. Also provides HSI mode as backup to Navigation Display under low power option.
Engine Instrument, Crew Alerting System (EICAS)	Engine Instruments, and expanded messages.
Multifunction Display (MFD)	Weather Radar Moving Map, integrated with radar. Checklist visual aid. Joystick waypoint positioning. Diagnostics. Backup to EICAS display.
Control Display Unit (CDU)	FMS, menu driven. Automatic radio tuning from flight plan data. Database retrieval of nav aids and airports.

BRIGHTNESS AND BALANCE

The NDs, PFDs, EICAS and MFD incorporate both BRT and BAL controls. Unit brightness (BRT) is provided to adjust maximum display brightness for the cockpit user. The BRT control should be adjusted for high ambient light conditions with the overhead light master switch OFF by rotating the knob fully CW then CCW until CRT dimming is just noticed.

NOTE

Leaving the BRT knob in the full CW position will bias the brightness circuitry and defeat any overhead light dimming control capability.

Unit balance or trim (BAL) adjustment is used for lighting balance between displays after BRT adjustment and is used to allow override control of brightness in the event of overhead light dimmer failure. It should be a nominally centered adjustment for pilot preference with the overhead light master switch OFF.

Overhead light panel dimming control is provided for zone (pilot, copilot and center panel area) dimming of the displays. The zones should be adjusted for low light conditions with the overhead light master switch ON. Once set, the pilot may switch between states of high and low ambient light conditions by simply pushing the overhead master light switch OFF or ON, respectively.

NOTE

Dimming changes are slewed within the CRTs and do not occur immediately.

OVER TEMPERATURE WARNING

If the NDs, PFDs, EICAS or MFD internal temperature monitor detects an approaching thermal cutoff, the affected CRT will display a red boxed DISPLAY TEMP, which will flash for ten seconds before becoming steady. If the condition continues the tube will shut down. As the tube cools down it will come back on line.

ALTITUDE/VERTICAL SPEED INDICATOR (ALI)

The ALI integrates the altimeter and vertical speed indicator (VSI). The altitude display consists of a circular scale and pointer which segments each hundred feet into twenty foot increments. In the center of the circular scale is a rotating drum which displays thousands and hundreds of feet. The VSI scale indicates ± 6000 fpm and is inside the altimeter scale. The portion of the VSI scale beyond ± 1000 fpm is displayed when the vertical speed is greater than ± 600 fpm and is removed when the vertical speed is less than ± 300 fpm. Altitudes below sea level are indicated by the display of a yellow NEG. The VSI indicates with a green arc.

BAROMETER SETTING

The altimeter setting is changed by turning the BARO knob. The setting can be displayed in either inches of mercury or millibars as determined by the BARO MB - INCHES switches on the pilot's and copilot's reversionary panels. Dependent upon the reversionary switch position, depressing the center of the BARO knob will select either 29.92 in Hg or 1013 mb.



2000-390-059

ALTITUDE INDICATOR AND ALTITUDE AWARENESS PANEL

ALTITUDE PRESELECT

The altitude preselect is set with the ALT SEL knob. The display momentarily becomes magenta if the left and right side preselect values do not agree and a preselect altitude is changed.

ALTITUDE ALERT

The ALT SEL knob is used to send a preselected altitude to the Automatic Flight Control System (AFCS) and to arm the altitude alerting system. When climbing or descending to a preselected altitude, the digits flash off and cyan when within 1000 feet, but more than 200 feet from the preselected altitude. After the altitude has been captured the digits are displayed as steady cyan. Once established at the preselected altitude, if the indicated altitude changes by more than 200 feet, the system will sound an aural warning and the digits will flash yellow. The digits will also flash yellow at ± 1000 feet from the captured altitude. Altitude alerts are cancelled by depressing the push button in the ALT SEL knob. When not cancelling an alert, depressing the push button in the ALT SEL knob tests the aural warning.

FLIGHT LEVEL 180 ALERT

When climbing through 17,800 feet, if the barometric pressure setting has not been set to either 29.92 in Hg or 1013 mb, the barometer set digits will begin to flash cyan. When descending the barometer set digits will begin to flash cyan at 18,500 feet.

Flight level 180 alerts may be cancelled by either turning the BARO set knob, pushing the button in the center of the BARO set knob, or disabling the alert function using either the pilot's or copilot's FL 180 DISABLE ALERT switches.

REFERENCE BUG

The center knob sets the vertical speed reference bug which can be positioned anywhere along the edge of the vertical speed scale. The setting will be repeated digitally in the upper left corner of the indicator in thousands of FPM. The vertical speed reference bug appears whenever the vertical speed reference knob is turned. It is toggled on or off by depressing the push button in the center of the vertical speed reference knob. The maximum range is ± 9900 feet per minute. If vertical speed information is missing, VS flashes yellow.

INITIALIZATION

The ALI requires a minimum of ten seconds to warm up from a cold start. Following warm-up, a copyright statement is displayed in blue near the center of the display for approximately 12.5 seconds.

IN-LINE MONITORING

Essential functions are monitored during operation. If any of these functions become invalid or are lost, the display is blanked.

FAILURE MODES

Internal failures cause loss of display. Failure of the input data source causes a red box with ADC inscribed in white to flash in the center of the display for 10 seconds before becoming steady.

ALTITUDE AWARENESS PANEL (AAP)

The Altitude Awareness Panel provides controls for decision height (DH) selection, reporting altitude (RPT), minimum descent altitude (MDA) and radio altimeter self test (RA).

Depress the center of the DH switch to select or deselect the decision height display on the PFD. To select the decision height rotate the DH SET knob. The RA TEST push button switch initiates the radio altimeter self test function. When depressed the PFD should indicate an altitude of 50 feet. The RPT/MDA switch selects either reporting altitude (RPT) or minimum descent altitude (MDA). Depressing the center of the RPT/MDA SET switch will select or deselect the RPT

or MDA display on the PFD. Rotation of the MDA/RPT SET knob changes the selected RPT/MDA display on the PFD.

AIRSPEED INDICATOR (ASI)

The ASI incorporates a circular scale which extends from 60 to 320 Kts with a green pointer for the airspeed needle and a digital readout in the center with one knot resolution. During acceleration or deceleration in flight, an airspeed trend vector (a magenta arc projected from the tip of the ASI needle in the direction of its movement) displays the computed change in airspeed that will occur in the next ten seconds assuming no change in acceleration or deceleration. TAS is displayed in the upper left corner of the ASI display. Indicated Outside Air Temperature (IOAT) is displayed in the lower left corner of the display. Depressing the OAT/ISA push button will toggle the temperature display between ISA and OAT. Depressing the push button once will display OAT, which is the IOAT adjusted for compressibility. Depressing the push button twice within five seconds will display the temperature difference between ISA and OAT. These temperature displays are on a five second automatic timeout after which the display returns to IOAT.

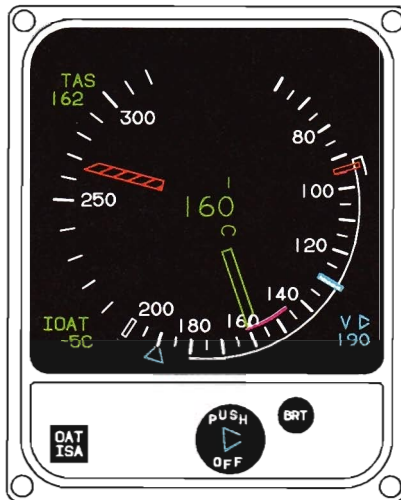

C9200568 C

AIRSPEED INDICATOR

REFERENCE BUG

The airspeed reference bug is manually set to a desired value by rotating the airspeed reference knob located below the ASI display. Pushing the button in the

center of the knob toggles the airspeed reference display on and off. The display can also be turned on (but not off) by rotating the knob.

The selected airspeed is also indicated by cyan digits in the lower right of the display. A vertical airspeed deviation indicator is displayed on the left side of the PFD.

DISPLAY MARKINGS

- The red striped V_{MO} pointer indicates the maximum operating airspeed for the existing flight conditions.
- The white box V_{LE} indicator indicates the maximum landing gear extension speed.
- The cyan box V_{YSE} line indicates the single engine best-rate-of-climb speed at the current altitude.
- The stationary red V_{MC} line indicates the minimum control speed.
- The stationary single white V_{FE} arc indicates the full flap operating range. The lower limit (V_{S1}) is the stalling speed at maximum weight with flaps retracted at idle power.
- The stationary dual white arc indicates the stall speed range. The lower arc limit is V_{SO} at maximum weight, flaps extended and idle power.
- In the event of an overspeed condition the IAS digits flash red for ten seconds and then become steady.
- The red ADC is displayed if the ADC computer fails. The message flashes for ten seconds and then becomes steady.

INITIALIZATION

A ten second warm-up is required from a cold start. Following warm-up, a copyright statement is displayed in blue near the center of the display for approximately 12.5 seconds.

AIR DATA COMPUTER (ADC)

Air data information (altitude, airspeed and air temperature) is converted to digital data and provided to the following: ASI, ALI, AHRS and the IAPS which includes the autopilot and flight director. From the IAPS this information is provided to the speed deviation indicator and the RTU for data transfer to the transponder.

STANDBY FLIGHT INSTRUMENTS

Three standby conventional instruments (Airspeed, Altimeter, and Attitude) are located below the center reversionary panel.

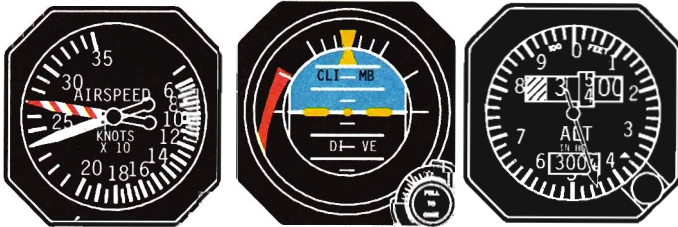

2000-390-036

STANDBY FLIGHT INSTRUMENTS

AIRSPEED INDICATOR

The standby airspeed indicator is a two-inch mechanical indicator and includes a variable V_{MO} indicator. The scale is marked from 60 to 350 knots. Electrical power is provided for illumination. The total pressure source for the indicator is the copilot's pitot-static mast. The static source is an average of the pilot's and copilot's pitot-static system. If the static source switch is placed in the ISOLATED position, the standby airspeed indicator is dependent upon the copilot's pitot-static source.

ALTIMETER

The standby altimeter is a two-inch mechanical indicator incorporating three drums and a pointer. Electrical power is provided for illumination and for an internal vibrator. The static source is an average of the pilot's and copilot's static sources. If the static source switch is placed in the ISOLATED position, the standby altimeter is dependent upon the copilot's static source.

ATTITUDE INDICATOR

The standby attitude indicator is a two-inch internal gyro indicator, operating on +28 VDC. It functions on an emergency battery during a complete electrical

failure. It will function and maintain $\pm 6^\circ$ accuracy for approximately nine minutes after removal of all electrical power, including the emergency battery.

CLOCKS

Digital clocks with liquid crystal displays are installed below the SDUs on the pilot's and copilot's instrument panels. Each clock contains a left and right display, each being capable of presenting three functions. The function abbreviation is shown at the bottom of each display.

The pilot's clock is the master clock for the airplane. The clock memory is powered by the hot battery bus.

LEFT DISPLAY

Trip Time (TRP) - This function starts and stops automatically using signals from the squat switch. A 45-second delay is built into this function to allow touch-and-go landings without resetting the timer.

Stopwatch Timer (SW) - This function is controlled using the start/stop (ST/SP) and zero/advance (Z/ADV) push buttons. The stopwatch displays elapsed time in hours, minutes, and seconds. Once initiated, other clock functions may be selected without affecting the stopwatch operation.

Downcounter Timer (DC) - This function is controlled using the SET, zero/advance (Z/ADV), and start/stop (ST/SP) push buttons. A given amount of time is preset into the display by the pilot. When the start/stop button is pushed, the time counts down to zero in hours, minutes, and seconds, then counts upward from zero with a flashing display to denote that zero has been passed. Once initiated, other clock functions may be selected without affecting the downcounter operation.

RIGHT DISPLAY

Local Time (LC) - The local time is displayed in a 24-hour format. The hours may be set using the SET and Z/ADV buttons. The minutes and seconds are the same values as used for the GMT clock.

Greenwich Mean Time (GMT) - The GMT time is displayed in a 24-hour format. The hours, minutes, and seconds may be set using the SET and Z/ADV buttons.

NOTE

The copilot's GMT display is synchronized with the pilot's clock when its GMT is reset.

Total Airplane Flight Hours (FHRS) - The flight hour meter is controlled by the squat switch and displays a running total of airplane flight hours in hours and tenths of hours. The flight time is rounded off to the nearest tenth of an hour and added to the previous total to obtain the running total. The display may be adjusted using a set switch located on the back of the clock and the SET and Z/ADV buttons on the face of the clock.

Five push buttons are located below the clock displays and perform the following functions:

ST/SP (Start/Stop) - Starts and stops the stopwatch timer or downcounter time, if either is displayed.

L SEL (Left Display Select) - Used to cycle through each function of the left display in the following order: TRP, SW, DC, blank display then back to TRP.

Z/ADV (Zero/Advance) - Zeros the stopwatch and downcounter, if displayed, and is used in setting the local time, GMT, downcounter, date, and total flight hours.

SET - Used in setting local time, GMT, downcounter, date, and total flight hours.

R SEL (Right Display Select) - Used to cycle through each function of the right display in the following order: LC, GMT, FHRS, blank display, then back to LC.

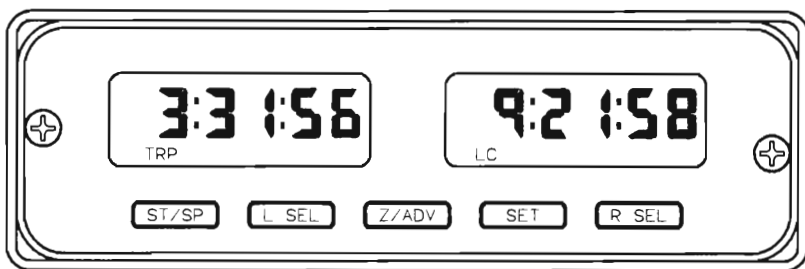

2000-390-035

CLOCK

USING AND SETTING THE CLOCK

STOPWATCH TIMER

1. Depress L SEL until stopwatch timer (SW) mode is reached.
2. Depress ST/SP to start or stop the timer.
3. Depress Z/ADV to reset timer to zero.

DOWNCOUNTER TIMER

1. Depress L SEL until downcounter timer (DC) mode is reached.
2. Depress SET and the hours will flash and SET will be displayed in the lower right corner of the display.
3. Depress Z/ADV to set the hours digits to desired value. (The first push zeros the display; subsequent pushes advance the hours.)
4. Repeat Steps 2 and 3 to set the minutes and seconds.
5. Depress SET and the seconds display will stop flashing, and SET will extinguish.
6. Depress ST/SP to start the timer. The counter will count down to zero and then begin to count up with a flashing display.
7. Depress ST/SP to stop the timer.
8. Depress Z/ADV to reset timer to zero.

GREENWICH MEAN TIME

1. Set left display to TRP or SW.

NOTE

If the left display is set to the DC mode, use of the set button will cycle through all DC digits before it affects the right display.

2. Depress R SEL until GMT mode is reached.
3. Depress SET and the hours will flash and SET will be displayed in the lower right corner of the display.
4. Depress Z/ADV to set hours digits to the desired value.
5. Depress SET and the hours will become steady and the minutes will flash.
6. Depress Z/ADV to set the minutes digits to the desired value.
7. Depress SET and the seconds will go to zero, and SET will extinguish.

LOCAL TIME

1. Set the left display to TRP or SW.

NOTE

If the left display is set to the DC mode, use of the set button will cycle through all DC digits before it affects the right display.

2. Depress R SEL until the LC mode is reached.
3. Depress SET and the hours will flash and SET will be displayed in the lower right corner of the display.
4. Depress Z/ADV to set the hours digits to the desired value.
5. Depress SET and the hours will become steady and SET will extinguish. The minutes and seconds are the same values used for the GMT clock. The minutes are set in the GMT mode and the seconds go to zero.

DATE

1. Remove the clock from the instrument panel following the instructions in Chapter 31 of the BEECHCRAFT Starship 1 Maintenance Manual.
2. Do not disconnect the electrical connector.
3. Using a screwdriver move the rotary switch to the SET DATE position. The display will blank, and the right display will show the month, day, and year; MM-DD-YY. The month will flash.
4. Depress Z/ADV to set the month.
5. Depress SET and the Days will flash.
6. Depress Z/ADV to set the day.
7. Repeat Steps 4 and 5 to set the year.
8. If SET is pressed again, the month will flash again, and the above process may be repeated.
9. Using a screwdriver move the rotary switch to the OFF position.
10. Install the clock in the instrument panel following the instructions in Chapter 31 of the BEECHCRAFT Starship 1 Maintenance Manual

TOTAL FLIGHT HOURS

1. Remove the clock from the instrument panel following the instructions in Chapter 31 of the BEECHCRAFT Starship 1 Maintenance Manual.
2. Do not disconnect the electrical connector.
3. Using a screwdriver move the rotary switch to the FHRS position.
4. The left display will blank, and the right display will show total flight hours, in hours and tenth of hours up to 99,999.9.
5. Each pair of digits is set using the SET and Z/ADV buttons.
6. Using a screwdriver move the rotary switch to the OFF position.
7. Install the clock in the instrument panel following the the instructions in Chapter 31 of the BEECHCRAFT Starship 1 Maintenance Manual.

(This Page Intentionally Left Blank)

ENGINE INSTRUMENT, CREW ALERTING SYSTEM (EICAS)

The EICAS displays engine data and annunciates airplane and avionic status in brief descriptive statements.

ENGINE DATA DISPLAYS

The EICAS engine displays are:

- Interstage Turbine Temperature
- Torque Meter
- Propeller Tachometer
- Propeller Sync
- Propeller Autofeather
- N1 Tachometer
- Oil Pressure
- Oil Temperature
- Fuel Flow

ITT-TORQ

Interstage Turbine Temperature and Torque indications for each engine are combined on circular displays with their respective digital readouts above and below the circular displays. ITT (white cross tip) is displayed in degrees centigrade and TORQ (green arrow tip) is displayed as a percentage of maximum allowable torque. The pointers and digital colors match.

ENGINE RUNNING

The displays have a white scale arc extending clockwise from the twelve o'clock position to the eight o'clock position which is divided into five equal segments.

The scale markings are:

Clockwise from twelve o'clock, each mark indicates either 100°C ITT or 20% TORQ.

YELLOW Arc	Yellow Caution Range	840°C - 850°C ITT
YELLOW ITT Symbol	Maximum Continuous Power	840°C ITT
CYAN TORQ Symbol	Maximum Normal Operating Power	80% TORQ.
RED Line	Maximum Limit	850°C ITT - 100% TORQ.
RED Triangle	Start Maximum Limit	1000°C ITT

BT00936

ENGINE START

The ITT scale arc extends clockwise up to a red start triangle. This scale extension is white and divided into segments with small scale marks representing 100°C ITT.

ITT OVERTEMP DISPLAY

When an ITT overtemp occurs, the pointer continues past the red line. The scale arc then extends past the red line to the pointer tip. The scale arc extension, pointer and digital readout are red. The scale factor and scale extension limits are the same as during engine start, however; in this case the scale does not extend beyond the pointer tip. ITT pointer travel is limited to the twelve o'clock position.



TYPICAL-OIL DISPLAY-SINGLE PAGE LIST



TYPICAL-OIL DECLUTTER-SINGLE PAGE LIST

2000-390-051

EICAS

OVERTORQUE DISPLAY

During an engine overtorque, the TORQ pointer continues past the red line. The scale arc extends past the red line to the pointer tip with each scale mark indicating 20% torque. The extended scale arc, scale marks, pointer and digital readout are all red.

PROP

The propeller rpm is shown on a circular analog display with a digital readout. Each propeller display has two distinct formats: a ground format for propeller speeds up to 1050 rpm, and a flight format for propeller speeds above 1100 rpm.

Up to 1050 rpm, the scale is a complete circle, divided into ten segments. Each scale mark corresponds to 100 rpm, so a complete pointer revolution corresponds to 1000 rpm. Since the format does not switch until 1100 rpm, the display will show normal ground operation propeller rpm without distracting format changes. Above 1100 rpm, the high rpm format is displayed until the propeller rpm has decreased below 1050 rpm, at which time the low rpm scale will return.

WHITE	Arc		0 to 690 RPM
RED	Arc		700 to 990 RPM
WHITE	Arc	Ground Operation	1000 to 1570 RPM
WHITE	Arc	Flight Operation	1000 to 1440 RPM
RED	Arc	Flight Operation	1450 to 1570 RPM
GREEN	Arc	Normal Operating Range	1580 to 1600 RPM
CYAN	Arc	Maximum Normal Operating Power	1610 to 1700 RPM
YELLOW	Arc	Yellow Caution Range	1690 to 1700 RPM
RED LINE		Limit	1710 RPM

BT00937

If propeller rpm exceeds the red line of 1700 rpm, the pointer continues clockwise and a red scale arc extends clockwise from red line to pointer tip. The pointer and digital readout are red during red line exceedances. Maximum pointer travel is to 1900 rpm on the scale. At propeller speeds above 1900 rpm, the pointer remains stationary at 1900 rpm but the digital readout continues to display propeller rpm up to 2200 rpm.

N₁

N₁ (gas generator) displays are circular with integral digital readouts. N₁ is displayed as a percentage of the gas generator speed of 37,468 rpm. A circular arc extends from the twelve o'clock position clockwise to approximately the nine o'clock position. Scale marks at the twelve o'clock and nine o'clock positions identify the 0% and 104% N₁. The pointers and digital readouts assume the color of the scale.

The scale markings are:

WHITE		0% to 64.9%
GREEN	Normal Operating Range	65% to 104%
RED Line	Maximum Limit	104%

BT00938

RED LINE EXCEEDANCE

In the event of a red line exceedance the pointer continues to rotate up to a maximum of 130%. The scale arc extends above the N₁ red line but not beyond the pointer. In this area the scale arc, scale marks, pointer and digital readout are all displayed in red.

If the N₁ data is unreliable, the scale is displayed but the pointer and digital readout are blanked.

SYNCHROPHASER DISPLAY

The propeller synchrophaser displays a series of square white boxes below the PROP display. When the boxes are motionless the left and right propeller rpm are synchronized. Relative motion is toward the side with a higher propeller rpm.

AUTOFEATHER DISPLAY

When the AUTOFEATHER switch on the center subpanel is set to arm, the AFX indication is displayed inside each PROP display and as a green AFX ENABLED message. This will occur only if the power levers are set above 90% N₁ with both engines functioning normally. If the right engine power drops a predetermined amount the left engine autofeather arm will be disabled. The AFX annunciator adjacent to the left PROP display is blanked but the AFX by the right PROP display

remains illuminated (left autofeather disabled, right autofeather armed). If the right engine power continues to drop and reaches autofeather threshold, the AFX annunciator at the right prop display is blanked and the right propeller is feathered. Thus, if autofeather is imminent on one side, cross-side autofeather is disarmed prior to on-side autofeather.

FUEL FLOW

Fuel flow to each engine is displayed as a digital readout of flow rate in pounds per hour. The display consists of a FUEL FLOW legend in white with green flow rates displayed digitally to its left and right.

OIL

PRESSURE

The oil pressure displays are dual vertical scales (one for each engine) with triangular pointers and digital readouts. The pointers and digital readouts assume the color of the scale.

The scale markings are:

RED	Minimum Limit	0 psi to 59 psi
YELLOW	Caution Range	60 psi to 89 psi
GREEN	Normal Range	90 psi to 135 psi
WHITE	Non-Approved Range	136 psi to 200 psi
RED	Maximum Limit	200 psi

BT00939

If an oil pressure data source has failed or is unreliable, the oil pressure pointer and digital display for that side are blanked.

TEMPERATURE

The oil temperature displays are dual vertical scales (one for each engine) with triangular pointers and digital readouts. The pointers and digital readout assume the color of the scale.

GREEN	Normal Range	0°C to 110°C
RED Line	Maximum Limit	110°C

BT00940

If an oil temperature data source has failed or is unreliable, the pointer and display for that side are blanked.

DSPL

An OIL DSPL key is provided to alternately display or suppress the oil pressure and oil temperature displays when all oil parameters are in their normal range. If the displays are suppressed they will automatically return if an oil temperature or pressure normal limit is exceeded.

CREW ALERTING DISPLAYS

The EICAS crew alerting display is a three-division list of messages regarding airplane and avionic systems status. Within each division, messages are shown in chronological order with the most current at the top. When a new message occurs, it is inserted at the top of the division. Once a message is displayed, it will remain for a minimum of four seconds.

CAUTION (YELLOW) Indicates a fault which requires immediate crew awareness and possible future crew action.

STATUS (WHITE) Indicates a condition which could be either normal or abnormal but does not require immediate crew alerting or action. These messages are displayed below the caution messages.

ADVISORY (GREEN) Confirms that an operation initiated or selected by the flight crew did occur as required. It does not require immediate crew alerting or any further action. These messages are displayed below the status messages.

When conditions for a new CAUTION message exist, the MASTER CAUTION annunciators flash. The flashing MASTER CAUTION annunciators can be extinguished by pressing the face of either of the flashing annunciators. Subsequently, when any caution annunciator illuminates, the MASTER CAUTION flashing annunciator will again be activated.

The total number of messages displayed at one time is limited by the display area. When more messages are current than the display area permits, the message list is divided into pages. The pages are numbered. The last page is denoted with an END after the last message.

The crew may review a multi-page list one page at a time by paging through the list. The keys Δ and ∇ are used to page up or down. Starting at page one the ∇ key is used to view pages two, three, etc. The Δ key is used to step back to the top of the list. Depressing either key causes the next page to be displayed. Holding either key results in a one second repeat of that key's function. The Δ key can not rollover from page one to the END page but the ∇ key allows rollover from the END page to page one. If the CAS fails a boxed red CAS flag will be displayed, which will flash for 10 seconds before becoming steady.

FAILURE MODES

The EICAS receives all inputs from two parallel data sources. The information is the same from both sources. These two parallel sources are redundant data bus drivers.

REVERSIONARY MODES

The EICAS has two reversionary modes. One transfers the entire EICAS display to the MFD. The other transfers the ITT, TORQ, PROP and N_1 truncated digital readouts to either RTU 1 or RTU 2.

To transfer the EICAS display to the MFD, set the EICAS switch on the center reversionary panel to REV.

To display ITT, TORQ, PROP and N_1 in truncated digital format, set the RTU 1 or RTU 2 switch on the center reversionary panel to ENG DATA.

TEST

The EICAS has no preflight, or inflight, crew activated test mode. A built in test routine is performed automatically during power up, and internal parameters are continuously monitored.

ANNUNCIATOR SYSTEM

The annunciator system consists of a WARNING annunciator panel with fourteen annunciators centrally located in the glareshield.

WARNING RED Indicates a hazard which requires immediate crew alerting and corrective action.

If the fault requires immediate crew alerting and corrective action, the appropriate red warning annunciator illuminates and both MASTER WARNING flashers begin flashing. Any illuminated annunciator will remain illuminated until the fault is corrected. However, the MASTER WARNING flashers can be extinguished by depressing the face of either MASTER WARNING flasher, even if the fault is not corrected. In such a case, the MASTER WARNING flashers will again be activated if an additional warning annunciator illuminates. When a warning fault is corrected, the affected warning annunciator will extinguish, but the MASTER WARNING flashers will continue flashing until one of them is depressed.

The brightness of the annunciators is controlled by the ambient light sensor located in the overhead lighting panel.

WARNING ANNUNCIATORS

NOMENCLATURE	COLOR	CAUSE FOR ILLUMINATION
L FUEL PRES LO	Red	Left fuel pressure is low.
L OIL PRES LO	Red	Left oil pressure is low.
DOOR UNLOCKED	Red	Cabin door not closed or locked.
CAB ALT HI	Red	Cabin altitude exceeds 10,000 feet.
ROLL TRIM FAIL	Red	Roll trim has failed.
L BLEED FAIL	Red	Left bleed air duct leak.
PITCH TRIM FAIL	Red	Pitch trim has failed.
FUS BLEED FAIL	Red	Fuselage bleed air duct leak.
RUD TRIM FAIL	Red	Rudder trim has failed.
R BLEED FAIL	Red	Right bleed air duct leak.
BATT CHG RATE	Red	Battery charging is abnormal.
CABIN DIFF HIGH	Red	Cabin pressure differential exceeds limits.
R FUEL PRES LO	Red	Right fuel pressure is low.
R OIL PRES LO	Red	Right oil pressure is low.
BT00721		

**EICAS MESSAGES
ATTITUDE GYRO (STANDBY)**

NOMENCLATURE	COLOR	CAUSE FOR ILLUMINATION
STBY ATTGYRO OFF	Yellow	Standby gyro power is not selected on.
STBY ATT BATT LO	Yellow	Battery pack for the standby attitude gyro is not charged to an adequate level.
STBY ATT BAT OK	White	Battery pack for the backup attitude display is charged to an adequate level.
STBY ATT BAT TST	White	Wait for battery test to be completed.
BT00726		

AVIONICS COOLING

NOMENCLATURE	COLOR	CAUSE FOR ILLUMINATION
AVIONIC AIR FAIL	Yellow	Insufficient air flow within avionics air distribution duct.
AV ALTN BLWR ON	Green	Alternate blower is operating for avionics cooling.
BT00727		

BLEED AIR

NOMENCLATURE	COLOR	CAUSE FOR ILLUMINATION
DUCT OVERTEMP	Yellow	Environmental duct air is too hot.
L BLEED OFF	Yellow	Left bleed air valve is not open.
R BLEED OFF	Yellow	Right bleed air valve is not open.
EMER BLEED ON	White	Emergency bleed air valve is open.
BT00715		

ELECTRICAL

NOMENCLATURE	COLOR	CAUSE FOR ILLUMINATION
L GEN INOP	Yellow	Left generator is off-line. Engine is not secured.
R GEN INOP	Yellow	Right generator is off-line. Engine is not secured.
L GEN TIE OPEN	Yellow	Left generator bus tie is open.
R GEN TIE OPEN	Yellow	Right generator bus tie is open.
BATTERY TIE OPEN	Yellow	Battery is isolated from generator buses.
EXT POWER CONN	White	External power unit is connected.
MAN TIES CLOSED	Green	Generator bus ties are manually closed.
BT00723		

ELECTRONIC FLIGHT DISPLAY

NOMENCLATURE	COLOR	CAUSE FOR ILLUMINATION
ROLL DISAGREE	Yellow	Number 1 and 2 displayed roll attitudes not in agreement.
PITCH DISAGREE	Yellow	Number 1 and 2 displayed pitch attitudes not in agreement.
HDG DISAGREE	Yellow	Number 1 and 2 displayed headings not in agreement.
LOC DISAGREE	Yellow	Number 1 and 2 displayed localizer deviations not in agreement.
GS DISAGREE	Yellow	Number 1 and 2 displayed glideslope deviations not in agreement.
ROLL COMP OFF	White	Roll comparator function is inoperative.
PITCH COMP OFF	White	Pitch comparator function is inoperative.
HDG COMP OFF	White	Heading comparator function is inoperative.
ALL COMP OFF	White	All comparators are inoperative.
BT00977		

ENGINE

NOMENCLATURE	COLOR	CAUSE FOR ILLUMINATION
L F/W VALVE FAIL	Yellow	Left fuel firewall valve has not reached its' selected position within 2 seconds.
R F/W VALVE FAIL	Yellow	Right fuel firewall valve has not reached its' selected position within 2 seconds.
L FUEL LEVEL LO	Yellow	Left fuel system contains approximately 135 pounds or less of fuel (level must be constant for 1 second).
R FUEL LEVEL LO	Yellow	Right fuel system contains approximately 135 pounds or less of fuel (level must be constant for 1 second).
L CHIP DETECT	White	Left engine oil contamination detected. Engine is not secured.
R CHIP DETECT	White	Right engine oil contamination detected. Engine is not secured.
L ENG SECURED	White	Left engine intentionally shutdown with propeller lever in feather, condition lever in cut-off, and firewall valve closed. This message replaces other messages normally displayed with a non-running left engine.
R ENG SECURED	White	Right engine intentionally shutdown with propeller lever in feather, condition lever in cut-off, and firewall valve closed. This message replaces other messages normally displayed with a non-running right engine.
FUEL TRANSFER >	White	Fuel is being transferred from the left to right fuel tank.
FUEL TRANSFER <	White	Fuel is being transferred from the right to left fuel tank.
L IGNITION ON	Green	Left engine ignition is on.
R IGNITION ON	Green	Right engine ignition is on.
BT00716		

FLIGHT CONTROLS

NOMENCLATURE	COLOR	CAUSE FOR ILLUMINATION
PITCH TRIM OFF	Yellow	Pitch trim is off.
PITCH TRIM SYNC	Yellow	Pitch trim is out of synchronization.
ROLL TRIM OFF	Yellow	Roll Trim is off.
ROLL TRIM SYNC	Yellow	Roll trim is out of synchronization.
RUDDER TRIM OFF	Yellow	Rudder trim is off.
RUD TRIM SYNC	Yellow	Rudder trim is out of synchronization.
L FLAP MON FAIL	Yellow	Left flap/forward wing monitor has failed the ground functional test.
R FLAP MON FAIL	Yellow	Right flap/forward wing monitor has failed the ground functional test.
BT00976		

ICE PROTECTION

NOMENCLATURE	COLOR	CAUSE FOR ILLUMINATION
ICING	Yellow	Ice detector is sensing icing conditions and all ice protection systems are not selected on.
L WING BOOT FAIL	Yellow	A left wing boot failed to inflate or deflate.
R WING BOOT FAIL	Yellow	A right wing boot failed to inflate or deflate.
L FWD BOOT FAIL	Yellow	Left forward wing boot failed to inflate or deflate.
R FWD BOOT FAIL	Yellow	Right forward wing boot failed to inflate or deflate.
MAIN DEICE FAIL	Yellow	Left ice detector is inoperative or primary auto deice controller has failed.
STBY DEICE FAIL	Yellow	Right ice detector is inoperative or standby auto deice controller has failed.
L ICE VANE FAIL	Yellow	Left engine ice vane has not reached its proper position within 30 seconds.
R ICE VANE FAIL	Yellow	Right engine ice vane has not reached its proper position within 30 seconds.
PNEU PRESS LOW	Yellow	Pneumatic system pressure is below 10 PSI and is too low to operate the deice boots.

ICE PROTECTION (Cont'd)

NOMENCLATURE	COLOR	CAUSE FOR ILLUMINATION
PITOT OVERHEAT	Yellow	Pilot and/or copilot pitot/static heat has been on for more than 2 minutes on the ground.
ICING	White	Ice detector is sensing icing conditions and all ice systems are selected on.
L ENG ANTICE ON	Green	Left engine ice vane is selected and operating and the left bleed air is turned on.
R ENG ANTICE ON	Green	Right engine ice vane is selected and operating and the right bleed air is turned on.
WSHLD STBY POWER	Green	Pilot's windshield standby heat system is operating.
BT04173		

LANDING GEAR

NOMENCLATURE	COLOR	CAUSE FOR ILLUMINATION
HYD FLUID LO	Yellow	Hydraulic fluid in power pack is low.
ANTI-SKID INOP	Yellow	Anti-skid system is inoperative.
POWER BRAKE INOP	Yellow	Power brake system is inoperative.
NS GEAR UP	White	Nose gear is fully retracted and alternate gear extension is selected.
L GEAR UP	White	Left gear is fully retracted and alternate gear extension is selected.
R GEAR UP	White	Right gear is fully retracted and alternate gear extension is selected.
NS GEAR IN TRANS	White	Nose gear neither fully extended or retracted and alternate gear extension is selected.
L GEAR IN TRANS	White	Left gear neither fully extended or retracted and alternate gear extension is selected.
R GEAR IN TRANS	White	Right gear neither fully extended or retracted and alternate gear extension is selected.
BT00725		

OXYGEN

NOMENCLATURE	COLOR	CAUSE FOR ILLUMINATION
OXYGEN NOT ARMED	Yellow	Oxygen system is not armed.
OXYGEN PRES LO	Yellow	Oxygen pressure is below 500 psi and the system is armed.
PASS OXYGEN ON	White	Passenger oxygen system is charged.
BT00722		

PROPELLER

NOMENCLATURE	COLOR	CAUSE FOR ILLUMINATION
AFX OFF	Yellow	Autofeather system is not armed.
AFX DISABLED	Yellow	Autofeather is selected, power levers have been advanced to a high N ₁ position, but the ARM signal has been lost while on the ground.
AFX DISABLED	White	Autofeather is selected, power levers have been advanced to a high N ₁ position, but the ARM signal has been lost while airborne.
AFX ENABLED	Green	Both left and right autofeather systems are armed.
BT00728		

STALL WARNING

NOMENCLATURE	COLOR	CAUSE FOR ILLUMINATION
L STALL WRN FAIL	Yellow	Left stall warn computer has failed.
R STALL WRN FAIL	Yellow	Right stall warn computer has failed.
PUSHER MOTOR ON	Yellow	Column pusher motor is energized and the pusher clutch is not energized.
PUSHER CLUTCH ON	Yellow	Column pusher clutch is energized and pusher motor is not energized.
PUSHER INOP	Yellow	Column pusher is inoperative.
BT00718		

OTHER MESSAGES

NOMENCLATURE	COLOR	CAUSE FOR ILLUMINATION
CAUTION TEST	Yellow	ANNUN test button has been depressed.
AHRS ALIGNING DO NOT TAXI	White	Left or right AHRS have not completed alignment procedures while on the ground.
AHRS ALIGNING	White	Left or right AHRS have not completed alignment procedures while airborne.
BT00978		

AUDIO SYSTEM

The pilot's audio system is powered by the triple-fed bus. The copilot's audio system is powered by the right generator bus. The PLT, COPLT, and CABIN circuit breakers are in the right circuit breaker panel. Audio is always provided to the headsets, and is selectable to the speakers.

SYSTEM CONTROLS

- Volume controls located in the center reversionary panel allow each radio to be adjusted individually.
- Pilot's and copilot's volume controls located in the center of the audio output rotary switches adjust overall volume.
- Pilot's and copilot's individual audio ON/OFF switches are used to select individual radios.
- Pilot's and copilot's rotary switches set the microphone output to one of the following:
 - COMM 1 or COMM 2
 - Cabin Speaker
 - Wheel well speaker
- Pilot's and copilot's microphone selector switch select one of the following microphones:
 - Hand held
 - Boom
 - Oxygen mask
- The MIC buttons on each control wheel activates the boom and mask microphones.
- Pilot's and copilot's audio speaker switches turn on the cockpit speakers.
- Pilot's and copilot's VOICE/IDENT switches apply to NAV stations only. They selectively allow the pilot or copilot to listen to identifiers only, voice only, or both.
- Pilot's interphone switch turns on the interphone between the pilot and copilot. The interphone has a hot-mic. The push-to-talk function is still required for other transmitting. If both pilot's and copilot's microphone switches are set to mask, the interphone outputs to the cockpit speaker in addition to the headsets.
- Pilot's audio alternate (ALTN) switch bypasses the audio amplifier and automatic gain control. Volume levels are then set with individual volume knobs. Headsets must be used in this mode.

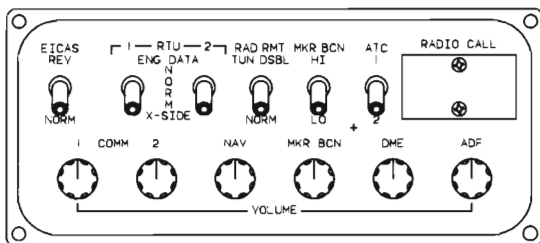

CENTER REVERSIONARY PANEL

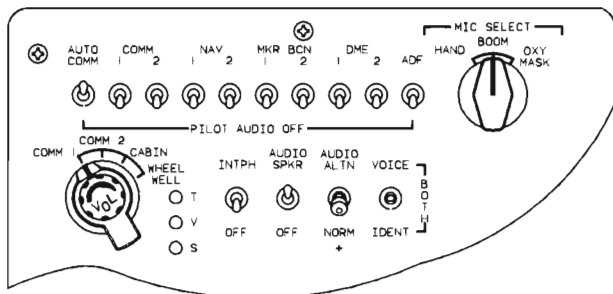

PILOT'S AUDIO CONTROLS

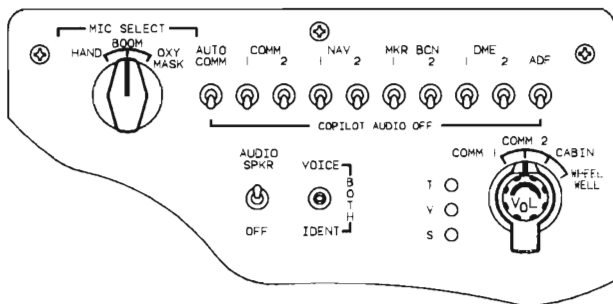

COPILOT'S AUDIO CONTROLS

2000-390-151

AUDIO SYSTEM CONTROLS

SENSOR DISPLAY UNIT (SDU)

The displays are high resolution, monochrome CRTs which incorporate selectable formats.

RMI

When the RMI format is selected by the FORMAT knob a full screen RMI will be displayed. The display is a 360° compass with letters at the cardinal points and numbers at 30° intervals. Additional index marks are located outside the compass rose, 45° to either side of the lubber line.

- **FORMAT** - The FORMAT is selected by rotation of the FORMAT knob. The selected format is annunciated above the left index mark. A circular arrow above the right index mark indicates the direction to turn the FORMAT knob to select a different format.
- **LOWER LEFT KNOB** - Displays the single pointer and selects the navigation source which drives it. The single pointer symbol is displayed near the knob with the selected navigation source above it.
- **LOWER RIGHT KNOB** - Displays the dual pointer and selects the navigation source which drives it. The dual pointer symbol is displayed near the knob with the selected navigation source above it.
- **LOCALIZER** - If a localizer is tuned while a VOR bearing is displayed, LOC 1 (single pointer) or LOC 2 (dual pointer) will be displayed and the respective pointer will be removed.



2000-390-167

RMI

VLF

When the VLF format is selected by the FORMAT knob, groundspeed (GS), magnetic track (TRK) and present position (LAT and LON) are displayed in the center of the display. When the bearing pointers are selected they are only partially displayed. VLF is displayed above the left index.

- LOWER LEFT KNOB - Displays the single pointer and selects the navigation source which drives it. The single pointer symbol is displayed near the knob with the selected navigation source above it.
- LOWER RIGHT KNOB - Displays the dual pointer and selects the navigation source which drives it. The dual pointer symbol is displayed near the knob with the navigation source displayed above it.
- LOCALIZER - If a localizer is tuned while a VOR bearing is displayed, LOC 1 (single pointer) or LOC 2 (dual pointer) will be displayed and the respective pointer will be removed.



2000-390-166

VLF

VOR

When the VOR is selected by the FORMAT knob the display will be that of an HSI. Bearing pointers are not displayed in this format. The selected format is displayed above the left index mark. A fixed airplane symbol pointing toward the lubber line is displayed in the center of the compass rose.

- HEADING SELECT - The lower left knob, identified on the display by HDG, controls the movement of the heading bug.
- COURSE SELECT - The lower right knob, identified on the display by CRS, selects the desired course angle. In the event of an AHRS failure the CRS annunciation is replaced by OBS.
- SELECTED COURSE POINTER - When set by the CRS SELECT knob this pointer indicates the selected VOR radial. The course is also displayed digitally near the CRS identifier.
- TO/FROM - The wedge shaped symbol indicates course TO/FROM direction. The symbol rotates with the SELECTED COURSE POINTER and points toward the tuned VOR station. The indicator changes direction when the course differs from the selected VOR radial by more than 90°.
- VOR COURSE DEVIATION - When the displayed NAV receiver is tuned to a VOR, a deviation bar and scale will be displayed. The degree of deviation is read on a scale of four dots, each dot equals 5° of deviation.
- LOC DEVIATION - When the displayed NAV receiver is tuned to a LOC, a deviation bar and scale will be displayed. The degree of deviation is read on a scale of four dots, with sensitivity dependent upon the actual localizer installation.
- GLIDESLOPE DEVIATION - When the displayed NAV receiver is tuned to a LOC frequency a glideslope pointer and scale will be displayed on the right side of the display. In a backcourse situation the glideslope pointer and scale will be removed and replaced with a vertical B/C symbol.
- DME - The DME distance in nautical miles is displayed between the lubber line and right index mark. If the DME data is invalid a boxed DME fail is displayed.
- DME HOLD - A boxed H by the right index mark is displayed when DME HOLD is selected.



2000-390-184

VOR

DME

When the DME format is selected by the FORMAT knob, DME, 1 and 2 data columns, which display ident/frequency and distance respectively are displayed in the center of the display. The DME is also displayed above the left index mark. When the bearing pointers are selected they are only partially displayed.

- DME data is digitally displayed in two data columns. Column 1 displays the number one (left side) DME parameters. Column 2 displays the number two (right side) DME parameters.
- IDENT/FREQUENCY - This line indicates the DME ident codes of the tuned stations. If a valid ident is not available, the DME frequency is shown. If DME hold is selected a boxed HOLD is shown.
- DISTANCE - The distance shows the computed DME distance in nautical miles to the tuned stations. If the DME data is invalid, a boxed DME fail is shown.
- SINGLE BAR POINTER - The lower left knob controls the single bar pointer. Rotation of the knob displays the pointer and selects the navigation source which drives the pointer. The selected source is displayed near the knob.
- DUAL BAR POINTER - The lower right knob controls the dual bar pointer. Rotation of the knob displays the pointer and selects the navigation source which drives the pointer.



2000-390-165

DME

MARKER BEACON

Marker Beacon information when received will be displayed in the lower left corner of the display.

- OUTER - Annunciated by a boxed O.
- MIDDLE- Annunciated by a boxed M.
- INNER - Annunciated by an empty box.

LOSS OF DATA

If selected source is lost, the corresponding bearing pointer will be removed. The CDI will be removed. In the DME mode the ident/frequency and distance lines change to dashes. In the VLF mode the center of the display will be all dashes. On-board failures cause the following:

- RMI The knob identifiers are X'ed out.
- VLF The format indicator is X'ed out.
- VOR The format indicator is X'ed out.
- DME The format indicator is X'ed out.

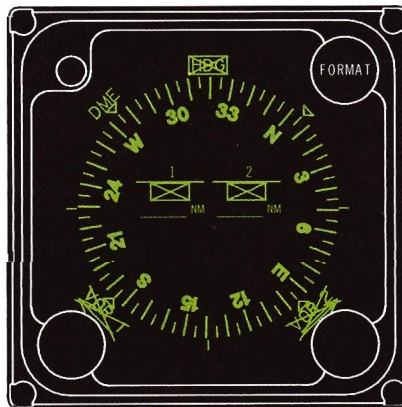

2000-390-162

NO NAV DATA

(This Page Intentionally Left Blank)

RADIO TUNING UNIT (RTU)

The RTUs provide direct manual control of the VHF communication transceivers, VHF and ADF navigation receivers and the transponder. Normally, each RTU controls its on-side avionics. The 1/2 key is used to momentarily monitor the cross-side frequency.

CONTROL FUNCTIONS

The RTU has concentric knobs for frequency/code setting, five line-select keys, and six dedicated function keys as follows:

KEY	FUNCTION
ATC ID	Transponder IDENT.
DME HLD	Holds DME to present frequency while VOR/LOC is tuned to another station.
COM SQ	Momentary COM squelch break.
ATC STBY	Sets transponder to standby or on.
1/2	Specifies pilot's side (1) or copilot's side (2) radio for tuning during an RTU reversion.
ADF TST	Verifies ADF signal strength. While the test push button is depressed, and the signal strength is usable for navigation, the bearing will abruptly swing 90° and a 1 KHz tone will be emitted. Releasing the push button returns the indication to normal.

SETTING FREQUENCIES AND CODES

1. Depress the 1/2 key to specify either the pilot's side (1) or copilot's side (2) radio, if the off-side reversion switch is in a reversionary mode. If the reversionary switches are in NORM, the 1/2 key can only be used to momentarily view the X-SIDE RTU data.
2. If the DME is to be kept on frequency, depress the DME HLD key.
3. Depress the line-select key to the right of any line to position the star on that line. If no selection is made, the star will return to the PRE line.
4. Rotate the knobs to set the frequency or code. The large knob selects the most significant digits, and the small knob selects the least significant digits. After 15 seconds of no knob rotation, the star moves back to the PRE line.
5. To reach the mode pages the star must be placed on the selected line by depressing the line-select key once. Depress the line-select again and the mode page for that line appears. Depressing the RTN line-select returns the main menu. The main menu will return automatically if there has been no activity for approximately 15 seconds.
6. Depress the PRE line-select to move the star to the PRE frequency line. Depress the PRE line-select again to interchange the PRE and COM frequencies. The old COM frequency is available for instant recall by depressing the PRE line-select key.

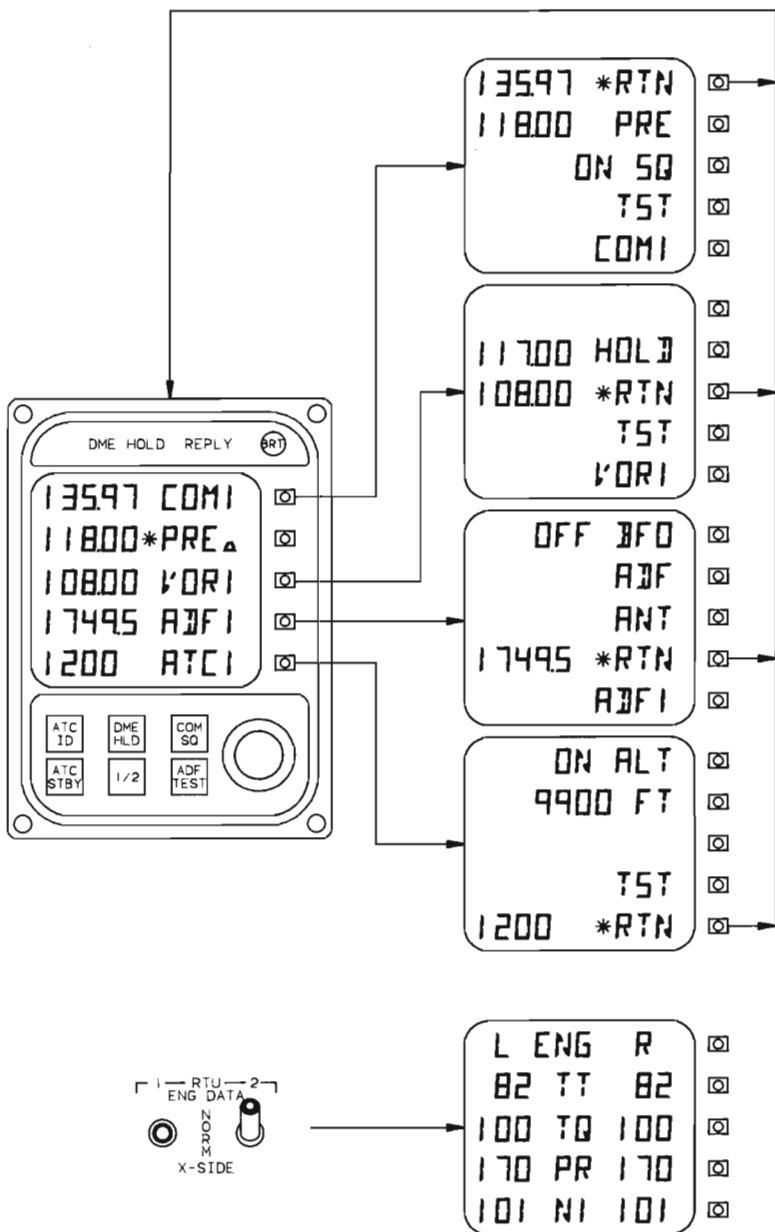

2000-390-150

RTU MODE CONTROL PAGES

MODE PAGES

Depressing the COM, NAV, ATC, or ADF line-select keys while the star is on that line displays the mode page for that function. All pages have a RTN line-select for returning to the main menu.

COM

- SQ** Toggles squelch on and off.
- TST** Activates the Built-In-Test (BIT). The audio is unsquelched for two seconds, and then quiet for two seconds. This same test is done on each power-up.

NAV

- TST** The VOR should indicate a 0° bearing with a TO indication, and the DME should indicate 100 NM, 60 minutes to station, and ID = A OK.

ADF

- BFO** This activates a 1000 Hz identification tone for stations which use an interrupted carrier signal. When the BFO key is depressed, the tone will sound while the carrier is on.

ADF

- ADF** This activates the loop antenna, enabling the bearing pointer on the SDU and/or the ND.

- ANT** This puts the ADF in a receive only mode. Receiver sensitivity is improved but no direction information is available.

ATC (TRANSPONDER)

- ALT** Toggles between Mode A and Mode C. If transponder was in STANDBY, it will go into Mode A.

- TST** The Reply Light should illuminate.

REVERSION

Moving either RTU ENG DATA switch from NORM to ENG DATA will cause truncated versions of the TT (ITT), TQ (TORQ), PR (PROP) and N1 digital readouts to be displayed on the designated RTU. If in flight on battery power only, one RTU would be used to display engine data, and the other to display radio data.

The RTU 1, RTU 2, X-SIDE allows the switching of the radio tuning from one RTU to the other.

The RAD RMT selects either NORM or TUN DSBL function. In the NORM position the RTUs accept tuning instructions from the IAPS. This allows the CDUs to remote tune the radios, and enables the FMS autotune function. In the TUN DSBL position the RTUs ignore remote tune instructions therefore radios may be tuned only through the RTUs.

CONTROL DISPLAY UNIT (CDU)

The CDU is the control for the Primary Flight Display (PFD), Navigation Display (ND), Flight Management System (FMS) and Radar. It also provides an additional method (other than the RTU) for entering radio frequencies and transponder codes. It uses a combination of displayed menus, line-select keys, a telephone style keypad, control knobs and dedicated control keys.

Dual CDUs are installed. In most cases, they can be operated simultaneously or independently. The pilot may change or edit the flight plan while the copilot changes frequencies. Neither CDU has priority. If both CDUs tune the same radio, the most recent change will prevail. However, some functions cannot be done simultaneously. Both CDUs cannot simultaneously edit the flight plan or a specific route, access the disk drive or initialize the system.

LTR (LETTER)

The LTR key cycles the character typed through the three letters on the key. The number 1 key becomes A, B, C, and back to number 1, depending upon how many times the LTR key is depressed.

NOTE

If data is being entered into a space where only numeric data is allowed, the LTR key is ignored.

CLR (CLEAR)

The CLR key deletes the last character entered each time it's depressed. Holding down the clear key for more than one second will delete one additional character each half second while the key is depressed.

ALPHANUMERIC KEYS

The remaining 12 keys are used for entering data into the Flight Management System and radio tuning. The telephone style keypad is used for numeric entry, and when combined with the LTR key, allows alphabetic entry.

CDU FUNCTIONS

NAVIGATION DISPLAY

- Weather Radar display ON/OFF
- Display Format: HSI, Arc, Map or Radar
- Map, Arc, and Radar display range
- Active and Preset NAV Source Course Selection (VOR, ILS, FMS)
- Bearing Pointer Source: VOR 1 or 2, FMS, or ADF 1

RADAR

- Basic Mode of Receiver/Transmitter (STBY, TEST, WX, WX + TURB, TURB ONLY, or GND MAP)
- Autotilt ON/OFF
- Ground Clutter Suppression ON/OFF
- Gain Control
- Tilt Control
- Channels SYNC/SPLIT
- WX Hold ON/OFF
- Target Alert ON/OFF
- Stabilization ON/OFF

RADIO TUNING

- VHF COMM Frequency and Presets
- Last Active Frequency Recall
- VHF NAV Frequency and Presets
- ADF Frequency and Presets
- Transponder Codes and Presets

FLIGHT MANAGEMENT SYSTEM (FMS)

- Waypoint Definition
- Route Definition
- Flight Plan Construction/Edit
- Auto/Manual Waypoint Advance
- Auto/Manual Station Select/Tune
- Flight Plan Look Ahead
- Initialization of Navigation Sensors
- Navigation Mode Select
- Data Base Inspect and Update
- System Message Reading

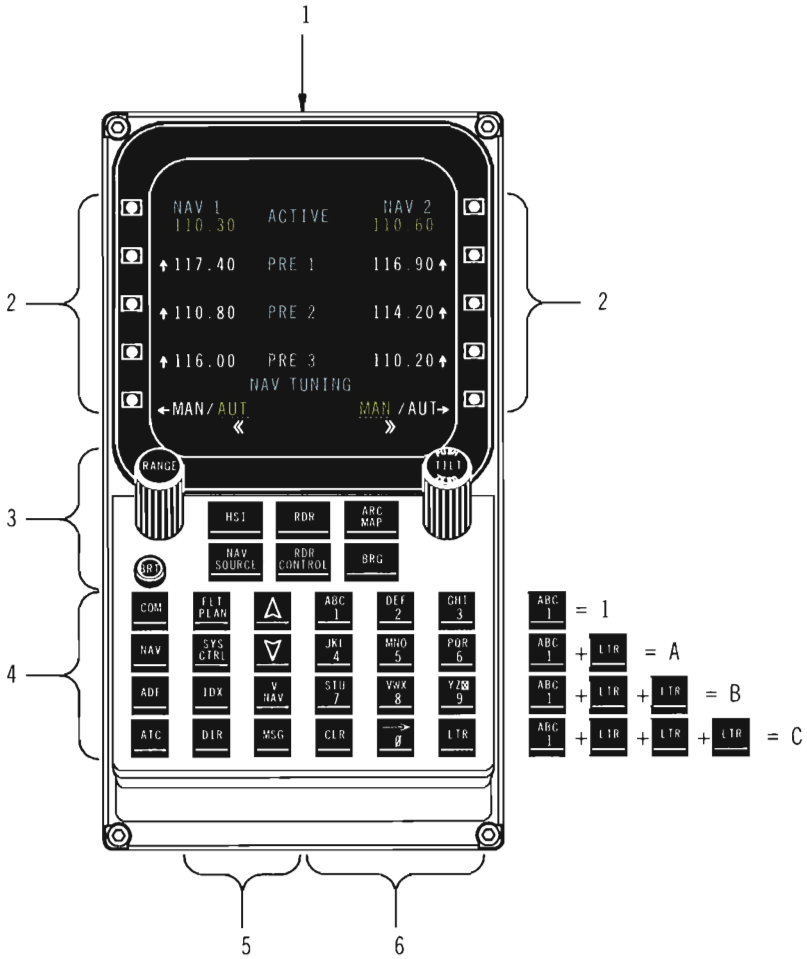

1. DISPLAY TUBE
2. LINE-SELECT KEYS
3. ND AND RADAR CONTROLS
4. RADIO CONTROL KEYS
5. FMS CONTROL KEYS
6. ALPHANUMERIC KEYPAD

2000-390-128

CDU MAIN COMPONENTS

DISPLAY FORMAT

The top line of the sixteen-line six-color CRT is for menu titles. Radio frequencies and transponder codes are displayed in two columns, left and right allowing a maximum of ten inputs and ten line-select keys. The first character on the bottom line is reserved for a scrolling symbol; when it appears use the scroll keys Δ and ∇ to scroll up or down. The right side of the bottom line is reserved to announce the presence of a system message. These characters will display MSG if a message is present and will flash at the onset of a new message until the MSG key is depressed.

LINE-SELECT KEYS

The line-select keys (five on either side) are used to select line options as displayed on the CDU. For example, depressing the line-select key to the left of ←VOR 1 will select VOR 1 as the active NAV.

The center section of the bottom screen line is the data scratch pad. Its use depends on the menu displayed. The scratch pad will be bracketed when active. When the brackets are present, all keystrokes appear first in the scratch pad and are then transferred to the desired input line by depressing the corresponding line-select key.

Line-select keys may be used to select items from a menu, transfer inputs from the scratch pad to an input line, toggle system modes between two or more modes, or as an entry key for data. When tuning radios, depressing a line-select key next to a frequency while the scratch pad is empty copies that line to the active line.

When line-select keys are used to toggle between two system control modes, both color and underlining are used to distinguish between the active and inactive modes.

PREDESIGNATION AND POSTDESIGNATION MODES

The system operates in both predesignation and postdesignation modes. In the predesignation mode, data is entered into preformatted fields of underscores. In the postdesignation mode, data is entered into the bottom line as a scratch pad and transferred to its ultimate location using the line-select keys.

When there is data in the scratch pad and a predesignation page on the CDU, the scratch pad data remains displayed until the first data key is depressed. Prior to any data entry, data can be loaded from the scratch pad into the predesignation field by depressing the adjacent line-select key.

The system is in the postdesignation mode when centered, outward-pointing chevrons are displayed on the scratch pad line. When in the postdesignation mode depressing any data key will cause the entered digit to appear in the scratch pad line and the underscore will then appear to the right of the entered digit. The underscore will remain until either data is loaded into a designation or the pilot clears the scratch pad line with the clear key.

COLOR CODING

COLOR	MEANING
Green	Active Flight Data and Normal Operation
Red	Failure Message
Cyan	Page Titles and Data Items
White	Menu Lists, Static Flight Data, Acknowledged Messages, Inactive modes, and Acknowledged MSG Alert
Magenta	TO Waypoint, Cancel, Clear and Erase
Yellow	Active Uncompleted Data Entry Fields, Scratchpad Data, Abnormal Modes, Unacknowledged Messages, and Unacknowledged MSG Alert

SYMBOLOLOGY

DATA	TYPE OF ENTRY
Outward Pointing Arrow	Adjacent Line-Select Key Is Active
Inward Pointing Arrow	Data Can Be Transferred Into This Location
Double Arrow Up/ Down	Scrolling Is Available (up or down)
Single Arrow Up	Displayed Data Will Transfer Up or Scrolling Up
Single Arrow Down	Scrolling Down
Line Of Dashes	No Computed Data Available
Question Marks Alternating With Entered Data	Entered data is inappropriate
Line of Underscores	Entry Is Expected (Predesignation)

MODE

Radio Frequencies/ ATC Codes	Postdesignation - Predesignation
Flt Plan Entry of WPT Names/Route Numbers	Predesignation -Postdesignation
Lat/Lon for Entered Waypoints	Predesignation
Radial/DIS Offsets	Predesignation
Reporting Point Radial	Predesignation
SEL TRK	Predesignation - Postdesignation
All Trip Planning	Predesignation - Postdesignation
Entry of Route Name	Predesignation
Position Update by Lat/Lon	Predesignation
Position Update By Ident	Predesignation - Postdesignation

RADAR AND ND CONTROLS

The two knobs and six large keys immediately below the CRT control the ND and radar formats.

RANGE KNOB

The RANGE knob sets the MAP display scale and is the primary control over the on-side radar. Six ranges are available: 10, 25, 50, 100, 200, and 300 NM. Radar may also be displayed on the MFD, which has its own range controls (Δ and ∇) and may be set to display either radar channel. If a radar channel is on the MFD only, then the scroll keys control the range for that channel. If the radar is on the ND, the RANGE knob on the CDU controls the range for that channel on both the ND and the MFD. If radar is added to the ND after it is already on the MFD, the radar display appears with the range that was in use on the MFD.

TILT KNOB

The TILT knob is the control for changing the antenna angle with respect to the horizon. The control range is $\pm 14^\circ$. Pushing the center of the knob returns the antenna tilt to 0° .

HSI

HSI selects a full compass rose HSI display on the ND. Weather radar cannot be displayed on the ND in this mode, but can be displayed on the MFD.

RDR

RDR selects radar for display on the ND. If the ND is displaying an HSI when radar is selected, it will be changed to ARC + RDR.

ARC/MAP

ARC/MAP toggles the display between ARC and MAP displays on the ND. The ARC format is an expanded 70-degree compass segment display. The MAP format superimposes a navigation map onto the ARC display; distance (10-300 NM) is selected by the RANGE knob.

NAV SOURCE

NAV SOURCE puts the active NAV menu on the screen, and then toggles the screen between ACTIVE NAV SOURCE and PRESET NAV SOURCE. The Δ and ∇ scroll keys also toggle between the ACTIVE NAV SOURCE and PRESET NAV SOURCE.

- The ACTIVE NAV SOURCE menu is used to select the active NAV from VOR/LOC 1, VOR/LOC 2, or FMS. The active NAV is the source for the course deviation pointer.
- The PRESET NAV SOURCE menu is used to select the preset NAV from VOR/LOC 1, VOR/LOC 2, or FMS. The PRESET OFF line, if selected OFF, will clear all existing presets. It will also show as OFF whenever there are no presets. The CHP controls the preset NAV course only when this menu is on the corresponding CDU.

To select any menu option, depress the corresponding line-select key.

CRS XFER AND RECALL CRS

Depressing the CRS XFER line-select transfers the preset NAV SOURCE to the ACTIVE NAV SOURCE. When this is accomplished the PRESET source is OFF and the CRS XFER line-select changes to RECALL CRS. Depressing the RECALL CRS restores the previous active nav source as the present nav source.

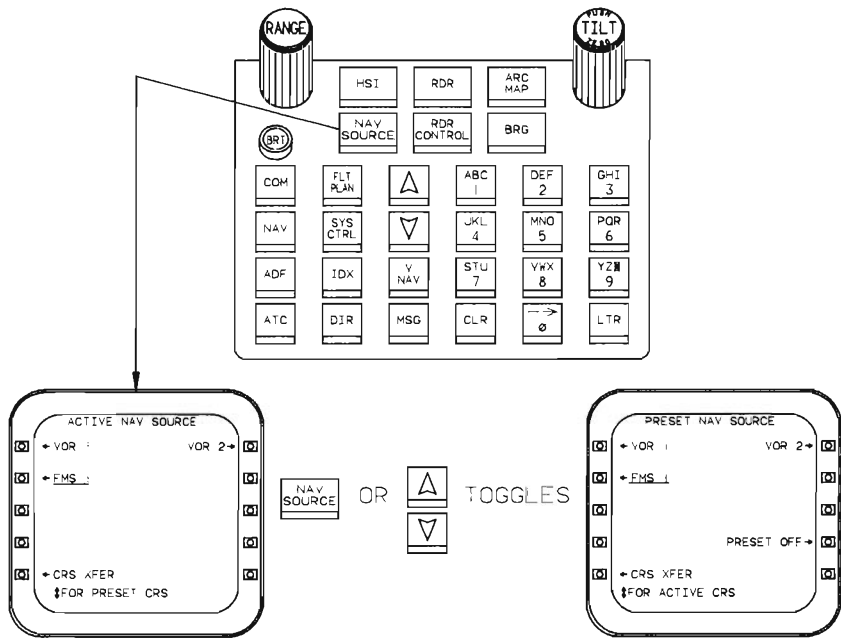

2000-390-070

NAV SOURCE MENU

RDR CONTROL

RDR CONTROL puts the RDR FUNCTIONS menu on the screen. Depressing the RDR CONTROL key again, or the NEXT PAGE line-select key toggles between the first and second menu pages. To select any menu option, depress the corresponding line-select key.

- STBY turns the radar transmitter off.
- WX is the radar's basic mode.
- WX+TURB enables the radar to detect both weather and turbulence within the 50 NM range.

NOTE

Turbulence detected in this mode is only that turbulence which is related to precipitation.

- TURB ONLY removes from the display the precipitation that has not been detected as turbulence. This mode automatically returns to WX+TURB after 30 seconds unless another mode is manually selected. This mode can only be used up to the 50 NM range.
- GND MAP causes the radar to display ground features instead of weather. The color format changes in this mode.
- CHANNELS SYNC/SPLIT toggles the two channel operation on and off. If SYNC is selected, the cross-side CDU radar mode is copied into the on-side CDU. When SPLIT is selected on either CDU, the radar behaves as if each CDU were controlling a separate radar. It does this by responding to each CDU on alternate antenna sweeps.
- HOLD ON/OFF is used to freeze a radar frame. This allows a weather pattern to be studied for changes by comparing the two displays. HOLD is displayed and selectable only when in WX, WX + TURB, TURB ONLY, or GND MAP modes. It is automatically switched off if any display mode is changed, or after 5 minutes.
- GND CLTR SPRS ON/OFF toggles ground clutter suppression on and off. When on, ground clutter is reduced, but so is sensitivity to low levels of precipitation.
- GAIN CAL/MAN enables or disables the receiver gain control. When in MAN, the scroll keys vary the receiver gain.
- TEST ON/OFF displays a test pattern showing all four colors. Test mode is automatically cancelled if the menu page is changed.
- STABILIZATION ON/OFF allows antenna stabilization to be toggled on and off.

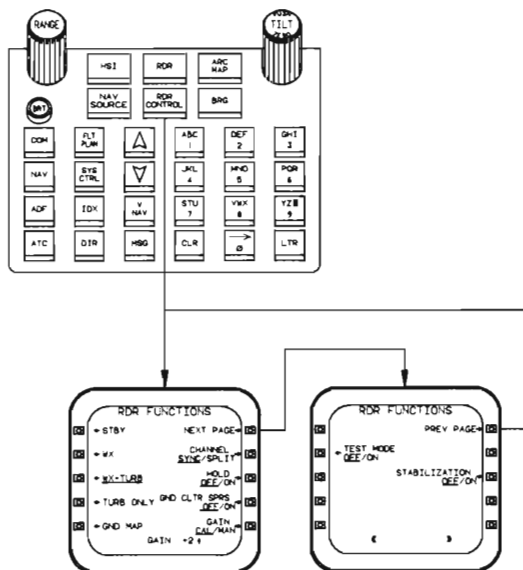

RDR FUNCTION MENUS

BRG

BRG displays the BRG POINTER SOURCE menu. VOR 1, VOR 2, ADF 1, ADF 2 (if installed), FMS, or bearing POINTER OFF may be selected. This applies to the bearing pointer on the ND only, not the one on the SDU.

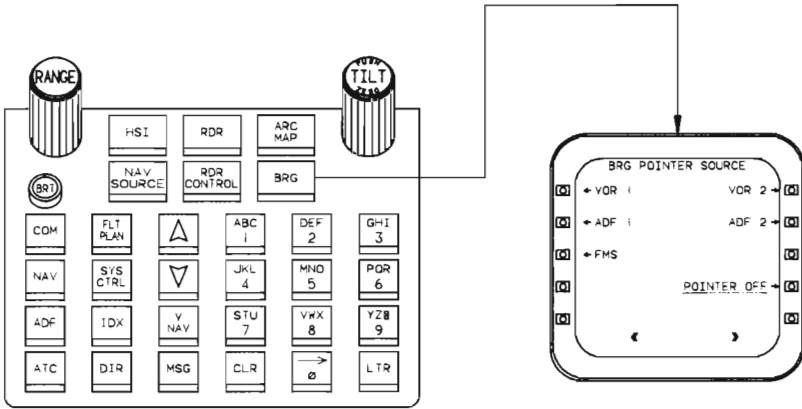

2000-390-129

BEARING SOURCE MENU

RADIO CONTROL

Each radio control key has a separate menu.

COM

The COM menu has five line-selects: ACTIVE, RECALL, PRE 1, PRE 2, and PRE 3. Each line has a COM 1 and a COM 2 column, allowing a total of ten frequencies on the menu. Frequencies entered on the alphanumeric keypad (numbers only, without decimals) appear in the scratch pad. With a number in the scratch pad, depressing the line-select key next to any frequency line except RECALL stores the frequency in that location. When an ACTIVE frequency is changed on the CDU, the former ACTIVE frequency is transferred to RECALL. If RECALL or any of the PRESET frequencies are selected without a new frequency in the scratch pad, then the selected frequency becomes ACTIVE and is displayed on both CDUs and the on-side RTU.

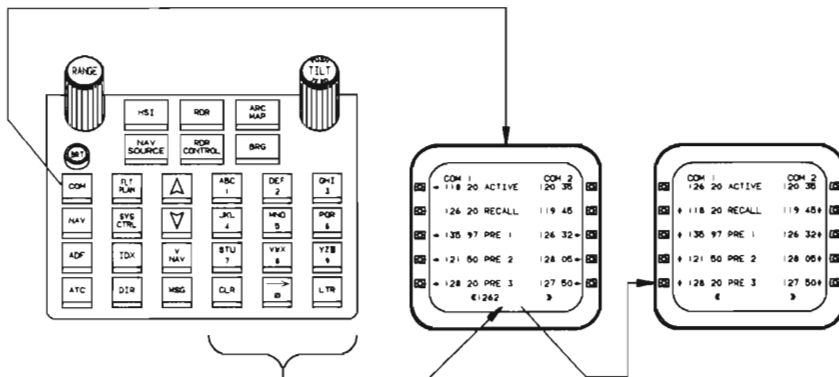

2000-390-068

COM MENUS

NAV (VHF NAVIGATION)

The NAV menu has five line-selects: ACTIVE, PRE 1, PRE 2, PRE 3, and NAV TUNING (MAN/AUT). Each line has a NAV 1 and a NAV 2 column, allowing a total of eight frequencies on the menu plus the NAV TUNING (MAN/AUT). VHF NAV stations may be tuned by frequency or by station identifier.

- When identifiers are used, the computer searches the data base for the identifier to match it with a frequency. If the identifier is not in the data base, it stays in the scratch pad which alternately displays question marks, and the line above the scratch pad displays IDENT?.
- If more than one station is found with the same identifier, (because worldwide VORs are in the data base) then the system loads the closest one and annunciates that a duplicate exists. The pilot can accept the displayed identifier (the country prefix will identify the correct one) or use the scroll keys to look at the alternates. If one of the choices is selected by depressing the line-select key next to OK, the tuning proceeds normally. If the menu page is changed without making a choice, the tuning change is aborted and the previous frequency is restored.

Frequencies (without decimals) may be entered on the alphanumeric keypad. They will then appear on the scratch pad. Depressing any active or preset line-select key stores the scratch pad frequency on the corresponding line. If the line-select key next to any of the PRESET frequencies is depressed while no frequency is in the scratch pad, then the corresponding frequency is transferred to the ACTIVE frequency and displayed on both CDUs and the on-side RTU. If the frequency in the scratch pad is not a valid frequency, it will not be transferred. It will remain in the scratch pad alternating with question marks until either corrected or a different page is selected.

NAV TUNING - AUT allows the FMS to tune enroute stations, and maintain valid position information throughout the flight. The following conditions are required for AUT tuning:

- The VHF NAV receiver must not be selected as an active or preset NAV source on either ND.
- Manually tuning a VHF NAV receiver using the CDU or RTU will force the NAV TUNING back to MAN.
- Any RNAV waypoint that becomes a TO waypoint will cancel AUT tuning.
- AUT TUNING is not available with DME HOLD selected.

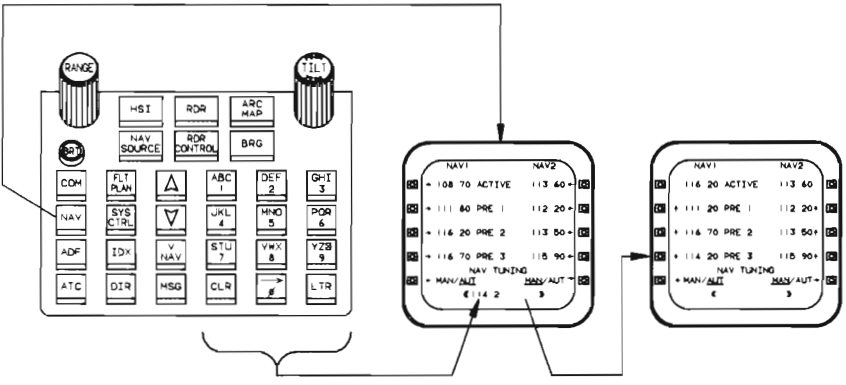

2000-390-067

NAV MENUS

ADF (AUTOMATIC DIRECTION FINDER)

The ADF menu has five line-selects: ACTIVE, PRE 1, PRE 2, PRE 3, and PRE 4. Each line has an ADF 1 and ADF 2 (if installed) column, allowing either five or ten frequencies on the menu. Frequencies entered in the alphanumeric keypad (numbers only, without decimals) appear in the scratch pad. Depressing any active or preset line-select key stores the scratch pad frequency on the corresponding line. If the line-select key next to any of the PRESET frequencies is depressed while no frequency is in the scratch pad, then the corresponding frequency is transferred to the ACTIVE frequency and is displayed on both CDUs and the on-side RTU.

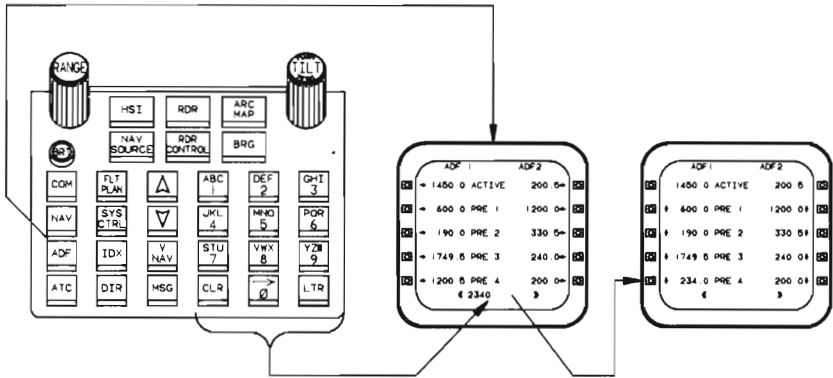

2000-390-066

ADF MENUS

ATC (ATC TRANSPONDERS)

The ATC transponder menu has five line-selects: ACTIVE, PRE 1, PRE 2, PRE 3, and PRE 4. Codes entered on the alphanumeric keypad appear in the scratch pad. Depressing an active or preset line-select key stores the code on that line. Codes entered on either CDU appear on both CDUs and the on-side RTU.

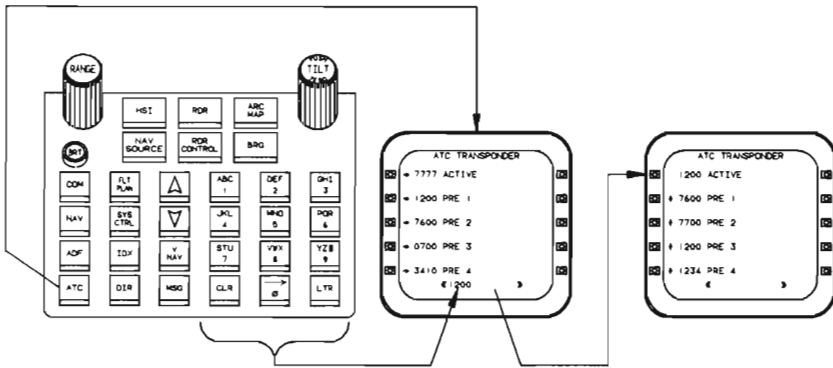

2000-390-072

TRANSPONDER MENUS

FLIGHT MANAGEMENT SYSTEM

FLT PLAN (FLIGHT PLAN)

The FLT PLAN menu is the entry into the FMS computer generated flight planning. The FMS contains a comprehensive menu-driven flight planning program with the following features:

1. Computer Generated Flight Plans
 - a. The FMS system has a data base containing all worldwide VHF nav aids (VOR/DME, VORTAC, and DME) and airport reference points for all worldwide IFR civil airports with a minimum of 3000 feet of hard surfaced runway.
 - b. Additional nav aid information is provided by geographical areas:
 - NA (North America) database includes information about ARINC regions USA and CAN.
 - NAN (North America Not) database includes information about ARINC regions EUR, EEU, MES, AFR, PAC, SPA, and LAM. The additional nav aid information that is available for each of the geographical areas is:
 - Named enroute waypoints and all NDBs.
 - Airport runway thresholds for the specified geographical area.
 - Terminal waypoints for the specified geographical area.
2. Manually Generated Flight Plans
 - a. Flight plans are constructed by entering a series of waypoints into the computer. Waypoints may be entered by name on the keypad or by using the joystick to move a symbol over a waypoint on an MFD map display.
3. Moving Map Displays
 - a. The MAP mode on the ND shows the airplane at the bottom and the heading at the top of the map. The flight plan route and waypoints are displayed in scales from 10 to 300 NM.
 - b. The PRESENT POSITION map mode on the MFD places the FMS present position at the map center with the heading at the top. The flight plan route and waypoints plus a choice of airports, low altitude NAVAIDS, and/or high altitude NAVAIDS, are shown in scales from 10 to 600 NM.
4. Automatic Tuning of VHF NAV Radios

When the system is set to NAV TUNING - AUT the computer will automatically tune the VHF NAV radios.

 - a. The computer will select NAVAIDS along or near the flight plan route which will provide the most accurate airplane position.
5. Depressing the FLT PLAN key displays the FLIGHT PLAN menu.

If the system was not initialized at power up:

 - a. The system tests the ship's clock. If the time and date are valid, then the VERIFY menu appears. Otherwise, the SHIP'S CLOCK FAILURE menu appears. The date must then be entered.
 - b. The system compares the data base date with the current date. If the database has expired, the VERIFY menu appears with a DATA BASE HAS EXPIRED! notice.

WARNING

Do not rely on an expired data base for navigation. It is the pilot's responsibility to verify the coordinates of all flight plan waypoints and nav aids.

READ/WRITE TO DISKETTE operation should be done while on the ground.

- c. If the data base is current, or after the pilot has updated, or elected to use the expired data base, the VERIFY menu appears. The VERIFY menu is used to verify or update the FMS present position. It should equal the airplane position as of the last time the electrical power was on.
- d. Updating requires a current data base diskette. When the update is started, the system first reads the diskette directory, and displays it on the screen. Data base diskettes have only one file, either FLT-DATA.NA (North America) or FLT-DATA.NAN (North America Not).
- e. After an update, the screen shows a list of changed waypoints that are used in stored routes. This allows modifying the routes as necessary because of invalidated waypoints.

The airplane position, data base, flight plan and route library remain in non-volatile memory so that they are preserved when the airplanes electrical power is off. Data base diskettes are issued on a 28 day revision cycle and should be stored onboard the airplane upon receipt. When the data base has expired, insert the current data base revision in the DBU prior to the selection to update the database or to READ FROM DISKETTE.

WARNING

The data base can be updated prior to its expiration date; however, the FMS and the data base must not be used until the effective date.

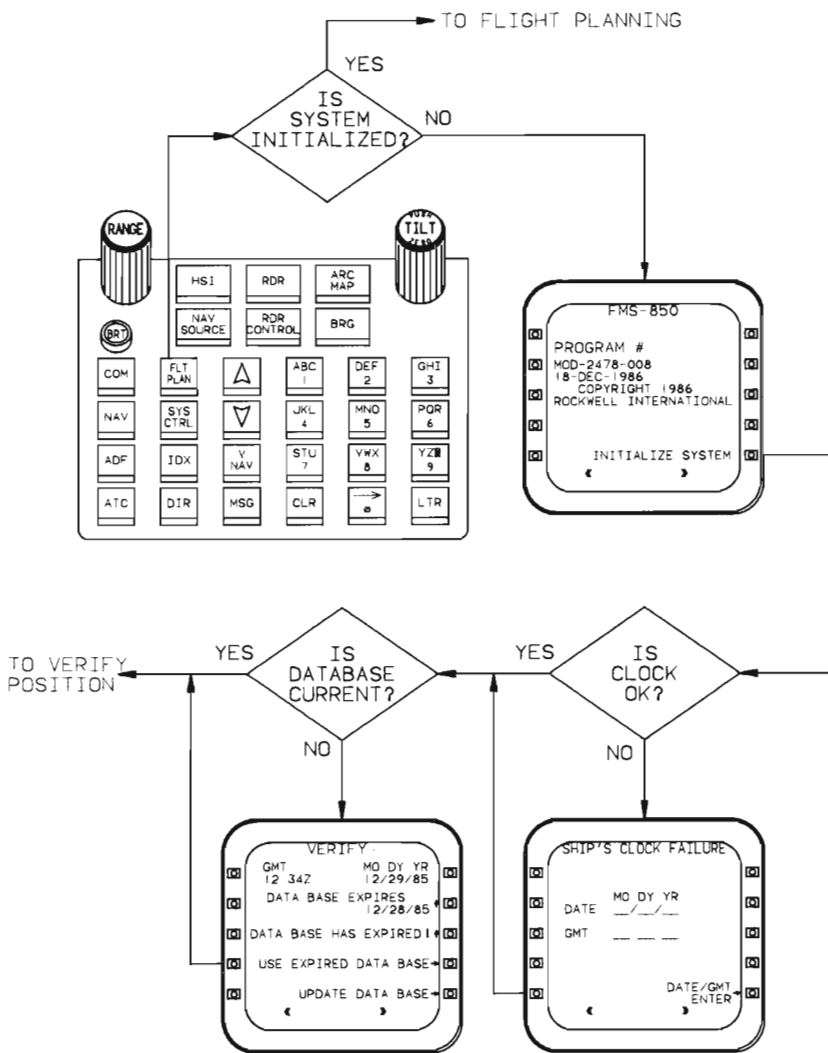

2000-390-073

VERIFY MENU

Waypoints without offsets which are moved less than .2 NM are changed without annunciation. Deleted waypoints, changed waypoints with offsets, and any waypoints moved .2 NM or more are invalidated. At the end of the update, the CDU will display a list of any invalidated waypoints that are used in the routes. If the route library is displayed on the CDU or the MFD, any route containing an invalidated waypoint is displayed in yellow. If the route is displayed, an ***INVALID WPT*** message appears at the waypoint location. The waypoint name and offset appears in parenthesis below the message. Invalid waypoints must be reentered.

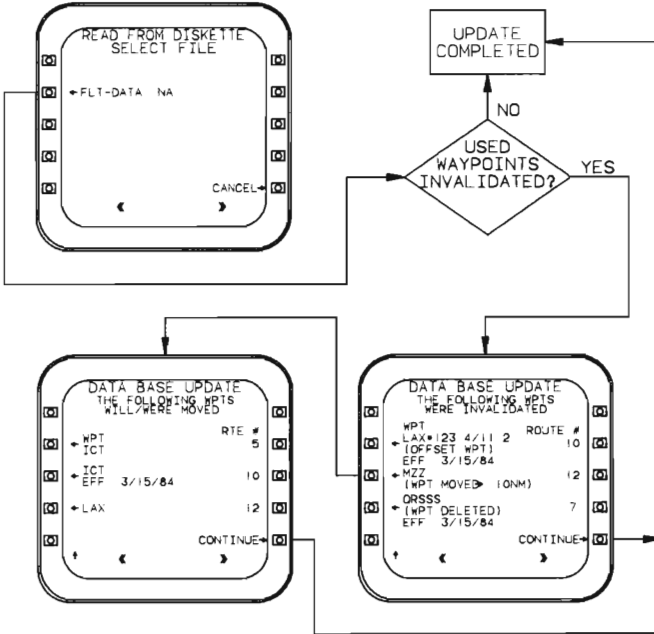

2000-390-071

DATA BASE UPDATE MENU

If there is a flight plan in memory, the FLT PLAN menu will appear with the flight plan. Otherwise the FLT PLAN menu will appear with the ADD WPTS prompt. Selecting the ADD WPTS line-select allows flight plan entries.

1. Route numbers may be entered if there are one or more routes stored in the route library.
2. Entering a named waypoint causes the system to locate the waypoint in the data base.
 - a. If the waypoint is found and it is unique, then the FLIGHT PLAN menu appears with the waypoint type identified (navaid, airport, or reporting point, etc). The LAT/LON coordinates are displayed for verification. If the waypoint is a VOR/DME, there are three choices:
 - 1) OK - Accepts the waypoint and returns to the ENTER RTE # OR WPT menu with the new waypoint added. If this is the first waypoint in the flight plan, this waypoint becomes the first part of the flight plan name.
 - 2) CANCEL WPT - Cancels the waypoint and returns to the ENTER RTE # or WPT menu.
 - 3) ADD RAD/DIS OFFSET - Goes to an ENTER OFFSET menu which allows the radial and distance offsets to be entered. Leading zeros must be used.

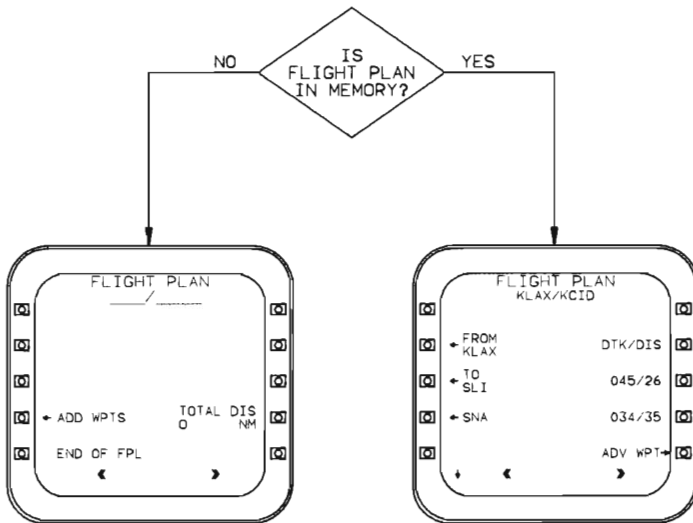

2000-390-065

FLT PLAN MENU WITH FLIGHT PLAN

- b. If the waypoint is an airport, the ADD RAD/DIS options are replaced with the following:
- 1) LIST TERM WPTS
 - 2) DISPLAY RUNWAYS
- Either of these selections produces a corresponding list. The selection from the list becomes the waypoint, and returns to the ENTER RTE # or WPT menu, ready to accept the next waypoint.
- c. If the waypoint is found in more than one place in the world, then the duplicate waypoints menu appears. This menu will indicate the number of duplicate waypoints under the CANCEL WPT line in the lower left of the screen. The correct waypoint can be identified by the country code. United States facilities have a K prefix. The menu will display the closest facility with its coordinates.

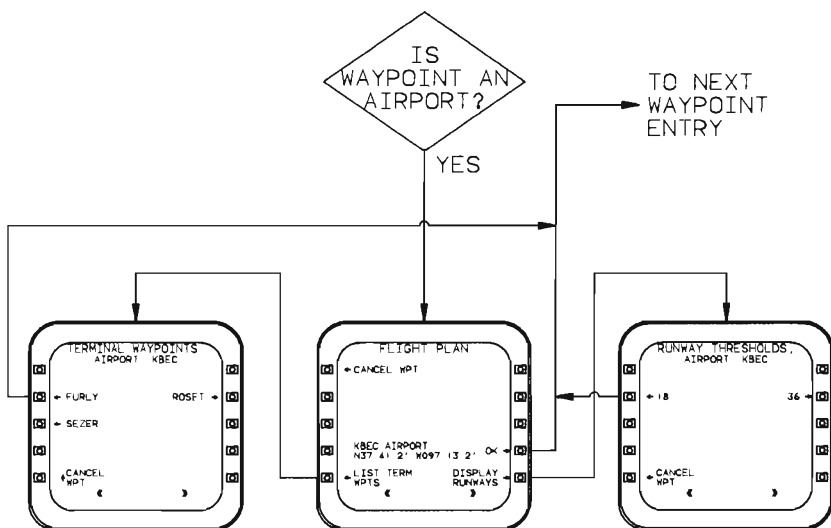

2000-390-194

AIRPORT WAYPOINT MENU

- d. If the waypoint is not found a boxed X, XYZ NOT IN MEMORY statement is displayed (XYZ is the waypoint name). The options are CANCEL WPT or DEFINE WPT. CANCEL WPT returns to the ENTER RTE # or WPT menu. If DEFINE WPT is selected, the system goes to a DEFINE USER WPT menu.

The following data may be entered:

- 1) TOGGLE N/S - Unless otherwise specified, the system assumes that all latitudes are north and all longitudes are west. To define a waypoint in the southern hemisphere, depress the line-select key next to TOGGLE N/S. The TOGGLE N/S automatically changes to TOGGLE E/W after the latitude has been entered. To define a waypoint in the eastern hemisphere depress the line-select key next to TOGGLE E/W.
- 2) LATITUDE - Entered in degrees, minutes, and tenths of minutes.
- 3) LONGITUDE - Entered in degrees, minutes, and tenths of minutes.
- 4) DEFINITION COMPLETE - Returns to previous menu with waypoint.
- 5) ADD RAD/DIS OFFSET - Same as previous ADD OFFSET.
- 6) CLEAR LAT/LON - Clears latitude and longitude inputs.
- 7) CANCEL WPT - Cancel waypoint and return to FLT PLAN menu.

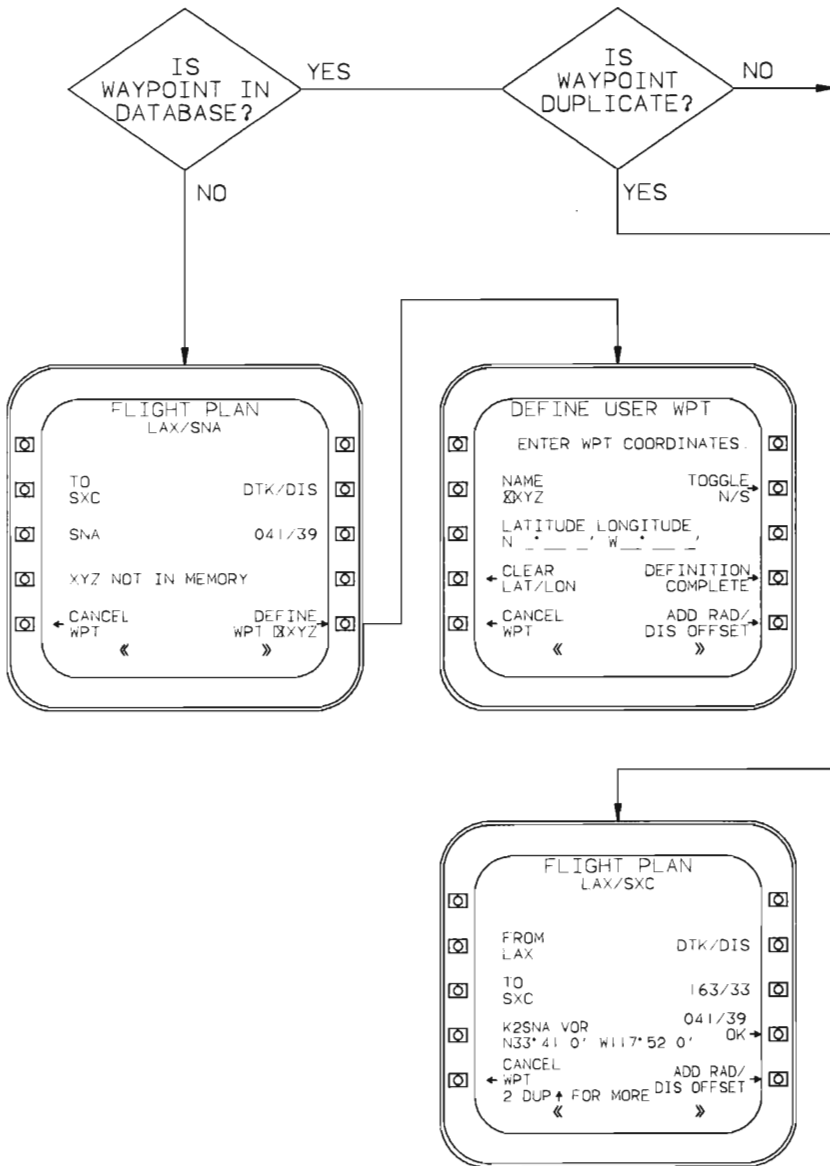

2000-390-077

PILOT DEFINED AND DUPLICATE WAYPOINT MENUS

- e. After the first waypoint is entered, the line under the FLIGHT PLAN title will be half completed. If the first waypoint is KLAX, the name line will change from ____/____ to KLAX/____.

Each time a new waypoint is entered, the next ENTER RTE # or WPT menu will show the last two waypoints above the line on which another waypoint or route may be entered. Routes may be joined into flight plans at any ENTER RTE # or WPT prompt.

If a route number is entered, the LOAD ROUTE menu appears, this menu provides three options in which to load waypoints:

- 1) NORMAL ORDER - The route is loaded as is from the route library.
- 2) REVERSE ORDER - The route is loaded to be flown in the opposite direction.
- 3) CANCEL ROUTE LOAD - Returns to previous menu with no changes.

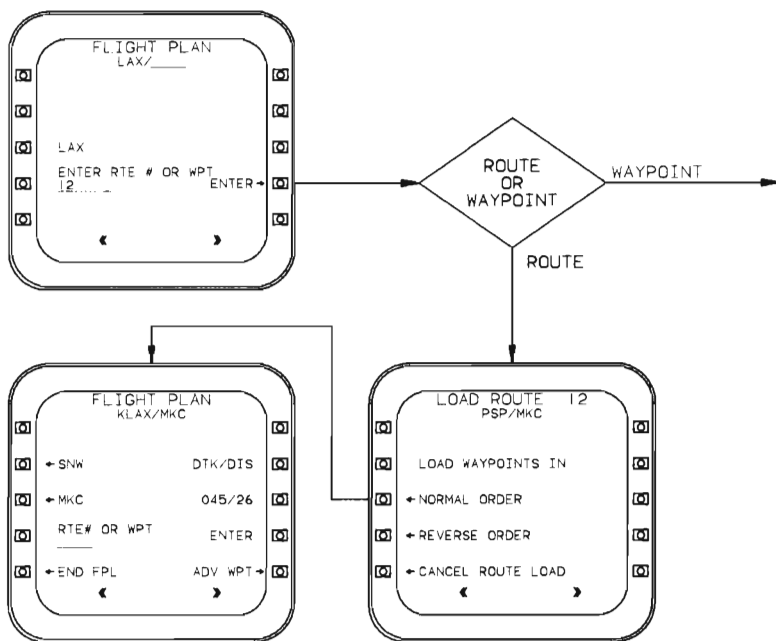

2000-390-078

LOADING A NUMBERED ROUTE INTO A FLIGHT PLAN

- f. After the second waypoint is entered, there is an END FPL line-select key added to the page. Use of this line-select produces an END OF FPL message. The page shows the last two waypoints, adds the total distance for the flight plan, an ADV WPT line select key and an ADD WPTS line-select key. Depressing this line-select returns to the ENTER RTE # or WPT menu.

The screen can display up to three waypoints at a time. Longer routes may be scrolled onto the screen with the scroll keys. Any time a waypoint line-select key is depressed, the system displays the SELECT CHANGE TYPE menu.

The options are:

- 1) INSERT WPT AFTER

This displays a modified ENTER RTE # or WPT menu. The ERASE FPL option is replaced with a CANCEL INSERT option. The waypoints before and after the inserted waypoint are shown along with a scroll symbol to allow changing the insert point. When the inserted waypoint has been keyed in and the ENTER line-select key is depressed, the waypoint name and its coordinates are displayed with an OK line-select key. If CANCEL INSERT is depressed, the system returns to the previous menu.

- 2) DELETE WPT

Deletes the selected waypoint from the flight plan and returns to the previous menu.

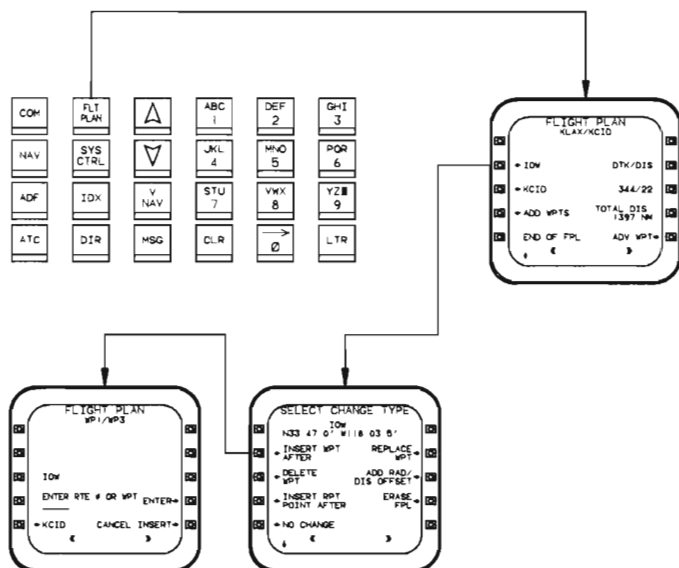

2000-390-075

END OF FLT PLAN AND SELECT CHANGE TYPE MENUS

- 3) INSERT RPT POINT AFTER
This computes the radial and distance of a point on the route that is abeam of, or on a selected radial from, an off-route navaid or point which the airplane is passing. It does not have to be a designated airway reporting point. When selected, the REPORTING POINT menu prompts for a BASE IDENT. The BASE is the off-route point from which the following options are calculated:
 - a) POINT ABEAM STATION - Refer to Flight Management System
 - b) POINT OF INTERSECTION WITH ____ RADIAL - Refer to Flight Management System
 - c) DIFF BASE - Returns to the BASE IDENT menu.
 - d) CANCEL INSERT - Returns to the previous menu without changes.
- 4) NO CHANGE
Returns to the original flight plan or route list.
- 5) REPLACE WPT
Returns to the ENTER RTE # or WPT menu.
- 6) ADD RAD/DIS OFFSET
Returns to the ENTER OFFSETS menu.
- 7) CHANGE COORDINATES
Returns to the CHANGE COORDINATES menu (if waypoint is user defined).
- 8) ERASE FPL
This will produce an ARE YOU SURE? prompt. Selecting YES returns to the ADD WAYPOINTS screen.

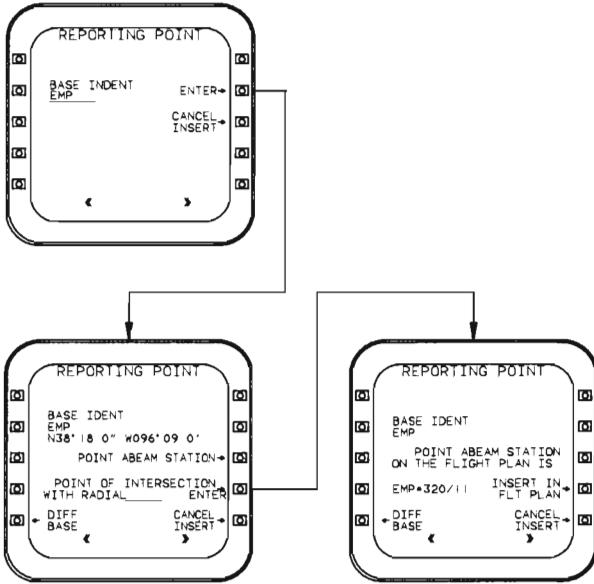

2000-390-074

REPORTING POINT MENUS

SYS CTRL (SYSTEM CONTROL)

The SYS CTRL menu offers a selection of the three FMS navigator modes:

1. AUTO LEG

This is the normal operating mode. The computer calculates a great circle route and the distance between each waypoint, and displays a track line on the MFD and/or ND map displays. The course displayed is inbound toward the TO waypoint. The current TO waypoint is automatically advanced to the next one on the route as the airplane passes each waypoint.

2. MAN LEG

The computer does not automatically sequence through the list of flight plan waypoints. To advance through the list of waypoints, the ADV WPT line-select key, found on the FLIGHT PLAN page, must be depressed for each advancement.

3. SEL TRK

There is no route computation or continuity between the TO waypoint and all other waypoints. The waypoints and their locations are still stored in memory, but as separate items on a list. The active waypoint must be advanced by depressing the line-select key on the FLIGHT PLAN menu next to ADV WPT, and the course must be set for each waypoint.

The menu contains two SEL TRK lines which appear when SEL TRK is active. The upper line activates the selected track mode and the course knob, which is then used to set the selected track. The lower line requires that the selected track be entered on the CDU keyboard. Then the line-select key must be depressed again to activate it. Subsequent course changes are made with the CRS knob. Since there is no continuity between the TO waypoint and the rest of the flight plan, it is separated on the CDU by a row of dashes beneath the waypoint line and a SEL TRK label plus the track angle displayed on the right side of the display.

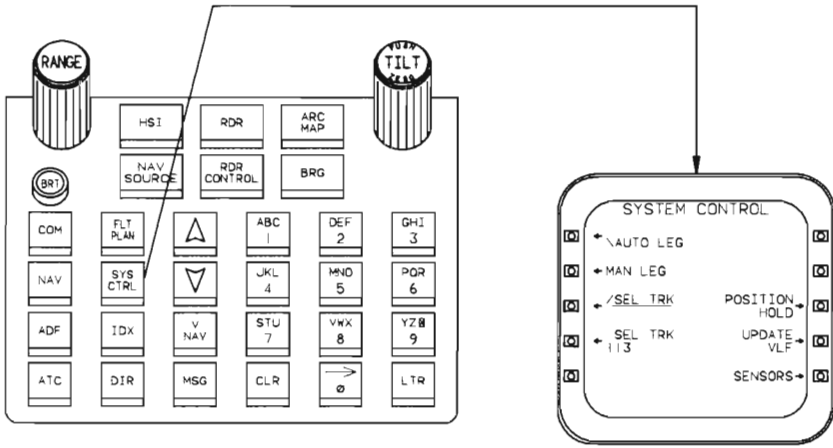

2000-390-080

SYSTEM CONTROL MENUS

POSITION HOLD

When this is depressed while exactly over a known fix, the CDU displays a menu showing the computed position that existed at the moment the POSITION HOLD line-select was depressed. Key in the FIX identifier and press ENTER. The fix's actual coordinates, and the difference between them and the POSITION HOLD coordinates are displayed.

The menu offers three options:

1. POS = FIX will reset the computed position to agree with the known fix.
2. CANCEL UPDATE returns to the SYSTEM CONTROL menu.
3. CHANGE FIX returns to the POSITION HOLD menu for a new fix entry.

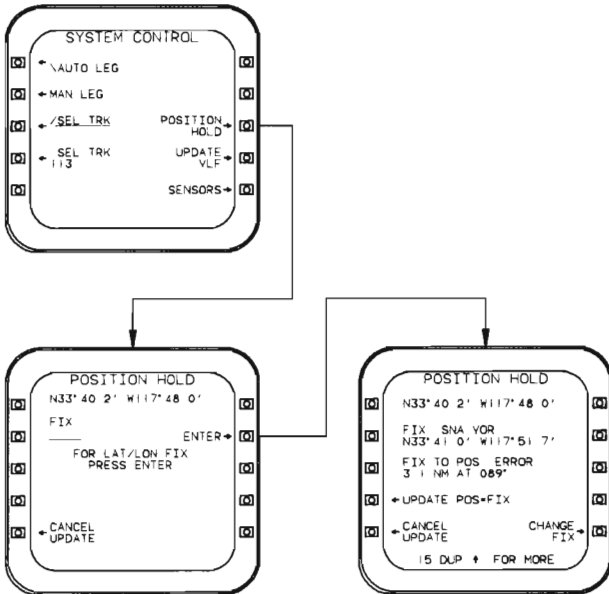

2000-390-083

POSITION HOLD MENU

UPDATE VLF

Displays a menu showing the difference between the VLF and FMS position. The pilot may then update the VLF from the FMS position, or cancel the update.

SENSORS

Displays the SENSOR CONTROL menu. This allows the selective use or non-use of both VOR/DME and VLF/OMEGA by the FMS. A VLF/OMEGA DESELECT option returns a list of VLF or Omega stations and allows individual stations to be used or not used.

A VLF/OMEGA SIGNAL STATUS option returns a list of signal strengths for the respective station (0 being the low signal and 9 being the high signal).

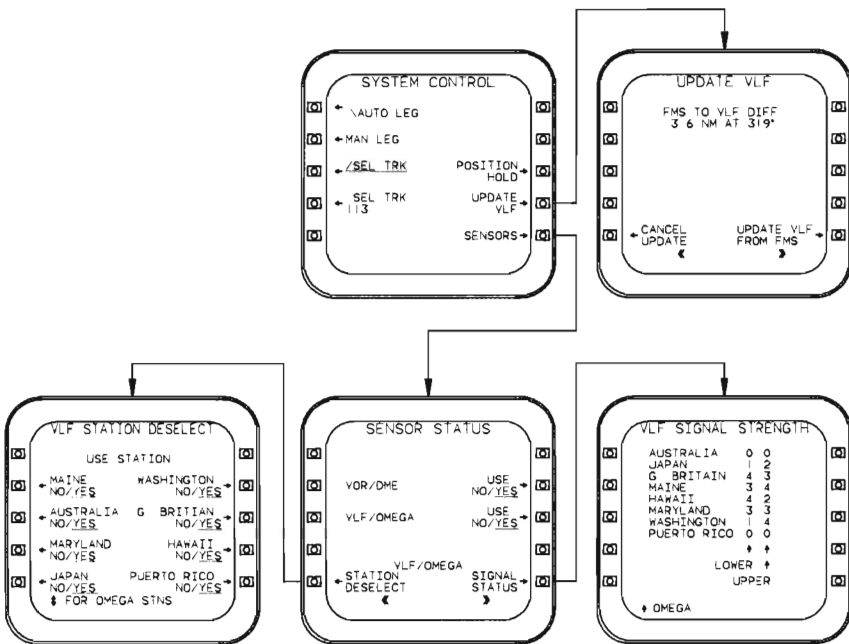

2000-390-084

VLF UPDATE AND SENSOR CONTROL MENUS

IDX (INDEX)

IDX produces a menu offering the following supporting functions:

1. ROUTE LIBRARY

This displays the list of flight plan routes stored in the library. The scroll keys are used to bring subsequent or previous route names into view. The MFD can also display the route library. The FMS has memory for 99 flight plan routes which can be used as is, used partially, or appended to a flight plan under construction. Routes may be selected with the line-select key on the ROUTE LIBRARY menu or by number. When a route is selected, the functions of the display, creation, and modification are the same as for flight planning, except for the following:

- a. The menu title is ROUTE followed by a route number.
- b. The second line of the route display is the route name. Unless specified otherwise, the route name is the first and last waypoints of the route. The route can be renamed by depressing the line-select key next to the route name.
- c. There are no TO or FROM waypoints in a route.
- d. FPL and FLIGHT PLAN labels are changed to RTE and ROUTE, respectively.
- e. The active flight plan may be stored in the route library by selecting an empty route and entering 00.

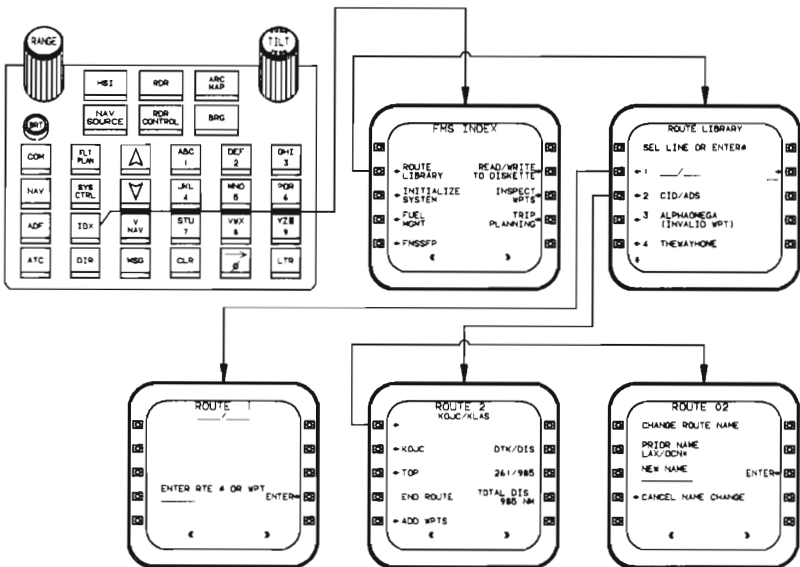

2000-390-085

INDEX AND ROUTE MENUS

2. INSPECT WAYPOINTS

This allows individual waypoints stored in either the data base or the user memory to be inspected as well as any pilot defined waypoints which are no longer in a flight plan. When a NAVAID waypoint is displayed for inspection, the USE NAVAID option allows the navaid to be deselected. This is useful when a NAV station is out of service, making the navaid unusable. All navaid deselections are cleared when the system does a cold start. If any navaids have been deselected, a message on the CDU message page prompts the pilot that the system has automatically reselected all deselected navaids.

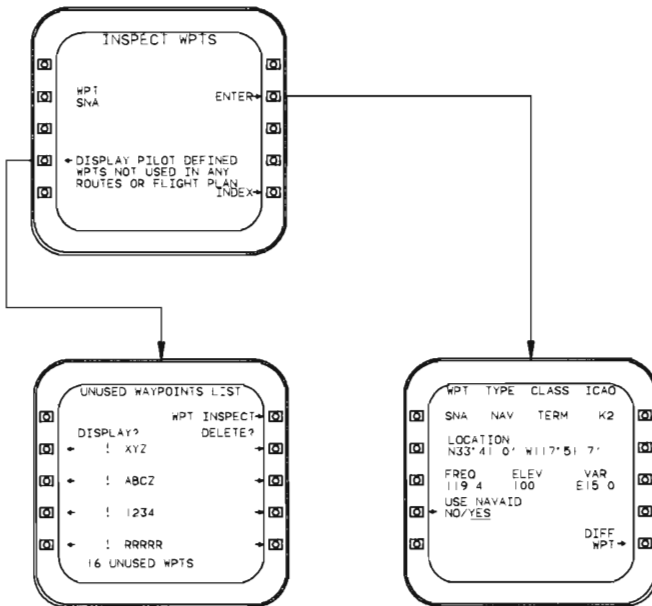

2000-390-089

INSPECT WAYPOINTS MENU

3. TRIP PLANNING

This displays a trip planning menu which requires the entry of the departure point, destination, estimated ground speed, and estimated fuel flow. The FMS will compute the bearing and distance to the destination, and estimated time and fuel enroute. If the FROM line-select key is depressed without an entry, the system allows either using the present position as the FROM waypoint, or entering a route from the route library.

4. INITIALIZE SYSTEM

Returns to the start-up menu.

5. FUEL MANAGEMENT

The fuel management option provides fuel consumption information. It will continuously compute fuel used, fuel remaining and endurance at the present fuel flow. The ENTER prompt will appear. Refer to FUEL MANAGEMENT under the FLIGHT MANAGEMENT SYSTEM.

6. READ/WRITE TO DISKETTE

The data base that the computer uses and the checklists which are displayed on the MFD are organized into files and stored on diskettes. Refer to READ/WRITE FUNCTIONS under the FLIGHT MANAGEMENT SYSTEM.

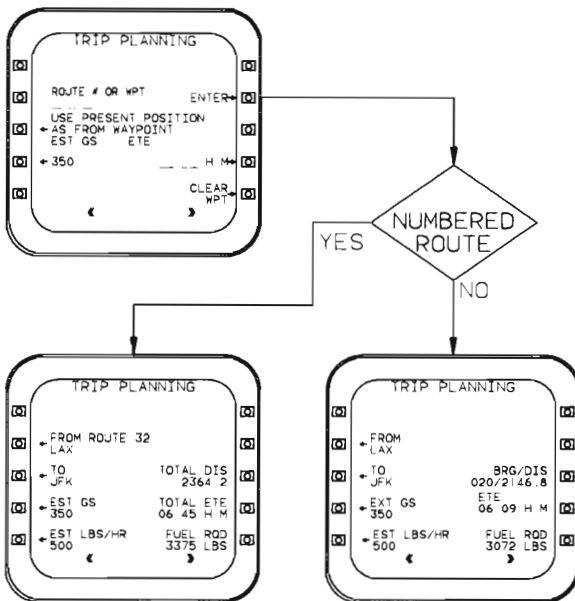

2000-390-090

TRIP PLANNING MENU

DIR (DIRECT)

The DIRECT TO menu is used to reroute the flight plan from the present position directly to a new waypoint.

The DIRECT TO options are:

1. WPT

This allows naming an off-flight-plan waypoint. If ENTER is depressed without a waypoint name or if the name entered is not found in the data base, then the DEFINE WAYPOINT menu is displayed.

a. ON FLIGHT PLAN WAYPOINT

The DIRECT TO menu will display the next two on-flight-plan waypoints. Subsequent or previous on-flight-plan waypoints can be selected with the scroll keys. Any of these may be selected, allowing quick rerouting either back to a previous point or ahead, thus bypassing intermediate waypoints.

b. FROM/TO LEG

This is used to proceed to a new waypoint via a nearby airway which must be intercepted. Both ends of the new direct route must be identified. The FMS will compute the intercept and the route.

c. CLOSEST AIRPORTS

This produces a menu titled THREE CLOSEST AIRPORTS. The three closest airports are listed with their bearing, distance and longest runway length. A direct route is computed to the selected airport.

SCROLL KEYS

The scroll keys (Δ and ∇) are used to scroll the lines up or down and, in some cases, to increment or decrement numbers on the screen. Lists will shift downwards when the up arrow is depressed, and shift upwards when the down arrow is depressed. Depressing a scroll key for more than one second will cause the system to execute an additional scroll action each half second while the scroll key is depressed.

V NAV (VERTICAL NAVIGATION)

This is non-functional.

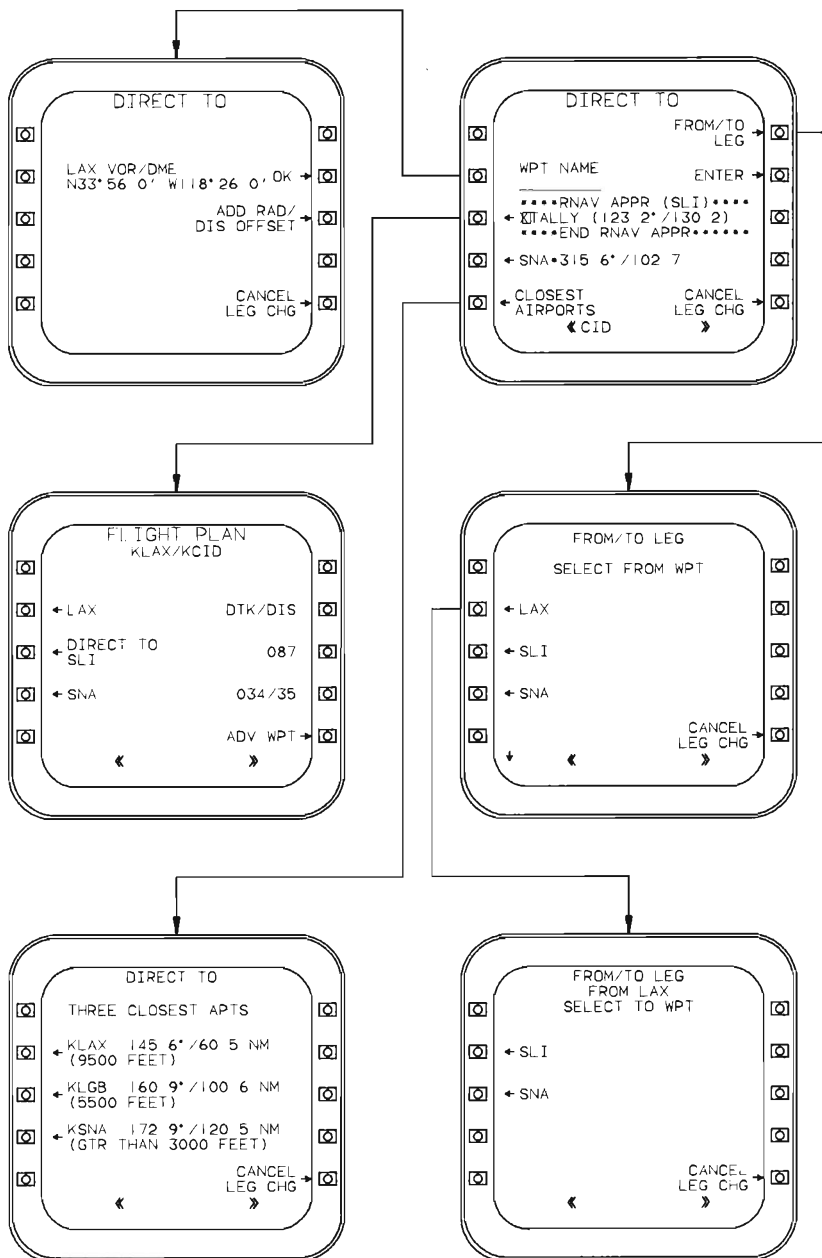

2000-390-188

DIRECT ROUTE MEMO

MSG (MESSAGE)

The last three spaces of the bottom line of the CDU are reserved for a MSG annunciation. Up to five messages can be displayed. New messages are displayed in yellow; subsequent displays of the same message are in white. Messages may be action or status messages.

ACTION MESSAGES

Action messages inform the pilot that corrective action is required. The required action is presented along with the message so that depressing the line-select key initiates the response. Action messages are non-cancellable until the action is performed.

MESSAGE-ACTION		MEANING
POSITION UNCERTAIN	UPDATE > POSITION	Radio signals being received do not match the FMS computed position.
FMS/VLF POS DISAGREE	UPDATE → VLF	The difference between the FMS position based DME or VOR/DME data and that of the VLF/OMEGA is greater than 2.5 NM. This message is removed when the difference drops below 2.3 NM.
VLF REQUIRES INITIALIZATION	UPDATE → VLF	The computer is requesting that the VLF be updated from the FMS.
SYS/VLF GMT DISAGREE	UPDATE > VLF	The VLF disagrees with the system clock by five minutes or more.

BT01431

STATUS MESSAGES

Status messages provide information but do not require specific immediate action.

MESSAGE	MEANING
ALL VLF/OMEGA STATIONS RESELECTED	Following a cold start, the system reselects for use any VLF/OMEGA stations that the pilot had previously deselected (cancellable).
ALL DISABLED WAYPOINTS RESELECTED	Following a cold start, the system reselects any data base waypoints that the pilot had previously disabled (cancellable).
FINAL WPT PASSED	The airplane has passed the last waypoint in the flight plan (non-cancellable).
DATA BASE EXPIRED	The data base is overdue for revision (non-cancellable).
INVALID WPT IN FLT PLAN	A data base update has invalidated one or more waypoints used in the flight plan (non-cancellable).
FMS IN DR MODE at 12:34	FMS is not receiving adequate signals for navigation at ____:____ (time)(non-cancellable).
MEMORY HAS 99X WPTS 1000 MAX ALLOWED	There are 900 or more waypoints in memory. Unused pilot defined waypoints are not included. This message reappears each time another waypoint is added (cancellable).
VOR/DME NOT TUNED FOR RNAV APPR	Neither VOR/DME is tuned to the navaid designated for the RNAV approach (non-cancellable).
POSITION ERROR MAY EXCEED 3 NM	The FMS position error is greater than 2.8 NM. The message is inhibited when the FMS is in RNAV APPR mode.
NAV DATA BASE FAULT	The computer has detected unreliable data on the data base diskette (non-cancellable).
NO RNAV APPR WITH DME HOLD	DME is tuned to RNAV, but is in HOLD, TO wpt is RNAV APPR wpt (non-cancellable).
VERIFY VOR/DME TUNED FOR RNAV APPR	FMS changes AUTOTUNE to MAN before wpt alert at wpt preceding first RNAV APPR wpt.
NO VOR/DME SIGNAL FOR RNAV APPR	Displayed 5 seconds after loss of valid RNAV signal.
CHECKLIST FAULT	FMC has detected a faulty or missing checklist in data base RAM.
AVIONICS FAULT	Fault in one of the avionics LRU's.

BT01434

ERRONEOUS DATA ENTRIES

The system will not accept any inputs that are not appropriate for the item selected.

It will reject the following:

- Radio frequencies out of range, or incorrect channel spacing.
- Latitudes greater than 90°.
- Longitudes greater than 180°.
- Minutes (Lat/Lon) greater than 59.9.
- Angles (Courses, Radials, Headings) greater than 360°.
- Offset distance entries greater than 299.9 miles.
- Letters where all numbers are required.
- Numbers where all letters are required.

If the pilot attempts to enter such inappropriate data, the line where the data was entered will alternately flash the bad entry and a line of question marks. One question mark appears in the place of each pilot entered character. All such messages are in yellow and overwrite any data already on the scratch pad line. (The scratch pad data is restored when the error message is no longer present.)

If the pilot depresses a key which is not active on the displayed menu, the message, KEY NOT ACTIVE is temporarily displayed on the scratch pad line. Then the previous scratch pad display is restored.

If the system detects a data entry error, the pilot can do one of three things:

1. If the entry is not valid for the line selected, but is valid for an alternate line, the pilot may depress the valid alternate line-select key or change to a menu where the entry is valid.
2. The pilot may restart the data entry by depressing any valid data entry key (0-9). The first depress of a data key causes the entry item (or scratch pad) to blank and the newly entered key will become the first key in the field.
3. Depressing the clear key once will erase the last entered digit and allow reentry of that digit. Each subsequent time the clear key is depressed, it will erase the previous digit until the entire field is clear.

Once the pilot starts to key in new data by depressing clear or a data key, any error message is removed from the screen and the flashing of entered data will stop.

ERROR MESSAGES

The following is a table of error messages for data entry errors.

DATA ENTERED	ERROR MESSAGE	MEANING
COM	NOT A COM FREQ NO ALPHAS ALLOWED	Not a valid COM frequency Letter entered in frequency
NAV (By Freq)	FREQ?	Not a valid NAV frequency
NAV (By Ident)	IDENT?	Identifier not found
ADF	NOT AN ADF FREQ NO ALPHAS ALLOWED	Not a valid ADF frequency Letter entered in frequency
ATC CODE	NOT AN ATC CODE NO ALPHAS ALLOWED	Not a valid ATC code Letter entered in code
WAYPOINTS	WPT LIST FULL WPT LIST FULL WPT LIST FULL	WPT list has more than 999 WPTs FPL has more than 99 WPTS FPL and RTE has more than 2499 WPTs
LATITUDE	DEGREES > 90 MINUTES > 59.9	Latitude cannot exceed 90° Minutes cannot exceed 59.9
LONGITUDE	DEGREES > 180 MINUTES > 59.9	Longitude cannot exceed 180° Minutes cannot exceed 59.9
RADIALS	DEGREES > 360	Degrees cannot exceed 360°
DISTANCE	DIS > 299.9 MILES	Distance cannot exceed 299.9 NM
WAYPOINT NAME	DUPLICATE	Entry duplicates previous name
REPORTING POINT	> 360	Bearing cannot exceed 360°
SEL CRS	DEGREES > 360	Course cannot exceed 360°
TIME	HOURS > 24 MINUTES > 59	Hours cannot exceed 24 Minutes cannot exceed 59

DATA ENTERED	ERROR MESSAGE	MEANING
DATE	MONTH > 12 DAYS > ALLOWED	Month cannot exceed 12 Days cannot exceed days in entered month
READ DISKETTE	DBU NOT AVAILABLE DISKETTE READ ERROR DIRECTORY NOT FOUND FILE NOT FOUND	DBU Disconnected or inoperative Diskette not formatted, not in DBU Diskette blank, has no files Requested file not on diskette
WRITE TO DISKETTE	DBU NOT AVAILABLE DISKETTE WRITE ERROR DISKETTE FULL DISK WRITE PROTECTED DISK UNFORMATTED	DBU disconnected or inoperative Diskette defective or not in drive File too large to fit on diskette Diskette write protect is On Diskette is unformatted
TRIP PLANNING	NO LETTERS ALLOWED	Letter entered, should be numbers only
ANY DATA	XXXX KEY STUCK	XXXX CDU key is stuck down

BT00932

CROSS SIDE CDU RESTRICTIONS

Each CDU can perform all system functions except for cross-side ND control. Cross-side ND control is performed in the reversionary mode. An XCDU annunciation on the ND and PFD is displayed when the pilot's or copilot's reversionary panel X-CDU switch is set to X-CDU. If both CDUs attempt to perform the same function, the CDU that finishes last prevails.

When one CDU is performing any of the following functions, the other CDU is blocked from the same function.

1. Actively editing the flight plan or a specific route.

NOTE

Editing is defined as changing or adding waypoints to the flight plan. This includes DIRECT TO functions. However, the cross-side CDU can always examine the flight plan or route.

2. Read/Write diskette.

If one CDU is doing one of the above tasks and the cross-side CDU attempts to do the same, the message X-SIDE USE-NO ACCESS will be displayed on the screen.

ABORT/RESTART OF NAVIGATION DATA ENTRY

All navigation data entry occurs under the FLT PLAN, INDEX, and SYS CTRL keys. Often such data entry is interrupted by using the mode control keys (NAV SOURCE, RDR CONTROL, BRG), the radio tune keys (COMM, NAV, ADF, ATC) or other menu keys. If a route creation is underway using the INDEX key and the process is aborted by tuning a radio or changing the active flight plan, then the next time the INDEX key is depressed, the INDEX menu returns to where it was prior to the abort. A second depression of the INDEX key displays the normal INDEX menu and fully aborts or cancels the edit in process.

Similarly, if the pilot is modifying the flight plan and interrupts to tune a radio or change NAV source, depressing the FLT PLAN key once restores the previous flight plan. Depressing the FLT PLAN key a second time cancels the edit and the display returns to the normal FLT PLAN menu.

Certain actions fully cancel any change in process. For example, if the pilot is editing the flight plan at one location and then begins an edit at another location without completing the first edit, the first edit is fully cancelled.

If one CDU does not complete a process, such as editing the flight plan, which is blocked on the cross-side CDU, the second CDU will remain blocked until the first CDU completes or fully cancels the operation in process.

(This Page Intentionally Left Blank)

PRIMARY FLIGHT DISPLAY

The PFD provides attitude indicator, flight director, and mode annunciator displays. Each PFD is a color CRT with a slip indicator in the lower bezel. The display format emulates an electro-mechanical attitude indicator. The following features are added to provide more information and make that information easier to interpret:

- Supplementary information, such as command cues, course deviation, glideslope deviation, and speed deviation scales are also shown.
- Radio altitude is displayed anytime the airplane is under 2500 feet AGL.
- There are no OFF flags. If a glideslope or course signal is not received, the pointer will not appear.
- If any data source fails, both its pointer and the scale disappears, and a warning flag appears.
- The course deviation pointer changes shape to indicate the source.
- In the event of display failure, the PFD and the ND have reversion modes which combine both displays into either one.
- During unusual attitudes, the display is cleared of everything except attitude, and autopilot disengage annunciations.

The standard PFD uses the chevron airplane reference symbol.



2000-390-003

PRIMARY FLIGHT DISPLAY

PITCH INDICATION

The display background is blue for the sky and brown for the ground. A full 90° of pitch is shown, with a wide white bar at 0°. Below 22° of pitch, the pitch scale and background move together. Above 22° of pitch, the blue-brown line remains in view near the edge of the display while the scale continues to move. The apex of the airplane reference symbol always indicates the actual pitch angle. When pitch exceeds +30° or -20° everything except the attitude and autopilot disengage annunciations are removed. Large red chevrons pointing towards 0° of pitch are in the pitch scale between +50° and +65°, +65° and +90°, -40°, -55°, -55° and -70°, and -70° and -90°. As pitch decreases to +25° or increases to -15°, full PFD information is restored.

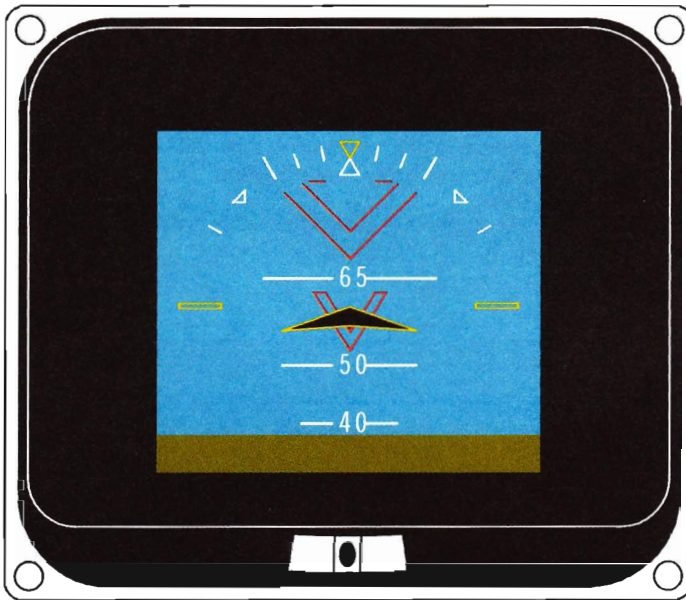

2000-390-006

EXTREME CLIMB



2000-390-007

EXTREME DIVE

ROLL INDICATION

The roll display is conventional with a full 360° of roll displayed.



2000-390-061

EXTREME RIGHT ROLL ANGLE

ATTITUDE FAILURE ANNUNCIATION

In the event of either pitch or roll input failure, all attitude information is removed from the display and the ATT flag is displayed. The red ATT flag flashes for 10 seconds and then becomes steady.



2000-390-008

ATTITUDE FAILURE

COMPARATOR FUNCTION

The PFDs compare left and right side displayed roll and pitch. Heading comparison is done by the PFD only in the reversionary mode.

REVERSIONARY MODE

In the event of a display failure, the PFD and ND can display in a composite mode on either display. The CMPST UP, NORM, CMPST DN switches are located on the pilot's and copilot's reversionary panels. In the CMPST UP position the ND and PFD are displayed in a composite mode on the PFD. In the NORM position, the PFD and ND information is displayed on their respective CRTs. In the CMPST DN position the PFD and ND are displayed in a composite mode on the ND.



2000-390-009

REVERSIONARY MODE



2000-390-010

CROSS-SIDE ANNUNCIATION

ATTITUDE HEADING REFERENCE SYSTEM (AHRS)

The AHRS consists of an Attitude Heading Computer, Internal Compensation Unit, and Flux Detector Units.

COMPUTER

The attitude heading computer provides the roll, pitch, and stabilized magnetic heading data for the displays and the Automatic Flight Control System. Instead of the traditional high speed gyros and synchro-transmitters, the computer uses relatively slow turning motion detectors with piezo-electric transducers. Airplane roll and pitch movements cause the motion detectors to exert gyroscopic forces on the transducers. The transducers convert these forces to voltages. The computer continuously sums the voltages to produce current attitude information. Magnetic heading inputs come from flux detectors located in each wing tip. IAS and VS inputs come from the Air Data Computer.

INITIALIZATION

The system aligns to the local vertical reference and slaves to aircraft magnetic heading within 70 seconds after power application. Inflight automatic realignment after power interruption will occur in approximately 20 seconds with initial degradation proportional to accelerations induced by turbulence and maneuvering.

The pilot or copilot can manually initialize the system at any time with either AHRS REINIT switch.

FAILURE MODES

Failures cause outputs to be flagged as invalid, or cause the output to stop transmitting. Flux detector or interface failures will flag the heading, but will not affect attitude.

REVERSION

If the on-side AHRS fails, either PFD can display information provided by the cross-side AHRS by setting the AHRS switch to X-SIDE. This places a XATT annunciation on the PFD and XHDG on the ND. The switches are located on the pilot's and copilot's reversionary panels.

INTERNAL COMPENSATION UNIT (ICU)

The ICU calibrates the flux detector outputs for an individual airplane. It is mounted on the outside of the AHRS computer case and remains with the airplane if the AHRS is replaced.

FAILURE MODES

Failures result in errors in the slaved heading or the display of a HDG flag.

FLUX DETECTOR UNIT (FDU)

The Flux Detectors, one in each wing tip, sense the horizontal component of the earth's magnetic field and generate output signals proportional to the airplane's magnetic heading.

FAILURE MODES

Failure causes loss of the compass system's slaved heading output and an invalid heading. The HDG flag will be displayed on the on-side ND and the cross-side SDU.

AHRS ALIGNING ANNUNCIATION

The EICAS and PFD both flash the message AHRS ALIGNING, DO NOT TAXI if on the ground. In flight, only the AHRS ALIGNING message is displayed. The messages are removed when AHRS alignment is successfully completed.

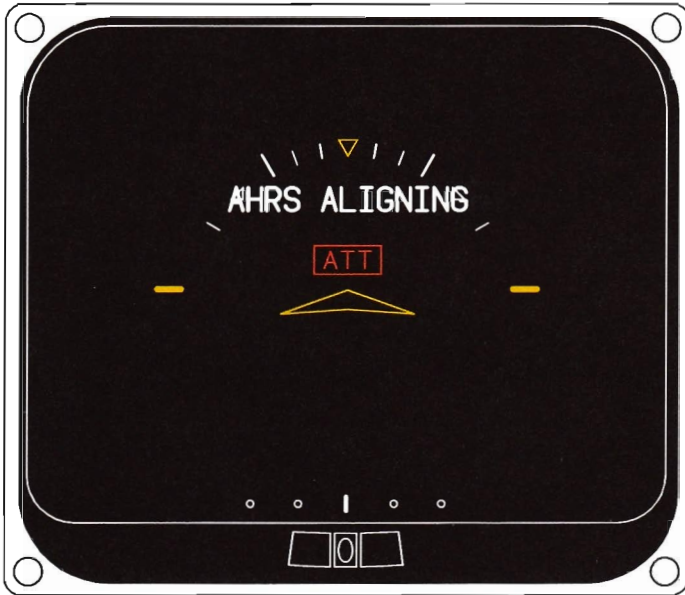

2000-390-182

AHRS ALIGNING ANNUNCIATION

COURSE DEVIATION

The course deviation scale and pointer are at the bottom of the PFD. The course deviation scale is angular in VOR and LOC modes and linear in the FMS mode. When in FMS mode, full scale equals 10 NM, or 2 NM when the APPR mode is selected on the mode select panel or when an RNAV waypoint becomes the TO waypoint. A 10 NM or 2 NM label is displayed on each end of the scale.

The pointer changes shape and color to indicate the current mode. The VOR deviation pointer is hexagonal, resembling a VOR symbol on an aeronautical chart. It is green for an on-side VOR and yellow for a cross-side VOR.



2000-390-011

VOR COURSE DEVIATION INDICATOR

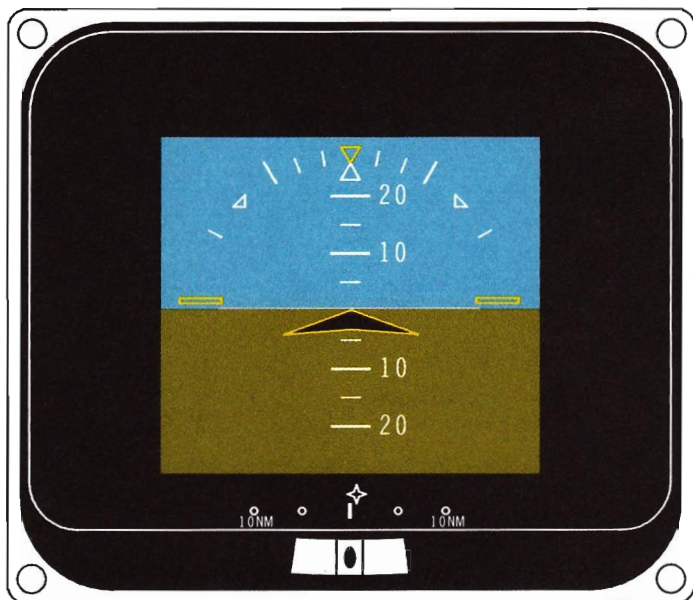

2000-390-013

FMS COURSE DEVIATION INDICATOR

The FMS pointer is a white 4-pointed star.

The localizer deviation pointer is trapezoidal, resembling a runway. It is green for an on-side localizer and yellow for a cross-side localizer.

EXCESS DEVIATION

During stabilized approach conditions, if the localizer or glideslope deviation becomes excessive, the pointer flashes yellow twice per second as long as the excessive deviation condition exists. This is done if either an on-side or cross-side excess glideslope or localizer deviation exists.

COMPARATOR FUNCTION

Comparison between left and right displayed localizer and glideslope is provided under stabilized final approach conditions when the same frequencies are tuned on the left and right navigational receivers.

GLIDESLOPE DEVIATION INDICATOR

The glideslope scale appears to the right of the attitude display when a localizer frequency is tuned and the heading is within 100°-110° of the active course setting. Full scale deviation equals 1.25°. The glideslope pointer is green for an on-side active NAV and yellow for a cross-side active NAV.



2000-390-019

GLIDESLOPE SCALE AND POINTER

BACK COURSE MODE

If the difference between the heading and the course setting exceeds $\pm 110^\circ$ while tuned to a localizer, or $\pm 100^\circ$ while tuned to a VOR, the back course mode is entered. In the back course mode, the course deviation indications and the flight director command cues are reversed to provide normal deviation indications and roll commands for capturing and tracking a course. If the NAV receiver is tuned to a localizer, the PFD and ND display BACK CRS where the glideslope would normally appear. There is no annunciation when tuned to a VOR. The back course mode requires the course be set to the front course approach bearing. The back course mode is cancelled if the airplane is turned to within 100° of the course setting while tuned to a localizer, or to within 90° of the course setting while tuned to a VOR.



2000-390-015

BACK COURSE MODE

FLIGHT DIRECTOR (FD)

When any FD mode is selected, the command cue is added to the PFD. The standard cue is the inverted V. The following are required for the command cue to be displayed:

- A Flight Director mode must be selected.
- Pitch and Roll sources and commands must be valid.
- The airplane must not be in an unusual attitude.



2000-390-016

FLIGHT DIRECTOR COMMAND CUE

RADIO ALTITUDE (2500 FEET TO 1000 FEET AGL)

Between 2500 and 1000 feet AGL, the green radio altitude display is labeled RA followed by four digits. This display appears at 2500 feet AGL on descent and at 1000 feet AGL during a climb. The digits change at 50 foot intervals.



2000-390-025

RADIO ALTITUDE DISPLAY (2500 FEET TO 1000 FEET AGL)

RADIO ALTITUDE (1000 FEET AGL TO GROUND LEVEL)

Below 1000 feet AGL the RA label is replaced by a circle surrounding the digits. The circle is segmented at 100 foot intervals. The digits change at 10 foot intervals. Within the circle, a colored arc shrinks from the 12 O'Clock position counterclockwise as the radio altitude decreases as follows:

- Green arc - Between radio altitude and decision height.
- White arc - Below decision height when radio altitude is greater than decision height.
- Yellow arc - When the radio altitude is equal to or less than the decision height.

The color of the digits follows the color of the arc.



2000-390-020

RADIO ALTITUDE DISPLAY (BELOW 1000 FEET AGL)

DECISION HEIGHT DISPLAY

The selected decision height displayed to the left of the radio altitude is preceded by the legend DH. The DH is displayed automatically below 2500 feet radio altitude or when selected by the DH control on the Altitude Awareness Panel above 2500 feet (clockwise rotation increases DH). When below 1000 feet AGL, the decision height is also displayed by a triangular pointer on the radio altimeter circular scale.



2000-390-021

DECISION HEIGHT DISPLAY AND ALERT

DH ALERT

This alert occurs when radio altitude reaches the selected decision height. The DH alert flashes for 10 seconds before becoming steady yellow. The DH alert is inhibited below 5 feet.

REPORTING ALTITUDE MDA READOUT

A digital display of either MDA or RPT is displayed.

MDA ALERT

When the on-side indicated barometric altitude reaches the selected MDA, the MDA alert flashes yellow for 10 seconds before becoming steady.

REPORTING ALTITUDE

When selected, the RPT is displayed in up to five digits, with the two least significant digits always zero. When the on-side barometric altitude equals the reporting altitude, the RPT legend and the digital readout flash cyan for 10 seconds before becoming steady.



2000-390-156

MDA ALERT

MARKER BEACON

The marker beacon annunciations are flashing boxes which enclose the beacon designator (OM, outer marker is cyan, MM, middle marker is yellow and the IM, inner marker is a white empty box).



2000-390-023

MARKER BEACON ANNUNCIATION

SPEED DEVIATION

Speed deviation is displayed on the left side of the attitude display. The pointer represents the deviation between indicated airspeed and the selected reference airspeed. Full pointer deflection represents a speed deviation of 10 knots. The display is available only when the IAS bug is selected on the ASI.



2000-390-022

SPEED DEVIATION INDICATOR

AUTOPILOT MODE ANNUNCIATION

Autopilot modes are displayed in the upper left corner of the PFD. The figure shows the basic PITCH and ROLL modes. Vertical modes appear below lateral modes.

AUTOPILOT ENGAGED/DISENGAGED

Autopilot engagement status appears on the PFD as shown:

STATUS	PFD ANNUNCIATORS
A/P Not Engaged	No Message
A/P Disengaged, A/P XFER Selected	White A/P →
A/P Engaged	Green A/P ← (plus the mode)
A/P Disengaged	Yellow A/P ← (flashing, without mode, clears after acknowledgement)
A/P Engaged, A/P XFER Selected	Green A/P → (plus the mode)
A/P Disengaged, A/P XFER Selected	Yellow A/P → (flashing without mode clears after acknowledgement)

BT01432



2000-390-024

AUTOPILOT MODE ANNUNCIATION

ARMED AND CAPTURE MODES

Selecting a lateral or vertical mode activates the flight director, bringing the command cue into view. If a mode is selected and the airplane is not in position to track that mode, the mode arms. Armed modes are displayed in white to the right of active modes, which are green. During an ILS approach, the glideslope will not arm until the localizer is captured.

Modes are annunciated as follows:

LATERAL AUTOPILOT MODES

AUTOPILOT MODE	PFD ANNUNCIATOR
Roll Hold	Roll
Heading Select	HDG
LOC 1 Capture	LOC 1 (Green) GS (White)
LOC 2 Capture	LOC 2 (Green) GS (White)
VOR 1 Capture	VOR 1 (Green)
VOR 2 Capture	VOR 2 (Green)
FMS Capture	FMS 1 (Green)
Go Around	GA (Green)

BT01444

VERTICAL AUTOPILOT MODES

AUTOPILOT MODE	PFD ANNUNCIATOR
Pitch Hold	Pitch
Airspeed	IAS
Airspeed Profile	IASP
Vertical Speed	VS
APPR	Dependent on NAV mode (GS, VOR, LOC, FMS)
Altitude Hold	ALT

ALTITUDE SELECT

Armed	ALTS (White)
Capture	ALTS CAP (Green)
Track	ALTS (Green)

VERTICAL AUTOPILOT MODES (Cont'd)

**AUTOPILOT
MODE**

Descent
Go Around

BT01445

**PFD
ANNUNCIATOR**

DES
GA



2000-390-111

ROLL AND PITCH MODE WITH ALTITUDE SELECT ARMED

YAW DAMPER DISENGAGE

If the FCC detects a failure in the Yaw Damper, or the Yaw Damper is disengaged, the YD annunciator flashes yellow for 10 seconds before becoming steady. This annunciation can be cancelled by depressing the AP/YD DISC button or re-engaging the yaw damper.

MISTRIM

If any autopilot servo continuously maintains more than a predetermined torque, the mistrim annunciator for that servo (ELEV, RUD, or AIL) flashes yellow for 10 seconds before becoming steady.

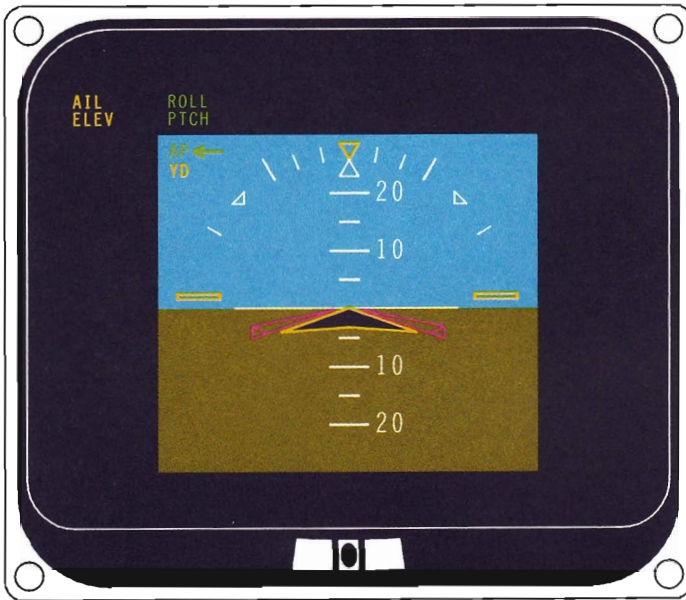

2000-390-155

YAW DAMPER AND MISTRIM ANNUNCIATIONS

STATUS ANNUNCIATIONS

COURSE/GLIDESLOPE STATUS

If the in-use VOR/ILS receiver or FMS fails, the PFD removes the applicable deviation scale and pointer and replaces it with the appropriate VOR, LOC, GS or FMS flag. The flag will flash red for 10 seconds before becoming steady. If no usable signal is received, the deviation pointers are not displayed.

FLIGHT DIRECTOR (FD)

In the event of either pitch, roll, or steering command input failures, the FD flag will appear. The FD flag will flash red for 10 seconds and then become steady.

RADIO ALTITUDE (RA)

If the radio altimeter fails, the PFD removes the normal display and replaces it with the red RA flag. The flag flashes for 10 seconds before becoming steady.

SPEED DEVIATION

If either the indicated airspeed or the reference airspeed equipment fails, the speed deviation scale and pointer are removed and replaced with the SPD flag. The SPD flag flashes red for 10 seconds before becoming steady. If the airspeed reference data is lost, the pointer is removed from the display.

CDU FAILURE ANNUNCIATION

If the CDU is invalid or failed, a CDU flag is annunciated. The flag flashes for 10 seconds before becoming steady.

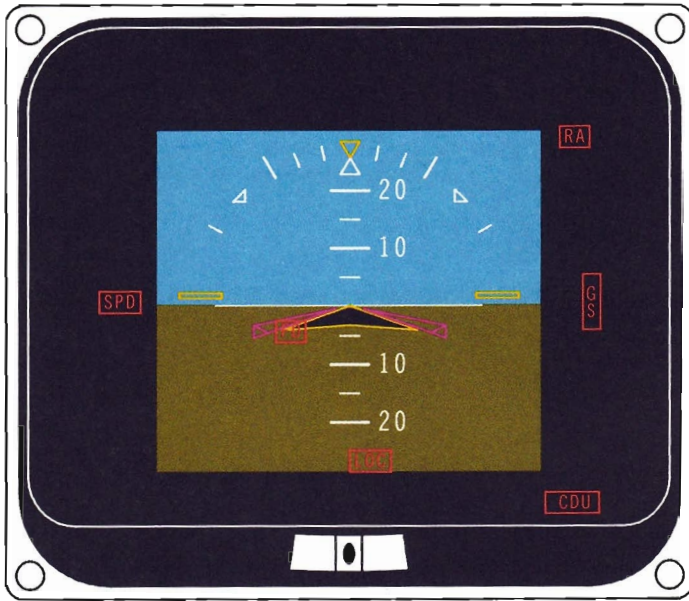

2000-390-014

STATUS ANNUNCIATIONS

NAVIGATION DISPLAY (ND)

The ND is the electronic replacement for the HSI. It can also display weather radar. Each display consists of a color CRT.

The following features are available:

- The formats HSI, ARC, MAP, and RDR are selected with push buttons on the Control Display Unit (CDU).
- Course deviation indicators, bearing pointers, and radar data are selected on the CDU.
- There are no OFF flags. If a course signal or glideslope is not received, the deviation bar or pointer will not appear.
- If any data source fails, its pointer disappears, and a warning flag appears.
- In the event of a display failure, both the PFDs and NDs have reversion modes which combine both displays into one.

NAVIGATION DISPLAY SYMBOLS

SYMBOL	HSI	ARC	MAP
ACTIVE COURSE	Course pointer Digital readout	Course pointer Digital readout	FMS Flt plan route Digital readout
CDI	Conventional	Conventional	Location of route on map display
TO/FROM	Conventional	Conventional	Solid line to station Broken line from station SEL TRK only
LIN ANNUNCIATOR	YES	YES	YES
STATION SYMBOLS	None	None	Positioned to scale if tuned
RADAR RETURNS	N/A	Positioned to scale	Positioned to scale
RANGE RINGS	None	Only with Radar	Yes
PRESET STATION	Double dashed	Double dashed	Double solid line TO, double dashed line FROM the station
BT00941			

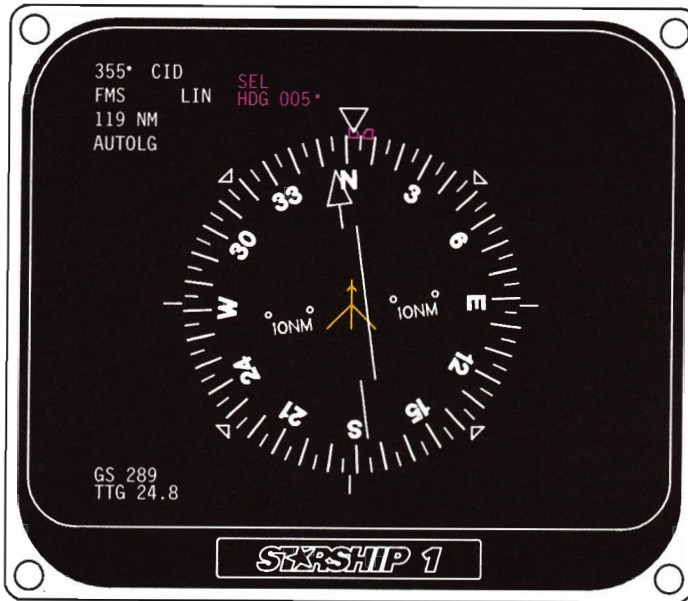

2000-390-049

NAVIGATION DISPLAY

READOUT DEFINITIONS

NAV data is displayed on the left and right sides of the ND. If the active NAV is a VOR, the course displayed is set with the COURSE knob on the CHP. If the active NAV is the FMS, and it is not operating in the selected track mode, a great circle course to the current TO waypoint is calculated.

When a navaid is tuned and the Morse code identifier received, the DME decodes the identifier and displays it to the right of the course. In FMS mode, the current waypoint name is displayed. This may be a station identifier, an airway reporting point name, or a pilot defined waypoint name. If a preset navigation source has been selected, the corresponding data for the preset is displayed on the right side.

LINE ONE - Identifies the active course and the station or waypoint name.

LINE TWO - Identifies the active NAV source, VOR1, VOR2, LOC1, LOC2, or FMS. When the active NAV is FMS, a LIN label is added to show that the course deviation indication is linear. If a preset navigation source has been selected, the corresponding data for the preset is displayed on the right side.

LINE THREE - Is the distance to the active NAV station or waypoint. If no DME signals are received from the station, this line will be dashes. If a preset navigation source has been selected, the corresponding data for the preset is displayed on the right side.

LINE FOUR - Annunciates FMS AUTOLG, FMS MAN LG, or SELTRK modes. If there is a preset, the right side of this line displays TO or FROM, as appropriate.

LINE FIVE - Displays VLF when the FMS is using VLF only for position fixing, or DR when the FMS is in the dead reckoning mode.

LINE SIX - annunciates XHDG when the AHRS switch on the reversionary panel is set to X-SIDE.

LINE SEVEN - Annunciates XCDU when the CDU switch on the reversionary panel is set to X-SIDE.

LINE EIGHT - Annunciates the manual radar gain setting when autogain is deselected. The range is from -3 to +3.

LINE NINE - Annunciates the radar antenna tilt setting.

LINE TEN - Annunciates HOLD when the hold option is selected on the radar control menu on the CDU.

LINE ELEVEN - Annunciates radar mode status, STBY, WX, MAP, WX+TURB or RDR FAIL.

LINE TWELVE - Is the ground speed relative to the active VORTAC or TO waypoint. If no DME signal is received, it will read GS ____.

LINE THIRTEEN - Is the time to go to the VORTAC or waypoint. If no DME is received, it will read TTG __:___

LINE FOURTEEN - Identifies the bearing pointer source. This may be either VOR, FMS or ADF. If no bearing pointer is selected, this line will be blank. If a source is selected but no signal is received, it will show the selection along with a miniature pointer.

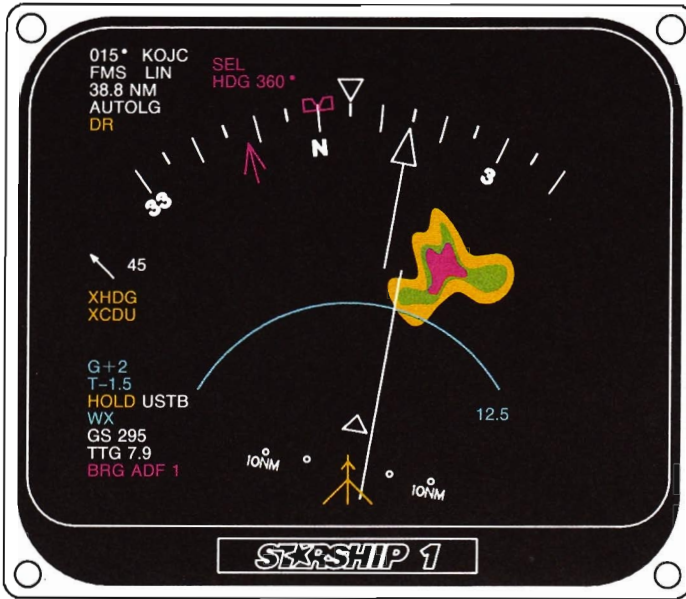

2000-390-187

ARC DISPLAY WITH ALL NAV DATA AND RADAR

NAVIGATION SIGNAL INPUTS

Navigation signals come from the VOR, ILS, ADF, FMS, and VLF/OMEGA. Any of these may be selected as the bearing pointer source. Either VOR or the FMS may be selected as the active NAV. The active NAV is the NAVAID on which the course guidance and distance readout is based. This is done with the NAV SOURCE and BRG push buttons on the CDU.

CONTROL INPUTS

Normal control inputs come from the CDU and the CHP. Each ND has its own CDU, which is used to set display modes, NAV and bearing pointer source, and radar mode. The single CHP has dual course set knobs, allowing separate courses, and a single heading selector.

STATUS INPUTS

All NAV and display systems are monitored by the flight management computer. Invalid inputs are removed from the display, and when appropriate, warning flags are displayed.

NAVIGATION DISPLAY FORMATS

HORIZONTAL SITUATION INDICATOR

If no NAV stations are received, the course deviation indicator (CDI) and TO/FROM indicator are not displayed. The active NAV status is displayed to the left of the compass rose. The active NAV is the NAV radio or FMS flight plan on which the course guidance is based. The minimum information displayed is the course setting on the top line, NAV source on the second line, and distance on the third line. At the lower left corner, the ground speed (GS) and Time To Go (TTG) to the station or waypoint are displayed. The selected heading digits are displayed immediately to the left of the lubber line. If the active NAV is a VOR receiver and no station is received, the CDI and TO/FROM indicators are not displayed.



2000-390-049

HORIZONTAL SITUATION DISPLAY

ARC DISPLAY

The ARC format narrows the view to approximately 70°. Other display features are the same as for the HSI display.

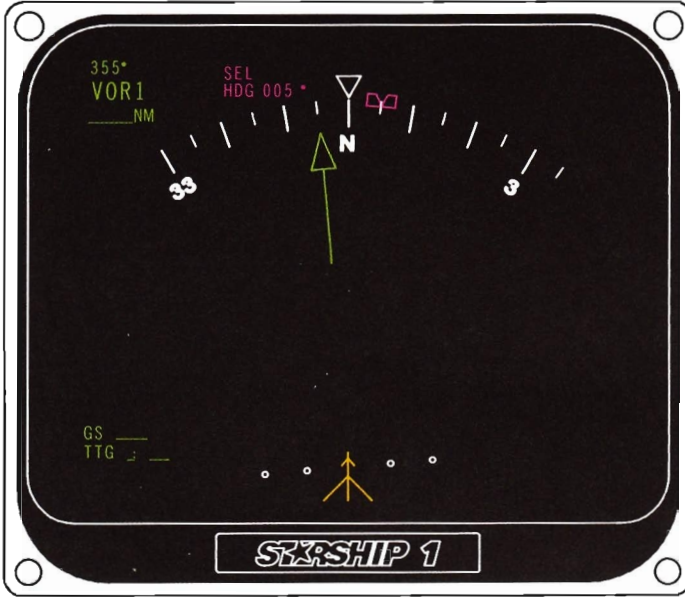

2000-390-042

ARC DISPLAY

MAP DISPLAY

The MAP format utilizes the ARC format's expanded compass segment, however the VOR, course arrow, and waypoint bearing pointers are replaced by geographically positioned symbols. Course lines replace the CDI and TO/FROM flags.



2000-390-043

MAP DISPLAY

WITH STATION SYMBOLS

If NAV stations are received, the station symbols and the selected course are displayed to scale. The station symbols contain the VOR/DME receiver number which is receiving the station. The course line is solid to the active VOR and dashed from it only if operating in VOR mode, not FMS. The symbols are geographically positioned relative to the airplane symbol. The top of the map is the magnetic heading.

SLANT RANGE CORRECTION

The DME distance to the active VOR is always slant range when operating in VOR mode. FMS distance is not slant range.

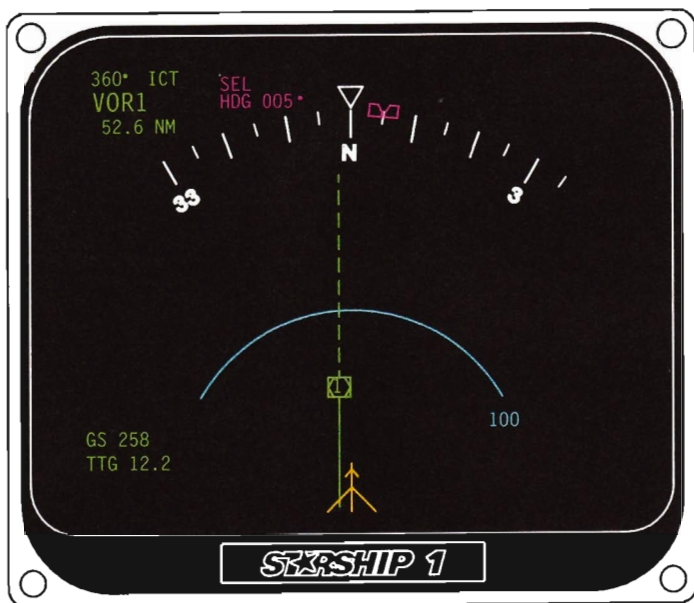

2000-390-044

MAP DISPLAY WITH STATION SYMBOLS

FMS FLIGHT PLAN

If FMS is the active NAV Source, the ND MAP displays the next three waypoints of the active flight plan. Waypoint symbols are white four pointed stars. All waypoints are identified by name adjacent to the waypoint symbol. When the FMS is in AUTOLG or MAN LG mode, route lines connect the waypoints. In SELTRK mode, the route line is solid to the waypoint and dashed from it.

WAYPOINT ALERT

Condition 1.

If a flyover condition exists (SELTRK mode, arrival at last flight plan waypoint, or AUTOLG/MAN LG mode and course change at the waypoint is 150° or more) the waypoint alert will be given 10 seconds before arrival at the waypoint. If the AUTOLG mode is active, the turn will not start until arrival at the waypoint. If MAN LG mode is active, the turn will start as soon as the waypoint is advanced.

Condition 2.

If a continuation leg exists (AUTOLG or MAN LG mode and the course change at the waypoint is less than 150°) the waypoint alert will be given 10 seconds before the FMS calculated start of the anticipated turn to the new course. The start of the anticipated turn is a function of TAS and course angle change at the waypoint. If the AUTOLG mode is active, the turn will start when the waypoint alert stops. If the MAN LG mode is active, the turn will start when the waypoint is advanced.

The waypoint alert causes the TO waypoint symbol and identifier to flash.

NAVIGATION MODE ANNUNCIATION

If the active NAV Source is the FMS, the ND displays the navigation mode in the upper left corner. This is selected on the SYSTEM CONTROL menu. The options are:

- AUTO LEG
- MAN LEG
- SEL TRK



2000-390-050

MAP DISPLAY WITH FLIGHT PLAN

NO FLIGHT PLAN ANNUNCIATION

If FMS is selected as the active NAV source and no flight plan exists, the ND displays the NO FLIGHT PLAN message. The course line, and digital course are removed from the display.



2000-390-045

MAP DISPLAY WITH NO FLIGHT PLAN

ACTIVE COURSE

The active course is the VOR or FMS flight plan route that is the navigation source. The selection is made with the on-side CDU NAV SOURCE push button. The pilot's and copilot's NDs may have different active courses.

COURSE POINTER

The course pointer is on the HSI and ARC displays. It is a conventional HSI course pointer and is set with the COURSE knob on the CHP. Depressing the center of either CRS knob, labeled PUSH Δ DIRECT, will change the present course to a direct course to the tuned station.

COURSE DEVIATION INDICATOR (CDI)

The CDI indicator is displayed along with the course pointer when a VHF NAV signal is received.



2000-390-048

HSI WITH CDI TO/FROM INDICATOR

TO/FROM

If the active NAV is a VOR, the TO/FROM indicator is displayed with the CDI and has the same color coding.

In the FMS mode, if TO is selected the TO/FROM symbol will be positioned at the head of the active course pointer. If FROM is selected the TO/FROM symbol will be positioned at the tail of the active course pointer.

HEADING BUG

The heading bug rotates around the compass rose or arc and is positioned with the heading knob on the Course Heading Panel. There is a matching digital readout immediately to the left of the lubber line. The heading bug and readout are displayed in magenta. Push the center of the HDG knob to synchronize the heading bug to the present heading.



2000-390-047

MAP DISPLAY WITH STATION

BEARING POINTER

A bearing pointer to a VOR, NDB, or FMS waypoint may be added to the NAV Display in either the HSI or ARC mode. The selected source is annunciated in the lower left corner. The selection is set on the CDU menu by depressing the BRG key. If a signal is received, the bearing is displayed in magenta. If a source is selected but no signal is received, the pointer is removed from the scale and displayed in miniature next to the bearing pointer annunciation.



2000-390-038

HSI WITH BEARING POINTER

ILS SYMBOLS

If the active nav is tuned to an ILS or localizer frequency, the active course display changes to LOC 1 or LOC 2 and the glideslope scale appears. If a usable glideslope signal is received, the glideslope pointer is added. The TO/FROM symbol is blanked in localizer mode.

COLOR CODES

The active course readouts are in the upper left corner of the displays. They follow the same color coding as the active course symbols.

The active symbols and readouts are color coded as follows:

- If the active course is on the on-side receiver, the pointer is green.
- If the active course is on the cross-side receiver, the pointer is yellow.
- If the active course is an FMS flight plan, the pointer is white.

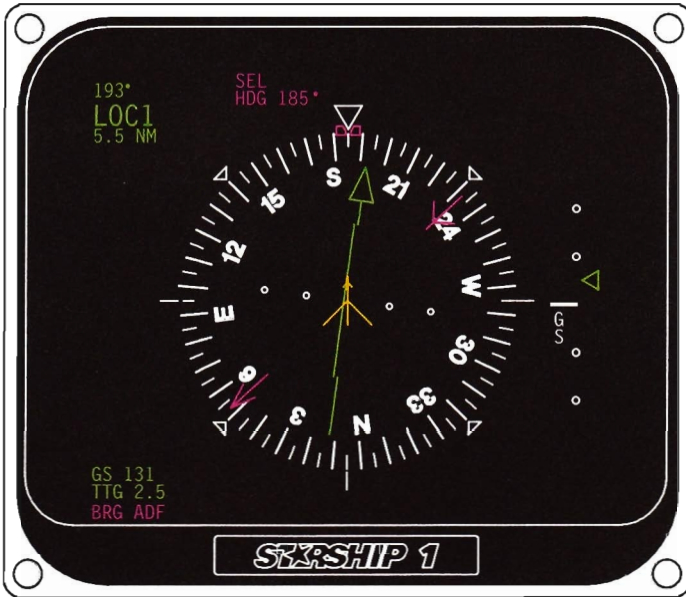

2000-390-039

HSI WITH LOCALIZER AND GLIDESLOPE

BACK COURSE MODE

In the back course mode, the flight director command cues are corrected to provide normal roll commands for capturing and tracking the localizer back course. The ND and PFD display BACK CRS where the glideslope would normally appear. For the back course mode to function, the course must be set to the front course approach bearing. The ND enters the back course mode under the following conditions:

- The active NAV is a localizer.
- The difference between course setting and the heading exceeds 110°.

The ND cancels the back course mode if the airplane is turned to within 100° of the course setting.

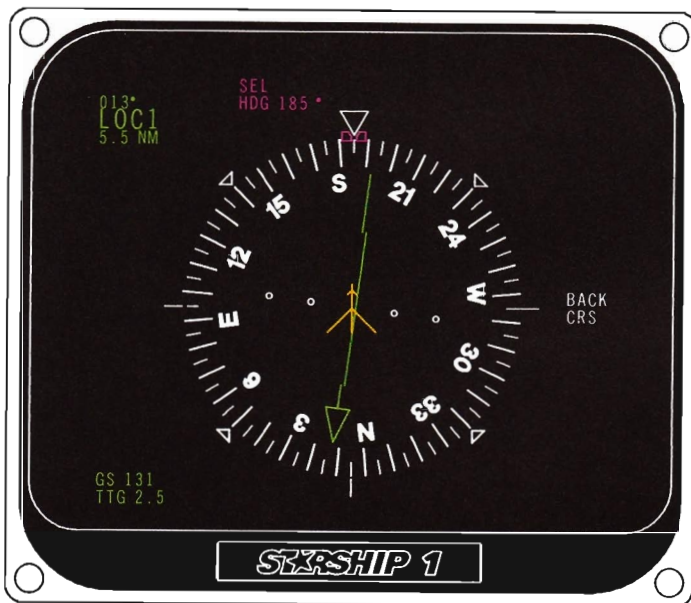

2000-390-116

HSI IN BACK COURSE MODE

WIND INDICATOR

The flight management computer compares the ground speed and track computed from navaid signals with true airspeed and heading and then computes the magnetic wind direction and velocity. The ND displays a wind vector symbol when the computer detects a wind velocity of seven knots or more. The symbol is an arrow which points downwind, with the velocity displayed to the right of the arrow. The arrow symbol is removed if the wind drops to five knots or less. If the FMS goes into DR mode, the computed wind vector is frozen until updated NAV data is received.



2000-390-115

HSI WITH WIND INDICATOR

WEATHER RADAR (RDR)

Radar returns are available when the ND is in either ARC or MAP modes. If radar is selected while displaying an HSI, the display will change to the ARC + WX display. Range rings are displayed in ARC + WX or any MAP mode, and are controlled by the RANGE KNOB on the CDU.

RANGE KNOB

The RANGE knob on the CDU is the primary range control for the on-side radar channel. Radar may also be displayed on the MFD which uses the scroll keys (Δ and ∇) as range controls. The MFD can display either radar channel. If a radar channel is on the MFD only, the scroll keys control the range for that channel. If the radar is then added to the ND, the RANGE knob on the CDU assumes control over the range for that channel on both the ND and the MFD.

TILT KNOB

The TILT knob is the primary control for changing the antenna angle with respect to the horizon. The control range is $\pm 14^\circ$. Depressing the center of the knob resets the antenna tilt to 0° .

ANTENNA STABILIZATION

Antenna stabilization is automatically selected at power-up. If antenna stabilization has been deselected, USTAB is annunciated in cyan.

HOLD

If the RDR system has been placed in hold, HOLD is annunciated in yellow.

GROUND CLUTTER SUPPRESSION

If RDR ground clutter suppression has been turned on, +CLT is added to the mode annunciation.

ARC

An RDR range arc and numeric distance label appear when weather is selected. The arc marks the midpoint of the maximum radar range as selected by the RANGE knob.



2000-390-046

MAP DISPLAY WITH RADAR

PRESET COURSE

The preset course option allows the pilot to preset an alternate course and then exchange the preset and active courses at the touch of a button. Any course which may be selected as an active course may be tuned as a preset course, except that FMS may not be selected as both active and preset course.

The preset course TO/FROM indicator is removed in HSI or ARC mode and the TO/FROM indication is shown in the upper right corner of the display.

SELECTION

The Preset Course NAV data can be displayed in HSI, ARC and MAP modes. The NAV sources are defined on the PRESET NAV SOURCE menu on the CDU. Once defined, depressing the line-select key next to CRS XFER causes the preset course to become the active course, suppresses the original active course and changes the line-select key to RECALL CRS. Pushing this line-select key will bring the previous active course key back on the display as a preset course and the line-select key becomes CRS XFER again.



2000-390-041

HSI WITH PRESET COURSE

MAP DISPLAY AND READOUT

The MAP displays the preset course with a double solid line to, and a double dashed line from the preset navaid. The NAV data for the preset course is also displayed in the upper right corner of the ND, and follows the same format as the active course data in the upper left corner. All preset course symbols and data are cyan.

DEVIATION BAR

Preset course deviation is presented in HSI format only, and uses an HSI-type deviation bar. The NAV source options are the same as the the active NAV source.

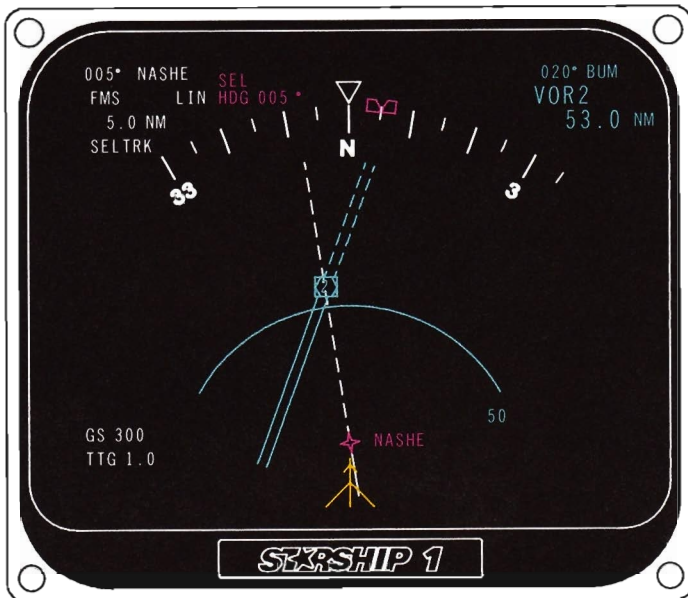

2000-390-040

MAP PRESET COURSE

STATUS ANNUNCIATIONS

ATTITUDE HEADING REFERENCE SYSTEM (AHRS) FAILURE

If the heading input fails, a red HDG flag replaces the lubber line. The flag flashes for ten seconds before becoming steady.

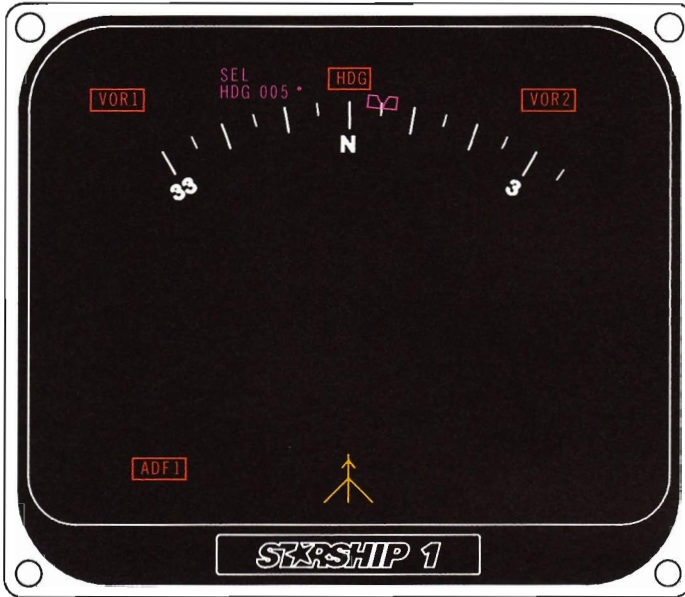

2000-390-174

FAILURE ANNUNCIATIONS

CROSS-SIDE REVERSION

If the on-side AHRS fails, either ND can display information provided by the cross-side AHRS by setting the AHRS switch to X-SIDE. This adds an XHDG annunciation to the display.



2000-390 175

CROSS-SIDE ANNUNCIATION

NAVIGATION SIGNAL SOURCE

The active NAV source is selected with the on-side CDU. This can be changed to cross-side by setting the CDU switch on the reversionary panel to X-SIDE. This adds the annunciation XCDU to the ND. When in X-SIDE, both NDs will have the same active NAV.

NAV SOURCE STATUS ANNUNCIATION

If the active NAV equipment fails, the NAV source annunciation turns red and flashes for 10 seconds prior to becoming steady, and the active course pointer and readout are removed.

DISTANCE STATUS ANNUNCIATION

If the DME equipment fails, the distance readout is replaced by red dashes that flash for 10 seconds prior to becoming steady.

DME HOLD ANNUNCIATION

The active DME hold is displayed by replacing the NM label with H next to the active distance readout.

If DME Hold is selected while in map mode, and the active NAV is VOR, then the station symbol, course line, and ident are removed from the display.

BEARING POINTER STATUS

If the bearing pointer source equipment fails, the bearing pointer symbol is removed and the bearing source annunciation turns red and flashes for 10 seconds before becoming steady.

ACTIVE COURSE TIME-TO-GO STATUS ANNUNCIATION

If the selected input for TTG fails, the TTG readout is replaced by red dashes that flash for 10 seconds and then become steady.

ACTIVE STATION IDENTIFIER

The active station identifier is displayed in the upper left corner.

DEAD RECKONING ANNUNCIATION

If the FMS is the active NAV Source and is in the dead reckoning mode, the DR annunciation is displayed in the upper left corner. There is also a DR annunciation for VOR station passage.

COURSE DEVIATION OUTPUTS

The ND outputs course deviation data to the autopilot. The scaling and meaning associated with this depends upon the active Nav source as follows:

NAV MODE	SCALING ANG/LIN	LAT DEV SCALE	FULL SCALE
VOR	ANG	5 DEG/DOT	±10.4°
LOC	ANG	1.25 DEG/DOT	±2.6°
FMS	LIN	5 NM/DOT	±10.4 NM
FMS APPR	LIN	1 NM/DOT	±2.18 NM
BT00942			

RADAR COMMAND FAULTS

The system monitors all control commands which go to both the ND and the weather radar (RDR). If any display command does not match the corresponding control command to the radar, a RDR control fault has occurred. If this condition exists, the radar returns are removed and the RDR CONTROL FAULT message is displayed.

COMPARATOR FUNCTION

The NDs compare left and right side displayed headings. Roll and pitch comparison is done only in the reversionary mode on the ND. In the event of mismatched attitude displays without a detected failure, the NDs will continue normal displays and send comparator status to the EICAS. The STATUS annunciators are ROLL DISAGREE (approach off 3°, all others 4°), PITCH DISAGREE (approach off 3°, all others 4°), and HDG DISAGREE (approach off 4°, all other 6°). The comparators are off when operating with x-side AHRS.

EXCESS DEVIATION

The ND provides a signal during an ILS approach if either on-side or cross-side localizer deviation becomes excessive. In addition, the deviation bar will flash yellow as long as the excess deviation exists.

(This Page Intentionally Left Blank)

MULTIFUNCTION DISPLAY (MFD)

The MFD can display the following:

- NORMAL PROCEDURES
- ABNORMAL PROCEDURES
- EMERGENCY PROCEDURES
- RADAR
- PRES POSITION MAP
- PLAN MAP
- FMS
- AVIONICS STATUS
- CREW NOTES
- MAINTENANCE
- EICAS (Reversionary mode)

MFD INITIAL DISPLAY

The MFD is controlled by the COPILOT INTEGRATED AVIONICS switch on the center subpanel. It performs a built-in-test (BIT) upon initial power application, and then displays the MFD index. If the BIT fails, the display will remain blank.

MFD INDEX

The index lists the display options. With any display option on the screen, the IDX label appears above the left-hand function key, which is then used to return to the index.

LINE-SELECT AND FUNCTION KEYS

Display options are selected from the index or one of the sub-menus by depressing the corresponding line-select key. The function under EMG is for the emergency procedures and is present for all displays.

CHECKLISTS

NORMAL AND ABNORMAL

To display the normal or abnormal checklists, depress the line-select key next to the corresponding label on the MFD index. The NORMAL or ABNORMAL CHECKLIST notification appears. The notification must be acknowledged before continuing. To acknowledge the notification, depress the line-select key next to ACKNOWLEDGE.

EMERGENCY

To display the emergency checklist, depress the function key below EMG. Except when the EICAS reversionary mode is selected (all MFD functions disabled) the EMG key is always active when the MFD is on. The emergency checklist title page appears immediately regardless of the previous MFD display mode.

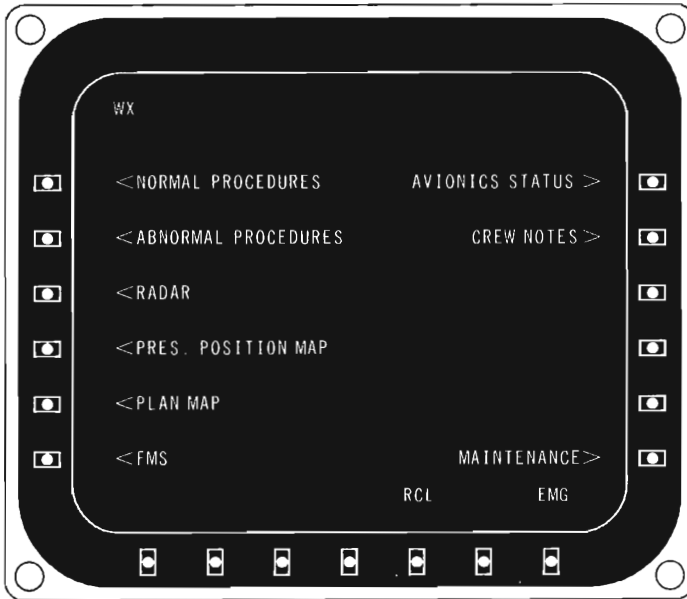

2000-390-097

MULTIFUNCTION DISPLAY INDEX

FUNCTION KEYS

IDX	Δ	∇	SKP	RCL	CLR	EMG
Return to MFD index	Scroll up one line	Scroll down one line	Skip this line	Recall skipped lines	Clear list, return to top	Emergency checklist.

BT00943

All checklists start with a title page that shows the checklist title, issue date, and table of contents. The table of contents lists up to six sections on each page, and may have additional pages.

The table of contents and checklist pages are advanced or backed up by moving the joystick up or down. Previous and subsequent sections may be displayed by moving the joystick left and right.

A checklist section is selected by depressing the line-select key to the left of the desired section. This causes the first page of that section to be displayed on the MFD. The first page displays the checklist title on line one and the section title on the left side of line three. The text or procedures begin on line five.

Checklist line items are displayed in three colors.

- Green - Completed items.
- Magenta - Current items.
- Cyan - Unaccomplished items.

Items are checked off by depressing the ∇ function key, or the LINE ADV button on the outboard horn of the control wheel. When the last item on a page is completed, if there is a subsequent page, it will be displayed. This continues until the last item in the section is completed. When a list is completed, the last page will remain until another display is selected.

To defer an item, depress the function key below SKP (skip). It will change to cyan and the next item changes to magenta and becomes the new current item. Any item(s) skipped can be recalled later, while in the same checklist section, by depressing the function key below RCL (recall). This will display the page where the first skipped item is located. That will be the current item and will be magenta. When that item is checked off, the next skipped item will become current. When all skipped items have been checked off, the list advances to the last page of that section and remains there until another display is selected.

The Δ function key (second from left) allows the operator to back up through a list. This changes the status of each item back to not completed.

An entire list section can be reset in two ways. To restart a list from the beginning, depress the function key below CLR (clear). To exit a list, depress the function key below IDX. When a list is selected from the index, it appears with all items unchecked.

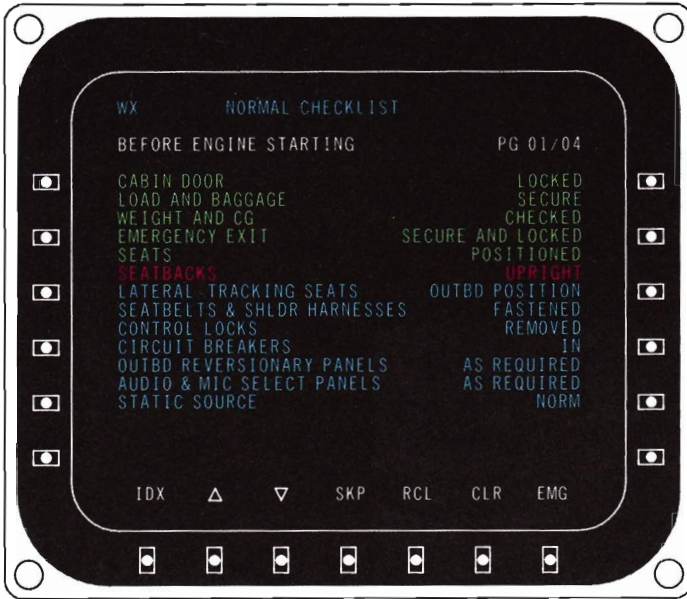

2000-390-118

NORMAL CHECKLIST

CREW NOTES DISPLAY

Selecting CREW NOTES on the MFD index page places the MFD in remote terminal mode and displays the Crew Notes file. The crew notes are maintained by the owner/operator.

CREATING CREW NOTES CHECKLIST (USRCKLST.ASC)

Use any text editor or word processor (such as QEDIT, EDLIN, WORDPERFECT, etc.) to create the crew notes ASCII file which consists of command and text characters. The use of an IBM or IBM compatible computer is required to create the crew notes checklist.

NOTE

The CREW NOTES checklist must be named USRCKLST.ASC.

BEFORE STARTING

Prior to writing the crew notes checklist, make a duplicate (Reference the DOS manual for DISKCOPY procedures) copy of the latest MFD Checklist diskette and the MFD conversion diskette (P/N: 98-30501) with the CONCREW1.EXE file onto a 1.0 MB capacity, 3.5-inch, double-sided, double-density diskette formatted to 720 KB. This is a precaution to protect the original diskettes.

Be sure to place the "write-protect" tab on the original diskette into the "read only" position as indicated by the arrows on the label. This procedure will protect information on the diskette from being accidentally written over or altered.

NOTE

IBM-DOS or MS-DOS version 3.2 or greater must be used.

FORMATTING DISKETTES (FORMAT)

Reference the DOS Manual.

DUPLICATING A DISKETTE (DISKCOPY)

Reference the DOS Manual.

RULES FOR EDITING

- Every line begins with a two-character command.
- All entries (commands and text) must be upper case letters.
- Each display page will accommodate up to sixteen lines. This does not include the "title" line.
- The command is followed by one space so that the text for any line starts in column four.
- Lines in the ASCII file having no command are ignored.

- The following letters and symbols are allowed to be in the text.
 - Upper Case Letters: A through Z, and space
 - Numbers: 0 through 9
 - These 26 Symbols: @ # \$ % & * () - = + [] ; : ' " , < . > / ? \ |
 - Degree Symbol: Use the "accent" for this symbol

Any other characters in the text will be converted to a box with an X through it.

TYPE OF COMMANDS ALLOWED

Date (DA)

Provides for 8 total characters in columns 4 through 11. Month/Day/Year format. All zero's must be present. The date command and date must be the first line in the ASCII text file. Only one date command may be present in the CREW NOTES file. The line immediately after the date must be blank.

Title (TI)

Provides for 31 character spaces in columns 4 through 34. This is the title of the checklist. A title less than 31 character spaces will be filled with spaces. The title command separates the lists within any particular file. The first title command will be placed on the third line immediately following the date (DA) command.

Line Item (LI)

Provides for 40 characters of text in columns 4 through 43. One line of text (cyan when unchecked, green when checked) that can be checked off normally.

Multiple Line Item (ML and MC)

Provides for 40 characters of text in columns 4 through 43. Two commands exist for this type of item; one for the first line of the item and one for the continuation lines. For example, a multiple line item line followed by three multiple line continuation lines would be checked off as a group of four lines (cyan when unchecked, green when checked). A multiple line item must terminate on the page of origin.

Advisory Note (AN)

Provides for 40 characters of text in columns 4 through 43. A line of text (white in color) that is skipped and not available for checkoff.

Cautionary Note (CN)

Provides for 40 characters of text in columns 4 through 43. A line of text (yellow in color) that is skipped and not available for checkoff.

Page Advance (PA)

This command goes on a line by itself and will cause the next procedure to begin on a new page. This command is required when a procedure extends past the sixteen line limit.

CREATING AND CONVERTING THE CREW NOTES CHECKLIST

1. Place the MFD checklist conversion diskette (P/N: 98-30501) containing the CONCREW1.EXE file into a 3.5 inch disk drive.
2. Change to the drive containing the CONCREW1.EXE file.
3. Using either a text editor or a word processor, create a file called USRCKLST.ASC.
4. Following "Rules for Editing" and "Types of Commands Allowed", create the checklist as desired.
5. After the checklist is completed, save the USRCKLST.ASC file to an ASCII text file.
6. Type: CONCREW1 and depress the ENTER key. Follow the prompts.

NOTE

The conversion program will prompt for a version number which will always be "001".

7. Copy the USRCKLST.ASC file to another diskette for safekeeping.
8. Using the DOS delete command, delete the USRCKLST.ASC file from the diskette to be loaded into the FMS-850.
9. The new crew notes file is now ready for loading into the FMS-850.



2000-390-183

CREW NOTES

FUNCTION KEYS

IDX

Return
to MFD
index

Not
Used

Not
Used

Not
Used

RCL

Recall
Menu
with
skipped
lines

Not
Used

EMG

Emergency
checklist.

BT00944

PRESENT POSITION MAP

The present position map is a moving map display, centered on the airplane symbol located one third of the way up from the bottom of the screen. The top of the map is the magnetic heading, and the map range, measured from the center of the airplane symbol to the outer range ring, may be set to 10, 25, 50, 100, 200, 300 or 600 NM.

To display the present position map, depress the line-select key next to PRES POSITION MAP. The map menu appears with the features available for display. Some of the menu's features are not available when the airplane is outside the area covered by the data base. For example, if the airplane is flown to Europe with the North American data base installed, the INTERSECTION, NDB, and TERMINAL WAYPOINT options will not appear on the menu.

TERMINAL WAYPOINTS appear on the menu only if the current flight plan destination airport has terminal waypoints designated.

MAP OPTIONS

To display any of these features on the present position map, depress the line-select key next to the desired items. This toggles the selection on or off. Selected items are displayed in green and underlined. The line-select key next to RDR OFF/1/2 is a three-way toggle.

MAP DISPLAY

To display the map, depress the line-select key next to DISPLAY.



2000-390-096

PRESENT POSITION MAP MENU

PRESENT POSITION MAP JOYSTICK OPERATION

A joystick symbol appears on the present position map whenever the joystick is moved. This symbol, a circle with crosshairs, is connected to the airplane symbol by a dashed line. The symbol moves in proportion to the time the joystick is held off center. The symbol, its magnetic bearing, distance, and dashed line are displayed until the joystick waypoint is entered into the flight plan or it will time out in 60 seconds. Any waypoint can be inserted in a flight plan route in this manner. To enter the waypoint into the flight plan, position the joystick waypoint where desired, and depress the function select key below ENT. After a delay of 3-5 seconds, the waypoint appears in the CDU scratch pad. In FLIGHT PLAN, select ADD WPTs, depress the RTE# or WPT line-select and enter. If the joystick waypoint coincides with a navaid, intersection, or airport symbol on the map display, the computer will recognize it and name the waypoint accordingly. An entire route can be constructed using joystick waypoints. All FMS waypoints entered into the flight plan route are connected by a solid white line.

FUNCTION KEYS

IDX	Δ	∇	MNU	RCL	ENT	EMG
Return to MFD index	Increase map range	Decrease map range	Return to map menu	Recall list with skipped items	Enter joystick waypoint into flight plan route	Emergency checklist.

BT00945

RANGE CONTROL

The Δ and ∇ function keys are not active when the radar channel displayed on the MFD is also on a NAV display. In that case, the RANGE knob on the CDU controls the map range.



2000-390-094

PRESENT POSITION MAP

PLANNING MAP

The planning map is a North-up map which displays flight plan routes and aeronautical facilities listed in the data base. The flight plan status determines the map center. Select CDU 1/CDU 2 to determine the map center. Example: The flight plan page is on CDU 1 and the route list is on CDU 2. By selecting CDU 2 a future flight plan may be entered in the route list with the benefit of the plan map.

If the flight plan is not completed, the planning map center is the last waypoint completely entered in the flight plan. The MFD function key below ENT sends the waypoint to the CDU scratch pad to be inserted and verified. The waypoint entry is complete when the CDU line-select key next to ENTER is depressed.

If the flight plan is completed, the planning map center is the top waypoint displayed on the CDU. Scrolling the list moves the map center.

The map has one range ring. The radius is displayed at the top, and set with the Δ and ∇ keys to 10, 25, 50, 100, 200, or 300 NM.

PLANNING MAP MENU

To display the planning map menu, depress the line-select key PLAN MAP on the MFD index. This planning map menu is identical to the present position map menu except WEATHER is not available. To display the map, depress the line-select key next to DISPLAY.

FUNCTION KEYS AND JOYSTICK OPERATION

The function keys and joystick symbol operation on the planning map are the same as on the present position map.

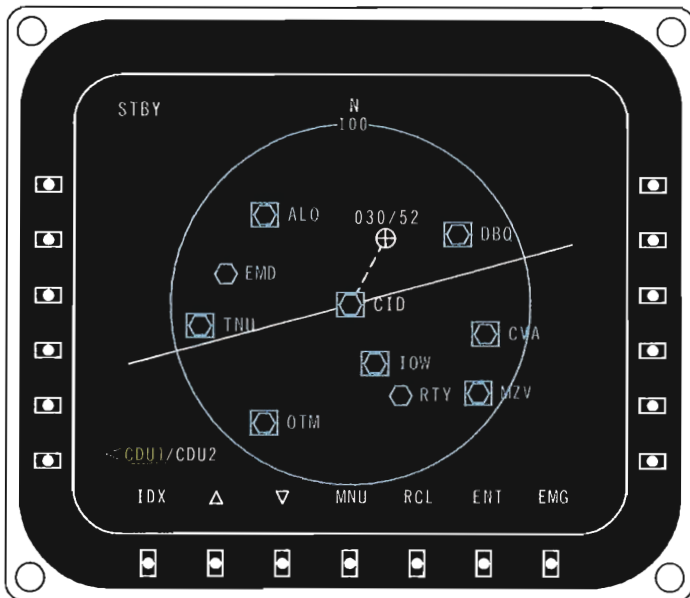

2000-390-093

MFD FLIGHT PLANNING MAP WITH JOYSTICK SYMBOL

FMS

The line-select key next to FMS causes the FMS Menu to appear. Each of the six options causes the MFD to display a different set of navigation data from the flight management computer.

FUNCTION KEYS

IDX

Return
to MFD
index

Not
Used

Not
Used

Not
Used

RCL

Recall
Menu
with
skipped
lines

Not
Used

EMG

Emergency
checklist.

BT00946



2000-390-099

FMS MENU

PERFORMANCE

The PERFORMANCE page displays data on the current waypoint. The top line displays the waypoint identifier, magnetic bearing, and distance. The second line is the waypoint LAT/LON coordinates.

The rest of the page is interpreted as follows:

TTG	HDG	DTK
Time-To-Go to waypoint in minutes	Magnetic Heading	Desired Track
ETA	BRG	TK
Estimated Time of Arrival	Waypoint Magnetic Bearing	Actual Ground Track
GS	DIST	XTK
Groundspeed	Distance from present position to waypoint	Cross Track, distance from actual track to desired track
TAS	WIND	DA (DRIFT ANGLE)
True Airspeed	Magnetic wind direction and velocity	Airplane track is L or R of the airplane heading

BT00947

FUNCTION KEYS

IDX			MNU	RCL		EMG
Return to MFD index	Not Used	Not Used	Return to FMS Menu	Recall Menu with skipped lines	Not Used	Emergency checklist.

BT00948



2000-390-105

PERFORMANCE MENU

PROGRESS

The PROGRESS page focuses on the flight plan. The DEPART time sets automatically when the airplane weight is not on the landing gear. The FLIGHT TIME starts automatically at the DEPART time. The rest of the page is interpreted as follows:

WPT	DIST	ETE	ETA	FUEL	
				REM	ENDR
Waypoint	Distance from present position	ETE at current ground speed	ETA at current ground speed	Fuel remaining	Flt time remaining with fuel available at current fuel flow

BT00949

FUNCTION KEYS

IDX	△	▽	MNU	RCL	EMG
Return to MFD index	Scroll up one line	Scroll down one line	Return to FMS Menu	Recall Menu with skipped lines	Not used Emergency checklist

BT00950



2000-390-104

PROGRESS MENU

ROUTE LIST

The route number and name of each route in the route library are displayed in two columns, 40 routes per page. The list may be advanced or backed up with the joystick. Route names are normally green. If a route contains an invalid waypoint, it is displayed in yellow.

FUNCTION KEYS

IDX	MNU	RCL	EMG
Return to MFD index	Return to FMS Menu	Recall Menu with skipped lines	Emergency checklist

BT00951



2000-390-103

ROUTE LIST

VOR/DME STATUS

The VOR/DME Status page shows the nav aids received by both VHF NAV radios and the three DME channels of each DME. The magnetic bearing to the VOR is shown on the VOR line. The distance to each DME is shown on the DME line.

FUNCTION KEYS

IDX		MNU	RCL	EMG		
Return to MFD index	Not used	Not used	Return to FMS Menu	Recall Menu with skipped lines	Not used	Emergency checklist

BT00952

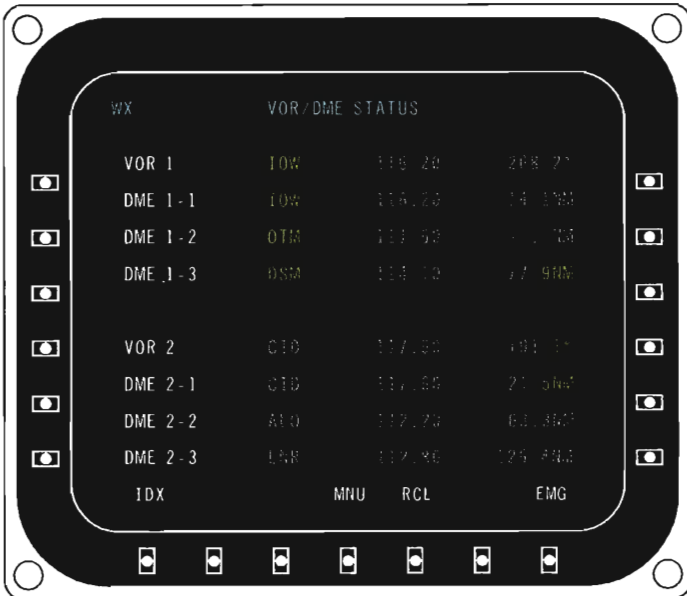

2000-390-102

VOR/DME STATUS

VLF/OMEGA STATUS

The VLF/OMEGA Status shows the following:

- Present Position as computed from VLF/OMEGA signals.
- Position Uncertainty (Internal function of VLF/OMEGA receiver).
- VLF/OMEGA Navigation mode.
- OMEGA synchronization state (Upon application of power, the sensor automatically synchronizes whenever at least one Omega station, including all four format frequencies is received).
- VLF/OMEGA Selection/Deselection status.

FUNCTION KEYS

IDX	MNU	RCL	EMG
Return to MFD index	Not used	Return to FMS Menu	Emergency checklist
		Recall Menu with skipped lines	

BT00953



2000-390-101

VLF/OMEGA STATUS

POSITION SUMMARY

The position summary shows the airplane present position as calculated by the computer. The POS DIFF is displayed as the bearing and distance of the VOR/DME derived position from the airplane present position. The data is normally displayed in green, changing to green dashes when no signals are received. If the VOR or DME fails, the dashes will be red.

FUNCTION KEYS

IDX		MNU	RCL	EMG
Return to MFD index	Not used	Return to FMS Menu	Recall Menu with skipped lines	Emergency checklist

BT00954

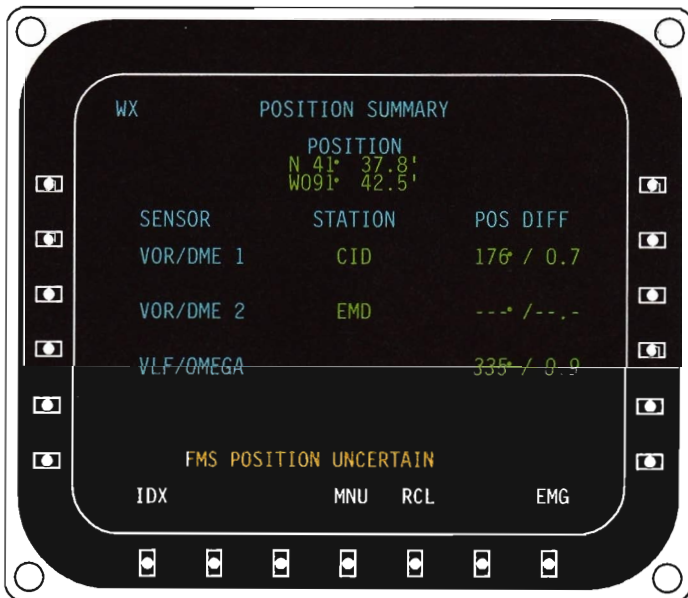

2000-390-100

POSITION SUMMARY

AVIONICS STATUS DISPLAY

The avionics status display lists avionic LRUs (Line Replaceable Units) that have failed or are not sending data. When all FMS monitored avionics are functioning properly, NO FAULTS is displayed. The avionics status is listed in three columns:

LRU

- Identifies any malfunctioning LRU. If malfunction cannot be isolated, all possible LRUs are listed.

STATUS

- If a failure is isolated, FAILED is displayed.
- If no status is reported, OFF-CHK BREAKER is displayed.
- If an IAPS module overheats, OVERHEAT is displayed.

FAULT CODES

- Assist in system troubleshooting.

Each page can display 14 LRU entries. Pages are advanced by depressing the control wheel PAGE ADV push button or by moving the joystick down. The previous page is called up by moving the joystick up. Advancing past the last page returns to the first.

FUNCTION KEYS

IDX

Return
to MFD
index

Not used

Not used

Not used

RCL

Recall
Menu
with
skipped
lines

Not used

EMG

Emergency
checklist

BT00956

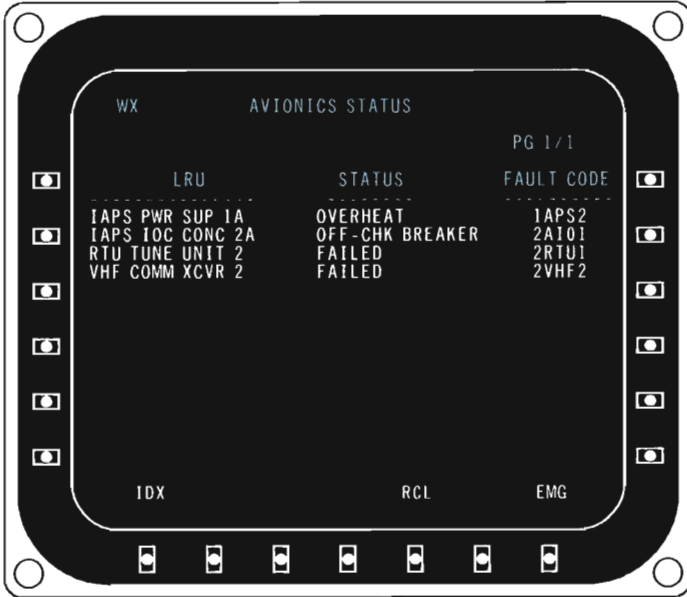

2000-390-117

AVIONICS STATUS DISPLAY

MAINTENANCE DISPLAY

Selecting MAINTENANCE on the MFD index calls up a menu of maintenance related screens as listed below:

- | | |
|----------------------------|---|
| LRU DIAGNOSTIC DATA | Lists each individual LRU or subsystem of integrated avionics with current status and fault codes. |
| LRU FAULT HISTORY | History of malfunctions listed. Similar to a flight log. Each flight lists malfunctions during that flight, up to 40 are permanently stored for future reference. |
| ENGINE EXCEEDANCES | A record of each occasion when any of the following engine parameters exceeded their approved limits: ITT, Torque, Propeller RPM and N ₁ |

Details of maintenance displays are covered in the BEECHCRAFT Starship 1 Maintenance Manual. These displays are not used during flight.

FUNCTION KEYS

IDX			MNU	RCL		EMG
Return to MFD index	Not used	Not used	Return to FMS Menu	Recall Menu with skipped lines	Not used	Emergency checklist

BT00951

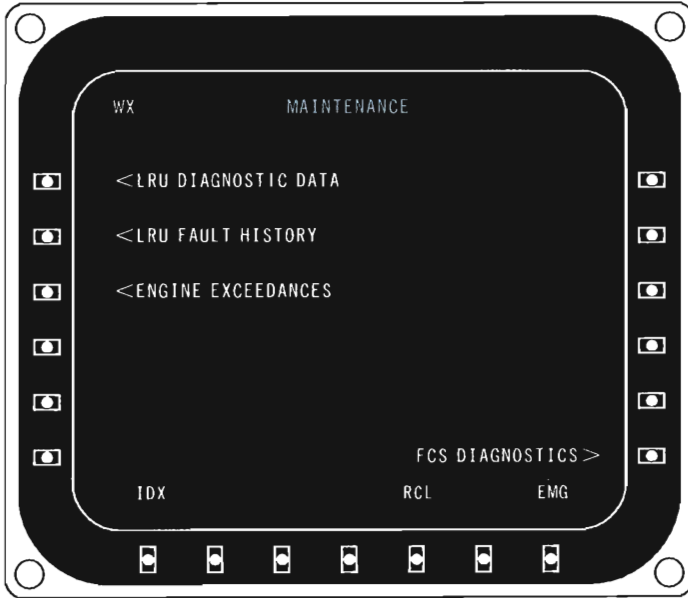

2000-390-106

MAINTENANCE FUNCTIONS

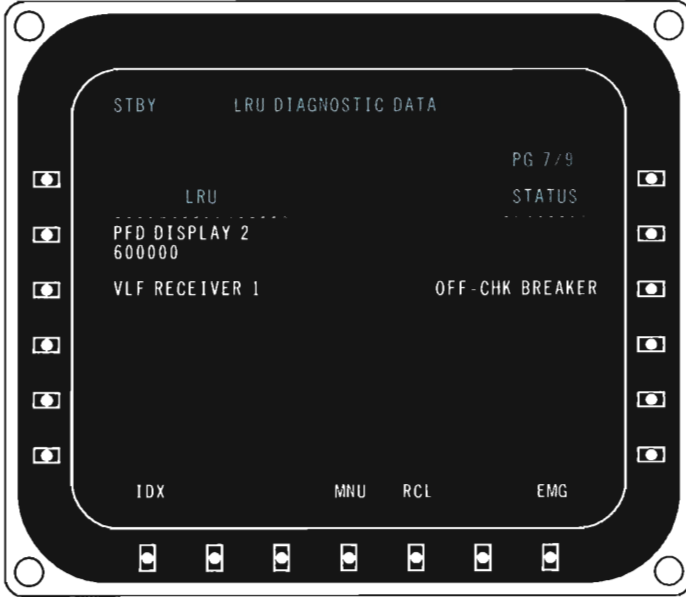

2000-390-186

LRU DIAGNOSTIC DATA

FAULTS FOUND	TIME	CODE	COUNTR
AIR DATA CMPT 2 000010	22:48Z	2ADC1	5
IAPS CDC CPLR 2B 502010	23:16Z	2BCD1	2
WEATHER RADAR(A) 004011	00:52Z	WXRA2	1
VOR RECEIVER 1 500A50	01:05Z	1VOR1	5
IAPS IOC CONC 1A 504CD0 IDX	01:08Z	1A1012 MNU RCL	1 EMG

2000-390-108

LRU FAULT HISTORY

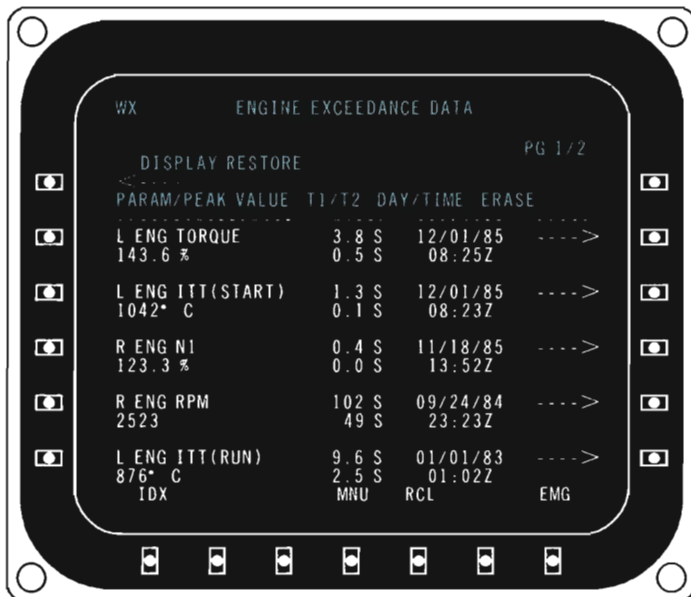

2000-390-109

ENGINE EXCEEDANCES

WEATHER RADAR (RDR)

The weather radar system provides a picture of the weather ahead of the airplane. Turbulent air itself contains nothing the radar can see, but most severe or extreme turbulence is associated with precipitation. Radar can see precipitation. Normally the areas of a rain storm with the densest concentration of precipitation are the most turbulent and should be avoided. In addition, TURB ONLY mode distinguishes between precipitation that is in smooth or turbulent air by sensing the precipitation motion. Radar cannot sense clear air turbulence.

DISPLAY

Radar can be displayed on either ND, both NDs or the MFD. Two-channel operation allows each side to show different displays. The antenna follows the pilot's commands during one sweep and copilot's commands during the other. The pilot's ND normally displays channel one and the copilot's side, channel two. If either control input channel fails, both display channels automatically slave to the valid one, with the appropriate annunciation on the display.

NAVIGATION DISPLAY

To display radar on the ND, depress the CDU RDR Key. If the ND is displaying an HSI, it will change to an ARC + RDR display.

MULTIFUNCTION DISPLAY

The MFD displays radar mode and status. Radar may be displayed on the MFD as radar only or added to a present position map. The radar only picture is approximately 50% larger. To display radar only, depress the MFD index line-select key next to RADAR. The radar display appears. It scans a 120 ° arc with five range rings. Three scale marks on each range ring mark scan center and 30° left and right of center. A moving scan mark along the outermost range ring shows the antenna sweep.

MODE/STATUS DISPLAY

The MFD displays mode and status even when the radar is not on the MFD.

RADAR MODE	MEANING
STBY	Radar power on, not transmitting
WX	Weather display on
TEST	Test Pattern Displayed
TRB	Turbulence Displayed
WX + TRB	Weather and Turbulence Displayed
GND MAP	Ground Map
STATUS MESSAGES	MEANING
Mode + CLT	Ground Clutter Suppression On
USTB (Yellow)	Antenna Not Stabilized for Pitch and Roll
USTB (Cyan)	Antenna Stabilization Selected OFF
HOLD	MFD Radar Display Frozen
T ±(X.XX)	Antenna Tilt Angle
G ±(X)	Receiver Gain
BT00957	

WEATHER COLOR CODE

COLOR	PRECIPITATION INTENSITY	DESCRIPTION
Black	Level 0	No Echoes
Green	Level 1	Light Rain
Yellow	Level 2	Moderate Rain
Red	Level 3	Heavy Rain
Magenta	Level 4	Extremely Heavy Rain
Yellow	Level 5	Path Attenuation Correction
Magenta	Level 6	Turbulence
BT00958		

GROUND MAP COLOR CODE

COLOR	GROUND ECHO INTENSITY	DESCRIPTION
Black	Level 0	No Echo, Flat Ground or Calm Water
Cyan	Level 1	Gentle Hills or Rough Water
Green	Level 2	Increasing levels of hilly terrain
Yellow	Level 3	and/or urbanization
Magenta	Level 4	Mountains or Urban Areas
BT00959		

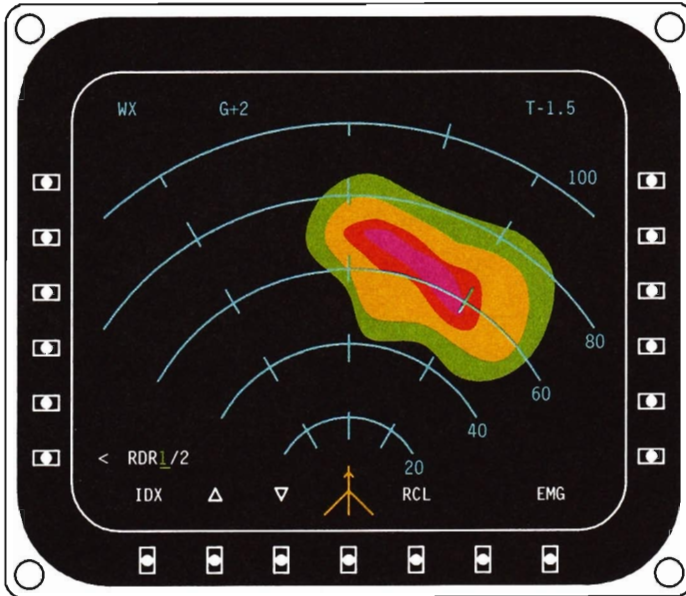

LEGEND	
■	LIGHT PRECIP.
■	MODERATE PRECIP.
■	HEAVY PRECIP.
■	EXTREME PRECIP.
■	TURBULENCE

MODE: WX
CHANNEL: CH1
RANGE: 100 NAUT. MI.
TILT: -1.5
GAIN: +2

RANGE CONTROL: AVAILABLE (Δ
AND ▽ IN VIEW)

2000-390-095

WEATHER RADAR

CONTROLS

All radar system controls are on the CDUs. The RDR CONTROL key displays the two-page RDR FUNCTIONS menu on the screen. Depressing the RDR CONTROL key again or the line-select key at the NEXT PAGE toggles between the first and second menu pages.

1. STBY - Turns off the radar transmitter.
2. WX - Basic weather mode.
3. WX+TURB - Increases sensitivity to precipitation which shows significant movement. These areas of movement are shown in magenta. Radar range must be 50 NM or less.
4. TURB ONLY - Suppresses the display of precipitation which does not show significant movement. This mode will automatically time out after 30 seconds. The display will return to WX+TURB. Radar range must be 50 NM or less.
5. GND MAP - Causes the radar to display ground features instead of weather.
6. CHANNEL SYNC/SPLIT - Toggles two channel operation on and off. If SYNC is selected, the CDU uses either cross-side radar mode selections. When SPLIT is selected, the radar behaves as if each CDU were controlling a separate radar. It does this by responding to each CDU on alternate sweeps of the antenna.
7. HOLD ON/OFF - Is used to freeze a radar frame. This allows a weather pattern to be studied for changes by comparing the two displays, with one on hold. Hold is selectable only when in WX, WX + TURB, TURB ONLY, or GND MAP modes. It is switched off automatically if any display mode is changed or after 5-minutes.
8. GND CLTR SPRS ON/OFF - Toggles ground clutter suppression on and off. When on, ground clutter is reduced, but so is sensitivity to low levels of precipitation.
9. GAIN CAL/MAN - Enables or disables the gain calibration mode. When MAN is selected the CDU scroll keys are used to set the gain.
10. TEST MODE ON/OFF - Displays a test pattern showing all four colors. Test mode is automatically cancelled if the menu page is changed.
11. STABILIZATION ON/OFF - Toggles antenna stabilization on and off.
12. RANGE SELECTION - The following ranges are selectable: 10, 25, 50, 100, 200 and 300 NM. The RANGE Knob is the primary radar range control for that side; however, if either radar channel is displayed on the MFD only, the MFD controls that channel's range display. In this case, the range scroll (Δ and ∇) symbols appear above the second and third MFD function keys. If the radar display is then added to the ND, it starts with the range setting that was in use on the MFD, and range control is returned to the CDU.

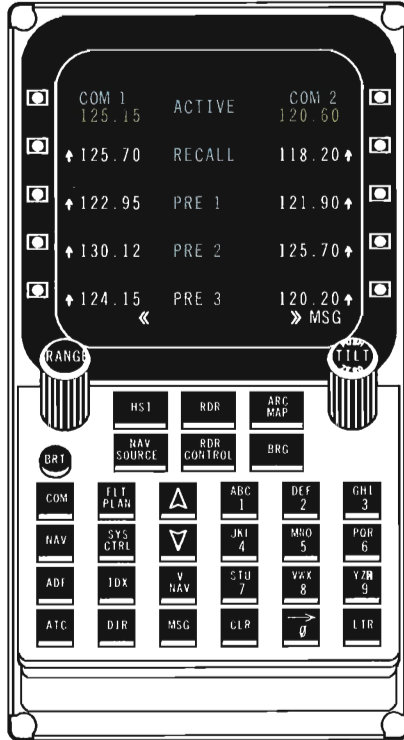

2000-390-057

CONTROL DISPLAY UNIT

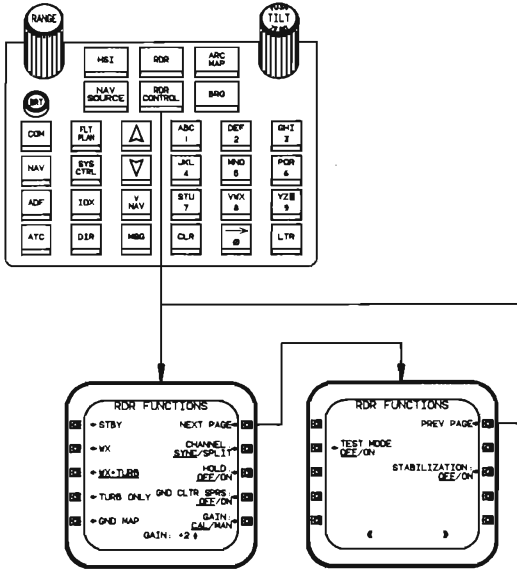

2000-390-069

RDR FUNCTION MENUS

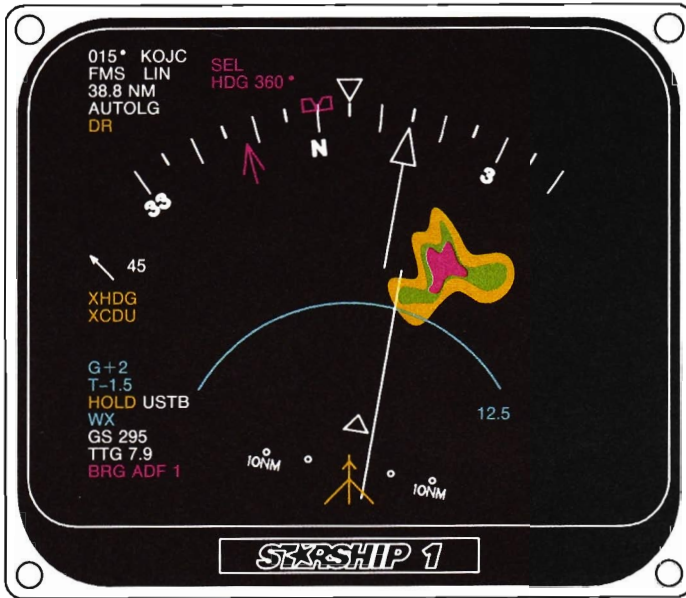

2000-390-187

ND WEATHER RADAR

FLIGHT MANAGEMENT SYSTEM (FMS)

SYSTEM DESCRIPTION

The Flight Management System is an integrated navigation system that provides worldwide point-to-point, and great circle navigation. The system uses a combination of multiplexed DME, VOR/DME, dual VOR, VLF/OMEGA, and DR. It contains a data base which has the appropriate nav aids and airports. When operating with all NAV data available, the system scans for DME signals which, according to its data base present position, are expected to be received. Both DMEs are multiplexed into three channels, allowing up to six DMEs to be scanned. As NAV station signals are received, their Morse code identifiers are decoded for station verification. If at least three properly positioned DME signals are received, the airplane position can be determined. When less than three DMEs are available, VOR bearing, VLF/OMEGA, and DR data are used as necessary to produce the most accurate fix possible.

The pilot enters the destination and intermediate waypoints as necessary to define the desired route. The FMS refers to all airway reporting points as intersections. The symbol for VORTAC and VOR/DME stations is that of a VOR/DME station.

The FMS will perform the following tasks automatically:

- Navigate a great circle route between departure and destination using names or identifiers to define the route.
- Continuously observe present latitude and longitude.
- Continuously observe present position relative to waypoints and nav aids on moving map displays.
- Store up to 100 flight plan routes.
- Store up to 1000 pilot defined waypoints.
- Define a direct course from present position to any named waypoint.
- Define a direct course from the present position to any of the three closest airports.
- Define a selected track through a named waypoint.
- Update the flight plan at any time.
- Update the VLF/OMEGA position.
- Tune any VOR using the identifier.
- Integrate weather radar and navigation displays.

OPERATIONAL SUMMARY

Before departure, the pilot verifies the present position, time and date, and enters the flight plan. If the route has been flight planned before, and stored as a route, it may be recalled from the route library. The FMS memory retains the last flight plan used. If waypoints are to be entered, they may be entered by LAT/LON, nav aid identifier, or by reporting point name. Manual operation is also available, allowing the pilot to tune the radios at any time. The system outputs are interfaced with the autopilot.

Communication frequencies are tuned with conventional frequency control knobs on the RTU or by typing them on the CDU keypads. Up to six preset frequencies

may be stored for quick access, and the most recent active frequency can always be instantly recalled.

NAV TUNING - AUT

The NAV TUNING - AUT, allows the FMS to select and tune the NAV receiver to the navaids which will provide the most accurate position fix. This is not necessarily the current TO waypoint. The last line on the NAV tuning menu displays the selected NAV TUNING mode for the NAV radios. If a NAV radio is selected for an active or preset NAV source, the automatic tuning of that radio is inhibited until the FMS is reselected as the active NAV source. Automatic tuning of a radio is inhibited if DME HOLD is selected. If a radio is manually tuned while in the autotune mode, the mode is changed to manual.

If AUT has been selected, AUT is displayed in underlined green. If MAN tuning has been selected, MAN is displayed in underlined green.

AUTOLEG

The AUTOLG advance feature is used to automatically advance the waypoints. Each time the airplane arrives at a waypoint, the AUTOLG feature will advance the current TO waypoint to the next waypoint on the flight plan. The process will continue until arrival at the last flight plan waypoint. The desired track to the last flight plan waypoint is displayed as a broken line extended beyond the last waypoint. The FMS computes a great circle route between the current FROM waypoint and the current TO waypoint. When nearing the TO waypoint the waypoint alert is annunciated by flashing the waypoint identification and the distance display on the ND.

INITIALIZATION

There are three types of initialization:

1. Factory Start:

The first time the FMS is used, there is nothing in memory. The data base must be loaded, and all menu selected options are off. This type of initialization may also occur after maintenance on the flight management computer.

2. Cold Start:

If the power has been off for more than .075 second, a cold start is necessary. Cold starts include the following:

- System self test
- Ship's clock check
- Data base expiration date check
- Position verification
- Flight plan edit in progress cancelled
- Route load in progress cancelled
- Scratchpad cleared
- Disabled data base navaids enabled
- De-selected VLF stations selected
- System messages cleared

- Position hold cleared
 - Radar to STBY and SPLIT
 - All other conditions return unchanged
3. Warm Start:
 A warm start is allowed if the power was off for not more than .075 second. Everything returns to the previous condition.

NORMAL POWER UP

As soon as power is applied, the CDUs initiate their own self-test function. Upon successful completion of the self-test, the CDUs are ready for radio tuning. However, the FMS must be initialized before any FLIGHT PLAN, FMS INDEX, DIR or SYSTEM CONTROL menu can be displayed.

To initialize the FMS, depress the line-select key next to INITIALIZE SYSTEM on either CDU.

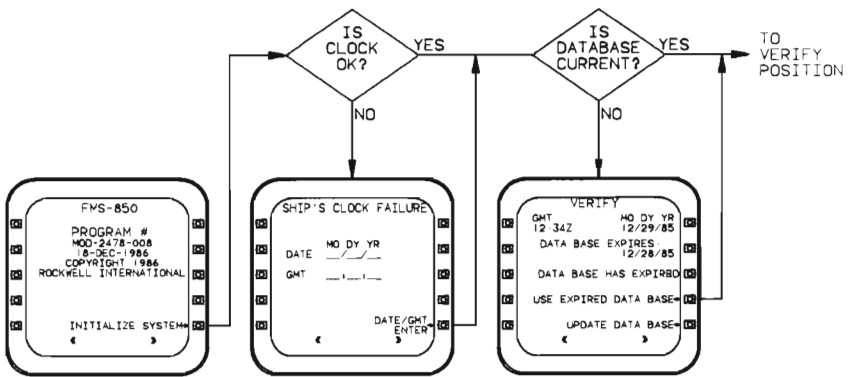

2000-390-178

SYSTEM INITIALIZATION

VLF/OMEGA

The VLF/OMEGA receiver uses VLF and OMEGA signals to determine position. This data can be displayed on the SDU and the MFD. It is also used by the flight management system in combination with VOR, and DME data. The CDU is used for initialization and station selection/deselection.

IN-LINE MONITORING

The system continuously monitors the received OMEGA status and VLF signals and, whenever the signals are insufficient to determine position, annunciates a VLF/OMEGA DR condition on the CDU message page. The sensor also monitors its internal circuitry operational status and, whenever a malfunction is detected, flags its output as invalid.

ACCURACY

When the signal conditions are adequate, the sensor will be accurate to within 1.5 NM, with a 95% probability for either cross-track or along-track components within two hours of initialization. The accuracy stipulated requires at least three OMEGA or VLF stations with adequate signal strength.

TAS AND HEADING LOSS

If TAS and/or heading data is lost, the sensor will continue to function, with degraded accuracy.

GEOGRAPHIC AREA OF NAVIGATION

The sensor can determine position world-wide.

PRIMARY NAVIGATION MODE

The primary navigation mode uses OMEGA format signals from the eight OMEGA network stations (NORWAY, HAWAII, L. REUNION, AUSTRALIA, LIBERIA, N. DAKOTA, ARGENTINA and JAPAN) as well as VLF signals from the following stations:

CALL SIGN	LOCATION
NAA	Cutler, Maine
NLK	Jim Creek, Washington
NWC	North West Cape, Australia
GBR	Rugby, Great Britain
NSS	Annapolis, Maryland
NPM	Lualualei, Hawaii
NDT	Yosami, Japan
NAU	Puerto Rico

DEAD RECKONING MODE

The sensor reverts automatically to a DR mode using the last known data, whenever inadequate OMEGA and/or VLF signals are received.

REACQUISITION

The sensor automatically resumes the primary navigation mode upon reacquisition of adequate VLF/OMEGA signals.

SYNCHRONIZATION

Upon power application, the sensor automatically synchronizes whenever at least one OMEGA station with an adequate signal is received.

RECOVERY FROM POWER DROP-OUT

With no operator intervention, the sensor recovers from a short power drop-out and resumes normal navigation. Longer power interruptions require reinitialization.

CLOCK CHECK

The FMS checks the ship's clock. The computer can't tell if the time and date are correct, only if the clock is functional. If the clock is functional, the computer sets its internal clock to the ship's clock when commanded by the initialization. Otherwise the CDU will display the SHIP'S CLOCK FAILURE menu. The pilot must either correct the problem or enter the time and date.

To enter the time and date:

1. Enter two digits each for the month, day, year, hours, minutes and seconds.
2. Depress the line-select key next to GMT/DATE ENTER

Entering the time and date in the CDU does NOT set the ship's clock.

DATA BASE UNIT (DBU)

The DBU uses 3.5 inch 720 KB diskettes for data storage and is PC-DOS, MS-DOS compatible.

DATA BASE CHECK

The FMS checks the date of the data base, if the data base is about to, or has expired, a message appears on the initialization menu.

REPLACING THE DISKETTE

The new data base diskette should be installed in the data base unit upon expiration of the present data base. After the diskette has been read and the data

base updated the diskette should be removed. To insert the diskette in the Data Base Unit (DBU):

1. Remove the upper forward panel inside the forward cabin closet.
2. Locate the disk drive.
3. To insert the new diskette, the label must be facing aft and the upper edge rotated 90° to the right.
4. Replace the upper forward panel.

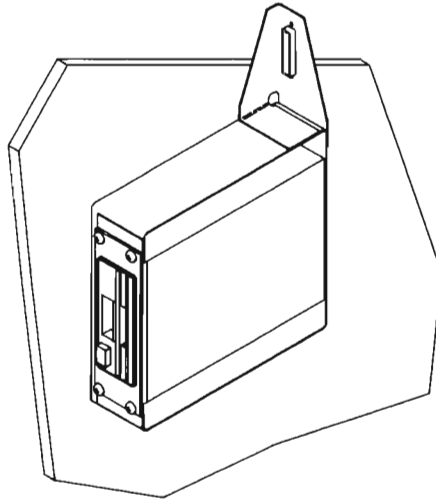

2000-490-4

DATA BASE UNIT (DISK DRIVE)

UPDATING THE DATA BASE

When the data base has expired, a message appears on the initialization menu. On the expiration date, an UPDATE DATA BASE option is added to the menu. The data base can be updated early with the DISKETTE READ option on the INDEX menu, however, any waypoints that are scheduled for change on the expiration date will be changed at the time of the update.

WARNING

The FMS and the data base must not be used until the effective date.

1. The VERIFY menu must be on the CDU.
2. Depress the line-select key next to UPDATE DATA BASE. The diskette directory appears on the CDU. Data base diskettes have only one file on them, either FLT-DATA.NA (North America) or FLT-DATA.NAN. (North America Not)
3. Depress the line-select key next to the file name. Updating the data base takes approximately six minutes.
4. After the update is complete a list of changed waypoints that are used in stored flight plan routes, and a list of those routes will be displayed. To continue, depress the line-select key next to CONTINUE. To inspect any changed waypoint, depress the line-select key next to that waypoint.

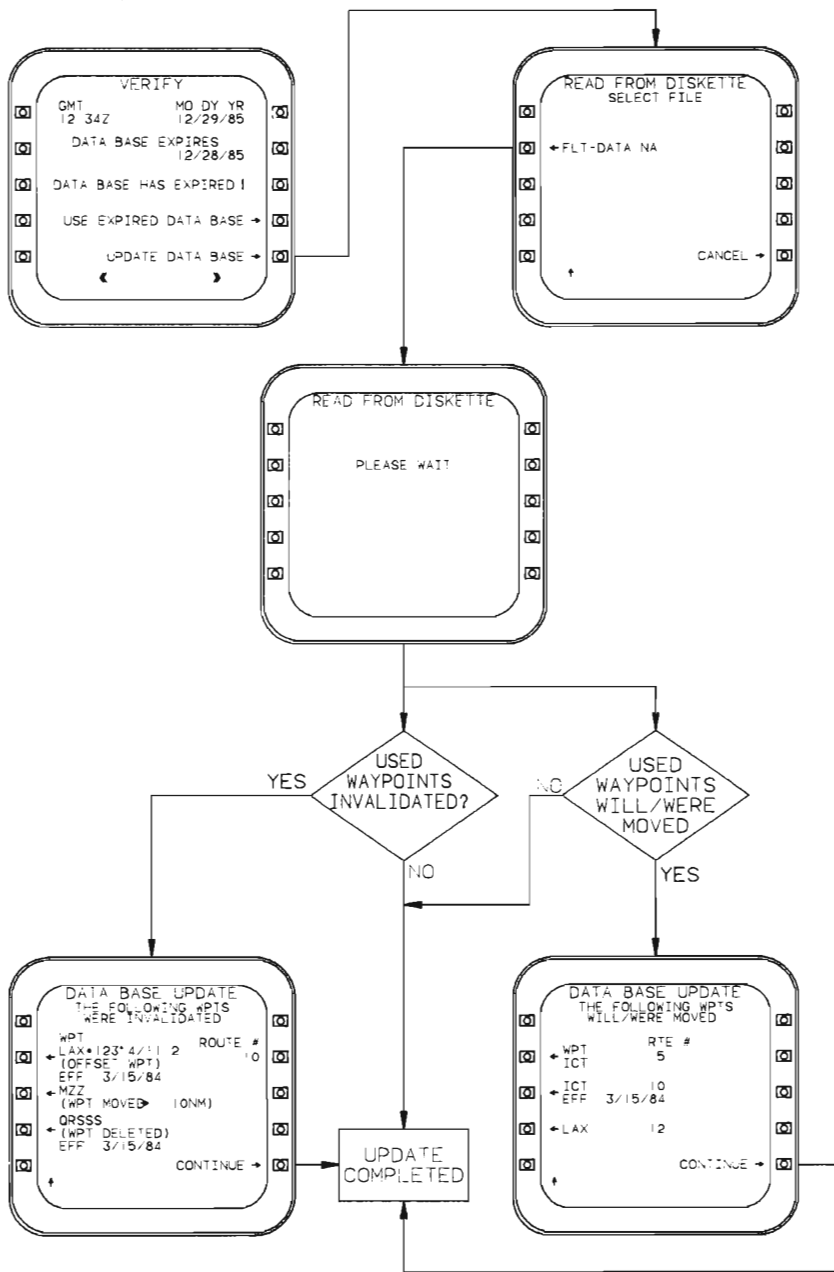

2000-390-124

DATA BASE UPDATE MENUS

USING AN EXPIRED DATA BASE

If unable to load a current data base, it is possible to use an expired data base.

WARNING

Do not rely on an expired data base. It is the pilot's responsibility to verify the coordinates of all waypoints used in the flight plan.

TO USE THE EXPIRED DATA BASE:

1. The Verify menu must be on the screen.
2. Depress the line-select next to USE EXPIRED DATA BASE. The system will advance to the VERIFY menu as if the data base were current.

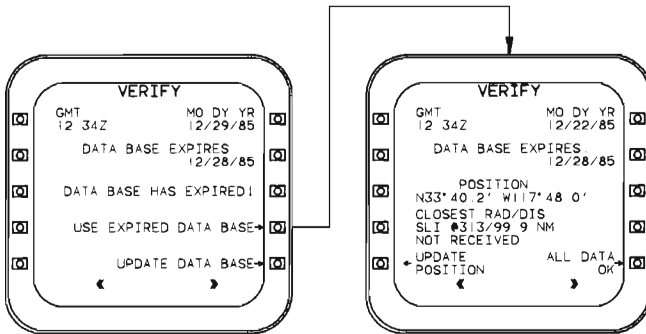

2000-390-122

USE EXPIRED DATA BASE

VERIFY PRESENT POSITION

If the data base is current, or after the pilot updates or uses the expired data base, the CDU displays the VERIFY menu with the FMS present position. This should always be correct. If not, one of the following is possible.

- The FMS has been improperly updated.
- The FMS computer memory is defective.
- The FMS computer memory has been repaired since the last flight.
- The airplane has been moved without electrical power.
- The airplane has been flown with no VOR, DME, or VLF/OMEGA signals available.

If the present position shown is correct, depress the line-select key next to ALL DATA OK.

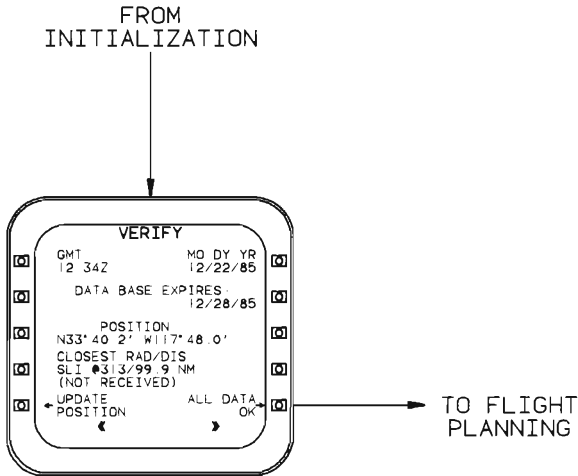

2000-390-125

VERIFY POSITION MENU

UPDATING PRESENT POSITION

The VERIFY menu must be on the CDU. To update present position:

1. Depress the line-select key next to UPDATE POSITION.
2. Choose one of the following methods of updating position and depress the corresponding line-select key:

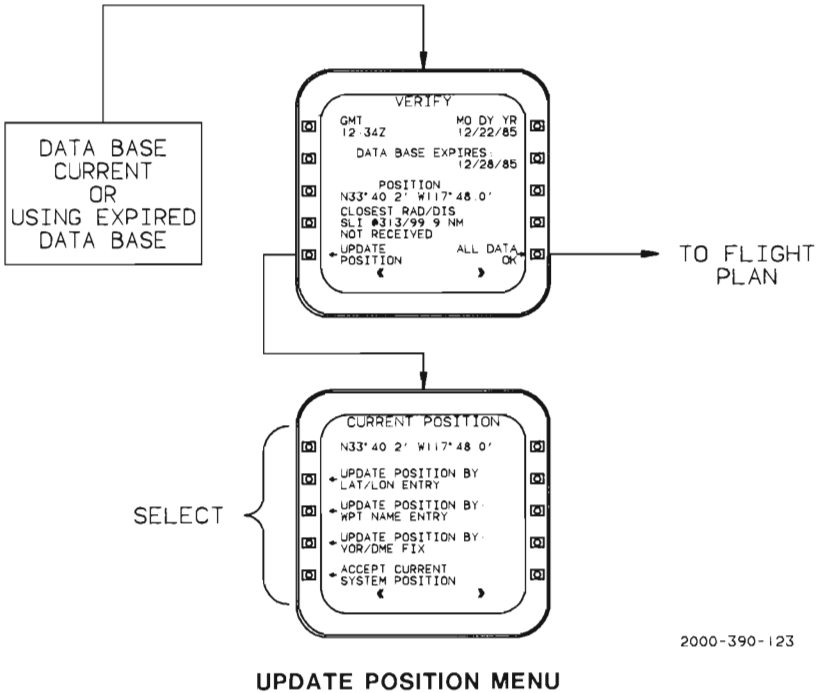

LAT/LON

To update the FMS position based on latitude and longitude:

1. The CURRENT POSITION menu must be displayed.
2. Depress the line-select key next to UPDATE POSITION BY LAT/LON ENTRY.
3. The POSITION UPDATE BY LAT/LON is displayed.
4. Enter latitude and longitude digits on the CDU keypad: two for latitude degrees, two for latitude minutes, one for tenths of minutes, three for longitude degrees, two for longitude minutes, and one for tenths of minutes. Unless otherwise specified, the system assumes and displays latitude as north, longitude as west.
5. Depress the line-select key next to ENTER.

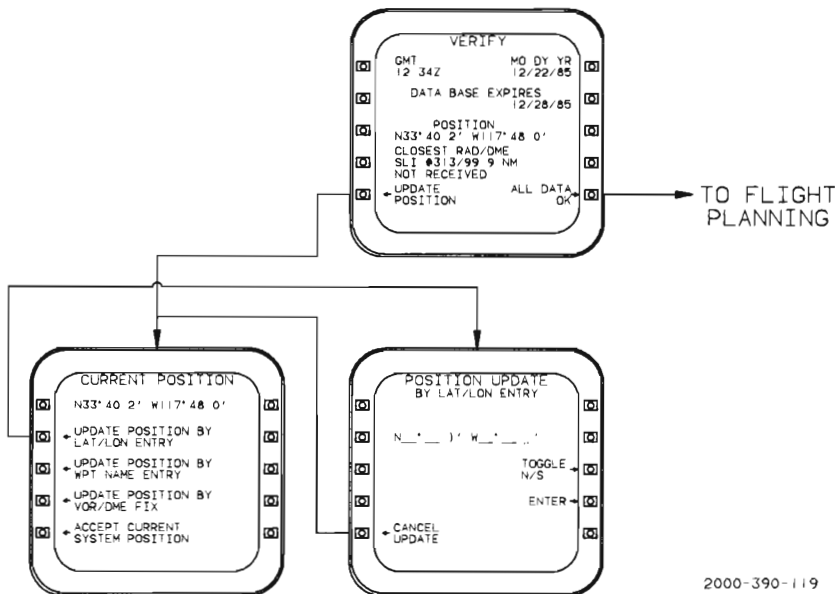

POSITION UPDATE BY LAT/LON

2000-390-119

WPT

To update the FMS position based on a particular waypoint:

1. The CURRENT POSITION menu must be on the CDU.
2. Depress the line-select key next to UPDATE POSITION BY WPT NAME ENTRY.
3. The POSITION UPDATE BY WPT screen is displayed.
4. Enter the waypoint name on the CDU keypad. Use the country prefix (K for the United States) to distinguish an airport from a VOR with the same identifier. If the waypoint entered exists in more than one place in the world, the system will display DUP Δ FOR MORE on the bottom line, and OK \rightarrow next to the line-select key across from the full waypoint identifier (country prefix included). To display other fixes with the same identifier, depress either scroll key.
5. Depress the line-select key next to ENTER.

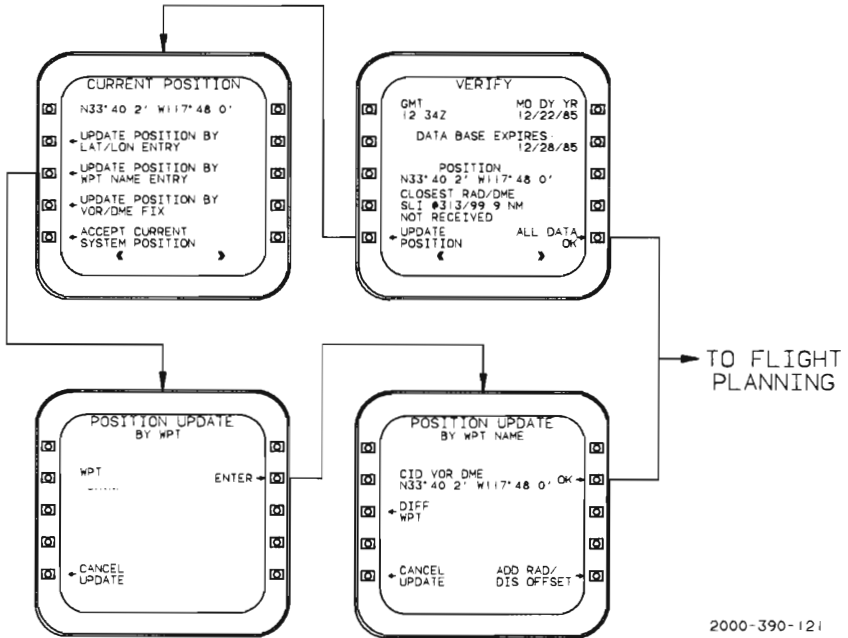

2000-390-121

POSITION UPDATE BY WAYPOINT

VOR/DME FIX

Update based on a VOR/DME fix is useful when at a location that is not in the data base.

To update the FMS position based on a VOR/DME fix:

1. The CURRENT POSITION menu must be on the CDU.
2. Depress the line-select key next to UPDATE POSITION BY VOR/DME FIX.
3. The POSITION UPDATE BY VOR/DME FIX is displayed.
4. Enter the station identifier to be used.
5. Depress the line-select key next to ENTER. If the fix entered is found in the data base but the station is not received, a WAITING TO RECEIVE message will be displayed until signals are received from the station or the option is cancelled.

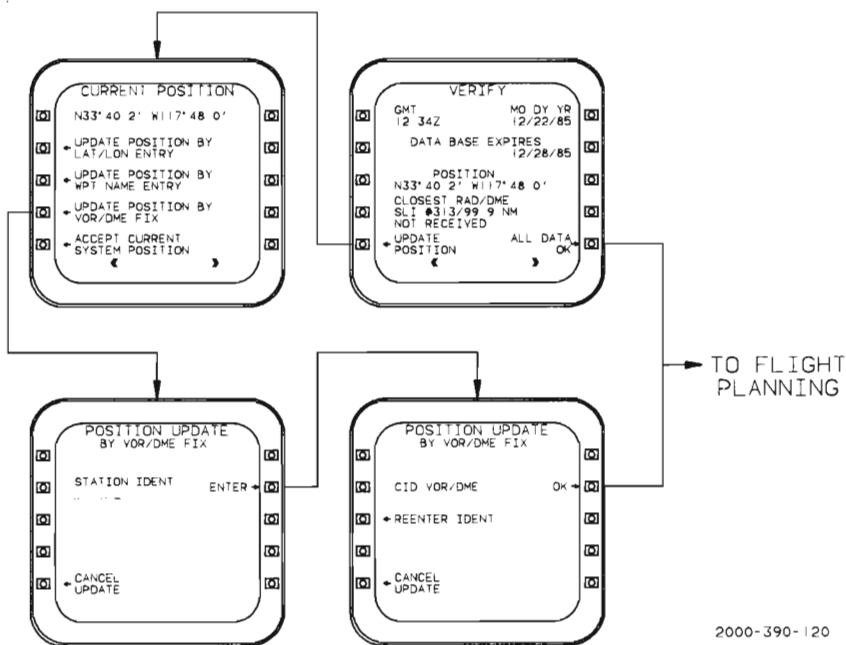

2000-390-120

POSITION UPDATE BY VOR/DME FIX

FLIGHT PLANNING FUNCTIONS

Flight plans may be identified by name or station identifier. The FMS searches for each waypoint in its data base, and displays what is found for verification by the pilot. Waypoints are displayed by name and coordinates on the CDU, and by location on the MFD.

NOTE

Airways, MEAs, MOCAs and special use airspace are not in the data base and are not shown on the MFD. Use current aeronautical charts for this information. It is the responsibility of the pilot to ensure that the flight plan route meets all altitude and airspace requirements.

CREATING A NEW FLIGHT PLAN

Flight plans must have at least two waypoints, departure and destination. A waypoint is any fixed point which is used as a reference for a navigational fix. It may be either predefined or pilot defined. Predefined waypoints are in the data base and are shown on aeronautical charts. They may be navaids, airports, or reporting points. Pilot defined waypoints are not in the data base until the pilot puts them there. They may be any point which the pilot locates by LAT/LON on the CDU or on the MFD with the joystick.

SELECTING THE CDU FLIGHT PLAN MENU

After initializing the system and verifying the position, the FLIGHT PLAN menu appears or is available. To put the FLIGHT PLAN menu on the CDU, depress the FLT PLAN key. If there is a flight plan in memory, it will be in the menu. Otherwise the FLIGHT PLAN menu will appear with a blank line and an ADD WPTS prompt. A flight plan can be added to, have waypoints inserted, deleted, modified, erased or stored in the route library for later recall.

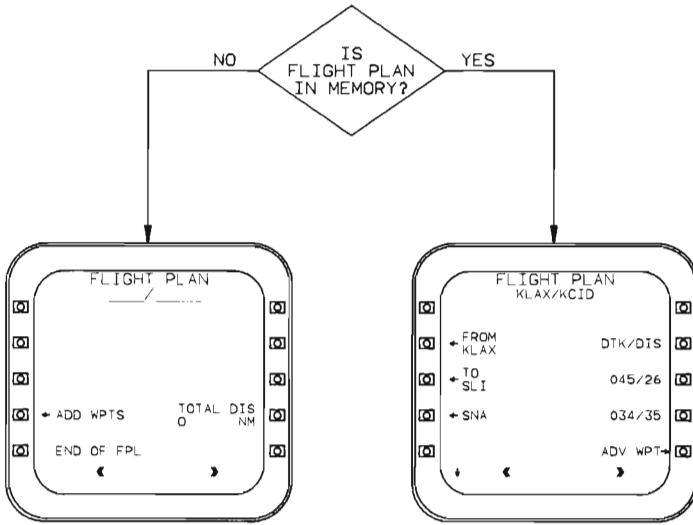

2000-390-065

FLIGHT PLAN MENUS WITH AND WITHOUT FLIGHT PLAN

ERASE THE EXISTING FLIGHT PLAN

Erasing a flight plan just clears the active memory for a new flight plan. If a flight plan will be needed later, refer to Storing A Route in the Route Library.

To erase an old flight plan:

1. A flight plan or partial flight plan must be displayed.
2. Depress any waypoint line-select key, the SELECT CHANGE TYPE menu will be displayed.
3. Depress the line-select key next to ERASE FPL. An ARE YOU SURE message appears on the ERASE FLIGHT PLAN menu.
4. Depress the line-select key next to YES, ERASE ALL WPTS.

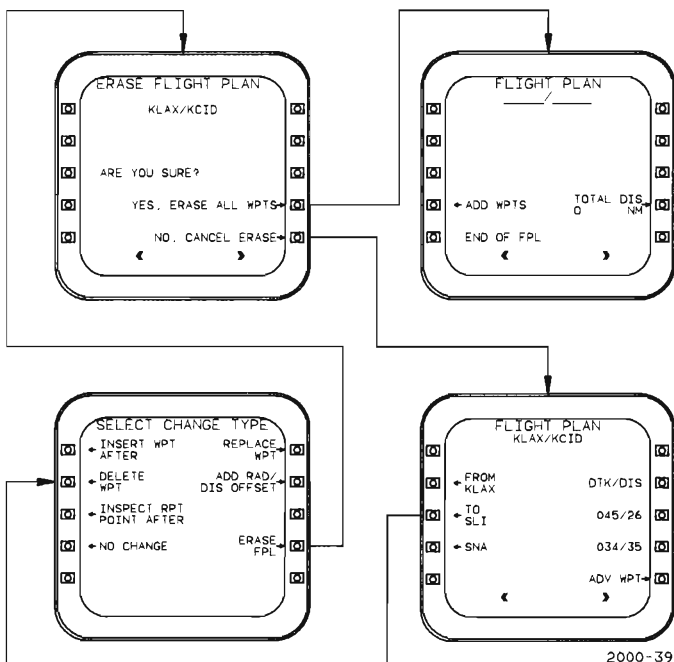

2000-390-127

ERASE FLIGHT PLAN MENU

ENTERING WAYPOINTS

1. Typing waypoint names on the CDU keypad.
To start a new flight plan, type the departure point identifier on the CDU. Use the country prefix, (K for United States) to distinguish an airport from a VOR with the same identifier. Depress the line-select key next to ENTER.

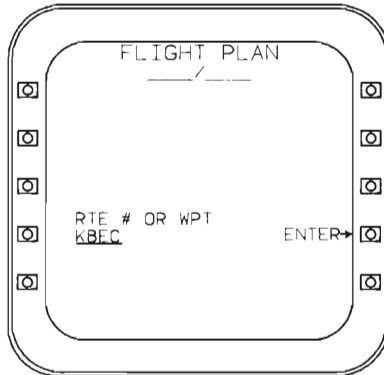

2000-390-130

NEW FLIGHT PLAN MENU

2. Each time a waypoint is entered, there are four possible results:
 - a. If the waypoint is not found the (WPT XYZ) NOT IN MEMORY response is displayed. The options are CANCEL WPT or DEFINE WPT. CANCEL WPT returns to the ENTER RTE # OR WPT menu. To define the waypoint, depress the line-select key next to the DEFINE WPT. The choices are:
 - 1) TOGGLE N/S - Unless otherwise specified, the system assumes all latitudes are north, and all longitudes are west. To define a waypoint in the southern hemisphere, depress the line-select key next to TOGGLE N/S. After the latitude is entered, this line will reflect TOGGLE E/W. To define a waypoint in the eastern hemisphere, depress the line-select key next to the TOGGLE E/W.
 - 2) LATITUDE - Enter five digits for degrees, minutes, and tenths of minutes. The numbers appear in the correct place as they are typed. Use leading zeros.
 - 3) LONGITUDE - Enter six digits for degrees, minutes, and tenths of minutes. Use leading zeros. The numbers appear in the correct place as they are typed.
 - 4) DEFINITION COMPLETE - After the coordinates are correctly entered, depress the line-select key next to DEFINITION COMPLETE.
 - 5) ADD RAD/DIS OFFSET - To add a radial and distance offset, enter eight digits, four for the degrees and tenths of degrees, and four for nautical miles and tenths of miles. Depressing OFFSET COMPLETE or CLEAR OFFSET returns to the VERIFY COORDINATES menu. Use leading zeros.
 - 6) CLEAR LAT/LON - The latitude and longitude inputs are cleared.
 - 7) CANCEL WPT - To abort the waypoint definition and return to the ENTER RTE # OR WPT menu, depress the line-select key next to CANCEL WPT.

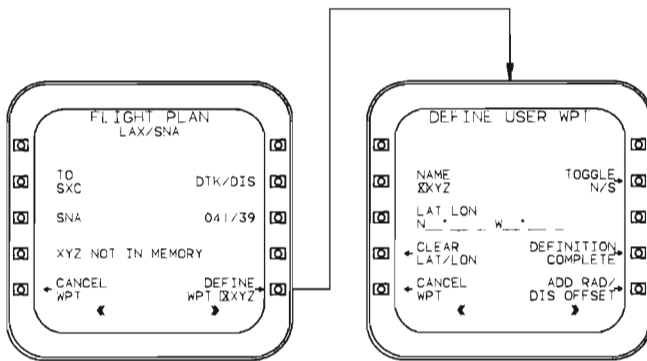

2000-390-131

DEFINE WAYPOINT MENU

- b. If the waypoint is found in more than one place in the world, the system will display DUP Δ and ∇ FOR MORE on the bottom line, and OK? next to the line-select key across from the full waypoint identifier (country prefix included). The waypoint coordinates will be on the line below. To display other fixes with the same identifier, depress either scroll key. To select the correct one, depress the line-select key next to OK.

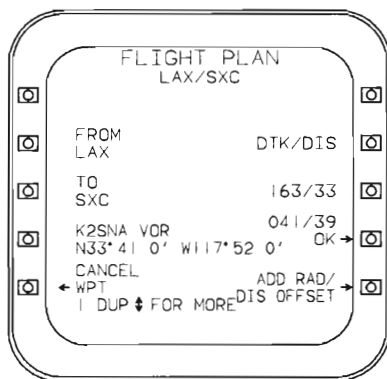

2000-390-132

DUPLICATE WAYPOINTS NOTICE

- c. If the waypoint is found and it is unique, the FLIGHT PLAN menu appears with the waypoint identified as a navaid, airport, or a reporting point. The LAT/LON coordinates are displayed for verification. If a waypoint is a VOR/DME, there are three choices:
- 1) To accept the waypoint as is, depress the line-select key next to OK. The ENTER RTE # OR WPT menu returns with the new waypoint added. If this was the first waypoint in the flight plan, that waypoint becomes the first part of the flight plan name.
 - 2) To cancel the waypoint depress the line-select key next to CANCEL WPT. The ENTER RTE # OR WPT menu returns without the waypoint.
 - 3) To offset the waypoint by a radial and distance, depress the line-select key next to ADD RAD/DIS OFFSET. This option goes to an ENTER OFFSET menu. The radial and distance are entered with eight digits, four for the degrees and tenths of degrees, and four for the nautical miles and tenths of miles. Use leading zeros. Depressing OFFSET COMPLETE or CLEAR OFFSET returns to the previous menu.

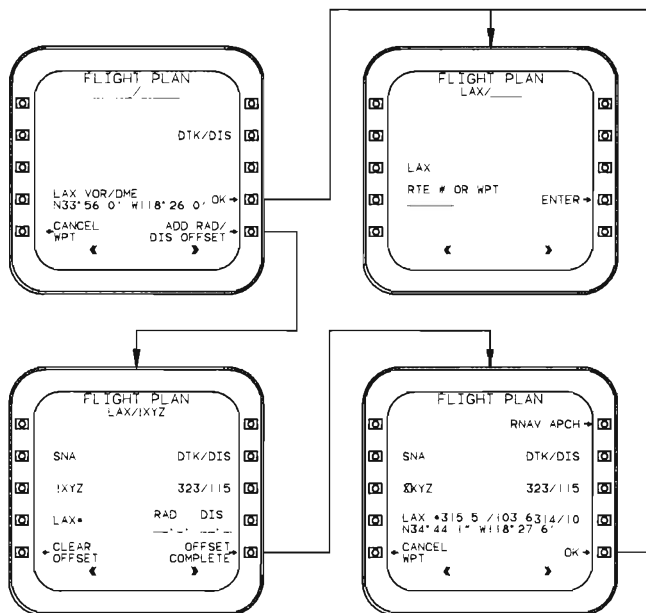

2000-390-133

FLIGHT PLAN MENUS

- d. If the waypoint is an airport, the options are changed. Some airports have designated runway threshold waypoints and/or terminal waypoints in the data base along with the airport itself. When such an airport is entered and displayed for verification, the following options appear next to the line-select keys:
- 1) DISPLAY RUNWAYS - To display a list of runways depress the line-select key next to DISPLAY RUNWAYS. To use a runway threshold from the list as a waypoint, depress the line-select key next to the desired threshold. The selected threshold coordinates will be presented for verification. If there are more than six runways, a SCROLL FOR MORE message appears in the scratch pad.
 - 2) TERMINAL WAYPOINTS - To display a list of the terminal waypoints, depress the line-select key next to LIST TERM WPTS. To use a terminal waypoint from the list depress the line-select key next to the desired terminal waypoint. The coordinates of the selected waypoint will be presented for verification. If more than one of the terminal waypoints are desired, depress the line-select key next to NEXT TERM WPTS. This displays the coordinates as before, but keeps the rest of the list on the CDU. After verification, additional waypoints from the list can be selected without reentering the airport name. To enter the terminal waypoint into the flight plan, depress the line-select key next to OK. The system returns to the FLIGHT PLAN menu.

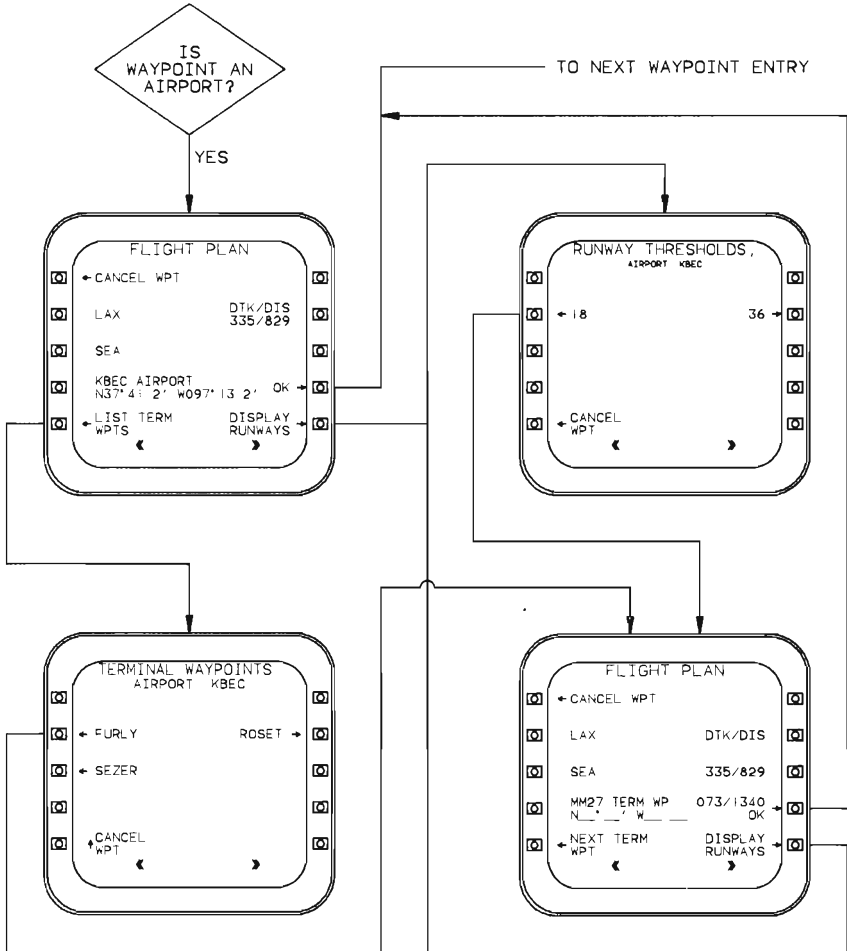

2000-390-076

TERMINAL WAYPOINTS MENU

RECALLING A STORED ROUTE

To enter a route from the route library, enter the route number at the ENTER RTE # OR WPT prompt. To find the route number, refer to the instructions for displaying the route library on the CDU. Use a leading zero (1 digit numbers), depress the line-select key next to ENTER. The LOAD ROUTE menu appears with the following options:

1. **NORMAL ORDER** - To load the route as is from the route library, depress the line-select key next to NORMAL ORDER. If a flight plan is in memory, the route is appended to it.
2. **REVERSE ORDER** - To load the route with the waypoint sequence and all desired tracks reversed, depress the line-select key next to REVERSE ORDER. This allows the same route to be used in both directions of a round trip.
3. **CANCEL ROUTE LOAD** - To return to the ROUTE# OR WPT menu with no changes, depress the line-select key next to CANCEL ROUTE LOAD.

Since waypoints are verified when the route is created, they are not presented for verification when the route is entered into the flight plan. The FMS still checks the routes against the current data base, and if a significant change has occurred which affects any of the waypoints in the route, that waypoint is shown in the route list as *****INVALID WPT*****.

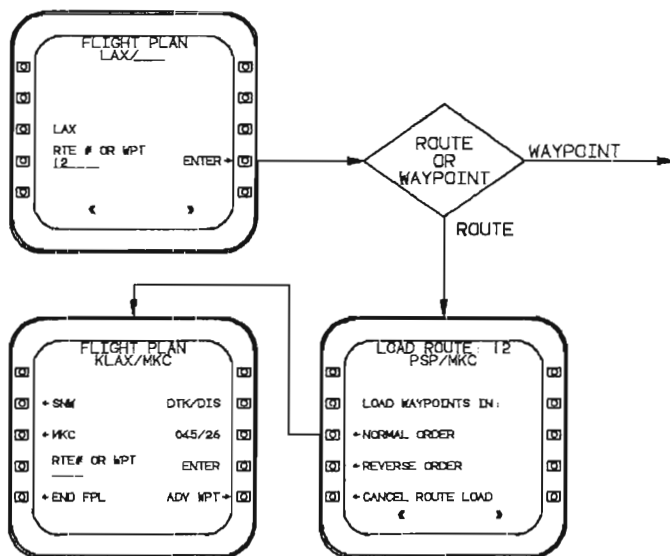

ROUTE LOAD MENU

To identify the desired route, display the library list on the MFD as follows:

1. Depress the IDX key. The MFD index appears.
2. Depress the line-select key next to FMS. The FMS menu appears.
3. Depress the line-select key next to ROUTE LIST. The route list appears.
4. To page list up or down, push the joystick in the desired direction.



2000-390-103

ROUTE LIBRARY ON MFD

To enter waypoints with the joystick:

1. Depress the PLAN MAP key on the MFD index.
2. Use the MFD scroll keys to set the map scale so that, as new waypoints are added, they will remain in view. The map will advance along the flight plan route as each new waypoint is entered.
3. The waypoint displayed at the center of the plan map is the waypoint displayed next to the center line-select on the controlling CDU.
4. Use the joystick to maneuver the waypoint symbol on the MFD to the desired position.
5. Depress the MFD line key below ENT. The Flight Management Computer will search the map data being provided to determine if a data point is located near the joystick waypoint position. If there are one or more data points, the Flight Management Computer will place the identifier of the closest point in both CDU scratch pads. If there are no data points close to the joystick waypoint, the waypoint appears in the CDU scratch pad OJOY with + in the O. The joystick waypoint identifier shall remain in the scratch pad until it is either entered into a route, the flight plan or is overwritten by a new entry to the scratch pad.

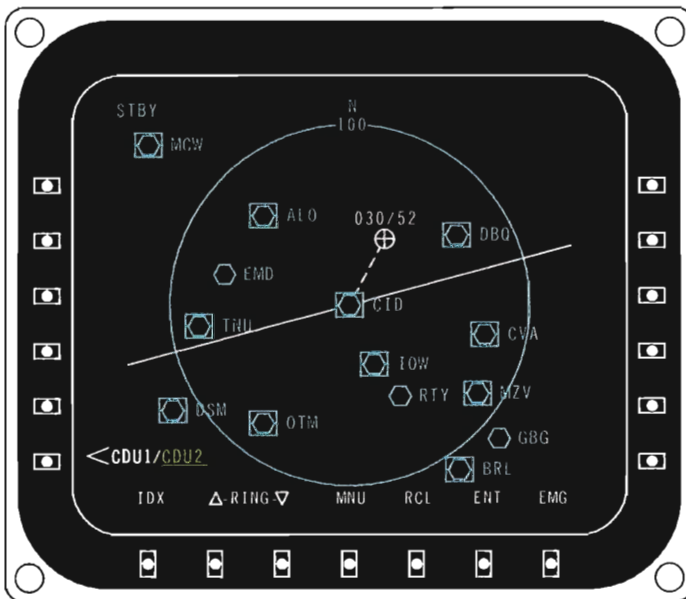

2000-390-185

ENTER WAYPOINTS WITH JOYSTICK

ENDING THE FLIGHT PLAN

When the first waypoint is entered, it becomes the first half of the flight plan name. After each new waypoint is entered, the CDU prompts the pilot to enter a route number or a waypoint. Waypoints may be added using any of the methods previously explained. It is not necessary to add the new waypoints in sequential order. The origin and destination waypoints may be entered first, and intermediate waypoints inserted as necessary. This has the advantage of seeing the flight plan route on the MFD as waypoints are inserted, so that waypoints can be selected that are on or close to the flight plan route.

To end the flight plan:

1. Verify the last waypoint in the flight plan by depressing the line-select next to OK→. The FLIGHT PLAN menu returns with an ←END FPL option.
2. Depress the line-select key next to ←END FPL. The FLIGHT PLAN menu returns with END OF FPL as a label rather than a menu option. An ←ADD WPTS option will be added. The right side of the CDU will display under DTK/DIS the Desired Track and distance between the last two waypoints, and the total distance of the flight plan route.

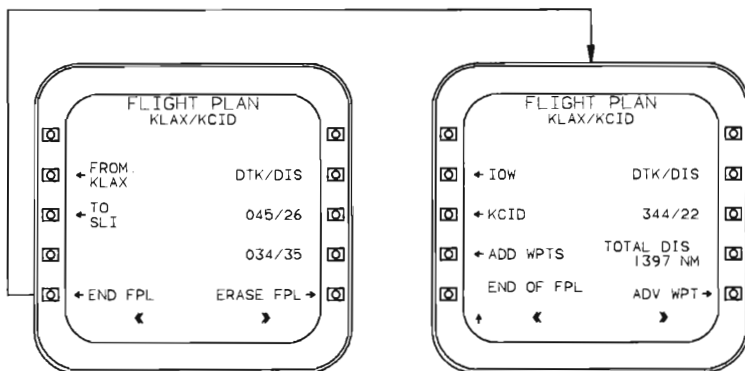

2000-390-154

END OF FLIGHT PLAN

RNAV APPROACH WAYPOINTS

Published RNAV approaches require using the VOR/DME station specified in the instrument approach procedure. RNAV approach waypoints are published as predetermined radial/distance offsets from the specified station.

NOTE

Entering FMS waypoints by name does not guarantee that the station specified in the published approach will be used in NAV TUNING.

The RNAV approach option makes entering those waypoints easier by allowing the entry of several waypoints (all radial/distance offsets from the same station) to be defined without repeating the the station identifier each time.

NOTE

There are no RNAV nor any other instrument approach procedures in the data base.

During flight planning, each time a waypoint is presented for verification, if the waypoint is a VOR/DME and an offset has been added to the waypoint a RNAV APPR option appears at the top right side of the menu. Depressing the line-select key next to RNAV APPR activates the RNAV Approach option. This causes the following changes in system operation:

1. If the FMS auto-tuning is active, the system tunes the VOR/DME to the designated reference station. If in manual tune, and neither VOR is tuned to the reference station, a status message is generated and an MSG prompt appears on the CDU.
2. Other NAV radios and VLF/OMEGA are not used. As the first RNAV waypoint becomes the TO waypoint in the flight plan, several changes occur relating to the RNAV approach.
 - A message on the CDU message page requesting pilot verification that a radio is tuned to the RNAV facility.
 - If automatic leg advance had been selected it changes to manual leg advance.
 - Automatic radio tuning is inhibited.
 - Course deviation scaling changes to 2 NM until an RNAV waypoint is no longer the TO waypoint.
3. The waypoints are identified on the CDU flight plan menu as RNAV APPR.

LEG ADVANCE FOR RNAV APPROACHES

The navigator switches from AUTOLG to MAN LG when leg advance occurs and the new TO waypoint is part of an RNAV approach. The selection of the AUTOLG mode on the SYSTEM CONTROL page will not be displayed until the TO waypoint is not part of an RNAV approach.

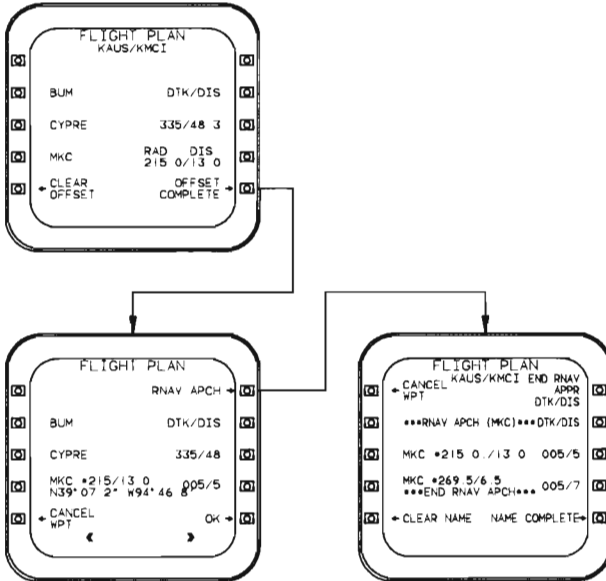

2000-390-136

RNAV APPROACH MENU

MODIFYING FLIGHT PLAN

1. If the flight plan is not yet completed (FLIGHT PLAN menu on CDU):
 - a. Use the scroll keys as necessary to bring the desired waypoint into view.
 - b. Depress the line-select key next to the desired waypoint. The SELECT CHANGE TYPE menu appears.

If the flight plan has been completed:

1. If the FLIGHT PLAN menu is not on the CDU, depress the FLT PLAN key on the CDU. The FLIGHT PLAN menu appears.
2. To add a waypoint, depress the line-select key next to ADD WPTS. The menu returns with the RTE # OR WPT prompt.
3. Enter the new waypoint. The route will be extended with the new waypoint added.

To change the flight plan:

1. To make a change before the end of the route, use the scroll keys as necessary to bring the desired waypoint into view.
2. Depress the line-select key next to the desired waypoint. The SELECT CHANGE TYPE menu appears.
3. Select one of the options on the menu, and depress the corresponding line-select key.

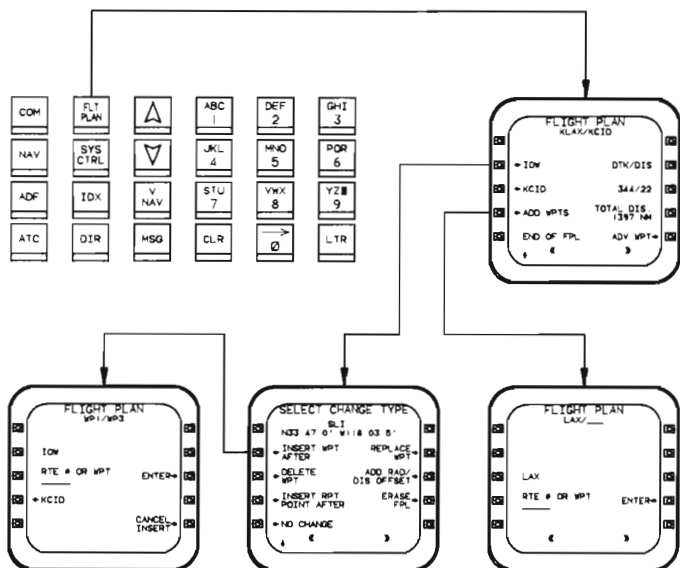

2000-390-193

SELECT CHANGE TYPE MENU

INSERTING A NEW WAYPOINT INTO A FLIGHT PLAN

1. On the FLIGHT PLAN menu, depress the line-select key next to the waypoint before the one to be added. The SELECT CHANGE TYPE menu appears.
2. On the SELECT CHANGE TYPE menu depress the line-select key next to INSERT WPT AFTER. The RTE # OR WPT menu returns immediately after the selected waypoint.
3. Enter the new waypoint.

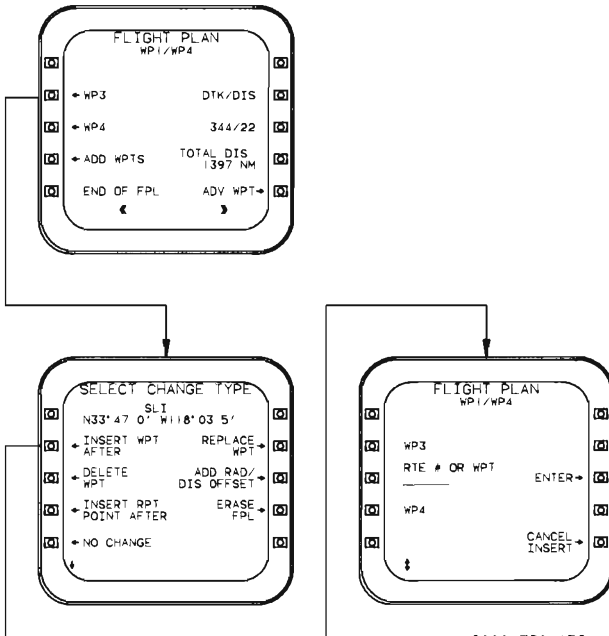

2000-390-152

INSERTING A NEW WAYPOINT

Replacing A Waypoint:

1. On the FLIGHT PLAN menu, depress the line-select key next to the waypoint to be replaced. The SELECT CHANGE TYPE menu appears.
2. On the SELECT CHANGE TYPE menu, depress the line-select key next to REPLACE WPT. The RTE # OR WPT menu returns with the selected waypoint deleted, prompting for a new waypoint.
3. Enter the new waypoint.

Deleting A Waypoint:

1. On the FLIGHT PLAN menu, depress the line-select key next to the waypoint to be deleted. The SELECT CHANGE TYPE menu appears.
2. On the SELECT CHANGE TYPE menu, depress the line-select key next to DELETE WPT. The Flight Plan List returns with the selected waypoint deleted from the flight plan with no further confirmation by the pilot.

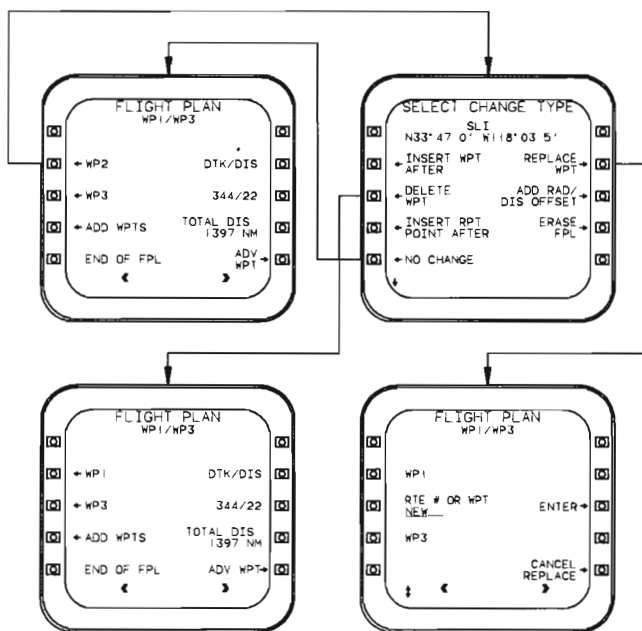

2000-390-134

REPLACING OR DELETING A WAYPOINT

Adding a Radial/Distance Offset to a Waypoint:

1. On the FLIGHT PLAN menu, depress the line-select key next to the waypoint to be modified. The SELECT CHANGE TYPE menu appears.
2. On the SELECT CHANGE TYPE menu, depress the line-select key next to ADD RAD/DIS OFFSET. If there were previously entered offsets, this line will say CHG RAD/DIS OFFSET. The ENTER OFFSET menu appears. Previously entered offsets can be removed by depressing the line-select key next to CLEAR OFFSET.
3. Enter the desired offset and depress the line-select next to OFFSET COMPLETE. The Flight Plan List returns with the offsets added to the selected waypoint.

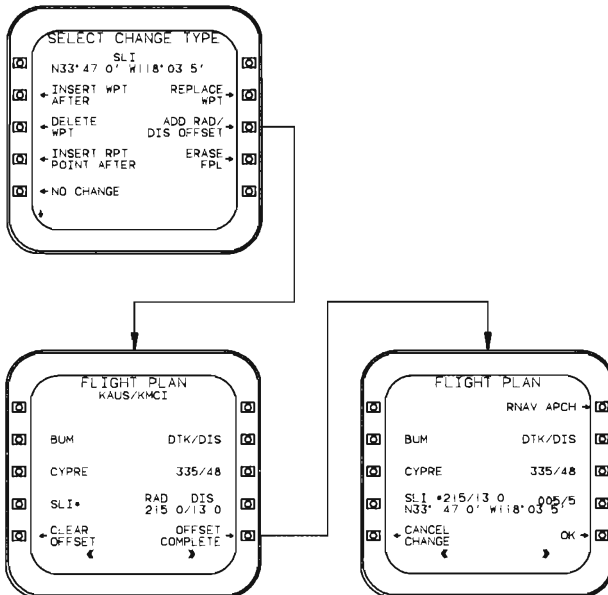

2000-390-135

ADD OFFSET MENU

INSERTING A REPORTING POINT IN A FLIGHT PLAN:

1. On the SELECT CHANGE TYPE menu, depress the line-select key next to INSERT RPT POINT AFTER. The REPORTING POINT menu appears prompting for a BASE IDENT.
2. Enter the navaid or waypoint identifier which the reporting point is abeam of, or on a specified radial from. The identifier appears on the line below the word BASE.
3. Depress the line-select key next to ENTER. The REPORTING POINT menu returns with the coordinates of the reporting point base.

Two options are offered:

- POINT ABEAM STATION
- POINT OF INTERSECTION WITH RADIAL _____

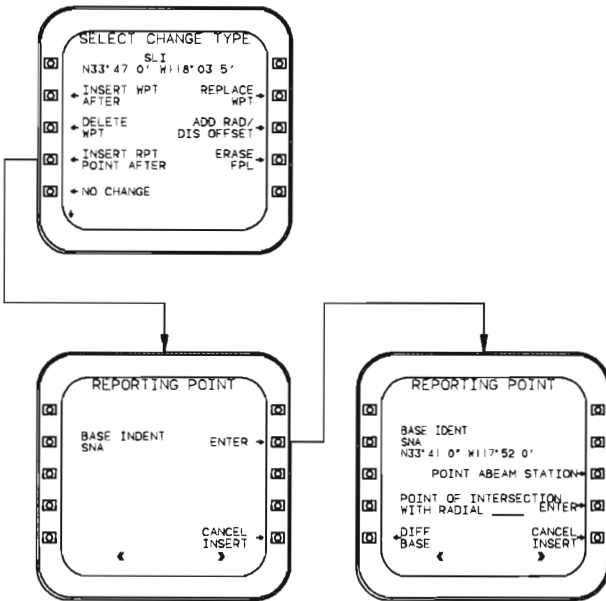

2000-390-138

REPORTING POINT MENUS

Point Abeam Station

To insert a POINT ABEAM STATION into the flight plan route:

1. Scroll as necessary to bring the last waypoint prior to the POINT ABEAM STATION insertion point into view.
2. Depress the line-select key next to that waypoint. The SELECT CHANGE TYPE menu appears.
3. On the SELECT CHANGE TYPE menu, depress the line-select key next to INSERT RPT POINT AFTER. The REPORTING POINT menu appears with a prompt for a BASE IDENT.
4. Enter the identifier of the navaid from which the REPORTING POINT will be offset. The system searches the data base and displays the entered navaid for verification. The REPORTING POINT menu returns with the BASE IDENT bearing and the coordinates.
5. Depress the line-select key next to POINT ABEAM STATION. The REPORTING POINT menu returns with the radial and distance of the point on the route which is abeam the VOR.
6. To insert the POINT ABEAM STATION into the flight plan, depress the line-select key next to INSERT IN FLT PLAN.
7. To calculate the point abeam a different station, depress the line-select key next to DIFF BASE. The BASE IDENT menu returns.
8. To cancel the insert, depress the line-select key next to CANCEL INSERT. The FLIGHT PLAN Completed menu returns.

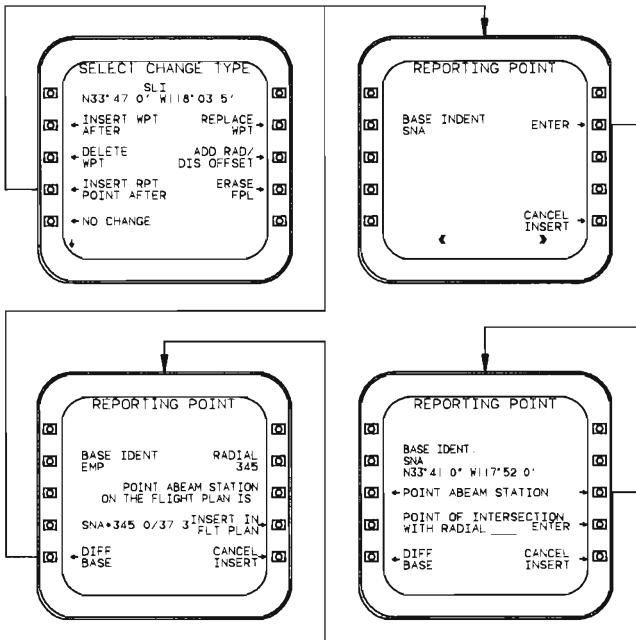

2000-390-139

COMPUTING POINT ABEAM STATION

Point Of Intersection With Radial

1. To calculate the point of intersection with a specific radial from the base station, with the REPORTING POINT menu on the CDU, enter a radial and depress the line-select key next to POINT OF INTERSECTION WITH RADIAL _____. The REPORTING POINT menu returns with the specified radial and the distance from the station on that radial which intersects the flight plan route.
2. To insert this in the flight plan, depress the line-select key next to INSERT IN FLT PLAN. The VERIFY Coordinates menu returns.
3. To calculate the point abeam a different station, depress the line-select key next to DIFF BASE. The BASE IDENT menu returns.
4. To cancel the insert, depress the line-select key next to CANCEL INSERT. The FLIGHT PLAN Completed menu returns.

NOTE

A reporting point inserted into the flight plan route between the current FROM and TO waypoints does not automatically become the TO waypoint. No annunciation of waypoint passage will occur unless it is selected for the TO waypoint.

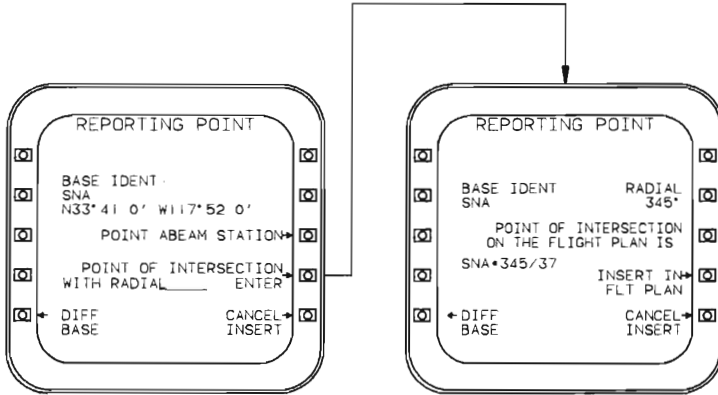

2000-390-140

POINT OF INTERSECTION WITH RADIAL

DISPLAYING FLIGHT PLANS

The flight route and waypoints may be displayed in text on the CDU, and/or graphically on the ND, if the airplane is oriented correctly relative to the flight plan. To display the flight plan on the ND, depress the ARC/MAP key on the CDU. If the ND is displaying an HSI, depress the key twice.

REVIEWING THE FLIGHT PLAN ON THE CDU

Depress the FLT PLAN key. Three flight plan list waypoints can be displayed. If the end of the flight plan is displayed, two waypoints are shown. The list can be scrolled up or down with the scroll keys to review the entire route. To show the current TO waypoint at the center of the display, depress the FLT PLAN key a second time. Waypoints designated as TO, FROM, RNAV approach, or the end of the flight are clearly indicated.

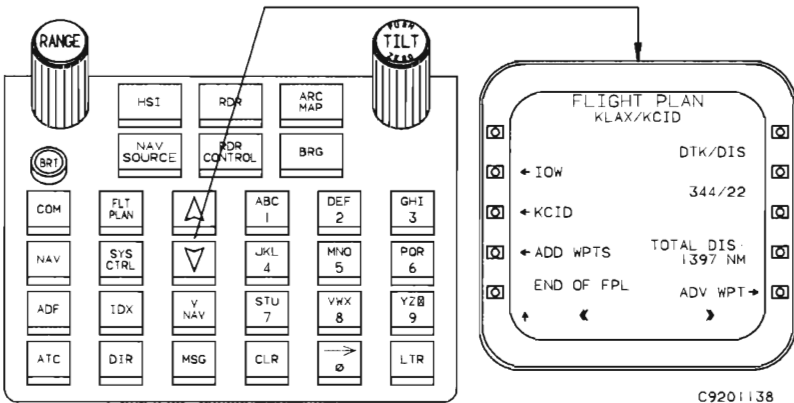

FLIGHT PLAN LIST

VIEWING THE FLIGHT PLAN ON THE MFD

1. Depress the MFD IDX key. The MFD Index menu appears.
2. Depress the MFD line-select key next to PLAN MAP. The Planning Map appears with the following options:
 - HIGH LEVEL VORS - To select or deselect, depress the adjacent line-select key.
 - LOW LEVEL VORS - To select or deselect, depress the adjacent line-select key.
 - INTERSECTIONS - To select or deselect, depress the adjacent line-select key.
 - NDBS - To select or deselect, depress the adjacent line-select key.
 - AIRPORTS - To select or deselect depress the adjacent line-select key.
 - TERMINAL WAYPOINTS - To select or deselect, depress the adjacent line-select key.
 - DISPLAY - To display the map, depress the adjacent line-select key.

The planning map, a North-up map, displays flight plan routes and aeronautical facilities listed in the data base. The status of the flight plan determines the map center.

To change the map display scale, depress the MFD scroll keys. The MFD will display any combination of high and low level VORs and airports. The more items displayed, and the larger the scale, the more crowded the display becomes.

The MFD function key below ENT sends the joystick waypoint to the CDU scratch pad to be inserted and verified and will only appear if the joystick has been used. The waypoint entry is complete when the CDU line-select key next to ENTER is depressed.

The planning map center is the center waypoint displayed on the CDU. Scrolling the list moves the map center.

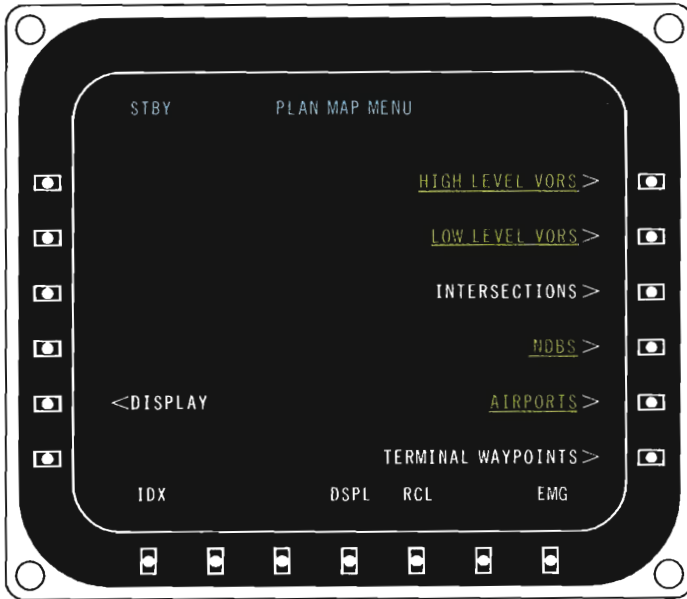

2000-390-137

SYSTEM CONTROL (SYS CTRL) FUNCTIONS

The System Control Functions allow auto/manual FMS leg selection, selected track navigation, position hold, VLF update, and sensor control.

FLYING A POINT-TO-POINT FLIGHT PLAN

Flight plans are normally executed in a point-to-point mode of operation proceeding from one waypoint to the next in the flight plan list. Desired Track (DTK), the course to be flown, is computed as the great circle route connecting sequential flight plan waypoints. Sequencing of flight plan legs as the flight progresses may be automatic or manual.

AUTOLG/MAN LG/SELTRK

To select:

1. Depress the SYS CTRL key on the CDU.
2. Depress the line-select key next to the desired mode. The active mode will be underlined and green. The other two will be white.

AUTOLG

In this mode the FMS automatically advances to the next waypoint as each waypoint is passed.

NOTE

AUTOLG is inhibited and deselected if the TO waypoint is an RNAV waypoint.

MAN LG

To retain pilot control over flight plan leg changes, use the MAN LG mode. This requires the manual advance of the FMS to the next waypoint as each waypoint is passed. To manually advance to the next waypoint:

1. Depress the FLT PLAN key on the CDU. The FLIGHT PLAN menu appears.
2. Depress the line-select next to ADV WPT.

This capability would normally be used to control the entry point to a leg-to-leg turn, to clear traffic in the vicinity of the waypoint, or fly an RNAV approach.

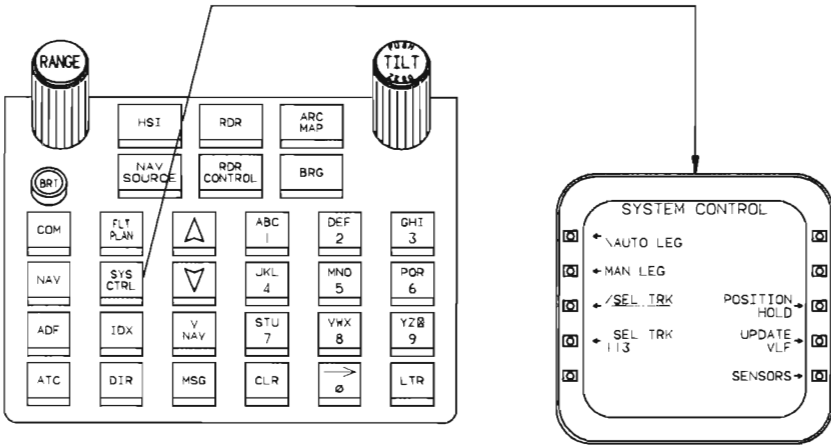

2000-390-195

SYSTEM CONTROL MENU

SEL TRK

To manually select a track to or from a particular waypoint, use the SEL TRK mode. Entering this mode breaks the continuity between the TO waypoint and the rest of the flight plan. It is annunciated on the CDU by a row of dashes beneath the waypoint line and a SEL TRK label with only the track angle displayed on the right side of the display.

There are two methods of setting up a selected track to or through a specific waypoint.

Method 1.

1. Depress the SYS CTRL key on the CDU.
2. Depress the line-select key next to SEL TRK.
3. Depress the FLT PLAN key on the CDU. The flight plan menu returns with the current TO waypoint separated from the rest of the flight plan by a row of dashes. The selected track will be through this waypoint. The course setting is displayed on the right side of the CDU below the label SEL TRK.
4. To change the active TO waypoint, depress the line-select key next to ADV WPT on the SYSTEM CONTROL menu.
5. Set the CRS knob on the CHP to the desired course.

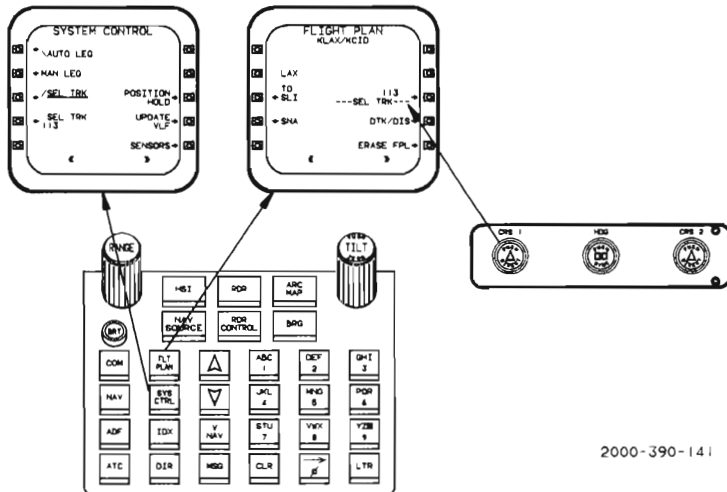

2000-390-141

SELECTED TRACK, METHOD 1

Method 2.

1. Depress the SYS CTRL key on the CDU.
2. Depress the line-select key next to ←SEL TRK with the number beneath it. This number is the course to the current TO waypoint. When the key is depressed, the number will blank. Enter the desired track on the CDU keypad. The track entered will replace the one that was blanked.
3. Depress the line-select key next to ENTER XXX again. This activates the selected track mode.
4. To change the track once it has been established, use the CRS knob on the CHP or complete item number three again.

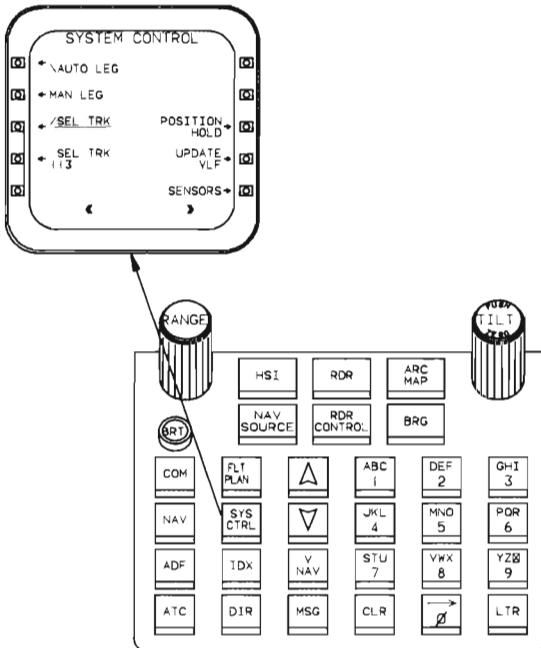

2000-390-153

SELECTED TRACK, METHOD 2

REJOINING THE ORIGINAL FLIGHT PLAN

1. Depress the SYS CTRL key on the CDU.
2. Depress the AUTOLG line-select key. The AUTOLG mode provides course guidance to the TO waypoint. If the airplane is outbound from the SEL TRK waypoint when AUTOLG is selected, the next waypoint in the route will become the TO waypoint. Otherwise the SEL TRK waypoint will be the TO waypoint and the inbound course will remain the selected track.
3. If the above steps cause undesired full scale deviation, or if the desired reentry waypoint is not the next one on the route, accomplish the following:
 - a. Depress the DIR key on the CDU.
 - b. Determine the waypoint at which the original flight plan route is to be reentered.
 - c. If the reentry waypoint is displayed on the CDU, depress the line-select key next to that waypoint. Otherwise, use the scroll keys to bring the waypoint into view and then depress the line-select key next to that waypoint. This immediately establishes a direct leg from the present position to the reentry waypoint.

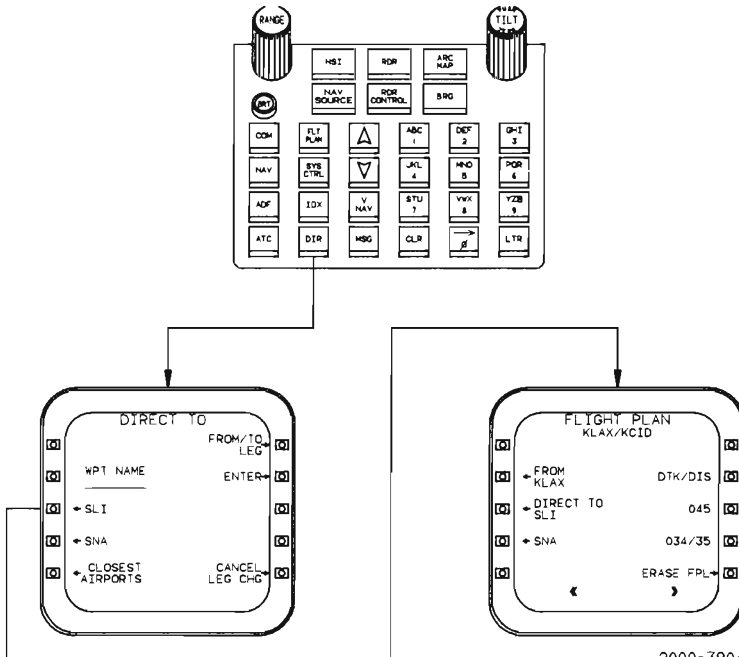

2000-390-170

REJOINING THE ORIGINAL FLIGHT PLAN

POSITION HOLD

Position Hold is used to check or update the present position relative to a visual fix.

1. Depress the SYS CTL key on the CDU.
2. Select a fix that is visually precise and whose position is known such as a navaid or runway threshold.
3. While exactly over the fix, depress the line-select key next to POSITION HOLD. The CDU will display the airplane LAT/LON coordinates at the moment the key was depressed.
4. Enter the fix name or identifier and depress the line-select key ENTER. The computer searches the data base for the named fix, and goes through the same identification and duplicate resolution process as for waypoint entry. If the fix does not have a name but the Lat/Lon is known, pressing ENTER will allow the definition of Lat/Lon. The CDU will then display the name and coordinates of that fix plus the difference between that fix and the FMS position at the moment the line-select key next to POSITION HOLD was depressed.
5. To update the position based on the fix, depress the line-select key next to UPDATE POS=FIX.
6. To maintain the held position and change the fix name, depress the line-select key next to CHANGE FIX.

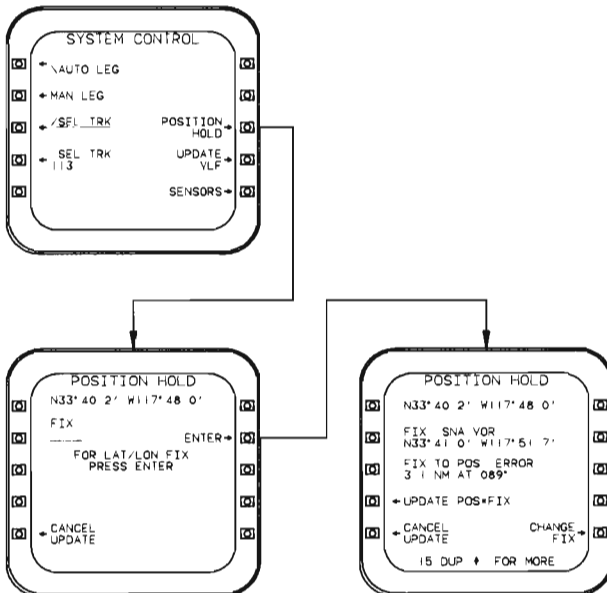

2000-390-083

POSITION HOLD MENU

VLF UPDATES

To update the VLF present position using the FMS as a reference:

1. Depress the SYS CTRL key on the CDU.
2. Depress the line-select key next to UPDATE VLF. The CDU will display the difference between the VLF and FMS present positions. Two options will be offered:
3. UPDATE VLF FROM FMS
4. CANCEL UPDATE
5. Depress the line-select key next to the desired option.

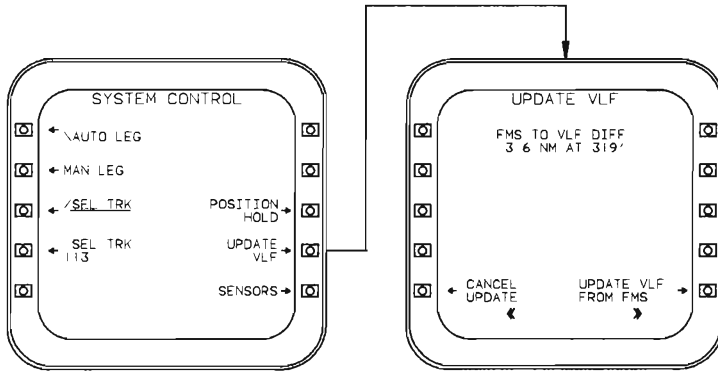

2000-390-147

UPDATE VLF MENU

SENSOR CONTROL

To override the automatic VOR/DME/VLF/OMEGA sensor mix used by the FMS:

1. Depress the SYS CTRL key on the CDU.
2. Depress the SENSORS line-select.
3. Depress the VOR/DME USE NO/YES so that NO is underlined. The VOR/DME then changes to yellow to indicate it is inactive.
4. Depress the VLF/OMEGA USE NO/YES so that NO is underlined. The VLF/OMEGA then changes to yellow to indicate that it is inactive.
5. Depress the STATION DESELECT under the VLF/OMEGA to display the VLF STATION DESELECT menu.
6. Depress the line-select next to the station to be deselected. The station identifier will change to yellow and will be underlined indicating the station is inactive. The deselection will remain in effect until the FMS is powered down or the station is reselected.
7. Depress the scroll key to display the OMEGA stations then repeat the above procedure for the OMEGA stations.

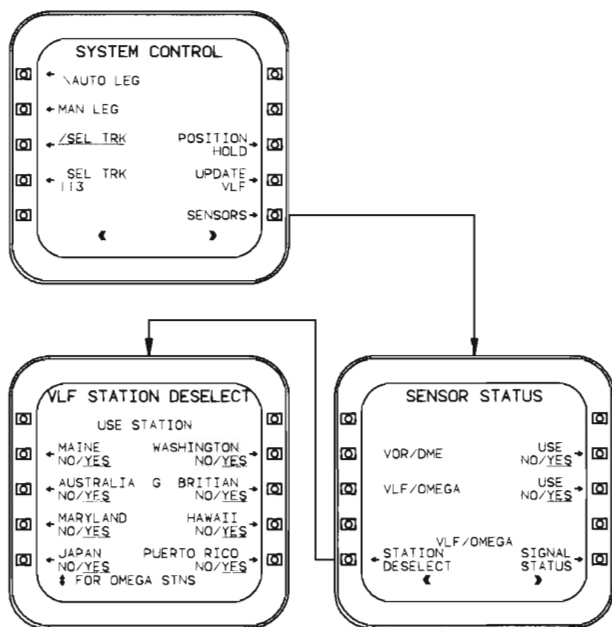

2000-390-191

SENSOR CONTROL MENU

FMS INDEX (IDX) FUNCTIONS

ROUTE LIBRARY

To perform any of the following functions on a route in the library; refer to the corresponding function in flight plans.

- Route list display
- Erasing a route
- Appending waypoints
- Waypoint entry verification, leg distance display, duplicate resolution, pilot defined and offset waypoints
- Inserting a route
- Creating RNAV approaches
- Modifying previously stored routes
- Inserting reporting points in routes
- Displaying and editing invalidated waypoints

The flight plan is actually part of the route library, route 00. The main difference is that only the flight plan is capable of being used as a NAV source, the rest of the route library is in storage. When the route is complete, it should have END OF RTE at the bottom of the waypoint list. If not, depress the line-select key next to END RTE at the ENTER prompt.

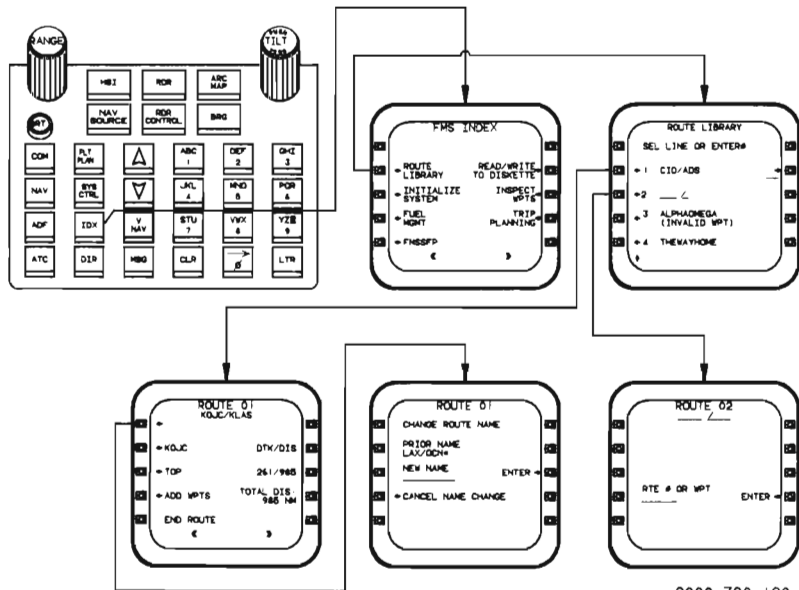

2000-390-190

ROUTE LIBRARY MENU

SYSTEM REINITIALIZATION

In addition to the required system initialization at start-up, the system can be reinitialized at any time as follows:

1. Depress the IDX key on the CDU.
2. Depress the line-select key next to INITIALIZE SYSTEM.

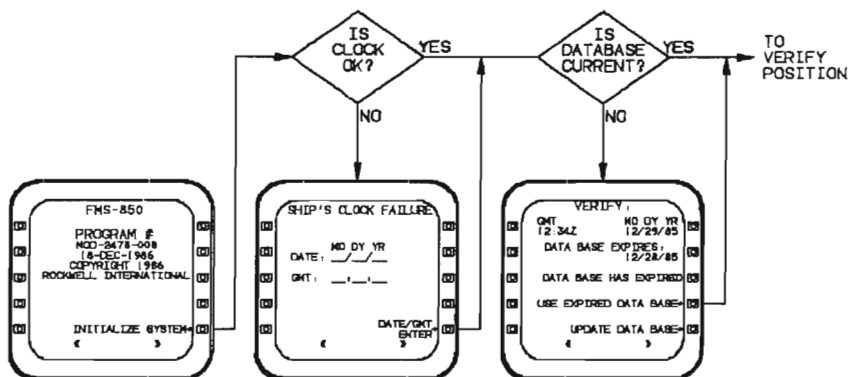

2000-390-178

SYSTEM INITIALIZATION

STORING A ROUTE IN THE ROUTE LIBRARY

1. Depress the CDU IDX key.
2. Depress the line-select key next to ROUTE LIBRARY. The CDU will display four routes at a time.
3. Use the scroll keys as necessary to display a different set of routes.
4. Select an empty or unneeded route number, and depress the corresponding line-select key. The selected route number will be the storage location of the the flight plan. If an occupied route number is selected, the ROUTE LIBRARY menu appears with the route from that location along with ADD WAYPOINTS prompt.
5. To replace the old route, depress the line-select key next to any waypoint and select ERASE RTE, and YES at the ARE YOU SURE? prompt.
6. To add waypoints to a route, depress the line-select key next to ADD WAYPOINTS. The route library menu returns with the ENTER RTE OR WPT prompt and the old route still present. The entry will be appended to the old route, rather than replacing it.
7. To load the current flight plan into a route, enter the number 00 and at prompt depress the line-select key next to ENTER. The ROUTE ENTRY page appears with a normal or reverse order prompt.
8. Any route can be appended or copied to any other with this procedure.

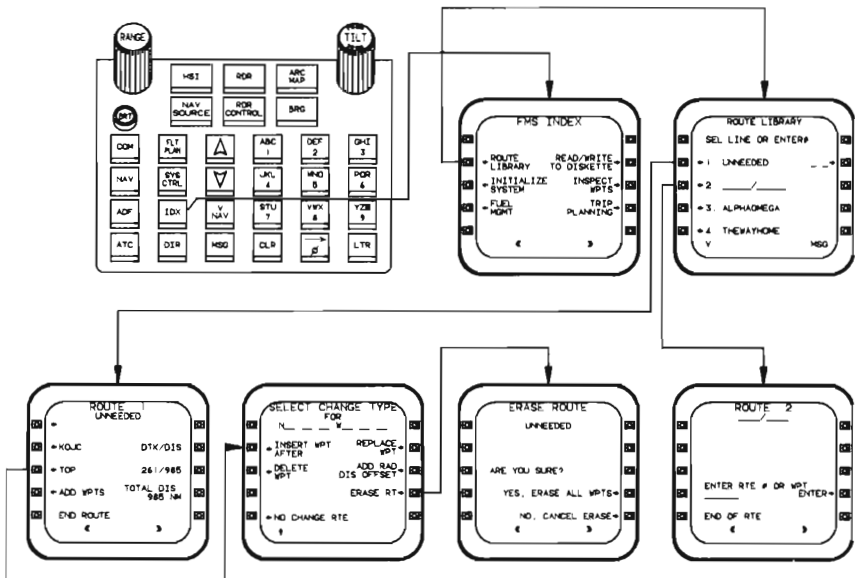

2000-390-157

ROUTE STORING

REVISING A ROUTE

1. Depress the IDX key on the CDU.
2. Depress the line-select key next to ROUTE LIBRARY. Use the scroll keys to bring the route into view and depress the line-select key next to the route to be revised.
3. Depress the line-select key next to the waypoint to be changed. If necessary, use the scroll keys to bring the appropriate waypoint into view. The SELECT CHANGE TYPE menu appears. Use the same method as for modifying flight plans.

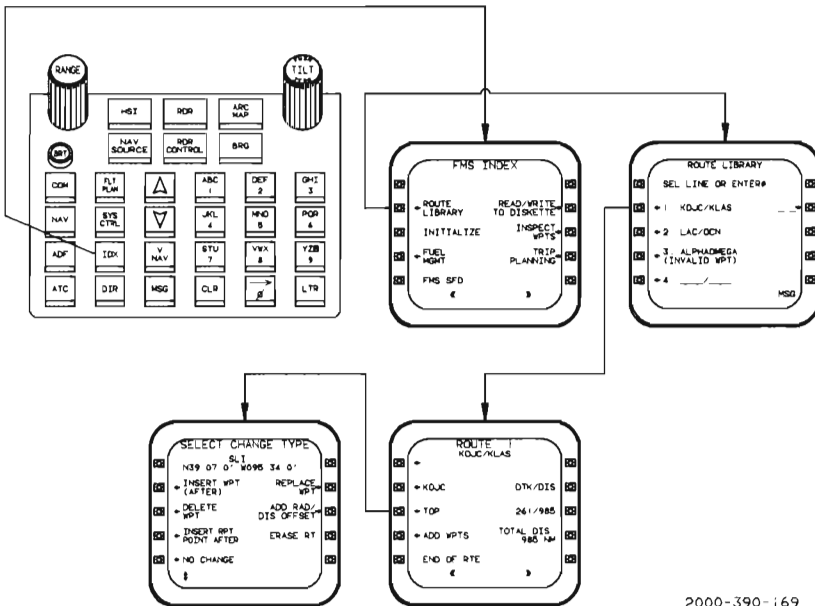

2000-390-169

REVISING A ROUTE

RENAMING A ROUTE

The FMS automatically names the route using the first waypoint identifier, a slash, and the last waypoint identifier. To rename the route, depress the line-select key next to ROUTE NAME. Enter the new name on the CDU keypad, and depress the line-select key next to ENTER.

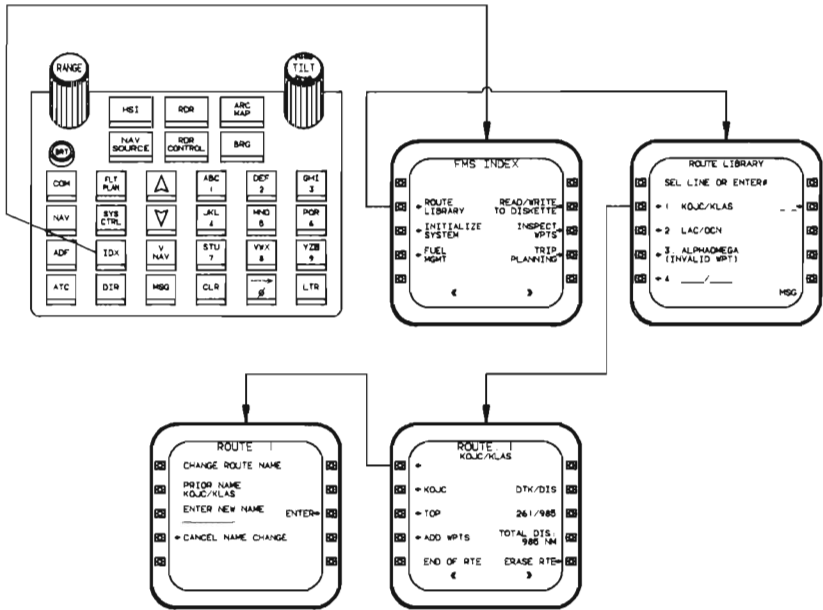

2000-390-158

RENAMING A ROUTE

FUEL MANAGEMENT

The fuel management section provides fuel consumption information. It will continuously compute fuel used, fuel remaining and endurance at the present fuel flow. This information will also be displayed on the FMS progress page on the MFD.

OPERATION

1. Depress the IDX key on the CDU.
2. Depress the line-select key next to FUEL MGMT.
3. Enter the starting fuel weight as a four digit number (with leading zero, if necessary) on the CDU keypad and depress the line-select key next to FUEL REMAINING. The entry will move from the scratch pad to below the FUEL REMAINING line. The ENTER prompt will appear.
4. Verify the entry and depress the line-select key next to ENTER.

If the left or right fuel flow is unavailable or invalid, all computed data fields will be dashed and a FUEL FLOW INVALID message appears. When the failed data becomes valid the message will change to FUEL FLOW DATA WAS LOST THEN RETURNED and the page will change to the FUEL REMAINING entry page.

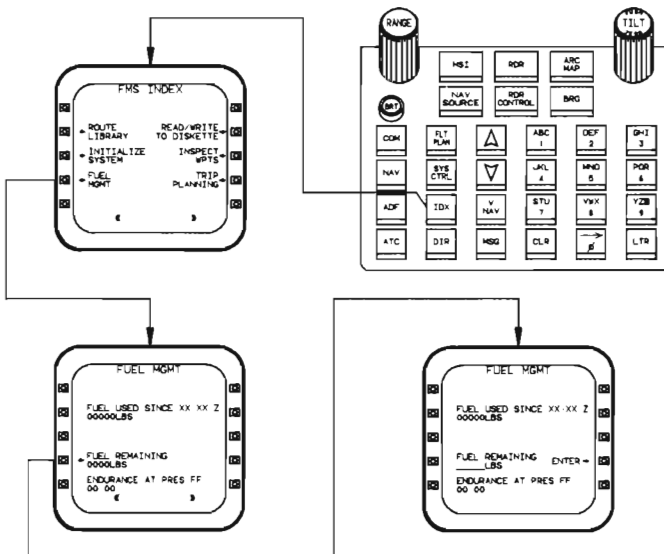

2000-390-144

FUEL MGMT MENU

READ/WRITE FUNCTIONS

READ

WARNING

Read and write functions should only be performed while the airplane is on the ground.

The data base that the computer uses and the checklists which are displayed on the MFD are organized into files and stored on a diskette. If the Flight Management Computer battery fails, all data will be lost and a factory start must be initiated. The battery's life expectancy is five years.

To read files from a diskette:

1. Depress the IDX key on the CDU.
2. Depress the READ/WRITE DISKETTE line-select. This will display the READ/WRITE TO DISKETTE screen.
3. Depress the READ FILE FROM DISKETTE line-select. The READ FROM DISKETTE PLEASE WAIT screen is displayed.
4. While the system reads the diskette directory READING DIRECTORY is added above the PLEASE WAIT message.
5. The READ FROM DISKETTE SELECT FILE screen is then displayed.
6. Depressing the line-select next to a file name causes the system to attempt to read and verify the selected file. The READ FROM DISKETTE PLEASE WAIT screen is displayed. When the file is being read the READING FILE message is added above the PLEASE WAIT message.
7. Depressing the CANCEL line-select returns to the FMS INDEX menu.
8. When the read is complete the READ/WRITE TO DISKETTE page adds a READ COMPLETE message.

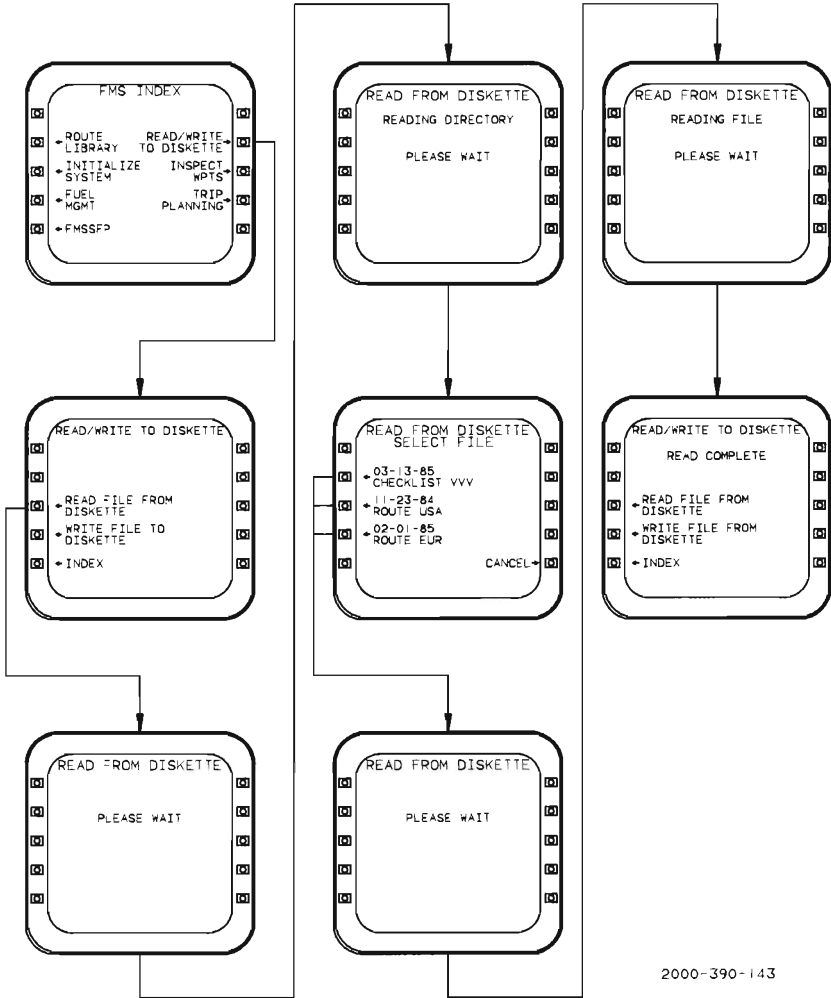

2000-390-143

DISKETTE READ/WRITE MENU

Occasionally a read will encounter an error and terminate. This will cause an error message to be displayed. The following is a list of the most common errors.

DBU NOT AVAILABLE	Diskette not fully/properly inserted DBU disconnected or inoperative
DISK READ ERROR	Diskette not formatted Defective /damaged diskette
DISK WRITE ERROR	Defective damaged diskette
DISK FULL	Not enough room on diskette for file
DISK WRITE PROTECTED	Diskette cannot be written to

WRITE

There are two ways to write user files on the diskette. The only file which can be created on the CDU is the route library. This should be copied onto the diskette for a back-up.

1. Depress the IDX key on the CDU.
2. Depress the READ/WRITE TO DISKETTE line-select key.
3. Depress the WRITE FILE TO DISKETTE line-select key.
4. The menu displays:
 - a. ROUTE FILE
 - b. CREW NOTES
 - c. ENGINE EXCEEDANCES
 - d. FAULT HISTORY
5. Depress the line-select next to the file name. The menu will display the file name and prompt for a version number. This entry need not be a number, any combination of letters and numbers is acceptable.
6. Depress the CHANGE FILE line-select key. The CDU will display the PLEASE WAIT message while it is getting ready to write the file. While the write is in progress, a WRITING FILE message is displayed.
7. If the file is already on the diskette, the CDU will display a FILE EXISTS message, and prompt for a choice of either replacing the existing file or changing the version ID. To proceed, depress the line-select key next to the desired option. There is room on the checklist diskette for approximately twenty pages of text. Each page is equal to one MFD screen. If a file is written onto an unformatted diskette, the system will automatically format the diskette. The formatting takes approximately three minutes.

INSPECTING WAYPOINTS

Waypoints are presented for validation by the pilot when the flight plan is assembled. However, the flight plan and its individual waypoints may be inspected at any time. Temporary conditions and NOTAMS may require that a particular navaid be deselected.

To examine and deselect individual waypoints:

1. Depress the CDU IDX key.
2. Depress the line-select key next to INSPECT WPTS.
3. Enter the identifier of the waypoint to be inspected and depress the line-select key next to ENTER, or depress line-select key next to DISPLAY PILOT DEFINED WAYPOINTS NOT USED IN ANY ROUTES OR FLIGHT PLAN. The waypoint data will be displayed for inspection.
4. To deselect a particular waypoint, such as an out-of-service navaid, depress the line-select key next to USE WPT NO/YES. This will toggle the condition between NO and YES. All deselected navaids are reselected automatically when the FMS is cold started.

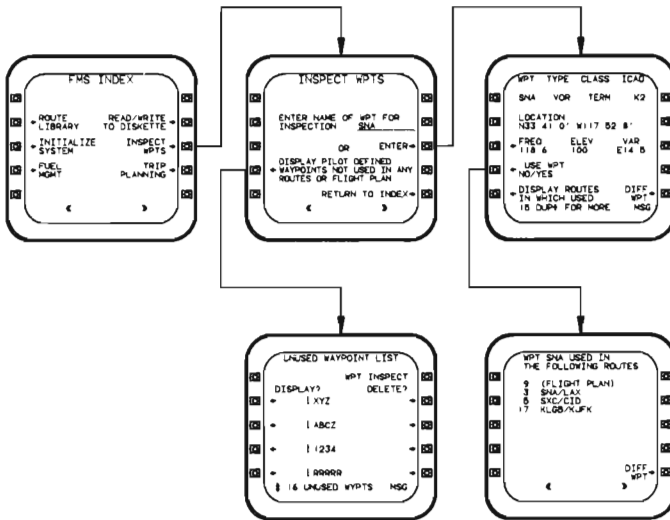

2000-390-148

INSPECT WAYPOINTS MENU

TRIP PLANNING

1. Depress the IDX key on the CDU.
2. Depress the line-select key next to TRIP PLANNING.
3. Key in the FROM and the TO waypoints.
4. Enter the estimated ground speed (EST GS) on the CDU keypad and depress the line-select key next to ENTER. The menu will display the ETE. The TRIP PLANNING menu displays bearing (BRG), and distance (DIS), between any two waypoints or between the first and last waypoints of any route, including the present flight plan that the pilot enters.
5. Enter the estimated fuel flow (EST LBS/HR) and depress the line-select key next to ENTER.
6. The fuel required (FUEL RQD) for the distance is displayed.

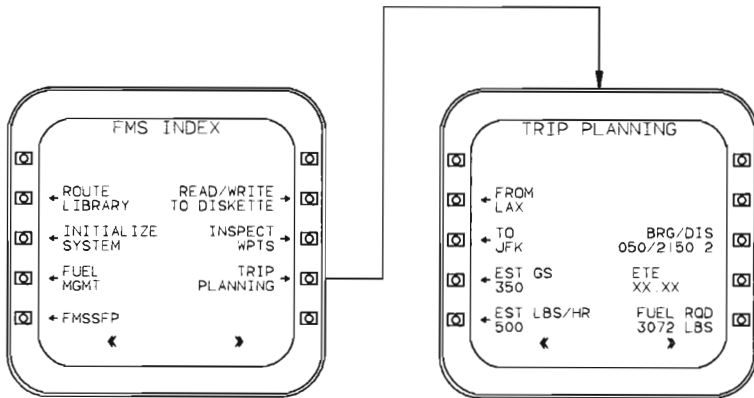

2000-390-145

TRIP PLANNING MENU

ENTRY OF FROM WAYPOINT OR ROUTE NUMBER

To enter a FROM waypoint or route number, depress the line-select key next to FROM. If a waypoint is entered, the TRIP PLANNING menu displays BRG, DIS, and ETE between the new FROM waypoint and the previously entered TO waypoint, using the previously entered estimated ground speed.

If a route number is entered, the TRIP PLANNING menu displays the route next to the FROM legend and displays TOTAL DIS and ETE from the first waypoint to the last in the route along the path defined by waypoints in the route. If 00 is entered for the route number, TOTAL DIS and ETE from the first to the last waypoint in the current flight plan are displayed.

If the flight plan is edited while the TRIP PLANNING menu is displaying information for route 00, the results of the editing are not displayed unless the pilot exits from the trip planning function and then reselects it. If the line-select key next to USE PRESENT POSITION AS FROM WAYPOINT is depressed, the TRIP PLANNING menu displays PRESENT POSITION as the FROM waypoint, and displays continuously updated BRG, DIS, and ETE from present position to the TO waypoint at the estimated ground speed. A new TO waypoint is entered in the same manner as a new FROM waypoint except that that only a waypoint (not a route) can be entered.

ENTRY OF ESTIMATED GROUND SPEED

The estimated ground speed can be changed by depressing the EST GS line-select key and entering any valid number between 1 and 999, then depressing the ENTER key.

DIRECT TO (DIR) FUNCTIONS

Direct TO functions allow direct navigation to named waypoints on specific courses, designated FROM/TO legs, and direct to closest airports.

To use the direct TO mode:

1. Depress the DIR key on the CDU. The DIRECT TO menu appears.
2. To proceed direct to an off-flight-plan waypoint, enter the name in the keypad, and depress the line-select next to ENTER. The FMS will go through the same verification procedure as for a new waypoint. When an airport is selected in this mode, runways are not available for use as a waypoint.
3. Depress the line-select next to the desired waypoint. Use the scroll keys as necessary to bring the waypoint into view.
4. To proceed direct to a specific FROM/TO leg, depress the line-select next to FROM/TO LEG. The CDU will prompt for a FROM waypoint, which may be any waypoint on the flight plan. Once the FROM waypoint is selected, the CDU prompts for a TO waypoint. Any waypoints in the flight plan between the FROM and TO waypoints will be deleted.

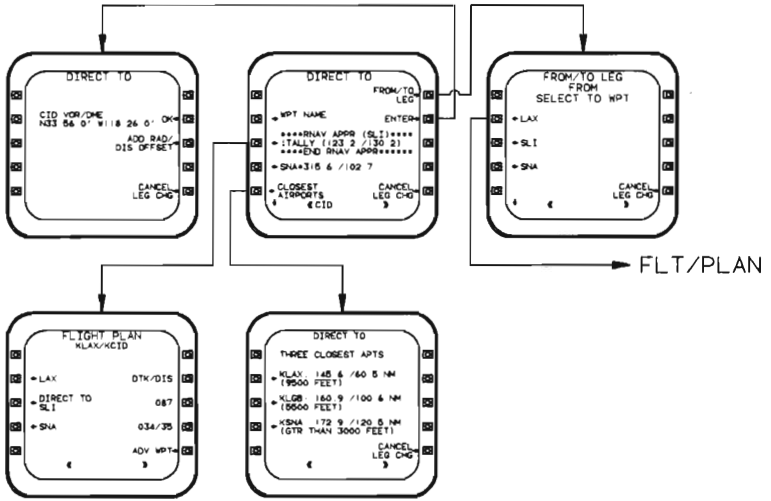

2000-390-088

DIRECT TO MENU

COURSE HEADING PANEL (CHP)

The CHP contains the course, heading, and joystick controls for the ND, FMS, AFCS, and VOR.

There are four controls:

- Course Knobs CRS 1 and CRS 2
- Heading Select Knob
- Joystick

COURSE KNOBS CRS 1 AND CRS 2

The CRS knobs control the active and preset course to the VOR-1 and VOR-2, respectively. The knobs are actually switches which produce a series of pulses, and have a clicking feel when turned. There is no fixed relationship between the knob position and the course. Depressing the center of each CRS knob, labeled PUSH Δ DIRECT, will change the present course to a direct course to the tuned station or next waypoint.

ACTIVE COURSE

The CRS knob's primary function is to control active course. When the active NAV is a VOR, the CRS knob moves the active course pointer.



2000-390-180

COURSE HEADING PANEL

PRESET COURSE

When the PRESET NAV SOURCE menu is on the CDU, and a preset NAV source is selected, the CRS knob moves the preset course pointer.

SELECTED TRACK

When FMS is the active NAV source and it is in the SEL TRK mode, the CRS knob changes the selected track. If both sides have FMS selected as the active NAV source, either CRS knob will change the selected track. The CRS knob is not active in the other FMS modes (AUTOLG or MAN LEG).

HEADING KNOB (HDG)

The single HDG knob controls the selected heading input to the AFCS. This is displayed as the heading bug and digital readout. The knob is actually a pair of switches which produce a series of pulses when turned. This gives the knob a clicking feel. There is no fixed relationship between the knob position and the heading. If one of the switches fails, two clicks will be required to change the heading by one degree. Depressing the center of the HDG knob labeled PUSH SYNC will change the selected heading to present heading.

JOYSTICK

The joystick is used to position waypoints on the MFD map.

To enter waypoints with the joystick:

1. Set the MFD for the planning map or present position map. If necessary, refer to VIEWING THE FLIGHT PLAN ON THE MFD for instructions.
2. Use the MFD scroll keys to set the map scale so that, as new waypoints are added, they will remain in view. The map will advance along the flight plan route as each new waypoint is entered.
3. Use the joystick to maneuver the waypoint symbol on the MFD to the desired position.
4. Depress the function key on the MFD below ENT. After approximately 3-5 seconds, the new waypoint appears on the CDU for verification. If the joystick bug was over a waypoint already defined in the data base, the waypoint will appear on the CDU with that name. Otherwise the new waypoint appears on the CDU as OJOY with + inside the O.
5. If the coordinates are correct, depress the line-select key next to ENTER. The MFD map center will advance to this waypoint.

(This Page Intentionally Left Blank)

AUTOMATIC FLIGHT CONTROL SYSTEM (AFCS)

The Automatic Flight Control System is a dual independent, fail passive autopilot, which provides dual independent flight directors, a 3-axis autopilot, and automatic 3-axis trim control. The AFCS controls consist of the autopilot panel, two mode select panels, disengage and sync push buttons on the control wheels, and two GO AROUND push buttons on the power levers.

The system incorporates two Flight Control Computers (FCC). The FCCs are semi-independent. Both must be working to engage the autopilot, but each operates its own flight director independently. If one FCC fails, the AFCS will disengage, but the operative FCC will continue to operate its flight director.

The system operates in the following modes:

- Pitch and Roll Hold
- Heading Select
- Navigation
- Approach
- Altitude Hold
- Altitude Preselect
- IAS
- Descend
- Vertical Speed
- Go Around
- Yaw and Roll Autotrim
- IAS PROF

AUTOPILOT PANEL

The autopilot panel located at the bottom of the control pedestal contains the following controls:

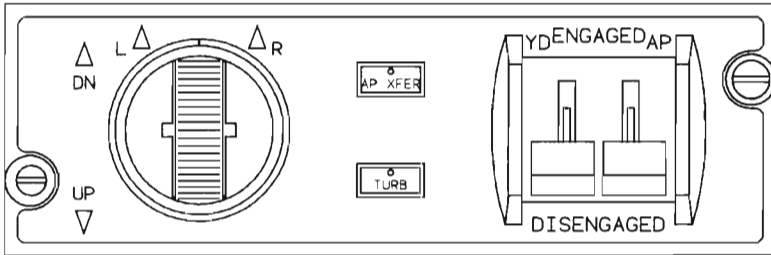

2000-390-037

AUTOPILOT PANEL

A/P LEVER

The A/P lever is spring loaded OFF (DISENGAGED) and held ON (ENGAGED) by a solenoid. To engage the autopilot, raise the A/P lever until the solenoid holds it engaged. If it fails to engage, it is because the computer has failed, or has detected a failure. Upon engagement, if any flight director mode is in use, the autopilot will follow the flight director commands. Otherwise, the autopilot will be in pitch and roll mode. All mode changes are synchronized to provide smooth transitioning.

Autopilot engagement is annunciated by a green AP← at the upper left corner of each PFD. When the A/P XFER is selected, and the autopilot is controlled by the #2 FD and MSP, the annunciation changes to AP→. A/P disengagement causes the annunciation to flash yellow. To cancel the yellow annunciation, depress the autopilot disconnect switch, the GO AROUND switch, or reengage the autopilot.

The autopilot can be disengaged by:

- Depressing the trim button on either control wheel.
- Operation of trim in any axis.
- Manual disengagement of the autopilot switch.
- Depressing the go-around button on either power lever.
- Depressing the control wheel disconnect button on either control wheel.

The control wheel disconnect button will disengage the yaw damper as well as the autopilot.

Automatic or manual autopilot disengagement will initiate an aural tone. The tone may be cancelled by:

- Depressing trim button on either control wheel a second time.
- Depressing the control wheel disconnect button (will cause yaw damper to disengage.)

YAW DAMPER LEVER (YD)

The yaw damper (YD) lever is spring loaded off (DISENGAGED) and held ON (ENGAGED) by a solenoid. To engage the yaw damper, raise the YD lever until the solenoid holds it engaged. When engaged, if the FCC detects a yaw damper failure, it disengages the YD. If the condition causing the disengagement was momentary, the pilot can reengage the YD after the condition passes. Automatic rudder trim is operational with the yaw damper engaged. Actuating the rudder trim will disengage the yaw damper.

MALFUNCTION MODES

Since the Autopilot Panel is common to both the pilot's and copilot's AFCS, an Autopilot Panel malfunction causes loss of the autopilot in both channels.

LIGHTING

Edge lighting and annunciator brightness is controlled by the CENTER DISPLAYS control in the overhead lighting panel.

A/P XFER PUSH BUTTON

Normally, the system responds to the pilot's mode select panel and flight director. To change to the copilot's, depress the A/P XFER button.

TURB PUSH BUTTON

TURB adapts the autopilot responses to compensate for turbulence. It is automatically cleared if a localizer is captured or the autopilot is disengaged.

PITCH KNOB

The pitch knob is spring loaded to return to center when released. The pitch angle attained prior to switch release will be maintained. The pitch knob commands AFCS pitch changes. Displacing the switch clears any vertical mode except glideslope capture and returns the AFCS to the pitch mode.

PITCH MODE

Pitch is the basic vertical mode. The AFCS is in pitch mode unless another vertical mode is selected. It maintains the pitch angle at initiation, or as commanded by the pitch knob.

TURN KNOB

The turn knob commands AFCS turns. Moving it clears any lateral mode except approach or localizer capture, returns the AFCS to roll mode, and commands a roll angle, up to 32°, proportional to the knob position. The knob remains in place when released. If out of its detent upon autopilot engagement, it is ignored until returned to its detent. Localizer capture disables the turn knob.

ROLL MODE

Roll mode is the basic lateral mode. The AFCS is in roll mode unless another lateral mode is selected. If the roll angle is less than 5°, roll mode levels the wings and holds the heading. If roll angle is between 5° and 32° when initiated, it holds the roll angle until the turn knob is turned. It rolls to a angle proportional to the turn knob position. If the roll angle is greater than 32° at initiation, the roll angle is reduced to the 32° limit and maintained.

AFCS MODE	PFD ANNUNCIATION
Pitch	PTCH (green)
Roll	ROLL (green)
Heading Hold	HDG (green)

MODE SELECT PANEL (MSP)

The MSP contains the autopilot mode select switches. All switches toggle their functions on and off with indicator lights above them to verify switch selection status. Also, mode selections and transitions (i.e. armed to capture) are displayed on the PFD by flashing the mode for 5 seconds before becoming steady. Lateral and vertical modes are independent of each other. The lateral and vertical switches are separated by a raised bar. Upon power up, the indicator lights flash on, then go off.

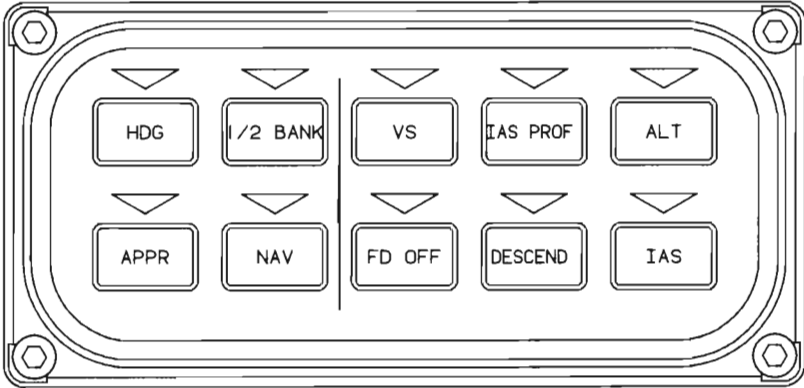

2000-390-198

MODE SELECT PANEL

HDG

Heading mode commands the airplane to turn to and maintain the heading set with the heading knob on the Course Heading Panel. The selected heading is indicated by the heading bug on the ND. The maximum commanded roll rate is 5 deg/sec and the maximum bank angle is 27 °. Heading mode is cleared by selecting another lateral mode.

1/2 BANK

Half bank mode reduces by one half the maximum commanded roll angle, including FMS steering commands and NAV captures. Overshoots may occur when using a non-FMS NAV source or when using an FMS NAV source without selecting AUTOLG. Approach mode capture clears half bank mode. Half bank mode selection is indicated by illumination of the indicator above the 1/2 BANK switch on the MSP and by the display of 1/2 BNK on the PFD. The 1/2 BANK mode must be used with the autopilot engaged above 30,000 feet.

NAV

NAV mode couples the active NAV course to the autopilot. If the airplane is in a position to track a course when NAV is selected, the AFCS will capture that course and track it. If the airplane is not in position to track the course, the AFCS will arm

that mode, but remain in the ROLL or HEADING mode until the airplane starts to intercept the course. Then the AFCS will capture the course and start tracking. Upon capture, the armed mode, which was displayed in white to the right of the active mode, becomes the active mode. The pilot must fly a heading that will intercept the course at less than 90°.

If any data or signals necessary to fly the selected course are missing or lost before capture, the system will still arm the selected mode but cannot capture. If the navigation or source mode data is lost or becomes invalid after capture, the capture mode will still be annunciated, but the steering is flagged as invalid. Changing the active NAV or the lateral mode cancels the capture. Dead reckoning (DR) is annunciated during station passage.

APPR

The type of approach is determined by the active navigation source. The APPR mode arms when the button is pressed, and automatically captures when capture conditions are met. Prior to capture, the system operates in the currently active lateral mode.

In an FMS approach, the capture point is determined by the computer.

In a non-FMS approach, the Flight Control Computer arms for glideslope capture (if glideslope is valid) after localizer capture (front course only). At glideslope capture commands are generated to maintain flight on the glide path.

LATERAL MODE ANNUNCIATIONS

AFCS MODE	PFD ANNUNCIATION
HDG	HDG (Green)
HALF BANK	1/2BNK (White)
NAV Arm	HDG or Roll(Grn) and FMS, VOR or LOC (White)
NAV Capture	FMS, VOR or LOC (Green)
Dead Reckoning	DR (White)

VS

Vertical speed mode commands the AFCS to maintain the vertical speed as specified by the VS reference on the ALI. Upon selection of VS mode, the VS reference, indicated by the VS bug on the ALI appears if not already in view, and sets to the current VS. It can be reset manually with the center knob on the ALI bottom panel. To reset the VS to the current VS, depress the SYNC push button while the FD is on and the AFCS is disengaged. The FD annunciation on the ALI indicates that the reference bug is commanding the flight director VS mode. The VS mode is cleared by the selection or capture of another vertical mode.

IAS PROF

The IAS profile mode commands the AFCS to maintain an IAS determined by a profile. Upon selection the FCC synchronizes to the current IAS. As altitude

changes the IAS reference is automatically adjusted by -2 knots per 1000 feet of altitude increase. To reset the IAS to the current IAS, depress the SYNC push button while the FD is on and the AFCS is disengaged. The IAS reference can never exceed V_{mo}. The IAS profile mode is cleared by the selection or capture of another vertical mode.

IAS PROF will not decrease IAS below 130 KIAS unless a lower speed is selected. If the selected speed is less than 130 KIAS, IAS PROF will maintain that speed even with altitude increase.

ALT

The ALT mode commands the AFCS to maintain the pressure altitude present at initiation. The altitude hold mode is cleared by the selection of another vertical mode or by glideslope capture.

ALTITUDE PRESELECT

Altitude preselect is armed by changing the ALT SEL knob on the altimeter while the FD cue is in view. To arm a preselected altitude that is already in view, rotate the knob back and forth at least one digit. A vertical mode must be selected that will allow the airplane to obtain the ALT SEL altitude. After preselect altitude capture, ALTS CAP is annunciated, all vertical modes except glideslope will be cleared. After the airplane is established on the ALT SEL altitude the ALTS CAP changes to ALTS in green. After preselect altitude capture, ALTS CAP is annunciated, all vertical modes except glideslope will be cleared. Changing the ALT SEL knob during ALTS CAP changes the vertical mode to PTCH. Changing the BARO setting causes the airplane to recapture the altitude. Changing the ALT SEL during alts track (ALTS) switches the AFCS to altitude hold until another vertical mode is selected.

FLIGHT DIRECTOR OFF

The FD OFF button can be used to clear the Flight Director command bars with a single button push. This button is only active when the autopilot is disengaged and cannot be used to disengage the autopilot.

DESCEND

The DESCEND mode automatically maintains a pre-programmed descent profile. The descent profile is based on V_{mo} minus 25 knots from 41,000 feet to 12,000 feet, reducing to 225 knots at 10,000 and below.

The power must be adjusted to obtain the desired rate of descent. When selected above 5,000 feet, the IAS bug appears (if not already in view) and sets itself to the profile IAS. The IAS reference can be changed with the IAS reference knob on the ASI but cannot be commanded greater than V_{mo}. When the IAS reference is changed, it will remain parallel to the profile during the descent. The FD annunciation on the ASI indicates that the reference bug is being set by the flight director. To reset the IAS to the current IAS, depress the SYNC push while the FD is on and the AFCS is disengaged.

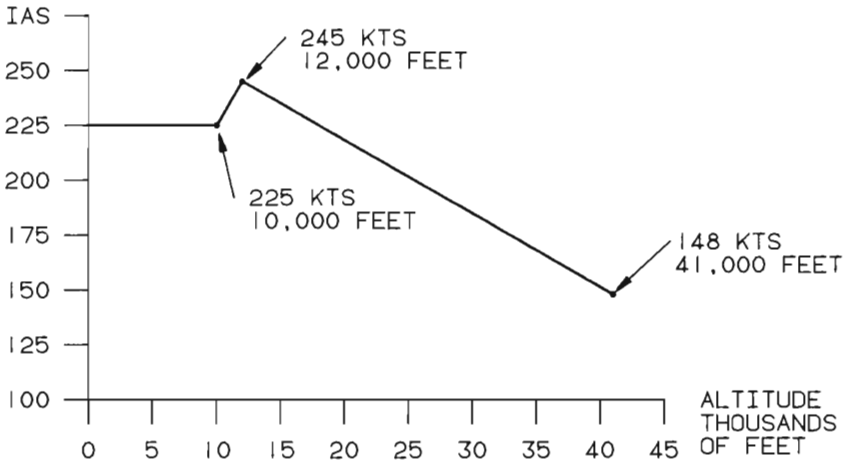

2000-601-03

DESCENT PROFILE

Below 5,000 feet, the commands transition from the previous vertical mode to a 1,000 FPM descent rate. The vertical speed reference may be changed, (to other negative values only) with the VS reference knob on the ALI. To reset the reference VS to the current VS, depress the SYNC push button while the FD is on and the AFCS is disengaged.

IAS

IAS mode commands the AFCS to maintain the reference IAS. On selection the IAS bug appears (if not already in view) and sets to the current IAS. This IAS reference value can be changed up to V_{mo}, using the IAS reference knob on the IAS indicator. To reset the IAS to the current IAS, depress the SYNC push button while the FD is on and the AFCS is disengaged. The FD annunciation on the ASI indicates that the reference bug is performing a command function.

MALFUNCTION MODES

With any failure that will result in loss of function, the AP XFR button should be depressed. This action will allow the autopilot to fly guidance commands from the right side FCC.

SECTION IV
FLIGHT PLANNING DATA
TABLE OF CONTENTS

SUBJECT *PAGE*

— **How To Use Graphs** 4-5

GRAPHS:

ISA Conversion 4-6
Fahrenheit-Celsius Temperature Conversion 4-7
Cabin Altitude For Various Airplane Altitudes..... 4-8
— Time, Fuel, And Distance To Cruise Climb..... 4-9
Climb - Two Engines - Flaps Retracted - MNOF..... 4-10

TABLES:

Maximum Cruise Power 4-11
— Maximum Cruise Power - 1600 RPM - ISA -30°C 4-12
Maximum Cruise Power - 1600 RPM - ISA -20°C 4-14
Maximum Cruise Power - 1600 RPM - ISA -10°C 4-16
Maximum Cruise Power - 1600 RPM - ISA 4-18
Maximum Cruise Power - 1600 RPM - ISA + 10°C 4-20
Maximum Cruise Power - 1600 RPM - ISA + 20°C 4-22
— Maximum Cruise Power - 1600 RPM - ISA + 30°C 4-24
Maximum Cruise Power - 1600 RPM - ISA + 37°C 4-26

GRAPHS:

— Speed At Maximum Cruise Power..... 4-28
Range Profile - Maximum Cruise Power..... 4-29

TABLES:

— Recommended Cruise Power..... 4-31
Recommended Cruise Power - 1600 RPM - ISA -30°C 4-32
Recommended Cruise Power - 1600 RPM - ISA -20°C 4-34
Recommended Cruise Power - 1600 RPM - ISA -10°C 4-36
Recommended Cruise Power - 1600 RPM - ISA 4-38
Recommended Cruise Power - 1600 RPM - ISA + 10°C..... 4-40
Recommended Cruise Power - 1600 RPM - ISA + 20°C..... 4-42

TABLE OF CONTENTS (Cont'd)

<i>SUBJECT</i>	<i>PAGE</i>
Recommended Cruise Power - 1600 RPM - ISA + 30°C.....	4-44
Recommended Cruise Power - 1600 RPM - ISA + 37°C.....	4-46

GRAPHS:

Speed At Recommended Cruise Power	4-48
Range Profile at Recommended Cruise Power	4-49

TABLES:

Maximum Range Power	4-51
Maximum Range Power - 1600 RPM - ISA -30°C.....	4-52
Maximum Range Power - 1600 RPM - ISA -20°C.....	4-54
Maximum Range Power - 1600 RPM - ISA -10°C.....	4-56
Maximum Range Power - 1600 RPM - ISA	4-58
Maximum Range Power - 1600 RPM - ISA + 10°C	4-60
Maximum Range Power - 1600 RPM - ISA + 20°C	4-62
Maximum Range Power - 1600 RPM - ISA + 30°C	4-64
Maximum Range Power - 1600 RPM - ISA +37°C.....	4-66

GRAPHS:

Range Profile - Maximum Range Power.....	4-68
Range Profile - Full Fuel.....	4-69
Endurance Profile - Full Fuel	4-70

TABLES:

One-Engine-Inoperative Maximum Cruise Power	4-71
One-Engine-Inoperative - Maximum Cruise Power - ISA -30°C	4-72
One-Engine-Inoperative - Maximum Cruise Power - ISA -20°C	4-74
One-Engine-Inoperative - Maximum Cruise Power - ISA -10°C	4-76
One-Engine-Inoperative - Maximum Cruise Power - ISA	4-78
One Engine Inoperative - Maximum Cruise Power - ISA + 10°C	4-80
One-Engine-Inoperative - Maximum Cruise Power - ISA + 20°C	4-82
One-Engine-Inoperative - Maximum Cruise Power - ISA + 30°C	4-84
One-Engine-Inoperative - Maximum Cruise Power - ISA + 37°C	4-86

TABLES:

Maximum Normal Operating Power.....	4-89
Maximum Normal Operating Power - 1600 RPM - ISA -30°C	4-90
Maximum Normal Operating Power - 1600 RPM - ISA -20°C	4-92
Maximum Normal Operating Power - 1600 RPM - ISA -10°C	4-94
Maximum Normal Operating Power - 1600 RPM - ISA	4-96

TABLE OF CONTENTS (Cont'd)

<i>SUBJECT</i>	<i>PAGE</i>
Maximum Normal Operating Power - 1600 RPM - ISA + 10°C	4-98
Maximum Normal Operating Power - 1600 RPM - ISA + 20°C	4-100
Maximum Normal Operating Power - 1600 RPM - ISA + 30°C	4-102
Maximum Normal Operating Power - 1600 RPM - ISA + 37°C	4-104

GRAPHS:

Pressurization Controller Setting For Landing	4-106
Holding Time	4-107
Time, Fuel and Distance to Descend at V_{MO-25} kts	4-108

(This Page Intentionally Left Blank)

HOW TO USE GRAPHS

1. In addition to presenting the answer for a particular set of conditions, the example on a graph also presents the order in which the various scales on that graph should be used. For instance, if the first item in the example is OAT, then enter the graph at the existing OAT.
2. The reference lines indicate where to begin following the guidelines. Always project to the reference line first, then follow the guidelines to the next known item by maintaining the same PROPORTIONAL DISTANCE between the guideline above and the guideline below the projected line. For instance, if the projected line intersects the reference line in the ratio of 30% down/70% up between the guidelines, then maintain this same 30%/70% relationship between the guidelines all the way to the next item.
3. The associated conditions define the specific conditions from which the performance parameters have been determined. They are not intended to be used as instructions; however, performance values determined from the graphs can only be achieved if the specified conditions exist.
4. All airspeeds presented in this section are indicated airspeeds (IAS) unless otherwise noted, assume zero instrument error, and were derived from calibrated airspeeds corrected per the Airspeed Calibration graph (See AFM, Section V).
5. All performance is assumed to have zero wind conditions.
6. The full amount of useable fuel is available for all approved flight conditions.
7. Notes have been provided on various graphs and tables to approximate performance with engine anti-ice ON. The effect will vary, depending upon airspeed, temperature, altitude, and ambient conditions. Performance degradations due to "normal ice accumulations" were determined for selected conditions as noted in "Icing Flight", Section V of the AFM.
8. The examples provided are illustrative in nature only, and therefore may provide answers for torque setting, fuel flow, and airspeed to a higher degree of accuracy than can be read from the instrument display.

NOTE

Should ambient air temperature or altitude be below the lowest temperature or altitude shown on the performance graphs or tables, use the performance at the lowest value shown. Extrapolation of performance values beyond those presented is not permitted.

ISA CONVERSION
PRESSURE ALTITUDE VERSUS OUTSIDE AIR TEMPERATURE

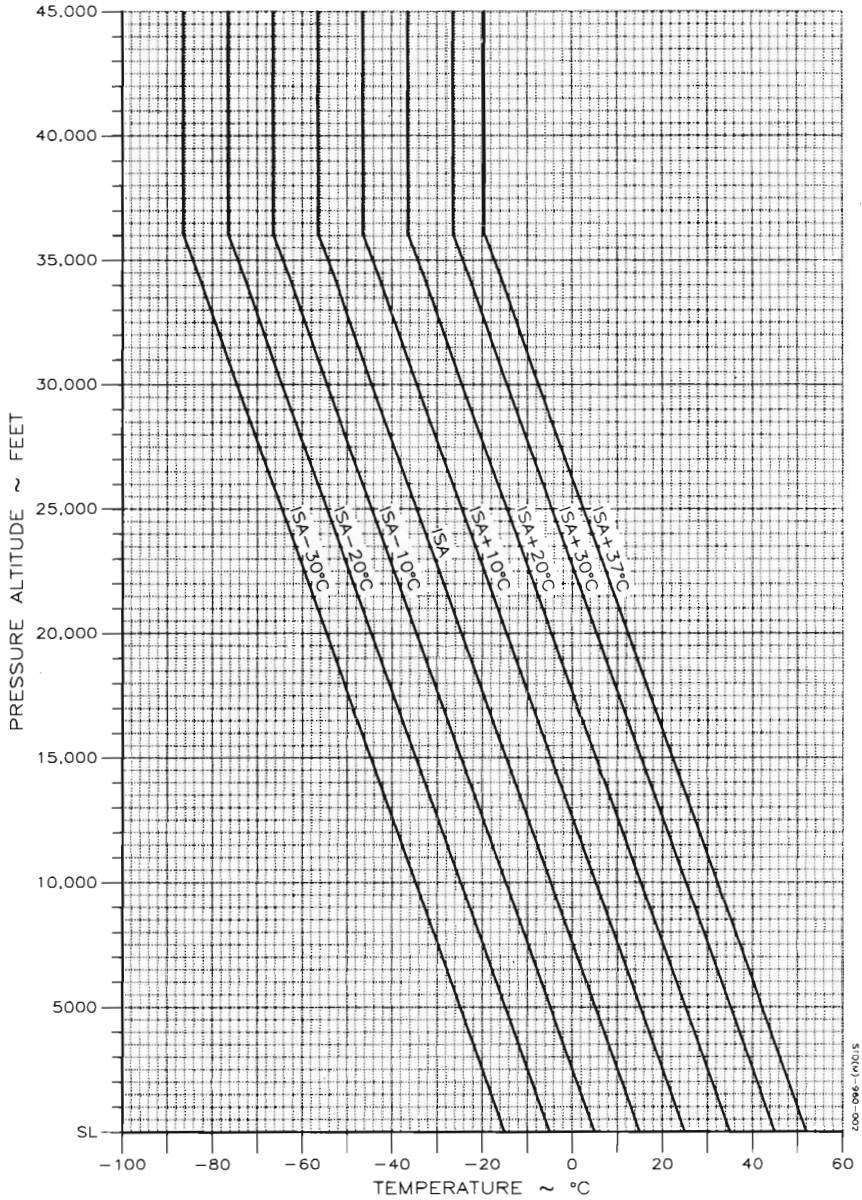

200-096-(r)0.15

FAHRENHEIT-CELSIUS TEMPERATURE CONVERSION

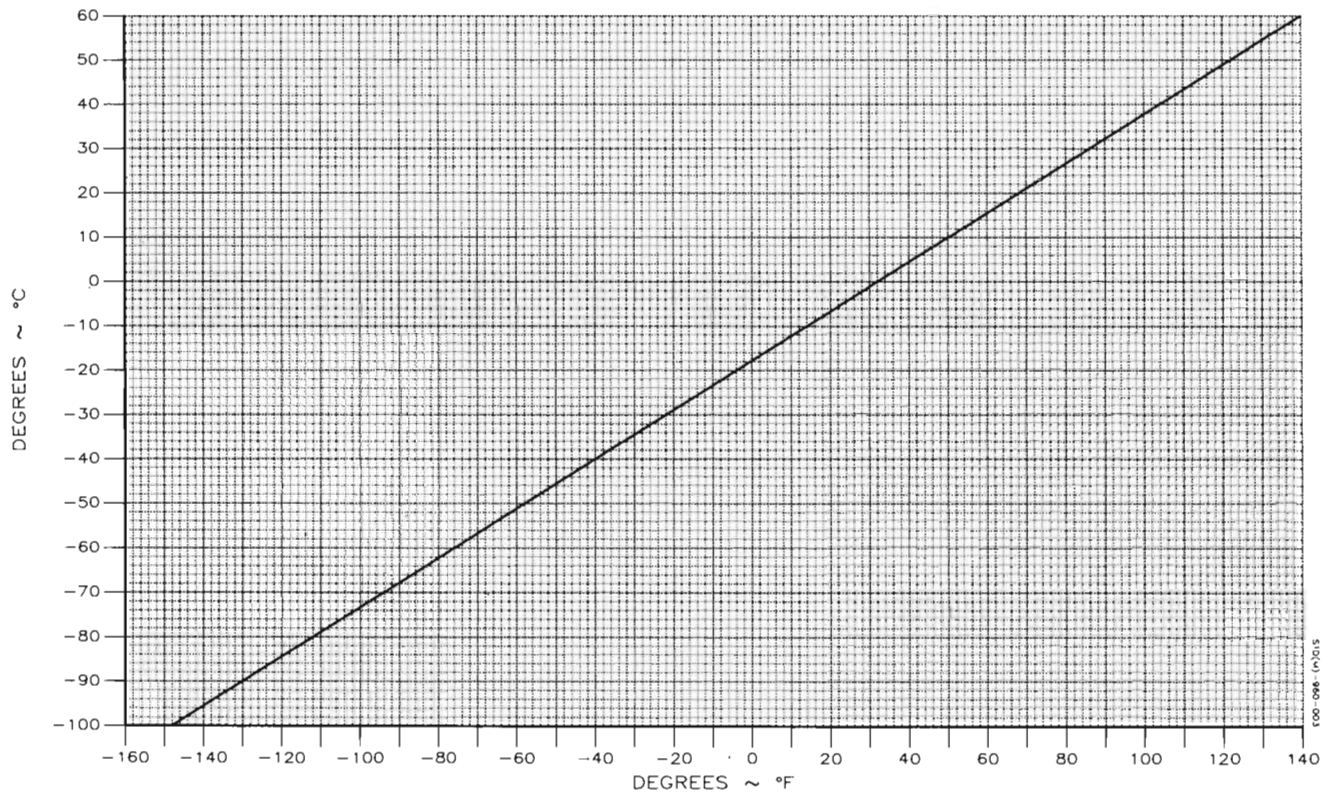

CABIN ALTITUDE FOR VARIOUS AIRPLANE ALTITUDES

EXAMPLE:
 AIRPLANE ALTITUDE 25,000 FT
 CABIN DIFFERENTIAL PRESSURE 4.0 PSI
 CABIN ALTITUDE 11,767 FT

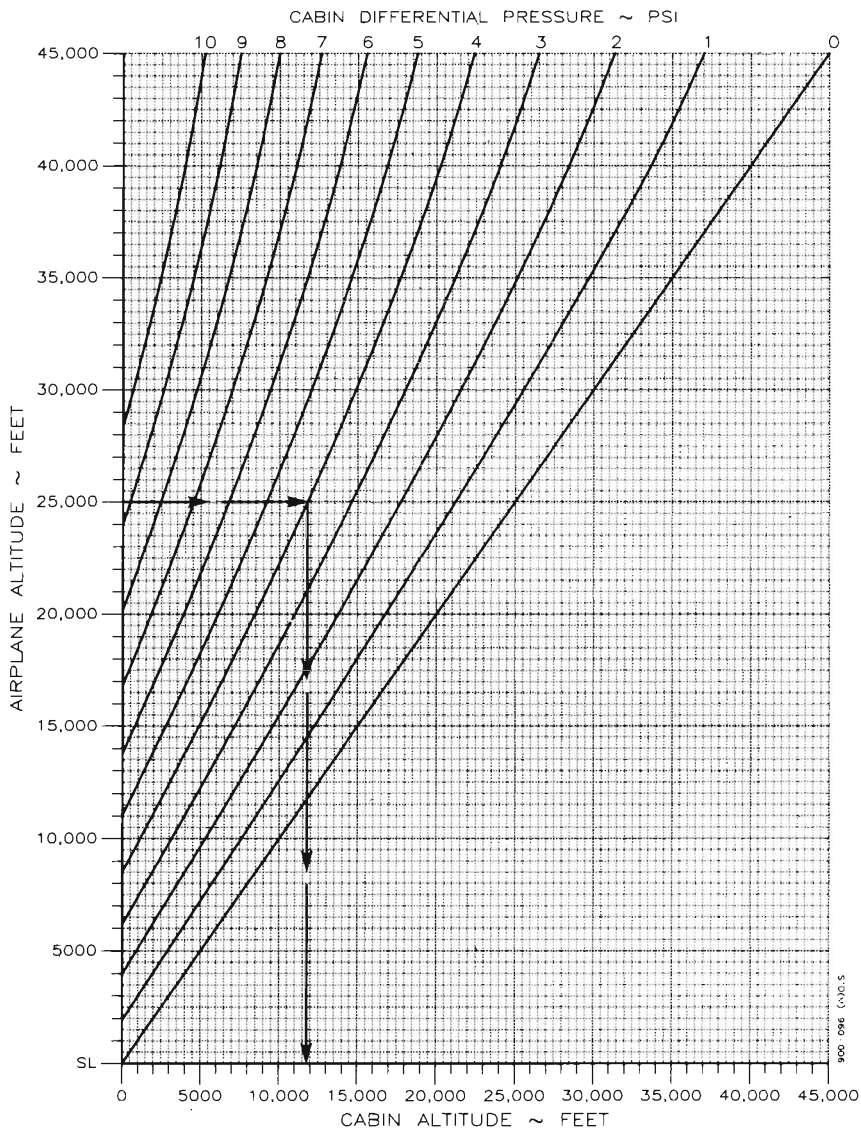

TIME, FUEL, AND DISTANCE TO CRUISE CLIMB

ASSOCIATED CONDITIONS:

POWER:
 ITT: MAINTAIN 800 °C
 PROPELLER SPEED: 1600 RPM

- NOTES: 1. ADD 110 LBS FUEL FOR START, TAXI, AND TAKEOFF.
 2. FOR OPERATION WITH ENGINE ANTI-ICE ON, ADD 10°C TO THE ACTUAL OAT BEFORE ENTERING THE GRAPH.

ALTITUDE ~ FEET	CLIMB SPEED ~ KNOTS
SL TO 10,000	180
10,000 TO 20,000	160
20,000 TO 30,000	140
30,000 TO 41,000	130

EXAMPLE:
 OAT AT TAKEOFF 28°C
 OAT AT CRUISE 20°C
 AIRPORT PRESSURE ALTITUDE 5003 FT
 CRUISE ALTITUDE 26,000 FT
 INITIAL CLIMB WEIGHT 13,000 LBS
 TIME TO CLIMB (15-2) 13 MIN
 FUEL TO CLIMB (277-54) 223 LBS
 DISTANCE TO CLIMB (48-7) 41 NM

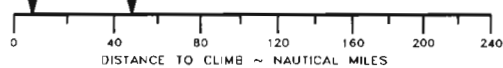
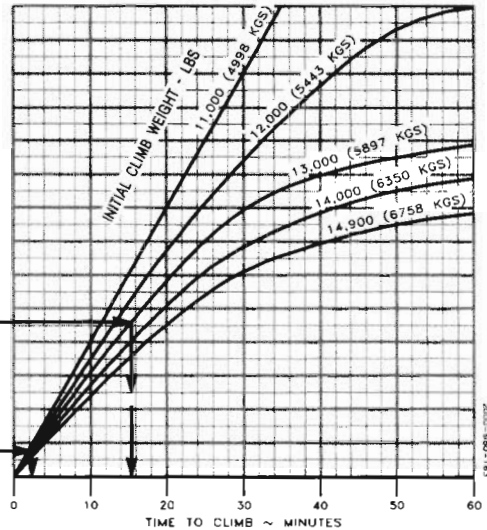
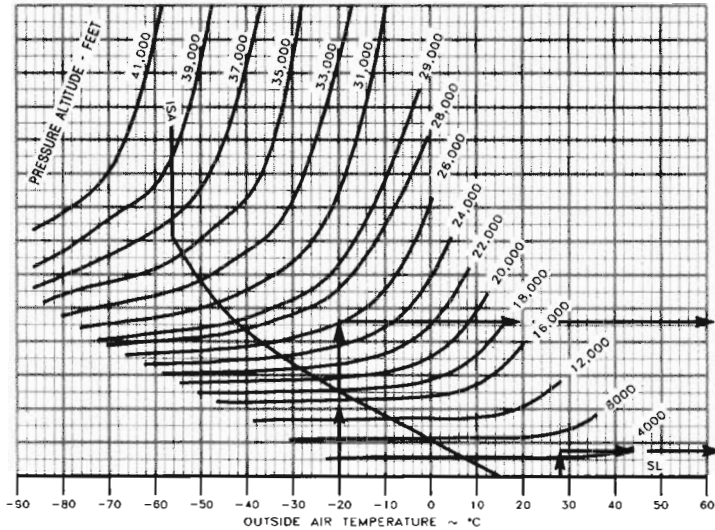

CLIMB - TWO ENGINES - FLAPS RETRACTED

MAXIMUM NORMAL OPERATING POWER

ASSOCIATED CONDITIONS:

LANDING GEAR UP
 AIRSPEED BLUE LINE + 10
 PROPELLER 1600 RPM

EXAMPLE:

OAT 17°C
 PRESSURE ALTITUDE 9000 FT
 WEIGHT 12,500 LBS
 RATE-OF-CLIMB 2273 FT/MIN
 CLIMB GRADIENT 13.5 %

NOTE: FOR OPERATION WITH ENGINE ANTI-ICE ON,
 RATE-OF-CLIMB IS NOT REDUCED.

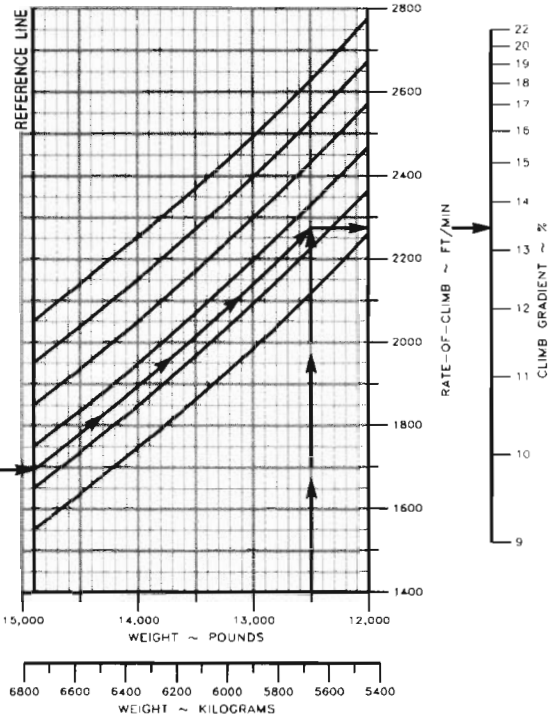
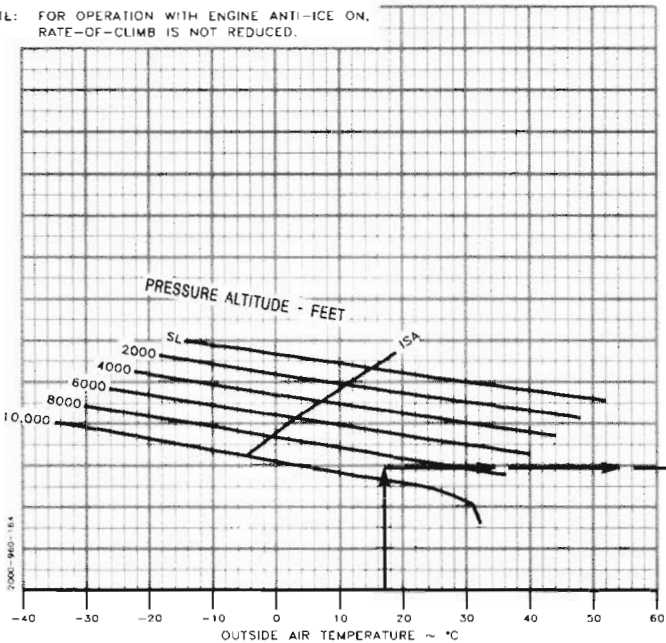

MAXIMUM CRUISE POWER

1. All fuel flows presented in this section represent average new engine performance with Jet A fuel. Use of other fuels, or operation with other than new engines may increase fuel flows.
2. Activation of engine anti-ice will decrease engine torque approximately 20%, true airspeed will be reduced approximately 30 knots, and fuel flow will decrease approximately 10%.
3. Operation with normal ice accumulations will additionally reduce true airspeed approximately 40 knots.

MAXIMUM CRUISE POWER
ISA - 30°C
1600 RPM

WEIGHT →			14,500 POUNDS					13,000 POUNDS				
PRES- SURE ALT	IOAT	OAT	TORQ PER ENG	FUEL FLOW P E R ENG	FUEL FLOW TOTAL	IAS	TAS	TORQ PER ENG	FUEL FLOW P E R ENG	FUEL FLOW TOTAL	IAS	TAS
FEET	°C	°C	%	LBS/HR	LBS/HR	KTS	KTS	%	LBS/HR	LBS/HR	KTS	KTS
SL	-9	-15	71	523	1046	245	229	70	519	1038	245	229
2000	-12	-19	72	510	1020	245	235	71	505	1010	245	235
4000	-16	-23	74	500	1000	245	242	73	495	990	245	242
6000	-19	-27	76	491	982	245	249	75	486	972	245	249
8000	-23	-31	78	483	966	245	256	77	478	956	245	256
10,000	-27	-35	80	476	952	245	263	78	471	942	245	263
12,000	-29	-39	97	534	1068	264	291	97	533	1066	265	293
14,000	-32	-43	97	524	1048	262	297	97	523	1046	263	299
16,000	-36	-47	97	515	1030	259	303	97	515	1030	261	305
18,000	-39	-51	97	508	1016	256	309	97	508	1016	258	311
20,000	-43	-55	97	501	1002	255	318	97	501	1002	257	319
22,000	-46	-59	97	498	996	253	324	97	498	996	255	326
24,000	-49	-63	97	496	992	250	331	97	495	990	252	333
26,000	-53	-67	97	495	990	247	338	97	494	988	249	340

NC000165a

MAXIMUM CRUISE POWER
ISA - 30°C
1600 RPM

WEIGHT →			12,000 POUNDS					11,000 POUNDS				
PRES- SURE ALT	IOAT	OAT	TORQ PER ENG	FUEL FLOW PER ENG	FUEL FLOW TOTAL	IAS	TAS	TORQ PER ENG	FUEL FLOW PER ENG	FUEL FLOW TOTAL	IAS	TAS
FEET	°C	°C	%	LBS/HR	LBS/HR	KTS	KTS	%	LBS/HR	LBS/HR	KTS	KTS
SL	-9	-15	69	516	1032	245	229	68	513	1026	245	229
2000	-12	-19	70	502	1004	245	235	70	500	1000	245	235
4000	-16	-23	72	492	984	245	242	71	489	978	245	242
6000	-19	-27	74	483	966	245	249	73	480	960	245	249
8000	-23	-31	76	475	950	245	256	75	472	944	245	256
10,000	-27	-35	78	467	934	245	263	77	464	928	245	263
12,000	-29	-39	97	532	1064	265	292	96	529	1058	265	292
14,000	-32	-43	97	523	1046	264	300	97	523	1046	265	301
16,000	-35	-47	97	515	1030	261	306	97	515	1030	262	307
18,000	-39	-51	97	508	1016	259	312	97	507	1014	260	313
20,000	-42	-55	97	501	1002	258	321	97	501	1002	259	322
22,000	-46	-59	97	498	996	256	328	97	497	994	257	329
24,000	-49	-63	97	495	990	253	334	97	495	990	254	336
26,000	-53	-67	97	494	988	251	342	97	494	988	252	343
28,000	-64	-70						97	494	988	249	351

NC000165b

MAXIMUM CRUISE POWER
ISA - 20°C
1600 RPM

WEIGHT →			14,500 POUNDS					13,000 POUNDS				
PRES- SURE ALT	IOAT	OAT	TORQ PER ENG	FUEL FLOW PER ENG	FUEL FLOW TOTAL	IAS	TAS	TORQ PER ENG	FUEL FLOW PER ENG	FUEL FLOW TOTAL	IAS	TAS
FEET	°C	°C	%	LBS/HR	LBS/HR	KTS	KTS	%	LBS/HR	LBS/HR	KTS	KTS
SL	2	-5	72	534	1068	245	233	71	529	1058	245	233
2000	-2	-9	74	522	1044	245	240	73	517	1034	245	240
4000	-6	-13	76	512	1024	245	247	74	507	1014	245	247
6000	-9	-17	77	502	1004	245	254	76	496	992	245	254
8000	-13	-21	79	493	986	245	261	78	487	974	245	261
10,000	-16	-25	81	485	970	245	269	80	479	958	245	269
12,000	-18	-29	97	539	1078	261	295	97	538	1076	263	296
14,000	-22	-33	97	528	1056	259	301	97	527	1054	260	302
16,000	-25	-37	97	518	1036	256	306	97	518	1036	258	308
18,000	-29	-41	97	512	1024	255	314	97	512	1024	257	316
20,000	-32	-45	97	507	1014	252	321	97	507	1014	254	323
22,000	-36	-49	97	503	1006	250	328	97	503	1006	251	330
24,000	-39	-53	97	499	998	247	334	97	499	998	249	337
26,000	-42	-57	97	498	996	244	342	97	498	996	246	344
28,000	-47	-60	91	468	936	235	340	91	469	938	238	344
29,000	-49	-62	87	451	902	230	339	88	453	906	233	343
31,000	-53	-66	81	420	840	219	335	81	421	842	223	340
33,000	-57	-70	74	390	780	209	331	75	391	782	213	337
35,000	-62	-74	68	359	718	197	325	69	361	722	202	332

NC000165c

MAXIMUM CRUISE POWER
ISA - 20°C
1600 RPM

WEIGHT →			12,000 POUNDS					11,000 POUNDS				
PRES- SURE ALT	IOAT	OAT	TORQ PER ENG	FUEL FLOW PER ENG	FUEL FLOW TOTAL	IAS	TAS	TORQ PER ENG	FUEL FLOW PER ENG	FUEL FLOW TOTAL	IAS	TAS
FEET	°C	°C	%	LBS/HR	LBS/HR	KTS	KTS	%	LBS/HR	LBS/HR	KTS	KTS
SL	2	-5	70	526	1052	245	233	70	523	1046	245	233
2000	-2	-9	72	514	1028	245	240	71	511	1022	245	240
4000	-6	-13	74	504	1008	245	247	73	501	1002	245	247
6000	-9	-17	75	493	986	245	254	75	490	980	245	254
8000	-13	-21	77	484	968	245	261	76	481	962	245	261
10,000	-16	-25	79	476	952	245	269	78	473	946	245	269
12,000	-18	-29	97	538	1076	264	297	97	538	1076	264	298
14,000	-22	-33	97	527	1054	261	303	97	527	1054	262	304
16,000	-25	-37	97	518	1036	259	309	97	518	1036	259	310
18,000	-29	-41	97	512	1024	258	318	97	512	1024	258	319
20,000	-32	-45	97	506	1012	255	324	97	506	1012	256	325
22,000	-35	-49	97	502	1004	253	331	97	502	1004	253	332
24,000	-39	-53	97	499	998	250	338	97	499	998	251	339
26,000	-42	-57	97	497	994	248	346	97	497	994	249	347
28,000	-46	-60	92	470	940	239	346	92	471	942	241	348
29,000	-48	-62	88	453	906	234	345	88	454	908	236	347
31,000	-52	-66	82	422	844	225	343	82	423	846	227	345
33,000	-56	-70	75	392	784	215	340	76	393	786	217	343
35,000	-61	-74	69	362	724	205	336	69	364	728	207	340
37,000	-63	-77	62	331	662	193	331	63	332	664	196	335

NC000165d

MAXIMUM CRUISE POWER

ISA - 10°C

1600 RPM

WEIGHT →			14,500 POUNDS					13,000 POUNDS				
PRES- SURE ALT	IOAT	OAT	TORQ PER ENG	FUEL FLOW PER ENG	FUEL FLOW TOTAL	IAS	TAS	TORQ PER ENG	FUEL FLOW PER ENG	FUEL FLOW TOTAL	IAS	TAS
FEET	°C	°C	%	LBS/HR	LBS/HR	KTS	KTS	%	LBS/HR	LBS/HR	KTS	KTS
SL	12	5	73	544	1088	245	238	72	539	1078	245	238
2000	8	1	75	532	1064	245	244	74	527	1054	245	244
4000	5	-3	77	522	1044	245	251	76	517	1034	245	251
6000	1	-7	79	513	1026	245	259	78	508	1016	245	259
8000	-2	-11	81	505	1010	245	266	79	499	998	245	266
10,000	-6	-15	83	500	1000	245	274	82	494	988	245	274
12,000	-8	-19	97	544	1088	259	298	97	544	1088	260	299
14,000	-12	-23	97	533	1066	257	305	97	533	1066	259	307
16,000	-15	-27	97	525	1050	255	311	97	525	1050	256	313
18,000	-19	-31	97	518	1036	252	318	97	518	1036	254	320
20,000	-22	-35	97	512	1024	249	324	97	512	1024	251	326
22,000	-25	-39	97	508	1016	247	331	97	507	1014	249	334
24,000	-29	-43	96	496	992	242	336	96	497	994	245	339
26,000	-33	-47	90	465	930	233	334	90	466	932	236	338
28,000	-37	-50	83	434	868	223	332	84	435	870	226	336
29,000	-39	-52	80	419	838	218	330	80	420	840	221	335
31,000	-44	-56	74	390	780	208	327	74	391	782	212	332
33,000	-48	-60	68	363	726	197	322	69	364	728	202	329
35,000	-52	-64	62	334	668	185	315	63	337	674	191	324
37,000	-56	-67	56	303	606	170	302	57	306	612	178	315
39,000	-57	-67	49	270	540	148	278	50	275	550	161	302
41,000	-57	-67						43	243	486	139	275

NC000165e

MAXIMUM CRUISE POWER
ISA - 10°C
1600 RPM

WEIGHT →			12,000 POUNDS					11,000 POUNDS				
PRES- SURE ALT	IOAT	OAT	TORQ P ER ENG	FUEL FLOW P ER ENG	FUEL FLOW TOTAL	IAS	TAS	TORQ P ER ENG	FUEL FLOW P ER ENG	FUEL FLOW TOTAL	IAS	TAS
FEET	°C	°C	%	LBS/HR	LBS/HR	KTS	KTS	%	LBS/HR	LBS/HR	KTS	KTS
SL	12	5	71	536	1072	245	238	71	533	1066	245	238
2000	8	1	73	524	1048	245	244	72	521	1042	245	244
4000	5	-3	75	514	1028	245	251	74	511	1022	245	251
6000	1	-7	77	504	1008	245	259	76	501	1002	245	259
8000	-2	-11	79	496	992	245	266	78	493	986	245	266
10,000	-6	-15	81	490	980	245	274	80	487	974	245	274
12,000	-8	-19	97	544	1088	261	300	97	544	1088	262	301
14,000	-11	-23	97	533	1066	260	308	97	533	1066	261	309
16,000	-15	-27	97	524	1048	257	314	97	524	1048	258	315
18,000	-18	-31	97	518	1036	255	321	97	518	1036	255	322
20,000	-22	-35	97	512	1024	252	328	97	512	1024	253	329
22,000	-25	-39	97	507	1014	250	335	97	507	1014	251	336
24,000	-29	-43	96	498	996	246	341	96	498	996	247	342
26,000	-33	-47	90	466	932	237	340	90	467	934	238	342
28,000	-37	-50	84	436	872	228	339	84	437	874	230	341
29,000	-39	-52	81	421	842	223	338	81	421	842	225	340
31,000	-43	-56	75	392	784	214	335	75	393	786	216	338
33,000	-47	-60	69	365	730	204	333	69	366	732	207	336
35,000	-51	-64	63	338	676	194	329	64	339	678	197	333
37,000	-54	-67	57	307	614	182	321	57	308	616	185	327
39,000	-55	-67	50	277	554	167	311	51	278	556	171	319
41,000	-56	-67	44	246	492	150	295	45	248	496	156	307

NC000185f

MAXIMUM CRUISE POWER

ISA

1600 RPM

WEIGHT →			14,500 POUNDS					13,000 POUNDS				
PRES- SURE ALT	IOAT	OAT	TORQ PER ENG	FUEL FLOW PER ENG	FUEL FLOW TOTAL	IAS	TAS	TORQ PER ENG	FUEL FLOW PER ENG	FUEL FLOW TOTAL	IAS	TAS
FEET	°C	°C	%	LBS/HR	LBS/HR	KTS	KTS	%	LBS/HR	LBS/HR	KTS	KTS
SL	22	15	74	556	1112	245	242	73	551	1102	245	242
2000	18	11	76	545	1090	245	249	75	540	1080	245	249
4000	15	7	78	535	1070	245	256	77	529	1058	245	256
6000	11	3	80	525	1050	245	263	79	520	1040	245	263
8000	8	-1	83	518	1036	245	271	81	512	1024	245	271
10,000	5	-5	85	511	1022	245	279	83	505	1010	245	279
12,000	2	-9	97	551	1102	258	302	97	551	1102	259	304
14,000	-1	-13	97	541	1082	255	308	97	540	1080	256	310
16,000	-5	-17	97	531	1062	252	314	97	531	1062	254	316
18,000	-8	-21	97	524	1048	249	321	97	523	1046	251	323
20,000	-12	-25	97	517	1034	247	328	97	517	1034	249	330
22,000	-15	-29	94	499	998	241	331	95	500	1000	243	333
24,000	-19	-33	89	468	936	232	330	89	469	938	234	333
26,000	-24	-37	83	438	876	223	328	83	439	878	226	332
28,000	-28	-40	77	410	820	213	325	77	411	822	216	330
29,000	-30	-42	74	395	790	208	323	74	396	792	212	328
31,000	-34	-46	68	367	734	197	319	69	369	738	202	325
33,000	-39	-50	63	341	682	186	313	63	343	686	192	321
35,000	-43	-54	57	314	628	174	304	58	316	632	181	315
37,000	-47	-57	51	284	568	156	286	52	287	574	167	304
39,000	-47	-57						45	256	512	148	284

NC000165g

MAXIMUM CRUISE POWER
ISA
1600 RPM

WEIGHT →			12,000 POUNDS					11,000 POUNDS				
PRES- SURE ALT	IOAT	OAT	TORQ PER ENG	FUEL FLOW PER ENG	FUEL FLOW TOTAL	IAS	TAS	TORQ PER ENG	FUEL FLOW PER ENG	FUEL FLOW TOTAL	IAS	TAS
FEET	°C	°C	%	LBS/HR	LBS/HR	KTS	KTS	%	LBS/HR	LBS/HR	KTS	KTS
SL	22	15	72	548	1096	245	242	72	545	1090	245	242
2000	18	11	74	536	1072	245	249	74	533	1066	245	249
4000	15	7	76	526	1052	245	256	75	523	1046	245	256
6000	11	3	78	516	1032	245	263	77	513	1026	245	263
8000	8	-1	80	509	1018	245	271	79	505	1010	245	271
10,000	5	-5	82	502	1004	245	279	81	498	996	245	279
12,000	2	-9	97	550	1100	260	305	97	550	1100	261	306
14,000	-1	-13	97	540	1080	257	311	97	540	1080	258	312
16,000	-5	-17	97	531	1062	255	317	97	531	1062	255	319
18,000	-8	-21	97	523	1046	252	324	97	523	1046	253	325
20,000	-11	-25	97	517	1034	250	331	97	516	1032	251	333
22,000	-15	-29	95	500	1000	244	335	95	501	1002	246	337
24,000	-19	-33	89	469	938	236	335	89	470	940	237	337
26,000	-23	-37	83	440	880	227	334	83	440	880	229	336
28,000	-27	-40	77	411	822	218	333	78	412	824	220	335
29,000	-29	-42	75	397	794	214	331	75	397	794	216	334
31,000	-33	-46	69	370	740	204	329	69	370	740	207	332
33,000	-38	-50	64	344	688	195	326	64	344	688	197	330
35,000	-42	-54	58	317	634	184	321	59	318	636	188	326
37,000	-45	-57	52	288	576	171	312	53	289	578	175	318
39,000	-46	-57	46	258	516	156	299	47	260	520	161	308
41,000	-48	-57	40	228	456	134	272	40	231	462	144	291

NC000165h

MAXIMUM CRUISE POWER

ISA + 10°C

1600 RPM

WEIGHT →			14,500 POUNDS					13,000 POUNDS				
PRES- SURE ALT	IOAT	OAT	TORQ PER ENG	FUEL FLOW PER ENG	FUEL FLOW TOTAL	IAS	TAS	TORQ PER ENG	FUEL FLOW PER ENG	FUEL FLOW TOTAL	IAS	TAS
FEET	°C	°C	%	LBS/HR	LBS/HR	KTS	KTS	%	LBS/HR	LBS/HR	KTS	KTS
SL	32	25	75	570	1140	245	246	74	565	1130	245	246
2000	29	21	78	558	1116	245	253	76	553	1106	245	253
4000	25	17	80	548	1096	245	261	78	542	1084	245	261
6000	22	13	82	538	1076	245	268	80	532	1064	245	268
8000	18	9	84	530	1060	245	276	83	524	1048	245	276
10,000	15	5	86	522	1044	245	285	85	516	1032	245	285
12,000	12	1	97	557	1114	255	305	97	557	1114	257	307
14,000	9	-3	97	546	1092	252	311	97	545	1090	254	313
16,000	5	-7	97	536	1072	250	318	97	536	1072	251	319
18,000	2	-11	97	529	1058	247	324	97	529	1058	249	326
20,000	-2	-15	92	500	1000	239	324	92	500	1000	241	327
22,000	-6	-19	87	471	942	230	324	87	471	942	233	327
24,000	-10	-23	82	441	882	222	322	82	442	884	225	326
26,000	-14	-27	76	413	826	212	320	77	414	828	216	325
28,000	-18	-30	71	385	770	202	316	71	386	772	206	322
29,000	-21	-32	68	370	740	197	314	68	372	744	201	320
31,000	-25	-36	62	344	688	186	308	63	345	690	191	316
33,000	-29	-40	57	319	638	174	301	58	321	642	181	311
35,000	-34	-44	52	293	586	160	288	53	296	592	170	304
37,000	-39	-47	45	262	524	136	256	47	266	532	153	287
39,000	-39	-47						40	235	470	127	251

NC000165i

MAXIMUM CRUISE POWER
ISA + 10°C
1600 RPM

WEIGHT →			12,000 POUNDS					11,000 POUNDS				
PRES- SURE ALT	IOAT	OAT	TORQ PER ENG	FUEL FLOW PER ENG	FUEL FLOW TOTAL	IAS	TAS	TORQ PER ENG	FUEL FLOW PER ENG	FUEL FLOW TOTAL	IAS	TAS
FEET	°C	°C	%	LBS/HR	LBS/HR	KTS	KTS	%	LBS/HR	LBS/HR	KTS	KTS
SL	32	25	73	561	1122	245	246	73	558	1116	245	246
2000	29	21	75	550	1100	245	253	75	547	1094	245	253
4000	25	17	77	539	1078	245	261	77	536	1072	245	261
6000	22	13	80	529	1058	245	268	79	526	1052	245	268
8000	18	9	82	521	1042	245	276	81	517	1034	245	276
10,000	15	5	84	513	1026	245	285	83	509	1018	245	285
12,000	13	1	97	557	1114	257	308	97	556	1112	258	309
14,000	9	-3	97	545	1090	255	314	97	545	1090	256	315
16,000	6	-7	97	536	1072	252	320	97	536	1072	253	322
18,000	2	-11	97	529	1058	250	328	97	529	1058	251	329
20,000	-2	-15	93	501	1002	242	329	93	501	1002	243	330
22,000	-6	-19	87	472	944	234	329	88	472	944	236	331
24,000	-10	-23	82	443	886	226	329	82	443	886	228	331
26,000	-14	-27	77	414	828	218	328	77	415	830	219	330
28,000	-18	-30	71	386	772	208	325	71	387	774	210	328
29,000	-20	-32	68	372	744	204	324	69	373	746	206	327
31,000	-24	-36	63	346	692	194	320	63	347	694	196	324
33,000	-28	-40	58	321	642	184	316	58	322	644	187	321
35,000	-33	-44	53	297	594	174	311	54	298	596	177	316
37,000	-36	-47	47	268	536	160	299	48	269	538	164	307
39,000	-37	-47	41	238	476	140	278	42	240	480	148	293
41,000	-38	-47						35	210	420	128	264

NC000165J

MAXIMUM CRUISE POWER

ISA + 20°C

1600 RPM

WEIGHT →			14,500 POUNDS					13,000 POUNDS				
PRES- SURE ALT	IOAT	OAT	TORQ PER ENG	FUEL FLOW PER ENG	FUEL FLOW TOTAL	IAS	TAS	TORQ PER ENG	FUEL FLOW PER ENG	FUEL FLOW TOTAL	IAS	TAS
FEET	°C	°C	%	LBS/HR	LBS/HR	KTS	KTS	%	LBS/HR	LBS/HR	KTS	KTS
SL	43	35	77	581	1162	245	250	75	575	1150	245	250
2000	39	31	79	569	1138	245	257	78	563	1126	245	257
4000	36	27	81	558	1116	245	265	80	552	1104	245	265
6000	32	23	83	547	1094	245	273	82	542	1084	245	273
8000	29	19	86	541	1082	245	281	84	534	1068	245	281
10,000	25	15	88	535	1070	245	290	86	529	1058	245	290
12,000	23	11	97	562	1124	253	308	97	561	1122	255	310
14,000	19	7	97	551	1102	250	314	97	551	1102	252	316
16,000	16	3	96	536	1072	246	319	96	536	1072	248	321
18,000	12	-1	91	506	1012	238	319	91	506	1012	240	322
20,000	8	-5	86	475	950	230	319	86	476	952	232	322
22,000	3	-9	80	446	892	221	317	81	447	894	224	321
24,000	-1	-13	75	416	832	211	314	75	417	834	215	319
26,000	-5	-17	70	388	776	201	311	70	389	778	205	317
28,000	-9	-20	64	361	722	191	306	65	362	724	196	313
29,000	-11	-22	62	348	696	186	303	62	349	698	191	311
31,000	-16	-26	57	322	644	174	295	57	324	648	181	306
33,000	-21	-30	52	297	594	160	283	53	299	598	169	299
35,000	-26	-34	46	271	542	142	262	48	274	548	156	287
37,000	-28	-37						41	245	490	135	261

NC000165K

MAXIMUM CRUISE POWER

ISA + 20°C

1600 RPM

WEIGHT →			12,000 POUNDS					11,000 POUNDS				
PRES- SURE ALT	IOAT	OAT	TORQ P E R E N G	FUEL FLOW P E R E N G	FUEL FLOW TOTAL	IAS	TAS	TORQ P E R E N G	FUEL FLOW P E R E N G	FUEL FLOW TOTAL	IAS	TAS
FEET	°C	°C	%	LBS/HR	LBS/HR	KTS	KTS	%	LBS/HR	LBS/HR	KTS	KTS
SL	43	35	75	572	1144	245	250	74	569	1138	245	250
2000	39	31	77	560	1120	245	257	76	557	1114	245	257
4000	36	27	79	549	1098	245	265	78	546	1092	245	265
6000	32	23	81	538	1076	245	273	80	535	1070	245	273
8000	29	19	83	531	1062	245	281	82	527	1054	245	281
10,000	25	15	85	525	1050	245	290	84	521	1042	245	290
12,000	23	11	97	561	1122	255	311	97	561	1122	256	312
14,000	19	7	97	550	1100	253	317	97	550	1100	254	318
16,000	16	3	96	537	1074	249	323	97	537	1074	250	324
18,000	12	-1	91	507	1014	241	323	91	507	1014	243	325
20,000	8	-5	86	476	952	234	324	86	477	954	235	325
22,000	4	-9	81	447	894	225	323	81	448	896	227	325
24,000	0	-13	75	418	836	217	322	76	418	836	218	324
26,000	-4	-17	70	390	780	208	320	70	390	780	210	323
28,000	-8	-20	65	363	726	198	317	65	364	728	201	321
29,000	-10	-22	63	350	700	194	315	63	351	702	196	319
31,000	-15	-26	58	325	650	184	311	58	325	650	187	316
33,000	-19	-30	53	301	602	174	306	53	301	602	177	311
35,000	-24	-34	48	276	552	162	297	48	277	554	167	305
37,000	-27	-37	42	248	496	146	280	43	250	500	152	293
39,000	-28	-37						37	221	442	134	272

NC000165m

MAXIMUM CRUISE POWER

ISA + 30°C

1600 RPM

WEIGHT →			14,500 POUNDS					13,000 POUNDS				
PRES- SURE ALT	IOAT	OAT	TORQ PER ENG	FUEL FLOW PER ENG	FUEL FLOW TOTAL	IAS	TAS	TORQ PER ENG	FUEL FLOW PER ENG	FUEL FLOW TOTAL	IAS	TAS
FEET	°C	°C	%	LBS/HR	LBS/HR	KTS	KTS	%	LBS/HR	LBS/HR	KTS	KTS
SL	53	45	78	594	1188	245	254	77	589	1178	245	254
2000	49	41	80	582	1164	245	262	79	576	1152	245	262
4000	46	37	83	571	1142	245	269	81	565	1130	245	269
6000	42	33	85	561	1122	245	277	83	555	1110	245	277
8000	39	29	87	553	1106	245	286	86	547	1094	245	286
10,000	36	25	89	546	1092	245	295	88	540	1080	245	295
12,000	32	21	93	548	1096	246	305	93	549	1098	248	307
14,000	29	17	89	519	1038	239	306	89	519	1038	241	309
16,000	25	13	84	490	980	231	306	84	490	980	234	309
18,000	21	9	80	462	924	223	306	80	462	924	226	309
20,000	17	5	75	433	866	215	305	75	434	868	218	309
22,000	12	1	71	407	814	206	303	71	408	816	210	308
24,000	8	-3	66	380	760	197	300	66	381	762	201	306
26,000	4	-7	61	354	708	187	295	61	355	710	192	302
28,000	-1	-10	56	328	656	175	287	57	330	660	181	297
29,000	-3	-12	53	315	630	168	282	54	317	634	176	294
31,000	-8	-16	49	290	580	154	270	50	293	586	164	286
33,000	-13	-20	44	267	534	137	250	46	271	542	152	276
35,000	-16	-24						41	248	496	137	259

NC0001650

MAXIMUM CRUISE POWER

ISA + 30°C

1600 RPM

WEIGHT →			12,000 POUNDS					11,000 POUNDS				
PRES- SURE ALT	IOAT	OAT	TORQ PER ENG	FUEL FLOW PER ENG	FUEL FLOW TOTAL	IAS	TAS	TORQ PER ENG	FUEL FLOW PER ENG	FUEL FLOW TOTAL	IAS	TAS
FEET	°C	°C	%	LBS/HR	LBS/HR	KTS	KTS	%	LBS/HR	LBS/HR	KTS	KTS
SL	53	45	76	585	1170	245	254	75	582	1164	245	254
2000	49	41	78	573	1146	245	262	77	570	1140	245	262
4000	46	37	80	562	1124	245	269	79	559	1118	245	269
6000	42	33	82	552	1104	245	277	82	548	1096	245	277
8000	39	29	85	543	1086	245	286	84	540	1080	245	286
10,000	36	25	87	536	1072	245	295	86	532	1064	245	295
12,000	33	21	93	549	1098	249	309	93	549	1098	250	310
14,000	29	17	89	519	1038	242	310	89	520	1040	243	311
16,000	25	13	85	491	982	235	311	85	491	982	236	312
18,000	21	9	80	463	926	227	311	80	463	926	229	313
20,000	17	5	76	435	870	220	311	76	435	870	221	313
22,000	13	1	71	408	816	212	310	71	408	816	213	313
24,000	9	-3	66	382	764	203	309	67	382	764	205	312
26,000	5	-7	62	356	712	194	306	62	356	712	197	310
28,000	1	-10	57	330	660	185	302	57	331	662	187	306
29,000	-2	-12	54	318	636	179	300	55	318	636	183	304
31,000	-6	-16	50	294	588	169	294	50	295	590	173	300
33,000	-10	-20	46	273	546	159	287	46	274	548	164	295
35,000	-15	-24	42	251	502	146	276	43	253	506	153	288
37,000	-18	-27						37	226	452	137	269

NC000165p

MAXIMUM CRUISE POWER

ISA + 37°C

1600 RPM

WEIGHT →			14,500 POUNDS					13,000 POUNDS				
PRES- SURE ALT	IOAT	OAT	TORQ P ER ENG	FUEL FLOW P ER ENG	FUEL FLOW TOTAL	IAS	TAS	TORQ P ER ENG	FUEL FLOW P ER ENG	FUEL FLOW TOTAL	IAS	TAS
FEET	°C	°C	%	LBS/HR	LBS/HR	KTS	KTS	%	LBS/HR	LBS/HR	KTS	KTS
SL	60	52	79	601	1202	245	257	78	595	1190	245	257
2000	56	48	81	589	1178	245	264	80	583	1166	245	264
4000	53	44	83	578	1156	245	272	82	572	1144	245	272
6000	50	40	86	569	1138	245	281	84	562	1124	245	281
8000	46	36	88	561	1122	245	289	87	555	1110	245	289
10,000	43	32	87	539	1078	241	293	87	540	1080	243	296
12,000	39	28	83	512	1024	234	294	83	513	1026	236	297
14,000	35	24	80	485	970	227	295	80	485	970	230	298
16,000	31	20	76	458	916	220	296	76	459	918	223	299
18,000	27	16	72	432	864	212	295	72	432	864	215	299
20,000	23	12	68	405	810	204	294	68	406	812	208	299
22,000	19	8	64	380	760	195	291	64	381	762	199	297
24,000	14	4	59	354	708	185	287	60	355	710	190	294
26,000	10	0	55	329	658	174	280	55	330	660	180	289
28,000	5	-3	50	304	608	161	270	51	306	612	169	282
29,000	3	-5	47	291	582	154	263	48	294	588	163	278
31,000	-2	-9	43	267	534	135	240	44	270	540	150	266
33,000	-6	-13						39	247	494	134	248

NC000165q

MAXIMUM CRUISE POWER

ISA + 37°C

1600 RPM

WEIGHT →			12,000 POUNDS					11,000 POUNDS				
PRES- SURE ALT	IOAT	OAT	TORQ PER ENG	FUEL FLOW PER ENG	FUEL FLOW TOTAL	IAS	TAS	TORQ PER ENG	FUEL FLOW PER ENG	FUEL FLOW TOTAL	IAS	TAS
FEET	°C	°C	%	LBS/HR	LBS/HR	KTS	KTS	%	LBS/HR	LBS/HR	KTS	KTS
SL	60	52	77	592	1184	245	257	76	589	1178	245	257
2000	56	48	79	580	1160	245	264	78	577	1154	245	264
4000	53	44	81	569	1138	245	272	80	566	1132	245	272
6000	50	40	83	559	1118	245	281	82	555	1110	245	281
8000	46	36	86	551	1102	245	289	85	547	1094	245	289
10,000	43	32	87	540	1080	244	297	87	540	1080	245	298
12,000	39	28	83	513	1026	238	299	84	513	1026	239	300
14,000	35	24	80	486	972	231	300	80	486	972	232	302
16,000	31	20	76	459	918	224	301	76	459	918	226	303
18,000	27	16	72	433	866	217	302	72	433	866	219	304
20,000	23	12	68	406	812	210	301	68	407	814	211	304
22,000	19	8	64	381	762	202	300	64	382	764	204	303
24,000	15	4	60	356	712	193	298	60	357	714	195	301
26,000	11	0	55	331	662	184	294	56	332	664	187	299
28,000	7	-3	51	307	614	173	289	51	308	616	177	294
29,000	4	-5	49	295	590	168	285	49	296	592	172	292
31,000	0	-9	44	271	542	156	277	45	273	546	161	285
33,000	-5	-13	40	249	498	144	265	40	251	502	150	277
35,000	-10	-17	36	226	452	127	244	36	229	458	137	263

NC000165r

SPEED AT MAXIMUM CRUISE POWER

1600 RPM
WEIGHT: 12,500 LBS

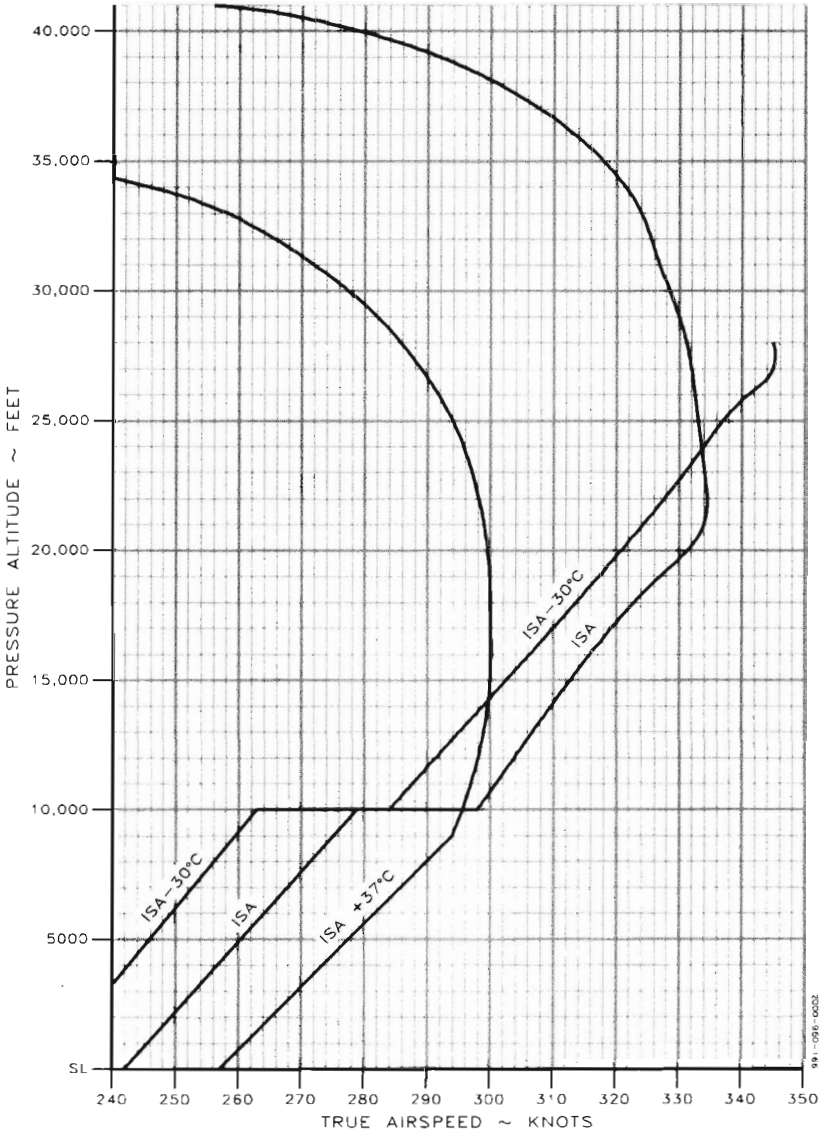

911-0916-0002

RANGE PROFILE - MAXIMUM CRUISE POWER

ASSOCIATED CONDITIONS:

WEIGHT *15,010 LBS BEFORE ENGINE START
 FUEL JET A
 FUEL DENSITY 6.65 LBS/GAL

1600 RPM

STANDARD DAY (ISA)
ZERO WIND

EXAMPLE:

PRESSURE ALTITUDE 29,000 FT
 FUEL 3200 LBS
 RANGE 1036 NM

NOTES: 1. RANGE ALLOWS FOR START, TAXI, AND RUNUP; INCLUDES CRUISE CLIMB AND DESCENT; AND ALLOWS FOR 45 MINUTES RESERVE FUEL AT MAXIMUM RANGE POWER.

* 2. AT 15,010 LBS RAMP WEIGHT, THE MAXIMUM ZERO-FUEL WEIGHT LIMITATION OF 12,600 LBS WOULD BE EXCEEDED AT FUEL LOADING LESS THAN 2410 LBS.

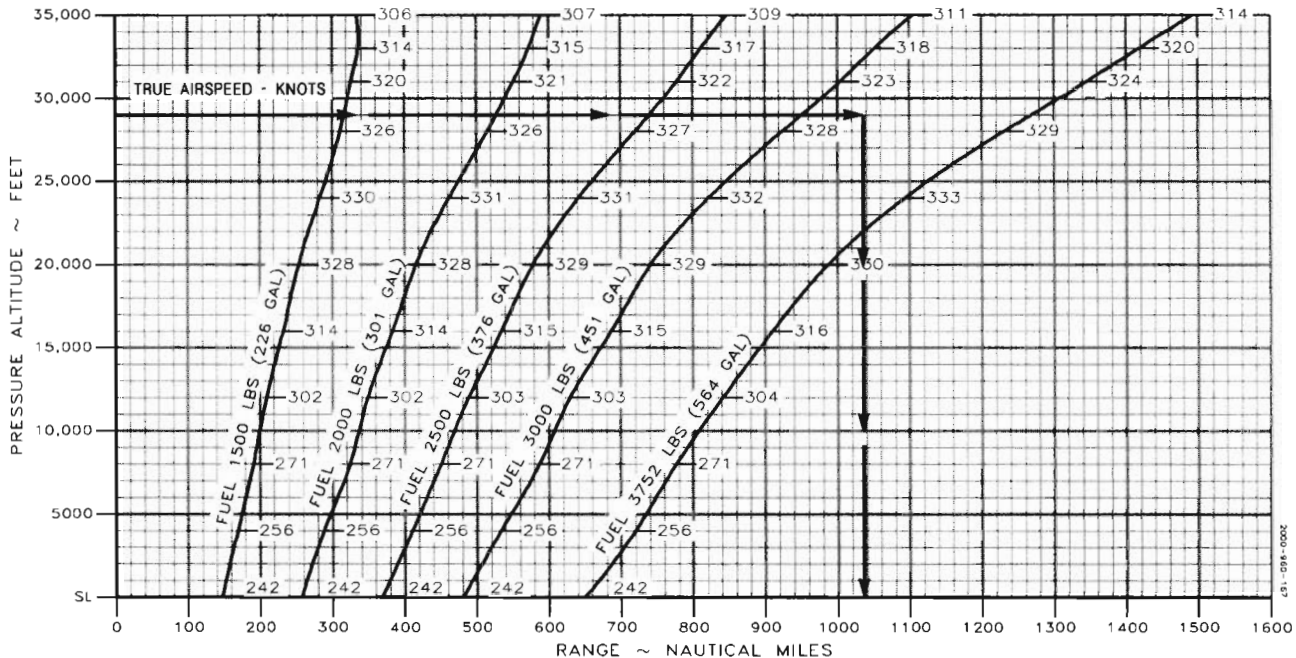

2000-945-1E7

(This Page Intentionally Left Blank)

RECOMMENDED CRUISE POWER

1. All fuel flows presented in this section represent average new engine performance with Jet A fuel. Use of other fuels, or operation with other than new engines, may increase fuel flows.
2. Activation of engine anti-ice will decrease engine torque approximately 20%, true airspeed will be reduced approximately 35 knots, and fuel flow will decrease approximately 10%.
3. Operation with normal ice accumulations will additionally reduce true airspeed approximately 40 knots.

RECOMMENDED CRUISE POWER
ISA - 30°C
1600 RPM

WEIGHT →			14,500 POUNDS					13,000 POUNDS				
PRES- SURE ALT	IOAT	OAT	TORQ PER ENG	FUEL FLOW PER ENG	FUEL FLOW TOTAL	IAS	TAS	TORQ PER ENG	FUEL FLOW PER ENG	FUEL FLOW TOTAL	IAS	TAS
FEET	°C	°C	%	LBS/HR	LBS/HR	KTS	KTS	%	LBS/HR	LBS/HR	KTS	KTS
SL	-9	-15	71	523	1046	245	229	70	519	1038	245	229
2000	-12	-19	72	510	1020	245	235	71	505	1010	245	235
4000	-16	-23	74	500	1000	245	242	73	495	990	245	242
6000	-19	-27	76	491	982	245	249	75	486	972	245	249
8000	-23	-31	78	483	966	245	256	77	478	956	245	256
10,000	-27	-35	80	476	952	245	263	78	471	942	245	263
12,000	-29	-39	89	497	994	253	280	89	496	992	255	282
14,000	-33	-43	89	487	974	251	286	89	486	972	252	287
16,000	-37	-47	89	478	956	248	291	89	478	956	250	293
18,000	-40	-51	89	471	942	246	297	89	470	940	248	299
20,000	-44	-55	89	464	928	243	303	89	463	926	256	305
22,000	-47	-59	89	458	916	240	309	89	458	916	242	312
24,000	-50	-63	89	455	910	240	318	89	454	908	242	320
26,000	-54	-67	89	453	906	237	324	89	453	906	239	327
28,000	-57	-70	89	453	906	234	331	89	453	906	237	334
29,000	-59	-72	89	454	908	233	335	89	453	906	235	338
31,000	-63	-76	84	430	860	224	334	84	432	864	228	338

ncbm168a

RECOMMENDED CRUISE POWER

ISA - 30°C

1600 RPM

WEIGHT →			12,000 POUNDS					11,000 POUNDS				
PRES- SURE ALT	IOAT	OAT	TORQ PER ENG	FUEL FLOW PER ENG	FUEL FLOW TOTAL	IAS	TAS	TORQ PER ENG	FUEL FLOW PER ENG	FUEL FLOW TOTAL	IAS	TAS
FEET	°C	°C	%	LBS/HR	LBS/HR	KTS	KTS	%	LBS/HR	LBS/HR	KTS	KTS
SL	-9	-15	69	516	1032	245	229	68	513	1026	245	229
2000	-12	-19	70	502	1004	245	235	70	500	1000	245	235
4000	-16	-23	72	492	984	245	242	71	489	978	245	242
6000	-19	-27	74	483	966	245	249	73	480	960	245	249
8000	-23	-31	76	475	950	245	256	75	472	944	245	256
10,000	-27	-35	78	467	934	245	263	77	464	928	245	263
12,000	-29	-39	89	496	992	256	283	89	496	992	257	284
14,000	-33	-43	89	486	972	253	289	89	486	972	254	289
16,000	-36	-47	89	477	954	251	294	89	477	954	252	295
18,000	-40	-51	89	470	940	249	301	89	470	940	250	302
20,000	-43	-55	89	463	926	246	307	89	463	926	247	308
22,000	-47	-59	89	458	916	244	313	89	457	914	245	314
24,000	-50	-63	89	454	908	243	322	89	454	908	244	323
26,000	-54	-67	89	452	904	240	329	89	452	904	242	330
28,000	-57	-70	89	453	906	238	336	89	452	904	239	337
29,000	-59	-72	89	453	906	237	339	89	452	904	238	341
31,000	-62	-76	84	433	866	230	341	85	433	866	231	343
33,000	-75	-80	30	162	324	133	211	30	163	326	141	224

ncbm 168b

RECOMMENDED CRUISE POWER
ISA - 20°C
1600 RPM

WEIGHT →			14,500 POUNDS					13,000 POUNDS				
PRES- SURE ALT	IOAT	OAT	TORQ PER ENG	FUEL FLOW PER ENG	FUEL FLOW TOTAL	IAS	TAS	TORQ PER ENG	FUEL FLOW PER ENG	FUEL FLOW TOTAL	IAS	TAS
FEET	°C	°C	%	LBS/HR	LBS/HR	KTS	KTS	%	LBS/HR	LBS/HR	KTS	KTS
SL	2	-5	72	534	1068	245	233	71	529	1058	245	233
2000	-2	-9	74	522	1044	245	240	73	517	1034	245	240
4000	-6	-13	76	512	1024	245	247	74	507	1014	245	247
6000	-9	-17	77	502	1004	245	254	76	496	992	245	254
8000	-13	-21	79	493	986	245	261	78	487	974	245	261
10,000	-16	-25	81	485	970	245	269	80	479	958	245	269
12,000	-19	-29	89	503	1006	251	283	89	503	1006	252	285
14,000	-23	-33	89	492	984	248	289	89	491	982	250	291
16,000	-26	-37	89	482	964	245	294	89	482	964	247	297
18,000	-30	-41	89	475	950	243	301	89	474	948	245	330
20,000	-33	-45	89	467	934	242	308	89	467	934	244	311
22,000	-37	-49	89	463	926	239	315	89	463	926	241	317
24,000	-40	-53	89	459	918	236	321	89	459	918	239	324
26,000	-44	-57	89	457	914	234	328	89	456	912	236	331
28,000	-47	-60	87	448	896	229	332	87	449	898	232	336
29,000	-49	-62	83	432	864	224	330	84	433	866	227	334
31,000	-54	-66	77	402	804	213	327	77	403	806	217	332
33,000	-58	-70	71	373	746	203	322	72	375	750	207	329
35,000	-62	-74	65	344	688	191	316	66	346	692	196	324
37,000	-65	-77	58	313	626	176	305	59	315	630	183	316
39,000	-67	-77	51	280	560	157	287	52	284	568	168	305
41,000	-67	-77						46	253	506	149	286

ncbm168c

RECOMMENDED CRUISE POWER
ISA - 20°C
1600 RPM

WEIGHT →			12,000 POUNDS					11,000 POUNDS				
PRES-SURE ALT	IOAT	OAT	TORQ PER ENG	FUEL FLOW PER ENG	FUEL FLOW TOTAL	IAS	TAS	TORQ PER ENG	FUEL FLOW PER ENG	FUEL FLOW TOTAL	IAS	TAS
FEET	°C	°C	%	LBS/HR	LBS/HR	KTS	KTS	%	LBS/HR	LBS/HR	KTS	KTS
SL	2	-5	70	526	1052	245	233	70	523	1046	245	233
2000	-2	-9	72	514	1028	245	240	71	511	1022	245	240
4000	-6	-13	74	504	1008	245	247	73	501	1002	245	247
6000	-9	-17	75	493	986	245	254	75	490	980	245	254
8000	-13	-21	77	484	968	245	261	76	481	962	245	261
10,000	-16	-25	79	476	952	245	269	78	473	946	245	269
12,000	-19	-29	89	502	1004	253	286	89	502	1004	254	287
14,000	-23	-33	89	491	982	251	292	89	491	982	252	293
16,000	-26	-37	89	482	964	248	298	89	482	964	249	299
18,000	-30	-41	89	474	948	246	304	89	474	948	247	305
20,000	-33	-45	89	467	934	245	312	89	467	934	246	313
22,000	-36	-49	89	463	926	242	319	89	462	924	243	320
24,000	-40	-53	89	459	918	240	326	89	458	916	241	327
26,000	-43	-57	89	456	912	237	333	89	456	912	238	334
28,000	-47	-60	87	449	898	233	338	87	450	900	235	340
29,000	-49	-62	84	434	868	228	337	84	434	868	230	359
31,000	-53	-66	78	404	808	219	335	78	405	810	221	337
33,000	-57	-70	72	376	752	210	332	72	377	754	212	335
35,000	-61	-74	66	348	696	199	328	66	349	698	202	332
37,000	-64	-77	59	317	634	187	322	60	318	636	190	327
39,000	-65	-77	53	286	572	173	313	53	288	576	177	320
41,000	-66	-77	46	256	512	157	300	46	258	516	163	310

ncbm 168d

RECOMMENDED CRUISE POWER
ISA - 10°C
1600 RPM

WEIGHT →			14,500 POUNDS					13,000 POUNDS				
PRES- SURE ALT	IOAT	OAT	TORQ PER ENG	FUEL FLOW PER ENG	FUEL FLOW TOTAL	IAS	TAS	TORQ PER ENG	FUEL FLOW PER ENG	FUEL FLOW TOTAL	IAS	TAS
FEET	°C	°C	%	LBS/HR	LBS/HR	KTS	KTS	%	LBS/HR	LBS/HR	KTS	KTS
SL	12	5	73	544	1088	245	238	72	539	1078	245	238
2000	8	1	75	532	1064	245	244	74	527	1054	245	244
4000	5	-3	77	522	1044	245	251	76	517	1034	245	251
6000	1	-7	79	513	1026	245	259	78	508	1016	245	259
8000	-2	-11	81	505	1010	245	266	79	499	998	245	266
10,000	-6	-15	83	500	1000	245	274	82	494	988	245	274
12,000	-9	-19	89	509	1018	248	286	89	509	1018	250	288
14,000	-13	-23	89	497	994	245	292	89	497	994	247	294
16,000	-16	-27	89	486	972	243	297	89	486	972	245	300
18,000	-19	-31	89	479	958	242	305	89	479	958	243	308
20,000	-23	-35	89	473	946	239	311	89	472	944	241	314
22,000	-26	-39	89	468	936	236	318	89	468	936	238	320
24,000	-30	-43	89	463	926	233	324	89	463	926	235	327
26,000	-34	-47	85	442	884	226	325	85	443	886	229	329
28,000	-38	-50	79	413	826	216	322	79	414	828	220	327
29,000	-40	-52	76	398	796	211	321	76	400	800	215	326
31,000	-44	-56	70	371	742	201	317	70	372	744	205	323
33,000	-49	-60	65	345	690	190	312	65	347	694	195	319
35,000	-53	-64	59	319	638	179	304	60	321	642	185	314
37,000	-56	-67	53	288	576	162	289	53	291	582	171	304
39,000	-59	-67	46	256	512	136	257	47	261	522	154	288
41,000	-59	-67						40	229	458	128	253

ncbm168e

RECOMMENDED CRUISE POWER
ISA - 10°C
1600 RPM

WEIGHT →			12,000 POUNDS					11,000 POUNDS				
PRES- SURE ALT	IOAT	OAT	TORQ PER ENG	FUEL FLOW PER ENG	FUEL FLOW TOTAL	IAS	TAS	TORQ PER ENG	FUEL FLOW PER ENG	FUEL FLOW TOTAL	IAS	TAS
FEET	°C	°C	%	LBS/HR	LBS/HR	KTS	KTS	%	LBS/HR	LBS/HR	KTS	KTS
SL	12	5	71	536	1072	245	238	71	533	1066	245	238
2000	8	1	73	524	1048	245	244	72	521	1042	245	244
4000	5	-3	75	514	1028	245	251	74	511	1022	245	251
6000	1	-7	77	504	1008	245	259	76	501	1002	245	259
8000	-2	-11	79	496	992	245	266	78	493	986	245	266
10,000	-6	-15	81	490	980	245	274	80	487	974	245	274
12,000	-9	-19	89	509	1018	251	289	89	509	1018	252	290
14,000	-12	-23	89	496	992	248	295	89	496	992	249	296
16,000	-16	-27	89	486	972	246	301	89	486	972	247	302
18,000	-19	-31	89	479	958	245	309	89	478	956	246	310
20,000	-23	-35	89	472	944	242	315	89	472	944	243	317
22,000	-26	-39	89	467	934	239	322	89	467	934	240	323
24,000	-30	-43	89	463	926	237	329	89	463	926	238	330
26,000	-33	-47	85	443	886	230	331	85	444	888	232	333
28,000	-37	-50	79	415	830	221	330	79	415	830	223	332
29,000	-39	-52	76	400	800	217	329	76	401	802	219	331
31,000	-44	-56	71	373	746	208	326	71	374	748	210	329
33,000	-48	-60	65	348	696	198	323	66	348	696	201	327
35,000	-52	-64	60	322	644	188	319	60	323	646	191	324
37,000	-55	-67	54	292	584	175	311	54	293	586	179	317
39,000	-56	-67	48	263	526	160	300	48	264	528	165	308
41,000	-57	-67	41	233	466	141	279	42	235	470	149	293

ncbm168f

RECOMMENDED CRUISE POWER

ISA

1600 RPM

WEIGHT →			14,500 POUNDS					13,000 POUNDS				
PRES- SURE ALT	IOAT	OAT	TORQ PER ENG	FUEL FLOW PER ENG	FUEL FLOW TOTAL	IAS	TAS	TORQ PER ENG	FUEL FLOW PER ENG	FUEL FLOW TOTAL	IAS	TAS
FEET	°C	°C	%	LBS/HR	LBS/HR	KTS	KTS	%	LBS/HR	LBS/HR	KTS	KTS
SL	22	15	74	556	1112	245	242	73	551	1102	245	242
2000	18	11	76	545	1090	245	249	75	540	1080	245	249
4000	15	7	78	535	1070	245	256	77	529	1058	245	256
6000	11	3	80	525	1050	245	263	79	520	1040	245	263
8000	8	-1	83	518	1036	245	271	81	512	1024	245	271
10,000	5	-5	85	511	1022	245	279	83	505	1010	245	279
12,000	1	-9	89	514	1028	246	289	89	514	1028	247	291
14,000	-2	-13	89	503	1006	244	296	89	502	1004	246	298
16,000	-6	-17	89	493	986	242	302	89	493	986	244	305
18,000	-9	-21	89	485	970	239	308	89	485	970	241	313
20,000	-13	-25	89	478	956	236	314	89	477	954	238	317
22,000	-16	-29	89	473	946	233	321	89	472	944	235	324
24,000	-20	-33	83	443	886	224	320	83	444	888	227	323
26,000	-24	-37	78	415	830	215	317	78	416	832	218	322
28,000	-29	-40	72	388	776	205	314	72	389	778	209	319
29,000	-31	-42	69	374	748	200	312	70	375	750	204	318
31,000	-35	-46	64	348	696	190	308	64	349	698	195	315
33,000	-39	-50	59	323	646	179	301	60	325	650	185	310
35,000	-44	-54	54	298	596	166	291	55	300	600	174	304
37,000	-48	-57	47	267	534	145	267	48	271	542	158	290
39,000	-48	-57						42	241	482	137	265

ncbm 168g

RECOMMENDED CRUISE POWER

ISA

1600 RPM

WEIGHT →			12,000 POUNDS					11,000 POUNDS				
PRES- SURE ALT	IOAT	OAT	TORQ PER ENG	FUEL FLOW PER ENG	FUEL FLOW TOTAL	IAS	TAS	TORQ PER ENG	FUEL FLOW PER ENG	FUEL FLOW TOTAL	IAS	TAS
FEET	°C	°C	%	LBS/HR	LBS/HR	KTS	KTS	%	LBS/HR	LBS/HR	KTS	KTS
SL	22	15	72	548	1096	245	242	72	545	1090	245	242
2000	18	11	74	536	1072	245	249	74	533	1066	245	249
4000	15	7	76	526	1052	245	256	75	523	1046	245	256
6000	11	3	78	516	1032	245	263	77	513	1026	245	263
8000	8	-1	80	509	1018	245	271	79	505	1010	245	271
10,000	5	-5	82	502	1004	245	279	81	498	996	245	279
12,000	1	-9	89	514	1028	248	292	89	514	1028	245	293
14,000	-2	-13	89	502	1004	247	300	89	502	1004	248	301
16,000	-5	-17	89	493	986	245	306	89	493	986	246	307
18,000	-9	-21	89	485	970	242	312	89	485	970	243	313
20,000	-12	-25	89	477	954	239	318	89	477	954	240	320
22,000	-16	-29	89	472	944	237	325	89	472	944	238	327
24,000	-20	-33	84	445	890	229	325	84	445	890	230	327
26,000	-24	-37	78	416	832	220	324	78	417	834	222	327
28,000	-28	-40	73	389	778	211	322	73	390	780	213	325
29,000	-30	-42	70	375	750	207	321	70	376	752	209	324
31,000	-34	-46	65	350	700	197	319	65	350	700	200	322
33,000	-38	-50	60	326	652	188	315	60	326	652	191	319
35,000	-43	-54	55	301	602	178	310	55	302	604	181	316
37,000	-46	-57	49	273	546	164	300	49	274	548	169	307
39,000	-47	-57	43	243	486	147	283	43	245	490	153	295

ncbm168h

RECOMMENDED CRUISE POWER

ISA + 10°C

1600 RPM

WEIGHT →			14,500 POUNDS					13,000 POUNDS				
PRES- SURE ALT	IOAT	OAT	TORQ PER ENG	FUEL FLOW PER ENG	FUEL FLOW TOTAL	IAS	TAS	TORQ PER ENG	FUEL FLOW PER ENG	FUEL FLOW TOTAL	IAS	TAS
FEET	°C	°C	%	LBS/HR	LBS/HR	KTS	KTS	%	LBS/HR	LBS/HR	KTS	KTS
SL	32	25	75	570	1140	245	246	74	565	1130	245	246
2000	29	21	78	558	1116	245	253	76	553	1106	245	253
4000	25	17	80	548	1096	245	261	78	542	1084	245	261
6000	22	13	82	538	1076	245	268	80	532	1064	245	268
8000	18	9	84	530	1060	245	276	83	524	1048	245	276
10,000	15	5	86	522	1044	245	285	85	516	1032	245	285
12,000	12	1	89	520	1040	245	293	89	520	1040	246	295
14,000	8	-3	89	508	1016	242	299	89	508	1016	244	301
16,000	4	-7	89	499	998	239	305	89	498	996	241	307
18,000	1	-11	89	491	982	236	311	89	490	980	238	314
20,000	-3	-15	87	474	948	231	315	87	475	950	234	318
22,000	-7	-19	82	446	892	223	314	82	447	894	226	317
24,000	-11	-23	77	418	836	214	312	77	419	838	217	316
26,000	-15	-27	71	391	782	205	309	72	392	784	208	315
28,000	-19	-30	66	364	728	195	305	66	365	730	199	311
29,000	-21	-32	63	351	702	189	302	64	352	704	194	309
31,000	-26	-36	58	325	650	178	295	59	327	654	184	305
33,000	-31	-40	53	300	600	165	285	54	302	604	179	298
35,000	-36	-44	48	275	550	149	269	49	278	556	160	288
37,000	-38	-47						43	250	500	142	268

ncbm 168j

RECOMMENDED CRUISE POWER

ISA + 10°C

1600 RPM

WEIGHT →			12,000 POUNDS					11,000 POUNDS				
PRES- SURE ALT	IOAT	OAT	TORQ PER ENG	FUEL FLOW PER ENG	FUEL FLOW TOTAL	IAS	TAS	TORQ PER ENG	FUEL FLOW PER ENG	FUEL FLOW TOTAL	IAS	TAS
FEET	°C	°C	%	LBS/HR	LBS/HR	KTS	KTS	%	LBS/HR	LBS/HR	KTS	KTS
SL	32	25	73	561	1122	245	246	73	558	1116	245	246
2000	29	21	75	550	1100	245	253	75	547	1094	245	253
4000	25	17	77	539	1078	245	261	77	536	1072	245	261
6000	22	13	80	529	1058	245	268	79	526	1052	245	268
8000	18	9	82	521	1042	245	276	81	517	1034	245	276
10,000	15	5	84	513	1026	245	285	83	509	1018	245	285
12,000	12	1	89	520	1040	247	296	89	520	1040	248	297
14,000	8	-3	89	508	1016	245	303	89	508	1016	246	304
16,000	5	-7	89	498	996	242	309	89	498	996	243	310
18,000	1	-11	89	490	980	239	315	89	490	980	241	316
20,000	-2	-15	87	476	952	235	320	87	476	952	236	321
22,000	-6	-19	82	448	896	227	319	82	448	896	229	321
24,000	-10	-23	77	419	838	219	319	77	420	840	221	321
26,000	-14	-27	72	392	784	210	317	72	393	786	212	320
28,000	-19	-30	67	366	732	201	315	67	366	732	203	318
29,000	-21	-32	64	352	704	197	313	64	353	706	199	317
31,000	-25	-36	59	327	654	187	310	59	328	656	190	314
33,000	-29	-40	54	303	606	177	305	54	304	608	180	310
35,000	-34	-44	49	279	558	166	297	50	280	560	170	304
37,000	-37	-47	44	252	504	150	283	44	253	506	156	293
39,000	-39	-47	38	223	446	130	256	38	225	450	139	276

ncbm 168k

RECOMMENDED CRUISE POWER

ISA + 20°C

1600 RPM

WEIGHT →			14,500 POUNDS					13,000 POUNDS				
PRES- SURE ALT	IOAT	OAT	TORQ PER ENG	FUEL FLOW PER ENG	FUEL FLOW TOTAL	IAS	TAS	TORQ PER ENG	FUEL FLOW PER ENG	FUEL FLOW TOTAL	IAS	TAS
FEET	°C	°C	%	LBS/HR	LBS/HR	KTS	KTS	%	LBS/HR	LBS/HR	KTS	KTS
SL	43	35	77	581	1162	245	250	75	575	1150	245	250
2000	39	31	79	569	1138	245	257	78	563	1126	245	257
4000	36	27	81	558	1116	245	265	80	552	1104	245	265
6000	32	23	83	547	1094	245	273	82	542	1084	245	273
8000	29	19	86	541	1082	245	281	84	534	1068	245	281
10,000	25	15	88	535	1070	245	290	86	529	1058	245	290
12,000	22	11	89	526	1052	242	296	89	525	1050	244	298
14,000	18	7	89	514	1028	240	302	89	513	1026	241	304
16,000	15	3	89	503	1006	237	308	89	503	1006	239	310
18,000	11	-1	84	475	950	229	308	84	476	952	231	311
20,000	7	-5	79	447	894	221	307	80	447	894	223	310
22,000	3	-9	75	420	840	212	306	75	421	842	215	310
24,000	-1	-13	70	393	786	203	303	70	394	788	207	308
26,000	-6	-17	65	367	734	194	300	65	368	736	198	306
28,000	-10	-20	60	342	684	183	294	61	343	686	189	303
29,000	-12	-22	58	329	658	177	291	58	331	662	184	300
31,000	-17	-26	53	304	608	165	281	53	306	612	173	294
33,000	-22	-30	48	279	558	149	266	49	282	564	160	284
35,000	-26	-34						44	258	516	146	270

ncbm168m

RECOMMENDED CRUISE POWER
ISA + 20°C
1600 RPM

WEIGHT →			12,000 POUNDS					11,000 POUNDS				
PRES- SURE ALT	IOAT	OAT	TORQ PER ENG	FUEL FLOW PER ENG	FUEL FLOW TOTAL	IAS	TAS	TORQ PER ENG	FUEL FLOW PER ENG	FUEL FLOW TOTAL	IAS	TAS
FEET	°C	°C	%	LBS/HR	LBS/HR	KTS	KTS	%	LBS/HR	LBS/HR	KTS	KTS
SL	43	35	75	572	1144	245	250	74	569	1138	245	250
2000	39	31	77	560	1120	245	257	76	557	1114	245	257
4000	36	27	79	549	1098	245	265	78	546	1092	245	265
6000	32	23	81	538	1076	245	273	80	535	1070	245	273
8000	29	19	83	531	1062	245	281	82	527	1054	245	281
10,000	25	15	85	525	1050	245	290	84	521	1042	245	290
12,000	22	11	89	525	1050	245	299	89	525	1050	246	300
14,000	18	7	89	513	1026	243	305	89	513	1026	244	306
16,000	15	3	89	503	1006	240	311	89	503	1006	241	313
18,000	11	-1	84	476	952	233	312	84	477	954	234	314
20,000	7	-5	80	448	896	225	312	80	448	896	226	314
22,000	3	-9	75	421	842	217	312	75	422	844	219	314
24,000	-1	-13	70	395	790	209	311	70	395	790	211	314
26,000	-5	-17	66	369	738	200	309	66	369	738	203	312
28,000	-9	-20	61	344	688	192	307	61	345	690	194	310
29,000	-11	-22	59	332	664	187	305	59	332	664	189	309
31,000	-16	-26	54	307	614	177	300	54	308	616	180	305
33,000	-20	-30	49	284	568	166	293	50	285	570	170	300
35,000	-25	-34	44	260	520	153	283	45	261	522	159	292
37,000	-28	-37	39	233	466	136	263	40	235	470	144	278

ncbm168n

RECOMMENDED CRUISE POWER

ISA + 30°C

1600 RPM

WEIGHT →			14,500 POUNDS					13,000 POUNDS				
PRES- SURE ALT	IOAT	OAT	TORQ PER ENG	FUEL FLOW PER ENG	FUEL FLOW TOTAL	IAS	TAS	TORQ PER ENG	FUEL FLOW PER ENG	FUEL FLOW TOTAL	IAS	TAS
FEET	°C	°C	%	LBS/HR	LBS/HR	KTS	KTS	%	LBS/HR	LBS/HR	KTS	KTS
SL	53	45	78	594	1188	245	254	77	589	1178	245	254
2000	49	41	80	582	1164	245	262	79	576	1152	245	262
4000	46	37	83	571	1142	245	269	81	565	1130	245	269
6000	42	33	85	561	1122	245	277	83	555	1110	245	277
8000	39	29	87	553	1106	245	286	86	547	1094	245	286
10,000	35	25	87	538	1076	242	292	87	538	1076	244	294
12,000	31	21	84	511	1022	235	292	84	512	1024	237	294
14,000	28	17	81	485	970	228	293	81	485	970	231	296
16,000	24	13	77	458	916	221	294	77	459	918	224	297
18,000	20	9	73	432	864	213	293	73	433	866	217	297
20,000	16	5	69	406	812	205	292	69	406	812	209	296
22,000	11	1	64	381	762	196	289	65	382	764	200	295
24,000	7	-3	60	356	712	187	285	61	357	714	192	292
26,000	3	-7	56	331	662	176	280	56	332	664	182	288
28,000	-2	-10	51	306	612	164	271	52	308	616	172	282
29,000	-4	-12	49	294	588	157	264	49	296	592	166	278
31,000	-9	-16	44	270	540	141	248	45	273	546	154	269
33,000	-12	-20						41	253	506	141	257

ncbm1680

RECOMMENDED CRUISE POWER
ISA + 30°C
1600 RPM

WEIGHT →			12,000 POUNDS					11,000 POUNDS				
PRES- SURE ALT	IOAT	OAT	TORQ PER ENG	FUEL FLOW PER ENG	FUEL FLOW TOTAL	IAS	TAS	TORQ PER ENG	FUEL FLOW PER ENG	FUEL FLOW TOTAL	IAS	TAS
FEET	°C	°C	%	LBS/HR	LBS/HR	KTS	KTS	%	LBS/HR	LBS/HR	KTS	KTS
SL	53	45	76	585	1170	245	254	75	582	1164	245	254
2000	49	41	78	573	1146	245	262	77	570	1140	245	262
4000	46	37	80	562	1124	245	269	79	559	1118	245	269
6000	42	33	82	552	1104	245	277	82	548	1096	245	277
8000	39	29	85	543	1086	245	286	84	540	1080	245	286
10,000	36	25	87	536	1072	245	295	86	532	1064	245	295
12,000	32	21	84	512	1024	238	296	84	512	1024	239	297
14,000	28	17	81	486	972	232	298	81	486	972	233	299
16,000	24	13	77	460	920	226	299	77	460	920	227	301
18,000	20	9	73	433	866	218	299	73	434	868	220	301
20,000	16	5	69	407	814	211	299	69	407	814	212	301
22,000	12	1	65	382	764	203	298	65	383	766	205	301
24,000	8	-3	61	357	714	194	296	61	358	716	197	300
26,000	4	-7	56	333	666	185	293	57	334	668	188	297
28,000	0	-10	52	309	618	175	288	52	310	620	179	293
29,000	-3	-12	50	297	594	170	285	50	298	596	174	291
31,000	-7	-16	46	275	550	160	278	46	276	552	164	286
33,000	-12	-20	42	255	510	149	270	42	256	512	155	280
35,000	-16	-24	38	234	468	136	257	39	236	472	144	271
37,000	-19	-27						33	210	420	126	247

ncbm168p

RECOMMENDED CRUISE POWER
ISA + 37°C
1600 RPM

WEIGHT →			14,500 POUNDS					13,000 POUNDS				
PRES- SURE ALT	IOAT	OAT	TORQ PER ENG	FUEL FLOW PER ENG	FUEL FLOW TOTAL	IAS	TAS	TORQ PER ENG	FUEL FLOW PER ENG	FUEL FLOW TOTAL	IAS	TAS
FEET	°C	°C	%	LBS/HR	LBS/HR	KTS	KTS	%	LBS/HR	LBS/HR	KTS	KTS
SL	60	52	79	601	1202	245	257	78	595	1190	245	257
2000	56	48	81	589	1178	245	264	80	583	1166	245	2642
4000	53	44	81	570	1140	242	270	81	570	1140	244	277
6000	49	40	80	548	1096	239	274	81	548	1096	241	276
8000	45	36	79	525	1050	234	277	79	525	1050	236	280
10,000	42	32	77	502	1004	230	280	78	502	1004	232	283
12,000	38	28	74	476	952	222	280	74	477	954	225	283
14,000	34	24	71	451	902	216	281	71	452	904	218	284
16,000	30	20	68	426	852	208	281	68	427	854	212	285
18,000	26	16	64	401	802	201	280	65	402	804	204	284
20,000	22	12	61	376	752	192	278	61	377	754	197	283
22,000	17	8	57	353	706	183	275	57	354	708	188	281
24,000	13	4	53	329	658	174	270	54	331	662	197	278
26,000	9	0	49	305	610	162	262	50	307	614	170	273
28,000	4	-3	45	282	564	148	248	45	284	568	158	265
29,000	1	-5	42	270	540	138	237	43	272	544	152	259
31,000	-2	-9						39	250	500	137	244

ncbm168q

RECOMMENDED CRUISE POWER
ISA + 37°C
1600 RPM

WEIGHT →			12,000 POUNDS					11,000 POUNDS				
PRES- SURE ALT	IOAT	OAT	TORQ PER ENG	FUEL FLOW PER ENG	FUEL FLOW TOTAL	IAS	TAS	TORQ PER ENG	FUEL FLOW PER ENG	FUEL FLOW TOTAL	IAS	TAS
FEET	°C	°C	%	LBS/HR	LBS/HR	KTS	KTS	%	LBS/HR	LBS/HR	KTS	KTS
SL	60	52	77	592	1184	245	257	76	589	1178	245	257
2000	56	48	79	580	1160	245	264	78	577	1154	245	264
4000	53	44	81	569	1138	245	272	80	566	1132	245	272
6000	49	40	81	548	1096	242	277	81	549	1098	243	278
8000	46	36	79	526	1052	238	281	79	526	1052	239	282
10,000	42	32	78	503	1006	233	285	78	503	1006	235	286
12,000	38	28	75	477	954	226	285	75	478	956	227	286
14,000	34	24	72	452	904	220	286	72	452	904	221	288
16,000	30	20	68	427	854	213	287	68	428	856	215	289
18,000	26	16	65	402	804	206	287	65	403	806	208	290
20,000	22	12	61	378	756	199	287	61	378	756	201	289
22,000	18	8	58	355	710	191	285	58	355	710	193	289
24,000	14	4	54	331	662	183	283	54	332	664	185	287
26,000	10	0	50	308	616	173	279	50	309	618	177	284
28,000	5	-3	46	285	570	163	273	46	286	572	167	279
29,000	3	-5	44	274	548	157	268	44	275	550	162	276
31,000	-1	-9	39	252	504	145	258	40	253	506	151	268
33,000	-6	-13	36	231	462	131	242	36	232	464	139	257

ncbm168r

SPEED AT RECOMMENDED CRUISE POWER

1 6 0 0 R P M
W E I G H T : 1 2 , 5 0 0 L B S

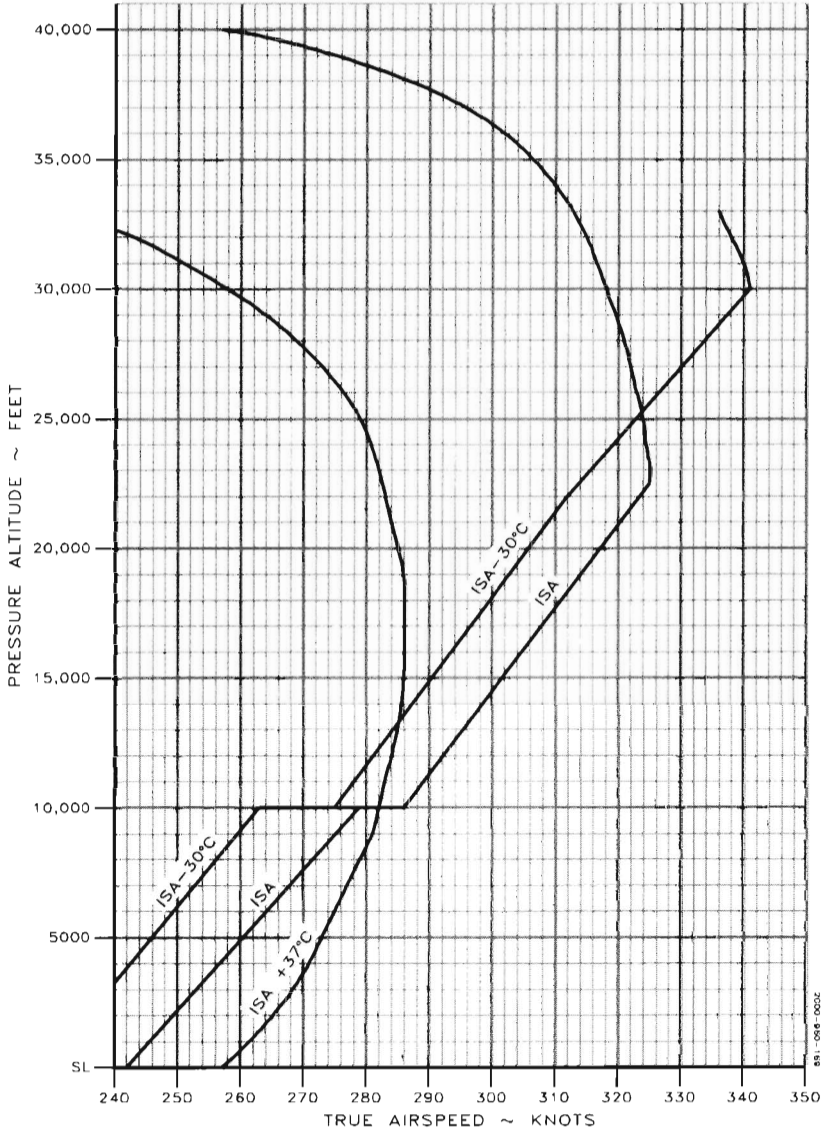

811-068-0002

RANGE PROFILE - RECOMMENDED CRUISE POWER

ASSOCIATED CONDITIONS:

WEIGHT *15,010 LBS BEFORE ENGINE START
 FUEL JET A
 FUEL DENSITY 6.65 LBS/GAL

1600 RPM
STANDARD DAY (ISA)
ZERO WIND

EXAMPLE:

PRESSURE ALTITUDE 29,000 FT
 FUEL 3200 LBS
 RANGE 1055 NM

NOTES: 1. RANGE ALLOWS FOR START, TAXI, AND RUNUP; INCLUDES CRUISE CLIMB AND DESCENT; AND ALLOWS FOR 45 MINUTES RESERVE FUEL AT MAXIMUM RANGE POWER.

* 2. AT 15,010 LBS RAMP WEIGHT, THE MAXIMUM ZERO-FUEL WEIGHT LIMITATION OF 12,600 LBS WOULD BE EXCEEDED AT FUEL LOADING LESS THAN 2410 LBS.

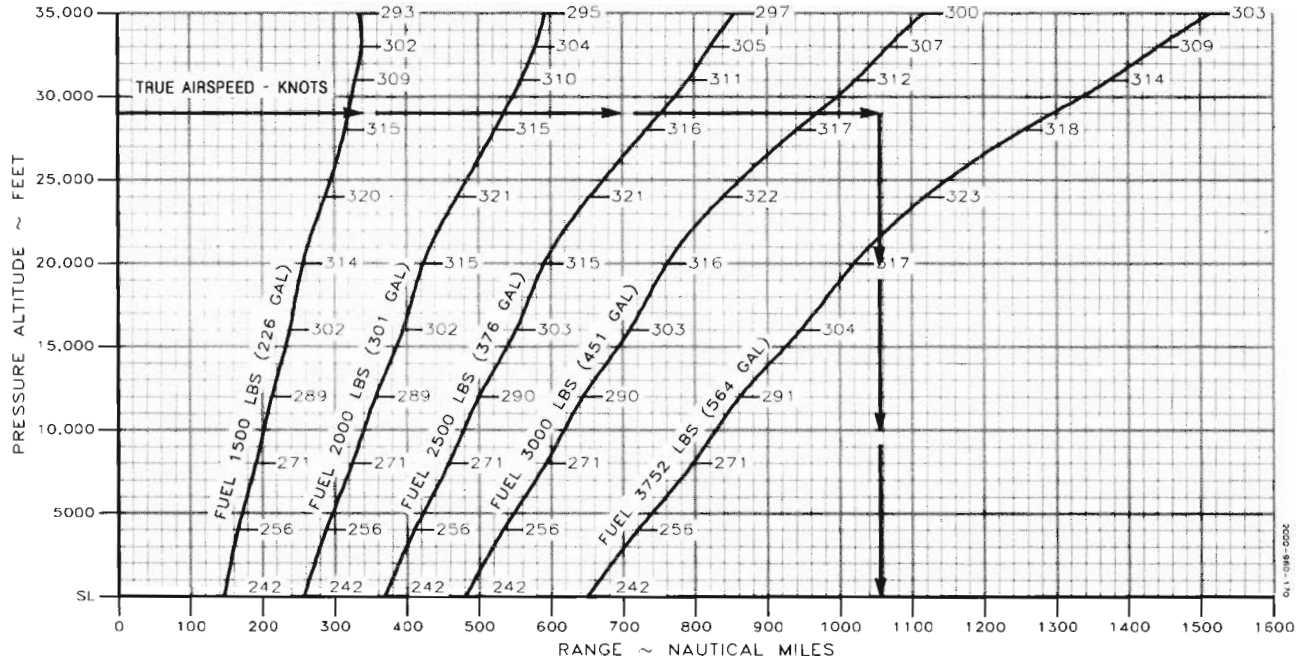

(This Page Intentionally Left Blank)

MAXIMUM RANGE POWER

1. All fuel flows presented in this section represent average new engine performance with Jet A fuel. Use of other fuels, or operation with other than new engines, may increase fuel flows.
2. During operation with engine anti-ice on, torque will decrease. Fuel flow will increase 10 lbs/hr/eng, and true airspeed will be reduced approximately 10 knots.

MAXIMUM RANGE POWER
ISA - 30°C
1600 RPM

WEIGHT →			14,500 POUNDS					13,000 POUNDS				
PRES- SURE ALT	IOAT	OAT	TORQ PER ENG	FUEL FLOW PER ENG	FUEL FLOW TOTAL	IAS	TAS	TORQ PER ENG	FUEL FLOW PER ENG	FUEL FLOW TOTAL	IAS	TAS
FEET	°C	°C	%	LBS/HR	LBS/HR	KTS	KTS	%	LBS/HR	LBS/HR	KTS	KTS
SL	-10	-15	55	465	930	222	208	51	446	892	217	204
2000	-14	-19	54	438	876	217	209	49	419	838	211	204
4000	-18	-23	52	417	834	212	211	47	397	794	206	205
6000	-21	-27	51	397	794	208	212	46	376	752	201	206
8000	-25	-31	50	379	758	204	215	45	358	716	201	208
10,000	-29	-35	50	363	726	200	217	44	342	684	193	210
12,000	-33	-39	50	351	702	198	221	44	329	658	190	213
14,000	-37	-43	49	337	674	194	224	44	316	632	187	216
16,000	-41	-47	49	324	648	191	227	44	304	608	185	220
18,000	-44	-51	49	314	628	188	230	43	294	588	182	223
20,000	-48	-55	48	303	606	185	234	43	283	566	179	227
22,000	-52	-59	49	296	592	183	239	43	275	550	176	231
24,000	-55	-63	49	289	578	181	244	43	267	534	174	235
26,000	-59	-67	49	284	568	179	250	43	261	522	172	240

ncbm171a

MAXIMUM RANGE POWER
ISA - 30°C
1600 RPM

WEIGHT →			12,000 POUNDS					11,000 POUNDS				
PRES- SURE ALT	IOAT	OAT	TORQ PER ENG	FUEL FLOW PER ENG	FUEL FLOW TOTAL	IAS	TAS	TORQ PER ENG	FUEL FLOW PER ENG	FUEL FLOW TOTAL	IAS	TAS
FEET	°C	°C	%	LBS/HR	LBS/HR	KTS	KTS	%	LBS/HR	LBS/HR	KTS	KTS
SL	-10	-15	48	435	870	213	200	45	424	848	210	197
2000	-14	-19	45	406	812	207	200	42	395	790	203	196
4000	-18	-23	44	384	768	202	201	40	371	742	197	197
6000	-22	-27	42	362	724	196	201	39	349	698	192	197
8000	-26	-31	41	344	688	192	203	37	330	660	187	198
10,000	-30	-35	40	327	654	188	204	36	313	626	183	199
12,000	-34	-39	40	314	628	185	207	36	299	598	180	201
14,000	-37	-43	40	301	602	182	210	36	286	572	176	204
16,000	-41	-47	40	290	580	179	214	36	275	550	174	207
18,000	-45	-51	40	280	560	177	218	36	265	530	171	121
20,000	-49	-55	40	270	540	174	221	36	255	510	169	215
22,000	-52	-59	40	261	522	172	225	36	248	496	167	219
24,000	-56	-63	39	253	506	169	229	36	239	478	164	223
26,000	-60	-67	40	246	492	167	234	36	232	464	162	228
28,000	-64	-70						36	227	454	160	232

ncbm 171b

MAXIMUM RANGE POWER
ISA - 20°C
1600 RPM

WEIGHT →			14,500 POUNDS					13,000 POUNDS				
PRES- SURE ALT	IOAT	OAT	TORQ PER ENG	FUEL FLOW PER ENG	FUEL FLOW TOTAL	IAS	TAS	TORQ PER ENG	FUEL FLOW PER ENG	FUEL FLOW TOTAL	IAS	TAS
FEET	°C	°C	%	LBS/HR	LBS/HR	KTS	KTS	%	LBS/HR	LBS/HR	KTS	KTS
SL	0	-5	57	476	952	223	213	53	459	918	219	209
2000	-3	-9	56	453	906	219	215	52	435	870	214	210
4000	-7	-13	55	434	868	215	218	51	415	830	210	213
6000	-11	-17	54	413	826	211	220	49	394	788	206	214
8000	-15	-21	53	393	786	207	222	48	375	750	201	216
10,000	-19	-25	52	376	752	203	225	48	358	716	198	219
12,000	-23	-29	52	361	722	199	227	47	343	686	194	222
14,000	-26	-33	51	347	694	196	230	46	329	658	190	224
16,000	-30	-37	51	335	670	192	234	46	316	632	187	227
18,000	-34	-41	51	324	648	190	237	45	304	608	184	230
20,000	-38	-45	51	314	628	187	242	45	293	586	180	234
22,000	-41	-49	51	307	614	185	247	45	284	568	178	238
24,000	-45	-53	51	299	598	182	252	45	277	554	176	243
26,000	-49	-57	51	292	584	180	257	45	271	542	174	249
28,000	-53	-60	49	281	562	174	257	45	265	530	172	254
29,000	-55	-62	48	274	548	170	256	45	262	524	170	256
31,000	-59	-66	47	265	530	164	256	44	252	504	164	257
33,000	-62	-70	48	268	536	163	264	42	242	484	157	255
35,000	-65	-74	50	273	546	164	274	43	241	482	155	261

ncbm171c

MAXIMUM RANGE POWER

ISA - 20°C

1600 RPM

WEIGHT →			12,000 POUNDS					11,000 POUNDS				
PRES- SURE ALT	IOAT	OAT	TORQ PER ENG	FUEL FLOW PER ENG	FUEL FLOW TOTAL	IAS	TAS	TORQ PER ENG	FUEL FLOW PER ENG	FUEL FLOW TOTAL	IAS	TAS
FEET	°C	°C	%	LBS/HR	LBS/HR	KTS	KTS	%	LBS/HR	LBS/HR	KTS	KTS
SL	0	-5	50	448	896	215	206	48	437	874	212	203
2000	-4	-9	49	424	848	211	207	46	413	826	207	204
4000	-8	-13	48	404	808	206	209	45	392	784	203	205
6000	-12	-17	46	382	764	202	211	43	370	740	198	207
8000	-15	-21	45	362	724	197	212	42	350	700	193	208
10,000	-19	-25	44	345	690	194	215	41	332	664	189	210
12,000	-23	-29	44	331	662	190	217	40	317	634	185	212
14,000	-27	-33	43	316	632	186	220	39	303	606	182	215
16,000	-31	-37	42	303	606	183	223	39	290	580	178	217
18,000	-35	-41	42	291	582	180	226	39	278	556	175	220
20,000	-38	-45	41	280	560	176	229	38	267	534	172	223
22,000	-42	-49	41	271	542	173	233	38	258	516	169	227
24,000	-46	-53	41	262	524	171	237	38	249	498	166	231
26,000	-49	-57	41	256	512	169	242	38	241	482	164	235
28,000	-53	-60	42	251	502	167	248	38	236	472	162	240
29,000	-55	-62	42	248	496	166	251	38	233	466	161	243
31,000	-59	-66	42	243	486	164	256	38	229	458	159	249
33,000	-62	-70	41	234	468	158	256	38	224	448	157	255
35,000	-67	-74	39	223	446	151	254	37	216	432	152	256
37,000	-68	-77	40	226	452	150	263	36	207	414	145	255

ncbm171d

MAXIMUM RANGE POWER
ISA - 10°C
1600 RPM

WEIGHT →			14,500 POUNDS					13,000 POUNDS				
PRES- SURE ALT	IOAT	OAT	TORQ PER ENG	FUEL FLOW PER ENG	FUEL FLOW TOTAL	IAS	TAS	TORQ PER ENG	FUEL FLOW PER ENG	FUEL FLOW TOTAL	IAS	TAS
FEET	°C	°C	%	LBS/HR	LBS/HR	KTS	KTS	%	LBS/HR	LBS/HR	KTS	KTS
SL	11	5	59	485	970	224	218	55	469	938	219	214
2000	7	1	58	463	926	220	220	54	446	892	215	216
4000	3	-3	56	441	882	215	222	52	424	848	210	217
6000	-1	-7	55	421	842	211	224	51	404	808	206	219
8000	-5	-11	54	404	808	207	227	50	387	774	203	222
10,000	-8	-15	54	387	774	203	229	49	369	738	199	224
12,000	-12	-19	53	371	742	200	232	48	353	706	195	227
14,000	-16	-23	52	355	710	196	235	48	337	674	191	230
16,000	-20	-27	52	342	684	193	239	47	324	648	188	233
18,000	-24	-31	52	332	664	191	244	47	312	624	185	236
20,000	-27	-35	52	323	646	189	249	47	302	604	182	241
22,000	-31	-39	52	315	630	186	254	47	294	588	180	246
24,000	-35	-43	51	303	606	181	256	47	285	570	177	251
26,000	-39	-47	49	290	580	175	256	47	277	554	174	255
28,000	-43	-50	48	278	556	168	255	45	268	536	169	257
29,000	-45	-52	48	276	552	166	256	44	261	522	166	256
31,000	-48	-56	49	278	556	166	265	43	250	500	159	255
33,000	-51	-60	50	280	560	165	273	43	249	498	157	260
35,000	-55	-64	50	277	554	161	276	45	251	502	157	270
37,000	-56	-67	54	293	586	165	295	45	251	502	153	275

ncbm171e

MAXIMUM RANGE POWER
ISA - 10°C
1600 RPM

WEIGHT →			12,000 POUNDS					11,000 POUNDS				
PRES- SURE ALT	IOAT	OAT	TORQ PER ENG	FUEL FLOW PER ENG	FUEL FLOW TOTAL	IAS	TAS	TORQ PER ENG	FUEL FLOW PER ENG	FUEL FLOW TOTAL	IAS	TAS
FEET	°C	°C	%	LBS/HR	LBS/HR	KTS	KTS	%	LBS/HR	LBS/HR	KTS	KTS
SL	10	5	52	458	916	217	211	50	448	896	214	208
2000	6	1	51	435	870	212	213	48	425	850	209	210
4000	3	-3	49	413	826	207	214	46	402	804	204	211
6000	-1	-7	48	393	786	203	216	45	381	762	199	212
8000	-5	-11	47	375	750	199	218	44	364	728	196	215
10,000	-9	-15	46	358	716	196	221	43	347	694	192	217
12,000	-13	-19	46	342	684	192	223	43	331	662	188	220
14,000	-17	-23	45	326	652	188	226	42	315	630	184	222
16,000	-20	-27	44	312	624	184	229	41	300	600	181	225
18,000	-24	-31	43	300	600	181	232	40	288	576	177	227
20,000	-28	-35	43	288	576	177	235	40	276	552	174	230
22,000	-32	-39	43	279	558	175	239	39	266	532	171	234
24,000	-35	-43	43	271	542	172	244	39	257	514	168	238
26,000	-39	-47	43	264	528	170	250	39	250	500	165	243
28,000	-43	-50	43	258	516	168	255	39	244	488	163	248
29,000	-45	-52	43	253	506	166	256	39	241	482	162	251
31,000	-49	-56	41	242	484	159	255	39	235	470	160	256
33,000	-53	-60	39	232	464	153	255	38	225	450	154	256
35,000	-56	-64	40	231	462	151	260	36	214	428	147	254
37,000	-58	-67	41	235	470	151	271	37	215	430	145	261
39,000	-57	-67	42	235	470	147	277	38	218	436	144	272
41,000	-57	-67						39	223	446	144	283

ncbm171f

MAXIMUM RANGE POWER

ISA

1600 RPM

WEIGHT →			14,500 POUNDS					13,000 POUNDS				
PRES- SURE ALT	IOAT	OAT	TORQ PER ENG	FUEL FLOW PER ENG	FUEL FLOW TOTAL	IAS	TAS	TORQ PER ENG	FUEL FLOW PER ENG	FUEL FLOW TOTAL	IAS	TAS
FEET	°C	°C	%	LBS/HR	LBS/HR	KTS	KTS	%	LBS/HR	LBS/HR	KTS	KTS
SL	21	15	56	479	958	218	216	52	461	922	213	212
2000	17	11	56	462	924	216	220	52	444	888	211	216
4000	13	7	56	445	890	213	224	52	429	858	209	220
6000	9	3	56	427	854	210	227	52	411	822	206	223
8000	6	-1	55	410	820	206	230	51	393	786	202	226
10,000	2	-5	54	393	786	203	233	50	375	750	198	228
12,000	-2	-9	54	378	756	199	236	49	360	720	194	231
14,000	-6	-13	53	364	728	196	240	49	346	692	191	234
16,000	-10	-17	53	352	704	194	245	48	332	664	187	237
18,000	-13	-21	53	340	680	191	249	48	319	638	185	241
20,000	-17	-25	53	328	656	187	253	47	308	616	182	246
22,000	-21	-29	52	315	630	182	255	48	300	600	180	251
24,000	-25	-33	50	301	602	176	254	47	289	578	176	254
26,000	-29	-37	49	290	580	171	255	46	278	556	171	255
28,000	-32	-40	49	288	576	169	261	44	265	530	163	254
29,000	-34	-42	50	289	578	169	266	43	261	522	161	255
31,000	-37	-46	51	288	576	167	273	44	259	518	160	262
33,000	-41	-50	50	284	568	162	275	45	261	522	159	270
35,000	-44	-54	53	296	592	166	291	45	256	512	155	273
37,000	-47	-57						47	266	532	157	287

ncbm171g

MAXIMUM RANGE POWER
ISA
1600 RPM

WEIGHT →			12,000 POUNDS					11,000 POUNDS				
PRES- SURE ALT	IOAT	OAT	TORQ PER ENG	FUEL FLOW PER ENG	FUEL FLOW TOTAL	IAS	TAS	TORQ PER ENG	FUEL FLOW PER ENG	FUEL FLOW TOTAL	IAS	TAS
FEET	°C	°C	%	LBS/HR	LBS/HR	KTS	KTS	%	LBS/HR	LBS/HR	KTS	KTS
SL	20	15	50	450	900	211	209	47	440	880	208	206
2000	16	11	49	433	866	208	213	47	423	846	205	210
4000	13	7	49	417	834	206	217	47	406	812	203	213
6000	9	3	49	400	800	203	220	46	389	778	200	217
8000	5	-1	48	382	764	199	223	45	371	742	196	219
10,000	1	-5	47	364	728	195	225	44	353	706	192	221
12,000	-3	-9	46	349	698	191	227	43	338	676	188	224
14,000	-6	-13	46	334	668	188	230	43	323	646	184	226
16,000	-10	-17	45	320	640	184	233	42	308	616	181	229
18,000	-14	-21	44	307	614	181	237	41	295	590	177	232
20,000	-18	-25	44	294	588	178	240	40	281	562	173	235
22,000	-21	-29	44	286	572	175	245	40	272	544	171	239
24,000	-25	-33	44	278	556	173	250	40	263	526	168	244
26,000	-29	-37	44	269	538	170	255	40	256	512	166	249
28,000	-33	-40	42	258	516	165	256	40	249	498	163	254
29,000	-35	-42	41	252	504	161	255	40	245	490	162	256
31,000	-39	-46	40	242	484	155	255	38	233	466	155	254
33,000	-42	-50	41	240	480	153	261	37	224	448	149	255
35,000	-46	-54	42	241	482	153	270	37	221	442	147	260
37,000	-48	-57	41	238	476	148	273	38	224	448	147	270
39,000	-46	-57	44	250	500	151	291	38	221	442	142	274

ncbm171h

MAXIMUM RANGE POWER

ISA + 10°C

1600 RPM

WEIGHT →			14,500 POUNDS					13,000 POUNDS				
PRES- SURE ALT	IOAT	OAT	TORQ PER ENG	FUEL FLOW PER ENG	FUEL FLOW TOTAL	IAS	TAS	TORQ PER ENG	FUEL FLOW PER ENG	FUEL FLOW TOTAL	IAS	TAS
FEET	°C	°C	%	LBS/HR	LBS/HR	KTS	KTS	%	LBS/HR	LBS/HR	KTS	KTS
SL	31	25	54	475	950	213	215	50	456	912	208	210
2000	27	21	54	458	916	211	219	50	439	878	206	214
4000	23	17	54	443	886	209	223	50	425	850	204	219
6000	19	13	54	426	852	206	227	50	409	818	202	222
8000	16	9	54	410	820	203	231	50	393	786	199	226
10,000	12	5	54	396	792	200	235	50	378	756	196	230
12,000	8	1	54	383	766	198	239	49	364	728	193	233
14,000	4	-3	54	370	740	196	244	49	350	700	190	237
16,000	1	-7	54	359	718	193	249	49	339	678	187	242
18,000	-3	-11	53	346	692	189	252	49	328	656	185	246
20,000	-7	-15	52	331	662	184	253	48	317	634	182	251
22,000	-11	-19	51	316	632	178	254	47	304	608	177	253
24,000	-15	-23	50	306	612	174	257	46	290	580	172	254
26,000	-18	-27	51	302	604	172	263	45	277	554	166	254
28,000	-22	-30	51	299	598	170	270	45	272	544	163	259
29,000	-24	-32	51	295	590	168	270	45	271	542	163	262
31,000	-28	-36	50	289	578	162	272	46	268	536	161	269
33,000	-31	-40	53	299	598	165	286	45	261	522	155	269
35,000	-35	-46						46	266	532	155	280

ncbm171i

MAXIMUM RANGE POWER

ISA + 10°C

1600 RPM

WEIGHT →			12,000 POUNDS					11,000 POUNDS				
PRES- SURE ALT	IOAT	OAT	TORQ PER ENG	FUEL FLOW PER ENG	FUEL FLOW TOTAL	IAS	TAS	TORQ PER ENG	FUEL FLOW PER ENG	FUEL FLOW TOTAL	IAS	TAS
FEET	°C	°C	%	LBS/HR	LBS/HR	KTS	KTS	%	LBS/HR	LBS/HR	KTS	KTS
SL	30	25	47	445	890	205	207	45	434	868	203	205
2000	26	21	47	427	854	203	211	45	416	832	200	208
4000	23	17	47	412	824	201	215	45	401	802	198	212
6000	19	13	47	397	794	199	219	45	386	772	196	216
8000	15	9	47	382	764	196	223	44	371	742	193	220
10,000	11	5	47	367	734	193	227	44	357	714	191	224
12,000	8	1	46	353	706	190	230	44	342	684	187	227
14,000	4	-3	46	338	676	187	233	43	327	654	184	230
16,000	0	-7	45	325	650	184	237	42	314	628	180	233
18,000	-4	-11	45	314	628	181	241	42	302	604	177	236
20,000	-7	-15	45	303	606	178	246	41	290	580	174	240
22,000	-11	-19	45	293	586	175	250	41	280	560	171	245
24,000	-15	-23	44	281	562	171	253	41	270	540	168	249
26,000	-19	-27	43	269	538	166	254	41	260	520	165	253
28,000	-23	-30	41	257	514	160	254	39	249	498	160	254
29,000	-25	-32	41	254	508	158	256	38	243	486	156	253
31,000	-28	-36	42	251	502	156	262	38	234	468	152	255
33,000	-32	-40	42	250	500	155	269	38	231	462	150	261
35,000	-36	-44	41	242	484	149	270	39	230	460	148	268
37,000	-37	-47	43	250	500	151	283	38	224	448	143	269

ncbm171j

MAXIMUM RANGE POWER
ISA + 20°C
1600 RPM

WEIGHT →			14,500 POUNDS					13,000 POUNDS				
PRES- SURE ALT	IOAT	OAT	TORQ PER ENG	FUEL FLOW PER ENG	FUEL FLOW TOTAL	IAS	TAS	TORQ PER ENG	FUEL FLOW PER ENG	FUEL FLOW TOTAL	IAS	TAS
FEET	°C	°C	%	LBS/HR	LBS/HR	KTS	KTS	%	LBS/HR	LBS/HR	KTS	KTS
SL	40	35	52	472	944	208	214	48	453	906	204	209
2000	37	31	52	456	912	206	218	48	436	872	201	123
4000	33	27	52	441	882	204	222	48	421	842	199	217
6000	29	23	52	425	850	201	226	48	407	814	197	221
8000	26	19	52	410	820	199	230	48	392	784	195	225
10,000	22	15	52	396	792	196	234	48	377	754	192	229
12,000	18	11	53	384	768	194	239	48	365	730	190	234
14,000	14	7	53	373	746	193	245	48	353	706	187	239
16,000	11	3	53	361	722	190	250	48	342	684	186	244
18,000	7	-1	53	348	696	186	253	49	332	664	183	249
20,000	3	-5	52	334	668	181	255	48	318	636	179	252
22,000	0	-9	52	326	652	179	260	47	306	612	174	254
24,000	-4	-13	52	320	640	177	266	46	295	590	170	256
26,000	-8	-17	52	311	622	173	269	46	289	578	168	262
28,000	-12	-20	50	300	600	166	269	47	283	566	165	267
29,000	-14	-22	51	299	598	165	272	46	279	558	163	269
31,000	-17	-26	53	306	612	167	285	45	269	538	157	268
33,000	-21	-30						47	273	546	157	279

ncbm171k

MAXIMUM RANGE POWER

ISA + 20°C

1600 RPM

WEIGHT →			12,000 POUNDS					11,000 POUNDS				
PRES- SURE ALT	IOAT	OAT	TORQ PER ENG	FUEL FLOW PER ENG	FUEL FLOW TOTAL	IAS	TAS	TORQ PER ENG	FUEL FLOW PER ENG	FUEL FLOW TOTAL	IAS	TAS
FEET	°C	°C	%	LBS/HR	LBS/HR	KTS	KTS	%	LBS/HR	LBS/HR	KTS	KTS
SL	40	35	46	441	882	201	207	43	430	860	198	204
2000	36	31	45	423	846	198	210	43	411	822	195	207
4000	33	27	45	408	816	196	214	43	396	792	193	210
6000	29	23	45	394	788	194	218	43	381	762	191	214
8000	25	19	45	380	760	192	222	43	368	736	189	219
10,000	21	15	45	366	732	189	226	43	354	708	186	223
12,000	18	11	45	353	706	187	230	43	342	684	184	227
14,000	14	7	45	340	680	184	235	42	329	658	181	231
16,000	10	3	45	329	658	182	239	42	317	634	178	235
18,000	7	-1	45	319	638	180	245	42	305	610	176	239
20,000	3	-5	45	308	616	177	249	42	295	590	173	244
22,000	-1	-9	45	297	594	173	252	42	286	572	171	249
24,000	-5	-13	43	284	568	168	253	41	275	550	167	252
26,000	-9	-17	43	273	546	164	256	40	262	524	162	253
28,000	-12	-20	43	267	534	161	261	39	251	502	157	255
29,000	-14	-22	43	264	528	160	264	39	247	494	155	257
31,000	-18	-26	43	258	516	157	268	39	243	486	153	263
33,000	-22	-30	41	250	500	151	268	39	239	478	151	268
35,000	-25	-34	43	253	506	151	279	38	230	460	145	267
37,000	-27	-37						40	237	474	146	281

ncbm171m

MAXIMUM RANGE POWER

ISA + 30°C

1600 RPM

WEIGHT →			14,500 POUNDS					13,000 POUNDS				
PRES- SURE ALT	IOAT	OAT	TORQ PER ENG	FUEL FLOW PER ENG	FUEL FLOW TOTAL	IAS	TAS	TORQ PER ENG	FUEL FLOW PER ENG	FUEL FLOW TOTAL	IAS	TAS
FEET	°C	°C	%	LBS/HR	LBS/HR	KTS	KTS	%	LBS/HR	LBS/HR	KTS	KTS
SL	50	45	51	472	944	204	213	46	451	902	220	208
2000	47	41	51	456	912	202	218	46	434	868	197	212
4000	43	37	51	441	882	200	222	47	420	840	195	217
6000	39	33	51	426	852	198	226	47	406	812	193	221
8000	36	29	51	412	824	195	230	47	392	784	191	225
10,000	32	25	52	400	800	194	236	47	378	756	188	229
12,000	28	21	55	397	794	196	246	47	365	730	186	233
14,000	25	17	56	387	774	195	252	47	354	708	184	238
16,000	21	13	56	375	750	192	257	48	347	694	184	246
18,000	18	9	55	362	724	189	261	49	338	676	182	252
20,000	14	5	54	347	694	184	263	49	327	654	179	257
22,000	10	1	53	334	668	179	265	49	318	636	177	261
24,000	6	-3	52	320	640	173	265	48	306	612	172	264
26,000	2	-7	52	317	634	171	272	47	293	586	166	265
28,000	-1	-10	53	317	634	170	280	46	285	570	162	267
29,000	-4	-12						47	286	572	162	272
31,000	-7	-16						48	285	570	160	280

ncbm171n

MAXIMUM RANGE POWER

ISA + 30°C

1600 RPM

WEIGHT →			12,000 POUNDS					11,000 POUNDS				
PRES- SURE ALT	IOAT	OAT	TORQ PER ENG	FUEL FLOW PER ENG	FUEL FLOW TOTAL	IAS	TAS	TORQ PER ENG	FUEL FLOW PER ENG	FUEL FLOW TOTAL	IAS	TAS
FEET	°C	°C	%	LBS/HR	LBS/HR	KTS	KTS	%	LBS/HR	LBS/HR	KTS	KTS
SL	50	45	44	439	878	197	206	42	428	856	194	203
2000	46	41	44	422	844	194	209	41	410	820	191	206
4000	43	37	44	407	814	192	213	41	393	786	188	209
6000	39	33	44	392	784	190	217	41	379	758	186	213
8000	35	29	44	379	758	188	221	41	365	730	184	217
10,000	31	25	44	365	730	185	225	41	352	704	182	222
12,000	28	21	44	352	704	183	229	41	340	680	179	226
14,000	24	17	44	340	680	180	234	41	327	654	177	230
16,000	20	13	44	329	658	178	238	41	315	630	174	234
18,000	17	9	44	321	642	177	245	41	305	610	172	238
20,000	13	5	45	311	622	175	251	41	296	592	170	244
22,000	9	1	45	303	606	172	256	41	288	576	168	250
24,000	6	-3	45	293	586	169	260	41	278	556	165	254
26,000	2	-7	45	284	568	166	264	41	270	540	162	259
28,000	-2	-10	43	272	544	160	264	41	263	526	159	263
29,000	-4	-12	42	267	534	157	264	40	258	516	157	264
31,000	-8	-16	43	265	530	156	272	39	247	494	151	264
33,000	-11	-20	44	263	526	154	279	39	241	482	148	269
35,000	-15	-24						40	242	484	148	278

ncbm1710

MAXIMUM RANGE POWER

ISA + 37°C

1600 RPM

WEIGHT →			14,500 POUNDS					13,000 POUNDS				
PRES- SURE ALT	IOAT	OAT	TORQ PER ENG	FUEL FLOW PER ENG	FUEL FLOW TOTAL	IAS	TAS	TORQ PER ENG	FUEL FLOW PER ENG	FUEL FLOW TOTAL	IAS	TAS
FEET	°C	°C	%	LBS/HR	LBS/HR	KTS	KTS	%	LBS/HR	LBS/HR	KTS	KTS
SL	58	52	52	484	968	206	218	46	455	910	190	209
2000	54	48	52	466	932	204	221	45	435	870	194	212
4000	50	44	52	451	902	201	226	45	419	838	192	215
6000	47	40	53	437	874	200	231	45	405	810	190	220
8000	43	36	54	426	852	199	237	46	391	782	188	224
10,000	39	32	56	418	836	199	245	47	382	764	187	231
12,000	36	28	56	406	812	198	250	48	375	750	188	239
14,000	32	24	56	391	782	194	255	50	368	736	188	247
16,000	28	20	55	377	754	191	258	51	359	718	187	253
18,000	24	16	54	361	722	186	260	51	346	692	184	257
20,000	21	12	53	345	690	180	261	50	332	664	179	260
22,000	17	8	53	335	670	177	265	48	317	634	174	261
24,000	13	4	54	331	662	175	272	47	304	608	169	262
26,000	9	0						47	299	598	167	269
28,000	6	-3						48	295	590	164	275

ncbm171p

MAXIMUM RANGE POWER
ISA + 37°C
1600 RPM

WEIGHT →			12,000 POUNDS					11,000 POUNDS				
PRES- SURE ALT	IOAT	OAT	TORQ PER ENG	FUEL FLOW PER ENG	FUEL FLOW TOTAL	IAS	TAS	TORQ PER ENG	FUEL FLOW PER ENG	FUEL FLOW TOTAL	IAS	TAS
FEET	°C	°C	%	LBS/HR	LBS/HR	KTS	KTS	%	LBS/HR	LBS/HR	KTS	KTS
SL	57	52	43	441	882	195	206	41	428	856	192	203
2000	53	48	42	420	840	191	208	40	408	816	188	205
4000	49	44	42	405	810	188	211	40	392	784	185	208
6000	46	40	42	391	782	187	216	40	377	754	183	212
8000	42	36	43	378	756	185	220	40	364	728	181	216
10,000	38	32	43	365	730	182	225	40	351	702	179	221
12,000	35	28	43	353	706	180	229	40	339	678	177	225
14,000	31	24	44	344	688	180	236	40	326	652	174	229
16,000	28	20	46	339	678	181	245	40	316	632	172	234
18,000	24	16	47	333	666	180	253	41	311	622	173	242
20,000	20	12	47	321	642	178	258	43	305	610	173	251
22,000	17	8	46	309	618	173	260	43	298	596	171	257
24,000	13	4	45	295	590	168	262	43	286	572	167	261
26,000	9	0	44	283	566	163	263	41	274	548	162	262
28,000	5	-3	44	278	556	161	269	40	262	524	157	262
29,000	3	-5	44	277	554	160	272	40	258	516	155	264
31,000	-1	-9						40	255	510	153	271
33,000	-4	-13						40	250	500	150	275

ncbm171q

ASSOCIATED CONDITIONS:

WEIGHT 15,010 LBS BEFORE ENGINE START
 FUEL JET A
 FUEL DENSITY 6.55 LBS/GAL

RANGE PROFILE - MAXIMUM RANGE POWER**1600 RPM****STANDARD DAY (ISA)
ZERO WIND**EXAMPLE:

PRESSURE ALTITUDE 29,000 FT
 FUEL 3200 LBS
 RANGE 1180 NM

NOTES: 1. RANGE ALLOWS FOR START, TAXI, AND RUNUP; INCLUDES
 CRUISE CLIMB AND DESCENT; AND ALLOWS FOR 45
 MINUTES RESERVE FUEL AT MAXIMUM RANGE POWER.

* 2. AT 15,010 LBS RAMP WEIGHT, THE MAXIMUM ZERO-FUEL
 WEIGHT LIMITATION OF 12,600 LBS WOULD BE EXCEEDED
 AT FUEL LOADING LESS THAN 2410 LBS.

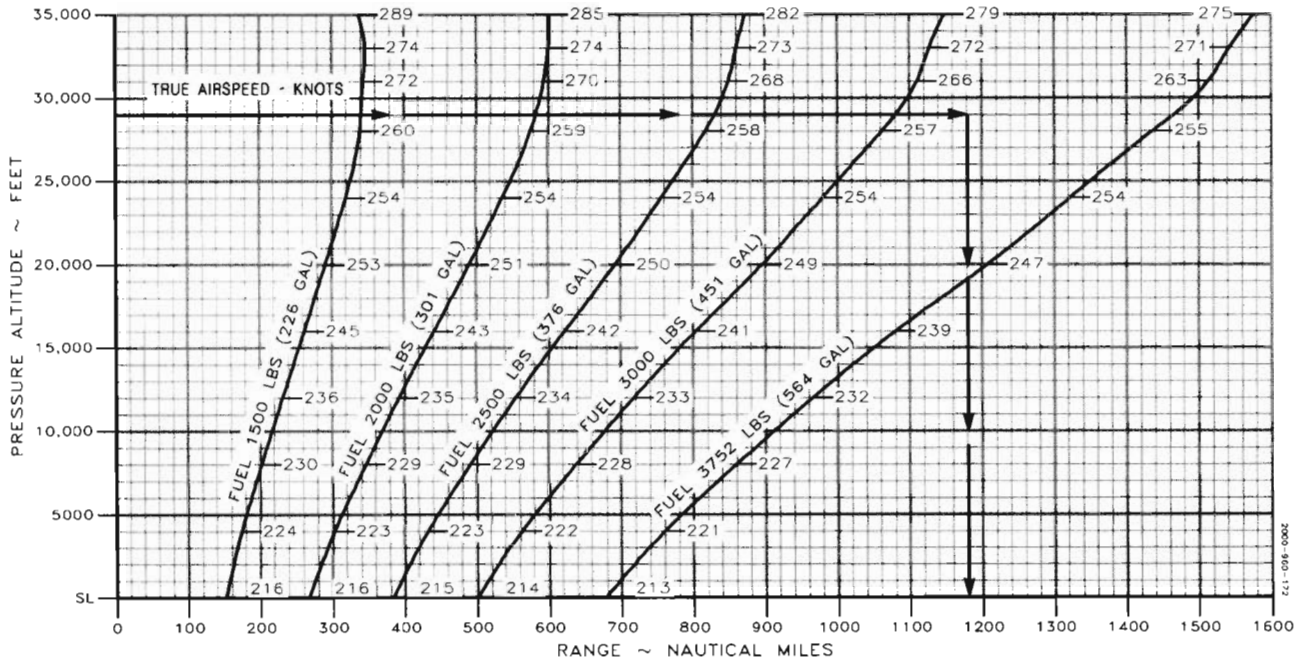

ASSOCIATED CONDITIONS:

WEIGHT 15,010 LBS BEFORE ENGINE START
 FUEL JET A
 FUEL DENSITY 6.65 LBS/GAL

RANGE PROFILE - FULL FUEL

1600 RPM
STANDARD DAY (ISA)
ZERO WIND

EXAMPLE:

PRESSURE ALTITUDE 29,000 FT
 RANGE AT MAXIMUM CRUISE POWER 1270 NM
 RANGE AT RECOMMENDED CRUISE POWER 1295 NM
 RANGE AT MAXIMUM RANGE POWER 1462 NM

NOTE: RANGE ALLOWS FOR START, TAXI, AND RUNUP; INCLUDES CRUISE CLIMB AND DESCENT; AND ALLOWS FOR 45 MINUTES RESERVE FUEL AT MAXIMUM RANGE POWER.

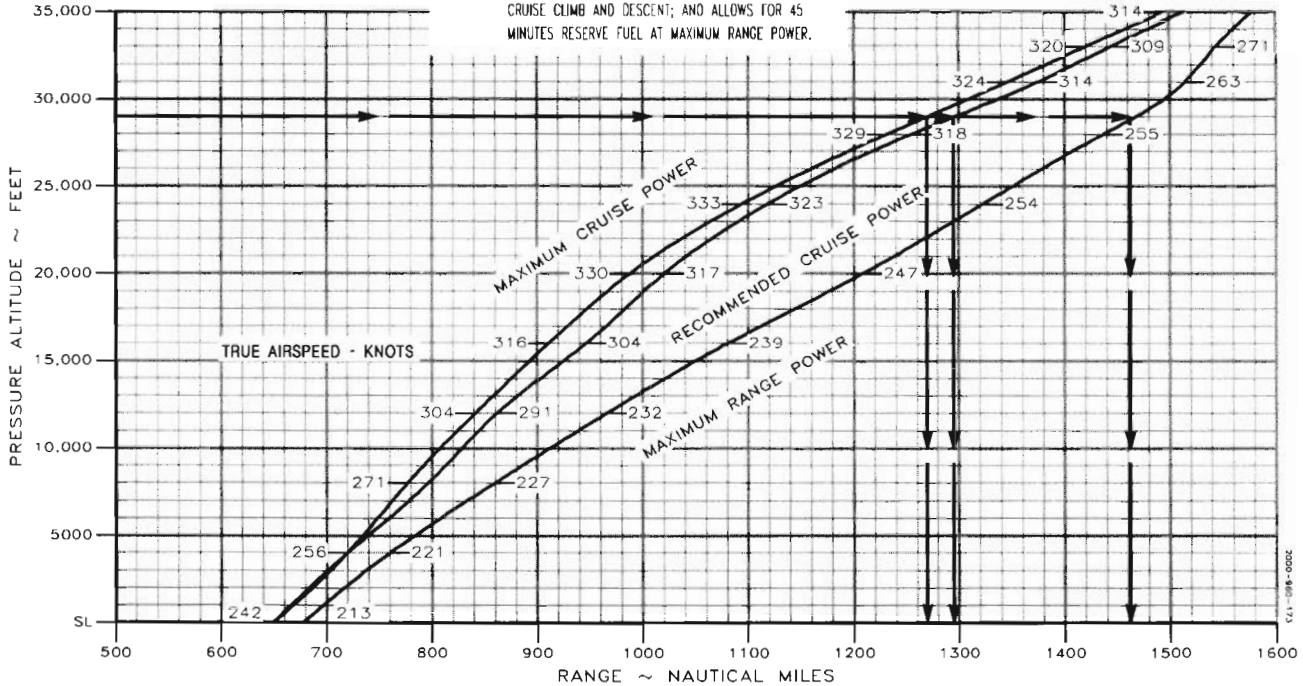

ASSOCIATED CONDITIONS:

WEIGHT 15,010 LBS BEFORE ENGINE START
 FUEL JET A
 FUEL DENSITY 6.65 LBS/GAL

ENDURANCE PROFILE - FULL FUEL

1600 RPM

STANDARD DAY (ISA)
ZERO WIND

EXAMPLE:

PRESSURE ALTITUDE 29,000 FT
 ENDURANCE AT MAXIMUM CRUISE POWER 4.06 HR
 ENDURANCE AT RECOMMENDED CRUISE POWER 4.26 HR
 ENDURANCE AT MAXIMUM RANGE POWER 5.75 HR

NOTE: RANGE ALLOWS FOR START, TAXI, AND RUNUP; INCLUDES
 CRUISE CLIMB AND DESCENT; AND ALLOWS FOR 45
 MINUTES RESERVE FUEL AT MAXIMUM RANGE POWER.

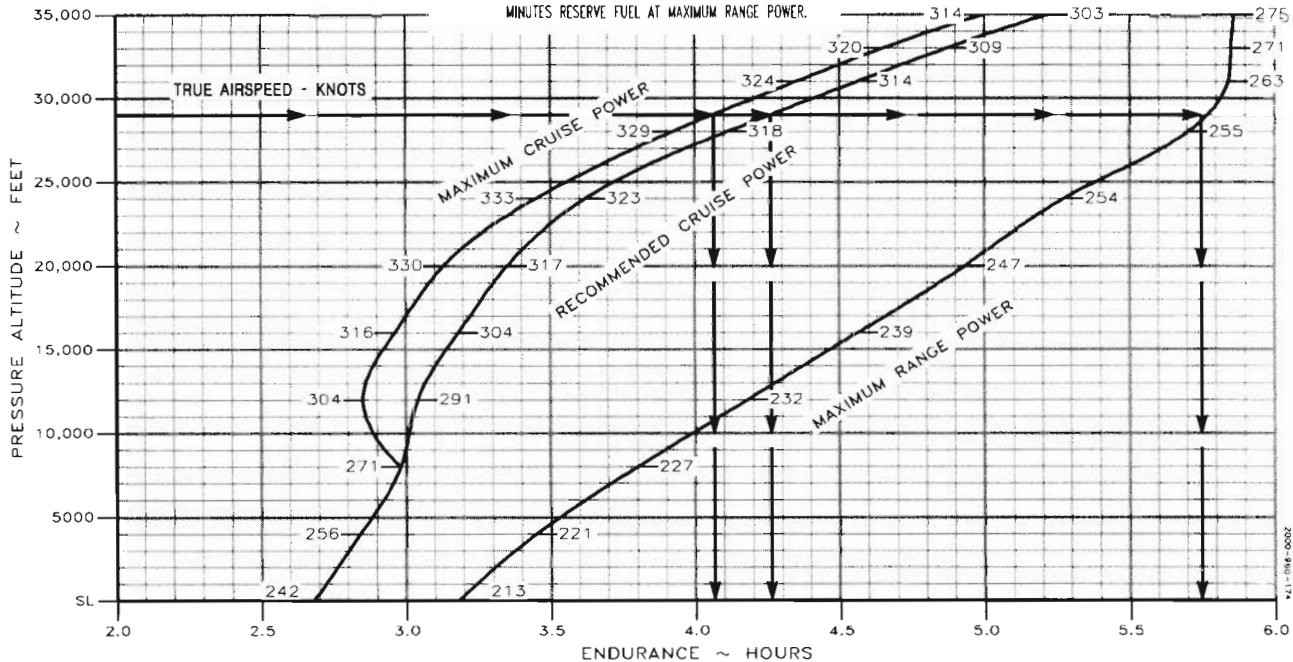

ONE-ENGINE-INOPERATIVE MAXIMUM CRUISE POWER

1. All flows presented in this section represent average new engine performance with Jet A fuel. Use of other fuels, or operation with other than new engines, may increase fuel flows.
2. Activation of engine anti-ice will decrease engine torque approximately 8%, true airspeed will be reduced approximately 10 knots, and fuel flow will decrease approximately 14 lbs/hr/eng.
3. Operation with normal ice accumulations will additionally reduce true airspeed approximately 35 knots.

**ONE-ENGINE-INOPERATIVE
MAXIMUM CRUISE POWER**

ISA - 30°C

1600 RPM

WEIGHT →			14,500 POUNDS					13,000 POUNDS				
PRES- SURE ALT	IOAT	OAT	TORQ P E R E N G	FUEL FLOW P E R E N G	FUEL FLOW TOTAL	IAS	TAS	TORQ P E R E N G	FUEL FLOW P E R E N G	FUEL FLOW TOTAL	IAS	TAS
FEET	°C	°C	%	LBS/HR	LBS/HR	KTS	KTS	%	LBS/HR	LBS/HR	KTS	KTS
SL	-11	-15	97	642	642	203	191	97	641	641	226	194
2000	-14	-19	97	617	617	201	194	97	617	617	204	197
4000	-18	-23	97	600	600	199	198	97	600	600	202	201
6000	-22	-27	97	586	586	196	201	97	585	585	199	204
8000	-26	-31	97	573	573	193	204	97	573	573	197	207
10,000	-30	-35	97	561	561	190	207	97	561	561	194	211
12,000	-33	-39	97	551	551	187	210	97	551	551	191	214
14,000	-37	-43	97	541	541	184	213	97	541	541	189	218
16,000	-41	-47	97	533	533	182	217	97	532	532	187	222
18,000	-45	-51	97	528	528	179	220	97	527	527	183	225
20,000	-49	-55	97	524	524	175	222	97	523	523	180	229
22,000	-53	-59	97	521	521	171	225	97	520	520	177	232
24,000	-56	-63	97	517	517	167	226	97	519	519	174	235
26,000	-61	-67	89	480	480	154	217	90	484	484	164	230
28,000	-66	-70	81	441	441	136	199	83	449	449	153	222
29,000								79	431	431	146	216

ncbm175a

**ONE-ENGINE-INOPERATIVE
MAXIMUM CRUISE POWER**

ISA - 30°C

1600 RPM

WEIGHT →			12,000 POUNDS					11,000 POUNDS				
PRES- SURE ALT	IOAT	OAT	TORQ PER ENG	FUEL FLOW PER ENG	FUEL FLOW TOTAL	IAS	TAS	TORQ PER ENG	FUEL FLOW PER ENG	FUEL FLOW TOTAL	IAS	TAS
FEET	°C	°C	%	LBS/HR	LBS/HR	KTS	KTS	%	LBS/HR	LBS/HR	KTS	KTS
SL	-10	-15	97	641	641	208	195	97	641	641	209	196
2000	-14	-19	97	617	617	205	198	97	617	617	207	200
4000	-18	-23	97	600	600	204	202	97	600	600	205	204
6000	-22	-27	97	585	585	201	206	97	585	585	203	208
8000	-26	-31	97	572	572	199	209	97	572	572	201	211
10,000	-29	-35	97	560	560	196	213	97	560	560	198	215
12,000	-33	-39	97	550	550	194	216	97	550	550	196	219
14,000	-37	-43	97	540	540	191	220	97	540	540	193	222
16,000	-41	-47	97	532	532	189	225	97	531	531	191	227
18,000	-44	-51	97	527	527	186	228	97	526	526	188	231
20,000	-48	-55	97	522	522	183	232	97	522	522	186	235
22,000	-33	-59	97	519	519	180	236	97	519	519	183	239
24,000	-56	-63	97	518	518	177	240	97	518	518	180	243
26,000	-60	-67	91	486	486	168	236	91	488	488	172	241
28,000	-64	-70	84	452	452	158	230	84	454	454	163	237
29,000	-66	-72	80	434	434	153	226	81	437	437	158	234
31,000	-72	-76						60	328	328	130	199

ncbm175b

**ONE-ENGINE-INOPERATIVE
MAXIMUM CRUISE POWER**

ISA - 20°C

1600 RPM

WEIGHT →			14,500 POUNDS					13,000 POUNDS				
PRES- SURE ALT	IOAT	OAT	TORQ PER ENG	FUEL FLOW PER ENG	FUEL FLOW TOTAL	IAS	TAS	TORQ PER ENG	FUEL FLOW PER ENG	FUEL FLOW TOTAL	IAS	TAS
FEET	°C	°C	%	LBS/HR	LBS/HR	KTS	KTS	%	LBS/HR	LBS/HR	KTS	KTS
SL	-1	-5	97	648	648	202	193	97	648	648	205	196
2000	-4	-9	97	630	630	199	196	97	630	630	202	199
4000	-8	-13	97	613	613	196	199	97	613	613	200	203
6000	-12	-17	97	595	595	194	202	97	595	595	197	206
8000	-16	-21	97	579	579	191	205	97	578	578	194	209
10,000	-20	-25	97	566	566	188	208	97	565	565	192	213
12,000	-23	-29	97	555	555	185	211	97	554	554	189	216
14,000	-27	-33	97	546	546	182	215	97	545	545	187	220
16,000	-31	-37	97	539	539	179	218	97	538	538	184	224
18,000	-35	-41	97	533	533	176	221	97	532	532	181	227
20,000	-39	-45	97	528	528	172	223	97	527	527	177	230
22,000	-42	-49	97	522	522	168	225	97	524	524	174	234
24,000	-47	-53	90	486	486	156	217	91	490	490	165	229
26,000	-52	-57	82	449	449	140	202	84	455	455	154	222
28,000	-55	-62						77	421	421	141	211
29,000	-58	-62						73	403	403	132	201

ncbm175c

**ONE-ENGINE-INOPERATIVE
MAXIMUM CRUISE POWER**

ISA - 20°C

1600 RPM

WEIGHT →			12,000 POUNDS					11,000 POUNDS				
PRES- SURE ALT	IOAT	OAT	TORQ PER ENG	FUEL FLOW PER ENG	FUEL FLOW TOTAL	IAS	TAS	TORQ PER ENG	FUEL FLOW PER ENG	FUEL FLOW TOTAL	IAS	TAS
FEET	°C	°C	%	LBS/HR	LBS/HR	KTS	KTS	%	LBS/HR	LBS/HR	KTS	KTS
SL	0	-5	97	648	648	206	198	97	648	648	208	199
2000	-4	-9	97	630	630	204	201	97	630	630	205	202
4000	-8	-13	97	613	613	202	204	97	613	613	203	206
6000	-12	-17	97	595	595	199	208	97	594	594	201	210
8000	-15	-21	97	578	578	196	211	97	578	578	198	213
10,000	-19	-25	97	565	565	194	215	97	565	565	196	217
12,000	-23	-29	97	554	554	191	219	97	554	554	193	221
14,000	-27	-33	97	545	545	189	223	97	544	544	191	225
16,000	-31	-37	97	538	538	186	227	97	537	537	189	229
18,000	-34	-41	97	532	532	183	230	97	532	532	186	233
20,000	-38	-45	97	527	527	180	234	97	526	526	183	237
22,000	-42	-49	97	523	523	178	238	97	523	523	180	241
24,000	-46	-53	91	492	492	169	235	92	493	493	173	240
26,000	-50	-57	85	458	458	160	230	85	459	459	164	236
28,000	-55	-60	78	425	425	149	223	78	427	427	155	231
29,000	-57	-62	74	408	408	143	218	75	411	411	150	227
31,000	-62	-66	67	375	375	128	202	69	379	379	139	219

ncbm175d

**ONE-ENGINE-INOPERATIVE
MAXIMUM CRUISE POWER**

ISA - 10°C

1600 RPM

WEIGHT →			14,500 POUNDS					13,000 POUNDS				
PRES- SURE ALT	IOAT	OAT	TORQ PER ENG	FUEL FLOW PER ENG	FUEL FLOW TOTAL	IAS	TAS	TORQ PER ENG	FUEL FLOW PER ENG	FUEL FLOW TOTAL	IAS	TAS
FEET	°C	°C	%	LBS/HR	LBS/HR	KTS	KTS	%	LBS/HR	LBS/HR	KTS	KTS
SL	10	5	97	656	656	200	195	97	656	656	203	198
2000	6	1	97	637	637	197	198	97	636	636	200	201
4000	2	-3	97	619	619	194	201	97	619	619	198	204
6000	-2	-7	97	603	603	191	204	97	603	603	195	208
8000	-6	-11	97	588	588	189	208	97	588	588	193	212
10,000	-9	-15	97	576	576	186	211	97	576	576	190	215
12,000	-13	-19	97	564	564	183	214	97	564	564	187	219
14,000	-17	-23	97	553	553	180	217	97	553	553	184	222
16,000	-21	-27	97	544	544	176	219	97	544	544	181	225
18,000	-25	-31	97	538	538	173	222	97	537	537	178	229
20,000	-29	-35	94	517	517	166	220	95	519	519	172	229
22,000	-33	-39	88	484	484	154	213	89	487	487	163	225
24,000	-38	-43	81	450	450	139	199	83	454	454	153	219
26,000	-41	-47						76	422	422	141	208

ncbm175e

**ONE-ENGINE-INOPERATIVE
MAXIMUM CRUISE POWER**

ISA - 10°C

1600 RPM

WEIGHT →			12,000 POUNDS					11,000 POUNDS				
PRES-SURE ALT	IOAT	OAT	TORQ PER ENG	FUEL FLOW PER ENG	FUEL FLOW TOTAL	IAS	TAS	TORQ PER ENG	FUEL FLOW PER ENG	FUEL FLOW TOTAL	IAS	TAS
FEET	°C	°C	%	LBS/HR	LBS/HR	KTS	KTS	%	LBS/HR	LBS/HR	KTS	KTS
SL	10	5	97	656	656	204	199	97	656	656	206	201
2000	6	1	97	636	636	202	203	97	636	636	204	204
4000	2	-3	97	619	619	200	206	97	619	619	201	208
6000	-2	-7	97	602	602	197	210	97	602	602	199	212
8000	-5	-11	97	588	588	195	214	97	588	588	197	216
10,000	-9	-15	97	575	575	192	218	97	575	575	194	220
12,000	-13	-19	97	564	564	190	221	97	563	563	192	223
14,000	-17	-23	97	552	552	187	225	97	552	552	189	227
16,000	-20	-27	97	543	543	184	228	97	543	543	186	231
18,000	-24	-31	97	537	537	181	232	97	537	537	184	235
20,000	-28	-35	95	520	520	176	233	95	521	521	179	237
22,000	-32	-39	89	489	489	168	230	90	490	490	117	235
24,000	-36	-43	83	456	456	159	226	84	458	458	163	232
26,000	-41	-47	77	425	425	149	220	78	427	427	154	228
28,000	-45	-50	71	394	394	137	210	72	397	397	145	221
29,000	-48	-52	68	379	379	130	202	69	382	382	139	217
31,000	-51	-56						63	353	353	127	204

ncbm175f

**ONE-ENGINE-INOPERATIVE
MAXIMUM CRUISE POWER**

ISA

1600 RPM

WEIGHT →			14,500 POUNDS					13,000 POUNDS				
PRES- SURE ALT	IOAT	OAT	TORQ PER ENG	FUEL FLOW PER ENG	FUEL FLOW TOTAL	IAS	TAS	TORQ PER ENG	FUEL FLOW PER ENG	FUEL FLOW TOTAL	IAS	TAS
FEET	°C	°C	%	LBS/HR	LBS/HR	KTS	KTS	%	LBS/HR	LBS/HR	KTS	KTS
SL	20	15	97	663	663	198	197	97	663	663	201	200
2000	16	11	97	644	644	195	200	97	643	643	198	203
4000	12	7	97	626	626	193	203	97	626	626	196	207
6000	8	3	97	610	610	190	206	97	609	609	193	210
8000	4	-1	97	595	595	187	209	97	595	595	191	213
10,000	1	-5	97	582	582	184	212	97	582	582	188	217
12,000	-3	-9	97	571	571	180	215	97	571	571	185	220
14,000	-7	-13	97	561	561	177	218	97	560	560	182	224
16,000	-11	-17	97	549	549	173	219	97	551	551	178	226
18,000	-15	-21	92	518	518	164	216	92	520	520	171	224
20,000	-19	-25	86	487	487	154	210	87	490	490	163	221
22,000	-24	-29	80	455	455	140	198	82	459	459	153	216
24,000	-27	-33						76	427	427	142	207
26,000	-32	-37						70	397	397	126	190

ncbm175g

ONE-ENGINE-INOPERATIVE MAXIMUM CRUISE POWER

ISA

1600 RPM

WEIGHT →			12,000 POUNDS					11,000 POUNDS				
PRES- SURE ALT	IOAT	OAT	TORQ PER ENG	FUEL FLOW PER ENG	FUEL FLOW TOTAL	IAS	TAS	TORQ PER ENG	FUEL FLOW PER ENG	FUEL FLOW TOTAL	IAS	TAS
FEET	°C	°C	%	LBS/HR	LBS/HR	KTS	KTS	%	LBS/HR	LBS/HR	KTS	KTS
SL	20	15	97	663	663	203	201	97	663	663	204	203
2000	16	11	97	643	643	200	205	97	643	643	220	206
4000	12	7	97	626	626	198	209	97	625	625	200	210
6000	9	3	97	609	609	196	212	97	609	609	197	214
8000	5	-1	97	595	595	193	216	97	595	595	195	218
10,000	1	-5	97	581	581	190	219	97	581	581	192	222
12,000	-3	-9	97	570	570	187	223	97	570	570	190	225
14,000	-7	-13	97	560	560	185	227	97	560	560	187	229
16,000	-10	-17	97	552	552	182	230	97	552	552	184	233
18,000	-14	-21	93	522	522	175	229	93	523	523	178	233
20,000	-18	-25	88	491	491	167	227	88	492	492	171	232
22,000	-23	-29	82	461	461	159	223	82	462	462	163	229
24,000	-27	-33	76	430	430	149	218	77	431	431	155	225
26,000	-31	-37	71	400	400	138	209	71	402	402	145	219
28,000	-36	-40	65	370	370	123	192	66	373	373	135	211
29,000	-37	-44						63	358	358	128	204

ncbm175h

**ONE-ENGINE-INOPERATIVE
MAXIMUM CRUISE POWER**

ISA + 10°C

1600 RPM

WEIGHT →			14,500 POUNDS					13,000 POUNDS				
PRES- SURE ALT	IOAT	OAT	TORQ PER ENG	FUEL FLOW PER ENG	FUEL FLOW TOTAL	IAS	TAS	TORQ PER ENG	FUEL FLOW PER ENG	FUEL FLOW TOTAL	IAS	TAS
FEET	°C	°C	%	LBS/HR	LBS/HR	KTS	KTS	%	LBS/HR	LBS/HR	KTS	KTS
SL	30	25	97	671	671	196	198	97	671	671	199	202
2000	26	21	97	650	650	194	202	97	650	650	197	205
4000	22	17	97	633	633	191	204	97	632	632	194	208
6000	18	13	97	616	616	188	207	97	616	616	191	211
8000	14	9	97	601	601	184	210	97	601	601	189	215
10,000	11	5	97	588	588	181	214	97	587	587	186	219
12,000	7	1	97	577	577	178	216	97	576	576	183	222
14,000	3	-3	94	554	554	172	216	95	555	555	178	223
16,000	-1	-7	89	521	521	163	211	90	523	523	170	220
18,000	-6	-11	83	488	488	151	203	84	490	490	161	216
20,000	-10	-15	77	453	453	136	190	78	457	457	150	209
22,000	-14	-19						73	429	429	140	202
24,000	-18	-23						69	400	400	126	187

ncbm175i

**ONE-ENGINE-INOPERATIVE
MAXIMUM CRUISE POWER**

ISA + 10°C

1600 RPM

WEIGHT →			12,000 POUNDS					11,000 POUNDS				
PRES- SURE ALT	IOAT	OAT	TORQ PER ENG	FUEL FLOW PER ENG	FUEL FLOW TOTAL	IAS	TAS	TORQ PER ENG	FUEL FLOW PER ENG	FUEL FLOW TOTAL	IAS	TAS
FEET	°C	°C	%	LBS/HR	LBS/HR	KTS	KTS	%	LBS/HR	LBS/HR	KTS	KTS
SL	30	25	97	671	671	201	203	97	671	671	203	205
2000	26	21	97	650	650	199	207	97	650	650	201	209
4000	22	17	97	632	632	196	210	97	632	632	198	212
6000	19	13	97	616	616	194	214	97	615	615	195	216
8000	15	9	97	601	601	191	217	97	600	600	193	220
10,000	11	5	97	587	587	188	221	97	587	587	190	224
12,000	7	1	97	576	576	186	225	97	576	576	188	227
14,000	3	-3	95	556	556	181	226	95	556	556	183	229
16,000	-1	-7	90	524	524	173	225	90	525	525	176	228
18,000	-5	-11	84	491	491	165	221	85	492	492	169	226
20,000	-9	-15	79	458	458	156	217	79	460	460	161	229
22,000	-13	-19	74	431	431	148	212	75	433	433	153	220
24,000	-17	-23	69	403	403	138	205	70	405	405	145	216
26,000	-21	-27						65	377	377	185	208
28,000	-26	-30						59	349	349	122	194

ncbm175j

**ONE-ENGINE-INOPERATIVE
MAXIMUM CRUISE POWER**

ISA + 20°C

1600 RPM

WEIGHT →			14,500 POUNDS					13,000 POUNDS				
PRES- SURE ALT	IOAT	OAT	TORQ PER ENG	FUEL FLOW PER ENG	FUEL FLOW TOTAL	IAS	TAS	TORQ PER ENG	FUEL FLOW PER ENG	FUEL FLOW TOTAL	IAS	TAS
FEET	°C	°C	%	LBS/HR	LBS/HR	KTS	KTS	%	LBS/HR	LBS/HR	KTS	KTS
SL	40	35	97	677	677	194	200	97	677	677	198	203
2000	36	31	97	657	657	192	203	97	657	657	195	207
4000	32	27	97	639	639	189	206	97	639	639	192	210
6000	28	23	97	622	622	186	209	97	622	622	190	213
8000	25	19	97	606	606	182	211	97	607	607	187	217
10,000	20	15	93	574	574	175	210	93	575	575	180	216
12,000	16	11	89	547	547	168	208	90	548	548	174	215
14,000	12	7	85	519	519	160	205	86	521	521	167	214
16,000	8	3	81	490	490	150	199	82	492	492	159	211
18,000	4	-1	75	458	458	136	187	76	461	461	150	205
20,000	0	-5						71	429	429	138	196

ncbm175k

**ONE-ENGINE-INOPERATIVE
MAXIMUM CRUISE POWER**

ISA + 20°C

1600 RPM

WEIGHT →			12,000 POUNDS					11,000 POUNDS				
PRES-SURE ALT	IOAT	OAT	TORQ PER ENG	FUEL FLOW PER ENG	FUEL FLOW TOTAL	IAS	TAS	TORQ PER ENG	FUEL FLOW PER ENG	FUEL FLOW TOTAL	IAS	TAS
FEET	°C	°C	%	LBS/HR	LBS/HR	KTS	KTS	%	LBS/HR	LBS/HR	KTS	KTS
SL	40	35	97	677	677	200	205	97	677	677	201	207
2000	36	31	97	657	657	197	209	97	657	657	199	211
4000	32	27	97	639	639	195	212	97	639	639	196	214
6000	29	23	97	622	622	192	216	97	621	621	194	218
8000	25	19	97	606	606	189	219	97	606	606	191	222
10,000	21	15	93	576	576	183	219	94	576	576	186	222
12,000	17	11	90	549	549	177	219	90	549	549	180	222
14,000	13	7	86	522	522	171	219	86	523	523	174	222
16,000	9	3	82	493	493	164	217	82	494	494	167	221
18,000	5	-1	77	462	462	155	213	77	463	463	160	219
20,000	1	-5	71	431	431	146	207	72	432	432	151	215
22,000	-4	-9	66	402	402	135	198	67	404	404	142	209
24,000	-8	-13						62	374	374	132	200

ncbm175m

**ONE-ENGINE-INOPERATIVE
MAXIMUM CRUISE POWER**

ISA + 30°C

1600 RPM

WEIGHT →			14,500 POUNDS					13,000 POUNDS				
PRES- SURE ALT	IOAT	OAT	TORQ PER ENG	FUEL FLOW PER ENG	FUEL FLOW TOTAL	IAS	TAS	TORQ PER ENG	FUEL FLOW PER ENG	FUEL FLOW TOTAL	IAS	TAS
FEET	°C	°C	%	LBS/HR	LBS/HR	KTS	KTS	%	LBS/HR	LBS/HR	KTS	KTS
SL	50	45	96	678	678	191	200	96	678	678	195	204
2000	46	41	94	649	649	186	201	94	649	649	190	205
4000	42	37	91	619	619	181	201	91	619	619	185	206
6000	38	33	88	589	589	174	200	88	590	590	180	206
8000	34	29	85	561	561	168	199	85	562	562	174	206
10,000	30	25	82	533	533	161	197	82	534	534	168	205
12,000	26	21	78	503	503	152	192	78	505	505	160	202
14,000	21	17	73	474	474	141	185	74	475	475	152	199
16,000	18	13						70	446	446	143	193
18,000	13	9						65	417	417	130	182

ncbm175n

**ONE-ENGINE-INOPERATIVE
MAXIMUM CRUISE POWER**

ISA + 30°C

1600 RPM

WEIGHT →			12,000 POUNDS					11,000 POUNDS				
PRES- SURE ALT	IOAT	OAT	TORQ PER ENG	FUEL FLOW PER ENG	FUEL FLOW TOTAL	IAS	TAS	TORQ PER ENG	FUEL FLOW PER ENG	FUEL FLOW TOTAL	IAS	TAS
FEET	°C	°C	%	LBS/HR	LBS/HR	KTS	KTS	%	LBS/HR	LBS/HR	KTS	KTS
SL	50	45	96	678	678	197	206	96	678	678	199	207
2000	46	41	94	650	650	193	207	94	650	650	195	209
4000	42	37	91	620	620	188	208	91	620	620	190	210
6000	38	33	88	591	591	182	209	88	591	591	185	211
8000	34	29	85	562	562	177	209	85	563	563	180	212
10,000	30	25	82	534	534	171	209	82	535	535	174	213
12,000	26	21	78	505	505	164	208	78	506	506	168	212
14,000	22	17	74	476	476	157	205	75	477	477	161	210
16,000	18	13	70	447	447	149	201	70	448	448	154	208
18,000	14	9	65	419	419	139	195	66	420	420	145	203
20,000	9	5	61	390	390	128	184	61	391	391	136	197

ncbm175c

**ONE-ENGINE-INOPERATIVE
MAXIMUM CRUISE POWER**

ISA + 37°C

1600 RPM

WEIGHT →			14,500 POUNDS					13,000 POUNDS				
PRES- SURE ALT	IOAT	OAT	TORQ PER ENG	FUEL FLOW PER ENG	FUEL FLOW TOTAL	IAS	TAS	TORQ PER ENG	FUEL FLOW PER ENG	FUEL FLOW TOTAL	IAS	TAS
FEET	°C	°C	%	LBS/HR	LBS/HR	KTS	KTS	%	LBS/HR	LBS/HR	KTS	KTS
SL	56	52	80	622	622	174	185	80	622	622	179	190
2000	52	48	79	597	597	170	186	79	598	598	176	192
4000	48	44	78	571	571	165	186	78	572	572	171	193
6000	44	40	76	546	546	160	186	76	546	546	166	193
8000	40	36	74	521	521	153	184	74	521	521	161	194
10,000	36	32	72	495	495	146	181	72	496	496	155	193
12,000	32	28	68	467	467	133	171	68	468	468	147	189
14,000	28	24						65	440	440	137	182

ncbm 175p

**ONE-ENGINE-INOPERATIVE
MAXIMUM CRUISE POWER**

ISA + 37°C

1600 RPM

WEIGHT →			12,000 POUNDS					11,000 POUNDS				
PRES- SURE ALT	IOAT	OAT	TORQ PER ENG	FUEL FLOW PER ENG	FUEL FLOW TOTAL	IAS	TAS	TORQ PER ENG	FUEL FLOW PER ENG	FUEL FLOW TOTAL	IAS	TAS
FEET	°C	°C	%	LBS/HR	LBS/HR	KTS	KTS	%	LBS/HR	LBS/HR	KTS	KTS
SL	56	52	80	622	622	182	192	80	623	623	184	195
2000	53	48	80	598	598	178	195	80	598	598	181	197
4000	49	44	78	572	572	174	196	78	572	572	177	199
6000	45	40	76	547	547	170	197	76	547	547	173	200
8000	41	36	74	522	522	165	198	74	522	522	168	202
10,000	37	32	72	497	497	160	198	72	497	497	163	202
12,000	33	28	68	469	469	152	195	69	470	470	157	200
14,000	29	24	65	441	441	145	192	65	442	442	150	198
16,000	24	20	61	414	414	135	185	61	414	414	142	19
18,000	21	16						57	388	388	133	188

ncbm175q

(This Page Intentionally Left Blank)

MAXIMUM NORMAL OPERATING POWER

1. All fuel flows presented in this section represent average new engine performance with Jet A fuel. Use of other fuels, or operation with other than new engines, may increase fuel flows.
2. Activation of engine anti-ice will decrease engine torque approximately 20%, true airspeed will be reduced approximately 30 knots, and fuel flow will decrease approximately 10%.
3. Operation with normal ice accumulations will additionally reduce true airspeed approximately 40 knots.

MAXIMUM NORMAL OPERATING POWER

ISA - 30°C

1600 RPM

WEIGHT →			14,500 POUNDS					13,000 POUNDS				
PRES-SURE ALT	IOAT	OAT	TORQ PER ENG	FUEL FLOW PER ENG	FUEL FLOW TOTAL	IAS	TAS	TORQ PER ENG	FUEL FLOW PER ENG	FUEL FLOW TOTAL	IAS	TAS
FEET	°C	°C	%	LBS/HR	LBS/HR	KTS	KTS	%	LBS/HR	LBS/HR	KTS	KTS
SL	-9	-15	71	523	1046	245	229	70	519	1038	245	229
2000	-12	-19	72	510	1020	245	235	71	505	1010	245	235
4000	-16	-23	74	500	1000	245	242	73	495	990	245	242
6000	-19	-27	76	491	982	245	249	75	486	972	245	249
8000	-23	-31	78	483	966	245	256	77	478	956	245	256
10,000	-27	-35	80	476	952	245	263	78	471	942	245	263
12,000	-30	-39	80	464	928	244	270	80	464	928	245	272
14,000	-34	-43	80	452	904	241	275	80	452	904	243	277
16,000	-37	-47	80	442	884	240	282	80	441	882	242	284
18,000	-41	-51	80	434	868	237	287	80	434	868	239	290
20,000	-44	-55	80	427	854	235	293	80	427	854	237	296
22,000	-48	-59	80	421	842	232	299	80	421	842	235	302
24,000	-51	-63	80	416	832	230	305	80	416	832	232	308
26,000	-55	-67	80	412	824	229	314	80	412	824	231	317

ncbm176a

MAXIMUM NORMAL OPERATING POWER
ISA - 30°C
1600 RPM

WEIGHT →			12,000 POUNDS					11,000 POUNDS				
PRES- SURE ALT	IOAT	OAT	TORQ PER ENG	FUEL FLOW PER ENG	FUEL FLOW TOTAL	IAS	TAS	TORQ PER ENG	FUEL FLOW PER ENG	FUEL FLOW TOTAL	IAS	TAS
FEET	°C	°C	%	LBS/HR	LBS/HR	KTS	KTS	%	LBS/HR	LBS/HR	KTS	KTS
SL	-9	-15	69	516	1032	245	229	68	513	1026	245	229
2000	-12	-19	70	502	1004	245	235	70	500	1000	245	235
4000	-16	-23	72	492	984	245	242	71	489	978	245	242
6000	-19	-27	74	483	966	245	249	73	480	960	245	249
8000	-23	-31	76	475	950	245	256	75	472	944	245	256
10,000	-27	-35	78	467	934	245	263	77	464	928	245	263
12,000	-30	-39	80	464	928	246	273	80	464	928	247	274
14,000	-33	-43	80	452	904	244	278	80	452	904	245	279
16,000	-37	-47	80	441	882	243	285	80	441	882	244	287
18,000	-40	-51	80	434	868	241	291	80	434	868	242	292
20,000	-44	-55	80	427	854	238	297	80	426	852	239	299
22,000	-48	-59	80	421	842	236	304	80	421	842	237	305
24,000	-51	-63	80	415	830	233	310	80	415	830	234	311
26,000	-54	-67	80	412	824	232	319	80	411	822	234	320
28,000	-64	-70						80	411	822	231	327

ncbm176b

MAXIMUM NORMAL OPERATING POWER
ISA - 20°C
1600 RPM

WEIGHT →			14,500 POUNDS					13,000 POUNDS				
PRES-SURE ALT	IOAT	OAT	TORQ PER ENG	FUEL FLOW PER ENG	FUEL FLOW TOTAL	IAS	TAS	TORQ PER ENG	FUEL FLOW PER ENG	FUEL FLOW TOTAL	IAS	TAS
FEET	°C	°C	%	LBS/HR	LBS/HR	KTS	KTS	%	LBS/HR	LBS/HR	KTS	KTS
SL	2	-5	72	534	1068	245	233	71	529	1058	245	233
2000	-2	-9	74	522	1044	245	240	73	517	1034	245	240
4000	-6	-13	76	512	1024	245	247	74	507	1014	245	247
6000	-9	-17	77	502	1004	245	254	76	496	992	245	254
8000	-13	-21	79	493	986	245	261	78	487	974	245	261
10,000	-16	-25	80	480	960	244	268	80	479	958	245	269
12,000	-20	-29	80	468	936	243	274	80	467	934	242	276
14,000	-23	-33	80	456	912	240	280	80	456	912	242	282
16,000	-27	-37	80	447	894	237	285	80	447	894	239	287
18,000	-31	-41	80	439	878	235	291	80	439	878	237	293
20,000	-34	-45	80	431	862	232	297	80	431	862	234	299
22,000	-38	-49	80	425	850	229	303	80	425	850	232	305
24,000	-41	-53	80	420	840	228	311	80	420	840	231	314
26,000	-44	-57	80	417	834	225	317	80	417	834	228	320
28,000	-48	-60	80	416	832	223	324	80	416	832	225	327
29,000	-50	-62	80	416	832	221	327	80	415	830	224	331
31,000	-53	-66	80	416	832	219	334	80	415	830	222	338
33,000	-57	-70	74	390	780	209	331	75	391	782	213	337
35,000	-62	-74	68	359	718	197	325	69	361	722	220	332

ncbm176c

MAXIMUM NORMAL OPERATING POWER
ISA - 20°C
1600 RPM

WEIGHT →			12,000 POUNDS					11,000 POUNDS				
PRES- SURE ALT	IOAT	OAT	TORQ PER ENG	FUEL FLOW PER ENG	FUEL FLOW TOTAL	IAS	TAS	TORQ PER ENG	FUEL FLOW PER ENG	FUEL FLOW TOTAL	IAS	TAS
FEET	°C	°C	%	LBS/HR	LBS/HR	KTS	KTS	%	LBS/HR	LBS/HR	KTS	KTS
SL	2	-5	70	526	1052	245	233	70	523	1046	245	233
2000	-2	-9	72	514	1028	245	240	71	511	1022	245	240
4000	-6	-13	74	504	1008	245	247	73	501	1002	245	247
6000	-9	-17	75	493	986	245	254	75	490	980	245	254
8000	-13	-21	77	484	968	245	261	76	481	962	245	261
10,000	-16	-25	79	476	952	245	269	78	473	946	245	269
12,000	-20	-29	80	467	934	245	277	80	467	934	246	278
14,000	-23	-33	80	456	912	243	283	80	456	912	244	284
16,000	-27	-37	80	446	892	240	289	80	446	892	241	290
18,000	-30	-41	80	438	876	238	295	80	438	876	239	296
20,000	-34	-45	80	431	862	236	301	80	431	862	237	302
22,000	-37	-49	80	425	850	233	307	80	425	850	234	309
24,000	-41	-53	80	419	838	232	316	80	419	838	233	317
26,000	-44	-57	80	417	834	229	322	80	416	832	231	324
28,000	-47	-60	80	416	832	227	329	80	415	830	228	331
29,000	-49	-62	80	415	830	226	333	80	415	830	227	335
31,000	-52	-66	80	415	830	223	341	80	415	830	225	343
33,000	-56	-70	75	392	784	215	340	76	393	786	217	343
35,000	-61	-74	69	362	724	205	336	69	364	728	207	340
37,000	-63	-77	62	331	662	193	331	63	332	664	196	335

ncbm 176d

MAXIMUM NORMAL OPERATING POWER

ISA - 10°C

1600 RPM

WEIGHT →			14,500 POUNDS					13,000 POUNDS				
PRES- SURE ALT	IOAT	OAT	TORQ PER ENG	FUEL FLOW PER ENG	FUEL FLOW TOTAL	IAS	TAS	TORQ PER ENG	FUEL FLOW PER ENG	FUEL FLOW TOTAL	IAS	TAS
FEET	°C	°C	%	LBS/HR	LBS/HR	KTS	KTS	%	LBS/HR	LBS/HR	KTS	KTS
SL	12	5	73	544	1088	245	238	72	539	1078	245	238
2000	8	1	75	532	1064	245	244	74	527	1054	245	244
4000	5	-3	77	522	1044	245	251	76	517	1034	245	251
6000	1	-7	79	513	1026	245	259	78	508	1016	245	259
8000	-2	-11	80	502	1004	245	267	79	499	998	245	266
10,000	-6	-15	80	488	976	243	272	80	488	976	244	274
12,000	-10	-19	80	475	950	240	277	80	475	950	242	279
14,000	-13	-23	80	462	924	237	282	80	462	924	239	284
16,000	-17	-27	80	452	904	234	288	80	451	902	237	290
18,000	-20	-31	80	443	886	232	294	80	442	884	234	296
20,000	-24	-35	80	434	868	231	302	80	434	868	233	304
22,000	-27	-39	80	429	858	228	307	80	429	858	230	310
24,000	-31	-43	80	425	850	225	314	80	424	848	228	317
26,000	-34	-47	80	421	842	222	320	80	421	842	225	324
28,000	-38	-50	80	419	838	220	327	80	419	838	223	331
29,000	-39	-52	80	419	838	218	330	80	419	838	221	334
31,000	-44	-56	74	390	780	208	327	74	391	782	212	332
33,000	-48	-60	68	363	726	197	322	69	364	728	220	329
35,000	-52	-64	62	334	668	185	315	63	337	674	191	324
37,000	-56	-67	56	303	606	170	302	57	306	612	178	315
39,000	-57	-67	49	270	540	148	278	50	275	550	161	302
41,000	-57	-67						43	243	486	139	275

ncbm176e

MAXIMUM NORMAL OPERATING POWER
ISA - 10°C
1600 RPM

WEIGHT →			12,000 POUNDS					11,000 POUNDS				
PRES- SURE ALT	IOAT	OAT	TORQ PER ENG	FUEL FLOW PER ENG	FUEL FLOW TOTAL	IAS	TAS	TORQ PER ENG	FUEL FLOW PER ENG	FUEL FLOW TOTAL	IAS	TAS
FEET	°C	°C	%	LBS/HR	LBS/HR	KTS	KTS	%	LBS/HR	LBS/HR	KTS	KTS
SL	12	5	71	536	1072	245	238	71	533	1066	245	238
2000	8	1	73	524	1048	245	244	72	521	1042	245	244
4000	5	-3	75	514	1028	245	251	74	511	1022	245	251
6000	1	-7	77	504	1008	245	259	76	501	1002	245	259
8000	-2	-11	79	496	992	245	266	78	493	986	245	266
10,000	-6	-15	80	488	976	245	275	80	487	974	245	274
12,000	-9	-19	80	475	950	243	280	80	475	950	244	281
14,000	-13	-23	80	462	924	240	286	80	462	924	241	287
16,000	-16	-27	80	451	902	238	292	80	451	902	239	293
18,000	-20	-31	80	442	884	235	298	80	442	884	236	299
20,000	-23	-35	80	434	868	234	306	80	433	866	235	307
22,000	-27	-39	80	429	858	232	312	80	429	858	233	314
24,000	-30	-43	80	424	848	229	319	80	424	848	230	320
26,000	-34	-47	80	421	842	226	326	80	420	840	228	328
28,000	-37	-50	80	419	838	224	333	80	418	836	226	335
29,000	-39	-52	80	418	836	223	337	80	418	836	224	339
31,000	-43	-56	75	392	784	214	335	75	393	786	216	338
33,000	-47	-60	69	365	730	204	333	69	366	732	207	336
35,000	-51	-64	63	338	676	194	329	64	339	678	197	333
37,000	-54	-67	57	307	614	182	321	57	308	616	185	327
39,000	-55	-67	50	277	554	167	311	51	278	556	171	319
41,000	-56	-67	44	246	492	150	295	45	248	496	156	307

ncbm176f

MAXIMUM NORMAL OPERATING POWER
ISA
1600 RPM

WEIGHT →			14,500 POUNDS					13,000 POUNDS				
PRES- SURE ALT	IOAT	OAT	TORQ PER ENG	FUEL FLOW PER ENG	FUEL FLOW TOTAL	IAS	TAS	TORQ PER ENG	FUEL FLOW PER ENG	FUEL FLOW TOTAL	IAS	TAS
FEET	°C	°C	%	LBS/HR	LBS/HR	KTS	KTS	%	LBS/HR	LBS/HR	KTS	KTS
SL	22	15	74	556	1112	245	242	73	551	1102	245	242
2000	18	11	76	545	1090	245	249	75	540	1080	245	249
4000	15	7	78	535	1070	245	256	77	529	1058	245	256
6000	11	3	80	524	1048	246	264	79	520	1040	245	263
8000	8	-1	80	508	1016	243	269	80	508	1016	245	271
10,000	4	-5	80	493	986	240	275	80	493	986	242	277
12,000	1	-9	80	481	962	238	280	80	480	960	239	282
14,000	-3	-13	80	468	936	235	285	80	468	936	237	287
16,000	-7	-17	80	457	914	232	291	80	457	914	234	293
18,000	-10	-21	80	448	896	231	298	80	447	894	233	301
20,000	-13	-25	80	440	880	228	304	80	439	878	230	307
22,000	-17	-29	80	434	868	225	310	80	434	868	228	313
24,000	-20	-33	80	429	858	222	317	80	429	858	225	320
26,000	-24	-37	80	426	852	220	324	80	425	850	222	327
28,000	-28	-40	77	410	820	213	325	77	411	822	216	330
29,000	-30	-42	74	395	790	208	323	74	396	792	221	328
31,000	-34	-46	68	367	734	197	319	69	369	738	220	325
33,000	-39	-50	63	341	682	186	313	63	343	686	192	321
35,000	-43	-54	57	314	628	174	304	58	316	632	181	315
37,000	-47	-57	51	284	568	156	286	52	287	574	167	304
39,000	-47	-57						45	256	512	148	284

ncbm 178g

MAXIMUM NORMAL OPERATING POWER

ISA

1600 RPM

WEIGHT →			12,000 POUNDS					11,000 POUNDS				
PRES- SURE ALT	IOAT	OAT	TORQ PER ENG	FUEL FLOW PER ENG	FUEL FLOW TOTAL	IAS	TAS	TORQ PER ENG	FUEL FLOW PER ENG	FUEL FLOW TOTAL	IAS	TAS
FEET	°C	°C	%	LBS/HR	LBS/HR	KTS	KTS	%	LBS/HR	LBS/HR	KTS	KTS
SL	22	15	72	548	1096	245	242	72	545	1090	245	242
2000	18	11	74	536	1072	245	249	74	533	1066	245	249
4000	15	7	76	526	1052	245	256	75	523	1046	245	256
6000	11	3	78	516	1032	245	263	77	513	1026	245	263
8000	8	-1	80	508	1016	246	272	79	505	1010	245	271
10,000	4	-5	80	493	986	243	278	80	493	986	244	279
12,000	1	-9	80	480	960	241	283	80	480	960	242	284
14,000	-3	-13	80	468	936	238	289	80	468	936	239	290
16,000	-6	-17	80	457	914	235	295	80	457	914	237	296
18,000	-10	-21	80	447	894	234	303	80	447	894	235	304
20,000	-13	-25	80	439	878	232	309	80	439	878	233	310
22,000	-17	-29	80	434	868	229	315	80	434	868	230	317
24,000	-20	-33	80	429	858	226	322	80	428	856	228	324
26,000	-23	-37	80	425	850	224	330	80	425	850	225	331
28,000	-27	-40	77	411	822	218	333	78	412	824	220	335
29,000	-29	-42	75	397	794	214	331	75	397	794	216	334
31,000	-33	-46	69	370	740	204	329	69	370	740	207	332
33,000	-38	-50	64	344	688	195	326	64	344	688	197	330
35,000	-42	-54	58	317	634	184	321	59	318	636	188	326
37,000	-45	-57	52	288	576	171	312	53	289	578	175	318
39,000	-46	-57	46	258	516	156	299	47	260	520	161	308
41,000	-48	-57	40	228	456	134	272	40	231	462	144	291

ncbm176h

MAXIMUM NORMAL OPERATING POWER
ISA + 10°C
1600 RPM

WEIGHT →			14,500 POUNDS					13,000 POUNDS				
PRES- SURE ALT	IOAT	OAT	TORQ PER ENG	FUEL FLOW PER ENG	FUEL FLOW TOTAL	IAS	TAS	TORQ PER ENG	FUEL FLOW PER ENG	FUEL FLOW TOTAL	IAS	TAS
FEET	°C	°C	%	LBS/HR	LBS/HR	KTS	KTS	%	LBS/HR	LBS/HR	KTS	KTS
SL	32	25	75	570	1140	245	246	74	565	1130	245	246
2000	29	21	78	558	1116	245	253	76	553	1106	245	253
4000	25	17	80	548	1096	245	261	78	542	1084	245	261
6000	22	13	80	531	1062	243	267	80	531	1062	245	269
8000	18	9	80	514	1028	241	272	80	514	1028	243	274
10,000	14	5	80	498	996	238	277	80	498	996	240	279
12,000	11	1	80	485	970	235	282	80	485	970	237	285
14,000	7	-3	80	472	944	234	289	80	472	944	236	292
16,000	4	-7	80	462	924	231	295	80	462	924	233	298
18,000	0	-11	80	454	908	228	301	80	454	908	231	304
20,000	-3	-15	80	446	892	225	307	80	446	892	228	310
22,000	-7	-19	80	439	878	222	313	80	439	878	225	316
24,000	-10	-23	80	434	868	220	320	80	433	866	223	324
26,000	-14	-27	76	413	826	212	320	77	414	828	216	325
28,000	-18	-30	71	385	770	202	316	71	386	772	206	322
29,000	-21	-32	68	370	740	197	314	68	372	744	201	320
31,000	-25	-36	62	344	688	186	308	63	345	690	191	316
33,000	-29	-40	57	319	638	174	301	58	321	642	181	311
35,000	-34	-44	52	293	586	160	288	53	296	592	170	304
37,000	-39	-47	45	262	524	136	256	47	266	532	153	287
39,000	-39	-47						40	235	470	127	251

ncbm176i

MAXIMUM NORMAL OPERATING POWER
ISA + 10°C
1600 RPM

WEIGHT →			12,000 POUNDS					11,000 POUNDS				
PRES- SURE ALT	IOAT	OAT	TORQ PER ENG	FUEL FLOW PER ENG	FUEL FLOW TOTAL	IAS	TAS	TORQ PER ENG	FUEL FLOW PER ENG	FUEL FLOW TOTAL	IAS	TAS
FEET	°C	°C	%	LBS/HR	LBS/HR	KTS	KTS	%	LBS/HR	LBS/HR	KTS	KTS
SL	32	25	73	561	1122	245	246	73	558	1116	24	246
2000	29	21	75	550	1100	245	253	75	547	1094	245	253
4000	25	17	77	539	1078	245	261	77	536	1072	245	261
6000	22	13	80	529	1058	245	268	79	526	1052	245	268
8000	18	9	80	514	1028	244	275	80	514	1028	245	276
10,000	15	5	80	498	996	241	280	80	498	996	242	281
12,000	11	1	80	485	970	238	286	80	485	970	239	287
14,000	8	-3	80	472	944	236	292	80	472	944	237	293
16,000	4	-7	80	462	924	235	299	80	461	922	236	301
18,000	1	-11	80	453	906	232	306	80	453	906	233	307
20,000	-3	-15	80	445	890	229	312	80	445	890	230	313
22,000	-6	-19	80	439	878	226	318	80	439	878	228	320
24,000	-10	-23	80	433	866	224	326	80	433	866	226	328
26,000	-14	-27	77	414	828	218	328	77	415	830	219	330
28,000	-18	-30	71	386	772	208	325	71	387	774	210	328
29,000	-20	-32	68	372	744	204	324	69	373	746	206	327
31,000	-24	-36	63	346	692	194	320	63	347	694	196	324
33,000	-28	-40	58	321	642	184	316	58	322	644	187	321
35,000	-33	-44	53	297	594	174	311	54	298	596	177	316
37,000	-36	-47	47	268	536	160	299	48	269	538	164	307
39,000	-37	-47	41	238	476	140	278	42	240	480	148	293
41,000	-38	-47						35	210	420	128	264

ncbm176j

MAXIMUM NORMAL OPERATING POWER
ISA + 20°C
1600 RPM

WEIGHT →			14,500 POUNDS					13,000 POUNDS				
PRES- SURE ALT	IOAT	OAT	TORQ PER ENG	FUEL FLOW PER ENG	FUEL FLOW TOTAL	IAS	TAS	TORQ PER ENG	FUEL FLOW PER ENG	FUEL FLOW TOTAL	IAS	TAS
FEET	°C	°C	%	LBS/HR	LBS/HR	KTS	KTS	%	LBS/HR	LBS/HR	KTS	KTS
SL	43	35	77	581	1162	245	250	75	575	1150	245	250
2000	39	31	79	569	1138	245	257	78	563	1126	245	257
4000	35	27	80	554	1108	244	264	80	552	1104	245	265
6000	32	23	80	535	1070	241	269	80	535	1070	243	271
8000	28	19	80	519	1038	239	274	80	519	1038	240	276
10,000	25	15	80	504	1008	237	281	80	503	1006	239	283
12,000	21	11	80	491	982	234	286	80	491	982	236	288
14,000	18	7	80	478	956	231	292	80	478	956	234	294
16,000	14	3	80	468	936	229	298	80	467	934	231	301
18,000	10	-1	80	458	916	226	304	80	458	916	228	307
20,000	7	-5	80	450	900	223	310	80	449	898	226	313
22,000	3	-9	80	444	888	220	316	80	444	888	223	320
24,000	-1	-13	75	416	832	211	314	75	417	834	215	319
26,000	-5	-17	70	388	776	201	311	70	389	778	205	317
28,000	-9	-20	64	361	722	191	306	65	362	724	196	313
29,000	-11	-22	62	348	696	186	303	62	349	698	191	311
31,000	-16	-26	57	322	644	174	295	57	324	648	181	306
33,000	-21	-30	52	297	594	160	283	53	299	598	169	299
35,000	-26	-34	46	271	542	142	262	48	274	548	156	287
37,000	-28	-37						41	245	490	135	261

ncbm176k

MAXIMUM NORMAL OPERATING POWER
ISA + 20°C
1600 RPM

WEIGHT →			12,000 POUNDS					11,000 POUNDS				
PRES- SURE ALT	IOAT	OAT	TORQ PER ENG	FUEL FLOW PER ENG	FUEL FLOW TOTAL	IAS	TAS	TORQ PER ENG	FUEL FLOW PER ENG	FUEL FLOW TOTAL	IAS	TAS
FEET	°C	°C	%	LBS/HR	LBS/HR	KTS	KTS	%	LBS/HR	LBS/HR	KTS	KTS
SL	43	35	75	572	1144	245	250	74	569	1138	245	250
2000	39	31	77	560	1120	245	257	76	557	1114	245	257
4000	36	27	79	549	1098	245	265	78	546	1092	245	265
6000	32	23	80	535	1070	244	272	80	535	1070	245	273
8000	28	19	80	519	1038	241	277	80	519	1038	242	278
10,000	25	15	80	503	1006	240	284	80	503	1006	241	285
12,000	21	11	80	490	980	237	290	80	490	980	238	291
14,000	18	7	80	478	956	235	296	80	478	956	236	297
16,000	14	3	80	467	934	232	302	80	467	934	234	304
18,000	11	-1	80	458	916	230	308	80	458	916	231	319
20,000	7	-5	80	449	898	227	315	80	449	898	228	317
22,000	4	-9	80	443	886	224	322	80	443	886	226	324
24,000	0	-13	75	418	836	217	322	76	418	836	218	324
26,000	-4	-17	70	390	780	208	320	70	390	780	210	323
28,000	-8	-20	65	363	726	198	317	65	364	728	201	321
29,000	-10	-22	63	350	700	194	315	63	351	702	196	319
31,000	-15	-26	58	325	650	184	311	58	325	650	187	316
33,000	-19	-30	53	301	602	174	306	53	301	602	177	311
35,000	-24	-34	48	276	552	162	297	48	277	554	167	305
37,000	-27	-37	42	248	496	146	280	43	250	500	152	293

ncbm176m

MAXIMUM NORMAL OPERATING POWER
ISA + 30°C
1600 RPM

WEIGHT →			14,500 POUNDS					13,000 POUNDS				
PRES-SURE ALT	IOAT	OAT	TORQ PER ENG	FUEL FLOW PER ENG	FUEL FLOW TOTAL	IAS	TAS	TORQ PER ENG	FUEL FLOW PER ENG	FUEL FLOW TOTAL	IAS	TAS
FEET	°C	°C	%	LBS/HR	LBS/HR	KTS	KTS	%	LBS/HR	LBS/HR	KTS	KTS
SL	53	45	78	594	1188	245	254	77	589	1178	245	254
2000	49	41	80	580	1160	245	262	79	576	1152	245	262
4000	46	37	80	561	1122	243	267	80	561	1122	244	269
6000	42	33	80	542	1084	240	272	80	542	1084	242	274
8000	38	29	80	525	1050	237	277	80	525	1050	239	280
10,000	35	25	80	509	1018	235	283	80	509	1018	236	285
12,000	31	21	80	496	992	232	288	80	496	992	234	291
14,000	28	17	80	482	964	229	294	80	482	964	231	297
16,000	24	13	80	472	944	227	301	80	471	942	229	303
18,000	21	9	80	462	924	223	306	80	462	924	226	309
20,000	17	5	75	433	866	215	305	75	434	868	218	309
22,000	12	1	71	407	814	206	303	71	408	816	210	308
24,000	8	-3	66	380	760	197	300	66	381	762	201	306
26,000	4	-7	61	354	708	187	295	61	355	710	192	302
28,000	-1	-10	56	328	656	175	287	57	330	660	181	297
29,000	-3	-12	53	315	630	168	282	54	317	634	176	294
31,000	-8	-16	49	290	580	154	270	50	293	586	164	286
33,000	-13	-20	44	267	534	137	250	46	271	542	152	276
35,000	-16	-26						41	248	496	137	259

ncbm176n

MAXIMUM NORMAL OPERATING POWER
ISA + 30°C
1600 RPM

WEIGHT →			12,000 POUNDS					11,000 POUNDS				
PRES- SURE ALT	IOAT	OAT	TORQ PER ENG	FUEL FLOW PER ENG	FUEL FLOW TOTAL	IAS	TAS	TORQ PER ENG	FUEL FLOW PER ENG	FUEL FLOW TOTAL	IAS	TAS
FEET	°C	°C	%	LBS/HR	LBS/HR	KTS	KTS	%	LBS/HR	LBS/HR	KTS	KTS
SL	53	45	76	585	1170	245	254	75	582	1164	245	254
2000	49	41	78	573	1146	245	262	77	570	1140	245	262
4000	46	37	80	561	1122	245	270	79	559	1118	245	269
6000	42	33	80	542	1084	243	275	80	542	1084	244	276
8000	39	29	80	525	1050	240	281	80	525	1050	241	282
10,000	35	25	80	509	1018	238	286	80	509	1018	239	288
12,000	31	21	80	496	992	235	292	80	496	992	236	294
14,000	28	17	80	482	964	233	298	80	482	964	234	300
16,000	24	13	80	471	942	230	305	80	471	942	231	306
18,000	21	9	80	462	924	227	311	80	462	924	229	313
20,000	17	5	76	435	870	220	311	76	435	870	221	313
22,000	13	1	71	408	816	212	310	71	408	816	213	313
24,000	9	-3	66	382	764	203	309	67	382	764	205	312
26,000	5	-7	62	356	712	194	306	62	356	712	197	310
28,000	1	-10	57	330	660	185	302	57	331	662	187	306
29,000	-2	-12	54	318	636	179	300	55	318	636	183	304
31,000	-6	-16	50	294	588	169	294	50	295	590	173	300
33,000	-10	-20	46	273	546	159	287	46	274	548	164	295
35,000	-15	-24	42	251	502	146	276	43	253	506	153	288

ncbm1760

MAXIMUM NORMAL OPERATING POWER
ISA + 37°C
1600 RPM

WEIGHT →			14,500 POUNDS					13,000 POUNDS				
PRES- SURE ALT	IOAT	OAT	TORQ P E R E N G	FUEL FLOW P E R E N G	FUEL FLOW TOTAL	IAS	TAS	TORQ P E R E N G	FUEL FLOW P E R E N G	FUEL FLOW TOTAL	IAS	TAS
FEET	°C	°C	%	LBS/HR	LBS/HR	KTS	KTS	%	LBS/HR	LBS/HR	KTS	KTS
SL	60	52	79	601	1202	245	257	78	595	1190	245	257
2000	56	48	80	584	1168	244	263	80	583	1166	245	264
4000	53	44	80	565	1130	241	268	80	565	1130	243	270
6000	49	40	80	546	1092	238	273	80	546	1092	240	275
8000	46	36	80	529	1058	236	279	80	529	1058	238	281
10,000	42	32	80	513	1026	233	285	80	513	1026	235	287
12,000	38	28	80	500	1000	231	290	80	499	998	233	293
14,000	35	24	80	485	970	227	295	80	485	970	230	298
16,000	31	20	76	458	916	220	296	76	459	918	223	299
18,000	27	16	72	432	864	212	295	72	432	864	215	299
20,000	23	12	68	405	810	204	294	68	406	812	208	299
22,000	19	8	64	380	760	195	291	64	381	762	199	297
24,000	14	4	59	354	708	185	287	60	355	710	190	294
26,000	10	0	55	329	658	174	280	55	330	660	180	289
28,000	5	-3	50	304	608	161	270	51	306	612	169	282
29,000	3	-5	47	291	582	154	263	48	294	588	163	278
31,000	-2	-9	43	267	534	135	240	44	270	540	150	266
33,000	-6	-13						39	247	494	134	248

ncbm176p

MAXIMUM NORMAL OPERATING POWER
ISA + 37°C
1600 RPM

WEIGHT →			12,000 POUNDS					11,000 POUNDS				
PRES- SURE ALT	IOAT	OAT	TORQ PER ENG	FUEL FLOW PER ENG	FUEL FLOW TOTAL	IAS	TAS	TORQ PER ENG	FUEL FLOW PER ENG	FUEL FLOW TOTAL	IAS	TAS
FEET	°C	°C	%	LBS/HR	LBS/HR	KTS	KTS	%	LBS/HR	LBS/HR	KTS	KTS
SL	60	52	77	592	1184	245	257	76	589	1178	245	257
2000	56	48	79	580	1160	245	264	78	577	1154	245	264
4000	53	44	80	565	1130	244	271	80	565	1130	245	272
6000	49	40	80	546	1092	241	277	80	546	1092	242	278
8000	46	36	80	529	1058	239	283	80	529	1058	240	284
10,000	42	32	80	512	1024	237	288	80	512	1024	238	290
12,000	39	28	80	499	998	234	294	80	499	998	235	296
14,000	35	24	80	486	972	231	300	80	486	972	232	302
16,000	31	20	76	459	918	224	301	76	459	918	226	303
18,000	27	16	72	433	866	217	302	72	433	866	219	304
20,000	23	12	68	406	812	210	301	68	407	814	211	304
22,000	19	8	64	381	762	202	300	64	382	764	204	303
24,000	15	4	60	356	712	193	298	60	357	714	195	301
26,000	11	0	55	331	662	184	294	56	332	664	187	299
28,000	7	-3	51	307	614	173	289	51	308	616	177	294
29,000	4	-5	49	295	590	168	285	49	296	592	172	292
31,000	0	-9	44	271	542	156	277	45	273	546	161	285
33,000	-5	-13	40	249	498	144	265	40	251	502	150	277
35,000	-10	-17	36	226	452	127	244	36	229	458	137	263

ncbm176q

PRESSURIZATION CONTROLLER SETTING FOR LANDING

EXAMPLE:
 ALTIMETER SETTING 29.52 IN. HG
 LANDING FIELD ELEVATION 2000 FT
 CABIN ALTITUDE SETTING 2892 FT

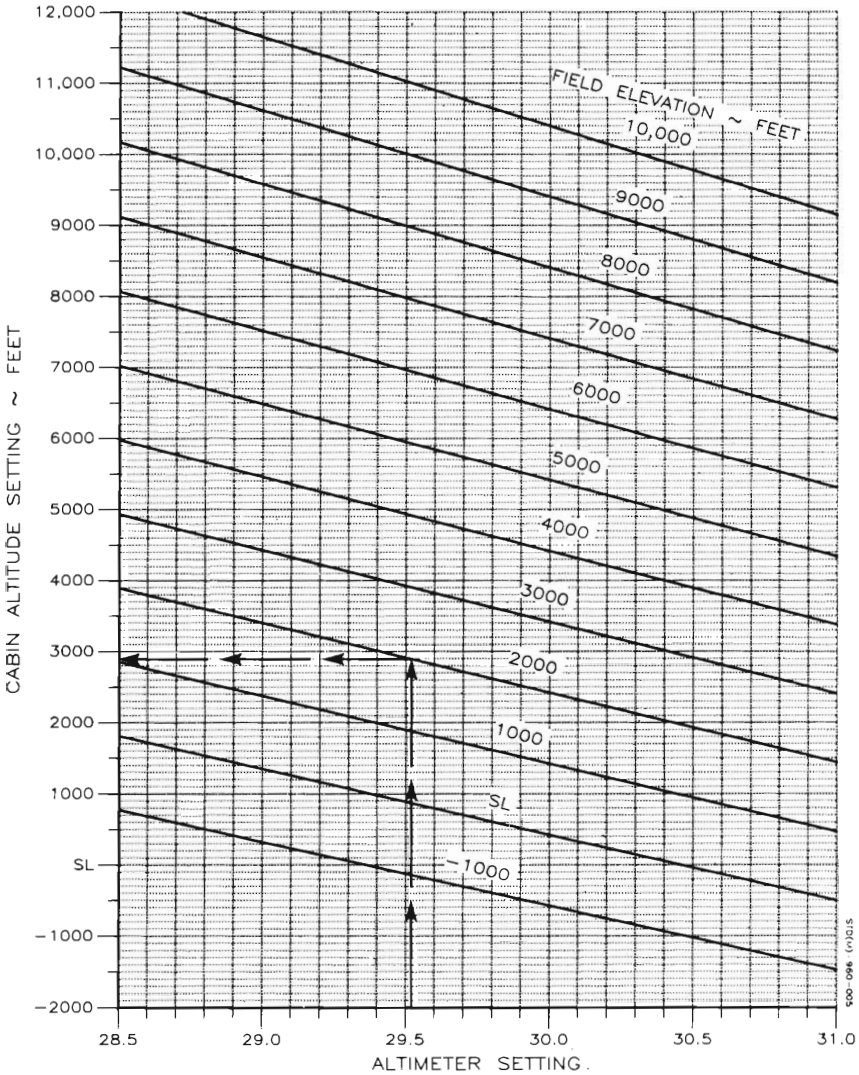

HOLDING TIME

ASSOCIATED CONDITIONS:

TORQUE AS REQUIRED TO MAINTAIN 160 KNOTS
PROPELLER SPEED 1600 RPM

- NOTES: 1. HOLDING TIME ASSUMES STANDARD DAY (ISA) CONDITIONS FOR AN AVERAGE WEIGHT OF 13,000 POUNDS.
2. FOR OPERATION WITH ENGINE ANTI-ICE ON, HOLDING TIME WILL BE REDUCED APPROXIMATELY 2%.

3. FOR OPERATION WITH ENGINE ANTI-ICE ON AND ICE ACCUMULATIONS PRESENT, HOLDING TIME WILL BE REDUCED APPROXIMATELY 18%.

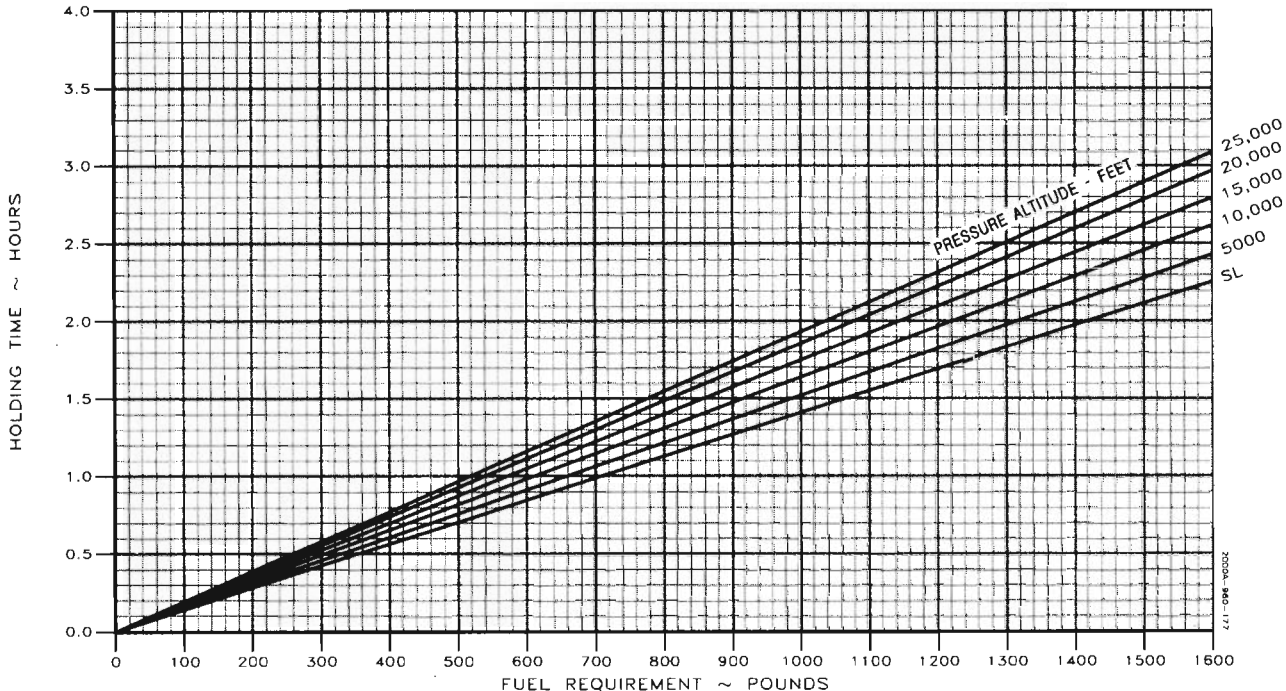

2000AL-860-177

**TIME, FUEL, AND DISTANCE TO DESCEND
AT V_{MO} MINUS 25 KIAS**

ASSOCIATED CONDITIONS:

POWER..... AS REQUIRED TO MAINTAIN
2000 FPM DESCENT TO 5000 FEET
PRESSURE ALTITUDE.
LANDING GEAR.... UP
FLAPS RETRACTED

EXAMPLE:

INITIAL ALTITUDE 26,000 FT
FINAL ALTITUDE 4502 FT
TIME TO DESCEND (16-5)..... 11 MIN
FUEL TO DESCEND (189-64)..... 125 LBS
DISTANCE TO DESCEND (65-15)..... 50 NM

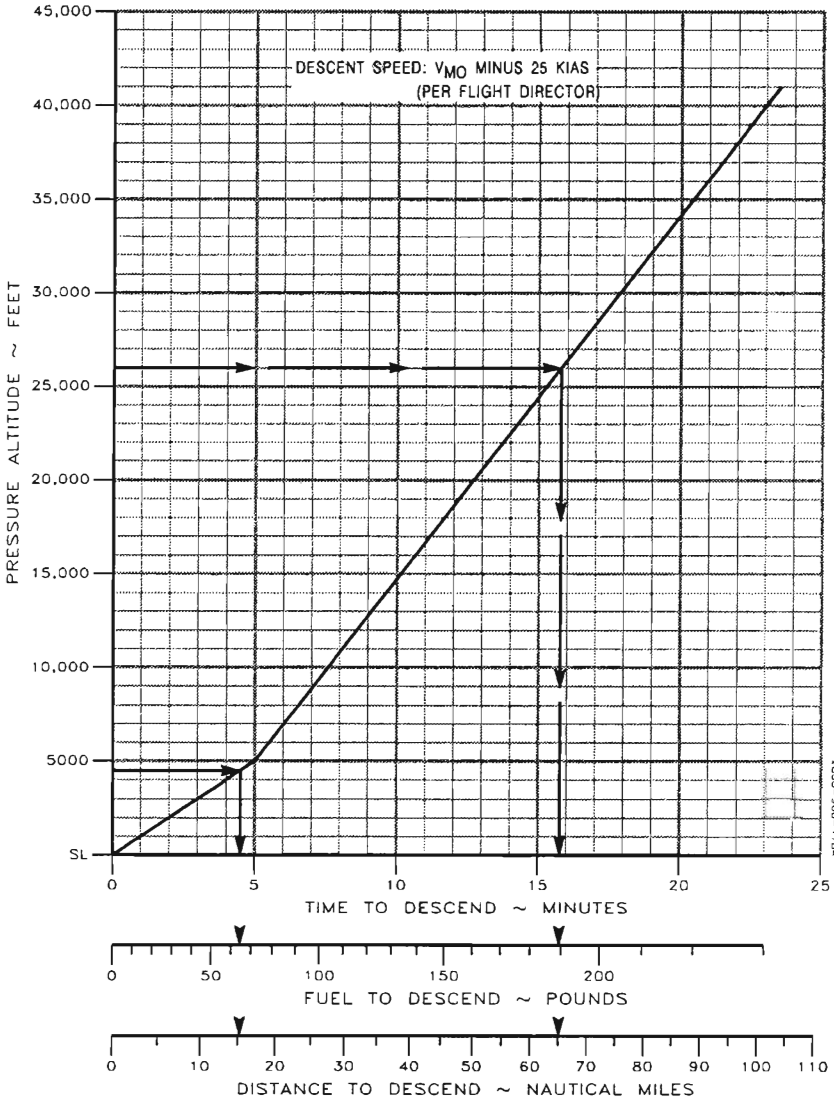

SECTION V
HANDLING, SERV, MAINT
TABLE OF CONTENTS

<i>SUBJECT</i>	<i>PAGE</i>
Introduction To Servicing	5-3
Publications	5-3
Airplane Inspection Periods	5-4
Special Conditions Cautionary Notice	5-4
Preventive Maintenance That May Be Accomplished by A Certificated Pilot	5-5
Alterations Or Repairs To Airplane	5-5
Ground Handling	5-5
Landing Gear And Nose Gear Door Lock Pins	5-5
Landing Gear Lock Pin Installation.....	5-6
Nose Gear Doors Lock Pin.....	5-6
Towing	5-6
Parking	5-6
Tie-Down	5-7
Jacking and Leveling	5-7
Landing Gear And Nose Gear Door Lock Pins.....	5-7
Landing Gear Lock Pin Installation	5-7
Nose Gear Doors Lock Pin	5-8
Jacking	5-8
Leveling.....	5-8
Prolonged Out-Of-Service Care	5-8
Engine Care In Salty Environments	5-8
Servicing	5-9
External Power	5-9
Battery	5-9
Hydraulic System	5-9
Propellers	5-9
Tires	5-10
Landing Gear And Nose Gear Door Lock Pins.....	5-10
Landing Gear Lock Pin Installation	5-10
Nose Gear Doors lock Pin.....	5-10
Shock Struts	5-10
Landing Gear And Nose Gear Door Lock Pins.....	5-11
Landing Gear Lock Pin Installation	5-11

TABLE OF CONTENTS (Cont'd)

<i>SUBJECT</i>	<i>PAGE</i>
Nose Gear Doors Lock Pin	5-11
Brake System	5-11
Oil System	5-12
Fuel System	5-12
Fuel Handling Practices	5-12
Filling The Tanks	5-13
Fuel Grade and Type	5-14
Oxygen System	5-14
Oxygen Components	5-14
Purging Oxygen System	5-14
Filling The Oxygen System	5-15
Air Conditioner	5-15
Cabin Air Filters	5-15
Miscellaneous Maintenance	5-16
Cleaning	5-16
Exterior Painted Surfaces	5-16
Plastic Cabin Windows	5-17
Windshields	5-18
Surface Deice Boot	5-19
Engine	5-19
Interior Care	5-19
Leather Or Vinyl	5-19
Fabrics	5-20
Laminate	5-20
Consumable Materials	5-20

INTRODUCTION TO SERVICING

The purpose of this section is to outline to the Owner and Operator the requirements for maintaining the BEEHCRAFT 2000 in a condition equal to that of its original manufacture. This information sets the time intervals at which the airplane should be taken to a BEEHCRAFT Authorized Outlet for periodic servicing or preventive maintenance.

The Federal Aviation Regulations place the responsibility for the maintenance of this airplane on the Owner and the Operator, who should make certain that all maintenance is accomplished by qualified mechanics in conformity with all airworthiness requirements established for this airplane.

All limits, procedures, safety practices, time limits, servicing and maintenance requirements contained in this handbook are considered mandatory.

BEEHCRAFT Authorized Outlets can provide recommended modification, service, and operating procedures issued by both FAA and Beech Aircraft Corporation, which are designed to get maximum utility and safety from the airplane.

If a question arises concerning the care of the BEEHCRAFT 2000, it is important that the airplane serial number be included in any correspondence. The serial number appears on the Manufacturer's Identification Plaque, located on the underside of the aft fuselage forward of the ventral fin.

WARNING

The BEEHCRAFT 2000 is a pressurized airplane. Modification, of any type to the pressure vessel must be accomplished with approval and supervision of Beech Aircraft Corporation Customer Support Department. Obtaining approval of the work is the responsibility of the owner or facility performing the work.

PUBLICATIONS

The following publications for the BEEHCRAFT 2000 are available through BEEHCRAFT Authorized Outlets.

1. Pilot's Operating Manual and FAA Approved Airplane Flight Manual.
2. Pilot's Check List
3. Maintenance Manual
4. Component Maintenance Manual (Includes Vendor Data)
5. Wiring Diagram Manual
6. Parts Catalog
7. Service Bulletins

NOTE

The following information may be provided to the holder of this manual automatically:

8. Original issues and revisions of BEECHCRAFT Service Bulletins.
9. Original issues and revisions of FAA Approved Airplane Flight Manual Supplements.
10. Reissues and revisions of the Pilot's Operating Manual and FAA Approved Airplane Flight Manual.

This service is free and will be provided only to holders of this handbook who are listed on the FAA Aircraft Registration Branch List or the BEECHCRAFT International Owners Notification Service List, and then only if listed by airplane serial number for the model for which this handbook is applicable. For detailed information on how to obtain "Revision Service" applicable to this handbook or other BEECHCRAFT Service Publications, consult any BEECHCRAFT Authorized Outlet, or refer to the latest revision of BEECHCRAFT Service Bulletin No. 2001.

AIRPLANE INSPECTION PERIODS

1. BEECHCRAFT Maintenance Manual
2. Servicing Schedule (later in this Section)

NOTE

The FAA may require other inspections by issuance of Airworthiness Directives applicable to the airplane, engines, propellers, and components. It is the responsibility of the owner/operator to ensure that all Airworthiness Directives are complied with, and when repetitive inspections are required, to prevent inadvertent noncompliance with subsequent inspection requirements. It is also the responsibility of the owner/operator to ensure that all FAA-required inspections and most Beech-recommended inspections are accomplished by properly certificated mechanics at properly certificated agencies (both meeting FAR 91 and FAR 43 requirements). Consult a BEECHCRAFT Authorized Outlet for assistance in determining and complying with these requirements.

SPECIAL CONDITIONS CAUTIONARY NOTICE

Airplanes operated for Air Taxi or other than normal operations and airplanes operated in humid tropics or cold and damp climates, etc., may need more frequent inspections for wear, corrosion, and/or lack of lubrication. In these areas, periodic inspections should be performed until the operator can set his own inspection periods based on experience. The required periods do not constitute a guarantee that the item will reach the period without malfunction, as the aforementioned factors cannot be controlled by the manufacturer.

PREVENTIVE MAINTENANCE THAT MAY BE ACCOMPLISHED BY A CERTIFICATED PILOT

1. A certificated pilot may perform limited maintenance. Refer to FAR Part 43 for the items which may be accomplished.
To ensure that proper procedures are followed, obtain a BEECHCRAFT Starship 1 Maintenance Manual prior to performing preventive maintenance.
2. All other maintenance must be performed by properly certificated personnel. Contact a BEECHCRAFT Authorized Outlet for further information.

NOTE

Pilots operating airplanes of other than U. S. registry should refer to the regulations of the country of registry for information on preventive maintenance that may be performed by a pilot.

ALTERATIONS OR REPAIRS TO AIRPLANE

The FAA should be contacted prior to any alterations of the airplane, to ensure that the airworthiness of the airplane is not violated.

NOTE

Alterations or repairs to the airplane must be accomplished by properly licensed personnel.

GROUND HANDLING

WARNING

Anytime the airplane is on the ground (whether on jacks or on wheels), the nose and main landing gear **MUST** be pinned in the down and locked position. The only exceptions to this would be landing gear operational checks, during the removal or installation of the landing gear components, and during taxiing operations prior to takeoff or after landing. When any work is being performed in the nose gear wheel well, the nose gear doors **MUST** be pinned in the open position.

LANDING GEAR AND NOSE GEAR DOOR LOCK PINS

The landing gear and nose gear door lock pins are identified as follows:

- The landing gear pins are the 1/4 inch diameter pins.
- The nose landing gear door pin is 7/16 inch in diameter.

LANDING GEAR LOCK PIN INSTALLATION

Install a LA4CR1500/NAS1756-24 lock pin into the lock link assembly of each landing gear. Refer to the BEECHCRAFT Starship 1 Maintenance Manual, Chapter 32-10-00 for specific instructions.

NOSE GEAR DOORS LOCK PIN

When any work is being performed in the nose wheel well the nose gear doors must be pinned in the open position. Install a LA7CR2500/NAS1756-24 lock pin (7/16 inch in diameter) according to the procedures found in the Starship 1 Maintenance Manual, Chapter 32-20-00.

TOWING

The tow bar connects to the tow fitting at the top of the nose gear fork. The airplane is steered with the tow bar when moving the airplane by hand, or it can be connected to a tug for towing of the airplane. Although the tug will control the steering of the airplane, someone should be positioned in the pilot's seat to operate the brakes in case of an emergency.



CAUTION

Before towing, or moving the airplane by hand, ensure that the lower nose skin panels are installed and secured. Do not tow the airplane with a flat shock strut.

The nose gear strut has turn limit marks (marked on the lower surface if the fuselage outboard of the nose landing gear wheel well), to warn the tug driver when the turning limits of the gear will be exceeded. Damage will occur to the nose gear and linkage if the turn limit is exceeded. The maximum nose wheel turn angle is 65° left and right. The tow fitting plug will be sheared if the turn limit is exceeded. When ground handling the airplane, do not use the propellers or control surfaces as hand holds to push or move the airplane.

For further information regarding towing, refer to the BEECHCRAFT Starship 1 Maintenance Manual.

PARKING

The parking brake may be set by depressing the toe portion of the pilot's rudder pedals, and then pulling outward the parking brake control located on the left side of the pedestal. The parking brake control closes a dual parking brake valve in the brake line that traps hydraulic pressure applied to the brakes and prevents pressure loss through the master cylinders. To release the parking brake, depress the pilot's brake pedals to equalize the pressure on both sides of the parking brake valve and push the parking brake control fully in.

NOTE

Avoid setting the parking brake when the brakes are hot from severe usage, or when moisture conditions and freezing temperatures could form ice locks.

The parking brake should be left off and wheel chocks installed while the airplane is unattended. Changes in ambient temperature can cause the brakes to release or exert excessive pressures.

TIE-DOWN

Three mooring eyes are provided: one at each of the main landing gears and one at the nose landing gear. To moor the airplane, install the control lock and tie down rings. Tie down the airplane at all three points and chock the wheels fore and aft. If extreme weather is anticipated, it is advisable to nose the airplane into the wind before tying it down. Install engine inlet and exhaust covers, propeller tie-down boots (one blade down), and pitot mast covers when mooring the airplane.

CAUTION

Unrestrained propellers are apt to windmill. Prolonged windmilling at zero oil pressures can result in bearing damage. Windmilling propellers are a SAFETY HAZARD.

JACKING AND LEVELING

WARNING

Anytime the airplane is on the ground (whether on jacks or on wheels), the nose and main landing gear **MUST** be pinned in the down and locked position. The only exceptions to this would be landing gear operational checks, during the removal or installation of the landing gear components, and during taxiing operations prior to takeoff or after landing. When any work is being performed in the nose gear wheel well, the nose gear doors **MUST** be pinned in the open position.

LANDING GEAR AND NOSE GEAR DOOR LOCK PINS

The landing gear and nose gear door lock pins are identified as follows:

- The landing gear pins are the 1/4 inch diameter pins.
- The nose landing gear door pin is 7/16 inch in diameter.

LANDING GEAR LOCK PIN INSTALLATION

Install a LA4CR1500/NAS1756-24 lock pin into the lock link assembly of each landing gear. Refer to the BEECHCRAFT Starship 1 Maintenance Manual, Chapter 32-10-00 for specific instructions.

NOSE GEAR DOORS LOCK PIN

When any work is being performed in the nose wheel well the nose gear doors must be pinned in the open position. Install a LA7CR2500/NAS1756-24 lock pin (7/16 inch in diameter) according to the procedures found in the Starship 1 Maintenance Manual, Chapter 32-20-00.

JACKING

Three jack points are provided to lift the airplane with tripod jacks for servicing. The nose jack point is located on the underside of the fuselage aft of the nose gear wheel well. The two wing jack points are located on the underside of the aft wing in line with the main gear wheel well outboard ribs. Each location is placarded JACK POINT & TIE DOWN.

LEVELING

Leveling of the airplane is accomplished through the use of a plumb bob support assembly and plumb bob attached to the upper airstair door frame. A permanent leveling screw in the airstair door threshold marks the plumb bob target.

Jack pad leveling may require the nose-gear shock strut to be secured in the static position to prevent its extension. The airplane can be leveled for wheel weighings by varying the amount of air in the shocks and/or tires.

PROLONGED OUT-OF-SERVICE CARE

For information pertinent to prolonged out-of-service care, refer to the BEECHCRAFT Starship 1 Maintenance Manual.

ENGINE CARE IN SALTY ENVIRONMENTS

When the airplane is operated in a salty atmosphere (such as near the sea) or off airstrips treated with salt:

1. Wash engine exterior as soon as possible with clean water.
2. Start engine and run at idle for a minimum of 10 minutes to remove moisture and salt residue.
3. Spray rust preventive material on fuel control assembly, control linkage assemblies, and any exposed metal parts.
4. Inspect the entire gearcase for corrosion and spray with rust preventive material at one-week intervals. Pay particular attention to the areas around studs and inserts.

SERVICING

EXTERNAL POWER

For ground operation and engine starting, 28-VDC electrical power may be supplied to the airplane from an external auxiliary power unit. The auxiliary power

unit can be connected to the airplane through an external power receptacle. The receptacle is located at the forward outboard corner of the left main landing gear wheel well. The external power relay is controlled by a sensor which will allow it to close only if the polarity of the voltage being supplied to the external power receptacle is correct. Overvoltage protection is also provided. The EXT POWER CONN message will display when an external DC power plug is connected to the airplane. Power to the airplane is controlled by the external power EXT PWR - OFF-RESET switch on the pedestal. The voltage can be monitored by the VOLTS-DC meter on the pedestal.

For further information pertinent to ground checkout, refer to the BEECHCRAFT Starship 1 Maintenance Manual.

BATTERY

Servicing the 24-volt, 20-cell, 36 ampere hour, nickel-cadmium battery is normally limited to checking the electrolyte level, cleaning the battery box and associated components, and equalizing the cells.

For further information pertinent to servicing of the battery, refer to the BEECHCRAFT Starship 1 Maintenance Manual.

HYDRAULIC SYSTEM

The hydraulic system power pack is located in the left nacelle forward of the firewall.

Incorporated in the reservoir cap is the systems dipstick marked FULL HOT - FULL COLD - ADD. The reservoir fluid level should be maintained between the FULL HOT and FULL COLD marks. Should the fluid level fall below the ADD mark, refer to the BEECHCRAFT Starship 1 Maintenance Manual for further information pertinent to the servicing of the hydraulic system.

PROPELLERS

When cleaning the propellers, solvent should not be allowed to collect in the cavity between the blade and hub. Prolonged exposure or saturation for a short time could cause performance degradation of the quad seal. Sparing use and short exposure to solvents is recommended.

For further information pertinent to acceptable cleaning solvents, refer to the BEECHCRAFT Starship 1 Maintenance Manual.

TIRES

The airplane has dual 19.5 x 6.75-10, 8 ply-rated tubeless tires on the main gear and a 19.5 x 6.75-8, 10 ply-rated tire on the nose gear.

Inflate the main wheel tires to between 80 and 87 psi unloaded and 95 \pm .4 psi loaded. The nose wheel tire should be inflated to 65 \pm .2 psi.

WARNING

Anytime the airplane is on the ground (whether on jacks or on wheels), the nose and main landing gear **MUST** be pinned in the down and locked position. The only exceptions to this would be landing gear operational checks, during the removal or installation of the landing gear components, and during taxiing operations prior to takeoff or after landing. When any work is being performed in the nose gear wheel well, the nose gear doors **MUST** be pinned in the open position.

LANDING GEAR AND NOSE GEAR DOOR LOCK PINS

The landing gear and nose gear door lock pins are identified as follows:

- The landing gear pins are the 1/4 inch diameter pins.
- The nose landing gear door pin is 7/16 inch in diameter.

LANDING GEAR LOCK PIN INSTALLATION

Install a LA4CR1500/NAS1756-24 lock pin into the lock link assembly of each landing gear. Refer to the BEECHCRAFT Starship 1 Maintenance Manual, Chapter 32-10-00 for specific instructions.

NOSE GEAR DOORS LOCK PIN

When any work is being performed in the nose wheel well the nose gear doors must be pinned in the open position. Install a LA7CR2500/NAS1756-24 lock pin (7/16 inch in diameter) according to the procedures found in the Starship 1 Maintenance Manual, Chapter 32-20-00.

For more information regarding detailed inspection and repair procedures, refer to the Starship 1 Maintenance Manual.

SHOCK STRUTS

Servicing the shock struts is normally part of each 100-hour inspection procedure. If it becomes necessary to service the shock struts due to the leakage of either hydraulic fluid or air, refer to the BEECHCRAFT Starship 1 Maintenance Manual.

WARNING

Anytime the airplane is on the ground (whether on jacks or on wheels), the nose and main landing gear MUST be pinned in the down and locked position. The only exceptions to this would be landing gear operational checks, during the removal or installation of the landing gear components, and during taxiing operations prior to takeoff or after landing. When any work is being performed in the nose gear wheel well, the nose gear doors MUST be pinned in the open position.

LANDING GEAR AND NOSE GEAR DOOR LOCK PINS

The landing gear and nose gear door lock pins are identified as follows:

- The landing gear pins are the 1/4 inch diameter pins.
- The nose landing gear door pin is 7/16 inch in diameter.

LANDING GEAR LOCK PIN INSTALLATION

Install a LA4CR1500/NAS1756-24 lock pin into the lock link assembly of each landing gear. Refer to the BEECHCRAFT Starship 1 Maintenance Manual, Chapter 32-10-00 for specific instructions.

NOSE GEAR DOORS LOCK PIN

When any work is being performed in the nose wheel well the nose gear doors must be pinned in the open position. Install a LA7CR2500/NAS1756-24 lock pin (7/16 inch in diameter) according to the procedures found in the Starship 1 Maintenance Manual, Chapter 32-20-00.

BRAKE SYSTEM

Brake system servicing is limited primarily to maintaining the hydraulic fluid level in the reservoir mounted on the upper left corner of the forward pressure bulkhead in the nose compartment, and to maintaining an accumulator precharge of 600 \pm 50 psi. Depress the brake pedals 15 to 20 times to deplete the brake fluid pressure of the accumulator. While pumping the pedals, have an assistant observe the accumulator pressure gage. When the reading on the gage reaches 600 \pm 50 psi (or less if the accumulator is not fully charged) and remains stationary, the fluid pressure has been depleted.

Brake assemblies are equipped with automatic adjusters to assure a positive clearance between disc and lining when the brakes are not applied.

Each wheel cylinder is provided with a means of conveniently checking brake wear. For more detail on servicing of the wheels and brakes, and airplanes equipped with brake deice, refer to BEECHCRAFT Starship 1 Maintenance Manual.

OIL SYSTEM

The oil tank is provided with an oil filler neck and a dipstick marked in U.S. quarts which indicates the last five quarts required to bring the system up to full. It is also equipped with an electronic dipstick. To check the oil level electronically, open the access plate located on the lower forward engine cowling and depress the button placarded PRESS TO CHECK OIL LEVEL. If the oil level is sufficient, a light located above the button will illuminate. Should the light fail to illuminate, the oil level will need to be checked by means of the engine oil quantity dipstick. The integrity of the light can be verified by depressing the face of the light.

Service the oil system with oil as specified in Consumable Materials. Do not mix different oil brands. Total system capacity is 14.5 U.S. quarts. Drain and refill will require approximately 13 U.S. quarts. The engine will trap approximately 1.5 quarts which cannot be drained.

NOTE

The dipstick indicates one quart below full when the oil level is normal. Overfilling may cause a discharge of oil through the breather until a satisfactory level is reached.

For further information pertinent to servicing of the oil system, refer to the BEECHCRAFT Starship 1 Maintenance Manual.

FUEL SYSTEM

FUEL HANDLING PRACTICES

All hydrocarbon fuels contain some dissolved, suspended water. The quantity of water contained in the fuel depends on temperature and the type of fuel. Kerosene, with its higher aromatic content, tends to absorb and suspend more water than aviation gasoline. Along with the water, it will hold rust, lint, and other foreign materials longer. Given sufficient time, these suspended contaminants will settle to the bottom of the tank. However, the settling time for kerosene is five times that of aviation gasoline. Due to this fact, jet fuels require good fuel handling practices to assure that the airplane is serviced with clean fuel. If recommended ground procedures are carefully followed, solid contaminants will settle and free water can be reduced to 30 parts per million (PPM), a value that is currently accepted by the major airlines. Since most suspended matter can be removed from the fuel by sufficient settling time and proper filtration, it is not a major problem. Dissolved water has been found to be the major fuel contamination problem. Its effects are multiplied in airplanes operating primarily in humid regions and warm climates.

Dissolved water cannot be filtered from the fuel with micronic type filters, but can be released by lowering the fuel temperature, such as will occur in flight. For example, a kerosene fuel may contain 65 ppm (8 fl oz per 1000 gallons) of dissolved water at 80°F. When the fuel temperature is lowered to 14°F, only about 25 ppm will remain in solution. The difference of 40 ppm will have been released as supercooled water droplets which need only a piece of solid contaminant or an

impact shock to convert them to ice crystals. Tests indicate that these water droplets will not settle since the specific gravity of ice is approximately equal to that of kerosene. The 40 ppm of suspended water seems like a very small quantity, but when added to suspended water in the fuel at the time of delivery, is sufficient to ice a filter. While the critical fuel temperature range is from -18°C to -29°C , which produces severe system icing, water droplets can freeze at any temperature below 0°C .

Water in jet fuel also creates an environment favorable to the growth of microbiological sludge in the settlement areas of the fuel cells. This sludge, plus other contaminants in the fuel, can cause corrosion of metal parts in the fuel system as well as clogging of the fuel filters.

Fuel temperature and settling time affect total water content and foreign matter suspension. Contamination can be minimized by keeping equipment clean. Use adequate filtration equipment and careful water drainage procedures, store the fuel in the coolest areas possible, and allow adequate settling time. Underground storage is recommended for fuels. Filtering the fuel each time it is transferred will minimize the quantity of suspended contaminants carried by the fuel.

The primary means of contamination control by the owner/operator is careful handling. This applies not only to fuel supply, but to keeping the airplane system clean. The following is a list of steps that may be taken to prevent and recognize contamination problems.

1. Know your supplier. It is impractical to assume that fuel free of contaminants will always be available, but it is feasible to exercise caution and be watchful for signs of fuel contamination.
2. Assure, as much as possible, that the fuel obtained has been properly stored, filtered as it is pumped to the truck, and filtered again as it is pumped from the truck to the airplane.
3. Perform filter inspections to determine if sludge is present.
4. Periodically flush the fuel tanks and systems. The frequency of flushing should be determined by the climate and the presence of sludge.
5. Use only clean fuel servicing equipment.
6. After refueling, allow a three hour settle period, whenever possible, then drain a small amount of fuel from each drain.

CAUTION

Fuel spills on tires have a deteriorating effect and the tires should be cleaned promptly.

FILLING THE TANKS

When filling the airplane fuel tanks, always observe the following:

1. Make sure the airplane is statically grounded to the servicing unit and that the airplane and servicing unit are both grounded to ground.
2. Do not rest fuel nozzle in tank filler neck, because this may damage the filler neck.

3. Allow a three-hour settle period whenever possible, then drain a small amount of fuel into a container from each drain point. Check fuel at each drain point for contamination.
4. When fueling the airplane, ensure fuel nozzle does not strike wing, as this may cause damage.

FUEL GRADE AND TYPE

Aviation Kerosene Grades Jet A, Jet A-1, Jet B, JP-4, JP-5 and JP-8 may be mixed in any ratio. Aviation Gasoline Grades 80 (80/87), 100LL, (100/130), and 115/145 are emergency fuels and may be mixed with the recommended fuels in any ratio; however, use of the lowest octane rating available is recommended. Operation on Aviation Gasoline shall be limited to 150 hours per engine during each time-between-overhaul (TBO) period. Refer to the FAA Approved Flight Manual, LIMITATIONS Section for additional limitations on the use of Aviation Gasoline and Fuel Additives.

CAUTION

Do not allow the fuel cells to dry out and crack. At a later servicing, the cracks would allow fuel to diffuse through the walls of the fuel cell.

For further information pertinent to servicing of the fuel system, refer to the BEECHCRAFT Starship 1 Maintenance Manual.

OXYGEN SYSTEM

OXYGEN COMPONENTS

Oxygen for unpressurized, high-altitude flight or other emergency use is supplied by a cylinder located in the right lower nose compartment. A 77-, or 115-cubic foot cylinder may be installed. The oxygen system is serviced through a filler valve accessible by removing an access plate on the right side of the forward fuselage. The system has two pressure gages, one located on the right subpanel in the crew compartment for in-flight use, and one adjacent to the filler valve for checking system pressure during filling.

For further information pertinent to servicing of the oxygen system, refer to the BEECHCRAFT Starship 1 Maintenance Manual.

PURGING OXYGEN SYSTEM

For further information pertinent to purging of the oxygen system, refer to the BEECHCRAFT Starship 1 Maintenance Manual.

FILLING THE OXYGEN SYSTEM

For further information pertinent to filling the oxygen system, refer to the BEECHCRAFT Starship 1 Maintenance Manual.

AIR CONDITIONER

If an extended period of time occurs during which the air conditioning system is not operated, moisture may condense and settle in the system low spots, resulting in corrosion of the refrigerant lines. Also, the system seals may dry out, shrink, and crack, due to lack of lubrication. In order to protect the integrity of the system, the air conditioner should be operated at least 10 minutes every month.

CAUTION

If for several weeks it is impossible to obtain an ambient temperature of at least 10°F, the recommended monthly interval for operating the air conditioner may be extended somewhat.

For further information pertinent to servicing of the air conditioner system, refer to the BEECHCRAFT Starship 1 Maintenance Manual

WARNING

Refrigerant and oil are under pressure within the refrigeration system. Injury to personnel or damage to the system could occur if maintenance is not performed properly. The refrigerant system should be serviced only by qualified air conditioner technicians.

CABIN AIR FILTERS

A flexible, fiberglass-type air filter covers the coils of the air conditioner evaporators. This filter should be inspected each 100 hours of operation, and replaced whenever dirty.

For further information pertinent to filter replacement, refer to the BEECHCRAFT Starship 1 Maintenance Manual.

MISCELLANEOUS MAINTENANCE

CLEANING

EXTERIOR PAINTED SURFACES

CAUTION

Polyester urethane undergoes a curing process for a period of 30 days after application. Uncured painted surfaces should be washed with a mild non-detergent soap (MILD detergents can be used on urethane finishes) and cold or lukewarm water only. Use soft cloths, keeping them free of dirt and grime. Any rubbing of the surface should be done gently and held to a minimum to avoid damaging the paint film. Rinse thoroughly with clear water. Stubborn oil or soot deposits may be removed with automotive tar removers.

Prior to cleaning, cover the wheels, ensuring the brake discs are covered. Attach the pitot cover securely, and make certain to plug or mask off all openings. Use special care to avoid removing lubricant from lubricated areas.

Washing may be accomplished by flushing away loose dirt with clean water, then washing with a mild soap and water, using soft cleaning cloths or a chamois. Avoid harsh, abrasive or alkaline soaps or detergents which could cause scratches. Thorough clear-water rinsing prevents buildup of cleaning agent residue, which can dull the paint's appearance. To remove oily residue or exhaust soot, use a cloth dampened with an automotive tar remover. Wax or polish the affected area if necessary.

WARNING

Do not expose elevator, rudder, and elevon trim tab hinge lines and their pushrod systems to the direct stream or spray of high-pressure soap-and-water washing equipment. Fluid dispensed at high pressure could remove the protective lubricant, allowing moisture from heavy or prolonged rain to collect at hinge lines, and then to freeze at low temperatures. After high-pressure or hand washing, and at each periodic inspection, lubricate trim tab hinge lines and trim tab pushrod end fittings (Brayco 300 per Federal Specification VV-L-800 preferred).

When using high-pressure washing equipment, keep the spray or stream clear of wheel bearings, propeller hub bearings, etc., and openings such as pitot tubes, battery, and avionics equipment cooling ducts which should be securely covered or masked off. Avoid directing high-pressure sprays where moisture and chemicals might easily enter the structure, causing damage to moving parts.

CAUTION

When using high-pressure equipment with solvent to clean wheel well areas, exercise care to avoid washing away grease from landing gear components. After washing the wheel well areas with solvent, lubricate all lubrication points, or premature wear may result.

During the paint curing period, do not make prolonged flights in heavy rain or sleet, and avoid all operating conditions which might cause abrasion or premature finish deterioration.

CAUTION

Do not apply wax, polish, rubbing compound, or abrasive cleaner to any uncured painted surface. Use of such items can permanently damage the surface finish. Also, waxes and polishes seal the paint from the air and prevent curing.

Waxing of polyester urethane finishes, although not required, is permitted; however, never use abrasive cleaner type waxes, polishes, or rubbing compounds, as these products cause eventual deterioration of the characteristic urethane gloss.

For waxing, select a high quality automotive or airplane waxing product. Do not use a wax containing silicones, as silicone polishes are difficult to remove from surfaces. A buildup of wax on any exterior paint finish will yellow with age; therefore, wax should be removed periodically. Generally, aliphatic naphtha is adequate and safe for this purpose.

NOTE

Before returning the airplane to service, remove all maskings and coverings, and relubricate as necessary.

PLASTIC CABIN WINDOWS

The plastic cabin windows should be kept clean and waxed at all times. To prevent scratches and crazing, wash the windows carefully with plenty of mild detergent and running water.

CAUTION

When washing the windows, do not use water from a bucket or pail. Sand, dirt particles or other debris may collect in the standing water and cause scratches in the plastic.

Use the palm of the hand to feel and dislodge dirt and mud. A soft cloth, chamois or sponge may be used only for the purpose of carrying water to the surface of the window. After washing, rinse the window thoroughly with running water and dry it with a clean, moist chamois. Rubbing the surface of the plastic window with a dry cloth will serve only to build up an electrostatic charge which attracts dust.

Remove oil and grease with a cloth moistened with kerosene then rinse the window with clear water.

CAUTION

Never use gasoline, benzene, alcohol, acetone, carbon tetrachloride, fire extinguisher or anti-ice fluid, lacquer thinner, or glass cleaner with a base of these materials, for such materials will soften the plastic and may cause crazing.

If it is desirable to use a commercial cleaner to clean the plastic windows, use only cleaners that are approved by Beech Aircraft Corporation. There are several cleaners available commercially that state that they are approved for use on acrylic surfaces. However, it has been discovered that some of these cleaners cause acrylic plastic to craze. Therefore, only the following products are approved as cleaners for acrylic plastic windows: Meguiar's MGH-10, Permatex 403D or Parko Anti-Static Polish. Follow the directions on the container.

After washing plastic windows with soap and water, apply a good grade of commercial wax. The wax will fill in minor scratches and help prevent further scratches. Apply a thin, even coat of wax and bring it to a high polish by rubbing lightly with a clean, dry, soft flannel cloth. Change the cloth frequently to avoid a buildup of gritty particles. Never use a power buffer, as the heat generated by the buffing pad may soften the plastic.

If the windows were cleaned with one of the commercial cleaners mentioned previously, it will not be necessary to apply wax. Each of these cleaners contains wax, as well as cleaning agents.

WINDSHIELDS

Glass windshields with anti-static coating should be cleaned as follows:

1. Wash excessive dirt and other substances from the glass with clean running water.
2. Clean the windshield with mild soap and water or with a 50/50 solution of isopropyl alcohol and water. Wipe the glass surface in a straight rubbing

motion with a soft cloth or sponge. Never use any abrasive materials or any strong acids or bases to clean the glass.

3. Rinse the glass thoroughly and dry, but do not apply wax.

NOTE

It is essential that the windshield wipers be kept thoroughly clean. Grit trapped by the wipers is the most common source of scratches in the glass. Do not attempt to polish such nicks or scratches out of the the glass surface.

SURFACE DEICE BOOT

The deice boots are made of soft, flexible stock, which may be damaged if fuel hoses are dragged over the surface of the boots or if ladders and platforms are rested against them. Keep deice boots free of oil, fuel, paint remover, solvents, and other injurious substances. Deice boots should be cleaned regularly with a mild soap and water solution. Refer to the BEECHCRAFT Starship 1 Maintenance Manual for cleaning procedures.

CAUTION

Do not use MEK on deice boots.

ENGINE

Clean the engine with neutral solvent. Spray or brush the fluid over the engine, then wash off with water and allow to dry.

CAUTION

Do not use solutions which may attack rubber or plastic. Protect engine switches, controls and seals; fluid applied at high pressure can unseat seals, resulting in contamination of the sealed systems.

INTERIOR CARE

LEATHER OR VINYL

Dust occasionally. To remove almost any stain, wash it in accordance with the following:

NOTE

Never use saddle soap, furniture polishes, oils, varnishes, ammonia water, or solvents of any kind.

1. Use lukewarm water.
2. With Castile, Ivory or any other mild soap, work up a thin layer of suds on a piece of cheesecloth, and apply to the stained area.
3. With a piece of cheesecloth dampened in clean water, remove the soap film.
4. Dry the dampened area with a dry, soft cloth.

CAUTION

The colors of many leathers may only be accomplished by surface dye processing. The color may be rubbed off by continuously dragging hard or coarse material across the leather. While working in the cabin, use protective covers on the leather upholstery. Use only mild detergent with a soft cloth to clean soiled leather.

FABRICS

Dust has impurities which affect fabrics. Vacuum fabrics often. Dry cleaning should be accomplished at regular intervals before excessive soil has accumulated. The actual cleaning of draperies and upholstery must be performed by a professional dry cleaner. Very few fabrics are washable.

LAMINATE

The decorative surface may be readily cleaned with warm water and mild soap. The use of abrasive or "special" cleansers should be avoided. Stubborn stains may be removed with organic solvents or two minutes exposure to a hypochlorite bleach such as "Clorox", followed by a clean water rinse.

CONSUMABLE MATERIALS

Vendors listed as meeting Federal and Military Specifications are provided as a reference only and are not specifically recommended by Beech Aircraft Corporation. Any product conforming to the specification may be used.

The products listed below have been tested and approved for aviation usage by Beech Aircraft Corporation, by the vendor, or by compliance with the applicable specifications. Other products which are locally procurable which conform to the requirements of the applicable Military Specification and/or the latest revision of Pratt and Whitney Service Bulletin 14001 may be used even though not specifically included herein.

MATERIAL	SPECIFICATION	BRAND	VENDOR
Recommended Engine Fuel	Commercial Grade: Jet A, Jet A-1, Jet B Military Grades: JP-4, JP-5, JP-8	Refer to BEECHCRAFT Starship 1 Maintenance Manual	
Emergency Engine Fuel	Aviation Gasoline Grades 80 *(80/87) (Red) 91/96 100LL (Blue)* 100 (100/130) (Green) 115/145 (Purple)	NOTE: Always select the available fuel having the lowest octane number. Use of Aviation Gasoline is limited to 150 hours per engine between engine overhauls. See FAA Approved Flight Manual LIMITATIONS Section for additional limitations on the use of Aviation Gasoline.	
Engine Oil	Pratt & Whitney Specification PWA 521 Type II (5 Centistokes Oil)	Aero Shell Turbine Oil 500	Shell Oil Company
<p>CAUTION: Do not mix oils of different brands, nor oils of different types produced by the same manufacturer, except as noted below.</p> <p>NOTE 1: Castrol 205 and Stauffer Jet II are identical and may be intermixed. Different brand names are used for reasons of market segmentations.</p> <p>NOTE 2: "Esso" and "Exxon" are interchangeable trade names dependent solely on marketing region. These brands are identical and may be intermixed.</p>		<p>BP Enerjet 51</p> <p>Caltex RPM Jet Engine Oil Castrol 205 (See Note 1)</p> <p>Stauffer Jet II (See Note 1) Chevron Jet Engine Oil 5</p> <p>Esso Turbo Oil 2380 (See Note 2)</p> <p>Exxon Turbo Oil 2380 (See Note 2) Mobil Jet Oil II Monsanto Skylube 450 Texaco Starjet 5</p>	<p>BP North America Ltd</p> <p>California Texas Oil Corp. Castrol Oil Inc.</p> <p>Stauffer Chemical Co. Chevron International Oil Co., Inc. Exxon Int. Co., Or Imperial Oil Limited</p> <p>Exxon Co., USA</p> <p>Mobil Oil Corp. Monsanto Co., Inc.</p> <p>Texaco, Inc.</p>
BT00751			

(This Page Intentionally Left Blank)

Section VI

Safety Section

Table of Contents

<i>Subject</i>	<i>Page</i>
Introduction	6-3
General	6-5
Sources of Information	6-5
Pilot's Operating Manual and FAA Approved Airplane Flight Manual	6-5
BEECHCRAFT Service Publications	6-5
Federal Aviation Regulations	6-6
Airworthiness Directives	6-6
Airman's Information Manual	6-7
Advisory Information	6-7
FAA Advisory Circulars	6-7
FAA General Aviation News	6-9
FAA Accident Prevention Program	6-9
Additional Information	6-10
General Information on Specific Topics	6-11
Maintenance	6-11
Hazards of Unapproved Modifications	6-12
Flight Planning	6-12
Passenger Information Cards	6-13
Stowage of Articles	6-13
Flight Operations	6-13
General	6-13
Preflight Inspection	6-13
Weight and Balance	6-13
Autopilot/Electric Trim Systems	6-14
Flutter	6-14
Turbulent Weather	6-15
Wind Shear	6-17
Flight in Icing Conditions	6-17
Weather Radar	6-19
Mountain Flying	6-21
VFR at Night	6-21
Vertigo - Disorientation	6-21
Flight With One Engine Inoperative	6-22
Air Minimum Control Speed (V_{MCA})	6-23
Intentional One-Engine-Inoperative Speed (V_{SSE})	6-23
One-Engine-Inoperative Best Rate-Of-Climb Speed (V_{YSE})	6-24
One-Engine-Inoperative Best Angle-Of-Climb Speed (V_{XSE})	6-24
Single-Engine Service Ceiling	6-24
Basic Single-Engine Procedures	6-24
Engine Failure on Takeoff	6-25
Stalls, Slow Flight and Training	6-25
Spins	6-26
One Engine Inoperative	6-26
Two Engines Operative	6-27
Vortices - Wake Turbulence	6-28
Take-Off and Landing Conditions	6-28
Medical Facts for Pilots	6-28
General	6-28
Fatigue	6-28

Section Section VI

Safety Section

Table of Contents (Continued)

<i>Subject</i>	<i>Page</i>
Hypoxia	6-28
Hyperventilation	6-30
Alcohol	6-30
Drugs	6-31
Scuba Diving	6-31
Carbon Monoxide and Night Vision	6-31
Decompression Sickness	6-32
A Final Word	6-32

INTRODUCTION

Beech Aircraft Corporation has developed this special summary publication of safety information to refresh pilots' and owners' knowledge of safety related subjects. Topics in this publication are dealt with in more detail in FAA Advisory Circulars and other publications pertaining to the subject of safe flying.

The skilled pilot recognizes that safety consciousness is an integral - and never ending - part of his or her job. Be thoroughly familiar with your airplane. Know its limitations and your own. Maintain your currency, or fly with a qualified instructor until you are current and proficient. Practice emergency procedures at safe altitudes and airspeeds, preferably with a qualified instructor pilot, until the required action is instinctive. Periodically review this safety information as part of your recurrency training regimen.

BEECHCRAFT airplanes are designed and built to provide you with many years of safe and efficient transportation. By maintaining your BEECHCRAFT properly and flying it prudently you will realize its full potential.

.....Beech Aircraft Corporation

WARNING

Because your airplane is a high performance, high speed transportation vehicle, designed for operation in a three-dimensional environment, special safety precautions must be observed to reduce the risk of fatal or serious injuries to the pilot(s) and occupant(s).

It is mandatory that you fully understand the contents of this manual and the other operating and maintenance manuals which accompany the airplane; that FAA requirements for ratings, certifications and review be scrupulously complied with; and that you allow only persons who are properly licensed and rated, and thoroughly familiar with the contents of the Pilot's Operating Manual and FAA Approved Airplane Flight Manual to operate the airplane.

IMPROPER OPERATION OR MAINTENANCE OF AN AIRPLANE, NO MATTER HOW WELL BUILT INITIALLY, CAN RESULT IN CONSIDERABLE DAMAGE OR TOTAL DESTRUCTION OF THE AIRPLANE ALONG WITH SERIOUS OR FATAL INJURIES TO ALL OCCUPANTS.

GENERAL

As a pilot, you are responsible to yourself and to those who fly with you, to other pilots and their passengers and to people on the ground, to fly wisely and safely.

The following material in this Safety Section covers several subjects in limited detail.

SOURCES OF INFORMATION

There is a wealth of information available to the pilot, created for the sole purpose of making your flying safer, easier and more efficient. Take advantage of this knowledge and be prepared for an emergency in the remote event that one should occur.

PILOT'S OPERATING MANUAL AND FAA APPROVED AIRPLANE FLIGHT MANUAL

You must be thoroughly familiar with the contents of your operating manuals, placards, and check lists to ensure safe utilization of your airplane. When the airplane was manufactured, it was equipped with placards and Pilot's Operating Manual and FAA Approved Airplane Flight Manual. If the airplane has changed ownership, the Pilot's Operating Manual and FAA Approved Airplane Flight Manual may have been misplaced or may not be current. If missing or out of date, a replacement handbook must be obtained from any BEECHCRAFT Authorized Outlet.

BEECHCRAFT SERVICE PUBLICATIONS

Beech Aircraft Corporation publishes a wide variety of manuals, service letters, service instructions, service bulletins, safety communiques and other publications for the various models of BEECHCRAFT airplanes. Information on how to obtain publications relating to your airplane is contained in BEECHCRAFT Service Bulletin Number 2001, entitled "General - BEECHCRAFT Service Publications - What Is Available and How to Obtain It."

Beech Aircraft Corporation automatically mails original issues and revisions of BEECHCRAFT Service Bulletins (Mandatory, Recommended and Optional), FAA Approved Airplane Flight Manual Supplements, reissues and revisions of FAA Approved Airplane Flight Manuals, Pilot's Operating Manuals, and original issues and revisions of BEECHCRAFT Safety Communiques to BEECHCRAFT owners addresses as listed by the FAA Aircraft Registration Branch List and the BEECHCRAFT International Owner Notification Service List. While this information is distributed by Beech Aircraft Corporation, we can not make changes in the name or address furnished by the FAA. The owner must contact the FAA regarding any changes to name or address. Their address is: FAA Aircraft Registration Branch (AAC250), P.O. Box 25082, Oklahoma City, OK 73125, Phone (405) 680-2131.

It is the responsibility of the FAA owner of record to ensure that any mailings from Beech are forwarded to the proper persons. Often the FAA registered owner is a bank, financing company or an individual not in possession of the airplane. Also, when an airplane is sold, there is a lag in processing the change in registration with the FAA. If you are a new owner, contact your BEECHCRAFT Authorized Outlet and ensure that your manuals are up to date.

Beech Aircraft Corporation provides a subscription service which provides for direct factory mailing of BEECHCRAFT publications applicable to a specific serial number airplane. Details concerning the fees and ordering information for this owner subscription service are contained in Service Bulletin Number 2001.

For owners who choose not to apply for a publications revision subscription service, Beech provides a free Owner Notification Service by which owners are notified by post card of BEECHCRAFT manual reissues, revisions and supplements which are being issued applicable to the airplane owned. On receipt of such notification, the owner may obtain the publication through a BEECHCRAFT Authorized Outlet. This notification service is available when requested by the owner. This request may be made by using the owner notification request card furnished with the loose equipment of each airplane at the time of delivery, or by a letter requesting this service, referencing the specific airplane serial number. Write To:

Supervisor, Special Services
Dept. 52
Beech Aircraft Corporation
P.O. Box 85
Wichita, Kansas 67201-0085

From time to time Beech Aircraft Corporation issues BEECHCRAFT Safety Communiques dealing with the safe operation of a specific series of airplanes, or airplanes in general. It is recommended that each owner/operator maintain a current file of these publications. Back issues of BEECHCRAFT Safety Communiques may be obtained without charge by sending a request including airplane model and serial number, to the Supervisor, Special Services, at the address listed above.

FEDERAL AVIATION REGULATIONS

FAR Part 91, General Operating and Flight Rules, is the law governing operation of airplanes. FAR Part 91 specifies the owner's and pilot's legal responsibilities. Some of the subjects covered are:

Responsibilities and authority of the pilot-in-command

Certificates required

Liquor and drugs

Flight plans

Preflight action

Fuel requirements

Flight rules

Maintenance, preventive maintenance, alterations, inspection and maintenance records

As a pilot, you have responsibilities under government regulations. The regulations are designed for your protection, the protection of your passengers and the public. Compliance is mandatory.

AIRWORTHINESS DIRECTIVES

FAR Part 39 specifies that no person may operate a product to which an Airworthiness Directive issued by the FAA applies, except in accordance with the requirements of that Airworthiness Directive.

Airworthiness Directives (AD's) are not issued by the manufacturer. They are issued and available from the FAA.

AIRMAN'S INFORMATION MANUAL

The Airman's Information Manual (AIM) is designed to provide airmen with basic flight information and ATC procedures for use in the national airspace system of the United States. It also contains items of interest to pilots concerning health and medical facts, factors affecting flight safety, a pilot/controller glossary of terms in the Air Traffic Control system, information on safety, and accident/hazard reporting. It is revised at six-month intervals and can be purchased from the Superintendent of Documents, U.S. Government Printing Office, Washington, D.C. 20402.

This document contains a wealth of pilot information. Among the subjects are:

- Controlled Airspace
- Emergency Procedures
- Service Available to Pilots
- Weather and Icing
- Radio Phraseology and Technique
- Mountain Flying
- Airport Operations
- Wake Turbulence - Vortices
- Clearances and Separations
- Medical Facts for Pilots
- Preflight
- Bird Hazards
- Departures - IFR
- Good Operating Practices
- Enroute - IFR
- Airport Location Directory
- Arrival - IFR

All pilots must be thoroughly familiar with and use the information in the AIM.

ADVISORY INFORMATION

Notams (Notices to Airmen) are documents that have information of a time-critical nature that would affect a pilot's decision to make a flight; for example, an airport closed, terminal radar out of service, or enroute navigational aids out of service.

FAA ADVISORY CIRCULARS

The FAA issues Advisory Circulars to inform the aviation public in a systematic way of nonregulatory material of interest. Advisory Circulars contain a wealth of information with which the prudent pilot should be familiar. A complete list of current FAA Advisory Circulars is published in AC OO-2, which lists Advisory Circulars that are for sale, as well as those distributed free of charge by the FAA, and provides ordering information. Many Advisory Circulars which are for sale can be purchased locally in aviation bookstores or at FBO's. These documents are subject to periodic revision. Be certain the Advisory Circular you are using is the latest revision available. Some of the Advisory Circulars of interest to pilots are:

*00-6	Aviation Weather
00-21	Shoulder Harness
00-24	Thunderstorms
00-30	Rules of Thumb For Avoiding or Minimizing Encounters with Clear Air Turbulence
*00-45	Aviation Weather Services
00-46	Aviation Safety Reporting Program
00-50	Low Level Wind Shear
20-32	Carbon Monoxide (CO) Contamination in Aircraft - Detection and Prevention
20-35	Tie-Down Sense
20-43	Aircraft Fuel Control
20-93	Flutter Due to Ice or Foreign Substance On or In Aircraft Control Surfaces
20-105	Engine Power-Loss Accident Prevention
21-4	Special Flight Permits for Operation of Overweight Aircraft
43-5	Airworthiness Directives for General Aviation Aircraft
43-9	Maintenance Records: General Aviation Aircraft
43-12	Preventive Maintenance
60-4	Pilot's Spatial Disorientation
60-6	Airplane Flight Manuals (AFM), Approved Manual Materials, Markings and Placards - Airplanes
60-12	Availability of Industry-Developed Guidelines for the Conduct of the Biennial Flight Review
60-13	The Accident Prevention Counselor Program
*61-21	Flight Training Handbook
*61-23	Pilot's Handbook of Aeronautical Knowledge
*61-27	Instrument Flying Handbook
61-67	Hazards Associated with Spins in Airplanes Prohibited from Intentional Spinning.
61-84	Role of Preflight Preparation
*67-2	Medical Handbook for Pilots
90-23	Wake Turbulence
90-42	Traffic Advisory Practices at Non-tower Airports
90-48	Pilot's Role in Collision Avoidance

90-66	Recommended Standard Traffic Patterns for Airplane Operations at Uncontrolled Airports
90-85	Severe Weather Avoidance Plan (SWAP)
91-6	Water, Slush and Snow On the Runway
91-8	Use of Oxygen by General Aviation Pilots/Passengers
91-11-1	Guide to Drug Hazards in Aviation Medicine
91-13	Cold Weather Operation of Aircraft
*91-15	Terrain Flying
*91-23	Pilot's Weight and Balance Handbook
91-25	Loss of Visual Cues During Low Visibility Landings
91-26	Maintenance and Handling of Air Driven Gyroscopic Instruments
91-28	Unexpected Opening of Cabin Doors
91-35	Noise, Hearing Damage, and Fatigue in General Aviation Pilots
91-43	Unreliable Airspeed Indications
91-44	Operational and Maintenance Practices for Emergency Locator Transmitters and Receivers
91-46	Gyroscopic Instruments - Good Operating Practices
91-50	Importance of Transponder Operations and Altitude Reporting
91-51	Airplane Deice and Anti-Ice Systems
103-4	Hazards Associated with Sublimation of Solid Carbon Dioxide (Dry Ice) Aboard Aircraft
210-5A	Military Flying Activities

* For Sale

FAA GENERAL AVIATION NEWS

FAA General Aviation News is published by the FAA in the interest of flight safety. The magazine is designed to promote safety in the air by calling the attention of general aviation airmen to current technical, regulatory and procedural matters affecting the safe operation of airplanes. FAA General Aviation News is sold on subscription by the Superintendent of Documents, Government Printing Office, Washington D.C. 20402.

FAA ACCIDENT PREVENTION PROGRAM

The FAA assigns accident prevention specialists to each Flight Standards and General Aviation District Office to organize accident prevention program activities. In addition, there are over 3,000 volunteer airmen serving as accident prevention counselors,

sharing their technical expertise and professional knowledge with the general aviation community. The FAA conducts seminars and workshops, and distributes invaluable safety information under this program.

Usually the airport manager, the FAA Flight Service Station (FSS), or Fixed Base Operator (FBO) will have a list of accident prevention counselors and their phone numbers available. All Flight Standards and General Aviation District Offices have a list of the counselors serving the District.

ADDITIONAL INFORMATION

The National Transportation Safety Board and the Federal Aviation administration periodically issue, in greater detail, general aviation pamphlets concerning aviation safety. FAA Regional Offices also publish material under the FAA General Aviation Accident Prevention Program. These can be obtained at FAA Offices, Weather Stations, Flight Service Stations or Airport Facilities. Some of these are titled:

12 Golden Rules for Pilots
Weather or Not
Disorientation
Plane Sense
Weather Info Guide for Pilots
Wake Turbulence
Don't Trust to Luck, Trust to Safety
Rain, Fog, Snow
Thunderstorm - TRW
Icing
Pilot's Weather Briefing Guide
Thunderstorms Don't Flirt . . . Skirt 'em
IFR-VFR - Either Way Disorientation Can Be Fatal
IFR Pilot Exam-O-Grams
VFR Pilot Exam-O-Grams
Impossible Turn
Wind Shear
Estimating Inflight Visibility
Is the Aircraft Ready for Flight
Tips on Mountain Flying
Tips on Desert Flying
Always Leave Yourself An Out
Tips on the Use of Ailerons and Rudder
Some Hard Facts About Soft Landings
Propeller Operation and Care
Torque "What it Means to the Pilot"
Weight and Balance - An Important Safety Consideration for Pilots

GENERAL INFORMATION ON SPECIFIC TOPICS

MAINTENANCE

Safety of flight begins with a well maintained airplane. Make it a habit to keep your airplane and all of its equipment in first-class, airworthy condition. Keep a "Squawk list" on board, and see that all discrepancies, however minor, are noted and promptly repaired.

Schedule your maintenance regularly, and have your airplane serviced by a reputable organization. Be suspicious of bargain prices for maintenance, repairs and inspections.

If repairs or modifications are made to the flight control system, make sure the control surfaces are properly balanced and the controls move freely from the cockpit through their designed range and in the proper direction of travel.

It is the responsibility of the owner and the operator to assure that the airplane is maintained in an airworthy condition and that proper maintenance records are kept.

Use only genuine BEECHCRAFT or BEECHCRAFT approved parts obtained from BEECHCRAFT approved sources, in connection with the maintenance and repair of Beech airplanes.

Genuine BEECHCRAFT Parts are produced and inspected under rigorous procedures to ensure airworthiness and suitability for use in Beech airplane applications. Parts purchased from sources other than BEECHCRAFT, even though outwardly identical in appearance, may not have had the required tests and inspections performed, may be different in fabrication techniques and materials, and may be dangerous when installed in an airplane.

Salvaged airplane parts or reworked parts obtained from non-BEECHCRAFT approved sources, or parts, components, or structural assemblies, the service history of which is unknown or cannot be verified, may have been subjected to unacceptable stresses or temperatures, or have other hidden damage not discernible through routine visual or nondestructive testing techniques. This may render the part, component or structural assembly, even though originally manufactured by BEECHCRAFT, unsuitable and unsafe for airplane use.

BEECHCRAFT expressly disclaims any responsibility for malfunctions, failures, damage or injury caused by use of non-BEECHCRAFT parts.

Airplanes operated for Air Taxi or other than normal operation, and airplanes operated in humid tropics, or cold and damp climates, etc., may need more frequent inspections for wear, corrosion and/or lack of lubrication. In these areas, periodic inspections should be performed until the operator can set his own inspection periods based on experience.

NOTE

The required periods do not constitute a guarantee that the item will function satisfactorily throughout the period without malfunction, as the aforementioned factors cannot be controlled by the manufacturer.

Corrosion and its effects must be treated at the earliest possible opportunity. A clean, dry surface is virtually immune to corrosion. Make sure that all drain holes remain unobstructed. Protective films and sealants help to keep corrosive agents from contacting metallic surfaces. Corrosion inspections should be made most frequently under high-corrosion-risk operating conditions, such as in areas of excessive airborne salt concentrations (e.g., near the sea) and in high-humidity areas (e.g., tropical regions).

If you have purchased a used airplane, have your mechanic inspect the airplane registration records, logbooks and maintenance records carefully. An unexplained period of time for which the airplane has been out of service, or unexplained significant repairs, may well indicate the airplane has been seriously damaged in a prior accident. Have your mechanics inspect a used airplane carefully. Take the time to ensure that you really know what you are buying when you purchase a used airplane.

HAZARDS OF UNAPPROVED MODIFICATIONS

Many airplane modifications are approved under Supplemental Type Certificates (STC's). Before installing an STC on your airplane, check to make sure that the STC does not conflict with other STC's that have already been installed. Because approval of an STC is obtained by the individual STC holder, based upon modification of the original type design, it is possible for two STC's to interfere with each other when both are installed. Never install an unapproved modification of any type, however innocent the apparent modification may seem. Always obtain proper FAA approval.

Airplane owners and maintenance personnel are particularly cautioned not to make attachments to, or otherwise modify, crew or cabin seats without approval from the FAA Engineering and Manufacturing District Office having original certification responsibility for that make and model.

Any unapproved attachment or modification to seat structure may increase load factors and metal stress which could cause failure of seat structure at a lesser "G" force than exhibited for original certification.

Examples of unauthorized attachments are drilling holes in seat tubing to attach fire extinguishers and drilling holes to attach approach plate book bins to seats.

FLIGHT PLANNING

FAR Part 91 requires that each pilot in command, before beginning a flight, familiarize himself with all available information concerning that flight.

Obtain a current and complete preflight briefing. This should consist of local, enroute and destination weather and enroute navaid information. Enroute terrain and obstructions, alternate airports, airport runways active, length of runways, and takeoff and landing distances for the airplane for conditions expected should be known.

The prudent pilot will review his planned enroute track and stations and make a list for quick reference. It is strongly recommended that a flight plan be filed with Flight Service Stations, even though the flight may be VFR. Also, advise Flight Service Stations of changes or delays and remember to close the flight plan at your destination.

shown in the Performance section; the stall speeds will be higher, and rate of climb, cruising speed, and range of the airplane will all be lower than shown in the Performance section.

An airplane loaded forward of its C.G. forward limit, will require additional control movements with correspondingly higher control forces. The pilot may lose control or have no control during takeoff and landing because of elevator control limits.

An airplane loaded aft of its C.G. limit will have lower stability or no/neutral stability. Characteristics of lower stability are: lower control forces, difficulty trimming the airplane, lower maneuvering control forces (with attendant danger of structural overload), unacceptable/unrecoverable stall characteristics, and reduced lateral-directional damping.

Ensure that all cargo and baggage is properly secured before takeoff. A sudden shift in balance at rotation can cause controllability problems.

Maintaining center of gravity within the approved envelope throughout the planned flight is an important safety consideration.

AUTOPILOT/ELECTRIC TRIM SYSTEMS

It is essential that every operator review his Pilots Operating Manual and FAA Approved Airplane Flight Manual and ensure that he fully understands the autopilot/trim installation on his specific airplane. Each pilot, prior to flight, must be fully aware of the proper procedures for engagement, operation, and particularly disengagement, of the system.

Ensure that all autopilot/trim buttons, switches and circuit breakers function as described in the Pilot's Operating Manual. If they do not, have the system repaired by a qualified service agency. If field service advice or assistance is necessary, contact Beech Aircraft Corporation, Customer Support Department.

As stated in the FAA Approved Airplane Flight Manual the preflight check must be conducted before the first flight of the day. The preflight check assures not only that the systems and all of their features are operating properly, but also that the pilot, before flight, is familiar with the proper means of engagement and disengagement of the autopilot/trim system.

IN CASE OF EMERGENCY, YOU CAN OVERPOWER THE AUTOPILOT TO CORRECT THE ATTITUDE, BUT THE AUTOPILOT AND ELECTRIC TRIM MUST THEN IMMEDIATELY BE DISENGAGED.

It can be difficult to distinguish an autopilot malfunction from an electric trim malfunction. The safest course is to deactivate the entire system. Do not re-engage until after you have safely landed. Then have the system checked by a qualified service facility prior to further flight.

FLUTTER

Flutter is a phenomenon that can occur when an aerodynamic surface begins vibrating. The energy to sustain the vibration is derived from airflow over the surface. The amplitude of the vibration can (1) decrease, if airspeed is reduced; (2) remain constant, if airspeed is held constant and no failures occur; or (3) increase to the point of

self-destruction, especially if airspeed is high and/or is allowed to increase. Flutter can lead to an in-flight break up of the airplane. Airplanes are designed so that flutter will not occur in the normal operating envelope of the airplane as long as the airplane is properly maintained. In the case of any airplane, decreasing the damping and stiffness of the structure or increasing the trailing edge weight of control surfaces will tend to cause flutter. If a combination of those factors is sufficient, flutter can occur within the normal operating envelope.

Owners and operators of airplanes have the primary responsibility for maintaining their airplanes. To fulfill that responsibility, it is imperative that all airplanes receive a thorough preflight inspection. Improper tension on the control cables or any other loose condition in the flight control system can also cause or contribute to flutter. Pilots should pay particular attention to control surface attachment hardware including tab pushrod attachment during preflight inspection. Looseness of fixed surfaces or movement of control surfaces other than in the normal direction of travel should be rectified before flight. Further, owners should take their airplanes to mechanics who have access to current technical publications and prior experience in properly maintaining that make and model of airplane. The owner should make certain that control cable tension inspections are performed as outlined in the applicable Beech Inspection Guide. Worn control surface attachment hardware must be replaced. Any repainting or repair of a moveable control surface will require a verification of the control surface balance before the airplane is returned to service. Control surface drain holes must be open to prevent freezing of accumulated moisture, which could create an increased trailing-edge-heavy control surface and flutter.

If an excessive vibration, particularly in the control column and rudder pedals, is encountered in flight, this may be the onset of flutter and the procedure to follow is:

1. IMMEDIATELY REDUCE AIRSPEED (lower the landing gear, if necessary).
2. RESTRAIN THE CONTROLS OF THE AIRPLANE UNTIL THE VIBRATION CEASES.
3. FLY AT THE REDUCED AIRSPEED AND LAND AT THE NEAREST SUITABLE AIRPORT.
4. HAVE THE AIRPLANE INSPECTED FOR AIRFRAME DAMAGE, CONTROL SURFACE ATTACHING HARDWARE CONDITION/SECURITY, TRIM TAB FREE PLAY, PROPER CONTROL CABLE TENSION, AND CONTROL SURFACE BALANCE BY ANOTHER MECHANIC WHO IS FULLY QUALIFIED.

TURBULENT WEATHER

A complete and current weather briefing is a requirement for a safe trip.

Updating weather information en route is essential. The wise pilot knows that weather conditions can change quickly, and treats weather forecasting as professional advice, rather than an absolute fact. He obtains all the advice he can, but stays alert to any sign or report of changing conditions.

Plan the flight to avoid areas of reported severe turbulence. It is not always possible to detect individual storm areas or find the in-between clear areas. Remember that radar-based turbulence detection systems cannot detect clear air turbulence.

The National Weather Service classifies turbulence as follows:

Class of Turbulence	Effect
Extreme	Turbulence in which the airplane is violently tossed about and is practically impossible to control. It may cause structural damage.
Severe	Turbulence that causes large, abrupt changes in altitude and/or attitude. It usually causes large variations in indicated airspeed. Airplane may be momentarily out of control.
Moderate	Turbulence that is similar to Light Turbulence but of greater intensity. Changes in altitude and/or attitude occur but the airplane remains in positive control at all times. It usually causes variations in indicated airspeed.
Light	Turbulence that momentarily causes slight, erratic changes in altitude and/or attitude (pitch, roll, yaw).

Thunderstorms, squall lines and violent turbulence should be regarded as extremely dangerous and must be avoided. Hail and tornadic wind velocities can be encountered in thunderstorms that can destroy any airplane, just as tornadoes destroy nearly everything in their path on the ground.

A roll cloud ahead of a squall line or thunderstorm is visible evidence of violent turbulence; however, the absence of a roll cloud does not mean that severe turbulence is not present.

Even though flight in severe turbulence must be avoided, flight in turbulent air may be encountered unexpectedly under certain conditions.

The following recommendations should be observed for airplane operation in turbulent air:

Flying through turbulent air presents two basic problems, the answer to both of which is proper airspeed. On one hand, if you maintain an excessive airspeed, you run the risk of structural damage or failure; on the other hand, if your airspeed is too low, you may stall.

If turbulence is encountered, reduce speed to the turbulent air penetration speed listed in the Normal Procedures Section of the FAA Approved Airplane Flight Manual. This speed gives the best assurance of avoiding excessive stress loads, and at the same time providing the proper margin against inadvertent stalls due to gusts.

Beware of overcontrolling in an attempt to correct for changes in attitude; applying control pressure abruptly will build up G-forces rapidly and could cause structural damage or even failure. You should watch your angle of bank, making turns as wide and shallow as possible. Be equally cautious in applying forward or back pressure to keep the airplane level. Maintain straight and level attitude in either up or down drafts. Use trim sparingly to avoid being grossly out of trim as the vertical air columns change velocity and direction. If necessary to avoid excessive airspeeds, lower the landing gear.

After exposure to possibly damaging levels of turbulence, a Turbulent Air Penetration Inspection should be conducted after landing (as outlined in Chap. 5 of the Maintenance Manual).

Thunderstorms also pose the possibility of a lightning strike on an airplane. Any structure or equipment which shows evidence of a lightning strike, or of being subjected to a high current flow due to a strike, or is a suspected part of a lightning strike path through the airplane should be thoroughly inspected and any damage repaired prior to additional flight.

During flight in an area of thunderstorms, always be aware that the risk of a lightning strike is increased when flying in icing conditions or in clouds near the freezing level.

WIND SHEAR

Wind shears are rapid, localized changes in wind direction, which can occur vertically as well as horizontally. Wind shear can be very dangerous to all airplanes, large and small, particularly on approach to landing when airspeeds are slow.

A horizontal wind shear is a sudden change in wind direction or speed that can, for example, transform a headwind into a tailwind, producing a sudden decrease in airspeed because of the inertia of the airplane. A vertical wind shear is a sudden updraft or downdraft. Microbursts are intense, highly localized severe downdrafts.

The prediction of wind shears is far from an exact science. Monitor your airspeed carefully when flying in storms, particularly on approach. Be mentally prepared to add power and go around at the first indication that a wind shear is being encountered.

FLIGHT IN ICING CONDITIONS

Every pilot should be intimately acquainted with the FAA Approved National Weather Service definitions for ice intensity and accumulation which we have reprinted below:

Intensity	Ice Accumulation
Trace	Ice becomes perceptible. Rate of accumulation slightly greater than rate of sublimation. It is not hazardous even though deicing/anti-icing equipment is not utilized, unless encountered for an extended period of time (over 1 hour).
Light	The rate of accumulation may create a problem if flight is prolonged in this environment (over 1 hour). Occasional use of deicing/anti-icing equipment will prevent or remove accumulation. It does not present a problem if the deicing/anti-icing equipment is used.
Moderate	The rate of accumulation is such that even short encounters become potentially hazardous and use of deicing/anti-icing equipment, or diversion, is necessary.
Severe	The rate of accumulation is such that deicing/anti-icing equipment fails to reduce or control the hazard. Immediate diversion is necessary.

Pilots and airplane owners must carefully review the Pilot's Operating Manual and FAA Approved Airplane Flight Manual to determine the required operable equipment

needed for flight in icing conditions. In addition, they must ascertain from the same sources the limits of approval or certification of their airplane for flight in icing conditions, and plan the flight accordingly, if icing conditions are known or forecast along the route.

Remember that regardless of its combination of deicing/anti-icing equipment, any airplane not fully equipped and functional for IFR flight is not properly equipped for flight in icing conditions. An airplane which is not approved or certificated for flight in icing conditions, or which does not have all critical areas protected in the required manner by fully operational equipment must not be exposed to icing encounters of any intensity. When icing is detected, the pilot of such an airplane must make immediate diversion by flying out of the area of visible moisture or going to an altitude where icing is not encountered.

Even airplanes fully equipped and certified for flight in the icing conditions described in Appendix C to FAR Part 25 must avoid flights into those conditions defined by the National Weather Service as "Severe". No airplane equipped with any combination of deicing/anti-icing equipment can be expected to cope with such conditions. As competent pilots know, there appears to be no predictable limits for the severest weather conditions. For essentially the same reasons that airplanes, however designed or equipped for IFR flight, cannot be flown safely into conditions such as thunderstorms, tornadoes, hurricanes or other phenomena likely to produce severe turbulence, airplanes equipped for flight in icing conditions cannot be expected to cope with "Severe" icing conditions as defined by the National Weather Service. The prudent pilot must remain alert to the possibility that icing conditions may become "Severe" and that his equipment will not cope with them. At the first indication that such condition may have been encountered or may lie ahead, he should immediately react by selecting the most expeditious and safe course for diversion.

Every pilot of a properly equipped Beech airplane who ventures into icing conditions must maintain the minimum speed (KIAS) for operation in icing conditions, which is set forth in the Limitations Section of his FAA Approved Airplane Flight Manual. The pilot must remain aware of the fact that if he allows his airspeed to deteriorate below the minimum speed, he will increase the angle of attack of his airplane to the point where ice may build up on the underside of the wings aft of the area protected by the deice/anti-icing equipment.

Ice build-up, and its extent in unprotected areas will not be directly observable from the cockpit. Due to distortion of the wing airfoil, increased drag and reduced lift, stalling speeds will increase as ice accumulates on the airplane. For the same reasons, stall warning devices are not accurate and cannot be relied upon in icing conditions.

Even though the pilot maintains the prescribed speeds for operating in icing conditions, ice is still likely to build up on the unprotected areas. Under some atmospheric conditions, it may even build up aft of the de-iced areas despite the maintenance of the prescribed speed. The effect of ice accumulation on any unprotected surface is aggravated by length of exposure to the icing conditions. Ice buildup on unprotected surfaces will increase drag, add weight, reduce lift, and generally, adversely affect the aerodynamic characteristics and performance of the airplane. It can progress to the point where the airplane is no longer capable of flying. Therefore, the pilot operating even a fully-equipped airplane in sustained icing conditions must remain sensitive to any indication, such as observed ice accumulation, loss of airspeed, the need for increased power, reduced rate of climb, or sluggish response, that ice is accumulating

on unprotected surfaces and that continued flight in these conditions is extremely hazardous, regardless of the performance of the deicing/anti-icing equipment.

Since flight in icing conditions is not an everyday occurrence, it is important that you maintain a proper proficiency and awareness of the operating procedures necessary for safe operation of the airplane and that the airplane is in a condition for safe operation.

Ensure moisture drains in the airplane structure are maintained open as specified in the Aircraft Maintenance Manual, so that moisture will not collect and cause freezing in the control cable area. Also, control surface tab hinges should be maintained and lubricated as specified in the Aircraft Maintenance Manual.

In icing conditions the autopilot should be disengaged at an altitude sufficient to permit the pilot to gain the feel of the airplane prior to landing.

Observe the procedures set forth in your FAA Approved Airplane Flight Manual during operation in icing conditions.

Test your MANUAL/AUTO surface deice systems before entering suspected icing conditions.

The following references are recommended reading for safer flight in icing conditions:

- FAA Advisory Circular 91-51 - Airplane Deice and Anti-ice Systems.
- Weather Flying by Robert N. Buck.

Finally, the most important ingredients to safe flight in icing conditions - regardless of the airplane or the combination of deicing/anti-icing equipment - are a complete and current weather briefing, sound pilot judgment, close attention to the rate and type of ice accumulations, and the knowledge that "severe icing" as defined by the National Weather Service is beyond the capability of modern airplanes and an immediate diversion must be made. It is the inexperienced or uneducated pilot who presses on "regardless", hoping that steadily worsening conditions will improve, only to find himself flying an airplane which has become so loaded with ice that he can no longer maintain altitude. At this point he has lost most, if not all, of his safety options, including perhaps a 180-degree turn to return along the course already traveled.

The responsible and well-informed pilot recognizes the limitations of weather conditions, his airplane and its systems, and reacts promptly.

WEATHER RADAR

Airborne weather avoidance radar is, as its name implies, for avoiding severe weather - not for penetrating it. Whether to fly into an area of radar echoes depends on echo intensity, spacing between the echoes, and the capabilities of you and your airplane. Remember that weather radar detects precipitation; it may or may not detect turbulence. Therefore, the radar scope provides no assurance of avoiding turbulence. The radar scope also does not provide assurance of avoiding instrument weather caused by clouds and fog. Your scope may be clear between intense echoes; this clear area does not necessarily mean that you can fly between the storms and maintain visual sighting of them.

Thunderstorms build and dissipate rapidly. Therefore, do not attempt to plan a course between echoes. The best use of ground radar information is to isolate general areas and coverage of echoes. You must avoid individual storms from in-flight observations either by visual sighting or by airborne radar. It is better to avoid the whole thunderstorm area than to detour around individual storms, unless they are scattered.

Remember that while hail always gives a radar echo, it may fall several miles from the nearest visible cloud and hazardous turbulence may extend to as much as 20 miles from the echo edge. Avoid intense or extreme level echoes by at least 20 miles; that is, such echoes should be separated by at least 40 miles before you fly between them. With weaker echos you can reduce the distance by which you avoid them.

Above all, remember this: never regard any thunderstorm lightly. Even when radar observers report the echoes are of light intensity, avoiding thunderstorms is the best policy. The following are some do's and don'ts of thunderstorm avoidance:

1. Don't land or take off in the face of an approaching thunderstorm. A sudden gust front containing low level turbulence could cause loss of control.
2. Don't attempt to fly under a thunderstorm even if you can see through to the other side. Turbulence and wind shear under the storm could be disastrous.
3. Don't fly without airborne radar into a cloud mass containing embedded thunderstorms. Scattered thunderstorms not embedded usually can be visually circumnavigated.
4. Don't trust the visual appearance to be a reliable indicator of the turbulence inside a thunderstorm.
5. Don't continue flight toward a radar shadow.
6. Don't assume that the lack of turbulence shown on the radar screen means a smooth ride through a storm.
7. Do avoid by at least 20 miles any thunderstorm identified as severe or giving an intense radar echo. This is especially true under the anvil of a large cumulonimbus.
8. Do circumnavigate the entire area if the area has 6/10 or more thunderstorm coverage.
9. Do remember that vivid and frequent lightning indicates the probability of a severe thunderstorm.
10. Do regard as extremely hazardous any thunderstorm with tops 35,000 feet or higher, whether the top is visually sighted or determined by radar.

If you cannot avoid penetrating a thunderstorm, the following are some do's BEFORE entering the storm:

11. Tighten your safety belt, put on your shoulder harness, and secure all loose objects.
12. Plan and hold your course to take you through the storm in minimum time.
13. To avoid the most critical icing, establish a penetration altitude below the freezing level or at an altitude where the OAT is -15°C or colder.
14. Verify that all anti-ice/deice systems are on. Icing can be rapid at any altitude and can cause almost instantaneous power failure and/or loss of airspeed indication.

MOUNTAIN FLYING

Pilots flying in mountainous areas should inform themselves of all aspects of mountain flying, including the effects of topographic features on weather conditions. Many good articles have been published, and a synopsis of mountain flying operations is included in the FAA Airman's Information Manual, Part 1.

Avoid flight at low altitudes over mountainous terrain, particularly near the lee slopes. If the wind velocity near the level of the ridge is in excess of 25 knots and approximately perpendicular to the ridge, mountain wave conditions are likely over and near the lee slopes. If the wind velocity at the level of the ridge exceeds 50 knots, a strong mountain wave is probable with extreme up and down drafts and severe turbulence. The worst turbulence will be encountered in and below the rotor zone, which is usually 8 to 10 miles downwind from the ridge. This zone is sometimes characterized by the presence of "roll clouds" if sufficient moisture is present. Altocumulus standing lenticular clouds are also visible signs that a mountain wave exists, but their presence is likewise dependent upon moisture. Mountain wave turbulence can, of course, occur in dry air and the absence of such clouds should not be taken as assurance that mountain wave turbulence will not be encountered. A mountain wave downdraft may exceed the climb capability of your airplane. Avoid mountain wave downdrafts.

VFR AT NIGHT

When flying VFR at night, in addition to the altitude appropriate for the direction of flight, pilots should maintain a safe minimum altitude as dictated by terrain, obstacles such as TV towers, or communities in the area flown. This is especially true in mountainous terrain, where there is usually very little ground reference. A Minimum clearance of 2,000 feet above the highest obstacle en route is recommended when operating in designated mountainous areas. Do not depend on your ability to see obstacles in time to miss them. Flight on dark nights over sparsely populated country can pose the same problems as flying in instrument meteorological conditions (IMC).

VERTIGO - DISORIENTATION

Disorientation can occur in a variety of ways. During flight, inner-ear balancing mechanisms are subjected to varied forces not normally experienced on the ground. This, combined with loss of outside visual reference, can cause vertigo. False interpretations (illusions) result, and may confuse the pilot's conception of the attitude and position of his airplane.

Under VFR conditions, the visual sense, using the horizon as a reference, can override the illusions. Under low visibility conditions (night, fog, clouds, haze, etc.) the illusions predominate. Only through awareness of these illusions, and proficiency in instrument flight procedures, can an airplane be operated safely in a low visibility environment.

Flying in fog, dense haze or dust, cloud banks, or very low visibility, with strobe lights or rotating beacons turned on can contribute to vertigo. They should be turned off in these conditions, particularly at night.

Motion sickness often precedes or accompanies disorientation and may further jeopardize the flight.

Disorientation in low visibility conditions is not limited to VFR pilots. Although IFR pilots are trained to look at their instruments to gain an artificial visual reference as a replacement for the loss of a visual horizon, they do not always do so. This can happen when: the pilot's physical condition will not permit him to concentrate on his instruments, when the pilot is not proficient in flying instrument conditions in the airplane he is flying, or when the pilot's work load of flying by reference to his instruments is compounded by such factors as turbulence. Even an instrument rated pilot encountering instrument conditions, intentional or unintentional, should ask himself whether or not he is sufficiently alert and proficient in the airplane to fly under low visibility conditions and in the turbulence anticipated or encountered.

All pilots should check the weather and use good judgement in planning flights. If any doubt exists, the flight should not be made or it should be discontinued as soon as possible.

A likely result of vertigo is loss of control of the airplane. If the loss of control is sustained, it will result in an excessive speed accident. Excessive speed accidents occur in one of two manners - either as an inflight airframe separation or as a high speed ground impact; they are fatal accidents in either case. All airplanes are subject to this form of accident.

Excessive speed accidents occur at airspeeds greatly in excess of two operating limitations which are specified in the manuals: Maximum maneuvering speed and the "red line" or maximum operating speed. Such speed limits are set to protect the structure of an airplane. For example, control surfaces are designed to be used to their fullest extent only below the airplane's maximum maneuvering speed. As a result, the control surfaces should never be suddenly or fully deflected above maximum maneuvering speed. Also, turbulence penetration should not be performed above that speed. The accidents we are discussing here occur at airspeeds greatly in excess of these limitations. No airplane should ever be flown beyond its FAA approved operating limitations.

FLIGHT WITH ONE ENGINE INOPERATIVE

Safe flight with one engine inoperative requires an understanding of the basic aerodynamics involved - as well as proficiency in engine-out procedures.

Loss of power from one engine affects both climb performance and controllability of twin-engine airplanes. Climb performance depends on the amount of power available above that required for level flight. Loss of power from one engine obviously represents a 50% loss of power but, in virtually all twin-engine airplanes, climb performance is reduced by at least 80%. A study of the charts in your FAA Approved Airplane Flight Manual will confirm this fact. Single-engine climb performance depends on four factors:

Airspeed	too little, or too much, will decrease climb performance
Drag	gear, flaps, and prop
Power	amount available in excess of that needed for level flight

Weight passengers, baggage, and fuel load greatly affect climb performance

Loss of power on one engine creates yaw due to asymmetric thrust. Yaw forces must be balanced with the rudder. In addition, yaw affects the lift distribution over the wing causing a roll toward the "dead" engine.

Airspeed is the key to safe single-engine operations. For most twin-engine airplanes the following airspeeds have been established:

Symbol	Description
V_{MCA}	Airspeed below which directional control cannot be maintained in the air.
V_{SSE}	Airspeed below which an intentional engine cut must never be made.
V_{YSE}	Airspeed that will give the best single engine rate-of-climb (or the minimum descent rate).
V_{XSE}	Airspeed that will give the steepest angle-of-climb with one engine out.

AIR MINIMUM CONTROL SPEED (V_{MCA})

V_{MCA} is designated by the lower red line on the airspeed indicator and indicates the minimum control speed, airborne at sea level. V_{MCA} is determined by FAA regulations as the minimum airspeed at which it is possible to recover directional control of the airplane within 20 degrees heading change and maintain straight flight, with not more than 5 degrees of bank if one engine fails suddenly with:

- Take-off power on both engines
- Rearmost allowable center of gravity
- Flaps in take-off position
- Propeller windmilling in take-off pitch configuration (or feathered if automatically featherable)

However, sudden engine failures rarely occur with all factors listed above, and therefore, the actual V_{MCA} in any particular situation may be slower than the red line on the airspeed indicator. Most airplanes will not maintain level flight at speeds at or near V_{MCA}. Consequently, it is not advisable to fly at speeds approaching V_{MCA}, except in training situations or during flight tests. Adhering to the practice of never flying at or below the published V_{MCA} speed for your airplane will virtually eliminate loss of directional control as a problem in the event of an engine failure.

INTENTIONAL ONE-ENGINE-INOPERATIVE SPEED (V_{SSE})

V_{SSE} is specified by the airplane manufacturer and is the minimum speed to perform intentional engine cuts. Use of V_{SSE} is intended to reduce the accident potential from loss of control after engine cuts at or near minimum control speed. V_{MCA} demonstrations are necessary in training but should only be made at a safe altitude above the terrain and with power reduction on one engine made at or above V_{SSE}.

ONE-ENGINE-INOPERATIVE BEST RATE-OF-CLIMB SPEED (V_{YSE})

V_{YSE} is designated by the blue line on the airspeed indicator. V_{YSE} delivers the greatest gain in altitude in the shortest possible time, and is based on the following criteria:

- critical engine inoperative, and its propeller feathered.
- operating engine set at not more than take-off power.
- landing gear retracted.
- wing flaps retracted.
- airplane flown with zero yaw (i.e., approximately 5° bank into the operating engine).

Drag caused by a windmilling propeller, extended landing gear, or flaps extended, will severely degrade or destroy single-engine climb performance. Since climb performance varies widely with weight, temperature, altitude, and airplane configuration, the climb gradient (altitude gain or loss per mile) may be marginal - or even negative - under some conditions. Study the Pilot's Operating Manual and FAA Approved Airplane Flight Manual for your specific airplane and know what performance to expect with one engine inoperative.

ONE-ENGINE-INOPERATIVE BEST ANGLE-OF-CLIMB SPEED (V_{XSE})

V_{XSE} is used only to clear obstructions during initial climb-out as it gives the greatest altitude gain per unit of horizontal distance.

SINGLE-ENGINE SERVICE CEILING

The single-engine service ceiling is the maximum altitude at which an airplane will climb at a rate of at least 50 feet per minute in smooth air, with one engine inoperative.

The single-engine service ceiling chart should be used during flight planning to determine whether the airplane, as loaded, can maintain the Minimum Enroute Altitude (MEA) if IFR, or terrain clearance if VFR, following an engine failure.

BASIC SINGLE-ENGINE PROCEDURES

Know and follow, to the letter, the single-engine emergency procedures specified in your FAA Approved Airplane Flight Manual for your airplane. However, the basic fundamentals of all the procedures are as follows:

1. Maintain airplane control and airspeed at all times.
THIS IS CARDINAL RULE NUMBER ONE.
2. Usually, apply maximum allowable power to the operating engine. However, if the engine failure occurs at a speed below V_{MCA} , or during cruise or in a steep turn, you may elect to use only enough power to maintain a safe speed and altitude. If the failure occurs on final approach, use power only as necessary to complete the landing.
3. Reduce drag to an absolute minimum.
4. Secure the failed engine and related sub-systems.

The first three steps should be done promptly and from memory per the check list. The check list should then be consulted to be sure that the inoperative engine is secured properly and that the appropriate switches are placed in the correct position.

Another note of caution: Be sure to identify the dead engine, positively, before securing it. Remember: First identify the suspected engine (i.e., "Dead foot means dead engine"), second, verify with cautious power lever movement, then secure.

ENGINE FAILURE ON TAKEOFF

If an engine fails before attaining V_1 , the only proper action is to discontinue the take-off. If the engine fails after V_1 , the FAA Approved Airplane Flight Manual procedure must be followed.

If you do find yourself in a position of not being able to climb, it is much better to reduce the power on the good engine and land straight ahead than try to force a climb and lose control.

Your FAA Approved Airplane Flight Manual contains charts that are used in calculating the runway length required to stop if the engine fails just prior to V_1 and also has charts showing the single-engine performance after takeoff.

Study your charts carefully. No airplane is capable of climbing out on one engine under all weight, pressure altitude, and temperature conditions. Know, before you take the runway, whether you can climb out if you lose an engine while the gear is still down. It may be necessary to off-load some weight or wait for more favorable conditions.

STALLS, SLOW FLIGHT AND TRAINING

The stall warning system must be kept operational at all times and must not be deactivated by any means. Compliance with this requirement is especially important in high performance multi-engine airplanes during engine-out practice or stall demonstrations, because the stall speed is critical to safe operation of high-performance airplanes.

The single-engine stall speed of a twin-engine airplane is generally slightly below the power off (engines idle) stall speed, for a given weight condition. Single-engine stalls in multi-engine airplanes are not recommended.

V_{MCA} demonstrations should not be attempted when the altitude and temperature are such that the engine-out minimum control speed is close to the stalling speed. Loss of directional or lateral control, just as a stall occurs, is potentially hazardous.

V_{SSE} , the airspeed below which an engine must not be intentionally rendered inoperative for practice purposes, was established because of the apparent practice of some pilots, instructors, and examiners, of intentionally rendering an engine inoperative at a time when the airplane is being operated at a speed close to, or below, the flight idle stall speed. Unless the pilot takes immediate and proper corrective action under such circumstances, it is possible to enter an inadvertent spin.

It is recognized that flight below V_{SSE} with one engine inoperative or simulated inoperative, may be required for conditions such as practice demonstration of V_{MCA} and for multi-engine pilot certification. Refer to the procedure set forth in the FAA Approved

Airplane Flight Manual for your airplane. This procedure calls for simulating one engine inoperative by reducing the power lever on one engine to zero thrust while operating at an airspeed above V_{SSE} . Power on the other engine is set at maximum, then airspeed is reduced at approximately one knot per second until either V_{MCA} or stall warning is obtained. During this transition, rudder should be used to maintain directional control, and ailerons should be used to maintain a 5° bank toward the operative engine. At the first sign of either V_{MCA} or stall warning (which may be evidenced by inability to maintain longitudinal, lateral or directional control, control column shaker, or aerodynamic buffet), recovery must be initiated immediately by reducing power to idle on the operative engine and lowering the nose to regain V_{SSE} . Resume normal flight. This entire procedure should be used at a safe altitude of at least 5,000 feet above the ground and in clear air only.

If stall warning is detected prior to the first sign of V_{MCA} , an engine-out minimum control speed demonstration cannot be accomplished under the existing gross weight conditions and should not be attempted.

SPINS

A major cause of fatal accidents in general aviation airplanes is a spin. Stall demonstrations and practice are a means for a pilot to acquire the skills to recognize when a stall is about to occur and to recover as soon as the first signs of a stall are evident. If a stall does not occur - A spin cannot occur. It is important to remember however, that a stall can occur in any flight attitude, at any airspeed, if controls are misused.

Your airplane has not been tested for spin recovery characteristics, and is placarded against intentional spins.

The pilot of an airplane placarded against intentional spins should assume that the airplane may become uncontrollable in a spin, since its performance characteristics beyond certain limits specified in the FAA regulations have not been tested and are unknown. This is why airplanes are placarded against intentional spins, and this is why stall avoidance is your best protection against an inadvertent spin.

Pilots are taught that intentional spins are entered by deliberately inducing a yawing moment with the controls as the airplane is stalled. Inadvertent spins result from the same combination - stall plus yaw. That is why it is important to use coordinated controls and to recover at the first indication of a stall when practicing stalls.

ONE ENGINE INOPERATIVE

In any twin-engine airplane, fundamental aerodynamics dictate that if the airplane is allowed to become fully stalled while one engine is providing thrust, the yawing moment which can induce a spin will be present. Consequently, it is important to immediately reduce power on the operating engine, lower the nose to reduce the angle of attack, and increase the airspeed to recover from the stall. In any twin engine airplane, if application of stall recovery controls is delayed, a rapid rolling and yawing motion may develop, even against full aileron and rudder, resulting in the airplane becoming inverted during the onset of a spinning motion. Once the airplane has been permitted to progress beyond the stall and is allowed to reach the rapid rolling and yawing condition, the pilot must then immediately initiate the generally accepted One-Engine-Inoperative spin recovery procedure for this airplane which is as follows:

Immediately move the control column full forward, apply full rudder opposite to the direction of the spin and reduce power on the operative engine to idle. These three actions should be done as near simultaneously as possible; then continue to hold this control position until rotation stops and then neutralize all controls and execute a smooth pullout. Ailerons should be neutral during recovery. **THE LONGER THE PILOT DELAYS BEFORE TAKING CORRECTIVE ACTION, THE MORE DIFFICULT RECOVERY WILL BECOME.**

TWO ENGINES OPERATIVE

In any twin-engine airplane, if application of stall recovery controls is delayed, a rapid rolling and yawing motion may develop, even against full aileron and rudder, resulting in the airplane becoming inverted during the onset of a spinning motion. Once the airplane has been permitted to progress beyond the stall and is allowed to reach the rapid rolling and yawing condition, the pilot must then immediately initiate the Two-Engines-Operative spin recovery procedure for this airplane, which is as follows:

If the control column pusher and/or stall recovery horn are activated:

Immediately move the control column forward, neutralize the rudder and roll inputs, and apply maximum allowable power. These actions should be done as nearly simultaneously as possible. Continue to hold these control positions until both the pusher and/or stall recovery horn have ceased operation; then execute a smooth pullout. **THE LONGER THE PILOT DELAYS BEFORE TAKING CORRECTIVE ACTION, THE MORE DIFFICULT RECOVERY WILL BECOME.**

Always remember that extra alertness and good pilot techniques are required for slow flight maneuvers, including the practice or demonstration of stalls or V_{MCA} . In addition to the foregoing mandatory procedure, always:

- Be certain that the center of gravity of the airplane is as far forward as possible. Forward C.G. aids stall recovery, spin avoidance and spin recovery. An aft C.G. can create a tendency for a spin to flatten out, which delays recovery.
- Conduct any maneuvers which could possibly result in a spin at altitudes in excess of five thousand (5,000) feet above ground level in clear air only.
- Remember that an airplane, at or near traffic pattern/approach altitudes, cannot recover from a spin, or perhaps even a stall, before impact with the ground. When descending to traffic altitude and during pattern entry and all other flight operations, maintain speed no lower than V_{SSE} . On final approach maintain the airspeed shown in the flight manual. Should a go-around be required, do not apply more power than necessary until the airplane has accelerated to V_{SSE} . Recognize that under some conditions of weight, density altitude, and airplane configuration, a twin-engine airplane cannot climb or accelerate on a single engine. Plan your approach accordingly.
- Remember that if an airplane being flown under instrument conditions stalls or enters a spin, the pilot, without visual references, is certain to become disoriented. He may be unable to recognize a stall, spin entry, or spin condition and he may be unable to determine even the direction of the spin rotation.
- Finally, never forget that stall avoidance is your best protection against an inadvertent spin. **MAINTAIN YOUR AIRSPEED.**

VORTICES - WAKE TURBULENCE

Every airplane generates a wake of turbulence while in flight. Part of this is from the propeller or jet engine, and part from the wing tip vortices. The larger and heavier the airplane, the more pronounced and turbulent the wakes will be. Wing tip vortices from large, heavy airplanes are very severe at close range, degenerating very slowly with time, wind and distance. These are rolling in nature, trailing from each wing tip. In tests, vortex velocities of 133 knots have been recorded. Encountering the rolling effect of wing tip vortices within two minutes after passage of large airplanes is extremely hazardous to small airplanes. This roll effect can exceed the maximum counter roll obtainable in a small airplane. The turbulent areas may remain for three minutes or more, depending on wind conditions, and may extend several miles beyond the airplane. Plan to fly slightly above and to the upwind side of other airplane's flight path. Because of the wide variety of conditions that can be encountered, there is no set rule to follow to avoid wake turbulence in all situations. However, the Airman's Information Manual, and to a greater extent Advisory Circular 90-23, Aircraft Wake Turbulence, provides a thorough discussion of the factors you should be aware of when wake turbulence may be encountered.

TAKE-OFF AND LANDING CONDITIONS

Use caution when landing on runways that are covered by water or slush which causes hydroplaning, a phenomenon that renders braking and steering ineffective because of the lack of sufficient surface friction. Snow and ice covered runways are also hazardous. The pilot should also be alert to the possibility of the brakes freezing.

Use caution when taking off or landing during gusty wind conditions. Also be aware of the special wind conditions caused by buildings or other obstructions located near the runway.

MEDICAL FACTS FOR PILOTS

GENERAL

When the pilot enters the airplane, he becomes an integral part of the man-machine system. He is just as essential to a successful flight as the control surfaces. To ignore the pilot in preparation for flight would be as senseless as failing to inspect the integrity of the control surfaces or any other vital part of the machine. The pilot has the responsibility for determining his reliability prior to entering the airplane for flight. When piloting an airplane, an individual should be free of conditions which are harmful to alertness, ability to make correct decisions, and rapid reaction time.

FATIGUE

Fatigue generally slows reaction time and causes errors due to inattention. In addition to the most common cause of fatigue, insufficient rest and loss of sleep, the pressures of business, financial worries, and family problems can be important contributing factors. If you are tired, don't fly.

HYPOXIA

Hypoxia, in simple terms, is a lack of sufficient oxygen to keep the brain and other body tissues functioning properly. There is a wide individual variation in susceptibility

to hypoxia. In addition to progressively insufficient oxygen at higher altitudes, anything interfering with the blood's ability to carry oxygen can contribute to hypoxia (anemia, carbon monoxide, and certain drugs). Also, alcohol and various drugs decrease the body's tolerance to hypoxia.

Your body has no built-in alarm system to let you know when you are not getting enough oxygen. It is impossible to predict when or where hypoxia will occur during a given flight, or how it will manifest itself. Some of the common symptoms of hypoxia are increased breathing rate, a light-headed or dizzy sensation, tingling or warm sensation, sweating, reduced visual field, sleepiness, blue coloring of skin, fingernails, and lips, and behavior changes. A particularly dangerous feature of hypoxia is an increased sense of well-being, called euphoria. It obscures a person's ability and desire to be critical of himself, slows reaction time, and impairs thinking ability. Consequently, a hypoxic individual commonly believes things are getting progressively better while he nears total collapse.

The symptoms are slow but progressive, insidious in onset, and are most marked at altitudes above ten thousand feet. Night vision, however, can be impaired starting at an altitude of 5,000 feet. Persons who have recently overindulged in alcohol, who are moderate to heavy smokers, or who take certain drugs, may be more susceptible to hypoxia. Susceptibility may also vary in the same individual from day to day or even morning to evening.

Depending upon altitude, a hypoxic individual has a limited time to make decisions and perform useful acts, even though he may remain conscious for a longer period. If pressurization equipment fails at certain altitudes the pilot and passengers have only a limited amount of time to get an oxygen mask on before they exceed their time of useful consciousness. The time of useful consciousness is approximately 3-5 minutes at 25,000 feet of altitude for the average individual and diminishes markedly as altitude increases. At 30,000 feet altitude, for example, the time of useful consciousness is approximately 1-2 minutes. Therefore, in the event of depressurization, oxygen masks should be used immediately.

Should symptoms occur that cannot definitely be identified as either hypoxia or hyperventilation, try three or four deep breaths of oxygen. The symptoms should improve markedly if the condition was hypoxia (recovery from hypoxia is rapid).

Pilots who fly to altitudes that require or may require the use of supplemental oxygen should be thoroughly familiar with the operation of the airplane oxygen systems. A preflight inspection of the system should be performed, including proper fit of the mask.

The passengers should be briefed on the proper use of their oxygen system before flight.

Pilots who wear beards should be careful to ensure that their beard is carefully trimmed so that it will not interfere with proper sealing of the oxygen masks. If you wear a beard or mustache, test the fit of your oxygen mask on the ground for proper sealing. Studies conducted by the military and oxygen equipment manufacturers conclude that oxygen masks do not seal over beards or heavy facial hair.

Federal Aviation Regulations related to the use of supplemental oxygen by flight crew and passengers must be adhered to if flight to higher altitudes is to be accomplished

safely. Passengers with significant circulatory or lung disease may need to use supplemental oxygen at lower altitudes than specified by these regulations.

Pilots of pressurized airplanes should receive physiological training with emphasis on hypoxia and the use of oxygen and oxygen systems. Pilots of airplanes with pressure demand oxygen systems should undergo training, experience altitude chamber decompression, and be familiar with pressure breathing before flying at high altitude. This training is available throughout the United States at nominal cost. Information regarding this training may be obtained by request from the Chief, Civil Aeromedical Institute, Attention: Aeromedical Education Branch, AAC-140, Mike Monroney Aero-nautical Center, P.O. Box 25082, Oklahoma City, Oklahoma 73125.

HYPERVENTILATION

Hyperventilation, or overbreathing, is a disturbance of respiration that may occur in individuals as a result of emotional tension or anxiety. Under conditions of emotional stress, fright, or pain, breathing rate may increase, causing increased lung ventilation, although the carbon dioxide output of the body cells does not increase. As a result, carbon dioxide is "washed out" of the blood. The most common symptoms of hyper-ventilation are: dizziness, nausea, sleepiness, and finally, unconsciousness. If the symptoms persist, discontinue use of oxygen and consciously slow your breathing rate until symptoms clear, and then resume normal breathing rate. Normal breathing can be aided by talking aloud.

ALCOHOL

Common sense and scientific evidence dictate that you must not fly as a crew member while under the influence of alcohol. Alcohol, even in small amounts, produces (among other things):

- A dulling of critical judgement.
- A decreased sense of responsibility.
- Diminished skill reactions and coordination.
- Decreased speed and strength of muscular reflexes (even after one ounce of alcohol).
- Decreases in efficiency of eye movements during reading (after one ounce of alcohol).
- Increased frequency of errors (after one ounce of alcohol).
- Constriction of visual fields.
- Decreased ability to see under dim illuminations.
- Loss of efficiency of sense of touch.
- Decrease of memory and reasoning ability.
- Increased susceptibility to fatigue and decreased attention span.
- Decreased relevance of response.
- Increased self confidence with decreased insight into immediate capabilities.

Tests have shown that pilots commit major errors of judgment and procedure at blood alcohol levels substantially less than the minimum legal levels of intoxication for most states. These tests further show a continuation of impairment from alcohol up to as

many as 14 hours after consumption, with no appreciable diminution of impairment. The body metabolizes ingested alcohol at a rate of about one-third of an ounce per hour. Even after the body completely destroys a moderate amount of alcohol, a pilot can still be severely impaired for many hours by hangover. The effects of alcohol on the body are magnified at altitudes; 2 oz. of alcohol at 18,000 feet produce the same adverse effects as 6 oz. at sea level.

Federal Aviation Regulations have been amended to reflect the FAA's growing concern with the effects of alcohol impairment. FAR 91 states:

"Alcohol or drugs.

(a) No person may act or attempt to act as a crewmember of a civil aircraft

(1) Within 8 hours after the consumption of any alcoholic beverage;

(2) While under the influence of alcohol;

(3) While using any drug that affects the person's faculties in any way contrary to safety; or

(4) While having .04 percent by weight or more alcohol in the blood.

(b) Except in an emergency, no pilot of a civil aircraft may allow a person who appears to be intoxicated or who demonstrates by manner or physical indications that the individual is under the influence of drugs (except a medical patient under proper care) to be carried in that aircraft."

Because of the slow destruction of alcohol by the body, a pilot may still be under influence eight hours after drinking a moderate amount of alcohol. Therefore, an excellent rule is to allow at least 12 to 24 hours between "bottle and throttle," depending on the amount of alcoholic beverage consumed.

DRUGS

Self-medication or taking medicine in any form when you are flying can be extremely hazardous. Even simple home or over-the-counter remedies and drugs such as aspirin, antihistamines, cold tablets, cough mixtures, laxatives, tranquilizers, and appetite suppressors may seriously impair the judgment and coordination needed while flying. The safest rule is to take no medicine before or while flying, except after consultation with your Aviation Medical Examiner.

SCUBA DIVING

Flying shortly after any prolonged scuba diving could be dangerous. Under the increased pressure of the water, excess nitrogen is absorbed into your system. If sufficient time has not elapsed prior to takeoff for your system to rid itself of this excess gas, you may experience the bends at altitudes less than 10,000 feet.

CARBON MONOXIDE AND NIGHT VISION

The presence of carbon monoxide results in hypoxia which will affect night vision in the same manner and extent as hypoxia from high altitudes. Even small levels of carbon monoxide have the same effect as an altitude increase of 8,000 to 10,000 feet. Smoking several cigarettes can result in a carbon monoxide saturation sufficient to affect visual sensitivity equal to an increase of 8,000 feet altitude.

DECOMPRESSION SICKNESS

Pilots flying unpressurized airplanes at altitudes in excess of 10,000 feet should be alert for the symptoms of 'decompression sickness'. This phenomenon, while rare, can impair the pilot's ability to perform and in extreme cases, can result in the victim being rendered unconscious. Decompression sickness, also known as dysbarism and aviator's "bends", is caused by nitrogen bubble formation in body tissue as the ambient air pressure is reduced by climbing to higher altitudes. The symptoms are pain in the joints, abdominal cramps, burning sensations in the skin, visual impairment and numbness. Some of these symptoms are similar to hypoxia. The only known remedy for decompression sickness is recompression, which can only be accomplished in an unpressurized airplane by descending. The pilot should immediately descend if it is suspected that this condition exists, since the effects will only worsen with continued exposure to the reduced pressure environment at altitude and could result, if uncorrected, in complete incapacitation. The possibility of decompression sickness can be greatly reduced by pre-breathing oxygen prior to flight and by commencing oxygen breathing well below the altitudes where it is legally mandatory.

A FINAL WORD

Airplanes are truly remarkable machines. They enable us to shrink distance and time, and to expand our business and personal horizons in ways that, not too many years ago, were virtually inconceivable. For many businesses, the general aviation airplane has become the indispensable tool of efficiency.

Advances in the mechanical reliability of the airplanes we fly have been equally impressive, as attested by the steadily declining statistics of accidents attributed to mechanical causes, at a time when the airframe, systems and powerplants have grown infinitely more complex. The explosion in capability of avionics systems is even more remarkable. Radar, RNAV, LORAN, sophisticated autopilots, EFIS and other devices which, just a few years ago, were too large and prohibitively expensive for general aviation size airplanes, are becoming increasingly commonplace in even the smallest airplanes.

Therefore, this Safety Information is directed to the pilot, for it is in the area of the skill and proficiency of the pilot that the greatest gains in safe flying are to be made over the years to come. Intimate knowledge of your airplane, its capabilities and its limitations, and disciplined adherence to the procedures for your airplane's operation, will enable you to transform potential tragedy into an interesting hangar story when the abnormal situation is presented.

Know your airplane's limitations, and your own. Never exceed either.

Safe Flying,
BEECH AIRCRAFT CORPORATION