

BE2270T0B0A

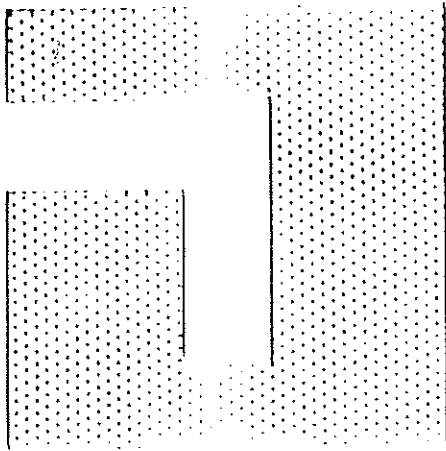

DDL 227

MODEL DDL 552 553 555

HIGH SPEED SINGLE NEEDLE,
LOCK STITCH
INDUSTRIAL SEWING MACHINE

INSTRUCTION BOOK

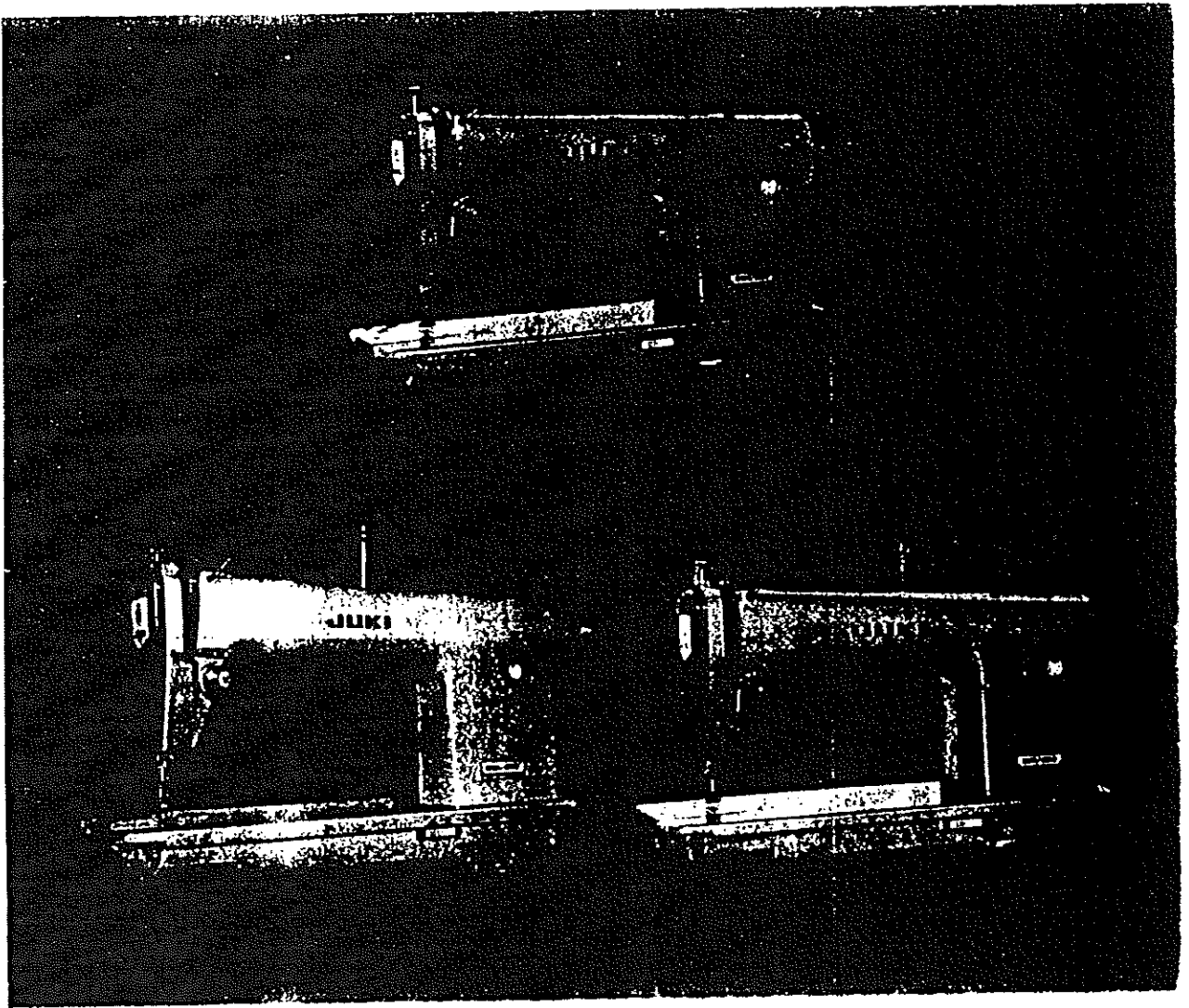

TOKYO JUKI INDUSTRIAL CO., LTD.

We thank you for purchasing JUKI Model DDL-227, DDL-552-553-555. high speed, single needle, lockstitch industrial sewing machines.

DDL-552 is best suited for sewing general fabric; DDL-553 is designed and constructed for sewing heavy weight materials and DDL-227, DDL-555 is equipped with reverse feed mechanism for a wide area of usage such as sewing men's shirts, blouses and other general garments.

The thread take-up, sewing hook, feed mechanism, etc. are all specially designed and constructed for high speed sewing. Therefore, at high speed sewing, the running sound is nominal and the stitching condition is superb.

Before operating these machines, please read this INSTRUCTION BOOK carefully and thoroughly digest the functions of these efficient machines and enjoy everlasting pleasure of using these machines.

SPECIFICATIONS

	DDL-552	DDL-553	DDL-555	DDL-227
Sewing type	Single needle lock stitch			
Usage	General fabric Medium heavy weight material	Medium heavy and heavy weight material	General fabric Medium heavy weight material	
Sewing speed	Up to 5,500 s.p.m. Normal speed: 5,000 s.p.m.	Up to 4,300 s.p.m.	Up to 5,500 s.p.m. Normal speed: 5,000 s.p.m.	Up to 4,500 s.p.m. Normal speed: 4,000 s.p.m.
Thread take-up	Link-type thread take-up			
Sewing hook	Automatic lubricating rotary hook			Dia. of hook shaft 7.94φ
Needles	DBx1 #11~18	DBx257 #14~22	DBx1 #11~18	
Feed amount	Max. 6 s.p.i.	Max. 5.5 s.p.i.	0~4mm(5/32")	
Stitch adjuster	Push-button system		Dial system	
Reverse sewing	None	None	Lever system	
Lubrication	Completely automatic lubrication (Rotating volute pump)			
Lubricating oil	New Defrix Oil No.1			
Table	JS type			

CONTENTS

	Page
Installing the oil reservoir	2
Motor pulley and the belt	2
Cautions on operating the machine	3
Lubrication	3
1. Adjusting the oil supply to the face part	4
2. The oil adjusting pin	4
3. Adjusting the oil supply to the hook components	4
Threading the machine	5
Preparation of the bobbin thread	6
Inserting & removing the bobbin case	6
Winding the bobbin thread	6
How to insert the bobbin	6
The thread tension	7
Adjusting the needle thread tension	7
Thread take-up spring	7
Adjusting the bobbin thread tension	7
Presser foot and feed dog	8
Adjusting the pressure of the presser foot	8
The presser foot hand lifter	8
Height of the feed dog	8
The stitch length	9
Adjusting the stitch length (DDI-552-553)	9
Adjusting the stitch length (DDI-555, DDI-227)	9
Reverse sewing (DDI-555, DDI-227)	9
Inserting the needle	10
Installing and removing the sewing hook	10
Relation between the hook and the needle	11
Adjusting the height of the presser bar	12
Adjusting the amount of the thread take-up	12
Adjusting the pressing pressure of the feed lever (DDI-555)	12

(Note) Due to improvements on the machine, some parts of the operational procedures of this INSTRUCTION BOOK might be changed without notice.

INSTALLING THE OIL RESERVOIR

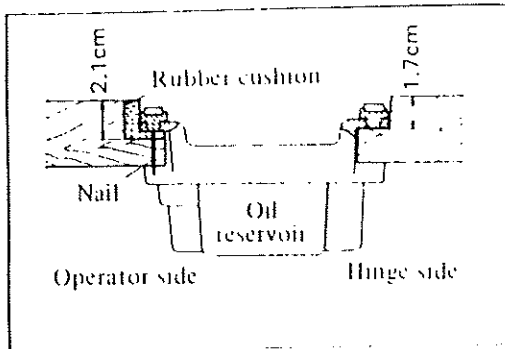

As shown in the figure, set the reservoir in such a way so that the 4 corners of the grooved part of the table will be supporting the reservoir.

1. Nail in the 2 rubber cushions in front to the protruding part of the table.
2. Place the oil reservoir on the protruding part of the table.

MOTOR PULLEY AND THE BELT

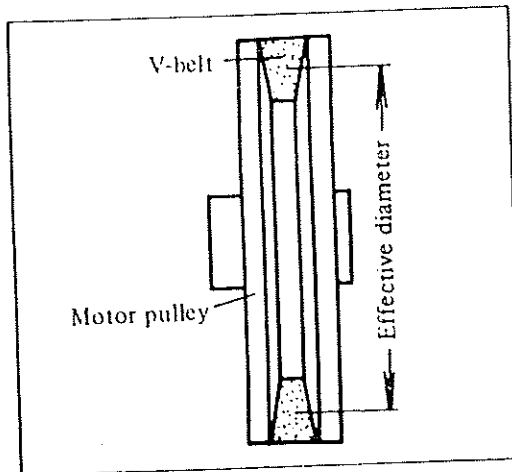

Model DDL-552 can sew at a high speed of up to 5,500 s.p.m., DDL-553 at a high speed of up to 4,300 s.p.m., DDL-555 at a speed of up to 5,500 s.p.m. and DDL-227 at a high speed of up to 4,500 s.p.m. For all of above models, use a 3-phase 400 W (1/2 HP) clutch motor when connected directly to the power source. Use a M type V-belt. The relation between the number of rotation of the machine with the dimension of the motor pulley is shown in the table. (Effective diameter)

* The effective diameter of the motor pulley means the diameter as measured from the center of the V-belt when the belt is wound around the machine.

Model	Hertz	No. of rotation of machine	Part No. of motor pulley	Effective diameter of motor pulley
DDL-552 DDL-555	50	5,060 s.p.m. 4,630 s.p.m.	MTK-PV120000 MTK-PO110000	120mm(4-47/64") 110mm(4-5/16")
	60	5,040 s.p.m. 4,540 s.p.m.	MTK-PV100000 MTK-PV090000	100mm(3-15/16") 90mm(3-35/64")
DDL-553	50	4,250 s.p.m. 3,850 s.p.m.	MTK-PV100000 MTK-PV090000	100mm(3-15/16") 90mm(3-35/64")
	60	4,320 s.p.m. 3,790 s.p.m.	MTK-PO085000 MTK-PO075000	85mm(3-11/32") 75mm(2-61/64")
DDL-227	50	4,530 s.p.m. 4,000 s.p.m.	MTK-PV110000 MTK-PO095000	110mm(4-5/16") 95mm(3-3/4")
	60	4,540 s.p.m. 4,040 s.p.m.	MTK-PV090000 MTK-PV080000	90mm(3-35/64") 80mm(3-11/64")

CAUTIONS ON OPERATING THE MACHINE

1. Do not run the machine, under any circumstances, before the oil reservoir is filled up with fresh oil
2. Always rotate the machine toward the operator. Do not run the machine in the reverse direction.
3. Although the machines can attain a maximum speed, for the first month drop the speed to normal speed and for DDI-552 operate at a normal speed of 4,500 s.p.m., for DDL-553 at 3,800 s.p.m., for DDL-555 at 4,500 s.p.m. and for DDL-227 at 4,000 s.p.m. After that, run the machines at an appropriate speed depending on the nature of work and the capability of the operator.

LUBRICATION

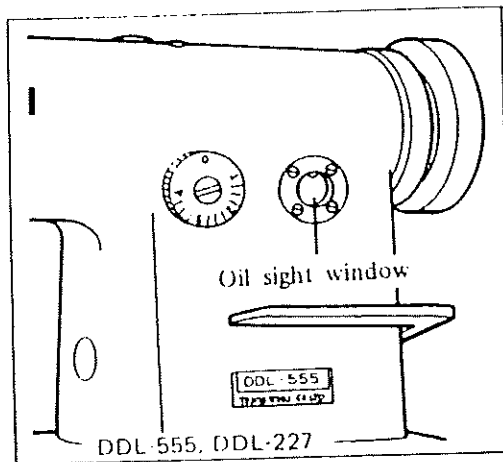
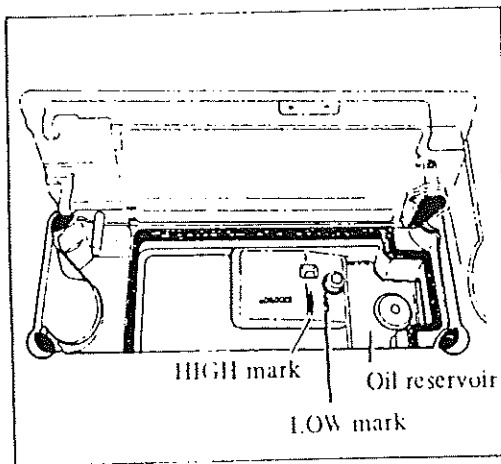

Before operating the machine

1. Fill up the oil reservoir with JUKI New Defrix Oil No. 1 up to the mark "HIGH".
 2. Watch and see that the oil level does not go below the "LOW" mark.
 3. Under normal conditions, when the machine is run after it is filled up with oil, the oil will spurt against the oil sight window.
- (Caution)**
- 1) When the oil gets dirty, change it with new, fresh oil. If the oil plug of the reservoir is removed, oil will come out.
 - 2) When the machine is to be run for the first time or when it was idle for a great length of time, run the machine at 3,000-3,500 s.p.m. for about 10 minutes and allow the machine to get well oiled.
 - 3) When the machine is to be run constantly at less than 3,500 s.p.m. adjust so that the oil supply to various parts be increased.

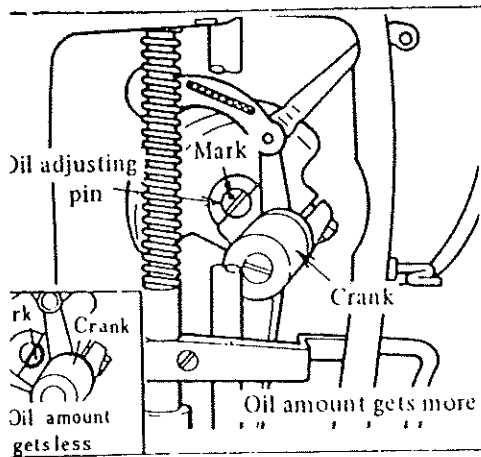

1. Adjusting the oil supply to the face part

When adjusting the oil supply to the thread take-up and needle bar crank components, remove the face plate and the oil preventing plate and adjust by turning the oil adjusting pin at the tip of the main shaft.

1. When the red mark of the adjusting pin comes near the crank, the oil amount gets less.
2. When the red mark comes to the opposite side of the crank, the oil amount gets more.

(Caution)

The oil amount does not change immediately after the adjustment, so when adjusting, have this in mind.

2. The oil adjusting pin

1. The oil adjusting pin has a carved groove as shown in the figure. When this groove and the oil hole of the main shaft come together, the oil amount gets more.
2. When the groove is at the opposite side of the oil hole, the oil amount gets less.
3. The red mark on the oil adjuster shows the side without the carved groove.

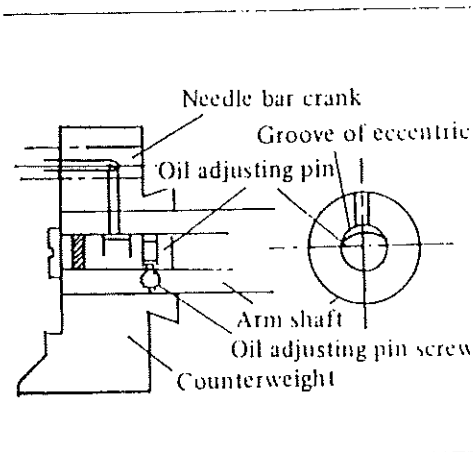

3. Adjusting the oil supply to the hook components

The supply of oil to the hook components can be adjusted by the oil regulating valve on the hook shaft.

1. If this valve is turned toward the right, the oil amount gets more.
2. If this valve is turned to the left, the amount gets less.

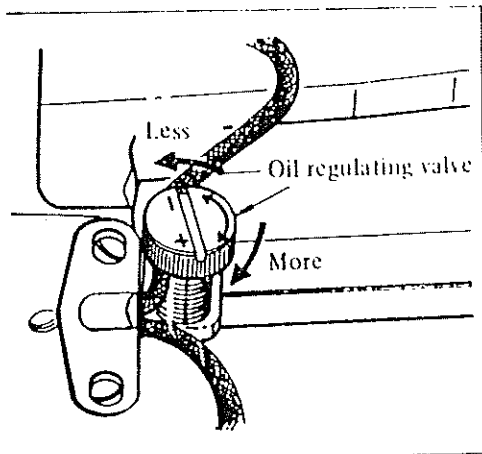

THREADING THE MACHINE

Rotate the hand wheel to right and place the thread take-up to the highest position.

1. Pass the needle thread in the order shown by the figure.
2. Pass the thread to the needle eye from left to right.
3. Pull out about 10 cm(4") of the thread from the needle eye.

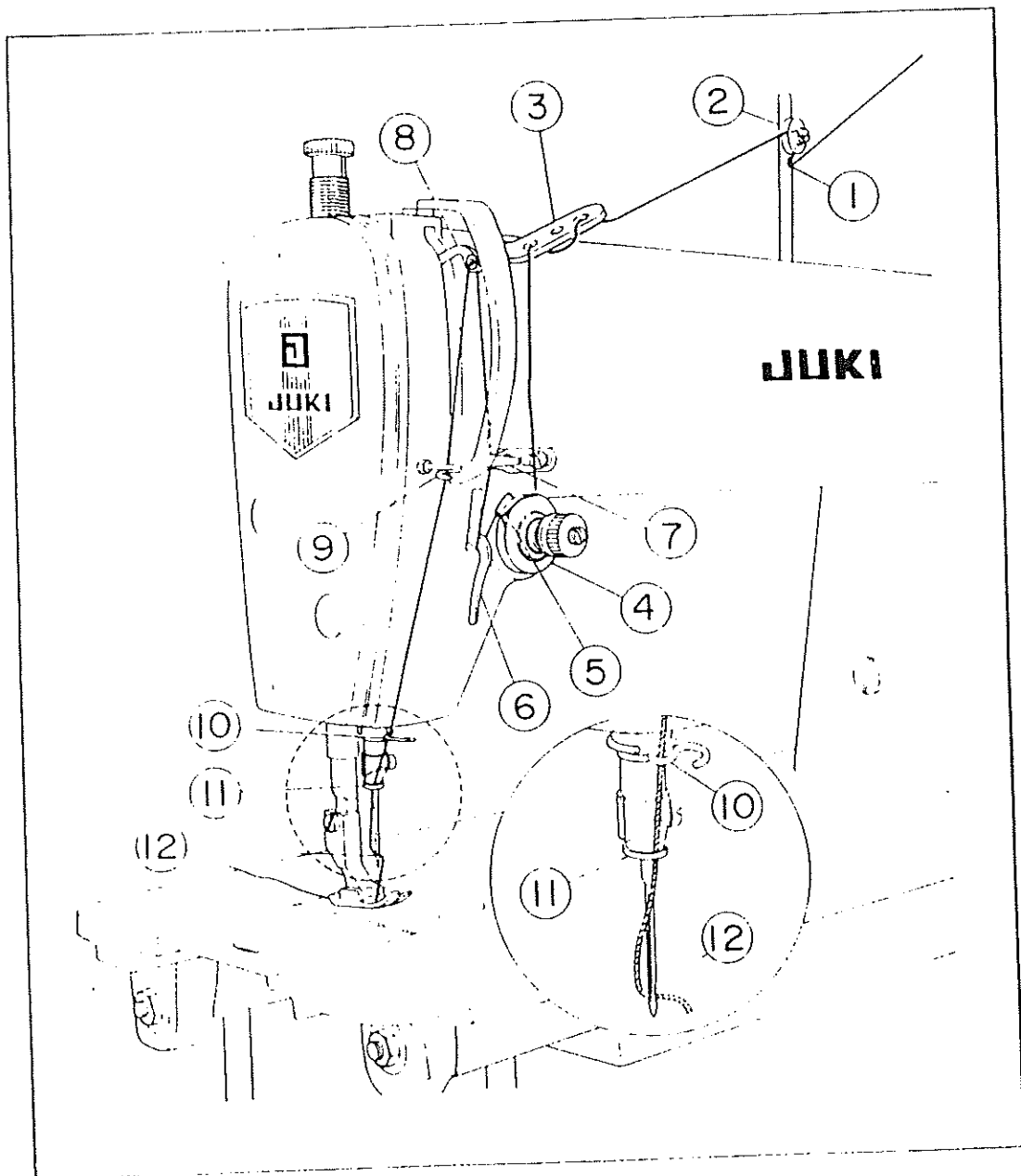

PREPARATION OF THE BOBBIN THREAD

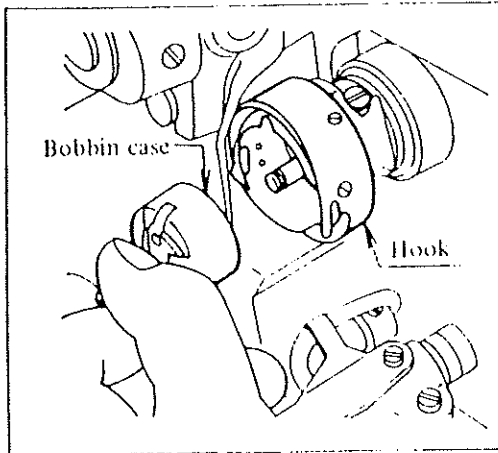

Inserting & removing the bobbin case

1. Rotate the hand wheel with your hand and bring the needle to its highest position.
2. Tilt the machine and support it by the head support on the table.
3. Lift up the knob of the bobbin case and take it out.
* If you hold the knob in open condition, bobbin will not fall off.
4. To insert the bobbin case, insert it deep into the shaft of the hook so that the nose of the bobbin case fully enters the groove of the hook and then close the knob.

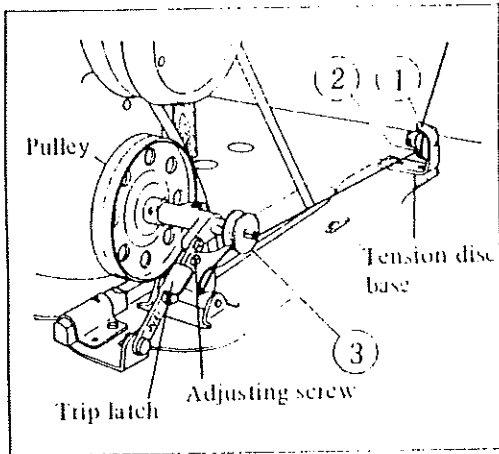

Winding the bobbin thread

1. Set the bobbin winder to the table with screws.
2. Pass the thread in the order shown in the figure and wind it around the bobbin several times.
3. Knock down the trip latch and contact the pulley to the left.
4. Adjust the winding amount by the winding adjusting screw so that about 80% is wound.
5. When the thread is wound unevenly, move the thread tension disc base to left and correct to even winding condition.
6. When the winding is completed, the trip latch will be released and the pulley will stop automatically.

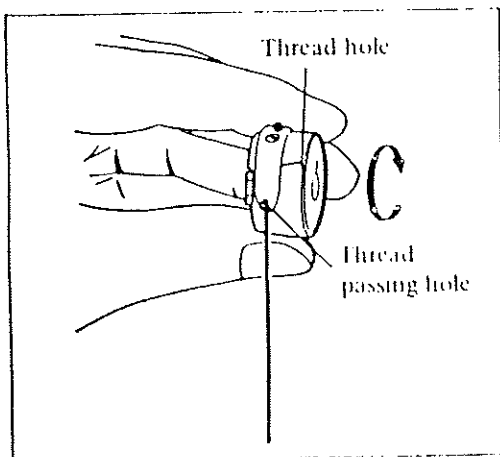

How to insert the bobbin

1. Hold the bobbin and insert it to the bobbin case so that the thread will be in right-twist condition.
2. Pass the thread to the thread passing hole of the bobbin case.
3. Then pull the thread and it will pass under the thread tension spring and can be pulled out through the thread hole.
* When pulling the bobbin thread, rotate the bobbin in the arrow direction.

THE THREAD TENSION

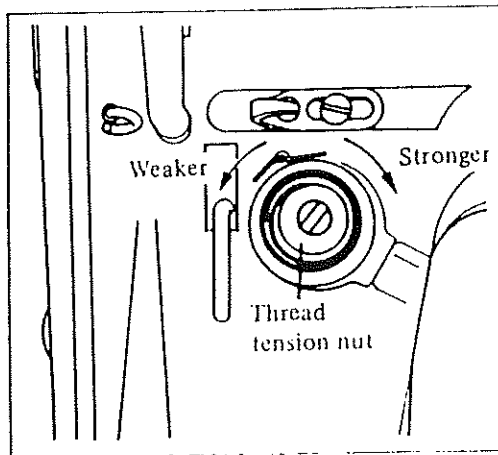

Adjusting the needle thread tension

Ideal stitches are formed when the needle thread and the bobbin thread are perfectly interlocked at the center of the cloth. The tension of the needle thread is adjusted by the thread tension nut.

1. Turn it to right to make the tension stronger and to the left to make it weaker.

Thread take-up spring

* To change the moving range of the thread tension spring:

1. Loosen the screw of the thread tension bracket.

2. Rotate the thread tension bar.

* To change the strength of the thread take-up spring.

1. Loosen the set screw, remove the thread tension bar.

2. Loosen the thread tension bar set screw and adjust.

3. When the thread tension bar is turned to right, the spring will get stronger and if turned to left, it will get weaker.

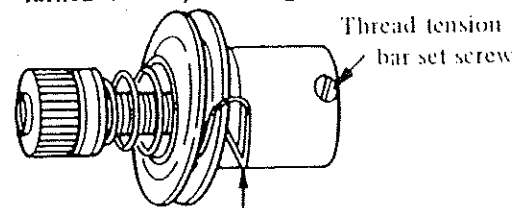
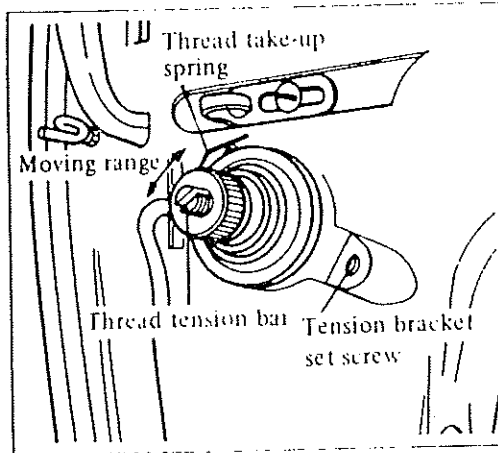

Thread take-up spring

Adjusting the bobbin thread tension

Rotate the thread tension screw of the bobbin case to adjust the bobbin thread tension.

1. Rotate it to right to make the bobbin thread tension stronger and to left to make it weaker.

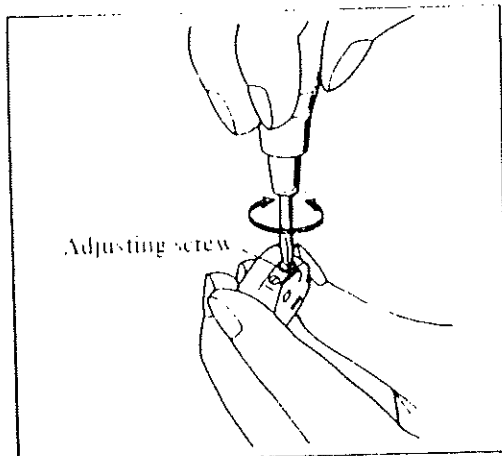

PRESSER FOOT AND FEED DOG

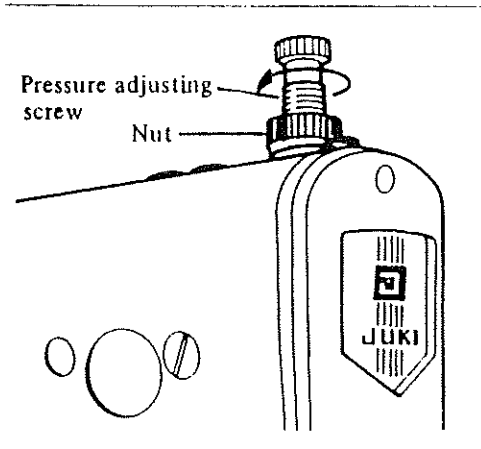

Adjusting the pressure of the presser foot

1. Turn the pressure adjusting screw to right to make the pressure stronger.
2. Turn this screw to left to make the pressure weaker.
Normal pressure for general fabric is about 5 kg (11 lbs).
3. After adjustment, firmly tighten the nut.

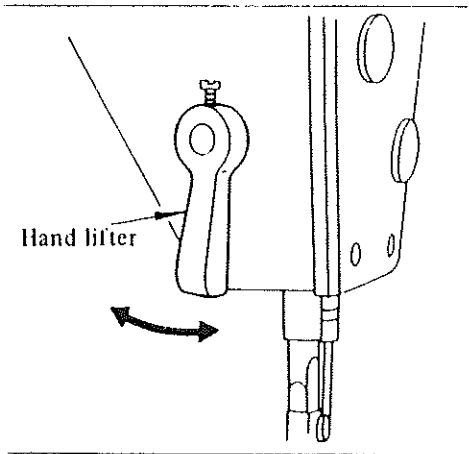

Presser lifter

Turn the hand lifting lever located in the rear of the machine head either to left or right, and the presser foot will go up for about 5 mm (13/64") from the throat plate surface.

Push down hand lifter, and the presser foot will come down to press the work. By the knee lifter, the presser foot will go up for about 10 mm (25/64") from the throat plate surface.

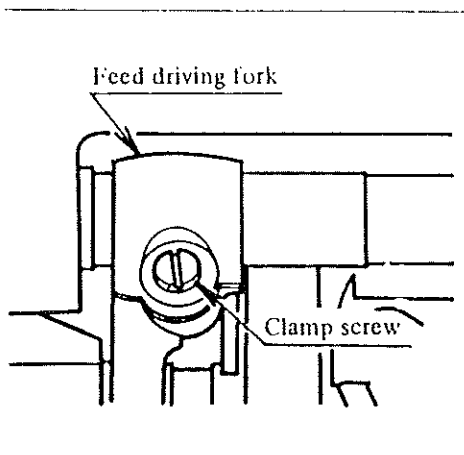

Height of the feed dog

The height of the feed dog from the surface of the throat plate is set from 0.7~0.8mm (1/32"). In sewing light weight materials, if this height is too high, shrink-stitching may result.

To adjust the height of the feed dog:

1. Loosen the clamping screw of the feed driving fork of the compound feed.
2. Move the feed dog base up and down and adjust.
3. After adjusting, tightly tighten the clamping screw.

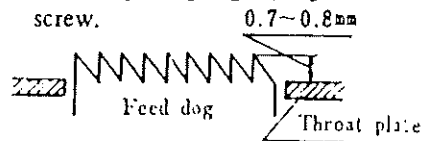

THE STITCH LENGTH

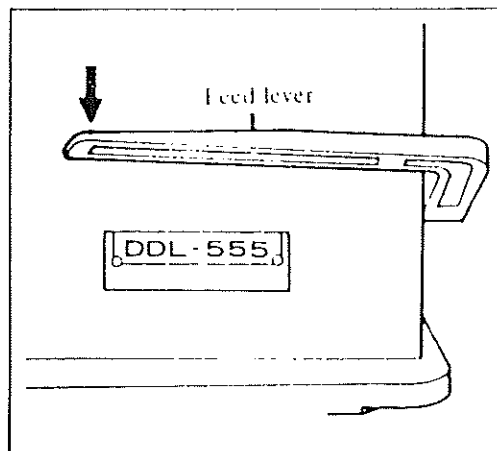
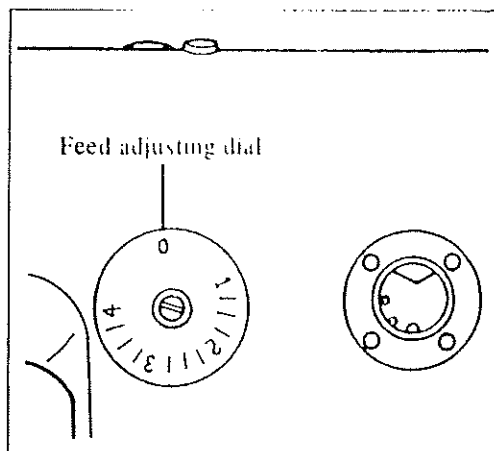
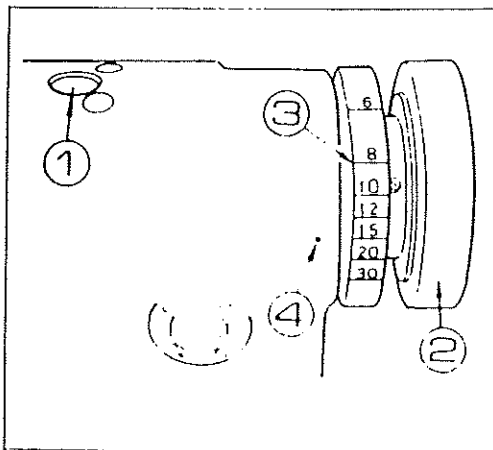

Adjusting the stitch length

(DDL-552-DDL-553)

The stitch length of DDL-552 and DDL-553 is adjusted by the push button (1) at the center of the upper surface of the arm. Rotate the hand wheel as you keep pressing down the button.

When the button drops down deep into the groove of the ratchet (you can feed it) push down the button further and by rotating the hand wheel, match the number of stitches wanted (3) with the indicator (4) of the frame. With this, the length of stitches can be obtained. The figures on the hand wheel indicate the number of stitches per one inch. Release the push button and verify that the button returns to the original position.

The maximum stitch length for DDL-552 is 6 s.p.i. and for DDL-553 is 5.5 s.p.i.

Reverse sewing can not be done.

(Caution) Do not touch the button while the machine is running.

(DDL-555, DDL-227)

The stitch length of this model can be adjusted by rotating the feed adjusting dial on top of the feed lever.

The figures on the graduation scale is shown in millimeter (mm).

1. Rotate the feed adjusting dial either to right or left and

2. Match the wanted figure with the pin coming out from the frame.

* The maximum stitch length is 4mm(5/32").

Reverse sewing (DDL-555, DDL-227)

1. For reverse sewing, push the feed lever down.

2. As long as this lever is kept down, reverse sewing can be performed.

3. Release this lever and the feed lever will return to original position and normal straight stitching can be resumed.

INSERTING THE NEEDLE

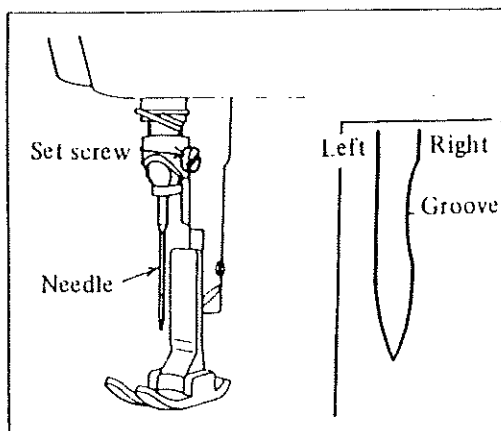

For DDL-552, DDL-555 and DDL-227 models, use DB x 1 needles and for DDL-553 model, use DB x 257 needle. There are many size numbers of needles but size numbers depend on the thickness of the using thread or the kinds of sewing cloth. So, select a correct size and number for your work.

1. Rotate the hand wheel and bring the needle bar to the highest position.
2. Loosen the needle clamp screw.
3. Hold the needle so that the long groove of the needle comes to your right side.
4. Insert the needle deep into the needle hole.
5. Then securely tighten the needle clamping screw.

INSTALLING AND REMOVING THE SEWING HOOK

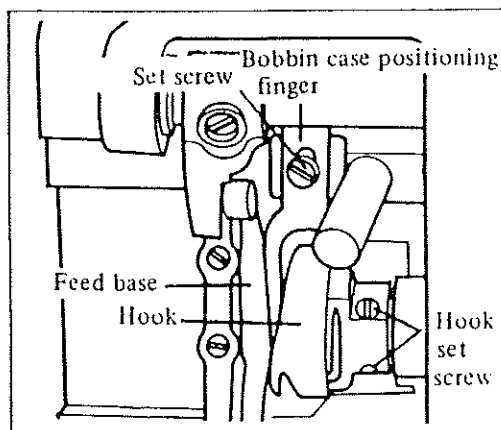

During the running of the machine, if thread hards get into the hook or the position of the hook changes for some reason or to exchange the hook with a new one, do as follows in order:

1. Rotate the hand wheel and bring the needle bar to the highest position.
2. Remove the bobbin case and the needle.
3. Remove the bobbin case base positioning finger set screw and take out the bobbin case positioning finger.
4. Loosen the 3 screws of the sewing hook.
5. Rotate the hand wheel and raise up the feed base to its highest position.
6. Rotate the sewing hook with your hand and place it in the position as shown in the figure.
7. Pull the hook to your left and take it out.
To install the hook back, reverse this procedure.

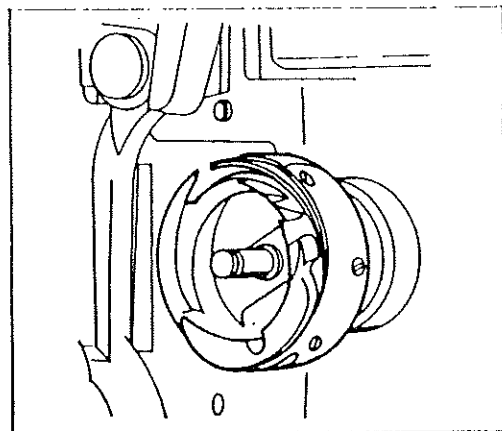

RELATION BETWEEN THE HOOK AND THE NEEDLE

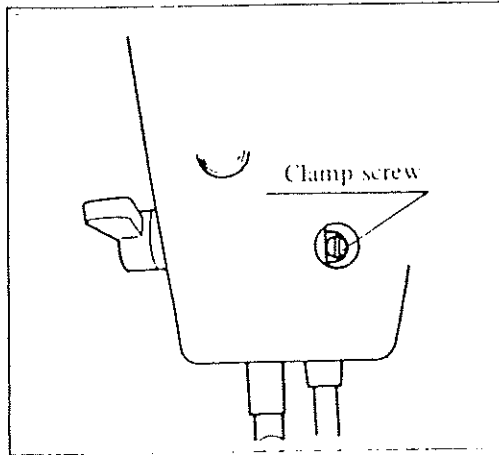

Match the needle with the sewing hook as follows:

1. Rotate the hand wheel and bring the needle bar to its lowest position.
2. Loosen the needle bar clamping set screw.

(Note)

When matching the timing of the needle and the sewing hook, be sure to set the feed adjusting dial to "0".

(Determine the height of the needle bar)

3. Match the upper carved line of the needle bar with the lower edge of the needle bar lower bushing.
4. Tighten the needle bar clamping set screw.

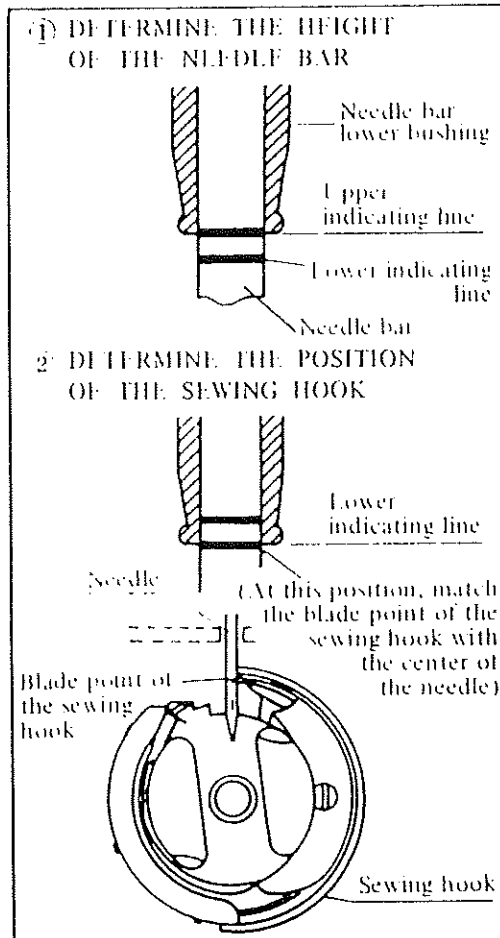

(Determine the position of the sewing hook)

5. Loosen the 3 clamping screws of the hook so that the hook can be rotated freely with the hand.
6. Place the hook with your hand to the thread passing position.
7. Rotate the hand wheel and match the lower carved line of the needle bar with the lower edge of the needle bar lower bushing.
8. In this condition, match the blade point of the hook with the center line of the needle.
9. Make the clearance between the needle and the hook blade point to 0.05 mm and
10. Securely tighten the hook clamping set screw.

ADJUSTING THE HEIGHT OF THE PRESSER BAR

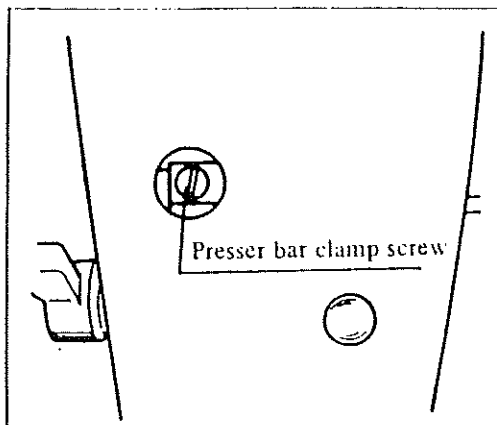

When the height or the direction of the presser bar is to be changed due to the exchange of presser foot:

1. Remove the rubber plug of the face plate.
2. From this hole, adjust by loosening the presser bar clamping screw.
3. After the adjustment, securely tighten the set screw.

ADJUSTING THE AMOUNT OF THREAD TAKE-UP

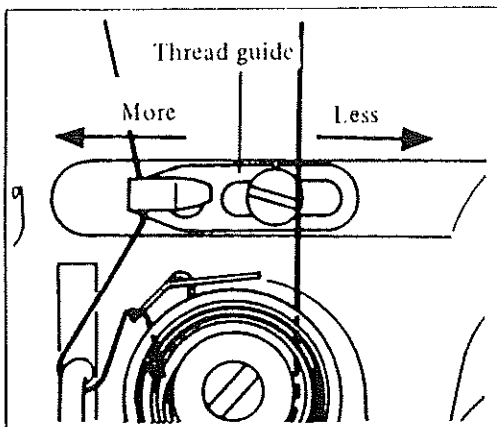

The amount of the thread take-up should be changed according to the length of stitches or thickness of the sewing cloth to produce ideal thread tension.

1. When sewing heavy weight materials, move the thread guide to your left.
The thread take-up amount of the take-up gets more.
2. When sewing light weight materials, move the thread guide to your right.
The thread take-up amount gets less.

ADJUSTING THE PRESSING PRESSURE OF THE FEED LEVER (DDL-555)

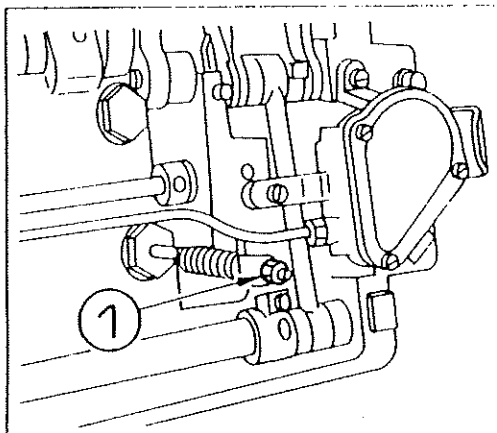

The reversing spring of the feed lever is strengthened somewhat so that at high speed sewing, no matter what kind of stitches are to be formed, the lever returns positively to the original position.

When the stitching pitch is small or when the machine is to be run by lowering the r.p.m., the pressing pressure of the feed lever can be lessened by loosening the adjusting nut 1 of the accompanying figure.

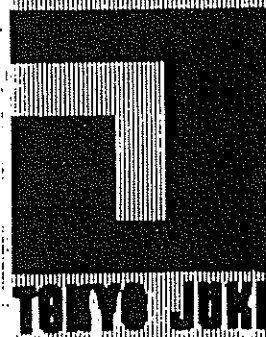

TOKYO JUKI INDUSTRIAL CO., LTD.

Head Office & Plant: 2-1, 8-chōme, Kokuryō-cho, Chofu-shi, Tokyo, Japan

Business Office: 23-3, Kabuki-cho 1-chōme, Shinjuku-ku, Tokyo 160, Japan

Cable: JUKI TOKYO Telex: 22967; 232-2301