



HALO[®]

Wireless pH Meters with
Bluetooth[®] Smart Technology

 **HANNA[®]**
instruments



Hanna Lab App

Available on iOS and Android

The first app that turns a smart phone or tablet into a full-featured pH meter.

The Hanna Lab App turns a compatible smart phone or tablet into a full-featured pH meter when used with HALO®. Functions include calibration, measurement, data logging, graphing, and data sharing. Measurement and logging of pH and temperature at one second intervals start as soon as the probe is connected. Measurements can be displayed alone, with tabulated data or as a graph. The graph can be panned and zoomed with pinch-to-zoom technology.



Real-time Data

Displays updated pH and temperature every second

Views

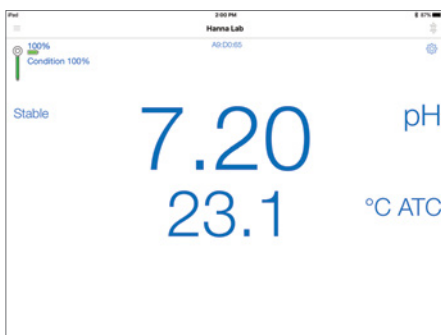

Just the Essentials

Basic view provides measurement information in a clean, straightforward manner.



All Information on Display

Table view is able to display measurement, time and date, annotations, and alarm status in a continuously updated table.

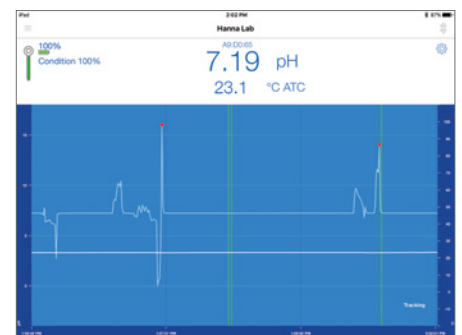

Fluid, Dynamic Graphing

Graph view provides measurement information linearly. Graph axes may be expanded using pinch-to-zoom technology for enhanced viewing



Data Logging

pH	mV	T (°C)	Date	Note	Status
7.219	-12.8	23.0	1/10/17, 2:01:46 PM		
7.221	-12.3	23.0	1/10/17, 2:01:47 PM		
7.209	-12.2	23.0	1/10/17, 2:01:48 PM		
7.220	-12.1	23.0	1/10/17, 2:01:49 PM		
7.200	-11.7	23.0	1/10/17, 2:01:50 PM		
7.200	-11.7	23.0	1/10/17, 2:01:51 PM		
7.202	-11.8	23.0	1/10/17, 2:01:52 PM		
7.200	-11.7	23.0	1/10/17, 2:01:53 PM		
7.200	-11.7	23.0	1/10/17, 2:01:54 PM		
7.199	-11.6	23.0	1/10/17, 2:01:55 PM		
7.207	-11.5	23.0	1/10/17, 2:01:56 PM		
7.207	-11.5	23.0	1/10/17, 2:01:57 PM		
7.207	-11.5	23.0	1/10/17, 2:01:58 PM		
7.207	-11.5	23.0	1/10/17, 2:01:59 PM		
7.207	-11.5	23.0	1/10/17, 2:02:00 PM		
7.207	-11.5	23.0	1/10/17, 2:02:01 PM		
7.207	-11.5	23.0	1/10/17, 2:02:02 PM		
7.207	-11.5	23.0	1/10/17, 2:02:03 PM		
7.207	-11.5	23.0	1/10/17, 2:02:04 PM		
7.207	-11.5	23.0	1/10/17, 2:02:05 PM		
7.207	-11.5	23.0	1/10/17, 2:02:06 PM		
7.207	-11.5	23.0	1/10/17, 2:02:07 PM		
7.207	-11.5	23.0	1/10/17, 2:02:08 PM		
7.207	-11.5	23.0	1/10/17, 2:02:09 PM		
7.207	-11.5	23.0	1/10/17, 2:02:10 PM		
7.207	-11.5	23.0	1/10/17, 2:02:11 PM		
7.207	-11.5	23.0	1/10/17, 2:02:12 PM		
7.207	-11.5	23.0	1/10/17, 2:02:13 PM		
7.207	-11.5	23.0	1/10/17, 2:02:14 PM		
7.207	-11.5	23.0	1/10/17, 2:02:15 PM		
7.207	-11.5	23.0	1/10/17, 2:02:16 PM		
7.207	-11.5	23.0	1/10/17, 2:02:17 PM		
7.207	-11.5	23.0	1/10/17, 2:02:18 PM		
7.207	-11.5	23.0	1/10/17, 2:02:19 PM		
7.207	-11.5	23.0	1/10/17, 2:02:20 PM		
7.207	-11.5	23.0	1/10/17, 2:02:21 PM		
7.207	-11.5	23.0	1/10/17, 2:02:22 PM		
7.207	-11.5	23.0	1/10/17, 2:02:23 PM		
7.207	-11.5	23.0	1/10/17, 2:02:24 PM		

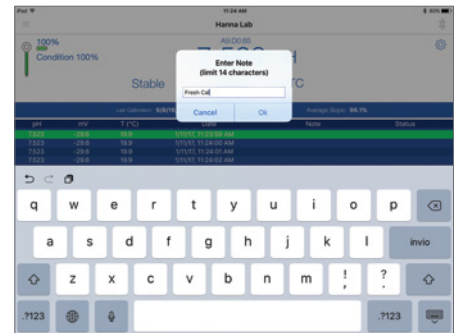
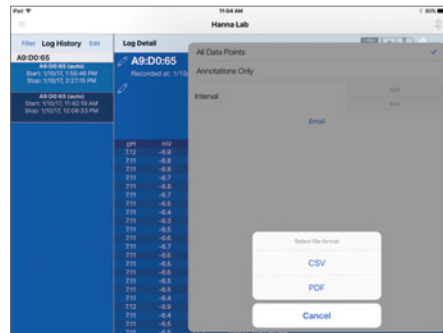

Data-logging

Data is automatically saved every hour. There are four ways to save and share data: All data since last auto save, Annotations only, All data within a timed interval, and Annotations within a timed interval.

Export Data

Share data via email in PDF or CSV format.

Custom Annotations

Saved data points may be annotated with measurement specific information.

GLP (Good Laboratory Practice)

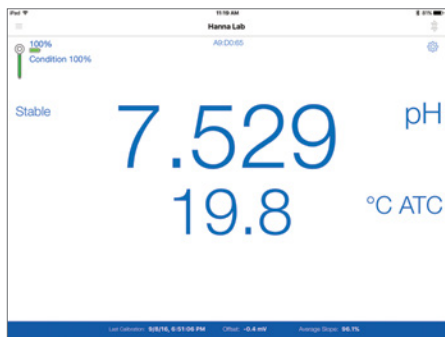

Basic GLP

Displays date and time of current calibration along with probe offset and average slope. For tablet displays, basic GLP can be also displayed in table and graph views.



Full GLP

Displays date and time of current calibration, probe offset, and average slope along with calibrated buffers, mV values, temperature and slopes between each buffer. For tablet displays, full GLP can be also displayed in table and graph views.

Calibration

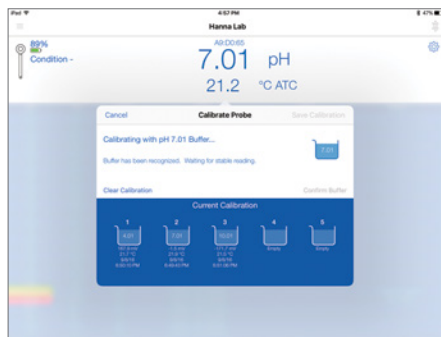

Clear and Concise Calibration Screens

The Hanna Lab App allows for calibration of up to five points. The buffer value is automatically detected and temperature corrected to 25.0°C during calibration.

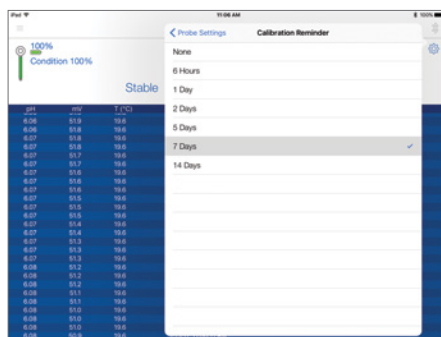

Calibration Reminder

Alerts users when HALO needs calibration.

Additional Features

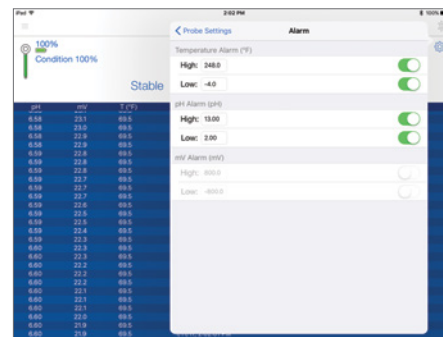

Measurement Alerts

Readings that exceed user-defined alarm thresholds are highlighted in yellow on the measurement screen, graph, and table. Readings that exceed the probe specifications are highlighted in red.

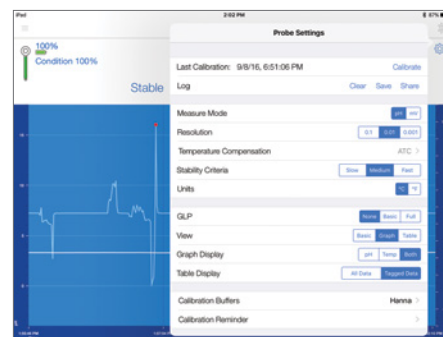

Settings

Tap the gear icon in the top right corner of the measurement screen to access the Settings menu.

Hanna Lab App Specifications*

Range**	-2.000 to 16.000 pH; ±800 mV; -20.0 to 120.0°C (-4.0 to 248.0°F)
Resolution	0.1; 0.01; 0.001 pH; 1; 0.1 mV; 0.1°C (0.1°F)
Accuracy (@25°C/77°F)	±0.005 pH; ±0.3 mV; ±0.5°C (±1.0°F)
Calibration Points	up to five-point calibration with seven standard buffers (1.68, 3.00 (HI10482 only) or 4.01, 6.86, 7.01, 9.18, 10.01, 12.45 pH)
Temperature Compensation**	automatic from -5.0 to 100.0 °C – 23.0 to 212.0 °F
Compatibility/System Requirements	see www.hannainst.com for latest compatibility requirements

Download Information



*HALO™ required for measurement use. **Limits will be reduced to actual probe/sensor limits.

Apple, the Apple logo, iPhone and iPad are trademarks of Apple Inc., registered in the U.S. and other countries. App Store is a service mark of Apple Inc. The Bluetooth® word mark and logos are registered trademarks owned by Bluetooth SIG, Inc. Android, Google Play and the Google Play logo are trademarks of Google Inc.



Help and Tutorials:

The Hanna Lab App also features demo probe mode, general app information, general HALO information, pH tutorial, maintenance tutorial, and contact information.



HALO®

Wireless pH Meters

Take lab grade measurements
using a smart phone or tablet.

HALO is the world's first professional pH probe with Bluetooth® Smart technology (Bluetooth® 4.0). This technology is energy efficient, allowing for low power consumption to maximize the life of the replaceable battery used in the pH electrode. HALO pH probes can be used virtually anywhere: in the field, laboratory, or classroom. Their versatility and ease of use will revolutionize the way pH is measured.

9 HALO models available:



p. 9

HI11312
HALO pH Meter
for Lab

This refillable, glass body electrode has many features that make it ideal for use in a wide variety of applications.



p. 10

HI11102
HALO pH Meter
for Lab

This gel filled, glass body electrode has many features that make it ideal for lab use.



p. 11

HI13302
HALO pH Meter
for Tests Tubes

This gel filled, glass body electrode has many features that make it ideal for measuring test tube samples.



p. 12

HI10832
HALO pH Meter
for Small Samples

This Viscolene filled, glass body electrode has many features such as a micro tip that make it ideal for small sample sizes in the lab.



p. 13

HI12302
HALO pH Meter
for Field Use

This gel filled, PEI body electrode has many features that make it ideal for use in the field or on the production floor.



p. 14

HI12922
HALO pH Meter
for Soil

This refillable, glass body electrode has many features such as a conic bulb making it is ideal for use in direct soil applications.



p. 15

FC2022
HALO Foodcare
pH Meter

This Viscolene filled, PVDF body electrode has many features such as clogging resistance and a conical tip that make it ideal for measuring food related products.



p. 16

HI10482
HALO pH Meter
for Wine with CPS™
Technology

This refillable, glass body electrode has many features such as CPS (Clogging Prevention System) technology that make it ideal for use in food and beverage industries including wine.



p. 17

FC2142
HALO pH Meter
for Beer

This gel filled, titanium body electrode with extractable cloth junction is ideal for beer applications.



One Press Connect

Connect to the Hanna Lab App at the press of a button via Bluetooth® wireless technology (10 m range (33')). Visible from a distance, the LED halo light indicates the probe is active and transmitting.

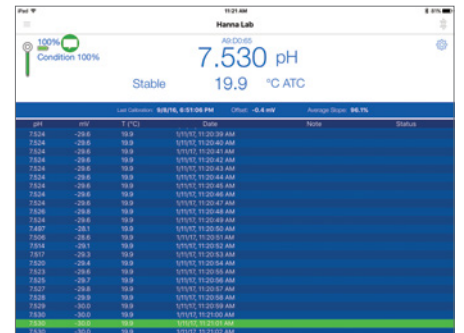

One Button Sample Tagging

Pressing the button on the HALO pH probe or the probe icon in the Hanna Lab App will tag sample data for easy reference.



Easy to Replace Battery

The HALO's CR2032 lithium ion battery is easily replaced and lasts for approximately 500 hours.

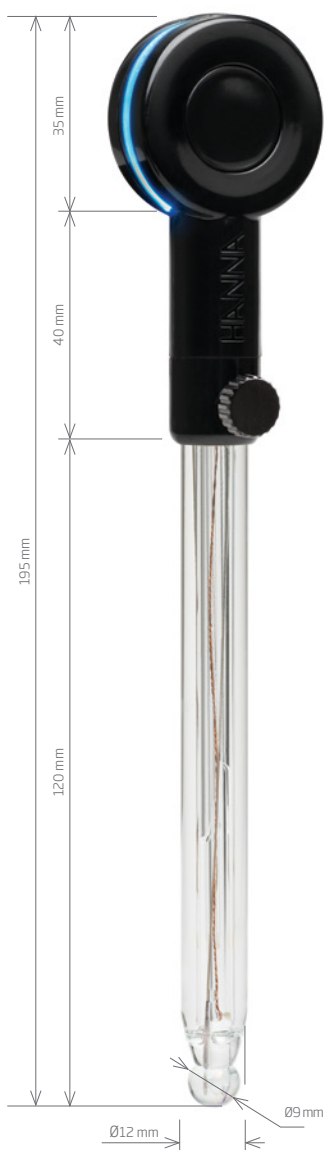

HI11312

HALO®

Compatible with:
iOS
Android™
edge blu

Ideal for lab applications

HI11312 HALO is an innovative, pH electrode with Bluetooth® Smart technology that allows the use of a compatible Apple or Android smart device to be used as a pH meter. The electrode is a general purpose, glass body pH electrode ideal for routine laboratory measurement.

- **Glass body**
 - Non-porous surface that withstands harsh chemicals
- **Double junction**
 - Silver free outer reference that is compatible with most samples
- **Built-in temperature sensor**
 - High accuracy temperature compensated measurements
- **Refillable**
 - Allows the filling of the reference cell with electrolyte fill solution

Glass Body

The glass body of the HI11312 is resistant to many harsh chemicals and is easy to clean making it ideal for general laboratory use.

Double Junction

HI11312 is a double junction pH electrode in which the Ag/AgCl necessary for the reference cell is located behind an inner ceramic junction. The gel electrolyte between the inner and outer junction is silver free. This is important to prevent the precipitation of silver by Tris buffer, metals, and sulfides that would clog the junction leading to erratic readings.

Built-in Temperature Sensor

HI11312 has a thermistor temperature sensor built into the tip of the pH electrode. A thermistor based temperature sensor provides for a high accuracy reading while being in the tip of the electrode allows for a rapid determination of the temperature as it impacts the effect on the glass membrane potential.

Refillable

HI11312 is a refillable pH electrode. Fill solution from the inside will diffuse through the ceramic junction as it is used and stored in storage solution. Electrolyte fill solution should be added to the probe when the level drops more than 1 cm (1/2") from the fill hole in order to maintain a good flow rate sustained by having adequate head pressure.

HALO Specifications	HI11312
Measurement Range	0.00 to 13.00 pH
Reference Cell Type	double, Ag/AgCl
Junction Type	ceramic
Electrolyte	3.5M KCl (refillable)
Body Material	glass
Tip / Shape	spheric
Temperature Operating Range	-5 to 80°C (23 to 176°F)
Body Length/Overall Length	120 mm / 195 mm
Temperature Sensor	integrated
Outer Diameter	12 mm (glass)
Connector Type	Bluetooth Smart (Bluetooth 4.0), 10 m (33') range
Battery Type/Life	CR2032 3V lithium ion / approximately 500 hours
Environment	0 to 50°C (23 to 122°F); electronic module is not waterproof
Ordering Information	HI11312 (HALO) is supplied with storage solution, cleaning solution, pH 7.01 buffer solution, pH 4.01 buffer solution, fill solution, battery, quality certificate and instruction sheet.

HI11102

HALO®

Ideal for lab applications

Compatible with:
iOS
Android™
edge blu

HI11102 HALO is an innovative, pH electrode with Bluetooth® Smart technology that allows the use of a compatible Apple or Android smart device to be used as a pH meter. This general purpose, glass body pH electrode is ideal for users that would prefer a laboratory pH electrode without the refill solution maintenance.

- **Glass body**
 - Non-porous surface that withstands harsh chemicals
- **Double junction**
 - Silver free outer reference that is compatible with most samples
- **Built-in temperature sensor**
 - High accuracy temperature compensated measurements
- **Gel-filled reference**
 - Maintenance free with no fill solutions required

Glass Body

The glass body of the HI11102 is ideal for laboratory use and for users that prefer to have a traditional laboratory pH electrode without having to maintain the proper fill solution level. The glass is resistant to many harsh chemicals and is easy to clean.

Double Junction

HI11102 is a double junction pH electrode in which the Ag/AgCl necessary for the reference cell is located behind an inner ceramic junction. The gel electrolyte between the inner and outer junction is silver free. This is important to prevent the precipitation of silver by Tris buffer, metals, and sulfides that would clog the junction leading to erratic readings.

Built-in Temperature Sensor

HI11102 has a thermistor temperature sensor built into the tip of the pH electrode. A thermistor based temperature sensor provides for a high accuracy temperature reading while being in the tip of the electrode allows for a rapid determination of the temperature as it impacts the effect on the glass membrane potential.

Maintenance Free Gel-filled Reference

HI11102 contains a silver free gel in the outer reference cell. There is no fill solution to replenish as the probe is used. Other than routine calibration and cleaning, this probe is maintenance free.

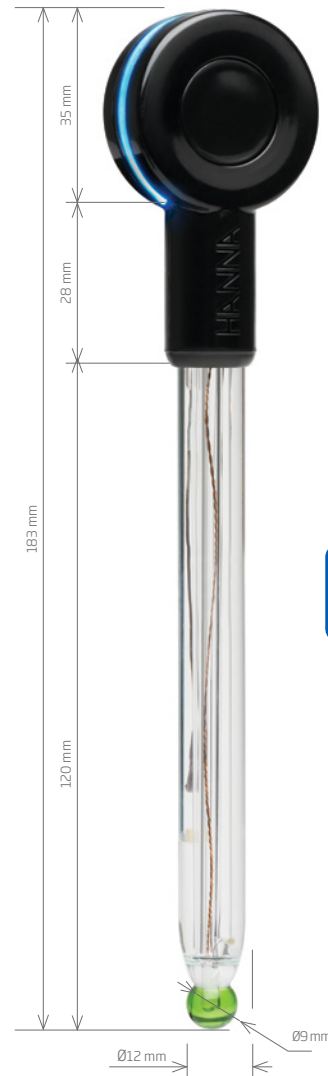

Also included
with edge®blu

HALO Specifications	HI11102
Measurement Range	0.00 to 12.00 pH
Reference Cell Type	double, Ag/AgCl
Junction Type	ceramic
Electrolyte	gel
Body Material	glass
Tip / Shape	spheric
Temperature Operating Range	-5 to 80°C (23 to 176°F)
Body Length/Overall Length	120 mm / 183 mm
Temperature Sensor	integrated
Outer Diameter	12 mm (glass)
Connector Type	Bluetooth Smart (Bluetooth 4.0), 10 m (33') range
Battery Type/Life	CR2032 3V lithium ion / approximately 500 hours
Environment	0 to 50°C (23 to 122°F); electronic module is not waterproof
Ordering Information	HI11102 (HALO) is supplied with storage solution, cleaning solution, pH 7.01 buffer solution, pH 4.01 buffer solution, battery, quality certificate and instruction sheet.

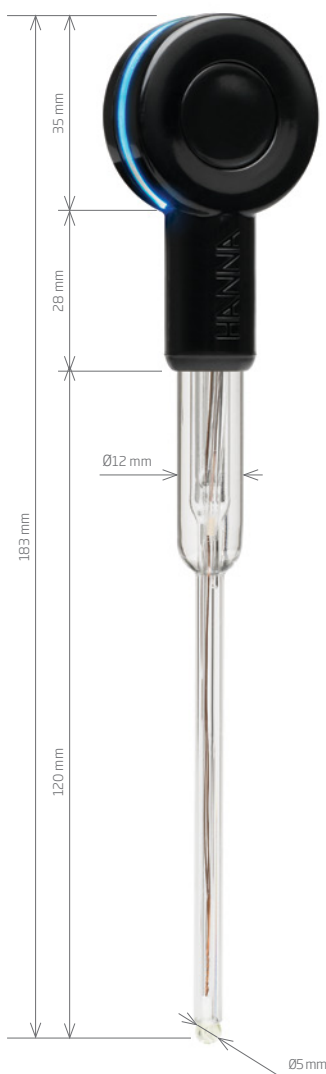

HI13302

HALO®

Compatible with:
iOS
Android™
edge blu

Ideal for test tube applications

HI13302 HALO is an innovative, application specific, pH electrode with Bluetooth® Smart technology that allows the use of a compatible Apple or Android smart device to be used as a pH meter. This electrode is designed for taking pH measurements in test tubes that are used by university, pharmaceutical, biotechnology, and food laboratories customers.

- **Small diameter bulb and body**
 - 5 mm diameter bulb fits easily into test tubes.
- **Built-in temperature sensor**
 - Provides accurate temperature compensated pH measurements
- **Open junction**
 - Permits a predictable flow rate of reference electrolyte for stability
- **Gel-filled reference**
 - Maintenance free with no fill solutions required

Small 5 mm Diameter Bulb and Body

HI13302 has a small pH-sensing bulb that is only 5 mm in diameter by 80 mm in length. The small diameter of the probe allows for pH measurements in test tubes, vials, and other small containers.

Built-in Temperature Sensor

HI13302 has a thermistor temperature sensor built into the tip of the pH electrode. A thermistor based temperature sensor provides for a high accuracy temperature while being in the tip of the electrode allows for a rapid temperature compensated measurement.

Open Junction Design

The reference half-cell has an open junction design in order to accommodate the 5 mm micro bulb and shaft. The open junction design is resistant to clogging from suspended solids and proteins found in biological samples. Any clogging that occurs will impede the measurement circuit between the indicating electrode and the internal reference resulting in slower response time and erratic readings.

Maintenance Free Gel-filled Reference

The open junction design consists of a solid gel (Viscolene) interface between the sample and internal ceramic reference junction. Other than routine calibration and cleaning, this probe is maintenance free.

HALO Specifications	HI13302
Measurement Range	0.00 to 12.00 pH
Reference Cell Type	double, Ag/AgCl
Junction Type	open junction
Electrolyte	Viscolene
Body Material	glass
Tip / Shape	spheric
Temperature Operating Range	-5 to 50°C (23 to 122°F)
Body Length/Overall Length	120 mm /183 mm
Temperature Sensor	integrated
Outer Diameter	5 mm (glass)
Connector Type	Bluetooth Smart (Bluetooth 4.0), 10 m (33') range
Battery Type/Life	CR2032 3V lithium ion / approximately 500 hours
Environment	0 to 50°C (23 to 122°F); electronic module is not waterproof
Ordering Information	HI13302 (HALO) is supplied with storage solution, cleaning solution, pH 7.01 buffer solution, pH 4.01 buffer solution, battery, quality certificate and instruction sheet.

HI10832

HALO®

Ideal for small sample
lab applications

Compatible with:
iOS
Android™
edge blu

HI10832 HALO is an innovative, application specific, pH electrode with Bluetooth® Smart technology that allows the use of a compatible Apple or Android smart device to be used as a pH meter. This pH electrode allows for the wireless measurement of very small sample sizes for laboratory customers in university, pharmaceutical, and biotechnology research.

- **Micro bulb tip**
 - The 3 mm diameter bulb can measure the pH in samples as small as 100 µL.
- **Open junction design**
 - Resists clogging and provides for fast response time
- **Gel-filled reference**
 - Maintenance free with no fill solutions required

Micro Bulb Tip

HI10832 has an extremely small pH-sensing bulb that is only 3 mm in diameter. The small diameter of the probe allows for the measurement of pH in 96 well plates, test tubes and vials. The HI10832 is ideal for use with expensive samples that offer little volume to work with.

Open Junction Design

The reference half-cell has an open junction design in order to accommodate the 3 mm micro bulb and shaft. The open junction design is resistant to clogging from suspended solids and proteins found in biological samples. Any clogging that occurs will impede the measurement circuit between the indicating electrode and the internal reference resulting in slower response time and erratic readings.

Maintenance Free Gel-filled Reference

The open junction design consists of a solid gel (viscolene) interface between the sample and internal ceramic reference junction. Other than routine calibration and cleaning, this probe is maintenance free.

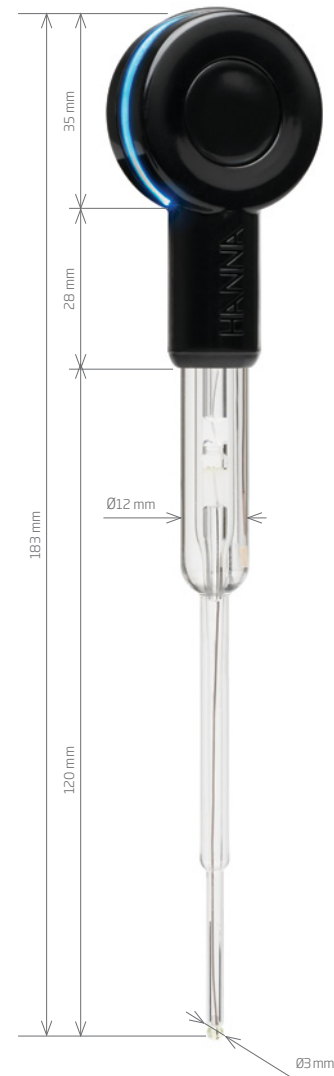

HALO Specifications	HI10832
Measurement Range	0.00 to 13.00 pH
Reference Cell Type	double, Ag/AgCl
Junction Type	open
Electrolyte	Viscolene
Body Material	glass
Tip / Shape	spheric
Temperature Operating Range	0 to 50°C (32 to 122°F)
Body Length/Overall Length	120 mm / 183 mm
Temperature Sensor	none
Outer Diameter	3 mm (glass)
Connector Type	Bluetooth Smart (Bluetooth 4.0), 10 m (33') range
Battery Type/Life	CR2032 3V lithium ion / approximately 500 hours
Environment	0 to 50°C (23 to 122°F); electronic module is not waterproof
Ordering Information	HI10832 (HALO) is supplied with storage solution, cleaning solution, pH 7.01 buffer solution, pH 4.01 buffer solution, battery, quality certificate and instruction sheet.

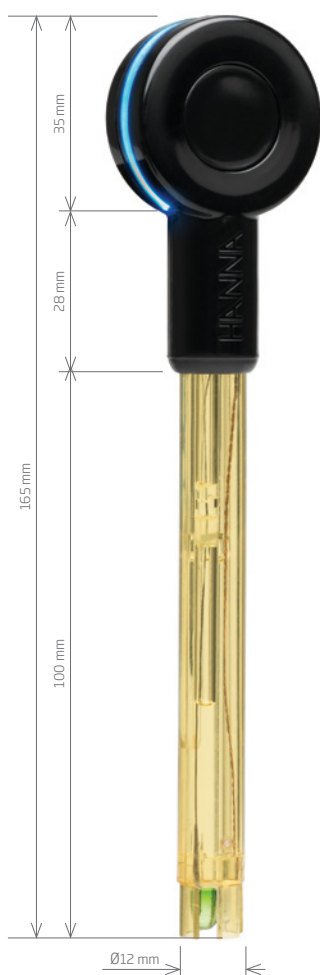

HI12302

HALO®

Compatible with:
iOS
Android™
edge blu

Ideal for field applications

HI12302 HALO is an innovative, pH electrode with Bluetooth® Smart device technology that allows the use of a compatible Apple or Android smart device to be used as a pH meter. HI12302 is a general purpose, PEI plastic body pH electrode for routine measurements in the field, lab or at home.

- **PEI plastic body**
 - Durable, chemically resistant plastic
- **Double Junction**
 - Silver free outer reference that is compatible with most samples
- **Built-in temperature sensor**
 - High accuracy temperature compensated measurements
- **Gel-filled reference**
 - Maintenance free with no fill solutions required

PEI Plastic Body

The body of the HI12302 is composed of polyetherimide (PEI) resin. PEI is a high quality plastic that is chemically resistant to many aggressive chemicals making it ideal for a wide range of applications. The PEI body excels in field measurements due to its durability. The shield around the spherical glass tip also helps to minimize breakage due to accidental bumping or dropping of the electrode.

Double Junction

HI12302 is a double junction pH electrode in which the Ag/AgCl necessary for the reference cell is located behind an inner ceramic junction. The electrolyte between the inner and outer junction is silver free. This is important to prevent the precipitation of silver by Tris buffer, metals, and sulfides that would clog the junction leading to erratic readings.

Built-in Temperature Sensor

A thermistor temperature sensor built into the tip of the pH electrode. A thermistor based temperature sensor provides for a high accuracy temperature reading while being in the tip of the electrode allows for a rapid determination of the temperature as it impacts the effect on the glass membrane potential.

Maintenance Free Gel-filled Reference

HI12302 contains a silver free gel in the outer reference cell. There is no fill solution to replenish as the probe is used. Other than routine calibration and cleaning, this probe is maintenance free.

HALO Specifications	HI12302
Measurement Range	0.00 to 12.00 pH
Reference Cell Type	double, Ag/AgCl
Junction Type	ceramic
Electrolyte	gel
Body Material	PEI
Tip / Shape	dome
Temperature Operating Range	-5 to 70°C (23 to 158°F)
Body Length/Overall Length	100 mm / 165 mm
Temperature Sensor	integrated
Outer Diameter	12 mm (plastic)
Connector Type	Bluetooth Smart (Bluetooth 4.0), 10 m (33') range
Battery Type/Life	CR2032 3V lithium ion / approximately 500 hours
Environment	0 to 50°C (23 to 122°F); electronic module is not waterproof
Ordering Information	HI12302 (HALO) is supplied with storage solution, cleaning solution, pH 7.01 buffer solution, pH 4.01 buffer solution, battery, quality certificate and instruction sheet.

HI12922

HALO®

Ideal for direct soil applications

Compatible with:
iOS
Android™
edge blu

The HI12922 HALO is an innovative, application specific pH electrode with Bluetooth® Smart technology that allows the use of a compatible Apple or Android smart device to be used as a pH meter. This electrode is designed for agricultural, hydroponics and greenhouse growers that need to monitor the pH of soil and soilless media in order to optimize plant growth.

- **Conic bulb**
 - Easy penetration into soft solids and semi-solids
- **Triple ceramic junction**
 - High flow rate for fast and stable response in slightly hydrated media
- **Refillable**
 - Allows the filling of the reference cell with electrolyte fill solution
- **Built-in temperature sensor**
 - High accuracy temperature compensated measurements

Conic Bulb

The conical shaped tip design allows for the easy penetration of the sensor into soft solids and semi-solids such as soil and soilless media. Soilless media includes hydroponics growing media including rockwool, coconut coir, and perlite.

Triple Ceramic Junction

The refillable HI12922 has three ceramic junctions in the reference cell. All pH electrodes have a reference junction that provides continuity between the internal reference wire and the sample. Utilizing a triple ceramic junction design allows for a higher flow rate of fill solution which helps provide for a fast and stable response in damp soil and soilless media.

Refillable

HI12922 is a refillable pH electrode. Fill solution from the inside will diffuse through the ceramic junctions as it is used and while stored in storage solution. Electrolyte fill solution should be added to the probe when the level drops more than 1 cm (1/2") from the fill hole in order to maintain a good flow rate sustained by having adequate head pressure (optional).

Built-in Temperature Sensor

The HI12922 has a thermistor temperature sensor built into the tip of the pH electrode. A thermistor based temperature sensor provides for a high accuracy temperature while being in the tip of the electrode allows for a rapid temperature compensated measurement.

Includes soil auger

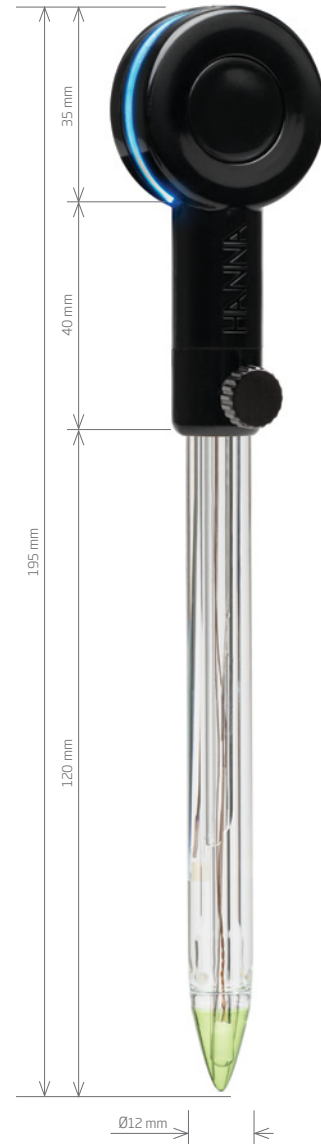

HALO Specifications

HI12922

Measurement Range	0.00 to 12.00 pH
Reference Cell Type	double, Ag/AgCl
Junction Type	triple ceramic
Electrolyte	3.5M KCl (refillable)
Body Material	glass
Tip / Shape	conic
Temperature Operating Range	-5 to 70°C (23 to 158°F)
Body Length/Overall Length	120 mm / 195 mm
Temperature Sensor	integrated
Outer Diameter	12 mm (glass)
Connector Type	Bluetooth Smart (Bluetooth 4.0), 10 m (33') range
Battery Type/Life	CR2032 3V lithium ion / approximately 500 hours
Environment	0 to 50°C (23 to 122°F); electronic module is not waterproof

Ordering Information

HI12922 (HALO) is supplied with soil auger, storage solution, cleaning solution, pH 7.01 buffer solution, pH 4.01 buffer solution, fill solution, battery, quality certificate and instruction sheet.

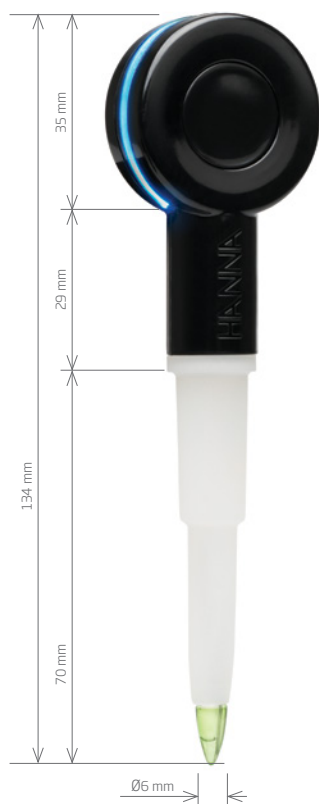

FC2022

HALO®

Compatible with:
iOS
Android™
edge blu

Ideal for food applications

The FC2022 HALO is an innovative, application specific pH electrode with Bluetooth® Smart technology designed for food processing companies that need to monitor the pH of their product for quality and compliance.

- **Conic bulb**
 - Easy penetration into soft solids and semi-solids
- **Low temperature glass**
 - Fast and accurate measurement of refrigerated products
- **Open junction**
 - Resists clogging and provides fast response time
- **Gel-filled reference**
 - Maintenance free with no fill solutions required
- **Built-in temperature sensor**
 - High accuracy temperature compensated measurements

Conic Bulb

The conical shaped tip design allows for the easy penetration of the sensor into soft solids and semi-solids such as cheeses, yogurt, meats, and sauces. It doesn't trap foods and is very easy to wipe clean.

Low Temperature Glass

The glass tip is made with Low Temperature (LT) glass formulation that has a lower resistance than standard glass types used with ordinary pH electrodes. This is beneficial since many food products are stored at low temperatures. FC2022 HALO is suitable to be used for measurements between 0 to 10°C (32 to 50°F).

Open Junction Design

The open junction design consists of a solid gel (viscolene) interface between the sample and internal reference. This interface not only prevents silver from entering the sample, but also makes it impermeable to clogging from food products, maintaining a fast response and stable reading.

Maintenance Free Gel-filled Reference

Because the internal reference is gel, there is no fill solution to replenish as the probe is used. Other than routine calibration and cleaning, this a maintenance free probe.

Built-in Temperature Sensor

The thermistor temperature sensor built into the tip of the pH electrode. A thermistor based temperature sensor provides for a high accuracy temperature while being in the tip of the electrode allows for a rapid temperature compensated measurement.

HALO Specifications	FC2022
Measurement Range	0.00 to 12.00 pH
Reference Cell Type	double, Ag/AgCl
Junction Type	open
Electrolyte	Viscolene
Body Material	PVDF
Tip / Shape	conic
Temperature Operating Range	0 to 60°C (32 to 140°F)
Body Length/Overall Length	70 mm / 134 mm
Temperature Sensor	integrated
Outer Diameter	12 mm to 8 mm taper (plastic)
Connector Type	Bluetooth Smart (Bluetooth 4.0), 10 m (33') range
Battery Type/Life	CR2032 3V lithium ion / approximately 500 hours
Environment	0 to 50°C (23 to 122°F); electronic module is not waterproof

Ordering Information

FC2022 (HALO) is supplied with storage solution, cleaning solution, pH 7.01 buffer solution, pH 4.01 buffer solution, battery, quality certificate and instruction sheet.

HI10482

HALO®

Compatible with:
iOS
Android™
edge blu

Ideal for wine, must and juice

HI10482 HALO is an innovative, application specific pH electrode designed for the winemaker that needs to monitor the pH of wine, grape juice, and must.

- **Clogging prevention system (CPS) technology**
 - Anti-clogging PTFE sleeve that maintains stability and fast response
- **Refillable**
 - Allows the filling of the reference cell with electrolyte fill solution
- **Built-in temperature sensor**
 - High accuracy temperature compensated measurements
- **Customized calibration buffer value**
 - Calibration to pH 3.00 to bracket the expected reading in wine

Clogging Prevention System (CPS) Technology

CPS technology is an innovation for the improvement of pH measurements in wine juice and must samples that have high solids content. Conventional pH electrodes use ceramic junctions that can clog quickly from solids found in juice and must. When the junction is clogged, the electrode does not function properly and erratic readings can result. The CPS technology utilizes a ground glass junction coupled with a movable PTFE sleeve to prevent clogging. The ground glass allows proper flow of the liquid, while the PTFE sleeve repels solids. As a result, pH electrodes with CPS technology take up to 20 times longer to be fouled as compared to conventional electrodes. When the electrode becomes fouled the PTFE sleeve can be moved to clean the ground glass surface rejuvenating the junction and extending probe life.

Refillable

HI10482 is a refillable double junction pH electrode. Fill solution from inside the probe will diffuse through the ground glass junction while it is in use and when it is stored in storage solution. Electrolyte fill solution should be added to the probe when the level drops more than 1 cm (1/2") from the fill hole in order to maintain a good flow rate sustained by having adequate head pressure.

Built-in Temperature Sensor

HI10482 has a built-in thermistor temperature sensor that is in the tip of the pH electrode. A thermistor temperature sensor provides a high accuracy temperature reading and should be as close as possible to the indicating pH electrode in order to compensate for the effect that temperature has on the membrane potential. Having a built in temperature sensor is important in wine since the measured pH values are more than 3 pH units away from the isopotential point. The further away from the isopotential point the greater the influence that temperature has on the observed reading.

Customized Calibration Buffer Value

The average pH of wine influences the choice of calibration buffers that should be used. Generally, most wines have a finished pH between 3 and 4. To ensure a high accuracy measurement, the HI10482 will prompt for pH 3.00 buffer in place of pH 4.01. This allows the calibration to bracket the expected value to be measured.

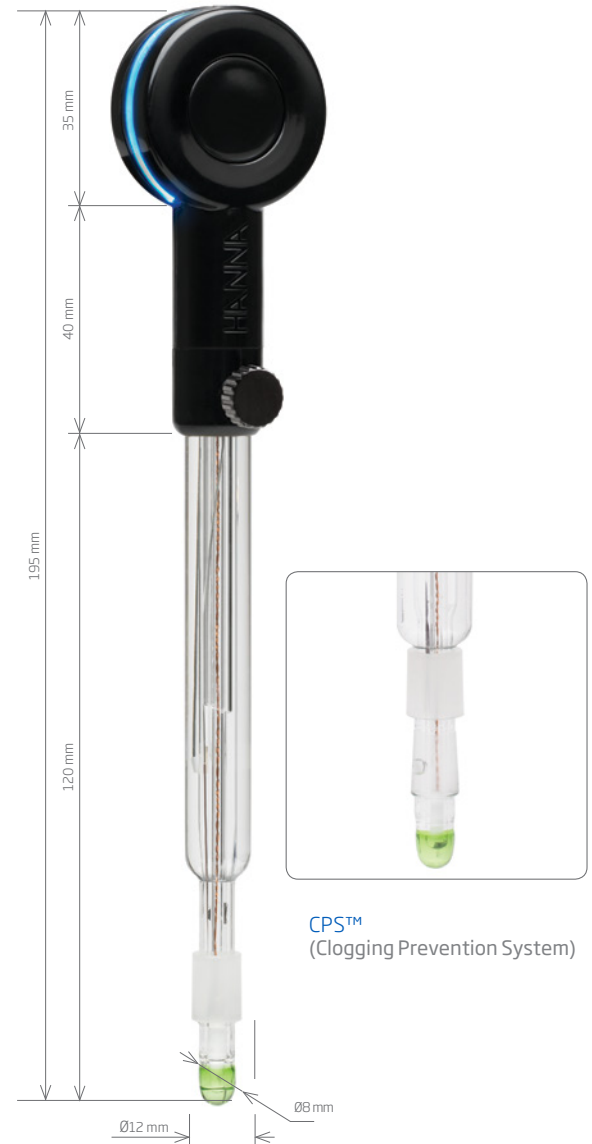

CPS™
(Clogging Prevention System)

HALO Specifications

HI10482

Measurement Range	0.00 to 12.00 pH
Reference Cell Type	double, Ag/AgCl
Junction Type	movable open junction
Electrolyte	3.5M KCl (refillable)
Body Material	glass
Tip / Shape	dome
Temperature Operating Range	0 to 80°C (32 to 176°F)
Body Length/Overall Length	120 mm / 195 mm
Temperature Sensor	integrated
Outer Diameter	12 mm (glass)
Connector Type	Bluetooth Smart (Bluetooth 4.0), 10 m (33') range
Battery Type/Life	CR2032 3V lithium ion / approximately 500 hours
Environment	0 to 50°C (23 to 122°F); electronic module is not waterproof

Ordering Information

HI10482 (HALO) is supplied with storage solution, cleaning solution, pH 7.01 buffer solution, pH 3.00 buffer solution, fill solution, battery, quality certificate and instruction sheet.



FC2142

HALO®

Compatible with:
iOS
Android™
edge blu

Ideal for brewers

FC2142 HALO is an innovative, application specific pH electrode designed for brewers to help monitor the pH of mash and wort.

- **High temperature glass**
 - Extends probe life when used with samples at elevated temperatures
- **Extractable cloth junction**
 - Quickly renew the junction to increase stability and extend probe life
- **Built-in temperature sensor**
 - High accuracy temperature compensated measurements
- **Titanium body**
 - Provides protection even at high temperatures as well as stability of measurement

High Temperature Glass

Standard pH glass deteriorates faster when used at high temperatures. FC2142 uses a special high temperature (HT) formulation glass that is suitable for measuring pH samples, such as with wort or mash, up to 80°C (176°F).

Extractable Cloth Junction

The advantage of the cloth junction is that it can be extracted from the probe exposing a fresh surface. This is very important since one of the major contributors to unstable measurements is a clogged junction. This is likely to occur when measuring the pH of mash that has a high solids content. Pulling out a small portion of the junction exposes a clean, unclogged portion that increases response time and extends the life of the pH electrode.

Built-in Temperature Sensor

FC2142 has a thermistor temperature sensor built into the tip of the pH electrode to provide highly accurate temperature readings and temperature compensated pH measurements.

Titanium Body

A pH measurement is a high impedance measurement, and as such is susceptible to interference from electrical noise and humidity. To overcome these issues a titanium body serves as a matching pin. A matching pin is a differential measurement technique used to eliminate electrical noise in the measurement system. The titanium body, being made of metal, is virtually unbreakable and offers additional protection from accidental breakage.

HALO Specifications	FC2142
Measurement Range	0.00 to 13.00 pH
Reference Cell Type	double, Ag/AgCl
Junction Type	cloth
Electrolyte	gel
Body Material	titanium
Tip / Shape	spheric
Temperature Operating Range	0 to 80°C (32 to 176°F)
Body Length/Overall Length	120 mm / 183 mm
Temperature Sensor	integrated
Outer Diameter	12.7 mm (titanium)
Connector Type	Bluetooth Smart (Bluetooth 4.0), 10 m (33') range
Battery Type/Life	CR2032 3V lithium ion / approximately 500 hours
Environment	0 to 50°C (23 to 122°F); electronic module is not waterproof
Ordering Information	FC2142 (HALO) is supplied with storage solution, cleaning solution, pH 7.01 buffer solution, pH 4.01 buffer solution, battery, quality certificate and instruction sheet.



HI181 • HI180

Compact Magnetic Mini-Stirrers

Available With and Without Detachable Electrode Holder

- **Electrode holder**
 - The HI181 series features an electrode holder that fits into the base of the stirrer
- **Round edge**
- **Dynamic design**
 - Easy to handle, these lightweight and compact stirrers need little room and are quickly recognizable on busy benches
- **Built to last**
 - Chemical resistant housing withstands damage by accidental spills

Common stirrers are manufactured with steel and aluminum components. These units are often too large and heavy to fit in the limited space of a laboratory. Hanna HI181 and HI180 models are compact, lightweight, and inexpensive.

Often in the lab, a sample is removed from a stirrer before reducing the speed. Normally, this would cause the motor to accelerate until it is destroyed. Hanna stirrers incorporate electronic controls that allow the user to regulate the speed with greater precision. In addition to speed control, the Speedsafe™ mechanism will assure that the maximum speed is never exceeded. Both models of mini-stirrers are available in eleven colors. The various colors can allow easy sample identification at a distance.

Speedsafe™

Specifications	HI181 • HI180
Maximum Stirring Capacity	1 liter (0.26 gallons)
Min. Speed Range	100 rpm
Max. Speed Range	1000 rpm
Power Supply	110/115 VAC or 220/240 VAC, 50/60 Hz
Installation Category	II
Cover Material	ABS plastic
Environment	0 to 50°C (32 to 122°F); RH max 95%
Dimensions	137 mm (dia) x 51 mm (h)
Weight	640 g (1.4 lbs.)
Accessories	HI731319 Magnetic micro stir bar (10)

HI181 Ordering Information

All models include detachable electrode holder, micro stir bar and instructions.



HI181-1 Black mini-stirrer (115V)



HI181W-1 Arctic white mini-stirrer (115V)



HI181F-1 Blue mini-stirrer (115V)



HI181M-1 Moss green mini-stirrer (115V)



HI181K-1 Orange mini-stirrer (115V)



HI181L-1 Lavender mini-stirrer (115V)



HI181J-1 Charcoal mini-stirrer (115V)



HI181I-1 Ivory mini-stirrer (115V)



HI181C-1 Glacier blue mini-stirrer (115V)



HI181E-1 Green mini-stirrer (115V)



HI181A-1 Yellow mini-stirrer (115V)

HI180 Ordering Information

All models include micro stir bar and instructions.



HI180-1 Black mini-stirrer (115V)



HI180W-1 Arctic white mini-stirrer (115V)



HI180F-1 Blue mini-stirrer (115V)



HI180M-1 Moss green mini-stirrer (115V)



HI180K-1 Orange mini-stirrer (115V)



HI180L-1 Lavender mini-stirrer (115V)



HI180J-1 Charcoal mini-stirrer (115V)



HI180I-1 Ivory mini-stirrer (115V)



HI180C-1 Glacier blue mini-stirrer (115V)



HI180E-1 Green mini-stirrer (115V)



HI180A-1 Yellow mini-stirrer (115V)



HI5000 Series

pH Technical Buffer Solutions (± 0.01 pH)

To obtain precise and valid pH measurements, the pH meter and electrode must be calibrated at a minimum of two different points, close to the value of the sample to be tested. For this type of calibration, Hanna offers technical solutions for each point of the pH scale.

This complete scale of buffer solutions offers a higher degree of accuracy for pH measurements in specific areas of application, as in monitoring the pH of must and wine. This line includes values of pH from 1.00 up to pH 13.00 with an accuracy of ± 0.01 pH, thus covering every point of the pH scale.

These solutions are dedicated to applications that require extremely accurate pH monitoring, and come with a certificate of analysis prepared by comparison against NIST standards.

The twist off cap and inner foil seal with pull tab allows for easier opening. Each bottle label is clearly marked with their respective value and includes a pH/temperature reference chart plus a designated spot to mark when the bottle was opened.

Also available are solution bottles that are colored according to a given standard calibration value: HI5004-R (Red), HI5007-G (Green) and HI5010-V (Violet).

Easy to Use Single Dose Sachets

For the highest level of reliability for field instrumentation, technical solutions are available in convenient single dose sachets in 10 or 25 pack quantities.

Bottles

pH Value @25°C	Code	Package
1.68	HI5016-012	120 mL
	HI5016-025	250 mL
	HI5016-050	500 mL
	HI5016-100	1 L
3.00	HI5003-012	120 mL
	HI5003-025	250 mL
	HI5003-050	500 mL
	HI5003-100	1 L
4.01	HI5004-012	120 mL
	HI5004-025	250 mL
	HI5004-050	500 mL
	HI5004-100	1 L
4.01	HI5004-R	500 mL (color coded solution)
	HI5004-R08	1 G (3.78 L) (2) (color coded solution)

pH Value @25°C	Code	Package
6.86	HI5068-012	120 mL
	HI5068-025	250 mL
	HI5068-050	500 mL
	HI5068-100	1 L
7.01	HI5007-012	120 mL
	HI5007-025	250 mL
	HI5007-050	500 mL
	HI5007-100	1 L
9.18	HI5007-G	500 mL (color coded solution)
	HI5007-G08	1 G (3.78 L) (2) (color coded solution)
	HI5091-012	120 mL
9.18	HI5091-025	250 mL
	HI5091-050	500 mL
	HI5091-100	1 L

pH Value @25°C	Code	Package
10.01	HI5010-012	120 mL
	HI5010-025	250 mL
	HI5010-050	500 mL
	HI5010-100	1 L
12.45	HI5010-V	500 mL (color coded solution)
	HI5010-V08	1 G (3.78 L) (2) (color coded solution)
	HI5124-012	120 mL
12.45	HI5124-025	250 mL
	HI5124-050	500 mL
	HI5124-100	1 L

Sachets

pH Value @25°C	Code	Package
1.68	HI50016-01	20 mL (10)
1.68	HI50016-02	20 mL (25)
3.00	HI50003-02	20 mL (25)
4.01	HI50004-01	20 mL (10)
4.01	HI50004-02	20 mL (25)
6.86	HI50068-02	20 mL (25)

pH Value @25°C	Code	Package
7.01	HI50007-01	20 mL (10)
7.01	HI50007-02	20 mL (25)
9.18	HI50091-02	20 mL (25)
10.01	HI50010-01	20 mL (10)
10.01	HI50010-02	20 mL (25)
12.45	HI50124-02	20 mL (25)



Specific Cleaning for a Top Performing Sensor



In many applications, electrodes become contaminated from use and produce inaccurate results. Since these contaminants cannot be removed during normal use, special cleaning solutions are needed.

The Cleaning Series ensures maximum efficiency and accuracy of your sensors when used for its designated application. Electrode cleaning is a fast and effective routine that should be performed on a regular basis as a preventative measure against using a dirty electrode and to ensure that the junction is not clogged.

Specific Cleaning Solutions - Bottles

Code	Description	Size
HI70630L	acid cleaning solution for meat grease and fats (food industry)	500 mL
HI70631L	alkaline cleaning solution for meat grease and fats (food industry)	500 mL
HI70632L	cleaning and disinfection solution for blood products	500 mL
HI70635L	cleaning solution for wine deposits (winemaking)	500 mL
HI70636L	cleaning solution for wine stains (winemaking)	500 mL
HI70640L	cleaning solution for milk deposits (food industry)	500 mL
HI70641L	cleaning and disinfection solution for dairy products (food industry)	500 mL
HI70642L	cleaning solution for cheese residues (food industry)	500 mL
HI70643L	cleaning and disinfection solution for yogurt products (food industry)	500 mL
HI70663L	cleaning solution for soil deposits (agriculture)	500 mL
HI70664L	cleaning solution for humus deposits (agriculture)	500 mL
HI70670L	cleaning solution for salt deposits (industrial processes)	500 mL
HI70671L	cleaning and disinfection solution for algae, fungi and bacteria (industrial processes)	500 mL
HI70681L	cleaning solution for ink stains	500 mL

Specific Cleaning Solutions - Sachets

Code	Description	Qty/Size
HI700601P	general purpose cleaning solution for laboratories	20 mL (25)
HI700630P	acid cleaning solution for meat grease and fats (food industry)	20 mL (25)
HI700635P	cleaning solution for wine deposits (winemaking)	20 mL (25)
HI700636P	cleaning solution for wine stains (winemaking)	20 mL (25)
HI700640P	cleaning solution for milk deposits (food industry)	20 mL (25)
HI700641P	cleaning and disinfection solution for dairy products (food industry)	20 mL (25)
HI700642P	cleaning solution for cheese residues (food industry)	20 mL (25)
HI700643P	cleaning and disinfection solution for yogurt products (food industry)	20 mL (25)
HI700661P	general purpose cleaning solution for agriculture	20 mL (25)
HI700663P	cleaning solution for soil deposits (agriculture)	20 mL (25)
HI700664P	cleaning solution for humus deposits (agriculture)	20 mL (25)
HI700670P	cleaning solution for salt deposits (industrial processes)	20 mL (25)



General Electrode Cleaning

Clean the sensing portion of your electrodes weekly to prevent fouling and to maintain accuracy. Immerse the electrode in the proper cleaning solution for at least 15 to 20 minutes and rehydrate in storage solution before use.

General Use Electrode Cleaning Solutions

Code	Application	Package
HI70000P	rinsing	20 mL sachet (25)
HI7061L	general purpose	500 mL bottle
HI8061L	general purpose	500 mL FDA bottle
HI7061-023	general purpose (GroLine)	230 mL bottle
HI7061-012	general purpose (GroLine)	120 mL bottle
HI7073L	proteins	500 mL bottle
HI7073M	proteins	230 mL bottle
HI8073L	proteins	500 mL FDA bottle
HI7074L	inorganic substances	500 mL bottle
HI7074M	inorganic substances	230 mL bottle
HI7077L	oil and fats	500 mL bottle
HI7077M	oil and fats	230 mL bottle
HI8077L	oil and fats	500 mL FDA bottle

Electrode Storage Solutions

To minimize junction clogging and ensure fast response time, always keep the glass bulb and the junction of your pH electrode moist. Store the electrode with a few drops of HI70300 storage or pH 4 or pH 7 buffer solution in the protective cap.



Electrode Storage Solutions

Code	Description	Package
HI70300L	electrode storage solution	500 mL bottle
HI70300M	electrode storage solution	230 mL bottle
HI70300-023	electrode storage solution (GroLine)	230 mL bottle
HI70300-012	electrode storage solution (GroLine)	120 mL bottle
HI80300L	electrode storage solution	500 mL FDA bottle
HI80300M	electrode storage solution	230 mL FDA bottle



Electrode Refilling Solutions

The electrolyte level in refillable electrodes should be checked before performing any measurement. If the level is low, refill with the proper electrolyte solution to ensure correct electrode performance. This simple maintenance helps guarantee adequate head pressure to keep the liquid junction flowing.



Electrode Fill Solutions

Code	Description	Package
HI7082	electrolyte solution, 3.5M KCl	30 mL bottle (4)
HI7082M	electrolyte solution, 3.5M KCl	230 mL bottle
HI7082L	electrolyte solution, 3.5M KCl	460 mL bottle
HI8082	electrolyte solution, 3.5M KCl	30 mL FDA bottle (4)

Hanna Instruments, USA

Highland Industrial Park,
584 Park East Drive,
Woonsocket, RI 02895

p: 1 (877) MY-HANNA
e: info@hannainst.com
hannainst.com

