

Uttar Pradesh Power Corporation Limited

Application No : 2415079

Test Center Name : Sunderdeep Group of Institutions

Test Date : 16/11/2013

Q.1 which Lake The deposition of sediments by the Mahanadi and the sandbar on the Bay of Bengal forms.

- 1) Chilika.
- 2) Vembanad
- 3) Lonar
- 4) Pulicat

Chosen Option : Not Attempted

Q.2 2014 के चुनावों के लिए जाति के मुद्दे पर सर्वोच्च न्यायालय द्वारा कौन सा आदेश पारित किया गया है?

- 1) जाति रैलियों पर रोक
- 2) जाति बाधाओं का उन्मूलन
- 3) जाति पंचायतों पर रोक
- 4) जातियों को कोई लाभ नहीं

Chosen Option : 1

Q.3 किस पारंपरिक चिकित्सा पाठ ने आयुर्वेद के सिद्धांत और अभ्यास को सुसंगत तरीके से व्यवस्थित किया?

- 1) कश्यप संहिता
- 2) अष्टांगसंग्रह
- 3) अष्टांगहृदयम
- 4) कणक संहिता

Chosen Option : 3

Q.4 What did the 61st amendment of the Indian Constitution in 1989 introduce?

- 1) Votes for Non resident Indians.
- 2) Votes for Women
- 3) Vote for 18 year olds
- 4) none of the above candidates vote option

Chosen Option : Not Attempted

Q.5 Which American civil rights leader was most influenced by Gandhiji?

- 1) James Powell .
- 2) Martin Luther King.
- 3) Stokely Carmichael.
- 4) Martin Luther .

Chosen Option : 2

Q.6 किस स्थान को "शांति एवं विज्ञान को समर्पित प्राकृतिक रिज़र्व" के रूप में वर्णित किया जाता है?

- 1) अंटार्कटिका
- 2) अमेज़न बेसिन
- 3) साइबेरिया
- 4) आर्कटिक समुद्र

Chosen Option : Not Attempted

Q.7 वर्ष 1991 से 2011 तक भारत में जनसंख्या वृद्धि दर की प्रवृत्ति क्या रही है?

- 1) पिछले 10 वर्षों की तुलना में अपेक्षाकृत निम्नतर स्तर तक गिरावट
- 2) चीन की तुलना में अपेक्षाकृत निम्नतर स्तर तक वृद्धि
- 3) आजादी के बाद से सबसे तेजी से गिरावट
- 4) आजादी के बाद से सबसे तेजी से वृद्धि

Chosen Option : 4

Q.8 Who has been given the Nobel prize for Physics in 2013

- 1) Saul Perlmutter, Brian P. Schmidt and Adam G Riess
- 2) Serge Haroche and David J. Wineland
- 3) Charles Keun Kao
- 4) François Englert and Peter W. Higgs

Chosen Option : 2

Q.9 यहाँ किस पश्चिम एशियाई देश का वर्णन किया गया है

5500 ई.पू. से सबसे आरंभिक ज्ञात मानव निवास,
गैस रिज़र्व और प्रति व्यक्ति आय की दृष्टि से विश्व का सातवाँ।

- 1) लेबनान
- 2) जॉर्डन
- 3) सउदी अरब
- 4) संयुक्त अरब अमीरात

Chosen Option : 2

Q.10 सारे विश्व के दूसरे देशों की तुलना में भारत में कौन सा रोग सबसे अधिक है?

- 1) तपेदिक
- 2) मलेरिया
- 3) एचआईवी एड्स
- 4) कुष्ठ रोग

Chosen Option : Not Attempted

Q.11 MAIRS (एमएआईआरएस = मानसून एशिया इंटीग्रेटेड रीजनल स्टडी = मानसूनी एशिया एकीकृत क्षेत्रीय अध्ययन) किन मुद्दों को संबोधित करता है?

- 1) मानसूनी एशिया पर मानसूनी दशाओं के पूर्वानुमान के तरीके
- 2) जलवायु परिवर्तन और मानसून पर प्रभाव
- 3) मानसून और उसकी गतिविधियों का अध्ययन
- 4) मनुष्यों और पारिस्थितिक दशाओं पर मानसून का प्रभाव

Chosen Option : 3

Q.12 Which Volcano has started erupting again in the last week of October 2013?.

- 1) Fujiyama
- 2) Etna
- 3) Vesuvius
- 4) Kilimanjaro

Chosen Option : Not Attempted

Q.13 प्राचीन भारत में जंगलों को साफ़ करने में किस धातु के औजार ने मदद की?

- 1) तांबा
- 2) कांसा
- 3) लोहा
- 4) सीसा

Chosen Option : 3

Q.14 Who proposed this law," that the ratio of the squares of the periods of revolution to the cubes of their average distances from the sun is the same for every one of the planets."

- 1) Kepler
- 2) Aryabhat.
- 3) Newton
- 4) Copernicus

Chosen Option : 1

Q.15 भारत नेपाल सीमा के काफी किनारे कौन सा राष्ट्रीय अभयारण्य स्थित है?

- 1) दुधवा
- 2) राधाकृष्णन
- 3) काजीरंगा
- 4) लोकतक

Chosen Option : 4

Q.16 Who won the 100 meters track and field event in the 2008 Beijing Olympics

- 1) Asafa Powell
- 2) Usain Bolt
- 3) Ben Johnson
- 4) Carl Lewis

Chosen Option : 2

Q.17 आग्नेय चट्टानों में निम्नलिखित में से क्या नहीं मिलता है?

- 1) रेडियोधर्मी खनिज पदार्थ
- 2) जीवाश्म
- 3) चुम्बकत्व
- 4) धातु

Chosen Option : 3

Q.18 सभी क्षेत्र विकास कार्यक्रमों के अंतर्गत वाटरशेड परियोजनाओं के क्रियान्वयन में ग्रामीण समुदायों को शामिल करने के लिए कार्यक्रम को कौन सा नाम दिया गया है?

- 1) पीयूआरए
- 2) हरियाली
- 3) आजीविका
- 4) अकालरक्षा

Chosen Option : 1

Q.19 कौन सी दो वस्तुएँ भारतीय निर्यात के 15% का निर्माण करती हैं?

- 1) खनिज पदार्थ और आभूषण
- 2) मोटरवाहन और रेलवे स्टॉक
- 3) प्याज और गन्ना
- 4) कागज़ और तम्बाकू उत्पाद

Chosen Option : 3

Q.20 In which year "The National Policy for Children" developed?

- 1) 1974
- 2) 2012
- 3) 1976
- 4) 2000

Chosen Option : 4

Q.1 एक विषम संख्या के तुरंत बाद कितनी बार एक विषम संख्या है लेकिन उसके ठीक पहले एक विषम संख्या नहीं है?

6 4 5 7 9 5 9 8 6 4 7 5 3 1 5 6 8 3 5 5 7 8 3 1 5 7

- 1) 5
- 2) 4
- 3) 3
- 4) 6

Chosen Option : 2

Q.2 The first two letter clusters on the left of the sign ‘::’ are related in a certain way. The same relationship holds for the second pair on the right of the sign ‘::’ of which one is missing. Choose the missing one from among the alternatives.

FKNS : DNJX :: ? : BJIV

- 1) EHNP
- 2) DMEA
- 3) AFNO
- 4) DGMQ

Chosen Option : 4

Q.3 If 'x' means addition, '-' means multiplication, '÷' means subtraction and '+' means division, which of the following is wrong?

- 1) $5 - 4 \times 15 + 5 = 20$
- 2) $21 \div 2 - 9 + 3 = 15$
- 3) $12 + 4 \times 17 \div 5 = 15$
- 4) $15 \times 10 + 2 - 4 = 35$

Chosen Option : 1

Q.4 Two statements are followed by three conclusions numbered I, II and III. Assuming the statements to be true, even if they are at variance with commonly known facts, decide which of the conclusions logically follow?

Statements: (1) All stars are planets; (2) Some moons are comets and the remaining are stars.

Conclusions: I. Some moons are stars.
II. All planets are stars.
III. Some planets are moons.

- 1) All the three follow
- 2) Only conclusions I and II follow
- 3) Only conclusion I follows
- 4) Only conclusions I and III follow

Chosen Option : 4

Q.5 After starting from Naren's house, his school bus takes two right turns and one left turn to reach his school. If the bus is facing West, when it reaches the school, which direction was it facing when the bus started from Naren's house?

- 1) East
- 2) North
- 3) South-East
- 4) South

Chosen Option : 4

Comprehension :

A solid cube is painted red, green and blue on pairs of opposite faces. It is then cut into 64 smaller cubes. Answer the following questions.

Q.6 How many smaller cubes will have only two colored surfaces?

- SubQuestion** 1) 48
No: 1 2) 32
3) 40
4) 24

Chosen Option : 4

Q.7 How many smaller cubes will have 2 faces painted green and blue with all other faces remaining unpainted?

- SubQuestion** 1) 4
No: 2 2) 16
3) 12
4) 8

Chosen Option : 4

Q.8 A car, which completes a journey in 10 hours, covers the first half of the distance at 21 km /hour and the rest at 24 km / hour. Find the distance covered in the journey.

- 1) 112
- 2) 220
- 3) 214

4) 224

Chosen Option : 4

Q.9 Which is the odd number-pair?

- 1) 13-17
- 2) 19-25
- 3) 23-29
- 4) 7-11

Chosen Option : 2

Q.10 If the position of the first and the fourth digits are interchanged in each of the following numbers and the second digit is increased by 1 and the numbers are arranged in ascending order, which will be the middle most number after rearrangement?

7293, 4527, 2698, 6787, 5548

- 1) 8793
- 2) 7624
- 3) 7886
- 4) 8645

Chosen Option : 3

Q.11 Seven friends A, B, C, D, E, F and G are sitting around a circle. B is between D and F. G is third to the right of C. D is second to the left of F, who is second to the left of E.

Who is third to the right of B?

- 1) C
- 2) A
- 3) E
- 4) G

Chosen Option : 3

Q.12 Which is missing in the following sequence of letter clusters?

bceh, iknr, svze, ? , glry

- 1) fgil
- 2) fkqx
- 3) fimr
- 4) fjou

Chosen Option : 4

Q.13 Which of the following groups of letters is the odd one out?

- 1) JRPL
- 2) GQNJ
- 3) BFEC
- 4) NUSP

Chosen Option : Not Attempted

Q.14 One of the numbers in the following number series is wrong. Which is the wrong number?

2, 10, 30, 78, 130, 222

- 1) 10

- 2) 78
3) 130
4) 30

Chosen Option : 3

Q.15

In a row, Navin is 9th from the left and Sajia is 16th from the right. If they interchange their positions, Navin becomes 19th from the left. How many persons are there in the row?

- 1) 35
2) 33
3) 34
4) 32

Chosen Option : 3

Q.16

Three faces of a cube are given below. Which number will be opposite 3?

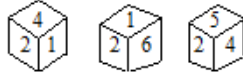

- 1) 2
2) 6
3) 4
4) 5

Chosen Option : 1

Q.17

How many quadrilaterals are there in the following figure?

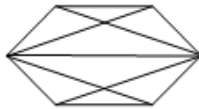

- 1) 10
2) 8
3) 6
4) 9

Chosen Option : 3

Q.18

In a family, there are two married couples. T is the granddaughter of V. S is the wife of R and mother of T. P is the grandmother of Q and mother of R. If the family has equal number of males and females.

which of the following is false?

- 1) Q is the brother of T
2) V is the husband of P
3) V has two grandsons
4) S is the son of V

Chosen Option : 4

Q.19

Choose the missing number from among the alternatives.

3	4	5
5	8	11
4	7	?
32	84	176

- 1) 11
2) 8
3) 7
4) 9

Chosen Option : 1

Q.20 How many such pairs of letters are there in the word 'STUDENT' each of which has as many letters between them in the word as in the English alphabet?

- 1) 5
- 2) 3
- 3) 4
- 4) 6

Chosen Option : 1

Q.1 कौन सा शब्द अर्थ की दृष्टि से अन्य शब्दों से भिन्न है?

- 1) द्रुम
- 2) गहना
- 3) आभूषण
- 4) अलंकार

Chosen Option : 1

Q.2 अर्ध-सरकारी पत्र में उपयुक्त संबोधन होगा-

- 1) प्रियश्री
- 2) महोदय
- 3) आदरणीय
- 4) मान्यवर

Chosen Option : 2

Q.3 वर्तनी की दृष्टि से शब्द का शुद्ध रूप कौन सा है?

- 1) व्यवहारीक
- 2) व्यवहरिक
- 3) व्यावहारिक
- 4) व्यावाहारिक

Chosen Option : 1

Q.4 दिए गए वाक्यांश के लिए एक शब्द का चयन कीजिये -

जो कहा न जा सके

- 1) अकरणीय
- 2) अकश्य
- 3) असम्भव
- 4) अकथनीय

Chosen Option : 4

Q.5 मूढ़ शब्द का पर्यायवाची शब्द है-

- 1) मूर्ख
- 2) छली
- 3) अनपढ़
- 4) भिक्ष

Chosen Option : 1

Q.6 'अपनी-अपनी ढपली अपना-अपना राग' लोकोक्ति का अर्थ है-

- 1) प्रत्येक व्यक्ति अपने ढंग से गाने को स्वतन्त्र है
- 2) अपने-अपने मन की करना
- 3) प्रत्येक व्यक्ति का काम करने का अलग ढंग होता है
- 4) संगीत साधना एकांत में की जाती है

Chosen Option : 2

Q.7 वाचाल शब्द का विलोम शब्द है-

- 1) शांत
- 2) मूक

3) निष्क्रिय

4) चालाक

Chosen Option : 2

Comprehension :

सामान्यतः लोग समझते हैं कि अनुशासन और स्वतंत्रता एक दुसरे के विरोधी हैं! वास्तविक बात यह है कि अनुशासन हमें जीवन को सही ढंग से जीना सिखाता है। इससे स्वतंत्रता का हनन नहीं होता। सड़क पर चलते समय हमें बाईं ओर चलना चाहिए, इसका पालन करना ही अनुशासन है। यदि हम सड़क के बीच में चलेंगे तो इससे न केवल दूसरों को असुविधा होगी अपितु हम अपने प्राणों को भी खतरे में डालेंगे। आज के नवयुवक कल के राष्ट्र निर्माता हैं, इसलिए अनुशासन का पालन करना और दूसरों को भी यह शिक्षा देना उनका परम कर्तव्य है।

Q.8 अनुशासन और स्वतंत्रता का परस्पर सम्बन्ध है

SubQuestion 1) तीन और नौ का

No: 1

2) तीन और तीन का

3) तीन और छः का

4) नौ और ग्यारह का

Chosen Option : 3

Q.9 हम सड़क पर बाईं ओर ही क्यों चलें?

SubQuestion 1) दूसरों को बीच में चलने देने के लिए

No: 2

2) हमारे हिस्से में इतनी ही सड़क आती है

3) सड़क पर हमारा स्वामित्व न हो

4) अपनों प्राणों की रक्षा के लिए

Chosen Option : 4

Q.10 आज के नवयुवक भावी भारत के राष्ट्र निर्माता हैं इसलिए-

SubQuestion 1) उन्हें स्वेच्छाचारी बनना चाहिए

No: 3

2) उन्हें अनुशासनप्रिय होना चाहिए

3) उन्हें स्वतंत्र रहना चाहिए

4) उन्हें किसी भी कीमत पर आगे बढ़ना चाहिए

Chosen Option : 2

Q.1 The below figure shows two linear time invariant discrete time system. Both are modelled by second order difference equations respectively. What is the order of difference equation of cascaded system?



1) 2

2) 2,4

3) 4,2

4) 4

Chosen Option : 4

Q.2 For a rectangular waveguide 3cm x 2cm dominant cut off wave length is-

1) 4 cm.

2) 6 cm.

3) 3 cm.

4) 1.5 cm.

Chosen Option : 2

Q.3 The initial state of MOD-12 down counter is 0110. After 28 clock pulses, the state of the counter will be-

1) 1011

2) 1010

3) 0010

4) 0001

Chosen Option : 3

Q.4 For the transfer function $= \omega_n^2/s^2 + 2 \xi \omega_n s + \omega_n^2$, the type and order of the system are -

1) type = 2, order = 1

2) type = 1, order = 1

3) type = 1, order = 2

4) type = 2, order = 2

Chosen Option : 3

Q.5 Slew rate of an OP-AMP is

1) Maximum change in the output voltage with respect to time

2) Difference of input voltage applied to the inverting and non inverting terminals

3) Ratio of common mode gain to differential mode gain

4) Average of input bias current

Chosen Option : 1

Q.6 For the circuit shown in the figure below, the maximum power is to be delivered to 2Ω resistor, then the value of R_1, R_2, R_3 is-

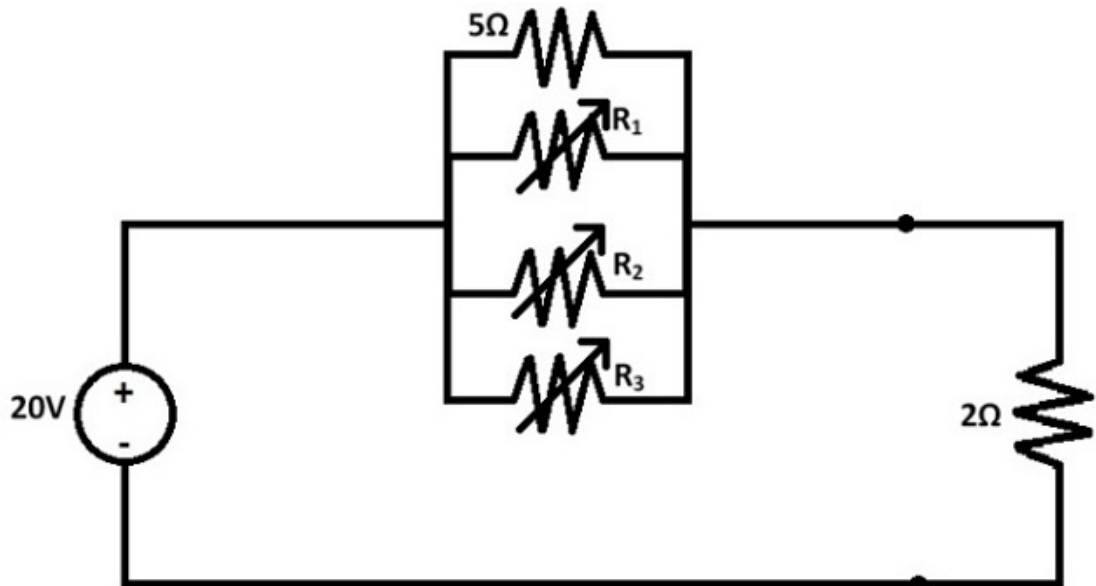

1) 5,5,3

2) 5,5,5

3) 1,1,5

4) 3,3,3

Chosen Option : 2

Q.7 The 8-bit Right Shift Register has initial reading as 11001010. After the three clock pulses the content of Shift Register will be

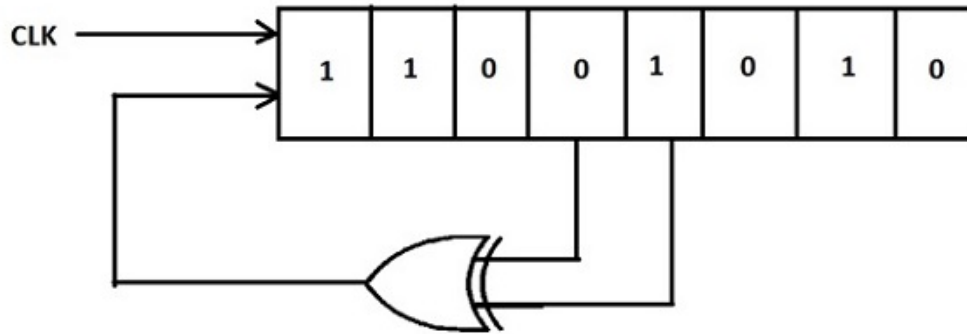

- 1) 10111001
- 2) 01011100
- 3) 11100101
- 4) 00110010

Chosen Option : 1

Q.8

Super heterodyne radio receiver suffers from -

- 1) carrier frequency problem
- 2) intermediate amplitude problem
- 3) Gain control problem
- 4) image frequency problem

Chosen Option : 4

Q.9

For the circuit shown in the figure below, what is the time constant?

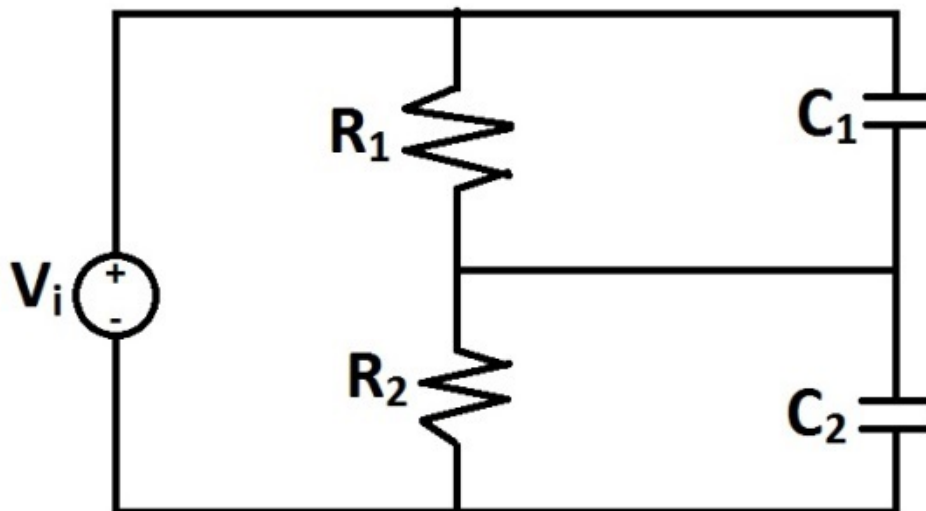

- 1) $(R_1 + R_2) (C_1 \times C_2 / C_1 + C_2)$
- 2) $(R_1 \times R_2 / R_1 + R_2) (C_1 + C_2)$
- 3) $(R_1 + R_2) (C_1 + C_2)$
- 4) $(R_1 \times R_2 / R_1 + R_2) (C_1 \times C_2 / C_1 + C_2)$

Chosen Option : 2

Q.10

If the numerator of second order transfer function $F(s)$ is a constant, then the filter is a –

- 1) Band stop filter
- 2) High pass filter
- 3) Low pass filter
- 4) Band pass filter

Chosen Option : 3

Q.11

Which transistor configuration is most suitable for impedance matching (CC- common collector, CB- collector base, CE- common emitter)

case, CE configuration cannot be)

- 1) CC configuration
- 2) CB configuration
- 3) CE configuration
- 4) CE and CB both

Chosen Option : 2

Q.12 Digital modulation requires-

- 1) bandwidth of both is same
- 2) more bandwidth compared to Analogy modulation
- 3) less bandwidth compared to Analogy modulation
- 4) unity Bandwidth

Chosen Option : 3

Q.13 If gain of a positive feedback amplifier is 18 and feedback factor is 0.5, the gain of the amplifier without feedback will be-

- 1) 1.8
- 2) 2
- 3) 3.6
- 4) 5

Chosen Option : 1

Q.14 The drain of an N-channel MOSFET is shorted to the gate such that $V_{GS} = V_{DS}$. The threshold voltage (V_T) of MOSFET is 1 volt. If the drain current (I_D) is 1 mA for $V_{GS} = 2V$, then for $V_{GS} = 3 V$, the drain current I_D is-

- 1) 4mA
- 2) 3mA
- 3) 5mA
- 4) 6mA

Chosen Option : 2

Q.15 Power of FM signal is-

- 1) same as unmodulated carrier
- 2) infinite
- 3) zero
- 4) unity

Chosen Option : 1

Q.16 If the field is non-solenoid-

- 1) Divergence do not exists
- 2) Divergence exists
- 3) Curl do not exists
- 4) Curl exists

Chosen Option : 4

Q.17 The transfer function of a system

$$\frac{Y(s)}{U(s)} = \frac{1}{s^4 + 5s^3 + 8s^2 + 6s + 3}$$

which one of the following will be 'A' matrix in state variable form?

- 1) $\begin{bmatrix} 0 & 1 & 0 & 0 \\ 0 & 0 & 1 & 0 \\ 0 & 0 & 0 & 1 \\ -5 & -8 & -6 & -3 \end{bmatrix}$

$$2) \begin{bmatrix} 1 & 0 & 0 & 0 \\ 0 & 1 & 0 & 0 \\ 0 & 0 & 1 & 1 \\ -3 & -6 & -8 & -5 \end{bmatrix}$$

$$3) \begin{bmatrix} 0 & 1 & 0 & 0 \\ 0 & 0 & 1 & 0 \\ 0 & 0 & 0 & 1 \\ -3 & -6 & -8 & -5 \end{bmatrix}$$

$$4) \begin{bmatrix} 0 & 1 & 0 & 0 \\ 0 & 0 & 1 & 0 \\ 0 & 0 & 0 & 1 \\ 3 & 6 & 8 & 5 \end{bmatrix}$$

Chosen Option : 3

Q.18

The junction area of a given G_e - diode is 4mm^2 at room temperature. The resistivity of holes and electrons are $1\text{mh}_0/\text{cm}$ and $0.1\text{mh}_0/\text{cm}$ respectively. If diffusion length of electrons and holes are each equal to 0.15cm , find I_0 (reverse saturation current) of the given diode.

- 1) $16.69\ \mu\text{A}$
- 2) $7.34\ \mu\text{A}$
- 3) $8.34\ \mu\text{A}$
- 4) $4.17\ \text{mA}$

Chosen Option : Not Attempted

Q.19

For the given block diagram the transfer function is

-

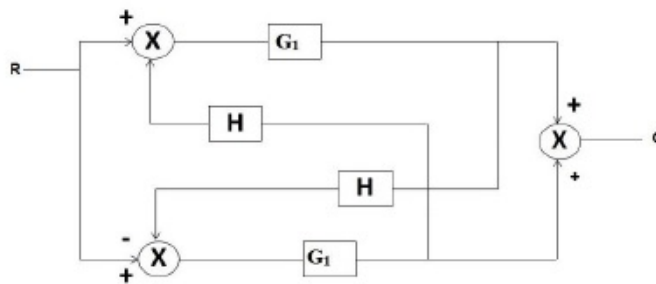

- 1) $4G_1/(1+G_1H)$
- 2) $2G_1/1+G_1+H+G_1H$
- 3) $G_1/(1+G_1H)$
- 4) $2G_1/(1+G_1H)$

Chosen Option : Not Attempted

Q.20

The diffusion length of free electrons L_e and holes L_h as charge carriers in a semiconductor is respectively given by

-:

- 1) $L_e = \sqrt{(D_e / \tau_e)}$, $L_h = \sqrt{(D_h / \tau_h)}$
- 2) $L_e = \sqrt{(D_e \tau_e)}$, $L_h = \sqrt{(D_h \tau_h)}$
- 3) $L_e = \sqrt{(\tau_e / D_e)}$, $L_h = \sqrt{(\tau_h / D_h)}$
- 4) $L_h = \sqrt{(D_h + \tau_h)}$, $L_e = \sqrt{(D_e + \tau_e)}$

Chosen Option : 2

Q.21

A circuit which introduces a d.c. level to an a.c. signal is called

- 1) Rectifier
- 2) Clipper
- 3) Amplifier

4) Clamper

Chosen Option : 3

Q.22 Given $x(n) = \{5, -2, 1, 0, 4\}$ and $y(n) = \{4, 3, 2, 1, 0\}$ for $-2 \leq n \leq 2$. Therefore sequence of $x(n) - y(n)$ is -

- 1) $\{-1, 1, 1, 1, 0\}$
- 2) $\{5, 3, 2, 1, 4\}$
- 3) $\{1, -5, -1, -1, 4\}$
- 4) $\{9, 1, 3, 1, 4\}$

Chosen Option : 3

Q.23 The locus of pinch off voltage in an field Effect Transistor(EFT) is-

- 1) Linearly increasing slope
- 2) Parabolic
- 3) Linearly decreasing slope
- 4) Exponentially decaying

Chosen Option : 2

Q.24 Signal to Noise ratio of companded PCM is -

- 1) Inversely proportional to signal bit rate
- 2) Depends on maximum amplitude
- 3) Depends on number of quantization levels
- 4) Proportional to maximum frequency of the signal

Chosen Option : 3

Q.25 The signal $(1 + A \cos 8\pi t) \cos(2\pi \times 10^3 t)$ contains frequency component (in Hz),

- 1) 996, 4, 1000
- 2) 996, 1000, 1004
- 3) 1000, 2000
- 4) 996, 998, 1000, 10002, 1004

Chosen Option : 2

Q.26 Capacitance of any CMOS transistor is -

- 1) Proportional to the width of CMOS transistor channel
- 2) Inversely proportional to the width of CMOS transistor channel
- 3) Inversely proportional to the length of CMOS transistor channel
- 4) Proportional to the length of CMOS transistor channel

Chosen Option : 2

Q.27 For a parallel RLC network shown in below, the steady state output voltage $V(t)$ for $\omega = 1$ rad /sec is

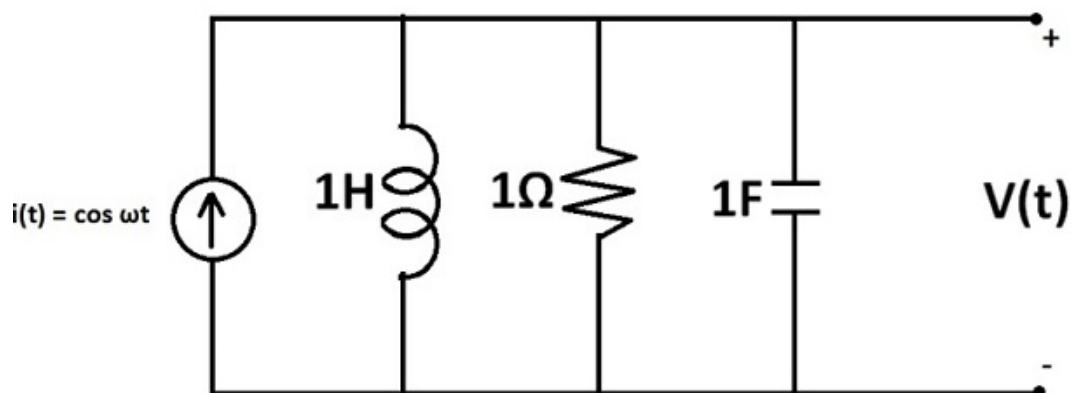

- 1) $\sin t$
- 2) $\sqrt{2} \cos t$
- 3) $\cos t$
- 4) $\sqrt{2} \cos (t - 450)$

Chosen Option : 3

Q.28 two-port network is represented by the following pair of equations $I_1 = 2 V_1 + V_2$ and $I_2 = V_1 + V_2$.

Its impedance parameters are given by

- 1) 1,-1,-1,2;
- 2) 1,1,1,2;
- 3) 2,1,1,1
- 4) 2, -1, -1, 1.

Chosen Option : 1

Q.29 “ The surface integral of curl of a vector field over an open surface equals the line integral of the vector field over the closed curve bounding the surface area “ this is the statement of –

- 1) Gauss theorem
- 2) Stoke’s theorem
- 3) Helmholtz’s theorem
- 4) Divergence theorem

Chosen Option : 2

Q.30 To reduce the inter symbol interference -

- 1) channel coding or source coding is used
- 2) bit rate of the signal must be low
- 3) bit rate of the signal should be high
- 4) pulse shaping circuit is used

Chosen Option : 4

Q.31 If the transfer function of a phase lead compensator is $s+c/s+d$ and that of a lag compensator is $s+q/s+r$, then which of the given condition must hold true -:

- 1) $c < d$ and $q > r$
- 2) $c > d$ and $q < r$
- 3) $c > d$ and $q > r$
- 4) $c < d$ and $q < r$

Chosen Option : 1

Q.32 The following figures show the input $x(t)$ to linear time invariant system and the impulse response $h(t)$ of the system. The output of the system is nonzero in the following time interval.

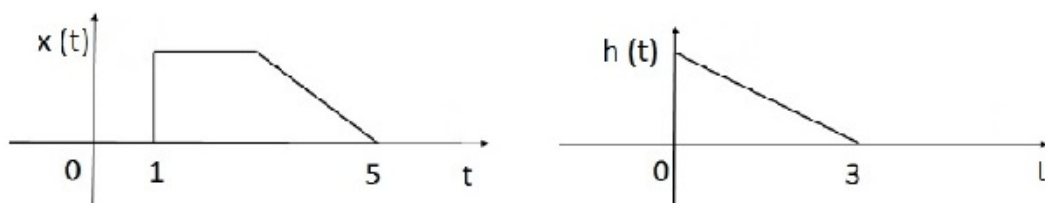

- 1) 1
- 2) 1
- 3) 0
- 4) 0

Chosen Option : 3

Q.33 BJT is a three terminal device which stands for bipolar junction transistor. Which of the following are true about BJT.

- (a) Base has smallest area to reduce the transit time.
- (b) Collector is provided with the largest area to withstand heat dissipation.
- (c) BJT is a current controlled device
- (d) BJT is a voltage controlled device.

- 1) a, b and c
- 2) a, b and d
- 3) only a and b
- 4) only b and d

Chosen Option : 1

Q.34 Transfer characteristic of any MOSFET is drawn between (V_{DS} - drain to source voltage, V_{GS} - Gate to source voltage, V_{GD} - Gate to drain voltage, I_D - drain current)

- 1) V_{GD} and I_D
- 2) V_{GS} and I_D
- 3) V_{DS} and V_{GS}
- 4) V_{DS} and I_D

Chosen Option : 2

Q.35 A linear second order single input continuous time system is described by the following

set of differential equation $\dot{x}_1 = 2x_1 + 4x_2$, $\dot{x}_2 = 2x_1 - x_2 - u(t)$, where x_1 and x_2 are state variable and $u(t)$ is the input to the system .

The system is -

- 1) Uncontrollable but stable
- 2) Controllable and stable
- 3) Controllable but unstable
- 4) Uncontrollable and unstable

Chosen Option : 2

Q.36 Program Counter Register in 8085 indicates

- 1) Instructions executed so far
- 2) The address of current instruction
- 3) The address of next instruction to be executed
- 4) The address of executed instruction

Chosen Option : 3

Q.37 An amplitude modulated wave has a power content of 800W at its carrier frequency. What will be the power content for each sidebands if percentage modulation is 80%. ?

- 1) 128 W
- 2) 320 W
- 3) 256 W
- 4) 64 W

Chosen Option : 1

- Q.38** Three signal 5 kHz, 6 kHz and 8 kHz are multiplexed. The required channel bandwidth will be-
- 1) 16 kHz
 - 2) 10 kHz
 - 3) 19 kHz
 - 4) 12 kHz

Chosen Option : 1

- Q.39** Class-C power amplifiers are generally -
- 1) Low frequency amplifier
 - 2) Wide band amplifier
 - 3) Transformer coupled between stages
 - 4) Tuned RF amplifier

Chosen Option : 3

- Q.40** The dominant mode of Rectangular waveguide is -
- 1) TE_{11}
 - 2) TE_{01}
 - 3) TM_{11}
 - 4) TE_{10}

Chosen Option : 3

- Q.41** Which one of the following condition is true for minimum conductivity (σ_{\min}) in an extrinsic semiconductor-
- 1) $\sigma_{\min} = (2n_i/q) \sqrt{\mu_n/\mu_p}$
 - 2) $\sigma_{\min} = (2n_i/q) \sqrt{\mu_n\mu_p}$
 - 3) $\sigma_{\min} = 2qn_i \sqrt{\mu_n\mu_p}$
 - 4) $\sigma_{\min} = 2qn_i \sqrt{\mu_n/\mu_p}$

Chosen Option : 3

- Q.42** The sampling interval W_0 to sample DTFT is equal to
- 1) $2\pi/N$
 - 2) $N/2\pi$
 - 3) $2\pi T/N$
 - 4) $2\pi/NT$

Chosen Option : 1

- Q.43** After the application of input, the time taken by output to show the change in state is called-
- 1) Transmission time
 - 2) Propagation delay
 - 3) State changing time
 - 4) Recovery time

Chosen Option : 2

- Q.44** In the circuit shown in the figure below, the power consumed in resistance 'R' is measured when only one source is active at a time, these values are 20 W, 100W, and 48 W. When all the sources are considered simultaneously, the maximum and minimum values of power in 'R' will be-



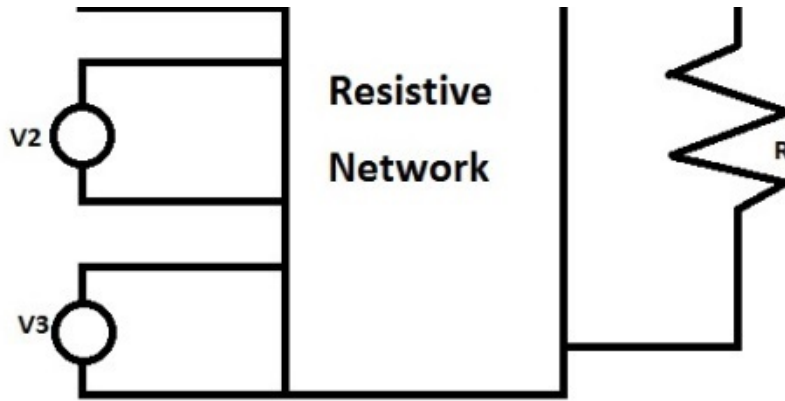

- 1) 155 W and 20 W
- 2) 155 W and 2 W
- 3) 458 W and 2 W
- 4) 100W and 20 W

Chosen Option : 3

- Q.45** A voice signal of maximum frequency 4kHz and amplitude 1V is applied to a delta modulator whose bit rate is 20 kbps. What will be the minimum step size for the delta modulator with no slope over load error?
- 1) 1.06
 - 2) 1.49
 - 3) 1.25
 - 4) 1.67

Chosen Option : 3

- Q.46** If a sequence is circularly shifted in time by 8 units, the magnitude response will
- 1) remain constant
 - 2) increase by 8
 - 3) remain unchanged
 - 4) shift by 8 units

Chosen Option : 3

- Q.47** Which of the following is the correct relationship between the band gap of a material used in a photodetector and the energy of incident photon -

(Where E_g = band gap energy, h = planck's constant, c = speed of light, λ = wave length of incident photon, ν = frequency of incident photon)

- 1) $h\nu \geq E_g$
- 2) $h\nu^2/\lambda \geq E_g$
- 3) $h\nu < E_g$

$$E_g \geq hc/\lambda$$

$$4) E_g \geq hc/\lambda$$

Chosen Option : 4

Q.48 Superposition theorem is not applicable to networks containing

- 1) non-linear elements
- 2) transformers
- 3) dependent source
- 4) linear elements

Chosen Option : 2

Q.49 A second order system has a transfer function

$$\frac{16}{s^2 + 4s + 16}$$

the time for second overshoot is –

- 1) $1.5 \pi/\sqrt{3}$ sec.
- 2) $\pi/\sqrt{3}$ sec.
- 3) $\pi/2\sqrt{3}$ sec.
- 4) $1.5 \pi/2\sqrt{3}$ sec.

Chosen Option : 1

Q.50 A center-tap transformer of 20 – 0 - 20 Volt is used in full wave rectifier circuit. For safe operation the PIV (peak inverse voltage) of each diode should be -

- 1) 20.20 Volt
- 2) 28.20 Volt
- 3) 40.20 Volt
- 4) 14.18 Volt

Chosen Option : 2

Q.51 Ready signal of 8085 processor is used for

- 1) Microprocessor is ready for use
- 2) To introduce WAIT state, when 8085 is communicating with slow peripheral device
- 3) 8085 is ready to execute instruction
- 4) Slow down the speed of fast peripheral device

Chosen Option : 3

Q.52 A random process is called ergodic process if-

- 1) Ensemble average is half of the time average.
- 2) Time average is half of the ensemble average.
- 3) Time average is equal to ensemble average.
- 4) Time average is more than ensemble average.

Chosen Option : Not Attempted

Q.53 The fundamental period of periodic sequence $x(n)=n$ modulo 6 is

- 1) 6 samples
- 2) 24 samples
- 3) 3 samples
- 4) 12 samples

Chosen Option : Not Attempted

Q.54 What is the relation between Laplace domain and Z domain.

- 1) $Z=e^{jST}$
- 2) $Z=e^{ST}$
- 3) $S=e^{ZT}$
- 4) $S=e^{-ST}$

4) $Z=e^{-s}$

Chosen Option : 2

Q.55 A Silicon BJT has leakage current I_{CBO} of 10 nA at 30°C. If the temperature rises to 60°C, calculate the leakage current-

- 1) 80 nA
- 2) 40 nA
- 3) 60 nA
- 4) 20 nA

Chosen Option : 1

Q.56 Differentiator circuit is also works as -

- 1) All pass filter
- 2) Band pass filter
- 3) High Pass filter
- 4) Low Pass filter

Chosen Option : 4

Q.57 If a channel having bandwidth of 2 kHz and signal to noise ratio is zero dB. Maximum bit rate for this channel will be-

- 1) 0 kbps
- 2) 0.5 kbps
- 3) 4 kbps
- 4) 2 kbps

Chosen Option : 1

Q.58 V-I characteristics of a device are shown in figure below - the element is

-

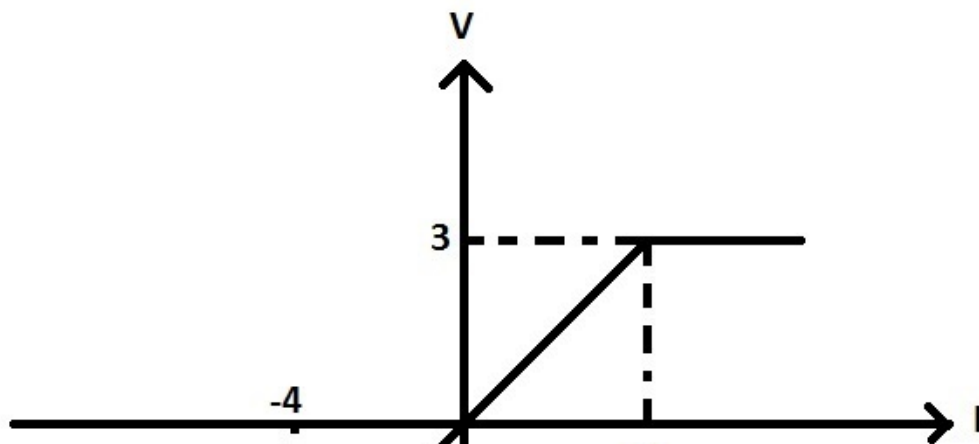

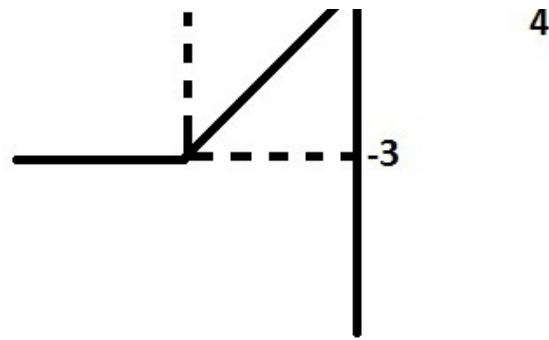

- 1) non- linear , active , bilateral
- 2) non- linear , passive , bilateral
- 3) non- linear, active , unilateral
- 4) linear , passive , unilateral

Chosen Option : 2

Q.59 The sets of commands in a program, which are not translated into machine instructions during assembly process, are called

- 1) Addresses
- 2) Directives
- 3) Mnemonics
- 4) Operands

Chosen Option : 2

Q.60 Binary 1 & 0 are corresponding to-

- 1) They are numbers
- 2) AC positive and negative cycle
- 3) They are two different DC voltages
- 4) They are two different AC voltage

Chosen Option : 3

Q.61 A control system has $G(s)H(s) = K (S+2) / S (S+4)(S+5)$. The root loci lies -

- 1) towards left of $S = - 4$
- 2) between $S = - 4$ and $S = - 5$
- 3) between $S = - 2$ and $S = - 4$
- 4) between $S = 0$ and $S = - 5$

Chosen Option : 2

Q.62 When the two signals are multiplied in Fourier domain, what happens in the time domain?

- 1) Addition
- 2) Division
- 3) Multiplication
- 4) Convolution

Chosen Option : 4

Q.63 An intrinsic impedance of free Space is-

- 1) 150Ω
- 2) 75Ω
- 3) 377Ω

4) 120 Ω

Chosen Option : 3

Q.64 When Junction Field Effect Transistor works in pinch off region

- 1) Drain current will be zero
- 2) Drain to source voltage will be constant
- 3) Gate to source voltage will be constant
- 4) Drain current will be constant

Chosen Option : 4

Q.65 8085 is a-

- 1) 8-bit Microprocessor
- 2) 4-bit Computer processor
- 3) 8-bit Miniprocessor
- 4) 4-bit Megaprocessor

Chosen Option : 1

Q.66 The function $f(A,B) = \Pi M(0,1,2)$ represents

- 1) NAND gate.
- 2) NOR gate,
- 3) AND gate,
- 4) OR gate,

Chosen Option : 1

Q.67 When N_m is the maximum electron density in per cubic meter then critical frequency f_c is given as -

- 1) $2\sqrt{N_m}$
- 2) $3/\sqrt{N_m}$
- 3) $9 N_m$
- 4) $10 N_m$

Chosen Option : 2

Q.68 Unit of permeability is -

- 1) Henry / meter
- 2) Henry
- 3) Henry / meter²
- 4) it is dimensionless

Chosen Option : 1

Q.69 While analyzing the stability of control system which of the following statements given below are true-

- (a) Root locus technique is a time domain analysis and Routh – Hurwitz criteria is a frequency domain analysis
- (b) Polar plot and Nyquist plot are frequency domain analysis
- (c) Bode plot is a frequency domain analysis and Routh- Hurwitz Criteria is a time domain Analysis
- (d) Gain margin and phase margin are time domain analysis

- 1) (c), (d)
- 2) (b), (c)
- 3) (a), (d)
- 4) (a) (b)

Chosen Option : 2

Q.70 The main purpose of feedback in a control system is

- 1) To have a reduced time constant
- 2) To make the system more stable
- 3) To decrease the response error
- 4) Sensitivity of the system is increased

Chosen Option : 2

Chosen Option : 2

Q.71 For a sine wave of frequency f_m and amplitude A_m applied to a delta modulator having step size of ' δ '. The slope over load distortion will occur if-----Here sampling periods is ' T_S '.

- 1) $A_m < \delta \cdot f_m/2\pi T_S$
- 2) $A_m > \delta/2\pi f_m T_S$
- 3) $A_m < \delta/2\pi f_m T_S$
- 4) $A_m > \delta \cdot T_S/2\pi f_m$

Chosen Option : 2

Q.72 Mobility of electrons and holes in a semiconductor depends on -

- (a) Type of semiconductor
 - (b) Temperature of semiconductor
 - (c) Scattering of impurities
 - (d) Relaxation time
- 1) a, b and c
 - 2) b, c and d
 - 3) a, c and d
 - 4) only b and d

Chosen Option : 2

Q.73 Cut off frequency of TEM mode is -

- 1) 0.5
- 2) ∞
- 3) 1
- 4) 0

Chosen Option : 4

Q.74 The maximum effective aperture of an antenna which has directivity of 800 -

- 1) $36.36\lambda^2$
- 2) $63.6\lambda^2$
- 3) $66.33\lambda^2$
- 4) $36.63\lambda^2$

Chosen Option : 2

Q.75 In a negative edge triggered J-K flip flop, in order to have the output state 1,0,0,1 in the next successive four clock pulses, the inputs J-K are-

- 1) 10,01,00,11
- 2) 01,00,00,01
- 3) 11,00,00,11
- 4) 10,00,00,11

Chosen Option : 4

Q.76 Find the probability of occupancy of the quantum state with energy of 6.26 eV at a temperature of 300°K and whose fermi level is 6.21 eV.

(Boltzman constant 'K' is taken as 8.62×10^{-5} eV/Kelvin)

- 1) 0.175 eV
- 2) 0.4 eV
- 3) 0.2 eV
- 4) 0.35 eV

Chosen Option : Not Attempted

Q.77 Consider the following statements regarding LASER -

(i) The emitted light is due to transition of electron from higher energy level to lower energy level

- (i) The emitted light is due to transition of electron from higher energy level to lower energy level
 (ii) The emitted radiation is due to transition of electron from lower energy level to higher energy level
 (iii) LASER stands for light amplification by stimulated emission of radiations and is a noisy device.
 (iv) Main components of a LASER are pumping source, a resonant cavity and LASERs are three level device

Which of the above statements are correct?

- 1) (iii) and (iv)
- 2) (i) and (iv)
- 3) (i) and (iii)
- 4) (ii) and (iii)

Chosen Option : 4

Q.78

The transmission (T) parameters for the network below is-

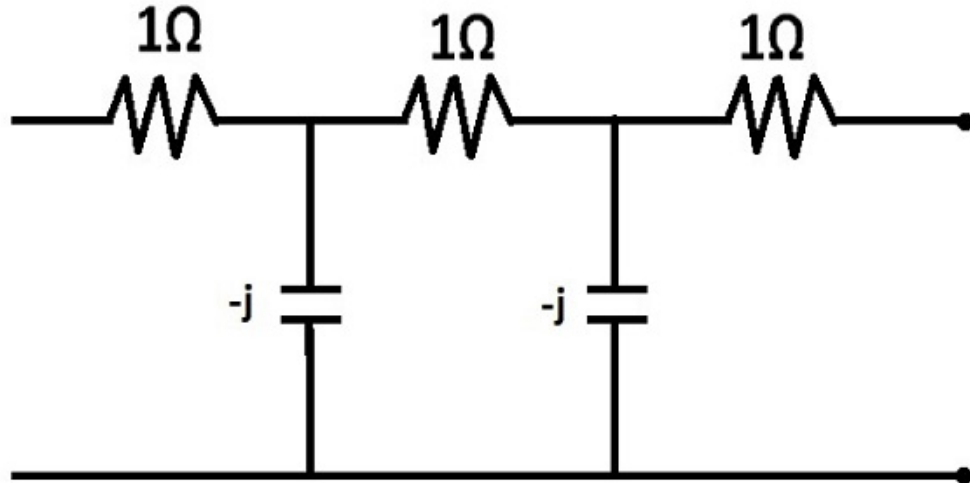

- 1) $\begin{pmatrix} 3j & -1 + 2j \\ 2 + 4j & 3j \end{pmatrix}$
- 2) $\begin{pmatrix} 3j & 2 + 4j \\ -1 + 2j & 3j \end{pmatrix}$
- 3) $\begin{pmatrix} -3j & -3 + 4j \\ 1 - 2j & -3j \end{pmatrix}$
- 4) $\begin{pmatrix} -3j & 3 - 4j \\ 1 + 3j & -3j \end{pmatrix}$

Chosen Option : Not Attempted

Q.79

m_3 & m_6 minterms are present in a function f of n variables. The number of Maxterms present in the same function f are-

- 1) $2^n - 1$,
- 2) $2^n - 3$,
- 3) $2^n - 2$.
- 4) $2^3 - 2$,

Chosen Option : 3

Q.80

A linear phase filter has a phase function $e^{-j2\omega}$. What is the order of the filter?

- 1) 5
- 2) 7
- 3) 3
- 4) 9

Chosen Option : 3

Q.81

The frequency response for a network function $H(s)$ is given below in figure in graphical form. $H(s)$ is given by -

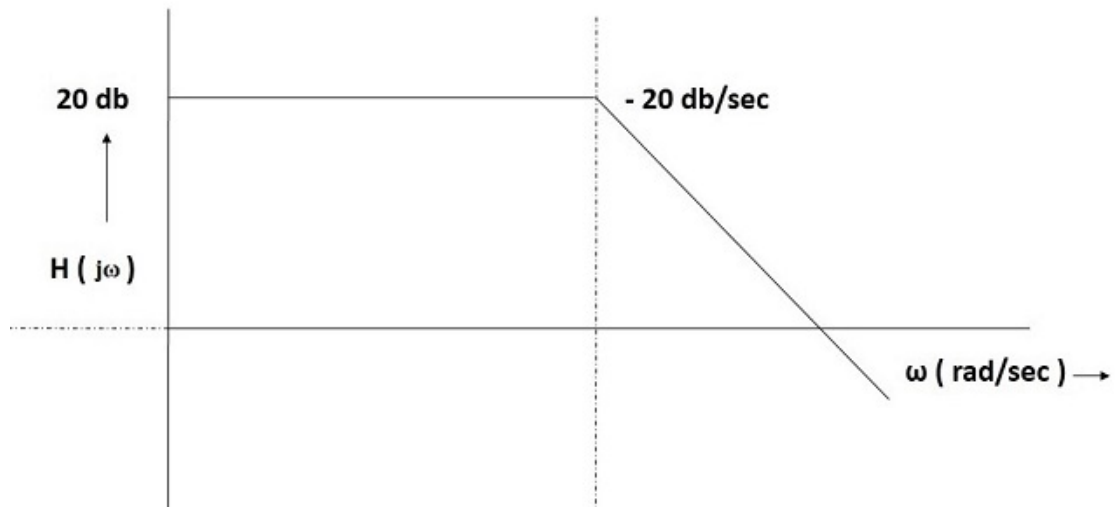

- 1) $10s/s+1$
- 2) $10/s+1$
- 3) $s/s+1$
- 4) $1/s(s+1)$

Chosen Option : 2

Q.82

Pinch-off voltage of Junction Field Effect Transistor (JFET) depends on

- 1) Supply voltage
- 2) Gate to source voltage
- 3) Drain to source voltage
- 4) Width of the original channel structure

Chosen Option : 2

Q.83

For what value of V_x such that maximum power is transferred from source to load

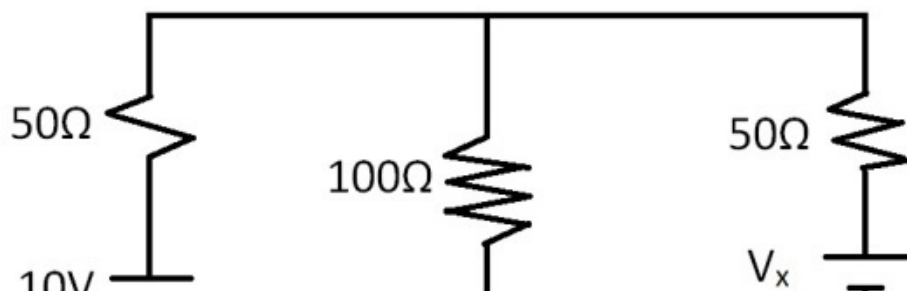



- 1) 4 V
- 2) 2.5 V
- 3) 7 V
- 4) 5 V

Chosen Option : Not Attempted

Q.84 Most widely used method for solving and analyzing control System is -

- 1) Signal flow graph (SFH)
- 2) State Model
- 3) Block diagram representation
- 4) Transfer function approach

Chosen Option : 2

Q.85 The Excess-3 code for decimal number 72 is-

- 1) 10100101
- 2) 10010000
- 3) 01110101
- 4) 01001011

Chosen Option : 4

Q.86 Which modulation is used in GSM system?

- 1) QPSK
- 2) PMSK
- 3) GMSK
- 4) QMSK

Chosen Option : Not Attempted

Q.87 Identify the type of filter of the network shown in the figure below

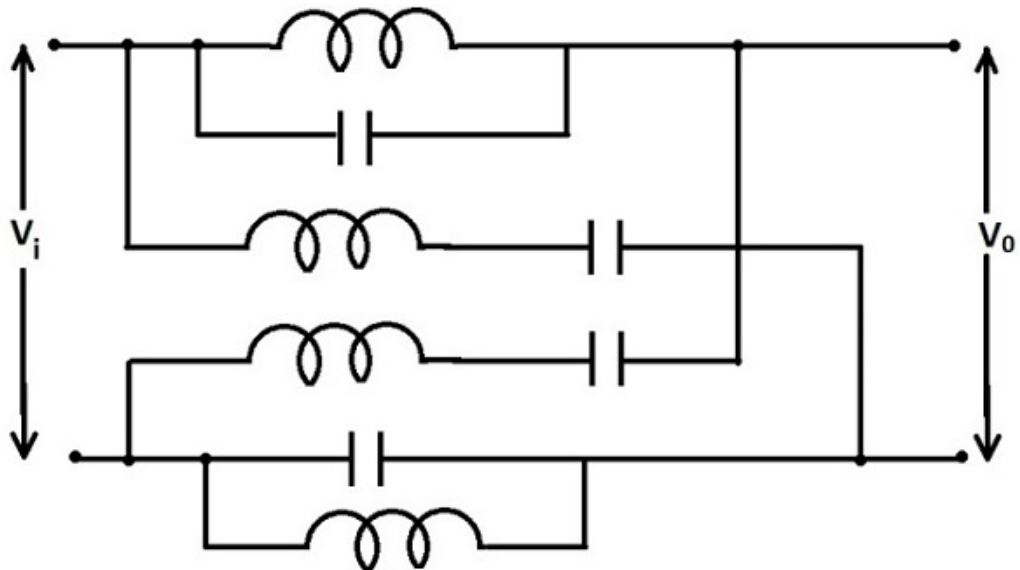

- 1) Low pass filter
- 2) All pass filter

3) Band elimination filter

4) Band pass filter

Chosen Option : 4

Q.88 GSM incorporates ----- concept for increasing subscribers number .

1) Cell split

2) Cell reuse

3) Cell Filters

4) Frequency reuse

Chosen Option : 4

Q.89 For the given block diagram of a control system determine the transfer function-

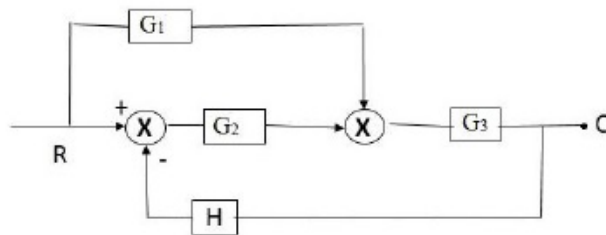

1) $(1+G_3/G_2) (G_1G_2/1+G_1G_2H)$

2) $(1+G_3/G_2) (G_2G_3/1+G_2G_3H)$

3) $(1+G_1/G_2) (G_2G_3/1+G_2G_3H)$

4) $(1+G_3/G_1) (G_1G_2/1+G_1G_2H)$

Chosen Option : Not Attempted

Q.90 In a parallel RLC Circuit the power factor at higher cut off frequency $f = f_H$ is -

1) 0.5 (lead)

2) 0.5 (lag)

3) 0.707 (lead)

4) 0.707 (lag)

Chosen Option : 4

Q.91 How is the damping ratio ' ξ ' and quality factor ' Q ' of a series RLC circuit are related to each other-

1) $\xi ; \sqrt{Q}$

2) $\xi ; 1/Q$

3) $\xi ; Q$

4) $\xi ; 1/\sqrt{Q}$

Chosen Option : 2

Q.92 The pinch - off voltage of n-channel junction FET is $V_P = -4V$ and the drain to source saturation current $I_{DSS} = 2$ mA. Its transconductance (g_m) for an applied gate to source voltage V_{GS} of $-2V$ is -

1) 1.0 mA/V

2) 0.25 mA/V

3) 0.75 mA/V

4) 0.5 mA/V

Chosen Option : 4

Q.93 Match List-I with List-II, and select the correct answer using the code given below the lists

List- I	List- II
(a) Ga As	(i) Gives orange or yellow light
(b) Ga As P	(ii) Gives infrared light
(c) Ga P	(iii) Gives green light
(d) LEDs	(iv) Emission of monochromatic light

1) (a)-i,(b)-iii,(c)-ii,(d)-iv,

2) (a)-iii,(b)-iv,(c)-ii,(d)-i,

3) (a)-i,(b)-ii,(c)-iii,(d)-iv,

4) (a)-ii,(b)-i,(c)-iii,(d)-iv,

Chosen Option : 4

Q.94

Entropy of any message will be Zero when-

- 1) Probability of message is Zero only
- 2) Probability of message is Zero or One both
- 3) Probability of message is One only
- 4) Probability of message is not constant

Chosen Option : 3

Q.95

DFT magnitude response exhibit complex conjugate property if the time sequence is

- 1) a real sequence
- 2) imaginary sequence
- 3) a complex sequence
- 4) not a real sequence

Chosen Option : 3

Q.96

In which circuit duty cycle of any pulse wave is 50%

- 1) Astable Multivibrator
- 2) Mono-stable Multivibrator
- 3) Bistable Multivibrator
- 4) Schmitt trigger

Chosen Option : 3

Q.97

For a given signal flow diagram, the transfer function is -

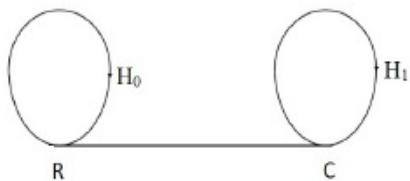

- 1) $1/(1-H_0)(1-H_1)$
- 2) $1/1-H_1H_0$
- 3) $1/1-H_1$
- 4) $1/(1-H_0)$

Chosen Option : Not Attempted

Q.98

The value of d_{v_c}/dt and d_{i_L}/dt at $t=0^+$ for the given circuit shown in below is -

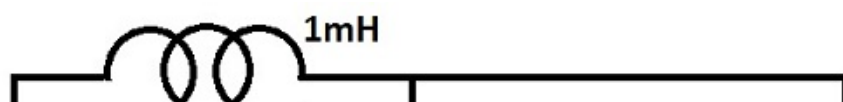

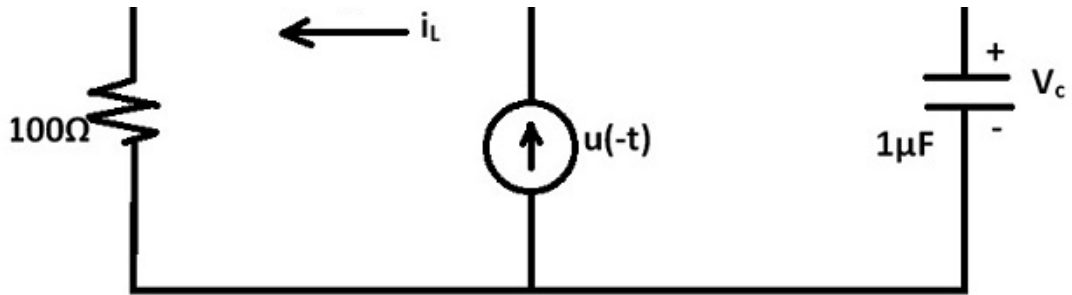

- 1) -10^6 A/sec , 0 V/sec
- 2) 10^6 A/sec , 0 V/sec
- 3) 0 A/sec , 10^6 V/sec
- 4) 0 A/sec , -10^6 V/sec

Chosen Option : 3

Q.99

Poynting vector gives -

- 1) rate of energy flow
- 2) Intensity of electric field
- 3) Intensity of magnetic field
- 4) Direction of polarization

Chosen Option : 1

Q.100

A transistor works in inverted region when (EB-emitter base, CB- collector base, FB- forward bias, RB- reverse bias)

- 1) EB junction is FB and CB junction is RB
- 2) EB junction is RB and CB junction is RB
- 3) EB junction is FB and CB junction is FB
- 4) EB junction is RB and CB junction is FB

Chosen Option : 2

Q.101

When an analog sinusoidal signal of frequency $8/\pi$ is sampled at a sampling rate above or below the Nyquist rate, the discrete time signal will be

- 1) Causal
- 2) Non causal
- 3) Aperiodic
- 4) Periodic

Chosen Option : Not Attempted

Q.102

Differential pulse code modulation system contains-

- 1) Decoder
- 2) Prediction Filter
- 3) Bit synchronizer
- 4) Multiplier

Chosen Option : 2

Q.103

A 4-bit D/A converter have a full scale output voltage of 8V. The output voltage when the input is 1010 is-

- 1) 160V
- 2) 16V
- 3) 5V
- 4) 0.5V

4) 80 V

Chosen Option : 3

- Q.104** The p-side and n-side of a germanium (G_e) diode have resistivity 2 ohm-cm and 1 ohm-cm respectively. The value of the potential barrier (V_0) -
- 1) 0.22 Volts
 - 2) 0.55 Volts
 - 3) 0.88 Volts
 - 4) 0.44 Volts

Chosen Option : Not Attempted

- Q.105** A wave is incident at an angle of 30 degree from air to Teflon, $\epsilon_r=2.1$. Angle of transmission is
- 1) 42 degree
 - 2) 10 degree
 - 3) 32 degree
 - 4) 20.18 degree

Chosen Option : 1

- Q.106** A circuit with a resistor, inductor and capacitor in series are in resonant of f_0 Hz. If all the component values are now doubled, the new resonant frequency will become
- 1) $f_0 / 4$
 - 2) f_0
 - 3) $f_0 / 2$
 - 4) $2f_0$

Chosen Option : 3

- Q.107** Radiation resistance of a $l/8$ wire dipole in free space is -
- 1) 100 Ω
 - 2) 31.84 Ω
 - 3) 17.3252 Ω
 - 4) 12.32 Ω

Chosen Option : 3

- Q.108** How many A.M. broadcast stations can be accommodated in a 50 kHz bandwidth if the highest frequency of a modulating carrier is 5 kHz ?
- 1) 20
 - 2) 5
 - 3) 15
 - 4) 10

Chosen Option : 4

- Q.109** Voltage Multipliers circuits are-
- 1) Combination of clippers
 - 2) Clamper circuits
 - 3) Combination of peak rectifiers
 - 4) Clipper circuits

Chosen Option : Not Attempted

- Q.110** Operating point 'Q' of the given circuit in figure is -

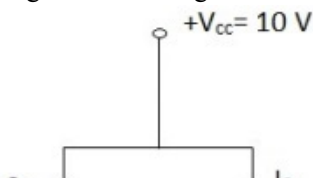

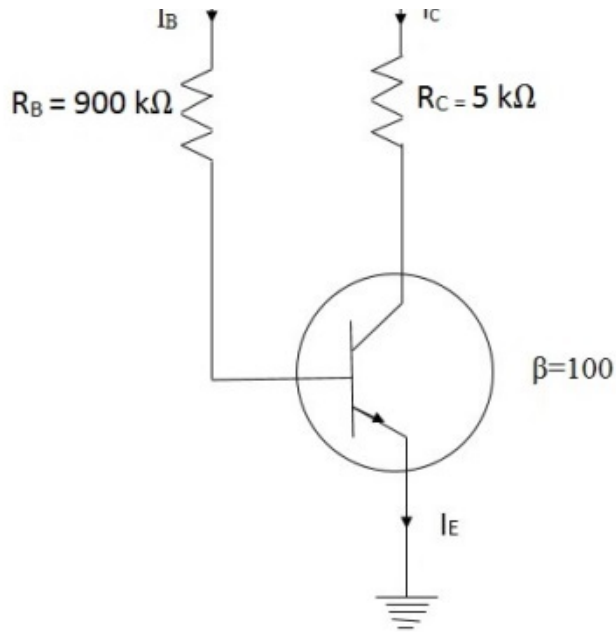

- 1) (4.833V, 1.03mA)
- 2) (6V, 1.03 mA)
- 3) (5V, 2mA)
- 4) (4.833V, 1mA)

Chosen Option : 1

Q.111 An ideal voltage and current sources are connected in series. This combination will have-

- 1) Both Thevnin and Norton equivalent
- 2) Norton but not Thevnin equivalent
- 3) Neither Thevnin nor Norton equivalent
- 4) Thevnin but not Norton equivalent

Chosen Option : Not Attempted

Q.112 The corresponding graph for the circuit shown in given figure will be-

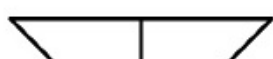
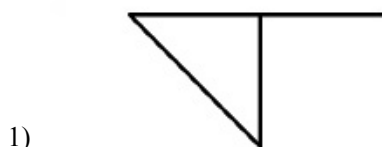
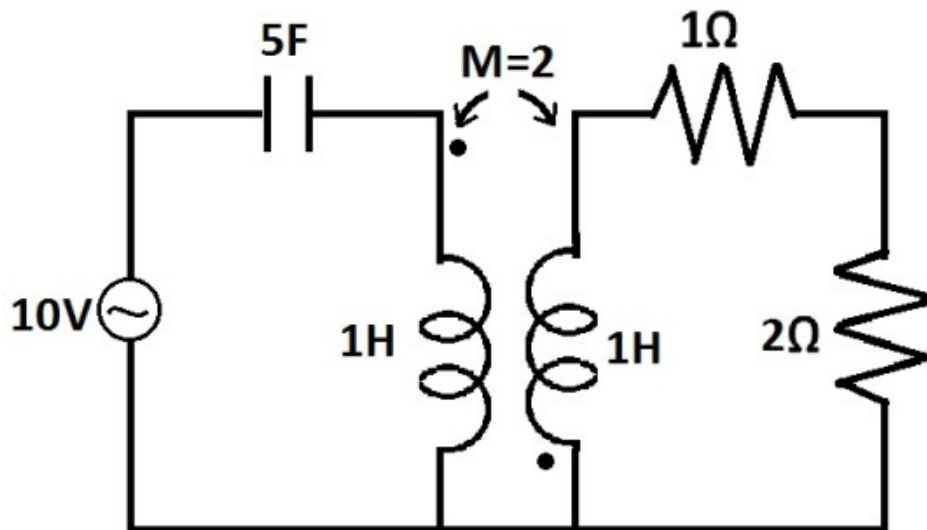

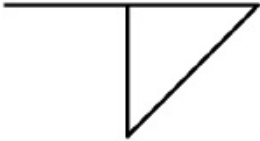
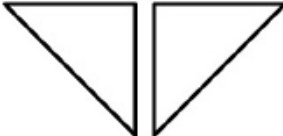
- 2) 
- 3) 
- 4) 

Chosen Option : 4

Q.113 Which one of the fundamental equation was modified by Maxwell to form the basis of electromagnetic theory?

- 1) Faraday Law.
- 2) Ampere Law
- 3) Gauss law of magnetostatic
- 4) Gauss law of electrostatic

Chosen Option : 2

Q.114 Skin effect resistance per unit length is-

- 1) proportional to the conductivity
- 2) proportional to the relative permittivity
- 3) inversely proportional to the permeability
- 4) inversely proportional to the conductivity

Chosen Option : 4

Q.115 The current distribution on a half wave dipole is -

- 1) Square
- 2) uniform
- 3) Sinusoidal
- 4) Triangular

Chosen Option : 4

Q.116 Crystal oscillator's works on the principle of-

- 1) Transconductance effect
- 2) Thermoelectric effect
- 3) Piezoelectric effect
- 4) Photoelectric effect

Chosen Option : 3

Q.117 for a wave guide with dimensions $a = 2.28\text{cm}$ and $b = 1.016\text{ cm}$. the cutoff frequency of TM_{21} mode will be-

- 1) 14.7644 GHz
- 2) 16.1564 GHz
- 3) 19.753GHz
- 4) 30.248 GHz

Chosen Option : Not Attempted

Q.118 The control system transfer function is given by $q(s) = s^3 + s^2 + 3s + 5 = 0$. Which of the given statements are true -

- (a) System is unstable
- (b) Number. of imaginary poles = 0, Left sided poles = 1
- (c) Right sided poles = 1
- (d) Total number of poles = 3 and system is unstable

- 1) a, b, d
- 2) b and c
- 3) b, c, d
- 4) a, b, c

Chosen Option : Not Attempted

Q.119 The equation

$$\nabla \times \vec{E} = -\frac{\partial \vec{B}}{\partial t}$$

is the generalization of -

- 1) Faradays law
- 2) Coulomb's law
- 3) Gauss's law
- 4) Amperes law

Chosen Option : 1

Q.120 Line regulation and load regulation of any regulated power supply should be-

- 1) Infinite
- 2) Maximum
- 3) Minimum
- 4) Unity

Chosen Option : 3

Q.121 Match the statements in right column with the name given in left column and select the correct answer using the code given below the list

(a) p - n junction diode	(i) Highly sensitive and high break down voltage diode
(b) Tunnel diode	(ii) Used for clipper clamper circuits
(c) Zener diode	(iii) Used in high frequency oscillator
(d) LED	(iv) Used as voltage regulator
(e) Avalanche photodiode	(v) Light is produced in response to current applied to the

- 1) (a)-ii,(b)-iii,(c)-iv,(d)-v,(e)-i
- 2) (a)-i,(b)-iv,(c)-iii,(d)-v,(e)-ii
- 3) (a)-ii,(b)-iii,(c)-v,(d)-iv,(e)-i
- 4) (a)-i,(b)-ii,(c)-iii,(d)-iv,(e)-v

Chosen Option : 1

Q.122 How many 1's are present in the binary representation of

$$(256 \times 7) (4 \times 16) (9 \times 4096) + 5$$

- 1) 8
- 2) 11
- 3) 9
- 4) 10

Chosen Option : Not Attempted

Q.123 A parallel polarized wave propagates from air into dielectric at Brewster angle of 45° . Calculate the relative dielectric constant of the medium is -

- 1) 0
- 2) $1/\sqrt{3}$
- 3) 1
- 4) 1.141

Chosen Option : 3

Q.124 Consider two energy levels : E_1 eV above the fermi level and E_2 eV below the fermi level. P_1 and P_2 are respectively the probabilities of E_1 being empty and E_2 being occupied by the electron, then

- 1) $P_1 = P_2$
- 2) P_1 and P_2 depend on number of electrons.
- 3) $P_1 > P_2$
- 4) $P_1 < P_2$

Chosen Option : 1

Q.125 Consider the following statements about a proportional plus derivative controller

- (a) The maximum or peak overshoot is less
- (b) The stability of the system is less
- (c) The stability of the system is increased
- (d) The settling time is increases

Which of the above statements are correct?

- 1) a, b, c
- 2) a, b, d
- 3) b and c
- 4) a and c

Chosen Option : 4

Q.126 In case of tunnel diode , which statements are true -

- (i) Quantum mechanical tunneling phenomena takes place in tunnel diode.
- (ii) Tunnel diode used for fine tuning of receivers
- (iii) In forward biased tunnel diode there is tunneling current depending on doping level of tunnel diode and the current is more than in the unbiased diode.
- (iv) Tunnel diode finds applications as a high frequency oscillator and is a heavily doped diode

- 1) (i), (ii), (iii) and (iv)
- 2) (i), (iii) and (iv)
- 3) (i), (ii) and (iv)
- 4) (i), (ii) and (iii)

Chosen Option : 3

Q.127 In a read only memory. The numbers of address lines gives-

- 1) Address of memory,
- 2) Numbers of bits stored in memory,
- 3) Physical dimension of memory,
- 4) Number of bytes stored in memory.

Chosen Option : 2

Q.128 For a sample of GaAs scattering time is $\tau_{sc} = 10^{-15}$ sec. and effective mass of electron is $0.076m$, where m is true mass of electron. If an electric field of 100 kV/cm is applied, the drift velocity produced is -

- 1) 14.8×10^6 cm/sec
- 2) 2.6×10^6 cm/sec

3) 2.31×10^2 cm/sec

4) 482 cm/sec

Chosen Option : Not Attempted

Q.129

The effective inductance across 'AB' of the infinite ladder shown in the figure below is-

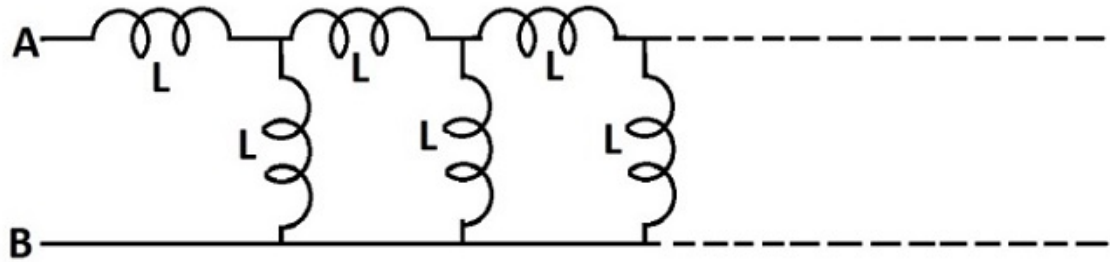
1) $(1 + \sqrt{3}) L$ 2) $(1 + \sqrt{5}) L / 2$ 3) $(1 + \sqrt{5}) L$ 4) $(1 + \sqrt{7}) L$

Chosen Option : 2

Q.130

The duration of the on time of any pulse of mono-stable multivibrator depends on

1) External R connected to the circuit only

2) R and C both

3) External C connected to the circuit only

4) External R but not external C

Chosen Option : 2

Q.131

Maximum signal to Noise ratio of a matched filter is Proportional to-

1) P&D of the Noise

2) P&D of the signal

3) Energy of the signal

4) Energy of the Noise

Chosen Option : 3

Q.132

The impulse function

$$\int_{t_1}^{t_2} x(t) \delta^n(t - t_0) dt$$

is equal to

1) $nx(t_0)$ 2) $x^n(t_0)$ 3) $x(t_0)$ 4) $(-1)^n x^n(t_0)$

Chosen Option : 3

Q.133

If a transmission line is terminated in an open circuit the VSWR is-

1) 0

2) 1

3) ∞

4) -1

Chosen Option : 3

Q.134

Match the statements in right column with the left column and select the correct answer using the code given below the lists

(i) lead compensator	(a) Maximum peak or overshoot decreases
(ii) Lag compensator	(b) Improves transient response
(iii) Proportional controller	(c) Steady state error reduces
(iv) Integral controller	(d) Improves the steady state response

- 1) (i)-d,(ii)-b,(iii)-a,(iv)-c,
- 2) (i)-c,(ii)-d,(iii)-b,(iv)-a,
- 3) (i)-b,(ii)-d,(iii)-c,(iv)-a,
- 4) (i)-a,(ii)-c,(iii)-d,(iv)-b,

Chosen Option : 4

Q.135

The input impedance and voltage gain of the given circuit in figure below is-

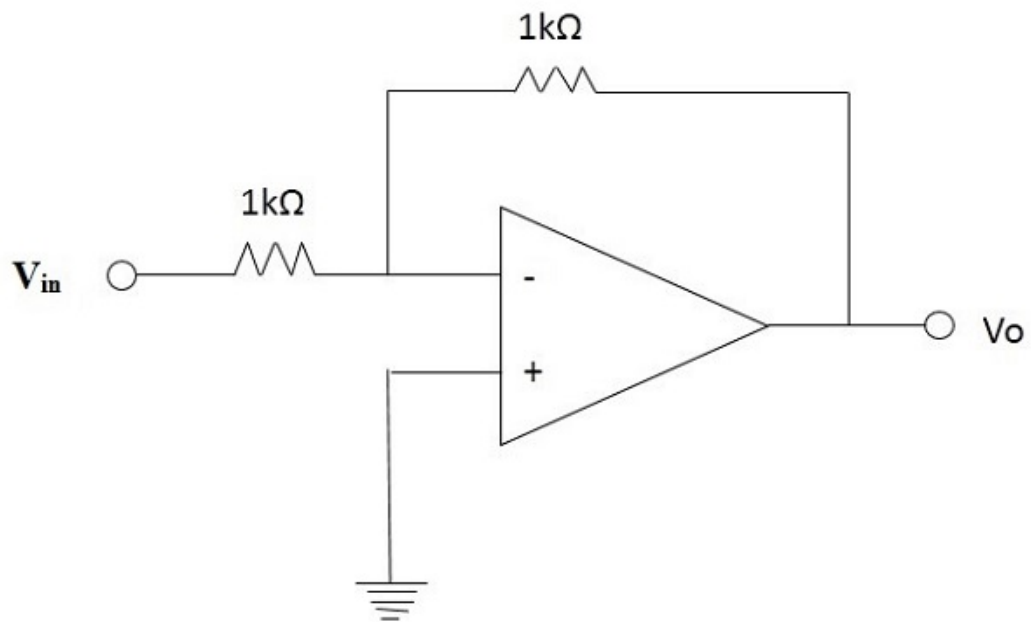

- 1) $2k\Omega$, 2
- 2) $2k\Omega$, 1
- 3) $1/2k\Omega$, 2
- 4) $1k\Omega$, 1

Chosen Option : 4

Q.136

Identify the correct statement about MOS capacitor -

- 1) for an N-type substrate, a negative voltage is applied and P-type inversion layer is formed
- 2) for a P-type substrate a negative voltage is applied and P-type inversion layer is formed
- 3) for an N-type substrate a positive voltage is applied and N-type inversion layer is formed
- 4) for a P-type substrate a negative voltage is applied and N-type inversion layer is formed

Chosen Option : Not Attempted

Q.137

If the electric field strength of a plane wave is 12v/m . What will be the strength of magnetic field in free space -

- 1) 0.04 A/m
- 2) 0.03 A/m
- 3) 0.02 A/m
- 4) 0.01 A/m

Chosen Option : 2

Q.138

A network contains only an independent current source and resistors. If the values of all resistors are doubled, the

- 1) remain unchanged
- 2) become half
- 3) become double
- 4) become zero

Chosen Option : 3

Q.139 For good response of a second order control system -

- (a) higher t_p (peak time) is needed
- (b) the maximum or peak overshoot must be less
- (c) The steady state error(ess)is less
- (d) The maximum or peak overshoot must be higher

Which of the above statements are correct?

- 1) (a),(b),(d)
- 2) (a), (b)
- 3) (a), (d)
- 4) (a),(b) (c)

Chosen Option : Not Attempted

Q.140 Which of the given graphs is the valid root loci of the given transfer functions

$$G(s) = \frac{k(s+a)}{s^2(s+b)} \quad |b| > |a|$$

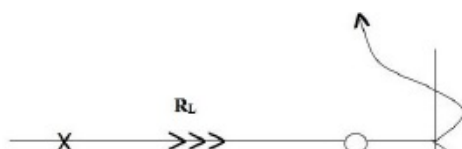
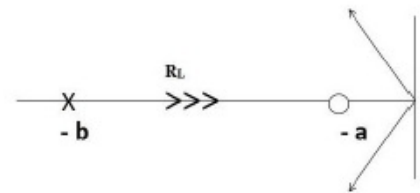
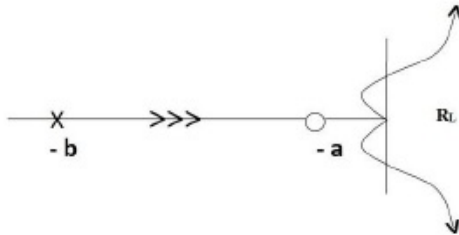



4)

Chosen Option : 4

Q.141

A message signal with its amplitude uniformly distributed between -2V and +2V is transmitted by a 8-bit binary PCM system. The $(SNR)_q$ would be

- 1) 37.8 dB
- 2) 49.8 dB
- 3) 43.8 dB
- 4) 25.8 dB

Chosen Option : 2

Q.142

The resonant frequency (ω_0) of the circuit is, when $R^2 = L/C$ is

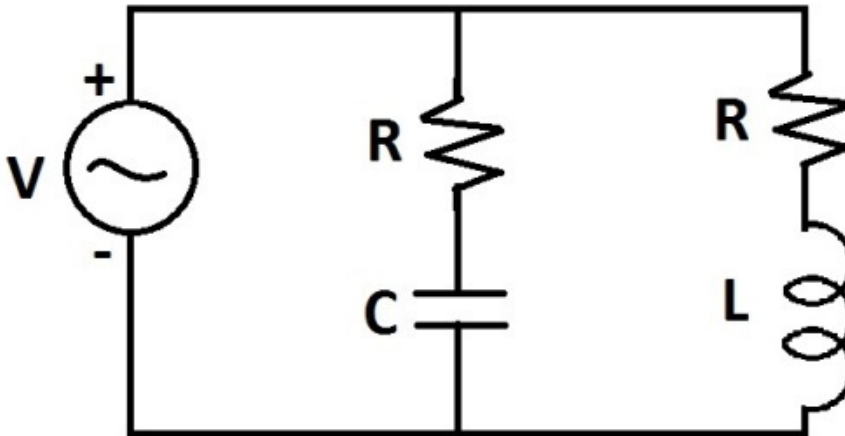

- 1) $\omega_0 = 1/\sqrt{LC}$
- 2) $\omega_0 = \sqrt{R}/\sqrt{LC}$
- 3) enhance of energy between L and C is not possible
- 4) resonate at all frequency

Chosen Option : Not Attempted

Q.143

The even part of a function $x(n)=u(n)+u(-n)$ is ?

- 1) $2u(n)$
- 2) $u(-n)-u(n)$
- 3) $u(n)-u(-n)$
- 4) $u(n)+u(-n)$

Chosen Option : 4

Q.144

Match the statements in right column with the name given in left column and select the correct answer using the code given below the lists

(a) BJT	(i) Has a poly-silicon gate
(b) JFET	(ii) Works only in depletion mode
(c) MOSFET	(iii) Highly sensitive to temperature and is noisy
(d) PIN diode	(iv) Useful at microwave frequencies

- 1) (a)-i,(b)-ii,(c)-iii,(d)-iv,
- 2) (a)-ii,(b)-iii,(c)-i,(d)-iv,
- 3) (a)-iii,(b)-ii,(c)-i,(d)-iv,
- 4) (a)-iii,(b)-i,(c)-iv,(d)-ii,

Chosen Option : 3

Q.145 For a M-ary frequency shift keying, bandwidth required will be given as-----if two signal are 20 kHz separated apart from each other.

- 1) M.40k
- 2) M.10k
- 3) M.20k
- 4) M.80k

Chosen Option : Not Attempted

Q.146 Determine the bandwidth of the FM signal for 5kHz audio signal modulated by a carrier of 50MHz causing a frequency deviation of 25kHz ?

- 1) 60 kHz
- 2) 90 kHz
- 3) 30 kHz
- 4) 80 kHz

Chosen Option : 1

Q.147 Electric field intensity due to the line charge of infinite length is-

- 1) $\rho L / 4\pi \epsilon R$
- 2) $2\rho L / \pi \epsilon R$
- 3) $2\rho L / 4\pi \epsilon R$
- 4) $\rho L / 2\pi \epsilon R$

Chosen Option : 4

Q.148 RC oscillator is basically a –

- 1) Square wave generator
- 2) Pulse generator
- 3) Sinusoidal wave generator
- 4) Triangular wave generator

Chosen Option : 3

Q.149 The characteristic equation of a control system is given as -

$$s^6 + 2s^5 + 8s^4 + 12s^3 + 20s^2 + 16s + 16 = 0 .$$

The number of roots of the equation which lie on the imaginary axis of s-plane are - :

- 1) 2
- 2) 6
- 3) 4
- 4) zero

Chosen Option : 1

Q.150 In a multiplexer, the numbers of selection lines are n. The size of multiplexer is-

- 1) $2^n \times n$,
- 2) $n \times 1$,
- 3) 1×2^n .
- 4) $2^n \times 1$,

Chosen Option : 4