

Solidremote 202U Series Stand Alone Receiver Instructions

Thank you for purchasing Solidremote 202U series stand alone receiver. Familiarise yourself with the following instructions prior to commencing set up. Store this information in a safe place for future reference.

Quick Operation Guide

The 202U series receivers have two relays on board which provide normally open or normally closed contact for controlling virtually any electronic device. Both relays can be programmed to any of three modes – pulse (momentary), hold (toggle) or latching.

Setting Relay Operating Modes

Pulse Mode – Relay contact is active whilst transmitter button is pressed.

Hold Mode – Relay changes state at each press of transmitter button. Hold, Release, Hold, etc. (like an on/off switch).

Latching Mode – Two relays will interact with each other, Relay 1 on then Relay 2 off, Relay 2 on then Relay 1 off. (useful in DC motor forward and reverse control)

DIP Switch 1	ON	ON	OFF	OFF
DIP Switch 2	ON	OFF	ON	OFF



Relay 1	Pulse	Hold	Latching	Pulse
Relay 2	Hold	Hold	Latching	Pulse

> Advanced working modes like timed output, sequenced output (normally used on electric locking devices and automatic doors) and more can be offered meeting a certain order quantity.

Storing Transmitter Code

Make sure to install the battery in the transmitter correctly.

1. Press and hold **PRG1** (for Relay 1) or **PRG2** (for Relay 2) on the receiver board.
2. Press the transmitter button you would like to use to control the device once until SIG flashes then release. (**press transmitter button too long will erase the just-learned code!**)
3. The **SIG LED** will flash quickly three times, indicating that the code has been stored.
4. Release **PRG** button.
5. Press the transmitter button to test operation.

Note: To remove a single transmitter's code from the receiver memory repeat steps 1-5 above. During removing process, the **SIG LED** on step 3 will flash slowly three times (instead of quickly), indicating that the code has been removed.

Deleting All Stored Transmitter Codes

1. Turn the power off to the receiver.
 2. Press and hold **PRG1** button.
 3. While holding **PRG1** turn power on again. After 5 seconds the **SIG LED** will illuminate to indicate receivers memory has been cleared.
 4. Release **PRG1**. All the stored codes should now be deleted.
- Confirm this by pressing the transmitters previously used to operate the device. There should be no response.

Receiver Function Diagram

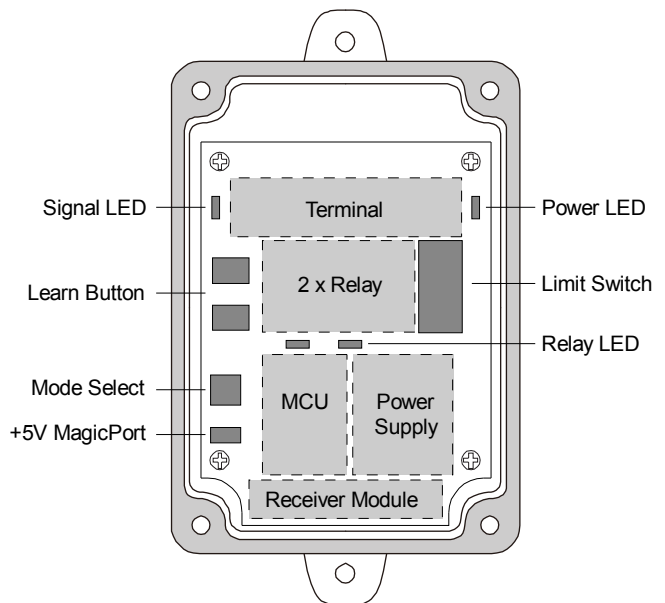

Technical Specifications

- Power Supply: 9V-24V AC or 9V-30V DC
- Frequency: 433.92MHz
- Memory Capacity: 400 Transmitter Channels
- Antenna Impedance: 50 Ohms (RG58)
- Relay Contact Rating: 10A @ 14V DC or 10A @ 120V AC
- Temperature Rating: -4°F to 131°F (-20°C to 55°C)
- Weight: 0.25 lbs. (0.11kg)
- Physical Size: 4.33"L x 2.36"W x 1.37"H (11cmL x 6cmW x 3.5cmH)

Visit solidremote.help if you need help

Basic Wiring Diagram

Since actual wiring may vary depending on different applications, so we just included two simple diagrams below to explain the basic idea.

i Basic electronics knowledge is required, and customer needs to make sure all parts in diagram meets our specifications (for example, light bulb not exceeding 10A), or it may cause unexpected results or damage.

Following examples are using 202U's Relay 1 for wiring, you can use Relay 2 of course, the idea is the same.

Basic connection using separate power supplies

The following is a simple wiring diagram for controlling light bulb on & off using our 202U receiver.

The light bulb is using 110Vac mains power, while our receiver is using 12Vac regulated power through power adapter or battery.

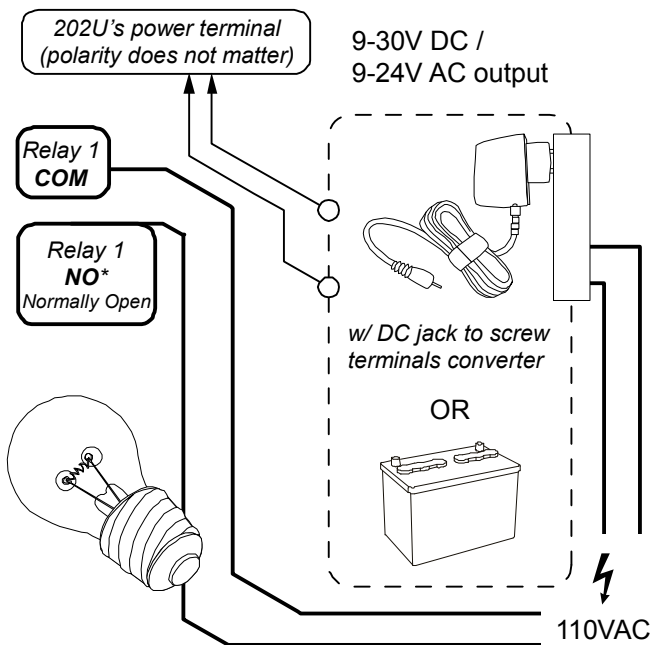

NO terminal means normally open (disconnected to COM), and it will close (connect to COM) when relay is activated (clicks).

When relay activated, the NO is connected to COM internally through onboard relay, the light bulb should be turned on.

Basic connection using same power supply

When the target circuit also uses low power such as 12Vdc (for example, the 12Vdc siren in diagram below), then our receiver can share the same power supply with target device.

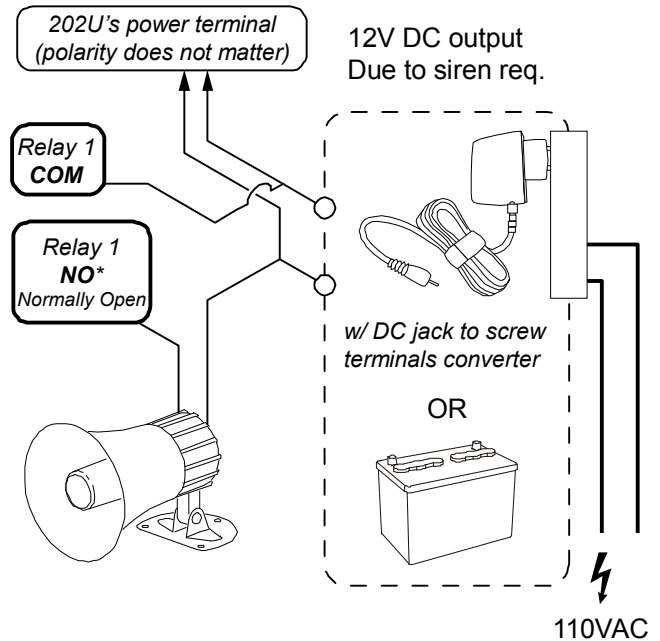

i Shared power sources is not recommended for motor or other electronics which introduce noise into power line. Although 202U doesn't care about polarity, your target device may care, so inspect wiring carefully before power up.

Onboard Limit Switches

LS stands for limit switch, LS1 & LS2 controls relay 1 & 2 respectively, they share a common ground connection, so the 3 blue terminals from up to down can be read as LS1 GND LS2.

For example, when LS1 is connected to GND (by limit switch outside or other sensor) then relay 1 will be forced off, even if remote control tells it to stay on.

Special Notice

The descriptions and illustrations contained in the present manual are not binding. Solidremote reserves the right to make any alterations deemed appropriate for the technical, manufacturing and commercial improvement of the product, while leaving its essential features unchanged, at any time and without undertaking to update the present publication.

Solidremote Technologies Limited

DOCID: SR-RCS-202U-170523 / Printed In China

Visit solidremote.help if you need help