

**MONACO GP AND
INDY 500 REPORTS**

**SOLBERG'S HEARTACHE
FROM THE INSIDE**

**DARIO FRANCHITTI
ON DAN WHELDON**

AUTOSPORT

LEWIS FIGHTBACK BEGINS **Red Bull throws away Monaco victory**

**“Letting him
past was
very painful”
Rosberg**



**ROSSI
TAKES INDY**
ROOKIE SCORES
SHOCK WIN



haymarket
9 770269 946272
22
June 2 2016
UK **£3.80**
CAN \$8.99

ACCELERATE INNOVATION



www.avl.com/racing



SIMULATE



ENGINEER



MAKE



TEST



RACE



Title fight is on, but Daniel deserved more

AS SOON AS IT BECAME CLEAR THE MONACO GRAND Prix would start in the rain, the chances of a fine race increased immeasurably. Wet events are often fascinating, even more so around Monaco thanks to its tight confines.

Not only did the weather make a race that can often be processional in the dry dramatic, it also helped the title fight. Things have generally not been going Lewis Hamilton's way this season, but a fine performance – along with a surprisingly chaotic pitstop from Red Bull – finally suggests the worst may be behind him. And Nico Rosberg's lacklustre drive will not have done Hamilton's confidence any harm either.

One person who it was very easy to feel sorry for was Daniel Ricciardo. The Australian responded brilliantly to the disappointment of seeing Max Verstappen steal 'his' win in Spain with electrifying speed in Monte Carlo. Pace in the wet is often a good barometer of confidence and ability, and Ricciardo was superb in the early stages. He deserved the win and the hope is that Red Bull (and perhaps, eventually, Ferrari?) can continue to take the fight to Mercedes at more conventional venues.

• I feel honoured and privileged to become the 17th editor of Autosport. I've been a reader since childhood, as the magazine has covered motorsport in its many forms, from F1 through to club racing. I hope to carry on the great work of my predecessors.



KEVIN TURNER EDITOR
 kevin.turner@haymarket.com
 @KRT917



COVER IMAGE
 Hone/LAT; Nelson/LAT

COVER STORY

4 Monaco Grand Prix report and analysis

PIT+PADDOCK

- 20** Bianchi family takes legal action
- 22** Growth of the Nurburgring 24 Hours
- 25** Feedback: your letters
- 27** Lawrence Barretto: in the paddock

FEATURES AND REPORTS

- 28** Rossi takes surprise Indy 500 victory
- 34** Dan Wheldon book extract
- 38** Joining Petter Solberg's WRX attack

RACE CENTRE

- 42** WTCC; Nurburgring 24 Hours; Indy Lights; NASCAR Sprint Cup; GP2; Formula Renault Eurocup; Japanese F3

CLUB AUTOSPORT

- 61** Carroll/Attard in new Ferrari for Brit GT
- 62** Drivers survive massive Oulton F3 crash
- 64** Humble Pye: the voice of club racing
- 65** National reports: Silverstone; Oulton Park; Brands Hatch; Castle Combe; Mallory Park; Kirkistown; Anglesey; Knockhill; Rockingham; Gurston Down

FINISHING STRAIGHT

- 78** What's on
- 80** From the archive: Jim Clark, 1967
- 82** Bucket list: drive the Nurburgring

AUTOSPORT SUBSCRIPTION OFFER

- 26** Sign up and get a FREE Ferrari cap

FIND US ON

- autosport.com
- twitter.com/autosport
- facebook.com/autosport
- instagram.com/autosportdotcom/
- youtube.com/AUTOSPORTdotcom
- the Apple App Store
- digitalmagazine.autosport.com
- Apple News



Ricciardo's pain, Hamilt



XPBIMAGES

on's gain

By Ben Anderson, Grand Prix Editor [@BenAndersonAuto](https://twitter.com/BenAndersonAuto)



Hamilton was behind Ricciardo and Rosberg at the safety-car start

EVEN IF YOU DO ABSOLUTELY EVERYTHING RIGHT, YOU STILL NEED A BIT

of luck to win the Monaco Grand Prix. Lewis Hamilton knows that better than most Formula 1 drivers. His only previous triumph around the streets of Monte Carlo came after losing control in the rain and hitting the barrier at Tabac corner in 2008.

Daniel Ricciardo did everything required of him to win the 2016 Monaco GP. He qualified his Red Bull on pole position, dominated the early stages of the race on a treacherously wet track and looked set to claim the fourth win of his burgeoning F1 career.

Yet fortune was not on his side.

At the end of a captivating 78-lap contest around the Principality, it was Hamilton who took pride of place in the winners' circle, finally sparking his stuttering season into life.

But this reversal of fortune was not just about luck. Hamilton drove exceptionally well and a few key decisions by the world champion and his Mercedes team helped put him in position to win when Red Bull threw away its own golden chance. Such a result looked highly unlikely after a qualifying session in which Hamilton's Mercedes was again struck by technical problems.

He started third on the grid, but heavy rain meant the first seven laps were spent behind the safety car, potentially robbing Mercedes of its best opportunity to overturn Ricciardo's pole advantage. This decision also robbed fans of the spectacle of the start, often the most exciting part of a Monaco GP. But that barely mattered, such was the drama that unfolded.

Hamilton looked downcast after yet another Saturday disappointment, but he was fired up for race day — apparent in his

request to race director Charlie Whiting to call off the safety car. "The spray is better now, let's get going!" he urged.

But when the officials complied and the race got under way on lap eight of 78, Hamilton just couldn't release his coiled spring. His Mercedes team-mate Nico Rosberg was struggling badly in second place, dropping 12 seconds to Ricciardo's Red Bull in just eight laps — even though two were spent under virtual safety car conditions after Jolyon Palmer's crash on the pit straight.

So Mercedes decided to enact team orders, telling Rosberg to let Hamilton past. He obliged by pulling over to the left-hand side of the track on the run up Beau Rivage on lap 16.

"The way Ricciardo was pulling away, it was clear that not reversing the situation between Nico and Lewis would definitely lose us the race," explained Mercedes team boss Toto Wolff. "Over the weekend, we have struggled to put the tyres in the right window. We looked at it for a couple of laps and hoped the tyre would switch on, but Ricciardo was 10 or 11 seconds gone. It was almost [like] a damaged car and this is why we decided to make that call. We debated it for quite a long time because it's not what we've done in the past, but it was clear there was a problem."

He added: "If I had Niki Lauda's red cap then I would take it off, because in such a difficult situation to give up the position and



XPBIMAGES



The virtual safety car was deployed when Palmer shunted

understand the global situation was great team play from Nico.”

Once freed from the shackles of tracking his team-mate, Hamilton immediately set the race’s fastest lap as he focused on reeling in Ricciardo’s Red Bull. In response the race leader upped his own pace, but Hamilton took more than two seconds out of Ricciardo’s lead before Red Bull decided to switch its man onto the intermediate tyre on lap 23.

Team-mate Max Verstappen had just begun lapping very quickly on this tyre as the track began to dry out – having stopped to ditch the full-wet rubber on lap 12 – so Red Bull figured this was also the right way to go for its lead driver.

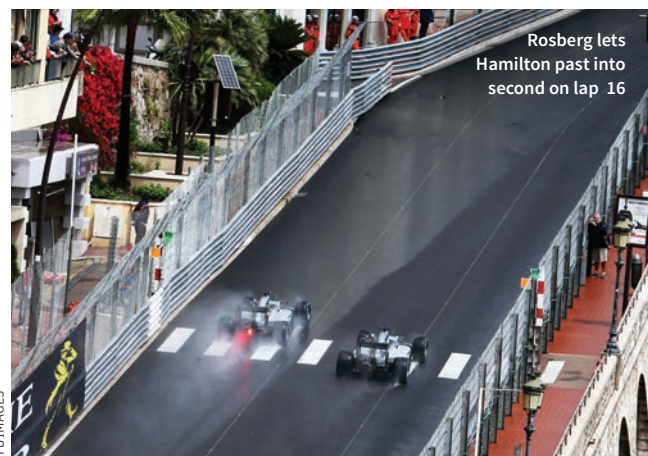

Rosberg lets Hamilton past into second on lap 16

XPBIMAGES

“We could see it was two to three seconds per lap quicker,” said Red Bull boss Christian Horner. “And with the forecast going towards dry conditions, we felt going to the intermediate before the slick would be sensible. We were one of the last to stop for the inters. Lewis elected not to, which looked quite a brave decision.”

This was the second part of Mercedes’ tactical push. Hamilton claimed the lead by choosing to stay out on the full-wet tyre until the end of lap 31, by which point every driver other than Manor’s Pascal Wehrlein had stopped at least once. Hamilton said: “I believed I could eke it out to be able to do just one stop.”

It seemed that Hamilton might become a sitting duck for >>



Ricciardo fury as Hamilton defends lead at the chicane

Ricciardo's rapidly closing RB12. But the reigning champion kept his cool under pressure from behind as he waited for track conditions to improve sufficiently for slicks.

"The only way of attempting a win was to gamble, to stay on the wet tyre," said Wolff. "We had a 28s gap to Nico [in third], and a pitstop is just short of 20s, so we knew there were 10s we could give up. We never needed those 10s, so it was the right call to stay out."

Mercedes switched Hamilton onto ultra-soft slicks at that one and only stop, while Red Bull called Ricciardo in for dry tyres on the next lap. At this point the race unravelled completely for the poleman. He got the call to pit exiting the tunnel on lap 32, but when he arrived the tyres were not ready to fit to his car. Ricciardo lost 10s while the mechanics were frantically searching for the correct set – "running around like headless chooks", as Ricciardo put it.

"Daniel was extremely quick on his in-lap, I think he was about seven or eight seconds quicker than Lewis was on his equivalent out-lap," explained Horner, who reckoned the tight confines of Monaco's pitlane played a part in his team's inability to locate the correct tyres at short notice.

"Having seen Mercedes put on the ultra-soft, which we felt was quite marginal to go to the end of the race, the call was made in plenty of time – or I certainly felt plenty of time for us to go one step harder on compound.

"It was gutting for the team to lose like that – all we can do is apologise to Daniel"

"If we were to come out behind Lewis – it wasn't clear at that point how much up or down he was going to be – we felt that [super-soft] tyre had better range. Based on how we're set up in Monaco, the pitwall is upstairs, the garage downstairs, tyres are on heat both in the garage and behind the garage. There was a scramble, with the mechanics originally having the soft tyre ready. When that change was requested to go to the super-soft, those tyres were actually right at the back of the garage and couldn't be got in time."

When Ricciardo did get back under way, he emerged just behind Hamilton's Mercedes, suggesting the pace of his mighty in-lap was

easily enough to get him back into the lead with a normal stop. It also suggested that Red Bull should have stuck with its original choice, rather than reacting to Mercedes' stop and changing its plan.

"It was gutting for the whole team to lose a victory like that," added Horner. "All we can do is apologise to Daniel that we haven't given him good enough service, having done a great job to get pole.

"Unfortunately this communication error between pitwall upstairs and the tyre-management [people] let us down today. We need to do a full analysis and ensure this doesn't happen again."

To win this race now, Ricciardo would need to do what is usually impossible in Monaco – pass for the lead on the track. His best chance came on lap 37. He got a run on Hamilton coming out of Portier and through the tunnel. Hamilton defended the inside line



XPBIMAGES



XPBIMAGES

but locked up and ran wide through the first part of the Nouvelle chicane. Ricciardo got better drive coming out of the second part and moved right to pass but lost traction on the damp part of the circuit as Hamilton moved across to block his path. With that, the Australian's best chance to retake the lead evaporated in a blur of wheelspin.

"What the f*** was that?!" Ricciardo fumed on the radio. The stewards looked at it, but decided no further action was warranted.

"If he was on his own and made a mistake, fair enough. But he made the mistake though defence and battle," Ricciardo said later. "It was a chance to maybe get the lead, so sure I questioned it." >>

Perez finished third thanks to a precise drive and a great pitstop strategy

QUALIFYING



TEELAT

GIVEN HE'D ALREADY WON THREE GRANDS PRIX BEFORE COMING to Monaco, it seemed odd that Daniel Ricciardo had previously started 93 races without taking a pole position in Formula 1.

He put that right with a sublime performance last Saturday in Monte Carlo, staving off a late rally from Mercedes to put Red Bull back on the front of the grid for the first time since 2013.

Ricciardo was fastest of all after Thursday's practice sessions, so things were already looking very good for the Aussie, but Mercedes and Ferrari both looked back in the hunt heading into qualifying.

Ricciardo was only fourth fastest in final practice, and slower than he was on Thursday, but he turned things around when it mattered, making full use of the RB12 chassis' poise and Renault's upgraded power unit to bag top spot.

A stunning 1m13.622s lap on Ricciardo's first run in Q3 proved enough to get the job done.

"I knew coming into the weekend we had a shot at it," he said. "I've always enjoyed this place. It's a driver's circuit. Sure you need a car to help you out – but confidence can go a long way.

"All season I've qualified well. The race didn't run in my favour in Spain, so I wanted to bounce back."

Team-mate Max Verstappen won at Barcelona but condemned himself to the last row of the grid in Monaco after breaking his right-front suspension by clipping the inside barrier at the Swimming Pool chicane and crashing heavily into the barriers on his first run in Q1.

"A miscalculation," he rued. "You don't want that to happen, especially in Q1 with a car that is comfortably top four..."

There were problems, too, for Ricciardo's main rivals for pole: Sebastian Vettel and the Mercedes drivers.

Both Lewis Hamilton and Nico Rosberg suffered pressure problems from overheating fuel at the start of Q3. Rosberg's was resolved in time for him to complete two unaffected runs but he could only get to 0.169s from Ricciardo.

Hamilton's problem only became apparent as he exited the garage, and the time it took to retrieve the car and correct the issue meant he only completed a single run in Q3. He had to wait four laps avoiding traffic before having a proper go, by which point his tyres were second-hand.

He was fastest of all in the first sector, but dropped nearly a tenth to Ricciardo in sector two and just over four tenths over the final part of the lap, so wound up third fastest. He felt pole was "absolutely" within reach without those setbacks.

Vettel was fastest in FP3 and Q1, so was "really disappointed" to lose grip and rhythm in Q3 and end up fourth, nearly a second down on his former Red Bull team-mate Ricciardo.

"Sure, you need a car to help you out – but confidence can go a long way"



“MY EARS DID NOT SPLIT, THE EARPLUGS CAME OUT”

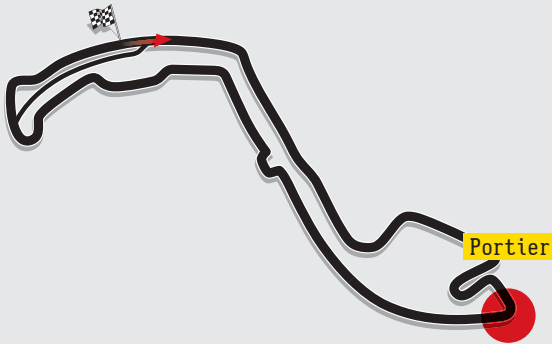

V6 HYBRID-TURBO FORMULA 1 has endured so much criticism for the subdued sound it produces compared with the wailing V8 days, but if there's one place they could possibly sound better it has to be Monaco's tunnel.

So that's where my free-practice journey began – to hear for myself. The experience was disappointing. My ears did not split in the way I expected. So the earplugs came out.

That's better! Monaco's man-made echo chamber really does amplify F1's assault on this sense and

you can better note the differences in tone and pitch between the power units.

These engines are never going to recapture the screaming rapture of F1's past, but my time in the tunnel suggested the stakeholders are right to pursue measures to fully amplify what they have. From there I wandered up to the preceding corner at Portier, to assess the low-speed prowess of the various cars.

There was a noticeable difference in approach between the Mercedes drivers in FP1, Lewis Hamilton taking a much wider line than Nico Rosberg. It's the longer way around, but



McLaren looked tricky through Portier

it opens up the corner, allows him to reduce the understeer effect and carry more speed.

Comparison between Red Bull, Ferrari and McLaren was also interesting. The RB12 looks the smoothest, with the best traction on exit. The Ferrari turns in well but seems to give up a touch at the rear from mid-corner to exit. The McLaren

stops and turns OK, but looks to be breaking traction too easily under power and has way more understeer dialled in to counteract that rear instability.

Fernando Alonso was more at ease with this balance than Jenson Button, just chucking the car in and waiting for the front to bite, manipulating the car into a quicker rotation

almost in spite of itself. Different colours, but it was a throwback to Alonso hustling that Renault to two consecutive world championships a decade ago – the days when F1 screamed through the tunnel, splitting ears instead of just bashing them a little.

BEN ANDERSON





Left: Hamilton takes the lead as delayed Ricciardo exits pits

Above: Hamilton, “better now than in 2008”, celebrates his second Monaco win

Hamilton felt he didn’t really gain an advantage during the incident. Instead, he was fortunate to not run wider and that Ricciardo simply couldn’t get the traction to blast past on the outside. At which point, Hamilton closed the door.

It took Ricciardo a few laps to regain his composure, with his engineer Simon Rennie telling him: “Come on, you’re quicker than him, get your head together.”

Hamilton extended his lead to two seconds before Ricciardo went on the attack again and closed to within striking distance. He got within half a second at the end of lap 44, but then Hamilton upped his pace and they began trading times at the front – Hamilton quicker some laps, Ricciardo others, the track improving all the time.

The chase finally began to unravel on lap 64, when Ricciardo dropped over a second to Hamilton in one lap. That pushed Hamilton’s lead back out to more than two seconds – for the first time since lap 41, when Ricciardo had been raging about Hamilton’s defensive tactics.

Ricciardo regrouped yet again, although a lock-up at Massenet with six laps remaining cost him another second and effectively called off the chase.

“Two weekends in a row now I’ve been screwed,” fumed Ricciardo afterwards. “We were quick in the wet, we had a comfortable lead, pitted for inters, got stuck behind Lewis, and we effectively put ourselves in a race we didn’t need to be in.

“I think I took Barcelona on the chin, but two in a row now. Massively, massively disappointed. It’s not like we’re Mercedes – we’re not able to win a race [on merit at all circuits], so to get it wrong twice now definitely hurts.

“I’m not sure where to go from here. Obviously they [the team] have got to understand what’s going on and learn from it, but this win I’ll never get back. That’s a fact.”

Instead, that win went to Hamilton, moving him back into second place in the world championship standings and closing to within 24 points of Rosberg, who trailed home seventh after

his battles with brake and tyre temperatures.

“People have asked me if I feel relieved, if justice is done. But I honestly came here thinking I’ve just got to go and do it,” said Hamilton. “No

one’s going to give it to me, it’s not going come out of thin air, I’ve got to go and earn it.

“I didn’t know if I could win the race, but knowing that it had rained opened up the window of opportunity. If it was dry, there was probably no chance.

“As soon as it rained I knew, having experienced here in 2008 that anything can happen, I was going to be on it whatever the case. And I’m better now than I was in 2008.”

He’s now a double winner of the Monaco Grand Prix to boot.

Ricciardo will have to wait for his time to come again, having seen his brilliant Monte Carlo performance go cruelly unrewarded. ❄

“I took Barcelona on the chin, but two weekends in a row now I’ve been screwed”



VERSTAPPEN APOLOGISES TO HIS TEAM AFTER TWO CRASHES

SPANISH GRAND PRIX winner Max Verstappen apologised to Red Bull for the two accidents that wrecked his Monaco Grand Prix weekend.

Verstappen crashed at the Swimming Pool complex before he could complete a proper flying lap in qualifying. This resulted in an overnight chassis change and a pitlane start.

After fighting up to ninth in the race, he then smashed into another barrier at the Massenet left-hander heading into Casino Square.

This capped a tough weekend for Verstappen, just two weeks after becoming the youngest winner in F1 history on his Red Bull debut.

"I'm just disappointed in myself because this shouldn't happen," said Verstappen. "I have to apologise to the team because they worked really hard to get the car prepared. I didn't give them the result they deserved, and I'm very sorry for that."

Red Bull team principal Christian Horner expects the 18-year-old to get over the disappointment of Monaco quickly.

"He is a bright, intelligent character and he'll definitely learn from it," said Horner. "I doubt you'll see him make the same mistakes this time next year."



Ferrari misses another opportunity

FERRARI ENDURED ANOTHER DISAPPOINTING RACE in the Monaco Grand Prix, as Sebastian Vettel finished fourth, behind Sergio Perez's Force India, while team-mate Kimi Raikkonen retired with crash damage.

Vettel was fastest in final practice and the first part of qualifying, but struggled for grip in Q3 and ended up fourth. Raikkonen was only sixth fastest and then dropped five places on the grid because of a gearbox change ahead of the session.

Vettel blamed himself for missing out on an opportunity to challenge for victory in the race because he got stuck behind Felipe Massa's Williams after stopping for intermediates.

Further delays behind a group headed by Nico Rosberg's struggling Mercedes then dropped Vettel behind Perez after the later round of stops for dry tyres.

"I'm not entirely happy because even if it was difficult to pass, I still expect myself to somehow pass," said Vettel. "I was

quicker than Felipe but it didn't happen. That is a missed opportunity and I mostly blame myself, but the team did a great job to get us in front of the Mercedes."

Vettel caught Perez in the closing stages and retained hope of fighting for victory, as he thought Lewis Hamilton and Daniel Ricciardo (both running softer tyres) would have to pit again. But this did not happen.

Team-mate Raikkonen scored no points, but escaped sanction for continuing to drive his Ferrari in a damaged condition after a brush with the barrier early on.

Raikkonen's front wing got lodged under the car, littered the track with debris and he inadvertently forced Romain Grosjean's Haas towards the wall.

Stewards ruled Raikkonen was allowed to try to make it back to the pits and stopped in the safest place possible, in the chicane run-off area, once he was told to do so.



Raikkonen retired after sustaining front wing damage

Points leader Rosberg endures 'painful' race to seventh – 93s down

WORLD CHAMPIONSHIP LEADER Nico Rosberg suffered from "a complete lack of confidence" during his lacklustre drive to seventh in the Monaco Grand Prix.

Rosberg cited brake issues as a potential cause for his struggles, while Mercedes team boss Toto Wolff suggested a failure to generate sufficient tyre temperature was also to blame.

Mercedes asked Rosberg to let team-mate Lewis Hamilton past in the rain-hit early laps, as Rosberg lost time to Daniel Ricciardo's leading Red Bull.

Asked whether it was painful to let Hamilton past, Rosberg replied: "It was more painful with the feeling I had in the car. There was a complete lack of confidence in those conditions, and around Monaco that is not good."

"I had to stay well away from the limit because otherwise I would have been in

the wall. At that point I realised, with that feeling, I wouldn't be able to fight to win.

"We are trying to understand it [the lack of pace]. There are already a few things that have come up.

"What we do know is there was a brake issue with the temperatures, quite a large one. It caused problems, but it's too early to say whether that was all of it. It's going to take a bit of analysing."

Rosberg dropped to sixth after his second pitstop. He couldn't get back past Fernando Alonso's McLaren-Honda for fifth. With rain falling again on the last lap, Rosberg lost sixth to Nico Hulkenberg's Force India at the finish line.

"I was on the ultra-soft and he was on the soft; he had loads of rubber left and I had no rubber left," said Rosberg.

"He had more temperature, and with the rain mine were stone cold."



McLaren still believes in chassis despite struggles

MCLAREN-HONDA HEADED INTO the Monaco weekend hoping either to challenge Ferrari or to be the fourth-best team, but it struggled for pace despite Fernando Alonso finishing fifth.

Alonso qualified 10th, behind the Ferraris, Toro Rossos and Force Indias, while team-mate Jenson Button was also beaten by Valtteri Bottas's Williams and Esteban Gutierrez's Haas.

The wet conditions, strategy and problems for rivals allowed Alonso to climb to fifth, while Button finished ninth. But the team was not satisfied.

"I'm not excited; I'm not celebrating," said racing director Eric Boullier, who still believes the MP4-31 is the third-best chassis in F1 on certain circuits and pointed to the GPS data from Monaco as backing up his claim.

"McLaren's ambition is to win. It's good to get the points and to have taken the opportunity, but this is the least you expect from us.

"We need to keep working. We were expecting to be a little bit more competitive this weekend. It has been a difficult weekend."

Q&A

SERGIO PEREZ
FORCE INDIA DRIVER

Was that your best drive in Formula 1 – or certainly the most satisfying?

It's definitely a very special podium. We wouldn't make it to the podium under normal conditions – we don't have the pace to do it. Certainly, in these conditions, it is one of my best races in Formula 1. The conditions were extremely difficult, it's so easy to make a mistake and on every single lap you had to be really focused. You cannot imagine what those damp conditions [are like].

What was the key to this result?

Every stop that we had was key, the first one by delaying it. I was coming into the pits to fit the inter tyre and I asked "how are the inters doing?" The team told me "not that good, it's your call". I decided to go a couple of laps more and that worked really well because we jumped Hulkenberg. Then we came into the pits together with Sainz and my team did a fantastic stop. The decisive moment was the last stop, as by going to the slick tyre one lap before Rosberg and Vettel we managed to jump them. Towards the end, I had pressure from Vettel. I knew it was going to be a very long stint on the softs so I was looking after my tyres, especially in these cold conditions. It worked really well. It is a fantastic result for the whole team. It's like a win.

Is this podium finish another message from you to the top teams in Formula 1?

I hope not only this one. I had a really tough time at McLaren and it seems this is what everyone remembers – no-one remembers my time at Sauber or at Force India. All I can do is keep doing my job, keep doing as well as I can, keep improving as a driver. In the last years I have improved a lot. I am a more complete driver – qualifying, racing, race pace, experience. So if the opportunity ever comes, I will be ready for it.



ERICSSON PUNISHED AS SAUBERS COLLIDE

MARCUS ERICSSON WILL receive a three-place grid penalty for the next race in Canada after colliding with Sauber team-mate Felipe Nasr at Monaco.

Sauber told Nasr to let Ericsson past for 15th place as they chased Pascal Wehrlein and Romain Grosjean in the middle stages of the Monte Carlo event.

Nasr rejected the suggestion and the team-mates collided when Ericsson attempted to pass him on the inside of Rascasse. The resulting damage ultimately forced both cars to retire.

Nasr said he was building tyre temperature and waiting for engine issues to be resolved. He also argued Ericsson had disobeyed similar instructions before.

"There were two occasions last year when Marcus was told to swap positions and he didn't do it," said Nasr. "We have to have confidence inside the team to trust that when an order like this comes it'll be done."

Ericsson said Nasr had ignored the Monaco order for "seven or eight laps" so had to try something. But he apologised to the team for the incident.

"It could have been avoided if orders were followed," he said.

Team boss Monisha Kaltenborn described the clash as "unacceptable".

She spoke to both drivers individually and then together following the race, to remind them of their responsibilities to the Sauber squad.



Palmer suffers heavy crash on main straight

FORMULA 1 ROOKIE JOLYON PALMER CRASHED out of the Monaco Grand Prix on the main straight thanks to losing it on white paint on the track surface.

The race started under the safety car, which had pulled into the pits at the end of the seventh lap to allow racing to start properly when Palmer, who was running 16th, got off line. He lost the rear of his Renault as he drove over a zebra crossing, which spat the car into the barrier on his left.

Palmer's damaged car then skated towards Ste Devote, hitting the barriers in the run-off area.

"The traction was appalling after the safety car and I got caught out," said Palmer, who also crashed twice during practice, first at Tabac on Thursday and then at Swimming Pool on Saturday.

"I had wheelspin in fifth gear on the white line that crosses the track. There was nothing I could do. I was just a passenger and went straight into the wall."



'Aggressive' Kvyat given Canadian GP grid penalty for Magnussen collision

TORO ROSSO'S DANIIL KVYAT WAS hit with a three-place grid penalty for next weekend's Canadian GP after clashing with Kevin Magnussen.

Kvyat was trying to unlap himself after an electrical problem forced him to pit during the early safety car laps. The pair made contact through the Swimming Pool complex, then ended up in the barriers at Rascasse after a second collision.

Kvyat felt Magnussen, whose brush with the barriers at Tabac allowed Kvyat to get a run on him, should have given him more space.

"He blocked me twice very strongly two corners before," said Kvyat. "At the next corner I tried to go on the inside and he blocked me. I couldn't go through the wall so I had to go through him."

Magnussen suggested Kvyat "lost his mind", while Renault racing director

Frederic Vasseur was also unimpressed.

"Kvyat was f***** aggressive," Vasseur said. "He had nothing to win, nothing to lose being two laps behind."

Kvyat retired to the pits, while Magnussen pitted for repairs before crashing on his own at Mirabeau after rejoining the race. This was a result of floor damage from the earlier collision.

Although he returned to the pits, the damage meant he could not continue.

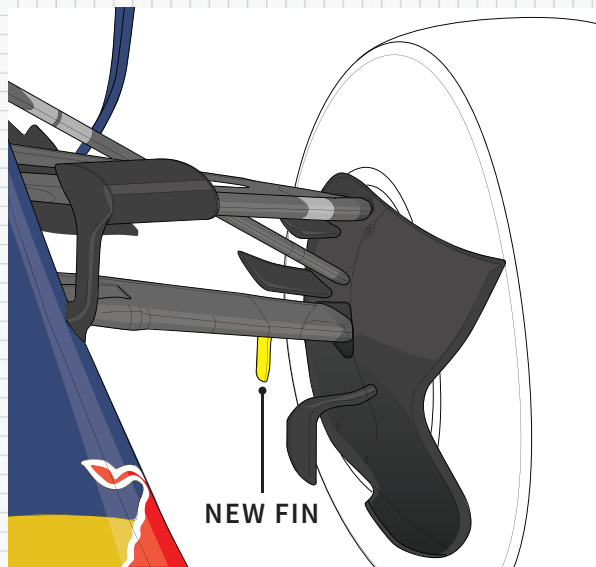

TORO ROSSO 'BRAKE DUCTS'

Toro Rosso ran a cheeky interpretation of the brake duct bodywork rules, where a fin was added to the front lower wishbone. Technically, the wishbones should be symmetrical in cross-section, but this new fin sits inside the 120mm area beside the wheel

for brake ducts, so is considered brake duct bodywork rather than the suspension. This part directs airflow off the front wing around the inner face of the tyre but, unlike the brake ducts themselves, the fin does not turn with the wheel.

MONACO MONKEY BUSINESS

As Monaco is a high-downforce, high-drag circuit, teams have to crank up the rear wing angles. This can lead to airflow separation underneath the steeply-angled undersurface.

To help prevent this, teams fit 'monkey seat'

winglets. These aren't used to generate their own downforce. Instead, they create an upwash airflow to help keep the air attached under the top element of the rear wing.

They fit into a small unregulated window under

the rear wing and are allowed to be 200mm wide.

Many have four or more elements stacked in pairs. Toro Rosso uses a three-element winglet, with slotted sides to expand the beneficial airflow beyond the 200mm limit.

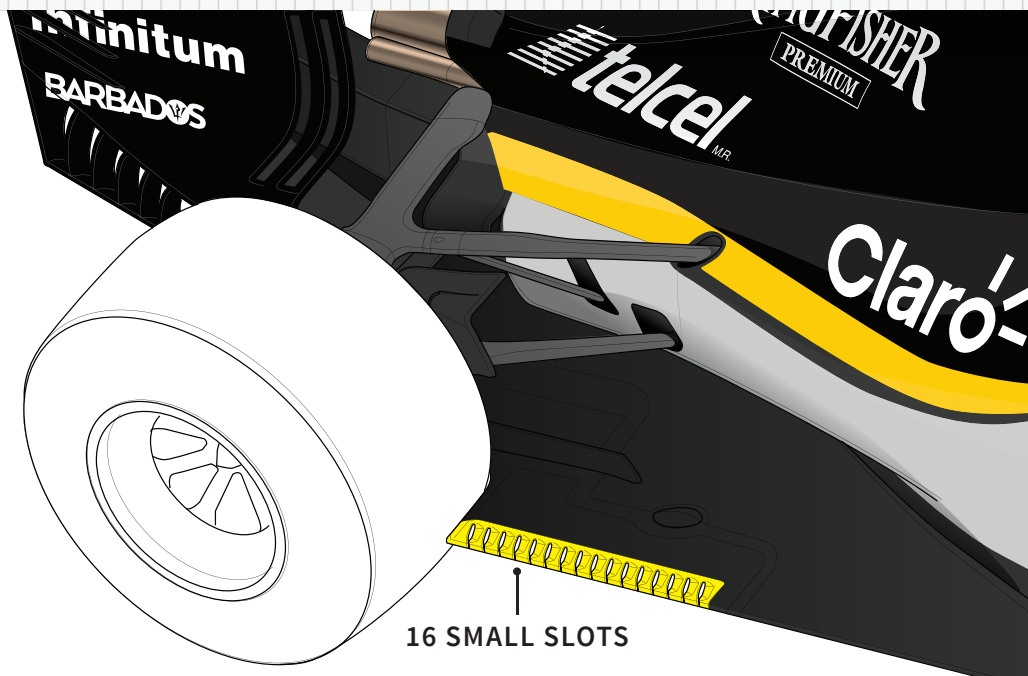
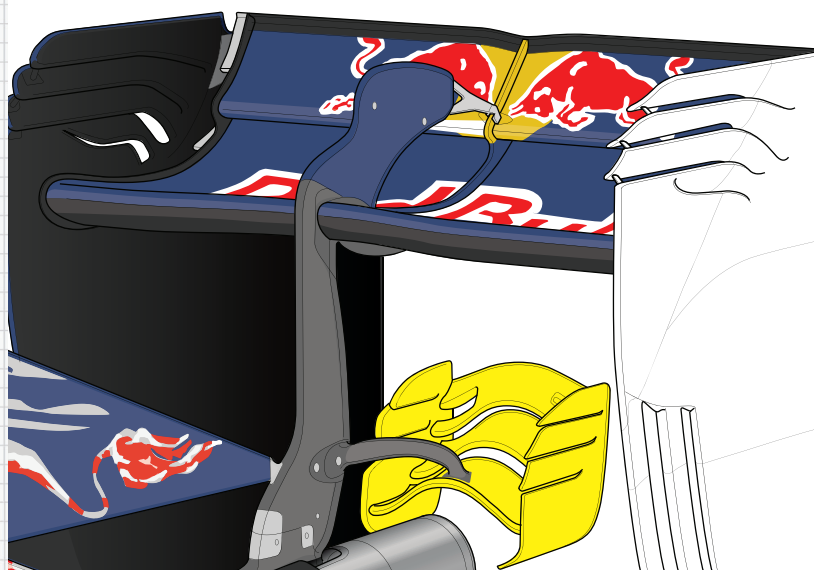

FORCE INDIA'S REVISED FLOOR

As an addition to its major update introduced at last month's Spanish GP, Force India brought a revised

floor treatment ahead of the rear tyres. A series of slots has been added to reduce the turbulence the

rear tyres direct under the floor and into the diffuser. From a simple set of slots before, now there are no

fewer than 16 slots bleeding high pressure above the floor to the inner face of the rear tyre.

ENDPLATES

Red Bull made a major change to its rear wing endplate design, following a direction taken by other teams. The new endplate has three angled strakes and louvres along its bottom. The strakes aid the upwash created around the rear end formed by the diffuser, rear wing and brake ducts. The louvres help pass more airflow through the wing and vent it out into the low pressure area behind the rear tyres. Both steps aid the rear wing efficiency, gaining downforce and cutting drag.

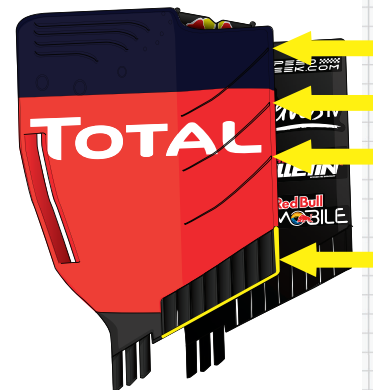

RACE REPORT/RESULTS

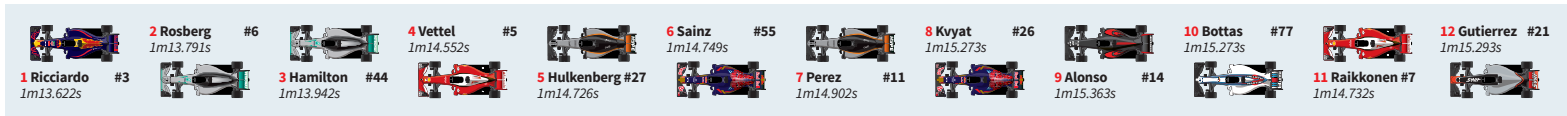

Race results / 78 laps – 161.734 miles

POS	DRIVER	TEAM	FINISH TIME	LED	TYRES	TIME IN PITS
1	Lewis Hamilton	Mercedes	1h59m29.133s	54	●●●	26.315s
2	Daniel Ricciardo	Red Bull-Renault	+7.252s	24	●●●	1m00.381s
3	Sergio Perez	Force India-Mercedes	+13.825s		●●●	51.322s
4	Sebastian Vettel	Ferrari	+15.846s		●●●	50.675s
5	Fernando Alonso	McLaren-Honda	+1m25.076s		●●●	52.348s
6	Nico Hulkenberg	Force India-Mercedes	+1m32.999s		●●●	52.279s
7	Nico Rosberg	Mercedes	+1m33.290s		●●●	54.378s
8	Carlos Sainz	Toro Rosso-Ferrari	-1 lap		●●●	55.850s
9	Jenson Button	McLaren-Honda	-1 lap		●●●	51.216s
10	Felipe Massa	Williams-Mercedes	-1 lap		●●●	50.116s
11	Esteban Gutierrez	Haas-Ferrari	-1 lap		●●●	53.451s
12	Valtteri Bottas	Williams-Mercedes	-1 lap		●●●	1m17.515s
13	Romain Grosjean	Haas-Ferrari	-2 laps		●●●	58.601s
14	Pascal Wehrlein	Manor-Mercedes	-2 laps		●●●	26.517s
15	Rio Haryanto	Manor-Mercedes	-4 laps		●●●	1m22.789s
R	Marcus Ericsson	Sauber-Ferrari	51 laps-collision		●●●	1m26.953s
R	Felipe Nasr	Sauber-Ferrari	48 laps-collision		●●●	1m41.108s
R	Max Verstappen	Red Bull-Renault	34 laps-spun off		●●●	51.063s
R	Kevin Magnussen	Renault	32 laps-spun off		●●●	2m01.514s
R	Daniil Kvyat	Toro Rosso-Ferrari	18 laps-collision		●●●	2m20.225s
R	Kimi Raikkonen	Ferrari	10 laps-spun off		●●●	-
R	Jolyon Palmer	Renault	7 laps-spun off		●●●	-

Fastest laps

POS	DRIVER	TIME	GAP	LAP
1	Hamilton	1m17.939s	-	71
2	Vettel	1m18.005s	+0.066s	62
3	Ricciardo	1m18.294s	+0.355s	67
4	Perez	1m18.446s	+0.507s	64
5	Sainz	1m18.519s	+0.580s	70
6	Rosberg	1m18.763s	+0.824s	74
7	Gutierrez	1m19.131s	+1.192s	69
8	Alonso	1m19.170s	+1.231s	72
9	Massa	1m19.213s	+1.274s	69
10	Bottas	1m19.223s	+1.284s	66
11	Hulkenberg	1m19.232s	+1.293s	74
12	Button	1m19.670s	+1.731s	66
13	Haryanto	1m19.868s	+1.929s	70
14	Grosjean	1m20.219s	+2.280s	65
15	Wehrlein	1m20.372s	+2.433s	60
16	Ericsson	1m21.342s	+3.403s	51
17	Nasr	1m21.889s	+3.950s	46
18	Verstappen	1m26.563s	+8.624s	34
19	Magnussen	1m29.802s	+11.863s	27
20	Kvyat	1m37.895s	+19.956s	14
21	Raikkonen	1m47.149s	+29.210s	10
22	Palmer	1m58.474s	+40.535s	2

WEATHER Wet, drying; track 19C, air 17C ● New ○ Used ● Ultra Soft ● Super Soft ● Soft ● Medium ● Hard ● Wets ● Intermediate

100
Hulkenberg started his 100th world championship F1 race in Monaco

1
Ricciardo's pole position was his first in F1

8
Prior to Monaco, Hamilton had not won in the previous eight races

2
This was only Magnussen's second retirement in 25 GP starts

13,037
Massa passed the 13,000-mark for laps raced in F1 – only the fifth to do so

43
Red Bull ended a run of 43 races without a pole, stretching back to the start of 2014

58
Red Bull's pole drew it level with Mercedes in fifth in the all-time list

Lap chart / What happened, when

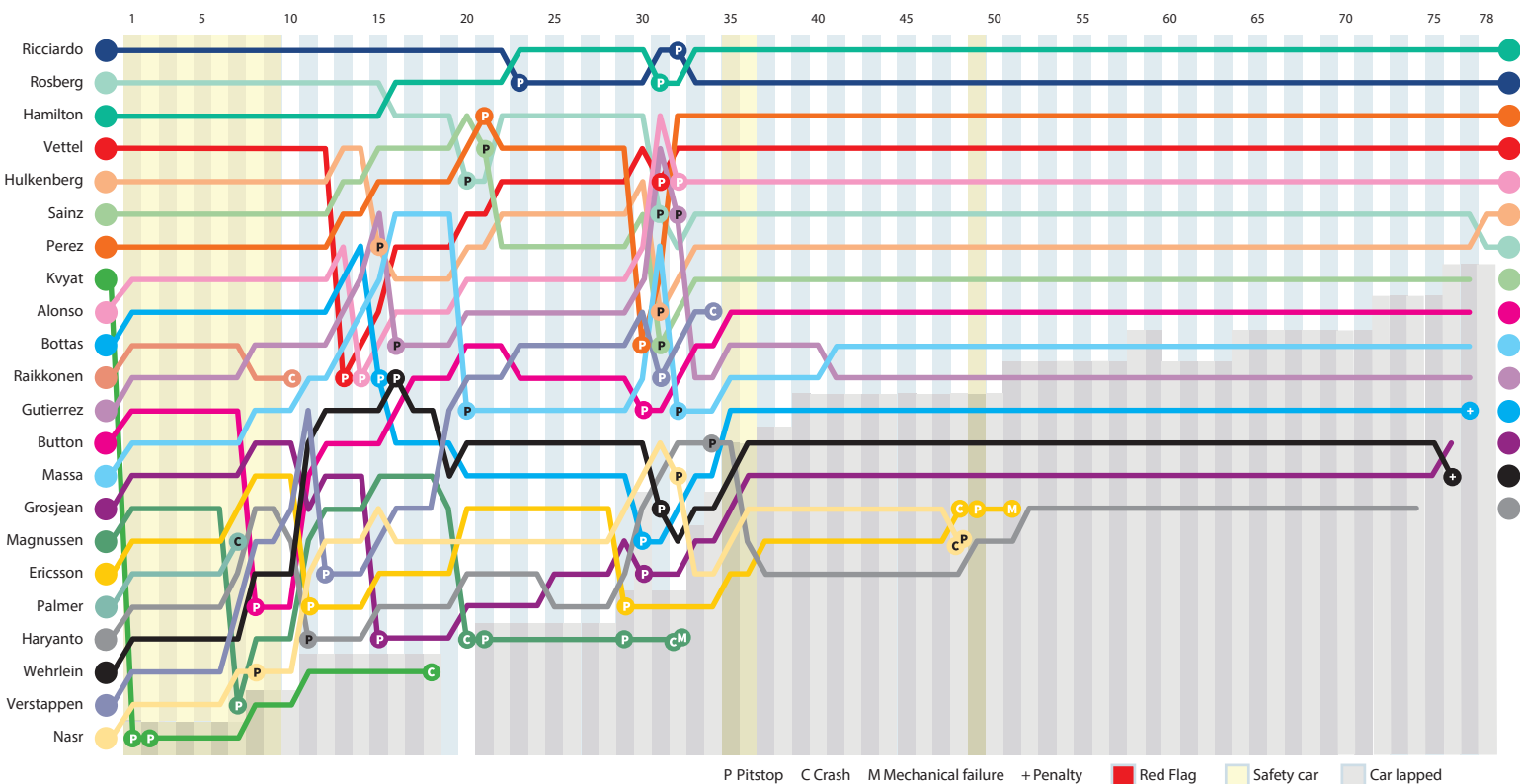



SEASON STATS

Qualifying 1 Qualifying 2 Qualifying 3

POS	DRIVER	TIME
1	Vettel	1m14.610s
2	Hamilton	1m14.826s
3	Rosberg	1m14.873s
4	Ricciardo	1m14.912s
5	Perez	1m15.328s
6	Hulkenberg	1m15.333s
7	Kvyat	1m15.384s
8	Grosjean	1m15.465s
9	Sainz	1m15.467s
10	Raikkonen	1m15.499s
11	Alonso	1m15.504s
12	Bottas	1m15.521s
13	Button	1m15.554s
14	Gutierrez	1m15.592s
15	Massa	1m15.710s
16	Magnussen	1m16.253s
17	Ericsson	1m16.299s
18	Palmer	1m16.586s
19	Haryanto	1m17.295s
20	Wehrlein	1m17.452s
21	Verstappen	1m22.467s
22	Nasr	no time

WEATHER Dry, sunny; track 41C, air 21C

POS	DRIVER	TIME
1	Rosberg	1m14.043s
2	Hamilton	1m14.056s
3	Vettel	1m14.318s
4	Ricciardo	1m14.357s
5	Raikkonen	1m14.789s
6	Kvyat	1m14.794s
7	Sainz	1m14.805s
8	Perez	1m14.937s
9	Hulkenberg	1m14.989s
10	Alonso	1m15.107s
11	Bottas	1m15.273s
12	Gutierrez	1m15.293s
13	Button	1m15.352s
14	Massa	1m15.385s
15	Grosjean	1m15.571s
16	Magnussen	1m16.058s

WEATHER Dry, sunny; track 41C, air 21C

POS	DRIVER	TIME
1	Ricciardo	1m13.622s
2	Rosberg	1m13.791s
3	Hamilton	1m13.942s
4	Vettel	1m14.552s
5	Hulkenberg	1m14.726s
6	Raikkonen	1m14.732s
7	Sainz	1m14.749s
8	Perez	1m14.902s
9	Kvyat	1m15.273s
10	Alonso	1m15.363s

WEATHER Dry, sunny; track 41C, air 21C

Race Briefing

GRID PENALTIES

RAIKKONEN Five-place penalty for a gearbox

RACE PENALTIES

WEHRLEIN 10s penalty for speeding under safety car

WEHRLEIN 10s penalty for ignoring blue flags

BOTTAS 10s penalty for causing collision with Gutierrez

Speed trap

Fastest for each constructor in qualifying

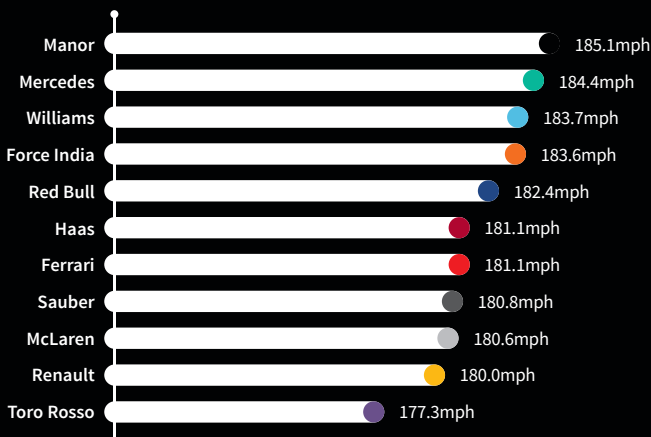

Free practice 1 Free practice 2 Free practice 3

POS	DRIVER	TIME
1	Hamilton	1m15.537s
2	Rosberg	1m15.638s
3	Vettel	1m15.956s
4	Ricciardo	1m16.308s
5	Verstappen	1m16.371s
6	Kvyat	1m16.426s
7	Hulkenberg	1m16.560s
8	Perez	1m16.697s
9	Raikkonen	1m16.912s
10	Sainz	1m17.130s
11	Bottas	1m17.562s
12	Grosjean	1m17.599s
13	Alonso	1m17.838s
14	Gutierrez	1m17.909s
15	Button	1m17.920s
16	Nasr	1m18.187s
17	Magnussen	1m18.274s
18	Ericsson	1m18.301s
19	Massa	1m18.746s
20	Palmer	1m18.871s
21	Haryanto	1m20.528s
22	Wehrlein	1m20.868s

WEATHER Dry, cloudy; track 28C, air 18C

POS	DRIVER	TIME
1	Ricciardo	1m14.607s
2	Hamilton	1m15.213s
3	Rosberg	1m15.506s
4	Verstappen	1m15.571s
5	Kvyat	1m15.815s
6	Sainz	1m15.981s
7	Raikkonen	1m16.040s
8	Perez	1m16.120s
9	Vettel	1m16.269s
10	Button	1m16.325s
11	Hulkenberg	1m16.487s
12	Alonso	1m16.723s
13	Gutierrez	1m16.782s
14	Bottas	1m16.849s
15	Grosjean	1m16.874s
16	Massa	1m17.286s
17	Magnussen	1m17.530s
18	Ericsson	1m17.562s
19	Palmer	1m17.761s
20	Nasr	1m17.999s
21	Haryanto	1m18.647s
22	Wehrlein	1m18.814s

WEATHER Dry, sunny; track 34C, air 19C

POS	DRIVER	TIME
1	Vettel	1m14.650s
2	Hamilton	1m14.668s
3	Rosberg	1m14.772s
4	Ricciardo	1m14.807s
5	Verstappen	1m15.081s
6	Kvyat	1m15.259s
7	Sainz	1m15.324s
8	Perez	1m15.368s
9	Raikkonen	1m15.555s
10	Hulkenberg	1m15.666s
11	Massa	1m16.068s
12	Alonso	1m16.257s
13	Button	1m16.298s
14	Bottas	1m16.347s
15	Gutierrez	1m16.406s
16	Magnussen	1m16.412s
17	Grosjean	1m16.527s
18	Nasr	1m16.867s
19	Ericsson	1m17.038s
20	Palmer	1m17.482s
21	Wehrlein	1m17.595s
22	Haryanto	1m18.180s

WEATHER Dry, sunny; track 33C, air 21C

Drivers' championship

1	Rosberg	106
2	Hamilton	82
3	Ricciardo	66
4	Raikkonen	61
5	Vettel	60
6	Verstappen	38
7	Massa	37
8	Bottas	29
9	Perez	23
10	Kvyat	22
11	Grosjean	22
12	Alonso	18
13	Sainz	16
14	Hulkenberg	14
15	Magnussen	6
16	Button	5
17	Vandoorne	1
18	Gutierrez	0
19	Palmer	0
20	Ericsson	0
21	Wehrlein	0
22	Nasr	0
23	Haryanto	0

Constructors' championship

1	Mercedes	188
2	Ferrari	121
3	Red Bull	112
4	Williams	66
5	Force India	37
6	Toro Rosso	30
7	McLaren	24
8	Haas	22
9	Renault	6
10	Sauber	0
11	Manor	0

Wins

Rosberg	4
Hamilton	1
Verstappen	1

Fastest laps

Rosberg	2
Hamilton	1
Hulkenberg	1
Kvyat	1
Ricciardo	1

Pole positions

Hamilton	3
Rosberg	2
Ricciardo	1

Qualifying head-to-head

ROS	3	3	HAM
VET	3	3	RAI
MAS	1	5	BOT
RIC	2	0	VES
RIC	4	0	KVY
PER	4	2	HUL
MAG	4	2	PAL
KVY	0	2	SAI
VES	3	1	SAI
ERI	5	1	NAS
AL	4	1	BUT
VAN	1	0	BUT
HAR	3	3	WEH
GRO	5	1	GUT

“Fantastic display of aggression”

Red Bull’s Daniel Ricciardo is the star of our Monaco driver ratings

By Ben Anderson, Grand Prix Editor

[@BenAndersonAuto](#)

MERCEDES



9 LEWIS HAMILTON
Looked utterly dejected after more technical trouble stymied his efforts to bag the top spot in qualifying. Third was a decent effort in the circumstances. Knew the wet weather was his best chance to steal victory. Had some help from his team-mate – and Red Bull! But drove superbly to pull off a one-stop strategy.



4 NICO ROSBERG
The recent King of Monaco was finally dethroned this year. Refused to blame fuel-pressure problems for failure to take pole, but pole wouldn’t have helped with his disastrous race pace. The suspicion is unusually cold brakes and tyres caused that. Knew he couldn’t win so helped Hamilton, then slipped further back.

FERRARI



6 SEBASTIAN VETTEL
Looked a potential pole contender after topping FP3 and Q1, but lost his way with tyre temperatures as the track improved in Q3 so wound up only fourth. Should have finished on the podium with Rosberg struggling, but got stuck behind Massa’s Williams after early stop for inters, then jumped by Perez after later stop for slicks.



3 KIMI RAIKKONEN
A terrible GP for Raikkonen. Never looked as comfortable as team-mate Vettel after Ferrari corrected the set-up mistakes of Thursday practice, but shouldn’t have qualified behind a Force India in any case. His race lasted only 10 laps before he locked the rear wheels downshifting for Loews and hit the wall.

WILLIAMS



6 VALTTERI BOTTAS
Thought there was more to be had in qualifying, so failing to make Q3 represented underperformance, even with tricky oversteer. Ran ninth early on, but got stuck behind Wehrlein’s Manor after a problem at his first stop. Charged after Gutierrez at the end, but got penalised for last-lap lunge at Rascasse.



7 FELIPE MASSA
Felt only Red Bull has improved more than Williams at this track compared to last season, but trailed team-mate Bottas with oversteer in qualifying, which he said cost him traction in the final sector. Bagged the final point, helped by the Raikkonen/Grosjean tangle before Portier and pass on Gutierrez.

RED BULL



10 DANIEL RICCIARDO
Harnesses the strength of the Red Bull chassis and improved power and driveability of the new Renault engine to bag his maiden pole in F1 with a fantastic display of controlled aggression on Saturday. Did everything right on Sunday too, but was undone by Red Bull’s pitstop blunder.



5 MAX VERSTAPPEN
F1’s youngest race winner came back down to Earth with hard bumps against Monaco’s unforgiving guardrails. Loses several marks for crashing at the Swimming Pool on his first Q1 run, when more margin is naturally available to faster cars. Made a superb recovery to ninth in the race, but then crashed again...

FORCE INDIA

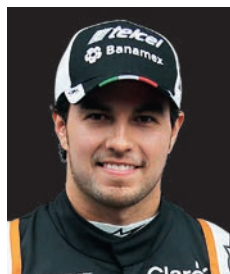

8 SERGIO PEREZ
Wasn’t happy on Thursday and his struggles continued into qualifying, where he got within two tenths of Hulkenberg but was braking earlier than in FP3 and still locking up. Key to a surprise podium result was a late stop for intermediates, plus pitstop misfortune for Sainz and Vettel’s struggles in traffic.



8 NICO HULKENBERG
This weekend was much better after tough recent run. Superbly outpaced Raikkonen’s Ferrari in qualifying. Poor strategy and a tardy second stop undid Hulkenberg’s race. Kept getting stuck behind slower cars. Won a drag race to the line with Rosberg for sixth, but knows a podium chance went begging.

RENAULT



5 KEVIN MAGNUSSEN
Armed with the other updated Renault engine. But he struggled, crashing in FP2 and only just edging out Marcus Ericsson’s undeveloped Sauber to squeak into Q2. Got involved in unnecessary scrap with lapped Kvyat in the race, was smashed off at Rascasse, then shunted again thanks to resultant car damage.

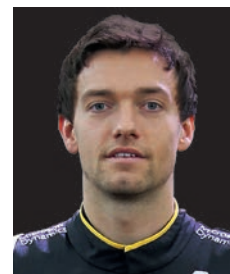

3 JOLYON PALMER
Palmer crashed twice in practice and struggled with the Renault’s “snappy” balance. Was just over three tenths off Magnussen in qualifying, two of which he put on his lesser-spec engine. Further crash on the pit straight after safety-car start ended his race early. Lost the rear over a zebra crossing.



Ricciardo drove away early on as Rosberg struggled in second

TORO ROSSO

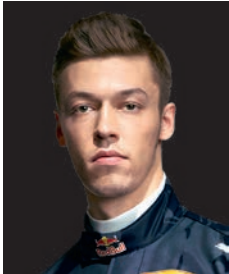

4 DANIIL KVIAT
Was the faster Toro Rosso driver in qualifying until a “big underperformance” in Q3. Was furious to find his car stuck at constant speed for the start of the race and lost his cool again when Magnussen got his elbows out. Got a Canada grid penalty for taking the Renault out at Rascasse. Needs to stay calm in the car.



8 CARLOS SAINZ JR
Would ordinarily have been delighted to come so close to outqualifying a Ferrari, but was a little frustrated to get upstaged by Hulkenberg’s Force India, feeling he could have extracted the few necessary hundredths from the car. Drove well in the race, but was undone by two slow pitstops.

SAUBER



4 FELIPE NASR
Looked to be the faster Sauber after practice, but only made it as far as the tunnel in qualifying before his engine blew. Refused team orders to let Ericsson past in the race, which triggered implosion. Suggested Ericsson has refused orders in the past, but following Rosberg’s example might have been wiser.



4 MARCUS ERICSSON
Was rightly happy with his driving in qualifying, where he split the Renaults and came within 0.046s of beating both. Was the faster of the two Saubers before his collision with Nasr. Attempt to pass looked clumsy rather than malicious, but taking team orders into his own hands means he has a costly grid penalty.

McLAREN



7 JENSON BUTTON
Was fractionally slower than Alonso in Q1, but couldn’t “get the tyre back” after locking up at Massenet in Q2, where he ended up 0.245s behind his team-mate. An early stop for inters compromised his chances of a better result in the race. Got stuck behind Wehrlein, then overtaken by Verstappen.

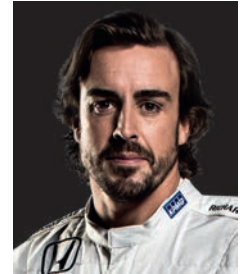

9 FERNANDO ALONSO
Seemed the more comfortable of McLaren’s two drivers with the chronic understeer that plagued the MP4-31, and hustled it to his second top-10 qualifying slot in succession. Was fast on intermediate tyres and produced a quick in-lap to jump Rosberg at the second round of stops. Then expertly held on.

MANOR



3 RIO HARYANTO
Maintained focus amid uncertainty over his future and outqualified team-mate by 0.157s. A good start. The wet part of his race was respectable, but he fell away badly after switching to slicks. Lost tyre temperature moving aside for blue flags and was very slow. Pitting improved his pace, but the damage was done.



7 PASCAL WEHRLEIN
Drove a feisty race on his first visit to Monaco, executing a Hamilton-esque stint on wets to mix it with faster cars. After pitting for slicks, Wehrlein remained ahead of Grosjean’s delayed Haas. Held it at bay, but two penalties (for speeding under the virtual safety car and ignoring blue flags) did Grosjean’s job for him.

HAAS

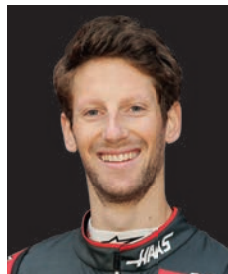

5 ROMAIN GROSJEAN
Was a superb eighth in Q1 but blamed traffic for his session unravelling. Reckoned points were possible without Raikkonen’s broken Ferrari delaying him. Lost a chunk more time to a slow first stop for intermediates. From the very back he was able to overtake one of the Manors but not the other.



6 ESTEBAN GUTIERREZ
Sat out a chunk of first practice with an electrical problem, but come qualifying he found a decent groove and did well to outpace both Button’s McLaren and Massa’s Williams. His race was less impressive. He looked decent in the wet, but struggled for pace on slicks and lost his hold on the final point to Massa.

TOP 10 AVERAGE RATING

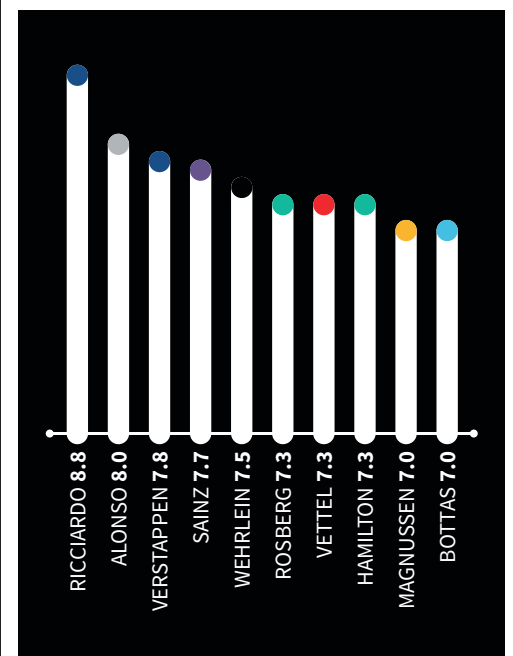



The FIA explaining Bianchi's crash a week after it happened
Left to right: Charlie Whiting, Jean Todt, Jean-Charles Plette and Dr Ian Roberts

FORMULA 1

FIA, FOM and Marussia

TWENTY MONTHS HAVE PASSED SINCE Jules Bianchi's crash in the 2014 Japanese Grand Prix, which ultimately led to his death in July last year. Following a period of grieving, Bianchi's parents, Philippe and Christine, have launched legal action against the FIA, Formula One Group and the Marussia team Bianchi drove for.

The family has appointed one of the UK's leading litigation-only law firms, Stewarts Law, to take the action under the 'Justice for Jules' banner. Pre-action letters have been sent to all three parties explaining why the family feels the actions of one or more of them, among others, might have contributed to the accident.

The letters invite the recipients to accept errors were made in the planning, timing, organisation and conduct of the race, which it is claimed took place in dangerous conditions during the typhoon season in Japan.

The recipients will be expected to respond to explain their actions and to indicate whether they dispute the claims.

This is the first step in what could be a long-drawn-out battle that may take years to settle if the Bianchi family does not receive the apology they feel they deserve from all concerned.

This course of action has not been taken lightly, especially when you consider the friendship that existed between Bianchi and FIA president Jean Todt, whose son Nicolas was the young Frenchman's manager. Both Todts were among the hundreds of mourners who attended Jules' funeral at Nice cathedral just over 10 months ago.

The main cause of the Bianchi family's concerns with what happened is the 396-page report issued by the FIA Accident Panel that examined the circumstances of Bianchi's crash at the Suzuka circuit. They feel it unfairly points an accusing finger at their son, and that there were others responsible for his death who should be held accountable.

Julian Chamberlayne, a partner at Stewarts Law, said: "It was surprising and distressing to the Bianchi family that the FIA panel in its conclusions, whilst noting a number of contributing factors, blamed Jules."

"The Bianchi family are determined that this legal process should require those involved to provide answers and to take responsibility for any failings."

Notably, the report suggested Bianchi



face Bianchi family legal action

did not slow sufficiently to avoid losing control at a part of the track where double-yellow flags were being waved. The yellows were on show as Adrian Sutil's Sauber had aquaplaned off the track in deteriorating wet conditions a lap earlier while running just behind Bianchi. His car was being removed by a recovery vehicle, a 6500kg Caterpillar mobile crane.

As a summary of the report noted, "if drivers adhere to the requirements of double yellow flags... then neither competitors nor officials should be put in immediate or physical danger".

It was also suggested Bianchi "over-controlled the oversteering car" before ploughing underneath the rear of the crane, sustaining a severe diffuse axonal injury to the brain that led to him being placed in a coma for nine months prior to his death.

The report also declared there to be "no apparent reason why the safety car should have been deployed before or after Sutil's accident".

Crucially with regard to Marussia, with Bianchi applying throttle and brake together,

using both feet, "the FailSafe algorithm designed to over-ride the throttle and cut the engine, was inhibited by the torque co-ordinator".

That controls the rear brake-by-wire system, but as Bianchi's Marussia "had a unique design of the system, it proved to be incompatible with the FailSafe settings".

It was suggested that as the FailSafe did not cut the engine torque requested, "it may have affected the impact velocity".

One complication with regard to the legal claim against the team is that since the accident it is now in the hands of new owners and been renamed Manor.

If no apology is forthcoming then they are more than willing to pursue the matter through the courts and, as such, you cannot then escape the fact that there may be financial repercussions.

It is understood that any financial recompense would go to a charitable organisation set up by Bianchi's parents in memory of their son, and which supports young and aspiring drivers.

Philippe Bianchi said: "As a family, we have so many unanswered questions and feel that Jules' accident and death could have been avoided if a series of mistakes had not been made."

The FIA and the team have so far issued no public responses, although Graeme Lowdon, who was Marussia's sporting director at the time, remarked: "I have said in the past that I always have been, and always will be, very supportive of the Bianchi family."

Representing the Formula One Group, Ecclestone said the Bianchi family "will do what they have to do", declining to expand further.

It is unique that the FIA and the Formula One Group are being pursued in such a way following the death of a driver. But there is a precedent in F1.

In 1975 Mark Donohue was killed during practice for the Austrian Grand Prix after the left-front tyre blew on his car. Citing negligence, the family successfully sued tyre supplier Goodyear and Donohue's team, Penske, receiving a \$9.6 million settlement after the initial ruling went to appeal. The case, however, took just under 11 years to settle.

IAN PARKES

"As a family, we have so many unanswered questions"

WHY FORMULA E NEEDS CALENDAR IMPROVEMENTS

THERE WILL BE NO London race in Formula E's third season, but the championship has bigger scheduling concerns as it nears the end of its second campaign.

Last week, a judicial review concerning the Battersea Park round was dropped, paving the way for the season-two finale to take place on July 2-3 – in return for the series not going back to the venue in the future.

While a race on the streets of London is in the pipeline for 2018/19, no replacement is forthcoming for Battersea.

A 2016/17 campaign without the British capital is not FE's only issue, though. Double-headers in New York and Montreal are high-profile planned additions to a heavily revised calendar proposal. But FE needs to be wary of compromising the championship as a whole in the pursuit of individual events.

The planned 12-round, 14-race calendar for season-three begins on October 9 in Hong Kong, has a gap before Marrakech on November 12 and a two-month wait until the third race in Mexico City on January 28.

FE cannot realistically expect to keep building momentum with such delays between races.

Likewise, fans want calendar timing they can rely on. We know, for instance, that the Le Mans 24 Hours is held in mid-June and the Monaco Grand Prix takes place late in May.

FE must make the most of its contrast with the traditional motorsport calendar and take advantage of the quiet months when Formula 1 isn't dominant.

It wasn't possible to adjust the 2016/17 calendar, FE boss Alejandro Agag says, because Hong Kong was locked into early October. So season four must start in November or December and blitz the first three months of the new year. A bigger off-season is not as much of a problem as making a big deal out of the start of a campaign and then waiting eight weeks for the next race.

FE almost exclusively uses street circuits, so piecing together a calendar is difficult.

Patience early on was crucial, now it needs to learn lessons quickly. The series is one of motorsport's few growth areas, but it needs a sensible structure.

Going to the right places is important, but it's no good planning big individual events without a proper championship built around it that people can get excited about.

SCOTT MITCHELL

The rise of the Nordschleife

Why the Nurburgring 24 Hours is becoming an increasingly significant event on the calendar

N

ORDSCHLEIFE VETERANS CALL THE NURBURGRING 24 Hours the ultimate challenge for the mind, Le Mans winners insist it's an essential target and the world's mightiest racing car manufacturers are ramping up their involvement. And the race is growing exponentially in popularity and significance.

Eight manufacturers brought works-backed efforts to last weekend's event, while Porsche had 37 cars.

With organisers ADAC retaining the multiple-class format that allows privateers to enter such cars as Opel Mantas and Renault Clios against the mighty GT3s, and a pit garage system that wedges six cars in double garage bays (evoking the delightfully chaotic sight of factory and privateer teams sharing fuel bowsers), the event carries a unique carnival feel not seen anywhere else.

"As a driver, once you have passed into a level of fitness, racing is all in the mind – and this place stresses the mind more than anywhere else," says Falken Motorsports Porsche 991 GT3R driver Peter Dumbreck.

"When you get it wrong here, the tendency is you are going in the wall. I suppose it is the ultimate thrill. The cars are reliable so the weak point becomes the weather and the driver, but it ultimately ends with the driver."

With an estimated 250,000 crowd and a 159-car entry, manufacturers are ever more interested in the event. So it is inevitably changing.

"More GT3 cars in the race ultimately means it's safer because it means there are fewer amateurs out on track, but it also means that it has become far more competitive," says Dumbreck.

"Twenty years ago, when it was more of a club event, you could have a fairly decent car that was reliable. You wouldn't have to push it to 100 per cent and you could still finish on the podium. Now, it is like a sprint race."

Le Mans 24 Hours winner Earl Bamber was only able to complete competitive laps in practice in the Manthey Porsche, as team-mate Nick Tandy crashed on the second lap. But it was enough to convince him the N24 is among the most important races to have on his CV.

"I love this place," he says. "It is one of the most amazing tracks in the world. What I like about it is that you have consequences here. If you make one small mistake you generally destroy the car. I don't like how so many tracks now there is zero penalty for a mistake."

Next year will be Dumbreck's 14th attempt at winning, but he knows that here, of all places, every lap of experience counts: "What you learn is to instinctively have this feeling for what is going to happen next. You're trying to read how much the flag marshal is waving his flag; when it rains – and it will rain – you're trying to work out when to switch between dry and wet lines. In the end, you just have to keep your mind open, accept what is going on with the car and just try and learn."

SIMON STRANG





JAGUAR'S FIRST TEST The new Jaguar Formula E powertrain had its first on-track test at Mallory Park last week, with a mystery driver at the wheel. The British manufacturer is returning to motorsport with a factory programme in 2016/17. The car completed a meaningful number of laps with a testing livery incorporating the #JaguarElectricifies hashtag. The livery is set to be unveiled at the Battersea Formula E finale on July 2/3

WORLD TOURING CAR CHAMPIONSHIP

Verdict floors Honda

THE HONDA TEAM HAS BEEN EXCLUDED from the Hungarian and Moroccan World Touring Car Championship rounds after its flat floor was deemed illegal.

Debate about the floor first surfaced at the Hungaroring, when three of its parts were investigated by FIA technical delegate Emanuel Leal and the stewards. Without enough time for a proper examination, the stewards concluded the investigation, signing it off as compliant.

A second investigation was then opened after Friday scrutineering in Marrakech, although news of that was not made public until Sunday evening. The findings confirmed that the results of that weekend and Hungary would remain provisional.

A convention of stewards was on call at the Nurburgring last Thursday, with its review of Leal's post-competition technical reports and submissions from Honda and Zengo concluding that the floors were illegal. This led to it losing its results, including Rob Huff's win in Morocco.

The floor was judged to differ from the homologated version, and the materials used in its construction did not match the FIA's definition of a composite. The parts in question are the "flat floor 2015-front section A complete", "flat floor 2015-front section B complete" and "rear hatch B".

"They are different to the part featuring in the homologation form extension A-5747 210/07 ER, as well as to the parts presented during the homologation inspection, breach of articles 263.003 and 263.004 of the Appendix J," the stewards' statement read.

"Their construction is not in compliance with the definition of composite applicable at the time of the homologation of the extension A5747 201/07 ER (article 251.2.1.11

of the Appendix J) breach of article 263.902 of the Appendix J."

Honda introduced a different floor for the third round of the season in Hungary. This version retained the same dimensions as the previous specification, but its construction pattern was altered.

This made the floor heavier, with the extra weight reducing the car's centre of gravity and improving its stability.

This also allowed the weight to be distributed better throughout the car – an added advantage when carrying success ballast, some of which can effectively be 'carried' in the floor.

The JAS Motorsport-run team reverted to its original floor for qualifying and the two races at the Nurburgring.

Honda is keeping its cards close to its chest, but has appealed the ruling. It is potentially facing a lengthy (not to mention expensive) legal process, so does not want to jeopardise any part of its defence. But it strongly believes its interpretation of the regulations is correct.

Proving the composites are compliant should be the easier part of Honda's defence. But the homologation question will be decisive. Articles 263.004 and 263.003 of Appendix J refer to the conditions of use and conformity of parts in relation to their homologation.

Article 263.003 states "unless explicitly permitted by the present regulations, the modification of a homologated point is forbidden", while the following article states that a car must conform with the present regulations, its group A homologation form and its Super 2000 kit variant homologation form and its homologation extensions.

JACK COZENS

IN THE HEADLINES



CODEMASTERS REVEALS F1 2016 DETAILS

The first details of the F1 2016 game have been released by Codemasters. A 10-season career mode has been reintroduced, with players now able to create their own driver character. The safety car also returns, along with the incorporation of the virtual safety car.

RED BULL TEAMS GET 2017/18 ENGINES

Red Bull and Toro Rosso will both run latest-specification Renault engines in 2017 and 2018. The teams will be free to badge the engines as they wish, meaning Red Bull could continue to use the TAG Heuer brand.

THREE TOKENS SPENT BY RENAULT

Renault spent three development tokens on its recent G1 engine upgrade, claimed to be worth up to 0.5s per lap. Red Bull and the works Renault team had one new unit each, which were used by Daniel Ricciardo and Kevin Magnussen during the Monaco GP weekend.

SAUBER AND FORCE INDIA COMPLAIN

Sauber and Force India have written to the FIA and Bernie Ecclestone to complain that engine cost-cutting measures have not gone far enough. Engine deal costs will be reduced by €1 million (£0.76m) next year, and then by a further €3m from 2018 through to '20.

MALDONADO CHASING F1 RETURN

Pastor Maldonado is speaking to a number of Formula 1 teams about a return to the grid in 2017 after losing his Lotus/Renault seat over the winter. "We have started conversations with teams and we are trying to negotiate something for next year," said the 31-year-old.

DI GRASSI WANTS FACTORY SUPPORT

Formula E championship leader Lucas di Grassi says his Abt Audi Sport Formula E team needs factory support from the Volkswagen Group "as soon as we can". Abt has represented Audi in the DTM for more than a decade and brought the manufacturer into Formula E as an affiliate, but Di Grassi believes more is needed to stay competitive.

HALO GETS GO-AHEAD FOR 2017









The Mercedes-conceived 'halo' design, trialled by Ferrari in pre-season testing, is set to be introduced next year. A modified version of the concept is understood to be more streamlined than the one seen earlier this year (below). Its introduction is dependent on it passing further safety tests on June 24.





Congratulations to AB Motorsport and Jack Sycamore who proved to be the Mazda MX-5 master with a hat-trick of victories at Croft and takes overall championship lead.

Be part of the winning team

-  **Arrive & Drive**
-  **Race Day Support**
-  **Track Day Hire**
-  **Driver Coaching**
-  **Race Car & Engine Builds**
-  **Rolling Road**
-  **Body & Paint Shop**
-  **Driving Experience/Corporate Days**



**For more information contact the team at
info@ab-motorsport.co.uk Ali Bray 07891 896779
Jack Sycamore 07814 106240**

ab-motorsport.co.uk

 **@abmotorsport76**

 **ABmotorsport76**

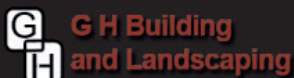

FEEDBACK

Max has already earned his spurs



Alberto Ascari, Juan Manuel Fangio, Jack Brabham, Graham Hill, Niki Lauda, and Sebastian Vettel. Multiple world champions all, but not a Formula 3 title between them.

Have none of these “earned their spurs” Mark Bennett (*Autosport* letters, May 26 issue)?

Motorsport is not the Football League. There is no automatic promotion or relegation (although the latter might be an interesting discussion to be had). The efficacy of different teams and cars (and budgets) in all formulae varies, so you cannot definitively say so-and-so is a better driver than his rival based purely upon championship positions.

Has Max Verstappen earned his place in F1? That’s a no-brainer.

Phil Oakes
Portishead, Bristol

We need more like Max

I really disagree with the Mark Bennett letter published last week. It is people

like Max Verstappen who turn the sport around and even upside down.

Remember Kimi? He came to an F1 drive with only one year in single-seaters and he, like Max, had no big money behind him. Unlike Jolyon Palmer, who has spent six years in single-seaters, and Lewis Hamilton, who spent five years in single-seaters, before winning their opportunities.

Palmer and Hamilton both had enormous budgets supporting them. So I say bring it on Max and let’s have more like you.

John Biggs
Cambridge

Well done Monaco marshals

As an ex-marshall (retired), previously at Silverstone for over 25 years, I was very impressed with the Monaco GP marshals’ tireless energy to have to brush up numerous dings before and during the race.

Congratulations to them. As for Red Bull, you need to brush up on

Verstappen and Monaco: both worthy of their spots in F1

yours comms problem that lost the race for Daniel and the team. Change the string and/or the tin cans on your intercom system!

We look forward to another Canadian GP in two weeks’ time.

Patrick Wickham
By email

Monaco deserves its place

While some may say Monaco is no longer worth its place on the Formula 1 calendar – the glitz and glamour overtaking the true aspect of racing and tight confines of the circuit preventing any meaningful action from taking place – I say that’s far from the truth.

Monaco surely remains the ultimate challenge, not just from a driving but also a technical and logistical perspective. We also need to celebrate and preserve not only its true heritage but also that of like-minded venues.

In recent years, state-of-the-art venues may have appeared on the scene but a lot of them seem soulless in comparison. It’s true that F1 should be seen in the context of a global world championship but that shouldn’t mean that its true heartlands are taken away.

Monaco, along with Silverstone, Monza and Spa, above all else just scream F1 and that’s why they should remain.

Michael Brierley
Stalybridge, Cheshire

HAVE YOUR SAY, GET IN TOUCH

Autosport editorial
Bridge House
69 London Road
Twickenham
TW1 3SP

@
E-mail
autosport@
haymarket.com

Twitter
twitter.com/
autosport

f
Facebook
facebook.com/
autosport

FREE

SEBASTIAN VETTEL OR KIMI RAIKKONEN FERRARI CAP

WHEN YOU SUBSCRIBE TO

SUBSCRIBE ONLINE AT

www.themagazineshop.com/asp/as616m

QUOTE THE PROMOTIONAL CODE

AS616MP FOR PRINT ONLY OR
AS616MW FOR PRINT AND DIGITAL ACCESS.

OR CALL US ON 0344 848 8817

VETTEL

Official Ferrari 2016 Replica Vettel cap. Velcro strap closure at back with number '5' on curved peak. Puma logo and red and green stripe detail. Scuderia Ferrari patch on right side. From the new 2016 Ferrari team wear line.



RAIKKONEN

Official Ferrari 2016 Replica Raikkonen cap. Velcro strap closure at back with number '7' on flat brim. Puma logo and red and green stripe detail. Scuderia Ferrari patch on right side. From the new 2016 Ferrari team wear line.



PRINT SUBSCRIPTION ACCESS
+ FREE GIFT

UNLIMITED ACCESS FOR JUST AN EXTRA £6.25



- ✓ SPREAD THE COST – PAY JUST £34.99 EVERY 13 ISSUES BY DIRECT DEBIT
- ✓ GREAT SAVING – 29% ON THE COVER PRICE
- ✓ FREE P&P – EVERY ISSUE DELIVERED TO YOUR DOOR

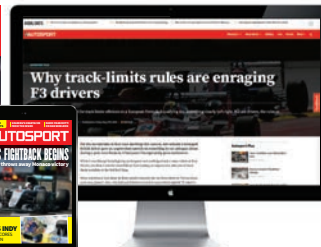

- ✓ FULL ACCESS TO autosport.com PLUS SAVE UP TO 53% ON THE COVER PRICE
- ✓ AUTOSPORT iPad EDITION SUBSCRIPTION
- ✓ AUTOSPORT DIGITAL MAGAZINE SUBSCRIPTION

TERMS AND CONDITIONS This offer is open to UK residents only. Overseas rates are available on +44 (0)1604 251 451. Please allow 35 days for delivery of your first issue. Direct Debit rates are valid for one year after which they are subject to change – should prices change we will inform you in writing. Should you wish to cancel your subscription it will be cancelled on expiry of the current term which will not be refundable, other than in exceptional circumstances. If your subscription includes access to autosport.com and the Autosport digital magazine, you can set-up your Autosport online account by visiting www.autosport.com/subs/magazine.html. You'll need to enter your activation code (your subscriber number) along with your email address to access your content. You will be emailed instructions on how to gain access to your iPad edition within 24 hours of your order being processed. Details of the Direct Debit Guarantee are available on request. The gift will be sent under separate cover from the magazine and will not be dispatched until your first payment has cleared. Should we run out of gifts, you will be offered an alternative gift – there is no cash alternative. Savings are based on the standard UK cover price of £3.80 and £2.99 for the digital price. **Offer ends July 11 2016.**

Haymarket Media Group Ltd uses a best-practice layered Privacy Policy to provide you with details about how we would like to use your personal information. To read the full privacy policy please visit our website www.haymarket.com/privacy or call us on 0344 543 8035. Please ask if you have any questions as submitting your personal information indicates your consent, for the time being, that we and our partners may contact you about products and services that will be of interest to you via post, phone, e-mail and SMS. You can opt-out at ANY time by emailing the datacontroller@haymarket.com or by calling 0344 543 8035.



Drivers should race

Formula 1 drivers don't often compete in other categories, but it could help them – and the popularity of the sport

By Lawrence Barretto, F1 Reporter

[@lawrobarretto](#)

ALEXANDER ROSSI'S SHOCK VICTORY IN THE INDY 500 was yet more proof that drivers with Formula 1 experience can race in other motorsports and enjoy success.

When Romain Grosjean was quizzed about the possibility of competing in a one-off NASCAR race, an idea Haas is working to make reality, a smile crept across his face. The Frenchman is keen. Why wouldn't you be? It's the chance to drive another racing car in an immensely competitive series.

Daniel Ricciardo is up for it too, having been given an open invite from Dale Earnhardt Jr to drive a JR Motorsports car on a road course. Lewis Hamilton got behind the wheel of a Chevrolet Impala NASCAR at Watkins Glen as part of a promotional car swap day with Tony Stewart back in 2011 and said he too wants to give it a proper go one day. Sergio Perez admitted last month that he fancied a shot at the Indy 500, though only once his F1 career was over.

But Nico Hulkenberg entering Le Mans last year during the season was a rare scenario. So why is that the case?

The obvious answer is time. Back when the likes of Mario Andretti and Sir Jackie Stewart were criss-crossing the Atlantic to compete Stateside alongside their F1 programmes, there were far fewer races on the calendar.

With 21 GPs this year, plus in-season and pre-season tests, there are few weekends when there aren't any races, let alone clashes. The Indy 500 clashed with Monaco (and long gone are the days an F1 driver would – or could – skip a world championship race to compete in the American classic), while this year's edition of Le Mans is on the same weekend as the European GP in Baku.

There are options. The Watkins Glen NASCAR round takes place on August 7, which falls nicely in the F1 summer break. The other non-oval is Sonoma, and that doesn't clash either.

But, as Grosjean pointed out, his wife probably won't be pleased that on one of the few weekends he has free, he's off to America. It wouldn't just be for one weekend, either, as Grosjean wants to do it properly. He wants enough time to get familiar with the car and the team he is working with.

Another reason is that they don't have to. Stewart and Andretti were picking up races in other series to earn more money. Nowadays, F1 drivers get paid quite handsomely.

There are also potential health issues through overworking. Stewart came down with a case of mononucleosis, a debilitating disease that sucks away your energy, in 1971 as a result of a busy workload that involved more than 80

transatlantic flights when racing in F1 and Can-Am.

There are also the practicalities of such a scenario. The Stewart-Haas Racing NASCAR team fields the maximum four cars permitted. The chances of Kevin Harvick, Kurt Busch, Stewart or Danica Patrick moving aside for Grosjean are remote. But entering him at another team is a possibility and SHR has an affiliation with midfield squad Scott Motorsports.

There is also the issue of contracts, which are far more complex these days. Drivers have deals to race full-time in F1 – Hulkenberg doing Le Mans last year was the exception not the rule – and their commitment must be to the team and to their sponsors. Should a one-off deal happen, it will be tricky to align sponsor interests of both series and the driver.

Formula 1 bosses may not be so keen because it considers NASCAR, IndyCar and Le Mans to be threats, but the reality is that it would only be a benefit.

There seems to be willingness from America to make it happen, evidenced by the potential Grosjean NASCAR outing. IndyCar driver Scott Dixon did Sebring and will race at Le Mans

too, for example. Hulkenberg was unable to defend his Le Mans title because a calendar shift forced a clash. It's time for F1 bosses to loosen the shackles.

I'm not saying drivers should try to balance two championships and overwork themselves. F1 should rightly be their main

focus. But a one-off race would be very cool and not have a detrimental effect in the grand scheme of things.

Remember the buzz when Valentino Rossi got behind the wheel of a 2008-spec Ferrari on GP2 tyres at Barcelona and got within 0.1s of Kimi Raikkonen's 2008 pole time (though conditions and car configurations were different)?

F1 is desperate to break America – Bernie Ecclestone wants six races Stateside. Putting an F1 driver in its most popular motorsport series would boost awareness of F1 and combine with efforts made by the United States GP and the Haas F1 squad.

Haas is planning to bring Busch out to the European GP for the inaugural race in Baku to give him an insight into the F1 world. That could be one step towards putting him in a car for a test or promo run. The interest in America would be huge.

In light of falling viewing figures across all forms of TV – globally F1 saw a drop of 25 million in 2015 – F1 needs to embrace opportunities that will capture fans' imagination.

It won't be easy to make it happen, but the best things in life rarely are. 🏁

“One-off races are cool, and have no detrimental effect”



ABBOTT/LAT

Rookie Rossi's risk pays off

A seemingly impossible fuel strategy paid off for the F1 reserve driver on his first Indy 500 start after a dramatic event

By Bruce Martin, IndyCar Correspondent

🐦 @BruceMartin_500

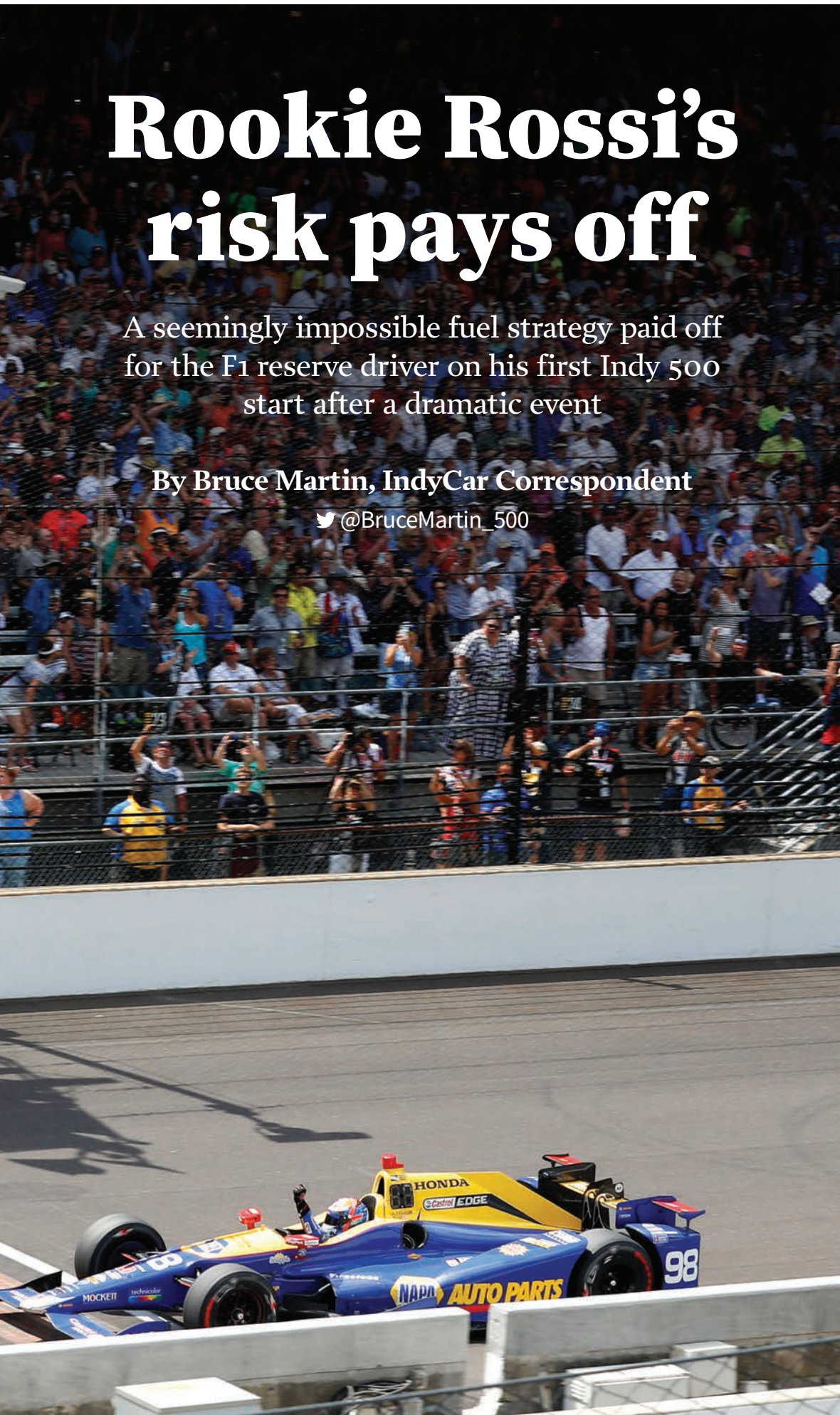

After decades of acrimony and controversy over the direction of the sport, last Sunday's 100th Indianapolis 500 restored the event to all of its grandeur and glory. And it was a 24-year-old rookie — a reserve driver for Manor in Formula 1 — who ended up being chosen by speed, strategy and fate to win America's greatest race.

Alexander Rossi stretched his final tank of fuel for the last 36 laps around the 2.5-mile course to score a stunning victory in his first race on a high-speed oval and only the second time he has ever competed on an oval. Earlier this year, Rossi finished an unimpressive 14th on the Phoenix International Raceway.

It was a dramatic finish to a race held under sunny, hot and very humid conditions in front of the first sellout crowd in over 20 years, estimated at 350,000 fans. It was also the first time since 1950 that Central Indiana residents could watch the Indy 500 on live TV.

Rossi's effort is a partnership between team owners Michael Andretti and Bryan Herta, who won the 100th Anniversary Indianapolis 500 in 2011 with the late Dan Wheldon.

To take victory, Rossi had to make a bold fuel strategy work. "I can't overstate how hard it was for Alex to do what I was asking on the radio," said Herta. "To drive to a fuel number that was almost impossible, but still keep pace and keep track position. We had a few debates about it, but he kept pushing, he kept digging. He did exactly what we asked."

Rossi ran out of fuel heading to the chequered flag but had enough of a lead to defeat Carlos Munoz by 4.5 seconds.

Rossi started 11th but quickly passed several "big-time cars" and said the notion that he could win first entered his mind, "probably lap five, if I'm honest. I was overtaking big cars so I knew we had the opportunity to go forward.

"There were a couple setbacks, pitstops that put us back. Every time we fell back, we were able to come forward. I knew we were strong, the pace was there, we were able to pass cars, follow cars."

Rossi had got out of pitstop sequence by six laps earlier in the race when he topped off his fuel tank after his first stop was followed by a caution. He hit the front for the first time on lap 122 on a restart when he passed Alex Tagliani and was also back in front for laps 129-137.

Even by losing downforce levels from the floor of the car with the addition of a "domed skid" that raised the ride height by a half-inch, the racing was just as fierce as in recent years. There were 54 lead changes between 13 drivers.

Most of the race featured 2014 Indy 500 winner Hunter-Reay, polewinner James Hinchcliffe, Josef Newgarden >>



WILLIAMS/LAT

and Townsend Bell up front.

Hunter-Reay and Hinchcliffe swapped the lead 14 times in the first 28 laps, and it was 47 laps before the first yellow flag slowed the field for debris in Turn 2. Most of the drivers pitted during the caution but Team Penske's Will Power pulled out and pushed Tony Kanaan's Ganassi car into the pitwall. Power was penalised for avoidable contact and sent to the back of the field.

The first proper crash in the race involved last year's winner Juan Pablo Montoya, who lost control in Turn 2 and smacked the wall on lap 64. "The car was just hard to drive and it was a little bit tighter there in that corner and it got away," said the ex-F1 racer.

Helio Castroneves took the lead for the first time on lap 92 and inserted himself as a prime contender for the win. Similarly, Sage Karam worked his way up to sixth place after starting 32nd and went three-wide in Turn 1 in a battle for position. The move didn't work and Karam crashed hard into the south chute between Turns 1 and 2.

On lap 117, after Mikhail Aleshin had crashed, two of the top Andretti

Autosport contenders were involved in a three-car crash leaving the pit area. Castroneves was in the fast lane out of the pits when Bell ran into him, bounced off and into Hunter-Reay. Instead of battling for the lead, Bell would finish 21st and Hunter-Reay 24th.

Hunter-Reay: "They said, 'Go, go, go!' It looked like Townsend got into Helio and bounced into me. At that point I would have just waited until they got by. As a driver you can't see anything. When you're released, you go. The car was so strong. The only time we ever spent any time [slower] was because I was saving some fuel. Other than that, it was a rocketship."

With the laps winding down, Castroneves had high-speed contact with JR Hildebrand and damaged the left-rear wheelpod, causing it to flop around. The Team Penske driver was in danger of being black-flagged before he caught a break when Takuma Sato hit the wall in Turn 4 and brought out the yellow flag.

The pits were opened one lap later and that allowed the three-time Indy 500 winner to come into the pits and replace the entire rear-wing assembly.

Above: Hinchcliffe leads at the start, but ended up seventh after leading for 27 laps

Michael Andretti (right) never won as a driver, but has four Indy wins as an owner

Afterwards, he pointed the finger of blame at Hildebrand: "I felt a bump and basically that put us in a situation that was almost impossible to come back. I'm really, really upset. Especially in a race that is so important and for someone who races once [Hildebrand is only slated to run in the 5000 – I can understand it if it's someone who's fighting for the lead – but, come on, it's ridiculous."

Hildebrand accepted that his role in the contact ruined any chance for Castroneves. "I've got to apologise," he said. "It starts to get really dicey when you don't know if you need to go to the outside, if you need to go to the inside, guys are running inside and outside."

"He stayed put longer, so I changed direction, caught him and flipped him on the bumper pod. I feel really bad about it. I know it screwed up his race. He deserves another serious shot, but at the end of the day it's so close out there."

Kanaan, Newgarden and Munoz traded the lead before having to pit, while Rossi drove to the finish without making a final stop. Kanaan pitted on lap 192 and Hinchcliffe on lap 195. Munoz led Rossi by 13 seconds, but one lap later Munoz



had to pit and that gave the lead to Rossi. He now had the hard task of saving fuel while maintaining a pace to stay ahead.

On the white-flag lap, Rossi led Munoz by 13.4s but Rossi was running out of fuel. He slowed in Turn 3 and the crowd rose to see if he could make it to the finish. As he came out of Turn 4, he went to the low side of the track and coasted to the line in a dramatic finish.

"It's amazing," said team boss Andretti. "At the start of the race, it looked really good. Ryan and Townsend were running really good up front. We thought they were going to be the guys to beat in the end. Unfortunately they had their problem in the pits there, which I could not believe. At that point I thought our day might have been over for a shot at winning.

"All of a sudden I watched the way Carlos and Alex were coming up through. After that last pitstop, I knew that Alex was going to try it. We had two cars that had a shot at winning with two different strategies, so to come home one-two is just incredible. My hat is off to Bryan Herta. He was the strategist there.

"Alex did an awesome job at saving fuel, to the point where he's pulling >>

ANDRETTI'S NEW INDY LUCK

MICHAEL ANDRETTI IS ONE OF THE MOST successful drivers in Indycar history, but none of his wins came in the Indianapolis 500.

Andretti holds the all-time record of most laps led by a driver who never won the 500, with 431. But for all of the 'Andretti Adversity' that plagued the son of 1969 Indy 500 winner and 1978 Formula 1 world champion Mario Andretti as a race driver, he has achieved incredible success as a team owner.

Alexander Rossi's 2016 victory was the fourth time a driver for Andretti's team finished with the wreath around his neck and a chance to drink the traditional bottle of milk.

The late Dan Wheldon took Michael Andretti to Victory Lane at Indy in 2005 – a season that would also include the championship. Dario Franchitti drove Andretti's car to rain-shortened success in '07. Two years ago, Ryan Hunter-Reay won a thrilling duel over Helio Castroneves in the second-closest finish in 500 history.

Andretti became a four-time Indy 500 winning team owner on Sunday in a most dramatic and unusual way when Rossi stretched his fuel mileage for the final 36 laps of the race.

The 53-year-old admits winning as a team owner is not quite the same as it would have been as a driver: "As a driver, there is that thing that you are the one that made it happen. You know what you did is the biggest part of it. As a team owner, it's a total team effort so it is completely different.

"It's no fun that I didn't win Indy as a driver. It's life, though. It's the biggest race in the world but you have to have everything go your way to win the race. For whatever reason it never worked

out for me but I won seven races at Toronto. I raced better at Indy than I did at Toronto."

His driving disappointments have been rewarded as a team owner. Consider that since 2005 Andretti has won more Indianapolis 500s than Roger Penske in that period – four wins to three.

Shortly after Rossi won, Andretti and his wife were gleefully heading down pit road to Victory Lane. "It's really crazy," Andretti said. "They did a great job with their strategy. I'm so happy and proud of them and excited. It was unexpected. I'm shocked. It still hasn't sunk in yet."

Andretti's smiles were in sharp contrast with his gloom-and-doom predictions after an IndyCar open test at the Indianapolis Motor Speedway in early April when teams used domed skids for the first time. They were deployed to keep the cars from going airborne when they go sideways, but the move also made the cars harder to drive in racing conditions.

There was a fear among drivers and a few team owners that it would dramatically affect the racing; that cars would not be able to race close to each other because the downforce lost from the undertray would have to be replaced with the wings.

Andretti was among the loudest critics. But the event featured some outstanding racing, with 54 lead changes.

"Yeah, I guess I was wrong," Andretti said with a smile after Sunday's win.

For a man whose driving career included frowns after every Indianapolis 500 he competed in, Andretti's team-owner career at Indy has given him plenty of reasons to smile.



IN THE HEADLINES



LEPAGE/LAT

PAGENAUD'S LEAD ON THE SLIDE

After winning three races in a row, Simon Pagenaud (above) was never a factor in the Indianapolis 500. He started eighth and finished 19th. The Team Penske driver saw his points lead trimmed to 57 over Scott Dixon, who finished eighth. With double points awarded for the race, in addition to qualifying points, Pagenaud has 292 to Dixon's 235 after six of 16 races.

NASCAR SHOWS ITS RESPECT

The 100th Indianapolis 500 was a celebration of international motorsport as NASCAR chairman Brian France and many of his top officials were on pitlane and the starting grid for the race. NASCAR often does its best to overshadow the Indy 500 but not this year. NASCAR Hall of Fame driver Mark Martin attended his first Indy 500, as did longtime NASCAR crew chief Frankie Stoddard and former Michael Waltrip Racing president Ty Norris.

CHAMP CRASHES TO LAST PLACE

It was "First to Worst" for Juan Pablo Montoya. Last year's Indy 500 winner finished 33rd after crashing his Team Penske Chevrolet into the Turn 2 barrier on his own on lap 64. Montoya became just the third reigning 500 winner to finish last at Indy, joining Jimmy Bryan in 1959 and Johnny Rutherford in 1977.

HONDA ECONOMY TAKES THE DAY

Honda extended its record to 11 Indianapolis 500 victories. Hondas have always been known for their exceptional fuel economy and Alexander Rossi stretched his final tank of fuel for a full 36 laps to the chequers – four more laps than any other competitor.

CHILTON 'LEARNED SO MUCH'

Ex-Formula 1 racer Max Chilton (below) started 22nd and finished 15th. "It was a long race," he said. "I learned so much out there today. It's the craziest start of a race I've ever done. There are moments where you're hanging on for your life."



ABBOTT/LAT

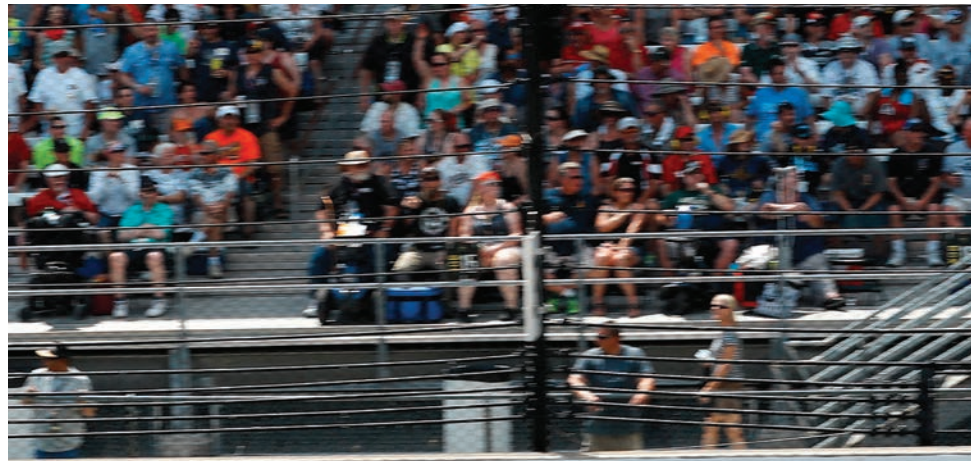

ABBOTT/LAT

in the clutch and coasting. To be a part of history, to win the 100th running, to win it with a one-two finish, is incredible."

Rossi was just as amazed: "I still don't know how it happened. I'm still on the last lap actually with Bryan yelling at me. He is like, 'Pull the clutch in and coast'.

"I was sputtering out of Turn 4. But I was afraid, so I just pulled in the clutch anyway. It was close.

"The emotional rollercoaster of this race is ridiculous. There were moments where I was stoked, moments where I was heartbroken, moments where I was stoked again. I need to see a psychiatrist after this!"

Munoz started fifth but quickly became a threat, leading four times. Just as Rossi pitted out of sequence, so did

Munoz, helping him take second despite having to stop with four laps to go.

"I knew I didn't have enough fuel," Munoz said. "I don't know how my teammate did it without stopping. If I'm honest, I want to know what he did. But it was a close one. I think me and Newgarden had the win, we were so strong. I cannot say I'm really happy; I'm just really sad and disappointed."

Newgarden started in the middle of front row and led four times, for 14 laps. He too was disappointed with one of the 'wrong' steps on the podium.

"It's really heartbreaking, to be honest," said the Ed Carpenter Racing man. "The reason is because I think we had a car to win. What I wanted was an opportunity to try to race those guys at the end. We

Bell is wheeled back after his clash in the pits with Hunter-Reay



COBB/LAT



Newgarden (21) and Kanaan (10) finished third and fourth

didn't get that. That's no fault to my guys. I think that's just how the race fell."

Without a caution in the final 35 laps, Kanaan's last pitstop came under green-flag racing 16 laps from the finish. He thus finished fourth.

Charlie Kimball finished third in last year's 500 and backed it up with a fifth this time. He started 16th but dropped as low as 21st before finding the speed following his second pitstop. He fought his way to fourth, only for Kanaan to pass him on the final lap.

"I hit a really big piece of debris," said Kimball. "It actually got lodged in the suspension in one of the earlier accidents, so we finished with a back-up front wing and a hole in the floor. We came in multiple times to get all the debris out of the sidepod."

As each driver spoke of their Indy 500 disappointment, Rossi was trying to put into words how a kid that started a path to F1 when he was just 10 years old had pulled off a win in the Indy 500. And now that he has a win in the world's biggest race, will he defend it next year?

"I'm not in a grand prix car anytime soon," he said. "I'm a reserve driver. I sit around and pretend to look important. There is no driving involved."

What Rossi could be involved in is a new era for the 500. Organisers are hoping it is a golden opportunity to reintroduce the 500 to fans who have been away for 20 years, and to attract a new generation who may have got hooked on Sunday's frantic action. ❄



Rossi made history as the winner of the 100th Indy 500

RESULTS ROUND 6/15, INDIANAPOLIS (USA), MAY 29 (200 LAPS – 500.000 MILES)

POS	DRIVER	TEAM/CAR	TIME	GRID
1	Alexander Rossi (USA)	Andretti Herta Autosport/Dallara-Honda	3h00m02.0872s	11
2	Carlos Munoz (CO)	Andretti Autosport/Dallara-Honda	+4.4975s	5
3	Josef Newgarden (USA)	Ed Carpenter Racing/Dallara-Chevrolet	+4.9304s	2
4	Tony Kanaan (BR)	Chip Ganassi Racing/Dallara-Chevrolet	+10.4963s	18
5	Charlie Kimball (USA)	Chip Ganassi Racing/Dallara-Chevrolet	+10.5218s	16
6	JR Hildebrand (USA)	Ed Carpenter Racing/Dallara-Chevrolet	+11.3459s	15
7	James Hinchcliff (CDN)	Schmidt Peterson Motorsports/Dallara-Honda	+12.7744s	1
8	Scott Dixon (NZ)	Chip Ganassi Racing/Dallara-Chevrolet	+15.1607s	13
9	Sebastien Bourdais (F)	KVSH Racing/Dallara-Chevrolet	+21.0613s	19
10	Will Power (AUS)	Team Penske/Dallara-Chevrolet	+21.5171s	6
11	Helio Castroneves (BR)	Team Penske/Dallara-Chevrolet	+22.1015s	9
12	Oriol Servia (E)	Schmidt Peterson Motorsports/Dallara-Honda	+23.8140s	10
13	Marco Andretti (USA)	Andretti Autosport/Dallara-Honda	+24.9700s	14
14	Graham Rahal (USA)	Rahal Letterman Lanigan Racing/Dallara-Honda	+28.2494s	26
15	Max Chilton (GB)	Chip Ganassi Racing/Dallara-Chevrolet	+28.7589s	22
16	Jack Hawksworth (GB)	AJ Foyt Enterprises/Dallara-Honda	+32.1748s	31
17	Alex Tagliani (CDN)	AJ Foyt Enterprises/Dallara-Honda	+32.1993s	33
18	Pippa Mann (GB)	Dale Coyne Racing/Dallara-Honda	-1 lap	25
19	Simon Pagenaud (F)	Team Penske/Dallara-Chevrolet	-1 lap	8
20	Gabby Chaves (CO)	Dale Coyne Racing/Dallara-Honda	-1 lap	21
21	Townsend Bell (USA)	Andretti Autosport/Dallara-Honda	-1 lap	4
22	Matthew Brabham (USA)	Team Murray (KVSH)/Dallara-Chevrolet	-1 lap	27
23	Bryan Clauson (USA)	Dale Coyne Racing/Dallara-Honda	-2 laps	28
24	Ryan Hunter-Reay (USA)	Andretti Autosport/Dallara-Honda	-2 laps	3
25	Spencer Pigot (USA)	Rahal Letterman Lanigan Racing/Dallara-Honda	-5 laps	29
26	Takuma Sato (J)	AJ Foyt Enterprises/Dallara-Honda	163 laps-accident	12
27	Mikhail Aleshin (RUS)	Schmidt Peterson Motorsports/Dallara-Honda	126 laps-accident	7
28	Stefan Wilson (GB)	KVSH Racing/Dallara-Chevrolet	119 laps-electrical	30
29	Conor Daly (USA)	Dale Coyne Racing/Dallara-Honda	115 laps-accident	24
30	Buddy Lazier (USA)	Lazier/Burns Racing/Dallara-Chevrolet	100 laps-lost wheel	32
31	Ed Carpenter (USA)	Ed Carpenter Racing/Dallara-Chevrolet	98 laps-engine	20
32	Sage Karam (USA)	Dreyer & Reinbold Racing/Dallara-Chevrolet	93 laps-accident	23
33	Juan Pablo Montoya (CO)	Team Penske/Dallara-Chevrolet	63 laps-accident	17

Winner's average speed 166.634mph. **Fastest lap** Rossi, 39.9488s, 225.288mph.

Championship 1 Pagenaud, 292; 2 Dixon, 235; 3 Castroneves, 224; 4 Newgarden, 211; 5 Hinchcliff, 205; 6 Rossi, 203; 7 Munoz, 199; 8 Kanaan, 192; 9 Kimball, 189; 10 Montoya, 187.

Q&A

Franchitti on Wheldon



MILLER/LAT



Franchitti with Wheldon's sister Holly



LIONHEART: REMEMBERING DAN WHELDON by former Autosport editor Andy Hallbery was launched at Indianapolis last week before the 100th running of the 500. This is an excerpt from this highly insightful book featuring Dan's younger sister, Holly, interviewing her brother's great friend and rival Dario Franchitti.

HOLLY WHELDON: When did you first meet Dan?

DARIO FRANCHITTI: My first recollection of Dan was not meeting him, but seeing him. It would have been 1985 maybe? Clive [Dan and Holly's Dad] was still racing. It was testing at Rye House in the UK and he'd have been about six or seven.

HW: So about the age Sebastian [Dan's son] is now.

DF: Yeah, and he was little. In the lunch break, he would go out and run around. It was a proper 100cc kart as far as I remember. It went like hell because he weighed nothing. I stood there, mouth wide open thinking, "Who the hell is that? This kid is really good..." I mean, I was only 11 or 12 and it was just shocking that this little kid could do this. I was driving a Deavinson Sprint and Clive drove a Sprint kart also, so I found out more about him and got to know Clive a little. But I never really spoke to Dan at that point.

I always remember Clive used to show up in his transit van from his plumbing business... then he showed up in a 911 turbo one day and I thought, "Wow! Plumbers aren't the same in Scotland as they are in England!" He was still racing then, and winning. There were some good guys back then.

HW: He never won a championship though. We always mock him for that.

DF: He was never doing it seriously. Clive had a business, a job, a family. He wasn't a professional. But he was very, very good. In 1986, Cadet karting started and my little brother Marino started racing with Dan – they were born something like two weeks apart. That's when I really got to know Dan. Well, I say I got to know him, but he was kind of a mouth on legs. Anyway, I was a teenager and way too cool to hang about with that lot. You've got no time for your little brother's mates at that age! >>

HW: I remember someone telling me that your parents and my parents would be together, and my mum used to make you sandwiches....

DF: Well my mum wouldn't come to races. She would stay at home and look after business. So dad would take Marino and me to the track. Your mum was always really kind and if I couldn't find Marino I knew he'd be in your motorhome with your mum feeding him loads of food! Our priority was getting the kart to go as fast as we could, so for us there was nobody, no sort of catering.... And, yeah, your mum was really very good to us.

Your dad took it very seriously, so there were guys like him, John Button, all these guys who were taking it very seriously. From day one, Clive was like that with Dan.

I remember when he won his first British championship; I think it was at Wombwell. That might have been the day Marino missed a race because he was out playing with his mates! But that was the thing to remember, they were kids. It was bad enough starting at 10 but these kids were eight years old. Dan was under a lot of pressure because, again, the level to which Clive took it. He gave Dan a massive opportunity to eventually go racing but he was expected to do well because of the effort that was put in.

There are all these funny stories about your dad taking the engines home at night to a hotel room and hiding them under the bed. Whether or not that's true, I don't know....

HW: That's definitely true! He told us that he would take the engines home at night and just put them in the hotel room that he was staying at, because he didn't want them to get taken or tampered with....

DF: In those days, Dan was just, like I say, he was a mouth on legs. He was so cocky and so loud – all those things. I was just like “God almighty!” (Laughs). But the thing was he could back it up. He was a bloody good young driver, and he made me laugh.

HW: What happened when you went to cars from karts?

DF: I moved to England in 1991. I was driving for the Leslies in Vauxhall Junior, so I had been commuting from Scotland. In 1992, I lived just outside Milton Keynes with my engineer, and then in 1993 I was there full time in Harrold – the next village up from you in Emberton. I was there two years before I went racing in Germany with Mercedes. At that point, Dan spent a lot of his time racing abroad with Terry Fullerton. I saw Dan a bit during this period, though, as we were living just a few miles apart and he was hanging out with Marino and Kristian Kolby and I was dating Kristian's sister Kirsten.

I went to America after that and next thing I know, I'm standing on the pitwall at Mid-Ohio and a much more serious, more professional Dan Wheldon comes up to me and says, “Hello, it's been a while,” or words to that effect. “Can you help me, I've never been here before?” He was racing Formula 2000. I said, “If there's anything you need pal, just let me know.” From that point until the end of 2005, he never stopped asking questions!

HW: I remember going to see him when he was in Atlantics in 2000. I can picture the apartment in my head. I would've been seven or eight.... So I guess the first time you actually raced him would have been in IndyCar?

DF: Yes, I was still in CART when Dan came on at the end of

“Honda trusted Dan, which says a lot as he was basically a rookie”



Herta, Franchitti, Wheldon and Kanaan got on well at Andretti

LEWIS LAT

2002 for a couple of IRL races. Tony [Kanaan] and I had signed for Andretti Green as the team moved to IRL for 2003. I'd been with them in CART for five years anyway by then. Dan came on to the team as a sort of development driver. Kim Green was a huge Dan fan; from day one he was massively impressed with Dan. Dan did a lot of the winter testing for us in the Indycar.

HW: I remember a story that you called and asked how the new boy was doing. You'd all sent him testing (laughs)...

DF: Yeah! Well, it was the early days of the Honda engine and Dan was trusted to do the work. Which says a lot about how they felt about him because he was basically a rookie.

I don't know if it was always apparent that he was going to take over from Michael [Andretti] after Indy, but I broke my back, and Dan did the race at Motegi in Japan, and then he did Indy, where he ended up upside down.

I wasn't at a lot of the races because I was having surgery getting my back fixed. I came back at the start of '04 and Dan was already a big part of the team. We'd gone from three to four cars because Bryan [Herta] had driven my car when Dan took over full time from Michael, and had done such a good job they wanted to keep him. So Bryan drove the XM car, which was a Honda development car. We used to call Bryan 'EB'. It stands for Engine Bitch, as he used to do all the development work. He got this monster engine they built for Michigan in '05 where he won. He came back after the celebrations; he turned to us and said, "Who's the Bitch now?"

HW: The 2005 season was a good one for Dan, though. A very good one!

DF: Yes, right from the start he was on it. He won Homestead, St. Pete, Motegi and Indy. He didn't win Phoenix... That was when we had a falling out. We'll come to that, as it shows how strong we were as a team.

But in Japan — after winning the races at Homestead and St. Pete — by Motegi, he was on a roll. At one of the restarts,

Dan got a run and went down the inside wheel to wheel into Turn 3 and we went through Turns 3 and 4 like that. You know those situations where you're just being stubborn? I should've just backed out of it, but I wasn't going to because he'd won a couple of races, and I was going to redress the balance. It was stupid, I got on the marbles and crashed, and he went on and won the race.

HW: So, come on then, why did you two have your falling out at Phoenix?

DF: I was battling Sam Hornish for the lead. Something had happened to Dan, and we came up to put him a lap down. He let Hornish go and then he held me up and I finished behind [in fourth]. He didn't let me through when he was a lap down. We had a meeting, me, him, Tony and Bryan. We gave it to him with both barrels!

That was how we sorted things like this out, how we worked in the team, the four of us. No team managers or anything like that; we always took care of ourselves. It was like we controlled ourselves because majority always ruled, whoever it was. Whether it was Dan, Tony, Bryan or me, whoever was not doing what they should do we had a chat to clear it up. Sometimes I got in trouble, sometimes it was Tony, sometimes it was Bryan, and sometimes it was Dan.

Phoenix was the first one of our really big meetings. We sat in a hotel room and it was explained to Dan that that was not what team-mates do. That's not the way we worked and not the way we were going to work. The team was bigger than any one of us and he wasn't going to do that and we were not going to condone that. He got really upset. Not combative, just very upset. He was really apologetic and he took it on board. It was serious, there was a lot of emotion in that meeting shall we say! But that was it. Then we had the next race, where we finished one, two, three, and four at St. Pete.

HW: There is a great photo from that St. Pete race of you all hugging after; I've seen a big print of it...

DF: That podium is one of those moments that — looking back — has special meaning now. I do remember how upset I was that day in Florida. I had a problem so we could only get a half tank of fuel at the stops. I remember Kyle [Moyer, strategist] coming on the radio and saying if we've got a full load in this time you've got it won. But we hadn't...

That podium was so special, we were up there and we saw Bryan standing at the side and called him to get up with us too. Looking back now at the whole situation; we'd fallen out at the previous race, had our big team meeting to sort it out, and set boundaries if you like — for all of us — and we scored the perfect result. And we did it in Dan's hometown.

HW: I remember Dan saying how you four looked out for each other. Are there any on-track moments that stick out?

DF: We were always in good shape at Indy. Tony was fast, I was fast, Dan was fast, and Bryan was too. One moment that reminds me how close the four of us were was also one of the bravest things I've ever seen. Bryan crashed at Turn 1 during qualifying in 2004, usual story. Went in and boom, backed it in. I think he went home to California.

He came back the next week and I remember Dan, Tony and myself standing at the data watching, and on his first lap he went through Turn 1 flat-out. The three of us were amazed. That gives you some idea of the kind of team morale we did have. People would call us the Gang of Four or The Dream Team and all that... but we were genuinely friends. We competed bloody hard. And we helped each other a lot too. Ultimately we were good friends.

The 500 in 2005 is another moment. Dan drove a belter. There was one restart where I thought I could have a shot at him near the end. I knew I had to get by him on a restart or I wasn't going to make it. Dan deserved that one, he really did. ✨

LIONHEART: REMEMBERING DAN WHELDON IS OUT NOW, AVAILABLE FROM AMAZON

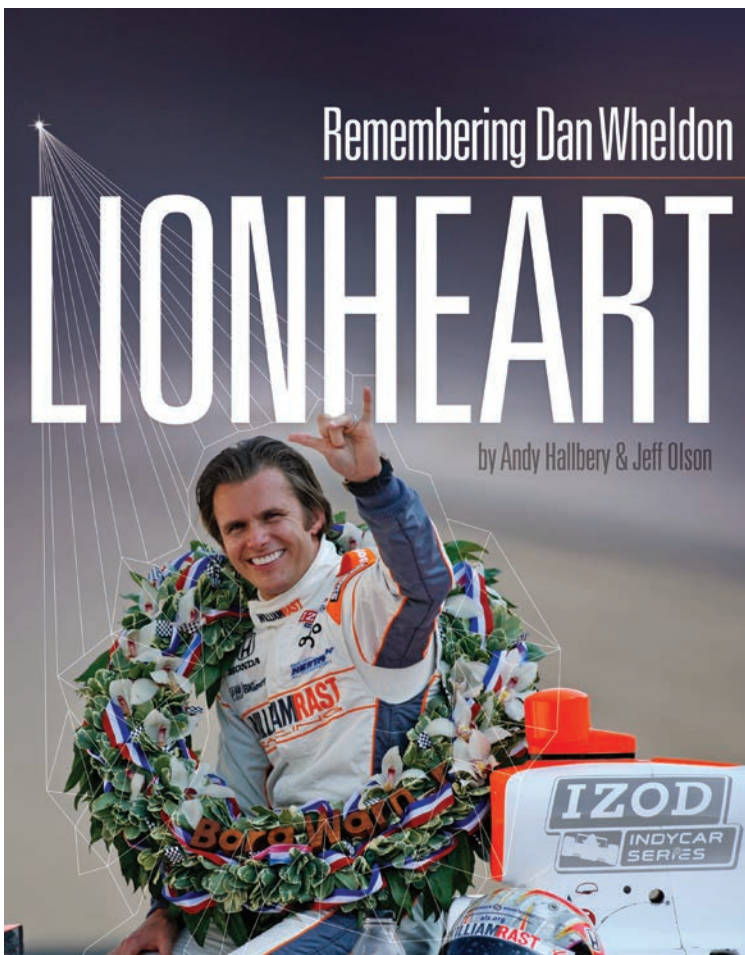

Up close and (very) personal with Petter Solberg

The World Rallycross champion invited Autosport to join him at Lydden Hill last weekend. The experience provided a fascinating insight into the Norwegian's world

By David Evans, Rallies Editor

[@davidevansrally](https://twitter.com/davidevansrally)



A

generator. Seriously? At this time of the morning? It's just before six on Sunday. It's light, cold and, let's be perfectly honest, a little bit smelly. Welcome to Petter's bus.

Autosport has joined Solberg's world tour in time for its stop at Lydden Hill, Kent, for Britain's round of the World Rallycross Championship. And that's how we've found ourselves sharing a confined but reasonably comfortable space with nine other blokes.

To the left, at a distance just about acceptable, is Per-Espen Lochen, Petter's PR man. He's awake too.

"You snore," he says.

Passing the bathroom, there's a more civil greeting from John 'Cudders' Cudmore, the number one technician at Solberg's PSRX team. "Morning," he grins, as he brushes his teeth.

The espresso machine's up and running and has been for a while, and there's a clamour for its nectar.

"How was the bed?"

When a three-time world champion asks that question, it tops what's been a fairly surreal time since eyes were opened.

Solberg's been for a run and has turned his attention to breakfast. In stereotypically journalist style, the run is dodged but there's significant enthusiasm for the food.

The offer of a weekend on the PSRX bus was an intriguing one. You're prepared for a lack of sleep, but you definitely need feeding. No worries... "Smoked salmon?" asks Solberg. "Scrambled egg, or you prefer the sausages and bacon?"

Right on cue, team caterer Gareth Williams pulls freshly baked croissants from the oven. All is well again.

"This is what I like," says Solberg, pointing to the hospitality set-up. "This is why we work like this. I have stayed in hotels all around the world and I'm fed up with them. This is much better. The mechanics and engineers, they all have the choice of going to the hotel, but they prefer to stay here."

Saturday was pretty much perfect, with Solberg's Citroen fastest just about every time it went on track.

That's the result of a week in Grimsby for the defending world champion's 600bhp supercar.

The team is usually based in Torsby,

Sweden, but when the racing's further south it's Cudmore's workshop on England's east coast that's the ideal halfway house for a reprep, rebuild or, like this time, redesign.

Belgium, the last event before Lydden, provided Solberg with an important wake-up call. Mattias Ekstrom took his second win on the bounce, with the Swedish Audi looking almost untouchable around the twisty Mettet circuit.

"This is motorsport for the masses – rough, ready and racier than ever this season"



Crucial team meeting – or a coffee after breakfast?



Pernilla Solberg was not pleased with finale

Solberg needed a rethink. A week in Grimsby was needed. "We knew we had to do something after Belgium," says Cudmore. "We wanted to change the suspension – that meant cutting the engine bay and moving the engine back a little. The geometry's much better now. And we fitted a bigger turbo and did some more work on the engine."

In layman's terms, there's more rubber on the road and more power under the pedal.

That week shows the difference between World Rallycross and the World Rally Championship: the Solberg car was reworked fairly radically between

two races without the need for homologation jokers and constant communication with the FIA. It's this flexibility that's pulling people in. And keeping them.

Breakfast done, there's time for a catch-up with Sebastien Loeb. The Frenchman's enjoying the delights of Lydden and the World Rallycross Championship for the first time. He's interested in the concept of sleeping on the bus. Having done the Dakar Rally for the first time this year, Loeb's used to a life away from the nearest Hilton, not to mention life outside the cosseted environment of a manufacturer entry.

He drives for the Hansen family team. Yes, it's reskinned Peugeot, but the public-facing side is similar to the rest of the paddock: a far cry from Formula 1. This is motorsport for the masses – it's rough, ready and racier than ever this season.

"As long as I can get a coffee," Loeb says, "I don't care about the size of the truck."

As Sunday progresses, all anybody cares about is three o'clock and a place in the semi-final.

The intensity builds. It's strategy time. The PSRX team gathers around Petter, but it's his wife Pernilla who drives the discussion. Mrs S is right behind her man. Nothing's changed.

"Actually it has," says Petter. "She used to come everywhere with me, but in Hockenheim she went testing with Oliver."

Oliver is the Solbergs' talented 14-year-old son, already a multiple crosskart champion himself.

Petter grins: "It's always the same when there's a younger man on the scene. Actually, Oliver is pushing me like hell >>



WORLD RALLYCROSS

now. He won last weekend and he's getting really cocky, telling me I have to win now. I'm doing my best... It's good to have them with me, but Oliver has school, so he and Pernilla can't be here all the time. I have to shut all of that out when I'm here and racing. If I start thinking about where are my family, what are they doing, then this can take up energy. I'm here to work."

Pernilla's attitude is exactly the same. For more than a decade she toured the world with a man called Hollywood. So how does a car park in Kent compare?

"I love it," she says. "Honestly. Like Petter says, we have done the best hotels in the world, but this is great family time for us."

When Subaru pulled out of the World Rally Championship at the end of the 2008 season, the Solbergs' life was turned upside down. There were no seats and very few options for 2009.

"At the time," Pernilla says, "people said to us, 'You have enough money now, it's time to relax, have some family time...'"

"Those people don't understand Petter. It's not about the money, it's never been about the money. It's about competition and motorsport. Both of us were born into motorsport families and, yes, life would go on without it, but it's what we do. We love it."

Two titles in the World Rallycross Championship is payback for some tough times trying to run a private team in the WRC, but Petter's under no illusion about the challenge that lies ahead. "It's getting tougher," he says. "All the time, we have to work harder and harder. We are alone here, we have no manufacturer helping us. OK, we have some sponsors and we couldn't compete without them, but at the same time it's hard when you are up against Peugeot, Ford and Audi. But, if something is worth having, it's worth fighting for."

"It's not about the money, it's never been about the money. It's about competition"

You won't see pure manufacturer teams here, not in the style of Volkswagen or Hyundai in the WRC, and that's the last thing rallycross needs. The minute a full factory squad arrives, budgets will spiral and the burgeoning bubble could burst.

"I understand all of that," says Solberg, "but the priority for me has to be to work with a manufacturer. All I need is a car and some budget; we can do the rest. I want to run my own team; I want to run a young-driver programme. I have a lot of plans."

But for now the plan is simple. Pole in the final has to be turned into victory. The wind has to be taken out of Ekstrom's sails before we get too far into the season.

There's concern, however. The #1 Citroen is proving hard on its left-front tyre, which is getting serious punishment in the fast right-hander at Paddock Bend.

As usual, Cudmore drives the car to the grid, giving Solberg a minute more to gather

his thoughts. "The tyre's on the limit," he says thinly. "Let's see..." With that, the hat's down, sunglasses on and smile fixed. He manages a good couple of steps before he's mobbed. Again. Solberg launched his own fan club on Saturday night and, already, the trademark black, gold and white caps seem everywhere.

Anything remotely resembling a good vantage point trackside disappeared hours ago. Pernilla and Per-Espen are installed in the spotters' tower. We'll stay in the paddock with engineer Ole Johan Rustad and Oliver.

Rustad's on the radio (connected to the spotters and Petter), on hand to add anything missed by anybody else.

There's silence. No emotion, just intensity. Eyes fixed on a huge telly, there's a nod of appreciation when Solberg drops the clutch and hits the front from pole. After that, it's solid mental calculation and 'what ifs?'

Taking on big operations from Peugeot, Audi and Ford gets the Solbergs going



The jokers have split the field and Ekstrom is down on split times; Solberg's looking good for 100 per cent in Kent.

He jokers and exits the right-hander nailed... to the left-rear of Ekstrom's Audi.

In a volley of apparently fruity Norwegian, Oliver disappears. He knows what's coming next.

For two more laps, Petter pushes to the limit of the tyre. There's nothing left. The gap between him and Ekstrom isn't getting any smaller. The Audi man's reign goes on: three wins in a row. His sails are fuller than ever.

The atmosphere flattens in an instant, before Rustad breaks the silence. "Second is good," he says, sounding as though he's trying the sentence for size. "The championship is still right there."

In the middle of trying to work out the difference between Ekstrom and Solberg in the title race – it's five points – Pernilla walks in. Forget 'second is good'; her chin's on the floor. "We needed those points," she says. There's not much more to say.

Solberg arrives, podium and press conference done. The smell of champagne coming off his overalls juxtaposes awkwardly with the atmosphere. "I had nothing left," he says. "When I was right behind him, there was nothing in the tyre, no grip. The car was moving so much in the corner, I just couldn't get the power down. But hey, come on guys, we have made a big step with the car. In Belgium we were worried, but we have made some speed here. The car was very impressive this weekend – that's positive."

Solberg seeks out Pernilla. She's sitting on the steps to the truck, chin on her hands. It's his turn to pick her up.

A hug helps, and cold beers work their magic elsewhere. The weekend wasn't so bad. Petter declines a cold one – he's got some sponsors to talk to. Pernilla sits down at the back of the room with a piece of paper. "It's what we have to work on," she says, starting to write. This is no time to stand still.

An hour ago, this was the dream weekend. It's a mark of the standards that PSRX sets itself that second sends everything south. But from here the bus heads north. To Norway. Home.

The Solberg family's world tour never stops. ❄️



Ekstrom makes it three in a row

MATTIAS EKSTROM arrived in Kent on a hat-trick, and departed with a superb third straight win in the World Rallycross Championship.

The amiable Swede admitted his rival Petter Solberg had been the pace man of the weekend but, when it came to the final handful of corners at the Lydden Hill circuit, the Norwegian's tyre strategy came up short and Ekstrom powered through for the win.

"I saved some new tyres for the semi-final," said Ekstrom. "That helped me."

He'd also escaped a rather more fundamental tyre problem in the final qualifying race, when he emerged with a puncture aboard his Audi S1. But it was edging Andreas Bakkerud in the second semi-final that really put Ekstrom on

course for three wins from three.

Solberg aside, it was Bakkerud who was impressing aboard his M-Sport-built and Hoonigan-run Ford Focus RS RX. Bakkerud set Saturday's fastest lap and put the new car's strong engine and slightly wider track to exceptional

"I'm sure there will be many more fights like this"

use through Lydden's fast and flowing corners. But that was as good as it would get for the Monster man, who failed to make an impression on Sunday's final race.

Disappointingly for the big crowd who'd made the journey to England's far south-east corner, the nine-time World Rally champion from just

across the water failed to make the final. A misfire aboard his Peugeot 208 WRX ended Sebastien Loeb's participation at the semi stage.

The same couldn't be said for his Hansen team-mates Timmy and Kevin Hansen, who ended the final third and fourth.

Timmy's been here and better before, but fourth in the final was great for Kevin, who turned 18 on Sunday.

"I never made it this far before," he said. "It's incredible. I didn't dare dream of this."

Solberg consoled himself with second after a superb fightback weekend, having been whitewashed by the Ekstrom Audi for the past two rounds.

"I'm sure there will be many more fights like this in the future," said Ekstrom. "But the final score only comes at the end of the weekend."

Left to right: Solberg, Ekstrom and Timmy Hansen are all smiles



RACE CENTRE

WTCC • NURBURGRING 24 HOURS • GP2 • FRENault EUROcup



Lopez has won three of four WTCC races on the Nordschleife

Lopez jumps to huge

WORLD TOURING CAR CHAMPIONSHIP
NURBURGRING (D)
MAY 28
ROUND 5/12

EVERY NOW AND THEN THERE ARE RACE weekends that appear to take on an added significance in title races. The World Touring Car Championship's visit to the Nurburgring undoubtedly felt like one of those, and a double for Jose Maria Lopez as recent Honda joy turned to woe means that things are looking very good for a third consecutive crown for Citroen's star.

Honda travelled to the 'Green Hell' on a high; a 1-2-3 in the Marrakech main race completed a fantastic weekend for the team, which had been genuinely faster than Citroen. How often has that passage been muttered in the past three seasons?

But while the Nurburgring's infamous micro-climate stayed away, a proverbial black cloud followed Honda all weekend, the team first thrown out of the previous two rounds (see p23) before losing what looked to be a hard-earned race-one victory within a few miles of the flag.

While Honda lacked the outright pace of the Citroen around the 16-mile circuit, Tiago Monteiro looked well placed to guide his Civic to a second win of the season after resisting

the two factory C-Elysees in race one. But instead a tyre failure allowed his chief rival in the championship, Lopez, to nip in to win and pad out a huge margin in the championship that, in the space of one round, serves a huge blow to Monteiro's title ambitions.

His task of keeping the Citroens behind looked as though it would be a difficult one as early as the first corner, as Yvan Muller and Lopez scythed through from ninth and 10th on the reversed grid into the top five, with Lopez darting around Tom Chilton's ROAL Chevy on the run to the Dunlop Kurve.

Monteiro's cause was boosted when Thed Bjork brilliantly forced his way past an off-line Mehdi Bennani for second, backing the field up, but Volvo man Bjork's exit from the race at the start of the second lap left only clear air between Monteiro and the pursuing Citroens. Muller and Lopez were able to catch the Portuguese's draft by the end of Dottinger Hohe on lap two, but Monteiro rebuffed their advances into the final corners and built a lead once more.

Monteiro continued to push, edging away from the pair, but on the final lap disaster struck. A right-front puncture spat him off at high speed, his Civic rebounding off the outside barrier and into the centre of the track, right into the path of



IN BRIEF

PORSCHE SUPERCUP

Porsche junior Matteo Cairoli took his second consecutive victory, leading in Monaco from pole position to chequered flag in sodden conditions in a safety car interrupted race. Guest driver Klaus Bachler finished second, despite causing the race to be red flagged by piling into the Ste Devote barrier, with Michael Ammermuller holding off Ben Barker for third.

ETCC

The European Touring Car Cup field shared the Nurburgring Nordschleife with the WTCC on a staggered grid. Petr Fulin edged Kris Richard by 0.012s in qualifying and the Czech SEAT racer barely built on that margin in the first race, beating the Swiss Honda man to the flag by 0.132s. Richard got his own back in race two, heading Christjohannes Schreiber (SEAT) and Fulin.

STCC

It was a Scandinavian Touring Car Championship double for Volvo team-mates and 2001 British Formula Ford title rivals Richard Goransson and Robert Dahlgren at Mantorp Park. Goransson won the first comfortably from Flash Racing Saab's debutant Bjorn Wirdheim, who passed the SEAT of Johan Kristoffersson at the last gasp. Dahlgren and Goransson battled their way up the reversed grid together in race two before finishing in that order, with Daniel Haglof's SEAT third.

SUPER TC2000

Relative newcomer Jose Manuel Urcera returned Fiat to the Super TC2000 winner's circle at Alta Gracia after Peugeot man Damian Fineschi took the chequered flag but was penalised by the stewards for what they considered a dangerous manoeuvre against Renault's Leonel Pernia while the two fought for the lead during the closing laps. The penalty led to Fineschi dropping to fourth behind Urcera (his first win in the division), Facundo Chapur (Peugeot) and Pernia.

WORLD CHALLENGE GT

The Lime Rock round was marred by a terrible practice shunt that left Bentley's Andrew Palmer with serious head injuries and Aston Martin driver Jorge de la Torre with broken bones. Alvaro Parente had won race one in his McLaren after an early scrap with Palmer, with Kyle Marcelli (Audi) second after a collision between Palmer and Pat Long, for which the Porsche driver took a drivethrough penalty. Portuguese star Parente led all the way in the second race to beat Long and Marcelli.

lead with double

two onrushing Citroens. Muller simply had nowhere to go and ploughed into the Civic, but somehow Lopez nipped past.

While Monteiro was taken to the medical centre and then the local hospital for checks, he was soon released.

Lopez had enough in hand to preserve a lead over second-placed Chilton, the Briton translating his strong form in the weekend's opening sessions into a second podium finish of the season in his Sebastien Loeb Racing Citroen.

Despite inheriting a win and extending his championship lead, there were no signs of *schadenfreude* from Lopez, who was thankful to have avoided the wreckage. "I'm glad they are OK, especially Tiago," said the Argentinian, who also thought he had a lap more to run. "It was spectacular, like a PlayStation accident. I just saw the car hitting the barriers and flying three metres in the air. It was a high-speed accident and the inertia had the potential to bring the car to the inside. I passed through really, really narrow."

With Coronel suffering a puncture earlier on the third lap, Honda's Norbert

Michelisz was promoted to third ahead of heroic team-mate Rob Huff, who charged from 16th to claim fourth after overtaking Bennani on the final lap.

Race two was less eventful, but Lopez was ruthless as he charged to his second win of the weekend.

The Citroen maestro raised hopes of an improbable fight for victory when he forfeited the lead of a truncated field to Michelisz at the first corner, the Hungarian having been promoted to second on the grid with Muller and Coronel unable to take the start. But those were comprehensively crushed just a handful of corners later as Lopez swept back around the outside at Turn 8 on the Grand Prix loop.

Lopez broke away ever so slightly from there and, after managing the gap back to preserve his tyres, he brought his C-Elysee home for his first double of 2016, winning by 0.435 seconds.

Chilton capped a fantastic weekend with third and was fully deserving of a second podium, not least for his measured defence of the position from Huff.

JACK COZENS

AT A GLANCE

RACE ONE

- 1 Lopez Citroen
- 2 Chilton Citroen
- 3 Michelisz Honda

RACE TWO

- 1 Lopez Citroen
- 2 Michelisz Honda
- 3 Chilton Citroen

P49 FULL RESULTS

Last-lap Nurburgring win for Engel, Schneider, Christodoulou and Metzger



Black Falcon Mercedes swoops in

NURBURGRING 24 HOURS
NURBURGRING (D)
MAY 28-29

"IT'S ABSOLUTELY INCREDIBLE AND A BIG dream come true for me to win such an amazing race," said Maro Engel, shortly after crossing the Nurburgring 24 Hours finish line.

Engel looked destined for success for much of the Nurburgring 24 Hours weekend; fast in practice, the German obliterated the competition in the 30-car superpole session, going 1.631 seconds faster than his nearest challenger in his #9 Black Falcon Mercedes-AMG GT3.

But it was in the sister #4 car where his greatest heroics were displayed, as Engel hunted down the race-leading HTP Merc of Christian Hohenadel before making a daring lunge past at Turn 8 of the Grand Prix circuit on the last of 134 laps to secure a dramatic victory, as Mercedes wiped the floor with their competition.

While the clock counted down the 24 hours from half past three on Saturday, in truth it was only by the time around five hours had ticked by that the race began to take shape, after it was halted when torrential rain and hail moved over the circuit just before the first hour was up.

A trickle turned into a torrent in an eyeblink at Aremberg and challenged anyone who'd made it back round onto the Nordschleife. If the streams there looked bad, there was yet worse still lurking around the corner as a freak hailstorm littered the track and battered those who'd survived the first test. The GT machinery

didn't take kindly to the interference and, with a host of cars parked on the track, the only sensible option was to stop the race.

Engel fell back quickly when racing resumed, admitting later that he had chosen the wrong tyres, but the mantle of Mercedes domination was quickly picked up by the two Haribo Racing machines (aided by the expiry of the lead Schubert Motorsport BMW M6 GT3's engine as darkness began to fall), which were soon able to pit and retain the lead.

While one of the Haribo cars was parked, the once-dominant sister Merc was, by mid-morning, forced to settle for a swap of the lead, as its Uwe Alzen/Lance David Arnold/Maximilian Gotz/Jan Seyffarth combination cycled in and out of the prime position along with the #9 Black Falcon car (crewed by Engel, Hubert Haupt, Yelmer Buurman and Dirk Muller) and the HTP entry (in which Hohenadel was joined by Christian Vietoris, Renger van der Zande and Marco Seefried).

After the exit of the last hanger-on – the other Schubert Motorsport M6 which, with Lucas Luhr at the wheel, was unceremoniously smashed out of the reckoning after being clattered by a stray M235i car – four Mercedes chariots remained in the lead group as the #4 Black Falcon car (with Engel joined by Bernd Schneider, Manuel Metzger and Brit Adam Christodoulou) joined the fray.

Four was whittled down to three when the #9 car dropped away from the cycle with a couple of hours to go, while a 1m32s time penalty

for the Haribo challenger for not respecting a double-yellow-flag zone effectively made the contest a two-horse race.

The HTP car completed its final pitstop with an hour and 15 minutes to go and, with the Black Falcon Mercedes rejoining 50 seconds back a couple of laps later, with Engel back aboard, Hohenadel looked to have victory in his grasp.

Job done, surely? Not quite. With the amount of time left to run, Hohenadel would have to run at least nine laps, which left him marginal on fuel. Sure enough, a late splash-and-dash was required, with Hohenadel emerging from the pits five seconds clear of Engel.

That gap was effectively wiped out over the course of the next 16-mile lap, and the pair's pace in the final stint had been so strong that they crossed the line with 45 seconds to spare, ensuring a last-lap shootout for the race win.

With the momentum, Engel hustled his AMG through the opening corners and stayed as close as he dared through the Schumacher Esses. Then, suddenly at Turn 8, came an opportunity.

"I could see he was really struggling for traction out of the Dunlop Kurve, then we had the Schumacher S," said Engel. "I was starting to close up and got a run on him, and to be honest I was surprised he didn't defend into the next corner."

Engel went for it. The pair made contact – though only as Hohenadel turned in for a line that Engel had already taken – but Engel stormed through unscathed, which was just reward for the audacity of his lunge.

That would prove to be the killer blow, as



XPE/IMAGES

Stoneman denies Jones

INDYLIGHTS
INDIANAPOLIS (USA)
MAY 27
ROUND 5/11

DEAN STONEMAN FOLLOWED UP HIS maiden Lights win on the Indy road course with a thrilling victory on the superspeedway over Ed Jones by 0.0024 seconds – the closest in the Brickyard’s 105-year history.

A late caution led to a one-lap dash to the flag, with Briton Stoneman’s Andretti Autosport car leading Juan Piedrahita and Jones as the field came to the restart. A miscalculation from Piedrahita meant he clipped the back of Stoneman, forcing the Colombian down the order, as Jones slipstreamed his Carlin car into the lead.

Stoneman challenged the Anglo-Dubai man as they went down the back straight, sweeping around the outside of Turns 3 and 4. While Jones came off the banking just in front, Stoneman’s momentum on the wider line carried him to the line just in front.

Shelby Blackstock – whose mum, Tennessee country singing star Reba McEntire, had given the start-engines command – also lost out as he was drafted



Stoneman (left) pipped Jones to the line

by Dalton Kellett in the battle for third on the final lap. Scott Hargrove was next home, followed by Felix Serralles, Neil Alberico and the disappointed Piedrahita. Ninth place was a disappointment for reigning European F3 champion Felix Rosenqvist, who suffered suspected engine problems.

RESULTS

1 Dean Stoneman, 40 laps in 41m08.6299s; **2 Ed Jones**, +0.0024s; **3 Dalton Kellett**; **4 Shelby Blackstock**; **5 Scott Hargrove**; **6 Felix Serralles**. **Points 1 Jones, 185**; **2 Stoneman, 156**; **3 Santiago Urrutia, 146**; **4 Kyle Kaiser, 144**; **5 Serralles, 140**; **6 Felix Rosenqvist, 120**.

to the light

a defeated Hohenadel dropped back on the Nordschleife before the finish and Engel secured the Black Falcon team its second Nurburgring 24 Hours success. Its winning margin – a comfortable-looking 5.697 seconds – was the closest in the history of the event, eclipsing the record set last year. There was a brief moment of doubt about the result after the HTP team lodged an appeal against Engel’s move, but that was quickly quashed by the stewards.

With Audi inexplicably off the pace and the leading BMWs encountering problems, the competition may have failed to deliver. But that mattered not as the Mercedes cars took it upon themselves to scrap for victory and gave a race that had bubbled under for so long the fitting finish it deserved.

JACK COZENS

RESULTS

1 Maro Engel/Bernd Schneider/Adam Christodoulou/Manuel Metzger (Mercedes-AMG GT3), 134 laps in 24h07m46.500s; **2 Christian Vietoris/Renger van der Zande/Christian Hohenadel/Marco Seefried (Mercedes)**, +5.697s; **3 Uwe Alzen/Maximilian Gotz/Lance David Arnold/Jan Seyffarth (Mercedes)**; **4 Hubert Haupt/Yelmer Buurman/Maro Engel/Dirk Muller (Mercedes)**; **5 Alexander Sims/Philipp Eng/Maxime Martin/Dirk Werner (BMW M6 GT3)**; **6 Sebastian Asch/Luca Ludwig/Daniel Keilwitz/Kenneth Heyer (Mercedes)**; **7 Christopher Bruck/Christian Menzel/Guy Smith/Fabian Hamprecht (Bentley Continental GT3)**; **8 Robin Frijns/Edward Sandstrom/Frederic Vervisch/Stuart Leonard (Audi R8 LMS)**; **9 Peter Dumbreck/Wolf Henzler/Martin Ragginger/Alexandre Imperatori (Porsche 911 GT3-R)**; **10 Christian Mamerow/Rene Rast/Marc Busch/Dennis Busch (Audi)**.

Truex dominates for win

NASCAR SPRINT CUP
CHARLOTTE (USA)
MAY 29
ROUND 13/36

AFTER HE’D MISSED OUT IN DAYTONA, Texas and Dover earlier in the year, Martin Truex Jr’s luck finally changed at Charlotte Motor Speedway last Sunday night, leading 588 of the fearsome event’s 600 miles – the most miles ever led by one driver in a single NASCAR race.

Truex was on pole in his Furniture Row Racing Toyota, and would have gone unchallenged for the majority of the evening if not for a late charge from Kevin Harvick.

Jimmie Johnson, Harvick and Joey Logano staked a claim on second place, but Logano dropped back thanks to a drivethrough penalty for his pit crew coming over the wall



Truex led all but eight laps in Charlotte

too early. It was quite the reversal of fortune for Logano after winning the \$1 million All-Star race a week earlier. His loss was Johnson’s gain, and the multiple champion took over in second position.

Traffic towards the end of the race began to slow the leader slightly, but he resisted late pressure; first from Johnson and, when the Hendrick man’s challenge faded, Harvick. It was then Harvick’s turn to set about trying to catch Truex, but to no avail, Harvick’s Stewart-Haas Chevy finishing two and a half seconds adrift of the winner.

Truex’s win means he joins Harvick, Johnson, Denny Hamlin, Brad Keselowski, Kyle Busch, Carl Edwards and Matt Kenseth in the provisional Chase for the Cup field.

RESULTS

1 Martin Truex Jr (Toyota Camry), 400 laps in 3h44m05s; **2 Kevin Harvick (Chevrolet SS)**, +2.572s; **3 Jimmie Johnson (Chevy)**; **4 Denny Hamlin (Toyota)**; **5 Brad Keselowski (Ford Fusion)**; **6 Kurt Busch (Chevy)**; **7 Matt Kenseth (Toyota)**; **8 Chase Elliott (Chevy)**; **9 Joey Logano (Ford)**; **10 Ryan Newman (Chevy)**. **Chase grid 1 Kyle Busch, 3 wins/405 points**; **2 Johnson, 2/409**; **3 Carl Edwards, 2/404**; **4 Keselowski, 2/404**; **5 Harvick, 1/457**; **6 Truex, 1/381**; **7 Kenseth, 1/347**; **8 Hamlin, 1/345**; **9 Kurt Busch, 0/421**; **10 Elliott, 0/374**; **11 Logano, 0/373**; **12 Austin Dillon, 0/344**; **13 Dale Earnhardt Jr, 0/341**; **14 Jamie McMurray, 0/318**; **15 Ryan Blaney, 0/309**; **16 Newman, 0/309**.



Early laps, and Markelov is behind de Jong (23), with Malja (11) to his outside

Is it Russian Time, or a Russian time

GP2 SERIES
MONTE CARLO (MC)
MAY 27-28
ROUND 2/11

"I'M LIKE SUPERMAN!" DECLARED feature race winner Artem Markelov. The stony glare on runner-up Norman Nato's face through the entire length of the Russian national anthem suggested that if that was the case, he was about to order some kryptonite.

Markelov's victory from 15th on the grid was certainly somehow otherworldly; whether it was superheroic or dubious was what was troubling those he'd just beaten. The maths behind it just didn't seem legally possible to them.

Winning had certainly looked impossible on Thursday afternoon, when Markelov comprehensively rearranged the Ste Devote barriers after launching himself over the inside kerbs, delaying the end of qualifying and leaving him 15th on the grid.

Another place was lost at the start, then regained with a pass on Sean Gelael. As half-distance approached and others' soft tyres faded, the forward progress began. Daniel de Jong and Nicholas Latifi were overtaken, the Canadian sliding into the tunnel wall trying to resist Markelov. That put Markelov in clear air and he began reeling off laps on a par with the leaders.

All the frontrunners pitted as late as they dared for super-softs. Russian Time was the boldest of them all but it could afford to be as its driver was getting faster and faster, lapping up to a second quicker than the erstwhile leaders were on brand-new super-softs. It made swashbuckling viewing too, Markelov sliding through Casino Square like he was on a 1970s Formula 1 pole lap.

Still this looked like a strategy and performance that were going to get Markelov some unlikely points, not an unthinkable victory. He was elevated into the lead as everyone else came in, but was only 15s clear of Nato. Engineers reassured their drivers not to worry about Markelov.

What left the likes of Nato so perturbed was that it was under virtual safety car periods that the battle turned. There were five during this messy race, including two in quick succession in the closing laps during which Markelov's lead roughly doubled from its previous 15 seconds to big enough to get him back out just in front of Nato and Oliver Rowland for what proved to be the final two laps of a timed race.

"I was really pissed off and angry when I saw him leading the race," said Nato. "I didn't really understand how a car could be in front of me when I pushed and made no mistakes for 40 laps."

Had this been as simple as Markelov

failing to slow for the VSCs, his win would not have stood. But it did. Russian Time was adamant its man just did a better job of reacting to restarts than the rest and always drove within the prescribed time limits.

Track positioning looked to be in his favour too. Time gaps will fluctuate during a VSC as the mandated pace costs drivers more time in sections where average speeds would be higher under green-flag conditions and less in sections that would be slower (and closer to VSC pace) anyway. Where you are when the VSC is called and called off can count for a lot. The theory is that it all evens out over the lap(s), as it did for Markelov in earlier VSCs, when his deficit to the front ballooned from 20s to 43s for a few laps, then sprang back.

It didn't hurt that Markelov was winding his way round the Mirabeau and Loews hairpins during a brief VSC for debris on lap 35, nor conversely that his main rivals were in that slow section while he could maximise the return to full pace on the run from the tunnel to Rascasse as the next VSC for Luca Ghiotto's stranded car was lifted on his in-lap.

Two elements of the race were indisputable: Markelov's pace on old tyres had been outstanding, and Nato had driven flawlessly. Of 2016's feature races, Nato has won one and could've/should've won the other. He beat poleman Sergey Sirotkin

AT A GLANCE

RACE ONE

- 1 Markelov Russian Time
- 2 Nato Racing Engineering
- 3 Rowland MP

RACE TWO

- 1 Matsushita ART
- 2 Kirchhofer Carlin
- 3 Marciello Russian Time

➔ P49 FULL RESULTS



warp?

off the line, resisted early attacks from the ART car and inched away. For the second event in a row, Sirotkin then crashed out while chasing Nato, prompting more distraught radio traffic and meaning the man in Stoffel Vandoorne's old car's only 2016 points so far come from a pole bonus.

A slightly slow pitstop was a scare for Nato, but he kept his composure on cold tyres as Rowland swarmed all over him and did his best to pass Markelov (full marks for a pop around the outside at Mirabeau). Nato's reward may not have been another Monaco victory to add to his 2014 Formula Renault 3.5 breakthrough, but he did leave with a one-point lead over Markelov.

Fourth and fifth places kept Alex Lynn in the hunt, eight points off the top. Other rivals have work to do. Nato's Racing Engineering team-mate Jordan King clouted the barriers while running second, and post-Barcelona leader Pierre Gasly had a nightmare combination of a practice crash, troubled qualifying that ended in exclusion for missing a weighbridge call, and then contact with Jimmy Eriksson.

ART has at least opened its 2016 GP2 win account even with Sirotkin in trouble. Team-mate Nobuharu Matsushita utterly dominated the sprint from reversed-grid pole, ahead of Carlin's rookie Marvin Kirchhofer and Markelov's team-mate Raffaele Marciello.



Fenestraz, last year's French F4 runner-up, is the only one who can see

Fenestraz splashes to win

FORMULARENAULT EURO CUP
MONTE CARLO (MC)
MAY 29
ROUND 2/7

FORMULA RENAULT'S RETURN TO MONACO after four decades featured only three laps of racing on a torrentially wet track as rookie Sacha Fenestraz took a pole-to-red-flag victory.

Franco-Argentinian Fenestraz (he's Jose Maria Lopez's brother-in-law) qualified third, but was elevated to pole in his Tech 1 Racing machine. First Lando Norris, who'd kept the opposition at arm's length throughout qualifying, was excluded for non-conforming parts (nuts, screws, bolts and uniballs), although the official bulletin said it did not enhance performance. That moved Ferdinand Habsburg to the top, but he was carrying a two-place grid penalty.

Once the safety car released the field, Habsburg grabbed second off Max Defourny

with an audacious move into Massenet, before Bruno Baptista's harpooning of Jehan Daruvala at the seafront chicane caused a safety car. This in turn was extended when David Porcelli – catching the field after a spin – inexplicably carried dry-weather speed into Ste Devote, with rather predictable results.

After the restart, Dorian Boccolacci pulled off a great move on Defourny for third at Ste Devote, before the hairy scrap for seventh between Harrison Scott and Gabriel Aubry ended with them in the barriers, Will Palmer unavoidably crunching Scott's car. With the red flags flying, Boccolacci lost his podium on countback.

RESULTS

1 Sacha Fenestraz, 7 laps in 15m48.612s; **2** Ferdinand Habsburg, +1.141s; **3** Max Defourny; **4** Dorian Boccolacci; **5** Nikita Mazepin; **6** Henrique Chaves Jr. **Points 1 Lando Norris, 68;** **2** Defourny, 62.5; **3** Harrison Scott, 44; **4** Boccolacci, 37; **5** Jehan Daruvala, 25; **6** Bruno Baptista, 18.

Mardenborough B-Maxes it

JAPANESE FORMULA 3
OKAYAMA (J)
MAY 28-29
ROUND 3/8

JANN MARDENBOROUGH TOOK HIS maiden Formula 3 win in the wet at Okayama.

Nissan's Welsh protege qualified his B-Max Dallara-Volkswagen on pole for both races, breaking the course record, but in the first race – which took place in the dry – he made a duff start and dropped to third.

Out front were the TOM'S cars of Toyota's young talent Kenta Yamashita and Sho Tsuboi. Mardenborough was pushing to catch up Tsuboi when he was called into the pits with a mechanical-warning flag, rejoining to finish eighth, while team-mate and fellow Nissan Blancpain ace Katsumasa Chiyo inherited third.

In the second race, Mardenborough pulled away inexorably on every lap, building up an

enormous 25-second lead by the finish.

Honda's Toda-run starlet Tadasuke Makino made a strong start from fifth to get up to second, while Tsuboi – who beat Makino to last year's F4 title – made it six podiums from six races in his rookie F3 season.

Conditions worsened for the Super Formula round. The race began under the safety car with poleman and reigning champion Hiroaki Ishiura leading the crocodile, and was red-flagged on the ninth lap without a racing lap being run. Half-points were awarded to the top 10.

JIRO TAKAHASHI

RESULTS

Race 1 1 Kenta Yamashita (Dallara-Toyota F312), 18 laps in 25m04.942s; **2** Sho Tsuboi (D-Toyota F314), +5.598s; **3** Katsumasa Chiyo (Dallara-Volkswagen F315); **4** Mitsunori Takaboshi (D-VW F312); **5** Hiroki Ohtsu (D-Mugen Honda F312); **6** Sena Sakaguchi (D-MH F312). **Race 2 1 Jann Mardenborough (D-VW F314)**, 25 laps in 43m24.904s; **2** Tadasuke Makino (D-Toda F314), +25.803s; **3** Tsuboi; **4** Sakaguchi; **5** Keishi Ishikawa (D-Toda F316); **6** Yamashita. **Points 1 Yamashita, 44;** **2** Mardenborough, 36; **3** Tsuboi, 34; **4** Daiki Sasaki, 29; **5** Chiyo, 11; **6** Makino, 10. **SUPER FORMULA 1 Hiroaki Ishiura (Dallara-Toyota)**, 8 laps in 22m06.947s; **2** Koudai Tsukakoshi (D-Honda), +0.718s; **3** Takuya Izawa (D-H); **4** Tomoki Nojiri (D-H); **5** Naoki Yamamoto (D-H); **6** Yuji Kunimoto (D-T). **Points 1 Yamamoto, 13;** **2** Kunimoto, 9.5; **3** Tsukakoshi, 8; **4** Ishiura, 6; **5** Stoffel Vandoorne, 6; **6** Takashi Kogure, 5.



Mardenborough thrived in 'Welsh' weather conditions

ISHIHARA/LAT



Follow us

 rockoil.lubricants

 rockoilnews

CARBON  Made in the UK

THE ULTIMATE COMPETITION OIL



The largest stocked FHR range available anywhere!

MSA MANDATE

FHR DEVICES will be a mandatory part of safety equipment for 2016*



ONLINE OFFER!
Please go online for details

BE SAFE Get your FHR Device today!
Call now for expert advice

*Please refer to latest MSA Mandate

www.demon-tweeks.co.uk 0844 375 2196

LOW CALL RATE CALLS MAY BE RECORDED FOR TRAINING PURPOSES MEDIA CODE: NZ252A

OUT NOW!

An emotional and poignant 216-page tribute to one of IndyCar's most popular drivers by those who knew and loved him.

Captivating and honest contributions from around the motorsport world are complemented by stunning photography, making this book a must-have for any race fan.



Available on Amazon now. Search for "Lionheart Wheldon"

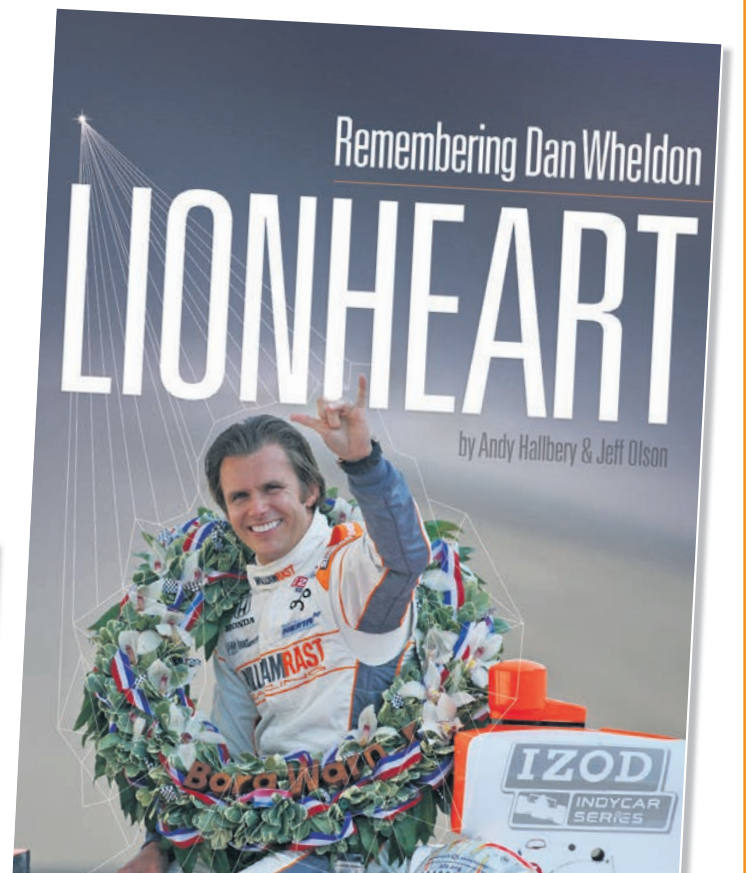

Personal memories from...

Jenson Button, Dario Franchitti, Scott Dixon, Helio Castroneves, Michael Andretti, Dale Earnhardt Jr, Mark Webber, Rubens Barrichello, Danica Patrick and of course Dan's family.

RESULTS ROUND-UP

GP2 SERIES

ROUND 2/11, MONTE CARLO (MC), MAY 27-28

RACE 1 (40 LAPS – 82.941 MILES)

1	Artem Markelov (RUS) <i>Russian Time</i>	1h01m27.183s
2	Norman Nato (F) <i>Racing Engineering</i>	+1.541s
3	Oliver Rowland (GB) <i>MP Motorsport</i>	+3.187s
4	Alex Lynn (GB) <i>DAMS</i>	+8.239s
5	Mitch Evans (NZ) <i>Campos Racing</i>	+11.723s
6	Raffaele Marciello (I) <i>Russian Time</i>	+15.025s
7	Marvin Kirchhofer (D) <i>Carlin</i>	+21.153s
8	Nobuharu Matsushita (J) <i>ART Grand Prix</i>	+21.582s
9	Daniel de Jong (NL) <i>MP Motorsport</i>	+22.343s
10	Arthur Pic (F) <i>Rapax</i>	+23.333s
11	Antonio Giovinazzi (I) <i>Prema Racing</i>	+25.037s
12	Sergio Canamasas (E) <i>Carlin</i>	+30.192s
13	Sean Gelael (R) <i>Campos Racing</i>	+31.295s
14	Gustav Malja (S) <i>Rapax</i>	+34.900s
15	Pierre Gasly (F) <i>Prema Racing</i>	+49.748s
16	Philo Paz Armand (R) <i>Trident</i>	-1 lap
R	Luca Ghiotto (I) <i>Trident</i>	35 laps-engine
R	Jimmy Eriksson (S) <i>Arden International</i>	32 laps-accident damage
R	Jordan King (GB) <i>Racing Engineering</i>	27 laps-accident damage
R	Nabil Jeffri (MAL) <i>Arden International</i>	23 laps-accident
R	Sergey Sirotkin (RUS) <i>ART Grand Prix</i>	22 laps-accident
R	Nicholas Latifi (CDN) <i>DAMS</i>	21 laps-accident

Winner's average speed 80.979mph.

Fastest lap Gasly, 1m20.469s, 92.764mph.

QUALIFYING

GROUP B 1 **Sirotkin**, 1m19.186s; 3 **King**, 1m19.691s; 5 **Rowland**, 1m19.852s; 7 **Giovinazzi**, 1m19.972s; 9 **Latifi**, 1m20.182s; 11 **Pic**, 1m20.360s; 14 **Gelael**, 1m20.877s; 15 **Markelov**, 1m22.160s; 17 **Armand**, 1m22.707s; 21 **Canamasas**, 1m20.600s*; 22 **Jeffri**, 1m22.722s*.

GROUP A 2 **Nato**, 1m19.894s; 4 **Evans**, 1m19.962s; 6 **Lynn**, 1m20.014s; 8 **Marciello**, 1m20.601s; 10 **Ghiotto**, 1m20.630s; 12 **Matsushita**, 1m20.744s; 13 **Kirchhofer**, 1m21.016s; 16 **Malja**, 1m21.965s; 18 **de Jong**, 1m21.978s; 19 **Eriksson**, 1m22.029s; 20 **Gasly**, 1m21.381s*.

* made to start from pitlane.

RACE 2 (30 LAPS – 62.205 MILES)

1 **Matsushita**, 41m59.392s; 2 **Kirchhofer**, +13.660s; 3 **Marciello**, +15.453s; 4 **Evans**, +20.894s; 5 **Lynn**, +32.560s; 6 **Nato**, +33.038s; 7 **Rowland**, +33.594s; 8 **Markelov**, +33.874s; 9 **Pic**, +36.777s; 10 **Canamasas**, +47.646s; 11 **de Jong**, +54.291s; 12 **Malja**, +55.476s; 13 **Gasly**, +55.981s; 14 **Ghiotto**, +56.501s; 15 **Eriksson**, +58.682s; 16 **King**, +1m09.193s; 17 **Jeffri**, +1m17.922s; 18 **Giovinazzi**, +1m17.997s; R **Latifi**, 13 laps-gearbox; R **Sirotkin**, 10 laps-extinguisher; R **Gelael**, 7 laps-accident; R **Armand**, 3 laps-collision.

Winner's average speed 88.886mph.

Fastest lap Matsushita, 1m21.554s, 91.530mph.

GRID FOR RACE 2

Decided by result of Race 1, with top eight finishers reversed.

CHAMPIONSHIP

1 **Nato**, 49; 2 **Markelov**, 48; 3 **Lynn**, 41; 4 **Gasly**, 33; 5 **Marciello**, 28; 6 **Matsushita**, 22; 7 **Rowland**, 22; 8 **Latifi**, 20; 9 **Kirchhofer**, 18; 10 **Evans**, 18.



Matsushita drove away from the field in race two

BLOXHAM/LAT

WORLD TOURING CAR CHAMPIONSHIP

ROUND 5/12, NURBURGRING (D), MAY 28

RACE 1 (3 LAPS – 47.307 MILES)

1	Jose Maria Lopez (RA) <i>Citroen Total / Citroen C-Elysee WTCC</i>	26m36.640s
2	Tom Chilton (GB) <i>Sebastien Loeb Racing / Citroen C-Elysee WTCC</i>	+0.526s
3	Norbert Michelisz (H) <i>Honda Racing Team JAS / Honda Civic WTCC</i>	+6.653s
4	Rob Huff (GB) <i>Honda Racing Team JAS / Honda Civic WTCC</i>	+7.971s
5	Mehdi Bennani (MA) <i>Sebastien Loeb Racing / Citroen C-Elysee WTCC</i>	+10.126s
6	Hugo Valente (F) <i>Lada Sport / Lada Vesta WTCC</i>	+12.568s
7	Gabriele Tarquini (I) <i>Lada Sport / Lada Vesta WTCC</i>	+12.890s
8	Fredrik Ekblom (S) <i>Polestar Cyan Racing / Volvo S60 WTCC</i>	+12.983s
9	Nicky Catsburg (NL) <i>Lada Sport / Lada Vesta WTCC</i>	+20.389s
10	Sabine Schmitz (D) <i>Munnich Motorsport / Chevrolet RML Cruze TC1</i>	+29.462s
11	Gregoire Demoustier (F) <i>Sebastien Loeb Racing / Citroen C-Elysee WTCC</i>	+36.301s
12	Ferenc Ficzá (H) <i>Zengo Motorsport / Honda Civic WTCC</i>	+38.331s
R	Tiago Monteiro (P) <i>Honda Racing Team JAS / Honda Civic WTCC</i>	2 laps-puncture
R	Yvan Muller (F) <i>Citroen Total / Citroen C-Elysee WTCC</i>	2 laps-accident
R	Tom Coronel (NL) <i>ROAL Motorsport / Chevrolet RML Cruze TC1</i>	2 laps-puncture
R	Thed Bjork (S) <i>Polestar Cyan Racing / Volvo S60 WTCC</i>	1 lap-oil leak
R	John Filippi (F) <i>Campos Racing / Chevrolet RML Cruze TC1</i>	1 lap

Winner's average speed 106.665mph.

Fastest lap Chilton, 8m47.586s, 107.601mph.

GRID FOR RACE 1

1 **Monteiro**; 2 **Bennani**; 3 **Bjork**; 4 **Catsburg**; 5 **Chilton**; 6 **Michelisz**; 7 **Coronel**; 8 **Muller**; 9 **Lopez**; 10 **Tarquini**; 11 **Valente**; 12 **Schmitz**; 13 **Filippi**; 14 **Demoustier**; 15 **Ficzá**; 16 **Huff***; 17 **Ekblom***.

RACE 2 (3 LAPS – 47.307 MILES)

1 **Lopez**, 26m29.665s; 2 **Michelisz**, +0.435s; 3 **Chilton**, +0.915s; 4 **Huff**, +1.908s; 5 **Bennani**, +2.431s; 6 **Catsburg**, +4.905s; 7 **Ekblom**, +6.072s; 8 **Bjork**, +8.008s; 9 **Tarquini**, +8.675s; 10 **Valente**, +13.860s; 11 **Schmitz**, +23.305s; 12 **Filippi**, +28.180s; 13 **Ficzá**, +33.913s; 14 **Demoustier**, +38.285s; NS **Muller**; NS **Coronel**; NS **Monteiro**.

Winner's average speed 107.134mph. Fastest lap Lopez, 8m48.359s, 107.444mph.

QUALIFYING

1 **Lopez**, 8m35.541s; 2 **Michelisz**, 8m40.578s; 3 **Chilton**, 8m41.163s; 4 **Catsburg**, 8m42.422s; 5 **Huff**, 8m43.559s; 6 **Bennani**, 8m44.466s; 7 **Ekblom**, 8m45.432s; 8 **Tarquini**, 8m46.000s; 9 **Valente**, 8m47.147s; 10 **Schmitz**, 8m48.381s; 11 **Filippi**, 8m48.687s; 12 **Demoustier**, 8m51.426s; 13 **Ficzá**, 8m56.037s; 14 **Bjork**, 8m42.482s*; NS **Muller**, 8m39.114s; NS **Coronel**, 8m40.067s; NS **Monteiro**, 8m45.405s. * made to start from back.

CHAMPIONSHIP

1 **Lopez**, 193; 2 **Monteiro**, 124; 3 **Huff**, 122; 4 **Michelisz**, 120; 5 **Bennani**, 103; 6 **Muller**, 83; 7 **Chilton**, 78; 8 **Catsburg**, 62; 9 **Coronel**, 44; 10 **Tarquini**, 44.



Chilton, here leading Huff, grabbed two podiums

GOODMAN/DPPI

WEB DIRECTORY

AWNINGS



No1 for Inflatable Structures.
With you from the Paddock to the Podium.
www.aireshelta.com

EQUIPMENT

RACEWEAR & MOTORSPORT EQUIPMENT 

QM *advantage motorsport*
www.advantage-motorsport.co.uk

EXHAUSTS

Inconel & Stainless Steel Specialists
SIMPSON
Race Exhausts
Tel: 01753 532222
www.simpsonraceexhausts.com  

GEARBOXES

Gearboxman.com
COMPETITION TRANSMISSION SERVICES
Gearboxes & Axles for Road, Race, Rally and more
Telephone: 01582 840008 Fax: 01582 840007

HELMET GRAPHICS

visit: www.liquidcolourdesign.com
Studio: +44 028 93378525
Mob: +44 0770 9442894 

liquidcolourdesign
Helmet Paint | Design | Airbrush | Custom Paint

Mike Fairholme Designs
Sole approved painter of Arai helmets.
Silver Birches, Corby Birkholme, Nr Grantham, Lincs NG33 4LE.
Tel: 01476 550630. Fax: 01476 550029.
email: fairholmedesigns@btconnect.com
www.fairholmedesigns.co.uk

MEMORABILIA



FINAL LAP
For Everything Formula One
www.finallap.net **WE BUY AND SELL**
+44 (0) 1245 287588 / 07771 920345

MOTORSPORT EQUIPMENT



MARDI GRAS MOTORSPORT
www.mardigras.co.uk

MOTORSPORT LEGAL ADVICE

MOTORSPORT LAWYER
JAMIE CHAMPKIN LL.B
National and International
CALL +44(0)1386 871287 ANYTIME
www@champkin.uk.com
email: info@champkin.uk.com

MOTORSPORT LEGAL ADVICE

Motor Sport Legal Advice
Tudor Alexander, LI.B Solicitor
tudor@fletcherday.co.uk
07887 713512

RACE PARTS



JJC *race and rally*
PASSIONATE ABOUT MOTORSPORT
www.jjcraceandrally.com

ARE DRY SUMP SYSTEMS
ARMSTRONG RACE ENGINEERING INC.
WWW.DRYSUMP.COM (916) 652-5282

RACE RADIO

Pit to Car **Autotel**
Radio solutions **Digital Race Radio**
0044(0)1508 528837
www.raceradio.co.uk

RACING

demon tweeks
MOTORSPORT
www.demon-tweeks.co.uk

AUTHORISED DISTRIBUTOR
OMP **YBRACING**
MOTORSPORT & PERFORMANCE
WWW.YBRACING.COM

RACING

PORSCHE SHOP
10% off with website
voucher code AUTOTEN
Or Call: 0121 585 6088

CARTEK
MOTORSPORT ELECTRONICS

info@cartekmotorsport.com
023 80 467747
www.CARTEKMOTORSPORT.COM

JORDAN RV
WWW.RENTAMERICANMOTORHOMES.COM
08703 008008

TRAILERS & TRANSPORTERS

BRIAN JAMES TRAILERS
» Connected to you
www.brianjames.co.uk

itchy feet
european & american motorhomes
0345 504 5550

WHEELS & TYRES

Image® Manufacturers of bespoke split rim alloy wheels
www.imagewheels.co.uk
IMAGE WHEELS INTERNATIONAL LTD.



TO ADVERTISE IN THE WEB DIRECTORY
PLEASE CALL **020 8267 5271**
OR EMAIL autosport.ads@haymarket.com

BRIAN JAMES TRAILERS

»» Connected to you



www.brianjames.co.uk

Ready to Race.

For over 35 years our trailers have been used at every motorsport competition up and down the country by professionals and club racers alike.

This long standing support within racing community has enabled us to engineer the best possible products focused at every level of motorsport.

The brand new Race Sport embraces class leading features along with a class leading price to make it one of the best investments in your motorsport equipment imaginable.

Race Sport 4.5m bed length £ 6,749.00 + vat
Race Sport 5.0m bed length £ 6,999.00 + vat

BJT also offers a wide range of open trailers like the C4 BLUE shown to the right. For more information on our trailer range or to find your nearest dealer visit:

www.brianjames.co.uk/dealer



RACE SPORT

T +44 (0)1327 308 833

For more information and details on the Brian James Trailers range, please contact our head office.



www.**WOODFORDTRAILERS**.com

HIGH QUALITY TRAILERS FOR CLUB, PRIVATE AND PRO MOTORSPORTS

DEVELOPED BY PROFESSIONALS, FOR PROFESSIONALS



**DEALERS WANTED
IN EUROPE**

**All Woodford Trailers have full
European Type Approval**

We have been designing and building our extensive range of high-quality, adaptable vehicle trailers from our Northamptonshire home for over 20 years, selling at highly competitive prices to suit a wide range of requirements. Please get in touch with us to discuss your needs.

Tel: 01327 263384 ● Mob: 07514 954751 (24 hrs)

● E-mail: sales@woodfordtrailers.com

● Web: www.woodfordtrailers.com

TRAILERS & TRANSPORTERS / MARKETPLACE

PRG TRAILERS

Finest Built British Trailers.



PRG Trailers | Cheshire | UK | Tel: +44 (0) 1270812402
Web: www.prgtrailers.co.uk | Email: info@prgtrailers.co.uk

CARS FOR SALE

3 x GP3/13 race cars for sale

Multiple race-winners in 2012 & 2014 Excellent condition & maintenance



-3 x 2015 GP3 race cars for sale

-Race-winners in 2012 & 2014

-Ex-Stanaway, Yelloly, Stockinger

-Complete cars, fully rebuilt

-Dallara chassis (1 only 12 months old)

-Magneti Marelli ECU

-Hewland gearbox w/paddle shift

-Koni dampers

-Brembo brakes

-Always prepared to highest standards

-Located Silverstone, UK

-Delivery available on request

-Per Car Price (+ VAT where applicable)

Please send offers to

jhs@statusgp.com

For further information, please contact Status Grand Prix on
+44 (0)1327 857 777 / info@statusgp.com

OILS

World Class Cooling Solutions.

Whatever you drive.



For over 25 years PWR Performance Products has helped lead some of the worlds biggest F1, WRC and other leading global motorsport series to victory across an international stage. Developing state of the art cooling solutions has established our unrivalled quality in the industry. Crafting premium cooling solutions doesn't mean you need an F1 budget. Whether you're a design engineer, purchasing manager or a racer yourself, talk to PWR about tailoring a solution for your race or rally car.



www.pwr.com.au

www.pwreurope.com

www.crracing.com

For further help and advice, please talk to our team of experienced Sales Engineers.

KARTING

THE FASTEST WAY TO EXPERIENCE KARTING

KKC and Vital Motorsport are proud to offer you the chance to try out some of the fastest Arive & Drive Karts in the UK for all ages from 6 in Daventry, Northampton

Our different packages are designed for people looking to try before you buy as well as people looking for a one off experience

With Rotax Max 125cc 2-stroke race Karts, that provide 75% more horse power than your standard corporate Kart, and championship winning TonyKart race chassis, this is the pinnacle of Kart racing

Prices starting from just **£125!**

More information and prices online at www.kkckart.com/rotaxexperience



☎ 01327 844320

🌐 www.kkckartshop.co.uk

@martyn@kkckartshop.co.uk 🚲 5 miles from M1 junc.16/18

🌐 Whilton Mill, Whilton Locks, Daventry, Northants, NN11 2NH



1983 WILLIAMS FW08C #11

An Iconic and highly desirable World Championship winning Patrick Head designed Williams which remains highly competitive in 2016.

- / Complete and fully operational in non-ground effect specification with period correct DFV.
- / Appeared and was highly competitive in several high profile events in 2015 including Austin Texas GP support race.
- / Current HTP/FIA papers and some spares included.
- / Ongoing preparation / race support available from highly experienced Ex Williams personnel.



CARS INTERNATIONAL

T +44 (0) 1488 71029

W www.carsinternational.com

E info@carsinternational.com



APPLY ONLINE
CHOOSE YOUR OWN START DATE

The WORLD'S FIRST ONLINE Motorsport Engineering Degrees

FdSc Motorsport Engineering | BSc (Hons) Motorsport Engineering



NMA Team - Lotus Evora GTE

Accelerate Your Career In Motorsport!

AFFORDABLE - FLEXIBLE - ONLINE

Who should do this course?

Do you...

- Want to improve your career prospects by becoming a highly qualified Motorsport Engineer?
- Work or volunteer in motorsport without a degree?
- Work in the automotive sector and would like a career change into motorsport?
- Want a motorsport degree but can't justify the time/travel & accommodation costs at university?
- Have work or family commitments & need to earn while you learn while studying for your motorsport qualification?

If you answered YES to any of the above, then the NMA Online BSc (Hons) Motorsport Engineering Degree is the course for you!

* Degrees are awarded by our partner Staffordshire University.



Why Study with NMA?

- 40% lower fees than other universities & access to student loans
- Choose your own start date, no term times or semesters, work at your own pace & study from anywhere in the world
- Mature students welcome - No upper age limit
- Earn while you learn
- No travel or accommodation costs
- Study Online & On-track
- Free industry standard CAD software



Race day experience for students

motorsport.nda.ac.uk

+44 (0)1159 123456



Poorboy's World

'Not much money... but what a shine'

Premium Car Care and Detailing Products



- Shampoos
- Polishes
- Swirl Removers
- Waxes/Sealants
- Quick Detailers
- and more...



www.poorboysworld.co.uk

Invisible Glass

Premium Glass Cleaners and Rain Repellents



Makes Glass Invisible!

"We use **Invisible Glass** at every race. Our drivers need the clearest view in all conditions"
- Shaun Goff, Optimum Motorsport



www.invisibleglass.co.uk

MARKETPLACE

MEMORABILIA

F1 COLLECTORS .COM



#1 FOR F1 MEMORABILIA & AUTOGRAPHS

We buy and sell F1 items
AYRTON SENNA specialists

Call CHRIS GRINT

01763 274448

email:- sales@f1collectors.com

TYRES

FOR ALL YOUR
AVON
TYRES
MOTORSPORT
RACING TYRES
Inc. ACB 10 Formula Ford
Contact

BMTR LTD

Tel: 0121 331 1122
Fax: 0121 331 1144
email: sales@bmtr.co.uk
see our new website at www.bmtr.co.uk

RACE PRODUCTS

CARTEK
MOTORSPORT ELECTRONICS



**INNOVATION
QUALITY
RELIABILITY
SAFETY**

SUPPLIERS TO:



**BATTERY ISOLATORS
FIA RAIN LIGHTS
POWER DISTRIBUTION
COOLANT LEVEL
SENSORS
WIRELESS STEERING
WHEEL CONTROLS
SHIFT LIGHTS**

GET IN CONTACT:

www.CARTEKMOTORSPORT.com
+44 (0) 2380 457747
info@cartekmotorsport.com

RACE PRODUCTS

London Motorsport Showroom
www.msar.co.uk



Order Hotline: 020 8655 7877

msar UK agent for SCHROTH RACING

Visit Us At Our New Larger Showroom

RACE PRODUCTS

Elite Carbon Fibre

Carbon fibre race car component manufacturer

EliteCarbonFibre Ltd.
Units 20-22 Norwich Road Ind. Est.
Watton, Thetford, Norfolk IP25 6DR

Contact – Dave Greenwood 07809390316
Email – davecarbonelite@googlemail.com
Website – elitecarbonfibre.co.uk

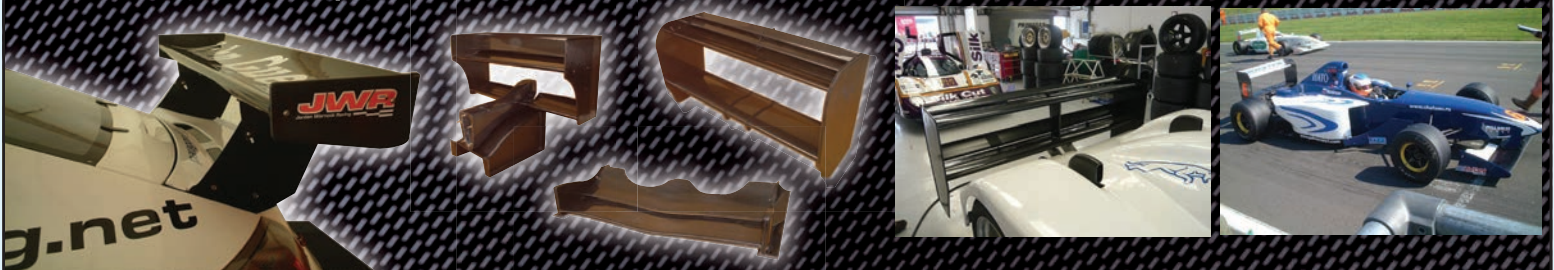

Carbon Composite Wings, Bodywork & Repairs

RACE PRODUCTS

FREE



2016 CATALOGUE

516 pages of the best motorsport parts, accessories
and innovative new products. Available to order now.

Online at www.demon-tweeks.co.uk Call **0906 250 1516**

Calls to 0906 numbers cost 50p per minute at all times. (Calls should last no longer than 11/2 minutes).

**demon
tweeks**
MOTORSPORT

AUTOSPORT

**IF YOU'D LIKE
TO ADVERTISE
YOUR PRODUCTS
AND SERVICES
PLEASE CALL
020 8267 5992**

MARKETPLACE

RACE PRODUCTS



PUMPS

High quality, reliable, quiet
Used by professionals



OTP 017
(P3017.1)

£52.00

Replaces: Bosch 0580 464 070

OTP 018
(P3018.1)

£56.00

Replaces: Bosch 0580 254 911

OTP 019
(P3019.1)

£58.80

Replaces: Bosch 0580 254 910/941/942



**'IN-TANK'
FUEL PUMPS**

ALL PRICES EXCLUDE VAT @ 20%

MOTORSPORT

OTP 020

(P3020.1)

£60.20

240 LTR/HR
210 LTR/HR @ 3BAR

Replaces: Bosch 0580 254 909

MOTORSPORT

OTP 979

(P3979.1)

£69.00

264 LTR/HR
228 LTR/HR @ 3BAR

Replaces: Bosch 0580 254 979

MOTORSPORT

OTP 044

(P3044.1)

£77.40

378 LTR/HR
318 LTR/HR @ 3BAR

Replaces: Bosch 0580 254 044



Tel: 01784 493 555 www.glencoeltd.co.uk Email: sales@glencoeltd.co.uk

FERRARI



Ferrari 458 Challenge GTR All Carbon Upgrade AeroKit & Power Performance

Quality, precision and fastidious attention to detail



Power upgrade to 620bhp and 4-way adjustable suspension also available

www.evo2motorsport.co.uk

Email: info@evo2.biz | Tel: +44 (0) 1608 730280 | Mobile: +44 (0) 7785 330690



MARKETPLACE / MOTORSPORT JOBS

DRIVES AVAILABLE

2016 F3 Cup Drives Available



★ Dallara F305-7 F3 cars for rent
Fully maintained, cars ready to race or test
Full or partial season with testing to suit your budget

★ Full preparation and maintenance package for *your* car
including the Dallara F308 - F311 cars

★ Exciting new 3 race format in the fastest UK single seater
championship

Omicron Motorsport

2014 & 2012 F3 Cup Teams Champions

Contact Tristan Cliffe on: 01508 570351

racing@omicronmotorsport.co.uk

www.omicronmotorsport.co.uk

AUTOSPORT

Want to advertise a motorsport job?
If you are recruiting in motorsport and
wish to advertise with
Autosport in print and online
please contact
Jamie.Brooker@haymarket.com
by email
or call 020 8267 5271.

For all current vacancies
advertised please visit
our website
www.autosport.com

MANOR RACING

Manor Racing are an upstart F1 team with a start up mentality. We are seeking smart, creative team players for the following roles:

NO1 MECHANIC (RACE TEAM) - Taking the lead for the preparation and set up of your allocated race car, you will have extensive experience of working in a similar role, preferably within an F1 team

NO2 MECHANIC (RACE TEAM) - Responsible for the preparation and set up of your allocated race car, the successful candidate will have proven experience of working as a mechanic within a Motorsport team

TRAVELLING COMPOSITES TECHNICIAN - Successful candidates will maintain and repair all race car composite parts and be skilled at composite bonding, wet layup, reading technical drawings and fitting hardware

TRAVELLING COMPOSITES/FABRICATOR - Experienced at both fabrication and composites, you will repair and maintain our pit equipment and support the wider race team. Proven experience of working in a similar role within Motorsport is preferred but not essential

RACE TEAM MECHANIC (FACTORY BASED) - Providing mechanical support, working within race and factory departments and assisting trackside, you will demonstrate proven knowledge and experience (ideally Motorsport), of all aspects of the preparation & operation of the car

SENIOR SYSTEMS ENGINEER (RACE TEAM) - The successful candidate will lead, coach and manage the trackside team, operating the electronic systems whilst building firm and effective relationships with all internal and external clients. We are seeking candidates who are educated to degree/HND level in an engineering discipline and have extensive experience of race car electronic systems within high level motorsport

Please apply by sending your CV and covering letter to:

Jobs@manorracing.com

WE GO FOR THE GAP

manorracing.com

 Manor Racing

 Manor Racing

DMAX

RACE AT THE HIGHEST LEVEL



**COMPETE IN THE UK'S FASTEST
ARRIVE + DRIVE CHAMPIONSHIP**

FIND OUT MORE www.daytonamax.co.uk
OR CALL 033 033 278 70



AMERICAN SPEEDFEST IV
BRANDS HATCH

11/12 JUNE 2016

IV

BRANDS HATCH

STARRING **NASCAR WHELEN EURO SERIES**

THE BIGGEST CELEBRATION OF AMERICAN-FUELLED MOTORING, MUSIC AND RACING THIS SIDE OF THE ATLANTIC!

WWW.SPEEDFEST.CO.UK
0843 453 9000

EURO NASCAR RACING ★ CLASSIC AMERICAN RACING ★ 1000+ AMERICAN SHOW VEHICLES ★ HOT ROD & CUSTOM DISPLAY ★ LIVE MUSIC ★ GREAT FOOD ★ FAMILY FUN
ADULT WEEKEND ONLINE - £29 ★ ADULT SUNDAY (MAIN DAY) ONLINE - £23 ★ UNDER 13S GO FREE ★ GRANDSTAND SEATS - FROM £5

*Advance tickets available until midday Wednesday 8 June. Postage fee applies. Calls will cost 7p per minute plus your telephone company's access charge.



CLUB AUTOSPORT

NATIONAL RACING • HISTORICS • HILLCLIMB • TRACK TESTS • FEATURES



Ferrari 488 GT3 will be in seasoned hands for Silverstone 500

Carroll to join Attard for Ferrari debut

THE FERRARI 488 GT3'S BRITISH GT Championship debut is set to come with Barwell Motorsport refugee Adam Carroll and 2014 champion Marco Attard behind the wheel.

Attard is in talks with FF Corse and Fox Motorsport to make a one-off return, sharing the new machine with pro racer Carroll in the marquee three-hour Silverstone 500 event on June 12.

The car was entered for owner Paul McNeilly and Jamie Stanley, but the pair are prepared to step aside to allow Attard and Carroll to give the 3.9-litre twin-turbo machine its British GT debut. Sources say the deal is 90 per cent settled, with only insurance remaining to be confirmed.

McNeilly and Stanley will instead race their Ginetta G55 GT4.

Attard, who won the 2014 British title and finished second last term, sharing an Ecurie Ecosse BMW Z4 GT3 with Alexander Sims, backed out of the class this year to focus on the Blancpain Endurance Series in a Barwell Motorsport Lamborghini Huracan.

Attard has now stepped aside to allow Phil Keen to share that car with

Leo Machitski and Marco Mapelli.

"The deal is very close and the plan is for us to race the Ferrari at Silverstone," Attard said. "I love British GT, and I want to do some racing this year after stepping back from Blancpain. The new-generation GT3 cars are more amateur-driver-friendly, so hopefully I can click with the Ferrari quickly."

Carroll has been standing in for Sims at Barwell while the BMW factory driver had clashes, a deal that ended with an Oulton Park win on Monday.

"Adam is a brilliant driver, he's just like Alexander – he only takes a few laps to get on the pace," Attard added. "We want a result out of this, so we're taking it seriously, but at the moment it's a one-off."

Shakedown in Italy

McNeilly and Stanley shook the new 488 GT3 down with Fox and FF at Adria last week, with the chassis due to arrive back with the team on Friday.

"Adria isn't the best track to test a leggy new GT3 car as it's mostly low-gear corners, but the 488 is a massive step forwards over the old 458,"



Marco Attard (right) is lined up to race the Ferrari 488 GT3 in the British GT. He won the title in 2014, sharing the drive with Alexander Sims (left)

said Stanley. "The chassis is superb and you can feel how stable it is under weight transfer. Things like the traction control and ABS have also been hugely improved to make it more accessible for the amateur drivers."

McNeilly added: "The plan was always to buy the car for commercial use, so I have no issues with renting it to drivers like Marco and Adam. We want to do selected GT3 rounds with it this year and hopefully the full British GT season next year."

Comprehensive motorsport insurance products to keep you on track;

- ✔ Accident damage On Track
- ✔ Liability
- ✔ Rally damage On Event
- ✔ Personal Accident
- ✔ Storage and Transit
- ✔ Track day

Log on to www.ryanmi.com to obtain your online quote
Email – info@ryanmi.com Tel – +44 (0)1799 524202

Ryan Motorsport Insurance Limited is an appointed representative (557405) of Independent Broking Solutions Limited who are authorised and regulated by the Financial Conduct Authority. Its Financial Services Register number is 312026

RYAN
MOTORSPORT INSURANCE



BRDC BRITISH F3

Vaidyanathan in huge crash

CARLIN DRIVER AMEYA VAIDYANATHAN WALKED away unscathed from a huge crash in last weekend's opening BRDC British Formula 3 race at Oulton Park.

Vaidyanathan had a run on HHC Motorsport's Sisa Ngebulana and passed on the right into the kink before Cascades. Ngebulana turned in and the cars made contact, launching Vaidyanathan into the air.

His Tatuus flipped end-over-end, sustaining serious damage. He required assistance to get out of the car and was taken to the medical centre. He was cleared by medical staff but observed for 30 minutes as a precaution.

"I had a good run on Sisa, he left room on the inside at the kink going into Cascades," said Vaidyanathan. "I was ahead of him from my point of view and then there was

contact between his front-right and my rear-left, which was quite disturbing.

"After that I felt a few big hits, but had no idea what direction they were or where they were coming from. I was in shock afterwards, but once the initial trauma subsided I was OK. I'm just very grateful to the people from Tatuus for the strength of their car."

Ngebulana was excluded from ninth place in the race results and hit with four penalty points.

HHC team boss Charlie Kemp said: "I think the punishment is a little harsh. Sisa has misjudged it slightly, particularly with the closing speeds. It was the lightest of touches, which is why it was such a big accident. Sisa was obviously distraught."

GT CUP

Record-setting GT2 Ferrari to return to race action

THE RECORD-SETTING FERRARI 430 GT2 MACHINE THAT WON the 2006 British GT Championship in the hands of Tim Mullen and Chris Niarchos could return to competition.

Seasoned club racer Mike Humphreys has bought the car, which won a record seven-straight British GT races during its title-winning season with the Scuderia Ecosse team a decade ago.

After GT2 cars were phased out for 2007, the machine raced in FIA GT before being stored by CRS Racing. Fun Cup regular Humphreys bought the car from CRS and has entrusted it to Intersport Racing, ahead of possible outings in the GT Cup,

Britcar and the Dutch Supercar Challenge.

"The GT2 Ferrari is a serious bit of kit," said Intersport boss Kevin Clarke, who shook the chassis down at Donington Park recently. "It's a huge step up for someone not used to racing powerful GTs. The closing speeds are amazing, even compared to some modern GT3s, so Mike has some learning to do.

"It's a great bit of engineering, and is so lovely to drive. You can put it where you want it and it gives you a real kick in the back whenever you hit the throttle. It's got a great history, so it's nice to get cars like that back out competing."

HSCC

AUTOSPORT 3 HOURS CUT TO ONE HOUR

This weekend's Autosport 3 Hours has been cut to one hour because of tyre wear problems with Dunlop's Chevron rubber.

A lack of entries for the enduro has led to the reduction in race length. Rapid front tyre wear on the pacesetter Chevron B6s and B8s is one of the main reasons for the poor entry levels.

Dunlop moved its historic tyre production from the UK to Portugal two years ago. Marketing and communications manager James Bailey said Dunlop is working to solve the problems.

"We always try and make the tyres the same, but when you move to a new factory it can be a couple of iterations before it's there," he said.

"We had an issue with the front tyres. It wasn't a safety issue, but the handling was inconsistent. We hope to have it addressed by August."

The move is also causing supply problems for certain types of historic racing tyre.

"There is a size of tyre we have not been able to produce yet. So far this year we have supplied more historic tyres than we have for the last three years, but there has been a spike in demand for certain tyres.

"We have been able to supply 98 per cent of demand and we will be increasing production in order to meet demand. We expect it to stabilise in the second half of the year. We're committed to historic motorsport – it's an important part of what we do."

Race organiser the Historic Sports Car Club and other clubs have relaxed tyre regulations to allow competitors to use alternative tyre suppliers when it is possible to do so.

OBITUARIES

Neil Cunningham: 1962-2016

RACERS FROM ACROSS motorsport have paid tribute to Neil Cunningham, who lost his brave fight against Motor Neurone Disease last week at the age of just 53. The former single-seater and British GT ace was diagnosed with the condition six years ago but faced it with typical good humour.

Although a New Zealander by birth, Neil arrived in Britain after starting racing in Formula Ford in Australia and soon made his name as a rising star of Formula Ford 1600.



When his single-seater career stalled, Neil moved to Eurocars, winning the 1996 V6 title. But it was in

sports and GT cars that he really found his perfect racing home.

He won multiple times in the British GT Championship, notably with Embassy Racing in a GT2 Porsche he shared with Ben Collins in 2005, finishing third in the standings

Later, he raced across Europe and then returned to the Le Mans 24 Hours in the LMP2 category, as well as appearing in historic racing categories.

An in-depth tribute to Neil will appear in the June 30 issue of Autosport.

Chris Meek: 1942-2016

CHRIS MEEK, THE former racer who saved Mallory Park in the 1980s, has died at the age of 73.

A successful property developer and racer of everything from Formula Ford and Formula Atlantic cars to production sportscars in the 1960s and '70s, Meeke was also

a key supporter of Tom Pryce as the young Welshman made his way towards Formula 1.

Meek first raced motorbikes and then moved to sportscars and single-seaters, racing in Formula Junior in the early 1960s. He enjoyed success in a Ginetta G4 and then

tried his hand at 1600cc Formula 2 later in the decade. Ford and Atlantic success followed.

However, it was in production sportscar racing that Meek had some of his most successful seasons and won six titles through the 1970s, racing cars ranging from a Lotus Europa to a TVR and a Panther Lima.

When Mallory Park seemed destined to close, Meek stepped in and his Titan Properties company acquired the circuit's freehold to ensure the venue's future.



BRITISH GT

Webster to make British GT debut



Webster took two GT Cup class wins at Silverstone

FORMER WORLD AND European karter Sam Webster will make his British GT debut at Donington Park this year.

Webster will share a Fox Motorsport Ginetta G55 with Jamie Stanley in the race in September after making his GT4 bow in the car in last weekend's GT Cup triple-header at Silverstone.

The 19-year-old took two GTA-class wins, one driving solo and one sharing with Stanley. The pair were third in class in the first race.

IN BRIEF



McLAREN BLAZE IN GT CUP

GT Cup racers Stuart and Lewis Proctor were forced to switch cars at late notice at Silverstone last weekend when their McLaren 650S GT Sprint caught fire (above) during the opener. McLaren GT's Andrew Kirkaldy said: "We think the car cracked an exhaust and that started to melt one of the bodywork surrounds. Stuart pulled over but the marshals took a long time getting there and it went from smouldering to fire. However, the damage was limited as the marshals put it out pretty quickly."

MINI MAN SUBS FOR TRAVIS DRUMMER

Mini Challenge star Jono Brown will stand in for Travis drummer Neil Primrose alongside Graham Roberts in the Track Torque team's GR8 in the British Endurance Championship at Donington Park this weekend. "Neil is away on tour so the team called me and offered me the seat," said Brown.

GIDDINGS BACK TO CLIOS AGAIN

Jake Giddings, the 2014 British GT4 champion, will make another Renault UK Clio Cup appearance this weekend. The 21-year-old returned to the category for the first time since 2013 at Thruxton last month and will again compete with his family Finesse Motorsport squad at Oulton Park. He is also driving an Aston Martin for JW Bird Motorsport in GT4 this year.

EQUIPE GTS GETS 62-CAR ENTRY

The Equipe GTS series has attracted a 62-car entry for its double-header at the MG Live meeting at Silverstone this weekend. The category (below) caters for pre-1966 cars with up to 2.5-litre engines and run to Appendix K rules. The Silverstone Grand Prix track has a limit of 58 cars so there is a waiting list. Over 30 MGBs have entered, while numerous Triumph TR4s and TVR Granturas will also race. Series organiser John Pearson admitted he was "surprised" at the size of the grid. "It's a combination of things," he said. "The racing is very close as the series is for smaller-engined FIA K cars. We don't have Marcos GTs or Lotus Elans or Ginetta G4s and the top 20 cars are usually within two or three seconds."





Brands Hatch brings out the best in racers

By Marcus Pye, the voice of club racing

[@Autosport](#)

NOT HINDERED BY BEING FUNDAMENTALLY FLAT like airfield circuits, Brands Hatch's delicious melange of inclines and cambers has been the source of inspiration for serious drivers since 1960. Exploiting the swoops and borrows of the Kentish woodland, the Grand Prix loop has always brought out the very best in competitors. I'm proud that my first (of few) race wins was scored there in Formula Ford in '82, a Dunlop-Autosport Star of Tomorrow heat, thus it harbours fond personal memories.

But for Dingle Dell corner, which has undergone some metamorphoses, the 2.43-mile circuit is essentially the same as that on which Jack Brabham, Graham Hill, Jim Clark, John Surtees and rivals starred in its infancy. It is also the stage of Pedro Rodriguez's mesmerising drive to victory in the 1970 BOAC 1000 Kilometres sportscar classic – the little Mexican famously dancing his savage JW Automotive Gulf Porsche 917K through a monsoon after an enforced pitlane visit rollicking from giant BRSCC clerk of the course Nick Syrett. And it's one that animates witnesses still.

Last weekend's Masters Historic Festival was not only distinguished by some superlative drives – take a bow Nick Padmore and Martin Stretton, FIA Formula 1 and Sports Car winners respectively – but also by a real atmosphere, which made the annual event special.

Seeing South Bank well populated by spectators' cars, plus a host of marque club members displaying cherished motors the length of the start/finish straight on Sunday, added considerably to the ambience.

Never has there been a greater clamour at Brands than at the 1976 British GP, when fans got behind their dashing hero James Hunt, cheering him to victory following a stoppage after a first

corner chain reaction shunt, triggered by Clay Regazzoni clipping Ferrari team-mate (and Hunt's title rival) Niki Lauda's car. I vividly recall watching from Druids as a barrage of cans was pitched onto the track when it became apparent that Hunt's repaired McLaren M23 – which had limped into the back of the pits, thus not completing the lap – might not be permitted to restart. Organisers capitulated, probably fearing a riot.

Forty years on, veteran commentator Brian Jones, who called the race that day, joined me in the commentary box for a tribute to Hunt that saw M23 and Hesketh F1 cars (including James's 1974 BRDC International Trophy-winning 308-1, driven by current custodian James Hagan) demonstrated. Also on track was Hunt's son Freddie, who returns to the NASCAR Euro Series arena in the forthcoming American Speedfest IV at Brands on June 12-13 in a Chevrolet Camaro, although his aspirations are entirely dependent on raising finance.

Coincidentally, I listened to the '76 Japanese GP, in which Hunt clinched the F1 title in typically dramatic style, on BBC radio from the house of relations at Eynsford, four miles from Brands and regular digs in my pre-driving days. Sunday dinner with pals in The Malt Shovel pub in the village brought more memories of that and myriad other pilgrimages past flooding back. Also 'in' was a cheery band of Dutch Historic Touring Car and GT racers for whom it has become a social tradition over the Masters weekend.

I can't end this column without mention of friends (long-time VSCC secretary) Mike Stripe, property developer racer and Mallory Park saviour Chris Meek and Kiwi ace Neil Cunningham, who died last month. Their passion for cars and motorsport remained undimmed. RIP.



DEVIS DEBUTS SENSATION TOJ

Belgian Marc Devis declared his TOJ SC303 a winner having finished second in Sunday's Can-Am 50 Interserie Challenge race at Brands Hatch. Devis acquired the TOJ, which failed to start the 1978 Le Mans 24 Hours after engine failure, from American Peter Read. Immaculately restored by Martin O'Connell's OC Racing team, the TOJ ran for the first time on Friday, but retired from Saturday's race with a broken master switch. Future plans include July's Silverstone Classic.



SMITH-HILLIARD'S SHADOW BOXING

Fresh from a brilliant second in the Monaco GP Historique's 1966-'72 F1 race with his Surtees TS9B, Max Smith-Hilliard debuted his ex-Tom Pryce Shadow DN5/5B in last weekend's Brands Hatch round of the FIA Masters Historic F1 championship. As Nick Padmore notched two outright victories on his promotion to MS-H's ex-Carlos Reutemann Williams FW07C-14, Max was twice runner-up in the Fittipaldi class – to Michael Lyons (Hesketh 308E) and Phil Hall (Theodore TR1) – in the Shadow.



Mini Challenge battle tightens after thrillers

A FINE DEFENSIVE DISPLAY GAVE UNITEC Motorsport's David Grady a hard-fought brace of JCW wins as he twice held off the charging Chris Smith. But three visits to the podium for Nathan Harrison, including second place in race two after a late issue for Smith, drew him level on points with Charlie Butler-Henderson at the head of the Mini Challenge championship.

"Bad qualifying, but then I couldn't have asked for more," said a relieved Butler-Henderson, who managed to turn his ninth place starting spot into a brace of podiums. "It's such a level playing field." Jono Brown fended off the charging Butler-Henderson in race three, with Harrison promoted to his third podium by Henry Neal's demotion from third place after a time penalty for disrespecting track limits.

In the Open, Cooper and Cooper S encounters, Steve Cocker once again appeared out of luck from pole position on Saturday, as continuing ECU issues for the Oakfield Motorsport man reared their ugly head in the opening two races.

Scott Jeffs took full advantage, easing clear of a fierce fight for second in race one before doubling up in the second event despite a slow start dropping him to fourth.

His fourth win of the season was followed by Cocker's second in race three, the latter recovering from an attack from Rob Austin at half-distance by retaliating at Copse two laps later. Max Blydson was again in a class of

his own in the Coopers, bagging a second hat-trick in two outings.

It was similarly close in the GT Cup, amid the brewing duel between Jordan Witt's Bentley Continental GT3 and the striking Porsche 935 of Richard Chamberlain. A damaged exhaust caused a fiery exit for the McLaren 650S GT Sprint of Stuart and Lewis Proctor in race one, although the delay did not deter the fast-starting Chamberlain, who hung on for victory. "I was flat-out", was Chamberlain's summary. "Jordan was always there. It's the first time the Bentley has been beaten fair and square."

Witt hit back later in more fortuitous circumstances, taking what he called a "bittersweet win" after erstwhile race two leader Chamberlain suffered a shock-absorber failure while defending the top spot.

After a supreme repair job to fix the 935, contact with Witt on lap 12 at Becketts ended Chamberlain's fight prematurely in the 50-minute endurance race. Witt's win extended his championship lead from the GTB-class BMW M3 paring of Tom and James Webb.

The unbeaten Mono Championship run continued for Robbie Watts. The Dallara F302 has taken him to the top step in all four races he has entered after two lights-to-flag victories at Silverstone, while engine failure in race one meant Tony Bishop surrendered his Mono F3 series lead to Ben Cater. The second Monoposto grid was dominated by the Dallara F399 of Jeremy Timms in the 1400 class, as he beat Chris Woodhouse and Craig Hurrans comfortably.

BMW E46 M3 driver Richard Bromley fought to Trackday Championship success from Mark Flower, while points leader Big Skidz Racing suffered retirement in the 45-minute encounter from fourth with a driveshaft problem.

Fifth was Andrew Ball's Porsche Boxster S, which was victorious in the Trackday Trophy after pouncing on Gary Burstow's BMW 328i with 13 minutes remaining.

DAN MASON



RESULTS

MINI CHALLENGE JCW (ALL 19 LAPS)

1 David Grady; 2 Chris Smith +0.307s; 3 Nathan Harrison; 4 Jono Brown; 5 Charlie Butler-Henderson; 6 Brett Smith. **Fastest lap** Henry Neal 1m04.369s (91.74mph). **Pole** Grady. **Starters** 27.

RACE 2 1 Grady; 2 Harrison +11.292s; 3 Butler-Henderson; 4 Brown; 5 C Smith; 6 B Smith. **FL** Jeff Smith 1m04.190s (92.00mph). **P** Grady.

S 27. RACE 3 1 Brown; 2 Butler-Henderson +0.927s; 3 Harrison; 4 B Smith; 5 Lawrence Davey; 6 Juan Diego Hernandez.

FL C Smith 1m04.376s (91.73mph). **P** Brown. **S 26.**

MINI CHALLENGE COOPER S, OPEN AND COOPER (ALL 18 LAPS)

1 Scot Jeffs (Cooper S); 2 Scot Adam (CS) +8.447s;

3 Rob Austin (CS); 4 Tim Porter (CS); 5 Keith Issatt (R56 Cooper S); 6 Richard Mills (R56 CS). **CW** Issatt (O180); Max Blydson (Cooper).

FL Austin 1m06.916s (88.25mph). **P** Steve Cocker. **S 28.**

RACE 2 1 Jeffs; 2 Adam +4.100s; 3 Austin; 4 Porter; 5 Stuart Lane (R53 Cooper S); 6 Issatt. **CW** Issatt; Blydson. **FL** Austin 1m06.607s (88.66mph). **P** Jeffs. **S 29. RACE 3 1 Cocker;** 2 Adam +0.599s;

3 Jeffs; 4 Austin; 5 Porter; 6 Richard Mills (R56 CS). **CW** Mills; Blydson. **FL** Austin 1m06.979s (88.17mph). **P** Cocker. **S 28.**

GT CUP (20 LAPS) 1 Richard Chamberlain (Porsche 935);

2 Jordan Witt (Bentley Continental GT3) +0.445s; 3 John Dhillon (Ferrari 458 GT3); 4 Colin Paton/Ross McEwen (Porsche 991 GT3 Cup); 5 Paul Bailey (Ferrari 458 Challenge); 6 Joe Tuckey (Porsche 991 GT3 Cup). **CW** Paton/McEwen; Tom Webb/James Webb (BMW M3 E46 GTR); Ian Anderson/Amanda Black (Ginetta G55). **FL** Chamberlain 55.358s (106.68mph). **P** Witt. **S 24.**

RACE 2 (25 LAPS) 1 Witt; 2 Darren Nelson (Lamborghini Huracan GT3) +12.761s; 3 Dhillon; 4 Nigel Hudson (Audi R8 GT3); 5 Kevin Riley (Lotus Evora GTE); 6 Bailey. **CW** Bailey; Nigel Armstrong (Porsche 997 GT3 Cup); Sam Webster (Ginetta G55). **FL** Witt 55.363s (85.39mph). **P** Chamberlain. **S 23. RACE 3 (50 LAPS) 1 Witt;** 2 Dhillon/Aaron Scott +25.340s; 3 Hudson/Adam Wilcox; 4 Riley/Gareth Downing; 5 Nelson/Stuart Moseley; 6 Bailey/Andy Schulz.

CW Bailey/Schultz; Jonathan Evans/Tom Bradshaw; Webster/Jamie Stanley. **FL** Nelson/Moseley 55.319 (106.75mph). **P** Witt. **S 22.**

MONO CHAMPIONSHIP F3/2000/CLASSIC (17 LAPS)

1 Robbie Watts (Dallara F302); 2 Ben Cater (Dallara F301) +5.856s; 3 Chris Hodgen (Dallara F304); 4 Daniel Hands (Dallara F301); 5 Chris Davison (Dallara F301); 6 Simon Tate (Dallara F302).

CW Terry Clark (Van Diemen RF00); Will McAteer (Reynard 923).

FL Watts 54.955s (107.46mph). **P** Watts. **S 27. RACE 2 (22 LAPS)**

1 Watts; 2 Cater +4.418s; 3 Hodgen; 4 James Rimmer (Dallara F302); 5 Davison; 6 Tate. **CW** Kevin Otway (Van Diemen F4); Chris Lord (Formula Vauxhall Lotus). **FL** Watts 55.122s (107.13mph). **P** Watts. **S 24.**

MONO 1800/1600/MOTO 1400/1000 (16 LAPS) 1 Jeremy Timms

(Dallara F399); 2 Chris Woodhouse (Spreads RM04) +17.400s;

3 Anthony Gauntlett (Formula Jedi); 4 Craig Hurrans (Jedi Mk6);

5 Andrew Gordon-Colebrooke (Dallara); 6 Jonathan Reed (Jedi Mk6). **CW** Woodhouse; Douglas McLay (Mygale SJ10); Eddie Guest

(Lola T640). **FL** Timms 56.080s (105.30mph). **P** Timms. **S 16.**

RACE 2 (9 LAPS) 1 Timms; 2 Hurrans +14.440s; 3 Reed; 4 Gauntlett;

5 Gordon-Colebrooke; 6 Kyle Cutts (Spreads RM05). **CW** Hurrans;

Philip Davis (Van Diemen RF98); Geoff Fern (Van Diemen RF89).

FL Timms 56.507s (104.51mph). **P** Timms. **S 14.**

MSVT TRACKDAY CHAMPIONSHIP (39 LAPS) 1 Richard Bromley

(BMW E36 M3); 2 Mark Flower (BMW E46 M3) +13.247s; 3 James

Britton (BMW M3); 4 Darren Goes (SEAT); 5 Andy Ball (Porsche

Boxster); 6 David Gardner/Christopher Mills (Porsche Boxster S).

CW Britton; George Wright/Jack Wright (Porsche 944); John Lyne

(VW Golf); Colin Tester/Adrian Timpson (Toyota MR2); Jason Francis

(Ford Puma). **FL** Goes 1m05.162s (90.63mph). **P** Bromley. **S 35.**

MSVT TRACKDAY TROPHY (37 LAPS) 1 Andrew Ball (Porsche

Boxster S); 2 Gary Burstow (BMW 328i) +15.224s; 3 Steve Hewson/

Matt Nossiter (Porsche 924); 4 John Lyne (VW Golf); 5 David

Scarborough (Lotus Elise S1); 6 Dean Hyde (BMW E30).

CW Burstow; David Hitchin (Renault Clio); Paul Hatfield/Tristan

Potkins (Ford Puma); Oliver O'Neill/Mike Newman (Ford Fiesta).

FL Ball 1m08.181s (86.61mph). **P** Ball. **S 28.**

OULTON PARK
BRITISH GT MAY 28, 30

Lamborghini and Bentley's Oulton Park breakthrough

FINE MARGINS DEFINED THE TWO races at Oulton Park, where Lamborghini claimed a first British GT win since Spa 2010, before Rick Parfitt and Seb Morris took their maiden victory in the GT3 division for Bentley.

Adam Carroll and Liam Griffin's pit strategy was the masterstroke behind their dominant race one win in the Barwell Lamborghini. Their decision went against most of the grid's tactics, with a crowded pitlane on the window's opening frustrating victory hopes of the polesitting Phil Keen and Jon Minshaw Huracan, as well as the rival Bentley.

Lessons were learned for the second race and Morris's incredible first stint before he pitted gave Parfitt the perfect platform to take their first win.

Pitstops had little impact in GT4, where Mike Robinson and Graham Johnson's outstanding pace in their Ginetta was enough to secure two convincing wins. Their first was a straightforward run to the flag, while the second relied on the duo keeping their noses clean as rivals faltered.

Race one

Ignoring the fashionable tactic of pitting for a driver change as soon as the pit window opens was the key to Carroll's commanding first victory for the Barwell Huracan. Like Jonny Adam and Derek Johnston at Brands Hatch, Griffin stayed out for an extra tour before handing over to Carroll at Oulton.

That decision was quickly vindicated. Griffin had been trailing the polesitting sister Huracan of Minshaw/Keen and



The Barwell Lamborghinis lead the field away

the Bentley, but would soon jump them. Those two cars ahead pitted at the window's opening and became embroiled in pitlane errors.

Minshaw would have to serve a seven-second success penalty carried from Rockingham, but the Bentley had no such hindrance. Yet that would count for nothing, as Morris was blocked in his pit box by the Ecurie Ecosse McLaren 650S of Rob Bell and Alasdair McCaig.

Morris lost crucial time – he estimated between 15-20 seconds – but the Bentley was impeded further when Keen was released incorrectly alongside.

Keen was then given a 10-second stop/go penalty for his part in the pit mess, but the McLaren proved the killer blow to Parfitt and Morris's hopes.

"We lost 20 seconds there," said Parfitt. "Everything was working perfectly. I knew once I didn't pass Minshaw, I had to just follow, and their success penalty would work for us but the McLaren blocked us and ended that."

While Keen could only return to finish seventh, Morris took the wheel of the Bentley and expertly carved his way up the order and into third.

Carroll was out of reach for Morris, but the AmD Tuning BMW of Joe Osborne lucked in during the stops and made ground to emerge second once the order worked out. Osborne ran just over 6s ahead of Morris with 10 laps left.

Osborne, boosted by the early pitting of their last generation Z4 by Lee Mowle, was forced to go defensive late on. The Bentley had the superior pace, but help from an unlikely source secured second for Osborne. The bonnet of Matthew George's GT4 Aston came loose and landed at Knickerbrook on the final lap, bringing out the yellow flags.

"It was a great battle with Joe," said Morris. "I finally had him on the final lap, I was going to pass at Knickerbrook, but the flags meant I had to pull out of the move and get third."



Bentley crew learned from their race one loss to come out on top later

ALL PICS: EBREV/LAT



In GT4, Johnson and Robinson took their second win of 2016. Racing at the last circuit considered to be “Ginetta-friendly”, the pair were untroubled as they cantered to victory.

Behind the winners, the Aston Martin of Jack Mitchell was able to jump the Team Hard Ginetta of Jordan Stilp for second during the pit window.

Race two

Team Parker Racing learnt its lessons from the opener. From pole, Morris put in a sensational opening stint that would secure the Bentley a maiden win.

With pro drivers starting the race, gaps between cars weren’t surprising, but Morris was almost an astonishing 12 seconds clear of Bell’s McLaren when he pitted to hand over to Parfitt.

With the success penalty of seven seconds, Morris had more than compensated for the loss of time, meaning that Parfitt came out well ahead. He then drove into the distance for the win ahead and Bell admitted the Continental had the pace advantage.

“It’s mixed emotions for us,” he said. “You never want to be second, but with our season so far, with gremlins here and there, it’s a good result. The car was very good, but the Bentley was so quick.”

Keen and Minshaw bounced back from their mishap in race one to secure the



final podium place, ahead of TF Sport’s Adam and Johnston.

While GT3 was largely processionary, GT4 had fascinating duels won by Johnson and Robinson. The pair had the pace, but the tight confines of Oulton meant they had to bide their time.

Early leader Scott Malvern was cruelly forced out of a comfortable lead with power steering failure, before Anna Walewska’s mistake led to a crash at Lodge. While Johnson inherited the lead as a consequence, he was made to fight hard for it as Abbie Eaton and Marcus Hoggarth regularly had their Ebor Maserati on the tail of the Ginetta.

TOM ERRINGTON

Graham Johnson and Mike Robinson twice topped the GT4 podium

RESULTS

RACE 1 (35 LAPS) 1 Liam Griffin/Adam Carroll (Lamborghini Huracan GT3); 2 Lee Mowle/Joe Osborne (BMW Z4 GT3) +11.620s; 3 Rick Parfitt Jr/Seb Morris (Bentley Continental GT3); 4 Mark Farmer/Jon Barnes (Aston Martin Vantage GT3); 5 Derek Johnston/Jonathan Adam (Aston Martin Vantage GT3); 6 Richard Neary/Martin Short (BMW Z4 GT3). Fastest lap Adam 1m34.895s (102.12mph). GT4 winners Graham Johnson/Mike Robinson (Ginetta G55 GT4) Pole Jon Minshaw (Lamborghini Huracan GT3). Starters 27
RACE 2 (32 LAPS) 1 Morris/Parfitt; 2 Rob Bell/Alasdair McCaig (McLaren 650S GT3) +10.514s; 3 Phil Keen/Minshaw; 4 Adam/Johnston; 5 Carroll/Griffin; 6 Ross Gunn/Andrew Howard (Aston Martin Vantage GT3). FL Morris 1m34.804s (102.22mph). GT4 Robinson/Johnson. P Morris. S 26. POINTS 1 Adam/Johnston, 97; 2 Griffin, 75.5; 3 Morris/Parfitt, 68.5; 4 Carroll, 53; 5 Keen/Minshaw, 48; 6 Gunn/Howard, 45.5.



OULTON PARK
BRITISH FORMULA 3 MAY 28,30

Flying Collard leaps to double in British F3

CARLIN'S RICKY COLLARD strengthened his hold at the top of the BRDC British F3 Championship, taking two wins, two poles and two fastest laps in a dominant showing.

Collard was consistently the fastest driver throughout the weekend, with his most impressive display coming in the finale.

Balancing a clutch problem, Collard was able to make a reasonable start going into Old Hall corner and made himself wide enough to hold off the fast-approaching Thomas Randle, then eased his way into a commanding lead.

"I knew I had to make it through the first few corners," he said. "The clutch made for a difficult start."

His ability to overcome issues was also shown in his other victory, the opening sprint on Saturday. With weather conditions constantly fluctuating on the first day of the event, Collard's tyres weren't at the optimum pressures.

"We were caught out by the weather for sure," he said. "I think the tyre pressure was too low and it showed as it took five laps for the tyres to come in."

Those five laps would prove to be the majority of the race. Collard retained his lead, again defending from Randle early on. On lap six, the race was abandoned after a huge crash between Sisa Ngebulana and Ameya Vaidyanathan. The two came together on the approach to Cascades, launching Vaidyanathan into a somersault and destroying the car.

Vaidyanathan was unharmed and, with no time to accommodate a restart, Collard was declared the winner.

The only race Collard didn't win was the reversed-grid second event. He lined up eighth on the grid and, with Oulton Park a difficult track to overtake on, the priority became setting a time for race three pole. There was to be little movement throughout the field, with all aiming for qualifying lap times.

A back and forth battle over the top

time between Carlin men Collard and Colton Herta dominated the end of the race, with Collard coming out on top.

At the front, the early stages provided a good battle between Toby Sowery and Enaam Ahmed. Ahmed led through the opening laps, but Sowery had a better run into Lakeside on lap two.

Ahmed attempted to defend his position and the pair made contact, briefly launching Sowery into the air and damaging his brakes and allowing Ahmed to ease clear. Post-race, Ahmed was handed a six-second penalty that demoted him to second behind Sowery.

"I think the decision was justified," said Sowery. "I would have got the place if there wasn't contact and they just reversed the positions so I think it is right. I am not over the moon but it is more points in the bag."

Ahmed replied: "I made a mistake defending my position."

While Sowery took his first win since round two at Brands Hatch, the weekend was Collard's. He was only eighth in the second race, but did secure the pole position that became the bedrock of his win in the finale.

"It's been absolutely surreal," said Collard. "The F3 dream is becoming a reality more and more by the second. I'm confident and relaxed and I'm in a great position in the championship."

TOM ERRINGTON

RESULTS

RACE 1 (6 LAPS) 1 Ricky Collard; 2 Thomas Randle +0.905s; 3 Colton Herta; 4 Matheus Leist; 5 Jan Jonck; 6 Enzo Bortoletto. **Fastest lap** Collard 1m31.533 (105.87mph). **Pole** Collard. **Starters** 21.

RACE 2 (13 LAPS) 1 Toby Sowery; 2 Enaam Ahmed +0.171s; 3 Bortoletto; 4 Leist; 5 Jonck; 6 Herta.

FL Collard 1m30.535s (107.04mph). **P** Ahmed. **S** 21.

RACE 3 (18 LAPS) 1 Collard; 2 Randle +1.854s; 3 Herta; 4 Ahmed; 5 Leist; 6 Bortoletto.

FL Herta 1m31.306s (106.14mph). **P** Collard. **S** 21.

POINTS 1 Collard, 269; 2 Randle, 232; 3 Leist, 221; 4 Sowery, 219; 5 Ahmed, 187; 6 Huovinen, 161.



Collard celebrates his points-lead extending brace



CHADWICK MOVES CLEAR IN GINETTA GT5

OLLIE CHADWICK WAS ABLE TO CONSOLIDATE HIS lead in the Ginetta GT5 Challenge, with two wins out of three. Starting from pole for the first race, Chadwick soon pulled clear and took Jonny Hadfield with him as Ryan Hadfield, Matt Palmer and Matt Chapman disputed third. Chapman finally claimed the place with two laps left, with Ryan Hadfield and Jack Minshaw fourth ahead of Palmer.

With three cars off at Old Hall on the first lap of race two, the safety car was called into action and stayed out for the duration. Chadwick had done enough on the one racing lap to take his second win, from Ryan and Jonny Hadfield, as Matts Chapman, Palmer and Flowers rounded off the top six.

Chapman took his first win in the finale, after easing past Ian Robinson into Old Hall on lap two. Jonny Hadfield worked through the reverse grid to secure second early on, with Chadwick closing in from third. Ryan Hadfield, Robinson and Palmer completed the top six.

Kevin Bird and Charles Hyde-Andrews-Bird comfortably won the Intermarque/Aston Martin GT Challenge in their BMW M3 GT4, having taken charge during the second half to head home Tom Black's Aston Martin GT4.

The TVR Griffith of Peter and Nathan Dod inflicted a rare defeat on Mark Halstead/Stuart McPherson's Lotus Elan in the Innes Ireland Cup/50s Sports Cars, both finishing over a minute up in third placed Paul Woolley's Cooper Monaco.

Phil House's Scirocco led from pole in the VW

Racing Cup opener but Tom Witts' Golf hit the front on the second lap and survived a safety car interlude to win. House lost second to Simon Rudd, before a hub failed and he went off at Lodge. Bobby Thompson came through to complete the podium, from Kenan Dole, Jack Walker-Tully and Paul Ivens.

Walker-Tully started from pole in race two and initially led a five-car train. Witts finally got by into Knickerbrook just after half-distance to secure his second win, as the erstwhile leader went wide and fell well back. Dole kept the pressure on from a closing second, with Thompson third.

Witts made a good start in race three but House soon pushed for the lead as Kieran Gordon looked on. House got through on the inside of Lodge to lead from lap three, then had his lead wiped out by the safety car before easing clear again at the green flag.

Witts held off Gordon to retain second, with Bobby and Cameron Thompson and Damani Marciano the top six after Dole spun out at Cascades.

Joe Spencer took his Stuart Taylor Locosaki to a third winning double in the Northern Saloons and Sports. Paul Brydon's BMW M3 led the pursuit in both races, losing out to Andrew Morrison's SEAT Leon on lap six in the first race, but successfully keeping his rival at bay at the second time of asking, following a multiple startline shunt.

Alaric Gordon's Carbir won the Sports 2000 Enduro, having hauled in the fast-starting MCR of Michael Gibbins before half-distance.

PETER SCHERER

RESULTS

GINETTA (8 LAPS) 1 Ollie Chadwick; 2 Jonny Hadfield +2.903s; 3 Matt Chapman; 4 Ryan Hadfield; 5 Jack Minshaw; 6 Matt Palmer. **Class winner** Glen Broster.

Fastest lap Chadwick 1m53.219s (85.59mph). **Pole** Chadwick. **Starters 21. RACE 2 (5 LAPS) 1 Chadwick;** 2 R Hadfield +0.315s; 3 Jonny Hadfield; 4 Matt Chapman; 5 Matt Palmer; 6 Matt Flowers. **CW** Ian Robinson.

FL Chadwick 2m17.817s (70.32mph). **P** Chadwick. **S 21.**

RACE 3 (8 LAPS) 1 Chapman; 2 J Hadfield +4.929s; 3 Chadwick; 4 R Hadfield; 5 Robinson; 6 Palmer.

CW Robinson. **P** Alexis Taylor. **S 20.**

INTERMARQUE/ASTON MARTIN GT CHALLENGE (24 LAPS) 1 Charles Hyde-Bird/Kevin Bird (BMW M3 GT4); 2 Tom Black (Aston Martin GT4) +6.419s; 3 Jeremy Cooke/Mike Dowd (BMW M3 GT4); 4 Robin Marriott (Aston Martin GT4); 5 Steve Atkinson (Porsche 968CS); 6 James Hilliard/James Guess (Porsche 968CS). **CW** Black; Martin Melling/Jason Minshaw (Aston Martin DB4 Lightweight); David Falkingham (Triumph TR7 V8). **FL** Hyde-Bird/Bird 1m48.305s (89.48mph). **P** Cooke/Dowd. **S 16.**

INNES IRELAND CUP & 50S SPORTS CARS (15 LAPS)

1 Peter Dod/Nathan Dod (TVR Griffith 400);

2 Mark Halstead/Stuart McPherson (Lotus Elan) +4.329s; 3 Paul Woolley (Cooper Monaco); 4 Gail Hill/Adam Crowton (Ford Mustang GT); 5 Josh Sadler/Mark Henderson (Ford Falcon); 6 Mike Thorne (Austin-Healey 3000). **CW** Halstead/McPherson; Woolley; Hill/Crowton; Jeremy Cooke/Mike Dowd (Cooper Bobtail); Paul Knelly (Jaguar XK150S); Glenn Pearson (Jaguar MK1); Robert Rawe (Austin-Healey 100M). **FL** Robert Bremner (AC Cobra) 1m57.294s (82.62mph). **P** Bremner. **S 23.**

VW RACING CUP (10 LAPS) 1 Tom Witts (Golf); 2 Simon Rudd (Golf) +1.421s; 3 Bobby Thompson (Polo); 4 Kenan Dole (Golf); 5 Jack Walker-Tully (Scirocco); 6 Paul Ivens (Scirocco). **FL** Walker-Tully 1m52.570s (86.09mph). **P** Phil House (Scirocco). **S 15. RACE 2 (11 LAPS) 1 Witts;** 2 Dole +0.914s; 3 B Thompson; 4 Rudd; 5 House; 6 Ivens. **FL** House 1m52.869s (85.86mph). **P** Walker-Tully. **S 14. RACE 3 (10 LAPS) 1 House;** 2 Witts +1.145s; 3 Kieran Gordon (Golf); 4 B.Thompson; 5 Cameron Thompson (Scirocco); 6 Damani Marciano. **FL** House 1m52.876s (85.85mph). **P** Witts. **S 15.**

NORTHERN SALOONS & SPORTS (10 LAPS) 1 Joe Spencer (Stuart Taylor Locosaki); 2 Andrew Morrison (SEAT Leon Eurocup) +46.173s; 3 Paul Brydon (BMW M3); 4 Matthew Kirkby (Caterham C400); 5 Neil Claxton (Suzuki SC100); 6 Mark Leybourne (Westfield FW). **CW** Morrison; Kirkby; Leybourne; Stephen Kell (Ford Sierra XR4x4); Martin Whitehouse (BMW 328); David Cox (Peugeot 205 GTi); Nathan Bolton (VW Golf Mk5). **FL** Spencer 1m45.077s (92.23mph). **P** Spencer. **S 34.**

RACE 2 (8 LAPS) 1 Spencer; 2 Brydon +20.726s;

3 Morrison; 4 Kirkby; 5 Stuart Carr (Caterham CSR);

6 Leybourne. **CW** Brydon; Kirkby; Leybourne; Kell;

Whitehouse; Steven Craggs (Ford Fiesta); Bolton.

FL Spencer 1m45.467s (91.88mph). **P** Spencer. **S 23.**

SPORTS 2000 (28 LAPS) 1 Alaric Gordon (Carbir);

2 Michael Gibbins (MCR) +5.821s; 3 Tom Stoten (Gunn TS11); 4 Giles Billingsley (MCR); 5 Peter Williams (MCR); 6 Mike Turner (MCR). **CW** Gibbins; Williams; Colin Feyerabend (Lola T90/90); Clive Steeper/Chris Snowdon (Tiga SC80); Ian Law/Joshua Law (Shrike P15).

FL Gordon 1m41.635s (95.35mph). **P** Sherrington. **S 23.**

BRANDS HATCH
MASTERS FESTIVAL MAY 28-30

Padmore and Stretton are masters of Brands Hatch

THE MASTERY OF BIG FIA WINNERS Nick Padmore and Martin Stretton on the majestic 2.43-mile Brands Hatch Grand Prix circuit and a poignant James Hunt tribute at the scene of the Formula 1 World Champion's 1976 fan mania thrilled a big audience at the best Masters Historic Festival yet.

Racing Max Smith-Hilliard's Williams FW07C for the first time, and on home soil, poleman Padmore passed Loic Deman (Tyrrell 010) – the Belgian subsequently excluded for ignoring flags following a jump start – directly after Saturday's safety car period. He dominated both legs of the Historic F1 round thereafter, revelling in the “unbelievable” increase in grip over last year's Pre-'78 title-winning Lotus 77.

Michael Lyons (who switched to dad Frank's Hesketh 308E after his McLaren M26 was garaged with quill-shaft failure) shot from the back to second, ahead of Mike Wrigley, driving his Williams FW07D superbly through continuous battles. Lyons' gearbox input shaft snapped on Sunday, leaving Deman and Steve Hartley (Arrows A4) to chase Padmore, and Phil Hall to claim Fittipaldi class honours in his ex-Keke Rosberg Theodore.

Following a caution called when the Cooper Monaco V8s of Chris Jolly and Keith Ahlers collided at Druids, Phil Hall looked set for FIA Masters Historic Sports Car victory in his Lola T210. Top qualifier Martin Stretton had other ideas. Having taken over Mark Piercy's T210, he passed Stefano Rosina's McLaren-DFV M8C and the T70s of Gary Pearson and Simon Hadfield (Chris Beighton's), closing relentlessly on his prey. Martin made up 30 seconds before going ahead on the penultimate lap, when Hall went herbaceous at Dingle Dell.

Which of the competitive Ford GT40s would win Saturday's packed “Three Hours” – trimmed to 149 minutes by a



Delighted Stretton reeled in Sports Car rivals for win



ALL PICS: HAWKINS

two-hour oil down, Ben Beighton's Mustang having split its gearbox in Pre-'66 Touring Car qualifying – was the question. All three led, but Andy Wolfe took too much out of American Jason Wright's, leaving 2015 Spa Six Hours victors Roger Wills/James Littlejohn to shade Tony Wood/Martin Stretton.

Best of the GTs was the AC Cobra of Andy Willis/Rob Hall in fourth, ahead of the giant-killing Ginetta G4R of Ron Maydon/James Hagan and Mike Whitaker's TVR Griffith, the only one of three not to totally fry its brakes. Having dramatically beached Wolfgang Friedrichs' Aston Martin DP214 at Clearways when a Dunlop peeled off the inner bead during qualifying, Simon Hadfield brought it back seventh.

Craig Davies narrowly prevailed in Sunday's Masters Touring Car hour, having charged his Ford Mustang past the rasping Lotus Cortinas of Andy Wolfe and Mark Sumpter, after Ron Maydon triggered a safety car by rolling his Mini at Clearways. Half-shaft failure halted Sumpter, but Wolfe tore after Davies, harassing him to the chequer as the red and gold notchback, tyres spent, slewed ever more sideways. Roger Wills (Mercury Comet Cyclone), Champion of Brands FF1600 veteran Warren Briggs (Mustang) and Jonathan Lewis' delightful Hesketh-liveried Cooper S led the chase.

Eighteen hundred horsepower and staggering torque sledgehammered Andy Newall and Frank Bradley ahead in the Can-Am 50 Interserie Challenge. Newall won both in the JCB McLaren M8F despite a grassy excursion, cutting a 100mph lap on Sunday when Bradley kept him focused before an off at Stirlings removed the ex-Helmut Kelleners March 717's nose.

Richard Piper trumped Michele Liguori among the two-litre runners, the Brit and his ex-Pierre Maublanc March 75S twice

Double winner Padmore leads the field exiting Graham Hill Bend

beating the Italian's slipperier and more powerful BMW-engined Lola T296. Belgium's Marc Devis howled his Toj-DFV SC303 past them and closed on Newall from the back on Sunday.

With Mike Wilds' BMW CSL out with expensive engine noises and Chris Compton-Goddard's Ferrari 308 fading once Dave Coyne handed it over, the Masters '70s Celebration mini-enduro distilled to a great scrap between poleman Roberto Giordanelli in Simon Watts' Datsun 240Z, Chris Beighton's hairy Sunbeam Tiger and Steve Dance's Ford Capri RS2600. Giordanelli chose “pirouette over contact” (with Beighton) into Paddock, flat-spotting a tyre, whereupon Dance pounced to win.

Repetition of the sticking throttle that curtailed practice forced Julian Bronson to trailer his Scarab-Offenhauser after retiring from the HGPCA Pre-'61 opener, leaving old rival Philip Walker (Lotus 16) to win both legs. Tony Smith drove his ex-Phil Hill 1960 Italian GP-winning Ferrari Dino brilliantly to deny Rod Jolley (Lister-Jaguar Monza) second both times, while Cooper-Bristol dicers Eddie McGuire and Paul Grant shared two-litre honours after frenetic tussles.

Richard Tarling outfoxed Ben Mitchell – who set a scintillating fastest lap in his historic Merlyn – to win Sunday's breathless Classic FF1600 GP circuit finale. Mitchell went ahead briefly when, three-abreast exiting Graham Hill Bend, they explored the grass each side of Kevin Howell's lapped Elden. Brazilian Adriano Medeiros had a grandstand view in third, clear of a six-car scrap. Back where Formula Ford began in 1967, Tarling, with brakes fading, won Monday's short track stanza shadowed by title-chaser Medeiros.

MARCUS PYE

Grand sport Campagne tastes Dutch Indy champagne



Campagne steered Corvette to victory after to-and-fro fight

MICHEL CAMPAGNE TAMED HIS RAUCOUS FISHTAILING Chevrolet Corvette Grand Sport to win a superb Dutch Historic Touring and GT race, which topped Monday's Indy circuit fare. Briton Richard Evans (Marcos 1800GT) and Dutchman Bob Stevens (Lotus Elan) continually outraked the monster in a gripping catchweight contest, but brute force triumphed over guile.

Pipped for third by Georg Nolte's Ford GT40, Stevens hit the Clearways gravel in the sequel then hurtled back to deny Marcos duo Evans and Mark Dols.

Rod Birley (Honda Integra) won the BARC SE Tin Tops opener, having survived "a concertina situation" on the exit of Druids that saw him inadvertently cannon polesitter Chris Whiteman's Honda Civic off.

Chris Bassett hounded Birley home, pursued by Peter Osborne's Vauxhall Astra as a four-car pile-up on the plunge to Graham Hill Bend brought red flags. Whiteman bounced back to win race two as early pacemaker Birley limped in 10th with a sick engine.

Birley's fortunes were also mixed in the Quaife Saloons set from which Dale Gent – who qualified his Subaru Impreza top on 49.956s – sizzled to a double victory. A blown turbo forced Rod to miss the opener, but Stuart Day's 140-mile dash to Basingstoke for a replacement enabled him to burn from the stern to second in the finale. BMW M3 rivals Laurie Grant and Mark Cripps were inseparable in Class C until a brush at Druids as Cripps dived ahead spun him out.

RESULTS

SATURDAY/SUNDAY, GRAND PRIX CIRCUIT

FIA MASTERS HISTORIC F1 (17 LAPS) 1 Nick Padmore (Williams FW07C); 2 Michael Lyons (Hesketh 308E) +16.137s; 3 Mike Wrigley (Williams FW07D); 4 Greg Thornton (Lotus 91/5); 5 Simon Fish (Ensign N180/MN014); 6 Rob Hall (Ligier JS17). Class winners Lyons; Ian Simmonds Tyrrell 012-1; Jamie Brashaw (Arrows A1). Fastest lap Padmore 1m20.133s (109.31mph). Pole Padmore. Starters 21.

RACE 2 (19 LAPS) 1 Padmore; 2 Loic Deman (Tyrrell 010) +6.727s; 3 Steve Hartley (Arrows A4); 4 Wrigley; 5 Thornton; 6 Hall. CW Simmonds; Phil Hall (Theodore TR1).

FL Padmore 1m20.287s (109.10mph). P Padmore. S 20.

FIA MASTERS HISTORIC SPORTS CARS (37 LAPS)

1 Mark Piercy/Martin Stretton (Lola-FVC T210); 2 Phil Hall (Lola-FVC T212) +6.094s; 3 Chris Beighton/Simon Hadfield (Lola-Chevrolet T70 Mk3B); 4 Carlos Monteverde/Gary Pearson (Lola-Chevrolet T70 Mk3B); 5 Robert Oldershaw (Lola-FVC T212); 6 Nick Pink/Scott Mansell (Lola-FVC T212). CW Beighton/Hadfield; Martin O'Connell (Chevron-BMW B8); Tarek Mahmoud/Karsten Le Blanc (Lola-Chevrolet T70 Mk3); Keith Ahlers/Billy Bellinger (Cooper-Ford Monaco T61 King Cobra); Mark Bates (Porsche Carrera 911 RS); Jamie Boot (Chevron-BMW B16). FL Stretton 1m30.618s (96.66mph). P Stretton. S 28.

MASTERS 3 HOURS (76 LAPS) 1 Roger Wills/James Littlejohn (Ford GT40); 2 Tony Wood/Martin Stretton (Ford GT40) +12.558s; 3 Andy Wolfe/Jason Wright (Ford GT40); 4 Andy Willis/Rob Hall (AC Cobra); 5 Ron Maydon/James Hagan (Ginetta G4R); 6 Michael Whitaker/Nigel Reuben/Eugene O'Brien (TVR Griffith). CW Willis/Hall; Mark Martin/Andrew Haddon (Lotus Elan); Michiel Campagne (Chevrolet Corvette Grand Sport).

FL Stretton 1m40.592s (87.08mph). P Littlejohn S 41.

MASTERS PRE-'66 TOURING CARS (30 LAPS)

1 Craig Davies (Ford Mustang); 2 Andy Wolfe (Ford Lotus Cortina) +1.241; 3 Roger Wills (Mercury Comet Cyclone); 4 Warren Briggs (Ford Mustang); 5 Jonathan Lewis (Austin Mini Cooper S); 6 Andrea Stortoni (Ford Lotus Cortina). CW Wolfe; Lewis; Roel Korsten (Ford Mustang).

FL Davies 1m48.669s (80.61mph). P Wolfe. S 34.

CAN-AM 50 INTERSERIE CHALLENGE (10 LAPS)

1 Andy Newall (McLaren-Chevrolet M8F); 2 Frank Bradley (March-Chevrolet 717) +10.109s; 3 Richard Piper (March-BDG 75S); 4 Michele Liguori (Lola-BMW T296); 5 Mike Donovan (Lola-Chevrolet T70 Mk3B/c); 6 Jonathan Loader (Chevron-FVC B19). CW Piper; Donovan; Loader.

FL Newall 1m28.887s (98.55mph). P Newall. S 16.

RACE 2 (14 LAPS) 1 Newall; 2 Marc Devis (Toj-DFV SC303) +7.952s; 3 Piper; 4 Liguori; 5 Paul Gibson (Broadley Lola T70



Huge 41-car grid took on Masters 3 Hours race, won by #5 Ford GT (left)

Mk3B); 6 Loader. CW Devis; Piper; Gibson. FL Newall 1m27.298s (100.34mph). P Newall. S 12.

MASTERS 70s CELEBRATION & ALLCOMERS (23 LAPS)

1 Stephen Dace (Ford Capri RS2600); 2 Simon Watts/Roberto Giordanelli (Datsun 240Z) +4.226s; 3 Jon Finnemore/Chris Beighton (Sunbeam Tiger); 4 Dave Coyne/Chris Compton-Goddard (Ferrari 308); 5 John Spiers (TVR Griffith); 6 Georg Nolte (Ford GT40).

CW Watts/Giordanelli; Finnemore/Beighton; Spiers.

FL Beighton 1m39.435s (88.09mph). P Giordanelli. S 17.

HGPCA PRE-'61 GRAND PRIX CARS (10 LAPS) 1 Philip

Walker (Lotus 16); 2 Tony Smith (Ferrari Dino 246) +17.181; 3 Rod Jolley (Lister-Jaguar Monza); 4 Steve Hart (Masterati 250F CM7); 5 Eddie McGuire (Cooper-Bristol Mk1); 6 Paul Grant (Cooper-Bristol Mk2). CW Jolley; Hart; McGuire; John Bussey (Cooper T43). FL Walker 1m44.552s (83.78mph).

P Walker. S 16. RACE 2 (15 LAPS) 1 Walker; 2 Smith +4.199s;

3 Jolley; 4 Hart; 5 Grant; 6 McGuire. CW Jolley; Hart; Grant; Bussey. FL Walker 1m45.220s (83.25mph). P Walker. S 15.

CLASSIC FF1600 (13 LAPS) 1 Richard Tarling (Crossle 32F);

2 Ben Mitchell (Merlyn Mk20) +0.867s; 3 Adriano Medeiros (Van Diemen RF80); 4 Tom Brown (PRS 03); 5 Kevin Mansell (Crossle 32F); 6 Stuart Kestenbaum (Van Diemen RF79). CW Mitchell. FL Mitchell 1m37.706s (89.65mph). P Tarling. S 28.

INDY CIRCUIT (23 LAPS) 1 Tarling; 2 Medeiros +0.108s; 3 Kestenbaum; 4 Nigel Lingwood (Van Diemen RF80); 5 Brown; 6 James Hagan (Crossle 32F). CW Chris Stuart (Crossle 16F).

FL Medeiros 51.572s (84.32mph). P Tarling. S 26.

MONDAY, INDY CIRCUIT

NK HTGT (27 LAPS) 1 Michiel Campagne (Chevrolet Corvette Grand Sport); 2 Richard Evans (Marcos 1800GT)

+0.379s; 3 Georg Nolte (Ford GT40); 4 Bob Stevens (Lotus Elan); 5 Nico Zonneveld (Morgan +4 Super Sports); 6 Frans van Maarschalkerwaart (Chevrolet Corvette). CW Evans; Stevens; van Maarschalkerwaart; Roel Korsten (Ford Mustang); Roger Ebdon (Mini Cooper S); Gerrit Jan van Leenen (Ford Lotus Cortina). FL Campagne 56.668s (76.73mph). P Stevens. S19. RACE 2 (27 LAPS) 1 Stevens;

2 Evans +14.085s; 3 Mark Dols (Marcos 1800GT); 4 Nolte;

5 Martin Bijleveld (Ford Falcon); 6 Jos Stevens (Lotus Elan).

CW Evans; Nolte; Bijleveld; Rhea Sautter (Jaguar E-type).

FL Bob Stevens 56.715s (76.67mph). P Campagne. S15.

QUAIFE CANNONS TIN TOPS (13 LAPS) 1 Rod Birley

(Honda Integra); 2 Chris Bassett (Peugeot 205 GTi) +1.421s; 3 Peter Osborne (Vauxhall Astra VXR); 4 Daniel Fisher (Honda Civic Type R); 5 Robert Hosier (SEAT Leon); 6 Daniel Adams (Proton Satria). CW Osborne; Mikey Day (Citroen Saxo); Gideon September (Mitsubishi Mirage). FL Birley 55.525s (78.45mph). P Chris Whiteman (Honda Civic Type R). S 28.

RACE 2 (16 LAPS) 1 Whiteman; 2 Osborne +3.787s;

3 Bassett; 4 Adams; 5 Graham Richardson (Honda Civic Type R); 6 Day. CW Osborne; Day; September.

FL Whiteman 55.570s (78.25mph). P Birley. S 22.

QUAIFE SALOONS (BOTH 18 LAPS)

1 Dale Gent (Subaru Impreza); 2 Malcolm Wise (Ford Escort Cosworth) +3.835s; 3 Tony Skelton (Renault Clio); 4 Dan Cowan (Ford Sierra RS500); 5 Alex Sidwell (Holden Commodore); 6 Andy Banham (Subaru Impreza).

CW Skelton; Laurie Grant (BMW E36 M3); Jamie Vanns (Renault Clio). FL Wise 51.254s (84.84mph). P Gent. S 19.

RACE 2 1 Gent; 2 Rod Birley (Ford Escort) +5.299s; 3 Cowan;

4 Skelton; 5 Sidwell; 6 Banham. CW Skelton; Grant; Vanns.

FL Gent 50.202s (86.62mph). P Gent. S 18.

CASTLE COMBE

CCRC MAY 29-30



Delighted Deegan leaves his squabbling Mini rivals standing

SHAYNE DEEGAN DOMINATED THE Mini Miglia races, with a stunning winning margin of just over 19s last Sunday. But all attention was focused on the enthralling battle for second place.

Six drivers swapped positions throughout but eventually Kane Astin emerged in second with Aaron Smith occupying the third step on the rostrum.

The second Miglia encounter was marred by an accident at Tower involving David Drew, which led to a red-flag stoppage. Deegan had been in control and he handled the second start with aplomb, taking his fifth victory from six races.

There was heartbreak in the first Mini Se7en encounter for Charlie Budd, mechanical maladies after qualifying on pole leading to an engine change and further issues in the race. Max Hunter emerged victorious by a margin of 0.7s from Lewis Selby in race one. Hunter fought off Kieren McDonald and Selby in a race-long duel to win race two.

The 750 Motor Club Roadsports race was dominated by Jamie Sturgess in his SEAT Leon Supercopa, while the first Castle Combe Sports Trophy race, exclusively for sports-racing machines, was an emphatic display by Josh Smith, with a 45s winning margin.

Domination was also a feature of the Sports v Saloons race. Nigel Mustill

finished well down the road in his new Lamborghini, with over a minute in hand over nearest rival, Caterham driver Tim Woodman. The Lamborghini also went on to win in Castle Combe GTs, resistance provided by the Mitsubishi Evo of Barry Squibb.

Craig Fleming controlled the first Sports Series race from Josh Smith, who was unable to challenge despite running faster than he had the day before.

The single Combe Saloon Car Championship encounter brought Dave Scaramanga's first win of 2016, although he was hounded for the duration by Simon Norris in his Mitsubishi Colt.

The Dave Allan Trophy race ended under red-flag conditions after leader Henry Neal endured an unfortunate accident at Folly in the car he shared with Craig Smith. The drama also took out the Chaz Ryles/James Blake MG ZR. The Honda Jazz driven by Henry's father and brother, Matt and Will Neal, was eventually declared the winner.

The opening Formula Ford race started with a bang, namely for Chase Owen who was spat out of the pack at Folly. A red-flag period ensued and at the restart Michael Moyers jumped ahead of Nathan Ward's Spectrum. Roger Orgee then snuck into second position and a fantastic duel began, with Orgee stalking



BTCC star Neal popped in and won the Dave Allan Trophy

Moyers, but he was unable to make an impact. Ward, meanwhile, was fighting Ben Norton for fourth until the pair clashed. Norton fell down the order but Ward still took a podium after Luke Cooper was denied third place by a penalty for a yellow-flag infringement.

Formula Ford action then rounded out the day with more drama, with a red flag required for a multi-car crash at Folly involving Hugh Robertson, Sam Street and Richard Higgins. On the restart Ward was able to control the race from the front of the field, ahead of Norton and Orgee, who scrapped throughout the race with Moyers and Cooper.

LEE BONHAM

➔ P76 FULL RESULTS



Dunn's Max5 double sets tone for day of dominance

NICK DUNN TOOK A CLEAN sweep of the two Max5 Racing Championship races at Mallory Park, on a day when almost every series produced a double winner.

Dunn demonstrated why he has a commanding points lead, winning race one by a colossal 15s margin.

Max5s are known for close racing and a five-car train battling for second allowed the championship leader to canter into a huge lead.

John Munro headed the chasing pack, recovering after falling down to fourth at the start with a poor getaway. He regularly swapped places with Russell Tamplin and Matthew Tidmarsh before coming out on top. Tamplin completed the podium.

The same rostrum order was repeated in the second race but after a much closer battle for the win.

Roles reversed at the start, as Dunn's poor getaway handed Munro the lead. Dunn recovered, and the top two ran nose-to-tail for lap after lap. The championship leader finally made a move stick through the Devil's Elbow, and a mistake late on at the Shaw hairpin wasn't enough to let Munro challenge again.

Ian Goodchild managed an even more impressive weekend in the Hyundai Coupe Cup. He took a clean sweep with pole position, two wins and two fastest laps. That form was a replica of his Cadwell Park round last time out, bar a lap record, and incredibly Mallory was just his fourth ever race weekend.

Goodchild had to hold off the advances of Jon Winter each time, narrowly coming out on top.

While Goddard enjoyed a clear track, Winter had to contend with the challenge of former Ginetta Junior racer William Taylforth, who took two third places behind him.

The double winner theme continued in the Intermarque Championship as Malcolm Blackman became the third driver to take two wins. These races were filled with attrition, a six-car accident at Gerard's Bend on lap one of the opener setting the tone.

On the same lap, polesitter Lewis Smith retired with a broken driveshaft, which allowed Blackman to charge to the finish unchallenged.

Smith returned for the second race and, in a reverse grid format, impressively jumped from 14th on the grid to third on the first tour.

He soon reached second, and hounded Blackman. The pair ran nose to tail, but a cruel second driveshaft breakage resigned him to retirement and let Blackman escape.

The fourth clean sweep came in the MG Owners' Club Championship, with David Mellor's ZR in charge.

Mellor secured pole for both races, but in the first Adrian Wray made a superior start. Wray continued to lead until backmarkers began to affect the lead duo. While Wray lost three seconds in a single lap, Mellor managed the traffic well and won.

His second victory was more straightforward, as Wray hit problems. After maintenance between the two races, a loose connector on Wray's ZR forced him into the pits and out of contention.

The Sevensque Series was the only championship to provide different winners, with David Tilley's homemade Hart winning the first encounter in a field of Caterhams before Anthony Bennett won the finale in Tilley's absence.

TOM ERRINGTON

[➔ P76 FULL RESULTS](#)

KIRKISTOWN
500MRCI MAY 28

Robinson beaten in BOSS, wins in FFord

BOSS IRELAND COMPLETED THE SET OF IRISH tracks with two rounds at Kirkistown, having already raced at Mondello Park and Bishops court, and Cian Carey was on a mission to reel in leader Noel Robinson.

Carey put his Formula Renault on pole over Jonathan Fildes, whose Ralt RT4 sported a new livery. Twenty years had passed since Fildes last raced at Kirkistown, back then at the wheel of a Formula Opel Lotus.

Fildes led from Carey but on lap two his race ended with a clutch problem. Robinson then attempted to catch Carey, to no avail. Carey led race two from pole, with Barry Rabbitt briefly making a challenge, before Robinson fought back to gain second. Then, in the closing laps, he made a major effort to take the lead. He pressured Carey, but Carey kept ahead to close within four points of Robinson in the championship.

Paul Conn produced a super start in the first Roadsports race, but it took just four laps for Jim Larkham to take the lead. Conn kept in touch with Larkham's Radical but had to be content with second. Mark Francis broke away from the pack to win Class B.

Larkham fell back to fourth after a poor start to race two, but again picked cars off before making the move on leader Conn to secure his now customary race win.

Jim Hutchinson gave his Escort GM its first appearance of the year in the Saloons, ASK Supercars and GT race. A few tweaks and the removal of the power steering were the only changes since Hutchinson's last outing, and not surprisingly he had pole and commanded proceedings while Peter Barrable broke clear of the Supercar pack. Andrew Armstrong was best of the Saloons in third. Two-time British Touring Car champion Colin Turkington made a guest appearance in the celebrity Supercar but it failed to start. Eventually he managed just a single lap.

Hutchinson was swallowed up at the start of race two as Ralph Jess led briefly in his BMW M3. Andy O'Brien then worked his way into first in his Supercar as his race one rival Barrable retired. Hutchinson had to fight through the traffic but eventually snatched the lead from O'Brien. Turkington's alternator was replaced and this time he completed the race, finishing fourth in class.

Robinson switched from his Tatuus FRenault to his Van Diemen and took pole for the first Formula Ford encounter from Alan Davidson. It was Davidson who led ahead of Stephen O'Connor at first, before Robinson and Davidson began a race-long lead battle in which Robinson very narrowly prevailed. The fight for third was just as fraught between O'Connor and Ryan Campbell, until O'Connor went off at the hairpin.

Robinson increased his championship lead with victory in the second race, as all those around him struggled. O'Connor was pinged for a jumped start and Kyle Young stalled on the line. Davidson and Robinson contested the lead before Robinson took the advantage at Debtors and never looked back.

Twenty-four Ford Fiesta Zetecs looked like a recipe for incidents and that proved the case as several drivers attended the stewards' office. Ben McCully kept it clean to take the win. The second race was much calmer and polesitter Jonny Forsythe took the honours.

IAN LYNAS

[➔ P76 FULL RESULTS](#)



BOURNE

ANGLESEY
BARC MAY 28-29

Irish guests rival Legends for thrills

FORMULA SHEANE CROSSED THE Irish Sea to provide three different winners over two days in North Wales. Anton Savage won the first race. He led until it was red-flagged, then trailed Kevin Sheane after the restart before a move on the exit of Rocket at half-distance. Brian Hearty retook David Parks for third on the last lap.

A trip across the kerbs at the end of the opening lap dislodged Savage's nose and cost him his early race-two lead. Sheane led from there on, with Parks just holding off Hearty for second, having nosed ahead at Rocket with two laps to go.

A reversed grid spiced things up for the finale, with poleman Charlie Linnane making a first-lap break as the rest fought for second. Chris McCabe hit the front on lap three and pulled clear, until he went off at the Corkscrew, which caused a safety car and handed the win back to Linnane. Parks, Niall O'Flynn and

Robbie Allen were in line astern behind. John Mickel and Ben Power's Legends weekends mirrored each other – Power won Saturday's final after Mickel had started the day strongly, and Power kicked off Sunday well before Mickel took charge.

Mickel commanded heat one from the second lap and was aided by Power spinning out of second place, leaving Robert King and Connor Mills to complete the top three. Mills led heat two initially but lost out to Mickel halfway through and then Power too with three laps to go. The trio took the flag 0.663 seconds apart.

Power overcame early leader King into the Banking hairpin on lap two of the final. With King then spinning away second at the Corkscrew, Power had to watch for a closing Mickel but took the flag 0.5s clear. Mills was a distant third.

Power made the decisive move on King cresting Rocket for the sixth time

The Formula Sheane pack produced three different winners. Linnane leads here

of 10 laps to take victory in the first of Sunday's heats, with Paul Simmons and Rickie Leggatt nose to tail for second after Nathan Anthony spun.

Mickel led the second heat from Rocket on the opening lap, while Power lost out to Mills too and had to battle until the penultimate lap to repass him.

Having eased himself clear on the opening lap of Sunday's final it was an easy win for Mickel, as five cars fell over themselves for second. Power claimed it a lap from home, only to receive a penalty and drop him behind Mills.

Greg Speight was unbeatable in the first two XR Challenge races. He led the first from lights to flag, with Robert Clapton and Steve Poole nose to tail for second and third for the entire race.

Michael Heath was just about to threaten Speight's domination in the second race, having climbed from the fifth row of the grid, when his engine blew. Poole reclaimed second place, while Lee Bowron's XR3i took third from Clapton out of the final corner. Heath was back for the finale and broke Speight's domination with a clear win from the very back, while Poole was third.

Jackie Cochrane's Sunbeam Tiger won both HRCA Ireland races. After losing the first NW Sports Saloons race to the Westfield of Garry Watson, Paul Rose (Saker) claimed race two following an early duel with Joe Spencer (Locosaki).

PETER SCHERER

Speight (5) and Heath were the class of the XR Challenge field



BOURNE



KNOCKHILL
SMRC MAY 29

Simpson and Crocker were among those battling behind the dominant Paterson

Paterson leaves the best of the action in his wake

ALTHOUGH RODDIE PATERSON took two dominant victories in his Caterham, the Scottish Saloons and Sportscar races provided some of the best action with intensely close battles.

In race one, Paul Brydon and his BMW M3 took up the chase in the early laps although he was delayed by a spinning Alastair McMillan and had to take avoiding action. This allowed Finlay Crocker to put his new Honda Civic TCR into second place, but he soon had to fend off the attentions of Colin Simpson before a spin for the Marcos Mantis driver too. It was left to Brydon to hunt down the Civic and he made a bold move at Duffus just past half-distance, which secured second place.

Brydon's form faded in race two and it was Crocker who provided the late-race drama after another frantic battle behind Paterson.

Crocker made a late lunge on the last corner against Simpson and survived a drag race by a tenth. Scottish BMW Championship leader Gary Clark extended his advantage with two similarly dominant wins. His nearest rival David McNaughton had a difficult day and dropped down the order with time penalties in race one for exceeding track limits. These were later rescinded, lessening the damage to his points tally. Lee Elrick resisted the pressure of a five-car train for second.

While Clark was edging away at the front, McNaughton drove a measured race to second in race two. The race was red-flagged after a violent crash for Colin Gillespie, who went off at high speed on the main straight but thankfully emerged unscathed.

Despite starting on pole position for Mini Cooper race one,

Malcolm McNab was left with little to cheer about on a weekend where he looked set to seize the points initiative. McNab led the opening lap, then slowed with a gearbox problem. This left Morgan Murray to fend off Ian Munro and take the win. Race two started in a similar vein, but Munro's chances were quickly spoiled by a loose bonnet that flipped up. Newcomer Robbie Dagleish could not keep pace with Murray but found himself in an exciting battle with Paul Bell, who snatched second after a safety car restart.

The top eight were reversed for race three, which promoted Hannah Chapman to pole. Realising the opportunity, she pulled consistently away from Dylan O'Donnell and controlled the race to take her first win. Bell provided some late drama after winning a drag race with rookie Brandon Walsh for third. McNab salvaged vital points with fifth place after his race-one setback.

Neil MacLennan moved further ahead in the Formula Ford standings with two wins in his Ray. The highlight came from Sebastian Melrose's third in race two after a race-long battle between four cars. Kevin Whyte continued his winning Fiesta form, while Steven Gray had the measure of XR2 rival Jim Deans in both races.

After a torrid previous meeting, reigning Legends champion John Paterson scored a hat-trick of wins to recover lost ground.

Harry Simpson took a deserved win in the second Classics race in his Ginetta G4 after exciting racing with race-one winner Tommy Gilmartin's Morgan.

JONATHAN CRAWFORD

[➔ P76 FULL RESULTS](#)

ROCKINGHAM
BARC MAY 28-29

Dorlin keeps winning in hard-fought Clio races

JAMES DORLIN CONTINUED his dominant start to the Michelin Clio Cup Series with a brace of victories to extend his championship lead, though he was kept honest by main rivals Brett Lidsey, Samuel Randon and Luke Pinder throughout.

Having controlled the first contest, Dorlin bogged down off the start in the second race and dropped to third behind Pinder and Randon. After a move for the lead into Deene left Randon stranded on the outside line into Yentwood, Dorlin reclaimed the runner-up spot before dispensing with Pinder on the penultimate lap as the frontrunners navigated their way through backmarkers.

Lidsey also passed Pinder heading into Brook chicane later that lap to ensure an identical podium to race one. Tom Barley was rewarded on his return to the fray with a pair of fifth-place finishes. Meanwhile, problems for Jack Fabby and Sarah Franklin in the first and second races respectively left Nic Harrison to claim the honours in the road class.

"That was a brilliant weekend – I couldn't have asked for me to come away with two poles and two wins," said Dorlin.

Phil Weaver continued the theme of domination in the Clubmans Cup, taking his Nemesis to two comfortable victories ahead of Jarred Lester's Mallock and Jonathan Hair's Beagle respectively. Weaver saw off early competition in each race, before gradually extending his advantages. Hair claimed the final victory on Sunday afternoon.

Paul Poulter joined the event's increasingly large club of double winners as he claimed the first two Pickup Truck wins, but was forced

to retire from the third round as Antony Hawkins timed his stint in front to perfection and secured his first win. Racing on the oval, the Pickups produced arguably the closest racing of the weekend, with the majority of the field enjoying a short stint at the head of the pack.

After taking a double win at Snetterton last time, Ed Moore surrendered his Junior Saloon Car Championship lead as Charlie Kennedy and Katie Milner put themselves in the frame for the title fight. Kennedy took victory in the opening contest after claiming the lead at the end of the first lap, before a late move into Deene Hairpin gave Milner second, with Ethan Hammerton third. Milner defended successfully from pole in race two, with early-season pacesetter Matteo Zanetti second ahead of Kennedy.

A quartet of Caterham grids provided a total of six different race winners. In the Sigma class, David Webber added another race victory to his tally for the season while Jamie Winrow, the only other man to win in the category, fended him off to take the honours in race two. The Super honours belonged exclusively to Edward Benson, with Andy Molsom and Toby Briant chasing. In Sigmax, Lee Bristow made two poor getaways from pole but, unlike in the first race when he was forced to settle for the runner-up spot behind Scott Lawrence, he was able to make a late move on Dylan Stanley in the closing stages of race two to claim victory. Glenn Burtenshaw took both Mega wins ahead of defending champion Oliver Gibson and Luke Cooper.

DAMIAN MEADEN

[➔ P76 FULL RESULTS](#)



Randon was one of those who made Dorlin work for it

Willis opens his 2016 account

TREVOR WILLIS TOOK HIS FIRST WIN of the season in round seven, but Scott Moran pushed to the front in the weekend's second shootout and put himself 17 points clear of Willis.

"I thought I had left the door open for Trevor," Moran admitted. Willis said his win was "all about the start", in which he managed a launch in excess of 1G.

David Uren continues to enjoy his best season yet. After a scare when his chain failed starting round seven (a problem he was given time to fix), Uren secured a brace of fourth places. His top three slot may soon be under threat as Wallace Menzies was back in action with a fresh engine after missing Harewood following his Craigantlet blow-up and took two third places. But the standout performance was from Menzies' wife Nicola, who shares with Uren.

She claimed a breakthrough eighth, beating the likes of experienced past run-off winners Eynon Price and Sean Gould in the works GR59, and earning a cheer from the crowd as her personal best time for Gurston flashed up on the screen above the timekeepers' lair.

Will Hall had appeared to be on the way back to form having reverted to a conventional throttle cable after recent electronic gremlins in his fly-by-wire set-up. He started well with six points in round seven, but it all went wrong in Q2 as he hit the barriers at Ashes – the final left-hander – with some damage to the Force WH but fortunately no injury.

Gurston specialist Ed Hollier again performed beyond expectation, hauling himself ahead of the absent Richard Spedding – who was tied up with moving house – for fifth in the standings with seventh and sixth place results.

Jason Mourant is getting on the pace in his ex-Tom New Gould-Judd clocking personal best times on every run and concluding with fifth in round eight.

The event featured the world hillclimbing competition debut of a hydrogen fuel cell electric car, the first Toyota Mirai in the UK, driven by Scottish motoring journalist David Finlay.

EDDIE WALDER

➔ **P77 FULL RESULTS**



Willis got a win but Moran fought back

WALDER

RESULTS ROUND

CASTLE COMBE CCRC, MAY 29-30

MINI MIGLIA (15 LAPS) 1 Shayne Deegan; 2 Kane Astin +19.012s; 3 Aaron Smith; 4 Daniel Wheeler; 5 James Coulson; 6 Sam Summerhayes. **Class winner James Burrows. Fastest lap Deegan** 1m17.456s (82.89mph). **Pole Deegan. Starters 12. RACE 2 (11 LAPS) 1 Deegan;** 2 Rupert Deeth +3.016s; 3 Wheeler; 4 Coulson; 5 Smith; 6 Summerhayes. **FL Deegan** 1m16.446s (87.09mph). **P Deegan. S 13.**

MINI SETEN (13 LAPS) 1 Max Hunter; 2 Lewis Selby +0.694s; 3 Spencer Wanstall; 4 Kieren McDonald; 5 Ashley Davies; 6 Steve Trench. **CW Leon Wrightman;** Josh Collins. **FL McDonald** 1m25.075s (78.28mph). **P Charlie Budd. S 21.**

RACE 2 (11 LAPS) 1 Hunter; 2 McDonald +0.856s; 3 Selby; 4 Davies; 5 Wanstall; 6 Andrew Deviny. **CW Wrightman;** Collins. **FL 1m24.332s** (78.97mph). **P McDonald. S 18.**

750 MOTOR CLUB ROADSPORTS SERIES (32 LAPS) 1 Jamie Sturgess (SEAT Supercopa); 2 Alec Livesley (Jensen Healey) +5.861s; 3 Matt Webster/Andrew Gaugler (Honda Civic); 4 Liam Crilly (Mazda RX-8); 5 Craig Wright/Kieren Simmons (Ford Fiesta); 6 Carl Swift/Endaf Owens (Honda Civic). **CW Webster/Gaugler;** Crilly; Wright/Simmons. **FL Sturgess** 1m15.305s (88.44mph). **P Sturgess. S 19.**

SPORTS TRPOHY (19 LAPS) 1 Josh Smith (Radical PR6); 2 Darcy Smith (Radical SR4) +45.528s; 3 Oliver Hewitt (Mittel MC-53); 4 Robert Gillman (Radical Prosport); 5 Richard Fearn (Radical SR8); 6 Chris Child (Prosport). **CW Fearn;** Hewitt. **FL J.Smith** 1m02.841s (105.98mph). **P J Smith. S 13.**

SPORTS V SALOONS (17 LAPS) 1 Nigel Mustill (Lamborghini Gallardo); 2 Tim Woodman (Caterham 7) +1m05.451s; 3 Jeremy Irvin (Vauxhall Tigra); 4 John Barnard (Vauxhall Astra); 5 Perry Waddams (TVR Tuscan); 6 Paul Arber (Sylvia Phoenix). **CW Irwin;** Craig Robertson (Citroen Saxo); Barnard. **FL Mustill** 1m08.586s (97.10mph). **P Mustill. S 18.**

GTS (15 LAPS) 1 Nigel Mustill (Lamborghini Gallardo); 2 Barry Squibb (Mitsubishi Evo) +3.218s; 3 Steve Hall (Audi TT RS); 4 Oliver Bull (Vauxhall Tigra); 5 Chris Vinall (SEAT Leon Supercopa); 6 Jamie Sturges (Leon Supercopa). **CW Squibb;** Hall; Bull; Vinall; Michael Harris (Peugeot 205 GTI). **FL Mustill** 1m07.598s (98.52mph). **P Squibb. S 13.**

SPORTS SERIES (18 LAPS) 1 Craig Fleming (Juno TR250); 2 Josh Smith (Radical PR6) +0.597s; 3 Darcy Smith (Radical SR4); 4 Robert Gillman (Radical Prosport); 5 Mark Nicholson (Radical SR3); 6 Brent Hill (SR3). **CW Richard Gray** (Radical SR4). **FL Fleming** 1m02.507s (106.54mph). **P J Smith. S 12.**

RACE 2 (19 LAPS) 1 J Smith; 2 D Smith +52.324s; 3 Gillman; 4 Nicholson; 5 Hill; 6 Neil Harris (Nemesis Prototype). **CW Gray. FL J Smith** 1m02.851s (105.96mph). **P J Smith. S 10.**

CASTLE COMBE SALOONS (15 LAPS) 1 Dave Scaramanga (VW Scirocco); 2 Simon Norris (Mitsubishi Colt) +0.879s; 3 Mark Wyatt (Vauxhall Astra); 4 Charles Hyde-Andrews-Bird (Renault Megane); 5 John Barnard (Vauxhall Astra); 6 Haydn Kind (Peugeot 106 GTi). **CW Norris;** King; Will Di Claudio (Citroen Saxo). **FL Scaramanga** 1m14.440s (89.46mph). **P Scaramanga. S 32.**

DAVE ALLAN TROPHY (29 LAPS) 1 Matt Neal/Will Neal (Honda Jazz); 2 Daniel Ludlow (Honda Civic Type R) +1 lap; 3 Carl Swift/Endaf Owens (Type R); 4 Alyn James/Daniel Wheeler (Civic); 5 Andy Thompson (SEAT Toledo); 6 Michael Harris/Gary Prebble. **FL Ben Scrivens/Dave Krayem** 1m11.027s (93.76mph). **P Scrivens/Krayem. S 29.**

FORMULA FORD 1600 (BOTH 13 LAPS) 1 Michael Moyers (Spectrum 011c); 2 Roger Orgee (Van Diemen RF00) +0.175s; 3 Nathan Ward (Spectrum); 4 Luke Cooper (Swift SC16); 5 Felix Fisher (Van Diemen RF02); 6 David Vivian (Swift SC92). **CW Vivian;** David Cobbold (Van Diemen RF89); Simon Davey (Van Diemen RF80). **FL Orgee** 1m10.293s (94.74mph). **P Ward. S 30.**

RACE 2 1 Ward; 2 Ben Norton (Spectrum) +1.667s; 3 Orgee; 4 Moyers; 5 Cooper; 6 Vivian. **CW Vivian;** Cobbold; Davey. **FL Norton** 1m10.376s (94.63mph). **P Ward. S 23.**

KIRKISTOWN 500MRCI, MAY 28

BOSS IRELAND (12 LAPS) 1 Cian Carey (Formula Renault); 2 Noel Robinson (Tatuus Renault) +1.37s; 3 Tim Buckley (Dallara F3); 4 Barry Rabbitt (Tatuus Renault); 5 Fergus Faherty (Tatuus Renault); 6 John Stewart (Mygale M12). **FL Jonathan Fildes** (Ralt RT4) 54.95s (99.06mph). **P Carey. S 7.**

RACE 2 (14 LAPS) 1 Carey; 2 Robinson +0.59s; 3 Rabbitt; no other finishers. **FL Robinson** 55.70s (97.72mph) **P Carey. S 5.**

ROADSPORTS (13 LAPS) 1 Jim Larkham (Radical Prosport); 2 Paul Conn (Crosle 47S) +4.33s; 3 John Benson (Crosle 37S);

4 John McCandless (Crosle 47S); 5 Mark Francis (Locost Honda); 6 Trevor Allen (GMS Honda). **CW Larkham;** Francis. **FL Larkham** 1m00.93s (89.33mph). **P Larkham. S 11. RACE 2 (13 LAPS) 1 Larkham;** 2 Conn +4.01s; 3 Benson; 4 McCandless; 5 Mark Francis; 6 Richard Francis (Westfield Honda). **CW Larkham;** Mark Francis. **FL Larkham** 1m00.96s (89.28mph) **P Larkham. S 10.**

ASK SUPERCARS/SALOON/GT (13 LAPS) 1 Jim Hutchinson (Escort GM); 2 Peter Barrable (ASK Supercar) +22.58s; 3 Andrew Armstrong (BMW M3); 4 Jonathan Fildes (ASK Supercar); 5 Barry Hallion (ASK Supercar); 6 Ralph Jess (BMW M3). **CW Hutchinson;** Barrable; Armstrong. **FL Hutchinson** 1m01.25s (88.86mph). **P Hutchinson. S 13. RACE 2 (13 LAPS) 1 Hutchinson;** 2 Andy O'Brien (ASK Supercar) +5.59s; 3 Stephen Traub (Honda Integra); 4 Hallion; 5 Bob Cameron (ASK Supercar); 6 Jess. **CW Hutchinson;** O'Brien; Traub. **FL Hutchinson** 1m00.96s (89.30mph). **P Hutchinson. S 12.**

FORMULA FORD 1600 (16 LAPS) 1 Noel Robinson (Van Diemen JL012K); 2 Alan Davidson (Mondiale M89S) +0.43s; 3 Ryan Campbell (Reynard FF89); 4 Mike Todd (Mondiale M84S); 5 Andrew Blair (Reynard FF84); 6 Henry Campbell (Reynard FF89). **FL Davidson** 1m01.71s (88.20mph) **P Robinson. S 14. RACE 2 (11 LAPS) 1 Robinson;** 2 Stephen O'Connor (Van Diemen RF90) +2.99s; 3 Ryan Campbell; 4 Davidson; 5 David Nicholl (Reynard FF89); 6 Todd. **FL Robinson** 1m01.83s (88.04mph). **P Robinson. S 13.**

FIESTA ZETEC (11 LAPS) 1 Ben McCully; 2 Thomas Agnew +0.53s; 3 Mark Stewart; 4 Paul Stewart; 5 Jonny Forsythe; 6 Stuart Agnew. **FL McCully** 1m16.81s (70.86mph). **P Forsythe. S 24.**

RACE 2 (11 LAPS) 1 Forsythe; 2 McCully +2.49s; 3 Adrian Finnegan; 4 Stuart Agnew; 5 Thomas Agnew; 6 Mark Stewart. **FL McCully** 1m16.97s (70.72mph). **P Forsythe. S 22.**

MALLORY PARK BARC, MAY 29

MAX5 RACING CHAMPIONSHIP (22 LAPS) 1 Nick Dunn (Mazda MX5 Mk3 2000); 2 John Munro (Mk3) +15.005s; 3 Russell Tamplin (Mk3); 4 Chris Webster (Mk3); 5 Paul Roddison (Mk3); 6 Ian Loversidge (Mk3). **CW Andrew Bayliss** (Mazda MX5 Mk3 1600). **FL Dunn** 55.237s (87.98mph). **P Dunn. S 17. RACE 2 1 Dunn;** 2 Munro +0.274s; 3 Tamplin; 4 Loversidge; 5 Tidmarsh; 6 Roddison. **CW Bayliss. FL Munro** 55.356s (84.26mph). **P Dunn. S 16.**

HYUNDAI COUPE CUP (16 LAPS) 1 Ian Goodchild (Hyundai Coupe 2000); 2 Jon Winter (Coupe) +4.689s; 3 William Taylforth (Coupe); 4 Kevin Middleton (Coupe); 5 Alex Cursley (Coupe); 6 Jeff Alden (Coupe). **FL Goodchild** 57.199s (84.96mph). **P Goodchild. S 9. RACE 2 (16 LAPS) 1 Goodchild;** 2 Winter +1.282s; 3 Taylforth; 4 Cursley; 5 Middleton; 6 Alden. **FL Goodchild** 57.330s (84.77mph). **P Goodchild. S 9.**

INTERMARQUE CHAMPIONSHIP (14 LAPS) 1 Malcom Blackman (Vauxhall Tigra 2000); 2 Chris Brockhurst (Tigra) +4.164s; 3 Michael Thurley (Tigra); 4 Steve Burrows (Peugeot 206cc 2000); 5 Reuben Taylor (206); 6 Ian Hales (Tigra). **FL Blackman** 47.549s (102.21mph). **P Lewis Smith** (Tigra). **S 16. RACE 2 (19 LAPS) 1 Blackman;** 2 Simon Smith (BMW Z4 2000) +12.174s; 3 Taylor; 4 Daniel Smith (VW Corrado 2000); 5 Burrows; 6 Hales. **FL Blackman** 47.344s (102.65mph). **P Richard Smith** (Mercedes SLK). **S 9.**

MG OWNERS CLUB CHAMPIONSHIP (22 LAPS) 1 David Mellor (MG ZR 1800); 2 Adrian Wray (ZR 1800) +4.730s; 3 Stuart Philips (ZR 1600); 4 Phil Walker (ZR 1800); 5 Simon Kendrick (F VVC 1800); 6 Nick Golhar (ZR 1800). **CW Kendrick;** Jim Baynam (B 1840 GT). **FL Philips** 54.872s (88.56mph). **P Mellor. S 21.**

RACE 2 (20 LAPS) 1 Mellor; 2 Philips +8.261s; 3 Walker; 4 Kendrick; 5 Golhar; 6 Stephen Williams (ZR). **CW Kendrick;** Baynam. **FL Mellor** 55.237s (87.98mph). **P Mellor. S 21.**

SEVENESQUE SERIES (BOTH 18 LAPS) 1 David Tilley (Hart Sports Racing 1998); 2 Anthony Bennett (Caterham R3000 2413) +21.302s; 3 Robert Grant (Caterham C400 2000); 4 Peter Hargroves (Caterham R300 2000); 5 Nigel Bathurst (Caterham R300 2000); 6 Billy Nairn (Caterham R300s 2000). **CW Bennett;** Grant; Nairn. **FL Tilley** 48.301s (100.61mph). **P Bennett. S 7.**

RACE 2 1 Bennett; 2 Robert Singleton (Caterham C400 2000); 3 Grant; 4 Hargroves; 5 Nairn; 6 Bathurst. **CW Singleton;** Nairn. **FL Bennett** 49.303s (98.57mph). **P Bennett. S 6.**

ANGLESEY BARC, MAY 28-29

FORMULA SHEANE (8 LAPS) 1 Anton Savage; 2 Kevin Sheane +0.631s; 3 Brian Hearty; 4 David Parks; 5 Niall O'Flynn; 6 Chris McCabe. **FL Savage** 1m12.373s (77.10mph). **P Hearty. S 14.**

RACE 2 (12 LAPS) 1 Sheane; 2 Parks +0.831s; 3 Hearty; 4 Robbie

ND-UP

Allen; 5 O'Flynn; 6 McCabe. **FL** Sheane 1m12.416s (77.05mph).
P Savage. **S 12. RACE 3 (11 LAPS) 1 Charlie Linnane;**
2 Parks +0.172s; 3 O'Flynn; 4 Allen; 5 Sheane; 6 Hearty.
FL O'Flynn 1m12.886s (76.55mph). **P** Leslie Shaw. **S 13.**
LEGENDS (SATURDAY) (10 LAPS) 1 John Mickel; 2 Robert King
+3.047s; 3 Connor Mills; 4 Rickie Leggatt; 5 Nathan Anthony;
6 Michael Mercer. **FL** Leggatt 1m19.565s (70.14mph). **P** King. **S 14.**
RACE 2 (10 LAPS) 1 Mickel; 2 Ben Power +0.290s; 3 Mills;
4 Anthony; 5 Jack Parker; 6 Paul Simmons. **FL** Power 1m19.325s
(70.34mph). **P** Anthony. **S 14. RACE 3 (12 LAPS) 1 Power;**
2 Mickel +0.530s; 3 Mills; 4 Simmons; 5 King; 6 Parker.
FL Mickel 1m19.570s (70.12mph). **P** Sean Smith. **S 13.**
LEGENDS (SUNDAY) (10 LAPS) 1 Power; 2 Simmons +4.305s;
3 Leggatt; 4 King; 5 Mills; 6 Mercer. **FL** Power 1m20.244s (69.53mph).
P King. **S 14. RACE 2 (10 LAPS) 1 Mickel;** 2 Power +2.560s; 3 Mills;
4 Simmons; 5 King; 6 Leggatt. **FL** King 1m19.694s (70.01mph).
P Mercer. **S 14. RACE 3 (12 LAPS) 1 Mickel;** 2 Mills +7.995s;
3 Power; 4 Simmons; 5 Leggatt; 6 Sean Smith.
FL Mickel 1m19.400s (70.27mph). **P** Mike Schlup. **S 12.**
XR CHALLENGE & PUMA CUP (ALL 15 LAPS)
1 Greg Speight (XR2); 2 Robert Clapton (XR2) +6.785s; 3 Steve
Poole (XR2i); 4 Ben Atkinson (XR2); 5 Michael Blackburn (XR3i);
6 Mark Buxton (XR2). **CW** Blackburn; James Clare (Puma).
FL Speight 1m23.248s (67.02mph). **P** Speight. **S 18.**
RACE 2 1 Speight; 2 Poole +2.570s; 3 Lee Bowron (XR3i); 4 Clapton;
5 Buxton; 6 Atkinson. **CW** L. Bowron; Ben Eacock (Puma).
FL Michael Heath (XR2) 1m22.731s (67.44mph). **P** Speight. **S 20.**
RACE 3 1 Heath; 2 Speight +1.695s; 3 Poole; 4 Buxton; 5 Clapton;
6 Atkinson. **CW** L. Bowron; Luke Johnson (Puma).
FL Heath 1m22.790s (67.39mph). **P** Speight. **S 20.**
HRCA IRELAND GEORGE MANGAN HANDICAP & GLEN OF THE
DOWN (BOTH 16 LAPS) 1 Jackie Cochrane (Sunbeam Tiger);
2 Bernard Foley (MGB GTV8) +25.016s; 3 Val Thompson (TMC
Costin); 4 Clive Brandon (Lotus Europa 47); 5 Graham Miller (Rover
SD1); 6 Liam Ruth (MG Midget). **CW** Brandon; Ken McAvoyn (MG
Midget). **FL** Cochrane 1m17.078s (72.39mph). **P** Cochrane. **S 9.**
RACE 2 1 Cochrane; 2 Foley +16.502s; 3 Thompson; 4 Miller;
5 Brandon; 6 Ruth. **CW** Brandon; Noel Kavanagh (MGB Roadster).
FL Cochrane 1m16.723s (72.72mph). **P** Cochrane. **S 9.**
CNC HEADS BARC NW SPORTS SALOONS (19 LAPS) 1 Garry
Watson (Westfield SEW); 2 Paul Rose (Saker RAPX) +1.388s; 3 Joe
Spencer (Stuart Taylor Locosaki); 4 David Harvey (Stuart Taylor
Locosaki); 5 Luke Armiger (Vauxhall Tigra); 6 Paul Dobson (Mazda
RX7). **CW** Rose; Spencer; Dobson; Piers Grange (Ford Escort Mk2);
Clive Dix (Ford Puma). **FL** Rose 1m09.385s (80.42mph). **P** Watson.
S 31. RACE 2 (18 LAPS) 1 Rose; 2 Spencer +4.474s; 3 Steve Harris
(Saker RAPX); 4 Harvey; 5 Armiger; 6 Dobson. **CW** Spencer; Armiger;
Dobson; Grange; Dix. **FL** Rose 1m09.122s (80.72mph). **P** Rose. **S 26.**

KNOCKHILL

SMRC, MAY 29

SCOTTISH SALOONS AND SPORTSCARS (BOTH 12 LAPS)

1 Roddie Paterson (Caterham); 2 Colin Simpson (Marcos Mantis)
+23.941s; 3 Paul Brydon (BMW M3); 4 Finlay Crocker (Honda Civic
TCR); 5 Phil Dryburgh (Ginetta G5); 6 Keith Cowie (SEAT Leon).
CW Thomson McIntyre (Subaru Impreza); Andrew Christie (MK Indy);
Simpson; Scott Tollan (Escort Cosworth). **FL** Paterson 52.387s
(87.061mph). **P** Paterson. **S 16. RACE 2 1 Paterson;** 2 Crocker
+28.204s; 3 Simpson; 4 Brydon; 5 Dryburgh; 6 Cowie. **CW** Crocker;
McIntyre; Tollan. **FL** Paterson 52.154s (87.449mph). **P** Paterson. **S 12.**

SCOTTISH BMW CHAMPIONSHIP (12 LAPS) 1 Gary Clark; 2 Lee
Erick +6.615s; 3 Alistair Smith; 4 David McNaughton; 5 Cliff Harper;
6 Neil MacInnes. **FL** Clark 1m03.543s (71.776mph). **P** Clark. **S 21.**

RACE 2 (8 LAPS) 1 Clark; 2 McNaughton +2.169s; 3 Erick; 4 Smith;
5 Harper; 6 MacInnes. **FL** Clark 1m03.743s (71.550mph). **P** Clark. **S 20.**

CELTIC SPEED SCOTTISH MINI COOPER CUP (ALL 9 LAPS)

1 Morgan Murray; 2 Ian Munro +0.468s; 3 Paul Bell;
4 Robbie Dalgleish; 5 Dylan O'Donnell; 6 Hannah Chapman.
FL Munro 1m03.168s (72.202mph). **P** Malcolm McNab. **S 26.**
RACE 2 1 Murray; 2 Bell +1.515s; 3 Dalgleish; 4 William Blake;
5 O'Donnell; 6 Mark Geraghty. **FL** Murray 1m03.699s (71.600mph).
P Murray. **S 25. RACE 3 1 Chapman;** 2 O'Donnell +0.896s; 3 Bell;
4 Brandon Walsh; 5 McNab; 6 Dalgleish. **FL** John Duncan
1m03.517s (71.805mph). **P** Chapman. **S 25.**

SCOTTISH FORMULA FORD (BOTH 12 LAPS) 1 Neil MacLennan
(Ray GR14); 2 Jamie Thorburn (Ray GR15) +4.308s; 3 Jordan
Gronkowski (Van Diemen JL012K); 4 Matthew Cowley (Van Diemen
JL13); 5 Matthew Chisholm (Van Diemen RF92); 6 Neil Broome



MG Owners' Club was part of first car racing weekend bill of the year at Mallory

(Swift SC93C). **CW** Chisholm. **FL** MacLennan 55.116s (82.750mph).
P MacLennan. **S 12. RACE 2 1 MacLennan;** 2 Thorburn +14.717s;
3 Sebastian Melrose (Ray GR15); 4 Cowley; 5 Gronkowski; 6 Chisholm.
CW Chisholm. **FL** MacLennan 55.169s (82.670mph). **P** MacLennan. **S 11.**
SCOTTISH LEGENDS (8 LAPS) 1 John Paterson; 2 Ryan McLeish
+8.571s; 3 Stewart Black; 4 Ivor Greenwood; 5 Steve McGill; 6 Ross
McCulloch. **FL** Paterson 59.812s (76.253mph). **P** McCulloch. **S 9.**
HEAT 2 (8 LAPS) 1 Paterson; 2 Black +6.745s; 3 Greenwood;
4 McLeish; 5 McCulloch; 6 Jeff Pritchard. **FL** Paterson 59.859s
(76.193mph). **P** McLeish. **S 8. FINAL (10 LAPS) 1 Paterson;**
2 Greenwood +4.035s; 3 Black; 4 McGill; 5 McLeish; 6 Pritchard.
FL Paterson 59.493s (76.662mph). **P** McGill. **S 8.**
SCOTTISH FIESTAS (BOTH 12 LAPS) 1 Kevin Whyte (Fiesta ST);
2 Peter Cruickshank (Fiesta ST) +13.889s; 3 Stephen Ward (Fiesta
ST); 4 Wayne Macaulay (Fiesta ST); 5 Liam Robertson (Fiesta ST);
6 Steven Gray (Fiesta XR2). **CW** Gray. **FL** Macaulay 1m01.980s
(73.586mph). **P** Whyte. **S 13. RACE 2 1 Whyte;** 2 Macaulay +5.734s;
3 Cruickshank; 4 Ward; 5 Robertson; 6 Gray. **CW** Gray.
FL Macaulay 1m02.215s (73.308mph). **P** Whyte. **S 12.**
SCOTTISH CLASSIC SPORTS AND SALOONS (BOTH 12 LAPS)
1 Tommy Gilmartin (Morgan +8); 2 Harry Simpson (Ginetta G4)
+0.245s; 3 Raymond Boyd (Porsche 911); 4 Andrew Graham
(Triumph TR8); 5 John Kinmond (Rover 3500); 6 Jimmy Crow (Ford
Escort). **CW** Simpson; Boyd; Ian Daltrey (Alfasud). **FL** Simpson
58.365s (78.143mph). **P** Gilmartin. **S 9. RACE 2 1 Simpson;**
2 Gilmartin +4.098s; 3 Graham; 4 Kinmond; 5 Crow; 6 Grant Allan
(Porsche 911). **CW** Gilmartin; Crow; Allan. **FL** Simpson 58.363s
(78.146mph). **P** Gilmartin. **S 8.**

FL Round-Garrido 1m43.212s (67.66mph). **P** Round-Garrido. **S 23.**
RACE 2 1 Milner; 2 Matteo Zanetti +1.970s; 3 Kennedy; 4 Round-
Garrido; 5 Adam Batty; 6 Browning. **FL** Milner 1m43.430s (67.52mph).
P Milner. **S 23.**

CATERHAM SIGMA (BOTH 14 LAPS) 1 David Webber; 2 Jamie
Winrow +5.815s; 3 Nigel Board; 4 Mark Gibson; 5 Jonathan Miller;
6 Stuart Thompson. **FL** Board 1m34.322s (74.04mph). **P** Webber. **S 14.**
RACE 2 1 Winrow; 2 Webber +0.633s; 3 Board; 4 Gibson; 5 Ian Payne;
6 Miller. **FL** Webber 1m34.138s (74.18mph). **P** Webber. **S 14.**

CATERHAM CLASSIC AND SUPER (BOTH 14 LAPS)
1 Edward Benson; 2 Andy Molsom +0.372s; 3 Toby Briant; 4 Harry
Cramer; 5 Anthony Jaffe; 6 Charles Elliott. **CW** Graeme Smith.
FL Molsom 1m33.407s (74.76mph). **P** Benson. **S 25. RACE 2 1 Benson;**

2 Briant +0.691s; 3 Molsom; 4 Cramer; 5 Elliott; 6 Jaffe. **CW** Steven
McMaster. **FL** Briant 1m33.494s (74.69mph). **P** Molsom. **S 24.**

CATERHAM SIGMAX (BOTH 14 LAPS) 1 Scott Lawrence;
2 Lee Bristow +0.255s; 3 Dylan Stanley; 4 Cedric Bloch; 5 Ray Gilliland;
6 Gareth Cordey. **FL** Bristow 1m31.359s (76.44mph). **P** Bristow. **S 14.**
RACE 2 1 Bristow; 2 Stanley +0.619s; 3 Bloch; 4 Zoltan Csabai;
5 Lawrence; 6 Tristan Judge. **FL** Stanley 1m31.337s (76.46mph).
P Bristow. **S 14.**

CATERHAM MEGA (BOTH 14 LAPS) 1 Glenn Burtenshaw; 2 Oliver
Gibson +0.247s; 3 Luke Cooper; 4 Ian Noble; 5 Andrew Skinner; 6 Keith
Pennington. **FL** Cooper 1m33.038s (75.06mph). **P** Cooper. **S 11. RACE 2**
1 Burtenshaw; 2 Gibson +1.689s; 3 Cooper; 4 Skinner; 5 Pennington;
6 Noble. **FL** Skinner 1m32.833s (75.23mph). **P** Cooper. **S 11.**

GURSTON DOWN

HILLCLIMB, MAY 28-29

MSA HILLCLIMB CHAMPIONSHIP ROUND 7 1 Trevor Willis

(3.2 OMS-RPE 28) 26.12s; 2 Scott Moran (3.5 Gould-NME GR61X)
26.19s; 3 Wallace Menzies (3.5 Gould-NME GR55) 26.50s;
4 Dave Uren (1.3t Force-Suzuki PC) 26.54s; 5 Will Hall (2.0
Force-AER/XTec WH) 26.63s; 6 Jason Mourant (3.5 Gould-Judd
GR55) 27.84s; 7 Ed Hollier (1.6 Empire-Suzuki 00 Evo) 28.41s;
8 Graham Wynn (3.5 Gould-Cosworth GR55) 28.47s; 9 Sean Gould
(1.6 Gould-Suzuki GR59) 28.82s; 10 Paul Haimes (1.3t Gould-Suzuki
GR59) 28.87s; 11 Peter Marsh (1.3s DJ-Suzuki Firehawk) 32.36s;
12 Simon Marsh (1.3s DJ-Suzuki Firehawk) 37.80s.

ROUND 8 1 Moran 26.10s BTD; 2 Willis 26.25s; 3 Menzies 26.73s;
4 Uren 27.05s; 5 Mourant 28.17s; 6 Hollier 28.62s; 7 Haimes 28.65s;
8 Nicola Menzies (1.3t Force-Suzuki PC) 28.80s; 9 Eynon Price (1.6
Gould-Suzuki GR59) & Wynn 29.02s; 11 Gould 29.40s; 12 Kelvin
Broad (1.3s Pilbeam-Suzuki MP101) 30.60s.

Class Winners James Gibson (1.0 OMS Hornet) 31.75s; David Finlay
(0.0 Toyota Mirai) 44.44s; Peter Tumbull (3.6 Porsche 911 GT3)
34.42s; Paul Webber (2.0 Mazda MX5) 38.21s; Simon Neve (2.3t
Mitsubishi Lancer Evo 6) 34.84s; David Warburton (2.5 Caterham-
Duratec) 32.85s; Andrew Russell (1.1 Ginetta G15) 38.30s; Colin
Satchell (2.0 Peugeot 205) 33.36s; Simon Purcell (1.8s Lotus Exige)
34.07s; Mike Rudge (2.3 Westfield Sei) 31.32s; Jonathan Gates (1.3
Force-Suzuki LM) 29.86s; Nic Mann (1.7t Mannic-Beattie) 28.32s;
Les Buck (0.6 OMS Hornet) 35.23s; Simon Fidoe (1.0 Empire-Suzuki
Wraith) 30.46s; Simon McBeath (1.6 Swift SC92 FF) 37.07s; Tim
Davies (2.0 Pilbeam MP88 29.55s; Hollier 28.47s; Uren 26.80s;
Willis 26.53s.

CHAMPIONSHIP POINTS 1 Moran, 79; 2 Willis, 62; 3 Uren, 39;
4 Menzies, 33; 5 Hollier, 30; 6 Richard Spedding, 29; 7 Hall, 23;
8 Gould, 20; 9 Mourant, 19; 10= Alex Summers & Wynn, 17.

ROCKINGHAM

BARC, MAY 28-29

CLIO CUP SERIES (BOTH 12 LAPS) 1 James Dorlin; 2 Brett Lidsey
+8.466s; 3 Luke Pinder; 4 Ben Palmer; 5 Tom Barley; 6 Samuel Randon.
FL Nic Harrison. **FL** Dorlin 1m31.539s (76.29mph). **P** Dorlin. **S 11.**
RACE 2 1 Dorlin; 2 Lidsey +1.871s; 3 Pinder; 4 Randon; 5 Barley;
6 Palmer. **CW** Harrison. **FL** Lidsey 1m31.466s (76.35mph). **P** Dorlin. **S 10.**

CLUBMANS CUP (11 LAPS) 1 Phil Weaver (Nemesis); 2 Jarred
Lester (Mallock Mk35) +3.228s; 3 Robert Manson (Mallock Mk20/21);
4 Steven Dickens (Mallock Mk29); 5 Peter Richings (Mallock Mk30PR);
6 James Clarke (Mallock Mk20B). **CW** Manson; Richings; Barry Webb
(Delapena Mallock Mk16BW). **FL** Weaver 1m24.386s (82.76mph).
P Ian Crombie (Mallock Mk28B). **S 19. RACE 2 (12 LAPS) 1 Weaver;**

2 Jonathan Hair (Beagle MkIV) +9.918s; 3 Lester; 4 Manson; 5 Dickens;
6 Peter Belsey (Haggispeed Mk10). **CW** Hair; Richings; Webb.
FL Weaver, 1m23.126s (84.01mph). **P** Weaver. **S 19.**

RACE 3 (9 LAPS) 1 Hair; 2 Manson +1.963s; 3 Dickens; 4 Lester;
5 Belsey; 6 Michelle Hayward (Mallock Mk27). **CW** Dickens; Hayward;
Webb. **FL** Manson 1m23.383s (83.75mph). **P** Weaver. **S 19.**

PICKUP TRUCK CHAMPIONSHIP (25 LAPS) 1 Paul Poulter;
2 Mark Willis +0.242s; 3 Freddie Lee; 4 Michael Smith; 5 Paul Tompkins;
6 David O'Regan. **FL** Poulter 40.105s (132.76mph). **P** Tompkins. **S 13.**
RACE 2 (28 LAPS) 1 Poulter; 2 Willis +0.134s; 3 Lee; 4 Scott Bourne;
5 Paul Jones; 6 Lea Wood. **FL** Anthony Hawkins 40.516s (131.41mph).
P Tompkins. **S 13. RACE 3 (35 LAPS) 1 Hawkins;** 2 Tompkins +1.486s;
3 O'Regan; 4 Willis; 5 Wood; 6 Lee. **FL** Wood, 40.503s (131.45mph).
P O'Regan. **S 13.**

JUNIOR SALOON CAR CHAMPIONSHIP (BOTH 10 LAPS)

1 Charlie Kennedy; 2 Katie Milner +0.463s; 3 Ethan Hammerton;
4 George Sutton; 5 Luke Browning; 6 Matthew Round-Garrido.

WHAT'S ON



AMERICA'S 500 SHOWPIECE EVENTS

How it's done in America

LEPAGE/LAT

OUR STAR-SPANGLED COUSINS DO like to put on a show. IndyCar's titular Indianapolis 500 and NASCAR's Daytona 500 are unlike any racing event you'll see on the UK's shores.

Both finally have consistent British television coverage, albeit on specialist channels, and the broadcasters are wisely choosing not to put a heavy-handed European slant on a very different mass spectacle.

The IndyCar Series and the headlining Indy 500 are part of a wider BT Sport package – the latest instalment in the still-fledgling sports broadcaster's motorsport portfolio.

If you tuned in for the 500 over the weekend, you'll have seen a chopped-up feed from the US, piggybacking off ABC's broadcast, with BT Sport's own UK studio segments sliced in to cover the American advert breaks.

So you have to hunt for NASCAR coverage in the UK, even with an event as big as the Daytona 500. Premier Sports shows the race live, with Daytona getting

the Fox Sports feed from the US, minus adverts. However, unlike BT, there's no messing about with a studio.

Premier appreciates that the category is niche, so the coverage is left to those in the know, those who live and breathe NASCAR week in, week out, direct from the US. When the Americans go to adverts, UK viewers simply get a commentary-free feed for a few minutes.

As with the Indy 500 on BT, Daytona gets the full works from Premier, from the pre-race build-up to the post-race celebrations in victory lane.

The Americans know how to put on a show when it comes to motorsport

Build-up is key to both of these events, with tradition playing a big part in the pre-race show and overall spectacle of the two 500-mile races. The US broadcasters embrace what's been laid on rather than filling the time with too many segments of their own. BT received heavy criticism when it skipped the Indy pageantry in favour of UK-based punditry on its first attempt in 2014, and it has learned from that.

Before you even see a car turn a wheel at Indianapolis, you sit through a lengthy driver parade. For those more familiar with Formula 1's "drivers looking sad on a flat-bed lorry" routine, IndyCar takes a different approach, with drivers introduced to fans row by row, backed by a booming voiceover.

Then you've got your military flypast and a ceremonial firing of guns in honour of Memorial Day Weekend.

It's all very American, with a pre-race blessing followed by a rendition of God Bless America from a children's choir and then a pause as the entire venue rises to



Premier Sports offers NASCAR TV coverage

GET AUTOSPORT ON THE MOVE

DOWNLOAD IT NOW FROM AUTOSPORT.COM



attention as the Star Spangled Banner blasts out across the Brickyard.

A Lady Gaga pace car came out, 500-miles later, Alexander Rossi is taking a swig from a bottle of milk and “kissing the bricks” having written his name into the history books and earned the right to get his face etched on the huge Borg-Warner Trophy.

For those raised on a European diet of racing, all that milk and bricks stuff is a bit strange, but tradition truly is the foundation of the 500.

Daytona’s NASCAR headliner follows much the same pace, only with more John Cena, less Gaga and occasionally more fighting.

As one-off events, the pair of 500s are unique in terms of motorsport TV spectacle, even shunted across the pond and hidden on niche channels.

They bury F1’s tired, copy-and-paste style race format and join the Le Mans 24 Hours – still the holy grail of motorsport TV – in a broadcast triple crown.

DAN PADDOCK



HOT ON THE WEB THIS WEEK

YouTube BANK HOLIDAY BARREL ROLL

Search for: *Onboard* Massive airborne crash for Vaidyanathan at Oulton Park

Full marks to the BRDC British F3 for capturing Ameya Vaidyanathan’s Oulton Park barrel-roll from two angles as his overtake attempt goes horribly wrong. Vaidyanathan escaped with bumps and bruises and was back in action on Sunday.



BTCC OULTON PARK
ITV4
Sunday 1115

The dramatic British Touring Car Championship is proving as unpredictable as ever in 2016, with seven different winners in the first nine races. Veterans Matt Neal and Rob Collard head the standings as the field moves to the picturesque Oulton Park. If you can’t make it, be sure to tune in to ITV4’s fine coverage, more than six hours on Sunday that also includes some of the competitive support series.

INTERNATIONAL MOTORSPORT

INDYCAR SERIES

Rd 7/15
Detroit Belle Isle,
Michigan, USA
June 4-5
WATCH ON TV
Live: BT Sport 1,
Saturday 2030

IMSA SPORTSCAR

Rd 5/11
Detroit Belle Isle,
Michigan, USA
June 4

DTM

Rd 3/9
Lausitzring, Germany
June 4-5
WATCH ON TV
Live: Race one BT Sport 1,
Saturday 1400
Live: Race two BT Sport 1,
Sunday 1400

ADAC GT MASTERS

Rd 3/7
Lausitzring, Germany
June 4-5



NASCAR SPRINT CUP

Rd 14/36
Pocono, Pennsylvania, USA
June 5
WATCH ON TV
Live: Premier Sports TV,
Sunday 1700

TCR INTERNATIONAL

Rd 5/11
Salzburgring, Austria
June 5

EUROPEAN RALLY CHAMPIONSHIP

Rd 4/10
Azores Rally,
Azores, Portugal
June 2-4
WATCH ON TV
Day-by-day coverage:
Eurosport 2, Thursday
2305; Friday 0500 and
0800; Saturday 0630 and
2300; Sunday 0700

EUROFORMULA OPEN

Rd 3/8
Paul Ricard, France
June 4-5

INTERNATIONAL GT OPEN

Rd 3/7
Paul Ricard, France
June 5
WATCH ON TV
Highlights: BT Sport 1,
Saturday 1930

V8 STOCK CARS

Rd 4/12
Santa Cruz do Sol, Brazil
June 5

MOTOGP

Rd 7/18
Barcelona, Spain
June 5
WATCH ON TV
Live: BT Sport 2, 1245
Highlights: BT Sport 1,
1930

UK MOTORSPORT

OULTON PARK BTCC

June 4-5
BTCC, MSA Formula,
Porsche Carrera Cup,
Renault Clio, Ginetta GT4,
Ginetta Junior
Live: ITV4, Sunday 1115

SILVERSTONE MGLIVE

June 4-5
Porsche Club, Morgans,

FISCAR, MG Trophy,
MG Challenge, MG Metro
Cup, Midgets and Sprites,
BCV8s, Iconic 50 Sports,
Thoroughbred Sportscars,
Cockshoot Cup, Equipe GTS

SNETTERTON HSCC

June 4-5
Autosport 3 Hours, Classic
Formula 3, Historic FF2000,

Historic FF1600, Classic
Racing Cars, Formula
Junior, Historic Touring
Cars, Classic Clubmans,
Classic FF2000, Archie Scott
Brown Trophy

BRANDS HATCH CSCC

June 4-5
Jaguar Saloon and GT,
Special Saloons, Tin Tops,

Swinging Sixties, Future
Classics, Magnificent 7s,
Modern Classics, Classic K,
New Millennium

DONINGTON PARK KART GP

June 4-5
Karts, Britcar, Britcar
Production, Junior Saloons





THE ARCHIVE

Jim Clark shares
an ice cream at the
1967 Italian Grand
Prix – years before
Kimi Raikkonen made
eating ice cream de
rigueur for F1 drivers...

www.latphoto.co.uk
[@latphotographic](https://twitter.com/latphotographic)

THE BUCKET LIST

DRIVE THE
NORDSCHLEIFE



NO CRASH HELMET. NO SAFETY BRIEFING. YOU DON'T EVEN NEED YOUR own car. All you need is some money and the stomach for 13 miles of some of motorsport's most hallowed asphalt.

When we say some money, we don't mean the usual racing definition. Here, 'some' start at €29. For a lap of the Nordschleife. Just let that sink in.

The Green Hell is accessible to all that follow the rules, and that makes it well worth a pilgrimage to Nurburg at some point. Just make sure you check the timings – you don't need to book a slot in advance but the circuit

is open to the public at different times on different days. It's open in the evenings during the week and during the day on weekends subject to race events. The last entry to the track is 15 minutes before the end of the session.

Cost-wise, it works out reasonably favourably, particularly given the location this is taking place on. This year, it's €29 for a single lap or €104 for four, €220 for nine, €550 for 25. But if you want to hammer in the laps, a trackday is a better option – and full-time driver instruction and taxi laps are not allowed on the normal sessions, so keep this in mind.

As mentioned, there are some rules – you have to drive on the right side, the highway code applies and your car must be road legal. There is an arrive-and-drive service that gives the option of a Renault Clio, Volkswagen Golf, Volkswagen Scirocco or Toyota GT86, with varying lap options (one to four), fuel, and fully comprehensive insurance (with varying excesses). To use this you have to have a valid driving licence and be at least 25 – some cars have a higher minimum age – while any passengers must be at least 12. Also, remember that all sorts of traffic will be using the track on these days. The list of other vehicles includes motorcycles and vans. ❧

Vans, cars and bikes, they're all allowed around this amazing place. You get to choose your vehicle and the number of laps you do, as long as you stick to the rules

AT A GLANCE

Where 53520 Nurburg
When Evenings during the week and weekends when not hosting race events.

Cost From €29 for a single lap in your own car, or hire a car from €269.

Key tip Store the emergency number 0800

03 02 112 in your phone. A European Health Card and travel insurance is handy. And don't turn into a seven-second 'Ring king.



FREE IMAGES.COM/ANTHONY DOWNS



Haymarket Consumer Media, Bridge House, 69 London Road, Twickenham TW1 3SP Tel +44 (0) 20 8267 5998
E-mail autosport@haymarket.com **Website** www.autosport.com
Individual e-mail firstname.surname@haymarket.com

Editorial

Editor-in-Chief **Edd Straw**
Editor **Kevin Turner**
Deputy Editor **Marcus Simmons**
Chief F1 Correspondent **Ian Parkes**
Grand Prix Editor **Ben Anderson**
F1 Reporter **Lawrence Barretto**
Features Editor **Scott Mitchell**
Chief Sub-Editor **Peter Hodges**
Executive Editor **Stuart Codling**
Group National Editor **Rob Ladbrook**
Rallies Editor **David Evans**
BTCC Correspondent **Matt James**
Art Editor **Lynsey Elliott**
Senior Designer **Michael Cavalli**
Office Manager **Joanne Grove**

Autosport.com

Editor **Glenn Freeman**
Deputy Editor **Matt Beer**
International Editor **Mitchell Adam**
Technical Team Leader **Geoff Creighton**
Senior Digital Designer **Amar Vijay**

Special Contributors

Gary Anderson, Alan Eldridge, Mark Glendenning, Marcus Pye, Dieter Rencken, Gary Watkins

Correspondents

Argentina Tony Watson **Australia** Phil Branagan
Austria Gerhard Kuntschik **Belgium** Gordon McKay
Brazil Lito Cavalcanti **Finland** Esa Illoinen **Germany** Rene de Boer
Greece Dimitris Papadopoulos **Italy** Roberto Chinchero
Japan Jiro Takahashi **New Zealand** Bernard Carpinter
Russia Gregory Golyshev **Spain** Raimon Duran **Sweden** Tege
Tornvall **USA** Bruce Martin, Jeremy Shaw **UK & Ireland** Pete Allen, Jack Benyon, Jonathan Crawford, Jack Cozens, Kerry Dunlop, Tom Errington, Linda Keen, Alex Kalinauckas, Lewis Larkam, Mark Libbeter, Stephen Lickorish, Marc Orme, Dan Paddock, Graham Read, Hal Ridge, Aaron Rook, Peter Scherer, Seb Scott, Ian Sowman, Oliver Timson, Ian Titchmarsh, Eddie Walder, Richard Young

Advertising

Tel +44 (0) 20 8267 5271
E-mail autosport.ads@haymarket.com

Sales Manager **James Robinson**

Display Advertising **Don Rupal, Karen Reilly**
Classified Advertising **Jamie Brooker, Jonathan King, Joe Andrews**
Autosport.com Sales Manager **Fiona Bain**
Online Advertising **Leah Mimms**
Advertising Director **Matthew Witham**

Advertising Production

Tel +44 (0) 20 8267 5588 Fax +44 (0) 20 8267 5320
Production Controller **Abbey Gunner** abbey.gunner@haymarket.com

Subscriptions

UK +44 (0) 344 848 8817 **Overseas** +44 (0) 1604 251451
Email help@autosport.themagazineshop.com

Back issues 0344 8488817

Direct Marketing Executive **Maria Fernandez** +44 (0)20 8267 8254

Autosport, ISSN number 0269946X, is published weekly by Haymarket Media Group, Bridge House, 69 London Road, Twickenham TW1 3SP, United Kingdom. Airfreight and mailing in the USA by agent named Air Business Ltd, c/o Worldnet Shipping Inc., 156-15, 146th Avenue, 2nd Floor, Jamaica, NY 11434, USA. Periodicals postage paid at Jamaica NY 11431. Subscription records are maintained at Haymarket Media Group, Bridge House, 69 London Road, Twickenham TW1 3SP. Air Business Ltd is acting as our mailing agent.

Licensing and Syndication

International Director **Alastair Lewis** +44 (0)20 8267 8606
Syndication enquiries **Isla Friend** +44 (0)20 8267 5024

Management

Group Director **Tim Bulley**
Group Commercial Director **Ben Guynan**
Group Publisher **Stuart Williams**
Group Editor **Anthony Rowlinson**
Group Publishing Manager **Sunita Davies**
Special Events Manager **Laura Coppin**
Digital Special Project Manager **Simon Strang**
Digital Product Manager **Simon Grayson**

© 2016, HAYMARKET MEDIA GROUP LTD

Publishing, trade and further subscription details on www.autosport.com. While due care is taken to ensure the contents of Autosport are accurate, the publishers and printers cannot accept liability for errors and omissions. Advertisements are accepted for publication in Autosport only upon Haymarket Media Group Ltd's Standard Terms of Acceptance of Advertising, copies of which are available from the Advertising Sales Department of Autosport.

CIRCULATION TRADE ENQUIRIES

Frontline Ltd, Park House, 117 Park Road, Peterborough, Cambs, PE21 2TS. Tel: +44 (0) 1733 955161. Printed in England by Wyndeham Peterborough Ltd. ISSN 0269-946X. Autosport, incorporating Autoclassic, is published weekly by Haymarket Consumer Media, Bridge House, 69 London Road, Twickenham TW1 3SP.

Editorial Director **Mark Payton**
Strategy and Planning Director **Bob McDowell**
Managing Director **David Prasher**
Chief Executive **Kevin Costello**



haymarket Haymarket is certified by BSI to environmental standard ISO14001



TOM CHILTON'S HOT LAPS



“WHAT AN AMAZING DAY OUT, SUCH A BUZZ AND MY CLIENTS REALLY ENJOYED IT. TOM WAS FANTASTIC AND HAD TIME FOR EVERYONE”

INCLUDED IN YOUR PACKAGE:

- HIGH SPEED PASSENGER RIDES WITH WORLD TOURING CAR STAR, TOM CHILTON
- DRIVE UP TO 5 RACING/SUPERCARS WITH A TRAINED INSTRUCTOR
- LETS RACE FULL MOTION F1 SIMULATOR WITH “TOP GEAR” STYLE LEADERBOARD
- REFLEX BATAK GAME AND COMPETITION
- AWARDS GIVEN OUT ON THE BRANDS HATCH PODIUM WITH CHAMPAGNE SPRAY
- VOUCHERS TO USE AT LETS RACE WWW.LETSRACE.CO.UK
- YOUR COMPANY LOGO ON EVERY TRACK CAR
- USB “HOT LAPS” STICK PRE-LOADED WITH YOUR RECORDED EXPERIENCE
- BRANDS HATCH KEY RING
- HOT LAPS BASEBALL CAP & WRIST BAND
- EVENT MANAGER AND HOSTESSES PROVIDED
- HOT LAPS EXECUTIVE FOOD & BEVERAGES
- HOSPITALITY SUITE FOR UP TO 100, VIEWS OVER LOOKING THE PIT LANE
- HOSPITALITY OPTIONS FOR UP TO 220 WITH BAR, VIEWS OVER LOOKING THE RACE TRACK

FROM £599 PER PERSON (BASED ON 100 PARTICIPANTS)

SUPERCARS



LAMBORGHINI 560LP

FERRARI F430



AUDI R8 V10

PORSCHE GT3



RACING CARS



LOTUS EXIGE S

RENAULT SPORT CLIO CUP



MAZDA MX-5 CUP



HOT LAPS CARS



ARIAL ATOM SUPERCHARGED

NISSAN SKYLINE GTR35 (720 BHP)



CHOOSE UP TO 5 CARS ACROSS ALL CATEGORIES
REPRESENTATIVE CARS. ACTUAL CARS MAY DIFFER



FOR MORE INFORMATION, AVAILABILITY AND BOOKINGS PLEASE CONTACT:

TIM.SILVEY@CROWNTALENTGROUP.COM

SelectMotorRacing.com

INTERNATIONAL MOTORSPORT EVENTS ▶ RACE TICKETS ▶ HOSPITALITY & TRAVEL



Run by Fans for Fans

Motorsport Travel + Tickets + Hospitality Flexible Travel Options

Escorted Tours | UK Travel Team | By Air | Coach Tours | Self Drive
Hospitality | Circuit | Yachts | Team Packages | Paddock | Amber Lounge



ALL FORMULA ONE IN 2016



WORLD ENDURANCE CHAMPIONSHIP



HOSPITALITY
BRITISH - SINGAPORE - ABU DHABI



GOODWOOD FESTIVAL OF SPEED &
GOODWOOD REVIVAL



UK TRAVEL TEAM: +44 (0) 1451 833 721
BOOK ONLINE: enquiry@selectmotorracing.com

