

ACTION-PACKED US GP REPORT

AUTOSPORT

NOVEMBER 22 2012 • £3.40 • autosport.com

COOL HAND LEWIS

**Hamilton heroics set up
Interlagos title showdown**

**"I raced wheel-to-wheel with
Seb - Fernando owes me one!"**



haymarket
9 770269 946234
4 7
£8.99

**BRITAIN'S NEW WORLD CHAMP
HUFF WINS - DESPITE BINNING IT!**



RENAULT MEGANE

**FROM £249
PER MONTH[†]**

- + TomTom Live Sat Nav
- + Bluetooth and iPod connectivity
- + Keyless entry

**NO MATTER
WHERE LIFE
TAKES YOU
WE'LL BE
THERE**



Car shown is a Mégane Coupé GT Line TCe 115 from £289 a month.^{††}

4 **FOUR YEARS
WARRANTY
ROADSIDE COVER
INCLUDED SERVICING
FINANCE PACKAGE**

RENAULT.CO.UK

The official fuel consumption figures in mpg (l/100km) for the Mégane Coupé range are: Urban 30.1(9.4) - 72.4(3.9), Extra Urban 51.4(5.5) - 88.3(3.2), Combined 40.9(6.9) - 80.7 (3.5). The official CO₂ emissions for the range are 159 - 90g/km.



4 Terms and exclusions apply. Warranty 100,000 miles; Service 48,000 miles. For finance, conditions apply. Guarantees and indemnities may be required. You must be at least 18 and a UK resident (excluding Isle of Man and Channel Islands) to apply. Finance, subject to status, provided by RCI Financial Services Limited, PO Box 149, Watford WD17 1FJ. Visit renault.co.uk/4plus for details.

[†]Rental stated is for Renault Lease. Comparable payments are available on our personal contract purchase product – ask your dealer for details. If you choose Renault Lease then you will not own the car. When you have paid the final rental at the end of the contract, you can keep using the car and pay an annual rental equivalent to one monthly rental. Typical example: Mégane Coupé Dynamique TomTom 1.6 110 advance rental **£1,999 inc. VAT**, followed by 49 monthly payments of **£249 inc. VAT**. Final rental **£4,514 inc. VAT**. ^{††}Car shown is a Mégane Coupé GT Line TCe 115 advance rental **£1,999 inc. VAT**, followed by 49 monthly payments of **£289 inc. VAT**. Final rental is **£5,143**. Finance available on new cars when ordered by 4 Feb 2013. Car shown with optional metallic paint at an extra £520 (i.d. paint).

CONTENTS

November 22 2012 – vol 210 no 8



AUTOSPORT.COM

Up-to-the-minute news and reports from F1, WRC and more. Subscribe for must-read opinion, stats and images

"It's a perfect end to a fantastic venture. Chevrolet and RML took a gamble on me. I hope I proved them right"
WORLD CHAMPION ROB HUFF

COVER IMAGE: ROBERTSON/GETTY
INSET: EBREY/LAT



REPORTS & FEATURES

- 32 United States Grand Prix**
The full story of the penultimate grand prix of the season – at the all-new Circuit of the Americas in Austin, Texas – including race report, technical analysis, full results, lap chart and behind-the-scenes goings-on
- 46 Macau F3 GP**
How Portuguese ace Antonio Felix da Costa cleaned up on the streets for Carlin
- 50 Macau WTCC**
Rob Huff crashed while leading from pole in race one, but fought back to second in race two to lift the drivers' world title
- 53 Macau GT Cup**
'Mr Macau' Edoardo Mortara took his second GT Cup win for Audi to add to his brace of F3 GP victories
- 54 World of Sport**
NASCAR; Japanese Super GT; Formula Nippon; V8 Supercar
- 56 Volvo S60 TTA racer on test**
Former British Touring Car champion Colin Turkington tries one of the Swedish tin-top series' frontrunning machines
- 61 My season**
Belgian sports car star Maxime Martin in his busy 2012

NEWS

- 8 It's Vettel versus Alonso in Brazilian GP showdown**
Red Bull and Ferrari chargers head to Interlagos for drivers' title decider, with the German holding a 13-point advantage
- 10 Austin track design sets new standard in F1**
Hermann Tilke pleased with amount of overtaking – and the positive reaction to his latest F1 playground
- 12 Penalty-point system mooted for F1 next season**
But only as long as there's steward consistency, say drivers
- 15 This week in F1**
The key stories coming out of America last weekend
- 16 Brazilian GP preview**
- 21 David Coulthard column**
- 24 BTCC rule changes get the thumbs-up**
Teams support tweaks to 2013 series rulebook
- 26 F3 to shun new-spec engines in Europe next year**
Stay of execution for current F3 powerplants
- 29 Options unclear for Huff after Chevy withdrawal**
World touring car champ faces uncertain future
- 31 Ostberg to choose between Ford and Mini for 2013**
Will Norwegian WRC ace take M-Sport or Prodrive gig?

REGULARS

- 5 From the editor**
- 6 Snapshot**
- 23 Mark Hughes column**
- 78 Subscribe and get six issues for £1**
- 84 Final drive**
Letters and latest gear
- 86 On track/on screen**
The best action in the next week
- 89 From the archive**
Jimmy Vasser versus Alex Zanardi, Champ Car 1997
- 90 Race of my life**
Rickard Rydell, Macau F3 GP 1992

SPORTS EXTRA

- 75 AF Corse plan Ferrari 458 British GT assault**
World championship-level squad to bolster UK ranks
- 76 Radical rethink for sportscar category in 2013**
Top British marque outlines top-spec SR8s from UK Cup
- 80 Single-seater reviews**
Formula Renault BARC; Formula Ford UK; Intersteps
- 82 Racing in the Walter Hayes Trophy**
National editor Ben Anderson braves the elements at Silverstone in Fford 1600 epic

REPORT UNITED STATES GP

LEWIS OUTGUNS SEB IN TEXAS SHOOT-OUT

After his recent run of disappointments, the McLaren driver had a 'fabulous' moment in Austin, hunting down and passing the Red Bull to win. **MAR HUGHES** reports

Hamilton's victory was a perfect end to a fantastic venture. Chevrolet and RML took a gamble on me. I hope I proved them right.

WORLD CHAMPION ROB HUFF

NEWS P1 & PADDOCK

SHOWDOWN

It's Sebastian Vettel v Fernando Alonso for the world championship this weekend. **By EDD STRAIN**

SEBASTIAN VETTEL leads the Red Bull team with 273 points, while **FERNANDO ALONSO** has 260 points.

2010: ALONSO'S LOST TITLE
The 2010 season was a rollercoaster for Alonso. He won the title in 2005 and 2006, but lost it to Vettel in 2010. This year, he's looking to reclaim it.

FERRARI SHOWDOWN RECORDS
Alonso has won the title twice, but Vettel has won it three times. This year, it's a battle between the two.

DOES IT GET ANY BETTER THAN THIS?

The Walter Hayes Trophy isn't glamorous, and always seems to take place in terrible weather. But it's probably the best Formula Ford event in the world. **By BEN ANDERSON**

THE CATEGORY STALWART
Stuart Dingle is the only driver to have won the trophy three times. He's a legend in the sport.

AUTOSPORT & TEAM HADFIELD
Team Hadfield is a leading force in the sportscar world. They've won many titles and are looking to continue their success.

ALL ROADS LEAD TO VICTORY WITH MICHELIN TYRES.



Congratulations to the winners of the 2012 FIA World Endurance Championship and the 2012 FIA World Rally Championship*.

In endurance and rally racing, drivers need to have confidence in their tyres' ability to cope. MICHELIN tyres with their excellent grip and long life give them that confidence, whatever the weather or terrain.

You could also benefit from the expertise Michelin has derived from motorsport with MICHELIN tyres. Experience the performance at www.michelin.co.uk/experience-the-performance



*Subject to publication of the official results by the FIA.

Teddington Studios, Broom Road, Teddington, Middlesex TW11 9BE, UK.
Tel: +44 (0) 20 8267 5804 Fax: +44 (0) 20 8267 5922
E-mail: autosport.editorial@haynet.com Website: www.autosport.com

EDITOR-IN-CHIEF

Andrew van de Burt
andrew.vandeburg@haymarket.com ext.5974

EDITOR

Charles Bradley
charles.bradley@haymarket.com ext.5889

AUTOSPORT.COM EDITOR

Simon Strang ext.5093
simon.strang@haymarket.com

GROUP F1 EDITOR

Jonathan Noble ext.5810
jonathan.noble@haymarket.com

F1 EDITOR

Edd Straw ext.5887
edd.straw@haymarket.com

FEATURES EDITOR

Kevin Turner ext.5432
kevin.turner@haymarket.com

NEWS EDITOR

Glenn Freeman ext.5309
glenn.freeman@haymarket.com

REPORTS EDITOR

Jamie O'Leary ext.5811
jamie.oleary@haymarket.com

MANAGING EDITOR

Peter Hodges ext.5903
peter.hodges@haymarket.com

WEB MANAGING EDITOR

Pablo Elizalde

RALLIES EDITOR

David Evans
david.evans@haymarket.com

CONTRIBUTORS

GRAND PRIX EDITOR

Mark Hughes
autosport.editorial@haynet.com

F1 COLUMNIST

David Coulthard

INTERNATIONAL EDITOR-AT-LARGE

Gary Watkins

NATIONAL EDITOR-AT-LARGE

Marcus Pyle

CORRESPONDENTS

ARGENTINA

Tony Watson

AUSTRALIA

Phil Branagan

AUSTRIA

Gorhard Kuntzsch

BELGIUM

Gordon McKay

BRAZIL

Lito Cavalcanti

FINLAND

Esa Iloinen

GERMANY

Rene de Boer

GREECE

Dimitris Papadopoulos

ITALY

Roberto Chinchero

JAPAN

Jiro Takahashi, Len Clarke

NEW ZEALAND

Bernard Garpinger

RUSSIA

Gregory Golshev

SOUTH AFRICA

Richard Asher

SPAIN

Raimon Duran

SWEDEN

Tege Formvall

USA

Jonathan Ingram, Bruce

Martin, David Phillips,

Diego Mejia, Robin Miller,

Jeremy Shaw,

UK & EIRE

David Addison,

Dual Candier, Jonathan

Crawford, Kerry Dunlop,

Leanne Fahy, Paul Healy,

Paul Jurd, Paul Lawrence,

Stephen Lickorick, Matt

Upton, Eddie Walder, Tim

Whittington, Richard Young

ADVERTISING

Tel: +44 (0) 20 8267 5820

Fax: +44 (0) 20 8267 5850

E-mail: autosport.ads@haymarket.com

COMMERCIAL MANAGER

Rachel Brock,
ext: 5820
rachel.brock@haymarket.com

DISPLAY ADVERTISING

Peter De Vries,
ext: 5961
peter.devries@haymarket.com

ONLINE ADVERTISING

Karen Reilly,
ext: 5576
karen.reilly@haymarket.com

CLASSIFIED ADVERTISING

Matt Simpkin,
ext: 5560
matt.simpkin@haymarket.com

AD PRODUCTION

Luke Ricketts,
ext: 5992
luke.ricketts@haymarket.com

ADVERTISING DIRECTOR

Matthew Witham

SPECIAL PROJECTS DIRECTOR

Derek Redfern

LICENSING DIRECTOR

Jim Jones

PRODUCTION MANAGER

Ailsa Donovan, ext: 5639
ailsa.donovan@haymarket.com

SENIOR DISPLAY PRODUCTION CONTROLLER

Roxy Agius, ext: 5740
roxy.agus@haymarket.com

PRODUCTION CONTROLLER

Marc Baker, ext: 5563
marc.baker@haymarket.com

BACK ISSUES

Tel: 0844 8488817

DIRECT MARKETING EXECUTIVE

Karen McCarthy, ext: 5658
karen.mccarthy@haymarket.com

MANAGEMENT

GROUP PUBLISHER
Rob Aherne

PUBLISHING MANAGER
Samantha Jemson

SPECIAL EVENTS MANAGER

Laura Coppin

SYNDICATION SALES MANAGER

Roshini Sethi, +44 208 267 5396
roshini.sethi@haymarket.com

CIRCULATION TRADE ENQUIRIES

Frontline Ltd, Park House, 117 Park Road
Peterborough, Cambs, PE21 2TS, Tel: +44
(0)1773 553414. Printed in England by
Wyndeham Heron Ltd. Cover and
centre sections printed by CSM Impact,
Basingstoke. Colour original: Colour
Systems, 20-22 Pentonville Road, London
N1 9HS (editorial and advertising). ISSN
0269-946X. AUTOSPORT, incorporating
Autoclassic, is published weekly by
Haymarket Consumer Media, Teddington
Studios, Broom
Road, Teddington,
TW11 9BE, UK.

EDITORIAL DIRECTOR

Mark Payton

CREATIVE DIRECTOR

Paul Harpin

STRATEGY AND PLANNING DIRECTOR

Bob McDowell

PUBLISHING DIRECTOR

Patrick Fuller

MANAGING DIRECTOR

David Preshor

CHIEF EXECUTIVE

Kevin Costello

Haymarket is certified by
BSI to environmental
standard ISO14001

POLE POSITION

Huff & Hamilton: Proud to champion their success



OUR TRANSATLANTIC COUSINS ARE QUICK to praise their own triumphs – and rightly so after Sunday's blockbusting inaugural grand prix at Austin. But we reserve the right to fanfare British success too, hence our green cover for Rob Huff's World Touring Car title as well as Lewis Hamilton's stellar drive to humble Sebastian Vettel in Texas.

You could say it's not before time, our first green cover since a Hamilton/Dario Franchitti Monaco GP/Indy 500 double (June 3, 2010). Huff's accomplishment has been a long while coming too, as RML Chevrolet team-mate Yvan Muller has consistently thwarted him – by just three points last year. But the way Huff refused to roll over this term, and bounced back stronger to seal the deal, was the equal of Hamilton's tenacity in chasing down Vettel at Austin.

After as thrilling a DRS pass as you'll ever see, Vettel went 'radio rental' (well, he does like rhyming slang) as Hamilton romped away. But with Fernando Alonso now requiring a minor miracle to overturn his 13-point deficit to Seb at Interlagos, is Lewis likely to do him any more favours this weekend? I very much doubt it.

Bradley

CHARLES BRADLEY EDITOR
charles.bradley@haymarket.com

Find us on



BAMBER'S WEEK



US GRAND PRIX

Lewis is coming to get you, Seb...

Easy to forget that Lewis Hamilton's US GP hopes didn't look great when he got stuck behind Kimi Raikkonen's Lotus after his pitstop, allowing leader Sebastian Vettel to scamper clear. But Hamilton wasn't to be denied his 21st F1 win. Report, p32.

Pic: Etherington/LAT



SNAPSHOT
PIT & PADDOCK



 **AUTOSPORT +**

**FOR THE BEST AUSTIN GP PICS ONLINE,
CLICK ON AUTOSPORT.COM/GALLERY**



SHOWDOWN

It's Sebastian Vettel v Fernando Alonso for the world

Sebastian Vettel heads into the Brazilian Grand Prix weekend as clear favourite for the world championship, with a 13-point lead over Fernando Alonso.

But the Interlagos circuit has produced its fair share of dramatic title shoot-outs. Even though Vettel holds all of the aces, with a points and car advantage at a track where Red Bull has won the past three races, a tame finale seems unlikely in this most unpredictable of seasons.

"I'm excited because the car seems to work very well, good enough to fight for a win," said Vettel after finishing second in the US GP. "We've been very quick in Brazil in the last couple of years, so plenty to look forward to. We are in the best possible position."

NO GO-SLOW

Even though a fourth place will be enough to

give Vettel the title, Red Bull team principal Christian Horner insists that Red Bull will be as aggressive as usual in its approach to the race.

"We will just take it normally," Horner told AUTOSPORT. "It's just one more race out of 20 and our focus will be on approaching the weekend in exactly the same way as the previous 19. It's great to take a lead there but as we've seen this year, anything can happen. We can't take anything for granted and it's guaranteed to be stressful."

A conservative approach, although logical, has its pitfalls. In 2010, Fernando Alonso lost the title in Abu Dhabi after the Ferrari team covered nearest rival Mark Webber, a conservative move dictated by the championship situation (see below). Two years earlier, Lewis Hamilton only prevailed after passing Timo Glock for fifth on the last lap, after McLaren left little margin for error with its cautious approach.



2010: ALONSO'S LOST TITLE

Fernando Alonso had an eight-point lead over Mark Webber, with Sebastian Vettel 15 points down and Lewis Hamilton 24 behind heading into the 2010 season finale in Abu Dhabi. A Ferrari strategy catastrophe handed the title to Vettel, who dominated the race, but Alonso ran a solid fourth early on. On lap 11, a struggling Webber pitted from fifth.

Ferrari covered him and Alonso pitted four laps later, while the top three didn't start pitting until lap 23. Alonso and Webber spent the rest of the race stuck behind Vitaly Petrov's Renault.

Hirohide Hamashima, then F1 tyre supplier Bridgestone's head of motorsport tyre development, reckoned that the mistake was caused by Ferrari's

DOWN

championship this weekend. By EDD STRAW

ALONSO'S RAIN DANCE

Rain appears to give Fernando Alonso the best chance of winning his first race since July's German GP.

Alonso won the rain-hit Malaysian GP, while his victory at Hockenheim and second place at Silverstone were founded on him overachieving in a wet qualifying session. The long-range forecasts indicate that it will rain at Interlagos at some point during the weekend. If it does, Alonso's confidence will be boosted by the fact that the worst qualifying performance of Vettel's Red Bull career since 2009 came in the wet in Brazil in that first year.

ALTERNATOR WORRIES

Mark Webber's retirement from the inaugural race in Texas last weekend was a reminder that Vettel himself has lost 33 points to alternator failures this year. As a precaution, Red Bull will switch to new-spec units in Brazil.

Renault has conducted extensive tests on the new alternators, examples of which were run by its other three teams – Lotus, Williams and Caterham – in America. Red Bull was nervous about racing an untried part in America and now heads into the weekend with an alternator that is considered something of an unknown quantity.

If Vettel were to retire, Alonso would need third to take the title.

FERRARI SHOWDOWN RECORD

While Red Bull has won its only title shoot-out to date thanks to Vettel in 2010, Ferrari's recent history has been more patchy.

That 2010 race was a disaster for the Scuderia, and in Brazil two years

Championship permutations**VETTEL WINS THE TITLE IF:**

- He finishes in the top four
- He finishes fifth, sixth or seventh and Alonso doesn't win
- He finishes eighth or ninth and Alonso is third or lower
- He finishes 10th or worse and Alonso isn't on the podium

ALONSO WINS THE TITLE IF:

- He wins and Vettel is fifth or lower
- He's second with Vettel eighth or lower
- He's third and Vettel is 10th or lower

earlier, Felipe Massa was robbed of the title with 20 seconds of the race remaining by Hamilton's pass on Glock. While Kimi Raikkonen did take an unlikely crown in 2007, Michael Schumacher suffered a puncture while chasing the 2006 title in the last race.

In 2003, Schumacher did everything he could to hand the championship to McLaren's Kimi Raikkonen, including driving into Takuma Sato, before nicking the title with eighth. The German prevailed in the 2000 decider at Suzuka, but Ferrari had lost out in the finale for the previous three seasons with Schumacher and Eddie Irvine.

Ferrari's hit rate in deciders is two from the past seven which, combined with Alonso having lost both of his previous two title deciders (2007 and 2010), is a worrying trend for the Scuderia. Add in the fact that only four of this year's 19 GPs – Malaysia, Europe, Germany and Italy – gave a result that would hand Alonso the title if repeated in Brazil, and it's clear how tough Ferrari's task is.

poor 2009 car giving a false read on tyre degradation in the previous year's race.

"Ferrari expected everybody to come into the pits just after they did," he told AUTOSPORT. "According to data from other teams in 2009, the degradation was about to stop when Alonso pitted. But Ferrari's 2009 data wasn't useful because their car was very slow. They should have analysed better cars because slower-car data does not always reflect reality."



Ferrari misjudged 2010 season finale

260
POINTS

Why Austin hit new F1 heights

Circuit designer Hermann Tilke tells AUTOSPORT why his track designs are getting better – and how hills help him



The success of the inaugural grand prix at Austin is proof that the sport is gaining a better understanding of what is needed to create a great Formula 1 track, according to circuit designer Hermann Tilke.

The new Circuit of the Americas received rave reviews from drivers and attracted a crowd of almost 120,000. Although a processional race was predicted thanks to Pirelli making the

understandable decision to allocate its hardest two tyre compounds, there was plenty of action, with overtaking at the first corner and Turn 15 as well as at the end of the DRS zone.

Tilke admitted that he was a little surprised by how much passing there was at the first corner, which did not have a DRS zone on the preceding straight. But, overall, he believes that the race validates the philosophy of new F1 track design.

When asked if the understanding of track design is improving, Tilke told AUTOSPORT: “Yes, of course. Other tracks are good for overtaking, but this is to the latest standard.

“We profited from experience. Here, we also had this fantastic elevation and we used it, which helped to create this good atmosphere. It’s nice if you have

hills, but if you have flat land, it’s flat land and you cannot make hills.”

Although Tilke emphasised that no earthworks were involved in the construction of the track, which featured an undulating first sector, changes were made to make best use of the topography. Originally, it was to be an orthodox clockwise circuit, but the decision was made to run anti-clockwise to make use of the steep climb to the first corner.

A lot of evaluation work was also done on the circuit using simulators, with Alex Wurz among the drivers who made a contribution to fine-tuning the layout. To aid overtaking, deliberately wide entries were adopted for Turns 1 and Turn 11. While there was little action at Turn 11, this was because it was difficult for cars to follow one another closely



Tilke expected less overtaking

through the sequence from Turn 3 to Turn 9. This section of track was designed to best showcase the high-speed performance of the cars, with the final sector putting a premium on allowing spectators to see the cars for a long time.

The drivers were positive about the challenge of the circuit. Turn 19, a downhill left-hander taken in third gear, caught out many during the weekend. On the inside of the corner,

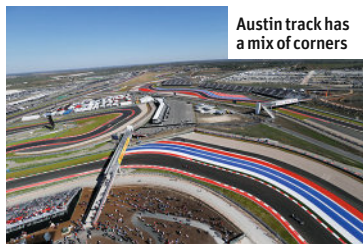

TILKE'S TOP F1 TRACKS

Formula 1 track designer Hermann Tilke refuses to single out a favourite of the 11 circuits he has designed that have hosted grands prix.

"I don't think about that," he said. "Whether it's

the best or not the best depends on your feeling so I cannot say. Maybe some other people can say if it's their favourite or not, but I won't."

Here, AUTOSPORT picks out four of his best:



1 AUSTIN

Last weekend's inaugural race was a triumph, with just under 120,000 spectators watching a great duel between Lewis Hamilton and Sebastian Vettel. The layout was popular with the drivers, too.



2 SEPANG

Tilke's first from-scratch F1 circuit has produced some dramatic races. The high-speed left-right swoop at Turns 5 and 6 is both spectacular and a genuine challenge for the drivers.



3 ISTANBUL PARK

Now sadly missing from the calendar, the hilly Istanbul Park configuration is rated by McLaren ace Jenson Button as his favourite Tilke track. The long, fast, four-apex Turn 8 was one of the best corners in F1.



4 INDIA

It has produced two flat races, but the drivers love the high-speed sections. Rated as one of the most difficult tracks on the calendar at which drivers can be consistently quick and error-free.



Purpose-built track was a hit

positive camber helped the cars to hug the apex, although a small error in terms of braking or line would rob a car of that assistance, thus creating more mistakes.

Michael Schumacher admitted: "Turn 19 gives a very odd balance. You get understeer on the way in then suddenly it snaps and goes to oversteer and everyone seems to be struggling with this. But going a little bit offline means more understeer and you go wide."

There was some criticism of the track surface, with the asphalt proving to be very greasy. At the start of Friday-morning practice, drivers struggled to avoid wheelspin even when gently opening the throttle at the pit exit, a problem exacerbated by low track temperatures. The grip levels and the temperature increased



and, although the surface was still slippery come the race, it didn't cause any issues. It's expected the track will have more grip next year after it has had more use.

The event was widely hailed a success, but this is only the start for F1 in the US. Having not had a real focal point since Watkins Glen hosted the last of its 20 grands prix in 1980, F1 now has a worthy home in America on which to build.

"We profited from experience. Other tracks are good for overtaking, but this is to the latest standard"

Hermann Tilke

AUTOSPORT SAYS...

EDD STRAW F1 EDITOR

edd.straw
@haymarket.com



Every great circuit needs a trademark. Visually, the strikingly steep climb to Turn 1 in Austin is its obvious calling card but the fast sweeps from Turn 3-6 are what separates this track from the average Tilkedrome.

Having had the privilege to watch from trackside at every circuit on the Formula 1 calendar, this section is the best place bar none to watch grand prix cars on song. It's like Becketts at Silverstone taken to the next level, with the high-speed changes of direction augmented by the rise and fall of the circuit and challenging camber changes.

When new circuits make their debut, the focus is usually on the quality of the overtaking that it allows. This is important and Turn 1 worked a treat. But it's essential to give space for these incredible machines to stretch their legs. From the Turn 5 grandstand in Austin, you can see exactly what makes a grand prix car so special.

There, you can see multiple, savage changes of direction and can see the suspension working hard.

Fans can no longer get up close to the track itself, so sections like this are vital to show that these cars aren't, as they often appear to be, being driven 'on rails'. It looked pretty good on TV too, although 'Stars' as well as 'Stripes' painted on the runoff areas would have been the perfect ident.

While the new Circuit of the Americas isn't perfect, parts of it come closer to capturing the spirit of the classic European circuits and repackaging them for the 21st century than any other new track.



US 'snake'

GET AUTOSPORT ON THE MOVE

● DIGITAL EDITION NOW AVAILABLE FOR IPAD

● STUNNING HI-DEFINITION VIDEO CONTENT

● ON SALE ALL OVER THE WORLD FOR ONLY £2.99



Download it now from the Apple Newsstand **AUTOSPORT**

Stars demand even-handed action from F1 stewards

Suggested penalty point system can only work if punishments are fair, drivers say



Drivers believe that the problems with consistency of stewarding in Formula 1 must be solved before the introduction of a super-licence penalty point system can work effectively.

The drivers support the idea of penalty points in principle, but many of those consulted by AUTOSPORT about the proposal, which FIA race director Charlie Whiting was due to put to the teams yesterday [Wednesday], referred to the issue of even-handedness.

Four stewards are used for each grand prix. However, even though they make repeat appearances during the season, the panel is never the same from one race to the next. This point, the drivers feel, encourages a lack of uniformity in decision making.

Grand Prix Drivers Association chairman Pedro de la Rosa told AUTOSPORT: "It [the penalty points system] would be a good way of moving forward, but we have to be

careful about consistency. This year, we have seen different types of penalties, depending on which group of stewards is appointed. It's a good idea, so the drivers will probably sort it, but it will require more consistent decisions. We need to know what is right and what is wrong."

The proposed system, which was revealed by Whiting ahead of the United States Grand Prix, is still in its early stages. Whiting suggested that it should award points for various infringements, both on and off track. In the style of a UK road licence, a ban (for one race) would be triggered automatically when a certain threshold is reached.

The system is seen as a necessary step because the FIA has failed to tackle repeat offenders in an era where driver punishment has become ever-more prevalent. This year, there have been 62 penalties and reprimands for driving offences, while Lotus' Romain Grosjean

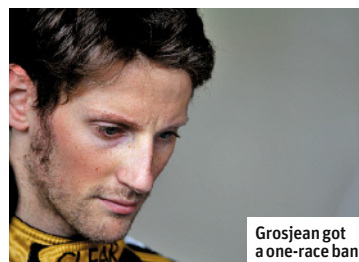

Grosjean got a one-race ban

became the first racer this century to be banned after triggering a startline shunt at Spa.

Currently, the only mechanism in the rules to discipline drivers for an accumulation of incidents is the reprimand system. Three reprimands triggers an automatic 10-place grid penalty, although stewards appear to go to great lengths to avoid awarding the vital final reprimand.

"It could be a good system," said Grosjean, whose Spa ban was the first punishment for driving he had received all season. "It is very

difficult to be consistent about decisions, but if there's a points system and you knew you had to be careful, then why not?"

Pastor Maldonado has been the heaviest offender this season (see sidebar), but has escaped a ban despite the FIA's concern over his spate of mid-season incidents.

The Venezuelan raised the same concerns as his rivals regarding consistency. "I agree with the idea, but it has to be the same for everyone," he said. "This year, the rules have not been the same for all of the drivers. Sometimes they [the stewards] have been very tough and sometimes they have been very easy. This is not good. Sometimes you get a penalty, sometimes not. There's big confusion."

De la Rosa, who is set to speak with Whiting to put the GPDA point of view across, suggested that the best way to correct the problem would be to appoint a permanent



Schuey has been penalised five times

stewarding panel. However, he accepted this might not be practical. "The ideal scenario is that you have the same three or four stewards for the whole championship," he said. "But that might not be feasible, so you could have [a pool of] eight or 10. At the moment, there are too many, and each has his own criteria."

Driving standards in F1 have come under the microscope this year. After criticism of Grosjean and Maldonado, Sauber's Sergio Perez has recently come under fire for his wild driving since Suzuka. Were a points system in place, his conduct would likely be self-policed, given that he might be one step away from a ban. It's doubtful the question of consistency can be fully resolved given the time and cost of a permanent panel of stewards. However, it is essential that the points system is implemented to ensure that troublesome drivers are forced to rein themselves in.

Biggest offenders of F1 2012

Pastor Maldonado has been the worst-hit driver in terms of penalties this season, based on an analysis of reprimands, grid penalties and in-race/post-race punishments. This disregards any issues attributable to the team, such as gearbox changes, unsafe releases or technical infringements.

PASTOR MALDONADO (8)
2 reprimands
1 drive-through
1 post-race time penalty
4 grid penalties

SERGIO PEREZ (5)
2 reprimands
1 drive-through

1 stop-go
1 grid penalty

SEBASTIAN VETTEL (5)
2 reprimands
2 drive-throughs
1 post-race time penalty

MICHAEL SCHUMACHER (5)
2 reprimands
1 drive-through
2 grid penalties

JEAN-ERIC VERGNE (4)
1 reprimand
1 drive-through
2 grid penalties

MARK WEBBER (3)
2 reprimands
1 post-race time penalty

CHARLES PIC (3)
1 reprimand
1 drive-through
1 post-race time penalty

ROMAIN GROSJEAN (2)
1 ban
1 stop-go

BRUNO SENNA (2)
2 drive-throughs

NARAIN KARTHIKEYAN (2)
1 drive-through
1 post-race time penalty

KAMUI KOBAYASHI (2)
1 drive-through
1 grid penalty

FELIPE MASSA (1)
1 in-race penalty

NICO HULKENBERG (1)
1 reprimand

HEIKKI KOVALAINEN (1)
1 grid penalty

VITALY PETROV (1)
1 drive-through

PEDRO DE LA ROSA (1)
1 reprimand

Lewis Hamilton, Jenson Button, Fernando Alonso, Nico Rosberg, Paul di Resta, Daniel Ricciardo, Kimi Raikkonen and Timo Glock have no serious offences.

J R M 

Design ■ Engineer ■ Deliver

NISSAN *nismo*

NISSAN GT-R NISMO GT3
Official Partner

JRM INVITES YOU

TO ATTEND OUR 2013 SPEC NISSAN GT-R NISMO GT3 CUSTOMER TEST

For your invitation to our test day at the Portimão circuit, Portugal, on November 27th and 28th, please contact Mark Dexter via mdexter@jrm-group.com or on +44 (0) 1327 307150.



**JUST 2 PLACES
REMAINING!**

NISSAN *nismo*

NISSAN GT-R NISMO GT3
Customer Racing

THIS WEEK IN F1

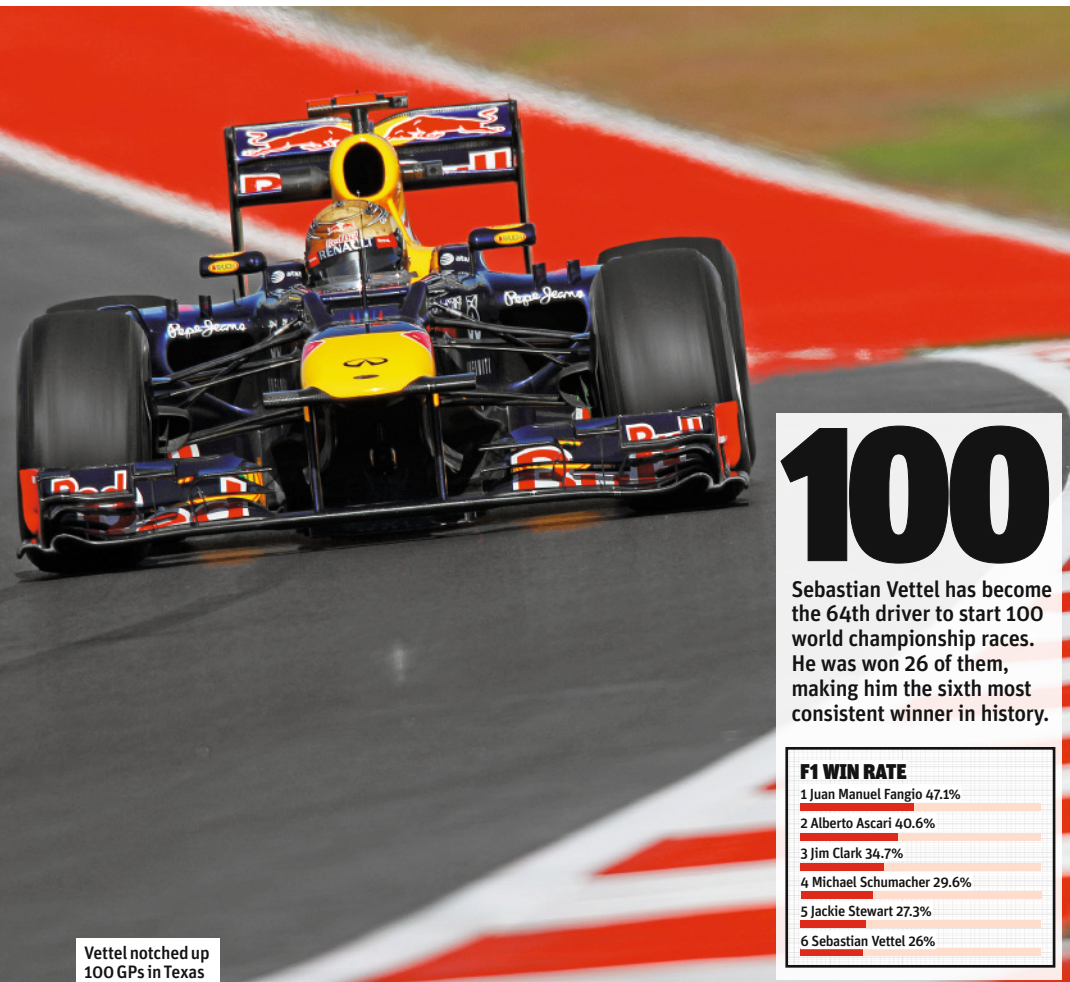

Vettel notched up 100 GPs in Texas

100

Sebastian Vettel has become the 64th driver to start 100 world championship races. He was won 26 of them, making him the sixth most consistent winner in history.

F1 WIN RATE

- 1 Juan Manuel Fangio 47.1%
- 2 Alberto Ascari 40.6%
- 3 Jim Clark 34.7%
- 4 Michael Schumacher 29.6%
- 5 Jackie Stewart 27.3%
- 6 Sebastian Vettel 26%

DRS rule change for 2013

The use of DRS will be restricted only to the designated zones during each GP weekend from the

start of next year. Currently, use of DRS is unrestricted throughout practice and qualifying.

FIA: no more force majeure

The FIA is planning to remove the phrase 'force majeure' from its regulations covering situations when cars do not complete in-laps in qualifying. McLaren and Red Bull initially argued force majeure when Lewis Hamilton and Sebastian Vettel

stopped on track at the end of qualifying in Spain and Abu Dhabi respectively. The term is set to be replaced with rules to "make it clear what is allowed and is not allowed," according to FIA technical delegate Charlie Whiting.

Caterham appeals over court ruling



Aerolab case back on

The copyright case between Force India and Aerolab/Caterham will return to court early next year after an appeal was granted. Caterham was found to have used some of Force India's intellectual property in its 2010 car and was ordered to pay £21,000 damages, with Force India paying £650,000 in costs.

Aabar sells Merc F1 stake

Aabar Investments has sold its 40 per cent stake in the Mercedes F1 team to Daimler, meaning Merc parent company Daimler is now the sole owner of the Brackley team.

HRT goes up for sale

Spanish team HRT needs a buyer to secure its future after it was confirmed by Thesan Capital that the team was for sale. HRT is known to be in talks with at least one potential Middle East-based buyer and has claimed there is other interest.

Will HRT cars be on 2013 F1 grid?



If another team principal is saying that we didn't make the right choice he's lying



Ferrari team principal Stefano Domenicali defends the decision to give Felipe Massa a gearbox penalty to assist Fernando Alonso's grid position

Maldonado aims for long-term Williams deal

Pastor Maldonado is hoping to get a multi-year contract with Williams next season. The Spanish Grand Prix winner is expected to remain at the team as part of the PDVSA sponsorship deal that stipulates a Venezuelan driver.

Maldonado wants to stay at Williams



F1 doctor not retained

The FIA has not offered a new contract to F1 medical delegate Gary Hartstein. The American, who has held the role since succeeding Sid Watkins in 2005, was keen to continue. The FIA would not comment on the decision.



Enlucet topped the penultimate round of the Castrol EDGE Grand Prix Predictor with a massive 147-point haul in the US Grand Prix. A perfect podium call was supplemented by backing Jenson Button for fifth and Romain Grosjean for seventh, helping the team to top a gameweek in which 1,306 teams called the podium trio.

Visit predictor.autosport.com to play.



BRAZILIAN GP PREVIEW

FACTS, STATS, TRACK GUIDE, TV LISTINGS AND MORE



Brazil hosts the F1 finale again

Interlagos centre stage for title decider

The Brazilian track is no stranger to F1 drama, and its tight confines will again play a part in the championship's outcome

Interlagos has a proud history of producing some of the most dramatic Formula 1 races of recent times, with the track configuration lending itself to good racing, even in dry conditions.

The long run up the hill from the Juncao, the final meaningful corner, to the Senna S allows cars to close dramatically even without the use of DRS, while it's difficult to close the door completely at the wide entry to Turn 1. It was here in 2001 that, famously, Juan Pablo Montoya passed Michael Schumacher to take the lead in only his third grand prix. It's typical of Interlagos

that Montoya was later taken out after being rear-ended by a lapped Jos Verstappen.

Despite the relative high cost of attending the race, there is always a good crowd at Interlagos, with the close proximity of the fans to the start/finish straight guaranteeing an intense atmosphere on the pre-race grid, especially when there's the chance of a home driver doing well.

As a driver's challenge, there are some quick corners, while the middle stages of the lap offer some long, slow, technical turns that ensure both a car's outright downforce and mechanical grip are tested.

→ P18

**TRACK
GUIDE
AND GARY
ANDERSON'S
AUTOSPORT
SUPERGRID**

The fans always turn out in force



Montoya stuns Schuey in 2001





Teams with most wins

Ferrari 8

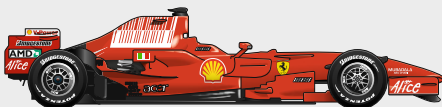

McLaren 7



Williams 4



Red Bull 3



Benetton 2

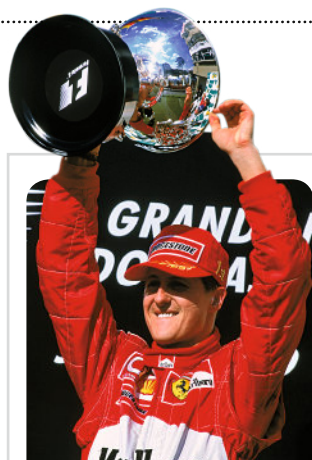

4 MICHAEL SCHUMACHER



2 EMERSON FITTIPALDI



2 MIKA HAKKINEN



2 FELIPE MASSA



2 JUAN PABLO MONTOYA



2 AYRTON SENNA

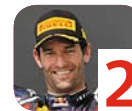

2 MARK WEBBER

Winning drivers

Rene Arnoux 1; David Coulthard 1; Giancarlo Fisichella 1; Damon Hill 1; Jacques Laffite 1; Niki Lauda 1; Nigel Mansell 1; Carlos Pace 1; Alain Prost 1; Kimi Raikkonen 1; Carlos Reutemann 1; Sebastian Vettel 1; Jacques Villeneuve 1

Races at Interlagos: 29



AVERAGE NUMBER OF FINISHERS

13.72



Average winning margin: 13.649s

Biggest: 1m18.455 (1994); smallest: 0.588s (2002)

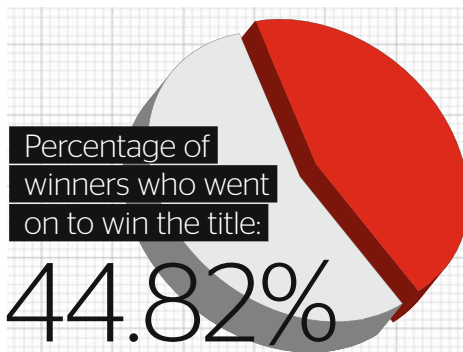

SAFETY CARS **4**



BRAZILIAN GP TV AND RADIO LISTINGS

FRIDAY NOVEMBER 23

- 1145-1350 Free Practice 1 LIVE (Sky Sports F1)
- 1155-1330 Free Practice 1 LIVE (BBC Red Button and 5Live SX)
- 1545-1800 Free Practice 2 LIVE (Sky Sports F1)
- 1555-1730 Free Practice 2 LIVE (BBC Red Button and 5Live SX)

SATURDAY NOVEMBER 24

- 1245-1410 Free Practice 3 LIVE (Sky Sports F1)
- 1255-1400 Free Practice 3 LIVE (BBC Red Button and 5Live SX)
- 1500-1745 Qualifying LIVE (Sky Sports F1)
- 1500-1730 Qualifying LIVE (BBC1)

SUNDAY NOVEMBER 25

- 1430-1915 Race LIVE (Sky Sports F1)
- 1500-1815 Race LIVE (BBC1)
- 1545-1800 Race LIVE (BBC Radio 5Live SX)
- 2000-2100 Race Highlights (BBC3)

GET THE LATEST FROM THE F1 PADDOCK AS IT HAPPENS WITH

AUTOSPORT+

ONLINE COVERAGE AUTOSPORT.com will bring you up-to-the-second coverage of every race weekend from our team of reporters in the paddock. Look out for improved PLUS features and live commentary too.

GARY ANDERSON'S SUPERGRID

AUTOSPORT technical correspondent Gary Anderson is compiling an index, created by taking each driver's percentage deficit to the outright pace over the season, using their best lap from each grand prix weekend. This graphic shows each driver's average after 19 races compared with the theoretical absolute pace, expressed as 100.

100%

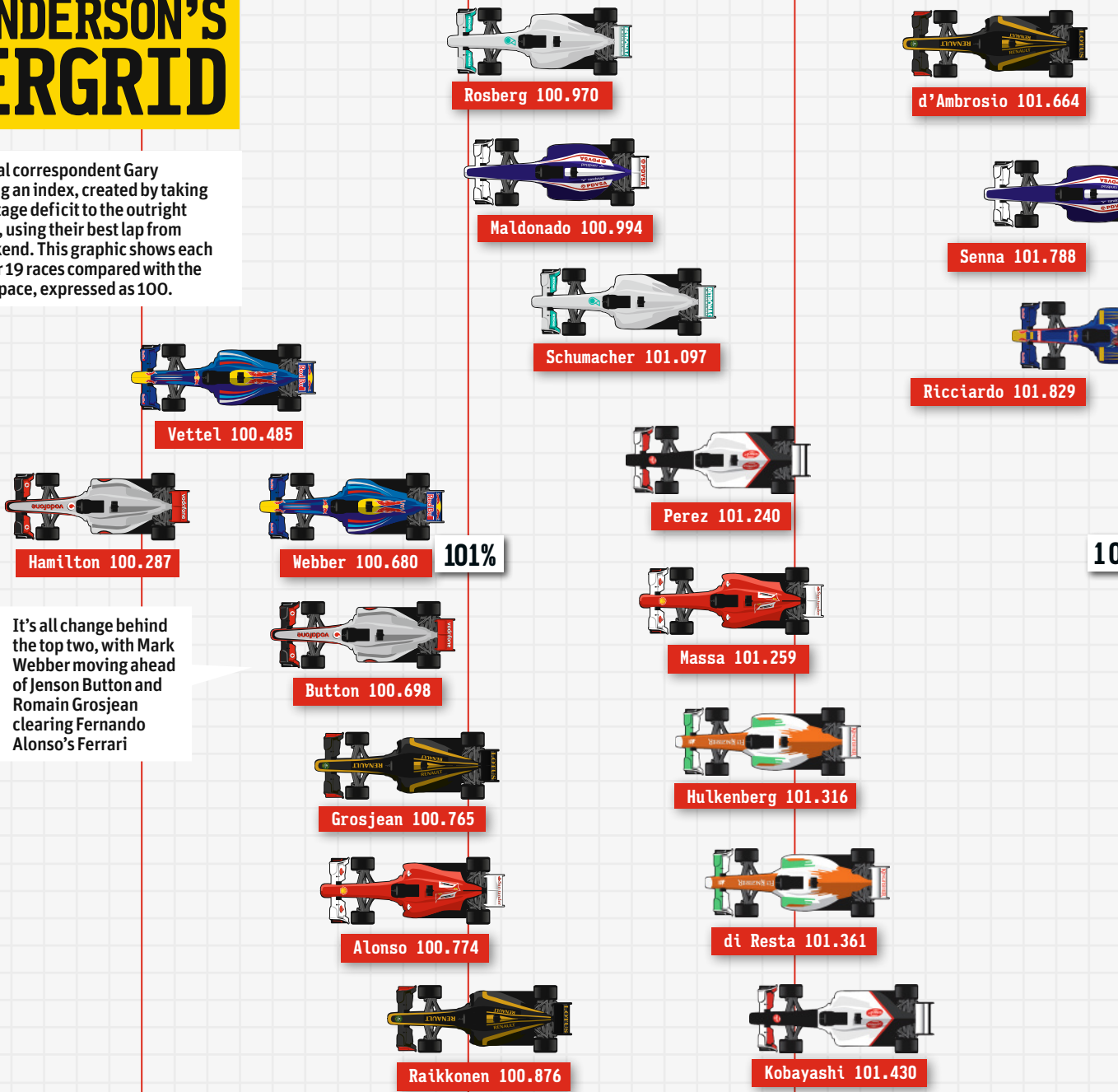

It's all change behind the top two, with Mark Webber moving ahead of Jenson Button and Romain Grosjean clearing Fernando Alonso's Ferrari



FLASHBACK

VETTEL WOE HANDS WEBBER VICTORY

Mark Webber capitalised on a rare piece of 2011 misfortune for team-mate Sebastian Vettel to take his first win of the season in the final race of the campaign. Vettel had been controlling the race from the front until a gearbox problem struck, forcing him to let Webber by on lap 29 as he nursed his car to the finish. Jenson Button came out on top in a scrap with Fernando Alonso for third.

2011 BRAZILIAN GP RESULTS

POS	DRIVER
1	MARK WEBBER (Red Bull)
2	SEBASTIAN VETTEL (Red Bull)
3	JENSON BUTTON (McLaren)

TYRE ALLOCATION

TYRES USED THIS WEEKEND

SUPER-SOFT



SOFT



MEDIUM



HARD





AND THE REST...

Marussia's impressive qualifying performance at Austin means Timo Glock has made up ground relative to the outright pace. Both HRTs also made progress, while Charles Pic slipped back ever so slightly.

Glock 104.897
Pic 105.164
de la Rosa 105.826
Karthikeyan 106.342

Both Caterhams lost a lot of ground on our scale after being outqualified by the Marussias in America

Petrov 103.873



Kovalainen 103.527

Bruno Senna now has both Toro Rossos behind him after jumping ahead of Daniel Ricciardo



Vergne 102.272

2%

103%

104%

TRACK GUIDE

INTERLAGOS	
NUMBER OF LAPS	71
CIRCUIT LENGTH	2.677 MILES
LAP RECORD	1m11.473s (MONTROYA 2004)
UK START TIME	4PM

TOP SPEED
194MPH

BIG BRAKE
SENNAS, 194MPH-71MPH
124 METRES, 4.8G 2.32S

DRS DETECTION

DRS ZONE

SECTOR 2

SECTOR 1

FASTEST CORNER
MERGULHO 140MPH
5TH GEAR 4.5G

Monaco 2013

Invitation

SUNDAY 26th MAY 2013



ONCE A YEAR ONLY A SELECT FEW ATTEND
FORMULA 1 GRAND PRIX DE MONACO 2013

A LUXURIOUS DAY OUT FLYING FROM HEATHROW TO NICE

Next year spoil a loved one, business colleague, friend or simply just enjoy yourself

Private Charter from Terminal 5 with British Airways

Breakfast onboard; Full English Breakfast, Bucks Fizz, Tea, Coffee

Transfers between Nice and Monaco

*Gorgeous lunch and view the race from the world renowned
CAFÉ DE PARIS, Casino Square, Monaco*

*After the race, early evening stroll in the garden of Casino Square
and enjoy a cocktail in the sunshine*

10pm return flight to London; 3 Course Meal, Wine and Soft Drinks



Make sure you are one of next years' select group

FULLY INCLUSIVE £899 per person, deposits are now being taken

*Alternatively, why not upgrade to one of our grandstand packages for a
fantastic race viewing experience - please enquire for prices*

5 Star Sofitel Heathrow T5, Saturday night from £80pp

Reservations 0207 935 6129 • www.sportoptions.com

F1, FORMULA 1, FIA FORMULA ONE
WORLD CHAMPIONSHIP, GRAND
PRIX and related marks are trade
marks of Formula One Licensing BV,
a Formula One group company.
All rights reserved.





STRAIGHT TALK DAVID COULTHARD

13-time GP winner and 2001 world title runner-up

Sebastian Vettel arrives in Brazil as the title favourite and Fernando Alonso the underdog, but F1 has a nasty habit of not going to plan. Whoever wins, says our man, either driver will make a worthy champion

It's remarkable that Fernando Alonso is still in contention and just 13 points behind Sebastian Vettel heading into the Brazilian Grand Prix. The intensity of the competition between the pair has been incredible, making this one of the greatest battles for the world championship in Formula 1 history.

We have seen so many amazing results this year that I wouldn't count anything out at Interlagos this weekend. After all, if you can imagine it, it can happen in F1.

Ferrari and Alonso don't have many victories this year, so you've got to ask just how does he keep himself in the hunt the way he does? He's had some great races, but he's usually been at a disadvantage in

terms of what he can achieve relative to the Red Bull and McLaren teams, so all credit to him. He is talking the talk, too – even before the race in Austin when all the signs were that Seb might wrap it up.

You can argue about how they stack up against the top drivers of different eras, but there is no doubt in my mind that Fernando, Sebastian and Lewis Hamilton are all among the true greats of the sport.

INTO THE UNKNOWN

Interlagos is not the first circuit you would choose for the title decider if you were in Vettel and Red Bull's shoes. It's a funny little track. There are not many turns, and you complete the lap very quickly. Because the lap time is short, it would be a mistake to assume Alonso won't be close there, even though if you look back over the season he clearly needs the intervention of other factors if he is to have any chance of gaining the upper hand.

Fernando will want rain. As we saw when he won in Malaysia, or took pole positions at Silverstone and Hockenheim, those conditions give him his best opportunity.

Sebastian can't afford to be conservative just because he seems to hold most of the cards, either. The last time we saw a driver going conservative while trying to wrap up a championship was Jenson Button in 2009, and he struggled during the second half of the year, so it's not necessarily the right approach. Seb, however, is young enough, quick enough, and confident and worldly enough to drive as normal. He'll react to his emotions and, as we heard last weekend, if he's upset, you'll know about it. Some people might not react

favourably to that, but he's got his heart on his sleeve and is incredibly good at handling the pressure.

Red Bull will inevitably be nervous given the situation. Ideally, the team would have wanted to wrap it up in Austin, but winning world championships is meant to be difficult. They'd certainly rather be going to Brazil with a 13-point lead and the car as it is rather than being in a different situation. They just have to go and get the job done.

What I love to see, though, and what I saw in Austin, was this incredible respect among the top drivers. We saw Sebastian pulling alongside Lewis after the chequered flag and applauding. That is absolute racing respect, and I'm sure we will see that again this weekend.

EVERYONE'S A WINNER

Neither Sebastian nor Fernando deserves to lose this championship. It doesn't matter who your heart lies with, both would be a very worthy 2012 world champion. I have to take my hat off to each. I had some reasonable races in my F1 career, but nothing comes close to what those guys deliver week in, week out.

I've never driven for Ferrari, so I don't have that emotional link to it, but I have worked with Adrian Newey and Red Bull. I can understand why a lot of people would love to see Fernando do it, because it's Ferrari and it hasn't won a drivers' championship since Kimi Raikkonen back in 2007. At the same time, it would be a completely deserved back-to-back-to-back championship for Vettel. And if that sounds like I'm sitting on the fence, it's because I can't choose between them! Both have driven brilliantly all year. ❧

PIC: THOMPSON/GETTY



“Seb, Fernando and Lewis are among the sport's true greats”

ULTIMATE PERFORMANCE.

Giving supreme control to race teams all over the world.
Radi-CAL™ only from AP Racing

Come see us in 2012 at
PMWE stand 5010
PRI stand 2791
IMIS stand 1845
and in 2013 at
Autosport Int stand 7500



Experience, technology and innovation go into our Radi-CAL™ caliper design, resulting in reduced weight, increased strength, stiffness and improved cooling.

We apply this same approach to our whole product range as we constantly explore new materials, techniques and systems in our quest for continuous improvement and race success.

Fit AP Racing brakes and clutches for ultimate performance.

T: +44 (0) 24 7663 9595 E: racetech@ap racing.co.uk

AP
RACING

The science of friction www.apracing.com



MARK HUGHES

GRAND PRIX EDITOR

Formula 1 was made more than welcome in its new home, and put on a great show for its hosts, but what a pity the sport still hasn't learned its lesson about how to deal with Americans

READ MARK HUGHES' FRIDAY GP FORM GUIDE ON
AUTOSPORT+

As a cast of hundreds of cowboys and cowgirls danced their routine on the grid, as the live rock band in the outfield played in the Texan sunset on Friday evening to a big crowd, as animated spectators filled the place with partying, as the drivers were taken for their circuit rides in Detroit muscle cars of the '60s, it was as if Formula 1 had found a natural home in Texas.

This is the American F1 venue the sport has been craving for the past couple of decades. It's a place where the teams and sponsors desperately want to be, and where, crucially, the fans want to come and watch. The Austin organisers put on a spectacular show, with every detail just right, and the event marketed extensively and really sold hard, just as you'd expect of the USA.

American fans, officials and even the ordinary citizens of the city seemed hugely excited by F1 visiting this party town. The circuit itself is fabulous, particularly the snaking

sequence of turns between 3 and 9, which is a mix of Maggotts/Becketts and the Suzuka Esses. Refreshingly, the track was the centrepiece, and not the stadium and paddock. From inside, this had the feel of an '80s venue – but in a good way. The buildings are nicely proportioned, the paddock and garages even a little cramped. It was more intimate and personal than the horrible white elephant monstrosities that have sprouted at an increasing number of races on the calendar – those overbearing arrogant statues of hubris and much of what is wrong with the sport. By contrast Austin had the feel of instant classic.

As the crowning glory, F1 put on a great show for the fans, too, with a terrific race that had an intense fight for the lead and pockets of wheel-to-wheel duelling right through the field.

In an era of the sport where it's become routine to go to places where no one wants to come to watch, where the event is very clearly only a bit of economic propaganda for a country or region, Austin was a triumph. That the local people and the organisers went out of their way to make the event the success it was did F1 a huge favour. As has frequently been acknowledged by the teams, grand prix racing needs America a lot more than America needs grand prix racing. The USA is not anti-F1, but it is anti being told that it should be subservient, or that it is being granted a favour by the category's mere presence.

What happened, though, to the stars and stripes that originally lined the circuit's run-off areas? These spectacular images screamed loud and proud the very message the

sport wanted to convey to the world: F1 is back in America. From the overhead helicopter shots following the cars, that red, white and blue emblem and the spectacular design around it – conceived by Roadgrip in consultation with the organisers – would have made a quite sensational statement that said all the sport wanted to say, for the benefit of everyone involved in it.

Instead, on the Tuesday before the race, the contractors were brought back in to remove the stars. All we were left with were the stripes – which said absolutely nothing and, in fact, looked like a Aquafresh toothpaste ad.

Why had the stars been removed? The circuit people looked at their feet and muttered when this was asked. However, a bit of digging revealed that they were removed at Bernie Ecclestone's insistence, that he felt it would detract from the impact of the circuit advertisers.

In that instruction is contained the whole arrogant attitude that doomed F1 to failure here the last time around. It was the act of someone used to dealing with regions falling over themselves to have the sport's favours bestowed upon them – and could hardly have been more inappropriate: essentially telling the USA that it cannot have the stars and stripes at its own event! It would have been nice if the organisers had told him where to stick that idea – and apparently they initially did, before then caving in to his demands in the interests of the event's smooth running.

America left a great taste in the mouth of F1 last weekend. It was a pity the commercial side of F1 didn't make that altogether mutual. ❧

PIG: TEE/LAT



Plenty of stripes, but where did the stars go?

“This is the US F1 venue that the sport has been craving”



Boost levels changed too often in 2012

BTCC

BTCC teams back rule changes

Boost-adjustment tweaks and introduction of soft tyres announced for British series in 2013. By KEVIN TURNER

British Touring Car Championship teams have generally welcomed the latest set of rule changes for next year.

Squads met with series bosses earlier this month and regulation tweaks were announced last week.

THE CHANGES

Chief among the changes are modifications to the turbo boost equalisation system. The rolling boost adjustment, which will remain based on lap times, will now be applied either to individual drivers or teams, rather than to each model of car.

The amount of turbo boost pressure adjustment is to be reduced, while the frequency of the adjustments is likely to be cut to only two or three times per season rather than every two races.

A new soft tyre will be introduced, to be used once a weekend. At all circuits except Thruxton, one set of a soft-compound Dunlop tyre will be available to each NGTC entry.

The faster tyre will not be allowed in qualifying, but teams will be able to choose which of the three races

to use it in at each meeting.

Finally, an additional penalty for bad driving will be brought in. Any driver who receives three penalties for on-track driving discipline offences, including verbal warnings, will be relegated six grid spots.

AUTOSPORT also understands that feature races, with pitstops, could return to the BTCC once the series goes all-NGTC.

TEAM REACTION

Despite some discontent with the boost system during 2012, teams have broadly agreed with the changes.

MG team principal Ian Harrison, who ran Jason Plato to third in the series this year, supports the continuation of the rolling boost.

"You've got to have something – all the engines are different and if you've got one that's not as good for development, you're in trouble for a whole season," he said.

"Giving individual drivers different boosts is probably a step too far, but doing it by team is right. Varying levels of talent and resources need to have an opportunity.



On-track offences could lead to grid penalties

"This is all about putting on a show – it's not purist racing – and we've got to accept that."

Eurotech boss Mike Jordan, who took both Independents' titles in 2012, said: "I really hope the boost variance is applied to teams, not drivers, as that can help a little between teams with large test budgets and those without, rather than helping drivers who are simply slow. To speed them up is, in my view, fundamentally wrong."

However, Honda team principal Steve Neal, who has scored a one-two with Gordon Shedden and Matt Neal

in each of the past two years, said: "It should be applied to drivers. If it's applied to teams, it specifically targets us – it would unfairly penalise teams with two top drivers because one of them is bound to have a good weekend each time."

Motorbase manager Oly Collins thinks reducing the amount the boost levels can be altered is key.

"The 0.125 bar adjustment used this year was far too much," he said. "The ideal would be about half that."

"The soft tyre is a brilliant idea. It could be interesting, and throw up some different thinking."

WHAT THE TEAMS THINK

OLY COLLINS – Motorbase

"The boost adjustment should be on teams or chassis, rather than drivers. The concept is to stop a chassis running away with the title. Success ballast is for drivers."



DICK BENNETTS – WSR

"I totally agree with the extra grid penalty for drivers to try to stop some of the naughtiness, and I think the use of a set of soft tyres is a novel idea."



CHRISTIAN DICK – Speedworks

"I want to see the driver penalty enforced. There are punishments already, but are they enforced as well as they could be? It's not a bad thing."



NASCAR

Dodge leaves NASCAR on a high

DODGE BELIEVES THAT ITS NASCAR

Sprint Cup title success with Penske Racing and Brad Keselowski has justified its 11 years in the series.

The manufacturer announced earlier this year that it was pulling out of NASCAR at the end of 2012, and it was able to celebrate its departure with its first Cup title since returning to the sport in 2001.

While that success is not going to change the company's mind about its withdrawal, its president and CEO of motorsport Ralph Gilles said it was the perfect way to leave the sport.

"To go out on top makes it all worthwhile," said Gilles. "Obviously this project wasn't one that was started yesterday.

"This has been an 11-year run with a lot of talented people who spent countless hours to make this championship possible. That's the Dodge way. The underdogs came up and did it. It's an amazing accomplishment for everyone."

Legendary team boss Roger Penske said he was proud to finally be able to



Penske and Keselowski took Sprint Cup crown

add NASCAR's top title to all of his successes in IndyCar racing.

"To be able to join this elite group and say that I'm a champion in NASCAR means a lot," said Penske.

"It took guts to stay in this sport. We could have thought we were a big deal because we've won the Indianapolis

500 15 times. But to compete at the top here and win is a big thrill. We've been close a long time ago in 1993 and '94 with Rusty Wallace, and this is a goal I wanted to achieve."

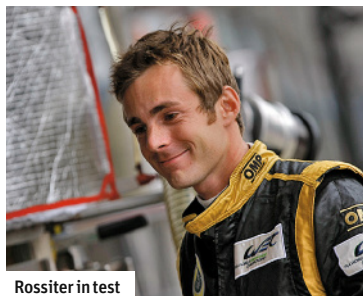

Rossiter in test

FORMULA NIPPON

Rossiter eyes Nippon switch

SPORTSCAR RACER JAMES ROSSITER IS evaluating a single-seater return next year after testing for top Formula Nippon squad TOM'S at Fuji this week.

The Briton, who had not driven a high-powered single-seater since testing an IndyCar for KV Racing in 2010, completed 25 laps. He is now keen to make a full-time move to the series.

"It was a great experience," Rossiter told AUTOSPORT. "It took a few laps to get up to speed, but once I did it was amazing. It was one of the quickest things I've ever driven, and hopefully an opportunity will come along to race for TOM'S next year."

Fellow Brit Richard Bradley also drove for TOM'S. Matt Howson and Irishman Gary Thompson both spent the test with SGC by KCMG.

ELMS

ORECA set to revamp LMPC class for ELMS

THE FRENCH ORECA

organisation plans to run at least four of its one-make LMPC prototypes in next year's European Le Mans Series.

The initiative, which will be run under the Team Endurance Challenge banner, has been launched to kick-start LMPC in the ELMS and to offer young drivers a low-cost route into sportscars. A seat in one of the Chevrolet-engined FLMO9s, which will be shared by two drivers in the three-hour ELMS races, will cost £145,000 for the five-race season.

ORECA team boss Hugues de Chaunac said: "This represents

a fantastic opportunity for a young driver to learn about long-distance racing for a reasonable budget. It is a good strategy to relaunch LMPC in Europe, at the same time as supporting the ELMS.

"This will be a real driver's formula. All our cars will be run by ORECA staff, so they will be equal."

De Chaunac said that he was hopeful of other teams competing in LMPC in Europe. He suggested that as many as four more cars could turn out for events.

The best duo from the Team Endurance Challenge will be offered an LMP2 test.



LMPC has been popular in ALMS

AUTOSPORT SAYS..

KEVIN TURNER
FEATURES EDITOR

Kevin.turner@haymarket.com



Regular readers will know that AUTOSPORT has not been a huge fan of the rolling boost adjustment in the BTCC, so it's a tad disappointing to see it remain.

Although the use of baseline boost levels to equalise all the various engines makes some sense, using lap times to adjust them merely penalises better drivers, chassis and teams. And now giving different squads or drivers with the same car different boost levels underlines the fact that it's about keeping the racing close rather than providing a level playing field.

Having said that, most of the changes are positive. Fewer, smaller, boost adjustments will make the swings less extreme and help keep things a bit more consistent, and the grid penalty for poor driving is also welcome.

Some of the driving standards were woeful this season, so a quantifiable impact on a contender's chances in the next race just might act

as a deterrent. However, as Speedworks boss Christian Dick points out, the key thing will be applying the penalties consistently.

The soft tyre is a gimmick, but why not? Formula 1 has used different tyre compounds to create better racing over the past couple of years, so it's not surprising that the BTCC fancies a go as well.

Perhaps MG team principal Ian Harrison summed it up best when he said: "This is all about putting on a show – it's not purist racing – and we've got to accept that."

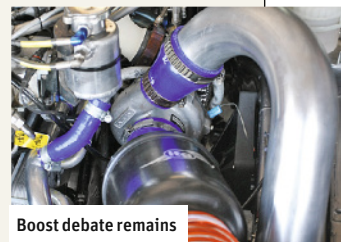

Boost debate remains

REMEMBER WHEN...



A Dodge driver last won NASCAR's top title? Brad Keselowski's crown ended a drought of 37 years since Richard Petty won 13 races and the crown in a Charger run by his own self-run Petty Enterprises outfit.



MACAU GP
DA COSTA WINS

Antonio Felix da Costa triumphed at last weekend's Macau Grand Prix to add Formula 3 success to his FR3.5 and GP3 wins this year. He became the first Portuguese driver since 1954 to win the event. Full report P46

F3

F3 to shun new engines in 2013

European series plans to delay introduction of bespoke engines until 2014 season. By MARCUS SIMMONS

Formula 3 looks virtually certain to continue using only older-generation engines in Europe in 2013.

While the revised FIA European F3 Championship's regulations will allow in new-spec powerplants with a performance-balancing equation in 2013, the British F3 International Series is to write them out of its rules for the season.

With most European teams enjoying varying levels of manufacturer support from Volkswagen and Mercedes, it is regarded as extremely unlikely that any outfit will switch to the

new-spec engines, which will become mandatory in 2014.

The FIA's Frederic Bertrand told AUTOSPORT at last weekend's Macau Grand Prix that he now has a signed pledge from the two German manufacturers to produce engines to the new rules, which allow bespoke racing engines, for 2014.

British F3 teams are generally more independent from manufacturers than their European counterparts, but teams group FOTA met in Macau, and decided to implement a new rule barring the new engines until 2014.

FOTA's Peter Briggs said: "This

eliminates the problem [of whether the performance balancing will work]. It gives potential drivers confidence that they will not end up with an uncompetitive engine. We are aiming to introduce it into our regulations for next year."

Meanwhile, the Japanese F3 Championship will go ahead with new engines. Toda (AUTOSPORT, March 1) and TOM'S are both set to field them, although the plans of Mugen are unclear.

TOM'S boss Susumi Koumi said: "The engine has been running on the dyno. We are using the standard cylinder block and head from the current Toyota, but other bits and pieces are being redesigned to suit the new regulations."

The FIA European F3 Championship will entirely replace the F3 Euro Series, which ends its 10-year existence. It will be promoted jointly by the DTM-organising ITR and the FIA. It will run at seven DTM rounds, two World Touring Car Championship events and the Silverstone 6 Hours.

Three races will be held at each round, with two qualifying sessions

and no reversed-grid races. Hankook tyres will be used. The calendar is provisional – a clash between the European round at Brands Hatch and the British F3 event at Pau meaning that there could be some negotiation to get teams from both series to the French street circuit.

Peter Fluckiger, boss of staunch Euro Series team Mücke Motorsport, welcomed the news. "It's good because we want to keep with the DTM as much as possible," he said. "They are well organised and have good TV coverage in Germany."

"They are not all F1 tracks, but it's the event that counts. If you are a good driver, you can learn more on tracks that are not to F1 standard. Look at Macau..."

But Carlin boss Trevor Carlin added: "It's a shame there are no rounds with British F3, as the goal was to have more cars on the grid, so it's a missed opportunity."



Current engines set to remain in Europe

P46 MACAU GP REPORT

INDYCAR

Rahal hopes to expand team next year

BOBBY RAHAL REMAINS OPTIMISTIC about adding a second car to the Rahal Letterman Lanigan Racing IndyCar stable next year, although he is adamant that the team will only do so if it is confident that both entries will be competitive.

The team made its long-expected confirmation that Graham Rahal will move across from Chip Ganassi Racing in 2013, taking the seat formerly occupied by Takuma Sato. Rahal said that he'd be keen to retain Sato if the second car comes to pass, but admitted that there are several drivers on his shortlist.

"I'm not really interested in having a second car for the sake of having a second car," the three-time CART champion and 1986 Indianapolis 500 winner said.

"It needs to be a car that can help this team achieve a high level of success and competition. If you have two competitive drivers pushing each other, you push the team, and that's the formula we're trying to achieve here. So we'd love to have Takuma back. There are other guys out there that are available, such as Ryan Briscoe and Justin Wilson, whom I have a great deal of



Rahal last ran his son at 2010 Indianapolis 500

respect for. I'm hoping by year's end that we'll have something put to bed."

AUTOSPORT understands that Briscoe's representatives have been in contact with RLLR about a potential deal for 2013 for

some time, although the Australian's preferred option is believed to lie in convincing Team Penske to retain its third car. He has also been linked to the AJ Foyt Racing seat left vacant by Mike Conway.

IN BRIEF



Filippi will test new car

FILIPPI TO TEST AUTO GP CAR

Luca Filippi will join Adrian Quaife-Hobbs in testing Auto GP's heavily-revised 2013 car at Barcelona on December 6. Both drivers will undertake development runs, while teams run their 2012-spec machines over the two days.

NEW INDYCAR RACE TROUBLE

IndyCar's hopes of adding a street race in the Florida city of Fort Lauderdale have hit a stumbling block after city representatives said that the asking price of \$20 million over five years by promoter Andretti Sports Marketing is too high. The event would be a double-header with the ALMS.

EVANS GETS DAMS GP2 TEST

GP3 champion Mitch Evans tested for GP2 title-winning outfit DAMS at Jerez this week. Marcus Ericsson, Ryo Haryanto and Stephane Richelmi were also due run-outs with the team as AUTOSPORT closed for press. Jolyon Palmer and Johnny Cecotto Jr drove for Lotus and Arden respectively.

ROOKIES TEST FR3.5s

British Formula 3 champion Jack Harvey had his maiden Formula Renault 3.5 test with Carlin at Aragon this week. F2 title winner Luciano Bacheta drove for Pons, while the top three competitors from FRenault NEC – Jake Dennis, Jordan King and Josh Hill – drove for Lotus BVM Target and ISR respectively.

LICHTENSTEIN JOINS CARLIN

Eric Lichtenstein has become the first driver to commit to next year's GP3 Series. The 18-year-old Argentinian, who raced in British Formula Ford in 2012, has been recruited by Carlin, for whom he tested recently at Jerez and Estoril.

NISSAN GT TEST FILLS UP

Six of the eight places available for a two-day test in the 2013-spec Nissan GT-R NISMO GT3 at the Algarve next week have been filled. JRM Racing, NISMO's European development partner, has organised the test to showcase the revised car to potential customers.



Nissan set to run in Portugal

BRITISH F3

Hill and King closing in on top British F3 drives

BRITISH FORMULA RENAULT RACE winners Jordan King and Josh Hill look set to graduate to the British Formula 3 International Series in 2013.

The McLaren AUTOSPORT BRDC Award finalists, who were second and third respectively in Formula Renault NEC this season, are both close to deals to step up – King with Double R Racing and Hill with Fortec Motorsport.

King, 18, recently tested a Double R Dallara-Mercedes at Anglesey, and has had a long association with team boss Anthony 'Boyo' Hieatt, who has acted as his career advisor.

Hieatt, who is planning a three-car team in the series' A-class, said: "Jordan did very well in the test. The car was an eye-opener for him, but he did almost 400 miles over two days in wet and dry conditions, and was excellent."

Hill, 21, has tested Fortec's older-spec Dallara at Snetterton,

and will be emulating his father, 1996 Formula 1 champion Damon Hill, who raced full-time in British F3 from '86-88.

Team boss Richard Dutton would not be drawn on the situation with Hill, who drove for Fortec in FRenault this year, although AUTOSPORT understands the deal is close. "We're talking to several drivers for British F3," said Dutton. "I think we'll run four cars in Britain and two or three in Europe. There's lots of interest."



King (l) and Hill want drives

AUTOSPORT INTERNATIONAL

10-13 January 2013, NEC



DI RESTA TO STAR ON STAGE

Force India Formula 1 driver Paul di Resta will appear on the AUTOSPORT stage on both public days to share his hopes for next season and meet fans.

HUFF ADDED TO LINE-UP

New World Touring Car champion Rob Huff is another star name to confirm his attendance. He will appear at various points during the four-day event.

WHELDON TROPHY FOR KARTING

One of late IndyCar star Dan Wheldon's actual racing trophies will be presented to the team that wins the revamped charity Karting Challenge at the show.

TICKET INFORMATION

AUTOSPORT International is open to the public on January 12-13, 2013 with trade days on 10-11. To buy tickets or for more information, please call 0844 5811420 or visit www.autosportinternational.com



Kent Surrey Sussex



Air Ambulance
A Charity That Saves Lives

Henry Surtees Challenge Trophy 2012

‘I would like to say a sincere thank you to all those who made this event possible and such a success on the day.

The star-studded cast of drivers, a number of whom had competed with Henry, put on a fantastic day’s racing.

£22.000 was raised for the programme we have with Kent Surrey Sussex Air Ambulance. Thank you.’ *John Surtees*

THIS EVENT WOULD NOT BE POSSIBLE WITHOUT THE GENEROUS SUPPORT OF:

ANDY PRIAULX

ARAI

ABARTH

AUTOGLYM

BERNIE ECCLESTONE

BUCKMORE PARK

CAMBERLEY KART CLUB

CARLIN MOTORSPORT

CAROLYNN HOY

CLUB 100

FALCON MOTORSPORT

HAYMARKET MEDIA GROUP

HEARING ELECTRONICS

HILLSPEED RACING

MANOR COMPETITION

MERCEDES-BENZ UK

MUMM

NBI

PUMA

RED BULL RACING

RENAULT UK

SEAT UK

SHELL UK

TENG TOOLS

TRAVEL PLACES

VEHVAC

WHITMORE’S

5GCREATIVE

Simon Rudd, Adrian Matthews, Paul Janes, Tom Banister, Luke Reade, Steve Bull, Anthony Whorton-eales, Matthew Bell, Alexander Sims, Abdul Ahmed, Charlie Eastwood, Peter Cole, Harrison Scott, Scott Martin, Andrew Johnson, Jack O’Neil, Andrew O’Neil, Matthew Parry, Terry Waller, Richard Crozier, Tom Ingram, David Pittard, Shaun Pirie, Shaun Hollingsworth, Jake Dalton, Nick Yelloly, Luca Loscalzo, Scott Malvern, Oli Webb, Ben Barnicoat, Jake Dennis, Laura Tillet, Oliver Rowland, Darryl Evans, Jack Harding, Alex Brundle, Mike Comber, Jacob Stilp, Cameron Twynham, Dylon Phibbs, David Robinson, Josh West, Jack Barlow

MOWER HOND
PLANT
SERVICES

odi
100 different



www.henrysurtreesfoundation.com



Huff became WTCC champ last weekend

IN BRIEF



Angelelli went fastest

ANGELELLI TOPS DAYTONA TEST

Max Angelelli was fastest in last week's two-day Grand-Am test at Daytona in a Wayne Taylor Racing Dallara-Corvette. No official times were issued for Conquest's Morgan-Nissan LMP2 2012, which ran on Daytona Prototype tyres. It is understood that the car was 1s off the best DP times.

TOURING CAR RACER DIES

Hong Kong driver Phillip Yau Wing Choi died last Friday after crashing at Mandarin bend during qualifying for the Macau Grand Prix-supporting CTM Touring Car Cup event. His death came just 24 hours after Luis Carreira was killed practising for the Superbike race at the same circuit.

FLYING LIZARD STEPS DOWN

American Le Mans Series GT team Flying Lizard has moved down to the one-make GTC class for 2013 just a week after announcing the loss of its Porsche factory status. Team owner Seth Neiman will share a 911 Cup car with Spencer Pumpelly.

BTCC TESTS FOR TRIO

Renault Clio Cup champion Jack Goff made his British Touring Car test debut in Tony Gilham Racing's Vauxhall Insignia at Silverstone last week. Mini champion Chris Knox was out in an ES Racing Vectra, while Stefan Hodgetts drove Rob Austin's Audi.

PETTY RETAINS NASCAR DUO

Marcos Ambrose and Aric Almirola have re-signed for Richard Petty Motorsports for next year's NASCAR Sprint Cup. The pair finished 18th and 20th overall this year.



Petty pair re-sign

WTCC

Huff: no deal for 2013

New champ may not be able to retain his WTCC title next year. By PETER MILLS

Rob Huff is facing the possibility of a year on the sidelines in 2013, despite becoming the World Touring Car champion at Macau last weekend.

The 32-year-old Briton found out in July that Chevrolet, for which he has driven in the championship since 2005, was pulling the plug on its WTCC programme. He has yet to secure a drive for next season.

"I'm working on many different things, but at the moment I've not got a contract in front of me and I haven't signed anything," he said.

Huff is desperate to defend his WTCC crown next year. RML, which has run Chevrolet's factory entry in the series for the past eight seasons, is known to be attempting to put together a privateer programme with at least two Chevrolet Cruzes, and this could be one option for Huff. He has also been investigating opportunities in V8 Supercars and the American Le Mans Series.

"I hope to be here to defend my title, but obviously I need a car to do that," said Huff in Macau. "At the moment, I don't have that, but that's what we're working towards."

Fellow Chevrolet drivers Alain Menu and Yvan Muller, who finished second and third in this year's championship, are also yet to confirm their plans for next year.

Veteran Menu, Huff's team-mate since 2005, denied that retirement was something he was considering, but is prepared to spend a year testing

if a manufacturer programme were offered to him. He is also looking outside Europe for drives.

"A development year with a manufacturer along with some races would be a good solution at this stage of my career," said the 49-year-old Swiss racer. "I don't know if it is possible to have a works drive developing a car and also race for a smaller team, but that would be ideal. But who else is coming in other than Citroen? I have also never done the Spa 24 Hours..."

Muller, meanwhile, denied rumours that he has signed a deal to race for Citroen alongside Sebastien Loeb when the French marque enters the WTCC in 2014.

"Citroen already has one driver," said Muller in reference to World Rally champion Loeb's entry. "I believe they have yet to decide who else they want for 2014, but it is normal to think I could be one of the drivers they will look at."



Retirement is 'not an option' for Menu

➔ P50 MACAU WTCC REPORT

MIS Motorsport - setting the standards in motorsport insurance

ON TRACK / ON EVENT / MOTOR TRADE / PERSONAL ACCIDENT / COMMERCIAL / LIABILITY

www.mismotorsport.com or call 01943 884 555

M.I.S. Motorsport Ltd is authorised and regulated by the Financial Services Authority.

MIS
MOTORSPORT

Race winning oils!



Driven Racing Oils are specially formulated for the specific needs of racing engines. The engine builders at Joe Gibbs Racing have put in countless hours perfecting the oil to maximise horsepower and protect vital parts.

Huge range of engine and gearbox oils in stock.

DRIVEN
RACING OIL

Anglo American Oil Company Ltd

+44 (0)1929 551557 (tel) info@aaoil.co.uk www.aaoil.co.uk

KUBICA WINS

Robert Kubica took a Citroën C4 WRC to victory on last weekend's Rally di Como, and the Pole is chasing another success on Rallye du Var this weekend.



WRC

Ostberg's big decision

Norwegian to choose M-Sport or Prodrive for 2013 WRC seat. By DAVID EVANS

Mads Ostberg will choose between a full-time drive with the M-Sport Ford team or Prodrive's Mini squad in next year's World Rally Championship after missing out on a Citroën seat to Dani Sordo.

Sordo was confirmed as Sebastien Loeb's replacement at Citroën last week, but Ostberg has insisted that the decision has not phased him.

He says that having a full-time deal for 2013 is far more important than being a factory driver.

"I want to go where I can do all the rallies," said Ostberg, who is expected to make his decision by the end of November. "This was always one of the main things for me and I wasn't sure with Citroën if I could take the full season. Now it's really a straight choice between Ford and Mini for the full season next year."

As well as the full complement of rallies, the 25-year-old Norwegian said an expanded test programme is also vital from any team he joins. Both M-Sport and Prodrive are ready



Ostberg has a big choice to make

to run Ostberg as a number-one driver next year. And Ostberg has extensive experience of both British outfits, having tackled 27 WRC rallies in Prodrive-run Subaru Imprezas and the remaining 25 in a Fiesta from M-Sport.

M-Sport managing director Malcolm Wilson said: "We're pretty

confident of seeing Mads in a Fiesta next year. He's always been a driver on my radar and he would certainly fit the bill as a team leader for us."

Meanwhile Prodrive business development director Richard Taylor said: "We have known Mads for a long time and we have been very, very impressed with the way his pace has improved this year. It's nothing short of sensational.

"We want Mads to drive our car next year. He has shown he's capable of winning rallies and we want to see him doing that with us in 2013 and challenging for the championship."

Ostberg, who claimed his first WRC victory on Rally Portugal this year, added: "I feel I can win rallies next year, providing I get the right testing programme."

Sordo admitted Citroën still had not confirmed his precise 2013 programme and, in particular, whether or not he will contest the five events in which Loeb will drive a DS3 WRC.

WRC

Latvala has first VW test

JARI-MATTI LATVALA'S VOLKSWAGEN

rally career got underway in Germany last week as he made his Polo R WRC test debut.

Neither VW nor the Finn confirmed that the test took place, but Latvala's team-mate Sebastien Ogier said he was glad to see one of his confirmed 2013 colleagues getting behind the wheel.

The Frenchman said: "It was interesting to get a second opinion, especially since he just left a car leading the championship.

By combining our comments, we have confirmed paths taken to focus the improvement of the car. He was pleased with the chassis settings that have been developed throughout this year. This is a good first step in our collaboration."

Last week's test was a continuation of VW's intensive programme. The German manufacturer will evaluate the Polo in Mexico, France and Sweden before the end of the year.

IN BRIEF



Schwarz finished seventh

SCHWARZ'S BAJA TROUBLES...

Armin Schwarz's hopes of winning the Baja 1000 were dashed when his BMW-based X6 trophy truck blew a seal on its torque converter. The resultant gearbox change cost him any chance of improving on the seventh place in which he was running.

...WHILE MEEKE HAS A BLAST

Kris Meeke was also present in Mexico and finished sixth in the solo motorbike class on his first attempt at the Baja. The former IRC champion completed the 1121-mile route in just over 40 hours.

CITROËN TESTS IN WALES

The Citroën WRC team returned to Wales this week for a three-day test with Mikko Hirvonen and Sebastien Loeb. The test was completed in an effort to find the reason for the French firm's poor showing on September's Rally GB.

2013 MONTE ROUTE REVEALED

The route for next year's WRC-opening Monte Carlo Rally has been revealed and includes a new stage on the penultimate day as well as a run through Sisteron. A third pass of the Col de Turini test has also been included on the final day of the classic event.

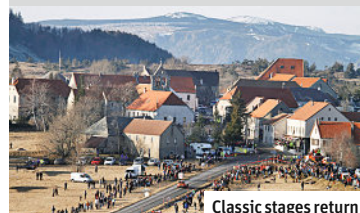

Classic stages return



Latvala got first Polo try-out in Germany



UNITED STATES GP

Circuit of
the Americas,
November 18

ROUND 19/20

LAPS 56

WINNER

Lewis Hamilton
1h35m55.269s

POLE POSITION

Sebastian Vettel
1m35.657s

FASTEST LAP

Sebastian Vettel
1m39.347s

RACE RATING

★★★★☆

Hamilton was inspired
and lots of great
passes throughout

DRIVERS STANDINGS

Vettel	273pts
Alonso	260pts
Raikkonen	206pts

MILESTONES

- Vettel's second place gave Red Bull constructors' title
- Austin is the 10th circuit to host the US Grand Prix



LEWIS OUTGUNS SEB IN TEXAS SHOOT-OUT

After his recent run of disappointments, the McLaren driver had a 'Yeehaw' moment in Austin, hunting down and passing the Red Bull to win. MARK HUGHES reports



QUALIFYING

Vettel squeezes out Hamilton as Alonso trips up in Texas

So Formula 1 made its return to America five years after it left, and the magnificent sweeping and diving Austin circuit could hardly have formed a starker contrast to the bland Indianapolis infield.

It's said that everything's bigger in Texas, and that certainly applies to the dramatic upward sweep of that first turn, which looks like a wall as you stand facing it. The hairpin that lies over the brow of that horizon sweeps sharply back down, daring the drivers to take the following right-handed kink of Turn 2 with DRS flap open, pulling sixth gear on exit, accelerating then to a series of switchbacks rivalling the Suzuka Esses. Sixth gear through the left of Turn 3, holding it on the entry to the right of 4, a downshift for the tightening left of 5, and opening out slightly uphill through 6 before climbing from 7 through another uphill to the summit of 9.

The rest of the track doesn't quite live up to that thrilling sector and a bit, although by the time of the multiple apex right of Turns 17-18 – a sort of Istanbul Turn 8 in reverse – it's getting fruity again. Through there, the left-hand tyres are getting pretty hot, and the car can feel a little unbalanced when braking for 19 – possibly a contributory factor to so many sliding wide onto the run-off there.

Another thing that was bigger in Texas was the number of qualifying laps necessary. The combination of another conservative tyre choice and a very low-grip surface meant multiple-lap runs for everyone. Even the option tyres (medium) took many laps to switch on. Until they did, it was like rallycross out there. Never in decades have so many F1 cars been so sideways in the dry. The rubber was incredibly sensitive here to not switching on at all, with no heat getting through to the carcass, and the whole tyre shuddering and gripless. However, when eventually they did come alive, the surface of the rears was very prone to overheating.

So it was there was wild variation in performance, especially between Q2 and Q3 as tyres came in and out of their windows. The two Red Bulls and Lewis Hamilton's McLaren seemed the only ones capable of regularly accessing their potential whenever



Vettel could not be dislodged from pole

it was needed, and Sebastian Vettel duly took a close-fought pole from Hamilton, with Mark Webber 0.5s adrift. No one else was even close. Among those flailing away in their wake, desperately trying to generate tyre heat, was Vettel's title rival Fernando Alonso, his Ferrari a disastrous ninth.

The Red Bull – new front and rear wings working just as in the team's simulations – was as if attached to the track by magnets through the fast switchback sections, but the McLaren (new front wing very effective) was almost as good there, and Hamilton was at his acrobatic best. "I'd seen from Seb's times through the practices and in Q2 that the Red Bulls were massively fast – Seb was almost 1s clear," said Hamilton. "I didn't know where I was going to be able to find that. So I just went as hard as I could, gave it absolutely everything. On my fastest lap, I was way over the limit, with a couple of big oversteer moments."

With Vettel's final lap already completed, it was all hanging on the last corner for Hamilton. He took in as much as he dared – his previous lap already the only one anywhere near Vettel's – but it was a little

too much, and correcting the slide lost just a little more than he'd gained coming in. He lost out by just over 0.1s.

Actually, second was potentially a much worse starting position than third, such was the contrast in grip between the inside and outside of the grid. Felipe Massa had done a practice start from there earlier that morning. The numbers said it was poorer than a wet start! Red Bull calculated that on acceleration numbers alone second would translate to seventh by Turn 1.

"We were carrying a small car issue in Q3," said Webber, "but it didn't cost me a grid place because those two guys were pretty quick."

Illustrating the capricious nature of the tyres, Romain Grosjean's Lotus and Pastor Maldonado's Williams had been pretty much as quick as each other in Q2. In Q3, though, Grosjean improved by 0.6s to go fourth quickest, while Maldonado was 0.8s slower than before and 10th. The Lotus was running an updated version of the Coanda exhaust layout, with bodywork changes and a tweaked front wing. It was mighty fast through the switchbacks, but less balanced through sectors two and three. Grosjean pipped team-mate Kimi Raikkonen by just over a tenth, but was taking a five-place grid penalty for a new gearbox.

Unconvinced about whether its Coanda exhaust was working as well as it should, Mercedes ran Nico Rosberg with the original, non-Coanda, system and Michael Schumacher with the newer layout. Rosberg only barely made it out of Q1, and was a struggling 17th in Q2. Schumacher comfortably made it into Q3, where he proceeded to go sixth quickest. Both cars,

though, were very prone to overheating the surface of those rear tyres.

Only after Schumacher did we come to the first Ferrari – and it wasn't Alonso. Felipe Massa had got a better balance and more traction, and was seventh, 1.3s off pole. Alonso, running a new diffuser, was 0.4s off even that and two places back. "Red Bull are fastest, we are seventh and ninth, and I still say we can outpoint them," said Alonso later. "But I don't know why really!"

Even worse, Grosjean's penalty knocked Alonso from ninth, but on the grippy side, to eighth on the 'wet' side. That was corrected by Ferrari tactically breaking the seal of Massa's gearbox, ensuring a five-place penalty and a clean-side start for Alonso.

Qualifying between the two Ferraris was Nico Hulkenberg's Force India, the German's attacking style proving more appropriate to generating tyre temperature than team-mate Paul di Resta who was mired in 13th.

Bruno Senna's Williams was 0.6s off Maldonado's in Q2, but that was good for 11th. Jenson Button had to pit partway through his Q2 run with a throttle problem, leaving him 12th. The Saubers could not generate tyre heat, allowing Jean-Eric Vergne's Toro Rosso to outqualify them. Daniel Ricciardo failed to make it out of Q1, his tyres temperatures falling disastrously through having to back off for a yellow.



Hamilton got close to Vettel's pole time

P42 RESULTS
All those vital stats





Alonso (left) about to sweep into fourth place



RACE CONDITIONS

Warm conditions, with an ambient temperature of 23C and a light breeze.

Lap 19, and in the McLaren pits things were getting pretty tense. Lewis Hamilton was losing pace. Over the past four laps, his deficit to leader Sebastian

Vettel had grown from one second to 3.2s. The rear option tyres were on their way out. They'd done six laps in Q3 the day before, having taken a long time to come in, but so had Vettel's, which were holding up fine. Vettel, however, had run out front from the start, whereas Hamilton had spent more than three laps racing and passing Mark Webber, and then closing the gap to the leader. It was logical they'd surrendered earlier, but this was strategically awkward timing.

McLaren had believed it could get that first set to lap 24-25 for a one-stop, giving the primes a final stint of 30-odd laps. Although there was minimal performance degradation because the compounds were so conservative, there was a concern about wear of the inner shoulders of the fronts. Stopping too early would risk running into that critical wear zone late in the race.

On Friday, the McLaren fronts were finished after 20 laps. Some other cars hadn't been able to get them beyond 15. Sure, the rubbering-in and cleaning up

of the track surface would probably defer the problem to longer than that – but how much longer? Hamilton's times had started dropping off on lap 16. Asking the final set of tyres to do 40 tours was just too risky. McLaren had to keep him going a few laps longer.

On lap 16, Hamilton had been 0.5s off his earlier pace when he'd been shadowing Vettel, screaming through those long switchbacks of the first sector, earlier into the turns than the Red Bull, keeping up the momentum for longer, but still being able to then change direction further. He definitely had more grip through there, but he'd only just got within DRS-sniffing distance when the tyres began giving out. Lap 17 was 0.7s off his peak pace, then 1.3s, then 1.5s. By then he was raggedly hanging it out over the extremes of the exit kerbs and Vettel was pulling neatly away. "Box this lap, Lewis," came the call. That was lap 20.

Vettel noticed the silver blur in his mirrors had faded away. His championship quest was going well. All he could do was control his own destiny and he was doing so flawlessly. He'd got away well, clear of the squabbling Mark Webber and Hamilton behind. However, his preference for sealing up the title here and keeping his fate from depending upon the randomness of Interlagos had taken a blow when Fernando Alonso had surged straight into fourth position from the start.

Ferrari had played a blinder in breaking the seal of Felipe Massa's gearbox, thereby incurring an



Button (bottom right) boxed in behind Senna

automatic five-place penalty, which took Alonso from the dirty, slippery eighth-place grid slot to the much grippier, rubbered-in seventh. Massa's practice start on Saturday morning from the left-hand side had given worse acceleration than a typical wet start, such were the impurities and gunk that come from newly laid asphalt until it's weathered in a little.

It was a tactical move and Massa – who had been quicker than Alonso throughout qualifying and seemed to have found a better way of bringing the tyres in – was gracious in accepting it. Alonso told him he was a rare teammate. Was Ferrari boss Stefano Domenicali not concerned that Red Bull might counter and do the same with Webber, putting Alonso back on the dirty side? "Yes," he answered.

Had Red Bull's Christian Horner considered it? "Yes. But then others

might have done the same, and before you know it Alonso would have been starting from the front row!"

Outaccelerating Nico Hulkenberg's Force India immediately, Alonso was initially alongside Michael Schumacher's Mercedes, but with the German preoccupied, trying to squeeze Kimi Raikkonen's Lotus to the inside, the Ferrari got a clean run right around the outside. A quick twitch of oversteer halfway round, and he was up to fourth, the minimum position he needed to take the title to Brazil.

Hulkenberg and Raikkonen went side by side through the fast downhill sweep of Turn 2. They rubbed wheels, with Raikkonen sliding onto the run-off and rejoining behind the Force India. Romain Grosjean's sister Lotus was just behind. From 11th, Massa had scythed up to eighth by Turn 1, but slid onto the same run-off as Raikkonen ▶

◀ and lost a couple of places. Jenson Button, one of only two drivers to start on the prime tyres, had made a terrible start in the McLaren from 12th and been boxed in further. He completed the opening lap in 15th, behind the similarly prime-shod Mercedes of Nico Rosberg and Daniel Ricciardo's Toro Rosso. How he must have been cursing that throttle problem in qualifying.

It was a stirring sight. The pack jostling beneath the blue Texan sky, blobs of colour, sunlight glinting off bodywork and visors, off the stars and stripes atop Hamilton's helmet – the glare and glint as the gladiators put on a show for the packed grandstands.

Through the snaking sector one, up the hill to the summit of Turn 9, the

“Vettel, Webber and Hamilton quickly put distance on Alonso as the Ferrari's tyres failed to switch on”

cars were highlighted against sky, doing 200mph down the back straight where the DRS zone would be, around the punishing never-ending right-hander of 17-18, the tricky left of 19 and onto the pit straight. Formula 1 was back in the land it should never have left.

Vettel, Webber and Hamilton were quickly putting distance on Alonso as the Ferrari's reluctance to switch on its tyres again became very apparent. The Spaniard was 2.6s off Vettel's pace on the second lap, but protected from behind during this vulnerable period by the obstacle that was Schumacher's horribly gripless Mercedes, and the dicing that created.

Hulkenberg got past the Mercedes up the inside into Turn 1. Raikkonen followed up with a slicing move at the hairpin of 11 on the third lap, but as he slid wide on the exit, Schumacher retaliated, and their squabbling

Alonso salvaged a podium from a seventh-placed start



Webber asks the fastest way back to the pits...



...after his Red Bull suffers another alternator failure

allowed Grosjean to nail them both at the end of the following DRS straight.

Hamilton, meanwhile, had just tried an optimistic move on Webber at the same place, briefly getting past before running wide. This was where the Red Bulls were vulnerable, though, because of their usual lack of end-of-straight speed. Vettel flashed past the trap

there at a best of 192mph. Hamilton reached 195mph and Massa 199mph.

At the same place on the next lap, Hamilton made the move stick, and Vettel was still only 1.6s up the road.

Into the sixth lap, Grosjean briefly took fifth from Hulkenberg at Turn 1, but went wide. At the end of the lap, the Lotus man spun on the downshift

into 19, the car looping around and heading backwards, rear wheels just nudging the gravel trap as he stopped. Grosjean lost four places immediately and a couple more later as his now flat-spotted tyres slowed him. He pitted at the end of lap nine for new primes.

Button was making great progress, cutting past slower cars like a shark

DRIVER BY DRIVER by Edd Straw

1  **8/10**
Event rating

SEBASTIAN VETTEL
Red Bull-Renault RB8-04
Start: 1st. Finish: 2nd
This has to go down as a win that got away. Yes, Vettel was unfortunate to happen upon Karthikeyan's HRT in just the wrong part of the track, which undid his strategy of trying to stay just out of reach of Hamilton. Still a good weekend, but Hamilton's opportunism prevailed.

2  **6/10**
Event rating

MARK WEBBER
Red Bull-Renault RB8-03
Start: 3rd. Finish: DNF
Didn't look to have the pace of his team-mate, and was half a second down in qualifying. Managed to get ahead of Hamilton at the start, but couldn't keep the McLaren behind. Would have been good value for a podium had he not had alternator failure that ended his race on lap 17.

3  **8/10**
Event rating

JENSON BUTTON
McLaren-Mercedes MP4-27-03
Start: 12th. Finish: 5th
A throttle problem in qualifying left him mid-grid, although he still wouldn't have been on his team-mate's pace with a clean run. Drove a very accomplished race, after starting on hards, to salvage fifth. Made some great passes, with one outstanding one on Raikkonen in particular.

4  **10/10**
Event rating

LEWIS HAMILTON
McLaren-Mercedes MP4-27-04
Start: 2nd. Finish: 1st
Had no business being close to Vettel's pole time, and his race drive was equally impressive. With Vettel keeping him at arm's length, traffic was his best chance, and he seized on the delay caused by Karthikeyan to close to within range of a DRS attack. A well-earned win.

5  **8/10**
Event rating

FERNANDO ALONSO
Ferrari F2012-295
Start: 7th. Finish: 3rd
Qualifying was disappointing, although there were question marks over whether his tweaked diffuser was an improvement over Massa's old-spec version. Had a blinding first corner to jump to fourth, then did his usual consistently strong job to keep himself in the title hunt.

6  **10/10**
Event rating

FELIPE MASSA
Ferrari F2012-294
Start: 11th. Finish: 4th
Outqualified Alonso, then had to take one for the team and drop five places to help the Ferrari number one. Even without a leap up the order at the start, he was still in a position to have jumped Alonso, requiring him to take it easy around his stop. Best weekend in years.



Flat in sixth gear, Kimi (right) blasts around Hulkenberg

overtaking opportunities had proven wide of the mark.

Speaking of passing, Raikkonen repeated his first-lap Turn 2 attempt on Hulkenberg, around the outside again in sixth gear, the Lotus teetering on the very edges of adhesion. This time, though, he made it through into fifth. Hulkenberg now had the irrepressible Massa on his tail, with the Ferrari going by for sixth in the DRS zone the following lap. Hulkenberg's tyres were past their best, and he'd be in earlier than planned for a new set.

At around this time, Webber, who'd dropped to almost 5s behind Hamilton, began to experience some worrying symptoms in his car. First the e-shift began playing up, then the KERS shut off. It had all the hallmarks of an alternator failure – which is exactly what it was. Webber pulled over on the 17th lap with a dead engine.

The team had been running 2011-spec alternators, in preference to the updated versions of the 2012 units, which have been giving trouble-free service at Lotus and Caterham. Red Bull will switch for Brazil, but in the meantime there was the obvious worry about the alternator in Vettel's car. A retirement here and a second for Alonso would have put the Spaniard comfortably ahead going into Brazil.

Shortly after, Hamilton began to fall back from Vettel, triggering McLaren's strategic dilemma. The Briton arrived at the McLaren pit, stopped on his marks, the articulated front jack swung into action, a twist of front wing was added as fresh primes were fitted. He was under way again in less than 2.4s.

Fourteen seconds later, third-placed Alonso arrived in the Ferrari pits. This stop went less well, a sticking right rear leaving him stationary for 6.3s. He rejoined just ahead of the yet-to-stop Button, who was still going quickly on his well-used primes.

Vettel's pace had begun to fall off just as Hamilton was pitting – and he was in on the next lap and under way ▶



Maldonado and Senna get too close for comfort

through minnows. Schumacher was going in the other direction, the Mercedes already wildly overheating its rears. "There must have been some damage for that first set of tyres to have performed so badly," he said later. The two drivers met on lap 10, Button moving to the Merc's inside as they surged uphill to Turn 1. Schumacher, in

his penultimate grand prix, played hard, shoving Button to the left, well over the pit exit line, with another shove just for good measure. Button was through, though – even as Schumacher finished off with some wheel rubbing through the turn.

This was for 11th place, and the German continued to drop like a stone



Button scythed through the 'minnows' for fifth

– being forced onto an unscheduled two-stop and finishing a lowly 16th from fifth on the grid.

Button would continue his surge forwards, the two Williams cars were his next victims. "I passed [Pastor] Maldonado four times, and he passed me three," he said. JB's pre-race pessimism about a potential lack of

7  **7/10**
Event rating

MICHAEL SCHUMACHER
Mercedes F1 W03-03
Start: 5th. Finish: 16th
Unlike his team-mate, he continued to run the latest-spec Mercedes exhaust, and did a very tidy job in qualifying to be on the third row. That was as good as it got as he plummeted down the order with tyre troubles in the race. A two-stop gamble just compounded the problem.

8  **7/10**
Event rating

NICO ROSBERG
Mercedes F1 W03-09
Start: 17th. Finish: 13th
It seems unfair to draw any conclusions about Rosberg's driving, given he was caught in the maelstrom of Mercedes' exhaust machinations. Made no impression in qualifying and never seriously threatened the points in the race, but tried to accentuate the positives.

9  **8/10**
Event rating

KIMI RAIKKONEN
Lotus-Renault E20-05
Start: 4th. Finish: 6th
Wasn't particularly happy in qualifying, but did a decent job for fifth, which became fourth after his team-mate's penalty. Did a good job in the race, too, the highlight being his staunch, but fair, defence against Button, which earned him a respectful handshake from his rival post-race.

10  **6/10**
Event rating

ROMAIN GROSJEAN
Lotus-Renault E20-03
Start: 8th. Finish: 7th
After three necessarily quiet and conservative races, Grosjean returned to form with fourth in qualifying, although a penalty dropped him to eighth. Impatience got the better of him on lap seven when he spun trying to pass Hulkenberg. Recovered to a solid seventh.

11  **4/10**
Event rating

PAUL DI RESTA
Force India-Merc VJM05-04
Start: 13th. Finish: 15th
Hard tyres and a non-abrasive track is a match made in hell for the smooth style of the Scot, and he wasn't able to get the car working in qualifying. The first stint went well, but his first stop was too late, and he then spun while dicing with Maldonado, flat-spotting his tyres and ruining his race.

12  **8/10**
Event rating

NICO HULKENBERG
Force India-Merc VJM05-03
Start: 6th. Finish: 8th
As has become the norm, it's difficult to find fault with Hulkenberg, as he stuck his car firmly in the top 10 in qualifying. Climbed as high as fifth with some opportunistic driving early on in the race, but the car didn't have the pace to do any better than eighth in the end.



Schumacher tries to put the squeeze on Button

◀ again in 2.7s. The timing of Vettel's stop was a relief to McLaren. At least they were in the same boat, and no one else looked in reach – for now. There was a complication, in that Raikkonen, who also hadn't stopped, now lay between Vettel and Hamilton. Would he delay the McLaren and amplify Vettel's advantage?

The Red Bull and the McLaren had been able to switch their tyres on pretty much instantly, and Vettel was lapping about 0.5s quicker than Raikkonen, who slowed Hamilton until the 24th lap, when the latter put a clean DRS move on the Lotus into Turn 12.

The gap to Vettel was now 2.4s. Raikkonen came in at the end of the lap, and had gone well enough during the intervening time to be on course to leapfrog Alonso for third – helped by how long it had again taken the Ferrari to switch on its rubber. However, the right-rear Lotus gunman wasn't quite able to hit the nut square – on as he went to torque-up the new wheel. Raikkonen complicated things by getting on the throttle in anticipation, spinning his wheels uselessly in the air. It left the Lotus stationary for 6.4s. Alonso was off the hook.

Massa was in a temporary fourth place, and still going quicker than the

“Hamilton fought relentlessly all day, keeping Vettel under pressure, never letting him off the hook”

cold-tyred Alonso behind him. This created an obvious awkwardness at Ferrari – especially when Button had delayed Alonso further by passing him at the end of the DRS zone. This put Massa 17s ahead of his team-mate – only slightly less than needed for a pitstop. Finally, on the fifth lap of asking, Alonso's tyres came in, and he was able to step up his pace to pull himself out of his team-mate's undercut range.

The plan was for Massa to stay out for three or more laps, but he saw a puncture alarm light up, and headed in on lap 26. He was quickly under way again, with the crew having found not a puncture, but a dislodged sensor. Now it was Massa's turn to suffer with the Ferrari's slow tyre heat build-up, and he was passed by Raikkonen into Turn 1 two laps into his stint.

Button made his original primes last until the 35th lap, still running quickly in a temporary third place. After



stopping, he rejoined in seventh, just behind Grosjean, who'd made up good ground after his premature stop. Hulkenberg had faded when he switched to the option tyre. He lagged behind Button, and would soon be defending hard from the Williams pair.

Cloud now moved in on that big Texan sky, and suddenly the Lotuses were struggling. That's how sensitive a pivot the tyre performance swung on this weekend. Raikkonen dropped back from Alonso and fell into the clutches of Massa, while Grosjean was soon devoured by Button in a neat move at Turn 15 on lap 37. Two laps later, Massa made a great move on Raikkonen side by side through Turns 1 and 2, sealing it around the outside of the fast downhill bend.

There was action everywhere, and the animated fans were spoilt for choice of where to look. Up front, Hamilton had come back at Vettel to get himself to where he'd been earlier

in the first stint – about 1s behind. But even with DRS activated, he wasn't close enough entering the straight to pass at its end. The Red Bull was faster through sectors two and three, but Lewis made it up again in the snaking Turns 3 to 7. Critically, however, the Red Bull was quicker out of Turn 9, preventing Hamilton getting within passing range. It looked like stalemate.

That snaking section of track was to be Hamilton's friend in more ways than one, though. On lap 42, the lead pair came upon Narain Karthikeyan's HRT just as they entered that section. So interlinked are these fast turns that there's nowhere to get out of the way.

The FIA's Charlie Whiting had told drivers earlier that they would not be penalised for ignoring blue flags between Turns 3 and 7, meaning this was disastrous timing for Vettel, which allowed Hamilton to finally close right onto the tail of the Red Bull. Karthikeyan duly got out of the

DRIVER BY DRIVER by Edd Straw

14  **5/10**
Event rating

KAMUI KOBAYASHI

Sauber-Ferrari C31-04
Start: 16th. Finish: 14th

A disappointing weekend for Kobayashi, who was shaded by his team-mate in qualifying and the race. Complained about tyre warm-up problems, and had an anonymous race after slipping down to 18th early on. The car wasn't great, but he could have done more.

15  **6/10**
Event rating

SERGIO PEREZ

Sauber-Ferrari C31-03
Start: 15th. Finish: 11th

The Sauber wasn't in the zone in America, but Perez probably should have found the couple of tenths needed to start ahead of Vergne. Drove a solid race with a few clean passes, but didn't have the pace to establish himself in the top 10, despite jumping to 11th at the start.

16  **6/10**
Event rating

DANIEL RICCIARDO

Toro Rosso-Ferrari STR7-04
Start: 18th. Finish: 12th

Had a pretty bad qualifying. He missed the cut in Q1 for only the second time this season, blaming traffic and a lack of tyre temperature. Made up for it in the race with an incisive, long first stint on medium rubber. Ran as high as fifth, but regressed to the mean of the car after his stop.

17  **7/10**
Event rating

JEAN-ERIC VERGNE

Toro Rosso-Ferrari STR7-02
Start: 14th. Finish: DNF

Outqualified Ricciardo for only the fourth time this year, although he admitted he could have gone a couple of tenths faster. His initial getaway was good, but he then fell to 16th. Retired early with a suspension problem unrelated to his scrap with the Mercedes drivers.

18  **8/10**
Event rating

PASTOR MALDONADO

Williams-Renault FW34-04
Start: 9th. Finish: 9th

Looked set for a very strong qualifying performance, but complained of a lack of grip and ended up the slowest of the Q3 runners. Had to work very hard in the race after losing places at the start, but fought back well. A forceful pass on his team-mate at Turn 1 late on netted two points.

19  **7/10**
Event rating

BRUNO SENNA

Williams-Renault FW34-03
Start: 10th. Finish: 10th

Yet again, it was a case of what might have been in qualifying after he was one of many drivers caught out at Turn 19. Despite that, he was just one spot behind Maldonado. Would have finished ahead of him in the race as well, had a KERS glitch not cost him some time.



Vettel was stalked by a relentless Hamilton

Caterham turned tables on Marussia in the race



wheels almost touching on the exit, but the Finn was impeccably clean, refusing to hang the McLaren out to dry. Button was through. Fifth was a good result from 12th, but without the throttle pedal trouble of the day before, he could surely have been on the podium. As it was, he'd set his KERS up with not enough harvesting power. "To maximise the harvest, I was getting rear locking under braking — it was just set up wrong. But otherwise the car was great."

That was a sentiment with which Hamilton, in his penultimate race for the team that's been his home for 14 years, could only agree with. It had been a quite brilliant personal performance from a man who's relaxed into driving at the very top of his form of late. "For my whole in-lap I was screaming. Not cool at all. Fantastic! On the last three laps I was getting quite emotional. It's special to finish on a high. To beat Red Bull is quite special. I just wanted it more than Seb today. It's a shame about what's happened in other races, otherwise we could be here fighting for the title."

Instead, that man is Alonso. Great on the opening corner, it had thereafter been quite a lonely day. "Losing just three points [to Vettel] maybe was in no one's thoughts yesterday night or Friday night after seeing the practice," he said. "This is like a victory for us."

But it was McLaren celebrating hard and loud as the Ferrari boys began packing up for that Interlagos finale. 🏆



Winning margin was just 0.675s

way on the exit of 7 as Vettel and Hamilton buzzed by him in almost a single blur. Up the hill to Turn 9, down the kinking straight past the DRS detection point, around the hairpin of 11 and up towards the DRS activation zone they ran, Vettel knowing he was defenceless, pressing

his KERS and going to block the inside. With his DRS flap open, however, Hamilton was massively quicker. He simply darted to the outside and past, even before the braking zone for 12.

Hamilton was in the lead. He'd fought relentlessly all day, never

allowing Vettel off the hook, kept him under pressure, and it was this that allowed him to be close enough to take advantage when a chance occurred. "He had one chance to pass, and he took it," said Vettel later, keen to point out that his radio rant at this point had not been at Hamilton, but Karthikeyan, although it's difficult to see what else the Indian could have done.

Hamilton wasn't sure if his tyres were going to last, and took care to eke out their life. Vettel kept the pressure on, but his prey was always able to stay out of DRS range.

The other McLaren was flying, too, Button now in full attack mode on Raikkonen's fifth place. He tried around the outside of Turn 1 on the 45th lap, but was held. The McLaren, though, had way more grip at this stage on its recent option tyres, and later in the lap Button went for the outside of Turn 12. Raikkonen hung on, and they went through there side by side, with

20 **5/10**
Event rating

HEIKKI KOVALAINEN
Caterham-Renault CT01-3
Start: 22nd. Finish: 18th
Had to play second fiddle to Petrov and complained of tyre temperature troubles all weekend. Considering how crossed-up his Caterham was at times during free practice, it's a very credible excuse. Passed Glock on lap 10 to give his team a one-two in the battle of the backmarkers.

21 **7/10**
Event rating

VITALY PETROV
Caterham-Renault CT01-2
Start: 21st. Finish: 17th
A good all-round weekend's work for Petrov. The highlight was taking to the outside line at the start to emerge ahead of both Marussias. After that, he was quick enough to keep team-mate Kovalainen at bay. Given the chasm ahead of him, 17th was the best result he could have achieved.

22 **6/10**
Event rating

PEDRO DE LA ROSA
HRT-Cosworth F112-03
Start: 23rd. Finish: 21st
Struggled badly with low tyre temperatures on Friday and reckoned making the grid would be tough if grip didn't improve. It did, and he comfortably made the cut. Prevailed over Karthikeyan in the intra-team battle, and survived his seat breaking five laps from home to finish.

23 **6/10**
Event rating

NARAIN KARTHIKEYAN
HRT-Cosworth F112-01
Start: 24th. Finish: 22nd
Considering his limited Friday running, he did a decent job to dip under the 107 per cent qualifying cut-off. In the race, he got ahead of his team-mate before immediately losing the position again after, ironically, lifting for a blue flag. Race pace was in a similar ballpark to de la Rosa.

24 **7/10**
Event rating

TIMO GLOCK
Marussia-Cosworth MR01-01
Start: 19th. Finish: 19th
Qualified within a second of Ricciardo, which was a good effort, and hooked up a lap that put team-mate Pic firmly in the shade. Had a tough first lap, slipping behind Petrov at Turn 1. The lack of KERS stung him and he was passed by Kovalainen, but still followed the two Caterhams home.

25 **6/10**
Event rating

CHARLES PIC
Marussia-Cosworth MR01-03
Start: 18th. Finish: 20th
Not one of his best weekends, but he still outqualified the two Caterhams, despite lagging six-tenths behind Glock in Q1. He was trapped on the inside at Turn 1, hitting Ricciardo as they all dived for the apex. This hobbled him and left him with understeer all afternoon.

Drawing board



Gary Anderson, Mark Hughes and Giorgio Piola give their thoughts on the technical updates that Red Bull, McLaren and Ferrari brought to Austin as the development war continued apace

PLANE SAILING FOR McLAREN

→ McLaren produced a new front wing with extensive changes (previous above, new below). Of the three vortex generators, the inboard one (1) has an enhanced curvature. The curved v-flap (2), in use since Singapore 2010, was replaced by a vertical fin similar to that on the Lotus. An inner section of endplate has been removed (see 3 compared with 4) and the back of the endplate is more rounded (5).

GARY ANDERSON: The treatment of the inboard end of the flaps, without the previous, very square corner, looks like a good improvement. Vortices get set off by square corners – and if that vortex goes to the right place, energising something else, that's fine. But if not, it can cause a lot of grief so most teams blend that corner off with a radius. Where the endplate meets the flap – a place where there is differing airflow speed over the vertical and horizontal planes – looks better blended too. It now looks more three-dimensional and therefore more robust and less prone to detaching. Get it right around the endplate and you get more downforce with steering lock – and that's when you need more front downforce than rear, as an F1 car will understeer in slow-speed, high-lock corners. The three different angles of vortex generators are all trying to guide the flow around the tyre, with the outer one trying to seal that flow.

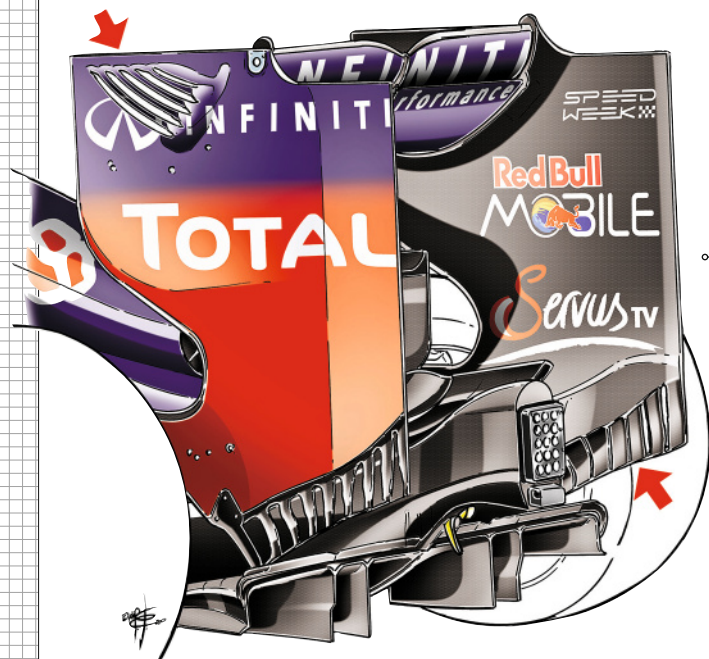
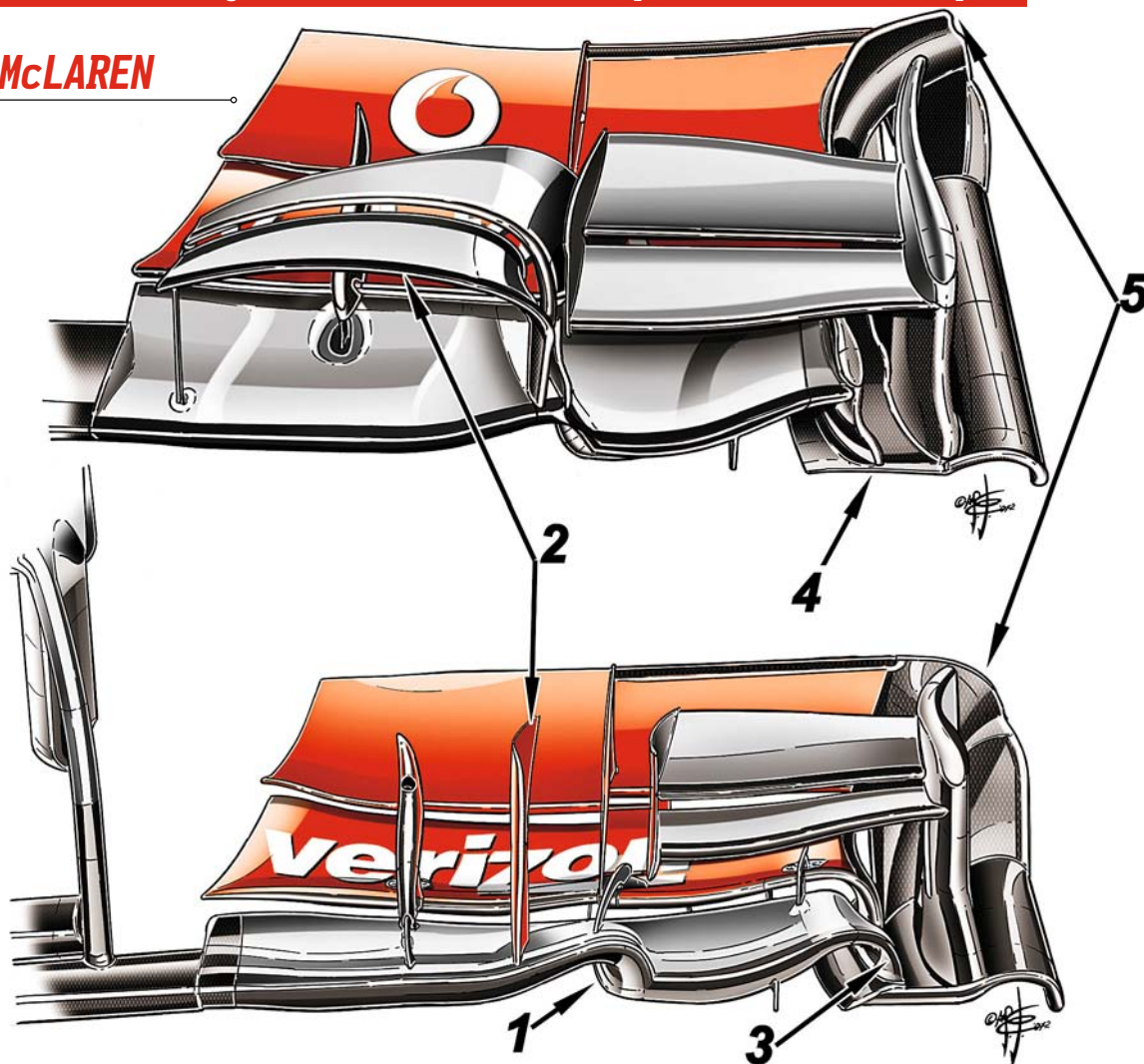

RED BULL'S STALL TACTICS

→ Red Bull's new rear wing was part of a package that included a further modified front wing. The rear wing featured shorter turning vanes at the bottom of the endplates (red arrow, bottom right).

GARY ANDERSON: The Red Bull looks able to manage the inevitable diffuser stall very well. This set-up turns the Coke-bottle and diffuser airflow behind the tyre, effectively creating a wider working area in which to create downforce, the flow hurrying to that low-pressure area behind the tyre and

pulling itself through and over the downforce-producing devices faster. These vanes help to achieve that but without limiting the diffuser's flow by being in the way. It's all part of the stall management. Other details show this, such as the three very basic splitters on the floor. Whenever the underfloor airflow through the centre section stalls, it comes through the tunnels, with these splitters doing a good job of containing the stall and preventing it from spreading across the rest of the diffuser's width.

FERRARI'S REAR GUARD

→ Ferrari ran a modified diffuser on Alonso's car (main pic, with the old design retained by Massa, inset left). The wing section running along the top of the diffuser was no longer retained around the top corner. The main picture shows the long endplate fins that have been on and off the car during practice since Singapore but which have never been raced. Again the car raced here with the shorter fins (inset right).

GARY ANDERSON: The outboard end of the diffuser, where the wing no longer comes down, is very difficult to get linked up with the low-pressure area behind the tyre – which is what you want to do because it effectively makes the whole rear width of the car work the diffuser. Cutting part of the diffuser wing section off may help with this, but it's a very sensitive area and you can easily get anomalous results. For example, sometimes the harder you make the outboard end work, the more stall-prone you make the centre section. As far as the long turning vanes go, you'd logically expect their bottom profile to follow the steep upsweep of the airflow wake from the diffuser – but they don't. That upwards sweep is much shallower than what you'd get from the diffuser air. The

idea of these vanes is that they help turn that diffuser wake around behind the tyre, giving an effect across the whole width of the car, hurrying that flow through and increasing downforce. But they must also not get in the way of that wake – and I wouldn't be surprised if they were getting in the way, hence the use of the shorter ones. You only want to affect the flow off the top of the diffuser,

not the bottom. Both the diffuser and the endplate modifications should be seen in light of the Ferrari's traits, which appears to be weak in the early part of braking and corner entry after the DRS has been deployed. When the DRS is open the wake off the rear wing is very different. The diffuser stalls earlier because it's not being helped by the wake of the rear wing and then, as the

back of the car rises up under braking, even with the DRS closed the diffuser is probably slow to re-attach – and that then makes the wing slow to re-attach, too. In race conditions, with no DRS, the wake of the rear wing will be strong enough to keep the diffuser working for longer before stalling. I think it's also probably why the Ferrari works well in the wet – there's no DRS allowed then.

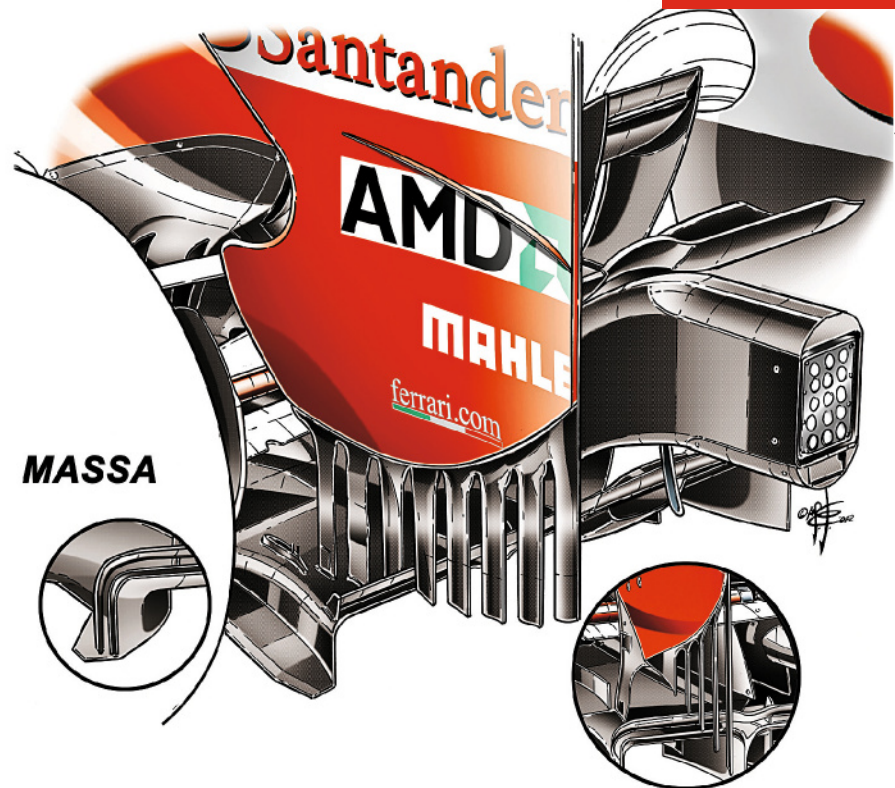

RED BULL SPIRITS NOT DAMPENED

→ Red Bull's third damper features a hydraulic connection, which has led to speculation of inter-connected front to rear suspension.

GARY ANDERSON: Front-to-rear interconnected suspension is actually still permitted. But it's not clear what this hydraulic line connects to. If you can control the rear rideheight whenever you are braking, so as the front dives you can drag the rear down. The dampers are all pressurised, with an air cylinder and the shaft displacement needs that air as

it displaces hydraulic fluid. You can use the damper to give some rising rate because as you put the damper shaft down into the damper it displaces fluid into a reservoir of air that is a certain pressure. Depending upon the size of that reservoir you can vary the pressure according to load. A very big reservoir would give hardly any increase in pressure and resistance but a small one would give a big effect. It would effectively give you some rising rate in the front suspension.



FIA COOLS OVER BRAKE-DUCT OPTIONS

→ In reaction to the temperature sensitivity of this year's Pirelli tyres, teams have been experimenting with ways of varying the brake cooling levels. The conflict between the need to get the tyres up to temperature quickly enough but then not have them overheat has led McLaren and Red Bull to look at variable cooling. McLaren ran a system in several races where the outer drum could be adjusted by hand at a pitstop,

while Red Bull recently investigated a system of an extra duct (pictured) with a mechanism that could open or shut it. The FIA refused to sanction this device. **GARY ANDERSON:** The area of that hole may not be big enough to do anything much to tyre temperature, but it's big enough to get the brakes to warm up quicker. The extra duct may be taking air away from the brakes so that they can deliberately waste the extra duct

cooling when it's hot by enclosing it and only having it open when it's cold. There's normally a big enough window of brake temperature to allow you to go a little bit hotter than ideal. I'd have thought you don't need to get too clever with it and I think it's good that the FIA has said no. Allowing intricate developments on brake ducts is the sort of thing that allows the big teams to leave the little teams behind.

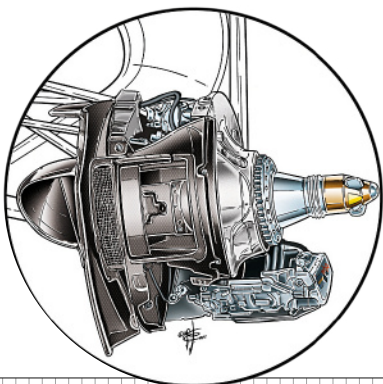

UNITED STATES GP RESULTS



PRACTICE 1: Friday

POS	DRIVER	TIME
1	VETTEL	1m38.125s
2	HAMILTON	1m39.543s
3	ALONSO	1m40.337s
4	BUTTON	1m40.528s
5	WEBBER	1m40.650s
6	MASSA	1m40.966s
7	HULKENBERG	1m41.023s
8	KOBAYASHI	1m41.036s
9	ROSBERG	1m41.159s
10	PEREZ	1m41.473s
11	DI RESTA	1m41.783s
12	RICCIARDO	1m41.825s
13	VERGNE	1m41.833s
14	RAIKKONEN	1m41.880s
15	GROSJEAN	1m41.998s
16	MALDONADO	1m42.539s
17	SCHUMACHER	1m42.588s
18	PIC	1m43.288s
19	KOVALAINEN	1m43.443s
20	PETROV	1m43.522s
21	GLOCK	1m44.464s
22	SENNA	1m44.548s
23	DE LA ROSA	1m46.917s
24	MA	1m48.559s

Weather: dry

PRACTICE 2: Friday

POS	DRIVER	TIME
1	VETTEL	1m37.718s
2	WEBBER	1m38.475s
3	ALONSO	1m38.483s
4	HAMILTON	1m38.748s
5	BUTTON	1m38.786s
6	MASSA	1m39.029s
7	ROSBERG	1m39.448s
8	SENNA	1m39.531s
9	KOBAYASHI	1m39.653s
10	SCHUMACHER	1m40.115s
11	RAIKKONEN	1m40.166s
12	MALDONADO	1m40.230s
13	GROSJEAN	1m40.246s
14	PEREZ	1m40.326s
15	RICCIARDO	1m40.435s
16	VERGNE	1m40.516s
17	HULKENBERG	1m40.700s
18	DI RESTA	1m41.430s
19	KOVALAINEN	1m42.476s
20	GLOCK	1m42.652s
21	PETROV	1m42.846s
22	PIC	1m43.538s
23	DE LA ROSA	1m44.453s
24	KARTHIKEYAN	1m45.114s

Weather: dry

PRACTICE 3: Saturday

POS	DRIVER	TIME
1	VETTEL	1m36.490s
2	HAMILTON	1m36.748s
3	MALDONADO	1m37.001s
4	ALONSO	1m37.180s
5	ROSBERG	1m37.247s
6	MASSA	1m37.262s
7	WEBBER	1m37.298s
8	PEREZ	1m37.415s
9	HULKENBERG	1m37.495s
10	BUTTON	1m37.538s
11	SENNA	1m37.569s
12	SCHUMACHER	1m37.760s
13	RAIKKONEN	1m37.765s
14	KOBAYASHI	1m37.953s
15	RICCIARDO	1m38.547s
16	DI RESTA	1m38.653s
17	GROSJEAN	1m38.753s
18	VERGNE	1m39.689s
19	GLOCK	1m40.407s
20	PETROV	1m40.753s
21	KOVALAINEN	1m41.011s
22	PIC	1m41.466s
23	DE LA ROSA	1m43.563s
24	KARTHIKEYAN	1m44.043s

Weather: dry

FRIDAY TESTERS



1 MA QING HUA

HRT 1m48.559s



QUALIFYING TIMES

POS	DRIVER	QUALIFYING 1	QUALIFYING 2	QUALIFYING 3
1	VETTEL	1m36.558s (1)	1m35.796s (1)	1m35.657s
2	HAMILTON	1m37.058s (2)	1m36.795s (4)	1m35.766s
3	WEBBER	1m37.215s (3)	1m36.298s (2)	1m36.174s
4	GROSJEAN	1m37.486s (4)	1m36.906s (5)	1m36.587s
5	RAIKKONEN	1m38.051s (12)	1m37.404s (10)	1m36.708s
6	SCHUMACHER	1m37.927s (10)	1m37.102s (8)	1m36.794s
7	MASSA	1m37.667s (8)	1m36.549s (3)	1m36.937s
8	HULKENBERG	1m37.756s (9)	1m37.066s (7)	1m37.141s
9	ALONSO	1m37.968s (11)	1m37.123s (9)	1m37.300s
10	MALDONADO	1m37.537s (6)	1m37.011s (6)	1m37.842s
11	SENNA	1m37.520s (5)	1m37.604s	-
12	BUTTON	1m37.565s (7)	1m37.616s	-
13	DI RESTA	1m38.104s (13)	1m37.665s	-
14	VERGNE	1m38.434s (15)	1m37.879s	-
15	PEREZ	1m38.500s (16)	1m38.206s	-
16	KOBAYASHI	1m38.418s (14)	1m38.437s	-
17	ROSBERG	1m38.862s (17)	1m38.501s	-
18	RICCIARDO	1m39.114s	-	-
19	GLOCK	1m40.056s	-	-
20	PIC	1m40.664s	-	-
21	PETROV	1m40.809s	-	-
22	KOVALAINEN	1m41.166s	-	-
23	DE LA ROSA	1m42.011s	-	-
24	KARTHIKEYAN	1m42.740s	-	-

Weather: dry

QUALIFYING STATISTICS

	HEAD TO HEAD	
VETTEL	11	8 WEBBER
BUTTON	4	15 HAMILTON
ALONSO	17	2 MASSA
SCHUMACHER	10	9 ROSBERG
RAIKKONEN	9	10 GROSJEAN/D'AMB
DI RESTA	8	11 HULKENBERG
KOBAYASHI	10	9 PEREZ
RICCIARDO	15	4 VERGNE
MALDONADO	17	2 SENNA
KOVALAINEN	14	5 PETROV
DE LA ROSA	18	1 KARTHIKEYAN
GLOCK	12	6 PIC



THE GRID

	2 HAMILTON McLAREN 1m35.766s Medium		1 VETTEL RED BULL 1m35.657s Medium
	4 RAIKKONEN LOTUS 1m36.708s Medium		3 WEBBER RED BULL 1m36.174s Medium
	6 HULKENBERG FORCE INDIA 1m37.141s Medium		5 SCHUMACHER MERCEDES 1m36.794s Medium
	8 GROSJEAN LOTUS 1m36.587s* Medium		7 ALONSO FERRARI 1m37.300s Medium
	10 SENNA WILLIAMS 1m37.604s Medium		9 MALDONADO WILLIAMS 1m37.842s Medium
	12 BUTTON McLAREN 1m37.616s Hard		11 MASSA FERRARI 1m36.937s* Medium
	14 VERGNE TORO ROSSO 1m37.879s Medium		13 DI RESTA FORCE INDIA 1m37.665s Medium
	16 KOBAYASHI SAUBER 1m38.437s Medium		15 PEREZ SAUBER 1m38.206s Medium
	18 RICCIARDO TORO ROSSO 1m39.114s Medium		17 ROSBERG MERCEDES 1m38.501s Hard
	20 PIC MARRUSSIA 1m40.664s Medium		19 GLOCK MARRUSSIA 1m40.056s Medium
	22 KOVALAINEN CATERHAM 1m41.166s Medium		21 PETROV CATERHAM 1m40.809s Medium
	24 KARTHIKEYAN HRT 1m42.740s Medium		23 DE LA ROSA HRT 1m42.011s Medium

*5-PLACE GRID PENALTY

UNITED STATES GP THE FINAL WORDS

THE RACE: LAP BY LAP

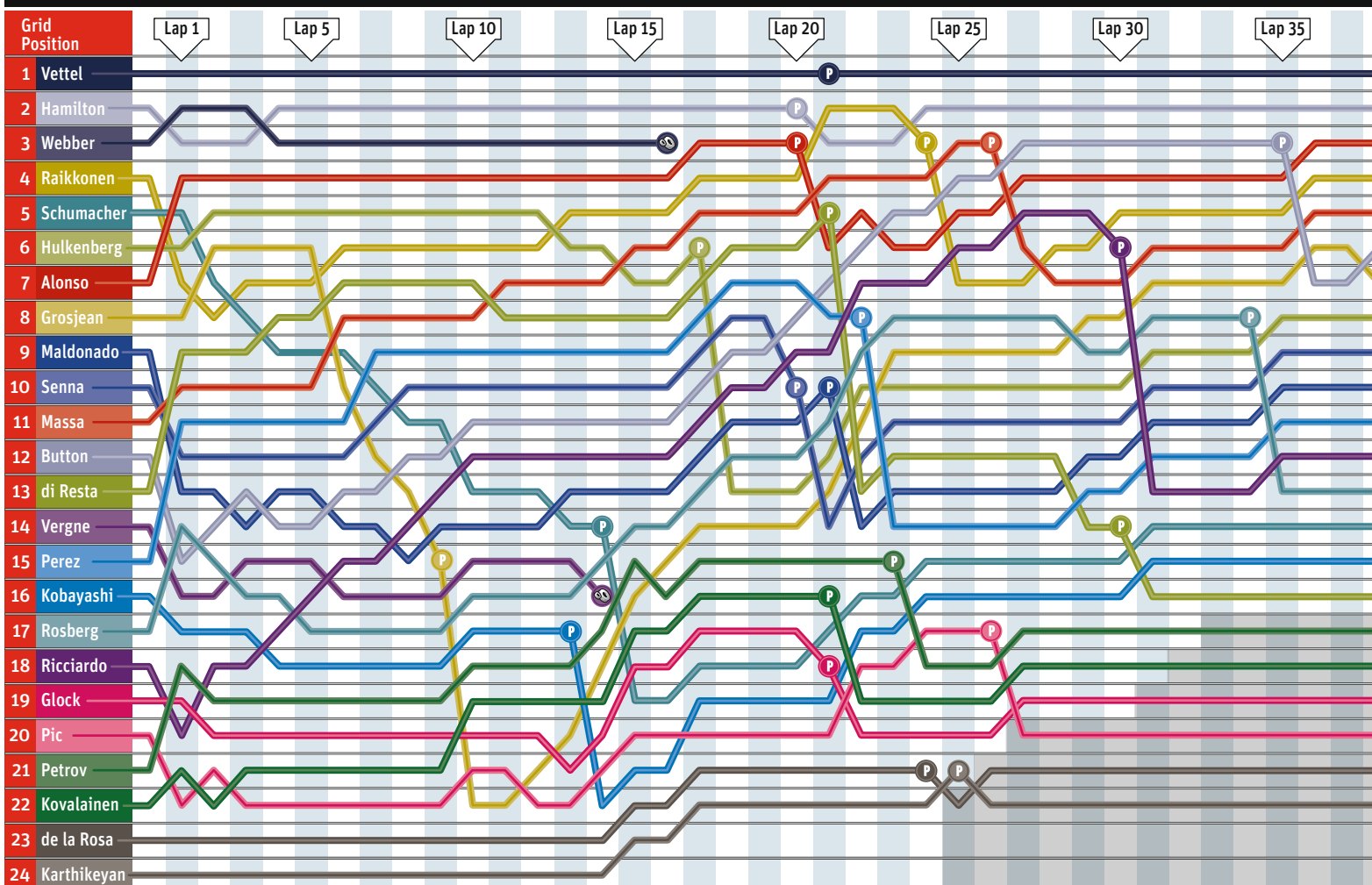

GRAND PRIX DIGEST

The weekend in a nutshell - on-track incidents, team radio and tweets that you might have missed...

THURSDAY

1104 Lewis Hamilton scotches Martin Whitmarsh's suggestion that he has had any moments of regret over signing for Mercedes.

1105 @vitalypetrov [right]: "Just finish track walk. Track looks cool!!!"



1111 Sebastian Vettel warns swearing is always a risk in televised sport: "If you are sensitive then you should watch some kids' show."

1155 Mark Webber slams the new podium ceremony, featuring driver interviews. "The podium should be for the drivers, no-one else," he says.

1513 The FIA's Charlie Whiting confirms that the use of DRS will be restricted to the race-activation zones in qualifying and practice next year.

1551 Ross Brawn confirms that Nico Rosberg will run the old Mercedes exhaust on Friday as part of an evaluation of its new Coanda exhaust system.

1810 @DanielRicciardo [right]: "Massively impressed with the circuit on my trackwalk today. This is up from turn 1 looking back"



FRIDAY

0900 Kimi Raikkonen becomes the first driver to hit the track in an official F1 session at Austin in Free Practice 1.



0902 Kamui Kobayashi and Timo Glock are first to have off-track moments.

0903 Felipe Massa: "It's very, very slippery the track. Very slippery."



1032 Paul di Resta is told: "For the benefit of the team and the guys at the factory, we'd like your balance comments on the radio." He frostily responds: "I wasn't in any clean air, I'll speak to you when I get out of the car."



1230 @JensonButton: "Very sad news from the #macauGP that 2 racers have been killed in the past 24hrs. My thoughts are with their families. RIP"



1310 Engineer to Vettel in FP2: "We've got a bit of a concern about the water system, sorry about that." He eventually hits the track at 1402.



1337 Lewis Hamilton: "My tyres are like icecubes." He is told: "OK Lewis, do everything you can with a hard outlap and brake warm-up." Hamilton later spins at T13 on that run.



1400 Jean-Eric Vergne hits Heikki Kovalainen at Turn 19. The Caterham suffers a left-rear puncture (right), with front-wing damage for the STR.



1726 Pedro de la Rosa admits to AUTOSPORT that HRT will struggle to qualify if grip levels don't improve.

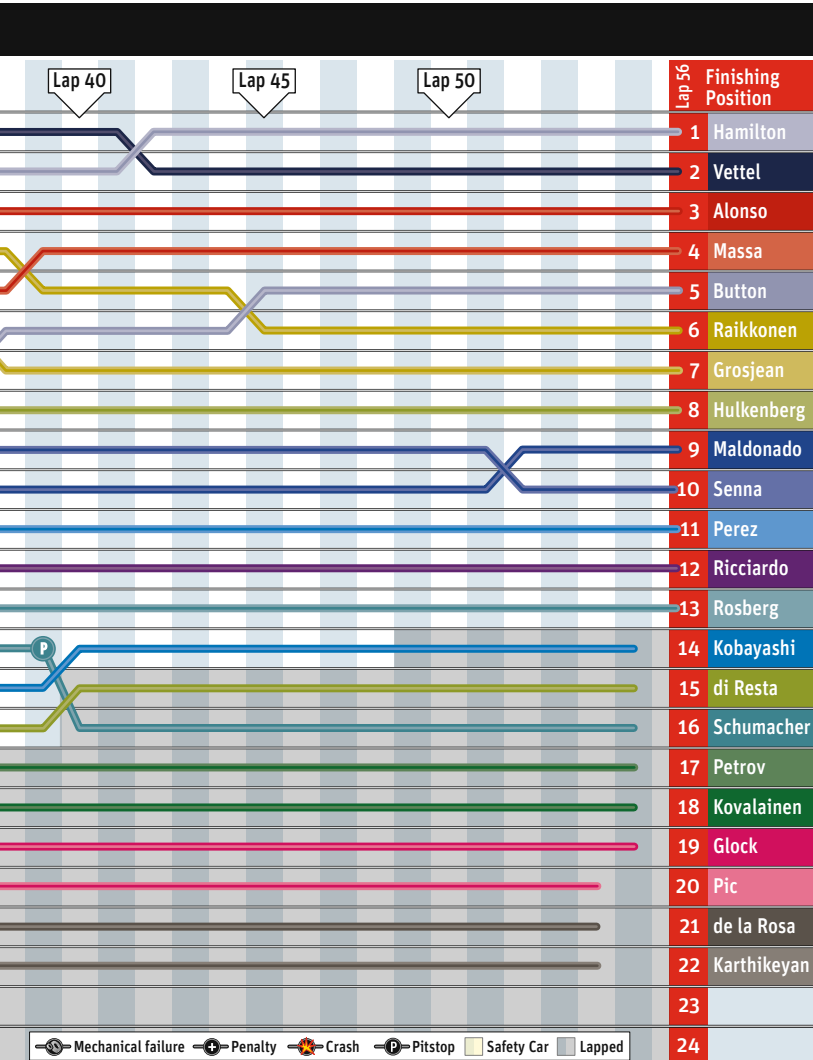

TRACKSIDE VIEW MARK HUGHES
GRAND PRIX EDITOR

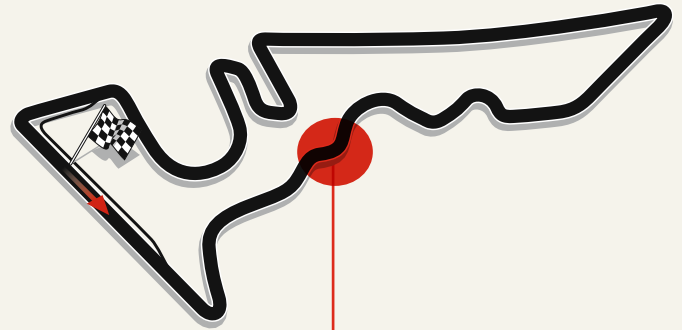

Build it and they will come, and on this blue, crisp-air Texas morning that dream becomes real. Down at the beginning of the esses sequence, turns 4-5 – a sixth-gear entry but tightening – that reality is mind-blowing. A howl of acceleration precedes the scarlet vision that unfolds – a flash of blue in the cockpit telling you that this is Fernando Alonso. Not that you’d need to identify him by the helmet, for what he is doing here is extraordinary. The Ferrari, though beautifully balanced through such fast sweeps, doesn’t have the grip of a Red Bull or McLaren but he runs it through there on faith, taking in immense momentum and just riding out what follows, the car flowing through there like a current. As it begins to edge out wide on the exit, he dares to demand just a little

more steering and it agrees, subservient to his touch even at the outer edges. Felipe Massa doesn’t carry quite the same entry speed and on one occasion hesitates about whether he can take in what he’s got and in an instant, as if sensing his unease, it bites him – a sixth-gear oversteer twitch. The car needs a silkier touch than that. Both McLaren drivers are using downshifts to trim the attitudes of their cars, Lewis Hamilton blipping it down just as he’s turned in, neutralising the understeer then just as it’s building up again through five, he picks it up by the scruff of the neck and demands, more forcefully than Alonso, more direction change. Jenson Button’s leaving his downchange until that second part, not quite as committed into four but possibly quicker through five as a result.

SATURDAY

- 0919** Sergio Perez clatters into Charles Pic at Turn 7 in FP3, spinning the Marussia around. Stewards later investigate, but take no action.
- 0922** @officialSF1team: “Uuuh. #Checo had a collision with Pic and came to the pits to have the car checked. Must have been a misunderstanding...”
- 0935** Jean-Eric Vergne [right] suffers a suspension breakage in the Esses: “I tried to take the inside kerb and broke the suspension; it’s finished.”
- 1055** Romain Grosjean forced to take a five-place grid penalty for a gearbox change after fourth gear breaks on his Lotus in FP3.
- 1217** Narain Karthikeyan’s HRT grinds to a halt at Turn 2 in Q1, and reports: “The engine has stopped.” It’s later traced to a lack of fuel.
- 1232** Alonso held up by Schuey: “Unbelievable Michael, unbelievable!”
- 1237** Jenson Button hits trouble in Q2: “Lost the power guys, no power, the throttle pedal is short.” He misses out on Q3 as a result.
- 1330** @alo_oficial: “Difficult saturday again! Good the points are given tomorrow.. :) We need to attack!”
- 1540** Mark Webber is reprimanded for missing the weighbridge during Q1.
- 1542** Schumacher escapes censure for impeding Alonso in Q2. The stewards state it was because both were on ‘preparation’ laps of a multi-lap stint.

SUNDAY

- 0953** @AussieGrit [Webber]: “At a VIP dinner last night an American woman asked me ‘where are you from?’ I said Australia, she said ‘wow your English is amazing’”
- 1129** Ferrari notifies the FIA that a gearbox seal has been broken on Massa’s car, triggering a five-place grid penalty that moves Alonso to the clean side of the grid.
- 1330** Jean-Eric Vergne pulls off at Turn 7: “The suspension is broken, but I didn’t touch anything,” he insists as he parks up.
- 1333** Ciaran Pilbeam to Webber: “[brake balance] three points rearwards, KERS has failed.” Soon after, he retires with alternator failure.
- 1343** Engineer to Kimi: “We are quicker than the leaders at the moment” Raikkonen: “I know, because I just passed [Hamilton] at the first corner.”
- 1421** Vettel after Hamilton pass: “Unbelievable. I have seen it [all] in F1 these days with these stupid overtakes...it was Karthikeyan’s fault.”
- 1453** Karthikeyan tells AUTOSPORT: “It’s impossible to get out of the way in that part of the track unless we drive off the circuit. I did nothing wrong.”
- 1554** Heikki Kovalainen avoids censure for what was deemed a racing incident after a clash with Timo Glock.
- 1600** @alo_oficial: “We are in that line, separates winning and losing, be good or magical, dream or reality, is a thin line, and became familiar to us recently.”

PICS: FOX, MASON, ROBERTSON, THOMPSON/GETTY, FERRARO/LAT

MACAU

CHINA

November 15-18
F3 Grand Prix

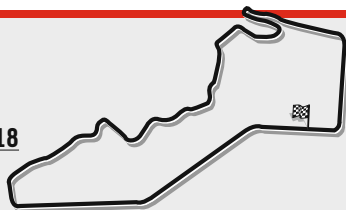

AT A GLANCE

- Winner A Felix da Costa
- Qual race da Costa
- Pole Alex Lynn
- Fastest lap da Costa



AFdaC completed epic season

Portugal reclaims Macau sovereignty

Antonio Felix da Costa takes a superb win in his country's former enclave



WHEN EDDIE CARVALHO drove his Triumph TR2 to victory in the first running of the Macau Grand Prix, in 1954, he could scarcely have imagined quite what a significant part of the international motorsport calendar the race would

become – or that he would be the last Portuguese to claim victory in the nation's Chinese enclave for 58 years.

Antonio Felix da Costa finally broke the drought for his country (the Macanese claim 2000 winner Andre Couto as one of their own)

when he swept his Carlin Dallara-Volkswagen F312 under the chequered flag last Sunday. It completed an incredible second half of the season for the Red Bull junior driver, in which he was the form man in GP3 and Formula Renault 3.5, and tested a Formula 1 car for his patrons.

Somehow the Portuguese national anthem had gone astray in the intervening period since Carvalho's success – possibly when the 'old-world' country handed the territory back to the Chinese in the new millennium. An unidentifiable tune began to peel out as da Costa stood on the podium and, after a bit of boing from the

Portuguese contingent in the pitlane, the music stopped, and they improvised by singing the anthem – with tears in their eyes – while an official rushed to download the correct piece of music on iTunes. Only then could the post-race formalities be completed.

Da Costa led all 25 racing laps across the qualification race on Saturday and the final on Sunday, but to say he dominated would be grossly inaccurate. Instead, any one of the top six qualifiers could stake a realistic claim to victory, and da Costa, Felix Rosenqvist and star rookie Alex Lynn drove a pulsating, flat-out race on Sunday

with never very much between them.

"These guys gave me an unbelievable race," said da Costa in recognition of his fellow podium men. "Every lap was on the limit. I'm so impressed with them, especially with Alex being a rookie.

"It's hard to keep your focus around here unless you push. They were doing the same and the three of us made no mistakes."

Da Costa conceded pole position to Lynn's Fortec Motorsport Dallara-Mercedes, the Briton getting a stonking lap time during Friday's second qualifying session, which was plagued with yellow and red flags. Da Costa had been fastest



Rookie Lynn took a blistering pole

RACE RATING

★★★★☆

It's Macau, and any race there is good! Great driving from top three

MILESTONE

Alex Lynn is first rookie polesitter at Macau since Kamui Kobayashi in 2006



REPORT F3 MACAU

MARCUS SIMMONS
reports



Da Costa was the man at Macau, leading every lap

Harvey's hopes came to nothing



Domestic champions come up short

Macau was a disaster for the champions of FIA-rules Formula 3 in 2012.

European champion Daniel Juncadella looked a strong contender to replicate his 2011 win all weekend, but the Prema Powerteam Dallara-Mercs were lacking straight-line speed for most of the event. The team gambled on an ultra-low-downforce set-up for Sunday's race, but it proved to be a bit lairy; Juncadella was running fourth when he got a big slide on at R Bend on the first lap and deranged the left-front suspension on the barriers.

"Even if I stayed on track I wouldn't have had a real chance to win," he said.

British title winner Jack Harvey was up there with Pascal Wehrlein and Alex Lynn in the battle to be best rookie in the first free practice session, but his weekend started to unravel with a steering-rack problem in first qualifying. Still he looked good for a top-10 result, but in the final race, while battling Carlin team-mates Carlos Sainz Jr and Will Buller, he clipped Buller as the Northern Irishman lifted in one of the kinks as he was passed by

Sainz. That damaged the front wing, and when it fell off he pitted to retire.

It was a shame to end such a fantastic season on a low note, as the result could have been much better. "First time in Macau and at least I didn't disgrace myself," he shrugged.

Japanese champ Ryo Hirakawa smashed the barriers at R Bend hard enough in Thursday free practice to rule his RSS Dallara-Toyota out for the whole day. He did the same again in the race, bouncing back into the path of the Van Amersfoort Racing car of

Lucas Auer, who ploughed into him. The week was a disaster for the VAR squad, with Auer and Dennis van de Laar having plenty of incidents and the Dutchman completing the sequence on the final lap when he had a huge shunt with Luis Sa Silva on the run to Lisboa.



Hirakawa's Saturday crash



Sainz and Juncadella ran better on Saturday

Jaafar was a midfielder on his TOM'S debut



on Thursday, but didn't improve on Friday – he took new Yokohamas during green-flag running and that cost him at least some time, and when he was out on track he was scuppered by the flags.

In both races, da Costa and Lynn were beaten away from the lights by Rosenqvist's Mücke Motorsport Dallara-Mercedes, but the Swede merely acted as a slipstream provider down to the first braking point at Lisboa. Rosenqvist never gave up in his pursuit of da Costa, and his best chance came at the restart after an early-race safety-car period in the final. Again he went wheel to wheel with da Costa, as

he had at the start, but once again could not quite find a way through.

From then on, he could never get close enough to da Costa at R Bend to benefit from a tow down the flat-out blind run through Reservoir and Mandarin Oriental, and it was a similar story for Lynn behind him.

"It's hard to slipstream this year," admitted Rosenqvist. "I don't know if it's the wind [there was a fairly stiff breeze for most of the meeting] or the aero of the new F3 car."

Also, da Costa was getting stronger as the race wore on. Before the safety car appeared his advantage had looked tenuous, but afterwards it he was able

to keep his opposition at arm's length. He paid tribute to his Carlin engineer Brice Gaillardon, who engineered Kevin Magnussen in 2011 but has moved onto the team's FR3.5 line-up this year (except for subbing for Jazeman Jaafar's engineer when he went on paternity leave in the summer). And it truly was a great achievement, in the ex-Jaafar car, for a man who had only completed 30 laps of testing in the F312 at Silverstone before heading to Macau...

"The car was really good," said da Costa. "They did the tyre pressures perfectly. I was struggling a bit at first, but from half distance it was much better. Brice is the man!" ▶

LETS RACE .co.uk

Race Simulation Centre

59/61 Brighton Road, Horley, Surrey, RH6 7HJ

10 Networked, full motion simulators

Full race formats with briefings

Spectator viewing

On site Cafe 'Fluid Dynamics'

Corporate hospitality designed to suit your brand

Well equipped conference room

Race Experience - £35

Includes 30 minutes in car, briefings and telemetry results. £300 for groups of 10

Yearly Membership - £50

Includes discount on all sessions, exclusive events and championships.



"Virtual Power

Real Passion"

Opening Times

Monday - Friday (14:00 - 22:00)

Saturday (10.00 - 20.00)

Sunday (11.00 - 18.00)

01293 826000

email: info@letsrace.co.uk

Follow Us
[@letsrace1](https://twitter.com/letsrace1)



vodafone DMAX

THE UK'S FASTEST GROWING CHAMPIONSHIP



Daytona would like to congratulate the winners of the

vodafone DMAX

2012 Enduro Championships

Light: Chris Hackworth

Inter: James Pratt

Heavy: Chris Carter

Tel: 0845 644 5504
www.daytonamax.co.uk



“Shit happens - but it's a shame it didn't happen somewhere else!”

Carlos Sainz Jr on stalling at the start

MILESTONE
Carlin's first Macau winner since Takuma Sato in 2001



REPORT
F3 MACAU

◀ The performance of the Carlin cars, which helped the squad to its first Macau victory since Takuma Sato in 2001, was impressive from the moment da Costa and Felipe Nasr – the two men most visibly on it at the start of play on Thursday – began to dance imperiously through the unforgiving barriers in first free practice. Performance in aero-dependent corners has been strong for the team in British F3 this season, although its cars have been left behind a little on straight-line speed.

But at Macau Carlin's straight-line speed was strong, with some of the team's cars even getting up to 170mph through the traps over the event, albeit with a tow.

“There's been tons of work,” said team boss Trevor Carlin. “There's nothing more we could have done, and the engineers haven't stopped working since the last British round.

“Our windtunnel has been out of commission for 12 months [due to the team's move to Farnham]. We've

been in the dark with the new car, and had to wait because we didn't want to spend the money twice. Since it's been running we did more testing in a month than we'd done in six – those guys deserve a proper pat on the back for getting it finished. It's nothing major that we've changed, just rethinking the way we approach things. I expect us to be back to our dominant form in 2013 – although 20 wins out of 28 in British F3 this year wasn't bad!”

Rosenqvist looked strong all week, and felt that pole had gone begging when a red flag appeared for Nasr's crash in second qualifying, just when he was half a second up on Lynn's benchmark as he neared the end of the lap. He and Lynn, who suddenly became a sensation with the international media after his remarkable pole, had pretty much the same pace as da Costa but could not get in front where it counted, into Lisboa.

Pascal Wehrlein, the second Mücke driver, ran Lynn pretty close in the



Rosenqvist grabbed a brief lead off the line

end for rookie honours. The German, who has been strong on the other street circuits this year at Pau and the Norisring, made stealthy progress into the frame. He had to back off a touch in the middle of the race due to tyre wear, but came on strong again near the end.

Nasr was a distant fifth, never quite getting back in the picture after his

qualifying shunt. Carlin team-mate Carlos Sainz Jr probably would have finished ahead of him, but could not believe it when he stalled at the start. He completed the first lap in 13th, but climbed to seventh, right in the middle of the dust-up between Fortec men Pipo Derani and Harry Tincknell and the Prema Powerteam car of Italian

Raffaele Marciello. Marciello's eighth place was the best result for the team that won last year with Daniel Juncadella (see panel), as Hannes van Asseldonk crashed out at Lisboa. The Dutchman had just drafted past Nasr for fifth, but had to lock up the anchors to avoid hitting Wehrlein and looped into a spin before hitting the wall. ❧

RESULTS

Macau Grand Prix, Macau Guia Circuit (PRC), November 15-18

MAIN RACE - 15 LAPS, 57.044 MILES

POS	DRIVER	TEAM	CAR	TIME	GRID
1	Antonio Felix da Costa (P)	Carlin	DVW F312	38m02.845s	1
2	Felix Rosenqvist (S)	Mücke Motorsport	DMB F312	+1.573s	2
3	Alex Lynn (GB)	Fortec Motorsport	DBM F312	+2.486s	3
4	Pascal Wehrlein (D)	Mücke Motorsport	DMB F312	+3.471s	7
5	Felipe Nasr (BR)	Carlin	DVW F312	+9.127s	9
6	Pipo Derani (BR)	Fortec Motorsport	DMB F312	+11.043s	13
7	Carlos Sainz Jr (E)	Carlin	DVW F312	+11.417s	4
8	Raffaele Marciello (I)	Prema Powerteam	DMB F312	+14.376s	11
9	Harry Tincknell (GB)	Fortec Motorsport	DMB F312	+16.944s	6
10	Will Buller (GB)	Carlin	DVW F312	+21.650s	14
11	Jimmy Eriksson (S)	Double R Racing	DMB F312	+22.955s	17
12	Daniel Abt (D)	Carlin	DVW F312	+24.025s	15
13	Kevin Korjus (EE)	Double R Racing	DMB F312	+24.632s	21
14	Hideki Yamauchi (J)	B-Max Engineering	DT F312	+26.502s	16
15	Alexander Sims (GB)	T-Sport	DN F312	+26.757s	10
16	Jazeman Jaafar (MAL)	TOM'S	DT F312	+27.834s	19
17	Tom Blomqvist (GB)	EuroInternational	DVW F312	+28.565s	18
18	Mitchell Gilbert (AUS)	Mücke Motorsport	DMB F312	+31.889s	20
19	Sven Muller (D)	Prema Powerteam	DMB F312	+32.744s	27
20	Felix Serralles (USA)	Fortec Motorsport	DMB F312	+33.276s	29
21	Yuichi Nakayama (J)	TOM'S	DT F312	+47.525s	30
22	Andrea Roda (I)	Jo Zeller Racing	DMB F312	+59.222s	28
23	Luis Sa Silva (AO)	Angola Racing Team	DMB F312	14 laps-accident	23
24	Dennis van de Laar (NL)	Van Amersfoort Racing	DVW F312	14 laps-accident	25
R	Ryo Hirakawa (J)	KCMG by RSS	DT F312	12 laps-accident	24
R	Lucas Auer (A)	Van Amersfoort Racing	DVW F312	12 laps-accident	22
R	Jack Harvey (GB)	Carlin	DVW F312	12 laps-front wing	12
R	Daniel Juncadella (E)	Prema Powerteam	DMB F312	2 laps-acc damage	5
R	Hannes van Asseldonk (NL)	Prema Powerteam	DMB F312	1 lap-accident	8
R	Lucas Wolf (D)	URD Rennsport	DMB F312	0 laps-accident	26

Q RACE GRID

1	LYNN	2:13.122
2	DA COSTA	2:13.400
3	JUNCADELLA	2:13.401
4	ROSENQVIST	2:13.420
5	SAINZ	2:13.421
6	NASR	2:13.556
7	TINCKNELL	2:13.577
8	WEHRLIN	2:13.721
9	ABT	2:13.758
10	MARCELLO	2:13.789
11	VAN *DUNK	2:13.885
12	DERANI	2:14.068
13	HARVEY	2:14.082
14	SIMS	2:14.085
15	SERRALLES	2:14.366
16	BLOMQUIST	2:14.648
17	BULLER	2:14.744
18	YAMAUCHI	2:14.790
19	JAAFAR	2:15.095
20	MULLER	2:15.391
21	KORJUS	2:15.768
22	GILBERT	2:15.804
23	NAKAYAMA	2:15.870
24	ERIKSSON	2:16.015
25	AUER	2:16.187
26	VD LAAR	2:16.559
27	SA SILVA	2:16.624
28	WOLF	2:16.766
29	HIRAKAWA	2:17.151*
30	RODA	2:18.140*

QUALIFYING RACE - 10 LAPS, 37.903 MILES

POS	DRIVER	TIME	GRID
1	da Costa	22m31.290s	2
2	Rosenqvist	+1.559s	4
3	Lynn	+4.567s	1
4	Sainz	+7.638s	5
5	Juncadella	+8.460s	3
6	Tincknell	+10.427s	7
7	Wehrlein	+11.452s	8
8	van Asseldonk	+12.264s	11
9	Nasr	+13.243s	6
10	Sims	+14.439s	14
11	Marciello	+16.747s	10
12	Harvey	+18.291s	13
13	Derani	+21.565s	12
14	Buller	+22.296s	17
15	Abt	+24.338s	9
16	Yamauchi	+24.778s	18
17	Eriksson	+30.092s	24
18	Blomqvist	+30.578s	16
19	Jaafar	+32.945s	19
20	Gilbert	+34.180s	22
21	Korjus	+40.698s	21
22	Auer	+42.149s	25
23	Sa Silva	+48.582s	27
24	Hirakawa	+49.825s	29
25	van de Laar	+50.579s	26
26	Wolf	+50.829s	28
R	Muller	8 laps-accident	20
R	Roda	8 laps-accident	30
R	Serralles	6 laps-suspension	15
R	Nakayama	3 laps-accident	23

Main race: winner's average: 89.95mph. Fastest lap: da Costa, 2m13.507s, 102.54mph.
Qualifying race: winner's average: 101.31mph. Fastest lap: Juncadella, 2m13.718s, 102.38mph
R=Retired. * = grid penalty.

Key: D=Dallara; MB= Mercedes-Benz/HWA; VW= Volkswagen / Spies; T= Toyota/TOM'S; N=Nissan/Tomei

MACAU

CHINA

November 17-18

WTCC

Round 12/12

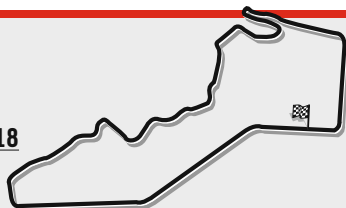

AT A GLANCE

- Race 1 **Yvan Muller**
- Race 2 **Alain Menu**
- Pole **Rob Huff**
- Fastest laps **Menu x 2**



Muller (l) and Menu had a win each while Monteiro gave Honda a podium



Huff celebrates crown with second in race two

Huff does enough for title

Briton's luck holds to hand factory Chevy team a farewell victory celebration

BY SMASHING HIS RACE- leading Chevrolet Cruze into a wall at close to full throttle, Rob Huff sparked an enthralling championship showdown on the streets of Macau. Prior to setting off for the Chinese territory, the four-time Macau race winner cautioned against complacency in his bid for the drivers' title. "In Macau, anything can happen," said the WTCC points leader.

On lap four of the opening race that "anything" did happen. Having exquisitely outraked factory Chevrolet team-mate Yvan Muller for the lead into Macau's treacherous 90-degree right Lisboa corner, Huff appeared set to complete a customary

victory that would seal his inaugural championship.

On the narrow and flowing mountain section of the Guia circuit, however, the Chevy snapped into oversteer, and Huff was presented with insufficient space to correct the slide.

"I have never, ever led a race and thrown it away," said a still-stunned Huff considerably later. "What a mistake! Maybe there was a bit of dirt, I don't know, but the car hasn't oversteered there for the past four days. Obviously I was saving it, but just ran out of room."

The limited timeframe of 15 minutes between races left the RML-run team with an intense workload to repair

damage to the rear suspension and front splitter. The crews from title rivals Alain Menu and Yvan Muller's sides of the garage pitched in to ready the car.

While a shaken Huff sat in the pitlane reflecting on his error, fellow eight-year RML driver Menu was launching a series of precarious passing attempts on the slightly ill-composed leader Muller.

The fight was spiced up by the knowledge that Menu's slim title hopes had been weakened at the preceding round in Shanghai when Muller unintentionally punted the Swiss veteran off.

As the race neared its end, Menu's inquisitive darts and jinks to find an opportunity

to pass resulted in the odd brush of bumper. At the top of Moorish on lap eight, Menu lunged to Muller's inside and sent the reigning champion into a powerslide.

"There was no possibility of passing there," said an unimpressed Muller, who recovered to record a 0.9s victory — his first at Macau. "He hit me before as well, so it was once on my left and once on the right. When you are the leader, there are certain places you are safe and can leave a margin."

Menu disagreed, but conceded: "It was always going to require him to back off a bit once I was alongside."

In parc ferme, there was minimal eye contact between

the two Chevrolet men, and both were aware that Huff remained title favourite.

To take his first major championship since 2000, Menu was tasked with winning race two, with Huff finishing in no higher than seventh place. Muller required a win, with Huff sixth or lower, to bridge a 19-point deficit. Menu's progress from eighth on the grid carried him past WTCC rookie Alex MacDowall into the lead at San Francisco on lap three.

"I turned in too late, and skimmed the barrier," said Bamboo Chevy man MacDowall. "That suddenly allowed Alain, [Indie points leader] Norbert Michelisz and Pepe Oriola to come through again."

MacDowall had recovered some ground back towards Oriola by the start of the following tour, but on the exit of the 145mph Mandarin bend, the chasing

RACE RATING

★★★★☆

A sensational climax to the WTCC season as Rob Huff's fortunes fluctuated

MILESTONE

First British World Touring Car Champion since Andy Priaulx in 2007



REPORT WTCC MACAU

PETER MILLS
reports



Muller tapped him into a violent accident.

"I am sorry, but I couldn't do much," said Muller. "Alex was fighting with Oriola and lost the apex by a good metre. He went a bit sideways and was probably 5-6mph slower there than the lap before."

"It doesn't matter what he says, Yvan was at fault," said MacDowall, who described the crash as the biggest of his life. "Pepe defended into Mandarin on a tighter line. That's why I had to go a bit slower. Yvan could see we were battling, but he just went in and hit me. Look at the car! It's like a hatchback."

Debris scattered everywhere, and as Muller backed off, Huff blitzed past to take fourth. It was not to be Huff's last near-miss.

On the restart from a safety car period, Michelsiz received a push down to Lisboa by Indie title challenger Oriola. The Zengo BMW was shunted sideways, tearing up the temporary apex and launching into the tyre barriers.

"I thought Pepe would make the corner," said Huff.

"But he bounced back out of the barriers just as I was going past."

The safety car was called out again, offering Huff's Cruze some respite on the way to winning a well-deserved championship, after it had picked up possible damage from touches with race one podium man Tiago Monteiro in the improved, and lighter, Honda Civic WTCC.

In the last appearance of the factory Chevrolets, the blue cars took their final chequered flag in familiar 1-2-3 formation.

On hand to witness the farewell was former Chevrolet Motorsport Europe boss Eric Neve, now working at HWA in Stuttgart. "I am happy Rob won it," said Neve. "When Chevrolet started in the WTCC in 2005, we employed Nicola Larini and Alain Menu as they were the reference points of touring car drivers. That meant we could afford to take on a younger driver. It is a great end to the story that Rob has rewarded the team's faith shown in him." ☼

Michelsiz (5) won title despite crash



Michelsiz takes indie crown in the pits

An opening lap pile-up at Lisboa accounted for all three Independents' title contenders in race one.

Points leader Norbert Michelsiz sustained a broken bumper and suspension in the confusion, while nearest rival Pepe Oriola picked up race-ending damage. Title outsider Stefano d'Aste was parked at a right angle across the track, causing a road block that delayed all but the top six cars by at least 30s.

Despite outwardly receiving more body damage

than the others, D'Aste made a determined effort to continue and chase some of the double Yokohama points on offer for Macau's final round.

"Stefano tried to keep going," said his Wiechers-Sport team boss Dominik Greiners, "but we saw the water temperature was shooting up, and we needed to bring him in to replace the water cooler before race two."

Oriola earned a €1000 fine for his race-two manoeuvre on Michelsiz, which resulted in both drivers' retirement. Amazingly, for the second race

in succession all three men in the Yokohama title chase were involved in trouble on the same lap. "We hit a bumper from the Michelsiz/Oriola crash," said Greiners. "The front wheels were well off the ground, and Stefano had no way to control the car."

Michelsiz, who scored one point for fastest lap in race one, duly picked up the title as neither of his rivals scored.

Untroubled by the dramas, Yokohama Macau pole winner and Hong Kong racer Darryl O'Young delighted his "home" fans with a double victory.

RESULTS

FIA World Touring Car Championship, round 12 of 12, Macau (PRC), November 18

GRID RACE 1		RACE 1 - 9 LAPS, 34.206 MILES						RACE 2 - 11 LAPS, 41.831 MILES				CHAMPIONSHIP TABLE		
POS	DRIVER (NATIONALITY)	TEAM	CAR	TIME	GRID	POS	DRIVER	TIME	GRID	POS	DRIVER	PTS		
1	HUFF	Chevrolet (RML)	Chevrolet Cruze 1.6T	23m08.977s	2	1	Menu	35m36.096s	7	1	Huff	413		
2	MULLER	Chevrolet (RML)	Chevrolet Cruze 1.6T	+0.915s	3	2	Huff	+0.320s	9	2	Menu	401		
3	MENU	Honda (JAS)	Honda Civic S2000 TC	+1.297s	5	3	Muller	+0.889s	8	3	Muller	393		
4	TARQUINI	Lukoil Racing Team	SEAT Leon WTCC	+1.967s	4	4	Monteiro	+9.015s	5	4	Tarquini	257		
5	MONTEIRO	Chevrolet (RML)	Chevrolet Cruze 1.6T	+11.519s	6	5	O'Young	+9.786s	4	5	Coronel	202		
6	O'YOUNG	ROAL Motorsport	BMW 320 TC	+55.136s	13	6	Engstler	+10.127s	11	6	Michelsiz	155		
7	MICHELISIZ	Team Engstler	BMW 320 TC	+1m04.037s	12	7	Dudukalo	+11.024s	17	7	d'Aste	144		
8	BENNANI	SUNRED Engineering	SEAT Leon WTCC	+1m09.730s	15	8	Barth	+11.399s	14	8	Oriola	131		
9	ORIOLA	Bamboo-Engineering	Chevrolet Cruze 1.6T	+1m16.524s	10	9	Boardman	+11.582s	13	9	Monteiro	95		
10	MACDOWALL	Special Tuning Racing	SEAT Leon WTCC	+1m22.194s	14	10	Monje	+11.900s	19	10	Bennani	68		
11	D'ASTE	Lukoil Racing Team	SEAT Leon WTCC	+1m22.372s	18	11	Couto	+12.412s	18					
12	ENGSTLER	Ford Focus S2000TC	Ford Focus S2000TC	+1m23.053s	16	12	Nash	+20.496s	15					
13	CORONEL	Arena Motorsport	Ford Focus S2000TC	+1m25.822s	17	13	Merzsei	+20.883s	20					
14	BOARDMAN	SUNRED Engineering	SEAT Leon WTCC	+1m29.347s	21	14	de Souza	+21.920s	24					
15	BARTH	SUNRED Engineering	SEAT Leon 1.6T	+2m12.582s	20	15	Dias	+22.760s	22					
16	NASH	Ho Chun Kei	BMW 320si	+2m19.429s	24	16	Mak	+24.741s	26					
17	CHILTON	Team Engstler	BMW 320si	+3m23.533s	23	17	K.Ng	+25.589s	25					
18	DUDUKALO	China Dragon Racing	Chevrolet Lacetti	-2 laps	27	18	de Jesus	+26.243s	23					
19	C.NG	China Dragon Racing	Chevrolet Lacetti	-2 laps	25	19	Cozzolino	-2 laps	29					
20	COUTO	ROAL Motorsport	BMW 320 TC	7 laps-accident	22	20	Tarquini	9 laps-floor	6					
21	MONJE	RPM Racing Team	BMW 320si	-3 laps	29	21	Michelsiz	8 laps-accident	3					
22	COZZOLINO	China Dragon Racing	Chevrolet Cruze LT	5 laps-suspension	28	22	Oriola	8 laps-accident	2					
23	MERZSEI	Chevrolet (RML)	Chevrolet Cruze 1.6T	4 laps-acc damage	1	22	d'Aste	8 laps-accident	10					
24	HO	Team Engstler	BMW 320 TC	4 laps-accident	19	R	Coronel	4 laps-radiator	12					
25	DIAS	Zengo Motorsport	BMW 320 TC	3 laps-acc damage	7	R	MacDowall	3 laps-accident	1					
26	DE JESUS	Wiechers-Sport	BMW 320 TC	2 laps-acc damage	11	R	Chilton	3 laps-accident	16					
27	DE SOUZA*	Five Auto Racing Team	Honda Accord Euro-R	1 lap-accident	26	R	Bennani	3 laps-accident	27					
28	K.NG*	SUNRED Engineering	SEAT Leon WTCC	0 laps-accident	9	R	Ho	1 lap-engine	21					
29	NAK*	Proteam Racing	BMW 320 TC	0 laps-accident	8	NS	C.Ng	Acc damage						

Race 1 Winner's average: 88.70mph. Fastest lap: Menu, 2m32.063s, 90.02mph. Race 2 Winner's average: 70.49mph. Fastest lap: Menu, 2m32.42s, 89.81mph. *Times disallowed.



CAR TRACKDAYS & TIGER HIRE!

NEW TIGER AND TRACK EXPERIENCE FROM £119 - CALL!

Open Pit Lane
 ARDS Instruction
 Discount Scheme - Free Track Days
 Photography

24 Nov Sat	Donington Park GP	£180
25 Nov Sun	Snetterton 300	£105
30 Nov Fri	Oulton Park	£105
08 Dec Sat	Donington Park GP	£120

1/2 DAY
£299

FULL DAY
£499



The Ultimate Gift - A full day in a Tiger!

www.focusedevents.com

0845 026 7272

Novice friendly trackday format.



THE PERFECT GIFT FOR CHRISTMAS

The virtual racing experience of your dreams

"Sturdily built, ingeniously designed & fully adjustable. The driving position feels faultless."
The Independent



Buy online now at GameRacer.co.uk



or call 02380 47117



© Venetia & Vectormart - Fotolia.com



XMAS GIFTS

SAVING
£25
PRICE
£60

BIKE RACING FANS WILL LOVE THIS XMAS COMBO



British Superbikes

2 x 2013 BSB TICKETS + PROGRAMME VOUCHER + KNOCKHILL GIFT BOX

UPTO
15%
OFF
UNTIL
31/12/2012

ENJOY A YEAR-LONG MOTORSPORT EVENT PASS



2013 Season Passes

2WHEEL + 4WHEEL + GOLD PASSES ON OFFER UNTIL 31st DECEMBER 2012

SAVING
£25
PRICE
£60

FILL THEIR STOCKINGS WITH 2013 BTCC TICKETS



British Touring Cars

2 x 2013 BTCC TICKETS + PROGRAMME VOUCHER + KNOCKHILL GIFT BOX

ONLY
£49
POTENTIAL
SAVING
OF £200

A GREAT GIFT FOR ANY BIKE TRACKDAY ENTHUSIAST



Bike Trackday Club

JOIN OUR 2013 BIKE TRACKDAY CLUB FOR ONLY £49

KNOCKHILL.COM

Make it a Knockhill Christmas this year... Honk! Honk!

MACAU

CHINA

November 17-18
GP supports

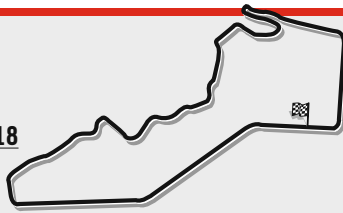

AT A GLANCE

- GT Cup Edoardo Mortara
- TC Cup Paul Poon
- Roadsports Sun Tit Fan
- Interport Chou Keng Kuan

REPORT MACAU SUPPORTS



Mortara was pushed hard by di Grassi

Mortara reigns supreme at Macau

EDOARDO MORTARA

cemented his status as the King of Macau by beating a handful of top sportscar names to win the GT Cup event and claim his fourth victory in as many years on the streets.

With the race essentially divided by a five-lap safety car period, the China Team Audi driver took the spoils ahead of Alexandre Imperatori's Starchase Porsche and Danny Watts's United Autosports McLaren.

But it was actually a driver who didn't make the podium that gave Mortara the hardest time over the 12 laps. Lucas di Grassi, racing a GT3 car for the first time, led the first three laps of the race in his AF Corse Ferrari after charging past Mortara at the start. While he was powerless to stop the Italian retaking the lead with a daring move into Lisboa at the start of lap four, di Grassi did manage to hang on to finish second on the road.

However, the Brazilian was quickly penalised for jumping the start. The 60

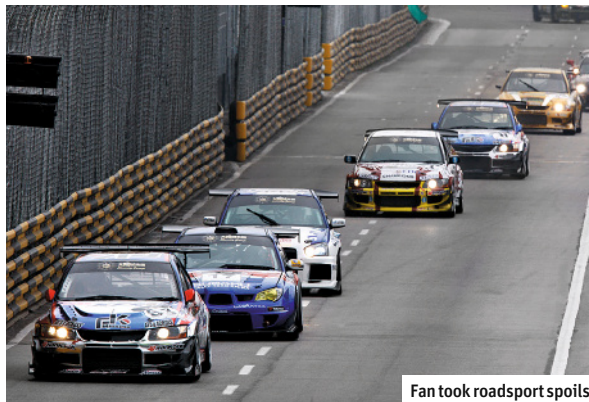

Fan took roadsport spoils

seconds that were added to his race time dropped him to 17th in the results.

That elevated a somewhat fortunate Watts into a podium position, the Briton admitting that he took too long to adapt to the needs of GT3 machinery compared with his usual ride in Strakka's LMP1 HPD.

Super GT regular Akira Iida and former Le Mans 24 Hours winner Romain Dumas were fourth and fifth in McLaren and Porsche machinery respectively.

While none of that affected Mortara and his

second Macau GT win to add to his pair of F3 titles here, he did praise di Grassi for his speed in the opening laps.

"It doesn't matter who your toughest competitor is, it's always tough," Mortara said. "Today, Lucas was pushing really hard. He obviously had a good package, and he put me in trouble. After the start, I thought the race win would be really difficult.

"I had to invent a move into Lisboa to overtake him. To be honest, I took a lot of risks, not only at Lisboa but through Mandarin as well.

"His car was faster on the straights, so I had to be faster in the corners. I just went flat out in Mandarin, almost crashed, and then braked 50 or 60 metres later than him into Lisboa."

China Dragon Chevrolet driver Paul Poon held off a late charge from the similar Pro Spec-run machine of Andy Yak Cheuk Wai to win the Touring Car Cup race by just 0.2s.

While it was a thrilling conclusion to the 12-lapper, the post-race celebrations were kept to a minimum following the death of Phillip Yau Wing Choi during Friday's qualifying session.

Chou Keng Kuan won the Interport race in his Leng Fung Honda, a last-lap dash after a late safety car period forcing him to defend hard from Alex Hui Ka Tai's similar Integra.

Local racer Sun Tit Fan won the Roadsport Challenge by just 0.1s after a terrific scrap with Nattavude Charoensukhawattana in a similar Mitsubishi.

● Andrew van Leeuwen

RESULTS

GT Cup 1 Edoardo Mortara (Audi R8 LMS Ultra), 12 laps in 37m43.538s; 2 Alexandre Imperatori (Porsche 911 GT3 R), +4.219s; 3 Danny Watts (McLaren MP4-12C GT3); 4 Akira Iida (McLaren); 5 Romain Dumas (Porsche); 6 Li Zhi Cong (Porsche); 7 Mok Weng Sun (Ferrari 458 Italia); 8 Frank Yu (Ford GT); 9 Hisao Shigeta (Porsche); 10 Hisamri Hayashi (Porsche). **Touring Car Cup 1 Paul Poon (Chevrolet Lacetti)**, 12 laps in 39m40.531s; 2 Andy Yan Cheuk Wai (Chevy), +0.200s; 3 Michael Choi (Honda Accord); 4 Jeronimo Badaraco (Honda); 5 Kenneth Lau (Honda); 6 Eric Kwong (Chevrolet Cruze).

Roadsport Challenge 1 Sun Tit Fan (Mitsubishi Lancer Evo IX), 10 laps in 28m33.109s; 2 Nattavude Charoensukhawattana (Mitsubishi), +0.121s; 3 Yam Chi Yuen (Mitsubishi); 4 Han Han (Subaru Impreza STI); 5 Un Wai Kai (Mitsubishi); 6 Alan Chan (Nissan Skyline). **Interport Challenge 1 Chou Keng Kuan (Honda Integra-R)**, 10 laps in 34m59.808s; 2 Alex Hui Ka Tai (Honda), +2.411s; 3 Alvaro Mourato (Honda); 4 Leong Chi Kin (Honda); 5 Billy Lo (Honda); 6 Wong Wan Long (Honda).

IN BRIEF

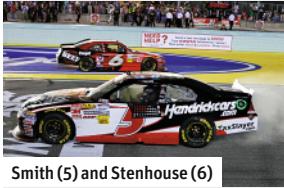

Smith (5) and Stenhouse (6)

NASCAR NATIONWIDE

Ricky Stenhouse Jr made it back-to-back titles for the Roush Ford squad by finishing sixth – and three places ahead of Elliott Sadler – at Homestead. Phoenix Chevy driver Regan Smith won on his first series start for five years.

V8 DEVELOPMENT SERIES

Holden Racing Team's Nick Percat twice beat the similar Commodore of Triple 8's Scott Pye at Winton to keep his title hopes alive. Dale Wood (Holden) won the other race. Kiwi Scott McLaughlin took the series lead after Chaz Mostert was penalised 50 points for reckless driving.

SUD-AM F3

After missing the past four races, Fernando Rezendes returned to Cesario Formula at Londrina and increased his series lead with a win and a seventh place. Former A1GP racer Felipe Guimaraes won the second race for Hitech.

BRTCC

Honda driver Andre Bragantini and Mitsubishi rival Fabio Fogaca took a win each at Londrina to both remain in the title hunt with a round to go. Series leader Ricardo Mauricio (Honda) was third in race one but retired later on and saw Denis Navarro reduce his series lead to just nine points.

NASCAR TRUCKS

Eddie Sharp Racing Chevy driver Cale Gale beat Kyle Busch by 0.014s to take his maiden series win at Homestead. A 13th-placed finish was enough to ensure Turner Chevy man James Buescher became champion by six points from Timothy Peters.

Gale (r) just beat Busch



Keselowski took the title for Penske

NASCAR SPRINT CUP HOMESTEAD (USA), NOVEMBER 18, RD 36/36

Keselowski ends Penske title drought

FOR ALL HIS SUCCESS IN IndyCar and sportscar racing, NASCAR's top prize had eluded Roger Penske. That anomaly was ended last weekend when Brad Keselowski out-scored Jimmie Johnson to claim the 2012 title.

A penalty for polesitter Joey Logano promoted Keselowski to the front row, but his pre-race intention of getting the jump on Marcos Ambrose to bag a bonus point by leading the opening lap fell well short.

In fact, Keselowski's understandably cautious approach dropped him into the pack, and he was soon racing wheel-to-wheel with Johnson, who wasted little time making up for a poor qualifying session.

Keselowski expertly called for a couple of changes to his Dodge at the first round of pitstops, and these brought it to life, allowing him to start moving to the front.

In a race of few cautions, the sensible thing to do seemed to be to pit whenever the opportunity

arose. But when Nationwide champ Ricky Stenhouse Jr put his Roush Fenway Ford in the wall not long after a caution for debris, Penske opted to keep his man out.

It was a dangerous tactic, and as the race ran under green to the finish, Keselowski looked certain to require one more stop than Johnson. It ought to have been nail-biting, but during what should have been Johnson's final stop a rare error from his Hendrick Motorsports crew resulted in a dropped lug nut. A subsequent drive-through penalty ended

his hopes of a sixth title.

This became academic a few laps later when the engine blew on his Chevy. The good news was relayed to Keselowski, who took his final stop without worry and crossed the line in 15th to wrap up a hard-fought title.

"Throughout my whole life I've been told I'm not big enough, not fast enough, not strong enough and I don't have what it takes," said the champ. "I've used that as a chip on my shoulder to carry me through my whole career. It took until this year for me to realise that that was right, man, they were right. I'm

not big enough, fast enough, strong enough. No person is. Only a team can do that."

As has been the case for much of the late season, Kyle Busch was the fastest man in the race, but he too had to make a late stop for fuel, as did race-long rival Martin Truex Jr. This left Jeff Gordon out in front from nemesis Clint Bowyer. But there were no shenanigans and they came home first and second.

● Connell Sanders Jr

RESULTS

1 Jeff Gordon (Chevrolet Impala), 267 laps in 2h48m56s; 2 Clint Bowyer (Toyota Camry), +1.028s; 3 Ryan Newman (Chevy); 4 Kyle Busch (Toyota); 5 Greg Biffle (Ford Fusion); 6 Martin Truex Jr (Toyota); 7 Aric Almiro (Ford); 8 Kevin Harvick (Chevy); 9 Kurt Busch (Chevy); 10 Dale Earnhardt Jr (Chevy). **Points** 1 Brad Keselowski, 2400; 2 Bowyer, 2361; 3 Jimmie Johnson, 2360; 4 Kasey Kahne, 2345; 5 Biffle, 2332; 6 Denny Hamlin, 2329; 7 Matt Kenseth, 2324; 8 Harvick, 2321; 9 Tony Stewart, 2311; 10 Gordon, 2303; 11 Truex, 2299; 12 Earnhardt, 2245.



Gordon made up for Phoenix fracas

QUICK RESULTS

- Race 1 **Jamie Whincup**
- Race 2 **Craig Lowndes**
- Poles **Mark Winterbottom/Whincup**
- FLs **James Courtney x2**

RACE RATING



Whincup's charge the highlight of an ever-changing second race

V8 SUPERCARS WINTON (AUS), NOVEMBER 17-18, RD 14/15

Whincup lands title with Winton charge

JAMIE WHINCUP SECURED HIS fourth V8 Supercar crown at Winton last Sunday by ripping through the field from 25th to third in a race won by his Triple 8 team-mate Craig Lowndes.

Whincup started Sunday's second race knowing that a victory in the opener 24 hours earlier had put him to within a fourth-placed finish of taking the title.

During the first half of the race the signs were good. Early leader Will Davison's advantage as the only man to start on the soft 'sprint' tyres, was eroded by a safety car, and when he got caught up with non-stopping

Michael Patrizi on the restart, Whincup blasted into the lead.

However, Whincup was soon handed a drive-through penalty for spinning his Holden Commodore's wheels before he had been dropped off his jacks at a pitstop. The time loss dropped him to 25th and led to one of the drives of 2012.

With seven laps left he had made a three-way fight for third between Shane van Gisbergen, Tim Slade and David Reynolds into a foursome, and picked off the three Fords quickly to move into the podium places.

Ford Performance Racing's



Whincup on his way to the title

Mark Winterbottom grabbed the lead as a result of Whincup's penalty, but was caught by Lowndes shortly after their final pitstops and lost the lead to the veteran before the flag.

Winterbottom lost third spot in race one to SBR's Lee Holdsworth out of the last bend after running out of fuel. James Moffat was fifth

in that race, the Dick Johnson Ford driver having led for a long time after bucking the trend and starting on the soft, rather than hard rubber.

RESULTS

Race 1 1 Jamie Whincup (Holden Commodore VE II), 46 laps in 1h08m36.375s; 2 Craig Lowndes (Holden), +3.235; 3 Lee Holdsworth

(Ford Falcon FG); 4 Mark Winterbottom (Ford); 5 James Moffat (Ford); 6 Tim Slade (Ford).

Race 2 1 Lowndes, 67 laps in 1h38m39.486s; 2 Winterbottom, +5.812s; 3 Whincup; 4 Shane van Gisbergen (Ford); 5 Slade; 6 Jason Bright (Holden). **Points** 1 Whincup, 3639; 2 Winterbottom, 3322; 3 Lowndes, 3259; 4 Will Davison (Ford); 5 van Gisbergen, 2554; 6 Slade, 2532.

SUPER GT SPRINT CUP FUJI (J), NOVEMBER 17-18

Honours even in GTs at Fuji

RONNIE QUINTARELLI AND Yuji Tachikawa were the winners of Super GT's two races at the JAF GP Sprint Cup at Fuji.

Double champion Quintarelli started ninth in Saturday's opening race, which was held in awful weather. He was up to sixth by the end of lap one and then overtook a rival on each lap until the Mola Nissan driver found himself leading from Kodai Tsukakoshi's Real Honda.

The sprint format meant only one of each driver

pairing took part in each race, and led to a totally different result the following day as Masataka Yanagida – Quintarelli's co-driver – was last of the classified finishers.

In the dry a great start gave Yuji Tachikawa's Cerumo Lexus the lead from fourth on the grid, with a battle swiftly developing between the Le Mans 24 Hours regular and recently-crowned Formula Nippon champion Kazuki Nakajima. Tachikawa won by a little

over 2s with Takuya Izawa's Kunimitsu Honda third.

● Jiro Takahashi

RESULTS

1 Ronnie Quintarelli (Nissan GT-R), 10 laps in 21m01.979s; 2 Kodai Tsukakoshi (Honda HSV-010), +0.756s; 3 Kazuya Oshima (Lexus SC430); 4 Michael Krumm (Nissan); 5 Naoki Yamamoto (Honda); 6 Joao Paulo de Oliveira (Nissan). **Race 2 1 Yuji Tachikawa (Lexus)**, 22 laps in 34m51.361s; 2 Kazuki Nakajima (Lexus), +2.632s; 3 Takuya Izawa (Honda); 4 Satoshi Motoyama (Nissan); 5 Bjorn Wirdheim (Nissan); 6 Daisuke Ito (Lexus).



Lotterer (leading) won on the road, but was excluded

FORMULA NIPPON SPRINT CUP FUJI (J), NOVEMBER 18

Izawa wins after Lotterer exclusion

TAKUYA IZAWA GAVE Dandelion Racing victory in the non-championship JAF GP Sprint Cup after on-the-road winner Andre Lotterer was disqualified.

TOM'S driver Lotterer made a rocket start from second on the grid to lead at the start and built up a 14-second margin by the finish. However, post-race scrutineering revealed his car's skid block to be under the regulation thickness and he was thrown out of the results.

Izawa's race had not been incident-free. He hit polesitter and team-mate Kodai Tsukakoshi at the first corner of the race, bending

the latter's front suspension and forcing him out. In the end his victory margin over Joao Paulo de Oliveira's Impul car was just 0.3s with Loic Duval third, the Frenchman having gone from eighth to fourth on the opening lap.

Champion Kazuki Nakajima was seventh for TOM's while IndyCar racer Takuma Sato finished 13th. ● Jiro Takahashi

RESULTS

1 Takuya Izawa (Swift-Honda FN09), 22 laps in 32m10.212s; 2 Joao Paulo de Oliveira (S-Toyota), +0.315s; 3 Loic Duval (ST); 4 Yuji Kunimoto (ST); 5 Tsugio Matsuda (ST); 6 Kohei Hirate (ST).



Nakajima (36) gave Tachikawa a hard time

AND NOW FOR SOMETHING COMPLETELY DIFFERENT

Sweden's TTA series is the newest take on the touring car concept. **ANDREW VAN DE BURGT** had a look and ex-BTCC champ **COLIN TURKINGTON** took one for a spin



What is a touring car? On the face of it a simple question but it's one that has many different, often contrasting, answers across the world. But it's not just geographical distance that causes a divergence of concepts, a mechanical take on Darwinism if you will.

Over the past decade a multitude of vaguely differing touring car rulebooks sprang up, and in Sweden there was a melting pot in which they all came together. BTC, S2000, turbo-powered S1600 and locally homologated bio-gas cars were all accommodated under the same STCC umbrella. It created a series of intriguing technical diversity, but also one in which constantly equalising the performance of the cars resulted in a privately run eight-year-old Alfa Romeo beating a semi-works BMW, handicapped by 100kg of ballast.

If this sounds like an untenable situation, it was. And four of Sweden's biggest touring car teams – Polestar, WestCoast Racing, Flash Engineering and Brovallen Design – set about drawing up their own rule book.

Their solution was to take a common chassis, engine and gearbox and cover them in bodywork that resembles the models the four associated car manufacturers – BMW, Citroen, Saab and Volvo – wish to promote. The base chassis was sourced from the French Solution F engineering specialists and is

closely related to the vehicle it supplies to the Race of Champions.

"It's very similar, but it's not the same," says Greger Landen, the TTA's technical director. "We have made some developments, we've adapted the width and length of the chassis so that it's more in tune with a touring car type of bodywork. In essence the gearbox and engine is pretty much the same, but we've made some adaptations for the Nordic market."

That engine, a 3.5-litre V6 producing over 400bhp, can trace its origins back to a Nismo-built version of the Nissan 350Z's motor, which was once used in the World Series single-seat racer.

"We have adapted the wings and cooling," Landen continues. "The RoC set-up is more for endurance racing, we did a lot of work on getting a sprint-race set-up. For instance, we have a programme focussed on getting the gearbox to be quick and crisp on downshifts. It's really a big step in the use of electronics, it has a completely new system."

This has been developed in conjunction with Solution F and Cosworth, which has allowed for a substantial amount of data-logging. With plenty of spare capacity to increase this as the series matures.

Over the winter of 2011/12 the four different body types were



tested in the Volvo windtunnel. Using the findings, various adjustments were made to the aero of each car to make them as equal as possible.

"We researched the bodywork in a very methodical way," says Landen. "We had really good help from the windtunnel guys who had their methodology mapped out. We started looking at how the attack angle of the rear wing could affect

COLIN TURKINGTON CV

Age: 30
BTCC starts: 218
Wins: 19
2009 champion
WTCC starts: 22
Wins: 1
STCC starts: 18
Best finish: 2nd (x3)



the bodywork. We wanted to keep as much adjustability as possible and still have equal aero.

“Another thing we worked a lot at was the flow into the sidepods and where we have the air intake into the engine, which had to be equal for everyone. In the end we came up with diveplanes for all the cars, and this allowed us to tune the flow to the sidepods. We realised that we could have different angles on the

rear wing – there are four different positions open to the teams – but we needed to tune the gurney for the different bodytypes. Based on the numbers that we have in terms of just the aero, the difference between the theoretically slowest and fastest is in the range of thousandths of a second, so we’re really happy with that.”

For touring car traditionalists, the notion of all the cars being identical

underneath the skin goes against the grain of what that branch of motorsport is all about. It may have been a long time since the ‘win on Sunday, sell on Monday’ adage was true, but how does a series like TTA appeal to a manufacturer when there’s basically none of its engineering on display?

Volvo’s executive director Derek Crabb reckons the fact the cars are basically the same is not an issue. ▶

◀ “Real enthusiasts know it’s not the real thing, but it’s not so far from what BMW do in the DTM and other series,” he says. “And therefore it presents Volvo and it presents the image of the S60. It’s worked for us, the cars look good.”

With the machines effectively all the same, the idea is that the driver who drives the best, and works most effectively with his team, prevails. So what can they do to find those all-important final few tenths?

“You can adjust the dampers, compression rebound, and we have a select set of springs that you can choose between, so you’re not completely locked down – there are three sets front and rear,” says Landen. “A lot of this is down to driver preference and whether you like a soft or a stiff car. There’s camber and toe settings and a lot of work with tyre pressures. There’s different settings for the anti-roll bars, and you can change anti-squat at the rear.”

Engines and gearboxes should easily last a season, as should the dampers. Brake discs, all supplied by Solution F but made by Performance Friction, are limited to three sets a season, while pads are unlimited. Hankook supplies its DTM-spec tyres – each driver allowed two sets (one new, one used) for Friday and the same for Saturday, although the sets cannot be transferred between days. There are three sets of wets for the season.

So what’s it like to drive? AUTOSPORT took Colin Turkington, the 2009 British Touring Car champion, who raced a Flash Engineering BMW in the 2011 STCC, to Anderstorp, where on a cool, wet afternoon he put Tommy Rustad’s Polestar Volvo S60 through its paces.

CHASSIS

Each car is built upon a Solution F steel-tube chassis. The teams make their own carbonfibre bodywork. Including the driver, the cars must weigh a minimum of 1100kg.

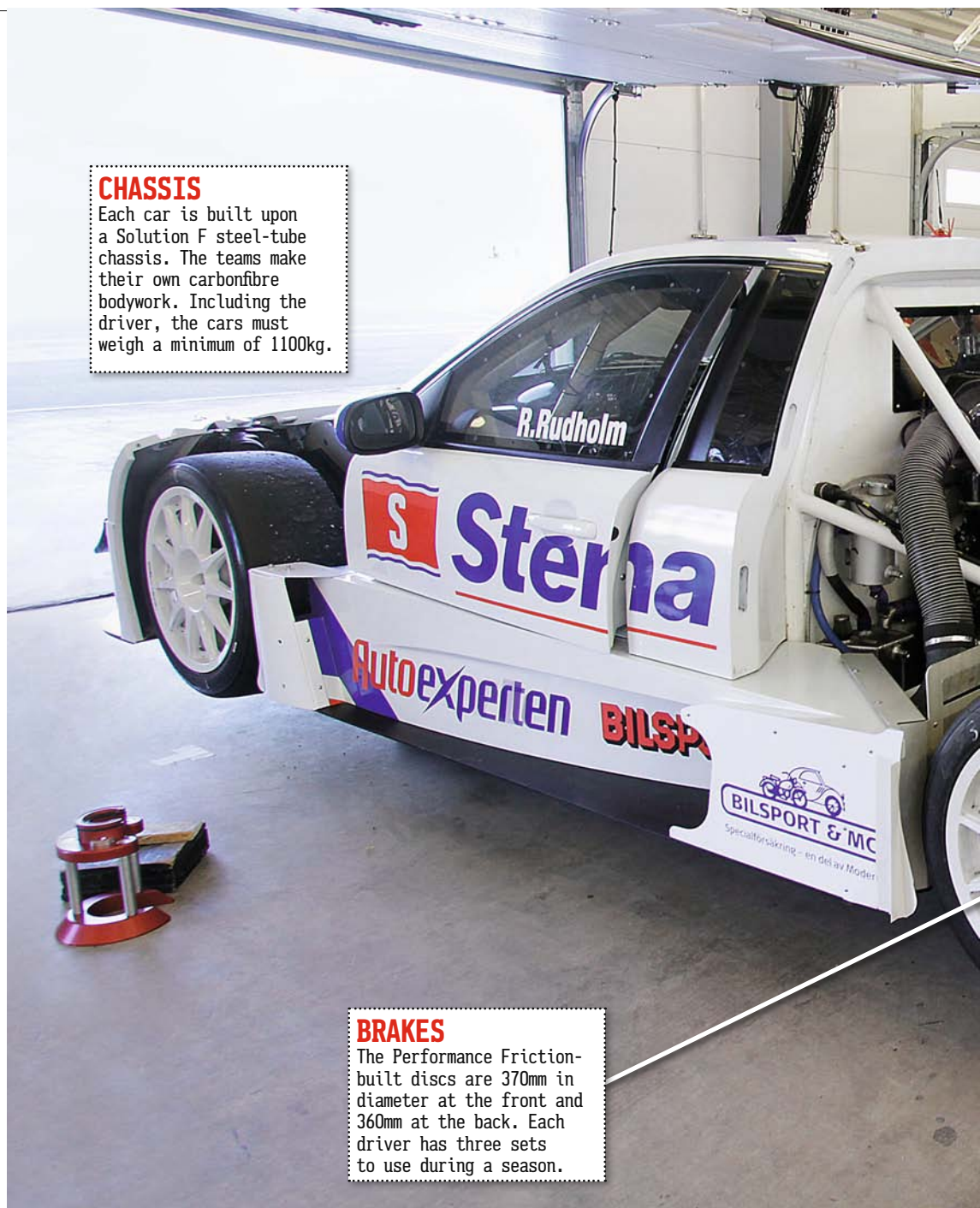

BRAKES

The Performance Friction-built discs are 370mm in diameter at the front and 360mm at the back. Each driver has three sets to use during a season.

The circuit

Anderstorp is arguably Sweden’s most famous race track having hosted six Swedish GPs from 1973-78. It features a long (800m) back straight and a series of three banked hairpins. It’s approximately 120km from Gothenburg in the rural Gisvaled municipality.

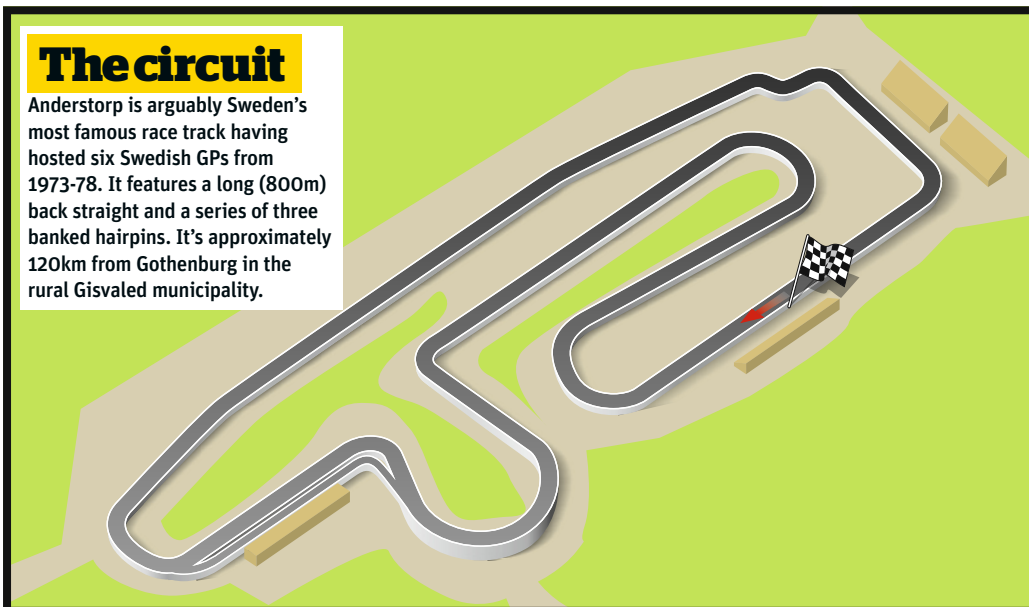

“The two things that stood out were that it felt like there was loads of power and loads of grip,” he says. “But that was sort of what I was expecting with reportedly 450bhp. You can see the aero on the car, too – and you can really feel the affect compared with a normal touring car.

“Even in the wet I was quite surprised by how much grip there was. Going out on cold tyres on a wet track you’d expect with that much horsepower just to light up the rear wheels, but the traction was very good, but I guess that was helped a lot by using the wet [electronic] map. The power’s slightly less aggressive and you don’t have as much access to the torque as you would in the dry.

“The gearshift is very impressive. The paddleshift gearbox makes the car feel very easy to drive – you don’t have to think about it at all. You don’t

ENGINE

The Nismo-derived 3.5-litre V6 engine is centrally mounted behind the driver and ahead of the rear axle. It produces over 400bhp and is designed to last well over a season before requiring a rebuild.

GEARBOX

The six-speed Solution F gearbox is operated via a paddleshift on the steering wheel. The ECU prevents downshifts outside of the correct rev range to stop over-revving. The clutch is operated by a foot pedal.

TYRES

The Hankook single-compound tyres are the same as those used in the DTM. Each driver gets two sets - a new and used one - to use during qualifying and the race.

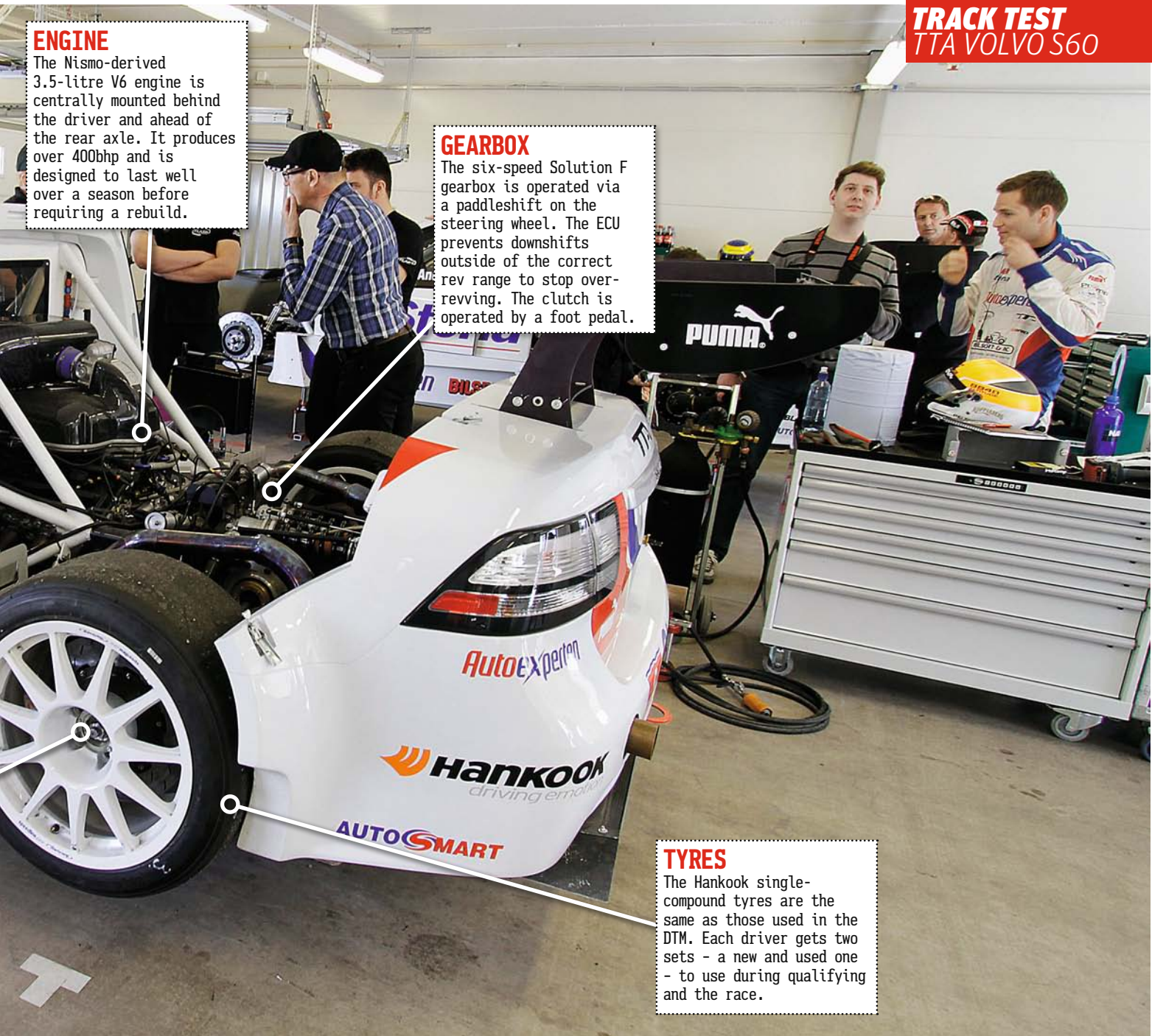

have to reach for anything, you don't have to worry about slotting it into the wrong gear like we did when I was using the H-pattern in the BMW. It goes up through the gears very quickly and you're in sixth gear in no time - halfway down that straight - and on the downshift when you turn into the corner it won't change gear until the revs drop to a certain figure, so it becomes pretty bulletproof.

"It doesn't feel like you're sitting in a touring car. You're really in a cockpit and you can't see anything out of the rear window - the vision is very restricted and even with what you've got [the left and right door mirror] it's not too great. I haven't done much driving in a single-seater, but it feels much more like a single-seater from that perspective. And the seating position as well: your seat is very straight at the back.

"It's very well balanced and you want to push on a bit more every lap. Also the front axle is very responsive, once you turn the steering there's an immediate reaction, the front end is quite pointy and there's quite a bit of aero there, which helps. Once you get the front in there's a bit of understeer too but I'm not sure how much that's down to the set-up we had, which I think was a full dry one.

"The biggest thing you feel is the rear grip. If I was going out in those conditions in any other touring car for sure it would take three or four laps to be confident in the rear end but with that car it was almost straight away.

"I'd love to have a day in the dry to see what the Volvo is really capable of and to get a proper feel for it. It's definitely a very fun and enjoyable car to drive." ❄

The cars

**BMW M3 COUPE
WESTCOAST RACING**

Top 2012 driver: Fredrik Larsson
(85 points, 4th overall, 1 win)



**CITROEN C5
BROVALLEN DESIGN**

Top driver: Alx Danielsson
(43 points, 8th overall)



**SAAB 9-3
FLASH ENGINEERING**

Top driver: Linus Ohlson
(126 points, 2nd overall, 2 wins)



**VOLVO S60
POLESTAR RACING**

Top driver: Fredrik Ekblom
(151 points, champion, 2 wins)



PICS: FRANSSON, LINDGREN/MEDIAEMPIRE AB

OWEN DEVELOPMENTS BTCC 2012 TURBO SUPPLIER

CONGRATULATIONS TO GORDON SHEDDEN ON WINNING THE 2012 BTCC TITLE

Since 1980, Owen Developments has been at the forefront of high performance turbo technology for both motorsport and fast road use. As the sole appointed Garrett performance turbocharger centre for the EU for Garrett GT turbos, we have exclusive access to the Garrett GT ball bearing performance turbocharger range and unique factory technical support.

Whatever your requirements, whether a basic fast road upgrade, an ECU remap for road or race use or a full WRC turbo rebuild, our emphasis is on delivering a friendly, informative and a superb level of service to all our customers as our reputation depends on it.



If you would like to discuss a purchase or service with Owen Developments' sales or technical team, please don't hesitate to contact us on +44 (0) 1865 821062 or go to www.owendevelopments.co.uk

MY SEASON MAXIME MARTIN

Belgian ace has been a star of GT racing in 2012, in several different series



"I like driving in the rain and that helps a lot. If you don't have the confidence, then you don't get the heat into the tyres"

Martin has been superb in BMW Z4

It seems strange to suggest that 2012 was a breakthrough year for a driver who already had four FIA GT1 World Championship race victories to his name. But even Maxime Martin admits that his talents came to the attention of a wider audience this season. He probably sums it up best when he puts it down to some "big performances in big races".

A stunning wet-weather drive in the Spa 24 Hours aboard the lead Marc VDS Racing BMW Z4 certainly brought him to the German manufacturer's attention. It was after that performance that he was contacted about the DTM test that came in October. But that was just one of a number of stand-out performances from the 26-year-old Belgian.

There was his fourth on his debut in the Nurburgring 24 Hours, also with Marc VDS, two more starring efforts in the wet in the Blancpain Endurance Series, at Monza and Silverstone, and

a phenomenal drive — you've guessed it, in the wet — at the Zolder GT1 round aboard an Aston Martin DBRS9.

Martin also won three times in the ADAC GT Masters series driving an Alpina BMW B6 and impressed at the wheel of an OAK Racing Morgan-Nissan LMP2 at the Le Mans 24 Hours over the course of a season in which he contested 25 events, and that's not counting a couple of historic outings and a one-off in the Spa Fun Cup event.

"It was a good season because I led a race at some point in every car I drove," he says. "That includes Le Mans, where we were leading in LMP2."

Martin's wet-weather prowess is what made him stand head and shoulders above BES team-mates Bas Leinders and Markus Palmtala. But ask him to explain why he's so good when it's raining, and he can't find an answer.

"I like driving in the rain, and that helps a lot," he says. "If you don't have



The DTM beckons for the Belgian

confidence, then you don't get heat into the tyres and everything goes wrong."

It is ironic that rain almost certainly prevented Martin from collecting the first major championship title of his career. He'd made it up to fourth in the Navarra BES finale after the lead Marc VDS Bimmer took a 10-place grid penalty carried over from the previous round. Any chance of moving up the one place required to assure him and his team-mates of the title disappeared when the torrential conditions first brought out the safety car and then caused the race to be red-flagged.

The target now is the DTM, though he claims he is yet to find out if he has a future with BMW. A seat with one of the DTM manufacturers offers the perfect scenario. "It is the highest level possible for me," he says, "but the manufacturers also give you other opportunities."

Which means that Martin should be back at Spa next July, whether or not he's a DTM driver. ☼

MARTIN'S CV

Born
March 20, 1986
From
Uccle, Belgium
2012 2nd Blancpain Endurance Series (4 wins), 4th ADAC GT Masters (3 wins)
2011 6th FIA GT1 World Championship (4 wins), 7th FIA GT3 European Championship
2010 14th FIA GT1 World Championship
2009 16th FIA GT3 European Championship (1 win), ADAC GT Masters (2 wins)
2008 2nd Eurocup Megane Trophy, 1st French Renault Clio Cup
2007 3rd Eurocup Megane Trophy
2006 4th Belgian Formula Renault 1600
2005 2nd Belgian Mini Cooper Challenge winter series



More success has come in Alpina B6

WEB DIRECTORY

CAR BROKERAGE

RACING CARS FOR SALE
ALAN CORNOCK FCS
BUYING - SELLING - BROKERAGE
www.racingcarsforsale.co.uk
TEL: 01480 891212

eLITE Rally & Race Gearboxes,
GearKits, LSD's and Driveshafts
Tel: 01782 280136 Fax: 01782 269913
Email: sales@eliteracingtransmissions.com
www.eliteracingtransmissions.com

Gearboxman.com
COMPETITION TRANSMISSION SERVICES
Gearboxes and Axles for Road, Race, Rally, and more
Telephone: 01582 840008, Fax: 01582 840007

HELMET GRAPHICS

Mike Fairholme Designs
Sole approved painter of Arai helmets.
Silver Birches, Corby Birkholme, Nr Grantham, Lincs NG33 4LE.
Tel: 01476 550630. Fax: 01476 550029.
email: fairholmedesigns@btconnect.com
www.fairholmedesigns.co.uk

MEMORABILIA

Speed King.cc
EXCLUSIVE MOTORSPORT MEMORABILIA
EST. 1996
We Buy Your Teamgear!

FINAL LAP
For Everything Formula One
www.finallap.net WE BUY AND SELL
+44 (0)1245 287588 / 07771 920345

JM AUTOMOBILIA America's #1 supplier
of CART and Formula
One Racing memorabilia. Large selection of signed
original collectables. See our ad under marketplace
Memorabilia. Call or fax or a mail listing at (609) 575 1143
or visit our website @ www.JMJAuto.com

THE F1 SHOP F1 Merchandise bought and sold.
Meadowhall, Sheffield
Tel: 0114 256 9835
www.theformula1shopandmore.co.uk

MOTORHOMES

BRIAN JAMES TRAILERS
CLUBMAN
Tel. 01327 308833
Web. www.brianjames.co.uk

ARE DRY SUMP SYSTEMS
ARMSTRONG RACE ENGINEERING INC.
WWW.DRYSUMP.COM (916) 652-5282

Pit to Car Autotel
Radio solutions Digital Race Radio
0044(0)1508 528837
www.raceradio.co.uk

demon tweeks
MOTORSPORT Direct
www.demon-tweeks.co.uk

RACE PRODUCTS

MARDI GRAS MOTORSPORT
www.mardigras.co.uk

msar LONDON
MOTORSPORT
SHOWROOM
www.msar.co.uk

PIPER
www.pipercams.co.uk

SCHROTH RACING
www.schroth.com

RACE PRODUCTS

www.porscheshop.co.uk
PORSCHESHOP
+44 (0) 121 585 6088

TEKNOFIBRA®
HEAT RESISTANT MATERIAL
Protection to 1000°C
web: www.walkersgarage.com
tel: 0044 (0) 1609 777221

JJC race and rally
PASSIONATE ABOUT MOTORSPORT
www.jjcraceandrally.com

GPR eparco uvex OMP
SCHROTH hons seat Arai BELL
RACEWEAR | KARTWEAR | SIMULATION
WWW.GPRDIRECT.COM

RACEWEAR

ALL OMP RACEWEAR
AVAILABLE NOW
www.ybracing.co.uk

WWW.ROYALPURPLE.CO.UK
ROYAL PURPLE
SYNTHETIC RACE OILS
01209 216 666

GARAGEPRIDE
Quality Storage for Home and Industry
www.garagestoragecabinets.co.uk
Tel: 0800-206-2303

Image Manufacturers of bespoke
split rim alloy wheels
www.imagewheels.co.uk
IMAGE WHEELS INTERNATIONAL LTD

RACING OILS

STORAGE

WHEELS

AUTOSPORT.COM

TO ADVERTISE IN THE WEB DIRECTORY PLEASE CALL
020 8267 5560 OR EMAIL: autosport.ads@haymarket.com

BRIAN JAMES TRAILERS

» Connected to you



Endurance & Efficiency

www.brianjames.co.uk

Race Transporter trailers demonstrate all the capability you require. Our passion for continual development underpins everything we do. The results are available for you.

RACE TRANSPORTER

T +44 (0)1327 308 833

For more information and details of your local BJT dealer please call or visit our website.

TRAILERS & TRANSPORTERS

WOODFORD TRAILERS

Call Us Now! tel. 01327 263 384

www.woodfordtrailers.com sales@woodfordtrailers.com



RL 2000
£4,900 + vat



RL 3000
£5,950 + vat

PRG Trailers

Look Beyond



optional colour finishes shown

PRG Trailers | Cheshire | UK | Tel: +44 (0) 1270 812402
Web: www.prgtrailers.co.uk | Email: info@prgtrailers.co.uk

RACE TRANSPORTER

- Tractor Unit, Trailer and Stegmaier Awning
- (2 x GTs, 3 X Single Seaters)

£45,000



Call Plans Motorsport on +44 (0)1483 548999

TO ADVERTISE YOUR TRAILER OR TRANSPORTER IN THIS SECTION OF

AUTOSPORT

PLEASE CALL 0208 267 5560

RACE & RALLY CARS

The race is on for this rare opportunity.

2011 Ligier JS51 CN

Race eligible for SPEED, VdeV series and various national sportscar series, this 2011 Ligier JS51 CN is highly competitive, finishing on the podium on four occasions in 2011. One of the last JS51s to leave the factory, it features a 2.0 litre Honda engine producing 250 CV mated to a Sadev 6-speed sequential box.

Specification includes:

- 1 race old Mugen refreshed engine
- Lightweight bodywork upgrade
- Suspension modifications including Koni dampers
- 3 sets of wheels

This was re-prepared at the end of 2011 and is ready for immediate circuit driving. The car is currently wrapped in blue Howards livery, which can be removed. It has only competed in five events in its lifetime.

Contact **Jonathan Coleman** on **07887 661 616** for more information.

Offers invited, part exchange possible.

Howards Motor Group are a family owned multi-franchise motor group with a range of brands, operating in Weston-super-Mare, Taunton, Yeovil and Dorchester.



RACE & RALLY CARS

Wanted

FF1600
and
FF2000

Telephone:
07761549454

Lola F3000 T9650

Genuine Tub, bodywork,
wings and wheels,
(no engine or gearbox)
ex race car used as static show car
£5450



for more info and race history
07956 515927

Factory Mazda

- SpeedSource built GT Mazda RX-8 - Race in the 2013 ROLEX series including 24 Hours, Indy, Sahlen's 6 Hours, Mid-Ohio, Circuit of the Americas. , Very Competitive, Team won 2012 Mazda Raceway event, Very Reliable, Zero Engine Failures in 60+ events over 3 years, Carbon Bodywork, Riley Chassis, Alcon Calipers and Rotors, BBS wheels, Pagid Pads, EMCO Sequential Gearbox with Paddle Shifters, Motec Dash, Many extras, including spare 3 Rotor Motor;
\$125,000



Contact Will Nonnamaker at Will@phoenixpromotions.com or 330-280-1603



Drive Available

- Abu Dhabi Yas Marina F1 Circuit
- Gulf 12 Hours 12-14 December 2012
- Drive available
- 1 seat remaining in the United Autosports 2012 Audi R8 LMS Ultra GT3 Car
- Contact Richard@unitedautosports.com



unitedautosports.com

www.twitter.com/unitedautosport

www.facebook.com/unitedautosports

1967 McLAREN M1C Chassis: 40/12

One of only 25 M1Cs built by the factory, chassis 40/12 was bought by David Hurley as a replacement for his famous streamlined M1B. Raced extensively throughout the 1980s by Pink Floyd drummer Nick Mason before joining the famous Rosso Bianco collection, where it was beautifully preserved for over 20 years. Completely restored by WDK Engineering, including a fresh Chevrolet engine from Mathwall Engineering, 40/12 won the Masters World Sports Car race at this year's Spa Six Hours on only its second outing!



FISKENS
FINE HISTORIC AUTOMOBILES



Where the world's greatest cars come to be sold - 14 QUEENS GATE PLACE MEWS, LONDON SW7 5BQ T: +44 (0)20 7584 3503 W: WWW.FISKENS.COM

MARKETPLACE

MEMORABILIA

F1 COLLECTORS .COM



#1 FOR F1 MEMORABILIA
 We buy and sell F1 items
 Ayrton Senna specialists
 Call CHRIS GRINT 01763 274448
 email: sales@f1collectors.com

JMJ Automobilia
 SUPPLIERS OF RACE
 MEMORABILIA SINCE 1992

Florida, USA (609) 575-1143

email: JMJAUTO.COM
WWW.JMJAUTO.COM

MOTORSPORT GENERATORS

Hyundai Power Equipment

Ideal for motorsport, home, office or business standby.



- * Generators * Air Compressors
- * Pressure Washers * Hand & Power Tools

Tel. 01646 663848
www.genpoweruk.co.uk

AUTOSPORT.COM

MOTORSPORT TYRES

FOR ALL YOUR

MOTORSPORT
 RACING TYRES
 Inc. ACB 10 Formula Ford
 Contact

BMTR LTD

Tel: 0121 331 1122
 Fax: 0121 331 1144
 email: sales@bmtr.co.uk
 see our new web site at www.bmtr.co.uk

NUMBER PLATES

FOR SALE

GLIITSY

THIINGY

£4995.00 ono each

contact:
pault03@globalnet.co.uk
 07831407649

MOTORSPORT SIMULATOR

BUSINESS OPPORTUNITY



F1 Show Car & Simulator System

£38,000+vat

Brian James RS3 Trailer Available - POA

For Further Details

E-mail: Info@f1party.co.uk

Or

Telephone: 01202 862360

MOTORSPORT DRIVING INSTRUCTION



ACCELERATE
 DRIVER DEVELOPMENT

RACING NEXT YEAR?...PLANNING TO MOVE UP THE GRID?

**ENGINE REBUILD?...SUSPENSION MODS?...MORE TESTING?
 HOW ABOUT IMPROVING YOUR CAR CONTROL?...A proven
 and cost effective method...ON ICE!**



Our 'Pre-Season' tailor-made race driver training on frozen lakes in Sweden with high performance cars will teach you so much about car control.



Other Courses include:
 Fun weekend, Corporate events for clients or Team Building,
 Valentines package for 2 – February 14th

Proven Techniques
 Swedish Rally Instructors
 English Speaking Course
 All inclusive of accommodation and meals
 2 days on the ice

check out the video clip – www.icedriving.net

"I have been racing for 9 years and a friend recommended Ice Driving. Net, I cannot believe how much I learned over two days. When I went out on track in the wet after the course, I felt so much more confident and my times were so much more competitive. If it's good enough for Michael Schumacher it's certainly good enough for me! I will be back!" Robert – Essex



Revealed:
The history of
Formula One

Senna



Rindt

Prost



Villeneuve

Mansell

Fangio



Fittipaldi

Hawthorn

Piquet

Hill

Ascari



Clark

Hamilton



Taruffi

Button

FI Collectables • Team Memorabilia • Clothing
Buy • Sell • Evaluations

One of Europe's largest collections

+44 (0) 1245 287588 • +44(0) 7771 920345 • sales@finallap.net

www.finallap.net



MARKETPLACE

RACE REPAIR



- High quality carbon repairs
 - Competitive Pricing
 - Unbeatable turnaround times
- Contact us for a no-obligation quote
 Tel: 01327 871847
 Email: mail@carbonfibrerepair.com
- Please visit carbonfibrerepair.com for more details

Elite Carbon Fibre Carbon fibre race car component manufacturer

Contact Dave Greenwood 07809390316
 Email - davecarbonelite@googlemail.com
 Website elitecarbonfibre.co.uk
 EliteCarbonFibre Ltd.
 Units 20-22 Norwich Road Ind. Est.
 Watton, Thetford, Norfolk IP25 6DR

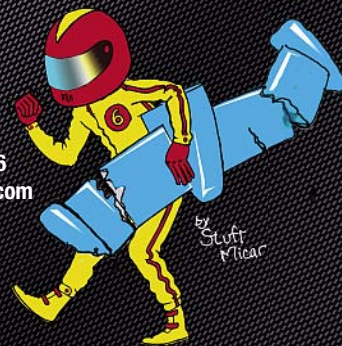

Carbon Composite Wings, Bodywork & Repairs

TO ADVERTISE IN THIS SECTION OF

AUTOSPORT

PLEASE CALL 0208 267 5560

RACE PRODUCTS



UK Distributor / Warehouse

GLENCOE Sytec

Tel: +44 (0)1784 493 555
 Fax: +44 (0)1784 493 222
 Email: sales@glencoeld.co.uk

"First Choice for the Professionals"
 "First - Full Motorsport Pump Range"
 "First Class Quality and Reliability"

MOTORSPORT (In Tank)
190 Ltr/hr (300 BHP)
225 Ltr/hr (500 BHP)
 High Flow / High Pressure Model
 Available with fitting kit + filter



MOTORSPORT (Out of Tank)
325 Ltr/hr (Max)
 5 Bar Fuel Pump
 (Similar to Bosch 0580 254 044)



NEW For **EXTREME MOTORSPORT**
 IN TANK FUEL PUMPS

2 YEAR WARRANTY

400 Ltr/hr **NEW**
 Pt. No. GST400 (90000262)
 Performance @ 13.5v :
 0 Psi (Free Flow) - 440 Ltr/hr
 40 Psi..... - 404 Ltr/hr
 60 Psi..... - 346 Ltr/hr
 90 Psi..... - 252 Ltr/hr



450 Ltr/hr **NEW**
 Pt. No. GST450 (90000267)
 Performance @ 13.5v :
 0 Psi (Free Flow) - 454 Ltr/hr
 40 Psi..... - 430 Ltr/hr
 60 Psi..... - 381 Ltr/hr
 90 Psi..... - 268 Ltr/hr



Prices! Please Check Our Website

www.glencoeld.co.uk

MARKETPLACE

RACE PRODUCTS

WWW.REIGERSUSPENSION.COM 

The best suspension for:

- Rally
- Rallycross
- Autocross
- MotoCross
- Quads
- Sidecar Cross
- Rallye Raid
- Trial



Reiger Suspension BV
Molenenk 5a
NL-7255 AX Hengelo Gld.
Tel.: +31 (0)575-462077 Fax: +31 (0)575-463316
Info@reigersuspension.com

RACE PREPARATION

Moffatt Engineering Ltd

- Preparation and set-up
- Restoration and repairs
- Fabrication and machining
- Race and testing support
- Covered transport and secure storage
- Components and consumables
- Single seater and sports racing specialists
- Close to Junction 10, M1

Mobile: 07793 502913 // paul@moffattengineering.co.uk
www.moffattengineering.co.uk

MARK FISH MOTORSPORT

ENGINEERING PASSION

From full workshop preparation to trackside support for current and historic saloon and sports cars.

www.markfish.co.uk

Multiple Championship winning team, Saloon and Sports cars since 1983

- Mini Challenge • Clio Cup • Most other Championships

Tel: 01279 431628

Mobile: 07775 752675

RACE PRODUCTS

mectech motorsport

2012 RADICAL Championship winning Team

- We have the capacity to undertake winter rebuilds and winter testing programmes either with customers own Radical cars or in one of our Radical SR3 race cars.
- 2013 Radical Championship all classes
- We have available capacity to prepare, transport and run SR1 and SR3 Radicals in all UK rounds.
- We have a full arrive and drive operation to run customer cars or rent one of our cars for the full season.
- For owners of cars who want awning space at all rounds with technical back up bespoke packages are available.

For A Head Start To Your 2013 Season Join The Winning Team!



Contact Mike Smith
Tel: 01277 372848
Mobile: 07860 598304
Email: mectechmotorsport@live.co.uk

Mectech Motorsport Limited,
Place Farm, Place Farm Lane,
Doddinghurst, Brentwood,
Essex CM15 0JA

MARKETPLACE

RACE PRODUCTS

**SCHROTH®
RACING**

**PROVEN TO WORK
PROVEN TO WIN**



hans
made by
SCHROTH®

www.schroth.com

FIA APPROVED

**demon tweeks™
MOTORSPORT Direct**

HAVE YOU GOT YOURS YET?

FREE 2013 CATALOGUE - 484 pages of the most comprehensive collection of motorsport parts, accessories and innovative new products - **GET YOUR COPY NOW**

TEL: 0906 250 1516 Calls to 0906 numbers cost 50p per minute at all times. (Calls should last no longer than 1 1/2 minutes).

www.demon-tweeks.co.uk



AUTOSPORT

**TO ADVERTISE IN THIS SECTION
PLEASE CALL 0208 267 5560**

RACEWEAR

**Grand Prix
Racewear**

RACEWEAR
KARTWEAR
SIMULATION

OFFICIAL
SUPPLIERS FOR:
uvex

WWW.GPRDIRECT.COM

08435 070 885



GPR

spiarco epinestar uvex OMP Arai HELMET BELL SCHROTH RACING hans seat

MARKETPLACE

RACEWEAR



FIA 3 Layer Racesuit £275, one of many bargains that are available at:

Plays Kool Motorsport

www.plays-kool.co.uk
sales@plays-kool.co.uk
Tel: 01388 762288

ROTARY ENGINES

Hayward ROTARY 

FOR ALL YOUR ROTARY ENGINED RACE CAR REQUIREMENTS CONTACT:



07877 632369 01635 255545

WWW.MAZDAROTARY.CO.UK

SHIPPING

CAR SHIPPING

WORLDWIDE SERVICE IMPORT/EXPORT AIR/SEA



Specialist Shipping Services for :
 Race cars & Collector cars (any value/spec)
 Race team shipping/logistics for one-off events
 Spare parts/urgent shipping - parcels/pallets
 General Shipping Services - all goods
 Customs Services : Import Bonds & Guarantees
 Carnet & Transit documents
 Marine Insurance



Contact : Rob Barnes - Race Car Specialist
 Tel : UK 01795 581366
 E : Rob@kleerfreight.com

www.kleerfreight.com



TOOLS FRANCHISE

Mac Tools
GREAT TO WORK WITH

Business for sale:

Mac Tools is part of StanleyBlack & Decker, an \$11+ billion global organisation and owner of the world famous Stanley Black & Decker and DeWalt brands. If you have the desire and passion to work for yourself, available cash of £15,000 and the ability to build relationships, our franchise businesses give you the power to drive your future with our training and support.



Call us on: 08450 6000 60
 Email: franchise@mactools.co.uk
www.mactools.co.uk

WEB DESIGN

GRID MEDIA

PERFORMANCE BY DESIGN

WEBSITE AND PRINT DESIGN

BLOG / SOCIAL NETWORK MANAGEMENT

MOBILE APPLICATIONS

SPONSORSHIP PROPOSAL KITS

TEAM / DRIVER / EVENT MARKETING

RESULTS MANAGEMENT

SEO & SOCIAL MEDIA MARKETING

TEAM / DRIVER BRANDING

MERCHANDISE DESIGN

LIVERY DESIGN

NEW MEDIA SOLUTIONS EXCLUSIVELY FOR THE MOTORSPORT INDUSTRY

0845 868 3971
 +44 (0)116 298 8204

WWW.GRID-MEDIA.CO.UK
 FACEBOOK.COM/GRIDMEDIA



AUTOSPORT

MOTORSPORT JOBS

PUBLICATION DATE EVERY THURSDAY

CALL 020 8267 5820

FOR ALL AVAILABLE VACANCIES PLEASE GO TO THE JOBS SECTION OF AUTOSPORT.COM

BOOKING DEADLINE MIDDAY MONDAY PRIOR TO PUBLICATION
COPY DEADLINE MONDAY 5PM PRIOR TO PUBLICATION
ALL ADVERTS PLACED FEATURE IN THE APPOINTMENTS SECTION OF AUTOSPORT.COM FOR ONE WEEK

RACHEL.BROCK@HAYMARKET.COM

autosport.ads@haymarket.com

To advertise call 020 8267 5820



Are entering the recently announced MSV F4 Championship and are employing dedicated motorsport professionals, both full time & contract, for the following positions:

- **Chief mechanic**
- **No1 mechanic**
- **No2 mechanic**
- **Truckie**

Please send up to date CV to:
Ken Page

E mail: ken@walkinshawracing.co.uk



Experienced Transmission Builder Required

We have a vacancy for an Experienced Transmission builder to join our Team in Hampshire. The main responsibilities will be to build new, rebuild and service transmissions to the highest standards covering a broad range of race cars from historic F1 to current Le Mans spec.

BPA Engineering are main Hewland Agents who supply and service transmissions to a broad customer base including all types of race and exotic road cars.

Please apply to admin@bpaengineering.com attaching CV and covering letter.



flybrid

Flybrid Automotive are the leading developer of mechanical high-speed flywheel based Kinetic Energy Recovery Systems (KERS). Originally developed for Formula One this technology is now being applied to a range of racing, road car and commercial vehicle applications.

New projects in all fields of application are driving growth of the business and we are currently seeking applicants for the following post:

- **Design Engineer**

Further details can be found on our website

www.flybrid.co.uk

Applications by email to careers@flybrid.co.uk or by post to Richard Tebbutt, Flybrid Automotive Ltd., Silverstone Technology Park, Silverstone Circuit, Northants NN12 8GX.

Closing date Friday 7th December 2012
No agencies please



GRAPHICS DEVELOPER (Biggin Hill)

Formula One Management Ltd operates within the dynamic and exciting world of motor racing and is responsible for the design and operation of many of the key technical systems used for the televising and administration of worldwide motor racing events.

The Television Production Department is looking to recruit a Graphics Developer to join a small, friendly team responsible for Formula One Management Ltd's television graphics production.

Working as part of the team you will be exposed to all aspects of the development life cycle, and will maintain and operate our systems for live production. This will involve the building and testing of new on-air graphics solutions, as well as working with our software developers on the integration of new data types and data access methods. You will also assist in the operation of the on-air graphic systems during live broadcasts.

Essential:

- A degree (or HND equivalent) in computing or a related subject, with a focus on graphics and multimedia
- Thoroughly confident with windows operating systems
- Knowledge of VB Scripting or similar programming languages
- An understanding of graphical and 3D design packages and practices
- Excellent communication and time management skills
- Meticulous attention to detail

Desirable

- Experience of working within a live broadcast environment
- Knowledge of Vizrt's suite of broadcast graphics systems or similar
- Knowledge of real-time broadcast graphics design principles
- An understanding of representing data using graphics
- Experience with SQL Server and XML
- Knowledge of networking and data transfer methods such as TCP/IP and UDP communication protocols

Please be aware that this role involves extensive worldwide travel.

Although we are currently advertising for a Graphics Developer with a focus on systems and technical development, we would welcome applicants with less experience who feel that they could add value and develop quickly within a supportive and knowledge-sharing environment.

A genuine interest and sound knowledge of Formula One and other motor sports is advantageous.

If you would like to apply for this role please send your CV and a covering letter (with your current salary) to the Human Resources Section, Formula One Management Ltd, Sapphire House, Churchill Way, Biggin Hill, Kent, TN16 3BN or email to recruitment@fomltd.com. Formula One Management Ltd is an Equal Opportunities Employer

Closing date: 7th December 2012

And here are the views of some of our satisfied clients:

'Autosport provides a consistently high quality recruitment service that enables GEMS to reach industry professionals for a variety of roles.'

Richard Hull, GEMS Performance Electronics Sales & Marketing

"We received an unexpectedly large amount of responses in only a few days. We would definitely consider Autosport for any future recruitment needs."

Jose Santos, Race Engineer Matech Concepts

"At Flybrid Systems we have used Autosport as a single source to advertise a range of jobs from design and development engineering roles to assembly technicians and administrators. We have always had a strong response and on the last occasion we received over 200 applications for 6 posts."

Jon Hilton FIMechE CEng, Managing Partner, Flybrid Systems LLP

"The decision to advertise for staff in Autosport was easy as the magazine is one of the most widely read motorsport publications in the world. The resulting response also met our expectations providing us with a large number of high quality candidates. What exceeded our expectations was the friendly and helpful nature of the Autosport staff who helped us with the timing and preparation of our advertisement. I would recommend the use of Autosport to any organization looking to recruit staff in our business."

Steve Hallam, Director of Competition, Michael Waltrip Racing

"Team WFR recognise Autosport magazine as one of the mainstream publications within the motorsport industry and therefore was an obvious choice when wishing to recruit new staff. We were thoroughly impressed with the extensive response to our advertisement and the quality of candidates that was received, just going to show that Autosport is read by high level motorsport professionals"

Jody Firth, Team WFR



Mercedes-Benz has been setting the standard in racing for over 100 years. The MERCEDES AMG PETRONAS Formula One™ Team continues the proud history of the legendary Silver Arrows with the clear ambition of winning the FIA Formula One™ world championships. Based in Brackley, UK, we are recruiting highly motivated, talented new members of our team.

AERODYNAMICIST

REF: SW423/0811

We have an exciting opportunity for an Aerodynamicist in one of our aero development teams. Reporting to the team leader, the primary focus of the role will be to add aerodynamic performance to the car. The successful candidate will be responsible for aerodynamic development projects, from initial concept, through CFD analysis, to design and wind tunnel testing.

Other responsibilities will include:

- Planning and running of development projects in the wind tunnel
- Integrating the available CFD resources into the design cycle
- Ensuring that wind tunnel results are reported clearly and accurately
- Ensuring that planned release deadlines to the design office are met
- Liaising with component designers to get concepts turned into model components as required

Relevant Experience and Qualifications:

- Educated to Degree level, preferably Postgraduate (in Aerospace or Aeronautical Engineering)
- Some Motorsport Aerodynamics experience would be an advantage but not essential

WIND TUNNEL MODEL DESIGNER

REF: JR3751709

We have a vacancy for a Wind Tunnel Model Designer reporting to the Head of Model Design within the Aerodynamics department.

Your main responsibilities will include:

- Surfacing of aerodynamic concepts, for wind-tunnel, CFD and full-size release
- Design of high-quality model components
- Creating drawings of components
- Producing assembly drawings
- Communicating with manufacturing, aerodynamicists and other designers to constantly improve our designs standards, methods and procedures

Candidates should have proven competences in surfacing and in detail design, preferably within an F1 aerodynamics environment or equivalent. Good knowledge of CATIA V5, 3D solid modelling and advanced surfacing design is required.

Other Qualities for both roles:

- Flexibility in hours and approach required
- Ability to communicate effectively at all levels
- Methodical with good organisation skills
- Ability to work under minimal supervision, to strict deadlines
- "Can do" and "team player" attitude

In return for your work and commitment, we offer a competitive package including bonus, life assurance, private medical cover, Mercedes company car lease scheme, 25 days holiday, on-site gym, subsidised restaurant facilities together with the chance to work in a truly unique environment.

If you wish to apply for this position, please forward your CV and letter of application with current remuneration details, quoting the reference number and where you saw the advertisement to recruitment@mercedes-amg-f1.com

Closing date for applications: **Friday 30th November 2012.**

Congratulations to Callum Grant



on winning the
HSCC Grandstand Motorsports Historic Formula Ford Championship
to become the club's youngest ever champion in his first full season.

A Special Thanks to Janet, Nigel, Pete and Neil Bolds who provided such great reliable engines.
This message was placed by your many adoring female fans.

Photograph by David Ellis. All copyright reserved.

AUGUST 22, 1952

The Autocar

NEWS OF THE WORLD

GOODWOOD 9 HOUR INTERNATIONAL CAR RACE

MINTEX

in Motorsport

- Over 75 years of success!!!

Mintex has been a major friction brand for over 100 years
and associated with motorsport since the 1920s.



Mintex friction linings were fitted to winning Bentleys at the Brooklands oval in the 1930s, and later, in the 1950s and 60s both Aston Martin and Jaguar won GT endurance events with Mintex friction – including multiple wins at the famous 24 hour races at Le Mans. In the world of rallying, some of the most famous drivers have driven with Mintex and in the 1980s and 90s Mintex held its very own event – the Mintex National Rally Series.

Motorsport is an extremely demanding environment for friction materials and only a handful of friction material manufacturers across the world today can meet the requirements at the highest levels of racing.

With Mintex Racing materials, TMD Friction is one of those few companies who manufacture a specific range of friction products to perform under the strenuous racing conditions, such as in Champ car, NASCAR, Formula 3, GT racing, Historic and many more.

WHEN HIGH PERFORMANCE COUNTS YOU CAN RELY ON **MINTEX** ALL THESE CARS USED MINTEX BRAKE LINERS.

MINTEX BRAKE AND CLUTCH LINERS are manufactured by British Belting & Asbestos Ltd., Cleckheaton, Yorkshire, and are obtainable from all Mintex Service Depots and Stockists.

Sports Extra

NATIONAL RACING • HISTORICS • CLUB • RALLY • RALLYCROSS • HILLCLIMB

AF Corse to British GT

Top Ferrari squad to run two 458s in the UK in 2013

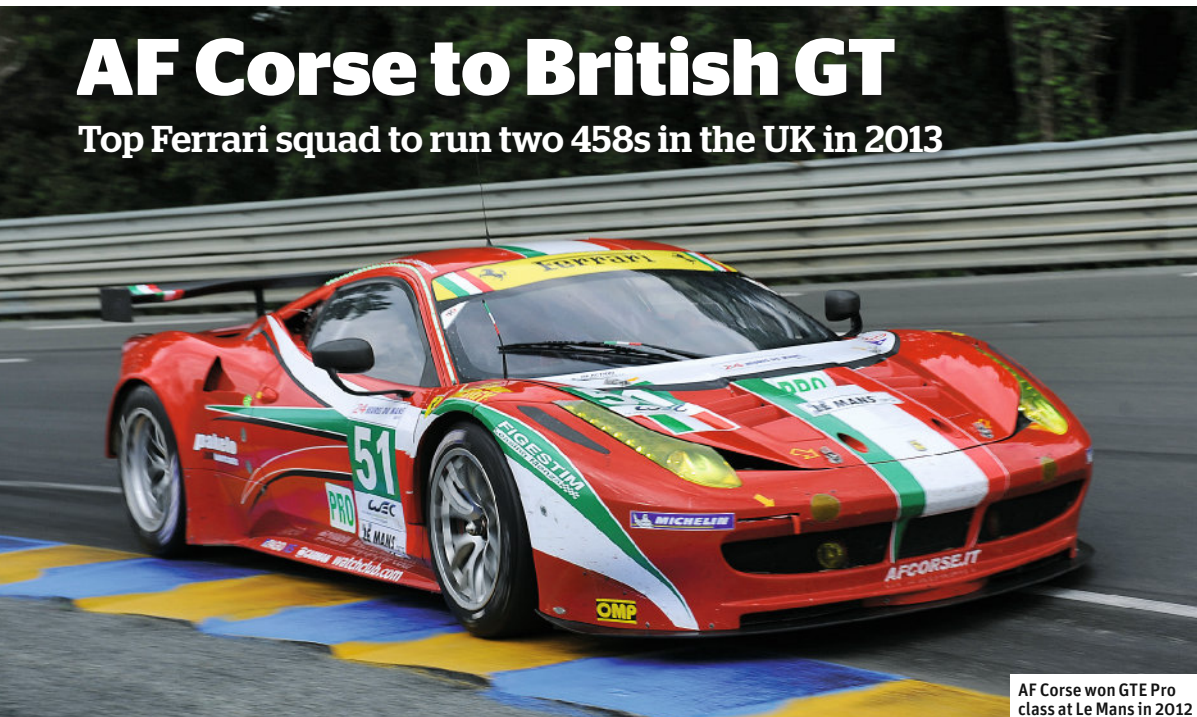

AF Corse won GTE Pro class at Le Mans in 2012

» **THE WORLD'S LEADING** Ferrari sportscar team, AF Corse, will join the British GT Championship next season with a pair of the Italian manufacturer's 458 Italia GT3s.

The Italian squad, which won the GTE Pro class teams' title in this year's FIA World Endurance Championship, has already firmed up one car for established series competitors Aaron Scott and John Dhillon. It is now negotiating to fill the seats in its second entry.

Team boss Amato Ferrari, who briefly raced in the UK in the British Touring Car Championship and British Formula 3000 in the early 1990s, said: "British GT is an interesting championship and has grown a lot; it is a good

championship for our team to join. "Our project is to send two cars and we already have good contacts for the second car."

Scott, who scored two top-six results sharing a Scuderia Vittoria Ferrari with Dhillon this season, said: "I raced in the Blancpain Endurance Series in 2012 [driving an Audi R8 LMS] against AF Corse, so I know all about the team. I heard there was a possibility of them coming to the UK. It all fitted together perfectly and we were able to have some easy conversations."

The deal for Scott and Dhillon to drive in Britain with AF was sealed after a successful two-day test with the team at Vallelunga last week.

Amateur driver Dhillon hopes that working with AF will allow him to

move to the next level as a driver.

"Due to the success they've had in other series, the team have a winning mentality, but don't apply a level of expectation," he said. "This will be a good environment for me to learn in and grow, and to have the deal in place before Christmas means we can prepare properly for next season."

AF's British campaign is only the second programme it has firmed up for 2013 after confirming it will return to the WEC with two GTE Pro class 458s, raced by a roster of factory drivers, one GTE Am Ferrari, and an LMP2 ORECA-Nissan entered under the Pecom banner.

TWEAKS FOR 2012

British GT will revise its rules for next season so that all types of driver pairing are balanced with weight.

This year a four-second time penalty was applied for each hour of a race to all-silver driver pairings, while all other combinations were equalised using ballast.

This led to criticism of the rules from SV boss Piers Masarati, who felt they unfairly penalised all-silver pairs (see AUTOSPORT, March 1).

Series boss Benjamin Franassovici said: "The spirit and success of British GT is Pro Am and I don't want this to be disrupted."

Franassovici also plans to expand the live TV format used for the 2012 finale at Donington Park to cover "at least two" events in 2013.



Dhillon (l) and Scott (centre) tested 458 at Vallelunga

PICS: LAT, AF CORSE

AUTOSPORT SAYS...

BEN ANDERSON
NATIONAL
EDITOR

ben.anderson
@haymarket.com



AFTER WHAT HAS ARGUABLY been the best season of British GT ever there is yet more good news on the horizon.

The arrival of famed Italian outfit AF Corse for 2013 means we will effectively have a factory Ferrari presence on the grid next year.

Lining up alongside a team that won the GTE class at Le Mans this year (with Giancarlo Fisichella, Gianmaria Bruni and Toni Vilander driving), won this year's World Endurance GTE teams' title, and lifted four FIA GT2 teams' titles, will raise the stakes considerably for the regular British GT squads.

That such a high-profile outfit wants to come and race in Britain is a testament to the strength of British GT3 at the moment. It's also exciting for drivers Aaron Scott and John Dhillon, who will no doubt be looking to Amato Ferrari's team to transform them into serious contenders after a difficult year, in which the best they could manage was two sixth-placed finishes having upgraded from an outdated Ferrari 430 to the latest 458 Italia.

Scott described the first part of 2012 as the toughest season of his career, as he battled to get on the pace in Scuderia Vittoria's 458 (which, don't forget, almost won the title with Michael Lyons and Charlie Bateman in 2011). An engineering re-shuffle had a transformative effect though, and performances improved markedly from June's Brands Hatch round onwards.

Scott says his amateur co-driver John Dhillon is getting better all the time, and will quietly hope they can become regular frontrunners in 2013.

Extra contact details

Kevin Turner, features editor
kevin.turner@haymarket.com

CONTENTS

p80 SEASON REVIEW
SINGLE-SEATERS

p82 RACE FOCUS
WALTER HAYES



Radical Sportscars

Radical to replace UK Cup

British marque gives SR3s chance to win as SR8s are banished from top UK series

SR3 drivers will get to fight for overall wins throughout 2013

THE RADICAL UK CUP will be replaced by a bespoke series for SR3 cars next season.

The SR3 Challenge, as the category will be known, will retain the UK Cup format of 40-minute endurance races, but exclude Radical's top SR8 model.

The championship will run at seven MSVR race meetings in 2013, and cars will be limited to one set of tyres per weekend to reduce costs.

The move follows a successful pilot race at Donington Park in October,

in which Radical attracted one of its best entries of the season by running separate grids for SR8 and SR3 cars in a combined event for the Radical European Masters and UK Cup.

Marque boss Phil Abbott expects the prospect of bespoke races for SR3s, rather than them being a class within a quicker SR8 field, will encourage more SR3s to take part.

"The consensus is that SR8 drivers like racing other SR8s and SR3 drivers like racing SR3s wherever possible,"

said Abbott. "We were lucky enough to have 16-18 SR3s at Donington, but we've made 800 of them, so there should be at least 30 on the grid.

"In the past, when we've had 22-24 cars, it's been about eight SR3s mixed in with the SR8s. At Donington, we had 16 or more of each. The SR3 field doubled, so from then on it's been a no-brainer."

SR8s will continue to race alongside SR3s in Radical European Masters events, while the format for the

entry-level Clubman's Cup will be unchanged until 2014, when updated cars from the new-for-2013 SR1 Cup for novice drivers will be allowed onto the grid.

RADICAL'S 2013 LADDER

SERIES	ELIGIBLE CARS
European Masters	SR8, SR3
SR3 Challenge	SR3
Clubman's Cup	SR3, PR6
SR1 Cup	SR1

Ginetta Junior

Woodhead joins HHC for title bid

GINETTA JUNIOR WINTER champion Harry Woodhead will return to the category next season for a main series title assault with leading squad HHC Motorsport.

Staffordshire racer Woodhead, 14, scored five podiums and finished sixth in the points in his rookie season this year, despite racing as a privateer for the second half of the campaign.

Woodhead went on to claim the winter title with the HHC squad that ran Charlie Robertson to the 2012 main series crown. He will remain with the team for the full 2013 season.

Woodhead will return after fine rookie season



"Due to my dad's business commitments, I decided that I needed to run with a team," said Woodhead. "I believe HHC Motorsport is the team that can give me a competitive car, and the rest will be up to me!"

Team boss Charlie Kemp added: "Taking the Winter Series title shows how well the team and Harry have gelled in only a short time."

Ginetta GT Supercup

Massot targets GT Supercup attack

GINETTA JUNIOR FRONTRUNNER Pepe Massot is eyeing a step up to the GT Supercup after testing a G55.

Massot took two wins on his way to fourth in his rookie Ginetta Junior season in 2012, driving for Hillspeed.

Massot tested a Century Motorsport G55 at Silverstone last week and team boss Nathan Freke is keen to sign him for 2013.

"It was a test to see how he got on, with a view to running him next year," said ex-G50 champion Freke.

"I'd love to run him next season - he's a nice kid and was super-quick in the test," he continued.

Century hopes to continue in the GT Supercup and British GT4 next season, and Freke has not ruled out expanding into the European SPEED sports-prototype series.

Massot had test for Century at Silverstone



MIS Motorsport - setting the standards in motorsport insurance

ON TRACK / ON EVENT / MOTOR TRADE /
PERSONAL ACCIDENT / COMMERCIAL / LIABILITY

www.mismotorsport.com or call 01943 884 555

M.I.S. Motorsport Ltd is authorised and regulated by the Financial Services Authority.

MIS
MOTORSPORT

GT Cup

GT Cup hopes for grid boost after MSA agrees to licence changes

GT CUP ORGANISERS BELIEVE tweaks to the series will help boost grid numbers next year.

Marc Haynes launched the initiative in 2007, and the GT Cup proved popular. Grids have been low this season, however, with this year's Knockhill round even having to be cancelled (see AUTOSPORT, August 30).

Organisers believe one of the main problems was a change to the driver eligibility rules. The Motor Sports Association had insisted GT Cup competitors hold a National A licence

this year, but a successful appeal means that National B will now be sufficient.

"We are very grateful to the MSA as we had to turn away a large number of drivers simply because of licence grade issues," said Haynes.

Two- and three-race events will feature at the seven 2013 meetings. Over two days, there will be three races: two 25-minute sprints and one of 40 minutes with a compulsory pitstop. One- and two-driver entries will be eligible for the latter. At single-day events, both races will be sprints.

"We have put a great deal of time and thought into our plans and consulted competitors and teams," said Haynes. "These exciting developments will take GT Cup forward in a positive way."

The first round will take place at Donington Park on April 27-28, followed by visits to Brands Hatch (twice), Oulton Park, Silverstone and Snetterton before the finale on Donington's GP circuit.



GT Cup expects grid to grow in 2013

MARCUS PYE

HUMBLE PYE

The voice of club motor racing



McMorran (left) with founder John Crossle and Arnie Black

The recent announcement that Paul McMorran has become the third owner in the 55-year history of the Crossle Car Company is wonderful news for the United Kingdom's oldest surviving manufacturer of racing cars. Born in Belfast in 1958 - the year after John Crossle founded the company in Hollywood, on the city's north-eastern fringes - McMorran is the natural successor to Arnie Black, who took the reins in 1997.

That McMorran has drawn a line under a 32-year career as engineer-turned-executive in the oil industry and relocated from Moscow to his native Northern Ireland says everything about his passion for the Crossle product. "For me, it was a fantastic opportunity, too good to miss," he says. "There will be challenges ahead, but I believe the future is bright."

An accomplished racer, NI Pre-'82 FF1600 champion McMorran's first competition car was a Formula Ford Van Diemen, the ex-'Quique' Mansilla RF81, which he did not get on with. "I bought my first Crossle [one of the classic 25Fs] 10 years ago, and found it so much easier to drive. I'm still using it more than any other car and, unintentionally at first, have been acquiring models ever since."

His stable now includes the 12F in which Roger Barr claimed the

1968 SCCA Formula B National championship (the marque's first overseas title), the unique one-litre F3 17F that made its debut driven by John Watson, the ex-Brian Nelson FAtlantic 22F, an FF1600 32F (of which a record 140 were made, one raced with huge success by Nigel Mansell) and the final 70F FF1600.

Crossle's reputation for strong, beautifully built cars will be fiercely guarded as McMorran concentrates on the core spares and service business, including rebuilds and restoration from the original factory. "The priceless thing is that John is still with us [his daughter Caroline is a valued director of the company], and I need Arnie [Black] to stay around for the foreseeable future. Their experience and knowledge is incredible."

Beyond the Ford Zetec-powered 9S - more than 30 'retro racer' derivatives of the splendid '60s sports car have been built to date - will Crossle seek to originate new racing cars, perhaps for different markets? "We should never say never," replies McMorran. "I will be focusing on different things and looking at ways to expand, but it would have to make commercial sense. With the sad demise of Lola, we are the last of the Mohicans."

A proud accolade in itself.

“With the recent sad demise of Lola, we at Crossle are the last of the Mohicans”



Toyota Racing Series

Lynn heads back to New Zealand

MACAU GRAND PRIX POLESITTER Alex Lynn is to contest the Toyota Racing Series in New Zealand for the second time.

Lynn, who competed down under in 2011 before his Formula Renault UK title-winning season, is making the trip with his 2012 Fortec Motorsport Formula 3 team-mates Felix Serralles and Pipo Derani.

"The Toyota series served me quite well first time around," said Lynn. "It played a major role in maturing the way I approach racing as a whole. It's easy to become complacent, and racing is all about the hard work you put in."

The 19-year-old, who will contest the 2013 FIA European



Lynn was a TRS race winner in the 2011 season

F3 Championship with the Prema Powerteam, added: "I want to come back for F3 in the right frame of mind, and this will help with that."

Formula Pilota China runner-up Dan Wells, who raced against Lynn in FRenault in 2011, also told AUTOSPORT that he is working on a deal for the series.

VW Racing Cup

Saxmax racer heads to VW Cup

BRITISH TOURING CAR RACER

Tony Gilham's Volkswagen Racing Cup team will run former karter Sam Morgan in the series next season.

Gilham is aiming to help young drivers towards the BTCC (see AUTOSPORT, May 24), and Morgan will race one of the squad's MkV Golf GTIs in the VW Cup.

Morgan, who was third in the 750 Motor Club's Saxmax championship this year, is not 16 until May, so will miss the start of the season. He then plans

to contest the rest of the campaign.

Gilham said: "Sam's very quick in karts and has a decent following, too, so we're happy to sign him."



Morgan graduated to cars in Saxmax

M1112P

AUTOSPORT

**TAKE OUT A SUBSCRIPTION
TO AUTOSPORT AND TRY
YOUR FIRST 6 ISSUES
FOR JUST £1**



ISSUES FOR £1

Subscribe online at:

www.themagazineshop.com

www.themagazineshop.com/ASPO/M1112P

Or call our hotline and quote offer code M1112P:

08448 488 817. Offer closes December 6, 2012.

GREAT REASONS TO SUBSCRIBE:

- **6 ISSUES FOR £1**
- saving 95% on the cover price
- **SAVE 20%** after your trial ends
- **SPREAD THE COST**
- with easy 4-issue payments
- **FREE P&P**
- every issue delivered to your door

Yes

please start my subscription to AUTOSPORT receiving 6 issues for just £1 followed by payments of £10.90 every 4 issues by Direct Debit, saving 20% on the cover price. I understand I can cancel at any time.

YOUR DETAILS - must be completed
(BLOCK CAPITALS PLEASE)

Title: Name:

Surname:

Address:

Postcode:

Telephone:

Mobile:

Email:

DIRECT DEBIT PAYMENT (UK ONLY)

To the manager, bank name:

Address:

Postcode:

Name of account holder(s):

Bank sort code - -

Bank/building society account number

Please pay Haymarket Media Group direct debits from the account detailed on this instruction subject to the standards assured by the direct debit guarantee. I understand that this instruction may remain with Haymarket Media Group and, if so, details will be passed electronically to my bank/building society.

Signature(s):

Date:

Please return this form to:
AUTOSPORT
FREEPOST RSBY-ZLLA-SZZS
PO Box 326
Sittingbourne ME9 8FA

Terms and conditions: This offer is open to UK residents only - trial offers are limited to 2 trials per title within a 12-month period and we reserve the right to refuse any orders over this limit. Overseas rates are available on +44 (0) 1795 592 974 and residents of USA and Canada should call +1 866 918 1446 or visit www.imsnews.com for rates. Offer ends December 6, 2012. Price is £1 for your first 6 issues then continuous Direct Debit payments of £10.90 every 4 issues, unless you cancel. Savings are based on the UK cover price of £3.40. Direct Debit rates are fixed for 12 months, after which they may be subject to change - should prices change you will be informed in writing. Details of the Direct Debit Guarantee are available on request. Haymarket Media Group Ltd uses a best-practice layered Privacy Policy to provide you with details about how we would like to use your personal information. To read the full privacy policy please visit our website www.haymarket.com/privacy or call us on 08448 482 800. Please ask if you have any questions as submitting your personal information indicates your consent for the time being, that we and our partners may contact you about products and services that will be of interest to you via post, phone, e-mail and SMS. You can opt out at ANY time by emailing the datacontroller@haymarket.com or by calling 08448 482 800.



HSCC wants annual F2 return to Thruxton

Historics

HSCC in Thruxton comeback

Historic club to race at high-speed Hampshire track for first time since '08

THE HISTORIC SPORTS CAR CLUB will return to Thruxton next season and hopes to run annual meetings there.

The club last appeared at the Hampshire venue in 2008 as part of the circuit's 40th anniversary celebrations. Now, Thruxton will host the second event of the HSCC's 2013 season on the March 30-31 Easter Bank Holiday.

The content of the meeting has yet to be determined but is likely to include the club's regular championships.

Circuit manager and historic racer Bill Coombs and HSCC chief executive officer Grahame White are also hoping to run a European Historic Formula 2 round at the meeting.

"Bill is a keen historic racer and a Thruxton meeting is something we've been talking about for a while," said White. "There aren't many opportunities to run there and the obvious thing to do was revive the traditional Easter meet. "We would like to headline it with F2.

It's an exciting prospect and we want to establish it as a regular event."

The HSCC's season will kick off at Donington on March 17. After Thruxton, the club will move to Cadwell Park, Silverstone GP, Snetterton, Brands Hatch GP, Croft, Oulton Park, Brands Indy and Silverstone National.

The club will also be involved in the Donington Historic Festival, Tour Britannia, the Silverstone Classic and the Walter Hayes Trophy.

IN BRIEF



Parry was on track at Donington last week

NEW INTERSTEPS CHAMPION

Matt Parry tested Formula Renault 2.0 machinery with Fortec Motorsport at Donington Park last Thursday. The Welshman plans to race for the squad in Europe next season.

FORMULA RENAULT BARC RACER

Raoul Owens will graduate into the 2.0 North European Cup next season. The 18-year-old, who finished 19th in FR BARC this season, will drive for Dutch squad MP Manor Motorsport.

PORSCHE GT3 CUP CHALLENGE

racer Pete Smallwood will step up into the Carrera Cup GB in 2013. He will drive in the Pro-Am2 class for Parr Motorsport.

ORGANISERS OF THE SWEDISH

Touring Car Championship will promote a new Swedish Formula Renault series for 2013. The series will use the new 1.6 Tatuus Formula Renault that is also set for the new NEC Junior championship.

SWEDISH TEENAGER ROBIN

Hansson has earned a scholarship into the 2013 Formula BMW Talent Cup after winning a shoot-out at the Lausitzring last week. Dutchman Jules Szymowiak won the first competition at Spielberg in October. The third and final shoot-out will take place at Valencia on November 25.

FORMER WORLD RALLY DRIVER

Gregoire de Mevius and current British historic champion Julian Reynolds are among an 81-car entry for this weekend's Roger Albert Clark Rally, which aims to recreate the RAC Rallies of the 1970s and 1980s. The event gets underway in Pickering on Friday afternoon and ends in Carlisle on Sunday.

BRITISH GT RACERS PIERS AND

Ron Johnson (no relation) tested the Barwell Motorsport-run Ecurie Ecosse BMW Z4 GT3 car at Silverstone last week, as they evaluate options for 2013. The pair have put the Speedworks Chevrolet Corvette Z06.R they've raced in GT3 for the past two seasons up for sale.



Johnsons sampled BMW Z4 at Silverstone

Tour Iberia

New tour event for historic cars



Iberian event will echo Tour Britannia

A NEW HISTORIC TOURING event will launch in Spain and Portugal next year.

The Targa Iberia will be run in the same spirit as France's Tour Auto and Britain's Tour Britannia, offering multi-discipline competition for cars built from 1919 to 1986.

The event is the brainchild of Spanish entrepreneur Jesus Pozo - mastermind of Barcelona's Espiritu de Montjuic historic race weekend - and is set to replace the defunct Tour Espana last run in 2008.

The route, still to be ratified, is planned to include races on four permanent circuits and sections

over the southern Iberian Peninsula's most spectacular roads.

Outright competition and regularity contests are open to Touring, Competition Touring, GT, Competition GT, GTP and Sports Prototypes, divided by age groups.

Pozo said: "There is a real growth in interest and demand for historic motorsport in Spain and Portugal.

"This event will be something new and different, not just for the area but also for competitors."

The event is likely to run in late October into November. Register interest with Pozo via jp@espiritudemontjuic.com

Historics

Le Mans support slot for Legends

SPORTSCARS OF THE 1949-1965 era will provide the historic support race for next year's Le Mans 24 Hours.

GTs and sports-prototypes of the 1950s and '60s have alternated with Group C/GTP at the French classic recently and organiser Motor Racing Legends has confirmed a return in 2013.

Next year's race will be a two-driver event on Saturday June 22nd, prior to the start of the main event.

Frontrunning cars are likely to include AC Cobras, Lister Jaguars, Ferraris and Aston Martins, while the 61-car field should be filled by smaller-engined entries such as Alfa Romeo TZ1s, Porsche 904/6s, Triumphs, Lotus, MGs and Austin-Healeys.

The last two Le Mans races for the class - in 2009 and 2011 - were won by Carlos Monteverde's Ferrari 250LM.



Historic sportscars will race at La Sarthe

Champ Malvern makes a point

Formula Ford ace claimed his maiden
slicks-and-wings title.

By MARC ORME



Malvern adapted well to downforce

Bucking the trend of rival series, Formula Renault BARC was a massive success in 2012 with its cost-effective basis providing near-capacity grids that delivered both quality and quantity.

This year's campaign marked a breakthrough for the category as it confirmed its position as an increasingly important rung on the junior single-seater ladder. Formula Renault BARC's global reach was also heightened, with no less than 11 nationalities represented.

Days before the Snetterton opener, any pre-season expectations went out of the window when 2011 runner-up Josh Webster announced a surprise 11th-hour return at the same time as reigning British Formula Ford champion Scott Malvern, the eventual FR BARC title winner, confirmed his unexpected 'slicks-and-wings' debut in the series.

Despite no real testing before the opening round at Snetterton, Webster – who made his return to the series after the demise of Formula Renault UK – used his past experience of the Tatuus FR2000 chassis, coupled with some misfortune for Malvern, to win the first race and build an early lead.

Fortec's single-seater newcomer Seb Morris, the 2011 Ginetta Junior champ, starred on his debut with a maiden win

in race two at Snett, having locked-out pole for all three races with an eye-opening performance in the damp.

Malvern, meanwhile, proved his class from the off and despite some early gearbox gremlins, which cost the Cliff Dempsey Racing driver a fairytale debut win in the opening race, he went on to take his deserved first victory in race three, in addition to a new lap record.

With Webster enjoying such a strong start, the signs were ominous for the rest, but a nightmare at Rockingham followed, which irreparably damaged his hopes. Webster was caught up in a qualifying accident for rookie racer Ovie Iroko, which wrecked his car. MGR worked miracles to get Webster out for the races, but he was only able to accrue minimal points.

Morris enjoyed an outstanding event, taking his fourth and fifth poles in succession and converting both into wins to leap to the top of the standings. Malvern was second in each race – again bagging a new lap record.

Malvern and Webster were evenly matched at Thruxton, taking a win apiece, and this time the bad luck fell the way of Morris, who encountered engine problems in qualifying and got caught up in an accident in race two.

Heading to Croft with the series lead for the first time, Malvern – now racing with his old Formula Ford squad Jamun (under the Cullen Motorsport banner) after parting ways with CDR – scored consistently well, but Webster added two more wins, before making it four in as many races during the next round

at Donington. Malvern hit back in race two, with MGR's David Wagner securing his long-awaited maiden success in race three after a great drive.

Going into the season finale on the BTCC's TOCA package, Malvern led by 14 points on dropped scores from Webster, who had performed superbly to get himself back into contention. Clawing back three points on Malvern in the first Silverstone race with second place, Webster's hopes finally expired when he was forced to avoid a two-car tangle in the last race.

The path was therefore clear for Malvern to add his second major single-seater title in as many years, doing so with second place and yet another lap record.

THREE WHO STOOD OUT



1. SCOTT MALVERN

Underlined his class with a fantastic campaign and adapted to the aerodynamics of Formula Renault superbly. Malvern has the pedigree to achieve much more – he just needs the backing.



2. JOSH WEBSTER

Again had to play bridesmaid through no fault of his own. Without Rockingham qualifying shunt the title could have been his. Had consolation of McLaren AUTOSPORT BRDC Award final.



3. SEB MORRIS

Sensational rookie season for Morris, who matched Webster's tally of five wins and dominated qualifying with seven poles. Took deserved Winter Series title too.

FORMULA RENAULT BARC FINAL STANDINGS

Driver (team)	Pts	Wins
1 Scott Malvern (CDR/Jamun)	368	3
2 Josh Webster (MGR)	335	5
3 Seb Morris (Fortec)	274	5
4 David Wagner (MGR)	243	1
5 Kieran Vernon (Hillspeed)	236	0
6 Macaulay Walsh (Scorpio)	214	0

Tough times, but they are a changing

Finn Antti Buri claimed Formula Ford's first EcoBoost crown. *By BEN ANDERSON*

By any measure, this won't go down as a classic season for British Formula Ford. Organisers took a big risk introducing a new car for 2012 and that gamble has yet to pay off.

Entries were already tailing off before series bosses introduced all-new machinery for this season. Turbocharged EcoBoost engines, allied to paddleshift gearboxes, were not everyone's idea of what Formula Ford should be, but it was hoped grids would grow as the season wore on.

The new era kicked off with eight new cars at Oulton Park's Easter opener, but finished with just seven on the grid at September's Donington Park finale.

Of the drivers that took the plunge, 2010 Finnish champion Antti Buri (in his sixth season of Formula Ford) took the title for JTR – thus ending Jamun Racing's unbroken run of seven consecutive drivers' titles. JTR felt it

stole a march on its arch-rival in the early part of the year, and Buri used this to win eight of the first 12 races. Jamun regained ground in the second half of the season though, winning all but one of the final 11 races as it got on top of some early reliability issues.

Impressive Argentinian rookie Eric Lichtenstein was their standout driver – winning nine of those final 11 races, and 11 in all across the year (more than any other driver). Five non-scores across the first 10 races, three of which were down to mechanical issues, scuppered his title hopes.

Jamun's Jake Cook, who on his day could fight Buri and Lichtenstein, bookended his season with wins and pipped Lichtenstein to second in the points when Eric clashed with Luke Williams in the final race of the season.

Ford revamped its scholarship class to allow previous generation Duratec



Buri (leading) was a force early on

cars to bolster the grids, but the standard among them wasn't high.

Champion Matt Rao's class pole time for the Oulton Park opener was 4.2s adrift of Scott Malvern's 2011 effort. There was progress though: runner-up Fabian Welter's Donington Park pole time (2.3s shy of Malvern's 2011 mark) would have put him 14th on the previous year's all-Duratec grid.

Ford is pinning its hopes on a revised package for 2013, with EcoBoost set to become a slicks-and-wings formula on Alan Gow's coveted TOCA package.

Special measures fail to transform ailing school

Ex-Formula BMW cars weren't enough to stop InterSteps falling off the single-seater ladder. *By BEN ANDERSON*

When BMW decided to end its range of junior single-seater series at the end of 2010, it looked as though Young Guns boss Martin Phaff might have pulled a masterstroke.

The end of Formula BMW presented the former Ginetta chief with a chance to revitalise his stuttering new series. Young Guns, which aimed to provide a first step into single-seaters for underfunded drivers aged 15-19, had struggled to take off in its inaugural year. But Phaff felt replacing the little-known bike-engined JKS car with the likes of Vettel, Rosberg, Perez, Hulkenberg, Senna, Ricciardo and Glock, would save the day.

Two years on and the championship is no more. The BMWs were expensive to run and maintain, grids barely

reached 10 cars on a consistent basis, and even the involvement of the Racing Steps Foundation wasn't enough to encourage more racers to give up karting early and join InterSteps.

The two drivers that fought out this year's title battle had already made that

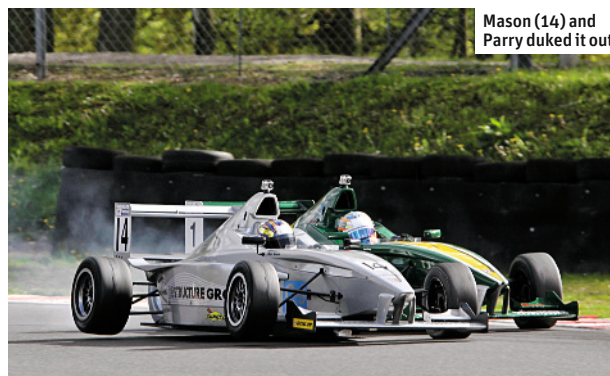

Mason (14) and Parry duked it out

step. In a battle of the Matts, former British Formula Ford racer Parry (Fortec) fought with Formula Renault BARC race winner Mason (MGR) for the crown.

Momentum swung between the two early on, before a run of 10 wins from 11 races (starting in May's Brands Hatch round) put Welshman Parry in control.

Mechanical problems in the penultimate round at Rockingham delayed Parry's coronation, but he duly wrapped up the honours with his 13th win of the year at the Croft finale.

The dominance of these two meant they won 21 of the 23 races between them, and runner-up Mason finished 99 points clear of the promising Jack Aitken (Fortec) – the only other driver to cross the finish line first in 2012.

You could make a case that Parry, 18, and Mason, 20 (but 19 at the start of the year), didn't really fit with the ethos of a category that was principally aimed at drivers not usually old enough to race single-seaters in Britain.

In the summer, the MSA made that distinction a moot point by rescinding the special dispensation that permits under-16s to race in InterSteps for next season. A few months later, the championship's stakeholders decided to bring the curtain down on their short-lived experiment.

DOES IT GET ANY BETTER THAN THIS?

The Walter Hayes Trophy isn't glamorous, and always seems to take place in terrible weather, but it's probably the best Formula Ford event in the world. By BEN ANDERSON

Is there a more competitive event in club motorsport than the Walter Hayes Trophy? Before you answer that, it was a rhetorical question.

For the recent edition of James Beckett's annual Formula Ford extravaganza at Silverstone, there were 116 drivers doing battle in Kent-engined cars on the National Circuit.

Of those 116 drivers,

AUTOSPORT counted 18 current or former car racing champions (six of which didn't make the final!) and a multitude of race winners. Whichever way you look at it, that's one highly competitive field.

Whisper it quietly, but the Walter Hayes has grown to become what the Formula Ford Festival used to be in its heyday. It's the only single-seater event left in the country that

can pull together enough drivers to enjoy proper, festival-style, knockout competition.

The diversity of drivers taking part every year is a major part of what makes the Walter Hayes so great, and every competitor has their own story to tell.

What follows are three different perspectives from the 12th running of one of the jewels in UK motorsport's crown.



The WHT is so good that Gough keeps coming back

THE CATEGORY STALWART

Stuart Gough is what you might call a Walter Hayes veteran. The former Champion of Oulton has competed in every WHT since 2004 (when he finished third after being taken out by Danny Watts while lying second!).

"Apart from the Hayes I've not raced at all this year, but what keeps me coming back is that this event is unique," says the man who is probably most famous for rolling spectacularly out of the 2009 edition after a tangle with Scottish champ Rory Butcher.

"It brings together so many competitive drivers. If you look at the entry there are at least 20 drivers who realistically have a shot at winning. If you come in the top 15 you've done really well; making the top six is exceptional. And in what other event could you put yourself up against 100-plus other drivers?"

Having put his trusty Ray GRS07 up for sale and stopped racing full time to bring up a family, Gough was loaned a Van Diemen RF92

for the 2012 WHT. The car belongs to West-Tec F3 mechanic James Oldfield, whose dad Peter used to rally against Stuart's dad Andy, and whose granddad also rallied against Stuart's!

Having finished second in the Brands Hatch Kent Festival a week earlier, Gough came to Silverstone in good shape. He qualified third for his heat and finished there after battling for the lead with Castle Combe aces Roger Orgee and Josh Fisher, Silverstone instructor Michael Moyers, and former Martin Donnelly Trophy winner Noel Robinson. He went on to finish fifth in his semi-final, but was forced to retire from the final after losing his rear brakes on the first lap. Despite another disappointment (Gough hasn't finished a WHT final since 2007), he's enjoyed himself.

"I'm not racing properly anymore because I've got a 16-month-old daughter," he adds. "But if I can just keep pitching up here every year, I'll be happy enough."



The Hayes is one of the UK's most competitive events



Powell had a great run on her Walter Hayes debut

THE OUTSIDER

The Walter Hayes Trophy always attracts a selection of drivers 'stepping down' from higher formulas. This year's grid featured 2007 British Formula Ford champion Callum MacLeod, World Endurance LMP2 race winner John Martin (who finished second), and GP3 racer Alice Powell.

Powell had never even sat in a Formula Ford before this year's Walter Hayes, so the event was uncharted territory for the 2010 Formula Renault BARC champion.

"My first experience of a Formula Ford was in the Thursday test. I didn't know much about the event, except that it was for Formula Ford, and I didn't expect this many entries," says Powell, who drove a Souley Motorsport Ray GRS09.

"It was quite wet so I took my time to build up to it. I had to get used to an H-pattern gearbox and there was nowhere near as much grip as in a slicks-and-wings car. It was tail-happy, but not too difficult to control."

Powell showed how quickly she adapted to her new environment by qualifying and finishing fifth for her heat (just behind double Combe champion Rob Hall, MacLeod, returning Irish ace Robert Barrable, and Combe specialist Felix Fisher).

"The races were quite short so it was over in the blink of an eye," adds Powell, who went on to finish 12th in her semi-final and the final. "You don't need to worry about losing the front downforce by following someone, or tyre degradation, so the racing is really close. There were loads of Formula Ford experts so it was really competitive – and very enjoyable."



Hadfield and Mitchell (r) give Anderson some tips

AUTOSPORT & TEAM HADFIELD

After competing in the Peter Gethin Memorial Trophy Formula 5000 race at this summer's Silverstone Classic, AUTOSPORT was invited to link up once again with Simon Hadfield's eponymous team at the Walter Hayes.

Our best hope for glory was ex-Historic Formula Ford star Ben Mitchell (son of Westie), who has won races in this year's BRSCC FF1600 series in his ex-Mike Gardner Van Diemen RF99. Things were looking good when Ben grabbed the lead of his heat, but his hopes were dashed by a hit from Irish ace Neville Smyth, which broke Mitchell's left-front suspension.

Mitchell burnt the tyre down to the carcass in limping home 12th and eventually battled through from the Last Chance Race to finish 23rd in the final. "Life goes on," was his philosophical attitude to the disappointment.

Dad Westie elected not to contest Sunday's horrendously wet repechage races after having a corner taken off his Van Diemen

RF89 (borrowed from Hadfield) in the heats.

Hadfield, meanwhile, dropped out after finishing 26th in his semi-final but was a main protagonist in the historic final. His Lotus 69 battled gamely with Mike Gardner's RF80 until Simon spun and collected the unfortunate Stuart Kestenbaum (another of the WHT's many champion drivers) trying to wrest the lead back at Luffield. "It was my fault, probably, I left a wheel in too long," said Hadfield, after missing out on the Bernard Baxter Trophy.

AUTOSPORT was handed Hadfield's white Van Diemen RF91 (once the property of Noel Dunne's brother) for the event and completed an anonymous weekend by splashing to 19th in the second semi-final and thus missing the cut for the final by one place. Still, that's one race further than we managed the last time we competed (in 2008), which represents progress in one of British motor racing's toughest challenges. Roll on next year!

YOUR SAY

What you think of the motorsport news of the past week

Austin's layout aids overtaking



Racing takes a turn for the better

Fabulous race from Austin and, in my opinion, the defining factor was the circuit. With so many of the turns having a very wide entry and exit, there was more than one quick way through them, meaning that blocking was just not possible.

Witness the first turn on lap one, those on the right taking a fast line through the corner, not bothering about the apex, were able to make up places on others who went left and had to slow at the apex, therefore missing out on exit speed. It rather makes you wonder why this hasn't been tried before. A way to further spice things up would be to bank the outer parts of such turns.

Andrew Bradshaw, Guildford, Surrey

AUTOSPORT.COM

TOP FIVE ON OUR WEBSITE

1. VETTEL REACTS LIKE A CHILD: VILLENEUVE
2. HRT PUT UP FOR SALE BY OWNER
3. WEBBER SLAMS NEW PODIUM PROCEDURE
4. VETTEL QUICKEST AGAIN IN SECOND PRACTICE
5. HAMILTON WANTS GRID CLEANED FOR US GP

AUTOSPORT+

TOP STORY ONLINE

HAMILTON: KEEPING THE FAITH

To read this exclusive feature and many others like it, log on to autosport.com/plus and choose which package you'd like. A month will cost £5.50, a year £46. Includes access to Forix – the ultimate stats website.

WIN!



ROAD ANGEL VANTAGE

This week's star letter will receive a Road Angel Vantage – a dedicated safety camera and blackspot locator that displays the legal speed limit of every road you drive, automatically and wirelessly updating its database every few minutes as you drive. For more details on Road Angel visit www.roadangelgroup.com Please ensure that your full address is included on all correspondence.

CORRECTIONS AND CLARIFICATIONS

● We incorrectly referred to JRM as a 'British GT squad' on page 77 last week. JRM is in fact the builder of the Nissan GT-R GT3 car that raced in British GT in 2012. Apologies for the mix-up.

EDITORIAL CONTACT mail@autosport.com

I don't agree with Julius

Thurgood's view that club racing organisers are being put at risk by circuit-hire prices (p73, November 15).

The MG Car Club has just completed a superb season of racing: six meetings in all and covered all costs.

The MGCC welcomed the Sprites from the Austin Healey Championship, and started Ecurie GTS to provide races for historic MGBs and other marques. This resulted in substantial grids.

Julius chose to try to do his own thing without cooperating with other clubs. MG racers

were faced with attending extra meetings. This did not create goodwill among drivers. **Paul Goodman** MGCC coordinator

Sure in F1 you gotta be

ruthless, but Ferrari's trick at Austin was pretty unsporting. The FIA's response should be to send both cars of an 'offending' team which breaks the seals without approval to the back of the grid, plus a whopping fine.

Dai Williams

By email

I'm not Ferrari's biggest fan

but I can't help admiring their

tactical sleight of hand. They played the game brilliantly, helping to ensure the title showdown that everyone, bar employees of an unpalatable energy-drink brand, wanted. **Frances Stewart** London SE12

I totally disagree with

Amanda Longhurst's view on Silverstone grandstand seating (Letters, Nov 15).

My son and I have been going to the GP for 15 years. Once we decided to 'upgrade' to grandstand seats and forego the 5am rush, the best feature has been the roving seat

facility on Friday and Saturday.

It's good to know you have a guaranteed seat for Sunday, but still be able to see the action from other parts of the track on the days before.

David Graves

Warrington

The roving ticket is an

excellent idea and one that makes Silverstone stand out from most other venues. It only causes problems if it rains; then everyone seeks the shelter of the covered stands, leaving the uncovered ones empty.

Richard & Karen Beardmore

By email

THE LATEST GEAR

Desirable new releases for motor racing fans: books, DVDs, models, art and gifts



THE RACE HUT - SLOUGH

From £25 per person
theracehut.com

If karting seems a bit cold or sweaty – not to mention unfair on your larger friends – a trip to The Race Hut is just the ticket. With 16 pods, you and your friends can race each other virtually in a huge variety of different cars and different tracks. They can even adjust the difficulty to help the novices among you, plus you can have a beer – if you're not driving home. A great place for a works Christmas party.

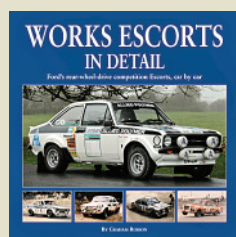

WORKS FORD ESCORT BOOK

£40 (978 1906 133 443)
herridgeandsons.com

If the number plates X00 355F, 000 96M, P00 505R and FEV 1T strike a chord, this is a must-own book for you. Graham Robson, rally historian par excellence, presents the complete line-up of factory-built race and rally Ford Escorts – the potted histories, archive images and key successes making it *the* Escort book.



GOODWOOD FoS 2012 DVD

£19.99 (116 mins)
autosport.com/shop

All the best bits of the 20th Goodwood Festival of Speed are captured on this two-hour official DVD. If you were there, you may well have missed something; if you've not experienced it yet, you'll want to put that right in 2013 after a gander at the most recent escapades of this unique event.



OPEL ASCONA 400 1:18

£67.99
autosport.com/shop

With opening doors, bonnet and bootlid, as well as working steering, Sun Star's 1:18-scale replica of Walter Rohrl's 1982 WRC-winning Opel Ascona 400 is superb. And, in a snub to the tobacco-branding police, it comes resplendent in big, fat Rothmans livery. Hurrah for that.

HOT ON THE WEB THIS WEEK

YOUTUBE: 'MR MACAU' EDOARDO MORTARA WINS AGAIN



SEARCH FOR: Audi R8 LMS CUP Macau GT Race Day 2012 - Edoardo Mortara (3:59)
Follow Italian Edoardo Mortara as he fends off GT3 virgin Lucas di Grassi in his bid to retain his GT Cup crown with Audi on the streets of Macau – and add it to his two F3 Grand Prix wins from 2009-2010.

WHAT'S ON...

Your guide to the best events taking place in the UK and around the world this week – plus TV and online

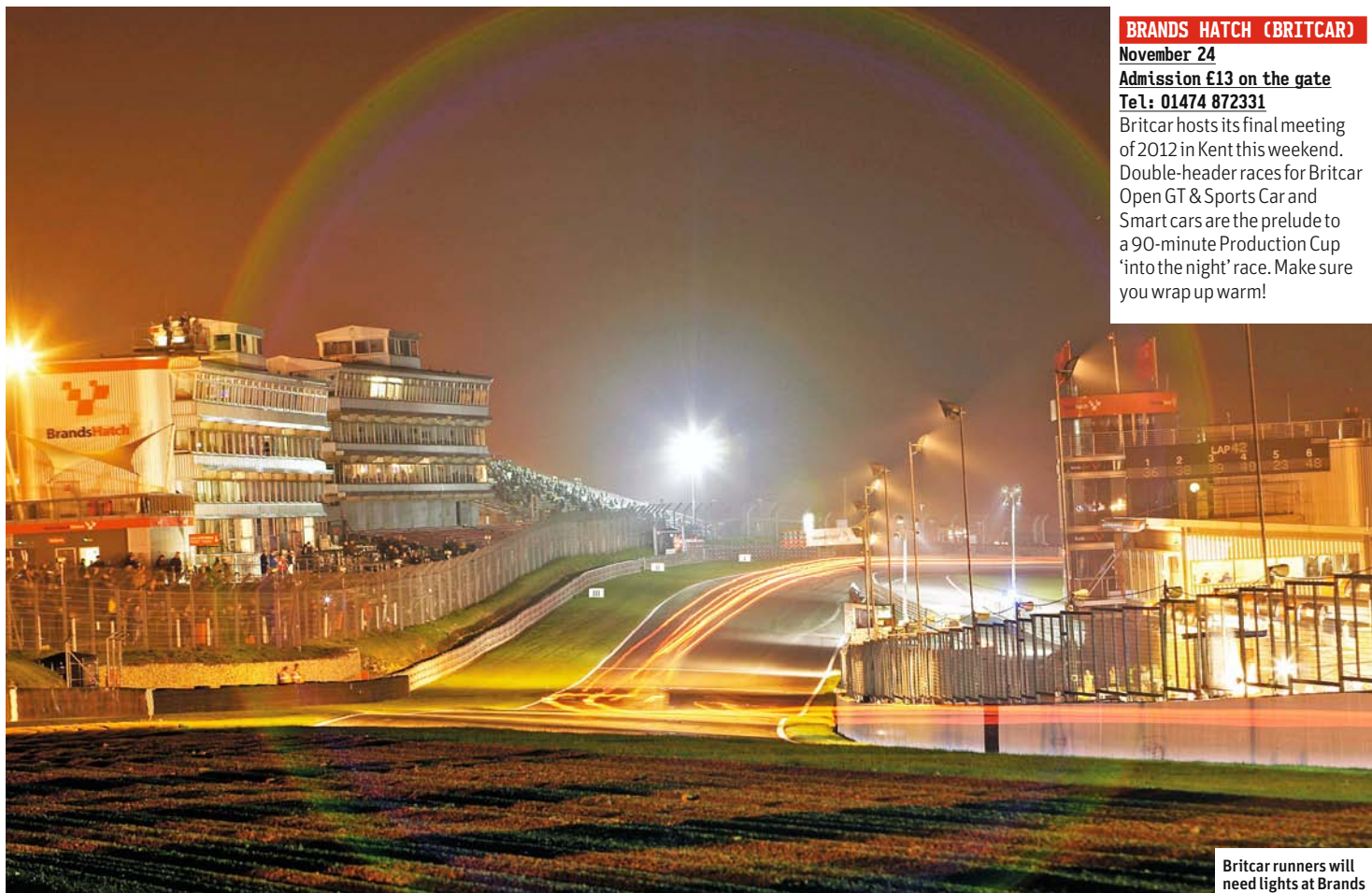

BRANDS HATCH (BRITCAR)

November 24

Admission £13 on the gate

Tel: 01474 872331

Britcar hosts its final meeting of 2012 in Kent this weekend. Double-header races for Britcar Open GT & Sports Car and Smart cars are the prelude to a 90-minute Production Cup 'into the night' race. Make sure you wrap up warm!

Britcar runners will need lights at Brands



Brazil will host another title decider this weekend

BRAZILIAN GRAND PRIX

Formula 1 World Championship

Rd 20/20

Interlagos, Brazil

November 25

formula1.com

The Formula 1 World Championship title battle will be fought out by Red Bull's Sebastian Vettel and Ferrari's Fernando Alonso. The German has a 13-point advantage, and is the odds-on favourite, but has concerns about his car's reliability. Interlagos also has a reputation for throwing up the unexpected, especially when it rains... The all-time-great status that comes with three drivers' championships awaits one of them.

NZ V8 SUPERTOURERS

Rd 7/7

Ruapuna, New Zealand

November 24-25

v8st.co.nz

TC2000

Rd 13/13

San Luis, Argentina

November 25

tc2000.com.ar

BRAZILIAN PORSCHE GT3 CUP

Rd 7/8

Interlagos, Brazil

November 24-25

porscheGT3cup.com.br

Television

THURSDAY NOVEMBER 22

0110-0210 [ESPN Classic](#)
Formula 1 Retro: 1977
0130-0230, 1000-1100 [Sky Sports 3](#)
DTM: Season Highlights
0900-1000 [Eurosport 2](#)
WTCC Macau: Highlights
1400-1500, 2000-2100 [ESPN Classic](#)
Formula 1 Retro: 1978
1300-1330 [Sky Sports F1 LIVE](#)
Brazilian Grand Prix: Drivers' Press Conference
1310-1515 [Motors TV](#)
GP3: Season Highlights
1515-1620 [Motors TV](#)
Formula Ford Festival

FRIDAY NOVEMBER 23

0000-0030 [Eurosport](#)
Inside WTCC
0900-1000, 1400-1500 [ESPN Classic](#)
Formula 1 Retro: 1979
1145-1350 [Sky Sports F1 LIVE](#)
Brazilian Grand Prix: Free Practice 1
1155-1330 [BBC Red Button LIVE](#)
Brazilian Grand Prix: Free Practice 1
1545-1800 [Sky Sports 2](#)
Racemax
1545-1800 [Sky Sports F1 LIVE](#)
Brazilian Grand Prix: Free Practice 2
1555-1730 [BBC Red Button LIVE](#)
Brazilian Grand Prix: Free Practice 2
1800-1840 [Sky Sports F1 LIVE](#)
Brazilian Grand Prix: Team Principals' Press Conference

SATURDAY NOVEMBER 24

0355-0420 [Channel 5](#)
Motorsport Mundial

1135-1340, 1855-2100 [Motors TV](#)
NASCAR Nationwide: Homestead
1245-1410 [Sky Sports F1 LIVE](#)
Brazilian Grand Prix: Free Practice 3
1255-1400 [BBC Red Button LIVE](#)
Brazilian Grand Prix: Free Practice 3
1340-1545, 2100-2305 [Motors TV](#)
V8 Supercars: Winton Highlights
1500-1730 [BBC1 LIVE](#)
Brazilian Grand Prix: Qualifying
1500-1745 [Sky Sports F1 LIVE](#)
Brazilian Grand Prix: Qualifying
1545-1855 [Motors TV](#)
Formula 2: Season Highlights
1735-1840, 2205-2300 [ESPN Classic](#)
Formula 1 Retro: 1971
1840-1945, 2310-0015 [ESPN Classic](#)
Alain Prost: Racing Through Life
2100-2000 [Premier Sports](#)
NASCAR Sprint Cup: Season Highlights

SUNDAY NOVEMBER 25

0900-1105 [Motors TV](#)
V8 Supercars: Winton Highlights
1230-1430 [Sky Sports F1](#)
Senna
1430-1915 [Sky Sports F1 LIVE](#)
Brazilian Grand Prix
1500-1815 [BBC1 LIVE](#)
Brazilian Grand Prix
2000-2100 [BBC3](#)
Brazilian Grand Prix Highlights
2030-2100 [Motors TV](#)
Colin Chapman and Lotus, 1972

MONDAY NOVEMBER 26

1100-1130 [ESPN Classic](#)
Formula 1 Archive: British GP 1973
1130-1200 [ESPN Classic](#)
Formula 1 Archive: British GP 1974

Online

AUTOSPORT+

Coming up in our premium web content this week

Alonso has his work cut out for title #3



VETTEL v ALONSO: THE FINAL BATTLE

F1 heads to its Brazilian showdown and AUTOSPORT's team brings you the final analysis from the US GP before assessing the strengths and weaknesses of the Red Bull and Ferrari title challengers as the Interlagos weekend unfolds.

FERRARI AND ITS UNWANTED PAST

Edd Straw looks at the impact the disappointing finales of 2008 and 2010 have had on the legendary F1 squad.



THE 10 BEST OF FIA GT1 IN 2012

Gary Watkins picks his top-10 drivers from a hard-fought GT1 season.



REVVED UP OVER WHAT'S ON THE BOX

We cast a critical eye over the best and worst of this week's TV coverage

Ex-racer Vaulkhard was spot-on in Macau comms



THERE'S AN OLD SAYING in advertising: 'sex sells'. And while those grid girls aren't selected on the quality of their written applications, the sad truth in motorsport is it's 'death sells' that's the guaranteed winner.

The massive boost in popularity Formula 1 received following Ayrton Senna's fatal crash at Imola is a case in point. Even more so is the explosion in NASCAR viewership during the tyre-war era of the 1990s, where, pre-HANS and SAFER barriers, stock car deaths were a common occurrence, so much so that

in an episode of *The Simpsons*, Homer laments: "Death... you made NASCAR races exciting."

It's a paradox that 'fans' on the one hand decry the sanitisation of the tracks, the lack of challenge to the drivers and the reduced perception of risk, while at the same time the sound of knees jerking can be heard across the web following a tragedy such as those that occurred at Macau last weekend. There were even some calls from keyboard experts to ban racing at Macau as a result.

The trade-off of having 'challenging' tracks is that

the ultimate penalty may have to be paid for getting it wrong. I bring up the deaths at Macau, mainly because Carlton Kirby couldn't help but refer to them throughout his commentary of the WTCC finale.

This was fair enough after the race-two clash between Alex MacDowall and Yvan Muller, which sent the Brit hard into the wall. Last week, I was shocked by the lack of condemnation

for Jeff Gordon's actions, so credit to Steve Bruce-soundalike Harry Vaulkhard for calling it as he saw it.

"The car behind can't hit somebody just because they're going quicker than them. Yvan was complaining about not hitting cars here because it's so fast, but you've got to practise what you preach." Amen.

Revved Up

"The trade-off of having 'challenging' tracks is that the ultimate penalty may have to be paid for getting it wrong"

THE WEEK IN PICTURES

Our lensmen pounding the beat, from Texas to Florida, via Macau



LOOK OUT ABOVE YOU, HEIKKI!
Never mind his Angry Birds-liveried helmet, Caterham's Heikki Kovalainen has an angry helicopter to deal with in Austin

EUGH! PARENTS ARE SO EMBARRASSING...
Great reaction from Gordon Jr as daddy Jeff snogs his wife, Ingrid Vandebosch

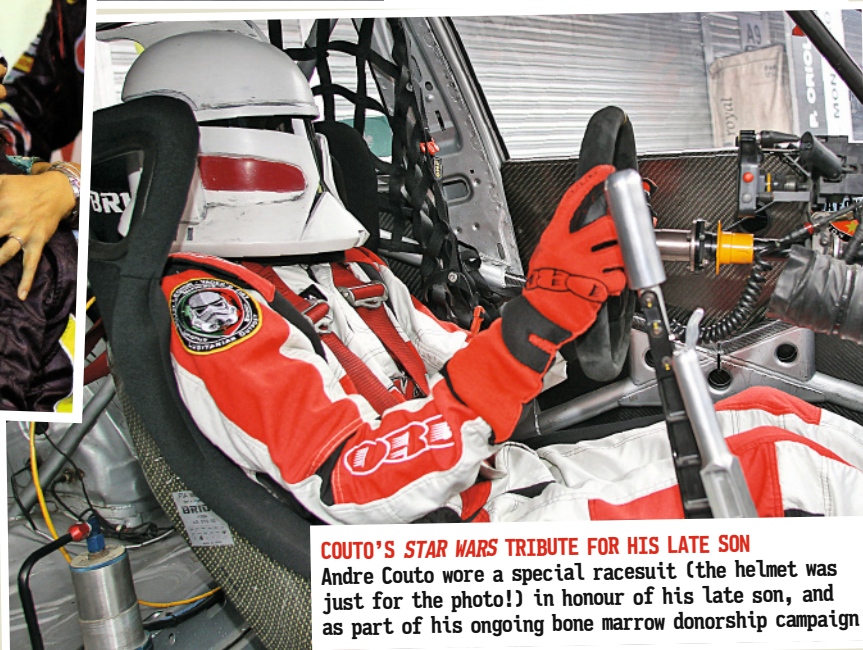
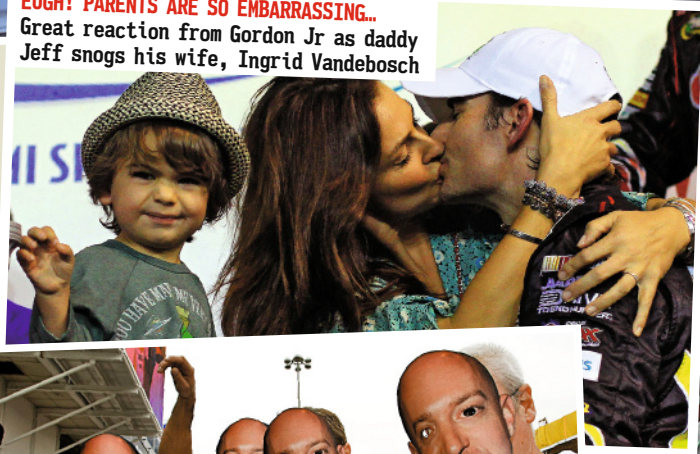

COUTO'S STAR WARS TRIBUTE FOR HIS LATE SON
Andre Couto wore a special racesuit (the helmet was just for the photo!) in honour of his late son, and as part of his ongoing bone marrow donorship campaign

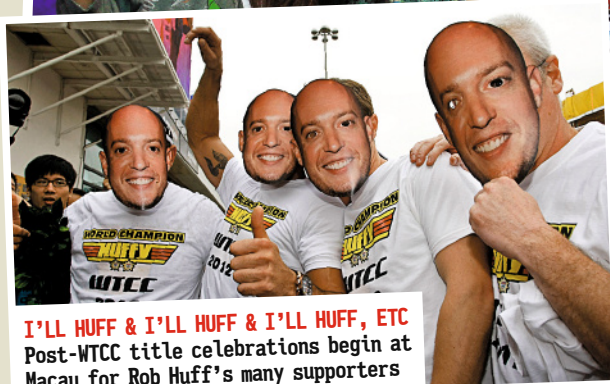

I'LL HUFF & I'LL HUFF & I'LL HUFF, ETC
Post-WTC title celebrations begin at Macau for Rob Huff's many supporters

PICS: GILHAM, TROTMAN / GETTY, EBREVILAT

NEXT WEEK BRAZILIAN GRAND PRIX REPORT

WHO WILL BE WORLD CHAMPION? **DON'T MISS IT!**

FROM THE ARCHIVE

Jimmy Vasser and Alex Zanardi clash at Laguna Seca, 1997

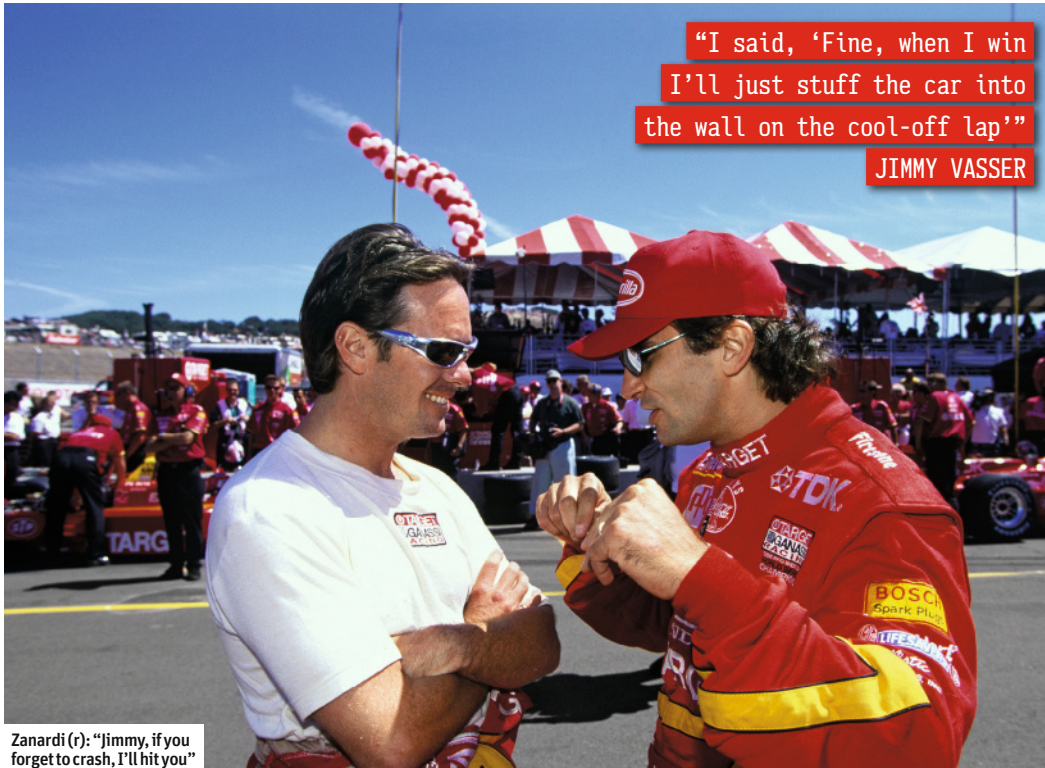

"I said, 'Fine, when I win I'll just stuff the car into the wall on the cool-off lap'"

JIMMY VASSER

Zanardi (r): "Jimmy, if you forget to crash, I'll hit you"

WITH JIMMY VASSER CELEBRATING HIS BIRTHDAY THIS week, we take a trawl through the archives and back to the 1997 Champ Car season, when his Laguna Seca win brought about one of the American's most memorable victory laps.

Vasser had come into the season as defending champion following his 1996 title success, but it hadn't been his year and he found himself struggling to keep up with Chip Ganassi Racing team-mate Alex Zanardi. The Italian had already won five times heading into the penultimate round at Laguna, while Vasser, in contrast, had yet to win a race that season.

The winless streak was finally ended at the Californian circuit as a long first stint provided the foundation for Vasser to come from sixth on the grid to lead the race after just 26 laps. He remained at the front for the duration, withstanding heavy pressure from Mark Blundell to clinch victory by just 0.543s. The action, however, wasn't finished...

"In 1997, I hadn't won any races all season," Vasser remembers. "Zanardi was kicking my ass big-time – both in qualifying and the races.

"He was off doing donuts every race – it was his celebration thing – and he kept asking me, 'What are you going to do when you win a race? What's going to be your celebration?'"

"I said, 'I'm just going to drive to the winner's circle. That's it. I'm not a showman like you'. And he just replied, 'No, no, you have to do something'.

"Finally – and remember, I wasn't winning any races – I said, 'Fine, when I win I'll just stuff the car into the wall on the cool-off lap. That will really piss Chip off'.

"He thought that was the funniest thing. Anyway, I forgot about it. I was just joking. So I won the race at Laguna in 1997 and Zanardi won the championship at the same race. I'm coming down to the last corner on the cool-off lap, and Zanardi pulls up next to me, and his arms are flailing. I thought he was just going, 'Yeah, you won, and I won the championship'. Then the next thing I know, boom, he hits me, and I spun and hit the fence.

"It still hadn't dawned on me what he was doing, so I was like, 'What the hell was that?' And he said, 'I was trying to tell you, it was the last corner, your last chance to stuff the car into the wall for your celebration!' He realised that I wasn't going to do it, so he did it for me.

"Then I jumped on Max Papis's car [for a ride back], and Max nearly killed me – he decided to do an effin' burnout, and I almost fell off the back." ❄

THIS WEEK IN...

Autosport



F3 in Britain and Europe



Lombard RAC Rally action

Petty's NASCAR title: Lees wins Mazda: Bajs 1050

NOVEMBER 22 1979

AUTOSPORT ARGUED THE TOSS OVER the FIA European and British Formula 3 championships this week in 1979, with our domestic series producing better races but the International equivalent unearthing a superior champion – 24-year-old Frenchman Alain Prost.

In the World Rally Championship, Ford was writing its own epitaph in the Lombard RAC Rally. The Blue Oval's factory operation, the Ford Competition Department, would be disbanded at the end of the event, but it would bow out on a high with Hannu Mikkola winning for a second straight year – the eighth successive triumph for Escort models.

The Escort RS would survive the loss of the factory squad, with Ari Vatanen winning four times over the next two seasons and lifting the '81 drivers' title.



PIC: LAT ARCHIVE



WIN PRIZES AND FAME

DESIGN YOUR OWN T-SHIRT

Think you could be a designer? Why not try your hand at your own product range. We've already got our own awesome new range, but now we want to see what you can do. Search for AUTOSPORT product range at www.shotdeadinthehead.com

Just post your ideas onto the AUTOSPORT Facebook page and we'll select the best ones. If your design is chosen we will produce an entire product range including a T-shirt, hoodie, mug and iPhone case and send you one of each. Just call it an early Christmas present.

Terms: Designs must not be offensive, or infringe personal or brand identity. Full terms see autosport.com.

Brought to you by CarPlan



RICKARD RYDELL

■ Macau Formula 3 Grand Prix ■ November 21-22 1992 ■ TOM'S-Toyota O32F ■ Victory at Macau at last



It was sixth-time lucky for Rydell in Macau GP

THE 1992 MACAU GRAND

Prix was my sixth time at the track. The reason why it's the race of my life is that it had become so special to me that I had to win it at least once in my life.

Even in 1988, my second year with my small team from the Swedish F3 championship – Picko Troberg Racing – I was third in the first heat. Then in 1989 with Eddie Jordan Racing I was on the front row. We didn't have a sponsor but because of my qualifying performance we got Viceroy money. But at the first corner Otto Rensing, who was on pole, crashed and bounced into me – I had nowhere to go.

In 1990 I had a Ralt run by Bertram Schafer, but I wasn't happy with that car and I finished fifth. The next year, with TOM'S GB, I was on pole with David Coulthard alongside me, but our TOM'S chassis was slow on the straights so I dropped back in the race.

For 1992 I had been racing with TOM'S in Japan, with Jacques Villeneuve as my team-mate and Tom Kristensen in the Navi Connection car. We were all good friends. We had a laugh most of the year, going to tenpin bowling and karaoke – actually, it was always Jacques who went on the karaoke.

"I was racing with Jacques Villeneuve and Tom Kristensen in Japan. We had a laugh, going bowling and to karaoke - actually, it was always Jacques on karaoke"

I had a great battle with Pedro Lamy and Roberto Colciago to take pole position. This was the first time a Japanese team had been anywhere near the front, and for TOM'S it was a very special moment. Some teams go to Macau not having tested in the right way – you have to put the ride-heights of the car higher than for a normal circuit and run a really low wing. We would go to Suzuka to test

with this set-up, just trying to improve it and go faster without changing it. We had really done our homework properly and got the car right from the start.

The first race needed a restart, and Colciago jumped the start just as he had done at the first. I caught and passed him, but Lamy then overtook me with a few laps to go. Then there was a yellow flag – Lamy slowed right down but I

didn't see the yellows in time and had to pass him otherwise I would have crashed into him. After the race they penalised me the margin by which I had won, so even though it was an aggregate result of two heats, it would depend entirely on who won the second part.

Colciago jumped the start again, and from the seventh row he was with me and Pedro before we even got to Lisboa! I had to get Pedro into that first corner, because I knew it would be difficult running second behind him. I outbraked him on the dust on the inside, and it looked like I was going to lock up, but I just managed to get past him. That was the key to my race and I held on.

I went back the year after with the Navi Connection TOM'S and went out with a holed radiator, but I set a new lap record that lasted until they widened the air restrictors for 1997. I just loved that track, especially in an F3 car.

I should have tried to go Formula 3000, but I had no sponsors whatsoever – in Sweden you could not even watch F1 on television. So instead I went into touring cars with Volvo. It was great, but it took me two years to accept I wasn't a single-seater driver any more. *Rickard Rydell was talking to Marcus Simmons*

IN PROFILE



AFTER SUCCESS IN FORMULA 3 in Sweden, Britain and Japan, Rickard Rydell moved into the BTCC with Volvo in 1994, winning the title in '98 with the S40, and came close again with Ford in 2000. Through the past decade he has won races for SEAT in the WTCC and also competed in sportscars, taking Le Mans GT1 honours with Aston Martin in '07. With Chevrolet Sweden, he became Scandinavian Touring Car champion in '11. He also still works for the family florist, Rydells.



Super strength car shampoo
Provides a long lasting shine
Contains 'water-dance'
technology

£5.99
500ml



Ultimate protection & shine
Suitable for all paint finishes
Easy on - Easy off formula

£10.99
500ml



Locks in the shine
Proven paintwork protection for
upto 12 months
Easy-on, No buffing
Patented formula

£11.99
500ml



FREE
with every purchase

Worth
£5.99

FREE

The Secret to Perfect Paintwork...

CarPlan Auto Finish with patented Nanomeric Technology brings the subtle blend of traditional Car Care & State of the Art Science together to give you the **Secret to Perfect Paintwork.**

If you love CarPlan Nanomeric, you will love CarPlan Auto Finish even more!

FREE Nanomeric Tyre & Trim Protect with every purchase online @motor-world.co.uk

'I can honestly say my car has never looked better. The depth of shine achieved with Auto Finish Advanced Resin Polish is incredible.'

Phil Taylor, Manchester

'The first thing my hubby did was protect my new black beauty with Auto Finish Mirror Gloss Sealant he swears by it. Thank you CarPlan.'

Miss S. Davis, Didsbury

'Auto Finish Advanced Resin Polish and Mirror Gloss Sealant have restored the showroom shine, I will definitely be using these again!'

Alison Kelly, Cardiff

'Auto Finish is a brilliant range which is easy to use, especially love the Advanced Wash and Wax, it has a great fragrance too.'

Melissa Wright, Kelly

'I don't use anything but Auto Finish for a perfect finish.'

Barry Wood, London

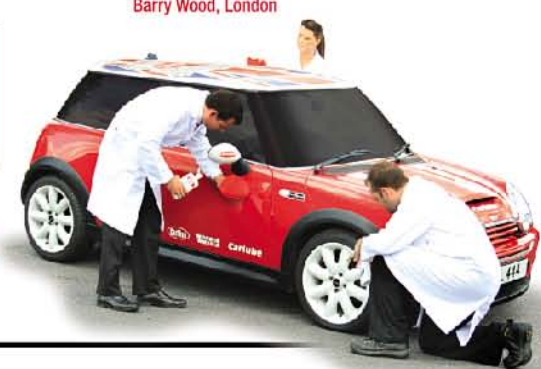

We ♥ cars@motor-world.co.uk



SPORTRAC 5



GIUGIARO
DESIGN

THE SPORTRAC 5 IS AN EXTREMELY QUIET AND COMFORTABLE SUMMER TYRE THAT EXCELS IN TERMS OF STABILITY AND SPORTY DRIVING ABILITY. THE TYRE OFFERS SUPERB HANDLING ON BOTH WET AND DRY ROAD SURFACES.

WWW.VREDESTEIN.CO.UK



VREDESTEIN
DESIGNED TO PROTECT YOU