

LOTUS LAUNCH SPECIAL ISSUE

AUTOSPORT

JANUARY 31 2013 • £3.50 • autosport.com

F1 2013 STARTS HERE

KIMI'S NEW LOTUS

**Can secret tech
tweak put him
back on top?**

PLUS
Lewis at Mercedes
"I'm in for the long haul"

F1 2013 tech special
What's new & find out
how DRS really works

Daytona 24 Hours
Epic duel - full report

haymarket



C\$8.99





CHEVRON GT CARS • COM

Chevron Cars Limited / +44 (0)1270 581 508 / info@chevronGTcars.com / @ChevronGTcars
CHEVRON GT / GT3 / GT4 information available on request





Up-to-the-minute news and reports from F1, WRC and more. Subscribe for must-read opinion, stats and images

"Gutted to hear news about British F3. It's too good and vital to a driver to lose"

REIGNING CHAMP JACK HARVEY IS ONE OF MANY TO FEEL F3 PAIN

COVER IMAGES: LOTUS F1



FEATURES & REPORTS

- 24 Lewis Hamilton**
The 2008 world champion talks of his hopes as his new life starts at Mercedes. One thing's for sure: he'll be flat-out
- 28 Formula 1: resolving the differences**
Our guide to what's new in 2013, from the technical details to changes in the qualifying system
- 32 Getting to grips with DRS**
Don't get into a flap (groan): here's how the system works
- 34 It's Bottas!**
That could be the name on F1's lips this year: how the Finnish rookie is shaping up for his Williams campaign
- 38 Daytona 24 Hours**
It's another close one, but there's never any doubt that Chip Ganassi Racing's all-conquering squad will win
- 42 World of Sport**
Toyota Racing Series
- 47 Introducing...**
New Zealand V8 sensation Scott McLaughlin
- 48 Nelson Piquet Jr**
Brazilian rehabilitates his career – and life – in NASCAR
- 51 2013: it's a crunch year for some**
Not literally, hopes Romain Grosjean. We take a look at who – and what – are standing at the crossroads
- 54 The battles to watch in the year ahead**
Pinpointing some flashpoints as the season approaches
- 56 Shane van Gisbergen: comeback kid**
He's only 23, but he's already retired. And returned
- 58 At home with Gabriele Tarquini**
Italy's touring car folk hero talks – and looks back

NEWS

- 8 Lotus E21: first out of the box**
Gary Anderson gives you the lowdown on the new racer from the team formerly known as Renault, Benetton and Toleman
- 10 Lotus bullish for 2013**
Team explains why it thinks it can make the top three
- 15 This week in F1**
What's been going on behind the scenes
- 18 Audi looks into Daytona Prototype assault**
Look out Chevy/Ford/BMW and co: Ingolstadt could enter top division of new-era US sportscar racing
- 20 Kubica shines as he tests DTM Mercedes**
Pole would be mega if he goes racing in tin-tops, says Merc's former champion Paffett after Valencia tryout
- 22 British F3 downscales amid crisis**
Teams pledge support for four-round mini-series

REGULARS

- 5 From the editor**
- 6 Snapshot**
- 17 Mark Hughes column**
- 76 Subscribe for a free gift**
- 80 Final drive**
Letters and latest gear
- 82 On track/on screen**
The best action in the next week
- 85 From the archive**
Alex Zanardi talks about his old boss Chip Ganassi
- 86 Race of my life**
Andrea Chiesa, 1992 Mexican Grand Prix

SPORTS EXTRA

- 73 Lotus Cortina gets celebration race event**
Oversteer assured as Brands Lotus Festival hosts races
- 74 New Caterham series is a non-starter**
R600 put on ice for a year due to insufficient entries
- 78 Driver profile**
Chatting to multiple Mazda MX5 champion Tom Roche



The one who flew over to Mercedes' nest

Lewis Hamilton has been a McLaren driver for most of his life, but this year he'll trade the purple of his old team for the silver of his new Mercedes (opposite page) **BY GARY ANDERSON**

It's a little bit of a shock to the world when you hear that Lewis Hamilton has left McLaren to join Mercedes. It's not like he's jumping ship to a rival team, or that he's been lured away by a rival team. It's more like he's been recruited by a team that's been built to win. And that's exactly what Mercedes wants. Hamilton is the perfect driver for Mercedes. He's got the speed, the skill, and the experience to win. And he's got the personality to be a team player. He's got the ability to work with his teammates and to be a leader. He's got the ability to be a team player. He's got the ability to be a leader. He's got the ability to be a team player. He's got the ability to be a leader.

Lotus kicks off the 2013 launch season

Lotus's new E21 is the most advanced F1 car yet, and it's ready to go. Here's a look at the key features that make it so special.

- PASSIVE DOUBLE DRS**: The new Lotus E21 has a passive double DRS system, which allows the driver to adjust the rear wing angle to suit the track conditions. This gives the driver more control over the car's aerodynamics and allows him to extract more speed from the corners.
- DRS**: The Lotus E21 has a DRS system that allows the driver to open the rear wing to reduce drag and increase top speed. This is a key feature that will help the car to be competitive in the 2013 season.
- FRONT SUSPENSION**: The Lotus E21 has a new front suspension system that is designed to provide better grip and stability. This will help the car to be more competitive in the 2013 season.
- REAR SUSPENSION**: The Lotus E21 has a new rear suspension system that is designed to provide better grip and stability. This will help the car to be more competitive in the 2013 season.
- DRIVER SEAT**: The Lotus E21 has a new driver seat that is designed to provide better support and comfort. This will help the driver to be more competitive in the 2013 season.
- NOSE STEP**: The Lotus E21 has a new nose step that is designed to provide better aerodynamics. This will help the car to be more competitive in the 2013 season.
- FRONT WING**: The Lotus E21 has a new front wing that is designed to provide better aerodynamics. This will help the car to be more competitive in the 2013 season.

Caterham cans new R600 series

Latest Seva will not get its own series in 2013 as British minie series struggles to gain momentum.

The new Caterham R600 series is a disappointment for many fans. The car is not as competitive as the previous series, and it's not as fun to drive. This is a shame, as the R600 series was one of the most popular minie series in the world. It's a shame that Caterham has decided to cancel the series, as it would have been a great opportunity for fans to see the R600 series in action.

Scuderia Vittoria to run Bailey Ferrari 430 in British Endurance

Scuderia Vittoria will run a Ferrari 430 in the British Endurance series. This is a great opportunity for the team to showcase the car's performance and to compete for the title.

Marcus Pye HUMBLE PYE

Marcus Pye is a talented driver who has achieved many successes in the world of motorsport. He is a true champion and a role model for many young drivers. His achievements are a testament to his hard work and dedication to the sport.

Hansen commits to ERC campaign

Hansen has committed to a full-time campaign in the European Rally Championship (ERC). This is a great opportunity for him to showcase his skills and to compete for the title.

ENGINEERED FOR EXCELLENCE BEYOND THE TRACK

The Rolex 24 at Daytona is one of the most grueling tests an automobile can endure.

Imagine 24 hours of driving at the absolute limit—where merely crossing the finish line is an accomplishment and a podium position is coveted.

APR Motorsport is proud to have achieved 2nd place in this year's Rolex 24 and would like to congratulate Audi Sport on their 1-2 finish and the first Rolex 24 at Daytona win for the Audi R8

You too can experience the passion, innovation, determination and excellence that goes into such a great motorsport accomplishment in each and every road car part APR offers for your Audi or other VAG vehicle.

GO APR!



EDITOR-IN-CHIEF

Andrew van de Burgt
andrew.vandeburgt@haymarket.com ext.5974

EDITOR

Charles Bradley
charles.bradley@haymarket.com ext.5889

GROUP F1 EDITOR

Jonathan Noble ext.5810
jonathan.noble@haymarket.com

F1 EDITOR

Edd Straw ext.5887
edd.straw@haymarket.com

FEATURES EDITOR

Kevin Turner ext.5432
kevin.turner@haymarket.com

NEWS EDITOR

Glenn Freeman ext.5309
glenn.freeman@haymarket.com

REPORTS EDITOR

Jamie O'Leary ext.5811
jamie.oleary@haymarket.com

IMAGING EDITOR

Peter Hodges ext.5903
peter.hodges@haymarket.com

RALLIES EDITOR

David Evans
david.evans@haymarket.com

DEPUTY NEWS EDITOR

Sam Tremayne ext.5952
sam.tremayne@haymarket.com

ART EDITOR

Aubrey Smith ext.5914
aubrey.smith@haymarket.com

PRESENTER/SUB-EDITOR

Henry Hope-Frost ext.5835
henry.hope-frost@haymarket.com

CHIEF SUB-EDITOR

Marcus Simmons ext.5807
marcus.simmons@haymarket.com

NATIONAL EDITOR

Ben Anderson ext.5425
ben.anderson@haymarket.com

SENIOR DESIGNER

Michael Cavalli
michael.cavalli@haymarket.com

PICTURE EDITOR

Peter Mills ext.5918
peter.mills@haymarket.com

TECHNICAL TEAM LEADER

Geoff Creighton
geoff.creighton@haymarket.com

AUTOSPORT.COM USER

INTERFACE DEVELOPER
Pete Holmes
peter.holmes@haymarket.com

SECRETARY

Joanne Grove
joanne.grove@haymarket.com
ext.5804

PHOTOGRAPHS

LAT Photographic

SPECIAL CONTRIBUTORS

Mark Hughes
David Coulthard
Gary Watkins
Marcus Pyle

Mark Glendenning
Adam Cooper
Gary Anderson
Giorgio Piola

Alan Eldridge
Jim Bamber
Pablo Elzalde
Matt Beer

CORRESPONDENTS

ARGENTINA

Tony Watson

AUSTRALIA

Phil Branagan

AUSTRIA

Gerdhard Kuntzschik

BELGIUM

Gordon McKay

BRAZIL

Lito Cavalcanti

FINLAND

Esa Iiloinen

GERMANY

Rene de Boer

GREECE

Dimitris Papadopoulos

ITALY

Roberto Chinchero

JAPAN

Jiro Takahashi, Len Clarke

NEW ZEALAND

Bernard Carpenter

RUSSIA

Gregory Golyshev

SOUTH AFRICA

Richard Asher

SPAIN

Raimon Duran

SWEDEN

Tege Formvall

USA

Jonathan Ingram, Bruce

Martin, David Phillips,

Diego Mejia, Robin Miller,

Jeremy Shaw,

UK & EIRE

David Addison,

Benard Candier, Jonathan

Crawford, Kerry Dunlop,

Leanne Fahy, Paul Healy,

Paul Jurd, Paul Lawrence,

Stephen Lidonish,

Marc Orme, Graham

Read, Peter Scherer, Ian

Sowman, Oliver Timson,

Ian Tichmarsh, Matt

Upton, Eddie Walder, Tim

Whittington, Richard Young

ADVERTISING

Tel: +44 (0) 20 8267 5820
Fax: +44 (0) 20 8267 5850
E-mail: autosport.ads@haymarket.com

COMMERCIAL

MANAGER
Rachel Brock,
ext: 5820
rachel.brock@haymarket.com

DISPLAY ADVERTISING

Peter De Vries,
ext: 5961
peter.de.vries@haymarket.com

CLASSIFIED

ADVERTISING
MANAGER
Matt Simpkin,
ext: 5560
matt.simpkin@haymarket.com

PRODUCTION

MANAGER
Ailsa Donovan, ext: 5639
ailsa.donovan@haymarket.com

SENIOR DISPLAY

PRODUCTION
CONTROLLER
Leanne Foley, ext: 5846
leanne.foley@haymarket.com

ONLINE ADVERTISING

MANAGER
Alex Newberry, ext: 5244
alex.newberry@haymarket.com

PRODUCTION

CONTROLLER
Marc Baker, ext: 5563
marc.baker@haymarket.com

ADVERTISING

MANAGER
Matt Simpkin,
ext: 5560
matt.simpkin@haymarket.com

PRODUCTION

MANAGER
Ailsa Donovan, ext: 5639
ailsa.donovan@haymarket.com

SENIOR DISPLAY

PRODUCTION
CONTROLLER
Leanne Foley, ext: 5846
leanne.foley@haymarket.com

ONLINE ADVERTISING

MANAGER
Alex Newberry, ext: 5244
alex.newberry@haymarket.com

PRODUCTION

CONTROLLER
Marc Baker, ext: 5563
marc.baker@haymarket.com

DIGITAL SPECIAL PROJECT

MANAGER
Simon Strang, ext: 5093
simon.strang@haymarket.com

DIGITAL PRODUCT

MANAGER
Simon Grayson, ext: 5245
simon.grayson@haymarket.com

CIRCULATION TRADE ENQUIRIES

Frontline Ltd, Park House, 117 Park Road
Peterborough, Cambs, PE21 2TS. Tel: +44
(0)1753 553149. Fax: +44 (0)1753 553149

BACK ISSUES

Tel: 0844 8488817

DIRECT MARKETING EXECUTIVE

Karen McCarthy, ext: 5658
karen.mccarthy@haymarket.com

MANAGEMENT

GROUP PUBLISHER

Rob Aherne

PUBLISHING MANAGER

Samantha Tompson

SPECIAL EVENTS MANAGER

Laura Coppin

EDITORIAL DIRECTOR

Mark Payton

CREATIVE DIRECTOR

Paul Harpin

STRATEGY AND PLANNING DIRECTOR

Bob McDowell

PUBLISHING

DIRECTOR
Patrick Fuller

MANAGING

DIRECTOR
David Pringle

CHIEF EXECUTIVE

Kevin Costello

HAYMARKET

Haymarket is certified by

BSI to environmental

standard ISO14001



PEFC Certified
This product is from sustainably
managed forests and
controlled sources

www.pefc.co.uk

POLE POSITION

Exciting times ahead in F1, but what next for British F3?



FORMULA 1 LAUNCH SEASON IS UPON US, and within these pages you'll find the full lowdown on Lotus's new E21, while details of McLaren (Thursday), Ferrari and Force India (Friday), Sauber (Saturday) and Red Bull (Sunday) launches will be a click away on autosport.com.

After that comes Tuesday's first F1 test at Jerez, where we'll start to get some tangible answers rather than mere hyperbole. Exciting times await us.

On the flipside, news of the radical downsizing of this year's British Formula 3 Champamyon calendar is a worrying development for one of the best, and historically famous, driver-development categories in this country. Only last Saturday I sat down for a chat over breakfast with reigning champion Jack Harvey, and later bumped into an old mate from my days covering the Brit F3 beat, Mark Webber. Two shining examples of the fantastic driving talent that this series has produced; two of many reasons why this series cannot be allowed to wither further.

Unless something is done – and soon – we risk losing a precious gem. Make no mistake: this country's rich motor racing tapestry is in peril.

Charles Bradley

CHARLES BRADLEY EDITOR
charles.bradley@haymarket.com

Find us on **AUTOSPORT PODCAST**

BAMBER'S WEEK





www.hiutdenim.co.uk

BRITISH FORMULA 3

Icy wind blows for British F3

Double R Racing took one of its Dallara-Mercedes F312s to Bruntingthorpe last week, and drifting exponent Matt Walton did his stuff. Sadly, the conditions proved an appropriate metaphor for what's been happening in British F3 (see news, p22).

Pic: Jakob Ebrey



Lotus kicks off the 2013 launch season

Kimi Raikkonen's team took the covers off of its new car on Monday. GARY ANDERSON casts his eye over the latest creation from Enstone

LOTUS-RENAULT E21

PASSIVE DOUBLE DRS

The so-called passive DRS wasn't on the launch car, but Lotus plans to use it in testing and fine-tune it for racing. It's going to be very difficult to make it work! The key will be not tripping up by spending too much time on it if it proves tricky.

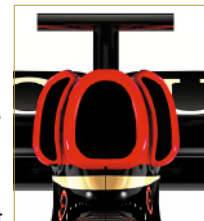

EXHAUST

As opposed to McLaren, which was shooting the exhaust gases across a gap, Lotus appears to have provided a surface to blow the brake ducts and create downforce. It looks like a logical evolution of the exhaust that Lotus ran in the final part of last season.



REAR SUSPENSION

There's nothing trick here and it's relatively conventional. Lotus certainly hasn't gone as far as Red Bull in trying to minimise the disruption of airflow to the Coke bottle.

DIFFUSER

Lotus is one of the teams that has really optimised the interaction between the edge of the diffuser and the low-pressure area around the rear tyre. There are aggressive turning vanes there, and the diffuser stops a bit short, which is a carryover from last year.



SIDEPODS

There are turning vanes on the front corner of the sidepod, *a la* Sauber or Red Bull. It's easy to get lift on the top of the sidepod. This is designed to limit that, particularly given that the exhaust design appears to have increased the surface area of the sidepod. Ahead of the rear tyre there is a duct, similar to Red Bull last year. Where that duct ends is unclear, but it looks like the radiator exit, helping to create a gap to better exploit the Coke-bottle area. Chances are, that duct runs to the middle of the diffuser.



FRONT SUSPENSION

The steering appears higher in the upright assembly, roughly halfway up the wheel, and the trackrod is separated a bit from that wishbone. That's quite a complicated system, but Kimi Raikkonen has always complained about the power steering (see p13) and this geometry change could help that. Moving the wishbone up also creates more room for the front brake duct, which is a very powerful thing because it calms the airflow displaced by the front tyre and prevents it from being sucked under the floor and further disrupting the airflow. This, in turn, can make the diffuser work harder.



FRONT WING

This looks very similar to last year. That's not surprising because Lotus has been very strong on development in this area in the past few years and it's logical that this is a subtle evolution. It's a three-main-element front wing, with the outboard part creating a fourth element to work the endplate area as a three-dimensional duct, which should help keep the airflow attached. It's hard to tell how different this wing is. Logically, the front wings on the E21 will be of the same family and there will surely be further versions in the pre-season testing. The mounting arrangement where it goes onto the centre-flap area is still very far back despite the new load test, so the team must have had to make its wing stiffer.

NOSE STEP

The step is still in the nose and there is no vanity panel (see p11). The reality is that the step in the nose is actually a slight advantage aerodynamically, so it's no surprise that this feature remains.

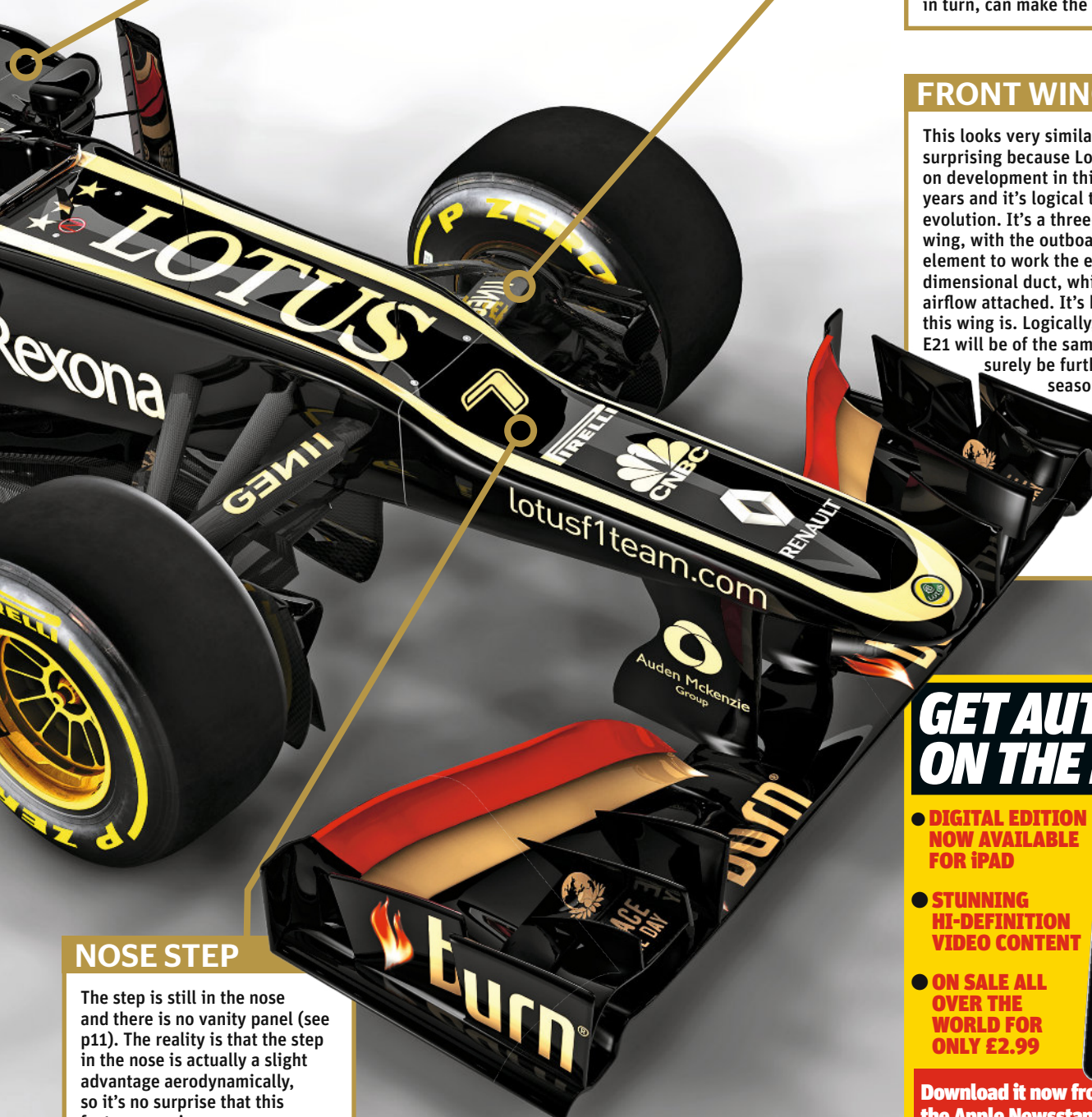

GET AUTOSPORT ON THE MOVE

- **DIGITAL EDITION NOW AVAILABLE FOR iPad**
- **STUNNING HI-DEFINITION VIDEO CONTENT**
- **ON SALE ALL OVER THE WORLD FOR ONLY £2.99**



Download it now from the Apple Newsstand **AUTOSPORT**

“Our mission now is to break into the top three”

Lotus boss Eric Boullier at E21's launch

Ambitions of former Renault team are not just pre-season talk. EDD STRAW explains why

Tempting as it may be, don't dismiss Lotus team principal Eric Boullier's bold target as throw-away launch-season fluff. The Enstone outfit has been on an upward curve since those dark days when it was on the brink of oblivion amid the fallout from the 2008 Singapore GP race-fixing scandal in 2009.

Two dramatic bumps in the road aside in 2011 – in the form of star driver Robert Kubica's potentially F1 career-ending rallying shunt and a misguided, but well-intentioned, forward-facing exhaust – the trend of recent seasons proves that the target is achievable. Doubly so if Kimi Raikkonen maintains the burgeoning form he showed in the second half of

his comeback campaign in 2012.

But just because it's realistic is not to say that it's easy to achieve. To improve on last year's P4 in the constructors' championship, Lotus must pick off one of Red Bull, Ferrari or McLaren, while simultaneously keeping Mercedes behind it. Highly-rated technical director James Allison, who is set to remain at the team despite interest from all three of the outfits he's aiming to overhaul, is under no illusions.

“Coming fourth for our team last year meant putting at least one of four better-funded teams behind us,” Allison told AUTOSPORT. “Our official target this year is third and that means putting two of them



behind us. That's a daunting challenge, but if you look at where we were last year, but for some disappointments, we had a chance of punting for second. So it's well within our compass if we've done a good car and we race it without error."

None of what Allison says is unrealistic. Setting aside the car, one area where Lotus is in rude health is on the driver front.

DRIVER LINE-UP

Raikkonen flirted with becoming a genuine championship contender

"In 2012, we had a chance of punting for second. So third's within our compass"

Lotus tech boss James Allison

last year and there are good reasons to expect his performance level to improve further in 2013. He started last season undercooked after two years playing in the mud and gravel of the World Rally Championship and arguably should have won in Bahrain and Hungary. But he will be fully up to speed from the off this year. Add to that new power steering – which is far more to his liking (see p13) – and things are looking very positive.

Alongside Raikkonen, Lotus has kept the faith with the incredibly fast Romain Grosjean, who must prove this year that he has the ability to assess risk more effectively in battle. If he doesn't, more mishaps will herald the end of his top-line F1 career. If he does, he has the ability to score heavily.

"This is the best pair of drivers that you can have on paper," claimed Boullier this week. "They are complementary and both gain something from the other.

"Kimi's approach was very

professional last year because he built up his speed through the course of the year and he had a very strong second part of the season. He's definitely more committed than ever to this team. That means that if he does have any room to improve and deliver even more, he will do everything to do it, which is exciting. But I'm sure that from race one he will be able to deliver a win if there is an opportunity to do so.

"For Romain, last year was not an easy one. We spent a lot of time over the winter with him and you can see a lot of changes in his approach. He has rebuilt his confidence. Because of the amount of pressure [in the second half of last year] he got a bit lost. But he has recovered. He has won every championship he has entered and I don't see any reason why he shouldn't deliver in F1."

Boullier's claim that his partnership is the best is perhaps stretching a point, but it is a potent pairing. Certainly, with question marks hanging over the Jenson Button/Sergio Perez axis at McLaren, one of the teams Lotus is gunning to beat, it could prove to be a big asset. If Grosjean can temper his speed with consistency, he will be a genuine threat to Raikkonen. ▶

NO TIME FOR VANITY



During launch season last year, the ugly step that appeared on the noses of the majority of the new cars was a big talking point. The step was created by a rule change lowering the height of the nose for safety reasons, combined with the desire to keep the front of the chassis as high as possible to maximise airflow under the car for aerodynamic advantage. The solution for 2013 is the 'vanity panel', an optional screen aimed at restoring the clean lines of old. Lotus has shunned that option, a direction in which the majority of the grid is likely to follow.

"We are not planning one at the moment," says James Allison. "The moment we can find a vanity panel that gives us a bit more downforce, we will pop it on. No-one ever designs a Formula 1 car with aesthetics uppermost. They are the ultimate expression of function and you get what you get looks-wise after you've tried to design as much speed into it as possible. The concept of a vanity panel is anathema to us."

While having the step exposed will inevitably have an effect on the airflow, Allison is certain that any such disturbance is irrelevant.

"It is invisible aerodynamically," he says. "It's the under-surface of these cars that does most of the work. Think what happens a bit further back from that step; there's a stand-up windscreen, an open cockpit, a driver's helmet. So the relatively smooth bump is invisible."

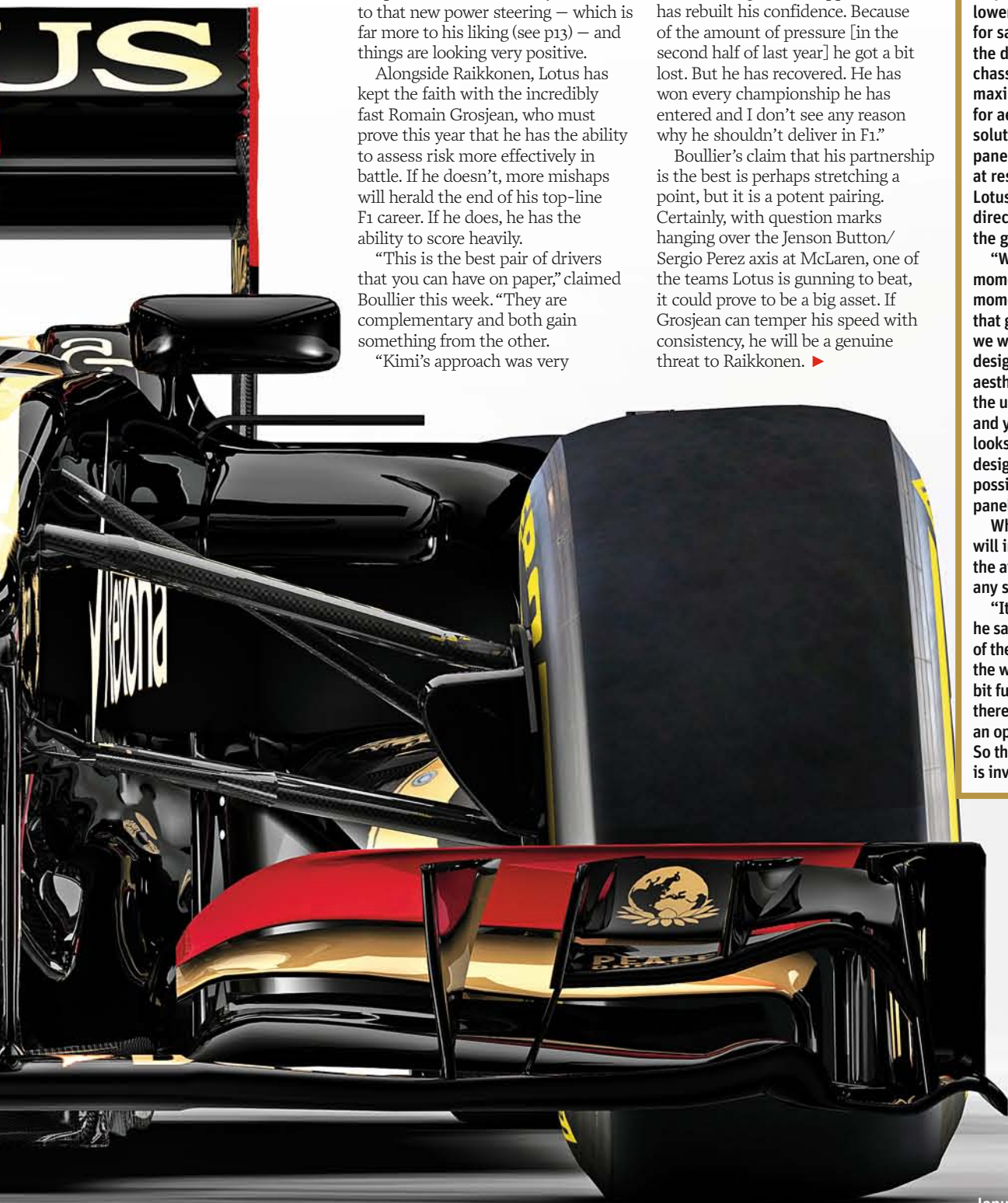

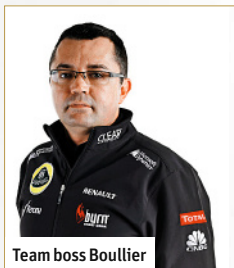

Team boss Boullier



Tech chief Allison



◀ “We had a pretty good relationship last year and he’s fast and motivated,” said Raikkonen. “On track, we were pretty close to each other at times but we didn’t have any issues. It’s good when you have a team-mate who’s fast and works hard. I think we should be fine in 2013.”

THE MAGIC BULLET?

Lotus will persevere with its passive DRS device in 2013. The team tried it during the second half of last season but never raced it. Despite that, Allison is confident that it will be a success this year. To call it a magic bullet would be disingenuous, especially as Lotus is not on its own in looking seriously at the concept, but in a season during which tiny performance gains could make a big difference in position, if it does work as hoped it will be a valuable weapon.

“We will try to make a success of the double DRS and have another bash at making that work for us,” said Allison. “There’s a reasonable amount of work to be done but I think it can be done during pre-season to get the fundamentals sorted and then we can go from there. The effort that we are prepared to put into it has to be justified by the gain we can get out of it. We’ve got a very stable regulatory environment so gains are more hard-won now. If we can get on top of this system, it will be most welcome.”

The passive DRS concept is designed to stall the rear wing on the straights by activating an aero ‘switch’ when a certain speed is hit. This diverts the airflow and stalls the rear

wing, cutting drag. The problem is ensuring that the switch activates and de-activates at the same speed, something that has proved tricky to achieve. This means that it might only be deployable at certain favourable circuits, although Allison is hopeful it can be universal.

“It all depends on how good we are engineering it,” he said. “It’s possible to imagine it being useful at every circuit. If we do a less good job than that, then it will only be at certain circuits, like Spa, where even a relatively crudely placed switch can bludgeon its way to a decent gain.”

EXHAUST GAINS

Key to Lotus’s late-2012 form was the introduction of the Coanda exhaust. This significantly improved rear-end traction and helped Raikkonen to that breakthrough win in Abu Dhabi. After making the exhaust switch late, Lotus was not getting the most out of the concept and if the version on the E21 is as good as hoped, it’s another area where the team can make a gain.

“Our first version of it was not a bad effort and made the car go quicker,” said Allison. “It certainly was what we were capable of given the race that we got the system out for [Korea]. But relative to the power loss that we were experiencing back then [with the Coanda set-up], the 2013 car will be at half that level.”

That should add up to an extra 6-8bhp thanks to mitigating the loss inherent in the more elaborate exhaust system. Combine that with the extra downforce, and it’s clear that the gains are there to be had.

WHY 2013 IS KEY

Lotus hasn’t been shy about admitting to its aspirations of becoming a title-winning force in the long-term and the rules reset in 2014 is an obvious point at which it can realise that ambition. But 2013 will play a significant role in making that step forward.

“It’s our ambition to be considered a top team, which should result in our capability to fight for a top-three position every year,” said Boullier. “If you build success one year, you can carry it into the second year. This will make this outfit attractive enough for sponsors that we want to be with us. If you can attract the best people, you can develop the best cars and in 2014 it’s very important to have a strong and stable technical department.”

This is why Lotus cannot afford to rest on its laurels in 2013 and focus on next year, an approach that is

open to some of its rivals. For all the question marks over future financing, the team is sure it has everything in place, including the budget, to achieve its aims, especially with investment in facilities – next up a new gearbox dyno – continuing apace.

When asked if he is confident he has the resources to lead his team into the top three, Allison replied: “The budgets for this year are greater than last year, so as long as we deliver a good car, there’s no reason why not.”

On paper, everything appears to be going in the right direction. The key question now is whether the E21 builds on the successes of its predecessor. If it does, expect more than just a single victory. ❖



LOTUS FORM GUIDE

2012

Drivers: Kimi Raikkonen, Romain Grosjean, Jerome d'Ambrosio
Drivers' championship: 3rd (Raikkonen)
Constructors' championship: 4th
Wins: 1 **Podiums:** 10
Best qualifying: 2nd **Points:** 303



2011 (As Renault)

Drivers: Nick Heidfeld, Vitaly Petrov, Bruno Senna
Drivers' championship: 10th (Petrov)
Constructors' championship: 5th
Best finish: 3rd **Podiums:** 2
Best qualifying: 6th **Points:** 73



2010 (As Renault)

Drivers: Robert Kubica, Vitaly Petrov
Drivers' championship: 8th (Kubica)
Constructors' championship: 5th
Best finish: 2nd **Podiums:** 3
Best qualifying: 2nd **Points:** 163



2009 (As Renault)

Drivers: Fernando Alonso, Nelson Piquet Jr, Romain Grosjean
Drivers' championship: 9th (Alonso)
Constructors' championship: 8th
Best finish: 3rd **Podiums:** 1
Poles: 1 **Points:** 26



POWER-STEERING BOOST FOR RAIKKONEN

Kimi Raikkonen's power-steering struggles were one of the major storylines of the early stages of his impressive comeback season.

The Finn favours steering that gives him as accurate feedback as possible in order to maximise his traction-sensing abilities. Lotus was under pressure to remove the hysteresis – the ability to absorb bumps and frequencies without influencing the steering angle – from the system. The team did a good job to get its system to a level that Raikkonen found acceptable, if far from perfect, but the 2007 world champion has good reason to be optimistic about the 2013 power steering.

The team's technical director James Allison said: "We relatively quickly got to a level that was tolerable and we finished the season in that state having had a few unhappy experiments along the way trying to improve on that. We were trapped largely by the flow capacity of the hydraulic pump that we had and in order to have the behaviour Kimi was after, we needed more flow out of it."

"This year, we have been able to engineer a slightly meatier pump into the car and we hope that we'll be able to use some of the extra flow that it affords us to buy us a bit of what Kimi likes from his power steering."



Steering set-up should suit Raikkonen more

BRANDS HATCH
KENT

OULTON PARK
CHESHIRE

SNETTERTON
NORFOLK

CADWELL PARK
LINCOLNSHIRE

MSV RACE EVENTS HIGHLIGHTS 2013

MotorSport Vision (MSV) is gearing up for a superb season in 2013, with a thrilling programme of major national and international race meetings at its four famous race circuits. Discounted advance tickets and the best grandstand seats are available online from our website.

23 March	Oulton Park	Masters Historic Race Day	6/7 July	Brands Hatch Indy/GP	Aston Martin Centenary
30 March/1 April	Oulton Park	British GT and F3 Cup	13/14 July	Brands Hatch GP	Historic Superprix
30/31 March	Brands Hatch	British Touring Car Championship	19/20/21 July	Brands Hatch GP	MCE Insurance British Superbikes
5/6/7 April	Brands Hatch	MCE Insurance British Superbikes	27/28 July	Brands Hatch GP	BRDC Formula 4 Championship
20/21 April	Brands Hatch	British Truck Racing Championship	3/4 August	Snetterton 300	British Touring Car Championship
20/21 April	Cadwell Park	Historic Wolds Trophy	9/10/11 August	Oulton Park	MCE Insurance British Superbikes
4/5/6 May	Oulton Park	MCE Insurance British Superbikes	10/11 August	Brands Hatch GP	British F3 and GT Championships
17/18/19 May	Brands Hatch	DTM (German Touring Cars)	24/25/26 August	Cadwell Park	MCE Insurance British Superbikes
25/26/27 May	Brands Hatch GP	Masters Historic Festival	24/25 August	Brands Hatch GP	Lotus Festival
8 June	Cadwell Park	Vintage Sports Car Championships	25/26 August	Oulton Park	Oulton Park Gold Cup
8/9 June	Brands Hatch	American SpeedFest	25/26 August	Snetterton 300	British Truck Racing Championship
8/9 June	Oulton Park	British Touring Car Championship	29 September	Snetterton 300	Vintage Sports Car Championships
15/16 June	Snetterton 300	British GT and Formula 4	12/13 October	Brands Hatch GP	British Touring Car Championship
22/23 June	Brands Hatch	Mini Festival	18/19/20 October	Brands Hatch GP	MCE Insurance British Superbikes
5/6/7 July	Snetterton 300	MCE Insurance British Superbikes	2/3 November	Brands Hatch	British Truck Racing Championship

Please note all dates are provisional and subject to change



MSV

For tickets and more information:
0843 453 9000 www.msv.com

THIS WEEK IN F1



ALONSO TO MISS JEREZ

Fernando Alonso will miss the first pre-season test at Jerez on February 5-8. Felipe Massa will drive on the first three days before handing over to new test driver Pedro de la Rosa. Alonso will complete three days at the second test at Barcelona and two in the final test at the same venue.

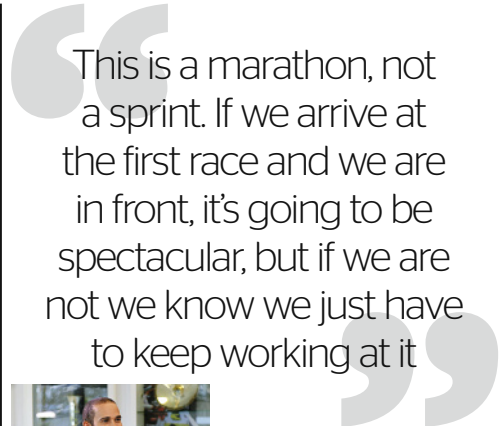

This is a marathon, not a sprint. If we arrive at the first race and we are in front, it's going to be spectacular, but if we are not we know we just have to keep working at it



Lewis Hamilton continues to keep expectations for 2013 in check

P24 LEWIS HAMILTON INTERVIEW

BUEMI STAYS AT RED BULL

Former Toro Rosso racer Sebastian Buemi will continue as Red Bull's reserve driver in 2013. The 24-year-old is slated to complete extensive simulator work alongside being on stand-by during race weekends.

BRAWN: NO PLANS TO LEAVE

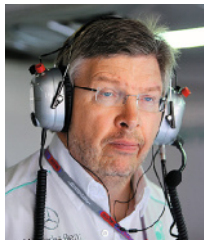

Ross Brawn insists that his future as Mercedes team principal remains in his hands. The team has identified McLaren technical director Paddy Lowe as a possible successor, but any move appears

unlikely in the short term. McLaren is understood to have sounded out Lotus's James Allison as a potential Lowe replacement, but he remains committed to the Enstone team.

RAIKKONEN TO PERFORM ON ICE

Kimi Raikkonen will contest the Race of Stars oval ice race event in Moscow on February 23. Charles Pic and Vitaly Petrov will also compete.



PORTUGAL EYES RETURN TO F1

Bernie Ecclestone has revealed that Portugal's Algarve circuit is pushing for the vacant slot on the F1 calendar for 2013. The chances of the German Grand Prix being staged this year are also receding, with the return of the French GP still possible.

2013 TYRES LAUNCHED



Pirelli launched its 2013 F1 tyres last week, which feature new construction and compounds, and a switch to orange markings for the hard tyre. The Italian company is confident that the rubber will recreate the uncertainty of the first half of the 2012 season.



ALGUERSUARI, DI GRASSI TO STICK WITH PIRELLI

Ex-F1 racers Jaime Alguersuari and Lucas di Grassi are set to continue as Pirelli's test drivers this year. "There is no reason to change what we have," said Pirelli motorsport boss Paul Hembery.

REMEMBER WHEN...



...Portugal last held an F1 grand prix? The last of Portugal's 16 world championship GPs was held at Estoril on September 22 '96. Jacques Villeneuve led home team-mate Damon Hill for a Williams-Renault one-two.

Trident
Racing Supplies



MS NAS AN

Unit 31 Silverstone Circuit Northants NN12 8TL UK
Tel: +44 (0)1327 857822 Fax: +44 (0)1327 858096
sales@tridentracing.co.uk www.tridentracing.co.uk

Think motorsport insurance.

Motorsport insurance for race cars, equipment and teams whether they are on or off track.

Our new and improved scheme for 2013 gives you great flexibility and the chance to receive no claims discounts.

We also have a range of additional covers so you can choose the package that's right for you.

Talk to us today or visit us online.

01638 608062
motorsport@bluefingroup.co.uk
insuremotorsport.com

Think Bluefin.

**LISTA
CABINETS
DIRECT**

www.listacabinets.co.uk
01228 560911 / 07733 157911
info@listacabinets.co.uk

Our 10 year
guarantee
ensures you
can trust in
our quality
products....



...couple this to
free shipping
to your door,
makes Lista
the perfect
package.

Lista Cabinets Direct are an authorised distributor for Lista products specializing in Motorsport
LISTA CABINETS DIRECT WILL NOT BE BEATEN ON PRICE
Most of our items are available in 12 standard colours or any custom colour on request

**Our 10 year guarantee ensures you can trust in our quality products!
Couple this to free shipping to your door, makes Lista the perfect package.**



MARK HUGHES

GRAND PRIX EDITOR

Could the planned resuscitation of what was HRT by Scorpion F1 Racing provide a new blueprint for the sport's top echelon? Or is it possible for such cut-price racing to continue beyond this season?

Scorpion F1 Racing is a new team hoping to rise from the ashes of HRT. At the time of writing a group of Canadian and American investors was in the process of acquiring the assets of the thwarted Spanish team and conducting due diligence. It hoped then to make a championship entry for this year, although there remain doubts whether this will be possible.

The initiative has received some support from Bernie Ecclestone and the plan is that the new team will be located at Silverstone from where updated versions of the 2012 HRT, with Cosworth engine and Williams gearbox, would be campaigned.

Is this just another crazy dream, one that's set to fail just as did the original team? Clearly the investors believe not. What's more they believe the team can be run on a budget of just €45 million – around €15m less than anyone else. It believes that this can be achieved with a staff level of just 60 people – i.e. around half that used by HRT last year. An established team owner currently operating in GP3 is set to

provide both a core of staff and be in charge of recruiting personnel to key engineering roles. Although extensive use of sub-contractors is part of the team's vision, these would be based around the British 'silicon valley' rather than spread out across the UK, three bases in Germany and others in Spain and Portugal – as was the case with HRT's modus operandi. But as with HRT, specialised components would be sourced from outside and the base would essentially be a race-preparation shop.

Effectively, it would be winding the clock back 20 years in terms of budget and staffing. Ecclestone is said to be keen that they prove this to be possible – as it's his belief this sort of back-to-the-future operation will come to be the bedrock of the sport in the coming years as the recession continues.

It's very easy to be dismissive of these aims from the outside, but given that it's only on the basis of using existing cars and therefore involves no design and build costs it becomes more believable. Scorpion

plans to operate from an industrial unit approximately half the size of even the next smallest team, it hopes to continue aerodynamic development using time in an established team's tunnel and the emphasis of the whole operation will be on no-frills efficiency.

Initial aero and engineering studies suggest that there are several relatively easy performance gains to be made from the existing car. Fundamental limitations in the car's braking system and its cooling – which prevented the Cosworth engines from being run at full power last year – are in the process of being addressed. The plan is to run Cosworth's new-for-2013 KERS unit, bringing it into line with Marussia.

It would be terrific if this vision turns out to be viable for this year. But what about after that? For 2014 there will be a new car for a new formula to be designed and built – not to mention a new more expensive turbo engine to pay for.

Or are we about to see a new push for customer cars? When that was last dismissed, the plan was to get costs of F1 participation down sufficiently that a fully-fledged constructor could operate on budgets comparable to 20 years ago. That is nowhere near to being achieved. Scorpion believes it can operate on such a relatively small budget precisely because it will be running an existing car. But the source of that car no longer exists. Therefore, the logic might go some time later in the season: why not let the small teams purchase existing cars from existing teams?

Should it go ahead, the Scorpion project could be a case study very significant to F1's future direction. ❄

PIC: LAT ARCHIVE



Customer-car history: Graham Hill in Rob Walker's Lotus, 1970

“A new team is hoping to rise from the ashes of HRT”



How R8-based DP might look

GRAND-AM

Audi eyes Daytona Prototypes

German manufacturer wants top-level US contender as Ford also steps up interest. By GARY WATKINS

Audi has left the door open to join the Daytona Prototype class or its successor after the American sportscar merger kicks in for 2014.

The German manufacturer has admitted an interest in the category courtesy of its desire to race at the highest level in sportscars in the US, one of its major sales markets. It previously competed for overall honours in the American Le Mans Series in 2000-2008, winning the title in each of those seasons.

Audi Sport boss Wolfgang Ullrich explained that racing with the R8 LMS, which is now in its second year in Grand-Am's GT category, would likely be only one arm of the manufacturer's US racing programme in the future.

"I do not think that racing for class victories should be our ultimate target," he said. "We are thinking about what we can do in US motorsport in the future and

we are constantly talking with people from all the motorsport authorities in the US."

Asked if Audi could produce its own body shape for the DP class like Chevrolet, along with an engine or even its own chassis, Ullrich said: "We need to look into that in detail, but we have to race in the top class and we have to race with relevant technology."

Ullrich did not set a timescale for an entry by Audi into the top flight of the as yet-unnamed merged series, which will combine Daytona Prototypes, LMP2 machinery and the DeltaWing in its premier division for at least 2014 and '15.

"We are not ready to jump into anything new tomorrow," he explained. "We are quite happy with the programmes we have at the moment."

News that Audi is at least considering a move to the DP category comes at a time when

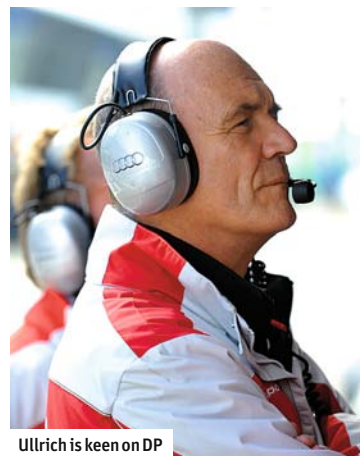

Ullrich is keen on DP

by long-time Ford partner Roush Yates and has already run in the back of a Michael Shank Racing Riley.

A test car ran on the oval at Daytona in the week after the official test ahead of last weekend's Daytona 24 Hours.

Shank said: "The engine is under development and we plan to do some cool things with it this year [believed to be a distance-record attempt] before racing it next year. I think we are going to see some cue elements on the car that give an indication of where Ford is going with its styling."

Aston Martin has also revealed an interest in taking advantage of Grand-Am's rules that allow a manufacturer to produce a bodykit styled after one of its road-going models.

Ford is looking to step up its involvement. It is already developing the first turbocharged DP engine to replace its existing normally-aspirated V8 and could produce its own DP body.

The new powerplant, a 3.5-litre twin-turbo V6, is being developed

➔ P38 DAYTONA 24 REPORT



Vipers returned in 2012 ALMS

LE MANS

Vipers primed for return to Le Mans

CHRYSLER'S VIPER WILL RETURN

to the Le Mans 24 Hours this year for the first time since 2003.

The US manufacturer's Street & Racing Technology brand, which badges the latest-generation Viper, has admitted that it has lodged two entries for the French enduro in June.

AUTOSPORT understands that key personnel involved in the Riley Technologies-masterminded project will be present at tomorrow's [Friday] announcement in Paris of the entry lists for Le Mans and the World Endurance Championship, which

confirms that it has been successful.

SRT director Beth Paretta, whose remit covers motorsport, said: "We hope to be there; we sent the letter away, we're hoping for the best and we have our passports ready."

"If we get the nod, we will be both humbled and excited. Le Mans is really why we are doing this programme."

Paretta played down expectations for the SRT Viper GTS-R, which will take on the Chevrolet Corvette, the Porsche 911 and the Ferrari 458 in the GTE class.

"First we want to be involved, then

we want to show well and then we want to win," she explained. "We know we are entering a lofty atmosphere in this class, so we have realistic ambitions for the first year."

Paretta explained that the SRT Motorsports squad run by Riley was unlikely to make significant changes to the driver line-up from the Viper's part-season in the American Le Mans Series in 2012, which included Dominik Farnbacher, Marc Goossens and Tommy Kendall. The exception will be Ryan Hunter-Reay, because Le Mans clashes with the Iowa IndyCar round.

'Rocky' in Corvette DP racer at Daytona



WEC/DTM

Rockefeller in DTM focus

MIKE ROCKEFELLER EXPECTS to be part of Audi's sportscar squad in the future, despite standing down from its Le Mans 24 Hours line-up this year.

Rockefeller, whose Daytona 24 Hours drive with the Action Express team last weekend was his only scheduled sportscar appearance of the season, is concentrating on his bid to win the DTM this year. He explained that he wants and expects to return to sportscars in the future.

"I would love to do sportscar racing again," said the 29-year-old German. "It could happen next year, but it depends on what Audi wants and where I

decide my focus will be.

"Definitely at some point in the future sportscars will be my focus. I'm not happy with what I have achieved so far in the DTM and I want to keep going there."

Rockefeller explained that a decision had been made ahead of the 2012 season for him to focus on the DTM for a minimum of two seasons. He joined the Le Mans squad last year when Audi opted to run four cars.

● Rockefeller's DTM team-mate Jamie Green had his first Audi test at Valencia last week. The Briton was joined by manufacturer veterans Mattias Ekstrom and Timo Scheider.

AUTOSPORT SAYS...

GARY WATKINS
SPECIAL CONTRIBUTOR

@gazzasportscars



Bet I'm not the only one who never envisaged Audi entering the Daytona Prototype arena. It would seem entirely out of character for a manufacturer that has set its stall on showcasing new technologies in the prototype ranks on the other side of sportscar racing's disappearing divide, but it might be a case of needs-must.

Remember, motorsport is a marketing tool these days, even if you are playing the technology card, and Audi needs something it can shout about in North America. That's not the R8 GRAND-AM project and it's not going to be a US-based DTM any time soon (or anytime at all), so why not a Daytona Prototype programme in some shape or form?

It could work for Audi and it would surely work for the unified US sportscar championship. The series is going to need more overt factory involvement if it is to scale the same heights as the American Le Mans Series in its pomp.

It is also worth noting the key role that European brands played in the ALMS in the early noughties and again later on in the decade, and I'm thinking Audi, BMW and Porsche here.

There's a long way to go before Audi commits to a DP programme, but if it happens it will be proof that US sportscar racing is headed for another golden era.

Audi dominated the ALMS for years



WEC

Starworks to defend titles

THE US-BASED STARWORKS TEAM

will defend its Le Mans 24 Hours and World Endurance Championship LMP2 titles this year.

Team boss Peter Baron confirmed that Starworks, which has split with its 2012 backer and driver Enzo Potolicchio, has made an entry for the full WEC. But he admitted that the plan, including the choice of chassis-engine combination, has yet to be decided.

Ryan Dalziel and Alex Popow, who race for Starworks in Grand-Am, will race with an undisclosed third driver.

Potolicchio, who has set up 8Star Motorsports, will step down from P2 this season to compete in GTE Am in conjunction with AF Corse. The Venezuelan will share a Ferrari 458 Italia with Marco Cioci and Rui Aguas.

Starworks sticks around



REMEMBER WHEN...

JUNE 17-18, 2000



...Vipers took on Corvettes at Le Mans?

It only happened once, in 2000, and Viper came out on top – winning the GTS class thanks to its line-up of Olivier Beretta, Karl Wendlinger and Dominique Dupuy.



V8 SUPERCARS

NEW-LOOK FALCON

This is the livery that Alex Davison's new-spec Ford Falcon Car of the Future will run in Australia's V8 Supercar series this year. The series returnee's car will be run by Charlie Schwerkolt Racing in conjunction with Ford Performance Racing.

DTM

Kubica on the pace in DTM test

Paffett praises injured Formula 1 driver's speed after maiden Mercedes test. By JAMIE O'LEARY

Robert Kubica made a big impression on Mercedes during his maiden DTM test at Valencia last week, virtually matching the pace of former series champion Gary Paffett.

The grand prix winner drove a C-coupe run by the German manufacturer's crack HWA squad for 114 laps in wet and dry conditions, having warmed up for his run with an outing in an Oregon Team-run Eurocup Megane

Trophy machine at San Martino del Lago in Italy 48 hours earlier.

Prior to that, his competitive driving since suffering horrific injuries in a crash on the Ronde de Andora Rally in 2011 had been limited to national rallies.

AUTOSPORT understands that the 28-year-old Pole's best lap was within 0.1s of Mercedes team leader Paffett's pace in the dry.

"He did a very good job," Paffett, the 2005 DTM champion told

AUTOSPORT. "This is the first time he's driven something this quick since his rally accident and it was really all about seeing how he would cope with a car with this kind of level of downforce and grip.

"His laps in the dry were very consistent and quick. You might say that's really impressive, but don't forget he was one of the top two or three F1 drivers in the world before he got injured, so really we should be expecting this from him."

Kubica's C-class was equipped with its paddle-shift gear lever to the left of the steering wheel, rather than the usual right. This was to enable him to use his left hand – which was not injured in the accident – to change gear and limit the amount of work done by his right.

A DTM car would be allowed to race in this specification if Kubica were to sign a full-time deal with Mercedes.

"I'd love to have him in the team," Paffett added. "Robert seems like a nice guy. He's obviously very quick and he's very well-known too, so he'd be a good addition to the series."

Glock's new mount



Glock inks BMW deal

SHOULD ROBERT KUBICA COMMIT TO a full DTM programme, he will join fellow ex-F1 driver Timo Glock, who signed a race deal with BMW last week.

The 30-year-old German tested an M3 for two days at Valencia after being released from his Marussia contract, and has targeted victories as his aim for the coming seasons.

"I know Formula 1 drivers have rarely been able to make an impact in the DTM, but I want to prove I'm different and challenge for victories," said Glock.

"Only time will tell if I am able to do this, but after spending three years in F1 being frustrated, I felt the time was right for a change."

Kubica tested Mercedes at Valencia last week



BTCC

Porsche ace joins Plato in MG team

PORSCHE CARRERA CUP RACE

winner Sam Tordoff will partner Jason Plato at MG in this year's British Touring Car Championship. Yorkshireman Tordoff contested a one-off BTCC round at Brands Hatch with Triple 8 Engineering – which now runs the works MG squad – in a Vauxhall Vectra in 2010.

He now makes a full-time graduation to the BTCC with the help of the 2013 KX Akademy, which is designed to help the careers of aspiring tin-top drivers.

"It's fantastic," Tordoff told AUTOSPORT. "KX have helped me get that little step I needed and I regard Triple 8 as the best team on the grid. It's a dream come true."

Tordoff, who finished third in the Carrera Cup last season, believes he can become a frontrunner during 2013. "Jason set the standard last year and



Tordoff makes BTCC step-up

the car will be capable of winning the championship, so I need to prove to people I deserve the seat," he added. "If I can win in the Carrera Cup I believe I can win races in the BTCC."

Two-time BTCC champion Plato, who will also act as Tordoff's mentor through the KX Akademy, said: "Sam's a great young talent and brings a lot to

our team. He's a fast learner and it will be great to see him on the podium – but I'm planning to be on the top step."

Team boss Ian Harrison added: "We've got a great team for 2013. Jason's obviously got the experience and Sam's out to prove himself now he's won a seat in a top team."

60 SECONDS WITH

ROB HUFF

Bathurst debutant

The World Touring Car champion will drive an Audi R8 LMS ultra at the Bathurst 12 Hours next month, and he has some other things in the pipeline too.

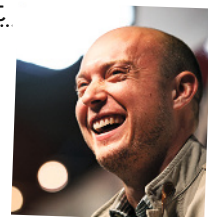

How did the drive come about?

I'd been exchanging texts with my old mate James Winslow because we were neck-and-neck for the BRDC Gold Star last year, and he eventually got in touch because he wanted to do the Dan Wheldon charity karting event at AUTOSPORT International. When he came over for that he mentioned Bathurst to me.

What are you driving?

It's an Audi GT3 car, so we'll be going for outright victory. I'll be sharing with James, which is nice because we made our race debuts together in a Jim Russell Racing School event at Snetterton in about 1998. Peter Conroy, whose team runs the car, will be the other driver.

Why do it?

Three reasons: firstly because I want to speak to some V8 Supercar teams about possible opportunities in the future, be they enduro drives or full-time; secondly because if I know the circuit then it's less of a risk for those teams to take me; and finally because it's Bathurst and I've always wanted to race there on the mountain.

Will you defend your World Touring Car title?

I'd really like to and in an ideal world that's what I'll be doing. Before AUTOSPORT International I had nothing on the table, but in the week after it I was presented with five or six different options.

Is remaining with RML your preferred option?

Of course. Who wouldn't want that if it were on offer to them? They are the best team and have the best car. If everyone had carte blanche, there would be 26 Chevrolet Cruzes on the grid this year. Nothing's decided for me yet though.



Rob Huff was speaking to AUTOSPORT's Jamie O'Leary

The Peter Conroy Audi that Huff will race



What the new car looks like



AUTO GP

More Auto GP tweaks

AUTO GP HAS FURTHER TWEAKED

the aero package of its heavily-revised single-seater ahead of the new season.

Since initial tests conducted by reigning champion Adrian Quaife-Hobbs at Barcelona last December, ex-Ferrari Formula 1 designer Enrique Scalabrini was commissioned to make a series of tweaks to the design of the car. These are now completed.

The result is a new engine cover featuring openings at its rear end, and adjusted sidepods featuring revisions to the turning vanes.

Series boss Enzo Coloni said: "We were happy at Barcelona that the new car was 1.5 seconds a lap faster than the old one, but we still identified areas where a slight redesign could gain performance. Now we're aiming for GP2 performance territory."

IN BRIEF

STONER CONFIRMS V8 DEAL

Two-time MotoGP champion Casey Stoner last week confirmed his switch to four wheels in Australia's V8 Supercar Development Series. He will drive a Triple 8 Holden Commodore.

NO V8s AT ABU DHABI GP

V8 Supercars has been axed from the Abu Dhabi Grand Prix support bill following the confirmation earlier this month that the GP3 Series will make an

appearance at Yas Marina. The calendar has been cut to 14 rounds as a result.

BVM TARGET REBRANDED

Formula Renault 3.5 team BVM Target has been renamed Zeta Corse following a management reshuffle. It is on the reserve list for a 2013 entry, but is expected to land the final slot.

VILLENEUVE v LOEB AT PAU

Jacques Villeneuve and Sebastien Loeb have both entered the Supertourisme 2L races that will support the Pau Grand Prix on May 18-20. Yvan Muller will also race the Mitjet-based cars if he does not have a WTCC programme in place.

TRUMMER'S GP2 TEAM SWITCH

Rapax has completed its GP2 line-up by signing Swiss ex-Arden driver Simon



Trummer is off to Rapax

Trummer to partner Stefano Coletti. Rival Addax has recruited American Jake Rosenzweig alongside Rio Haryanto.

ERIKSSON GETS STATUS

Swede Jimmy Eriksson, who won last year's German Formula 3 title, has joined Status GP for GP3 in 2013. Meanwhile, race winner Patric Niederhauser remains at Jenzer Motorsport, while David Fumanelli has moved from MW Arden to Trident Racing, where he joins Formula Abarth graduate Emanuele Zonzini.



No trip to Yas Marina for V8s



BF3's last race as a full series, Donington 2012

BRITISH F3

Teams face up to Brit F3 crisis

Leading lights pledge support as single-seater series is slashed to four rounds. By MARCUS SIMMONS

British Formula 3 International Series teams Carlin, Fortec Motorsport and Double R Racing have pledged to support the championship this year after it was downscaled to four rounds.

The three teams will shift their British F3 squads to the Formula 3 European Championship, but want to contest the four British rounds at Silverstone, Spa, Brands Hatch and the Nurburgring.

Carlin boss Trevor Carlin told AUTOSPORT: "We will shift all our drivers [currently four] to the European championship because they believe F3 is the best training car and that's the only game in town."

"We, of course, will do every British round as well, and we'll put some extra cars out if we have them available. We'll run all six – if we're allowed to! [a series ruling restricted the team to five in 2012]"

Fortec boss Richard Dutton, who was understood to be close to a deal with Josh Hill for BF3, wants to move the Formula Renault NEC race-winner to his European team – comprising Felix Serralles and Pipo Derani – and run all of them in the BF3 rounds.

"That would most probably

BRITISH F3'S NEW 2013 CALENDAR

Rd	Circuit	Date
1	Silverstone (GB)	May 25-26
2	Spa (B)	July 25-27
3	Brands Hatch (GB)	August 10-11
4	Nurburgring (D)	September 21-22

work," said Dutton. "Although it's a bit sad, you've just got to get on with it, and it was no good pretending we were suddenly going to get 15 cars for British F3."

Double R chief Anthony Hieatt, who already had Antonio Giovinazzi and Sean Gelael on board for BF3, added: "We will do

our best to do a four-round BF3. We hope to have three or four drivers in European F3 and we could either get new drivers in for BF3 or give our existing ones a bit more track time. It's a sad day."

Meanwhile, T-Sport was already set for a shift to European F3. Team boss Russell Eacott is doubtful that he can commit to the whole BF3 schedule due to the logistical problems of rebuilds in Japan for his ThreeBond Nissan engines.

"For us it's rather difficult," he said. "But we will endeavour to look at doing something. And if

someone wants to race our National Class cars in BF3 we could do that quite easily."

Benjamin Franassovici, who manages the series for promoter the Stephane Ratel Organisation, said: "We didn't have enough cars to go ahead with our current format. No one wants to see BF3 disappear, so we agreed [SRO, the teams and tyre supplier Cooper Avon] to go down to four rounds and try to make it attractive."

"We need to keep the British F3 heritage going, and this is the right move before it's too late."

Carlin, Fortec and others will major on Euro F3



INDYCAR

Indy chief aims for pitlane consistency

INDYCAR RACE DIRECTOR BEAUX

Barfield is aiming for a more consistent policy on keeping pitlanes open during full-course yellows this year, although no changes have been enshrined in the rules.

Several drivers, notably 2012 series runner-up Will Power, complained last year that it was too difficult to predict whether the pitlane would remain open following an incident, which could in turn compromise race strategy. Barfield told AUTOSPORT that changes have been made to enable the pitlane to be left open more often, although flexibility will be needed to make exceptions when needed.

"There were factors that I thought were important to consider last year in opening or closing the pits," said Barfield. "We've decided in discussions during the off-season that these don't need to weigh so heavily. That puts us in the position to more-consistently leave the pits open this year, which is certainly one of our goals.

"But there still are scenarios where we need to dispatch equipment and get the



Pitlanes could stay open more in 2013

track shut down as quickly as possible. Closing the pits is the best option to be able to achieve that."

Barfield announced a number of changes to the 2013 rules last week. Race distances for St Petersburg, Milwaukee, Mid-Ohio and Long Beach have been tweaked to discourage fuel-saving strategies, and polesitters and race leaders have been

relieved of the option to choose which side of the track to line up from for starts and restarts. Other tweaks include adjustments to the points system to encourage competition among lower-placed cars.

● Schmidt Peterson Motorsport was due to announce Indy Lights champion Tristan Vautier as Simon Pagenaud's full-time team-mate as AUTOSPORT closed for press.

IN BRIEF



Conway: one-race deal

CONWAY GETS RAHAL DEAL

Briton Mike Conway has signed a one-race deal with Rahal Letterman Lanigan Racing to contest the IndyCar race at Long Beach in one of the team's Dallara-Chevrolests. Veteran Alex Tagliani, meanwhile, has kept his drive with Bryan Herta Autosport.

ZANDVOORT'S AUTO GP DATE

Dutch track Zandvoort has taken the vacant spot on the Auto GP calendar, on July 13-14. AGP teams Virtuosi UK and Euronova have recruited Formula 3 graduates Andrea Roda and Kimiya Sato respectively for the season.

NISSANY STEPS UP TO F3

Israeli Roy Nissany, a race winner in ADAC Formel Masters, will contest the Formula 3 European Championship with Mücke Motorsport. German F3 National Class champ Andre Rudersdorf has joined rival team Ma-con Motorsport.

GRIFFIN'S DOUBLE DEAL

Matt Griffin will undertake dual assaults on the World Endurance Championship and European Le Mans Series in GTE Ferraris. The Irishman will share an AF Corse car with Jack Gerber in the WEC and a Ram Racing entry with Johnny Mowlem in ELMS.

PANIS RETURNS TO SPA

Ex-F1 star Olivier Panis will drive a Hexis Racing McLaren MP4-12C at the Spa 24 Hours in July. He will share the team's Pro-Am car with French Carrera Cup driver Come Ledogar and French GT regulars Laurent Cazenave and Eric Debard.

US SERIES TO BE NAMED

The name for the unified US sportscar series will be announced during the run-up to the Sebring 12 Hours in March.

TK-S STAYS WITH GREAVES

British sportscar racer Tom Kimber-Smith will stay with Greaves Motorsport for an attack on the LMP2 class of the Le Mans 24 Hours and Sebring 12 Hours. He will also race one of its Zytek-Nissan Z11SNs in the Spa WEC event.



More LMP2 action for TK-S

MRF CHALLENGE

Hill to enter Indian single-seater races

MCLAREN AUTOSPORT BRDC AWARD

finalist Josh Hill is planning to contest the final round of the MRF Challenge in India.

Hill, 22, finished third in the Formula Renault NEC standings last season and is hoping to graduate to Formula 3 this year.

He hopes to race one of the Dallara-built chassis at Madras on February 9-10 to get his hand in ahead of any 2013 campaign.

"We're just trying to sort out a deal," Hill told AUTOSPORT. "It's always good to keep racing and we haven't yet got

any other testing in Europe planned."

MRF is currently led by Hill's Formula Renault rival Jordan King, and Hill believes he can be competitive.

"We get testing on the Wednesday and Thursday, so there's a lot of driving, and the car is similar to a Formula Renault," added the son of 1996 F1 world champion Damon. "Hopefully we should be there or thereabouts."

Hill confirmed negotiations for his 2013 activities are ongoing but admitted he could end up with an "11th-hour deal".



Hill hopes to head to India



WRC is on TV, but not in UK

WRC

WRC UK TV unlikely for Sweden

WORLD RALLY CHAMPIONSHIP

officials remain optimistic of a deal for British fans this season, but the chances of bagging one in time for next weekend's Rally Sweden look increasingly remote.

There is no deal in place for the WRC to be shown on any channel in Britain, but series promoter Sportsman Media's Olivier Ciesla told AUTOSPORT that negotiations with a broadcaster were ongoing. He could not, however, promise anything for the start of the second round of the WRC.

Ciesla said: "We had more talks on this subject at the end of last week and now we have to wait for the broadcaster to come back to us. I'm optimistic we will get a broadcaster in place for the season, but Sweden is very close."



Big task faces
Lewis Hamilton

The one who flew over to Mercedes'

nest

Lewis Hamilton has been a McLaren driver for most of his life, but this year he'll trade the glories of Woking for the challenge of hauling Mercedes up the grid. *By BEN ANDERSON*

No matter who you are, sometimes you just need a fresh start – a chance to reinvigorate your life and discover fresh motivation. Most people achieve this by moving house or changing jobs; Lewis Hamilton hopes to get there by altering where he does his job.

Hamilton has spent his grand prix career to date at McLaren. In fact, he's spent most of his life there, nurtured as he was from teenaged karting ace into 28-year-old superstar F1 driver. Regardless of achievements, prospects and relationships, that's a long time for anyone to spend in one place, knowing only one way of doing things.

If you view Hamilton's move from McLaren (one of the most successful teams in F1 history, which has propelled him to 21 wins and a world championship in six seasons) to Mercedes (a squad that has achieved a single victory and five other podiums since returning to F1 in 2010) only through the prism of the competitive order, it doesn't make sense. After all, why would any sane driver trade a

team that has challenged for the world title consistently over the past three seasons for one that hasn't come close during that time?

But this is about more than results – it always was. Hamilton has proved time and again that he is a world-class grand prix driver, capable of delivering race wins and world championships in the right equipment. But there's always been a nagging sense that McLaren has overshadowed his rising star – a paternal master that told him what to do and directed his destiny. It's a natural legacy of a relationship formed when Hamilton was very young. McLaren was like a surrogate family – a second home. But every bird needs to fly the nest some day...

But why Mercedes? The short answer is that it's the next best option – what with Fernando Alonso locked in as team leader at Ferrari and Sebastian Vettel having organically assumed that role at Red Bull (with whom Hamilton's management team held discussions about a move). Mercedes might have finished woefully adrift of the big players in last season's constructors'

title race, but it represents a chance for Hamilton to become an unchallenged team leader, the focal point for its competitive energy in the way that Michael Schumacher Mk1 was for Ferrari, and the way Alonso is for the Scuderia now. That's something Hamilton could never quite achieve at McLaren, due to its natural way of operating and the nature of his relationship with the team. And that's before we consider his own desire for greater commercial freedom.

Shortly after signing for Mercedes late last year, Hamilton famously said he didn't expect to win races or challenge for the title in his first season with the Three-Pointed Star, and he continued to dampen down expectations during his first official press engagement as a Mercedes man at the team's Brackley base last week.

"It's important to be patient and it's important to be realistic," he says. "You've got to remember how long it takes to develop a car and to find one second throughout the season in F1.

"Knowing that Mercedes was one second behind in Brazil – I think it ►

◀ was almost two seconds at Suzuka – you’ve got to be very understanding that with an evolution of that car it’s going to be difficult for them in three months to gain that. I’ve just got to be very aware of that, but I know that the guys are working as hard as they can.”

Hamilton’s move is really all about 2014, when F1 introduces its new 1.6-litre turbocharged V6 engine formula, and direct alignment with one of only three manufacturers building powerplants for that formula should prove to be a shrewd move.

“This is a marathon, not a sprint,” says Lewis. “I hope that this year we can be competitive. If we arrive at the first race and we’re in front, it’s going to be spectacular, but if we’re not we know we just have to keep working at it.”

“I’ve not even driven the car so I don’t even know what problems they had. It’s not like I can say, ‘We need to look in this area.’ [But I think that] they didn’t have enough downforce last year.

“Of course 2014 is probably a slightly

better opportunity, because things start again [with the regulations], but you’ve got to remember that I had a couple of half-dodgy cars, one particular year in 2009, but it did get better so perseverance is going to be key for all of us. I hope to have quite a big impact in those first days of driving the car, because I’ll be able to compare one car to the other and say what we do and don’t have and what the car is and how it could be better. But it’s going to take some time to get up to speed with the controls and the different settings, characteristics, aero balance.

“I don’t know how long it will take but I’m on top of it, I’m ready.”

Hamilton arrives at his new team amid a swirl of speculation surrounding the future of team principal Ross Brawn, and a degree of upheaval in the senior management structure. Mercedes’ long-serving motorsport boss Norbert Haug has stepped aside, Williams chief executive Toto Wolff has come in as a co-owner alongside triple world champion Niki Lauda,



Hamilton does tour of duty at Stuttgart...

...and Brixworth, with Merc F1 engine chief Andy Cowell

HAMILTON AGAINST HIS TEAM-MATES

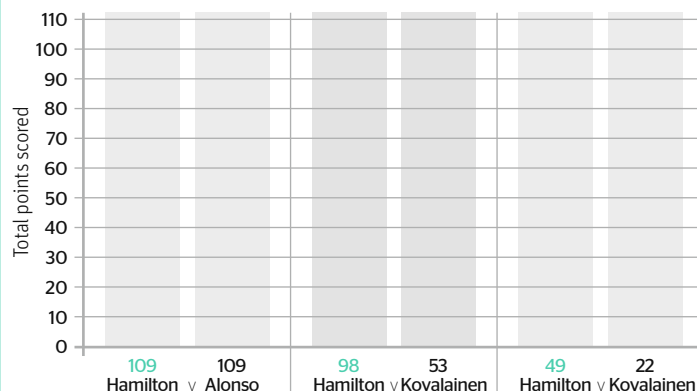

Matches his reigning world champion team-mate as a rookie and almost takes the crown in his first season.

Pips Ferrari's Felipe Massa to the title at the Brazil decider and leaves his Finnish running mate trailing.

A difficult season for McLaren, but Hamilton battles to two wins as Kovalainen fails to make the podium.

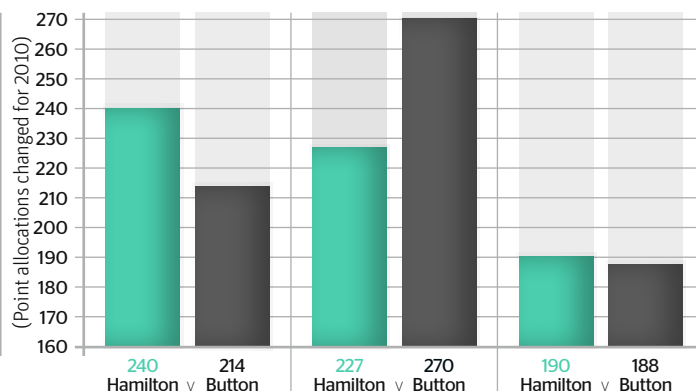

Misses out on the title at Abu Dhabi decider but outscores his reigning world champion team-mate.

Wins three races but is trounced by Button amid various on-track errors and off-track personal turmoil.

Produces one of his finest campaigns yet as operational errors and unreliability put him out of title contention.



INTERVIEW
LEWIS HAMILTON

Hamilton joins Rosberg, will he also join the midfielders?

WHY LEWIS NEEDS TO UNLEASH HIS INNER CHURCHILL

AUTOSPORT's resident mind coach, Don Macpherson, analyses Hamilton's switch to Mercedes and asks how he's going to cope mentally with what's ahead

Lewis Hamilton did a good job in 2012: I place him second, behind Fernando Alonso and ahead of Sebastian Vettel, in my mind-management league. But he faces very different mental challenges this year. The question is, does he have the tools to deal with them, or will there be more 'WTF' tweets? Maybe Nicole Scherzinger or Ross Brawn should confiscate his phone over race weekends...

He often likes to tweet inspirational quotes, such as "The time is always right to do what is right" – Martin

Luther King. Pity he didn't check this one out: "A lie gets halfway around the world, before the truth gets a chance to put its pants on" – Winston Churchill.

His over-the-top reaction last year to thinking Jenson Button had 'unfollowed' him, and was therefore disrespectful, played right into the hands of his twitter 'haters', and showed a rather worrying mental immaturity. It turned out to be complete rubbish, as most of the time the only thing Jenson was following was the back of Lewis's car!

The well-documented twitter drama at Spa showed he was so desperate to explain his poor qualifying to his adoring followers that he was even prepared to give his own team's secrets away. Not the actions of a balanced mind.

Can he stay calm when McLaren launches its new car, and still remain positive that he has made a good decision? An even bigger mental challenge will come at the first test, especially if his new Mercedes is off the McLaren's pace. But the biggest

mental test will come if he is overtaken (or lapped?) by Perez in 'his' car.

Then there's the usual challenge of being quicker than his team-mate. I think he knows he's got that covered. Nico Rosberg is not mentally weak, but Hamilton is stronger.

His real challenge is to match what Alonso and Vettel are doing now: build the team around you, be the team leader. Maybe he should read more of Churchill's quotes – Winston knew how to win a war.
www.donmacpherson.co.uk

and rumours are rife that McLaren technical director Paddy Lowe is being lined up to replace Brawn. Whatever the hiring and firing strategy at Merc, Hamilton is relaxed about the situation and doesn't feel as though he's walking into a team in turmoil.

"I've been assured by Ross that his commitment is for the long term and he is here to try to win with me, which reassures me and continues to give me a positive feeling," counters Hamilton. "There are lots of good people here and I believe in all the people in this team. There is a great spirit here. The guys seem hungrier than any group of people I've seen before. Every year there was always a great atmosphere at McLaren, but this is a different environment to come to and a different feeling because it's new and fresh. But the guys seem to be just as one [as the guys at McLaren], if not more.

"It's important that they're always analysing and seeing what can be

improved and what adjustments need to be made. That's a big positive for me – to see that they're not scared of making changes and doing whatever they have to do to win."

Triple world champion Jackie Stewart said at AUTOSPORT International earlier this year that Hamilton was taking a risk by joining an underperforming manufacturer team that could pull out of the sport at any moment if better results are not forthcoming. But Hamilton appears relaxed about the challenges he faces.

While it's true that Jenson Button narrowly outscored him during their three seasons together at McLaren, Hamilton's personal form during the latter part of last year was sublime, and only some unfortunate operational and reliability issues at Woking prevented him from maintaining a title challenge. And few would predict he'll struggle to get on top of Mercedes incumbent Nico Rosberg – a very

capable driver, but one who is yet to convince the world that he's an absolute top-line driver.

So in theory, the way is clear for Hamilton to mould this team around his own will, conducting its competitive energies in a way that might return the glories of the 1950s to the Silver Arrows (if the car is good enough) and elevate Hamilton's own standing to that of a true grand prix legend. Whatever the obstacles to that ambition in the short term, you know he will back the depth of his own driving talent to pull the team through.

"I'll be flat-out all the way and working as hard as I can to drive the team to success," he says. "It's not a one-man band, it's a team effort, and while they're putting in 100 per cent I'll be doing exactly the same."

For Lewis Hamilton and Mercedes, now is the time to show the world what they're really made of. ❁

What's new in F1 2013

There aren't many rules tweaks for F1 teams to get their teeth into this season, but the devil is in the details. Here is AUTOSPORT's guide

This year's Formula 1 cars will be, by definition, the best of breed. There have been plenty of tweaks to the current rule set, introduced in 2009, over the years but this is the end of the line for this family of machinery. The Red Bull RB9, launched on Sunday, is a direct descendent, the great-great grandson, of the machine that earned the team its first victories four years ago. While the rules that define the thoroughbreds breaking cover during launch season are largely unchanged from 2012, there are some differences that could prove very significant.



1. WEIGHT INCREASE

The minimum weight (F1 regulations stipulate that this figure is car and driver) of an F1 car has been increased by two kilos. This is because of the slight increase in weight of the 2013 Pirelli rubber. The weight distribution continues to be regulated, with 292kg/343kg minimum front/rear.



Cars will be a fraction heavier

343kg

2. DRS ZONES APPLY IN EVERY SESSION

For the first two seasons of the DRS era, deployment of the system was unrestricted in practice and qualifying with its use in the race restricted to designated zones. In 2013, the restricted zones will be used throughout the weekend.

The DRS zones are now restricted all weekend



2

Cars must pass tougher crash tests



3. CRASH TESTS

More stringent crash tests to the roll structure and the survival cell have been introduced. However, these should make no obvious difference to the look of the cars. As per last year, all crash tests must be passed before testing starts.

3

4. BANNED: DOUBLE DRS

The 'active' double DRS designs, which relied upon exposing holes in the rear wing endplate hooked up to a system of tubes to stall various parts of the car, are banned. Both Mercedes, which stalled the front wing, and Red Bull used such a concept last year. The impact of this change is limited because, unlike the previous two seasons, use of the DRS is no longer free during qualifying (see below). The 'passive' double DRS systems trialled by Mercedes and Lotus last year, however, remain legal (for more on how DRS works, see p32).

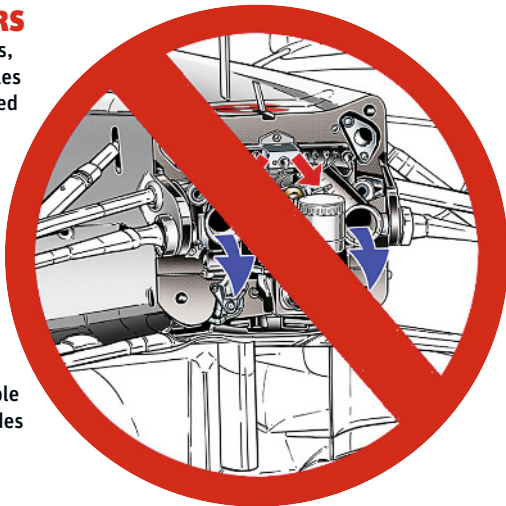

Flexi-wing tests have been tweaked



6. CRACKDOWN ON FLEXI-WINGS

The force applied in tests for flexible front wings was increased last year, but the change made this year is about how that force is applied. Bodywork is not allowed to deflect more than 10mm when a 1000N force is applied to it. Previously, this was applied in the centre of the front wing, but this year it will be applied in two different places. One is 675mm forward of the front wheel centreline and the other is 300mm further forward. This is to tackle wings designed to pass the test, but flex under real-world loads.

1 642kg
(640kg)

5. SEXIER CARS? 'VANITY' PANEL

The unsightly step in the nose of most cars was a major talking point during launch season last year. This was a result of regulations being changed to lower the nose for safety reasons in the case of a T-bone accident, combined with the aerodynamic benefit from keeping the height of the chassis itself as high as possible. To tackle this problem, teams can now put a laminate 'vanity panel' over the step. This is *not* mandatory.

5

100kg 10mm

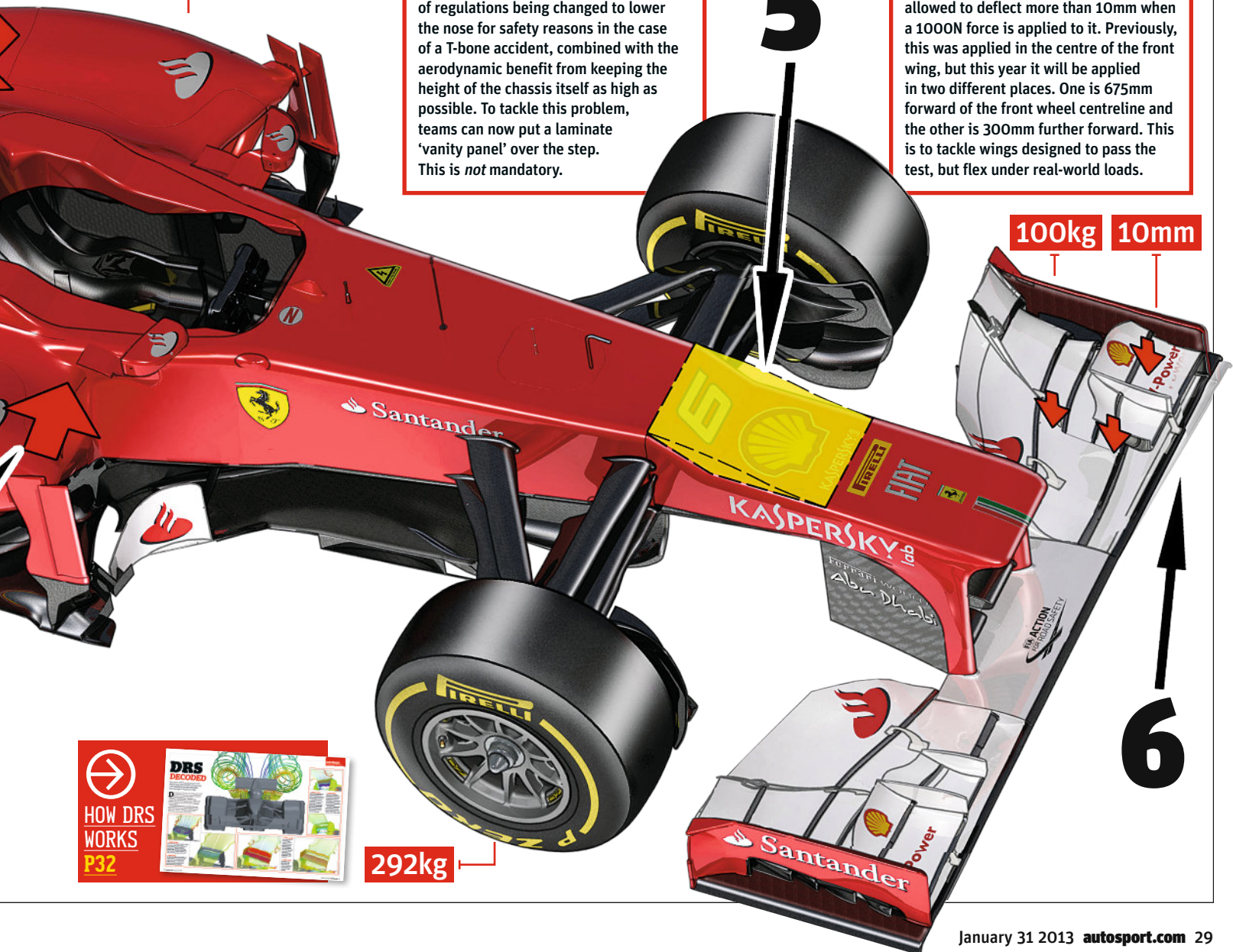

HOW DRS WORKS
P32

Things that will SHAPE

F1 2013

As well as the technical tweaks, there are a number of other factors that could affect the results on Sunday afternoons. *EDD STRAW* and *JONATHAN NOBLE* guide you through them

NEW-SPEC PIRELLI TYRES

Pirelli grabbed the attention in the early part of 2012 with its new rubber. There was a consensus in the paddock that the team that understood the nature of the tyres first would unlock the secret to winning the world championship.

As it happened, most of the teams got a grip on the situation at the same time. So, by the end of the campaign, that increased knowledge, allied to some conservative choices with compounds, left F1 delivering a few one-stop processional events.

For this season, Pirelli is shaking things up again – but this time going much further than by simply choosing some softer rubber to make things difficult for teams and drivers.

Yes, there will be some more aggressive compound choices (the new hard will be roughly where last year's medium was), but the structure of the tyre is being stiffened up.

The two changes have been brought about with the aim of helping increase the warm-up characteristics – and also to push the tyres much quicker into

thermal degradation.

The new tyres are predicted to deliver around a three per cent improvement in grip, and the differences should be felt particularly strongly in areas of corners where there are combined traction needs.

The gaps between compounds is aimed to be around 0.5 seconds per lap – thereby opening out more strategic options in 2013.

One visual tweak is that the hard compound is no longer the 'silver' it was last year. To avoid confusion its sidewall has been painted orange for 2013.

One key improvement the teams will like is that the operating window of the tyres should be wider than last year – when there were numerous headaches caused by teams struggling to get a handle on the temperature balance between the front and rear tyres.

The changes will not only impact on the racing – because two pitstops should now be the minimum at every event – but drivers themselves will feel a difference in the cockpit.



The improvements should make turn-in a lot sharper – so drivers like Fernando Alonso will be especially happy.

Improved mechanical grip from the rubber should also result in the grid being closer – because lap time performance is not so

dependent on downforce.

Pirelli is determined not to let tyres move out of the spotlight. Its changes for this season are the most aggressive it has made since it returned to F1 – and it is convinced its efforts will help bring 'uncertainty' back to the sport.



INTERMEDIATE



WET



SUPERSOFT



SOFT



MEDIUM



HARD



COANDA EXHAUSTS

As teams worked to harness the downforce-generating potential of exhaust gases last year in the wake of rule changes designed to outlaw exhaust-blown diffusers, there was much talk of the 'Coanda Exhaust'. These were exhaust concepts that harnessed the Coanda Effect, named after Romanian Henri Coanda. This effect is the tendency of a gas (or liquid) emerging as a jet to be attracted to a nearby surface.

This, along with the downwash effect of high-speed airflow passing over the sidepods, allows the exhaust gases to be

directed downward to create downforce by blowing on parts such as brake ducts. This partly nullifies the rule change that mandated exhaust exits were higher than previously and must point upwards.

But as with all exhaust-blowing designs, it takes time to get the design right. To get the biggest benefit from such blowing, the exhaust must create downforce at lower speeds. While the Coanda Effect is strong enough to allow this to happen, as teams such as Mercedes discovered, making it work is not always straightforward.

PASSIVE DOUBLE DRS

While the 'active' double DRS has been outlawed (see page 28), there is nothing preventing teams running so-called passive systems. These rely upon a 'switch' that rechannels airflow based purely on the speed of the car. Lotus and Mercedes (right) experimented with such designs last year, although struggled to make them work.

At circuits with a large number of straights, this design could be worth significant lap time, particularly with the use of the DRS limited to the designated zones each weekend in 2013. But the danger is that teams will spend a lot of time trying to get it to work.

The problem is not activating the switch and creating the stall effect; instead, it's solving the difficulty that the switch deactivates at a lower speed than it activates. This means that a car can be without the required downforce for braking and cornering at certain speeds.

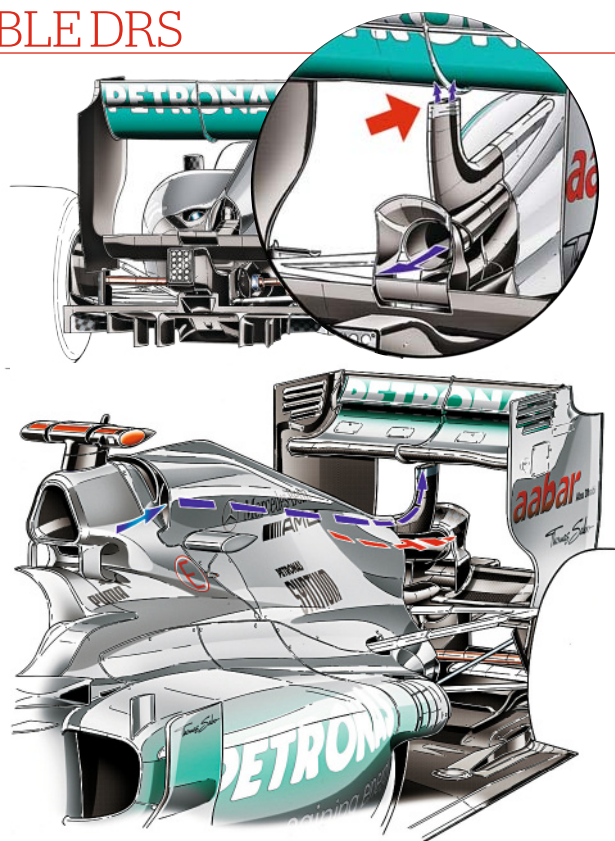

QUALIFYING REVISED

The demise of HRT means a small tweak to the qualifying system that will have a big impact. With 22 cars left, six, rather than seven cars, will be knocked out in each of Q1 and Q2, with Q3 remaining a top 10 shoot out.

For the previous three seasons, Q1 has generally been an exercise in sorting out the order of the Caterhams, Marussias and HRTs and eliminating one midfield runner. Now, even if the two remaining now-not-so-new teams continue to be cast adrift, the rest will be fighting to avoid two knockout spots. This could have a serious knock-on effect, with more having to use the faster tyre in Q1 to ensure they don't drop out.

FORCE MAJEURE CHANGE

When Lewis Hamilton stopped on his slowdown lap after taking pole in Spain last year and Sebastian

Vettel did the same thing in Abu Dhabi (right), several hours were wasted over what constituted force

majeure. This year, things will be more clear cut with force majeure no longer in the regulations.

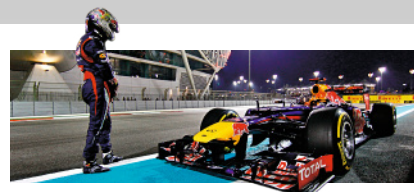

DRS DECODED

The problem with F1 aero is you can't see it. With the help of AUTOSPORT's CFD drawings, GARY ANDERSON and JONATHAN NOBLE shed some light on the dark art of DRS

Downforce on a Formula 1 car is produced by speed – so the faster you go, the more downforce you create. As a car goes from 100km/h to 200km/h it has four times more downforce.

But there is a limiting factor – and that's drag. At speed, the rear wing generates a lot of vortices at the endplate, which the F1 car effectively has to pull along. This also creates the 'dirty' air that makes overtaking far more difficult.

The solution to that lack of overtaking action was the introduction in 2011 of the drag reduction system, which opens the rear-wing flap in a designated zone when a car is within 1 second of the one in front. This is what then happens to the airflow...

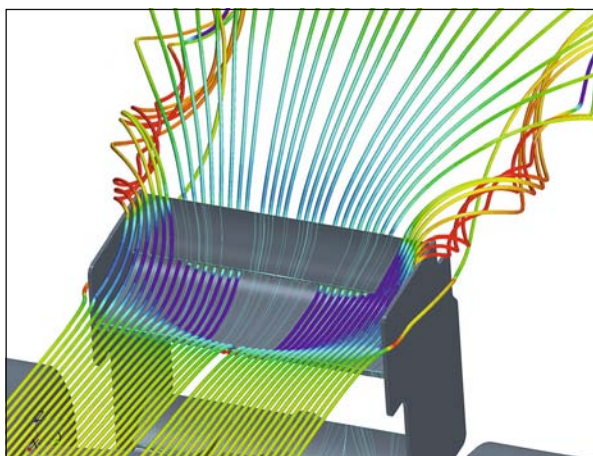
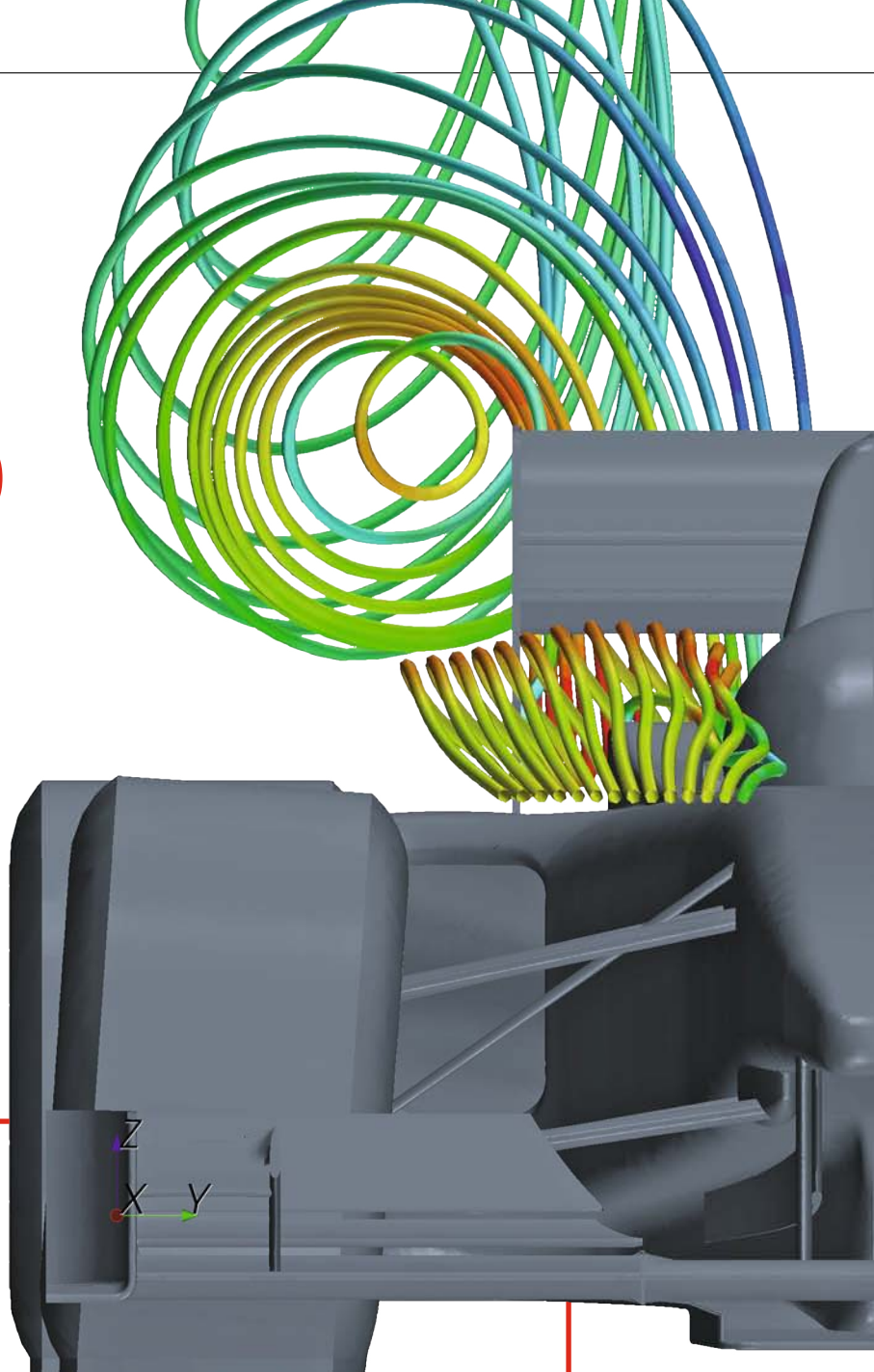

▲ **FIGURE 1 (CLOSED)**

You can see here clearly the vortices coming off the top corners. There is high pressure on top of the wing and low pressure underneath it – and there is also static pressure. When all three of these forces meet it creates a rotating movement and that's getting pulled along with the car.

► **FIGURE 2 (OPEN)**

The main aim of DRS is to get a reduction in both downforce and drag. When the wing is open, you can see how much smaller the vortex is – which means the wing is doing a lot less work. The wing is now much more efficient.

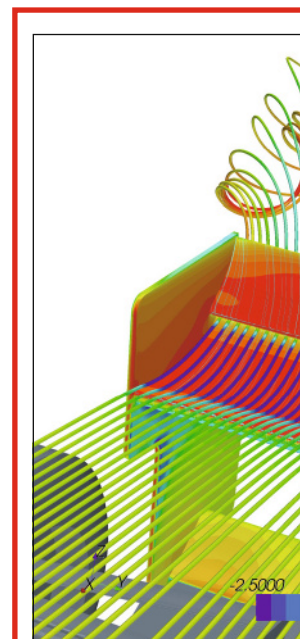
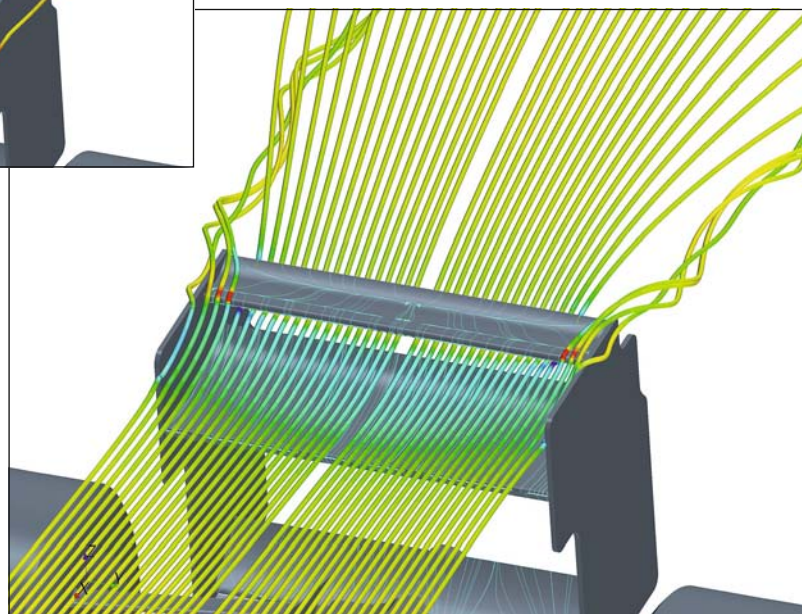

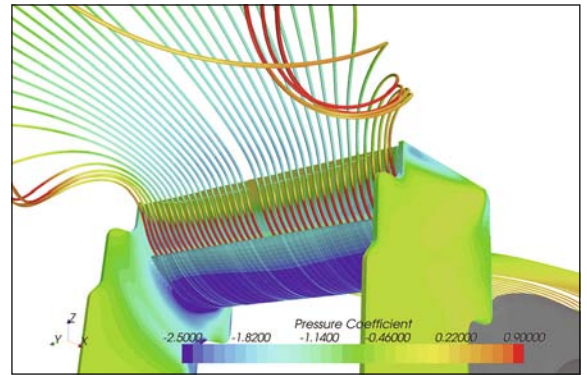
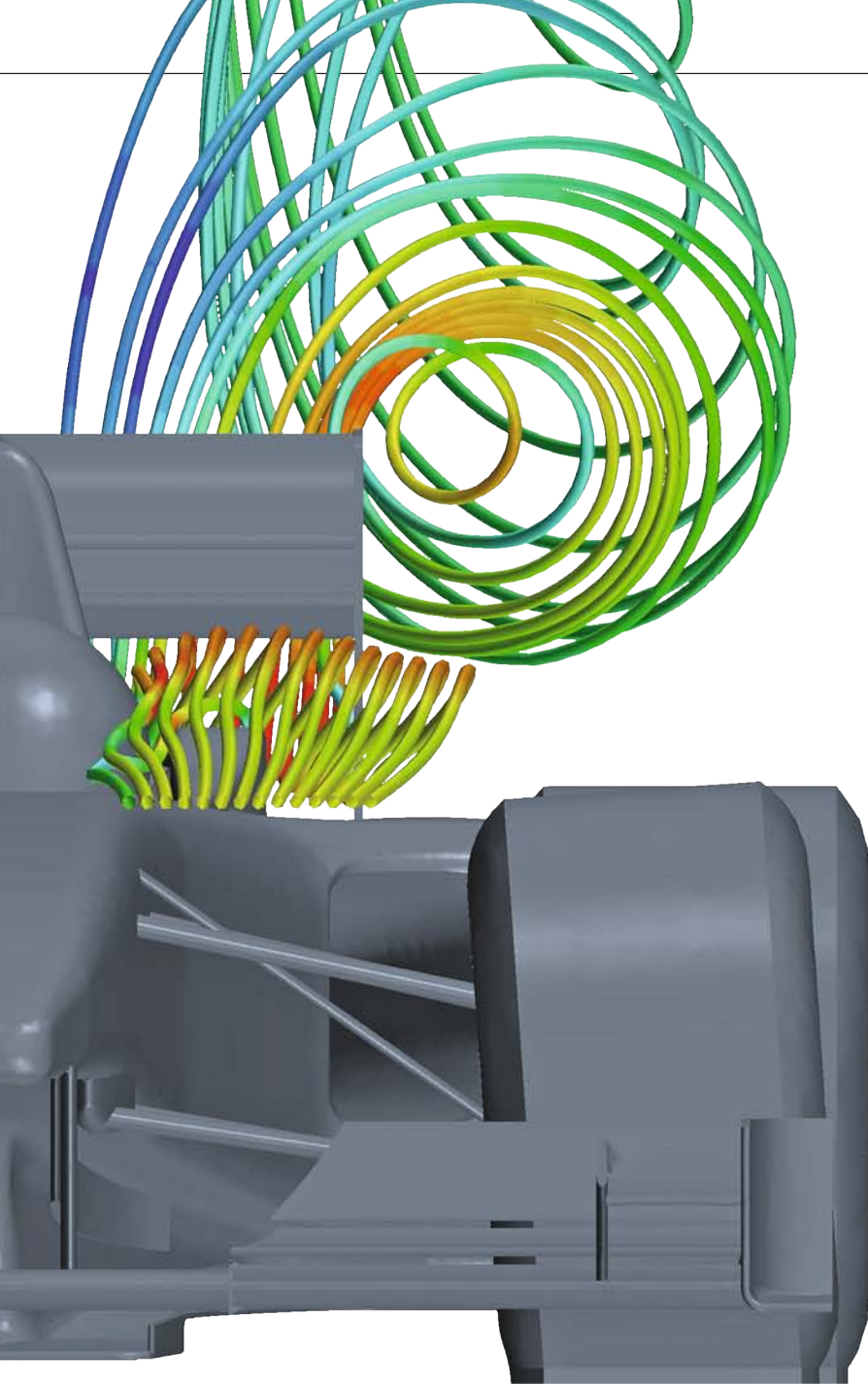

▲ **FIGURE 5 (CLOSED)**
Under the rear wing you can see the low-pressure area, which is marked in blue. That's what is giving you downforce.

If you took a rear-wing assembly like the ones used at Barcelona, if it fell off and you had the appropriate gearing, you could probably go 30-40km/h faster. With DRS you get about 15km/h, so it loses about one third of the rear-wing drag.

▼ **FIGURE 6 (OPEN)**
Here you can see that the low-pressure area underneath the wing (blue) doesn't have enough power to reach the trailing edge. This means there is very little downforce being produced by the wing when it's in its open position.

The further forward the low-pressure area is on the wing, the more downforce you are losing – but the longer it could take to re-attach under braking.

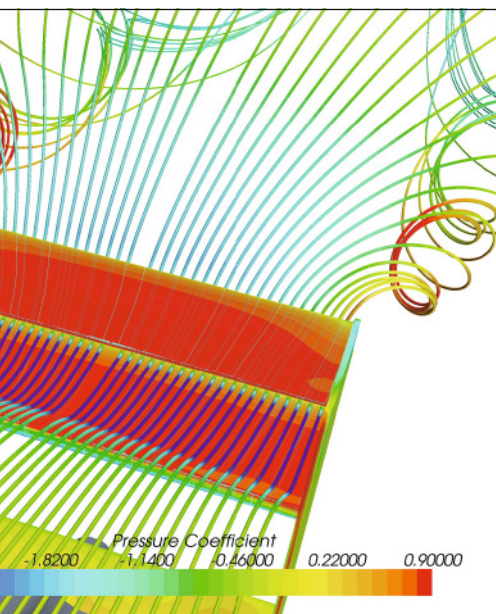
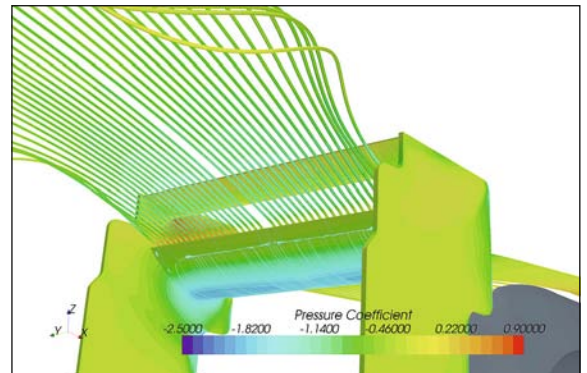

◀ **FIGURE 3 (CLOSED)**
The slot gap between the rear wings is essential. In normal conditions the 12mm gap helps keep the airflow attached to the wing. Without it, the surface area would be too great, the air would 'give up', as you would be asking too much of it, and it would stall.

▶ **FIGURE 4 (OPEN)**
DRS allows the slot gap to open up to 50mm. With more airflow going through, a lot less downforce is generated under the wing.

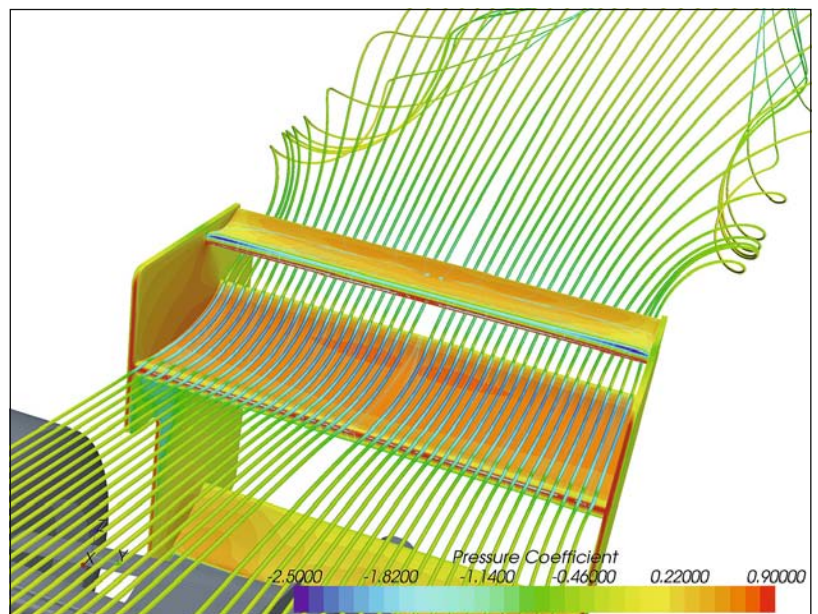

BOTTAS

A READY ROOKIE

One of the highlights of the 2013 Formula 1 season should be the arrival of Valtteri Bottas on the grid. *EDD STRAW* spoke to him and found the latest flying Finn is ready to make a big impression with Williams

Pick one word to describe 23-year-old Valtteri Bottas on the eve of his rookie season as a grand prix driver with Williams, and it would be, quite simply, 'ready'.

The Finn is a calm, composed, unexcitable character who recognises that the time is right for him to step up into the big league, but accepts there is much still to be learned. Believing you've made it as a driver once you land a Formula 1 seat is a potentially crucial error, and it's not one that Bottas is foolish enough to make. He recognises that his toughest tests are to come.

Most pressing among those is pre-season testing. Bottas has not far off 3000 miles of serious running in an F1 car under his belt already, much of it in last year's Williams FW34. Since being picked up as junior driver by the Grove squad as the successor to newly-promoted race driver Nico Hulkenberg in 2012, Bottas has been groomed for his graduation. His CV is impressive: it lacks race action at a higher level than Formula 3/GP3, but is partly counterbalanced by 15 outings in Bruno Senna's car during Friday-morning practice in 2012.

The race team knows him well, he's a familiar face around the factory and he

has already proved he has the pace to cut it in the most illustrious company. Expectations are, rightly, high.

"I've got the most preparation compared to any driver at my age because, while some teams have done Friday practice with their [reserve] drivers, it's not as many as 15," says Bottas. "That was a big commitment from the team as well, so I feel really prepared after three years with them."

"I'm really comfortable with how the team works, but there is always more you can learn. I will double the number of test days I have so far in F1 cars in winter testing. That's quite a lot and I need to make the most out of it to improve my tyre management and driving style."

Judging the success of Bottas in 2013 will be relatively simple. Regardless of where the new Renault-engined FW35 ends up in the pecking order (and there's no reason to expect it will be anything other than as good as, or better, than the car that arguably should have finished fifth in last year's constructors' championship), Bottas has team-mate Pastor Maldonado as a yardstick. Whatever you say about the Venezuelan, there is no doubt that he is seriously quick. If the newcomer can perform at a similar level – or better – than the 2012 Spanish Grand

BOTTAS CV

2012 F1 Friday driver for Williams
2011 1st in GP3 (4 wins), 1 British F3 win in one-off appearance
2010 3rd in F3 Euro Series (2 wins), 1st in F3 Masters, 3rd in Macau GP
2009 3rd in F3 Euro Series, 1st in F3 Masters, 5th in Macau GP
2008 1st in Formula Renault Eurocup (5 wins), 1st in Formula Renault NEC (12 wins)
2007 3rd in Formula Renault NEC (2 wins); three wins in FRenault UK Winter Series

Prix winner, it will be a tremendous endorsement of his potential.

Don't doubt that Bottas, privately, fancies his chances. In many ways, Maldonado is the perfect team-mate if you want to make an impression. For starters, he's quick enough to ensure that beating, matching or even getting close to him early on constitutes a job very well done. Maldonado is also a driver capable of following up a stunning victory with a nine-race pointless run punctuated with many mishaps, so outscoring him is eminently possible. The smart money is on Bottas showing very well indeed compared to his team-mate, especially given many at Williams believe that Friday practice last year often showed him to be the quicker of the two.

"I would hope to be with him straight away, but I'm fully aware that he's a really quick driver," says Bottas, again confident, but not underestimating the challenge. "He's had some impressive races and some really impressive qualifying performances. Some of the laps he's put together have been really nice to watch. He's a good reference, so I really hope I can match him immediately. It's not just a team of one driver – it's a team of two drivers and two cars."

That last point is crucial: Williams ▶



◀ desperately needs both cars to perform to their potential consistently. Some may assume that, in 2012, Maldonado was doing all the heavy lifting, but while his peaks were far higher than team-mate Senna, his points advantage was a mere 14.

Technical director Mike Coughlan told AUTOSPORT in December that Williams should have finished three places higher than its eventual eighth place in the constructors' championship and it's tough to argue with that. The drivers must carry the lion's share of the blame for underachieving.

By taking Bottas over Senna, whose sponsorship was worth around \$14 million, it's a clear statement of intent by Williams. While some cash has been raised off the back of Bottas, it's not as much as the Brazilian could have provided. Bottas must make up for that with results. Chances are, he will. Certainly, it's inconceivable that he won't make it into Q3 more than the once Senna managed last year, provided the car is up to it.

Crucially, Williams knows exactly what it's letting itself in for with Bottas. This is a promotion that's fully merited, and as well as preparing him, the Friday running allowed him to make a tangible contribution to the majority of race weekends. So there's plenty of confidence in Bottas. Aside from a crash during practice at Hockenheim, there were no mishaps of note and Bottas's approach impressed.



Bottas at work in last year's Williams, during Friday practice at Suzuka

LIFE BEFORE F1: AN EMERGING TALENT

Valtteri Bottas has never been short of confidence. Before he'd even made it to Formula 3 he had turned down a chance to join the Renault Driver Development scheme in 2008. "I want to keep my options open for the future," he politely told the French manufacturer.

When Bottas did step up to F3, he went straight in with category powerhouse ART Grand Prix. Jules Bianchi's dominant 2009 campaign prevented Bottas from winning a points-paying race, but he did take victory in the prestigious F3 Masters at Zandvoort and finished the year as top rookie.

After a fearless debut performance at Macau that put Bianchi in the shade, the foundations were laid for the Finn to become ART's seventh consecutive F3



Second year in F3 should have netted Euro Series crown, but he had to settle for second Masters success



Bottas won inaugural GP3 championship

Euro Series champion in 2010. But that dream was demolished by Volkswagen's big-budget attack with Signature and Edoardo Mortara. Bottas struggled initially, as the realisation set in that this title wouldn't be his, but the turning point in his season came when he accepted that the championship was lost. The mistakes stopped, and he became the form man in the series, nearly poaching second in the points from Signature's second driver Marco Wittmann. He also became the first driver to win the Masters twice.

A move to the F1-supporting GP3 series with ART meant Bottas went into 2011 again expecting to have title-winning machinery. But the French squad made a mess of the early part of the year, and once more it seemed a case of right place, wrong time.

Then Bottas and team-mate James Calado got their heads down and helped ART turn its car around. By the end of the year the team was the class of the field, and Bottas put in an accomplished second half of the season to vault from 12th in the standings and take the title.



BOTTAS IN F1: THE STORY SO FAR

Valtteri Bottas heads into pre-season testing with 2801 miles of Formula 1 running under his belt on grand prix weekends and in official tests, making him better prepared than the average rookie. Despite that, his running pales in comparison to the amount that rookies would rack up prior to their debuts in the days before testing became restricted. Here's how his running to date breaks down.

November 15-16 2011	February 22 2012	May 1 2012	July 12-13 2012
Abu Dhabi Young Driver test	Barcelona pre-season test	Mugello in-season test	Silverstone Young Driver Test
Distance: 549 miles	Distance: 338 miles	Distance: 91 miles	Distance: 754 miles
Debut F1 test in 2011	First taste of Williams-	Running restricted by rain	Completes first full
Williams-Cosworth FW33	Renault FW34		race simulation

FRIDAY MILEAGE IN 2012

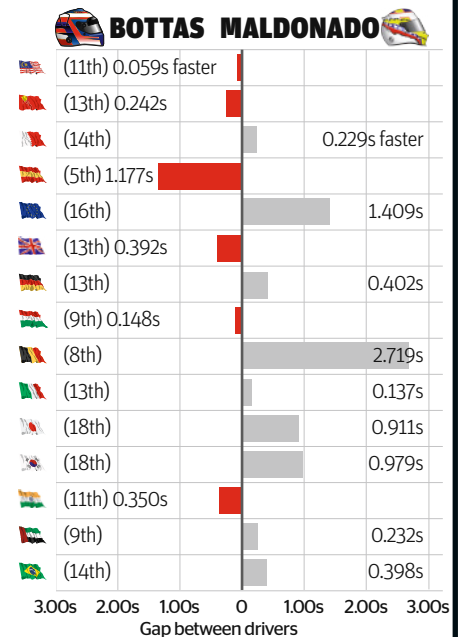
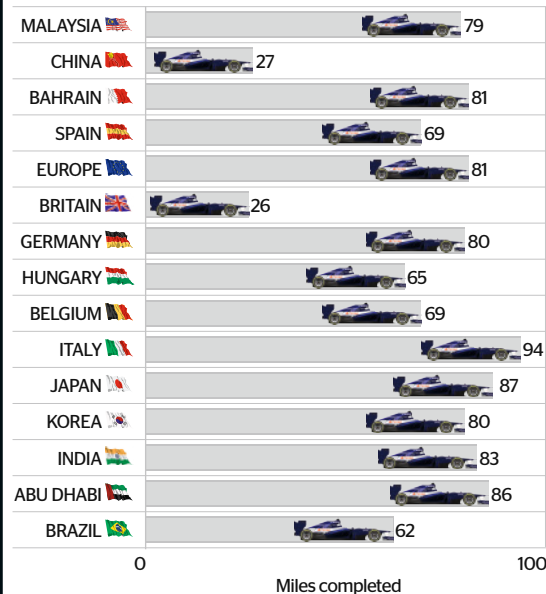

There is also no doubt that the particular challenges of running during a grand prix event, even if it only averaged out at just over 70 miles per outing, offer a more intense learning experience than test sessions.

"I'm quite happy with how the Fridays went," says Bottas. "I would have liked not to make the mistake at Hockenheim, but I learned from it. This year, there will be mistakes because everyone makes mistakes. The main thing is not to repeat them and to learn. We really made the most out of the Fridays and I'm happy, but now it's time to take it to the next level.

"It's completely different from a test day. On Friday of a race weekend, you have much less possibility to spend time on the track. Normally, it's just one set of tyres. It all comes to making the most of the one session and getting as much information as possible for the next one, qualifying and the race. Being part of that in the race weekend has been really good for me to see what actually happens from one session to another, what are the best ways to collect the data, and how to develop the car in the short period of time."

Fortunately, it does not weigh too heavily on Bottas's shoulders that one

of the great grand prix teams has staked so much on him. Three years ago, he was just an F3 driver on glorified work experience, putting in a few weeks in the various departments of the team to gain an insight into the vast amount of hard work that goes into putting a grand prix car on the grid. Now he arguably holds the hopes of the team's continuing revival in his hands.

"It doesn't make a difference, but I do notice the team expects me to be on the pace quickly and to do the job," he admits. "That's why I got the drive. They trust that I can do it. It doesn't bring any pressure.

"People in Finland think that when a Finnish driver gets to F1, he's going to be world champion one day and many ask if there's a pressure. But there's not. It all comes from my side. I want to be a good driver and one day be the best. I want to develop and get some good results. The more people who are supporting that and pushing for that, the better."

At least history is on Bottas's side when it comes to Finns at Williams. The only other driver from the country to race for Williams in F1, a certain Keke Rosberg, didn't do badly after all... ❄

Williams's new boy is replacing Bruno Senna for 2013

DAYTONA

USA

January 26-27
Grand-Am
Round 1/12

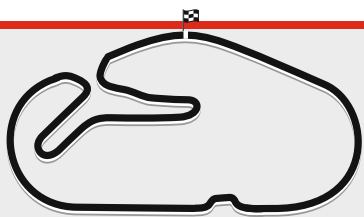

AT A GLANCE

- **Winners Pruet्त/Rojas/
Montoya/Kimball**
- **Pole Scott Pruet्त**
- **FL Scott Dixon**



The victors celebrate another Ganassi Daytona win for the Riley-BMW



Let the Chips fall where they may

There's no beating Ganassi's quartet of Pruet्त, Rojas, Montoya and Kimball - as Grand-Am's finest discovered



Ganassi's #01 machine led at the start - and the finish

ANOTHER DAYTONA 24 HOURS and another multi-car sprint to the flag after a late-race yellow. Only this time, there was never any doubt as to the outcome of the race. You'd have struggled to have got much in the way of odds on Chip Ganassi Racing taking victory on Sunday afternoon at the self-proclaimed 'World Center of Racing'.

Ganassi's pair of BMW-engined Riley MkXXVIs were the fastest things around the 3.56-mile Daytona 'roval' from the get-go at the Grand American Sportscar Series opener. Its two cars locked out the front row in qualifying, veteran Scott Pruet्त edging out younger namesake Dixon, and then the Riley-Bimmer combo had a clear advantage from

the moment the green flag dropped on Saturday.

Put simply, one of the two Ganassi cars was always going to win, and it ended up being the full-season entry for Pruet्त and Memo Rojas, who were joined at Daytona by Juan Pablo Montoya and, for one double stint, Ganassi IndyCar driver Charlie Kimball. The other entry, in which Dixon was joined by Dario Franchitti, Jamie McMurray and Joey Hand, had the pace of its sister car, but lost time in the night when McMurray hit the wall leaving the pits. It had gained back three of the five laps it had lost to repairs when a final-drive failure brought its race to an end in the 21st hour.

Ganassi's dominance was the talking point of the weekend, especially among

the Chevrolet-powered posse. They argued that a late rule change ahead of the race, which robbed them of a shade over 20bhp, gave the fleet of Corvette-bodied Daytona Prototypes no chance.

Grand-Am reacted to their arguments after qualifying on Thursday and ahead of final practice on Friday,

opening up the inlet-trumpet restrictors on the Earnhardt Childress Racing Engines V8 to give back somewhere in the region of four or five horses. It was an empty gesture, according to the Chevrolet camp.

"If they took away the restrictors entirely, we still wouldn't be able to beat them," argued Wayne Taylor,

whose eponymous team ended up leading the Chevy charge with its Corvette-bodied Dallara DP01.

"They have all this sophisticated simulation technology, but they don't appear to react to what they should be seeing with their own eyes. We weren't as fast as them at the test."

That was a reference to

WTR trio needed late fuel splash



RACE RATING

★★★★☆

It was always close - the yellows saw to that - but there was only going to be one winner

MILESTONE

Scott Pruett equals Hurley Haywood's record of five wins, set in 1991



REPORT DAYTONA 24 HOURS

GARY WATKINS reports



Starworks Riley wasn't as strong as in '12



Electrical glitch cost Stallings drivers

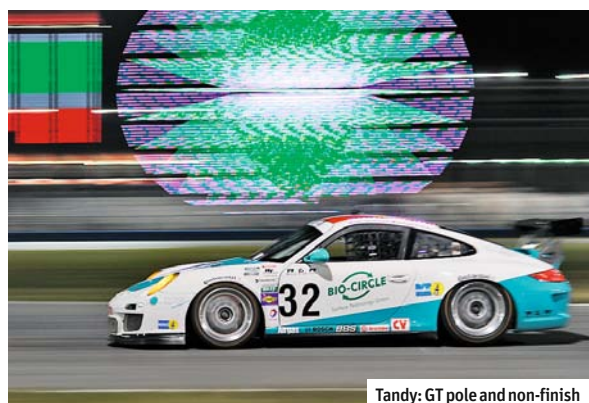

Tandy: GT pole and non-finish

Bellarosa's Sunoco prize drive

Before the race I only had 18 laps in the Starworks Riley and that was very hard. It's also tough having five drivers who don't know each other and a crew that don't know each other.

Also, I right-foot brake, but the team changed the position of the throttle pedal before the race and that made it very hard to downchange.

In the night my teammate Brendon Hartley had a crash with another car at the chicane and we lost 79 laps. When I went out I had a feeling that there was still something wrong with the car.

In the morning, I had passed Alex Popov at the Kink, and at the next corner I lost the rear. I asked Alex if he hit me and he said, "Oh, no, no!" but there was some damage at the rear... I don't know.

But it was a great experience, and I love the possibility of returning.



the pace of the BMW-engined cars – both the Ganassi entries and DP newcomer Team Sahlen – in the official Daytona test at the beginning of January.

The unspoken – publicly at least – allegation from Grand-Am was that the Chevrolet teams had been sandbagging, which is why an ECR Engines V8 had been put on the dyno at Grand-Am sister organisation NASCAR's research-and-development facility in Concord, North Carolina in the wake of the test.

The latest Grand-Am rulebook has done away with varying rev-limits for the different engines and now prescribes power and torque curves that each powerplant must match. The inlet restrictors were imposed on the Chevy motor to bring it

into line with those levels, according to the Grand-Am officials who only speak off the record these days.

Yet for anyone present at Daytona last weekend – or watching on TV for that matter – it was hard to believe that NASCAR's boffins had got it right. The Ganassi Rileys were able to drive around the Chevrolet and Ford-powered cars up on the famous 31-degree Daytona banking almost at will.

Yet it wasn't as clear cut as the Bimmer having a massive power advantage, according to Ganassi. Montoya argued that his team had the best set-up to exploit the differing demands of Daytona's banking and infield sections.

"Their car was good on the infield, but they paid the

price on the banking," said the Colombian of the Wayne Taylor Racing Dallara. "The #9 Action Express car was just as fast as us on the banking, but not so good on the infield."

The Daytona International Speedway is Riley territory, and always has been. The US constructor, formerly Riley & Scott, is now unbeaten in the 24 Hours since 2004 and has a total of 12 victories in the US enduro to its name.

Rileys are always good in the mechanical-grip department, and at Daytona that makes for a car that is strong on the infield and can be trimmed out for straight-line speed on the banking. That undoubtedly played a part in Ganassi's victory last weekend.

But there was still an air of pessimism emanating from

everyone who didn't have a Dinan-tuned BMW V8 behind him at Daytona. "We are going into the race with our hands tied," reckoned WTR's Max Angelelli. "The problem is that we can't beat them in a straight fight if we're racing them at the end," said Spirit of Daytona driver Richard Westbrook.

This time the straight fight began with 51 minutes still left on the clock. The final yellow flew with exactly one hour to go and the pack shuffled as the four cars that remained on the lead lap dived into the pits.

Montoya, who had taken over from Pruett for the run to the flag, had just retaken the lead he had lost to AJ Allmendinger thanks to some sharp pitwork by the Michael Shank Racing squad at the previous round of stops.

This time the Shank car dropped to fourth.

Angelelli had been the only frontrunner to take a new set of the Continental-branded Hoosier tyres during the penultimate yellow and leapfrogged to the front of the pack when he was the only driver to forgo a new set this time around.

No one was pretending that his position at the front of the queue made Angelelli favourite in the Dallara he shared with Jordan Taylor ▶

DAYTONA

USA

January 26-27
Grand-Am
Round 1/12

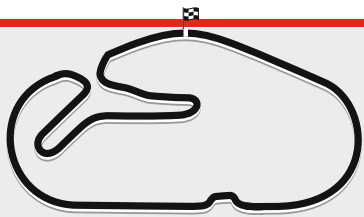

GT AT A GLANCE

- **Winners Albuquerque/Jarvis/Mortara/von Moltke**
- **Pole Nick Tandy**
- **Fastest lap Patrick Pilet**



Winning team boss Job plays the tune



Fog brought out a caution, and another, and another...

◀ and Ryan Hunter-Reay. That status still lay with Montoya and did even when he dropped to fourth.

Angelelli did his best to ensure that Montoya didn't get a clean getaway when the green flew. That allowed both Joao Barbosa – in the best of the Action Express Racing Coyote-Chevrolet Corvette CPMs – and Allmendinger to get the jump on the Ganassi car.

Allmendinger, who shared the MSR Riley with Justin Wilson, John Pew, Marcos Ambrose and Oswaldo Negri Jr, then made an move on Barbosa around the outside of the first infield hairpin.

There was contact, and Allmendinger ended up taking to the grass on the exit and allowing Montoya back up to third. The Grand-Am officials also penalised Barbosa, which put the Ganassi car, in which Montoya later admitted he was biding his time, back to second when the Action



Corsa Ferrari (behind) was a contender in GT, despite this

Express car came in for the resulting stop-go.

Montoya caught Angelelli in less than a lap, took the lead with minimal opposition from his Italian rival and then drove away. The race was over, or was it?

There was a hope at WTR – and concomitant fear at Ganassi – that the Dallara could make it to the finish without stopping again for fuel. It proved ill-founded when Angelelli came in for a splash one lap after Montoya. Any lingering

doubt over the outcome disappeared, and Ganassi claimed its fifth Daytona 24 Hours victory in 10 years by a comfortable 21 seconds.

Allmendinger had to pit after his off to have radiators cleaned, but the Shank car still finished ahead of the Action Express Coyote Barbosa shared with Burt Frisselle and Mike Rockenfeller.

Third place was a remarkable achievement for a car that lost seven laps in the opening hour

when a tie-rod broke.

The multiple yellows that again interrupted the 24 Hours and the convoluted safety car procedure not only prevented Ganassi from making a break from the pack, it allowed the MSR crew to make up the lost laps even after losing more time with a fuel-pump issue. The car was back on the lead lap in the 19th hour, but it was never going to beat Ganassi.

Fifth place behind the Action Express car went to the Spirit of Daytona Coyote-Chevrolet. The car had dropped off the lead lap in the 23rd hour when a failed alternator fried the electrics and, once fifth place was secure, the car was parked courtesy of a myriad of problems including a broken floor and failed powersteering.

The sixth-placed Starworks Riley-Ford, in which Allan McNish and Sebastien Bourdais joined

Ryan Dalziel and Alex Popow, had been in the mix too until the 22nd hour when a sticking throttle and overheating problems sent it behind the wall for repairs.

The seventh-placed Bob Stallings Racing Riley-Chevrolet lost 45 minutes to electrical problems early in the race, while the second Action Express Coyote dropped out of contention when Nelson Piquet Jr crashed on the exit of the pitlane during the night.

The drivers in any of the above cars could have argued that they would have been in the mix for the now traditional Daytona fight to the flag, but the reality was that none of them would have been able to beat Ganassi. They would have been fighting for the podium positions at best.

The combination of the Riley chassis and the BMW engine – or maybe just the BMW engine – was just too strong. ❁

GT RACE RATING

★★★★★

A real race between Porsche, Audi and Ferrari

“The last three hours were crazy. When I got in the car, no one really believed we could win”

Filipe Albuquerque on his GT win with Oliver Jarvis, Edoardo Mortara and Dion von Moltke

REPORT DAYTONA 24 HOURS

GT

Audi quartet gets the job done... just

➤ Alex Job Racing's Audi didn't look a potential class winner of the Daytona 24 Hours with three and a half hours to go. The car had just lost a lap courtesy of a penalty better described as bizarre than harsh, and there were still six cars ahead battling it out on the lead lap.

Edoardo Mortara, who was joined in the R8 GRAND-AM by Filipe Albuquerque, Oliver Jarvis and Dion von Moltke, had been given a 60-second penalty when he was

incorrectly judged to have made contact with the best of the AIM Autosport Ferrari 458s. The lost lap was only made back during the final yellow-flag period.

Albuquerque made a flying restart to put the car fifth and then moved into the lead when the top two – the AIM Ferrari, in which Mark Wilkins replaced Anthony Lazzaro, and Rene Rast in the APR Motorsport Audi – pitted for fuel and tyres.

Albuquerque managed to overcome gearbox problems to build enough of a lead



Albuquerque was on board victorious AJR Audi at end

to exit the pits after a late splash still ahead of Markus Winkelhock in the Rum Bum Audi and Rast.

Winkelhock was forced to pit on the final lap, giving second place to Rast and team-mates Frank Stippler, Marc Basseng and Ian Baas.

The Audi wasn't the fastest car over one lap, but over the course of a stint it was a match for all but the quickest of Porsche's 911 GT3 Cup cars. The Magnus Racing Porsche squad was delayed by four changes of the front splitter – including one right at the death – yet still

would have finished third had not Richard Lietz run out of fuel 200 metres from the flag.

NGT Motorsport's Porsche was even faster, at least in the hands of Sean Edwards and Patrick Pilet, but retired with suspension damage with four hours to go.

RESULTS

Daytona 24 Hours, Daytona (USA), January 26-27, Grand-Am, round 1 of 12

GRID	
1 PRUETT 1:40.553	2 DIXON 1:40.646
3 CAMERON 1:41.213	4 VALIANTE 1:41.236
5 WESTBROOK 1:41.844	6 A'DINGER 1:41.905
7 DALZIEL 1:41.920	8 GURNEY 1:42.032
9 SARRAZIN 1:42.160	10 JAMES 1:42.205
11 FITTIPALDI 1:42.392	12 ANGELELLI 1:42.547
13 BARBOSA 1:42.749	14 BRAUN 1:42.869
15 HARTLEY 1:43.291	16 JUNQUEIRA 1:45.370
17 TANDY 1:47.631	18 LALLY 1:47.828
19 S EDWARDS 1:48.007	20 P LONG 1:48.137
21 BALZAN 1:48.260	22 A'QUERQUE 1:48.282
23 SEEFRIED 1:48.319	24 LIDDELL 1:48.330
25 SERRA 1:48.521	26 LAZZARO 1:48.577
27 RAST 1:48.581	28 SEGAL 1:48.643
29 B'WEISTER 1:48.643	30 DAVIS 1:48.711
31 B'NOLAN 1:48.716	32 WINKELHOCK 1:48.865
33 AGUAS 1:49.065	34 MARSAL 1:49.067
35 ESPENLAUB 1:49.304	36 DUMAS 1:49.611
37 HEYLEN 1:49.612	38 AUERLEN 1:49.719
39 CURRAN 1:49.827	40 STIEDLER 1:49.850

56 cars started

709 LAPS, 2524.04 MILES

POS	DRIVERS	TEAM	CAR	CLASS	TIME	GRID
1	Scott Pruett (USA)/Memo Rojas (MEX)/Juan Pablo Montoya (CO)/Charlie Kimball (USA)	Ganassi/Sabates	Riley-BMW MkXXVI	DP	24h00m37.699s	1
2	Max Angelelli (I)/Jordan Taylor (USA)/Ryan Hunter-Reay (USA)	Wayne Taylor Racing	Dallara-Chev Corvette DP01	DP	+21.922s	12
3	AJ Allmendinger (USA)/Oswaldo Negri (BR)/John Pew (USA)/Justin Wilson (GB)/Marcos Ambrose (AUS)	Michael Shank Racing	Riley-Ford MkXXVI	DP	+55.585s	6
4	Joao Barbosa (P)/Burt Frisselle (USA)/Mike Rockenfeller (D)	Action Express Racing	Coyote-Chev Corvette CPM	DP	-1 lap	13
5	Richard Westbrook (GB)/Antonio Garcia (E)/Oliver Gavin (GB)/Ricky Taylor (USA)	Spirit of Daytona	Coyote-Chev Corvette CPM	DP	697 laps-DNF	5
6	Ryan Dalziel (GB)/Alex Popow (YV)/Sebastien Bourdais (F)/Allan McNish (GB)	Starworks Motorsport	Riley-Ford MkXXVI	DP	-13 laps	7
7	Alex Gurney (USA)/Jon Fogarty (USA)/Memo Gidley (USA)/Darren Law (USA)	Bob Stallings Racing	Riley-Chev Corvette MkXXVI	DP	-14 laps	8
8	Christian Fittipaldi (BR)/Brian Frisselle (USA)/Felipe Nasr (BR)/Nelson Piquet Jr (BR)	Action Express Racing	Coyote-Chev Corvette CPM	DP	-21 laps	11
9	Filipe Albuquerque (P)/Oliver Jarvis (GB)/Edoardo Mortara (I)/Dion von Moltke (ZA)	Alex Job Racing	Audi R8 GRAND-AM	GT	-31 laps	22
10	Rene Rast (D)/Marc Basseng (D)/Frank Stippler (D)/Ian Baas (USA)	APR Motorsport	Audi R8 GRAND-AM	GT	-31 laps	27
11	Anthony Lazzaro (USA)/Emil Assentato (USA)/Guy Cosmo (USA)/Nick Longhi (USA)/Mark Wilkins (CDN)	AIM Autosport	Ferrari 458 Italia	GT	-31 laps	26
12	Alessandro Balzan (I)/Marco Frezza (I)/Alessandro Pier Guidi (I)/Olivier Beretta (MC)	Scuderia Corsa	Ferrari 458 Italia	GT	-31 laps	21
13	Andy Lally (USA)/Nicolas Armindo (F)/Richard Lietz (A)/John Potter (USA)	Magnus Racing	Porsche 911 GT3 Cup	GT	-31 laps	18
14	Jeroen Bleekemolen (NL)/Damien Faulkner (IRL)/Marco Holzer (D)/Cooper MacNeil (USA)	Alex Job Racing	Porsche 911 GT3 Cup	GT	-31 laps	31
15	Markus Winkelhock (D)/Frank Biela (D)/Christopher Haase (D)/Matt Plumb (USA)	Rum Bum Racing	Audi R8 GRAND-AM	GT	677 laps-gearbox	32
16	Rui Aguas (P)/Clint Bowyer (USA)/Michael Waltrip (USA)/Robert Kauffman (USA)	AF-Waltrip	Ferrari 458 Italia	GT	-32 laps	33
17	Mike Hedlund (USA)/Ed Brown (USA)/Scott Sharp (USA)/Johannes van Overbeek (USA)	Extreme Speed M' sports	Ferrari 458 Italia	GT	-36 laps	42
18	Claudio Burtin (RA)/Jack Baldwin (USA)/Mario Farnbacher (D)/Martin Ragginger (A)/Robert Renauer (D)	Burtin/Goldcrest	Porsche 911 GT3 Cup	GT	-37 laps	48
19	Marco Seefried (D)/Klaus Bachler (A)/Sascha Maassen (D)/Madison Snow (USA)/Melanie Snow (USA)	Snow/Wright M' sports	Porsche 911 GT3 Cup	GT	-41 laps	23
20	Matt Bell (USA)/David Empringham (CDN)/Joey Farano (CDN)/Alex Figue (USA)/Dave Lacey (CDN)	APR Motorsport	Audi R8 GRAND-AM	GT	-42 laps	43
21	Dane Cameron (USA)/Wayne Nonnamaker (USA)/Simon Pagenaud (F)/Bruno Junqueira (BR)	Team Sahlen	Riley-BMW MkXXVI	DP	-45 laps	3
22	Andrew Davis (USA)/Leh Keen (USA)/Marc Lieb (D)/Bryan Sellers (USA)	Brumos Racing	Porsche 911 GT3 Cup	GT	-46 laps	30
26	Shane Lewis (USA)/David Donohue (USA)/Nelson Canache (YV)/Jim Norman (USA)	Napleton Racing	Porsche Cayman	GX	-74 laps	52
28	Bill Auberlen (USA)/Paul dalla Lana (CDN)/Billy Johnson (USA)/Maxime Martin (B)/Boris Said (USA)	Turner Motorsport	BMW M3	GT	-78 laps	38
31	Jorg Bergmeister (D)/Dominik Farnbacher (D)/Ben Keating (USA)/Kuno Wittmer (CDN)	TRG	Porsche 911 GT3 Cup	GT	622 laps-gearbox	29
32	Jeff Segal (USA)/Giancarlo Fisichella (I)/Max Papis (I)/Toni Vilander (FIN)	AIM Autosport	Ferrari 458 Italia	GT	614 laps-electrics	28
34	Stephane Sarrazin (F)/Anthony Davidson (GB)/Pedro Lamy (P)/Nicolas Minassian (F)/Enzo Potolicchio (YV)	8 Star Motorsports	Coyote-Chev Corvette CPM	DP	612 laps-gearbox	9
36	Robin Liddell (GB)/John Edwards (USA)/Jan Magnussen (DK)/Tommy Milner (USA)	Stevenson Motorsports	Chevrolet Camaro GT.R	GT	595 laps-gearbox	24
37	Scott Dixon (NZ)/Dario Franchitti (GB)/Joey Hand (USA)/Jamie McMurray (USA)	Ganassi/Sabates	Riley-BMW MkXXVI	DP	594 laps-final drive	2
39	Sean Edwards (GB)/Henrique Cisneros (USA)/Kuba Giermaziak (PL)/Patrick Pilet (F)	NGT Motorsport	Porsche 911 GT3 Cup	GT	535 laps-susp'ion	19
40	Ian James (GB)/Frank Beck (USA)/Carlos de Quesada (USA)/Byron Defoor (USA)/Jim Pace (USA)	Fifty Plus Racing	Riley-BMW MkXXVI	DP	517 laps-acc dam	10
41	Michael Valiante (CDN)/Chris Cumming (CDN)/Jorge Goncalvez (YV)/Gustavo Yacamán (CO)	Michael Shank Racing	Riley-Ford MkXXVI	DP	508 laps-susp'ion	4
43	Brendon Hartley (NZ)/Ivan Bellarosa (I)/Scott Mayer (USA)/Jan Charouz (CZ)/Gaetano Ardagna Perez (YV)	Starworks Motorsport	Riley-Ford MkXXVI	DP	441 laps-acc dam	15
44	Bruno Junqueira (BR)/Will Nonnamaker (USA)/Joe Nonnamaker (USA)/Joe Sahlén (USA)/Tony Drissi (USA)	Team Sahlen	Riley-BMW MkXX/XXVI	DP	422 laps-accident	16
46	Ricardo Mauricio (BR)/Rubens Barrichello (BR)/Nuno Figueiredo (BR)/Felipe Giaffone (BR)/Tony Kanaan (BR)	Dener Motorsport	Porsche 911 GT3 Cup	GT	352 laps-engine	41
47	Emmanuel Anassis (CDN)/Anthony Massari (USA)/Louis-Philippe Dumoulin (CDN)/Tonis Kasemets (EE)	BTE Sport	Riley-Ford MkXX	DP	304 laps-accident	51
48	Colin Braun (USA)/Jon Bennett (USA)/Jim Lowe (USA)/Paul Tracy (CDN)	Doran Racing	Doran/Dallara-Ford JE4	DP	286 laps-acc dam	14
51	Nick Tandy (GB)/Michael Christensen (DK)/Christian Engelhart (D)/Lance Willsey (USA)	Konrad M'sport/Orbit	Porsche 911 GT3 Cup	GT	181 laps-acc dam	17
53	Tom Long (USA)/Jonathan Bomarito (USA)/Marino Franchitti (GB)/James Hinchliffe (CDN)/Sylvain Tremblay (CDN)	Speedsource	Mazda6 GX	GX	51 laps-engine	56
55	Jan Heylen (B)/Tony Ave (USA)/Doug Peterson (USA)/Moses Smith (USA)	Vehicle Technologies	Dodge Viper	GT	44 laps-p'steer	37
NS	Michael Marsal (USA)/Bill Auberlen (USA)/Maxime Martin (B)/Andy Priaulx (GB)/Gunter Schaldach (USA)	Turner Motorsport	BMW M3	GT	accident damage	34

Winners' average: 105.12mph. Fastest lap: Dixon, 1m41.177s, 126.67mph; GT: Pilet, 1m47.893s, 118.69mph. Driver listed on grid set qualifying time and started the race.



Lynn produced a dominant double

TOYOTA RACING SERIES TAUPO (NZ), JANUARY 26-27, ROUND 3/5

Lynn lifts Hulme trophy after double

ALEX LYNN DOMINATED THE third round of the Toyota Racing Series at Taupo, taking two poles and two victories to launch himself into title contention.

The 19-year-old Essex driver, who went to New Zealand to keep himself race-sharp ahead of his European Formula 3 season with Prema Powerteam, was a cut above in the opening race and the flagship Denny Hulme Trophy that closed the weekend.

But just as impressive was his recovery in the

reversed-grid second race. The M2 Competition driver was spun down to 17th and last by Damon Leitch, but brilliantly recovered to eighth by the end of the 15-lap race.

“You can’t get emotional about being spun off and I absolutely enjoyed the rest of the race,” Lynn said. “The car was fantastic this weekend, which makes my job a lot easier. I’m loving every minute of my time in New Zealand.”

Lynn’s points haul for the weekend was matched by

Bruno Bonifacio. The Giles Motorsport-run Brazilian won the reversed-grid race from pole and added a fourth and a third in the other two encounters.

Austrian Lucas Auer, who led the series after showing great speed at the first two rounds, posted a fifth and a third in the first two races, distinguishing himself by overtaking reigning champion Nick Cassidy around the outside at the end of the main straight.

But at the start of race three, Auer and Dutchman Steijn Schothorst tangled, the resultant puncture forcing Auer into the pits for a tyre change.

Auer’s incident allowed M2-run Cassidy – who has not won this year – to take over the championship lead by six points. The local star finished second, fourth and second in the three races.

Felix Serralles dropped from second to third in the

points after going off the road in race one and then scoring ninth and sixth-placed finishes.

Schothorst had his best round with third, second and fourth spots. “The car is new for me,” he said. “The car is getting better and I’m improving too.”

Brit Jann Mardenborough made the top six for the first time.

● Bernard Carpinter

RESULTS

Race 1 Alex Lynn, 15 laps in 21m25.948s; 2 Nick Cassidy, +4.653s; 3 Steijn Schothorst; 4 Bruno Bonifacio; 5 Lucas Auer; 6 Jann Mardenborough. **Race 2** 1 Bonifacio, 15 laps in 21m18.832s; 2 Schothorst, +1.116s; 3 Auer; 4 Cassidy; 5 Tatiana Calderon; 6 Akash Nandy. **Race 3** 1 Lynn, 20 laps in 30m07.926s; 2 Cassidy, +3.040s; 3 Bonifacio; 4 Schothorst; 5 Damon Leitch; 6 Felix Serralles. **Points** 1 Cassidy, 517; 2 Auer, 511; 3 Serralles, 477; 4 Lynn, 471; 5 Schothorst, 451; 6 Bonifacio, 448.



Bonifacio won second race

IN BRIEF

ANDROS TROPHY

Mini man Jean-Philippe Dayraut is virtually certain of the title thanks to a win and a second at St Die des Vosges. Main rival Benjamin Riviere was fourth in both events, as Bertrand Balas won race two.

CONTINENTAL SERIES

Billy Johnson and Jack Roush Jr won at Daytona in their Roush Ford Mustang, beating the Porsche of Matt Plumb/Nick Longhi by 1.8s. BTCC ace Andrew Jordan was seventh in the ST class in a Honda Civic shared with James Colborn.

MIDDLE-EAST RALLY

Nasser Al-Attayah kicked off his title defence with a 10th Qatar Rally win. The Ford Fiesta RRC driver beat the Citroen DS3 of Khalid Al-Qassimi, co-driven by Scott Martin, by 55.7s.

Al-Attayah: 10 wins in Qatar



PICS: ELIAN CAMERON

Calling ALL GT and Historic Drivers



uk



france



sweden



germany



holland



spain



europa's leader in american
motorhome rental & sales



10% Discount on ALL Rental
bookings made before 28 February 2013.
Just quote 'AUTOSPORT' to receive your discount.

Please contact Simon at Stingray RV
on +44 870 241 5614 or simon@stingrayRV.com

www.stingrayRV.com



Europe's Official
Main Dealer



Ivan Bellarosa, 2013 Sunoco Rolex 24 At Daytona Challenge winner, had an action packed Daytona debut. The #8 Starworks Motorsport Ford Riley DP showed great pace, however Sunday morning saw the team withdraw from the race with a cracked gearbox.

The Sunoco Daytona Challenge will continue for 2013 and give racers in eligible championships a chance to race in the 2014 Rolex 24 At Daytona.



Participating series*



* correct at time of print



Gana

January, glorious Florida
For more info visit: [www.sunoco.com](#)



Position	Class	No	Laps	Drivers
Winner	DP	01	709	Pruett/Rojas/Montoya/K...
2	DP	10	709	Angelelli/Taylor/Hunter-...
3	DP	60	709	Pew/Negri/Allmendinger...
1	GT	24	678	Albuquerque/Jarvis/Mor...
2	GT	52	678	Stippler/Rast/Baas/Bass...
3	GT	69	678	Assentato/Stanton/Long...
1	GX	16	635	Canache/Donohue/Lewis...
2	GX	22	625	Clay/O'Young/Rogers/Th...
3	GX	38	614	Davis/Eversley/Foss/Mo...

For more information and technical advice on Sunoco Race Fuels and the Sunoco Daytona Challenge please call European and Middle East distributor:

Ganassi delivers!

Florida sunshine and a 24hrs sprint race - absolutely amazing!
www.grand-am.com and www.sunocodaytonachallenge.com



Jimball/Dixon
 Reay
 Ambrose/Wilson
 Tara/von Moltke
 Eng
 Chi/Lazzaro/Wilkins
 s/Norman
 Thomas/Thomson
 s/ing/Tecce

Team
 Chip Ganassi Racing/Felix Sebates
 VelocityWW
 Michael Shank Racing
 Audi Sport Customer Racing/AJR
 Audi Sport Customer Racing/APR
 AIM Autosport Team FXDD with Ferrari
 Napleton Racing Porsche Cayman
 Bullet Racing Porsche Cayman
 BGB Motorsports Porsche Cayman



Anglo American Oil Company Tel +44 (0)1929 551557 • Fax +44 (0)1929 551567
racing@aaoil.co.uk • www.sunoco.co.uk

J R M

Design ■ Engineer ■ Deliver

NISSAN *nismo*

NISSAN GT-R NISMO GT3
Official Partner

2013 NISSAN GT-R NISMO GT3 - WHERE WOULD YOU LIKE TO WIN IN 2013?

*BLANCPAIN ENDURANCE SERIES
24 HOURS OF SPA
ADAC GT MASTERS
INTERNATIONAL GT OPEN
EUROPEAN LE MANS SERIES
VLN
NATIONAL GT CHAMPIONSHIPS*

Call: +44 (0)1327 307150
Email: mdexter@jrm-group.com
www.jrm-group.com



Manufacturer and race team of the 2011 FIA GT1 World Championship-winning NISSAN GT-R.

INTRODUCING SCOTT McLAUGHLIN

The V8 Supercar-bound Kiwi teenager who has already won two touring car titles

"I've watched V8s since I was a kid and loved it all the way so there was never any doubt that was where I wanted to be"



En route to the SuperTourers title at the Ruapuna finale...

Most touring car drivers take a career to notch up two championships – if they manage it at all.

Not Scott McLaughlin. After becoming the inaugural champion in New Zealand V8 SuperTourers last November, the Kiwi took just seven days to add the Australian V8 Development Series title to his CV. Now he's preparing for the big time, having bagged a spot in V8 Supercars with Holden team Garry Rogers Motorsport. And all at just 19 years of age.

SINGLE-SEATERS DON'T APPEAL

New Zealand has produced a hotbed of single-seater racing talent over the past five years, with Mitch Evans, Richie Stanaway and Brendon Hartley

all achieving success in Europe.

But while this trio ventured north with ambitions of Formula 1, McLaughlin was always determined to make it in V8s.

"I watch F1 now and enjoy it, but I've watched V8s since I was a kid and loved it all the way, so there was never any doubt that was where I wanted to be.

"Plus I'm quite a big guy, so single-seaters probably isn't going to be the best place for me."

BUSY SEASON BRINGS EXPERIENCE

McLaughlin's inexperience certainly didn't show in 2012, when he emerged triumphant in the inaugural season of V8 SuperTourers in his homeland, beating, among others, boyhood hero Greg Murphy to the title at the Ruapuna finale.

The experience gained in the enduros – in which he shared his Holden Commodore with Jonathon Webb, paid dividends when he made his V8 Supercar debut at – of all places – Bathurst.

Driving for the midfield Tekno Holden squad, he and Webb delivered an astonishing sixth-placed finish that marked him out as a name for the future. McLaughlin had another chance to impress at the season-ending Homebush event, substituting for Alexandre Premat, who was struck down with heat exhaustion while at the wheel.

"I'd just won the DS title and at the bottom of the podium steps my Dad said, 'You've got the #33 drive! I thought he was talking about 2013, so I thought, 'Ah, sweet' and brushed it off. Good job I didn't drink the champagne, because I then saw Garry waiting, and realised what dad meant."

With his GRM deal now confirmed McLaughlin is keeping his targets modest for the season.

"Things in V8s are so close that nobody's going to think badly of me if I'm regularly in the top 15, and if I'm regularly qualifying in the top 10, I'll look like a bloody hero," he says. "I've tested the Car of The Future and it feels like the car I race in New Zealand, far softer than an old Supercar, so that's good for me too. Could be a good season." ❄

McLAUGHLIN CV

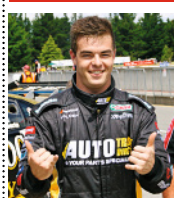

Born June 10, 1993

From Christchurch, New Zealand

2012 1st in V8

Development Series

(4 wins), 1st in

V8 SuperTourers

(6 wins), 4 starts

in V8 Supercars

2011 4th in V8 DS

(1 win)

2010 10th in V8 DS

2000-09 Karting,

One New Zealand

title, four Australian

state titles

...with the V8 DS title coming a week later





Piquet: a Truck winner at Michigan

Piquet Jr: my life is back on track

After that deliberate F1 crash at Singapore, Nelson Piquet Jr is loving life in NASCAR – and winning. *DIEGO MEJIA* caught up with him

Nelson Piquet Jr is enjoying his new life, living the American dream. The Singapore Grand Prix crash scandal that put a death sentence on his Formula 1 career is now behind him. He doesn't mind talking about it, admitting he did wrong in that infamous 2008 race. He has moved on.

"I was very young, I was by myself, I had no managers, I had no parents [there]," recalls Piquet. "I was a 23-year-old kid living a very different life, under pressure, and yeah I think it was a mistake. I'm sure if I could go back I never would have done it. I would have dealt with things a bit differently."

Three years on, Nelsinho is winning races again – just as he had done on his way to F1 during his Formula 3 and GP2 days. He is now trying to succeed where other big names coming from F1 and IndyCar have failed to make an impact: the US's most popular form of racing is where he is making a name for himself and Charlotte, NASCAR's Mecca, is his new home.

Ever since he first arrived in the States, the Brazilian has acknowledged that this form of racing required a very humble approach even if he was landing there from F1.

After 61 stock car races in the US, more than twice the number of grands prix he started for Renault, he is still a couple of steps away from NASCAR's top series, the Sprint Cup. Piquet has had to knock on doors to find sponsors and, although Brazilian and other

PIQUET JR CV

2012 7th in NASCAR Truck Series (2 wins);
1 win in NASCAR Nationwide Series;
1 win in K&N Pro Series East
2011 10th in NASCAR Truck Series
2010 Races in ARCA, NASCAR Trucks and Nationwide Series
2009 21st in Formula 1 World Championship (with Renault)
2008 12th in F1 (Renault)
2007 F1 Renault test driver
2006 2nd in GP2 Series (4 wins)
2005-06 2 wins in A1GP
2005 8th in GP2 Series (1 win)
2004 British F3 champion (6 wins)
2003 3rd in British F3 (6 wins)
2002 South American F3 champion (13 wins)
2001 5th in South American F3 (1 win)



Flying flag for Brazil in States

international companies have backed his American foray, it hasn't come easy for the son of a three-time world champion.

Last season he started to prove he belongs in NASCAR in only his second year running full-time in the Truck Series. He scored two victories, both on ovals, first at the ultra-fast Michigan, where he combined speed with strategy and fuel-saving tactics. Later he drove to Victory Lane again at Las Vegas following a last-lap pass for the win, true NASCAR-style.

Before all that he had won from pole at the tough Bristol half-miler in the regional NASCAR K&N East Series and then in June he made the most of his road-racing background to claim victory in the Nationwide Series at Road America. All added, Piquet won in every series he competed in last year.

"I couldn't be happier," says Piquet convincingly. "We're winning races, I'm with a great team, living in a great place – really, really happy. Considering everything I've done before, coming over here I think I'm doing OK."

Last year Piquet drove for Turner Motorsports, the squad that eventually went on to win the Truck title with James Buescher, the team owner's son-in-law. It was Buescher's fourth season in the series, and four victories along with a very consistent display gave him and team owner Steve Turner their first NASCAR title.

Piquet's numbers were not that far off Buescher's, only that he had more bad days than his team-mate, counting five non-finishes. As far as speed goes, nobody matched Piquet for pole positions: four times during the year he led the field to the green flag at the start.

Juan Pablo Montoya, who was a title

Fittipaldi in NASCAR

Although Nelson Piquet Jr was the first Brazilian to win a national NASCAR-sanctioned race, he wasn't the first from his country to compete in NASCAR.

Fellow ex-F1 racer Christian Fittipaldi raced in 16 Sprint Cup events between 2002 and '03, most of them driving for 'The King' Richard Petty. Miguel Paludo, a team-mate for Piquet at Turner, has also competed in NASCAR since 2010.

Now a new generation of Fittipaldi – both of them Emerson's grandsons – has tackled the NASCAR ladder from its very roots, racing Bandoleros and Late Models.

Piquet takes up their story: "There's two Fittipaldi coming along – Pietro and Enzo. They're still in Late Models and stuff, but they're my neighbours and we get along very well. I'm sure Enzo is going to have a bright future. He's going to be the first Brazilian to start from the ground, from the roots of NASCAR."

Both Pietro (16) and Enzo (11), sons of Emerson's daughter Juliana, have been winners at their respective levels already. Juliana's sister Tatiana is married to racer Max Papis, who works for Richard Childress Racing.



Pietro Fittipaldi (1) in action at Richmond

contender during the 2009 Chase for the Sprint Cup, has yet to win on an oval in NASCAR, although besides a short spell in the Nationwide Series in his rookie season, the Colombian has only raced at Cup level. Despite having won at three different ovals, Piquet knows well where his achievements stand when put into perspective.

"In a certain way, the level that I'm at, it suits me," says Piquet. "I'm sure that if Juan Pablo would've done a few seasons in Trucks he would've won a few races. But I think I'm the kind of driver who wants to be winning; I want to be in a good team, I want to have the chance to win every race I enter... I know when you reach Cup it's a bit different."

This year Piquet hopes to move another step up the NASCAR ladder and, although his credentials are already good enough to at least attempt a Sprint Cup debut, he doesn't see the need to rush it.

"I want to be in Cup when I'm ready, when I'm prepared, when I have a good opportunity with a team," he says. "I don't want to force my way in with a sponsor. I want a Hendrick or a Joe Gibbs or a Roger Penske to say, 'Hey, we're interested in you, come up.' That would be my dream."

A drive with a team capable of at least winning races in the Nationwide Series is Piquet's immediate goal, and recent changes in his management team have opened some doors. Looking beyond, he wants to let his roots grow in NASCAR.

"I would like to spend my life over here," he says. "I want to be in the sport for a long time. I want to establish myself, I want to win races, win championships, be the first Brazilian to be really successful over here and make a life out of it." ❧



Teesside
Autodrome



COME & RACE

SEASON 2013

THE BEST VALUE KART CHAMPIONSHIP IN THE UK
EPEC HIRE KART ENDURANCE CHAMPIONSHIP

TOP TEAMS FROM AROUND THE UK
6 HOUR ENDURANCE EVENTS
VISITING THE TOP CIRCUITS
WHEEL TO WHEEL UP TO 40 TEAMS
EXCITING NEW **FORMAT**
£450

DATES
10 MARCH
14 APRIL
12 MAY
26 MAY
21 JULY
15 SEPT
20 OCT
10 NOV

VENUE
WHILTON MILL
TEESSIDE NATIONAL
ELLOUGH PARK
CLAY PIGEON
WHILTON MILL
ROWRAH
LYDD
TEESSIDE INTERNATIONAL



T: 01642231117

WWW.TEESIDEKARTING.CO.UK



Extraordinary Offer

COME AND RACE THE BRITISH 24 HOUR
SATURDAY 24TH / SUNDAY 25TH AUGUST 2013

**Just released, 20 standard hires - only
£1000 each.**

**Come and race up to 70 other teams on
the worlds longest Kart Circuit 2.1k**

All inclusive hire package.

Biz Le Mans style Karts.

**Guaranteed best prepared Karts in the
country.**

***This is a special one off price for January and
February only.***

T: 01642231117
WWW.TEESIDEKARTING.CO.UK

Who needs a BIG

2013?

In AUTOSPORT's annual pre-season look at who is under the most pressure to perform during the coming year, we pick out the drivers, teams and categories that are in the spotlight for 2013



Romain Grosjean (F1)

Grosjean's first full season in Formula 1 gave ammunition to his supporters and doubters in equal measure. For every competitive performance there was an on-track incident to forget, but his Lotus team clearly felt it had seen enough glimmers of hope to give him a second season.

In the wake of his re-signing for 2013, Grosjean spoke candidly of learning from his mistakes. If he wants his F1 career to last beyond this year, he will have to put those words into action on track. He proved in his title-winning GP2 campaign of 2011 that he can recover from being the black sheep of the paddock. Judging by his cautious – and at times nervous – approach to the final few races of last year following his one-race ban for the Italian Grand Prix, the winter break will have offered a much-needed chance to press the reset button for this season. ▶

◀ Sergio Perez (F1)

So what's it going to be, Checo? Are you the next Mika Hakkinen, or the next Heikki Kovalainen?



His move to McLaren is second only to the Hamilton-to-Mercedes F1 2013 narrative. Perez's charging drives in Australia, Malaysia, Canada, Germany and Italy for Sauber last year will be demanded every time he starts a race – no room for spasmodic swallows in McLaren's summer – and that wobbly end of season form won't be tolerated.

Career-defining seasons don't get bigger than this and the young Mexican must gel with the team, solidify his scratchy qualifying form and prove his worth as a top-liner on a week-in, week-out basis.

Paul di Resta (F1)

After spending much of 2012 trading blows with the highly rated Nico Hulkenberg at Force India, Paul di Resta's stock took a slide in the eyes of some with a troubled end to the campaign.



Hulkenberg then signed for Sauber, while rumours of a move to a big team (and talks with McLaren) faltered for di Resta. A third season with the Silverstone squad awaits, but with the long-term futures of Mark Webber and Felipe Massa always up in the air, the door is open for di Resta to prove his leadership skills and land himself the drive further up the grid that he craves.

Carlos Sainz Jr (GP3)

He has phenomenal natural talent, but Sainz's F3 season in 2012 was underwhelming – except in the wet, when he was sensational. In theory, GP3 – with a higher power-to-grip ratio than F3 – should better suit the Spaniard's instinctive style, as should qualifying on a 'green' track first thing on Saturday mornings. What is crucial is that he beats Arden team-mate and fellow Red Bull junior Daniil Kvyat.



WRC

There are fears the sleeping giant may be unconscious. Luckily for rally fans, smelling salts and a big slap around the face with a wet fish are right around the corner.

Whichever way you chop it, the WRC is down, but it's not out. And this year, it has to find its way back. A liquidated promoter ruined last season, but now it's a new dawn. The WRC has a solid and very sensible investor behind it – Red Bull Media House, no less – and a new manufacturer in Volkswagen. The German influence will steady the ship and build quality into what's already a very racy product.

Sebastien Loeb's decision not to win a 10th world title means the series' silverware will actually be up for grabs this year – and the WRC must make the most of the reinvigorated competition.

M-Sport (WRC)

Malcolm Wilson's riding his luck this year. The canny Cumbrian bagged some bounce from Qatar and then got his drivers to chip in as well. The result is a workable budget for 2013 so the Christian Loriaux-penned Fiesta will remain at the sharp end, but can Wilson's boys – Mads Ostberg, Thierry Neuville and Evgeny Novikov – do the job?

Formula 3

British F3's future is on a tightrope, with a slimline four-round calendar that is a last-ditch effort to save its title; Italian F3 is officially dead after a 49-year run; and German F3 has just radically changed its calendar to include just one round abroad.

What's more, the Masters at Zandvoort doesn't have a date and is in doubt due to the FIA European F3 series' sporting regulations, and no-one seems to know what the engine

rules are going to be for Macau.

It's a shambles, but amid all this uncertainty at least the FIA's flagship series is looking ultra-strong and, whatever the motivations of the behind-the-scenes politicking, that is definitely what the category needs. Only a classic season here would justify the gloom elsewhere.

Also, European F3 Open – with spec Dallara-Toyotas – is doing well, with competitors flocking to the category's well-promoted, low-budget alternative.

This is a crucial season for F3



WHO DELIVERED (& WHO DIDN'T) IN 2012?

Which of the drivers, teams and series that AUTOSPORT said needed a strong season at the start of last year actually delivered?

LEWIS HAMILTON

Bounced back after a troubled 2011 to be one of the stars of 2012. Only McLaren unreliability kept him out of the title hunt and he left for Mercedes on his own terms.



Hamilton had a strong 2012

MARK WEBBER

After being trounced by Sebastian Vettel in 2011, Webber looked much more comfortable with the RB8 and its more conventional exhaust system. He fell away as the car improved, but again retained his seat.

STEFANO DOMENICALI

Before the season it looked like the Ferrari team principal's head might roll, but the genius of Fernando Alonso saved his bacon. His faith in tech chief

Pat Fry increasingly paid off, and he impressively turned Felipe Massa from flounderer to frontrunner.

JEAN TODT

The Frenchman's under-the-radar approach to the FIA president's role means it's hard to quantify how useless/successful he's been. However, under his watch the WRC almost sank, and F1 is heading straight for a financially choppy ride. More storms are expected.

MIKKO HIRVONEN

The Finn did precisely the job he was asked to do when he joined Citroen. He didn't/couldn't trouble Loeb yet helped return the manufacturers' title to Paris. If anything, with Loeb gone, 2013's the real deal for Mikko.

MINI

Prodrive certainly did enough to produce a rally-winning and potentially world-beating John Cooper Works WRC. Unfortunately, the BMW deal didn't



The M-Sport Fiestas must deliver in the 2013 WRC



No-excuse time for Mercedes this year



Mercedes (F1)

Big budget? Check. State of the art facilities? Check. One of the world's top three drivers? Check. On paper everything seems to be in place for Mercedes to fight at the front of the F1 field, yet for three seasons this has only happened sporadically. Cue a managerial overhaul and the obvious need for improved results.

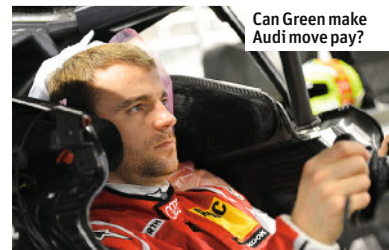

Can Green make Audi move pay?

Jamie Green and Andy Priaulx (DTM)

Jamie Green's move from Mercedes to Audi was the big DTM switch of the winter, and the Briton needs to hit the ground running with his new employer if his dream of winning the title is to be realised in 2013. A re-energised Mattias Ekstrom and Timo Scheider, plus the emergence of Edoardo Mortara as a title contender, means Green will have to be on top form.

Andy Priaulx has a similar task ahead of him. BMW's top finisher in its return race, he failed to match the results of Bruno Spengler, Augusto Farfus and co late-season. One strong result will undoubtedly lift his confidence and from that point, anything is possible.

The pressure's on Motorbase squad



Motorbase (BTCC)

David Bartrum's squad gave up on its 2012 campaign to develop its first self-built racer, the NGTC Focus. The car showed promise, but Motorbase and lead driver Mat Jackson have to step up this year to challenge Honda and MG. If the British GT title-winning team can add a BTCC crown, it can rightly be considered one of the country's best tin-top outfits. ❧

work out and the car's vast potential will remain unfulfilled.

SAM BIRD AND JULES BIANCHI

Bird and Bianchi ran at the sharp end in Formula Renault 3.5 as expected last year, but both were beaten to the crown by rookie sensation Robin Frijns. Bird never quite had the car to handle the Dutchman, while Bianchi was in reach of the title when he was biffed off the road by Frijns in the season finale in Barcelona.

JUAN PABLO MONTOYA

Twenty-second in points – light years away from the Chase – and just two

top-10 finishes. For Montoya, 2012 was a write-off. Big changes were made behind the scenes at Ganassi, and they didn't work. Another year like that and perhaps the changes will be made behind the wheel...

KYLE BUSCH

For 2013 Joe Gibbs has assembled a "superteam" of Denny Hamlin, Matt Kenseth and Kyle Busch. Kyle needs to rediscover his consistency to avoid becoming the junior partner in this equation – just as he did when he drove for Hendrick. He's supremely talented, so it's time those skills delivered results every weekend.

KURT BUSCH

Controversy follows Kurt Busch like seagulls follow a trawler, and one suspects the 2004 champ would find affinity with troubled ex-football

Things went awry for Kurt

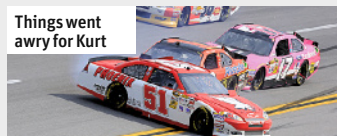

ace Eric Cantona. His short-lived tenure at Phoenix promised much but delivered little more than a series of bent cars. Needs results at Childress-supported Furniture Row.

RANDY BERNARD/INDYCAR

The IndyCar boss listened and brought new ideas. But he got sacked. Bernard now works for a countrified American TV channel, whose output includes live cattle auctions and the must-see *Classic Tractor Fever*. Really.

WTCC

The commitment of factory campaigns from Honda and Lada in 2012 was offset by Chevrolet's announcement to withdraw. On the plus side, calendar instability issues were resolved, but the series is unlikely to gain real momentum until the anticipated arrival of Citroen and revised rules in 2014.



Hamilton joins Rosberg at Merc

Rivalries to watch in 2013

Here are the main rivalries AUTOSPORT has identified as ones to watch out for in Formula 1, GP2, IndyCar, the World Endurance Championship, British touring cars and NASCAR

Hamilton v Rosberg (F1)

No other driver has ever come close to what Nico Rosberg achieved over the past three seasons. He out-qualified, out-scored and out-raced Michael Schumacher in equal equipment. Yet despite this, and a breakthrough first F1 win, there are probably more questions about his ultimate ability now than there were when he signed for Mercedes.

All that will change this year. There are no doubts about the form of new team-mate Lewis Hamilton, in contrast to the ring-rustiness at first attributed to Schumacher that morphed into a suspicion that he was now 'past it'. Hamilton was absolutely on top of his game during 2012, and is rightly regarded as one of the top-three F1 drivers in the world. How Rosberg fares against him will define how he is perceived for the rest of his career.

They've been team-mates before, back in their karting days, and they

get on well, although it will be interesting to see how long the mood remains jovial if one of them gets a distinct upper hand. Their junior career records are similar, but whereas Hamilton was parachuted into a championship-winning team, Rosberg has seldom had the car to run at the front. This season, regardless of where he's running, we'll know for sure how well he's running.



These two get on well – for now...



Factory feud: it'll be German v Japan again

Audi v Toyota (WEC)

Three victories from six races. Toyota's success on its return to international sportscar racing in the World Endurance Championship surprised even themselves and has surely made them favourites not only to take Audi's world title but perhaps even to supplant the German manufacturer as the king of the Le Mans 24 Hours in 2013.

Yet it's not quite as simple as that. Audi's focus last season, as usual, was on building a car – or rather cars – for the unique demands of Le Mans. Toyota, on the other hand, produced a lithe and nimble racing machine that shone on more conventional circuits. The story of the 2013 season could well be about how the respective focus shifts for the two LMP1 factories. The big question is whether Audi will put less onus on Le Mans this year.

The other question mark concerns how much scope for development there remained in Audi's and Toyota's respective hybrid challengers, the turbodiesel R18 e-tron quattro and the petrol TSO30 HYBRID TSO30, at the end of last season.

The answers will start coming thick and fast when the WEC kicks off at Silverstone on April 14.

TECH FOCUS

For all the visual similarity between the Audi R18 e-tron quattro and the Toyota TSO30, under the skins their powertrains are as different as they could be under the LMP1 rules. Firstly the choice of engine differed, with Audi retaining a turbodiesel engine in a wide-angle, V6 layout, whereas Toyota – with its recent F1 experience – opted for a V8 3.4-litre fed with petrol. For their hybrid systems (illustrated below), Audi chose to drive the front wheels with a motor/generator mated to a flywheel storage system. Toyota, on the other hand, elected to use a motor/generator mounted in the gearbox to drive the rear wheels and used super-capacitors for the energy storage.

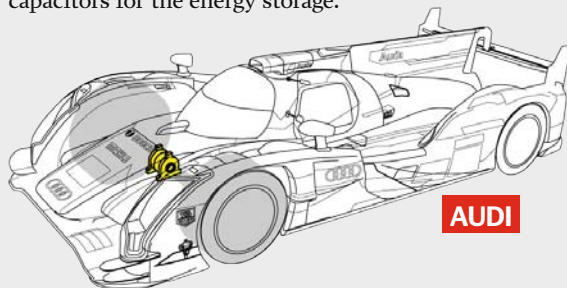

AUDI

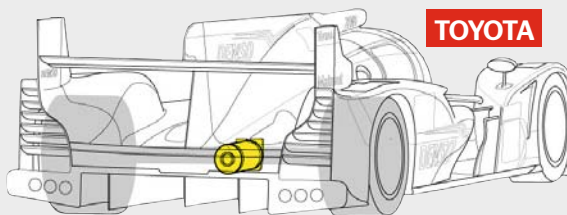

TOYOTA

Daniel Ricciardo v Jean-Eric Vergne (F1)

Year two at Scuderia Toro Rosso is critical for any driver. Just ask Scott Speed and Sebastien Bourdais – neither got to the end of their second seasons with the Red Bull junior squad, while Vitantonio Liuzzi was not retained for a third year. Sebastien Buemi and Jaime Alguersuari fared slightly better: both got a third campaign with the squad, after which neither was considered up to the job.

Triple world champion Sebastian

Vettel remains STR's only success story, and it's his promotion to Red Bull's senior team that must spur on Ricciardo and Vergne this year. It was hard for either to shine in a car that seemed more Minardi than Red Bull at times in 2012, but with Formula Renault 3.5 title favourite Antonio Felix da Costa waiting in the wings (no pun intended), Ricciardo and Vergne are heading into an 'every man for himself' scrap to stay in F1.



It's a crucial year for the STR boys

NASCAR: It's all about duels!

NASCAR is a team sport. All the heroics a driver can perform behind the wheel can be erased in the drop of a lug nut in a pitstop. For once, the Jimmie Johnson/Chad Knaus/Hendrick Motorsport team dropped the ball. And, for once, a Penske driver was there to pounce.

By delivering Penske's maiden NASCAR Cup, Brad Keselowski was catapulted into the big time. He's a no-nonsense character who's knocked a few noses out of joint, but there was a mutual

respect between him and Johnson, which could become the defining rivalry of this generation.

However, the headlines are likely to be grabbed by Johnson's car owner and four-time champ Jeff Gordon and his bitter rival Clint Bowyer. Gordon's frustration with Bowyer's "elbows out" style boiled over at Phoenix, Gordon deliberately wrecking Bowyer's car and slim title hopes. The finale was incident-free – almost certainly on NASCAR's orders – but don't expect that to last long this year!



Bowyer (15) and Gordon have form

Will Power v Dario Franchitti (IndyCar)

It feels strange to leave out reigning champion Ryan Hunter-Reay and Scott Dixon, arguably the fastest guy in the IndyCar Series, from this equation. But if Will 'bridesmaid' Power and Dario 'four-time' Franchitti can rekindle their rivalry of seasons past, then we're in for a treat. Their 2010-11 title duels were as intense a rivalry as you could find; there's gunpowder between them that doesn't take much to ignite.



Watch out for Power (1) and Franchitti

James Calado v Felipe Nasr (GP2)

James Calado and Felipe Nasr were two star rookies of the 2012 GP2 field, and, naturally, the fact that both have stayed on means they'll be expected to be title contenders in year two. Calado laid better foundations for that in year one at ART, while Nasr's switch from DAMS to his old F3 team Carlin should raise his game.



Calado v Nasr for GP2 glory?

Jason Plato v Honda (BTCC)

Honda is on a roll in the BTCC, having taken the past two titles, and now Gordon Shedden has joined team-mate Matt Neal as a champion. On the other hand, Jason Plato and Triple Eight now have a year of development under their belts with the MG6. As always in the BTCC, there should be fireworks.



JP is out to topple title holder Honda

Retired aged 23, back two months later

V8 Supercar star Shane van Gisbergen announced his shock retirement after a troubled 2012. Now the New Zealander tells *ANDREW VAN LEEUWEN* why he's already back

This will probably go down as the shortest retirement in V8 Supercar history. Last November, series frontrunner Shane van Gisbergen announced he was walking away from the sport. At just 23 years of age, and with a seemingly lucrative drive at Stone Brothers Racing, the Kiwi made the decision to give it all up, citing "personal reasons" and declining to comment further.

Now, just over two months later, he's back with a brand-new deal with Tekno Autosports to drive a Triple Eight-built Holden Commodore in 2013.

Let's get something straight: this whole thing wasn't solely a stunt to break van Gisbergen's contract with SBR, which was due to run until 2015. When he retired, he intended to retire. Between an ongoing rift with SBR management, and the year-long flirtation between the team and millionaire property mogul Betty Klimenko (which eventually morphed into a complete takeover), van Gisbergen had decided he would rather not race at all than stay at SBR. So he decided to retire. He was ready to take some time off, but on the other hand there was the chance that he *may* be tempted back if another offer arose...

"The way things were last year was not good," says van Gisbergen. "Turning up to the race track, I just didn't want to be there. I wasn't



Leading the way at Sandown in 2012

VAN GISBERGEN CV

Born May 9 1989
From Auckland, New Zealand
2012 6th in V8 Supercars
2011 4th in V8 Supercars
2010 6th in V8 Supercars
2009 12th in V8 Supercars



SVG in Stone Bros Ford

2008 15th in V8 Supercars
2007 2nd in Toyota Racing Series; V8 Supercar debut
2006 1st in New Zealand Formula Ford Championship

in a good frame of mind. I had a contract with SBR that was through to 2015, so I made the decision to stop completely.

"I had planned to take the year off. I spoke to some other teams, but having a contract in place made it hard. So I thought 'OK, I'm just going to stop, try some other forms of racing and just cruise'.

"I had a few plans for things in New Zealand. I tested a rally car, and started looking at options for 2013. It was good fun, and it gave me a chance to see that I could still enjoy my racing."

Why van Gisbergen was so desperate to get out of the SBR environment is complicated. On the face of it, the new era of SBR/Erebus looks fantastic: a new owner with plenty of cash; a new deal with AMG to bring Mercedes cars into V8s; and a shiny new C63 to drive during



Other side of the stone

There are two sides to every story, but Stone Brothers Racing is showing very little interest in discussing its version of events.

While the Gold Coast-based team has spent plenty of time in the media spotlight recently, the subject of Shane van Gisbergen is one the team has been completely silent on since the announcement.

When contacted by AUTOSPORT for further comment, the team – which formerly took Marcos Ambrose and Russell Ingall to V8 titles – still referred us to the original statement, released last November.



All quiet on the Stone Bros front

“Shane’s motives to quit the sport are private and SBR have agreed that the best way forward for all parties is to release Shane from his current three-year contract,” said Ross Stone in that original statement.

“This decision will also not in any way affect the newly-formed partnership between SBR and Erebus Motorsport, nor will it have any impact on the current sponsorship contracts we have.”

the week. But it’s worth noting the Mercedes project is a customer deal, not a factory effort. Having been so closely aligned with Ford for so long, the thought of being in a customer team unsettled van Gisbergen.

There were also problems with owner Ross Stone, that relationship having soured after five years together.

“Sandown was the start of it,” he reveals.

“We qualified on pole, and then made a meal of the race and went backwards. A lot of stuff happened that shouldn’t have happened that weekend, and it didn’t get fixed. It kept happening for the rest of the season.

“It was the same stuff over and over, and I just had enough. At around the same time the Erebus thing started to happen, and it all added up. It was all a bit much for me.

“The relationship between Ross and I... it was just a lot of little things that had added up over time, and it all came out. But that wasn’t the reason I wanted to leave. I’d made that decision before then anyway.”

Now a new chapter in the career of Shane van Gisbergen is about to start. With the SBR contract finally dissolved, a drive with Tekno beckons. Yes, the Steve Webb-owned team is a customer squad as well, but it has strong ties to both Holden and Triple Eight, and the engineers at Tekno – whose team manager is ex-Paul Stewart Racing British F3 chief Bruce Jenkins – have been working closely with T8 on the build of the brand-new Car of the Future.

After a strong 2012 with Jono Webb and Michael Patrizi, a top-line driver such as van Gisbergen could be just what the team needs to become a challenger to T8 and Ford Performance Racing.

“When we first spoke to Tekno, the guys were up at Triple Eight building the shocks,” says van Gisbergen.

“They’re up there nearly every week working through set-up data, whereas I don’t think any other customer teams were quite that closely aligned.

“I believe we can win races this year.

Triple Eight were testing their new cars months before anybody else, so I’m pretty sure we can come out and win races if we go about it the right way.

“There’ll always be a settling-in period with a new team and a new engineer, but we can be competitive.”

Another advantage of the switch to Tekno is the freedom for van Gisbergen to indulge in some of his other loves, such as rallying and drifting. While everything non-V8s was discouraged by SBR, Tekno has a differently philosophy. With his new-found freedom, he’s even planning on tackling selected rounds of the 2013 New Zealand Rally Championship.

“Tekno encourage this stuff,” he says. “I mean, if I’m drifting and rallying, it’s only going to be good for my car control and my versatility. I was never told by SBR not to go out and ride my quad bike or do things like that, but I certainly was never encouraged to do it. I always felt uncomfortable about it.”

The season-opening Clipsal 500 at Adelaide may still be a month away, but you can bet it will be a busy four weeks for van Gisbergen as he deals with the inevitable fallout of this unique situation.

But, typical of the quietly spoken ‘Giz Kid’, he’s just focused on shutting it all out and going racing: “Hopefully all of the legal stuff is quickly forgotten and I can get on with it. [David] Reynolds went through almost the same thing a year ago with Kelly Racing, and now nobody really remembers that.

“I’m finally going to be in the right environment, and that makes me feel a whole lot better about going V8 Supercar racing again.” ❄



Most of the time he wasn't leaping for joy last season

P47 THE NEXT BIG KIWI

Half-century HERO

Gabriele Tarquini endured a difficult Formula 1 career, but he doesn't regret it, and is still enjoying his life in the world of tin-tops at the ripe old age of 50. By *ANTHONY PEACOCK*

One of the funniest things some racing drivers do is earnestly claim that the only real reason they moved to – insert name of salubrious tax haven here – was because of the mountains/sea/lake/weather/low crime rate (delete as appropriate).

Perversely, these same people are often still described as “favourite sons” of whichever place they were born, even though they would obviously never dream of ever setting foot there again.

Which is what makes Gabriele Tarquini somewhat different. He was born in Giulianova – halfway down the eastern coast of Italy, more or less directly opposite Rome – and that's where he still lives now: right in the bustling centre of the town, in a spacious apartment overlooking the main square.

“Why would you live somewhere like Monaco when you can live here?” he gestures from his balcony, indicating Giulianova's picturesque piazza with its church shaded by palm trees and beyond that the sea, flanked by a lengthy promenade where beautiful people in pastel-shaded clothing come

out to see and be seen every evening.

Turn round and you can look out from the balcony to the mountains behind, covered in dense greenery through which an ancient monastery is clearly visible. It's pretty close to being idyllic.

The apartment that Tarquini – the oldest-ever FIA world champion, having clinched the 2009 World Touring Car title aged 47 years and 266 days – shares with his wife Beatrice and their children is modern and sparsely furnished. In fact, an engineer is busy fiddling with the latest flavour of digital TV box as we speak, with Tarquini occasionally breaking off to offer assistance. The television remains obstinately blank.

But in a corner there is a mass of trophies that takes over one wall. They tell the story of what is arguably the most polarised career in motorsport: success in karting followed by a spell in Formula 1 – best known for the unenviable record of the most failed attempts to qualify for a grand prix – followed by a switch to touring cars that led to the ultimate prize only three years ago.

When Tarquini won the 2009 touring

car title, it was exactly 25 years since he clinched the 1984 World Karting Championship: one of the biggest trophies on the shelf.

Not only that, but he shows no sign of stopping. At the age of 50 he is almost certainly the oldest factory driver in top-line motorsport, having signed for Honda's new WTCC team.

As usual, it's just for one year.

“It's best that way: it keeps my motivation fresh and allows me to stop if I feel I'm not quick enough anymore, which is a question I'm always asking ▶

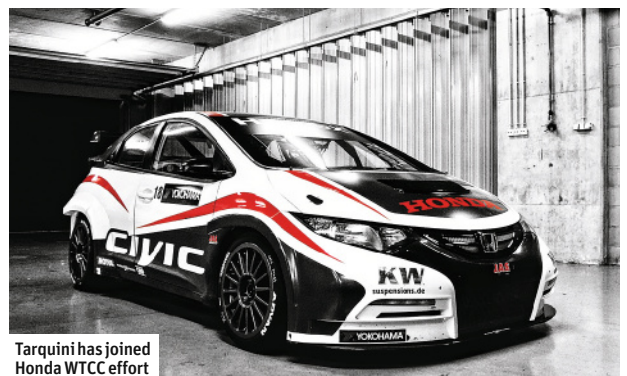

Tarquini has joined Honda WTCC effort

Tarquini has raced for 17 years in top-level tin-tops



◀ myself,” he points out. “But so far I’ve never felt disadvantaged by my age: in fact it’s an advantage. I’m as quick as I always was, only this time with more experience.”

That’s not quite correct. Relative to his opposition, he’s actually way faster than he used to be. Because this is the man who used to drive a Coloni: one of F1’s most notorious mobile chicanes. Tarquini looks back on his tortuous years in F1 (from 1987 to 1995, but skipping the 1993 and 1994 seasons) with fondness and even nostalgia.

This is despite the fact he would regularly embark on flights to destinations as far afield as Australia and Brazil in the absolute certainty that he would be on the same plane home just a couple of days later. In total, he failed to qualify a soul-destroying 40 times (including 24 eliminations in pre-qualifying). Often, the teams he drove for would even have their return flights booked in advance, knowing they stood about as much of a chance of putting their chronically underfunded shed on the grid as they did of landing it on the moon.

“It was a fairly regular humiliation: if you didn’t pre-qualify, you had your team paddock passes physically taken off you, so you couldn’t even go in,” remembers Tarquini. “That was a big problem for the sponsors, who rarely got to see a race. We were always wondering where the next budget would



Jerez 1990: as close as he'd ever get to Senna!

“If Formula 1 is the best car, then touring cars is the best racing”

Gabriele Tarquini

come from. It was day-to-day survival.”

AGS, for example, went through “six or seven” changes of ownership during Tarquini’s three years there. “It was pretty crazy: we’d get to a grand prix and find out that the team had been sold while we’d been travelling,” he says.

“Then of course there would be no money to race with. The worst time was Phoenix one year, where we actually had a whip-round to pay for the fuel.”

Yet even though the whole experience felt much like banging his head repeatedly against a wall (the low point was probably 1990, where he failed to qualify 12 times out of 16, with a best race result of 13th in Hungary) he never once let that head drop.

“It didn’t get me down at all,” he says. “At the time I was so young and it was all a big adventure. I had never dreamed I would one day get to F1. And I always thought there were better times just round the corner.”

For a while, there were. Tarquini had a couple of standout races in his career. One was Monaco in 1989, when he was running fourth – until an electrical connector on his AGS failed. The following race was Mexico, where he finished sixth. A photograph of that moment still hangs on his wall.

“Those were the occasions when I thought it was possible my life could change,” he reflects, sitting on his sofa directly underneath that photograph.

“But as time went on, I eventually knew the opportunity was missed. In F1, you either make the quantum leap or you disappear.

“Even though I never reached the top, I have no regrets at all. I took away some beautiful memories and I’m very happy to have scored points, even just the one time. Because in a very small way, that means I left my tiny trace on the history of Formula 1. Otherwise, people might not have known I had even been there.”

It’s a surprisingly moving little speech, heartfelt in its humility and sincerity, summarising the weight of history and persistence of memory in a more articulate way than most people could manage.

But if Tarquini only scratched the surface of F1, he carved his name into touring cars.

“If F1 is the best car, then touring cars is the best racing,” is how he puts it.

And Tarquini is above all a racer. About 10 years ago, he worked for Sky TV in Italy as an F1 pundit. “I stuck at it for two or three years, in between my racing, because I always thought that this was going to be a new career once I stopped,” he explains. “But I never stopped. Because I enjoy it too much.”

And while Tarquini rubbishes the comparison (“one was absolutely stratospheric, the other was just quite good”) this is the thing he has in common with Juan Manuel Fangio: the man whose long-standing record of ‘oldest FIA champion’ he broke. Both of them enjoyed it too much to stop. ❄



TARQUINI'S CAREER HIGHLIGHTS

1987 IMOLA F3000

Took his best Formula 3000 result in First Racing March 87B, with P2 behind eventual champ Stefano Modena.



1989 MEXICAN GP

Scored his only F1 point with sixth in his AGS, a lap down on winner Ayrton Senna's McLaren.

1994 BRITISH TOURING CAR CHAMPION

Led the crack Alfa Romeo team in its assault on the BTCC and took the crown in its first year with eight wins in controversial 155 TS.



2003 EUROPEAN TOURING CAR CHAMPION

After racking up 12 BTCC wins and a brief spell in the DTM, Tarquini won the European crown in Alfa Romeo 156.

2009 WORLD TOURING CAR CHAMPION

Took his SEAT Leon TDI to three wins and the world crown, aged 47.



PIT EQUIPMENT



SHOWTRAX
INTERNATIONAL

Pit Equipment Experts

www.showtrax.net

**FOR ALL YOUR
PIT EQUIPMENT NEEDS**

Tel: +44 (0)1234 782800 sales@showtrax.net www.showtrax.net

HAMILTON Classic LTD

Specialists in Race & Rally Marquees and Accessories



Swift Shade Instant Race & Rally Marquees + Optional Printing
Set up in minutes. Steel or Alloy frames to suit all budgets. From £185 inc Vat





Luxury Car Covers, Indoor & Outdoor Soft Breathable Materials
Fitted Car Floor Mats with Logo's, Minilite Wheels and
Many More useful products for Modern & Classic Cars

www.hamiltongrouponline.com
Email office@hamiltonclassic.co.uk tel +44(0)118 973 7300



Instant INFLATABLES

**Call today!
0117 978 0127**

Inflatable Spider Domes, Pit Garages, VIP Marquees, Arches & more...

We design and manufacture a wide range of Inflatable Domes, Marquees, Pit Garages and Start / Finish line arches that are put to use every week by motorsport teams and event organisers throughout Europe.

Our eye catching Spider Dome structure is the best selling model in our range, and with prices starting from just £1,199 + VAT you can see why.

- Sizes ranging from 3m to 15m diameter
- Sealed Air and Constant Air designs
- Inflate in as little as 60 seconds
- Full range of printing options
- Free mock up design service
- Lead times from just 10-14 days

Visit **www.instantinflatables.co.uk**
or call our team on **0117 978 0127**

Instant Inflatables is a trading brand of Instant Promotion (UK) Ltd.
Instant Promotion (UK) Ltd, Unit 1 Axis, Hawkfield Business Park, Bristol BS14 0BY



4M X 4M SEALED AIR SPIDER DOME



10M DIAMETER CONSTANT AIR SPIDER DOME



5M X 5M SEALED AIR SPIDER DOME WITH 3.5M FEATHER FLAGS

WEB DIRECTORY

AWNINGS



THE AWNING CO
The Awning Company (UK) Ltd
01204 544900 www.theawningcompany.co.uk

CAR BROKERAGE

RACING CARS FOR SALE
ALAN CORNOCK FCS
BUYING - SELLING - BROKERAGE
www.racingcarsforsale.co.uk
TEL: 01480 891212

EXHAUSTS

Inconel & Stainless Steel Specialists
SIMPSON
Race Exhausts
Tel: 01753 532222
www.simpsonraceexhausts.com

GEARBOXES



Rally & Race Gearboxes,
GearKits, LSD's and Driveshafts
Tel: 01782 280136 Fax: 01782 269913
Email: sales@eliteracingtransmissions.com
www.eliteracingtransmissions.com

GEARBOXES

Gearboxman.com
COMPETITION TRANSMISSION SERVICES
Gearboxes and Axles for Road, Race, Rally, and more
Telephone: 01582 840008, Fax: 01582 840007

HELMET GRAPHICS

Mike Fairholme Designs
Sole approved painter of Arai helmets.
Silver Birches, Corby Birkholme, Nr Grantham, Lincs NG33 4LE.
Tel: 01476 550630. Fax: 01476 550029.
email: fairholmedesigns@btconnect.com
www.fairholmedesigns.co.uk

MEMORABILIA



www.
Speed King.cc
EXCLUSIVE MOTORSPORT MEMORABILIA
EST. 1996
We Buy Your Teamegear!



FINAL LAP
For Everything Formula One
www.finallap.net WE BUY AND SELL
+44 (0)1245 287588 / 07771 920345

MEMORABILIA



JMJ AUTOMOBILIA America's #1 supplier
of CART and Formula
One Racing memorabilia. Large selection of signed
original collectables. See our ad under marketplace
Memorabilia. Call or fax or a mail listing at (609) 575 1143
or visit our website @ www.JMJAuto.com

MERCHANDISE



F1 Merchandise bought and sold.
Meadowhall, Sheffield
Tel: 0114 256 9835
www.theformula1shopandmore.co.uk

RACE PARTS



ARE DRY SUMP SYSTEMS
ARMSTRONG RACE ENGINEERING INC.
www.DRYSUMP.COM (916) 652-5282

RACE PRODUCTS



demon tweeks
MOTORSPORT Direct
www.demon-tweeks.co.uk

RACE PRODUCTS



MARDI GRAS MOTORSPORT
www.mardigras.co.uk



msar LONDON
MOTORSPORT
SHOWROOM
www.msar.co.uk



PIPER
www.pipercams.co.uk



SCHROTH RACING
www.schroth.com

RACE PRODUCTS

www.porscheshop.co.uk
PORSCHESHOP
+44 (0) 121 585 6088

RACE RADIO

Pit to Car Autotel
Radio solutions Digital Race Radio
0044(0)1508 528837
www.raceradio.co.uk



JJC) race and rally
PASSIONATE ABOUT MOTORSPORT
www.jjcraceandrally.com



CROYDON RACE & RALLY CENTRE
www.croydonraceandrally.co.uk
220-222 Portland Road
South Norwood
London SE25 4QB
For Racewear & Motorsport equipment
FORECOURT PARKING Tel: 020 8656 7031

RACEWEAR



GPR SPORCO SCHROTH hays seat Arai BELL
RACEWEAR | KARTWEAR | SIMULATION
WWW.GPRDIRECT.COM

TRAILERS AND TRANSPORTERS



PRG TRAILERS
www.prgtrailers.co.uk
Phone no: +44 (0) 1270 812402

BRIAN JAMES TRAILERS
CLUBMAN
Tel. 01327 308833
Web. www.brianjames.co.uk

WHEELS



Image Manufacturers of bespoke
split rim alloy wheels
www.imagewheels.co.uk
IMAGE WHEELS INTERNATIONAL LTD

AUTOSPORT.COM

TO ADVERTISE IN THE WEB DIRECTORY PLEASE CALL
020 8267 5560 OR EMAIL: autosport.ads@haymarket.com

BRIAN JAMES TRAILERS

» Connected to you



Endurance & Efficiency

www.brianjames.co.uk

Race Transporter trailers demonstrate all the capability you require. Our passion for continual development underpins everything we do. The results are available for you.

RACE TRANSPORTER

T +44 (0)1327 308 833

For more information and details of your local BJT dealer please call or visit our website.

TRAILERS & TRANSPORTERS



Call Us Now! tel. 01327 263 384

www.woodfordtrailers.com sales@woodfordtrailers.com



RL 5000
£7,300 + vat



RL 6000
£9,500 + vat

PRG Trailers

All trailers now come with European COC certificate

optional colour finishes shown

PRG Trailers | Cheshire | UK | Tel: +44 (0) 1270 812402
Web: www.prgtrailers.co.uk | Email: info@prgtrailers.co.uk

ABL LOGISTICS

Specialising in car movements and race support offering tractor units, an 18 ton two-car transporter, with moveable deck to hold 2 cars, large external lockers and an enclosed race shuttle. For long/short term hire. Also able to supply drivers/truckies.

For hire for the 2013 season

Contact- James on 07973 746025
or email: james.goodwin5@yahoo.co.uk
or Sean on 07766101845
or email: weeman.smg@hotmail.co.uk

STARHOME

FREE UK DELIVERY & COLLECTION*

Luxury trackside accommodation

Hire the ultimate motorhomes sleeping up to 18 people in centrally heated, air conditioned luxury for events in UK / Europe.

For reservations please call Heidi Crawford on 07711 665 622 or the office 0161 452 3630
www.starhomehire.com

*For bookings during February & March 2013

New for 2013

Ferrari 458 Challenge Upgrade

VISIT US AT AUTOSPORT INTERNATIONAL SHOW, NEC BIRMINGHAM STAND NO. 2403

The E2M Phase II kit comprises of:

- 1 New Anhedral Rear Wing
- 2 Billet Alloy Rear Wing Support
- 3 Carbon Ultra - Lite Doors - uses factory window and locks
- 4 Carbon Aero Vented Carbon Rear Bumper
- 5 Carbon Rear Diffusor
- 6 Carbon Aero Vented Front Wings
- 7 Carbon Aero Vented Louvered Bonnet
- 8 Carbon Aero Vented Front Bumper
- 9 Carbon Dive Planes
- 10 Carbon 100mm Front Splitter with Integral Carbon Floor and Strengthened Carrier
- 11 Power Upgrade to 625 BHP
- 12 4 Way Adjustable Suspension

Evolution 2 Motorsport now offers an all new for 2013 ultra lite performance aerokit, to both reduce weight and improve aerodynamic performance. With over 25 years of race winning experience, the aerokit has been designed and manufactured to factory standards. All parts use existing mounting points, with excellent fit, quality and finish.

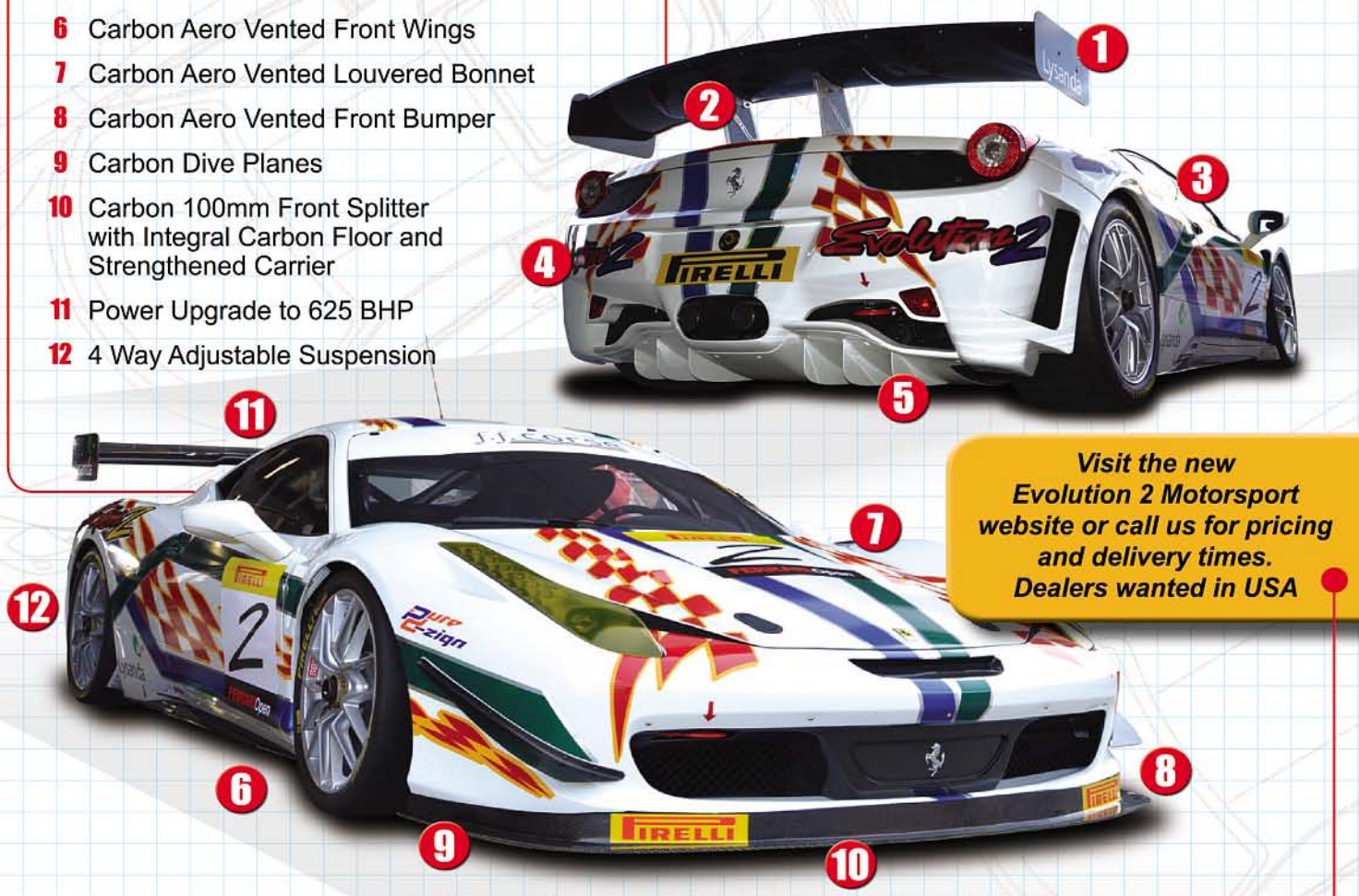

Visit the new Evolution 2 Motorsport website or call us for pricing and delivery times. Dealers wanted in USA



Email info@evolution2motorsport.com
 Telephone +44 (0) 1753 885 453
www.evolution2motorsport.com

RACE & RALLY CARS

Tuning for Performance & Economy

- VW/Audi
- Seat
- Skoda
- Land Rover
- Mercedes
- Porsche
- BMW & New Mini
- Ford
- Vauxhall/Opel

FOR SALE!
AmD's VW Golf BTCC
Car is for sale

AmD[®]

serious about tuning

AmD
Tuning.com



facebook.com/AmD-Essex
twitter.com/amdessex



AmD Tuning are selling the car to move onto the new full NGTC regulations in 2013

AmD Tuning

- 2/4wd rolling road *
 - Power runs with Power Graph*
 - Special rates for clubs and Shoot Out days*
 - Workshop hourly rate £60+vat
 - Set price menus
 - Free fitting on Milltek Exhausts
 - Coilover Fitting just £100+vat
 - 4 Wheel Laser Alignment
 - Air con servicing
 - Servicing and diagnostics with OEM Parts
 - MOT Testing
 - Wi-Fi Internet and Playstation equipped Waiting Area*
 - Courtesy shuttle service to Local Town Centre or Station
 - Courtesy car available
- * Applies to AmD Essex only

The BTCC will provisionally run a \$2000 Cup in 2013 which will run concurrently with the full NGTC cars.

The car would also be eligible for numerous other championships internationally and nationally.

AmD Tuning could run the car in the BTCC for buyer if required.

PRICE:
£45k+vat - for the complete car.
£30k+vat - Spare engine/spares package
£65k+vat ono - Car and spare package

Description:
 VW Golf built and raced in the British Touring Car Championship 2010-2012 with numerous Top 10 positions. Car available after the final round of 2012 BTCC at Brands Hatch in October 2012.

The car comes complete with a full spares package including spare engine, body panels inc bumpers, wings, tailgate, bonnet, doors, panel moulds, suspension, brakes, wheels/tyres, exhaust systems, radiators, intercoolers, gear ratios plus everything you would need to run the car - too much to list!

Spares package alone cost £75k!

Please contact shaun@amdtuning.com for further details.

Part exchange for GT or Porsche Cup car might be interesting?

Call: 01708 861827 to discuss



Special offer Coilover Suspension Fitting - just £100 + VAT includes laser 4 wheel alignment

AmD Tuning Close to M25 & Dartford Crossing
 Next to Lakeside Shopping Centre and Ikea.
 Unit 6, Cliffside Trade Park, Motherwell Way,
 West Thurrock, Essex RM20 3LE
Telephone: +44 (0) 1708 861827
 E-mail: essex@amdtuning.com

Opening Times: Mon-Fri: 8.30am - 6.00pm. Sat: 9.00am - 4.00pm.
 Sun: Club Rolling Road Shoot-Out days by appointment only

AmD Northampton (Near Silverstone Circuit) Watling Street,
 Paulerspury Nr Towcester, NN12 6LQ
 Tel: 01327 811001
 e: northampton@amdtuning.com
 Join the AmD dealer network.
 Contact us on
dealers@amdtuning.com

AmD Harrow
 Unit 24, Hawthorn Centre
 Elmgrove Road
 Harrow, HA1 2RF
 Tel: 020 8427 7688
 e: harrow@amdtuning.com

Custom Exhausts →

Can't find an exhaust for your car?
 AmD can make it for you from T304
 stainless steel.



www.amdtuning.com

New!
 Anything from
 a tailpipe to a
 full system.

All systems
 come with a
 Lifetime
 Warranty

New!

RACE & RALLY CARS

YOUR ENTRY OPPORTUNITY INTO GROUP C RACING

With this superb example of a Le Mans endurance racecar

£98,950



1986 Tiga GC286 - immaculately engineered and presented by professional race team.

GC286-335 was one of the first of this model, and was initially operated under the race number 98 by Roy Baker in the WEC in C2 in 1986 when it ran at Le Mans and in the other championship rounds. In 1987 it ran with the Ceesports Team. For 1989 the car was rebuilt with Rover-Cosworth V6 4V power for Andrew McAlpine to contest the BRDC Sportscar Championship in the UK. In Historic Group C races the car achieved two Class Wins at Nurburgring in 2005 with Matt Manderson driving.

Acquired in 1989 by the current owner, the chassis has been preserved in the narrow-track, side radiator form in which it ran in period, now with fresh engine and gearbox, and new fuel cell. Special trailer and full spares package including eight sets of wheels, bodywork and moulds also available

For more information please contact
natkins286@btopenworld.com or telephone 07836 230 031



Rolling chassis sports racer. Alloy tub, Reynard suspension, transmission, steering, Reynard Hewland G/Box, 4 pots, many new parts, 8 mounted slicks, 4 mounted wets, centre lock wheels, complete with body moulds. Regular class winner. Space needed. £6500-00 +VAT May exchange race shuttle. BDG/BDA installation. Suitable for BRSCC open sports. Would make good sports 2000.

Woodcote Racing
Tel: 01327 858074
Fax: 01327 858286

MARKETPLACE

CAR TYRES

FOR ALL YOUR
AVON
TYRES
MOTORSPORT
RACING TYRES
Inc. ACB 10 Formula Ford
Contact

BMTR LTD

Tel: 0121 331 1122
Fax: 0121 331 1144
email: sales@bmtr.co.uk
see our new web site at www.bmtr.co.uk

FLOORING

Kiwi Tiles

Interlocking Plastic Floor Tiles, as used by leading race teams throughout Europe.

- Easy installation & removal
- Many colours
- Lightweight
- Strong and durable
- Compact & easy to store
- Top quality
- Value for money

Stock Colours:
Red, Blue, Green,
Yellow, Silver, Orange,
Grey, Black, White,
Dayglo Red

Ralt Engineering

Tel: 01865 883354 Fax: 01865 883789
Email: enquiries@kiwitiles.com
www.kiwitiles.com

FOR RENT



PCM are pleased to offer a newly vacant business unit on their Long Buckby Site. Located 250 yards from the A5 and 10 minutes from J16 or 18 of the M1 Motorway, it is strategically located at the heart of the South Midlands. The accommodation has an existing trade counter and fully racked stores, workshop and offices. The total area including mezzanine being 5250 sq ft. It has car parking for up to 10 vehicles and for one large HGV. The building could be reconfigured and refurbished to your specification or let "as is" at a reduced rent. The overall site contains 8 other units and is fully security fenced. PCM are the site owners and therefore able to negotiate directly and quickly with potential clients.

Contact John Plant on: 01327 842808
or email: accounts@pcmfluidpower.co.uk

GEARBOXES



SPECIALISING IN GEARBOX REBUILD,
REPAIR AND SERVICING FOR GT,
LMP, F3 AND MORE...

HEWLAND SPECIALIST

Call 07976 877 612 or email jono@racing-transmissions.co.uk
www.racing-transmissions.co.uk

MARKETPLACE

AUTOMOBILIA

F1 COLLECTORS.COM



#1 FOR F1 MEMORABILIA

We buy and sell F1 items
AYRTON SENNA specialists
Call CHRIS GRINT 01763 274448
email: sales@f1collectors.com

JMJ Automobilia
SUPPLIERS OF RACE
MEMORABILIA SINCE 1992

Florida, USA (609) 575-1143

email: JMJAUTO.COM
WWW.JMJAUTO.COM

MARKETPLACE

RACE PRODUCTS

SCHROTH RACING

ACCEPT ONLY THE BEST

www.schroth.com

FIA APPROVED

EXPERT ADVICE • MASSIVE STOCKS • RAPID DELIVERY

Stilo

www.demon-tweeks.co.uk **QZ252A**

DON'T DELAY, CALL TODAY **0844 375 2196**

demon tweeks MOTORSPORT Direct

LOW CALL RATE CALLS MAY BE RECORDED FOR TRAINING PURPOSES

London Motorsport Showroom

www.msar.co.uk

msar UK agent for **SCHROTH RACING**

ORDER HOTLINE: 020 8655 7877

Logos for: HONDA, ARAI, SHOWTRAX, TRILITT, BELL, lifeline, Safety Devices, SCHROTH, AUL, and others.

WILLANS

LEADERS IN DRIVER SAFETY SINCE 1967

When only the best will do...

www.willans.com

Tel: 01488 669001

Fax: 01488 668141

sales@willans.com

WWW.REIGERSUSPENSION.COM  

The best suspension for:

- Rally
- RallyCross
- AutoCross
- MotoCross
- Trial
- Quads
- Sidecar Cross
- Rally Raid

REIGER Racing Suspension

Reiger Suspension BV
Molenenk 5a
NL-7255 AX Hengelo Gld.
Tel.: +31 (0)575-462077 info@reigersuspension.com



MARKETPLACE

RACE PRODUCTS



ADVANCED SUSPENSION TECHNOLOGY

OHLINS HAVE WON OVER 200 WORLD CHAMPIONSHIPS

MICK GARDNER RACING



OFFICIAL DISTRIBUTION FOR ALL OHLINS PRODUCTS

Factory Trained Technicians // Large Stocks of Shocks, Springs and Parts
 Official Sales and Service Centre // Fast Turnaround on Servicing, Revalving, etc.
 Bespoke Shock Absorbers Built to Customer Spec

CONTACT RUSS WALTON @ MICK GARDNER RACING NOW

E-mail: russwalton@mickgardnerracing.com

Website: www.mickgardnerracing.com

Telephone: 01226 240 099



**MARDI GRAS
 MOTORSPORT**
 Saloon Car Preparation



Unit 45, Silverstone Circuit
 Towcester
 Northampton NN12 8TL

tel: 01327 858006 fax: 01327 858800
 email: info@mardigras.co.uk
 web: www.performanceclutch.co.uk
 buy online at www.mardigras.co.uk

Distributors and agents for:



RACEWEAR

**Grand Prix
 Racewear**

WWW.GPRDIRECT.COM

2013

CATALOGUE

**AVAILABLE
 NOW**

REQUEST YOUR COPY
 GO ONLINE OR CALL US ON:

08435 070 858

RACEWEAR | KARTWEAR | SIMULATION



<<<<
 Scan code
 to view it
 online now

**Grand Prix
 Racewear**
 2013 Catalogue

DRIVEN BY PASSION

WEB DIRECTORY

TRAILERS & TRANSPORTERS

RACE & RALLY CARS

MARKETPLACE

MOTORSPORT JOBS

AUTOSPORT

MOTORSPORT JOBS

PUBLICATION DATE EVERY THURSDAY

CALL 020 8267 5820

FOR ALL AVAILABLE VACANCIES PLEASE GO TO THE JOBS SECTION OF AUTOSPORT.COM

BOOKING DEADLINE MIDDAY MONDAY PRIOR TO PUBLICATION

COPY DEADLINE MONDAY 5PM PRIOR TO PUBLICATION

ALL ADVERTS PLACED FEATURE IN THE APPOINTMENTS SECTION OF AUTOSPORT.COM FOR ONE WEEK

RACHEL.BROCK@HAYMARKET.COM

autosport.ads@haymarket.com



Richard Childress Racing

Tire Analyst / Vehicle Dynamics Engineer

Richard Childress Racing, a major competitor in NASCAR's Sprint Cup, Nationwide and Camping World Series is looking for a tire analyst with vehicle dynamics experience. The candidate should be well versed in basic tire mechanics and experienced in the analysis and treatment of tire force and moment data for use in vehicle dynamics simulations. Work done in correlation and model development with on-track force and moment measurements as well as machine measurements (MTS Flat-Trac or the like) would also be considered as a bonus. Familiarity with the unique characteristics of oval track racing is desired.

As a requirement for this position the candidate should possess, at minimum, an engineering degree (B.S. or equivalent). A focus in motorsport and vehicle dynamics also considered as a bonus.

To be considered for this position, please email Dr. Kent Day at kday@rcrracing.com include a current CV with your salary expectations.



...A Local Source To A Global Capability...

Due to continued growth and investment into additional machinery we are urgently seeking to recruit a CAD/CAM Programmer/ Machinist to fully support our Machine Shop Supervisor, based in Buckingham. In return we offer a competitive salary, company pension scheme, onsite parking and 25 days holiday as a minimum for the right candidate.

The successful CAD / CAM Programmer / Machinist will be responsible for:

- Manipulating data supplied by our customers using the Delcam software (PowerShape and PowerMill)
- An element of customer quoting will be required (full training will be given on this if required)
- Deputise for the Machine Shop Supervisor in times of absence

The essential qualities of the CAD / CAM Programmer / Machinist include:

- You will be an experienced programmer who is capable of using your own initiative
- Must have previous experience of the above systems Delcam Software (PowerShape and PowerMill)
- Strong understanding of engineering drawings
- Be able to programme and use the five CNC machines

If you are enthusiastic and keen to join a growing sector within our Company, then we will be pleased to hear from you. Send CV & covering letter to jobs@sigmacomposites.co.uk. Closing date 8/2/13. No Agencies.

To advertise call 020 8267 5820



At McLaren we believe that winning matters most. We know what it takes to win and we achieve this by working together and encouraging innovation in an extraordinary high performance environment.

We currently have the following exciting opportunities:

MRL 173	SENIOR MODEL MAKERS
MRL 176	QUALITY CONTROL INSPECTOR
MRL 179	GARAGE SUPPORT TECHNICIAN
MRL 218	DESIGN ENGINEER (MECHANICAL SYSTEMS)
MRL 219	STRUCTURAL DESIGN ENGINEER
MRL 220	SYSTEMS TECHNICIAN

We also have opportunities in Machining, Laminating, Pattern Shop and Production Engineering.

For further information on the above roles and details of how to apply, please visit www.mclaren-jobs.com



LOOKING TO RECRUIT FOR 2013?

CHECK OUT OUR NEW MOTORSPORT JOBS WEBSITE

- The Motorsport Jobs page of the website receives on average 200,000 page impressions per month
- The magazine you are looking at has a readership of 144,000 (Source: NRS Survey Q3)
- All job adverts placed in Autosport magazine are listed on the website.

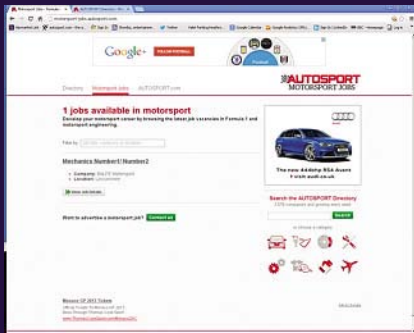

<http://motorsport-jobs.autosport.com/>

AUTOSPORT

WHERE ARE YOU ADVERTISING YOUR MOTORSPORT JOB VACANCIES?

haymarket®

Entry Level Sales Executives

Full-time position

Looking to start your career in media sales? Then Haymarket could have an opportunity for you. We are currently looking for entry level sales executives to join our expanding dynamic teams.

Haymarket publish a range of marketing leading magazine including What Car?, FourFourTwo, Stuff, AUTOSPORT, Practical Caravan and many more. We currently have vacancies across a few of our titles for entry level sales executives.

You will be given your own client base but will work within a team towards a team target. Your day to day tasks will include:

- Maintaining and developing existing relationships with clients
- Increasing sales revenue
- Sourcing leads from competitors
- Flat planning

Ideally you will already have some sales experience although this is not essential as a full professional development programme is provided.

We offer a competitive starting salary of £19k plus up to 40% commission, while those successful candidates who prove themselves will find many opportunities for development and promotion to regularly increase this salary.

To apply, please send you CV and covering letter to recruitment@haymarket.com



HYUNDAI

NEW
THINKING.
NEW
POSSIBILITIES.

To support the development of the new Hyundai i20 WRC Rally Car, we are looking for the following positions.

Location : Alzenau, Germany (40km from Frankfurt-am-Main International Airport)

Design Engineer

The successful candidate will need to justify a strong background in Mechanical Engineering as well as very good knowledge with CATIA. He/She will have to follow the whole process of design from 3D to calculation and drawing. The experience of one or more fields among those ones would be an advantageous:

- Suspension design
- Bodysell and structure design
- Surface design
- FEM calculation

Qualification required:

- Engineering degree or equivalent
- Excellent team work and communications skills
- Flexible approach to working hours
- Fluent English.

Senior Design Engineer

The successful candidate will need to justify a strong background in Mechanical Engineering, as well as very good knowledge with CATIA. He/She will have to support Design Engineers into their design process and follow sub-assembly design from basic requirements to testing. One or more significant experience in WRC or other high level of Motorsport is required. The experience of one or more fields among those ones is required:

- Non Linear FEM calculation
- Vehicle dynamics
- Driveline dynamics simulation.

Qualification required:

- From 5 to 10 years of experience in Motorsport.
- Engineering degree or equivalent
- Excellent team work and communications skills
- Flexible approach to working hours
- Fluent English.

Engine Development Engineer

The successful candidate will need to demonstrate a thorough understanding of race engine and their application within WRC. He/She should have experience and knowledge in combustion of gasoline turbo direct injection engine, lubrication, cooling, valve-train dynamics. Previous experience in the dedicated motorsport engine control system would be required.

Good communication skills, attention to detail and the ability to manage multiple priorities are the key to success in this diverse role. A flexible approach to working hours and tasks is essential.

Qualification Required:

MSc level or similar in engineering with race engine development program.

If you wish to be considered for above positions, please email: jobs@hyundai-ms.com, attaching an up-to-date CV

**Hyundai Motorsport GmbH
Carl-Zeiss-Strasse 4
63755 Alzenau
Germany**

CATERHAM FI TEAM

TYRE ANALYSIS ENGINEER Ref: CF1/TE/147/13

Reporting to the Head of Tyres, the successful candidate will:

- Be involved with all on & off track tyre analyses, including some trackside support.
 - Develop tyre analysis techniques, monitor tyre performance during events and advise on improving tyre usage.
 - Lead the tyre rig testing activities, and assist in the development of testing procedures.
- Liaise with:
- Race Engineering, Design, and R&D, to provide informed advice on tyre characteristics.
 - The tyre supplier's track support engineer, & act as a first point of contact for all technical issues.

The successful candidate will ideally:

- Have a minimum of 2 years experience in a similar role
- Be able to demonstrate a high level of understanding of tyres in a motorsport environment
- Have an innovative and flexible approach to solving problems, and the ability to tackle tasks in a methodical and analytical way
- Have an excellent knowledge of data analysis techniques, and tyre dynamics
- Have good skills in MatLab and Atlas (or similar). Some knowledge of Multi-body modelling would also be an advantage

CAR BUILD TECHNICIAN Ref: CF1/CBT/146/13

We are looking for a Car Build Technician that will be responsible for all chassis assembly for Race, Test and Show Events, Mock-Up Build and to assist/ work alongside Car Build Manager, Stores Personnel and Race Team Parts.

The successful candidate must:

- Have previous relevant Formula 1 experience working within a similar department or Race Team
- Be able to demonstrate good problem solving skills, and be able to work to tight deadlines
- Be able to work unsupervised after being given clear instruction and direction
- Have previous experience in Life check, SAP, or similar
- Be capable of quickly integrating into the existing environment and be able to converse with various departments
- Have good communication skills, be self-motivated and have a flexible approach to working hours
- Be willing to travel to Tests and/or Races at short notice

If you wish to be considered for this post, please email: hr@caterhamf1.com, attaching an up to date CV and indicating your salary expectations.

T. +44 (0) 1953 851 411

Closing date for applications: 1st February 2013



And here are the views of some of our satisfied clients:

"We received an unexpectedly large amount of responses in only a few days. We would definitely consider Autosport for any future recruitment needs."

Jose Santos, Race Engineer Matech Concepts

"At Flybrid Systems we have used Autosport as a single source to advertise a range of jobs from design and development engineering roles to assembly technicians and administrators. We have always had a strong response and on the last occasion we received over 200 applications for 6 posts."

Jon Hilton FIMechE CEng, Managing Partner, Flybrid Systems LLP

"Team WFR recognise Autosport magazine as one of the mainstream publications within the motorsport industry and therefore was an obvious choice when wishing to recruit new staff. We were thoroughly impressed with the extensive response to our advertisement and the quality of candidates that was received, just going to show that Autosport is read by high level motorsport professionals"

Jody Firth, Team WFR



**MERCEDES AMG
PETRONAS** FORMULA ONE™ TEAM

Mercedes-Benz has been setting the standard in racing for over 100 years. The MERCEDES AMG PETRONAS Formula One™ Team continues the proud history of the legendary Silver Arrows with the clear ambition of winning the FIA Formula One™ world championships. Based in Brackley, UK, we are recruiting highly motivated, talented new members of our team.

RACE TEAM MECHANIC

REF - SW495/2401

We have an exciting opportunity for a Race Team Mechanic to join our team. Reporting to the Race Team Chief Mechanic, you will be responsible for the preparation of the race car.

Liaising with the No.1 Mechanic on all build specifications and set up sheets to ensure the car is prepared to the highest possible standards at all times.

Responsibilities will include:

- Liaising with the No.1 Mechanic on all gearbox, hydraulics, sub-assembly, electronics, composite specifications and building the car following Mercedes AMG PETRONAS procedures
- Responsible for informing the No.1 Mechanic/Spares Co-ordinator of any car part changes during all running times
- To be available to attend all race events and also available to attend any test race requirements throughout the year
- Responsible for keeping a clean and tidy working environment while at the circuit and whilst at Mercedes AMG PETRONAS Operations Centre
- To report any chassis, engine or equipment technical faults to the number 1 and Chief Mechanic
- To assist the team in dismantling the pit garage system at the end of an event and to assist in any other way as directed by the Team Manager and/or Chief Mechanic
- Attend team meetings and health and safety meetings as required

Relevant Experience and Qualifications:

- Single seater or sports car experience competing at a high level is required

Flexibility in hours and approach is required, along with a 'can do', 'team playing' attitude. Good verbal and written communication skills are very important. The ability to work under minimal supervision to strict deadlines and in a professional manner is essential.

In return for your work and commitment, we offer a competitive package including bonus, life assurance, private medical cover, Mercedes company car lease scheme, 25 days holiday, on-site gym, subsidised restaurant facilities together with the chance to work in a truly unique environment.

If you wish to apply for this position please forward your CV and letter of application with current remuneration details/salary expectations, quoting the job title/reference and where you saw the advertisement to recruitment@mercedes-amg-f1.com

Closing Date: 15th February 2013.

NO AGENCIES PLEASE.

Sports Extra

NATIONAL RACING • HISTORICS • CLUB • RALLY • RALLYCROSS • HILLCLIMB



The Cortina was one of the best tin-tops of the 1960s

Special race for Lotus Cortina

Brands Hatch event to celebrate 50th birthday of iconic saloon

» **THE 50TH ANNIVERSARY** of the Lotus Cortina will be celebrated with two races on the Brands Hatch Grand Prix circuit in August.

The Cortina-only grid will appear at the Lotus Festival meeting on August 24-25 and organisers are hoping for a large entry, as well as a number of cars for display.

Each race will be 25 minutes long. They will be for solo drivers, but entries will be allowed to run different drivers across the two.

Carol Spagg of race organiser Historic Motor Racing said: "We had 28 Cortinas on a 60-car grid at Silverstone last year. This

year's one-off race will give us the opportunity to have a record-breaking number of Lotus Cortinas all racing together. It is bound to be popular with drivers and spectators."

MotorSport Vision's Kevin Ritson confirmed the exact technical rules have yet to be finalised, but expects both Appendix K and Historic Racing Saloons Register machines to be eligible. "The idea is to get as many as possible," he said. "We'd be pleased with 30 cars.

"It's also the 50th anniversary of Jim Clark's first F1 title so we're hoping Classic Team Lotus can bring something along too."

The 1558cc Lotus-developed

Ford tin-top was homologated in September 1963. It went on to score many race and rally successes, including the 1964 British Saloon Car Championship (now BTCC) in the hands of Jim Clark and the 1965 European Touring Car Championship with Sir John Whitmore.

Historic ace Simon Hadfield, who has scored many Lotus Cortina successes with Leo Voyatzides in recent seasons, welcomed the initiative, but also warned against making the regulations too open.

"It's a good thing," he said. "They're a fantastic racing car and are a bedrock of historic motorsport. If Leo or somebody else wanted to do it I'd love to.

"Its success or failure will be how it works around everyone else's racing. That's what hurt the Elan anniversary races last year – too close to other events.

"If they make it Appendix K how many HRSR cars would they knock out? Not many. If they keep it to Appendix K everyone will know where they are."



Many Cortinas are still raced with verve

AUTOSPORT SAYS...

BEN ANDERSON
NATIONAL
EDITOR

ben.anderson
@haymarket.com



THIS IS THE YEAR OF A NUMBER

of significant motorsport milestones: legendary UK sportscar marque Aston Martin is celebrating its centenary, while the home of motor racing in the North West of England - Oulton Park - is 60 years old. In addition, the seminal Porsche 911 and the Ford Lotus Cortina will both turn 50 in 2013.

Special 'celebration' races are in vogue for 50th birthdays right now, and the half-century of the iconic Lotus-developed Ford tin-top will be celebrated with something along similar lines at Brands this summer.

Piggybacking the established Lotus Festival in August is a sensible move - one that paid off reasonably well for the Classic Sports Car Club's 2012 'Lotus Elan 50' celebration. Where that arguably over-stretched itself (with a second race at Donington later in the year), the Cortina event will sensibly stick to a single weekend.

After all, it won't be possible to achieve the sheer volume of cars that gave us 2011's E-type Challenge anniversary series; two races, at one big event, makes sense.

But there is a potential snag in the timing. MSV's August 24-25 date clashes with the HSCC's Oulton Park Gold Cup meeting, which includes a grid for Historic Touring Cars. That means Gold Cup Cortina loyalists will probably have to choose between the North West and the South East.

The Brands event is also just one week before a round of the U2TC series at Paul Ricard, which means the European racers that make up the bulk of the Silverstone Classic's healthy Cortina following may stay away in an act of preservation.

Let's hope not; the sight of 20-plus Cortinas, sideways and three-wheeling, would be a fine one indeed.

Extra contact details

Kevin Turner, features editor
kevin.turner@haymarket.com

LOTUS CORTINA STATS

ENGINE: 1558cc twin ohc straight-four
BTCC WINS: 7
ETCC WINS: 17
TRANS-AM WINS: 1

CONTENTS

p78 PROFILE
TOM ROCHE



Caterham R600

Caterham cans new R600 series

Latest Seven will not get its own series in 2013 as British marque struggles with numbers

THE NEW CATERHAM R600 Superlight series will not run in 2013, after failing to attract enough drivers to guarantee a viable grid.

AUTOSPORT understands the Dartford manufacturer set itself a minimum target of 15 cars for the new five-round series, which Caterham conceived to replace the slickshod R400 formula that was last run in 2009.

Caterham has decided to suspend the new series until 2014 and remains hopeful a slickshod, supercharged category will offer a next step on the Caterham ladder for graduates of the R300 Superlight series, which has grown strongly since its launch in 2009.

A Caterham spokesman said: "We imposed the 15-car limit from the start and didn't quite reach it. It's hard to say exactly why but it's

probably a combination of factors. "It's a big decision to delay it for 12 months, but probably a sensible one. It's disappointing for the guys that have signed up, but the car is brilliant and we're confident we'll get a good grid for next year."

Leading Caterham team boss Derrick Rowe, whose DPR squad planned to run several cars in the new series, suggested a late launch for the R600, combined with similar

costs to rival Ginetta and Radical series, had made it difficult for Caterham to reach its 15-car target with the R600.

He said his team would now revert to running four cars in R300. "R600 is potentially a real low-cost alternative for someone aspiring to GTs so hopefully it will appear in 2014," he said. "In the interim we will continue to run an ultra-competitive R300 squad."

Clio Cup

Wakefield and Modell to Clios

RENAULT CLIO CUPSQUAD

Scuderia Vittoria will run two more cars in the 2013 championship after adding Ginetta GT Supercup refugee Josh Wakefield and ex-karater Devon Modell to its line-up.

The team has already announced KX Akademy racers Stefan Hodgetts, Ant Whorton-Eales and Luke Herbert for 2013. The additions of ex-Trofeo Abarth racer Wakefield and car-racing rookie Modell mean the line-up now stands at five cars, with more expected.

Team boss Danny Buxton said: "Josh has had a couple of testing years in different formulas, but has



Wakefield had a difficult season in Ginetta G55

shown he possesses great pace. I'm confident he'll do well.

"Devon is a really exciting talent who held a huge reputation in karting by beating the likes of Max Chilton and Adrian Quaife-Hobbs along the way."

"He is a very intelligent, calm and confident driver, who possesses great pace, and I'm sure he will surprise a lot of people in the TOCA paddock."

BRDC F4

Dalton makes F4 switch with MGR

FORMULA RENAULT BARC

podium finisher Jake Dalton will switch to the new BRDC Formula 4 Championship this season.

Dalton, 17, will remain with the Mark Godwin Racing squad that ran him to eighth overall in the Renault BARC standings in 2012.

Dalton said: "Getting to race on some fantastic circuits and support the DTM and F3, not to mention the prize fund, [means] I feel this could open lots of doors for my future and makes it the right choice."

MGR team principal Mark Godwin added: "We're delighted to welcome Jake back to the MGR team and I

know he's going to be a great addition to our line-up.

"I was impressed with his pace and attitude last year, and I'm really looking forward to continuing this partnership in F4."



Dalton finished eighth in FR BARC in 2012

IN BRIEF

FORMER SILVERSTONE

24 Hours race winners John Gaw and Phil Dryburgh will



Gaw/Dryburgh Aston is back

race an Aston Martin Vantage in British GT in 2012. Richard Poole/Mark Abra have also committed to a full season in their new Barwell-run Vantage.

INTERSTEPS CHAMPION

Matt Parry has confirmed

plans to graduate to Formula Renault NEC this year. The 18-year-old Caterham F1-backed Welshman will also contest selected Eurocup races with the Fortec squad that guided him to the InterSteps crown in 2012.

FORMULA RENAULT

squad Mark Burdett Motorsport will run 20-year-old Colombian Andres Mendez in the NEC this season. Mendez, who raced in Star Mazda last year, joined the team after reviewing onboard footage

of ex-Burdett racer and 2012 Star Mazda champ Jack Hawksworth.

EX-BRITISH GT AND BTCC

racer Phil Glew will return to Time Attack in 2013. The 2009 Clio Cup champion, who won Time Attack when

he last contested a full programme in 2007, will drive a Subaru Impreza.



Glew will drive BC Impreza

Britcar

Scuderia Vittoria to run Bailey Ferrari 430 in British Endurance

BRITISH ENDURANCE

Championship frontrunners Paul Bailey and Andy Schulz will link up with successful British GT and Clio Cup squad Scuderia Vittoria for a renewed title attack this season.

The pair finished fourth overall and second in Class 1 of the Britcar-run series in 2012, but have decided to switch to Vittoria from SB Race Engineering after



Bailey/Schulz Ferrari ran at the front in 2012

suffering what Bailey described as reliability issues with his Ferrari 430. SB will continue to run Bailey in Ferrari Challenge events in a 458.

Bailey said: "The 430 has been completely stripped down and is currently being rebuilt as we speak. Changes have already been made that will help our challenge in the British Endurance Championship this year, which is good news.

"We had a few reliability issues with the car in 2012, but I'm sure that Scuderia Vittoria will provide us with a reliable package going forward."

Schulz added: "To be working with Scuderia Vittoria in 2013 is brilliant news. SB Race Engineering will still run Paul in the Ferrari Challenge, but this way we can ensure that we are getting the optimum out of each car."



Willhire-winning Ford Capri restored to former glory

Neil Godwin-Stubbart has nearly finished rebuilding the Ford Capri that won the 1985 edition of the Willhire 24 Hours at Snetterton. Godwin-Stubbart hopes to campaign it in the new HSCC Touring Car Trophy.

European Rallycross

Hansen commits to ERC campaign

EX-SINGLE-SEATER ACE TIMMY

Hansen, the eldest son of 14-time European Rallycross champion Kenneth, will make a full-time switch to the FIA ERC this season in his family team's Citroen DS3 Supercar.

Hansen Jr, 20, finished third in Formula BMW Europe in 2010 and seventh in the '11 Formula Renault Eurocup before dropping out of last season's 2012 Eurocup after a few races.

"After four years competing in single-seaters, I'm ready to move up to one of the most interesting series in motorsport," said the Swede.

"I drove a one-off race in Finland last

year and understood why my father stayed so many years in the sport.

"A Supercar is a tiger - wild, strong and needs to be treated with respect. The high level of fidelity I learned in circuit racing will suit rallycross."



Hansen has abandoned single-seaters for ERC

MARCUS PYE

HUMBLE PYE

The voice of club motor racing

Witt has big plans for Chevron name



I don't know David Witt personally but, over the course of an introductory telephone conversation with the gentleman who has reunited the Chevron Cars Limited name with its hallowed yellow trademark, I needed no convincing that he is fanatical about the marque founded by Derek Bennett in 1965.

The 59-year-old South Shields native - whose business empire makes clothing for Marks and Spencer - achieved his burning ambition to own and race Ferraris, but now is hell-bent on making a household name of Chevron, whose glorious cars emerged from an old redbrick textile mill in Bolton.

Witt, who funded the development of the GR8 project - built by Chevron Racing Ltd, initially under the direction of former Bennett employee Vin Malkie - has now relocated that business to workshops in Crewe and re-merged it with Chevron Cars Ltd, thus ending years of confusion and uncomfortable dialogue.

In buying Chevron Cars (the original entity that left Lancashire and went via Laurence Jacobsen, Leslie Cuthbertson and Robin Smith to Scotland) from Roger Andreason (who retains a shareholding), Witt is committed to moving the name and product forward on all levels.

"As I got more and more interested in the business, I had a

clear vision of its future," said Witt. "It is important to respect the past, but not live in the past. We want to re-establish the brand through racing, and building competitive GT3 cars for a third of the price of a McLaren or Ferrari. And build a road car to challenge the supercars."

Ever proactive, Witt has brought Paul Brown (the respected former Zakspeed and Maurer designer responsible for the GR8 concept) back on board, and is working closely with a community of engineers in the North West, among them Dennis Aldred of Motor Sport Components, to supply parts.

The refocusing of Chevron's car manufacture and racing activities under one umbrella, with Andreason heading up Chevron Heritage - offering genuine parts from original jigs and patterns to service historic models - in Bolton, is a "win, win, win situation" for owners and enthusiasts according to Witt.

As a self-confessed Chevron nut since youth (I've been privileged to race B1, B6, B8, B16, B19, B21/23, B25, B26, B31/36, B37, B40 and B61 models, hillclimb B34 and B47, own a couple, and test many more of the 'Bolton Wanderers'), I need to get up to date at the start of a bright new era for the marque.

“In buying Chevron Cars, David Witt is committed to moving the name and product forward on all levels”

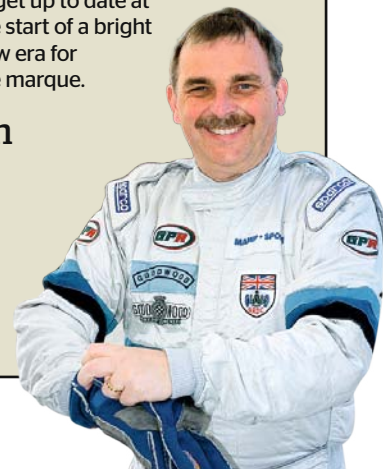

MO113P

AUTOSPORT

FREE AUTOGLYM VALET KIT

WHEN YOU SUBSCRIBE TO AUTOSPORT

BEAT THE PRICE RISE!

**AUTOSPORT is now £3.50 an issue,
BUT SUBSCRIBE TODAY
and you'll pay our current
subscription prices
ALL YEAR!**

**SAVE
23%
ON THE
COVER
PRICE**



**JUST
~~£3.50~~
£2.69
AN ISSUE**

GREAT REASONS TO SUBSCRIBE:

- **FREE AUTOGLYM VALET KIT**
- worth £42
- **BEAT THE PRICE RISE**
- save 23% on the cover price
- **SPREAD THE COST**
- just £34.99 every 13 issues with
easy direct debit instalments
- **FREE P&P**
- every issue delivered to your door

Subscribe online at:

the**magazineshop.com**

www.themagazineshop.com/ASPO/MO113P

Or call our hotline and quote offer code MO113P:

08448 488 817

Offer closes February 7, 2013. Please have your bank details ready

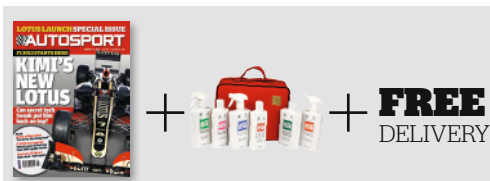

Terms and conditions: This is a direct debit offer open to readers in the UK only. Overseas rates are available by calling +44(0)1795 592974 or for US rates call +1 866 978 1446. Direct debit prices are valid for one year, after which they are subject to change. Should prices change you will be informed in writing. We ask that you enter into a Direct Debit agreement with the intention that your subscription will continue for a minimum period of 12 months, even if the frequency of payment is for a shorter period; however, you will still have the right to cancel your Direct Debit in accordance with Direct Debit Guarantee. Should you wish to cancel your subscription it will be cancelled on expiry of the current term which will not be refundable, other than in exceptional circumstances. If a gift is included as part of the subscription offer we reserve the right to request the return of the gift. Details of the Direct Debit Guarantee are available on request. Savings are based on the standard UK cover price of £3.50. Offer ends February 7, 2013. Please allow 35 days for delivery of your first issue and gift. Gift will be sent under separate cover. Should we run out of gifts you will be offered an alternative - there is no cash alternative.



Fortec took 2012 Winter title with Morris (third)

Formula Renault BARC

Fortec gets four for FRenault

European karting ace Sam MacLeod and Hong Wei Cao to lead 2013 assault

LEADING SINGLE-SEATER TEAM Fortec Motorsport has attracted four drivers for this season's Formula Renault BARC Championship.

British and European karting ace Sam MacLeod, who competed in some Formula Ford 1600 events towards the end of last year, and Chinese racer Hong Wei Cao, who finished fifth in the 2012 FR BARC Winter Series with Fortec, will spearhead its attack.

The Daventry squad, which ran

Seb Morris to the 2012 Winter Series title, will also run cars for Malaysian JK Racing Asia Series graduate Wei Ron Tan and Hong Kong-born racer Wei Fung Thong, who finished third in Asian FRenault in 2012.

Team manager Steve Lynch said: "We're really pleased to have all four deals done so early. It's going to be a very open season with so many of the experienced guys having moved on.

"It'll be a learning year for Sam but

he's been very quick in testing and we're confident he and Martin [Cao] will be fighting at the front for regular podiums. Sam's already proving himself to be a very good driver and we're looking for Martin to continue where he left off in the Winter Series – he's committed to a big push this year.

"It'll be a new challenge for Tan and Thong but we're sure they'll both make strong progress, setting a strong base for the future."

Tasman Revival

Ross and Proctor beat 'King' Kenny



Ross leads race one in his McRae GM1

STEVE ROSS AND CLARK

Proctor beat the previously invincible Ken Smith as the MSC F5000 Tasman Revival headed the second half of the New Zealand Festival of Motor Racing celebrating Denny Hulme at Hampton Downs last weekend.

Reigning champion Ross (McRae GM1) bested Smith (Lola T332) by 0.7s in the battle for pole and narrowly beat the veteran in both heats. Lola T400 drivers Andrew Higgins and Briton Mark Dwyer completed the respective podiums, with Chris Lambden (GM1) fourth on Sunday.

The 15-lap feature final brought a new winner in former speedway and

NZV8 racer Proctor (March 73A), who asserted himself at the first corner, taking Higgins past the favourites, and stayed there for a popular victory.

"I knew my car could turn in nice and tight at Turn 1 on cold tyres and I knew Steve [Ross] would diamond the corner, which would probably catch Kenny [Smith] out," said Proctor.

After Higgins retired and Ross gyrated, Smith powered into the Aucklander's slipstream, but a gravelly moment for Smith let Proctor off the hook and the 71-year-old finished second again. Ross was third, ahead of Brit Greg Thornton (GM1), Dwyer and Brett Willis (Lola T330).

Historics

Guards Trophy gets Spa date

THE HSCC'S GUARDS TROPHY series, for 1960s sports-racers and GT cars, will have an overseas race for the first time in its history this season.

The series attracted 139 registered competitors last season and the club hopes a trip to Spa on June 15-16 will boost numbers further.

A series spokesman said: "This is a fantastic opportunity for our regular members to race on the greatest track in the world."

The club wants to try and break the 150 mark for registered contenders for this season's championship, and is particularly keen to hear from drivers looking for a warm-up before tackling the Spa Six Hours in September.

HSCC CEO Grahame White said: "We would love to get some Ford GT40s and AC Cobras to join our grid for this race."



Guards Trophy field will head abroad in 2013

IN BRIEF



APO will return to British GT with Ginetta

BRITISH GT SQUAD APO SPORT

will return to the series' GT4 class this season. James May and Alex Osborne will again share driving duties in the team's Ginetta G50.

BELGIAN MOTORSPORT FOLK HERO

Marc Duez has been appointed race director for the Euro Racecar NASCAR Touring Series. The former Nurburgring and Spa 24 Hours winner is responsible for maintaining driving standards in the burgeoning pan-European series.

VW RACING CUP STALWART

Richard Kingsnorth will be part of Tony Gilham's planned nine-car squad in the series this season. The Essex racer, who will drive a converted Mk5 Golf GTI, joins Andy Wilmot, Emma Selway, Sam Morgan and Henry Gilbert at Team HARD.

GINETTA JUNIOR PRIVATEER TOM

Jackson will return to the series this season. Jackson is the second driver to sign-up for the Junior Race Car Academy satellite team for privateers, set up by HHC Motorsport boss Charlie Kemp.

SOUTHAMPTON RACING TEAMS

Brookspeed and Startline Services have joined forces for 2013. Winning Porsche Boxster outfit Brookspeed wants to raise its profile in historics, where Startline drivers have won GP Masters and Classic F3 titles. Startline will run Eric Bailey's Royale RP27 in FF2000.

ANGLESEY CIRCUIT BOSS RICHARD

Peacock won a lifetime achievement gong at last week's Anglesey Tourism Awards.

TRIPLE OLYMPIC TRACK CYCLING

gold medalist Jason Kenny will graduate to the main G40 class of the Ginetta GT5 Challenge in 2013, after trading in the G20 he used to contest the 2012 finale at Donington Park. Ex-Combe Saloons ace Will Burns will return for a title assault with the Academy Motorsport squad that ran Sean Huyton to the 2012 crown.



Kenny will trade Ginetta G20 for G40

A winning mentality

Tom Roche is a force in Mazda MX5 racing, and last year won AUTOSPORT's Golden Helmet. By BEN ANDERSON

Tom Roche only started car racing in 2007, but no one has won more races in the British Isles over the past five seasons than the 25-year-old Welshman. What's more, Roche has notched up his victories in single-make Mazda MX5 races – arguably the most competitive branch of UK club competition we've seen in recent years.

Like most young racing drivers, Cardiff native Roche began his career in karting. He became Welsh champion before moving into the UK-wide super-competitive British Super 1 series in the TKM class. He reached the top 12 in the standings, but lacked the funds to run with a team, or afford the new equipment that could have made him a frontrunner.

Frustrated, he decided to move into cars, following his friend Dan Rochester into the BARC's Mazda MaX5 championship in 2007. "I loved it compared to karting – the way the car moved around, sliding all the time," Roche recalls enthusiastically.

"I started really well and won my third race at Croft. I qualified fourth or fifth, I think, and then managed to get the lead. Paul Sheard was behind me and he was quicker, but there was no way I was going to let him past!

"When I started, Jonathan Greensmith and Paul Sheard were brilliant to race against – really clean but ultra-competitive. I learned a lot from racing them. In my first seven race meetings I had to go and see the clerk of the course a lot for hitting people.



Roche (r) received his award at ASI in Birmingham

Coming from Super 1 – where if you can hit someone off you do it – I had to calm it down. Car racing is a lot more gentlemanly!"

Roche was a regular podium finisher in his first season, as Greensmith and Sheard tied ahead of him at the top of the points. Then came a split within the Mazda community as Jonathan Blake created his breakaway Ma5da Racing initiative. Roche returned to MaX5, winning his first car racing title, but Blake secured sponsorship from Scalextric, which allowed Roche to contest Ma5da races as well.

He won at total of 13 races across the two series in 2008, before going on to win dozens more (and three Ma5da titles) over the next four years. He says the key to his success has been his ability to take calculated risks and better analyse his own driving having become an instructor at Silverstone.

"Mazda MX5s are great – if you can afford to do it, you can afford to win"

Tom Roche

"It's important to know when you're beaten," he says. "I've seen a lot of accidents where people don't concede a place and crash. You should just concede it and get it back on the next lap. Like anything, the Mazdas are fairly sensitive to set-up and the engine is important, but once you've got a base they don't take a lot of tweaking. As long as your car is there or thereabouts, there's so much more to be found in the driver."

Roche has wanted to move on several times, but says he couldn't afford the next step. "We always looked for other championships, but couldn't find another one for the same budget that was worth doing," he explains. "Within club motorsport, Mazdas is about as big as it gets. The thing that's great about it is if you can afford to do it, you can afford to win."



A familiar sight: Roche leads jostling MX5 pack

ROCHE CV

Age 25
From Cardiff
2012
1st in Ma5da MX5
2011
1st in Ma5da MX5
2010
2nd in Ma5da MX5
2009
1st in Ma5da MX5
2008
1st in BARC MaX5
2007
3rd in BARC MaX5

Roche has branched out a little recently, winning his class in the HSCC 70s Road Sports race at the 2011 Oulton Park Gold Cup in an Alfa Romeo 2000 GTV. He has also dabbled in the Lotus Elise Trophy, in which former Ma5da rival Rob Boston starred last season. But the focus has been primarily on Mazdas, where Roche has been able to build his own race team – Blendini Motorsport – thanks to his extraordinary success.

"It started when I became friends with [fellow Mazda racer] Charles Plumley," explains Roche. "He asked me how I was winning and I gave him some tuition and we saw that other people were running cars and earning money. Charles said, 'I've got the money and no time, and you've got time and no money, so I'll pay for it and you do all the work!'"

"We started with a truck and one hire car and grew to running 14 cars at one



meeting last year. I enjoy it but it can be really stressful. It was getting to the point last year where I couldn't remember the drivers' names! We won't run so many this year – especially if we end up to doing GTs."

Having become a fixture at the front of MX5 racing, Roche is finally planning to step up this year by teaming up with former Welsh Sports and Saloons champion Dom Evans in British GT3 – provided drivers can be found to race Evans' Blendini-run Ginetta G50 in GT4, and Roche can find the money to pay his own way.

"I'd like to do a bit of Mazdas on my favourite tracks, but to be honest I'll be totally skint!" he says. "Racing money doesn't seem like real money [further up the sport]. A set of GT tyres costs more than all the race weekends in Mazdas..."

"But I'm really excited to be moving



Roche scored his first win at Croft in 2007

on to GTs – I really enjoyed driving the Lotus last year, because it was something different, but GT3 will be a massive step forward. I've had a few people tell me I can't move on because I'm 'Mr Mazda'; but then I'm also told there are people who will be glad to see me gone!"

It will certainly improve their chances of winning Mazda races. ❄

BIG NUMBER

80

The number of wins (including class victories) for Tom Roche since he started car racing in '07

YOUR SAY

What you think of the motorsport news of the past week



Just four chances to see Brit F3 action in 2013

Worrying decline of British F3

The news about this year's British F3 series is worrying to say the least. A previously prestige championship reduced to this?

But in reality, given a fragmented single-seater career path for young drivers and the general economic situation, is it such a surprise? Sadly for spectators it means less choice, fewer events and for the circuits less gate income – and what for the teams themselves? I feel this is a worrying development for F3 and its future, and has wider implications for the sport itself in this country.

Andrew Groves, by email

AUTOSPORT.COM

TOP FIVE ON OUR WEBSITE

1. WOLFF GIVES BRAWN HIS BACKING
2. LEWIS HAILS MERCEDES' DETERMINATION
3. ANALYSIS: BRAWN AND HAMILTON DEFIANT
4. ANALYSIS: F1'S TECH BOSS SILLY SEASON
5. KUBICA 'NOT YET FIT TO TEST F1 CAR'

AUTOSPORT+

TOP STORY ONLINE

HRT: ALWAYS DOOMED TO FAIL?

To read this exclusive feature and many others like it, log on to autosport.com/plus and choose which package you'd like. A month will cost £5.50, a year £46. Includes access to Forix – the ultimate stats website.

WIN!



ROAD ANGEL VANTAGE

This week's star letter will receive a Road Angel Vantage – a dedicated safety camera and blackspot locator that displays the legal speed limit of every road you drive, automatically and wirelessly updating its database every few minutes as you drive. For more details on Road Angel visit www.roadangelgroup.com Please ensure that your full address is included on all correspondence.

CORRECTIONS AND CLARIFICATIONS

- The James Hunt picture at the top of p29 in last week's issue is from the 1973 European F2 race at Mallory Park, not the F1 Race of Champions, as claimed.
- In last week's story about the revival of the Commander Yorke Trophy (p79), we said the race was continued for sportscars in the '60s; not so, says Duncan Rabagliati: it was for Formula Junior, with two future F1 drivers as victors: Mike Spence winning in '61 with a Paul Emery-built Emeryson and Richard Attwood in '62 in an MRP Cooper T59.

EDITORIAL CONTACT mail@autosport.com

1977 Race of Champions.

A bare-foot James Hunt patiently signs autograph after autograph to a raft of fans, including this then-10-year-old, before sweeping to victory.

Sixteen years later, inspired by Hunt, I was a Formula Ford racer and instructor at Brands Hatch when Brian Jones broke the news of James's tragically early passing – and my first hero was gone.

As with his brilliant analysis last year of Gilles Villeneuve, Mark Hughes has used his insight to flesh out

the truth about James the racing driver (January 24).

Thank you for this fabulous appreciation of a charismatic, underrated and above all much-loved champion.

Simon Hill
By email

I've just read the very personal and warm tribute by Niki Lauda to James Hunt (January 24, p26).

I hope the forthcoming movie captures the essence of what was clearly a very real friendship.

Arnold Brazenall
Annan, Dumfries & Galloway

As a great fan of Damon Hill,

I very much appreciated your Legends series in an otherwise dull January.

Yes, I'm from Germany – but I was always disgusted at what a certain driver (I won't use the S-word) did to Hill at Adelaide in 1994.

Ludwig Eller
Landshut, Germany

Best news of the week:

new footbridge at Oulton Park; after many years I will no longer have to decide to watch at Lodge or Old Hall (the view is not the same on the inside of the circuit) or go

to the paddock and then trek to Cascades or Knickerbrook when the racing starts.

Ian Dunbobbin
Billericay, Essex

I have loved F1 for much

of my life. But I'm unsure whether I can continue to use the same term of endearment when I read of more top-line drivers failing to get into race seats due to lack of funding.

Surely something is not right when so many of the teams have drivers who pay to be there.

Anthony Willis
London SE26

THE LATEST GEAR

Desirable new releases for motor racing fans: books, DVDs, models, art and gifts



SUNSTAR SUBARU IMPREZA 1:18 MODEL

£77.99
autosport.com/shop

Inspired by last weekend's BBC *Racing Legends* documentary on the life of the late Colin McRae, we had to share details of SunStar's incredible 1:18-scale diecast replica of the Impreza 555 used by the Scot to win Rally New Zealand in 1994. With the doors, bonnet and boot opening you get a full appreciation of the detail, inside and out. And, better still, it comes with full 555 branding.

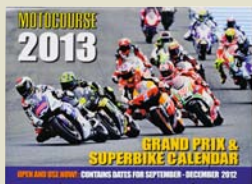

MOTOCOURSE CALENDAR
£11.99
autosport.com/shop

Respected bike-racing annual Motocourse also produces glossy calendars and its 2013 Grand Prix and Superbike version is now available. There are images from both MotoGP and World Superbikes – the top-two series in the two-wheeled world. Calendars come protected with card and shrink-wrap.

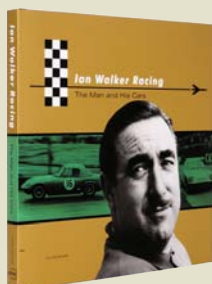

IAN WALKER RACING BIOG
£78 (978 1902 351 476)
autosport.com/shop

Julian Balme's in-depth portrayal of the life and times of Ian Walker and his famous green-and-gold sportscars raced by such as Jim Clark, Graham Hill and Jackie Stewart, is superbly researched, with huge amounts of unseen material from the Walker family archive. Sure, it's pricey but it's fabulous.



FUJIMI McLAREN 1:24
£44.95
grandprixmodels.com

McLaren's new supercar, the MP4-12C, was soon converted into a successful GT3 racer and it wasn't long before the model makers cottoned on. Japanese guru Fujimi's 1:24-scale plastic kit is a great version with well laid-out instructions and the finished kit looks ace in McLaren papaya orange.

HOT ON THE WEB THIS WEEK

YOUTUBE: DAYTONA 24 HOURS HIGHLIGHTS



SEARCH FOR: Montoya Won 2013 Rolex 24h Grand-Am Race at Daytona (12:19) Highlights from last weekend's Daytona 24 Hours in which Chip Ganassi Racing quartet Scott Pruett, Memo Rojas, Juan Pablo Montoya and Charlie Kimball took their Riley-BMW to a 21-second victory to mark record-breaking fifth win.

WHAT'S ON...

Your guide to the week ahead, including TV listings and online – plus opinion columns



The ERC season continues in Latvia

EUROPEAN RALLY CHAMPIONSHIP

Rd 2/13
Rally Liepaja-
Ventpils, Latvia
February 1-3
fiaerc.com

TOYOTA RACING SERIES

Rd 4/5
Hampton Downs,
New Zealand
February 2-3
toyotaracing.co.nz

ANDROS TROPHY

Rd 7/7
Super Besse, France
February 2
tropheeandros.com

AUTOSPORT SOAPBOX



It's the big question, so how do you pick the greatest driver? By KEVIN TURNER

The British Legends issues have raised that classic question in the AUTOSPORT office about who is the greatest driver.

First of all, defining what is 'great' is difficult and tends to vary depending on who you ask. That's why there are such a variety of answers: if you have different criteria – different qualities – you admire, you will come up with different names.

Check any dictionary and you'll see 'legend' carries a certain level of mystique or unknown about it. Wiki says "a majority of legends operate within the realm of uncertainty, never being entirely believed by the participants, but also never being resolutely doubted".

In racing terms, some people feel 'great' tends to carry a similar feeling to it. Legends or greats are those who could achieve something special, add some excitement, perhaps in dubious machinery. It often doesn't even matter if those drivers never cracked the code of winning regularly. Ronnie Peterson and Gilles Villeneuve are rightly considered legends, but won no world titles and only 16 GPs between them.

For others, it's about how charismatic or otherwise a driver is outside the car. They are effectively judging the driver based on the man (or woman) they are, which is surely not the same thing.



Moss in full flow, but is he the greatest?

Someone could be a total bore or unbearably arrogant outside the car, but when judging where they slot in the all-time great drivers list, surely they need to be judged by on-track efforts?

Yet more people see 'greatest' as more akin to the best, which in theory is more fact-based. Of course, given the complexities of the sport and the fact it's hard to compare drivers across teams and categories, never mind eras, there is no right answer.

When it comes to the best, I like to start with the people who define their eras, by

their level of success and/or how their peers regarded them. Taking the post-war drivers this way, you get the following list: Fangio, Moss, Clark, Stewart, Prost, Senna, Schumacher. The two missing eras are the 1970s, for which it's difficult for anyone to agree on who was the best (though Lauda is statistically ahead), and now because we are enjoying an incredible period at the top of F1. AUTOSPORT had Fernando Alonso and Lewis Hamilton ahead of Sebastian Vettel in our top 50 2012 drivers, but it is the German who is a triple champion...

Even with that list, where you position them depends on what you value. Do you like your drivers to be all-rounders, able to race anything? Do you prefer them to be amazing in the wet? Is winning with different teams important? Are their on-track ethics a big deal? Did they prove they could win in underdog cars? Could they make the most of dominant ones?

Does anyone tick all these boxes?

As I said, there is no right answer. But, just between you and me, it's Sir Stirling Moss.

Television

THURSDAY JANUARY 31

0900-1035, 2235-0010 **Motors TV**

Andros Trophy Highlights:
Saint Die Des Vosges

1515-1620 **Motors TV**

AUTOSPORT International:
Charity Karting

See how celebrity racers got on in this year's race, held in celebration of Dan 'Lionheart' Wheldon.

1825-2130 **Motors TV**

Grand-Am Daytona 24 Hours: Highlights

2300-2330 **Premier Sports**

NASCAR Sprint Cup: 2012 Review

1700-1800 **Sky Sports 4**

Racemax

FRIDAY FEBRUARY 1

0215-0315, 1340-1445 **Motors TV**

AUTOSPORT International:
Charity Karting

1240-1340 **Motors TV**

AUTOSPORT International: Highlights

1545-1855 **Motors TV**

Grand-Am Daytona 24 Hours: Highlights

1900-1930 **Sky Sports F1**

Lotus E21 Unveiling

SATURDAY FEBRUARY 2

0355-0425 **Channel 5**

Motorsport Mundial

0900-1005 **Motors TV**

AUTOSPORT International: Highlights

1300-1400 **Sky Sports F1**

F1 Legends: John Surtees

1400-1500 **Sky Sports F1**

F1 Legends: Mario Andretti

1545-1855 **Motors TV**

Grand-Am Daytona 24 Hours: Highlights

1600-1700 **Sky Sports 4**

Hakkinen on the limit in 1999



Max Power

1930-2000 **Sky Sports F1**

Lotus 2013 Unveiling

SUNDAY FEBRUARY 3

1300-1400 **Sky Sports F1**

F1 Legends: Mika Hakkinen

1400-1500 **Sky Sports F1**

F1 Legends: Sir Stirling Moss

1855-2000 **Motors TV**

AUTOSPORT International:

Charity Karting

MONDAY FEBRUARY 4

0115-0410 **Motors TV**

British F3: 2012 Season Review

In the wake of British F3 slashing its 2013 calendar to just four rounds, take a look at how last year's championship panned out.

0630-0700 **Eurosport 2**

European Rally Championship:

Latvia Review

1800-1830, 2100-2130 **Sky Sports F1**

Force India 2013 Unveiling

2000-2030 **ITV4**

GT Academy

2030-2100 **ITV4**

TT Legends

2305-0215 **Motors TV**

AUTOSPORT International:

Stage Interviews

Online

AUTOSPORT+

Coming up in our premium web content this week



Crucial F1 work: driving a sim

F1's INVISIBLE MEN: THE KEY TO 2014

AUTOSPORT's Edd Straw looks at the role of the simulator driver in Formula 1, and explains why they could be vital to how the competitive order pans out when the new technical regulations that come into force next year.

DAKAR STAR'S GREATEST RACE

Stephane Peterhansel picks out his best events from a stellar career.



AUTOSPORT'S SECRET F1 VOICE

We kick off a new series from an anonymous figure from the world of F1.



REVVED UP OVER WHAT'S ON THE BOX

We cast a critical eye over the best and worst of this week's TV coverage

Like father, like son: Jimmy (right) & Colin



"NEXT ON BBC1: THE NUDES with Fiona Bruce." While some TV captioning errors are more titillating than others, some are unacceptable: "Next on BBC2: Racing Legend, Colin Macrae" (sic).

After that heinous crime, it set me on edge for the final installment of the trilogy – following a few weeks after the Stirling Moss and Jackie Stewart 'legends'. The first I enjoyed, the second I disliked as James Martin hadn't got the memo that it was meant to be about JYS and not him. Fortunately, this presenter, Olympic

legend Chris Hoy, understood his role and carried it out with aplomb – even if hearing his voice did give me a strange craving for Bran Flakes.

Unlike the other two episodes, tragically the subject matter is no longer with us, and this caused an obvious quandary. Sure, we had fantastic archive footage of Colin, from toothy teenager tearing up the roads of Britain, to deforesting large swathes of Finland with a Subaru Legacy, to his world championship success, through to his Ford and Dakar days. All the right

talking heads gave their insights – the Catalunya '95 team-orders controversy being expertly covered in particular.

Hoy proved adept behind the wheel, driving a Talbot Sunbeam, the McRae Enduro Dakar special and, ultimately, Subaru Impreza 'L555 BAT' alongside Derek Ringer. He was proficient at driving and presenting (a second career clearly awaits him in either) – but my true star of the show was Colin's father Jimmy.

Right from the moment he unveiled Colin's stunning car collection

and hopped in the family Sierra RS Cosworth and opposite-locked down his driveway – contemporary McRae magic was with us.

"Sliding through the mud, with Jimmy McRae alongside telling you what to do, it doesn't get better than that," summed up Hoy, as Jimmy gave him the brilliant driving instructions in the Sunbeam of "Throttle! Throttle! Throttle! Throttle! Throttle! Throttle! Throttle! Throttle!"

And then in the Dakar machine: "It's best to drive as fast as possible."

I wish he was my dad too. *Revved Up*

THE WEEK IN PICTURES

Our lensmen pounding the beat, from Austria to America, via Cumbria and Spain

M-SPORT LAUNCHES R5 FIESTA TEST CAR
Malcolm Wilson's boys revealed the R5 car with a QR-code livery. We assume 'QR' stands for Quality Rallying!



FISICHELLA FIZZES IN FLORIDA FERRARI
Giancarlo Fisichella presses on in AF Corse's 458 Italia at Daytona



KUBICA ALL SMILES AFTER MERCEDES DTM TEST
Robert Kubica declared himself happy with his performance in a recent DTM test at Valencia



YOU WON'T SCARE ME, SUNSHINE
Bernie Ecclestone hitched a ride with Seb Loeb in an Austrian ice buggy event

PICS: BUSATO/LAT

FROM THE ARCHIVE

Alex Zanardi on American racing superboss Chip Ganassi

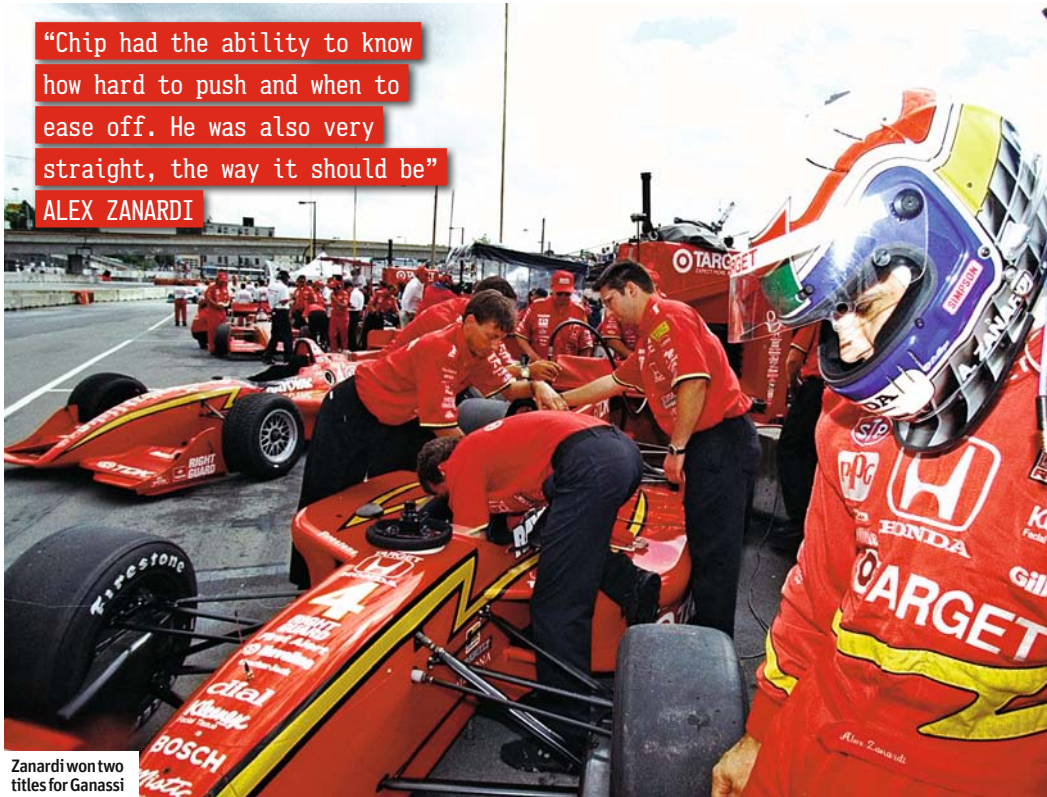

“Chip had the ability to know how hard to push and when to ease off. He was also very straight, the way it should be”
ALEX ZANARDI

Zanardi won two titles for Ganassi

CHIP GANASSI'S FIFTH DAYTONA 24 HOURS VICTORY added yet more silverware to a trophy cabinet that has grown ever since the American completed his takeover of the Patrick Racing Indycar team 22 years ago.

While the squad had already enjoyed success – winning the 1989 CART title with Emerson Fittipaldi – what has followed since Ganassi's takeover has been unprecedented. In addition to multiple CART and IndyCar titles, Ganassi became the first team owner in history to win NASCAR's Brickyard 400 and Daytona 500 and IndyCar's Indianapolis 500 in 2010. Within the same 12-month period, he also added the Daytona 24 Hours crown.

Success did not follow immediately, but in 1996 Jimmy Vasser delivered what would be the first of a plethora of open-wheel championships. That year a new man also arrived at the team – Alex Zanardi, an Italian who would go on to dominate the following two seasons and contribute immeasurably to the Ganassi tale.

“It's really difficult to be liked as a leader, because sometimes you have to take very difficult decisions,” Zanardi says. “But if everything you do is for the good of the team, down the road the people who work with you will benefit. And I did indeed profit from working with Chip.”

“I was his pick – he has had many other great drivers, and I don't want to be arrogant, but I think I was his first discovery. I wasn't just his driver either: he was also my radio man, and we had a fantastic relationship.

“We also had incredibly different characters, perhaps only united by our fiery tempers. I remember one time things had gone wrong and it was down to me to fix it; I was furious but he kept talking down the radio. I exploded, and everyone turned to see how he would react and whether I'd be fired. He just laughed and said, 'OK man, we're in your hands'.

“He had that ability to know how hard to push and when to ease off. He was also very straight. I've had other team managers who are very nice even when things are going wrong, only to then knife me in the back and replace me.

“With Chip it was the opposite: I remember I crashed in my first four oval races, and at the fifth Chip told me one more and I was out. I objected that one crash was because my wheel fell off, but he said he didn't give a shit. That's the way it should be. To some I was super fast, a rising star, but to the team's budget I was also dangerous, and Chip always served the team.

“He had all those abilities, but he has also always seen further than others, there's no doubt about that.”

THIS WEEK IN...



FEBRUARY 4 1993

FERRARI'S NEW F93A HAD AN inauspicious start this week in 1993, as top engineers John Barnard and Harvey Postlethwaite failed to find a solution to Gerhard Berger's and Jean Alesi's collective discomfort.

“We have a balance problem with the car which we can't find the key to fixing,” Berger reported. “We are in trouble because we are running out of time.” His fears were realised: the car took three podiums all season, leaving Ferrari a very distant fourth in the constructors' fight.

Across the pond Jaguar and Nissan were also hitting problems at Daytona, paving the way for Toyota, that had set the early pace but then faltered, to take its maiden 24 Hour race win with PJ Jones, Mark Dismore and Rocky Moran.



PIG: LAT ARCHIVE

NEXT WEEK

F1 LAUNCH SPECIAL **DON'T MISS IT!**
REVEALED: NINE 2013 CARS, INCLUDING NEW RED BULL, McLAREN, FERRARI AND MERCEDES

ANDREA CHIESA

■ Mexican GP ■ Autodromo Hermanos Rodriguez ■ March 22, 1992 ■ Fondmetal GR01 ■ Scraping onto the grid



Wedged into tiny GR01, Chiesa fends off Stefano Modena's Jordan

MAKING MY FIRST F1 START

was a dream but getting into the race had been a nightmare.

The Fondmetal GR01 chassis was quite competitive in 1991 when Gabriele Rumi bought the team from Enzo Osella. But by 1992 when I joined the team it was not so quick. The biggest problem was that the cockpit was so tiny.

To make it worse, at the start of 1992 the FIA started a rule that the pedals had to be behind the front axle. So there was some space but I just couldn't use it. Crazy. At least the new GR02 car was coming after three races, or at least that was what Signor Rumi told me!

Going into qualifying we were really up against it because the team had to change the engine. The mechanics were working frantically but it was not possible to get everything ready until halfway through the qualifying session. So, I got in the car and flew out of the pitlane – no speed limit in those days! I went up through the gears, down the long straight and when I got to the first corner the throttle was wide open still. Luckily there was a lot of grass at the exit of the first corner and I was able to stop before I hit anything.

"The lap came from a very deep anger within me. When I got out of the car all the mechanics lifted me out and threw me in the air and cheered. It was fantastic"

At this stage there was 20 minutes to go in qualifying and my adrenalin levels were out of control. I ripped the seat out of the cockpit and started running back up the side of the track to the pitlane. Well, I can tell you that it was the best work-out I have ever had! Over one kilometre with overalls and helmet on, running

like crazy in 85-degree heat at massive altitude and with all that air pollution, too. I got back to the pits and was close to a heart attack.

The mechanics had seen me running back and got the T-car ready, but it was set up for [team-mate Gabriele] Tarquini who has much shorter legs than me. I threw my seat in and they

did the belts up. It was crazy, like when you are a kid in a toy car.

To this day I do not know how I made it into the race but I qualified in 23rd position. The lap came from a very deep anger within me and it worked. When I got out of the car in parc ferme all the mechanics lifted me out and threw me up in the air and cheered. It was a fantastic feeling.

Lining up on the grid the next day was a tremendous experience and there I was making my grand prix debut. The race itself was good but I spun on lap 37, mainly due to the cramp I got in my legs because of the lack of room in the cockpit.

Of course those three races that Signor Rumi promised in the GR01 became seven! When I finally got into the GR02 at Magny-Cours, [Mauricio] Gugelmin pushed me off on the first lap and the chassis was destroyed. That was the end of racing for me in F1 because I was forced back in to the GR01 for Silverstone and Hockenheim and there was no chance of getting it on the grid again. But I will never forget my first GP, especially what it took to get there. ✪
Andrea Chiesa was talking to Sam Smith

IN PROFILE



RUNNER-UP IN THE 1987 ITALIAN

Formula 3 Championship, Milan-born Swiss Andrea Chiesa spent four seasons in the FIA Formula 3000 series, winning at Sicilian venue Enna-Pergusa for Roni Motorsport in 1989 before claiming two second-place finishes the following season. He competed in three grands prix for Fondmetal (Mexico, Spain and France) during 1992 before turning to sportscars. More recently, Chiesa, now 48, has raced in International Superstars.

French Approved Breathalysers Now in Stock!



If you drank 4 pints between 9pm and midnight, you may not be sober until noon the following day*. That's why almost 1 in 5 drink drive accidents happen the "morning after"**. AlcoSense quickly and accurately shows your blood alcohol level, so you know when you're clear.



AlcoSense One Only £24.99

Entry level breathalyser. Provides a reading up to 1.5 times the UK drink drive limit. Accurate to +/-0.02%BAC at the drink drive limit. Recommended waiting time between tests: 1 hour



AlcoSense Lite Only £39.99

Reliable
Intermediate level sensor for good accuracy, blow tubes for improved sample quality.
Clear
Results in seconds. Alerts you when close to or over the drink drive limit.



AlcoSense Elite Only £59.99

Accurate
Premium semi-conductor sensor for high accuracy, blow tubes improve sample quality.
Consistent
Blow Pressure Sensor and self cleaning increases accuracy and consistency.
Clear & Future Proof
Results in seconds. Alerts you when you when close to or over the limit. Recalibratable for many years of use.



✓ Accurate ✓ Quick ✓ Easy



Available nationwide from

that's helpful that's halfords

or online at www.halfords.com

alcoSense®

DIGITAL BREATHALYSER

Order online or phone
www.alcosense.co.uk 0800 195 0088

** 17.1% of drink drive accidents are between hours of 5am and 1pm (Source: Dept. for Transport, Road Accidents and Safety Annual Report 2010)

* 4 Pints of Abbot Reserve contain 14.8 units of alcohol (Source: Greene King) and each unit takes 1 hour to leave the body (Source: NHS). Therefore 14.8 hours after 9pm the alcohol will have passed from the body.

International Motorsport Events: Race Tickets, Hospitality & Travel

SelectMotorRacing.com

● Formula One ● Le Mans 24hr ● MotoGP ● Superbikes ● Historic

Run by Fans for Fans

Free 2013 Brochure

Book Now for 2013 Formula One GP Tours / Tickets



LE MANS 24 HOUR

- Race Tickets & Hospitality
- Circuit Camping
- Self Drive Packages
- 15 Coach Tour options
- Night Qualifying with Drivers Parade and Circuit Excursion
- Coach Tour prices from £155

FORMULA ONE GRAND PRIX TRAVEL PACKAGES

OUR UK TRAVEL TEAM WILL LOOK AFTER YOU THROUGHOUT THE TOUR

Coach Tours

- Executive Coach Travel
- Free Excursions
- Circuit Transfers each day

Go By Air

- Choice of Hotels
- Airport meet and greet
- Return Hotel Transfers
- Circuit Transfers each day
- Free Excursions
- Free find a flight service

RACE TICKETS

- Grandstands
- Circuit Hospitality
- Paddock Club
- Monaco Yachts

HISTORIC TOURS

TRAVEL PACKAGES

- Mille Miglia
- Goodwood Festival of Speed
- Goodwood Revival

contact us on **+44 (0) 1451 833 721** or email enquiry@selectmotorracing.com



www.selectmotorracing.com