

Extra Window Replacement

NOTE:

- Put on gloves to protect your hands.
- Wear eye protection while cutting the glass adhesive with piano wire.
- Use seat covers to avoid damaging the seat.
- Use glass adhesive set P/N 08C73-X0230N.

1. Remove these items:

- [Tailgate lower trim](#)
- [Tailgate upper trim panel](#)
- [Tailgate middle trim panel](#)
- [Tailgate side trim, both sides](#)
- [High mount brake light](#)

2. Remove the screws.

- #### 3. Apply protective tape along the inside and outside edges of the tailgate. Using an awl, make holes through the upper and lower adhesive from inside the vehicle at 300 mm (11.8 in.) from both sides of extra window.

4. Pass the piano wire (A) through beside lower side of the adhesive (B).

- 1. Push the piano wire through the hole from outside the vehicle.
- 2. Bend a top of the piano wire.
- 3. Push the top the piano wire through between the clip bases (C) and the adhesive on three places.
- 4. Cut the piano wire of bent part.
- 5. Push the piano wire out through the hole from inside the vehicle, and wrap each end around a piece of wood.

Fastener Locations

► : Screw, 2

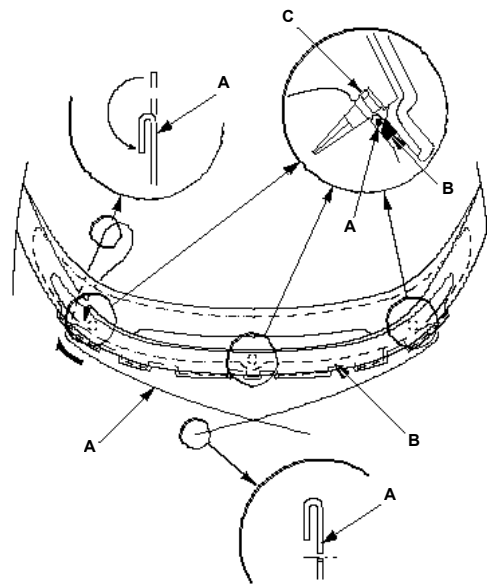
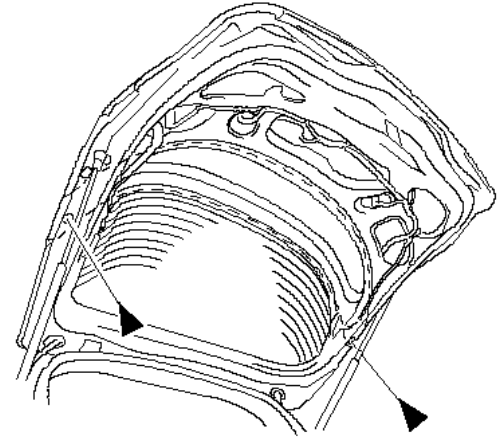
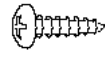

5. Hold a piece of wood, and with a helper on the other side, pull back the piano wire (A) to carefully cut through the adhesive.

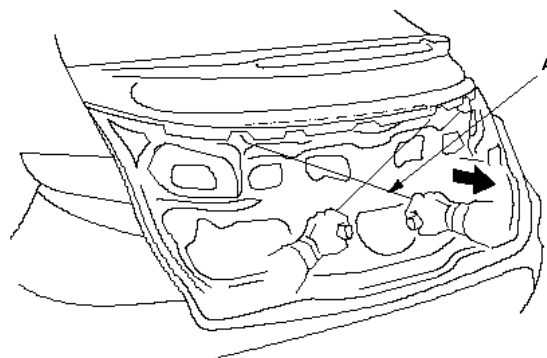

6. Push the piano wire (A) through the hole from up side of the extra window.
- 1. Push the piano wire through the hole between the adhesive (B) and clip (C).
 - 2. Push the piano wire through the cut hole from up side of the extra window, and wrap each end around a piece of wood.

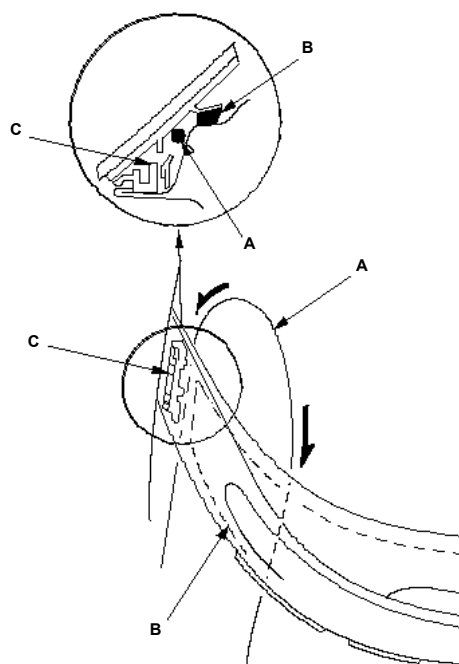

7. Hold a piece of wood, and with a helper on the other side, pull back the piano wire (A) to carefully cut through the adhesive.
8. Repeat on opposite side of the extra window adhesive.

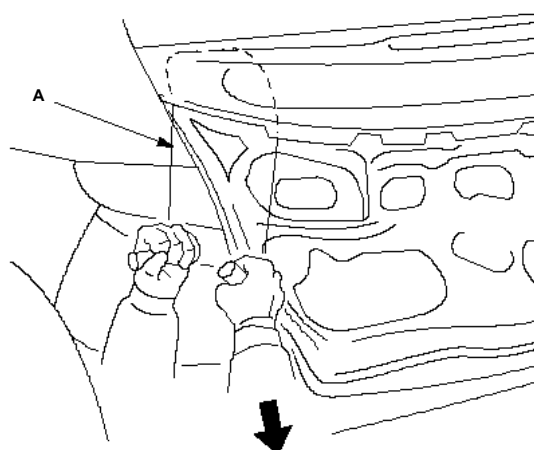

9. Pass the piano wire (A) through beside upper side of the adhesive (B).
 - 1. Push the piano wire through the hole from outside the vehicle.
 - 2. Bend a top of the piano wire.
 - 3. Push the top of the piano wire through between the clip bases (C) and the adhesive (D) on three places.
 - 4. Cut the piano wire of bent part.
 - 5. Push the piano wire out through the hole from inside the vehicle, and wrap each end around a piece of wood.

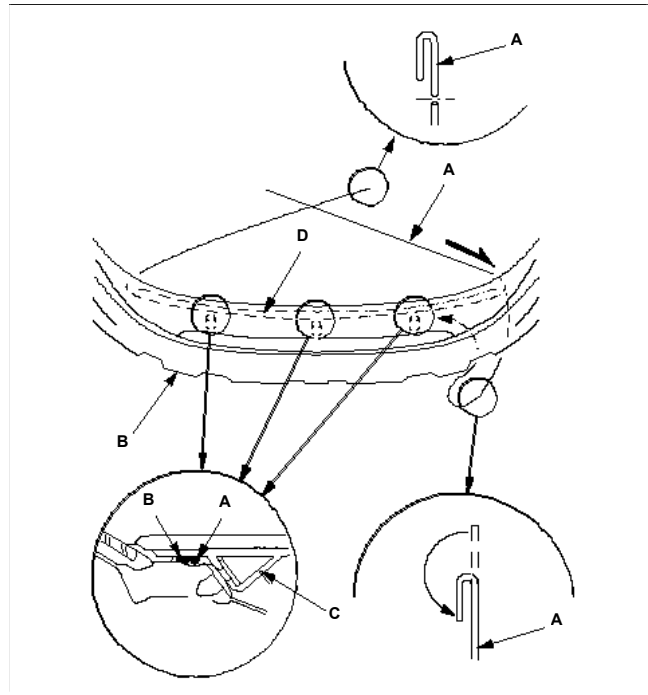

10. Hold a piece of wood, and with a helper on the other side, pull back the piano wire (A) to carefully cut through the entire extra window adhesive.

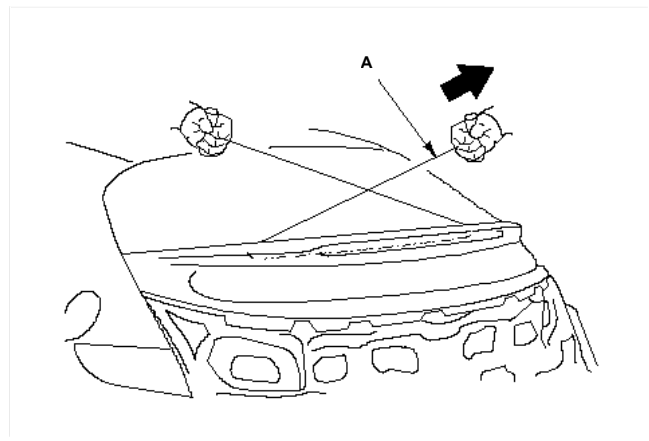

11. Release the clips (A, B, C) that hold the extra window (D), then carefully remove the extra window.

12. Remove the seal from the upper edge of the extra window.

13. With a putty knife, scrape the old adhesive smooth to a thickness of about 2 mm (0.08 in.) on the bonding surface around the entire extra window opening flange. Do not scrape down to the painted surface of the body; damaged paint will interfere with proper bonding.

14. Clean the tailgate bonding surface with a sponge dampened in neutral detergent. After cleaning, keep oil, grease and water from getting on the surface.

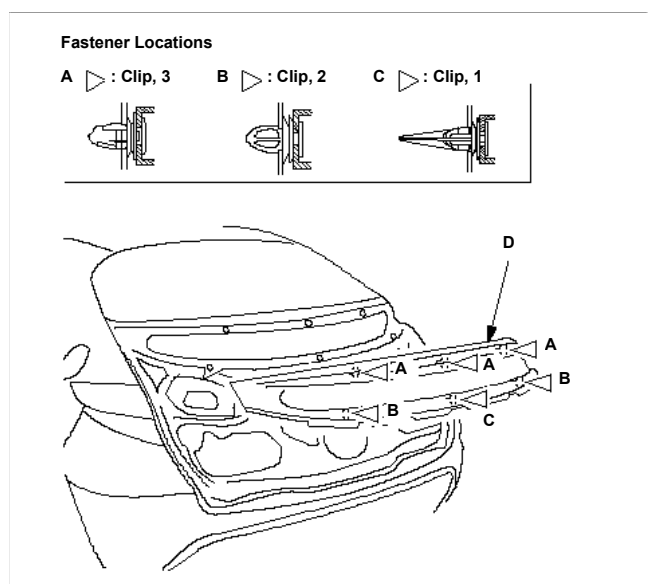

15. Check for damaged or stress-whitened clips (A, B, C, D), and if necessary, replace them with new ones.
16. If the old extra window is to be reinstalled, use a putty knife to scrape off all of the old adhesive, the clips and the rubber dams from the extra window. Clean the inside face and the edge of the extra window with neutral detergent where new adhesive is to be applied. Make sure the bonding surface is kept free of water, oil and grease.

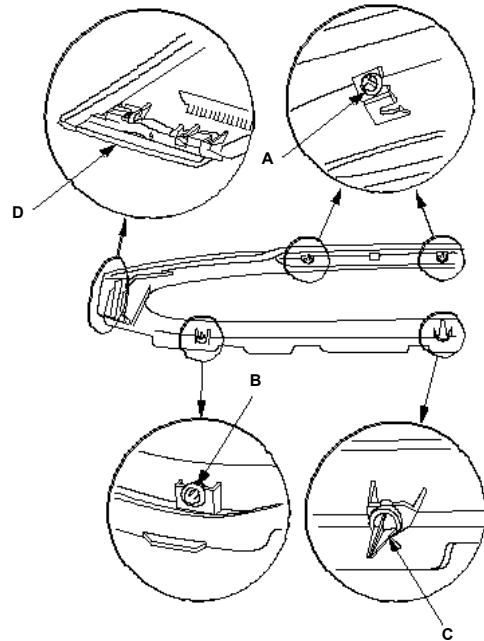

17. Attach the rubber dam (A) with adhesive tape and the seat gasket (B) to the inside face of the extra window (C) as shown:
- Be sure the rubber dam line up with the alignment line (D).
 - Be sure the rubber dam contacts the inclined portion (E) of the extra window.
 - Be careful not to touch the extra window where adhesive will be applied.
 - Seat gasket is sticking not to overflow more inside than mark (F).

Adhesive tape: **Thickness 0.16 mm (0.006 in.)**
Width 6 mm (0.24 in.)

 : Apply body primer here.

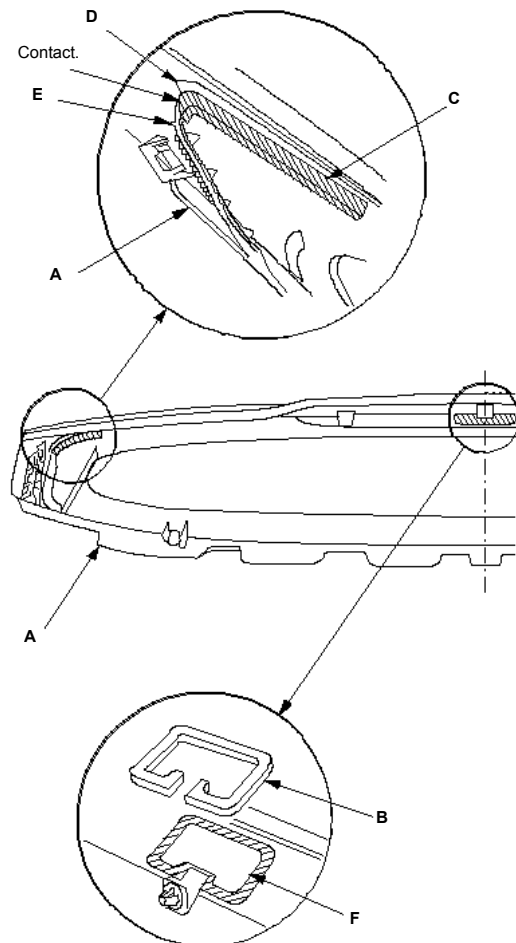

18. Attach the seal (A) with adhesive tape to the upper edge of the extra window (B). Be careful not to touch the windshield where adhesive will be applied.

Adhesive tape: **Thickness 0.4 mm (0.02 in.)**
Width 4.5 mm (0.18 in.)

 : Apply body primer here.

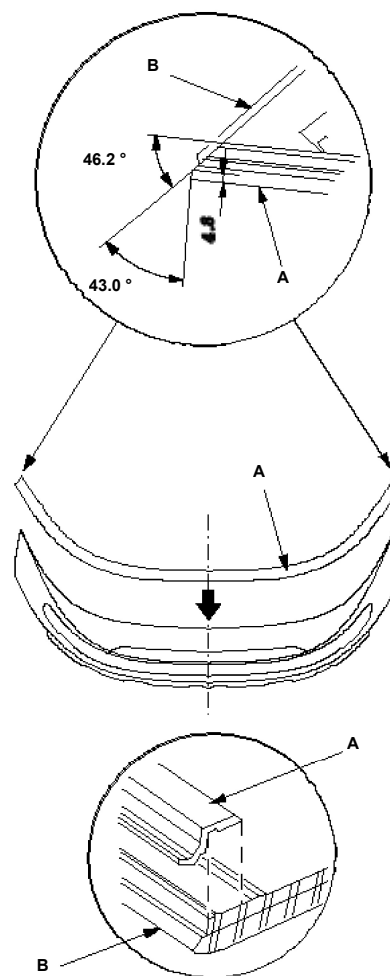

21. Cut a "V" in the end of the adhesive cartridge nozzle (A) as shown.

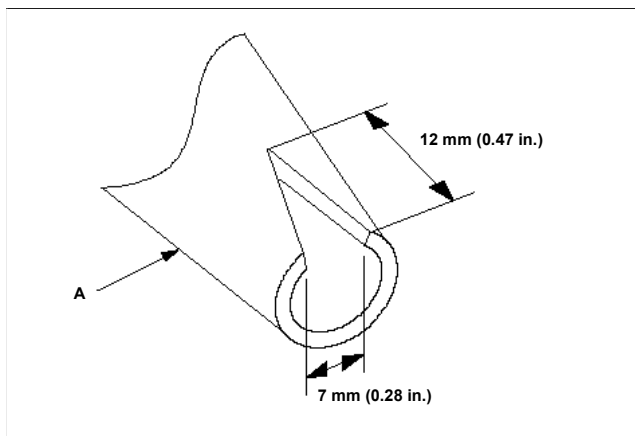

22. To face the clips (A) toward upside, extra window (B) should be supported with the sponge (C) and foaming material (D). Take care not to scratch the extra window.

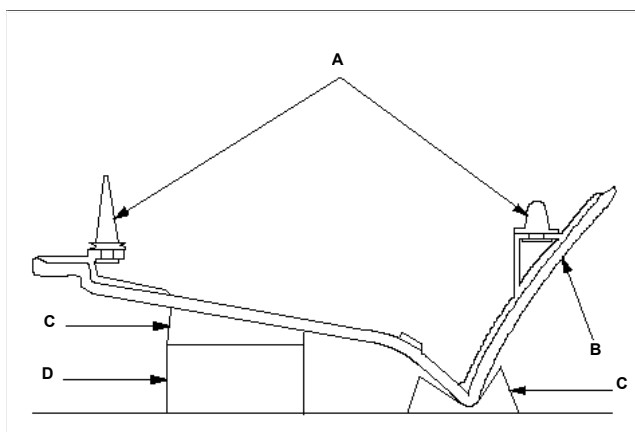

23. Pack adhesive into the cartridge without air pockets to ensure continuous delivery. Put the cartridge in a caulking gun, and run a bead of adhesive (A) on the rear window (B) around the edge of the upper rubber dam (C), corner moldings (D), side moldings (E), and lower rubber dam (F) as shown. Apply the adhesive within 30 minutes after applying the glass primer. Make a slightly thicker bead at each corner.
24. Use suction cups to hold the windshield over the opening, align the clip, and set it down on the adhesive. Lightly push on the extra window until its clips snap into place securely and its edges are fully seated on the adhesive all the way around. Do not open or close the doors until the adhesive is dry.

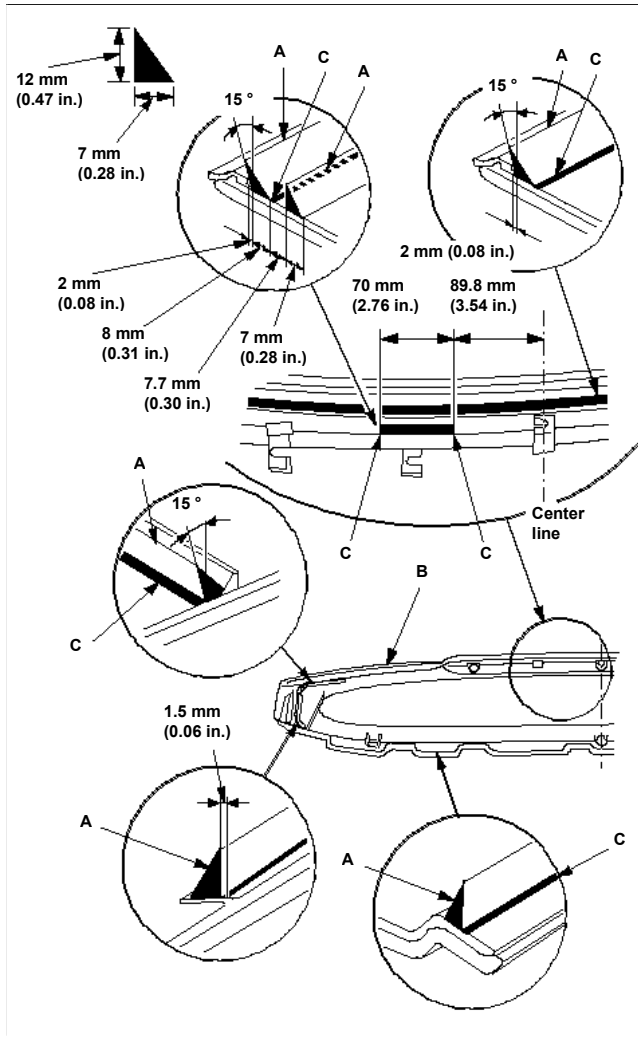

25. Fasten the extra window with the screws.
26. Scrape or wipe the excess adhesive off with a putty knife or towel. To remove adhesive from a painted surface or the windshield, wipe with a soft shop towel dampened with alcohol.
27. Let the adhesive dry for at least 1 hour, then spray water over the windshield and check for leaks. Mark leaking areas, and let the windshield dry, then seal with sealant:
 - Let the vehicle stand for at least 4 hours after windshield installation. If the vehicle has to be used within the first 4 hours, it must be driven slowly.
 - Keep the windshield dry for the first hour after installation.
28. Reinstall all remaining removed parts.
NOTE: Advise the customer not to do the following things for 2 to 3 days:
 - Slam the doors with all the windows rolled up.
 - Twist the body excessively (such as when going in and out of driveways at an angle or driving over rough, uneven roads).

Fastener Locations

▶ : Screw, 2

