



CREATING A CLEANER, SAFER, HEALTHIER WORLD.

EQUIPMENT



S30

MID-SIZED RIDER SWEEPER

- Deliver excellent sweeping performance and dry dust control with 3-stage SweepSmart™ system
- Clean indoors and out, without compromising performance
- Improve operator safety with low 80 dBA noise rating and innovative cab forward design

A QUIET AND PRODUCTIVE INDOOR/OUTDOOR SWEEPER THAT TAKES ON THE TOUGHEST ENVIRONMENTS



Engineered for reliable, industrial-strength sweeping, the Tennant S30 rider sweeper excels in both indoor and outdoor environments. The S30 features the exclusive SweepSmart™ dust control system and a low dBA noise level.

EXCELLENT SWEEPING PERFORMANCE

Easily pick up everything from fine grains of sand to light debris on a variety of surfaces. The Tennant S30 offers true indoor/outdoor flexibility while delivering exceptional cleaning results.

FOCUS ON SAFETY

The Tennant S30 provides clear operator sightlines with cab forward design, reduced noise levels, and easy operation. The S30 is recognized by Underwriter's Laboratory (UL®).



SIGNIFICANTLY IMPROVE AIR QUALITY

Maintain cleaner air while delivering powerful sweeping results with the SweepSmart™ dust control system.

STAGE 1

Keep bulky debris, moisture and dirt in the hopper with the first stage Perma-filter™.

STAGE 2

Remove fine dust and moisture by redirecting it into the hopper with the second stage cyclonic filters.

STAGE 3

Filter submicron dust particulates down to 0.5 microns at 99% efficiency with a third stage, flame retardant, nanofiber canister filter.

Reliably provide a clean, safe, and productive environment with SweepSmart technology.



INSIDE THE

S30

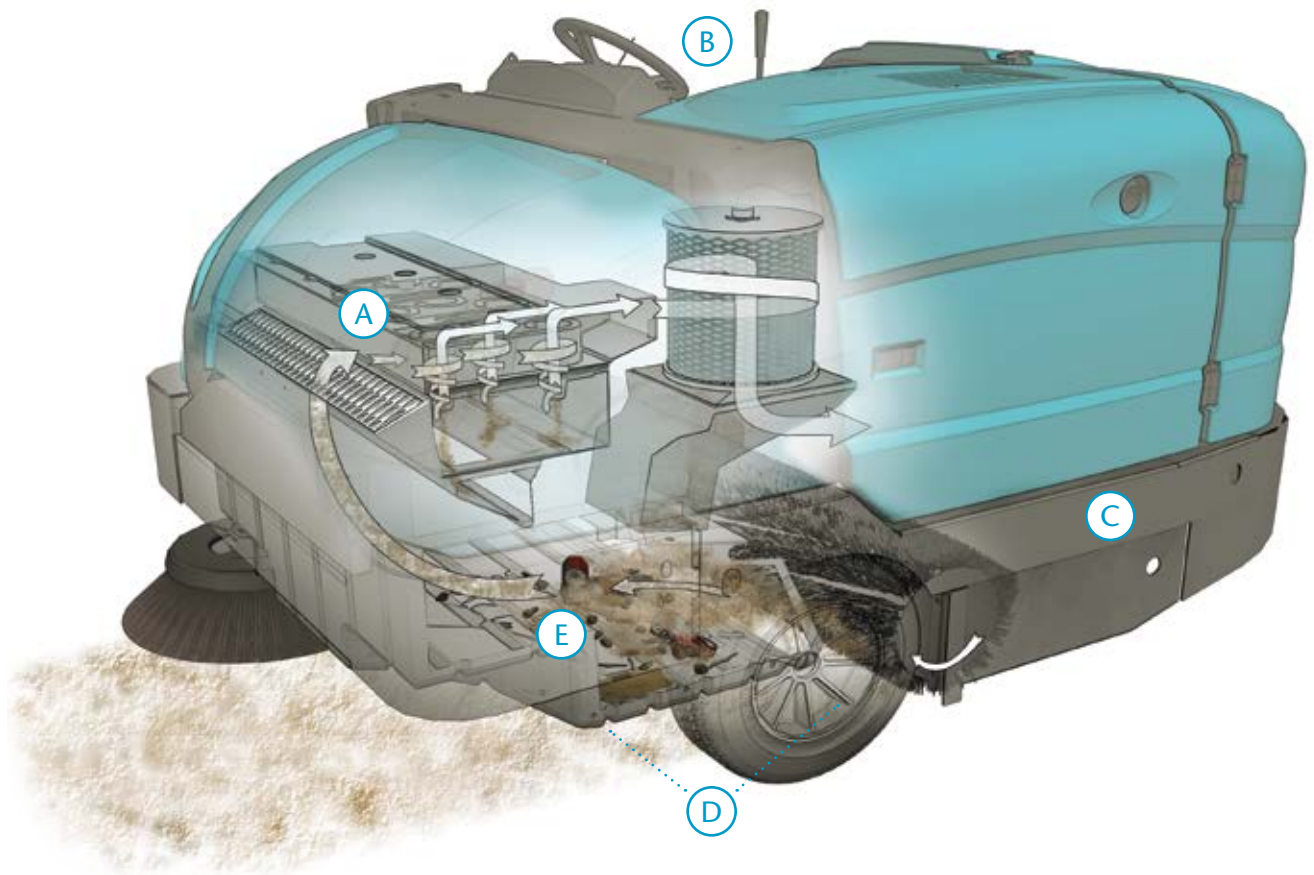

A Provide air flow filtration and dry dust control for sweeping all floor surfaces with the SweepSmart™ system.

B Effectively remove different types of debris with the II-Speed™ sweep system. This increases the speed of the main brush, side brush, and vacuum fan by 20%.

C Depend on long-term structural reliability with a heavy-gauge steel machine frame designed for strength, rigidity, and long life.

D Improve sweeping results with the retractable, spring-loaded flap that recirculates debris that may escape over the main brush.

E Ensure operator safety by alerting and shutting down sweeping functions if increases in hopper temperature are sensed by Thermo-Sentry™.

MAXIMIZE PRODUCTIVITY, REDUCE COSTS, INCREASE SAFETY

- ▶ Reduce downtime, service time, and maintenance costs
 - EasyOpen™ service access
 - Onboard diagnostics and patented color-coded brush wear indicator
 - Large capacity hydraulic oil tanks, triple accessory pumps and micro component in-line filter
 - Soft ride, higher load capacity solid tires
 - Integrated string and twine guard
- ▶ Maximize productivity indoors and outdoors
 - Dumps at any height from ground level to 60 in / 1525 mm and reaches up to 30 in / 760 mm into a dumpster
 - Touch-N-Go™ operation with 1-Step™ decreases operator training time
 - Rear hopper door contains debris during transport
 - II-Speed™ sweeping increases main brush, side brush, and vacuum fan speeds up to 20%
 - Dynamic steering responsiveness and rear suspension system
 - 4-wheel stability for large area cleaning (with the S30 X4 model)
- ▶ Enhance operator safety
 - ErgoSpace™ cab forward operator compartment for improved visibility and operator comfort
 - Thermo-Sentry™ hopper temperature sensor
 - Lowest noise level for an engine-powered sweeper in this class – 80 dBA



Achieve outstanding results in diverse environments with dual side brushes which, combined with a large 14 ft³ / 395 L Duramer™ hopper, allow you to sweep up to 80 in / 2,030 mm in a single pass.

Travel between work sites safely and quickly with the S30 X4 configuration that travels up to 15 mph / 24 km/h on a stable 4 wheel platform with comfortable leaf spring suspension.

Operate safely and comfortably in even the most severe environments, with an optional FOPS certified (ISO 3449) pressurized cabin, available with heat and air conditioning.



- Reduce rework, labor and safety costs by using only TennantTrue parts and service.
- Ensure optimal cleaning performance by selecting a TennantTrue Service program provided by a network of over 400 factory-trained Tennant service representatives.
- Improve uptime by leveraging TennantTrue parts and service.
- Simplify budgeting by bundling TennantTrue service plans, including parts, into the purchase or financing of your machine.

Choose GE Capital or U.S. Bancorp, our leasing providers, for simple, quick financing with flexible upgrade options.

S30 RIDER SWEEPER

SWEEPING SYSTEM

Cleaning path	
Single side brush	62.5 in / 1,590 mm
Dual side brush	80 in / 2,030 mm
Main brush	
Main brush length (<i>tubular</i>)	45 in / 1,145 mm
Main brush lift	Mechanical or Hydraulic
Main brush change	No-tool
Side broom	
Side broom diameter	26 in / 660 mm
Debris hopper	
Volume capacity	14 ft ³ / 395 L
Weight capacity (<i>plastic</i>)	1,080 lb / 490 kg
Weight capacity (<i>steel</i>)	1,200 lb / 545 kg
Dump height (<i>variable to</i>)	60 in / 1,525 mm
Dump reach	30 in / 760 mm

DUST CONTROL SYSTEM

Filter system (<i>triple stage</i>)	
Stage 1	Perma-filter™
Stage 2	Cyclonic pre-filter
Stage 3	Nanofiber canister filter
Filter area	80.8 ft ² / 7.5 m ²
Dust filtration (<i>up to</i>)	0.5 microns @ 99% efficiency
Vacuum fan speed	
Normal sweeping mode	4,600 rpm
Litter sweeping mode	5,500 rpm
Vacuum diameter	11 in / 280 mm

PROPELLING SYSTEM

Propel speed forward (<i>variable to</i>)	8/13 mph / 13/21 km/h
Propel speed reverse (<i>variable to</i>)	3 mph / 5 km/h
Engine-gasoline/LPG (2.0 L)	50 hp / 37.2 kW
Engine-diesel (1.5 L)	37.5 hp Kubota / 28 kW Kubota
Gradeability	
Full hopper	10° / 18%
Empty hopper	14° / 25%
Ground clearance	4 in / 100 mm

MACHINE SPECIFICATIONS

Length	93 in / 2,360 mm
Width	62.5 in / 1,590 mm
Height	
With overhead guard	82.5 in / 2,095 mm
Without overhead guard	58 in / 1,475 mm
Weight (net)	3,520 lb / 1,595 kg
Minimum aisle turn	113 in / 2,870 mm
Sound level	80 dBA

WARRANTY

See your local representative for warranty information.

Specifications subject to change without notice.

SEEING IS BELIEVING

For a demonstration or additional information, call +1.800.553.8033 or email info@tennantco.com

Tennant
701 North Lilac Drive
Minneapolis, MN 55422 USA

USA/Canada: +1.800.553.8033
Quebec: +1.800.361.9050
Overseas: +1.763.540.1315

www.tennantco.com
info@tennantco.com