



Ham Radio Ireland

Servientes Traditiones et Spiritus Experimentalis Radio

Editor: *Steve Wright EI5DD* *wright14@gmail.com* Vol. 2 Issue 07 July 2023



In This Issue

**Forthcoming Events - RSGB Region 8 News - Are You a Whiperer
The BALUN in Action - Getting Started on FT8 - Don't Give Up
Collective Communication DF Event - A Six Metre Squalo Antenna
Meteor Scatter - Club Reports**

**Ham
Radio
Ireland**

Ham Radio Ireland was the logical progression from what started as a Magazine covering the Province of Connacht in the West of Ireland.

In point of fact we are the only Independent Radio Magazine in Ireland geared towards the Radio Experimenter.

All clubs and groups are welcomed to submit reports and promotions of their activities and special events. If you are a homebrewer and designer we would welcome your articles.

The format and content of the Magazine will remain the same and we will naturally continue to support Home Brew projects, QRP Radio, Antenna Projects, HF, VHF, UHF, SHF Portable operation, SOTA, POTA, Short Wave Listening, Digital Voice and Data Modes, Hints for the shack, New developments in Radio and Electronics, Radio experimentation, Current technology CB Radio, PMR 446, and much more.

We repeat forthcoming events in our News Section right up to their date of operation. In this way we hope to encourage as many groups or clubs to take part. If you have an event planned feel free to promote it through our Magazine

We are not affiliated to any Group, Club, or Society and therefore remain unbiased and inclusive. This magazine is for all radio and electronics experimenters! We remain non political in all respects of the hobby.

We welcome any articles submitted for publication and encourage those who have never written for a magazine before.

We welcome Feedback
If you enjoyed this publication please email
Steve EI5DD
wright14@gmail.com

Contents

July 2023

News and Events

Forthcoming Events 5
Region 8 News from Northern Ireland 8

Features

Are you a Whisperer?9
The Balun in Action 11
Getting Started on FT813
Don't Give Up! 15
Collective Communications ARDF Event .. 17
Building a 6m Squalo Antenna 18
The Perseids Meteor Shower 19

Radio Club's News

RSGB Region 8 Northern Ireland News 8
Galway Radio Club..... 22
Mayo Radio Experimenter's Network 23
Galway VHF Group 25

Submitting Items To This Magazine

We are always delighted to receive any radio related material for this magazine.

Please E-mail us in advance of submission so that space can be allocated.

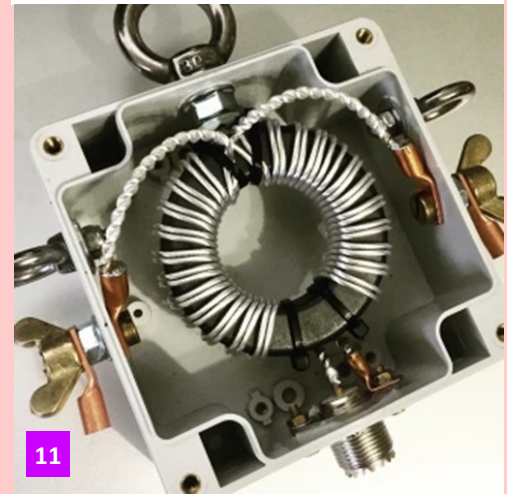
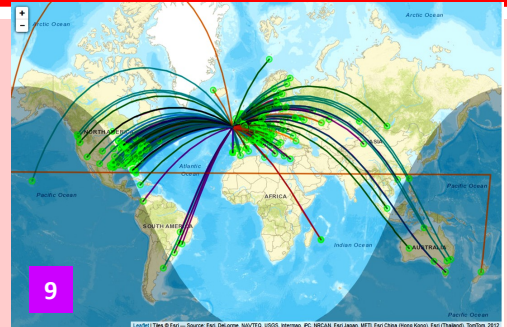

Cover Image
Jamie Daly operating the Collective Communications Station at Kilmurrin Cove

Views expressed in this publication do not necessarily reflect the views of the Editor, those of the Carrion Press or the Galway VHF Group

Get out and about with an ML&S portable antenna this Summer!



NEW JCT MC-750. Antenna on the Go!

7MHz-50MHz, 100W PEP.

Supplied with carry bag, radials, 7MHz Coil & FREE TRIPOD worth £34.95.

Only £229.99.

See HamRadio.co.uk/MC750

FREE



MyDEL JPC-7 (Dipole Version) & JPC-12 (Vertical)

Both antennas cover 40-6m, 100W PEP. All contained in a small carry case for ideal portable use. Beautifully manufactured to a very high standard.

Special deals: JPC-7: £340.00. JPC-12: £199.96

See MLandS.tv for our full video review of both antennas.

For more details see HamRadio.co.uk/JPC

SuperAntenna MP1DXG2PLUS

Portable HF-VHF Antenna Kit.

- 1 x MP1C (this includes: FG1 frequency guide SWR ruler, 2 ER1 Extension Rods, TW1 telescopic whip, TH1 thumb screw).
 - 1 x UM3 mount
 - 1 x Super Spike
 - 1 x MR4010 Radial Set for 40-10m Bands
 - 1 x MR642 Radial Set for 6m-4m Bands
 - 1 x MC2 SuperPlexer
- £199.95

CHAMELEON CHA MPAS 2.0

Modular Portable Antenna System.

The most popular Modular Portable Antenna System in the WORLD!
£639.95



Windcamp Gipsy

5-55MHz HF Portable dipole antenna.

For operation in the 5-55MHz frequency range. The operating frequency is continuously adjustable giving you a full-size portable, horizontal dipole antenna. The antenna was designed with portable operation in mind. £71.95



Buddipole Deluxe Kit W3-BP-DELUXE

The Buddipole™ Deluxe Package includes everything you need for setting up an efficient portable antenna solution anywhere in the world in just a few minutes.
£574.95



AlexLoop HamPack

Ultimate Portable Magnetic Loop Antenna Solution.
£599.95



Diamond RHM-10

Portable/Mobile Antenna. 7-430MHz, 130W, SSB, Telescopic.
£199.95

Windcamp WA-4

HF Portable Windom Antenna. 4 bands 7/14/28/50MHz QRP. £50.95

WINDCAMP



12months warranty! WINDCAMP workshop

Comet HFJ-350M

9-band 3.5-50MHz portable Antenna with plastic carrying pouch. Ideal for use with FT-891 and similar radios. Intended to go on your vehicles' antenna mount when you are parked up (Mobile use not recommended).
£89.95

Wonderwand Widebander MK2

Widebander QRP Portable Antenna System. Latest design from the masters of rig-placed Wide band antennas. The new Widebander is a compact Antenna covering a massive 1.8-432MHz.
£129.95



Trustpilot HamRadio Reviews Like our service? Why not leave a review? <https://uk.trustpilot.com/review/www.hamradio.co.uk>

MARTIN LYNCH & SONS LTD

THE WORLD'S FAVOURITE HAMSTORE
Wessex House, Drake Avenue, Staines, Middlesex TW18 2AP

E-mail: sales@hamradio.co.uk

Opening Hours: Mon - Fri: 8.30am to 5pm. Sat: 9am to 4.30pm

Tel: **0345 2300 599**

International Tel: +44 1932 567 333

www.HamRadio.co.uk

SAFE ONLINE SHOPPING. E&OE



**50W C4FM/FM 144/430MHz
Dual Band C4FM/FM Digital Mobile
Transceiver**

Yaesu FTM-500DE



IT'S NEW & IT'S IN STOCK!

Front Speaker with AESS* Dual Speaker System

Total 9W Clear & Powerful High-fidelity Audio, delivered by the Front Panel 6W and the Main Unit Internal 3W speakers

E2O (Easy to Operate) - IV

Innovative, Smart Operating System with TOUCH&GO / SEARCH&GO / PMG** Functions.

*(AESS: Acoustic Enhanced Speaker System) **(PMG: Primary Memory Group Monitor)

- 144MHz, 430MHz C4FM Digital / FM / AM (Air Band Receive) True Dual Band Operation, C4FM/C4FM Digital D-D Dual Receive
- Advanced C4FM Digital Mode with AMS (Automatic Mode Select), DG-ID feature and Smart Navigation
- 2.4-inch High-Resolution Full-Colour Touch-panel Display and Demountable Front Panel Controller
- Swing-Head adaptable Front Panel improves display visibility
- Single-Touch Spectrum Scope function
- High speed Band Scope function
- Built-in 66ch High precision GPS receiver and External GPS device connectivity
- Wireless Operation Capability with the Bluetooth® Headset - Optional Swing-head Kit (SJK-500) allows the Flexible angle adjustment of the Front Control Panel
- Customized Function List (CFL) Display allows checking and immediately executing priority functions. (Up to 8 functions or settings from the set-up menu can be registered.)
- MAG (Memory Auto Grouping) Function allows Memory channels to be automatically categorized in ALL, AIR band, VHF band, UHF band and OTHER.
- VFO Band Skip Function
- Memory Channel Data Transfer to the VFO Register
- Single-Touch Spectrum scope function: Instantly switches the operating screen between "Scope display operation" and "Dual Receive operation" while in MAIN channel operation
- High speed Band Scope function
 - *up to 61 channels centred on the current frequency displayed in VFO mode and up to 21 channels of signal information in memory channel mode
 - 1104 Memory Channels including 5 "Home" channels,
- 50 sets of memories for programmable memory scan and 999 "Basic" memories.
- Built-in 66ch High precision GPS receiver and External GPS device connectivity,
- 1200/9600bps APRS® Data Communication
- Wireless Operation Capability with a Bluetooth® Headset
- WiRES-X Portable Digital Node or HRI-200 Fixed Node capability
- Voice Recording of the received and transmitted audio
- 50W Stable High-Power with Heavy Duty Heat Sink and FACC (Funnel Air-Convection Conductor) *Selectable 50W / 25W / 5W
- Micro SD Card Slot (up to 32GB)
- Supplied Accessories: DTMF Microphone, SSM-85D Radio unit, Mounting Bracket, Control Cable for operation with adjustable front panel mountings, DC Power Cable & Operating Manual

YAESU

ML+S

a Perfect Partnership

"We may all sell the same products, but the service from ML+S is in a different league".

ML+S

★★★★★ 4.9

Trustpilot HamRadio Reviews
Like our service? Why not leave a review?
<http://uk.trustpilot.com/review/www.hamradio.co.uk>

MARTIN LYNCH & SONS LTD

THE WORLD'S FAVOURITE HAMSTORE

Wessex House, Drake Avenue, Staines, Middlesex TW18 2AP

E-mail: sales@hamradio.co.uk

Opening Hours: Mon - Fri: 8.30am to 5pm. Sat: 9am to 4.30pm

Tel: **0345 2300 599**

International Tel: +44 1932 567 333

www.HamRadio.co.uk

SAFE ONLINE SHOPPING. E&OE

Breach of Copyright

On a sad note, we had a report of copyright infringement on one of our articles in the May and June editions entitled "A Mains Filter for the Hamshack". The design and the photographs were all unauthorised copies from GM3SEK's article 'Clean Up Your Shack - 2019' which was published in his blog <https://gm3sek.com/2019/10/11/clean-up-your-shack-2019/> and also featured in an RSGB Conference video.

Ham Radio Ireland apologises openly and unreservedly to Ian, GM3SEK, for such an infringement and will talk to the author concerned.

As editor of the magazine, I have spoken with the author of the article who subsequently apologised to Ian, GM3SEK.

News from the DARC

The Federal Minister of Digital Affairs and Transport, Germany, Dr. Volker Wissing, signed a news Amateur Radio Ordinance on the 22nd of June 2023. A short video of the signing was shown as a greeting during the opening of the 46th HAM Radio

The Ordinance will thus go into effect in one year on the 21st of June 2024. Chairman Christian Entsfellner, DL3MBG, was pleased that a large part of the demands of the Amateur Radio Round Table (RTA) had thus been implemented. Here are the highlights of the new regulation in summary:

Introduced is a three-tiered amateur radio class system, which includes the new N beginner class. In addition to 2 m and 70 cm for Class N, this will also allow operation on the 10 m band.

Remote operation is enabled, marking of the remote station by /R on the callsign is optional. —/—

In the future, a separate callsign is no longer required for training radio operation; the instructor marks the training station with /T (trainee) on his callsign. Existing training callsigns will remain valid for the time being until December 31, 2028.

750 W is possible on 50 MHz, the 23 cm band remains in full operation.

Hamnet stations can now operate with 1000 W EIRP.

Automatically operating stations can be operated with up to 50 W under certain conditions.

As far as training is concerned, DARC-AJW referee Matthias Jung, DL9MJ, gives some more hints. The first examination according to the new questionnaire could thus take place at HAM RADIO 2024. Until then, the old exam can be taken. Thus planning security for amateur radio courses exists.

In the course of the upcoming changes, the current draft of the new question catalog must be slightly adjusted again and reviewed by the Bundesnetzagentur (Federal Office for Network Control). After that, there will be nothing standing in the way of publication.

Irish Net

Active not only on Sundays, but most weekdays starting at around **16:00 UTC, the informal gathering on 14.156 MHz** frequently suffers from QRM during contests and DXers unaware of this long standing net of North American operators with an Irish connection. In a recent contact on 20m with WI1DP, QTH Tuscon Arizona, operator Jerry confirmed that the net now also uses the **17m band operating on 18.114 MHz**, avoiding the increased QRM on 20m and taking advantage of improved propagation conditions

The 59th NATIONAL STEAM RALLY
STRADBALLY, CO. LAOIS
6TH & 7TH August 2023

STEAM & VINTAGE PARADE
SATURDAY 5TH AUGUST @ 7PM
STRADBALLY VILLAGE

PET FARM
FOOD TENT
AMUSEMENTS
TRADE STALLS
CRAFT VILLAGE
SAWBENCH DISPLAY
SAWING WITH STEAM
LAWNMOWER RACING
CHILDREN'S ACTIVITIES
BLACKSMITH'S VILLAGE
ROAD MAKING DISPLAY
STEAM ENGINE DISPLAY
OUTSIDE BROADCAST WITH MIDLANDS 103
SHEEPDOG DEMONSTRATIONS & MUCH, MUCH MORE

Acibheann's PINK TIE
OUR NOMINATED CHARITY FOR 2023

NATIONAL STEAM RALLY

STRADBALLY WOODLAND RAILWAY
RUNNING ALL WEEKEND

IRISH STEAM
PRESERVATION SOCIETY CLG

CONTACT RALLY SECRETARY
086 822 7802

CAMPING & CARAVAN AVAILABLE
FREE CAR PARKING ON BOTH DAYS
WWW.IRISHSTEAM.NET

News and Forthcoming Events Planning 2023

British Railways Amateur Radio Society

During 2023, the British Railways Amateur Radio Society will be marking 55 years since the withdrawal of steam from British Railways in 1968. Special Event Callsigns GB0LMR and the Club call GX4LMR will be active throughout the year operated by Mark G1PIE active from Preston. QSLs via the Bureau, eQSL, or direct to Pam, 2E1HQY enclosing a SAE. More information from <https://www.qrz.com/>



RSGB Mock Examination Papers Released



The RSGB Examinations and Syllabus Review Group (ESRG) has provided an additional set of four mock exam papers.

These cover Foundation, Intermediate, Full and Direct to Full exams.

You can find the papers [on the RSGB website](#)

RSGB Releases OFCOM Consultation Video Guide

The RSGB recently released a video in which RSGB Spectrum and Licensing expert, Murray Niman, g6JYB explains more about OFCOM's Consultation entitled Updating the Amateur Radio Licensing Network.

This is the biggest revamp of Amateur Radio Licensing and callsign policy in a generation. The Video forms part of the RSGB's guidance for Radio Amateurs in this consultation.

You can watch it on the [RSGB's YouTube channel](#) or on the Society's [consultation web page](#).

The Society encourages clubs to use this video to start a discussion about the consultation at their club meetings.

The closing date for responses to this consultation is the 4th of September 2023. According to OFCOM, the proposals aim to provide greater operating freedom for Radio Amateurs, and make the process of getting a license simpler.

Here is a brief synopsis:

- I. Only permit Licensees to hold a single license requiring the surrender of lower licenses as they progress.
- II. Streamline and modernise callsign assignment
- III. Increase the maximum permitted transmit power to allow 20 watts for foundation and 100Watts for intermediate licensees in most bands; and 1000Watts for Full Licensees in Bands where amateur radio has a primary allocation.
- IV. Permit the deployment of Repeaters, Beacons, and Gateways without requiring a NOV in most cases.
- V. Allow Foundation licensees to build their own equipment and access the 2.4GHz and 5GHz bands.

The [full proposal is available via PDF](#) on the Ofcom website

ComReg Spectrum Management Proposal

When ComReg sought submissions for their Spectrum Management document in 2021, there was overwhelming support, from individuals and radio clubs, for a *Tiered Licensing System* and also an *Increase in Power Levels* for all licensees rather than the chosen few that enter contests. In fairness these proposals were included in the document and nothing said against them by ComReg. Nothing has been done to date about these well-supported items documented in the Final ComReg Management Document.

Why are these items not being discussed or followed up in a similar way here in Ireland?



We're delighted to announce that we will be holding our annual RSGB Convention from 13 – 15 October at Kents Hill Park hotel and conference centre in Milton Keynes. With lecture streams, forums, special interest groups, presentations and all the usual activities, there is something for everyone. Join hundreds of others at the RSGB Convention in October for one of the best social events in amateur radio. Bookings are open now and you can take advantage of early bird pricing until the end of August: rsgb.org/convention

RSGB News Services

For your weekly fix of GB2RS, from 80m to UHF DMR. Full schedule available from rsgb.org.uk/gb2rsschedule.

09:30 145.5250 FM

10:00 3.6400 LSB

12:00 DMR BM TG2354

19:30 DMR Phoenix TG880

News and Forthcoming Events Planning 2023

International Lighthouse/Lightship Weekend



The ILLW weekend takes place over the weekend of August commencing from **00:00 19th to 23:59 on the 20th of August 2023**. August seems to have become the international weekend for lighthouses. Countries all over the world have become involved in one for or another of lighthouse activity. Some years ago the United States Congress declared August 7th as their National Lighthouse Day and during that first week in August amateur radio operators in America set up portable stations at lighthouses and endeavour to make contact with each other. This event is known as the US National Lighthouse Week.

In Britain the Association of Lighthouse Keepers, ALK, conducts International Lighthouse Heritage Weekend on the same weekend as the ILLW in August. Their objective is to encourage Lighthouse managers, keepers and owners to open their lighthouse or light station and related visitors' centres to the public with a view to raising the profile of lighthouses, lightvessels and other navigational aids, and preserving our maritime heritage.

The ILLW usually takes place on the 3rd full weekend in August each year and attracts over 500 lighthouse entries located in over 40 countries. It is one of the most popular international amateur radio events in existence probably because there are very few rules and it is not the usual contest type event.

List of Irish/Northern Irish Participants As of the 21st of July

Participating Irish Stations

EI0NDR	Baily Lighthouse	Dublin	IE0025
EI0SW	Old Head of Kinsale		IE0007
EI1E	Ballycotton		IE0015
EI2WRC	Hook Lighthouse		IE0003
EI3CC	Ballinacourty Point		IE0018
EI9CJ	Dundalk Lighthouse		IE0028

Participating Northern Irish Stations

GB1RP	Rathlin Rue Point	UK0185
GB2WL	Rathlin West	UK0217
GB2EL	Rathlin East, Low & High	UK0055-56
GB5BL	Blackhead Lighthouse	UK0032
GN0LIX	Chaine Memorial Tower	UK0033
MN0JQS	Lightship "Petrel", Ballydorn	UK0092

British Inland Waterways On The Air 2023

Saturday 26th to Monday 28th August

The event is open to all Amateurs who are boaters, cyclists, walkers and other users of the canals, rivers, towpaths, riverbanks for work or recreation.

Many clubs and individual Amateurs on or near the UK inland waterways obtain Special Event Station (SES) callsigns. Others operate mobile or portable using their own callsigns.

Many more like to contact the BIWota stations.

It is also a good chance for WAB enthusiasts to get some rare WAB squares.

If you are interested in taking part in the event please register at

www.nharg.org.uk/biwota

We look forward to hearing you on the air.

Photograph courtesy of Kev Driver, MTKSD



POTA
E13CC will be QRV
On Sat 22 Sun 23 July
At the Saleens Tramore



So why not call down and say hello and have with a cup of tea and even operate the radio

Eircode X91P267 just down the lane and we are there



Episode 29 of TX factor is currently available with an excellent review of the ICOM IC-905 all mode VHF, UHF and SHF transceiver. In fact they test two of them on each of the bands and also demonstrate ATV on 5GHz with the picture displayed on the IC-905's own screen. Also featured is a trip to the UK's last remaining shortwave transmitting station in Woofferton, near Ludlow.

Link: <http://www.txfactor.co.uk/>

News and Forthcoming Events Planning 2023

Jamboree-on the Air JOTA Friday 20th to Sunday 22nd October 2023



Jamboree-on-the-Air, or JOTA, is the largest Scouting event in the world. It is held annually the third full weekend in October. JOTA uses amateur radio to link Scouts and hams around the world, around the nation, and in your own community. This jamboree requires no travel, other than to a nearby amateur radio operator's ham shack. Many times you can find the hams will come to you by setting up a station at your Scout camporee, at the park down the block, or perhaps at a ham shack already set up at your council's camp.

The Purpose of JOTA

- Promote and support Amateur Radio, science, technology, engineering and mathematics (STEM) activities in a fun and interesting way across the scout and guiding troops of Ireland, particularly the annual global JOTA-JOTI scouting event
- Provide a focal point for amateur radio equipment donations and distribute on loan or on a permanent basis such donations to scout troops who wish to take part in amateur radio and radio scouting activities
- Contribute to IRTS, Scouting & ComReg consultations in order to help promote Radio Scouting activities in Ireland

Special Interest Badges

Radio Scouting Ireland have resources to help scouts and scouters devise an implement amateur radio related programs for Special Interest Badges.

Facilitation

RSI have resources, training videos and equipment available for loan to help yourt scouts learn about radio communication.

Facebook Page

<https://www.facebook.com/RadioScoutingIreland/>

At this point in time there is plenty of time to make arrangements with you local scouting group and assess their needs and what type of special event callsign they would like to use for the occasion.

In addition to the operation of the amateur radio station with both voice and data modes, one can set up a morse key and oscillator and maybe operate a treasure hunt over PMR 446 radios.

In the last few years, there were basic electronics projects available to give the opportunity for scouts to wield a soldering iron. This courted great interest amongst the scouting groups in Galway. Indeed it also appealed to Galway Radio Club members.

It is possible to find a scouting group in your area at the Scouting Ireland site at <https://www.scouts.ie/>

Online Amateur Radio Community (Northern Ireland)

The Online Amateur Radio Community runs a 40m slow-to-medium speed CW net every Monday evening at 7pm. All are welcome to join in. For more information see morse.oarc.uk On the first and third Saturdays of the month, the group holds a virtual social night called 'The Rubber Duck' on Zoom. For more information, see oarc.uk The Online Radio Club has a virtual radio club night at 7.30pm every Thursday via Zoom. It is suitable for all radio enthusiasts regardless of individual skill level.

East Leinster Radio Club

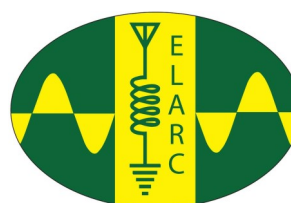

Members of "East Leinster Amateur Radio Club (ELARC) EIOEL" plan to activate Claremont Cairn (EI/IE-021) on Sunday 30th Aug starting about 11.30. 2m, 4m and HF. Hope to catch up with some of you then.

Would You Like to Promote Your Club and its Activities?

Is your club planning an event in the next month?

Are you planning a club activity?

Are you setting up a new Repeater or Gateway?

Drop us a line or two and we will include your item in the Ham Radio Irelandletter

**We Have a Facebook Page
The Ham Radio Ireland
Magazine**



<https://www.facebook.com/groups/1437072523434876>



Northern Ireland Radio Club Meetings

The Strangford High Frequency Enthusiasts Group is accepting UK-wide enrolments for the next UK Full licence training programme. They also use Google Meets on Monday evenings. It is completely free, email GI0VKP@gmail.com for details or see the [QRZ.com](#) entry for GI0VKP.

Carrickfergus Amateur Radio Group continue to meet for Club nights on Tuesday evenings from 7pm in **Elim Pentecostal Church, North Road, Carrickfergus, BT38 8ND**. All visitors are welcome. Contact the Club: carg@hotmail.co.uk

Bushvalley Amateur Radio Club has a club net on Tuesdays at 8.30pm on 145.300MHz. On Thursday, the club meets at The United Services Club, Roemill Road, Limavady. Contact Jason, MI3UIW, via email to Bushvalleyarc@gmail.com

West Tyrone ARC holds regular monthly meetings on 2nd Wednesday each month at 19:30 in Strathroy Community Centre, Omagh, BT79 7XE. Contact: info@wtarc.org.uk for more information

Lough Erne Amateur Radio Club normally meets at 7:30pm on the first Monday of each month at the Share Centre, Lisnaskea. More information from: <https://lougherneradioclub.co.uk/>

The Mid Ulster Amateur Radio Club (MUARC) has been active since 1965, our Club call sign is **MN0VFW**. Please take time to look through our website, where you will find information on our club, activities, events and members as well as a great gallery full of images of our latest activities. Mid-Ulster Amateur Radio Club meets on the air weekly on the GB3WT repeater every Monday evening at 7.30pm. There will always be a net controller from the club but everyone is welcome to call in and join the conversation. The club meets socially on Zoom twice each month. If you're in the region, and would like to take part, the club secretary can be contacted on the following email address: muarc.secretary@yahoo.co.uk

You can go to www.youtube.com/muarcmedia and that will bring you to our YouTube channel with all our previous lecture videos and much more content in the pipeline.

The Online Radio Club has a virtual radio club night at 7:30 pm every Thursday via Zoom. It is suitable for all Radio Enthusiasts regardless of individual skill level. To to the website for the meeting link <https://onlineradioclub.org/>

Ballymena Amateur Radio Club meets every Thursday at 70, Nursery Road, Gracehill, Ballymena except during the summer months (June, July, and August) when we only officially on the first Thursday of the month, however there are some members there nearly every Thursday Night. Details from Hugh Kernohan GI0JEV (Secretary) HKernohan@aol.com

City of Belfast Amateur Radio Society meets on the first Monday of each month a 8pm in the Shorts Recreation Clun, Aircraft Park, Holywood Road, Belfast BT4 1SL Contact Paul Irwin GI6FEN for more information. paulirwin@btinternet.com

Mid Ulster Amateur Radio Club meets on the second Sunday of Each month in the Brownlow Resource Centre, Craigavon, Co Armagh. For more information contact muarcsecretary@yahoo.com

If your club is not included on this page please notify us and we will add it to the next issue
Contact ei5dd.steve@gmail.com

GB100RAF at Airwaves Portrush Airshow

The RSGB Region 8 Team is pleased to announce that it has been given the opportunity to showcase amateur radio by hosting the Special Event Call GB100RAF in the STEM Village (Science, Technology, Engineering and Maths) from 1-2 September at the 2018 Portrush Airshow, AirWaves.

Mid Ulster Amateur Radio Club will provide their display trailer for the weekend and RAF Amateur Radio Society members will facilitate the GB100RAF call sign. The team is aiming to run the SES for the full weekend as part of the ongoing RAF100 commemorations, whilst demonstrating amateur radio and its technological diversity to the general public.

Clubs and amateurs from around the region are welcome to come along and join the fun. We'd be delighted if you can stay to chat to visitors, pass on some of your passion for the hobby and even take a turn at operating GB100RAF.

The team hopes to be QRV on VHF/UHF and HF, posting more detail via social media during the days if possible.

QSL information for GB100RAF is via G8FC, the club call sign of HQ RAF Amateur Radio Society



Are you a “Whisperer”?

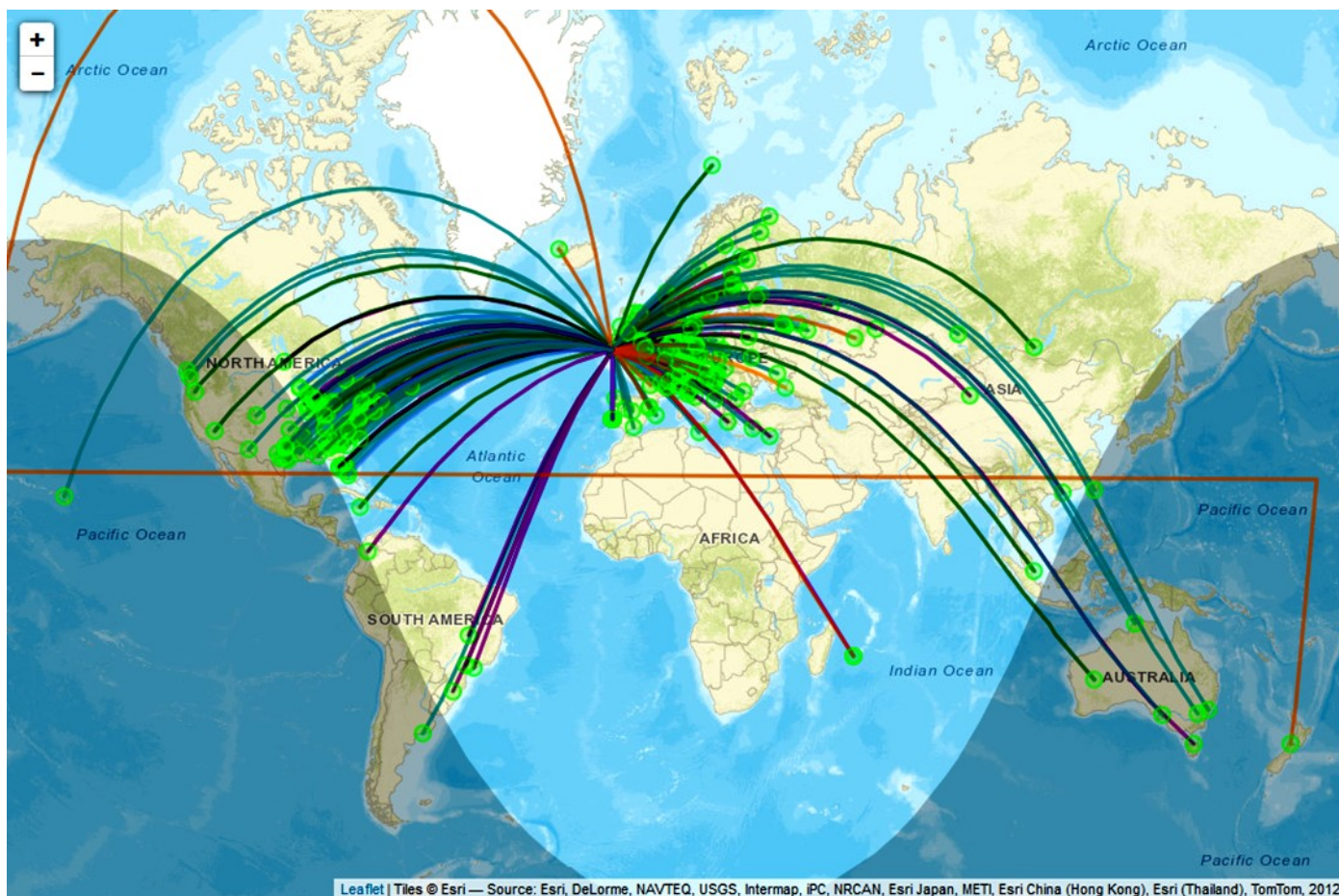

My tiny WSPR Transmission received all over the world

No? Well then read on, because you might be missing something. Grab you favourite Cuppa, or that well deserved Pint and all shall be revealed. Just a wee bit of background might be appropriate here. For 15 years I was absent from the Hobby and when I returned 3 years ago so very much had changed. My Radio Experimenter friends bamboozled me with: How are you getting on with FT8?, C4FM, Whisper, JS8CALL and many more words I had never even heard off.

What do you think of DMR and DSTAR? Dwhat I said? It quickly became clear to me that things had mightily changed. Are you on Allstar yet, but what do you think of Winlink Express and VARA. All gobbledegook to me folks.

Fellows, I nearly decided to give Ham Radio a miss and go back to bed, , my olde brain just about keeled over.

But.... Fortunately for me....EI7KN (Dave) heard about my plight and came to my rescue. 7KN embodies all that you could wish for in a friend and teacher. (At times he must have thought I was a lost cause but we both persevered and heh.... I am a “Whisperer” now.

Whisper was written by Joe Taylor (a ham with a Nobel Price) and there aren't that many of those about. Just click on this link and note that K1JT is SMART guy

https://w6yx.stanford.edu/images/Talks/Amateur_Radio_Leads_to_a_Nobel_Prize_sm.pdf

As this article is written to introduce you to “Whisper” an explanation might be helpful. In a Nutshell Whisper is a Weak Signal Propagation Reporter. Just have a look at the picture In this article. ALL these contacts have been made with between 80 and 200 milliwatts. YES, you are reading that right. EIGHTY minimum... 200 MILLIWATT

MAXIMUM.

Now.. before you fall of your perch..... These are **verified** ONE WAY contacts. Wait a minute I can hear you... what are you on about. Verified ONE WAY contacts.... There surely isn't such a thing. Well.. actually, there is and here is how it works: When my Whisper signal is received by another station, that station uploads my Call, Signal strength, Time, locator, etc to a central database. All that is done automatically. If He or She does not receive my Whisper transmission, nothing is uploaded. I do not get an acknowledgment, QSL card, or the like from him, he just auto uploads that he received EI7II at his station.

So... if EI7II (me) wants to see if anyone has heard him..... he (me) just logs into the database and has a look. Heh..... it shows that ZL2005SWL heard me on 7.040145 MHz, at 0.2watts ,my signal strength at his location was -34DB ,date/ time received, , his locator is RE68mx and the distance between us was 18805KM. See the photo above, he is the orange coloured signal, orange meaning that this was a signal on the 40 meter band. (All ham bands have their own colour). A quick point here folks: NOTE the signal strength..... MINUS 34 dB!

If you have a brilliant set of ears, and are highly trained you might get a CW signal at say -15 but that is on the noise floor.

At -34dB, you would have never even known that there was a signal.

One thing to bear in mind, he reports me using 200 milliwatts. But that he gets from MY transmit signal setting, as that is a setting in my transmission field. The

Are you a “Whisperer”?

rest he provides when he uploads what he received.

To help you out here, here is a link to a database I often use: <http://wspr.aprsinfo.com/>

To use: Provide the call you want to track, the count you want, the band(s) you want, over what period you want to see, hit load, and the data will load in front of your eyes.

It is important to note that the transmitters have to be licensed amateurs... but the receivers do not. Note my ZL example above... this guy is an SWL with a super set of antennas and a very sensitive receiver.

BTW... you could use PSKREPORTER , if you use that program . It has an option to show you Whisper signals, as well as many many others.

Another great way to introduce yourself to Whisper is to pick up one of the countless KIWI SDR receivers. They have Whisper decoders build in. You just find a KIWI receiver anywhere in the world, hook up to it, with your browser, select the extension (Whisper) and of you go.

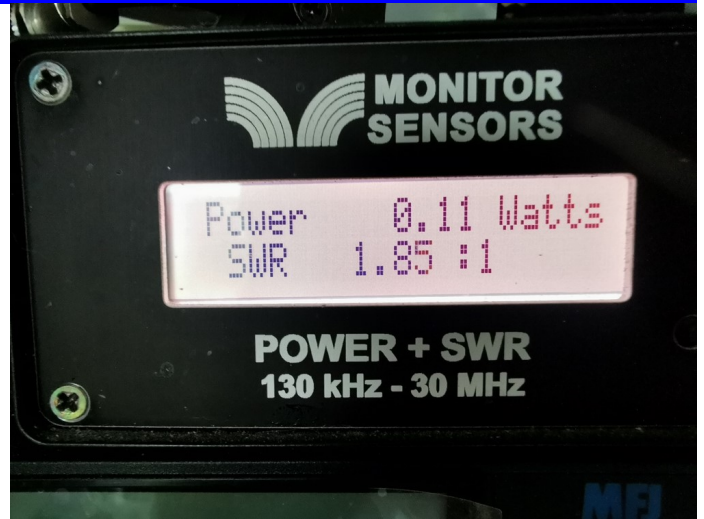

The power output of the WSPR transmitter

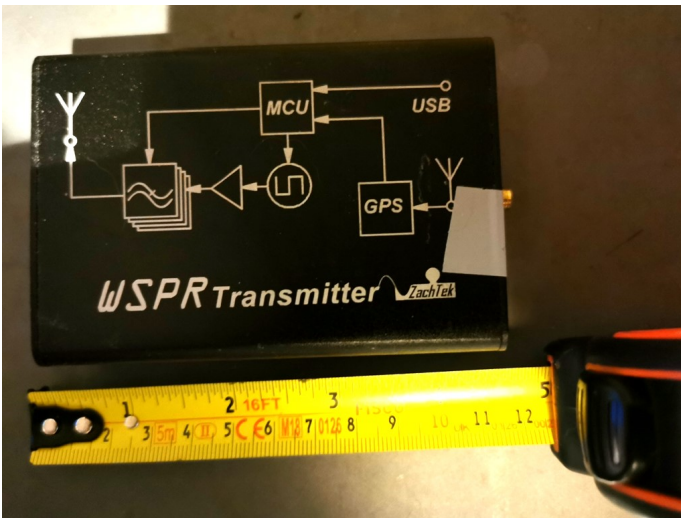

The ZachTek WSPR-TX desktop

Notice that the latest KIWI S/W release has added FT8 and FT4 decoders too. All this without costing you one single cent! Here are some useful links: http://kiwisdr.com/ks/using_Kiwi.html

Here is the w/w receiver database, we have six of ‘em (KIWI’s) in Ireland. <http://kiwisdr.com/public/>

Now, this article would not be complete without Mr. Harry Harrison. Grab that Tennessee Sipping Whiskey and read on. Harry makes cigarette sized Whisper transmitters.

It is the one I almost always use. Harry hand builds them and does an absolutely super job. Harry lives in Sweden.. so if you buy one, at least no customs/VAT or all that other misery. Mine can operate between 80-10 but you can set it to whatever band YOU want. As to the unit.... God knows how he does it so well. (Very occasionally I let my FT991A do the “heavy lifting” at 5 watts, the 991A minimum power level.) In that case I can upload too, as the Yeasu of course receives as well.

A Harry Example ? One day.... Turned the thing on and a few hours later ... hours... not minutes!!! I thought I have a look. Heh, no one had received EI7II. It would be a miracle indeed if they had.... the unit had no antenna connected to it and had been happily transmitting into the Blue Yonder. NO damage done at all. Note: PC only needed for set up and never again unless you break it. The unit comes complete with an active GPS antenna. Truly self-contained, runs on standard shack 12-15 DC power supply. Here is a link to his site: <https://www.zachtek.com/> Do note, as timing is critical the Zachtek needs to see a GPS signal so Harry supplies an active antenna with it.

All in all.... If you haven’t done so already... I suggest you explore this mode. You may be pleasantly surprised.

Albert Kleyn EI7II ei7ii.ie@gmail.com

ZachTek

Handmade products for radio amateurs and RF enthusiasts.

Welcome to ZachTek, here you will find RF related products and information.

Some of my more popular products are different models of WSPR transmitters that is made for the radio amateur that wants a standalone transmitter for mobile or stationary use.

With these in your shack you can run WSPR 24/7 without tying up your regular transceiver.

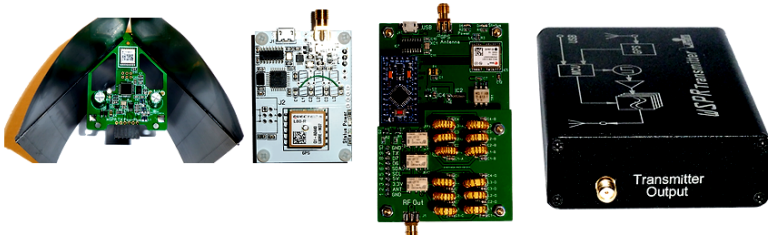

QRP LABS

<http://shop.qrp-labs.com/>

Check us out
Many projects here
are capable of
transmitting and receiving
WSPR

The BALUN in action - Mike Higgins - EI0CL

In an earlier article we promised we would discuss using a BALANCED to UNBALANCED transformer (BALUN). Consider height ASL and near field obstacles and the like in HF transmitting—mad things such as marketing ploys used to sell stuff as DX commanders and Double Bazookas—what are they actually?

Well, the first mentioned is a multi-band vertical antenna—the second is simply a broadband dipole—it's so easy to make your own version.

Always remember a single vertical antenna will deliver just 0.3 watts of power per degree of compass—when 100watts is applied to the feed point QRP effectively. A horizontal dipole is more efficient—especially if its one half wave above ground.

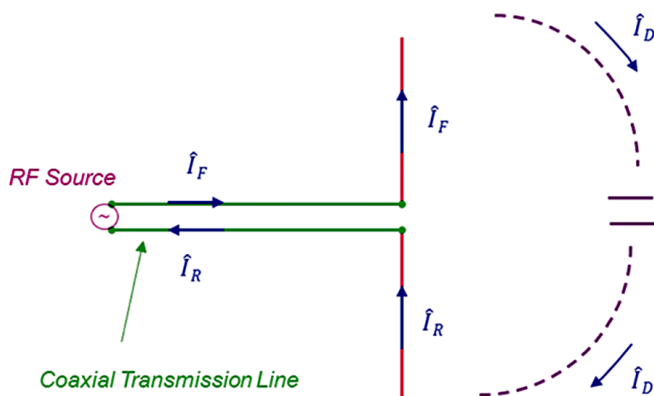

Considerations on using a balun in a dipole antenna. Referring to an earlier article on building one, your own wire antenna system such as a dipole or a multi element wire antenna in Yagi configuration and where the dipole is now the driven element. Why use a balun at all? What essentially does a balun do?

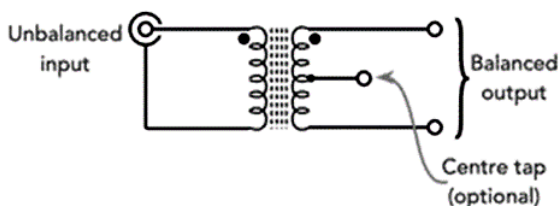

The basics of any BAL-UN is that it transfers power & (transforms) an unbalanced feeder system to a balanced system—or visa versa—so it's a balanced to unbalanced transformer in the first instance, all transformers have also a ratio of transformation i.e. 1:1, 1:4, 1:9 or 1:49 etc. Various impedance ratios are found along the length of any two antenna elements frequency dependent.

Another feature of the typical balun these days is the RF choke component; this discourages RF flowing backward towards the feeder and thus demands more accurate sizing of the element lengths. As a result, the more accurately the elements are sized, relevant to frequency, the better the power transfer to the radiating elements. Bandwidth, discussed earlier, is also an issue. Here the outer diameter

of the radiating elements is important, the larger this is the more broadband the antenna is. This is about the only good feature of the so-called bazooka antenna shown below.

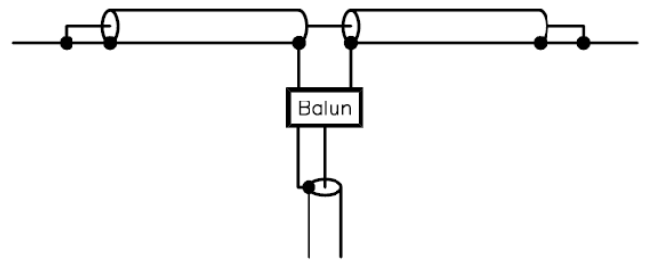

Simply use a co-axial cable closed at both ends, instead of the typical thinner 2 mm copper wire. The advantage—is that it is more broadband. The disadvantage is water ingress more likely and weight is also a problem.

Below the WESCOM DESIGN 1000 Watt 1:1 balun IP65 rated 1.8 - 54 MHz one of the best in the industry.

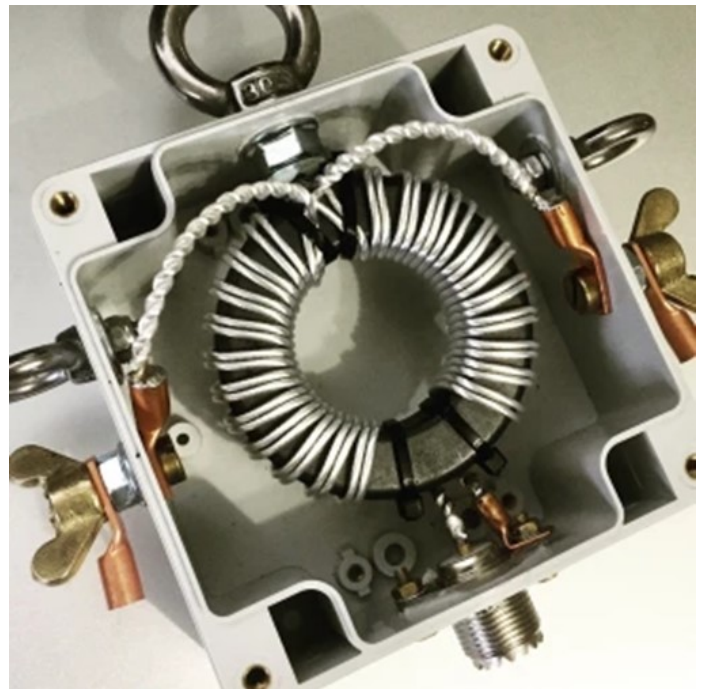

Coaxial cable is inherently unbalanced and is typically 50-75 Ohms in impedance. This is very convenient when connecting the average 1 transmitter output or receiver input via co-axial cable to an antenna. The critical factor is of course matching the co-axial cable to the relevant antenna.

For a receiver only, the best match at the desired frequency is important for best reception but will not generally cause other problems.

For a transmitter achieving a good or perfect impedance match it is however of critical importance—here a mismatch will cause all sorts of problems from a loss in transmitting power—spurious emissions—distortion & possible overheating or even destruction of power amplifiers.

The BALUN in action - Mike Higgins - EI0CL

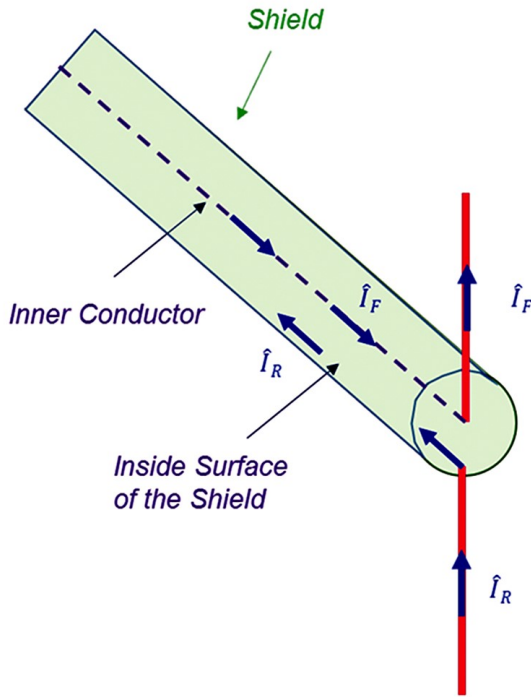

We know that for a simple dipole the typical impedance at the feed point is approximately 50 ohms. Now that's also convenient. In this case the transformer ratio is of course 1:1, so the function of the balun here is the balanced feature of the two element antenna is matched to the unbalanced co-axial feeder and the choke characteristic demands the elements are accurately sized. Power transfer is at its most efficient and the maximum power possible is radiated.

What happens without this balun and where after sizing the elements a good match is achieved. Why is this just not as efficient? Without the balun/choke, RF finds its match point much earlier in the sizing (cutting) of the elements down along the feeder co-axial cable. The co-axial now becomes part of the resonant antenna, however, that part of the feeder used by the RF to find its resonance will not radiate at all. This means the power in the elements is below that of the truly balanced system due to the resultant loss of radiating power.

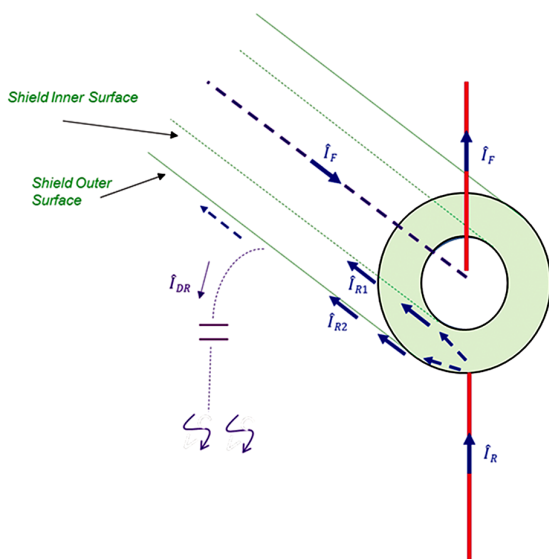

The alternative to using a balun is of course to use instead balanced feeder lines; always a great alternative and very low loss-economic and almost unlimited in length of feedline. The impedance is then going to be anything from $2/300 \Omega$ to 600Ω or more, depending on spacing and wire diameter, however, none of this really matters as one is always now going to use some method of impedance transformation (generally adjustable) to resolve the mismatch that will occur between a transmitter (PA) output, typically 50Ω , and this feeder line. These impedance transformers are adjustable and variously called ATU,s Z Matches and the like . generally, they all do the same job; transform the feed line impedance to match the PA output impedance and convert the balanced lines to match the generally unbalanced output from the PA. (PA=Power Amplifier. To make a balanced feed line is easy—all you need is the wire, spacers, and a little intuition.

Building an adjustable impedance transformer ATU is so well documented we will not re-invent the wheel here. An ideal design may be found at <https://www.oz1bxm.dk/station/ant-tuner.htm>

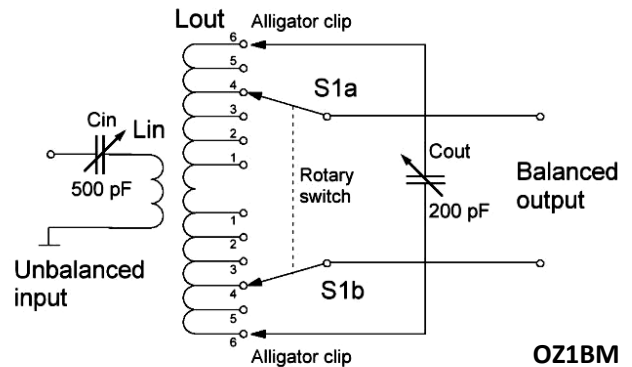

A typical adjustable impedance transformer ATU

Consider the cable run, obstacles, twisting or winding of the feeder in windy conditions and the weight of the feeder when considering this option. Also consider keeping the antenna and the feeder as one unbroken wire as there is no need to cut and re-join if one thinks out the antenna beforehand.

The open wire feedline is perfect especially when one does not know what the impedance is at the feed point of the antenna as in Vee beams & other such systems right back to the simple dipole (DI-POLE= 2 Pole) no matter its half wave, $3/8$ or $5/8$ wave or indeed any random length centre fed -end fed or off -centre fed.

In a following article we plan to discuss the advantages and disadvantages of HF transmission operating at high altitudes, low altitudes with reference to ASL and near and far field obstacles.

Getting Started on FT8 - Lez EI4GEB

The Mode that broke the Ham Bands

FT8 is a digital communication mode used by amateur radio operators for shortwave radio communication. It is designed for weak signal communication and is highly efficient in terms of bandwidth and power usage. FT8 is known for its ability to make contacts under challenging propagation conditions. Its also causes great debates in the amateur radio world.



To get set up and started with FT8, here are the general steps:

Equipment:

You will need an amateur radio transceiver capable of operating on the desired HF bands, or VHF/UHF (e.g., 20 meters, 40 meters, 2 meters, 70cm etc). A built-in sound card or a standalone sound card. A computer running Windows, macOS, or Linux with the sound card interface connected to the radio.

Connect your transceiver to your computer using an appropriate interface cable.

Configure WSJT-X to recognize your radio and audio interface by following the software's setup instructions.

Set the appropriate audio input and output levels on your computer to ensure proper audio transmission and reception.

Operating Procedure:

Launch WSJT-X and select the FT8 mode.

Set your operating frequency and other parameters as desired.

Monitor the FT8 activity on the waterfall display to identify active stations.

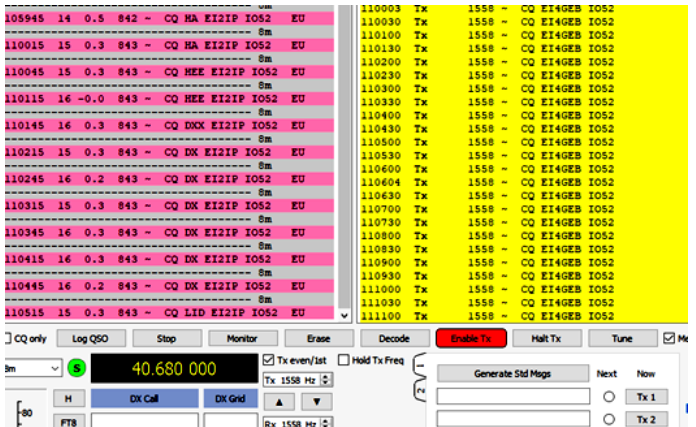

When you find a station, you want to contact, click on their signal in the waterfall display to initiate the contact.

Allow the software to automatically exchange necessary information with the other station, such as callsign, signal report, and location.

Once the contact is complete, the software will display a confirmation, and you can proceed to the next contact.

The Controversy

FT8, like any subject of interest, can generate varying opinions and discussions among amateur radio operators.

Here are a few reasons why FT8 might cause controversy

Automation and Minimal Operator Involvement: FT8 is known for its highly automated and structured nature. Some operators argue that this automation reduces the skill and involvement traditionally associated with amateur radio. They believe that it takes away from the "human element" and the personal interactions that other modes of communication, such as voice or Morse code, offer.

Bandwidth Usage and Crowding: FT8 operates in a narrow bandwidth, allowing for many simultaneous contacts on the same frequency. This can lead to crowded bands, especially during popular events or peak activity periods. Some operators believe that the widespread use of FT8 can limit opportunities for other modes of communication and reduce the overall diversity of activities on the bands.

Controversies in Operating Procedures: Occasionally, there may be disagreements or controversies regarding proper operating procedures or etiquette during FT8 contacts. These can range from issues like signal strength reporting accuracy to the use of automated sequences or



This Photo by Unknown Author is licensed under CC BY

Software Installation:

Download and install the WSJT-X software, which is the primary software used for FT8. It is available for free from the official website: <https://physics.princeton.edu/pulsar/k1jt/wsjt.html>

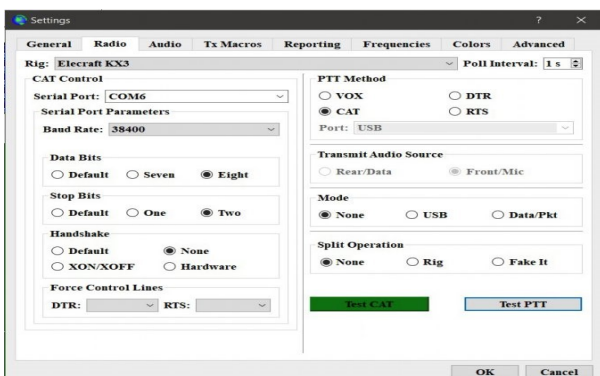

This Photo by Unknown Author is licensed under CC BY

Getting Started on FT8 - Lez EI4GEB

other technical aspects. Different operators may have different opinions on what constitutes fair play or good operating practices.

Impact on Traditional Modes: FT8 has gained immense popularity due to its ability to make contacts under challenging propagation conditions. However, some operators of traditional modes, such as CW (Morse code) or SSB (voice), may express concerns that the rise of FT8 could diminish interest in and utilization of these modes, leading to potential declines in their respective communities

Changing Landscape of Amateur Radio: FT8, with its efficient and effective weak-signal capabilities, represents a shift in amateur radio practices. This change can challenge the status quo and traditional notions of what defines amateur radio. Consequently, discussions and controversies arise as the hobby adapts to innovative technologies and modes of communication.

It is important to note that controversy and differing opinions are not unique to FT8 but can be found in various aspects of amateur radio, reflecting the diverse perspectives and interests within the community. Constructive dialogue and mutual respect are key to fostering understanding and finding common ground amidst these discussions.

I have found others in the amateur family berate people for using FT8, yet these so called ham police use this mode under the guise of **“I was only using it to do an experiment”**, or **“I wanted to see if I could get 100 DXCC,s in a week”**. But we all know they secretly love it Hi, Hi.

Some of us remember the controversy over SSB back in the day. But it is important to remember its all part of the hobby, and what a hobby it is.



[This Photo](#) by Unknown Author is licensed under [CC BY-NC](#)

Conclusion.

It is important to note that FT8 and amateur radio operation, in general, require an appropriate amateur radio license in your country. Make sure to obtain the necessary license and familiarize yourself with the regulations before transmitting on amateur radio frequencies. It is always a clever idea to ask an experienced operators who has used FT8 for many years for help, if needed. So that early mistakes can be avoided. I have seen one or two rants online blaming other operators for bad operation, when it is their own bad operating causing the problem.

Additionally, it is beneficial to consult the WSJT-X software documentation and join online communities or amateur radio forums to learn more about FT8 and gain insights into a great and enjoyable mode.

A photograph of a man with glasses and a mustache, wearing a dark green shirt, smiling in a workshop. The workshop is filled with various electronic equipment, cables, and tools. A blue banner is overlaid on the bottom of the image with white and yellow text.

Dave Wood Ham Radio & CB Repairs
dave.g4tiw@hotmail.co.uk 07785 294916
(emails are read each morning) (Mon-Fri, 9am to 5pm)

Don't Give Up

My name is Jamie Daly and have been a SWL for 5 years or more. I have learning difficulties and trouble reading and writing. I write this article, with assistance from the editor of the magazine, outlining my frustrating quest to pass the Amateur Station Licence examination.

My introduction to SWLing was listening with a scanner. After picking up a UHF repeater I decided to make a call on it. Very quickly, Hugh, EI2HI, came back to me informing me that this was an amateur radio repeater, a licence is required to use the system. Naturally, this was of great interest as I had often heard many operators with callsigns calling through the system. After more enquiries, I decided to join the online classes run by the NSWLC based in Cork.



Operating the Collective Communications Club Station at Kilmurrin Cove

them that I got the opportunity to operate an amateur radio station for the first time. This was the icing on the cake. I had watched others and was dying to make a contact myself. I was really hooked at this point.

I confess that I do have trouble making head or tail of the theory side of radio. It seems fine while I am at the lecture, but trying to explain it myself afterwards is difficult. In short taking the exam was going to be problematic.

I must thank John, EI3HQB, who did explain things to me and has helped me put up antennas. It was John who gave me the first opportunity to operate the Collective Communications club station. As a result, I received a certificate from John O'Toole. MOHEM.

To sit the examination is a problem. I need a scribe and somebody to read the questions to me. This has to be organised prior to the exam. Unfortunately, on one occasion, I was told that there was no scribe available and I was left to brave it out alone. This was totally unsatisfactory and was a waste of yet another opportunity.

I have taken the exam 5 times to date. Unfortunately, I came close to but never managed a pass mark in the exam. I would dearly love to pass this exam and set up my own Amateur Radio station.



My Mobile/Portable CB Station

I get the impression that many are complacent as they can join a class, sit an exam and pass without any



Setting up the Portable station

I attempted to join a local radio club in my area but was not accepted for membership with no reason given. I found one or two who encouraged my interest and they offered assistance and explanations on some of the topics for the Radio Exam. Unfortunately, my learning difficulties got in the way.

I really have a passionate interest in amateur radio and would desperately like to participate.

Some months later, I joined a group that are very active and engage in many portable operations. It was through

Don't Give Up



My Station at the Home QTH where I do a lot of Shortwave Listening on all Bands and Operate on 11 metres

difficulty. Well for them! Sadly, there have been others who are quite unsympathetic to my cause and made fun of me via social media and chat groups.

I have taken advice through social media and continue to garner encouragement. I will not give up as it is something that I really want to achieve. I know that I am not on my own here and there are others encountering similar problems. Some took a couple of attempts before passing the exam but they kept trying to attain that pass. Well done – they stuck with it and deserved their success as a result of perseverance. Others, like me, have been less fortunate!

My advice to anyone in a similar position is not to give up. Keep trying as it is a fantastic hobby and worth putting in the effort.

What else can be done to help people in a position similar to my own? Radio clubs play an important part as there are a group of people from all walks of life who have varied interests in the hobby. Some have the gift of explaining things in easier terminology whilst others, who are probably very technically competent, can not explain things in layman's terms however hard they try.



Attending a club's portable activities, and field days, gives one the opportunity to see a station assembled from scratch. Erecting antennas and even constructing a new antenna on site is educational. Operating the station under supervision is also one of the most exciting experiences. I have learned more by being part of such activities and thank all those who have included me in their activities and events.

I was asked my feelings about the introduction of a "tiered licensing system". Well, I would be 100% supportive of such a system. It would be a golden opportunity for somebody with my disabilities to complete the passage towards a full license in stages. I would be happy to have a Novice license with restrictions and then work through an intermediate stage towards a full licence. Naturally, I find that just to be able to operate a station would probably teach me more.

I am very active on CB radio and I have set up my own station, tuned the antennas, and worked a huge amount of DX. It is not that I am unable to do this much. I have the feel for the 11 metre band and I am always there when the band opens. I enjoy communication and being part of a hobby resulting in many new friends through this medium.

I enjoy operating my station from the home QTH and portable locations. I have no problem setting up the station in the car. For portable operation I generally use the half wave vertical antenna which has always worked well for me.



I have received many QSL cards from stations in Europe and many other countries. I have an active account with eQSL and some of the cards arrive in the post direct..

I know that I am not alone and there are many in a similar position but afraid to speak out.

If anyone reading this can offer me assistance, or suggestions, I would be indebted to them. Is there a possibility of getting one-to-one tuition from somebody who has the experience to teach somebody with my disabilities? I would be most grateful if they could contact me.

In conclusion, I really do encourage anyone with similar disabilities to persevere and push themselves to the limit to pass the exam. Despite falling foul of some individuals, who have not been too pleasant on social media, I will continue to put everything I have into passing the exam and will not be put off by the begrudgers and naysayers. I hope ComReg will eventually follow up on the Tiered Licensing system which would help people like me. Many European countries, including the UK, have such a system; why not Ireland?

If the National Society, of which I am a member, is truly representing all radio enthusiasts, I am sure that they will follow up on the Tiered Licensing system as a matter of urgency without reservation or equivocation..

Don't give up!

Jamie Daly

jamedaly224@gmail.com

Collective Communication ARDF Event

On June 11th EI3CC held an ARDF (fox hunt) in Stradbally the event was to introduce members of the NSWLC and scout Ireland into the world of ARDF and of course to take away information and techniques on how detection finding was carried out .

Kick off was set for 12pm and once we were sure everyone had arrived then Keith EI5KJ set about explaining how the day would be run and for those who never tried ARDF how-to set up radio's and 3rd harmonics etc.

After a brief discussion on what to listen for and look for everyone was supplied with a radio if needed and the recent built club tape measure ARDF antenna. So off to the woods they went in different groups and after a time as they returned they explained how they had found the said fox and technique from body shielding and changing polarity from H -V



Again fox's were placed this time 3 x's and this proved more of a challenge some finding all 3 some only 1-2 but all enjoying the day tea-coffee and cake and biscuits were on hand as and when needed from our newly restored mobile shack or as we call it (RCU radio control unit)



this was its first long run out after the front axle had undergone a major repair.

All in all the day was a great success everyone had learned about the ARDF and were surprised how difficult it was , one participant newly licensed Howard had traveled all the way from Kerry a round trip of 580 Klm to be with us for the day.

So again we held another successful activation 16 people on the ground and a lot of public interaction and interest in what we were doing.



EI3CC continues to grow and we will continue to fly the flag of our wonderful hobby the second half of the year is to be even busier so keep an eye on our Face book page / twitter or even enjoy watching some of our video's on our YouTube



Building a 6m Squalo Antenna - Jer Aspell - EI3HGB

Chris (EI3HBB) and I were discussing what type of antenna we could use to get on the 6m band as it was summertime and 6m conditions were picking up and we had no antenna for that frequency and with Chris's location a yagi antenna would not be viable due to high winds, so after a bit of research on the Internet, I stumble on the Squalo antenna by PA3CHM <https://www.pa3hcm.nl/?p=312> which ticked all the boxes for our needs, Horizontally polarized, Omni directional, small size and easy to gather materials. Squalo antenna was originally designed by KG4OSA which is in fact just a square folded dipole that radiates in every direction.

The Build

So after purchasing all the materials that I needed, I began by cutting the copper to the lengths required, I then did a dry fit to make sure everything was measuring okay, and after that, I used the wire wool to clean up all the copper pipe ends for soldering, applied flux paste to the joints and then used the mapp gas torch to solder the antenna together..

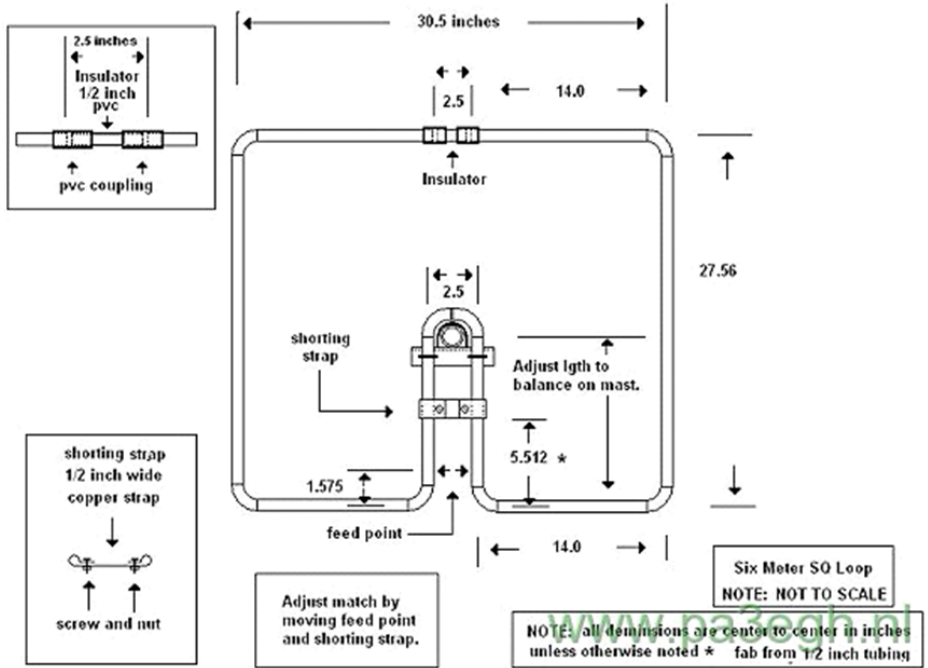

The original design of the Squalo Antenna by PA3EGN

To make up the shorting brackets and connection hardware brackets I flattened a piece of the 1/2" copper pipe, cut to the size required, and bent the ends to suit. Attaching the shorting strap to the antenna I used the stainless screws, I had pre-drilled the copper brackets to allow for the screws and did the same for the connection hardware brackets.



Building a 6m Squalo Antenna - Jer Aspell - EI3HGB



You can use a wooden dowel for the insulating section but I had some 15mm PVC pipe left over from another project and used that by sweating the ends to go over the 1/2" copper.

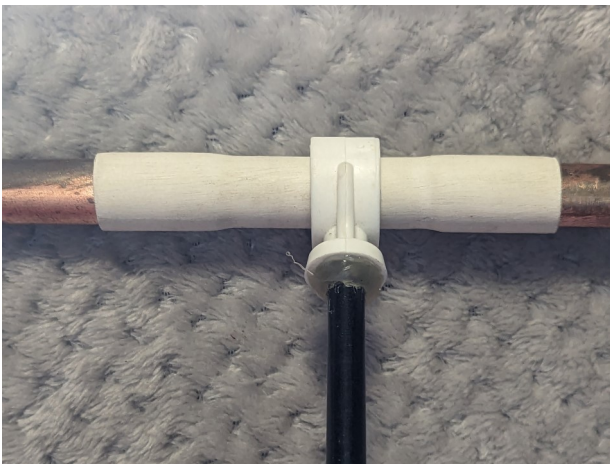

For mounting the antenna to the mast I used a piece of 40mm aluminum angle attached to the antenna and the 60mm u-bolot attached to the mast
Optional part

If you want to give the loop some bit of support you can add an angle bracket from the insulation section of the antenna to your mast, I used an old length of fiberglass tent pole and a 1/2" pipe clip and used a stainless jubilee clip with 6mm rod to mount to the mast.

Testing

I had no problem with the SWR of the loop from the measurements given in the drawing, but if you need to adjust the SWR you can do so BY moving the shorting strap and feed points to your desired frequency but mine was flat 1-1 on 50.300mhz ideal for FT8.



The Results

After mounting the antenna up on a temporary pole at about 21ft I left it on receive for the day on FT8 and the picture below is the results which I was very happy with after that I moved the Squalo up on the main mast which is up around 36ft and so far I have had a nice few contacts made and some new DXCC for the log. The last thing to do is make another one up for Chris (EI3HBB) also I'm going to make a second for my location and have them stacked which should give me at least a 3dB gain



Building a 6m Squalo Antenna - Jer Aspell - EI3HGB



Materials

- 1 length of 1/2" copper pipe
- 8 x 1/2" solderable elbows
- wire wool
- solder paste (plumbers flux)
- 15mm PVC pipe for the insulating section
- Stainless screws and bolts
- 1 x SO239 chassis mount connector
- Mapp Gas Torch for soldering
- 60mm U bolt for mounting to a mast
- 40mm aluminum angle

References

- <https://www.pa3hcm.nl/?p=312>
- <https://w5nor.org/antennas/squalo/>

Jer Aspell - EI3HGB
ei3hgb@gmail.com

Join the G-QRP Club

The G-QRP-Club is an organisation run entirely by volunteers to promote Low Power Radio (QRP).

The G-QRP CONVENTION: 2nd - 3rd September 2023

The 2023 Convention will be Saturday 2nd and Sunday 3rd September at the Harper Adams University Campus, near Telford, TF10 8NB. More information to follow as plans develop.



The quarterly magazine, SPRAT, provides interesting reading. Articles covering Antennas, Test gear, Transmitters and Receivers of varying complexity. More information: <https://www.gqrp.com/index.htm>

In this issue:
RF Generation for Superhets - The Matchbox Radio Line
ytrnMAS Transceiver - 455kHz BFO - FSLVG Regen RX
New Way of Constructing Baxends - High Gain LM386
Sabin News - Value Day Report
Antennas Anticodes and Awards
Communications and Contests - Member's News

Membership Service include a QSL Bureau, component supplies books and reprints

Overlapping Applications of Capacitor Types

Ceramic Capacitors

Film Capacitors

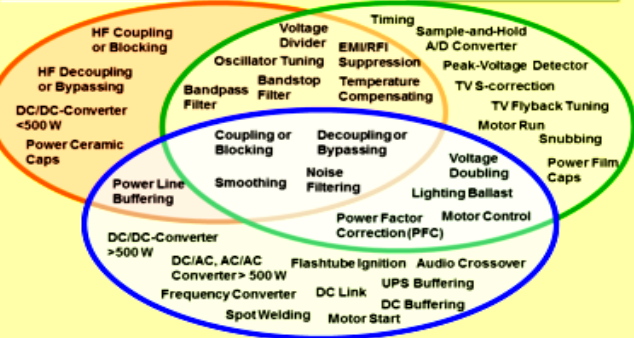

Aluminum Electrolytic Capacitors



Hardware for
Hardware-Defined
Amateur Radio

Check out our site: <https://mostlydiyrf.com/>

Kits and modules available including :

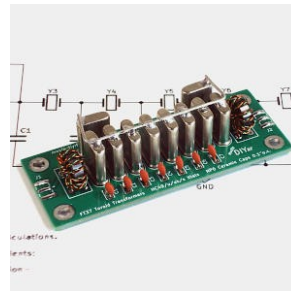

8-Pole QER Crystal Filters



TIA-AGC IF Amplifier

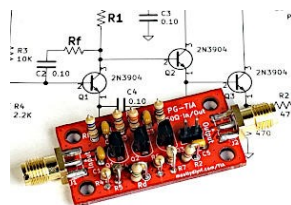

ematic follows Hayward W7Z01 and Kopski K3 termination-insensitive IF amps [http://w7z01ched.amplifier.pdf]. This version is for a single directional amp. This makes it usable in non-stems or paired together for bi-directional i
istors are 2N3904. All resistors are 1/4 Watt

ADE-1 Double Balanced
Diode Ring Mixer

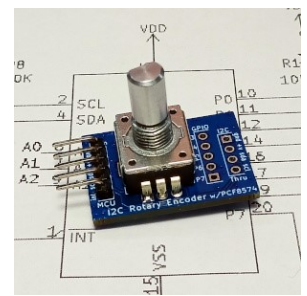

12C Rotary Encoder

There is more coming so subscribe to be alerted of our new products

Meteor Scatter Communication Via the Perseids Shower

The Perseids Meteor Shower has been observed for over 2,000 years and is named after its radiant point in the constellation Perseus. As Earth traverses the debris trail of the Swift-Tuttle comet, particles collide with our atmosphere, creating a breathtaking display of bright meteors streaking across the night sky. The Perseids are renowned for their intensity, with up to 100 meteors visible per hour during their peak.

The concept of using meteor showers for communication stems from the phenomenon known as "meteor scatter." When a meteoroid burns up in the Earth's atmosphere, it leaves behind an ionized trail consisting of charged particles. These ionized trails can reflect radio waves, enabling the transmission of signals over long distances.

Unlike traditional communication methods, such as radio waves traveling in straight lines, meteor scatter communication allows signals to "bounce" off the ionized trails, reaching locations beyond the horizon or around obstacles that would otherwise block direct communication. This opens opportunities for long-distance communication without the need for additional infrastructure like satellites or extensive networks of ground-based stations.

While the idea of using the Perseids Meteor Shower for communication is promising, several significant challenges must be addressed. First and foremost, meteor showers, including the Perseids, are unpredictable to a certain extent. While astronomers can forecast the general timing of meteor showers, pinpointing the exact moments when meteors will burn up and produce ionized trails remains challenging. This unpredictability poses a considerable challenge for coordinating communication efforts effectively.

Moreover, meteor scatter communication has limitations regarding bandwidth and data transfer rates. The ionized trails left by meteors only persist for a brief period, typically on the order of milliseconds. As a result, the amount of data that can be transmitted during each meteor event is limited. This makes real-time communication for large amounts of data challenging and restricts the types of information that can be efficiently shared.

What frequencies? Normally 50 MHz, 70 MHz, 2m and even 70cms may be utilised although 70cms is at the absolute limit. Of course we, in Ireland have the 40Mhz band also. During the course of any day the occasional ping may be heard where a fragment of a transmission reflects off a trail of ionisation from the chance entry of a meteor burning up in the ionosphere.

Meteor Scatter communications is vastly different to more traditional forms of radio communications. The burst of for short lived communications paths, resultant from a trail of ionisation, between to stations requires the use of

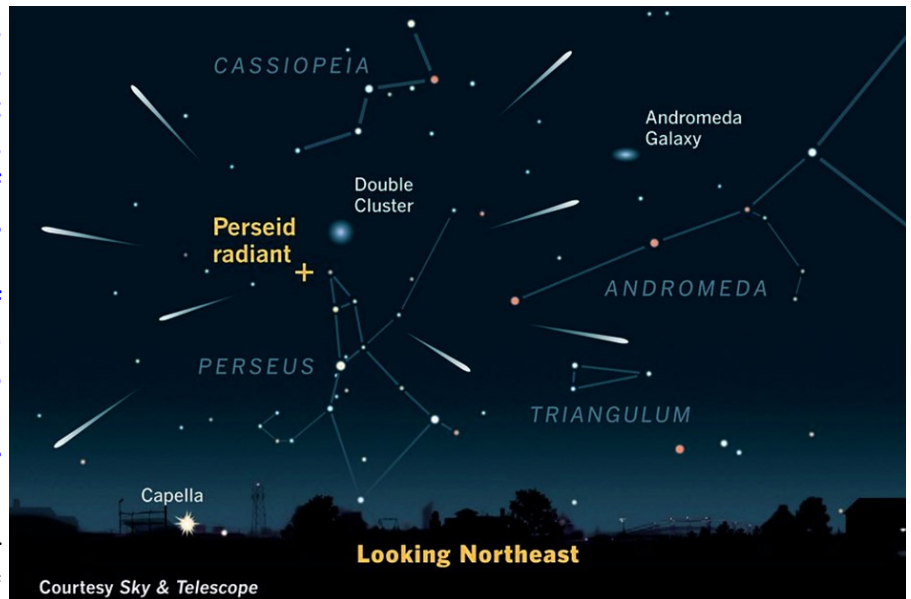

specialised techniques of Communication. High speed morse transmission of up to 800 wpm were used. The messages were preprepared and speeded up using tape recorder. The reverse process was used to decode the message. Nowadays, the advent of the PC in the shack has resulted in the creation of specialises transmission modes dedicated to Meteor Scatter operation.

Specialised modes found in the WSJTX software which include JT6M, JT65 and MSK144 are commonly used for Meteor Scatter communications. MSHV is another open-source software program supporting FSK 441, JT6M, JT65, JT9, and MSK144. Both programs have sophisticated decoding algorithms to recover signals buried in Noise.

Primary Frequencies for Meteor Scatter

6m	50.260 - 50.280 - Secondary Frequency 50.285
4m	70.260
2m	144.360

Timing is essential and the Computer's time should be synchronised using a program such as Dimension4.

The best time of day to communicate via the Perseids is 06:00 UTC or between 04:00 - 08:00

The duration of a meteor scatter transmission is 30 secs with one station transmitting at 00 secs and the second station replies at the 30sec mark A local MS operator informed me that we in the west would call in the second period at 30secs.

Resources and More Information

<https://www.space.com/32868-perseid-meteor-shower-guide.html>

https://en.wikipedia.org/wiki/Meteor_burst_communications

https://www.electronics-notes.com/articles/ham_radio/amateur-propagation/meteor-scatter-burst-communications.php

<https://g7rdx.co.uk/vhf/meteor-scatter/>

<https://www.youtube.com/watch?v=wBTi2nzYOw0>

Galway Radio Experimenters' Radio Club

Our Club Monthly Meetings

The Galway Radio Club met in the Menlo Park Hotel for the monthly club night. It is generally held on the first Monday of every month, except if it is a Bank Holiday in which case, we meet on the second Monday of the month. We also support a virtual presence via. Jitsi (<https://jitsi.org/>).

It generally a well-attended night with members being both physically and virtually present.

Focus:

The focus of our monthly club night is, as a rule, all things Ham Radio is about – learning about new things, sharing information on what works (or doesn't work), showing new (or old) pieces of equipment and giving presentations/demo's where we can. Any "club administration" is handled separately by our committee and only bring to the Monday night meeting anything that the club members need to be made aware of. Of course, Monday night club members can also raise questions/concerns/issues etc. to the committee.

Last Club Night:

Last club night (12-June), was a good night – we had a good number of members present and we had 2 good presentations.

Upcoming Events

There was one upcoming local event that we want to participate in, namely:

Date	Event
21-July	Joyce Country Challenge

However, we spent most of our time discussing the upcoming HAM RADIO in Friedrichshafen, Germany on 23-25 of June. There was about 10 club members going to the rally, and during our conversation we noted a few things to watch out for (especially for those going for the first time):

- For the Flea market - bring cash
- Bringing back radio equipment is usually not an issue with Ryan Air, although I suspect carrying the components for a large HexBeam might be a challenge
- There is a free bus from the Friedrichshafen train station to the rally
- Get the ticket for the Rally online
- Don't forget your EHIC (European Health Insurance Card) if you have one.
- Don't forget your travel insurance details either Get trains to Lindau-Insel instead of Lindau as you will still need to get across to the island
- Watch out for pickpockets!!!
- And finally - wear sunscreen - according to weather.com, the weather is going to be hot - up to the 30's as well as thunderstorms !!

After that, we then moved on to presentations by Aoife and Paul.

SSTV

Aoife (EI8HOB) did a great demo on how to receive and later transmit SSTV. She started off with a closed loop demo between a tablet and a PC showing how a signal generated from one was picked up by the other and decoded. The image was a static image of one of her cats with some text at the top of the image giving her name (Aoife's name not the cats name) along with her call-sign.

The second part of the demo was then showing a radio based transmission using RTL-SDR, a tablet, a PC and a handheld - again showing how the setup works, and some of the challenges with the setup and how she overcame that when switching to using TCP/IP connectivity with a Raspberry Pi. Again, the same image of a cat was used for the transmission.

All of the above was then combined into a movie which was played on the club night, followed later by a Q&A session. Out of the discussion one of the frequencies noted for SSTV was 14.230-14.240.

It should be noted that no cats were harmed in the making of this movie!!

St. Patrick's Day and TiddlyWiki

Like the previous club night, this was not so much a demo, but more a review of a Radio Journal that Paul (EI5IPB) kept for the St. Patricks Day/Week all on FT8. The journal showed daily screen captures of PSK Reporter (<https://pskreporter.info/pskmap.html>) showing how far his signal was being received across different bands.

TiddlyWiki (see <https://tiddlywiki.com/>) was shown again as a tool that can not only be used for note taking, but also as a Journal - being able to capture screenshots etc. to track progress over a number of days.

This led to a discussion on PSK Reporter (<https://pskreporter.info/pskmap.html>) and how it can be used for tracking signals of different bands from source/target across the world. Great for seeing how far your signal is potentially being received.

AOB

We had some general discussions towards the end of the meeting, including a brief discussion on Ham Radio Deluxe (<https://www.hamradiodeluxe.com/support/>) and how it was great for almost everything that could be used. We then broke up for the night.

Our Next Club Night is Monday 07 Aug



Our Next Meeting



The Mayo Radio Experimenters Network will hold their next club meeting on Wednesday evening 2nd of August at 9pm in the Breaffy House Hotel, Breaffy Co. Mayo. Everybody is

welcome to come along for the evening.

The IRTS News Bulletin is read on Sunday at 9pm by a club member. Everyone is welcome to call in and give a signal report on the reception of the bulletin.

Galway VHF Group News

The Galway VHF Group assisted with the communications at the Galway Regatta held on the 3rd of June. The weather was superb on the occasion with a slight breeze resulting in some of the crews being blown off course and into the reeds. There was a huge turn out on the occasion and the event ran from 8am through to 6pm.

The Castlebar 4 days Walking Festival was another event for which Tom EI2GP and Steve EI5DD gave assistance. All of the Marshals on the walk were on PMR 446 while Tom and Steve would monitor and move in to assist if there was a crisis. As always this was uneventful but great fun with walkers from many countries in attendance.

A few projects underway at present in the form of WSPR Beacons also a QDX QRP data modes transceiver kit is under construction.

A new Portable JNC Radio antenna is under test in the field. It is quite promising and plots using the VNA show that it is very easy to tune up. As part of the testing a WSPR TX was connected and left sending for 30 minutes to see how far the transmissions were being picked up. Hopefully this will be written up for the August edition. There are other antennas for testing which include the Buddipole, the Alex Loop and an MP-1 super antenna..

The Digital Repeaters have gone amazingly quiet and it would appear that the novelty has worn off the Digital Voice Modes for the time being. The Allstar Gateway on 4 metres, has gone very quiet with the majority of the activity coming in from the UK via HubNet UK.

A few other projects have been resurrected for the Microwave bands although antennas are urgently required to do any meaningful experiments. Once they have been purchased it will facilitate a few trips to the east of the country to see if any DX from the UK is possible.

At this point in time the next project will be to obtain the parts for a station to work into the QO-100 satellite. Hopefully this will be completed for next year.

QRP portable activities are planned for the Summer and a trip across to the Aran Islands is very much on the cards. This will probably encompass HF and VHF operating using the Icom IC-705 and associated antennas.

There will be another EmComms event in August for the Galway Walking Club Marathon which is traditionally held along a stretch of the western way in Connemara. We tend to use 80 metres for communication through the hills and valley and it has proven the best method of communication

What's the Frequency?

Here are the worldwide frequencies for Amateur Radio on the International Space Station

Crossband voice repeater
437.800 down / 145.990 up (PL 67.0 Hz)

Packet Radio - Currently APRS
145.825 up and down

Educational Contacts
145.800 down



RADIO BUILDER

THE RADIO LAB FOR BUILDERS

- All the building blocks to experiment and build radios:
- AM, SSB and FM
- LW to VHF
- 0 – 2GHZ RF Amplifiers
- 0 – 500MHz Mixers
- Variable Gain 60dB IF amplifier
- 7 Watt Audio Amplifier
- 3 Signal Generators 8KHz to 160MHz
- Color Display
- ESP32 Controller
- Custom RF and IF Filter
- 3 Prototyping areas



Order your kit now from <https://radiobuilder.org/>

If you know
stuff... you
can do stuff.



soldersmoke.blogspot.com

Latest Titles in the RSGB Book Shop

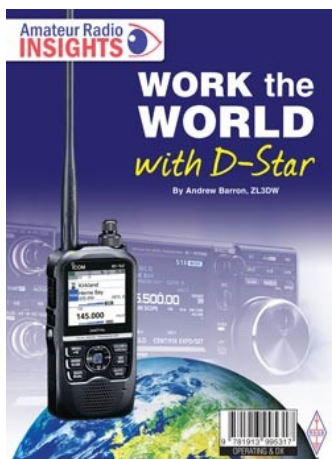

Work the World With D-Star

By Andrew Barron, ZL3DW

Work the World with D-Star is a practical guide that explains the steps that you need to follow to make your new D-Star radio work through your local repeater or hotspot. There are terms to discover, including dashboards, reflectors, gateways, hotspots, and Echo. Also, acronyms like AMBE+2, DR, DV, CS, and MMDVM. The book covers how to link to a reflector and what to say when you are making your first calls. If you are using a hotspot you can link to a reflector using the hotspot's Pi-Star dashboard or using the functions on the radio. Or you can use PC software or a phone app. There is guidance on MMDVM (multi-mode digital voice modem) 'hotspots' and step-by-step instructions for configuring the Pi-Star modem. Information on the D-Star data structure and the advantages and disadvantages of digital voice technology over FM, and other digital voice modes such as System Fusion, DMR, and P25 is also discussed. Work the World with D-Star even includes programming instructions for some popular Icom D-Star radios such as the ID-52A, ID-51A +2, IC-705, and IC-9700. As always, not forgotten is Andrew's guide thoughts on "which is best," and "what should I buy?"

Work the World with DMR

By Andrew Barron, ZL3DW

The Work the World with DMR practical approach explains the steps that you need to follow to make your new DMR radio work on your local repeater or hotspot, and for worldwide contacts. Amateur Radio DMR is not as simple as entering a couple of frequencies and setting a CTCSS tone the way you would for an FM radio. So, you can expect a steep learning curve but of course that's where this book will be the most helpful. You will discover lots of new terms including dashboards, zones, receive groups, colour codes, code plugs, hotspots, Parrot, talk groups, and time slots. Also, acronyms like MMDVM, CPS, IPSC2, DMR-MARC, TGIF, and DMR+. MMDVM (multi-mode digital voice modem) 'hotspots' are very popular accessories and there is information here about their uses and configuration. You will also find coverage of duplex hotspots and the perhaps more familiar simplex hotspots, including a section on how to assemble a hotspot from a kit, a Raspberry Pi, and an SD card. There is even step by step instructions for configuring the Pi-Star hotspot operating system.

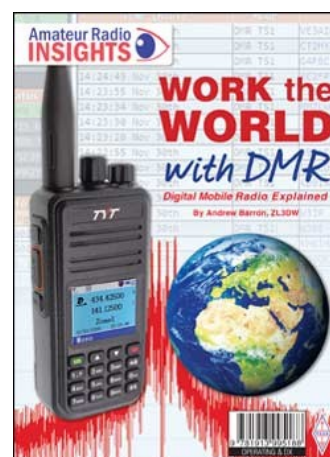

Work the World With System Fusion

By Andrew Barron, ZL3DW

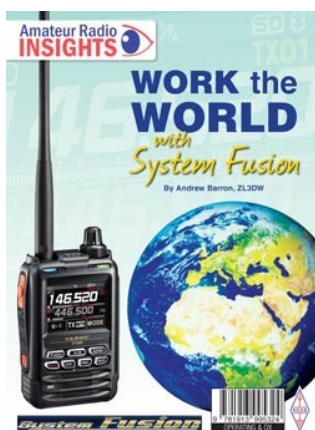

System Fusion and Wires-X are exclusive to Yaesu. Although you have to use a Yaesu radio to access Yaesu Wires-X 'rooms' anyone can access thousands of YSF and FCS reflectors using a hotspot, a DV dongle, or a non-Yaesu repeater. Many of these reflectors are in turn linked to DMR talk groups, D-Star reflectors, Wires-X rooms, and other digital voice modes.

As usual Andrew explains in Work the World with System Fusion the base technology from the C4FM (continuous 4-state frequency modulation) which is similar to the 4FSK modulation used by DMR and the GMSK modulation used for D-Star. The DN digital narrow mode and what happens when you press the Wires-X button. For example, if you are connected to a genuine Yaesu repeater or a PDN or HRI-200 Wires-X node, the search function on the radio will list the available Wires-X rooms. If you are using a hotspot, multi-mode repeater, DV dongle, or non-Yaesu repeater, the search function will list YSF and FCS reflectors. A powerful set of features indeed. There is much more besides in this book, with using the various reflectors explained, alongside Hotspots, Troubleshooting and there is even advice on 'What should you buy!'

DV SCOTLAND PHOENIX WEEKLY NETS



MONDAY NIGHT NET
8PM TILL 9.30PM UK

SATURDAY NIGHT
COAST TO COAST NET
9PM TILL 10PM

STATIC ON TG 23555 & 23556

 HAMSHACK HOTLINE : 94110
HAMS OVER IP : 25001

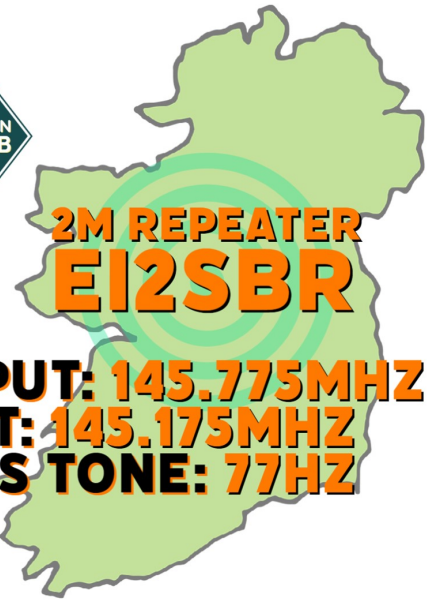

OUTPUT: 145.775MHZ
INPUT: 145.175MHZ
CTCSS TONE: 77HZ



Handmade Ham Radio Gadgets



Contact : 0877775249
EI9GWB Arek

Drop by our Online SolderSmoke Store



<https://www.cafepress.com/soldersmoke>

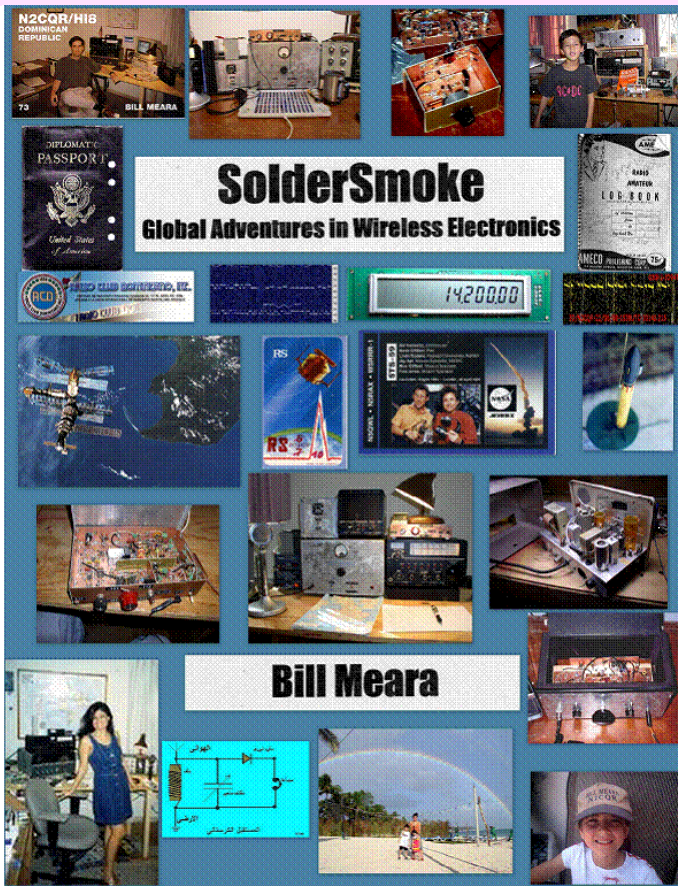

If you know stuff... you can do stuff.

[soldersmoke.blogspot.com](https://www.cafepress.com/soldersmoke)

Books are available from the Lulu Website:

<https://www.lulu.com/>

SOLDER SMOKE THE PODCAST



Serving the world-wide community of radio and electronic homebrewers

Host - Bill N2CQR

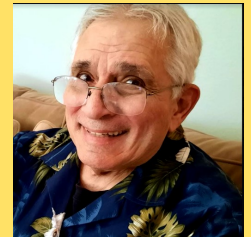
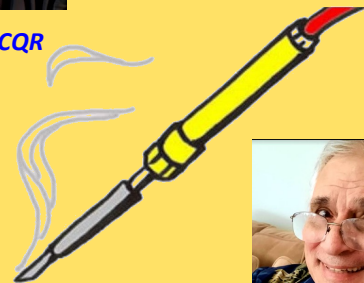

Co Host - Pete N6QW

<https://soldersmoke.blogspot.com/>

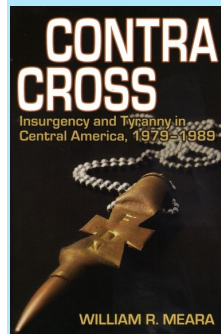

A journey through the Central American wars of the 1980s as seen through the eyes of a young American officer who worked on both sides of insurgency in the region: In El Salvador Bill Meara supported efforts to defeat insurgents; with Nicaraguans he worked to keep an insurgency alive. One of very few Americans to see both sides up close, he takes readers into his world as an advisor struggling with cultural differences and human rights violations while trying to stay alive in murderous El Salvador. We join him on dangerous helicopter rides into contra base camps on the Honduran-Nicaraguan border and into a U.S. Embassy under attack. From Special Forces school at Ft. Bragg to Joan Baez's back-stage party in Managua to a contra POW camp deep in the jungle, we get a taste of Meara's world up close.

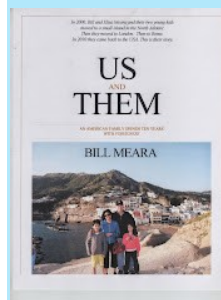

What happens if you take an American family and send them to Europe for ten years? In the summer of 2000, Bill and Elisa Meara, accompanied by 2 year-old Billy and 4 month-old Maria, left their home in the suburbs of Washington, D.C. and moved to the Azores. There they experienced the highs and lows of diplomatic life on a small distant island. After three years in the Azores, they spent four years London and three years in Rome. Overseas they lived in two houses and two apartments, went to five schools, used four different health care systems, experienced one earthquake, 9-11, the terrorist attack on London, tea with the Queen, the election of Barack Obama... and all the ordinary things that families go through. They lived mostly with the locals, learned Portuguese, Italian, and a bit of Cockney, and made many friends (foreign friends!) They returned to the United States in 2010 with a changed view of the world. This is their story



KANGA PRODUCTS

Kits and Parts for the Radio Enthusiast

Morse Tutors

ATU and Dummy Loads

QRP TX, RX and Audio kits

<https://www.kanga-products.co.uk/>

Walford Electronics

We are suppliers of electronic kits, with very detailed instructions, for home construction, using mainly analogue circuits which are often used in simple Amateur Radio equipment.

You can choose from [Simple](#) projects for beginners, or slightly more advanced [Intermediate](#) ones, right up to our [Advanced](#) projects for skilled constructors, and of course there are also many [Accessories](#)!

Get in Touch

Walford Electronics Ltd.
Vedal House, Vedal Drove, Long Sutton,
Langport, Somerset TA10 9FB
e mail electronics@walfords.net phone
0044 (0)1458 241103

Shannon Basin's Automated Stations

Sliabh Bán Repeater O/P: 145.775 ,I/P :145.175, CTCSS 77Hz

Roscommon Multimode Digital Gateway EI2BED 144.8625 MHz

Current Systems Active in Galway

70cm DMR Repeaters

EI7RHD	I/P 430.450	O/P 439.450	CC1
EI7LRD	I/P 430.475	O/P 439.475	CC1
EI7AKR	I/P 438.425	O/P 430.825	CC1
EJ7IBD	I/P 430.500	O/P 439.500	CC1

Yaesu Fusion Repeater

EI2KMR I/P 145.025 O/P 145.625 Wires -X

Gateways

EI2SHD	144.8125	Wires-X Gateway
EI2GCD	145.850	P25 Gateway
EI4GCG	70.425	ALLSTAR node

What is Waiting in the Wings?

1 x 70cm D-Star Repeater

1 x 70cm DMR Repeater completing the network to the South East.

Radio Society of Great Britain
Advancing amateur radio since 1913

ARE YOU A MEMBER OF THE RSGB YET?

ARE YOU MISSING THE BEST AMATEUR RADIO MAGAZINE EVERY MONTH?

www.rsgb.org

MFJ
Luca Clary
MFJ's brands Ambassador for Europe & Italy

+39 327 23 911 40
ambassadoreult@mfjenterprises.com
www.mfjenterprises.com
The world leaders in Ham Radio Accessories!

RSGB Radio News Services From GI

10:00 3640KHz LSB Dungiven

12:00 TG2354 Time Slot 2 BM Network

19:30 TG 880 Time Slot 2 Phoenix Network



Visit the WESCOM Radio Shop

SolderSmoke Daily News

Serving the worldwide community of radio-electronic homebrewers.

<http://soldersmoke.blogspot.com/>

Providing blog support to the Solder Smoke podcast: <http://soldersmoke.com>



UK Six Metre Group

Dedicated to promoting 50MHz activity around the world



An Amateur Radio publication for the Microwave Enthusiast

scatterpoint

Published by the UK Microwave Group



ARRL

The National Association for Amateur Radio®

<http://www.arrl.org/>



<https://www.eurao.org/en/welcome>

Dates for the Diary

National Steam Rally Stradbally 6th - 7th Aug

British Waterways on the Air 16th - 17th Aug

International Lighthouses on the air 19th - 20th Aug

GB100RAF @ Portrush Airshow 1st - 2nd Sept

RSGB Convention 2023 13th - 15th Oct

Jamboree on the Air 20th - 22nd Oct

RSGB



The Radio Society of Great Britain (RSGB) is the national membership organisation of amateur radio enthusiasts. The society was founded in 1913 and incorporated in 1926. The Society is dedicated to the development of the science and practice of amateur radio. It works to increase awareness and understanding of amateur radio and to make the hobby accessible to everyone. Amateur radio licences were issued to the first UK radio amateurs in 1934. The RSGB represents the interests of UK licensed radio amateurs and is a not-for-profit organization that:

- Promotes the general advancement of the science and practice of radio communication or other relevant subjects.
- Facilitates the exchange of information and ideas on these subjects among its members.

The RSGB aims to obtain the maximum liberty of action consistent with safeguarding the interests of all concerned. RSGB membership is open to all who have an interest in radio communications. The national governing body (The Board) is elected nationally. The regional governing body (The Regional Council) is elected on a regional basis. The day-to-day management of the society is under the control of a small team of full-time employees who are based at the society's head office in Bedford. *RSGB Membership is just £59.00 and this includes 12 monthly technical magazines.* Affiliate your club and get the opportunity for all members to log in and read the online publication of RADCOM, RADCOM Basics and RADCOM Plus as well as receiving a hard copy of the Magazine for the Club. Apply here: <https://rsgb.org/main/join-us/join-the-rsgb/>



Welcome To EI3CC

What ever your interest in radio is then maybe we can help you.

Our aim is operating stations outdoors and getting involved with as many groups as possible. Scouting, youth clubs etc are all welcome.

So come join us and enjoy the world of

Collective Communication

WESCOM RADIO SHOP

<https://wescom.ie/>

WESCOM RADIO SHOP

<https://wescom.ie/>

AVIONIC – EXPERIMENTER / AMATEUR – MARINE RADIO



Full Range of ICOM Experimental/Amateur Radio Equipment



Tennadyne World Class Antenna systems



Spid Rotators



ACOM Linear Amplifiers



Baluns and UNUNs to suit all applications



ICOM Marine Radio



Spiderbeam, Poles and Accessories

Check out our Clearance Section on the Website

Contact Us
00 353 (0)87 2552578
wescomradio@gmail.com
Deerpark, Oranmore,
Co. Galway, H91 X2YH