

TS83

—



Easy action
door closer

THE MULTI-FUNCTION, MULTI-PURPOSE DOOR CLOSER

Outstanding versatility.

Quality assured.

Tested to EN 1154.

Decades of experience have gone into the development of the DORMA TS 83.

The result is user comfort coupled with outstanding versatility. It can be adjusted to suit almost all types

of door. Additional anti-corrosion protection for exposed or aggressive conditions is available to special order. Fixing couldn't be easier and last but not least – it's engineered for excellence. Certified to ISO 9001.

PLUS POINTS ...

... for the trade

- Streamlined product range means low inventory costs and reduced stocking requirement.
- Comprehensive choice of accessories provides practical and effective solutions to meet special applications.

... for the specifier/architect

- Compact closer design and sturdy flat-form arm assembly.
- Wide range of standard functions supplemented by optional extras.
- Suitable for fire doors. (CERTIFIRE approved Ref. CF 118)

... for the installer

- Easy to fix.
- Can be "tailored" to the requirements of the door by simple adjustment.
- Just one model for RH (ISO 5) and LH (ISO 6) doors and for standard and frame/lintel fixing and parallel arm.
- Spring strength range EN 2-5/EN 3-6 to suit virtually every application.

... for the user

- Optimum wall and door protection thanks to "thinking" backcheck.
- Closing speed virtually unaffected by temperature fluctuations.
- High mechanical efficiency gives easy-action opening.

Data and features		TS 83		
Variable closing force	Spring strength	EN 2-5	EN 3-6	EN 7
Standard doors ¹⁾	≤ 1250 mm	●	-	-
	≤ 1400 mm	-	●	-
	≤ 1600 mm	-	-	●
External doors, outward opening ¹⁾	≤ 1250 mm	●	-	-
	≤ 1400 mm	-	●	-
	≤ 1600 mm	-	-	●
Fire and smoke check doors ¹⁾	≤ 1250 mm	●	-	-
	≤ 1400 mm	-	●	-
	≤ 1600 mm	-	-	●
Non-handed		●	●	●
Arm assembly type	Standard	●	●	●
Closing force variable by means of adjustment screw		●	●	-
Closing speed adjustable at 2 separate valves	180° - 15°	●	●	-
	15° - 0°	●	●	-
Closing speed variable by means of valve adjustment		-	-	●
Adjustable latching action	by arm	●	●	●
Backcheck	self-regulating	●	●	●
	adjustable at valve	●	●	●
Delayed action variable at valve		○	○	-
Anti-corrosive model		-	○	-
Hold-open		○	○	○
Weight in kg		1.7	1.7	3.3
Dimensions in mm	Length	245	245	293
	Overall depth	46	46	47.5
	Height	60	60	60
Door closer tested to EN 1154		●	●	●
CE mark for construction products		●	●	●

● yes - no ○ option

¹⁾ For applications involving particularly heavy or wide doors, and doors which have to close against wind resistance, the next highest closer size or a higher spring strength should be applied.



The TS 83 complies with the requirements and/or recommendations of the following: CERTIFIRE approved for fire doors ITT 120; MM/IMM 240; Ref. CF 118

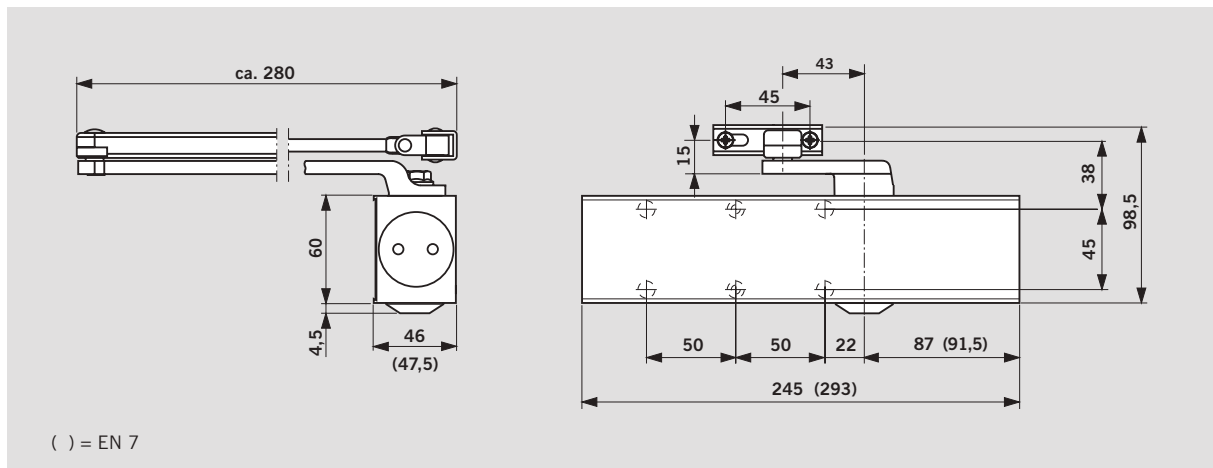

() = EN 7

DOOR LEAF FIXING, PULL SIDE (example shows LH (ISO 6) door; RH (ISO 5) doors mirrored arrangement)

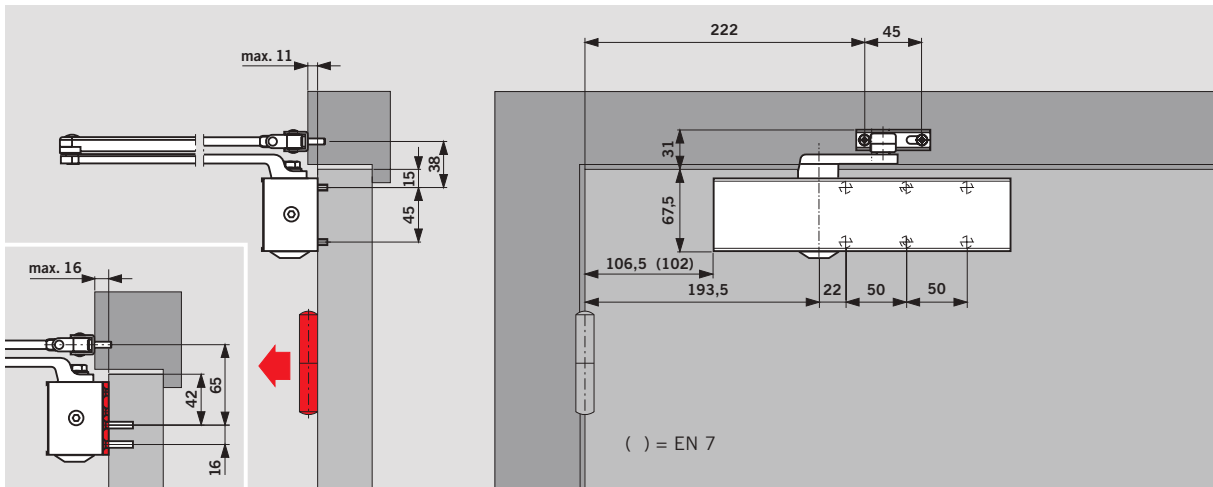

TRANSOM FIXING, PUSH SIDE (example shows LH (ISO 6) door; RH (ISO 5) doors mirrored arrangement)

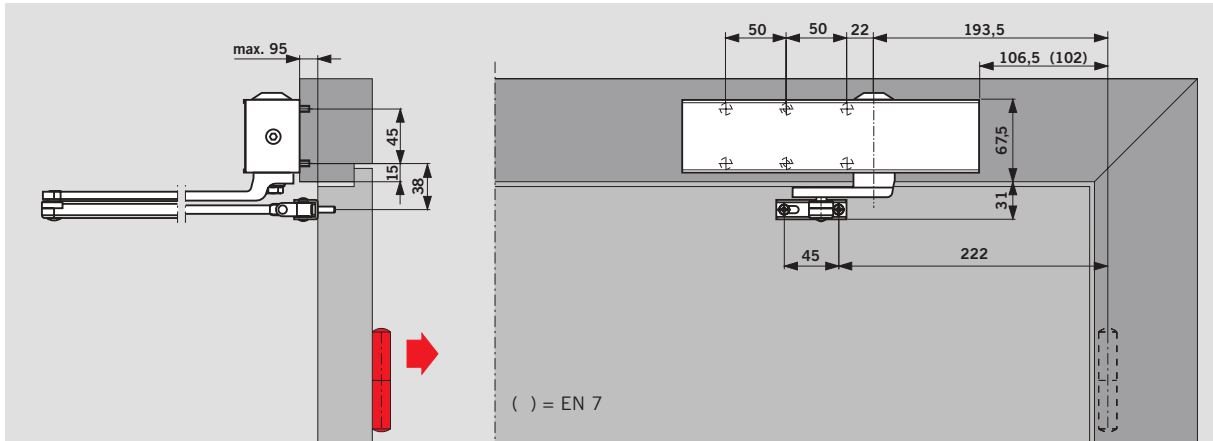

With transom-fixed closers, the backcheck comes in later at between 85° and

90°, depending on the door thickness and projection of the hinge used; the delayed

action, on the other hand, releases the door at an earlier point in its closing sweep.

DOOR LEAF FIXING, PUSH SIDE (parallel arm installation)

(example shows LH (ISO 6) door; RH (ISO 5) doors mirrored arrangement)

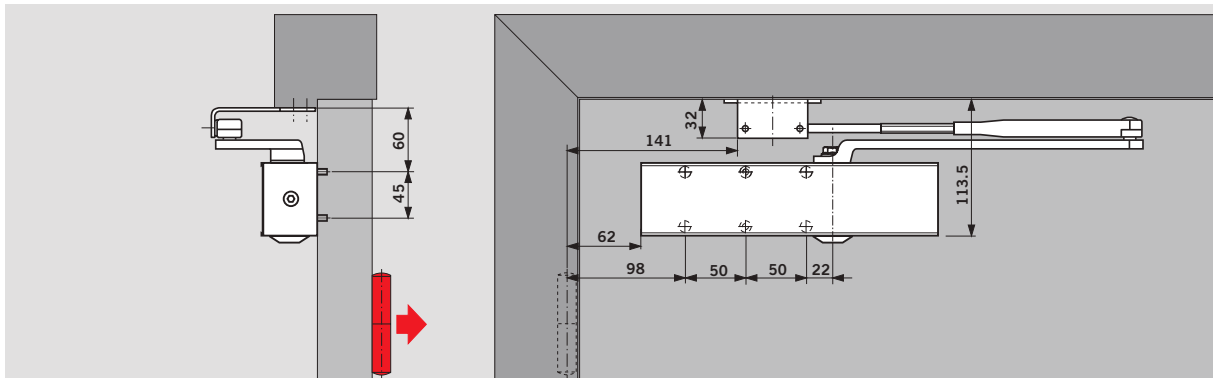

With parallel arm application, the backcheck comes in later at between 85° and 90°, depending on the door thickness and projection of

the hinge used; the delayed action, on the other hand, releases the door at an earlier point in its closing sweep.

Technical details

installation	interior door widths up to	closer size	interior door widths up to	closer size
standard/frame	1250 mm	2 – 5	1400 mm	3 – 6
parallel arm	1100 mm	2 – 4	1250 mm	2 – 5

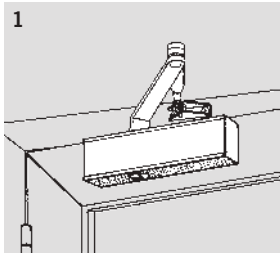

Standard installation

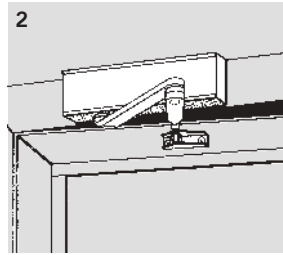

Frame installation

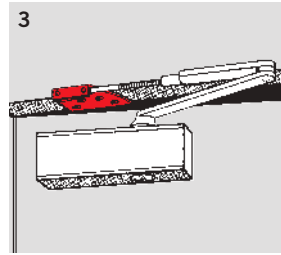

Parallel arm installation
(The above bracket is supplied with every TS 83 standard door closer.)

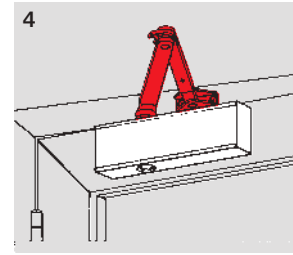

Hold-open arm installation
Adjustable for hold-open up to 150°. Can be switched off to act as a standard arm.

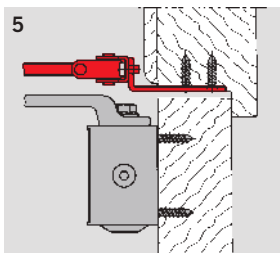

Soffit bracket and arm for standard installation with shaped architrave

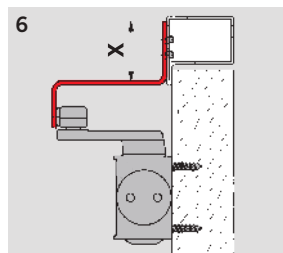

Parallel arm bracket with upstand
(*upstand 35 or 60 mm)

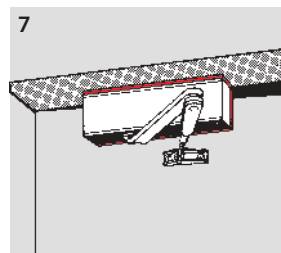

Angle bracket installation
Frame installation for outward opening doors with extra deep reveals.

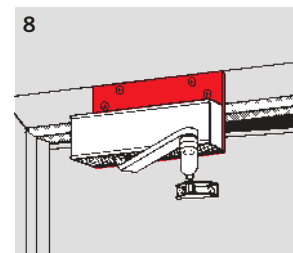

Drop plate installation
For installation on frame (or door) when direct fixing of closer is not possible.

Specification text TS 83 EN 2-5

DORMA TS 83 rack and pinion door closer; with adjustable power size EN 2 - 5, according to EN 1154, carries the CE mark, integral self-regulating backcheck; closing speed adjustable in two independent ranges and adjustable latch action. Non-handed.

- Model**
- with additional, adjustable delayed action
 - with standard arm
 - with hold-open arm with switch

Accessories

Make: DORMA TS 83
 TS83

- Colour**
- silver
 - white (sim. RAL 9016)
 - other
 - (sim. RAL _____)

Specification text TS 83 EN 3-6

DORMA TS 83 rack and pinion door closer; with adjustable power size EN 3 - 6, according to EN 1154, carries the CE mark, integral self-regulating backcheck; closing speed adjustable in two independent ranges and adjustable latch action. Non-handed.

- Model**
- with additional, adjustable delayed action
 - with standard arm
 - with hold-open arm with switch

Accessories

Make: DORMA TS 83
 TS83

- Colour**
- silver
 - white (sim. RAL 9016)
 - other
 - (sim. RAL _____)

Specification text TS 83 EN 7

DORMA TS 83 rack and pinion door closer; with power size EN 7, according to EN 1154, carries the CE mark, integral self-regulating backcheck; adjustable closing speed and adjustable latch range. Non-handed.

- Model**
- with standard arm
 - with hold-open arm with switch

Accessories Colour

- silver
- white (sim. RAL 9016)
- other
- (sim. RAL _____)

Model make DORMA TS 83
 TS83

STANDARD FUNCTIONS

WITH “THINKING” BACKCHECK – MODEL BC/ÖD

Thanks to an innovative design concept, the resistance developed by this backcheck system is directly proportional to door acceleration as the door is opened beyond approx. 70°. It is almost imperceptible when the door is opened slowly. However, if the door is opened roughly, the backcheck responds in equal measure.

And if the door should be flung open at speed – whether deliberately, thoughtlessly, accidentally or as a result of a gust of wind – the backcheck reacts at full strength, protecting the wall and door from damage.

If no backcheck function is required, the system can simply be switched off.

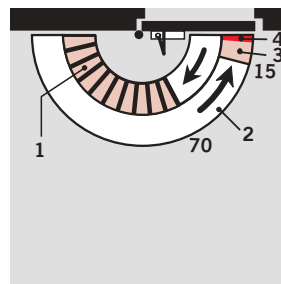

- 1 Self-regulating backcheck
- 2 Infinitely variable closing speed in the range 180° – 15°
- 3 Infinitely variable closing speed in the range 15° – 0°
- 4 Adjustable latch range (by arm)

WITH ADDITIONAL DELAYED ACTION – MODEL BC/ÖD + DC/SV

This model with its additional, integrated delayed action enables the closing cycle to be retarded within an adjustable range from 180° – 70° so that disabled

persons, mothers with prams and people carrying bulky items are able to pass through the door without difficulty.

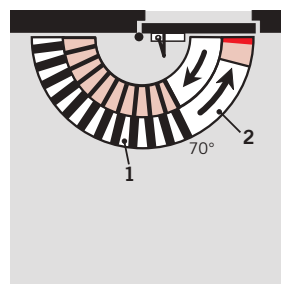
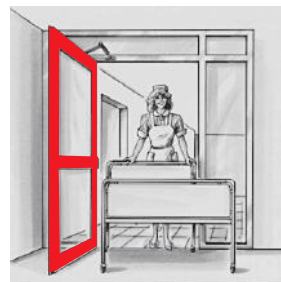

- 1 Adjustable delayed action
- 2 Fully controlled closing with adjustable speed

WITH OPTIONAL HOLD-OPEN ARM

Combining the TS 83 with a hold-open arm enables the door to be held open at an appropriate angle (up to approx. 150°).

The hold-open function of the standard hold-open arm can be switched on and off by the user by simply pressing a switch.

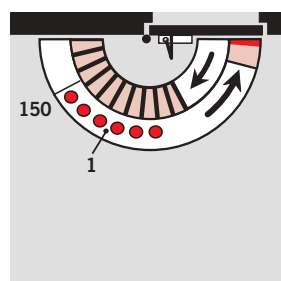
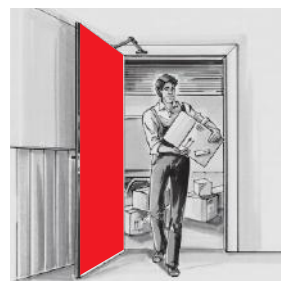

- 1 Hold-open range

Hold-open arms are not permitted on fire doors



DORMA UK Limited
Wilbury Way
Hitchin
Hertfordshire
SG4 0AB

Tel: 01462 477600
Fax: 01462 477601
E-mail: hardware@dorma-uk.co.uk
www.dorma-uk.co.uk

DORMA Ireland Limited
PO Box 1050
Maynooth
Co. Kildare

Tel: 01 295 8280
Fax: 01 295 8284
E-mail: dormadublin@dorma.ie
www.dorma.ie

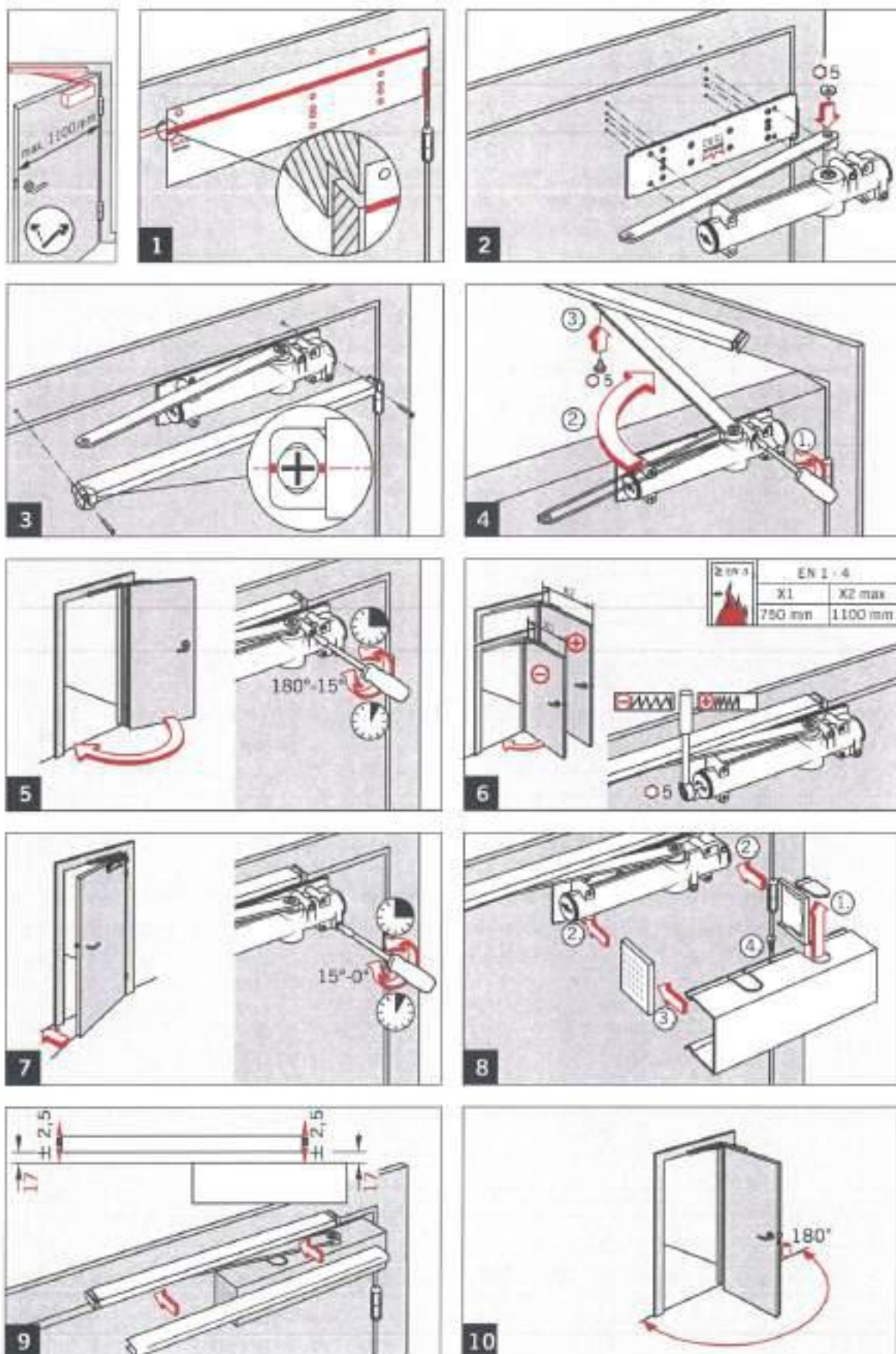

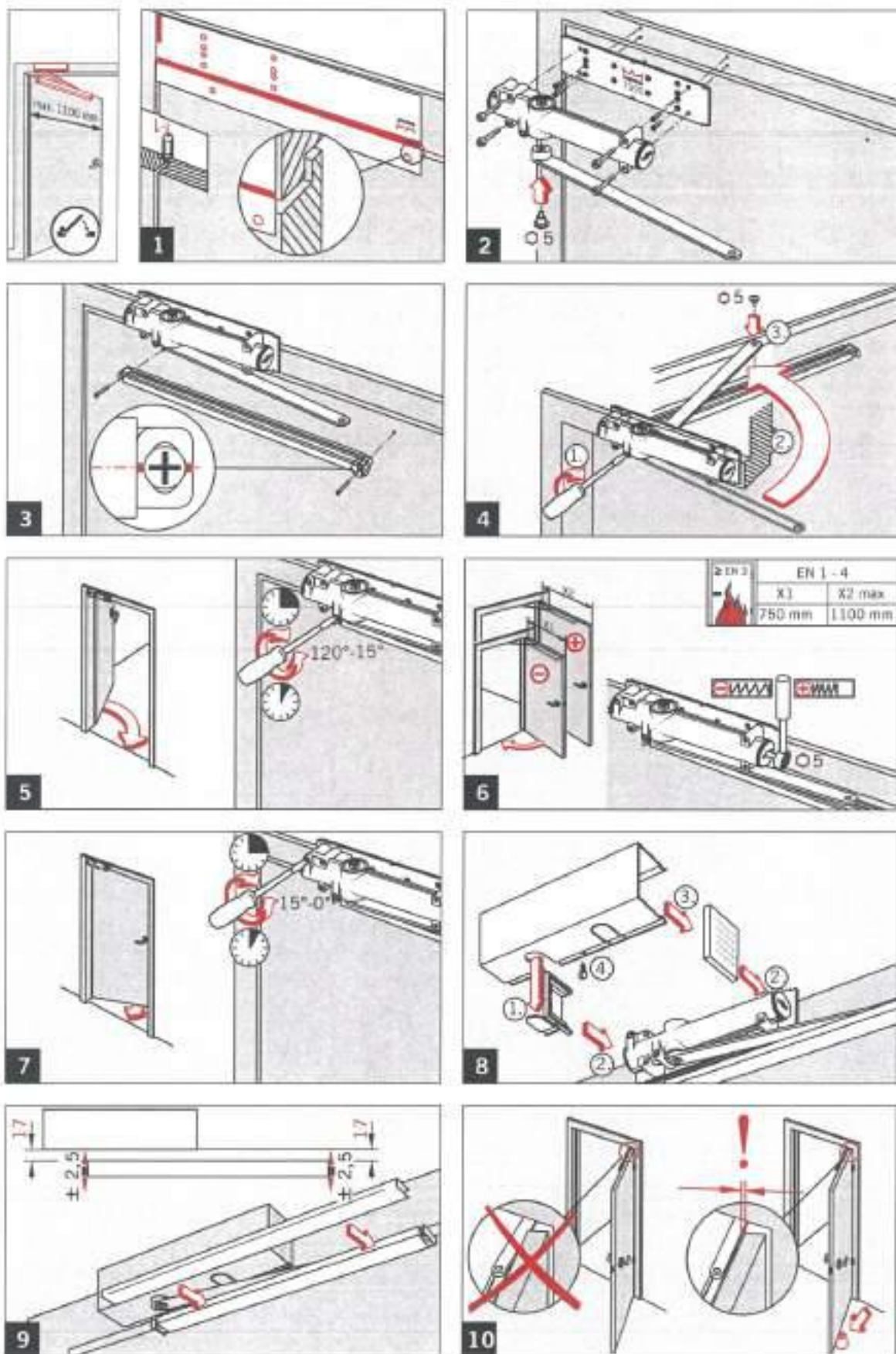

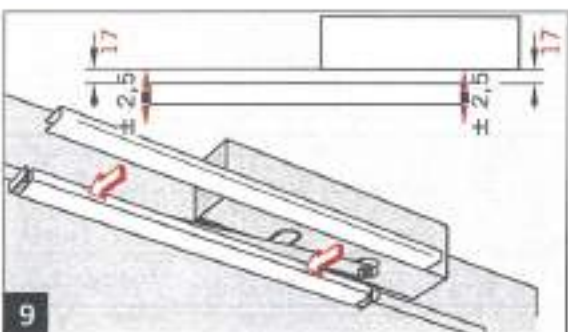
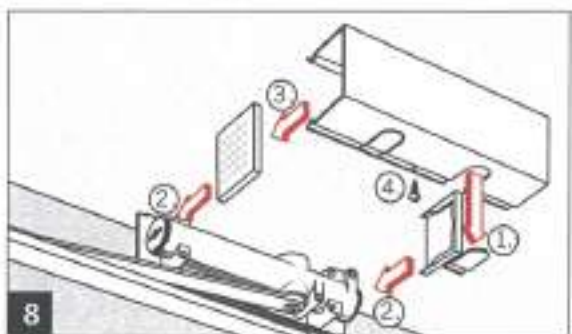
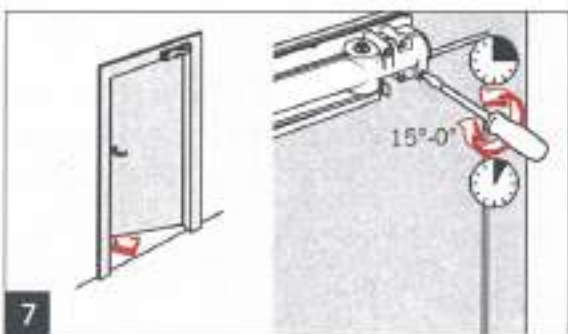
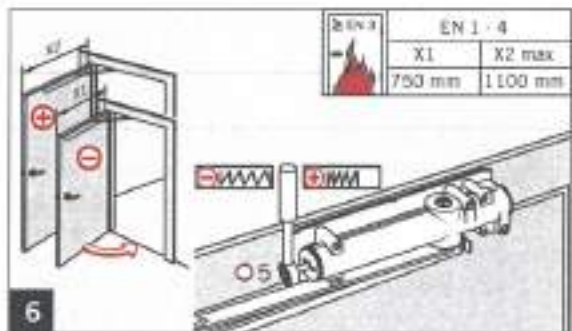
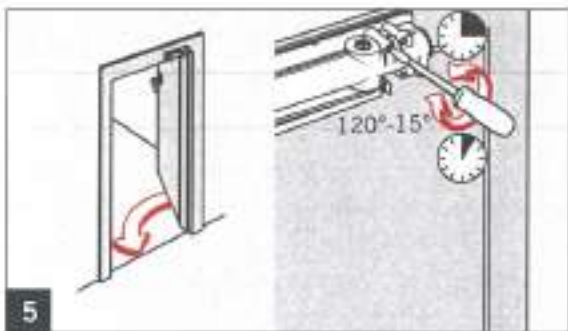
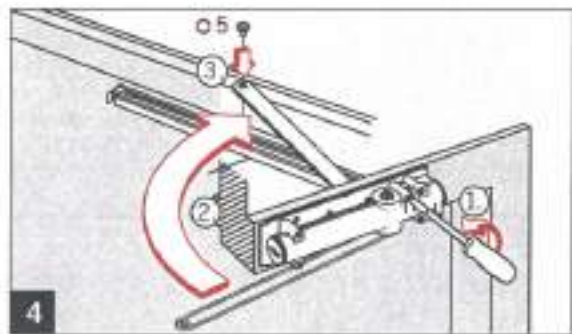
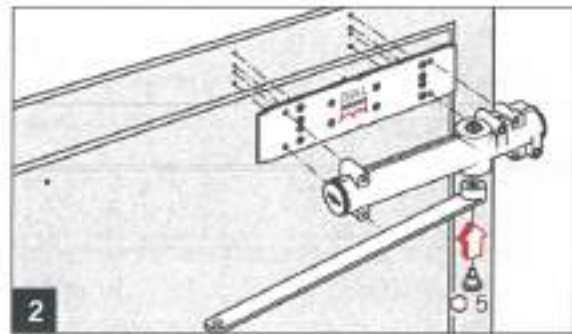
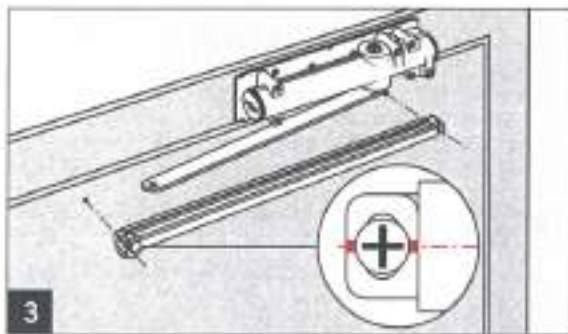
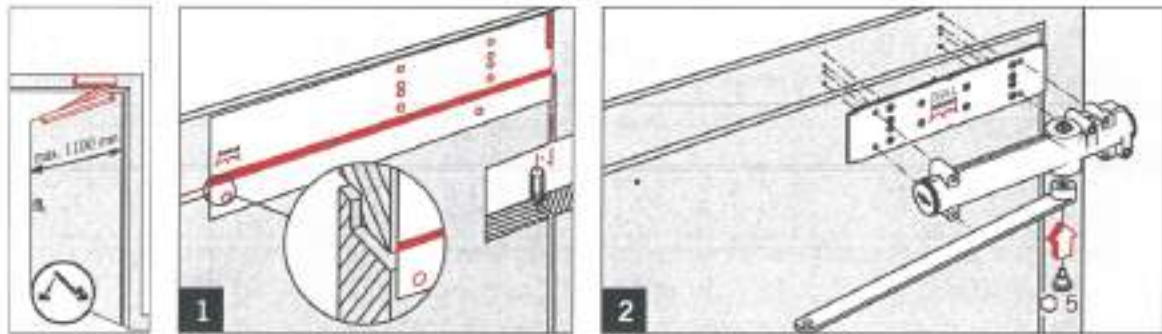

Änderungen vorbehalten.
Subject to change without notice.



Abryll Range

High Security Single Point Locking Range, offering a multitude of functions including Panic and Emergency Escape, Mechanical and Electro-Mechanical Deadlocking options.





The MICO Abryll Range has established itself as the most approved Single Point Locking Range for high security applications. Manufactured from stainless steel as standard the Abryll Range offers a robust high security solution for even the harshest environments. Tested and approved on selected single and double doorsets to LPCB SR 2,3,4,5 & 6 and with additional HM Government approvals the MICO Abryll Range is the ideal choice where security is paramount. The Abryll Range also boasts Panic and Emergency Escape functions which carry the latest BS EN 179 and BS EN 1125 accreditations for your added peace of mind.

Customer Care / Installation / Maintenance

At Tindall Engineering we pride ourselves on customer care. Based on trust, we have built up a solid customer base over the years through personal service, bespoke products, arrangements and a highly professional working environment. It doesn't stop with the sale, our site engineers are highly trained meaning we can offer a professional after sales service including installation, maintenance and repair.

Certifications

Security: The Loss Prevention Certification Board LPS1175 SR1, SR2, SR3, SR4, SR5 and SR6



Escape: BS EN 1125:2008 & BS EN 179:2008



Quality:





Technical Overview

Stainless Steel construction as standard.

Dimensions (H) 235mm (W) 165mm.

Standard Push Plate width supplied as 800mm.

Handing – This unit is handed as per diagram below, add code when ordering.

37mm bolt throw.

Handing

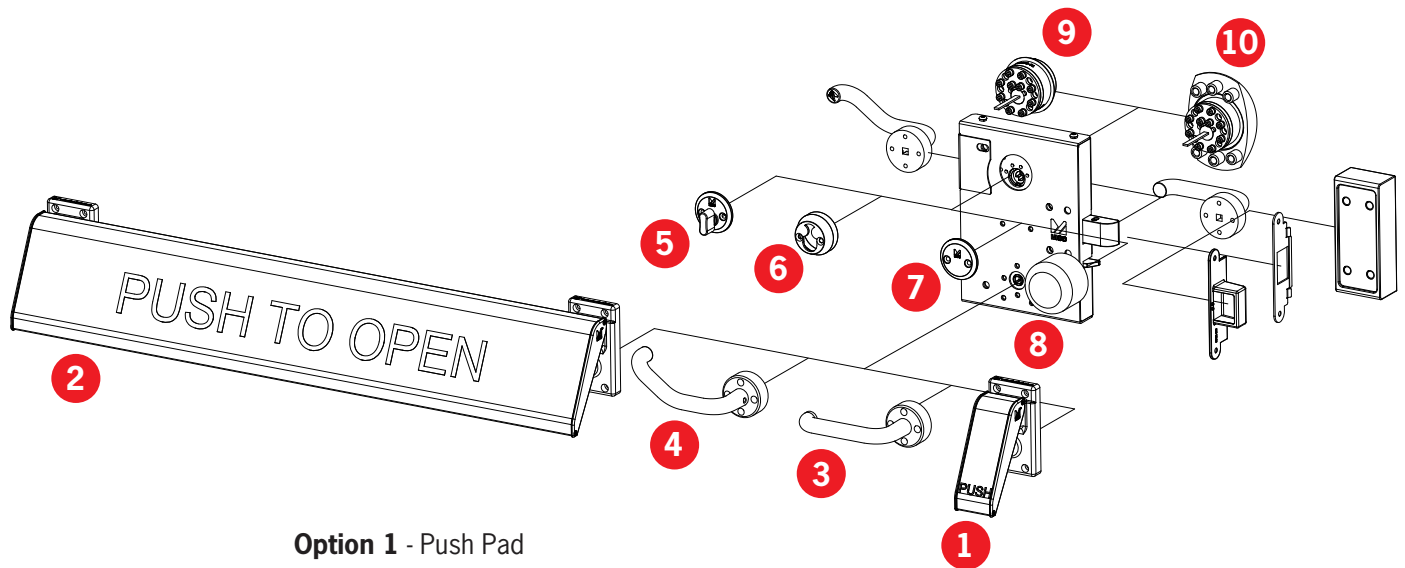
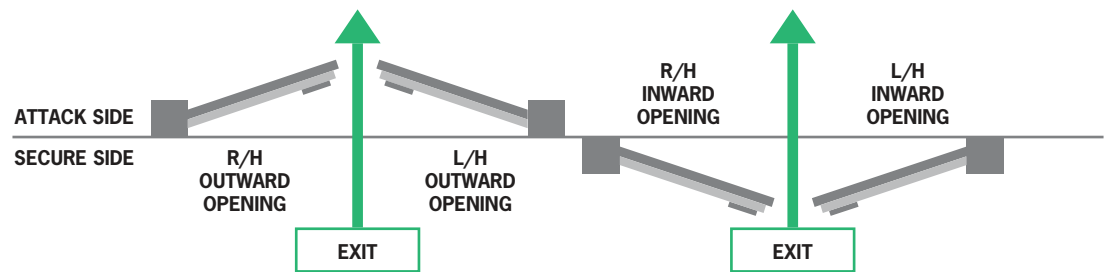

- Option 1** - Push Pad
- Option 2** - Full Width Push Plate
- Option 3** - Lever Handle
- Option 4** - Cranked Lever Handle
- Option 5** - Thumbturn
- Option 6** - Internal Cylinder Ring
- Option 7** - Blind Rose
- Option 8** - Breakdome Thumbturn
- Option 9** - Level 4 Cylinder Guard
- Option 10** - Level 5 Cylinder Guard



MICO Abryll PE

The MICO Abryll PE Range offers Single Action **Panic Escape** at all times via either a Lever Handle, Push Pad, or Full Width Push Plate with the lettering PUSH TO OPEN on the point of use.



Abryll PE 1

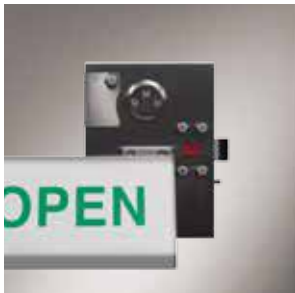

Abryll PE 2



Abryll PE 3

OPERATION

Single Action Panic or Emergency Escape at all times via either a Lever Handle, Push Pad to BS EN 179 or a Full Width Push Plate to BS EN 1125 standards.

APPLICATIONS

For use in high security accredited applications where rapid escape in an emergency is always required. Suitable for timber, steel and composite doorsets. Examples include utilities such as water, power, gas, telecommunications, data centres, banks, hospitals and high value retail outlets.

OPTIONS

Abryll PE 1 = Push Pad with lettering PUSH on the point of use.

Abryll PE 2 = Full Width Push Plate with lettering PUSH TO OPEN on the point of use.

Abryll PE 3 = Internal Lever Handle.

Micro switching of bolt status – add code BSM.

External Access via padlock Hasp & Staple.

See External Devices.

CHDL = Ergonomically designed Cranked Handle for lighter more user friendly operation.

LPS 1175 SR5	LPS 1175 SR6	BLAST
LPS 1175 SR3	LPS 1175 SR4	4HR FIRE
LPS 1175 SR1	LPS 1175 SR2	BALLISTIC
BSEN 179	BSEN 1125	1M CYCLES

Ratings gained on selected doorsets



MICO Abryll AD

The MICO Abryll **Automatic Deadlocking** Range offers instant deadlocking upon door closure. Key and Lever Handle can be used to gain entry whilst an internal Thumbturn with a Lever Handle can be used for Twin Action Exit. The AD Range can be fitted with our SATE override option which gives the function of Single Action Panic & Emergency Escape at all times, even if deadlocked from the external secure side.



Abryll AD 3

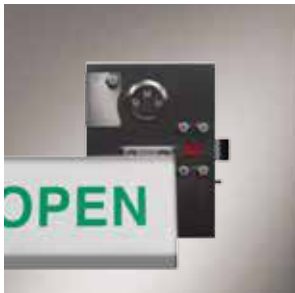

Abryll AD 2 SATE



Abryll AD 3 SATE

OPERATION

Surface mounted high security Single Point Locking System with integrated mechanical automatic deadlocking. Automatic bolting is fitted as standard which automatically deadlocks the bolt in the locked position when the door is closed.

Entry: Key Cylinder and Lever Handle - (To suit Scandinavian Oval Rim Cylinder as standard, other profiles available on request).

Exit: Rotate Thumbturn and depress Lever Handle. Single Action Escape via Handle, Push Pad or Full Width Push Plate if fitted with SATE function.

APPLICATIONS

For use in high security areas where automatic deadlocking is required for instant security. Suitable for timber, steel and composite doorsets. Examples include utilities such as water, power, gas, telecommunications, data centres, banks and high value retail outlets.

OPTIONS

SATE = Adding SATE function to any AD System will offer a permanent mechanical Single Action Escape function which complies to either BSEN 179 or 1125 for Emergency or Panic Escape.

Abryll AD 1 SATE = Push Pad with lettering PUSH on the point of use.

Abryll AD 2 SATE = Full Width Push Plate with lettering PUSH TO OPEN on the point of use.

Abryll AD 3 SATE = Internal Lever Handle.

Micro switching of bolt (BSM) or Deadlock Status (DSM) or Both.

External Access via a wide range of Key Cylinder profiles and manufacturers. Supplied to suit Scandinavian Oval Rim Cylinders as standard.

External cylinder protection options to meet LPCB SR 2, 3, 4, 5, & 6 on selected doorsets. See External Devices.

CHDL = Ergonomically designed Cranked Handle for lighter more user friendly operation.

LPS 1175 SR5	LPS 1175 SR6	BLAST
LPS 1175 SR3	LPS 1175 SR4	4HR FIRE
LPS 1175 SR1	LPS 1175 SR2	BALLISTIC
BSEN 179	BSEN 1125	1M CYCLES

Ratings gained on selected doorsets



MICO Abryll MD

The MICO Abryll **Manual Deadlocking** Range can be unlocked externally via Key Cylinder allowing the user to depress the Lever Handle and retract the shoot bolt. Internally the deadlock can be deactivated via Key Cylinder, Thumbturn or via our internal SATE override option which gives the function of Single Action Panic & Emergency Escape at all times, even if deadlocked from the external secure side. These systems are ideal for areas requiring additional levels of security outside normal working hours.



Abryll MD 3



Abryll MD 3 VI

OPERATION

Surface mounted high security Single Point Locking System with integrated mechanical manual deadlocking. Manual deadlock fitted as standard allowing passage function during certain times of the day (working hours). At the close of business the bolt may be deadlocked by key.

Entry: Key Cylinder and Lever Handle - (To suit Scandinavian Oval Rim Cylinder as standard, other profiles available on request).

Exit: Key Cylinder and Thumbturn or Lever Handle exit.

Single Action Escape at all times when fitted with our SATE option.

APPLICATIONS

Manual deadlock fitted as standard makes this system ideal for allowing passage function during working hours or at certain times of the day. At the close of business or when required the shoot bolts may be deadlocked by key.

OPTIONS

SATE = Adding SATE function to any MD System will offer a permanent mechanical Single Action Escape function which complies to either BSEN 179 or 1125 for Emergency or Panic Escape.

Abryll MD 1 SATE = Push Pad with lettering PUSH on the point of use.

Abryll MD 2 SATE = Full Width Push Plate with lettering PUSH TO OPEN on the point of use.

Abryll MD 3 SATE = Internal Lever Handle.

Micro switching of bolt (BSM) or Deadlock Status (DSM) or Both.

External Access via a wide range of Key Cylinder profiles and manufacturers. Supplied to suit Scandinavian Oval Rim Cylinders as standard.

External cylinder protection options to meet LPCB SR 2, 3, 4, 5, & 6 on selected doorsets. See External Devices.

CHDL = Ergonomically designed Cranked Handle for lighter more user friendly operation.

VI = Visual Indicator allows instant visibility of deadlock status.

LPS 1175 SR5	LPS 1175 SR6	BLAST
LPS 1175 SR3	LPS 1175 SR4	4HR FIRE
LPS 1175 SR1	LPS 1175 SR2	BALLISTIC
BSEN 179	BSEN 1125	1M CYCLES

Ratings gained on selected doorsets



MICO Abryll EM

The MICO Abryll Single Point **Electro-Mechanical** Range to be used with any 12v Access Control System. It can be configured to offer full entry in and out, or entry in with Emergency Escape out when fitted with our SATE option. Supplied as standard operation of Access Control in and out for full audit trail. The internal Breakdome or external Key Cylinder can override the system in the event of Access Control failure. The SATE option can be fitted to allow Access Control entry with mechanical Single Action Escape at all times from the internal side.



Abryll EM 3

OPERATION

Access Control in and out with the ability to mechanically override from either side. Auto bolting and deadlocking upon door closure.

Entry: Swipe / Access Control and Lever Handle. With mechanical key override function fitted as standard.

Exit: Swipe / Access Control and Lever Handle. Mechanical override via Thumbturn shrouded in a Breakdome. Single Action Escape via Handle, Push Pad or Full Width Push Plate if fitted with SATE function.



Abryll EM 1 SATE

APPLICATIONS

Suitable for use in areas where high security with controlled monitored operation is required. The MICO Single Point Electro-Mechanical System is suitable for use in areas where high security with controlled full audit trail are required.



Abryll EM 3 SATE

OPTIONS

SATE = Adding SATE function to any EM System will offer a permanent mechanical Single Action Escape function which complies to either BSEN 179 or 1125 for Emergency or Panic Escape.

Abryll EM 1 SATE = Push Pad with lettering PUSH on the point of use.

Abryll EM 2 SATE = Full Width Push Plate with lettering PUSH TO OPEN on the point of use.

Abryll EM 3 SATE = Internal Lever Handle.

Micro switching of bolt (BSM) or Deadlock Status (DSM) or Both.

External Access via a wide range of Key Cylinder profiles and manufacturers. Supplied to suit Scandinavian Oval Rim Cylinders as standard.

External cylinder protection options to meet LPCB SR 2, 3, 4, 5, & 6 on selected doorsets. See External Devices.

CHDL = Ergonomically designed Cranked Handle for lighter more user friendly operation.

LPS 1175 SR5	LPS 1175 SR6	BLAST
LPS 1175 SR3	LPS 1175 SR4	4HR FIRE
LPS 1175 SR1	LPS 1175 SR2	BALLISTIC
BSEN 179	BSEN 1125	1M CYCLES

Ratings gained on selected doorsets





Bespoke Abryll Solutions

As designers and manufacturers, we are often asked to provide solutions to meet the needs of individual customer requirements. This ranges from simple modifications through to complete redesigns as one off solutions to specific security requirements. Below are some recent developments which have helped to secure project work for our customers.



Abryll EM DD

High Security Double Solenoid Systems offer an additional remote over deadlocking for verification before allowing a user to gain entry with their code / fob / token or even a mechanical Key Cylinder.

Giving total control by locking out until verified entry to your secure sites.



Abryll FS / FS Range

Twin Solenoid System that offers full swipe in / swipe out audit trail. In the event of power failure the system will fail safe internally allowing Single Action Escape. Externally it will fail secure requiring key override to gain entry. Total security with safety when required.



Abryll Cabinet Lock

High security surface mounted Single Point Cabinet Locks have been redesigned by removing the external handle to allow key driven only access. A full range of operations including Manual or Automatic. Deadlocking and Electro Mechanical / Solenoid Deadlocking for use with Access Control Systems.



Abryll OD Range

Having additional deadlock fitted integrally within the system allows for a multitude of controlled security operations.

Examples:

Twin Lock: Both cylinders work independently from each other to release deadlock.

Tandem Lock: Requires both key holders to be present at the same time to release deadlock.

Lockdown: Allows master key holder to control access. Second cylinder only releases deadlock if master key holder has released deadlock on first cylinder.



External Devices



MICO USCH 2, 3 & 4

The MICO Cylinder and Anti Drill discs are manufactured from bespoke hi-tech materials and protects the cylinder from attack and forced entry. A Cylinder Tail connects the Key Cylinder to the MICO unit.

For use with Scandinavian Oval Rim Cylinders as standard. Additional inserts and packers can be requested to accept Round Rim or Euro Profile Cylinder options.

LPS 1175 SR 2, 3 or 4 tested Key Cylinder Guard (on selected doorsets).



MICO USCH 5

Designed for a higher level of security where the possibility of disc cutters may feature with potential attackers.

For use with Scandinavian Oval Rim Cylinders as standard. Additional inserts and packers can be requested to accept Round Rim or Euro Profile Cylinder options.



MICO USCH 6

Designed for a higher level of security where the possibility of disc cutters may feature with potential attackers.

For use with Scandinavian Oval Rim Cylinders as standard. Additional inserts and packers can be requested to accept Round Rim or Euro Profile Cylinder options.



Hasp and Staple SR2

Single Action Escape high security pad-lockable external device. Manufactured completely in full 316 stainless steel as standard. For use with MICO PE Locking Ranges.

ENTRY – Removal of the padlock allows user to gain entry by lifting up the hasp and turning it clockwise or anti-clockwise to retract the internal shoot bolt of the MICO Panic Escape Systems.

EXIT – Even when the MICO Hasp & Staple is padlocked, the MICO internal hardware still allows for Panic Escape at all times.



Hasp and Staple SR3

Single Action Escape high security pad-lockable external device. Manufactured completely in full 316 stainless steel as standard. For use with MICO PE Locking Ranges.

ENTRY – Removal of the padlock allows user to gain entry by lifting up the hasp and turning it clockwise or anti-clockwise to retract the internal shoot bolt of the MICO Panic Escape Systems.

EXIT – Even when the MICO Hasp & Staple is padlocked, the MICO internal hardware still allows for Single Action Escape at all times.



Ratings gained on selected doorsets



Company Overview

MICO Locking Systems are specified on a wide range of applications from schools & nationwide retail stores using panic hardware through to high security national infrastructure facilities HM Central Government and the Telecommunications industry, requiring LPS 1175 SR 2,3,4,5 or 6.

Fully tested and approved, MICO Single and Multipoint Locking Systems are certified to the highest levels for security whilst maintaining the relevant safety standards, our patented design and modular mechanisms allow a multitude of selectable options from any combination of:

Entry = Access Control, Manual Deadlocking, Automatic Mechanical Deadlocking, Double Deadlocking or Combination Lock.

Exit = Key Cylinder, Panic & Emergency Escape, Thumbturn Release, Access Control, Triple Deadlocking.

The MICO Single and Multipoint Ranges are the UK's highest security rated locking systems. Tested to BRE's Security Standard - LPCB 1175 and achieving SR 2, 3, 4, 5 and 6 on selected single and double doorsets.

BRE is the UK's leading security testing house. BRE assess our locking systems together with a doorset to the LPS 1175 loss prevention standard. The purpose of this standard is to evaluate the resistance to unauthorised access offered by various physical security products. The standard specifies various grades of security according to the tools and time likely to be used by a criminal. Specifiers can therefore select products and systems that provide the level of security to match specific needs.

We also work closely with manufacturers of timber, steel and composite doors to integrate our MICO Systems with their products. As part of these selected doorsets MICO Locking Systems have also been tested to various fire, high level ballistic, blast protection and HM Central Government standards. Contact our technical department for further information.

However demanding the application, MICO Single and Multipoint locks can be relied on. Manufactured from stainless steel as standard, the MICO Single and Multipoint Ranges carry full CE certification together with BS EN 179 and BS EN 1125 for safety.

Tindall Engineering offer fully comprehensive product training, sales and customer service. With over 30 years' experience as a precision engineering company, we ensure our customers receive a quality product. Our systems are extremely cost effective due to our unique patented designs. We are proud to manufacture our locking systems in the UK at our factory in Oldham, Lancashire, where we have an extensive onsite demonstration room.

For more information about Tindall Engineering and any of the products in the MICO Range, please contact us on +44 (0)161 620 0666, sales@mico-tindall.com or via our website contact form.



Industry Sectors

Currently we supply to various industries throughout the UK helping secure sites of CNI. This includes industries such as:

- Utilities such as Water, Gas and Electric
- Rail, Airports + Transport
- Clearing Banks + Cash Handling Centres
- Nationwide Retail Stores
- Telecommunications Industry
- Local Authorities and HM Government
- Hospital, Radiation and Medical Dispensary



WATER



COMMUNICATIONS



TRANSPORT



ENERGY



GOVERNMENT



HEALTH



FOOD



EMERGENCY SERVICES



FINANCE



OFF SHORE



EDUCATION



RETAIL



Tindall Engineering Ltd
Unit 8, Laurel Trading Estate,
Higginshaw Lane,
Royton, Oldham,
OL2 6LH
United Kingdom

+44 (0)161 620 0666
sales@mico-tindall.com
www.mico-tindall.com



INT Multipoint Range

High Security INT Multipoint Locking Range, offering a multitude of functions including Panic Escape, Mechanical and Electro-Mechanical Deadlocking options.





The MICO INT Multipoint Range has established itself as the most approved INT Multipoint Locking Range for high security applications. Manufactured from stainless steel as standard, the INT Multipoint Range offers a robust high security solution for even the harshest environments. Tested and approved on selected single and double doorsets to LPCB SR 2,3,4,5 & 6 and with additional HM Government approvals the MICO INT Multipoint Range is the ideal choice where security is paramount. The INT Multipoint Range also boasts Panic Escape functions which carry the latest BS EN 179 and BS EN 1125 accreditations for your added peace of mind.

Customer Care / Installation / Maintenance

At Tindall Engineering we pride ourselves on customer care. Based on trust, we have built up a solid customer base over the years through personal service, bespoke products, arrangements and a highly professional working environment. It doesn't stop with the sale, our site engineers are highly trained meaning we can offer a professional after sales service including installation, maintenance and repair.

Certifications

Security: The Loss Prevention Certification Board LPS1175 SR1, SR2, SR3, SR4, SR5 and SR6



Escape: BS EN 1125:2008 & BS EN 179:2008



Quality:



Technical Overview

Stainless steel mechanism housed in an aluminium box section.

Dimensions (H) 2150mm (W) 80mm.

Standard Push Plate width supplied as 800mm.

Handing – This unit is handed as per diagram below, add code when ordering.

28mm bolt throw.

Handing

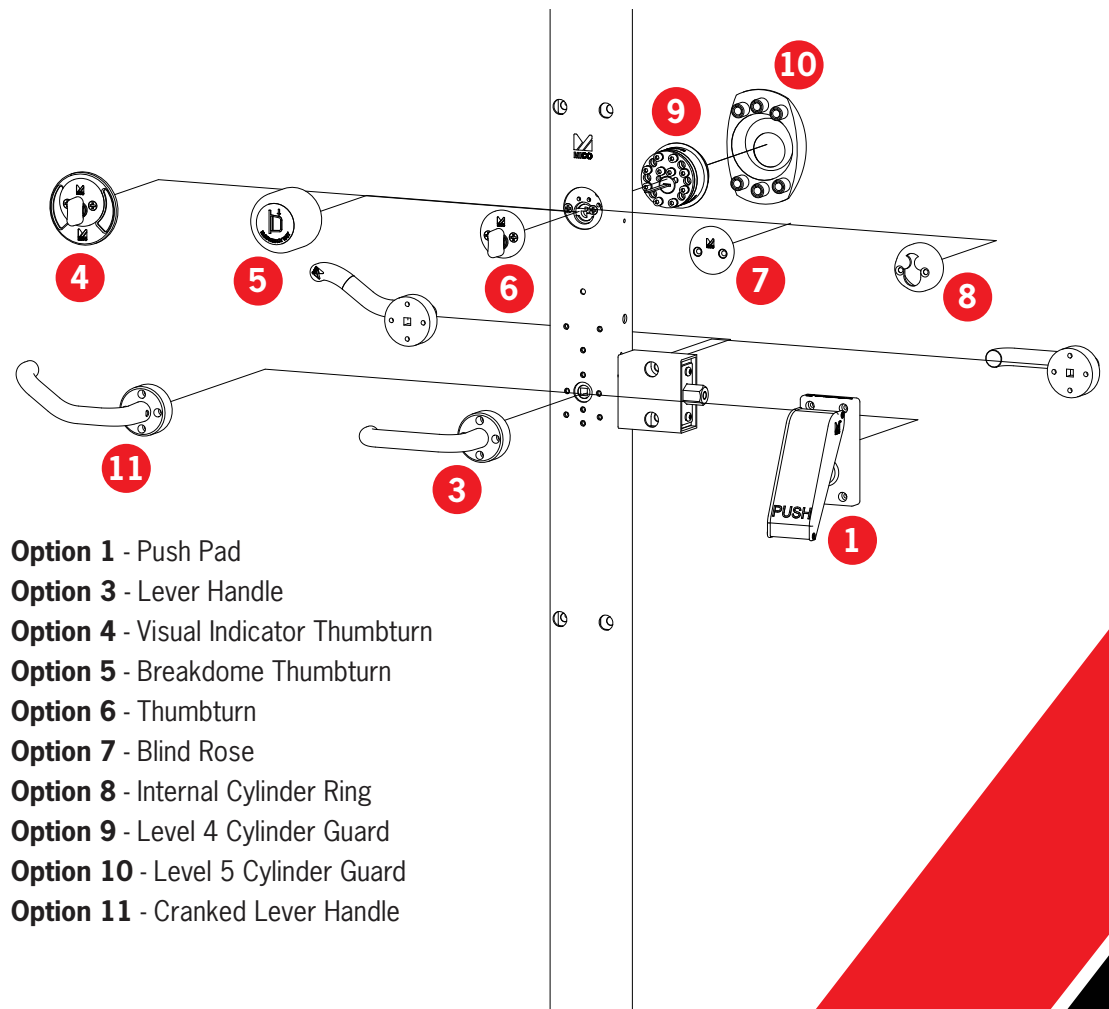
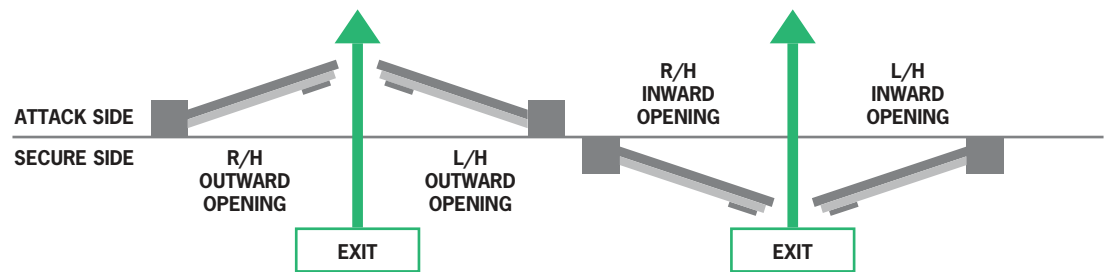



MICO INT Multipoint PE

The MICO INT Multipoint PE Range offers **Panic & Emergency Escape** at all times via either a Lever Handle, Push Pad, or Full Width Push Plate with the lettering PUSH TO OPEN on the point of use. Entry can be gained by using External Key Access Devices.

OPERATION

Panic or Emergency Escape at all times via either a Lever Handle, a Push Pad to BSEN 179 or a Full Width Push Plate to BS EN 1125 standards.

APPLICATIONS

For use in high security accredited applications where rapid escape in an emergency is always required. Suitable for timber, steel and composite doorsets. Examples include utilities such as water, power, gas, telecommunications, data centres, banks, hospitals and high value retail outlets.

OPTIONS

942-3P = Push Pad with lettering PUSH on the point of use.

942-3 = Full Width Push Plate with lettering PUSH TO OPEN on the point of use.

942-3L = Internal Lever Handle.

Micro Switching of bolt status – add code BSM.

External Access via MICO ELK or Hasp & Staple.

See External Devices.

Ergonomically designed Cranked Handle for lighter more user friendly operation.



942-3P



942-3



942-3L

LPS 1175 SR5	LPS 1175 SR6	BLAST
LPS 1175 SR3	LPS 1175 SR4	4HR FIRE
LPS 1175 SR1	LPS 1175 SR2	BALLISTIC
BSEN 179	BSEN 1125	1M CYCLES

Ratings gained on selected doorsets



MICO INT Multipoint AD

The MICO INT Multipoint **Automatic Deadlocking** Range offers instant deadlocking upon door closure. Key and Lever Handle can be used to gain entry whilst an internal Thumbturn with a Lever Handle can be used for twin action exit. The AD Range can be fitted with our SATE override option which gives the function of Single Action Panic & Emergency Escape at all times, even if deadlocked from the external secure side.



942-3L INT AD

OPERATION

Surface mounted High Security Multipoint Locking System with integrated Mechanical Automatic Deadlocking. Automatic bolting is fitted as standard which automatically deadlocks the bolt in the locked position when the door is closed.

Entry: Key Cylinder and Lever Handle - (To suit Scandinavian Oval Rim Cylinder as standard, other profiles available on request).

Exit: Rotate Thumbturn and depress Lever Handle. Single Action Escape via Handle, Push Pad or Full Width Push Plate if fitted with SATE function.



942-3 INT AD SATE

APPLICATIONS

For use in high security areas where automatic deadlocking is required for instant security. Suitable for timber, steel and composite doorsets. Examples include utilities such as water, power, gas, telecommunications, data centres, banks and high value retail outlets.

OPTIONS

SATE = Adding SATE function to any AD System will offer a permanent mechanical Single Action Escape function which complies to either BSEN 179 or 1125 for Emergency or Panic Escape.

942-3P INT AD SATE = Push Pad With lettering PUSH on the point of use.

942-3 INT AD SATE = Full Width Push Plate with lettering PUSH TO OPEN on the point of use.

942-3L INT AD SATE = Internal Lever Handle.

Micro switching of bolt (BSM) or Deadlock Status (DSM) or Both.

External Access via a wide range of Key Cylinder profiles and manufacturers. Supplied to suit Scandinavian Oval Rim Cylinders as standard.

External Cylinder protection options to meet LPCB SR 2, 3, 4, 5, & 6 on selected doorsets. See External Devices.

Ergonomically designed Cranked Handle for lighter more user friendly operation.



942-3L INT AD SATE

LPS 1175 SR5	LPS 1175 SR6	BLAST
LPS 1175 SR3	LPS 1175 SR4	4HR FIRE
LPS 1175 SR1	LPS 1175 SR2	BALLISTIC
BSEN 179	BSEN 1125	1M CYCLES

Ratings gained on selected doorsets





MICO INT Multipoint MD

The MICO INT Multipoint **Manual Deadlocking** Range can be unlocked externally via Key Cylinder allowing the user to depress the Lever Handle and retract the shoot bolt. Internally the deadlock can be deactivated via Key Cylinder, Thumbturn or via our internal SATE override option which gives the function of Single Action Panic & Emergency Escape at all times, even if deadlocked from the external secure side. These systems are ideal for areas requiring additional levels of security outside normal working hours.



942-3L INT MD



942-3L INT MD VI

OPERATION

Surface mounted High Security INT Multipoint System with integrated mechanical manual deadlocking. Manual deadlock fitted as standard allowing passage function during certain times of the day (working hours). At the close of business the bolt may be deadlocked by key.

Entry: Key Cylinder and Lever Handle - (To suit Scandinavian Oval Rim Cylinder as standard, other profiles available on request).

Exit: Key Cylinder and Thumbturn or Lever Handle exit.

APPLICATIONS

Manual deadlock fitted as standard makes this system ideal for allowing passage function during working hours or at certain times of the day. At the close of business or when required the shoot bolts may be deadlocked by key.

OPTIONS

SATE = Adding SATE function to any MD System will offer a permanent mechanical Single Action Escape function which complies to either BSEN 179 or 1125 for Emergency or Panic Escape.

942-3P INT MD SATE = Push Pad with lettering PUSH on the point of use.

942-3 INT MD SATE = Full Width Push Plate with lettering PUSH TO OPEN on the point of use.

942-3L INT MD SATE = Internal Lever Handle.

Micro switching of bolt (BSM) or Deadlock Status (DSM) or Both.

External Access via a wide range of Key Cylinder profiles and manufacturers. Supplied to suit Scandinavian Oval Rim Cylinders as standard.

External cylinder protection options to meet LPCB SR 2, 3, 4, 5, & 6 on selected doorsets. See External Devices.

Ergonomically designed Cranked Handle for lighter more user friendly operation.

VI = Visual Indicator allows instant visibility of deadlock status.

LPS 1175 SR5	LPS 1175 SR6	BLAST
LPS 1175 SR3	LPS 1175 SR4	4HR FIRE
LPS 1175 SR1	LPS 1175 SR2	BALLISTIC
BSEN 179	BSEN 1125	1M CYCLES

Ratings gained on selected doorsets



MICO INT Multipoint EM

The MICO INT Multipoint **Electro-Mechanical** Range to be used with any 12v Access Control System. It can be configured to offer full entry in and out, or entry in with Emergency Escape out when fitted with our SATE option. Supplied as standard operation of Access Control in and out for full audit trail. The internal Breakdome or External Key Cylinder can override the system in the event of Access Control failure. The SATE option can be fitted to allow Access Control entry with mechanical Single Action Escape at all times from the internal side.



942-3L INT EM

OPERATION

Surface mounted High Security Multipoint System with integrated mechanical manual deadlocking. Manual deadlock fitted as standard allowing passage function during certain times of the day (working hours). At the close of business the bolt may be deadlocked by key.

Entry: Swipe / Access Control and Lever Handle with Mechanical Key Override function fitted as standard.

Exit: Swipe / Access Control and Lever Handle. Mechanical Override via Thumbturn shrouded in a Breakdome. Single Action Escape via Handle, Push Pad or Full Width Push Plate if fitted with SATE function.



942-3P EM SATE

APPLICATIONS

Suitable for use in areas where high security with controlled monitored operation is required. The light action in the event of escape makes the MICO 3 Point Electro-Mechanical system ideal for cash rooms, bureau de changes, or areas where security must be maintained in the event of power loss.



942-3 INT EM SATE

OPTIONS

SATE = Adding SATE function to any EM System will offer a permanent mechanical Single Action Escape function which complies to either BSEN 179 or 1125 for Emergency or Panic Escape.

942-3P INT EM SATE = Push Pad with lettering PUSH on the point of use.

942-3 INT EM SATE = Full Width Push Plate with lettering PUSH TO OPEN on the point of use.

942-3L INT EM SATE = Internal Lever Handle.

Micro switching of bolt (BSM) or Deadlock Status (DSM) or Both.

External Access via a wide range of Key Cylinder profiles and manufacturers. Supplied to suit Scandinavian Oval Rim Cylinders as standard.

External Cylinder protection options to meet LPCB SR 2, 3, 4, 5, & 6 on selected doorsets. See External Devices.

Ergonomically designed Cranked Handle for lighter more user friendly operation.

LPS 1175 SR5	LPS 1175 SR6	BLAST
LPS 1175 SR3	LPS 1175 SR4	4HR FIRE
LPS 1175 SR1	LPS 1175 SR2	BALLISTIC
BSEN 179	BSEN 1125	1M CYCLES

Ratings gained on selected doorsets



External Devices



MICO USCH 2, 3 & 4

The MICO Cylinder and Anti Drill discs are manufactured from bespoke hi-tech materials and protects the cylinder from attack and forced entry. A Cylinder Tail connects the Key Cylinder to the MICO unit.

For use with Scandinavian Oval Rim Cylinders as standard. Additional inserts and packers can be requested to accept Round Rim or Euro Profile Cylinder options.

LPS 1175 SR 2, 3 or 4 tested Key Cylinder Guard (on selected doorsets).



MICO USCH 5

Designed for a higher level of security where the possibility of disc cutters may feature with potential attackers.

For use with Scandinavian Oval Rim Cylinders as standard. Additional inserts and packers can be requested to accept Round Rim or Euro Profile Cylinder options.



MICO USCH 6

Designed for a higher level of security where the possibility of disc cutters may feature with potential attackers.

For use with Scandinavian Oval Rim Cylinders as standard. Additional inserts and packers can be requested to accept Round Rim or Euro Profile Cylinder options.



Hasp and Staple SR2

Single Action Escape high security pad-lockable external device. Manufactured completely in full 316 stainless steel as standard. For use with MICO PE Locking Ranges.

ENTRY – Removal of the padlock allows user to gain entry by lifting up the hasp and turning it clockwise or anti-clockwise to retract the internal shoot bolt of the MICO Panic Escape Systems.

EXIT – Even when the MICO Hasp & Staple is padlocked, the MICO internal hardware still allows for Panic Escape at all times.



Hasp and Staple SR3

Single Action Escape high security pad-lockable external device. Manufactured completely in full 316 stainless steel as standard. For use with MICO PE Locking Ranges.

ENTRY – Removal of the padlock allows user to gain entry by lifting up the hasp and turning it clockwise or anti-clockwise to retract the internal shoot bolt of the MICO Panic Escape Systems.

EXIT – Even when the MICO Hasp & Staple is padlocked, the MICO internal hardware still allows for Single Action Escape at all times.



Ratings gained on selected doorsets



Cut To Height Service

HEIGHT & WIDTH

We supply each system in our standard 2150mm height, but offer options to increase the height to either 2500mm or 3000mm. We can cut the systems to any height you require helping reduce fitting times. Just add your desired length to the product when ordering. Please see cut to height diagram below.

The MICO Aluminium Push Plate is set at an 800mm width as standard but can be any length you require from 550mm to over 2700mm depending on your door width. For applications requiring smaller push plates we can reduce our lettering to read only PUSH. Just add your desired length to the product when ordering.

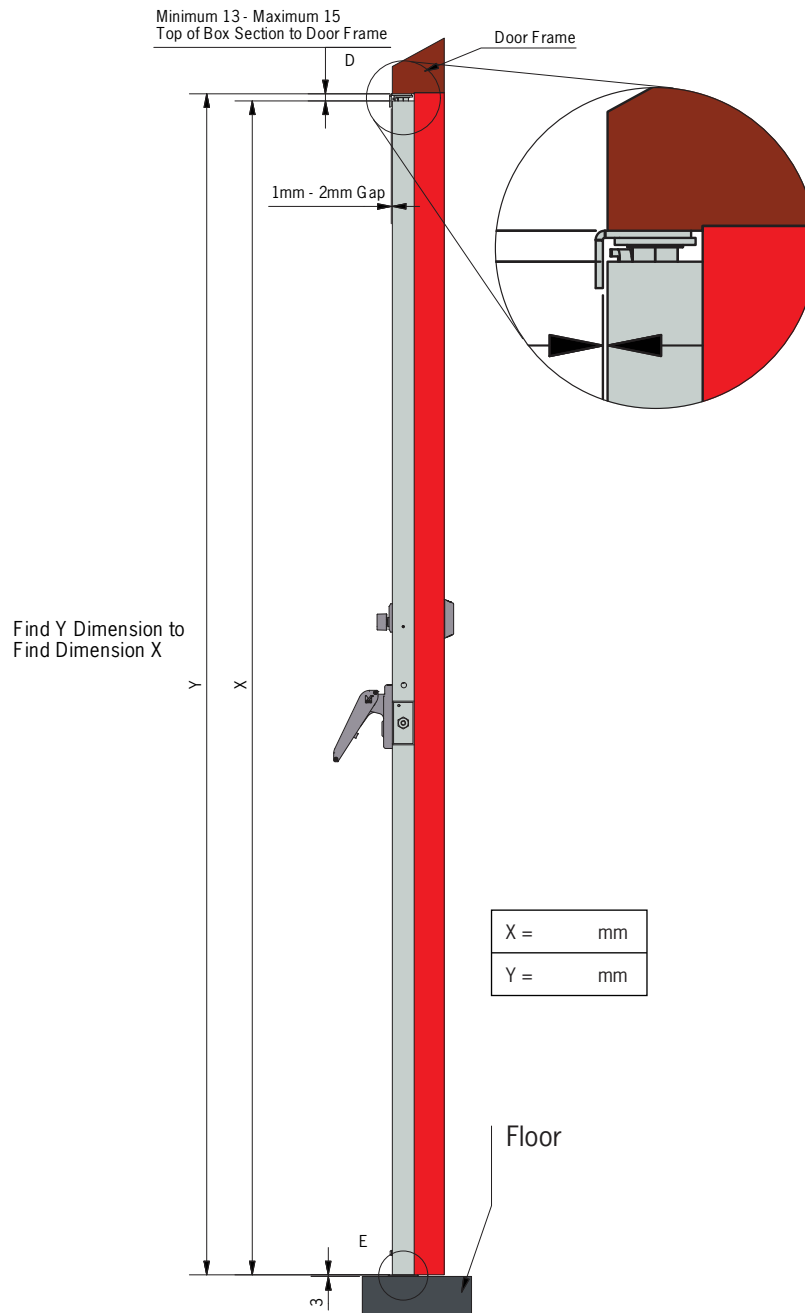



Company Overview

MICO Locking Systems are specified on a wide range of applications from schools & nationwide retail stores using panic hardware through to high security national infrastructure facilities HM Central Government and the Telecommunications industry, requiring LPS 1175 SR 2,3,4,5 or 6.

Fully tested and approved, MICO Single and Multipoint Locking Systems are certified to the highest levels for security whilst maintaining the relevant safety standards, our patented design and modular mechanisms allow a multitude of selectable options from any combination of:

Entry = Access Control, Manual Deadlocking, Automatic Mechanical Deadlocking, Double Deadlocking or Combination Lock.

Exit = Key Cylinder, Panic & Emergency Escape, Thumbturn Release, Access Control, Triple Deadlocking.

The MICO Single and Multipoint Ranges are the UK's highest security rated locking systems. Tested to BRE's Security Standard - LPCB 1175 and achieving SR 2, 3, 4, 5 and 6 on selected single and double doorsets.

BRE is the UK's leading security testing house. BRE assess our locking systems together with a doorset to the LPS 1175 loss prevention standard. The purpose of this standard is to evaluate the resistance to unauthorised access offered by various physical security products. The standard specifies various grades of security according to the tools and time likely to be used by a criminal. Specifiers can therefore select products and systems that provide the level of security to match specific needs.

We also work closely with manufacturers of timber, steel and composite doors to integrate our MICO Systems with their products. As part of these selected doorsets MICO Locking Systems have also been tested to various fire, high level ballistic, blast protection and HM Central Government standards. Contact our technical department for further information.

However demanding the application, MICO Single and Multipoint locks can be relied on. Manufactured from stainless steel as standard, the MICO Single and Multipoint Ranges carry full CE certification together with BS EN 179 and BS EN 1125 for safety.

Tindall Engineering offer fully comprehensive product training, sales and customer service. With over 30 years' experience as a precision engineering company, we ensure our customers receive a quality product. Our systems are extremely cost effective due to our unique patented designs. We are proud to manufacture our locking systems in the UK at our factory in Oldham, Lancashire, where we have an extensive onsite demonstration room.

For more information about Tindall Engineering and any of the products in the MICO Range, please contact us on +44 (0)161 620 0666, sales@mico-tindall.com or via our website contact form.



Industry Sectors

Currently we supply to various industries throughout the UK helping secure sites of CNI. This includes industries such as:

- Utilities such as Water, Gas and Electric
- Rail, Airports + Transport
- Clearing Banks + Cash Handling Centres
- Nationwide Retail Stores
- Telecommunications Industry
- Local Authorities and HM Government
- Hospital, Radiation and Medical Dispensary



WATER



COMMUNICATIONS



TRANSPORT



ENERGY



GOVERNMENT



HEALTH



FOOD



EMERGENCY SERVICES



FINANCE



OFF SHORE



EDUCATION



RETAIL



Tindall Engineering Ltd
Unit 8, Laurel Trading Estate,
Higginshaw Lane,
Royton, Oldham,
OL2 6LH
United Kingdom

+44 (0)161 620 0666
sales@mico-tindall.com
www.mico-tindall.com



MICO External Access Range

High Security External Access range, offering a multitude of key driven and padlockable security solutions and functions including panic and emergency escape.





The MICO External Access Range is an established High Security series of surface mounted external devices. Ranging from key driven access to padlockable solutions. MICO external access devices have been tested and are LPCB rated to SR 2,3,4,5 & 6 on selected doorsets. They are compatible with all variants of the MICO single and multipoint panic escape hardware and offer a full Stainless Steel construction throughout.

Customer Care / Installation / Maintenance

At Tindall Engineering we pride ourselves on customer care. Based on trust, we have built up a solid customer base over the years through personal service, bespoke products, arrangements and a highly professional working environment. It doesn't stop with the sale, our site engineers are highly trained meaning we can offer a professional after sales service including installation, maintenance and repair.

Certifications

Security: The Loss Prevention Certification Board LPS1175 SR1, SR2, SR3, SR4, SR5 and SR6



Escape: BS EN 1125:2008 & BS EN 179:2008



Quality:



Technical Overview

Stainless Steel construction as standard.

Handing – This unit is handed as per diagram below add code when ordering.

Handing

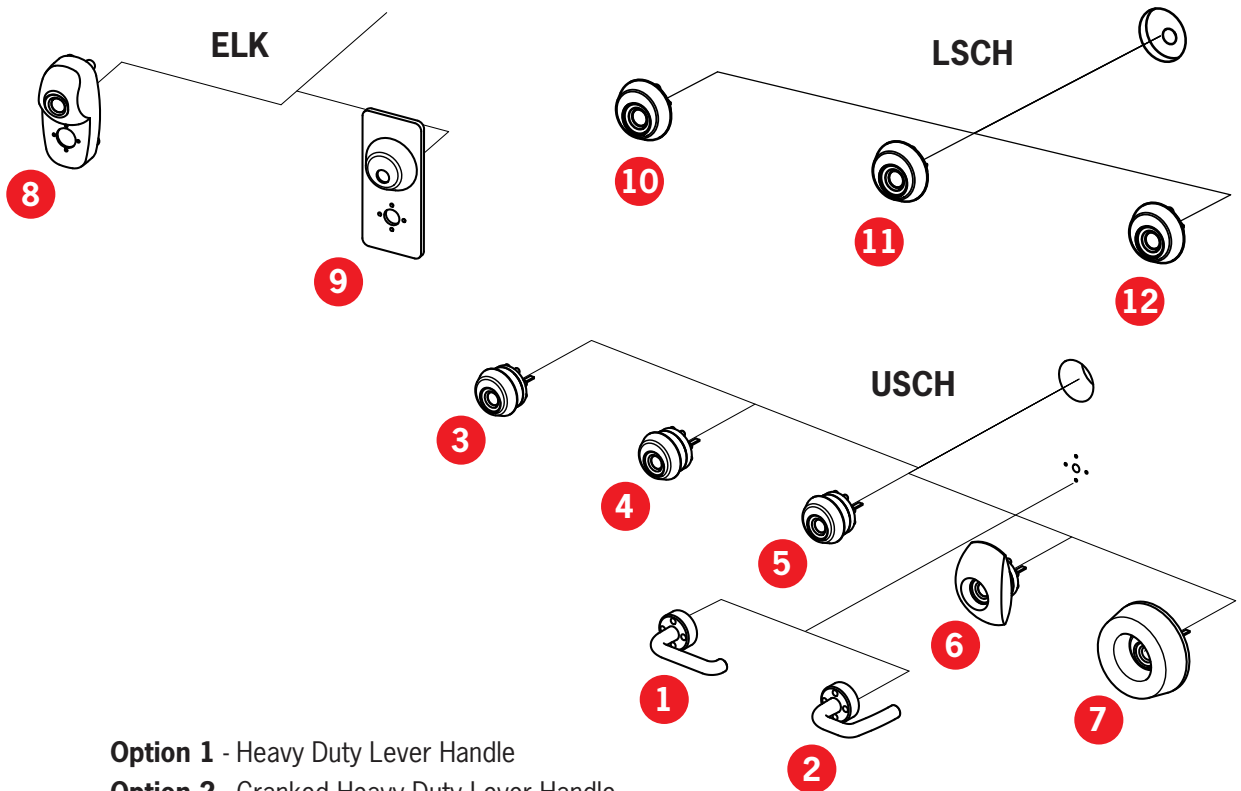
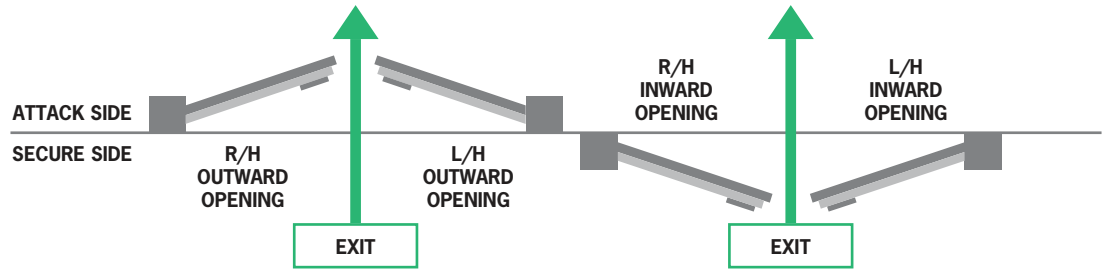

- Option 1** - Heavy Duty Lever Handle
- Option 2** - Cranked Heavy Duty Lever Handle
- Option 3** - USCH2
- Option 4** - USCH3
- Option 5** - USCH4
- Option 6** - USCH5
- Option 7** - USCH6
- Option 8** - ELK Lite
- Option 9** - ELK
- Option 10** - LSCH2
- Option 11** - LSCH3
- Option 12** - LSCH4



MICO Cylinder Protection, USCH 2,3,4

The MICO external locking attachment (USCH) has been specifically designed to house and protect the cylinder from a sustained attack. A Cylinder Tail connects the Key Cylinder to the MICO unit. Tested and approved on selected doorsets to LPS 1175 SR 2, 3 and 4. The MICO USCH is supplied with an external Heavy Duty Lever Handle.



USCH 2

OPERATION

Entry via Key Cylinder and lever handle.

The MICO external cylinder guards offer protection for Scandinavian Oval Rim, Euro profile or Round Rim cylinders from physical attack. The MICO cylinder guard and Anti-Drill discs are manufactured from bespoke hi-tech materials to resist a sustained drilling attack. Compatible with all MICO Multipoint and Single point deadlocking system.



HD Handle

APPLICATIONS

Suitable for use in areas where security is of importance and where an attack may come from a more determined opportunist criminal by bodily physical force. These include banks, high value retail outlets, commercial properties, schools, data centres and hospitals.

OPTIONS

- MICO USCH 2 - Complete with heavy duty Stainless steel external lever handle.
 - MICO USCH 3 - Complete with heavy duty Stainless Steel external lever handle.
 - MICO USCH 4 – Complete with heavy duty Stainless Steel external lever handle.
- For use with Scandinavian Oval Rim as standard, Euro Profile and Round Rim cylinders.
 CHDL = Ergonomically designed Cranked Handle for lighter more user friendly operation.

LPS 1175 SR5	LPS 1175 SR6	BLAST
LPS 1175 SR3	LPS 1175 SR4	4HR FIRE
LPS 1175 SR1	LPS 1175 SR2	BALLISTIC
BSEN 179	BSEN 1125	1M CYCLES

Ratings gained on selected doorsets





MICO Cylinder Protection, USCH 5

The MICO external locking attachment (USCH) has been specifically designed to house and protect the cylinder from a sustained attack. A Cylinder Tail connects the Key Cylinder to the MICO unit. Tested and approved on selected doorsets to LPS 1175 SR 5. The MICO USCH 5 is supplied with an external heavy duty lever handle.



USCH 5

OPERATION

Entry via Key Cylinder and lever handle.

The MICO USCH 5 has been specially designed for a higher level of security where the possibility of a sustained attack may occur. Anti-Drill discs are manufactured from bespoke hi-tech materials to resist a drilling attack. Compatible with all MICO Multipoint and Single point deadlocking system.



HD Handle

APPLICATIONS

Suitable for use in areas where security is of paramount importance and where an attack may come from an experienced attempt at forced entry using bodily physical force and a wide selection of attack options. These include utilities such as water, power, gas, telecommunications, data centres, banks and high value retail outlets.

OPTIONS

MICO USCH 5 - Complete with heavy duty Stainless steel external lever handle.

For use with Scandinavian Oval Rim as standard, Euro Profile and Round Rim cylinders.

CHDL = Ergonomically designed Cranked Handle for lighter more user friendly operation.

LPS 1175 SR5	LPS 1175 SR6	BLAST
LPS 1175 SR3	LPS 1175 SR4	4HR FIRE
LPS 1175 SR1	LPS 1175 SR2	BALLISTIC
BSEN 179	BSEN 1125	1M CYCLES

Ratings gained on selected doorsets





MICO Cylinder Protection, USCH 6

The MICO external locking attachment (USCH) has been specifically designed to house and protect the cylinder from a sustained attack. A Cylinder Tail connects the Key Cylinder to the MICO unit. Tested and approved on selected doorsets to LPS 1175 SR 6. The MICO USCH 6 is supplied with an external heavy duty lever handle.



USCH 6



HD Handle

OPERATION

Entry via Key Cylinder and lever handle.

The MICO USCH 6 has been specially designed for a higher level of security where the possibility of a sustained attack may occur. Anti-Drill discs are manufactured from bespoke hi-tech materials to resist a drilling attack. Compatible with all MICO Multipoint and Single point deadlocking system.

APPLICATIONS

Suitable for use in areas where security is of paramount importance and where an attack may come from an experienced attempt at forced entry using bodily physical force and a wide selection of attack options. These include utilities such as water, power, gas, telecommunications, data centres, banks and high value retail outlets.

OPTIONS

MICO USCH 6 - Complete with heavy duty Stainless steel external lever handle.

For use with Scandinavian Oval Rim as standard, Euro Profile and Round Rim cylinders.

CHDL = Ergonomically designed Cranked Handle for lighter more user friendly operation.

LPS 1175 SR5	LPS 1175 SR6	BLAST
LPS 1175 SR3	LPS 1175 SR4	4HR FIRE
LPS 1175 SR1	LPS 1175 SR2	BALLISTIC
BSEN 179	BSEN 1125	1M CYCLES

Ratings gained on selected doorsets





MICO Cylinder Protection, LSCH 2,3,4

The MICO external locking attachment (LSCH) has been specifically designed to house and protect the cylinder from a sustained attack. A Cylinder Tail connects the Key Cylinder to the MICO unit. Tested and approved on selected doorsets to LPS 1175 SR 2, 3 and 4. The MICO LSCH is supplied with a Heavy Duty External Lever Handle.



LSCH

OPERATION

Entry via Key Cylinder and lever handle.

The MICO external cylinder guard offers protection for Euro profile cylinders from physical attack. The MICO cylinder housing and Anti-Drill discs are manufactured from bespoke hi-tech materials to resist a sustained drilling attack. Compatible with all MICO Multipoint and Single point deadlocking systems.



HD Handle

APPLICATIONS

Suitable for use in areas where security is of importance and where an attack may come from a more determined opportunist criminal by bodily physical force. These include banks, high value retail outlets, commercial properties, schools, data centres and hospitals.

OPTIONS

LSCH 2 - Complete with external Stainless steel lever handle.

LSCH 3 - Complete with external Stainless steel lever handle.

LSCH4 - Complete with external Stainless steel lever handle.

For use with Euro Profile Cylinders.

CHDL = Ergonomically designed Cranked Handle for lighter more user friendly operation.

LPS 1175 SR5	LPS 1175 SR6	BLAST
LPS 1175 SR3	LPS 1175 SR4	4HR FIRE
LPS 1175 SR1	LPS 1175 SR2	BALLISTIC
BSEN 179	BSEN 1125	1M CYCLES

Ratings gained on selected doorsets





MICO ELK 2,3,4

MICO ELK external device offers protection for Scandinavian Oval Cylinders from physical attack. The outer casing is designed to resist impact from a sustained attack. The MICO ELK is compatible with all MICO Multipoint Panic and Emergency Locking Systems. Key retention is fitted as standard ensuring the system will deadlock once the key is removed. Supplied as standard with Scandinavian Oval Cylinder and 2 keys. Tested and approved on selected doorsets to LPS 1175 SR 2, 3 and 4.



ELK 2



ELK 3



ELK 4

OPERATION

Entry via key cylinder and depress lever handle.

APPLICATIONS

Suitable for use in areas where security is of high importance and where attack may come from experienced attempt at forced entry using bodily force and a selection of attack options.

OPTIONS

ELK 2 – Complete with external stainless steel lever handle.

ELK 3 – Complete with external stainless steel lever handle.

ELK 4 – Complete with external stainless steel lever handle.

Key Removal - Allows the external device to be unlocked to allow access during a specified period. Key must be then used to re-lock the ELK when security is required. (Manual Locking)

Euro Profile versions available.

CHDL = Ergonomically designed Cranked Handle for lighter more user friendly operation.

LPS 1175 SR5	LPS 1175 SR6	BLAST
LPS 1175 SR3	LPS 1175 SR4	4HR FIRE
LPS 1175 SR1	LPS 1175 SR2	BALLISTIC
BSEN 179	BSEN 1125	1M CYCLES

Ratings gained on selected doorsets



MICO ELK Lite

The MICO ELK LITE is the latest offering in the MICO External Access Range. This innovative and aesthetically pleasing design is manufactured from hi-tech materials and offers cylinder protection to LPS 1175 SR2 & 3 (on selected doorsets). Supplied with a MICO Heavy Duty Lever Handle as standard.



ELK Lite

OPERATION

Entry via key cylinder and depress lever handle.

APPLICATIONS

Suitable for use in areas where security is of high importance and where attack may come from experienced attempt at forced entry using bodily force and a selection of attack options.

OPTIONS

ELK 2 - Complete with external stainless steel lever handle.

ELK 3 - Complete with external stainless steel lever handle.

Key Removal - Allows the external device to be unlocked to allow access during a specified period. Key must be then used to re-lock the ELK when security is required. (Manual Locking)

CHDL = Ergonomically designed Cranked Handle for lighter more user friendly operation.

LPS 1175 SR5	LPS 1175 SR6	BLAST
LPS 1175 SR3	LPS 1175 SR4	4HR FIRE
LPS 1175 SR1	LPS 1175 SR2	BALLISTIC
BSEN 179	BSEN 1125	1M CYCLES

Ratings gained on selected doorsets



MICO Hasp & Staple SR2

High security surface fixed external pad-lockable device is compatible with all variants of the MICO Single and Multipoint panic escape hardware. The unique design offers panic escape at all times while secured from the external side with a pad-lock. Manufactured in full 316 stainless steel as standard. Tested and approved to LPS 1175 SR2 on selected door-sets.



H&S SR2

The MICO Panic Hasp and Staple range is compatible with a wide range of padlocks from leading manufacturers such as Abloy, Kaba and Squire.

OPERATION

ENTRY: Removal of the padlock allows users to gain entry by lifting up the hasp and turning it clockwise or anti-clockwise to retract the internal shoot bolt of the MICO Panic escape system.

EXIT: Even when the MICO Hasp and Staple is pad locked, the MICO internal hardware still allows for Panic Escape at all times.

APPLICATIONS

Suitable for areas where rapid escape in event of an emergency is required. These include Utilities such as water, power, gas, telecommunications, data centres, banks, hospitals and high value retail outlets.

OPTIONS

Compatible with a wide range of padlocks from Abloy, Kaba and Squire.

LPS 1175 SR5	LPS 1175 SR6	BLAST
LPS 1175 SR3	LPS 1175 SR4	4HR FIRE
LPS 1175 SR1	LPS 1175 SR2	BALLISTIC
BSEN 179	BSEN 1125	1M CYCLES

Ratings gained on selected doorsets



MICO Hasp & Staple SR3

High security surface fixed external pad-lockable device is compatible with all variants of the MICO Single and Multipoint panic escape hardware. The unique design offers panic escape at all times while secured from the external side with a pad-lock. Manufactured in full 316 stainless steel as standard. Tested and approved to LPS 1175 SR3 on selected door-sets.



H&S SR3

The MICO Panic Hasp and Staple range is compatible with a wide range of padlocks from leading manufacturers such as Abloy, Kaba and Squire.

OPERATION

ENTRY: Removal of the padlock allows users to gain entry by lifting up the hasp and turning it clockwise or anti-clockwise to retract the internal shoot bolt of the MICO Panic escape system.

EXIT: Even when the MICO Hasp and Staple is pad locked, the MICO internal hardware still allows for Panic Escape at all times.

APPLICATIONS

Suitable for areas where rapid escape in event of an emergency is required. These include Utilities such as water, power, gas, telecommunications, data centres, banks, hospitals and high value retail outlets.

OPTIONS

Compatible with a wide range of padlocks from Abloy, Kaba and Squire.

LPS 1175 SR5	LPS 1175 SR6	BLAST
LPS 1175 SR3	LPS 1175 SR4	4HR FIRE
LPS 1175 SR1	LPS 1175 SR2	BALLISTIC
BSEN 179	BSEN 1125	1M CYCLES

Ratings gained on selected doorsets



Company Overview

MICO Locking Systems are specified on a wide range of applications from schools & nationwide retail stores using panic hardware through to high security national infrastructure facilities HM Central Government and the Telecommunications industry, requiring LPS 1175 SR 2,3,4,5 or 6.

Fully tested and approved, MICO Single and Multipoint Locking Systems are certified to the highest levels for security whilst maintaining the relevant safety standards, our patented design and modular mechanisms allow a multitude of selectable options from any combination of:

Entry = Access Control, Manual Deadlocking, Automatic Mechanical Deadlocking, Double Deadlocking or Combination Lock.

Exit = Key Cylinder, Panic & Emergency Escape, Thumbturn Release, Access Control, Triple Deadlocking.

The MICO Single and Multipoint Ranges are the UK's highest security rated locking systems. Tested to BRE's Security Standard - LPCB 1175 and achieving SR 2, 3, 4, 5 and 6 on selected single and double doorsets.

BRE is the UK's leading security testing house. BRE assess our locking systems together with a doorset to the LPS 1175 loss prevention standard. The purpose of this standard is to evaluate the resistance to unauthorised access offered by various physical security products. The standard specifies various grades of security according to the tools and time likely to be used by a criminal. Specifiers can therefore select products and systems that provide the level of security to match specific needs.

We also work closely with manufacturers of timber, steel and composite doors to integrate our MICO Systems with their products. As part of these selected doorsets MICO Locking Systems have also been tested to various fire, high level ballistic, blast protection and HM Central Government standards. Contact our technical department for further information.

However demanding the application, MICO Single and Multipoint locks can be relied on. Manufactured from stainless steel as standard, the MICO Single and Multipoint Ranges carry full CE certification together with BS EN 179 and BS EN 1125 for safety.

Tindall Engineering offer fully comprehensive product training, sales and customer service. With over 30 years' experience as a precision engineering company, we ensure our customers receive a quality product. Our systems are extremely cost effective due to our unique patented designs. We are proud to manufacture our locking systems in the UK at our factory in Oldham, Lancashire, where we have an extensive onsite demonstration room.

For more information about Tindall Engineering and any of the products in the MICO Range, please contact us on +44 (0)161 620 0666, sales@mico-tindall.com or via our website contact form.



Industry Sectors

Currently we supply to various industries throughout the UK helping secure sites of CNI. This includes industries such as:

- Utilities such as Water, Gas and Electric
- Rail, Airports + Transport
- Clearing Banks + Cash Handling Centres
- Nationwide Retail Stores
- Telecommunications Industry
- Local Authorities and HM Government
- Hospital, Radiation and Medical Dispensary



WATER



COMMUNICATIONS



TRANSPORT



ENERGY



GOVERNMENT



HEALTH



FOOD



EMERGENCY SERVICES



FINANCE



OFF SHORE



EDUCATION



RETAIL



Tindall Engineering Ltd
Unit 8, Laurel Trading Estate,
Higginshaw Lane,
Royton, Oldham,
OL2 6LH
United Kingdom

+44 (0)161 620 0666
sales@mico-tindall.com
www.mico-tindall.com

Component List

MICO Fitting Instructions & MICO Maintenance Procedures
 MICO Surface Mounted Mechanism Housing Assembly
 MICO Top Catch Bracket Assembly
 MICO Screw Kit(s)

All models except type -L:

MICO Push Plate Endcaps c/w Screws (Pair)
 MICO Panic Bolt Mechanism Bracket Assembly
 MICO Label Plate

All models except types -L and -P:

MICO Hinge Bracket Assembly
 MICO Hinge Bracket Extension Kit
 MICO Stand-off Extension Piece
 MICO Standard Lettered Push Plate
 MICO Push Pad Mounting Plate c/w Screws

Type -L only:

ASSA Lever Handle

Type -P only:

MICO Push Pad Cover Plate

Three point locking versions only:

ML Shoot Bracket Assembly



FITTING INSTRUCTIONS

MULTI-POINT RANGE OF EMERGENCY EXIT HARDWARE

No modifications of any kind other than those described in these instructions are permitted.

We advise reading these instructions through to ensure that they are fully understood before attempting to fit the MICO Panic Exit Device.

942 & 942-3 Range of Panic Bolts

	TINDALL ENGINEERING LTD Abyrl House Wright Street off Yorkshire Street Oldham Lancashire England OL1 3TF
0832 - 808	05
EN 1125:1997 + A1:2001	3 7 6 0 1 3 2 1 A

942P & 942-3P Range of Panic Bolts

	TINDALL ENGINEERING LTD Abyrl House Wright Street off Yorkshire Street Oldham Lancashire England OL1 3TF
0832 - 808	05
EN 179:1998 + A1:2001	3 7 6 0 1 3 4 1 B

942L & 942-3L Range of Panic Bolts

	TINDALL ENGINEERING LTD Abyrl House Wright Street off Yorkshire Street Oldham Lancashire England OL1 3TF
0832 - 808	05
EN 179:1998 + A1:2001	3 7 6 0 1 3 4 1 A

Designed and manufactured by:

Tindall Engineering Limited, Abyrl House,
 Wright Street, OLDHAM OL1 3TF
 Email: sales@mico-tindall.fsnet.co.uk
 Tel: 0161 620 0886 Fax: 0161 620 3966

**These units are HANDED**

Handing must be specified when ordering

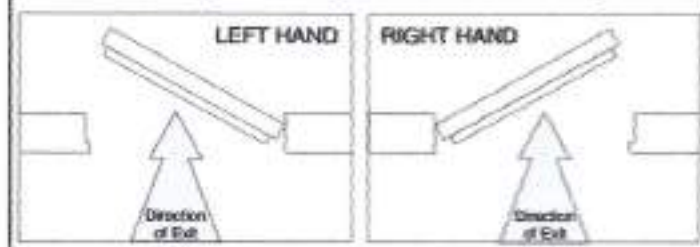
**DOOR SIZE LIMITATIONS ARE (+/- 2%):**

HEIGHT: 2150mm
 WIDTH: 1300mm
 WEIGHT: 200kg

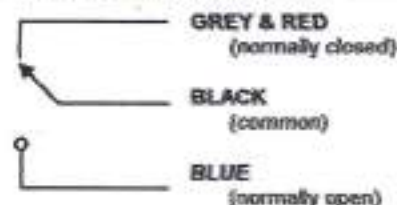
WIRING DIAGRAM

**STEP ONE
INSTALL EXTERNAL LOCKING KNOBSET
(IF REQUIRED)**

- 1) Fit Knobset, if required, using Countersunk Screws and the instructions provided, to the height shown in Diagram 1.3.

**STEP TWO
INSTALL ACTUATOR (A or B)**

A – FIT LEVER HANDLE (SEE DIAGRAM 1.1)

- 1) Insert the spindle into the square follower on the Mechanism Housing.
- 2) Fit the Handle onto the Spindle using the two M5 x 20mm Countersunk Screws.

B – FIT MECHANISM BRACKET (SEE DIAGRAM 1.2)

- 1) Remove the Restrictor Plate by unfastening the two M4 x 16mm Machine Screws.
- 2) Lift the Push Plate Receiver to the open position and fasten the Mechanism Bracket to the Mechanism Housing using the two M6x20mm Socket Cap Screws and Retaining Washers.
IMPORTANT: The Lever must locate below the Drive Plate. This is best achieved if the Locking Shoots are retracted.
- 3) Rest the Slide Plate on the leg of the Slide Plate Spring. When the Push Plate Receiver is closed the Lever should slightly compress this spring-loaded Slide Plate.
- 4) Fit the Finger Cover Plate using the two M4 x 12mm Countersunk Screws.
- 5) Re-fit the Restrictor Plate using two M4 x 16mm Machine Screws.

IMPORTANT: It is essential that the Restrictor Plate is fitted to ensure the correct operation of the Exit Device.

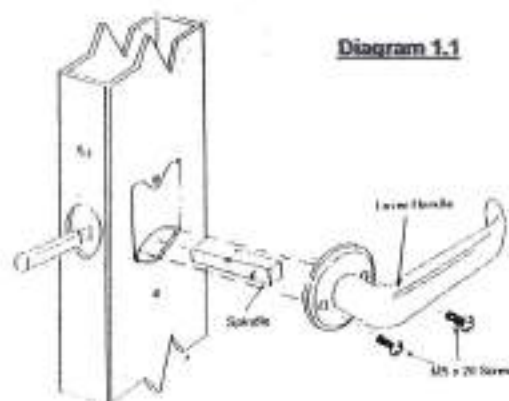

Diagram 1.1

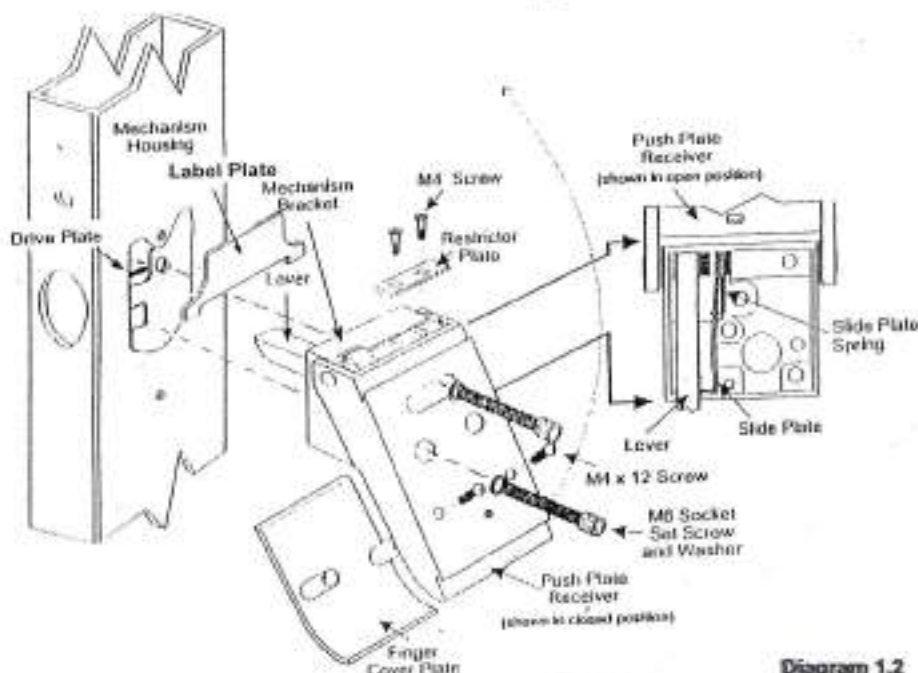

Diagram 1.2

**STEP THREE
CUT THE PANIC BOLT TO CORRECT HEIGHT**

- 1) Withdraw the Top Tripping Bracket Assembly by unfastening the Angled Socket Screw (using an M3 Allen Key) and pressing the Tripping Arm clear of the groove on the Ratchet Locking Shoot.
- 2) Remove the Ratchet Locking Shoot by unscrewing from the Threaded Rod.
- 3) Measure the clear height between the head of the door frame and bottom of the door, then deduct 10mm to allow clearance for the top Catch Bracket.
NOTE: if the Top Catch Bracket is to be recessed into the door frame, then only 6mm clearance should be deducted).
- 4) Mark out the Mechanism Housing squarely to the dimension obtained (units should be shortened from the TOP only). Cut to length using a hacksaw. With the bolts in the extended position cut the Threaded Rod 15-17mm longer than the Mechanism Housing.
- 5) Replace the Ratchet Locking Shoot onto the Threaded Rod so that approx. 22mm projects above the Mechanism Housing.
- 6) Slide the Top Ratchet Tripping Mechanism into the Mechanism Housing allowing the Ratchet Locking Shoot to pass through the Nylon Bush. Lock into place using the Angled Socket Screw.

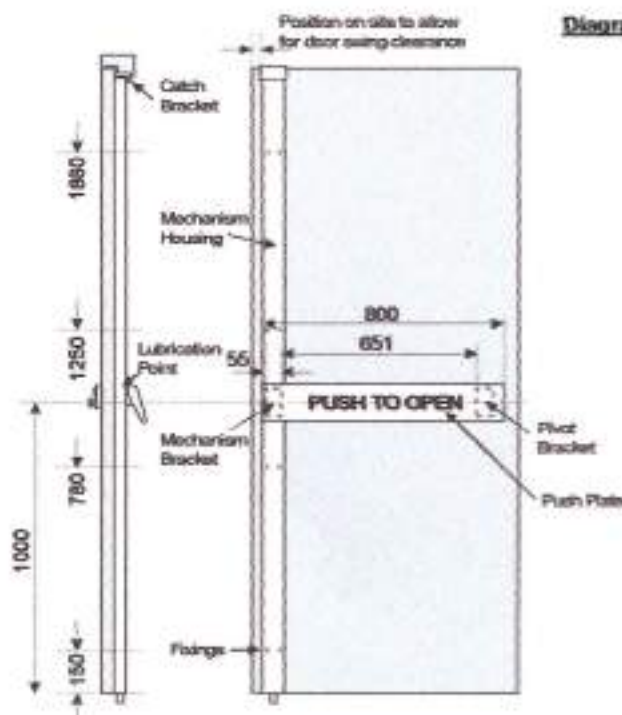

Diagram 1.3

STEP FOUR ADJUST CLEARANCE OF BOTTOM SHOOT

- 1) The bottom shoot is supplied to suit a standard clearance of 3mm between the base of the door and the threshold. This should be checked by aligning the Mechanism Housing on the door before fixing it.
- 2) If the clearance requires adjusting, remove the Bottom Shoot Bracket Assembly by unfastening the two M4x12mm Countersunk Screws.
- 3) Adjust the Bottom Shoot up or down (maximum 12mm) by turning clockwise or anti-clockwise.
- 4) Replace the Bottom Shoot Bracket Assembly and secure using the two M4x12mm Countersunk Screws.

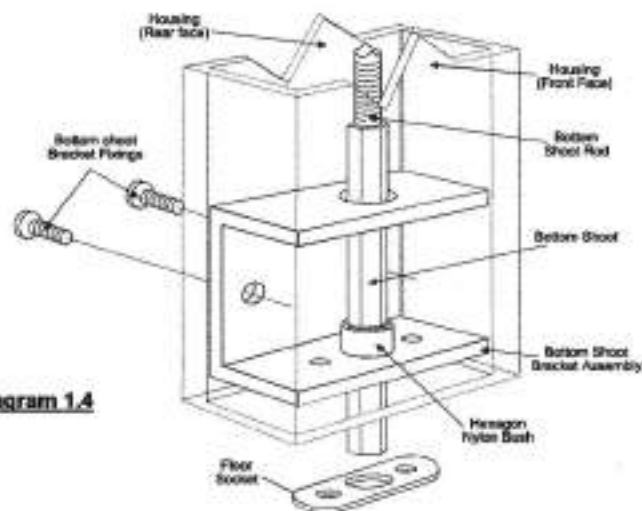

Diagram 1.4

STEP FIVE FIT MECHANISM HOUSING TO THE DOOR

- 1) Fasten the Mechanism Housing to the face of the door using the eight 2"x10s Woodscrews and Fixing Spacers. The Mechanism housing must be a maximum of (A) from the door frame to effect the door swing clearance. Allow 2mm extra (B) or the receiver if this is not recessed into the frame. (SEE TABLE A).
- 2) For 3 Point Locking Systems only Insert the 3rd point Locking Shoot through the Hexagonal Nylon Bush in the Lock Housing, hold in position and operate the Panic Bolt. The 3rd Point Locking Shoot should fully retract and be flush with the end face of the Lock Housing. It may be adjusted by screwing it clockwise or anti-clockwise.
- 3) Check the final position, 960mm from the base of the housing to the bottom of the MICO unit. Secure to the door using the two 2"x10s Woodscrews and Fixing Spacers.
- 4) Fit the Screw Cover Caps.

TABLE 'A'

BACKSET (mm)	(A) mm	(B) mm
50	53	55
75	78	80

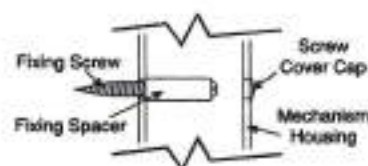
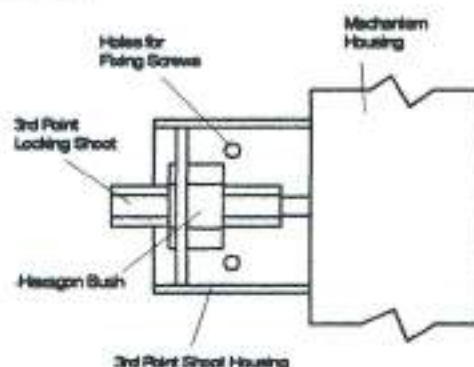

Diagram 1.5



STEP SIX ADJUST THE RATCHET LOCKING SHOOT

- 1) Depress the Actuator to retract the Locking Shoots. The Tripping Arm should engage in the top groove on the Ratchet Locking Shoot.
- 2) To set this position turn the Ratchet Locking Shoot clockwise or anti-clockwise. **IMPORTANT:** to obtain full movement the Ratchet Locking Shoot must retract a maximum of 1mm below the Ratchet Groove.
- 3) A final adjustment of up to +3mm is available using the Bottom Ratchet Groove. A further +8mm adjustment can be obtained by raising the Top Tripping Bracket Assembly within the Mechanism Housing.
- 4) **IMPORTANT:** the Ratchet Locking Shoot must be locked into position. Turn the Socket Pivot Screw anti-clockwise using an M5 Allen Key until the Lock Plate is securely positioned against the bottom of the Bracket. It may be necessary to turn the Ratchet Locking Shoot slightly to allow the Lock Plate to align on the hexagon of the shoot.



Diagram 1.6

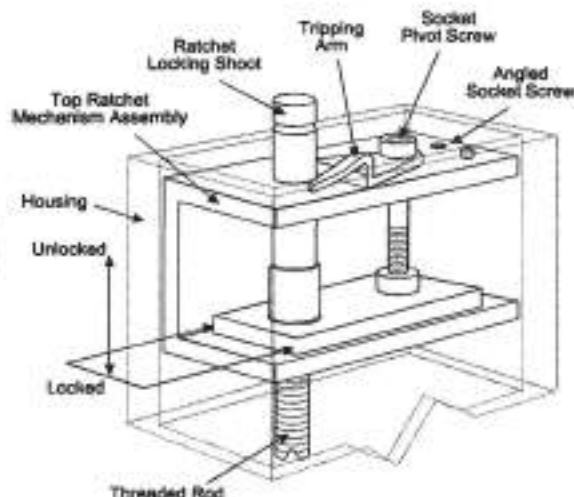

STEP SEVEN FIT CATCH BRACKET AND FLOOR SOCKETS

- 1) Align and fit the Catch Bracket to the head of the doorframe using four 1/4"x8s Woodscrews.
- 1) Align and fit the Floor Socket to the door threshold using two 1/4"x8s Woodscrews.

Diagram 1.7**STEP EIGHT
FIT PIVOT BRACKET (IF REQUIRED)**

- 1) Remove the Hinge Pin and separate the Push Plate Receiver from the Mechanism Bracket.
- 2) Fit the Hinge Bracket Extension to the Mechanism Bracket using the two 3/8" x 6s Self Tapping Screws.
- 3) Re-fit the Push Plate Receiver, align and replace the Hinge Pin.
- 4) Re-fit the Restrictor Plate using the two M4 x 16mm Machine Screws.
- 5) Fit the Finger Cover Plate using the two M4 x 12mm Countersunk Screws.

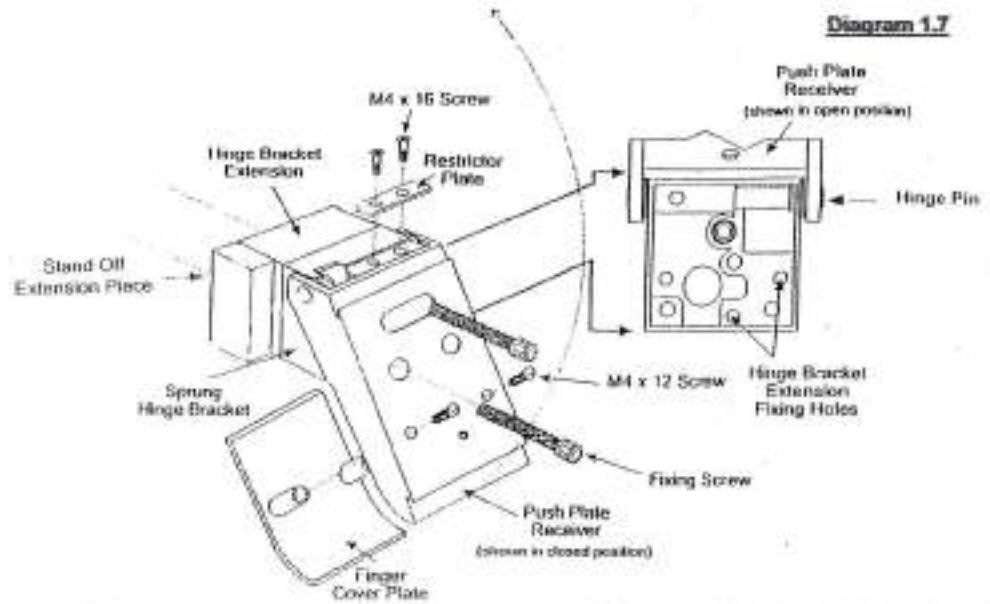
**STEP NINE
FIT PUSH PLATE (IF REQUIRED)**

- 1) Slide the factory-cut Push Plate onto the Push Plate Receivers.
- 2) Lock the Push Plate into position by fastening the Push Plate Lock Screws using a M3 Allen Key. These can be accessed through the holes in the underside of the Finger Cover Plates.
- 3) Fit the two Push Plate End Caps ensuring that the Locating Pegs align with the holes in the Push Plate. Carefully press/tap fully into position and secure using the four M3.5 x 10mm Countersunk Screws.
- 4) Fit the self adhesive Stand-off Extension Pieces onto the outer face of the Hinge Bracket Extension as shown in Diagram 1.7.
- 5) Fit the self adhesive Label Plate onto the MICO Mechanism Housing as shown in Diagram 1.2.

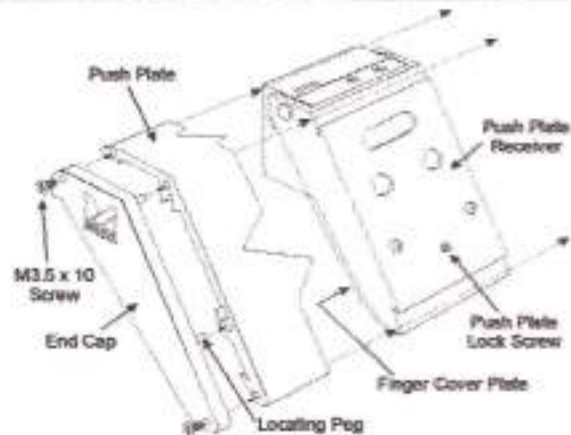
**Diagram 1.8****MAINTENANCE**

The Mico range has been tested to 200,000 operations, and should provide many years of service. However, in order to obtain the best from this product, it is important that the following routine maintenance is carried out by the occupiers or their approved representatives:

MONTHLY

*Inspect and operate the Panic Device to ensure that all components are in a satisfactory working condition.
Ensure that the Shoot Bolt Receivers are free from obstruction.*

EVERY SIX MONTHS

Remove the cover of the Lubrication Point and spray a light oil over the internal mechanism.

FOR A FULL MAINTENANCE GUIDE REFER TO THE SEPARATE MICO MAINTENANCE PROCEDURES SUPPLIED WITH THIS PRODUCT.

LH Combination 6 Way Core



- 5. RED
- 6. GREEN
- 7. WHITE
- 8. YELLOW
- 9. BLUE
- 10. BLACK

BS-MS
DL-MS

BOLT STATUS MICROSWITCH
-YELLOW
-BLUE
-BLACK

DEADLOCK STATUS MICROSWITCH
-RED
-GREEN
-WHITE

RH Combination 6 Way Core

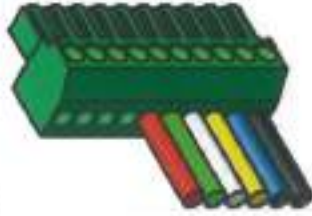

- 5. RED
- 6. GREEN
- 7. WHITE
- 8. YELLOW
- 9. BLUE
- 10. BLACK

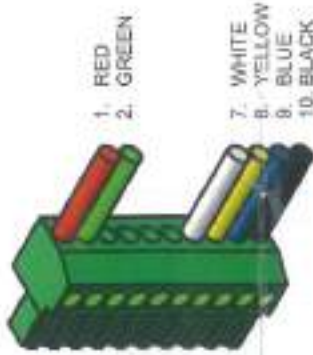

- 1. RED
- 2. GREEN
- 7. WHITE
- 8. YELLOW
- 9. BLUE
- 10. BLACK

EM
DL-MS

SOLENOID F/SAFE - F/SECURE
-RED
-GREEN

BOLT STATUS MICROSWITCH
-YELLOW
-BLUE
-BLACK

Fail Secure = 12V - 14.5W - 1.2A - 10 ohms
Fail Safe = 12V - 6.3W - 0.5A - 25 ohms



- 1. RED
- 2. GREEN
- 7. WHITE
- 8. YELLOW
- 9. BLUE
- 10. BLACK



- 1. RED
- 2. GREEN
- 5. BLUE
- 6. BLACK
- 7. WHITE
- 8. YELLOW

EM
BS-MS

SOLENOID F/SAFE - F/SECURE
-RED
-GREEN

DEADLOCK STATUS MICROSWITCH
-BLUE
-BLACK
-WHITE

Fail Secure = 12V - 14.5W - 1.2A - 10 ohms
Fail Safe = 12V - 6.3W - 0.5A - 25 ohms

FINISH		COLOUR		DO NOT SCALE - IF IN DOUBT ASK REMOVE ALL BURRS	
MATL	DRAWN BT	DRG No	M0510-A	TOLERANCES ON DIMENSIONS UNLESS OTHERWISE SPECIFIED	
	SCALE	DESCRIPTION		THIS DRAWING IS LOANED - NOT TO BE REPRODUCED OR COPIED IN ANY MANNER WITHOUT THE WRITTEN CONSENT OF THE COMPANY	REVISED BY DATE
	CHECKED	Wiring Diagram 6 Way		FINISH	BY

ISSUE	DESCRIPTION	DATE
A	First Issue	03/12/12