



ROVER 75

Electrical Circuit Diagrams

Publication Part No. RCL0544ENG
Published by MG Rover Group After Sales
© MG Rover Group Limited 2003

COLOUR CODES**DRAADKLEURCODES****CODICI COLORI DEI CAVI****CODES DES COULEURS DES FILS****CODIGOS DE COLORES DE LOS CABLES****KABELFARBCODES****CÓDIGOS DAS CORES DOS FIOS**

| CODE | COLOUR | CODE | KLEUR | CODE | COULEUR | CODE | FARBE | CODICE | COLORE | CODIGO | COLOR | CÓDIGO | COR |
|------|--------------|------|------------|------|------------|------|----------|--------|------------------|--------|----------------|--------|-------------|
| B | BLACK | B | ZWART | B | NOIR | B | SCHWARZ | B | NERO | B | NEGRO | B | PRETO |
| G | GREEN | G | GROEN | G | VERT | G | GRÜN | G | VERDE | G | VERDE | G | VERDE |
| K | PINK | K | ROZE | K | ROSE | K | ROSA | K | ROSA | K | ROSA | K | ROSA |
| LG | LIGHT GREEN | LG | LICHTGROEN | LG | VERT CLAIR | LG | HELLGRÜN | LG | VERDE CHIARO | LG | VERDE CLARO | LG | VERDE CLARO |
| N | BROWN | N | BRUIN | N | BRUN | N | BRAUN | N | MARRONE | N | MARRON | N | CASTANHO |
| O | ORANGE | O | ORANJE | O | ORANGE | O | ORANGE | O | ARANCIONE | O | NARANJA | O | LARANJA |
| P | PURPLE | P | PAARS | P | VIOLET | P | LILA | P | PORPORA | P | PURPURA | P | ROXO |
| R | RED | R | ROOD | R | ROUGE | R | ROT | R | ROSSO | R | ROJO | R | VERMELHO |
| S | SLATE (grey) | S | LEIGRIJS | S | GRIS | S | GRAU | S | ARDESIA (grigio) | S | PIZARRO (gris) | S | CINZENTO |
| U | BLUE | U | BLAUW | U | BLEU | U | BLAU | U | BLU | U | AZUL | U | AZUL |
| W | WHITE | W | WIT | W | BLANC | W | WEISS | W | BIANCO | W | BLANCO | W | BRANCO |
| Y | YELLOW | Y | GEEL | Y | JAUNE | Y | GELB | Y | GIALLO | Y | AMARILLO | Y | AMARELO |

CONTENTS

| | | | | | |
|---------------------------------------------------------------|-----|--|--|--|-------------------------------------------------|
| 4 POWER DISTRIBUTION | 6 | | | | |
| ENGINE COMPARTMENT | 6 | | | | |
| PASSENGER COMPARTMENT | 10 | | | | |
| 8 EARTH DISTRIBUTION | 15 | | | | |
| 12 ENGINE MANAGEMENT | 24 | | | | |
| DIESEL | 24 | | | | |
| KV6 | 27 | | | | |
| K SERIES | 31 | | | | |
| 16 CHARGING AND STARTING | 34 | | | | |
| KV6 | 34 | | | | |
| K SERIES | 35 | | | | |
| DIESEL | 36 | | | | |
| 20 FUEL PUMP | 37 | | | | |
| 24 ENGINE IMMOBILISATION | 38 | | | | |
| 28 ANTI-THEFT ALARM | 40 | | | | |
| 36 AUTOMATIC TRANSMISSION | 44 | | | | |
| PETROL | 44 | | | | |
| DIESEL | 46 | | | | |
| 40 SHIFT INTERLOCK | 48 | | | | |
| 44 ANTI-LOCK BRAKING SYSTEM AND TRACTION CONTROL | 49 | | | | |
| 60 CRUISE CONTROL | 52 | | | | |
| PETROL | 52 | | | | |
| DIESEL | 54 | | | | |
| 64 SUPPLEMENTARY RESTRAINT SYSTEM | 56 | | | | |
| LOW-LINE | 56 | | | | |
| HIGH-LINE | 57 | | | | |
| 72 ROTARY COUPLER | 59 | | | | |
| 80 FUEL BURNING HEATER | 60 | | | | |
| 84 AIR CONDITIONING | 62 | | | | 132 HORNS |
| 85 AIR TEMPERATURE CONTROL | 65 | | | | 136 SEATS |
| 88 COOLING FANS | 68 | | | | MEMORY |
| K SERIES | 68 | | | | HEATED |
| K SERIES AUTO | 69 | | | | NON MEMORY |
| KV6 | 70 | | | | |
| DIESEL | 71 | | | | 140 DOOR MIRRORS |
| 92 HEATED WINDOW | 72 | | | | FOLDING |
| 96 WINDOWS | 73 | | | | 141 REAR VIEW MIRROR |
| FRONT | 73 | | | | |
| REAR | 74 | | | | 144 AUDIO SYSTEMS |
| 100 SUNROOF | 75 | | | | HARMONY |
| 101 REAR SUNBLIND | 76 | | | | SYMPHONY |
| 104 WIPERS AND WASHERS | 77 | | | | SYMPHONY PLUS PREMIUM AUDIO |
| FRONT | 77 | | | | |
| REAR | 79 | | | | 148 NAVIGATION SYSTEMS |
| HEADLAMP POWER WASH | 80 | | | | LOW-LINE |
| HEATED WASHER JETS | 81 | | | | HIGH NAVIGATION PLUS TV AND PREMIUM AUDIO |
| 108 EXTERIOR LAMPS | 82 | | | | HIGH NAVIGATION PLUS TV AND PREMIUM AUDIO |
| HEAD/SIDE LAMPS | 82 | | | | (JAPAN ONLY) |
| DIRECTIONAL INDICATOR/HAZARD WARNING LAMPS .. | 84 | | | | HIGH NAVIGATION PLUS TV |
| FOG LAMPS REAR | 87 | | | | HIGH NAVIGATION PLUS TV (JAPAN ONLY) |
| HEADLAMP LEVELLING | 88 | | | | HIGH NAVIGATION |
| BRAKE AND REVERSE LAMPS | 89 | | | | HIGH NAVIGATION PLUS PREMIUM AUDIO |
| FOG LAMPS FRONT | 91 | | | | |
| 112 INTERIOR LAMPS | 92 | | | | 156 BODY CONTROL UNIT |
| 116 INTERIOR ILLUMINATION | 94 | | | | 160 COMMUNICATION DATABASES |
| 120 INSTRUMENTS | 97 | | | | 164 DIAGNOSTIC SOCKET |
| 124 CLOCK | 100 | | | | 172 TRAILER SOCKET |
| 128 CIGAR LIGHTER | 101 | | | | 176 PARK DISTANCE CONTROL |
| | | | | | 180 HEADER JOINTS |
| | | | | | 184 SPLICES AND CENTRE TAPS |

HOW TO USE THE CIRCUIT DIAGRAMS

All of the information in the Circuit Diagrams is intended for use with the Electrical Reference Library.

The circuit diagrams are presented with Power and Earth distribution first, followed by individual circuits for each electrical system on the vehicle.

Power Distribution

The Power Distribution diagram shows the connections from the battery to the engine and passenger compartment fuse boxes. It also shows the internal circuitry of the fuse boxes.

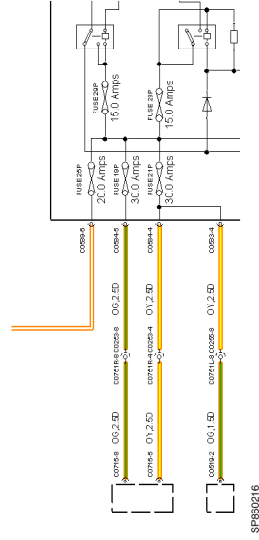

Splices and centre taps

Header and splice tables present the joint(s) and wiring up to the first component. Splices are identified by a number with an alphabetical prefix and the wire colour.

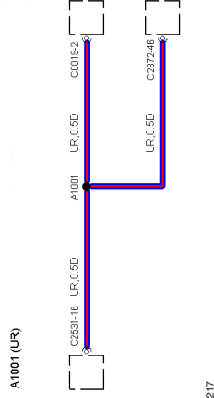

The splice information shown on individual system circuits is not complete. Always refer to the splices circuit for complete information on each splice.

Wire attributes

Additional information (separated by a ':') is shown alongside the wire colour.

Wire gauge - the cross-sectional area of the wire in square millimetres. This is included to help you select the correct wire during harness repair.

Some wires do not have a gauge shown, these wires are of unique construction and will have a three or four letter code printed after the colour code, e.g. MAB. The code identifies the type of wire for manufacturing purposes. Usually, only the first two characters have significance in service, but in some instances the third character also becomes significant, see table.

Wire type

The following table lists the wire type codes together with an explanation of their meaning.

| Code | Description |
|-----------------------------------|-------------------------------------------|
| D | Single core DIN wire |
| F | Single core flexible wire |
| H | Single core high temperature wire |
| SA* | Single core resistive wire (0.9 ohms/m) |
| SB*, SC*, SD* | Single core dual extruded wire |
| SE*, SF* | Single core fusible wire |
| MAC, MAD, MAE, MAF, MAG, MAH | Coaxial screened wire |
| MB*, MC*, MAK | Single core screened wire |
| MC*, MI*, MP*, MQ*, MAB, MAP | Twin core screened wire |
| MD*, MJ*, MAM | Twin core ABS sensor wire |
| ME*, TA*, TB*, MM*, MN*, MU*, MAI | Twisted pair of wires |
| MF* | Heated oxygen sensor (HO2S) screened wire |
| MG* | Twin core twisted, screened wire |
| MH | four core twisted, screened wire |
| MK* | Three core SRS sensor wire |
| ML*, MAA, MAF | Four core screened wire |
| MR* | Six core screened, flexible wire |
| MS* | Four core screened, flexible wire |
| MT* | Single core screened, flexible wire |
| MV* | Twin core flat wire |
| MW* | Three core round wire |
| MX*, MY* | Seven core round wire |
| MZ* | Three core screened, flexible wire |
| MAJ | Twin core round cable |
| MAQ, MAU | Three core screened wire |
| MAS | Single core, double sheath wire |
| MAT | Double core, double sheath wire |
| MAL | SFS wire |
| MAN | Twin core braided, screened wire |

HOW TO USE THE CIRCUIT DIAGRAMS

Connectors

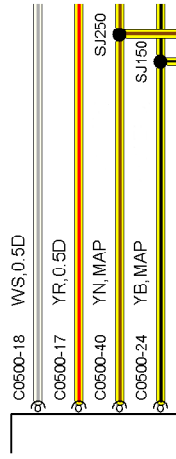

SF660215

Connectors have a numbered suffix to indicate the pin-out detail of the wire, i.e. C500-17 identifies connector 500, pin number 17. Wire insulation colour is identified in the normal way. Where wires have a predominant colour with a secondary colour stripe, the main colour is identified first, i.e. YR - Yellow with a Red stripe.

Line Types



SF660211

This means the wire connects to another circuit.

Earth points

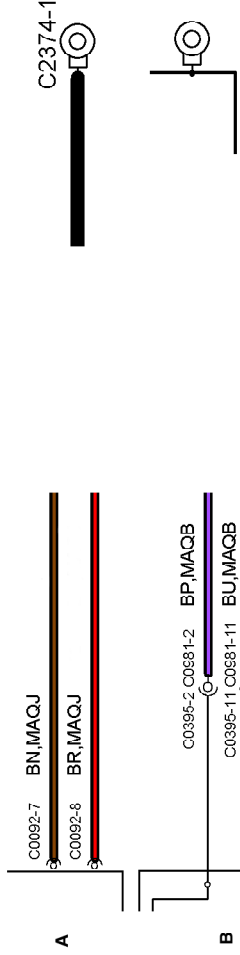

SF660212

Earth points are identified with an eyelet symbol and a connector number, except where components are grounded through their fixings, when only the eyelet is shown.

Fuses and Diodes

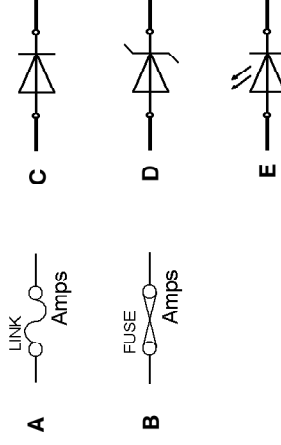

SF660218

Fusible links (A) and current rated fuses (B) are identified as shown. The direction of the arrow in a Diode symbol (C) indicates the direction of current flow. The Zener diode (D) - prevents current flow until a precise voltage is reached. A light emitting diode (LED) illuminates when current flows through it.

The cup and ball symbol indicates the male and female halves of connector.

- A. Connector plugs directly into component.
- B. Plug on lead (Flylead) wired directly to the component.

Components

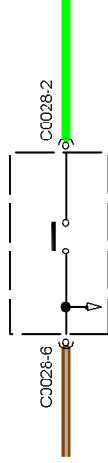

SF660214

A dotted outline indicates that the component is not shown in its entirety.

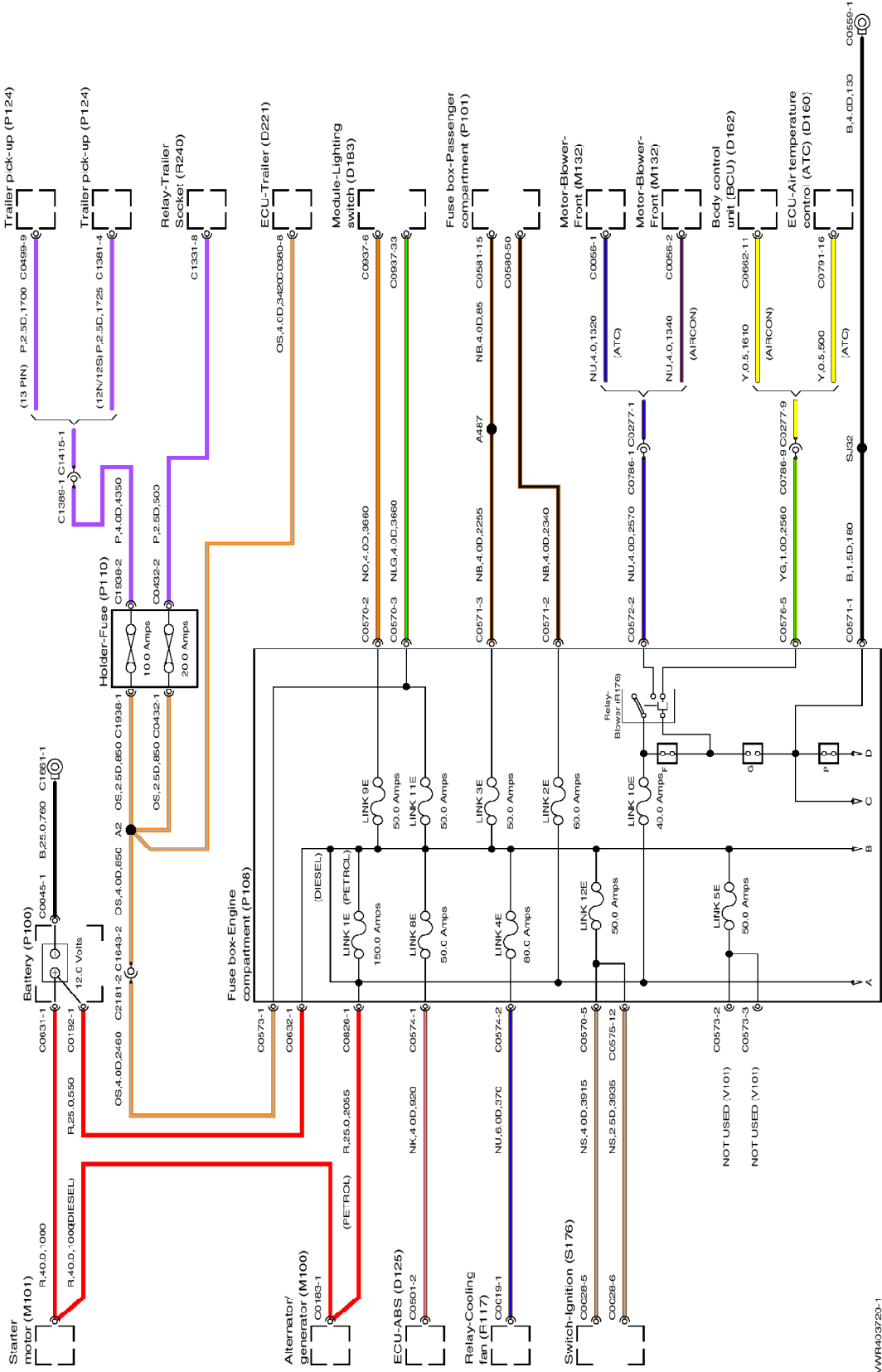

VWR403720-1

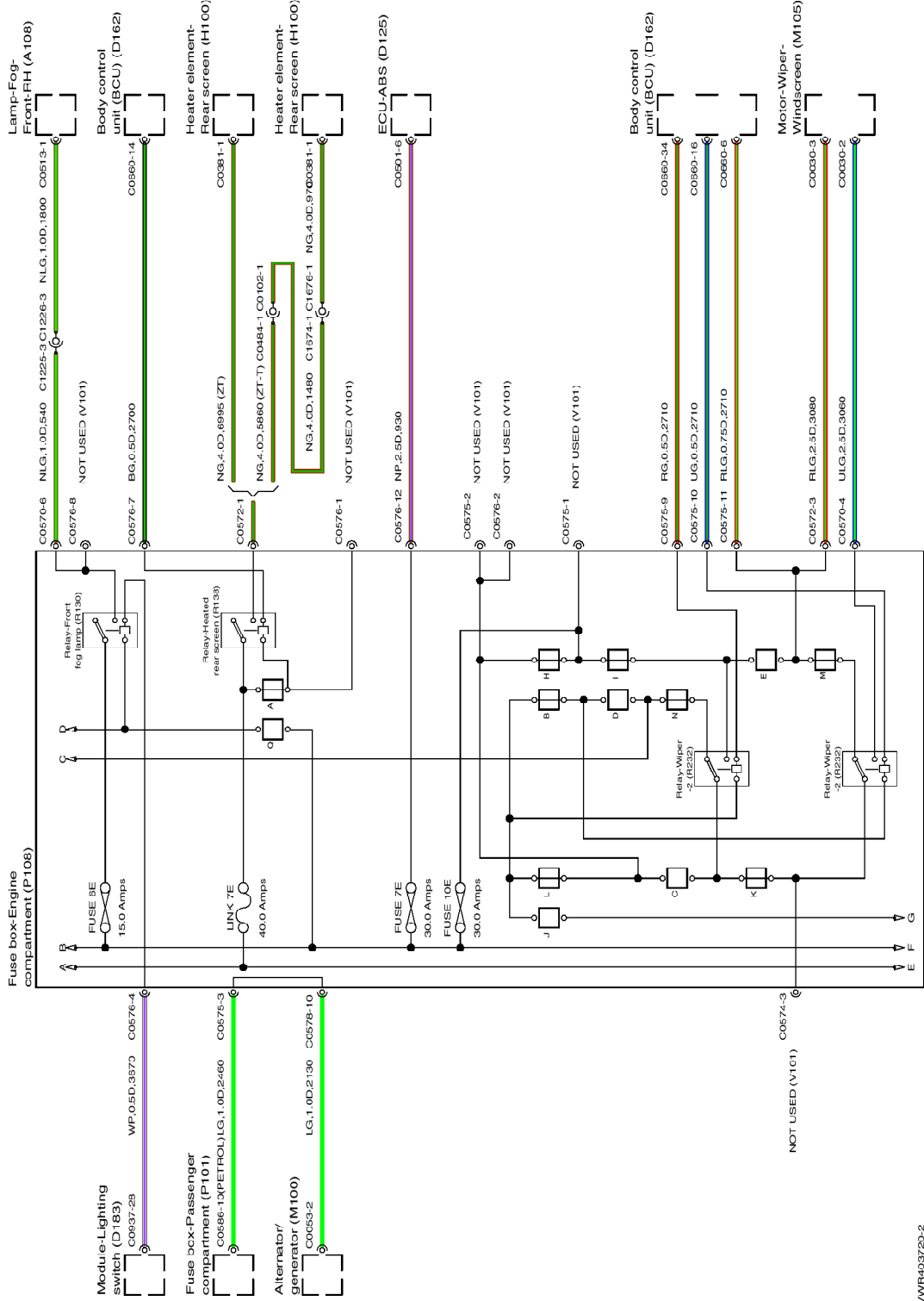

VWR403720-2

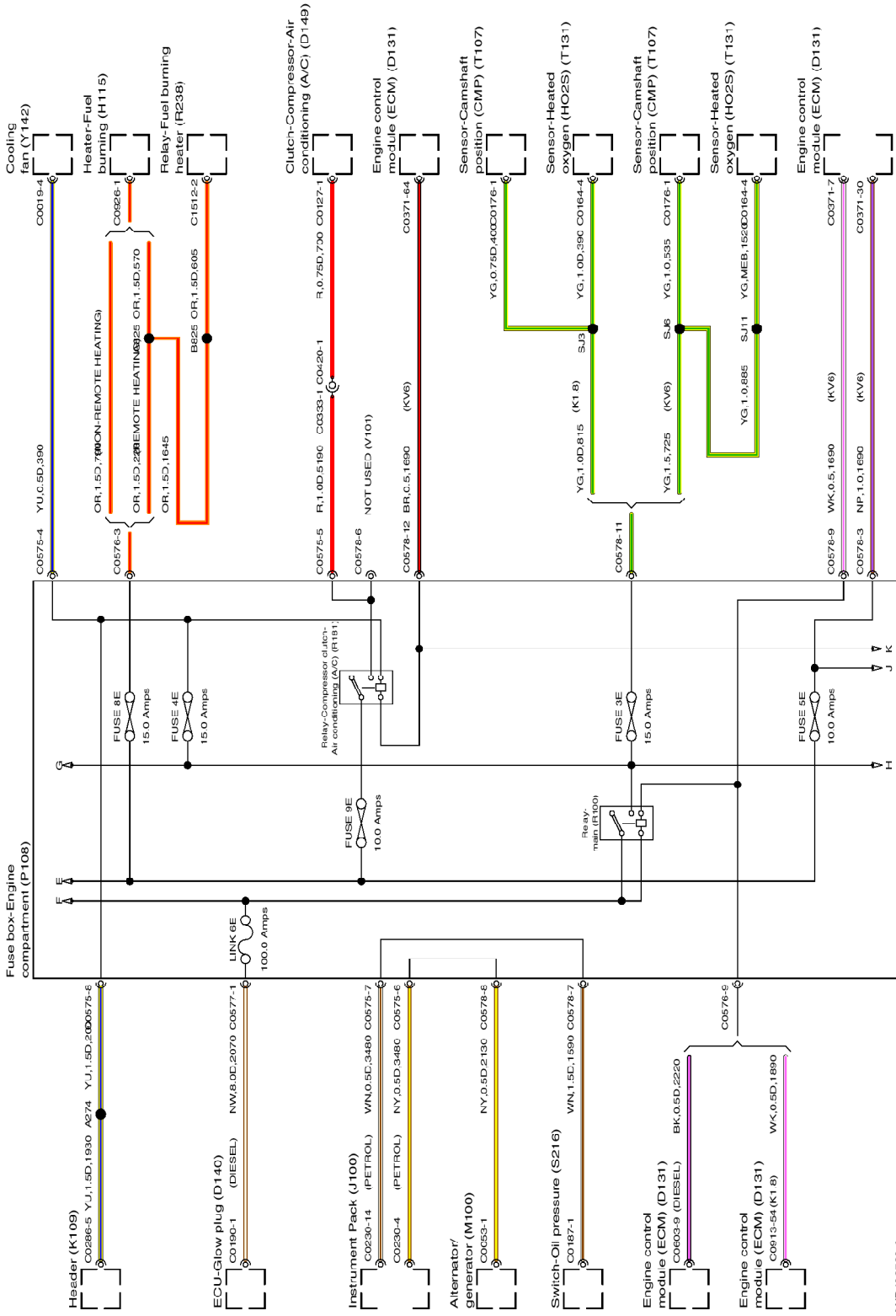

VWR403720-3

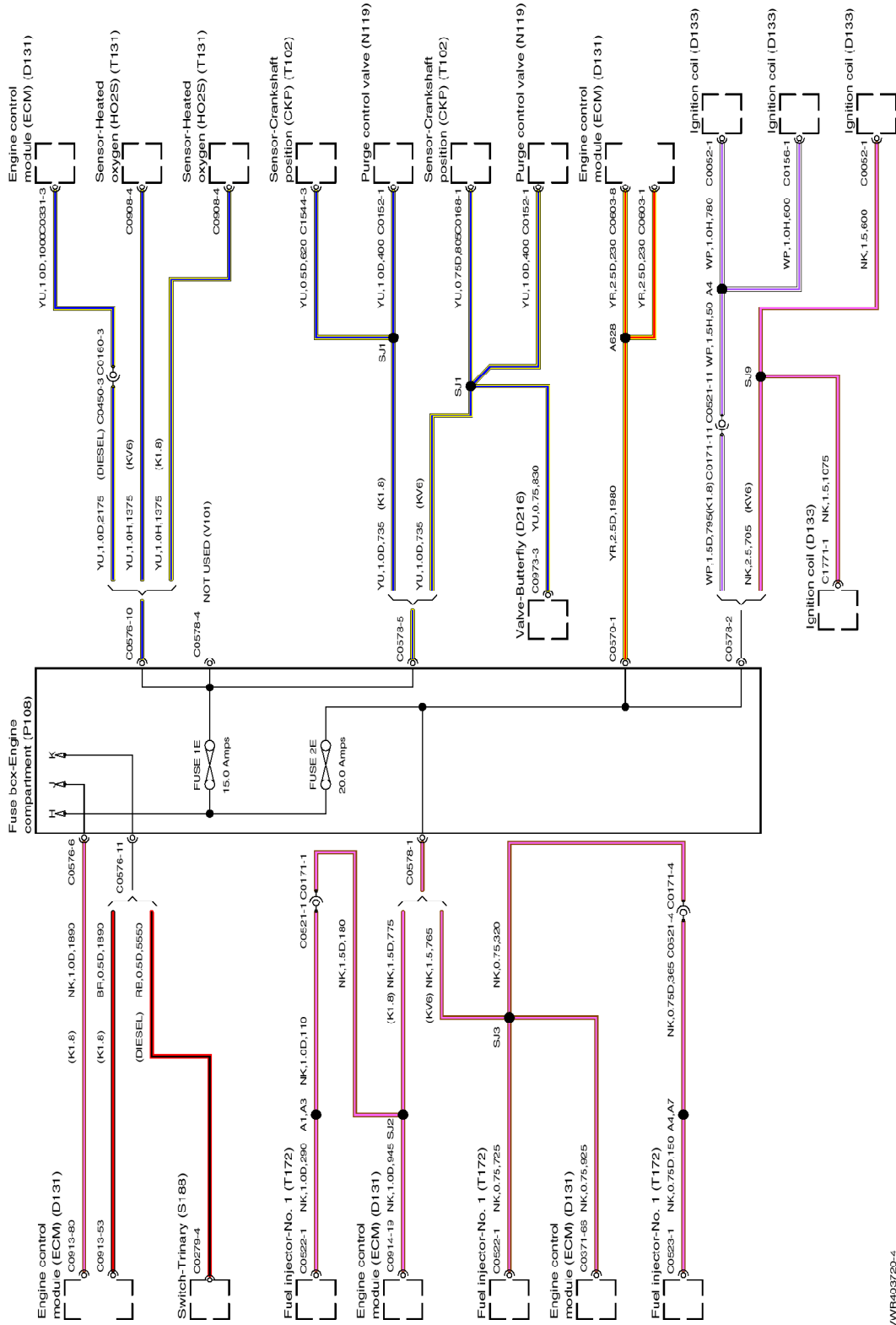

VWR403720-4

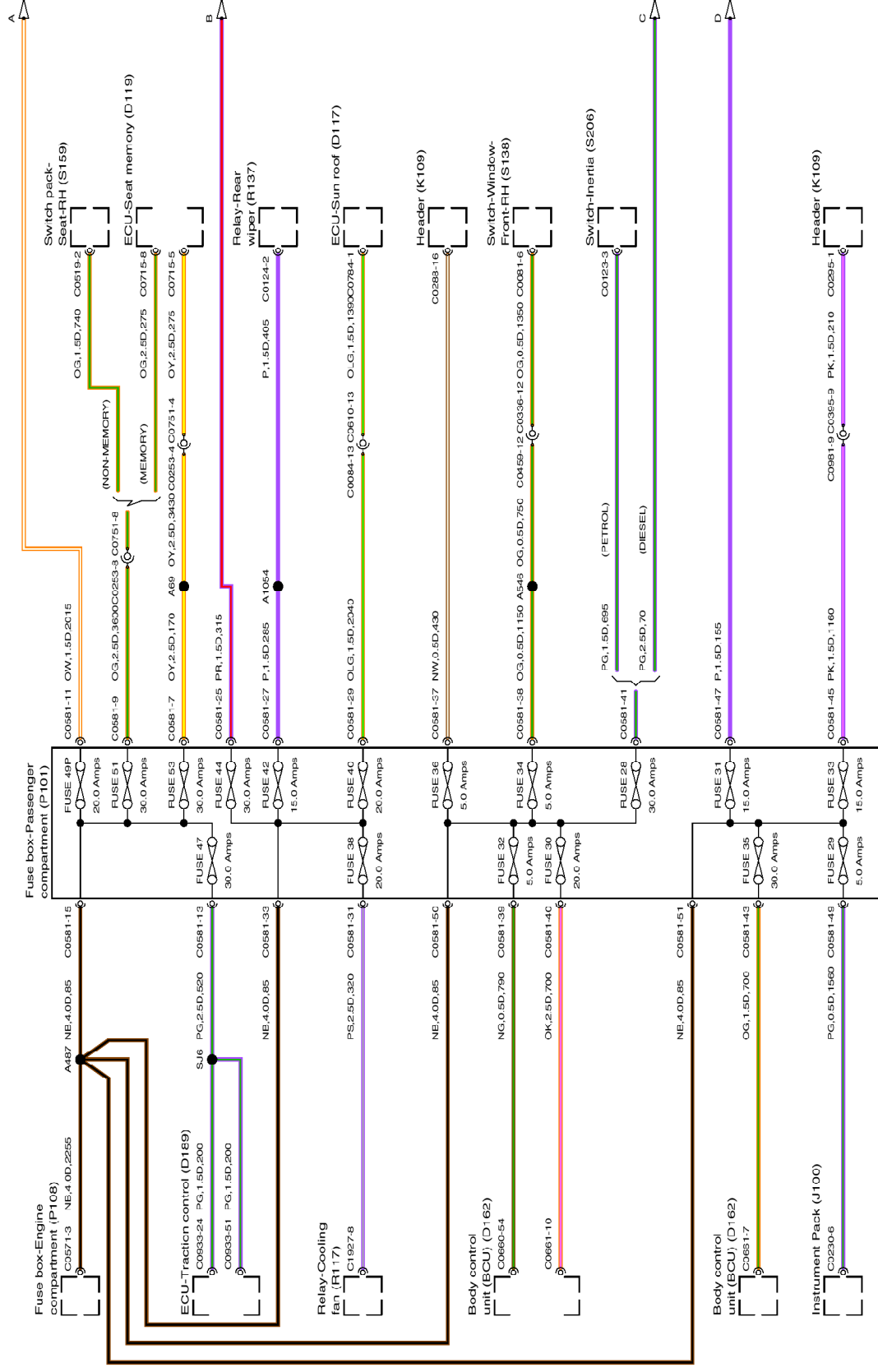

VWR403740-1

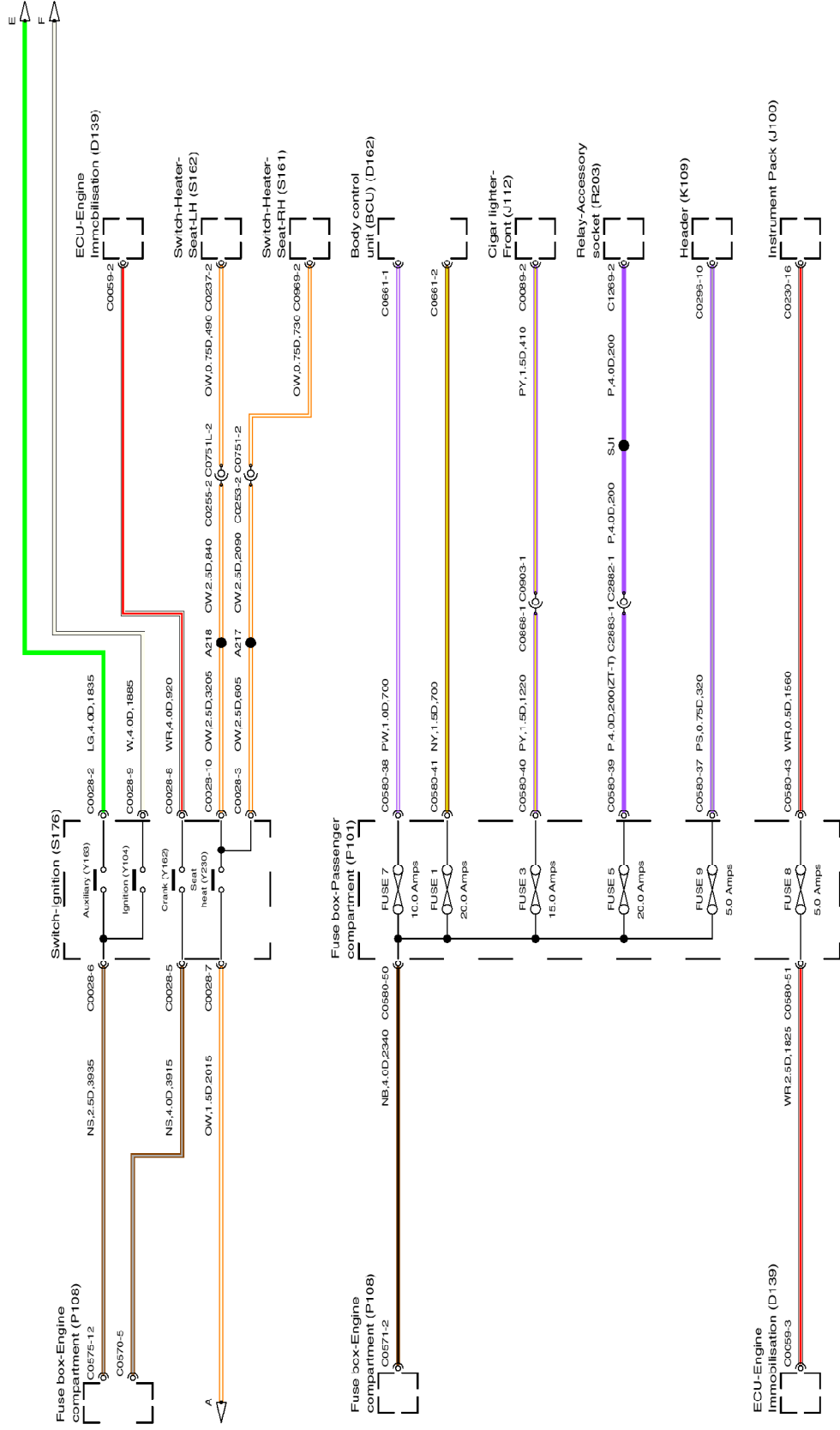

VWR403740-2

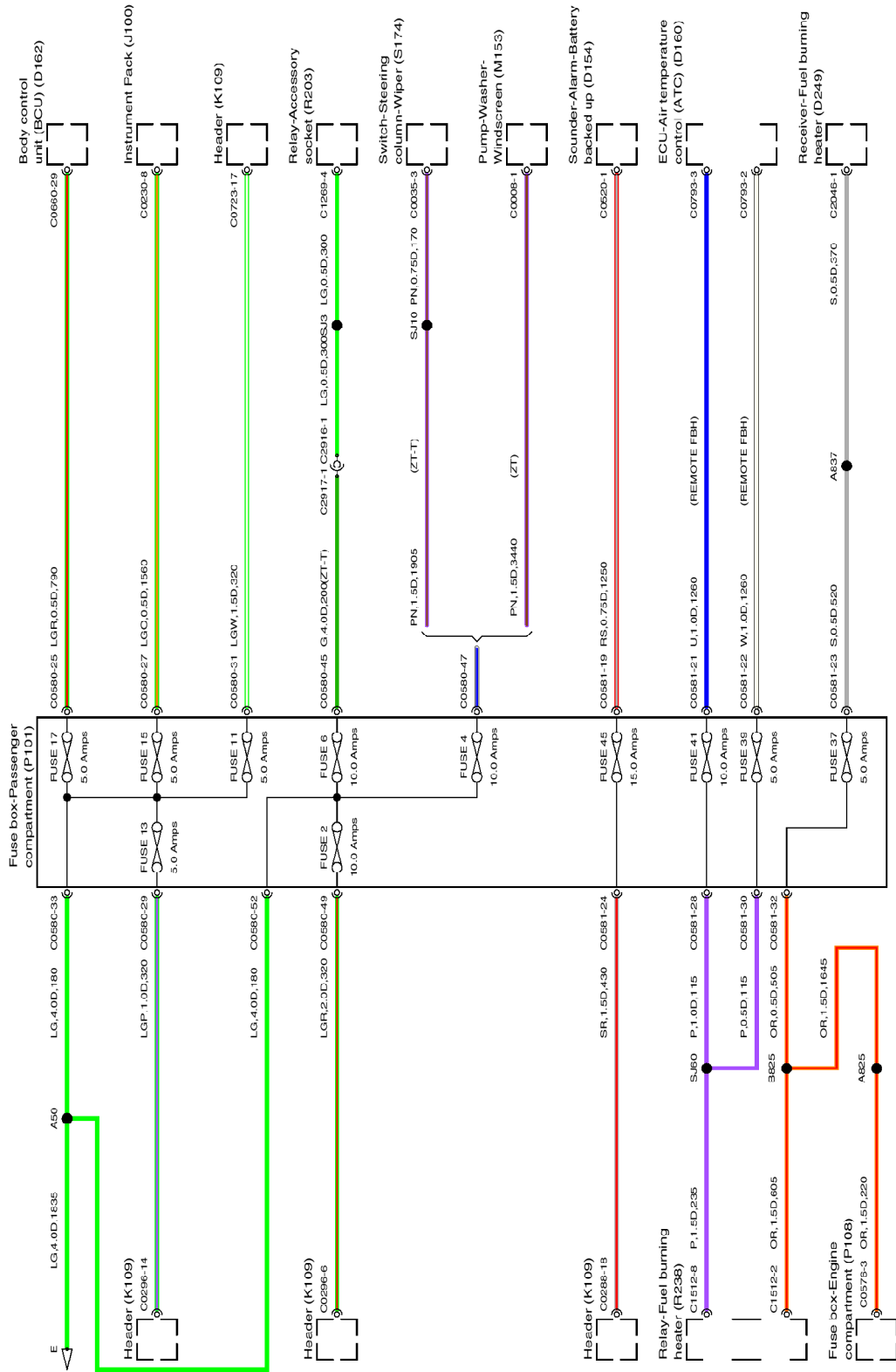

VWR403740-3

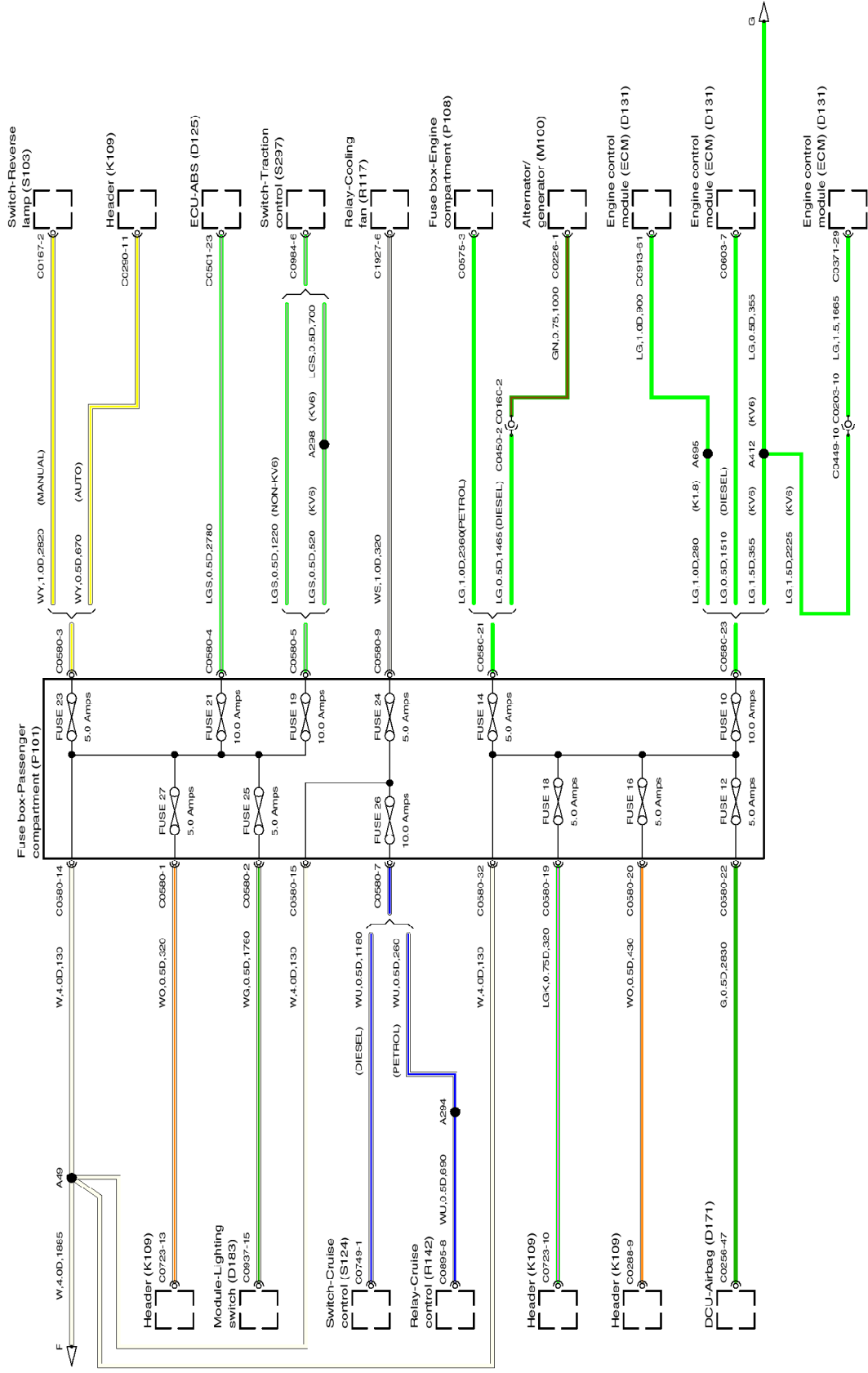

VWR403740-4

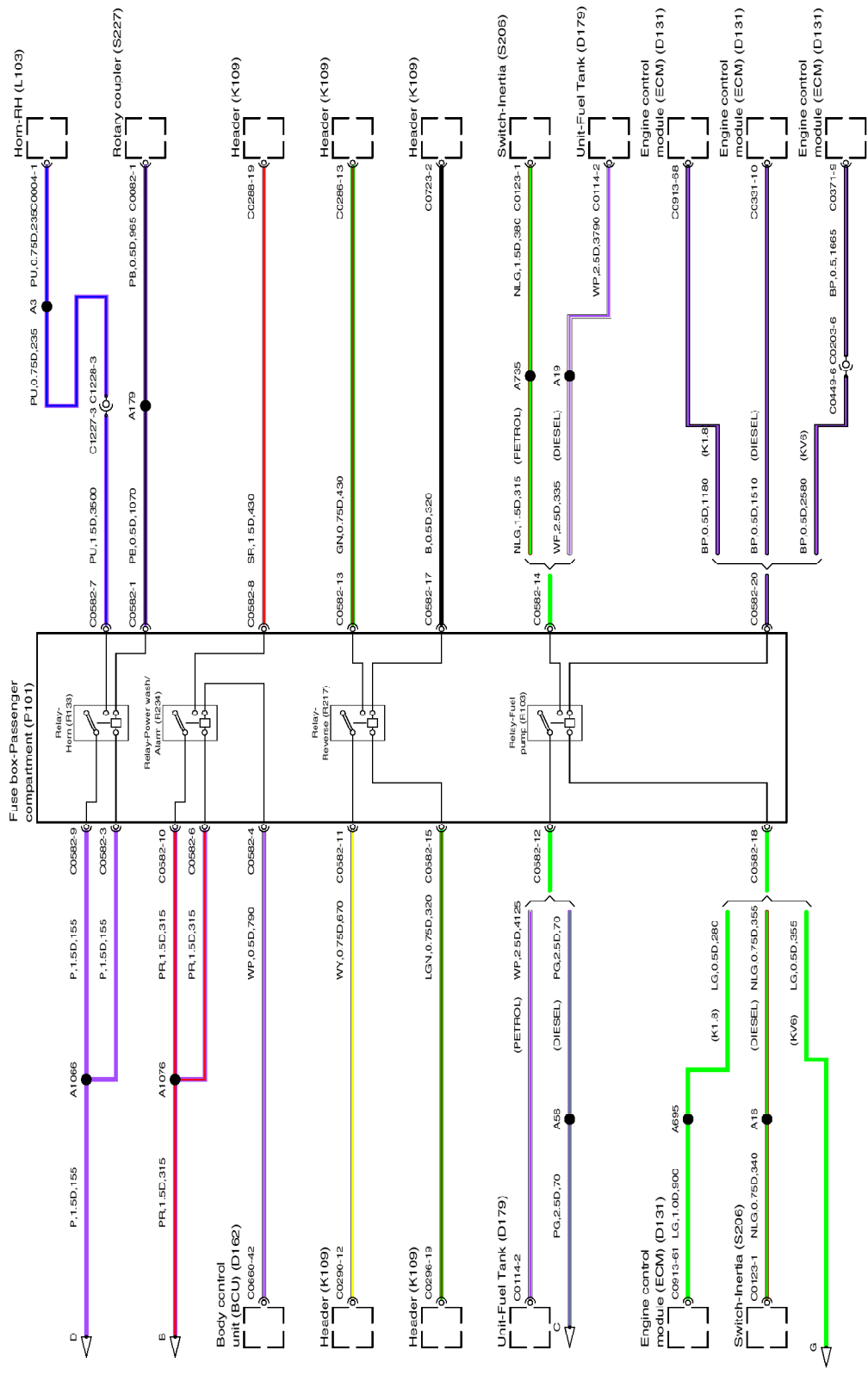

VWR403740-5

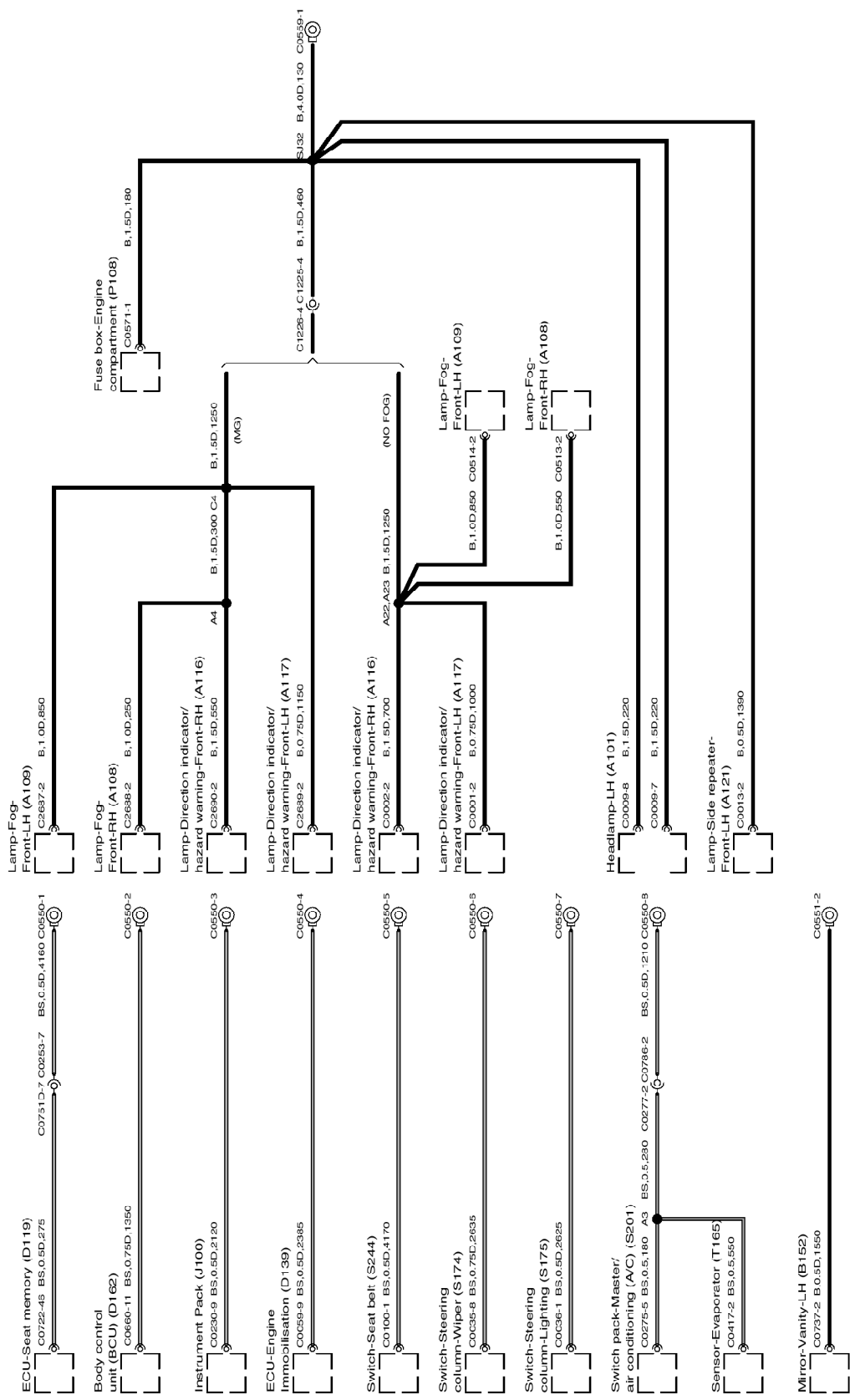

VWR403020-1

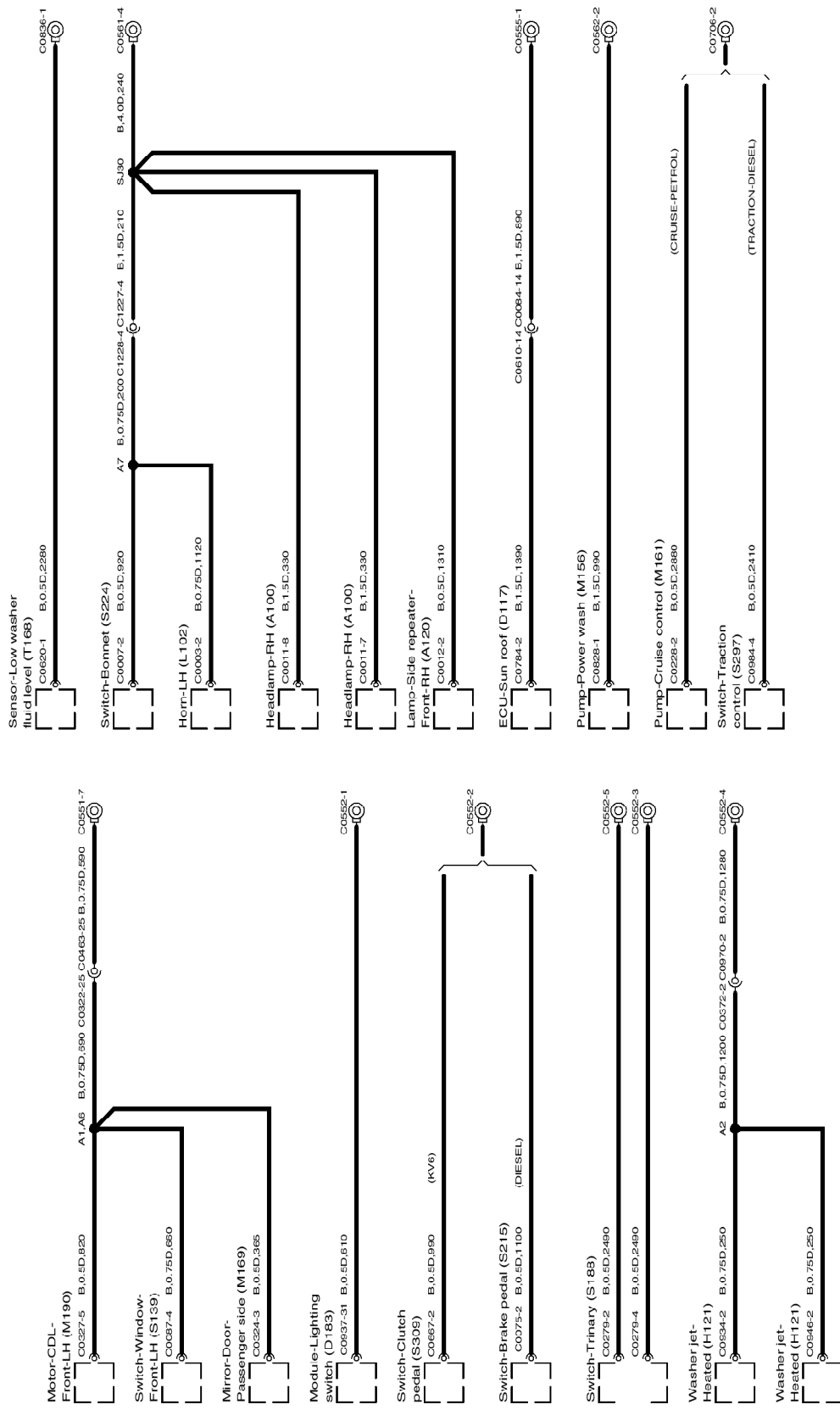

VWR403020-2

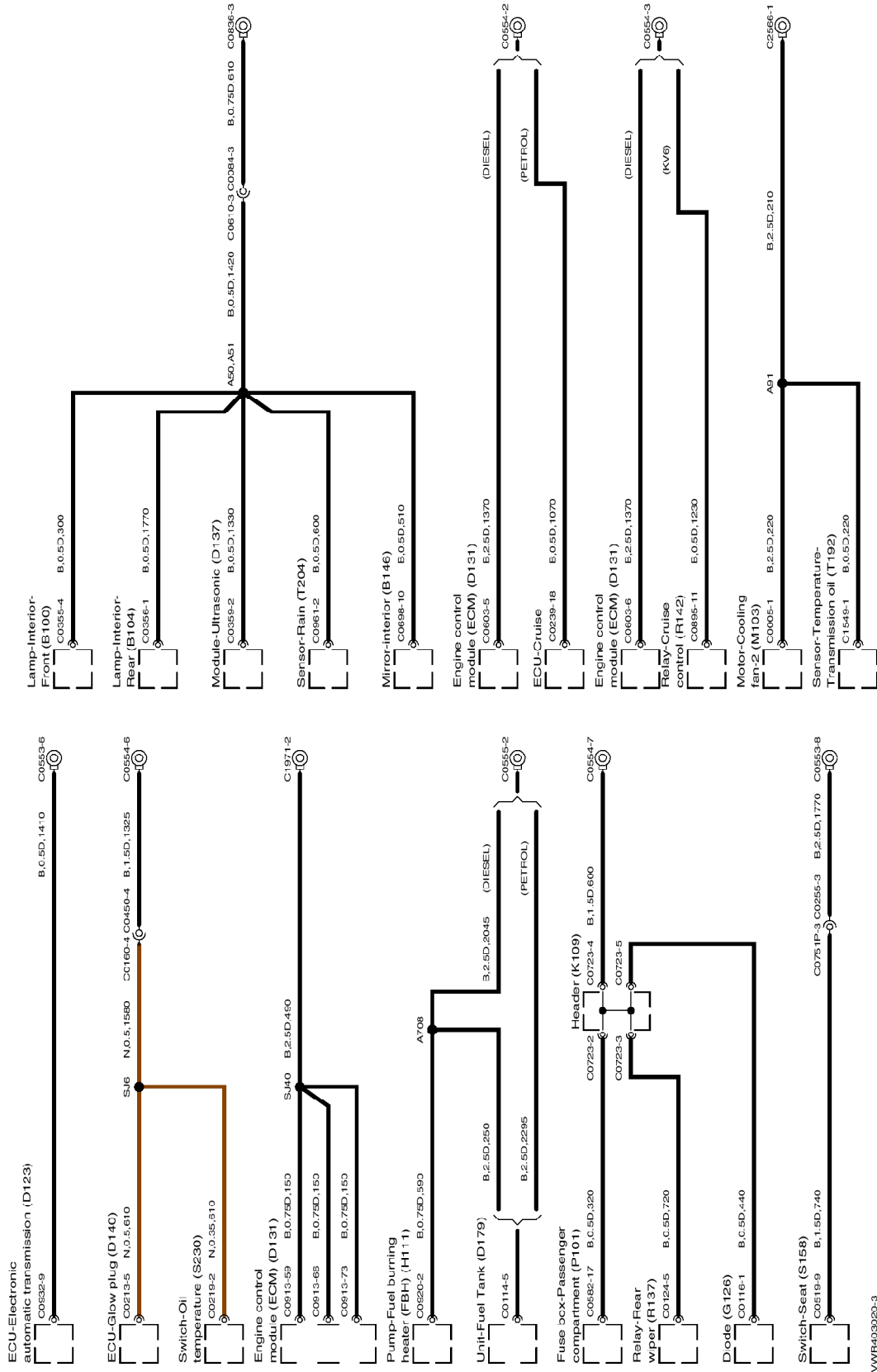

VWR403020-3

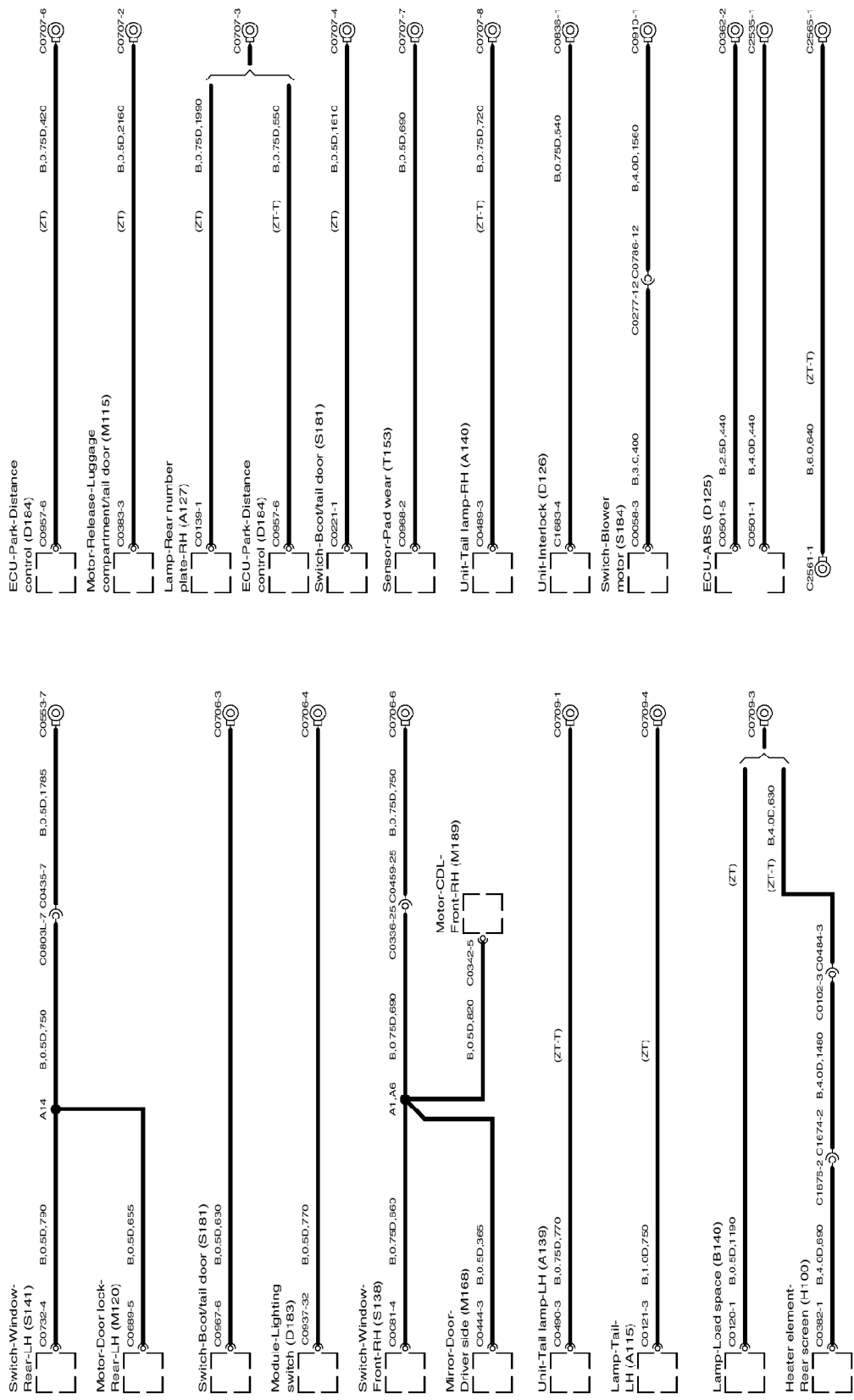

VWR403020-4

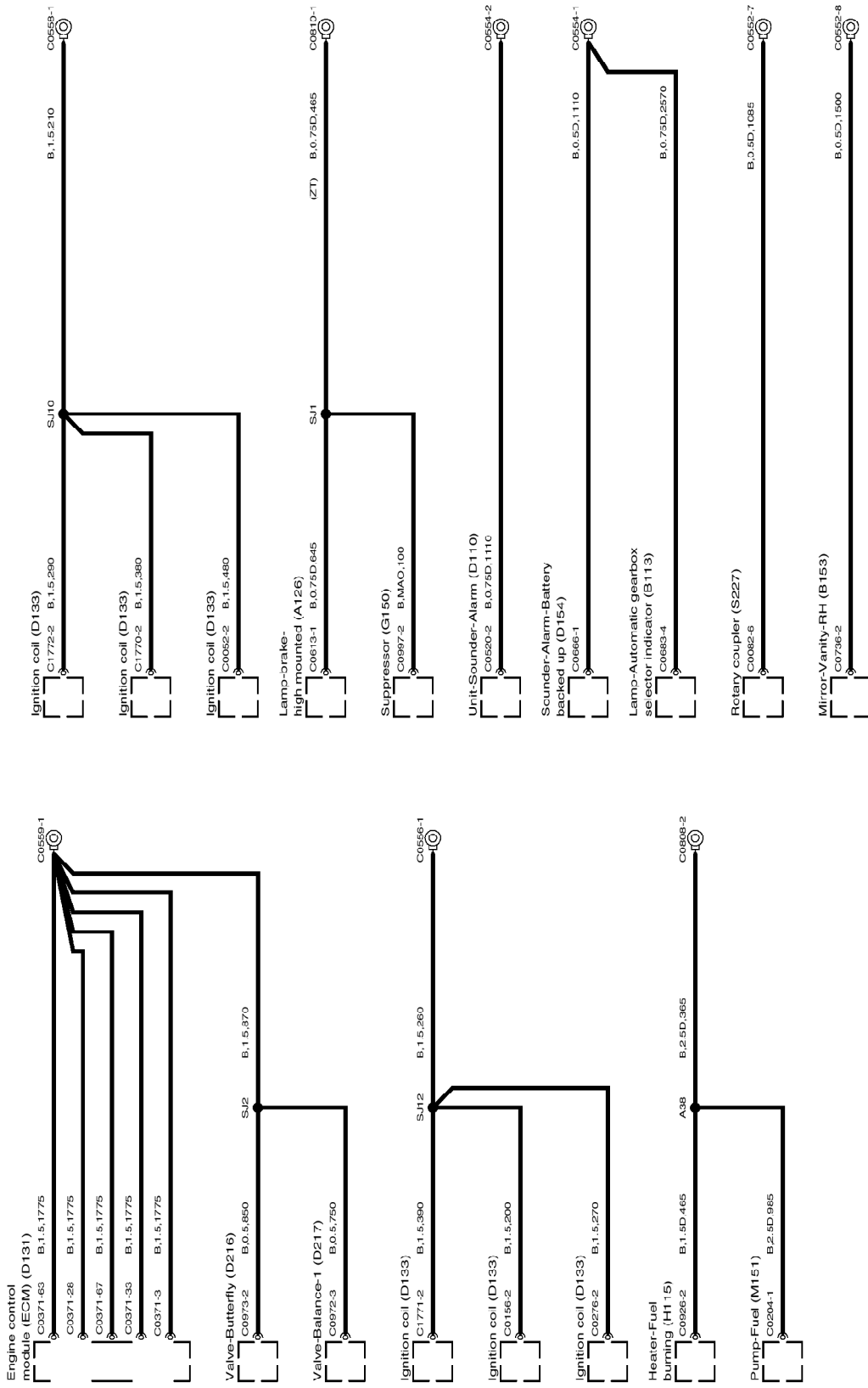

VWR403020-5

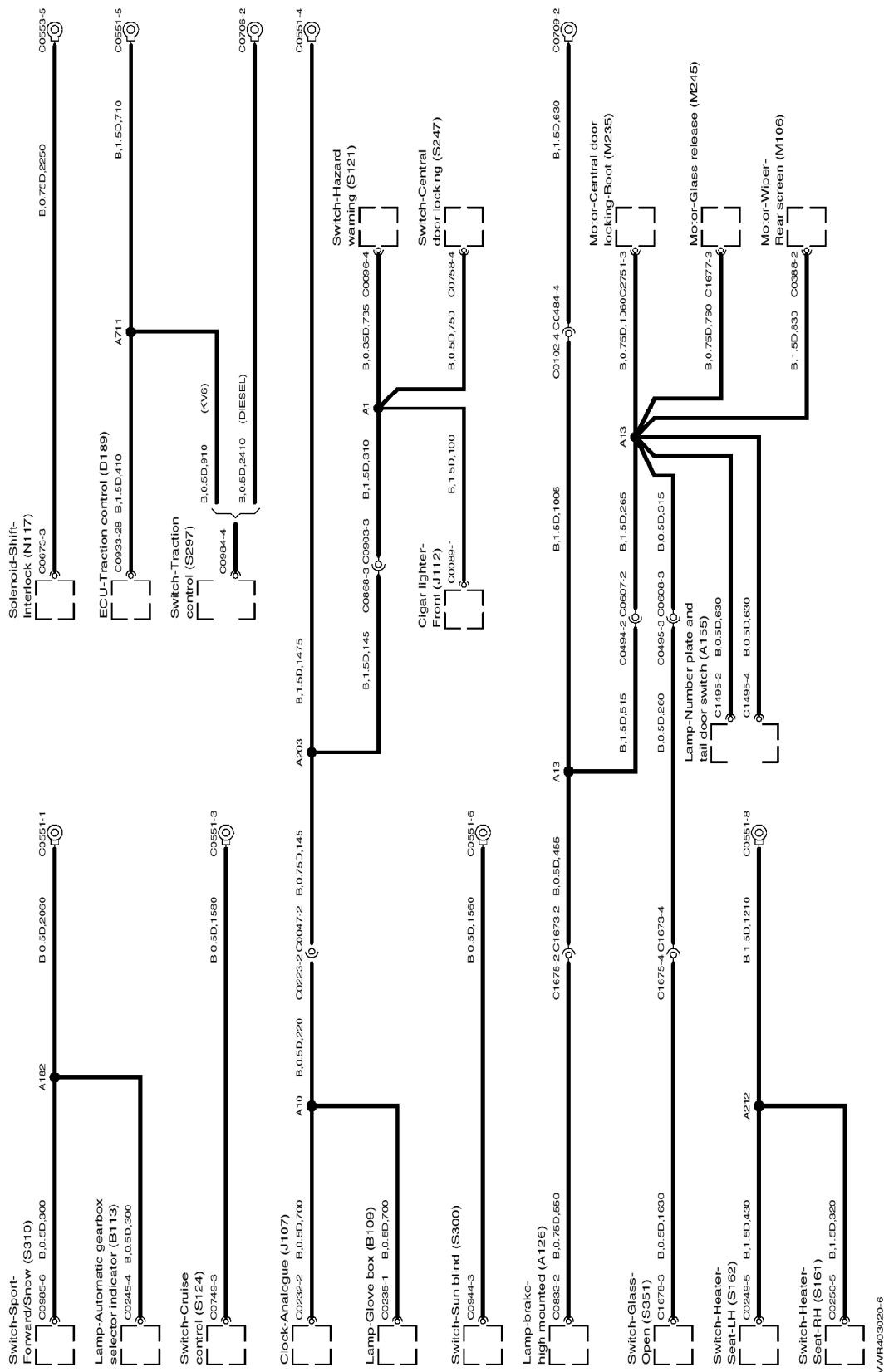

VWR403020-6

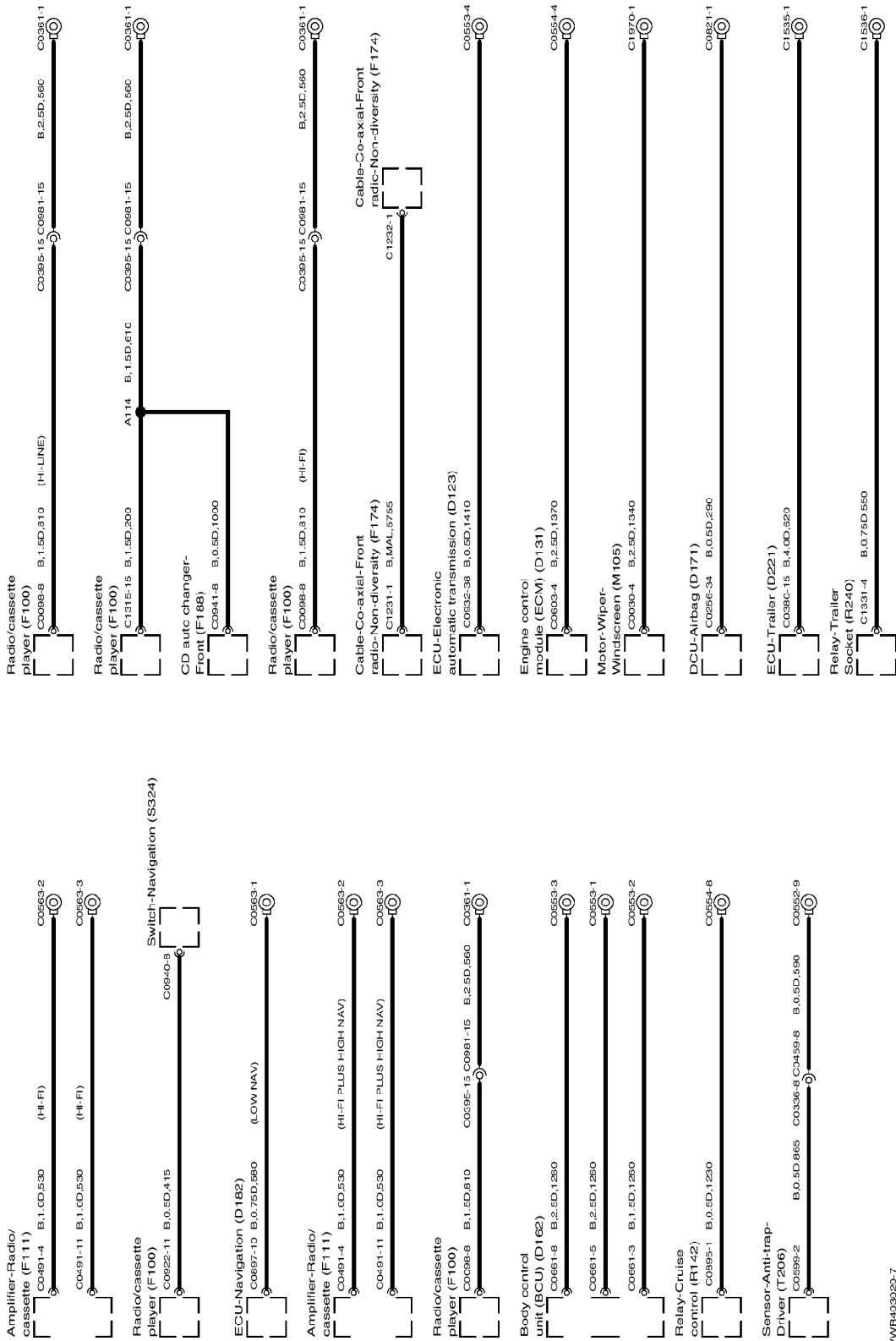

VWR403020-7

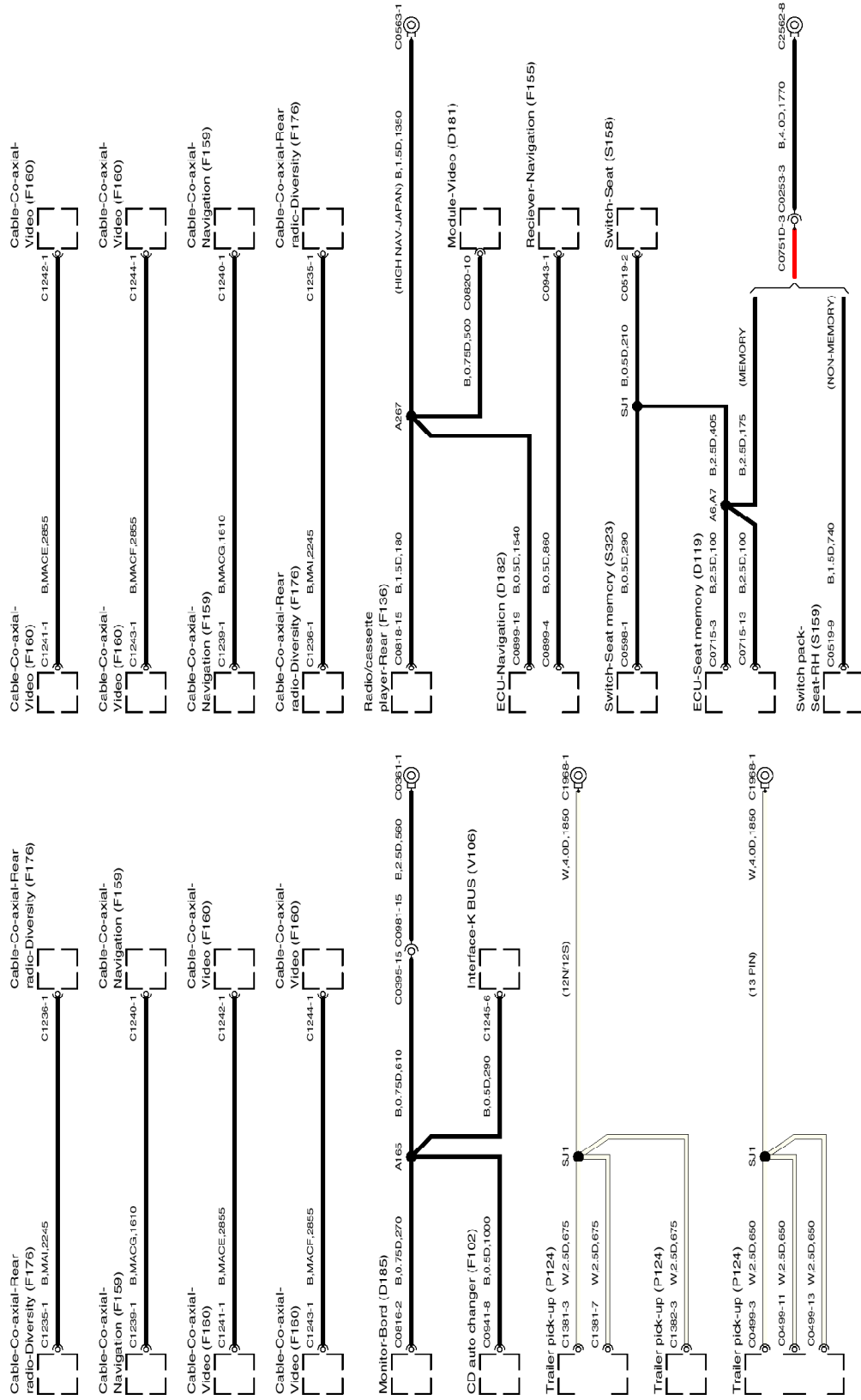

VWR403020-8

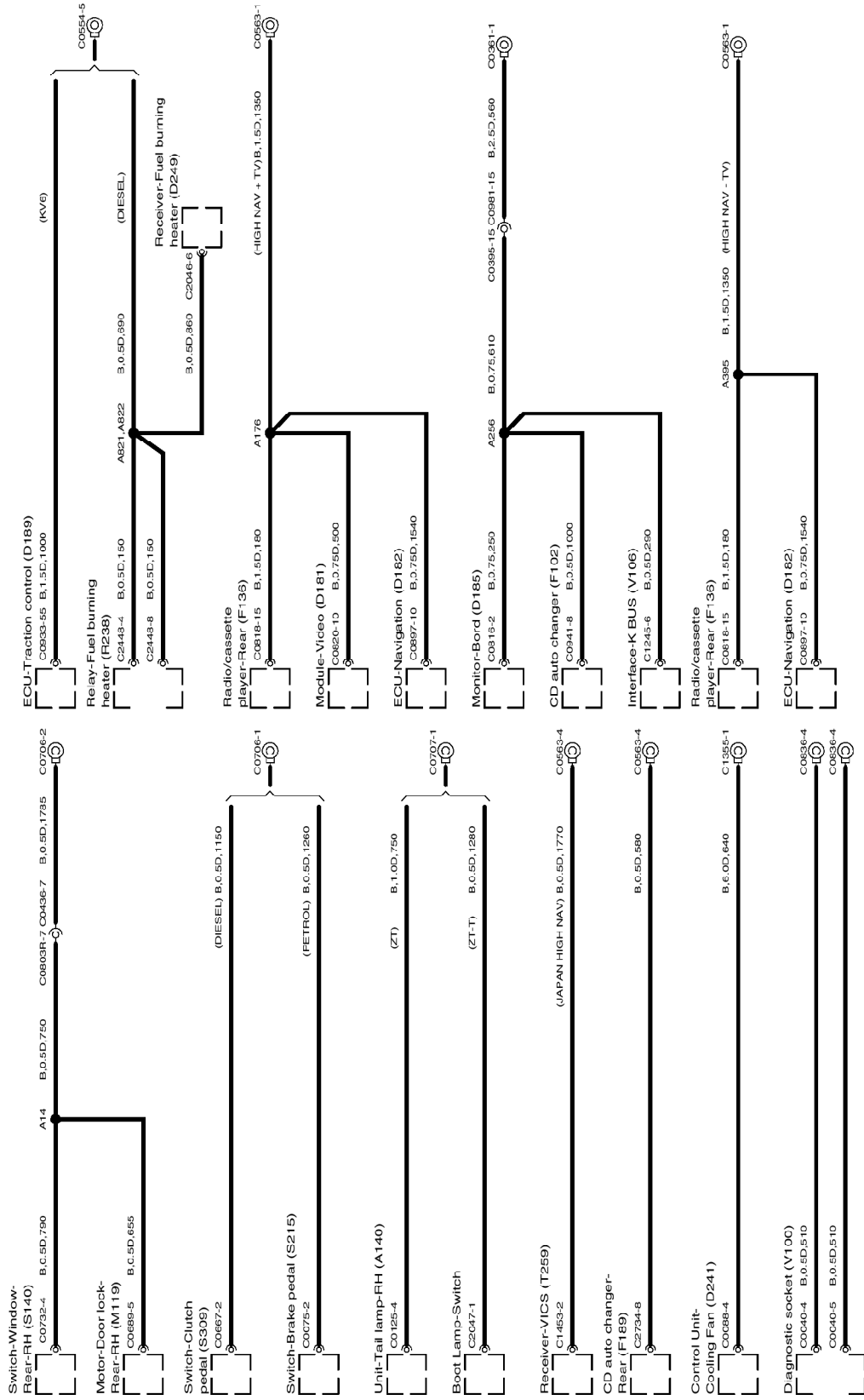

VWR403020-9

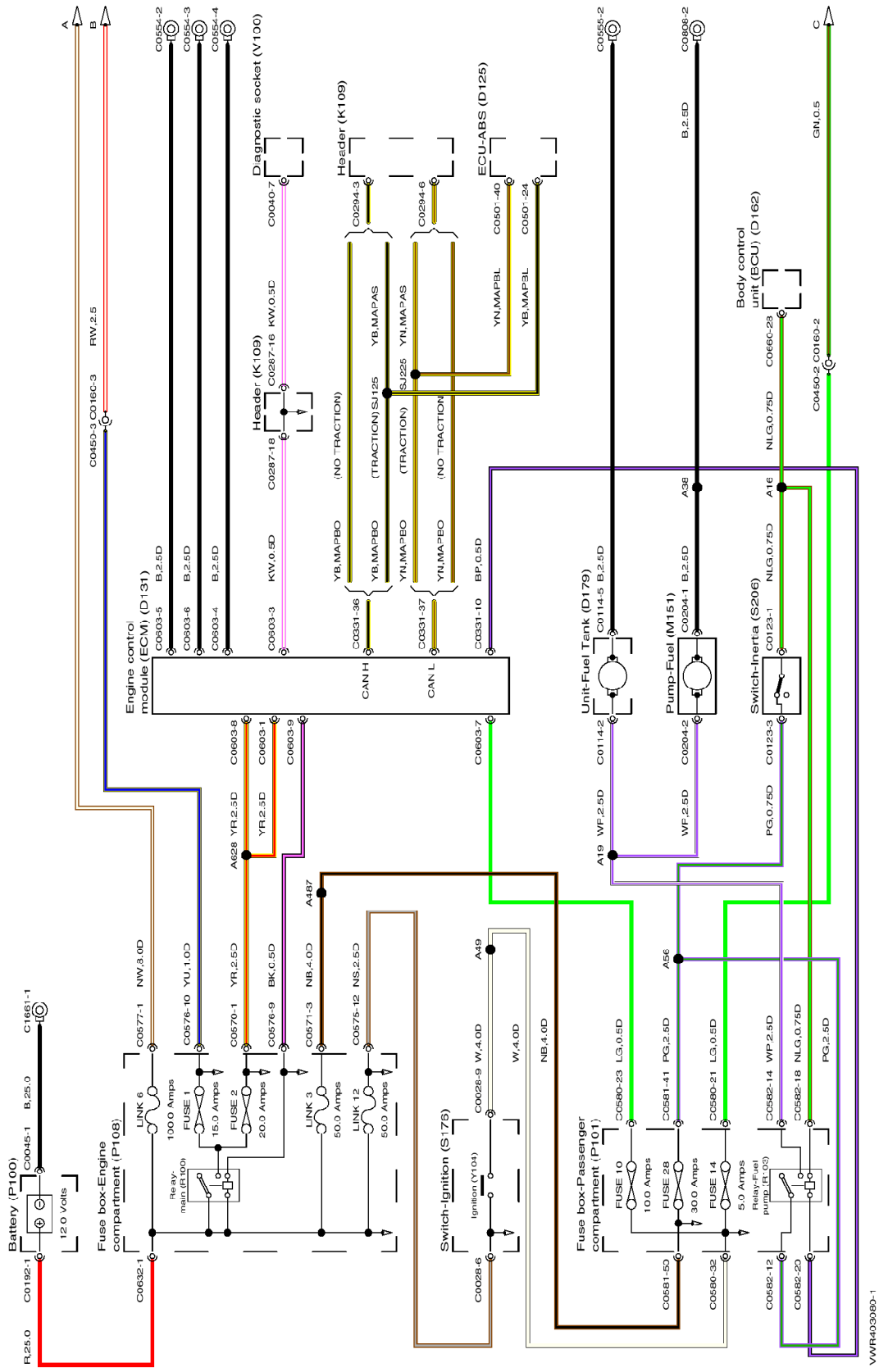

VWR403080-1

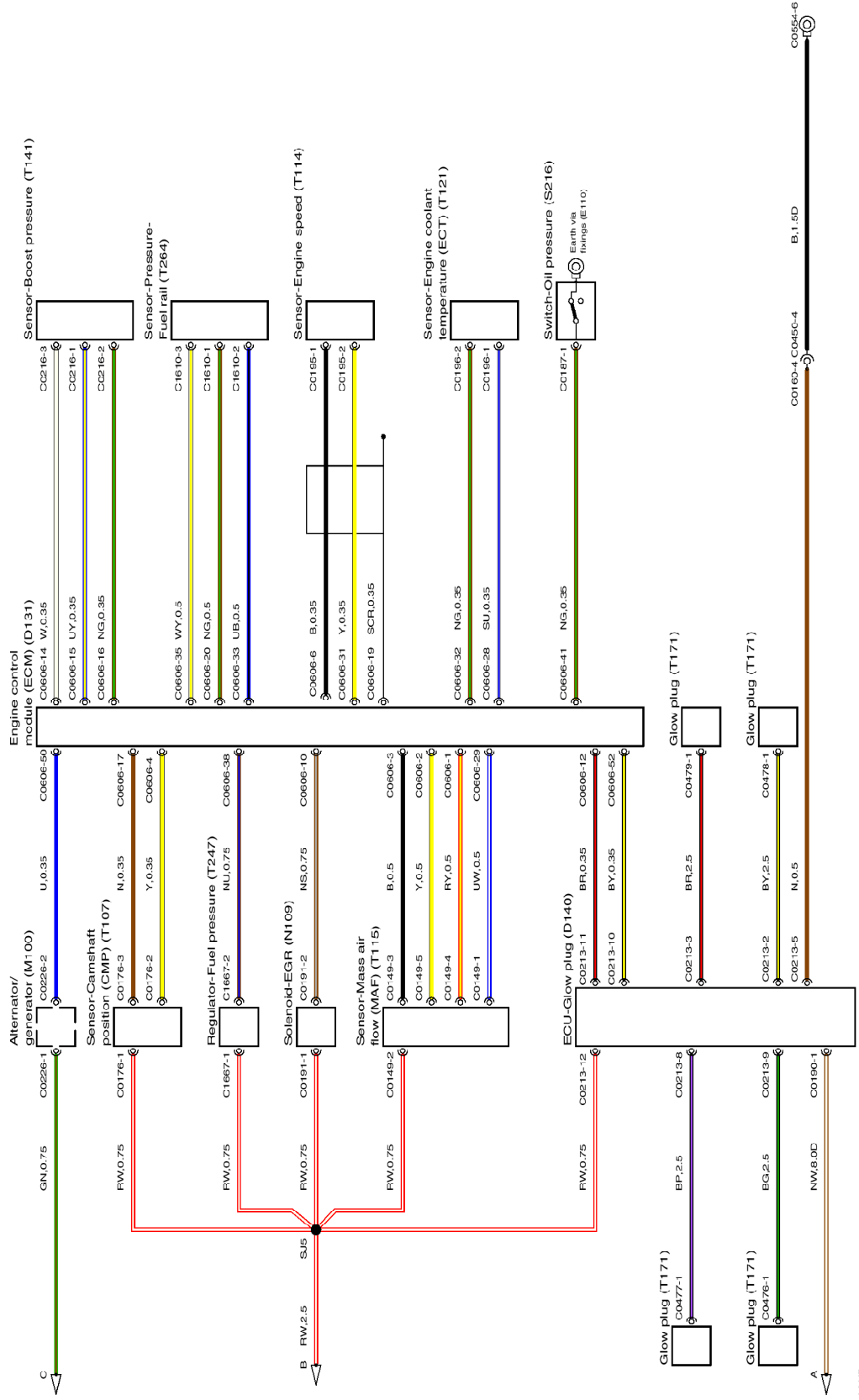

VWR403080-2

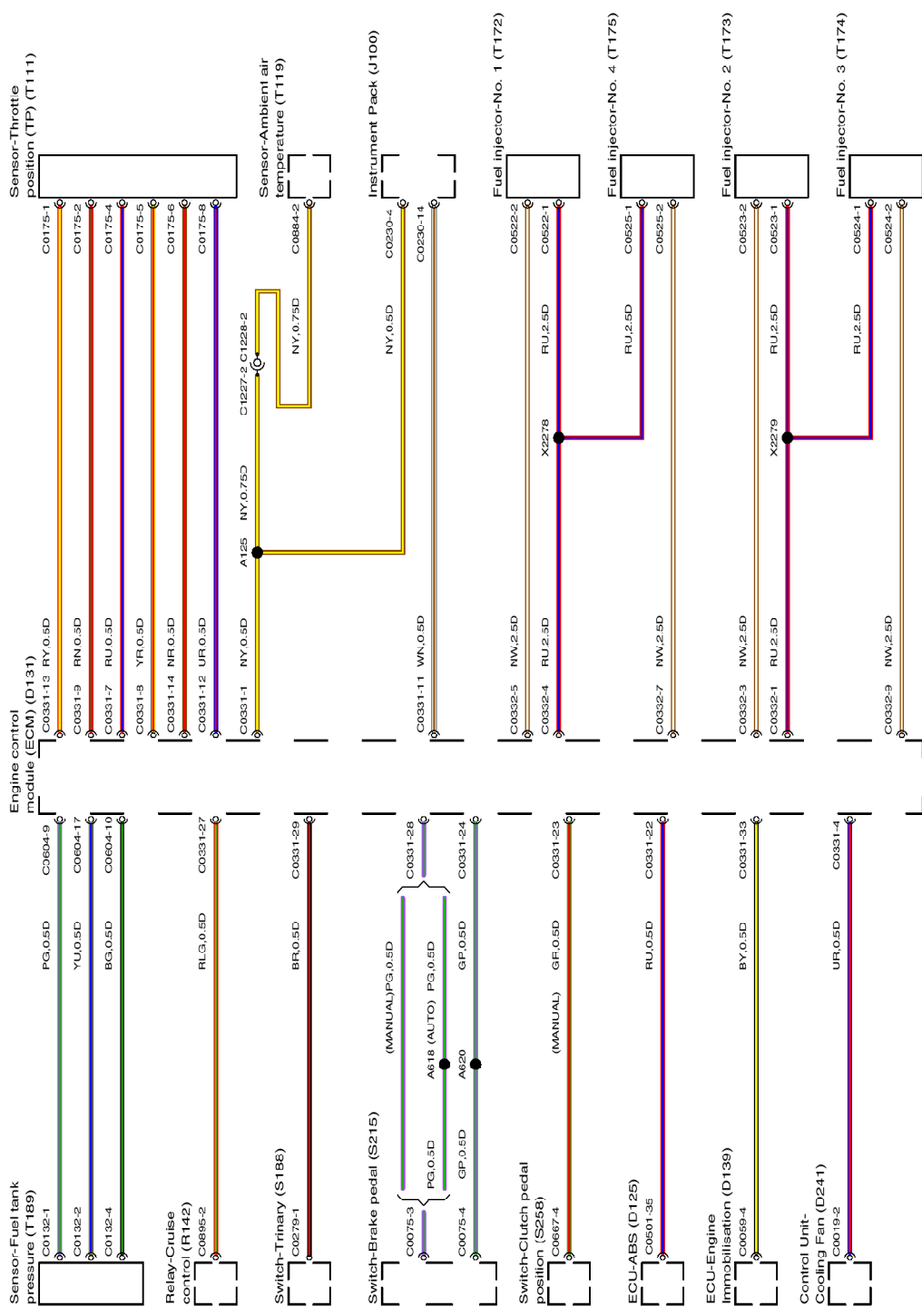

VWR403080-3

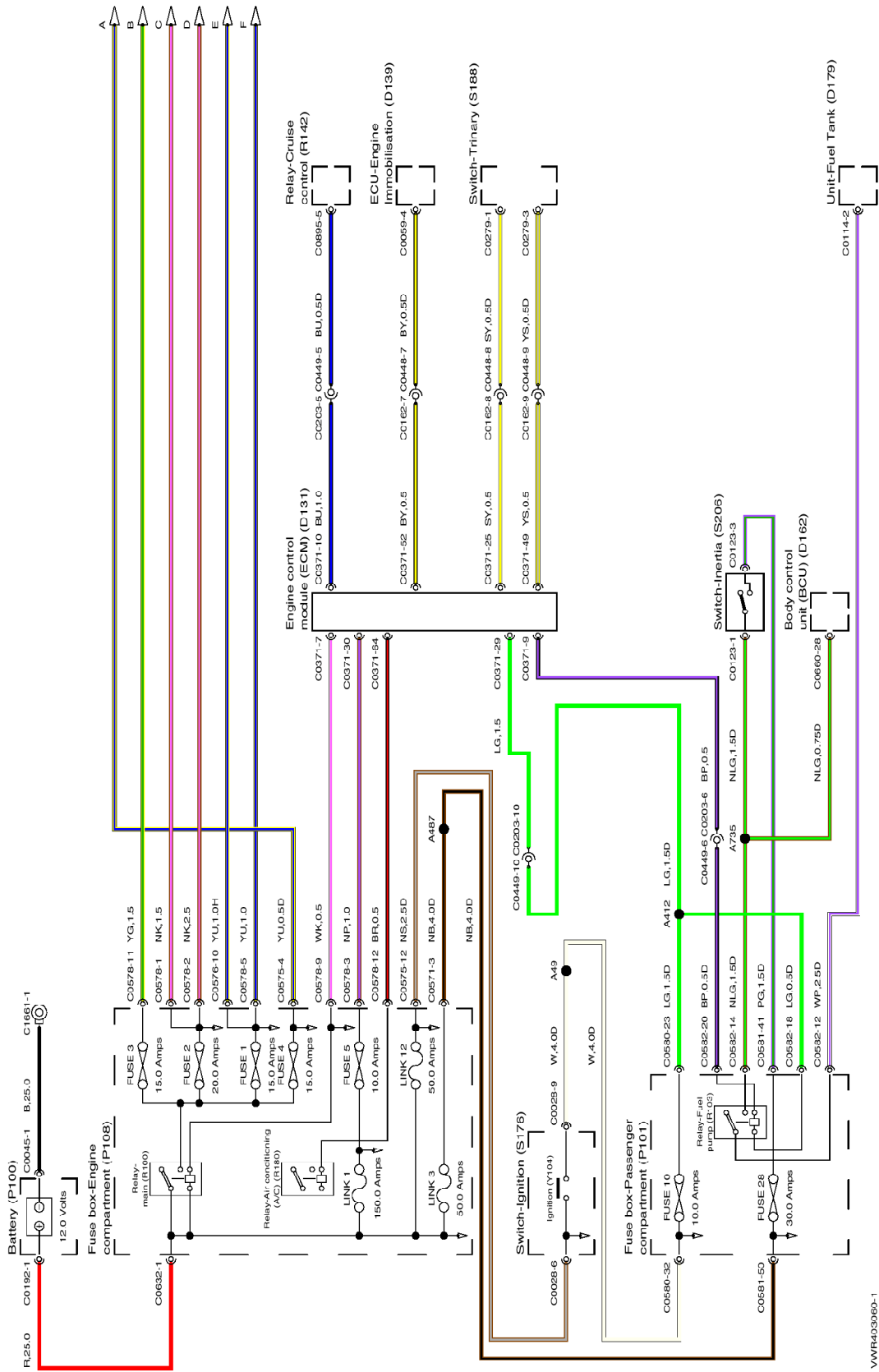

VWR403090-1

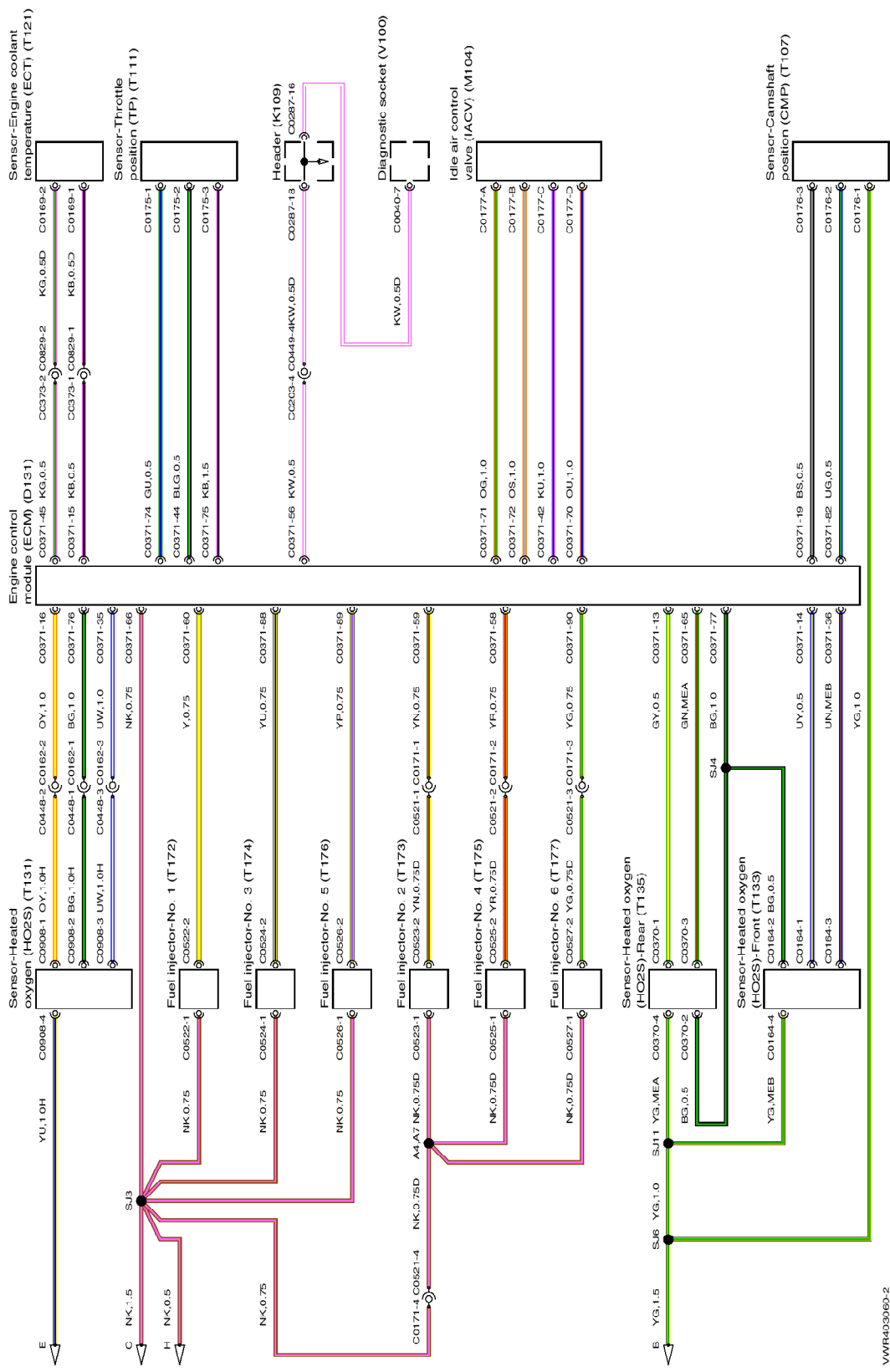

VWR403060-2

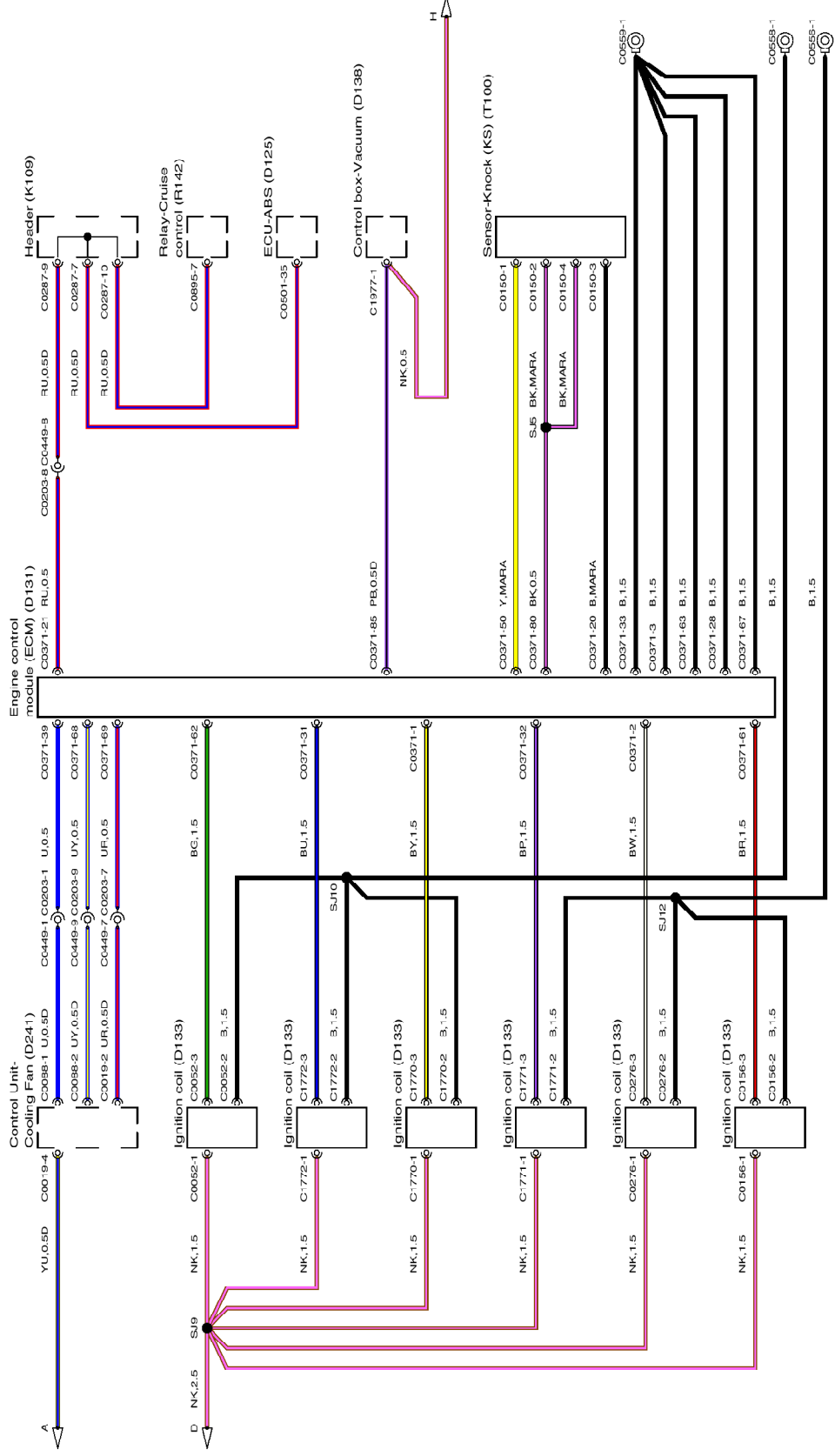

VWR403060-3

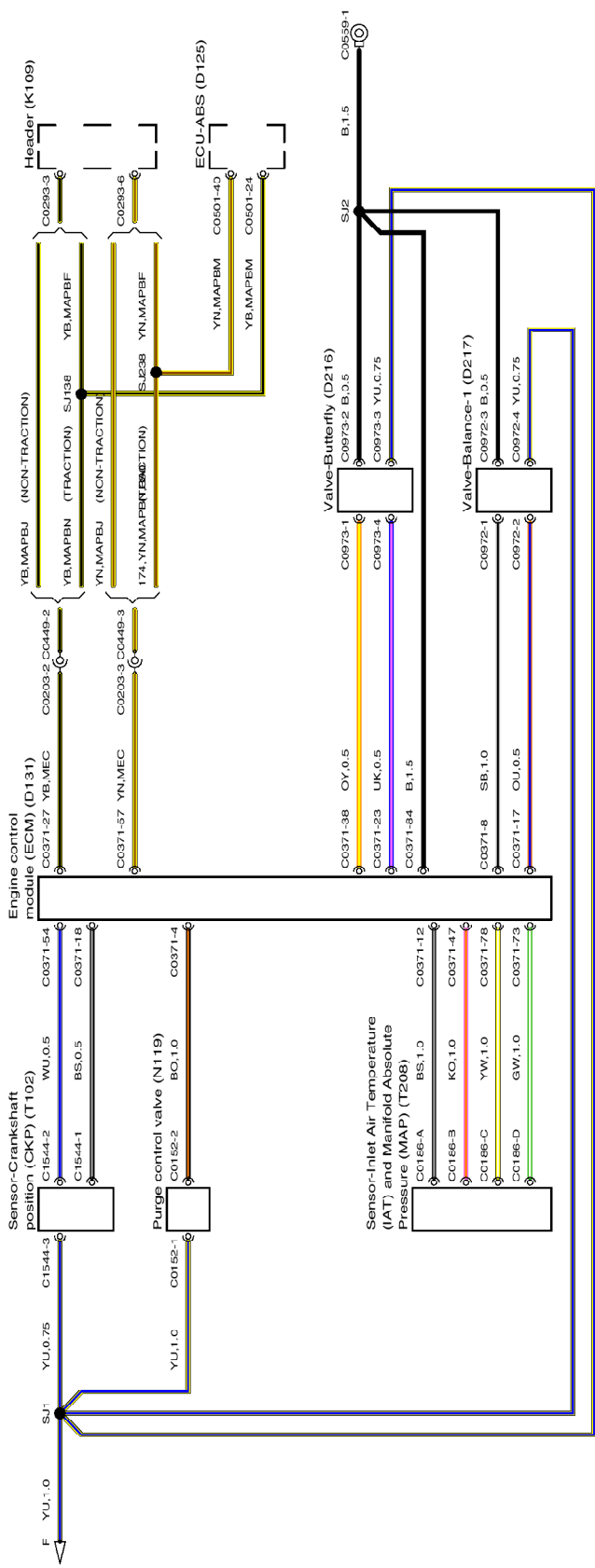

VWR403060-4

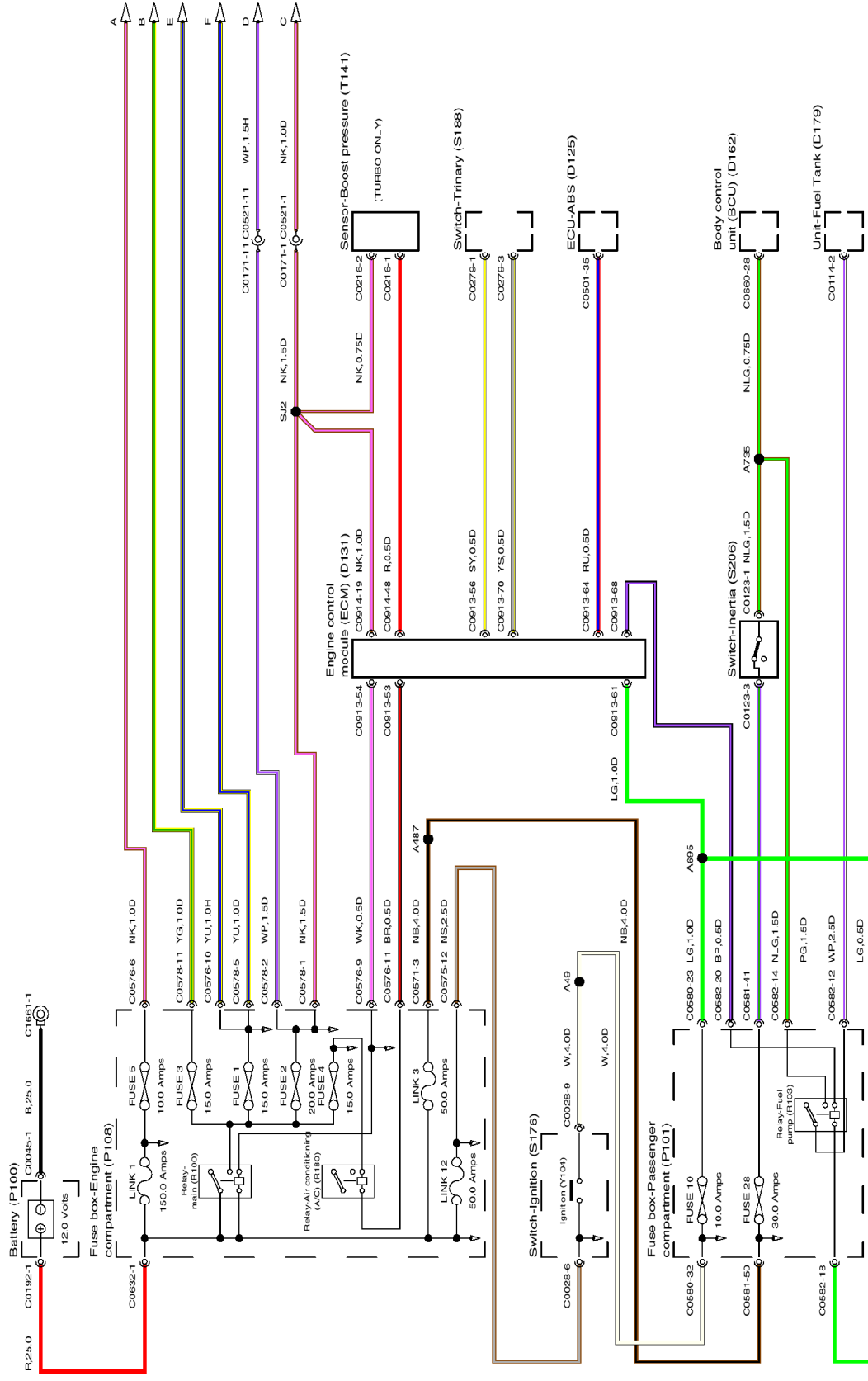

VWR403040-1

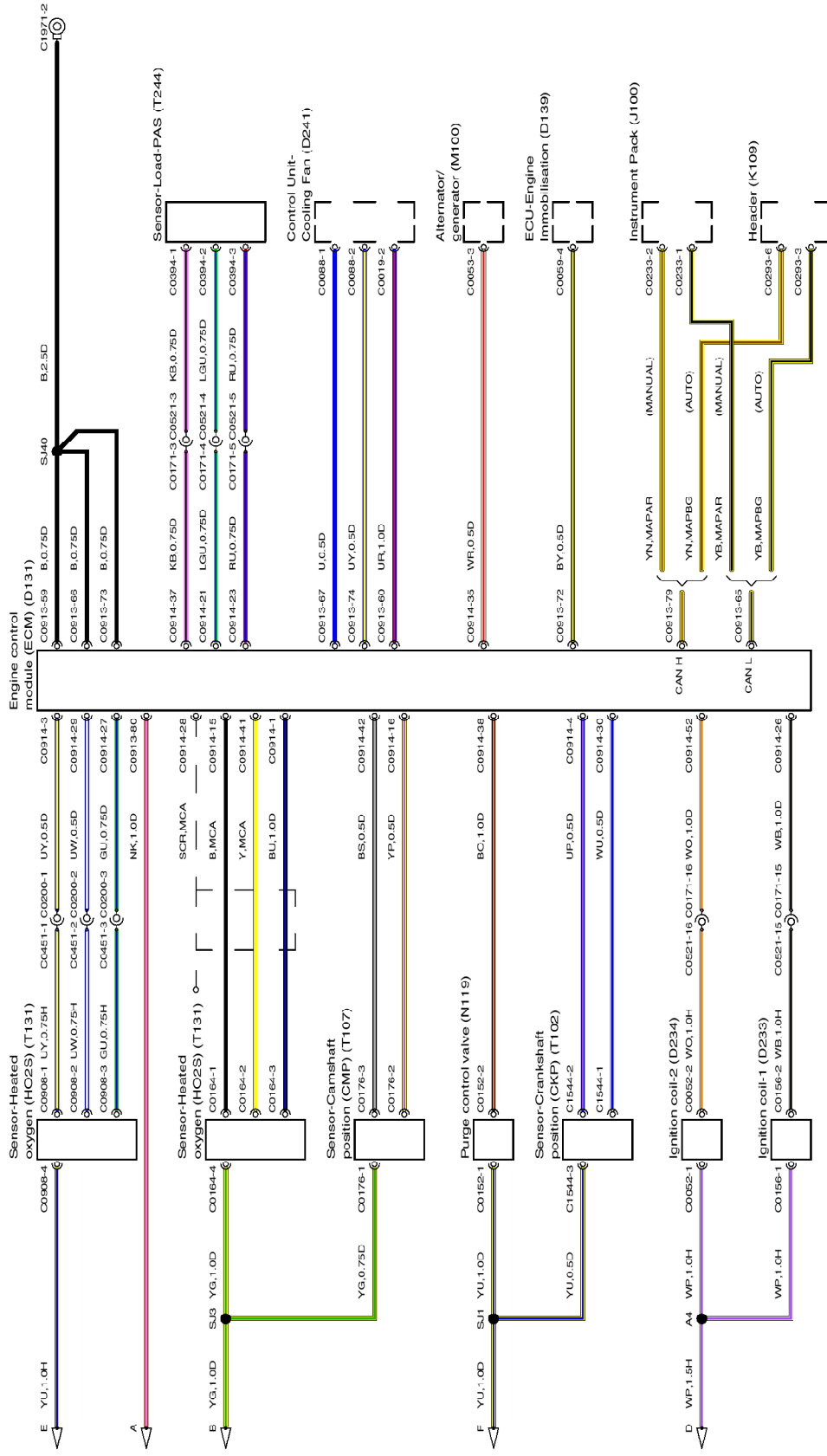

VWR403040-2

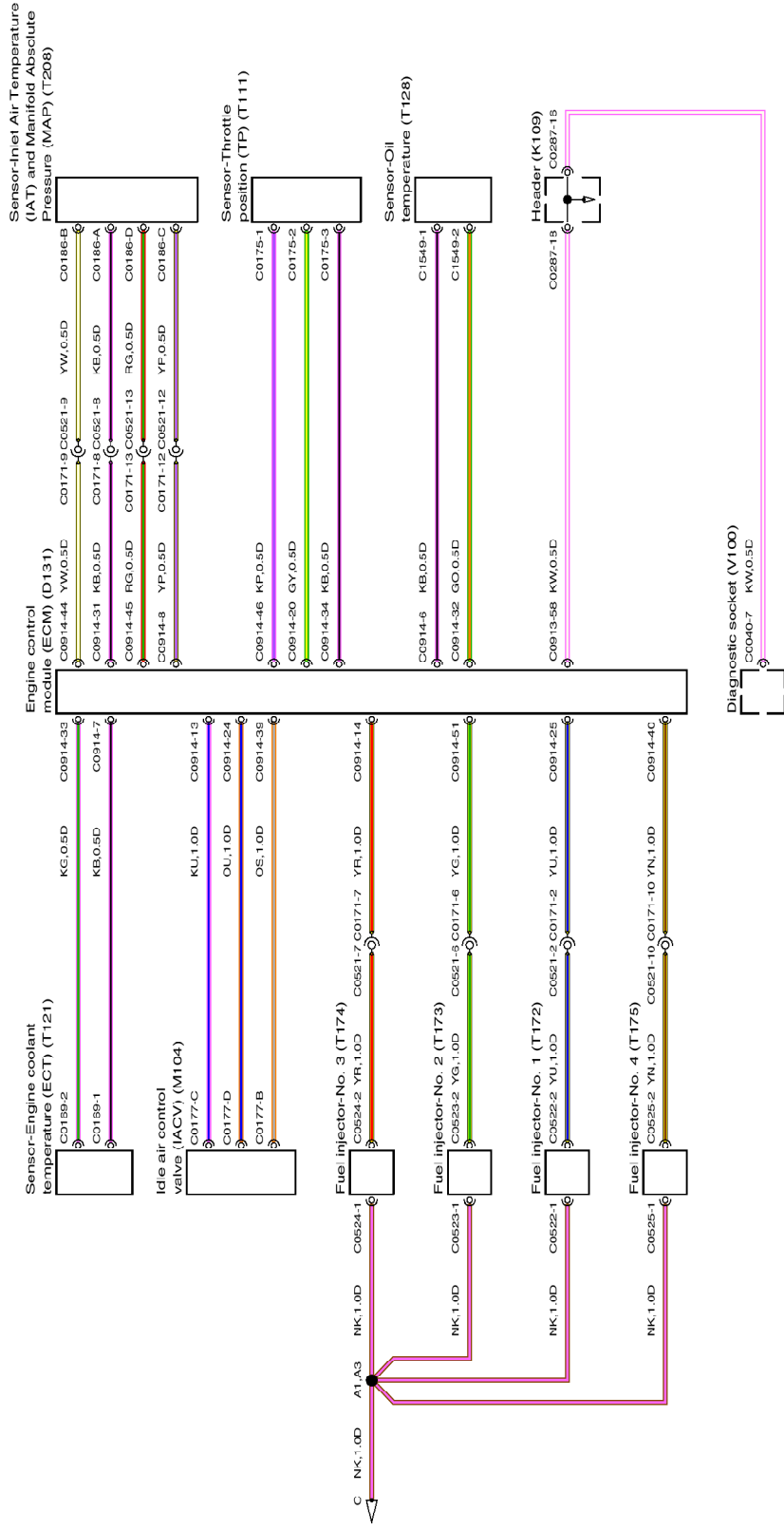

VWR403040-3

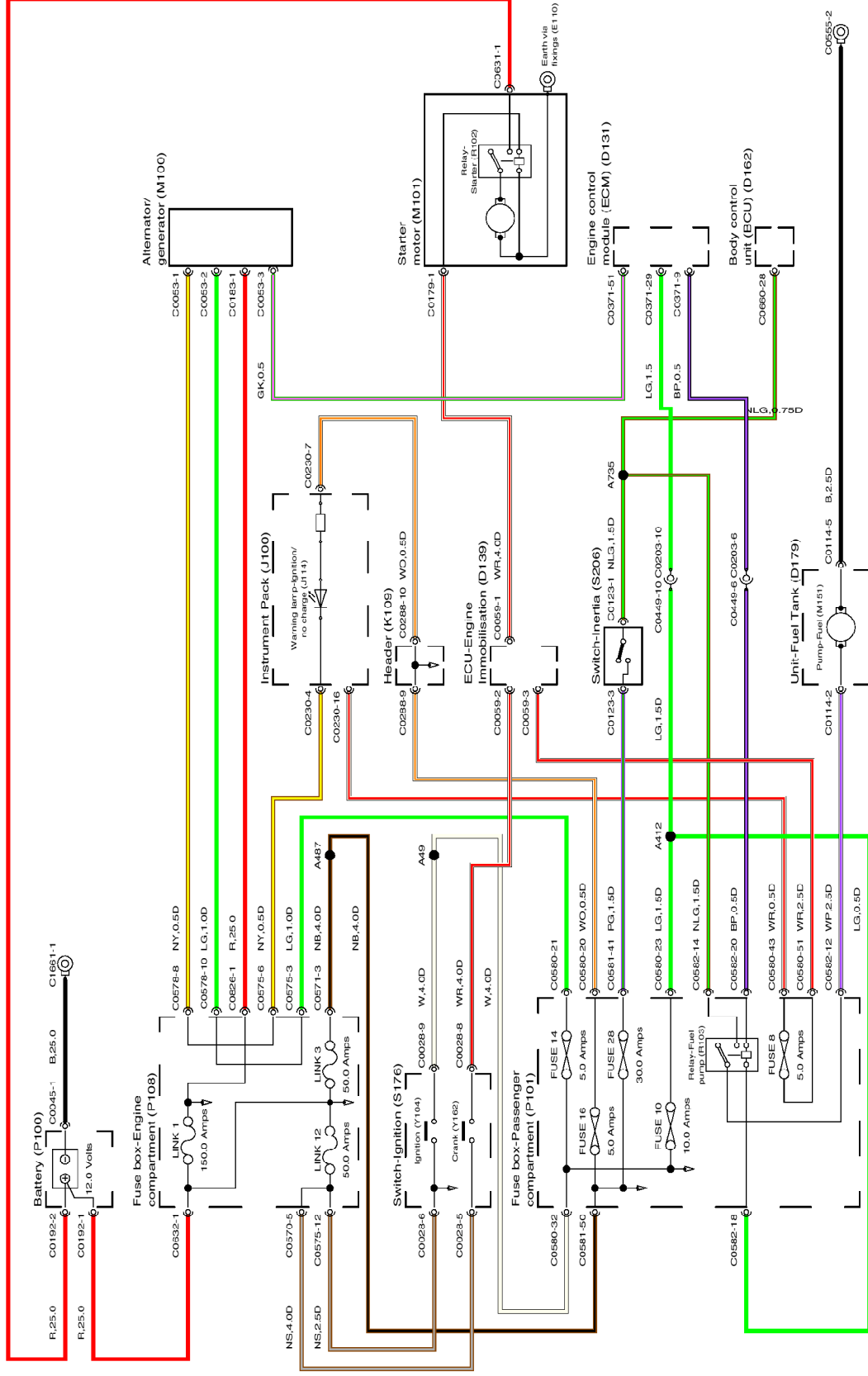

VWR403980-1

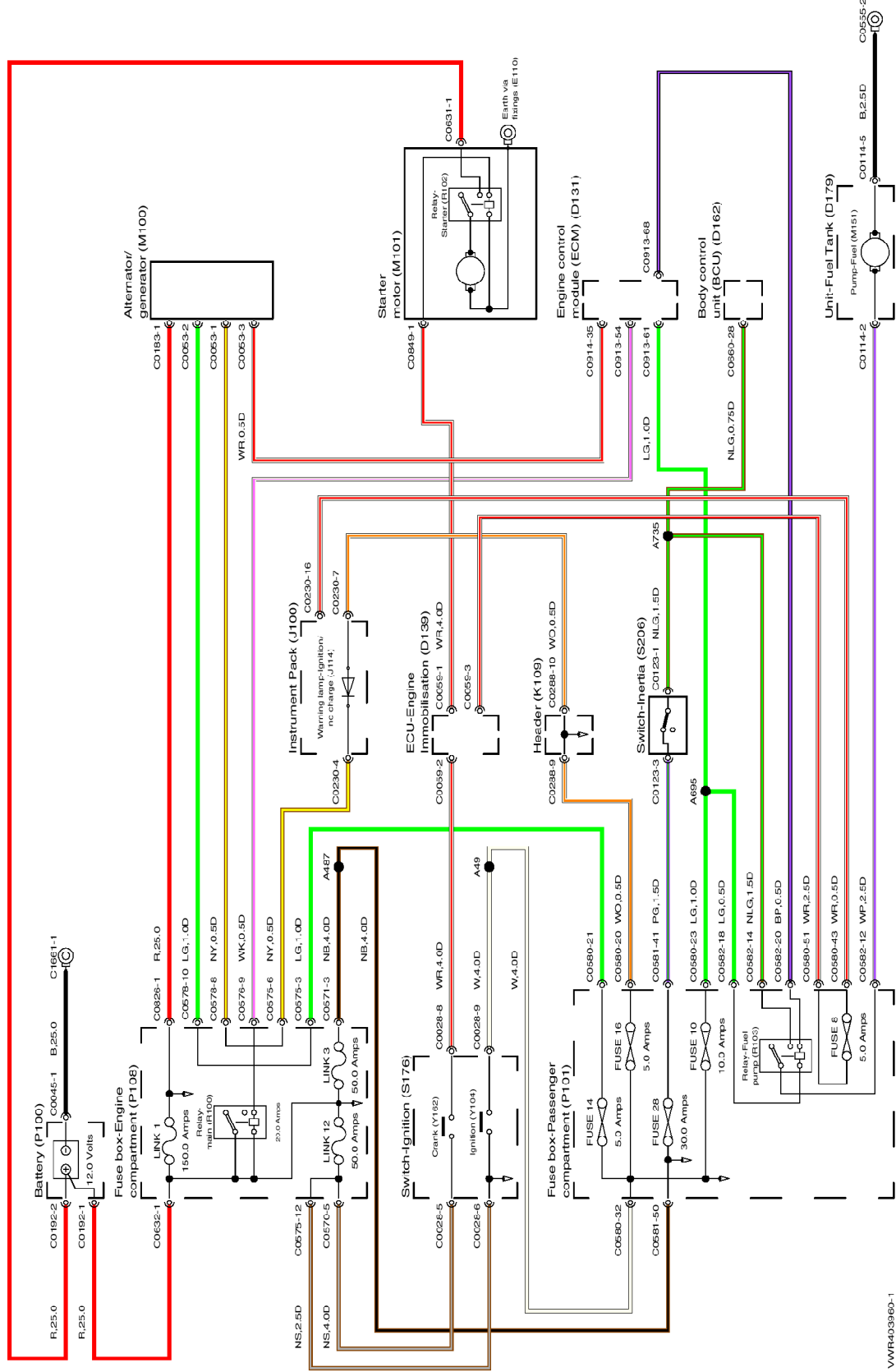

VWR403960-1

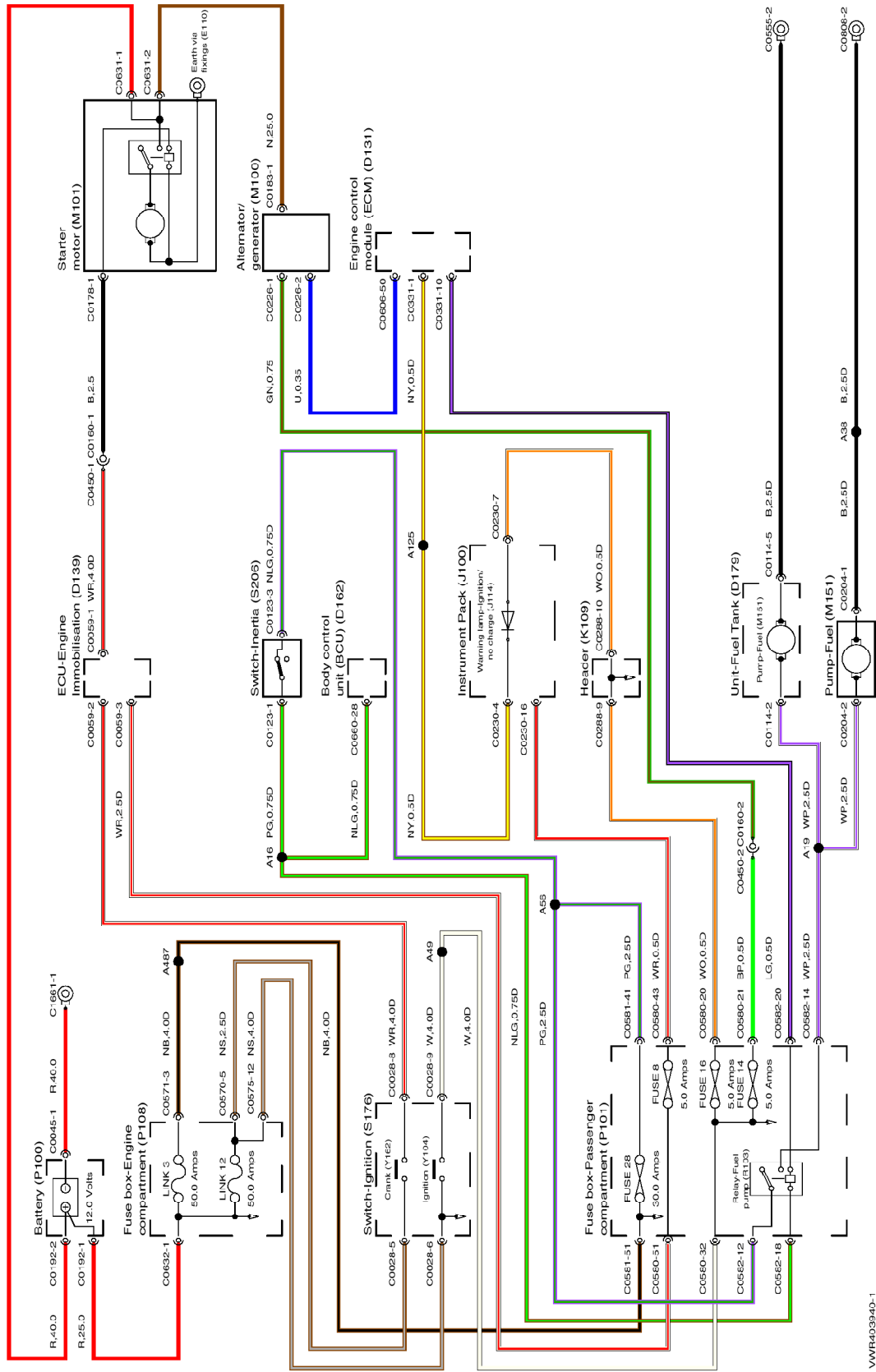

VWR03940-1

20 FUEL PUMP

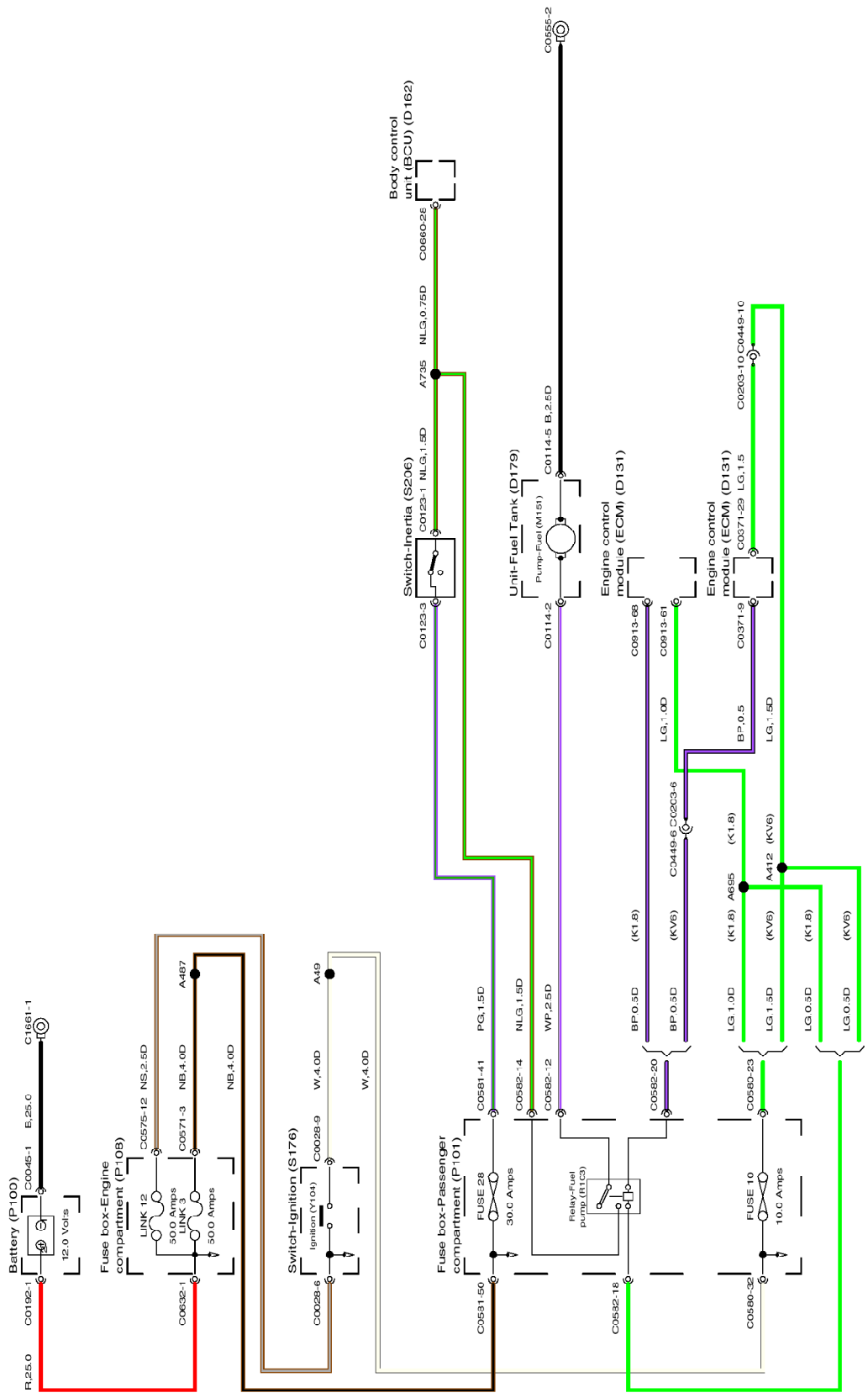

VWR403160-1

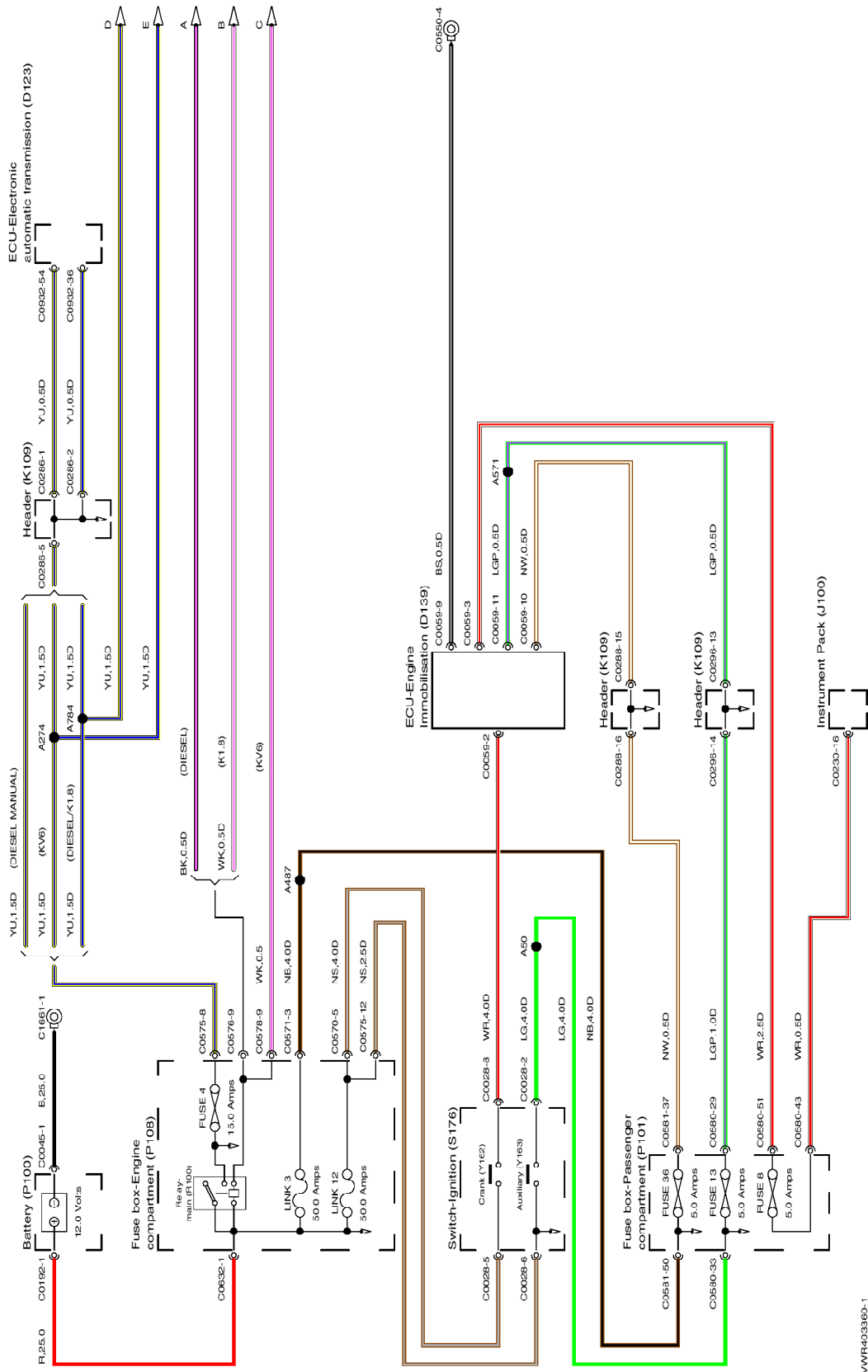

VWR403360-1

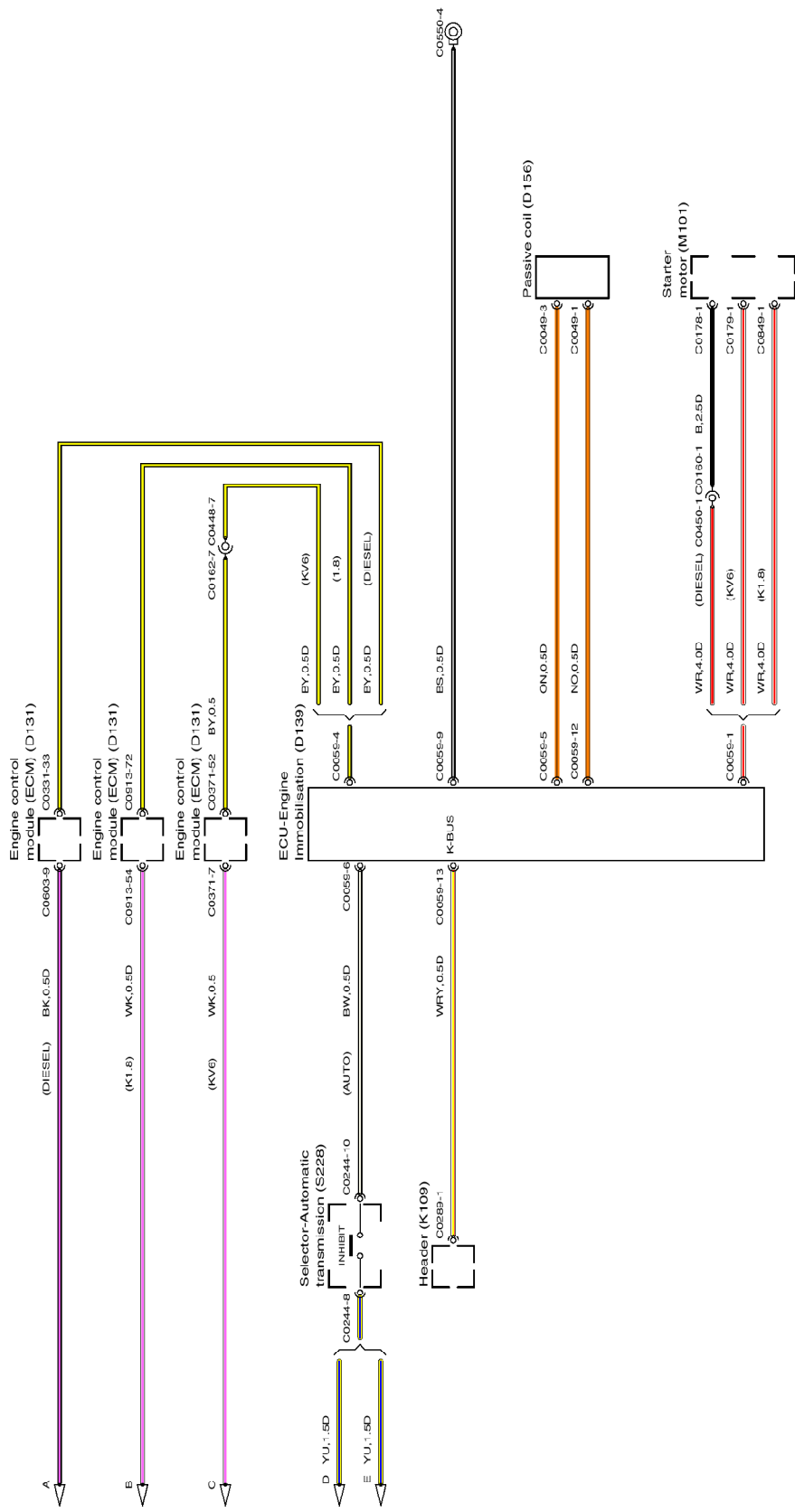

VWR403360-2

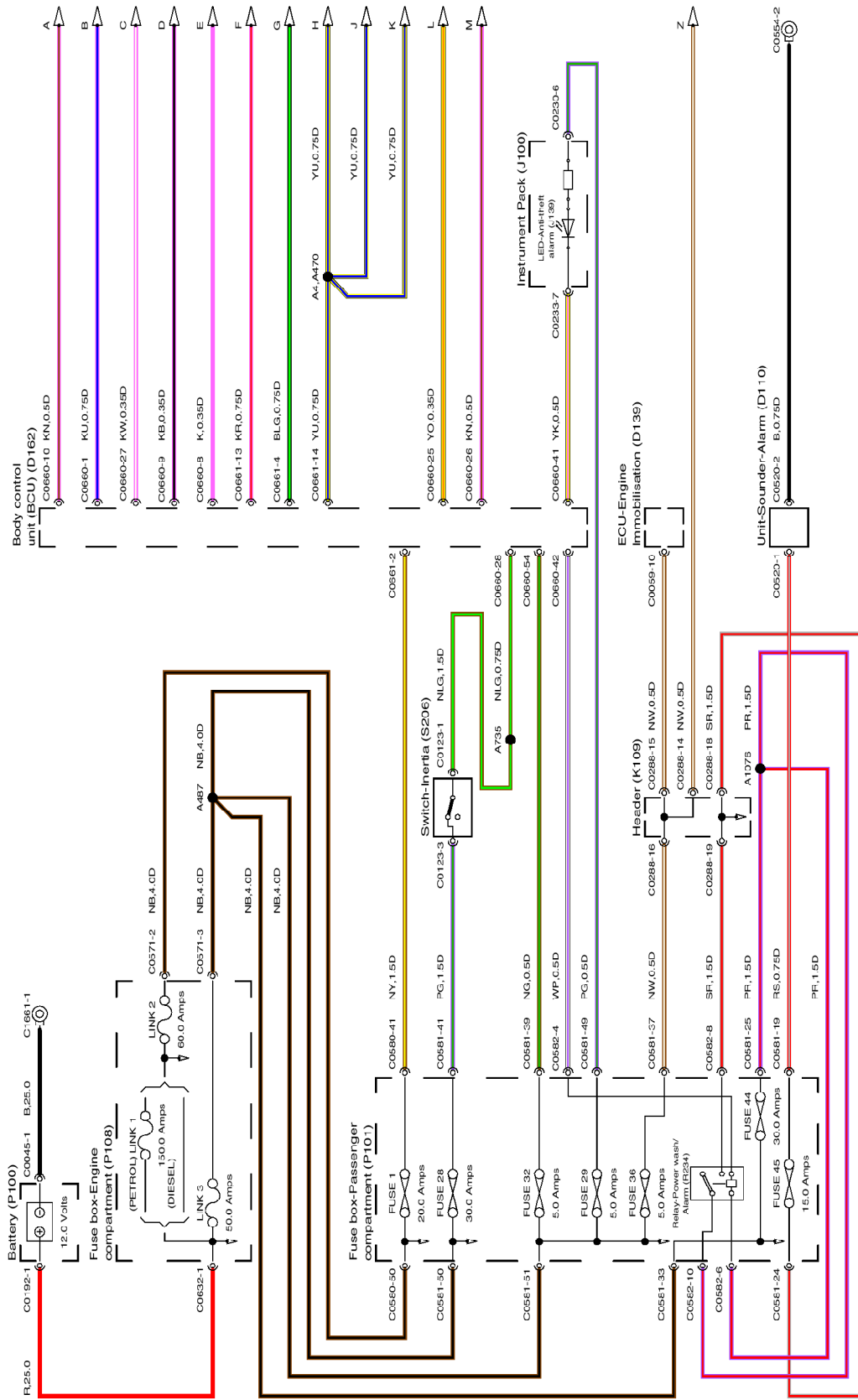

VWR402780-1

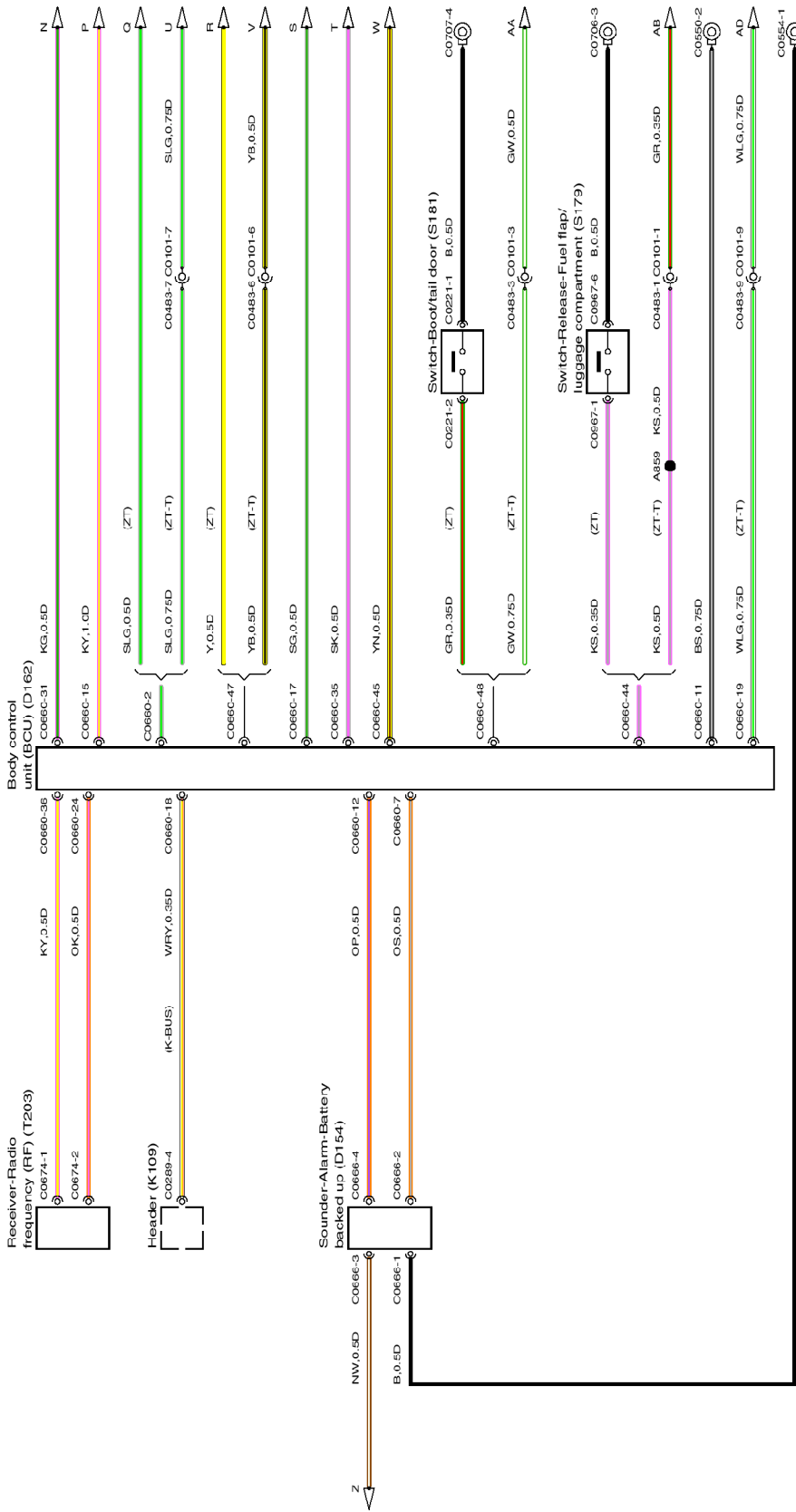

VWR402780-2

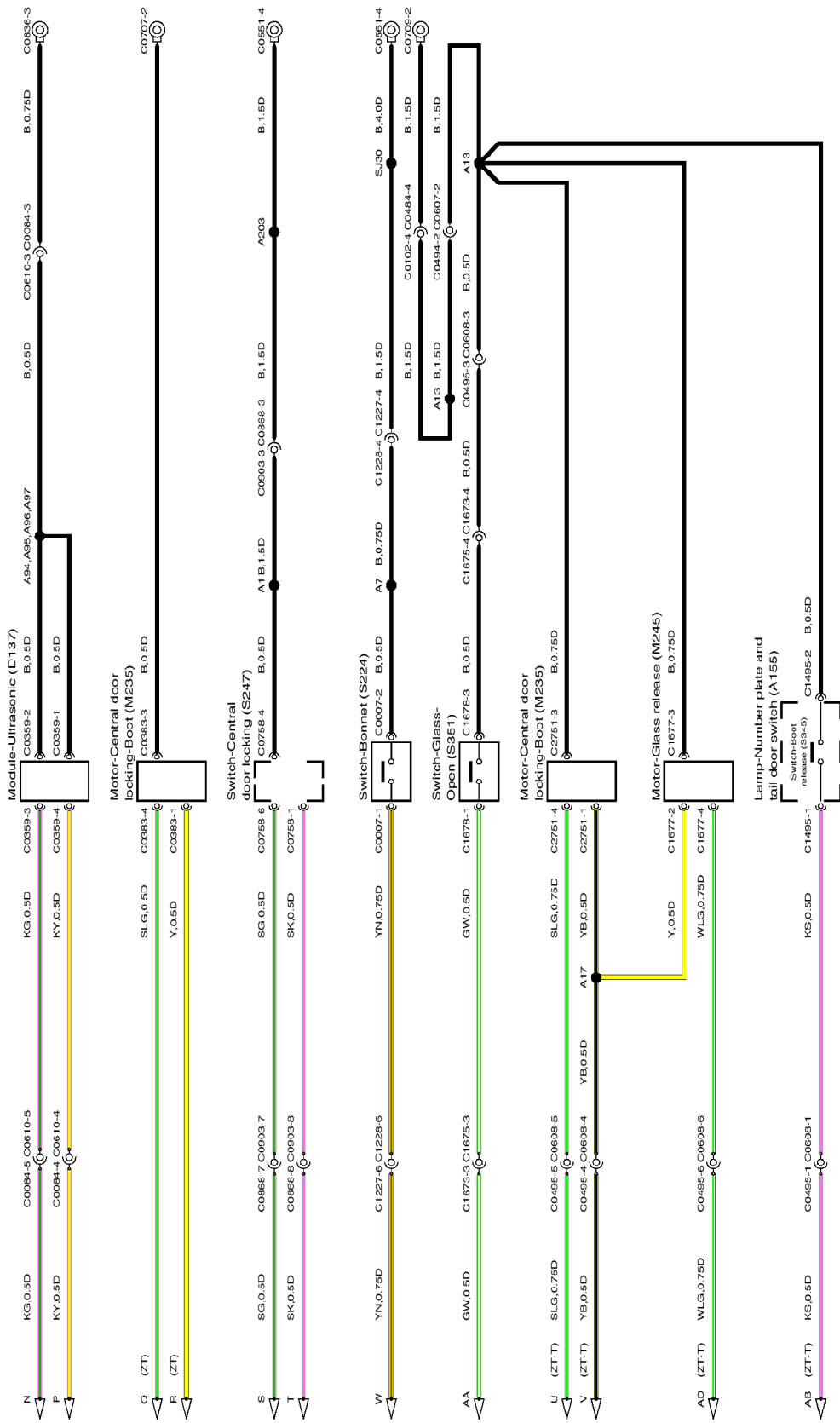

VWR402780-3

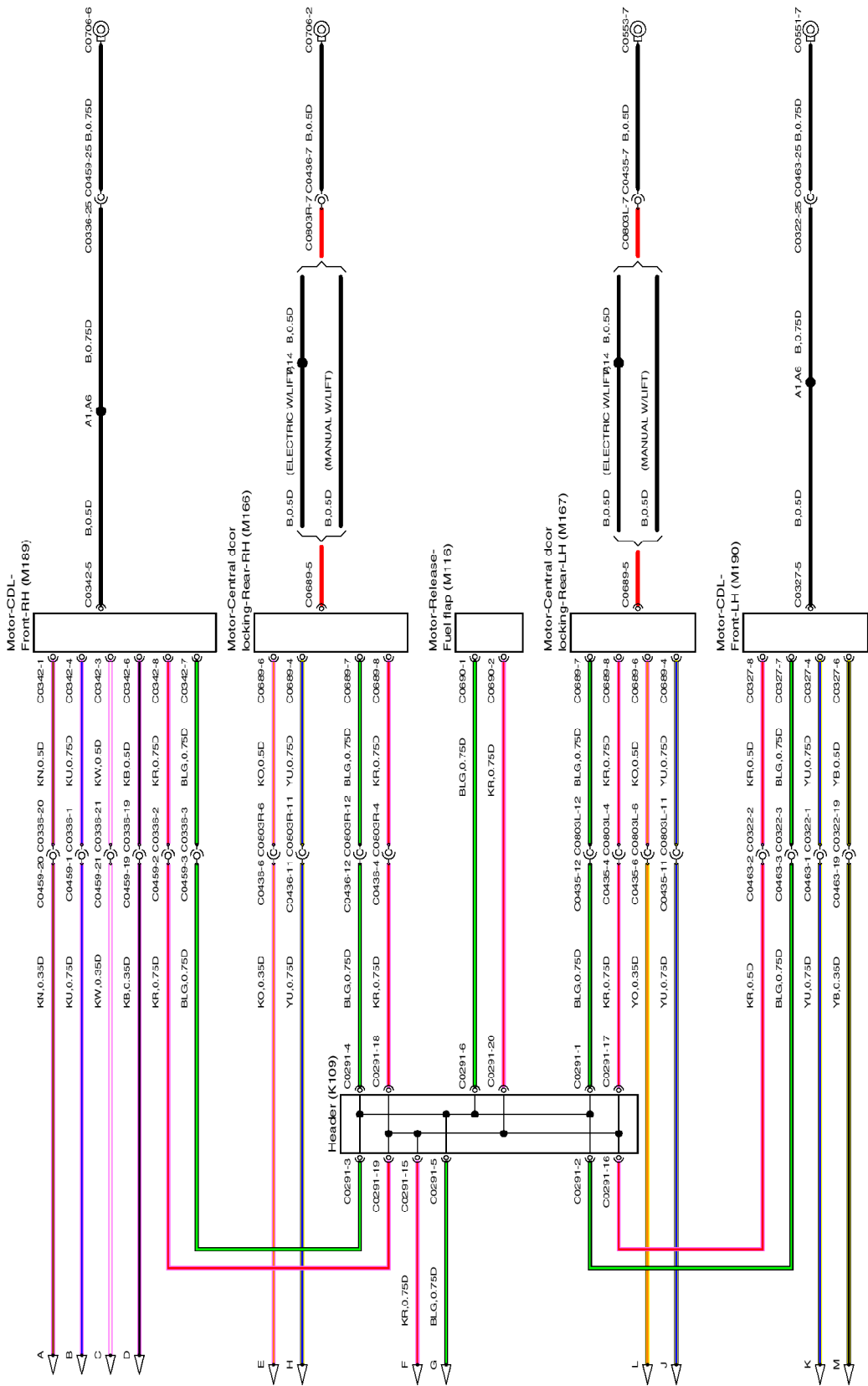

VWR402780-4

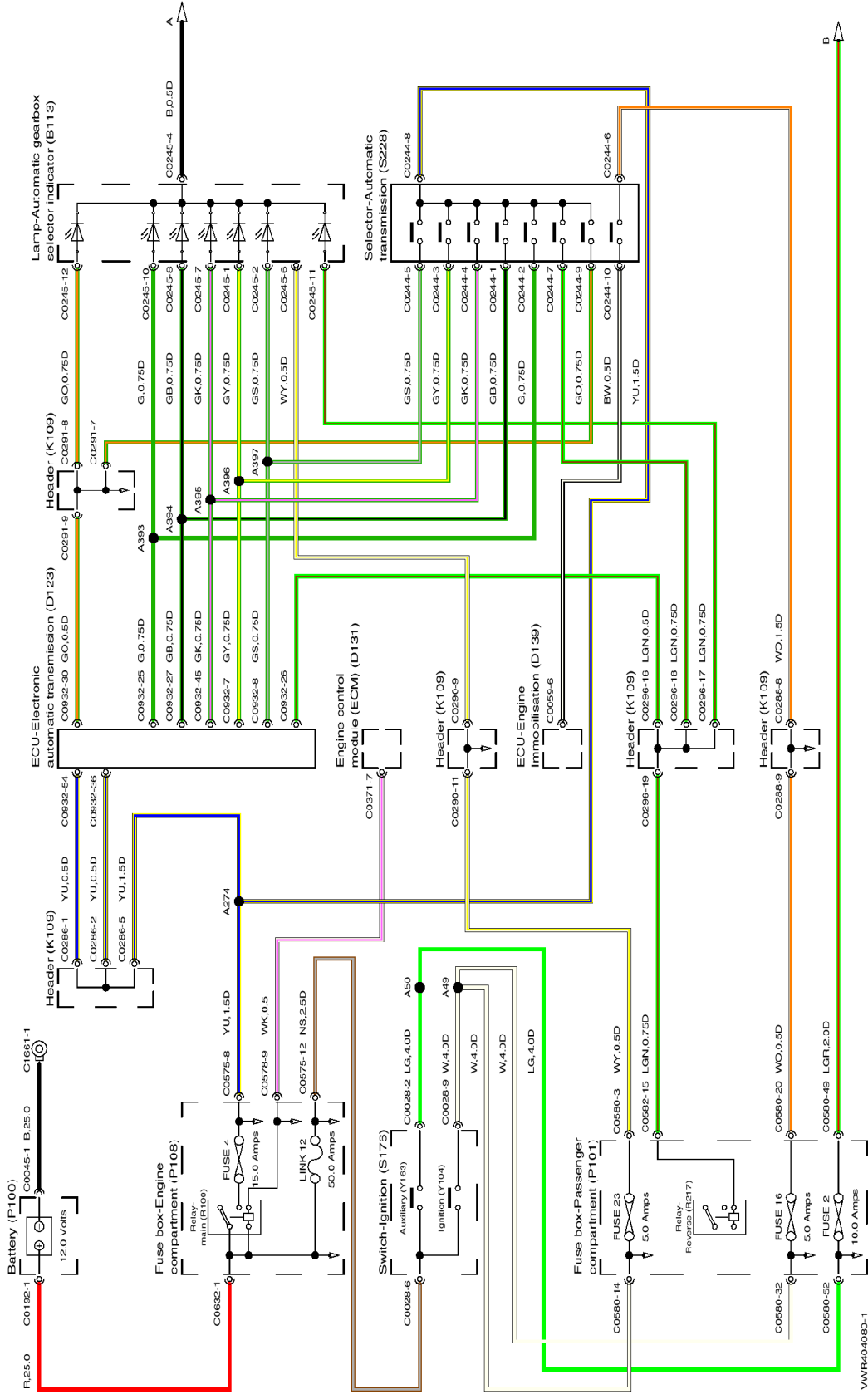

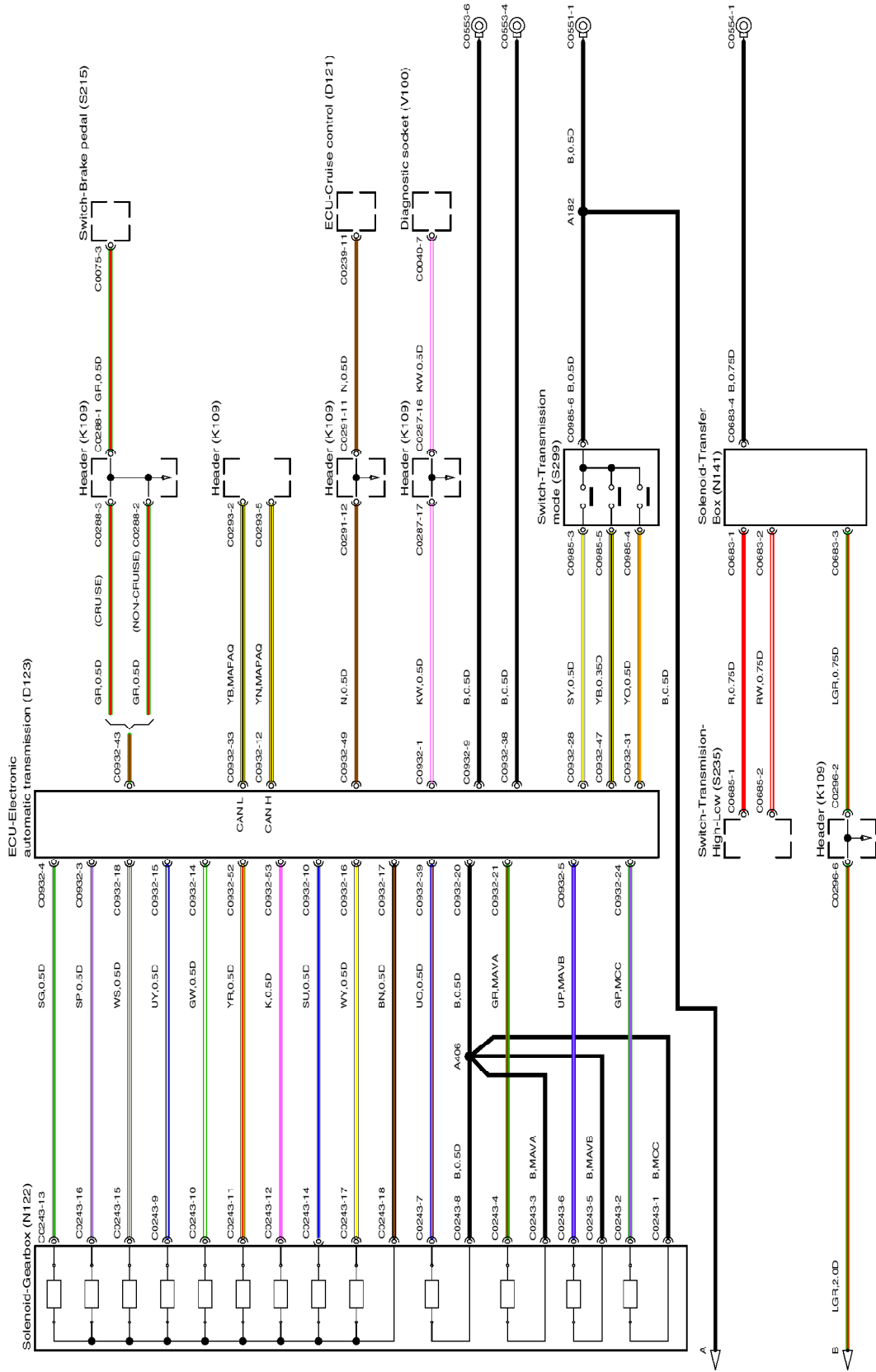

VWFR404090-2

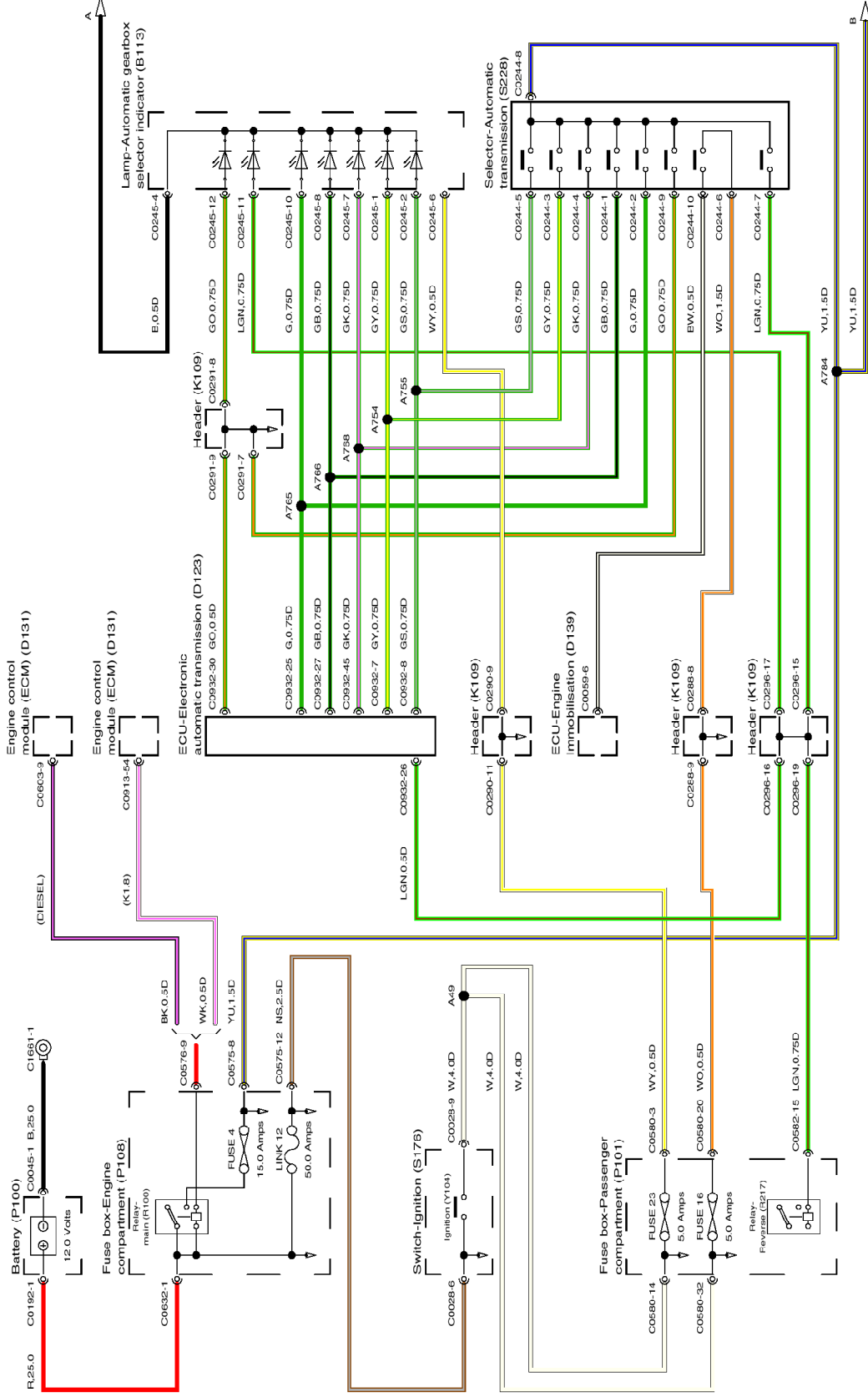

VWVR404090-1

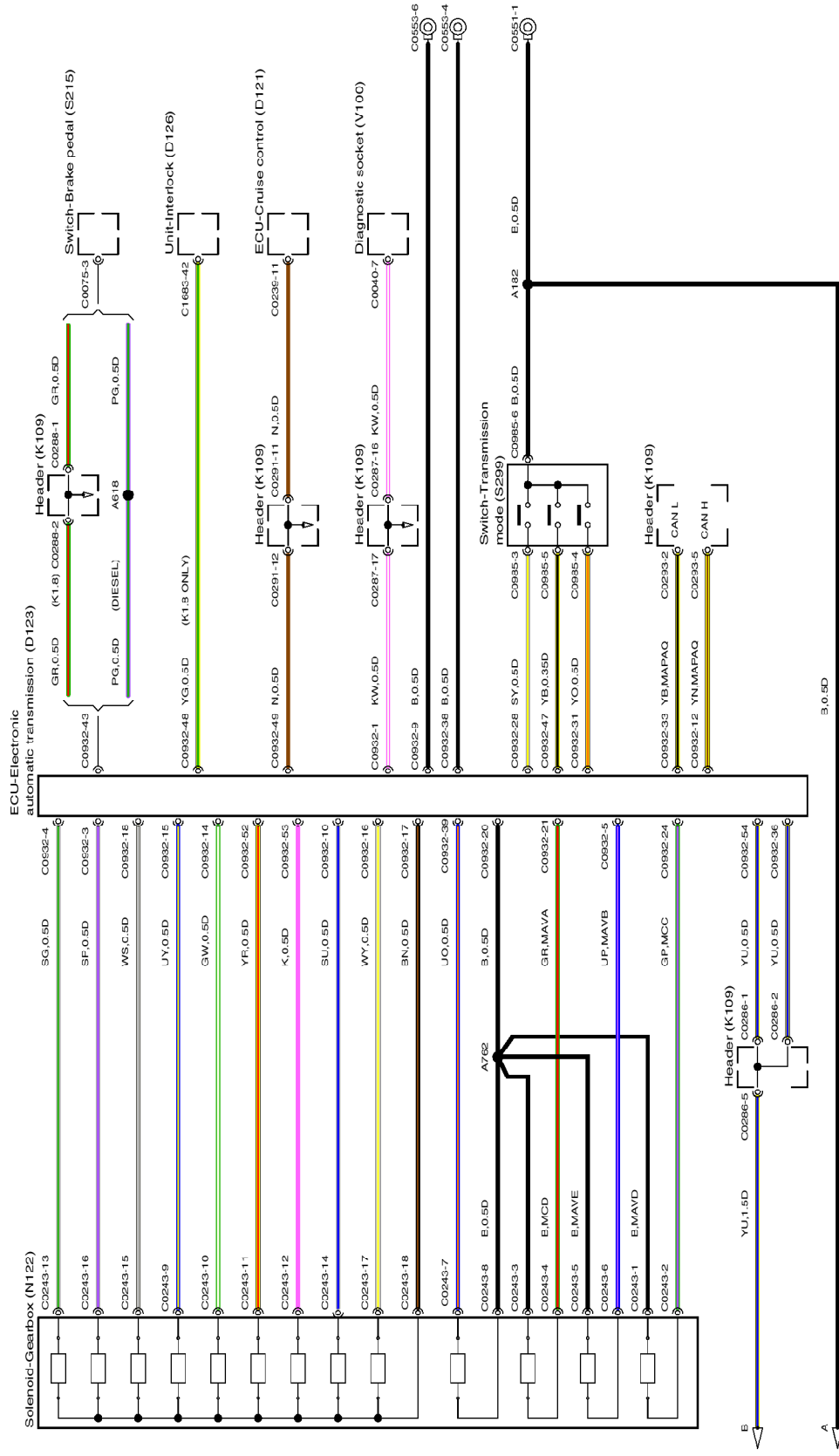

VWR404060-2

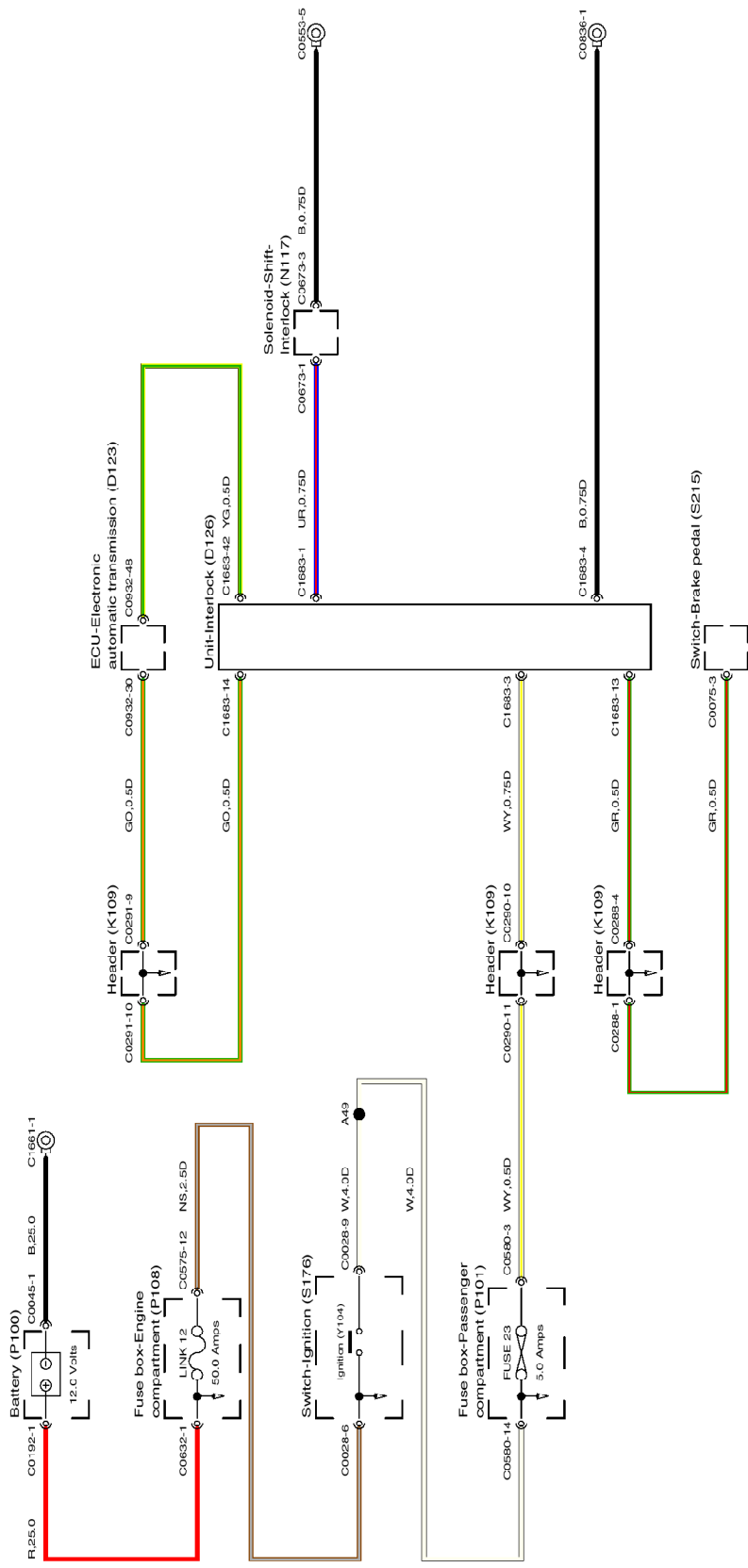

VWR403860-1

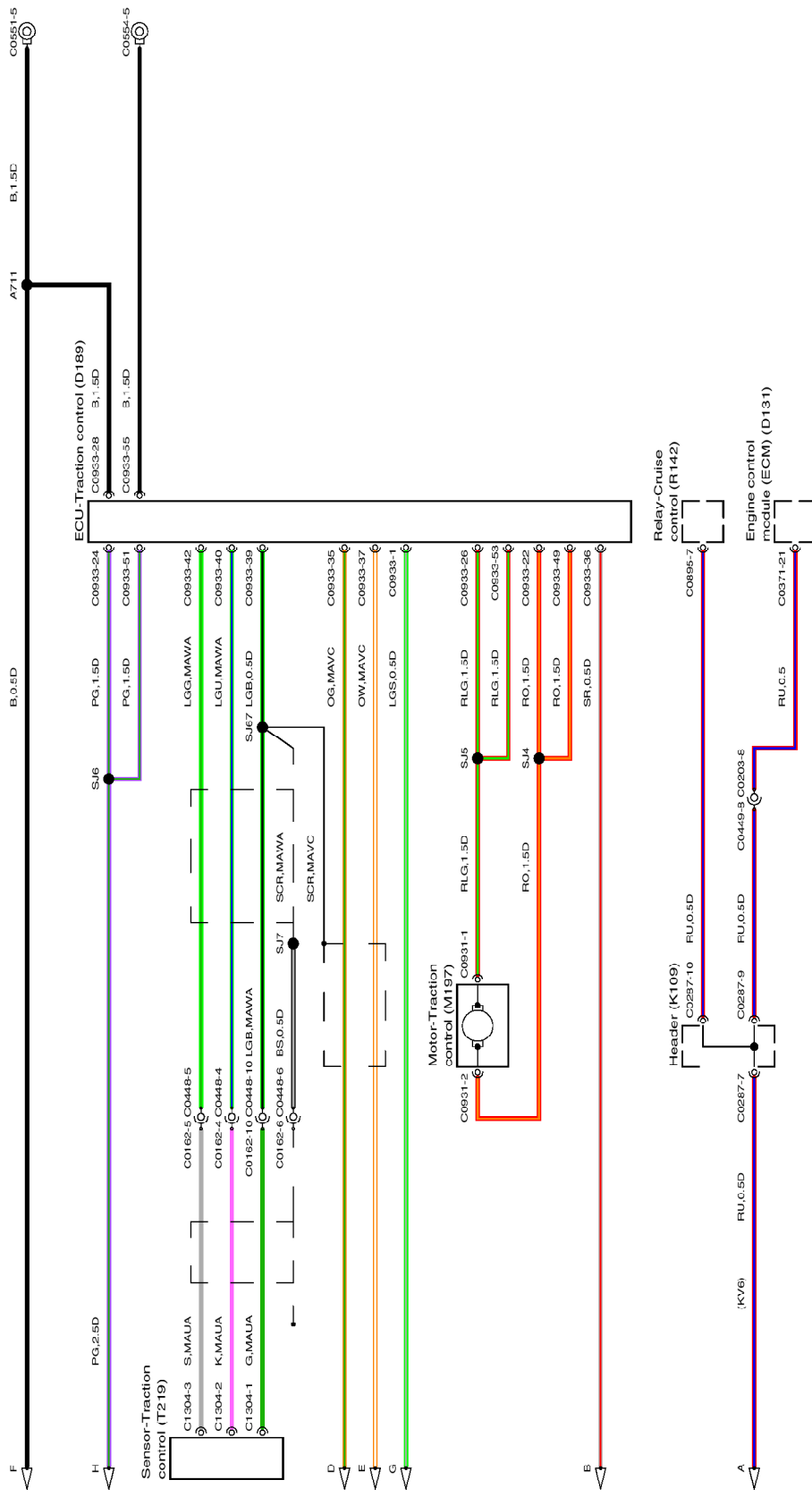

VWR402700-2

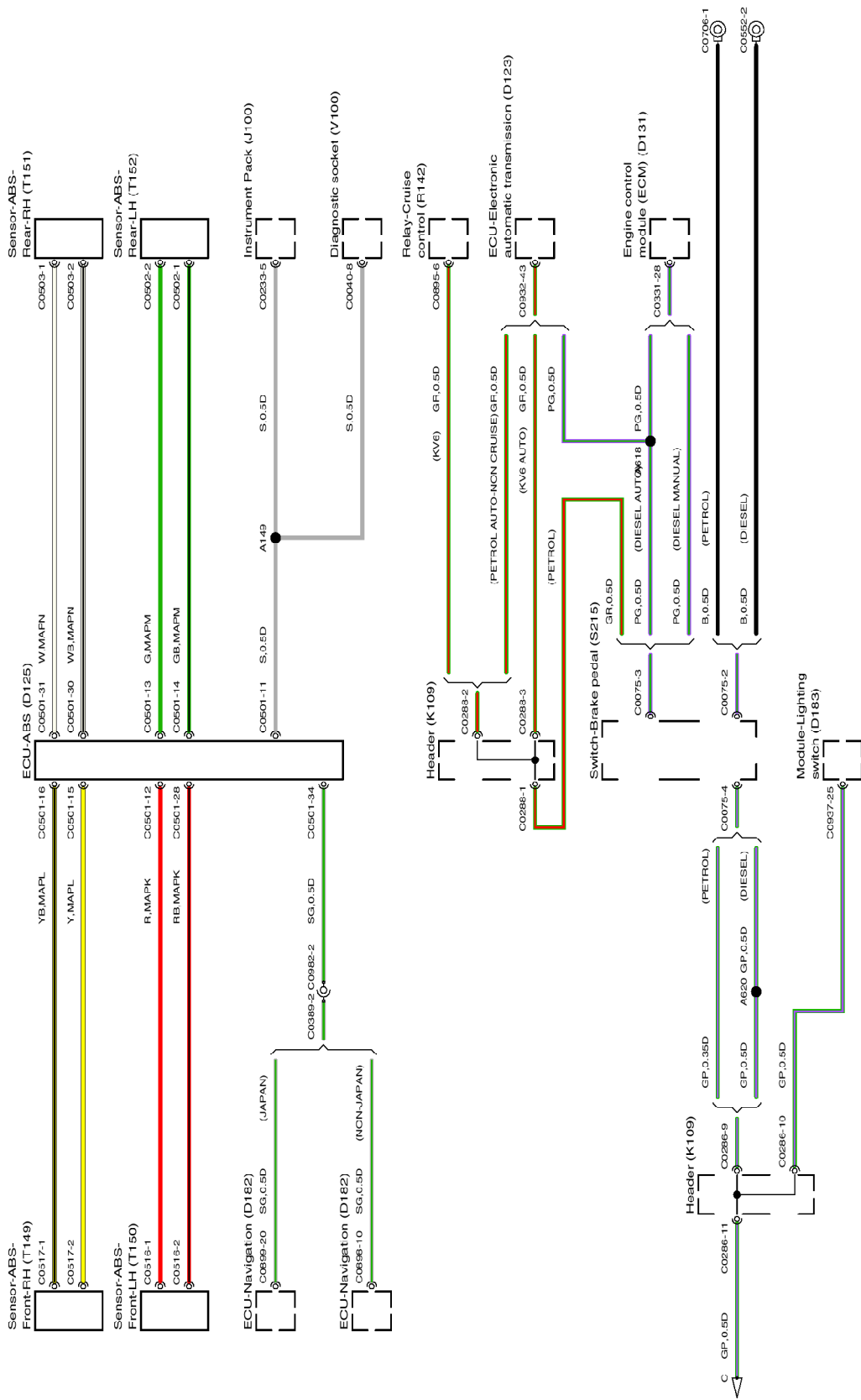

VWR402700-3

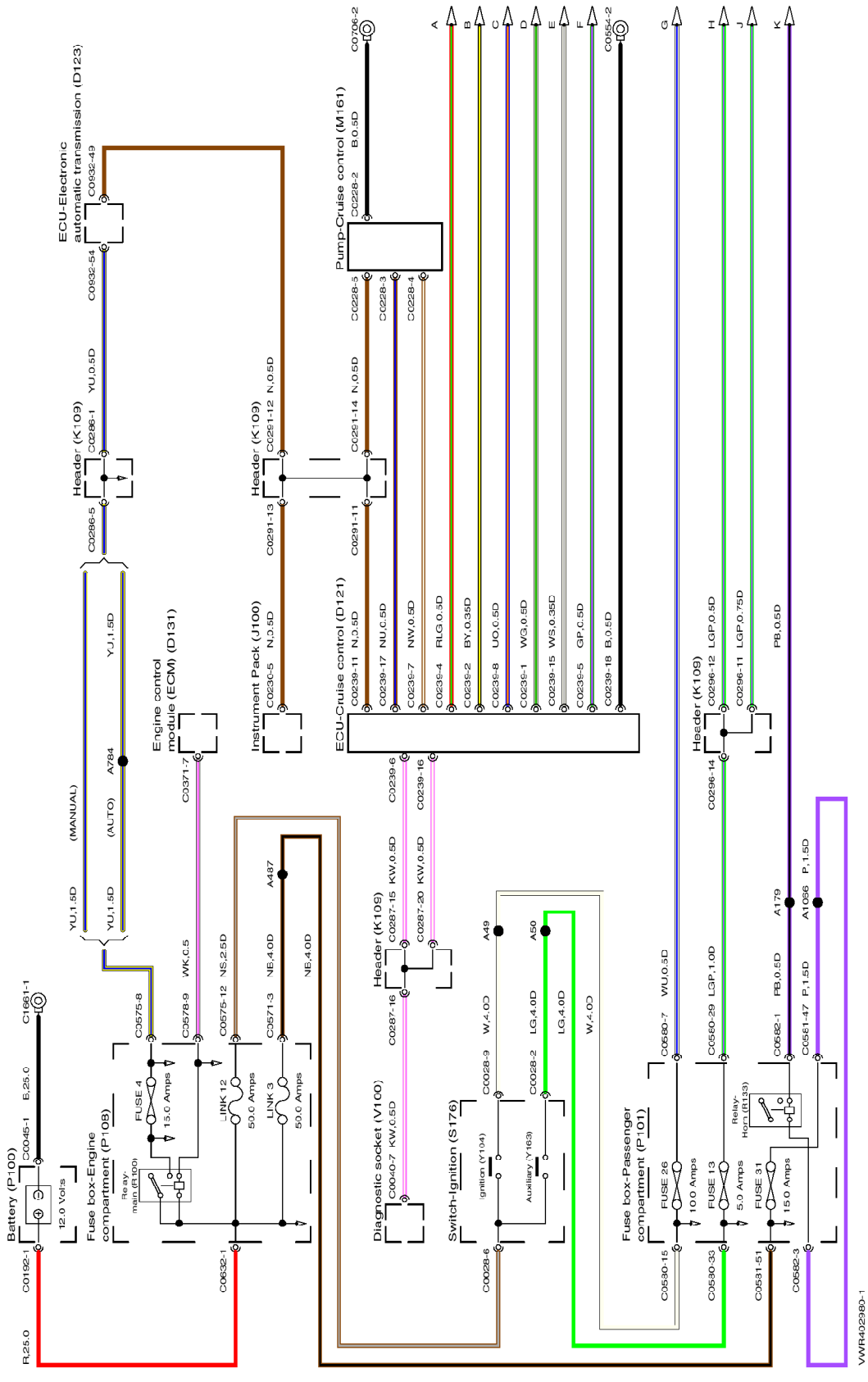

VWR402980-1

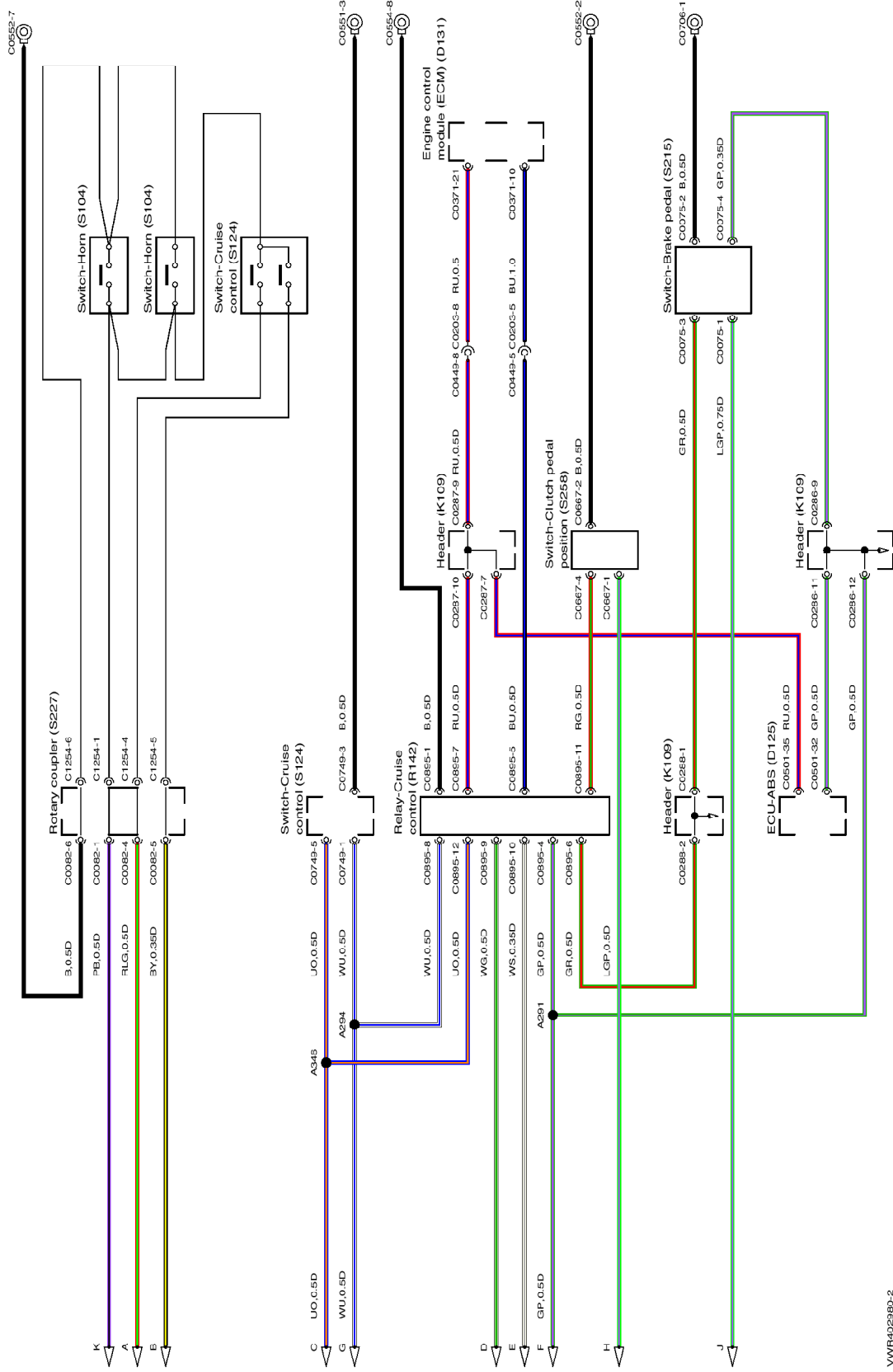

VWR402380-2

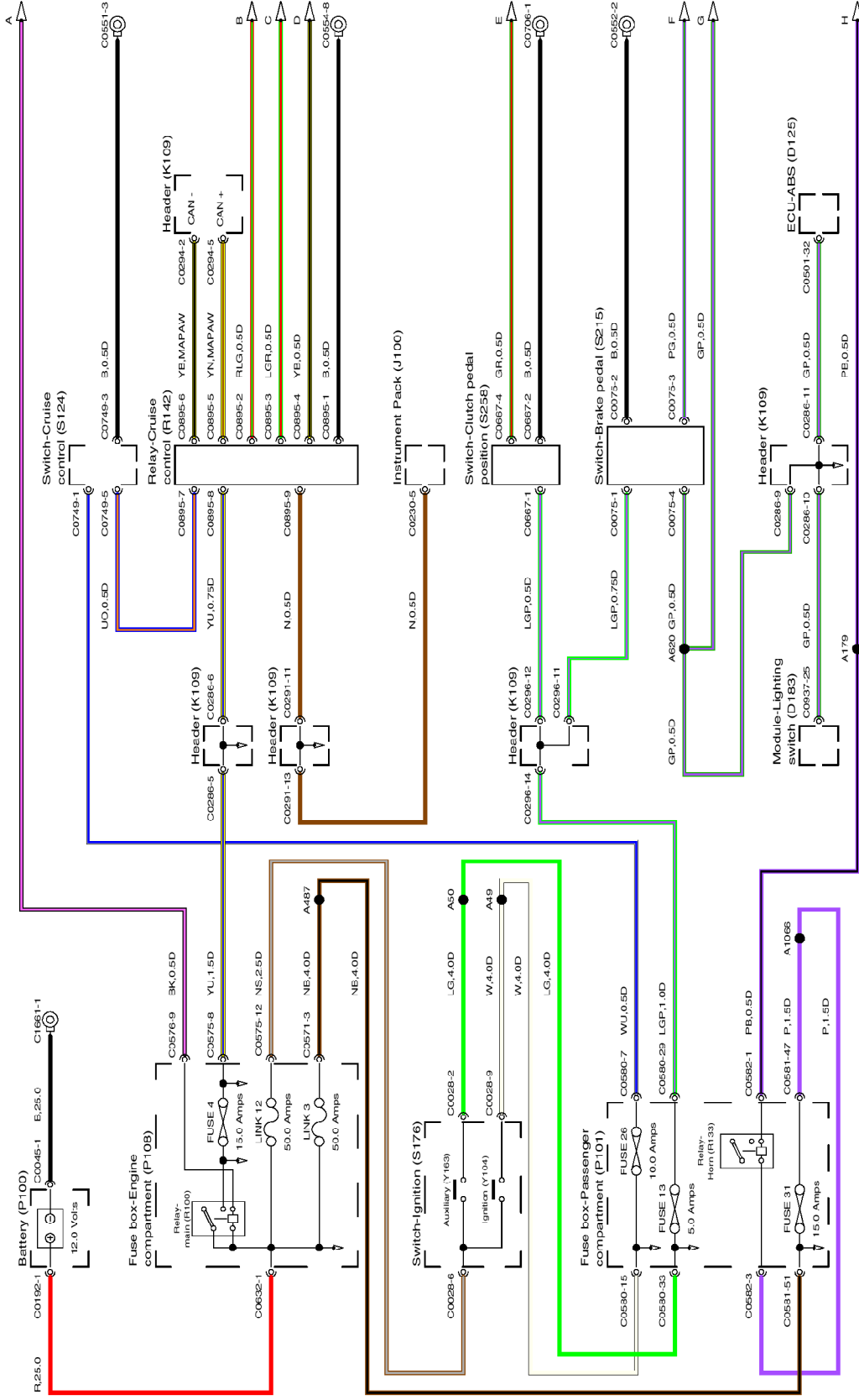

VWR402960-1

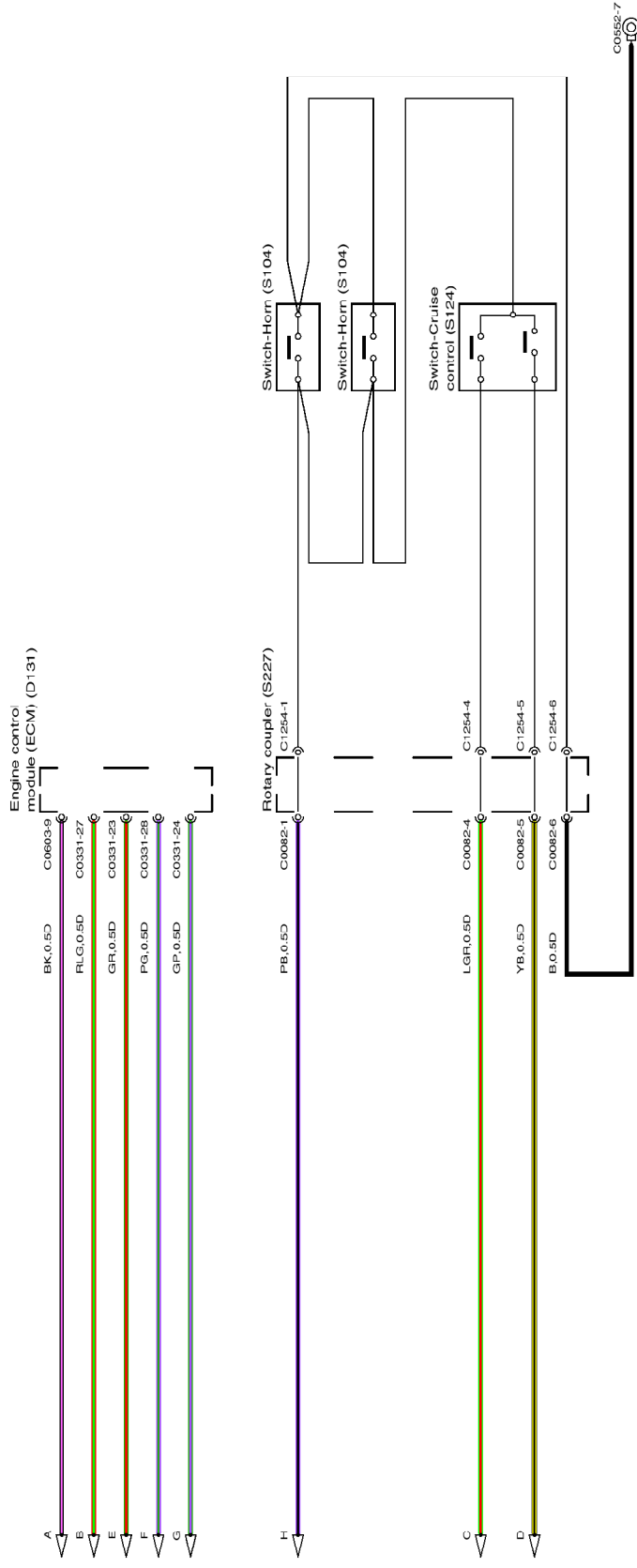

VWR402960-2

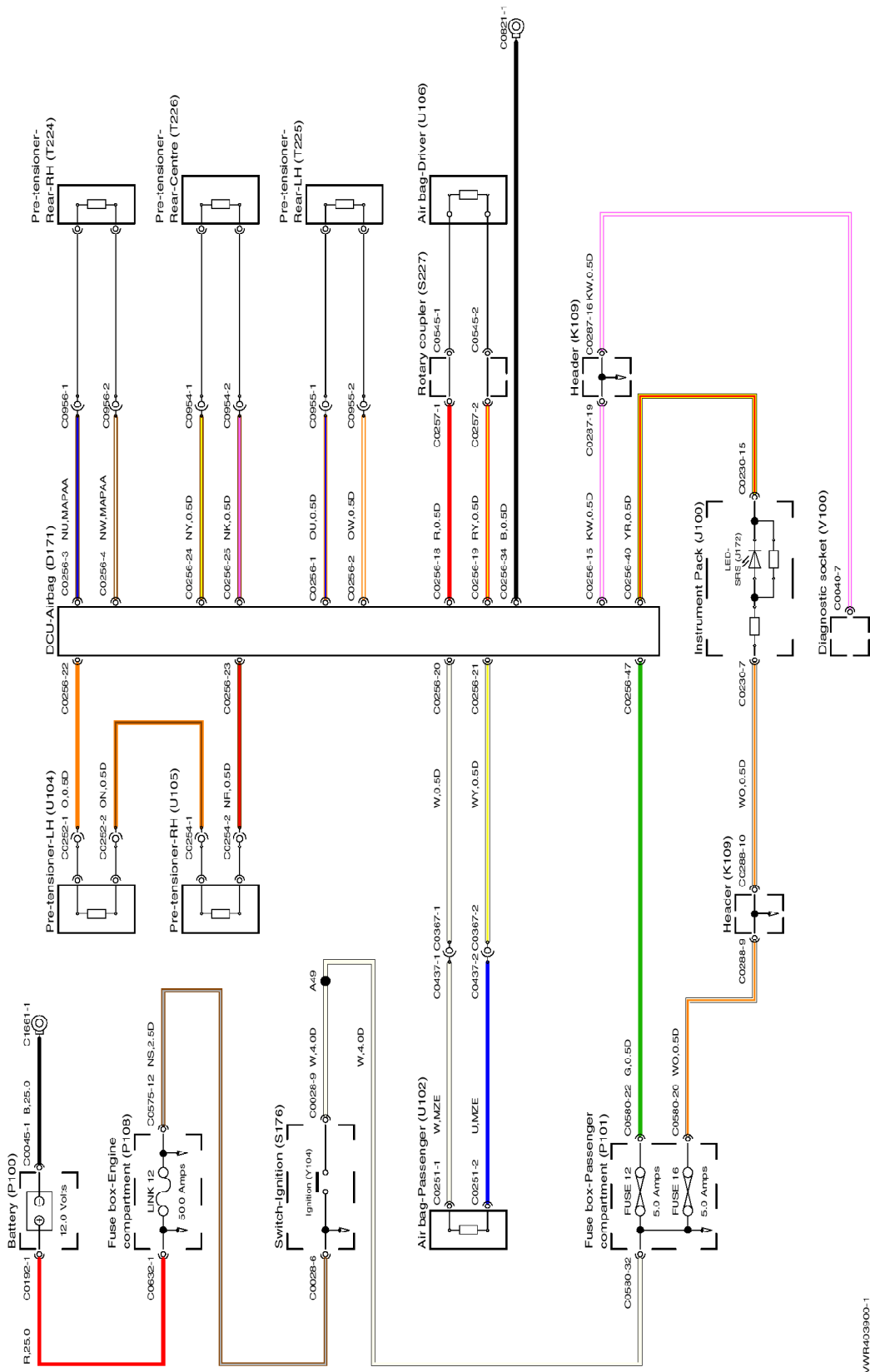

VWR403900-1

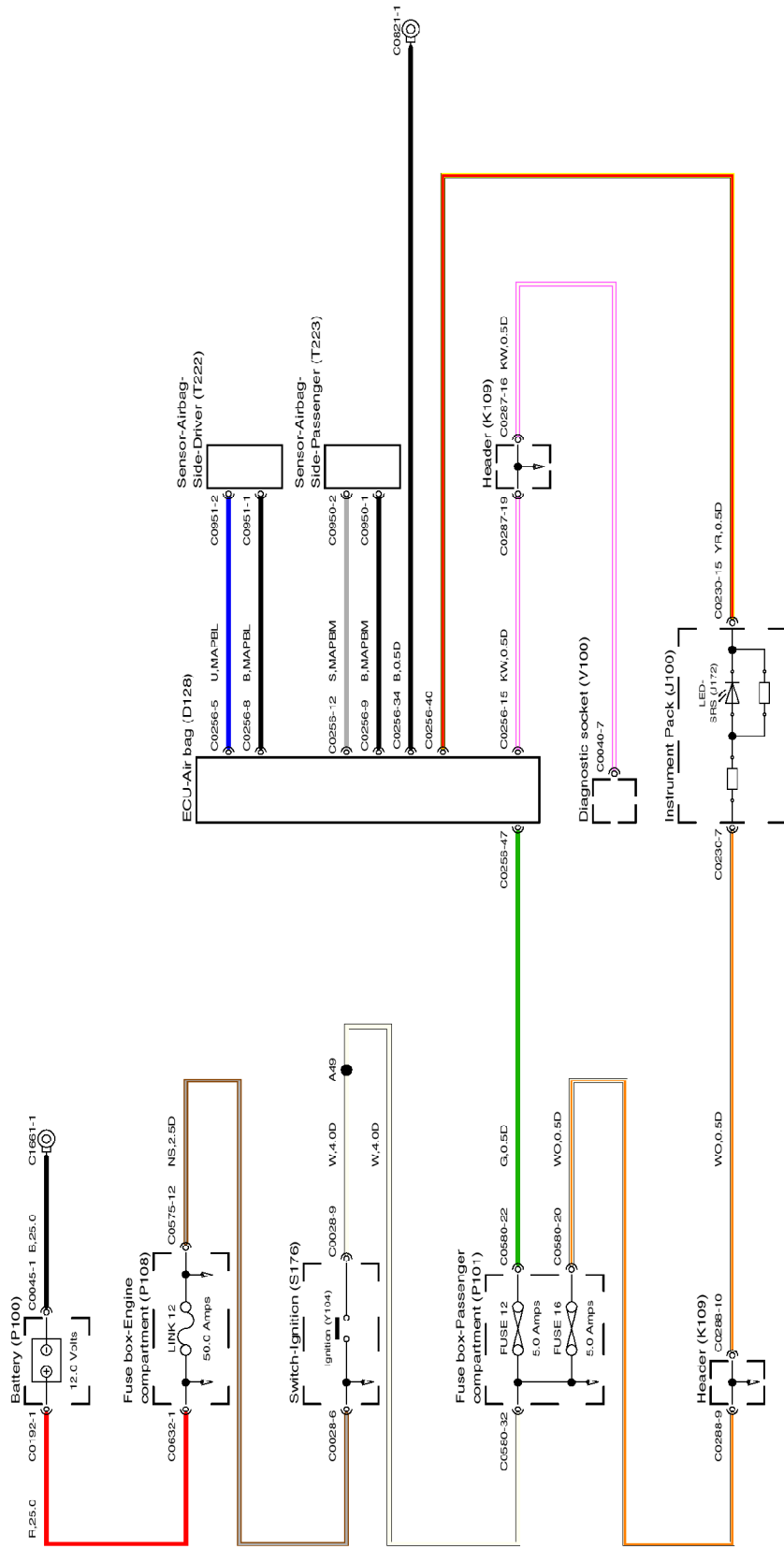

VWR403920-1

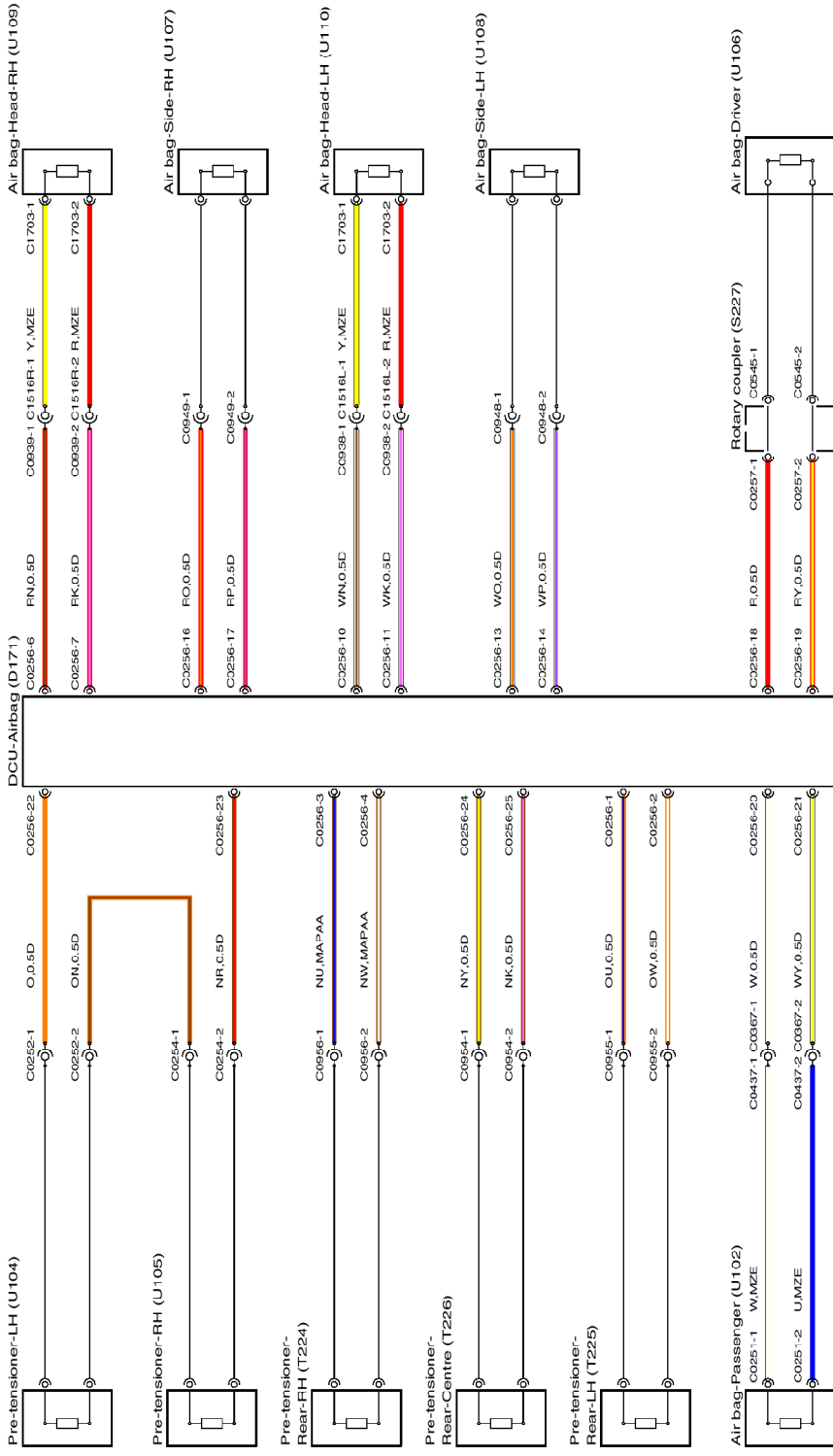

VWR403920-2

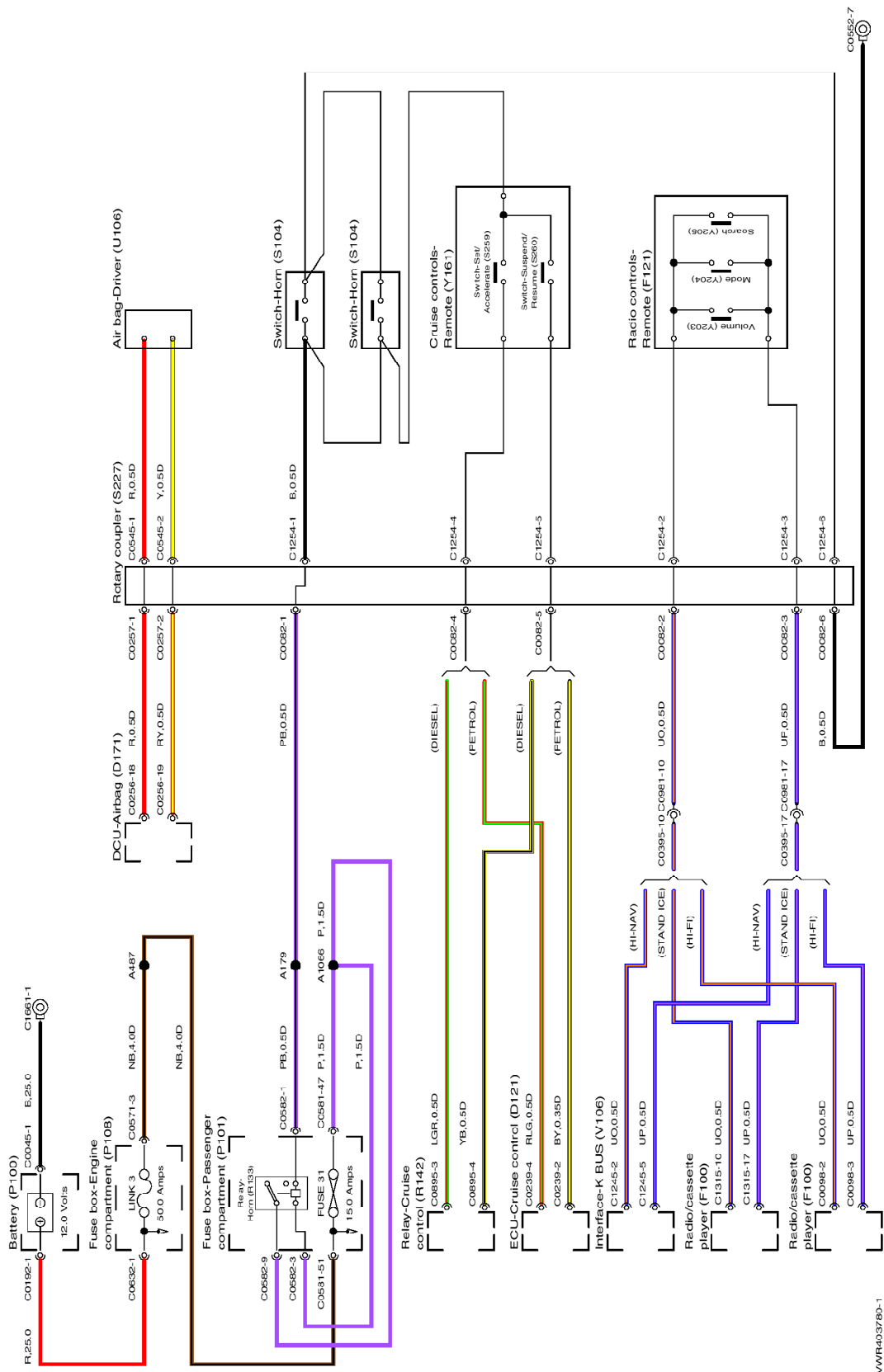

VWR403780-1

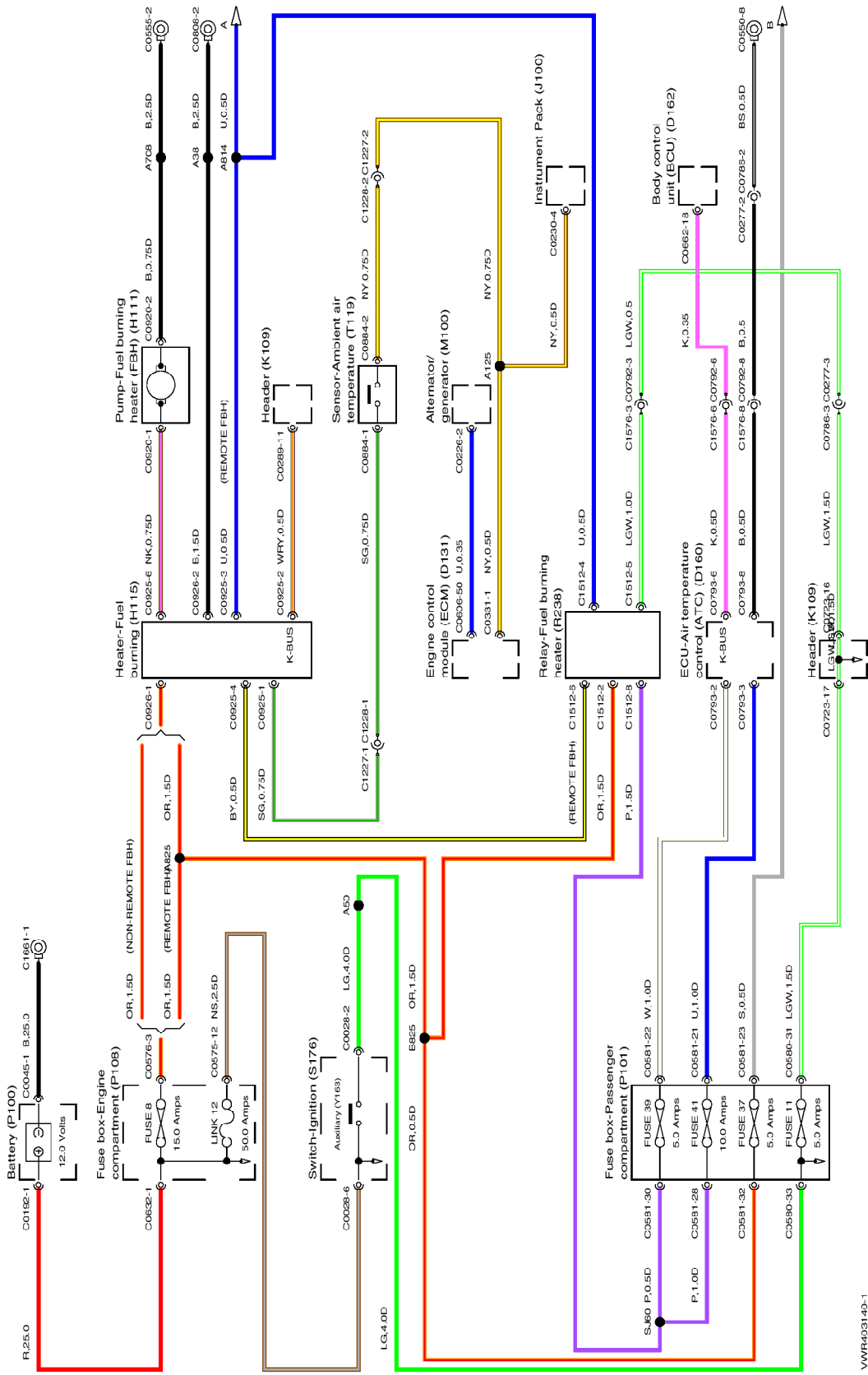

VWR403140-1

80 FUEL BURNING HEATER

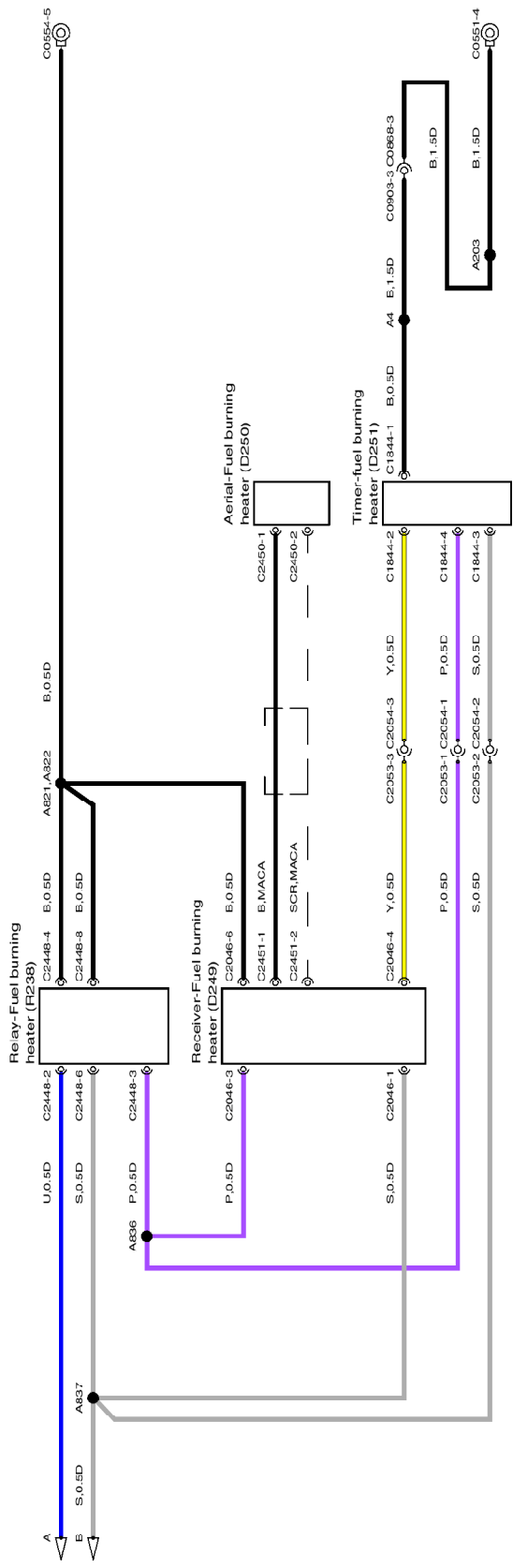

VWR403140-2

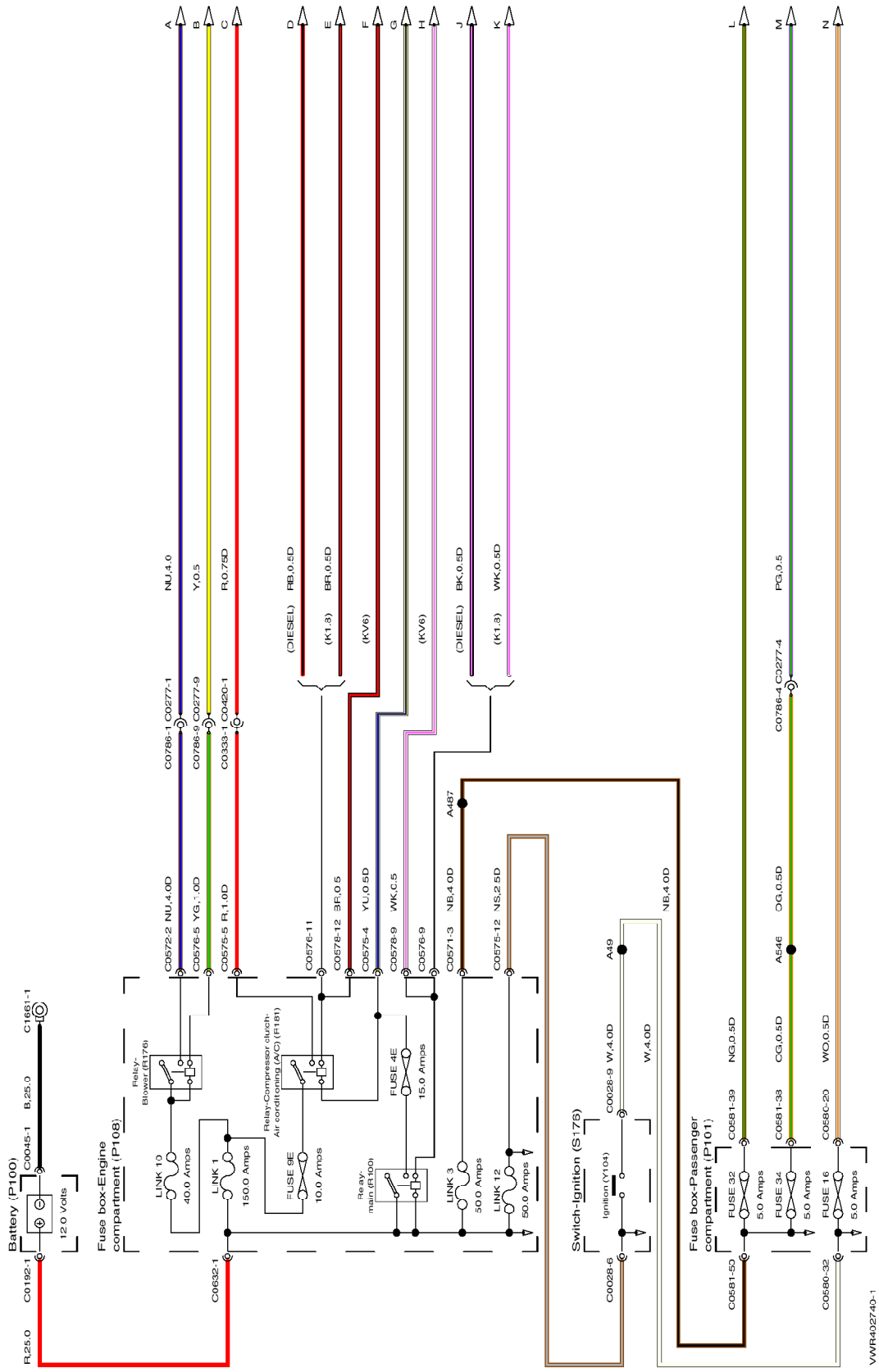

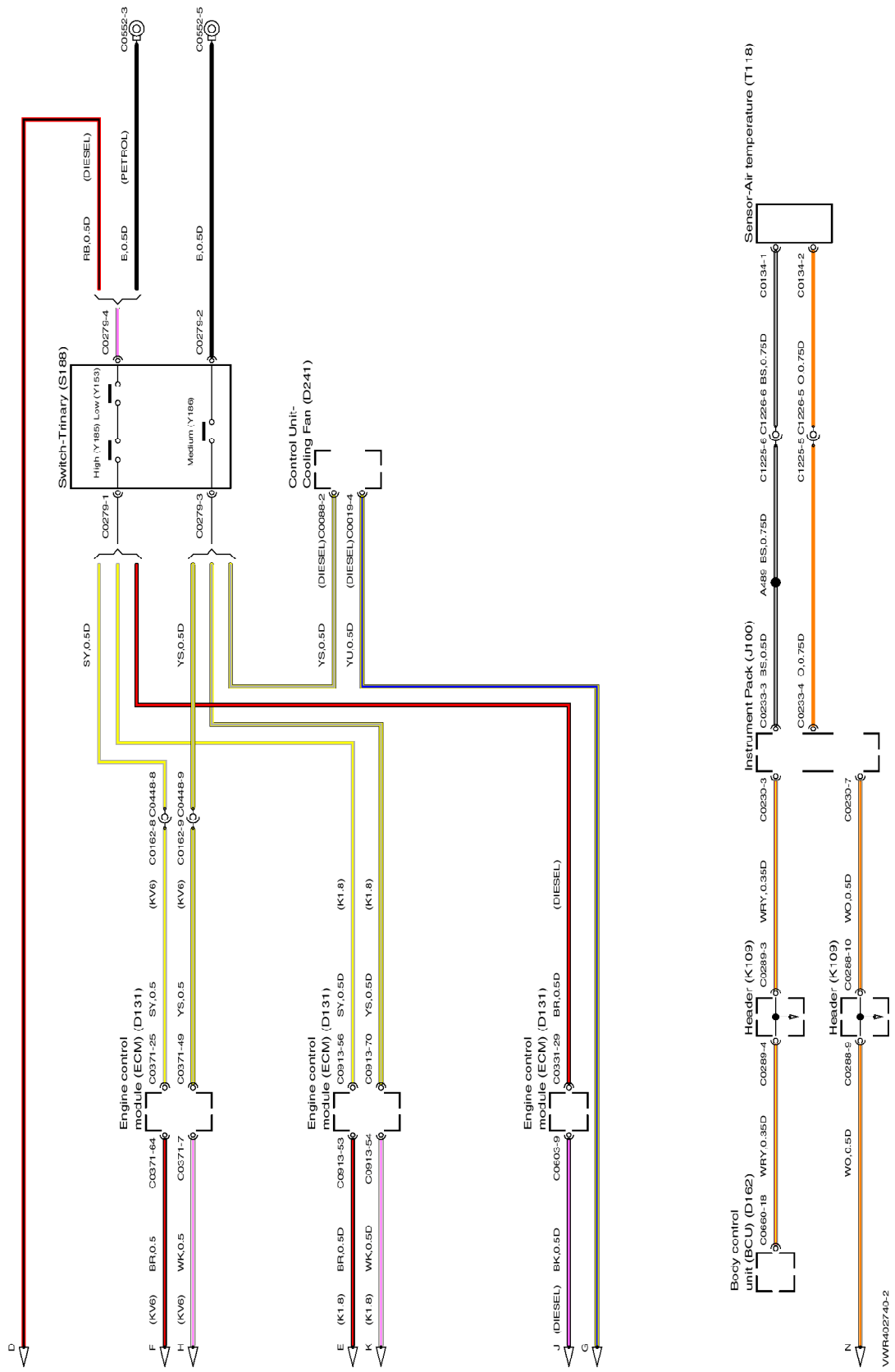

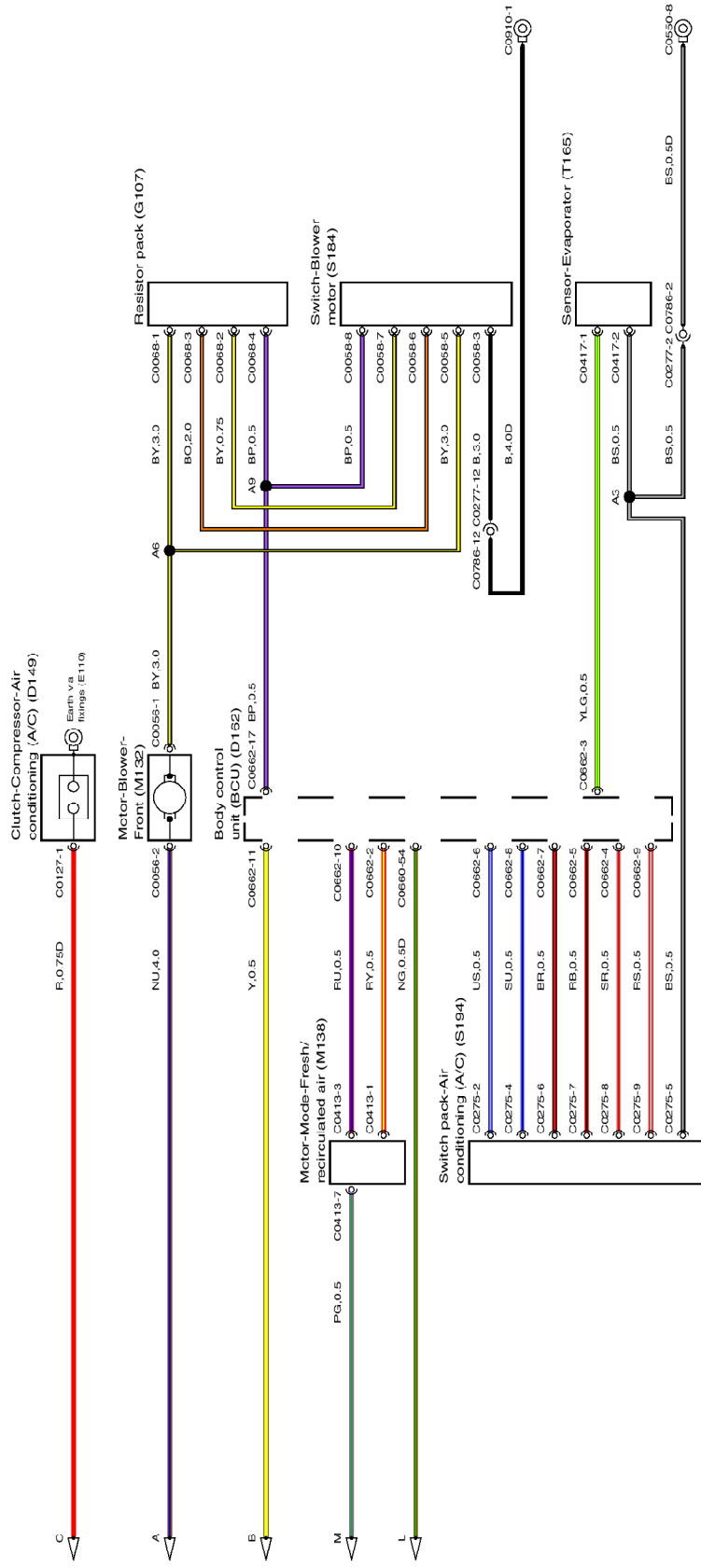

VWR402740-3

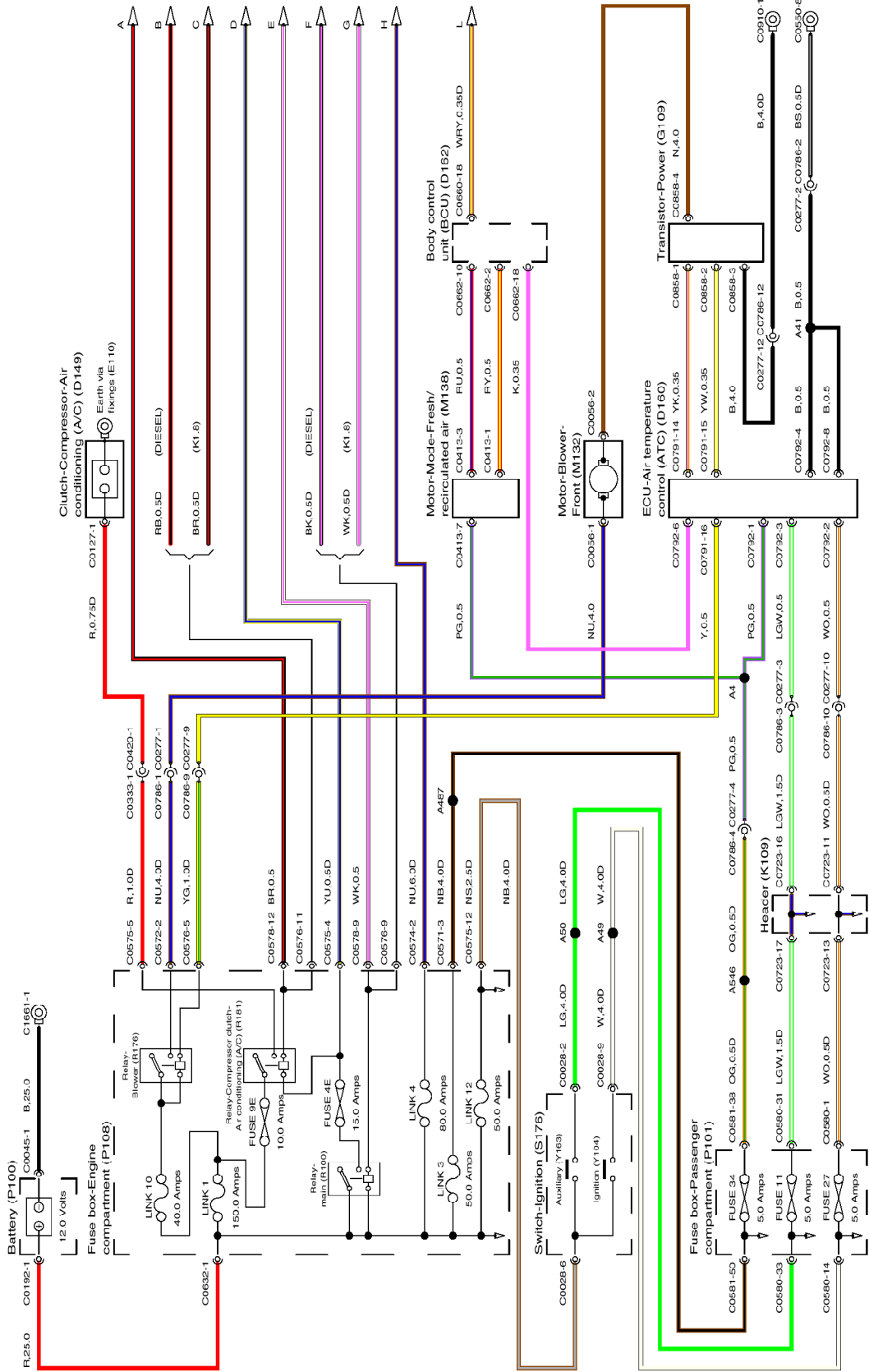

VWR402760-1

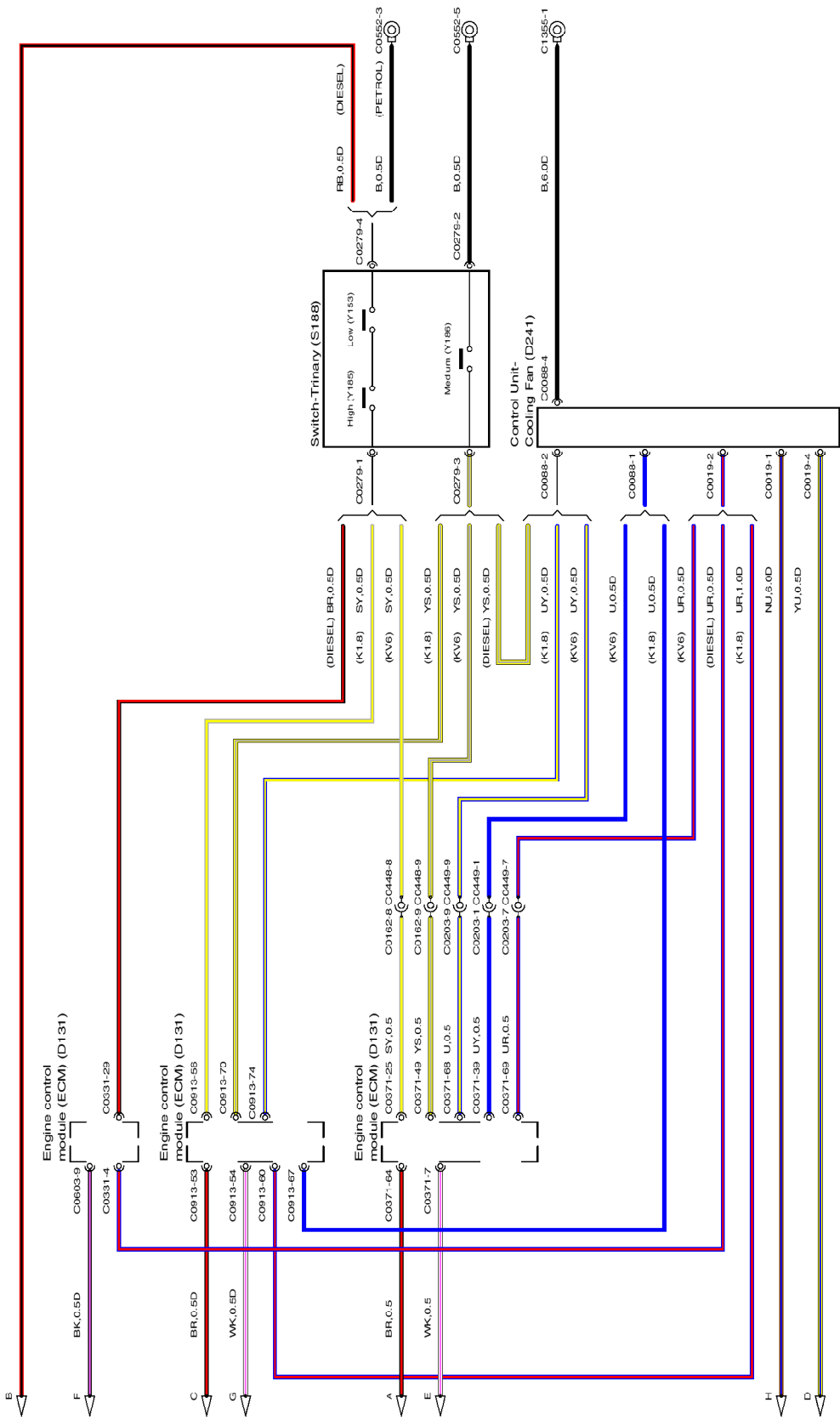

VWR402760-2

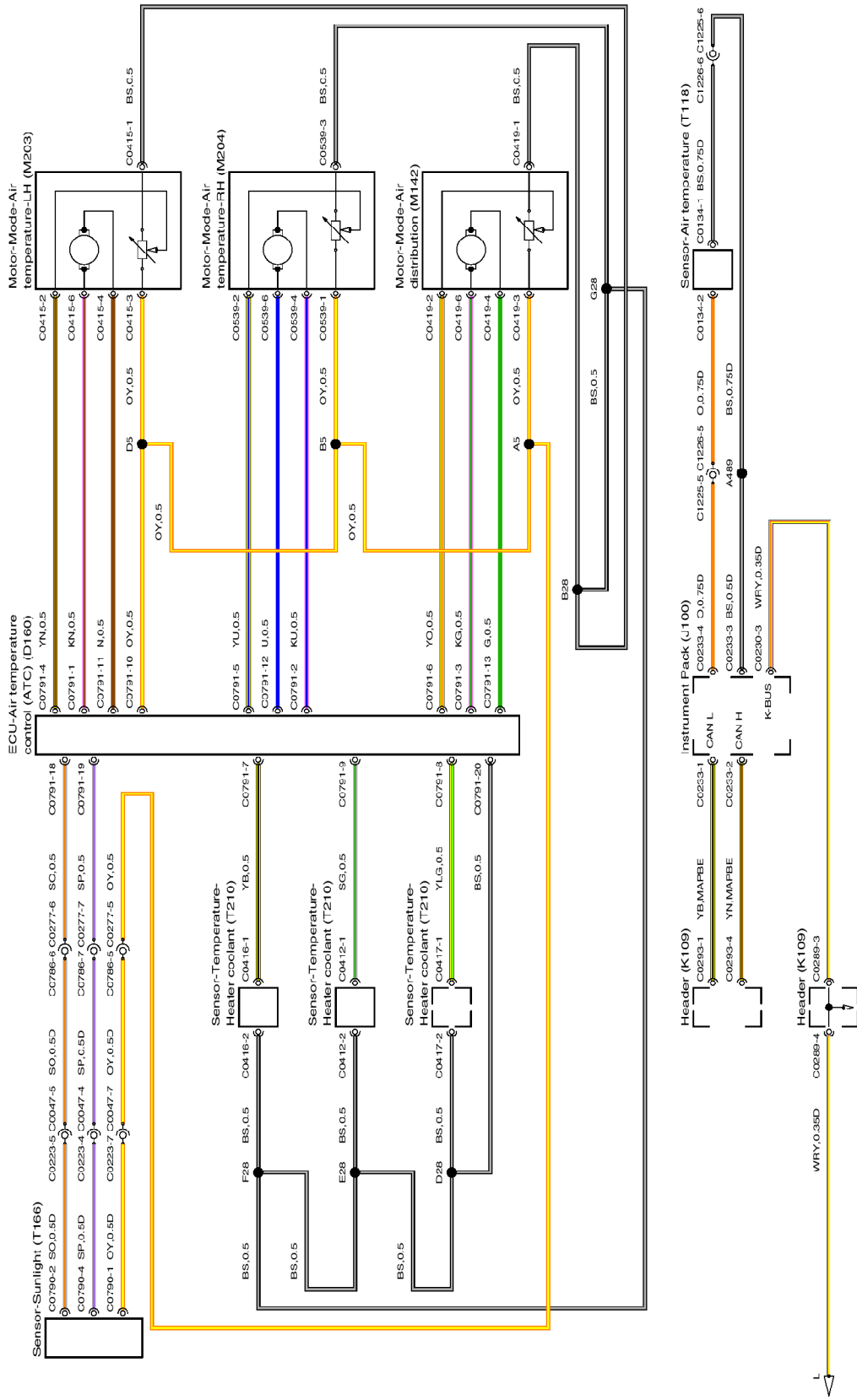

VWR402760-3

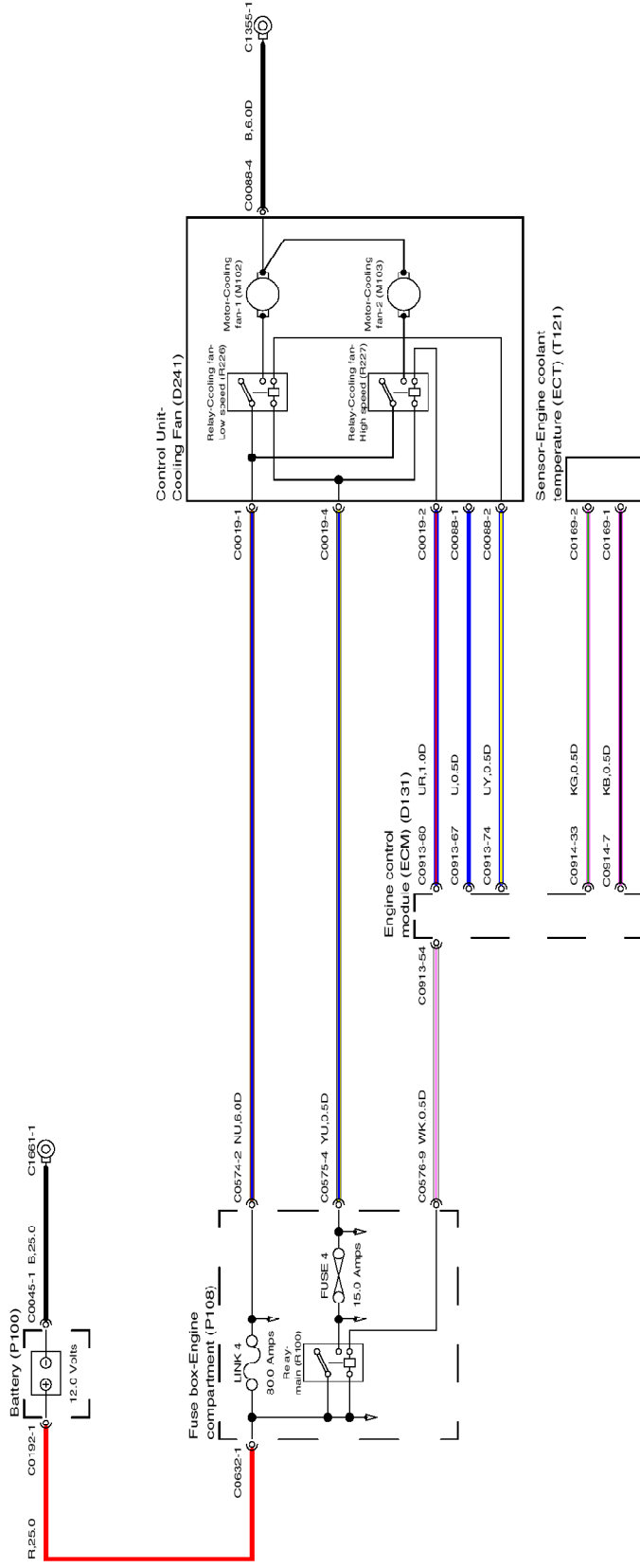

VWR402380-1

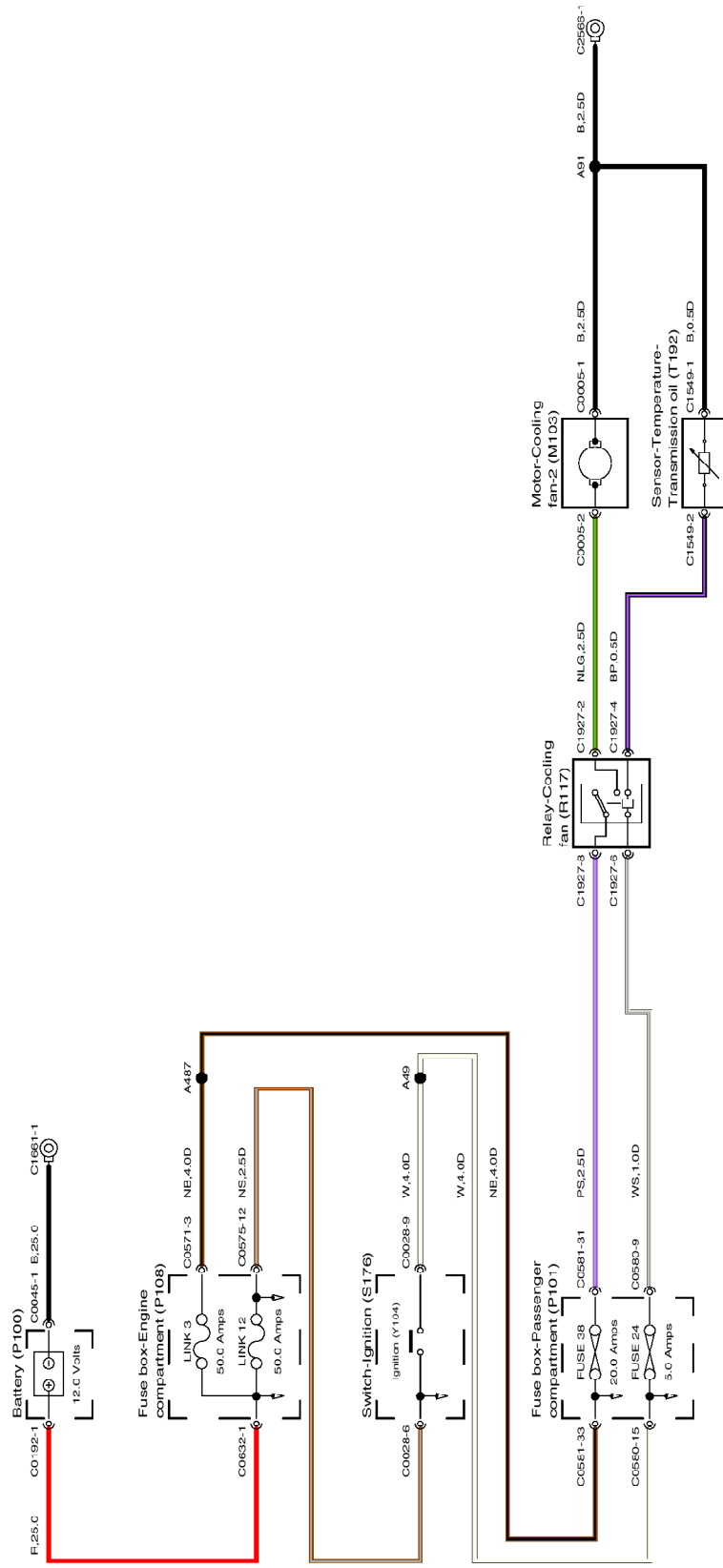

VWR402900-1

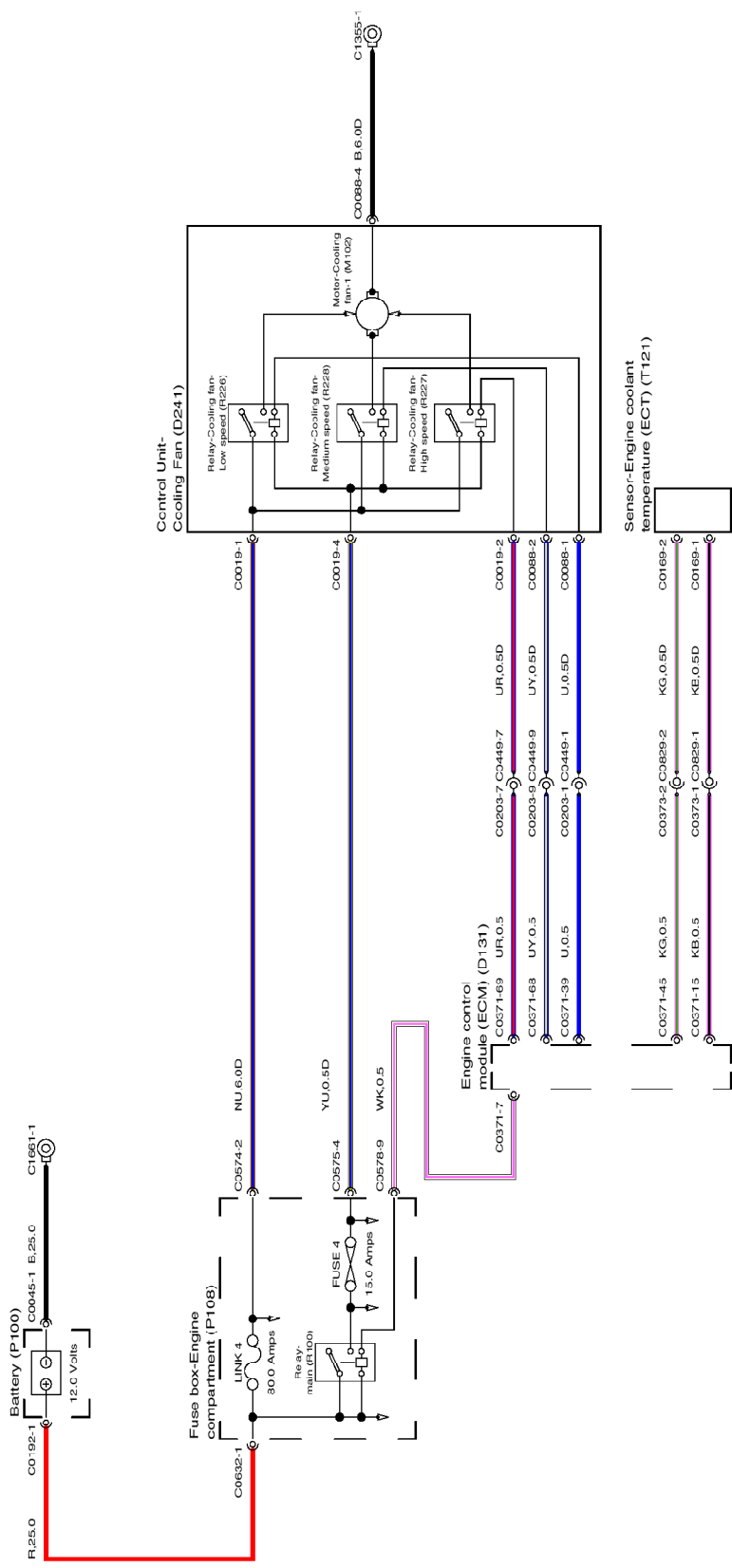

VWR402940-1

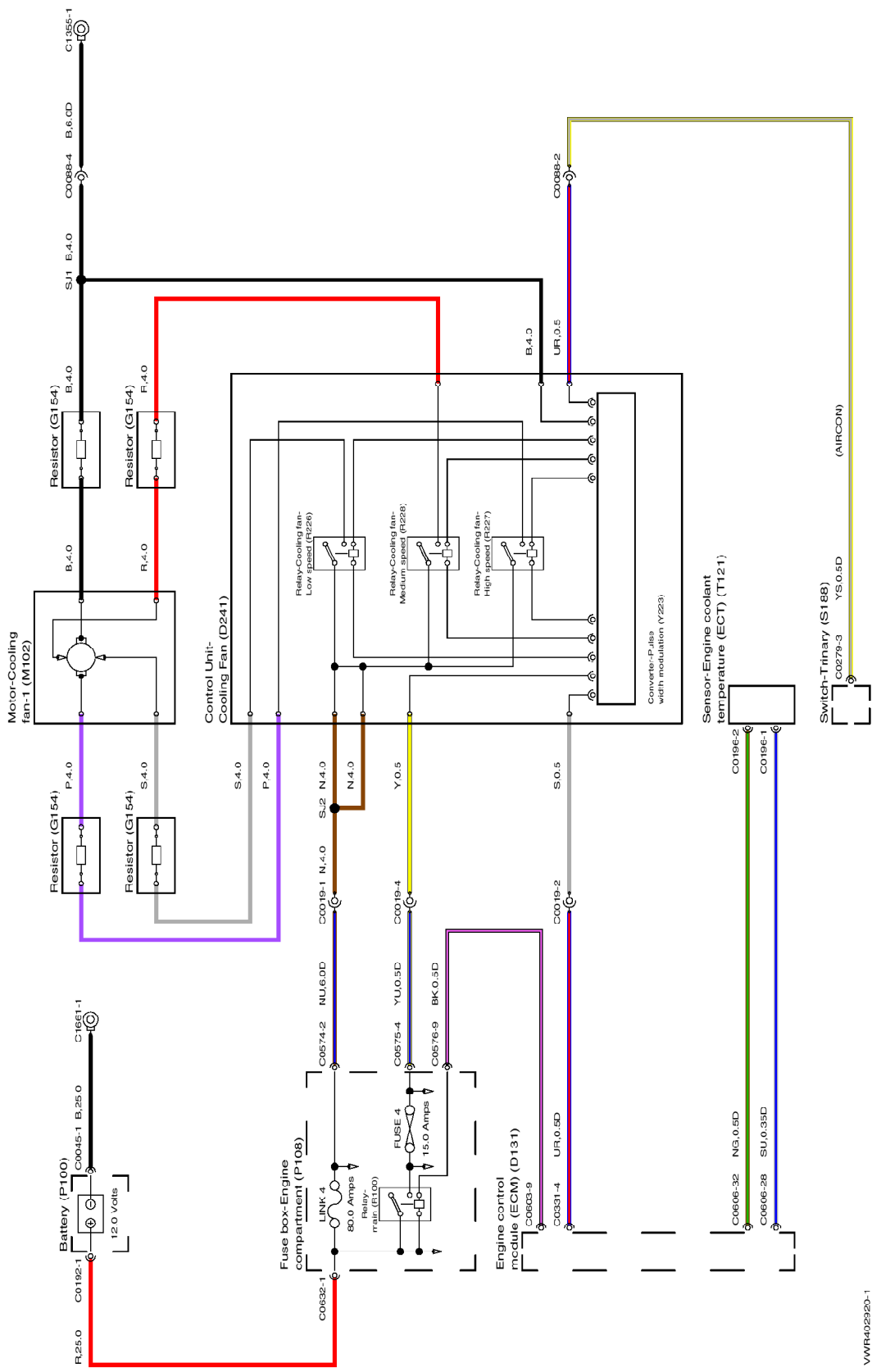

VWR402920-1

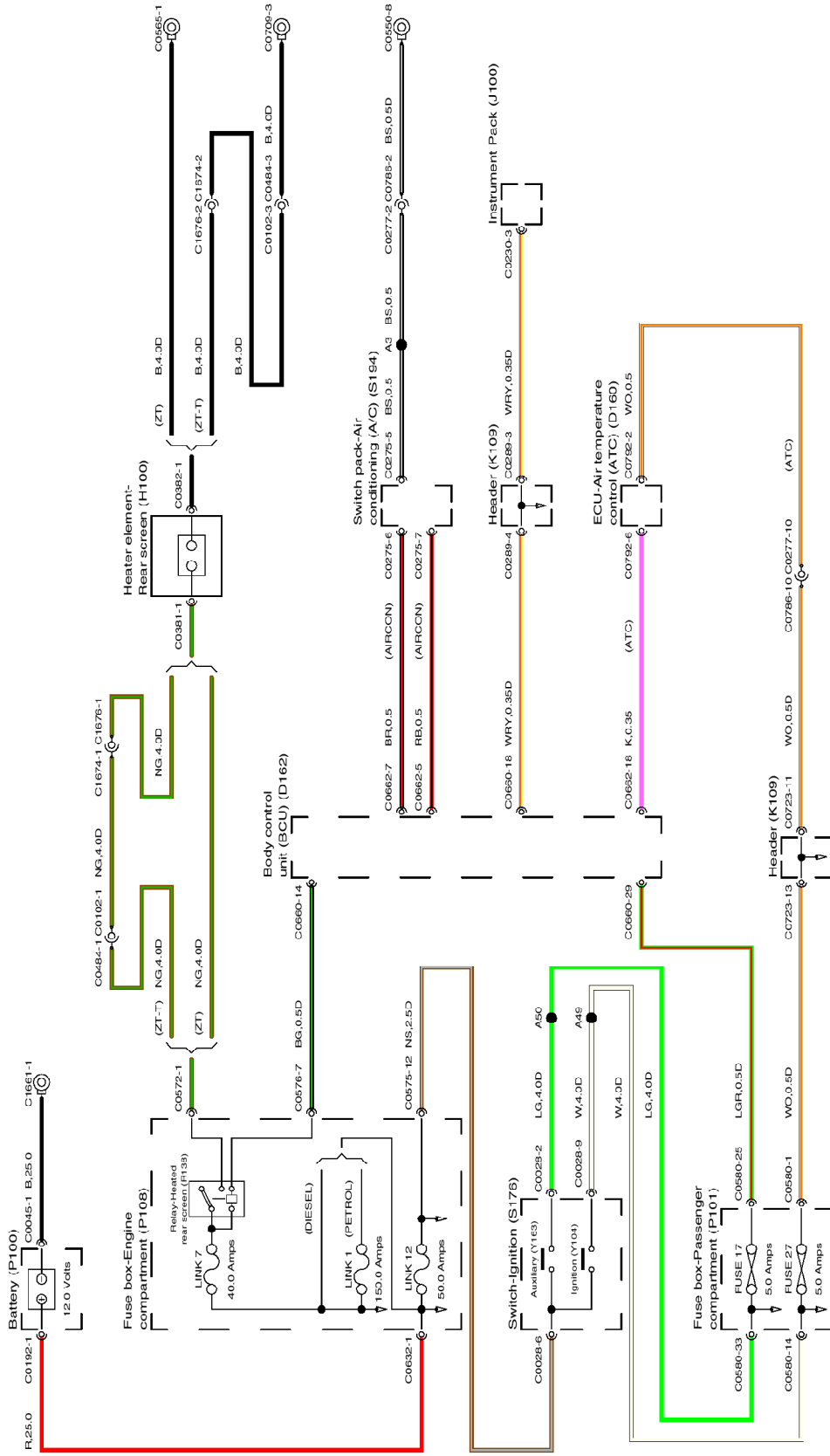

VWR403240-1

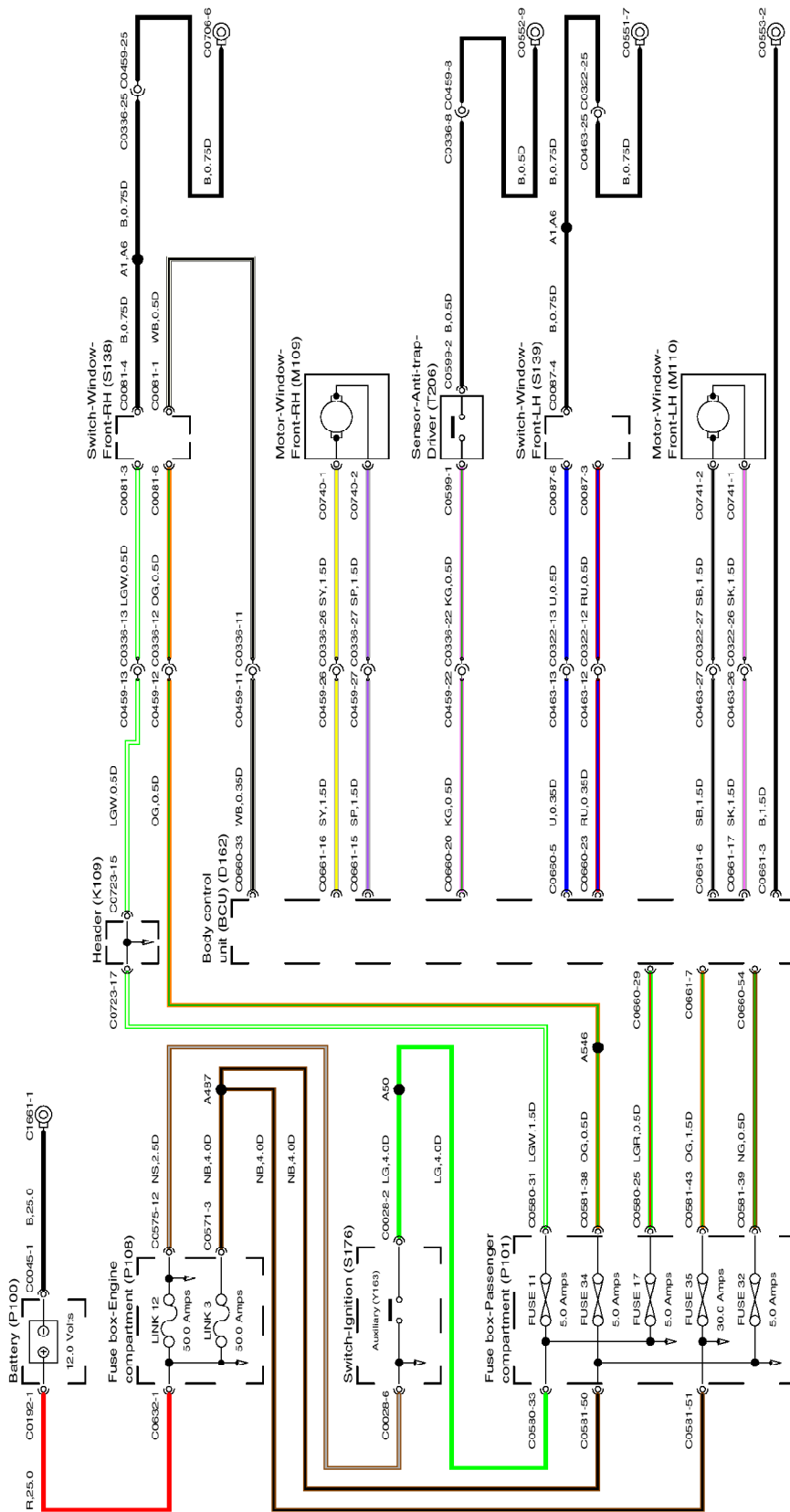

VWR404140-1

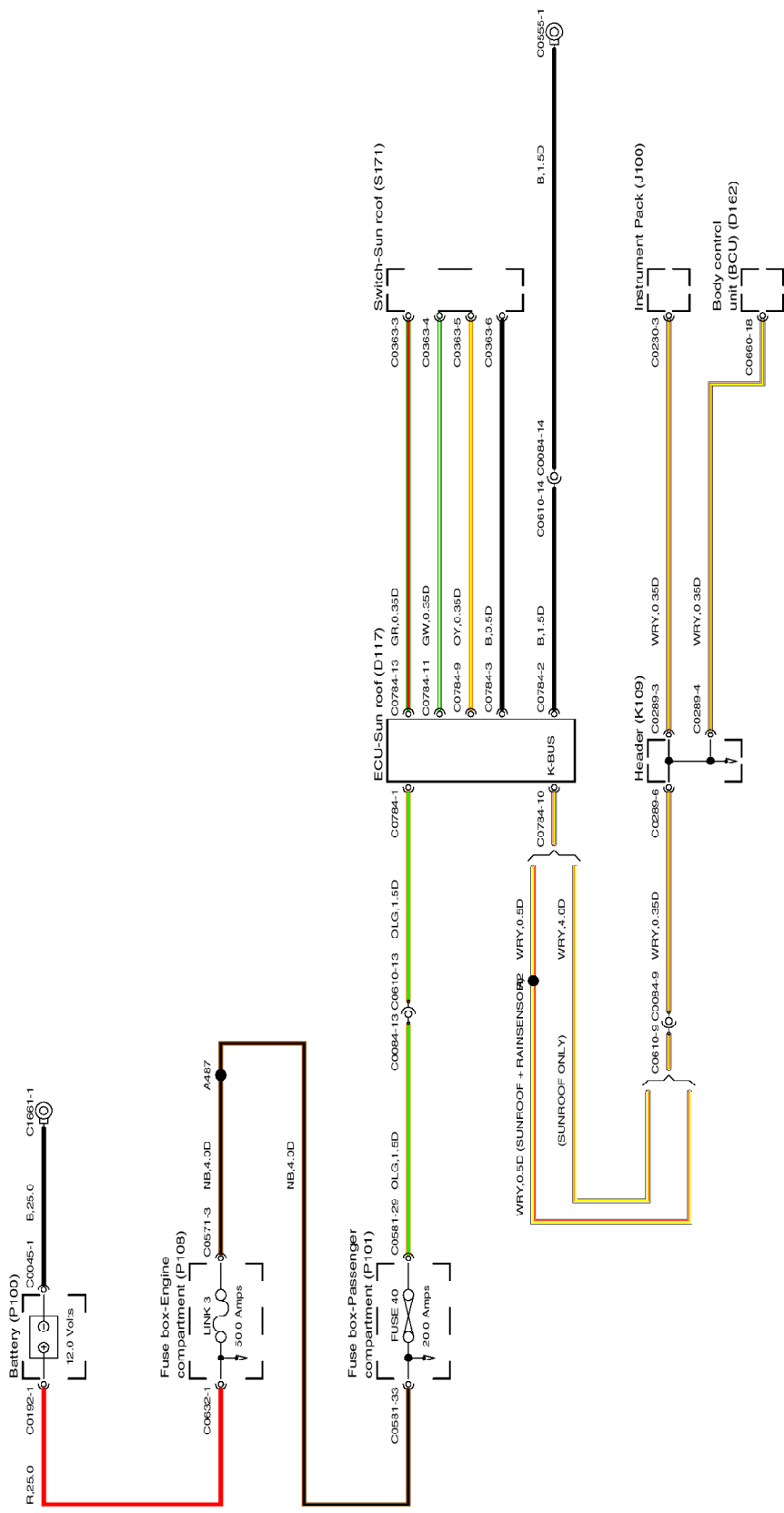

VWR404020-1

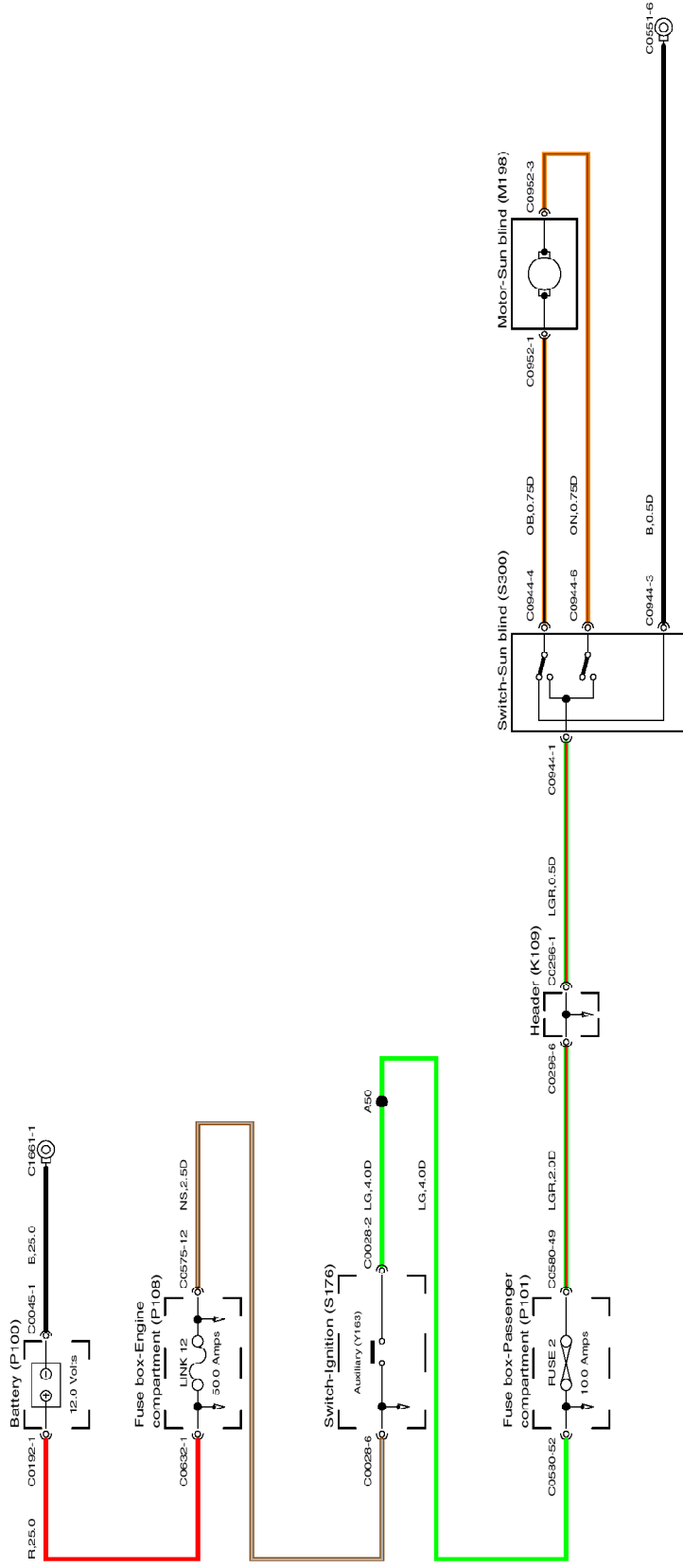

VWR404000-1

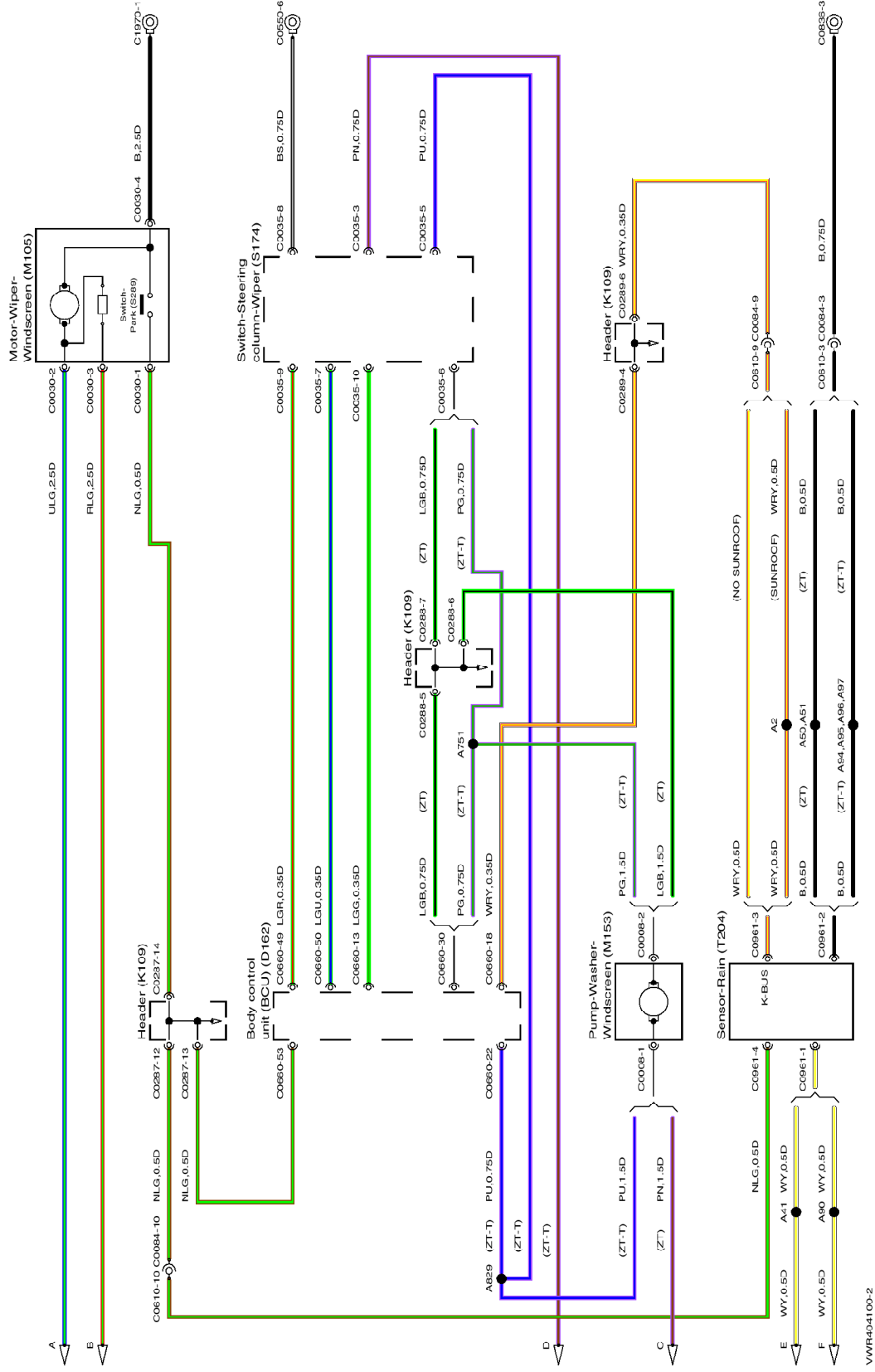

VWR404100-2

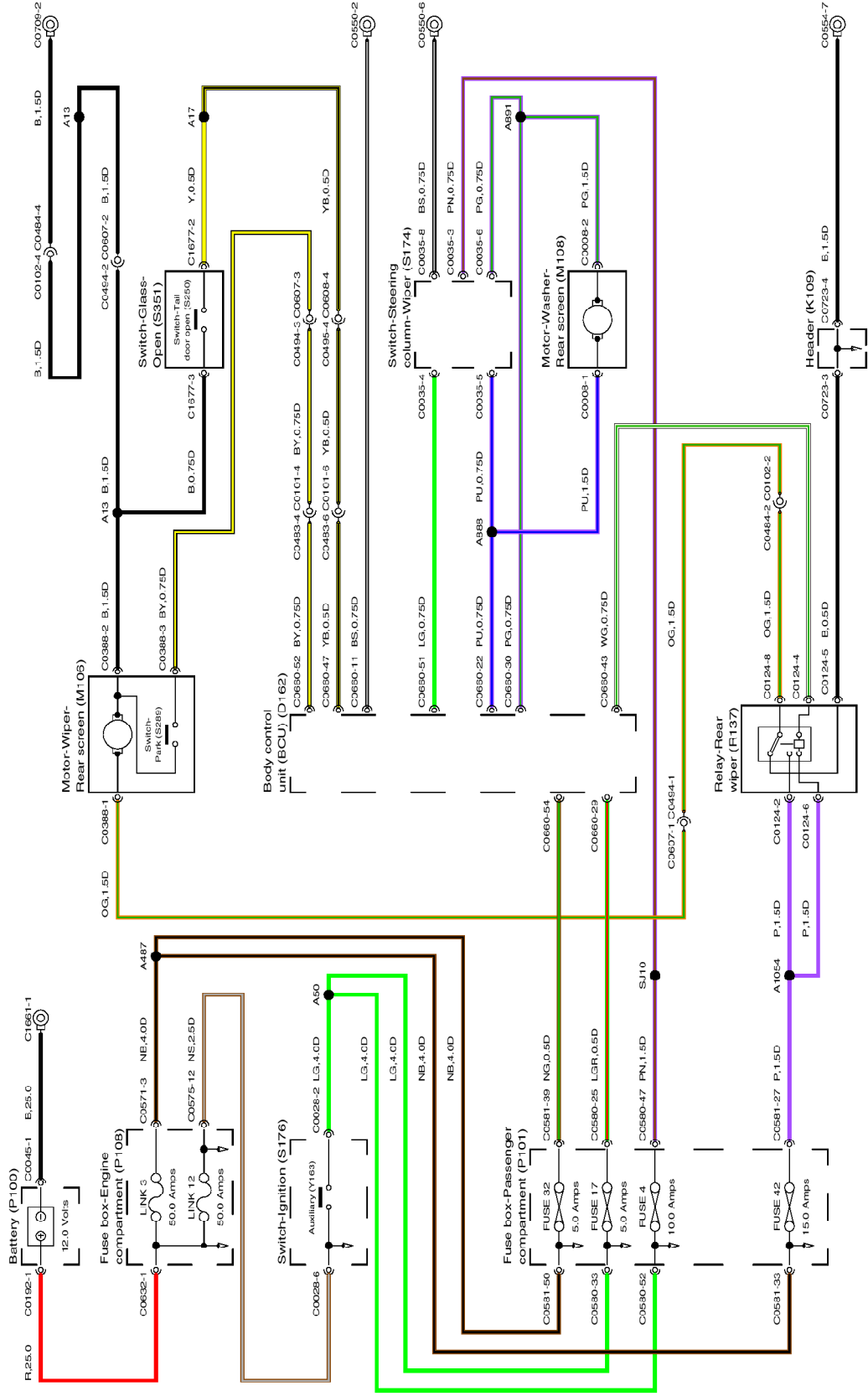

VWR404120-1

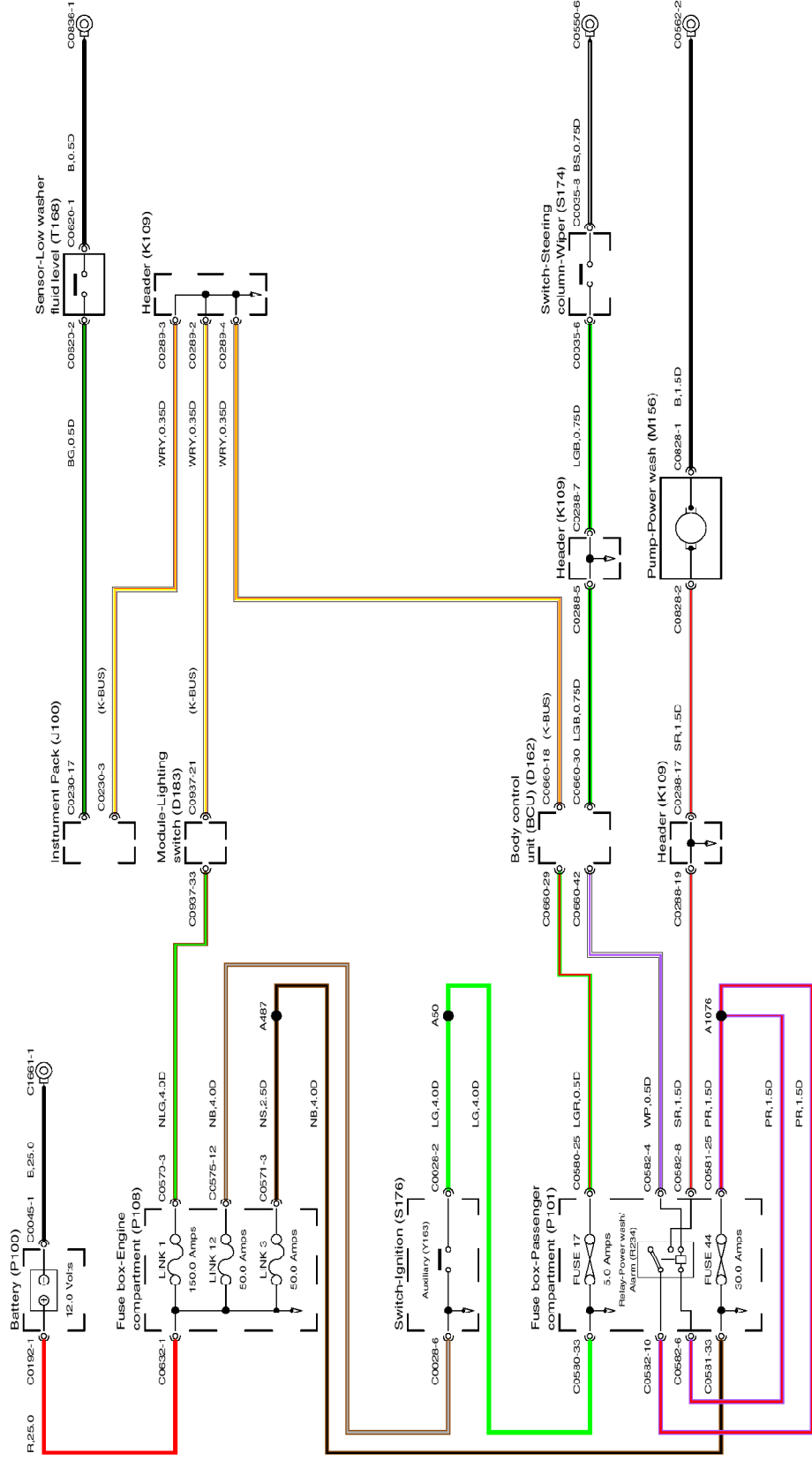

VWR403760-1

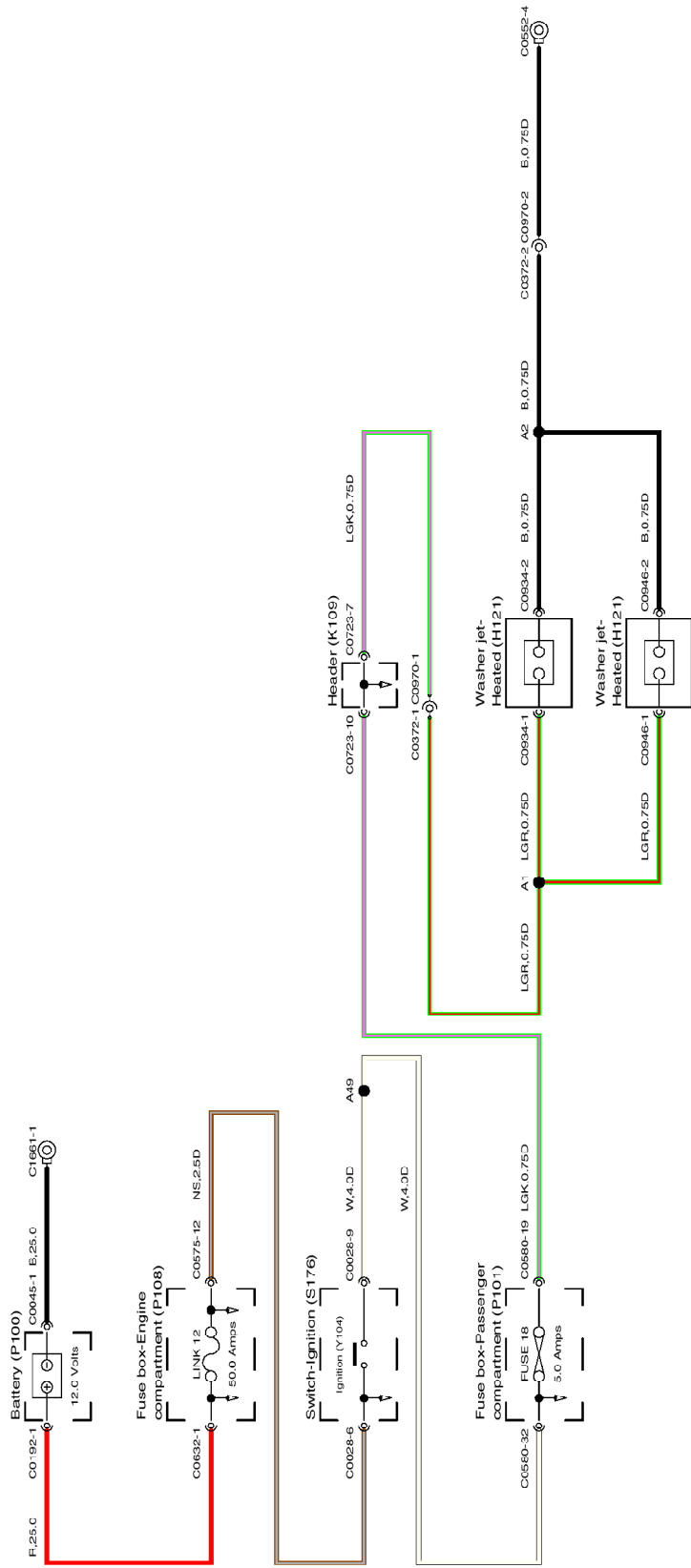

VWR403260-1

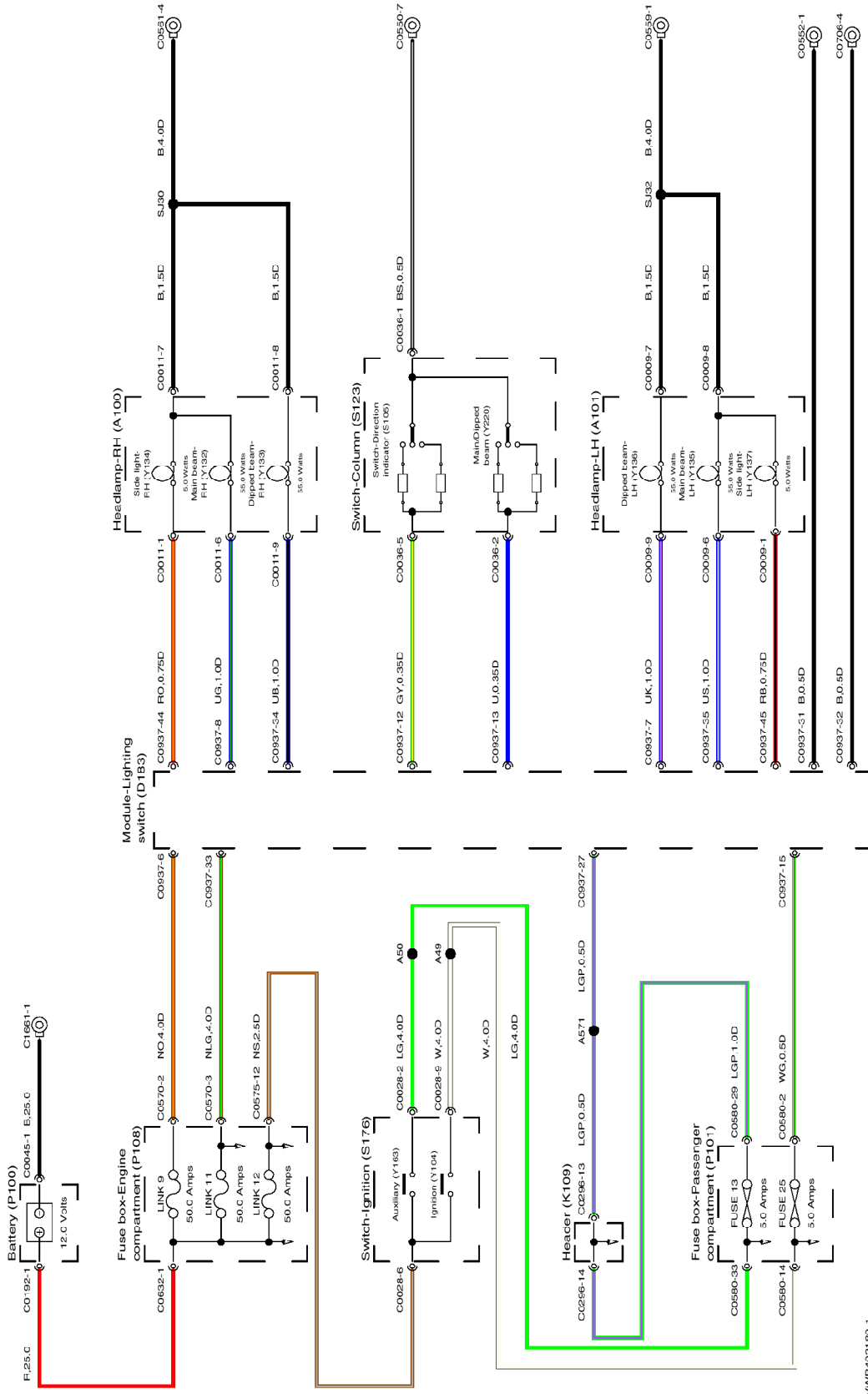

VWR403180-1

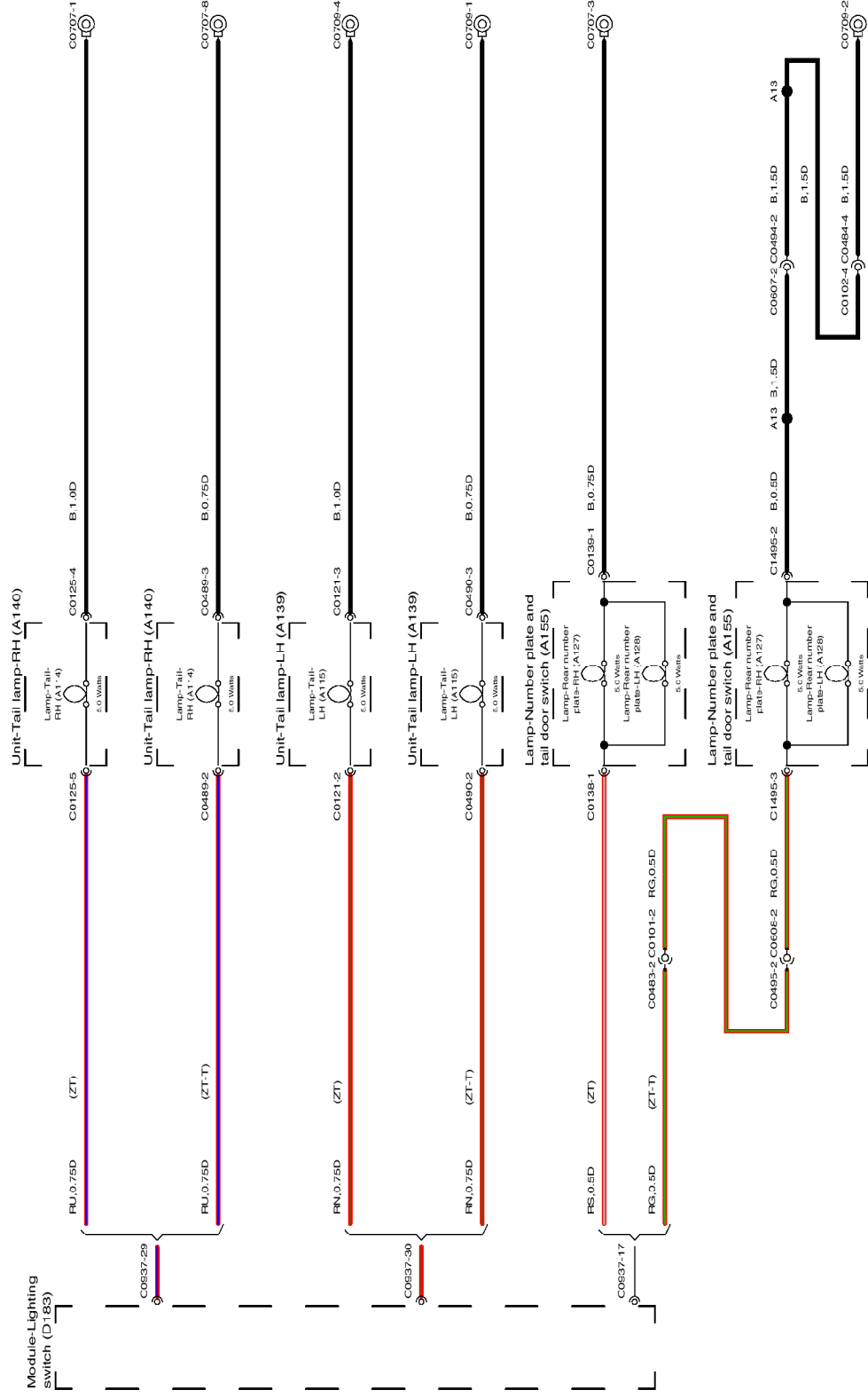

VWR403180-2

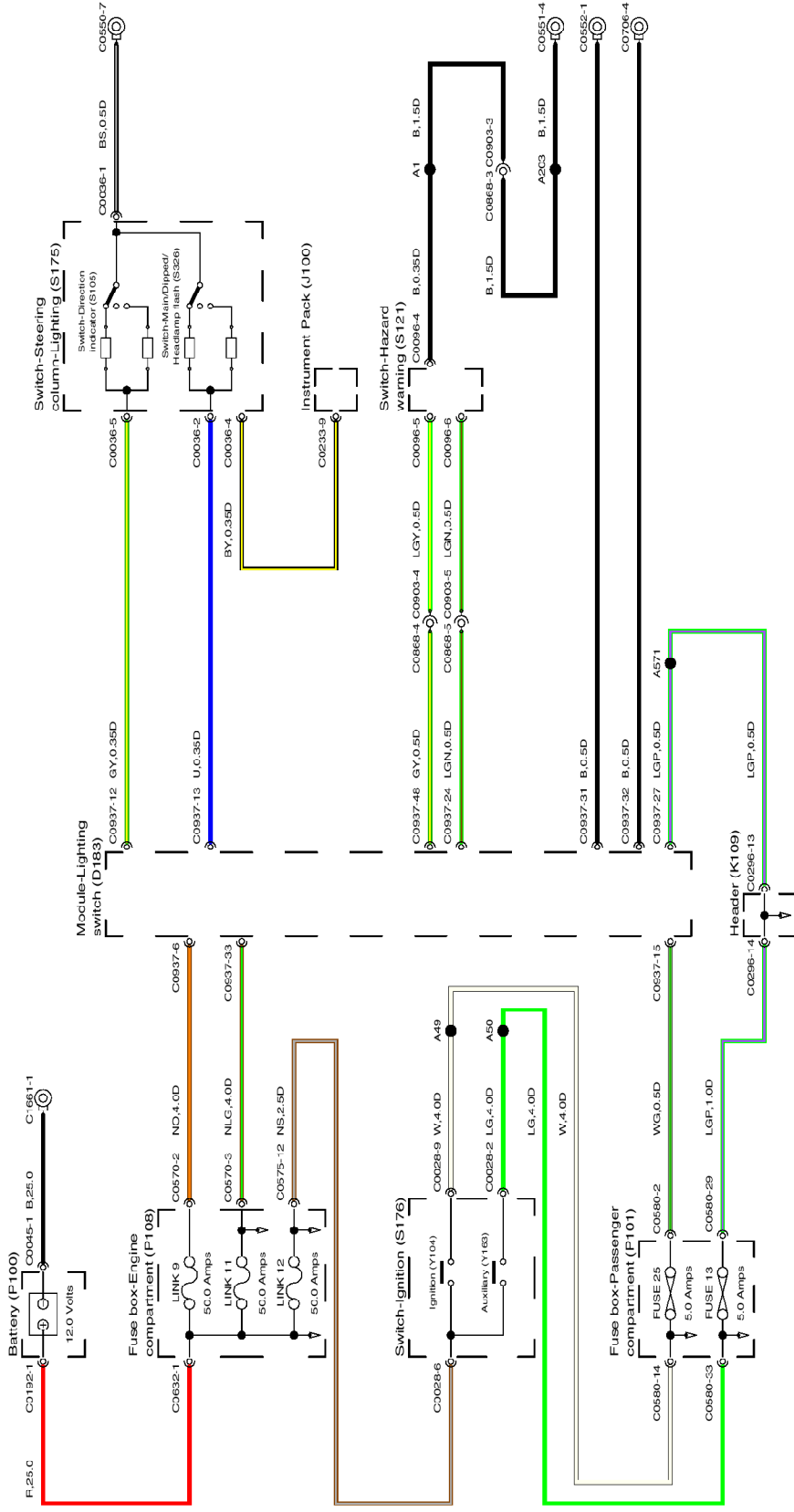

VWR403429-1

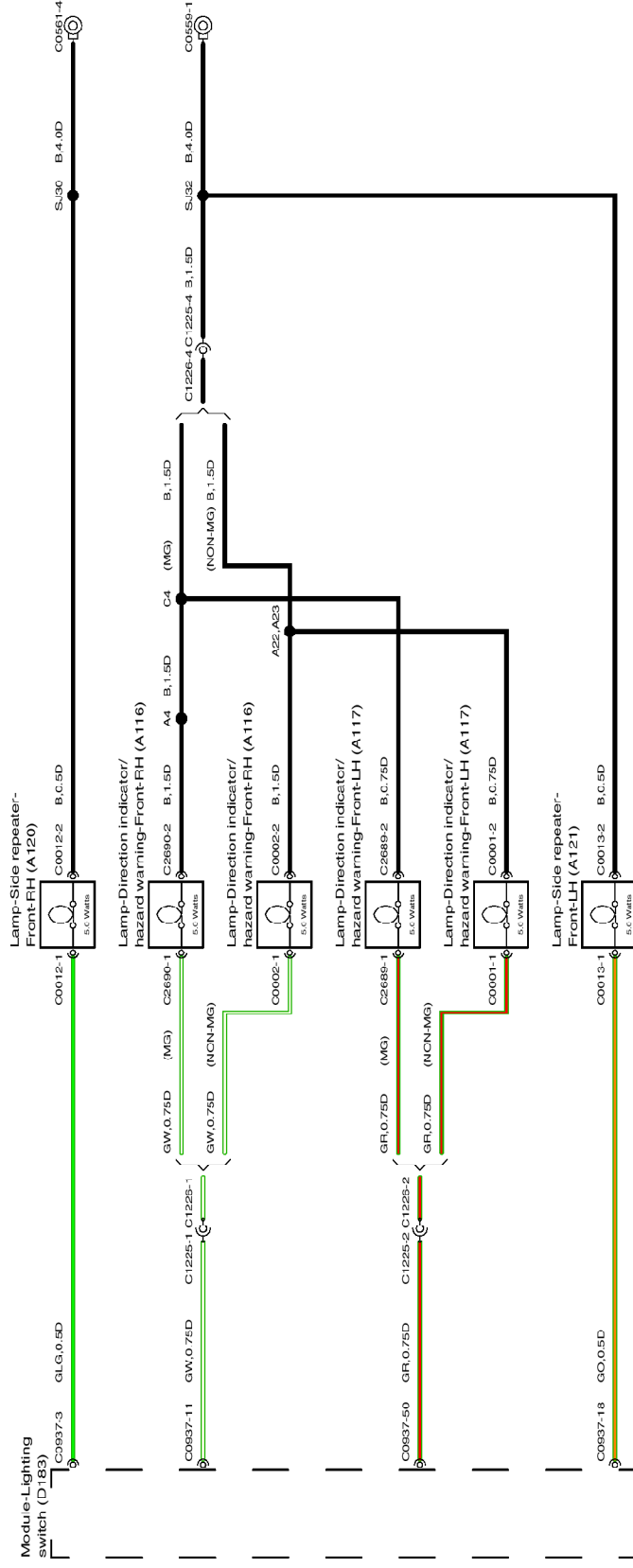

VWR403420-2

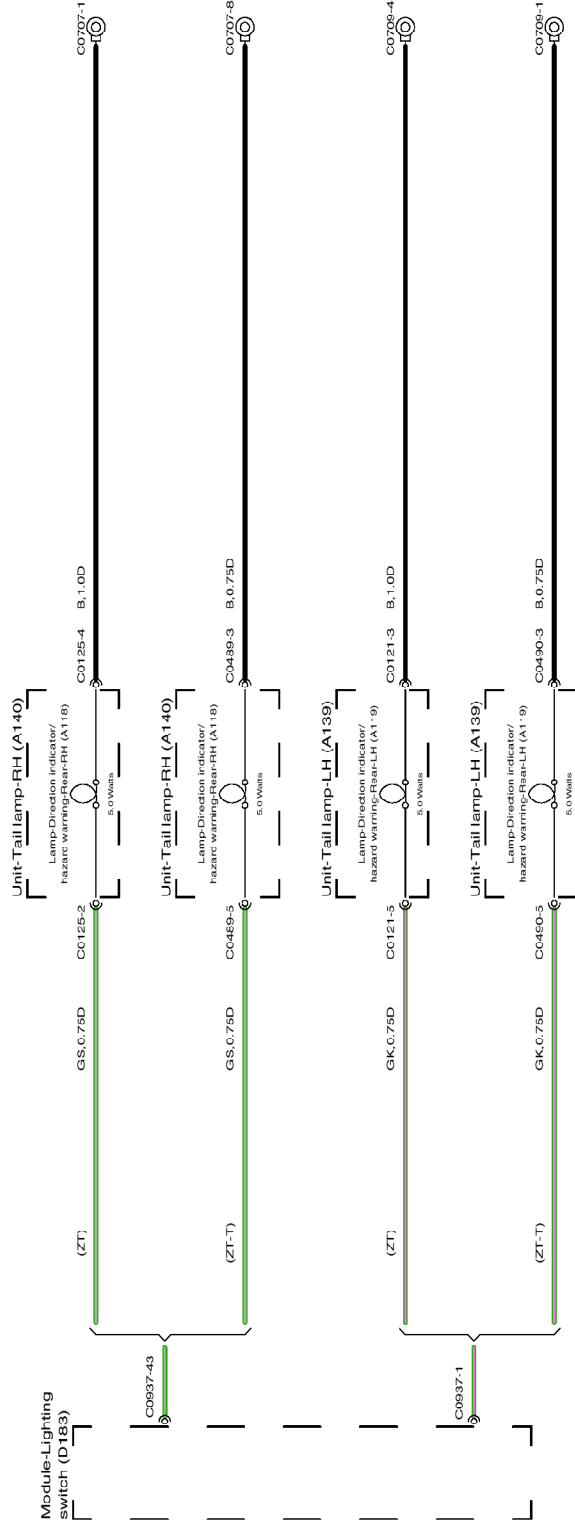

VWR403420-3

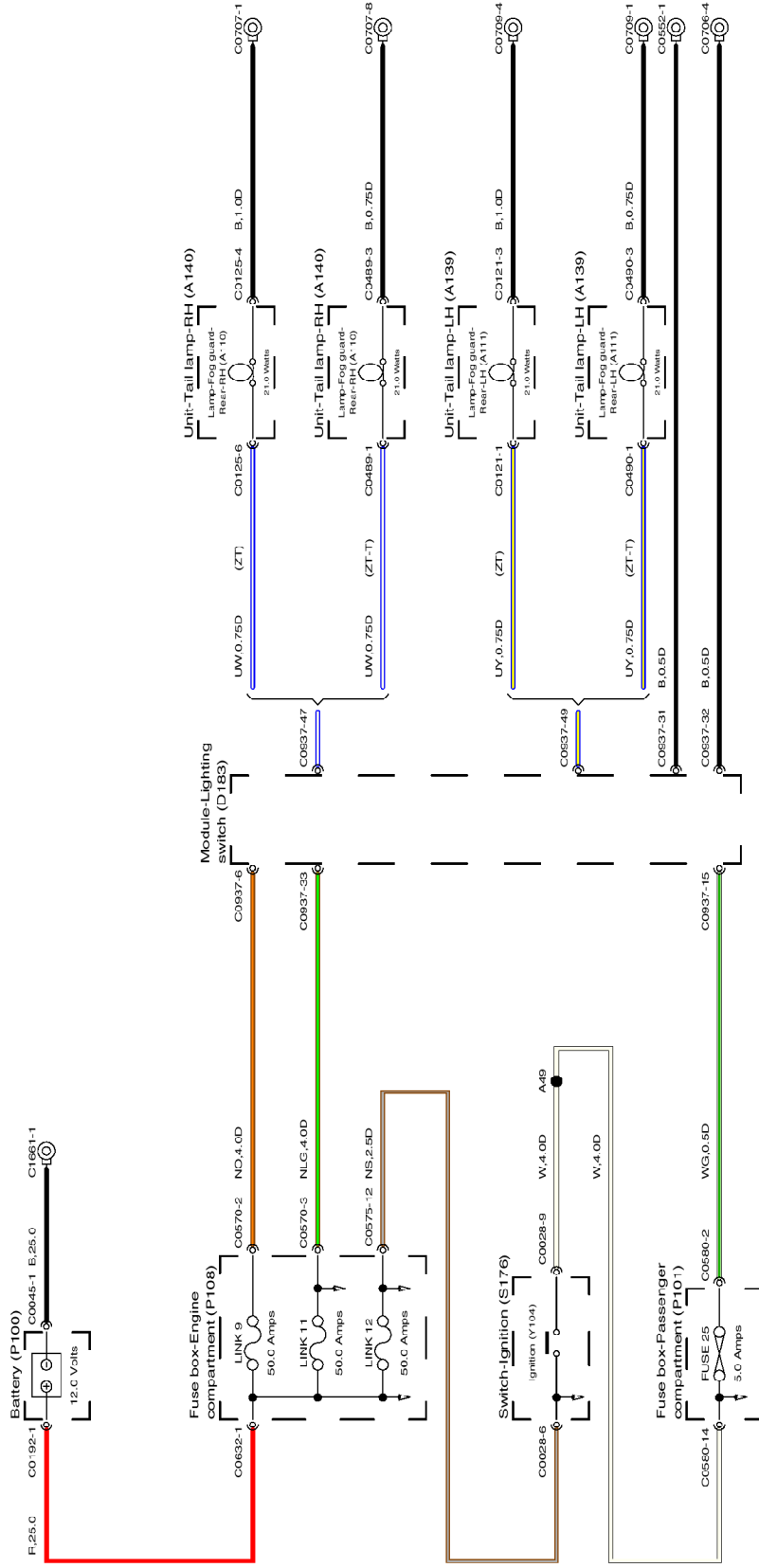

VWR403120-1

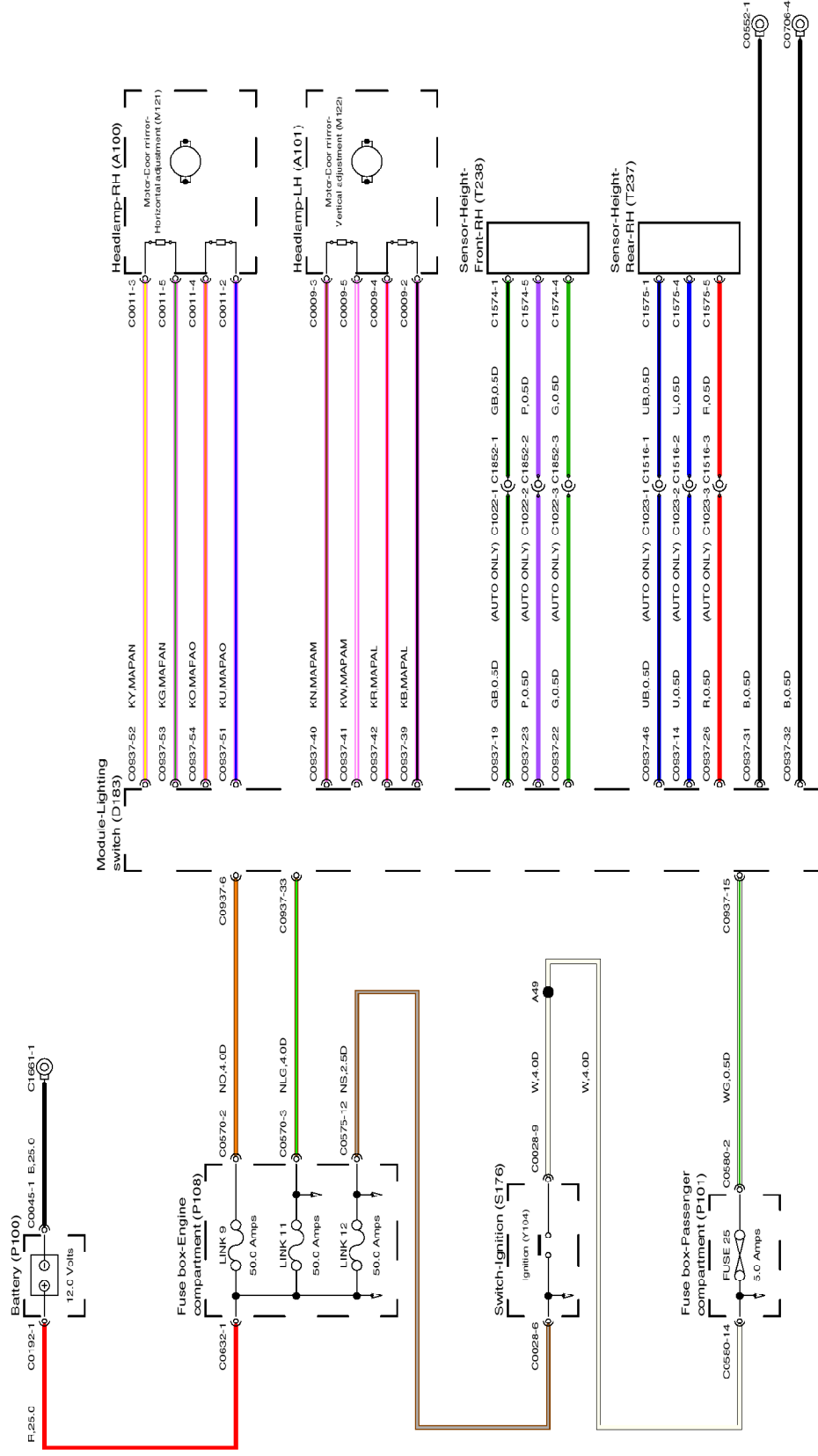

VWR403229-1

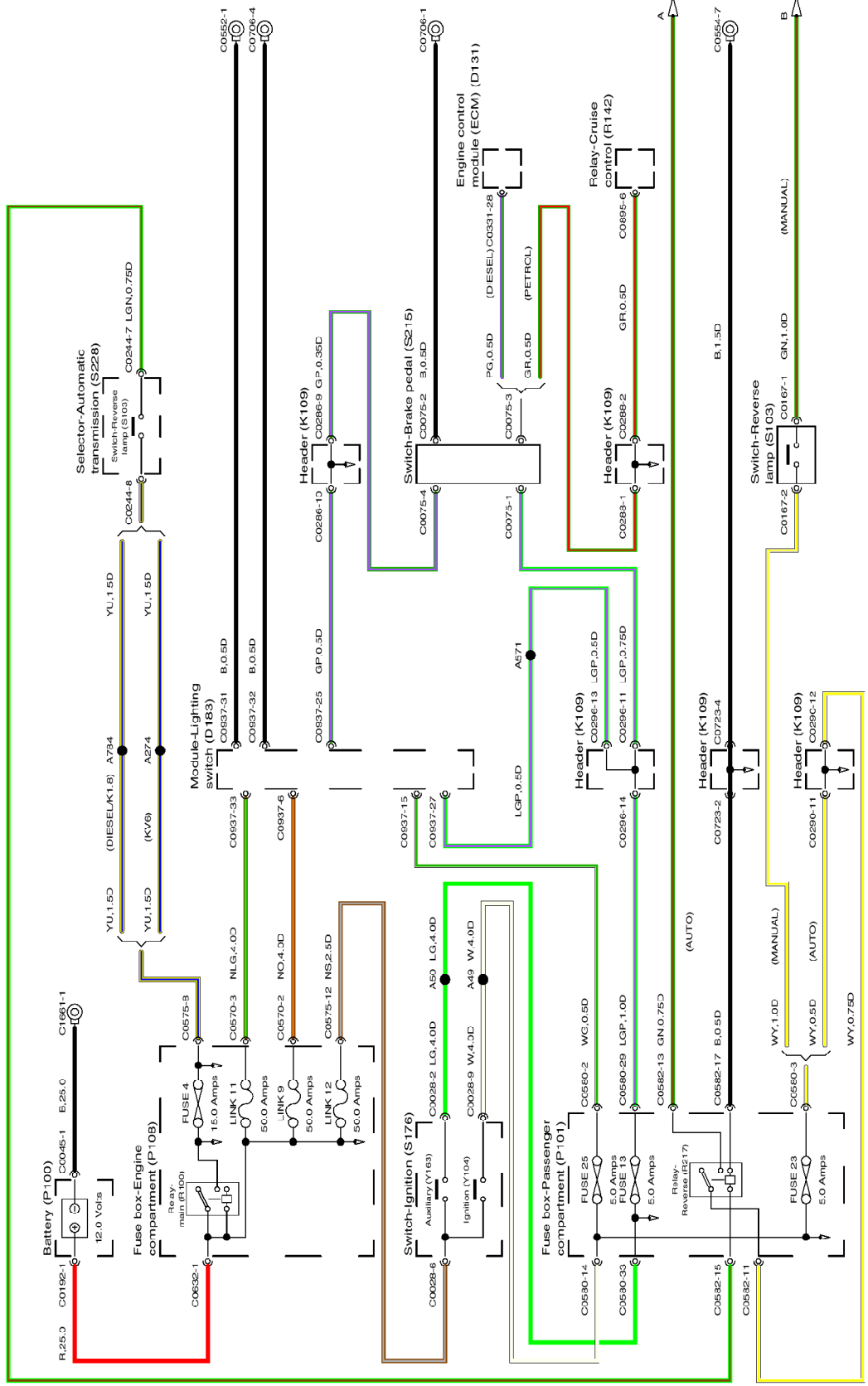

VWR402800-1

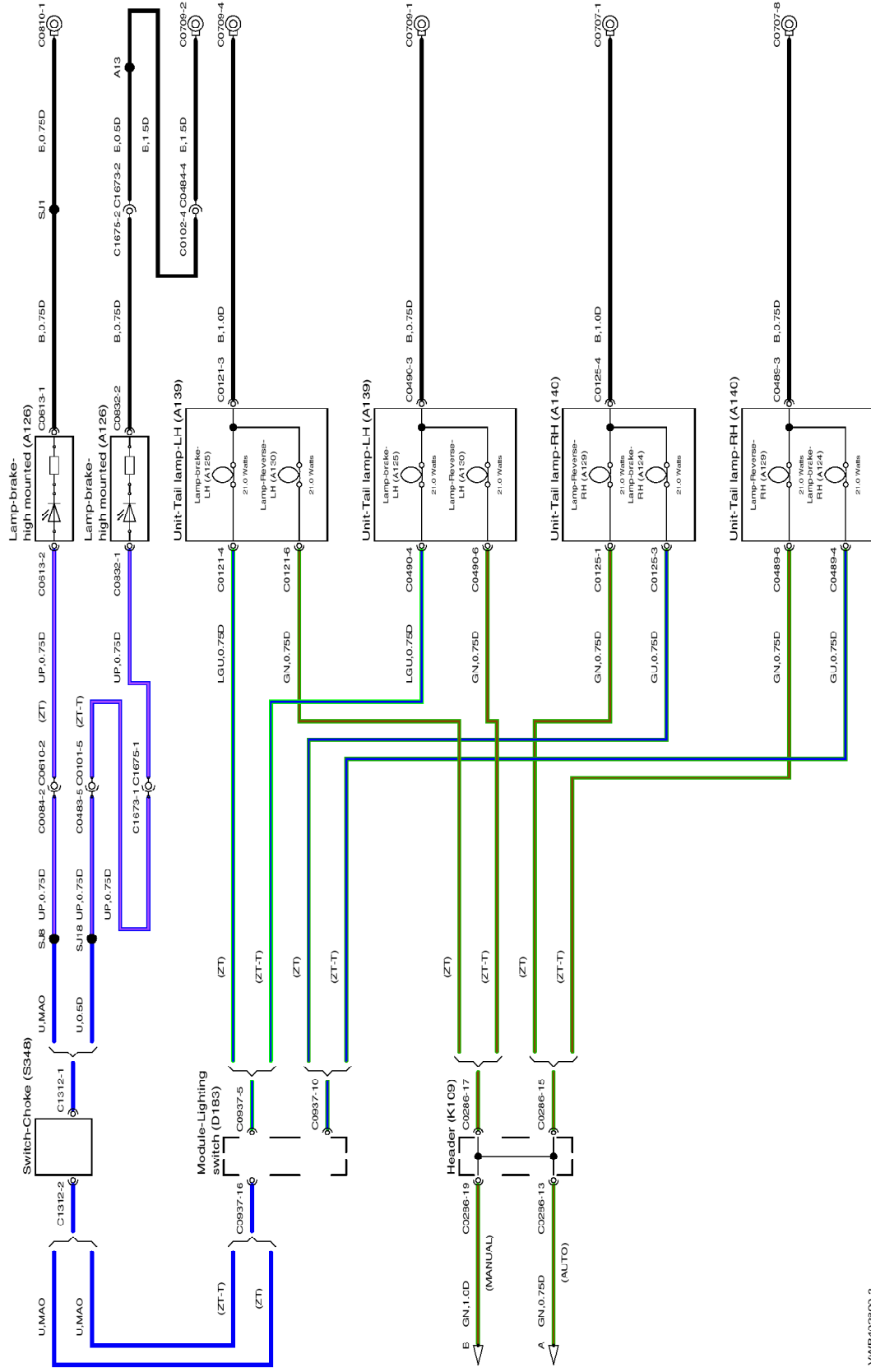

VWR402300-2

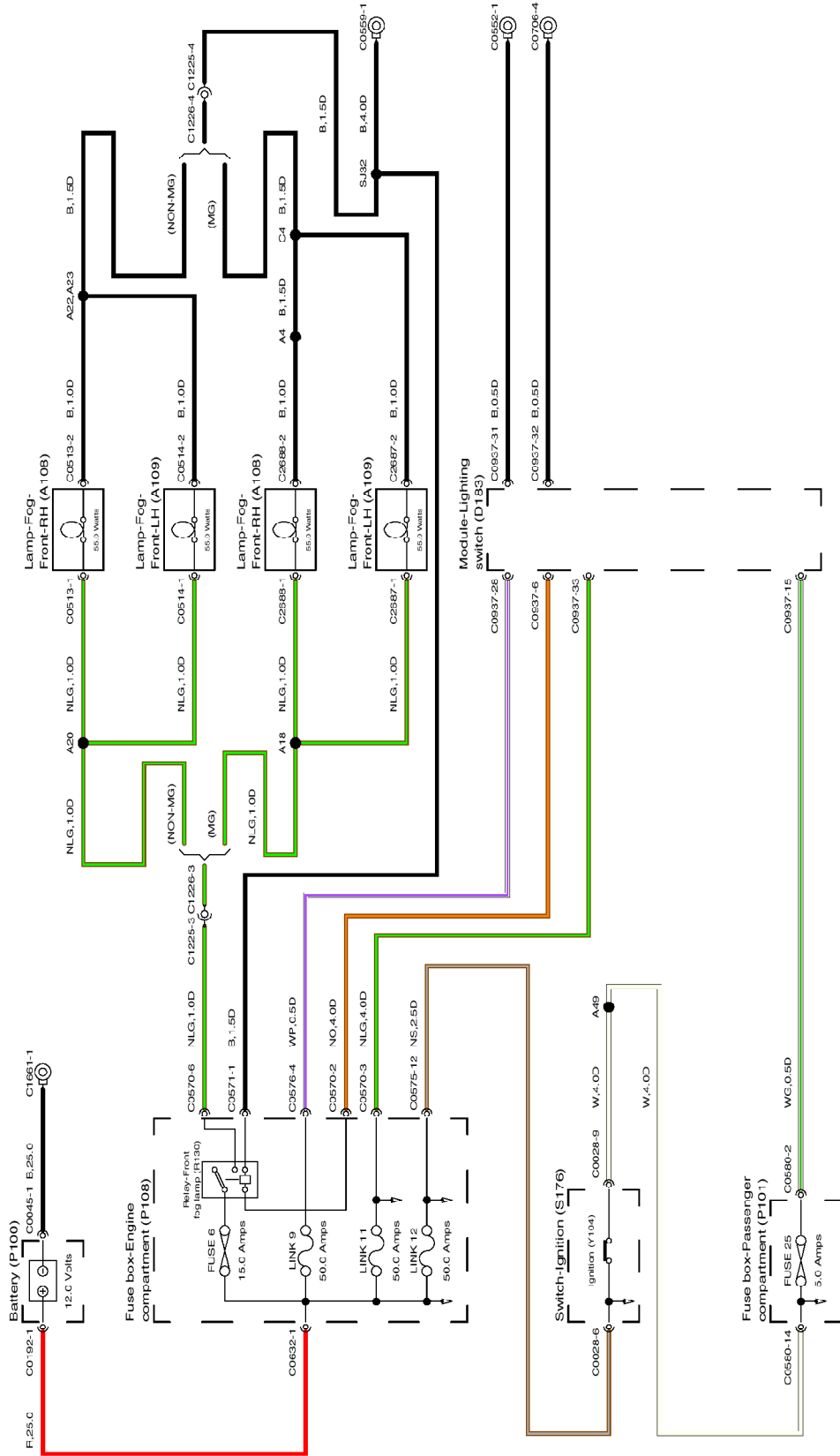

VWR403100-1

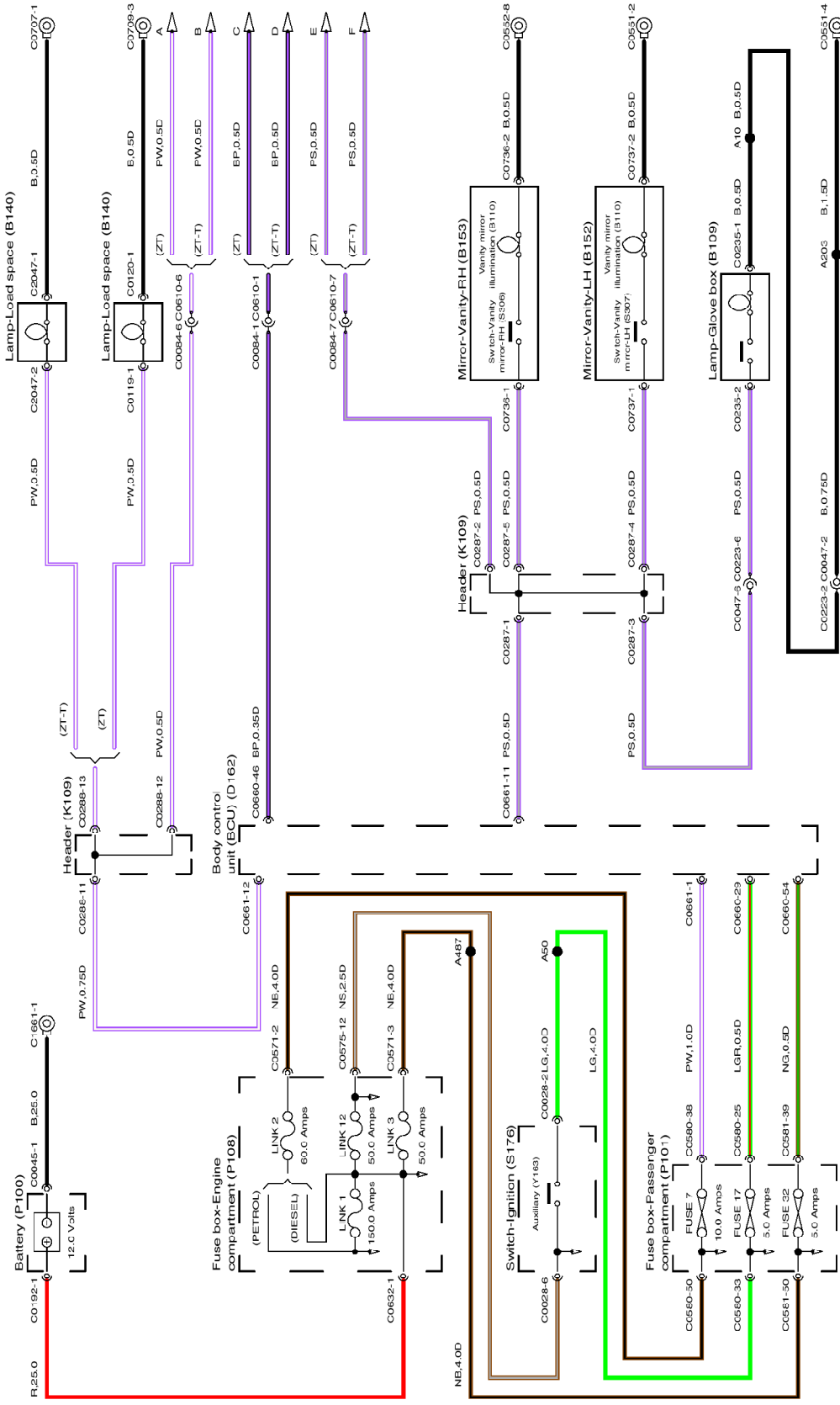

VWR403480-1

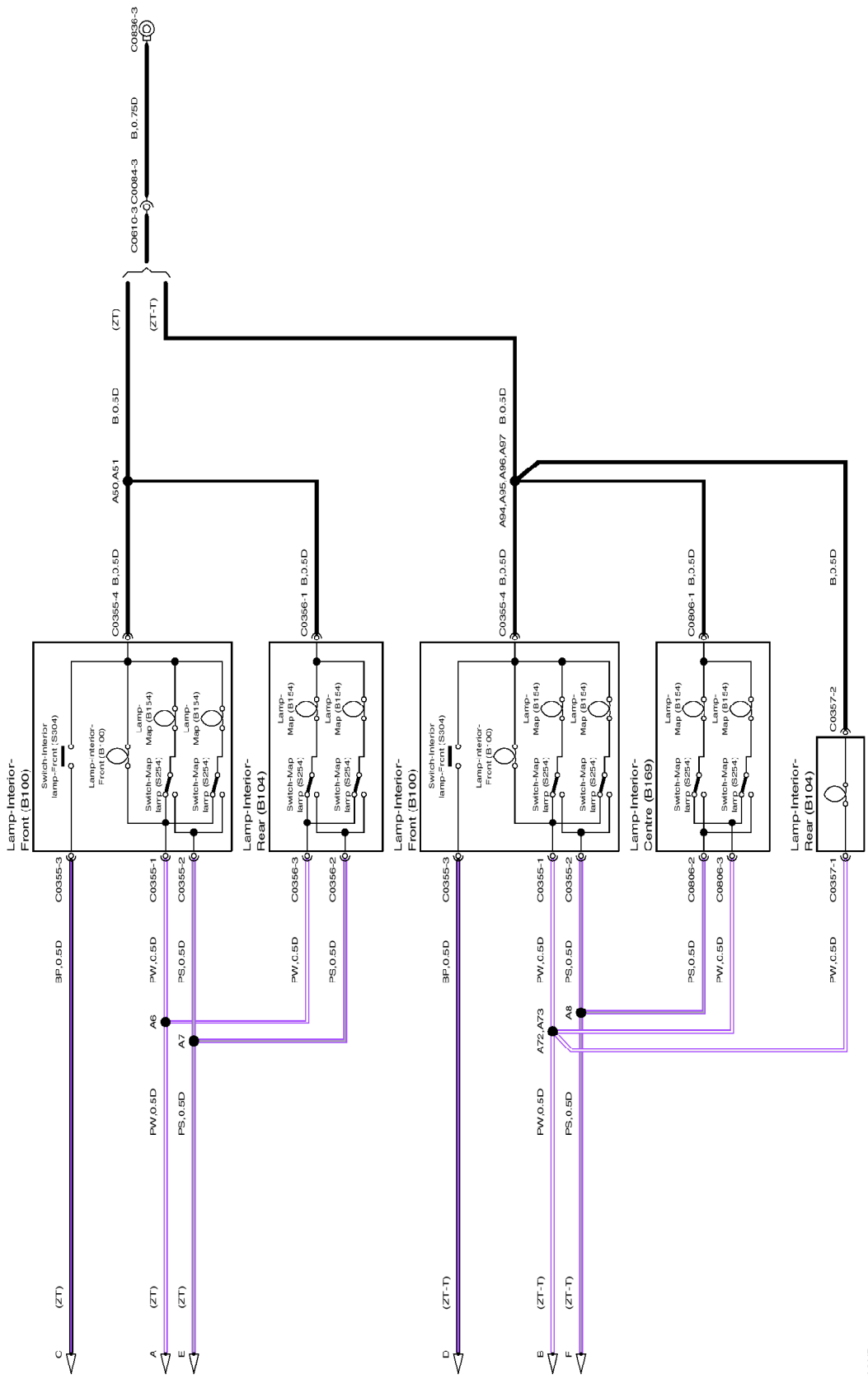

VWR403480-2

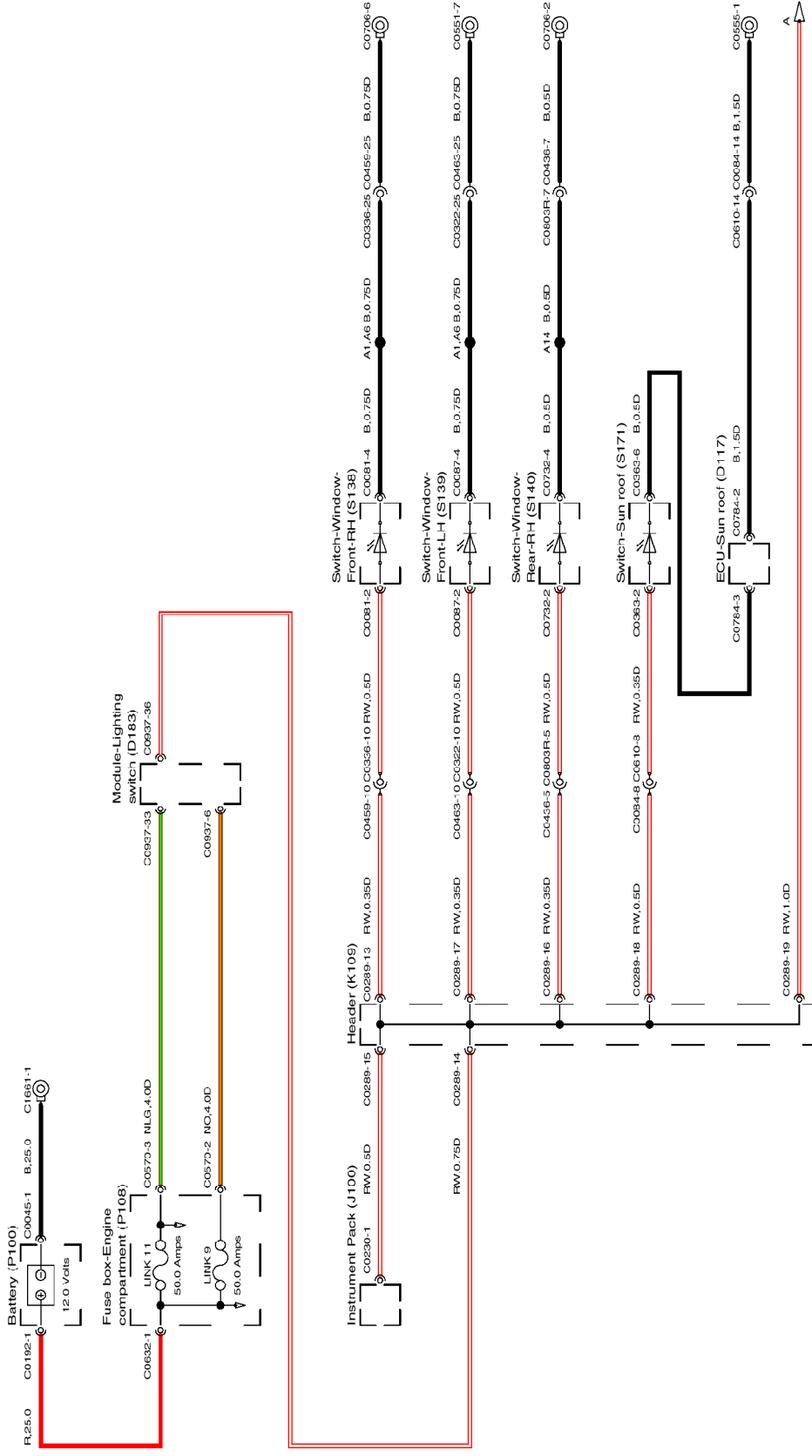

VWR403460-1

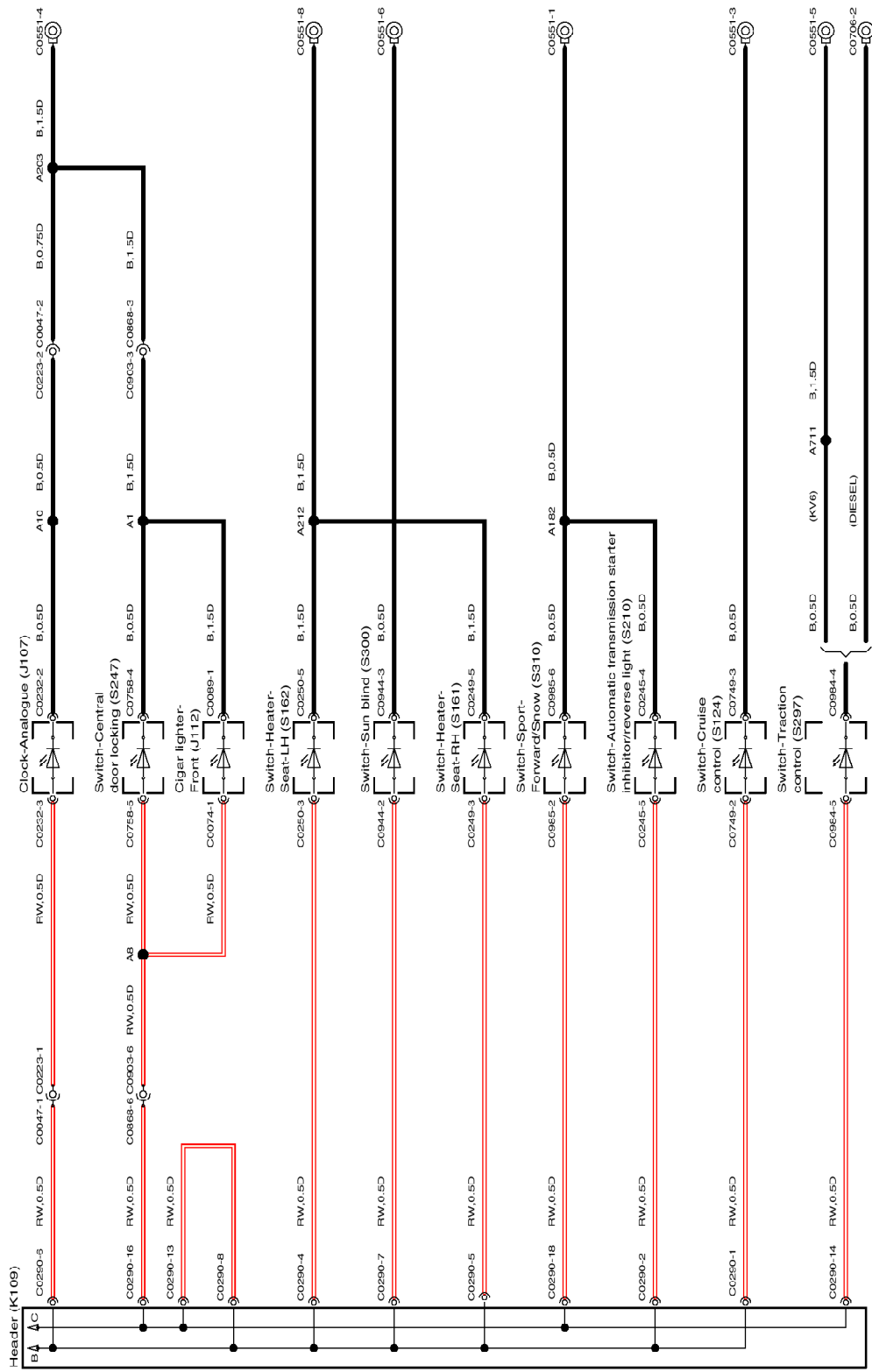

VWR403460-2

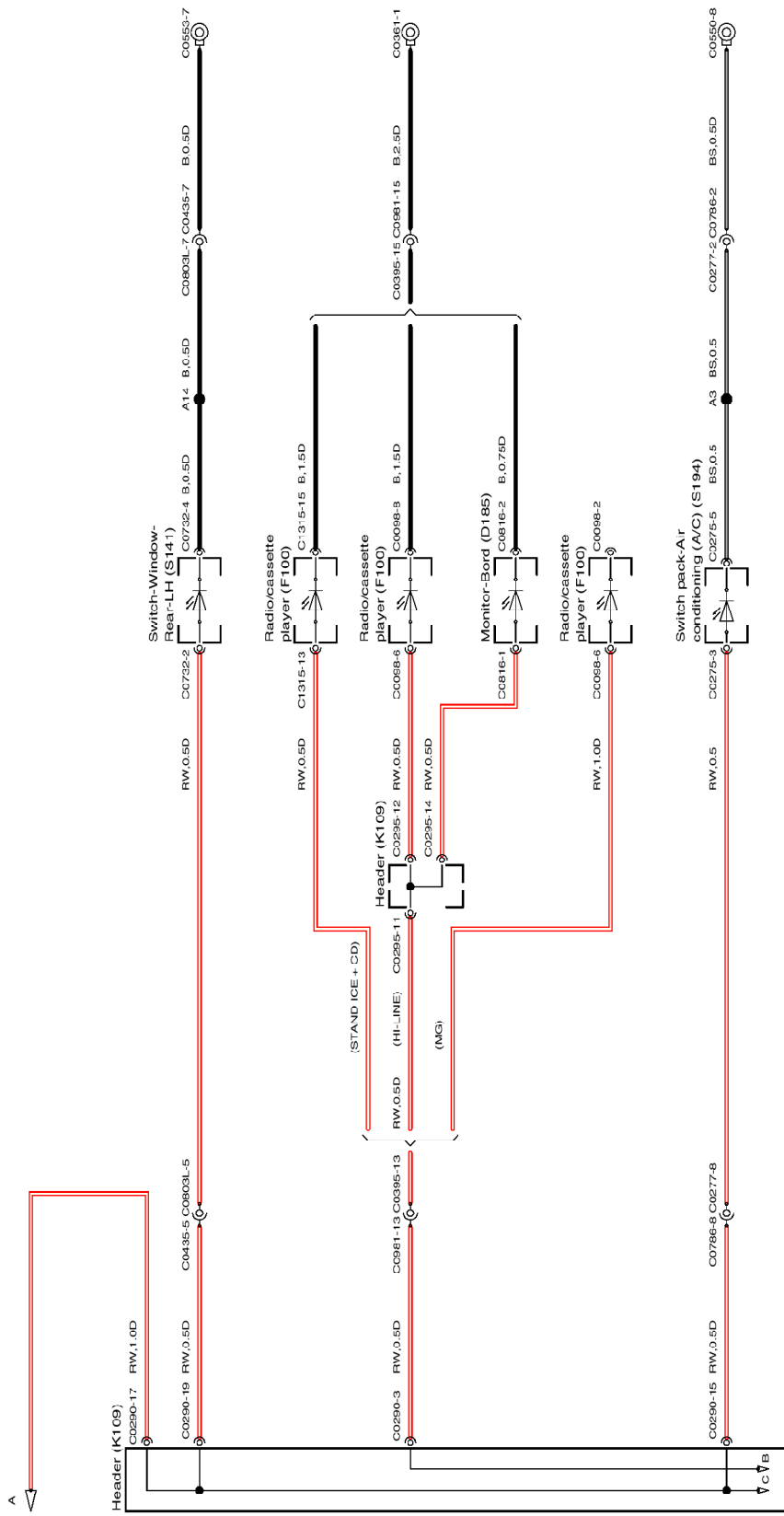

VWR403460-3

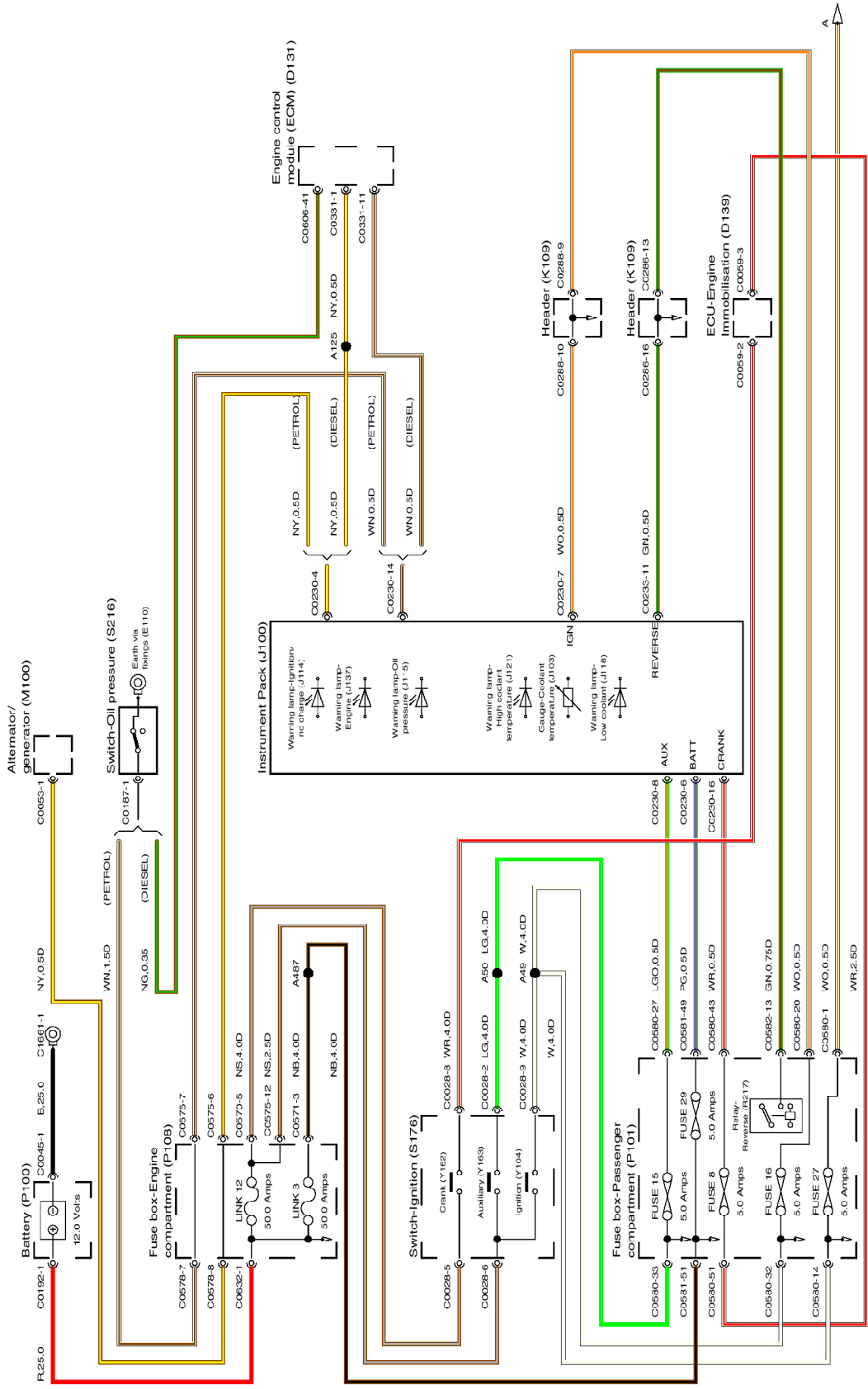

VWR403440-1

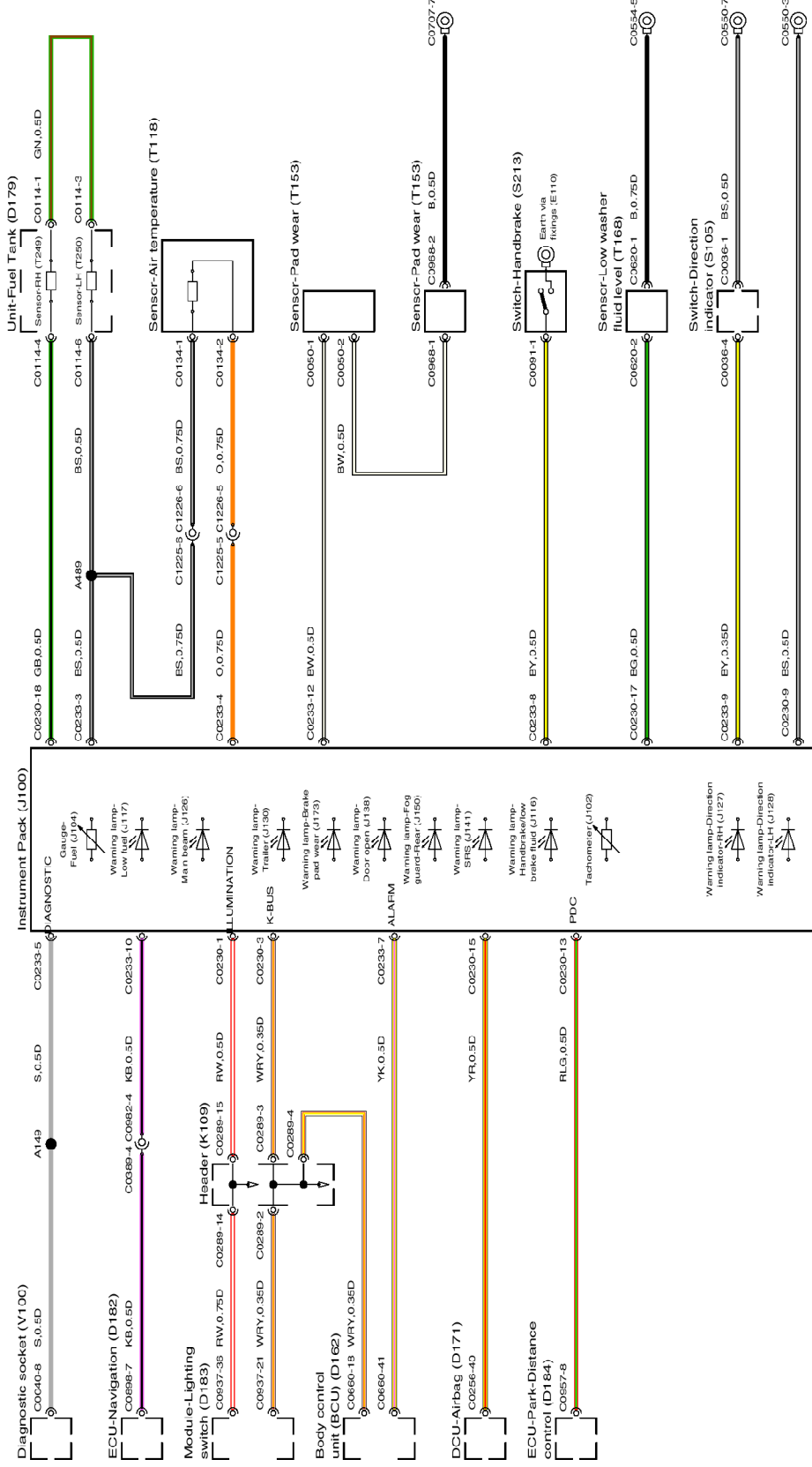

VWR403440-2

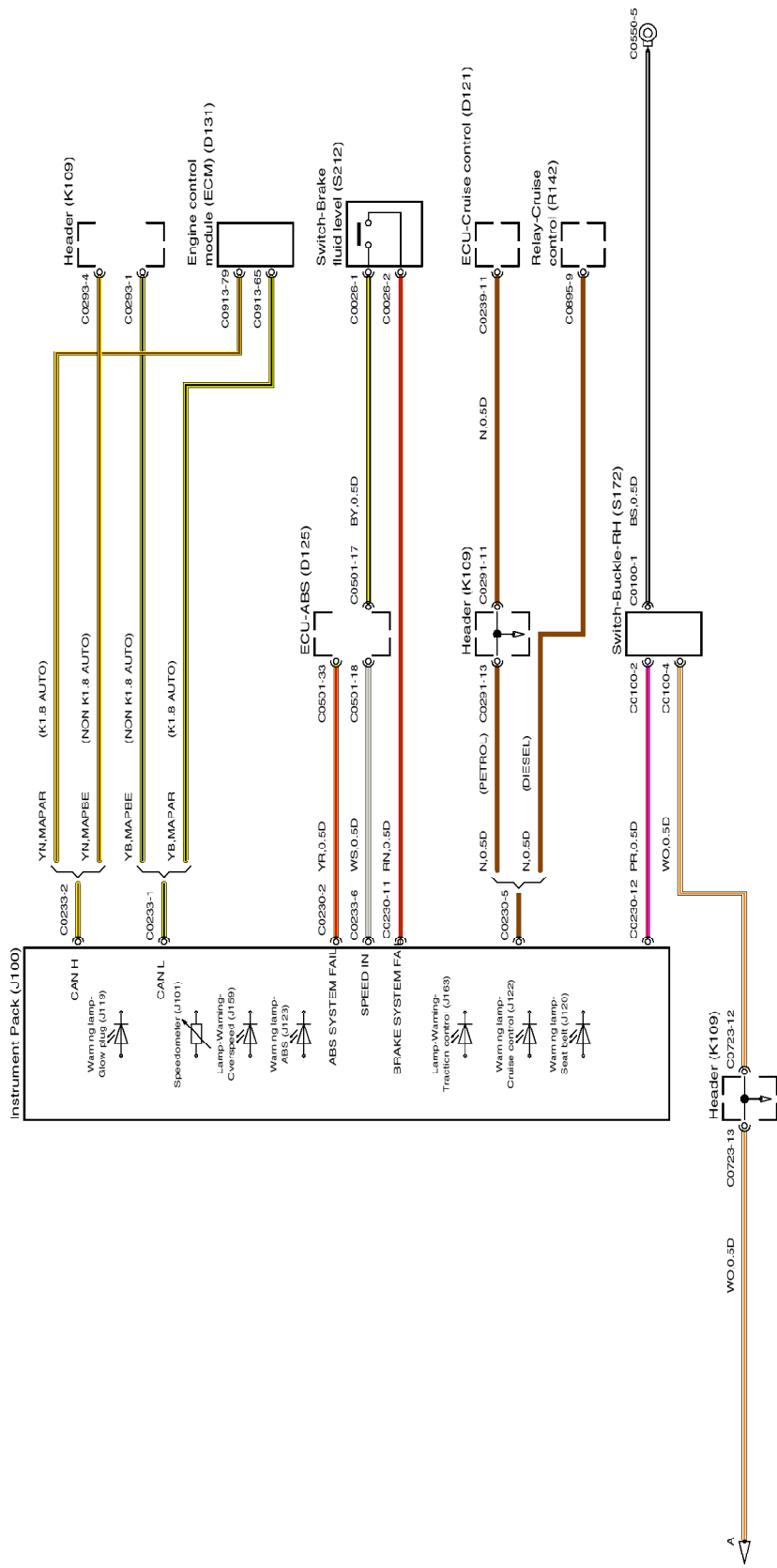

VWR403440-3

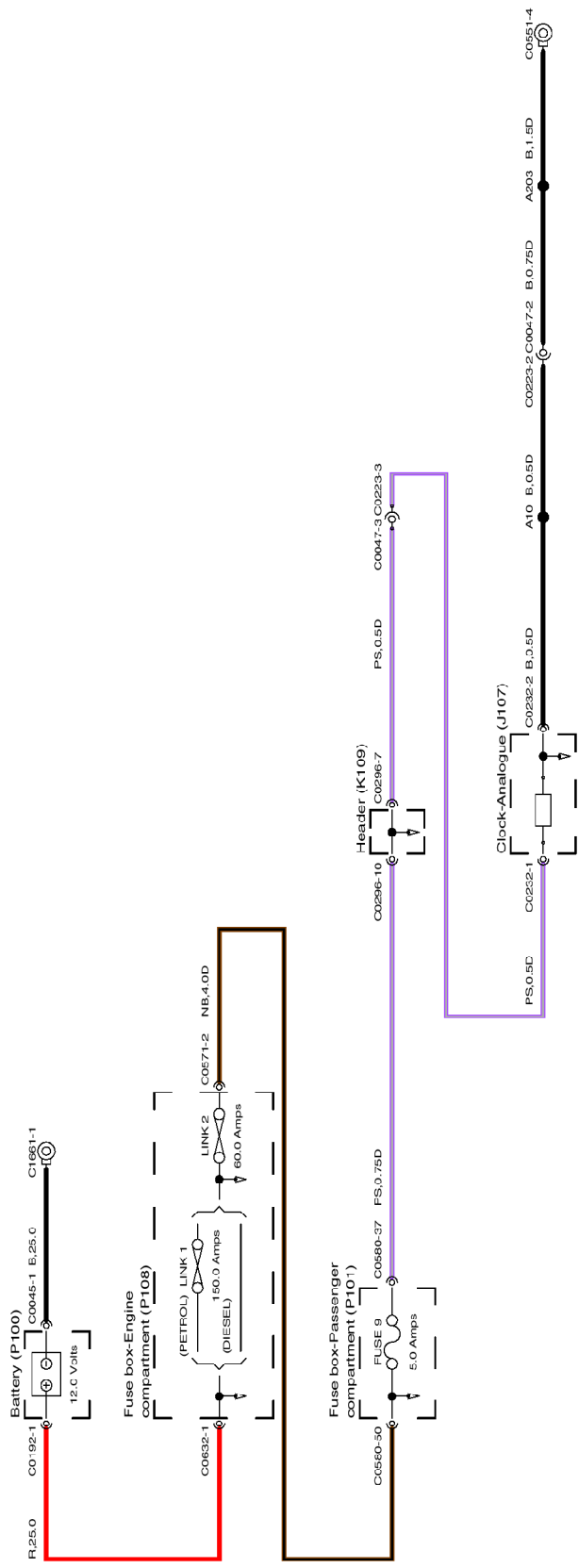

VWR402340-1

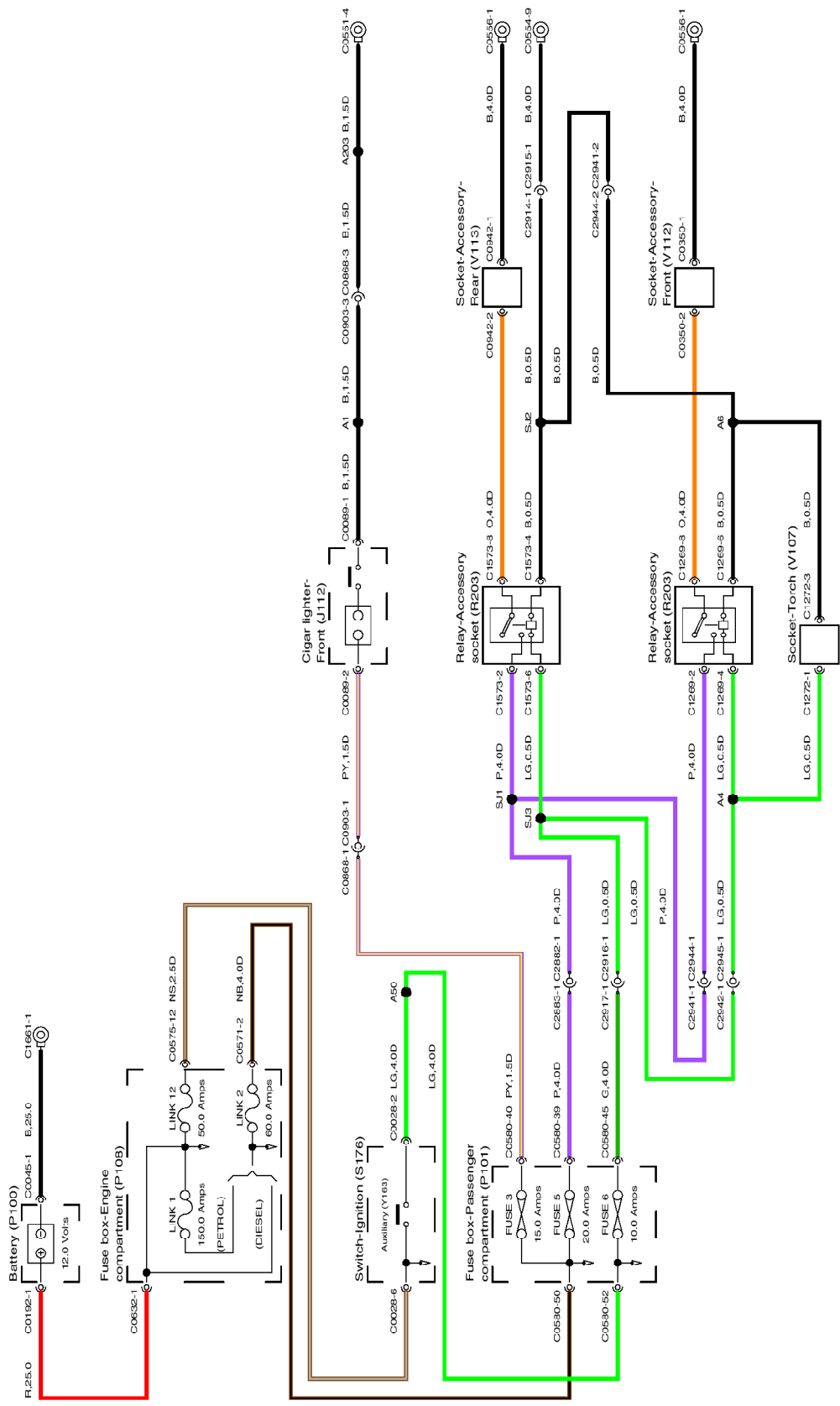

VWR402720-1

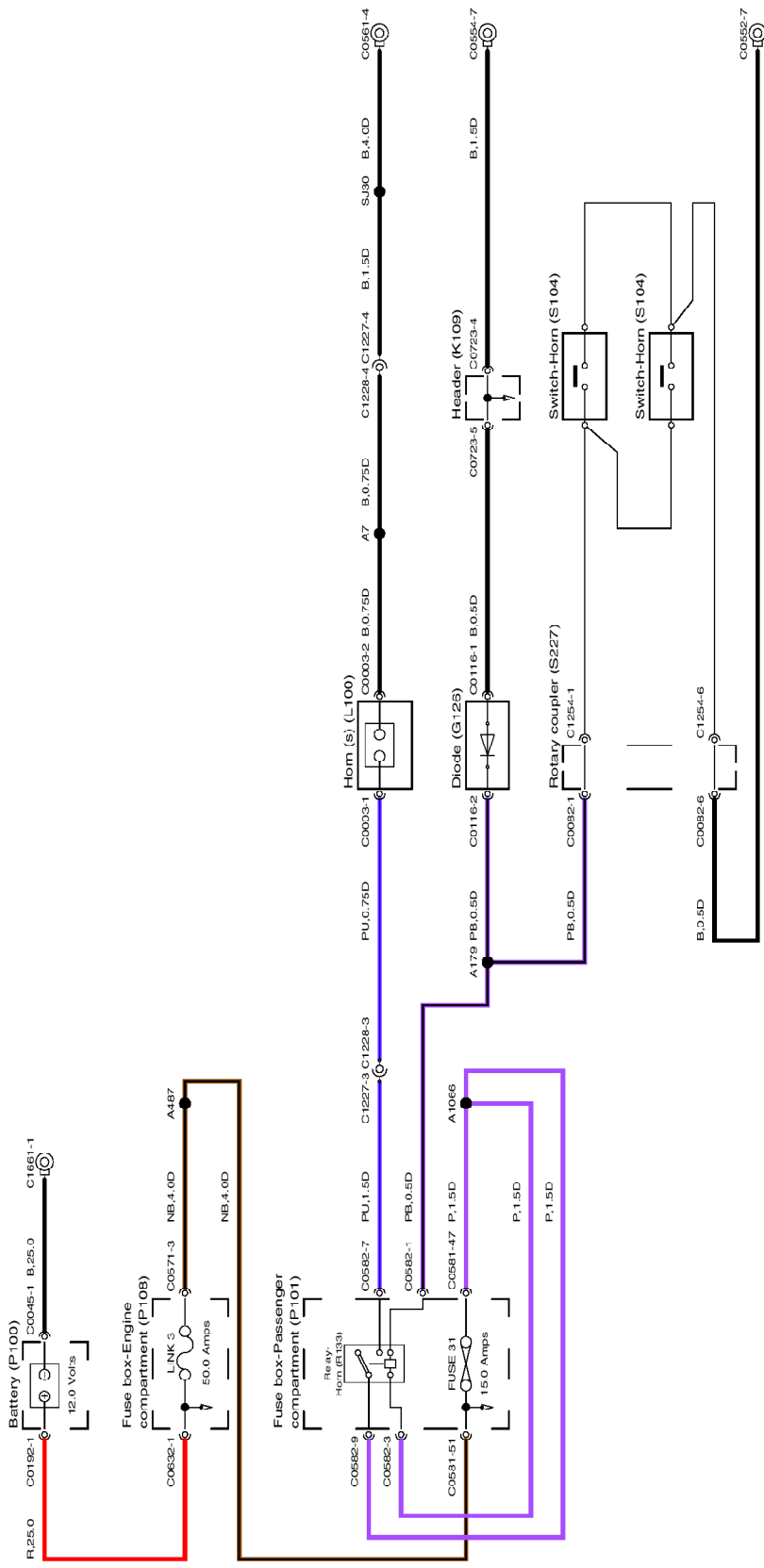

VWR403280-1

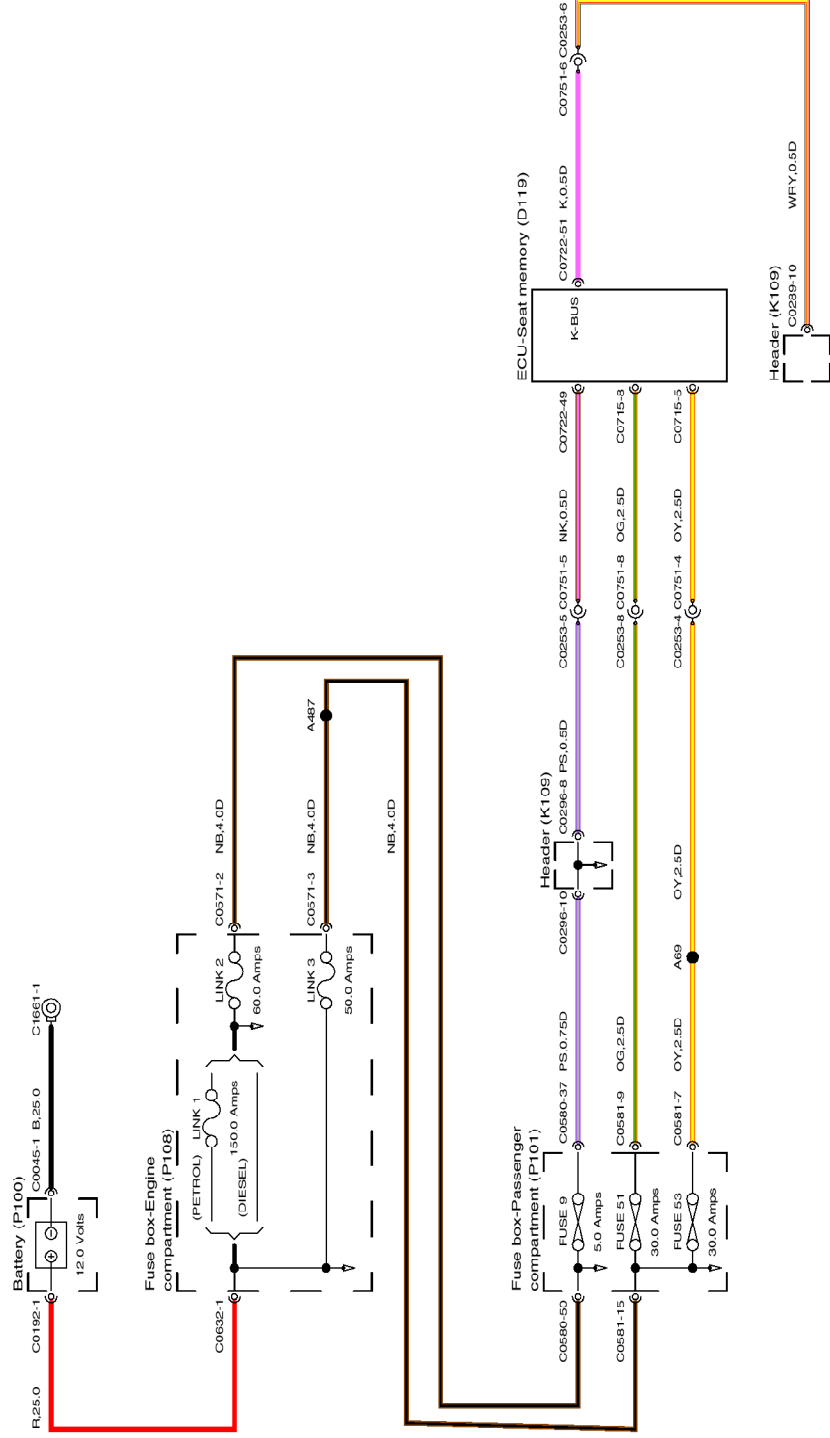

VWR403820-1

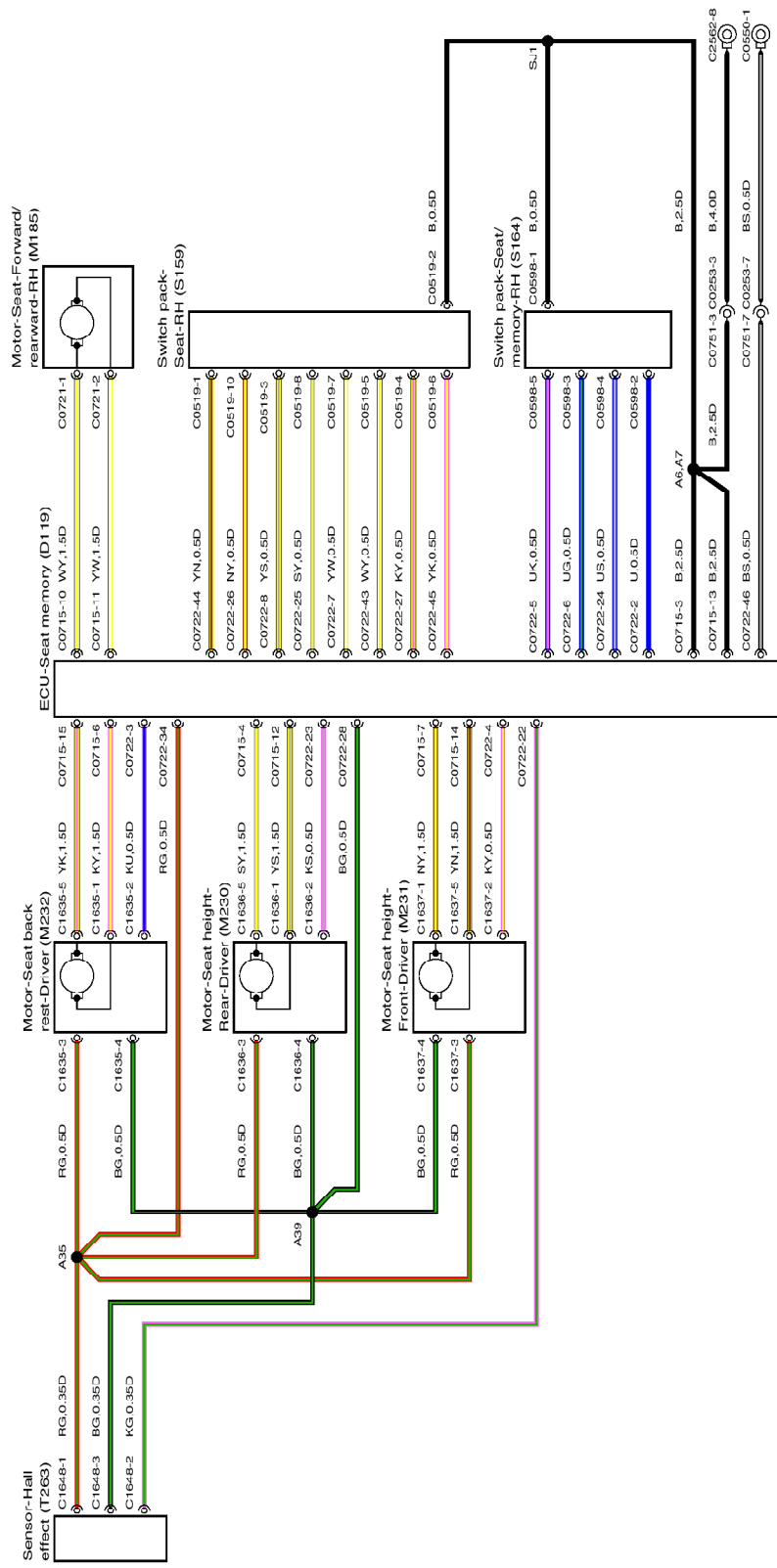

VWR403320-2

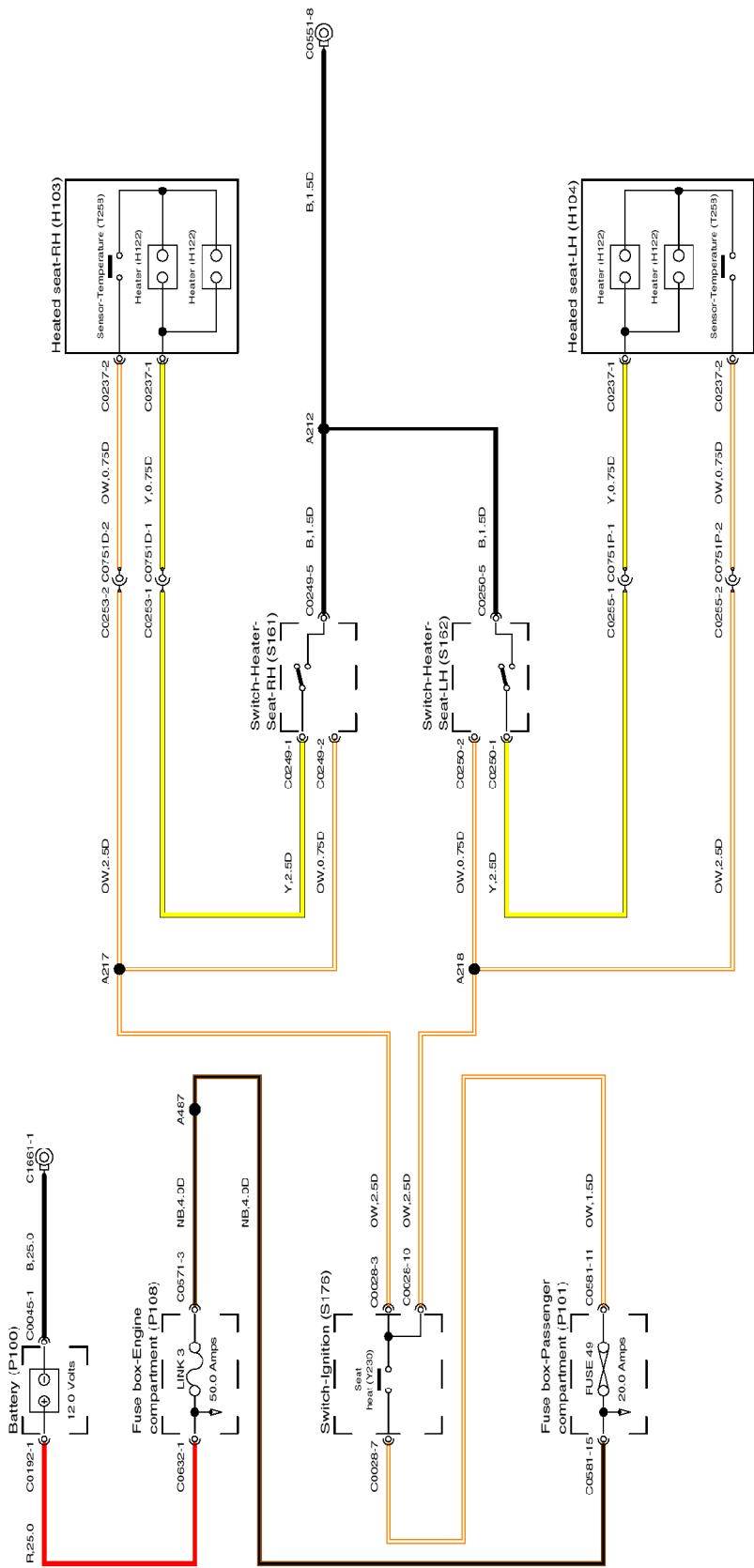

VWR403800-1

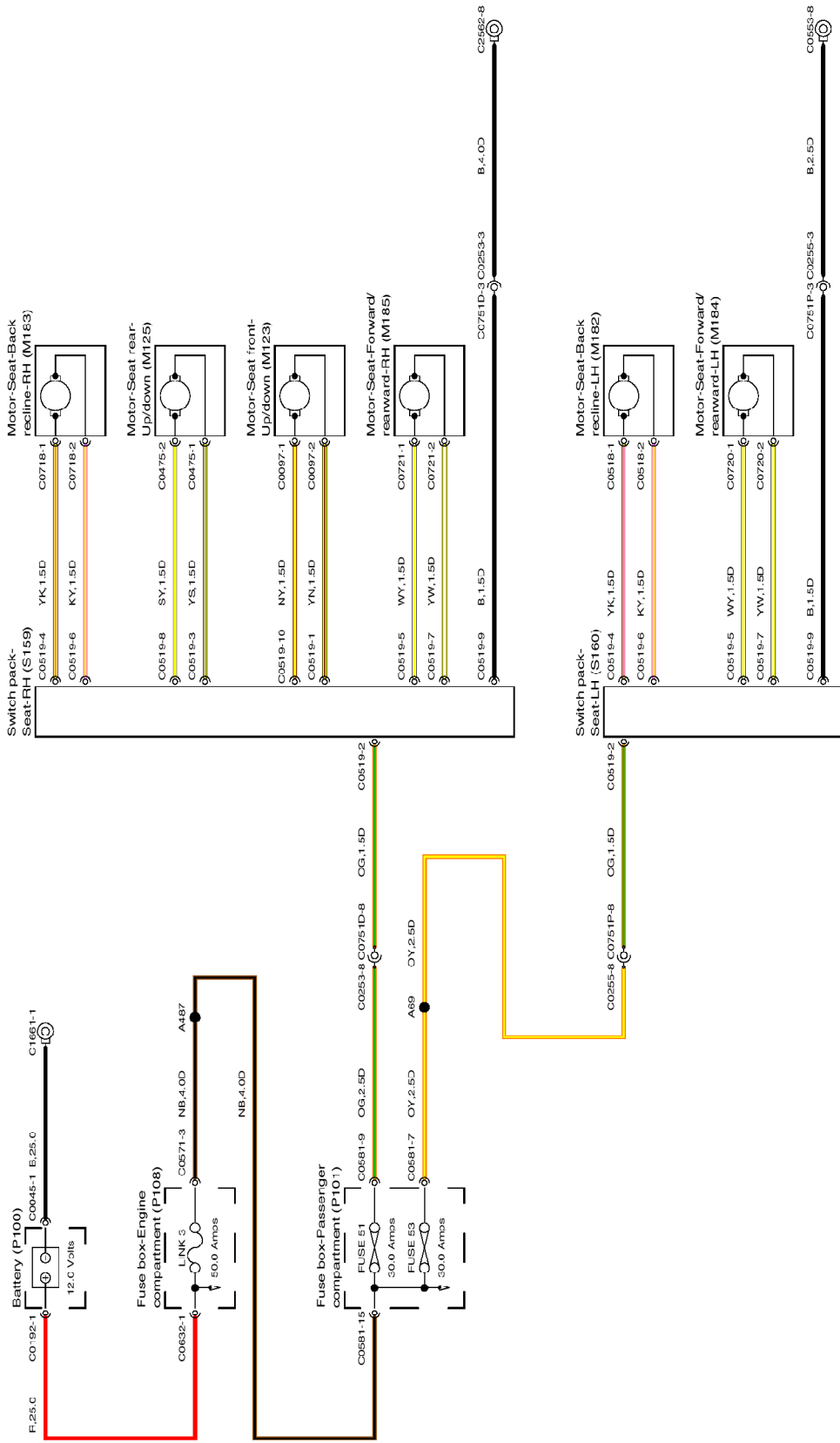

VWR403840-1

140 DOOR MIRRORS

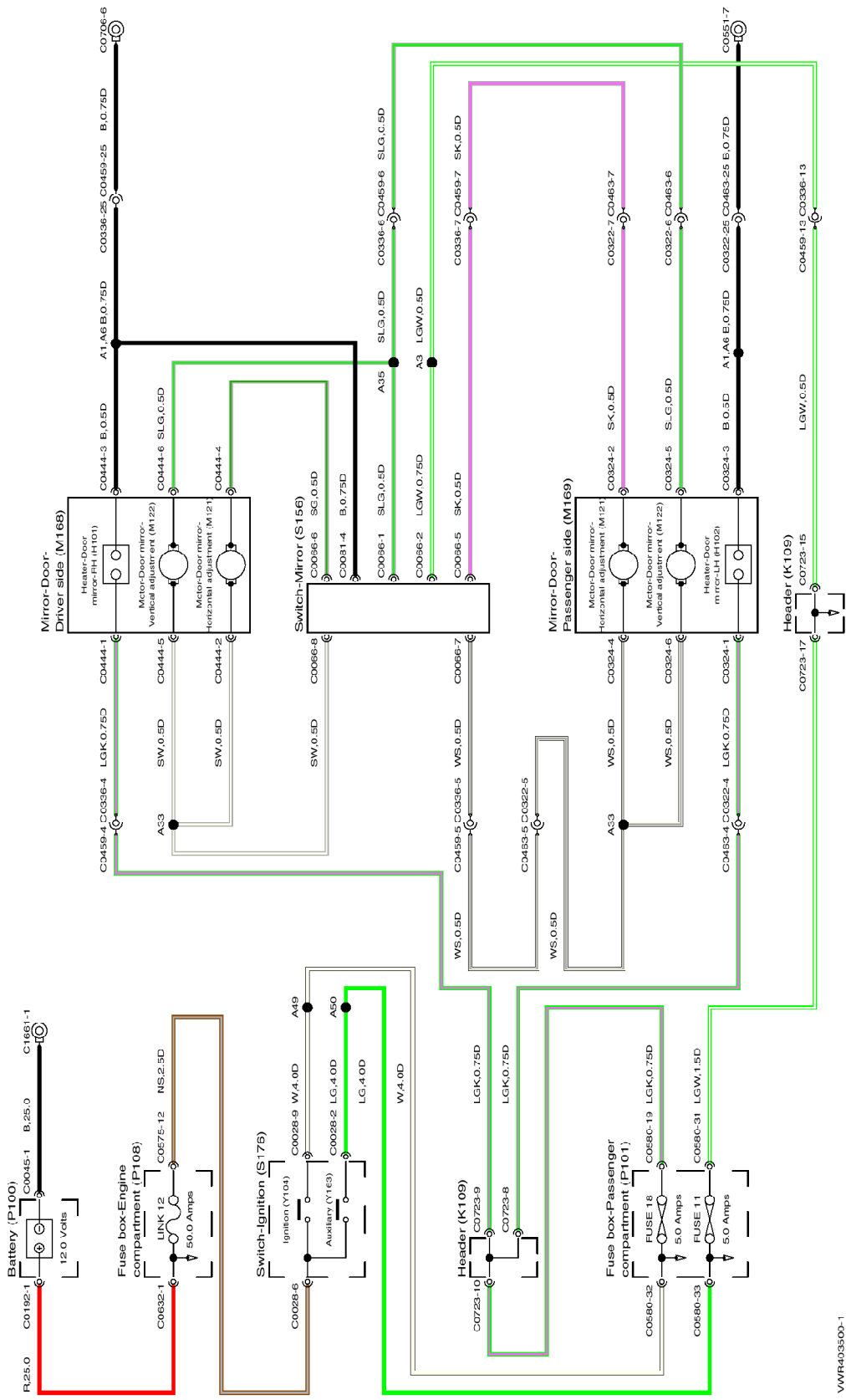

VWR403500-1

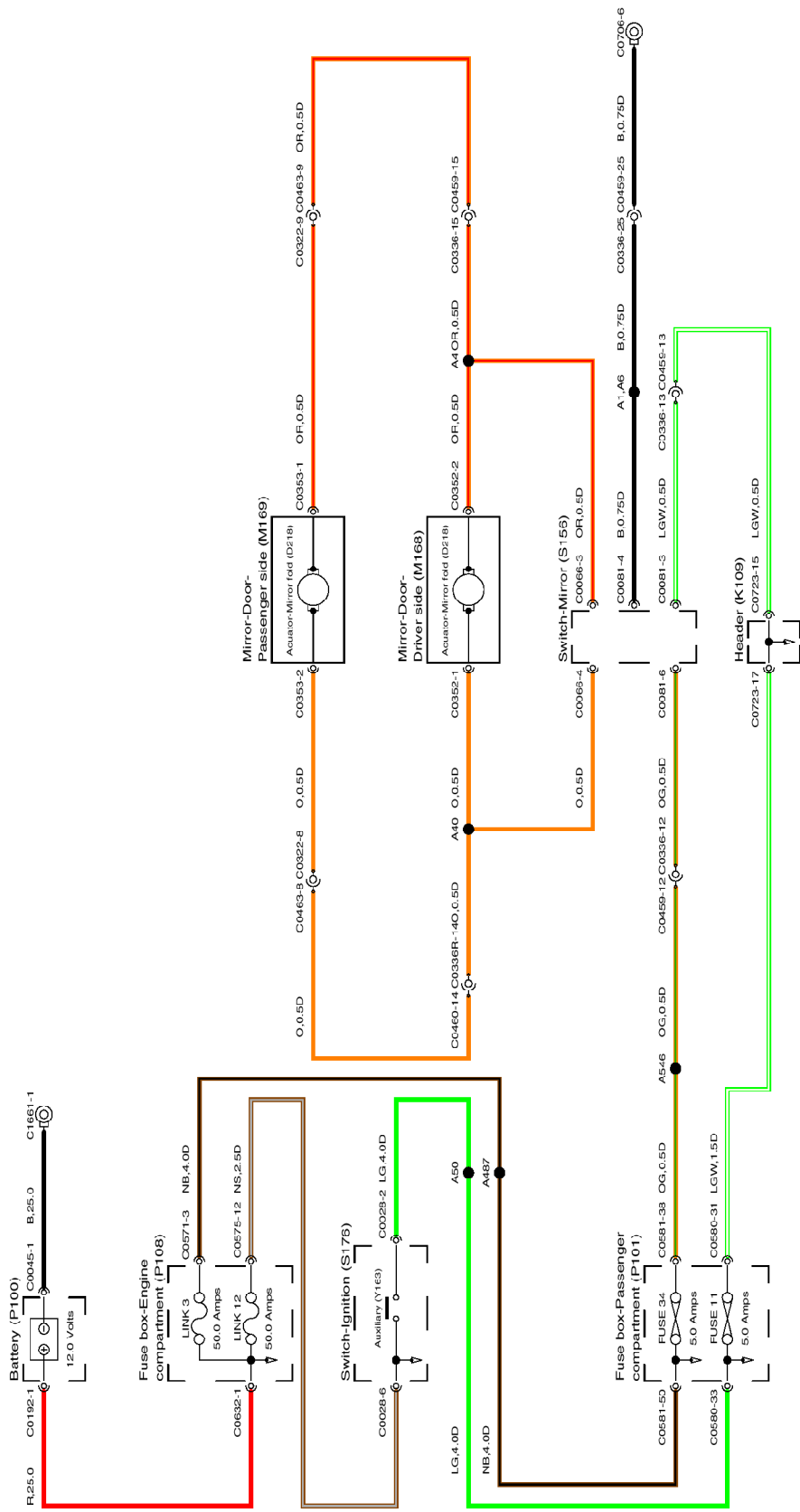

VWR403529-1

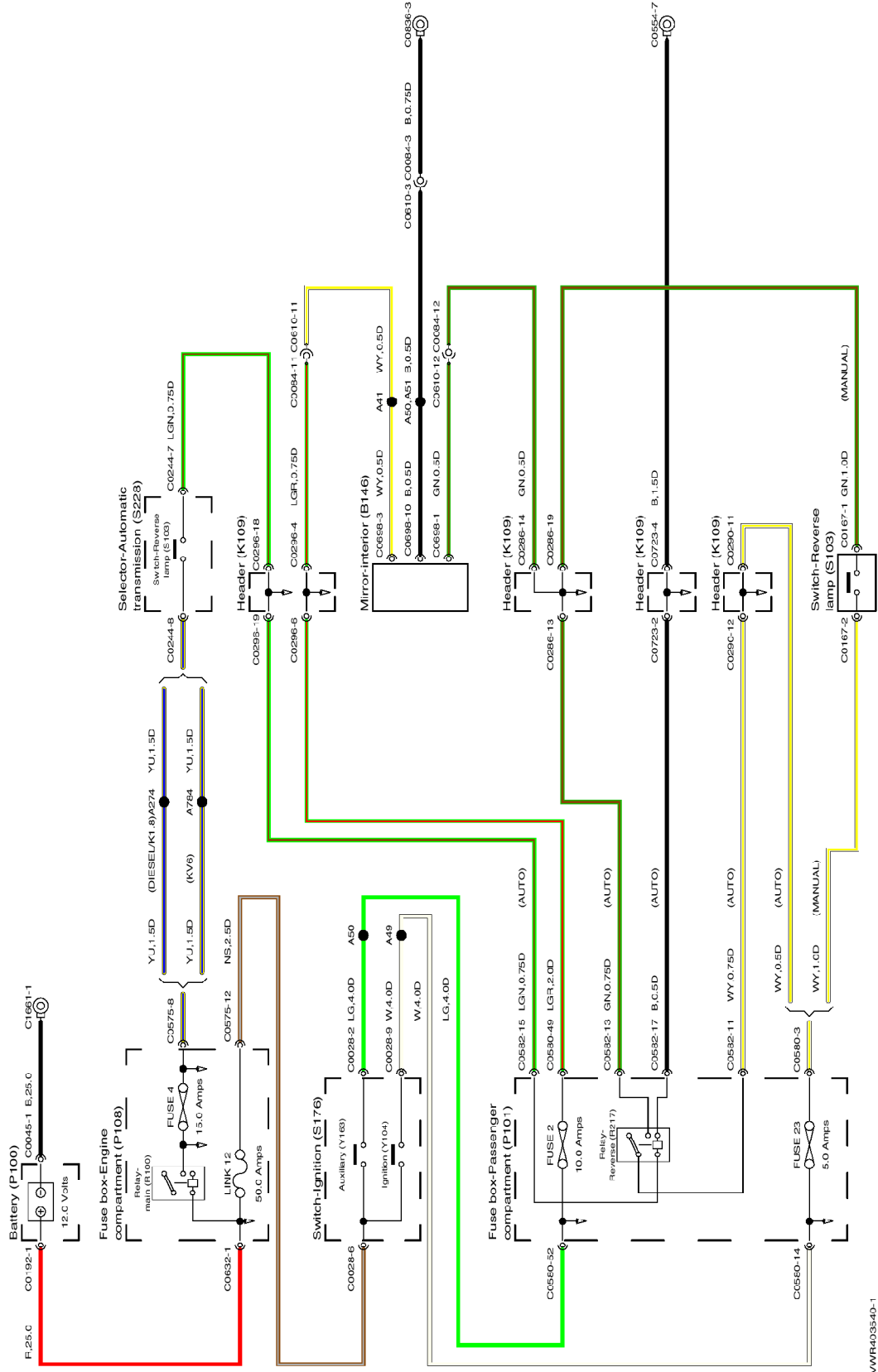

VWR4035-40-1

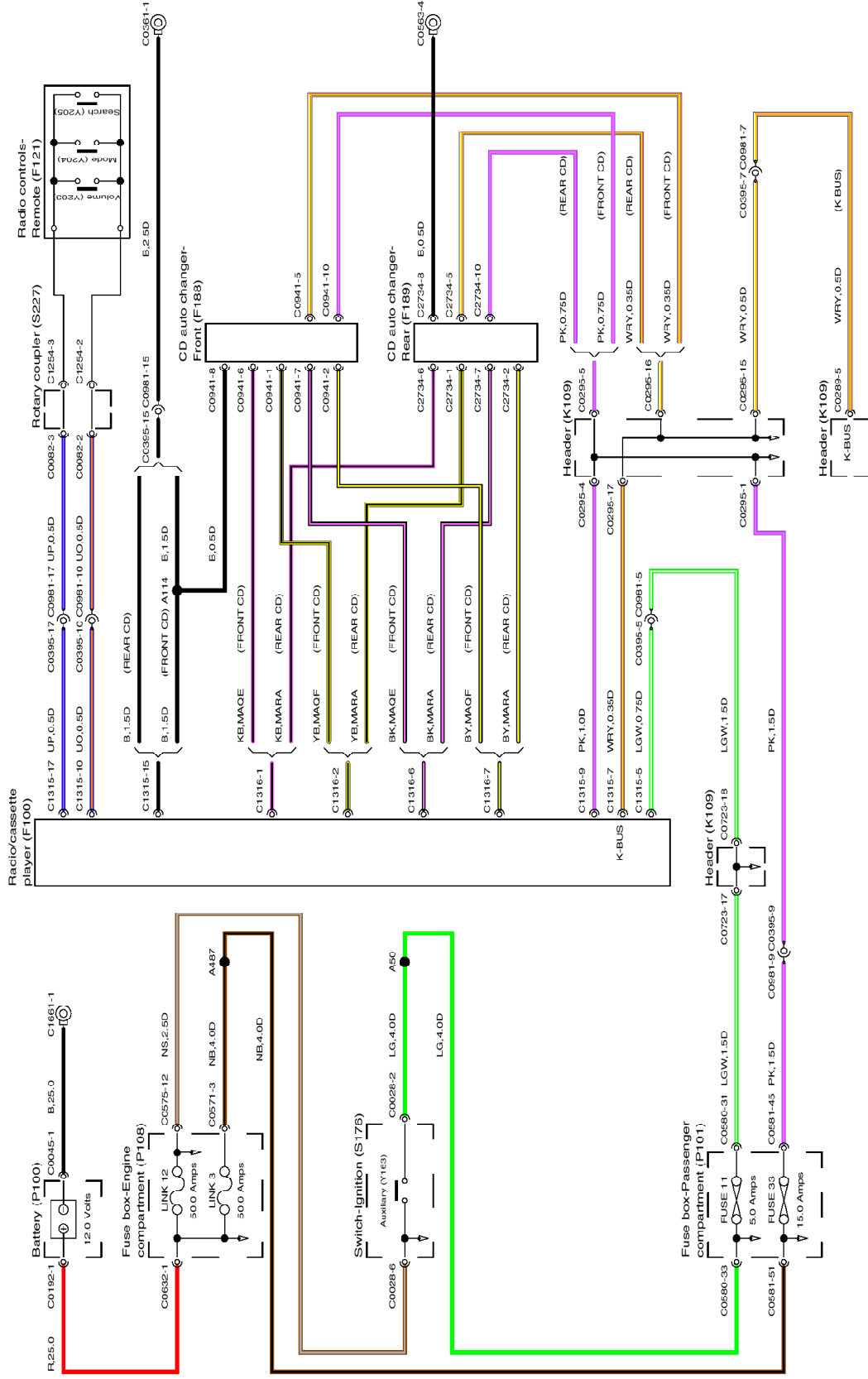

VWR403340-1

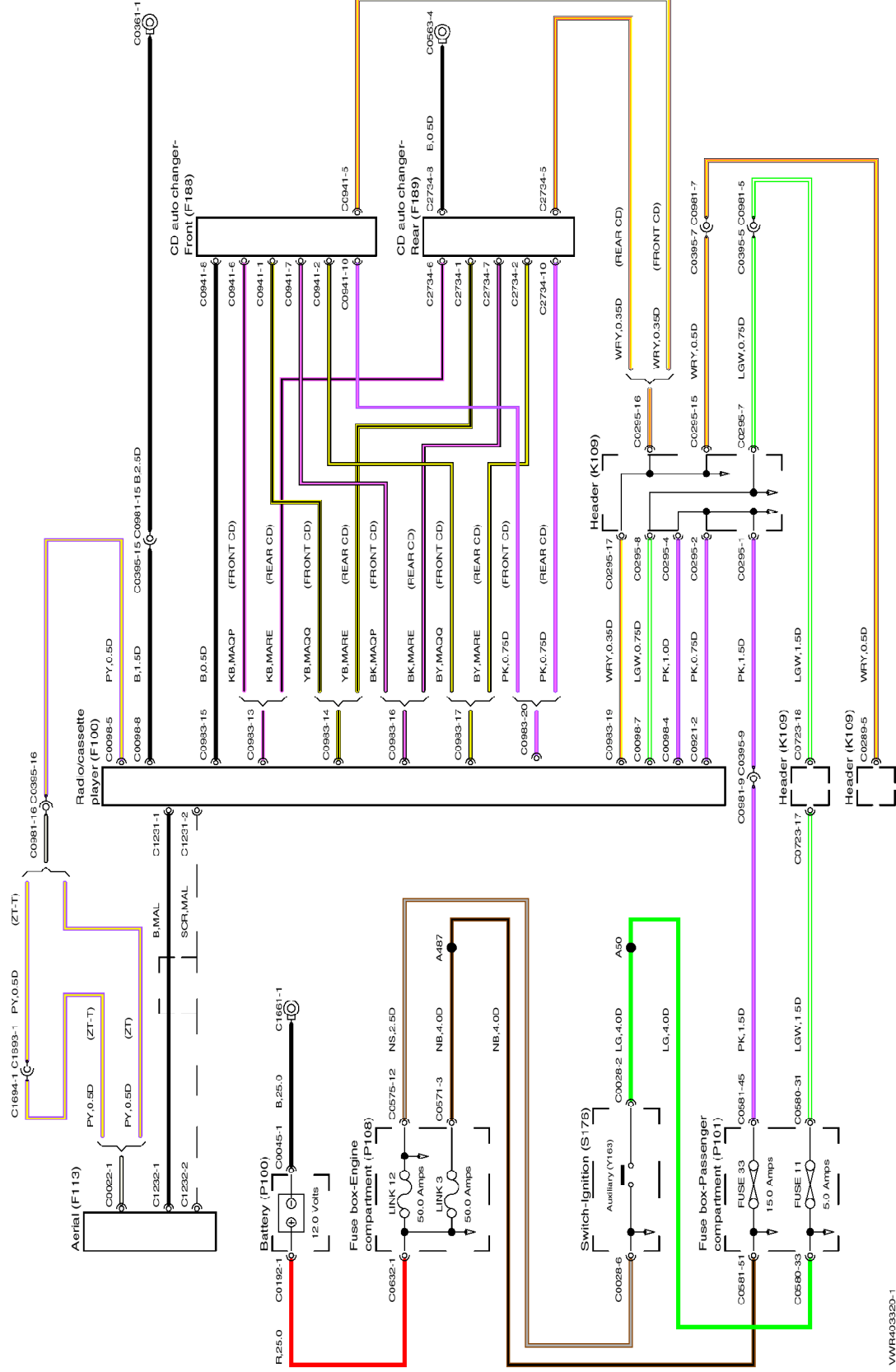

VWR403320-1

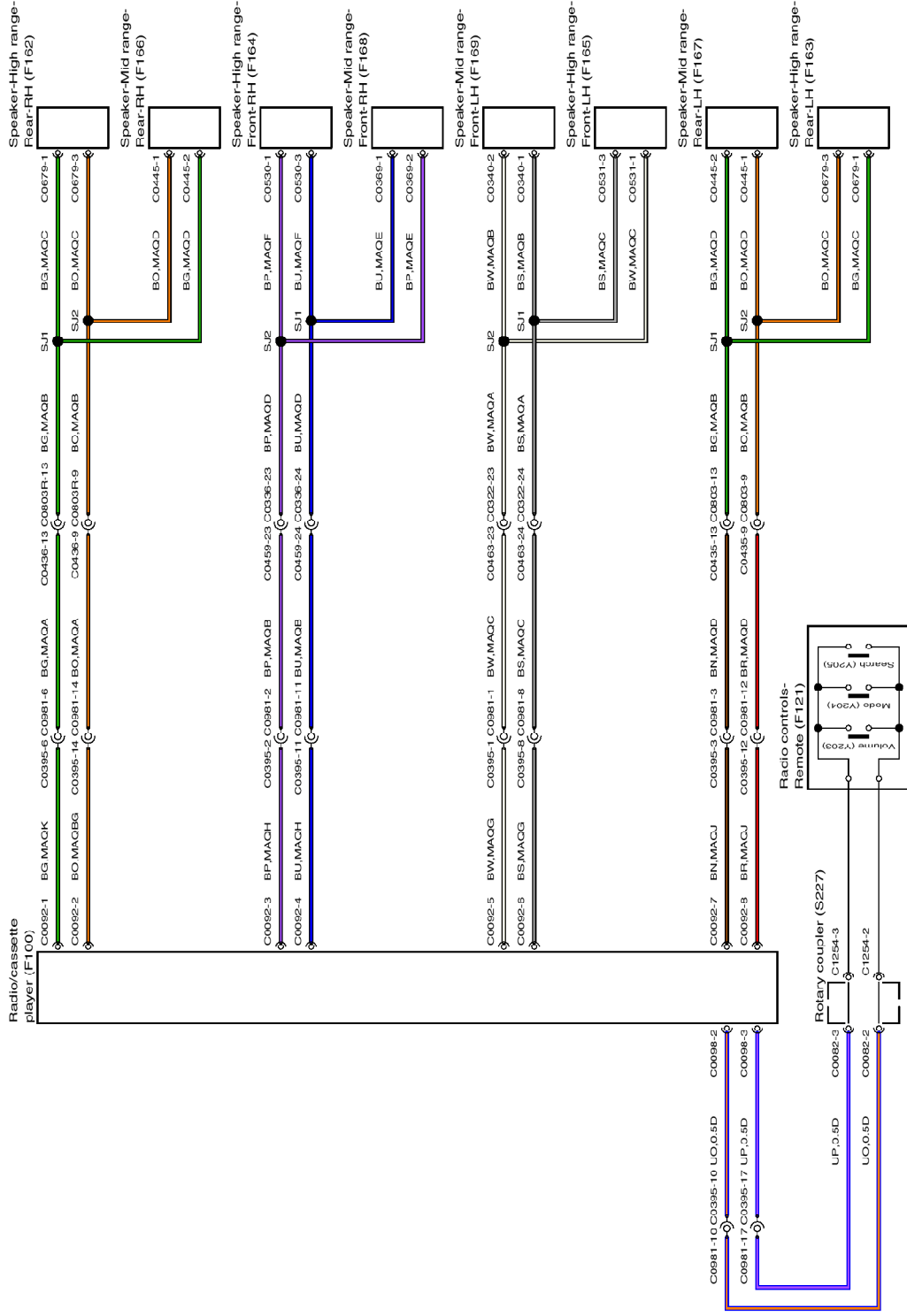

VWR403320-2

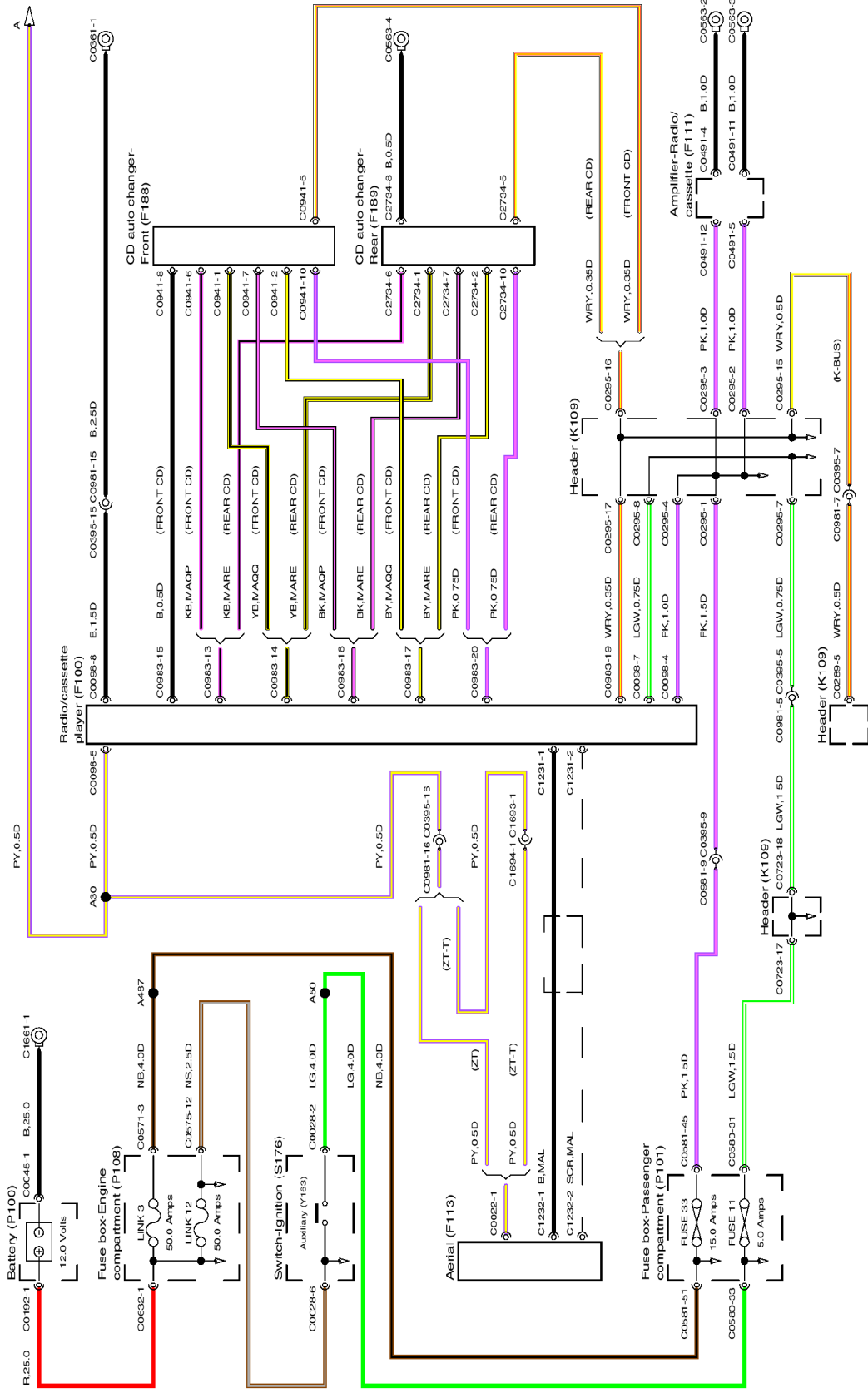

VWR403300-1

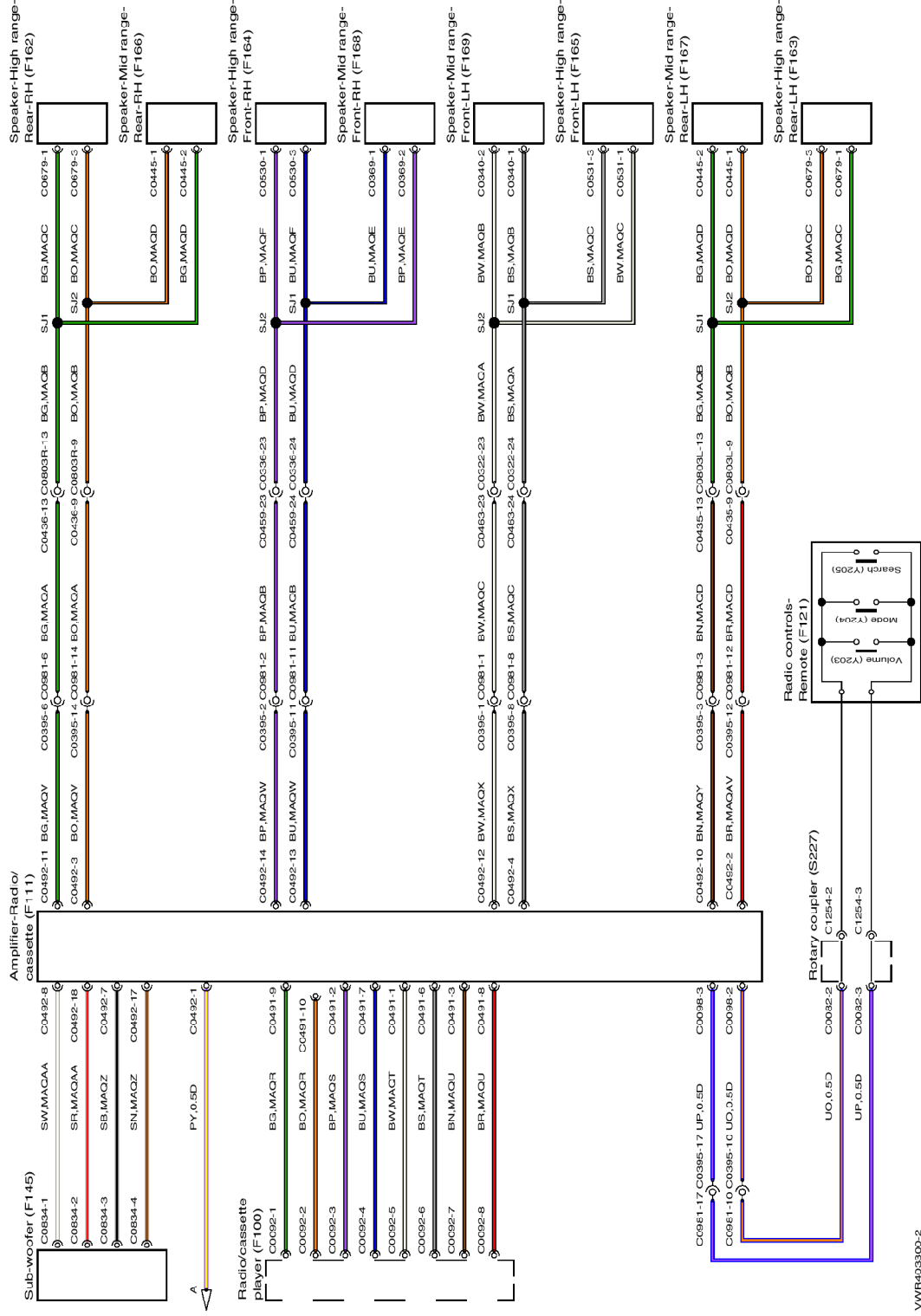

VWR403300-2

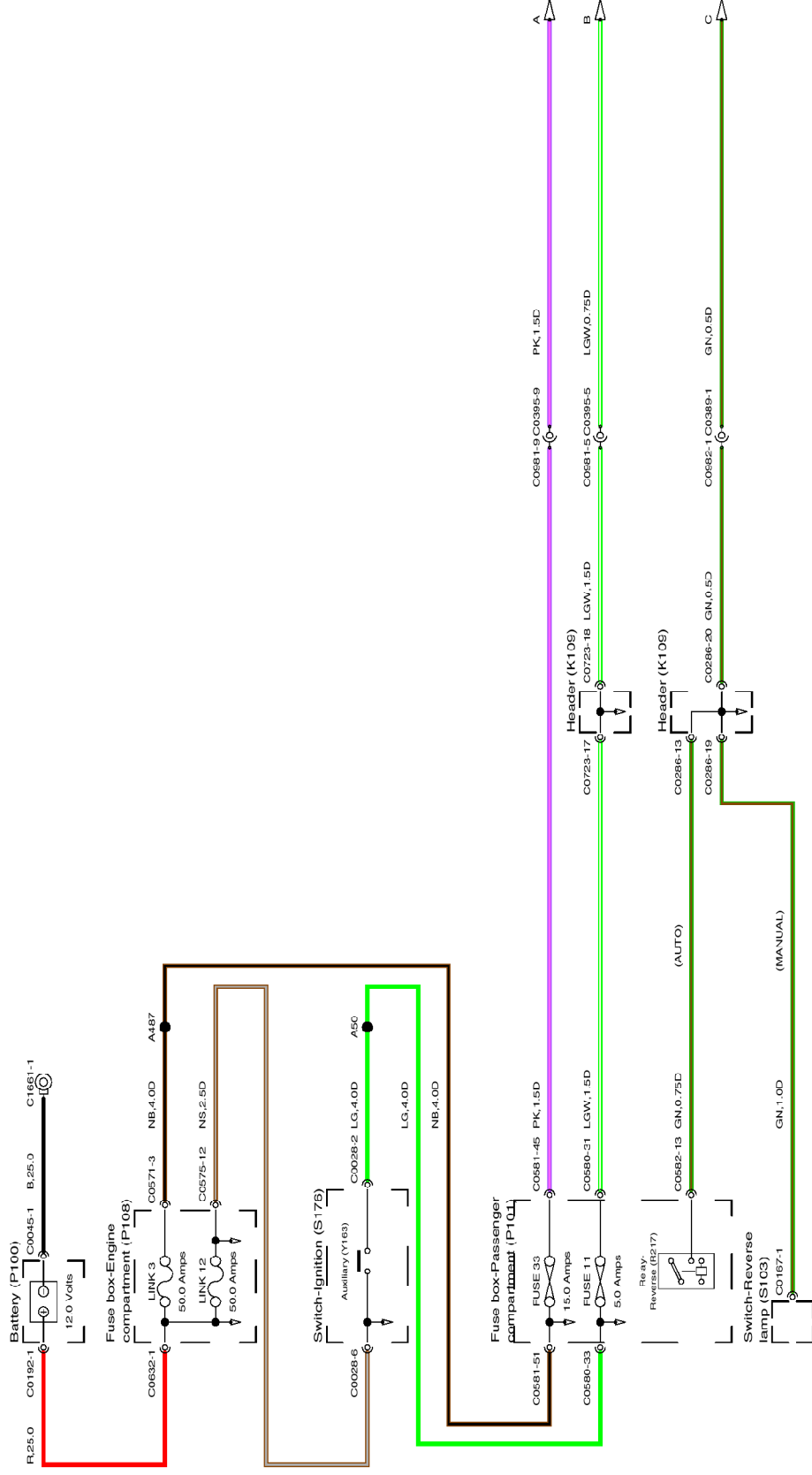

VWVR403680-1

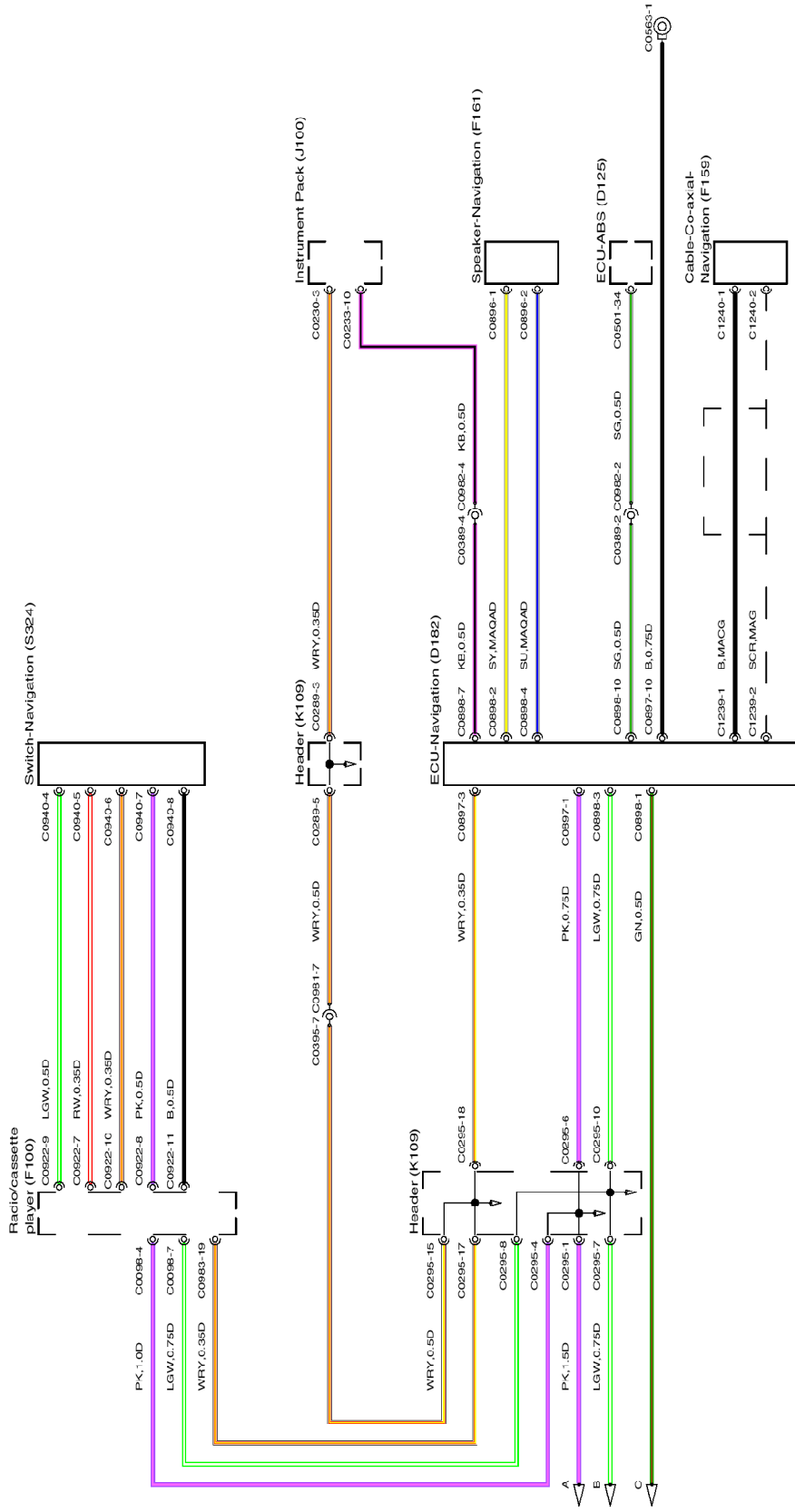

VWR403580-2

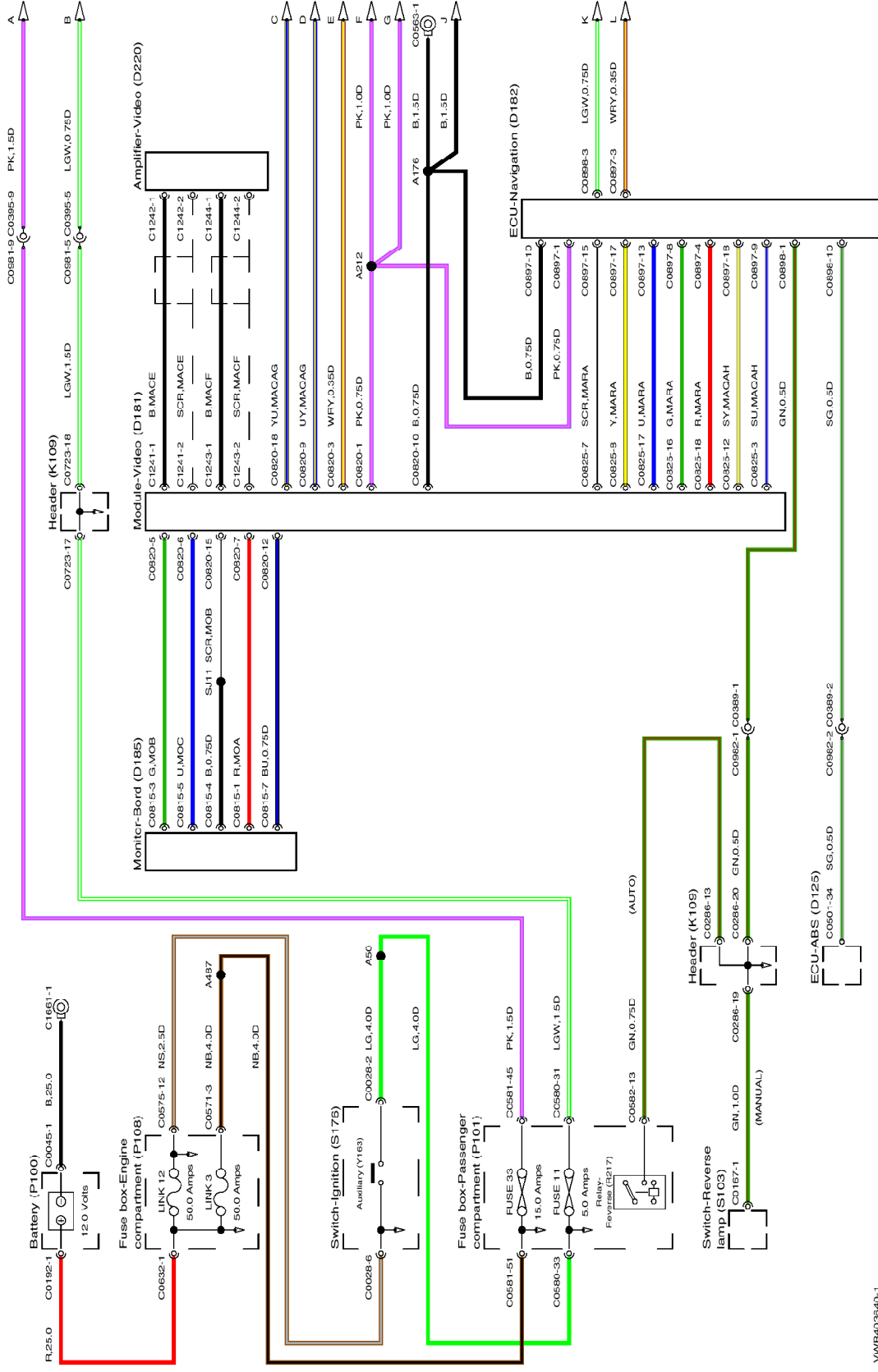

VWR403640-1

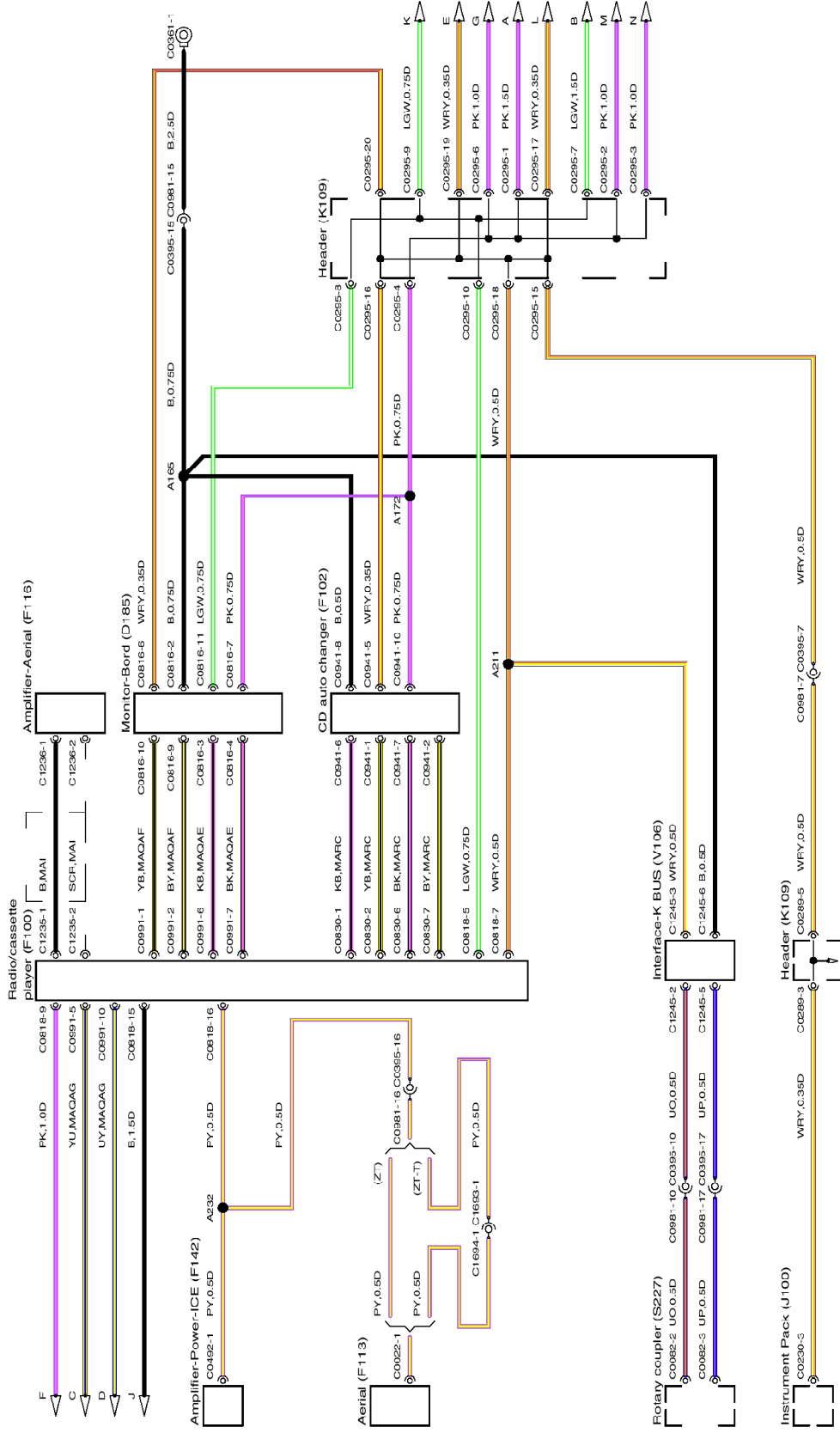

VWR403540-2

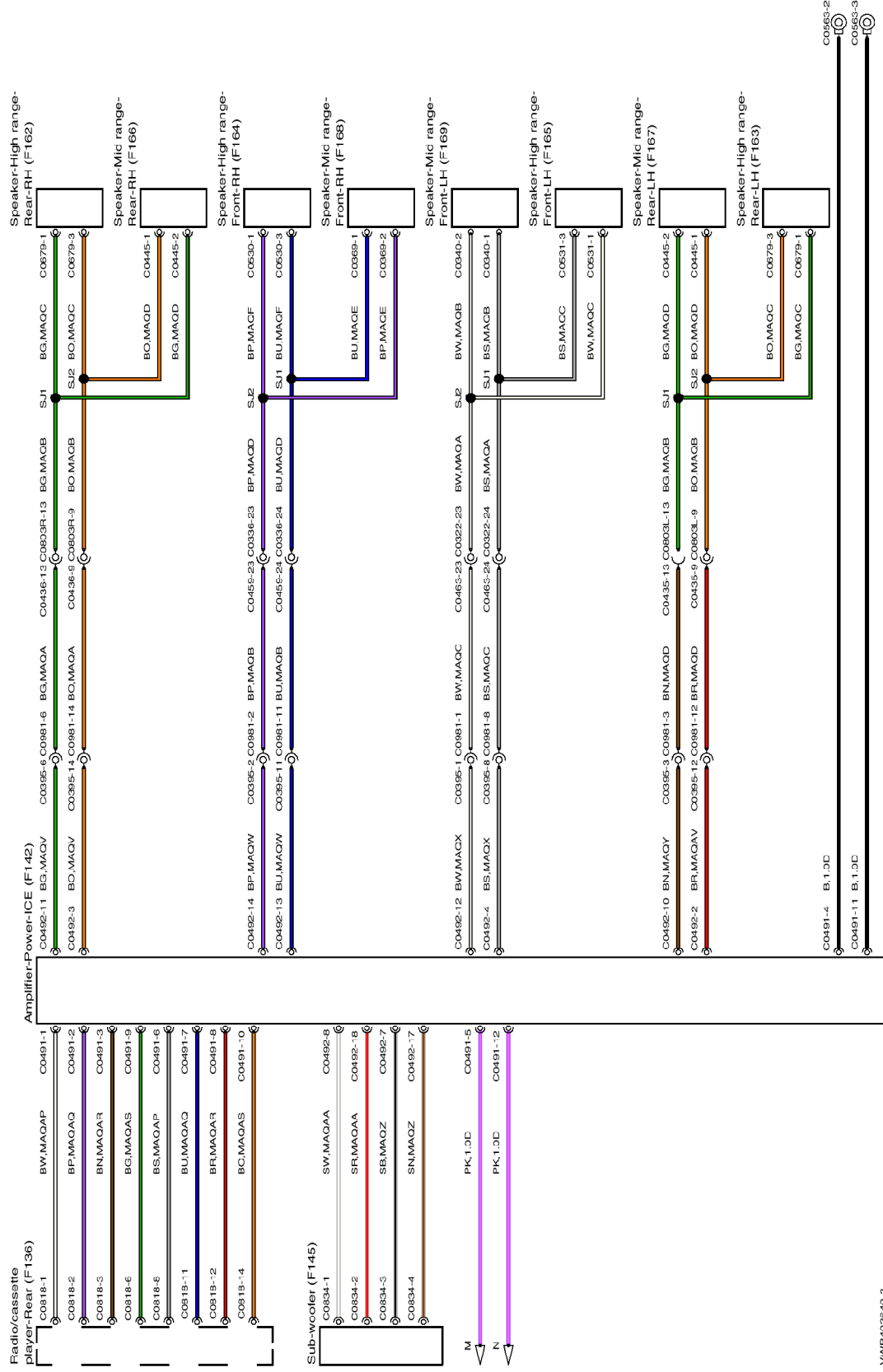

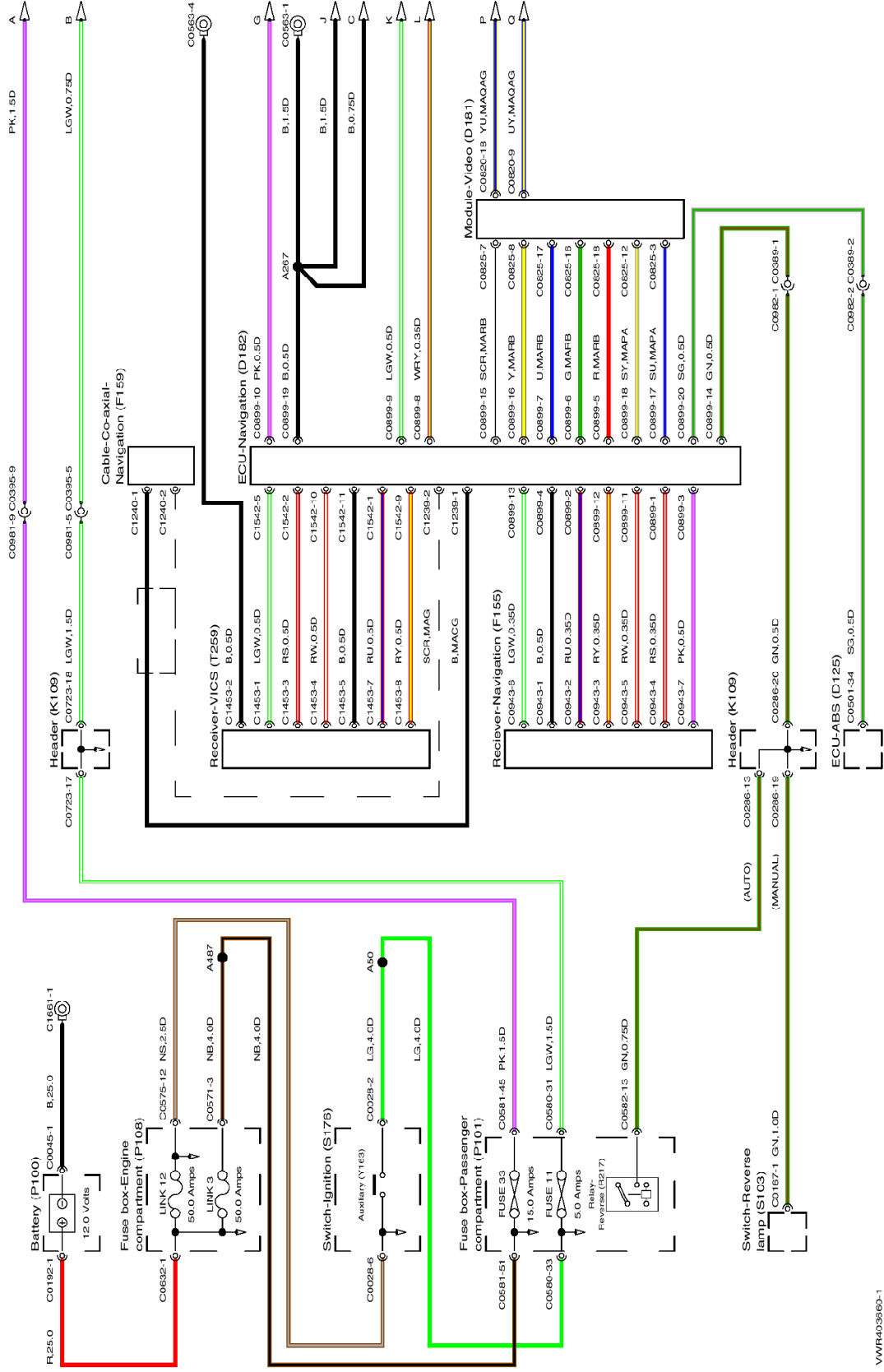

VWR403959-1

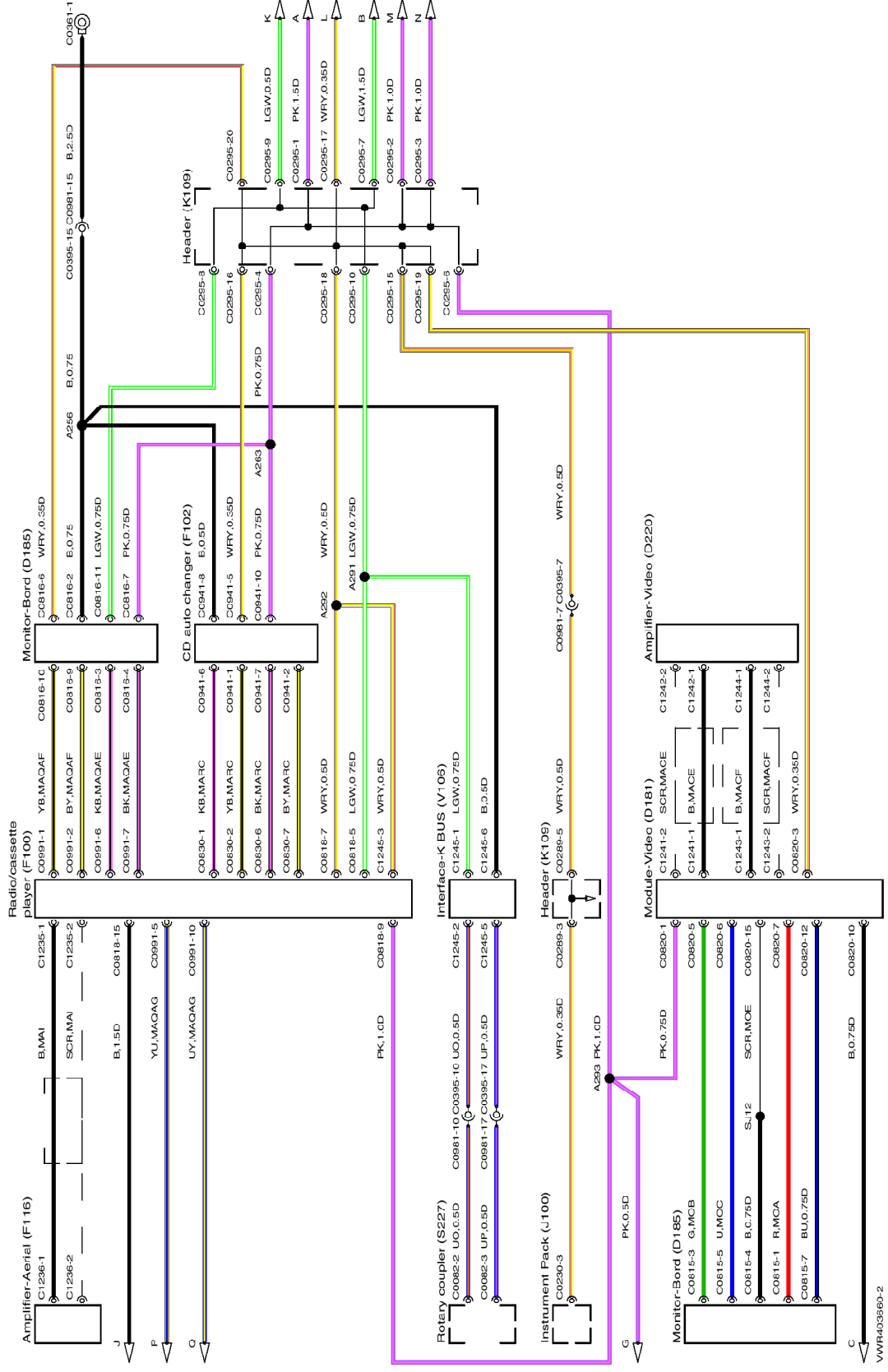

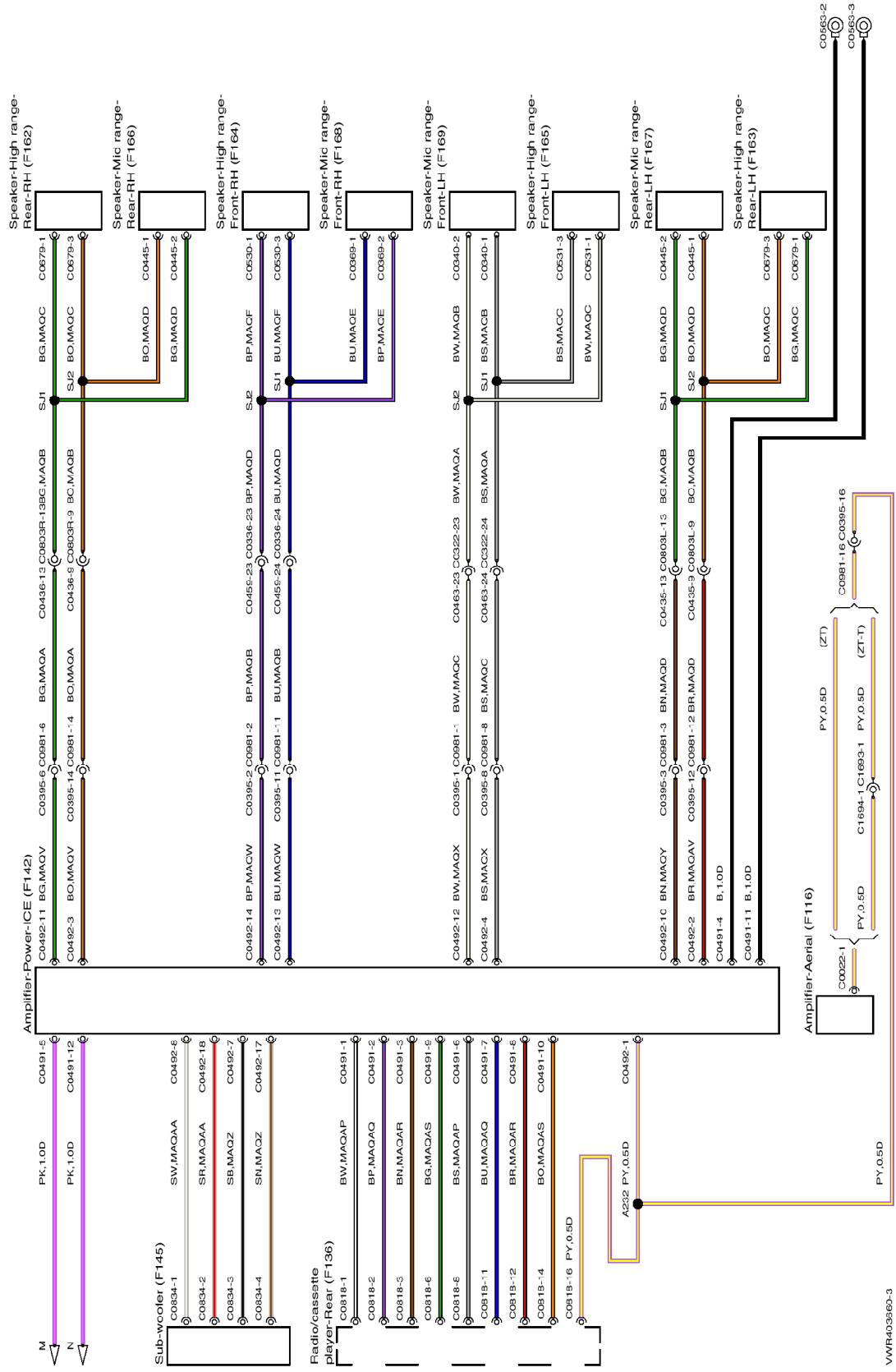

VWR403560-3

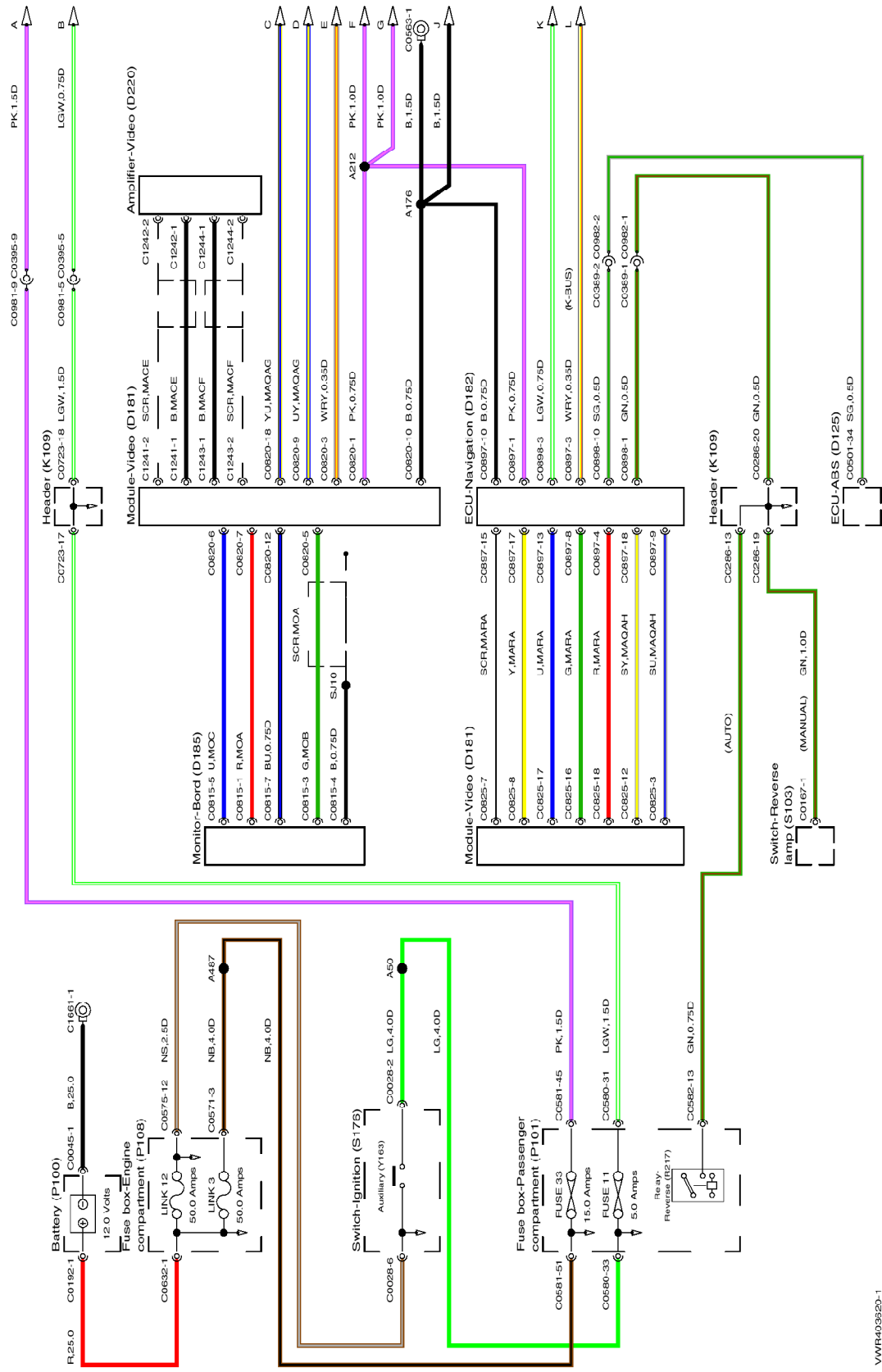

VWR403620-1

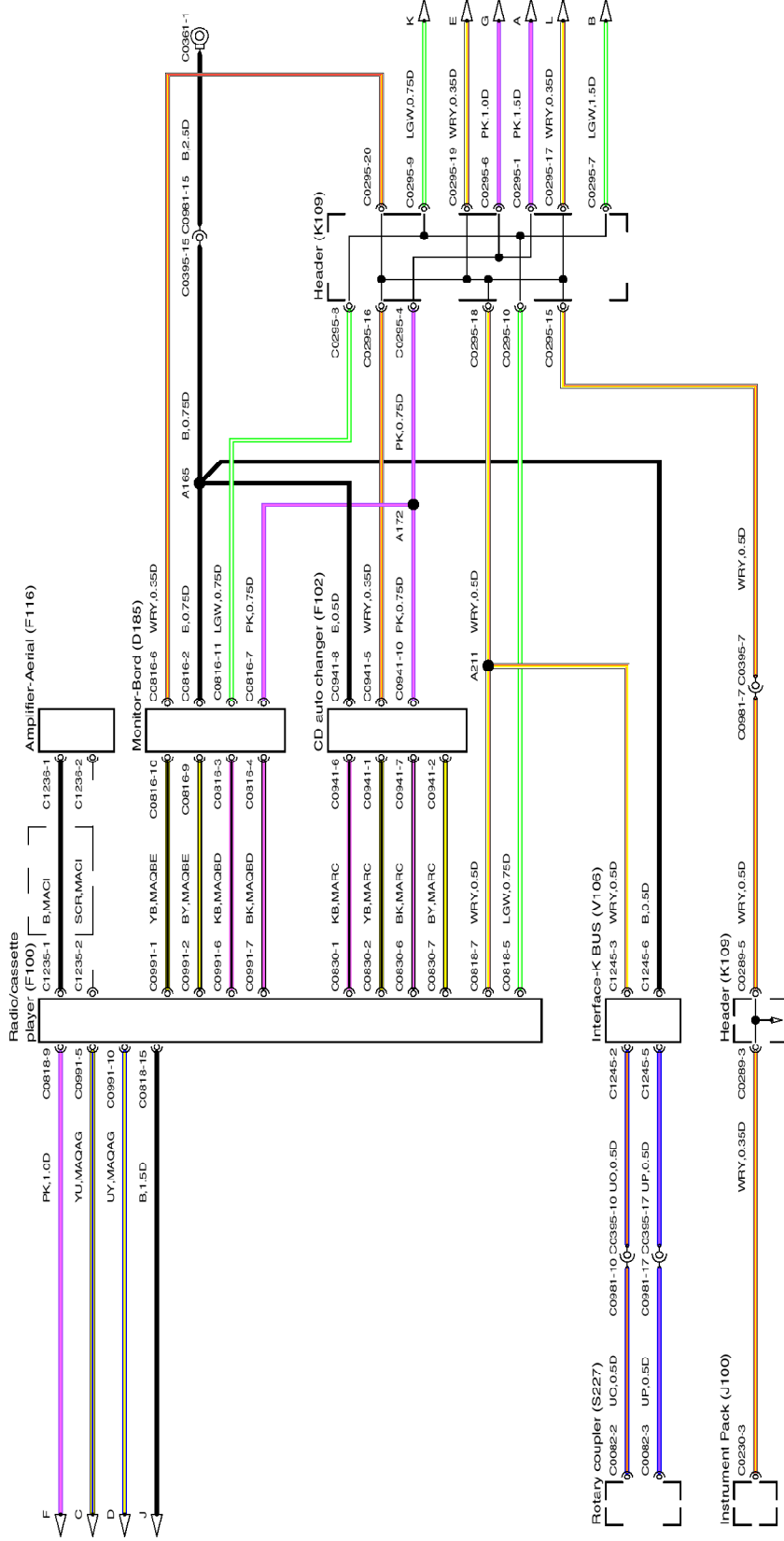

VWR4038520-2

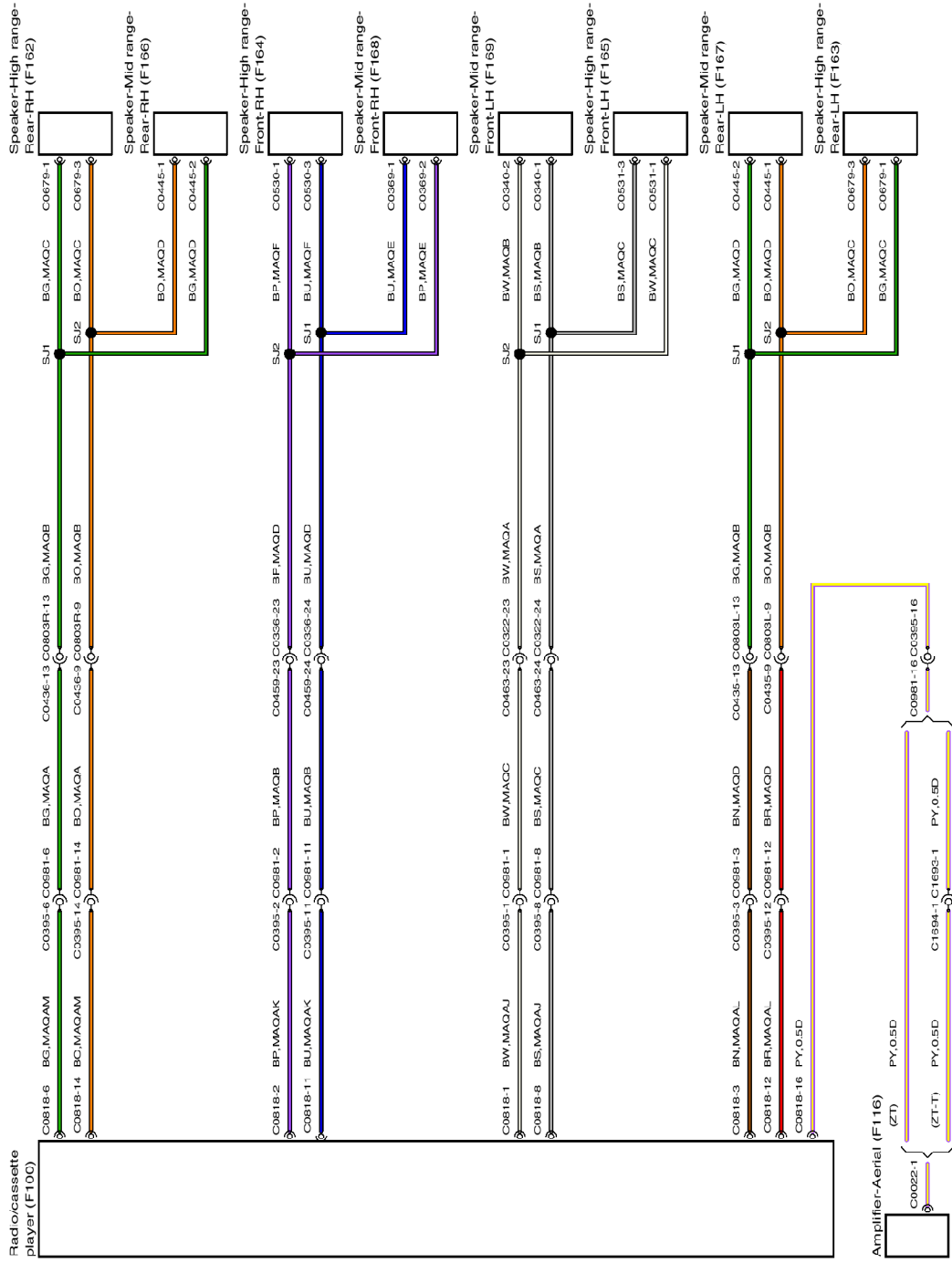

VWR40320-3

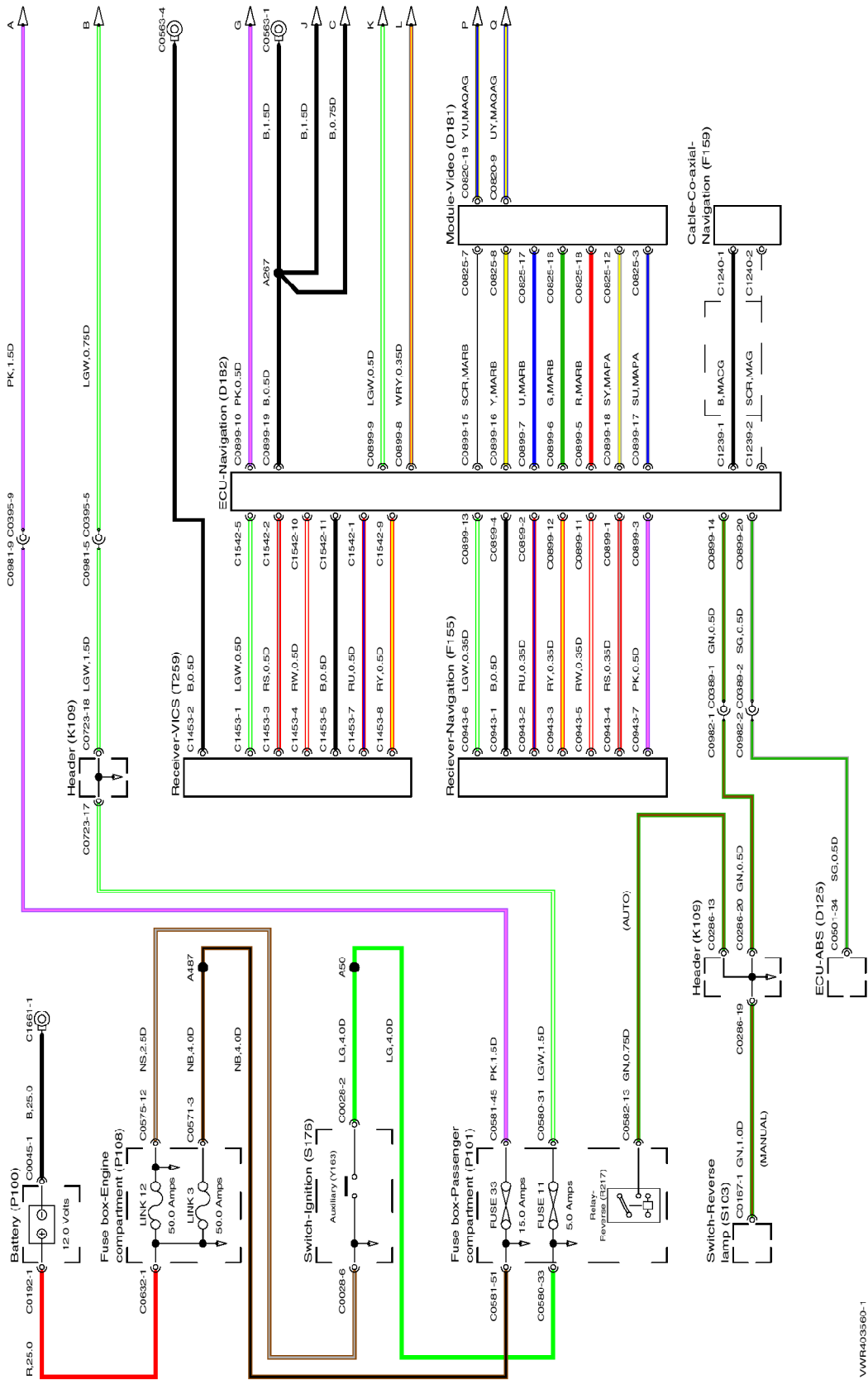

VWR403560-1

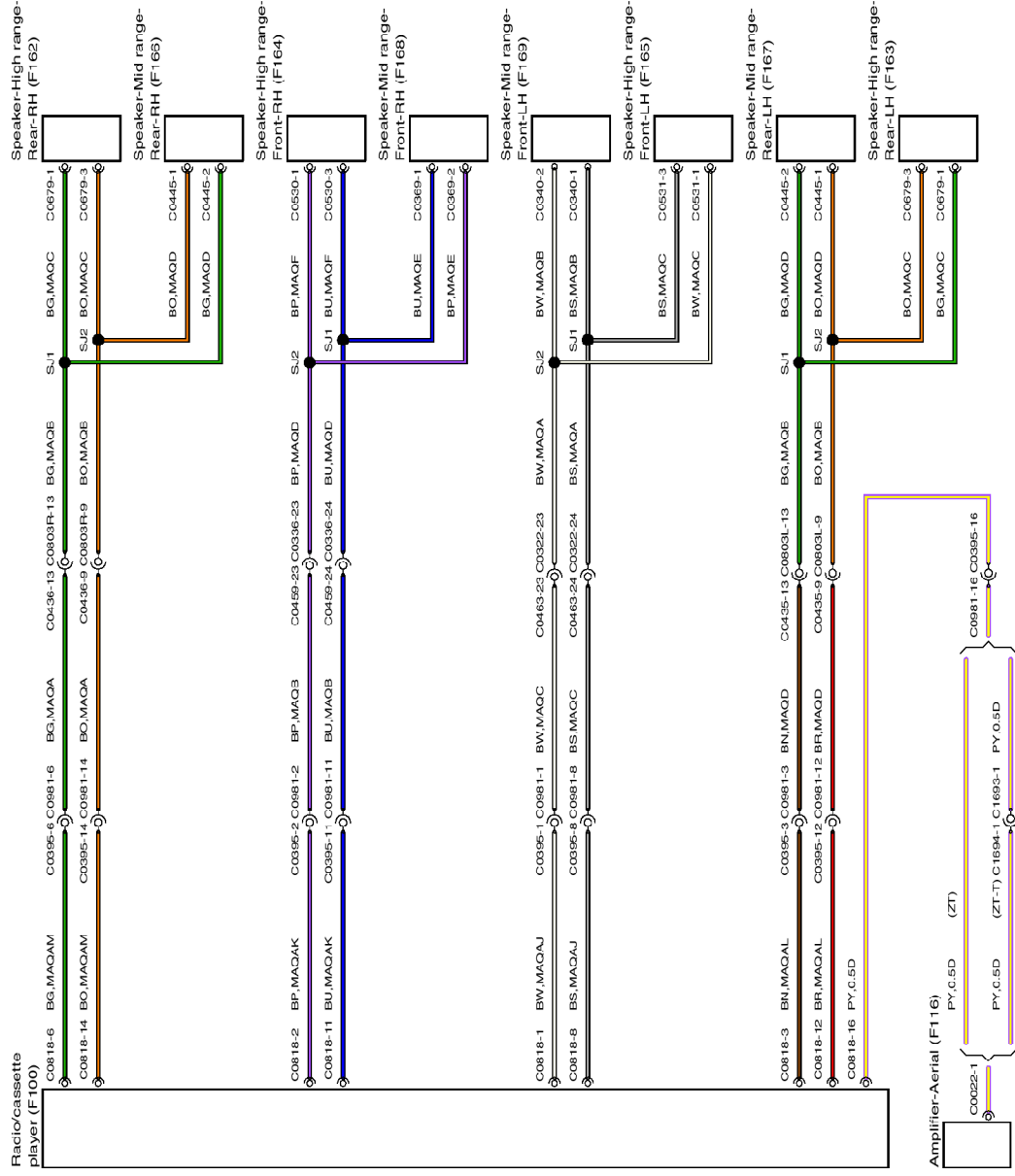

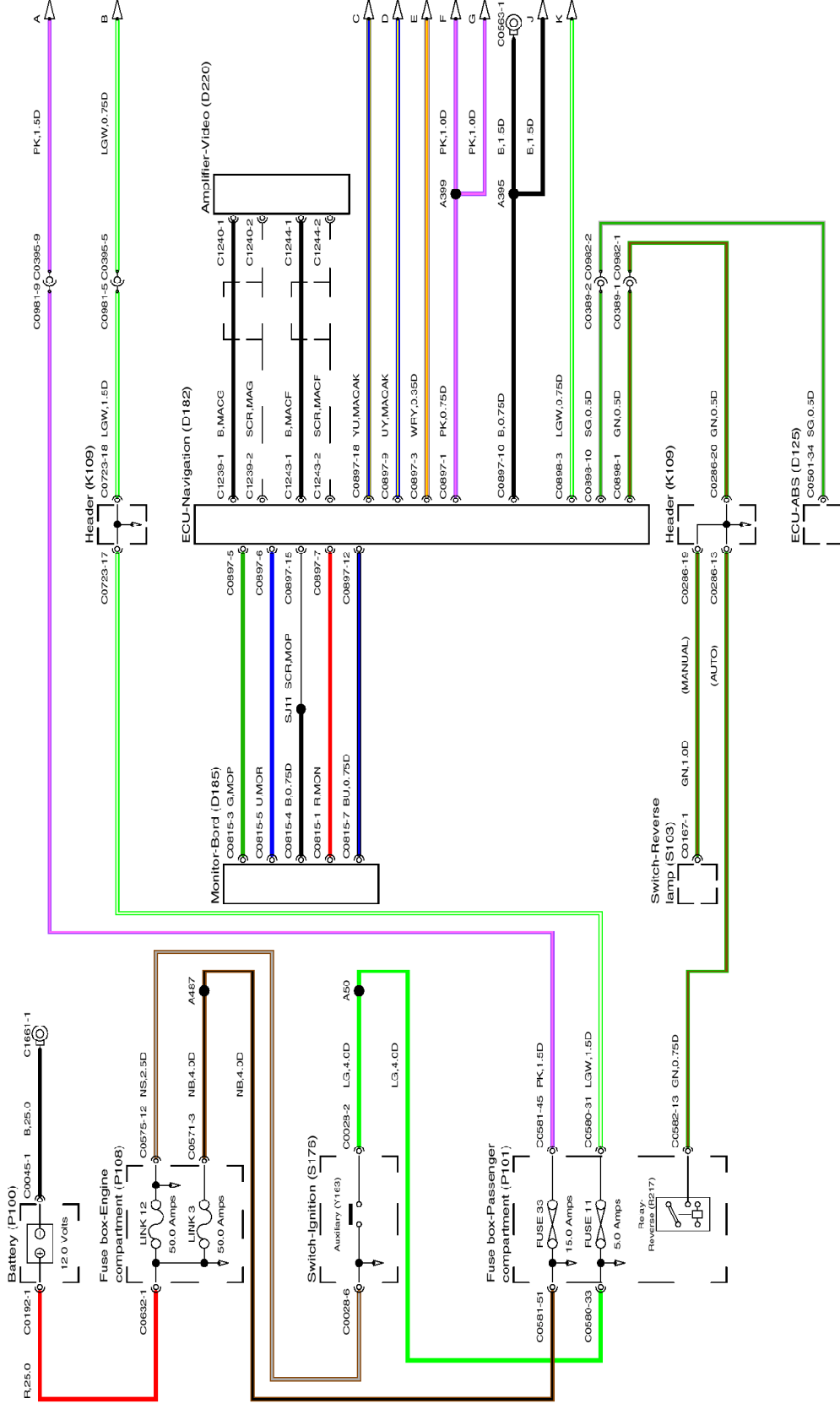

VWR403589-1

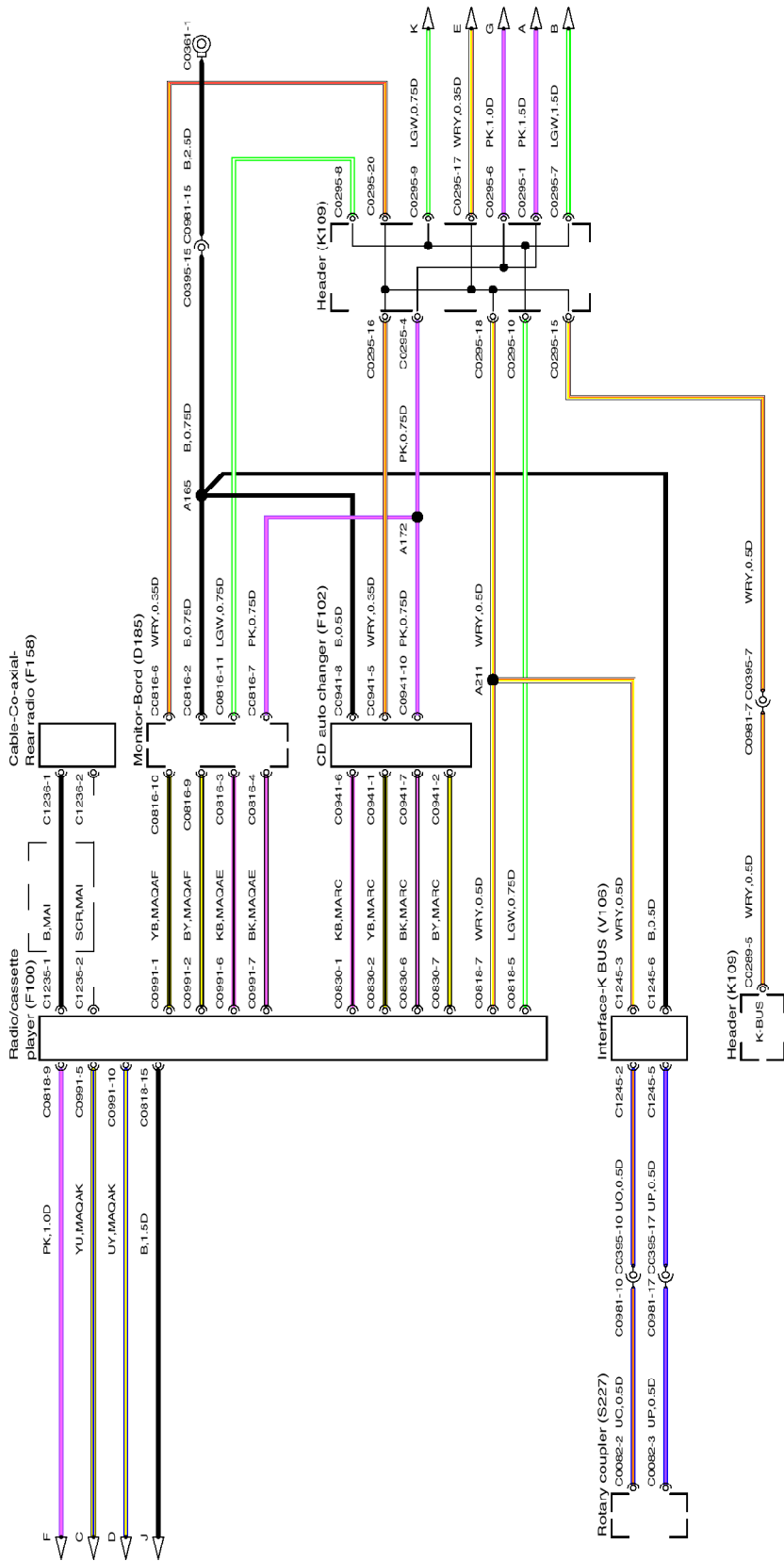

VWR403580-2

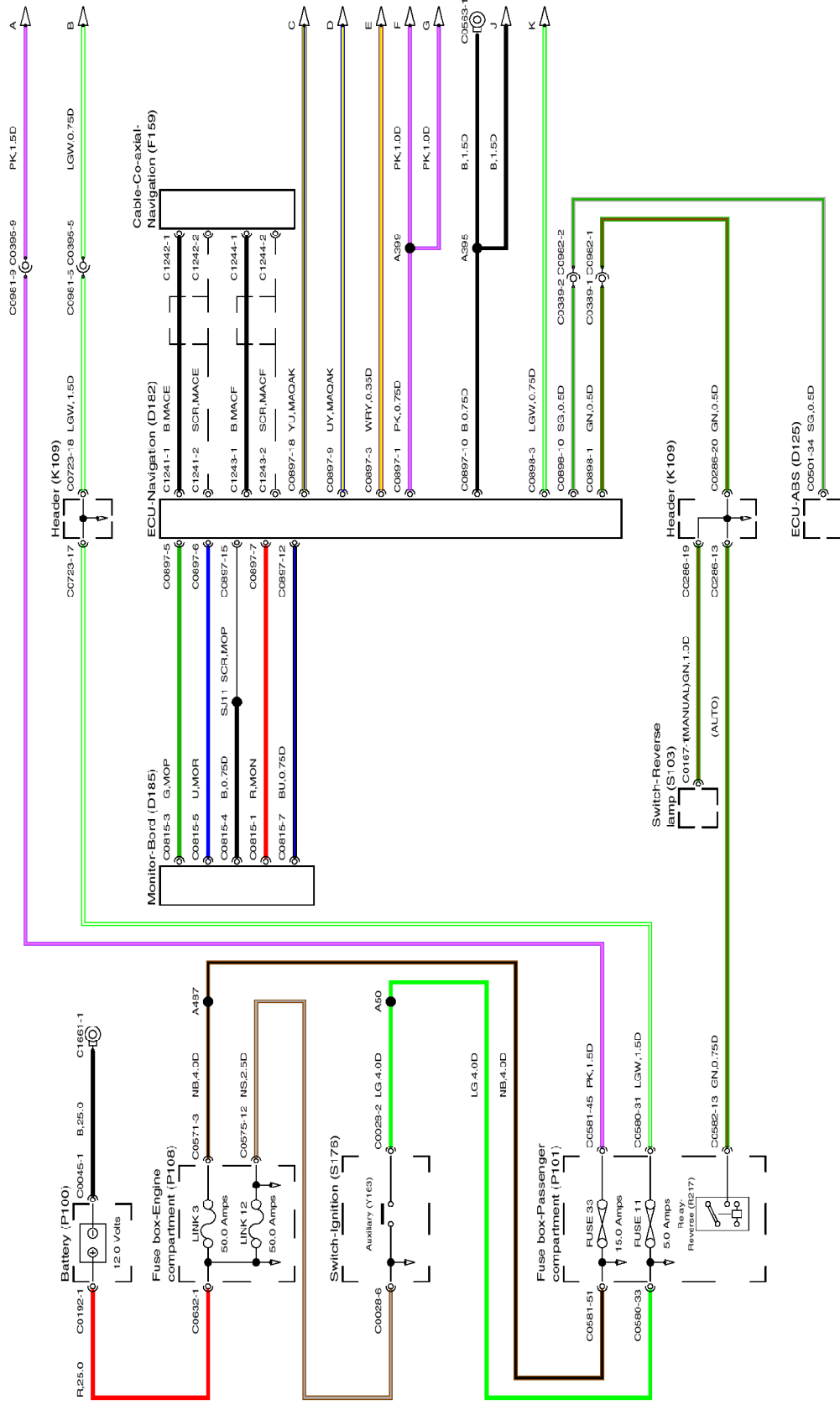

VWR403800-1

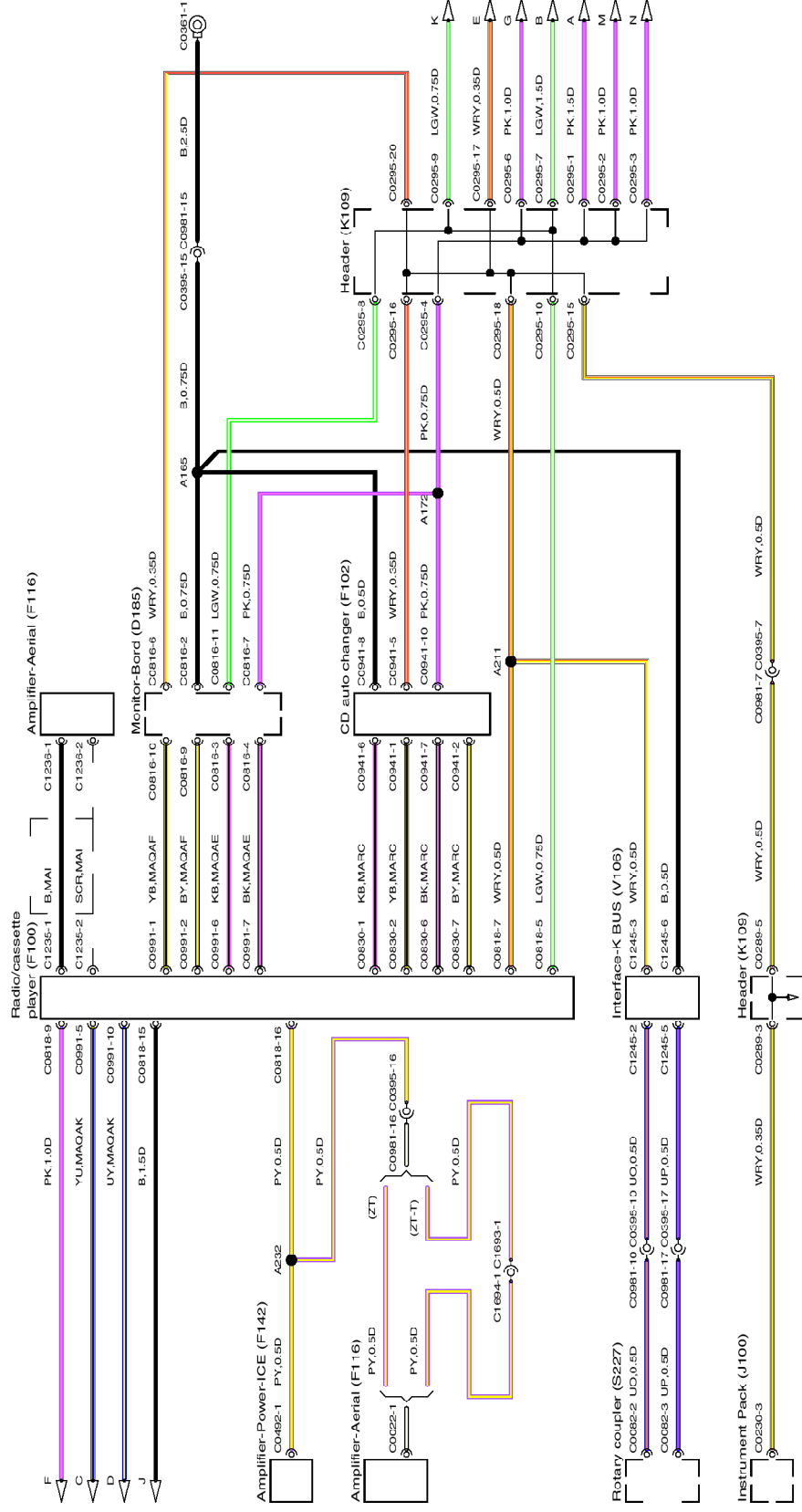

VWR40300-2

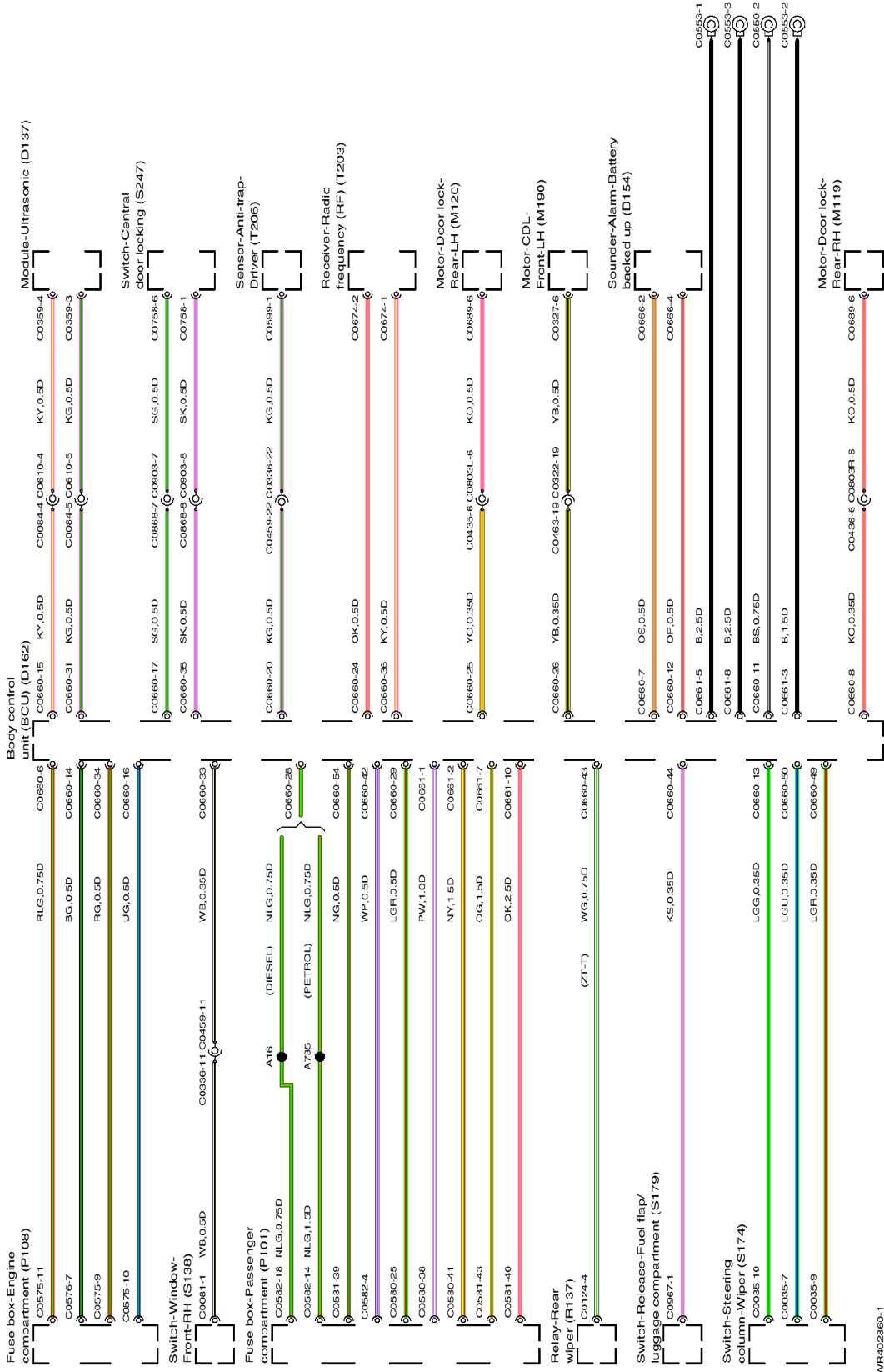

VWR402360-1

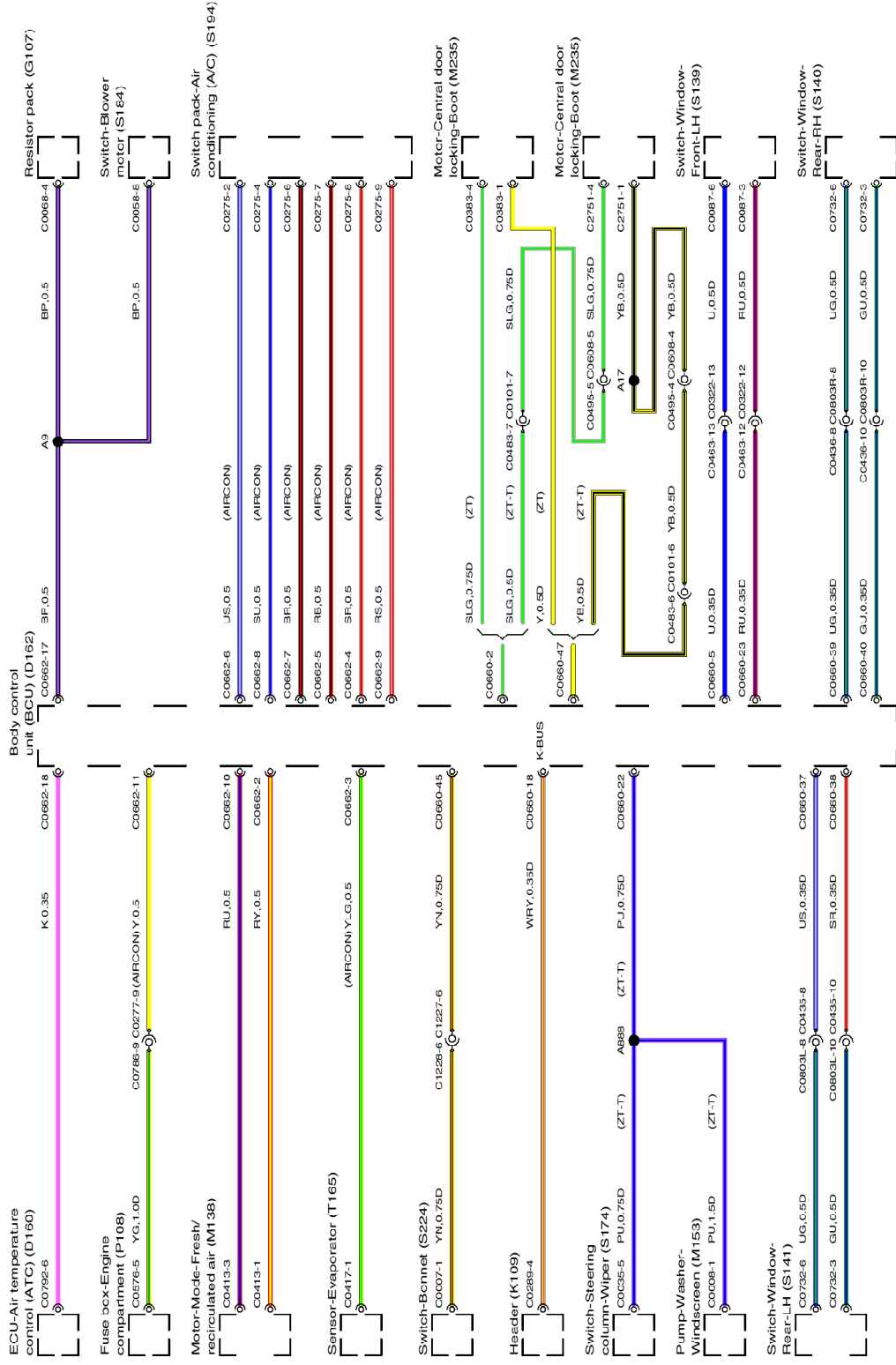

VWR402360-3

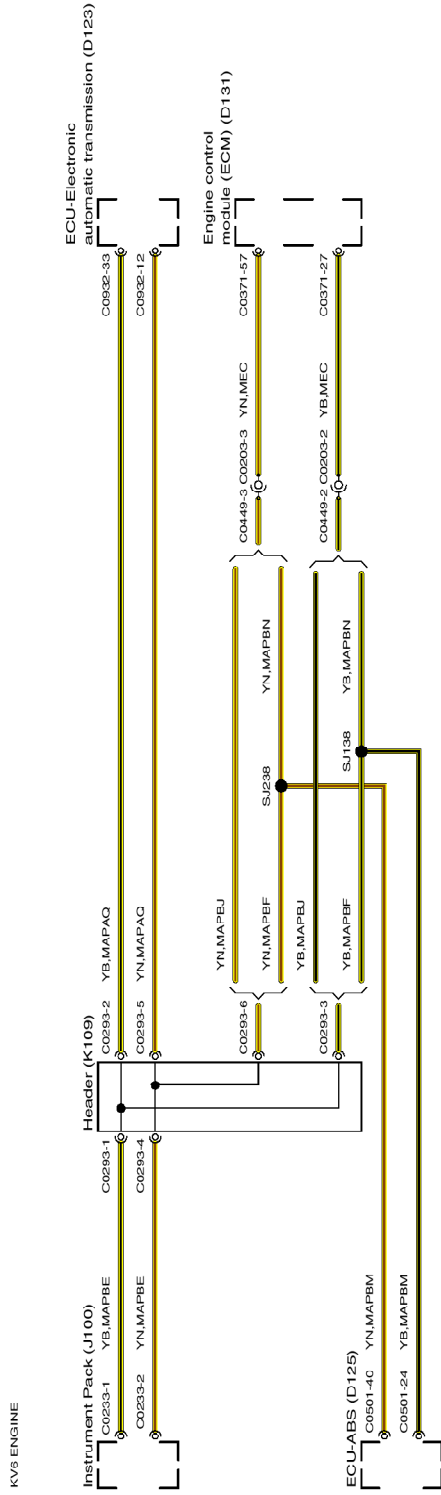
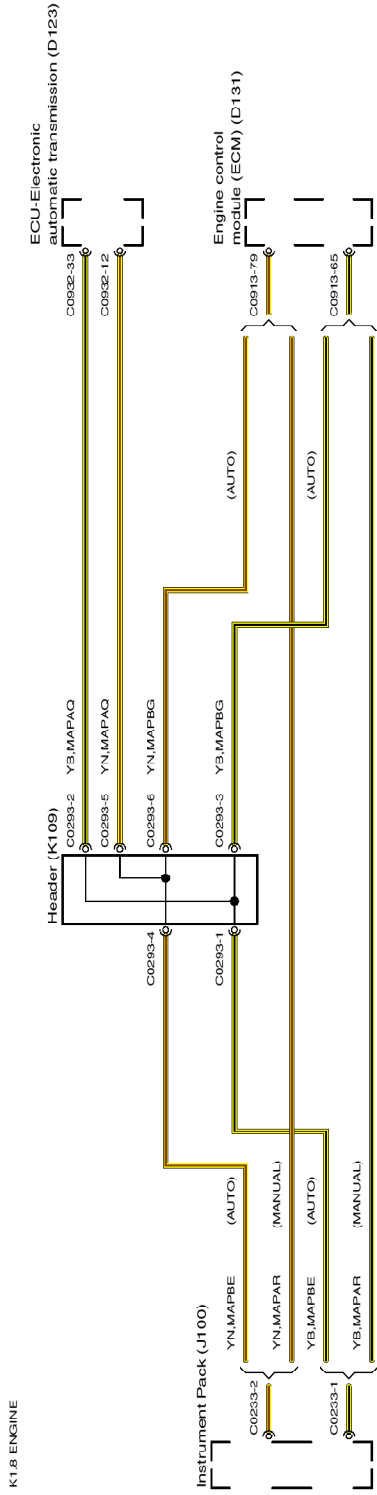

VWR402820-1

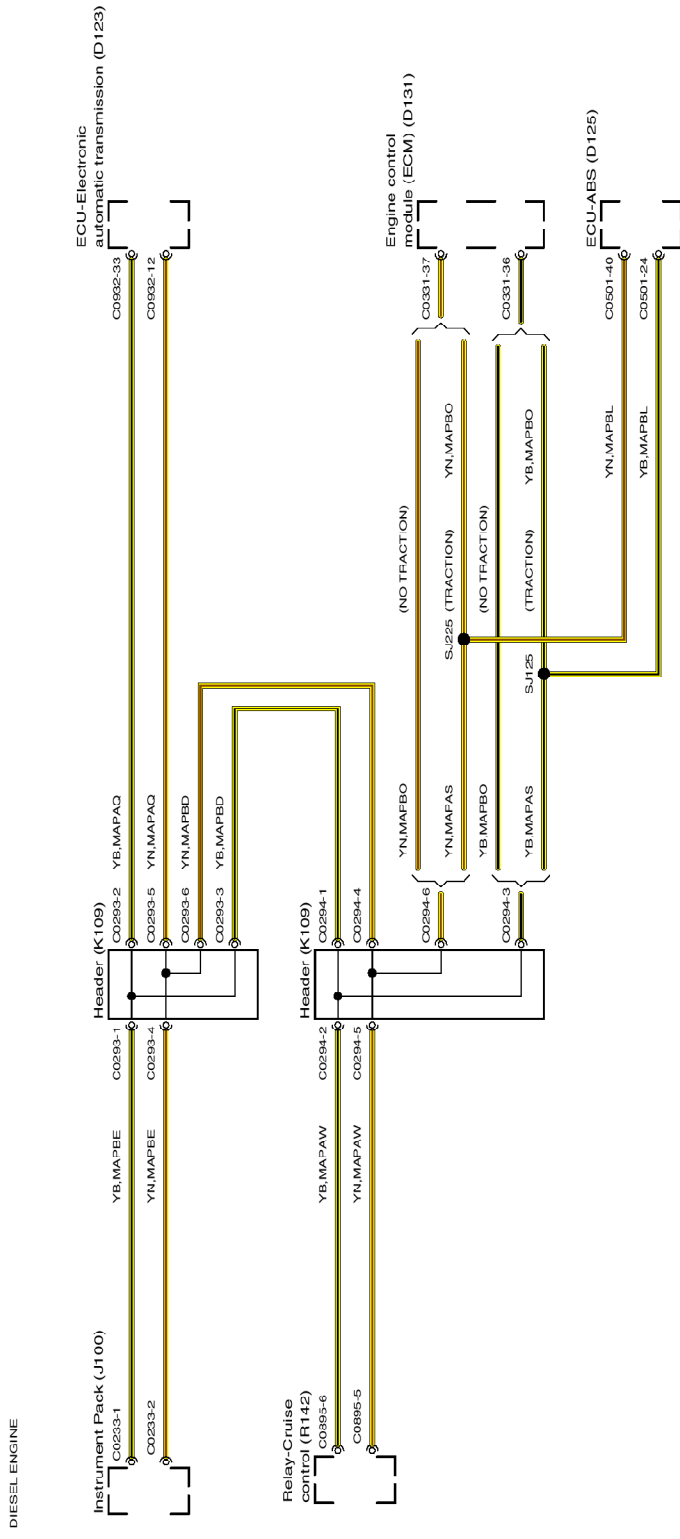

VWR402320-2

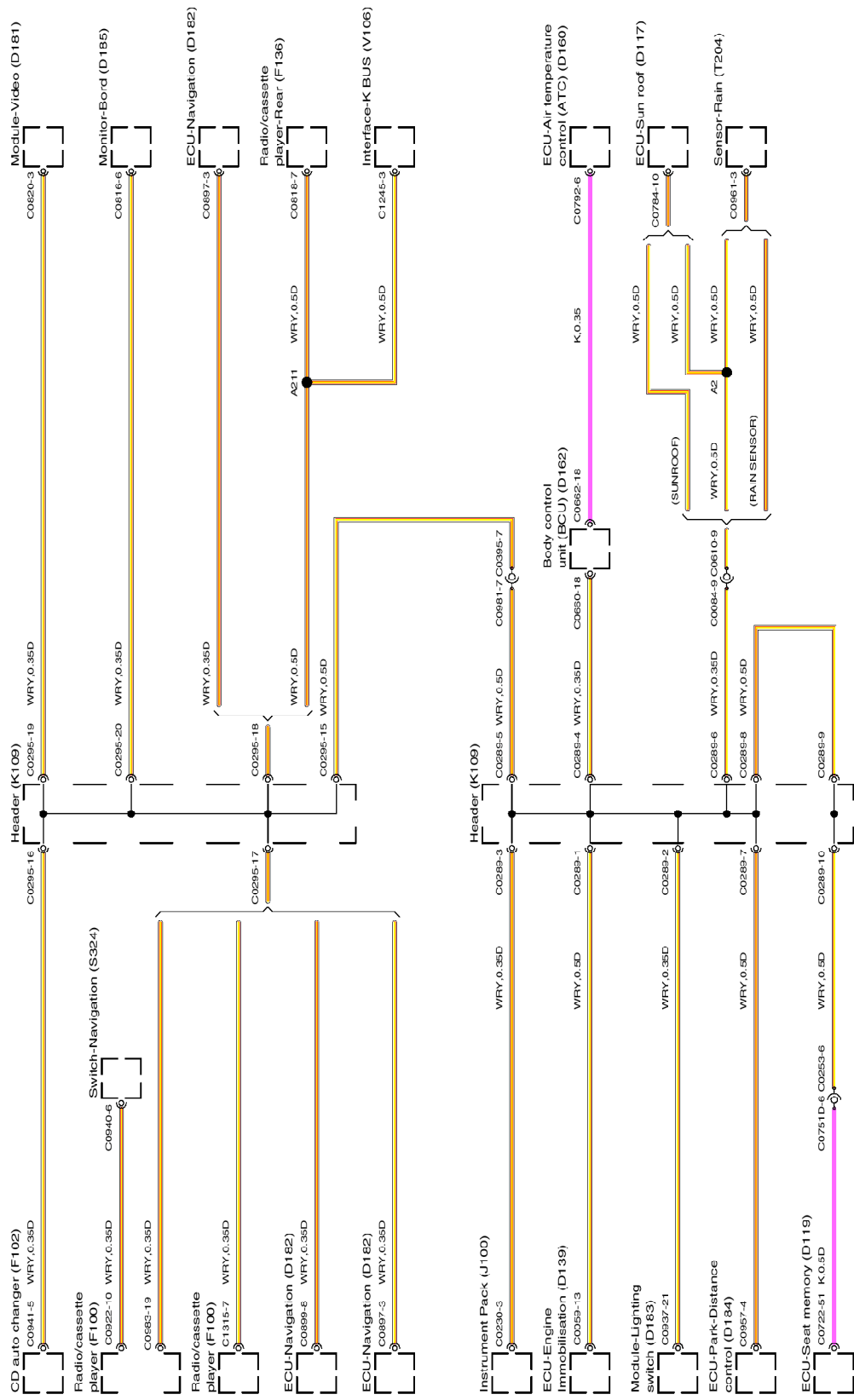

VWR402320-3

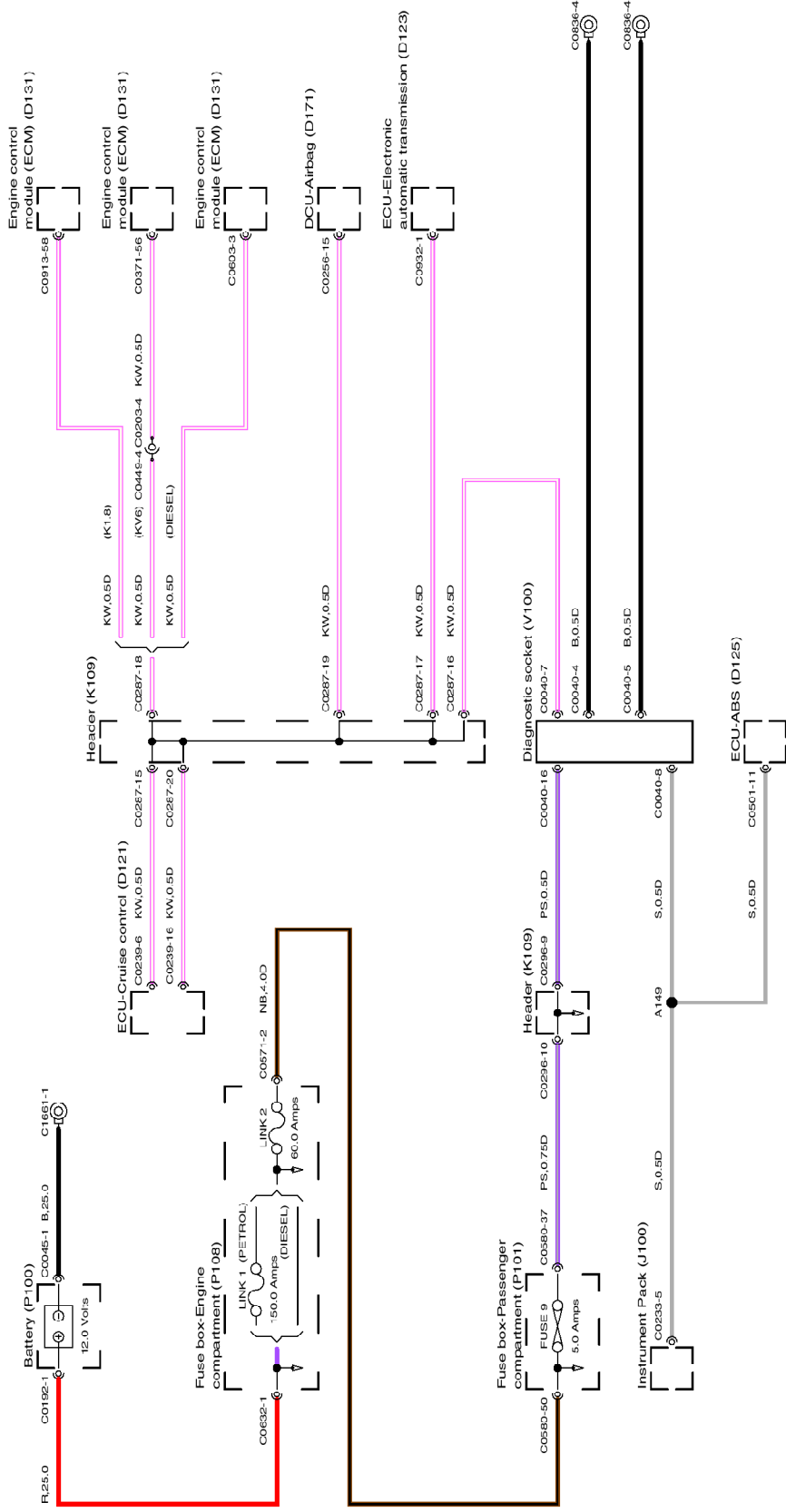

VWR403000-1

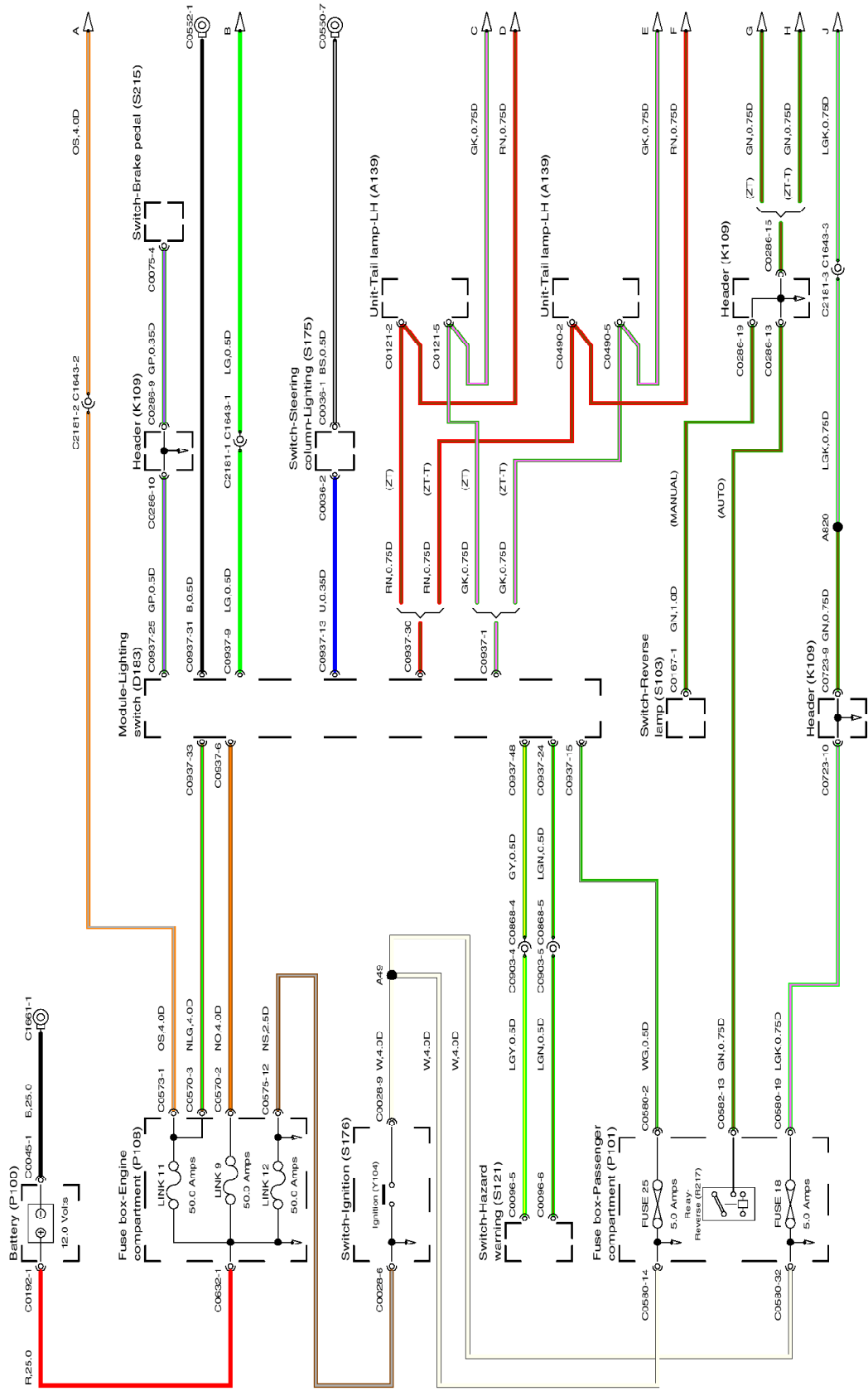

VWR404040-1

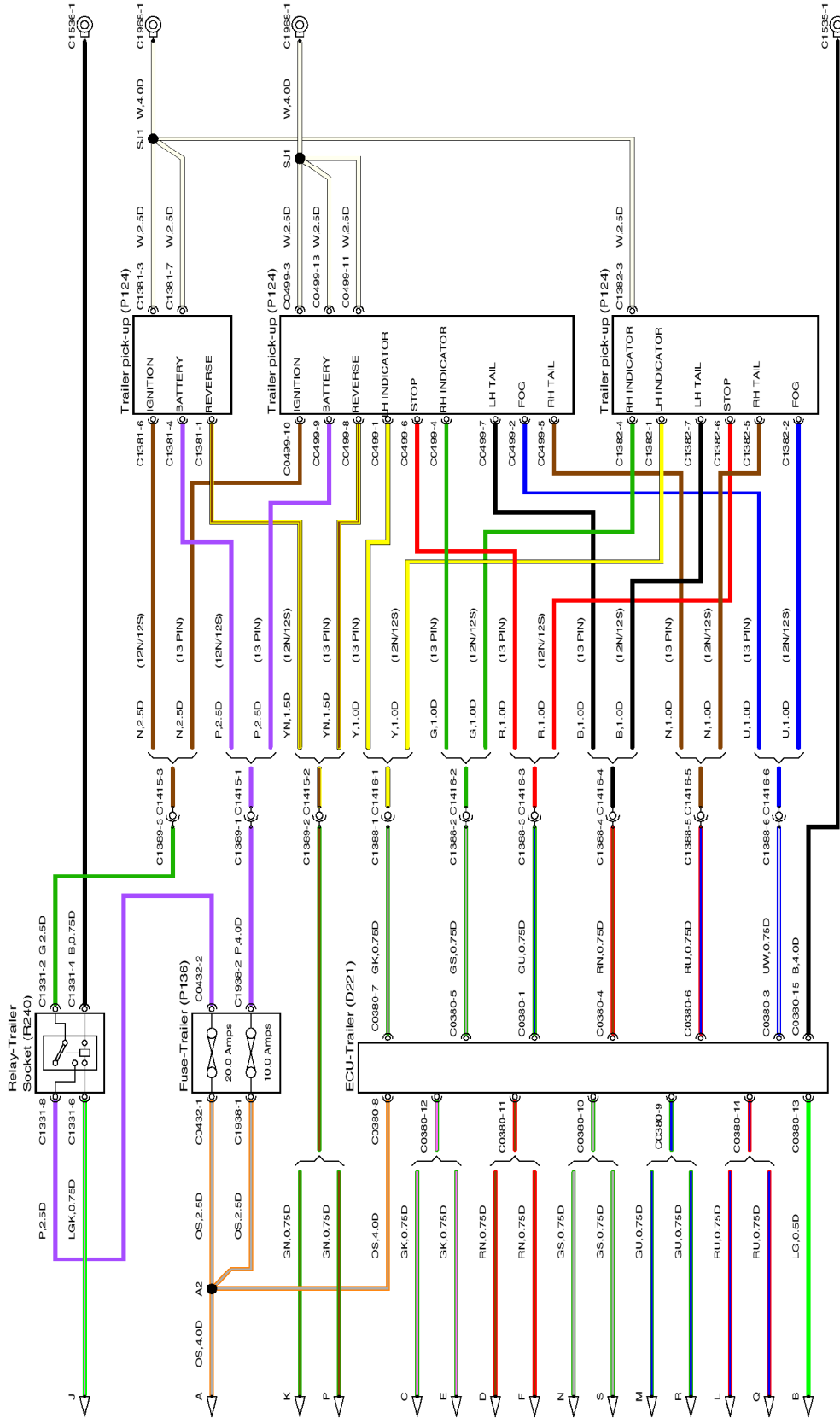

VWR4040-2

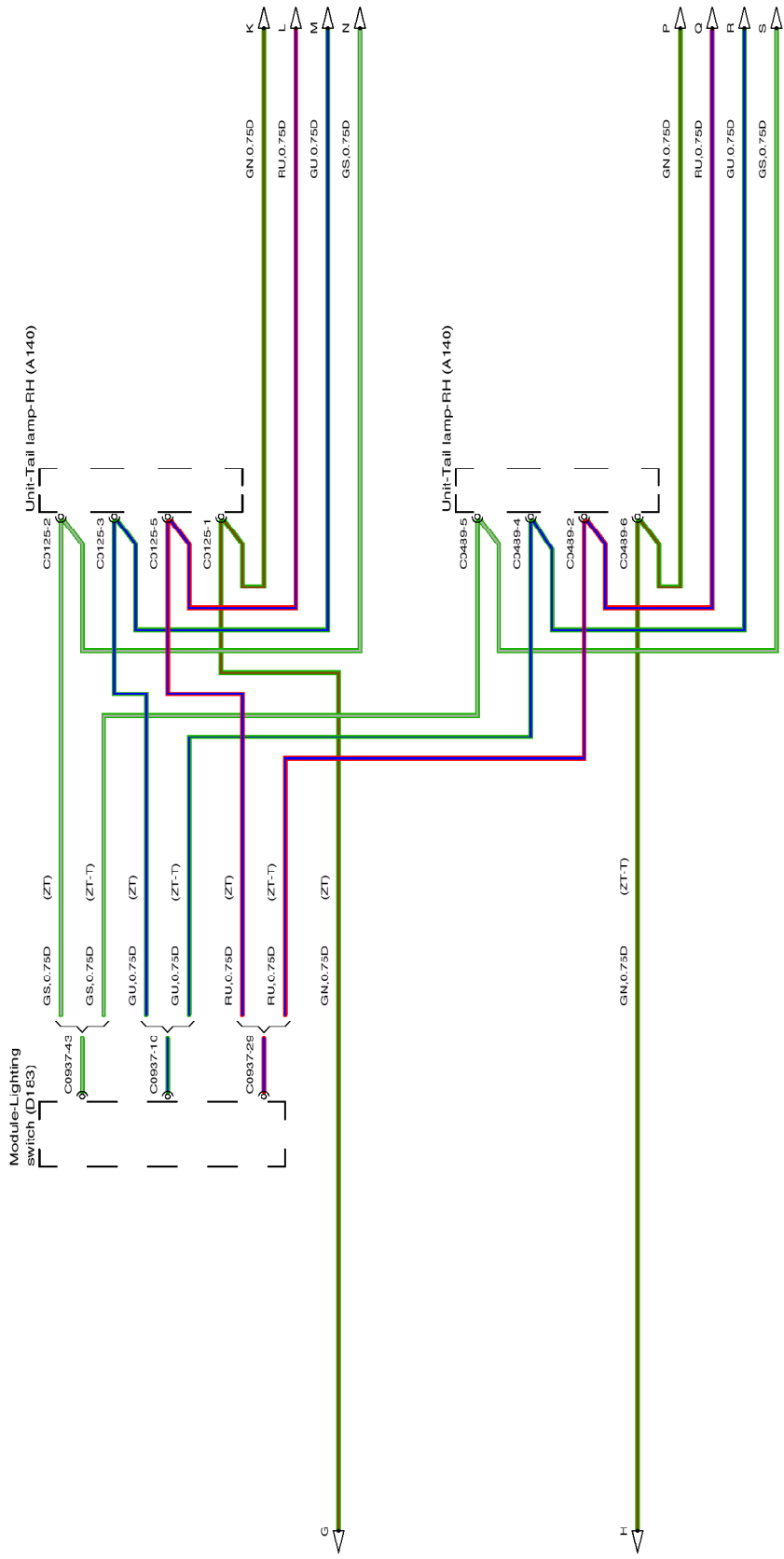

VWR404040-3

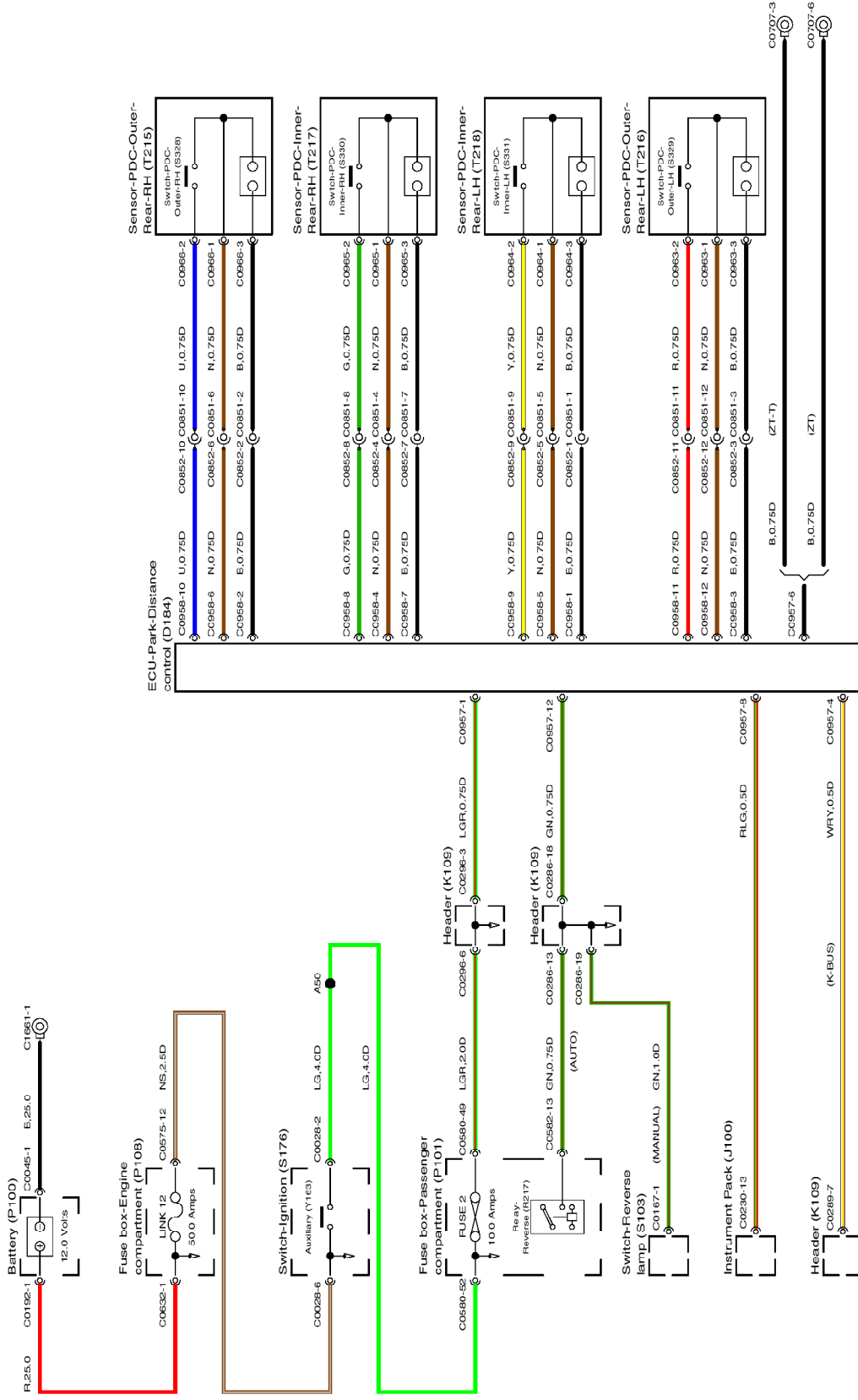

VWR403700-1

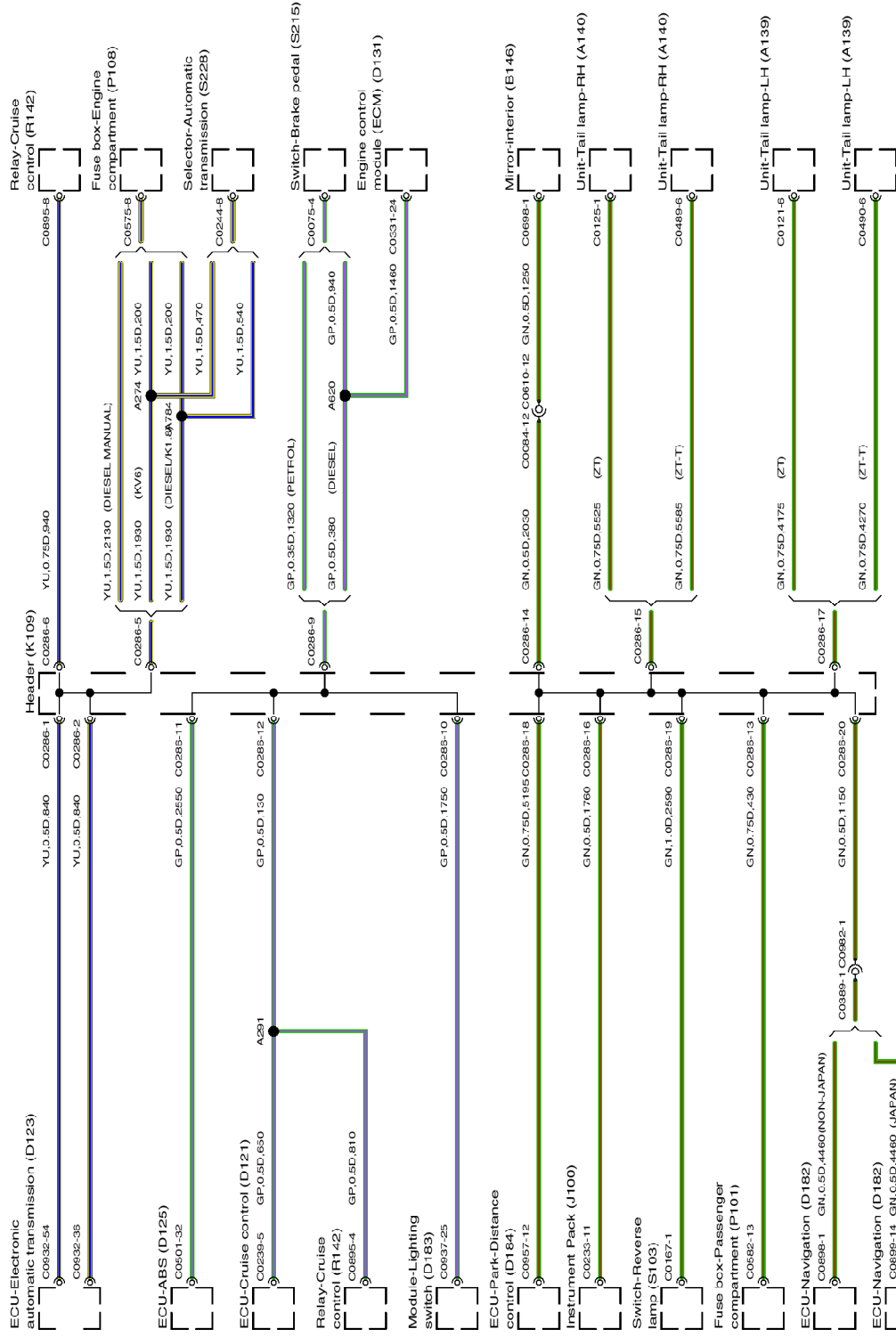

VWR403200-1

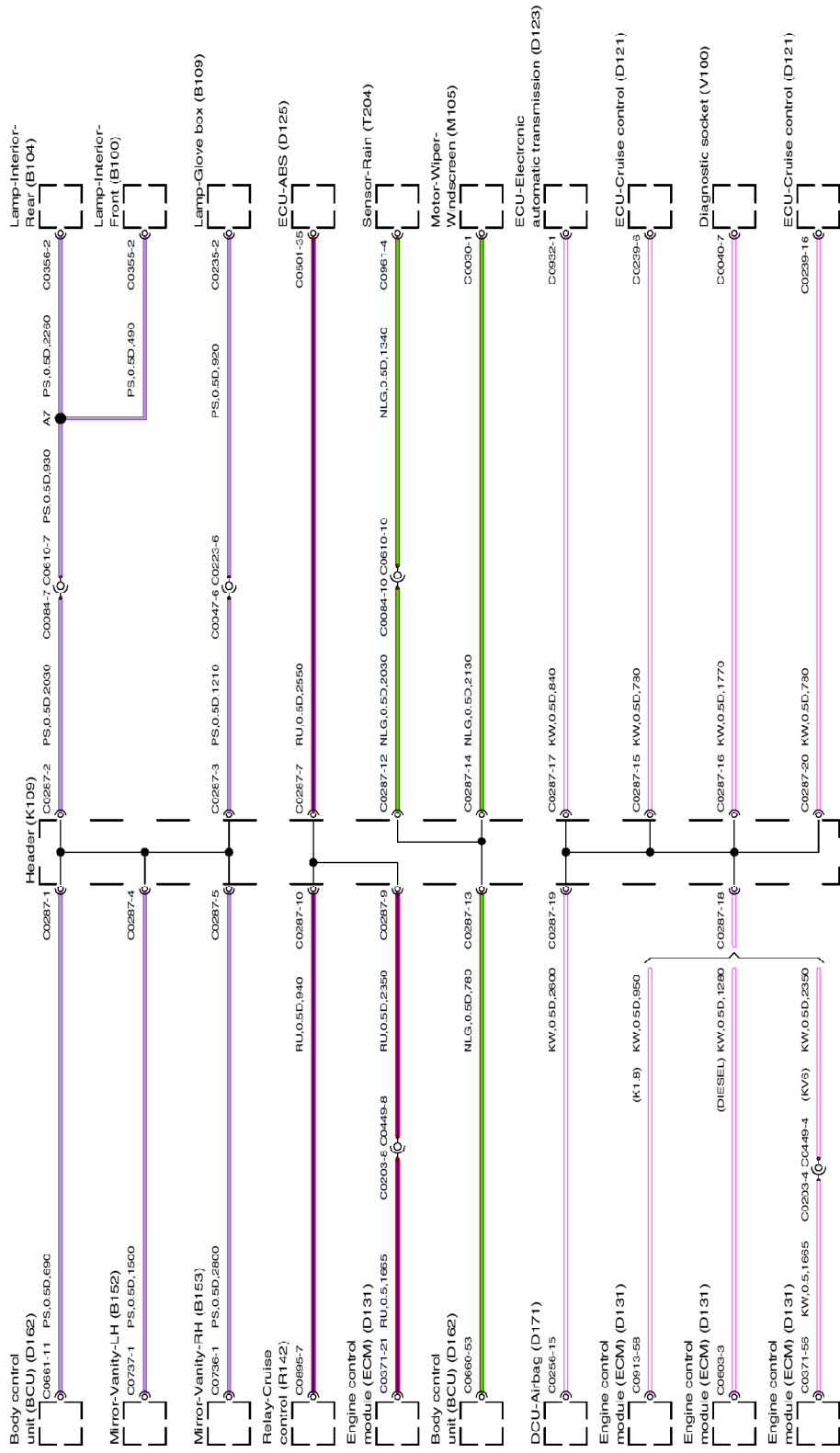

VWR403200-2

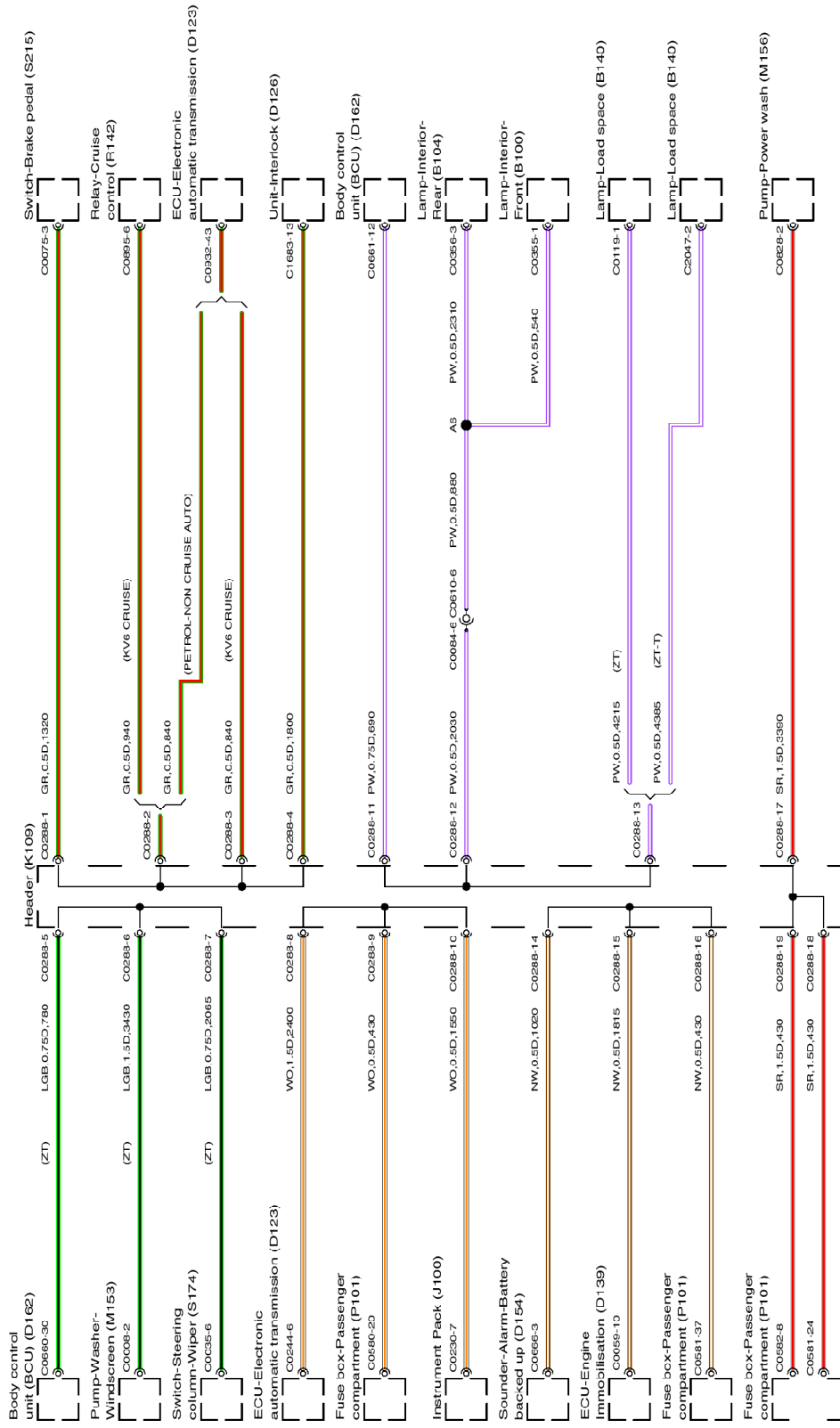

VWR403200-3

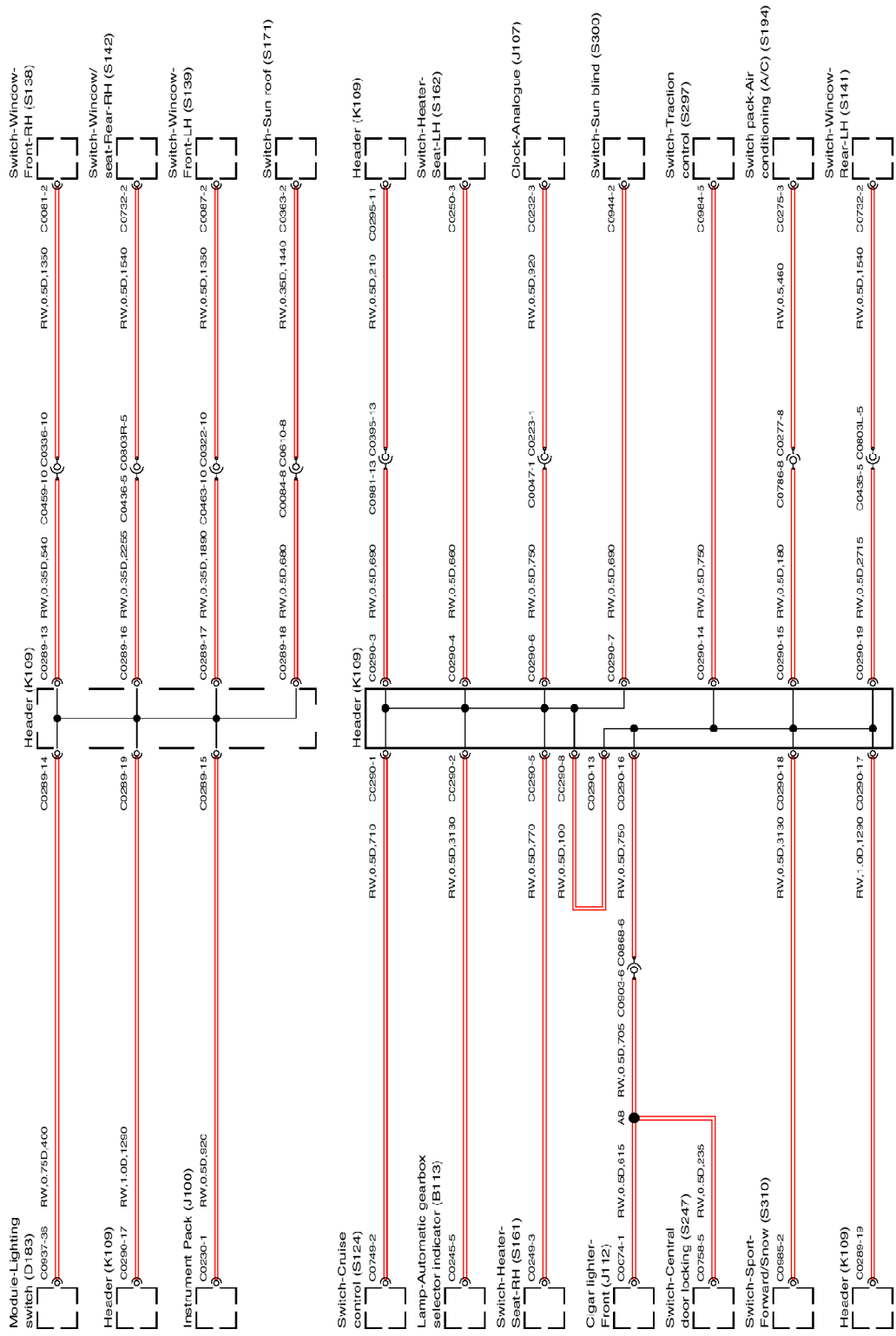

VWR403200-4

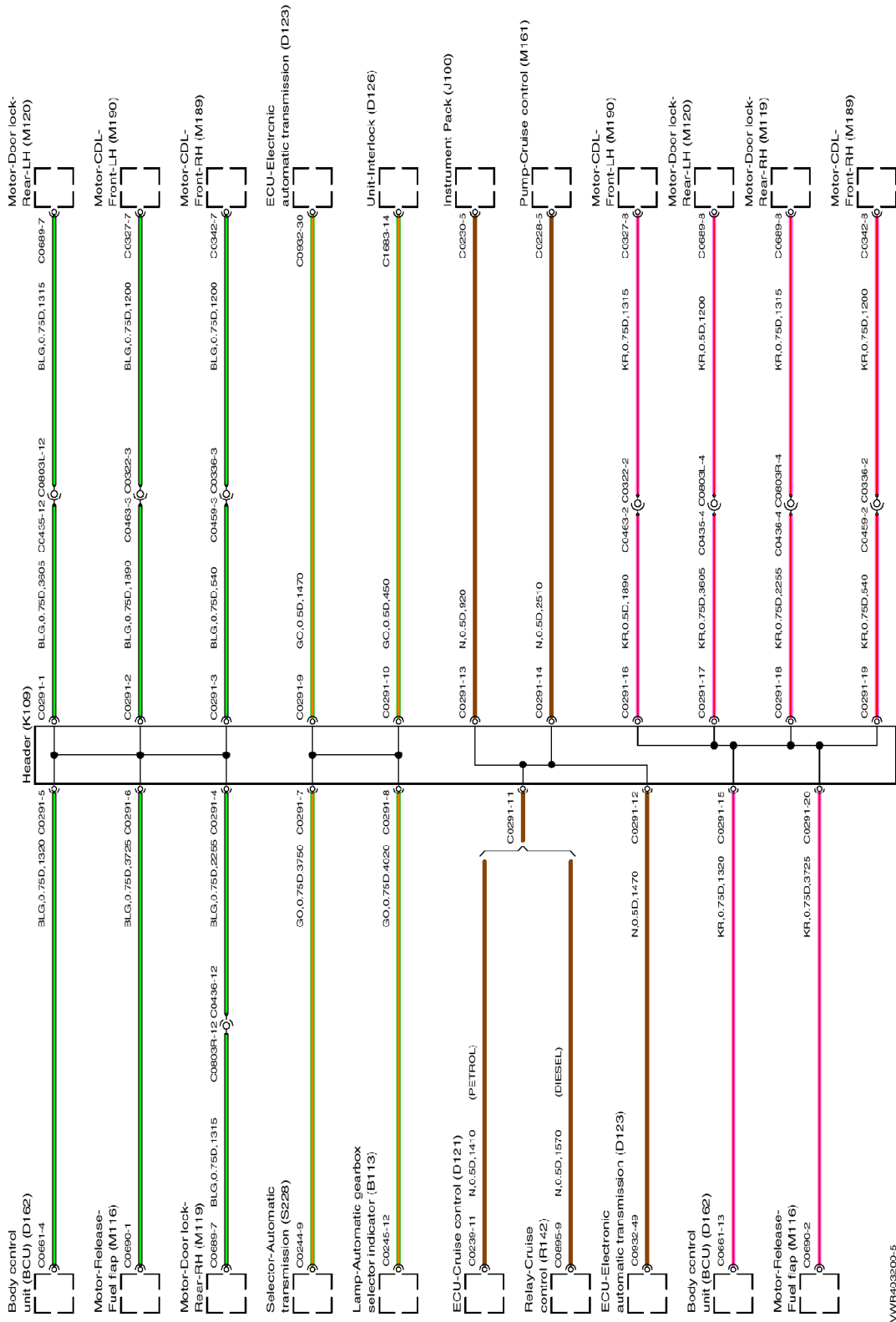

VWR403200-5

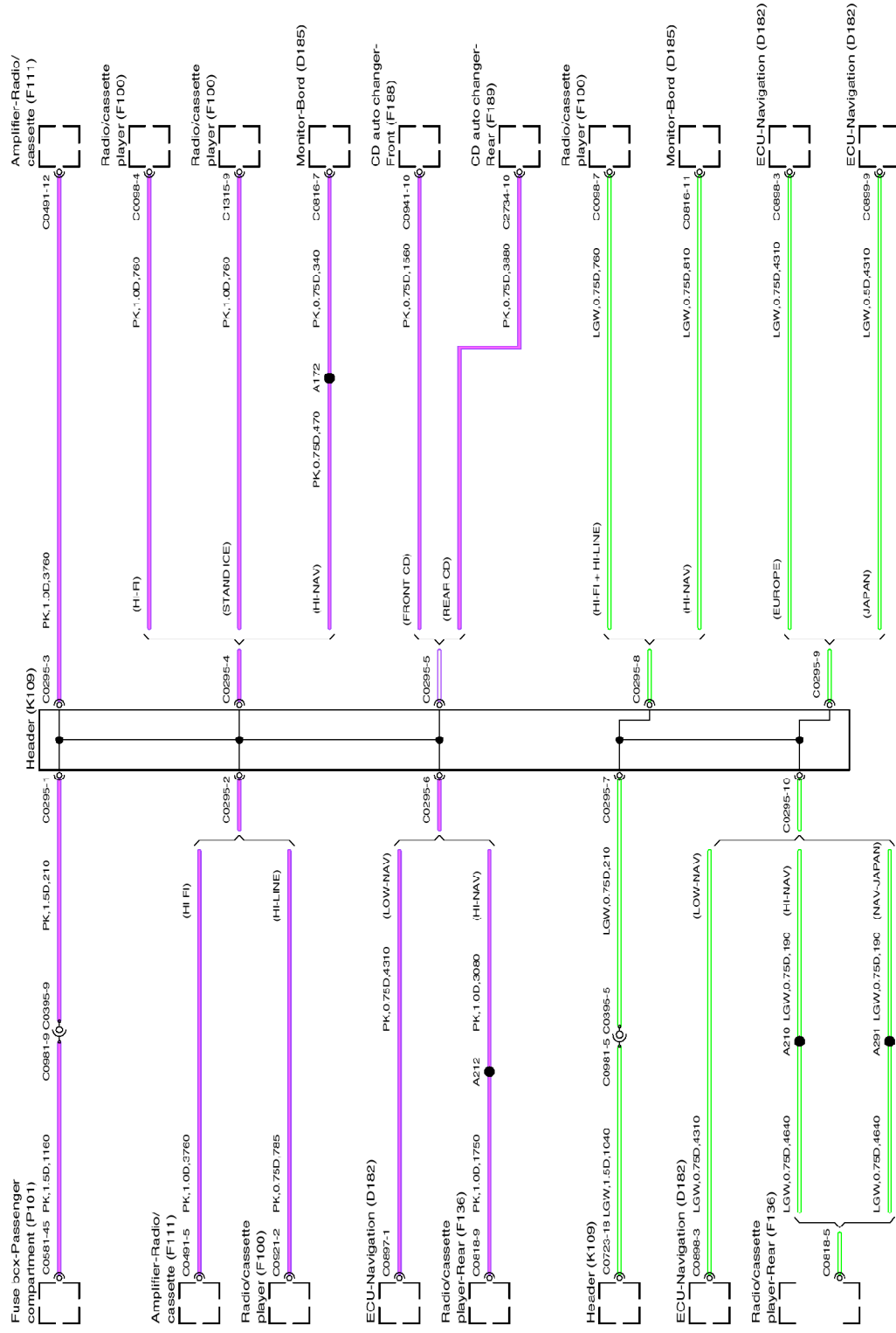

VWR403200-6

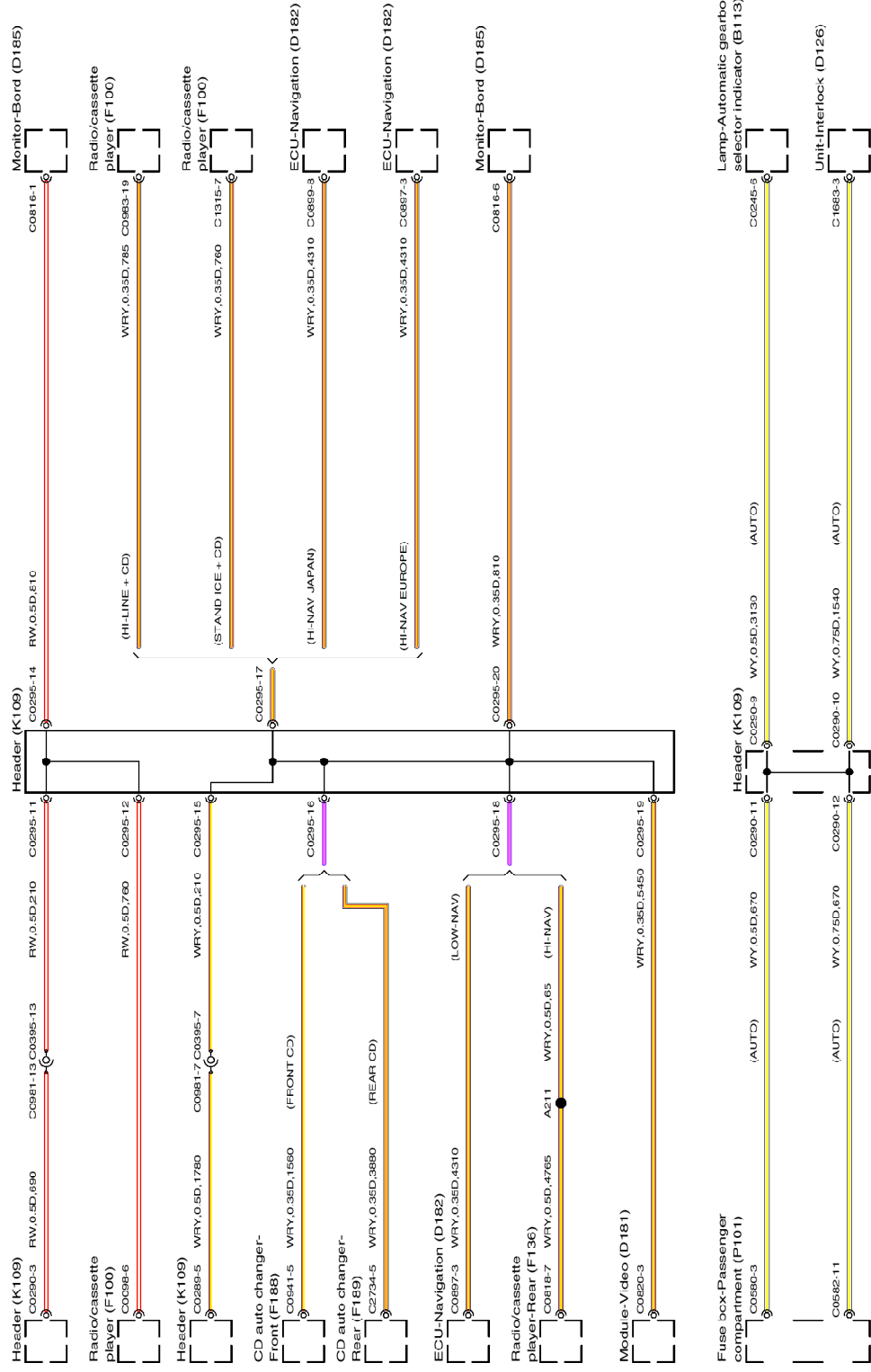

VWR403200-7

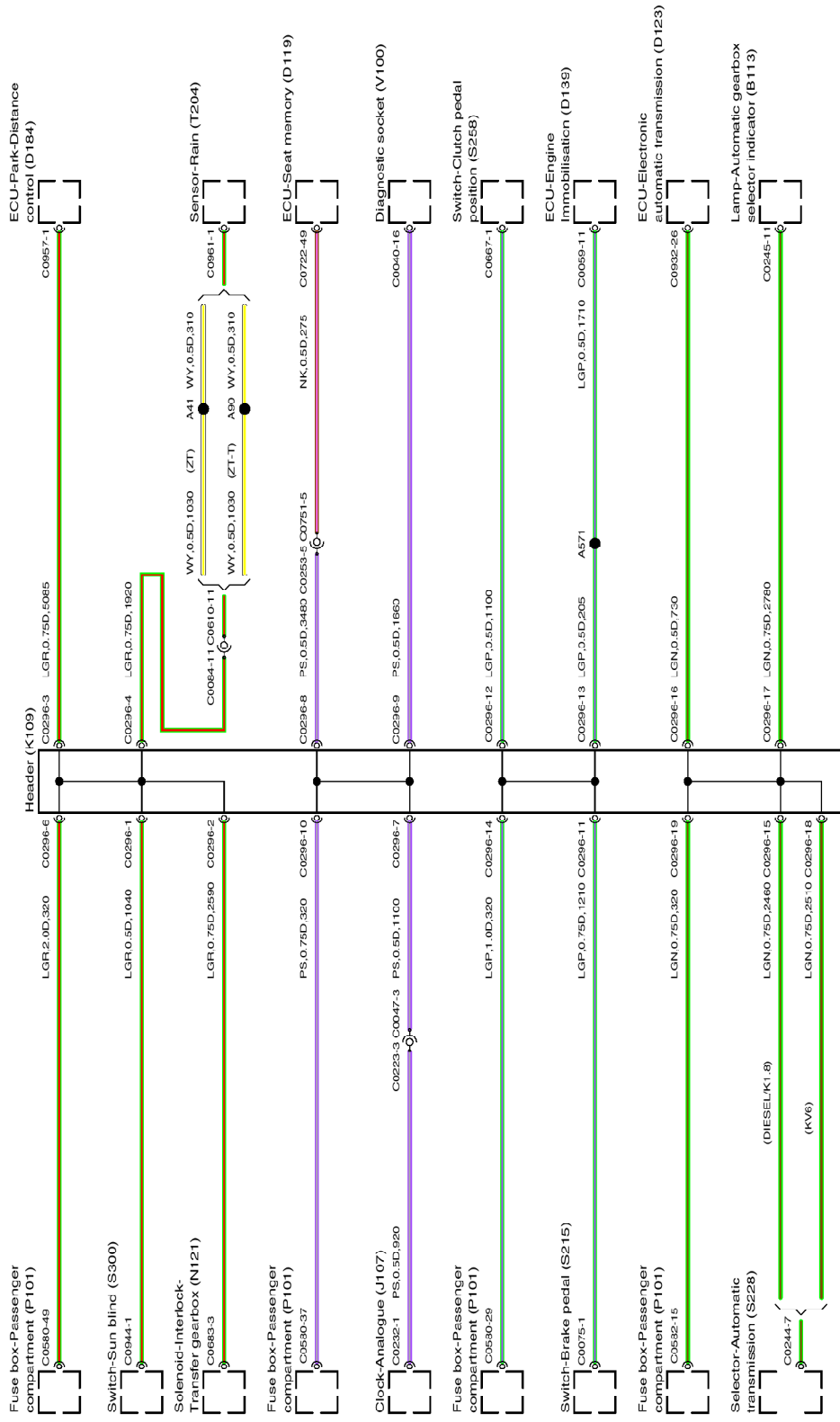

VWR403200-8

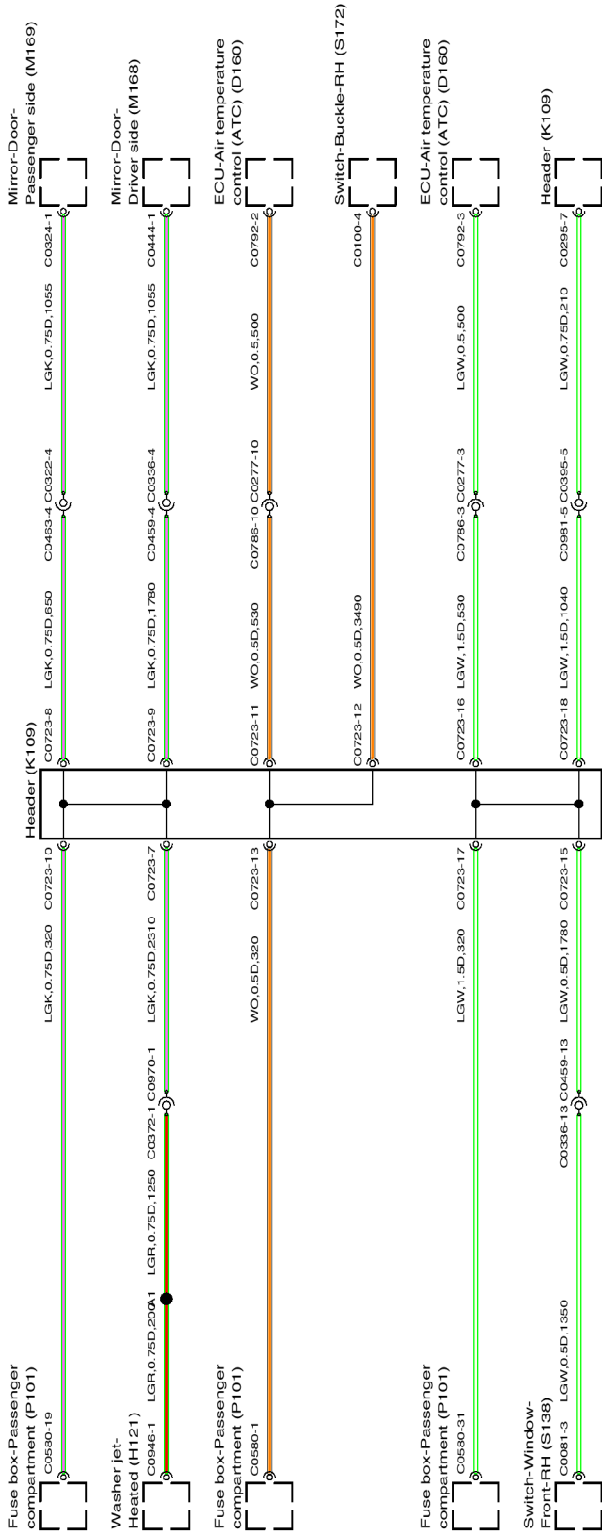

VWFR403200-8

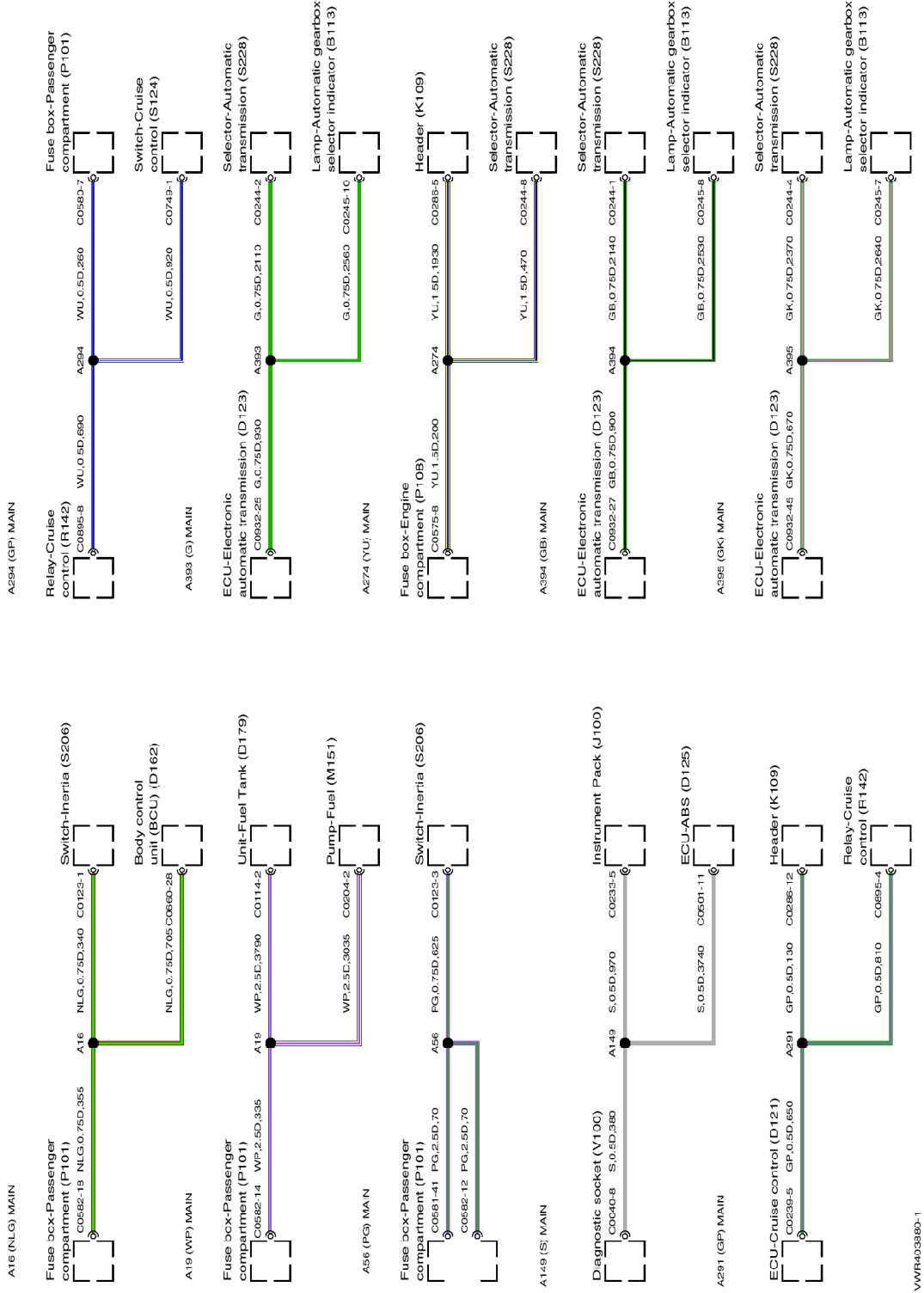

VWR403890-1

184 SPLICES AND CENTRE TAPS

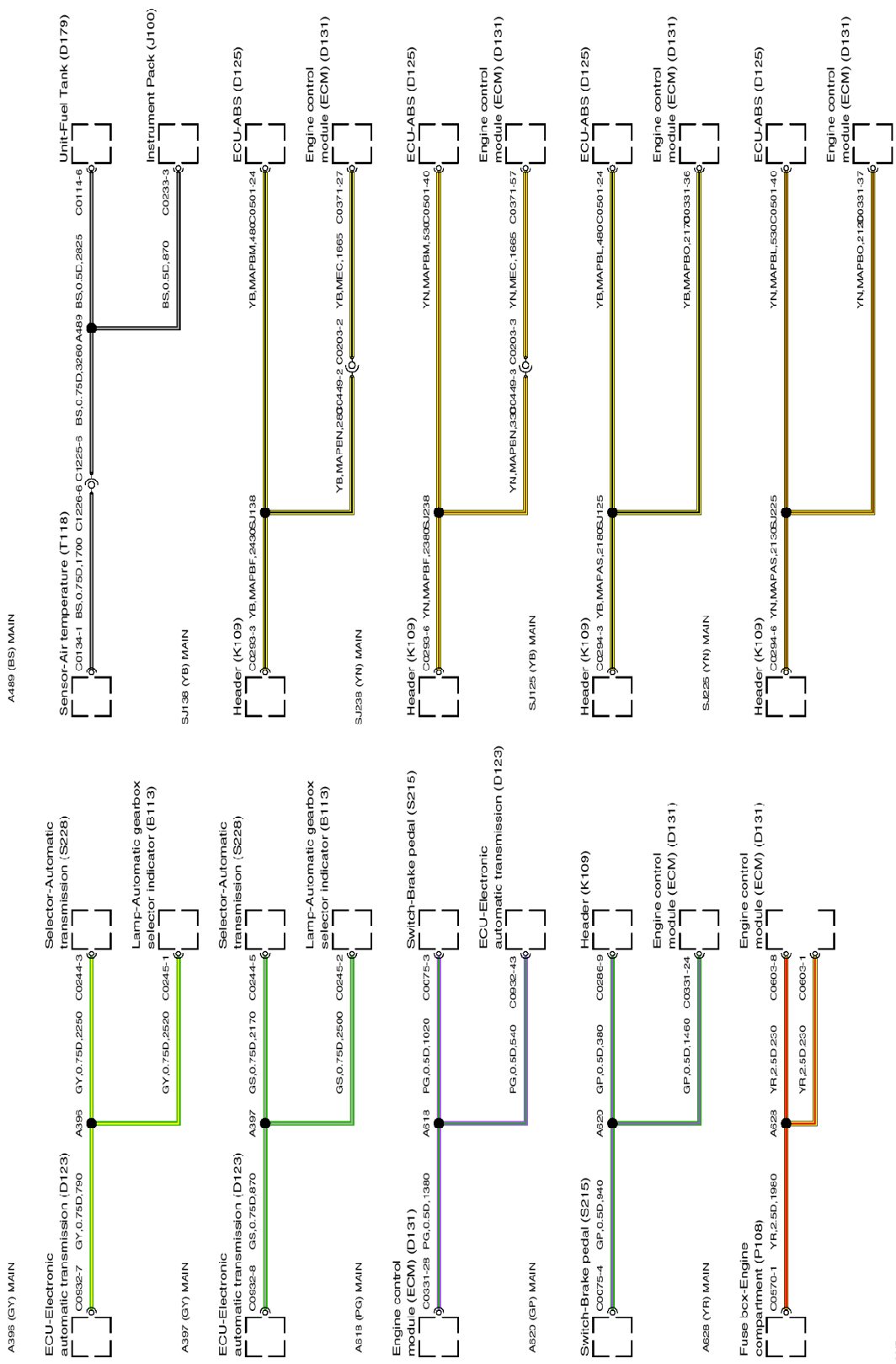

VWR403880-2

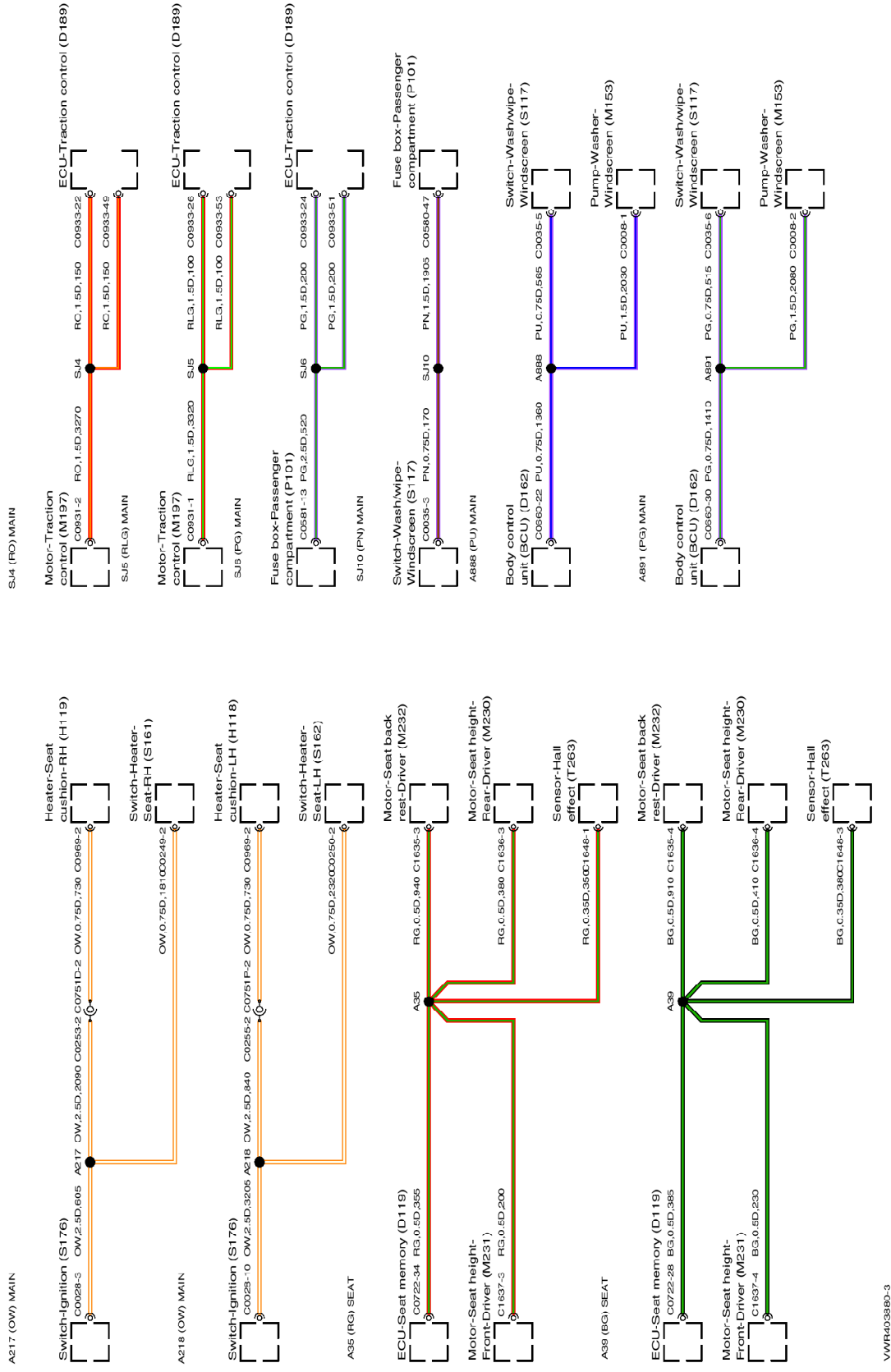

VWR403380-3

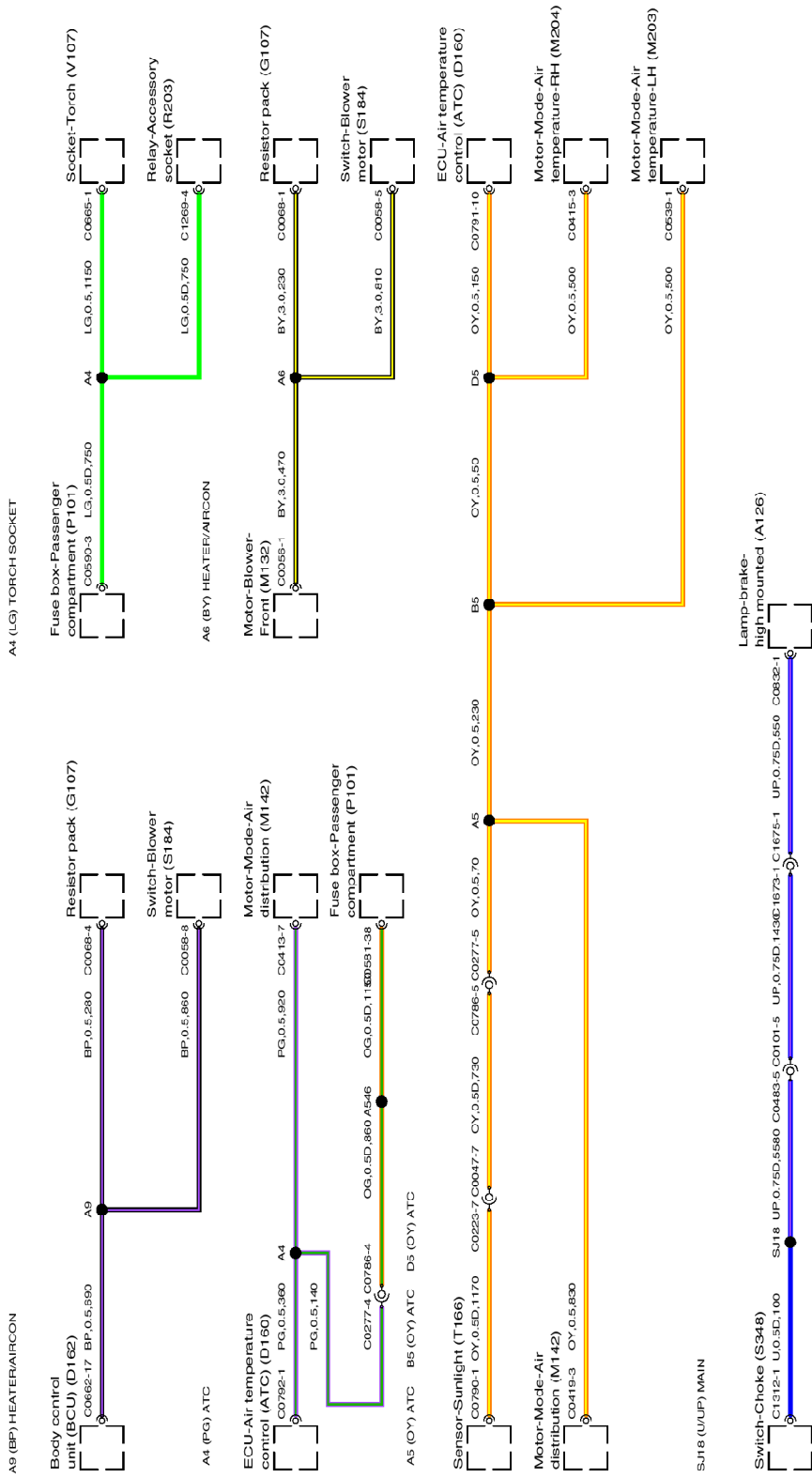

VWR403880-4

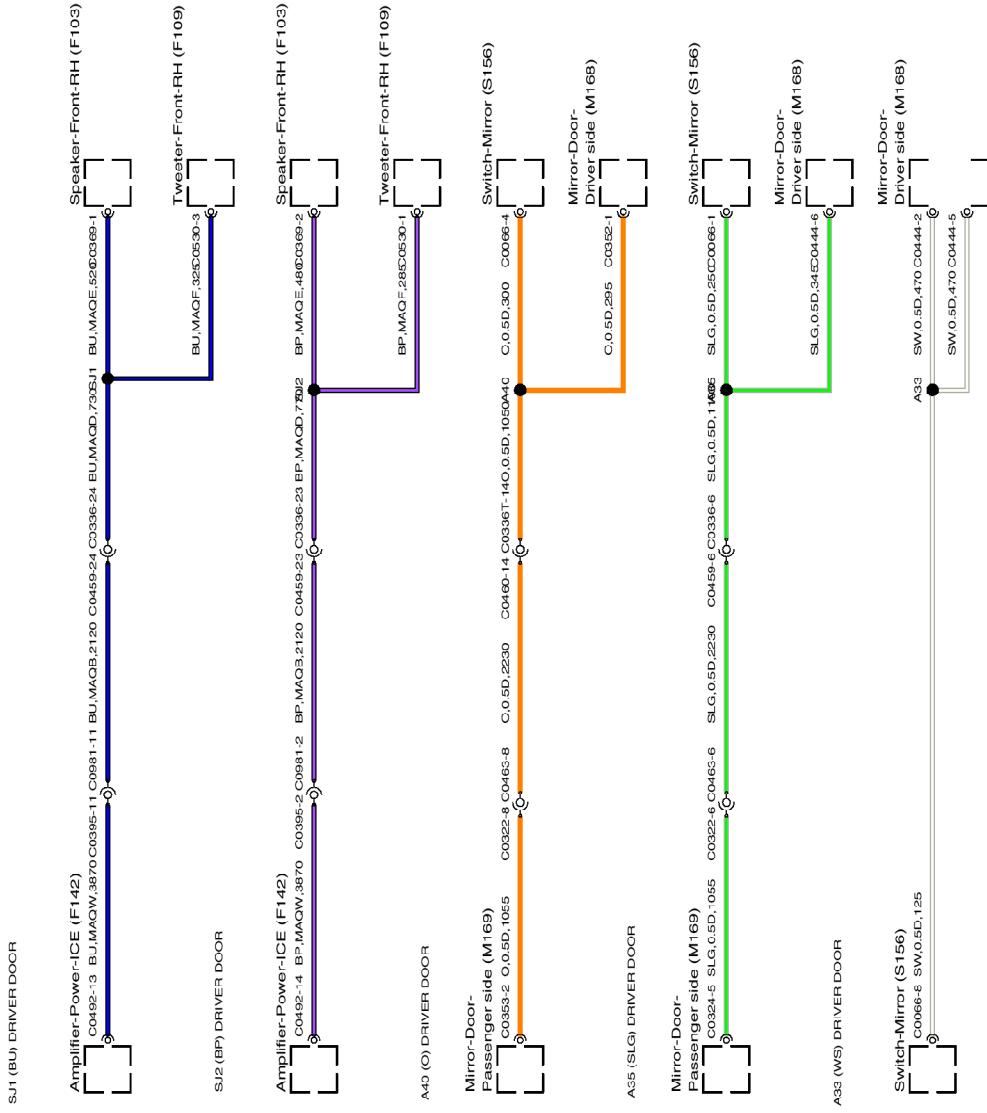

VWR403380-5

184 SPLICES AND CENTRE TAPS

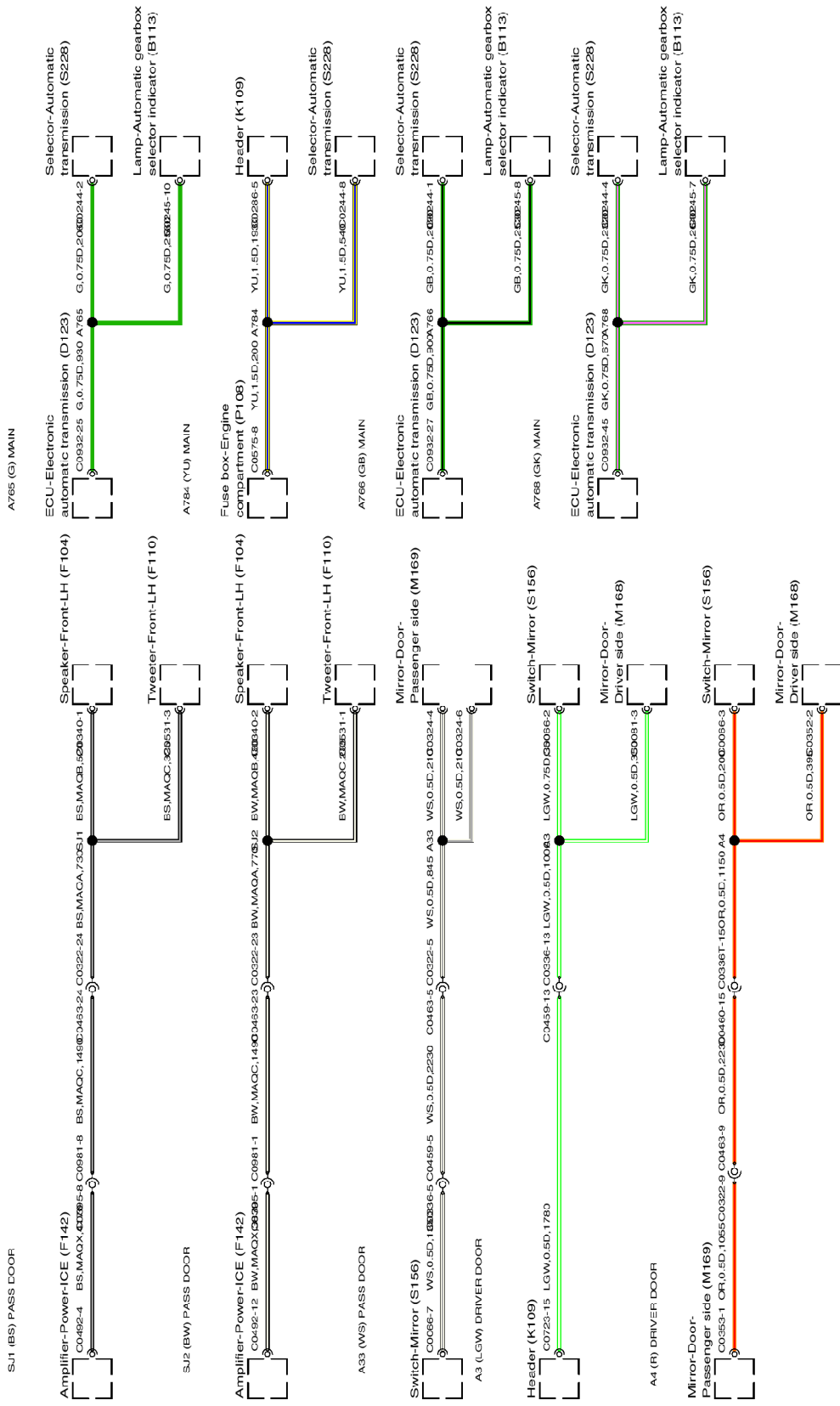

VWR4033890-6

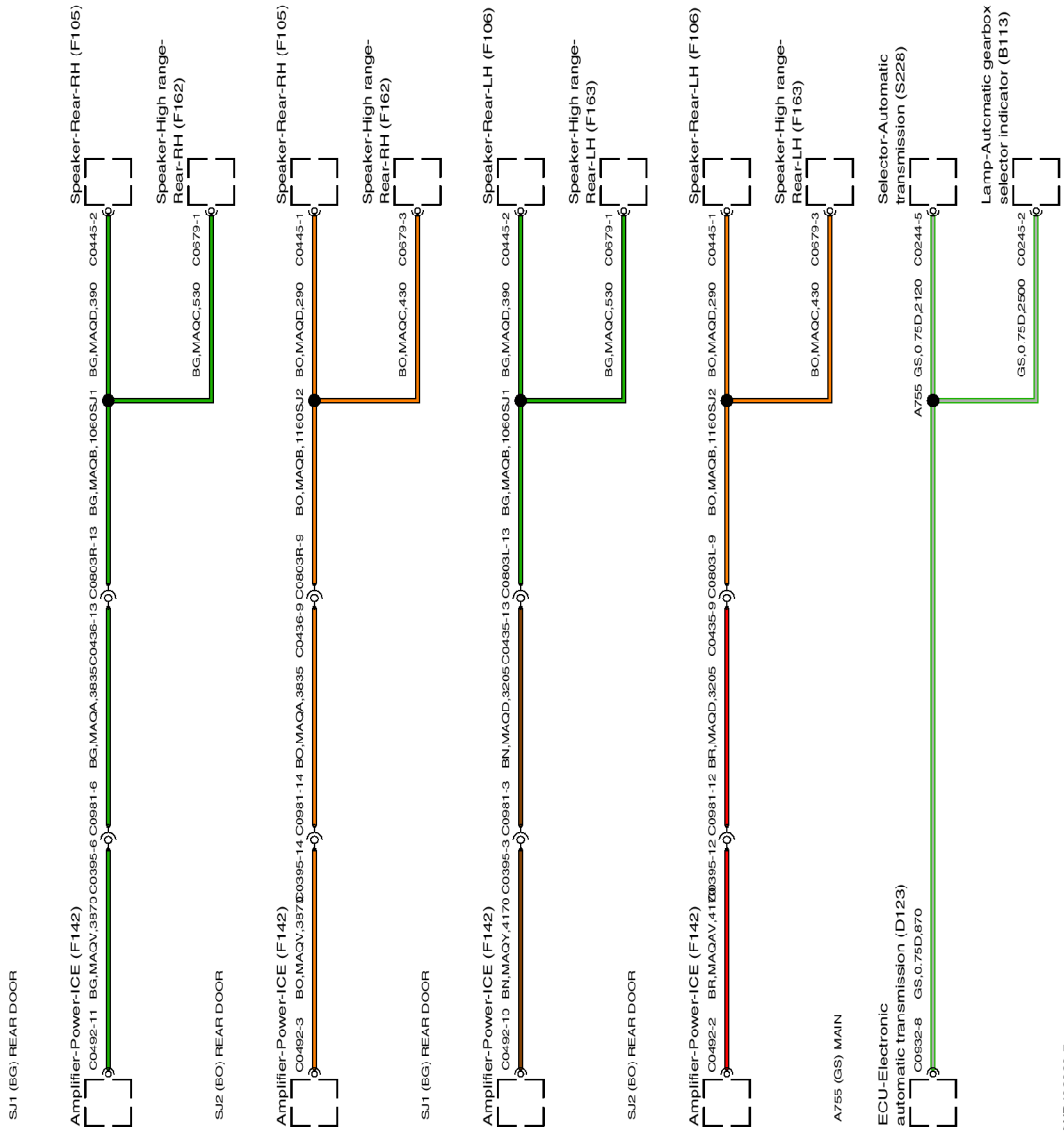

VWR403380-7

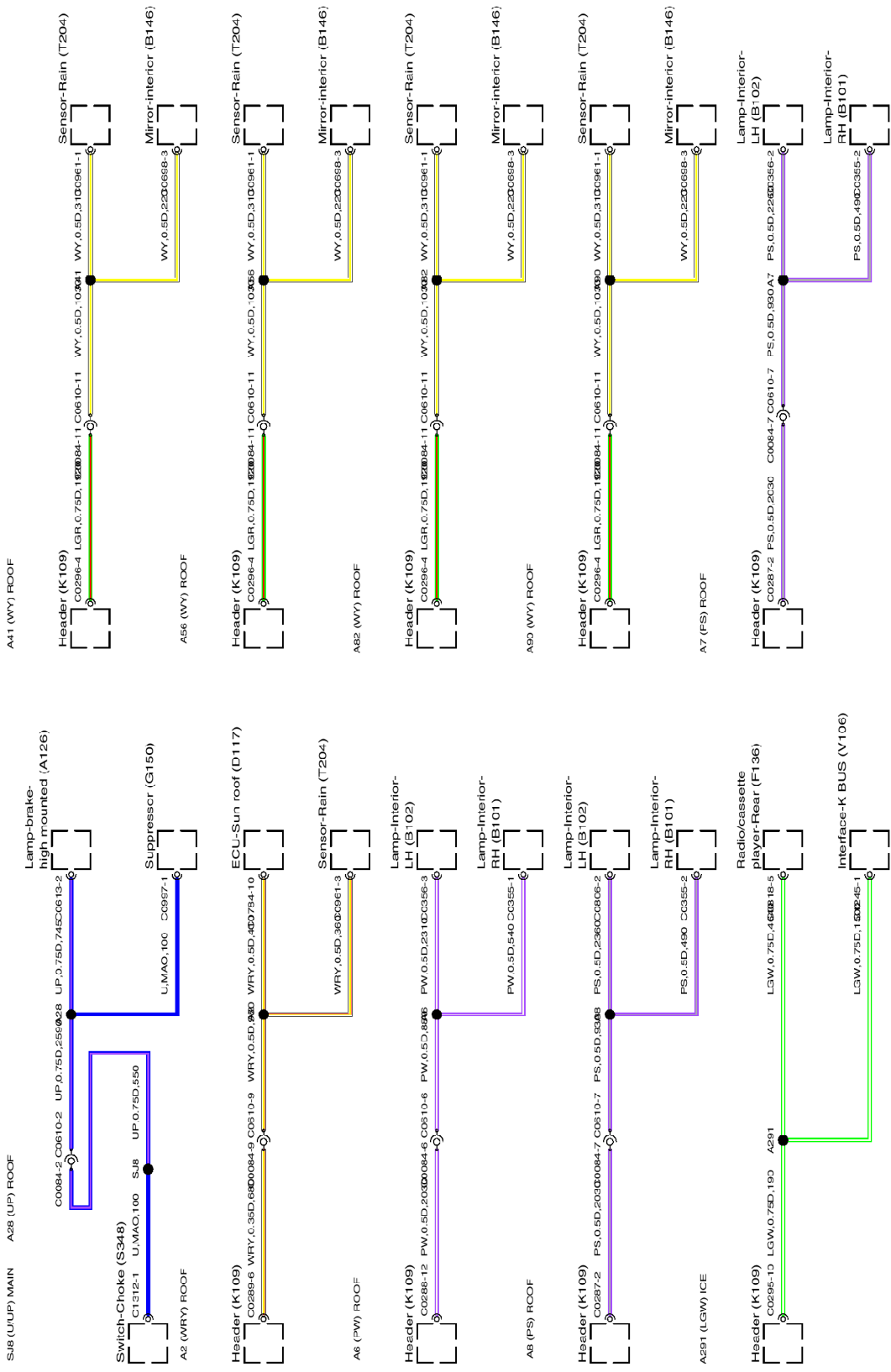

VWR403380-8

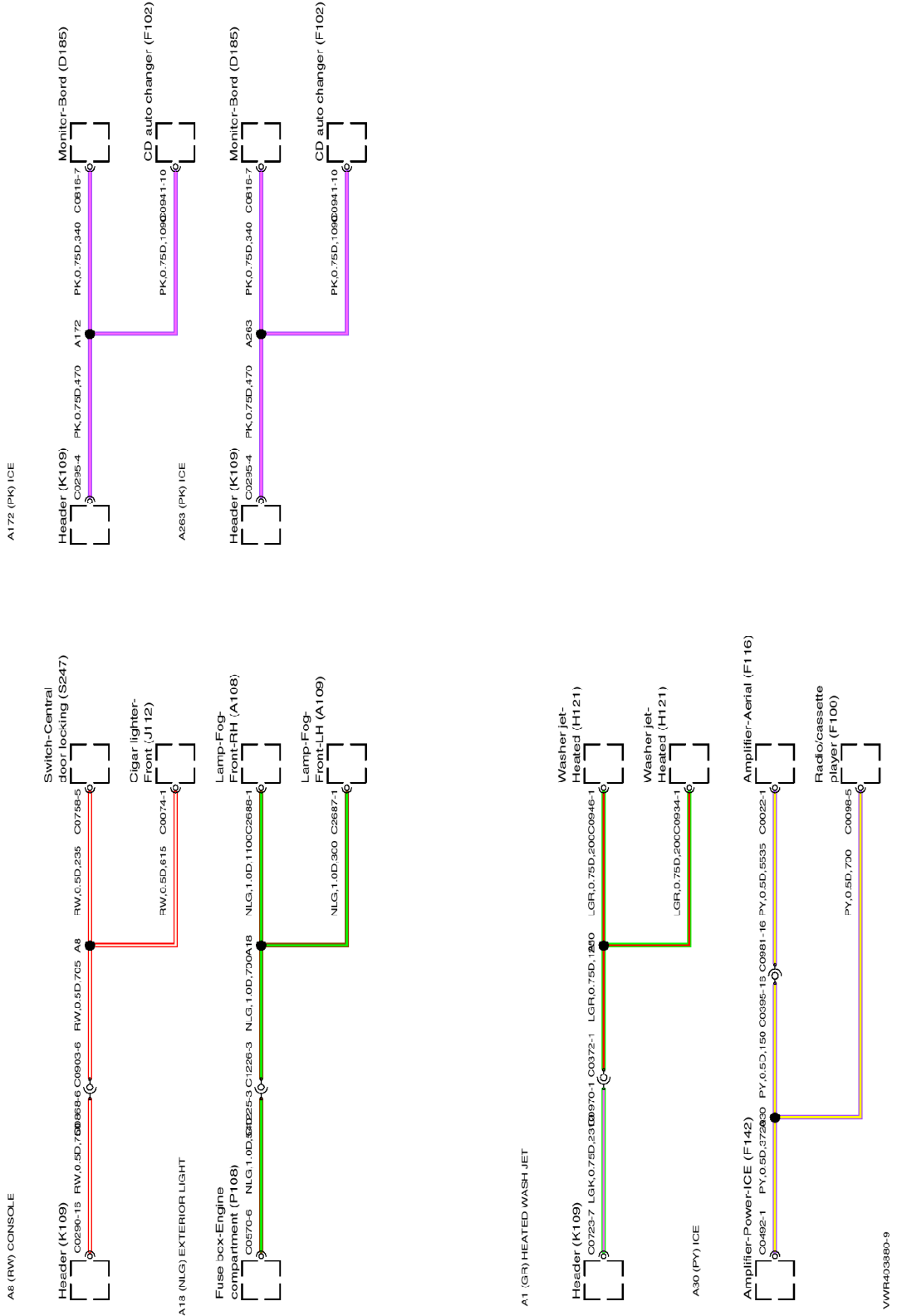

VWR403380-9

184 SPLICES AND CENTRE TAPS

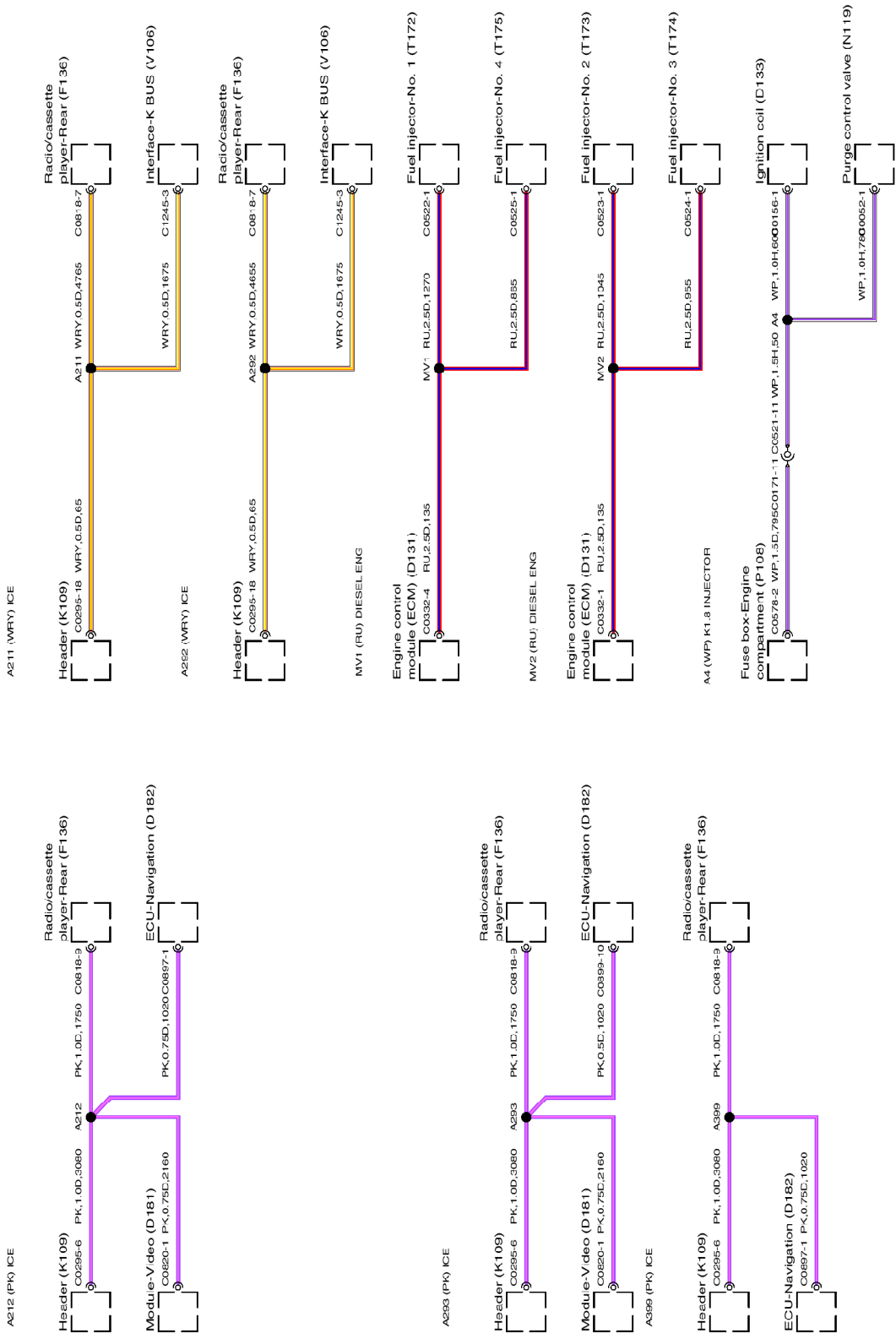

VWFR403880-10

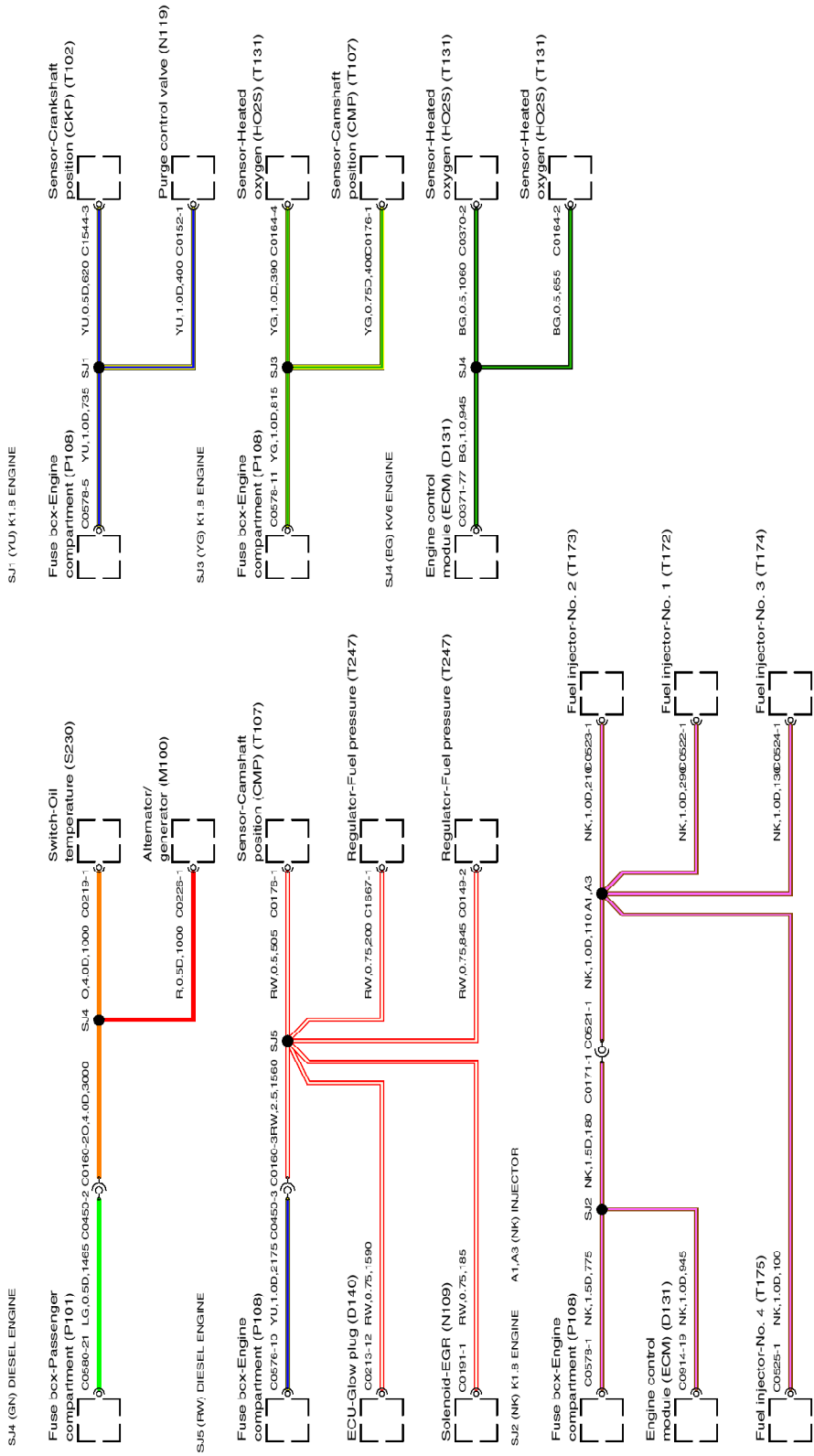

VWVFR403680-11

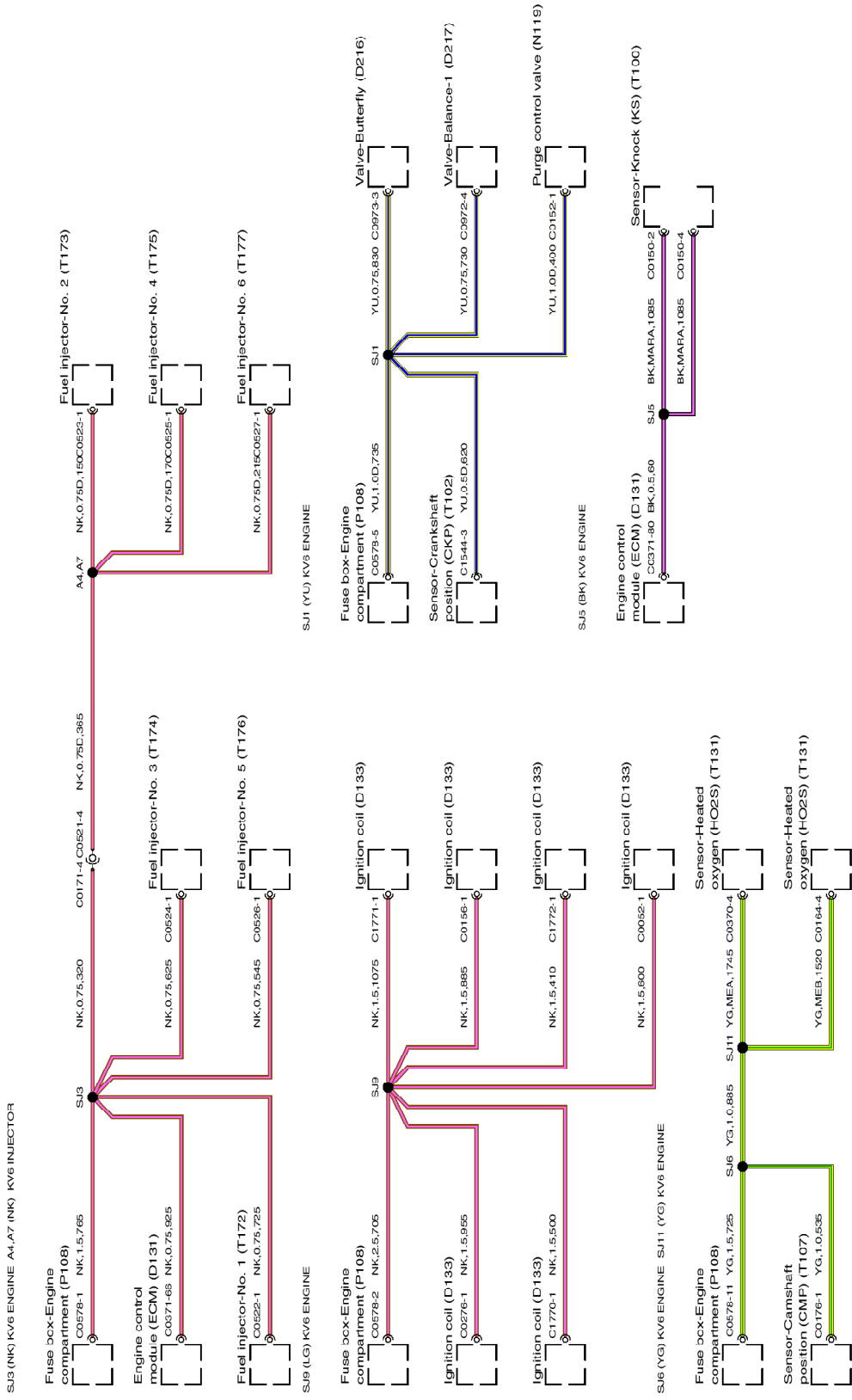

VW/F403680-12

