

8

**Sectional views of the services control valve with solenoid valves  
[tractor with Dual Command (2 Speed Power Shift)]**

- |   |  |
|---|--|
| <p><b>A.</b> Lever position with PTO synchronized with gearbox engaged.</p> <p><b>B.</b> Lever position with electrohydraulic PTO commanded by flywheel engaged.</p> <p>1. 4WD disengagement solenoid valve.</p> <p>2. Front or rear differential lock engagement solenoid valve.</p> <p>3. Front or rear differential lock delivery union.</p> <p>4. 4WD engagement line pressure gauge.</p> <p>5. Oil flow cut-off lever to solenoid valve (14), flywheel PTO clutch engagement, when engaged the PTO is synchronized with gearbox.</p> | <p>6. Cam to adjust valve stroke (11).</p> <p>7. 4WD engagement delivery union.</p> <p>10 External plug on outlet line.</p> <p>11 Oil delivery to solenoid valve (14) control valve rod.</p> <p>12 Bolt retaining valve (11).</p> <p>13 Valve seal and dust seal (11).</p> <p>14 Solenoid valve for oil flow to PTO clutch or clutch brake.</p> <p>15 Clutch brake delivery union.</p> <p>16 PTO clutch engagement cylinder delivery union.</p> <p>17 Outlet line to transmission casing.</p> <p>19 Solenoid valve support delivery union.</p> |
|---|--|

## DESCRIPTION AND OPERATION OF ELECTROHYDRAULIC PTO

The PTO installed on the tractor transfers motion to the transported or towed implements. It can be controlled:

- a) directly by the flywheel;
- b) synchronized with the gearbox.

The electrohydraulically engaged/disengaged PTO is available in three versions.

The description and operation is of the most complete PTO, i.e.: the 540 – 750 – 1000, for the other two versions see page 19 of the TL series service manual print 603.54.420.00.

The controls are located inside the cab on the right-hand side to the rear of the driving position.

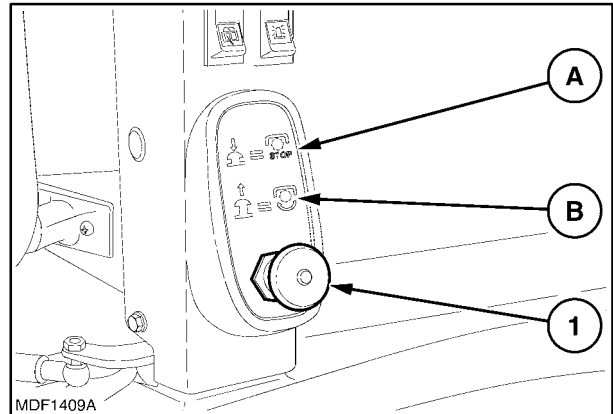

9

### a) PTO Independent electrohydraulically controlled power take-off (directly by flywheel)

To engage, proceed as follows:

1. Check that the knob (1, fig. 9) is in the STOP position (A), equivalent to oil delivery solenoid valve (1, fig. 12) de-energized.

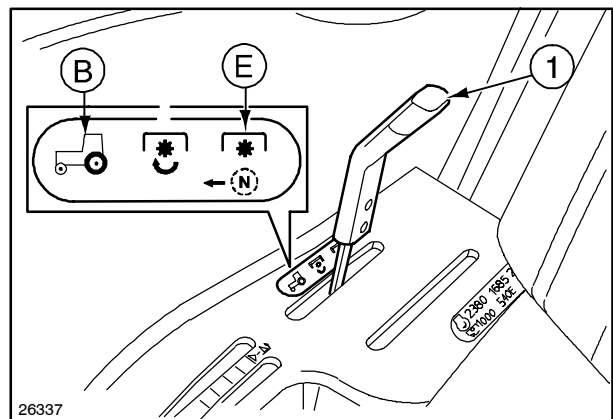

10

2. Move the PTO operation selection lever (1, fig. 10) onto (E).

In this position the sleeve (2, fig. 11) is freed from the toothed coupling of the gearbox gear (1), so only the PTO connected to the flywheel via the shaft (3) can work.

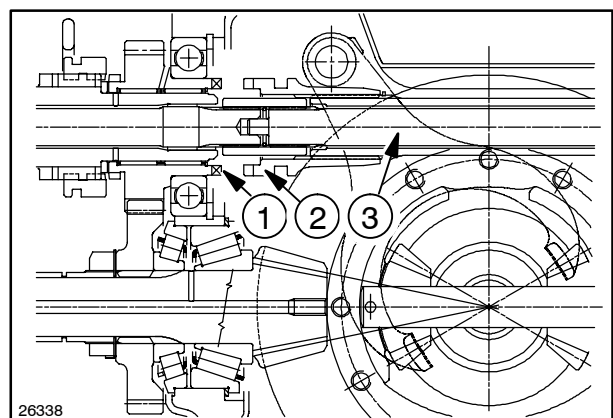

11

Moving the lever (1, fig. 10) onto (E) acts, via the control levers, also on the rod of the control valve (4, fig. 12), which takes on the above-mentioned position.

With the rod (4) in this position and the solenoid valve (1) deactivated, the control valve hydraulic diagram is as shown in fig. 12.

The line (11) receives pressurized oil from the pump and the control valve (4) directs the pressurized oil to the solenoid control valve (1).

With the solenoid valve (1) deactivated, the delivery line to the PTO clutch engagement cylinder (2) discharges and is connected to line (10), whereas the delivery line to the clutch brake (3) remains pressurized.

Under these conditions the PTO clutch is disengaged

and the clutch brake is engaged.

The hydraulic diagram shown in fig. 20, of print 603.54.420.00, illustrates this phase.

In this phase the delivery line (7, fig. 20) is discharged, so the lubrication control valve (8) takes on the position shown in fig. 20, permitting lubrication of just the rear bearing of the clutch (3).

The pressurized oil from line (11, fig. 12) can also be used for the services on lines (8) and (9).

The figure shows solenoid valves (5) and (6) deactivated.

With solenoid valve (5) deactivated, the delivery line (9) discharges and the 4WD engages.

With solenoid valve (6) deactivated the delivery line (8) discharges, with the relative disengagement of the front and rear differential lock.

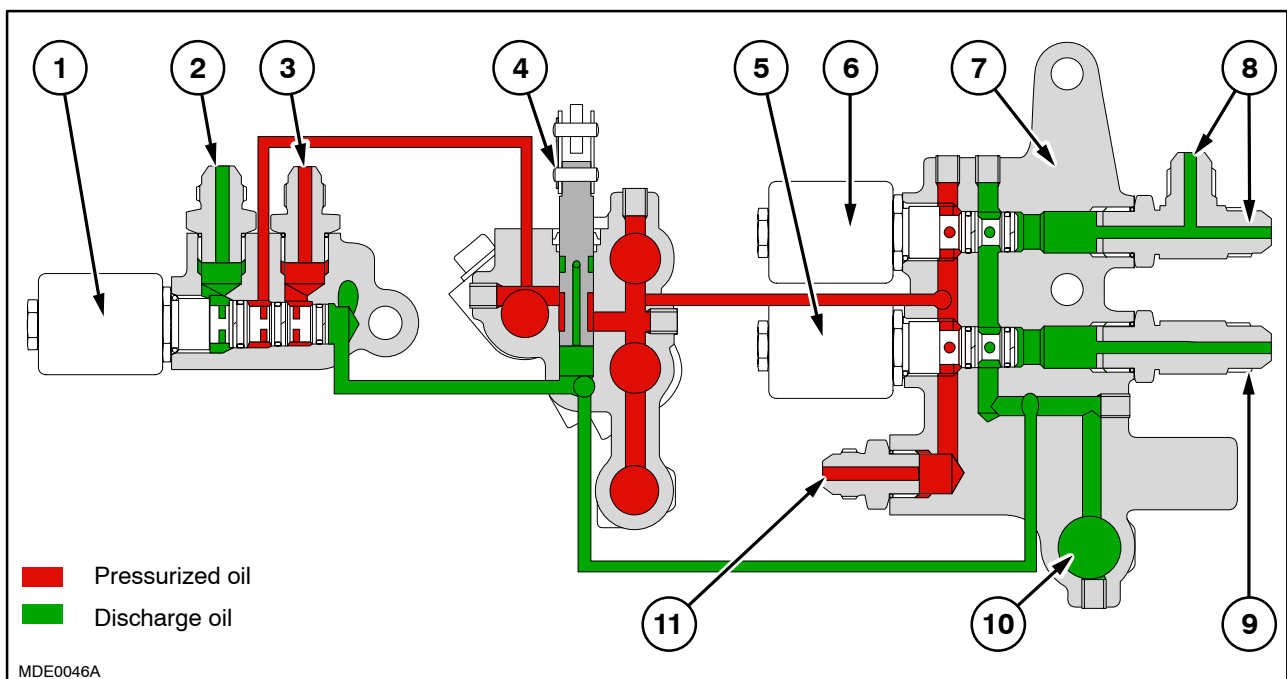

12

**Service control valve hydraulic diagram (points 1–2 page 13)**

1. Oil delivery solenoid valve to PTO clutch or clutch brake (deactivated).
2. Delivery line (discharging) to the PTO clutch engagement cylinder.
3. Delivery line (pressurized) to the clutch brake.
4. Control valve stem position (4) when the lever (1, fig. 10) is in position E.
5. 4WD disengagement solenoid valve.
6. Front or rear differential engagement solenoid valve.
7. Control valve support.
8. Delivery lines discharging (front and rear differential disengaged).
9. Delivery line discharging (4WD engaged).
10. Outlet line to transmission casing.
11. Delivery line from the pump to the services control valve (7).

- After having carried out operation (2, page 13), turn the knob (1, fig. 13), onto (B), equivalent to solenoid valve (1, fig. 15) energized. This transfers movement from the flywheel, via shaft (12, fig. 21, of the TL service manual print 603.54.420.00) and clutch (3), to the PTO grooved terminal.

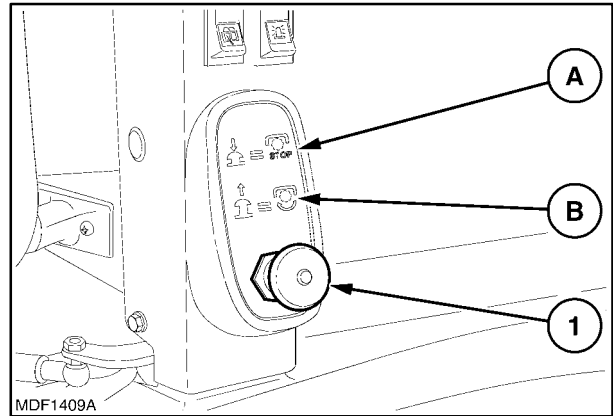

For the hydraulic operation derived from operations 2 and 3, see the description on page 16.

13

With operations 2 and 3 (previously described) the independent PTO is electrohydraulically engaged and directly controlled from the flywheel.

### Power take-off speed selection lever

Proceed as follows.

- Turn the knob (1, fig. 13) onto the STOP position (A) in order to disengage the clutch (3, fig. 21, of the TL service manual print 603.54.420.00) of the power take-off.
- Pull the stop knob (1, fig. 14) upwards and move the lever (2) onto sector (3) on the selected speed; this operation acts on parts (7 and 8, fig. 4, of the TL service manual print 603.54.420.00) and on the speed engagement sleeve forks (9).
- Turn the knob (1, fig. 13) onto (B) to re-engage the PTO clutch.

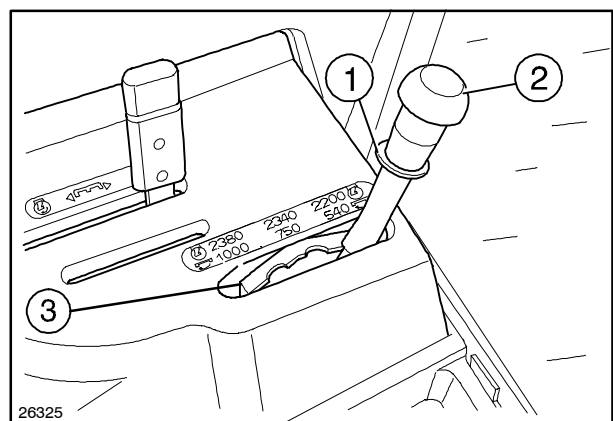

14

## DESCRIPTION AND OPERATION

With lever (1, fig. 10) on E and solenoid valve (1, fig. 15) energized, the hydraulic diagram of the control valve is the one shown in the figure 15.

The line (11) receives pressurized oil from the pump and the control valve (4) directs the pressurized oil to the solenoid control valve (1).

With the solenoid valve (1) activated, the delivery line to the PTO clutch engagement cylinder (2) is pressurized, whilst the delivery line to clutch brake (3) discharges and is connected to line (10).

The PTO clutch is therefore engaged and the clutch brake is disengaged.

The hydraulic diagram shown in fig. 21, of the TL ser-

vice manual print 603.54.420.00, illustrates this phase. In this phase the delivery line (7, fig. 21) is pressurized, so the lubrication control valve (8) takes on the position shown in the figure, permitting lubrication of the clutch front/rear bearings and the clutch.

The pressurized oil from line (11, fig. 15) can also be used for the services on lines (8) and (9).

The figure shows solenoid valve (5) and (6) activated.

With the solenoid valve (5) activated, the delivery line (9) is pressurized and 4WD is disengaged.

With the solenoid valve (6) activated, the delivery line (8) is pressurized and the front and rear differential lock is engaged.

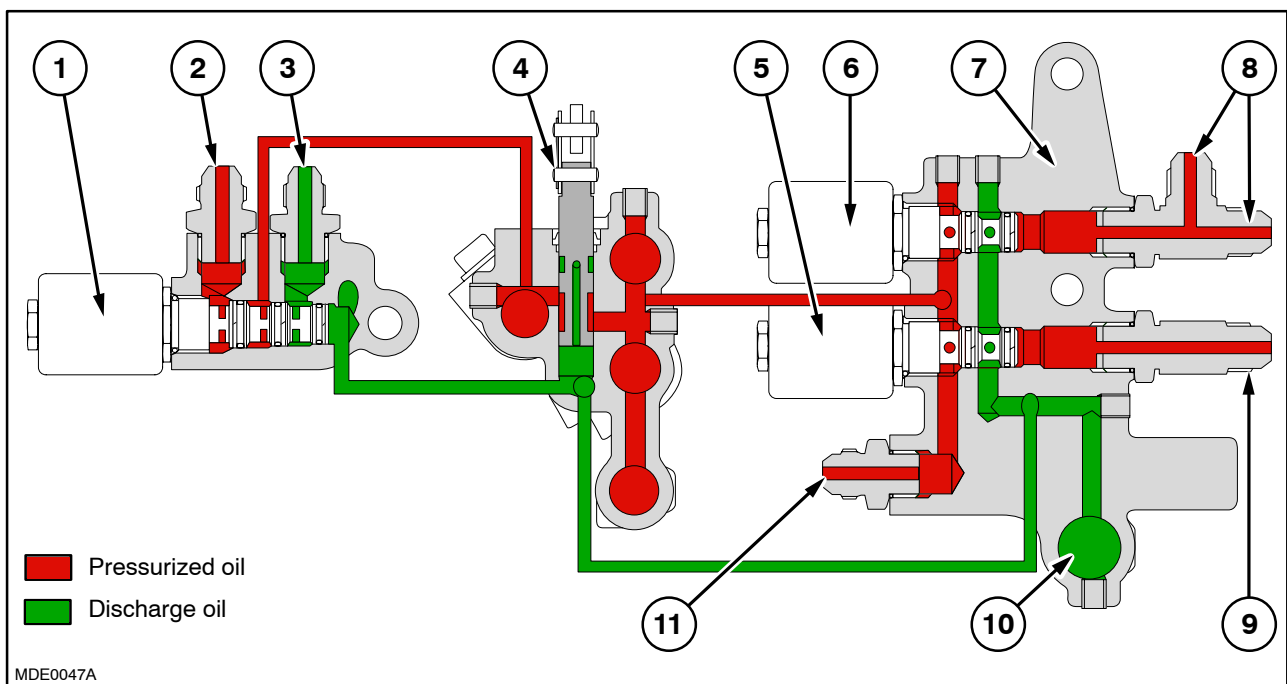

15

Services control valve hydraulic diagram (points 2 and 3 pages 13 and 15)

1. Oil delivery solenoid valve to PTO clutch or clutch brake (energized).
2. Delivery line (pressurized) to the PTO clutch engagement cylinder.
3. Delivery line (discharging) to the clutch brake.
4. Position of the control valve rod (4, fig. 15) when the lever (1, fig. 10) is in position A.
5. 4WD disengagement solenoid valve.
6. Front or rear differential engagement solenoid valve.
7. Control valve support.
8. Pressurized delivery lines (front and rear differential engaged).
9. Delivery line pressurized (4WD disengaged).
10. Outlet line to transmission casing.
11. Delivery line from the pump to the services control valve (7).