

DYNX REV A

Introduction

Let me introduce this nice Compressor/Limiter and Gate/Expander in the style of a British console comp/gate. I have designed this familiar unit in 500 API compatible format. It works in 500 VPR or 51X lunchboxes on the +16V and -16V rails. I used mainly the schematics of the Orange 4000 Dynamics Section with an extra THAT 1246 In- and THAT 1646 Outputstage. In my version I added Output Trim for getting more flexibility in colouring the sound with this Dynamics Module. This Guide will help with setting up this nice Comp/Gate. Have Fun!

TABLE OF CONTENTS

Introduction	1
Functions	2
Stuffing Boards	3
Potentiometers, Switches and LEDs	4
Final Assembly	6
Calibration	7
PCB layout for reference	9
Schematics	10
Bill of Materials (BOM)	11

DISCLAIMER: Proceed at your own risk. I am not liable for any damage, harm or loss of any kind resulting from the assembly and/or use of this PCB set. Safety provisions should always be exercised whenever working with any electronics. The following instructions are guidelines only. I can make no guarantee of the accuracy of contents contained within this document.

Functions

When turned to 1:1, the compressor/limiter section is inactive. Turning the control clockwise increases the compression ratio, giving a true limiter at the fully clockwise position. The compressor normally has an 'over-easy' characteristic.

Provides a faster attack time (3mS for 20dB gain reduction). When off the attack time is slower and less aggressive (30mS for 20dB gain reduction).

Sets the time constant (speed) with which the compressor returns to normal gain settings once the signal has passed its maximum.

Determines the depth of gating or expansion. When turned fully anti-clockwise, this section is inactive. When turned fully clockwise, a gate depth or range of 40dB can be obtained.

Normally, a controlled linear attack time of 1.5ms per 40dB is provided. Press this button to select a fast attack time (100µs per 40dB). The attack time is the time taken for the Gate/Expander to 'open' once the signal level is above the threshold.

This determines the time constant (speed), variable from 0.1 to 4 seconds, at which the Gate/Expander reduces the signal level once it has passed below the threshold.

This set the Unit in to Stereo Link with a second unit connected in your Lunchbox. The VCA of the second unit will be controlled and interacts with the control voltage of this unit. LED activity will not be shown on the second unit.

The ON button switches the entire module in and out of circuit. (TRUE BYPASS)

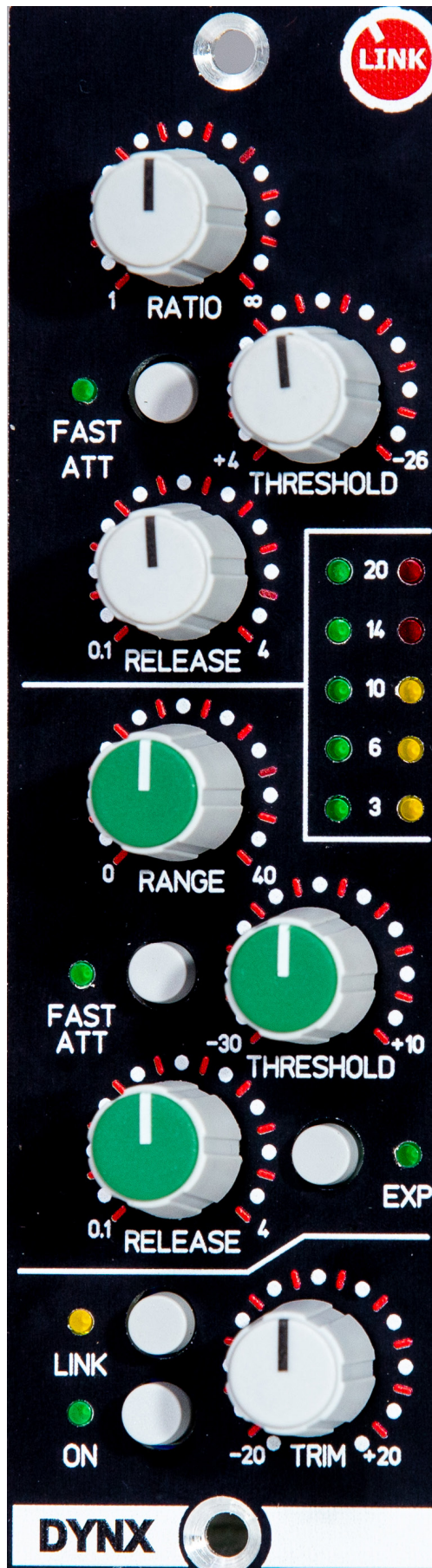

Whenever a signal exceeds the level set by this control, the compressor will start to act at the ratio set by the RATIO control

The two vertical rows of LEDs, located centre right, provide an indication of dynamics activity. The row of green LEDs to the left show Gate/Expander activity whilst those to the right indicate operation of the Compressor/Limiter.

Determines the level at which the gate opens or the level below which gain reduction begins (EXP selected), adjustable from +10dBu to -30dBu. Variable hysteresis is incorporated in the threshold circuitry which increases as the threshold is lowered. This is very useful in music recording as it allows instruments to decay below the open threshold before gating or expansion takes place.

Gate/Expander - This section can act as a 20:1 Gate or as a 2:1 Expander when the EXP button is pressed.

This is an Output Trim. You can level up or level down the whole unit by 20dB. This also works as a Makeup Gain.

Stuffing Boards

First Step is to place all Resistors and Diodes. Check your Resistors with the Multimeter or by Colour Codes. Check before Soldering if your Diode-Placement is right. Check for right Diode orientation before soldering! Also take special care about the 6V8 Zener Diode and 1N34A Diode.

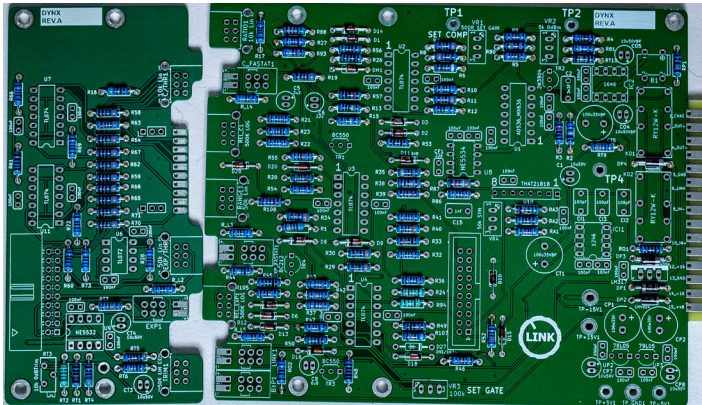

Now we change over to bigger parts like Relais, Voltage Regulator, Trimmers and Electrolyt Capacitors. Pay extra attention to the orientation of C6,CT4,CT3 ,CP7,C1,CP8,C9,C5,P1,CP2 as they are polarized. The other Capacitors(C04,C05,CT1,CT5) are NonPolarized/Bipolar so the Orientation doesn't matter. Also add the 1x3 pins on the Subboard. This is the place we later add the small LED Mini Board. After this step you can clean the boards. After cleaning boards with alcohol/water/your preferred method you can solder the trimpots. But don't clean after the Trimpots are installed. Switches, Potentiometers don't like cleaning and that can lead to problems with electrical contact. So I normally don't clean after this step again. Let the Boards dry enough after you cleaned them.

After Placing and Soldering all Resistors, we solder the next bigger parts like IC-Sockets, VCA-Socket Bridge Rectifier and small Capacitors, like 100nF and 22pF.

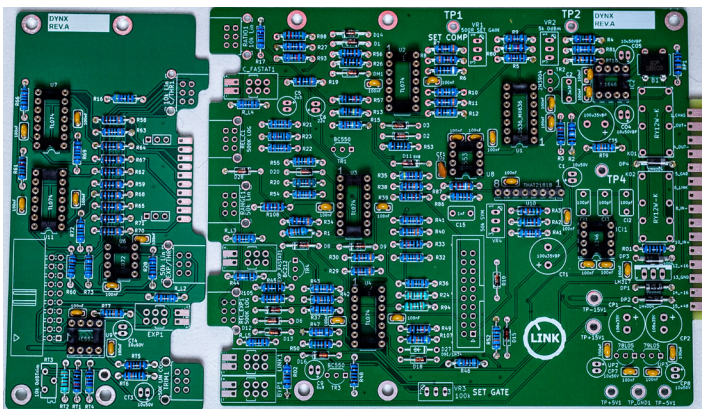
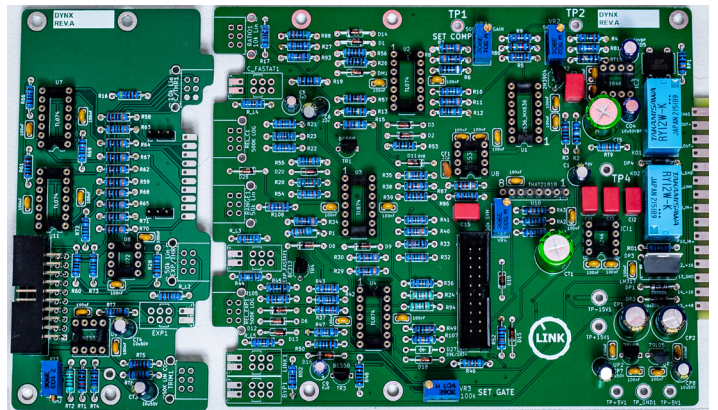

After that Step solder all Wima Capacitors and Board Connectors like on the pictures.

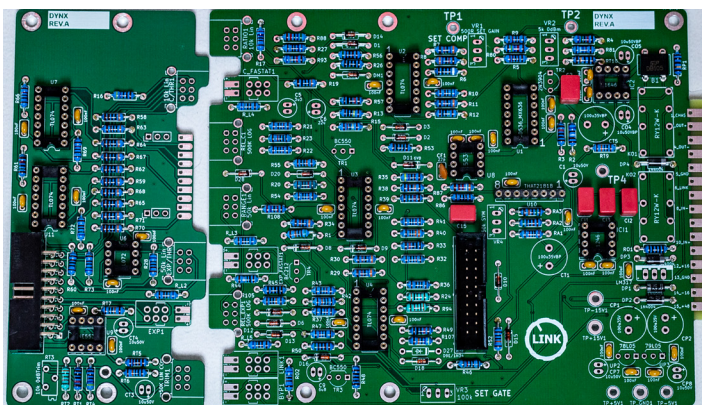

Potentiometers, Switches and LEDs

Now we are heading to the backside of the boards. First we cut all leads that are too long, cut them as short as possible. We will be doing this process later also with the potentiometers since we need to make sure that this Dynamics module don't touch any neighbour modules of any kind.

After we shortened all the pins we install all pots on this board at the same time. Get all pots on the PCB and solder just one pin in the middle and press the POT as much as possible on to the PCB. After Soldering one Pin make sure the alignment of the pot is flush and straight. You can check that with printed silkscreen on the PCB. We have 4 different Potentiometers for this Project. There are 2x50K Linear and 1x50K Linear with Center Detent. So check that you have them sorted alright. The other Potentiometers are 500K Logarithmic and 10K Linear.

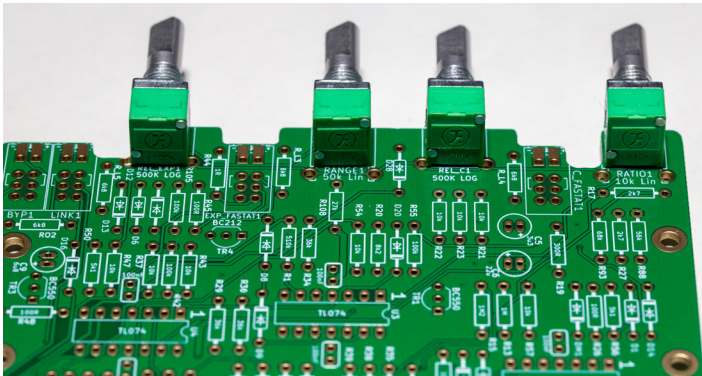

After having one pin of each pot soldered we add the bracket. The direction of the bracket is shown in the picture below. After having all pots screwed to the bracket, we can solder all pins, then we need to cut the pins.

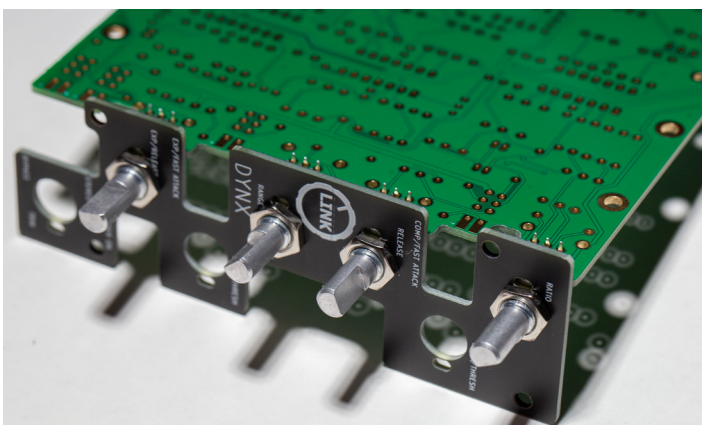

I cut all the pins before soldering, then they look better, but you can also cut them afterwards. Then unscrew the board from the bracket again.

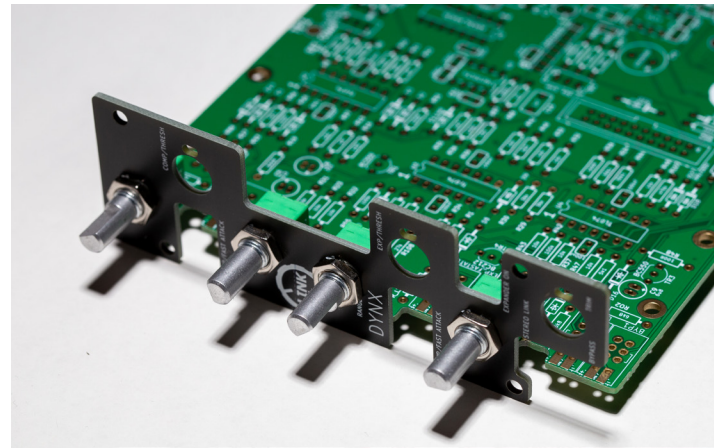

The next step is focusing on the pots and switches of the upper subboard, we can solder all pots and switches. Make sure to press them flush and firm to the board and fix them with one solder point.

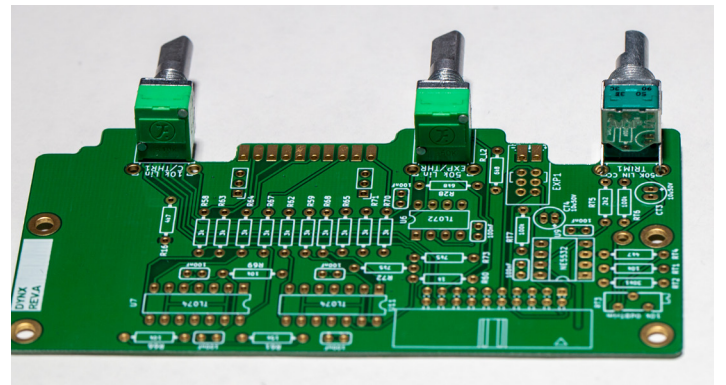

Check the alignment of the switches and pots from the upside again and try to bring them in line like the silkscreen is printed. After that install the blank bracket on the upper subboard and solder the pots in place.

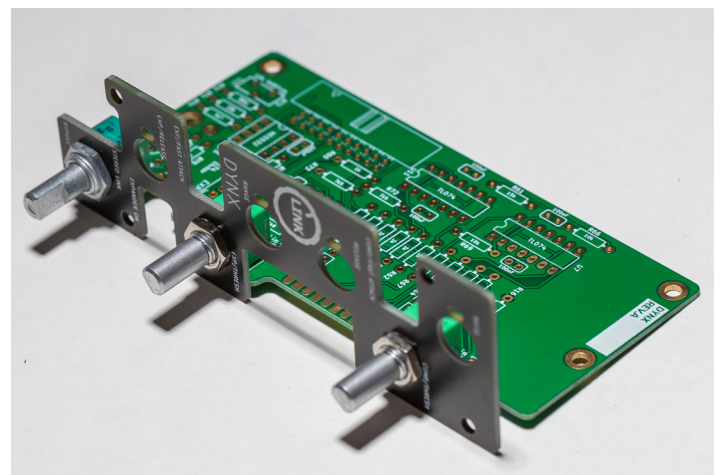

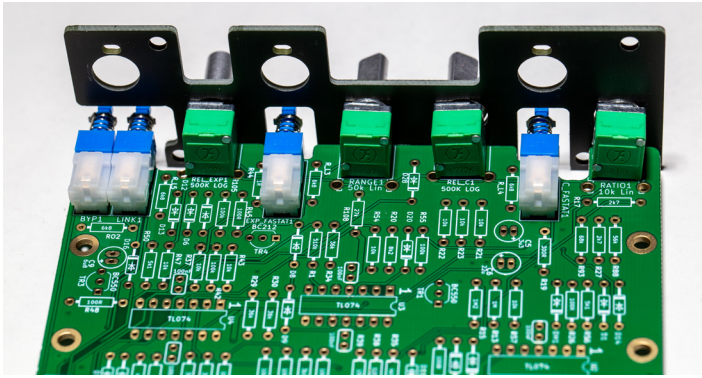

Now it's time to use the Frontpanel for the first time to get the Switches and LEDs in place. Use the spacers and bring the Frontpanel in place with the subboard. You can use the nuts to screw it together, but you also can use clamps to press bracket and frontpanel together. Install the pushbuttons and rearrange the switches on the PCB until they are in the middle of the hole of the Frontpanel. After this process you can solder them completely. After soldering in all of the Pots and Switches make sure that their leads are also trimmed short.

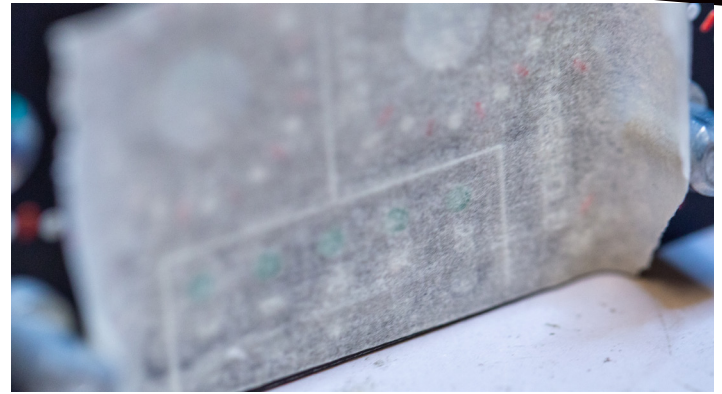

To get all LEDs perfectly in place I use a piece of masking tape and move the LED directly to the tape and then solder.

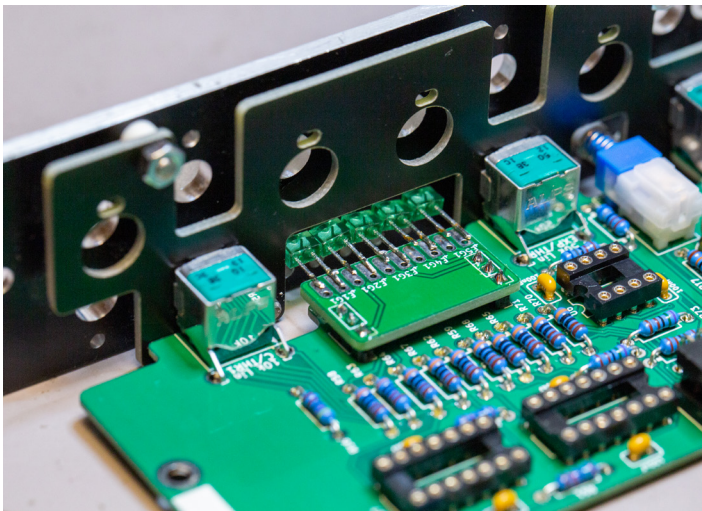

Now we will cut the LEDs legs. Make sure you have the right leg for + and - (Long leg is + and short leg is -). I usually don't cut them straight and keep two different size legs, so you still know which leg is + and which is -. Make sure the LED is sitting flush with the frontpanel. For the next step I place the small Led Board like in the Picture above and solder it directly to the board. Then I do first the Green LEDs for Gate Indication and just solder one leg to make sure the LED is in place, then solder the other leg. After soldering all LEDs to the Miniboard, I turn around the board and add the LEDs for the Switches and for Compression Indication.

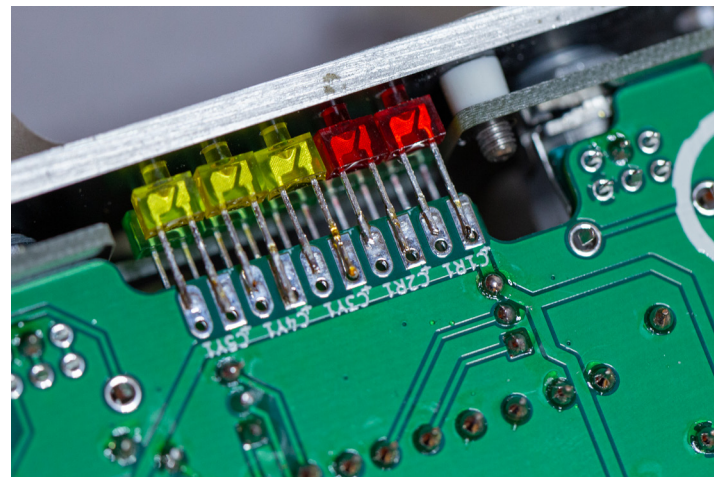

Once all solder points are done, remove and unscrew the Frontpanel and bracket again, we need that for next step.

Final Assembly

Now we have soldered all parts and want to check without the IC and Opamps installed if the voltages are right.

For that we don't use the Frontpanel or the bracket. We use the ribbon cables to connect the boards. Use an adapter for your lunchbox/or power it up on another way to measure all Voltages near the ICs. The Voltage Meter should show something like +/-15,3V, because of the drop of the diodes at the power input. Check also if the LEDs on the switches are working and the relais are switching.

There are 4 Testpoints for different Voltages on the Bottom of the Board. The Circuit uses different Voltages. So you should read Testpoint the labeled and corresponding Voltage. Then we head over to each special IC and measure if all Voltages are alright.

TL074 PIN4:+15,3V PIN11:-15,3V
 TL072 PIN8:+15,3V PIN4:-15,3V
 NE5534 PIN7:+15,3V PIN4:-15,3V
 NE5532 PIN8:+15,3V PIN4:-15,3V
 AD536 PIN14:+15,3V PIN3:-15,3V
 THAT 2181B PIN7:+15,3V PIN5:-15,3V
 THAT 1246 PIN7:+15,3V PIN4:-15,3V
 THAT 1646 PIN6:+15,3V PIN5:-15,3V

If everything seems good install the ICs. Check the Orientation of each IC before installing. Check the Datasheets of NE5534, NE5532, TL074, TL072, THAT2181B, AD536AJQ, MX636AJN, THAT1246 and THAT1646 to find the Input Pins where the Opamps get their Voltage and make sure everything is in place.

First we use the bracket to install the mainboard with the M7 nuts for the Pots. Then check all ICs for the right orientation again. Next put all the ribbon cables on the mainboard.

Now we install the upper subboard by holding it angled and connect the ribbon cables at the same time. Add the nuts for the M7/M9 Pots. Now we add the 24mm Spacers between the two boards and screw them together.

Now it's time to add the Frontpanel to complete the Dynamics. Use the spacers and the M3 Nuts to finish it. The Caps for the Knobs are sorted as following:

Grey - Compressor and Output Trim
Green - Expander and Gate

After finishing try to run Audio through the unit. If that works we need to Calibrate the unit later on.

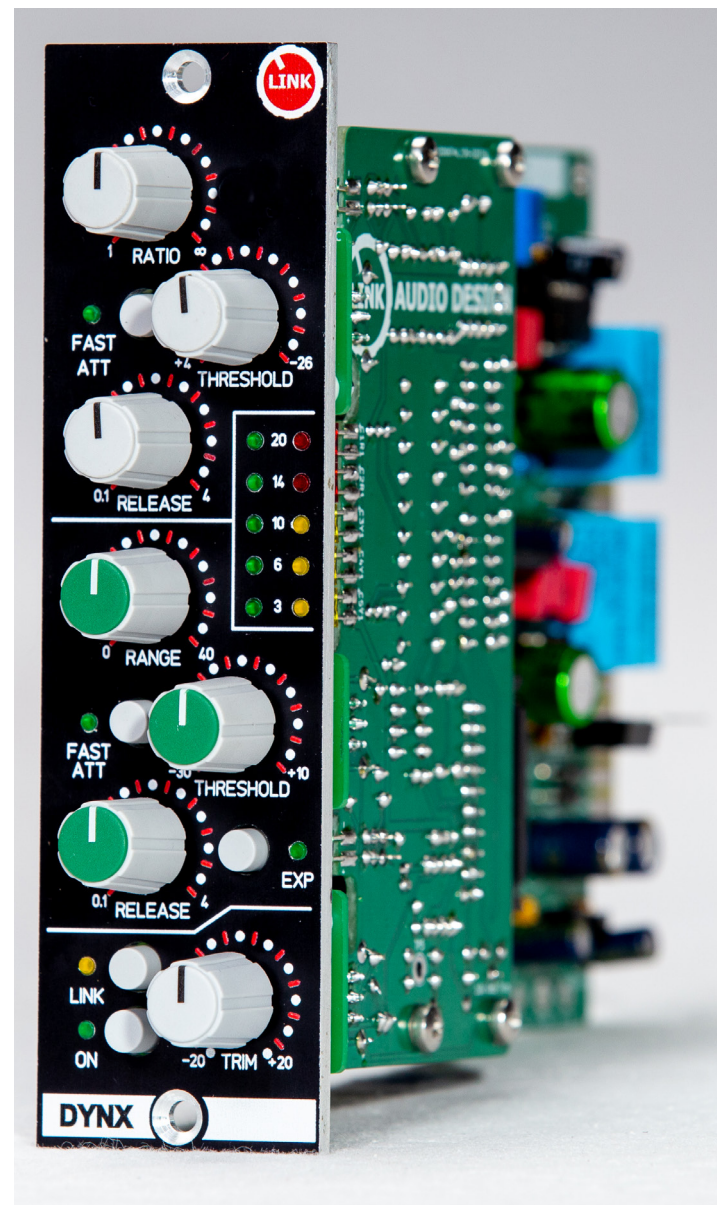

Calibration

AD536 = MX636 = SAME PROCEDURE

Calibration of this unit is no Rocket Science and it's quite easy. You need to playback different Sinus tones in different levels and make sure you can get the level of these signals coming out of the module measured again. Make sure you have enough headroom that you don't get clipping when capturing the response of the Dynamics. That Calibration works with every DAW but the easiest way to calibrate this Dynamics is using the freeware software REW.

First of all we need a constant reference level, I use the Software REW. I calibrated my Output Measure signal to +6dBu as my maximum output and Input, you should read on your multimeter 1,545Volts. I switch in REW for a better Overview to dBFS scaling.

To calibrate your Measuring System and learning about levels I highly recommend. The Setup of REW by DIYRE (3 parts on Youtube):

<https://www.youtube.com/watch?v=OwwKV-4QTfwU>

To calculate levels from dBu to Volts and dBV etc. i use the Calculator of Sengpiel:

<http://www.sengpielaudio.com/Rechner-db-volt.htm>

Compressor Calibration

- First set controls
- Ratio Comp: 1 (Anticlockwise ACW)
- Treshold Comp: +4 (ACW)
- Fast Attack Comp: (Push Button In)
- Fast Release Comp: 0.1 (ACW)
- Ratio Gate: 0 (Anticlockwise ACW)
- Treshold Gate: -30 (ACW)
- Fast Attack Gate: (Push Button In)
- Fast Release Gate: 0.1 (ACW)
- EXP Switch OFF
- Link Switch OFF
- Output Trim at center detent position

- Set the Oscillator frequency to 1kHz
- Read the Voltage at TP4 - adjust your level of your Generator until you read 1,54Volts AC with your Multimeter
- Read the Voltage at TP2, adjust VR2 to -5,00 Volts with „5k 0dBm“ next to the Testpoint.
- Ratio Comp: infinity (CW) fully engaged
- Treshold Comp: -26 (CW) fully engaged
- Read the Voltage at TP2 again, readjust if VR2 is not -5,00 Volts
- Your unit should give you at that moment a indication on the LED Meter with Compression.
- Reduce your level off the sine wave until you see no compression.
- Raise the sine level until you see the first GR meter LED come on.
- Take note of the level reading in your Measurement System.
- The level should stay fairly constant (within +/- 1 dB) as you raise the sine level from here, because your ratio is at infinity.
- If your unit is compressing more adjust VR1(500R SET GAIN) „SET COMP“.
- I use this procedure: Lower your sine level until there is no more Gain Reduction. Raise the sine until you see some GR, make note of the peak level at that point, then continue raising. If the output level doesn't go past then 1dB of compression, you've made the correct adjustment. If it got worse, you need to turn the trim pot the other direction.
- Once you've met the condition that the output stays within +/- 1dB of where it is when GR begins, your compressor is set!
- After setting VR1 check again TP2 with an input of 1,55Volts at TP4. Sometimes the -5,00 Volts drift away for some mV readjust this to -5,00 Volts.
- With a calibrated unit i getting mostly close to these Measurements.
- Sine Signal(6dBu) at TP4: 1,55Volts(AC), TP2: -5,00Volts (DC), TP1: -0,536Volts(DC)
- Sine Signal(-23,4dBu) at TP4: 0,052Volts(AC), TP2: -1,832Volts (DC), TP1: -3,694Volts(DC)
- Don't calibrate to fixed Voltage at TP1. Better check for your gain reduction.

Gate Calibration

- First set controls
 - Ratio Comp: 1 (Anticlockwise ACW)
 - Treshold Comp: +4 (ACW)
 - Fast Attack Comp: (Push Button In)
 - Fast Release Comp: 0.1 (ACW)
 - Ratio Gate: 40 (CW) fully engaged
 - Treshold Gate: +10 (CW) fully engaged
 - Fast Attack Gate: (Push Button In)
 - Fast Release Gate: 0.1 (ACW)
 - EXP Switch OFF
 - Link Switch OFF
 - Output Trim at center detent position
- Set the Oscillator frequency to 1kHz
 - Read the Voltage at TP4 - adjust your level of your Generator until you read 1,54Volts AC with your Multimeter
 - Adjust VR3 „SET GATE“ „100k“ until the signal passes through the gate.

Output Trim Calibration

- First set controls
 - Ratio Comp: 1 (Anticlockwise ACW)
 - Treshold Comp: +4 (ACW)
 - Fast Attack Comp: (Push Button In)
 - Fast Release Comp: 0.1 (ACW)
 - Ratio Gate: 0 (Anticlockwise ACW)
 - Treshold Gate: -30 (ACW)
 - Fast Attack Gate: (Push Button In)
 - Fast Release Gate: 0.1 (ACW)
 - EXP Switch OFF
 - Link Switch OFF
 - Output Trim at center detent position
- Set the Oscillator frequency to 1kHz
 - Read the Voltage at TP4 - adjust your level of your Generator until you read 1,54Volts AC with your Multimeter
 - Read the Level at TP5, adjust Level to 1,54Volts with „10K 0dB Trim“ at the Subboard.

Symmetry Calibration

For Symmetry Calibration you need a tool that measures THD. In REW you can analyze THD in realtime with the RTA feature. Enable „Show Distortion“

- First set controls
 - Ratio Comp: infinity (CW) fully engaged
 - Treshold Comp: -26 (CW) fully engaged
 - Fast Attack Comp: (Push Button In)
 - Fast Release Comp: 0.1 (ACW)
 - Ratio Gate: 0 (Anticlockwise ACW)
 - Treshold Gate: -30 (ACW)
 - Fast Attack Gate: (Push Button In)
 - Fast Release Gate: 0.1 (ACW)
 - EXP Switch OFF
 - Link Switch OFF
 - Output Trim at center detent position
- Set the Oscillator frequency to 1kHz
 - Read the Voltage at TP4 - adjust your level of your Generator until you read 1,54Volts AC with your Multimeter
- We will focus on the second harmonics of the THD Analyzer. We want to try to reduce the amount of harmonics added by the unit by turning VR4 „50k SYM“.
 - You will notice that the amount of the distortion will vary by turning in each direction, You need to find a middle position where the distortion is less.
 - Once you've met all the conditions, your new Dynmaics module is set!

Schematics

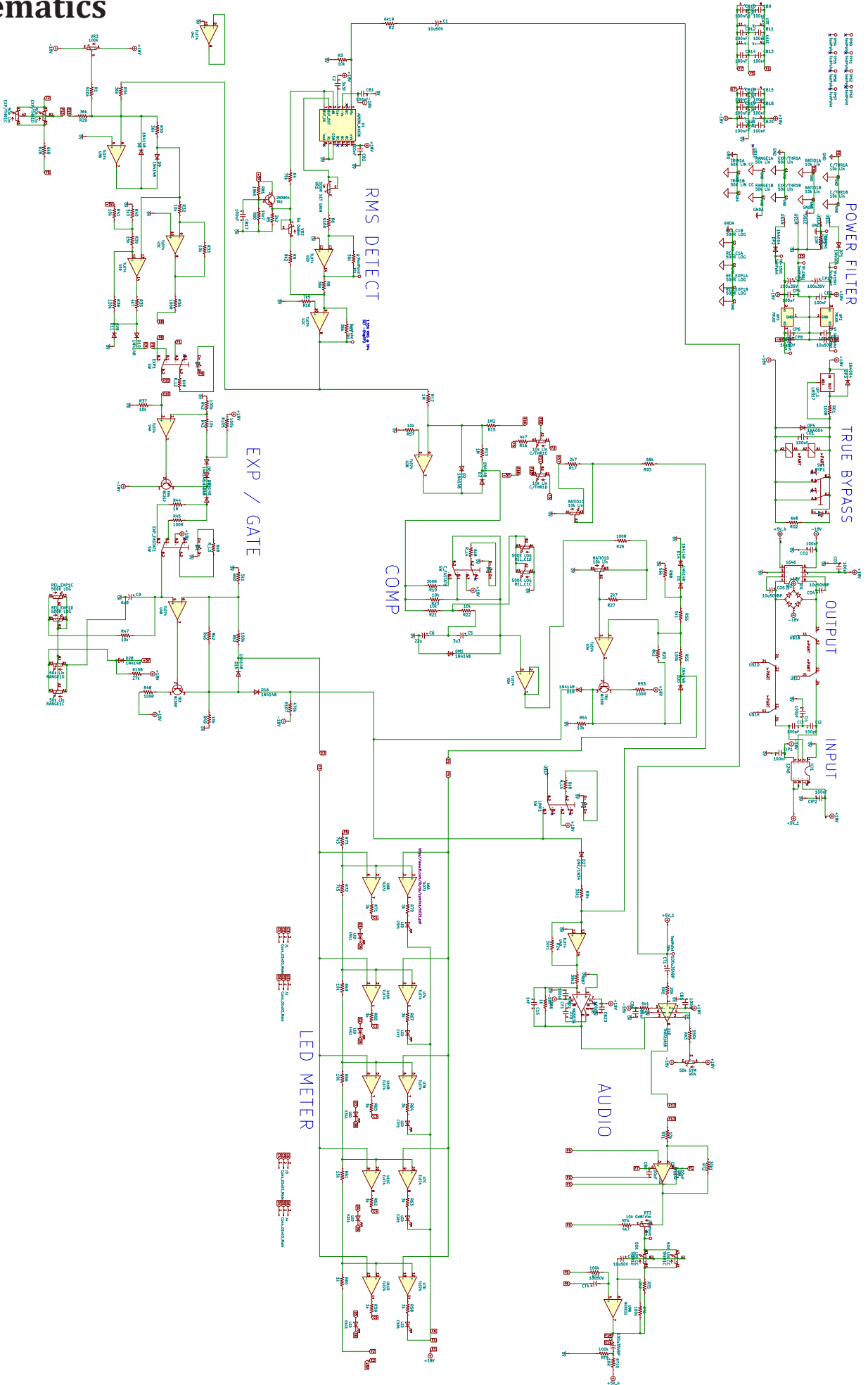

Bill of Materials (BOM)

ID	PART ON PCB	TYPE	COUNT	VALUE
1	R55,RT9RT6,RT7,R42,R105,R52	Resistor	7	100k
2	R48,R45,RO1,R26,R53,R36	Resistor	6	100R
3	R69,R41,R23,R21,R66,R3,R33,R57,R54,R32,R22,R37,RT1,R47,R43,R49	Resistor	16	10k
4	RP1,RT10	Resistor	2	10R
5	R38	Resistor	1	120k
6	R80	Resistor	1	14k7
7	RA3	Resistor	1	150k
8	R61,R39	Resistor	2	15k
9	R81	Resistor	1	19k6
10	R60,R86	Resistor	2	1k
11	R13,R12	Resistor	2	1M
12	R15	Resistor	1	1M2
13	R44	Resistor	1	1R
14	RA1	Resistor	1	20k
15	R108	Resistor	1	27k
16	RT5,R5	Resistor	2	2k2
17	R27,R17	Resistor	2	2k7
18	R19	Resistor	1	300R
19	R94,R24,RT2	Resistor	3	30k1
20	R34,R8,R30,R11,R29,R7	Resistor	6	36k
21	R87	Resistor	1	39k2
22	R65,R63,R67,R68,R58,R70,R71,R64,R59,R62	Resistor	10	3k
23	R40	Resistor	1	3k3
24	R107	Resistor	1	470k
25	R35,R16,RT4	Resistor	3	4k7
26	R1	Resistor	1	510k
27	R88	Resistor	1	56k
28	RA2,R50,R56	Resistor	3	5k1
29	R93	Resistor	1	68k
30	R2	Resistor	1	6k19
31	R_L2,RO2,R_L5,R_L3,R_L4,R28	Resistor	6	6k8
32	R4	Resistor	1	75k
33	R73,R72,R10	Resistor	3	7k5
34	R20,R9,R46	Resistor	3	8k2
35	R6	Resistor	1	910R

ID	PART ON PCB	TYPE	COUNT	VALUE
36	CB23,CO3,CP5,CB8,CB20,CIP1,CB7,CB13,CB12,CB11,CB22,CB15,CB5,CB6,CB16,CP6,CP3,CB19,CB18,CP4,CB21,CB9,CB10,CB14,CO1,CO2,CIP2,CB2,CB17,CB1	C025-050X025	30	100nF
37	CF1	C025-050X025	1	22pF
38	CI3,CI1,CI2	WIMA 5mm	3	100pF
39	C15	WIMA 5mm	1	1nF
40	C2	WIMA 5mm	1	3n3F
41	C6	Electrolytic	1	22uF
42	CT4,CT3,CP7,C1,CP8	Electrolytic	5	10uF50V
43	C9	Electrolytic	1	6,8uF
44	C5	Electrolytic	1	3,3uF
45	CO4,CO5	Electrolytic Bi-polar	2	10u50VBP
46	CP1,CP2	Electrolytic	2	100u35V
47	CT1,CT5	Electrolytic Bi-polar	2	100u35VBP
48	LINK1,EXP_FASTAT1,C_FASTAT1,EXP1,BYP1	Switch	5	SW
49	KO2,KO1	Relais	2	RY12W-K
50	J5	2x10_P2.54mm	1	Connector Sub-board
51	J6	2x10_P2.54mm	1	Connector Mainboard
52	J1,J3,J4,J2	1x03_P2.54mm	2	Connector LED-board
53	C/THR1,RATIO1	Potentiometer	2	B10k Linear
54	TRIM1	Potentiometer	1	B50K Linear CenterClick
55	RANGE1,EXP/THR1	Potentiometer	2	B50k Linear
56	REL_EXP1,REL_C1	Potentiometer	2	A500K Log
57	RT3	TRIMMER 64Z	1	10k 0dBTrim
58	VR3	TRIMMER 64W	1	100k GATE
59	VR1	TRIMMER 64W	1	500R SET GAIN
60	VR2	TRIMMER 64W	1	5k 0dBm
61	VR4	TRIMMER 64W	1	50k SYM

ID	PART ON PCB	TYPE	COUNT	VALUE
62	TR2	Transistor	1	2N3904
63	TR4	Transistor	1	BC212
64	UP3	Regulator	1	79L05
65	TR3,TR1	Transistor	2	BC550
66	UP2	Regulator	1	78L05
67	UP_1	Regulator	1	LM317
68	U10	VCA	1	THAT2181B
69	IC2	INPUT OPAMP	1	THAT1646
70	ICI1	OUTPUT OPAMP	1	THAT1246
71	C5Y1,C4Y1,C3Y1,STEREO LINK	LED YELLOW	4	LED
72	C1R1,C2R1	LED RED	2	LED
73	E3G1,E4G1,E2G1,E1G1,E5G1,FAST ATT EXP,EXP,ON,FAST ATT COMP	LED GREEN	9	LED
74	U8	Opamp	1	NE5534
75	U4,U7,U3,U11,U2	Opamp	5	TL074
76	U1	RMS to DC Converter	1	AD536_MX636
77	U6	Opamp	1	TL072
78	U9	Opamp	1	NE5532
79	D3,D14,DM1,D18,D2,D16,D13,D28,D10,D15,D8,D6, D20,D1,D9,D12	Diode	16	1N4148
80	D11	Diode	1	6V8
81	D27	Germanium Diode	1	D9E/1N34
82	DP3,DP4,DP1,DP2	Diode	4	1N4004
83	B1	Bridge Rectifier	1	DIL
84	Socket 8	Socket 8	5	GS 8P
85	Socket 14	Socket 14	5	GS 14P
86	Knob	Knob	5	Pushbutton Knob
87	Knob	Knob	7	Knob 11mm
88	Knob	Knob	3	Knobcap Green
89	Knob	Knob	4	Knobcap Grey
90	Hardware	Hardware	4	24mm Spacer
91	Hardware	Hardware	8	Screw M3
92	Hardware	Hardware	4	Nut M3
93	Hardware	Hardware	4	Spacer 0.145
94	Hardware	Hardware	6	Washer M7
95	Hardware	Hardware	6	Screw M7
96	Hardware	Hardware	1	Washer M9
97	Hardware	Hardware	1	Screw M9