

Leading-Edge Motorsport Technology Since 1990

# Racecar engineering™

October 2014 Vol24 No10 www.racecar-engineering.com UK £5.95 US \$14.50



## New world order? We examine the future DTM regulations

### Honda RA806E

Stripping down the last of the 'Third Era' F1 V8 engines

### Aerodynamic principles

Simon McBeath analyses the effect of underfloor air flow

### Toyota's WRC return

First sight of TMG's new R3-spec GT86 on Rally Deutschland

# Xtraordinary All-Fluid Filters

4 DIFFERENT SERIES... MODULAR... TONS OF OPTIONS



**71 SERIES** - Our largest capacity filters. 2.47" diameter body, available in two lengths. Reusable pleated stainless steel wire elements: 10, 20, 45, 60, 75, 100 or 120 micron, all with high-pressure perforated support core. End caps (sizes -6 through -20) are available in AN style or Clamshell Quick Disconnect. Options include: 15 PSI differential pressure by-pass valve; Inlet end caps with -10 Female ORB auxiliary port for temperature probe, secondary inlet or bypass for a pressure regulator; Outlet end caps with two female 1/8" pipe differential pressure gauge ports to measure pressure drop across the filtering element.



**72 SERIES** - Same large-capacity 2.47" diameter body as our 71 Series but with a 2-piece body that couples together with a Clamshell Quick Disconnect for quick service. 72 Series uses the same stainless steel elements, mounting hardware and end fittings as 71 Series.

## 71 SERIES MULTI-STACK - FAILSAFE STAGED FILTRATION

Multi-Stack adapter sections allow the stacking of two or more 71 Series bodies, long or short, so you can combine a variety of filtration rates or backup elements. Use a coarse micron screen element to filter out large debris upstream, followed by a tighter micron second-stage element to get smaller contaminants. Options include: adapters with take-off ports to facilitate the use of a differential pressure gauge which monitors contamination levels in all stages of the filter assembly.



Stack and Stage for Maximum Protection On Race Day

## SPACE SAVER SERIES - OUR MOST COMPACT FILTERS

3 Body Styles - 7 Choices of Screens

About 1 1/8" diameter, they fit everywhere and they do the job right for so many applications! 2 sets of O-Rings for a variety of racing fluids. Choose from 10, 20, 40, 60, 75, 100, or 120 micron screens to suit all needs.



**SPACE SAVER DRY SUMP** - Same space-saving size, these dry sump filters include a coarse-screen #16 mesh filter that protects your pump in high-volume race applications.



## INTRODUCING THE NEW 70 SERIES

Compact 1.97" diameter body features a springless design to maximize filtering area in tight spaces. 70 Series filters are ideal for applications where space and weight are of primary concern. Bodies are available with AN-style end caps, sizes -4 through -12, in heavy or lightweight wall versions. 70 Series filter elements come in two varieties: pleated cellulose (10 or 20 micron) or reusable pleated stainless steel wire (10, 20, 45, 60, 75, 100, or 120 micron). Undercut inlet end caps (sizes -4 through -10) offer a maximum weight savings and modern look.

## 70 SERIES Pleated Stainless Steel or Cellulose Elements



Follow us on Instagram #XRPracing



Like us on Facebook XRPinC

Go to [WWW.XRP.COM](http://WWW.XRP.COM) for catalog downloads & new products or contact us for 100-page color catalog.

# XRP®

THE XTREME IN RACECAR PLUMBING

UNITED STATES XRP, Inc. sales@xrp.com tel 562 861 4765 fax 562 861 5503  
EUROPE JLS Motorsport motorsport@lister.co.uk tel 44 (0) 121 525 5800 fax 44 (0) 121 525 4833

**COVER STORY**

- 8 DTM steps into the future**  
A new car for BMW and major car upgrades for this year, but motorsport chiefs are looking further into the future

**COLUMNS**

- 5 Ricardo Divila**  
Pure nostalgia? Or have the newest tracks had a charisma by-pass?
- 7 Mike Blanchet**  
Our man considers the allure of sportscar racing

**FEATURES**

- 16 Toro Rosso**  
A new cooling system for the Renault engine and a natty gearbox casing set the STR9 apart from the rest of the field
- 25 Tech Update**  
Formula 1 fires back into life following the summer break, and it turns out that teams have been busy
- 28 Toyota GT86 R3**  
A version of the GT86 appeared on the Rally Finland, but TMG's 2wd R3 debuted at Rally Deutschland shortly afterwards
- 37 WRC 2017**  
Everyone else appears to be looking at 2017 to introduce new regulations, so why not the WRC?

**TECHNICAL**

- 41 Consultant**  
A host of questions for our correspondent dealing with suspension issues on the other side of the Atlantic
- 44 AeroBYTES**  
We put another Formula Student car in the wind tunnel and consider the results of University Team Bath
- 48 Honda**  
Analysis by *Race Engine Technology's* editor Ian Bamsey of Honda's 'Third Era' Formula 1 engines
- 56 Underbody Aero**  
One of the least discussed parts of racecar set-up, Simon McBeath delves under the car and explores aero effects
- 67 Fluid Management**  
The latest advances in controlling temperatures in racecar engines and gearboxes
- 73 Danny Nowlan**  
With Formula E about to kick off and electric racing taking its first tentative steps, Danny takes us through electric car simulation
- 79 Tech Discussion**  
An intriguing look at an ambitious Formula Ford project taking cutting edge aerospace technology into the workshop

**BUSINESS NEWS & PEOPLE**

- 82 Industry News**  
Bernie is out of the dock; Melbourne secures GP for a further five years, while the National Guard retreats from racing
- 88 Racecar People**  
Managing director Craig Wilson on some of the exciting new projects at Williams, plus all the latest race moves
- 95 Products**  
A round-up of the latest products and services from the motorsports industry
- 96 Autosport International Show**  
Computer simulations and an interview with Quaife
- 98 Bump Stop**

**Subscribe to *Racecar Engineering* – find the best offers online**  
**[www.racecar-engineering.com](http://www.racecar-engineering.com)**

Contact us with your comments and views on [Twitter @RacecarEd](#) or on [Facebook.com/RacecarEngineering](#)

# 45 Years of Experience Engineering and Manufacturing Racing Fasteners



Manufactured in the U.S.  
Raced All Over the World

ARP fasteners provide strength and reliability for every type of racing.

All ARP fasteners are engineered and manufactured entirely in our own ISO 9001 and AS9100 registered facilities in Southern California.



ARP is proud to be a part of the Ilmor team for 21 of the past 30 years.

1993



Download our 2014 catalog  
[www.arp-bolts.com](http://www.arp-bolts.com)

1863 Eastman Ave • Ventura, CA 93003

Outside the U.S. +1.805.525.1497 • Toll-free in the U.S. 1.800.826.3045





# Legends lost in time

Memories of racing on some of the iconic circuits

**A**ge is something that doesn't matter, unless you are a cheese'. (Luis Buñuel)

One can dissent with this opinion, especially when talking about racetracks. This year's racing calendar has taken me three times each to Spa and the Nurburgring Nordschleife, aka Der Ring or 'Die grüne Hölle'. Going to other tracks seems a bit mundane after those majestic old layouts.

How do I love them? Let me count the ways. Selective blind corners over brows of hills, sequences of corners where the first corner conditions the following series (Silverstone has this, which saves it from turning into a humdrum circuit, so has Suzuka, so has Mexico City.) Lack of chicanes. Corners where some lift, and some don't.

Somehow these old tracks embody a mystique not only related to the patina they have, even if Spa itself is a rump of the long circuit, but all the drivers seem to agree with my assessment.

They have character, an ingredient missing from many bland clone circuits, littered with chicanes, pointless hairpins and which are characterised by monumental pit buildings with glass enclosed VIP rooms, busily hoovering up B2B money from corporate dos. They might have their place, but the reason we are there is to race, not be wined and dined in soundproofed ersatz club lounges.

## Count 'em up

Tracks have a general resemblance to the region they are in, either by osmosis or more logically because the terrain and contour lines are a characteristic of the region, and so is the vegetation, and the same contractors that pave the surrounding roads do the track surface. Bumpy local roads? Look at the damper settings for the local track. Low grip asphalt? The track's friction ( $\mu$ ) coefficient will be the same. The only exceptions lie in some tracks in America which have been sectioned off an airport's taxiing roads, and which – when done in concrete – provide some interesting challenges on setup and damping. Cleveland, Sebring anyone?

Over years of racing, I have run cars on 157 different tracks, not counting the variations at Silverstone or Interlagos due to layout changes, or tracks like Autódromo Juan y Oscar Gálvez in Buenos Aires, which has 15 distinct circuits. No exceptions, they all count as one. I do count oval tracks that are distinct from the road course, such as Twin Ring Motegi, but not Fontana, Indianapolis, Daytona, or Autódromo Hermanos Rodríguez which use part of the oval for the layout.

Many leave small traces on my cortex despite still needing the usual work to sort out ratios for

whatever car I am running there, sorting out the springs, ride-heights and choice of high, medium or low down force setup, damping rates, brake cooling and sometimes even what side of the car the refuelling hatch has to be.

For some unknown reason, all the ovals I have been to are anti-clockwise. Most tracks run clockwise, but the Circuit of the Americas, Imola, Istanbul Park, Yas Marina Circuit, Laguna Seca, Singapore, Phillip Island Grand Prix Circuit, Korea International Circuit and Circuit Ricardo Tormo in Valencia go anti-clockwise.

Others make one look forward to going there. Suzuka, Brno, Brands Hatch, Sugo, Laguna Seca, Mugello, Portimão, Trois-Rivières, Navarra and Zeltweg (even in its new incarnation as the Red Bull Ring) all stand out for the gradient differences. And we will not even speak about The Ring.

Spa has the niggling aberration of the chicane last corner. The bus stop was much better, although still technically a chicane, but I will forgive it for the sheer challenge of Pouhon and Blanchimont. Eau Rouge is not the challenge it used to be, following the addition of major run-off areas. The straw-bales that protected the rock-face (not so much the cars and drivers) are long gone. Corners that can be taken flat by everyone are not a separator of men and boys.

## Interlagos memories

The one that breaks my heart is the demise of Interlagos (Now Autódromo José Carlos Pace), my home track, where I saw my first races, learned to love this sport and did countless laps on, racing and as a driving instructor. The grandiose 8km track has been butchered to a more manageable 4.309km (loose translation, cut to reduce number of cameras needed for TV coverage).

Gone are the corners 1 and 2, where few did it flat, say four out of 26 F1 drivers. It was a daunting 250 km/h corner, slightly banked, leading on to

the back straight, at the end of which there was a plunging, banked corner leading on to the infield. Great braking zones, overtaking points and the whole of the track, apart from the Bico de Pato, visible from the grandstands.

It had fast corners, slow corners, uphill, downhill, and sequences of technically challenging corners that put a premium on setup and driving ability. No chicanes, that scourge of racetracks everywhere. those pestilential, second gear,

## The one that breaks my heart is the demise of Interlagos, my home track



Interlagos once featured fast banked corners among its other thrills for drivers and fans

vacuous scuffle-through flip-flops, whose main purpose seems to be to give cameras time to linger on sponsors' logos. Hairpins are more morally justified, especially when at the end of a long straight, elevating braking skills and testicular fortitude to a new level. Sad to say, today's drivers consider it an interesting circuit, but I will have to listen to Haruki Murakami: 'Memories warm you up from the inside. But they also tear you apart.'

While we're in a Japanese mood, Fuji was a quite simple track, in both of its previous guises, but it had interesting challenges. The first track had its mega-banked corner and the second manifestation had a challenging, bumpy 100R with the Armco inches from the tarmac. Today, it has been Tilke-ised into a Mickey Mouse

sector three, which satisfies neither man nor beast (erm... engineer nor driver). Others escaped more lightly, the emasculation of 130R at Suzuka has not changed the challenge of the rest.

Silverstone lost its magnificent layout early on. The first time I went back after the major change, the track-walk ended in confusion, when we couldn't decide from the map, or the track, which part of the apparent parking lot before Woodcote was the supposed line. Hockenheim, simple as it may have been, was better before the rebuild, and at Monza, after the wholesale dumping of chicanes, insult is added to injury by the parking lot run-off at the Parabolica. Arghhh...

Proust, that great chronicler of memory said 'Remembrance of things past is not necessarily the remembrance of things as they were.'

But I am sure. Those were great tracks.



# QUALITY AND RELIABILITY



**HIGHER FLOW RATES**  
**LESS FRICTION**  
**MORE POWER**

With more than 40 years of experience manufacturing high performance racing valves, Supertech utilizes the finest material and design to make available the most durable, high performance racing valves on the market today. Supertech valves are forged, CNC machined, and hand polished for strength and reliability.

All Supertech parts are measured against the strictest tolerances in the industry and utilize finite element analysis, enabling us to provide a high performance product, without sacrificing durability. Regardless of your high performance needs, Supertech is the best choice for you if quality, durability and performance are vital to your needs.



3580 Charter Park Dr. San Jose, CA. 95136 USA (408) 448-2001  
[www.supertechperformance.com](http://www.supertechperformance.com)



# Enduring reflections

Technical innovation at Le Mans has not spoiled the show for the online fans

**A**s the endurance racing world turns its attention to the second half of the WEC, which starts in Austin, Texas, on September 20, I wanted to pass comment on this year's Le Mans live online, and watched almost the entire race. It's the first time I've done this; previously I've either been there or seen TV highlights only. The overwhelming feeling I had was of being mightily impressed. It's a hell of an event to organise, and the ACO nowadays does a fine job of managing it. After all, it's a proper – and very long and fast – road racing track, not an artificial circuit as is becoming increasingly the norm in F1. And the drivers race at night, not under floodlights, but in the real dark with only headlights paving the way. (F1 is worried about falling TV figures. Maybe bland circuits unidentifiable one from another are part of the reason. Night racing for F1? That's not natural either). Endurance racing doesn't need gimmicks.

It was also an opportunity to get an overview of the action that you don't get when directly involved, your attention then being so focused on your car and its immediate opposition. It can actually be quite surreal in the pit garage, especially at night. Your car comes in, there's a flurry of activity, a brief, tangible link with machinery and driver, then the driver speeds off to combat the conditions and traffic for the next 50 minutes or so. Apart from information from the pit-to-car radio and the TV monitors, everyone simply prepares and waits for the next time the increasingly grubby racer suddenly appears, as if by magic, in the pool of light outside the garage. Assuming all is going to plan, of course, which it often doesn't.

What struck me most, perhaps, from the excellent TV coverage was the level to which safety provisions have moved, at a venue which used to be highly criticised and notoriously risky. When the skies opened so suddenly – and potentially lethally – not long after the start, the handling of the situation was exemplary. Thanks to this, the integrity of the barriers and the fantastic crash-resistance of current racing machinery, no serious injuries ensued. One criticism however still is how long it takes to repair damaged barriers and fencing, causing long 'yellows'. The new Slow Zones help by avoiding full-circuit safety cars, but need better clarity as to the meaning of 'Slow'; to help further the ACO may consider employing a more modular barrier system that involves quick replacement rather than lengthy repair of sections when damaged. As it is now, it's still a lot better than the one bloke with a spanner plus two 'supervising' that embarrassed and irritated everyone for many minutes at the British GP recently past!

An innovation this year was the requirement for drivers new to Le Mans, or who have not participated for five years, to undergo a simulator test. At €3,000 a pop, someone is doing good business but in the overall scheme of things this is not so significant and potentially even a life-saver. I suspect this idea will be copied.

Quite clearly endurance racing is entering an unprecedented period in its history. Never before have there been three manufacturer teams of such professionalism entered in the WEC. Nor of course has there been such a level of technology. Probably also there has seldom been this depth of talented drivers. For F1 people who look down their noses at any other form of motor racing, Mark Webber acted as a good yardstick by which to make comparisons.

## Le Mans, despite its duration, has something going on all the time

He was by no means the fastest driver in his Porsche crew. Apart from how short-sighted it is to believe that F1 represents the best in everything, it highlights how specialised each type of racing has become and the unique challenge that LM24 presents. I don't doubt that Mark will become as fast, but it will take time.

Equally clearly is that there is undoubtedly something refreshing about endurance racing compared to its F1 cousin. Perhaps it's a lack of the sleaze and overwhelming focus on money which depressingly characterises the latter. Yes, of course

politics plays a significant part in the ACO's rule-making, but with respected major manufacturers not having to dance to a commercial organ-grinder's tune and little evidence of shadowy team backers who wish to remain anonymous, plus a healthy dialogue between the competitors and the organisers, it does come over as more about sport despite the large budgets being committed. There is also room for high-quality amateurs to participate, something unique in World Championship motor racing. And less whingeing – I haven't heard nor seen a word of complaint about the noise that the cars make, although generally (Toyota LMP1s and GT cars apart) they are aurally worse than the F1 Power Units (the Audis in particular sounding like a bag of nails from the in-car link, with an MGU whine that imitates a transmission about to go bang!).

Funny also that, while F1 Power Units are regulated in almost every way, even to the primary engine bore size, cylinder spacing, c of g, v-angle and overall dimensions, all allegedly to save cost, WEC has a healthy grid of cars equipped with as wide a range of PUs as one could wish for. Perhaps it's a case of where and how the money gets used...

Unlike F1 races, where the action overall tends to be at the start and is then dictated by pit-stops, themselves dependent on tyre strategy and performance, Le Mans, despite its duration, has something going on all the time. This is constant drama as it happens. Grabbing some sleep and resisting the temptation to take my meals in front of the laptop caused me to wonder as I resumed viewing what I had missed and had me simultaneously referring to ongoing race bulletins to catch up. I was most definitely hooked. 



Watching the Le Mans 24 hours for almost its duration was intoxicating, and our man found, highly addictive

# Achtung baby

Major changes are on the horizon for the Deutsche Tourenwagen Masters, as the big German prestige manufacturers demand a touring car series that reflects evolving technology and markets

By SAM COLLINS

**T**o some it is the ultimate touring car championship with extreme machines, superstar drivers and great racing, but to others it is a mockery of its former self. The Deutsche Tourenwagen Masters, known universally as DTM is certain to spark debate amongst fans and industry figures alike. BMW, Mercedes and Audi all field multi car teams and there is bitter rivalry between them.

Ever since the DTM started (and later restarted) the manufacturers involved have been free to develop the cars as they see fit, at least within the technical regulations. But in 2012 all that changed and the series adopted a whole new concept, where every car used essentially identical underpinnings and had more restrictions technically in general.

While the cars look like heavily modified production cars, there are no production parts used in their construction at all. The bodies must be proportionally identical to the standard model, but with the rules tightly defining the width height and length of the DTM car, the dimensions of the standard shape have to be stretched or shrunk according to set of equations defined in the regulations.

The aerodynamic regulations in DTM are relatively liberal in what the manufacturers can do in some areas and incredibly restrictive

in others. The floors of the car are largely fixed by the rules, so its leaves the regions where the manufacturers are allowed to develop of crucial importance.

Looking at the car from the side, there are essentially two areas, divided by an imaginary line running along the top of the wheel arches and the about halfway down the door. Above this line, the standard body shape of the base car must be used. The only freedom above that line are the bonnet surface and the wing mirrors. With all the focus on these small areas the





manufacturers pack them full of aerodynamic elements which give the DTM cars that trademark aggressive look.

What was allowed to be developed independently was fixed at the start of that season and then homologated and locked in, after which nothing else could be done. But at the start of the 2014 season, it was clear that things had changed. BMW turned up at pre-season testing with a new model, the M4, while both Audi and Mercedes had fitted significant aerodynamic updates to their cars too. While it almost appeared that there had been another new rulebook introduced, in fact it was the continuation of the plan started in 2012.

'There are a lot of changes visually, because we were allowed to homologate new bodies,' Dieter Gass, head of DTM at Audi Sport explains. 'The biggest rule changes are not really that visible and relate to the front splitter, but aside from a few clarifications, the aerodynamic regulations are largely the same.'

'I think the original idea was that the cars would be homologated for two years, then updated, and BMW used that to homologate [a new car]. But we will face a situation sooner or later when we want a model change too. That may not align with the homologation window, so we are currently discussing how to allow a

model change, but it should be possible as the only areas of freedom are below the line and that can stay the same.'

As a result, the introduction of a new model for BMW was perhaps no bigger task than that faced by its rivals. 'Going from the M3 to the M4 meant taking the production car shape and manipulated to fit the DTM shape on the top,' says Jens Marquardt, BMW's motorsport director. 'The rest of the car was just an evolution of what we had. We needed to have a wider window of operation for the car. In 2012 we had a fairly balanced setup, but last year, when the option tyre was introduced, things changed and the window became smaller and the car was a bit limited. So, for 2014, we wanted a wider window back and it has worked, we have made a good step.'

The manufacturers all do their aero development separately, with Audi using the scale tunnel at Dallara alongside CFD, while BMW uses its own in-house capabilities including a full scale wind tunnel. 'Using our own R&D means that we can give back to the production car side,' Marquardt continues. 'That is one of our strengths, all of our programmes use our own facilities and that means that the staff are shared from motorsport to production they learn from racing, especially in terms of process.'

The DTM cars are not equally balanced in terms of aerodynamic performance, and officially the only performance balancing that takes place is in the shape of success ballast.

This means that on track there are often notable differences between the brands. 'In terms of top speed, we are a little bit down, that's obvious,' Marquardt continues. 'But our efficiency seems to be very good.'

Despite the range of dimensional restrictions that the DTM technical regulations impose on the manufacturers, the cars overall still produce very high levels of downforce. 'Our downforce is massive, so is our efficiency,' says Gass. 'I think in comparison to the R18 Le Mans Prototype they are not all that far away, but the DTM car has a bit more downforce than the R18, but of course they are designed for different things, the LMP is for Le Mans and the DTM for sprint racing.'

## Fan criticism

But this high level of downforce has raised some criticism of the current DTM formula, fans quietly suggest when questioned that the racing is not as good as it once was. It is a sentiment that seems to be widely held and it is something that the manufacturers are not oblivious to as they negotiate a new rule book for 2017 (see sidebar).

'My personal opinion is that it means that the cars do not have enough horsepower. I think in dry conditions they are a bit too easy to drive,' says Gass. Marquardt too feels that the drivers, all of whom are full professionals, have it a bit too easy. 'I would say that the current car is over-gripped and underpowered. 2017 is an opportunity to shift the balance. We have to figure out the best solution to give wheel to wheel and door to door racing.'



“There is not enough power, the cars are too easy to drive”



Mercedes livery in testing serves to indicate the body areas of the cars that are allowed to deviate from the base car template. Dazzle camouflage may be to deter eyeball analysis of aero elements by opposition



Large displacement naturally aspirated V8s have track appeal, but are no longer the norm for luxury and performance cars. Four cylinder turbo, possibly hybrid, power units are likely to be mandated from 2017 (see The Future of DTM, p14)



Audi, BMW and Mercedes have carved up the European market, but taking the series to the US would lure Japanese brands

One of the major factors in this situation is the engine. The regulations state that DTM engines must be normally aspirated V8s with no more than 4000cc. The block and heads must be aluminium and many other areas such as bore spacing, crank position, and all of the component materials are tightly defined. Even the gudgeon pin diameter is defined (at 47mm). Once the engine design has been finalised it is homologated and the specification frozen with almost no development allowed at all.

'We can do almost nothing, it is like it was in F1 where you can only make changes for reliability reasons,' Gass continues. 'Of course it can happen that your reliability update gives you performance, but really you are locked in. We are limited to ten engines for the season to be used across eight cars.'

The engines used by both Mercedes and Audi have been locked in for many years, with English firm NBE supplying Audi's units and HWA working with Mercedes. But in 2012 when BMW returned to the series after an absence of almost two decades it had to create an engine from scratch, allowing them to use more up to date technology, but the rules did not let the Munich based company build the engine quite as it would have liked. 'We looked at using a production block for our engine, but because of the way that the rules were written there was nothing in our production line up that would suit,' says Marquardt. 'The base regulations are so old, you would not do an engine like this.'

## New engines

In the event, Audi and Mercedes both felt rather uncomfortable that the newcomers would be able to do use tools such as modern engine simulation software that simply did not exist when they first developed their V8s.

'We and Mercedes both had old engines used for many years when BMW joined in 2012,' adds Gass. 'There was a lot of discussion about that, as there were suggestions that the BMW engine was ahead of everyone else, but the situation has calmed down since then. I think it is fair to say that things are quite balanced now. With the air restrictor, things are fairly level.'

Marquardt, however, feels that BMW was actually at a disadvantage by being late to the party, despite having access to nearly a decade of technical development. 'There are two sides to that debate; you could argue that the longer the engine has been run for the more optimised it is. We started later, but the regulations were so old! If you were to do an engine using the same philosophy and principle today it would be completely different. You would not do a normally aspirated engine. I think the delta in engines is very small now, anyway.'

**“I think we are on the limit. We have to have a lot of careful consideration how to move on. We spend a lot of money on very small modifications”**

# PREMIER

# MOTORSPORTS STEERING



Supplier of 2014 DTM  
COMPLETE  
STEERING GEAR

MVO USA, Inc. Provides:  
(Formerly Bishop Steering Technology, Inc)

- Complete Steering Gear
- Variable assist Power Steering Valve
- Constant or Variable Ratio Steering Rack
- High Precision Pinion Gear
- Hydraulic Power Steering Components
- Engineering and Manufacturing Support

info@mvousa.com  
www.mvousa.com



MVO USA



The 2014 regulations allow for DRS on the rear wing but, as currently implemented, the added cost and complexity hasn't yet delivered closer racing or more overtaking

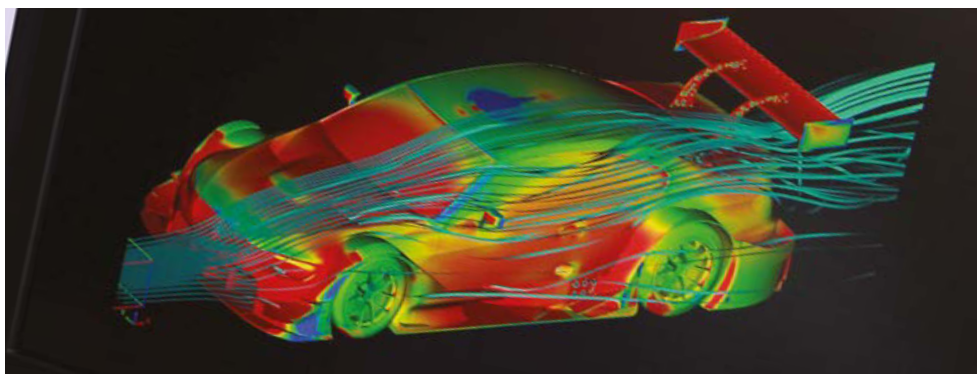

Distinctive look of DTM cars results from tightly-regulated upper surfaces and relative freedom below wheel arch level

The age of the regulations and lack of power from the large capacity normally aspirated engines is something that the three manufacturers are keen to change and they are working hard on creating a new engine formula for the 2017 season (see sidebar).

Elsewhere under the bodywork much of the DTM package is made up of common parts including the chassis, transmission (including fixed ratios), uprights, dampers, fuel system, and many other parts it could be said that there is little technical freedom. Indeed, there are a total of 77 single specification parts listed in the technical regulations. Those regulations are hugely detailed – running to 193 pages in English, more than double the size of the

Formula 1 regulations. Despite these tight regulations there are windows which allow the engineers some freedom. One of these became immediately apparent when the 2014 DTM cars first started testing. The door mirrors on the cars had become hugely exotic in with some even featuring multi element wings with endplates.

'There was not really a rule change on the wing mirrors, but everyone more or less started thinking about the same thing around the same time. If you saw what we ran in winter testing it was far more extreme than now. But the DMSB suggested that this area should be cut down a little bit,' Gass reveals.

While some of the suspension components, such as the uprights and dampers, are control

parts there is still some scope in this area too. 'We have freedom with the suspension geometry,' Marquardt adds. 'While some of the pickup points are defined, you have several options there. Beyond that you are totally free to develop your own kinematics. The geometry and wishbones are all free.' An anti roll bar can be added if desired (although to a very strict design) and while geometry is free, the wheelbase must remain between 2740mm and 2760mm, and track is set between 1944mm and 1956mm.

The small scope of technical freedom in the rules is far from ideal according to some in the DTM paddock and they would like to introduce a more liberal approach in future. 'I think with the current situation we are on the limit, for the future we have to have a lot of careful consideration how to move on. We spend a lot of money on very small modifications right now,' Gass admits. 'The restrictions are frustrating but you have to be realistic about it. The reason you cannot talk about cost control with engineers is because you pay your engineers to come up with all kinds of ideas to make the car go as fast as possible, but that normally does not keep costs down. On the other hand, I also think it is important not to restrict things too much because if you have too much restriction all you do is end up chasing small details like we are now, and it ends up being big money for small output. Sometimes if you have more freedom you need less money to achieve a lot more, small money for big output.'

## Spiralling costs

The budgets of the manufacturers DTM programmes are a jealously guarded secret but RE understands that in 2012 the cost of a car was around €880,000 (£705,000), significantly higher than the forecasted half a million that the new rules were intended to reduce costs to (see *RCEV22 N6*) However, this is still cheaper than the 2011 car cost according to Gass. 'In 2012, when we did the first season with the new cars, we did have a significant reduction on the price of a car but since then it has been creeping back up again, even with the cost of the common parts falling you are spending more elsewhere because you are focusing on the small things. Overall, the budgets are going up.'

With each manufacturer believed to be spending in the region of €30m (£24m) per season on DTM, the question could be asked; is it actually worth it in terms of marketing? Gass: 'That discussion is ongoing everywhere is that does the spend on DTM justify itself in terms of production car sales? We don't experience "win on Sunday sell on Monday" any more, but I think DTM is a marketing exercise and an image building exercise. DTM gives us the chance to compete at the highest level with our main opposition on the market, that is Mercedes and BMW, so for us it is of very high value. It is not only just the German market, it's all the markets. Mercedes and BMW are the main opposition. ↳

**“You cannot talk about cost control with engineers because you pay them to come up with all kinds of ideas to make the car go as fast as possible”**



**DOMINATE THE TRACK. RULE THE STREET.**



IMPERIAL RANGE



METRIC RANGE



TENDER | HELPER



OFF ROAD



COIL SLEEVE



BUMP STOPS

**ERS | Eibach Race Spring System**

- Over 1,300 single components - main and tender springs - metric and imperial, various auxiliary race suspension accessories, ready and in stock on 5 continents
- Comprehensive Program of single components
- Single Main Springs with highest rate-linearity and lowest rate tolerance
- Progressive Characteristics via set-up of different springs serially - double or even triple spring combinations
- Extreme Low Weights achieved through Super Hi-Ten materials and manufacturing technology
- Smallest Solid heights, maximized spring travels and higher maximum loads
- Spring Surface Stabilization through specialized shot peening
- Every ERS Spring preset to block
- Block and Sag Resistant
- Smallest Tolerances and precise plane parallelism of spring ends
- High Dynamic Durability - under Motorsports conditions
- High quality corrosion protection by phosphating and epoxy coating
- Springs Printed with part-number (speaking code = rate and dimensions)
- Individual protective single box packaging



eibach.com



Aero door mirrors highlight a small free area in the extensive DTM regulations for the upper parts of the cars

You cannot ignore the Japanese brands, but they are not so prevalent on the European market – and that is why we are looking at the USA. It would be interesting to compete against them there. I can assure you, for example, that the LMP programme is not cheaper than the DTM. I must add that there is absolutely an interest in reducing costs, but it is difficult. If you look at the rule changes that are coming you wonder how the costs will be saved. There is a complete new engine coming which you have to develop, there is the possibility of a hybrid system on the car. None of this is going to reduce the cost. That means the savings would have to come elsewhere. On one hand, you want to limit aero development, but on the other that ends up costing more because you spend loads of money developing tiny things.'

Meanwhile, Marquardt is seemingly more comfortable with current DTM spending, though he too suggests that there are probably other areas where costs could be reduced.

## The Future of DTM

In 2014, the GT500 class of Super GT adopted most of the DTM technical regulations and common parts. This was the first step on a journey that is hoped will ultimately see the two series running to an identical rulebook, and possibly the return of an ITC style global championship. 'For us to grow the regulations and to have DTM cars running in multiple series is the target,' BMW Motorsport Director Jens Marquardt explains, 'We will run in Asia. China is one of the most important markets for us, and to showcase the two series together - why not?'

The pact between the Japanese and Germans has a substantial impact on the rules for the 2017 DTM, especially in terms of the power units. There is

general agreement that the new units will be two-litre turbocharged four cylinder engines with direct injection, but there is still some uncertainty about the exact details, not least because the Germans have to factor in the demands of Toyota, Honda and Nissan as DTM pushes for a common rule book with the Japanese GT500 class of Super GT. That category has already adopted a four cylinder engine dubbed the 'Next Racing Engine' or NRE.

'There are some obstacles, because there are different philosophies between us and Japan, in terms of ongoing development,' says Dieter Gass, head of DTM at Audi Sport. 'Also engine life is an issue. We are getting closer to working it all out

but we are still not there in GT500 they have long distance races and DTM is sprint racing and that puts different requirements on the engine.'

It is likely that the new engines will be fuel flow limited, something that already is a feature of GT500, but the DTM is also investigating using Formula 1-style fuel flow meter as well as the use of the Toyota-developed fuel flow restrictor used in the Japanese series.

### Sound reasoning

This move has raised some concern from die hard DTM fans that the distinct sound of the current engines will be lost and replaced by something less interesting. However, motor racing in general is going this way, and Gass says that he does not think that this is a major issue. 'There have been questions about the sound of the new engines, but what we have currently, with the way the exhausts are, is really not the sound of a V8. It's the sound of a four cylinder. The only difference you have is the turbocharging. Earlier this year I went to the Super GT race at Sugo – because I needed to understand what those cars and that series is – and I like to have some idea of what I'm talking about. I thought the sound there was good. What was especially interesting because of the different car concepts is that the different engines sound different, especially the Honda which is mid engined, and for me that sounded the best. But the sound was no worse or better than DTM.'

Additionally, there is the suggestion that in 2017 the new rules will allow or even enforce the use of hybrid power trains. In 2012 the new chassis was specifically designed to accommodate a hybrid system but to date nobody in Europe has fitted one. However, in Japan, Honda has used a Zytec-based battery-electric hybrid system on its GT500 cars.

'The design of the chassis was originally for hybrid, it's true,' confirms Gass. 'But, it will not come anytime soon. For 2017, there are discussions about using hybrid, so it's a possibility but not decided yet. As part of that process, we are trying to get common regulation with GTA. We are close, but it's not there yet.'

### Hybrid options

Indeed, that process could be aided by the use of Zytec's well proven technology in both GT500 and Super Formula (which shares the same engine regulations), as a European company implementation of it in DTM may be fairly straight forward, and many in the DTM paddock favour a common system.

'What we need to have in DTM are regulations that are relevant to the production cars and, at the same time, are affordable. There is always the danger of spending a huge amount of money on a technology, so if we are to have a hybrid system in DTM it will have to be a common part to avoid excessive spending,' Marquardt adds.



Four cylinder turbo Lexus GT500 is close to DTM specs in terms of aero. Rules could converge for 2017

# “I think the competition is extremely close, and the quality of racing is alright. But we make our lives difficult with complicated rules”

‘I’m happy with the cost of DTM, but there are always areas that could be improved, and we are constantly looking at cutting our operating costs with the other manufacturers. And that could make it more attractive for other manufacturers to join,’ says Marquardt. ‘That’s what we are working on with the guys from IMSA, discussions are always going on with other manufacturers. I think the cars are fairly sophisticated, it’s a proper race car, the field is very tight and there are areas to play with, but I think we are in a good place. I think we are cautious about costs and it’s not the right approach to develop a car in areas where the fan does not see it.’

While the current DTM cars have aesthetics that are almost universally popular, the quality

of on-track action has come in for some criticism, not only from fans but also from the manufacturers. ‘I think the competition is extremely close, and the quality of racing is alright,’ continues Gass. ‘Somehow we make our lives difficult with complicated rules that make races hard to follow. Not just for fans, sometimes for the officials too. There is a lot of criticism of the consistency of the decisions too. Touring car racing is not open wheel racing.’

For 2014, in an attempt to improve the on-track action, the series introduced a rear wing drag reduction system, but Gass feels that while it is effective, the current regs prevent it from being as much of a factor in race strategy as it could be. ‘DRS is an example. It does work, but the sporting rules are not there yet. In Austria

you had too big a DRS window, so all of the cars run with the DRS activated and nobody passes.’

Another idea to improve the show is a system of success ballast, but it has to be questioned how effective this is. Despite carrying the maximum ballast in his BMW at the Nurburgring, Marco Wittmann was substantially faster than other professional drivers in otherwise identical but lighter BMWs – raising a few eyebrows.

DTM will continue with the current cars until 2017, when the new rules, much-awaited in both Germany and Japan, will be introduced while plans for an American series with these cars continue to take shape. If the balance between innovation and competition is right, DTM could create a new world order in touring car racing. 

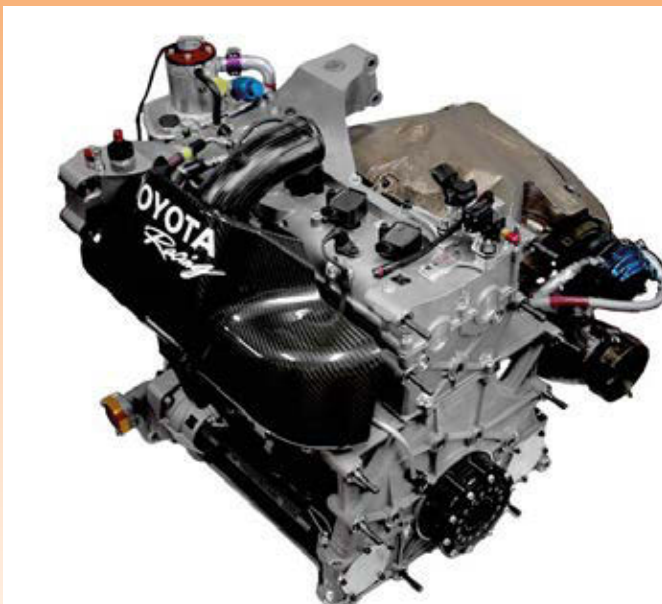

GT500 in Japan initially ran with 3.4-litre V8s but, for 2014, GTA rules demand 2.0-litre turbocharged four cylinder powerplants like this Lexus unit



Honda’s mid-engined NSX Concept-GT hybrid might prove influential in the future direction of Super GT and DTM. Great sounding powerplant is a bonus

‘There is still enough in strategy and boundary conditions to have some unique settings in place with a hybrid for each manufacturer without the costs going through the roof. But my understanding is that, for example, the power units in F1 have been very expensive, and for DTM that is out of the ball park. So we need to make sure it not like that.’

However, some see the addition of a hybrid system into the series as an added expense that simply isn’t needed. ‘In terms of being green, I’m not convinced that you need a hybrid system in a sprint race,’ Gass contests.

The next step on the road to full unification between GT500 and DTM could come next year, with the GTA (organisers of Super GT) proposing a joint test session between GT500 and DTM in China, with all of the cars running together.

## Aligning with GT500

‘There is an idea from GTA that we need to discuss more. The original idea was to hold joint event, with a DTM race and a Super GT race on the same day, but separate. But having a common test day with the cars all running together, that is what the

Japanese prefer. For us, it is pointless to have competition between the cars when they have an engine that produces more horsepower. And they have a tyre war, which means that they have significantly more grip than us. If we competed against GT500 right now, we would look a bit silly. It’s something for more discussion,’ Gass explains candidly.

While the Super GT cars do have more power than the DTM machines and more grip from the tyres Gass does feel there are some areas where the Germans have the edge. ‘Aerodynamically, the rules are

similar, but they have high and low downforce configurations and we just have one. I think having the tyre war like they do means that they don’t put the same emphasis on detailed aero development that we have in DTM. For them, it is much easier to get performance elsewhere, so they spend the money on that instead.’

At a meeting held in early 2014 at Daytona, the DTM, GTA and IMSA broadly agreed that, in 2017, DTM-rules cars could be used globally, in whatever championships, with identical regulations, but it is clear that the detail is still to be resolved. 

# Stuck in the middle?

Red Bull's bashful sister team has managed to take a little of the limelight in 2014, but reliability issues are still holding it back

By SAM COLLINS



It had all started so well for the Austrian owned Italian team, Scuderia Toro Rosso. It had managed to get its car, the Renault-powered STR9, built before all of its rivals and was one of the first to run a 2014 car on track, when its new driver took the car to a soaking wet circuit not far from the factory, and ran trouble free.

But by having one of the first new cars to appear Toro Rosso, Red Bull's second F1 team was also in line to take the brunt of the unintended consequences of the new-for-2014 rules. During the launch, held at the Jerez

circuit pictures of the front impact structure on the car went viral and even prompted a chain of English sex shops to suggest on twitter that the design was inspired by one of its most popular 'toys'.

Despite being ridiculed from the moment the car left the garage at Jerez, the team knew that the joke was on the rule makers who had forced the teams to adopt the strange looking noses prevalent on the 2014 Formula 1 grid. With the coverage the noses received it could not get much worse. Toro Rosso felt that it was fully prepared for the first test.

'We felt that the pre season testing was really important,' Toro Rosso Technical Director James Key admits, 'not just for our younger driver but also for our established driver, because the cars are fundamentally different and the driver workload with the new systems has increased. They had to get used to it. So at the start of the year we focussed on being ready, we were the first Renault powered team to fire up the car, and the first one to run. I think we were also the second team to run a car at the first test too I think.'



**“We are not where we should be in terms of reliability. We had eight non-finishes out of the first 18 car starts. That is not good enough”**

The Toro Rosso STR9 is pretty conventional in 2014 F1 terms, with the exception of the extra central airduct behind the driver's head routed to twin oil coolers

Everything looked good, even after the first shakedown run but there were serious problems brewing. Renault had made something of a miscalculation with its power unit, something that was not seen on the dyno or during Toro Rosso's shakedown run. 'The winter testing situation has been well documented now, and it's no secret that we had a lot of issues,' admits Key. 'For us it started off well, but we were not running in a fully optimised condition at the start and as we started to introduce new elements on the power unit in that first test, the issues started

to appear. Unfortunately, there were some relatively complex ones for us to deal with.'

Those issues surrounded the Renault RS34 power unit, and ultimately ruined the first test for not only Toro Rosso, but also sister team Red Bull, with both teams struggling to complete many laps at all at full power. Many of the issues went on to be resolved but development that would normally have been conducted in pre season testing went on into the season, indeed even during the summer months there were reliability related upgrades being introduced with the RS34.

'Obviously winter testing was not what we wanted, and the first time we managed to get a car to run for a race distance was the Australian Grand Prix. It was the first durability test for everything,' Key continues. 'Just being able to do that was the result of a massive amount of work for us. There were three strands where you would normally have one, namely car developments for Melbourne. While we did that as normal and brought a major aerodynamic update for the first race, with a few mechanical bits, we additionally had a lot of chassis-based work to do as a result of

## “We went through 17 different cooling schemes before we came up with the one we put on the car. Since then we have changed it twice”

some things we discovered in winter testing and some others we knew before the car ran. Finally, we were fighting all of the reliability issues with the power unit and its installation. It tripled the workload.’ Despite this, Toro Rosso made it to the first race, and came home in the points.

During the preseason tests and the opening races, much of the design of the Toro Rosso STR9 was revealed, and in general it is clearly a fairly conventional 2014 specification grand prix car. It has wishbone suspension all round with pushrod actuated dampers, allied to torsion bars at the front and a pullrod arrangement at the rear. But one detail stood out, a large duct underneath the conventional roll hoop inlet for the charge air, something seen in a smaller form on the 2012 Toro Rosso STR7.

It was a clue that the Toro Rosso cooling system was rather different to that of the other Renault powered designs. ‘It was very difficult to second guess what to do with cooling, we had no reference point at all,’ says Key. ‘We looked at a lot of things, but it was hard to tell how much effort competitors were putting into new technologies for cooling, particularly charge air cooling. If you looked at using a more traditional solution you would immediately start worrying that you may be two years behind everyone. In the end, we built it around where we thought that the heat rejection numbers would end up based on what Renault told us.’

The unique layout saw the extra duct behind the drivers head feeding twin oil coolers, one mounted above each side pod under the engine

cover, while in the side pods themselves are the water coolers and twin intercoolers under them.

‘The central duct is something we discussed for a long while. Originally the car did not have it, but we recognised that if we were to have everything covered we would have to do it. Once everything in the design was together we realised that there were compromises in what we had and putting the coolers fed by the central duct where we have is our solution,’ Key explains. ‘Looking at the others, you see how they have dealt with the same compromises. Red Bull has ended up with very long narrow coolers which is a very clever idea. Looking at the packaging, it’s incredible, and would have meant an enormous amount of work. It wouldn’t be easy for us to do, especially as they have gone for a completely different technology in terms of charge cooling, that has a knock-on effect on everything else. As soon as you move something fundamental, like a cooler or the big electronic boxes, every else is impacted. I think we went through 17 different cooling schemes before we came up with the one we put on the car. Since then we have changed it twice, so that’s at least 19 layouts. The package we introduced at Monaco is based on the original geometry but is completely different in the way it works. Cooling has become a big development item that it never was before.’

While it has been speculated that the STR9 layout raises the centre of gravity of the car Key denies this and states that the main water coolers are no higher than those of the Red Bull, they are just a bit wider. ‘Our coolers are mounted quite high up in the car at first glance, but it does not have an impact on centre of gravity, it’s an optical illusion – the top of the radiators is still at the same location as you would expect. But overall, the cooler layout we have got has some good little

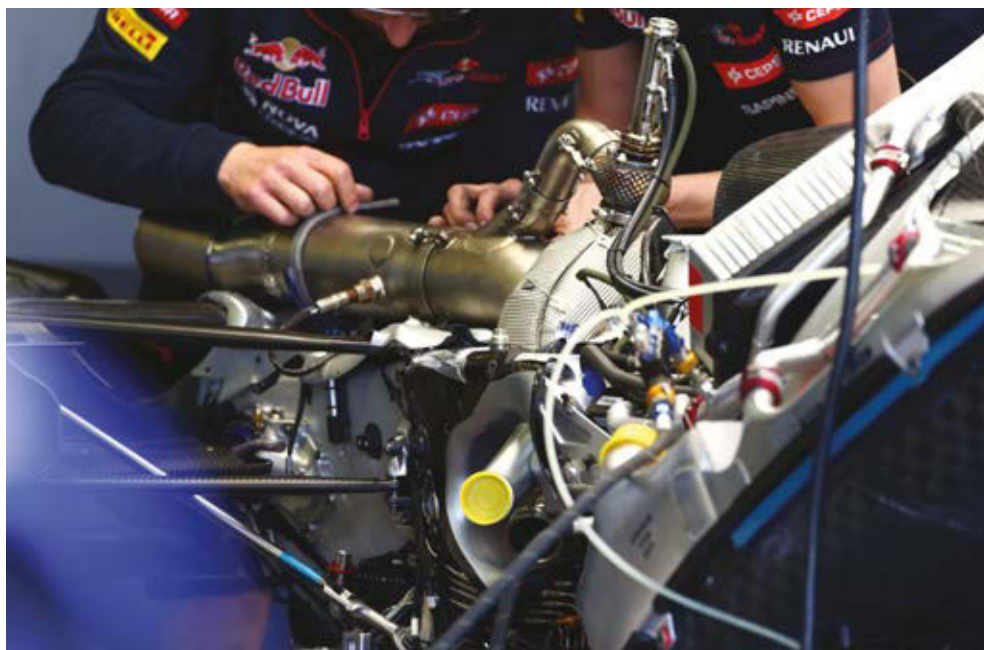

Tight packaging of the rectangular oil cooler with the integrated radiator and intercooler is evident from this view. Turbo, exhaust and wastegate assembly is close behind



Bulkhead arrangement of the STR9 features a fairly conventional pushrod front suspension. Turning vanes and brake shroud assemblies are also visible in this shot



Toro Rosso gearbox shares internals with other Renault F1 cars, but features a unique aluminium casing. Other teams have opted for all carbon designs

**pankl**  
RACING SYSTEMS



High Tech | High Speed | High Quality



**Pankl Engine Systems GmbH & Co KG**

A member of Pankl Racing Systems

A-8600 Bruck/Mur, Kaltschmidstrasse 2-6

Phone: +43(0)3862 51 250-0

FAX: +43(0)3862 51 250-290

e-mail: [engine@pankl.com](mailto:engine@pankl.com)

[www.pankl.com](http://www.pankl.com)

## Stopping power

**B**raking systems have been a key area of performance for all teams in the 2014 F1 season, and Toro Rosso is no different. According to James Key, Toro Rosso's technical director, the team hopes for further improvements in this area.

'There is still scope for optimisation in the brakes, it's a completely different scenario to what we are used to because the control system does everything on the rear axle now. In theory that means that what the driver demands he should get, but in practice you don't see that. It's been one of our issues on the STR9, we have noticed that our braking system is a little bit too weak compared to others.'

'Going forward, I think there is also scope to start looking at materials again, going for a

much lighter rear brake and a standard front. With that in mind, there are so many knock-ons to consider. The brakes pump heat into the tyres, but if you suddenly lose a load of that heat from the disc you can end up in the bizarre situation of rear tyre warm up problems. In winter testing sometimes we actually saw that,' he says.

'The problem is that, in theory, you should be getting particular braking torque at the wheel, but there is no way of actually knowing that without looking at the contact patch. Even when you look at all the related systems it is still highly complex. It's very difficult to monitor what is actually happening at the wheel and it is not that obvious, it can be very transient. You can measure at one point and it may not be accurate

as things change with lots of little factors like compliances and things like that. You can only estimate the torque, you don't know for sure.

'Anti-effects are also a factor. If you have lots of different hydraulic pressures going on through a braking phase as a result of the MGU-K interaction, it can also change your anti-effects a bit too.

'It's pages and ages of maths, but eventually you want to get to the point where the driver has no idea if it's the MGU or the hydraulic brakes doing the work. As a team, we are getting pretty close to that. We were nowhere near that at the start of the year. The drivers feel the tiniest little subtlety and it can make them feel uncomfortable as they try to modulate the brakes, and if they do feel that, they can back off disproportionately. They just want a consistent feel.'

efficiencies about it. We may apply a similar philosophy next year as well.'

The fact that Red Bull and Toro Rosso have adopted such different cooling layouts on their cars is a hint at one of the major differences between the approaches of power unit suppliers. Notably, the Lotus cooling layout (See *Racecar Engineering* V24 N9) and the Caterham layout (V24 N6) are also drastically different.

According to Key, this also could be the root of some of the problems experienced by the Renault runners at Jerez. 'I don't think some of the issues that Renault had were down to engineering errors, I think to an extent it is down to the business model. If you look at the other two power unit suppliers they both have factory teams, so the ability for them to have very close working between power unit development and chassis development is very strong. That's their business model, and you see the effect on some chassis related item, the Mercedes 'log' exhaust is a classic example of that,' Key highlights. 'Renault is not in that position, it is a power unit expert, so we (the Renault teams) have a very different way of working to the others. We have been very open with Renault. It is something I don't think you would get with another supplier as they would be focused on what's best for the factory team, and sell that to everyone else. With Renault we get a bit of freedom and that's why the four Renault cars are so diverse. We are more able to play with things.'

One area where there is some more fundamental similarity between the Renault-powered cars is the transmission, Caterham, Red Bull and Toro Rosso all use identical gearbox internals (although Lotus has taken a different approach). However, it is immediately apparent that the Toro Rosso has a substantially different casing around those internals; it's made of aluminium, whereas Red Bull and Caterham have carbon fibre cases.

## Transmission casing

'It made a huge amount of sense to work closely with Red Bull Racing on the transmission, they had already done a fair amount of work with Renault on the type of gearbox that you would need to cope with the demands of the power units and the new regulations,' says Key. 'They had been in the loop with Renault for a lot longer than we had so it made no sense to do a separate thing.' But this did not mean the end of Toro Rosso (and Minardi's) long history of manufacturing gearboxes.

'We share the internals, but we couldn't share the same gearbox case because Red Bull was working to a different timetable to us. They would define their gearbox case at the last possible minute, so they get something that is fully optimised. We wanted to define our box quite late as well, and it's too tricky for both teams to define at the same late point with perhaps some different requirements,' Key continues. 'So we just went for the important

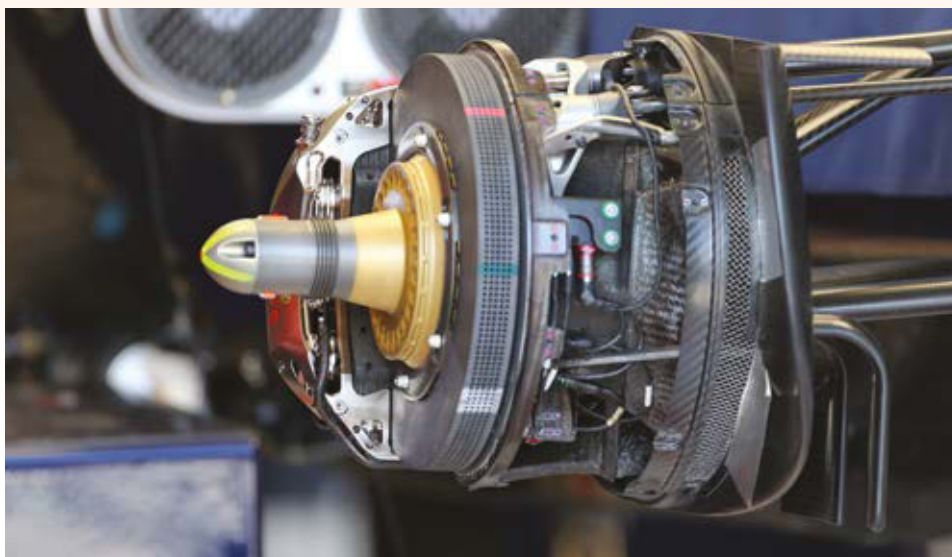
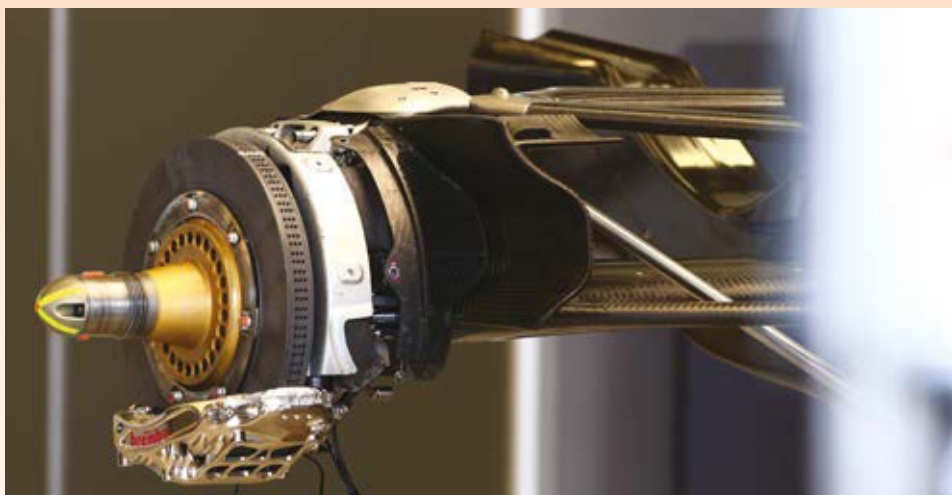

**Top:** Brembo componentry features in the STR9's brake by wire system. Three-row ventilation drilling visible on rears

**Bottom:** Front brakes show five-row drilling and electrical connections



**40**  
YEARS  
OF INNOVATION  
1974-2014



AT THE HEART  
OF THE WORLD'S  
MOST POWERFUL  
ENGINES



[www.arrowprecision.com](http://www.arrowprecision.com)

Give us your requirements and we'll find a high-performance solution,  
no matter how extreme.

Call our sales team: +44 (0) 1455 234200 Email us: [enquiries@arrowprecision.com](mailto:enquiries@arrowprecision.com)

## That nose



**T**oro Rosso's original 'Ann Summers' nose has been adjusted significantly since the car first appeared requiring a new frontal crash test for the car. 'It is a bit of a performance area, its hard to say how many iterations of nose we will go through but perhaps three or four,' explains James Key. 'It's become an area because the aero has been developed for ages around high noses, so all of that knowledge has been carried over. If you try to recreate a high nose aerodynamically with a low nose, you end up with the shapes we have now.'



**Barbecued beef:** The Toro Rosso team endure yet another technical failure, as Daniil Kvyat's STR9 catches fire and is retired from the German Grand Prix at Hockenheim in July, after qualifying ahead of both Force Indias

bit in terms of reliability which is the internals, and it's worked out really well. Doing our own casing means that we have complete freedom over our rear suspension and wheelbase.'

The tradition looks set to continue for the same reason but Toro Rosso may eventually move away from metal transmission cases according to Key. 'I think it takes a while to satisfactorily develop a composite case these days, probably a couple of years,' he says. There are definite advantages to doing it both structurally and weight-wise, but aluminium is a really well known technology and that's where we are at the moment. For 2014, we need something that worked but we are looking at other options for later seasons. I think there are different ways of using the materials to explore, and we are keeping an eye on a lot of things.'

Key, and the rest of the Toro Rosso management, are keen to move the team

forwards, and recent improvements to the team's facility in Faenza in Italy show that. Indeed, the investment in design capability has opened up some new avenues for the organisation.

'Optimising the car has taken a bit of a new direction, we have a new CFD cluster and it has some spare capacity because of the limits placed on us by the regulations, so we are now using that for some other vehicle dynamics work, and the cluster is developing into more of a super computer rather than a pure CFD tool. Actually because we have gone so far with the hardware for CFD the software needs to catch up a bit,' Key reveals.

Toro Rosso did enough to secure seventh place in the constructors' championship going into the mid-season break, but is a substantial way behind sixth place. While the team had hoped for better performance reliability and team errors have prevented a higher score. 'We

## TECH SPEC

### Chassis construction

Carbon monocoque structure

### Front suspension

Upper and lower carbon wishbones, pushrod, torsion bar springs, central damper and anti-roll bars

### Rear suspension

Upper and lower carbon wishbones, pullrod, torsion bar springs, central damper and anti-roll bars

### Transmission

Scuderia Toro Rosso aluminium alloy 8-speed sequential hydraulically actuated, supplied by Red Bull Technology

### Clutch

AP Racing, pull-type

### Dampers

Penske/Multimatic

### Wheels

Apptech, Magnesium alloy

### Tyres

Pirelli

Fronts: 245/660-13

Rears: 325/660-13

### Brake system

Brembo pads and discs, brake by wire

### Steering

Scuderia Toro Rosso

### Fuel system

ATL Kevlar-reinforced rubber bladder with Scuderia Toro Rosso internals

### Electronic systems

FIA SECU standard electronic control unit

### Cooling system

Scuderia Toro Rosso for radiators, heat exchangers, intercoolers

### Cockpit

Seatbelts: OMP/Sabelt

### Engine

Renault Energy F1-2014, 1.6-litre 90 degree 6-cylinder. Max rpm 15,000, 24 valves. Cylinder block in aluminium

are in a tricky situation. Williams and Force India are strong this year and they are typically our competition, but they are benefiting from the great job Mercedes has done with its power unit. We are compensating for that. Perhaps we are a bit behind but the playing field is not quite level.'

Franz Tost the team principal, adds to that sentiment. 'We are not where we should be in terms of reliability as we had eight non-finishes out of the first 18 car starts, or nine races. That is not good enough. In addition, the team has not been perfect, making mistakes that led to faults like suspension failure. The solution is straightforward, we simply need to be more disciplined in order to avoid making further mistakes,' he stated openly during the mid season break. 'We will come up with some further developments, including a new aero package in Singapore, with more to come in the last part of the season.'

With this in mind, it seems unlikely that the STR9 will become the second Faenza-built car to win a Grand Prix, but it could improve and in that role take crucial points away from bigger teams. It will be a car to watch, and not just because of that nose.





# The right tools for the job...

**Enabling exceptional service and supply  
of championship-winning castings.**

By working closely with our clients, we deliver outstanding results.  
Right people, right technology, right expertise. **Right tools for the job.**

[www.gwcast.com](http://www.gwcast.com)



EXCELLENCE THROUGH INNOVATION™



GRAINGER & WORRALL



RACING

**BALANCED BRAKING PERFORMANCE**

**All the way to the APEX**

**B**ITE

**D**ECELERATION

**M**ODULATION

**R**ELLEASE

THE DRIVER'S  
PAD

# FERODO RACING BRAKE PADS

developed and engineered to perform in all four phases of the braking event.

In addition to the bite and deceleration expected from a world class race pad, Ferodo pads offer the superior modulation and instantaneous release for maximum exit speeds.



[www.ferodoracing.com](http://www.ferodoracing.com)

**Circuit Supplies (UK) Ltd**, Unit 8, Eden Court,  
Eden Way, Leighton Buzzard, Beds LU7 4FY  
Tel: 01525 385 888 • Fax: 01525 385 898  
[info@circuitsupplies.com](mailto:info@circuitsupplies.com)  
[www.circuitsupplies.com](http://www.circuitsupplies.com)

SELECTED RANGE NOW AVAILABLE  
THERMALLY BEDDED



# F1 power struggle

**A change to the Red Bull's downforce setup pays off at Spa, while Caterham's stand-in driver André Lotterer invites some illuminating comparisons between F1 and LMP1 performance**

By **SAM COLLINS**

**R**ed Bull Racing arrived after the summer break not expecting much from the high speed tracks at Spa and Monza. 'Possibly, at Singapore we have a chance', said a thoughtful Adrian Newey after the free practice sessions. 'I think it goes without saying that the circuits that have the shorter straights are the ones that suit us best. It is likely this race will be damage limitation unless weather plays a part in the race and we manage to get that right or unless we are plain lucky, then given a sort of normal dry race, it seems very unlikely that we will be battling for the win.'

Yet 48 hours after that, Newey's RB10 design won the Belgian Grand Prix, a track that in the past had the longest full-throttle section in F1. During the race, Red Bull was hitting 342km/h at the end of the first sector, was clearly running in a low drag setup and had the smallest rear wing of any car on the grid.

One other major difference on the Red Bull was a decision to change its gear ratios. In 2014, teams have to run identical ratios for the entire season with the exception of a single irreversible change of gear ratio pairs and dog rings for re-nominated ones. Red Bull decided to take up this 'wild card' option during the Belgian GP.

Despite the tiny rear wing and revised gear ratios, the Red Bull's straight-line and lap speed was not enough to match the Mercedes W05s, which achieved a peak speed of 337km/h in damaged condition at the first intermediate, but ran a much larger rear wing. These speeds, are of course, influenced by traffic and DRS.

'We took a gamble and ran a very low downforce configuration,' Red Bull team boss Christian Horner admits. 'I think for Monza we will have to take the wing off, I apologise to our sponsors who were totally invisible on that wing this weekend,' he joked, as his driver stood on top of the podium. 

**In wet conditions, the LMP1 on Michelin tyres is a very potent machine indeed compared to a Caterham on Pirellis**

The Caterham CT05 gets to grips with a wet track during the Belgian Grand Prix at Spa. Technical test feedback from LMP1 driver André Lotterer suggests there are lessons to be learned from sportscar racing





Rear wing set almost flat, Red Bull found some speed at the expense of downforce...



...while Mercedes seemed to have enough grunt to run a steep wing and still go faster

But perhaps it was only half a joke. For most of the race weekend, the silver cars were over a second clear of the field and the only reason that they did not take another dominant victory was a lack of discipline from its drivers.

The larger wings of the Mercedes, perhaps the biggest on the grid, suggest that the Mercedes PU106 A power unit remains the most powerful in Formula 1.

## Renault improvements

However, despite the Red Bull being fully trimmed out, trap speeds in other cars – such as the Toro Rosso (338km/h) – suggest that the Renault RS34 power unit has been improved in terms of performance. But the Parisian power unit still clearly has some reliability issues and crucially these mean that Renaultsport can continue upgrading its product to resolve that unreliability and those updates regularly bring performance as a side effect.

One team that may benefit from that is Caterham, which contested its first race under new ownership and arrived with the first



After a change of ownership, the Caterham's nosejob is the first major update to the car in many months

significant update to its CT05. Most notable was its new nose which has done away with the distinctive 'cheese wedge' section in favour of a smoother, more rounded solution. Caterham had expected to introduce a major aerodynamic update at the Spanish Grand Prix many months ago, but the uncertain status of the team's long term future stalled development. This now seems to have restarted.

Also brought into the team for the Belgian Grand Prix was Audi WEC and Toyota Super

Formula driver André Lotterer who, it was hoped, would give good technical feedback on the car's performance.

'There is a lot more power – it would be nice to have that much power in an LMP1 car, but then in the corners it is the opposite,' Lotter told the media. 'I think our Michelin in WEC tyres are a bit better, we can push them much harder and do over 700km on one set of tyres. There's more downforce as well, so you can push an LMP1 car a bit more in the corners, so that was the surprising thing. But we did come here a bit low on downforce, so I expect the car to become better. But you do have to restrict yourself and apply yourself a lot.'

These comments are interesting when comparing the sector times at Spa between a 2014 specification Audi R18 and the Caterham CT05. In the first sector of the lap, which is maximum acceleration to top speed, the R18's best sector during the WEC meeting is 104 per cent of that of the F1 car. In the second sector, made up mostly of corners, it is 105 per cent off the pace compared to the CT05. Most curiously though, in the final sector, almost entirely made up of a flat-out uphill run back to the start finish line with just one braking area, the R18 is only 102 per cent off the green car's best time.

The above comparison was done using the best sectors of both car types on a dry track, but it is also possible to compare sector times in wet conditions. The R18 actually set faster times in all sectors in the wet WEC qualifying session at Spa, and its times in sectors 2 and 3 would have been quicker than the entire F1 field. Its best lap in the wet is faster than the best time set by a Formula 1 car in the same conditions.

Of course, the amount of standing water, air temperatures and fuel loads are all likely to have varied, and it is worth highlighting that the R18 is built to a minimum weight of 870kg and the CT05 to 691kg. But none the less, this all suggests that, at least in wet conditions, the LMP1 on Michelin tyres is a very potent machine indeed compared to a Caterham on Pirellis.

## Adrian Newey on education

Red Bull's junior team, Toro Rosso, has signed a 16-year-old driver to race for it next season. He will be the youngest driver in the history of Formula 1 and his youth has raised many eyebrows and some criticism. Adrian Newey, while not directly critical of the signing has raised concerns about the educational welfare of young racing drivers. 'I don't think age *per se* is particularly important. Over the years we've seen a huge spread in driver ages: Fernando is still one of the very top drivers but has been in it for many seasons. I think Nigel Mansell was 40 years old when he won. Formula 1 is a sport where drivers,

providing their motivation remains, can have a very long career, so you could argue that when they enter is not that important. I think what is a much more concerning question, personally, is the effect on education that happens for these drivers to get there at that age. A lot of the drivers in karting and in junior formulas frankly just aren't going to school. They don't go to school at all. The parents then hide behind that by saying that they have private tutors, but I think in many cases – not all, I'm sure, but in many cases – that's actually a complete sham. I think that if you asked a lot of those kids to sit their baccalaureat or GCSEs, or whatever,

it might be that the results would tell a fairly depressing story. So all credit to the few kids that do get through. Fantastic. There's something to be said for being at a motor race and so forth, the kids do learn in a different way, though not academically. But I think for many of those children that don't quite make the grade, they have spent all that time not going to school, not having a proper tuition, and then what happens to them afterwards is altogether another question. It's something which motor racing as an industry urgently needs to look at, because personally I think we're being irresponsible allowing that to happen.'

# TEST DRIVE OUR NEW WEBSITE



[www.fhsracing.co.uk](http://www.fhsracing.co.uk)

**Flexible Hose & Fittings**

**Rigid Lines & Swagette**

**Filtration**

**Solenoid valves**

**Ancillary Parts & Services**

With full information on our products and services, plus an inventory of product downloads, our website is the ideal place to start planning your next fluid transfer assembly, whatever your formula of racing. Check it out or call us at the number below for an intelligent conversation. Make the connection.

- 3D cad design service
- hose assembly
- hard-line manufacture
- cnc machining
- filtration design
- laser marking

**FHS**  
MOTOR RACING

**+44 (0)1753 513080**

**INTELLIGENT CONNECTIONS**

# Rearguard traction reaction?

Toyota's new front engine, rear-drive WRC challenger could herald a return to classic tail-out rallying in the intermediate classes

By **MARTIN SHARP**

Lower than its compact hatch rivals and with power going to the rear wheels, Toyota's GT86 CS-R3 coupé has plenty of driver appeal



The Audi Quattro's four-wheel-drive and turbocharger heralded a change in the layout and technicalities of rally cars. The German stormer hit the sport at a time when the technical regulations were due to change from Group Four to Group B, and top competitive rally cars were predominantly rear-wheel-drive, like their volume production sisters.

All the top Group B cars were four-wheel-drive, but by the time Group B was banned from the beginning of 1987, many road cars had become front-wheel-drive. Initially there were just two four-wheel-drive turbo cars in Group A (the default highest category after the Group B ban); the Mazda 323 4WD Turbo and the Lancia Delta HF 4WD (later to become Integrale). While the Mazda's 1.6-litre

turbo engine was not sufficiently powerful in opposition and its transmission proved weak, the 2-litre turbo Lancia dominated as rival teams rushed to produce and homologate similarly equipped cars for rallying.

Rally cars in Group A and Group N categories must be equipped with the power train layouts of their qualifying production cars. Hence, outside of the 'homologation specials', front-wheel-drive rally cars have predominated over recent years.

This year, there has been an inspiring development – the return of rear-wheel-drive to rallying at world level. The front-engined rear-drive Toyota GT86 CS-R3 is a refreshing approach to the R3 class, and Tuthill Porsche's rear-engined rear-drive 997-based 911 is an early contender for spoils in the R-GT category.

We'll bring you full details of the R-GT Porsche next month, but first here's the pukka Toyota GT86 CS-R3... and a rather different Toyota.

## Evocative heritage

Toyota big boss Akio Toyoda first drove the GT86 'WRC' in Finland on the 29th July (see sidebar); the day before TMG announced its rear-wheel-drive GT86 CS-R3 rally car would debut as zero car with Isolde Holderied behind the wheel on Rally Germany, the next WRC round a little over two weeks after Finland.

TMG's initiative to introduce a modern rear-wheel-drive car to rallying has certainly fired the imagination of many fans – and prospective customers. Back in the day there were many evocative rear-wheel-drive Toyota





TMG's welded-in rollcage and stiffening structures for the rear-wheel-drive GT86 CS-R3 are shown in red

rally cars, perhaps the most notable of which was the African rally-conquering Group B TA64 Celica Twin Cam Turbo.

The last rear-drive car to win the WRC was Lancia's 037 Rally in 1983; but that was mid-engined and supercharged. The last 'old-conventional' (front-longitudinal, rear-drive) car to win a WRC rally was Didier Auriol's turbocharged Sierra Cosworth on the 1988 Tour de Corse. The normally aspirated GT86 CS-R3 also has that 'conventional' layout, but it won't be winning WRC events outright.

As its name implies, the Toyota will be homologated into the FIA's R3 category; territory of the Citroën DS3 R3 and the recently announced Renault Clio R3, both 1.6-litre

turbocharged front-wheel drive machines. TMG's Customer Motorsport engineering boss explained that the normally aspirated 1998cc four-cylinder 'boxer'-engined GT86 is part of a long-term plan for a TMG customer motorsport range covering both rallying and racing bases.

This was launched two years ago with the Yaris R1A, followed shortly by the GT86 Cup. The latter is a race series, known internally as V3, in which the cars are close to production specification and has provided TMG with much insight to the GT86 in competition: 'We know the strong and the weak points of the car and we've made now two years of experience with this car and for sure all these experiences are helping us – or have helped us already – to develop the R3 car,' explains Nico Ehlert, TMG's Principal Engineer, Customer Motorsport.

### FIA approval

It was plainly evident to TMG's customer division that stepping up from the R1 class in rallying had to be the next step. After investigating each rallying category as a customer rallying series, R3 is seemingly the most applicable and interesting to TMG. Having scrutinised the regulations, TMG contacted the FIA over the feasibility of the GT86 as an R3 car.

The rules covering the FIA's current 'R'-type technical regulations for rally cars are still based on the 'Touring Cars or Large Scale Series Production Cars' Group A requirements, which mandate a minimum of 5000 cars to

be produced over a period of 12 consecutive months and require certain minimum cockpit interior specifications and dimensions for eligibility. Although the GT86 is yet to be homologated into R3, in the second week of June this year the FIA technical delegate carried out a factory inspection in Japan to validate numbers, and confirm the car's interior complies with the Group A rules.

The production coupé does have four seats – albeit low buckets suited only to short-legged (preferably below-knee amputee) gnomes in the rear – and it is claimed to be the most compact four-seater sports car available today.

The internal dimensions 'are perfectly OK [to comply with the FIA rules],' says Ehlert. 'We know it's a small car [inside]; the interior is not that luxurious [commodious] like on other series cars like a Golf or Polo, but it's still suitable and I think from the beginning somebody had it in mind to design it in that direction [to comply with Group A interior dimensions]. It fits very well.'

R3 homologation is planned for the end of 2014; although this depends on FIA timing, but it will be approved by the end of January 2015 latest. Hence the car that appeared at Rally Germany was in the prototype phase, and not all component designs – or suppliers – were 100 per cent confirmed. Running as zero car on that rally was part of the team's overall test schedule; a good opportunity for the team to show the car in public and at the same time obtain some worthwhile proving of components and systems

# SAVE over £26

WHEN YOU SUBSCRIBE TO **RACECAR ENGINEERING**

**ALSO AVAILABLE AS A DIGITAL EDITION £34.99**

#### SPECIAL UK PRINT RATES:

**Annual Direct Debit – 12 issues for £44.95**

(usually £71.40)... **SAVE OVER £26**

**Debit/Credit Card – 12 issues for £49.95**

(usually £71.40)... **SAVE OVER £21**

#### SPECIAL OVERSEAS PRINT RATES:

**US Debit/Credit Card – 12 issues for \$99.95**

(usually \$162)... **SAVE OVER \$62**

**ROW Debit/Credit Card – 12 issues for £64.95**

(usually £99)... **SAVE OVER £34**

- ◆ Choose print or digital
- ◆ Never miss an issue
- ◆ Get it before it hits the shops
- ◆ Keep ahead of the competition



**TO ORDER:** Go to [www.chelseamagazines.com/racecar-P410](http://www.chelseamagazines.com/racecar-P410)  
 Or call: **01795 419837** quote code P410 **Digital edition:** [www.chelseamagazines.com/racecar-P410D](http://www.chelseamagazines.com/racecar-P410D)

# CS-R3

racing by **TMG**



## JOIN THE RWD REVOLUTION IN RALLY



The GT86 CS-R3 brings the thrills and spectacle of rear-wheel drive rallying back to the stages for the 2015 season.

TMG, with its proud rally history, has focused on weight reduction as well as safety, fun and value for money.

Designed according to FIA R3 specifications, the CS-R3 is eligible for local, national and international championships, including WRC 3.

An introductory price of €79,000 (+ VAT) for orders before February 2015 makes the CS-R3 an attractive option for professional and amateur alike.

An upgraded engine delivers 240-250hp while a six-speed sequential gearbox and limited slip rear differential give a true motorsport feel.

The first cars, including rally-specific items, complete powertrain and OE bodysell with safety cage, will be delivered in kit form within Q1 of 2015.



Toyota Allee 7, Cologne, 50858, Germany | +49 2234 1823 0 | [motorsport@toyota-motorsport.com](mailto:motorsport@toyota-motorsport.com)

[www.toyota-motorsport.com/motorsport](http://www.toyota-motorsport.com/motorsport)



**Affordable and exciting to drive, Toyota hope to attract a number of customers to the CS-R3 kit at an initial €79,000 plus VAT**

on actual WRC stages. TMG is fully prepared to make changes to parts depending on driver feedback from the Rally Germany testing, and plans to make all such modifications in-house.

The car is designed with customer budgets firmly in mind. Ehlert: 'Currently the plan is that the R3 is always close to production and we always have to stick to regulations. Certain parts are not allowed to be modified; or be redesigned to a complete new part: sometimes the regulations restrict you by saying you can modify the existing OE part but not build, or design, a

complete new part. So, depending on the part, and on the regulation, you are [sometimes] allowed to design a new part. This we will do definitely if we see a real performance benefit, otherwise if it's not allowed or the benefit is not there then we will redesign or rework the existing original one.

'It's a matter of cost for the end customer; what is the best solution? If this part is proven and applicable, the OE part, then we do some modification that keeps the spare part cost for the customer extremely low rather than designing a new part.'

Running gear decisions are not yet finally formed; currently the front uprights (rear-drive car, so less stressed than those in a front-drive) are original, but the team will investigate the feasibility of modifying the standard front uprights after final early testing, particularly on gravel; while some parts in the rear wishbones will definitely be new designs.

Geometry, however is specific: 'We have a complete kinematic model of the whole car, front and rear. The road car is mainly made for fast and comfortable driving; we wanted to keep that DNA – of a Toyota-built car. This is our first aim because this car is, from the production model, already fun to drive.

'So we would like to keep the DNA but the intention is to adapt this to rallying. Some adjustments to the kinematics for sure need

to be done in order to make a proper rally car.' Ehlert will not currently be drawn on the planned amounts of wheel travel, but says that the car will have similar amounts of wheel displacement to that of other R3 competitors.

## Coupé advantages

The low-slung GT86 is not a hatchback saloon, of course: 'I would say the car is a completely different platform to all the other competitors, especially the competitors being Citroën and Renault's recently launched Clio R3,' says Ehlert. 'As we are launching a coupé, the exterior dimensions in terms of height and wheelbase are completely different to what they offer, so our strategy is completely different.

'The centre of gravity of this car is very low, and this is a big advantage, not only on the race car; it's a big advantage everywhere where you are looking for race [competition] applications. And this makes, definitely, the car. Besides the rear-wheel drive, which is the most unique point, the centre of gravity is absolutely a unique point of this car.'

However the currently quoted 240bhp to 250bhp maximum R3 output from the TMG-modified Toyota/Subaru horizontally opposed four-cylinder engine is a matter of some conjecture. This is a hike from the standard car's 197bhp through revised camshaft designs, HJS exhaust manifold and system plus motor sport-

**“I would say the car is a completely different platform to all the other competitors, especially the Citroën and Renault”**

## Pirelli plays its WRC tyre joker

While Formula 1 folk enjoyed a mid-season 'break' – by mostly sitting sipping cocktails on a yacht off the Costa Smeralda – World Rally Championship people had been pretty busy on theirs.

Rally Finland was the first WRC event after that break, and French tyre manufacturer Michelin appeared with its – fully approved – new gravel tyres. They offered a commitment to the series until 2016; and a completely revised range of asphalt covers for Rally France and beyond.

Meanwhile, Formula 1 tyre supplier Pirelli showed up in Finland after the WRC summer break with its new joker Scorpion 'Reinforced K' gravel tyres for world championship rallies. This came as something of a surprise, as it was not expected by many.

For the first part of the 2014 season, Pirelli had offered its XR tyre as its approved gravel specification, featuring a wider contact patch with a comparatively closed tread pattern. In effect, it was a gravel tyre which worked well on smooth, clean dirt.

Yet it proved to be not so effective when conditions became looser, working more like an asphalt tyre. The particular stage surface characteristics of Finland and the gravel rallies to come this year in Australia and Great Britain encouraged Pirelli to play its joker before Finland.

Before this year's XR, the firm's gravel rally tyre was the K-type tyre, which suffered durability issues in the most rigorous WRC events, but this new Reinforced K version shows more promise in terms of survival.

So, for the forthcoming rougher 2014 events the Reinforced K has been introduced. Few people knew about this new Reinforced K gravel Pirelli, including the FIA, which holidays too.

As a result, approval came late. A Pirelli spokesman explained that there was 'nothing that was out of expectation from the norm when it comes to dealing with the FIA. Nothing that was a big deal in the end.'

However, after gaining approval for this joker tyre, there was no time available before the Finnish rally to either produce sufficient Reinforced K tyres to suit demand. Nor to effectively promote their arrival.

Jarkko Nikara was the driver chosen to monitor the performance of the new Pirelli tyre in Finland because of his potential for fast times,

given his full-on 'shit or bust' approach to the event in his rented Ford Fiesta RS WRC.

Sadly for Pirelli, that approach was bust by a rally-ending crash from 11th place on stage three. 'There was always that risk as well – but nobody expected him going off on stage three! Now we don't really know what went on with the tyres,' said a Pirelli spokesperson.

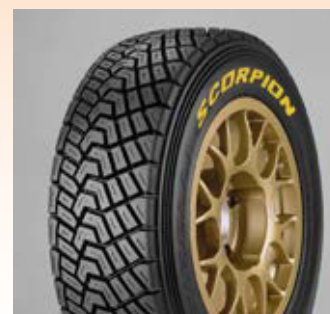

**The Italian tyre manufacturer showed up in Finland after the WRC summer break with its new joker 'Reinforced K' gravel tyres**



WWW.REIGERSUSPENSION.COM  

The best suspension for:

- Rally
- RallyCross
- AutoCross
- MotoCross
- Trial
- Quads
- Sidecar Cross
- Rally Raid

Reiger Suspension BV  
Molenenk 5a  
NL-7255 AX Hengelo Gld.  
Tel.: +31 (0)575-462077  
Info@reigersuspension.com



**REIGER**  
Racing  
Suspension

# SOLE UK DISTRIBUTOR FOR **texense** SENSORS

used by over 90% of the F1 grid



## Renvale Harnessing & Sensors

Renvale is a leader in electrical harness manufacture for all major motorsport categories. We are specialists in full system design, trackside support and are the sole UK distributor of Texense sensors.

### Texense Sensors

- Texense huge range of temperature, inertial and aerodynamic sensors are used by over 90% of the F1 grid
- Texense Infrared sensors are used by the major tyre and brake manufacturers, giving the customer accurate data correlation
- All Texense CAN sensors are now offered with CAN multiplexing to optimise logging table capacity

### Texense Wireless Sensors



#### Wireless IRN-RC-W flexible multi-head sensor

- Option from 3 to 8 sensing heads.
- Designed specifically for closed wheel cars and Moto GP and WSB Swingarm mounting.
- Connects into the wireless emitter.



#### IRN-RC-W Wireless Emitter

- Robust 868/915mhz transmission.
- One emitter connects to each sensor.
- User changeable primary lithium battery with accelerometer based intelligent wake-up.



#### Wireless Master Receiver

- Fully programmable using Texense android app.
- Capable of pairing with up to 12 x IRN8-W wireless sensors.
- Sophisticated wireless key system allows hot swap between any of the 12 sensors paired to it.



Visit our online shop at [www.renvalle.com](http://www.renvalle.com)

Find us on:   @RenvaleLtd  [www.texense.com](http://www.texense.com)

specific proprietary management hardware with TMG-developed software. However, 'it's been difficult to get the power out of the engine, especially as we are forced to reduce the compression ratio. The FIA regulation is 12:1 and we want[ed] to declare either maximum 12:1 or as per the original, which is 12.5:1. But that was not possible, so we had to reduce the compression ratio. We lost a bit of power and then we had to increase it: but I'm quite confident that we have certain development stages – engines are currently running on dynos in parallel and we will hopefully end up with the expected horsepower.' It is understood the prototype CS-R3 running as zero car on Rally Germany had 235bhp.

Ehlert concedes that a 400cc capacity advantage with the normally aspirated 2-litre does not meet the torque output advantage of

the CS-R3's turbocharged 1.6-litre rivals: 'With a normally aspirated engine you will not get the torque as from a turbocharged engine. This is comparing two different things.'

He remains upbeat however: 'We know already, from testing, the advantage of our competitors is there but we think that we could compensate this with better traction. The traction of the car is quite good already, especially from first to second gear – or first gear out of a hairpin corner. And if you have this high torque on a front-wheel drive it's sometimes difficult to get the power down to the track and I see already a little advantage.'

The GT86 has a very favourable weight distribution (R3 is exclusively two-wheel drive, and the GT86's front-drive rivals have predominantly heavier front ends), a significantly superior centre of gravity and the throttle

customers can compete in the same class at the same [price] level. It's quite likely our option list will be similar to rivals.'

The six-speed sequential transmission and plate-type mechanical rear limited slip differential – with various final drive ratio options – are Dutch-made Drenth units with the rear lsd in the standard casing: 'It is appropriate enough, and this makes it easier to source from existing parts and keep the costs lower for the customer.'

Customers can buy all the relevant TMG CS-R3 competition parts instead of a complete kit, but currently the possible option of using a donor car to build an R3 GT86 is under investigation. Ehlert: 'It would definitely be very tricky, looking at our field of applications.'

## DIY not an option

'And knowing those customers are taking a bare chassis from an accident car or whatever, taking our kit and putting it in there; and building their own [installing the TMG] roll cage, we cannot fly over to inspect the roll cage [installation]; for sure that is logistically not possible. Basically, I'm sure there will be a customer who wants to build on their own; but [then] it's not FIA-spec any more, it's not R3 spec because the bodyshell and roll cage need to come from us. So for national rallies or some rallies which don't stick to the R3 rules this is quite typical,' says Ehlert.

Renowned rally engineer Jean-Claude Vaucard; the man behind the designs and successes of all PSA's top rally machines from the Peugeot 205T16 on, and a talented driver, is now retired – and still a rally fan: he was at Rally Germany to spectate.

He told *Racecar* that, two years ago, he was one of the drivers in a sports car group test for a French magazine, his opinion: 'The [standard] GT86 is a good car, I really enjoyed driving it. We wholeheartedly voted it as the best in the group. As an R3 rally car, it should be fun.'

Following the rally, Ehlert gave his verdict: 'Overall it has been a very positive experience for us and an important step in the development of the CS-R3,' he said. 'The was a first prototype so we expected some challenges but I am pleased to say the weekend was smoother than expected. Being in an environment where time is limited and the pressure is high gave us the chance to understand not only the performance of the car but also its operational needs. We have found a few areas to improve both in terms of technical performance and service park handling. As well as a positive weekend from a technical point of view, it was also great to see how the CS-R3 has been received. Fans were really happy to have a rear-wheel-drive car back in rally and the customer interest has been very encouraging. It's a rear-drive, normally aspirated front-engine, nicely balanced, FIA-legal rally car. A comparatively low cost sideways special with a tremendous heritage. For gentleman drivers wanting something fun to race – to go out there and have have a real blast.



## “Fans were really happy to have a rear-wheel-drive car back in rallying”

response advantages of normal aspiration must go some way to balancing the R3 Toyota's potential against rivals on certain events.

Certainly, with rear-wheel-drive this car has many more component parts than its front-drive rivals but TMG's experience with the GT86 Cup racers has highlighted which bits can shed weight and the team is confident it will be able to meet its 1080kg R3 class weight limit target for customer cars. The prototype car running on Rally Germany weighed-in at 1120kg.

## Competitive pricing

Before Rally Germany Ehlert was confident TMG could hit an R3-competitive price target: 'We have a little bit of a disadvantage because with the rear-wheel drive we have a lot more parts in the car – this makes definitely the car, on the first thinking, more expensive; but we have designed it cleverly, we have a clear strategy and I think we will really really be on a good competitive [price] level.'

This was proven when TMG announced the price of a tarmac specification GT86 CS-R3 kit at Rally Germany. The kit contains all rally-specific mechanical components, the complete drivetrain and all OE parts including bodyshell complete with welded-in roll cage for assembly by the customer. For orders confirmed before 31 January 2015, the kit costs €79,000 plus VAT. After that date, it rises to €84,000 plus VAT.

Rival R3 manufacturer option lists are extensive and influence final total cost; Toyota's CS-R3 option list was not available at press time, making direct comparison not possible. Yet, 'if you sell a product like this your aim is that

### TECH SPEC

#### TMG GT86 CS-R3

**Engine:** TypeFA20

**Layout:** Boxer, flat four

**Displacement:** 1998cc

**Max. power:** 240-250hp

**Exhaust:** HJS racing exhaust + exhaust manifold

**Fuel cell:** 75ltr FT3 safety cell

#### Chassis:

**Bodywork:** Steel monocoque bodyshell and roof ventilation

**Roll cage:** Homologated R3 safety cage

#### Transmission:

**Type:** Rear wheel drive

**Gearbox:** Drenth 6-speed sequential

**Differential:** Drenth limited slip differential with variable ramp settings

**Final drive:** Short final drive, options available

**Clutch:** Racing clutch and lightweight flywheel

**Steering:** JTEKT hydraulic power steering with quick ratio

#### Suspension:

**Type:**

**Front:** MacPherson type

**Rear:** double wishbone

**Shock absorber:** Tarmac: Reiger, three-way adjustable

**Gravel:** Reiger, three-way adjustable

**Anti-roll bar:** Several options

**Rims:** Tarmac: OZ 7" x 17"

**Gravel:** OZ 6" x 15"

#### Brakes:

**Front disc:** Tarmac: 330mm x 30mm

**Gravel:** 300mm x 30mm

**Rear:** Tarmac: 300mm x 10mm

**Gravel:** 300mm x 10mm

**Calliper:** Front: Four-piston

**Rear:** Two-piston (by regulation)

#### Dimensions:

**Overall length:** Length: 4240mm

**Width:** 1775mm

**Wheelbase:** 2570mm

**Minimum car weight:** 1080kg (by regulation)

## The four-wheel-drive TMR GT86

The Tommi Makinen Racing GT86 features a 4wd layout with a degree of Impreza DNA, transplanted via its close relative, the Subaru BRZ



**D**etail differences between the rear-wheel-drive, normally aspirated Toyota GT86 and Subaru BRZ road cars (badged Scion FR-S in USA) are so minimal it is therefore hardly a surprise the 'breed' has become known as 'Toybaru' in Europe.

However a very different, yet definitive Toybaru appeared at the 2014 Rally Finland. This was a four-wheel-drive GT86 built and developed by Tommi Mäkinen Racing [TMR]. It was driven in public over part of a Rally Finland test stage by four-time World Rally Champion Mäkinen and Toyota Motor Corporation's President and CEO Akio Toyoda, who was there to get a taste of world rallying – and send a strong signal of his company's future intentions.

It was stated at the time that Toyota Motorsport GmbH [TMG] had no knowledge of this four-wheel-drive GT86 project before its appearance in Finland, although the official TMG Customer Motorsport line now is: 'It did not come as a surprise, but this is an activity which we are not involved in. This has nothing to do with any other plans; it is something which is separate.'

It is understood TMG managing and technical director Pascal Vasselon did discuss the car with Japan. The production rear-drive Toybaru GT86/BRZ boasts a favourable 53/47 front/rear weight bias, a low – 460mm from the ground – centre of gravity; with suspension

geometry promoting a petrolhead-pleasing oversteer-based handling feeling.

Achieving this weight ratio however requires the car's longitudinal power train to be located further rearwards than, say, in a four-wheel-drive Subaru. Some consider that, for complexity/cost reasons this production rear-drive machine's standard power train layout precludes an all-wheel-drive option.

However, TMG's Principal Engineer for Customer Motorsport, Nico Ehlert, disagrees. 'Nothing is impossible. If you really want something you can manage for sure, but we in our department are currently looking on [at] customer motor sport and for a customer such a project needs to be definitely cost-effective,' Ehlert states. He continues: 'As far as I know the car that was built [the four-wheel-drive GT86 in Finland] was only the bodyshell – the outer 'shell' – of the GT86: the chassis itself was not GT86.'

### A question of balance

Which, in principle, is partly the case. However, it is not a simple case of a GT86 body over a Subaru Impreza chassis as suspected by some. The GT86/BRZ floorpan is based on that of the Impreza, and TMR's work to introduce front drive involved substituting an Impreza gearbox and removing material from its bellhousing to shorten it. This necessitated

using a special small clutch and shortened gearbox input shaft.

Its 2-litre Subaru EJ20 boxer four turbo engine ran a 35mm inlet restrictor, a unique exhaust manifold and stronger pistons and conrods. This produced some 335bhp; ball park for a WRC car, although delivered in a more 'lazy' fashion. Modification of the GT86 front end to accommodate these unique engine components apparently caused no major headaches for TMR.

A special propshaft had to be custom-built to take drive to the rear, and the front drive demanded modified Impreza driveshafts, no doubt with Impreza CV joints. A complete Impreza R4 rear suspension was also fitted because of its rose-jointed set-up and the fact installing it in the rear of the Toyota was simply a bolt-in job. Corner weight checks after the work showed almost ideal figures and a similar front/rear weight ratio to the rear-wheel-drive GT86. After his first turn behind the wheel with the car straight out of the workshop, the four-time World Rally Champion pronounced the car as really nice to drive.

At around the time the GT86 'WRC' Toybaru appeared in Finland, TMG's Global-engined Toyota Yaris WRC prototype was testing on gravel, but TMG's Customer Motorsport people would only comment: 'This not a project coming from our side.'



# We win.

## Do you?

- 30 years' experience of delivering solutions for any requirement.
- A proven pedigree of titles at every level.

**31 World Rally Championships**

- Major WRC, F1, WTCC, NASCAR and Rally cross supplier.
- An innovative, forward-thinking ethos.

**5 Le Mans 24-hour race wins**

- Manufacturers of quality carbon, sintered and cerametallic clutches.
- The authority in braking technology.

**9 IRL Championships**

Alcon specialist brakes and clutches - providing quality braking solutions in motorsport and beyond for over 30 years.



Rally



Touring cars



Rallycross



Dakar



NASCAR

T: 01827 723 700  
E: [info@alcon.co.uk](mailto:info@alcon.co.uk)  
W: [www.alcon.co.uk](http://www.alcon.co.uk)

**alcon**  
specialist brakes & clutches



# Rally rules 2017

**After two-and-a-half years of closed-door discussions between the teams and FIA on World Rally Car regulations, the teams are united in their opinions of the best direction for the future**

By **MARTIN SHARP**

**E**arlier this year, the FIA announced its intention to modify the regulations controlling the design of World Rally Cars from the beginning of 2017 and following Rally Deutschland there were more top-level meetings to establish a clear direction. Top teams have considered the potential options and had preliminary discussions with the FIA during a Technical Working Group meeting, during which each manufacturer team explained what they would like to have.

Nearly all the teams agree to the same ideas, which involve retaining similar rules to those existing, reasoning that 2017 is comparatively close in terms of car development and completely different regulations would mean new developments, and thus more budget.

The FIA has already stated its desire to increase the spectacle in the sport provided by the cars and to make the cars more attractive. Current World Rally Cars are based on B-segment models, and it has been suggested that the base models jump up a segment to the larger C-segment cars. Additionally, there are potential moves toward increasing engine power, and possibly enabling manufacturer teams to diversify the type of engines used through metered fuel flow.

However, the only manufacturer which is prepared to consider C-segment WRCs is Hyundai, as its team boss Michel Nandan explains: 'Hyundai doesn't care if it is B or C segment. The marketing department doesn't care because this programme is more related to marketing than to motor sport. Marketing-wise, B or C is important – one or the other – but Volkswagen, Citroën and Ford prefer B-sector, so OK, let's go with that. One thing that we were quite keen on was that when you have the WRC car it should at least look like the production car – for the marketing it's really important, so we don't really want a silhouette car.'

Conversely, currently without a mainstream corporate marketing department to please, M-Sport supremo Malcolm Wilson has his own ideas on the subject: 'For me, you just make them look a bit more lary... make a wider rear wing, make them look really horny, make them look aspirational – look WOW!'

Wilson also points out: 'If you went C class you'd end up with all the C class looking the same. We could do the [Ford] Focus as a big car, it would still be down to the same weight. We could still do a Focus now if we wanted under the same regulations [as current]. When you think how big the last Focus WRC was... that was a big car, and we were still on the weight.'

Retired legendary rally engineer Jean-Claude Vaucard, who was responsible for the design of some of the most successful PSA rally cars, compares the Citroën Xsara WRC and DS3 WRC to make a further point: 'To be at the weight limit with the Xsara was a big job because the body was heavy. It was very expensive to modify the body to reduce the weight.'

'With the DS3, you're not allowed to touch it. Effectively, you pay for nothing on the body. So, on this point, it was not too expensive and not a big job. You can change a body almost

immediately, but when you have to change a chassis, [in the case of the Xsara] it was months and months to work on the car.'

M-Sport has been running a Fiesta WRC with a 34mm restrictor, which doesn't produce a great deal more power than when equipped with the current WRC-legal 33mm diameter unit. However, as Wilson points out: 'if you changed to a better turbo, went away from the [current] FIA regulation turbo and went back to what the previous [WRC aspiration equipment] was, then you could probably get good power. But then, of course, the cost of the turbo would go from between £3000-£4000 to £10,000.'

On the subject of more speed for WRCs, Wilson makes a particularly valid point: 'The one thing that frustrates me is people saying the cars need to be faster. Because, I'd like to put all of the people who were saying that in the passenger seat of a World Rally Car, put them in with a top



**“Make a wider rear wing: make them look really horny, make them look aspirational – look WOW!”**



The FIA needs to control costs to keep manufacturers involved in any future WRC series, but most teams are keen to avoid the silhouette cars seen on the South American Maxi rally series, as typified by this Argentinian Chevrolet Agile



Designer Jean-Claude Vaucard spent a lot of money getting the 2006 Citroën Xsara shell down to race weight, a cost that all teams want to avoid



Toyota is waiting in the wings with the new Yaris WRC and is thought to favour a hybrid formula for the future

driver and then, when they come out of the car ask them to hold their hand still and tell me that the car should be faster!

Given the concept of FIA metered fuel flow and freeing up of engine rules, the manufacturer teams (current – and potential, ie Toyota) are in concert that hybrid power trains are not the answer for a current rally car. 'Nobody wants hybrids,' says Hyundai Motorsport's Nandan. 'I think it would be quite expensive, and could be dangerous in some aspects.' Wilson is adamant on the topic: 'If it goes to hybrids then we're out of business, because I don't have the sort of money to develop [the systems]. For me, if we still had Ford and Ford was interested... but at the moment it's the last thing I would need.'

Volkswagen Motorsport's chief engineer François-Xavier Demaison is certain: 'The costs will go ballistic,' says the Frenchman. 'OK, maybe you could interest one manufacturer, but scare off four or five others. Just to test this solution

## With all drivers effectively driving to the capabilities of their tyres, they tend to post very similar times

will be expensive. Expensive in terms of parts and development. So I don't plan at the moment to put a lot of money or energy into the technical part of rallying. I think more of the promotional aspect has to be looked at first.'

'Technically, everybody would like it much as it is,' says Nandan. 'Especially for the engine, because this is what is costing the money. That, and the chassis. If we want hydraulic diffs it would be expensive. What everybody agreed is that it has to be regulation like it is now in order to control the cost. In the evolution of the [current] regulation, the cost control was quite good and we don't want it costing more.'

### Power hike

Nandan has doubts about the suggested fuel metering concept. 'It's completely different in a rally [compared to circuit] because you have refuelling zones if you really want to control the consumption,' he says, 'I think it's [metering] a lot of things for not a lot. And so I don't know what they [the FIA] will do, because it is just a list of wishes and then afterwards, they say we will do something. They were quite keen to listen to the ideas of the manufacturers.' In fact, the FIA has said little on the subject, apart from stating that details of the new/revised regulations should be known by the end of this season.

All teams are generally agreed that the existing regulations are working well to provide competitive cars at reasonable cost, albeit perhaps lacking some spectacular angles on the special stages for spectators and television.

A slight hike in power is supported by all the teams – something of the order of 80bhp – possibly simply achieved by increasing the diameter of the engine intake restrictor. However, such a move does not necessarily guarantee an enhanced spectacle for the fans for a fundamental reason; the cars' sole contact with terra firma – their tyres.

And this is valid on both gravel and asphalt surfaces. Today's current tyre regulations call for gravel covers to have a close tread pattern. This means a reduced capacity to evacuate loose gravel, thereby restricting possibilities of bold manoeuvres and effectively forcing drivers to stick to the clean line. Which in turn results in a procession of cars looking as if they are comporting themselves in the same fashion.

This has been the case since 2008. Before then tread patterns were more open, and teams were allowed to cut extra sections out of the treads according to upcoming stage conditions. This provided more forgiving circumstances, allowing drivers to venture more boldly – slightly more into 'dirty' parts of the stage surface, and be more spectacular.

### Tyre options

For tarmac rallies, under the 2008-on rules there is just one tread pattern and two compounds. This demands compromise. The Alpine stages of the Monte-Carlo Rally are unique challenges and accordingly require a special approach to tyre selection, yet the tarmac stages of Germany, France and Spain offer subtle differences which are not really catered for by the limited options.

Rally Spain, for example, has a good number of wide stages with smooth surfaces. Speeds are high, but top drivers are restricted in how much they can push because of the ever-present danger of tyre overheating and subsequent damage. Additionally, aggressive steering inputs to the current tarmac tyres can cause road car-like understeer through tyre roll. And these tyres must cope competitively with everything between fully wet and high-temperature dry surface conditions.

And so, with all drivers effectively driving to the capabilities of their tyres they tend to be restricted to very similar lines and, unsurprisingly, post very similar times: 'You have to listen to your tyre and you can't stress it. You can't do anything, you just have to drive clean. So that's not spectacular at all,' says Demaison.

If the tyre rules remain as they are, it is unlikely then that a power hike will affect the spectacle of the cars. Similarly, with the same sort of tyre friction coefficients, widths and diameters, it is unlikely the existing transmission systems will be affected in any major way..

However, the VW engineer's solution to this 'drive to the tyres' situation is hardly rocket engineering: 'For me, on gravel you need to have more choice in the pattern. On tarmac, just put on slick tyres, that's it.' All team engineers and bosses agree. As Hyundai's Nandan says: 'Actually, you can have a spectacular car if you do different tyres.'

An informal meeting between the FIA and various rallying luminaries, after Rally Germany, was followed two days later by the World Rallies Commission, just after our press deadline. It is likely that detail of the new rules will appear after December's World Council meeting. 

# We bring the simulator You bring the models



The most sophisticated 'off the shelf' full-motion professional simulator is now completely accessible using any vehicle modelling package that supports Simulink interfacing.

With ePhyse Net, race teams can run their own unmodified vehicle models with Cruden simulators on their own PCs natively, in co-simulation.

**No compiling code. No need for Real Time Workshop. Simple.**

We also still offer our own fully open Simulink Vehicle Model (CSVM) and can integrate customer MATLAB/Simulink-based models.

Find out more - [www.cruden.com/motorsport/](http://www.cruden.com/motorsport/)

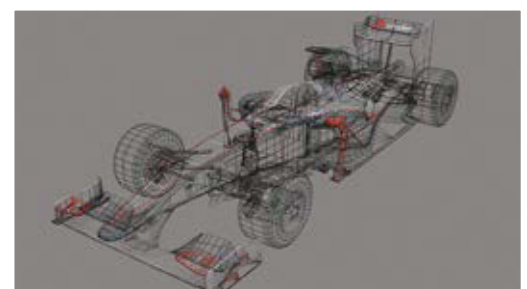

What's the  
**secret**  
about the new 911 GT3 Cup's  
**new brakes?**



**It's Quicker.**



OFFICIAL PARTNER

**PORSCHE**  
MOTORSPORT

**PFC**  
BREMSE



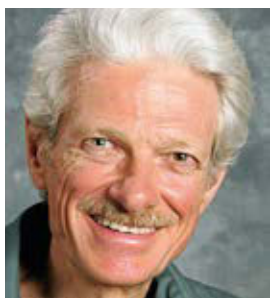

# Real world racecar suspension advice

Racers and engineers pose their questions

## Add front anti-roll bar and reduce understeer

### Question

A very long time ago, I raced in the Bilstein Rabbit series. A rule change finally let us add sway bars to the cars (legally). Despite the car's tendency to push, and a front sway bar's tendency to make understeer worse, the best thing we did was have the front so stiff it was all but welded. Why?

### The consultant says

There are at least two things that can cause an increase in front roll resistance to decrease understeer.

The first is that with independent suspension, any reduction in roll improves camber. If a car has better camber recovery in roll at the rear than at the front, a reduction in roll helps front camber more than rear camber. The most extreme case of this is a car with MacPherson strut front suspension, lowered for racing, and beam axle rear suspension.

The second, which is particularly relevant to front-drive cars, is that as long as the inside rear wheel is off the ground, an increase in front roll resistance does not add any front load transfer at a given lateral acceleration. It will, however, reduce roll, and therefore generally improve front camber. Again, this especially applies to strut suspensions when lowered for racing, as these generally have poor camber recovery in roll.

The Rabbit (Mk 1 VW Golf) has little camber recovery in roll at either end. The front is a strut system. The rear has a twist beam that looks a little like an axle, but it's a trailing arm layout geometrically. The twist beam adds roll resistance and lateral rigidity, but it doesn't provide beam axle camber properties.

My suggestion for a car like that, particularly on a smooth track, is to use lots of anti-roll bar at both ends, with enough at the rear so the car still corners on three wheels – but at a small roll displacement.

The penalty is that some bumps will not be absorbed well. The setup is a compromise between the need to minimize roll and camber change and the need to minimize wheel load changes over bumps.

## Mumford linkage in a Cobra kit car

### Question

I have been researching ways to lower the roll centre on a live axle for a Cobra kit car to solo race and I have looked at the Mumford link. Are the claims that it can set the roll centre as low as you want true?

### The consultant says

Basically, yes. You can set the roll centre as low as you're likely to want to, anyway. More specifically, you can set it below any point on the hardware.

It's questionable whether this is any better than setting it three or four inches off the ground, as you can with a Panhard bar or Watt's linkage in a low-slung solo car.

For those who have never heard of the Mumford linkage, it is a form of straight line motion device similar to the Watt's linkage, but slightly more complex. The Watt's linkage has a rocker and two links. The Mumford linkage has two rockers and three links, one of which just connects the two rockers. There are various ways of applying either concept. The rockers can be close together near the centre of the car, or out close to the wheels. The rockers can be attached to the frame or to the axle.

The July 2011 newsletter discusses at length the various forms of the Mumford linkage and their effects. Back issues are available free upon request.

The car best known for using the Mumford linkage was one of Arthur Mallock's designs. It allowed a low roll centre with a smooth belly pan that swept upward under the axle and into a diffuser.

With a very low roll centre on a live axle rear, you get the advantage of being able to run a lot of elastic roll resistance at the rear, reducing torque roll and torque wedge. There are perhaps better ways to compensate for driveshaft torque using the longitudinal linkages, but if one is already committed to longitudinal linkage that does not have such properties, having lots of rear elastic roll resistance, and a low rear roll centre to go with that, is the next best thing.

A low roll centre means less lateral translation of the contact patches in the roll mode. However, with a beam axle, less lateral translation at the bottom of the tyres in roll implies more lateral translation at the top of the tyres. This requires that the bodywork have room for that. That could be a problem in a Cobra kit car.

The original Shelby Cobra had independent rear suspension. The rear fenders were widened dramatically from the original AC Ace to accommodate the car's big tyres. The aluminium bodywork was closely wrapped around the envelope in which the rear tyres moved. With most designs of independent suspension, the top of the tyres swing in slightly as the suspension compresses, never out. With a beam axle, the top of the tyres go straight up as the suspension compresses in pure ride, and can even move outboard in some combinations of ride and roll displacement.

Manufacturers offering Cobra replicas with beam axles have to widen the fenders a bit more to accommodate the additional tyre movement with that suspension. If one uses a suspension that further increases lateral movement at the top of the tyres, it's likely that further measures will be necessary to accommodate that. That isn't necessarily a reason to throw out the whole concept, but it is something to be aware of.



Some limitations of a live axle Cobra replica can be overcome, but resultant rear wheel movement is not identical to the IRS of the original

## General road racing sedan setup principles

### Question

My background is short track asphalt stock car racing. I do chassis setup and custom valve shocks for guys. I am looking at branching out into the road racing area as I am about to buy a NASA American Iron Mustang. What kind of spring/shock setups do you see in these cars? I hear a lot about stiff springs and stiff compression valving. If that is true, that is the exact opposite of stock cars. What is the

general theory for chassis set up for a fast road race 3000lb sedan?

### The consultant says

First of all, there are three NASA American Iron classes, and they all have different rules, regarding tyres, ride heights, and chassis modifications. And for each of these, setup will vary depending on the track, the thinking of whoever does the setup, and the driver.

However, certain general principles will apply. As noted in the answer to the last question above, for all cars the decision of how stiff to make the springs and bars is a compromise between the need to reduce roll and the need to make the car ride bumps. That never changes, but some tracks are bumpy and some are smooth.

A difference from oval track setup is that we face limitations in using static settings to compensate for roll when the car has to turn both ways. We can set the wheels with static negative camber on both sides of the car. That helps the outside wheel at the expense of the inside one. Up to a point, there's a net gain in cornering, but it comes at a cost in braking, propulsive traction, and tyre wear.

Damping is very much a driver-specific thing, in oval track or road racing. I tend to like stiffer rebound than compression for most purposes. It gives a better ride than stiffer compression, certainly. However, it tends to unload the tyres more over crests, and when really excessive it can make the car jack down over chatter bumps.

I also tend to like stiffer low-speed damping at the rear than at the front, especially for tight turns and chicanes. It helps de-wedge the car on entry and wedge it on exit.



The variable tight turns and chicanes of road racing demand a more adjustable ride/handling setup than oval tracks

## Pushrod suspension – just at the rear

### Question

In a car with rear pushrod suspension and front coilover a-arms, how does one go about tuning the suspension after setting ride height, camber and caster to suggested values?

### The consultant says

That sounds like a rather unusual design. However, there are not necessarily any particular tuning strategies that are specific to a car that has the coilovers acting through a

pushrod and rocker at one end and not at the other. The thing that matters at either end of the car is the forces at the wheel. Pushrod or no pushrod, there is a motion ratio relationship between the coilover and the wheel. The wheel rate is the spring rate times the square of the spring-to-wheel motion ratio.

With rockers, we have greater opportunities to vary the motion ratio as the suspension moves. We can adjust ride height with the pushrods as well as the rockers. In some cases, that allows us to have the suspension bottom out or top out at different displacements, as in a 'zero droop' setup.

Pushrods also facilitate advanced tricks in suspension interconnection. For example, the DeltaWing car has a clever system at the rear involving a second set of links (pullrods) running back from the rockers to a rocking beam. The beam actuates coilovers that are outboard of the secondary links. In ride, the beam displaces fore and aft, like the top of a T-bar anti-roll bar – which essentially is what it is. In roll, the coilovers have a higher motion ratio than in ride; they displace more than the pull rods. This allows not only the elastic forces

but also the hydraulic forces to be greater in roll than in ride.

It is not true, as is sometimes supposed, that pushrods and rockers make a suspension transfer wheel loads in some dramatically different manner. The springs and bars still exert displacement-sensitive forces and the dampers still exert velocity-sensitive forces, and the tyres don't know what connection there is between the coilovers and the wheels. They only see the resulting forces at the wheel. The car responds the same to spring, bar, and damper changes whether the coilovers act through a pushrod or not. 



Pushrod suspensions transfer the same forces as other designs. The important thing is balancing the car's response to them

### CONTACT

**Mark Ortiz Automotive** is a chassis consultancy service primarily serving oval track and road racers. Here Mark answers your chassis setup and handling queries. If you have a question for him, get in touch.

**E:** markortizauto@windstream.net

**T:** +1 704-933-8876

**A:** Mark Ortiz

155 Wankel Drive, Kannapolis  
NC 28083-8200, USA

# MOTORSPORT CONNECTORS M SERIES



A ratchet screw system enables quick and secure coupling of the connectors.

## An innovative solution for harsh environments

- Very high contact density
- Ratchet screw coupling mechanism
- 6 different sizes
- Lightweight aluminium shell
- 2 to 114 contacts
- Optimum space saving
- Oil and fuel resistant
- IP 68
- High shock and vibration resistance
- Vibration absorption flange
- Arctic grip or knurled design
- Lightning test passed
- USB version available



### LEMO SA - Switzerland

Phone: (+41 21) 695 16 00  
Fax: (+41 21) 695 16 02  
info@lemo.com



Contact your local partner on [www.lemo.com](http://www.lemo.com)



## Two Seminars One Winning Outcome

Get a head start as you begin to design or set up your car for the next race. Register today for our seminars and you'll be armed with all the information and tools you'll need to get to the finish line faster and smarter.

### APPLIED VEHICLE DYNAMICS

This seminar is designed to push participants to go beyond experience and intuition and begin to ask "why," "how," and "how much" specific factors affect the performance of a vehicle. We'll cover every aspect of vehicle dynamics and wrap up with data acquisition and analysis.

### DATA DRIVEN PERFORMANCE ENGINEERING

In this seminar, you'll learn how to use data from simulation, testing, and data acquisition to improve your car's performance. From measurement and modeling to performance prediction, this seminar is filled with practical examples and hands-on exercises that will help you outperform the competition.

## 2014 SCHEDULE

### APPLIED VEHICLE DYNAMICS

September 22-25	Montreal, Canada
September 27-30	Graz, Austria
November 4-7	São Bernardo do Campo, Brazil
November 10-12	Cologne, Germany
November 17-19	Paris, France [in French]
November 21-23	Oxford, UK
December 8-10	Indianapolis, Indiana
December 16-19	Melbourne, Australia

### DATA DRIVEN PERFORMANCE ENGINEERING

November 16-18	Cologne, Germany
December 14-16	Indianapolis, Indiana

For more information and to register,  
visit [www.optimumg.com/seminars2014/](http://www.optimumg.com/seminars2014/)  
or email [susanne.chastain@optimumg.com](mailto:susanne.chastain@optimumg.com)

+1 303 752 1562  
[www.optimumg.com](http://www.optimumg.com)

**OPTIMUM**  
vehicle dynamics solutions

© 2014 OptimumG



# The flying limpet

We take one of the most interesting looking Formula Student designs from the 2014 UK competition to the MIRA wind tunnel

Covering Formula Student gives the *Racecar Engineering* editorial team a close-up view of what's happening in this well-supported competition and, inevitably, the opportunity to make their own judgements about each entry. *Racecar* Editor Andrew Cotton remarked that; 'the University of Bath presented a novel design that we thought merited further investigation, so it was to them that we made the offer of a half day in the MIRA full-scale wind tunnel.'

The University of Bath has been contesting Formula Student for over 10 years, first as Bath University Racing Team (BURT) and since 2006 under the Team Bath Racing (TBR) banner. At Silverstone in July 2014, TBR finished seventh overall and was second highest UK entry with its Aprilia V-twin powered TBR14. This was the third year that TBR had run with wings on

the car, and clearly a great deal of design and manufacturing time had gone into this aspect, especially where the front wing was concerned. TBR was therefore expecting high levels of grip enhancement from its 2014 aerodynamics. What would the wind tunnel results say?

First, a brief tour of TBR14's aerodynamics package is in order. The car (**Figures 1 & 2**) is dominated by its large plan area wings, although it did also have a new cooling package this year, housed in the left hand sidepod (the exhaust is contained within the smaller right hand sidepod). The rear wing (**Figure 3**) is a straightforward large chord three-element design with no span-wise deviation in the selected profiles, mounted high and just aft of the rear axle line. The front wing (**Figure 4**) however, is something of a work of art, featuring a tapering span, variable

span-wise ground clearance, a complex end plate with vertical openings just ahead of the flaps and, underneath, a sculpted chord-wise inverted channel just inboard of the end plate's footplate (**Figure 5**). One might surmise that some Formula 1 influence was exerted here!

On to the first baseline runs then, with the usual caveat about the MIRA wind tunnel's fixed floor and that the test car's wheels remain stationary. The boundary layer control fence, used in all RE's sessions, was in place throughout, but the front wing's ground proximity to the fixed floor will have produced a degree of underestimate of forces and calculated coefficients.

## Speed sensitivity

As usual, the first runs were conducted at different test speeds to check for any changes



Figure 1: Team Bath Racing's nicely constructed TBR14 was dominated by its wings



Figure 2: Front and rear wings were especially potent



Figure 3: Rear wing was a conventional large chord triple-element design



Figure 4: Front wing was a complex design

in the aerodynamic performance. The results as coefficients at approximately 40mph (17.9m/s) and 60mph (26.0m/s) are given in **Table 1**, with the changes reported in 'counts', one count being a coefficient change of 0.001.

The first observation to make is that in baseline trim TBR14 set two new Aerobytes records; the highest drag coefficient and highest negative lift coefficient we have seen in our MIRA sessions. It would go on to achieve even greater heights during the session! Facetious remarks aside though, the aim with TBR14 was to generate high downforce with wings, and this it most certainly did. The inevitable penalty for that is high drag, but the team's approach was to not be concerned about drag; downforce was the target.

The coefficient changes brought about by changing speed initially looked puzzling in some respects. The drag coefficient reduced slightly at the higher speed, as is often seen; but the overall negative lift coefficient decreased in magnitude at the higher speed, and this is not what is usually seen. The front 'downforce' coefficient (-CLf) certainly followed the usual pattern of increasing at the higher speed, this most likely down to improved flow attachment under the front wing's suction surface as speed increased. But for the rear downforce coefficient to reduce significantly at the higher speed was unusual.

We have seen more modest 'speed sensitive' losses of -CL magnitude due entirely to aerodynamic and related mechanical effects in the past, for example on the University of Hertfordshire Formula Student Racing Team's

## The aim with TBR14 was to generate high downforce with wings, and this it most certainly did. The inevitable penalty for that is high drag

UH16 racecar (RE December 2013, V23N12) on which a 75 count gain at the front combined with a loss of 36 counts at the rear. The primary cause in TBR14's case, however, appeared to be that the rear mounts in the rear wing were (inadvertently) allowing the wing to pivot to a reduced angle as air speed increased. Although the difference in wing angle between 40mph and 60mph was not measured, and most of the angle reduction appeared to be at quite low speed, the difference in the -CL values would seem to be most reasonably explained this way, accompanied too, as it was, by a significant drop in drag.

### Inevitable comparisons

For those who haven't already reached for their December 2013 issues, the comparative baseline run data on the two Formula Student cars we have now tested are shown in **Table 2**. The fundamental difference between the two cars' aerodynamic configurations was that the University of Hertfordshire's car featured a dual-element rear wing compare to TBR14's triple-element rear wing.

While the two cars did not have the same aerodynamic balance in their respective baseline configurations, they both had

maximum wing and flap angles set at front and rear, so in that sense the comparison is valid. The main difference was obviously due to TBR14's triple-element rear wing, which required that it needed more front downforce to attain the desired balance (45-50 per cent front) whereas UH16 needed less front downforce to attain a balance.

### Relativity

As discussed in our earlier analysis of the University of Hertfordshire's UH16, the benefit to grip that is derived from downforce is relative to the car's weight. So, **Table 3** shows downforce at 60mph as a proportion of all-up vehicle weight including driver on two high downforce single seaters and on the two Formula Student cars we have tested. Clearly, any comparison between cars running to different regulation sets has little technical validity, but it is of more than passing interest!

The F1 Honda's high minimum weight clearly hampered its downforce to weight ratio, whereas the hillclimber had no minimum weight limit. Both of these designs, however, developed a significant proportion of their downforce with their underbodies, and so downforce values will have been



**Table 1: baseline aerodynamic coefficients on TBR14 at different speeds**

	CD	-CL	-CLf	-CLr	%front	-L/D
40mph	1.446	2.430	0.900	1.530	37.02	1.701
60mph	1.389	2.355	0.970	1.385	41.20	1.695
Change	-57	-75	+70	-145	+4.18	-6
% change	-3.9%	-3.1%	+7.8%	-9.5%	-	-0.4%

**Table 2: baseline data on two Formula Student cars at 60mph**

	CD	-CL	-CLf	-CLr	%front	-L/D
UH16	1.146	1.797	1.055	0.742	58.70	1.568
TBR14	1.389	2.355	0.970	1.385	41.20	1.695
Difference	+243	+558	-85	+643	-	+127



Figure 5: Interesting underside detail on the front wing



Figure 6: Setting up the trip strips on the front tyres



Figure 7: The front wing deflected air over the top of the tyres



Figure 8: The front end plates also deflected air around the outside of the tyres

Table 3: downforce at 60mph as a proportion of vehicle weight including driver

Car	Downforce at 60mph as % of all-up weight
Honda RA107 Formula 1, best configuration	18%
DJ Firestorm hillclimber, best configuration	26%
UH16, baseline configuration	28%
TBR14, baseline configuration	46%

Table 4: the effects of trip strips on the tyres

	CD	-CL	-CLf	-CLr	%front	-L/D
Without, 40mph	1.446	2.430	0.900	1.530	37.02	1.701
With, 40mph	1.470	2.497	0.900	1.597	36.03	1.699
Change	+24	+67	nil	+67	-0.99	-2
Without, 60mph	1.389	2.355	0.970	1.385	41.2	1.695
With, 60mph	1.401	2.409	0.946	1.463	39.26	1.719
Change	+12	+54	-24	+78	-1.94	+24

underestimated by the MIRA fixed floor wind tunnel. The Formula Student cars' front wings may have been held back to an extent by the fixed floor, but their total downforce readings would have been closer to reality on track.

For all that though, UH16's downforce to weight ratio at 60mph was very respectable,

## The TBR14 could drive across the ceiling, if it were able to get there, at a remarkably low 86.8mph

yet it's clear from a glance at the figures that of TBR14 was well ahead, the car generating almost half its own weight in downforce at just 60mph. It should be added that this was partly due to its commendably low vehicle weight, but aerodynamics certainly played the major role. The inevitable calculation immediately follows, which is to establish the speed at which TBR14 could drive across the ceiling, if it were able to get there, and 'Vceiling' works out at a remarkably low 86.8mph (38.74m/s).

### Wheel lift

To conclude this first extended episode on this year's Formula Student car we'll examine the effect that 'trip strips' on the tyres had. Readers will recall that the purpose of fitting trip strips just downstream of the tops of the tyres is to better simulate the manner and location that the flow would separate from the tyres if they were rotating. It is well established that the flow remains attached further down the downstream side of non-rotating exposed tyres than when they are rotating, and this leads to erroneous drag and lift readings. By installing the right-angled strips in the appropriate location, more representative values for overall drag and lift are generated.

As to the exact location of the trip strips, the rule of thumb used at MIRA is to tape trip strips that are about 15mm (0.6in) tall aft of, and level with, the tyre top (see **Figure 6**), which puts them at about the '11 o'clock' or '1 o'clock' position, depending from which side you view. The strips are also tapered on the outside corners, again to enable more realistic flows to develop. How did they affect TBR14's aerodynamic data? **Table 4** reveals all.

In all but one respect these results fitted the usual generally observed pattern of drag and downforce increasing with the trip strips in place; earlier flow separation creating bigger wheel wakes, hence drag increases,

and lift-inducing flow over the tyre tops is 'spoiled', hence total downforce increases. However, front downforce did not follow the usual pattern, with no change at 40mph and a modest reduction at 60mph. **Figures 7** and **8** may provide clues to this behaviour. In **Figure 7** we can see the steep, high upper flap is deflecting air over the tyres and in **Figure 8** we can see the end plate is also deflecting air outboard of the front tyres.

**NEXT MONTH:** Further details on our studies of Team Bath Racing's TBR14. *Racecar Engineering's thanks to the staff and students at Team Bath Racing.*

### CONTACT

**Simon McBeath** offers aerodynamic advisory services under his own brand of SM Aerotechniques – [www.sm-aerotechniques.co.uk](http://www.sm-aerotechniques.co.uk). In these pages he uses data from MIRA to discuss common aerodynamic issues faced by racecar engineers

Produced in association with MIRA Ltd



**Tel:** +44 (0) 24-7635 5000  
**Email:** [enquiries@mira.co.uk](mailto:enquiries@mira.co.uk)  
**Website:** [www.mira.co.uk](http://www.mira.co.uk)



Base Performance  
SIMULATORS

Driver development simulators for single seater and GT racing

HIRE | CORPORATE EVENTS | SALES

Base Performance Simulators provides state of the art simulator packages tailored to the needs of drivers and teams from its base near Banbury, just twenty minutes from Silverstone.

www.baseperformance.net  
+44 (0) 1295 276611

info@baseperformance.net  
@BaseSimulators

man  machine

 AUTODESK.  
Platinum Partner

 AUTODESK.  
Authorised Training Centre

# Did you know?

Not only is the UK home to eight Formula One teams but there are around 2,350 component manufacturers actively involved in the UK Automotive supply chain.

**Man and Machine** offer CAD solutions including training, consultancy, support and software for design engineers across the whole Automotive manufacturing industry.



Software includes:

Alias

VRED

3dsMax

Showcase

Inventor

Product Design Suite

Get in touch today  
for more information.

E: [training@manandmachine.co.uk](mailto:training@manandmachine.co.uk)

W: [www.manandmachine.co.uk/training](http://www.manandmachine.co.uk/training) T: 01844 263 700

Connect with us



# Lean machine

Honda's last foray into Formula 1 was not its most successful. Race Engine Technology's editor examines the full details of the Japanese V8 power unit

By IAN BAMSEY

The Honda factory squad contested three of the V8 years, winning one race





Cutaway block shows lightweight rod and piston and an oil jet spray nozzle directed up into the piston skirt

**H**onda considers the power unit it is currently developing for the exclusive use of McLaren next season to be the start of its 'Fourth Era' in Formula One. The 'First Era' began in 1964 and lasted just five years, netting two wins. The second ran from 1983 through to 1992 and added a further 71 victories. From 1993 until 1999 Honda provided support for Mugen's customer engine programme, a development of its early nineties V10s. Nevertheless, Honda does not consider its 'Third Era' to have commenced until 2000.

From 2000 through to 2005, Honda supplied BAR with 3.0-litre V10s. Then, from 2006, with the switch to 2.4-litre V8s, it assumed full control of the winless team. The Honda factory squad contested three of the V8 years, winning one race. Although the third era was thus mainly barren, for much of the V10 phase Honda is widely considered to have fielded the most powerful engine of all. This article is based on the report 'Honda R&D Technical Review – F1 Special – The Third Era Activities', which was published by Honda after its withdrawal from F1 at the end of the 2008 season.

## The 'Third Era' engines

Honda contested 2001 with a modified version of its naturally aspirated 3.0-litre V10 from the previous season, but thereafter it produced a new engine design each year through to the V8 switch. After that, engine homologation locked Honda into its initial V8 design, which had also suffered compared to the V10s by more restrictive design constraints. From 2007, it was also subject to a 19,000rpm rev limit.

Honda's last 'Second Era' V10, a 3.5-litre engine subsequently replaced by a V12, produced 670 horsepower at a peak power speed (PPS) of 12,250 rpm. When Honda returned in 2000, Formula 1 engines, reduced to 3.0-litres, were still running to 400km and its RA000E ran to a comparatively astonishing 17,500rpm.

There were steady increases in maximum speed through to 2004, at which stage an increased mileage requirement pegged further progress. Nevertheless, 2005's RA005 ran to 19,200rpm and produced 966 horsepower at a PPS of 18,700rpm. Honda targeted 20,000rpm for 2006 and a higher figure for 2007 but the 19,000rpm cap stymied that plan. It admits that in 2006 it ran at 20,000rpm on the dyno but didn't exceed 19,600rpm on track.

Honda reduced the weight of its reciprocating components – piston and con rod assembly – from 399g in 2000 to 358g in 2008, a reduction of just over 10 per cent. The weight fell from 2000 to 2001, then climbed again in 2002 with the move to a 2mm larger bore, then fell steadily to 2004, when a minimum of circa 330g was reached. After that it rose due to the mileage requirement then the material restrictions of 2006.



Weight of the reciprocating assembly was progressively reduced to achieve 20,000rpm+ reliability



Increasingly lightweight piston pins could survive F1 conditions with the addition of DLC coatings

Honda used titanium aluminium piston pins and MMC pistons in 2005 but both solutions were excluded under the V8 regulations. In terms of the significant engine mileage increases, not surprisingly Honda points to the widespread use of DLC coatings throughout the engine as a key factor. It also significantly improved piston cooling via oil jet provision.

## The package

Aside from performance, the 'Third Era' engines were specifically intended to set new standards in terms of size, weight, centre of gravity height and impact on car aerodynamics. The RA100E V10 of 1990 was 633mm long and weighed 160kg whereas by contrast the RA005E was 581.5mm long and weighed only 89kg.

In essence, the reduction in length, despite an increase in bore size, came from reductions of bore pitch, timing drive width and bank offset. Bore pitch was reduced by a move to a closed deck linerless block for 2003. This increased cylinder bore stiffness, which in turn reduced operating friction and blow-by. In addition Honda moved from a conventional cylinder head gasket to individual O-rings sealing just the perimeter of each cylinder,

## The interference between cylinders of a V8 can be addressed through airbox design and the optimisation of individual ports

also helping reduce the distance between adjacent bore surfaces.

Engine stiffness was further enhanced by the introduction of oil and water pump housings integral with the block from 2002. It was improvement in timing gear material strength and a reduction in gear vibration that together permitted a move away from the use of compound (overlapping) gears in the 'Second Era'. The 2000 Honda V10's timing drive was 19.5mm wide, compared to 38mm for the 1999 Mugen V10. Subsequently advances in con rod

bearings allowed them to be made narrower, reducing the amount of bank offset.

In terms of weight reduction, Honda cites the introduction of 3D design software as a key factor, having implemented CATIA V5 around 2003. It calculated that in the absence of the minimum weight of 95kg and of the new material restrictions, its 2006 V8 would have weighed only 78kg.

## Induction development

Honda notes that air filter flow resistance and air box design can both contribute to enhanced volumetric efficiency. Originally it used a sponge-type air filter but this proved unable to cope with the fine desert sand of Bahrain, which was first visited in 2004. The use of an adequate filter as developed for mass market vehicles in dusty areas cost 4kW, so Honda set about development of a more satisfactory alternative. This led to development of a wet non-woven fabric filter.

For 2006 the switch to V8s led to frequent backfiring and consequent airbox fires. The filter was switched to a fire resistant material. Backfiring at least no longer caused the filters to burn. In design of its airbox, Honda initially assumed a homogeneous supply through the single central intake aperture situated over the roll hoop. However, in 2007 detailed investigation revealed this not to be the case, to the extent that there was a 5kW loss compared to the theoretical ideal around which the airbox form had been developed. Advanced CFD was employed to design a suitable airbox form in respect of the new knowledge.

Honda's V10 engines exploited variable length intake runners. A vertical 'splitter' wall was formed within the airbox to separate the two banks beneath the air filter, which in reducing bank to bank interference gained 7kW. Variable length intake technology was outlawed with the advent of the V8 engine in 2006. It was still found important to use a splitter between the banks.

Honda also notes that the interference between cylinders of a V8 can be addressed both through airbox design and through the optimisation of individual ports in the light of it. It adds that such optimisation is possible using advanced CAE, including CFD.

## Exhaust development

On each cylinder bank Honda's 'Third Era' engines used a 5-into-1 (V10)/4-into-1 (V8) exhaust system. Stepped primaries beneficially influenced exhaust pressure wave tuning. Normally Honda's system was backward facing but in 2007, instead a system that faced forward before turning 180 degrees after the collector was employed. This was to the benefit of car aerodynamics and was also found to improve engine power output. Alas, it caused heat damage to car components and was consequently abandoned for 2008.





# SOLUTIONS MADE OF PASSION

At Kaiser we manufacture the Racechassis, -engine and -gearbox components our customers require within the shortest possible and agreed production time. We manufacture prototypes and small batches for the top end of motorsport, aerospace and the automotive industry.



- suspension wishbones and rods (incl. carbon)
- torsion bars incl. scragging and antiroll bars
- rockers, hubs, spacers, nuts
- shock absorbers (incl. rotary-dampers)
- steering housings
- steering racks and pinions
- steering columns, quick releases and paddles
- hydraulics
- brake calipers and -cylinders
- chassis parts in metal and carbon
- engine valvetrain
- conrods
- crankcases
- cylinderheads
- pump bodies, gears and shafts
- clutch components
- gearbox-cases
- gearbox-internals
- gearbox-hydraulics
- turbo components
- energy recovery system and e-motor components
- and many more ...

**Kaiser Werkzeugbau GmbH**

Gewerbegebiet Helferskirchen

56244 Helferskirchen · Germany

Tel. +49 2626 9243-0 · Fax +49 2626 9243-20

[www.kaiser-wzb.de](http://www.kaiser-wzb.de) · [kontakt@kaiser-wzb.de](mailto:kontakt@kaiser-wzb.de)

**KAISER®**



Power gains were found from creating a splitter between the left and right bank of intakes in the V8 airbox

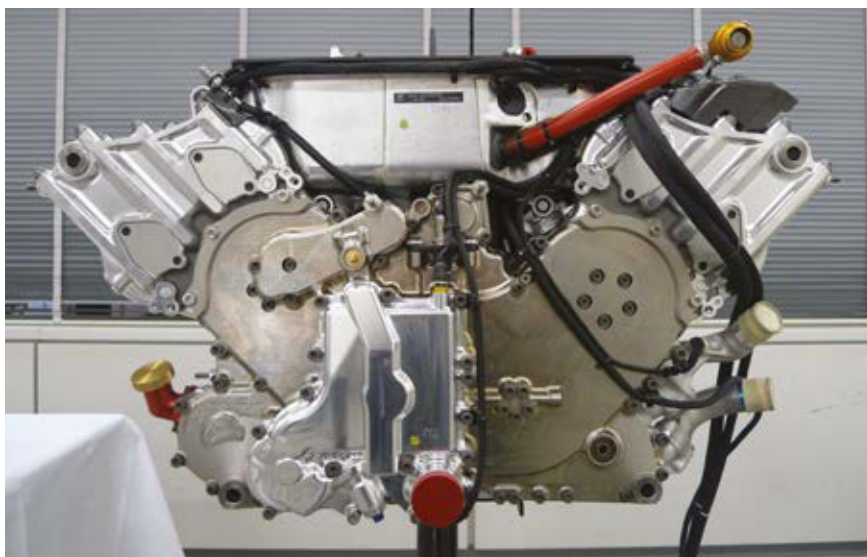

Integrating water and oil pump assemblies into the block minimised flex and vibration

For 2008 Honda introduced a 'compact exhaust' to save space and weight within the engine bay. This employed non-circular section primaries and ellipsoidal steps. To make the collector lighter, this shared the outer wall between all four pipes. Precision casting was necessary to obtain the required form while the increased thermal loading implicit in a shared wall called for, in place of the normal Inconel, the use of Rene 41, a nickel-based superalloy developed by General Electric that maintains high strength up to almost 1000degC.

Honda also found that it could enhance low speed torque with no loss at higher operating speeds through modification of the collector's internal walls. In effect, it was able to introduce geometry that beneficially modified pulsation characteristics at low engine speeds.

With traction control banned for 2008, Honda experimented with interconnecting primary pipes on each bank as a means of manipulating

pulse tuning to the benefit of driveability. This boosted power by 12kW between 8500rpm and 10,500rpm with a loss of 2.5kW at 17,000rpm. It also flattened the torque curve at low rpm at partial throttle. On the track, however, drivers did not find this offered the anticipated benefit and the 220g weight penalty of the system, together with concern over durability meant that it was not raced.

## Crankshaft development

Throughout its 'Third Era', Honda used nose fed crankshaft oiling. It came across instances of crankpin seizure due to various momentary oil supply abnormalities. In view of this, and to save 1kg or more, it developed a hollow crankshaft using friction welding.

The hollow crankshaft's cavity functioned as an oil supply channel, an oil tank and a damping chamber. Honda remarks that it 'exceeded initial predictions in helping to increase oil supply. The

## Honda commenced its 'Third Era' using four or six oil jet sprays to the underside of each piston and eventually had as many as 24

instantaneous minimum oil pressure that had previously been negative due to oil pressure pulsation returned to 500kPa and prospects for durability were good'. Alas, hollow crankshafts were specifically outlawed for 2006.

In 2005, Honda introduced a plain metal con rod bearing made from a high copper alloy with added silicon (a silicon bronze) for the shell (with no intermediate lining, just a thin lead-based overlay). This provided the required higher mileage performance. An additional development was the use of a copper alloy with silicon and nickel added (a Corson-type alloy) for further enhanced strength, thermal conductivity and sliding performance.

In an effort to further reduce friction, in 2005 Honda introduced roller main bearings, using tool steel. However, pitting of the sliding surfaces and fracturing of the retainers were issues that were not overcome, making the 1500 kilometre durability required 'a challenge'. It also proved impossible to properly seal adjacent crankcase chambers, the consequent pumping loss judged to have largely counteracted a 4kW frictional gain. On that basis the roller bearing programme was abandoned.

## Oil system development

Honda commenced its 'Third Era' using four or six oil jet sprays to the underside of each piston and eventually had as many as 24. These were fed the same amount of oil as the previous six-orifice arrangement while the enhanced targeting permitted by additional jets significantly reduced maximum piston temperature.

Honda used gerotor-type oil pressure and scavenge pumps having four inner and five outer teeth. It reported that the flow rate requirement in litres per minute built with increasing engine speed to around 75 at 19,000rpm, with the majority accounted for by the piston oil cooling jets, the big end bearings and, to a lesser extent, the valvetrain (main bearings and miscellaneous others have relatively marginal requirements, little affected by engine speed).

With increasing engine speed, the oil supply pressure requirement increased from 7 bar to 9 bar. Honda gives two reasons for this. 'The first was to increase the volume of oil that might





## FUEL CELLS

FIA-Approved Fuel Cells  
for Race & Rally



## REFUELLING EQUIPMENT

Stockists of Red Head & Stäubli Refuelling Equipment



## FUEL SYSTEM SPARES

Your One-Stop Fuel System Shop



**ATLL LTD.COM**

**sales@atlltd.com**

**+44 (0) 1908 351700**



## THE NEW LEADER IN POWER MANAGEMENT



Model shown PM2  
with optional extra keypad

## THE PM1 & PM2 FROM GEMS

- > CAN multiplexed control system
- > Up to 64 outputs in a network
- > Fully programmable logic
- > Interface to keypads or switches
- > Current and diagnostic reporting



**www.gems.co.uk**



'Third Era' engines, such as this 2005 unit, were more compact and almost 50 per cent lighter than their predecessors



Honda's engineers experimented extensively with exhaust system design and pulse tuning

contact the piston ceiling (underside) close to top dead centre by increasing the 'injection speed' of the jet. The second was that the supply of oil to the big end journals against centrifugal force necessitated higher pressure to achieve a stable oil supply at high engine speeds'. On the other hand, 'if the pressure is too high, the oil pressure pulse will increase and there will be an effect from negative pressure waves.'

The efficiency of the pressure pump was addressed. Pump geometry was altered to obtain a 30 per cent increase in flow rate. Above 17,000rpm, torsional resonance caused an issue of pump driveshaft fracturing, even though it was made from a special carburised steel. In response, one section of the shaft was reduced from 12mm to 8mm diameter to alter the torsional stiffness of the shaft as a whole. Further problems, caused by a change in rotor inertia, were solved by the same approach.

Throughout the 'Third Era' Honda's crankcase was fully compartmentalised. 'This helps prevent

pumping loss due to the volumetric transfer of blow-by gas by the alternate actions of the pistons; the gas exhausted by the falling pistons would be sucked up by the rising pistons,' Honda remarked. It added: 'For the same reason, it is desirable to prevent contact between the crankshaft chambers via the scavenge pump.'

The initial scavenge pump design used one pump for multiple chambers; later independent pumps were introduced. Later again came pick ups at both the front and the rear of each chamber, 'to ensure stable collection of oil in the case in which the oil is unevenly distributed to the front or the rear.'

Honda further remarked: 'The main function of the scavenge pumps is the collection of oil, but blow-by gas also plays an important role in this. Just as a vacuum cleaner would not be able to suck up dust in a vacuum, the scavenge pumps would be unable to collect oil in the absence of blow-by gas. For this reason engine breathing supplies an optimum volume of blow-

by gas from the upper volume of the oil tank to the heads and the gear housings, where blow-by gas is not normally present.

'However, oil mixed with large quantities of blow-by gas can have a variety of negative effects on the feed [pressure] pump including interfering with filling and producing bearing damage.' For this reason, oil collected by the scavenge pumps was separated using centrifugal oil/air separator, then sent to the tank via separate routes.

Honda noted that, like someone drinking through a straw, scavenge pump pick ups must be completely immersed in oil to be effective. 'In the initial scavenge pump design, oil struck by the crankshaft and con rods flew into the scavenge pump under the force of its own inertia. This design was not optimal for the stable collection of oil because oil did not collect in the pump inlet when cornering g-force was produced in the opposite direction. The use of

## Above 17,000rpm, torsional resonance caused pump driveshaft fracture, even though it was made from a special carburised steel

an oil trap in the scavenge pump inlets from 2004 increased the efficiency of oil collection.'

The scavenge pumps collected oil and blow-by at a pressure in the region of 2-4 bar and sent it out through the respective channels pressurised to the region of 15-25 bar. Given such high compression it proved effective to modify the pump to act as a compression pump rather than a conventional one. It was necessary only to change the inlet port shape for a delayed opening. A compression ratio of 2 was employed, reducing drive resistance by 30 per cent and engine friction by 3kW.

A pressure relief valve on the rotor side avoided damage when oil alone was absorbed. The pump rotors were initially made from a sintered aluminium powder material but later a magnesium alloy was employed for the inner rotor and a plastic material for the outer. This halved the weight of the rotors.

These are just a few of the innovative solutions employed by Honda during the 'Third Era'. It is clear that the company learned valuable lessons that it can take forward into the new, 'Fourth Era' which it will contest with McLaren.

*Ian Bamsey is editor of Race Engine Technology, which is published by High Power Media*

**Getecno**  
MOTORSPORT QUALITY  
ROD ENDS & SPHERICALS



SALES REPRESENTATIVE AND  
STOCKING DISTRIBUTOR  
in EUROPE for  
AURORA BEARING COMPANY



inch sizes  
metric sizes

**INTERNATIONAL DISTRIBUTORS**  
**AURORA® · RODOBAL® · Seals-it®**  
widest range in Europe

ROD ENDS ACCESSORIES:  
lateral seals  
protection boots,  
jam-nuts  
right-hand, left-hand

Getecno srl - GENOVA - Italy

fax +39 010 835.66.55  
phone +39 010 835.60.16

internet: [www.getecno.com](http://www.getecno.com)  
e-mail: [info@getecno.com](mailto:info@getecno.com)

contacts in English, Deutsch, Français, Italiano

**SST**  
**SS TUBE TECHNOLOGY**  
ENGINEERED BY DESIGN

Visit us at  
PMW  
Stand 4126



**EXHAUST SYSTEM DESIGN AND MANUFACTURE**  
**HEAT SHIELDS · EXHAUST LAGGING**  
**THERMAL MANAGEMENT SOLUTIONS**

[www.sstubetechnology.com](http://www.sstubetechnology.com)





Oxfordshire Tel: +44(0)1865 731 018  
Email: [info@sstubetechnology.com](mailto:info@sstubetechnology.com)

**TAM**

TORQUE AND MORE

### DRIVE SHAFT TORQUE



The true non-contact sensing technology accurately measures the torque forces passing through drive- or gearbox shafts. Simply place the sensor nearest to the shaft and start measuring torque immediately. No further setup required.

-  Easily Retrofit to Most Steel Shafts
-  Any Shaft Diameter
-  Truly Non-Contact
-  Small as a 'Sugar Cube'



### WING ADJUSTER TOOL

Quickly and precisely adjust the wings on your race car with this specially designed tool. Set the amount of desired (partial) revolutions, press the trigger and the tool will automatically stop at precisely the right moment.

-  Faster Pit Stops
-  High Reliability
-  Precision Sensor System
-  Compact and Lightweight

Contact Us!



[www.tam-sensors.com](http://www.tam-sensors.com)

Torque And More GmbH • Münchener Str. 33 • D-82319 Starnberg • Tel: +49 8151 368 981 30 • [info@tam-sensors.com](mailto:info@tam-sensors.com)

# Understanding underbodies

Of all the downforce-inducing devices, the underbody is maybe one of the least well understood. We go back to basics with the help of ANSYS CFD

By SIMON MCBEATH

Invariably, when constructing a ground effect underbody for the first time, or when trying to improve the performance of an existing one, questions arise about key parameters such as diffuser angle, ground clearance, chassis rake, and so forth. So we ran a CFD study to look at the generic effects of changes to some of the basic parameters.

The approach taken was to create a simple 'bluff body' that, with eyes half shut, bears a passing resemblance to a sports racing car as seen in **Figure 1**. However, the model was without any complicating design features, with the exception that partial cylinders representing the wheels and tyres were included as these clearly have a major influence on the flows under a racecar. Thus,

while our simulations cannot be directly related to an actual racecar, nevertheless they enable us to see how things changed, semi-quantitatively and qualitatively, with alterations to the geometry. Often the first question that gets asked is 'how steep should a diffuser be?' We'll start with that then.

## Diffuser angle

The simplest possible shape for a diffuser is, viewed side on, a triangular section with an angled roof and vertical, parallel sides. Practical limitations (as well as regulatory ones in many cases) dictate the dimensional boundaries, and in this case the diffuser width was set to 1300mm (51in) to give 50mm (2in) clearance to the inside of the rear

wheels. One of many other oft-asked questions is 'how long should the diffuser be', which we will examine in due course. However, for this first exercise a length had to be selected, and in this case a rule that often applies nowadays, that the diffuser transition can be no further forward than the vertical tangent on the front of the rear tyres, was invoked. **Figure 2** shows a diffuser 0.605m (24in) long. A set of models with diffusers of this length and angles between 2 degrees and 18 degrees was then created and placed in turn in the flow domain – the virtual wind tunnel – to be meshed, boundary conditions to be set up, and solutions to be run, a workflow applied to each area of study in this little project. The results of changing diffuser angle are shown

in the graphs in **Figures 3 and 4**. Ground clearance was 50mm (2in) in all cases (overall length was 3550mm or ~140in, so h/L was 0.0141).

Looking first at the data in **Figure 3**, it's apparent that generally drag (CD) declined modestly with increasing diffuser angle, whereas downforce (-CL) increased initially very markedly but then more modestly, up to around 14 degrees before levelling off. We'll return to possible mechanisms for this behaviour shortly.

**Figure 4** shows another important aspect, and that's the change to aerodynamic balance across the diffuser angle range. At the shallow diffuser angles there was very little downforce on the front end of our bluff body. In fact initially there

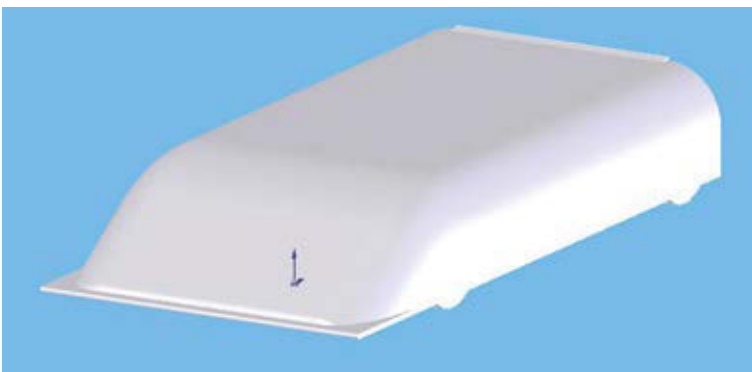

Figure 1: The test body used in our simulations

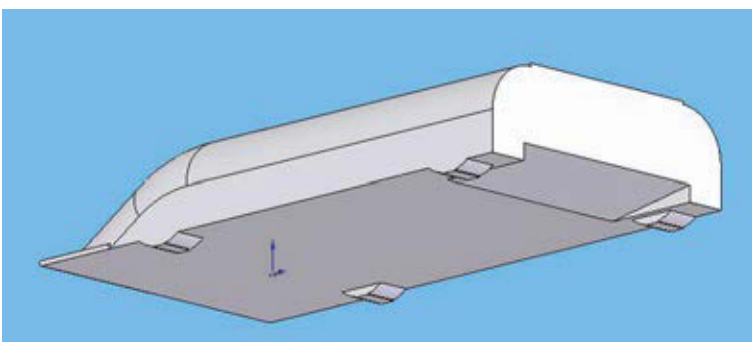

Figure 2: The short diffuser

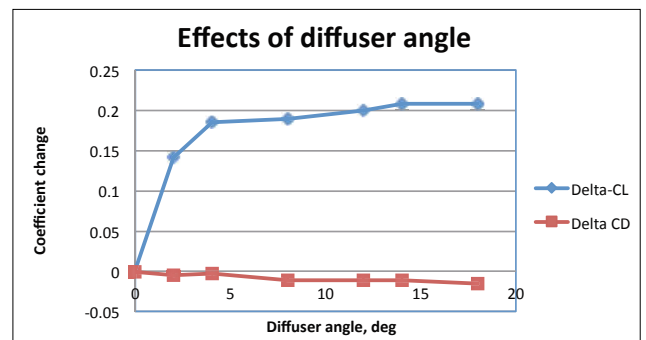

Figure 3: Diffuser angle had marked effects on downforce and drag

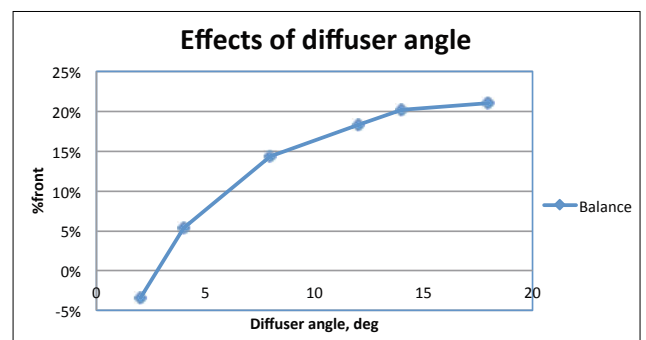

Figure 4: Aerodynamic balance was also profoundly affected by diffuser angle



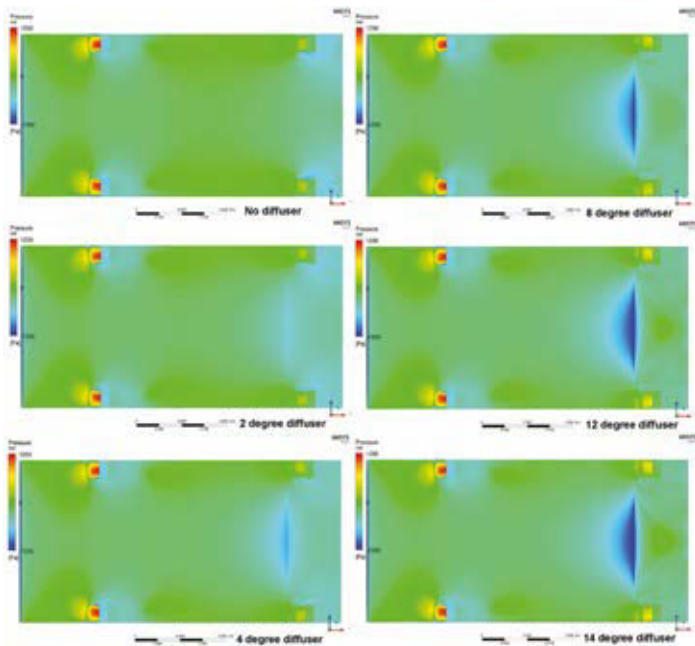

Figure 5: Pressure distributions across the floor altered with changing diffuser angle

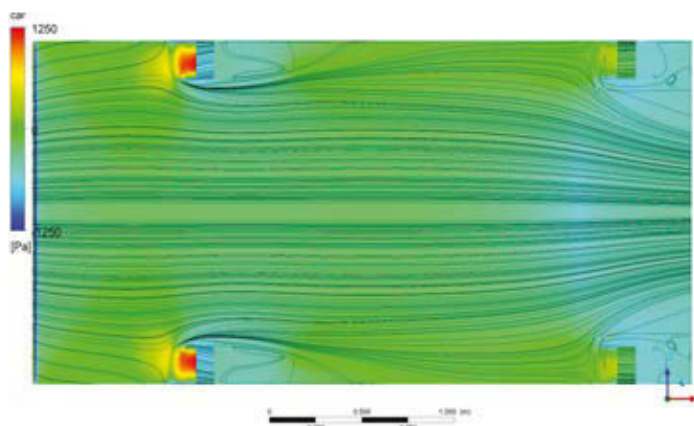

Figure 6: Streamlines show flow directions with the shallowest diffuser

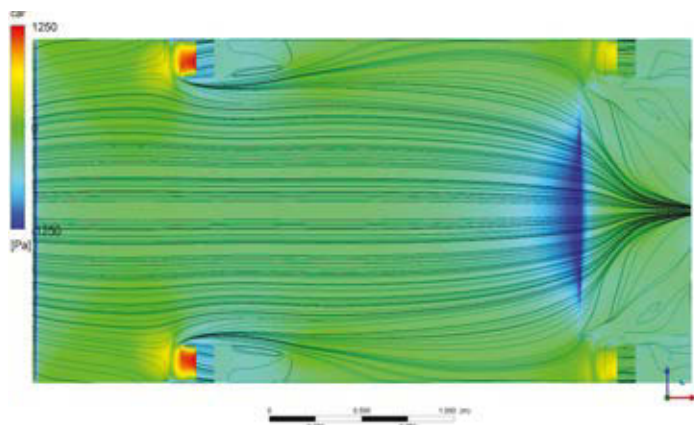

Figure 7: The steepest diffuser produced very different streamlines

was front lift but, as diffuser angle increased, we can see that the %front value climbed significantly.

How do we explain these changes? The drag reductions would in part be explained by the reduction in basal area, and hence wake size, with each increase in diffuser angle, but to explain the downforce and balance changes

some visualisations will help. **Figure 5** shows the static pressure plots of the model's underside across the range of diffuser angles from 0 degrees at top left to 14 degrees at bottom right. Blues represent negative static pressure, reds represent positive static pressures, and the airflow is coming from the left. So there was a 'suction peak' under the leading edge

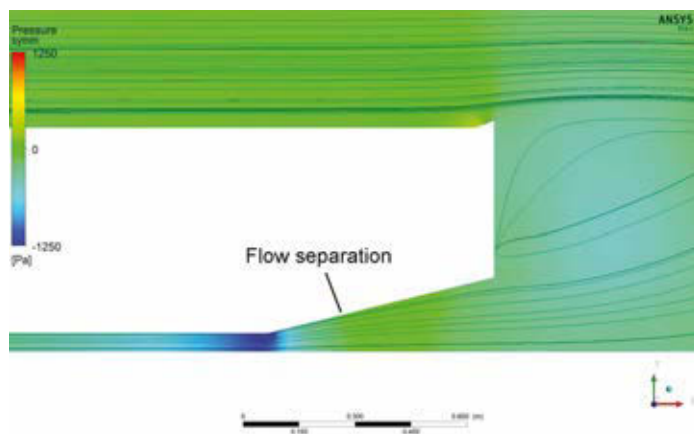

Figure 8: The steepest diffuser in side view shows flow separation even on the symmetry plane

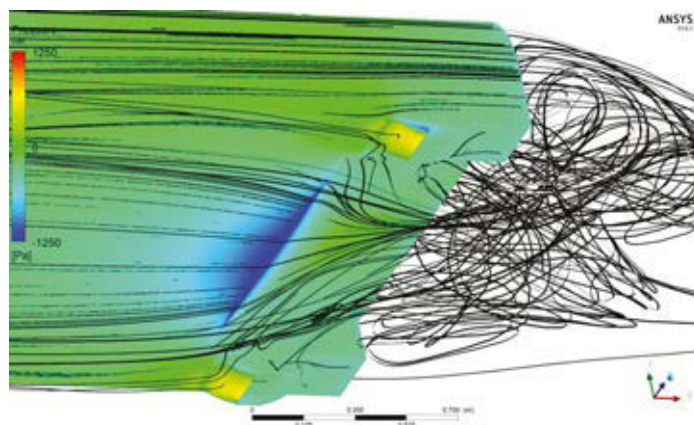

Figure 9: 3D streamlines and oblique view emphasise the complexity of the flows in the diffuser, with some reverse flow in the outer sections

of the splitter; there were positive pressure areas in front of the front tyres; and aft of that we see a change in the distribution and extent of low pressure in response to the presence and angle of the rear diffuser.

In the 'no diffuser' case, there was some low pressure behind the rear wheels, and also between them, the result of the lateral convergence here that, with the added constraint of the ground, accelerated the flow and hence caused some pressure reduction. However, as soon as even the shallowest diffuser was introduced the pressure reduction at the transition became more marked, becoming more so and extending ever further forwards with each extra increment of diffuser angle. The net result was that the centre of pressure gradually moved forwards and at the same time the overall -CL value increased.

**Figures 6** and **7** show the 2-degree and 14-degree cases from underneath with surface streamlines plotted, and the difference in the amount of lateral convergence in the flows was very marked. Much

of the flow across the 14-degree diffuser had separated from the diffuser roof, and this phenomenon was seen to gradually increase as diffuser angle was increased beyond an optimum point. Even along the centreline of the diffuser, we can see in the side view of the symmetry plane in **Figure 8** that the flow had partially separated, indicating that the adverse pressure gradient from the diffuser transition rearwards was just too steep in this case. And the oblique view in **Figure 9** with 3D streamlines plotted reveals something of the extreme complexity of the flows across the diffuser, with even some reverse flow in the outer sections. These flow patterns quite closely replicate our experience in previous testing, where we have seen this before in wind tunnel sessions in the Aerobytes series, for example on the GT3 Ferrari F430 (**Figures 10** and **11**), so qualitatively these simulations matched reality.

The above simulations were all carried out with zero rake, but we know from trials in the MIRA wind tunnel that (even with a fixed tunnel



Figure 10: The Ferrari F430's diffuser showed 'clean' flow emerging from its centre...



Figure 11: ... but disturbed, and even reversed, flow aft of the outer sections

floor and stationary wheels) chassis rake can be a potent aerodynamic tuning tool. So, a medium diffuser angle was set (the diffuser exit was set to 100mm or 3.94in, corresponding to 9.4 degrees roof angle) and the chassis was rotated about the front tyre contact line to a range of rake angles from zero to 0.4 degrees. These rake angles corresponded to the changes to front and rear ground clearance, and the data arising are shown in the plots in **Figures 12 and 13**.

**Figure 12** shows a modest, non-linear increase in total downforce (-CL) and an essentially linear increase in drag with increasing rake angle. Much more striking, though, was the change in aerodynamic balance shown in **Figure 13**, which was highly linear and very pronounced. Clearly, a much broader matrix of configurations and rake angles is called for, but with approximately 12mm (1/2in) of rake, the model went from being aerodynamically 'front light' to something that would be very close to being balanced at 45 per cent front.

**Figure 14** shows the marked change in the pressure distribution on the car's underbody between

zero rake and 0.4 degrees rake. The big suction peak at the diffuser transition was much reduced in the 0.4-degree rake case, and the pressure under and behind of the splitter was generally lower in this case too, both factors helping to shift the centre of pressure further forwards. Clearly rake is not only a powerful tuning tool but also a parameter that needs to be dynamically controlled to avoid unwanted shifts in aero balance out on the track.

## Diffuser length

The third of the most often asked-about basic parameters, diffuser length, isn't always one over which technical regulations allow any freedom. However, there are still a few categories where the freedoms do exist as well as those historical ones, such as Croup C and IMSA sports prototypes where long diffusers, or more accurately long tunnels, were *de rigueur* and which are therefore of great interest. So, the same diffuser as in the previous section was modified to increase diffuser length and height while retaining the same roof angle (see **Figure 15**). The results are shown in **Figures 16 and 17**.

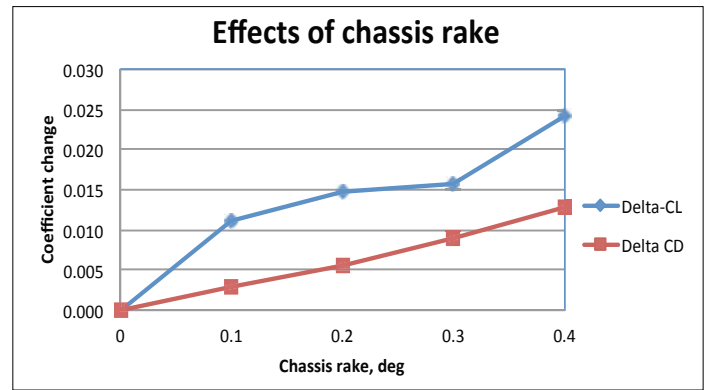

Figure 12: Adding chassis rake altered downforce and drag

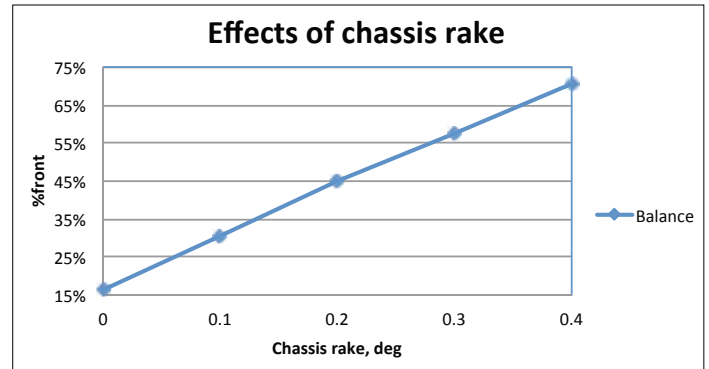

Figure 13: Balance was profoundly affected by chassis rake adjustments

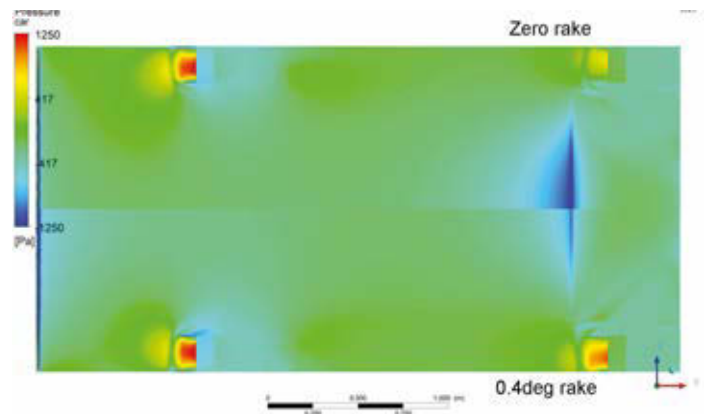

Figure 14: Underbody pressure distribution was significantly modified by chassis rake

The increases in downforce here were enormous compared to the gains obtained with changing diffuser angle and chassis rake with the shortest of these diffusers. In light of this, it's perhaps easier to see how Group C/IMSA prototypes generated such high downforce figures, and also that diffuser length was the obvious parameter for the regulators to target in order to reduce downforce! Drag can be seen to have also increased slightly with diffuser length here, but the efficiency (-L/D) of the model rose from 1.022 to 5.973!

**Figure 18** once again shows the pressure distributions on the lower surface of the shortest and longest diffusers tested. Not only did the suction peak at the diffuser transition

move forwards, it also became much more extensive, and pressure was lower in the case of the longest diffuser as far forward as the splitter, with a pronounced low pressure 'jet' visible in the diffuser itself, the result of a potent vortex that formed as the flow converged over the sharp edge on the outer wall of the diffuser. Overall though, the aerodynamic balance shifted significantly forwards with increasing diffuser length.

## Strakes

Few diffusers are seen without vertical, more or less fore-aft aligned fences located within them, so what would they be worth on our model? In this case the baseline model was the short diffuser at 0.2 degrees





# HIGH PERFORMANCE CONNECTORS AND ACCESSORIES

## IMMEDIATE DELIVERY

- MOST CONNECTORS AND ACCESSORIES IN STOCK
- PIECE PARTS FOR ASSEMBLY STOCKED FOR RAPID ON SITE ASSEMBLY

## WIDE BSTA RANGE

- SMALLEST SHELL SIZE 2 THROUGH TO 24
- NEW HIGH DENSITY & HIGH POWER CONTACT LAYOUTS
- PCB MOUNTING OR STANDARD CRIMP TERMINATION

## BSTA ACCESSORIES FROM STOCK

- HEAT SHRINK BOOTS
- NUT PLATES
- PANEL GASKETS
- ASSEMBLY TOOLING
- 3D CAD MODELS

MANUFACTURED BY  
**SOURIAU**  
 HELLERMANN TYTON  
**Weald**  
 ELECTRONICS

FC LANE ELECTRONICS LTD  
 WWW.LANEMOTORSPORT.COM MOTORSPORT@FCLANE.COM  
 TEL. +44 (0) 1403 790 661



## TRIPLE EIGHT RACE ENGINEERING

- Floor Mounted Push Type Pedal Box
- Billet Machined Aluminum Construction
- Compact & Lightweight Packaging
- Fly By Wire & Cable Throttle Options
- Adjustable Pedal Pads with Heatproof Options
- Adjustable Trunnion Brake Bias Balance Bar
- Control Pedal Box for V8 Supercars Australia



### Technical Specifications

- Length 262mm
- Width 256mm
- Height 315mm
- Weight 5.7kgs with M/cylinders
- Material Spec. 7075

e: customersupport@tripleeight.com.au T: +61 7 36357008 www.tripleeight.com.au

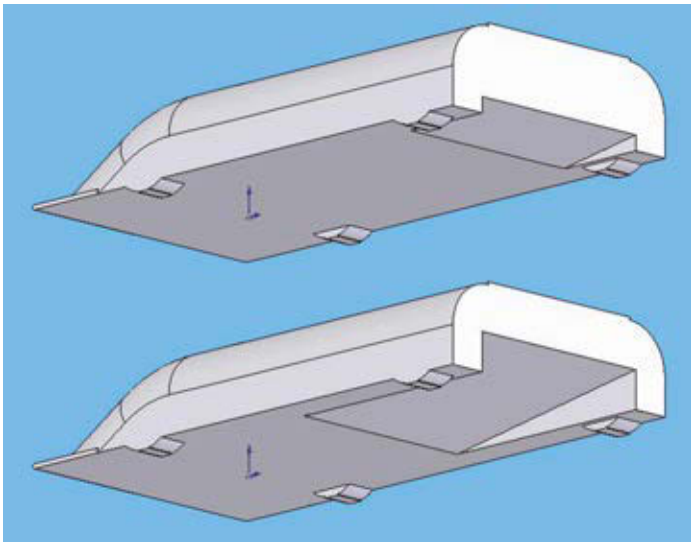

Figure 15: Diffuser length and height were adjusted while retaining a fixed angle

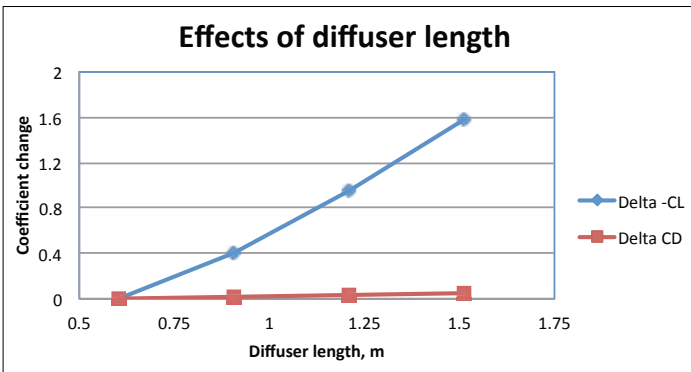

Figure 16: Diffuser length had a massive effect on downforce with minimal change in drag

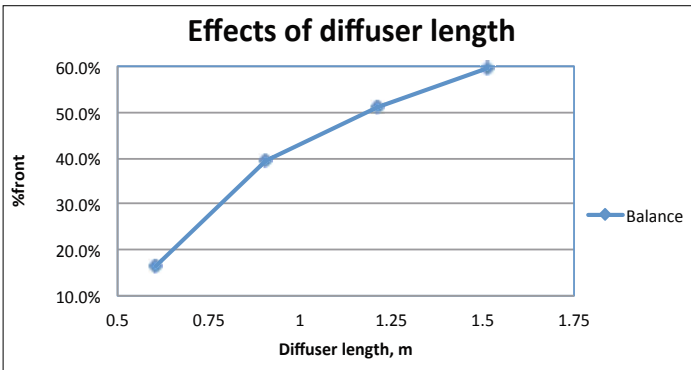

Figure 17: Longer diffusers shunted aero balance significantly forwards

rake to provide a model that had a reasonable aerodynamic balance with which to begin. Then one, two and finally three strakes were added to each side of the diffuser, at 150mm (5.9in), 300mm (11.8in) and 475mm (18.7in) respectively from the outer walls (see Figure 19 showing all the strakes in place). Figures 20 and 21 illustrate the results. In Figure 21 we see a classic 'diminishing returns' downforce plot, the first pair of strakes producing a moderate gain, with successively smaller gains thereafter. Drag barely

changed initially but then seemed to jump slightly with the second and third pairs of strakes. Nevertheless the overall efficiency gains were significant, -L/D rising from just over 1.0 to just over 1.6. Constrained to a short diffuser, on the strength of this data strakes looked well worthwhile. Figure 21 shows that aerodynamic balance shifted rearwards in this case as extra strakes were installed, again with the initial effect being quite marked, followed by a lesser but linear effect. Figure 22 once more shows the underside pressure

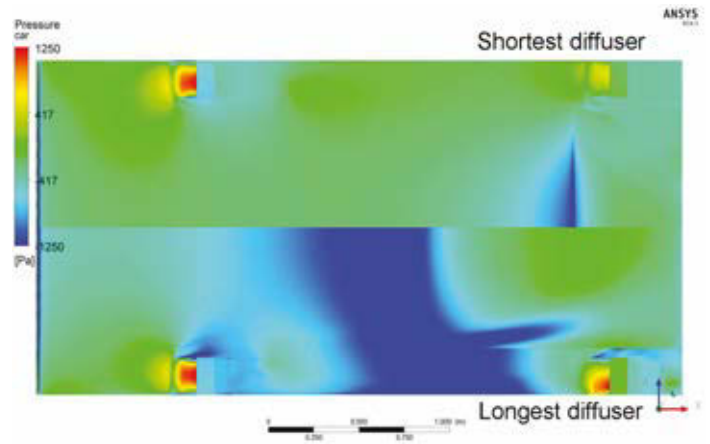

Figure 18: Pressure distribution was markedly different with the longest diffuser

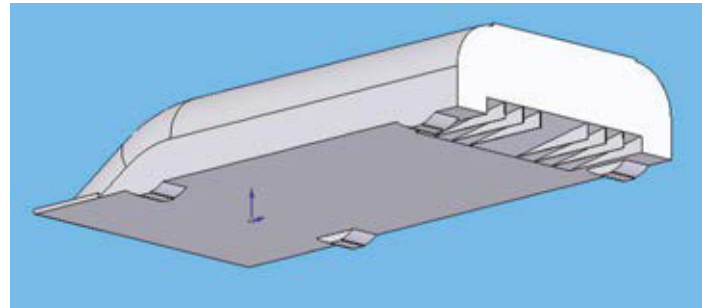

Figure 19: Simple strakes were added a pair at a time, six being the maximum

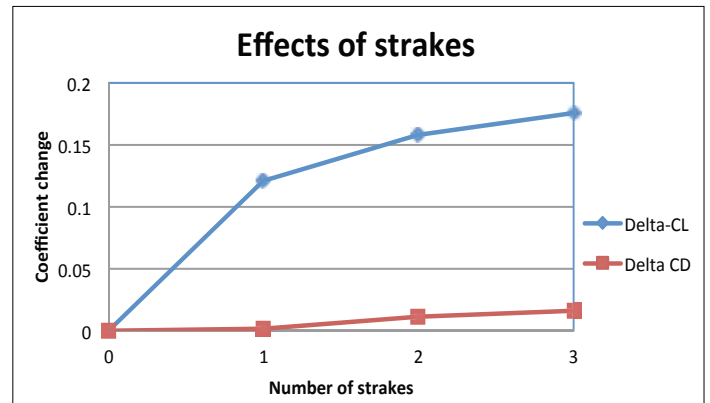

Figure 20: Adding strakes produced diminishing but quite efficient downforce

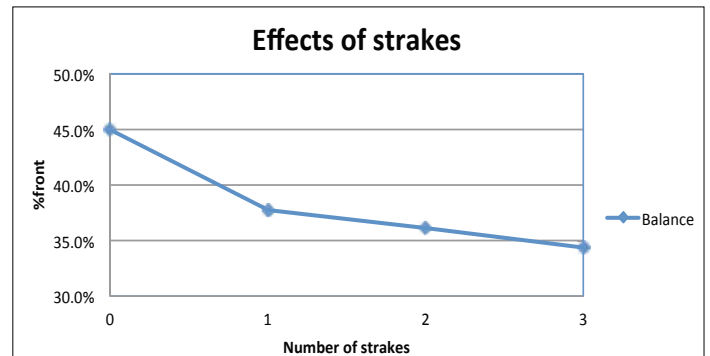

Figure 21: Strakes had their effect on balance

distributions, this time with surface streamlines also plotted. The suction peak ahead of the diffuser transition can be seen to have strengthened with the fitment of the first pair of strakes, and the formation of a pair of small vortices was also evident in the blue 'jets' that started just inboard

of the leading edge of the strakes. Generally the pressure in the diffuser was lower. The surface streamlines show the flow to be better organised in the outer part of the main diffuser inboard of the strakes, with less of the flow from in front of the rear tyres reaching the central diffuser. With



180 MPH WITHOUT MOVING AN INCH

Take cutting-edge wind tunnel technology. Add a 180 mph rolling road. And build in the best in precision data acquisition capabilities. When we created the world's first and finest commercially available full-scale testing environment of its kind, we did much more than create a new wind tunnel. We created a new standard in aerodynamics.



+1 704 788 9463

INFO@WINDSHEARINC.COM

WINDSHEARINC.COM

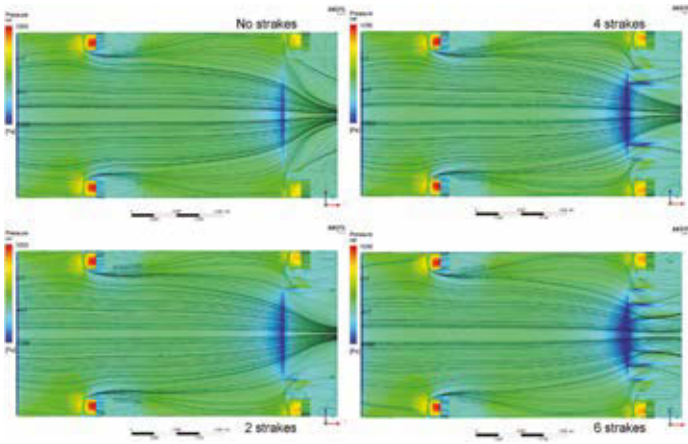

Figure 22: Strakes created changes to pressure distributions and streamline patterns

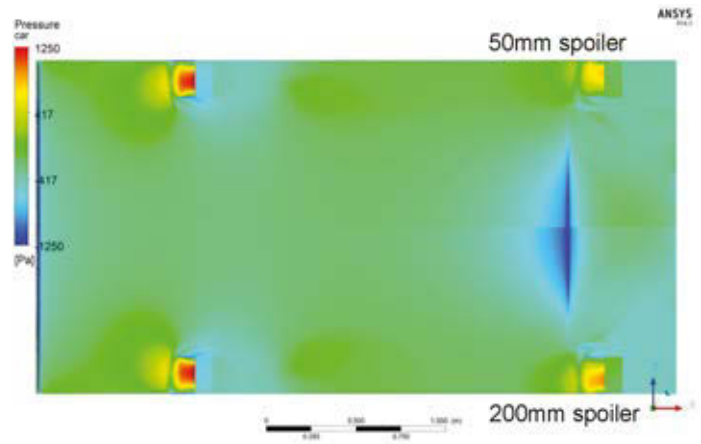

Figure 25: Underbody pressures were influenced by changes to rear spoiler length

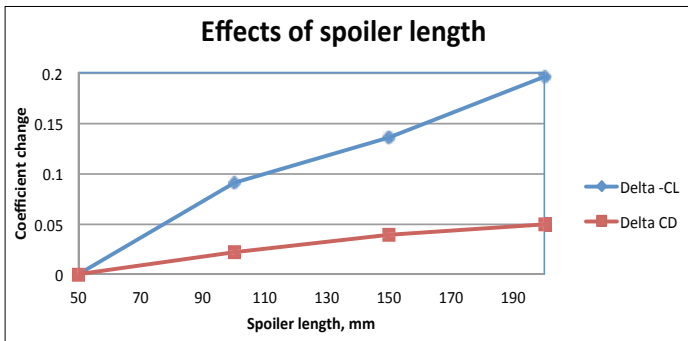

Figure 23: Increasing spoiler length produced the expected changes to the coefficients

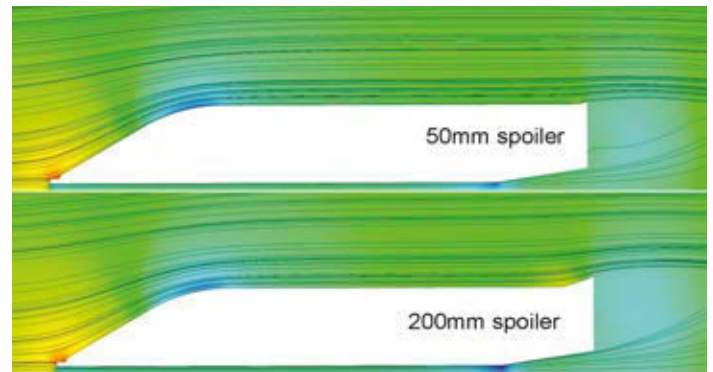

Figure 26: In side view the difference in wake pressure and streamline pattern on the symmetry plane at the rear are visible

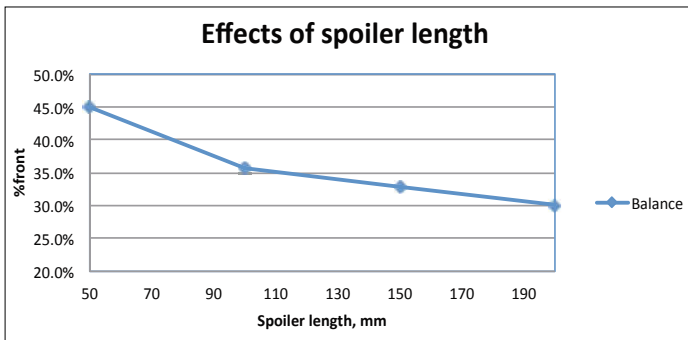

Figure 24: Longer spoilers altered aero balance

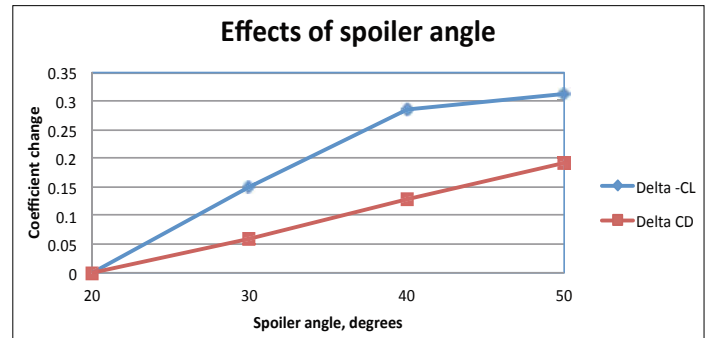

Figure 27: Spoiler angle affected downforce and drag

four strakes, the main suction peak was strengthened, but very evident here was the pair of additional, even stronger vortices just inboard of the second pair of strakes, which contributed to further reduced pressure in the diffuser. Finally, the inner pair of strakes appeared to have less effect on the main suction peak but another pair of low pressure vortices was set up. The overall flow direction was also more significantly influenced by this third pair of strakes.

If simple strakes markedly increase overall downforce, it would be interesting to study strake curvature to see, for example, what would be the effect of aligning the leading edges of the strakes with the oncoming airflow direction. Would vortex formation be reduced,

diminishing the attendant low pressure regions to produce less downforce? Or would the organised flow lower pressures in the diffuser, producing increased downforce? More work is needed.

## Spoilers

Our test body initially featured a small front splitter and rear spoiler. What would be the effect of increasing spoiler size and angle? Intuitively, we might expect more total downforce with a more rearward bias. But would a rear spoiler also interact with the diffuser? Two trials were done using the 0.2-degree rake, short diffuser model. The first used a 20-degree spoiler angle and increased the spoiler's length in 50mm increments up to 200mm; the second kept the

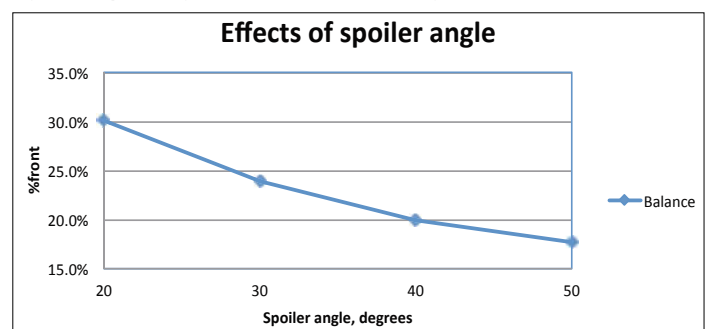

Figure 28: Aero balance was altered by changing spoiler angle

200mm length and increased the angle in 10-degree increments up to 50 degrees.

The results of the spoiler length trial are shown in **Figures 23 and 24**. Downforce increased with increasing spoiler length while the smaller increase in drag tailed off slightly. The

downforce gains were reasonably efficient, -L/D climbing from 1.056 to 1.507. Balance did indeed shift rearwards, more rapidly with the first increase in spoiler length than with subsequent increases. What of the underbody? **Figure 25** shows a comparison of the static pressure



**AUTOSPORT**  
INTERNATIONAL  
**Engineering Show**  
8-9 JANUARY 2015 BIRMINGHAM NEC  
In association with **Racecar**  
Leading-Edge Motorsport Technology Since 1990  
engineering



**TECHNOLOGY**  
**SUPPLIERS**  
**BUYERS**

# **BUSINESS** **STARTS HERE**



**REGISTER NOW 0844 417 0272**  
**WWW.AUTOSPORTINTERNATIONAL.COM**

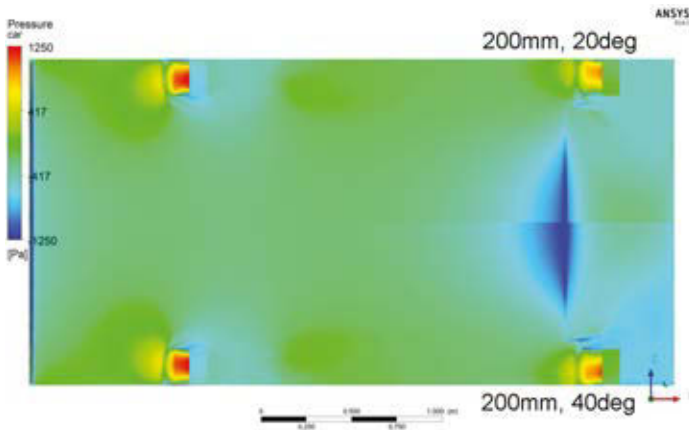

Figure 29: Underbody pressure distributions continued altering as spoiler angle was increased, up to a point

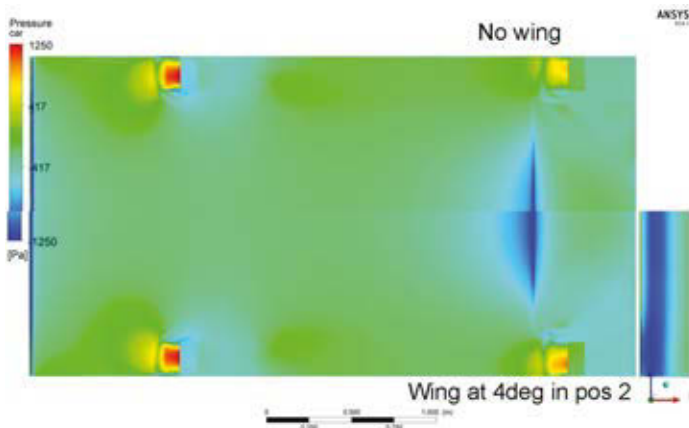

Figure 30: The presence of an overhanging wing altered the underbody pressures

distribution of the baseline short spoiler case (top) alongside the longest spoiler case, and it is clear that the extent of the low pressure area near the diffuser transition was considerably greater in the long spoiler case, and pressures in the outer rear sections of the diffuser were also lower. The side view of the pressure distributions on the symmetry plane in **Figure 26** shows the slightly lower pressure in the wake immediately behind the body in the long spoiler case (bottom), and also how the streamlines exiting the diffuser appeared to turn more, in concert with the streamlines leaving the top of the spoiler. Continuing

with the longer spoiler, but applying greater angles continued the theme, as **Figures 27 and 28** show, while **Figure 29** illustrates clearly that there was ever more potent underbody interaction with the surface pressures in the diffuser.

## Wings

Finally, a brief look at wings reinforces the thought that these trials are but a toe in the water. The short diffuser model with 0.2 degrees rake was used as the basis again, and a 300mm (11.8in) chord NACA 63(2) 415 wing at 4 degrees angle of attack was added in three different locations, initially with the wing trailing edge

Table 1: The effects of adding and moving a wing

	NACA 63(2)-415 at 4deg	Delta CD	Delta -CL	%front	-L/D
No wing	Short, 9.4deg diffuser plus 0.2deg chassis rake	0.000	0.000	44.0%	1.002
Pos 0	EP top edge at 0.9m, T/E in line with rear of body	0.016	0.126	27.2%	1.390
Pos 1	Height a/a, 0.2m further back	0.040	0.302	20.6%	1.849
Pos 2	Height a/a, 0.1m further back, L/E above spoiler T/E	0.044	0.332	16.8%	1.927

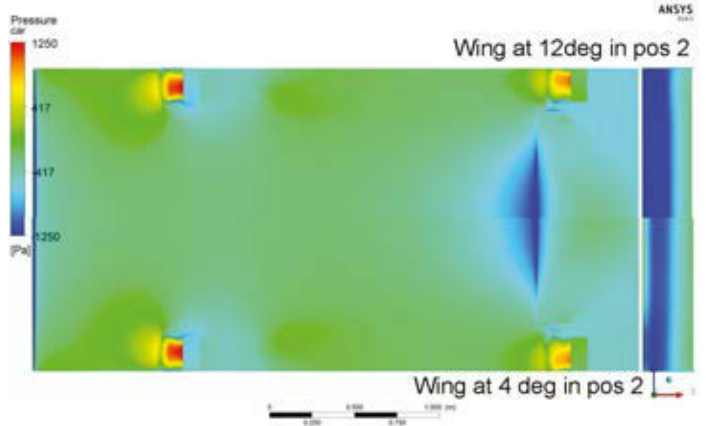

Figure 31: Increasing the wing's angle also affected the underbody pressures

Table 2: Comparison between spoiler and wing downforce efficiency levels

Configuration	CD	-CL	%front	-L/D
spoiler, 20cm long, 50deg, atop trunk	0.509	0.791	17.7%	1.553
Wing pos2, 12deg, L/E just aft of spoiler	0.383	0.856	7.6%	2.234

vertically above the main body's rear edge, then 200mm further aft, then a further 100mm aft, putting the wing's leading edge vertically above the main body's termination. The results are shown in **Table 1**.

Downforce and drag increased as the wing moved back, but the gains tailed off with each move, and balance responded as might have been expected. The effect on underbody pressures when the wing was over the deck was barely discernible, but when overhanging it was quite marked, as **Figure 30** shows.

Increasing the angle of the wing continued the downforce increase and the rearward balance shift, but

also strengthened the interaction with the diffuser, as shown in **Figure 31**. The wing thus had a similar effect on the underbody to the spoiler, but the efficiency figures were much better with the wing at similar overall downforce level, as shown in **Table 2**.

## Summary

There are clearly more variables than have been covered here, ground clearance for example, and an infinite number of combinations of all the variables! But even with this introductory look at some of the more obvious parameters, a few generic questions may have been answered.

## CAD and CFD parameters

**A**nsys CFD-Flo software was used, with the CAD model set up in a flow domain with ground and airspeed both set at 100mph (approximately 44.7m/s or 160km/h). Base model dimensions:  
**Length: 3.55m (139.8in)**  
**Width: 1.80m (70.9in)**  
**Wheelbase: 2.28m (89.8in)**  
**Frontal area: 1.45m<sup>2</sup> (15.6sq.ft)**

The CAD model incorporated a splitter and, initially, a 50mm (1.97in) long, 20 degree rear spoiler to ensure it generated net downforce in baseline trim, which saw ride height at 50mm and chassis rake at zero.

Tetrahedral mesh with boundary layer prisms was generated by the meshing module of ANSYS, with mesh sizes between 1.2 and 1.5

million nodes (approximately 4 to 6 million elements), ANSYS CFX being a vertex based solver. The shear stress turbulence k-omega model, preferred choice when adverse pressure gradients and separating flow are encountered, was invoked. Force monitors calculating drag and downforce were used and solutions were run until forces were steady.

Aerodynamic balance (%front) was ascertained by dividing the pitch moment by the downforce calculated by the CFD at the model's CAD origin (the front wheel contact line at ground level, hence drag did not contribute to the pitch moment) to determine a centre of pressure (CoP) location and attributing the front and rear percentages proportionately.



# The Lightest, Most Flexible Hose and Fitting Combination Available!

**USA North Carolina**

704.793.4319  
sales@bmrsusa.com

**California NEW!**

714.415.0080  
socialsales@bmrsusa.com

**UK Slough**

01753.545554  
sales@bmrsuk.com

[www.bmrs.net](http://www.bmrs.net)



## ENGINEERING THE ADVANTAGE THROUGH QUALITY DESIGN

Our innovative design and precision performance engineering makes us your perfect Motorsport partner. Our world-class engineers are committed to delivering world class services where your exacting requirements will be mirrored by our exacting standards.

Contact us to see how we can engineer your competitive advantage.

T. +44 (0) 1480 474402  
sales@titan.uk.net

[www.titan.uk.net](http://www.titan.uk.net)



Dynamic Engineering



# Competition Plus Hollow Stem Valves

Ferrea Racing Competition Plus Hollow Stem Valves are 22% lighter than conventional stainless steel alloy valves. Their proprietary manufacturing process gun drills and micro polishes the bore of the valve stem. These valves are also made from Super Alloy materials which resist heat much better than conventional Inconel materials.

- Friction Welded Hard Tips
- Radial Groove (Shot Peened & Rolled)
- Micro Polishes & Gun Drilled Stems  
(22% lighter than conventional stainless alloy valves)
- "Avionics" Chrome Plated Stems (10 microns thick)
- Superflow (undercut) Stems (Improved flow design)
- 42 Rc Seat Hardness (Long life - resists fatigue fractures)



## FERREA RACING COMPONENTS

Tech Line: 954-733-2505 • Toll Free: 888-733-2505  
www.ferrea.com

FOLLOW US ON:

Ferrea Now Offers Discounts for Active Duty Military Members and Veterans. \*Online purchases only.



# Rottler CNC True Vertical Honing

Linear slideway stroking and precision ball screw mechanisms create precise cross hatch angle & repeatable accuracy

NHRA Nitro Methane Funny Car  
Rottler Makes Power Fast  
"Tim Wilkerson"

- Two Stage Honing System Roughs & Finishes in 1 Automatic Cycle
- Intuitive Rottler Software
- Automatic Load & Force Control

Rottler Software senses interference for Automatic Crash Prevention

- Fast Cycle Time  
- Dual Stage Honing Capability  
- Quick Turn Tool Change



So Advanced, It's Simple

www.rottlermfg.com  
www.youtube.com/rottlermfg  
www.facebook.com/rottlermfg  
contact@rottlermfg.com



8029 South 200th Street  
Kent, WA 98032 USA  
+1 253 872 7050

1-800-452-0534

# Keeping cool

Controlling the temperature of race engines has spawned a huge industry, creating lighter and more efficient cooling systems

By GEMMA HATTON

The inefficiency of combustion is a well known problem, with a racing ICE (Internal Combustion Engine) still only managing thermal efficiencies of approximately 35 per cent. This essentially means that just over a third of the energy created from the combustion process is converted into mechanical work to turn the crankshaft. Next to overcome is the mechanical friction of the system as the crankshaft transforms the reciprocating linear motion of the pistons into circular motion, which is then transmitted through the gearbox to the wheels.

In some road car applications this means that the vehicle's overall efficiency is only 20 per cent. There has been a big push in motorsport to address this problem, with Formula 1 limiting the fuel to 100kg per race and the WEC (World Endurance Championship) specifying a maximum fuel amount per lap depending on the chosen ERS (Energy Recovery System)

configuration – resulting in teams being forced to maximise their fuel allocation. Indeed, this has seen some innovative solutions an example being this year's Le Mans winning Audi R18 e-tron Quattro which used approximately 23 per cent less fuel than last year's car, while maintaining the performance and matching the lap times of its 2013 predecessor.

This wasted energy from combustion is mainly lost through the exhaust, transferred into the engine oil or dissipated as heat to the surroundings. This sheer amount of heat in the engine creates a major headache for engineers. With temperatures of up to 1500-2000degC reached by the burning gases, the continual threat of detonation, pre-ignition and the resulting lower performance desperately requires a system to take the heat, which comes in the form of a cooling system.

On average, around a third of all the heat produced from combustion is absorbed by the

cooling system and whether in F1, WEC, WRC, NASCAR or any other form of motorsport the underlying principal of any cooling system is thermal equilibrium. This is the first law of thermodynamics, which is a function of the conservation of energy principle. It essentially means that any substance with high heat energy will transfer its energy to a cooler substance with less heat energy until both temperatures are the same and thermal equilibrium is achieved.

Previous cooling systems for championships such as F1 used a water and oil cooler for the engine, a further oil cooler for the gearbox and a small water cooler for electrical systems such as KERS. However, this year's regulations not only introduce a turbocharger that spins 1,500 times per second, generating huge amounts of heat, but also an ERS system with its MGU-K (Kinetic energy recovery system) component producing around three times the amount of heat compared to last year's V8 KERS unit.



**On average, around a third of all the heat produced from combustion is absorbed by the cooling system**

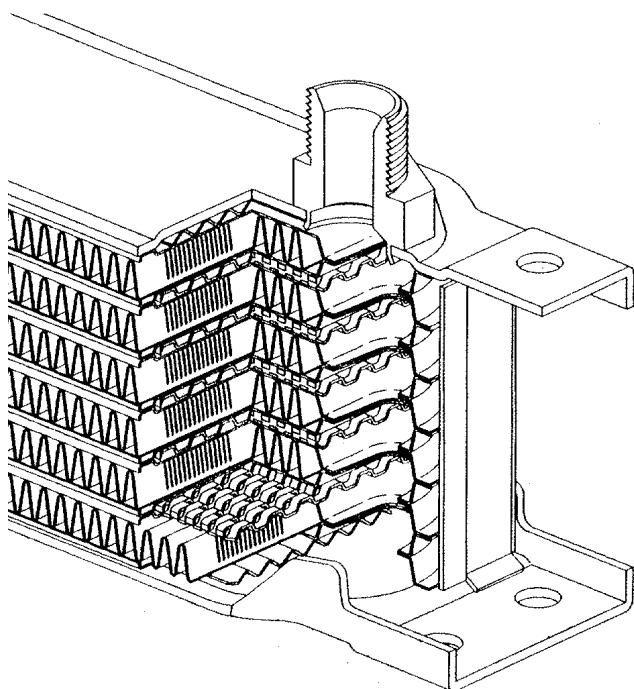

A sectioned drawing showing the inner workings of a pressed plate cooler. Notice the small turbulators in between the larger external fins that are brazed to aluminium plates. Courtesy of Think Automotive

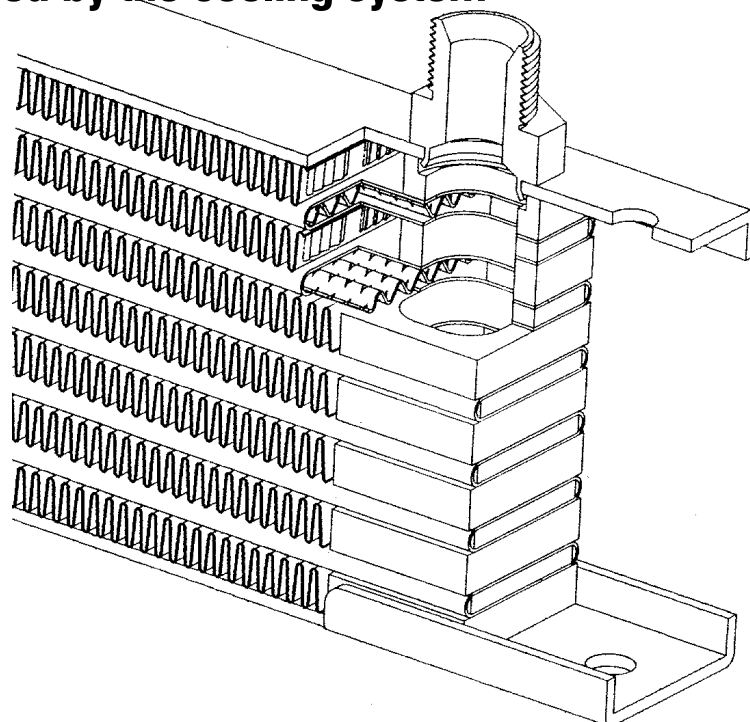

This sectioned drawing shows a tube and fin layout. Here, the turbulators are situated inside whole tubes rather than being pressed between two plates. Courtesy of Think Automotive

Below: This Slimline oil cooler from Setrab was designed specifically to suit the packaging demands of the motorsport industry  
 Right: C&R Racing's Air Spring is found in the pressure can with a pressure relief valve and is utilised in pressurised cooling systems



The Proline Intercoolers from Setrab features both external and internal fins for maximum cooling capacity, and achieves low weight by it's all-aluminium brazed design

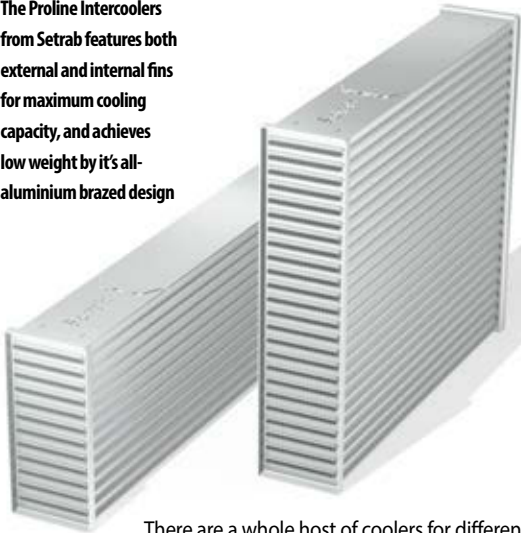

There are a whole host of coolers for different parts of the car and whether it be an engine oil cooler, a turbocharger intercooler or an electrical cooler, there are predominantly two types of construction; bar and plate and tube and fin. Both types operate on a similar principal where the hot fluid (either air, oil or coolant depending on the application) flows through tubes in the core, and conducts its heat to the tube walls, which then transfers this heat to the external fins which finally dissipate the energy to the surroundings.

A bar and plate cooler is often used in high end motorsport, where aluminium pressed plates form the tubes and end tanks and are



A comparison of C&R Racing's NASCAR products. A 27mm single core which has been carefully designed can actually outperform the 56mm double core

surrounded by external fin. Within these tubes are turbulators, or internal fins, which aim to disrupt the liquid flow and break down the boundary layer effect to increase the contact surface area between the fluid and the tubes, enabling maximum heat dissipation without a pressure drop. The advantage of this design is that the thickness of the core can be varied, and the water and air pressures can be tuned against each other to meet the performance requirements better than a tube and fin.

On the other hand, a tube and fin design uses preformed flattened tubes that surround turbulators and are interspersed with corrugated aluminium to form the external fins for the airways. Although restricted to specific tube sizes, the fin density, measured in 'fins per inch' (FPI), and tube spacing can be adjusted to balance the two flows. Incorporating more FPI increases the surface area for maximum dissipation which is why, in applications such as F1, Indycar and NASCAR, fin pitches are as tight as 25. Decreasing the tube spacing, in other words reducing the height of the external fins, can increase cooling capacity, and therefore achieve higher durability.

radiator's life. Heat transfer degradation with age due to fins bending and thus reducing air flow, or clogging with tyre debris can be critical. There is no point qualifying well if the car over heats in the race.'

In previous years, radiators have been made out of copper and brass due to a higher thermal conductivity (a measurement of the ability of a material to exhibit heat transfer), but aluminium has been the material of choice recently. Not only does it allow brazing of tube and fin coolers into one consistent part, but an aluminium core weighs approximately 30 per cent of a comparable copper and brass core. 'With the traditional aluminium tube and fin radiators, thinner wall tubes without tubes 'ballooning' and minimising tube spacing has been the direction of development,' highlights Belli. 'But micro tubes have now taken over, as cylindrical tubes are naturally stiffer to the internal pressures, so the wall thickness can be very small, promoting good heat transfer. Also, the tubes can be very close together enabling the cooling air to be close to the medium being cooled (water, oil or charge air).'

Micro channel radiators provide more heat exchange area per unit volume and higher heat transfer coefficients. One company which has won awards for developing such a design is Mezzo Technologies whose MicroChannel radiators use nearly 8km (5 miles) of stainless steel micro tubes which measure less than 0.5mm (0.197in) in diameter. 'Our version of micro channel utilizes thousands of small diameter tubes which make up the core,' explains Kevin Kelly, president of Mezzo. 'Our expertise involves a good understanding of the thermal performance such as heat transfer and pressure drop correlations for various tube bank geometries. In general, these products offer increased heat transfer, lower air pressure drop, and reduced volume and weight.'

## Keep it sealed

Race teams world-wide go to incredible lengths to get the smallest edge over the competition. From expensive R&D and exotic materials, the attitude for some teams is 'spend more money, get better results'. However, the attitude in a lot of cases should be 'cut your losses' says Chris Gregory from Gregseal Technology. Gregseal Technology (GST) have been providing bespoke seals for all engine and driveline applications over 35 years, including 20 years devoted to global motorsports, high performance road, and off-road vehicles. Their attitude is, evaluate your current tools and make them work as efficiently as possible. GST provide innovative solutions to power losses from sealing problems, and a full consultancy service to ensure all aspects of sealing your race engine are covered. Working with ever increasing tolerances of race engines provides new challenges for race engine designers and the teams every year. With loss savings of up to 80% to be found through proper fluid sealing including gearbox to crankcases, intakes, and oil seals throughout the engine, sealing is a consideration that should be taken first. <http://www.gstracing.co.uk>

## Airflow considerations

The radiator thickness vs frontal surface area still remains a topic of controversy, which is why you see NASCAR teams actually taping up the front of the grill to force the air to flow over the car, improving downforce. 'Aerodynamically, you do not want radiators, as they get in the way of nice efficient down force producing surfaces,' explains Tino Belli, director of aerodynamic development for Indycar. 'Radiator shape is also an issue, as it is expensive and difficult to produce the three dimensional shapes that the aerodynamicist would ideally like to have. Maximum heat transfer per unit airflow is important, but so is retaining this characteristic throughout a

**“Aerodynamically, you do not want radiators, as they get in the way of nice efficient downforce producing surface”**

**UKAS accredited calibration and on-site technical support services to the motorsport industry.**

**Test Bed / Rig Calibration • Vehicle Instrument Calibration**



**FORMULA • SPORTS • TOURING • RALLY • PERFORMANCE**  
*No-one measures up to our standards*

[www.youngcalibration.co.uk](http://www.youngcalibration.co.uk)

Unit 4, Ham Business Centre, Brighton Road, Shoreham by Sea, BN43 6RE +44 (0)1273 455572



**C&R RACING  
INCORPORATED**

Most people know us for our radiators.  
The industry knows us for so much more.

C&R RACING, INC.  
6950 Guion Road  
Indianapolis IN 46268 USA  
p - +1.317.293.4100

C&R RACING, INC.  
301 Cayuga Drive  
Mooresville, NC 28117 USA  
p - +1.704.799.0955

[WWW.CRRACING.COM](http://WWW.CRRACING.COM)

A selection of Mocal coolers for various motorsport applications from Think Automotive

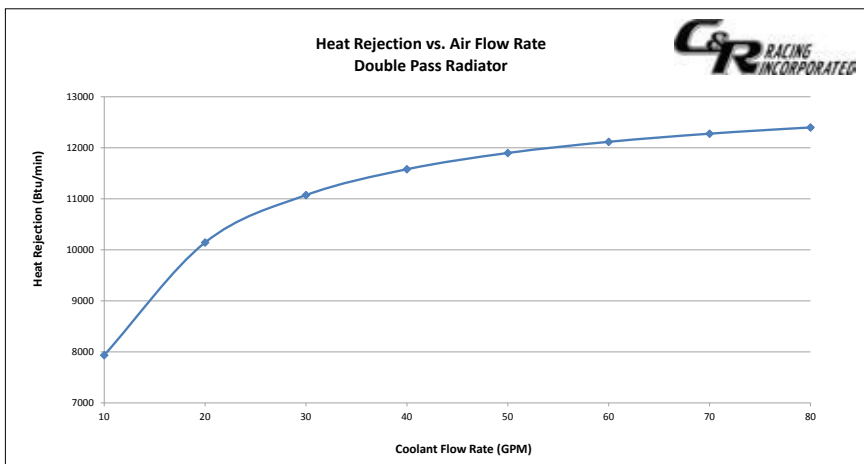
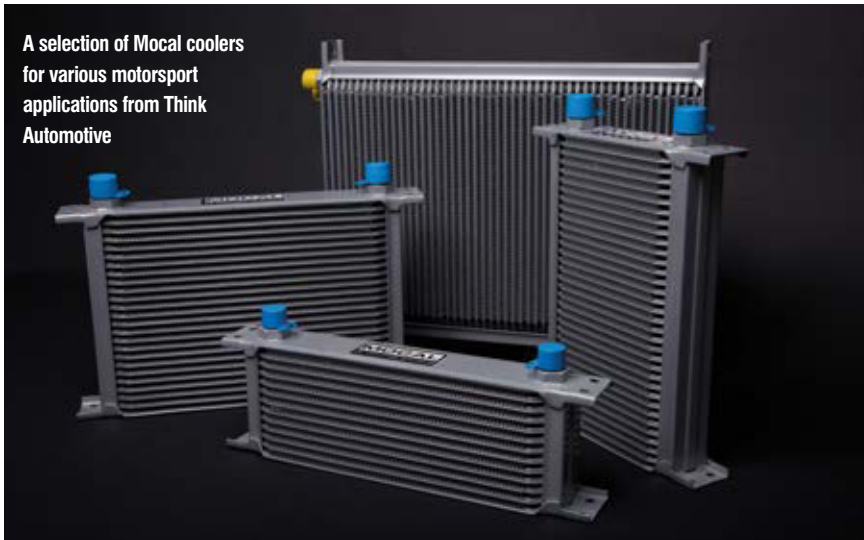

A graph showing heat rejection vs flow rate for a double pass radiator. Up to 60GPM, the increase in heat rejection is substantial for a double pass design and therefore is most effective. After 60GPM, the line flattens, demonstrating that the gains in heat rejection are minimal, so single pass radiators are used instead



Setrab's ProLine STD oil coolers available in 700 different sizes and can suit all types of cooling on a vehicle from engine oil to power steering

## Design options

Such designs are suited for applications such as Indycar as they can provide more heat transfer on extremely hot days. 'Mezzo radiators have no fins, so they don't degrade through the race as the fins bend and don't clog with debris. The micro tubes are naturally strong, so they don't puncture if hit by stones, and if someone is unfortunate enough to have a tube leak, the rate of leakage is very low because the tubes are so small. No one has ever gone out of a race because of a Mezzo radiator leak,' says Belli.

The performance of radiators can also be tuned depending on whether they are single or double pass, where the fluid to be cooled is passed through the radiator either once or twice. 'The decision to build single or double

pass comes down to optimizing heat rejection based on water flow rate as it works with the core design,' explains Chris Paulsen, president of C&R Racing, the largest supplier of aluminium radiators for NASCAR Sprint Cup, Nationwide, Camping World Series and Indycar. 'The basic rule of thumb is to go single pass if the flow rate is high. On a stock car size radiator, we would single pass as long as we have at least 60 GPM of flow rate, any less should go to a double pass. This is very much dependent on the water velocity through the core. We want high velocity for turbulence. The more turbulence, the higher the heat rejection.'

Pressurised cooling uses an accumulator which has a predetermined air space that acts as an air spring to avoid overheating. 'This air spring allows for temperature expansion without losing water via the hydraulic action of the expansion in a closed system, explains Paulsen. 'With a typical radiator cap system, there isn't enough air space, so if too much tape is applied to the grill opening or the radiator gets clogged with rubber or debris, the temperature will rise, the pressure will overcome the pressure threshold of the cap, thus pushing out water and pressure. With a properly engineered pressurized system, the air spring is

## Intercoolers

The 2014 F1 rules saw the introduction of turbocharged engines, which arguably created the biggest challenge for the cooling system. As air is compressed by a turbocharger it becomes heated, which decreases horsepower, so to reduce the air temperature and allow maximum density to enter the engine, an intercooler is required. 'For any intercooler, it is vital to find the perfect balance between the inner and outer heat dissipating areas,' explains Bengt Hasslert, Sales Manager for Setrab. 'Our motorsport intercoolers are designed using rolled tubes and more intricate inner and outer fin designs. Also, as weight is a major consideration, we use a header and tube design where the material thickness of the individual components has been optimized for low weight without forgoing durability.' Setrab supply to a wide range of championships including DTM, NASCAR, GT3 and WTCC. Hasslert also revealed that current and future development of cooling systems is all to do with cooling circuits for hybrid technology as the regulations continue to push for such racecars.

calculated based on the volume of the cooling system. We build in plenty of margin to stay in front of the boiling point. In NASCAR, it's not unusual to see certain teams run over 260degF all day long with no overheating issues.'

'In the early stages of our NASCAR programme, we used bar and plate core construction. It had ample thresholds for adding pressure to the cooling system over and above the normal temperature expansion,' says Paulsen. 'Today, extruded tube and welded tube cores hold adequate pressure for our NASCAR product and we use very little two row cores. We can outperform the standard 56mm two row core with 27mm single tube cores.'

As with most engineering tasks, designing the perfect cooler is a battle of compromises. Robert Potter, managing director of Think Automotive, specialists in off-the-shelf oil coolers, explains: 'The first consideration is the effect on the aerodynamics of the vehicle. The jury is still out on whether to have an air-to-oil cooler or a water-to-oil cooler connected to an air-to-oil cooler – the answer lies in the packaging. Next, is how to minimise the oil pressure drop and few people realise that a narrow cooler with many tubes will be more efficient, pressure drop wise, than a wider cooler with less tubes and the same face area. The size of the cooler can be determined to achieve the desired temperature drop for the specific amount of air/coolant and oil. This information is rarely available so this is where experience comes in and the engineers from Think Automotive can make an assessment.'



Bespoke design of energy-efficient Oil Seals for all Engine & Driveline applications.



Innovative designs & race-proven technologies minimise parasitic power losses & maximise racing advantage

## GST Racing Seals

A division of GregSeal Technology UK Ltd

Tel: 077 1753 4027 • Fax: 02380 224104

info@gstracing.co.uk • www.gstracing.co.uk



**mezzo**  
TECHNOLOGIES

Mezzo's designs and fabricates micro channel heat exchangers for a number of industries including automotive racing, aerospace and defense. Mezzo's products deliver superior performance in terms of increased heat transfer, reduced weight, and decreased volume. Mezzo's products are also very damage tolerant, easily maintained, and reasonably priced.

With respect to automotive racing, Mezzo radiators were first used by the Andretti Green Racing (AGR) of the Indy Racing League (IRL) in 2008. Mezzo was an approved supplier of radiators for the IRL 2010 & 2011 seasons. Mezzo won the 2010 Louis Schwitzer Award for innovation for its micro channel radiator and will continue to develop its technology for high performance racing applications. Mezzo Technologies' products are currently being used in high performance racing including Indy Car, F1, LeMans and GT.

Mezzo takes pride in handling the toughest thermal management problems. Give us a call!



7167 Florida Boulevard, Baton Rouge, LA 70806, USA.

Tel: +1 (225) 706-0191 Fax: +1 (225) 706 0198

[www.mezzotech.com](http://www.mezzotech.com)

Email: [kelly@mezzotech.com](mailto:kelly@mezzotech.com)

# HIGH PERFORMANCE RACING DEMANDS THE BEST TITANIUM

*For 25 years, engineers and designers have relied on Titanium Engineers to provide the highest quality titanium alloys combined with world class technical support.*

*Call us to discuss how our titanium alloys can improve your performance.*

**TE TITANIUM ENGINEERS**

Birmingham, UK: +44 (0) 1675-464200  
contactus-UK@titaniumengineers.com

Houston, USA: +1 (281) 265-2910  
contactus@titaniumengineers.com

Stavanger, Norway: +47 51315785  
contactus-NO@titaniumengineers.com

T I T A N I U M E N G I N E E R S . C O M



- THE MOST POPULAR COMPONENT IN MOTORSPORT
- COMPREHENSIVE RANGE OF COOLING ACCESSORIES
- **BRITISH** DESIGN & MANUFACTURE

FOR THE BEST IN OIL COOLING SYSTEMS...

**...MAKE IT MOCAL!**



**WINNING RACES SINCE 1967**

Worldwide enquiries go to:

[www.mocal.co.uk](http://www.mocal.co.uk)

USA enquiries go to:

[www.mocal.us](http://www.mocal.us)

0208 232 3525



Like Us

# FUEL SAFE Racing Cells

Go Fast!

Be Safe!

**YOUR CHOICE IN RACING FUEL CELLS**



COMPLETE FUEL CELL PORSCHE 911/930

WEDGE BLADDER P/N CB400



CUSTOM TIRE WELL BLADDER



PRO CELL® IN TRIUMPH OEM CAN



VINTAGE RACER CUSTOM CELL

ASK ABOUT OUR

## FLEX FUEL CELL

Race Gas • Alcohol Fuels  
Ethanol Blends • Diesel  
**YOUR ONE FUEL CELL!**



**International Shipping Available**

SHOP ONLINE AT [FUELSAFE.COM](http://FUELSAFE.COM)

CALL TODAY 800-433-6524





# Simulation techniques for electric racing Part 1

**Battery theory and technological advances from the RC model industry give a starting point for motorsport-focused simulation**

By **DANNY NOWLAN**

It's not that often that what you do as a hobby and what you do professionally coincides. This is exactly what happened when a couple of weeks ago a potential customer approached me about incorporating an electric vehicle propulsion module into ChassisSim. Given that electric Powertrains are an emerging area of motorsport technology this is a matter that needs to be discussed.

This will be the first of a two part series about the application of electric Powertrains in motorsport. What we'll be discussing in this article is the basics of what you need to know to get going. We'll talk about some basic circuitry, how to understand a lithium polymer cell discharge curve and how this ties into engines. We'll then talk about some basic hand

calculations for understanding current draws and show you what to expect from current draw over the lap. In part two, we'll talk about the more advanced engineering ramifications because there is a lot to consider, but that can wait till the next article. Before we get underway, there are a number of things I need to touch upon.

## RC developments

Firstly, it is very rare for me to talk about ChassisSim work in progress but, given the importance of electrics (in Formula E, for example, which hits the world stage this year), this has to be addressed. For any data or race engineer reading this, in particular the younger ones, you will be engineering an electric car at

some point. Consequently you had better get your head around how electrics work.

Secondly, as I touched upon in the introduction, I've been flying high performance radio controlled (RC) aircraft for nearly 20 years and we'll be drawing on this experience. I started off on NiCads and balsa and now I fly brushless/lithium polymer monsters that put the fear of God into the neighbours. We are talking pylon racers that will outclimb an F-18 Hornet to 100m and break 240 km/h without a sweat, and a 2.5kg 3D aircraft that will blast out of hover like a bat out of hell and do 180 km/h in a straight line. I don't claim to be Nicola Tesla or a lithium polymer genius. However, I've blown up enough LiPo (lithium polymer) packs, fried enough motors and speed controls – and



Electric racing is going to become more relevant and Formula E is just the first step into this new world. Engineers will need to be aware of simulation techniques to make the most of it

**EQUATIONS**

**EQUATION 1**

$$V = I \cdot R$$

$$P = V \cdot I$$

Here we have,

- V = Voltage of the element (V)
- I = Current of the element (Amp)
- R = Resistance of the circuit/element (Ohms)
- P = Power dissipated in the circuit (W)

**EQUATION 2**

$$R = \frac{V}{I}$$

$$= \frac{10}{30}$$

$$= 0.33\text{Ohms}$$

$$P = 10 \cdot 30 = 300W$$

**EQUATION 4**

$$P = \frac{V^2}{R}$$

$$= \frac{14^2}{0.33}$$

$$= 593.9W$$

$$I = \frac{14}{0.33}$$

$$= 42.4A$$

**EQUATION 5**

$$No\_Series \cdot S - No\_Parrallel \cdot P$$

$$V_p = No\_of\_Series \cdot V_{CELL}$$

$$Ah_p = No\_of\_Parrallel \cdot Ah_{CELL}$$

Here we have,

- No\_Series = No of cells in Series
- No\_Parrallel = No of cells in Parrallel
- V\_p = Voltage of the pack (V)
- Ah\_p = Capacity or C rating of the pack (Ah)
- V\_CELL = Voltage of the cell (V)
- Ah\_CELL = Capacity or C rating of the cell (Ah)

**EQUATION 6**

$$I = \frac{P}{V}$$

$$= \frac{166000}{500}$$

$$= 332A$$

**EQUATION 7**

$$Amp\_h = I \cdot \frac{t}{3600}$$

$$= 332 \cdot \frac{52}{3600}$$

$$= 4.8Ah$$

had one trip to hospital (after my finger had an argument with a propeller) – that hopefully you can learn from my mistakes.

Lastly, before we get underway, electric propulsion presents a fantastic opportunity for us in motorsport to lead and drive this technology. In recent years, the RC electric aircraft community has driven battery/motor technology in its demands to fly harder, faster and longer. The requirements of electric powertrains for motorsport will push this to the next level. The FIA has decided to go down a spec route for Formula E and I can understand their trepidation since we are in uncharted territory. However, electric propulsion offers an opportunity for us to take the initiative and we won't do that by clinging to the crutch of the spec formula format. Also, as we are about to discuss, electric is not that hard to grasp.

To kick off this discussion we need to discuss some basic circuitry maths equations. In particular we need to talk about Ohm's law and the electric power **Equation 1**.

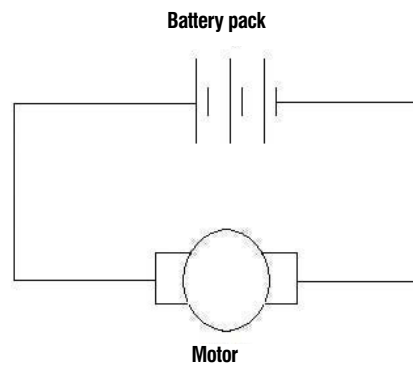

**Figure 1: Basic motor circuit diagram**

I realise that what I have just discussed is high school level physics but it has some big-time ramifications because, in its simplest form, an electric power train can be represented by a voltage source and an engine. This can be illustrated by the circuit diagram, **Figure 1**.

To illustrate what we have discussed let's talk about some basic calculations to get a rough handle on current levels. On my 1.2 m balsa 3D aircraft on a 3S pack (output about 10V under load) swinging a 13in x 6.5in prop I was drawing about 30A. So the resistance of the motor and prop combination and the power will be given by **Equation 2**.

At this point you might be thinking 'so what?' Let's just say we want to go to a 4S pack which is running about 14V under load. So as a rough rule of thumb we have **Equation 3**.

So plugging in our numbers from what we just worked out we are going to project our power and current draw. We have **Equation 4**.

**Cell discharge**

In reality, when I made the jump I dropped the prop down to a 12in x 6in prop, so I was pulling about 40A but what we have just seen in **equation 3** is a great rule of thumb to get going and was taught to me by my flight instructor in the mid-1990s. It has served me well. You'll see the ramifications for this a little bit later.

The next step in understanding electric is how to read a voltage cell discharge diagram. The reason this is important is the voltage cell diagram is a critical element in telling you how much performance you'll get from an electric power train. The key to understanding electric Powertrains is to recognise that the cells and

**SLPB 100216216H 1.0C = 40.0A**

- ◆ Charge : CC-CV, 0.5C, 4.2V, 2.0A Cut-off @ 23°C ±3°C
- ◆ Discharge : CC, 0.5C~10.0C, 2.7V Cut-off @ 23°C ±3°C

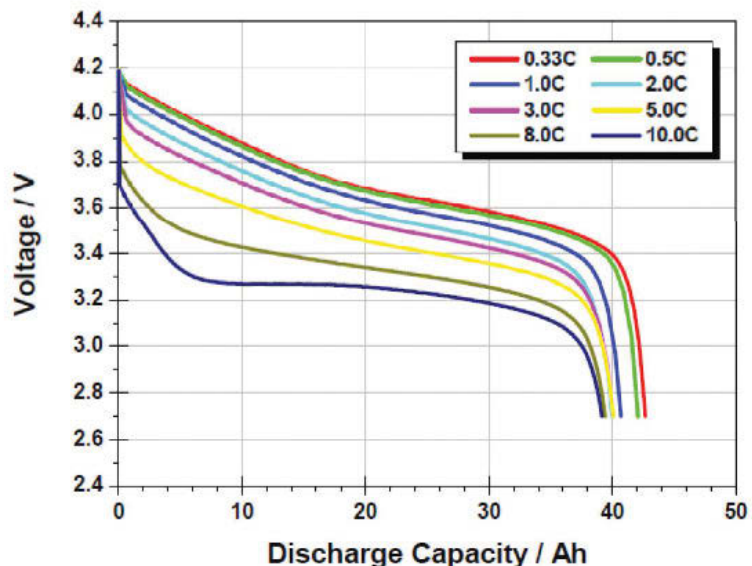

**Figure 2: Lithium Polymer Cell discharge courtesy of EV Systems Australia**

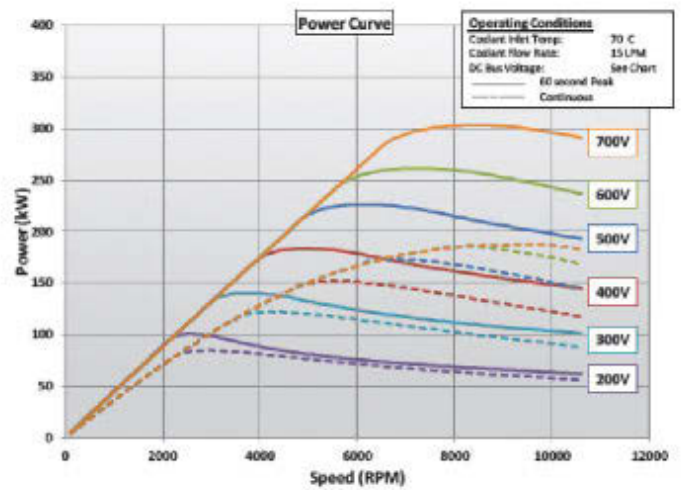
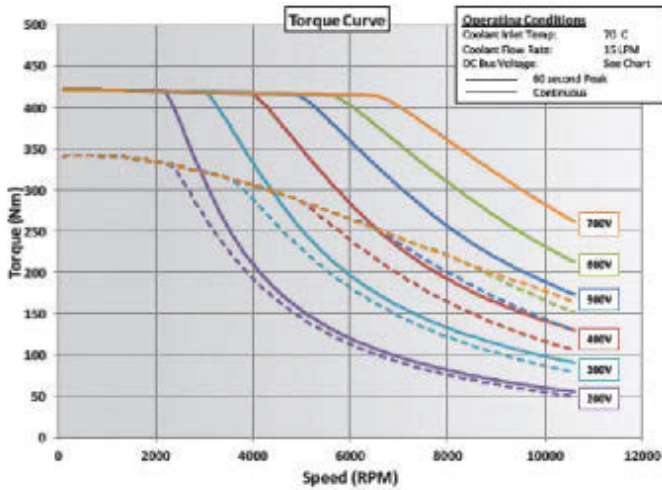

Figure 3: electric torque curve for RPM and Voltage. Courtesy of EV Systems Australia.



Figure 4: A plot of Speed, Throttle and RPM for a lap

the motor are fundamentally linked to the grunt you'll have on tap. The discharge curve for a typical lithium polymer cell is shown in **Figure 2**.

First things first – let's explain the axis. The vertical axis is voltage or how much energy you'll have on tap. The horizontal axis is the discharge of the cell. You'll see here the scale is in Ah. You'll also see cells quoted as kWh. Either convention is up to you, but for me Ah makes a bit more sense. You'll see the various discharge curves quoted in C. What this means is the current that is applied to the cell is multiplied by the discharge capacity. The more current that is applied, the more the cell voltage will drop off. The ideal cell drops off a little bit then it flat lines. It pretty much keeps that flat line until we are almost at the end of the C rating of the battery or how many Ah it can store. In an ideal world it starts to drop off at the 80-85 per cent mark. The more voltage it can keep, the better the cell.

The other thing to keep in mind when choosing a lithium polymer cell is it's C rating in charge and discharge. You don't have to

be a rocket scientist to figure out the bigger the C-rating the better the cell. For example, when I made the switch to lithium polymer in the early-2000s, I was running packs that could be discharged continuously at 20C and charged at 1C. To put that in perspective for a 2200mAh pack you could draw 44A continuous and charge at 2.2A. Modern generation lithium polymer for RC aircraft (such as Thunder Power) use can be continuously discharged at 70C of the capacity rating and charged at 12C. Again to put numbers to this, for my current cells which are 2700 mAh, if I wanted to I could draw 189A continuous and charge it at 32.4A. It goes without saying that the performance of the modern cells represents a quantum leap from the cells of 10 years ago.

I should also add that when it comes to battery cells, lithium polymer/lithium ion is the standard, which is why I'm limiting my discussion of cells to these. When it comes to energy density – how they can be discharged and how hard – NiCads and NiMh belong in the history books. In F1 and Formula E the current

## EQUATIONS

### EQUATION 8

$$I_{CHARGE} = \frac{P}{V}$$

$$= \frac{100000}{500}$$

$$= 200A$$

### EQUATION 9

$$Amp\_h\_c = I_{CHARGE} \cdot \frac{t}{3600}$$

$$= 200 \cdot \frac{8.8}{3600}$$

$$= 0.5Ah$$

### EQUATION 10

$$No\_Series = \frac{500}{3.5V} = 142.8$$

### EQUATION 11

$$Pack\_m = 143 \times 5 \times 0.2$$

$$= 143kg$$

standard is lithium ion. That being said, given the benefits of lithium polymer, it won't be that long before we see LiPo cells take over as the standard for motorsport use.

The finishing touch to this discussion is to discuss how you specify a battery pack. When specifying a battery pack using LiPos this is the convention that is used; **Equation 5**. For a rough rule of thumb, put the cell voltage at 3.5V. It's a number I use for my calculations that



# It goes without saying that the performance of the modern cells represents a quantum leap from the cells of 10 years ago

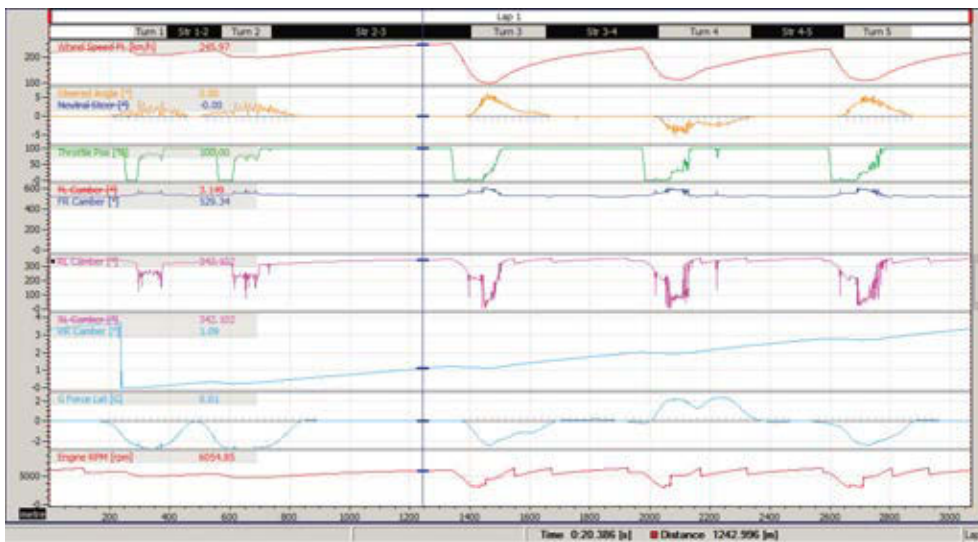

**Figure 5: Prototype ChassisSim Electric Vehicle Power train conversion. The traces in question are pack voltage (trace 4, dark blue), current (trace 5, pink), and current draw (trace 6, light blue)**

works pretty well. The next essential step in understanding electric Powertrains is reading a torque engine curve for an electric motor. This is illustrated in **Figure 3**.

The first thing that jumps out at is the flat nature of the torque curve. The bigger the voltage the more this is maintained through out the rev range. Depending on the power you'll need and the rev range that is required, you can determine the required pack voltage from the associated power curve. This is a good rule of thumb if you are converting from an internal combustion engine. For example, looking at the power curve, if we need to run between 150-200kW and be able to rev at 6000-6500rpm, then we can calculate that we'd have to run a pack voltage in the order of 400-500V.

## While the current draws presented here might seem big, they are not particularly outrageous

One big implication of electric Powertrains is the gearing will be fundamentally different to what you are used to. This is primarily due to the flat nature of the torque curve. So much of what we do with gearing a racecar is to keep the engine in a certain rpm envelope. When you have a flat torque curve your gearing is going to be dictated by when you hit peak power.

Now that we have discussed the power train basics, let's consider an electric conversion based around an F3 car. A typical F3 car has an engine power of 220 hp or about 160 kW. For the sake of the argument let's target 166 kW. From **Figure 3**, this means we need to be targeting a pack voltage between 400-500V. To make things easier, let's target 500V. From the power equation the current we need is **Equation 6**.

For the sake of the argument, let's say we are using the cells in **Figure 2**. That has a C

rating of 40Ah. So with this battery we would be drawing 8.3C, which is quite acceptable.

The initial challenge is to calculate the current consumed for the lap, which is not as onerous as you would think. The first stage is to bring up a plot of a conventional car which is shown in **Figure 4**. Note I have plotted this against time. To get us into the ballpark, we are going to add all the time we are on full throttle. For this lap, this happened to be 52 seconds. The amount of current we will discharge for this lap is expressed by **Equation 7**.

Let's presume we have some form of energy recovery system fitted to the car, so we can recoup a certain amount of energy under braking. For the sake of the argument, let's say we can harvest 100kW of brake energy. The charge current will be given by **Equation 8**.

What this means is we can charge our pack at a charge rate of 5C so we are not going to fry the cells. Looking at the lap the car spends 8.8 seconds on the brakes. So, as an approximation, the amount of charge we can put back into the pack is shown in **Equation 9**.

Over the course of a lap we'll discharge 4.8Ah, but we can recharge 0.5Ah, so we'll be losing 4.3Ah for this one-minute lap. While this isn't exact, at least it gives us a target to shoot at. We'll see in a moment how this compares to a more advanced analysis.

While the current draws presented here might seem big, they are not particularly outrageous. To put this in perspective, 6S 3D aircraft can pull 70A of current for periods of well over 2 minutes. Also Castle Creations, one of the chief manufacturers of brushless speed controls for RC aircraft and cars, offers a 200A electronic speed control. This is stuff that you

can order online, so the numbers we are talking about aren't fantasy land. If you don't believe me, check out [www.aveox.com](http://www.aveox.com).

The next step is to explore the specification and size and weight of the battery pack. Firstly we need to determine the number of cells in series. Working on our assumption of 3.5V per cell, the number of cells in Series will be **Equation 10**.

Let's round this up to 143 cells in series. The big question though is what is the weight of the battery pack? To get an approximation I'm going to use one of the Thunder power 65C cells with a C rating of 7.7Ah. This has a weight of 200g per cell. From **Equation 5**, to get to our 40Ah specification, we need five cells in parallel. So the weight of the pack will be as shown in **Equation 11**.

## Preliminary simulation

By the time you add in wiring and a box, you would probably walk away with a pack that weighs in the order of 160kg, give or take. We'll discuss in the next article the ramifications for this and how to use it.

To nail all this down you need to use simulation. This is where the electric vehicle power train module of ChassisSim comes in. To illustrate, I've done a simulation of our electric spec F3 car. The results are shown in **Figure 5**.

Please bear in mind this is a beta plot. That being said, there is promise here. The variables to pay attention to are in the fourth trace that plots pack voltage, the fifth trace that plots current and the sixth trace that plots the Ah used by the pack. You can see very clearly the voltage dropping down as the current increases, and the voltage increasing as the current draw drops down. You can also see the pack voltage starting at 535V at the start of the lap and dropping down to 521V. However what is of particular interest is the projected current draw which is 3.7Ah for the lap (please note the lap started from the start of turn 1). Our approximation of 4.3Ah wasn't that far off, but bear in mind we used some simple assumptions. We will build on this for the next article.

To sum up, the purpose of this article was to introduce you to the basics of electric Powertrains. We talked about Ohm's law and the power equation and how to use this in a simple circuit to project current draw. We then talked about the importance of cells and how this interacted with the motor. We then talked about some simple techniques for calculating current used over the lap. Lastly, I gave you a taster of what is coming down the road for electric vehicles for ChassisSim.

In the next article, we are going to use this to explore the ramifications of electric vehicles and things to watch for when implementing an electric vehicle system. We'll then compare to its petrol engine counterpart. I expect these results to be fascinating!

**Technical Specifications**

Length 360 mm

Width 410 mm

Height 230 mm

Dry Weight 5.5kgs

Coolsuit pump current draw 0.8 amp

Driver Helmet fan current draw 4.0 amp

**Driver Coolsuit & Fresh Air System**

The Triple Eight designed Coolsuit & Fresh Air system combines the features of a standard coolsuit with the added feature of filtered cooled air supplied to the drivers helmet.

The insulated carbon ice chest can carry 8kg of dry ice enabling the unit to operate efficiently at an optimum 8-12 deg C for 2 hours continuously.

(Up to 4hrs with Enduro Option)

Unit is supplied with driver coolsuit bypass switch & Dry Break Quick Connections for Endurance Racing Requirements.

System includes Triple Eight design low voltage fan with Carbon Monoxide filtration integrated.



As used by Red Bull Racing Australia V8 Supercar Team

e: [customersupport@tripleeight.com.au](mailto:customersupport@tripleeight.com.au) T: +61 7 36357008 [www.tripleeight.com.au](http://www.tripleeight.com.au)

# The Next Generation in Tyre Monitoring

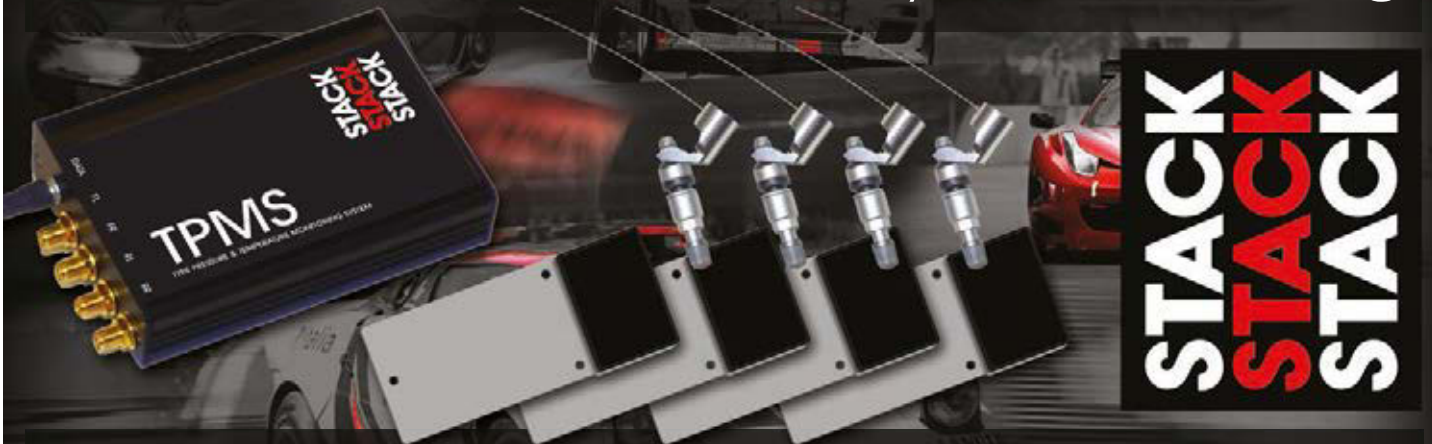

- No battery or complicated sensor electronics providing unrivalled reliability.
- No user maintenance required during full service life - significantly lower total operating cost.
- One module interrogates 1, 2 or 4 wheels - suitable for cars, trucks and bikes.
- Models available with 1, 5 or 10Hz sampling.
- Specialist high sampling rate modes - up to 20Hz on bikes or 40Hz on one wheel.
- Supports up to 100 wheel sets.
- Secure operation - transmitted data unreadable by other teams and sniffers.
- Automatic sensor identification - no need to allocate sensors to individual wheel corners.
- Compact, lightweight interrogator module.
- Pressure and temperature data output on user configurable CAN bus

*Bright ideas...*

**MELECTRONICS** 

ELECTRONIC SYSTEMS SOLUTIONS

**LED LIGHTING - POWER CONTROL - CUSTOM DESIGN**

MELECTRONICS SYSTEMS LTD. [WWW.MELECTRONICS.CO.UK](http://WWW.MELECTRONICS.CO.UK) [INFO@MELECTRONICS.CO.UK](mailto:INFO@MELECTRONICS.CO.UK)

# -35mm Worlds apart

**Our technology centre is the most advanced in Europe.**  
That is how we can achieve a negative radius of up to -35mm. Extreme engineering and precision that other performance cam manufacturers in Europe cannot match. All our camshafts and ancillaries have been developed by the best to be the best.

**Nº1** *Kent Cams – the best in Europe:*

- No.1 for product development expertise
- The greatest performance increase of any single modification
- The widest range of camshaft ancillaries produced on site

**The most advanced technology:**

- Negative radius to -35mm
- CBN wheels with constant surface speed
- Multi-angle lobes with CNC dressing
- Marposs 3D C and Z axis position probe
- Microphonic wheel dressing
- Lotus Concept Valve Train software

**KENT CAMS**

**HIGH PERFORMANCE ENGINEERING**  
[www.kentcams.com](http://www.kentcams.com)

Cams + Pulleys, Belts & Chains :: Valves & Valve Springs :: Performance Cam Kits & Valve Spring Kits :: Followers & Tappets

# Dragon's den

## A job-lot of parts becomes an innovative Formula Ford project with inspiration from jet fighter design

**H**alfway through the decade-long restoration of my Lotus 47, I decided to take a break by finally designing and building a Formula Ford, that I had designed and redesigned over and over in my mind. A few of the criteria I decided on because of the very restrictive rules (which I love as a great challenge) included small frontal area, low centre of gravity, simplicity, stiff chassis and good weight distribution.

Because of a lack of money, I decided to start with uprights from a production Formula Ford. I chose the Bowmans, since I recalled the article by Dave Hancock in the May, 1998 issue of *Racecar Engineering* (V8N4) about the Bowman Formula Continental/FF-2000. Coincidentally, my friend, Glenn Taylor had just joined Highcroft Racing who had begun their switch to the ALMS series. I asked Glenn to approach Highcroft about my purchase of four uprights because the designer, Sergio Rinland, had used the same upright castings front and rear. The answer was swift and to the point: No... but I could buy the whole team! Ridiculous was the first word that came to mind.

I had been forced to retire when Tyco bought the company, US Surgical, where I worked. Then, Glenn said he would talk to Duncan Dayton again, and, somehow, he worked out a deal that I could handle by regaining much of my money by selling the race cars and the spares. So, I raided my meagre retirement savings and bought the whole shebang!

### Taking stock

I ended up with three rolling chassis with LD 200 gearboxes, two prototype chassis, two dozen plastic containers of spares, a large pile of aluminium radiators, a large pile of machined, cast aluminium cam covers, a pile of narrow and a pile of wide-track suspension arms, three plastic 'tackle boxes' of CNC machined pickup points, studs, and other components. Also, there were wings, body parts, a nose crash box, an unused bell housing, plus a total of 42 wheels.

I moved two of the rollers to their temporary storage place, Glenn's race trailer. I had snatched them from their palatial, purpose-designed and built, race shop. It had been designed by Duncan Dayton, and he had been schooled at the Frank Lloyd Wright architecture school at

Taliesen, Wisconsin. The then-new Highcroft race shop was equipped with offices upstairs, a glass fronted showroom, race prep bays, a chassis dyno, a machine shop, and indoor storage for two tractor trailers, end to end, plus a huge pillarless shop area for lease to other race teams.

Since a semi-recumbent driver constitutes the largest item to affect the car's frontal area. I began with the driving position and decided to keep all components in line with the driver. By using four lengths of one inch plastic water pipes, punching four holes in one wall of a large cardboard box, I determined the smallest frontal area I could function with.

The cardboard box served as the firewall. Then I made a quickly three view drawings, then proceeded to build the chassis. The first iteration of my front pyramid had the radiator slung under the pyramid. This presented problems with support for the intake and body work, so, I changed the front so that the radiator would become part of the front crush area, and the intake opening is less difficult to make. The upper two elements of the pyramid are nested in the longitudinal frame tubes and are silicon

bronzed in shear so that a sharp blow from the front will allow the elements to slide into the frame tubes. The lower elements are square tubes turned 45 degrees to allow the air easy flow into the radiator and are notched to clear the radiator. The notches allow the elements to bend when struck at the front.

To keep the point of the pyramid from inflicting a damaging blow to a competitor, I added a tube frame as the opening for air to the radiator. The floor of the front end is attached to this tubular frame with steel rivets. I chose to use a VW cased gearbox since, in this application, where the case is fitted upside-down, it conveniently leaves a cavity underneath into which the spring/shock assembly can be built. This helps in keeping the centre of gravity as low as possible, at the rear as well as the front. The first exhaust I built was a four-into-one design, all enclosed in the body work. I then changed my mind and made a four into-two-into-one setup. I had to add an aluminium cover piece to protect the bodywork, settling on a Swift Atlantic decklid to allow hot air from the engine and exhaust to be released from under the engine cover.



Richard H Yagami observed that vortex generators are seen on many fighter jets, intended to smooth flow over fuselage

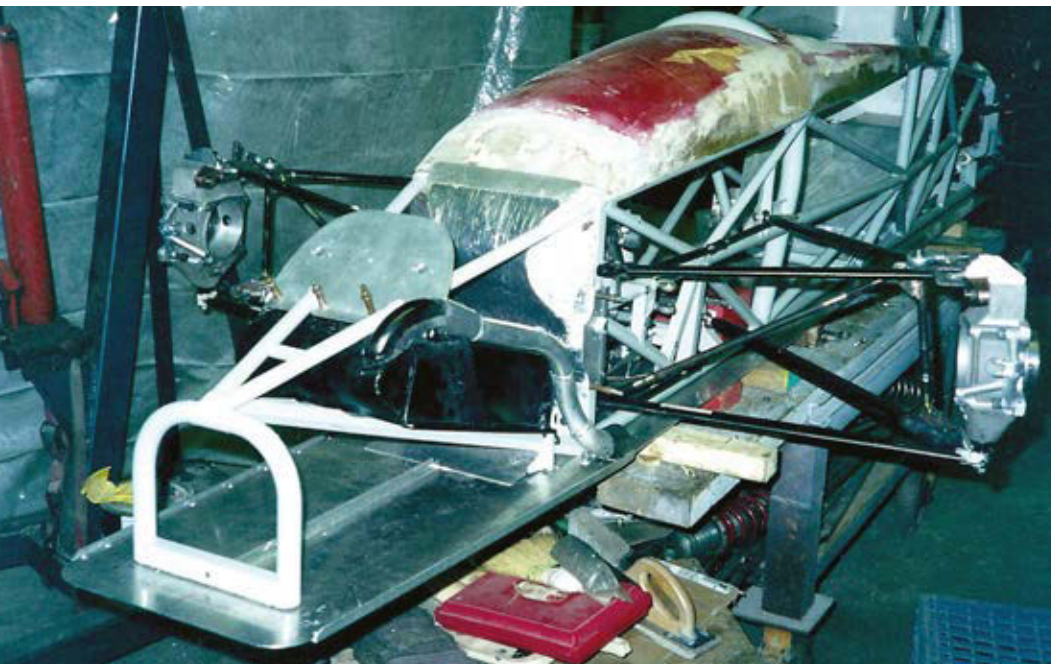

Work begins on the radiator intake and exit ducts which will be formed by the nose bodywork

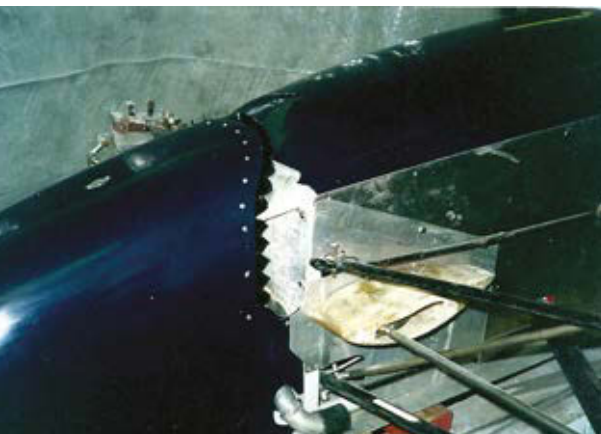

'Yag's Dragon's Teeth' are bared in this detail of the radiator exit duct design

As a child, I had seen and heard some Porsches running on the streets of my home town of Pasadena, California. The exhausts were very loud and were in the centre of large holes in the body work. Decades later, in an unrelated article in *Hot Rod* magazine, I learned that Porsche had contracted Fletcher Aviation, then in Pasadena (later to relocate to Australia), to study air cooling driven by the exhaust gases.

I thought that I could use the exhaust to extract hot air and pull cool air over the rear spring/shock unit, thereby pulling air from under the floor. Recently, I ran another bench test of the concept, reaffirming that the concept works and in addition, I found that a secondary benefit occurs in that the air pulled through by the exhaust, in turn, pulls air towards the body thus helping reduce the turbulence induced by the body moving through air.

I also decided to fair in the half shafts since a rotating cylinder causes much mischief. Then I wondered if I could turn a simple, very thick symmetrical airfoil into a directional airfoil.

Earlier, when I read an article about a patent issued to NASA for the sawtooth trailing edge of a wing, I immediately saw the possibility of a further improvement of the sawtooth trailing edge. I changed the sawtooth to what I call 'Yag's Dragon's Teeth' (are drivers the only ones allowed an ego?) The fairing for the halfshafts has a ratio of three (thickness) to nine (chord), I also used the Dragon's Teeth on the exit duct of the radiator. In fact, the nose bodywork acts as both the sides of the intake duct to the radiator and as the sides of the exit duct from the radiator.

I investigated the Dragon's Teeth a bit further by adding a saw-tooth trailing edge to a piece of Glenn Taylor's Ralt RT4. The air leaves the trailing edge in a line tangent to the lower curve of the wing at the trailing edge. When I added the Dragon's Teeth to the wing's trailing edge, the air moved to a 10 degree angle to the tangent line from the rear edge. The only thing that I couldn't determine was the drag that might be induced, since a large vortex was induced that ran parallel to the trailing edge, hence the concern about the increased drag.

Dragon's Teeth added to the radiator exit duct tend to pull air out of the exit. Lately, I've seen that European military aircraft have added vortex generators a little past the noses... planes such as the Typhoons, Mirages and even Swedish Grippens. Photos show that the vortices generated by these added small generators tend

to stay close to the fuselages whereas the wing generated vortices tend to follow the leading edges of the wings, then begin to trail back.

It should be noted that the Mirages and Typhoons have canard wings at the front, yet generators have been fitted. The vortices generated by these added parts stay close to the body thus reducing the drag by smoothing out some of the turbulent flow along the side of the body. This follows what I found when I traced the vortices generated by the endplates of the front splitter used on the Nissan NPT90 GTP car as designed by Yoshi Suzuka. The vortices left the end plates rose to the centre of the side pods and ran straight as an arrow at about six inches from the sides, unaffected by the open wheel wells and the rotating wheels and tyres.

Back on my Formula Ford, the rear bodywork acts as the exhaust support 6 inches from the end of the pipe, as the rules require. The exhaust of course, pulls air over the spring/shock units, air through the body work and pulls air from under the floor of the car (shades of Gordon Murray's Brabham fan car).

The first fuel cell I had made was too long fore and aft for driver comfort, so, I redesigned the cell and had another made. The second one is taller and shortened front to back.

## The finished article

The front suspension is one area where I did *not* want to rebuild to take suspension loads through the pivots, so, I used a push-pull setup. Using the original flanges on the lower control arms, I ran a vertical push rod, kept from wandering around by running it through a rod end. Flanges on the vertical rod end connect to the pull rod. The vertical rod moves in the rod end only 0.020 inches which I consider tolerable.

The Bowman steering rack is very short and our local track's extremely tight, so I increased the steering lock by using a walking beam, which I also decided to enclose in a fairing.

In the cockpit area, I use a 'SPA' digital tachometer and shift light setup. The bodywork allows the front cockpit hoop to protrude to act as a deflector for the driver. Also, the three shift lights protrude through the body work, and are shielded by the hoop. Both sides of the chassis are sheathed in 16 gauge, 6061 T6 aluminium, thus reducing the possibility of harm from penetration in an accident.

The finished dry weight for the car, which I called Kishi (Japanese for Knight), was 406kg. With a driver and fluids, the weight ended up at just over the minimum weight of 499kg.

I still believe that all drivers should run in Formula Ford in order to learn what mechanical changes will do and what effects can be achieved against otherwise roughly equal opposition.

So that is my Formula Ford chronicle.

Richard H Yagami  
Ridgefield, CT, USA



## I immediately saw the possibility of a further improvement of the sawtooth trailing edge





## World Leading BMW Performance



### Clutch & Flywheel Kits

- » Tilton Metallic & Carbon Clutches
- » Twin & Triple Disc Options
- » 5.5" & 7.25" Clutches
- » Includes Lightweight Flywheel



### ATI Harmonic Dampers

- » Reduces crankshaft vibrations
- » Reduces internal engine wear
- » Releases horsepower & torque
- » VAC Exclusive (BMW M50, S54, & more)



### BMW Valve Train

- » VAC High Performance Valves
- » High Performance Valve Springs
- » A must for High HP cars
- » For BMW N54, S65, S54 and more

[www.vacmotorsports.com](http://www.vacmotorsports.com)

+1.215.462.4666

[sales@vacmotorsports.com](mailto:sales@vacmotorsports.com)



**Call us first...**



Unit 31 Silverstone Circuit Towcester Northants NN12 8TN  
T: 01327 857822 F: 01327 858096 [www.tridentracing.co.uk](http://www.tridentracing.co.uk)

# Melbourne clinches new five-year grand prix deal

Melbourne has signed a new race deal with Formula 1 Management (FOM) which will see the city host the Australian Grand Prix until at least 2020. The new contract extension was signed in London after 12 months of intense negotiations, and the race now looks set to retain its season-opening slot for 2015, with March 15 looking like the most likely date.

Melbourne's grand prix has been beset with political difficulties over recent years, with questions raised about its environmental impact and also the cost to the local Victorian state government of staging the event – said to be more than A\$50m (\$46m) in 2013.

However, the premier of Victoria, Denis Naphthine, welcomed the deal, saying that it was central to the state's promotional strategy, which is largely based on high-profile sporting occasions: 'Formula 1 is a key pillar of Victoria's major sporting events strategy,' he said. 'This calendar is unrivalled worldwide, commencing with the Australian Tennis Open and Asian Football Cup in January, followed by the ICC Cricket World Cup in February, the Formula 1 Australian Grand Prix in March, the AFL Final

Series [Australian rules football], and the Spring [horse] Racing Carnival.'

Victoria's major events strategy is said to contribute A\$1.4bn (\$1.3bn) to the state economy annually and generate some 3500 jobs, while it's claimed the Formula 1 grand prix alone creates between 351 and 411 jobs and up to A\$39m (\$36m) in economic benefits.

The state's minister for tourism and major events, Louise Asher, also added that: 'The worldwide broadcast [of the grand prix] delivers invaluable promotion and coverage to Melbourne and Victoria.' Naphthine now hopes the city will be able to capitalise on the success of Australian driver Daniel Ricciardo, who at the time of writing was the only driver to break Mercedes' stranglehold on F1 in 2014 with two grand prix wins in his Red Bull. 'Within this contract we hope to see Australia's own Daniel Ricciardo win the Formula 1 Australian Grand Prix and become world champion,' Naphthine said.

The attractive lakeside Albert Park circuit has been part of the F1 calendar since 1996, when it replaced Adelaide's street circuit as the host venue for the Australian GP.



Melbourne will keep its grand prix until at least 2020

## SEEN: Jaguar Lightweight E-type



Jaguar has launched what might be described as a 'brand new old racecar' in the shape of its recreation Lightweight E-type. The car, just six of which will be hand-built by Jaguar craftsmen in a new facility at the company's Browns Lane plant in Coventry, is the first project for the all-new Jaguar Heritage department, part of the company's Special Operations Division.

The specification includes an aluminium bodysell with doors, boot lid, hardtop and bonnet also in aluminium – as per the original

cars back in the '60s. The 6-cylinder XK engine also mirrors the original power units, with an aluminium block, wide angle aluminium cylinder head and dry sump lubrication. It's not all about shine and nostalgia, though, and the cars will all be sold as period racers and will be eligible for FIA homologation for historic motorsport use.

Only 12 originals were built at Jaguar's Browns Lane competitions department in 1963-64. The price of the 'new' Jag had not been disclosed at the time of writing.

## IN BRIEF

### No USC for Indy

The United Sportsscar Championship will not be racing at the Indianapolis Motor Speedway (IMS) next year. This season, the first for the combined ALMS/GrandAm championship, saw the USC share the bill with NASCAR at Indy, the sports cars taking to the road course on the Thursday and Friday, the stockcars using the oval configuration during the weekend. But IMS president Doug Boles has said this caused logistical difficulties and the arrangement will not be repeated, although he also said the gates to the fabled circuit remain open to the USC should it wish to return, on a different date to NASCAR, after 2015.

### Hub dubbed

The UK Government's Advanced Propulsion Centre (APC) scheme, which has been set up to help the development of low carbon power units and systems, has selected the University of Warwick as its 'hub location'. APC, which is supported with £1bn of Government money, says the central hub will provide the UK automotive industry with resources and facilities to develop advanced propulsion systems and supply chains. Warwick was chosen as the location of the hub after a selection process overseen by an independent, industry-led assessment panel.

# Ecclestone retakes control of F1 as German case ends in \$100m payment

**Formula 1 ringmaster Bernie Ecclestone is back in charge following his agreement to pay a \$100m (£60m) settlement to bring his Munich bribery trial to an end.**

The 83-year old billionaire has made use of a clause in German law which allows defendants in certain types of cases to pay a settlement rather than see a trial through.

If found guilty, Ecclestone could have faced up to 10 years in prison, although Ecclestone says that he never feared the prospect. The prosecutors in Munich accepted that the circumstances of the Ecclestone case meant the \$100m payoff was acceptable.

Ecclestone had been on trial since April, charged with paying a \$44m (£26m) bribe to banker Gerhard Gribkowsky in 2006, to help make sure the sale of the BayernLB bank's 47 per cent share of Formula 1 went to private equity firm CVC Capital Partners. While Gribkowsky was jailed in 2012 for eight years for receiving the bribe, Ecclestone's defence was that he paid the money because he was being blackmailed – specifically

that Gribkowsky had threatened to make revelations about Ecclestone's tax status public.

Due to the nature of the settlement Ecclestone was found neither not guilty nor guilty, and as the trial is now over he will almost certainly be allowed to retake his seat on the board of Delta Topco, F1's controlling company.

Asked by Judge Peter Noll if he could raise the \$100m settlement fee Ecclestone replied 'yes'. It is believed that this is a record sum for such a payment. Judge Noll said \$99m would go to the Bavarian state while \$1m would be donated to a children's hospital. Prosecutors said they agreed to the settlement deal due to Ecclestone's advanced age and what they described as 'other extenuating circumstances', while Judge Noll said the arrangement was made because the trial had not looked likely to come to a decision.

Ecclestone's lawyers said that the outcome was not a 'deal nor a settlement, nor a buying out'. Rather, they insisted, it showed that 'a conviction of Mr Ecclestone could not be expected with any likelihood'.

XPB



**The result cost Bernie \$100m, but the closure of the matter means that he may regain his position on the board of Delta Topco**

## IN BRIEF

### Braking good

Motorsport and high performance brake producer Brembo is to build a new factory to manufacture brake discs in Albion, Michigan. The \$100m (£60m) investment on the part of Brembo North America (the US arm of the Italian company) will create up to 250 jobs in the area. Construction of the foundry is to begin in 2015 and is expected to be completed in 2017, and once finished the facility will cover an area of around 300,000sq.ft. The company, which supplies F1, IndyCar and NASCAR, already has other facilities in the same district, where it provides jobs for 450 employees. Brembo expects North America to become its biggest market by the end of this year.

### Renault return

Formula Renault UK is to make a return to British tracks next season. The championship will use the Tatuus-designed FR2.0/13 chassis currently raced in Europe, and will compete alongside BARC Formula Renault – which uses the 14-year-old original spec Tatuus – with the older cars forming a Class B. Formula Renault UK petered out in the UK at the start of 2011 after the then-new Barazi/Epsilon car failed to attract drivers. The new Formula Renault will now go head-to-head with the other UK junior single seater championships, BRDC Formula 4 and FIA Formula 4 (née Formula Ford), in the bewilderingly crowded entry level single seater scene.

## National Guard sounds the retreat on motorsport sponsorship

**The National Guard is to end its sponsorship arrangements in both IndyCar and NASCAR as the US Army's reserve force faces up to cuts in its budget.**

In a move that will affect Hendrick Motorsports in NASCAR and Rahal Letterman Lanigan Racing in IndyCar, the National Guard is looking at making savings of \$44m by withdrawing from motorsport. Currently it spends \$32m on its NASCAR Sprint Cup programme and \$12m with the IndyCar campaign. This figure includes recruiting drives linked to the sponsorships.

The decision follows a piece in the *USA Today* newspaper earlier this year which revealed that the National Guard had spent \$26.2m on its NASCAR sponsorship in 2012 and yet failed to recruit a single soldier through the programme.

Major General Judd H Lyons, acting director of the Army National Guard, said the organisation is now looking to find alternative means to promote itself to potential recruits because of ever-tightening budget. 'Significantly constrained resources and the likelihood of further reductions in the future call for more innovative and cost-effective ways of doing business,' Lyons said. 'We believe industry and open competition can help us identify effective and efficient solutions to help us meet our marketing and recruiting objectives within budget constraints.'

However, while the National Guard has said it intends to wrap up its motorsport involvement at the end of this year – when the agreement with RLL comes to an end – Hendrick Motorsports will still have a year to run on its contract, and at the time of writing it said it was unaware of the National Guard's decision to cease backing its Dale Earnhardt Junior-driven Sprint Cup entry: 'Our team has a contract in place to continue the National Guard programme at its current level in 2015,' it said. 'We have not been approached by the Guard about potential changes and plan to honour our current agreement.'

Military backing of US motorsport has proved controversial in recent years and Democrat senator Claire McCaskill has led a push in defence spending debates in Congress to end such sponsorships, saying the funding is 'wasting a bunch of money'.

XPB



**The US National Guard is to end its NASCAR sponsorship**

# Porsche importer snares Kyalami

**Porsche's South African importer has snapped up the legendary race track of Kyalami and has vowed to bring racing back to the fabled circuit.**

Porsche South Africa's importer Toby Venter bought the track in what was the largest single lot property auction in South African history. It is understood it was one of 10 bidders interested in the track, with some reports suggesting Richard Branson was among them. Other bidders were believed to be planning on using the land for property development.

The circuit has been beset with legal problems over recent years – chiefly involving disputes between the track operator and its owners – and it has seen very little use since 2011. But fears that the venue would be lost to the sport forever were put at rest after just two minutes of bidding at the auction when Venter bid R205m (£11.4m), securing the site. He then said the reason for the purchase was to make sure Kyalami remains a racing circuit, and that a motorsport museum may also feature in future plans.

Venter told South African news outlets that Porsche was the sole buyer of the track and said the main aim of the purchase was to 'preserve Kyalami as a race track for as long as possible.'



Superstars touring car action at Kyalami in 2010

Christo Kruger, Porsche SA public relations manager, agreed: 'The spirit is really to preserve the track for racing enthusiasts and petrolheads,' he said.

Porsche will be setting up a number of its own business units at the circuit, but it has made it clear that other manufacturers and companies will be welcome to base themselves at the site, too.

The Johannesburg circuit hosted the South African Grand Prix from 1967 until 1985, when F1 belatedly joined the sporting world's boycott of South Africa because of its then current apartheid policy. Formula 1 returned in 1992 and 1993.

# NASCAR and IMG in global TV push

**NASCAR has teamed up with renowned management, media and promotions group IMG in an effort to spread its TV reach across the world.**

IMG fought off 10 other companies for the contract, including MP & Silva, Lagardere and ESPN – the latter of which has been responsible for NASCAR's overseas TV distribution for the past eight years. The new deal, which is to run for the next 10 years, will mean IMG will sell NASCAR TV rights packages to all markets outside of North and South America.

The contract, the financial details for which have not been disclosed, comes into force at the start of 2015. This will coincide with the start of the huge US rights deal NASCAR has forged with both Fox Sports and NBC Sports – which is valued at \$8.2bn in total and runs from 2015 until 2024.

NASCAR races are actually already broadcast in 175 countries, yet it has always been difficult to pull in big money rights deals for territories outside of the USA. Brent Dewar, NASCAR's chief operating officer, believes

the IMG deal shows NASCAR's desire to change this situation. 'This long-term partnership with IMG Media signals to the world our strong intentions to grow the sport in every corner of the world,' Dewar said.

All of NASCAR's current international broadcast rights will expire at the end of the 2014 season and IMG says it will then begin assisting NASCAR with creating and executing a new international media strategy for 2015 and beyond.

Hillary Mandel, senior vice president and head of media North America at IMG, said: 'We have a history of working with blue chip world class sports in the US and developing brands internationally. This experience and expertise will ensure the right broadcasters embrace NASCAR for the renowned sports property it is.'

Mandel added: 'Our dedicated team will work with NASCAR and our unrivalled global sales force to ensure extensive media coverage across all platforms and increased awareness worldwide. We are extremely excited by the opportunities ahead.'



NASCAR is big on TV in the US, but will IMG be able to sell it worldwide?

## CAUGHT

NASCAR has hit Joe Gibbs Racing with a massive fine and penalty after its Denny Hamlin-driven Sprint Cup Toyota was found to be running at Indianapolis with irregularities on the covers attached to the rear firewall of the driver's compartment. As a result of the infraction, the car's crew chief, Darian Grubb, was handed a whopping \$125,000 fine and suspended for six rounds of the championship. Car chief Wesley Sherrill received a similar suspension. Hamlin and the car's owner, Joe Gibbs, were each docked 75 points in their respective championships. The large fine and penalty – one of the heaviest in NASCAR history – were levied because the covers, which are designed to protect the driver from fire, have the potential to improve downforce if they are loose.

**FINE: \$125,000 PENALTY: 75 points**

Rodney Childers, the crew chief on the No 4 Stewart-Haas Chevrolet driven by Kevin Harvick in the NASCAR Sprint Cup, has been fined \$25,000 in the wake of a bizarre weight infraction at Watkins Glen, where the car was found to be running with a bean bag within the driver's compartment during the race. These are normally placed in the car to represent the driver's weight at scrutineering or during set-up, but team mechanics forgot to remove one of the bags before the start. It then slid under the driver's seat, and down into the pedal box, during the race. Harvick took an unscheduled pitstop to remove the bag, which NASCAR then classified as an unattached and unapproved weight.

**FINE: \$25,000**

Eric Phillips, the crew chief on the No 51 Kyle Busch Motorsports Toyota in the NASCAR Camping World Truck Series, has been fined \$6000 and placed on probation until the end of the year after the truck he tends failed to meet the ride height requirements in scrutineering after the Iowa Speedway round of the series. Erik Jones (driver) and Kyle Busch (owner) each lost 10 points in their respective championships.

**FINE: \$10,000 PENALTY: 10 points**

Jonas Bell, the crew chief on the No 23 Chevrolet in the NASCAR Nationwide Series, was fined \$10,000 and placed on probation until the end of the year after a ballast weight fell off the Rick Ware Racing-run car during practice at the Iowa Speedway round of the series.

**FINE: \$10,000**

The crew chief of the No 17 Red Horse Racing-run Toyota in the NASCAR Camping World Truck Series, Paul Richmond, has been fined \$7500 and placed on probation until the end of December after irregularities were found in the throttle set-up on the Tundra truck at Pocono. Explaining the infraction, NASCAR said: 'The combined thickness of the throttle shaft and the throttle plates (butterflies) must not be less than 0.197in.'

**FINE: \$7500**

# Peterson

FLUID SYSTEMS

**OIL TANKS**

OPTIONAL HEATER BUNG

FULL INTERNAL BAFFLING

**MADE IN THE USA**

- AN aluminum fittings.
- Custom configurations available.
- No blowing oil.
- Better deaeration.
- Better lubrication.

**1-800-926-7867 petersonfluidsys.com**

# TOP QUALIFIER

Around the world or around the track, you won't find a higher quality line of bearings and rod ends with Aurora's proven 40 year track record.

**Aurora Bearing Company**  
901 Aucutt Road  
Montgomery IL. 60538

**AURORA**

Complete library of cad drawings and 3D models available at:  
[www.aurorabearing.com](http://www.aurorabearing.com)

Ph: 630-859-2030

# JLS MOTORSPORT

**Air Jacks**

- Designed & manufactured by JLS Motorsport, bespoke strokes are available.
- Manufactured with forged alloys & high tensile steels.
- Lightweight & compact in design.
- Delivering maximum performance & optimum safety.
- All Air Jacks are supplied with 3 location rings for positioning & alignment.

**Air Jack Lance**

**Air Jack Probe**

Made in the UK  
European Sales  
JLS Motorsport  
email : motorsport@lister.co.uk  
tel : +44 (0)121 525 5800  
fax : +44 (0)121 525 4833

**USA Sales**  
**XRP** THE XTREME IN RACECAR PLUMBING  
XRP Inc. email : sales@xrp.com  
tel : 562 861 4765 fax : 562 861 5503

**lister**

# SHX

## SHOCK FLUID

BORN FROM JOE GIBBS RACING

**DRIVEN** RACING OIL

**SHX** SYNTHETIC FORMULA SHOCK FLUID

COMPETITION PROVEN TO DELIVER CONSISTENT PERFORMANCE

- Consistent, Fade Free Performance
- Low Friction Formula Reduces Seal Drag
- Air Release Technology Stops Foaming
- Resists Heat, Oxidation & Varnish

1 U.S. QT. (946 ml)

**European Dealer:**  
**Anglo American Oil Company Ltd**  
[WWW.AAOIL.CO.UK](http://WWW.AAOIL.CO.UK)  
+44 (0)1929 551557

BORN FROM JOE GIBBS RACING  
**DRIVEN** RACING OIL  
DRIVEN TO WIN  
[DRIVENRACINGOIL.COM](http://DRIVENRACINGOIL.COM)

93409-1

# Welsh circuit to host British Motorcycle Grand Prix by 2016

The £315m Circuit of Wales development at Ebbw Vale in the south Wales valleys is a step closer to realisation with the news that it has secured the rights to host the British round of the MotoGP World Championship.



Michael Carrick says gaining the bike grand prix is a significant landmark for the Circuit of Wales development

The motorcycle British Grand Prix deal is for five years beginning in 2015, with an option of a further five-year contract on top of that. However, for the first year of the deal the race will take place at a different track – either Donington or current venue Silverstone – as the Welsh circuit will not be completed in time.

Securing the MotoGP deal is a huge boost for the project, the business plan for which is hinged upon it landing a major motorsport event. The project itself is based upon a 3.5-mile circuit – which will ultimately also be used for car racing – surrounded by leisure, motorsport and automotive business developments.

The aim of the Circuit of Wales is to kick start the economy in a deprived part of the UK, and it is understood the Welsh and UK governments have agreed to put up close to £50m of public funding between them.

Michael Carrick, chief executive of the Circuit of Wales, said of the new deal: 'Our agreement with Dorna [MotoGP's promoter] is a significant

landmark in the development of the Circuit of Wales. MotoGP is the pinnacle of global motorcycle racing and expectations within the series and of its millions of fans worldwide are for a truly world class event at iconic and state-of-the-art venues.

'We look forward to meeting those expectations when we welcome MotoGP to Wales from 2016 and we are now working closely with Dorna and the FIM, MotoGP's governing body, with regard to the [alternative location of the] 2015 British round of the MotoGP World Championship.'

The Circuit of Wales is currently behind schedule because of delays with planning applications – building was due to commence in the spring of this year. Also, at the time of writing, there had been no word of significant investors becoming involved in the project, although insiders have told *Racecar Engineering* that many were waiting on the outcome of the MotoGP talks with Dorna.

## Ginetta snaps up Juno expertise for new LMP3 project

Ginetta has bought the Juno sports prototype and Formula Ford constructor as part of a plan to build cars for the all-new LMP3 category.

Juno, headed by ex-Williams F1 man Ewan Baldry, has now relocated its entire operation to Ginetta's base in Yorkshire. Baldry is now technical director at Ginetta and will design the new LMP3.

While the full details have yet to be finalised by the ACO it is known the cars will be of carbon composite monocoque construction and they will pack a 420bhp V8 developed by French firm ORECA.

Ginetta plans to build six of the new Ginetta-Juno LMP3 cars in time for next season, when LMP3 is set to replace the poorly supported spec LMPC category in both the European Le Mans Series and its Asian equivalent. In the longer term, Ginetta also hopes to compete at Le Mans. LMP3 cars are to be cost-capped at €195,000 (£154,000) with a likely budget of £300,000 for the ELMS.

Ginetta chairman Lawrence Tomlinson said: 'Le Mans holds a special place in my heart and it is with great pleasure I can achieve my goal of taking Ginetta-Juno into ELMS and ALMS, with a broader plan of competing in a Ginetta at the Le Mans 24 Hours. There is definitely a market for an affordable top-tier sportscar and I have no doubt our innovative new partnership will be a winning combination.'

Baldry, who was originally planning on building his own Juno-badged LMP3, said: 'Lawrence has already taken Ginetta from a small manufacturer to a worldwide renowned motorsport player. Juno has worked successfully in sports prototype motorsport and it is great to be moving up the ladder. We are very confident the Ginetta-Juno LMP3 car will be a force to be reckoned with.'

The design is said to be progressing well, Ginetta tells us, with the first CFD runs showing 'very favourable' results.

Ginetta has bought in Juno know-how for its new carbon LMP3 car build



## SEEN: LAMBORGHINI LP620-2



Lamborghini has shown off the latest in its new cup racers, the Huracán LP 620-2 Super Trofeo. The new car will be used in the European, Asian and North American series in 2015.

The chassis features an exceptionally light roll cage at just 43kg that extends to the rear axle, and impressive torsional stiffness that represents a massive 45% improvement compared to the previous model. The frame is a hybrid carbon/aluminum construction with modified geometries to house an improved radiator up front and better accommodate the racing gearbox at the rear, which also provides better aerodynamics. The bodywork is in composite

materials and aerodynamic development has been done in collaboration with Dallara.

Power comes from the roadcar based V10 direct injection engine that delivers a maximum output of 620bhp. Unlike the previous all wheel drive Super Trofeo car the new model is rear wheel drive only. The drive is transmitted via a Xtrac sequential gearbox developed specifically for the Huracán Super Trofeo with an electric actuator designed by the Magneti Marelli Motorsport division. Electronics are governed by a MOTEC M182 that controls data, gear changes and the new TFT display mounted on the dashboard.

# PEGASUS



Exclusive North American  
Motorsports Distributor for Beta Tools



US importer of Jabroc® skid plate sheets

Stocking distributor of MS21071 Apex Joints  
(all sizes, 1/4" to 1 1/4")



Pegasus Auto Racing Supplies • New Berlin, WI USA  
800-688-6946 • 262-317-1234

**PegasusAutoRacing.com**

*Racers serving racers around the world since 1980*

# CARTEK

MOTORSPORT ELECTRONICS

**NEW**



Battery Isolators



Power Control Panels



FiA Rain Lights



Shift Lights



Power Distribution Modules



Wireless Steering Wheel Controls



Coolant Level Alarms



Suppliers to:



[www.CARTEKMOTORSPORT.com](http://www.CARTEKMOTORSPORT.com)  
CARTEK AUTOMOTIVE ELECTRONICS Ltd  
02380 637600  
[info@cartekmotorsport.com](mailto:info@cartekmotorsport.com)

## Snapdragon ENGINEERING, LLC



Contract manufacturing of high value, high performance components to an international clientele in formula, sports car and rally competition.

Authorized sales, service and testing of Ohlins racing dampers.

Exclusive North American agents for Farrington data acquisition systems.

413.256.0861 Amherst, Massachusetts, USA [www.snapdragonms.com](http://www.snapdragonms.com)

# EARL'S PERFORMANCE PRODUCTS

CUSTOM BRAKE LINES | OIL COOLERS | HOSE | FITTINGS  
ADAPTERS | FILTERS | NOS | FUEL PUMPS & REGULATORS



Visit [www.earls.co.uk](http://www.earls.co.uk) for the full range  
Online Shop now Available

Earl's Performance Products UK Ltd  
Units 15-16 Silverstone Circuit, Northants, United Kingdom NN12 8TL

QUOTE "RCE10"  
WHEN ORDERING TO  
RECEIVE 5% DISCOUNT

+44(0)1803 869850 | [sales@earls.co.uk](mailto:sales@earls.co.uk)

INTERVIEW – Craig Wilson

# Technology transfer

**Williams Advanced Engineering invited the British Prime Minister, David Cameron, to open its new facility in Grove. The company has big ambitions for it**



**“The environment is quite large for engineering solutions in a lot of different sectors”**

**T**here are few companies with the caché of Williams, the Formula 1 team that was started by Sir Frank Williams in 1977. The team has won a total of nine Formula 1 Constructors World Championships and seven drivers' titles, was involved in BMW's victory at Le Mans in 1999, and has more recently been involved in Audi's Le Mans wins through its flywheel technology and secured one of the sexiest Formula 1 liveries of the modern era following a deal with drinks brand Martini.

The company's Williams Advanced Engineering arm is a specialist in high performance hybrid and EV systems, lightweight structures, aerodynamics and thermal engineering, high performance dynamics, and specialist low-volume delivery.

In July, the company's global standing was underlined when the Prime Minister, David Cameron, opened a new Advanced Engineering facility in the company's Grove headquarters, just outside Didcot in the UK. It is an industry that is growing fast and the company is recruiting in all areas, from software analysts to application engineers to cope with demand.

The company recently hit the headlines in 2014 following the sale of its flywheel system to British company GKN for £8m. Having developed the system and proven it in racing with Porsche, and then with Audi at Le Mans, it also developed the system for public transport with remarkable results, estimating a fuel saving and reduction in greenhouse gasses by up to 30 per cent in a city bus.

## Partnerships

The sale left Audi with a new partner for its Le Mans programme, but GKN has affirmed its commitment to the racing programme. The reason for sale was simply the rapid commercialisation of the project. 'It required an industrial partner,' says Craig Wilson, managing director of Williams Advanced Engineering. 'We are not a volume manufacturer, we are an engineering company with a technology company included in that. We took that concept to TRL 6 or 7, proof of concept, and needed an industrial partner. GKN was a great partner that could take that on quickly, so that is why the decision was taken, to allow it to reach its full potential.'

'They didn't have the technology base, but they had the manufacturing base. Having succeeded with some of the fuel trials – in racing it was proven in the Audis and in the bus applications it was proven – it needed an industrial partner to take it on quickly. That could rapidly become a big business for them. Some of these things, you have a window of opportunity, you maximise where you are. They were there, they were ready. It was the right thing to do, to commercialise that quickly.'

This could signal a rapid change in the way our buses around the country are powered, using stored kinetic energy to accelerate away from stops. Williams has worked with the Go-Ahead Group to develop and produce buses with a retrofitted Gyrodrive hybrid flywheel system, providing electro mechanical energy. It has also worked with Alstom Transport to see hybrid

energy storage technology applied to trams. Additionally, it is embarking on a project to install flywheel energy storage to two remote Scottish communities. There is no direct government support for what we are doing here,' says Wilson. 'We are working on three programmes that are TSB supported so there is a level of support. We have a flywheel programme that has Department of Energy and climate change support attached. I believe it is an area of opportunity for us. For us to benefit from government investment, and that is part of our strategy, that would be programme supported. We are essentially self-funded.'

However, the company is also working in racing, outside its high-profile Formula 1 project. The company has partnered with Spark Racing Technology to design and assemble battery systems for 42 cars. The Formula E batteries are huge, but the design work to make them flight-safe has been an engineering challenge not to be underestimated. It is also involved in various government-supported programmes, so much so, that the decision was taken in 2011 to build a new facility to house the burgeoning business.

'Strategically, the wider business had decided part way through the Jaguar C-X75 programme that there was a greater business opportunity, to utilise the assets at Grove and diversify into other sectors, under the umbrella of advanced engineering,' says Wilson. 'Some of the projects being worked on, be it motor sport or road vehicles, were to be put under that one umbrella. The decision was taken in 2011 to invest in new facilities, so it was planned at the time that the Jaguar would be built on-site. But it wasn't only about that. That was only ever one programme.'





'It was the fact that there was a strategic decision made to move into this field and support other sectors and businesses. Where we are today, we have a growing portfolio of customers that we are working with, sectors that we are working in, all interested in the application of synergy between the capabilities that we have. Fundamentally, we are an engineering business. Formula 1 is about engineering, despite the show and the racing. Advanced engineering is an extension of that. Legislation is driving demand for new solutions, quickly – performance requirements. And we are in a very dynamic age in a number of different sectors. We are well placed because of our agility and collaborations. We can quickly achieve good results.

'Where we are going is based on what we have seen from some of our own market research. The environment is quite large for engineering solutions in a lot of different sectors.'

## Balanced portfolio

So, with a diverse range of business, where is the company looking to recruit? 'Electric will be part of the company's make up, but there is no silver bullet here,' says Wilson. 'The large part of our business will be aerodynamic and thermodynamic requirements. It is about having a balance. With engineering consultancy, you need to have a balanced portfolio of customers and sectors. There is a commercial requirement to have a balanced portfolio. Some sectors that traditionally weren't interested are now waking up to the fact that they need to look at different ways of doing things. We are seen very much as supportive, not as a threat, but as good engineering support in the thinking that we can bring to programmes.

'Electric machines, controls and software development is important as it holds it all together. Aerodynamics is another area, very competent mechanical design is another high requirement that we have. We also work in race programmes outside of Formula 1, materials, for instance, and a lot of knowledge there comes from experience. So as long as you have basic foundations and good principles that you can apply through applications. It is a little bit of as the business develops you tune it for programmes.

'We are discussing a programme that is a bit electrical driven. Applications and software are the most important, but we have a broad portfolio. One of the great things that we are finding is that some of the guys who were involved in Formula 1 have an interest to work outside of Formula 1 and they find it almost like a second life. It is a fantastic dynamic that we have.'

**Engineering excellence within the Williams racing programme has allowed the company to forge new technical partnerships**



## RACE MOVES

XPB



Highly-regarded V8 Supercars engineer **Campbell Little** is no longer with Dick Johnson Racing, both parties citing financial reasons for the split. Little had been with DJR since November last year and the team said it would be promoting from within to fill the void his departure leaves.

NASCAR crew chief **Greg Ives**, currently tending the JR Motorsports Nationwide Series car driven by **Chase Elliott**, is to move to the Sprint Cup in 2015, where he will be the crew chief on the Hendrick Motorsports Chevrolet of **Dale Earnhardt Junior**. Earnhardt's current crew chief, **Steve Letarte**, is to take up a job in broadcasting next season.

**Michael Wilson** is now head of race operations at Mercedes DTM. Wilson has moved from the company's F1 engine arm – Mercedes AMG High Performance Powertrains in Brixworth. He is the second Mercedes F1 man to switch to the DTM, with former tech head **Bob Bell** recently joining the touring car operation in an advisory role.

**Tim Ramsberger** has resigned from his post as president of Florida IndyCar street race the Grand Prix of St Petersburg to take up a role with Andretti Sports Marketing, a company owned by IndyCar team boss **Michael Andretti**.

NASCAR and IndyCar team boss **Chip Ganassi** has been awarded with the inaugural Cameron R Argetsinger Award for his contributions to motorsport. The award is named after the man who conceived and organised – and drove in – the first

post-war road race in America in 1948, which used the roads around the Watkins Glen area. He then brought Formula 1 to the Watkins Glen track in 1961, the circuit going on to host the US Grand Prix for 20 years. Argetsinger died in 2008.

Historic racer and Austin Healy expert **Denis Welch** has died as a result of an accident at the Silverstone Classic. Welch, who died at the wheel of a 1960 Lotus 18 after the former grand prix car rolled, was the man behind motorsport parts business Denis Welch Motorsport and was a very well-respected member of the historic racing community.

Mercedes F1 bosses **Toto Wolff** and **Paddy Lowe**, and race engineer **Jock Clear**, were injured in a cycling pileup in the run up to the Hungarian Grand Prix. The accident occurred during a team building event. Wolff suffered a broken wrist and concussion, Lowe got away with cuts and bruises, while Clear cracked three ribs.

The **Grand Prix Mechanics Trust** has presented the final instalment of a four-year £100,000 contribution to BEN, the automotive industry charity. The Trust was set up for former and current grand prix mechanics and their families in times of need. The donation will go towards a new care centre near Ascot in the UK.

Former BTCC team owner and driver **Mike Smith**, who was better known as a TV presenter, has died at the age of 59 from complications following heart surgery. Smith raced in saloon cars throughout the '80s and he came to broadcasting through his work in PR at Brands Hatch. In 1989 he established the Trakstar team which won the 1990 BTCC with a Sierra Cosworth.

Actor **James Garner**, not only a star of countless TV programmes and films – including the racing flick *Grand Prix* – but also a one-time race team boss, has died at the age of 86. Garner, a keen and quick amateur driver in his time, owned the American International Racers outfit from 1967 until 1969.

Ginetta chairman **Lawrence Tomlinson** has been appointed to the board of directors of the British Racing Drivers' Club. Tomlinson, who bought Ginetta in 2005 and quickly established it as a major player in UK motorsport, was proposed by **Nigel Mansell** and seconded by **Damon Hill**.

# Marmorini out as Ferrari restructures F1 tech team

**Long-time Ferrari F1 engine boss Luca Marmorini has now left the team as part of a shake up within the Scuderia's technical staff.**

Marmorini's departure has come after a disappointing season for the team thus far, and a particularly troubled start for its new 1.6-litre turbocharged engine. The Ferrari V6 is widely believed to be overweight, lacking power and harsh in its power delivery.

Marco Mattiacci, who was brought in to replace Stefano Domenicali as team principal has now placed former Lotus

technical director James Allison in overall charge of both the engine and the chassis divisions within the team.

Mattia Binotto – a former engine engineer for Michael Schumacher when he was at Ferrari – is now the head of the engine department, while Lorenzo Sassi, who has worked at Ferrari's engine department since 2006, is now its chief engine designer.

Since he left Ferrari, Marmorini has been linked with a position at Renault's Formula 1 engine operation in France.

XPB



**Mark Gillan**, a former chief operations engineer at the Williams F1 team, is now the head of a new motorsport technology group at US sensor and test system specialist MTS Systems. Gillan had a long career in F1, working at McLaren, Jaguar/Red Bull and Toyota before moving to Williams, which he left at the end of 2012.

According to reports, Toro Rosso head of vehicle performance **Laurent Mekies** is leaving the Faenza team. Meanwhile, it's been suggested that **Jody Eggington**, one of the 40 staff recently made redundant at Caterham, is to join the Red Bull-owned Italian outfit.

**David Ingram** has retired after 36 years working in the VW Group, 34 of these with Audi. A key product expert in the UK and latterly a PR man, Ingram was well-known in the motorsport industry, and once worked in the pits at Le Mans – as a fuel man for the **Jonathan Palmer, Richard Lloyd and Jan Lammers** Porsche 956 in 1983.

NASCAR executive vice president **Jim France** and motorsport entrepreneur **Don Panoz** were jointly awarded with the Bob Russo Heritage Award for outstanding contributions to the motorsport industry at the 26th Annual Motorsports Hall of Fame of

America Induction Ceremony in Detroit in August.

**Troy Cupples**, a crew member in the NASCAR Camping World Truck Series, has been indefinitely suspended from all NASCAR competition for violating the sanctioning body's strict substance abuse policy.

Red Bull has made it clear that it will not be appointing a technical director to replace **Adrian Newey**, who is to take a less hands-on role within the F1 team from next season. It will instead be giving more responsibility to those now directly below Newey; namely **Rob Marshall** (chief designer), **Paul Monaghan** (chief engineer) and **Dan Fallows** (head of aerodynamics).

Former Formula 1 driver **Ivan Capelli** has been elected to the board of directors of the Automobile Club of Milan, which organises the Italian Grand Prix at Monza. He will now spearhead an effort to make sure the historic event stays on the F1 calendar – earlier this year F1 boss **Bernie Ecclestone** threatened to drop the famous race.

DTM drivers now have a group to represent their interests, the **DTMDA (DTM Driver Association)**, which met for the first time at the Spielberg round of the hi-tech international touring car championship. Ex-driver **Manuel Reuter** is the DTMDA's spokesman.

The Association of Scottish Motoring Writers has presented motorsport medic **Dr John Harrington** with the Jim Clark Memorial Award for 2014. Harrington has been involved in motorsport medicine since 1987. These days he recruits new doctors and paramedics to the Scottish Motorsport Marshals Club and also runs medically-related training for race marshals.

◆ Moving to a great new job in motorsport and want the world to know about it? Or has your motorsport company recently taken on an exciting new prospect. Then email with your information to Mike Breslin at [bresmedia@hotmail.com](mailto:bresmedia@hotmail.com)

## OBITUARY - Dieter Lamm

**Dieter Lamm, described as the 'heart and soul' of the iconic Schnitzer Motorsport team, has died at the age of 59 following a serious illness.**

'It is difficult to say in a few lines what Dieter has done as he has been in motor racing for such a long time,' said his brother, Charly. 'Given our family situation, Dieter's motor racing life' started as he was a young school boy and goes along with the history of Team Schnitzer.'

Dieter and Charly were born on May 19, 1955 and Dieter started as a mechanic's apprentice in 1970. He tuned BMW road cars and at the weekends worked with Team Schnitzer, started by their elder half brothers Josef and Herbert Schnitzer, who began racing in 1963.

Throughout the 1970s Schnitzer competed in European hillclimb series and the European Touring Car Championship. Josef Schnitzer designed the BMW Schnitzer 20-4 two litre, 16 valve engine. Dieter Lamm worked on the engine between 1972 and 1975. He then worked as a race team mechanic until 1978 and headed up the race workshop responsible for logistics and team coordination from 1980.

The team became a formidable force in touring car racing, and won the Spa 24 hours for the first time in 1985. It went on to win many touring car titles around Europe, won Le Mans in 1999 with BMW and currently contests the DTM series.

**Dieter Lamm 1955-2014**

## OBITUARY - Dr John Melvin

**Dr John Melvin, a man credited with vastly improving the driver safety in NASCAR and other motorsport categories, has died at the age of 76.**

Melvin was credited with helping persuade NASCAR drivers to start using the HANS device, while he was also a key developer of black box data recording for racecars, helping sanctioning bodies learn from accidents. Serving as a consultant to NASCAR after his retirement from General Motors – where he worked for 40 years as a research scientist focussing on safety – Melvin pushed for improvements in racing seats, seat belts and the use of the SAFER barrier at race tracks. He also worked on safety issues with a number of other sanctioning bodies, and with the

Society of Automotive Engineers.

NASCAR president Mike Helton said: 'NASCAR and the entire motorsports industry lost a giant with the passing of Dr John Melvin. [He] was a pioneer in the field of driver safety, particularly in the area of driver restraint systems. His many contributions as a safety consultant to NASCAR for more than 13 years forever changed the sport. We lost a colleague, and a friend. He will be greatly missed by the entire racing community.'

Brad Keselowski, one of the many NASCAR drivers to benefit from Melvin's tireless work on their behalf, said: 'Dr Melvin is the biggest reason for the lack of driver fatalities [in NASCAR] since 2001.'

**Dr John Melvin 1938-2014**

**NEW DAYS FOR  
2014, NOW THURSDAY,  
FRIDAY AND SATURDAY!**

**FREE TO ATTEND REGISTER ONLINE NOW!**

**NO ENTRY TO THE GENERAL PUBLIC**

# TRADE ONLY FROM CLUBSPORT TO F1

**250+**  
EXHIBITORS

SEE WEBSITE  
FOR DETAILS

## TECHNOLOGIES ON SHOW

- Race Engine and Component Manufacturers
- Performance equipment
- Race car equipment/accessories
- Testing and development
- Safety equipment
- Paddock equipment
- Transportation and logistics
- Race circuit technology

Professional  
**MotorSport**  
WORLD EXPO 2014



**13, 14, 15 NOVEMBER 2014**  
COLOGNE, GERMANY

**BOOK  
YOUR  
STAND  
NOW!**

**PROFESSIONAL MOTORSPORT WORLD EXPO 2014**  
**CONTACT:** Phil White Tel: +44 1306 743744 Email: philip.white@ukipme.com  
UKIP Media & Events, Abinger House, Church Street, Dorking, Surrey, RH4 1DF, GB

[www.pmw-expo.com](http://www.pmw-expo.com)



# PRI 2014 Indianapolis

**December 11–13, 2014**

- The World's Largest Racing Trade Show
- 1,100 Exhibiting Companies
- 72 Countries Represented



[www.pri2014.com](http://www.pri2014.com)

UK funding available through the Motorsport Industry Association (MIA)  
Contact Clare at [clare.kelly@the-mia.com](mailto:clare.kelly@the-mia.com)

# ONLY RACE

Credentials Required

# 14



# Let's talk business

Motorsport is always facing new challenges, but that also means new opportunities

I am asked to write an 'opinion piece' on the business of motorsport. As so much is happening right now I hope you enjoy a few snapshot opinions, following the summer break. I'd love to hear your opinions ([chris.aylett@the-mia.com](mailto:chris.aylett@the-mia.com)) on these, so we all understand our business world better.

Formula 1 is still the pinnacle of our business interest, and here the Bernie saga continues to run following an inconclusive outcome from his German trial, with further court appearances for civil action ahead. Entering a new season with such a leadership position is unlikely to help attract the new sponsors and investors desperately needed by F1, even though it strangely continues to benefit CVC. New circuits are still signing up and new teams joining to compete in a growing calendar. We still await news from the Romanian and US teams who will

this to happen, but it appears they just cannot collaborate and so are impotent at this time.

I am sorry that the FIA has not enjoyed the benefit of promoting the quality of its visionary regulations. Yes, I believe they should have stepped forward and claimed the 'high ground' being responsible for new technical regulations which help the future motorist. In both Formula 1 and Le Mans, these global series now effectively race hybrids, demonstrating their performance to the public and benefitting the OEMs future sales. Yet those who wrote

car ranks, in Europe and the USA too. This is good news, as it spreads the sponsorship and commercial opportunities across the wider world of motorsport to everyone's benefit.

My urgent call to all in European motorsport, unlike the USA, is to wake up to and see that you are diminishing the value of real character in your drivers. Unleash their personalities, allow them to speak freely, grab some headlines, stimulate crowd interest and create new heroes. Look at other sports competing for our audience – even a spin bowler in English cricket, with a long shaggy beard, can be made into a hero for many. If that pedestrian sport can do it, just imagine what we could do by unshackling the characters that exist in motorsport.

In the USA, I am pleased to see IndyCar gaining strength each race. The next two years will see this series grow stronger and attract the sponsorship it deserves, with a new car in 2016/17 to stimulate increased interest. The United SportsCar Championship will soon end of its first full season with some satisfaction. Racing was close, TV coverage substantial, and spectators beginning to return. Next year's race dates have already been announced to help secure more sponsors and teams, and costs remain under tight control with new cars in 2016 and 2017 moving closer to the European model. Sportscar drivers from Europe can accelerate earnings by racing in a transatlantic market using similar machinery – a real boon for the drivers and our industry.

It is good news that UK and USA consumer spending is growing consistently. Europe still struggles as a whole, but its best hope remains Germany – the largest motorsport marketplace in the Eurozone. The focus for international sales in 2015/16 will be the UK which exports to the wider world; Germany with its powerhouse of OEM brands using motorsport to sell their products; and the USA in its entirety. The Motorsport Industry Association ([www.the-mia.com](http://www.the-mia.com)) is heavily involved in assisting companies to grow their business in these markets with funding and events, and the busy show season starts soon with SEMA, PMW in Cologne, then PRI in Indianapolis and finally the Autosport International Show in Birmingham. I predict record sales at every one of these shows. Confidence is returning, sponsors will pick up that message, and the motorsport supply chain will strengthen.

I hope these opinions interest, amuse and annoy, so please write in to the magazine or me at the MIA and share your opinions with us all – a good debate harms no-one!

## The next two years will see IndyCar grow stronger and attract the sponsorship it deserves

join from 2016. The new owners of Caterham are sure to make changes, although there is disappointment that, following their early decision to reduce their staff, they face court action from 40 employees – again, not a good news story for F1.

F1 teams, in general, are in weak financial condition, with engine suppliers finding the new formula quite a challenge and solutions very expensive. However, the new powertrain formula has delivered close results at the front and this keeps fans happy. The ugly sound will undoubtedly be overcome next season, but the on-track performance of the cars is different – clearly more unpredictable – so adding to the entertainment. Yet the audience still slips away from F1. This needs strong experienced leadership and remedial surgery, but 'marketing F1' has never been part of the FOM remit – races are marketed locally by circuits – so this leaves little cohesion in attracting a global fan base. The suggestion from Mr Ecclestone that Flavio Briatore will return to help bring back the crowds must dishearten both current and potential sponsors. A glimpse of progress made by other sports shows how new media, in all its various forms, is revolutionising their audience base, yet F1 sits back and allows its fan base to dwindle. I am surprised the teams allow



**Gloomy news from the Caterham factory, but there are signs of the green shoots of recovery elsewhere**

the rules are strangely silent when they should claim success and show the influence they can have in making motorsport technology more relevant for the public.

Kvyat, Magnussen and Ricciardo, who were not outstanding successes in the feeder formulas, appear to be able to seriously challenge 'the best drivers in the world' in Formula 1. Is this a chance for teams to bring in more new, young talent, save substantially on salaries, and still entertain their audience?

The lack of spectators at the German Grand Prix to welcome Vettel, their home-grown world champion, shows that F1 doesn't know how to create heroes. If this is the case, then why not blood new, young unknowns and let the crowds choose their own next generation heroes.

It is ever more obvious that young aspiring drivers recognise the expensive 'valley of death' which they face, raising funds to secure an F1 drive where real talent is so easily replacable by a larger budget. They switch their attack and secure excellent careers in the other formula, which boosts the quality of the GT and sports



# D.A.T.A.S. LTD.

Data Analysis Tools And Simulation

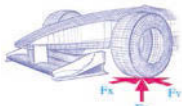

## RaceSim version 2.7

- **Expert:** Steady state, transient, 4 post, optimisation, strategy, etc
- **Standard:** Low cost lap simulation
- **NasCar:** Stock cars with live axle
- **F3 Lite:** Incl. Dallara F3 car model
- **RaceAlzyer:** Race strategy tool
- **ManagePart:** Parts management tool



## Consultancy

- Vehicle Dynamics
- Racetrack support
- Software Development

## Multi Media

- Photo realistic virtual animations
- Technical Features for TV
- Animated virtual walk thro' grid



D.A.T.A.S. LTD. THE OLD CHAPEL NORFOLK IP21 4XP

TEL: +44 (0)1603 506526 +44 (0)7802 770345

http://www.datas-ltd.com e-mail: info@datas-ltd.com

Championship Winning  
**Semi-Automatic Electronic Gearshifters**  
for Racecars & Superbikes

**PRO-SHIFT™**  
electronic gearshift

Now available  
This superfast and highly sophisticated  
**Gearshifting PS3 Paddleshift System** suitable  
for **Racecars and Superbikes** with over 170  
adjustable parameters

**PS3 System**  
Offering Fully Closed Loop Gearshifting for  
both Racecars and Superbikes

**Auto-Blip & Downshift Lockout**  
For clutchless downshifts plus engine over-rev protection

**Graduated Ignition Cuts**  
Individually programmable for all gears

**Auto Upshift Facility**  
Max power upshifting at full throttle...!

For more information:  
email: **info@proshift.com**  
telephone: +44 (0)1332 668100

**www.proshift.com**

ECU/Exchange Loom/Throttle Body Packages available

## Complex modern engine? We can manage it

ECU solutions for:

Honda S2000 and K20A  
Ford ST170 and Duratec  
Toyota 2ZZ  
BMW Single / Twin VANOS  
Audi 1.8T and 5 cylinder  
Chevrolet LS7.



Our ECU's are capable of dealing with the most complex of modern engines without the need to change sensors or sacrifice key features such as variable camshafts.

**S** series

Get the very best from  
any engine and from only £495.00 + VAT.

DTAfast, 10 Boston Court, Kansas Ave, Salford M50 2GN  
Tel: +44 (0)161 877 1419 Fax: +44 (0)161 877 7086  
Email: office@dtafast.co.uk Website: www.dtafast.co.uk

## DOCKING Advanced Cooling Systems

**Water Radiators  
Intercoolers  
Oil Coolers  
Heat Exchangers  
System Design  
Ancillary Products**

Manufactured to your requirements by the UK's leading supplier.

E info@dockingengineering.com

Tel 00 44 (0) 1327 857164

Fax 00 44 (0) 1327 858011

Website **www.dockingengineering.com**

Unit 15 Silverstone Circuit • Silverstone Northants • NN12 8TL • United Kingdom

## Engineering services Low friction surface finishing



The Sandwell Superfinishing process is designed to refine and polish surfaces to enhance component performance. This is an engineered finish with the benefit of producing a low friction surface that will reduce rolling resistance and hence contact stresses. Of benefit on transmission parts as well as sliding and rotating surfaces.

[www.sandwell-uk.co.uk](http://www.sandwell-uk.co.uk)

## Brake systems Racecar ABS from Bosch



Bosch Motorsport have released two new versions of their Motorsport ABS system. First up is the Clubsport kit, containing a generic wiring harness designed to fit to virtually all vehicles at a substantially reduced cost to the normal bespoke system, and the Porsche 991 cup car kit, complete with all required fittings.

[www.boschmotorsport.co.uk](http://www.boschmotorsport.co.uk)

## Brake components Sintered pads from CL



CL Brakes are high performance sintered brake pads. This unique material results in high friction coefficient, its incompressible material offers excellent pedal and brake modulation. Pads operate from cold, but efficiency doesn't fade with high temperatures.

Used by professional race and rally teams worldwide.

[www.murraymotorsport.com](http://www.murraymotorsport.com)

## Machine tools Rottler H75A Honing Centre



Rottler has added to its extensive range of advanced machining equipment with the new H75A Honing Centre specifically for performance engine builders and engine remanufacturers. True vertical honing creates superior bore finishes. Crash protection and 'hole to hole' features automatically protect valuable hardware. High accuracy ball screw mechanisms quickly rough and finish bores with maximum versatility.

[www.rottermf.com](http://www.rottermf.com)



# BUSINESS EXCELLENCE AWARDS 2014

NOW IS THE TIME TO HAVE YOUR SAY AND RECOGNISE  
EXCELLENCE WITHIN THE MOTORSPORT INDUSTRY

# NOMINATIONS NOW OPEN

Closing date 1st December 2014 – The Awards will be presented at the Dinner, NEC on 8 January 2015

### AWARDS AVAILABLE FOR NOMINATION:

The Teamwork Award • The Business of the Year Award • The Small Business of the Year Award  
The Service to the Industry Award • The Export Achievement Award • The New Markets Award  
The Technology and Innovation Award

Download the Nomination Form at [www.the-mia.com](http://www.the-mia.com)

MIA Contact: Helen Jones +44 (0)2476 692 600 email [helen.jones@the-mia.com](mailto:helen.jones@the-mia.com)

# Computer generation

**Computer games have changed dramatically over the years and they are now even helping to launch the careers of drivers**

It wasn't so long ago that Jacques Villeneuve arrived in Formula 1 and claimed to have learned his way around the daunting Spa circuit by playing a computer game. The technology developed, with design and development work undertaken on the simulator. Today, simulator work is so advanced that it is unthinkable to the modern driver that they shouldn't spend time lapping in the virtual world. Some drivers are better than others at it - many suffer from sickness following their first laps in the simulator - but they quickly get the hang of it and, with testing restrictions on track, computer technology is now a critical development tool.

Gran Turismo is the game credited with introducing a physical rather than fantastical reality to racing and its success owes everything to how well it measures up to the real thing. Although its cars may be virtual creations, everything about them is designed to behave as closely as possible to the genuine article.

However, the game's designers still needed to overcome the lack of movement and the lack of sensation of the car reacting to the road. Sensing a marketing opportunity, Sony teamed up with Nissan to form the GT Academy in 2008. It was a one-off project created to answer a simple question: could you take a gamer and successfully put them into a real racing car? 'Motorsports for motorsports sake is dying,' says Nissan's Director of Global Motorsport, Darren Cox, a regular visitor to the Autosport International Show. 'Therefore you have got to have a reason for what you are doing, and we wanted to be innovative, so we are turning gamers into racecar drivers. We have to get more people looking at motorsport. Other than Formula 1, people are looking less and less at motorsport. NASCAR is well seen by everyone to be in trouble.

'We are all car guys, and it is becoming more obvious that talented drivers no longer make it to the top. They can't. It has become more obvious and it has become depressing now to look at single seaters and how people are getting to that position. As a motorsport guy, as a car guy, there has to be a different way and that is what we are offering. What are the chances of the best driver in the world being the son of a billionaire? Very slim. What are the chances that one of 800,000 people entering the European GT academy are better than them? I reckon it is a pretty high chance. The point was to do things differently.

'We are about being an accessible brand. With our electric car, we could have built a supercar, but we built a five-seater family car. Whether we were right or not time will tell. With the GTR, we could have built a car that cost five times as much and sold ten times less, but what's the point? It was half the price of a Porsche 911 turbo, and faster. It is about accessibility. We knew this was going to happen, but the level of the gamers surprised us.'

Lucas Ordóñez, a 23 year-old Spaniard, won the first online and then real-world challenge and, after intensive training, he raced as one of Nissan's team of factory drivers. The programme was further developed and in 2011 Jann Mardenborough emerged victorious from the Academy, beating 90,000 online entrants in the process.

Computer technology is now common place within the motorsport industry, helping to develop the latest products, cars and drivers. With the continued evolution of computer and simulator technology, along with success stories such as Mardenborough and Ordóñez, it will be interesting to see if the next generation of young drivers opt to pick up a remote control rather than head to the kart track to develop their racing skills.



Games keep improving and simulators are now an essential motorsport tool. Is this where new driver talent will emerge?

## Dunlop reveals future racecar



As part of Dunlop's collaborative design project 'Dunlop Future Racecar Challenge', the company has gathered the opinions of industry experts and motorsport fans about what the 'racecar of the future' might look like.

Dunlop enlisted the help of grand prix and Le Mans race car designer Sergio Rinland to review the suggestions and combined all of the technological ideas into an innovative sketch.

## Q&A WITH QUAIFE

Gearbox manufacturer Quaife has exhibited at every Autosport International since the show's inception back in 1991. Peter Knivett, brand and communications manager at Quaife, provides an insight into the industry and the future of motor racing.

**Q. Quaife has been in the industry for a number of years, what has been the most significant change that you have noticed over that time?**

**A.** The global growth of the industry in South America, the Middle East and Asia has been a major change to our business and has helped to shape Quaife into an export-driven business.

**Q. Autosport International is celebrating its 25th anniversary in January 2015, and Quaife has been at every show. What has been the most notable anniversary for your business?**

**A.** Quaife's 40th anniversary in 2005 was a significant milestone in the company's history, while the successful launch of our R40 concept



## Zenos Cars set to create 24 new jobs in Norfolk



At Autosport International 2014, Zenos Cars introduced the world to its brand new ultra-light sports car and the company has now announced a new £1.2m project to produce the car in Norfolk. With production set to start in early 2015, the company will be creating 24 new skilled engineering jobs.

sports car at Autosport International that year really helped propel the business profile forward. Quaife celebrates its 50th anniversary in 2015 and the company is currently busy making plans to commemorate the occasion.

**Q. What are the main challenges that you currently face working in the motorsport industry?**

**A.** Maintaining a significant level of investment in plant and machinery is always a challenge, as is recruitment and the retention of skilled staff.

**Q. What can we look forward to seeing from Quaife in 2015?**

**A.** Something quite extraordinary and very exciting that will help to cement Quaife's reputation as a market-leading company in the high performance drivetrain technology sector.

**Q. Many people in the industry talk about a lack of skilled talent and graduates in the engineering industry. What are your thoughts?**

**A.** Quaife has tried to address this by employing apprentices and ensuring that all our staff members are subject to continuous improvement training, which helps to develop talent and engender loyalty.

**Q. The motorsport industry has changed considerably over the past 25 years. What one element do you feel will change most over the next 25 years?**

**A.** The rise of India and China as motorsport markets, along with the associated new car manufacturers from those countries, represents both a huge challenge and an opportunity

**The Quaife QBM1M sequential gearbox for oval racing is just one of its advanced drivetrain products**



**AUTOSPORT**  
INTERNATIONAL  
**Engineering Show**  
8 - 9 January 2015 NEC Birmingham, UK  
In association with **Racecar**  
engineering

## A great start to the year

Autosport International has become a traditional way for us to start the year by showcasing our new products for Formula One, GT racing and rallying, as well as our premium road car tyres. It's a useful platform for us to meet professionals from the media as well as the automotive industry as a whole, but equally it's a very good opportunity for us to engage with the public and motorsport fans. Our Formula 1 simulator proved to be a particular hit, and we were even able to raise some money for the Great Ormond Street Hospital Children's Charity.

**Tricia Stone**

Pirelli UK, advertising manager

**T**ickets are on sale for the Autosport International Engineering show, held at the Birmingham NEC, on 10-11 January 2015. Advanced Adult tickets cost £32, children £21 (under fives go free). Group tickets are available. Paddock passes cost from £42, VIP from £120.

Paddock passes include general admission plus access to the Driver Signing Area, the backstage Paddock Area and a paddock guide.

VIP tickets include: access to the VIP enclosure at the Live Action Arena, complimentary champagne and canapés, a Club Lounge, free parking, access to Driver Signing Area and dedicated VIP signing sessions, fast-track entry to the Live Action Arena and access to the backstage Paddock Area.

For more information call +44 (0)844 581 1420 or visit [www.autosportinternational.com](http://www.autosportinternational.com)

**T**rade stands are available for the Autosport Engineering Show, held in association with Racecar Engineering. Don't miss out on your opportunity to exhibit in a trade-dedicated area for two days ahead of the main show. To exhibit, please log on to [www.autosportinternational.com/trade](http://www.autosportinternational.com/trade), or contact Tony Tobias; [tony.tobias@haymarket.com](mailto:tony.tobias@haymarket.com)

## PIT CREW

## Editor

Andrew Cotton  
 @RacecarEd

## Deputy editor

Sam Collins  
 @RacecarEngineer

## News editor

Mike Breslin

## Design

Dave Oswald

## Chief sub editor

Kevin Younger

## Technical consultant

Peter Wright

## Contributors

Ian Bamsey, Mike Blanchet, George Bolt jr, Ricardo Divila, Gemma Hutton, Simon McBeath, Danny Nowlan, Mark Ortiz, Martin Sharp

Correction: In the September edition of Racecar Engineering, the article on page 76 was written for Exe-rc by Rob Biggs. We apologise for any inconvenience caused.

## Photography

James Moy, XPB

## Deputy managing director

Steve Ross

Tel +44 (0) 20 7349 3730

Email [steve.ross@chelseamagazines.com](mailto:steve.ross@chelseamagazines.com)

## Head of business development

Tony Tobias Tel +44 (0) 20 7349 3743  
 Email [tony.tobias@chelseamagazines.com](mailto:tony.tobias@chelseamagazines.com)

## Advertisement manager Lauren Mills

Tel +44 (0) 20 7349 3740  
 Email [lauren.mills@chelseamagazines.com](mailto:lauren.mills@chelseamagazines.com)

## Advertisement sales executive

Stewart Mitchell Tel +44 (0) 20 7349 3745  
 Email [stewart.mitchell@chelseamagazines.com](mailto:stewart.mitchell@chelseamagazines.com)

## Marketing manager Will Delmont

Tel +44 (0) 20 7349 3710  
 Email [will.delmont@chelseamagazines.com](mailto:will.delmont@chelseamagazines.com)

## Publisher Simon Temlett

## Managing director Paul Dobson

## Editorial

Racecar Engineering, Chelsea Magazine Company, Jubilee House, 2 Jubilee Place, London, SW3 3TQ  
 Tel +44 (0) 20 7349 3700

## Advertising

Racecar Engineering, Chelsea Magazine Company, Jubilee House, 2 Jubilee Place, London, SW3 3TQ  
 Tel +44 (0) 20 7349 3700  
 Fax +44 (0) 20 7349 3701

## Subscriptions

Subscriptions Department  
 800 Guillat Avenue, Kent Science Park  
 Sittingbourne, Kent ME9 8GU  
 Tel +44 (0) 1795 419837  
 Email [racecar@servicehelpline.co.uk](mailto:racecar@servicehelpline.co.uk)  
<http://racecar.subscribeonline.co.uk>

## Subscription rates

UK £66 (12 issues)  
 USA \$162 (12 issues)  
 ROW £84 (12 issues)

## News distribution

Seymour International Ltd, 2 East Poultry Avenue, London EC1A 9PT  
 Tel +44 (0) 20 7429 4000  
 Fax +44 (0) 20 7429 4001  
 Email [info@seymour.co.uk](mailto:info@seymour.co.uk)

## Printed by Wyndeham Heron

## Printed in England

ISSN No 0961-1096  
 USPS No 007-969



[www.racecar-engineering.com](http://www.racecar-engineering.com)

# Going with the flow

Fuel flow sensors were the talk of the town as the new regulations for Formula 1 and the World Endurance Championship were being finalised in time for this season. The sensors were integral to the entire regulation set and such a young technology has taken time to perfect. Following the first grand prix in Melbourne, for example, the Red Bull team finished up in court as the team contested the repeatable accuracy over the duration of the weekend.

Since that very public challenge that brought the fuel flow meter to the fore in the public eye (and no one in the general audience particularly understood the difference between average and instant flow, or that the world's most prestigious racing series could be governed by a small mechanical component which, according to Red Bull, was unreliable), there has been very little to write about in terms of its reliability.

Teams at Le Mans had to change a couple of sensors during the race, but in sports car racing each of the LMP1s had to carry at least one spare as a back up, and so it was not a race decider. In F1, there are only four grand prix in which the total fuel flow will be an issue this year. For the rest, we are looking at instant flow only. There have been steady updates to the existing fuel flow sensor software in F1, which have cost the teams money, but none have spoken out about them in public recently. Perhaps interest has waned slightly but now, with new regulations coming in the next two or three years to other series, regulation writers are starting to look at this as a viable alternative to air restrictors.

In June a new company, Sentronics, launched its fuel flow sensor with a view to supplying the mid and lower end of the market, as well as to the F1 and WEC standard. In our cover feature this month, we discuss the possibility of the German DTMs running a fuel flow sensor in the new regulation set that it will introduce for 2017. This is still manufacturer racing, but it seems certain that the cost of fuel flow sensors is set to drop dramatically over the next couple of years, and even today's competition puts fuel flow sensor in direct price competition with the existing air restrictors. These air restrictors can be made from carbon, and multiple sizes must be carried to cope with the various change of performance balancing, sometimes on a race-by-race basis in some series. The WRC is talking about fuel flow sensors too – champions of the technology such as Ulrich Baretzky have always said that this is a better way of working than air restrictors and boost pressure limits.

With this in mind, I thought back to the original conversations that I had with Fabrice Lom, head of drivetrain at the FIA in January 2013. Back then, the introduction of the fuel flow sensor was, it transpired, still several months away. However, manufacturers such as Audi had already said that, if they weren't delivered by Easter and properly tested, they could not be introduced for 2014. It was relevant to ask then about their progress, but also to ask about taking them to other race series.

'We can produce a small amount of sensors, double check them and triple check them, we are sure they are OK, and deliver them, it is a controlled, small field,' said Lom of the introduction into the rarefied atmosphere of Formula 1, and the three manufacturers in LMP1, Toyota, Audi and Porsche. 'If you go to Formula 3 for example, you will have 100 cars around the world if it is successful, managed by the ASNs, not by the FIA. It is lower cost. I don't think that the sensors will be cheap in the first year; I don't think we are close to putting them on the lower categories, but it is an aim. To have the performance [from the air restrictor] you put more air into the engine and more fuel to increase the power. It is not efficient. To do a fuel flow meter it improves efficiency and the FIA wants to improve efficiency.'

If it is so that the fuel flow meters have become accurate enough, and there is competition in the

marketplace that will drive accuracy up and costs down, then regulation writers and engine constructors should start to consider sensors seriously for non-manufacturer racing too, but this requires some planning. When Toyota was required to develop the RV8KLM engine to work with the fuel flow meter in the back of the Rebellion R-One for the WEC, there was significant work undertaken. The compression ratio was changed to work with a fuel flow restricted engine, reduce the maximum rev limit to below 10,000, looked at cam timing and intake length to make it run cleanly and efficiently. When the car raced at Le Mans, it was allowed to run with no instantaneous fuel limit and no maximum flow to increase competitiveness, although clearly that harmed fuel consumption and so was of limited value to the team.

With a wealth of new engines coming into Formula 3, with the DTM looking to introduce new regulations in 2017 that will also incorporate the GT500 cars, the WRC considering them too and with fuel becoming an ever-more valuable commodity, it is time to think about the possibility of fuel flow sensors becoming a major part of our sport.

ANDREW COTTON Editor

## The cost of fuel flow sensors is set to drop dramatically

To subscribe to *Racecar Engineering*, go to [www.racecar-engineering.com/subscribe](http://www.racecar-engineering.com/subscribe) or email [racecar@servicehelpline.co.uk](mailto:racecar@servicehelpline.co.uk) telephone +44 (0) 1795 419837

\* Racecar Engineering, incorporating Cars & Car Conversions and Rallysport, is published 12 times per annum and is available on subscription. Although due care has been taken to ensure that the content of this publication is accurate and up-to-date, the publisher can accept no liability for errors and omissions. Unless otherwise stated, this publication has not tested products or services that are described herein, and their inclusion does not imply any form of endorsement. By accepting advertisements in this publication, the publisher does not warrant their accuracy, nor accept responsibility for their contents. The publisher welcomes unsolicited manuscripts and illustrations but can accept no liability for their safe return. © 2014 Chelsea Magazine Company. All rights reserved.

\* Reproduction (in whole or in part) of any text, photograph or illustration contained in this publication without the written permission of the publisher is strictly prohibited. Racecar Engineering (USPS 007-969) is published 12 times per year by Chelsea Magazine Company in England.

*Brake control  
from green light  
to chequered flag.*







Double DTM Champion Mattias Ekström has clinched his first-ever FIA World Rallycross Championship victory after a flawless drive in the Audi S1 EKS RX in Holjes, Sweden.

In his RX campaign, Mattias relies on the supreme stopping power of PAGID RST racing brake pads – high initial bite, constantly high friction over temperature with excellent modulation over the whole temperature range. With the highest degree of braking performance, PAGID RST racing brake pads deliver the competitive edge that successful drivers demand.



[www.pagidracing.com](http://www.pagidracing.com) · [info@bremsentechnik.de](mailto:info@bremsentechnik.de)  
+ 49 6172 59 76 60

Pagid is a registered trademark of TMD Friction

**TMD FRICTION**  
A NISSHINBO GROUP COMPANY

# What's the **secret** about the new 911 GT3 Cup's **new brakes?**



It's Quicker.™

