

TITLE: GC_FET-DI		REV: 1.0
	Company: ProAudio G.C.	Sheet: 1/1
	Date: 2021-06-22	Drawn By: G.C.

# Input Transformer Assembly and Fitting

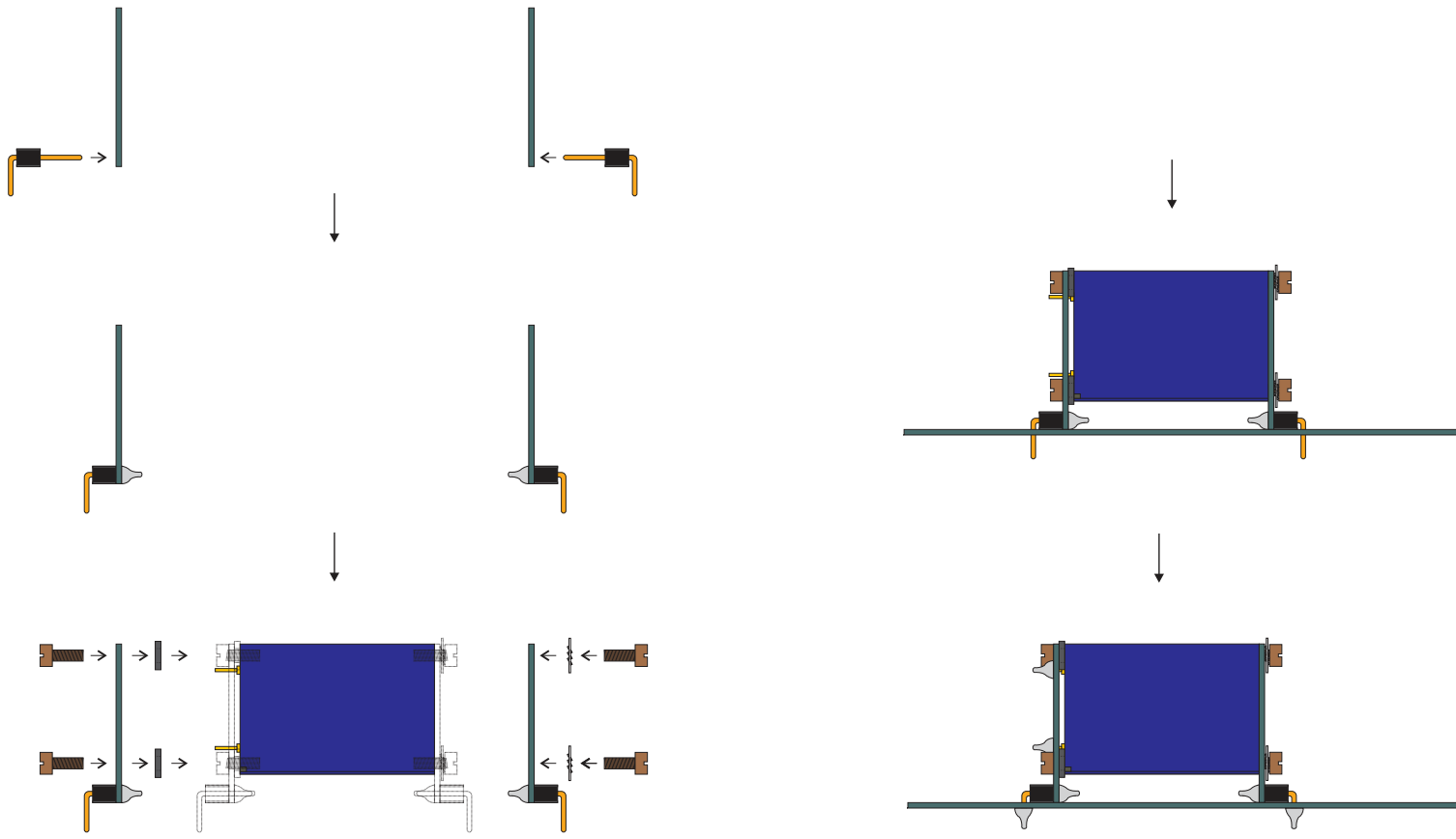

# Output Transformer Connection

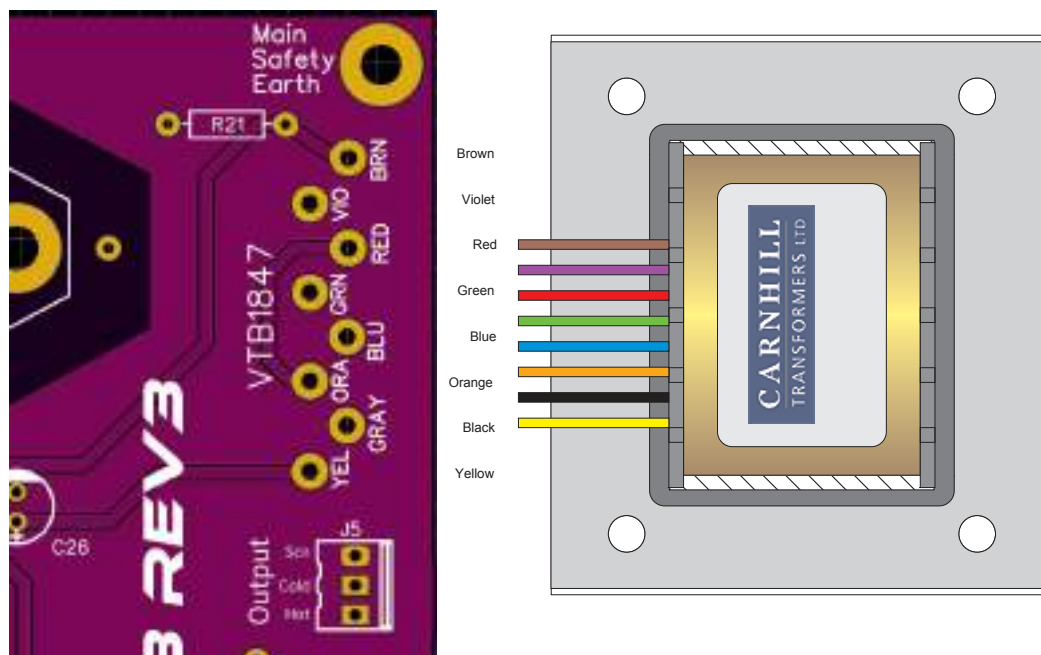

# Input XLR Connection

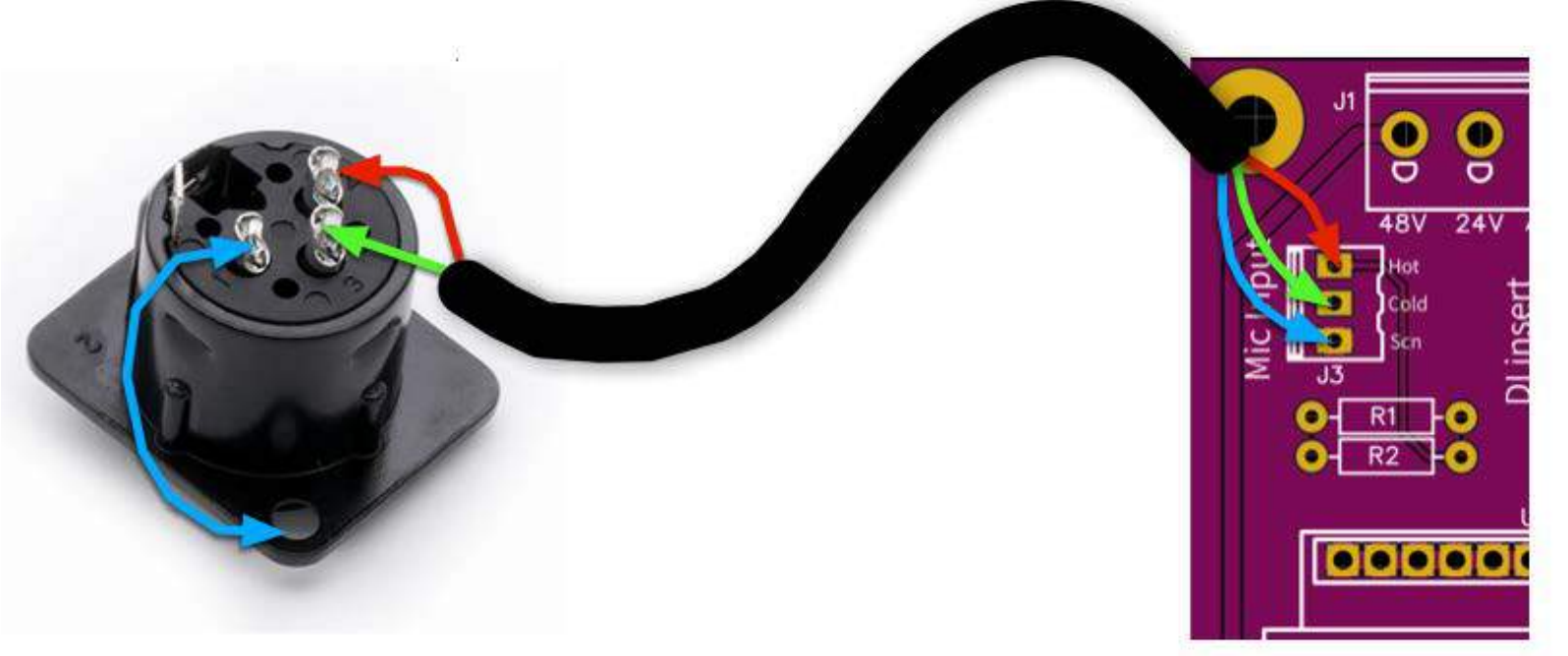

# Output XLR Connection



## GC-73 Calibration / Setup

### Output Bias Setting\*;

Measure the voltage across R6 on the GC-PW board

You should initially get a reading of about 70-80mV DC

Adjust R63 until you read 130mV

\* If you have the equipment available, the “correct” way to do this is by measuring the output distortion and adjusting R63 for minimum. However, you will probably end up with a current of about 130mA anyway so the above method works fine.