

1P

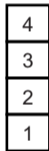

2P



3P

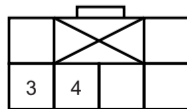
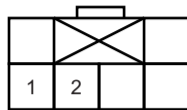

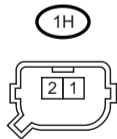
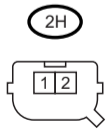
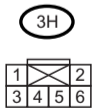
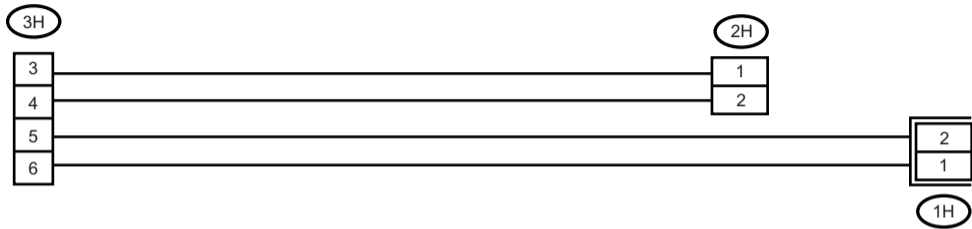

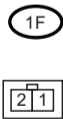
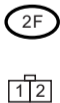
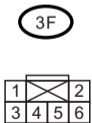
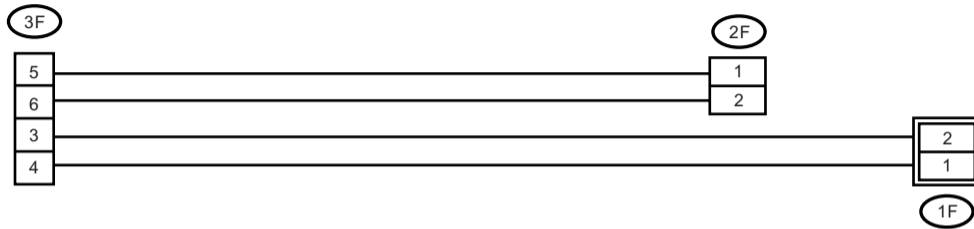

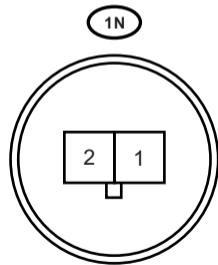
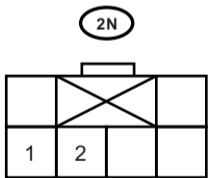
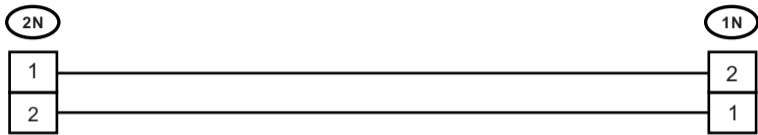

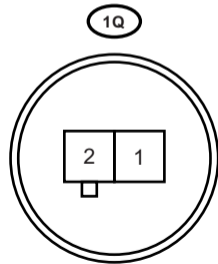
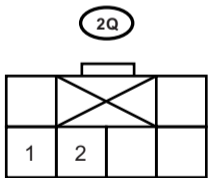
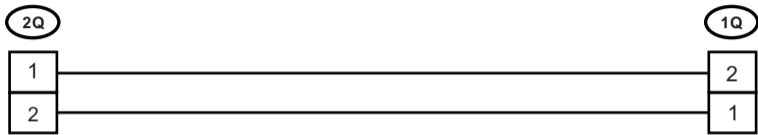

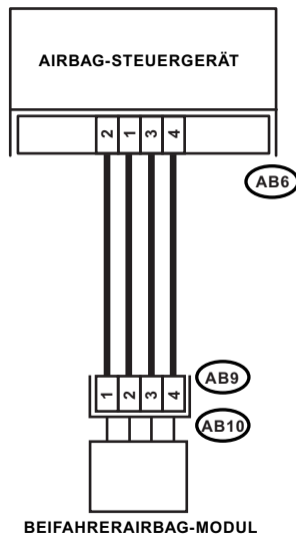

AB9



AB6

1	2	3	4	5	6	7	8	9	10
11	12	13	14	15	16	17	18	19	20
21	22	23	24	25	26	27	28	29	30

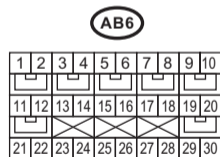
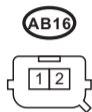
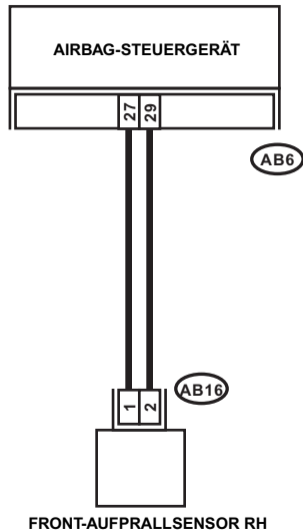

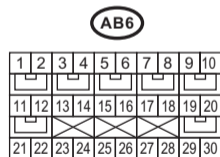
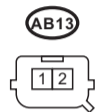
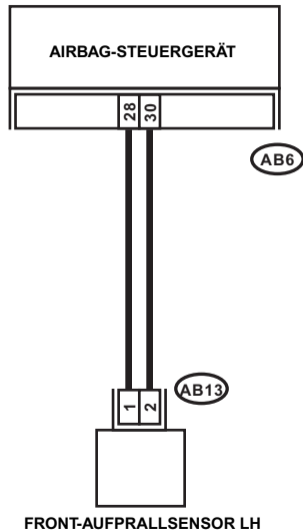

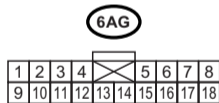
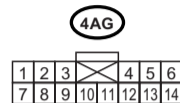
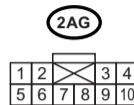
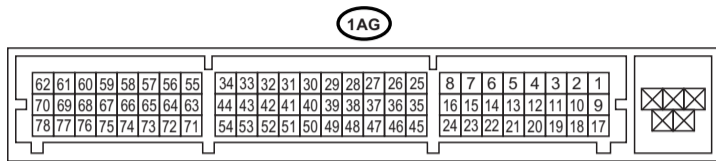

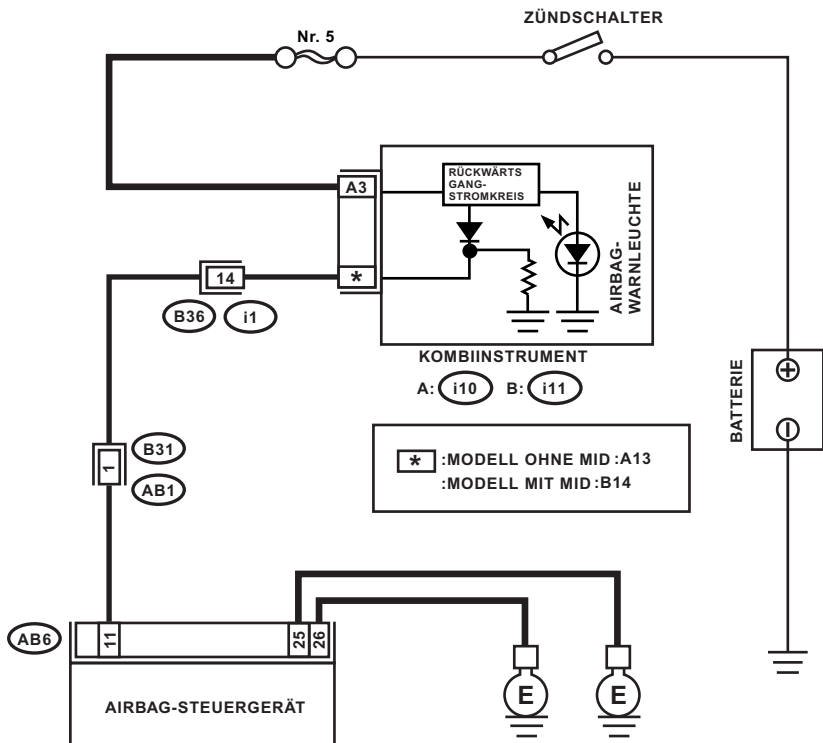

AB1



A: i10

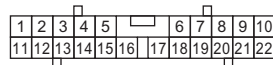

B: i11

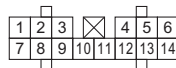

AB6

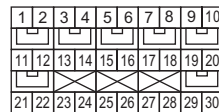

i1

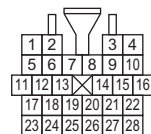

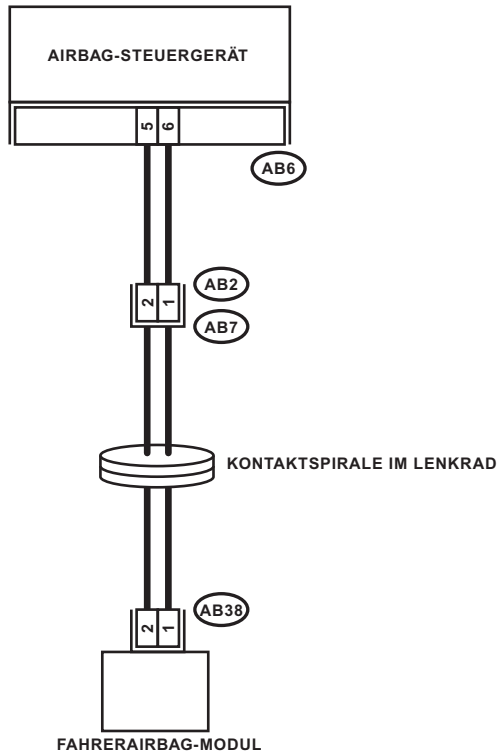

AB38



AB2



AB6

1	2	3	4	5	6	7	8	9	10
11	12	13	14	15	16	17	18	19	20
21	22	23	24	25	26	27	28	29	30

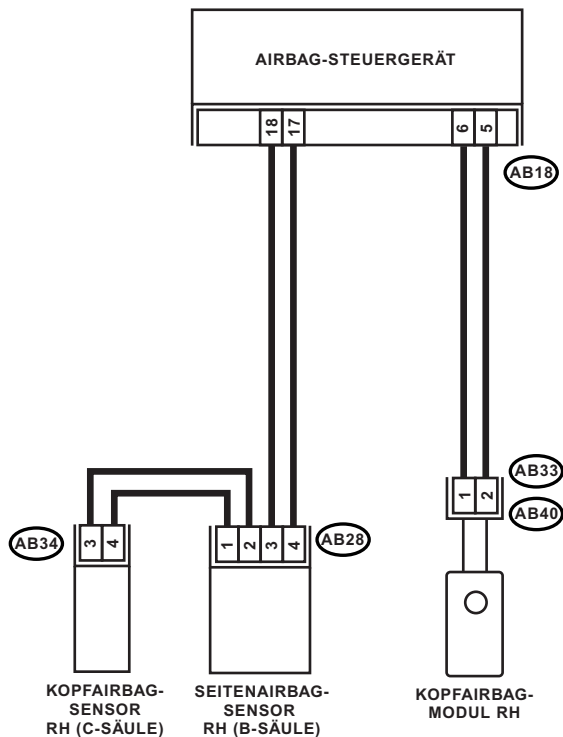

(AB33)

1 2

(AB28)

(AB34)

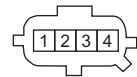

(AB18)

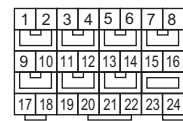

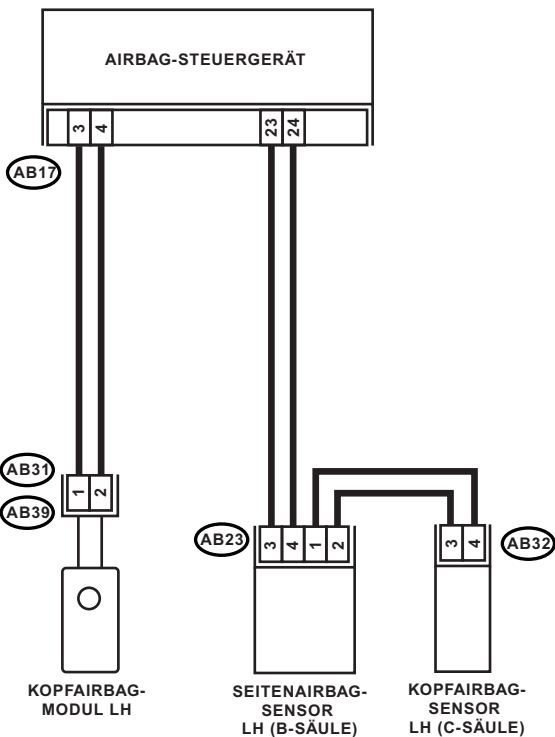

AB31



AB23

AB32

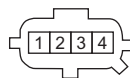

AB17

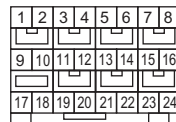



OS : MODELL OHNE SEITENAIRBAGS
WS : MODELL MIT SEITENAIRBAGS



OS : **AB18**

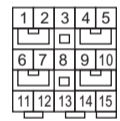

WS : **AB18**

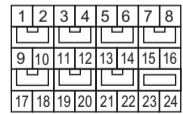

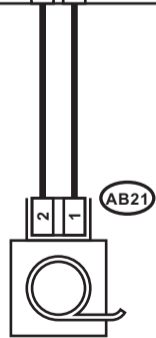

GURTSTRAFFER LH

OS : MODELL OHNE SEITENAIRBAGS
WS : MODELL MIT SEITENAIRBAGS

(AB21)



OS : (AB17)

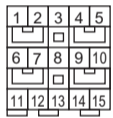

WS : (AB17)

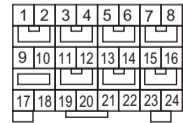

2AH

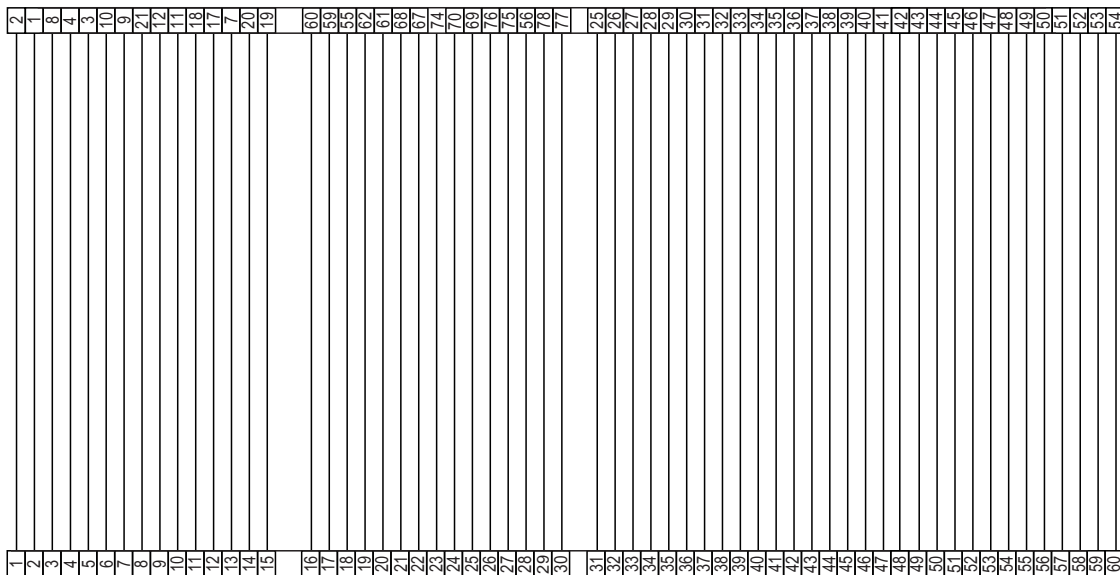
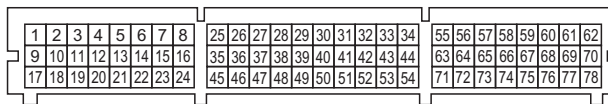

1AH

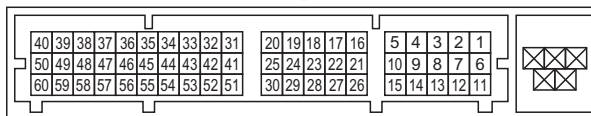

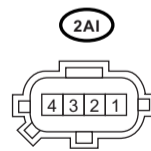
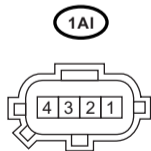
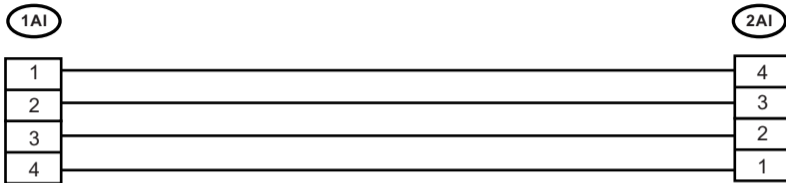

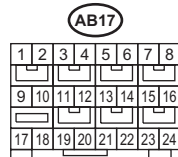
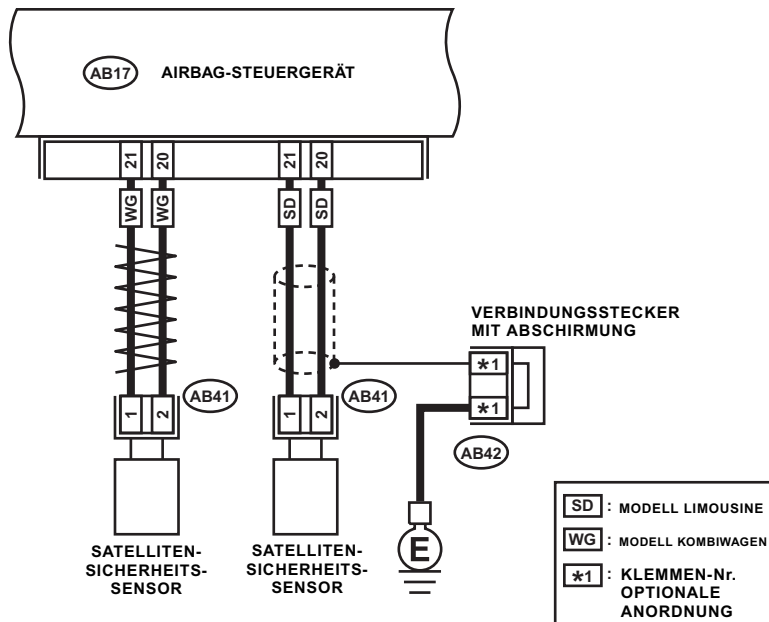

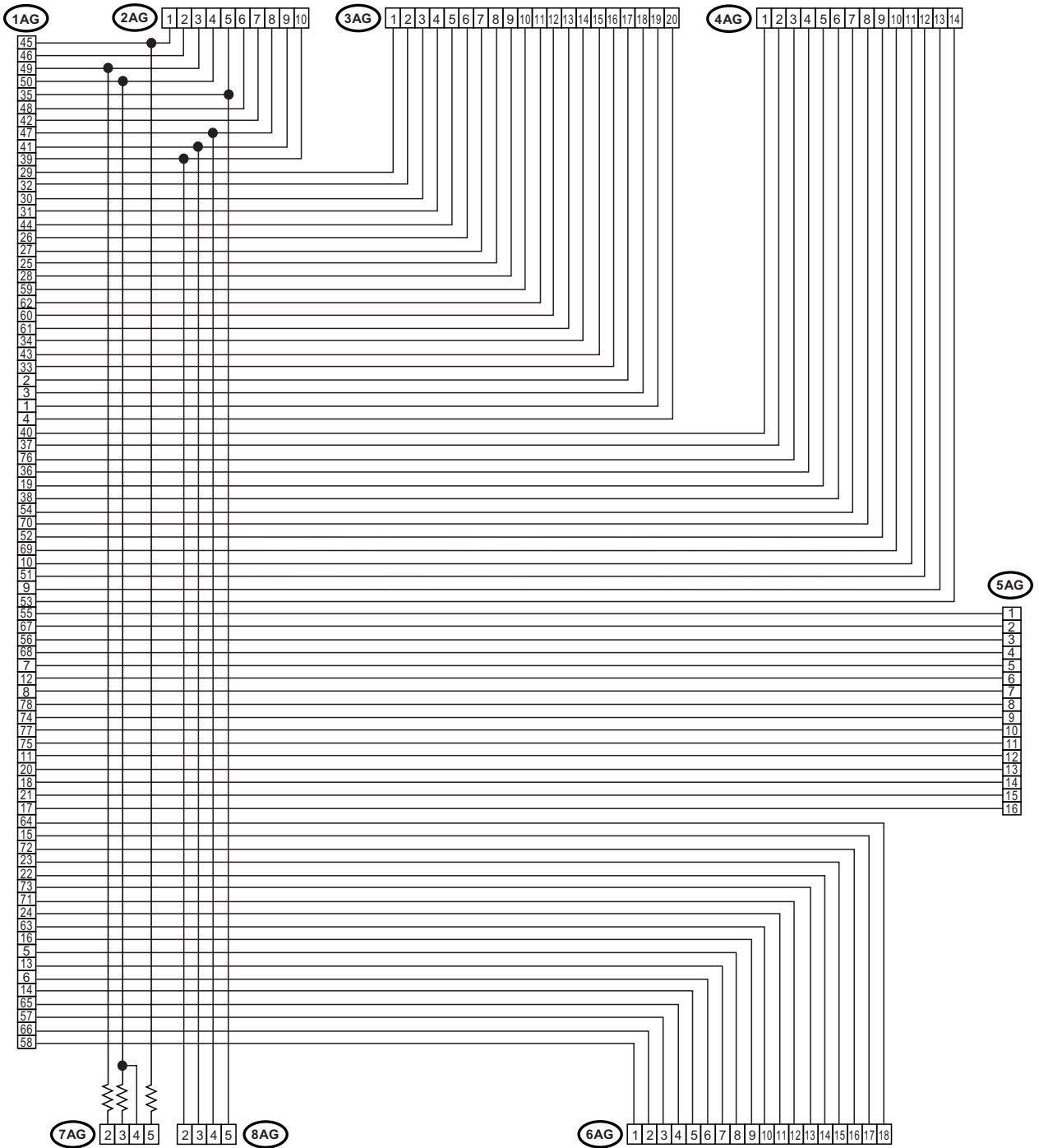

(2)

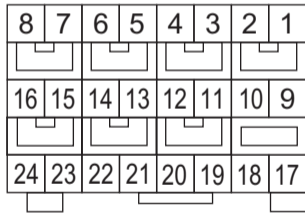

(1)

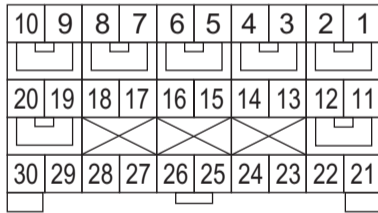

(3)

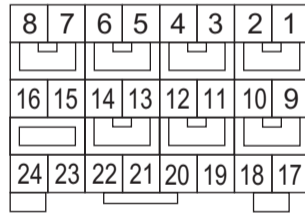

(1)

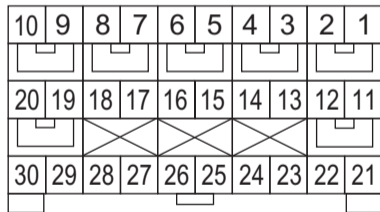

(2)

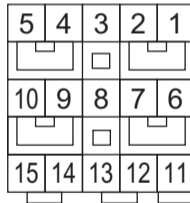

(3)

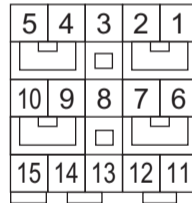

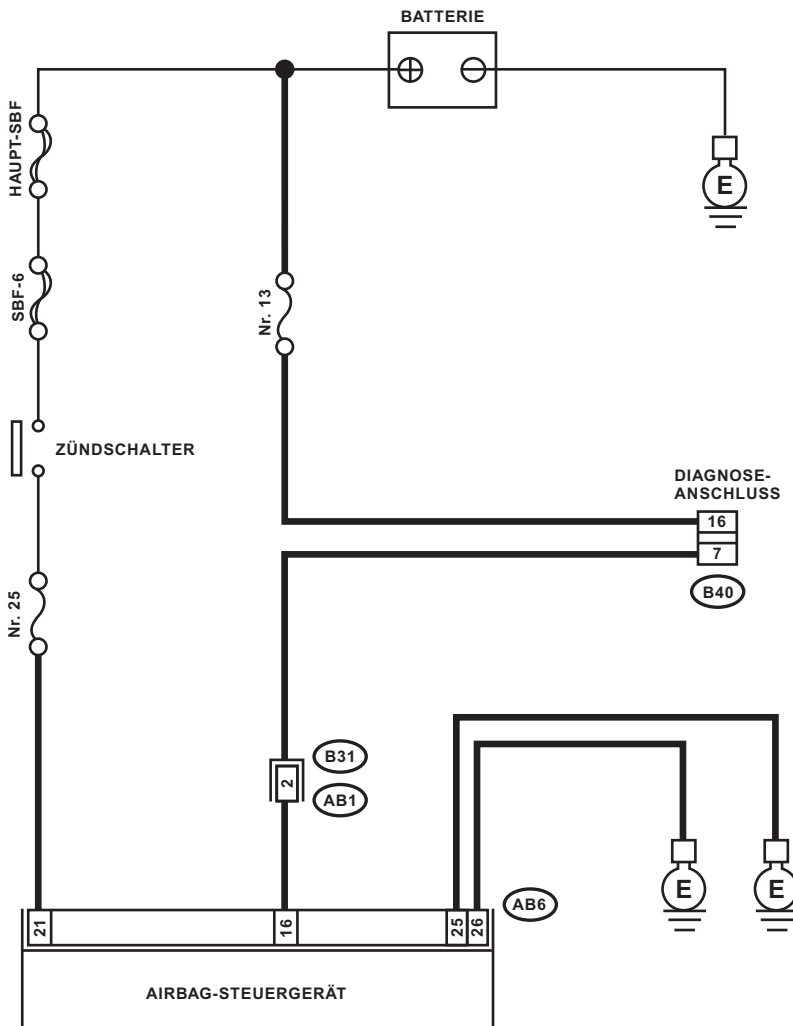

AB1



B40

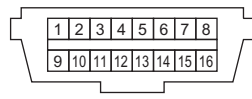

AB6

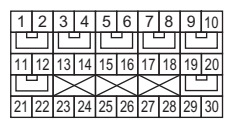

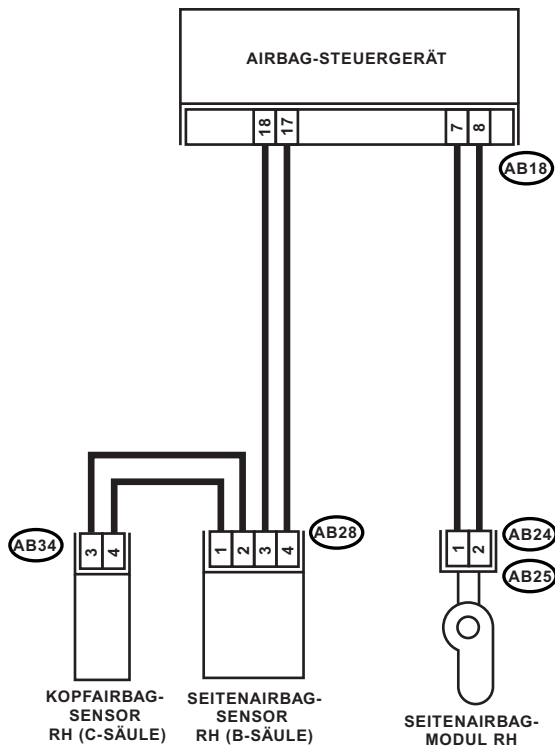

AB24

1 2

AB28

AB34

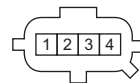

AB18

1	2	3	4	5	6	7	8
9	10	11	12	13	14	15	16
17	18	19	20	21	22	23	24

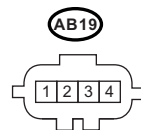
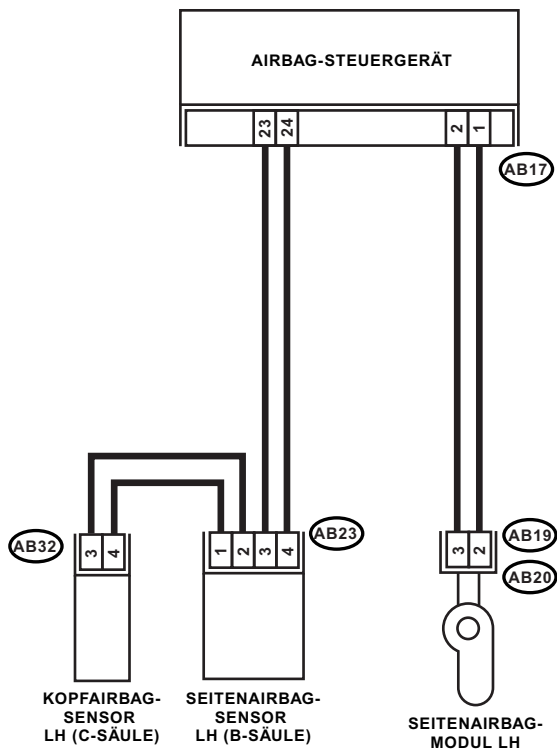

AB32

AB23

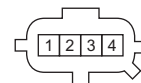

AB17

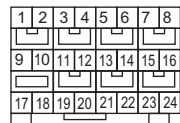

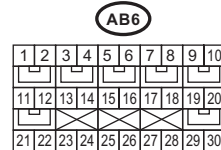
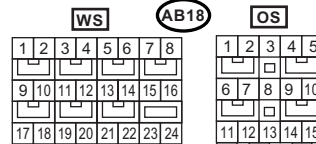
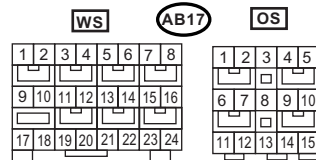
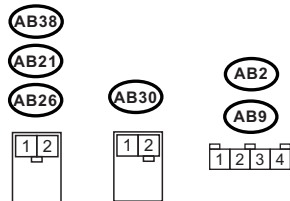
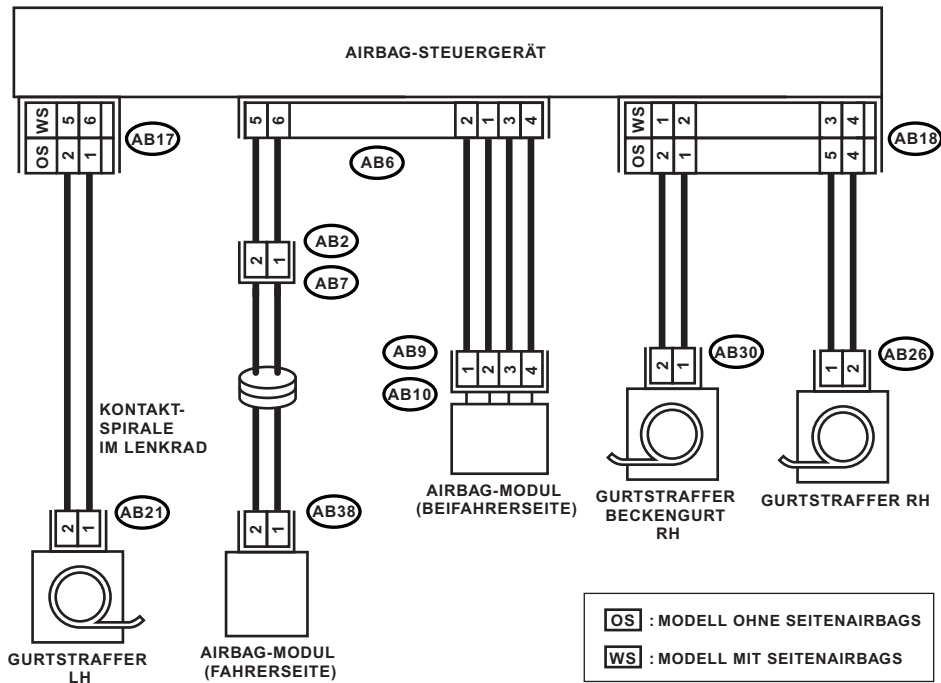

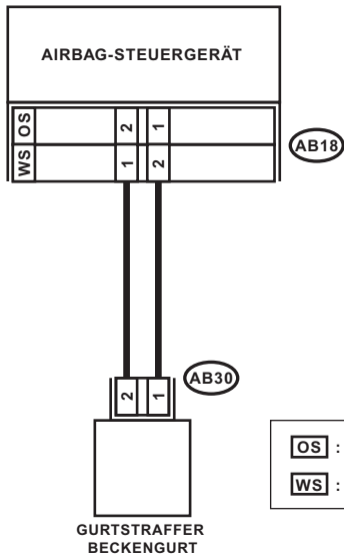

OS : MODELL OHNE SEITENAIRBAGS
WS : MODELL MIT SEITENAIRBAGS

AB30



OS **AB18**

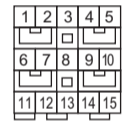

WS **AB18**

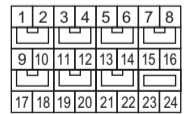

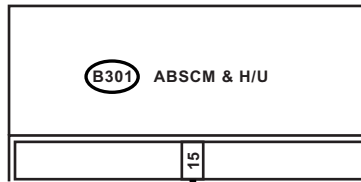

B301

12	13	14	15	1	2	3	4	5	6	7	8	9	10	11
				16	17	18	19	20	21	22	23	24	25	26

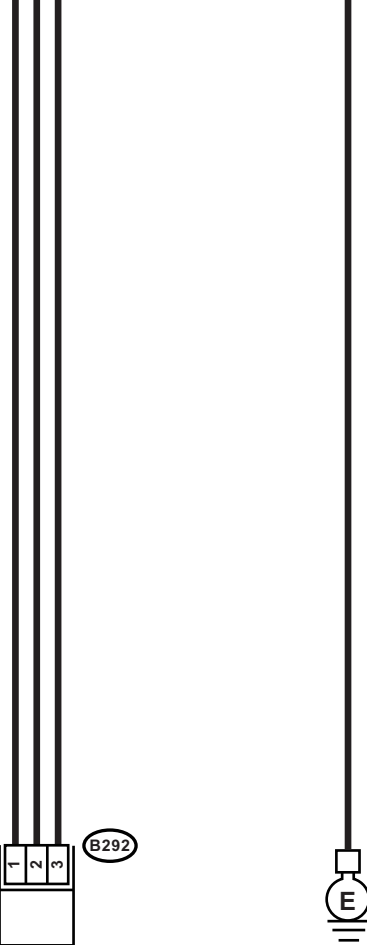
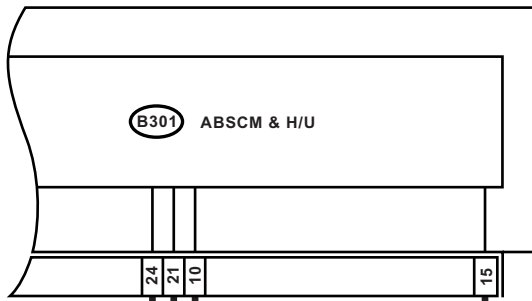

ABS G-SENSOR

B292



B301

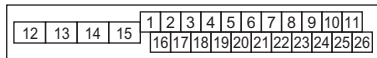

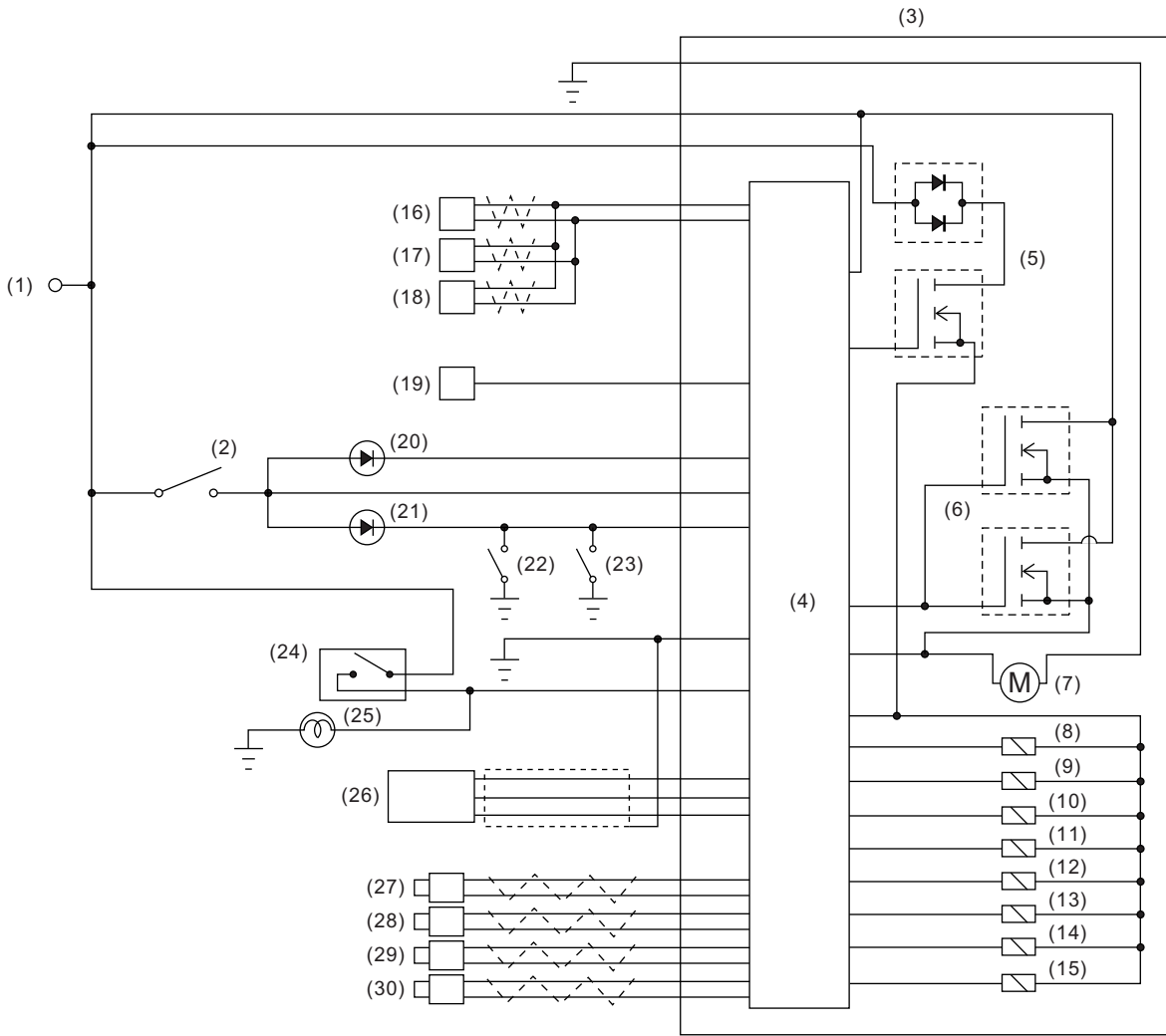

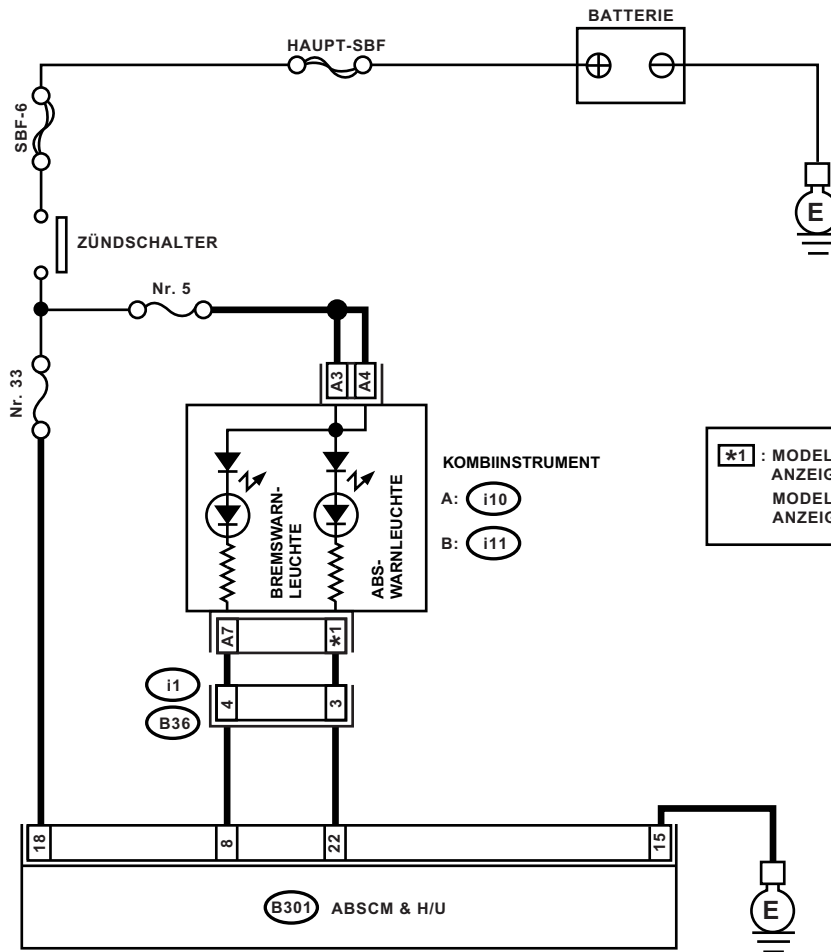

*1 : MODELL MIT NORMALER ANZEIGE : A5
 MODELL MIT ANZEIGE MIT MID : B5

A: i10

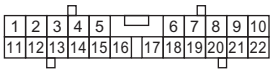

B: i11

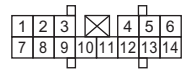

B301

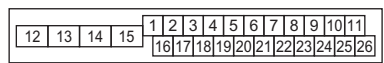

i1

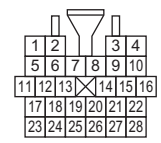

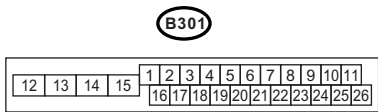
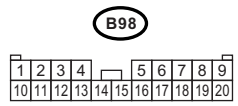
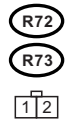
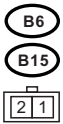
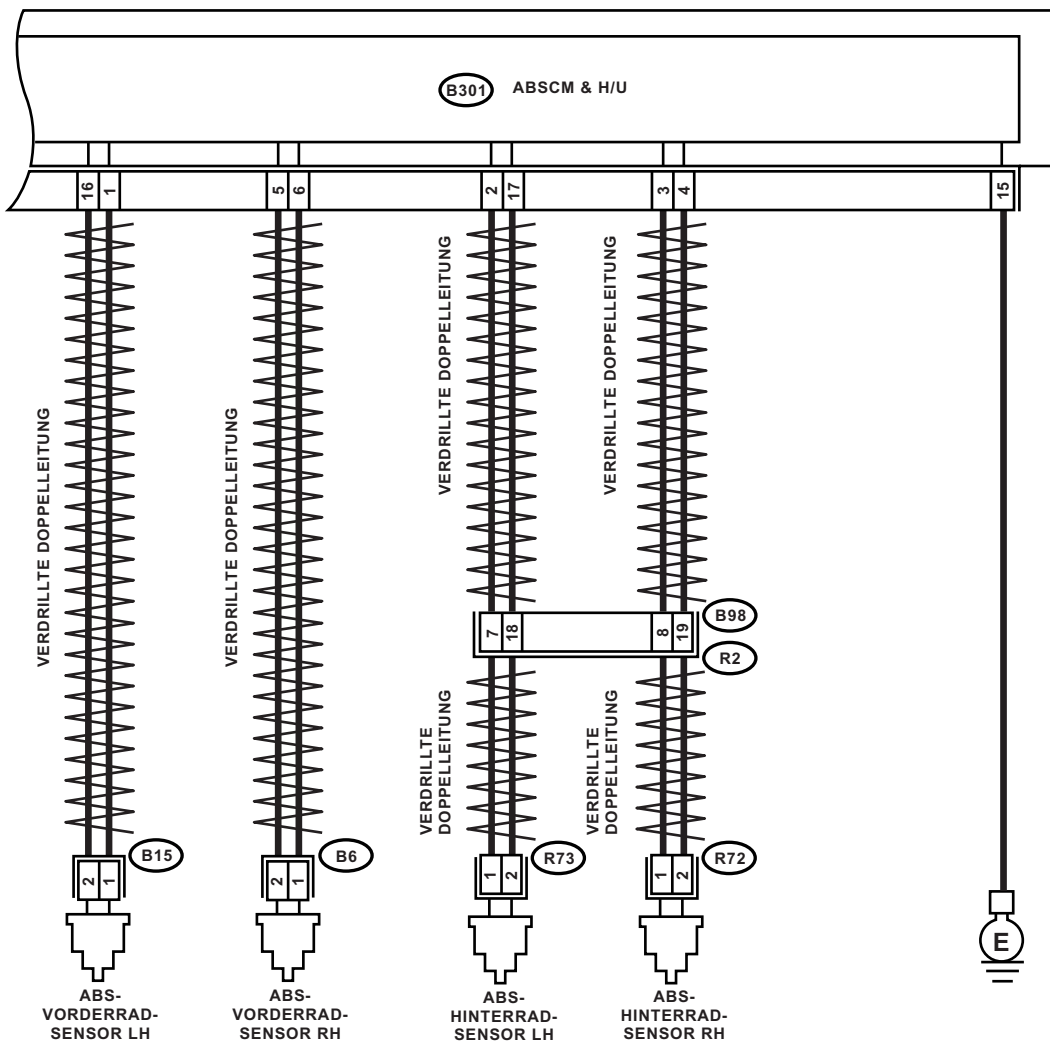

B301 ABSCM & H/U

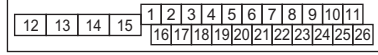
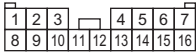
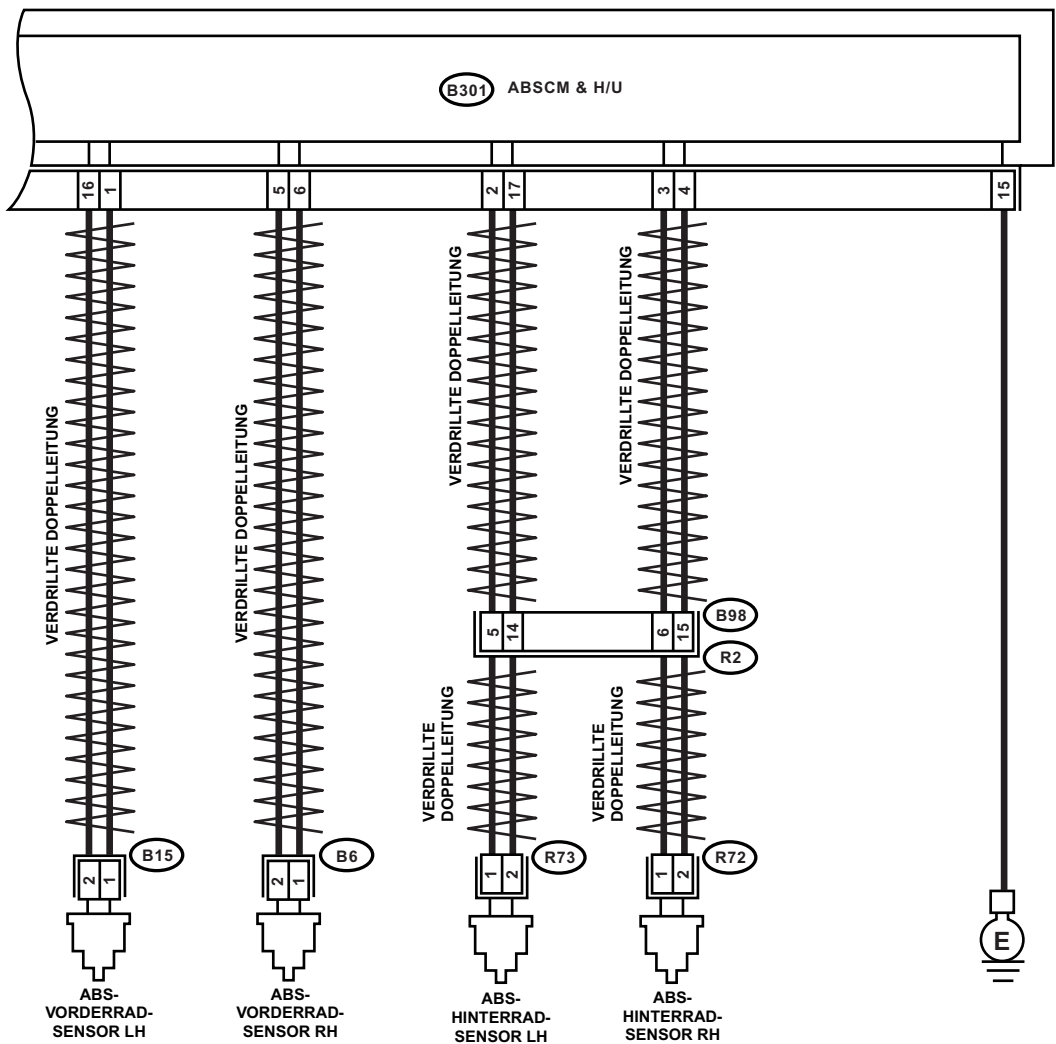

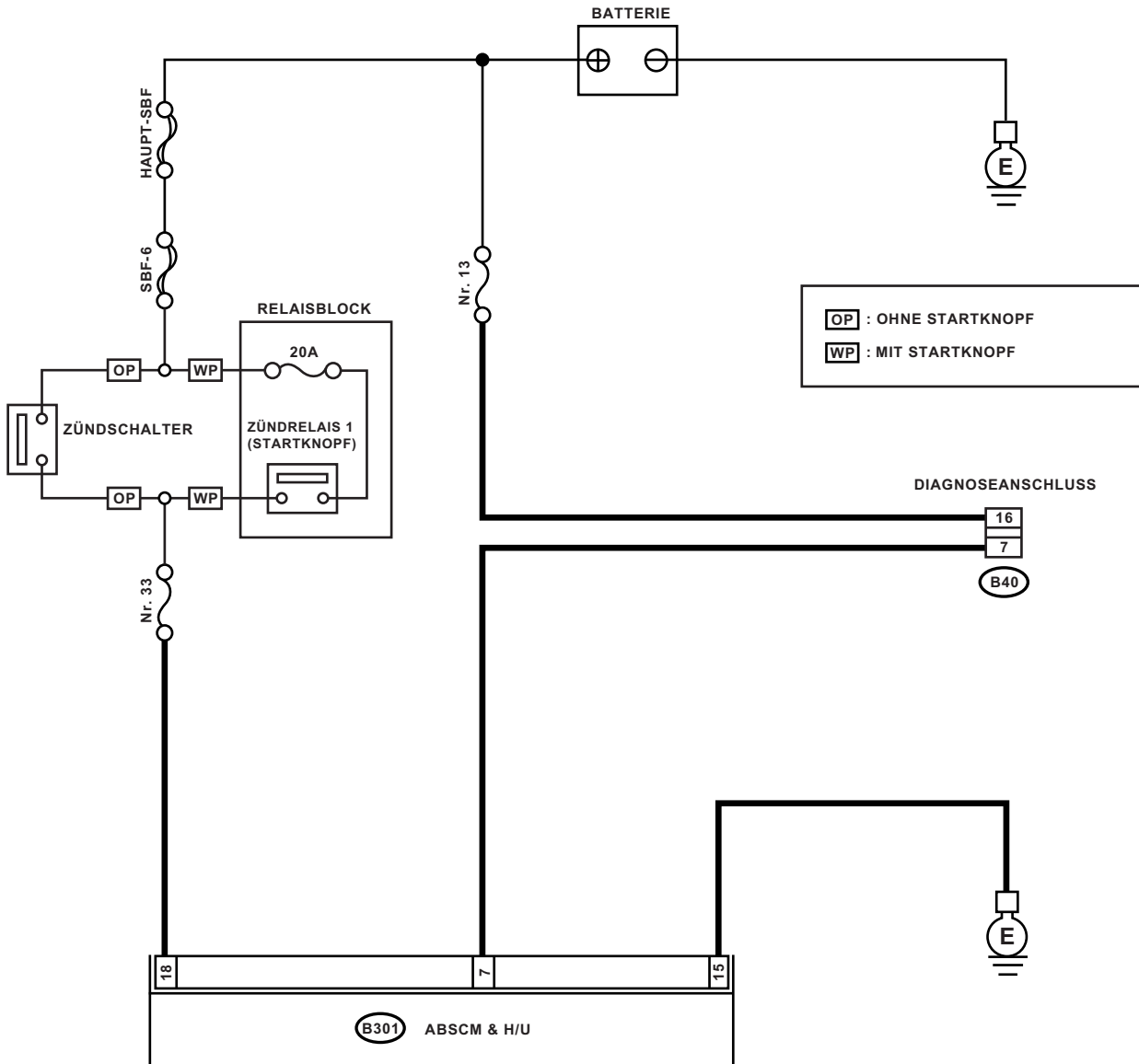

B40

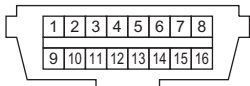

B301

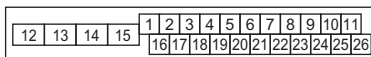

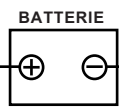

HAUPT-SBF

SBF-6

RELAISBLOCK

20A

ZÜNDRELAIS 1
(STARTKNOPF)

ZÜNDSCHALTER

OP

WP

OP

WP

Nr. 33

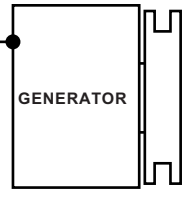

OP : OHNE STARTKNOPF
WP : MIT STARTKNOPF

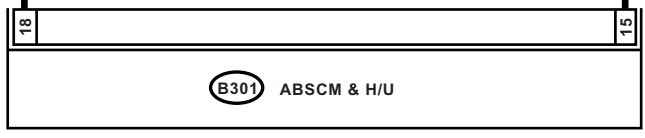

B301 ABSCM & H/U



B301

12	13	14	15	1	2	3	4	5	6	7	8	9	10	11
				16	17	18	19	20	21	22	23	24	25	26

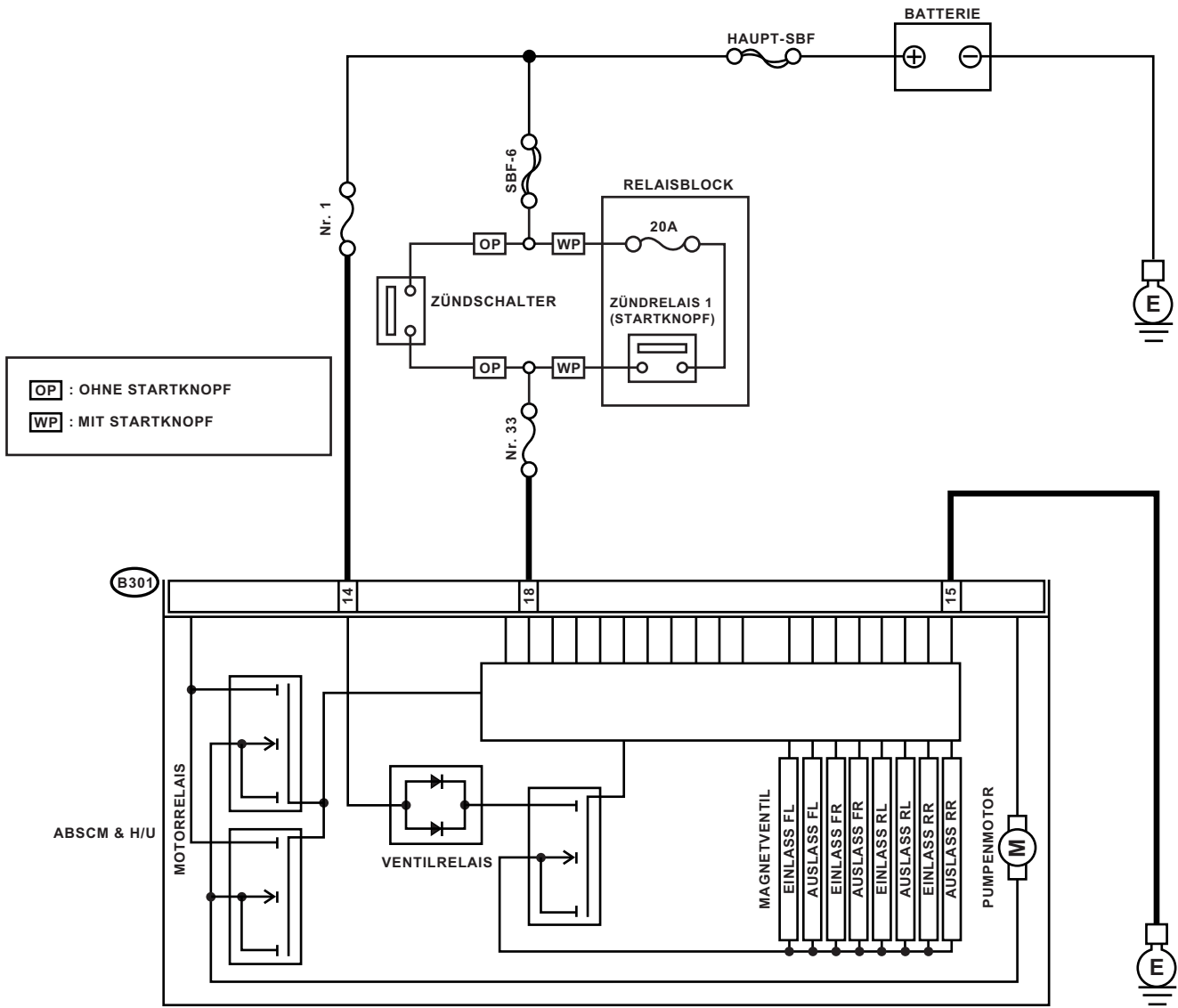

B301

12	13	14	15	1	2	3	4	5	6	7	8	9	10	11
				16	17	18	19	20	21	22	23	24	25	26

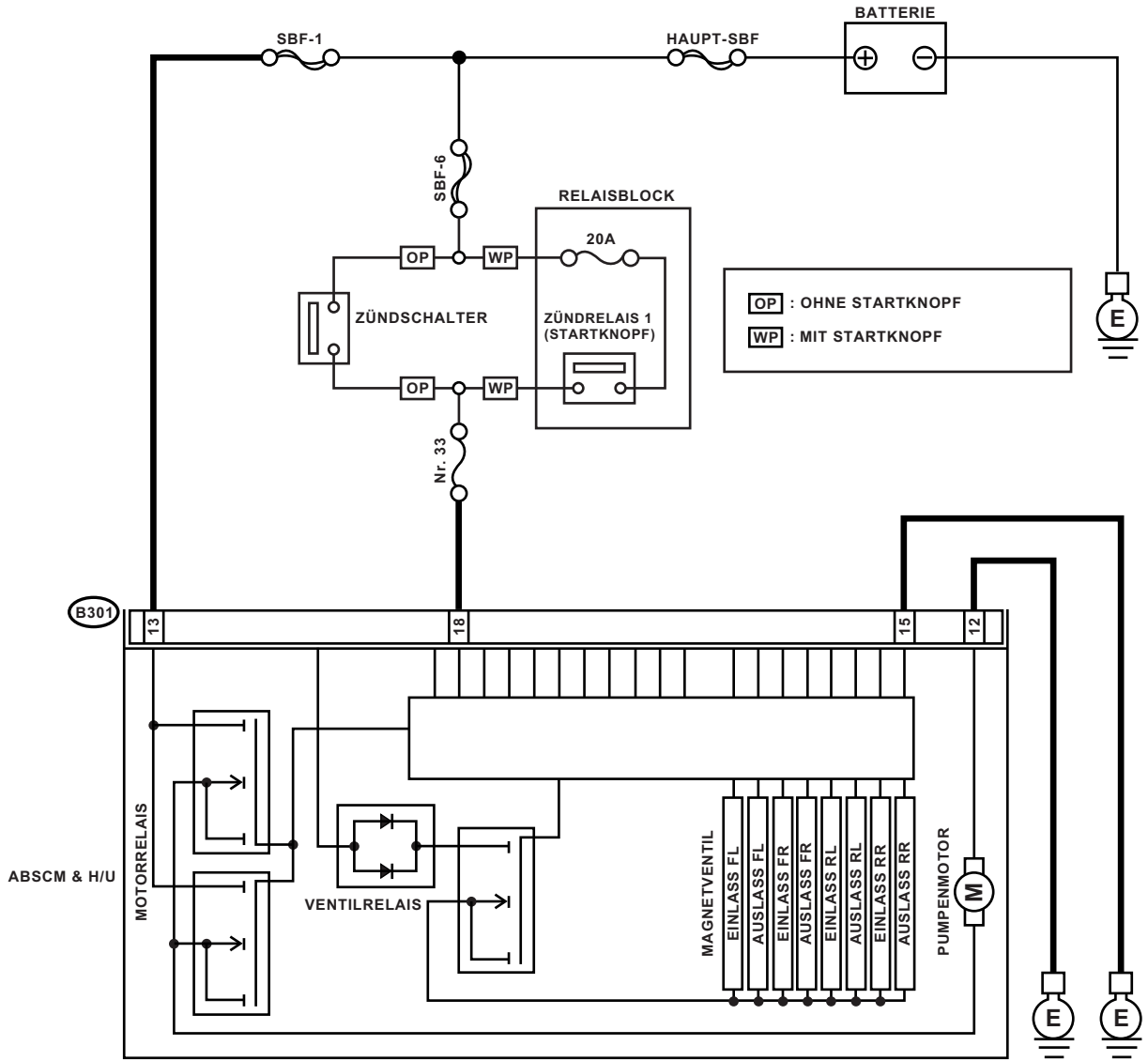

B301

12	13	14	15	1	2	3	4	5	6	7	8	9	10	11
				16	17	18	19	20	21	22	23	24	25	26

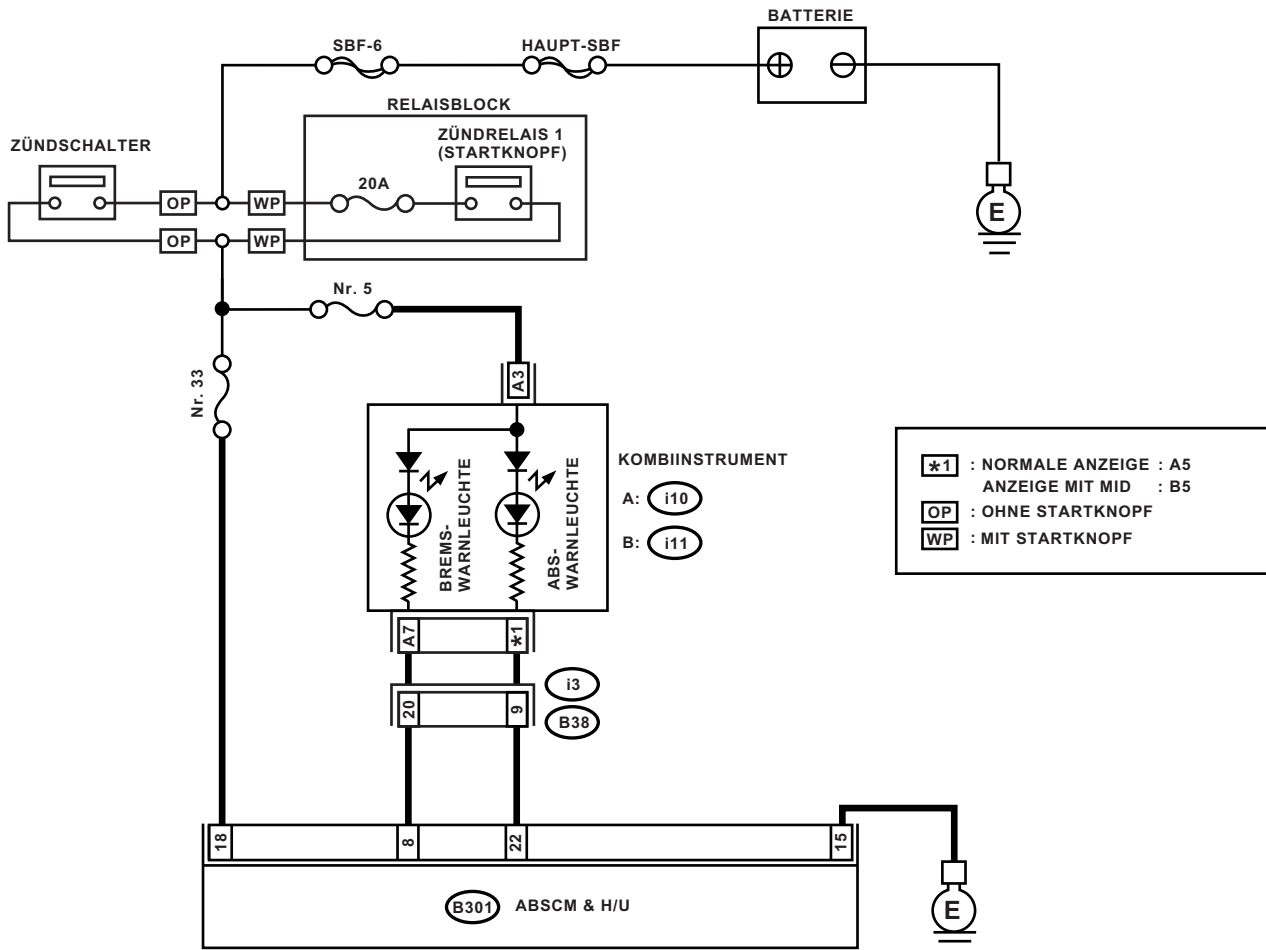

A: **i10**

B: **i11**

B301

B38

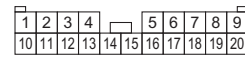
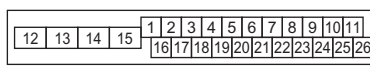
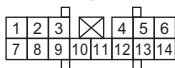
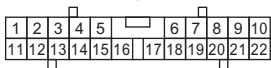

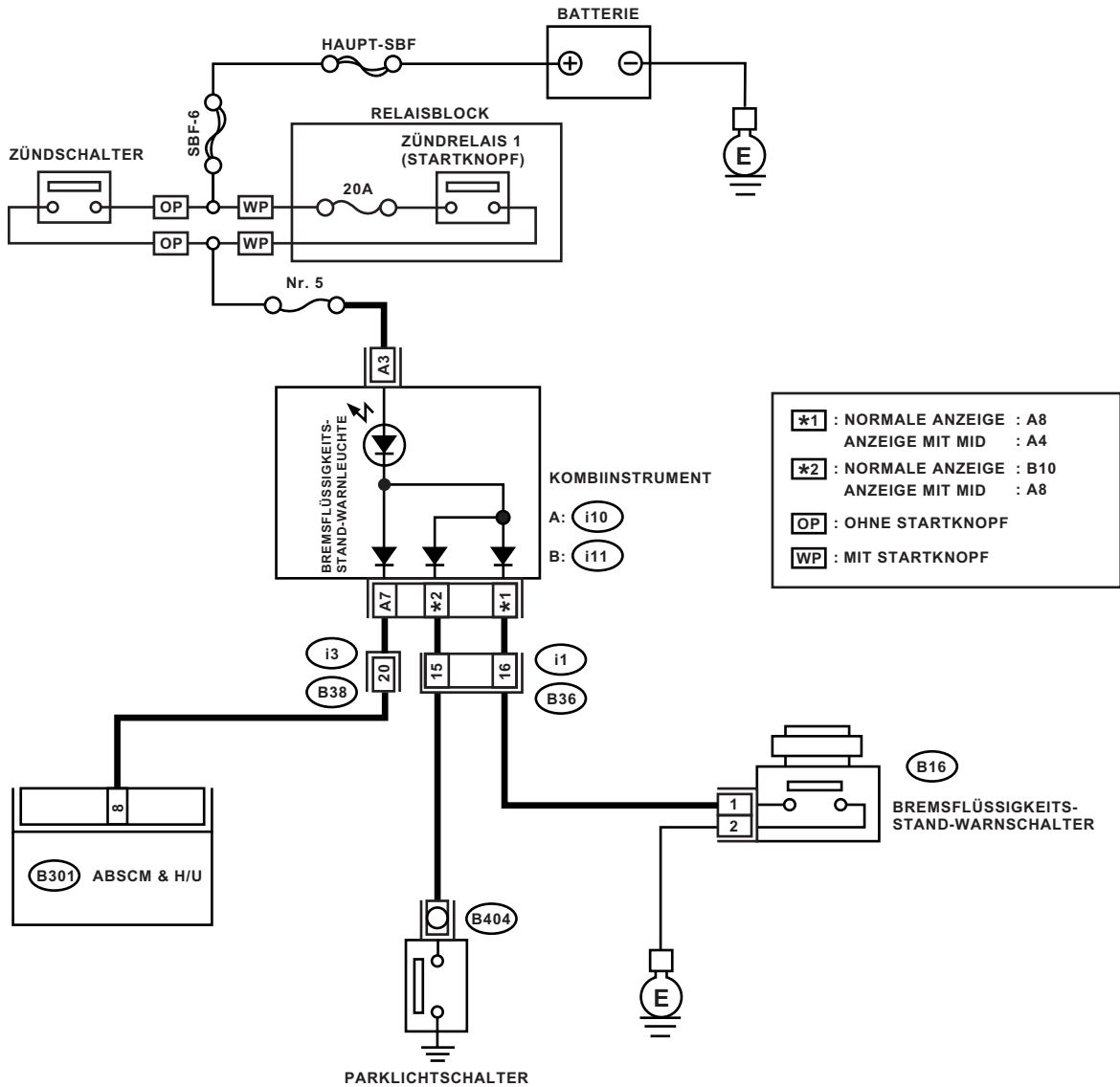

B16



i1

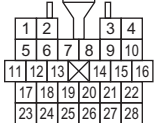

B301

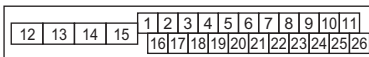

A: i10

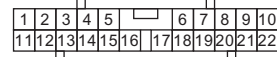

B38

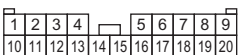

B: i11

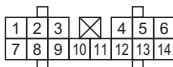

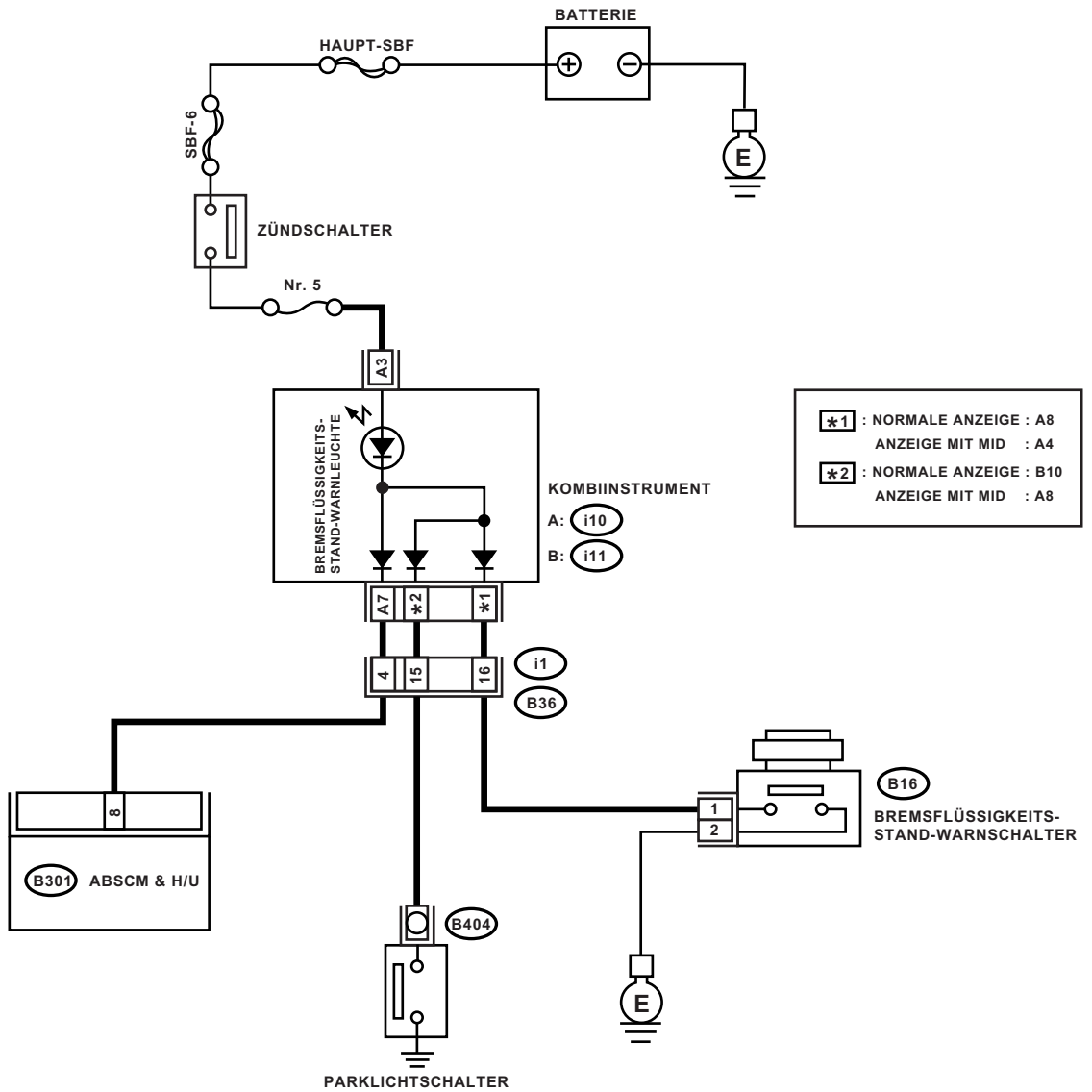

B16



i1

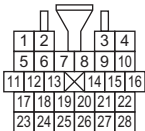

B301

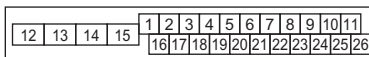

A: i10

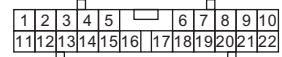

B: i11

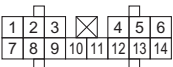

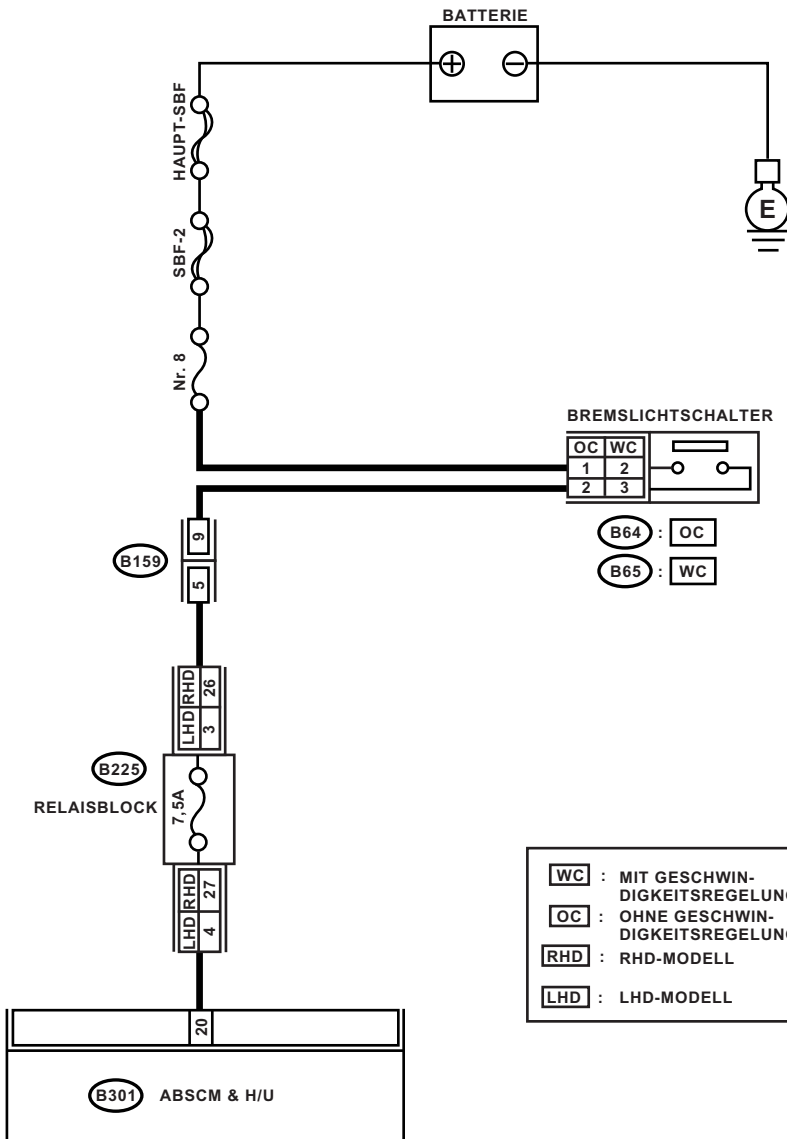

B64



B65



B159

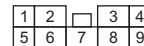

B301

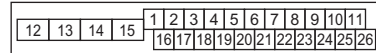

LHD : B225

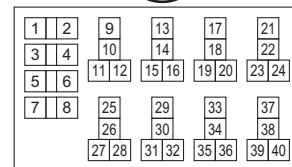

RHD : B225

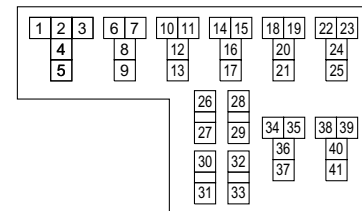

- WC** : MIT GESCHWINDIGKEITSREGELUNG
- OC** : OHNE GESCHWINDIGKEITSREGELUNG
- RHD** : RHD-MODELL
- LHD** : LHD-MODELL

B282

20	19	18	17	16	15	14	13	12	11	10	9	8	7	6	5	4	3	2	1
40	39	38	37	36	35	34	33	32	31	30	29	28	27	26	25	24	23	22	21

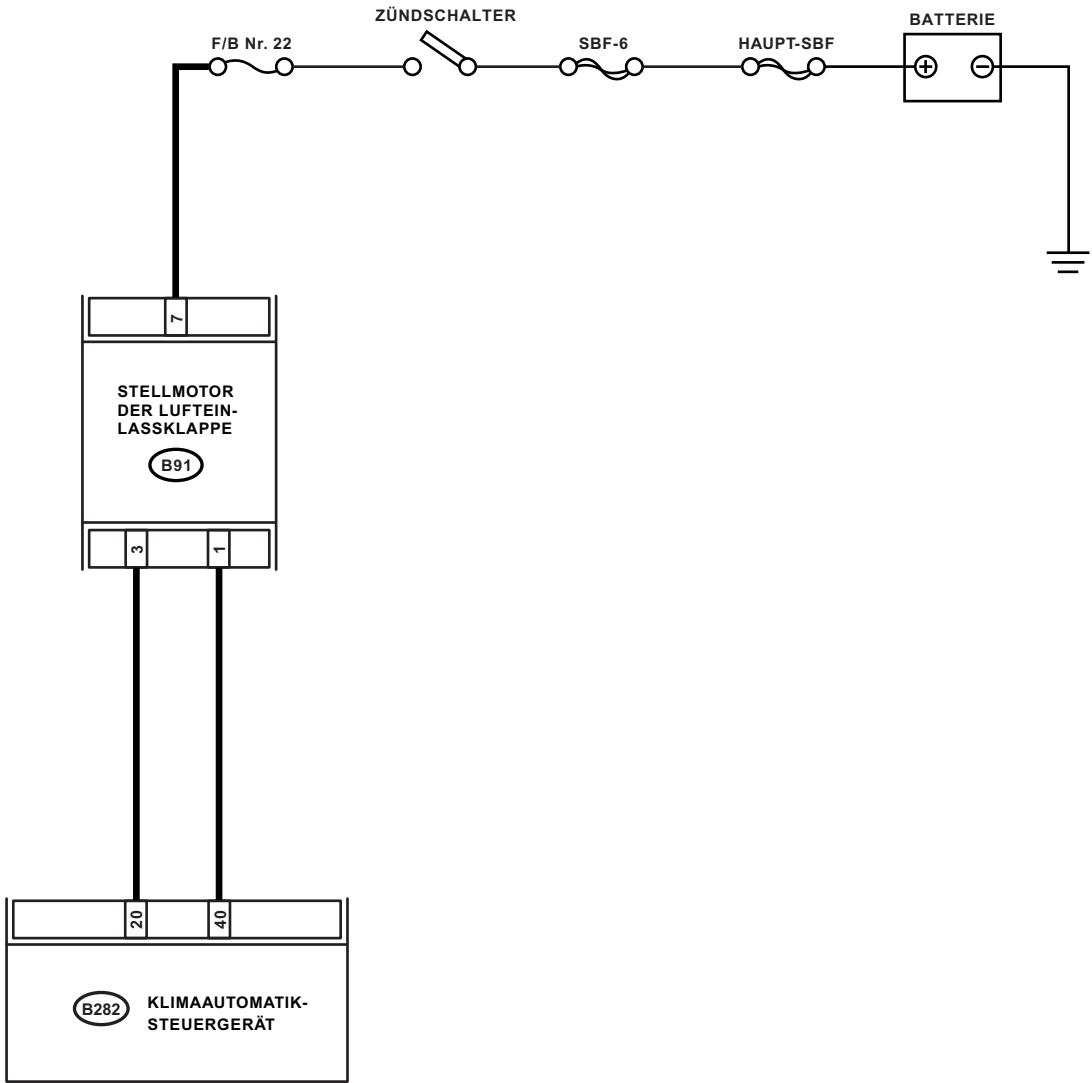

B91

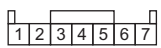

B282

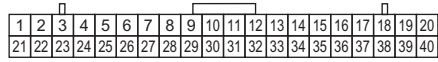

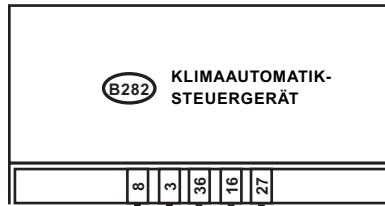

**STELLMOTOR DER
 LUFTVERTEILUNGSKLAPPE**

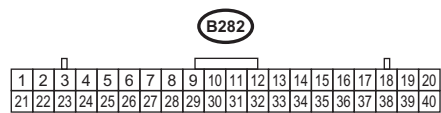
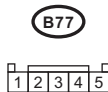

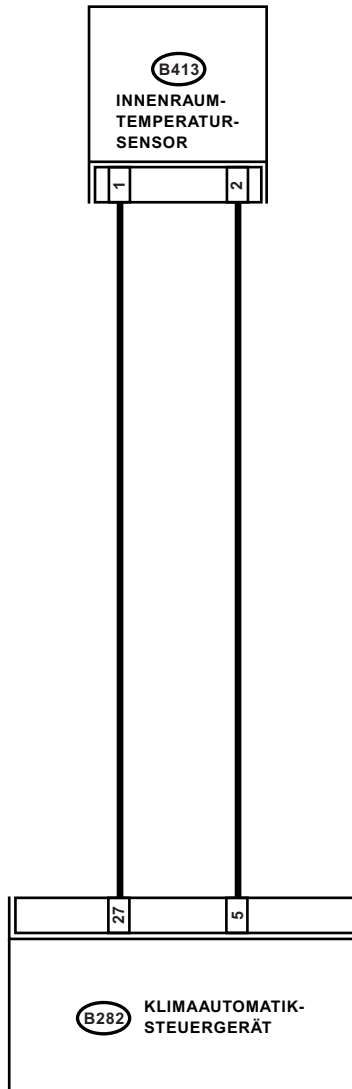

B413



B282

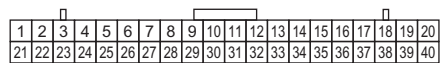

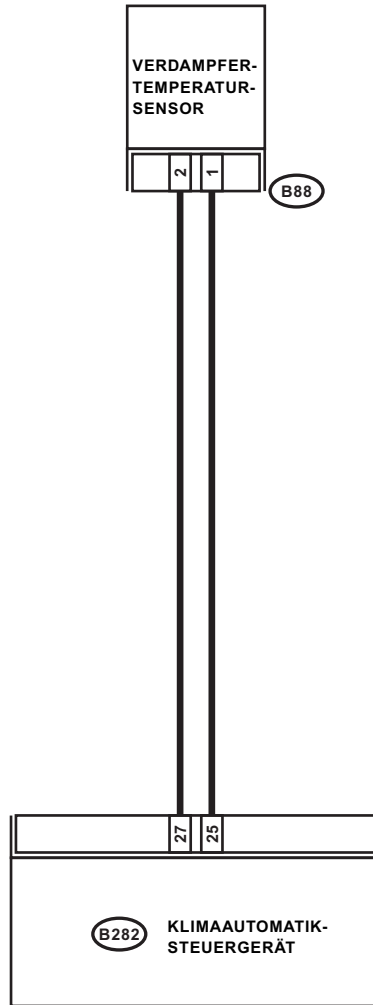

B88



B282

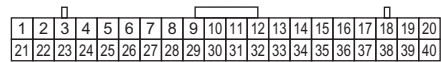

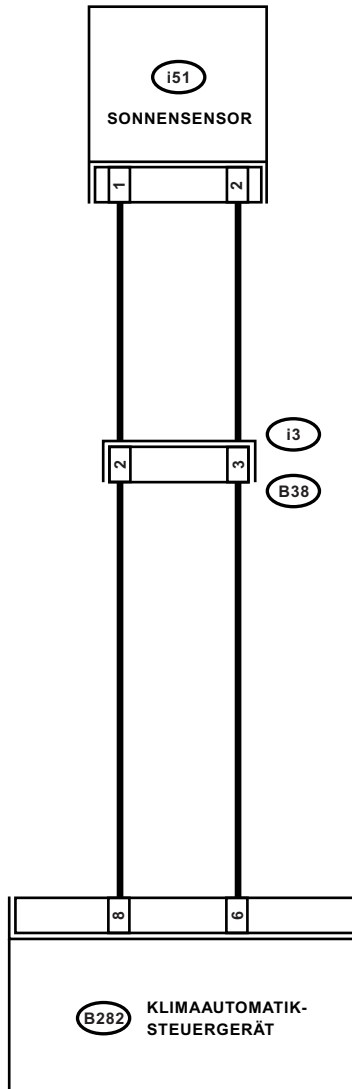

i51



B38

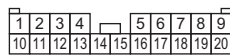

B282

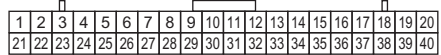

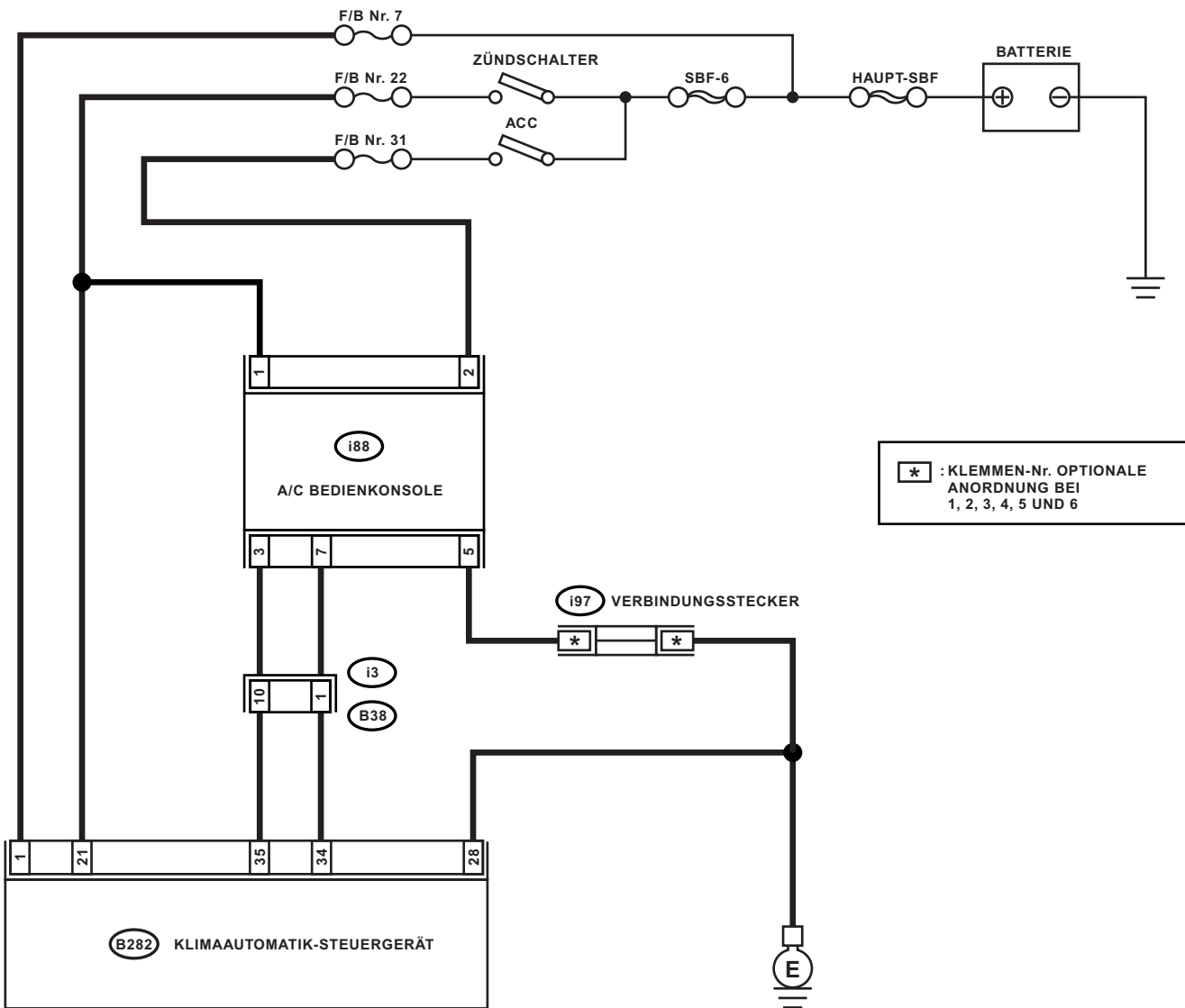

i88



i97

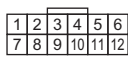

B38

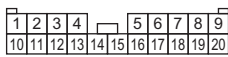

B282

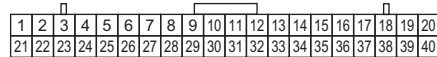

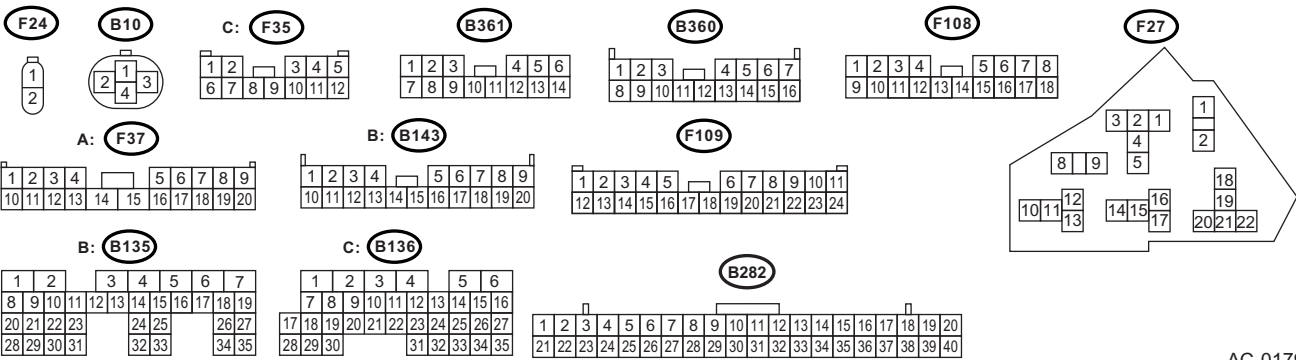
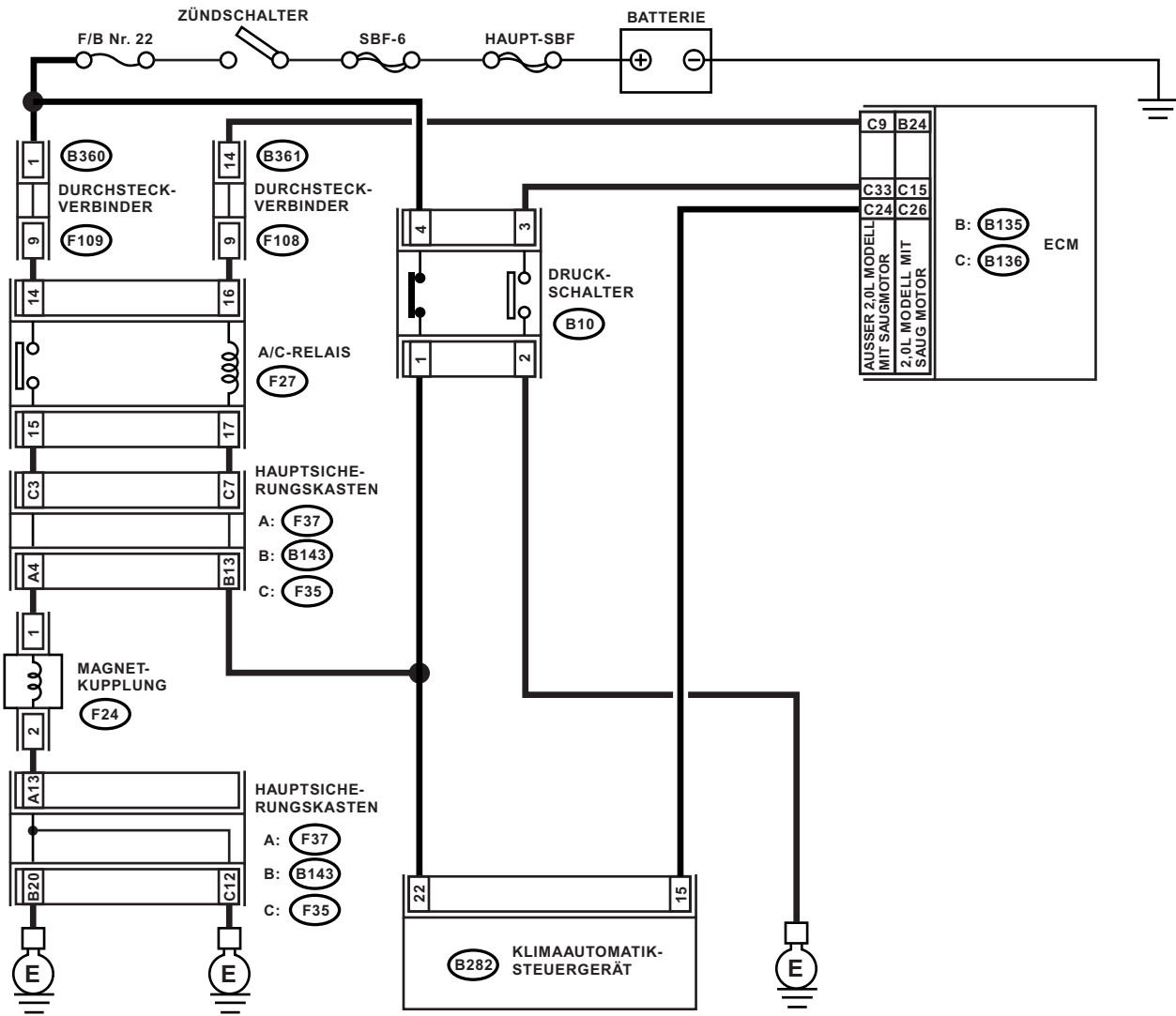

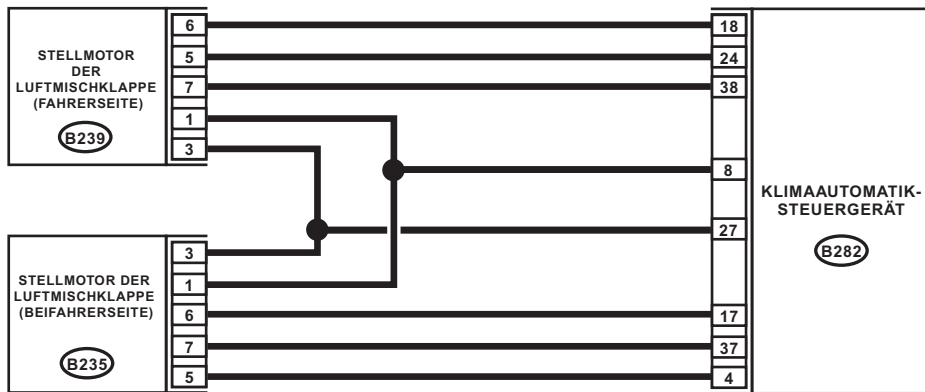

(B235) (B239)

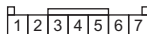

(B282)

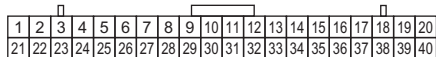



B238

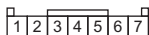

B282

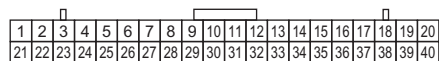

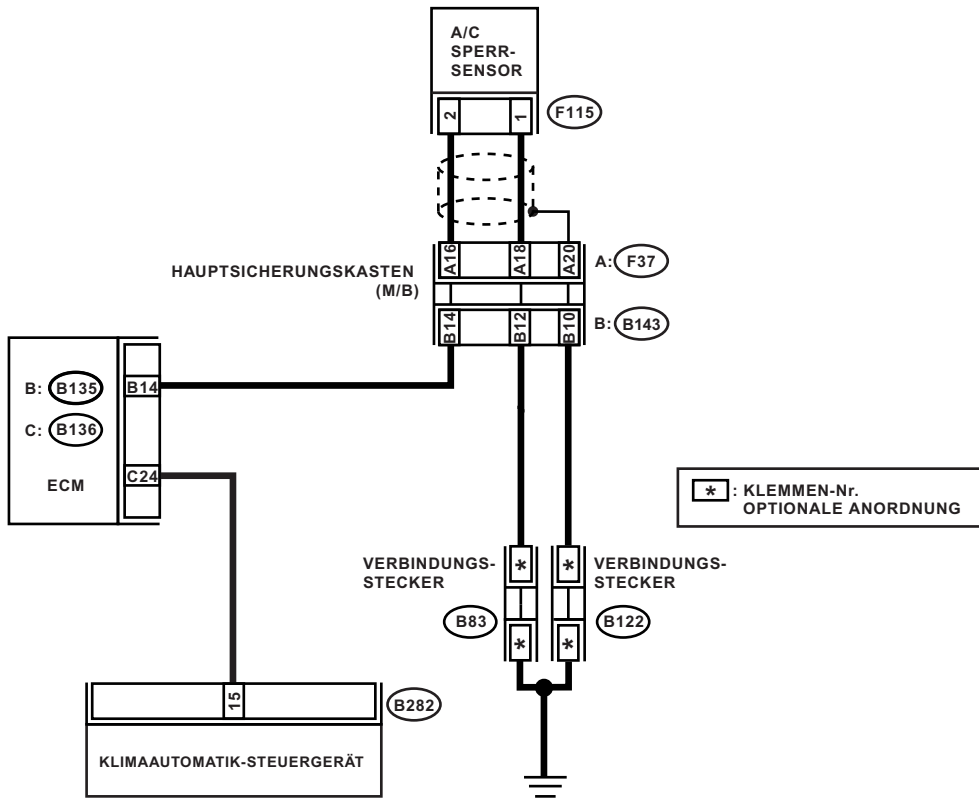

F115



B83 B122

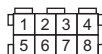

B282

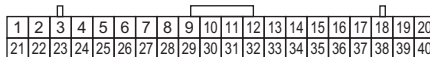

B: B143



A: F37

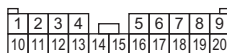

C: B136

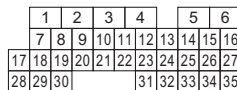

B: B135

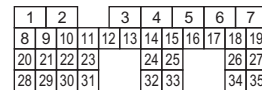

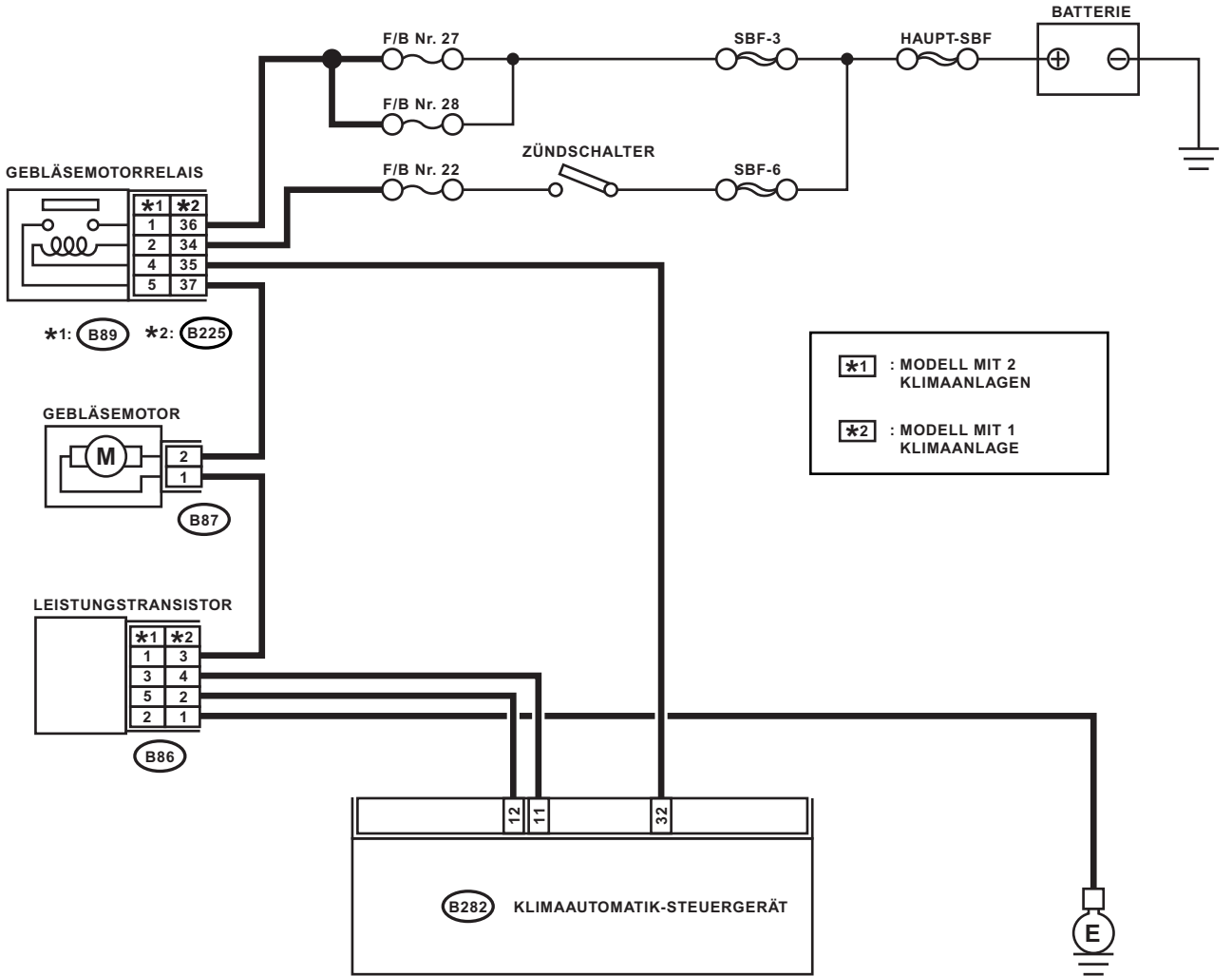

B87



*2 B86



*1 B86



B89

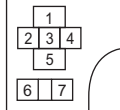

B225

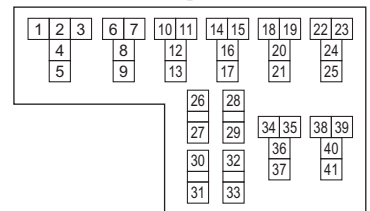

B282

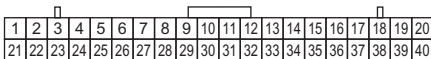

ZU **B55**

7	6	5	4	3			2	1			
19	18	17	16	15	14	13	12	11	10	9	8
27	26			25	24			23	22	21	20
35	34			33	32			31	30	29	28

ZU **B54**

6	5			4	3	2	1			
16	15	14	13	12	11	10	9	8	7	
27	26	25	24	23	22	21	20	19	18	17
35	34	33	32	31				30	29	28

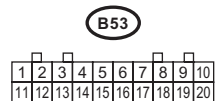
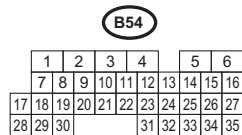
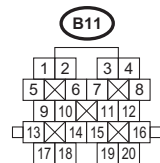
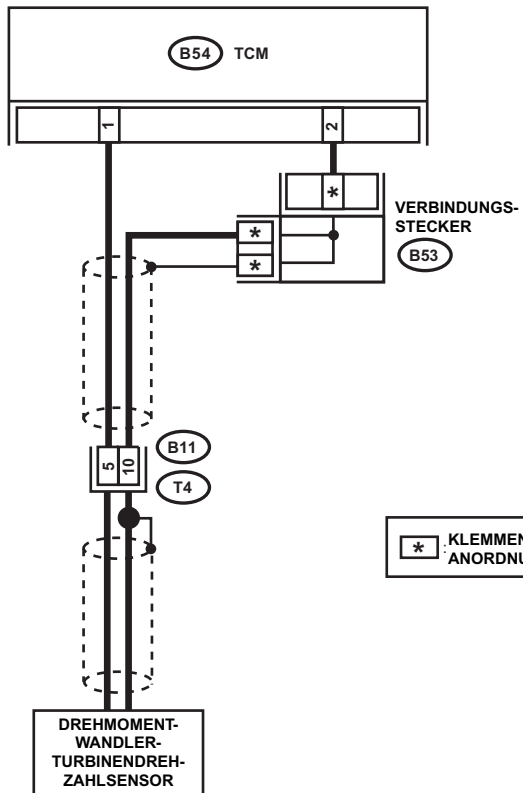

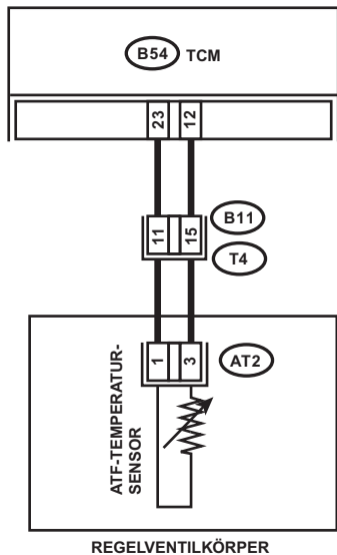

REGELVENTILKÖRPER

AT2



B11

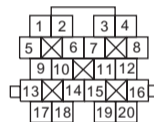

B54

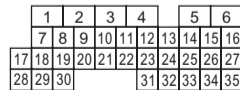

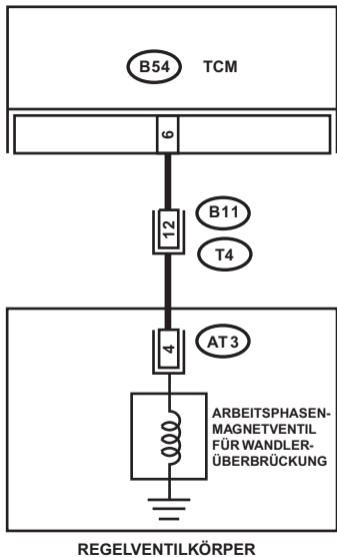

REGELVENTILKÖRPER

AT3

1	2	3
4	5	6

B11

1	2	3	4
5	6	7	8
9	10	11	12
13	14	15	16
17	18	19	20

B54

1	2	3	4	5	6
7	8	9	10	11	12
13	14	15	16	17	18
19	20	21	22	23	24
25	26	27	28	29	30
31	32	33	34	35	

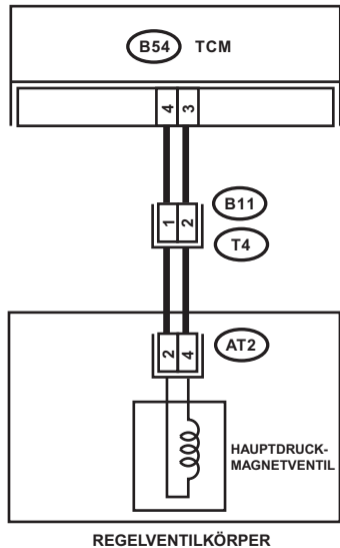

AT2



B11

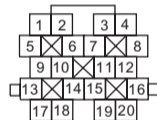

B54

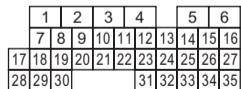

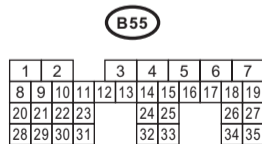
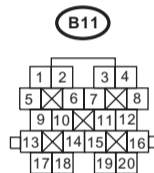
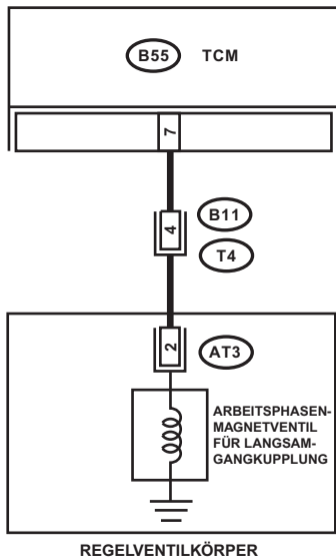

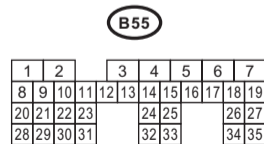
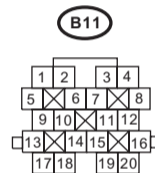
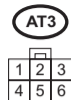
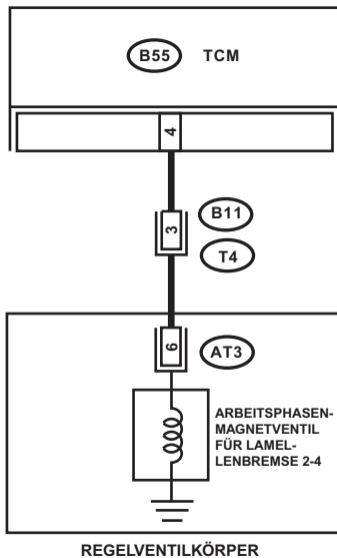

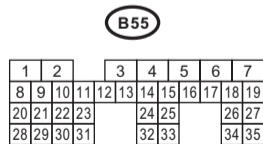
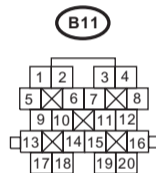
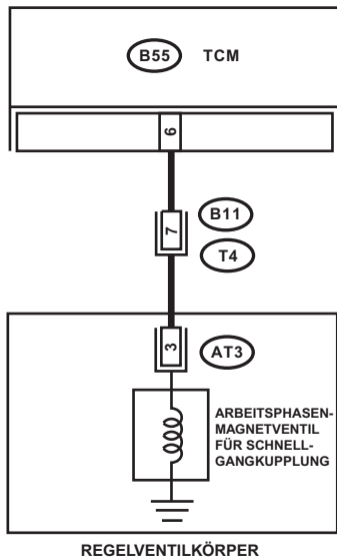

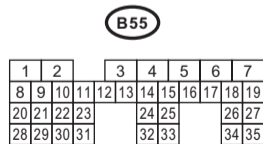
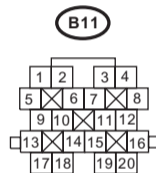
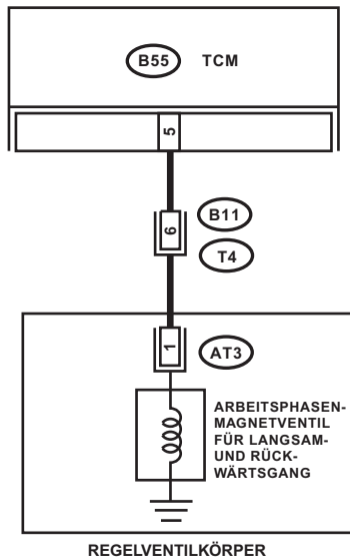

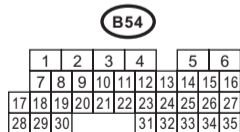
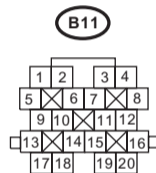
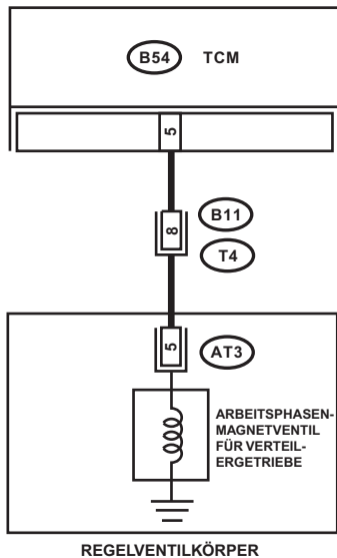

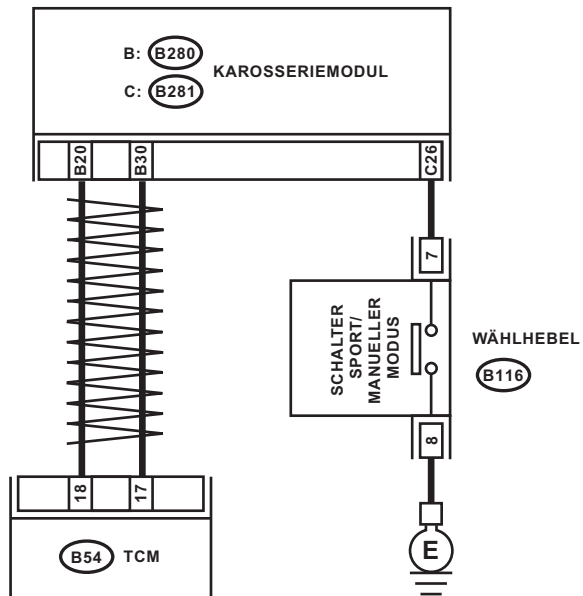

B116

1	2		3	4
5	6	7	8	9 10

B: **B280**

1	2	3			4	5		6	7			
8	9	10	11	12	13	14	15	16	17	18	19	20
21	22		23	24	25		26	27		28	29	30

C: **B281**

1	2	3				4	5	6	7		
8	9	10	11	12	13	14	15	16	17	18	19
20	21		22	23		24	25	26		27	28

B54

	1	2	3	4		5	6			
	7	8	9	10	11	12	13	14	15	16
17	18	19	20	21	22	23	24	25	26	27
28	29	30				31	32	33	34	35

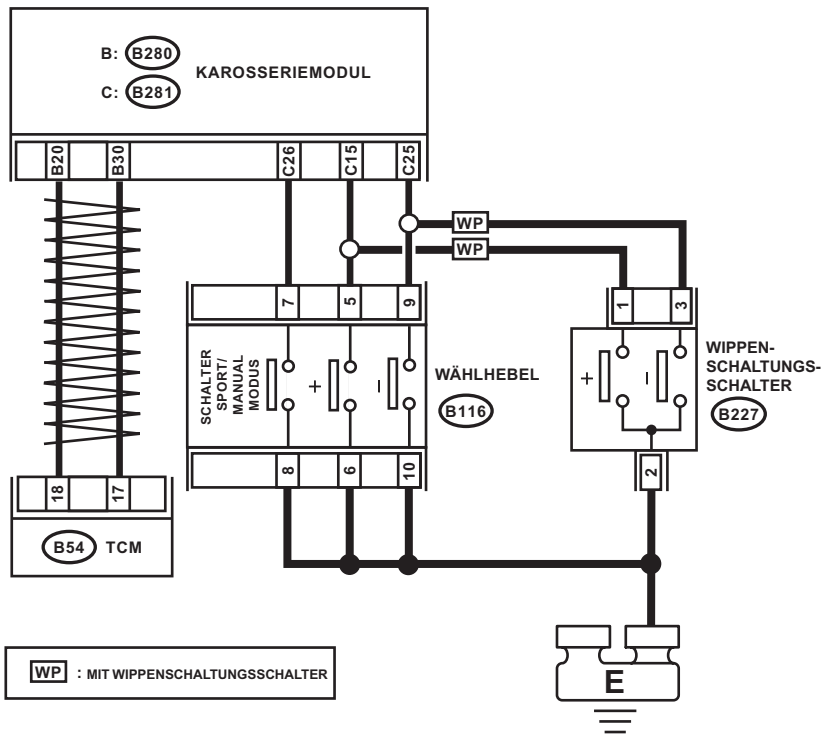

(B227)



(B116)

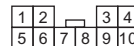

B: (B280)

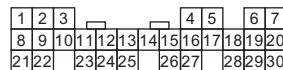

C: (B281)

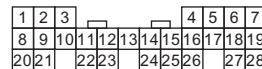

(B54)



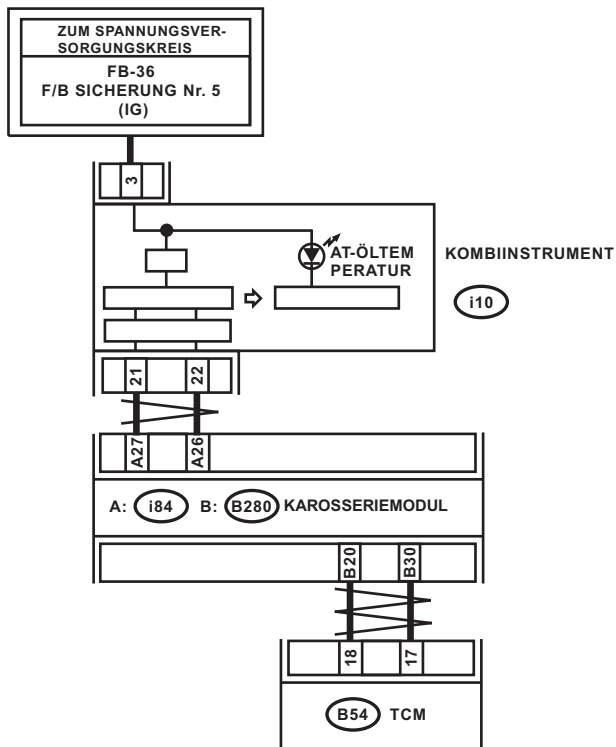

i10

1	2	3	4	5		6	7	8	9	10	
11	12	13	14	15	16	17	18	19	20	21	22

A: i84

1	2	3	4			5	6	7	8					
9	10	11	12	13	14	15	16	17	18	19	20	21	22	23
24	25	26	27	28	29	30	31	32	33	34	35			

B: B280

1	2	3			4	5	6	7				
8	9	10	11	12	13	14	15	16	17	18	19	20
21	22	23	24	25	26	27	28	29	30			

B54

	1	2	3	4	5	6				
	7	8	9	10	11	12	13	14	15	16
17	18	19	20	21	22	23	24	25	26	27
28	29	30			31	32	33	34	35	

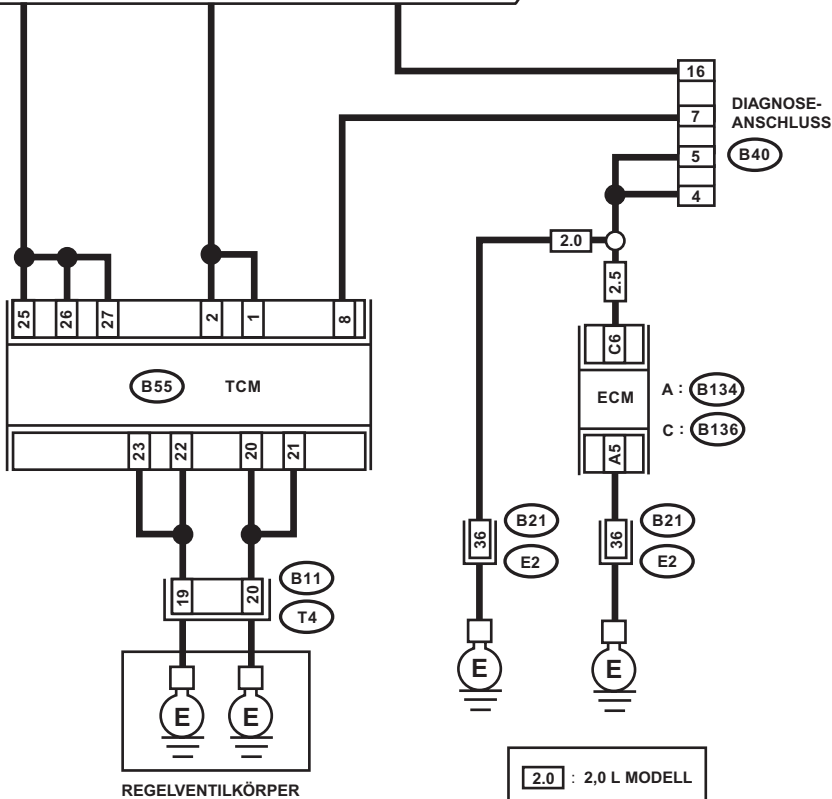

2.0 : 2,0 L MODELL
2.5 : 2,5 L MODELL

B40

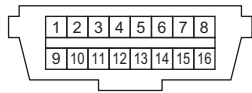

B11

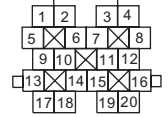

B55

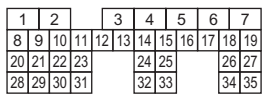

A: B134

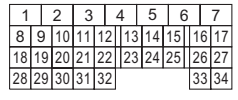

C: B136

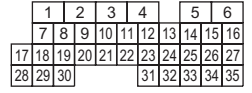

B21

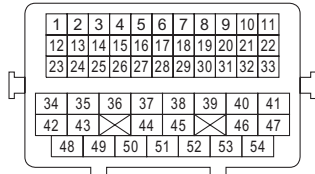

ZUM SPANNUNGS-
VERSORUNGSKREIS
FB-36
F/B SICHERUNG Nr. 5
(IG)

KOMBIINSTRUMENT

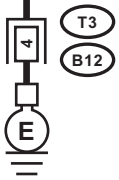
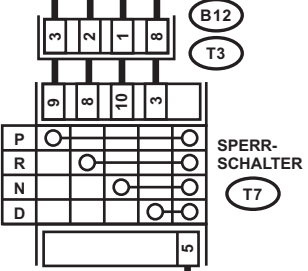
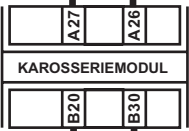
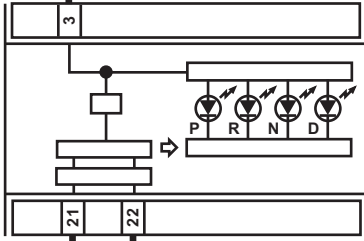

i10

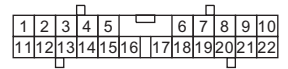

A: i84

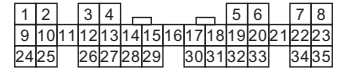

B: B280

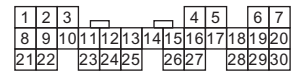

B54

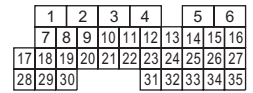

B12

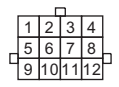

T7

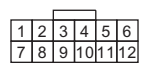

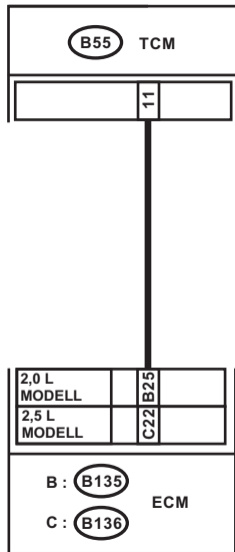

B55

1	2		3	4	5	6	7				
8	9	10	11	12	13	14	15	16	17	18	19
20	21	22	23			24	25			26	27
28	29	30	31			32	33			34	35

B : **B135**

1	2		3	4	5	6	7				
8	9	10	11	12	13	14	15	16	17	18	19
20	21	22	23			24	25			26	27
28	29	30	31			32	33			34	35

C : **B136**

	1	2	3	4		5	6			
	7	8	9	10	11	12	13	14	15	16
17	18	19	20	21	22	23	24	25	26	27
28	29	30				31	32	33	34	35

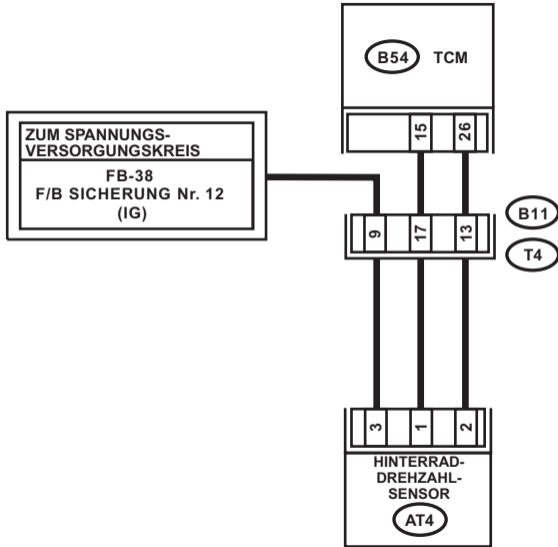

AT4



B11

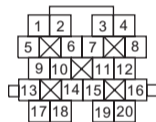

B54

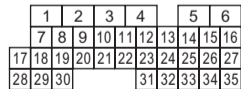

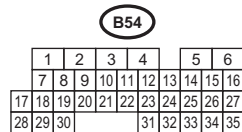
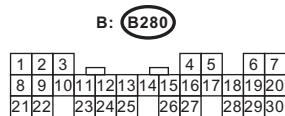
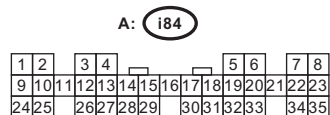
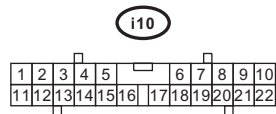
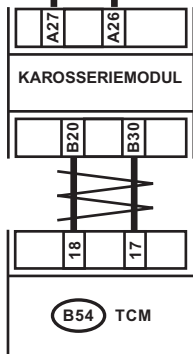
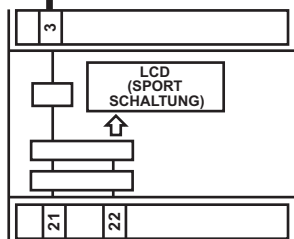

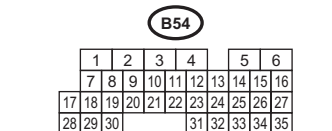
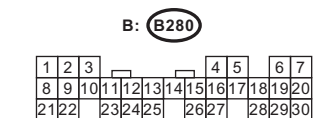
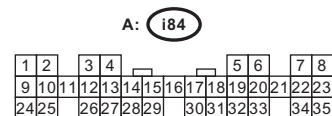
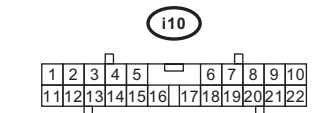
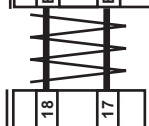
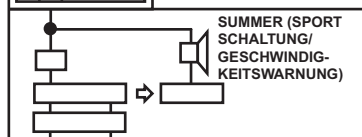
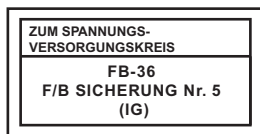

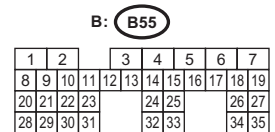
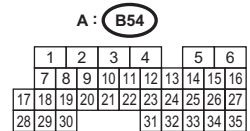
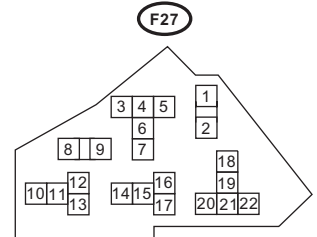
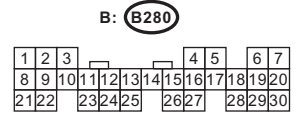
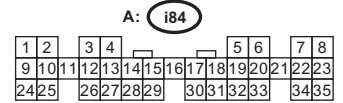
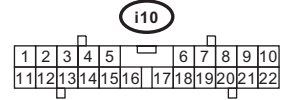
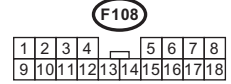
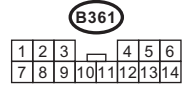
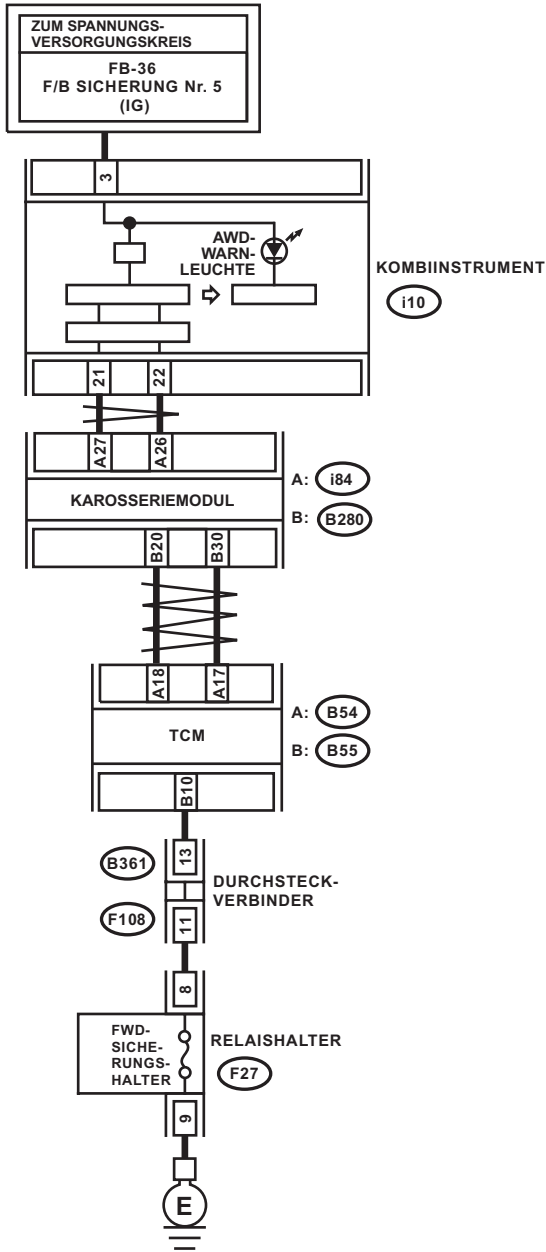

ZU **B54**

9	8	7	6	5	4	3	2	1
18	17	16	15	14	13	12	11	10
24	23	22				21	20	19

ZU **B55**

9	8	7	6	5	4	3	2	1
18	17	16	15	14	13	12	11	10
24	23	22				21	20	19

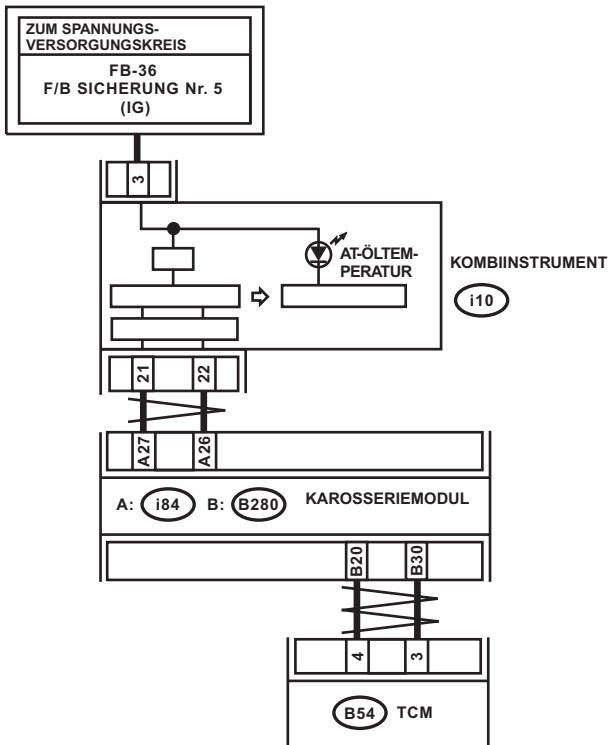

i10

1	2	3	4	5		6	7	8	9	10	
11	12	13	14	15	16	17	18	19	20	21	22

A: i84

1	2	3	4			5	6	7	8					
9	10	11	12	13	14	15	16	17	18	19	20	21	22	23
24	25	26	27	28	29	30	31	32	33	34	35			

B: B280

1	2	3			4	5	6	7				
8	9	10	11	12	13	14	15	16	17	18	19	20
21	22	23	24	25	26	27	28	29	30			

B54

1	2	3	4	5	6	7	8	9
10	11	12	13	14	15	16	17	18
19	20	21				22	23	24

ZUM SPANNUNGSVERSORUNGSKREIS

MB-26
M/B SICHERUNG Nr. 12
(B)

FB-38
F/B SICHERUNG Nr. 12
(IG)

MB-27
M/B SICHERUNG Nr. 13
(B)

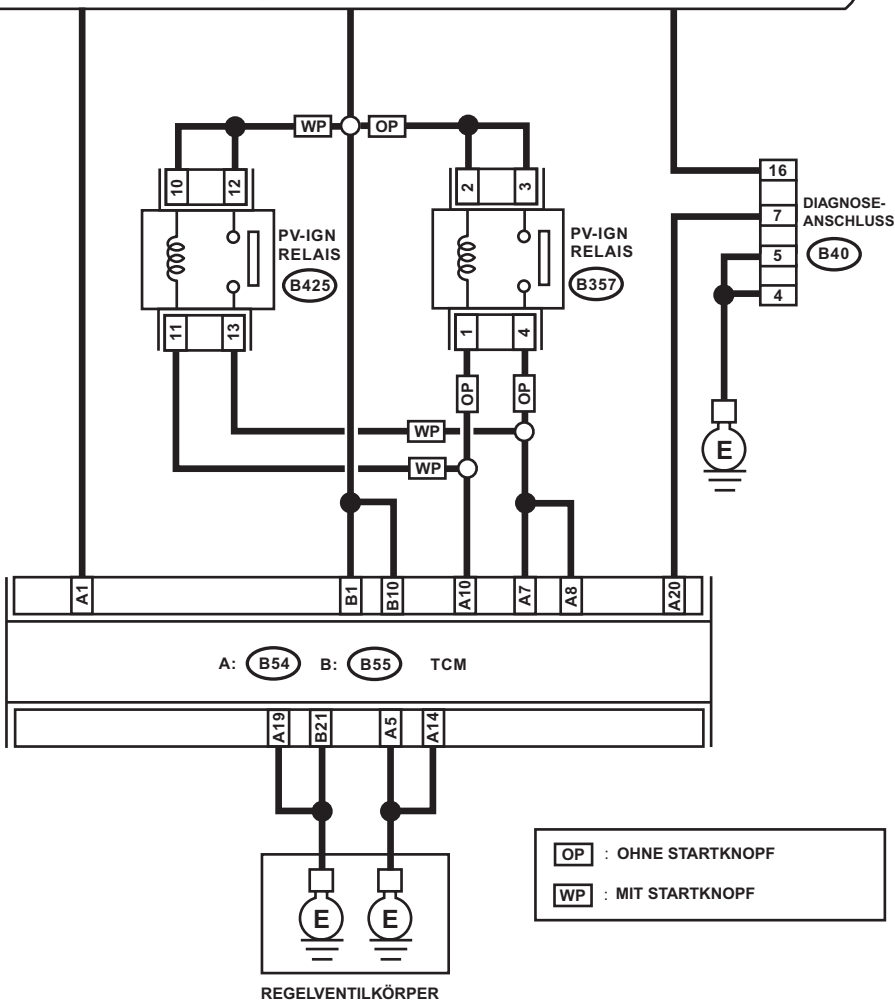

OP : OHNE STARTKNOPF
WP : MIT STARTKNOPF

B357 : **OP**



B40

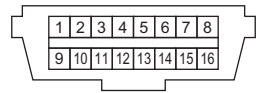

DIAGNOSE-ANSCHLUSS

B40

A: **B54**

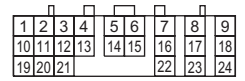

B: **B55**

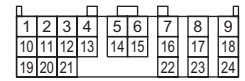

B425 : **WP**

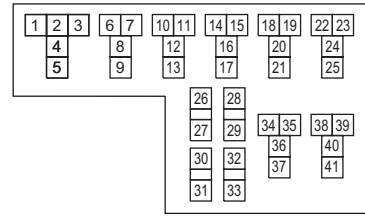

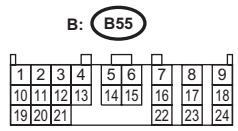
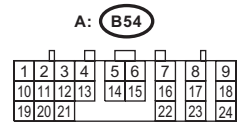
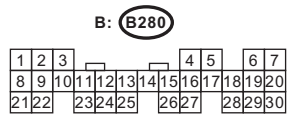
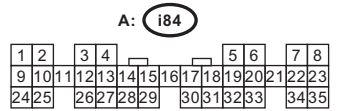
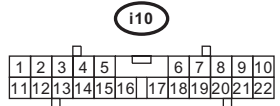
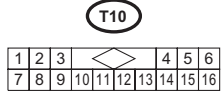
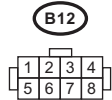
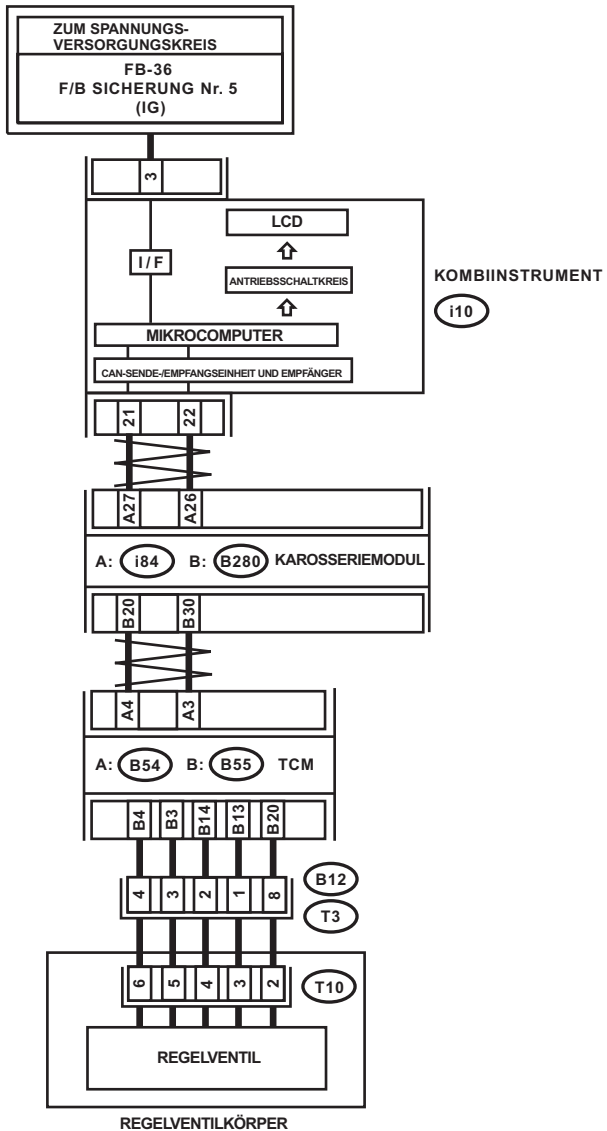

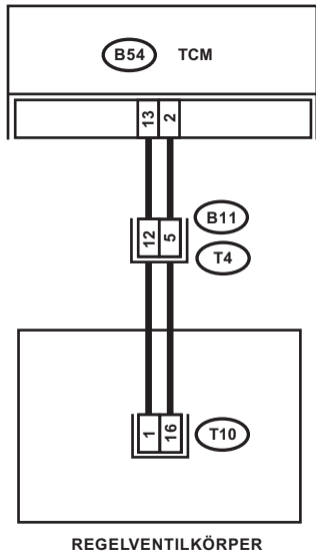

REGELVENTILKÖRPER

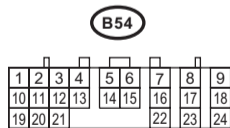
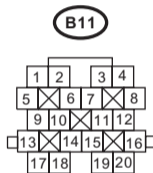
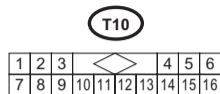

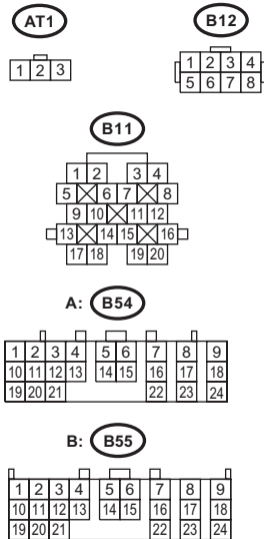
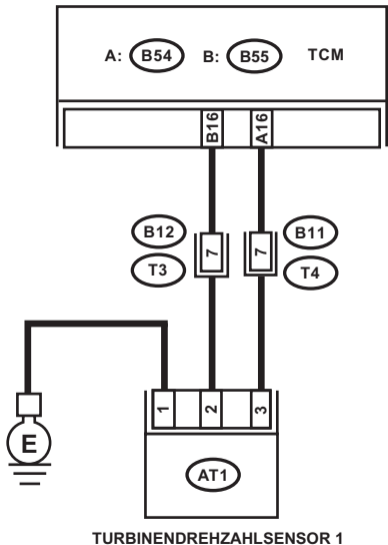

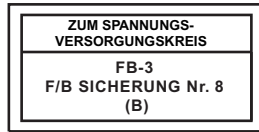

BREMSLICHTSCHALTER



SICHERUNGS- UND
RELAISKASTEN (F/B)



SICHERUNGS
(RELAISBLOCK)



OC : OHNE GESCHWINDIGKEITSREGELUNG

WC : MIT GESCHWINDIGKEITSREGELUNG

OP : OHNE STARTKNOPF

WP : MIT STARTKNOPF

LH : LHD-MODELL

RH : RHD-MODELL

*2 : LHD-MODELL : 3
RHD-MODELL : 26

*3 : LHD-MODELL : 4
RHD-MODELL : 27



F : B159



B : B280

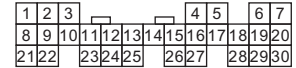

C : B281



B54

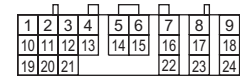

B225 : LH

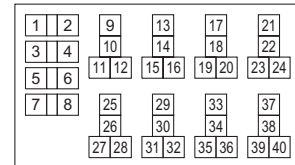

B225 : RH

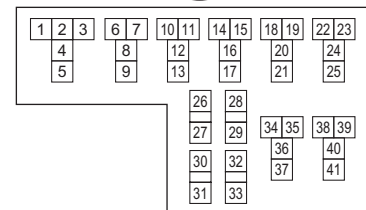

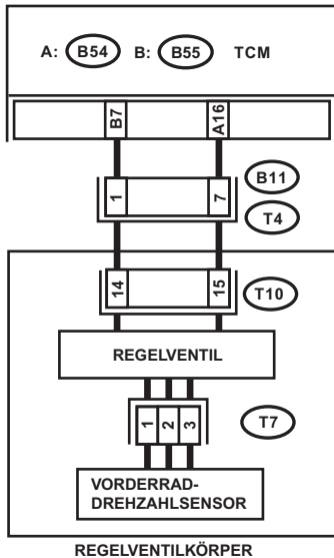

T7



T10



B11

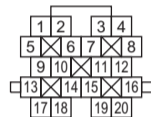

A: B54

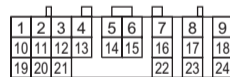

B: B55

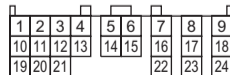

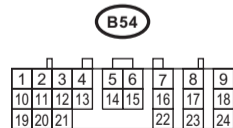
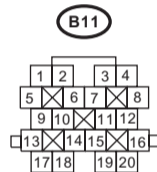
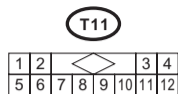
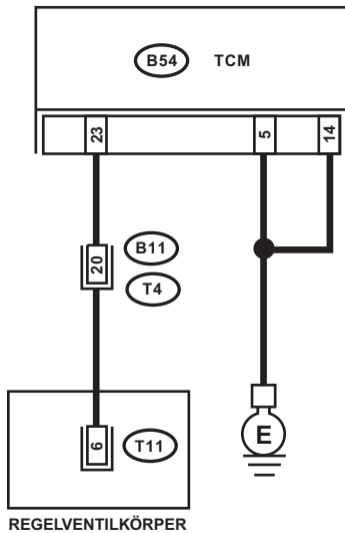

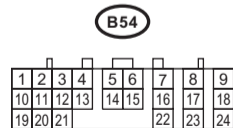
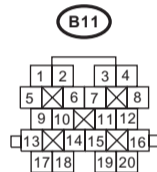
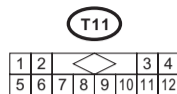
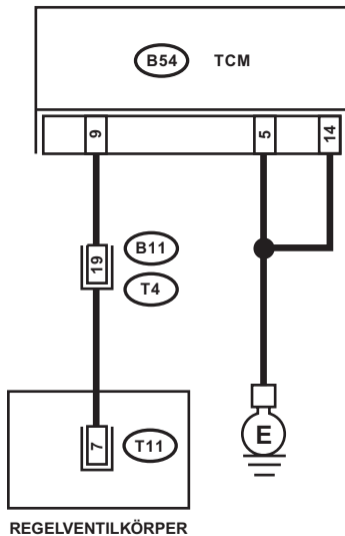

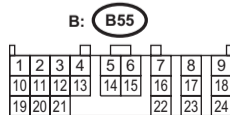
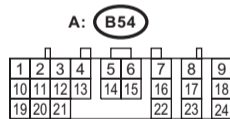
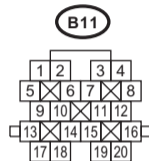
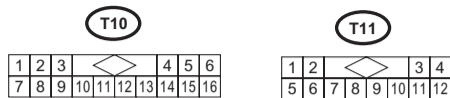
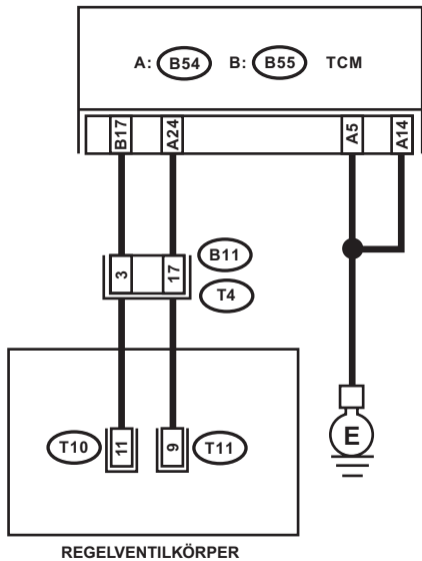

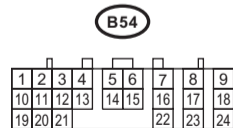
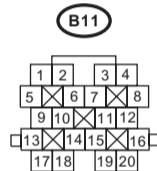
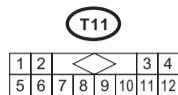
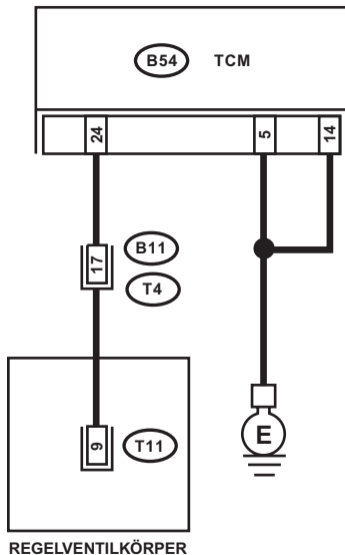

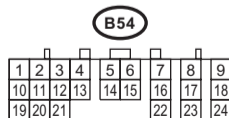
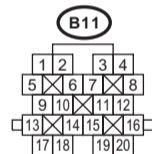
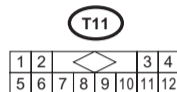
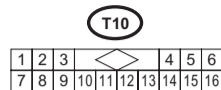
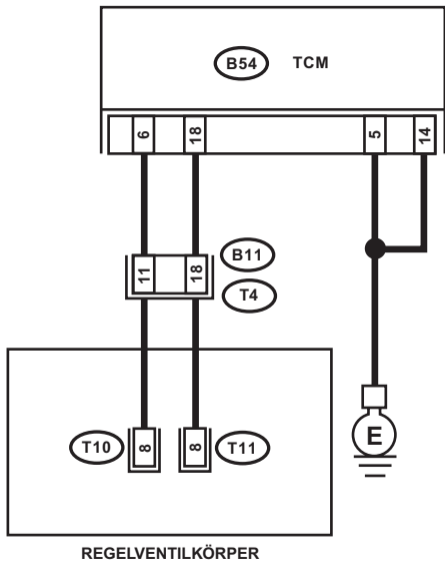

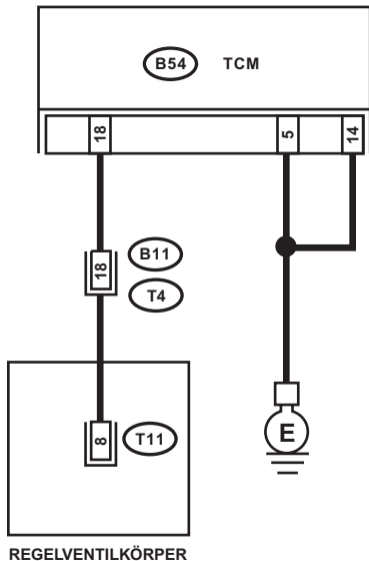

REGELVENTILKÖRPER

T11

1	2	◇	3	4
5	6	7	8	9
10	11	12		

B11

	1	2		3	4
5	×	6	7	×	8
	9	10	×	11	12
13	×	14	15	×	16
	17	18		19	20

B54

1	2	3	4	5	6	7	8	9
10	11	12	13	14	15	16	17	18
19	20	21				22	23	24

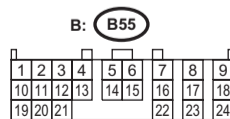
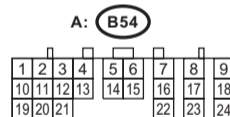
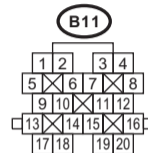
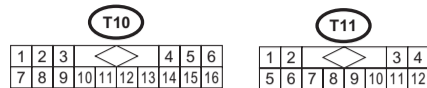
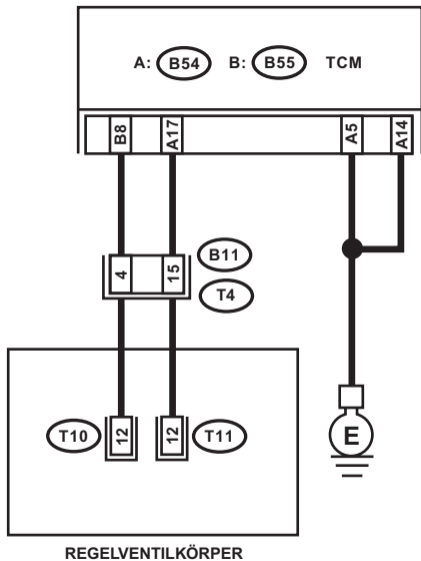

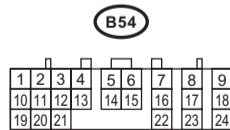
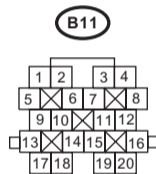
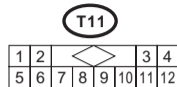
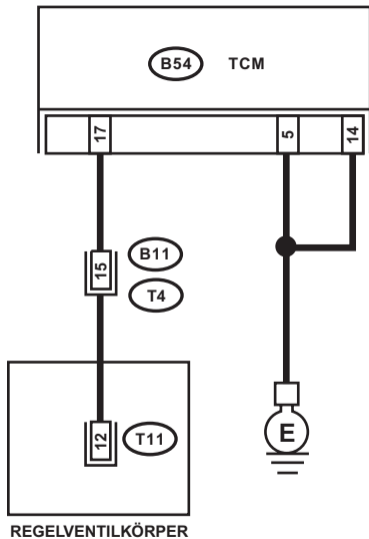

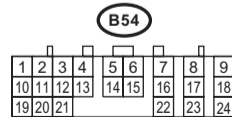
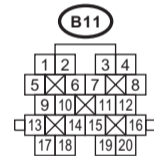
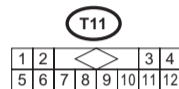
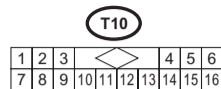
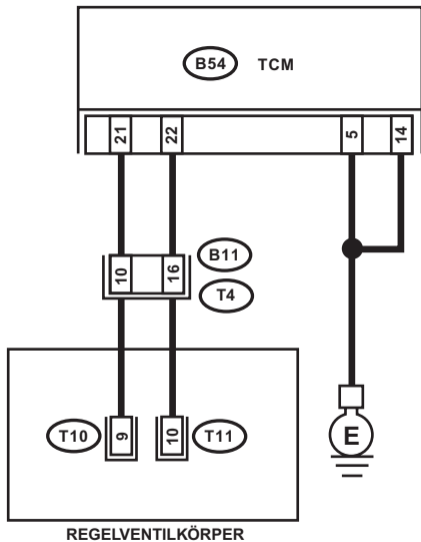

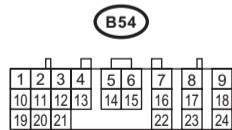
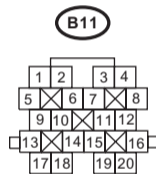
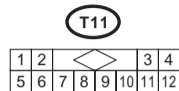
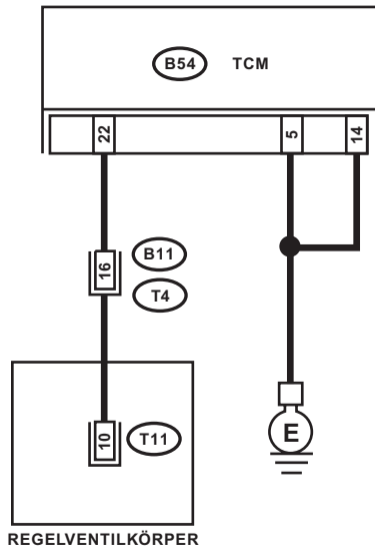

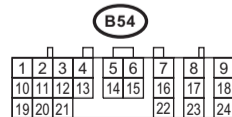
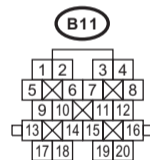
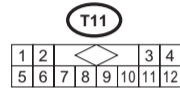
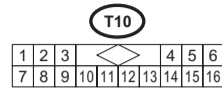
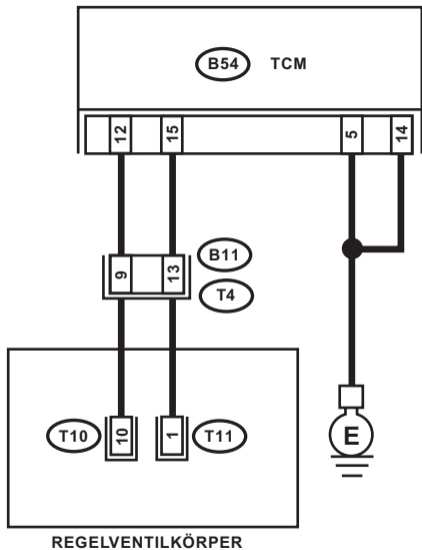

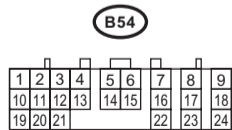
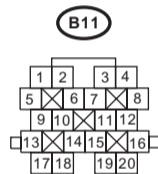
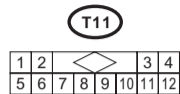
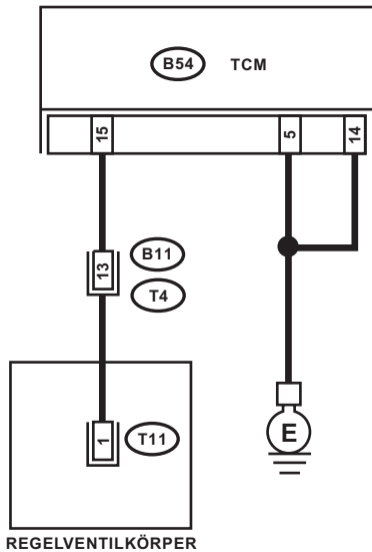

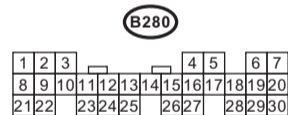
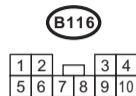
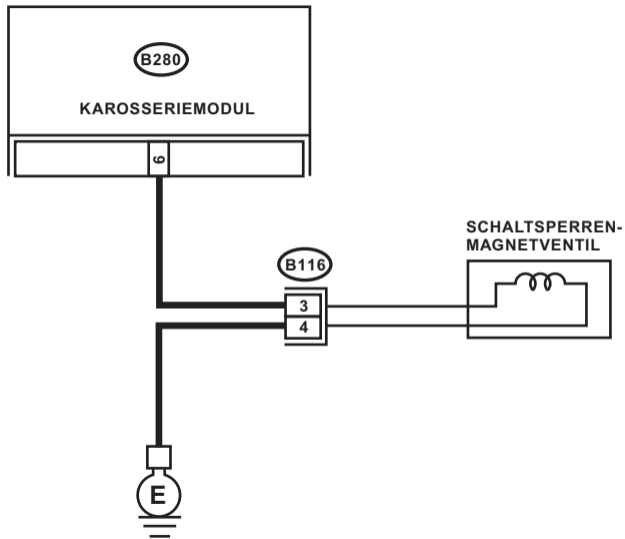

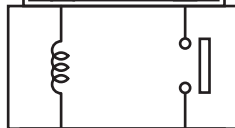
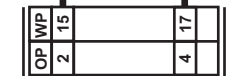
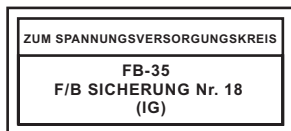

RÜCKFAHRSCHEINWERFERRELAIS

B425 : WP

B356 : OP

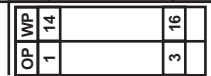

RÜCKFAHRSCHEINWERFERSYSTEM

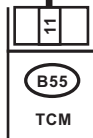

OP : OHNE STARTKNOPF

WP : MIT STARTKNOPF

B356 : OP



B55

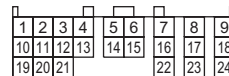

B425 : WP

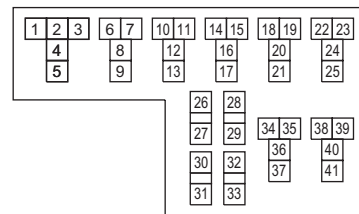

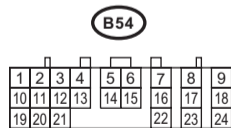
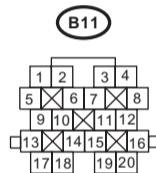
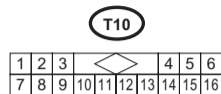
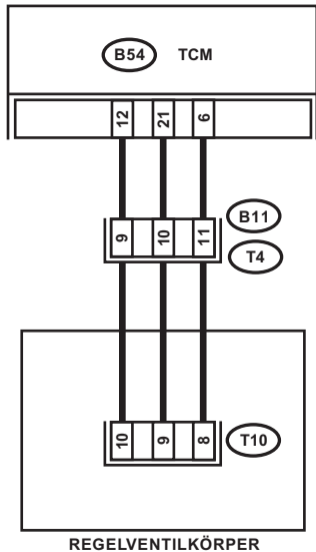

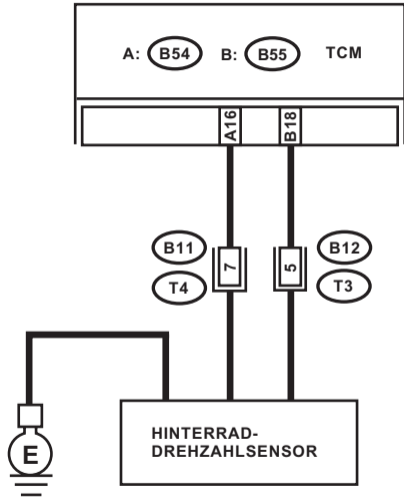

B12



B11

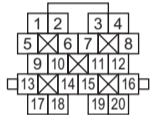

A: B54

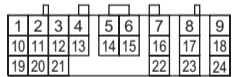

B: B55

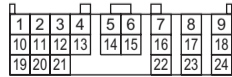

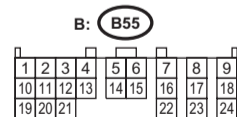
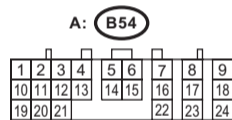
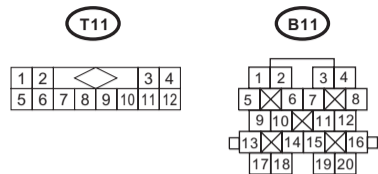
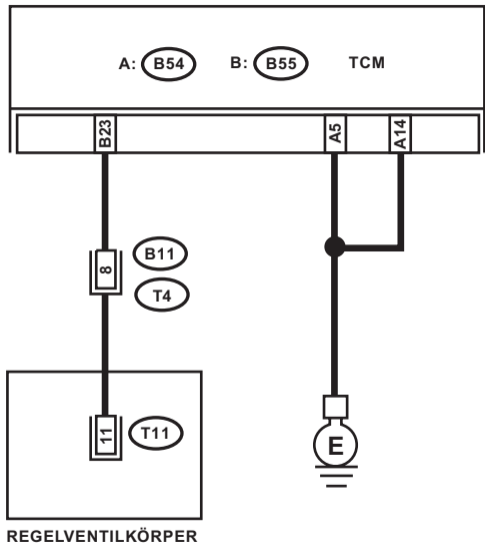

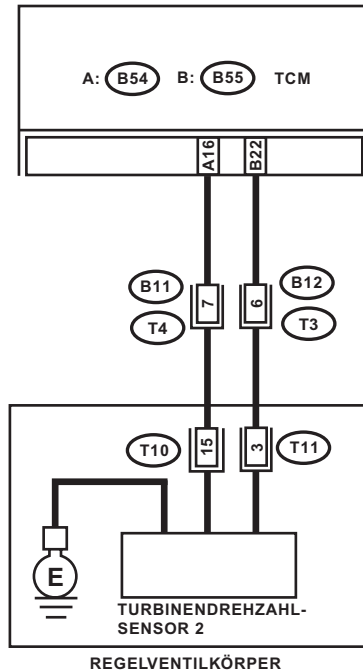

T11

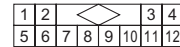

B12

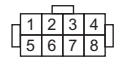

T10

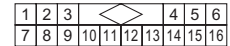

B11

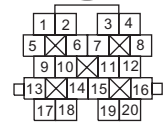

A: B54

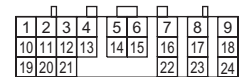

B: B55

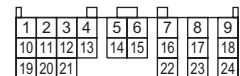

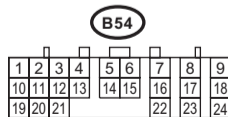
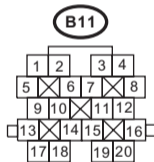
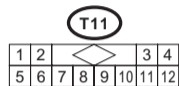
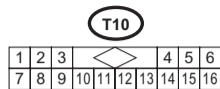
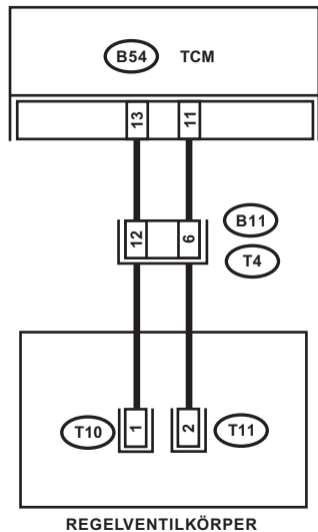

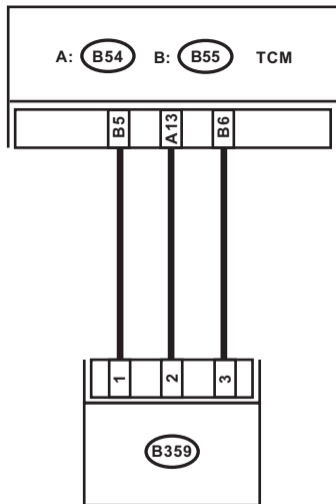

QUERBESCHLEUNIGUNGSSENSOR

B359



A: B54

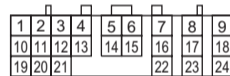

B: B55

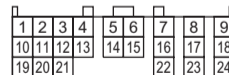

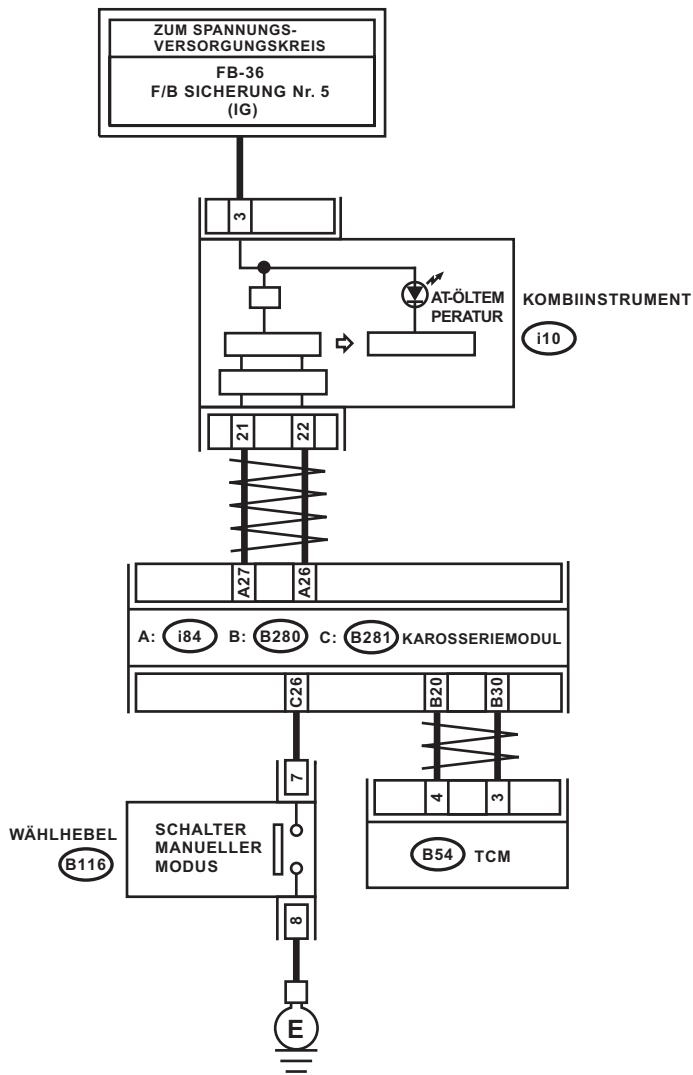

A: **i84**

1	2	3	4			5	6	7	8					
9	10	11	12	13	14	15	16	17	18	19	20	21	22	23
24	25	26	27	28	29	30	31	32	33	34	35			

B: **B280**

1	2	3			4	5	6	7				
8	9	10	11	12	13	14	15	16	17	18	19	20
21	22	23	24	25	26	27	28	29	30			

C: **B281**

1	2	3			4	5	6	7			
8	9	10	11	12	13	14	15	16	17	18	19
20	21	22	23	24	25	26	27	28			

B116

1	2		3	4	
5	6	7	8	9	10

i10

1	2	3	4	5		6	7	8	9	10	
11	12	13	14	15	16	17	18	19	20	21	22

B54

1	2	3	4	5	6	7	8	9
10	11	12	13	14	15	16	17	18
19	20	21			22	23	24	

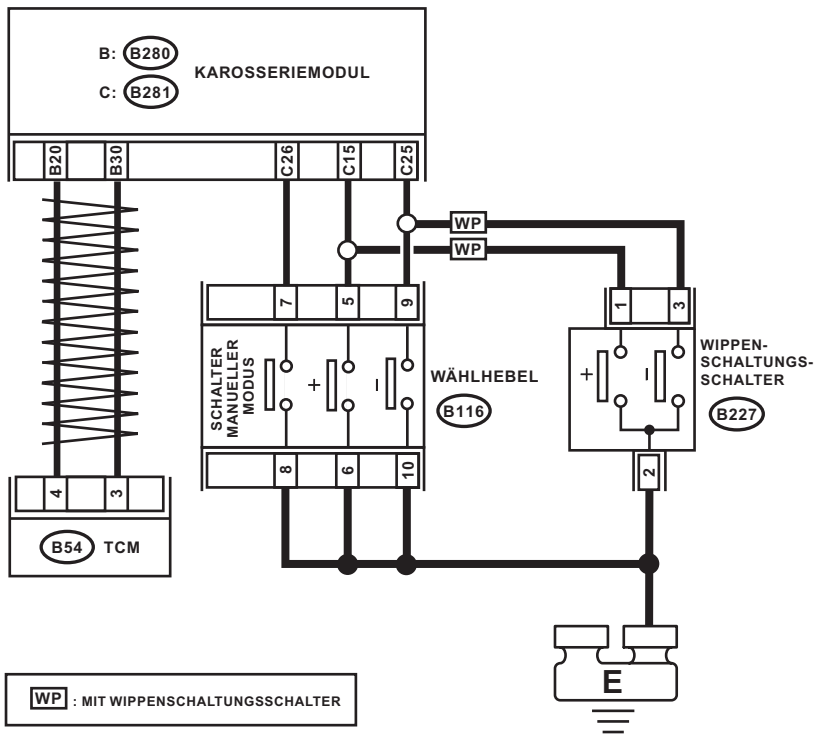

(B227)



(B116)

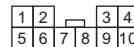

(B54)

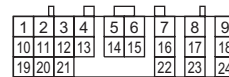

B: (B280)

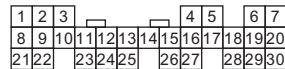

C: (B281)



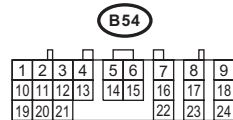
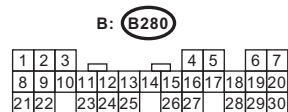
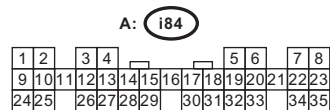
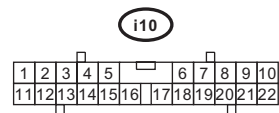
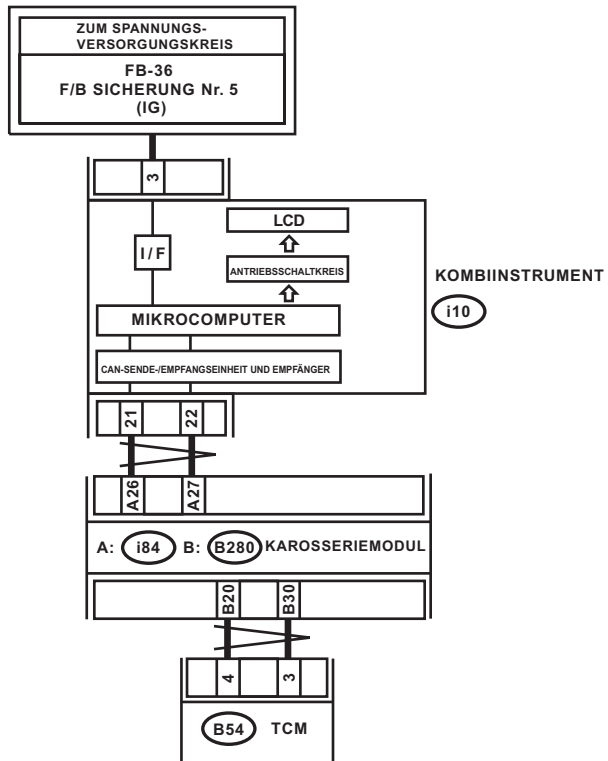

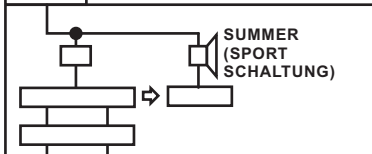
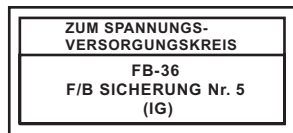

KOMBIINSTRUMENT

i10

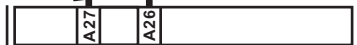

A: i84 B: B280 KAROSSERIEMODUL

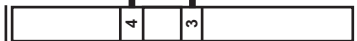

B54 TCM

i10

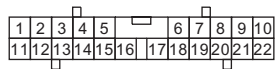

A: i84

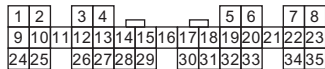

B: B280

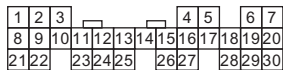

B54

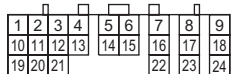

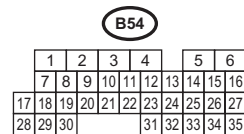
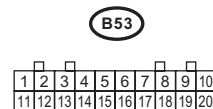
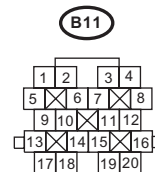
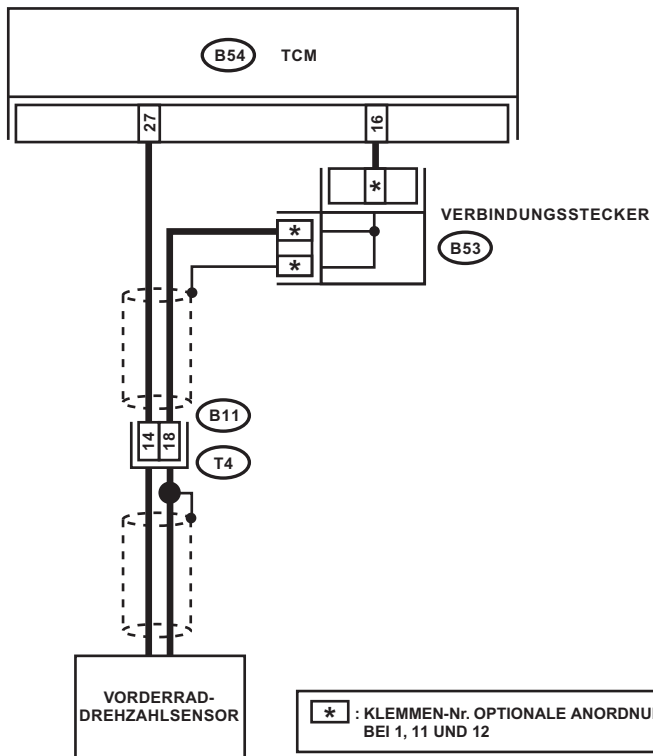

ZU A: **B134**

7	6	5	4	3	2	1			
17	16	15	14	13	12	11	10	9	8
27	26	25	24	23	22	21	20	19	18
34	33			32	31	30	29	28	

ZU B: **B135**

7	6	5	4	3		2	1				
19	18	17	16	15	14	13	12	11	10	9	8
27	26		25	24		23	22	21	20		
35	34		33	32		31	30	29	28		

ZU C: **B136**

6	5		4	3	2	1				
16	15	14	13	12	11	10	9	8	7	
27	26	25	24	23	22	21	20	19	18	17
35	34	33	32	31			30	29	28	

ZU D: **B137**

7	6	5	4	3	2	1			
17	16	15	14	13	12	11	10	9	8
25	24		23	22	21	20	19	18	
31	30		29	28			27	26	

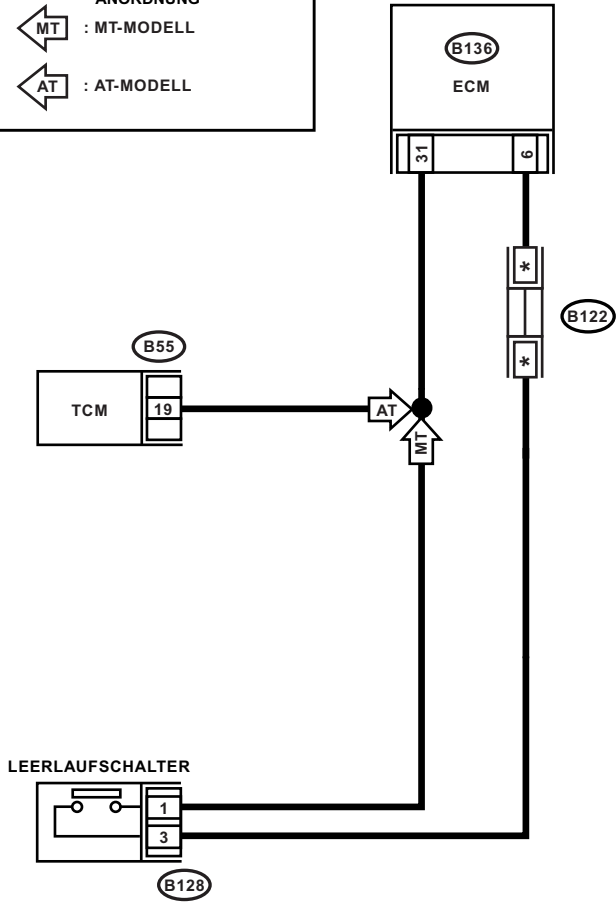
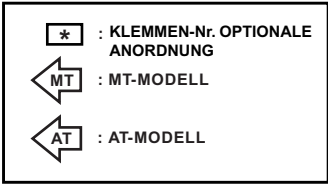

B128



B122



B55

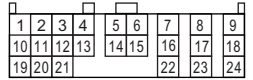

B136

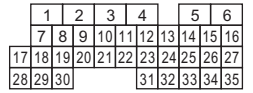

BETÄTIGUNGSSCHALTER
DER GESCHWINDIGKEITSREGELUNG

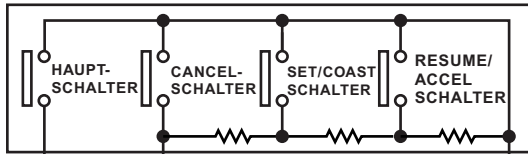

KONTAKTSPIRALE
IM LENKRAD

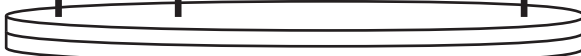

ST3

ST1

B68

B122

* : KLEMMEN-Nr.
OPTIONALE
ANORDNUNG

2,0 L MODELL	B12 C14	B24 C23	C6 B3	B4
2,5 L MODELL	B12	B24	C6	B3
3,0 L MODELL	B12	B24	C6	B3

B: (B135) C: (B136) ECM

ST3

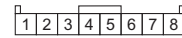

B122

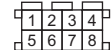

B68



B: (B135)

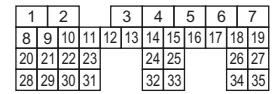

C: (B136)

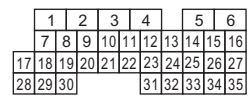

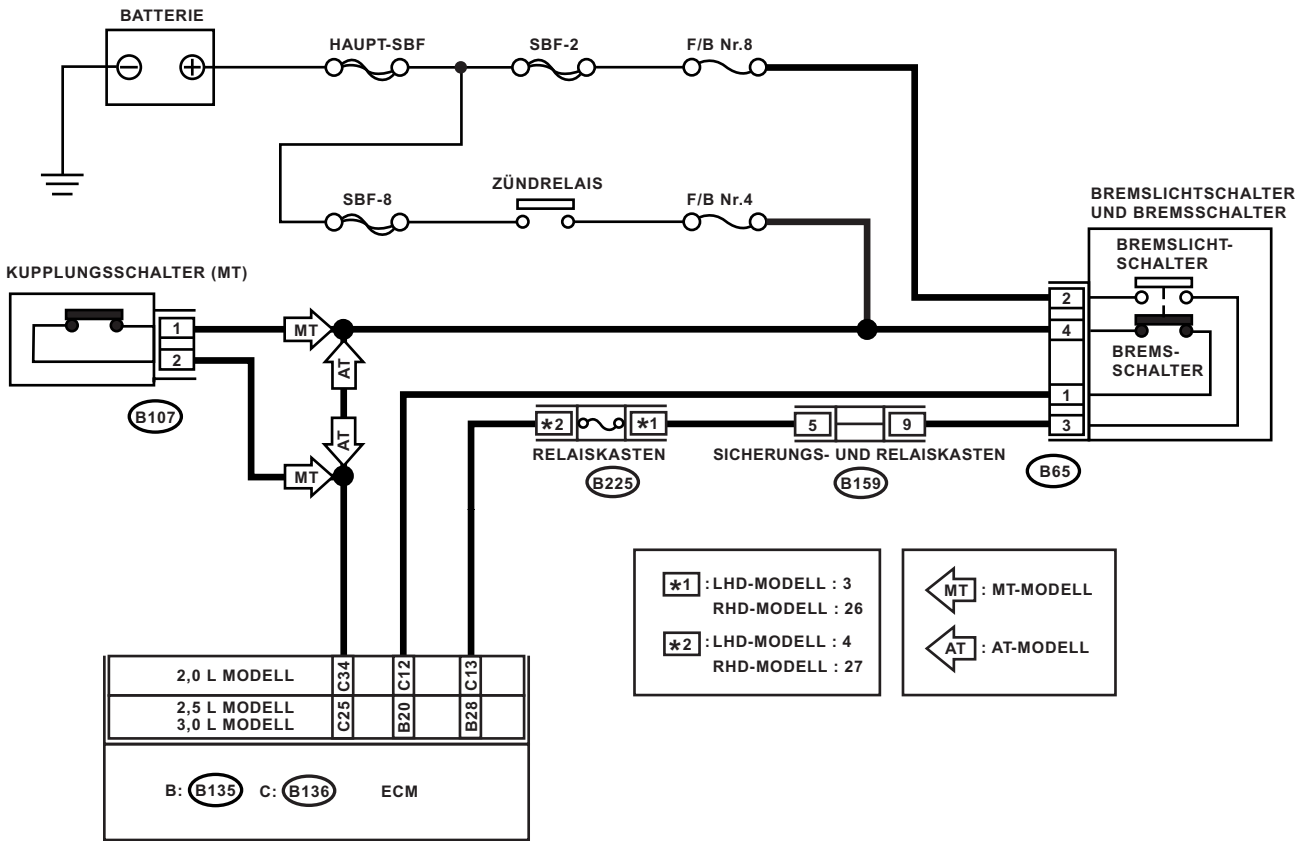

B107



B65



B159



B: B135

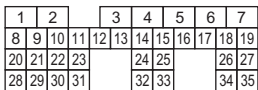

C: B136

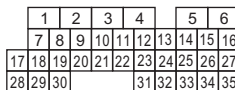

B225

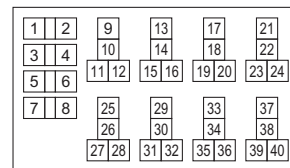

RELAISBLOCK

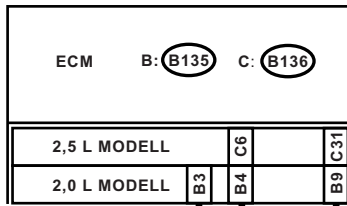

VERBINDUNGS-
STECCKER

B122



B12

T3

T7

SPERRSCHALTER

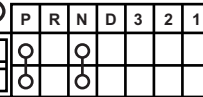

SIEHE ANLASSERSYSTEM
[ST(L20&L25)-01]
[ST(R20&R25)-01]

B25

LEERLAUF-
SCHALTER

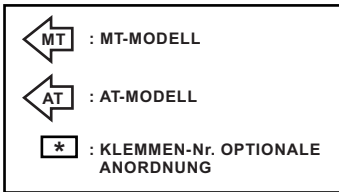
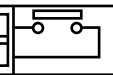

B25



T7

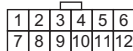

B12



B: **B135**

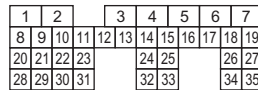

C: **B136**

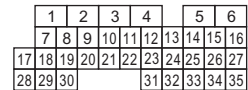

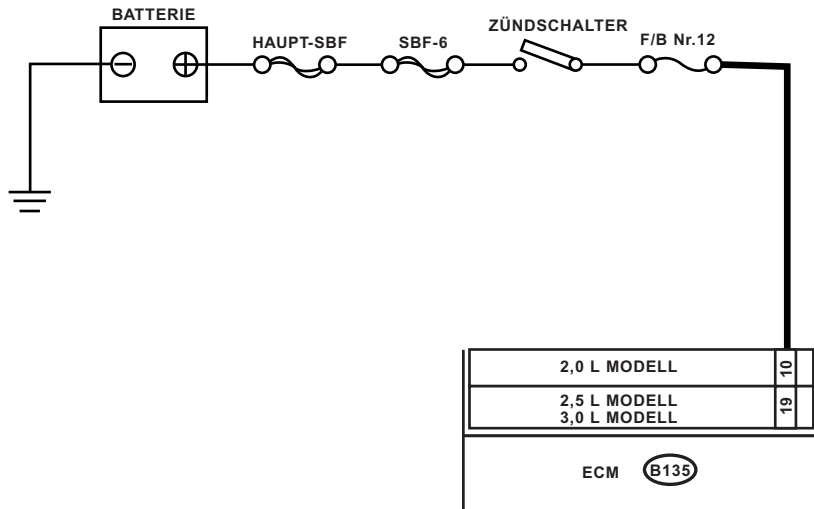

B135

1	2	3	4	5	6	7					
8	9	10	11	12	13	14	15	16	17	18	19
20	21	22	23		24	25			26	27	
28	29	30	31		32	33			34	35	

ECM **B135**

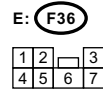
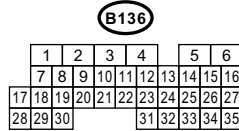
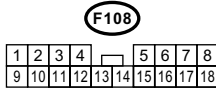
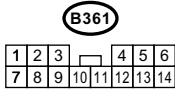
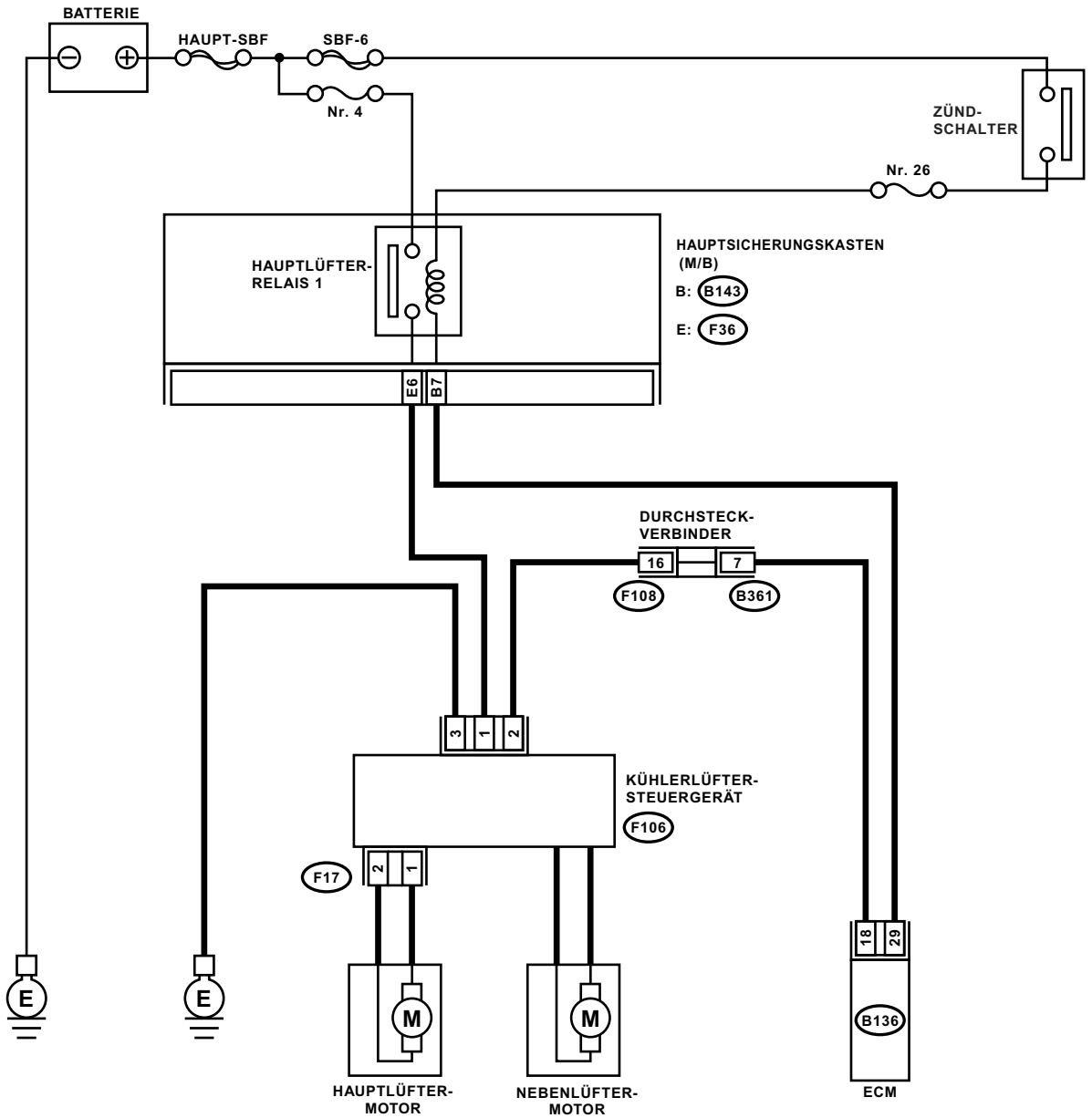

B: B143

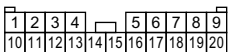

F17



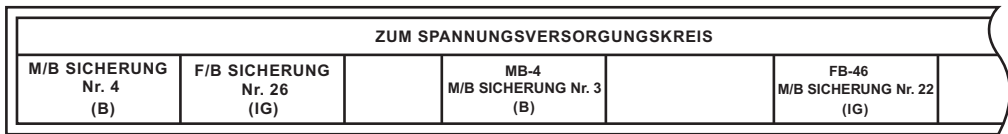

HAUPTSICHERUNGS-
KASTEN (M/B)

- B: **(B143)**
- C: **(F35)**
- E: **(F36)**

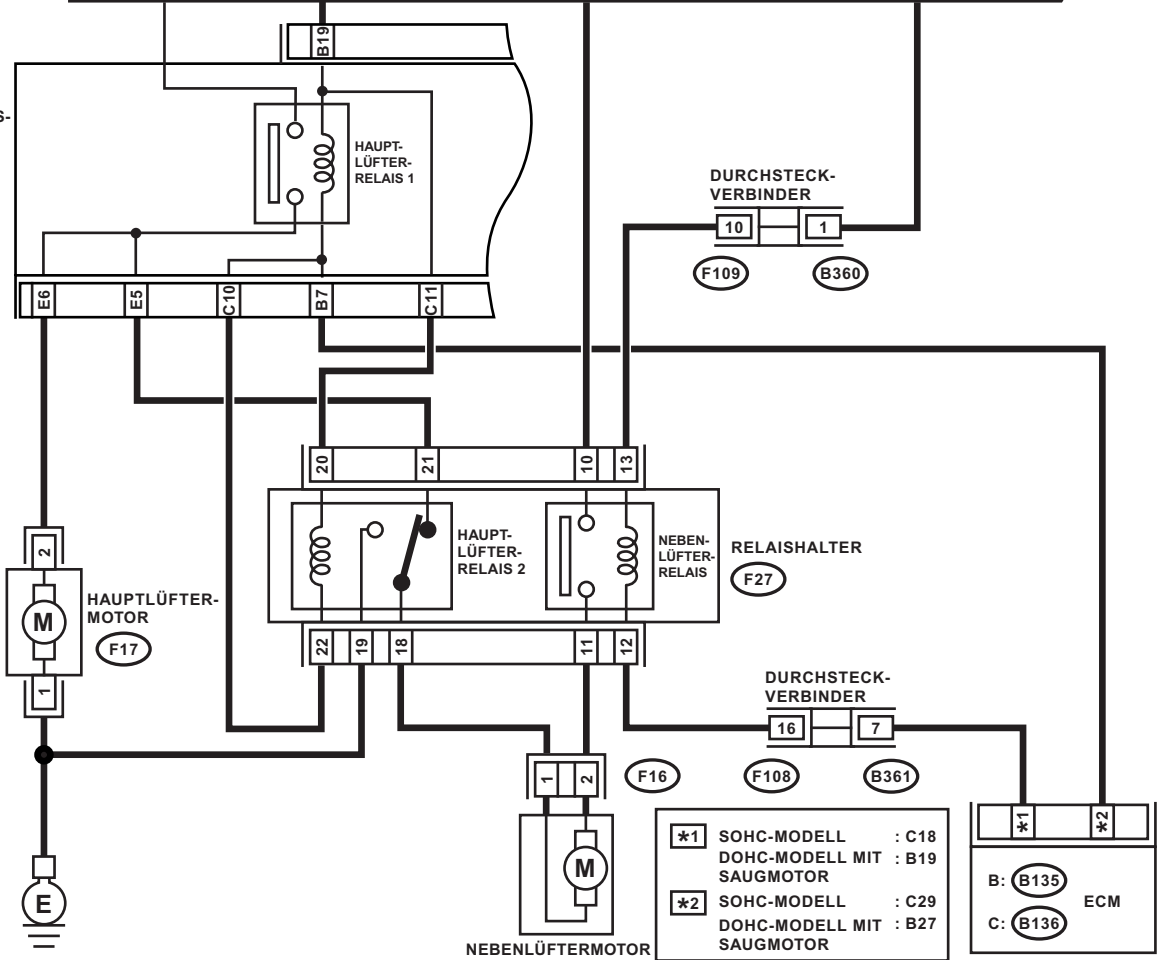

- *1 SOHC-MODELL : C18
DOHC-MODELL MIT : B19
SAUGMOTOR
- *2 SOHC-MODELL : C29
DOHC-MODELL MIT : B27
SAUGMOTOR

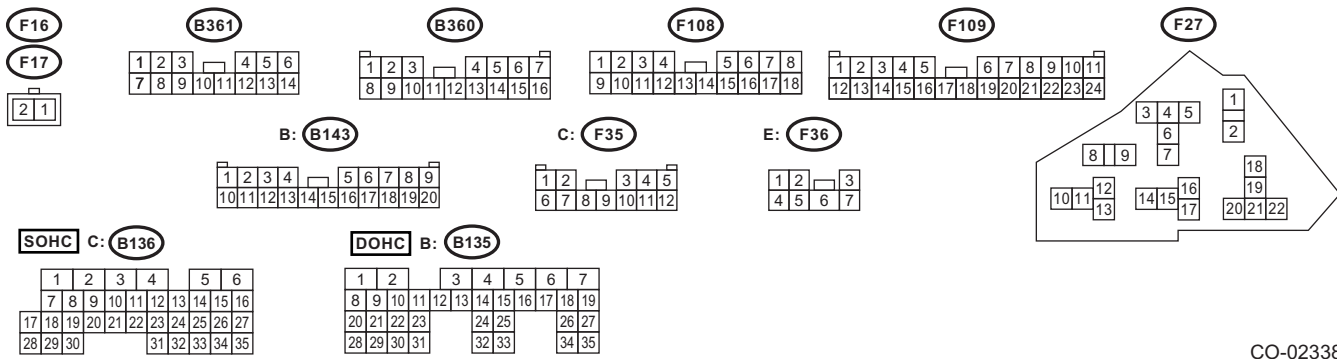
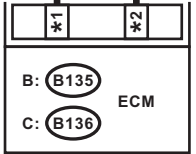

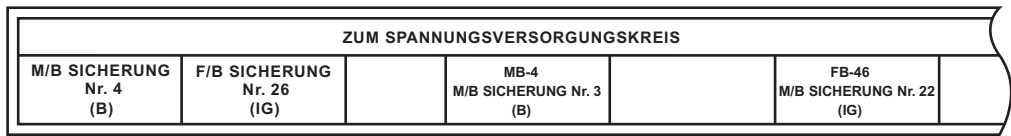

HAUPTSICHERUNGSKASTEN (M/B)

- B: (B143)
- C: (F35)
- E: (F36)

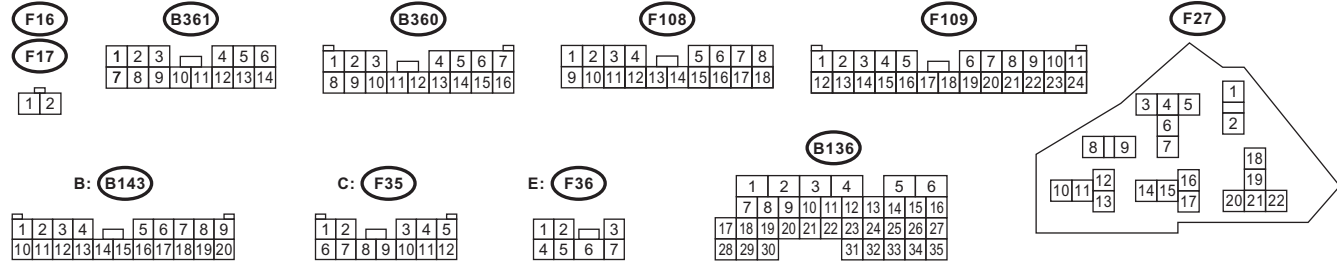
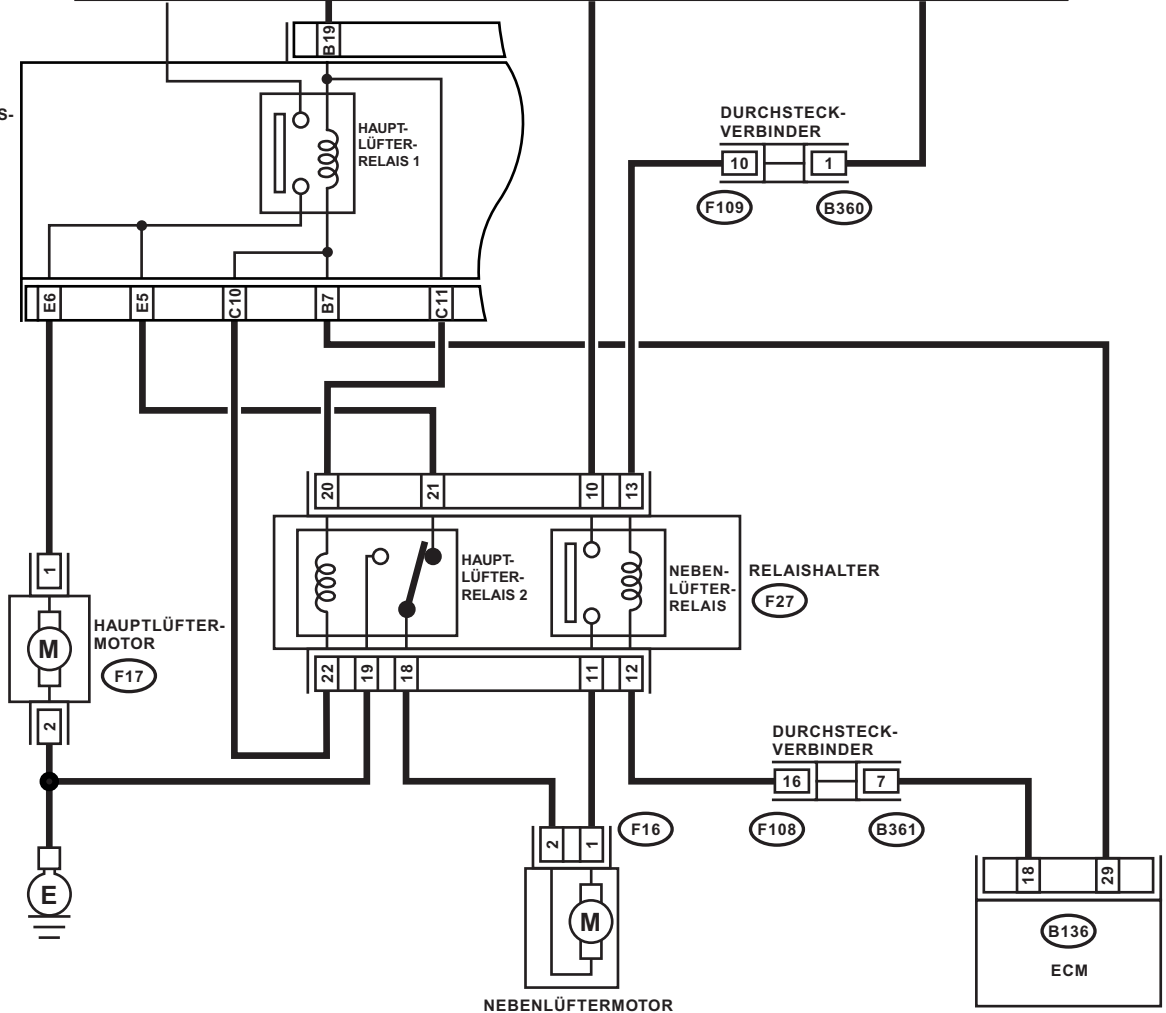

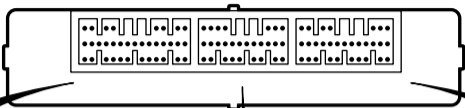

Seite **i84**

8	7	6	5			4	3	2	1					
23	22	21	20	19	18	17	16	15	14	13	12	11	10	9
35	34	33	32	31	30	29	28	27	26	25	24			

Seite **B281**

7	6	5	4					3	2	1	
19	18	17	16	15	14	13	12	11	10	9	8
28	27	26	25	24	23	22	21	20			

Seite **B280**

7	6	5	4					3	2	1		
20	19	18	17	16	15	14	13	12	11	10	9	8
30	29	28	27	26	25	24	23	22	21			

ZÜNDSCHALTER

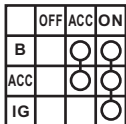

Nr. 12

Nr. 31

Nr. 8

Nr. 7

BATTERIE

198 MASSEVERBINDUNGSSTECKER

* : KLEMMEN-Nr. OPTIONALE ANORDNUNG BEI 1, 2, 3, 4, 5 UND 6

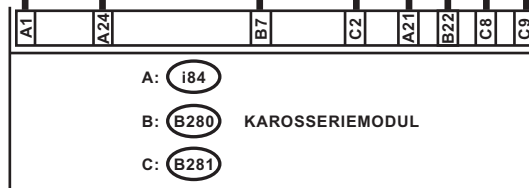

A: i84

B: B280

C: B281



i98

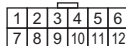

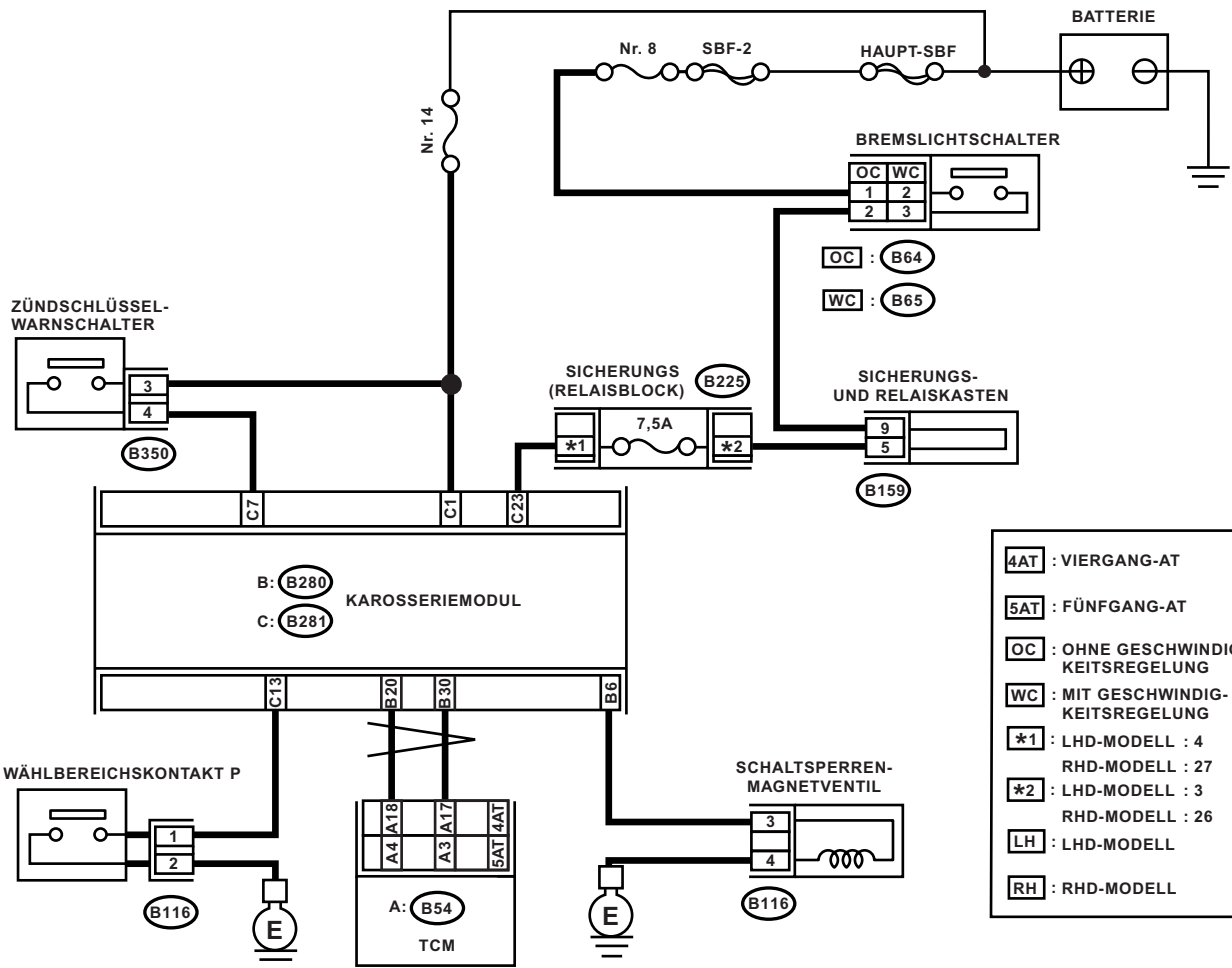

B65



B64



B116

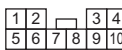

B159



B : B280

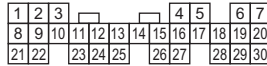

C : B281



LH : B225

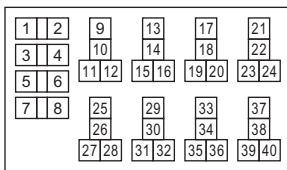

RH : B225

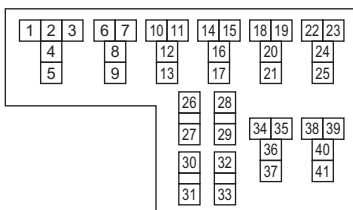

A : B54 : 4AT

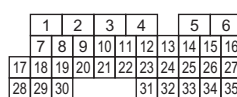

A : B54 : 5AT

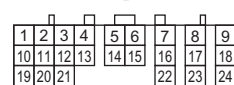

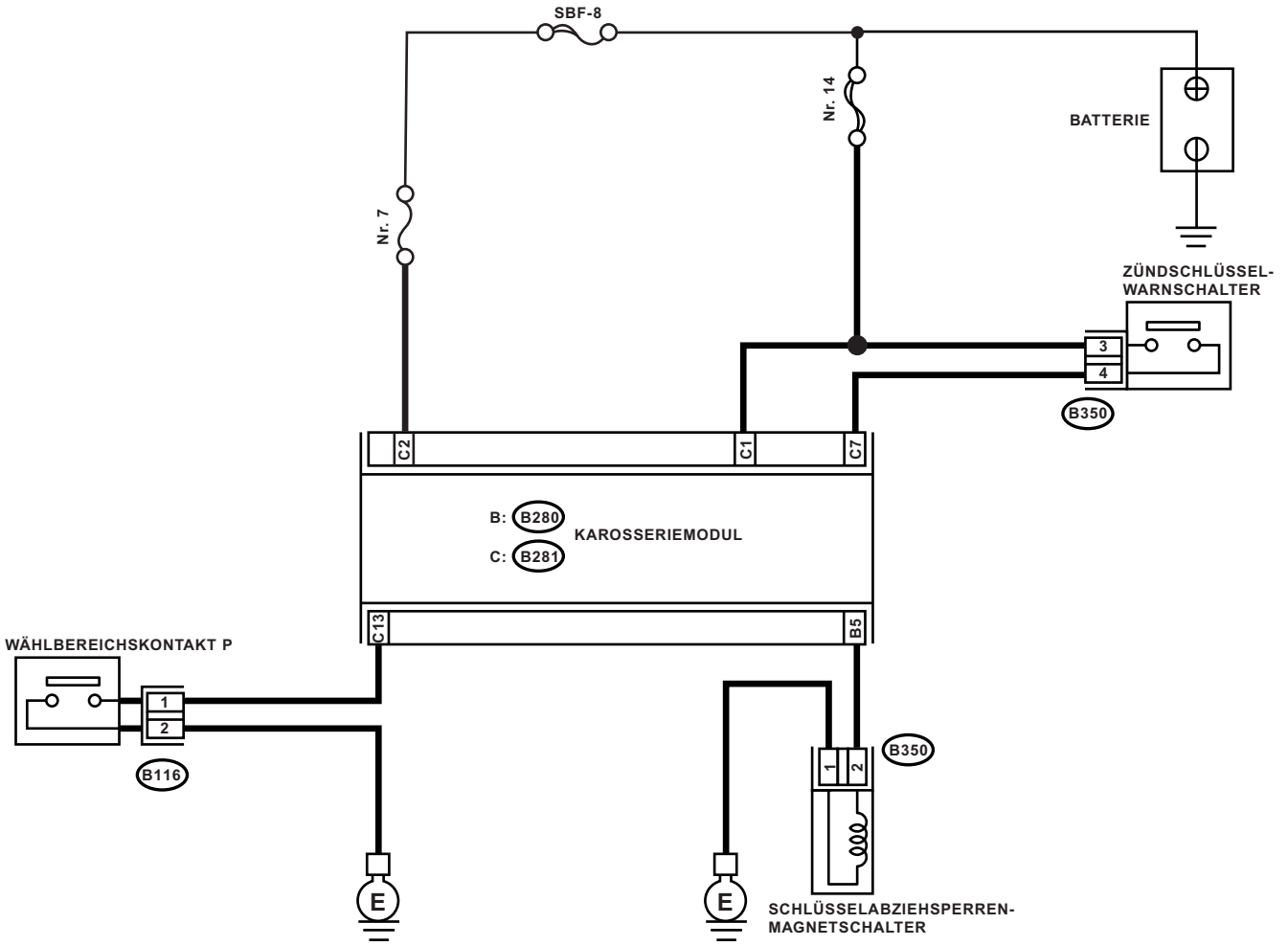

B350



B116

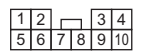

B: B280

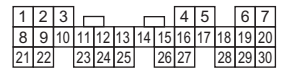

C: B281

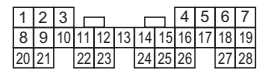

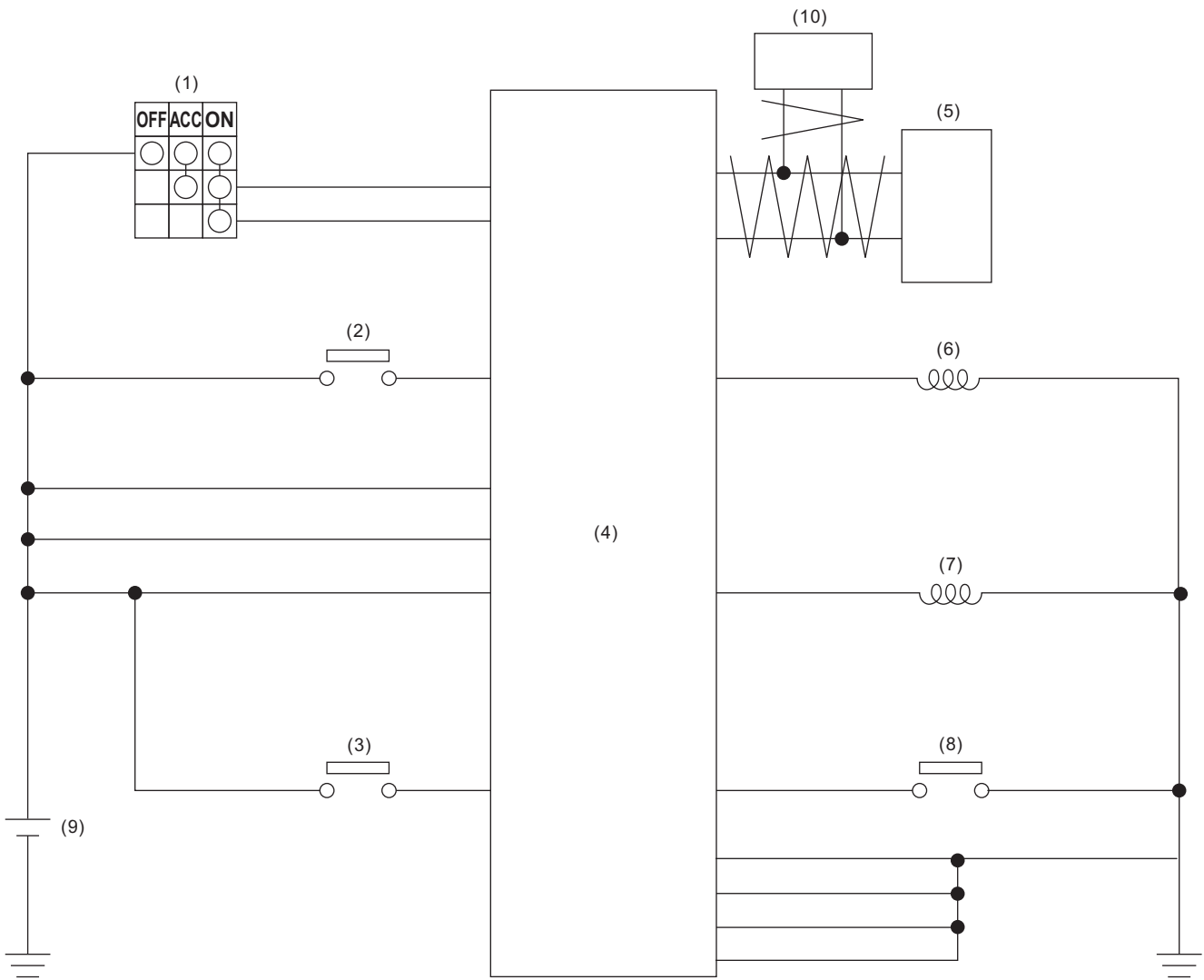

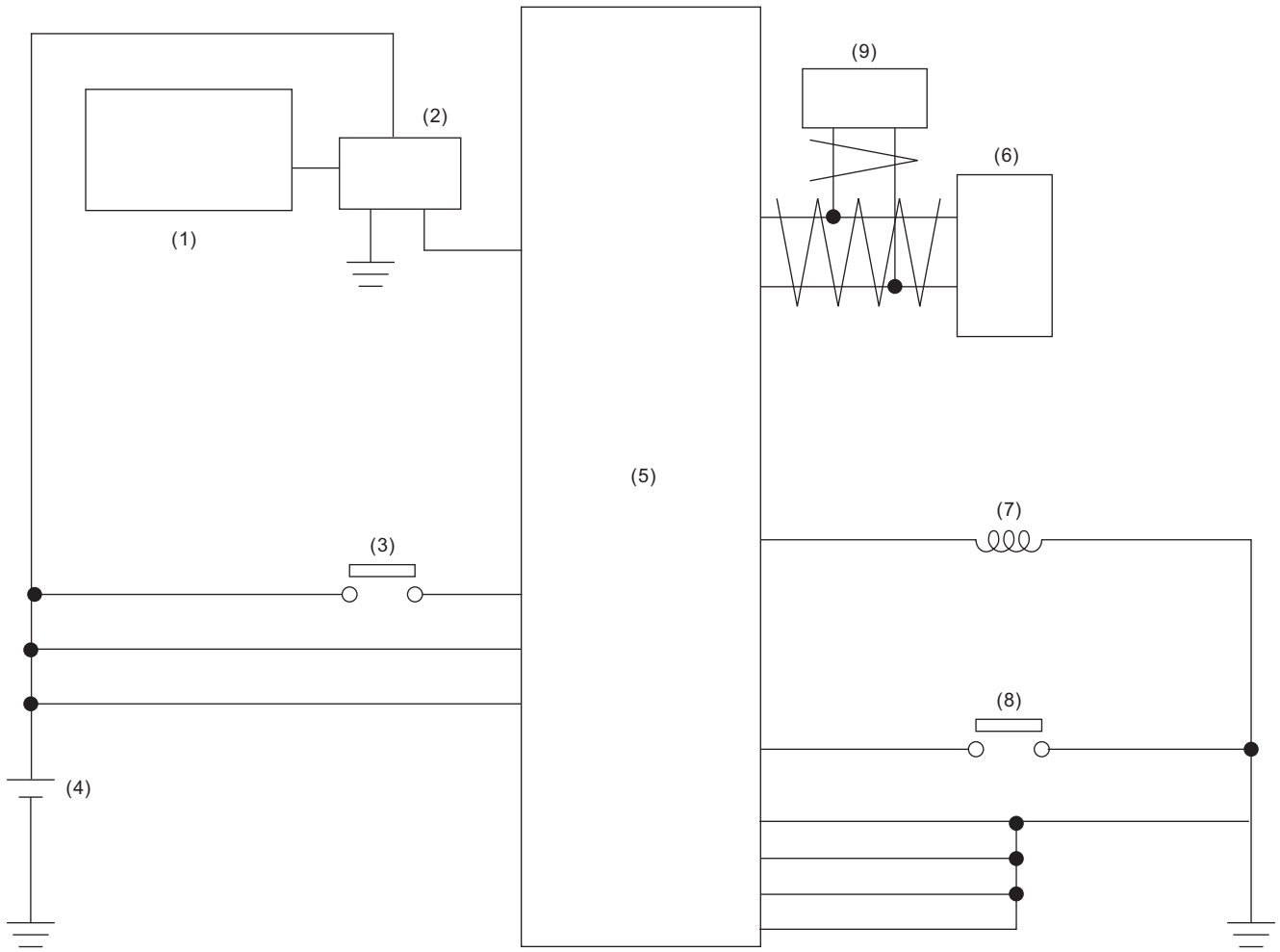

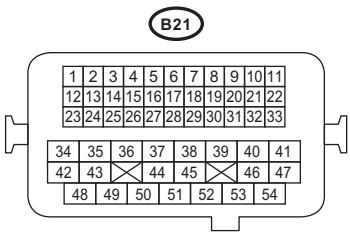
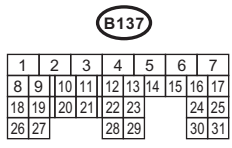
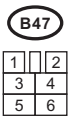
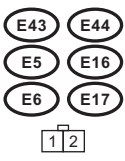
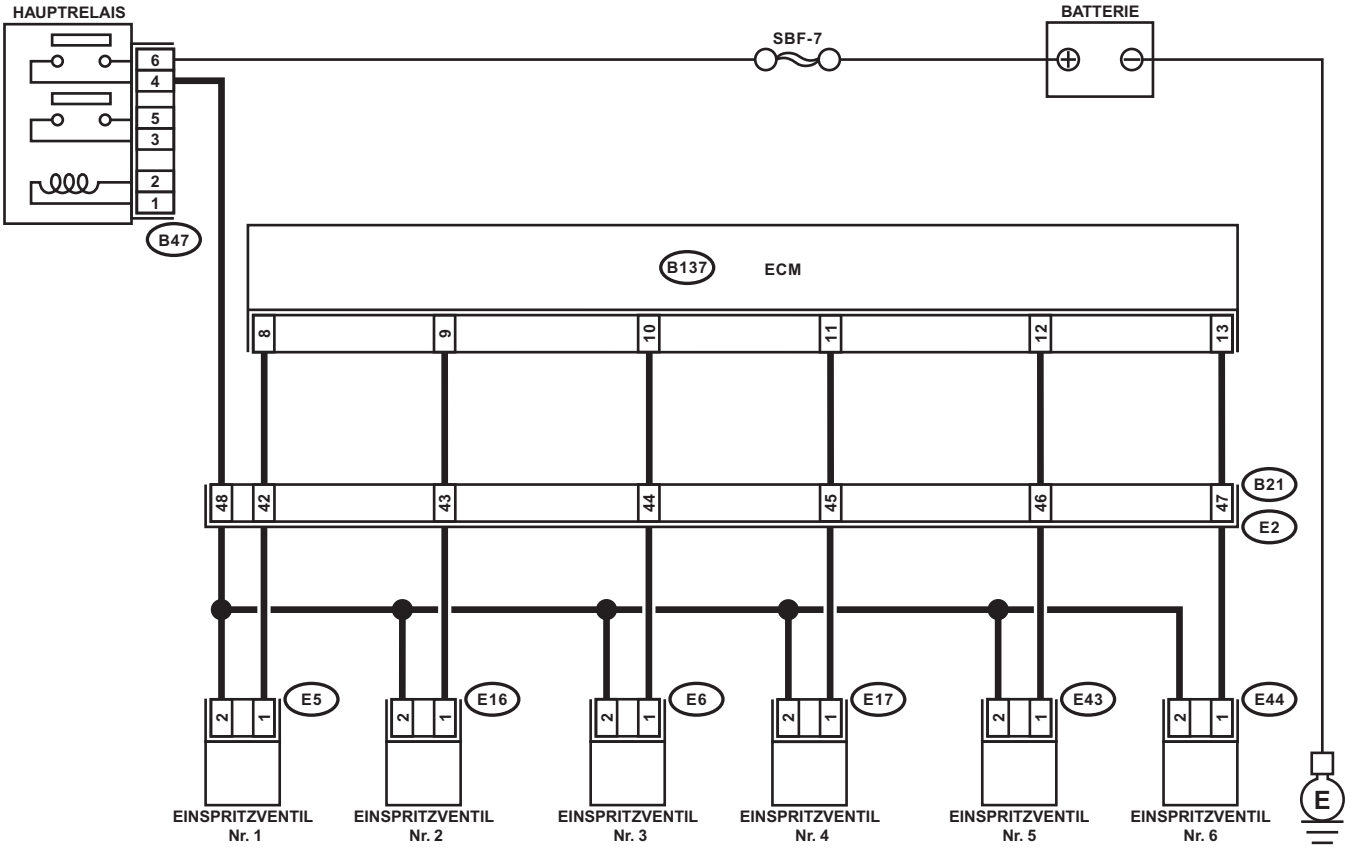

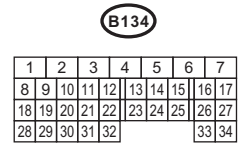
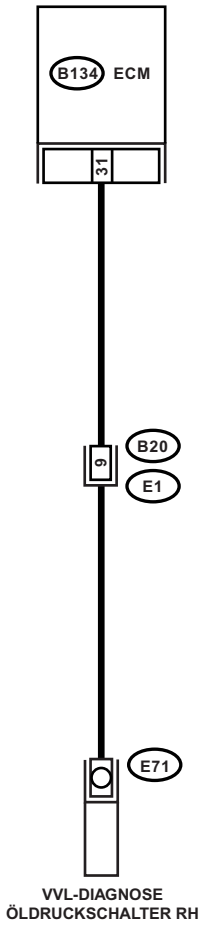

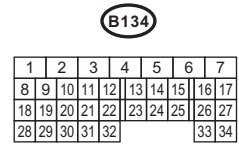
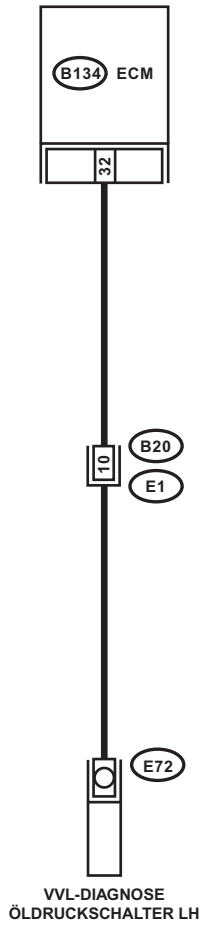

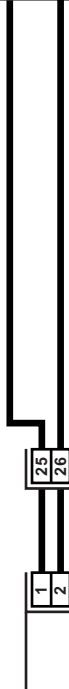
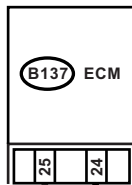

ÖLSCHALT-MAGNETVENTIL RH

B137

1	2	3	4	5	6	7
8	9	10	11	12	13	14
15	16	17	18	19	20	21
22	23	24	25	26	27	28
29	30	31				

B21

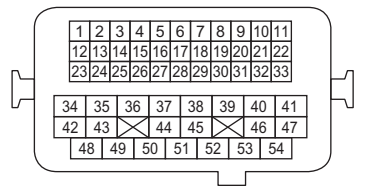

E69



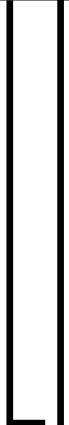
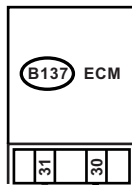

B21

E2



E70



ÖLSCHALT-MAGNETVENTIL LH

B137

1	2	3	4	5	6	7
8	9	10	11	12	13	14
15	16	17				
18	19	20	21	22	23	
24	25					
26	27		28	29		30
						31

B21

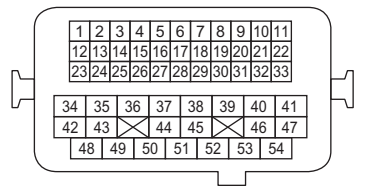

E70



HAUPTRELAIS

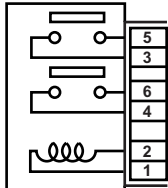

B47

SBF-7

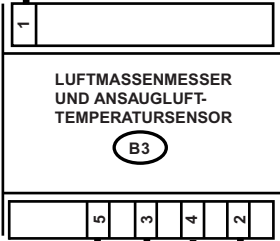
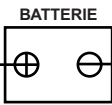

B3



B83

* : KLEMMEN-Nr. OPTIONALE ANORDNUNG

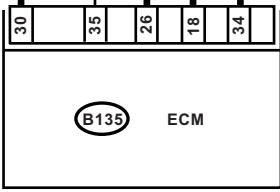

B135 ECM



B3

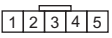

B47



B135

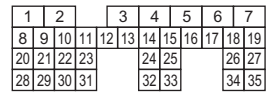

B83

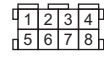

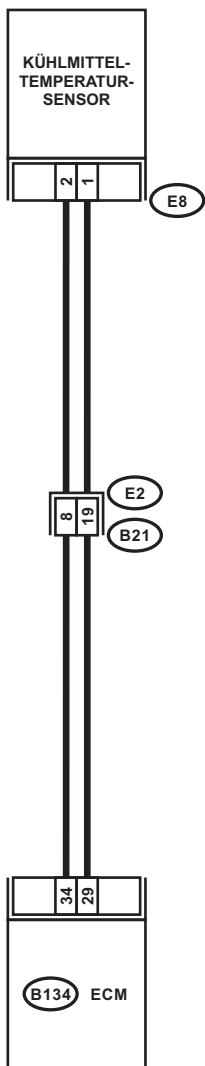

E8

1 2

B21

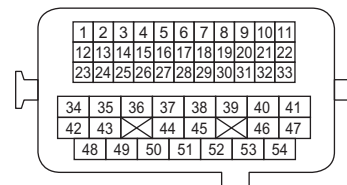

B134

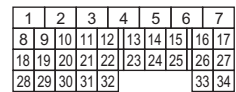

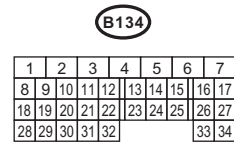
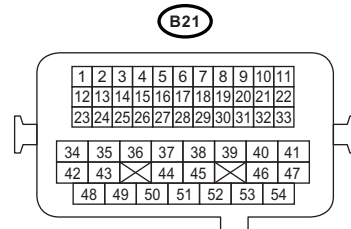
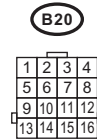
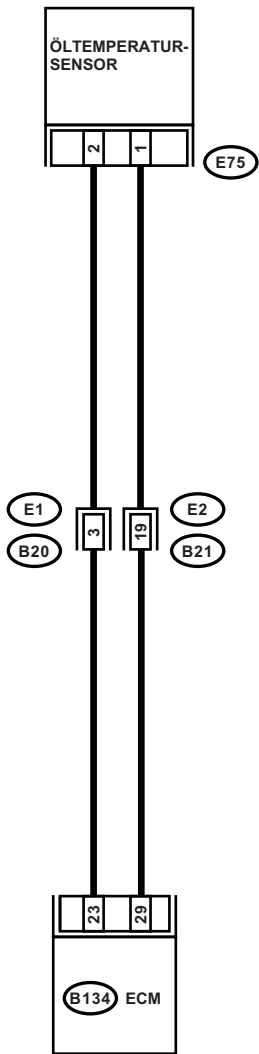

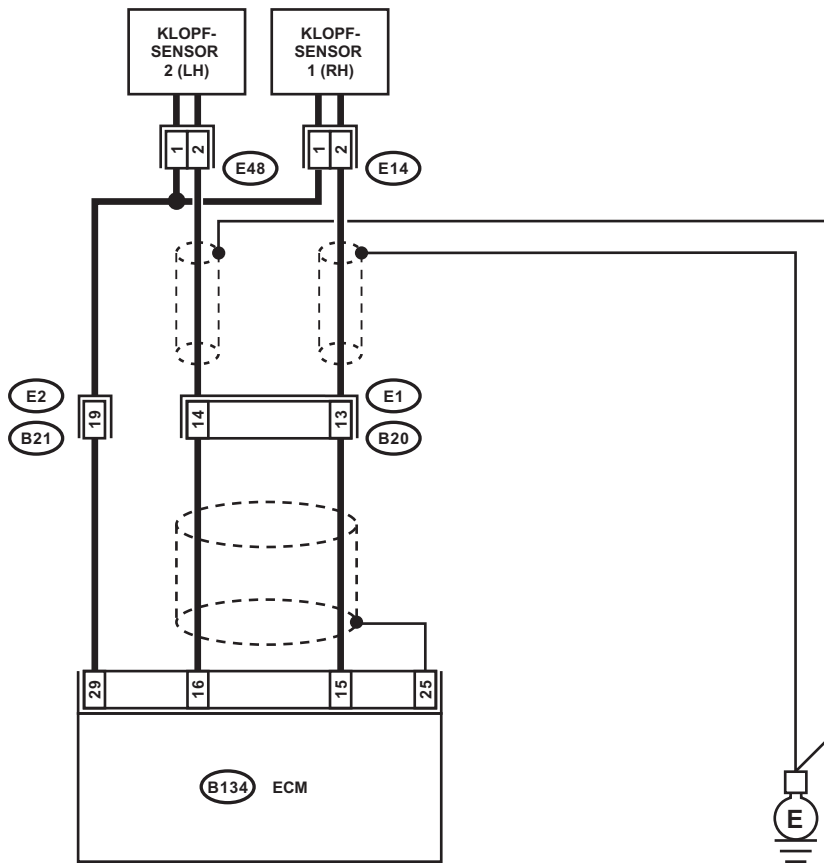

E48

E14



B20



B134

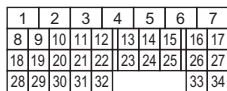

B21

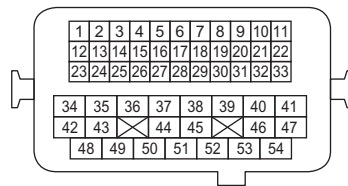

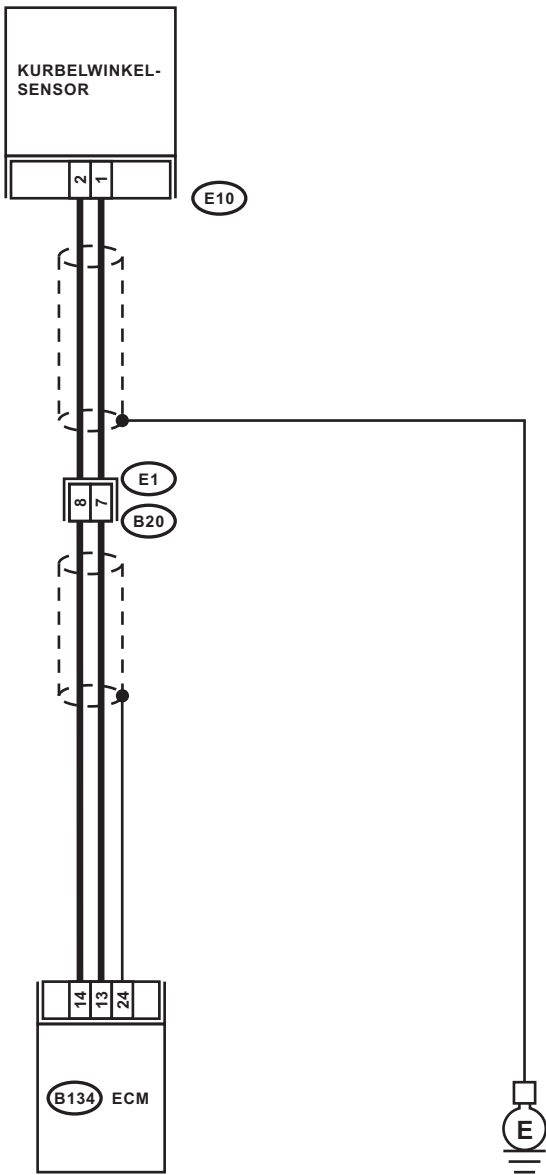

E10

1	2
---	---

B20

1	2	3	4
5	6	7	8
9	10	11	12
13	14	15	16

B134

1	2	3	4	5	6	7
8	9	10	11	12	13	14
15	16	17	18	19	20	21
22	23	24	25	26	27	28
29	30	31	32	33	34	

HAUPTRELAIS

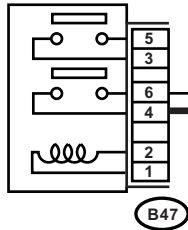

BATTERIE

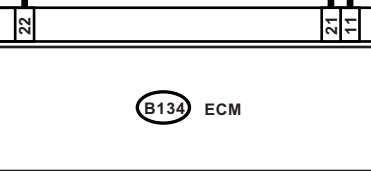
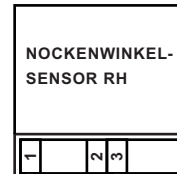
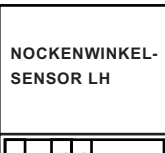
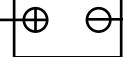

E73

B47

B20

B134

B21

E74

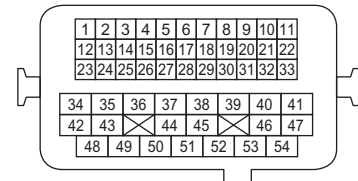
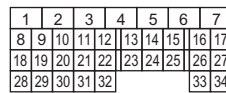

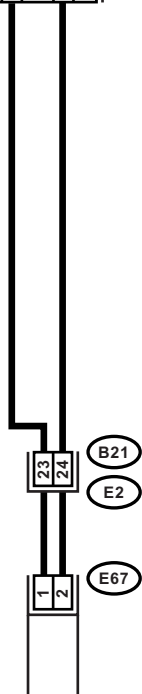
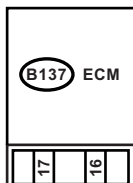

ÖLFLUSS-STEUERMAGNETVENTIL RH

B137

1	2	3	4	5	6	7			
8	9	10	11	12	13	14	15	16	17
18	19	20	21	22	23		24	25	
26	27			28	29		30	31	

B21

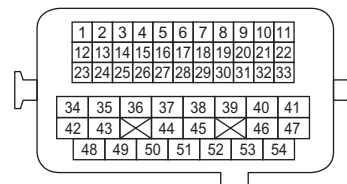

E67



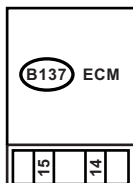

ÖLFLUSS-STEUERMAGNETVENTIL LH



1	2	3	4	5	6	7
8	9	10	11	12	13	14
15	16	17	18	19	20	21
22	23	24	25	26	27	28
29	30	31				

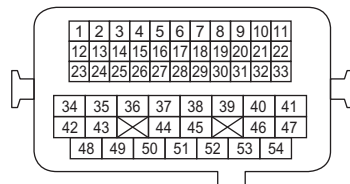

HAUPTRELAIS

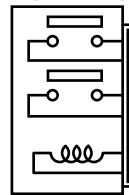

B47

B21

E2

E76

E77

E18

EGR-VENTIL

E18

E77

E76

E2

B21

B134 ECM

BATTERIE

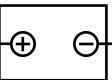

E18



B47



E77



B21

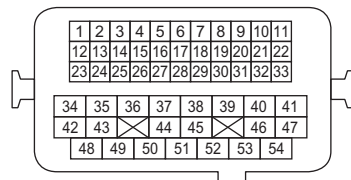

B134

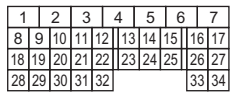

HAUPTRELAIS

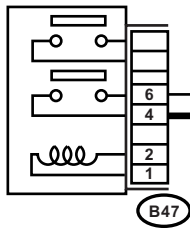

B47

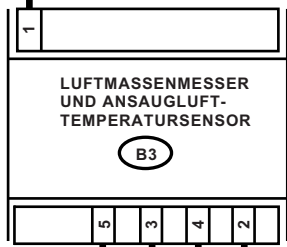

B3



B83

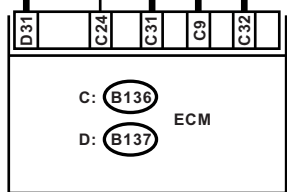

C: B136

D: B137

ECM

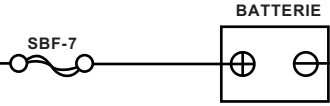

* : KLEMMEN-Nr. OPTIONALE ANORDNUNG BEI 1,2,5 UND 6

B3

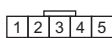

B47



C: B136

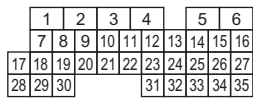

D: B137

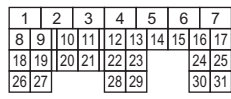

B83

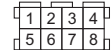

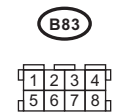
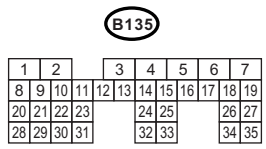
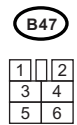
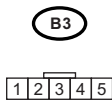
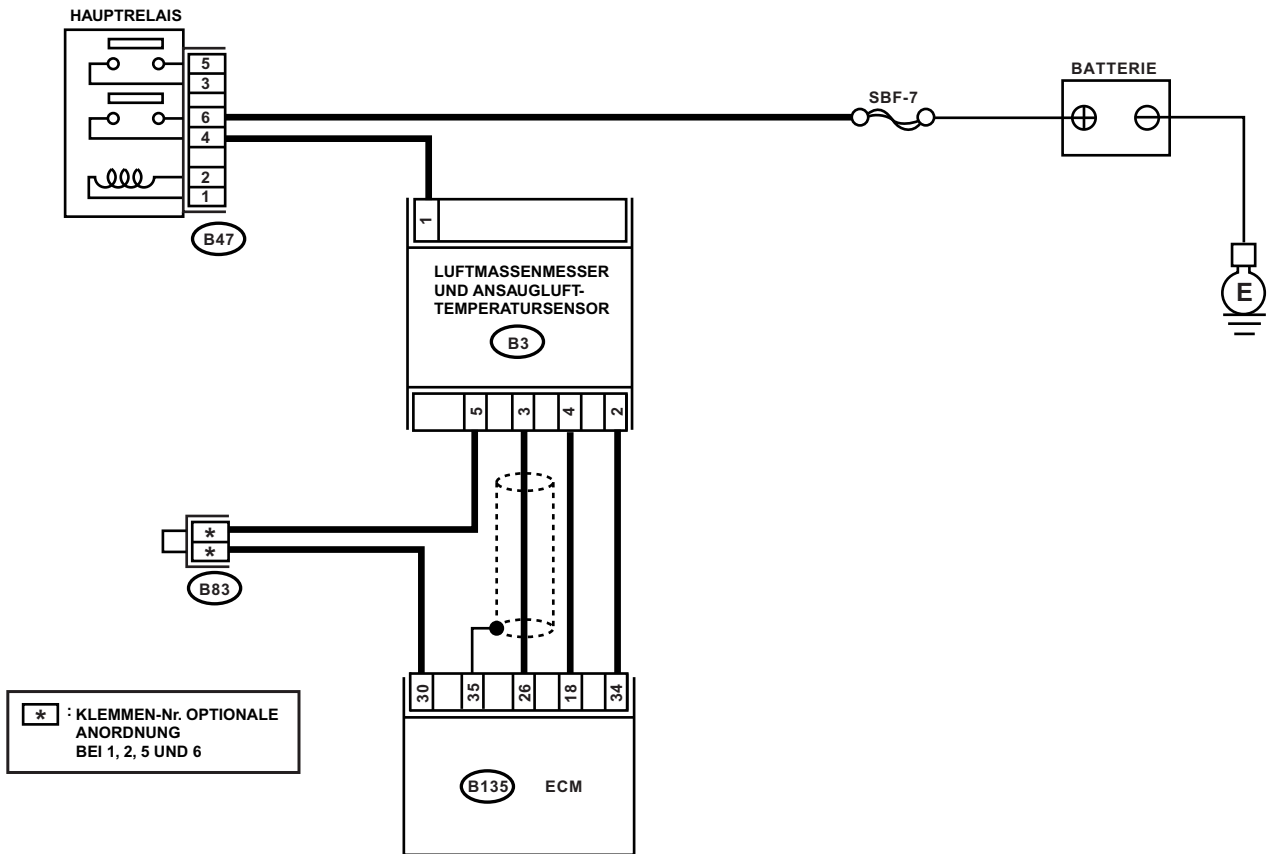

HAUPTRELAIS

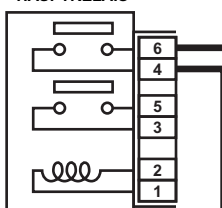

B47



BATTERIE

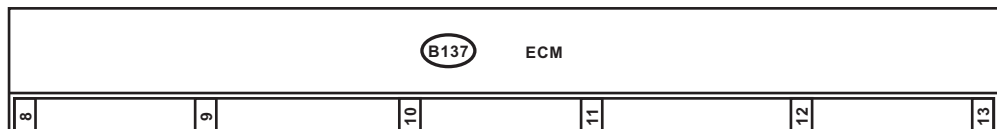

B137 ECM

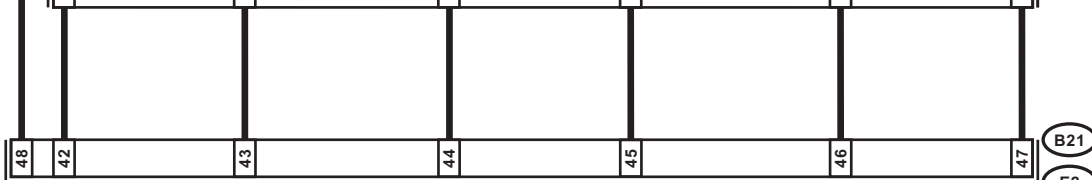

B21

E2

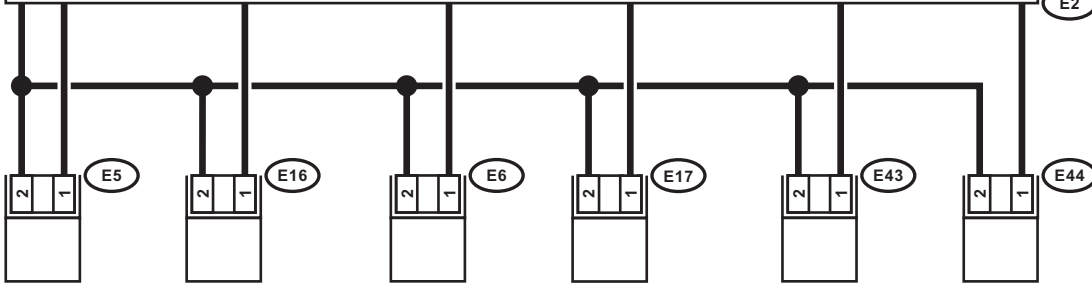

EINSPRITZVENTIL Nr. 1

EINSPRITZVENTIL Nr. 2

EINSPRITZVENTIL Nr. 3

EINSPRITZVENTIL Nr. 4

EINSPRITZVENTIL Nr. 5

EINSPRITZVENTIL Nr. 6

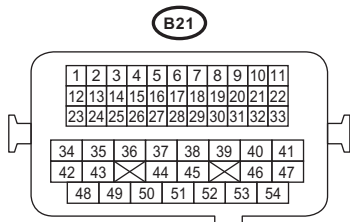

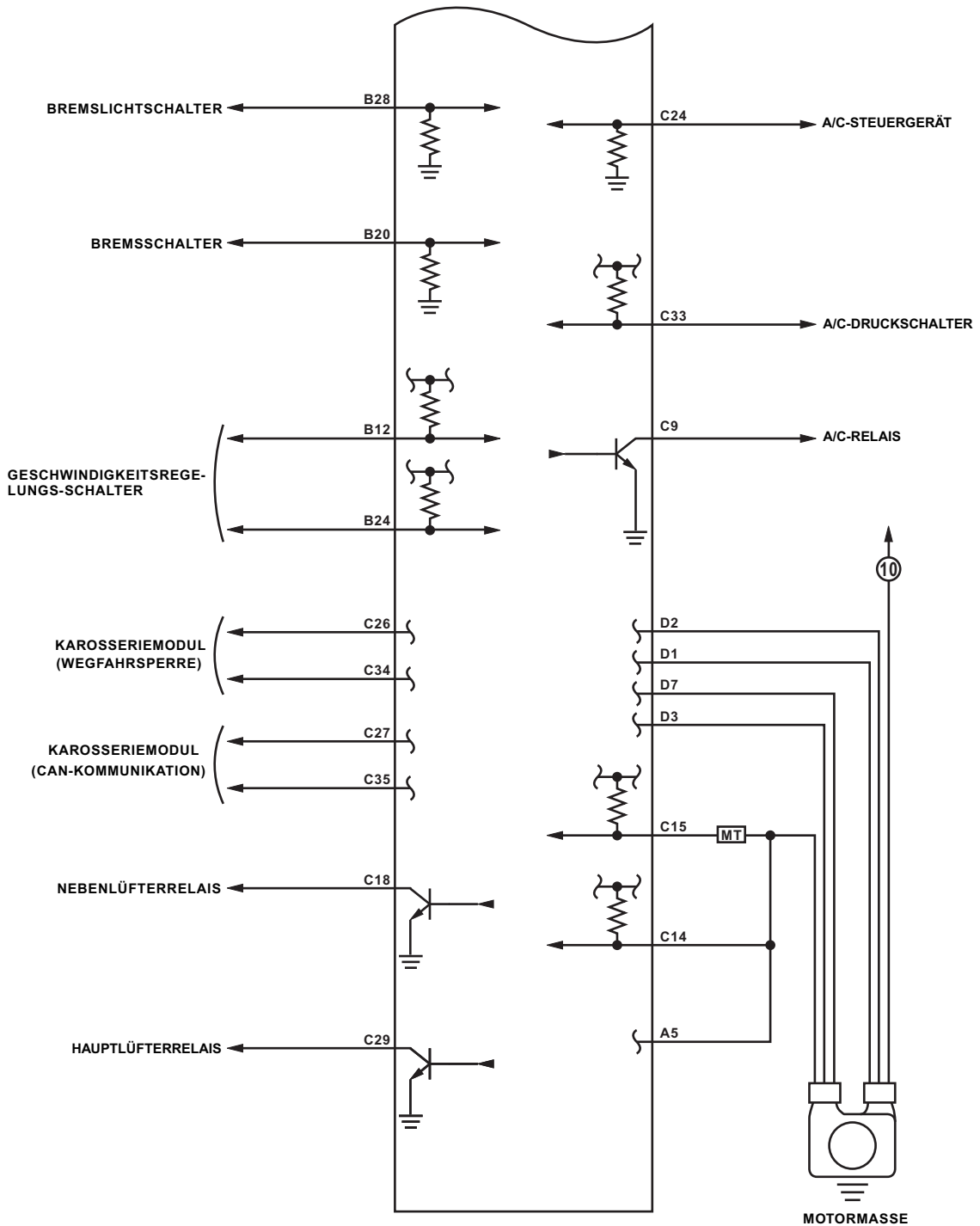

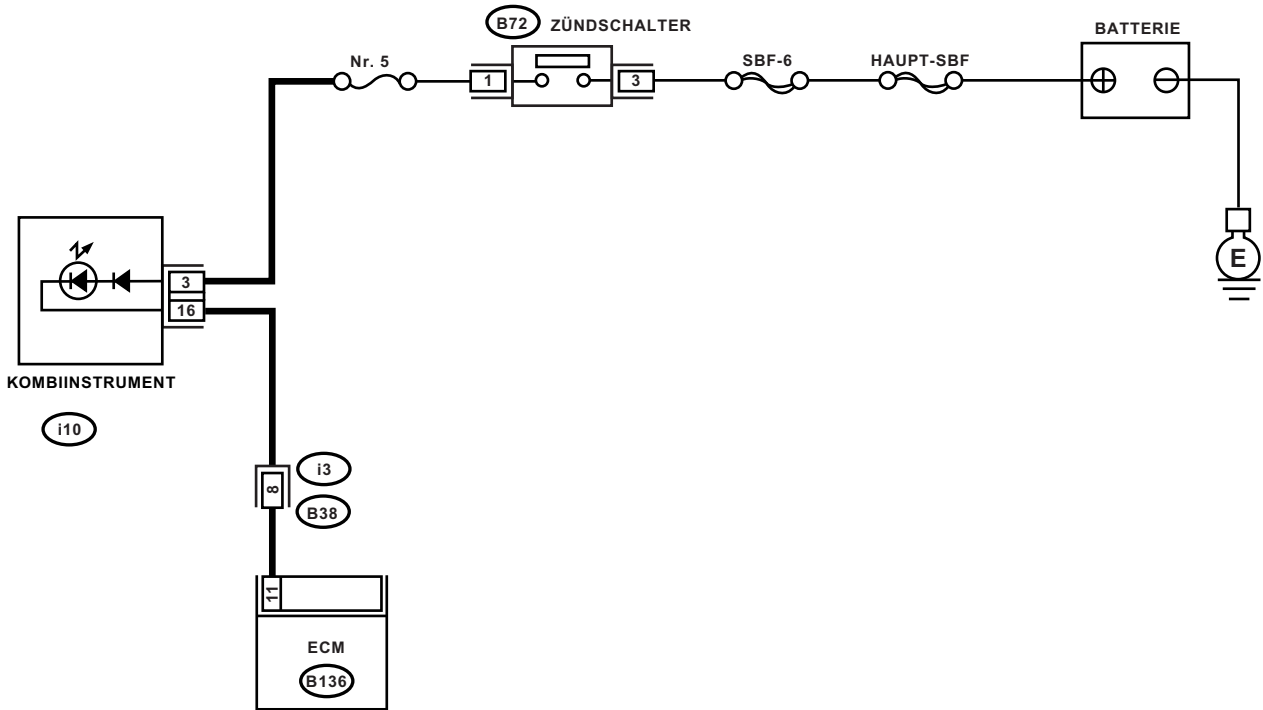

i10

1	2	3	4	5	6	7	8	9	10
11	12	13	14	15	16	17	18	19	20
21	22								

B72

1	2	3
4	5	6

B38

1	2	3	4	5	6	7	8	9
10	11	12	13	14	15	16	17	18
19	20							

B136

1	2	3	4	5	6
7	8	9	10	11	12
13	14	15	16	17	18
19	20	21	22	23	24
25	26	27	28	29	30
31	32	33	34	35	

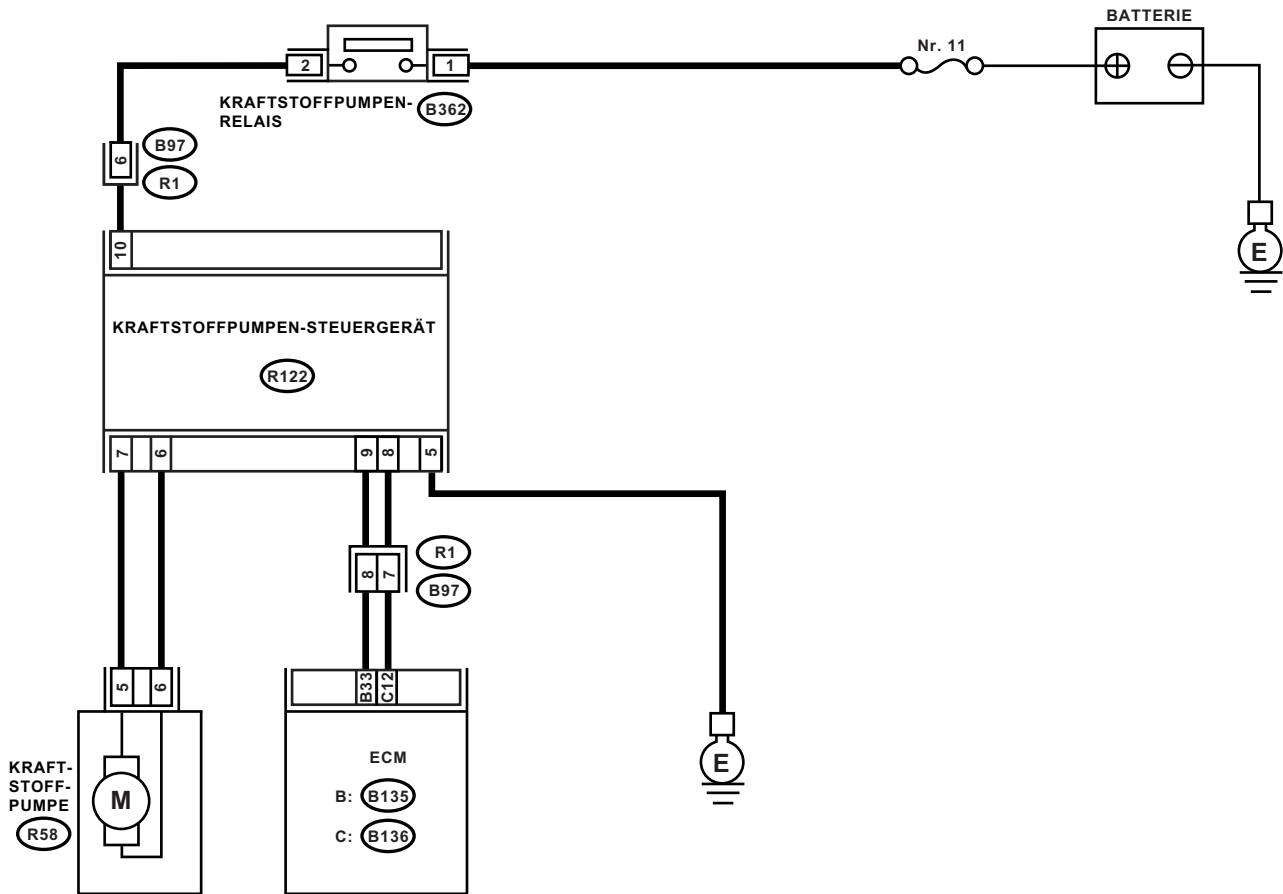

B362

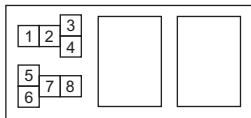

R58



R122

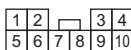

B97

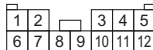

B: (B135)

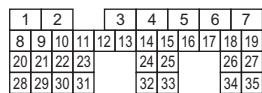

C: (B136)



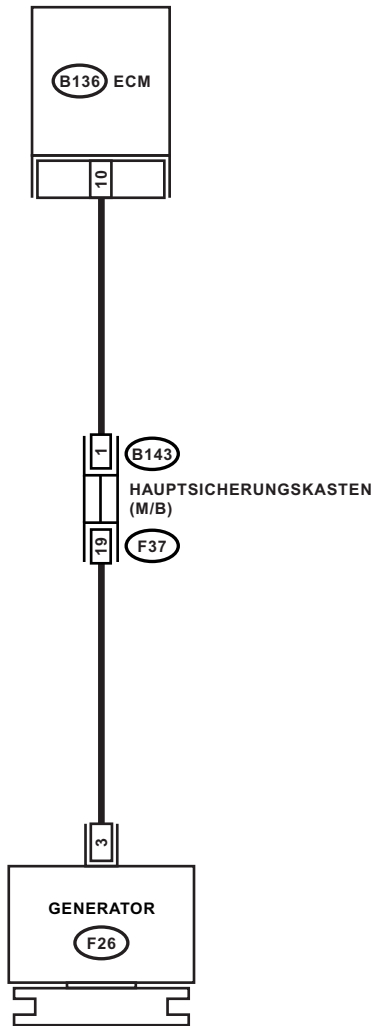

F26

1	2	3
---	---	---

F37

1	2	3	4		5	6	7	8	9	
10	11	12	13	14	15	16	17	18	19	20

B136

1	2	3	4	5	6					
7	8	9	10	11	12	13	14	15	16	
17	18	19	20	21	22	23	24	25	26	27
28	29	30				31	32	33	34	35

B143

1	2	3	4		5	6	7	8	9	
10	11	12	13	14	15	16	17	18	19	20

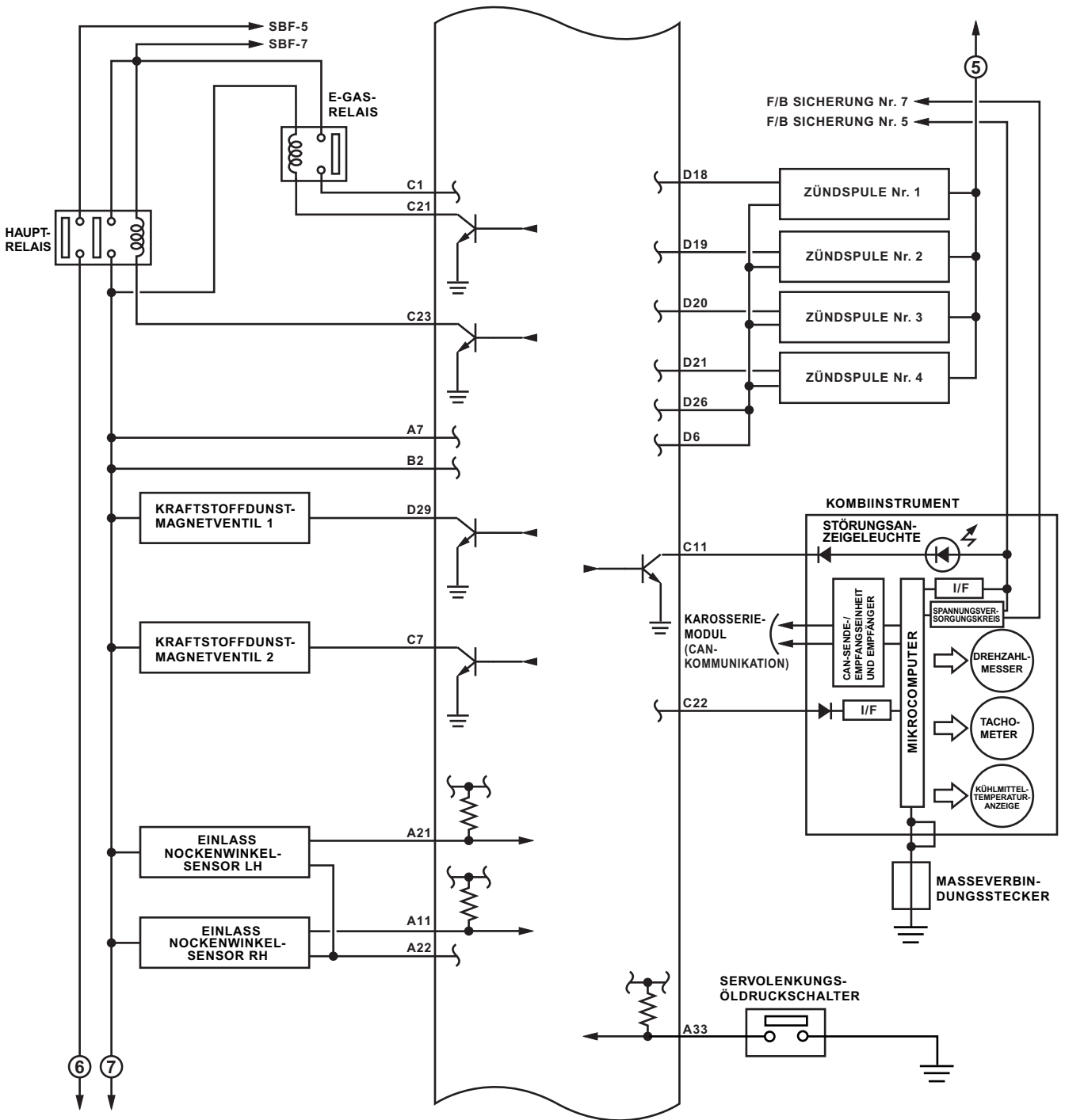

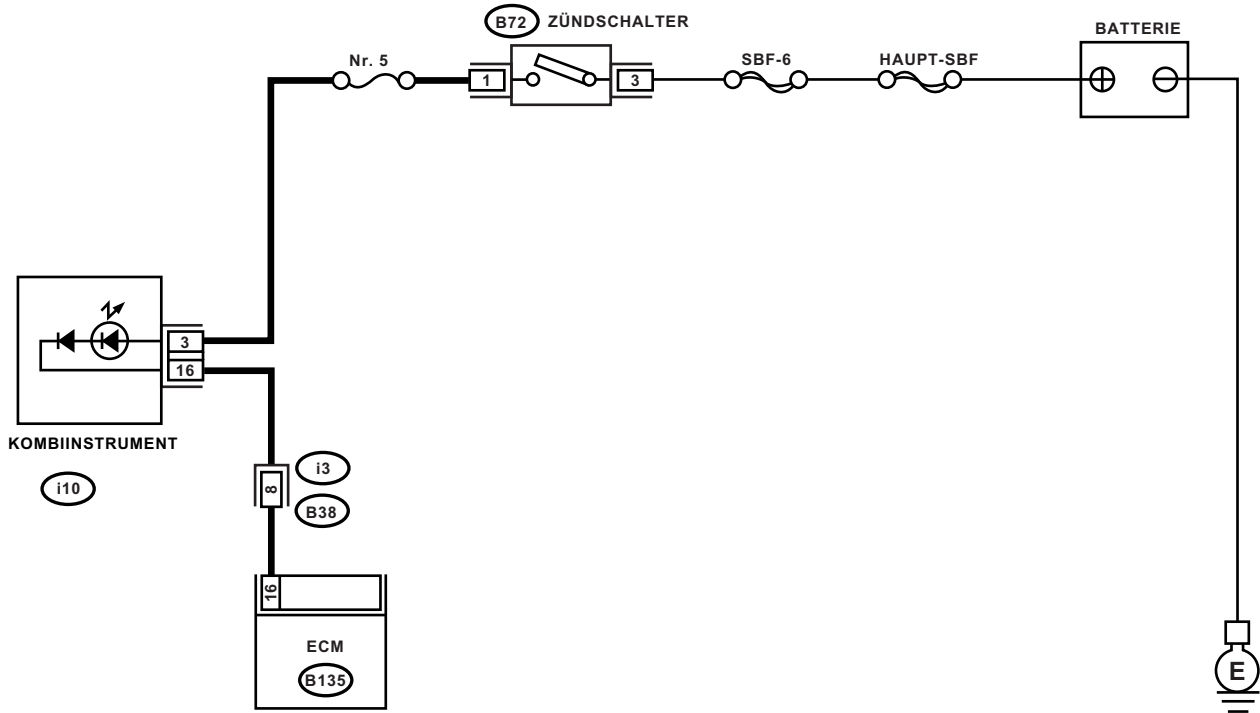

i10

1	2	3	4	5	6	7	8	9	10
11	12	13	14	15	16	17	18	19	20
21	22								

B72

1	2	3
4	5	6

B38

1	2	3	4	5	6	7	8	9
10	11	12	13	14	15	16	17	18
19	20							

B135

1	2	3	4	5	6	7
8	9	10	11	12	13	14
15	16	17	18	19		
20	21	22	23	24	25	26
27	28	29	30	31	32	33
34	35					

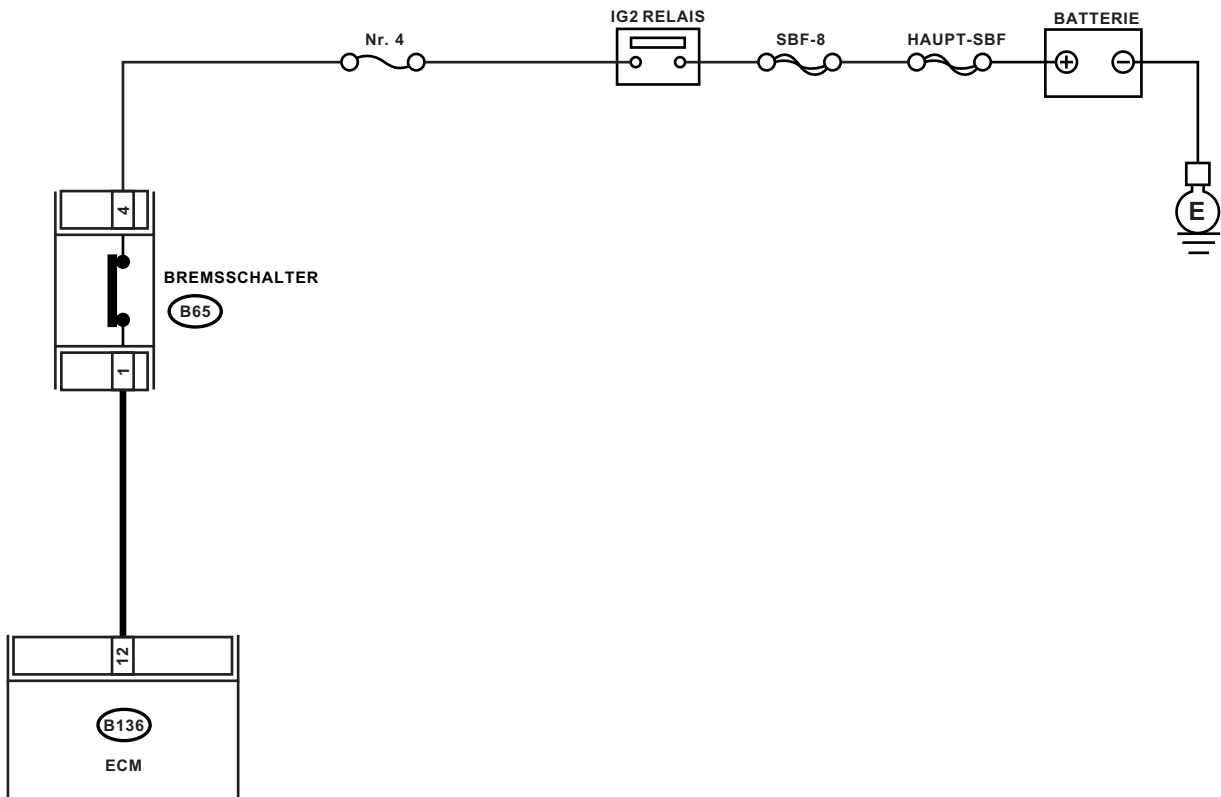

B65



B136

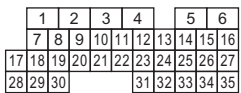

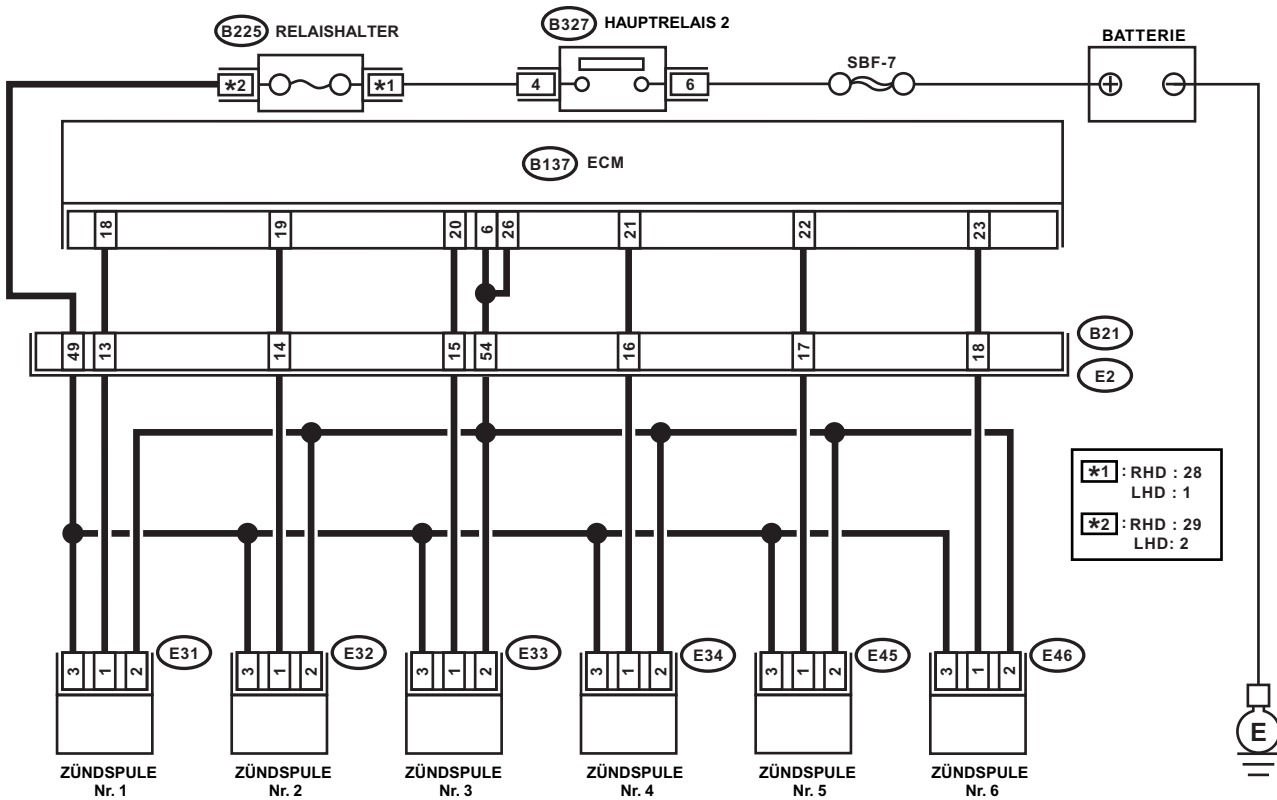

B137

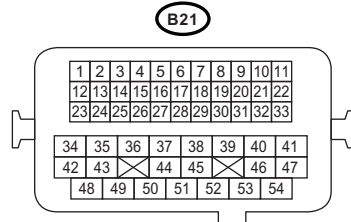
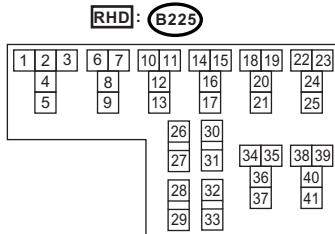
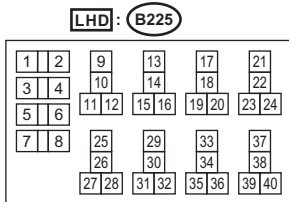
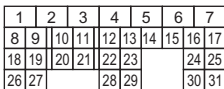

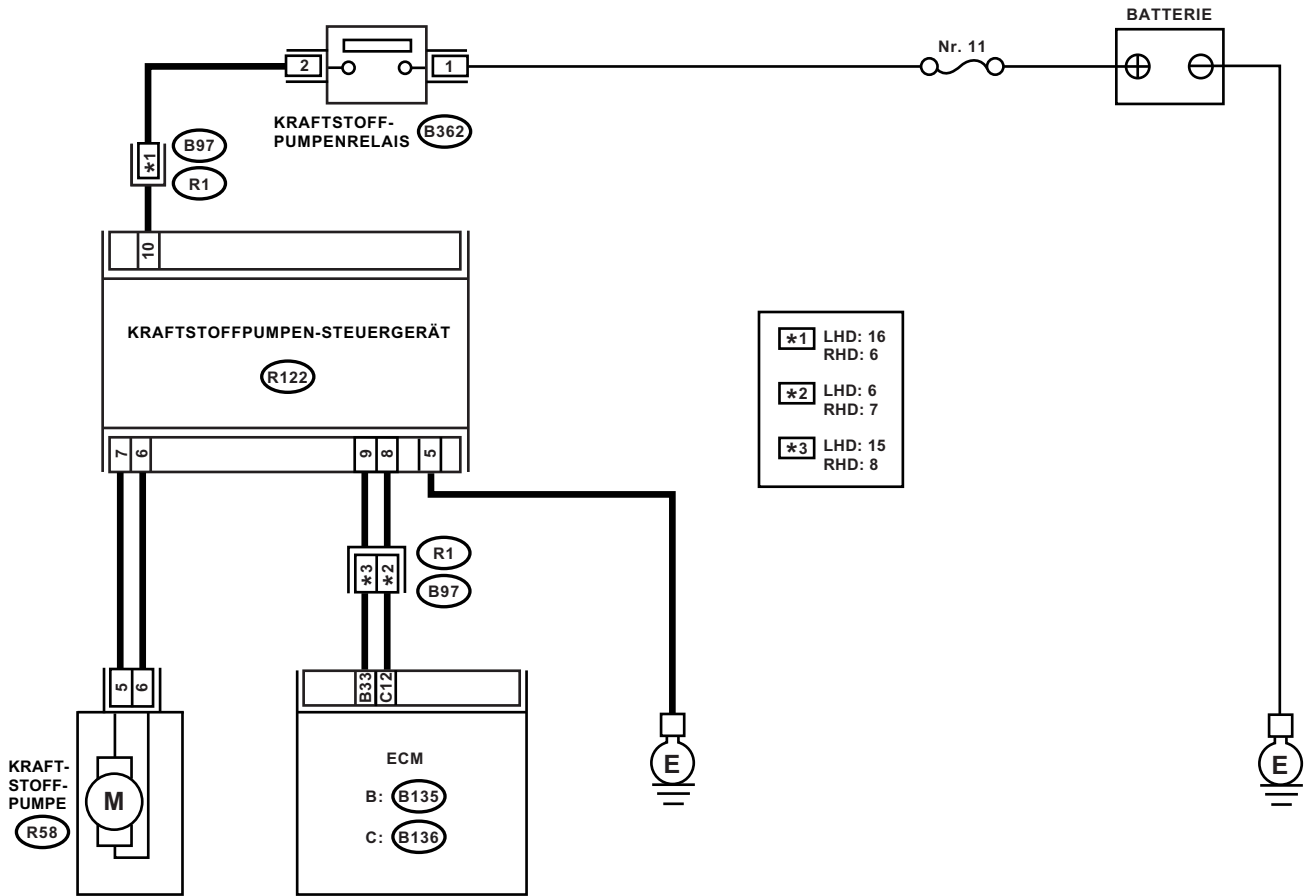

(B362)

RHD: (B97)

(R122)

(R58)

B: (B135)

C: (B136)

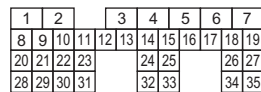
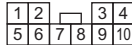
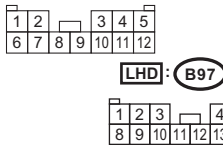
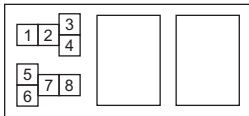

ZU A: **B134**

7	6	5	4	3	2	1			
17	16	15	14	13	12	11	10	9	8
27	26	25	24	23	22	21	20	19	18
34	33				32	31	30	29	28

ZU B: **B135**

7	6	5	4	3		2	1				
19	18	17	16	15	14	13	12	11	10	9	8
27	26			25	24			23	22	21	20
35	34			33	32			31	30	29	28

ZU C: **B136**

6	5		4	3	2	1				
16	15	14	13	12	11	10	9	8	7	
27	26	25	24	23	22	21	20	19	18	17
35	34	33	32	31				30	29	28

ZU D: **B137**

7	6	5	4	3	2	1				
17	16	15	14	13	12	11	10	9	8	
25	24			23	22	21	20	19	18	
31	30			29	28				27	26

HAUPTRELAIS

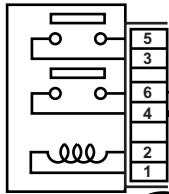

B47

BATTERIE

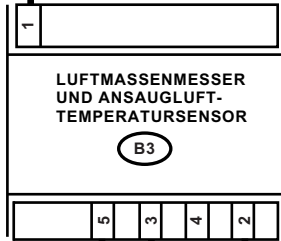
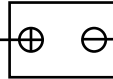

B3



B83

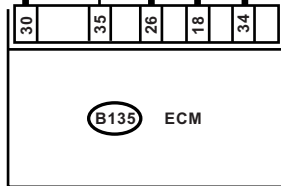

B135 ECM

* : KLEMMEN-Nr. OPTIONALE ANORDNUNG
BEI 1, 2, 5 UND 6



B3

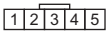

B47



B135

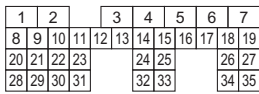

B83

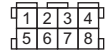

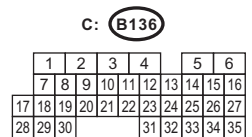
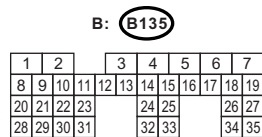
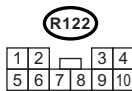
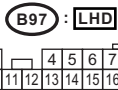
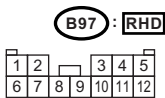
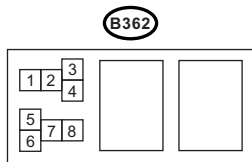
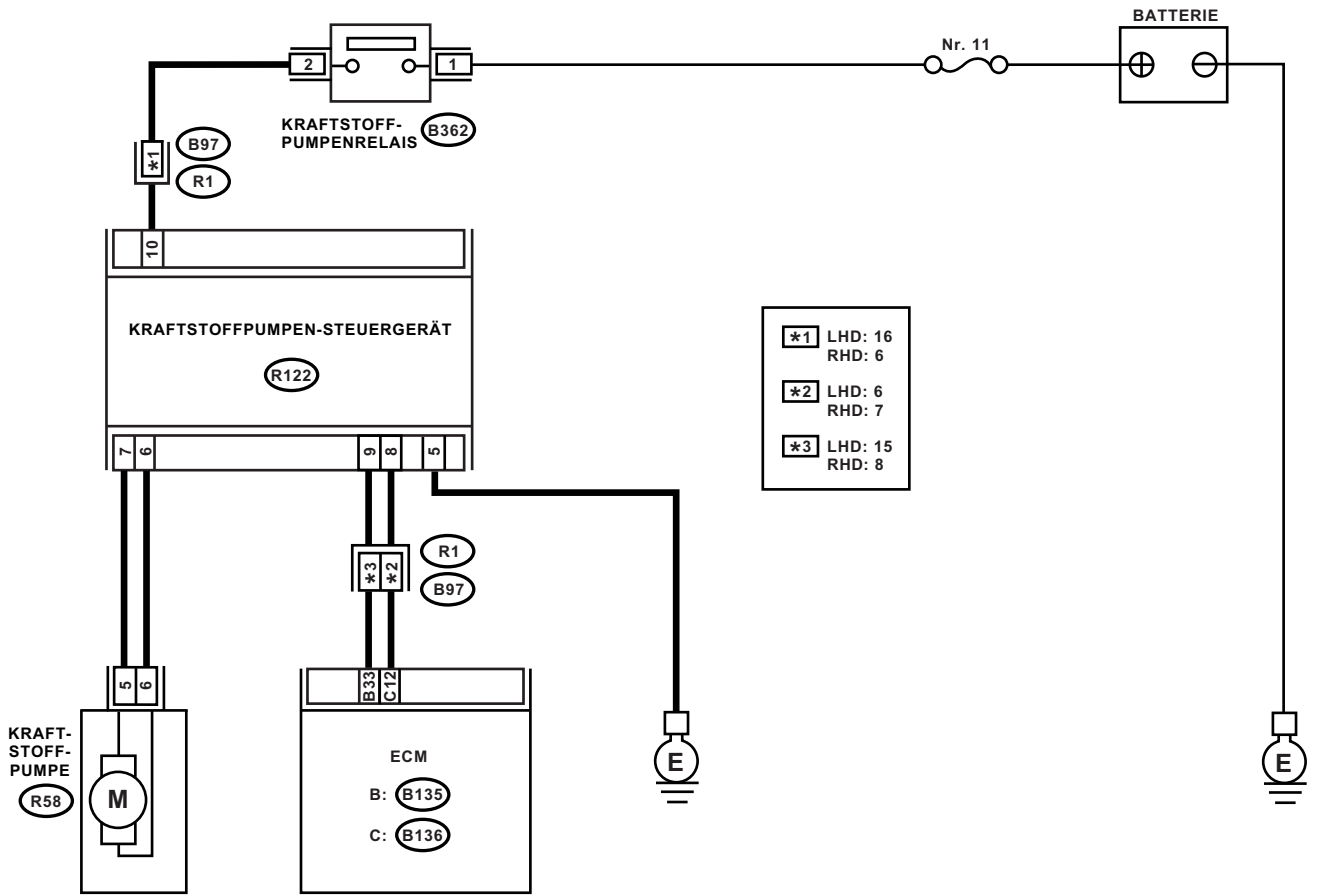

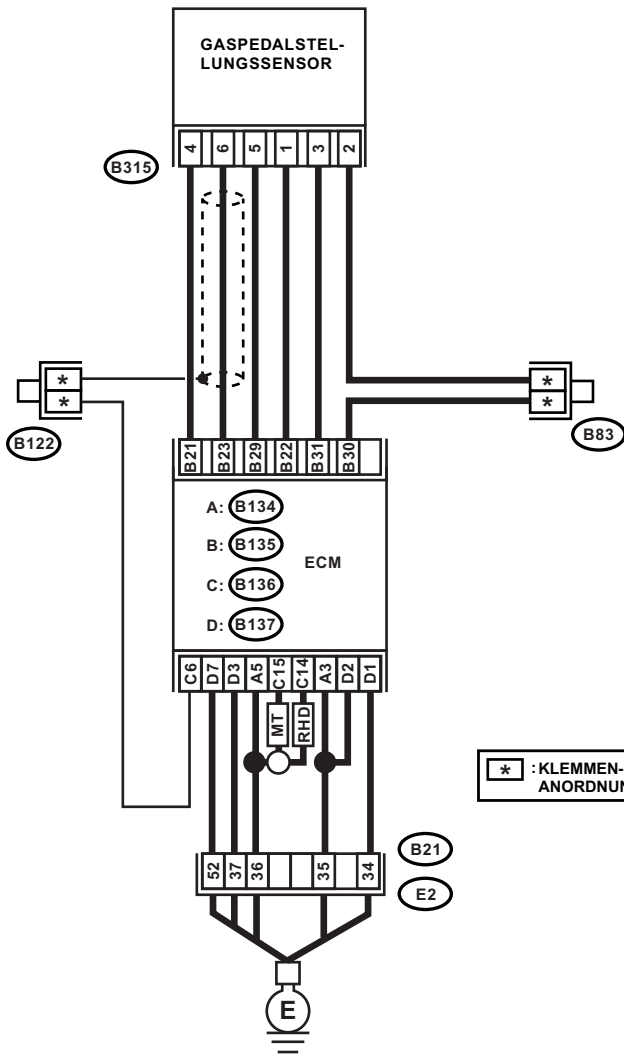

B315

1	2	3	4	5	6
---	---	---	---	---	---

B83

B122

1	2	3	4
5	6	7	8

B21

1	2	3	4	5	6	7	8	9	10	11
12	13	14	15	16	17	18	19	20	21	22
23	24	25	26	27	28	29	30	31	32	33
34	35	36	37	38	39	40	41			
42	43	44	45	46	47					
48	49	50	51	52	53	54				

A: B134

1	2	3	4	5	6	7			
8	9	10	11	12	13	14	15	16	17
18	19	20	21	22	23	24	25	26	27
28	29	30	31	32				33	34

B: B135

1	2		3	4	5	6	7				
8	9	10	11	12	13	14	15	16	17	18	19
20	21	22	23		24	25			26	27	
28	29	30	31		32	33			34	35	

C: B136

	1	2	3	4		5	6			
	7	8	9	10	11	12	13	14	15	16
17	18	19	20	21	22	23	24	25	26	27
28	29	30				31	32	33	34	35

D: B137

1	2	3	4	5	6	7			
8	9	10	11	12	13	14	15	16	17
18	19	20	21	22	23			24	25
26	27			28	29			30	31

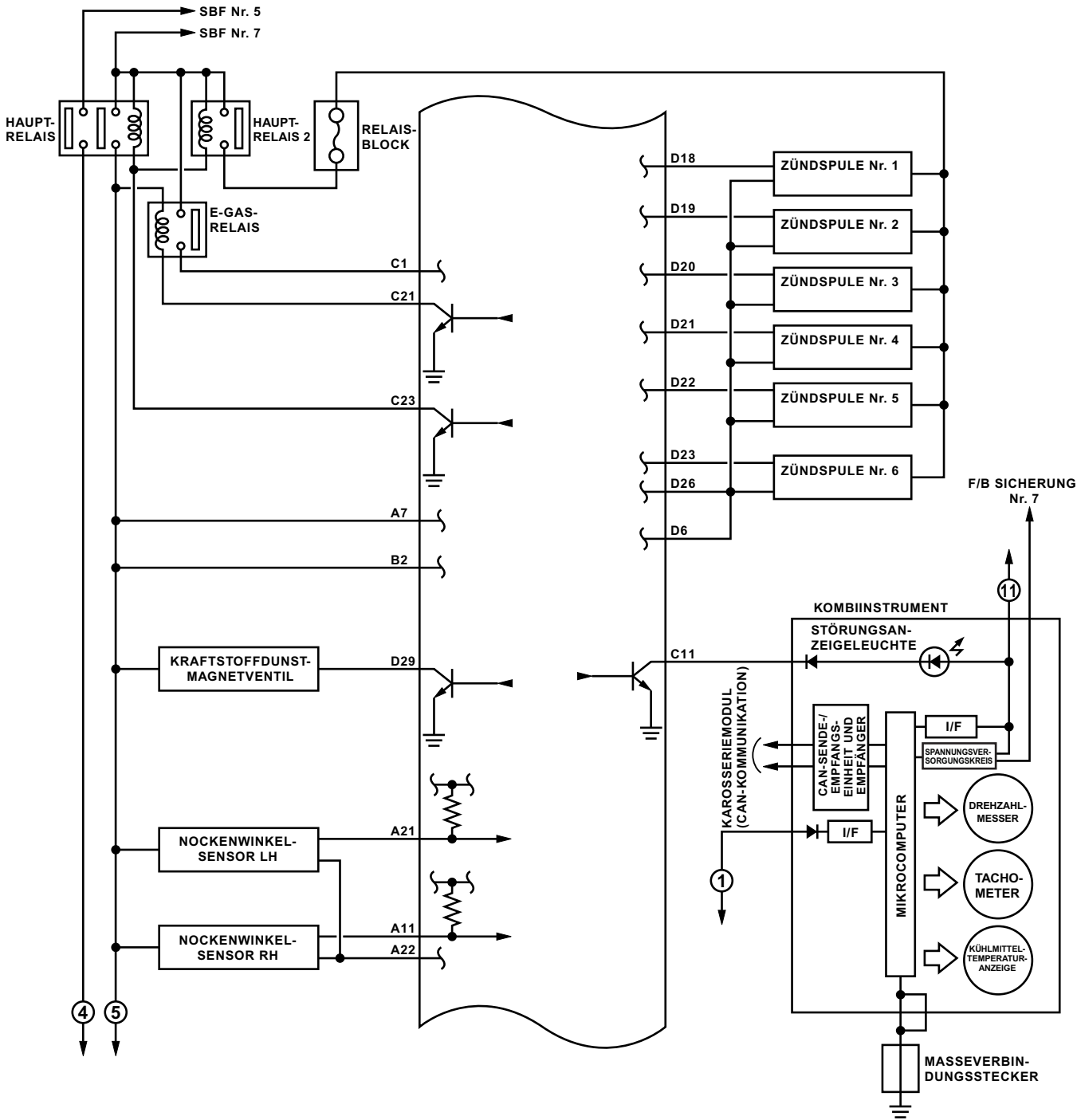

HAUPTRELAIS

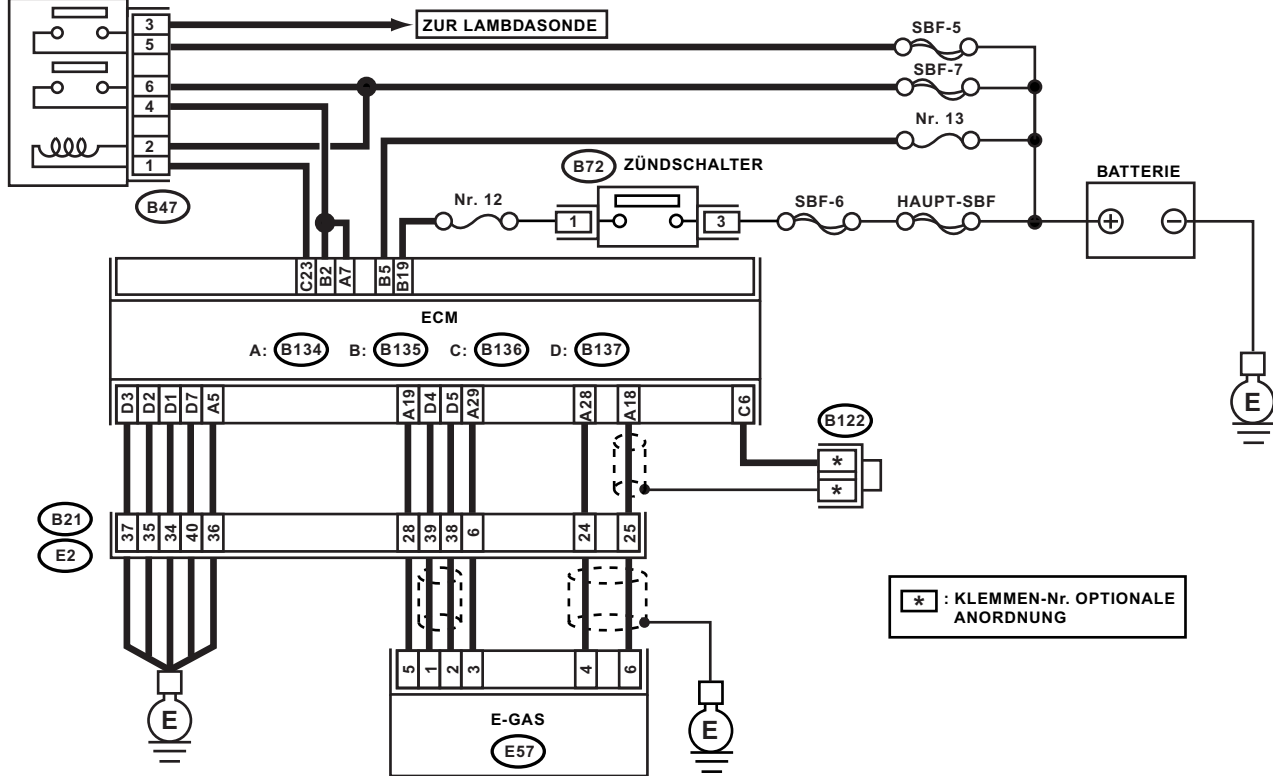

* : KLEMMEN-Nr. OPTIONALE ANORDNUNG

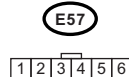

A: B134

B: B135

C: B136

D: B137

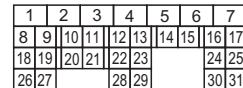
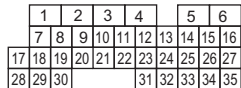
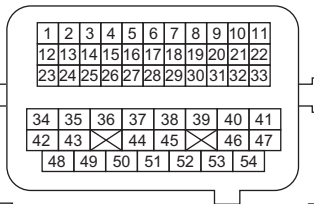
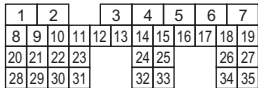

SAUGROHR-STEUERVENTIL RH
(MIT INTEGRIERTEM SENSOR)

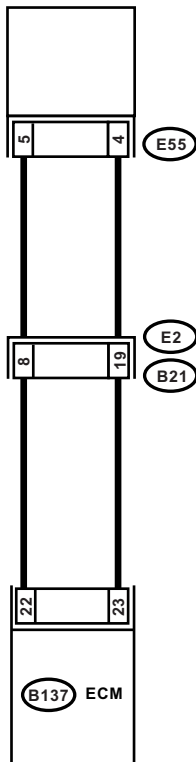

E55

1	2	3
4	5	

B21

1	2	3	4	5	6	7	8	9	10	11
12	13	14	15	16	17	18	19	20	21	22
23	24	25	26	27	28	29	30	31	32	33
34	35	36	37	38	39	40	41			
42	43	44	45	46	47					
48	49	50	51	52	53	54				

B137

1	2	3	4	5	6	7
8	9	10	11	12	13	14
15	16	17	18	19	20	21
22	23	24	25	26	27	28
29	30	31				

SAUGROHR-STEUERVENTIL LH
(MIT INTEGRIERTEM SENSOR)

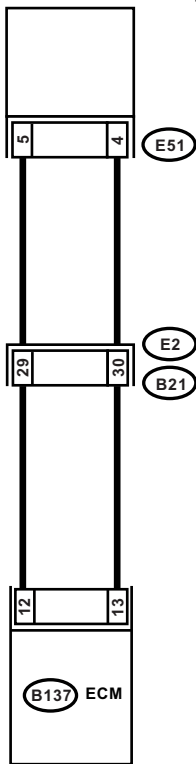

E51



B21

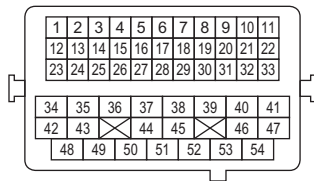

B137

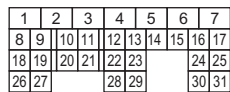

SAUGROHR-STEUERVENTIL RH
(MIT INTEGRIERTEM SENSOR)

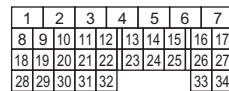
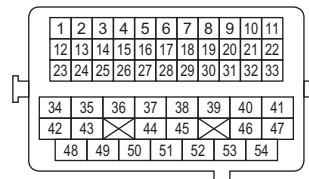
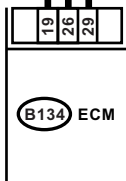
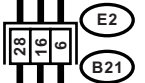
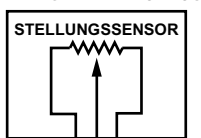

SAUGROHR-STEUERVENTIL LH
(MIT INTEGRIERTEM SENSOR)

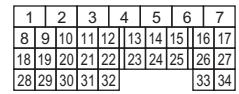
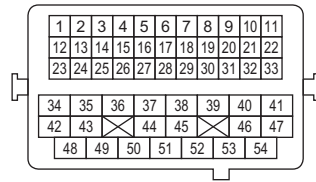
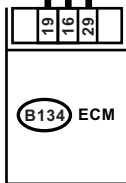
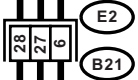
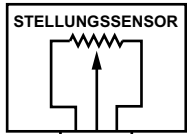

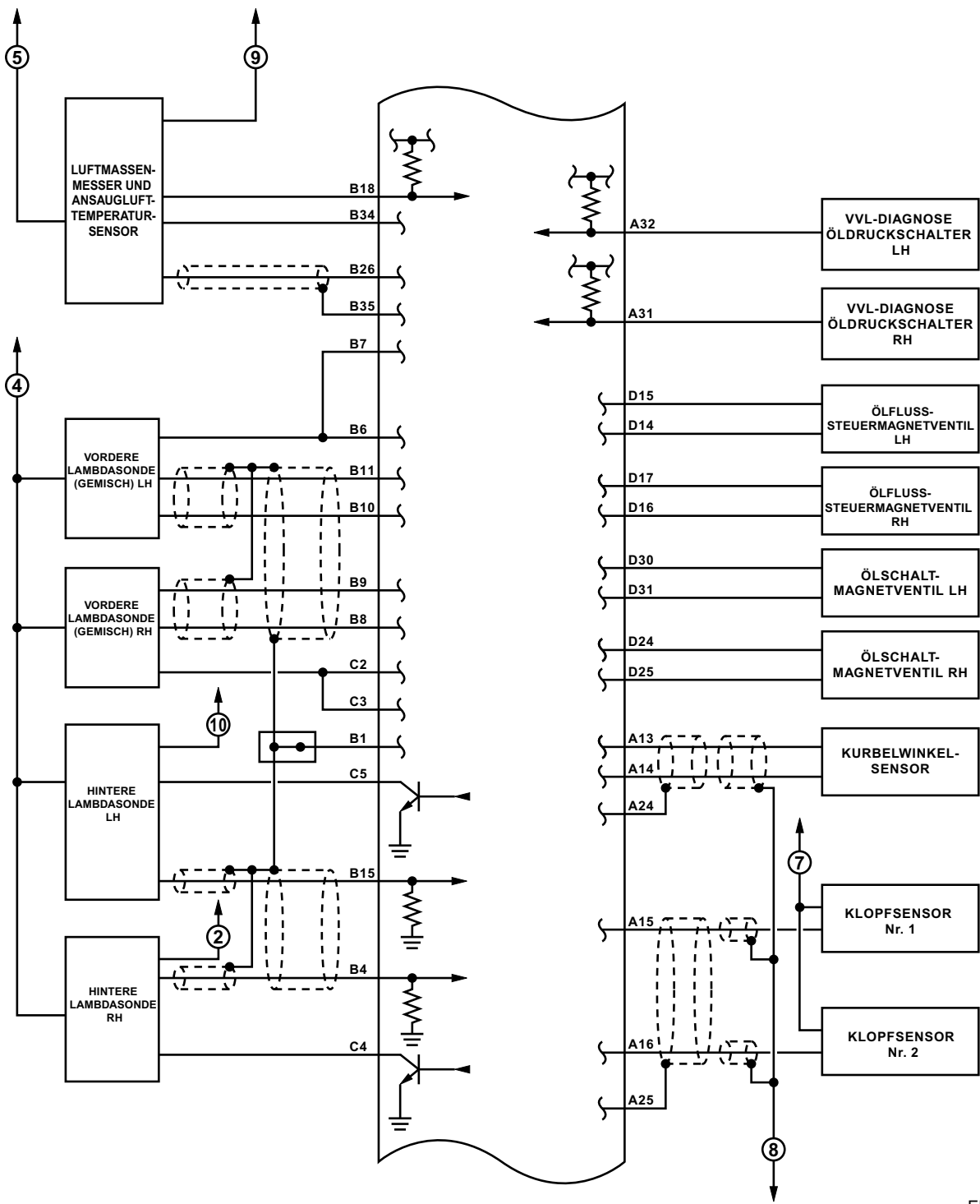

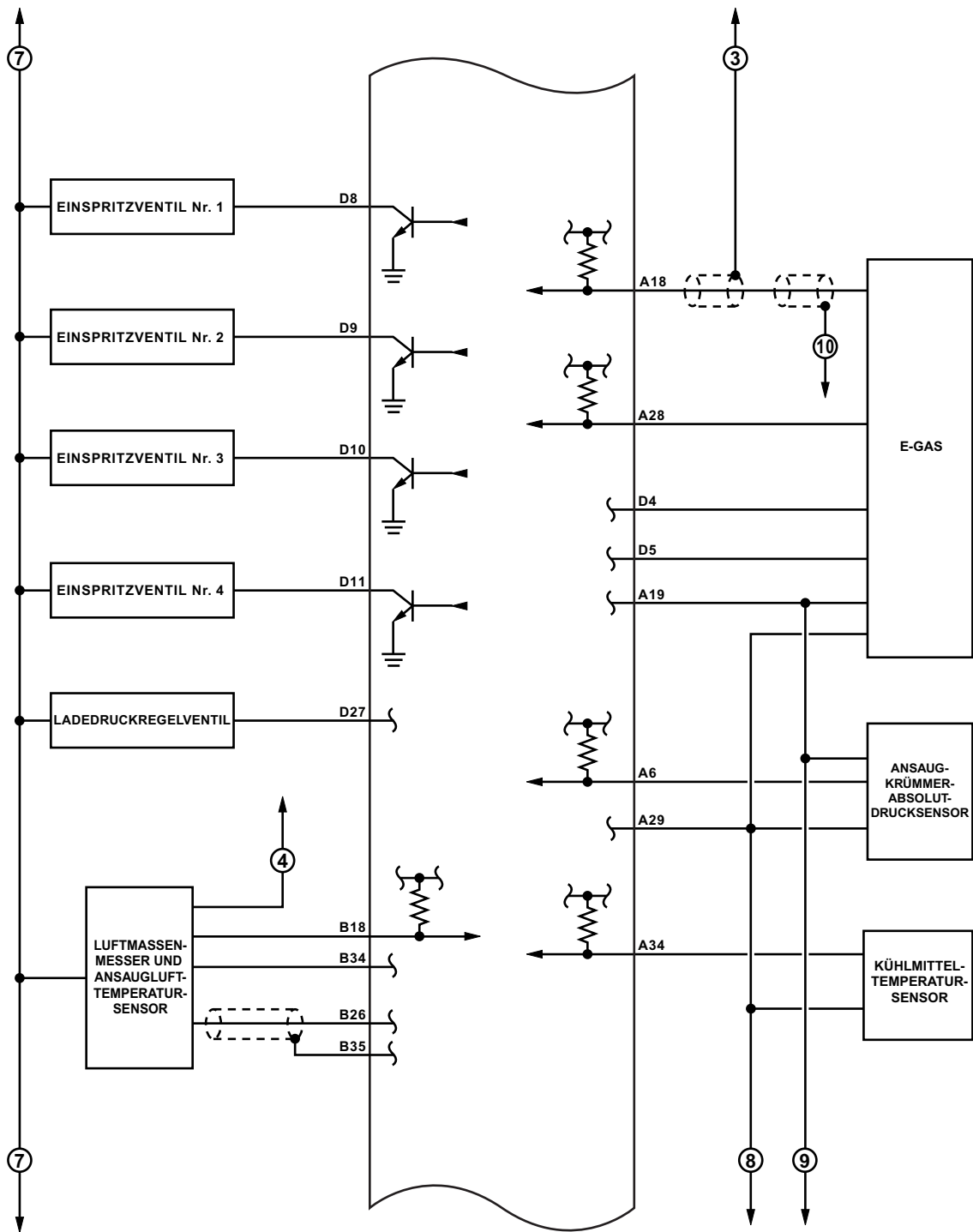

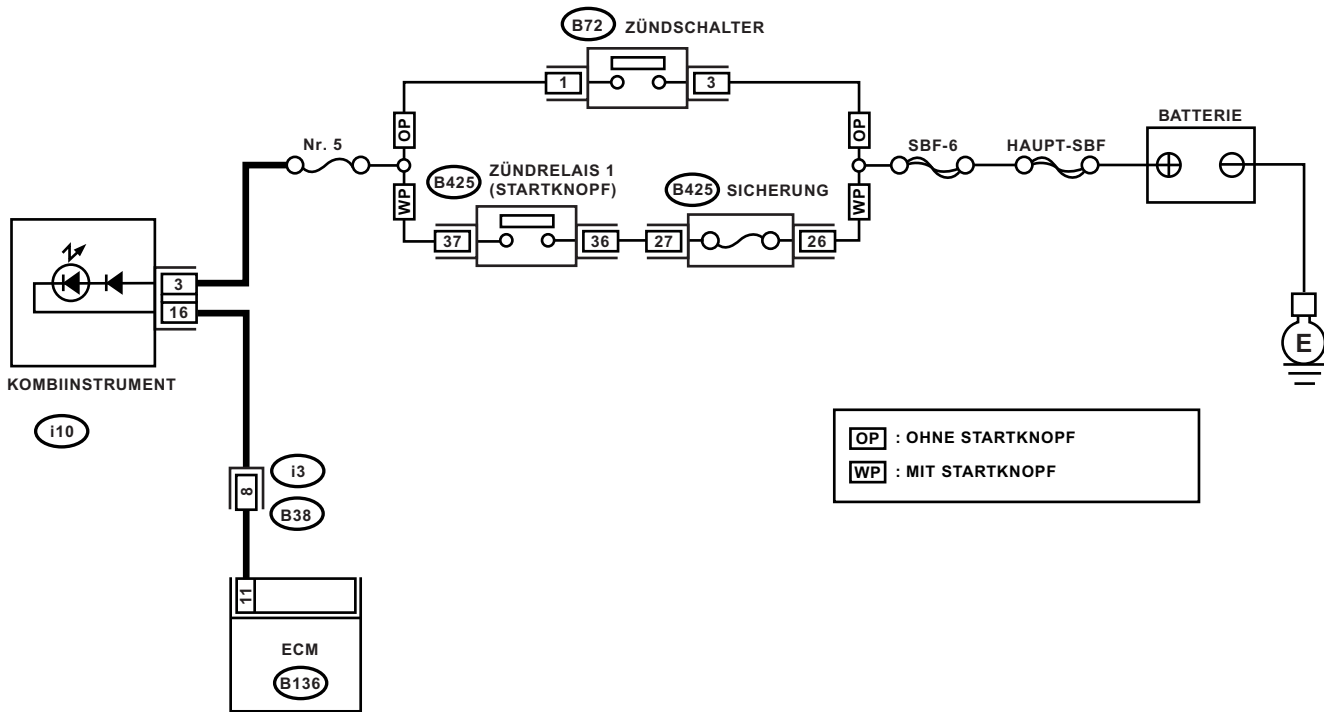

i10

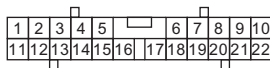

B72



B38



B425

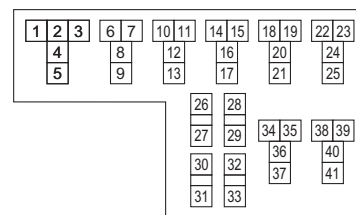

B136

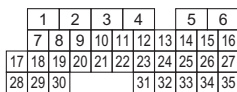

HAUPTRELAIS

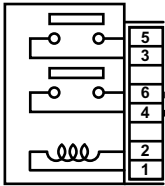

B47

BATTERIE

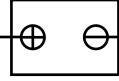

SBF-7

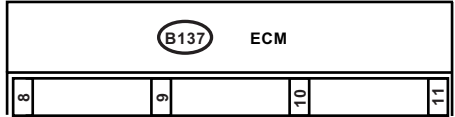

B137 ECM

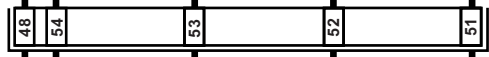

B21

E2

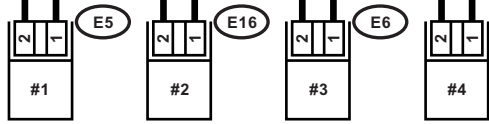

E5

E16

E6

E17

EINSPRITZVENTIL

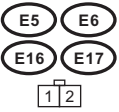

B21

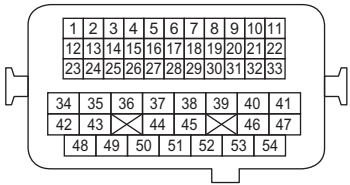

B47



B137

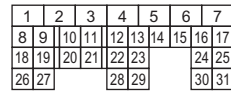

HAUPTRELAIS

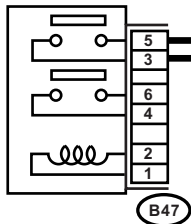

BATTERIE

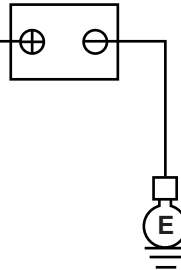

SBF-5

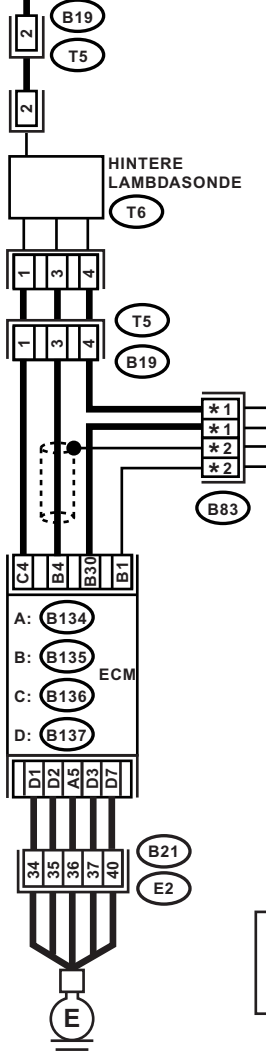

HINTERE LAMBDAZONE

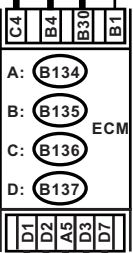

- A: (B134)
- B: (B135)
- C: (B136)
- D: (B137)

ECM

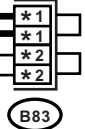

*1 : KLEMMEN-Nr. OPTIONALE ANORDNUNG BEI 1, 2, 5 UND 6
 *2 : KLEMMEN-Nr. OPTIONALE ANORDNUNG BEI 3, 4, 7 UND 8

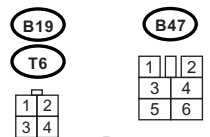

(B21)

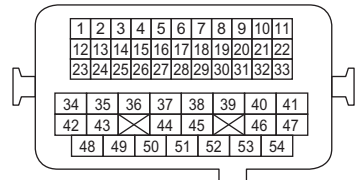

A: (B134)

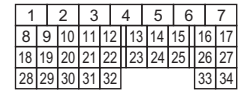

B: (B135)

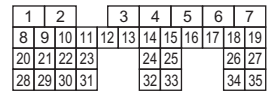

C: (B136)

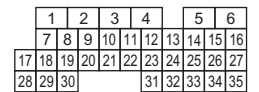

D: (B137)

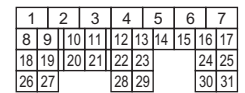

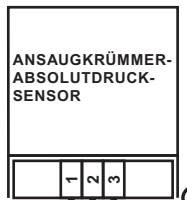

E21



E2

B21

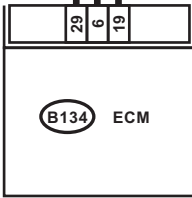

E21



B21

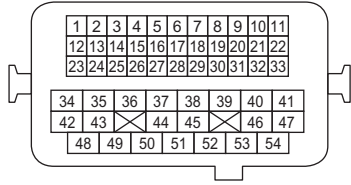

B134

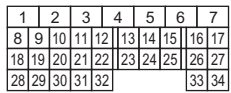

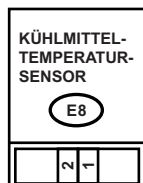

E2

B21

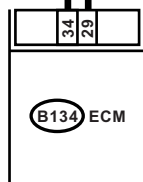

E8



B134

1	2	3	4	5	6	7			
8	9	10	11	12	13	14	15	16	17
18	19	20	21	22	23	24	25	26	27
28	29	30	31	32				33	34

B21

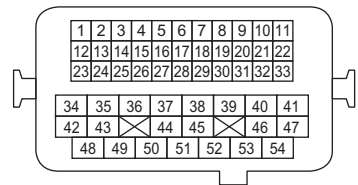

HAUPTRELAIS

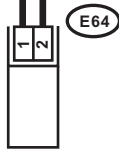
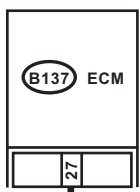
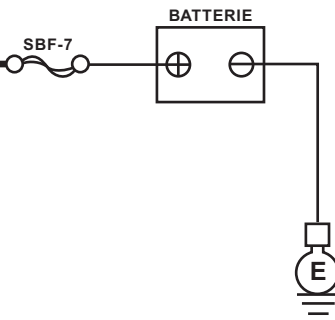
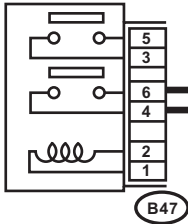

LAEDRUCK-MAGNETVENTIL

B47

1	2
3	4
5	6

B137

1	2	3	4	5	6	7			
8	9	10	11	12	13	14	15	16	17
18	19	20	21	22	23			24	25
26	27			28	29			30	31

E64

1	2
---	---

B21

1	2	3	4	5	6	7	8	9	10	11
12	13	14	15	16	17	18	19	20	21	22
23	24	25	26	27	28	29	30	31	32	33
34	35	36	37	38	39	40	41			
42	43	44	45	46	47					
48	49	50	51	52	53	54				

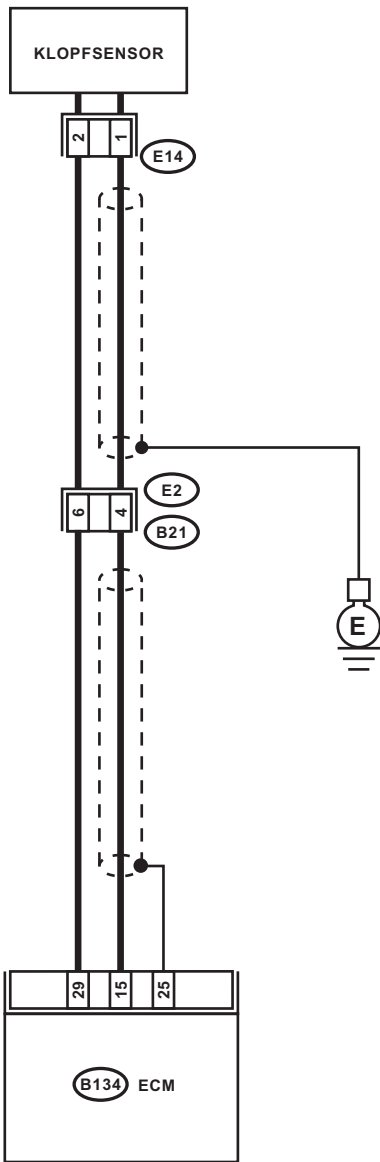

E14

1	2
---	---

B134

1	2	3	4	5	6	7			
8	9	10	11	12	13	14	15	16	17
18	19	20	21	22	23	24	25	26	27
28	29	30	31	32			33	34	

B21

1	2	3	4	5	6	7	8	9	10	11
12	13	14	15	16	17	18	19	20	21	22
23	24	25	26	27	28	29	30	31	32	33
34	35	36	37	38	39	40	41			
42	43	⊗	44	45	⊗	46	47			
48	49	50	51	52	53	54				

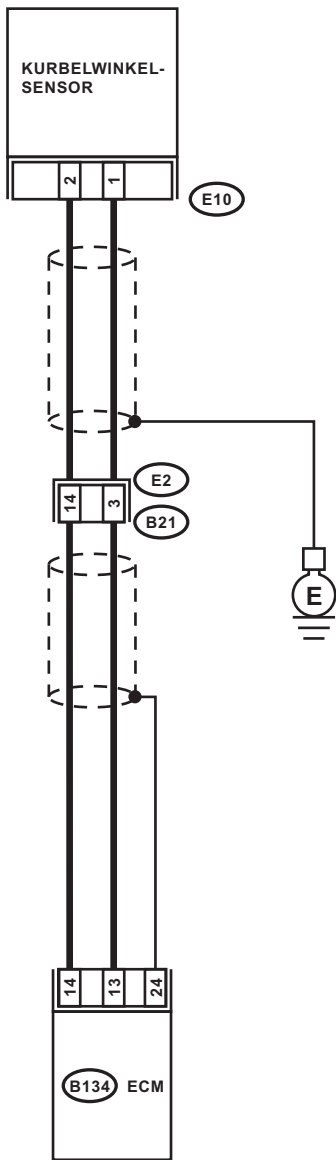

E10



B134

1	2	3	4	5	6	7
8	9	10	11	12	13	14
15	16	17	18	19	20	21
22	23	24	25	26	27	
28	29	30	31	32		33
						34

B21

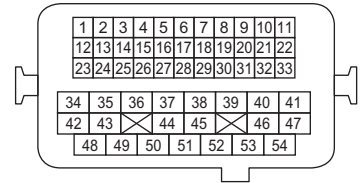

HAUPTRELAIS

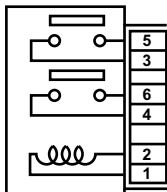

B47

SBF-7

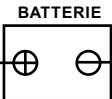

E35



E36



E2

B21



B134 ECM

E35

E36



B47



B134

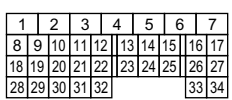

B21

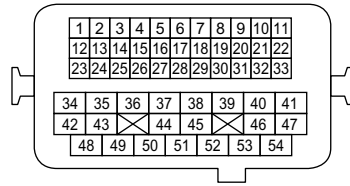

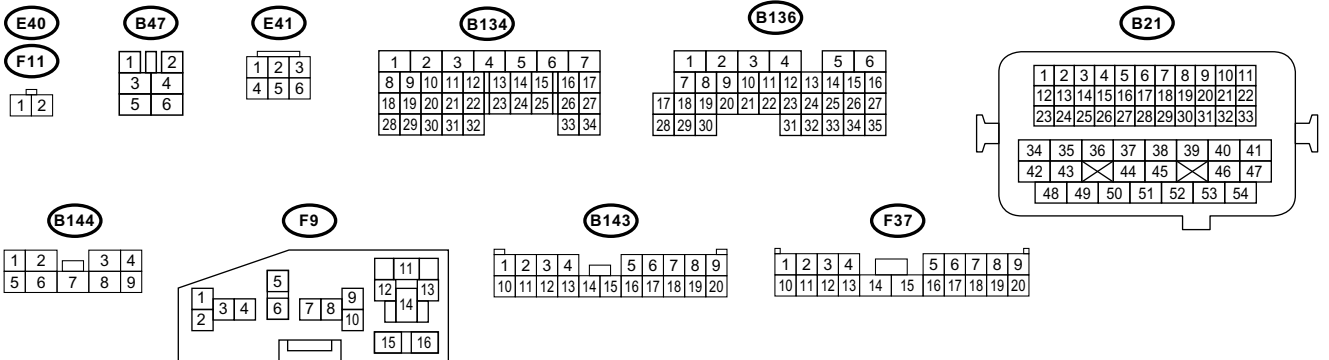
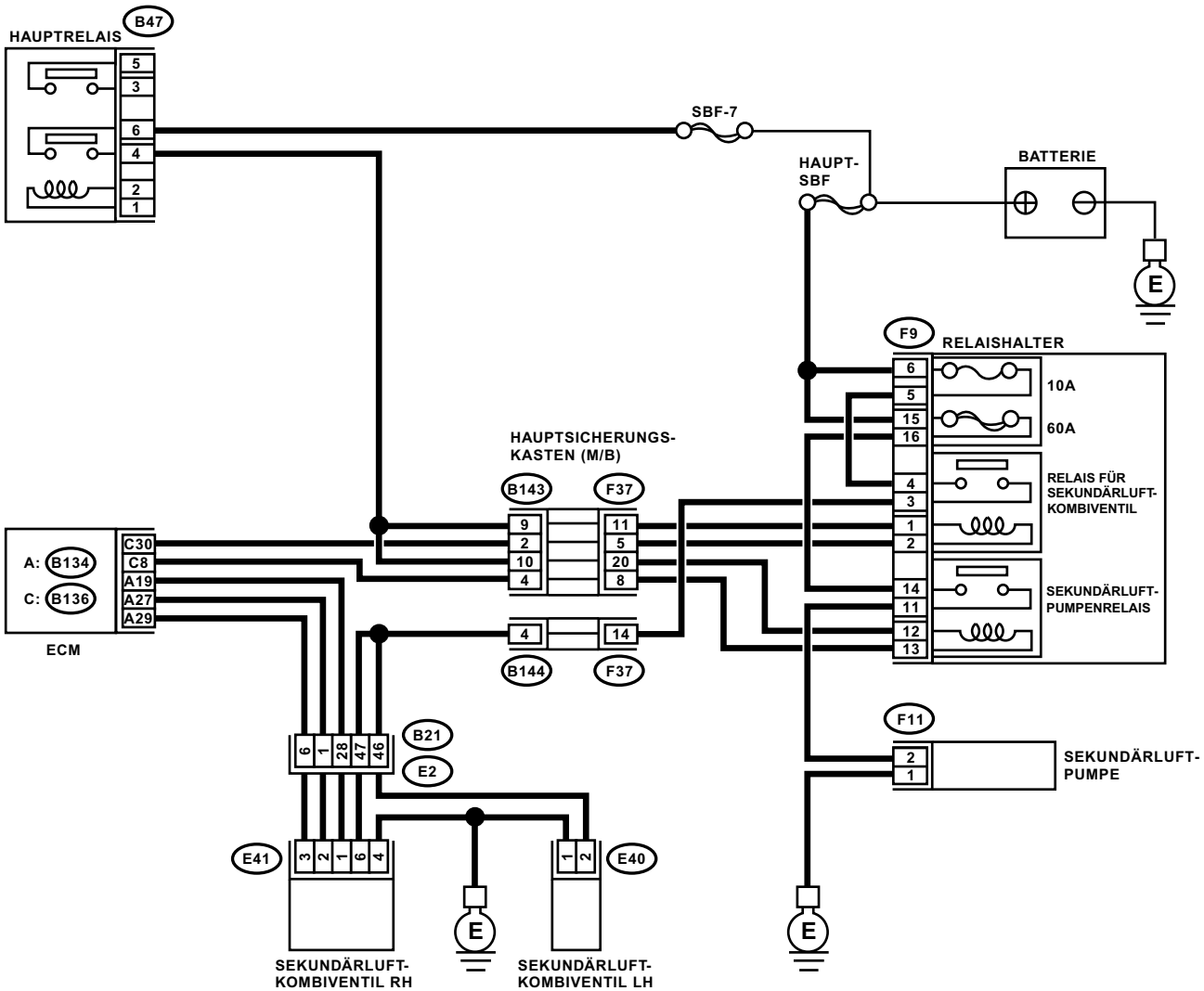

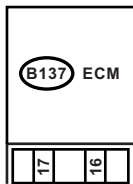

B21

E2

E38

ÖLFLUSS-STEERMAGNETVENTIL
RH EINLASS

B137

1	2	3	4	5	6	7			
8	9	10	11	12	13	14	15	16	17
18	19	20	21	22	23			24	25
26	27			28	29			30	31

B21

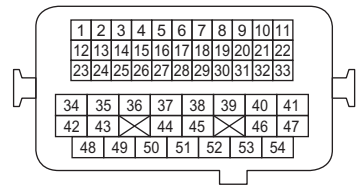

E38



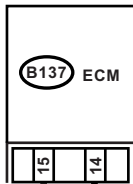

ÖLFLUSS-STEERMAGNETVENTIL
LH EINLASS



B21

E2

E37

B137

1	2	3	4	5	6	7
8	9	10	11	12	13	14
15	16	17				
18	19	20	21	22	23	24
25	26	27	28	29	30	31

B21

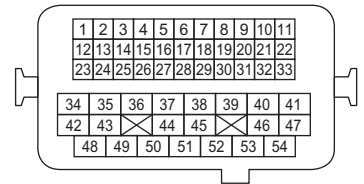

E37



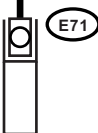
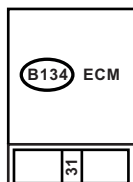

VVL-DIAGNOSE
ÖLDRUCKSCHALTER RH

B21

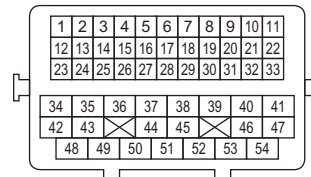

B134

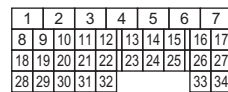

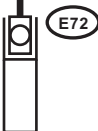
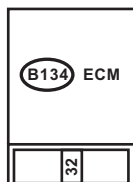

VVL-DIAGNOSE
ÖLDRUCKSCHALTER LH

B21

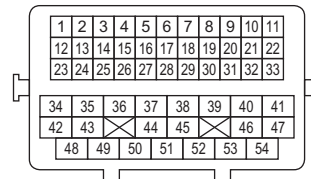

B134

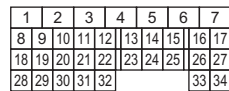

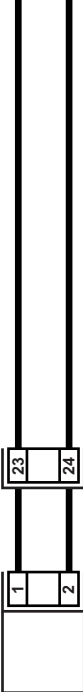
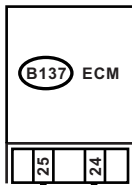

B21

E2

E69

ÖLSCHALT-MAGNETVENTIL RH

B137

1	2	3	4	5	6	7
8	9	10	11	12	13	14
15	16	17	18	19	20	21
22	23	24	25	26	27	28
29	30	31				

B21

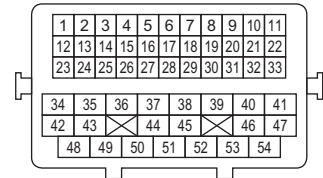

E69



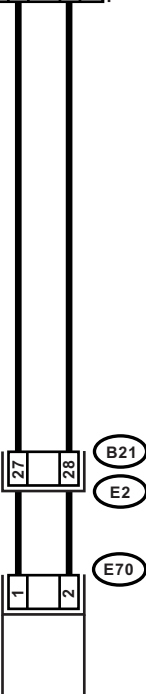
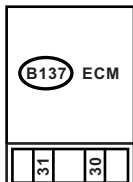

ÖLSCHALT-MAGNETVENTIL LH

B137

1	2	3	4	5	6	7			
8	9	10	11	12	13	14	15	16	17
18	19	20	21	22	23	24	25		
26	27	28	29	30	31				

B21

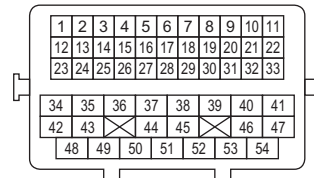

E70



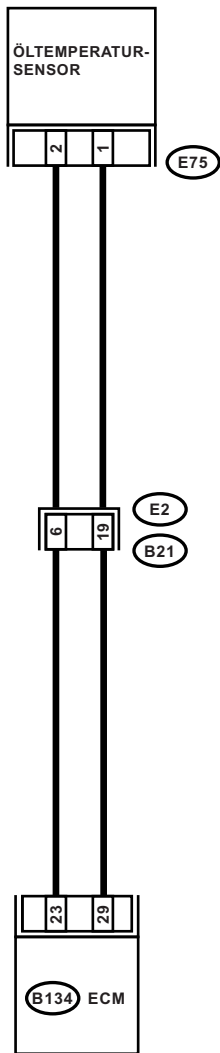

E75

1 2

B21

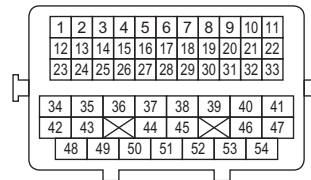

B134

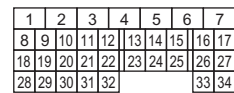



E21



E2

B21



* : KLEMMEN-Nr. OPTIONALE ANORDNUNG BEI 1, 2, 5 UND 6

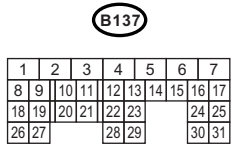
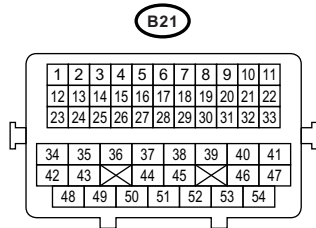
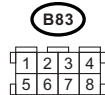
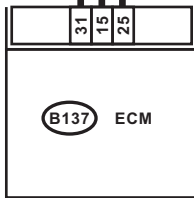

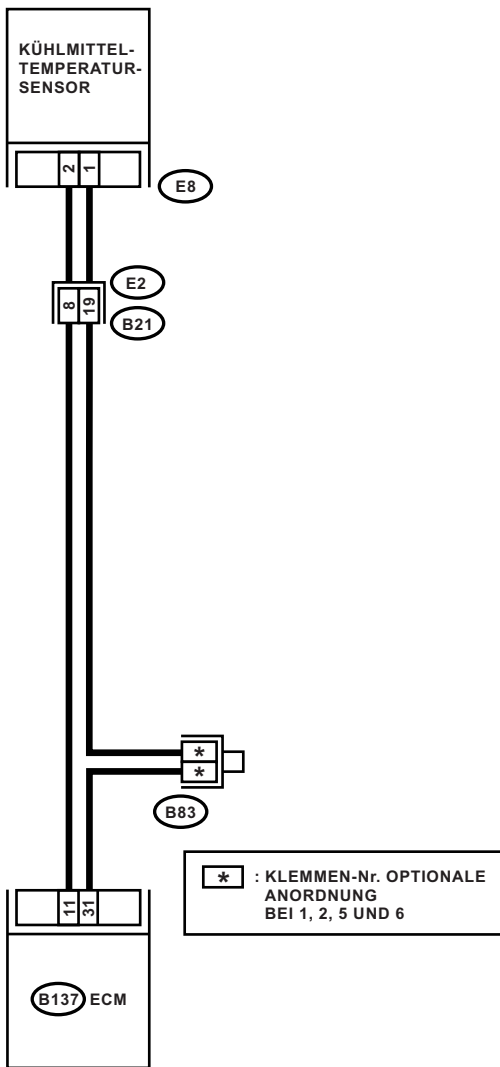

E8



B83

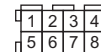

B137

1	2	3	4	5	6	7
8	9	10	11	12	13	14
15	16	17				
18	19	20	21	22	23	24
25	26	27		28	29	30
						31

B21

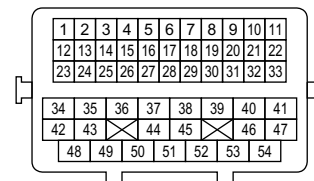

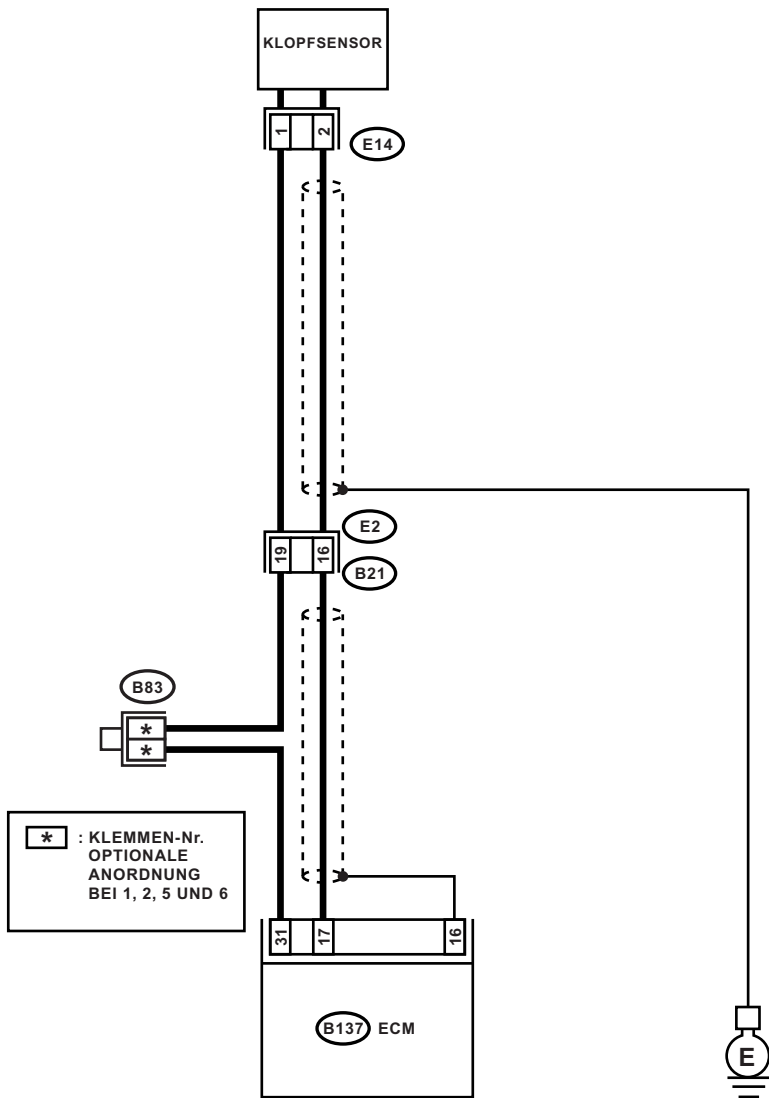

* : KLEMMEN-Nr.
OPTIONALE
ANORDNUNG
BEI 1, 2, 5 UND 6

E14



B83

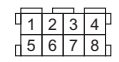

B137

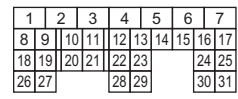

B21

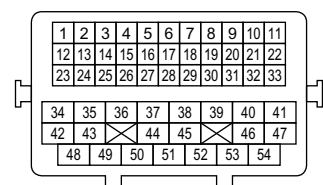

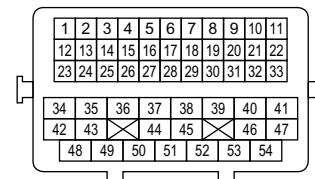
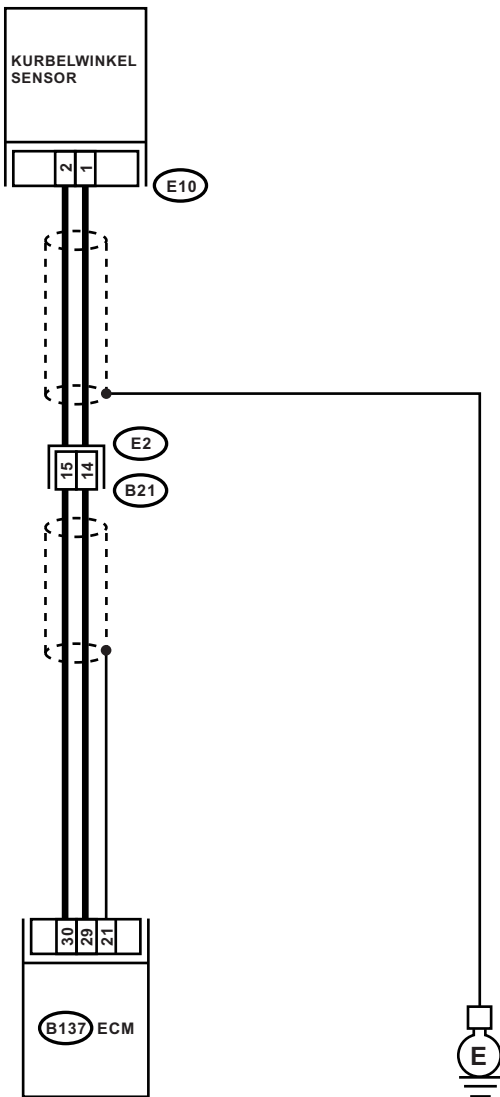

HAUPTRELAIS

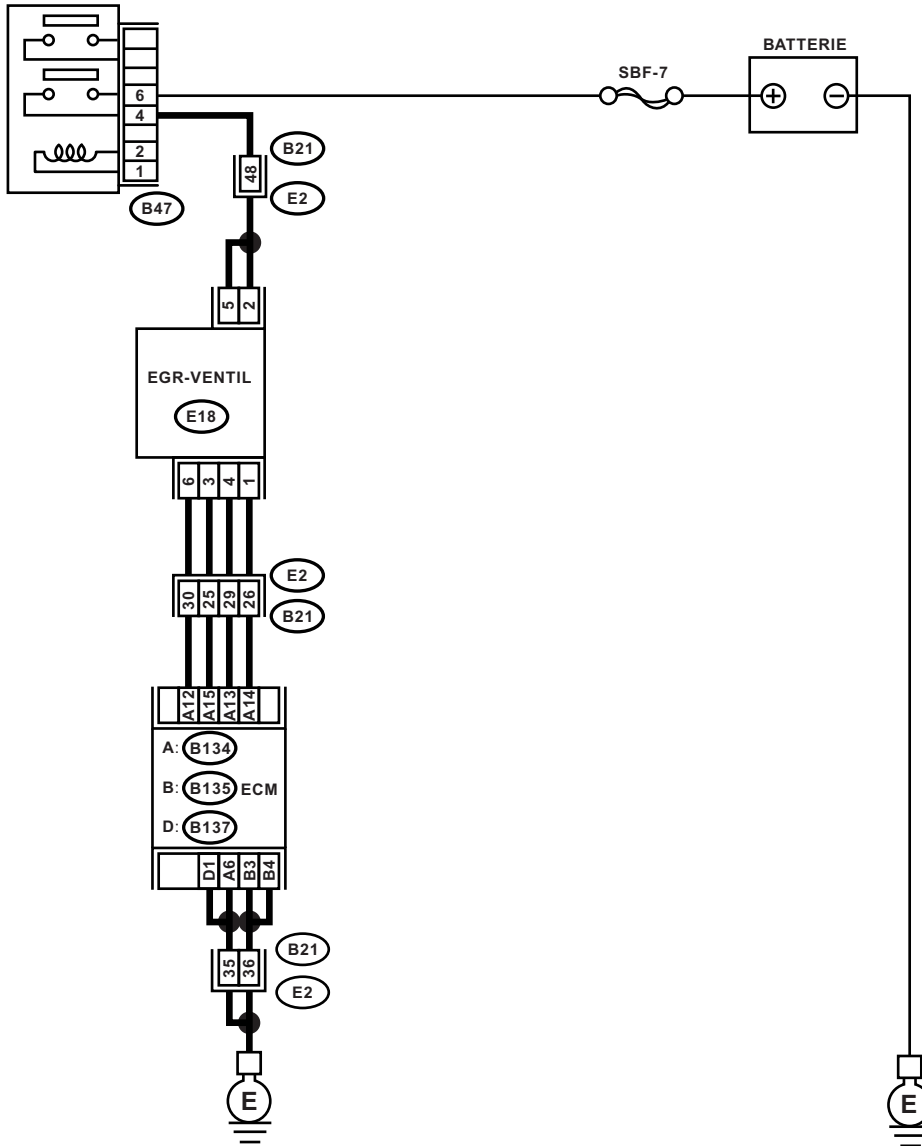

E18

1	2	3
4	5	6

B47

1	2
3	4
5	6

A: **B134**

1	2	3	4	5	6	7			
8	9	10	11	12	13	14	15	16	17
18	19	20	21	22	23	24	25	26	27
28	29	30	31	32				33	34

B: **B135**

1	2		3	4	5	6	7				
8	9	10	11	12	13	14	15	16	17	18	19
20	21	22	23		24	25		26	27		
28	29	30	31		32	33			34	35	

D: **B137**

1	2	3	4	5	6	7			
8	9	10	11	12	13	14	15	16	17
18	19	20	21	22	23		24	25	
26	27			28	29			30	31

B21

1	2	3	4	5	6	7	8	9	10	11
12	13	14	15	16	17	18	19	20	21	22
23	24	25	26	27	28	29	30	31	32	33
34	35	36	37	38	39	40	41			
42	43	44	45	46	47					
48	49	50	51	52	53	54				

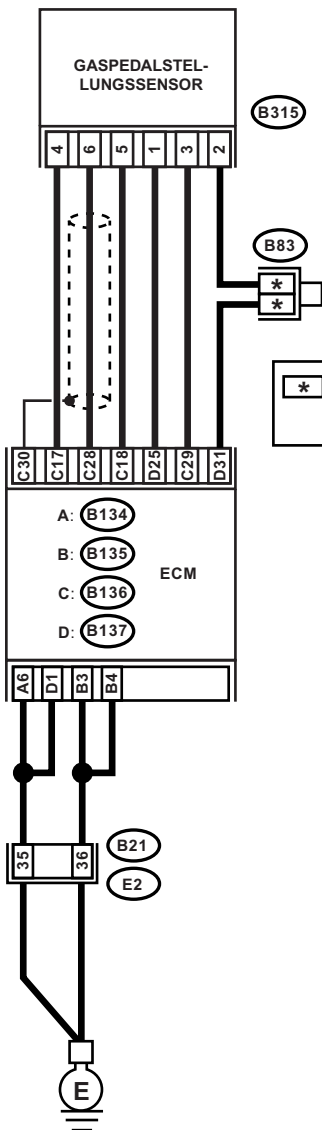

B315

B83

***** : KLEMMEN-Nr. OPTIONALE ANORDNUNG BEI 1, 2, 5 UND 6

B315

1	2	3	4	5	6
---	---	---	---	---	---

B83

1	2	3	4
5	6	7	8

A: B134

1	2	3	4	5	6	7
8	9	10	11	12	13	14
15	16	17	18	19	20	21
22	23	24	25	26	27	28
29	30	31	32	33	34	

B: B135

1	2	3	4	5	6	7
8	9	10	11	12	13	14
15	16	17	18	19	20	21
22	23	24	25	26	27	28
29	30	31	32	33	34	35

C: B136

1	2	3	4	5	6
7	8	9	10	11	12
13	14	15	16	17	18
19	20	21	22	23	24
25	26	27	28	29	30
31	32	33	34	35	

D: B137

1	2	3	4	5	6	7
8	9	10	11	12	13	14
15	16	17	18	19	20	21
22	23	24	25	26	27	28
29	30	31	32	33	34	35

B21

1	2	3	4	5	6	7	8	9	10	11
12	13	14	15	16	17	18	19	20	21	22
23	24	25	26	27	28	29	30	31	32	33
34	35	36	37	38	39	40	41	42	43	44
45	46	47	48	49	50	51	52	53	54	

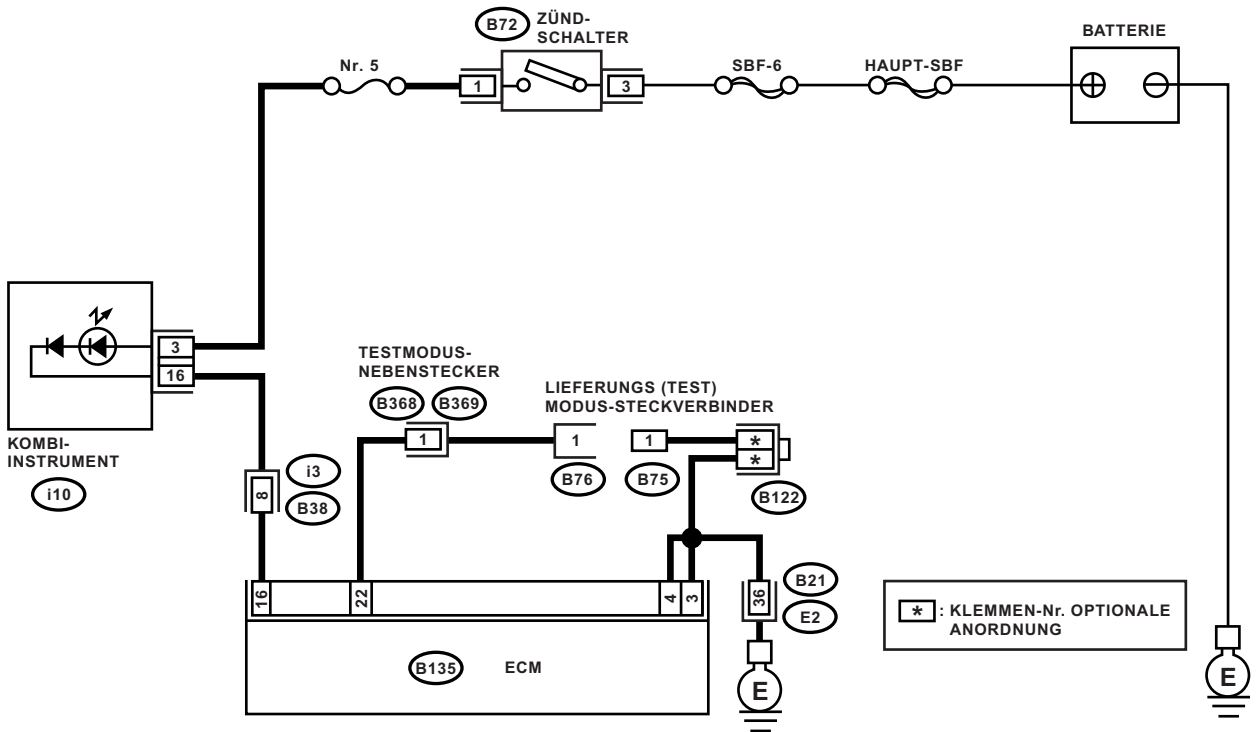

* : KLEMMEN-Nr. OPTIONALE ANORDNUNG

B368

B75



B369

B76



B72



B135



B122

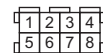

i10

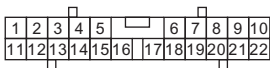

B38

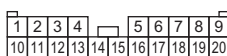

B21

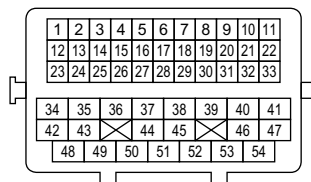

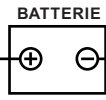
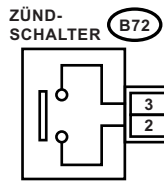

Nr. 21

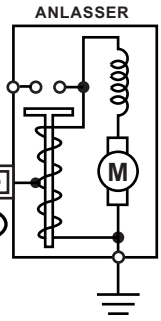
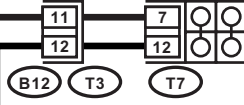
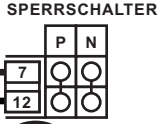
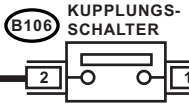

LM : LHD MT-MODELL
EM : AUSSER LHD MT-MODELL

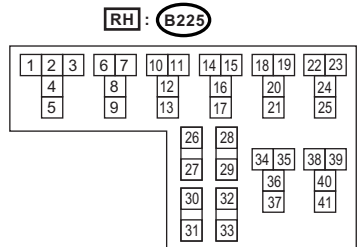
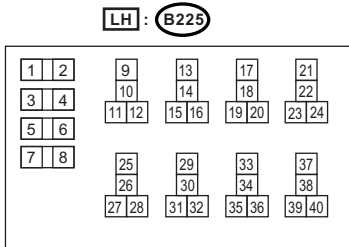
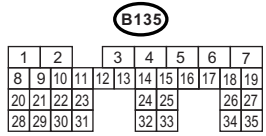
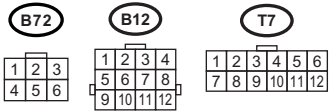
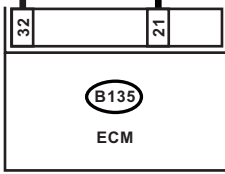

HAUPTRELAIS

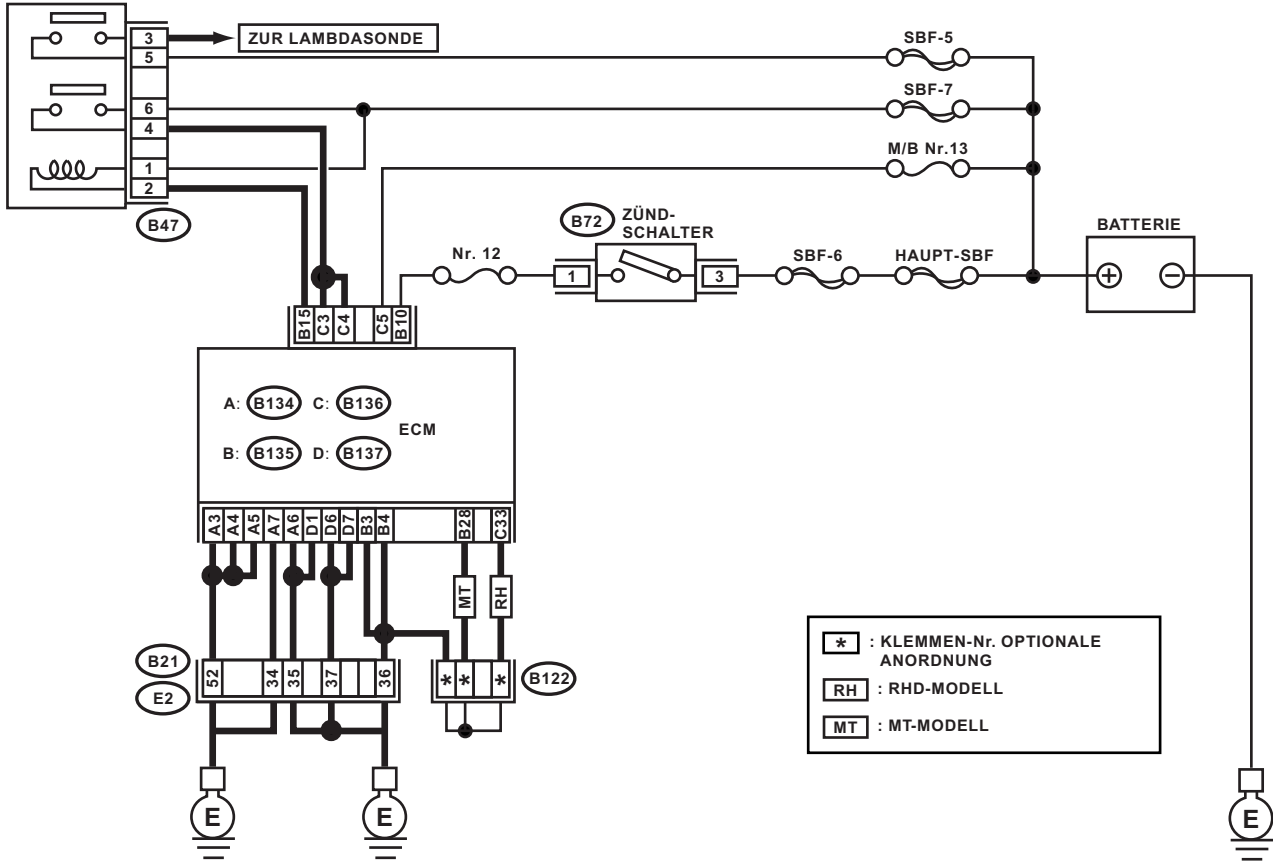

* : KLEMMEN-Nr. OPTIONALE ANORDNUNG
 RH : RHD-MODELL
 MT : MT-MODELL

B21

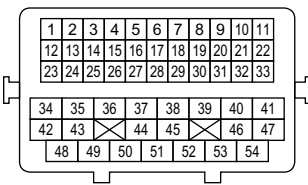

A: B134

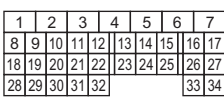

B: B135

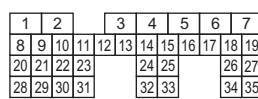

C: B136

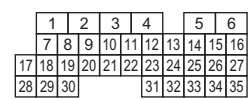

B72



B47



B122



D: B137

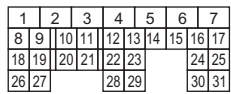

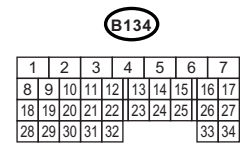
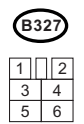
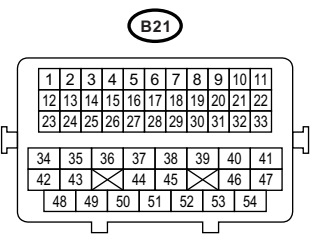
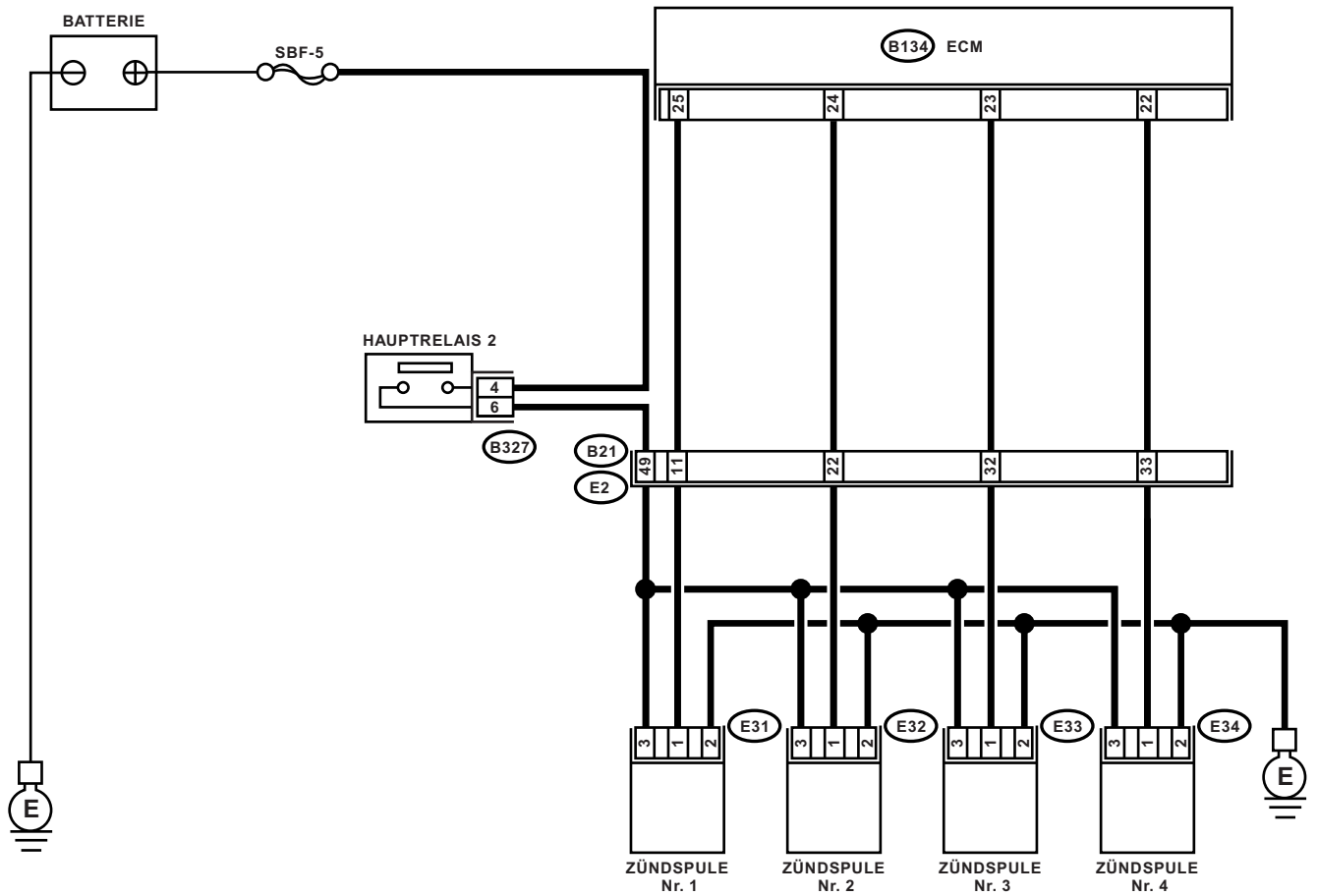

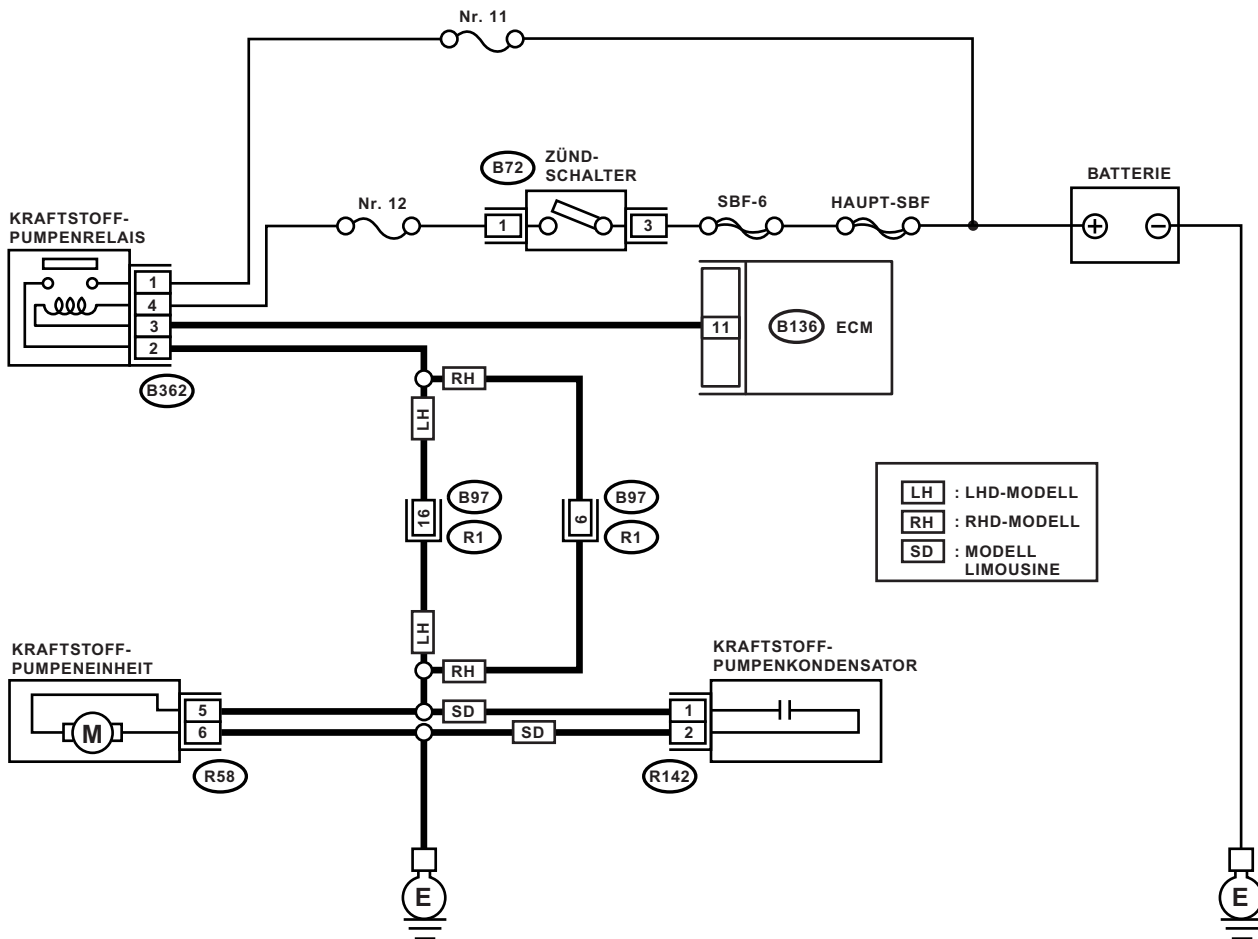

B362

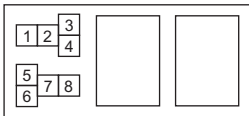

R142



R58



B72



RH : B97

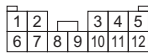

LH : B97



B136

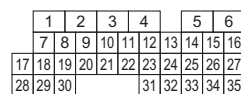

HAUPTRELAIS

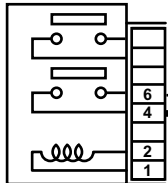

B47

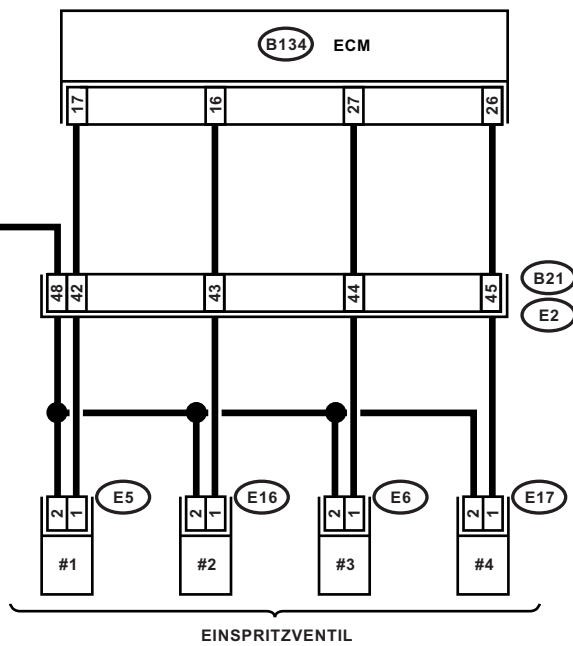
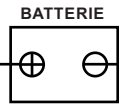

B21

E2

E5

E16

E6

E17

EINSPRITZVENTIL

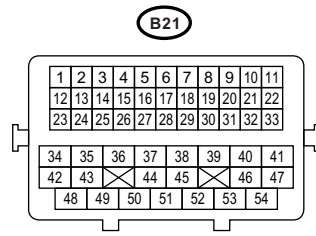
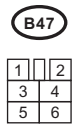
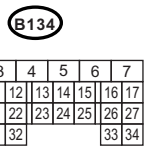
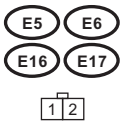

HAUPTRELAIS

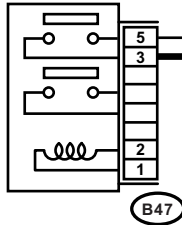

B21 E2

B47

SBF-5

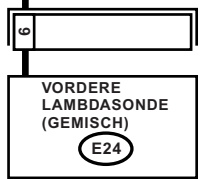
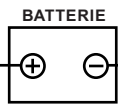

E24

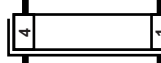

E2

B21

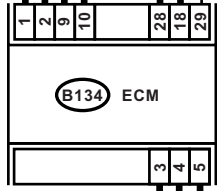
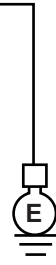
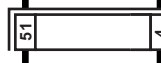

B134 ECM



B21

E2

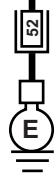

B21

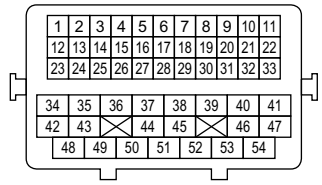

B134

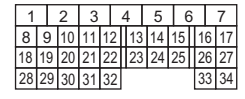

HAUPTRELAIS

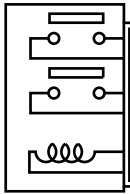

B47

BATTERIE

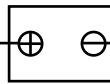

SBF-5

B21
E2



HINTERE
LAMBDA-SONDE
E22

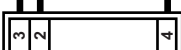

E2

B21

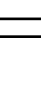

E2



B83

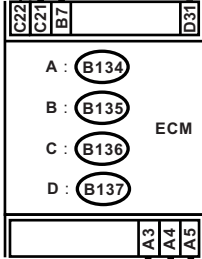

A : B134

B : B135

C : B136

D : B137

ECM

*1 : KLEMMEN-Nr. OPTIONALE ANORDNUNG BEI 3, 4, 7 UND 8

*2 : KLEMMEN-Nr. OPTIONALE ANORDNUNG BEI 1, 2, 5 UND 6



B21
E2



E22



B83

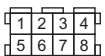

B47



A : B134

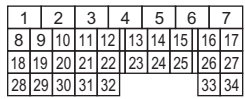

B : B135

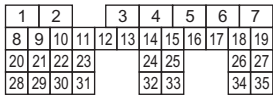

C : B136

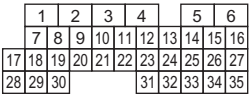

D : B137

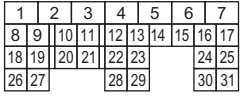

B21

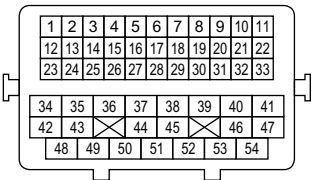

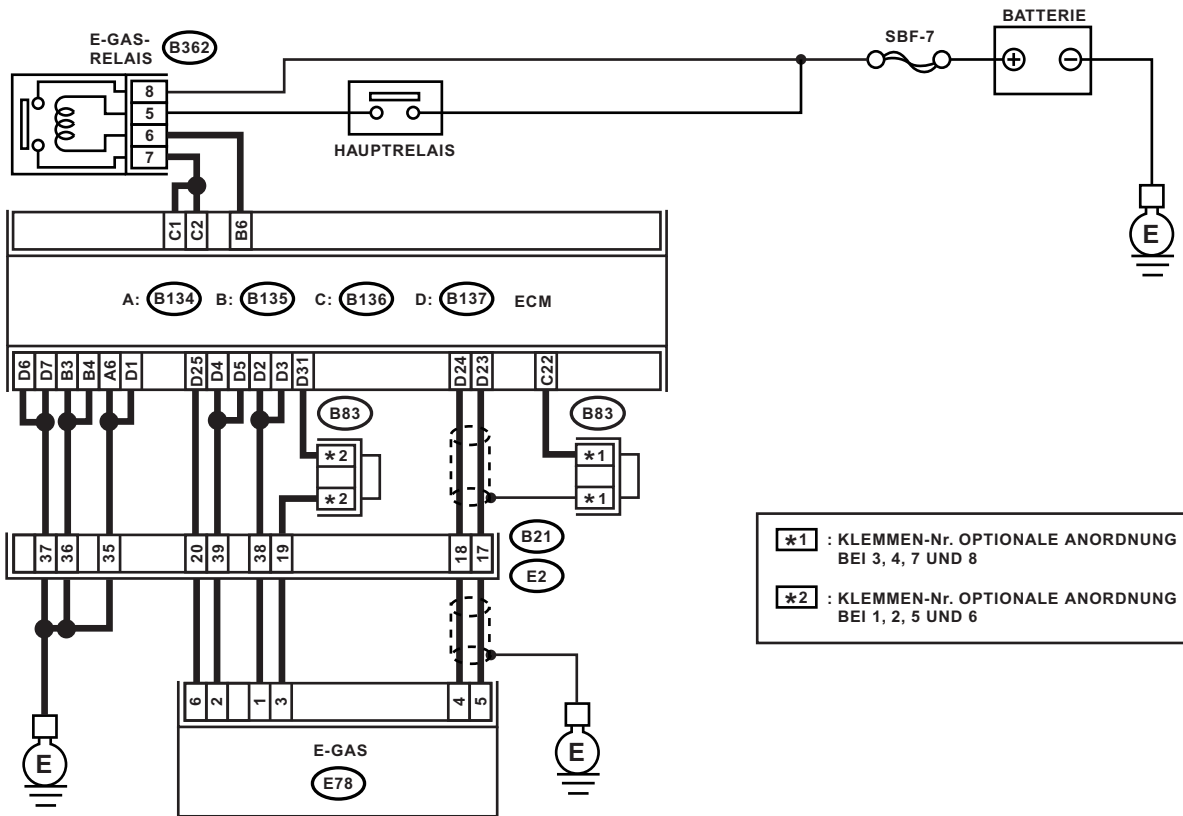

*1 : KLEMMEN-Nr. OPTIONALE ANORDNUNG
BEI 3, 4, 7 UND 8

*2 : KLEMMEN-Nr. OPTIONALE ANORDNUNG
BEI 1, 2, 5 UND 6

B362

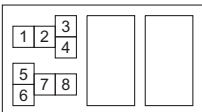

A: B134

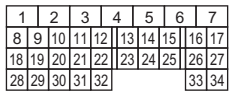

B: B135

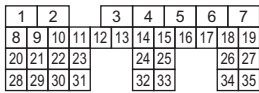

B21

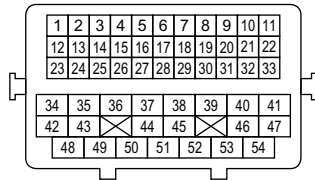

E78

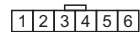

B83

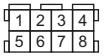

C: B136

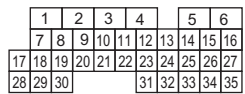

D: B137

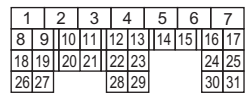

HAUPTRELAIS

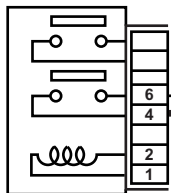

B47

BATTERIE

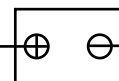

SBF-7



E35

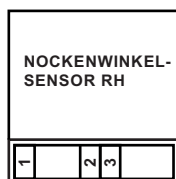

E36

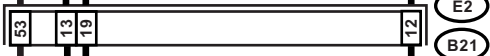

E2

B21

B83

B137 ECM

* : KLEMMEN-Nr. OPTIONALE ANORDNUNG BEI 1, 2, 5 UND 6



E35

E36



B47



B83

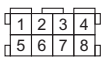

B137

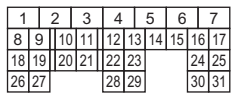

B21

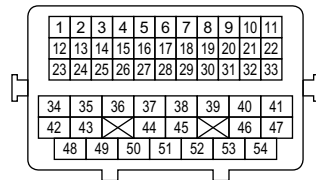

HAUPTRELAIS

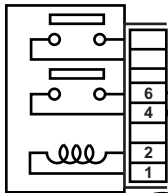

B47

BATTERIE

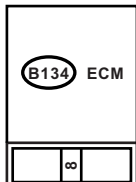
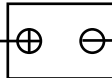

B134 ECM



B21

E2



E4

KRAFTSTOFFDUNST-MAGNETVENTIL



B47

1	2
3	4
5	6

B134

1	2	3	4	5	6	7			
8	9	10	11	12	13	14	15	16	17
18	19	20	21	22	23	24	25	26	27
28	29	30	31	32				33	34

B21

1	2	3	4	5	6	7	8	9	10	11
12	13	14	15	16	17	18	19	20	21	22
23	24	25	26	27	28	29	30	31	32	33
34	35	36	37	38	39	40	41			
42	43	44	45	46	47					
48	49	50	51	52	53	54				

E4

1	2
---	---

HAUPTRELAIS

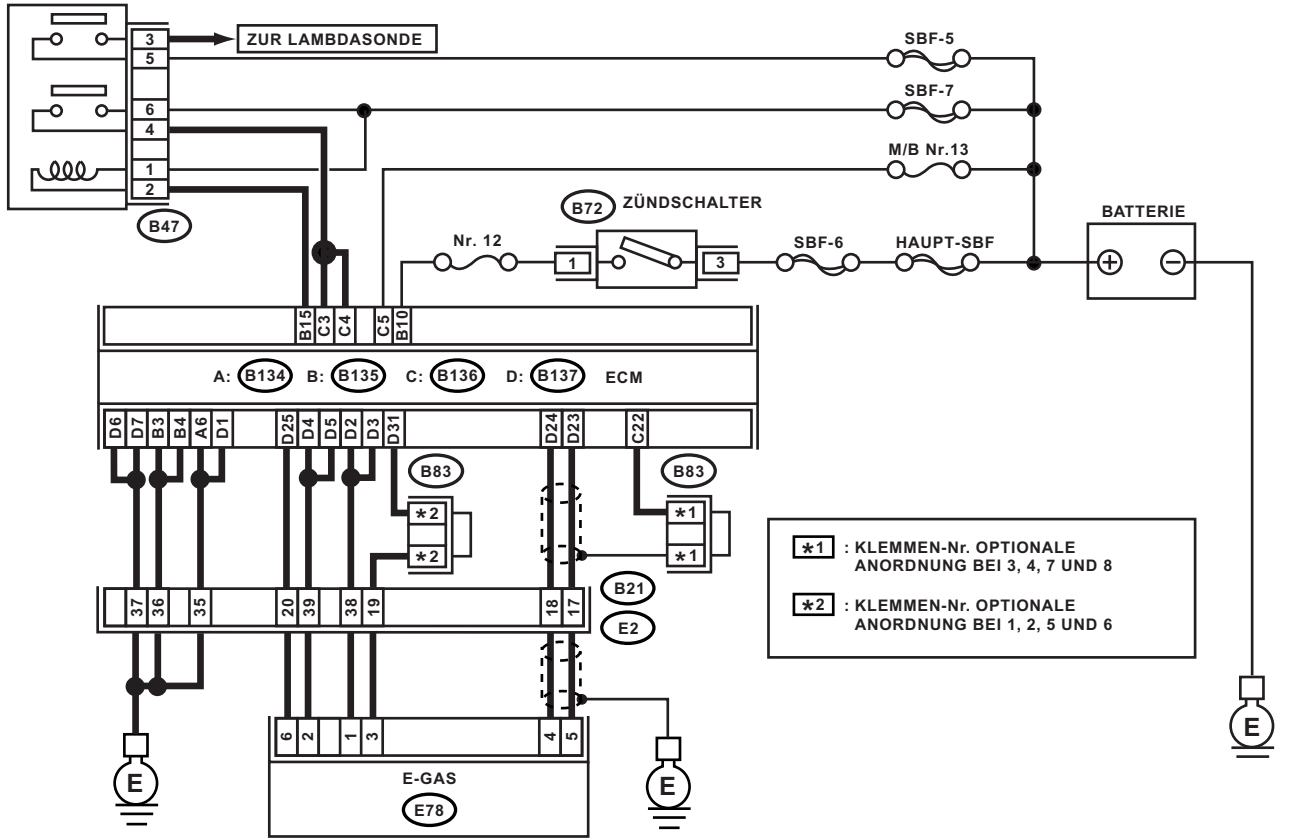

B47



B72



A: (B134)

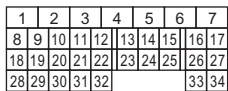

B: (B135)

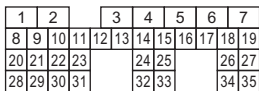

B21

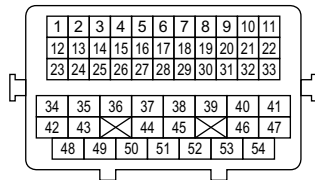

E78

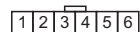

C: (B136)

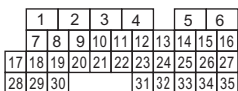

D: (B137)

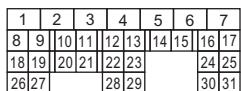

B83

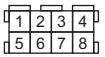

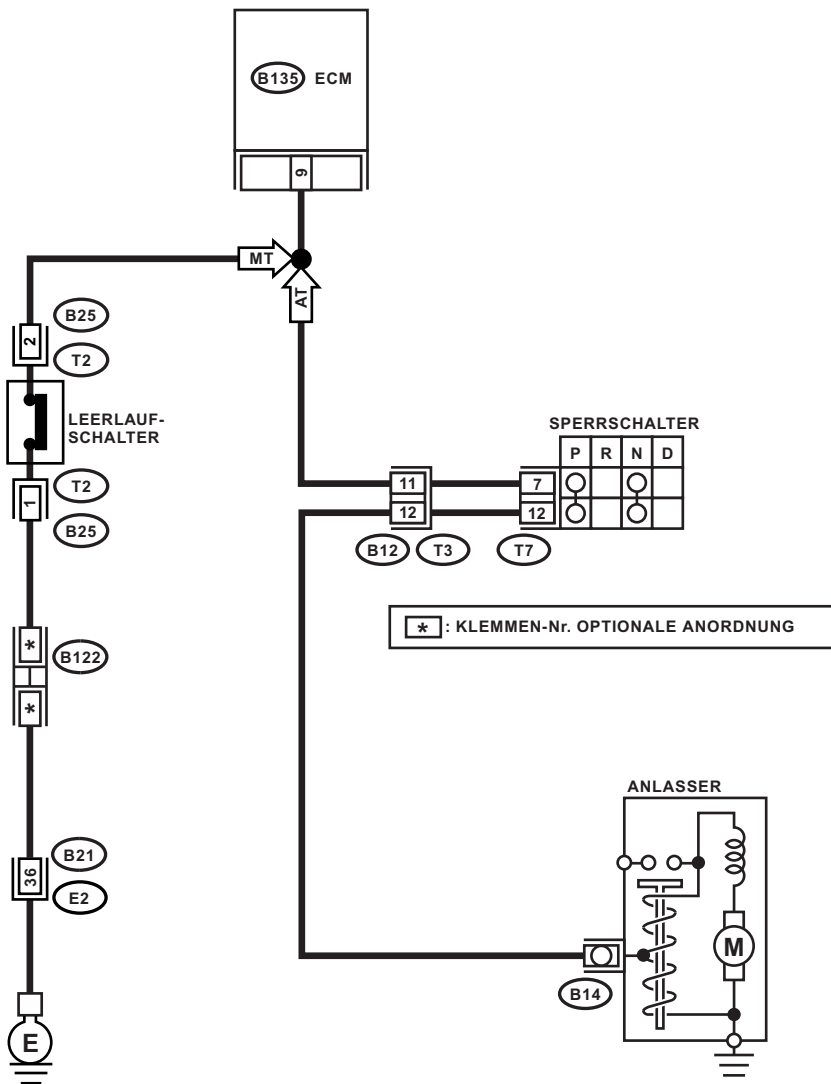

B135

1	2	3	4	5	6	7					
8	9	10	11	12	13	14	15	16	17	18	19
20	21	22	23	24	25	26	27				
28	29	30	31	32	33	34	35				

B25

1	2
---	---

B12

1	2	3	4
5	6	7	8
9	10	11	12

T7

1	2	3	4	5	6
7	8	9	10	11	12

B122

1	2	3	4
5	6	7	8

B21

1	2	3	4	5	6	7	8	9	10	11
12	13	14	15	16	17	18	19	20	21	22
23	24	25	26	27	28	29	30	31	32	33
34	35	36	37	38	39	40	41			
42	43	44	45	46	47					
48	49	50	51	52	53	54				

HAUPTRELAIS

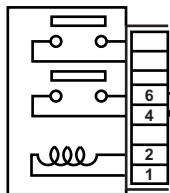

B47



BATTERIE

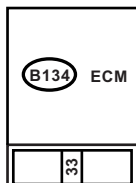
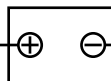

B134 ECM



B21

E2



E38

ÖLFLUSS-STEERMAGNETVENTIL RH



B134

1	2	3	4	5	6	7			
8	9	10	11	12	13	14	15	16	17
18	19	20	21	22	23	24	25	26	27
28	29	30	31	32				33	34

B21

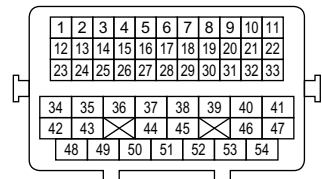

E38



HAUPTRELAIS

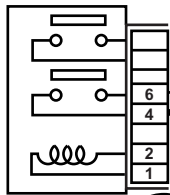

B47

BATTERIE

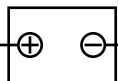

SBF-7

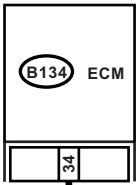

B134 ECM

34

53 27

B21

E2

1 2

E37

ÖLFLUSS-STEERMAGNETVENTIL LH



B47

1	2
3	4
5	6

B134

1	2	3	4	5	6	7			
8	9	10	11	12	13	14	15	16	17
18	19	20	21	22	23	24	25	26	27
28	29	30	31	32				33	34

E37

1	2
---	---

B21

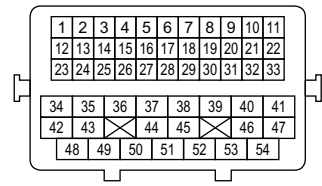

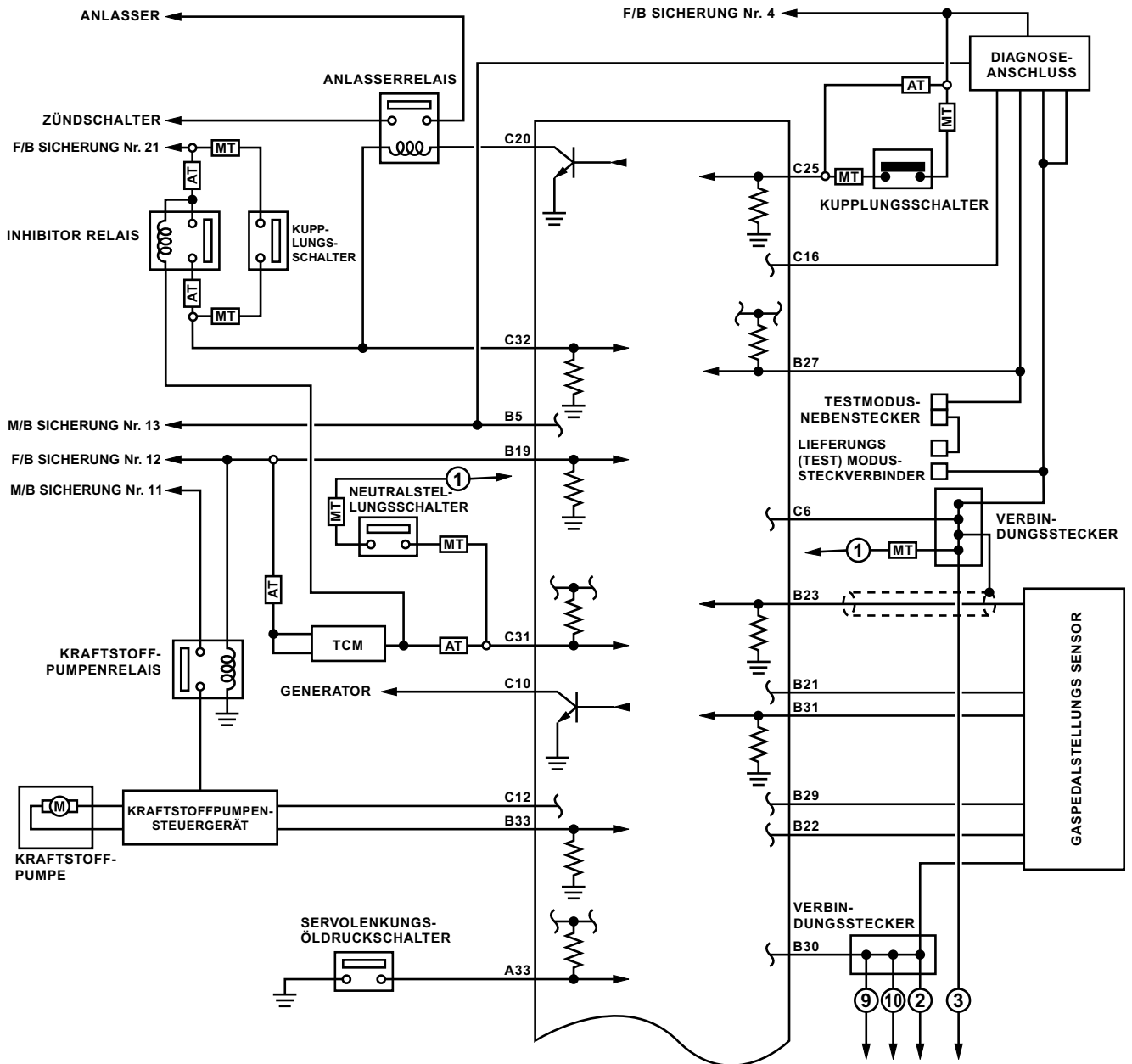

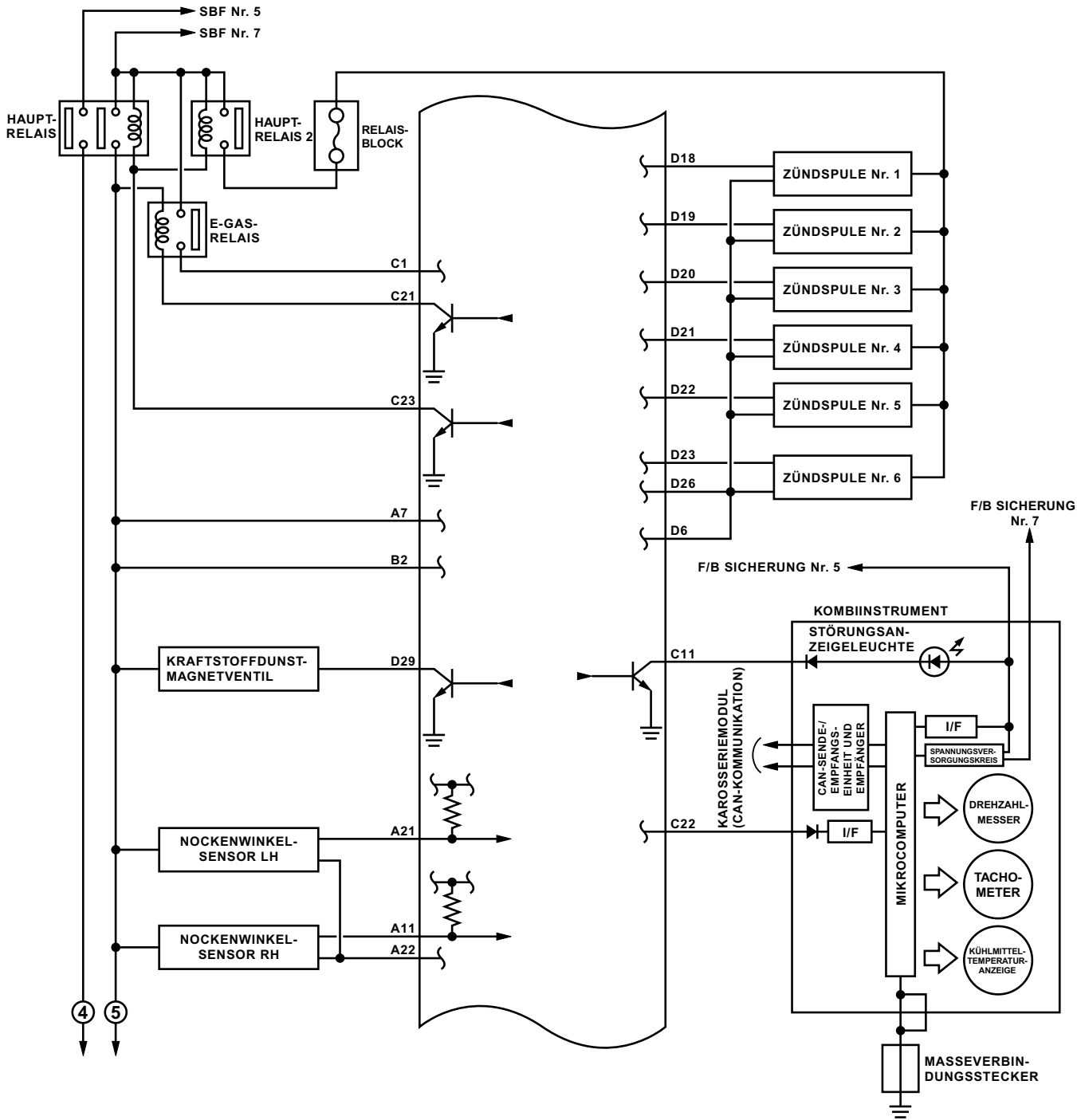

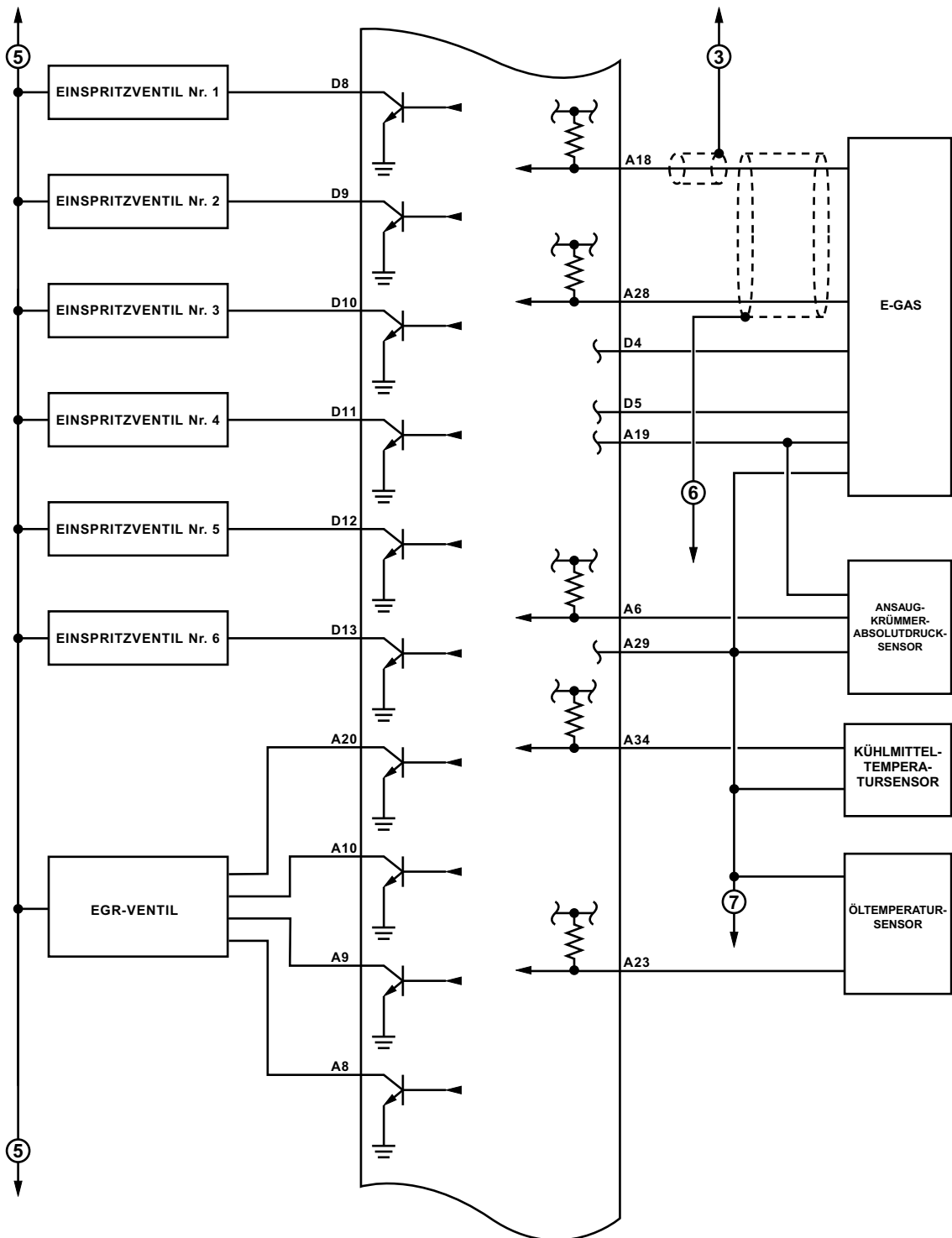

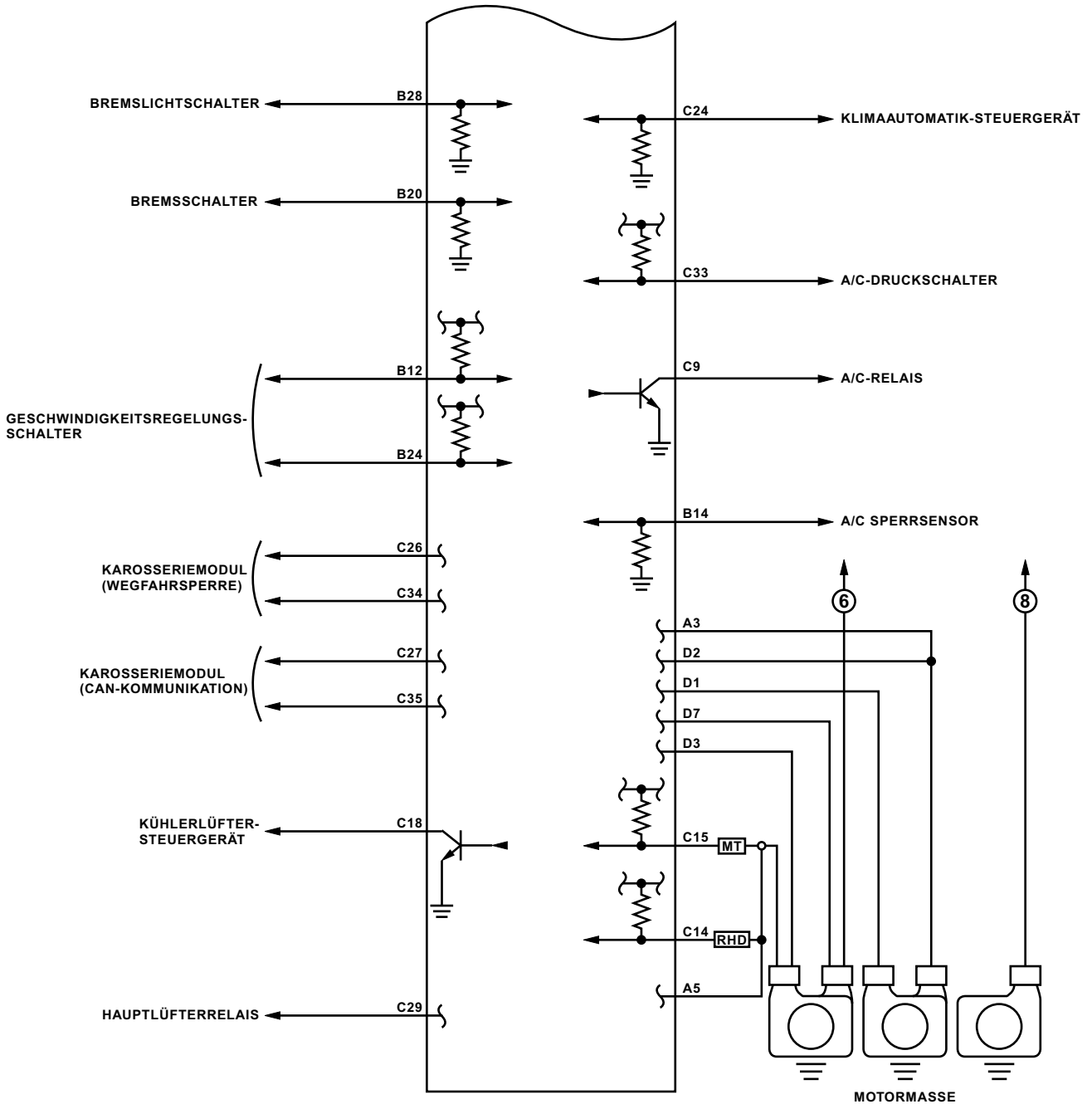

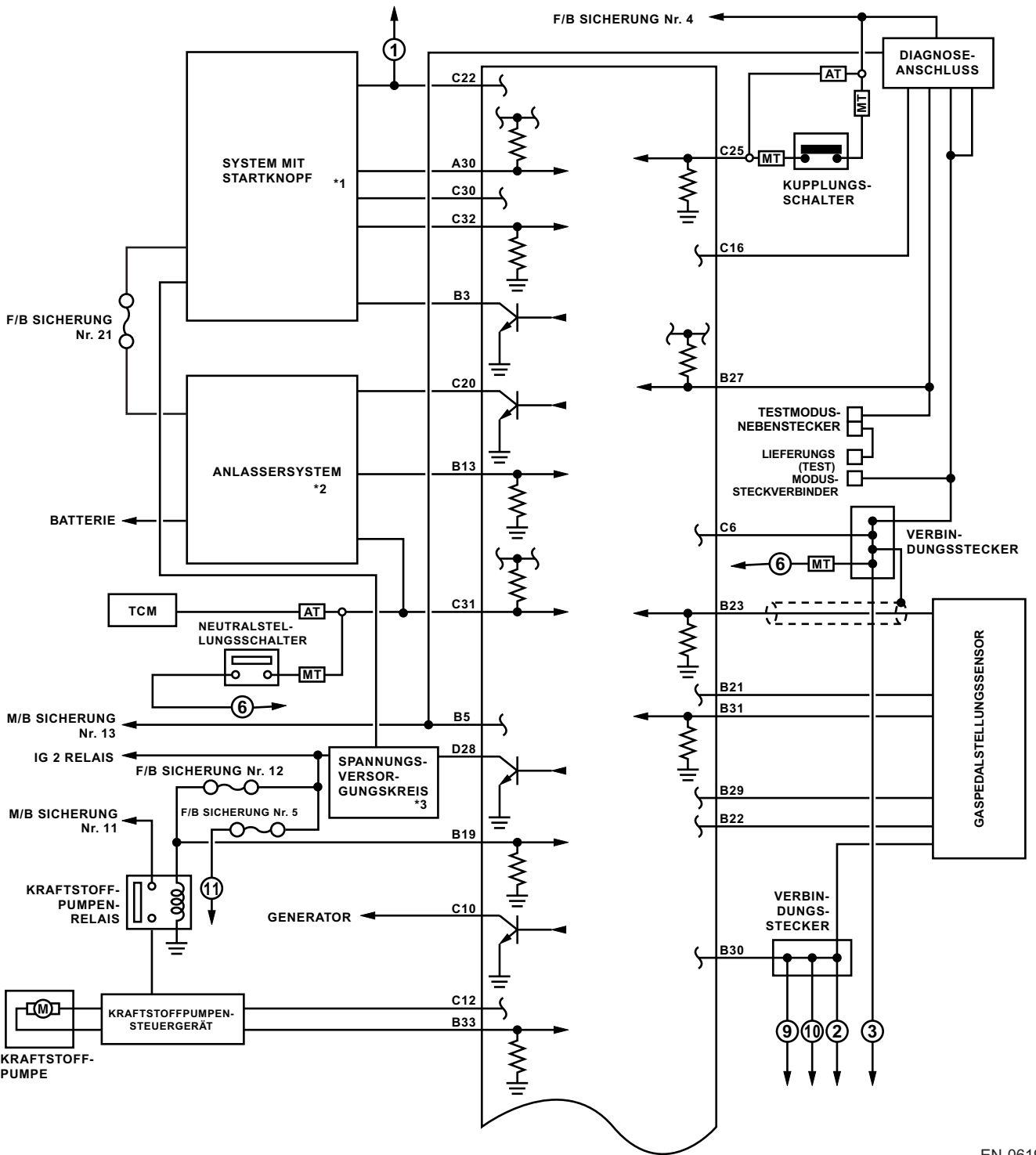

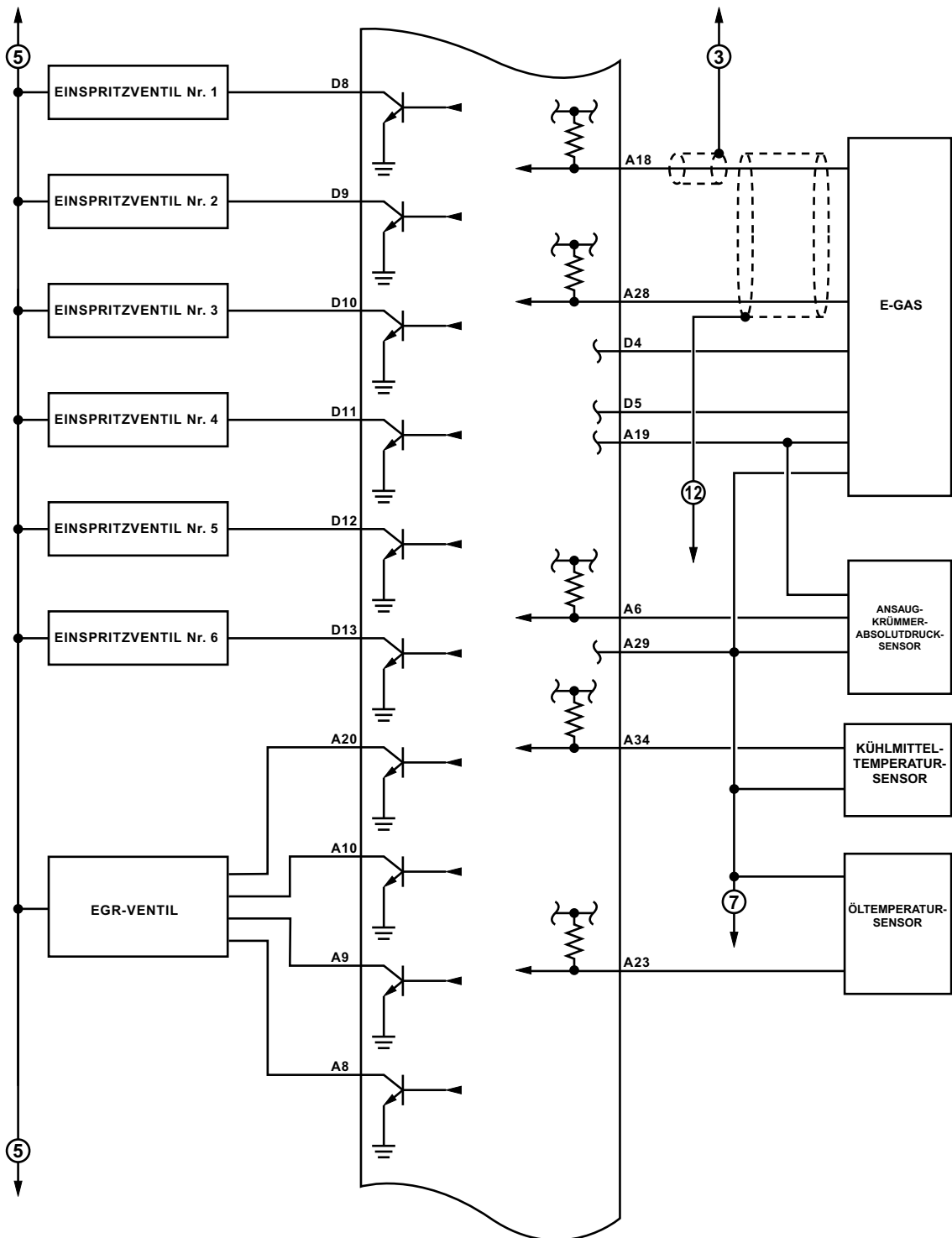

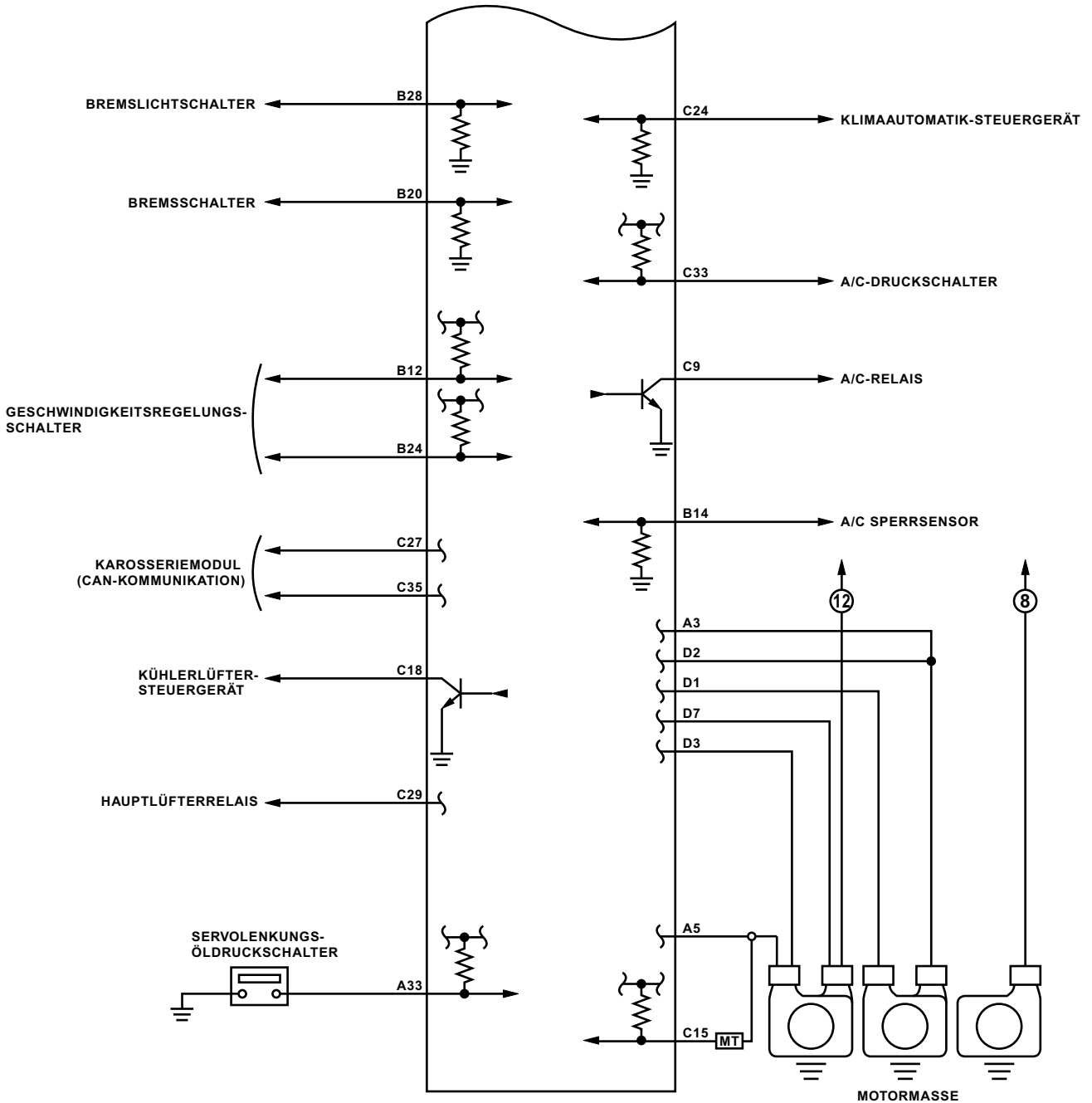

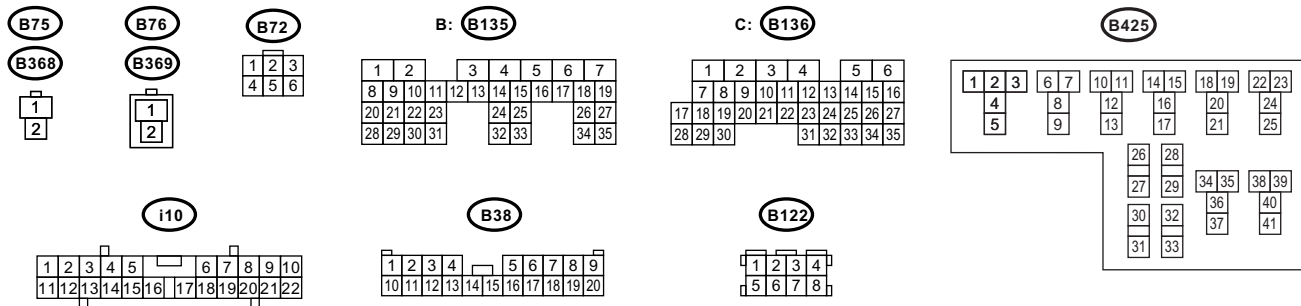
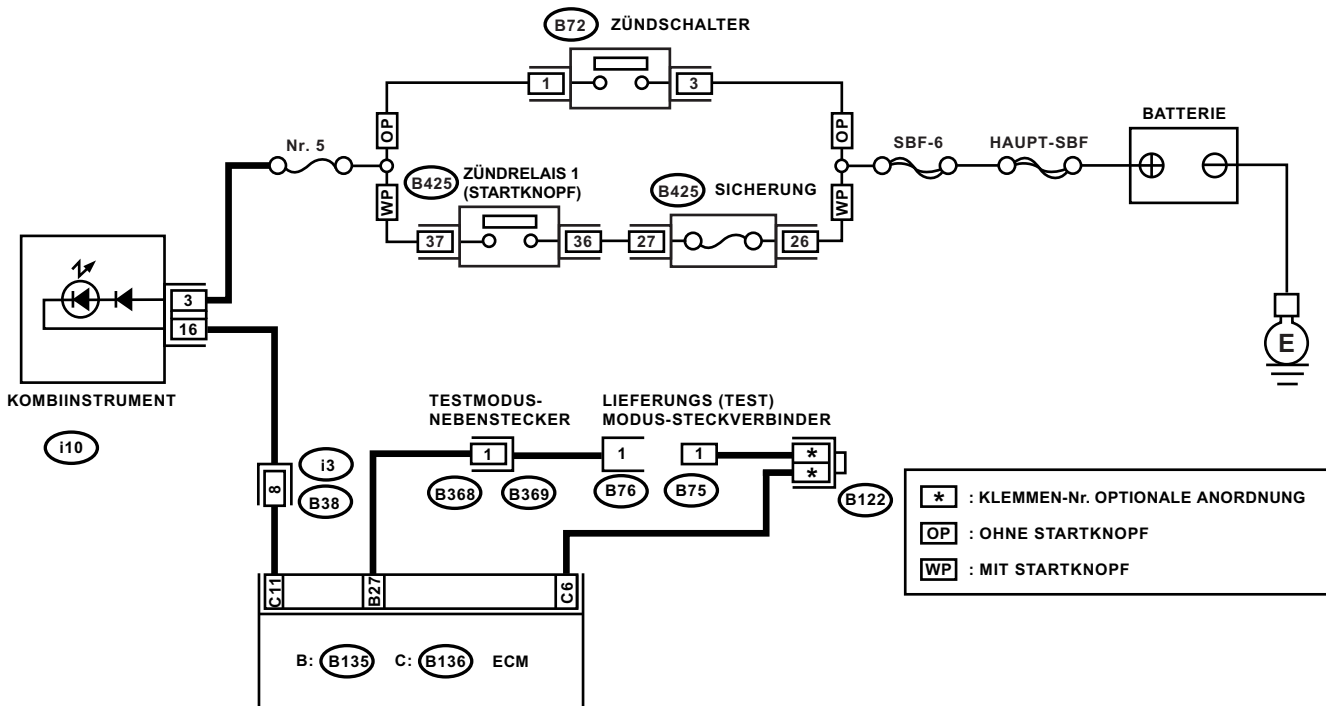

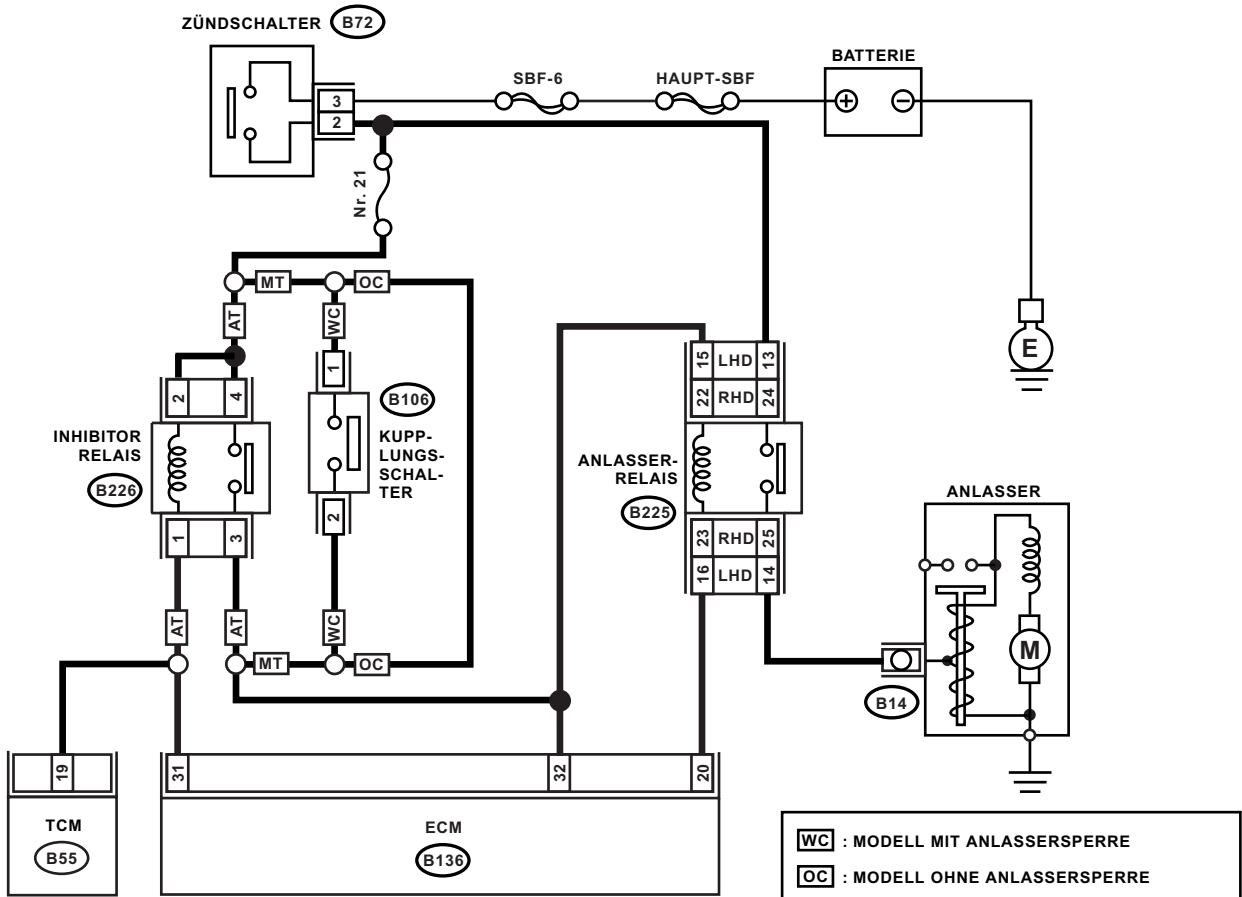

B226



B72



B55

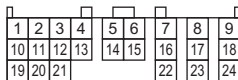

B106



LHD : B225

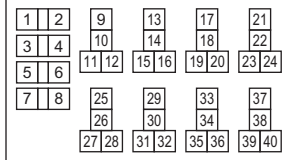

RHD : B225

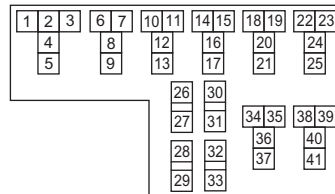

B136

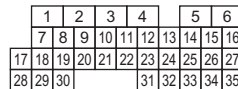

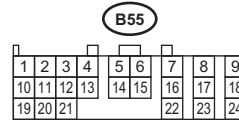
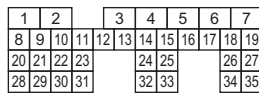
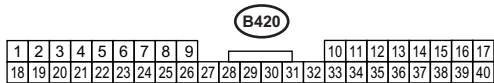
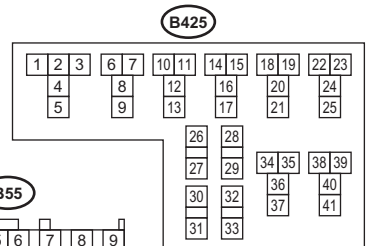
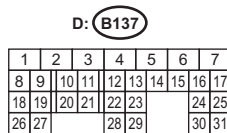
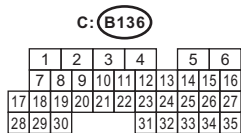
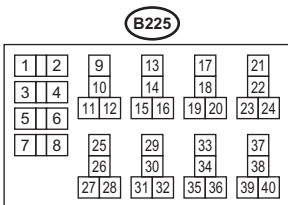
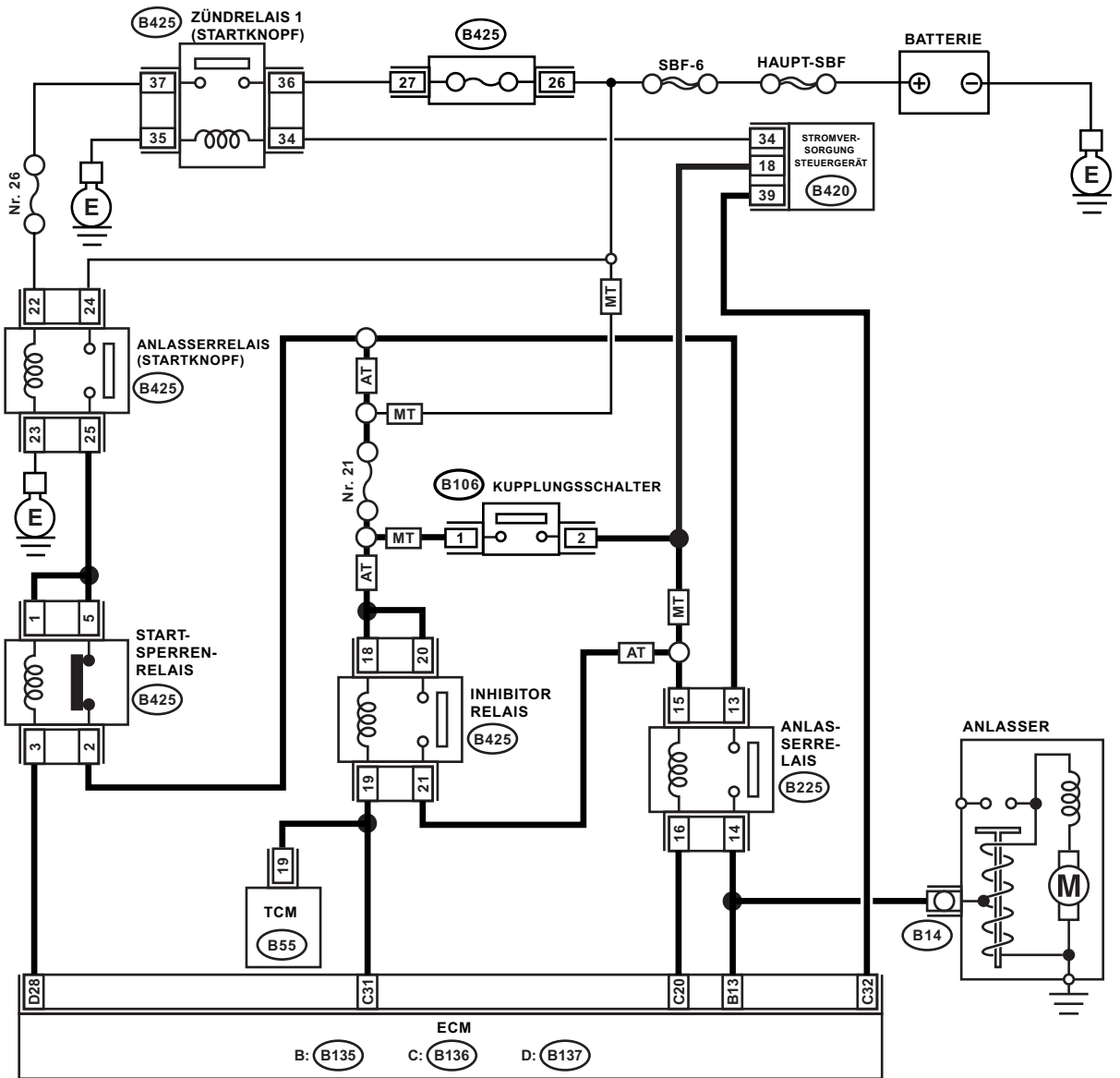

HAUPTRELAIS

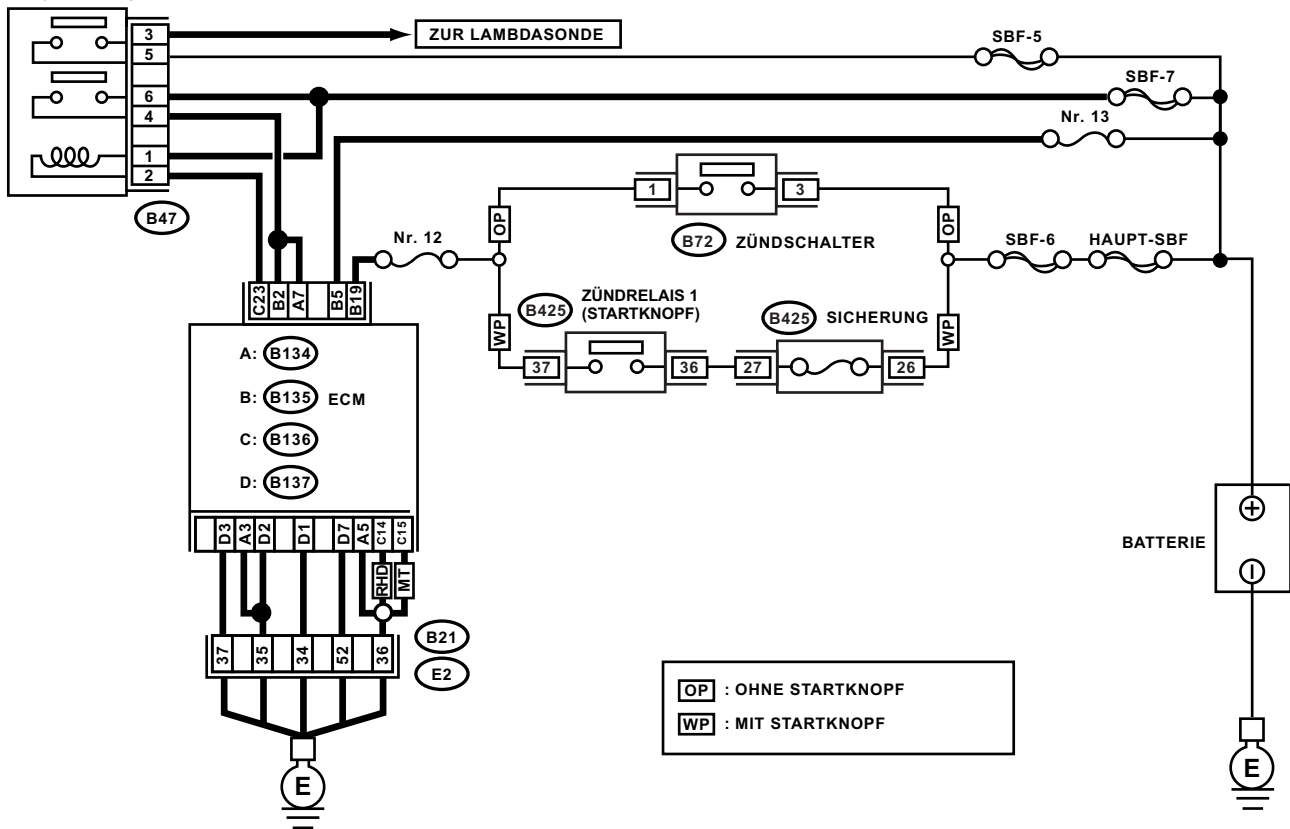

B72

1	2	3
4	5	6

B47

1	2
3	4
5	6

B21

1	2	3	4	5	6	7	8	9	10	11
12	13	14	15	16	17	18	19	20	21	22
23	24	25	26	27	28	29	30	31	32	33
34	35	36	37	38	39	40	41			
42	43	44	45	46	47					
48	49	50	51	52	53	54				

B425

1	2	3	6	7	10	11	14	15	18	19	22	23
4			8		12		16		20		24	
5			9		13		17		21		25	
					26		28					
					27		29					
					30		32		34	35	38	39
					31		33		36	37	40	41

A: B134

1	2	3	4	5	6	7
8	9	10	11	12	13	14
15	16	17	18	19	20	21
22	23	24	25	26	27	28
29	30	31	32	33	34	35

B: B135

1	2	3	4	5	6	7
8	9	10	11	12	13	14
15	16	17	18	19	20	21
22	23	24	25	26	27	28
29	30	31	32	33	34	35

C: B136

1	2	3	4	6	5
7	8	9	10	11	12
13	14	15	16	17	18
19	20	21	22	23	24
25	26	27	28	29	30
31	32	33	34	35	

D: B137

1	2	3	4	5	6	7
8	9	10	11	12	13	14
15	16	17	18	19	20	21
22	23	24	25	26	27	28
29	30	31	32	33	34	35

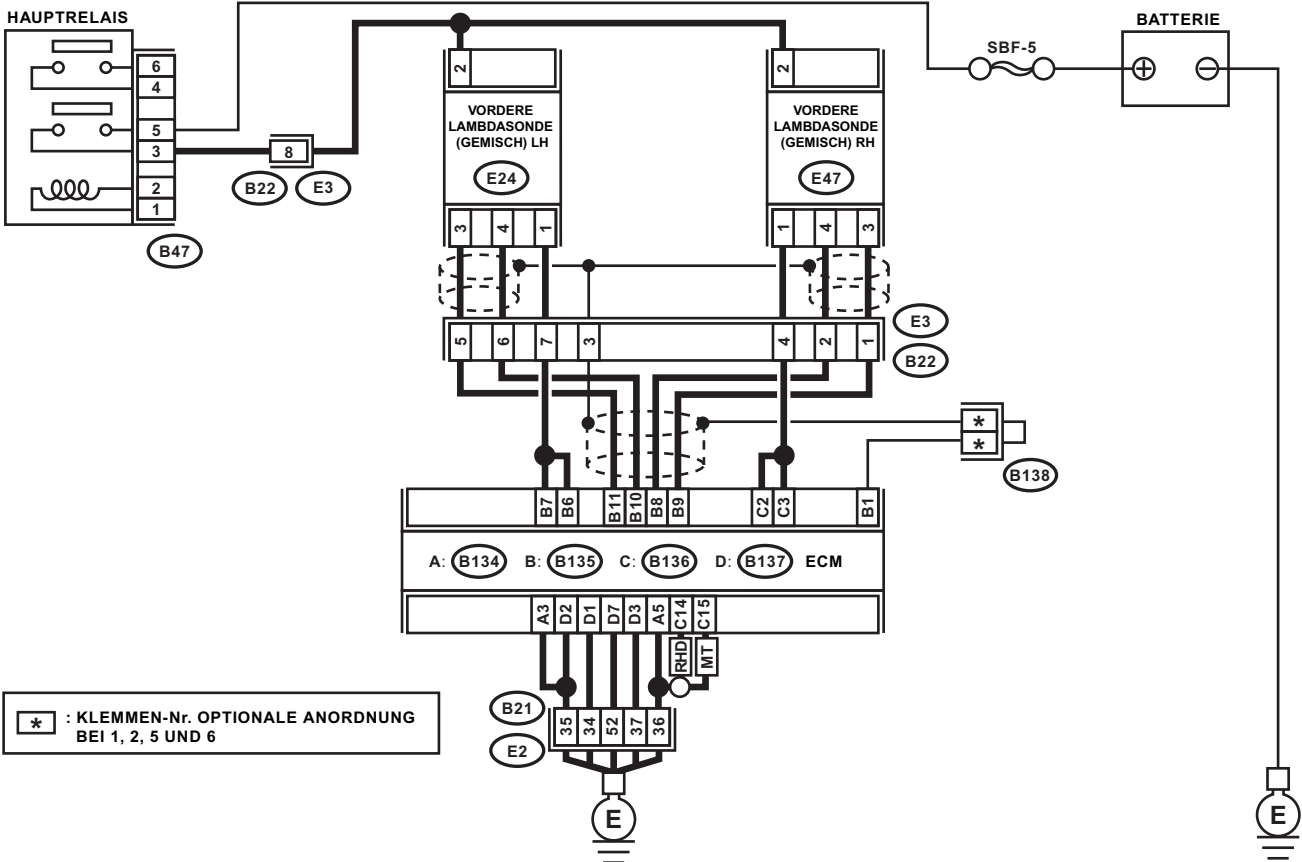

* : KLEMMEN-Nr. OPTIONALE ANORDNUNG
BEI 1, 2, 5 UND 6

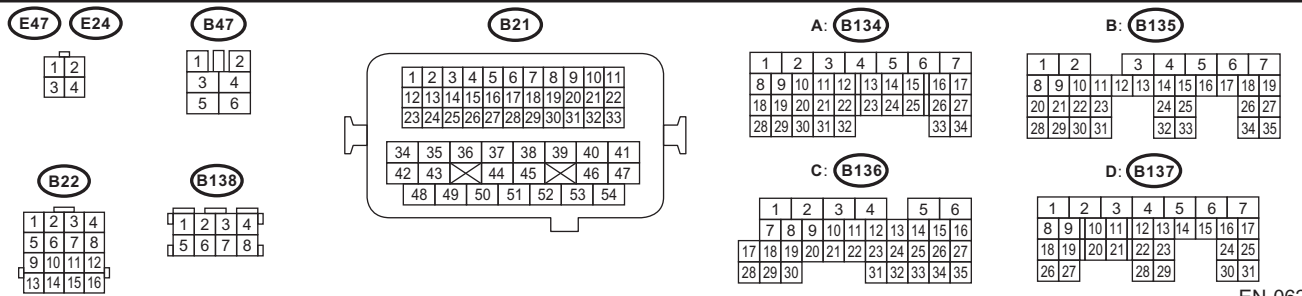

HAUPTRELAIS

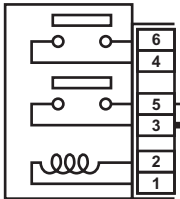

B47

B22 E3

14



SBF-5

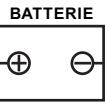

* 1 : KLEMMEN-Nr. OPTIONALE ANORDNUNG
 * 2 : KLEMMEN-Nr. OPTIONALE ANORDNUNG BEI 1, 2, 5 UND 6

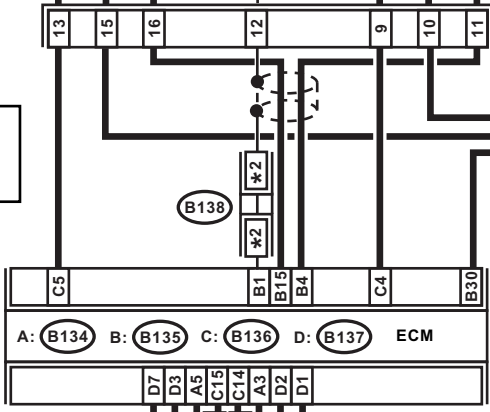

B138

*1 *1 *1
 B83

E3
 B22

B21
 E2

E

E

E25 E61



B47



A: B134

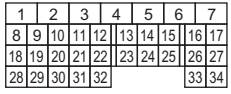

B: B135

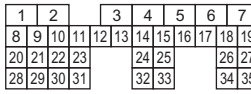

B21

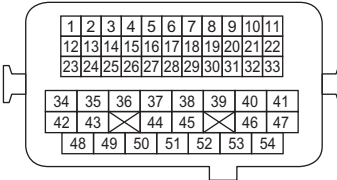

B138 B83

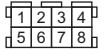

B22



C: B136

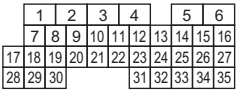

D: B137

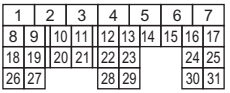

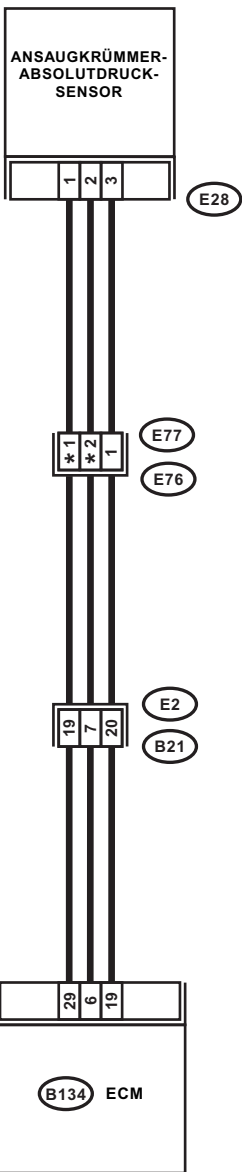

- WE** : MODELL MIT EGR
- OE** : MODELL OHNE EGR
- * 1** : MIT EGR : 5
OHNE EGR : 6
- * 2** : MIT EGR : 8
OHNE EGR : 5

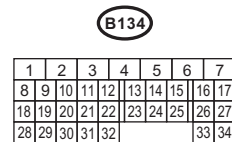
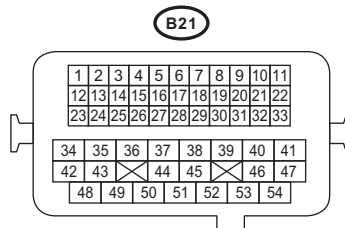
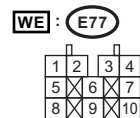
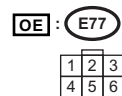

HAUPTRELAIS

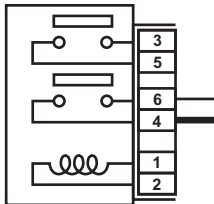

B47

BATTERIE



SBF-7

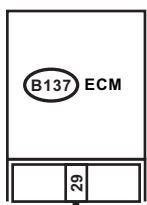

B137 ECM

29



B21

E2



E76

E77



E4

**KRAFTSTOFFDUNST-
MAGNETVENTIL**

- WE** : MODELL MIT EGR
- OE** : MODELL OHNE EGR
- *** : MIT EGR : 10
OHNE EGR : 3



B21

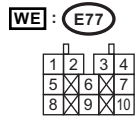
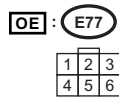
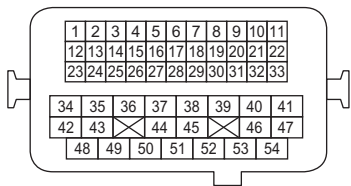

B137

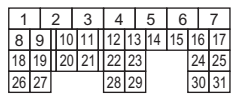

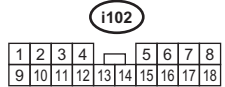
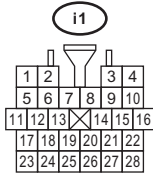
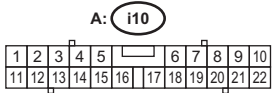
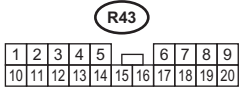
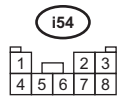
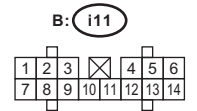
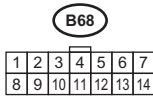
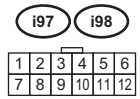
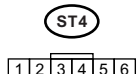
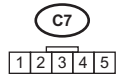
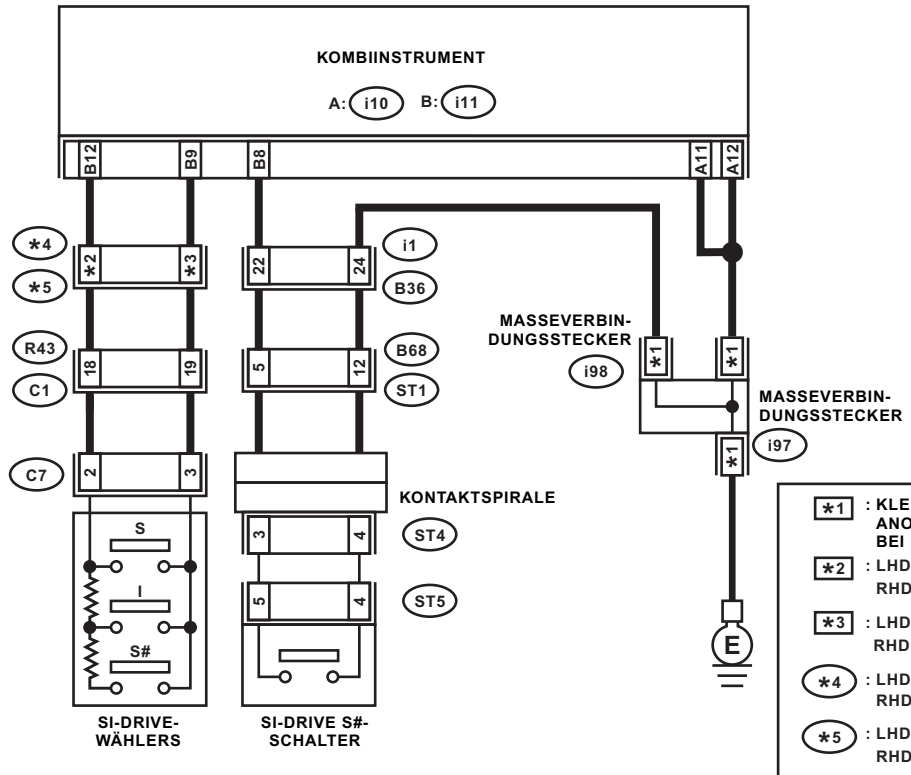

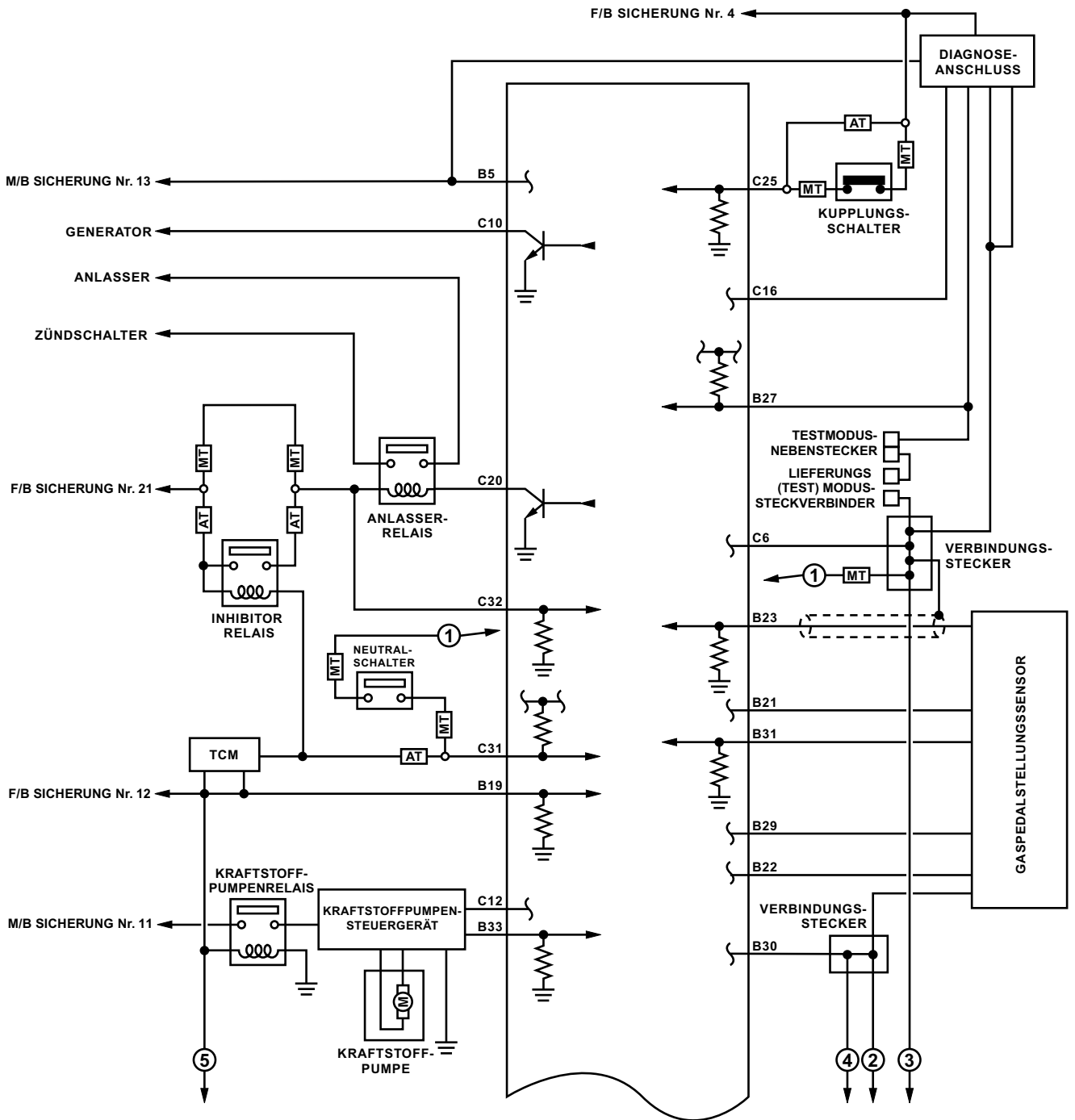

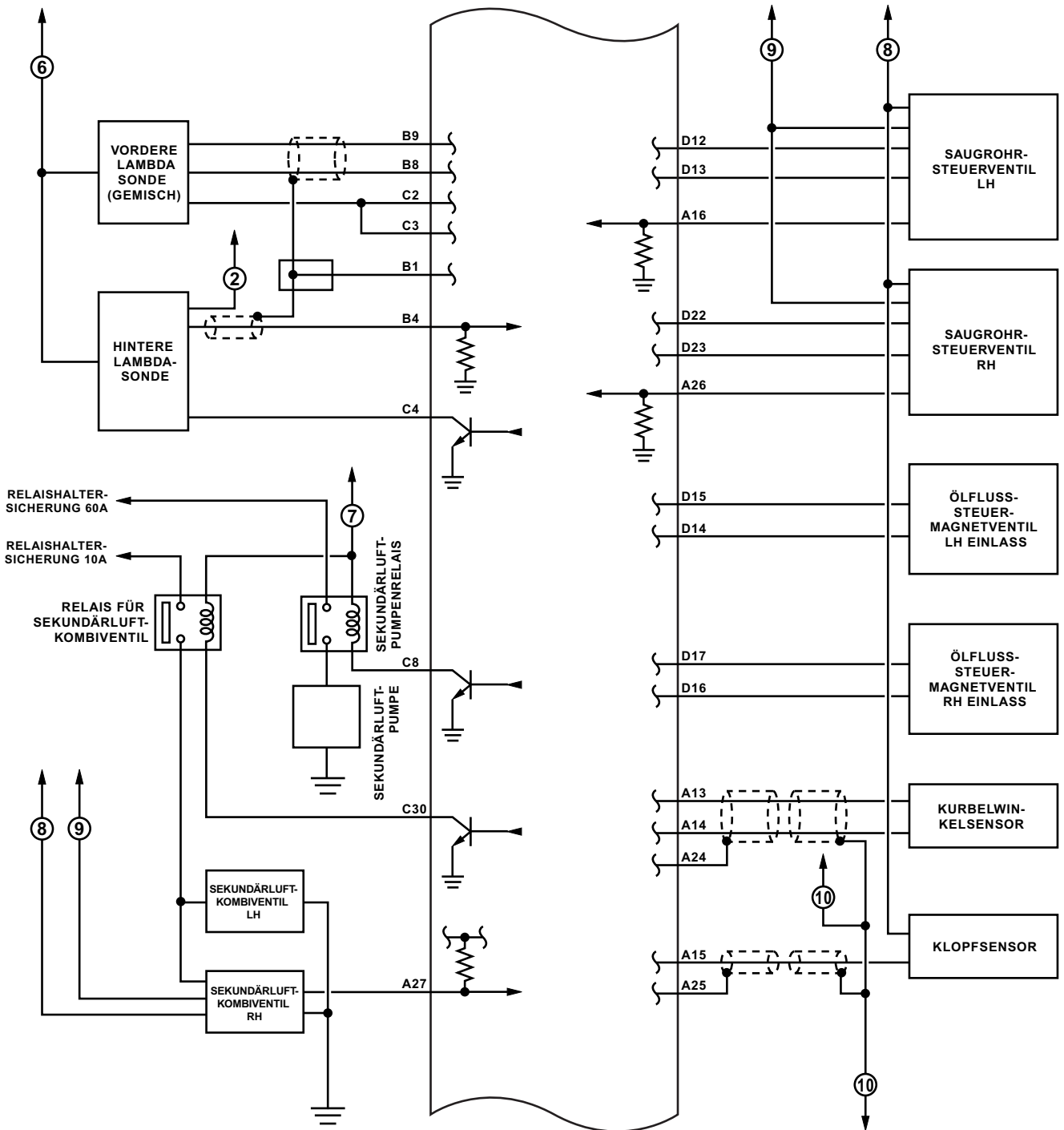

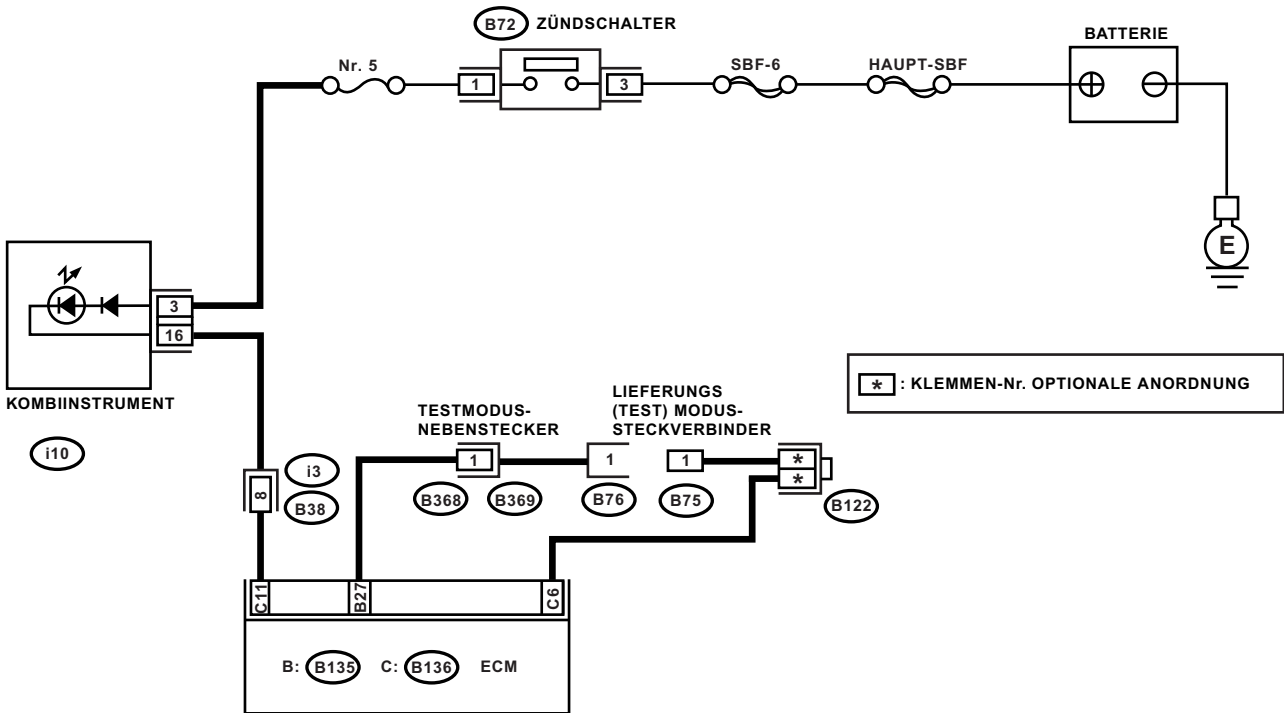

B75

B368



B76

B369



B72



B: B135

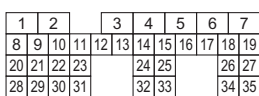

C: B136



i10

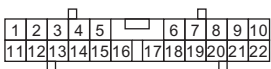

B38

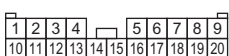

B122



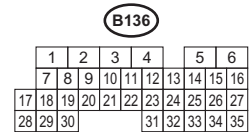
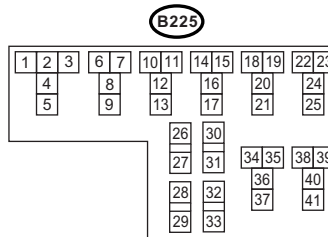
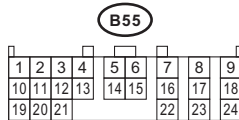
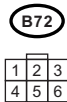
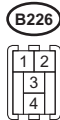
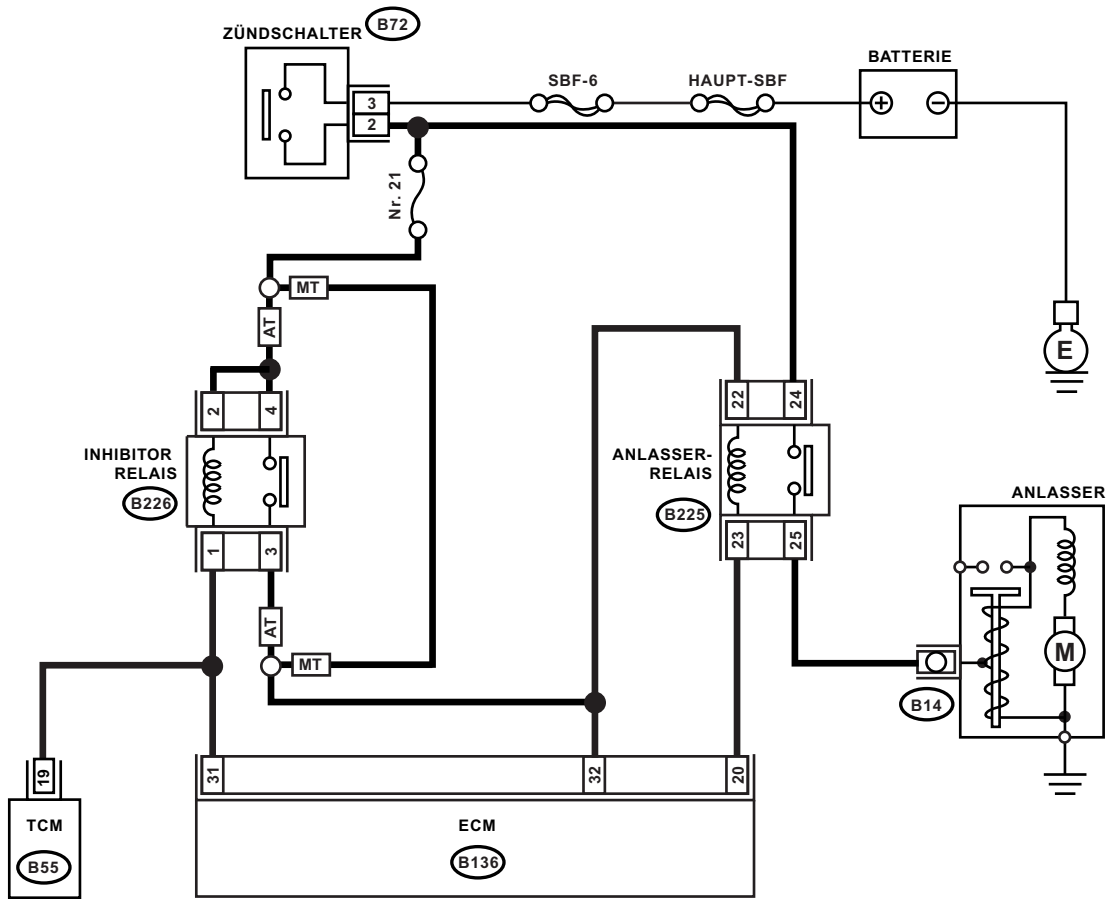

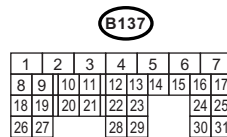
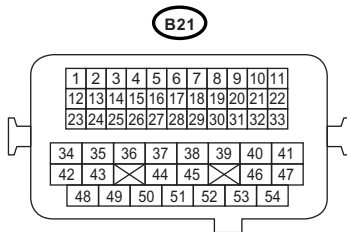
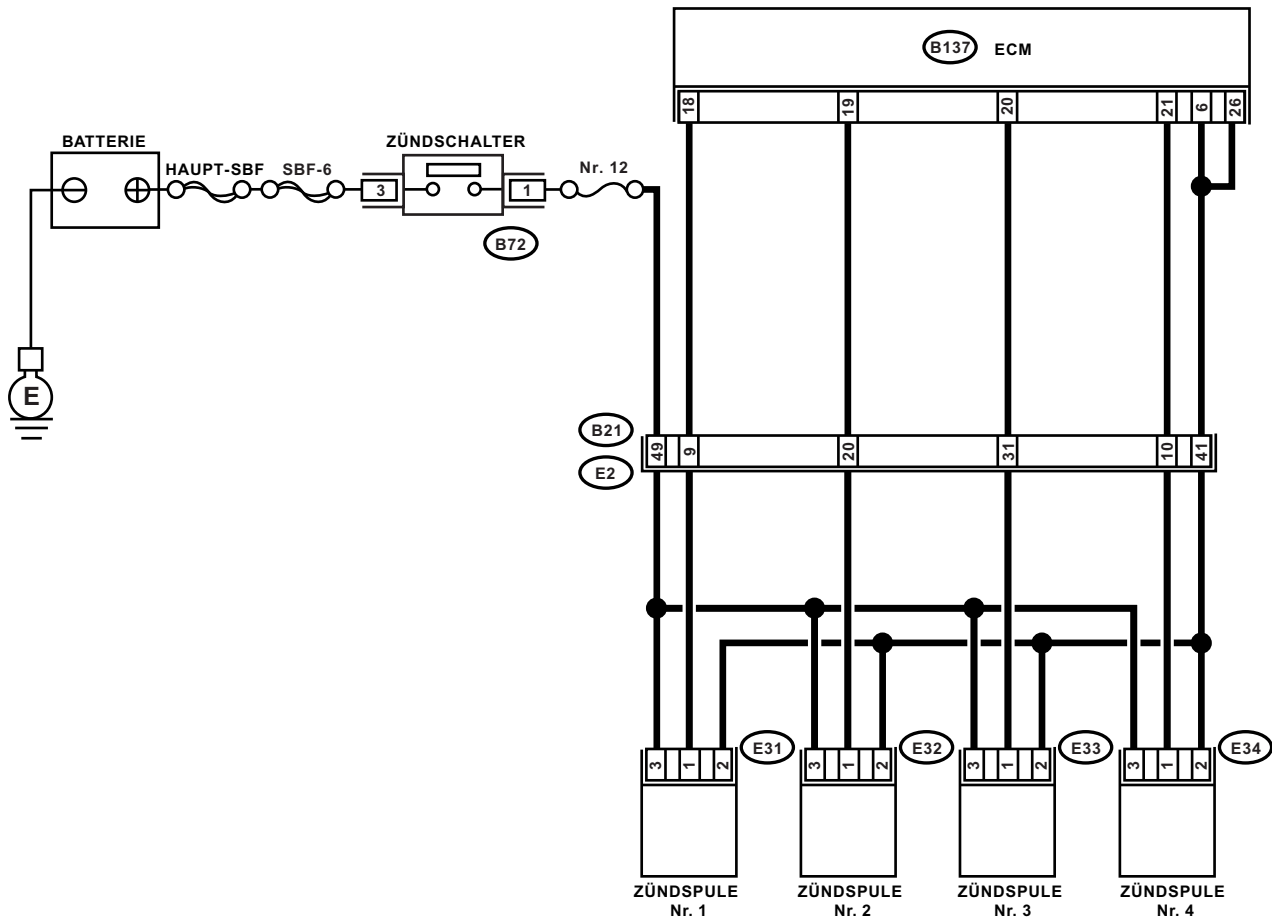

HAUPTRELAIS

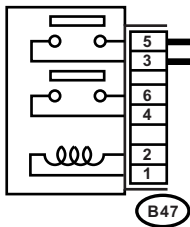

BATTERIE

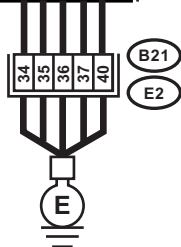
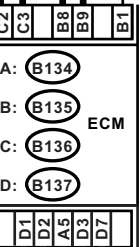
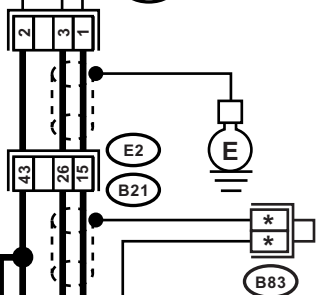
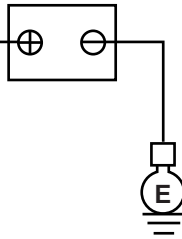

* : KLEMMEN-Nr. OPTIONALE ANORDNUNG
BEI 3, 4, 7 UND 8

E79

1	2
3	4

B47

1	2
3	4
5	6

B21

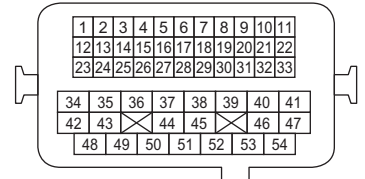

A: B134

1	2	3	4	5	6	7
8	9	10	11	12	13	14
15	16	17	18	19	20	21
22	23	24	25	26	27	28
29	30	31	32			33
						34

B: B135

1	2		3	4	5	6	7
8	9	10	11	12	13	14	15
16	17	18	19	20	21	22	23
24	25					26	27
28	29	30	31		32	33	34
							35

C: B136

1	2	3	4		5	6
7	8	9	10	11	12	13
14	15	16	17	18	19	20
21	22	23	24	25	26	27
28	29	30			31	32
					33	34
						35

D: B137

1	2	3	4	5	6	7
8	9	10	11	12	13	14
15	16	17	18	19	20	21
22	23				24	25
26	27			28	29	
					30	31

B83

1	2	3	4
5	6	7	8

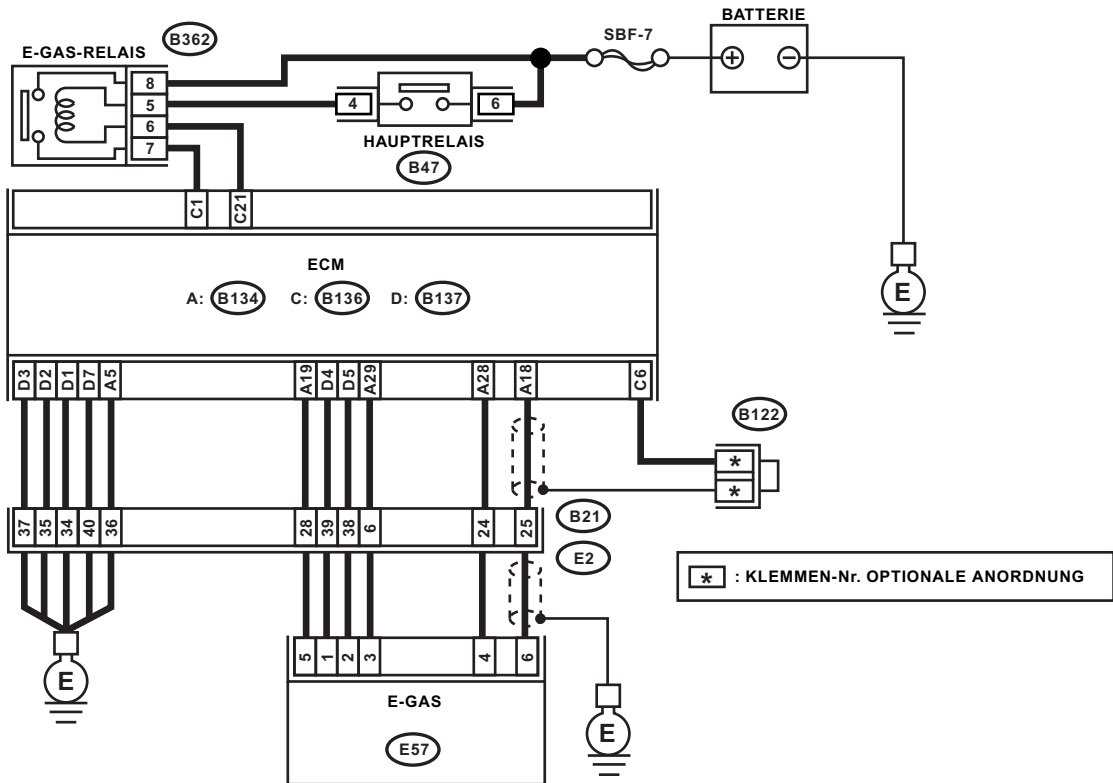

* : KLEMMEN-Nr. OPTIONALE ANORDNUNG

B362

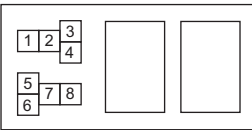

B122



B21

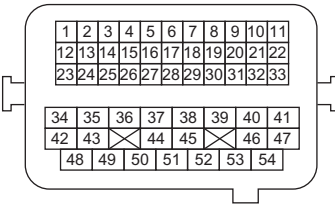

E57

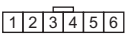

B47



A: B134

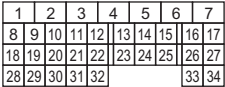

C: B136

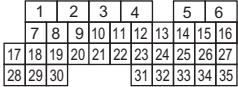

D: B137



HAUPTRELAIS

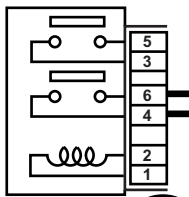

(B47)

BATTERIE

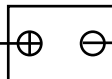

SBF-7

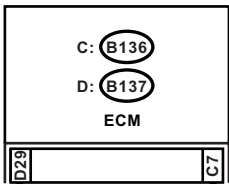

C: (B136)

D: (B137)

ECM

D29

C7

48

11

44

(B21)

(E2)

(E4)

(E52)

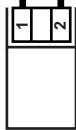

KRAFTSTOFFDUNST-
MAGNETVENTIL 1

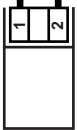

KRAFTSTOFFDUNST-
MAGNETVENTIL 2

(B47)

1	2
3	4
5	6

C: (B136)

1	2	3	4	5	6
7	8	9	10	11	12
13	14	15	16	17	18
19	20	21	22	23	24
25	26	27	28	29	30
31	32	33	34	35	

D: (B137)

1	2	3	4	5	6	7
8	9	10	11	12	13	14
15	16	17	18	19	20	21
22	23	24	25	26	27	28
29	30	31	32	33	34	35

(B21)

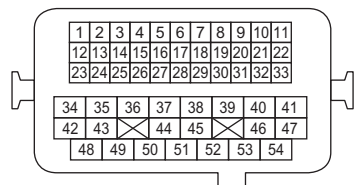

(E4)

(E52)

(1 2)

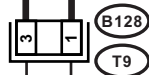
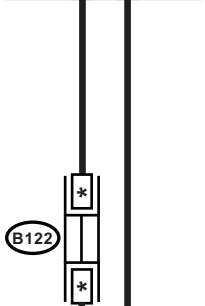
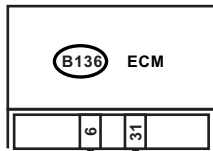

* : KLEMMEN-Nr. OPTIONALE ANORDNUNG

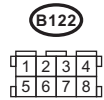
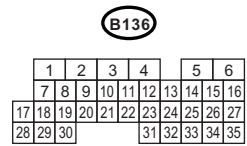

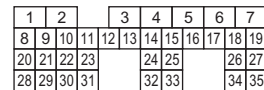
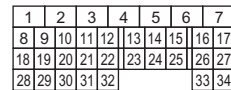
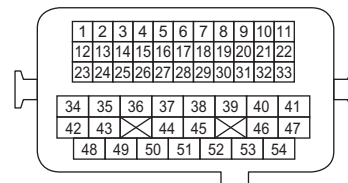
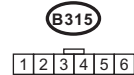
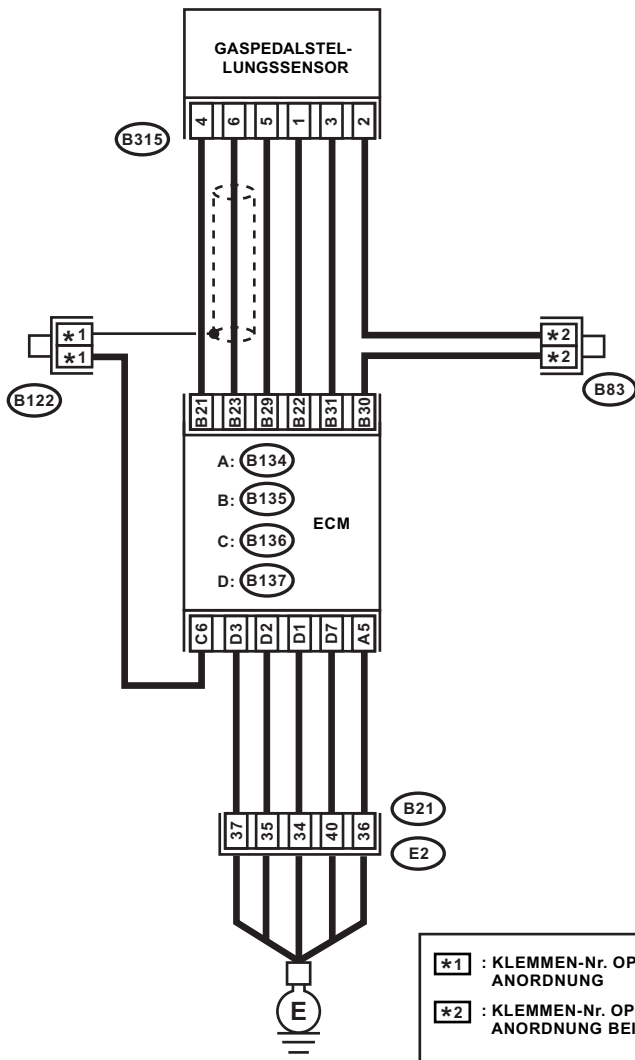

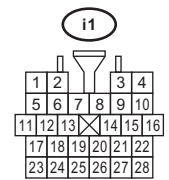
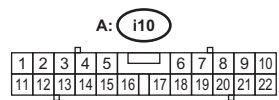
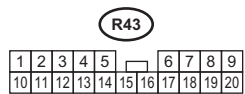
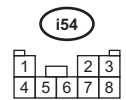
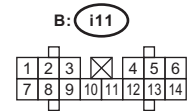
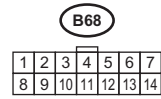
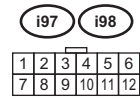
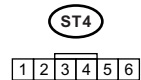
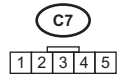
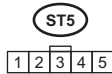
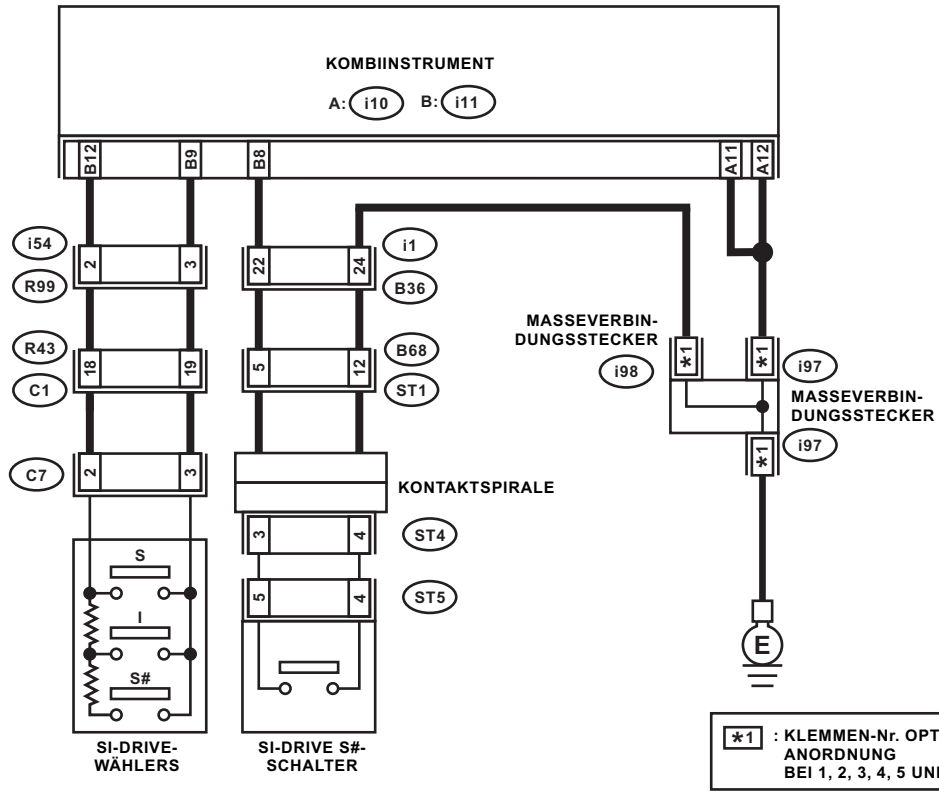

HAUPTRELAIS

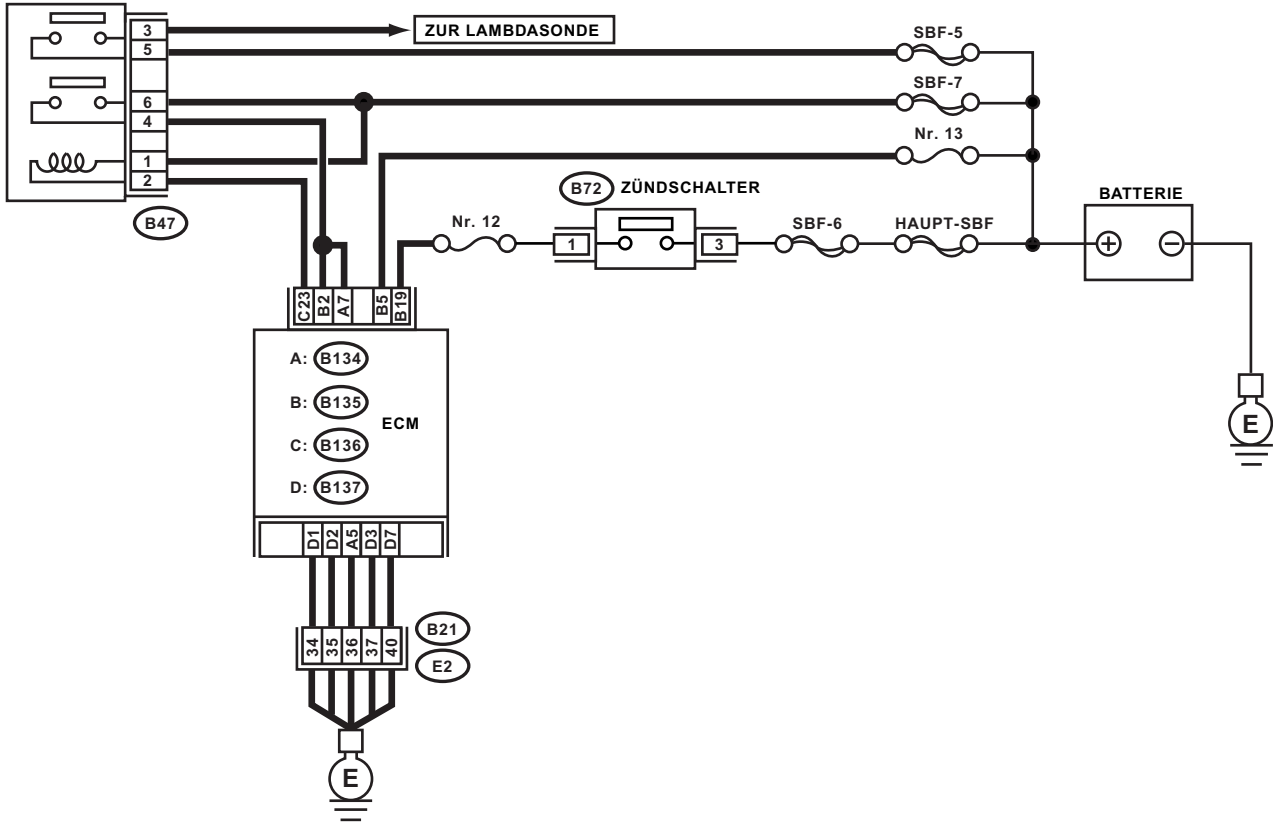

B72

1	2	3
4	5	6

B47

1	2
3	4
5	6

B21

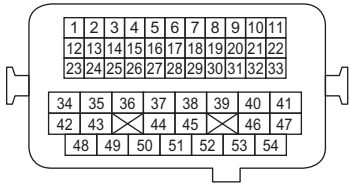

A: B134

1	2	3	4	5	6	7			
8	9	10	11	12	13	14	15	16	17
18	19	20	21	22	23	24	25	26	27
28	29	30	31	32	33		34		

B: B135

1	2	3		4	5	6	7				
8	9	10	11	12	13	14	15	16	17	18	19
20	21	22	23	24		25	26		27		
28	29	30	31	32		33	34		35		

C: B136

1	2	3	4	5		6				
7	8	9	10	11	12	13	14	15	16	
17	18	19	20	21	22	23	24	25	26	27
28	29	30	31		32	33	34	35		

D: B137

1	2	3	4	5	6	7				
8	9	10	11	12	13	14	15	16	17	
18	19	20	21	22	23	24		25		
26	27	28		29	30		31			

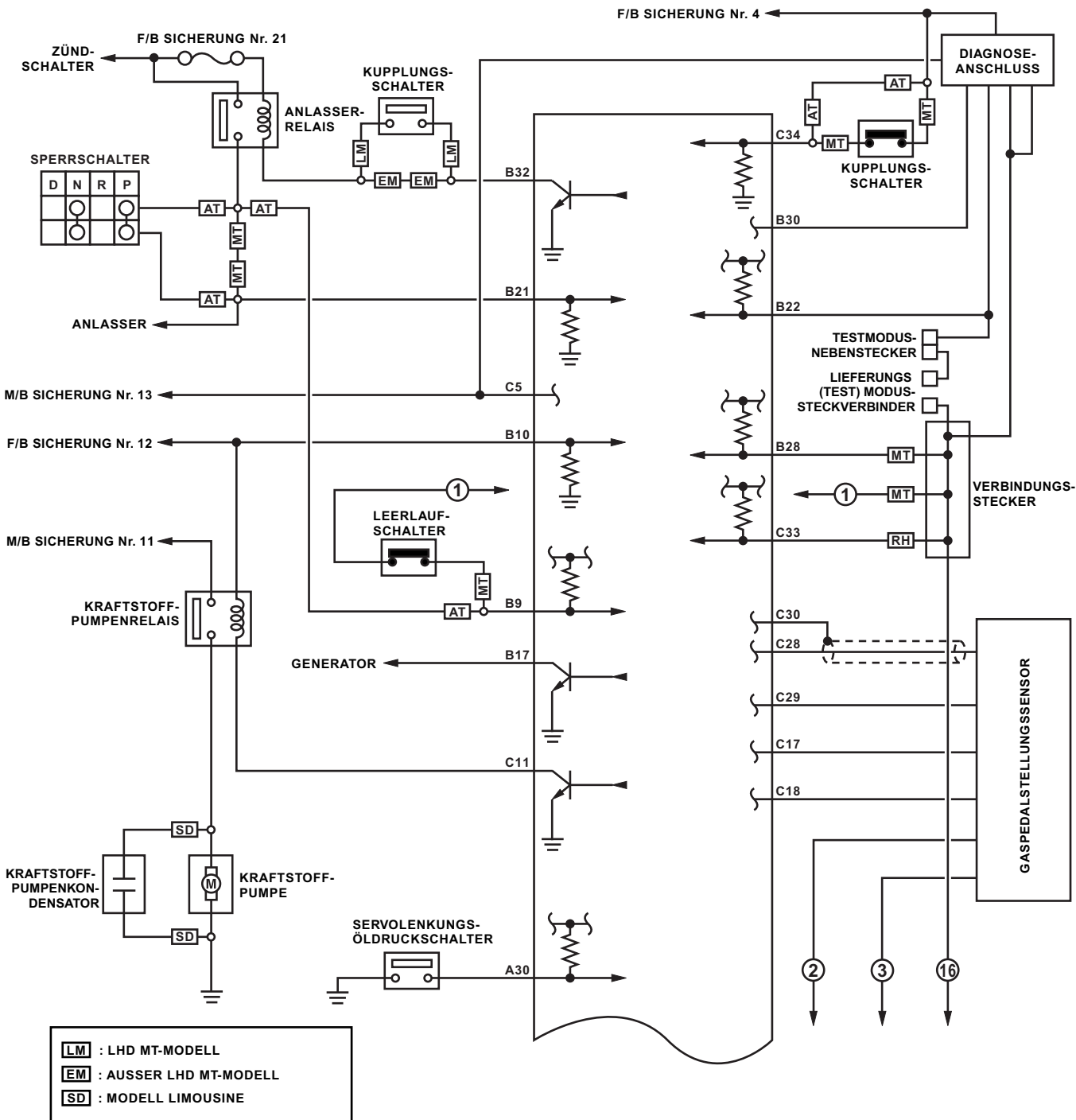

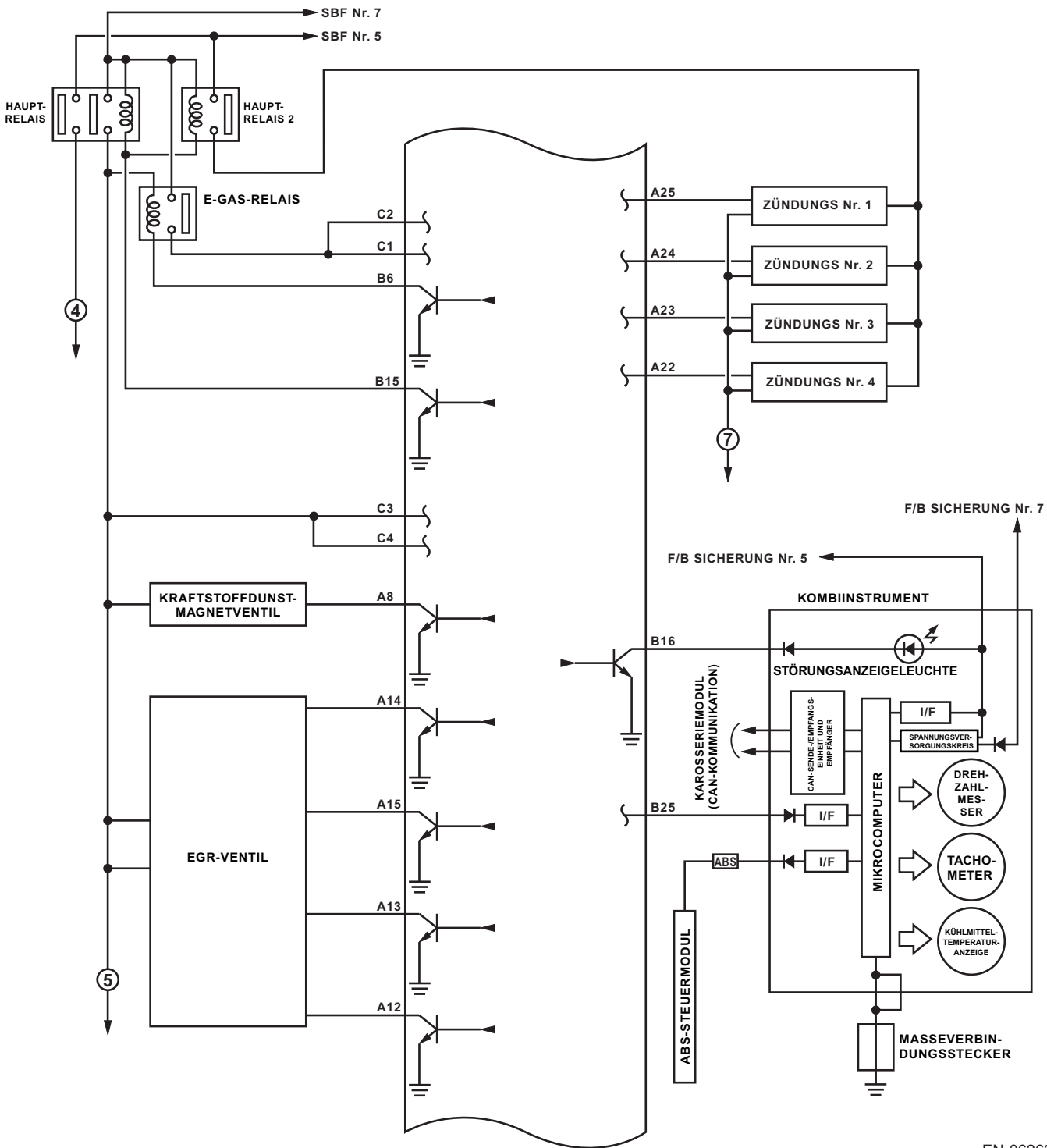

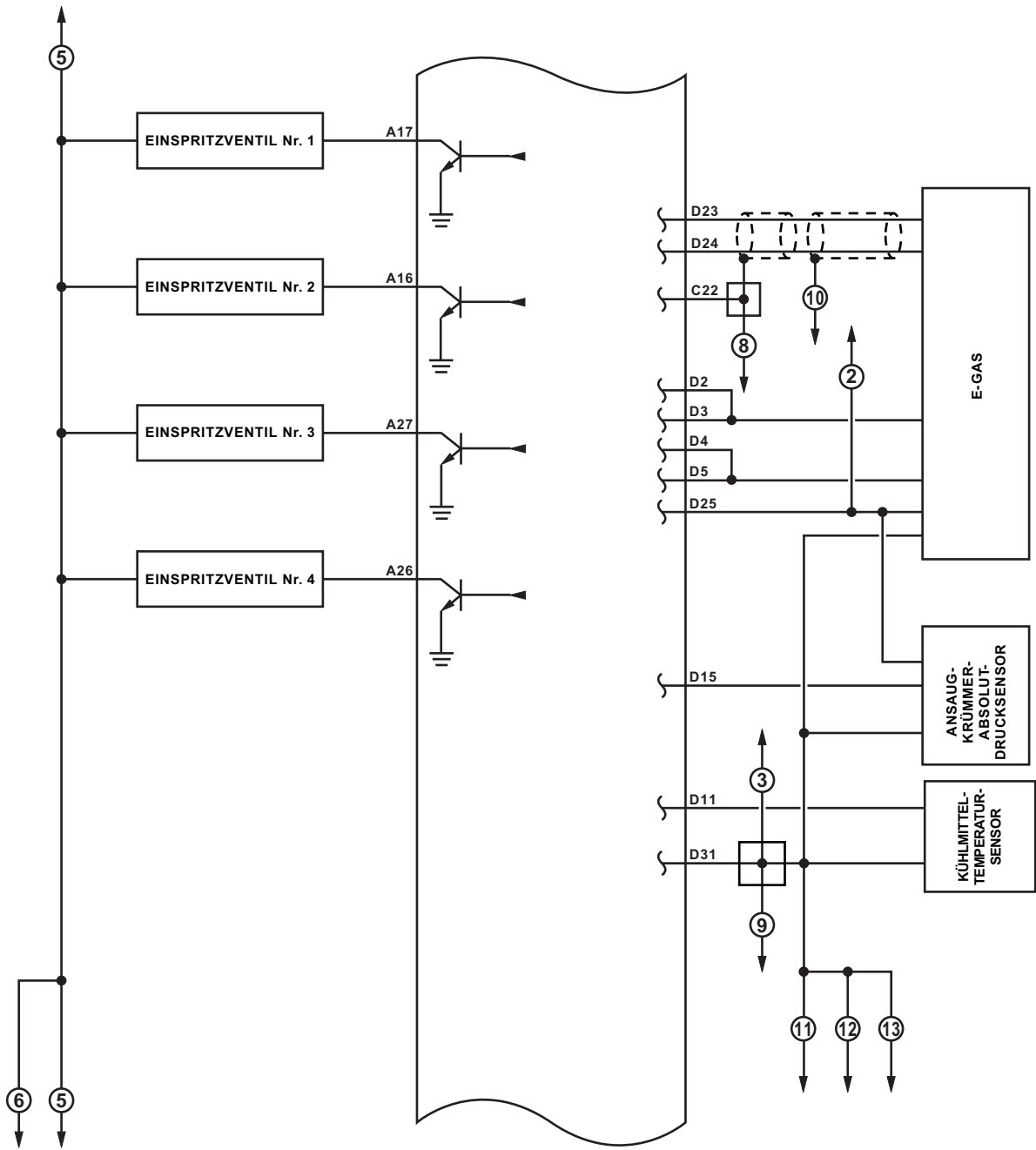

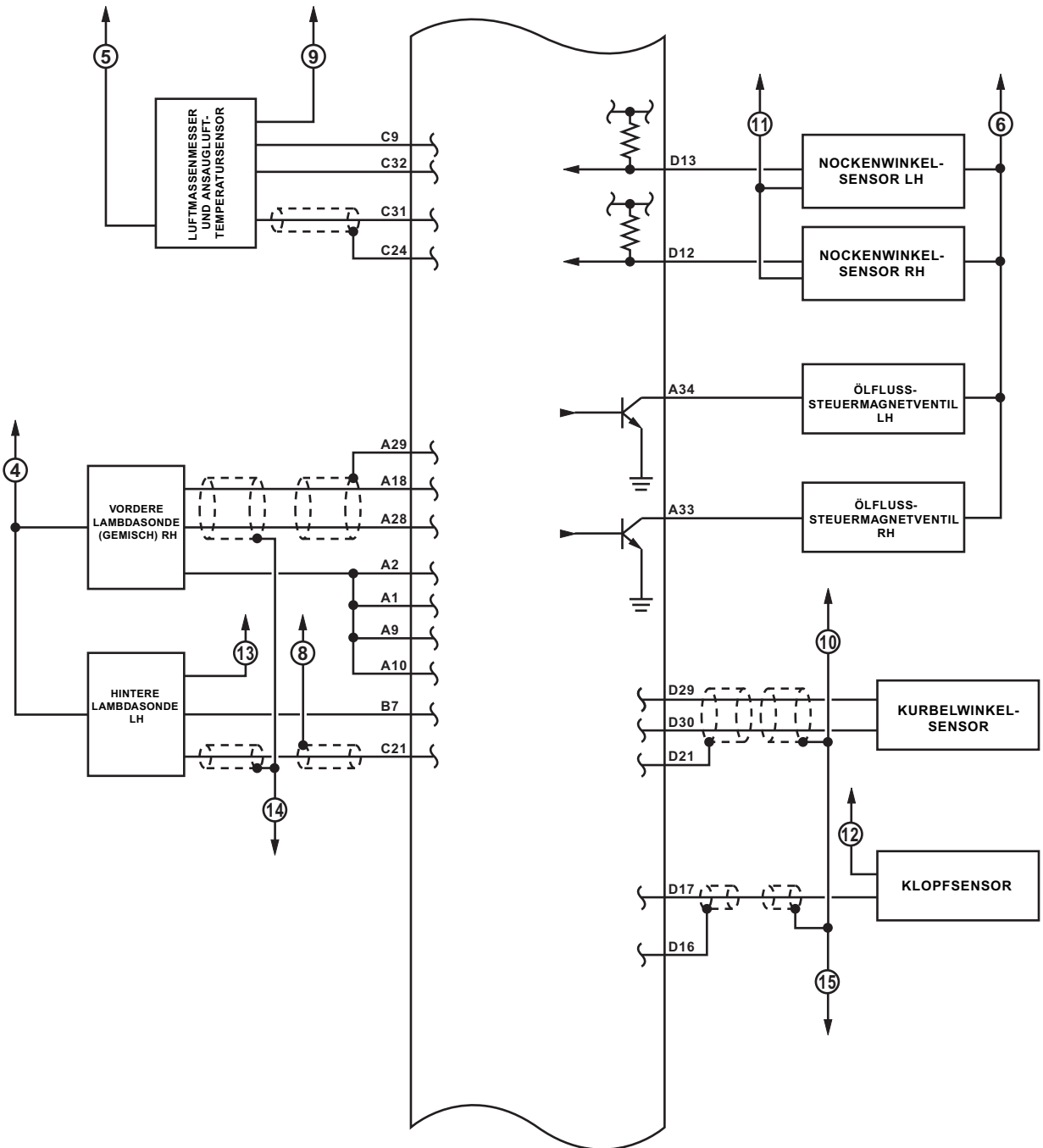

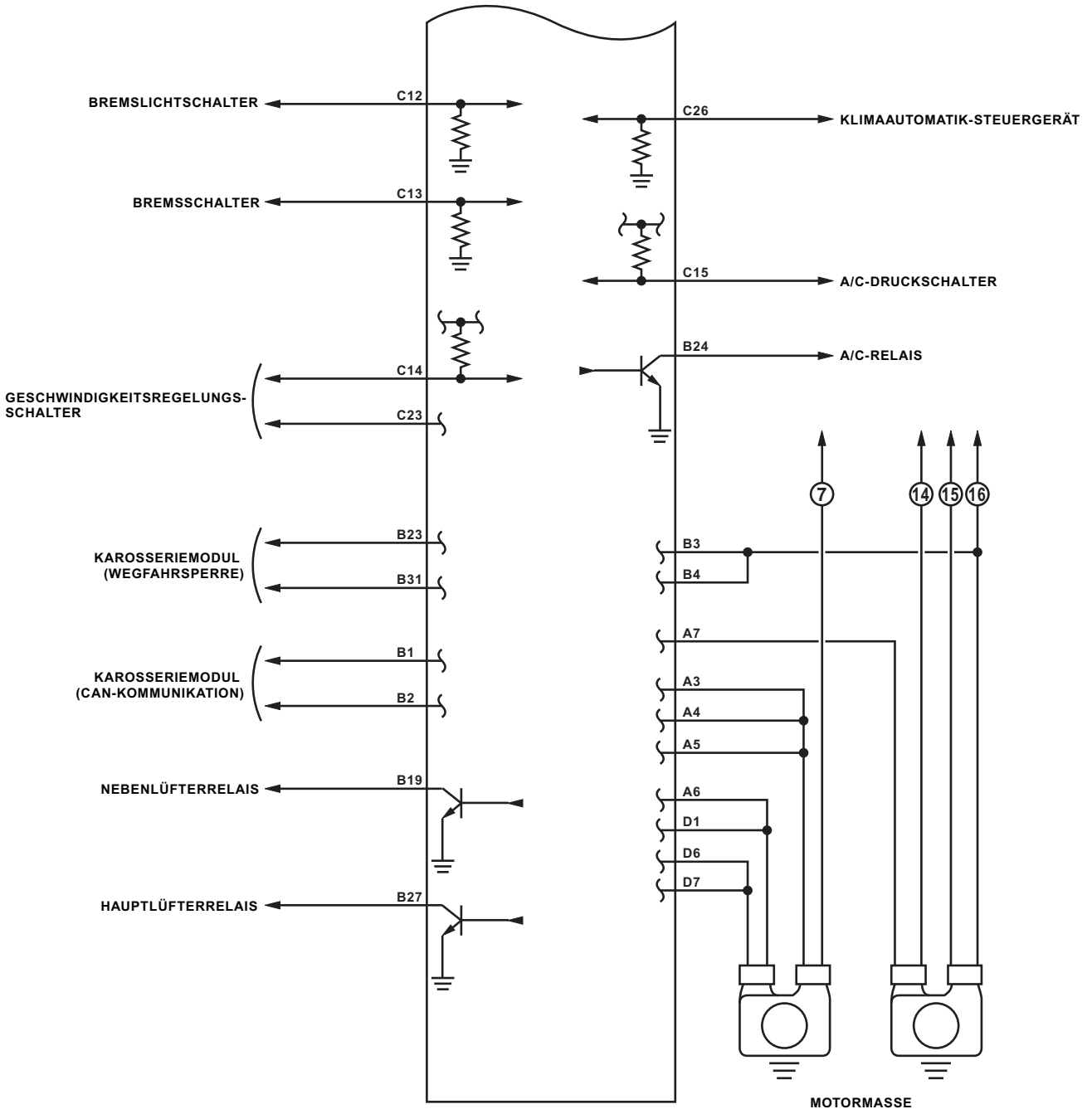

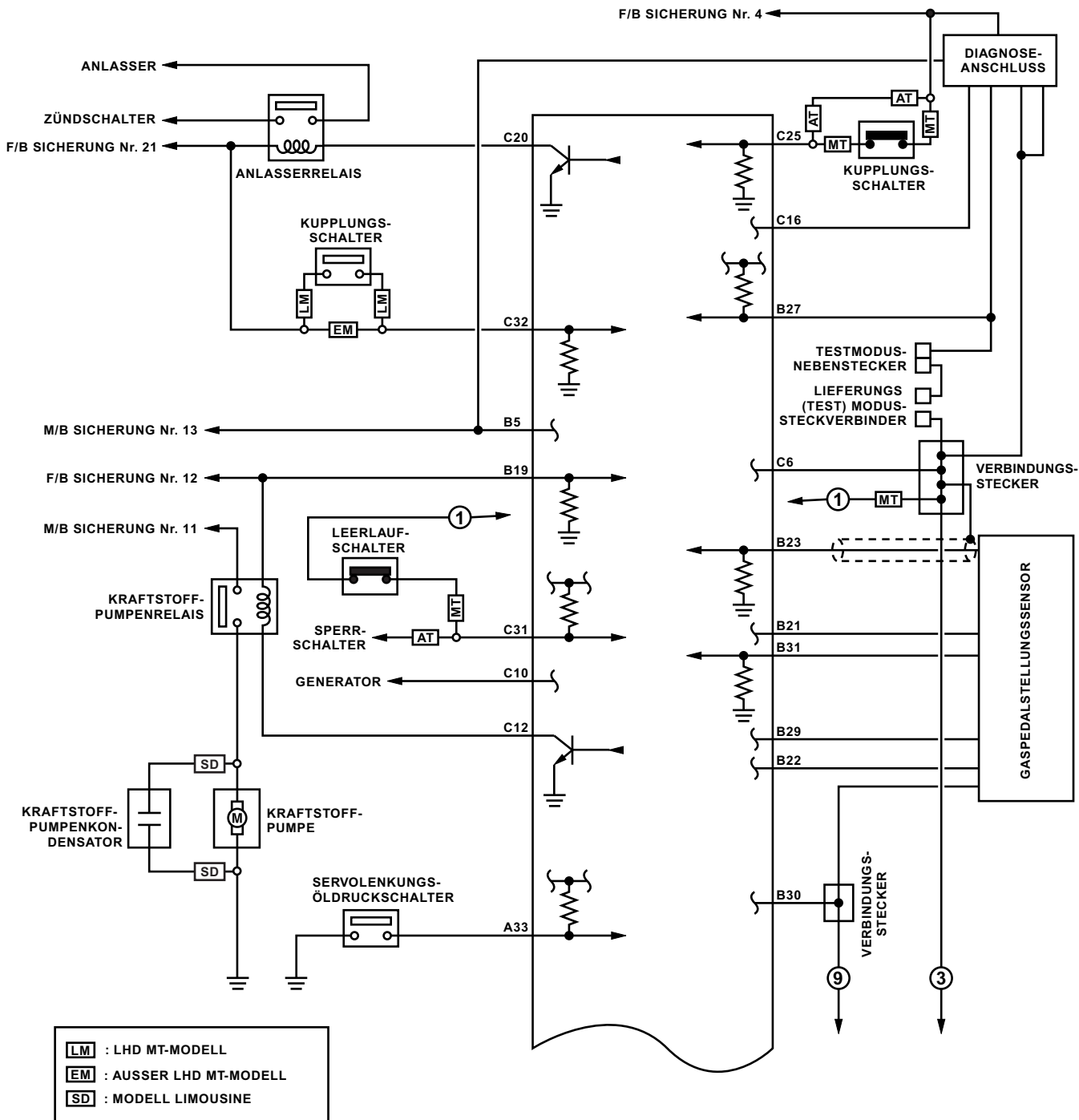

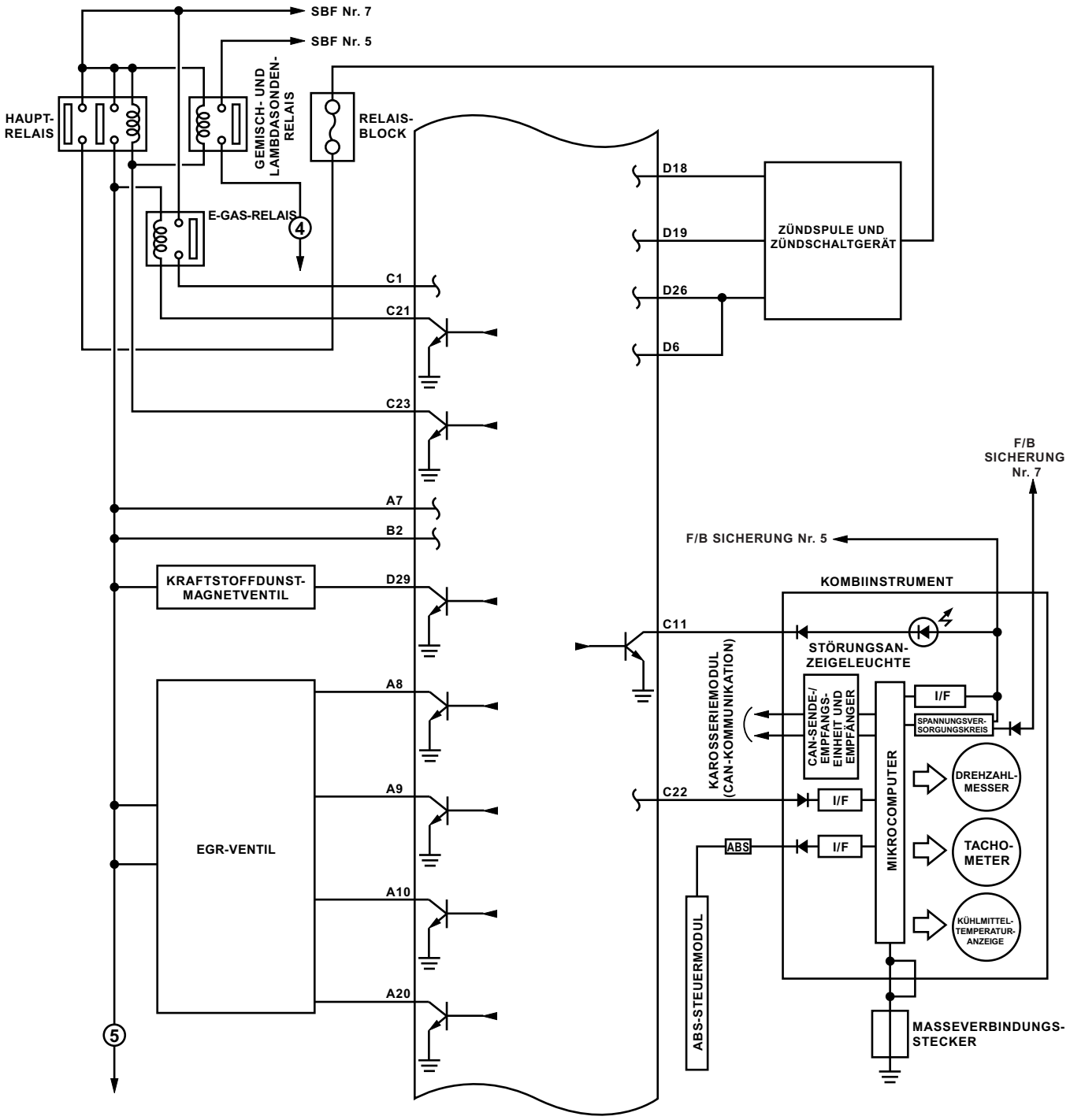

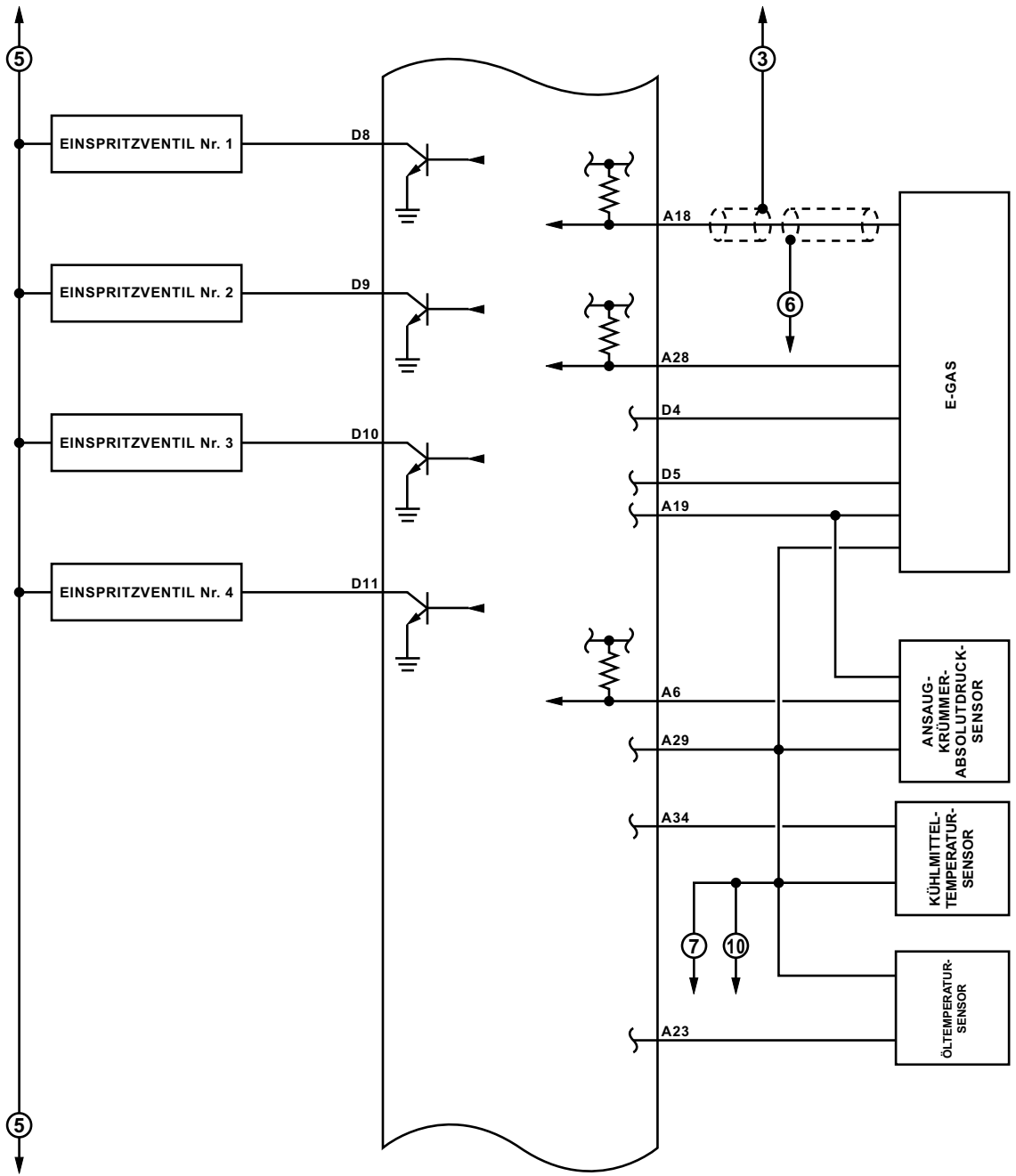

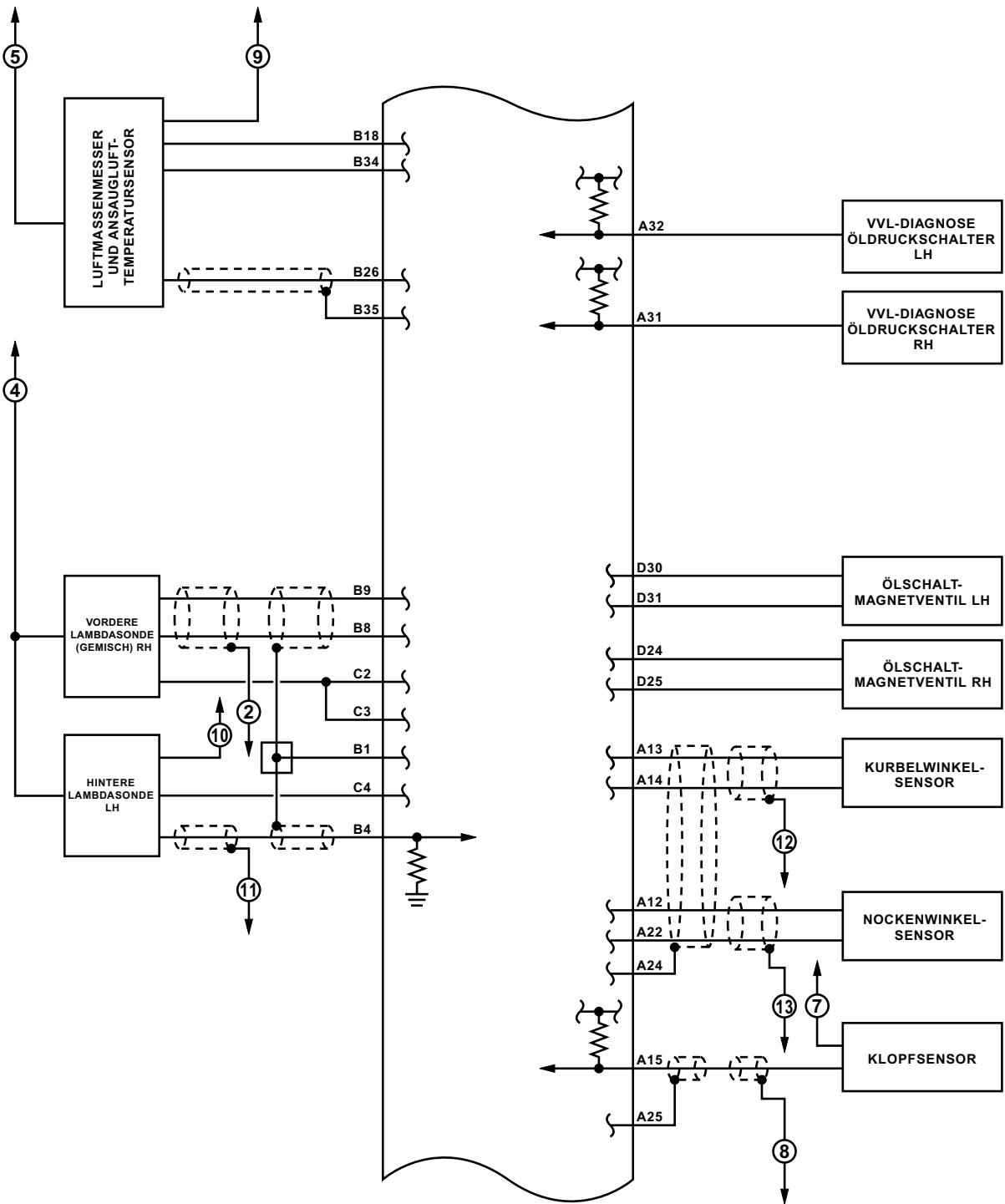

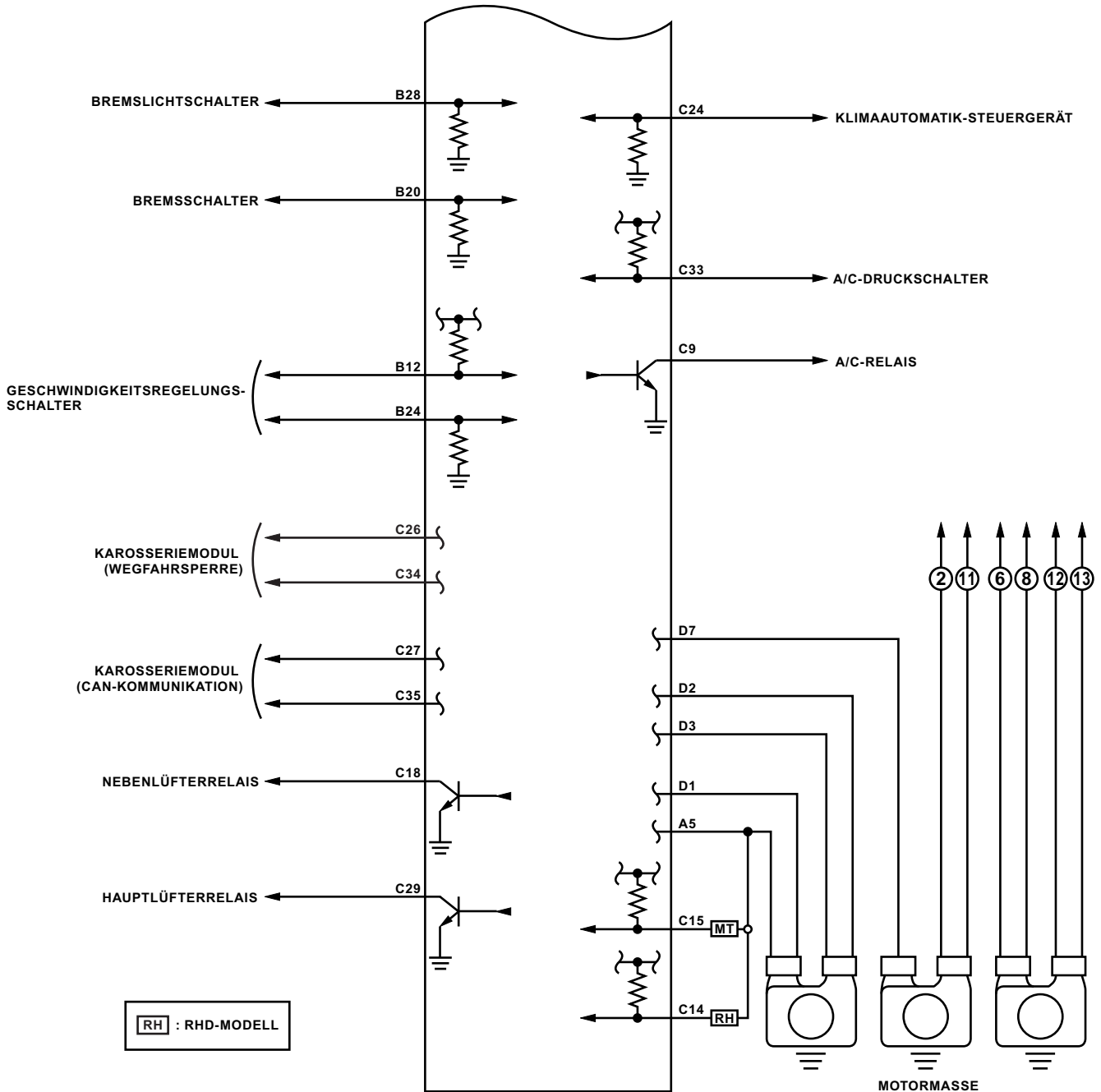

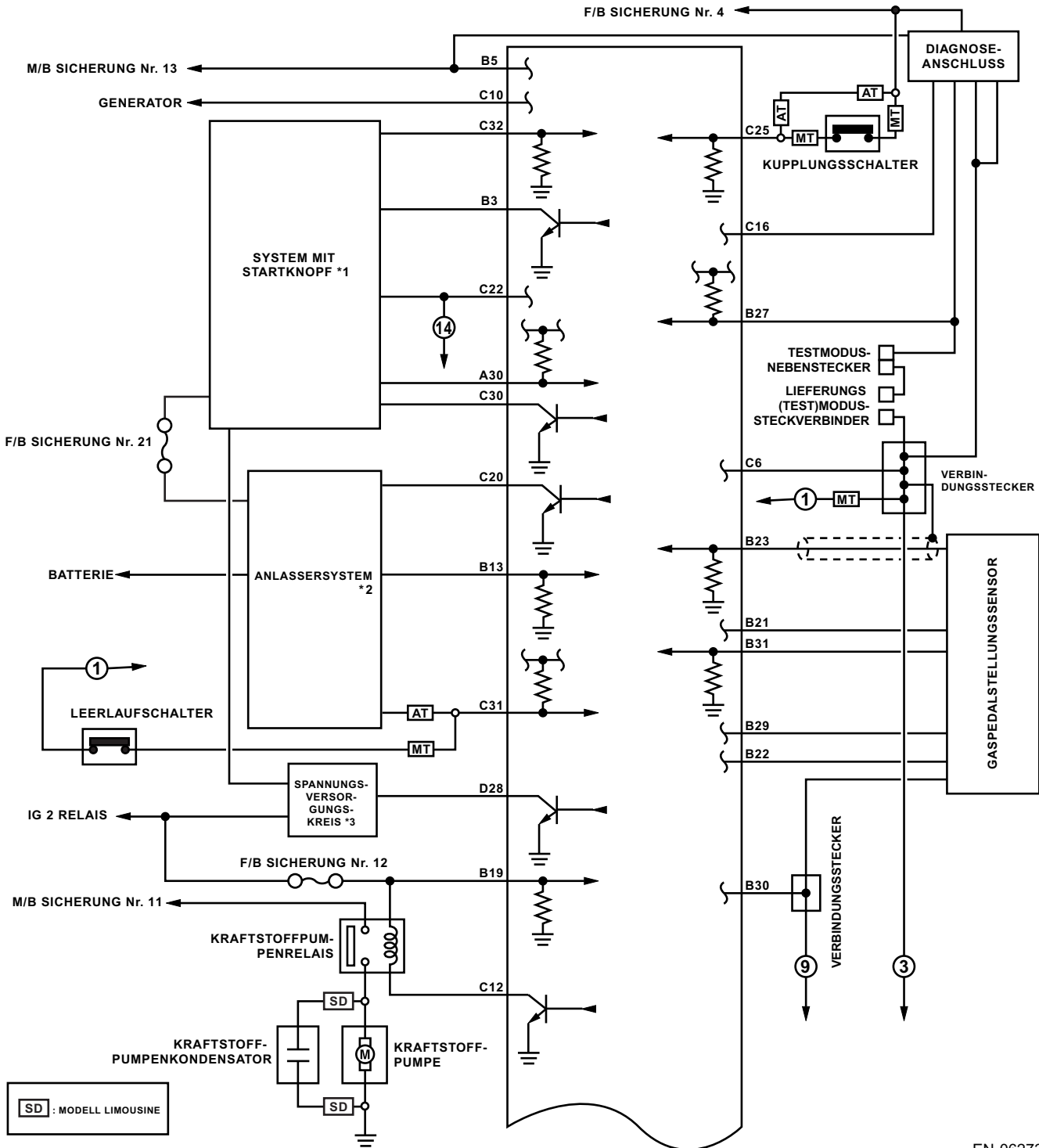

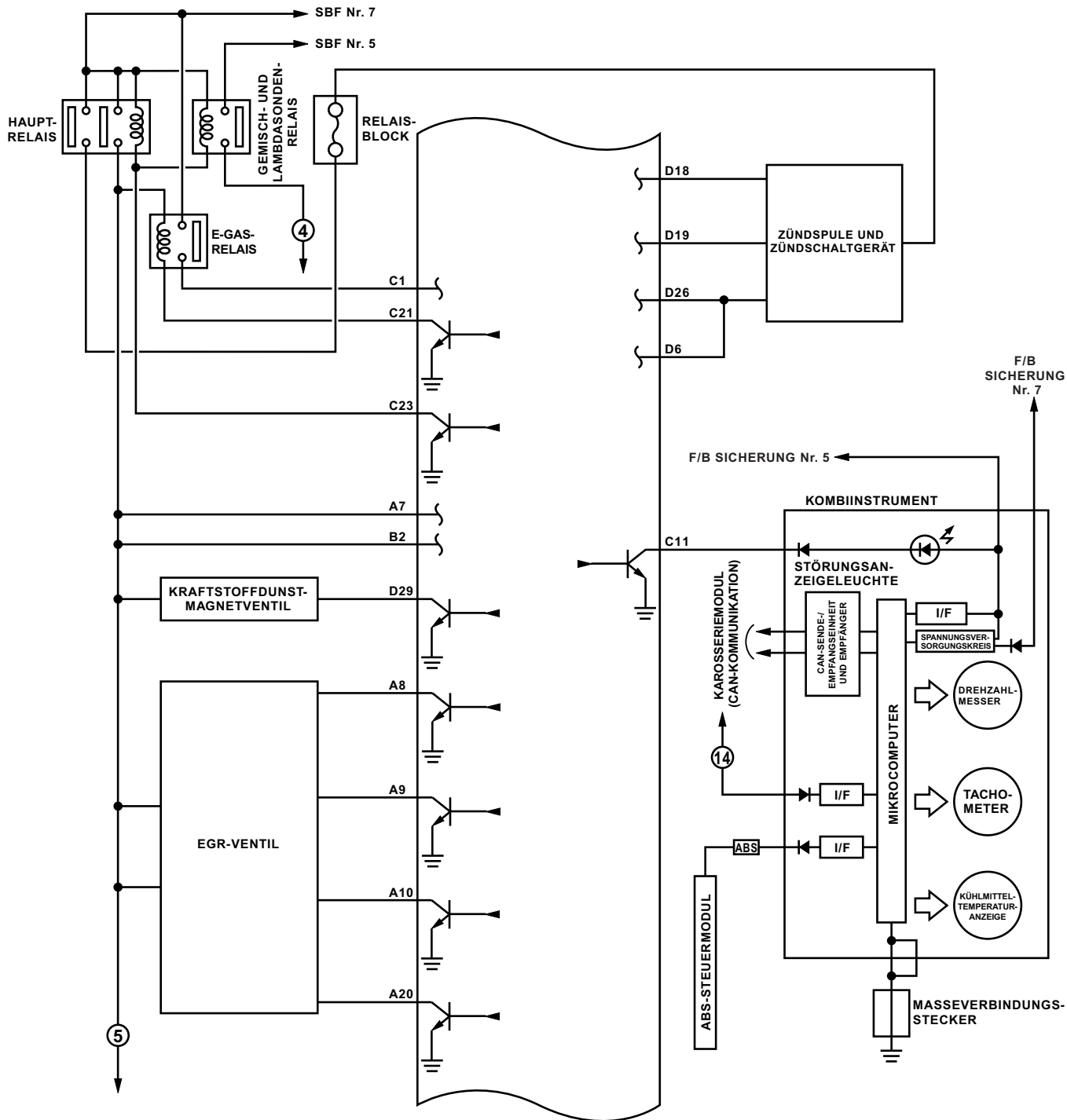

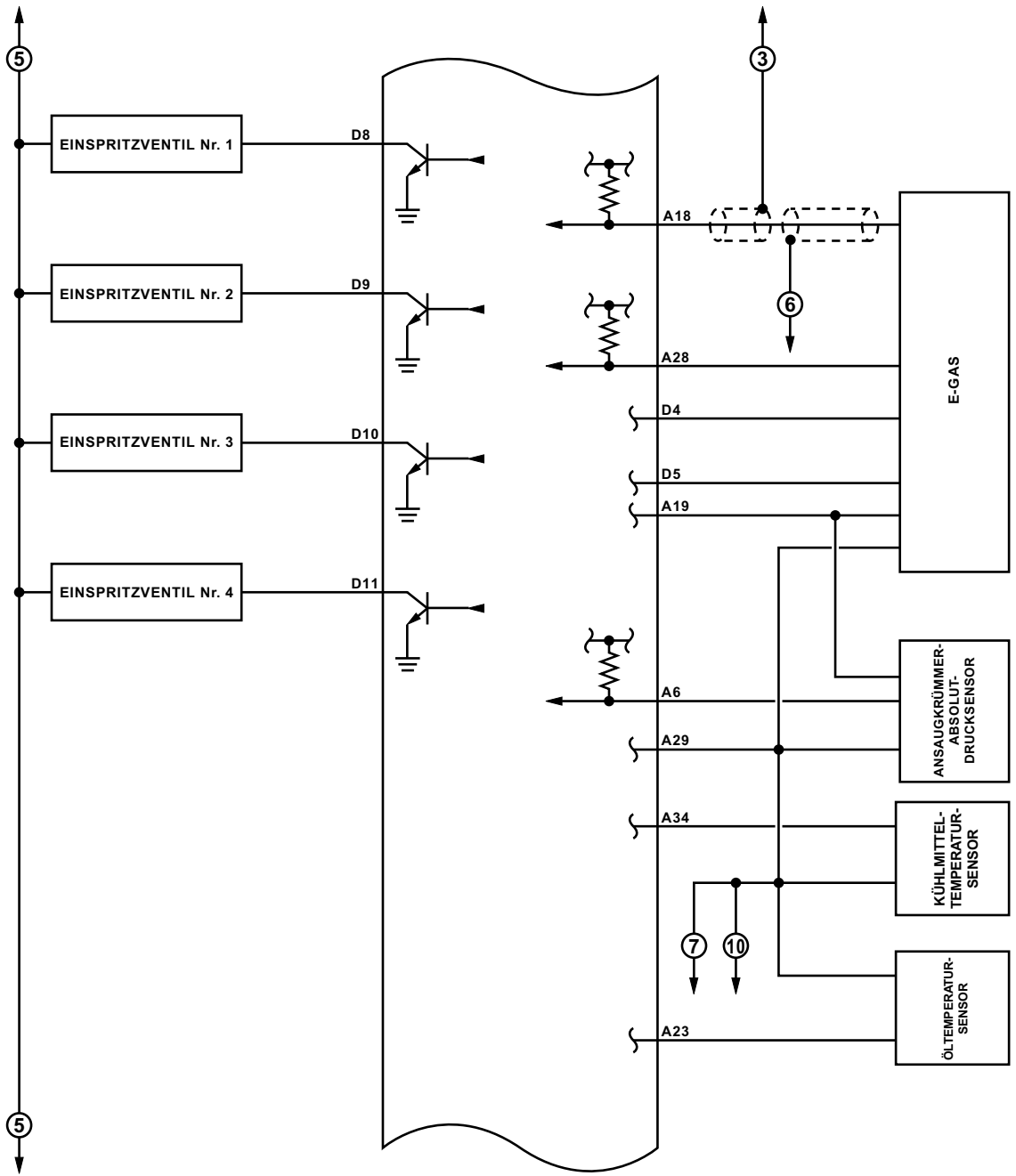

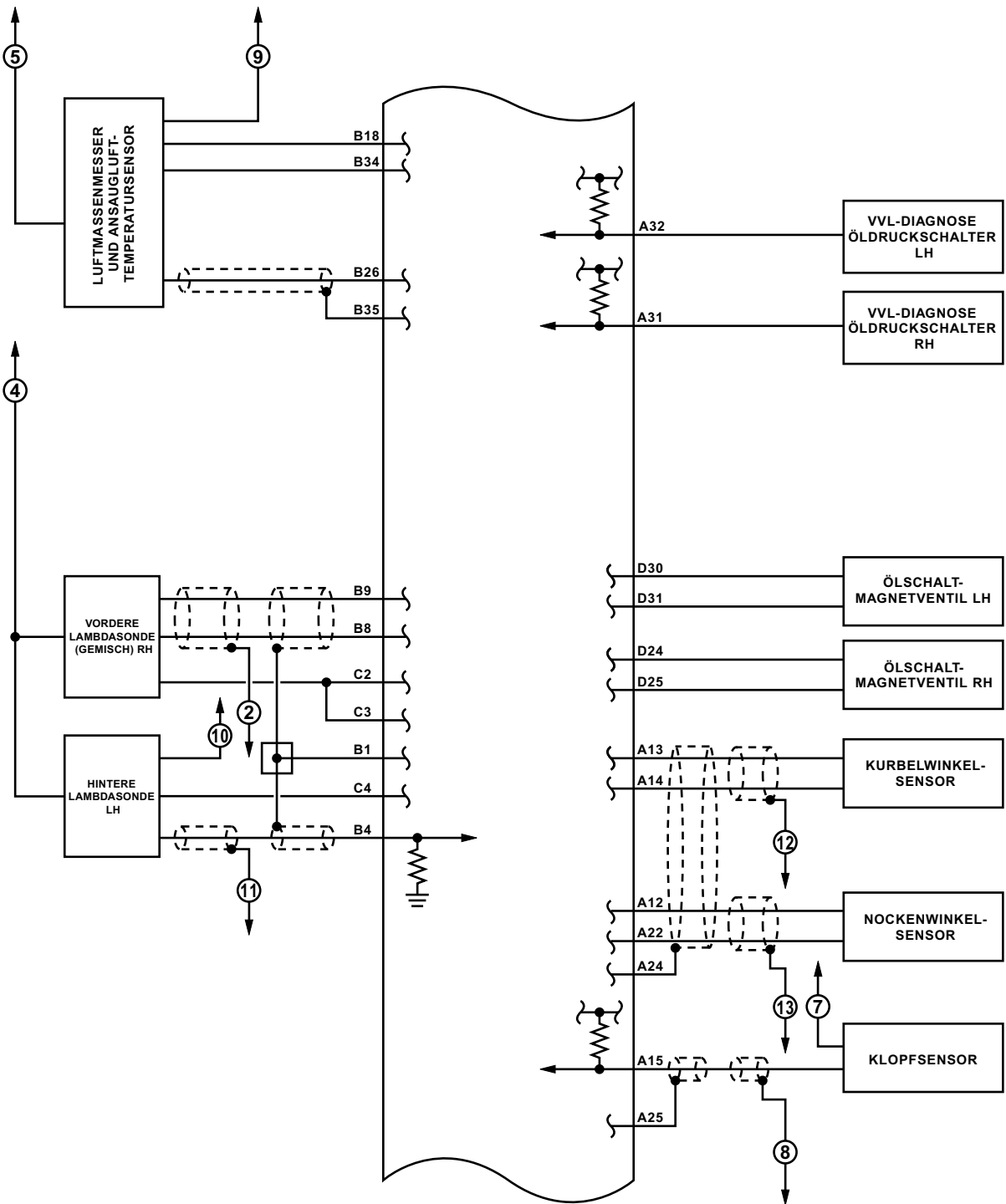

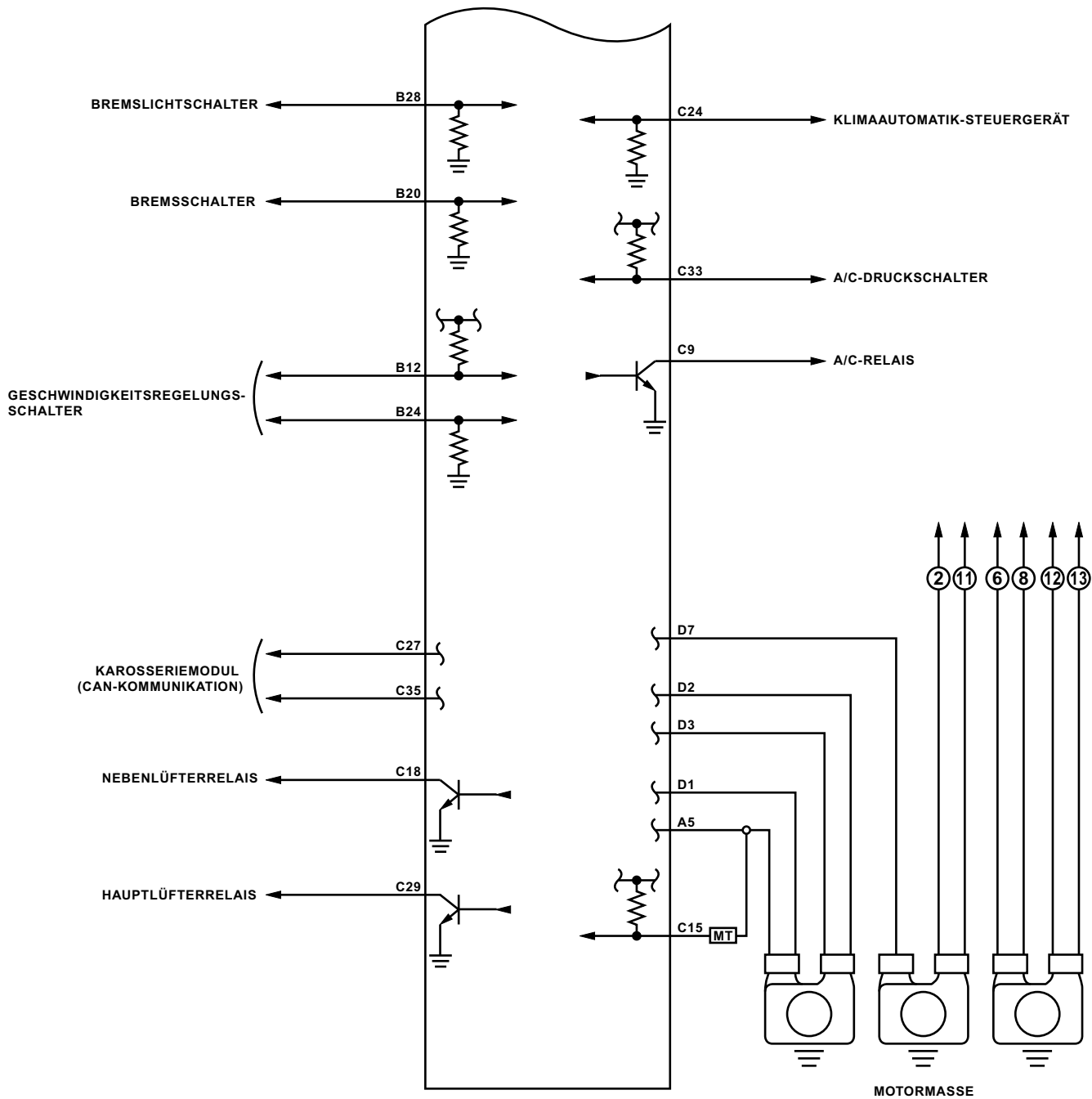

HAUPTRELAIS

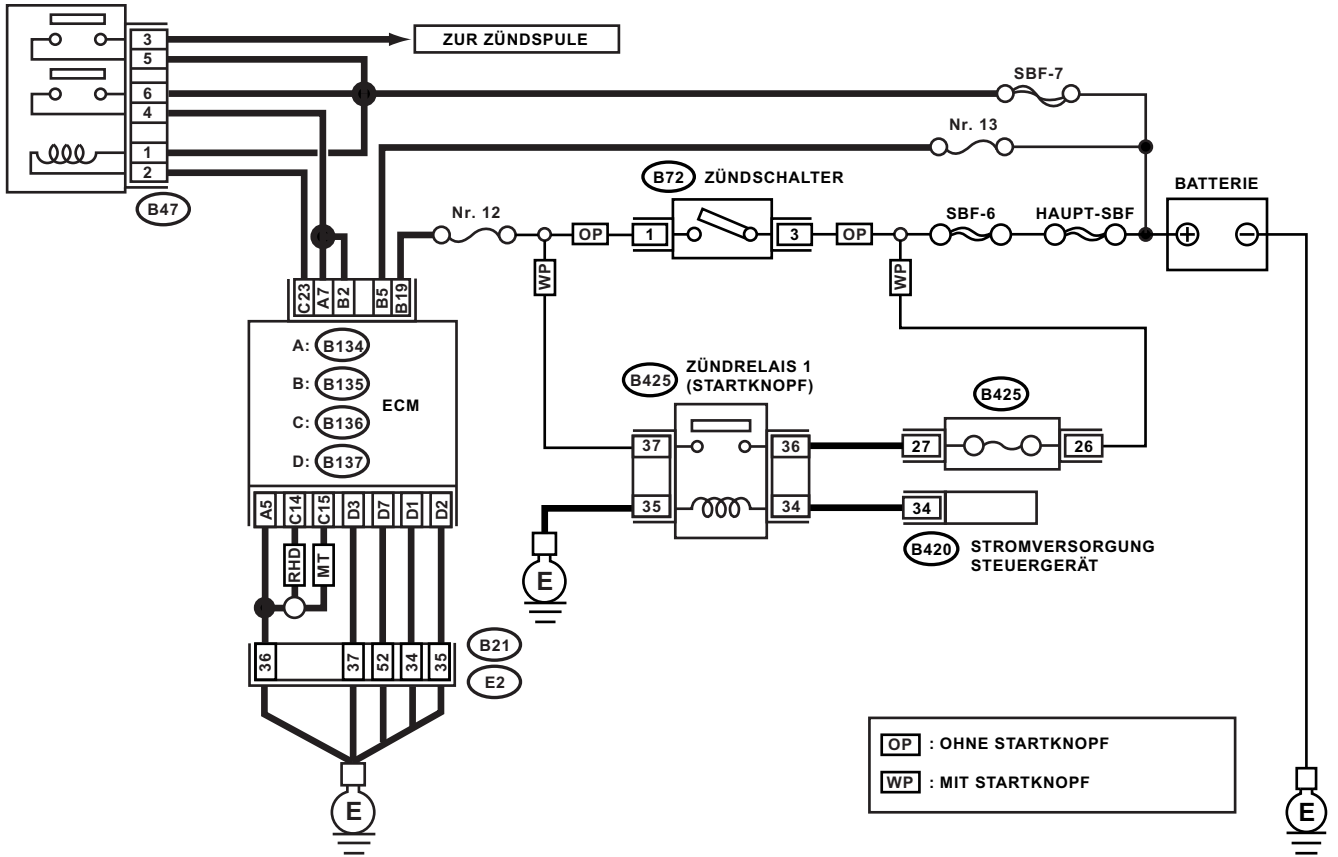

A: B134

1	2	3	4	5	6	7			
8	9	10	11	12	13	14	15	16	17
18	19	20	21	22	23	24	25	26	27
28	29	30	31	32	33	34			

B: B135

1	2	3	4	5	6	7					
8	9	10	11	12	13	14	15	16	17	18	19
20	21	22	23	24	25	26	27	28	29	30	31
32	33	34	35								

C: B136

1	2	3	4	5	6					
7	8	9	10	11	12	13	14	15	16	
17	18	19	20	21	22	23	24	25	26	27
28	29	30	31	32	33	34	35			

D: B137

1	2	3	4	5	6	7			
8	9	10	11	12	13	14	15	16	17
18	19	20	21	22	23	24	25	26	27
28	29	30	31						

B21

1	2	3	4	5	6	7	8	9	10	11			
12	13	14	15	16	17	18	19	20	21	22			
23	24	25	26	27	28	29	30	31	32	33			
34	35	36	37	38	39	40	41	42	43	44	45	46	47
48	49	50	51	52	53	54							

B47

1	2
3	4
5	6

B425

1	2	3	6	7	10	11	14	15	18	19	22	23
4	5	8	9	12	13	16	17	20	21	24	25	
26	28	34	35	38	39							
27	29	36	37	40	41							
30	32	33										
31	33											

B72

1	2	3
4	5	6

B420

1	2	3	4	5	6	7	8	9	10	11	12	13	14	15	16	17						
18	19	20	21	22	23	24	25	26	27	28	29	30	31	32	33	34	35	36	37	38	39	40

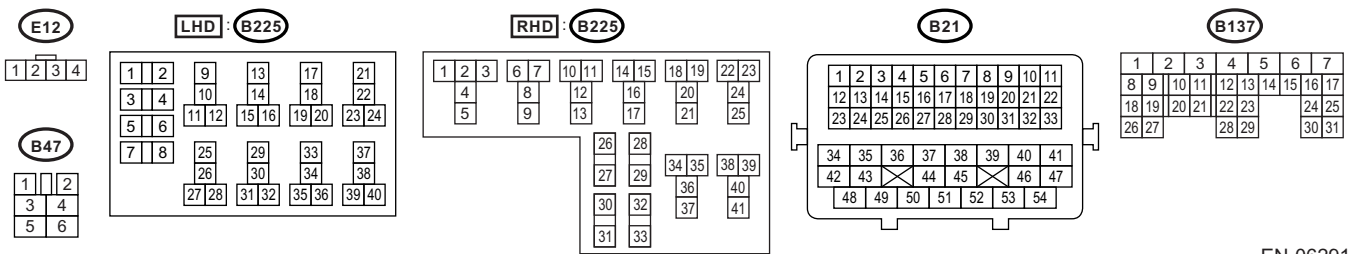
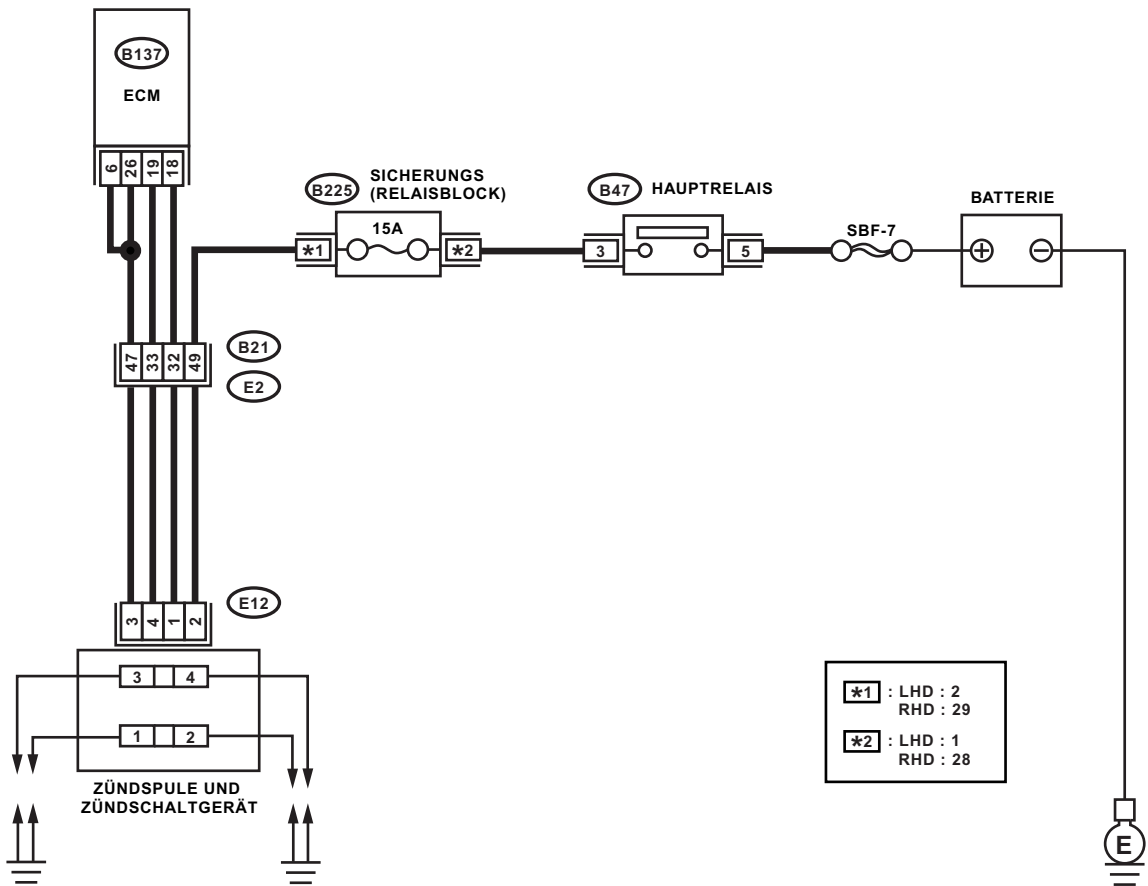

HAUPTRELAIS

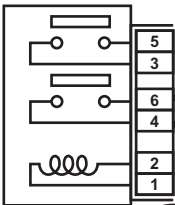

(B47)

BATTERIE



(B137) ECM

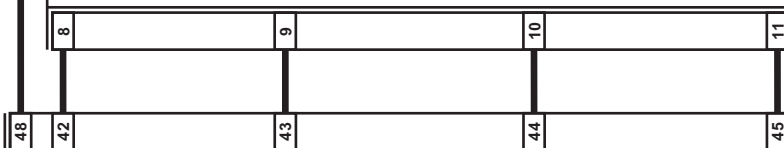

(B21)

(E2)

(E5)

(E16)

(E6)

(E17)

**EINSPRITZVENTIL
Nr. 1**

**EINSPRITZVENTIL
Nr. 2**

**EINSPRITZVENTIL
Nr. 3**

**EINSPRITZVENTIL
Nr. 4**

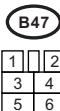
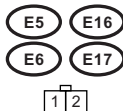

(B21)

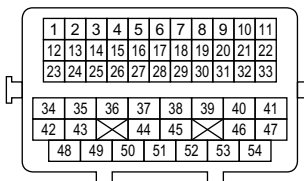

(B137)

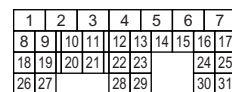

GEMISCH- UND LAMBDA-SONDEN-RELAIS

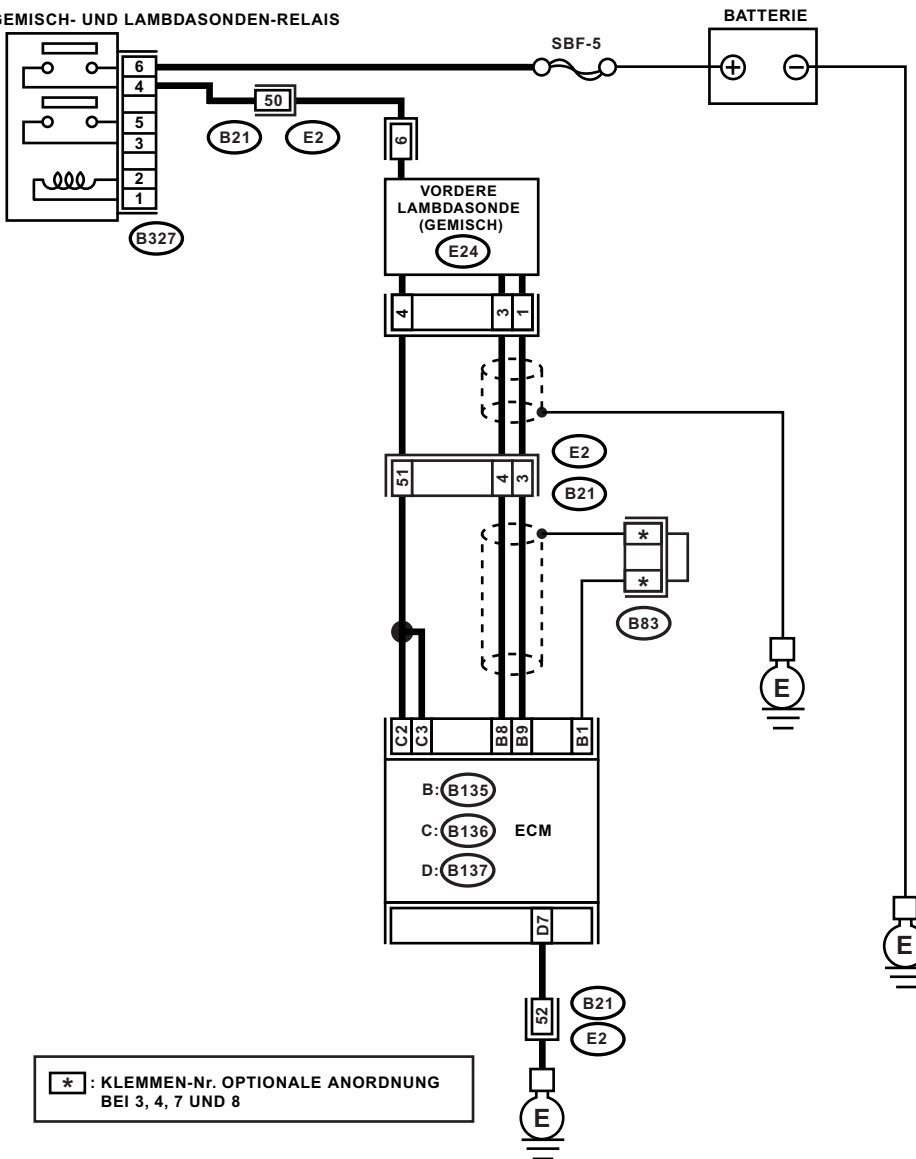

B327

1	2
3	4
5	6

E24

3	2	1
6	5	4

B83

1	2	3	4
5	6	7	8

B21

1	2	3	4	5	6	7	8	9	10	11
12	13	14	15	16	17	18	19	20	21	22
23	24	25	26	27	28	29	30	31	32	33
34	35	36	37	38	39	40	41			
42	43	44	45	46	47					
48	49	50	51	52	53	54				

B: B135

1	2	3	4	5	6	7
8	9	10	11	12	13	14
15	16	17	18	19	20	21
22	23	24	25	26	27	28
29	30	31	32	33	34	35

C: B136

1	2	3	4	5	6
7	8	9	10	11	12
13	14	15	16	17	18
19	20	21	22	23	24
25	26	27	28	29	30
31	32	33	34	35	

D: B137

1	2	3	4	5	6	7
8	9	10	11	12	13	14
15	16	17	18	19	20	21
22	23	24	25	26	27	28
29	30	31	32	33	34	35

GEMISCH- UND LAMBDA-SONDEN-RELAIS

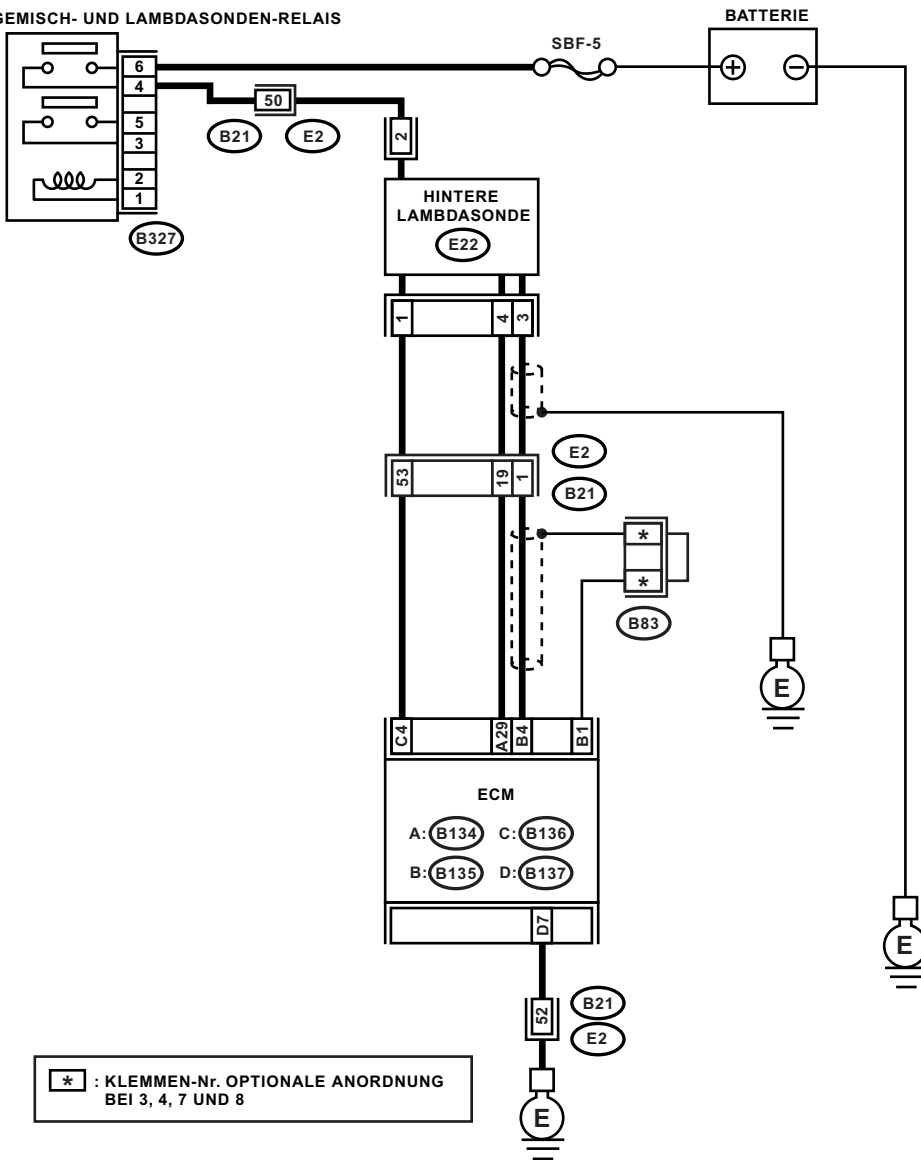

B327



B83

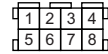

E22



B21

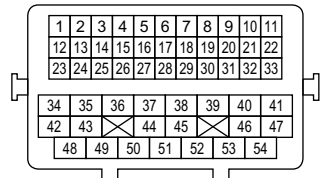

A: B134



B: B135



C: B136

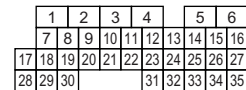

D: B137

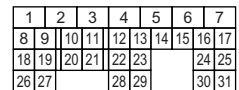

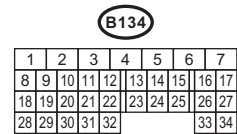
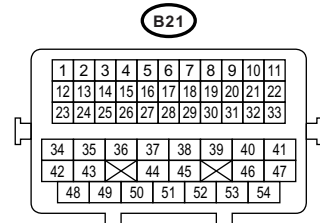
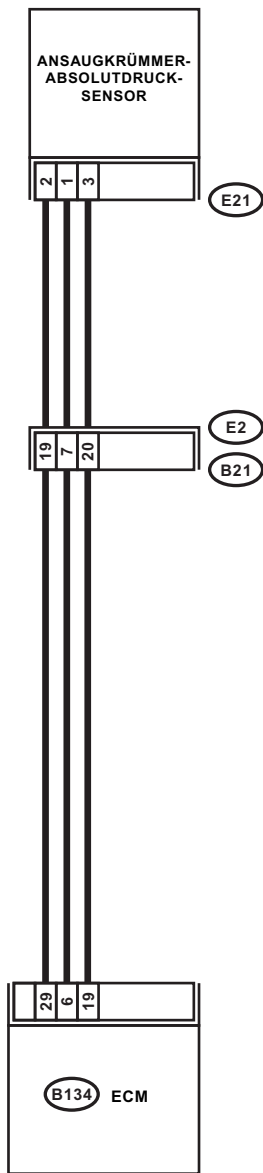

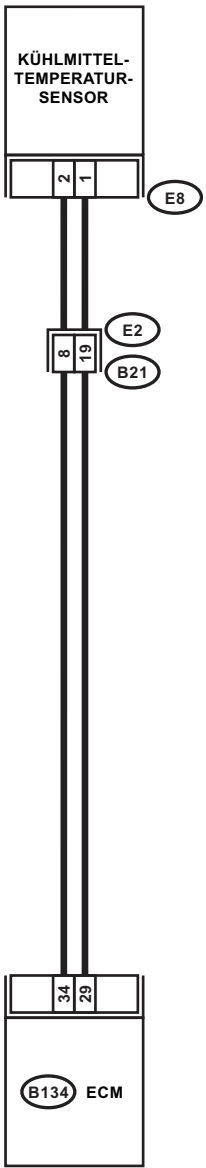

E8



B21

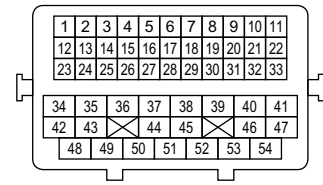

B134

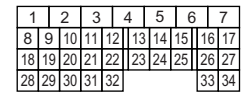

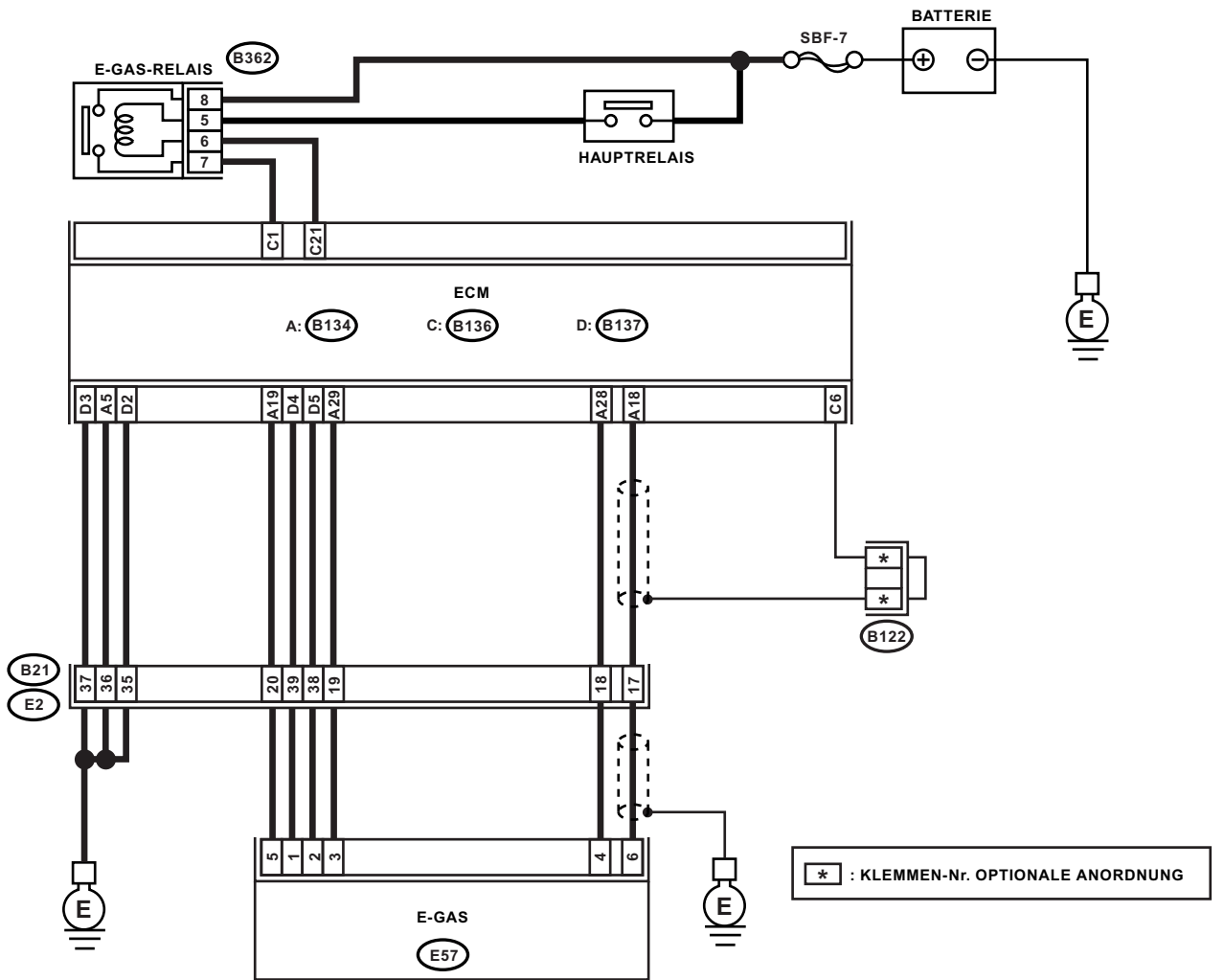

B362

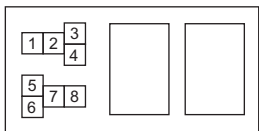

B122

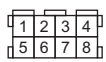

B21

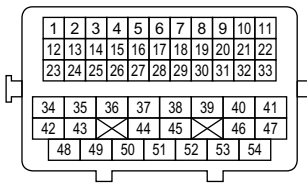

E57

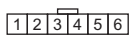

A: B134

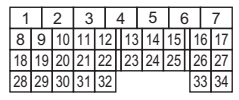

C: B136

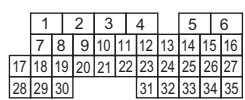

D: B137

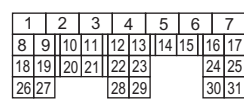

HAUPTRELAIS

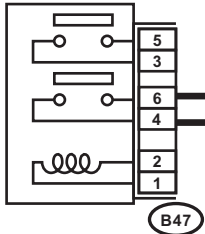

BATTERIE

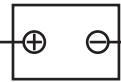

B137 ECM

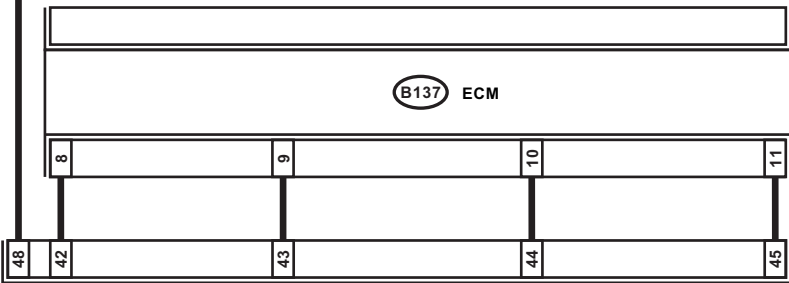

EINSPRITZVENTIL
Nr. 1

EINSPRITZVENTIL
Nr. 2

EINSPRITZVENTIL
Nr. 3

EINSPRITZVENTIL
Nr. 4

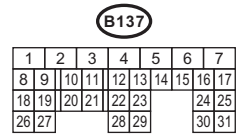
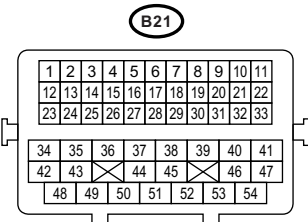
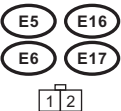

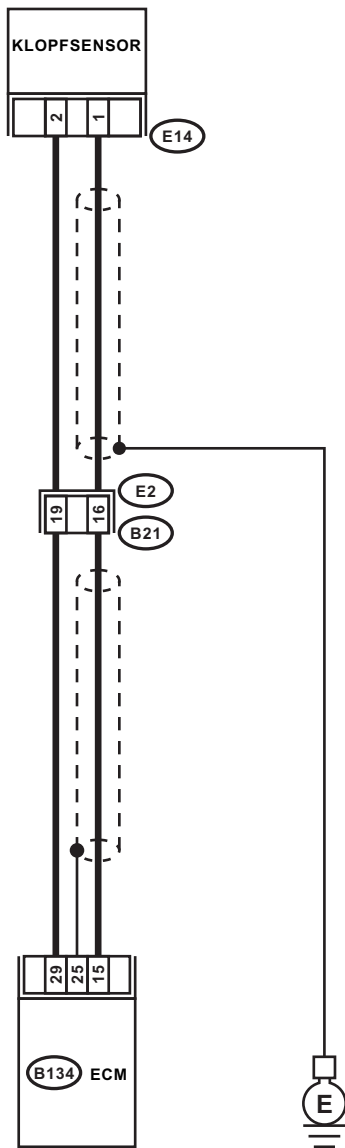

E14

1 2

B134

1	2	3	4	5	6	7			
8	9	10	11	12	13	14	15	16	17
18	19	20	21	22	23	24	25	26	27
28	29	30	31	32				33	34

B21

1	2	3	4	5	6	7	8	9	10	11
12	13	14	15	16	17	18	19	20	21	22
23	24	25	26	27	28	29	30	31	32	33
34	35	36	37	38	39	40	41			
42	43	44	45	46	47					
48	49	50	51	52	53	54				

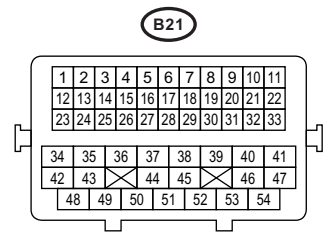
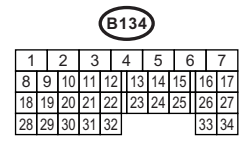
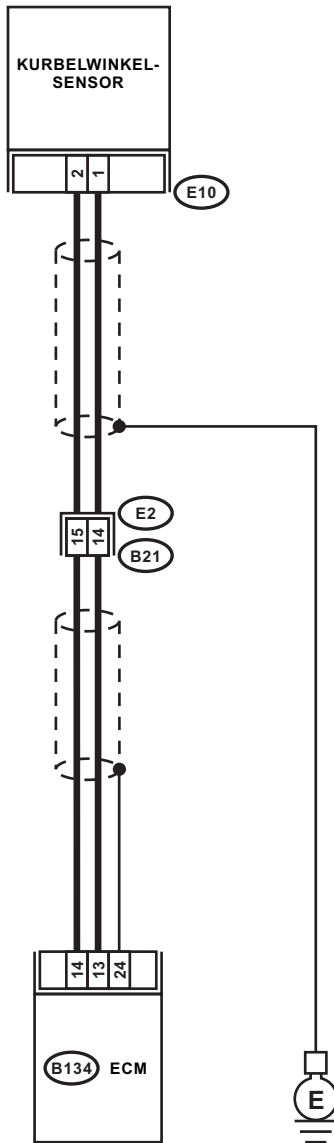

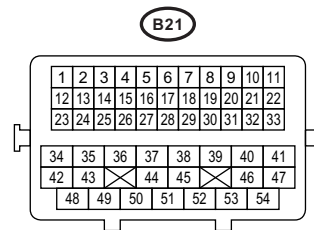
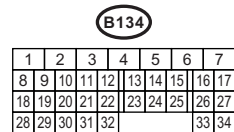
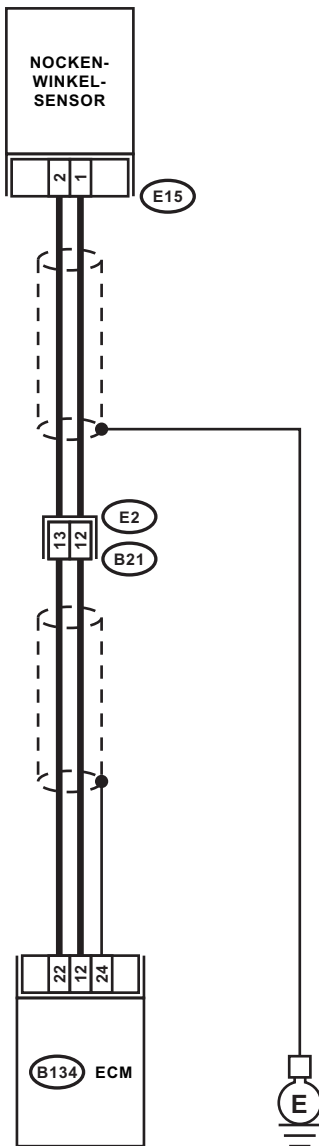

HAUPTRELAIS

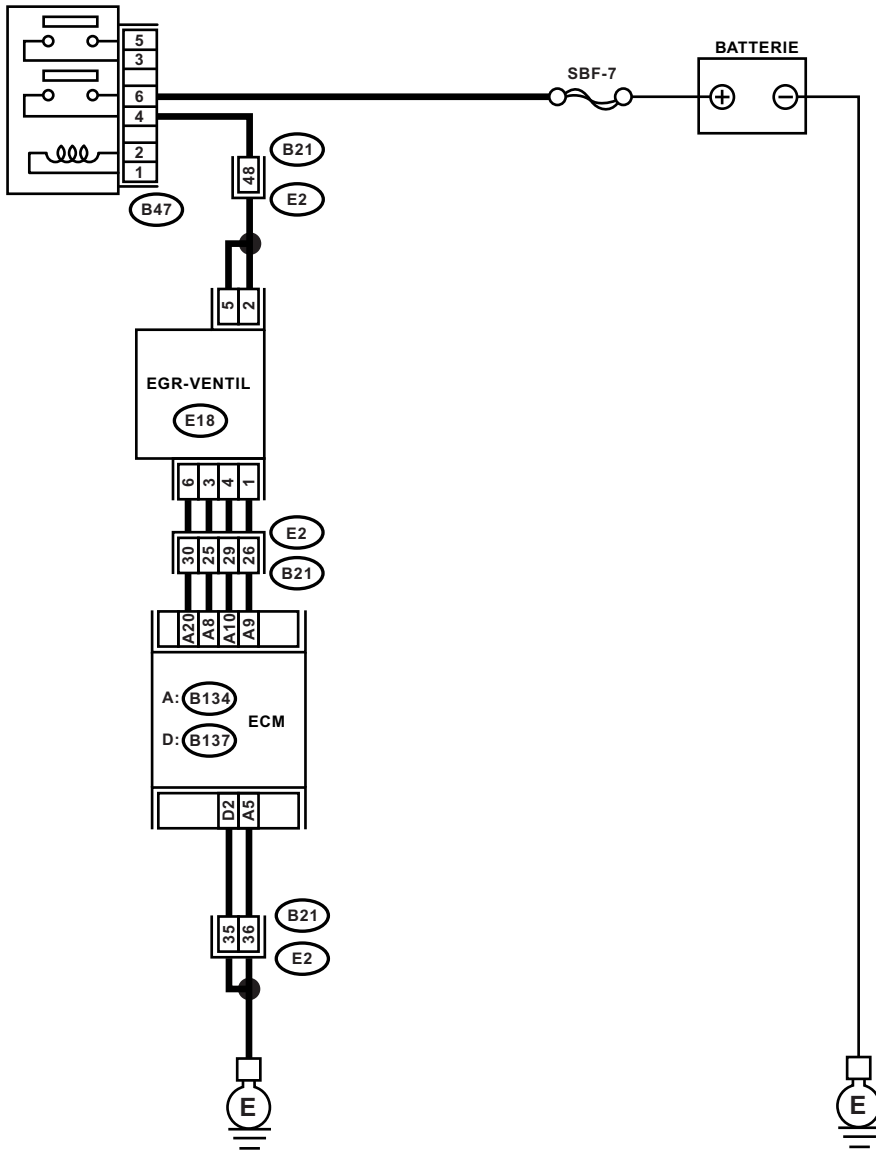

E18

1	2	3
4	5	6

B47

1	2
3	4
5	6

B21

1	2	3	4	5	6	7	8	9	10	11
12	13	14	15	16	17	18	19	20	21	22
23	24	25	26	27	28	29	30	31	32	33
34	35	36	37	38	39	40	41			
42	43	44	45	46	47					
48	49	50	51	52	53	54				

A: B134

1	2	3	4	5	6	7
8	9	10	11	12	13	14
15	16	17	18	19	20	21
22	23	24	25	26	27	
28	29	30	31	32		33
34						

D: B137

1	2	3	4	5	6	7
8	9	10	11	12	13	14
15	16	17	18	19	20	21
22	23	24	25	26	27	
28	29	30	31			

HAUPTRELAIS

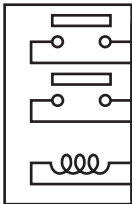

B47

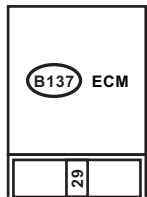
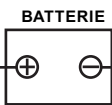

B137 ECM



B21

E2



E4

KRAFTSTOFFDUNST-MAGNETVENTIL



E4



B47



B21

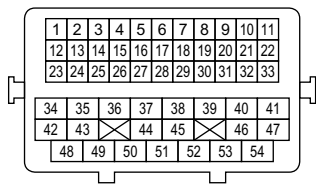

B137

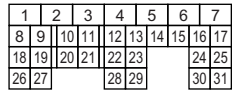

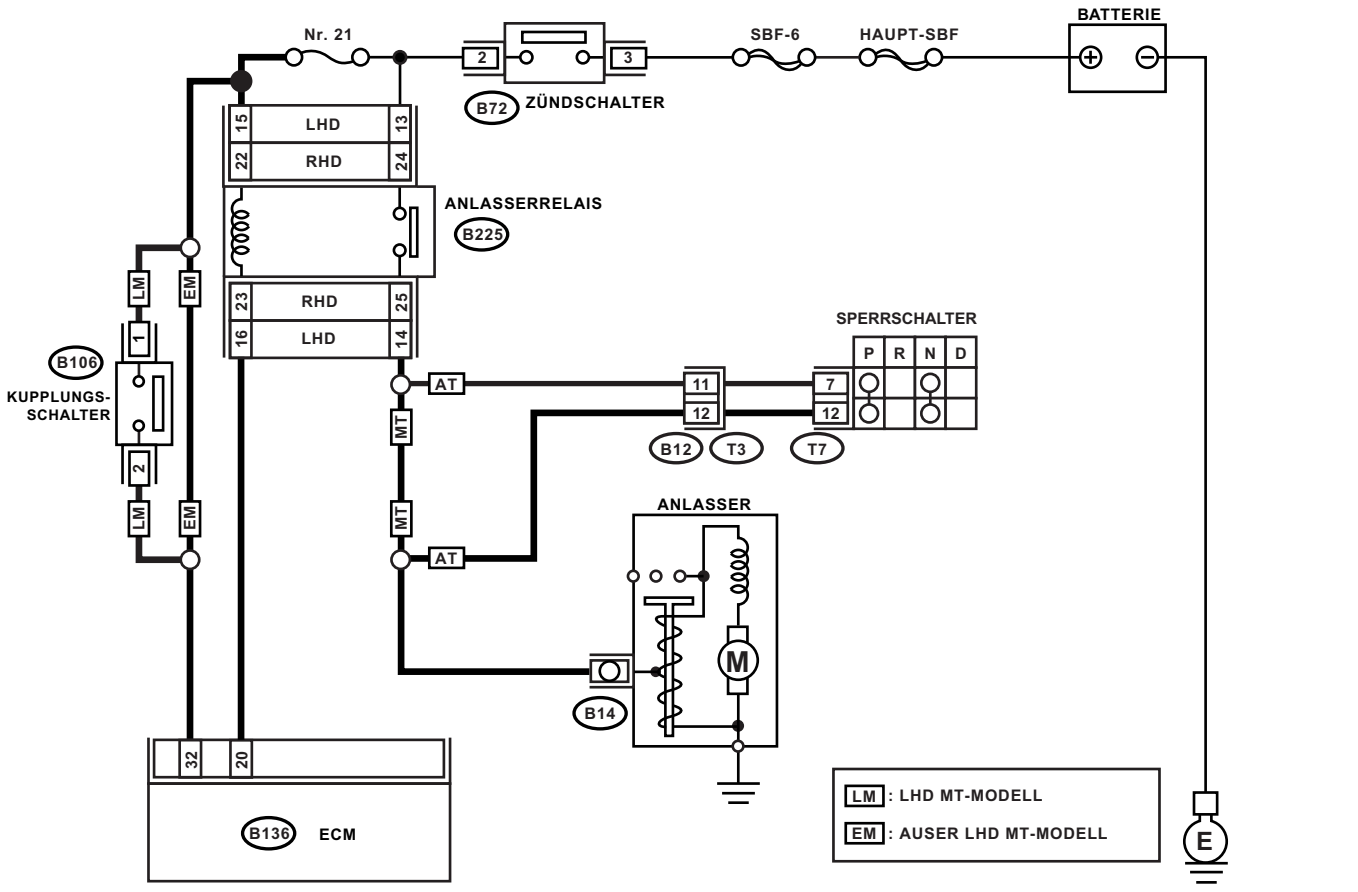

LHD : B225

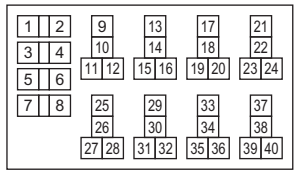

RHD : B225

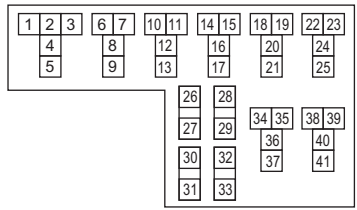

B136

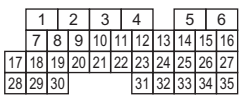

B12

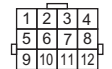

T7

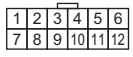

B106



B72



HAUPTRELAIS

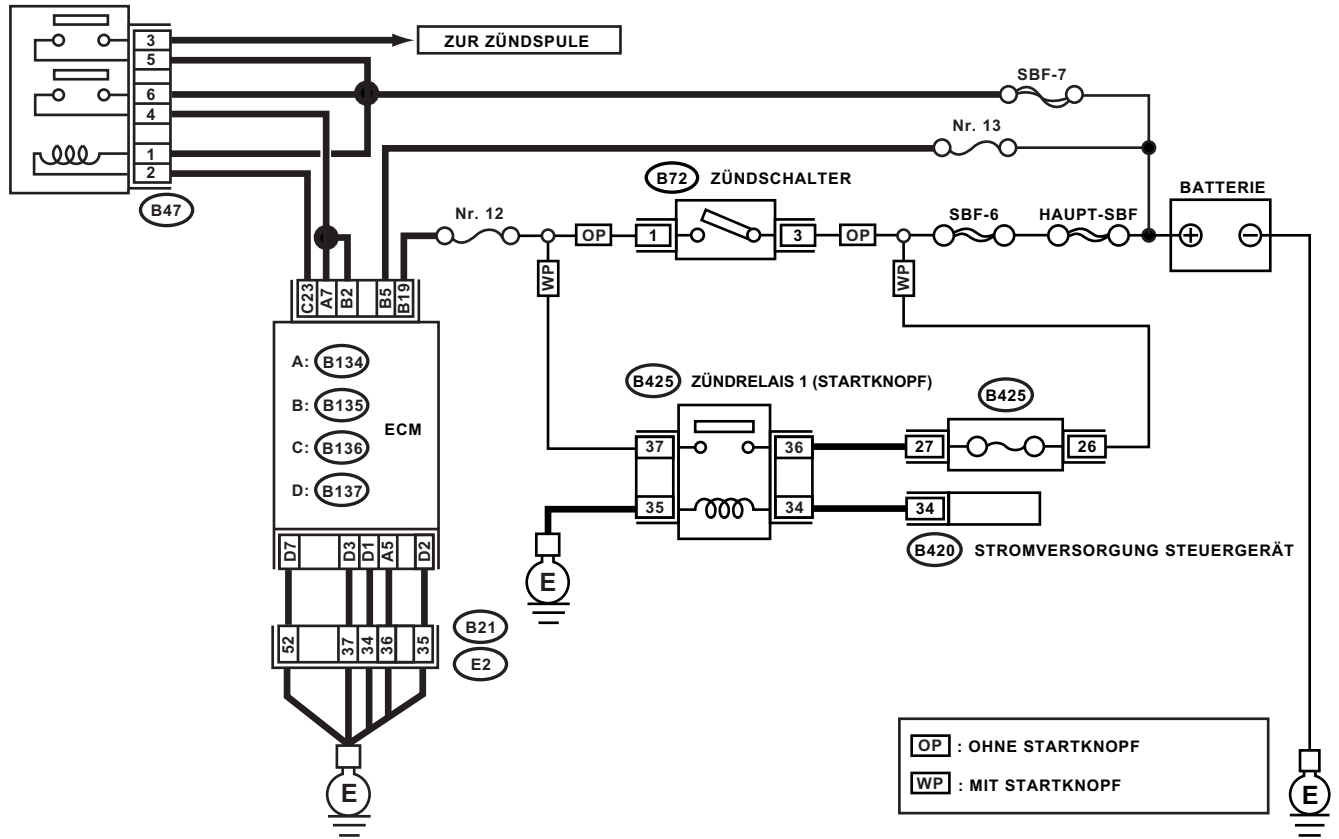

B72

1	2	3
4	5	6

B47

1	2
3	4
5	6

A: B134

1	2	3	4	5	6	7			
8	9	10	11	12	13	14	15	16	17
18	19	20	21	22	23	24	25	26	27
28	29	30	31	32				33	34

B: B135

1	2	3	4	5	6	7					
8	9	10	11	12	13	14	15	16	17	18	19
20	21	22	23		24	25		26	27		
28	29	30	31		32	33		34	35		

C: B136

1	2	3	4		5	6				
7	8	9	10	11	12	13	14	15	16	
17	18	19	20	21	22	23	24	25	26	27
28	29	30		31	32	33	34	35		

D: B137

1	2	3	4	5	6	7			
8	9	10	11	12	13	14	15	16	17
18	19	20	21	22	23		24	25	
26	27		28	29		30	31		

B21

1	2	3	4	5	6	7	8	9	10	11
12	13	14	15	16	17	18	19	20	21	22
23	24	25	26	27	28	29	30	31	32	33
34	35	36	37	38	39	40	41			
42	43	44	45	46	47					
48	49	50	51	52	53	54				

HAUPTRELAIS

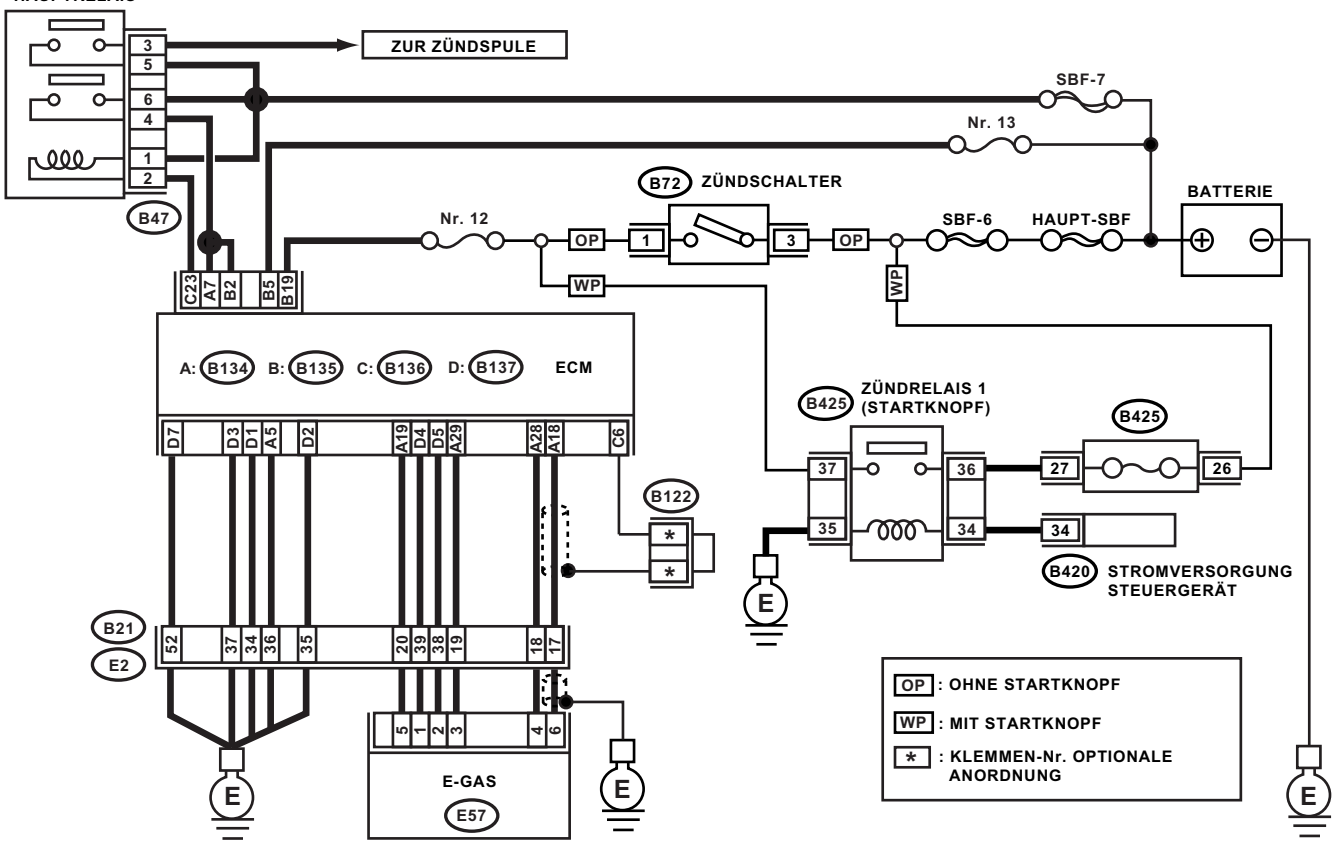

A: **B134**

1	2	3	4	5	6	7			
8	9	10	11	12	13	14	15	16	17
18	19	20	21	22	23	24	25	26	27
28	29	30	31	32	33	34			

B: **B135**

1	2	3	4	5	6	7					
8	9	10	11	12	13	14	15	16	17	18	19
20	21	22	23	24	25	26	27				
28	29	30	31	32	33	34	35				

B21

1	2	3	4	5	6	7	8	9	10	11
12	13	14	15	16	17	18	19	20	21	22
23	24	25	26	27	28	29	30	31	32	33
34	35	36	37	38	39	40	41			
42	43	44	45	46	47					
48	49	50	51	52	53	54				

B47

1	2
3	4
5	6

B425

1	2	3	6	7	10	11	14	15	18	19	22	23
4	8	12	16	20	24							
5	9	13	17	21	25							

C: **B136**

1	2	3	4	5	6					
7	8	9	10	11	12	13	14	15	16	
17	18	19	20	21	22	23	24	25	26	27
28	29	30	31	32	33	34	35			

D: **B137**

1	2	3	4	5	6	7			
8	9	10	11	12	13	14	15	16	17
18	19	20	21	22	23	24	25		
26	27	28	29	30	31				

B72

1	2	3
4	5	6

E57

B420

1	2	3	4	5	6	7	8	9	10	11	12	13	14	15	16	17						
18	19	20	21	22	23	24	25	26	27	28	29	30	31	32	33	34	35	36	37	38	39	40

B122

1	2	3	4
5	6	7	8

26	28	34	35	38	39
27	29	36	40		
30	32	37	41		
31	33				

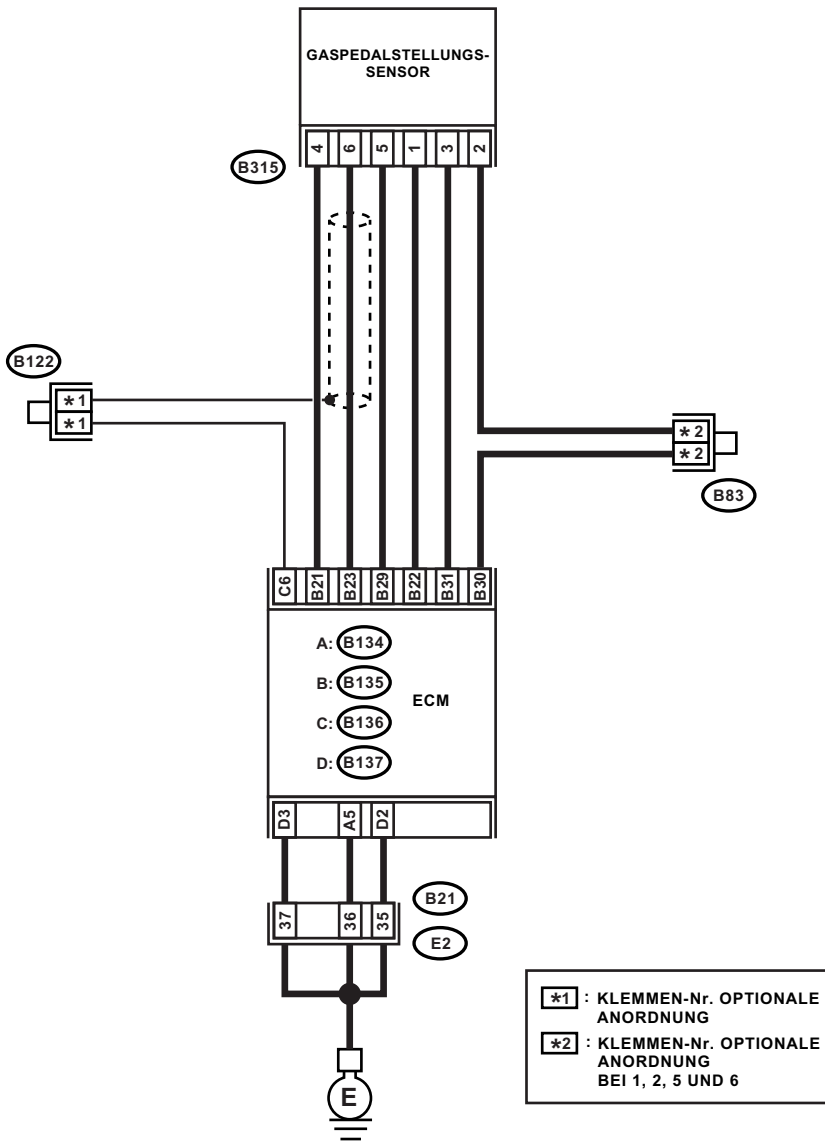

B315

1	2	3	4	5	6
---	---	---	---	---	---

B83

1	2	3	4
---	---	---	---

B122

1	2	3	4
5	6	7	8

B21

1	2	3	4	5	6	7	8	9	10	11
12	13	14	15	16	17	18	19	20	21	22
23	24	25	26	27	28	29	30	31	32	33
34	35	36	37	38	39	40	41			
42	43	44	45	46	47					
48	49	50	51	52	53	54				

A: **B134**

1	2	3	4	5	6	7
8	9	10	11	12	13	14
15	16	17	18	19	20	21
22	23	24	25	26	27	
28	29	30	31	32		33
34	35					

B: **B135**

1	2		3	4	5	6	7
8	9	10	11	12	13	14	15
16	17	18	19	20	21	22	23
24	25		26	27			
28	29	30	31		32	33	34
35							

C: **B136**

1	2	3	4		5	6
7	8	9	10	11	12	13
14	15	16	17	18	19	20
21	22	23	24	25	26	27
28	29	30		31	32	33
34	35					

D: **B137**

1	2	3	4	5	6	7
8	9	10	11	12	13	14
15	16	17	18	19	20	21
22	23		24	25		
26	27		28	29		30
31						

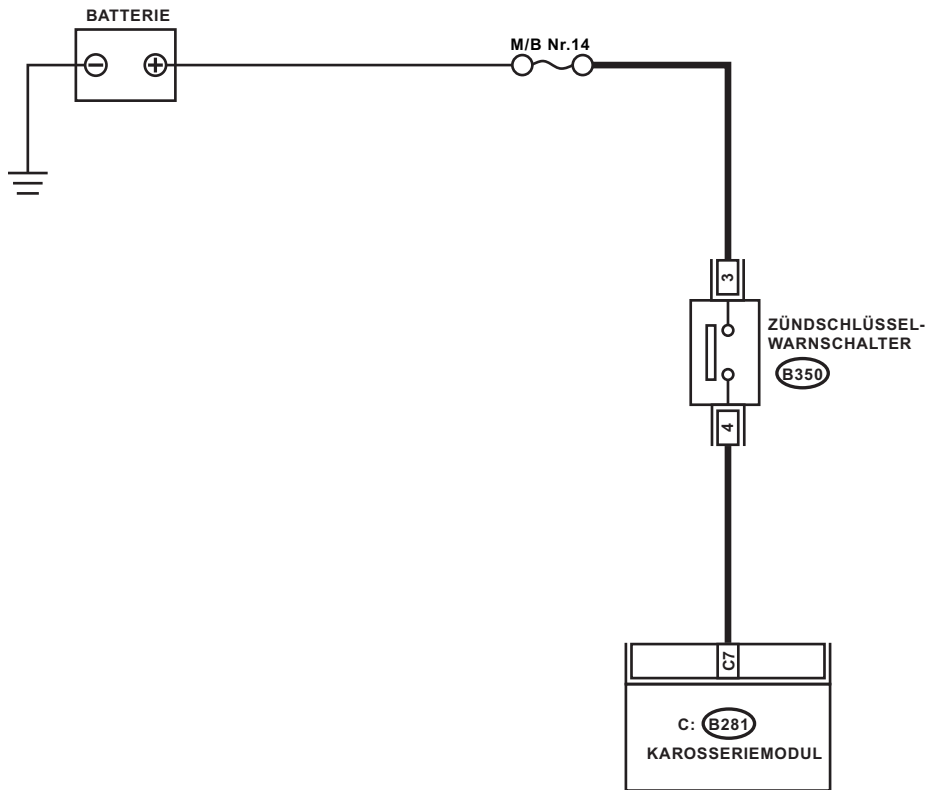

B350



C: B281



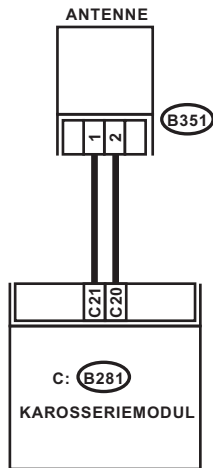

B351



C: **B281**

1	2	3			4	5	6	7			
8	9	10	11	12	13	14	15	16	17	18	19
20	21	22	23	24	25	26	27	28			

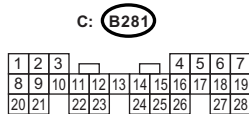
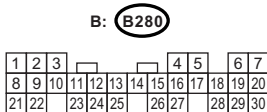
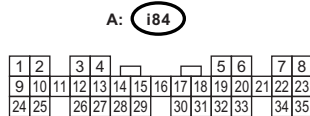
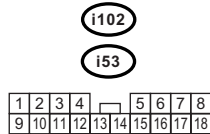
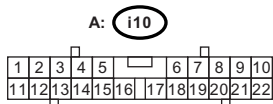
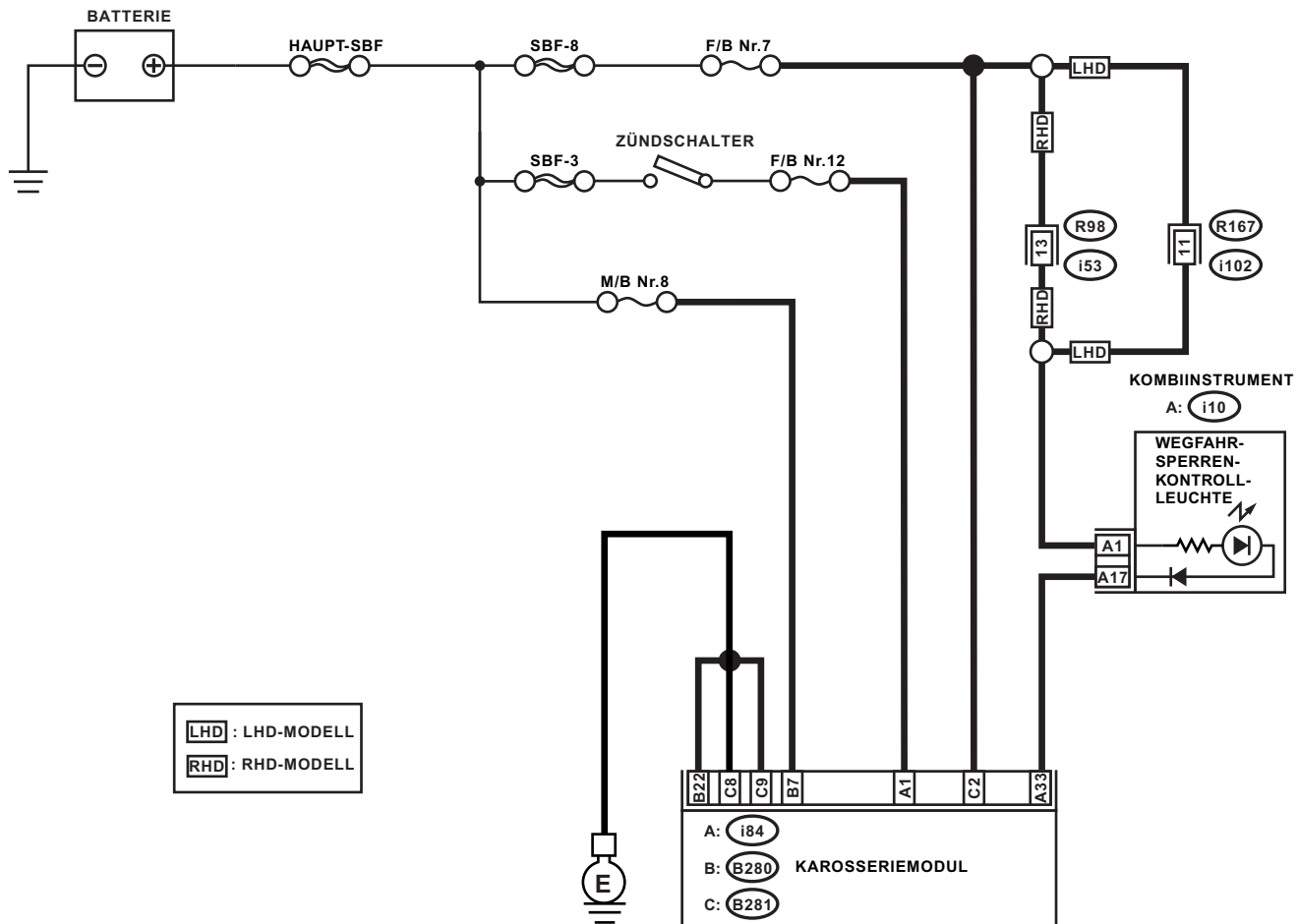

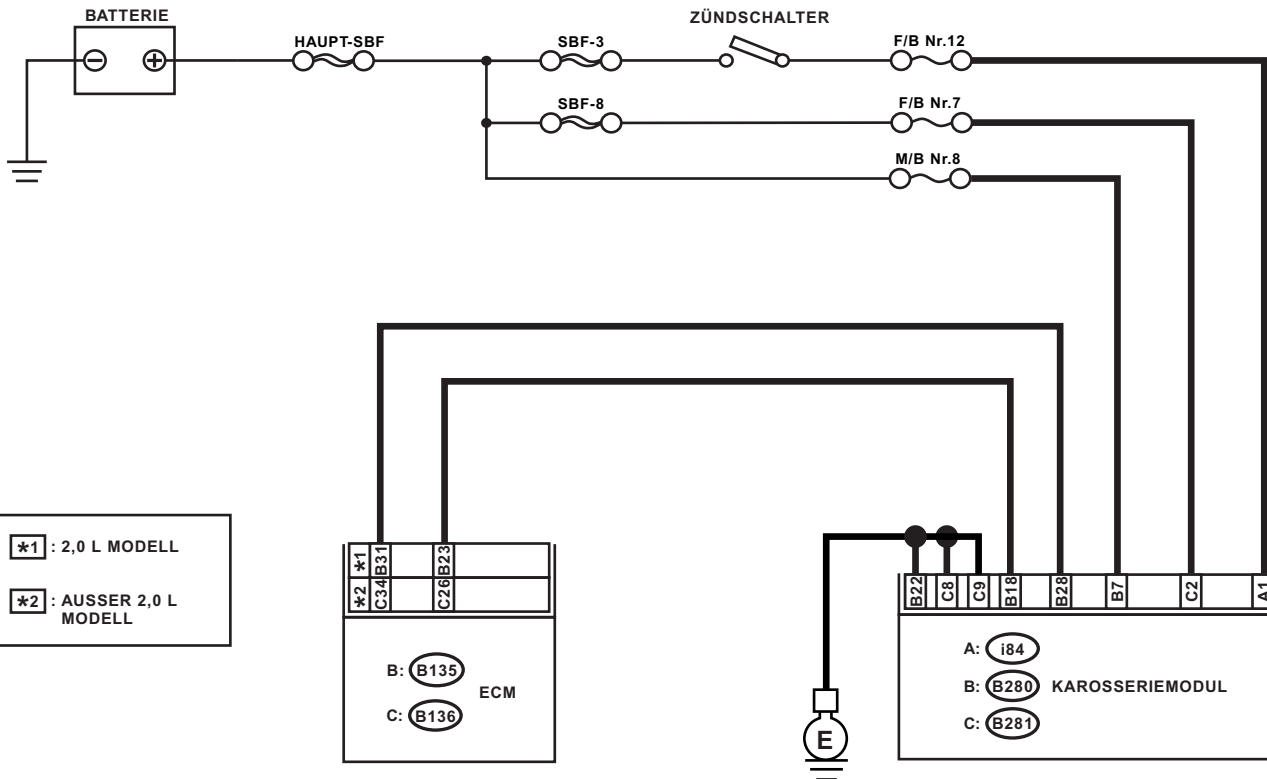

A: i84

1	2	3	4		5	6	7	8						
9	10	11	12	13	14	15	16	17	18	19	20	21	22	23
24	25	26	27	28	29	30	31	32	33	34	35			

B: B280

1	2	3			4	5	6	7				
8	9	10	11	12	13	14	15	16	17	18	19	20
21	22	23	24	25	26	27	28	29	30			

C: B281

1	2	3			4	5	6	7			
8	9	10	11	12	13	14	15	16	17	18	19
20	21	22	23	24	25	26	27	28			

B: B135

1	2		3	4	5	6	7				
8	9	10	11	12	13	14	15	16	17	18	19
20	21	22	23		24	25		26	27		
28	29	30	31		32	33		34	35		

C: B136

	1	2	3	4	5	6				
7	8	9	10	11	12	13	14	15	16	
17	18	19	20	21	22	23	24	25	26	27
28	29	30			31	32	33	34	35	

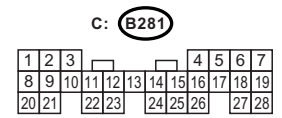
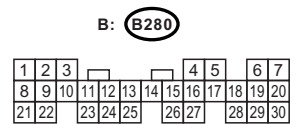
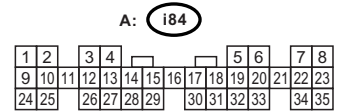
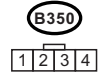
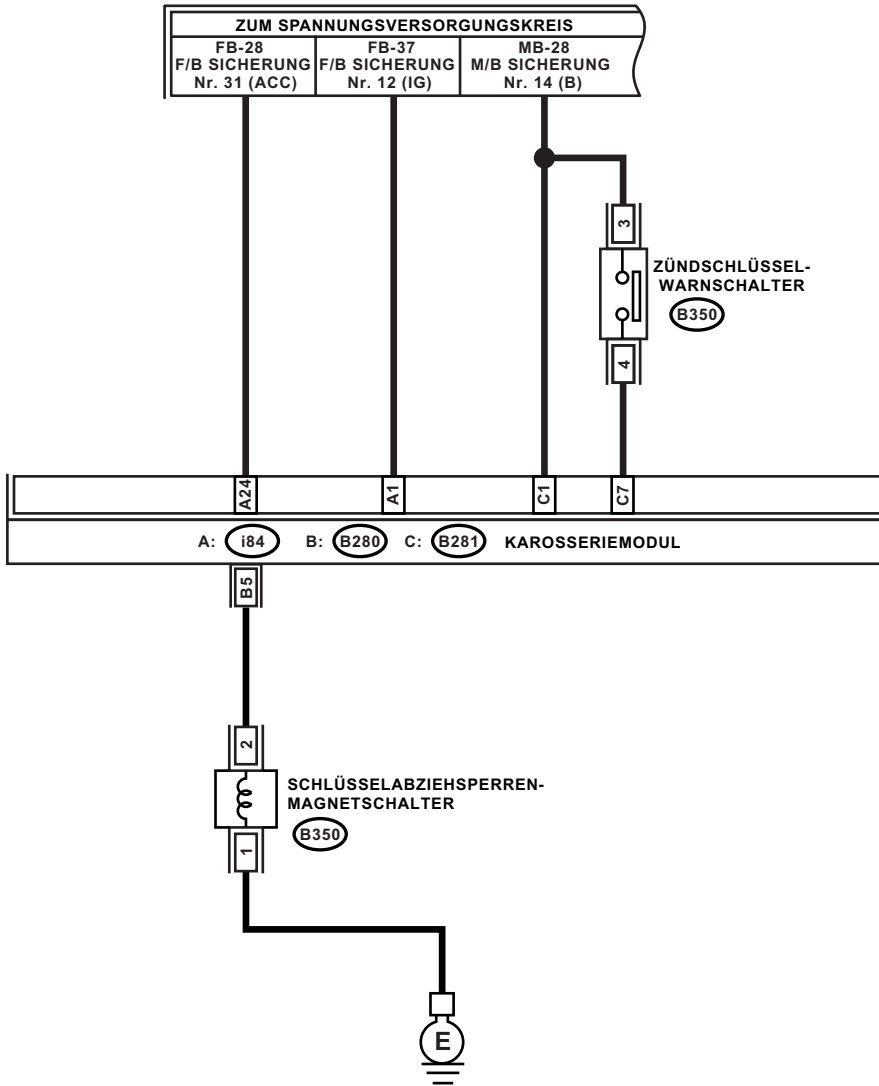

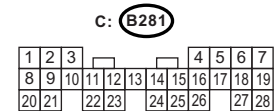
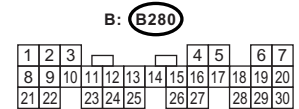
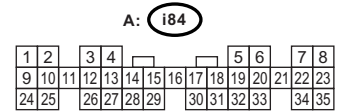
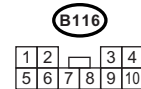
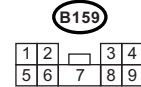
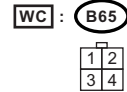
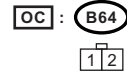
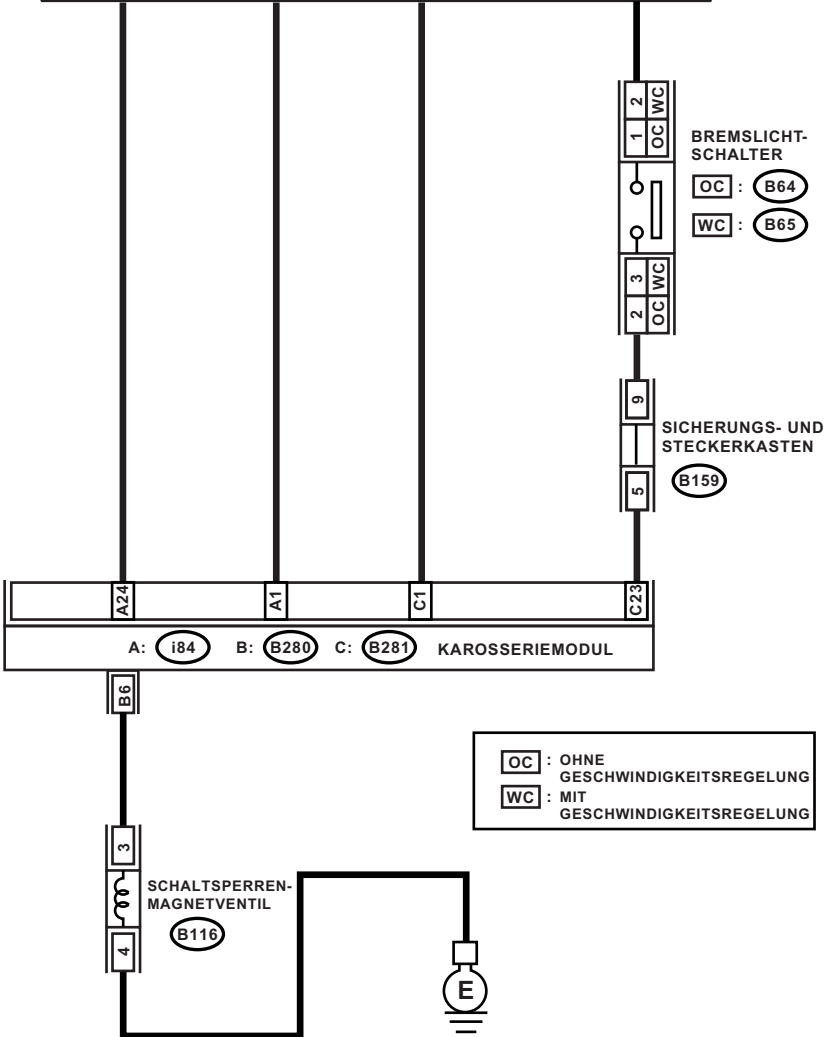
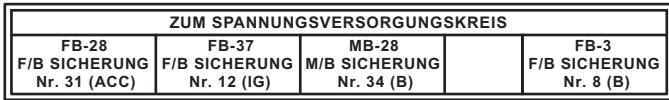

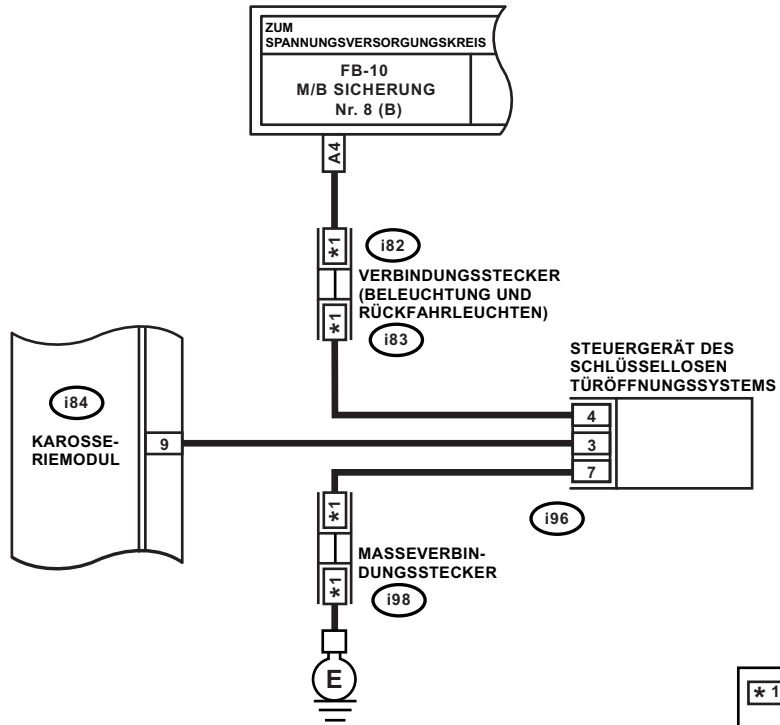

* 1 : KLEMMEN-Nr. OPTIONALE ANORDNUNG BEI 1, 2, 3, 4, 5 UND 6

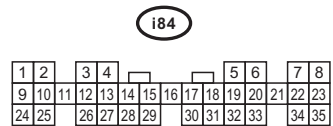
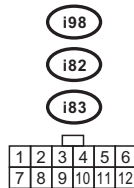
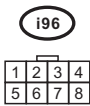

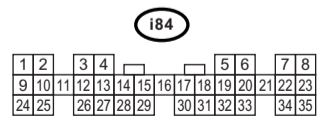
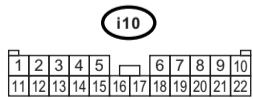
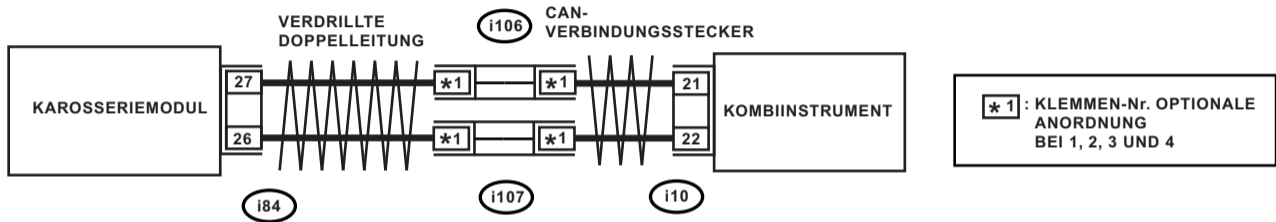

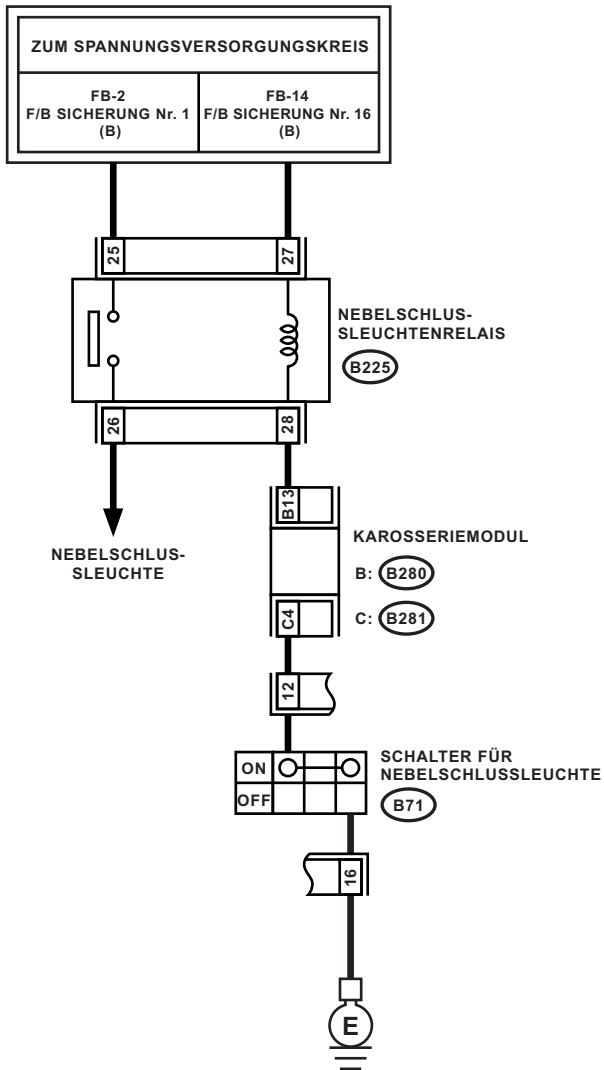

B71

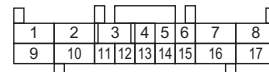

B: B280



C: B281



B225

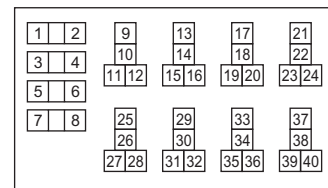

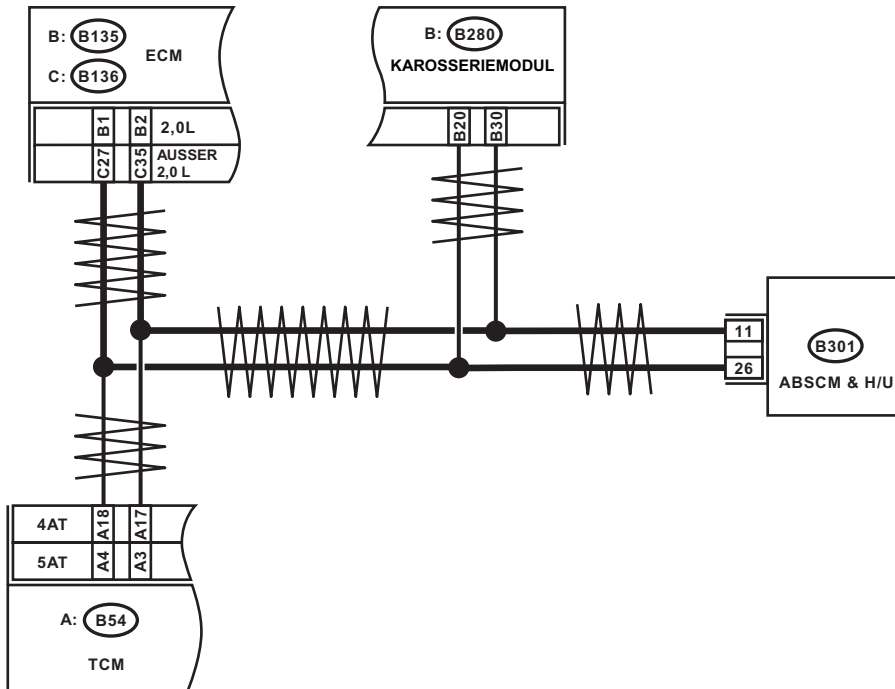

B301

12	13	14	15	1	2	3	4	5	6	7	8	9	10	11
				16	17	18	19	20	21	22	23	24	25	26

B: B280

1	2	3			4	5	6	7				
8	9	10	11	12	13	14	15	16	17	18	19	20
21	22	23	24	25	26	27	28	29	30			

B: B135

1	2		3	4	5	6	7				
8	9	10	11	12	13	14	15	16	17	18	19
20	21	22	23		24	25		26	27		
28	29	30	31		32	33		34	35		

A: B54 C: B136

1	2	3	4		5	6				
7	8	9	10	11	12	13	14	15	16	
17	18	19	20	21	22	23	24	25	26	27
28	29	30		31	32	33	34	35		

- EH** : MODELL MIT NAVIGATIONSSYSTEM (AUDIO-INTEGRIERT)
- EE** : MODELL MIT DVD-NAVIGATIONSSYSTEM
- OP** : OHNE STARTKNOPF
- WP** : MIT STARTKNOPF

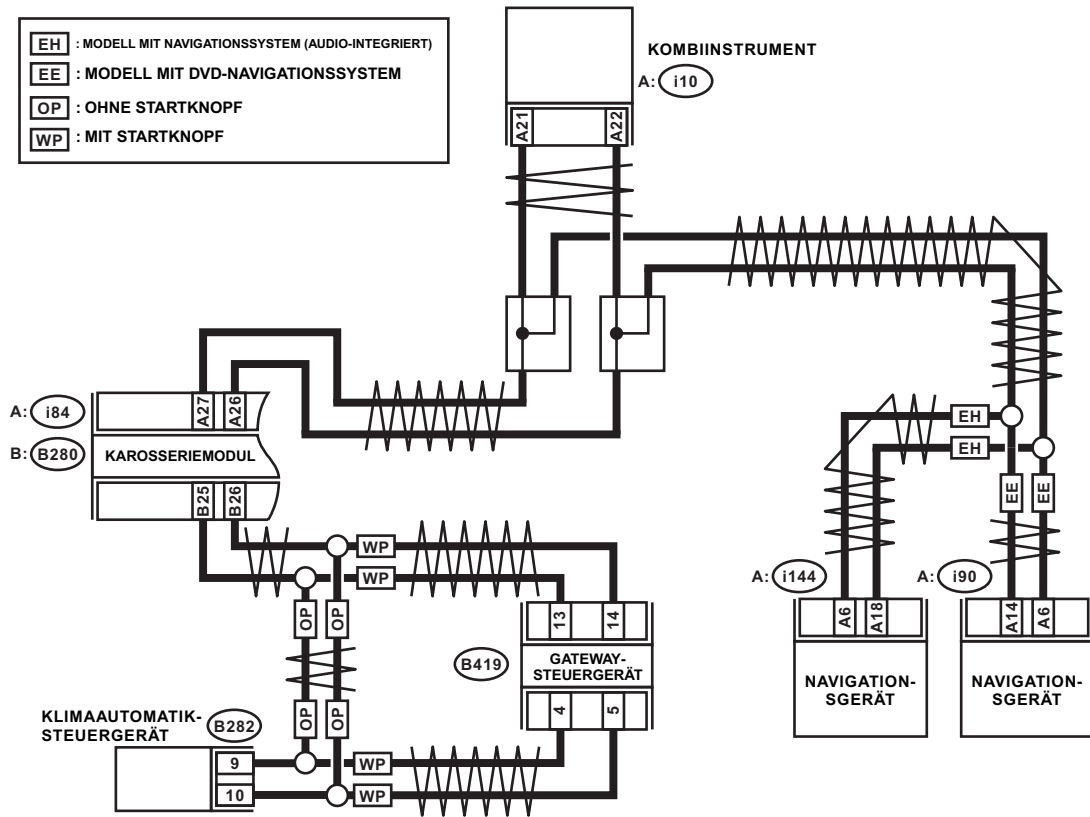

A: i90

1	2	3	4	5	6	7	8
9	10	11	12	13	14	15	16

A: i10

1	2	3	4	5	6	7	8	9	10		
11	12	13	14	15	16	17	18	19	20	21	22

B419

1	2	3	4	5	6	7	8	9						
10	11	12	13	14	15	16	17	18	19	20	21	22	23	24

A: i144

1	2	3	4	5	6	7	8	9	10	11	12
13	14	15	16	17	18	19	20	21	22	23	24

B: B280

1	2	3	4	5	6	7						
8	9	10	11	12	13	14	15	16	17	18	19	20
21	22	23	24	25	26	27	28	29	30			

A: i84

1	2	3	4	5	6	7	8							
9	10	11	12	13	14	15	16	17	18	19	20	21	22	23
24	25	26	27	28	29	30	31	32	33	34	35			

B282

1	2	3	4	5	6	7	8	9	10	11	12	13	14	15	16	17	18	19	20
21	22	23	24	25	26	27	28	29	30	31	32	33	34	35	36	37	38	39	40

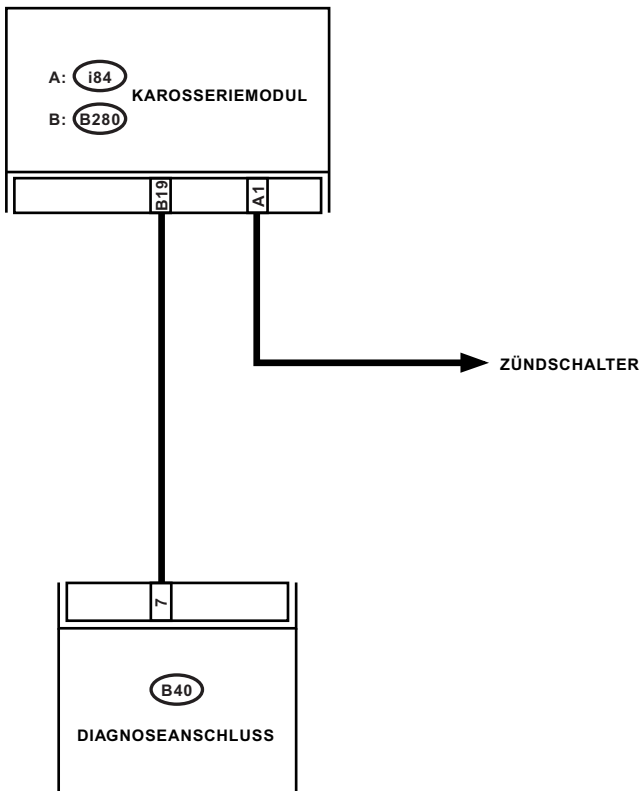

A: **i84**

1	2	3	4		5	6	7	8						
9	10	11	12	13	14	15	16	17	18	19	20	21	22	23
24	25	26	27	28	29	30	31	32	33	34	35			

B: **B280**

1	2	3		4	5	6	7					
8	9	10	11	12	13	14	15	16	17	18	19	20
21	22	23	24	25	26	27	28	29	30			

B40

1	2	3	4	5	6	7	8
9	10	11	12	13	14	15	16

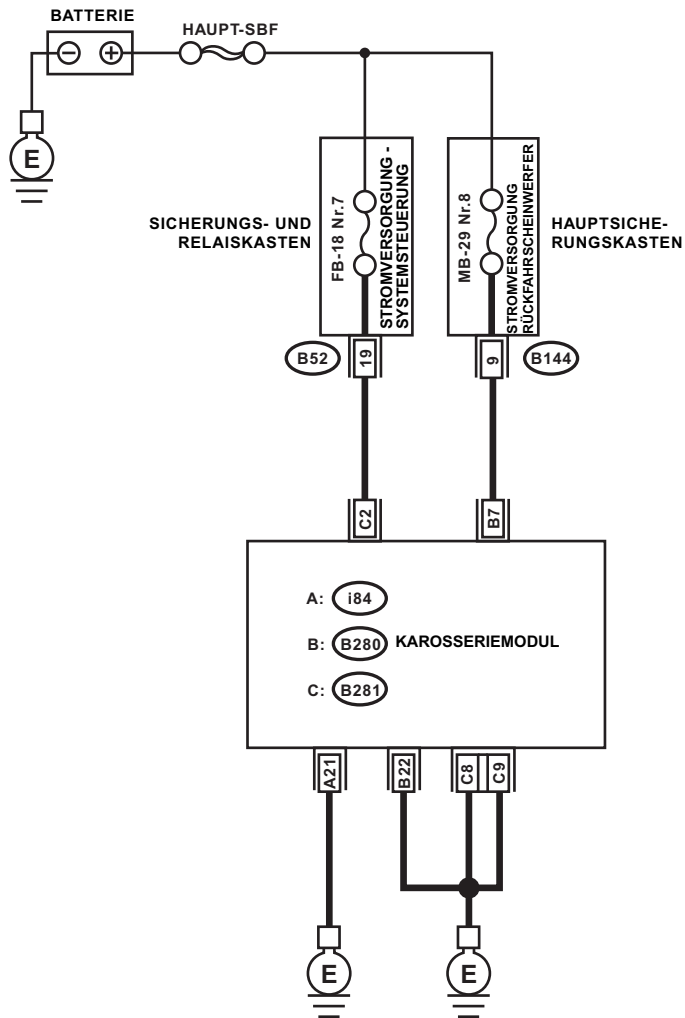

A: **i84**

1	2	3	4			5	6	7	8
9	10	11	12	13	14	15	16	17	18
19	20	21	22	23	24	25	26	27	28
29	30	31	32	33	34	35			

B: **B280**

1	2	3			4	5	6	7	
8	9	10	11	12	13	14	15	16	17
18	19	20	21	22	23	24	25	26	27
28	29	30							

C: **B281**

1	2	3			4	5	6	7	
8	9	10	11	12	13	14	15	16	17
18	19	20	21	22	23	24	25	26	27
28									

B52

1	2	3	4	5		6	7	8	9	10	11
12	13	14	15	16	17	18	19	20	21	22	23
24											

B144

1	2		3	4
5	6	7	8	9

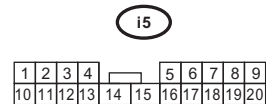
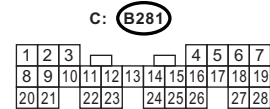
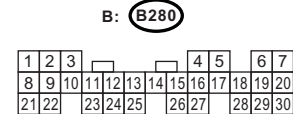
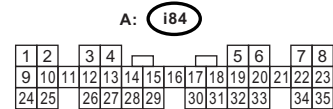
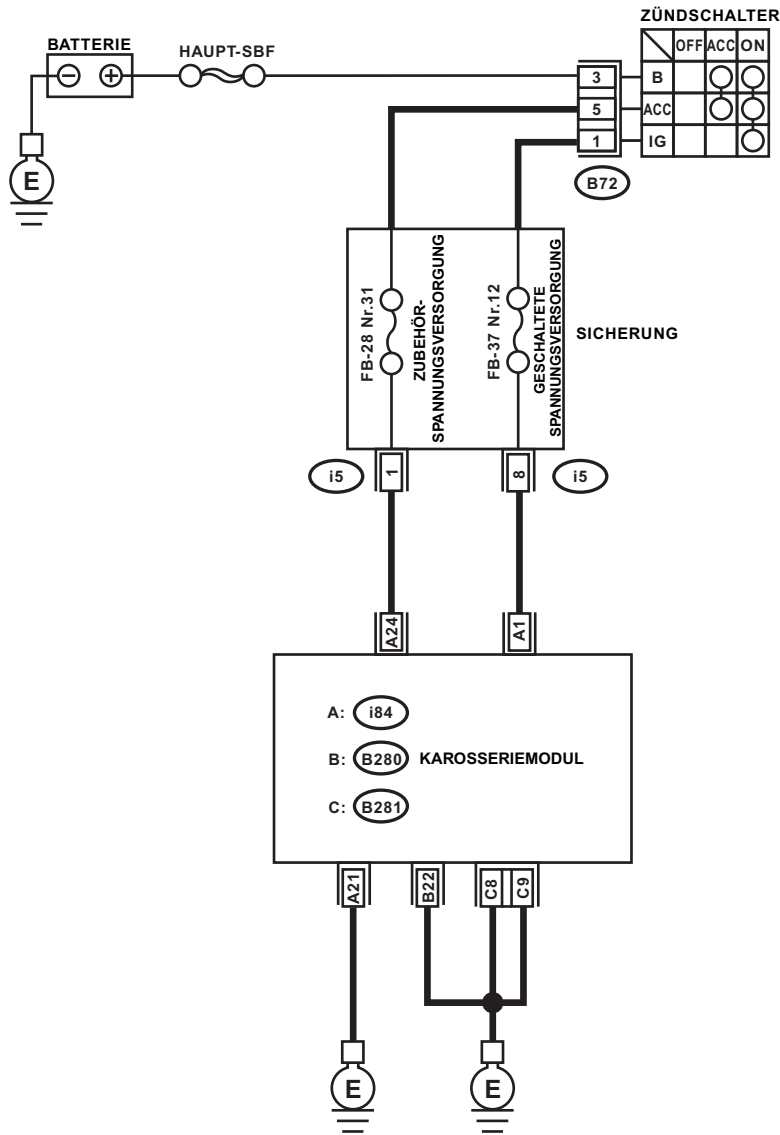

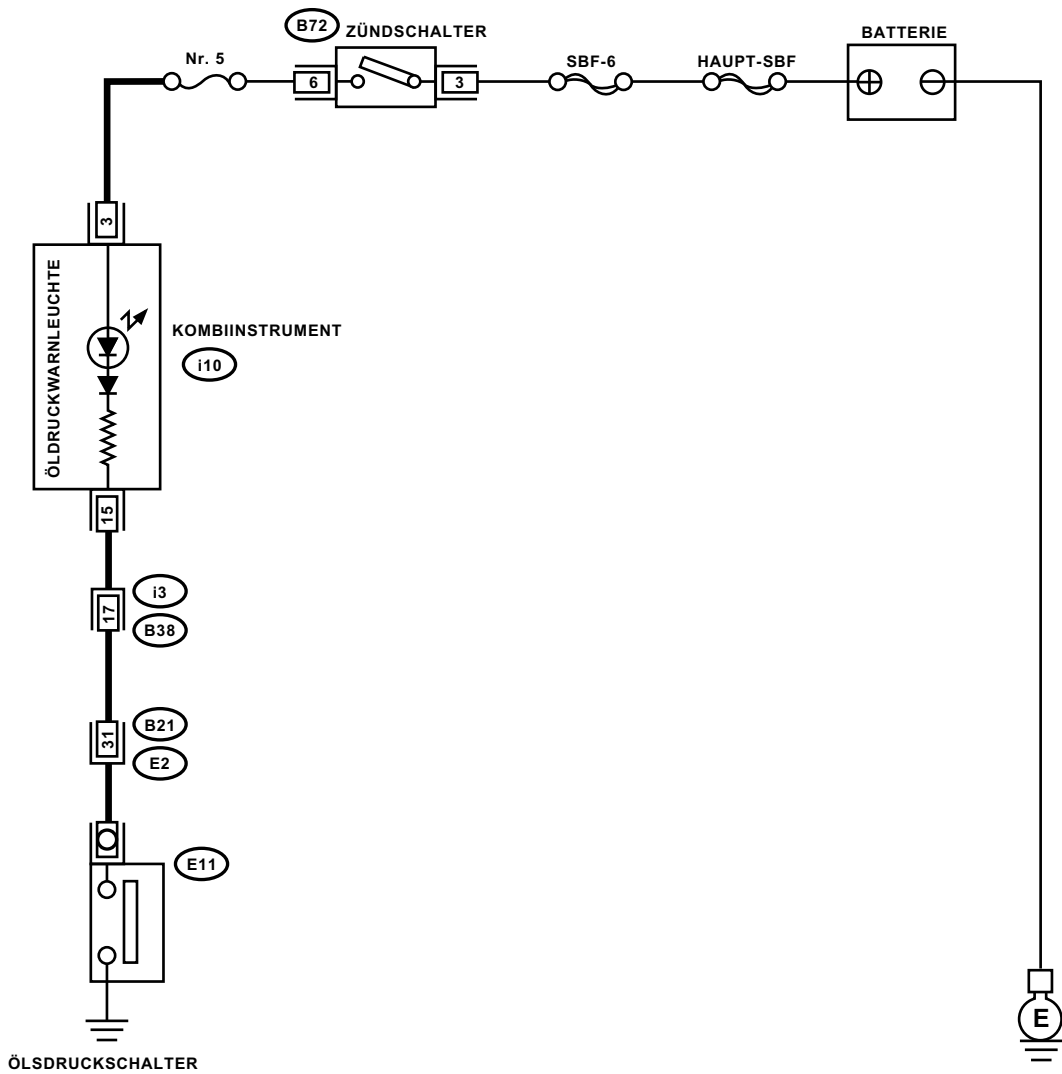

B72

1	2	3
4	5	6

i10

1	2	3	4	5	6	7	8	9	10
11	12	13	14	15	16	17	18	19	20
21	22								

B38

1	2	3	4	5	6	7	8	9
10	11	12	13	14	15	16	17	18
19	20							

B21

1	2	3	4	5	6	7	8	9	10	11
12	13	14	15	16	17	18	19	20	21	22
23	24	25	26	27	28	29	30	31	32	33
34	35	36	37	38	39	40	41			
42	43	44	45	46	47					
48	49	50	51	52	53	54				

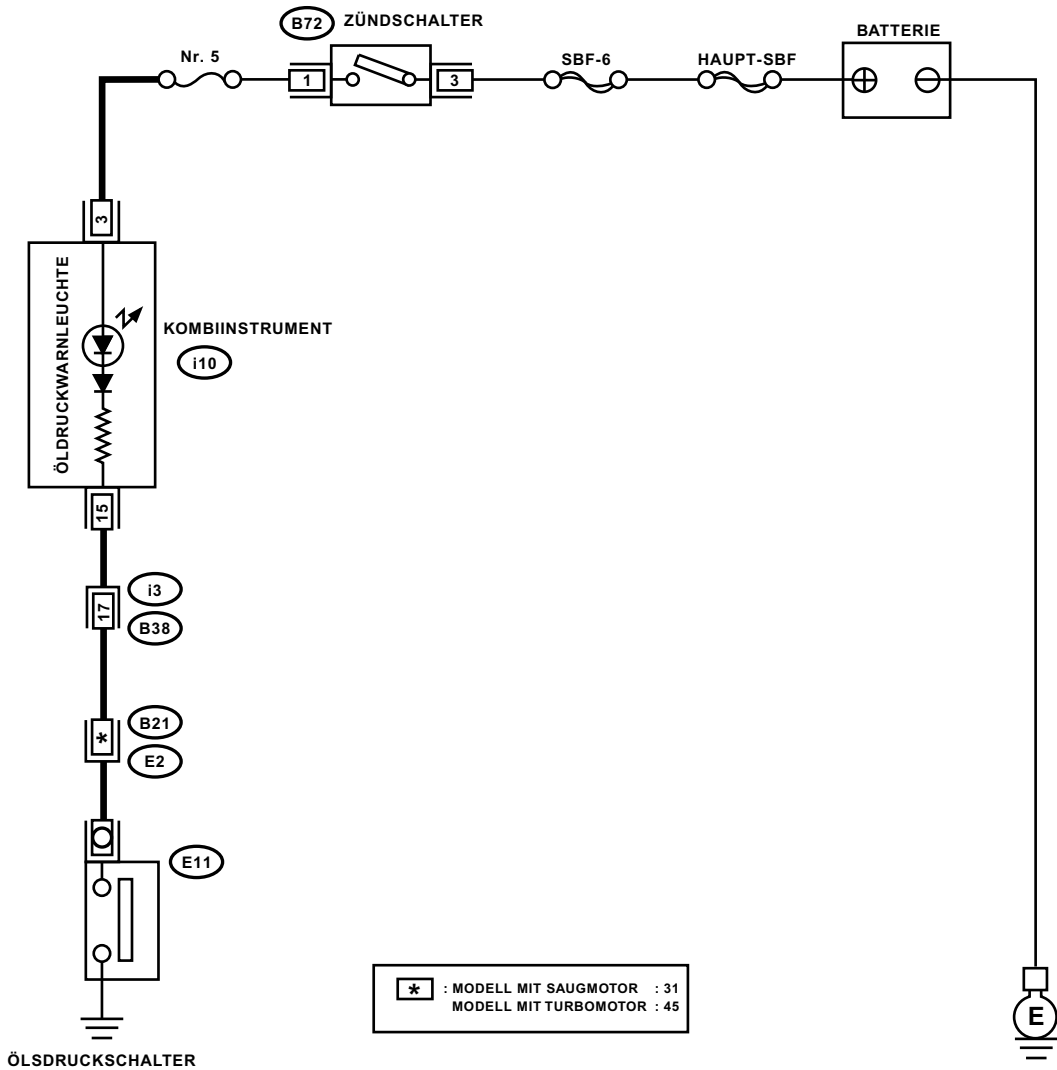

B72



i10

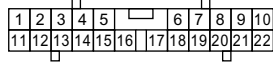

B38

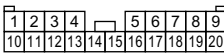

B21

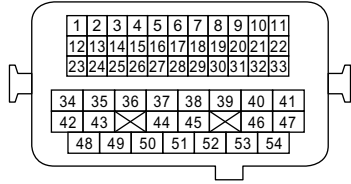

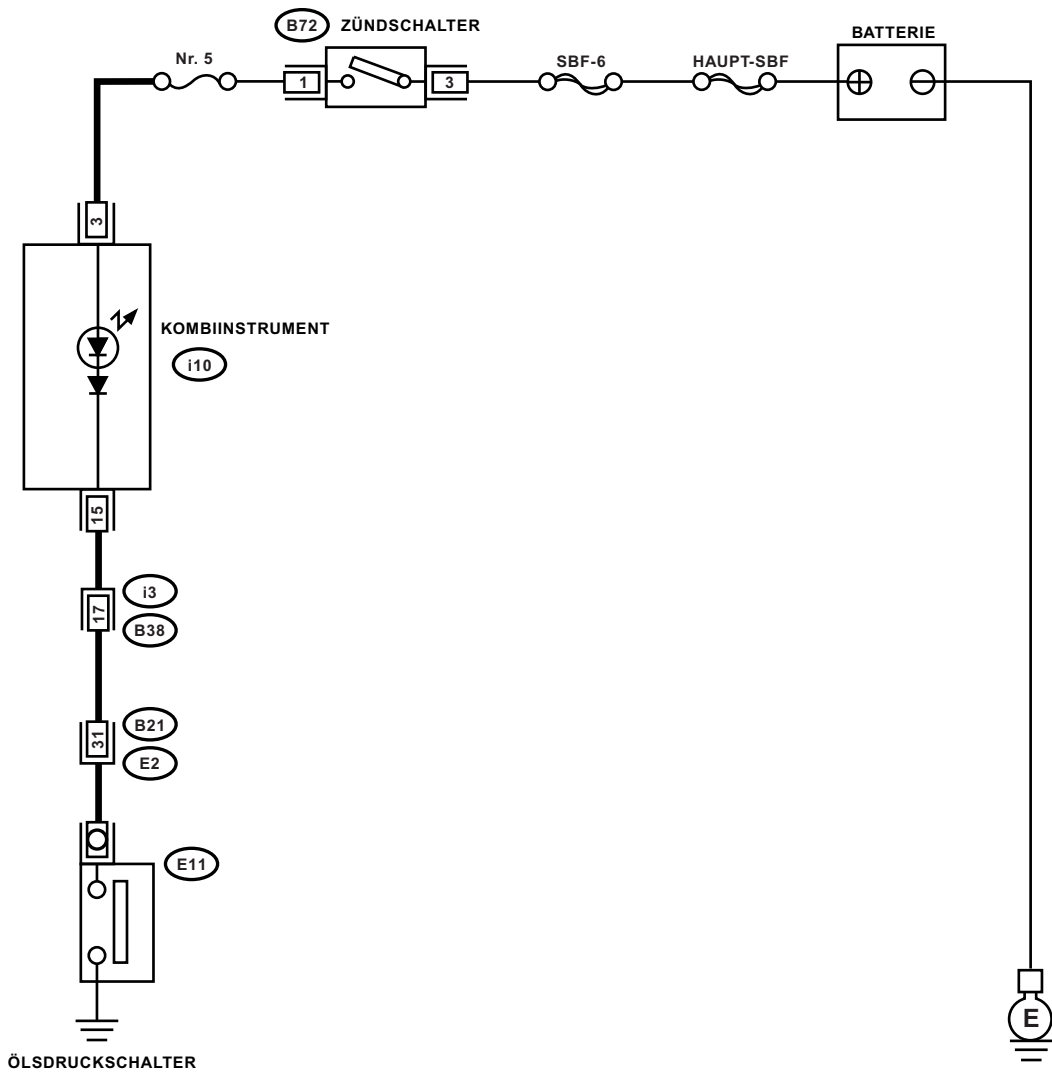

B72

1	2	3
4	5	6

i10

1	2	3	4	5	6	7	8	9	10
11	12	13	14	15	16	17	18	19	20
21	22								

B38

1	2	3	4	5	6	7	8	9	10
11	12	13	14	15	16	17	18	19	20

B21

1	2	3	4	5	6	7	8	9	10	11
12	13	14	15	16	17	18	19	20	21	22
23	24	25	26	27	28	29	30	31	32	33
34	35	36	37	38	39	40	41			
42	43	44	45	46	47					
48	49	50	51	52	53	54				



B421

17	16	15	14	13	12	11	10		9	8	7	6	5	4	3	2	1					
40	39	38	37	36	35	34	33	32	31	30	29	28	27	26	25	24	23	22	21	20	19	18

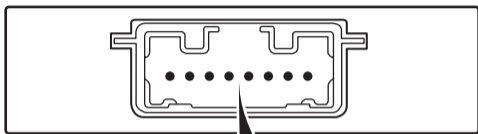

B422

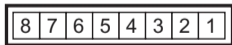

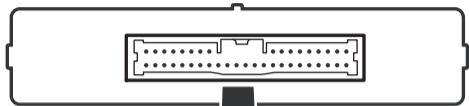

B420

17	16	15	14	13	12	11	10		9	8	7	6	5	4	3	2	1					
40	39	38	37	36	35	34	33	32	31	30	29	28	27	26	25	24	23	22	21	20	19	18



B419

9	8	7	6		5	4	3	2	1					
24	23	22	21	20	19	18	17	16	15	14	13	12	11	10

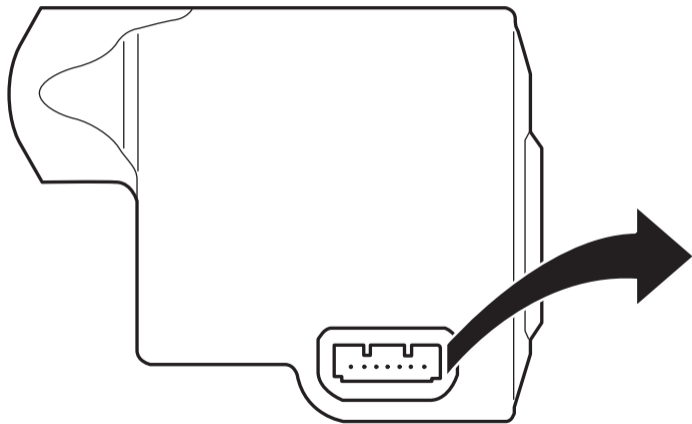

B424

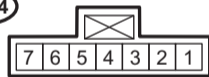

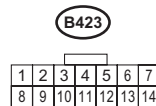
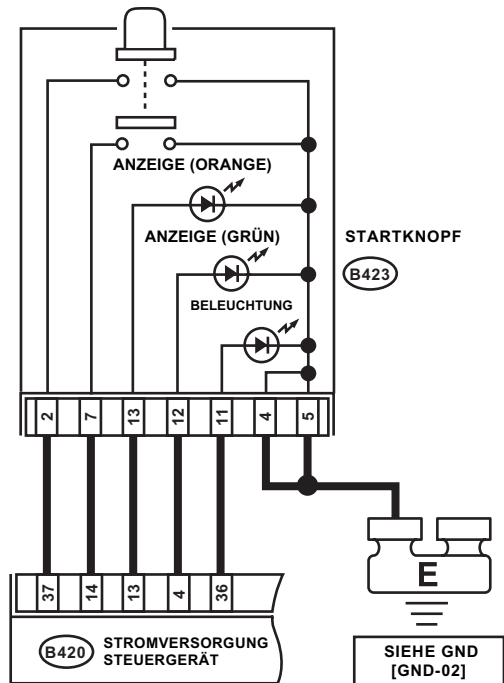

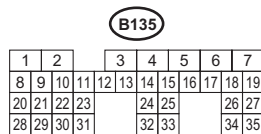
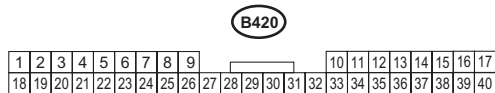
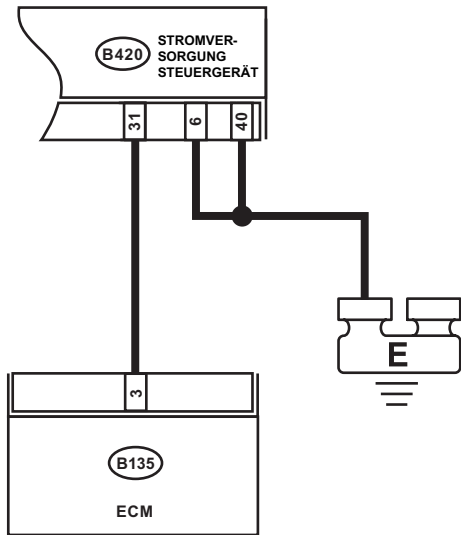

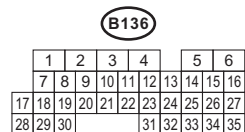
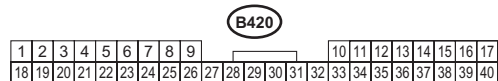
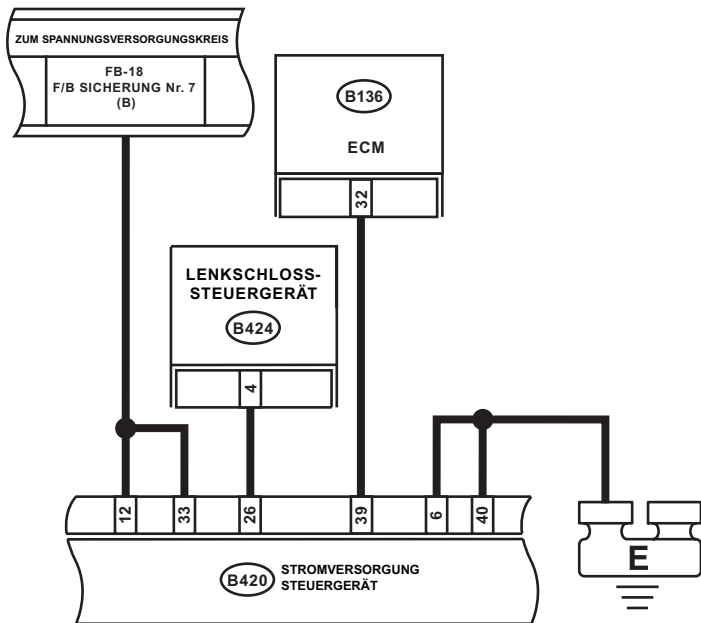

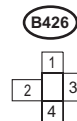
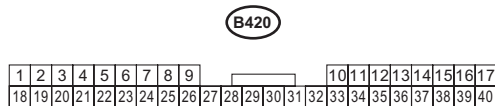
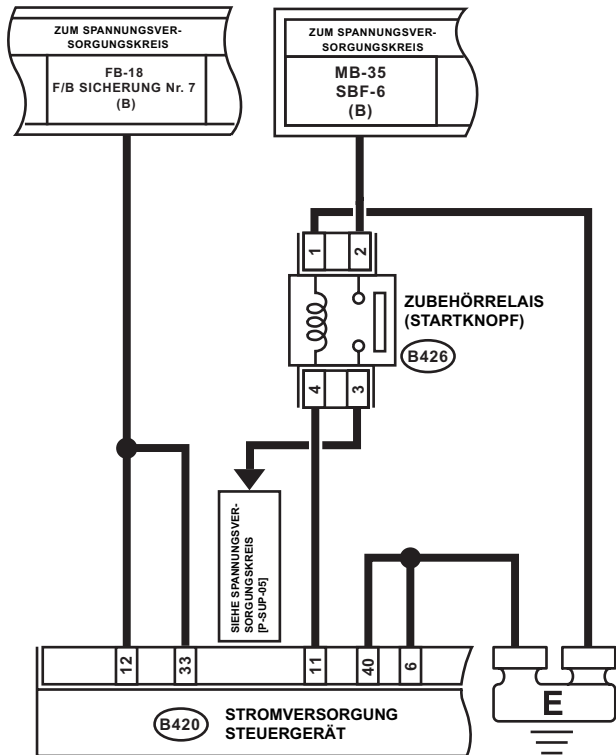

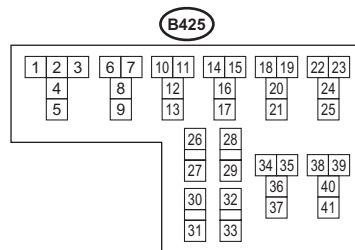
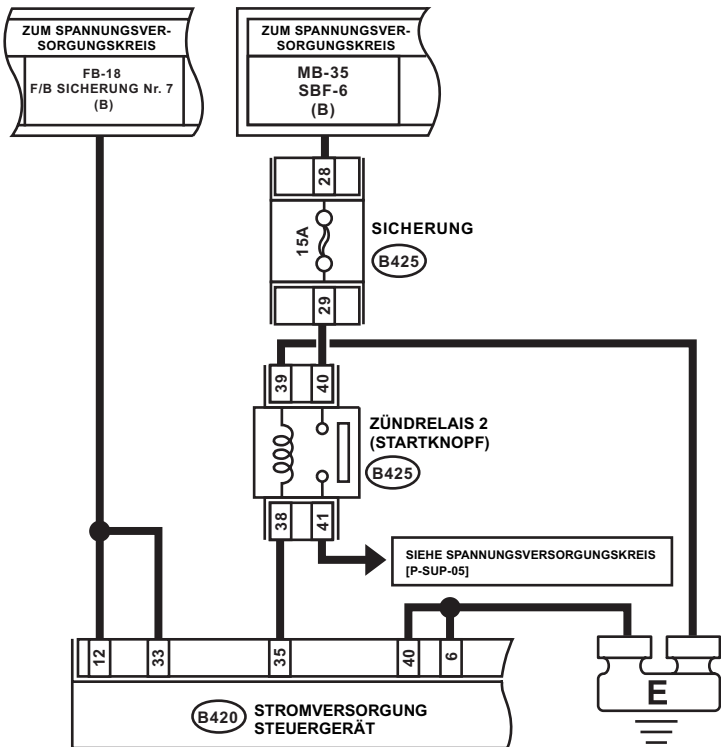

RELAISBLOCK

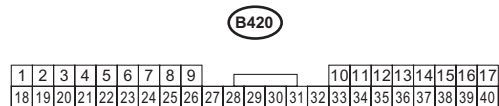

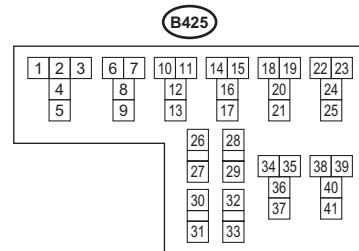
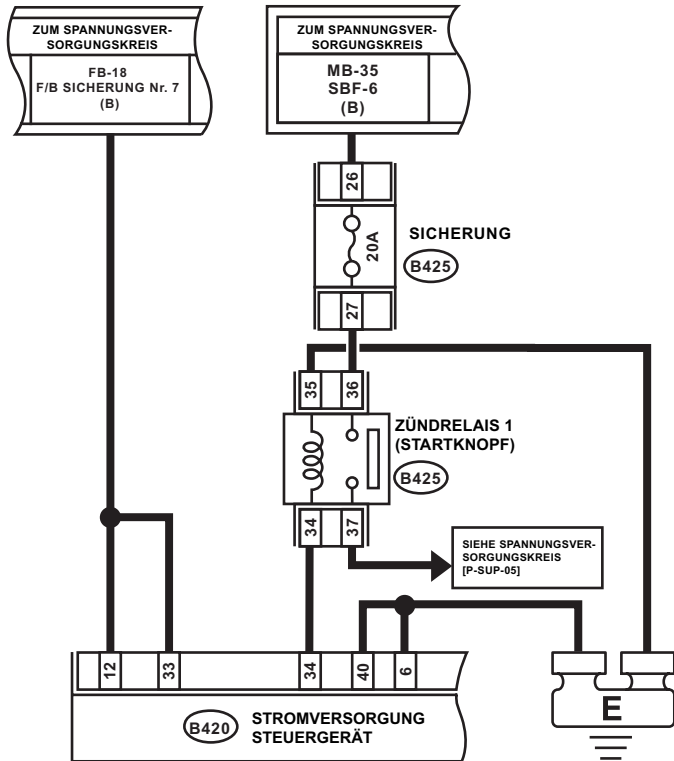

RELAISBLOCK



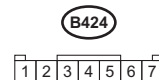
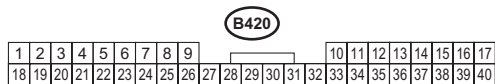
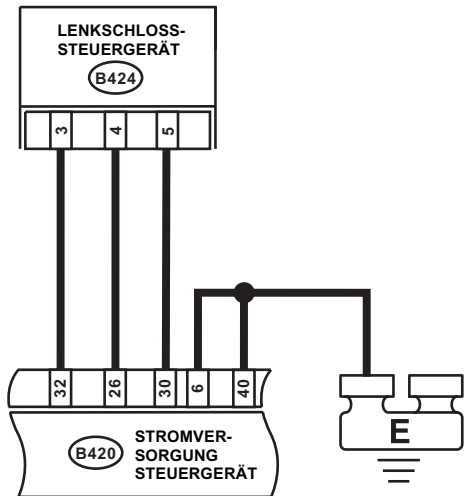

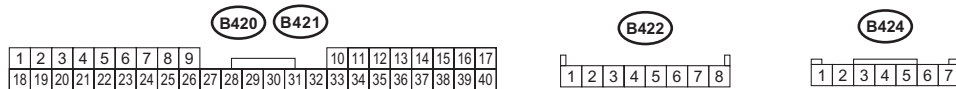
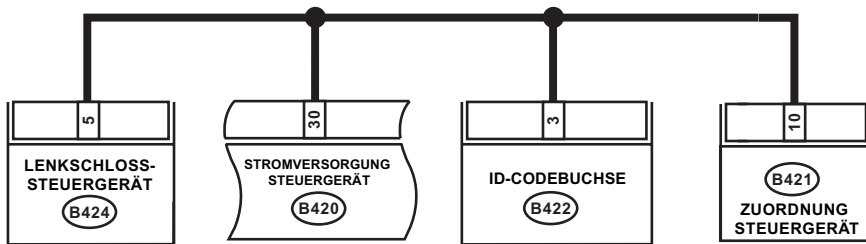

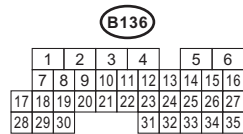
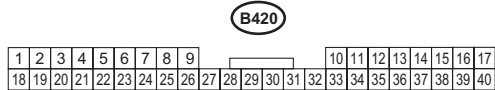
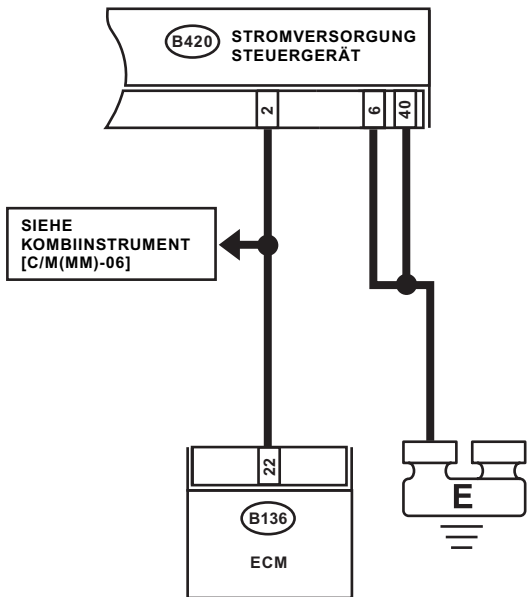

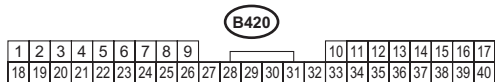
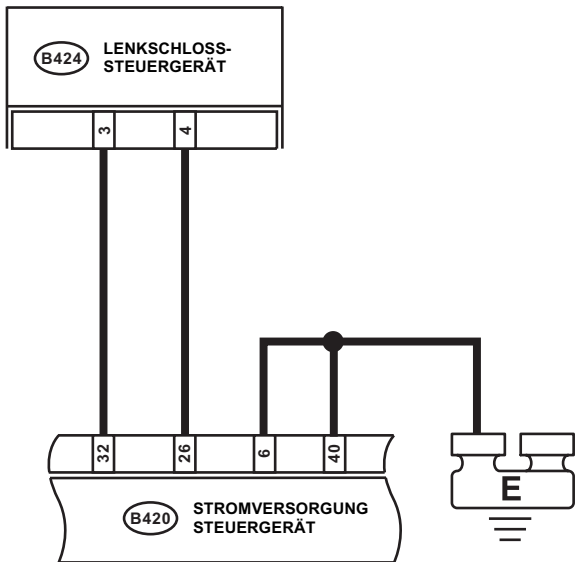

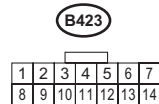
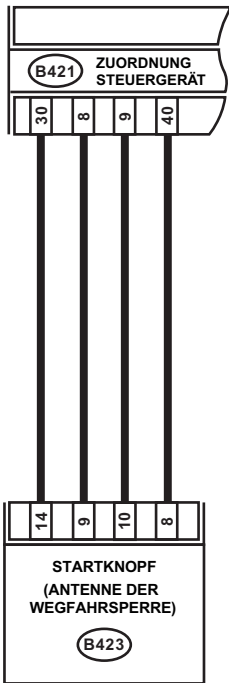

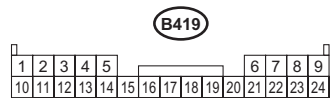
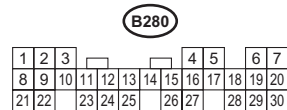
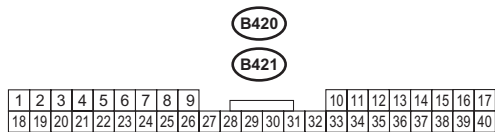
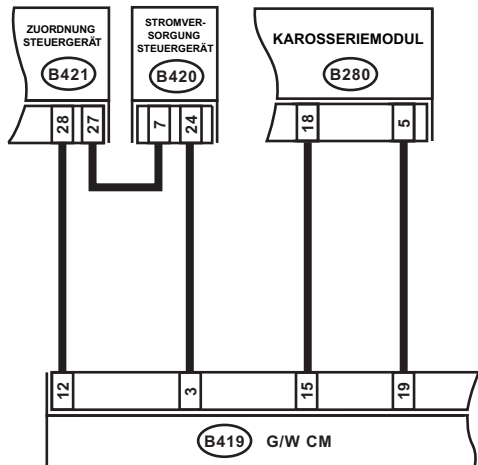

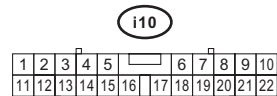
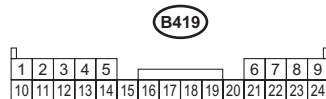
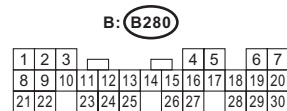
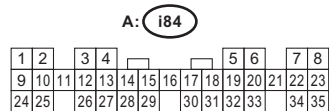
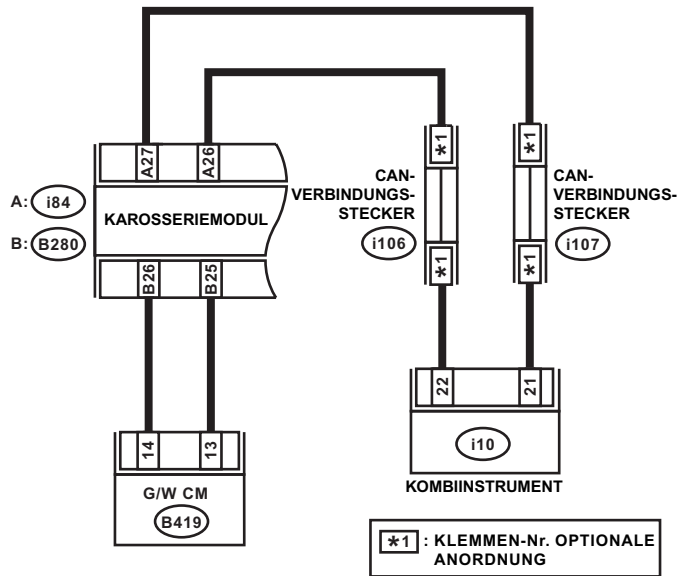

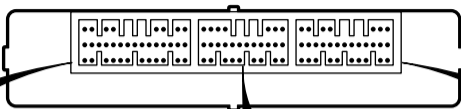

ZU A: **i84**

8	7	6	5					4	3	2	1			
23	22	21	20	19	18	17	16	15	14	13	12	11	10	9
35	34	33	32	31	30	29	28	27	26	25	24			

ZU B: **B281**

7	6	5	4					3	2	1	
19	18	17	16	15	14	13	12	11	10	9	8
28	27	26	25	24	23	22	21	20			

ZU C: **B280**

7	6	5	4					3	2	1		
20	19	18	17	16	15	14	13	12	11	10	9	8
30	29	28	27	26	25	24	23	22	21			

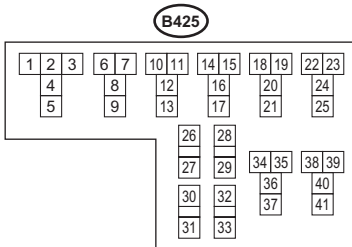
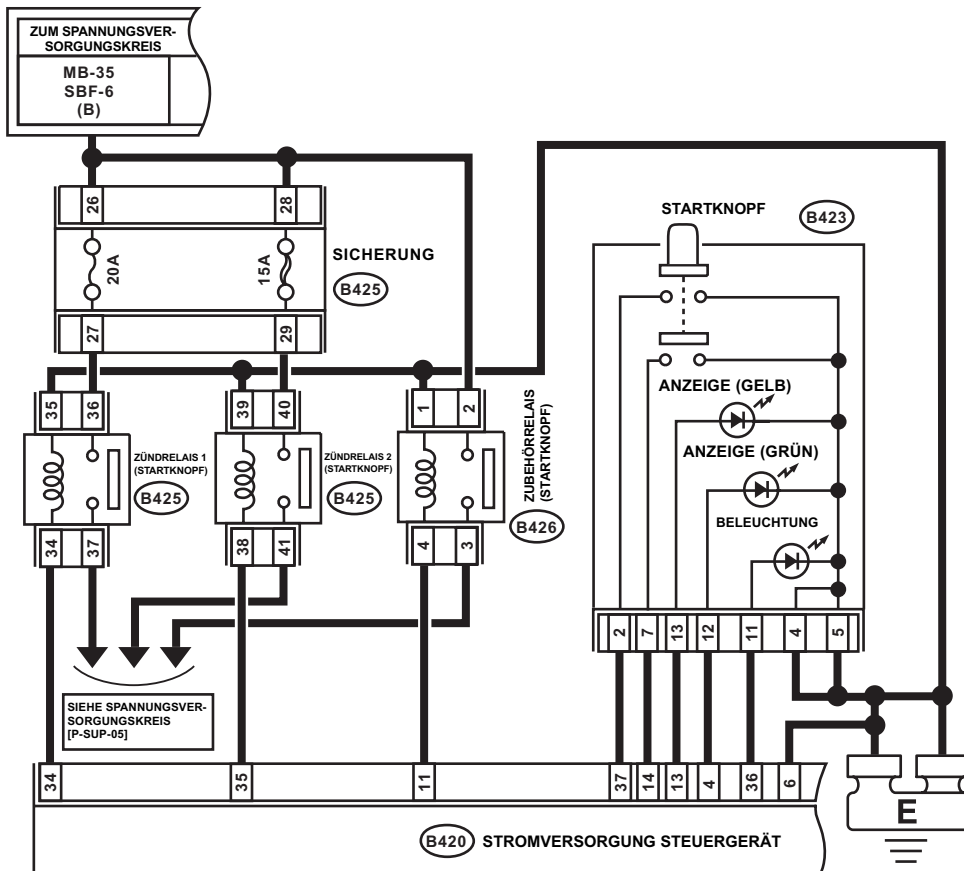

RELAISBLOCK

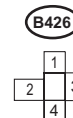
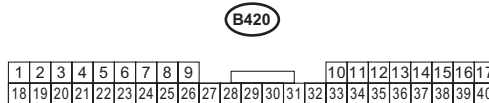

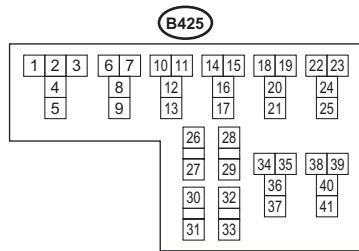
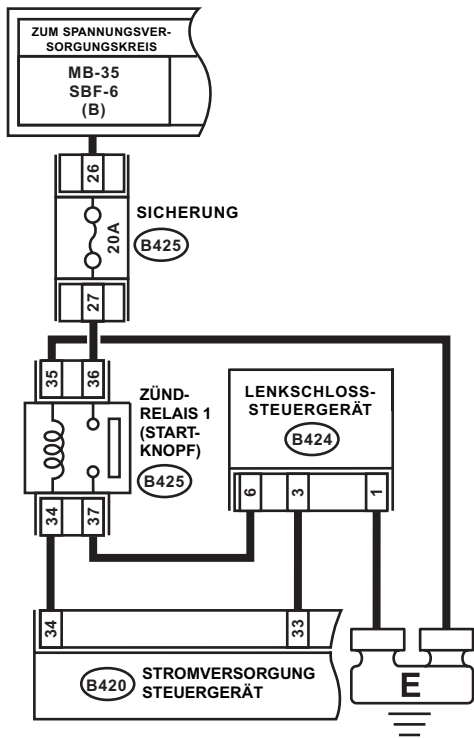

RELAISBLOCK



B420



B424

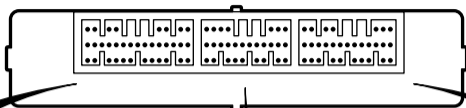

i84 : A

8	7	6	5					4	3	2	1			
23	22	21	20	19	18	17	16	15	14	13	12	11	10	9
35	34	33	32	31	30		29	28	27	26		25	24	

B280 : B

7	6		5	4						3	2	1
20	19	18	17	16	15	14	13	12	11	10	9	8
30	29	28		27	26		25	24	23		22	21

B281 : C

7	6	5	4							3	2	1
19	18	17	16	15	14	13	12	11	10	9	8	
28	27		26	25	24		23	22		21	20	

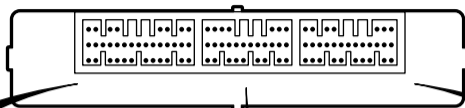

i84 : A

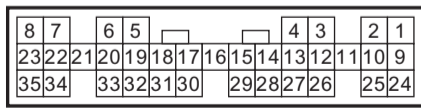

B281 : C

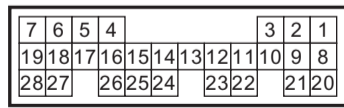

B280 : B

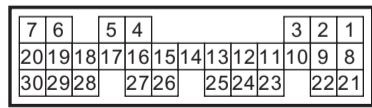

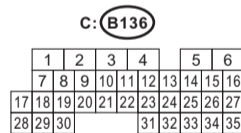
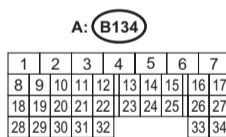
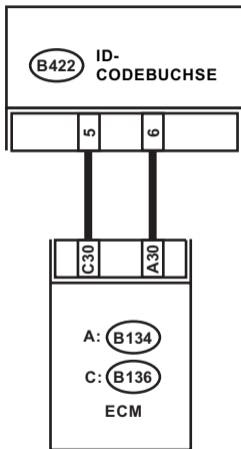

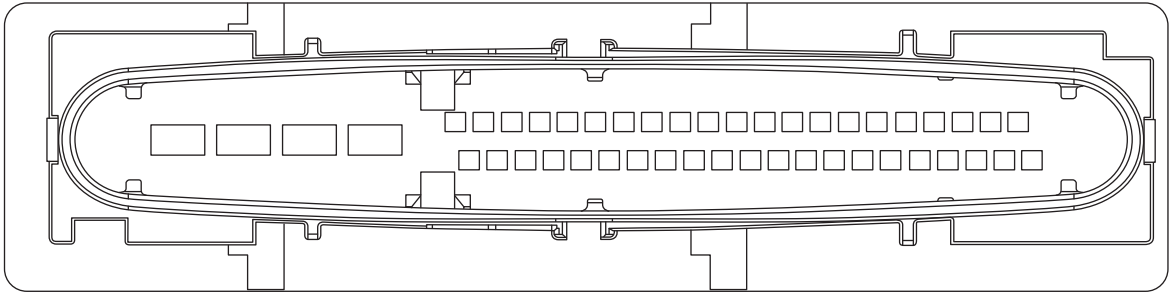

B310

22	23	24	25	1	2	3	4	5	6	7	8	9	10	11	12	13	14	15	16	17	18	19	20	21
				26	27	28	29	30	31	32	33	34	35	36	37	38	39	40	41	42	43	44	45	46

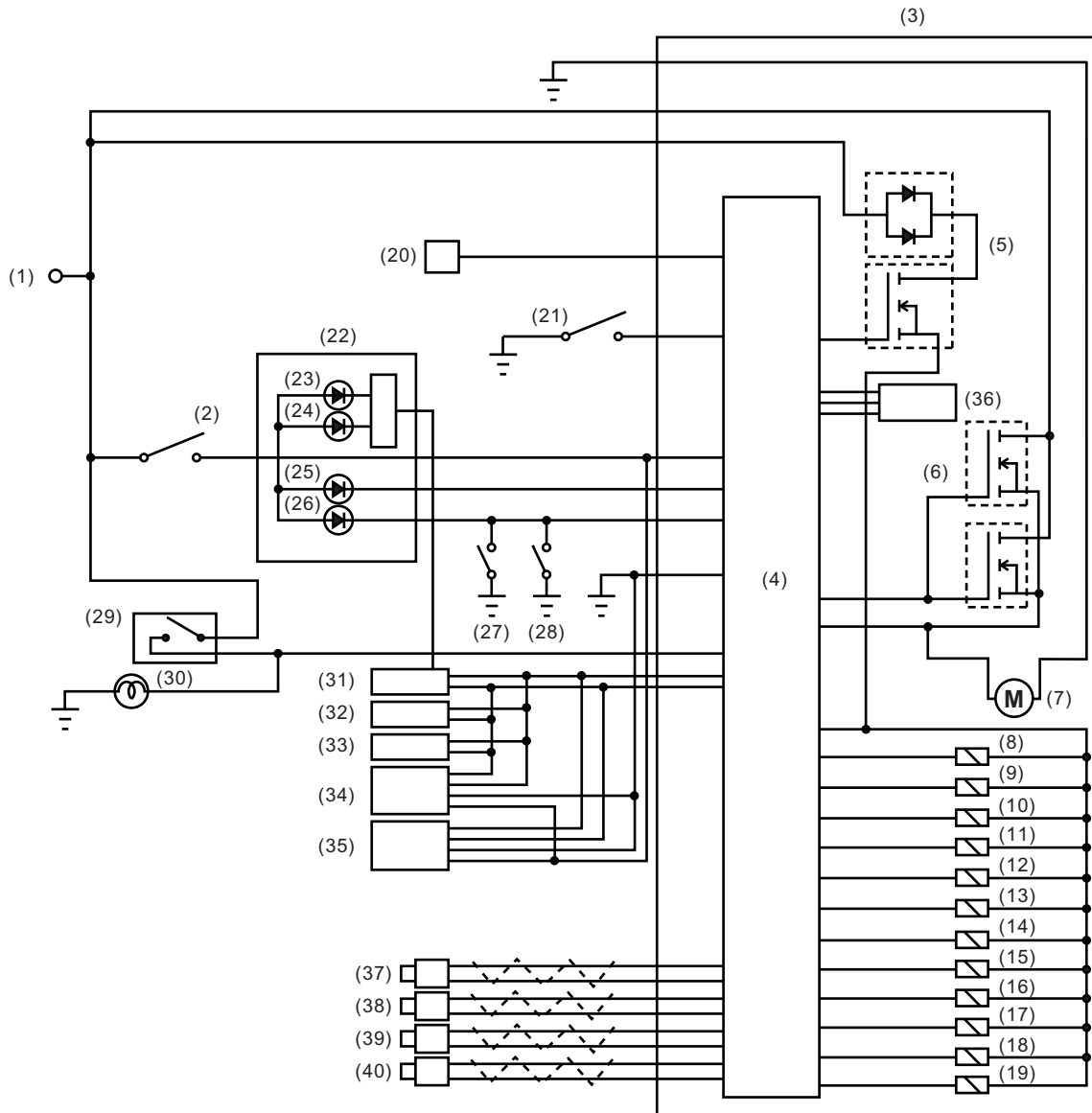

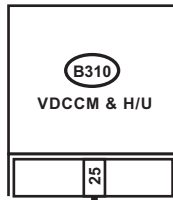

B310

22	23	24	25	1	2	3	4	5	6	7	8	9	10	11	12	13	14	15	16	17	18	19	20	21
				26	27	28	29	30	31	32	33	34	35	36	37	38	39	40	41	42	43	44	45	46

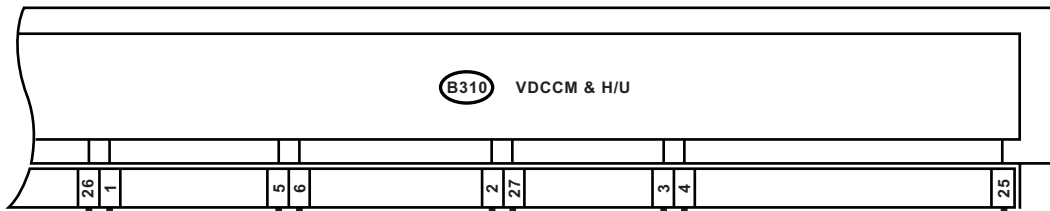

VERDRILLTE DOPPELLEITUNG

VERDRILLTE DOPPELLEITUNG

VERDRILLTE DOPPELLEITUNG

VERDRILLTE DOPPELLEITUNG

ABS-VORDERRADSENSOR LH

ABS-VORDERRADSENSOR RH

ABS-HINTERRADSENSOR LH

ABS-HINTERRADSENSOR RH



B6

R72

B98

B310

B15

R73

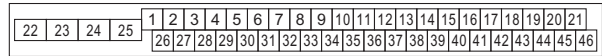
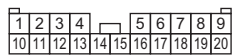

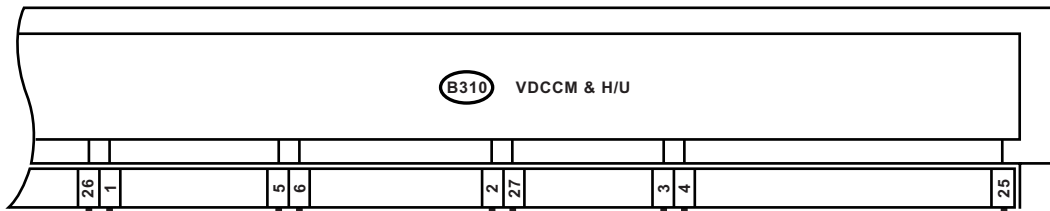

(B310) VDCCM & H/U

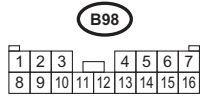
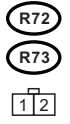
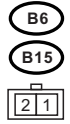
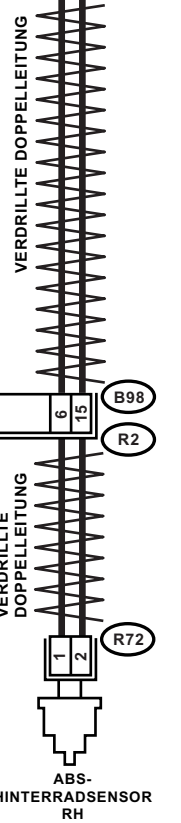
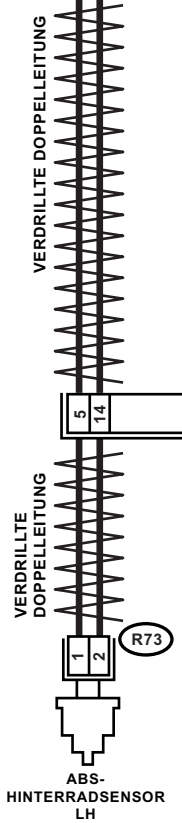
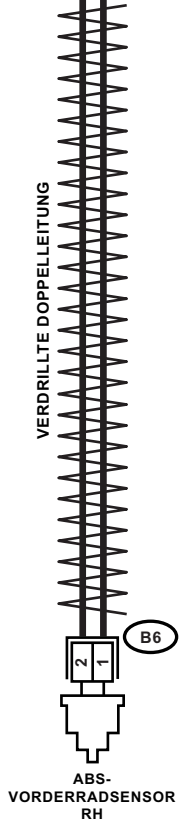
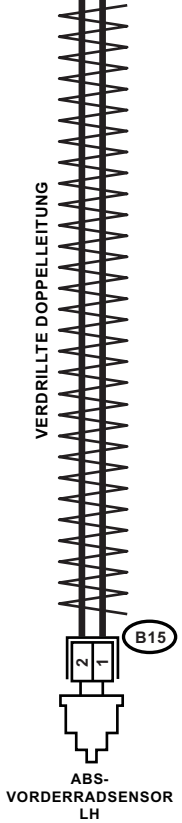

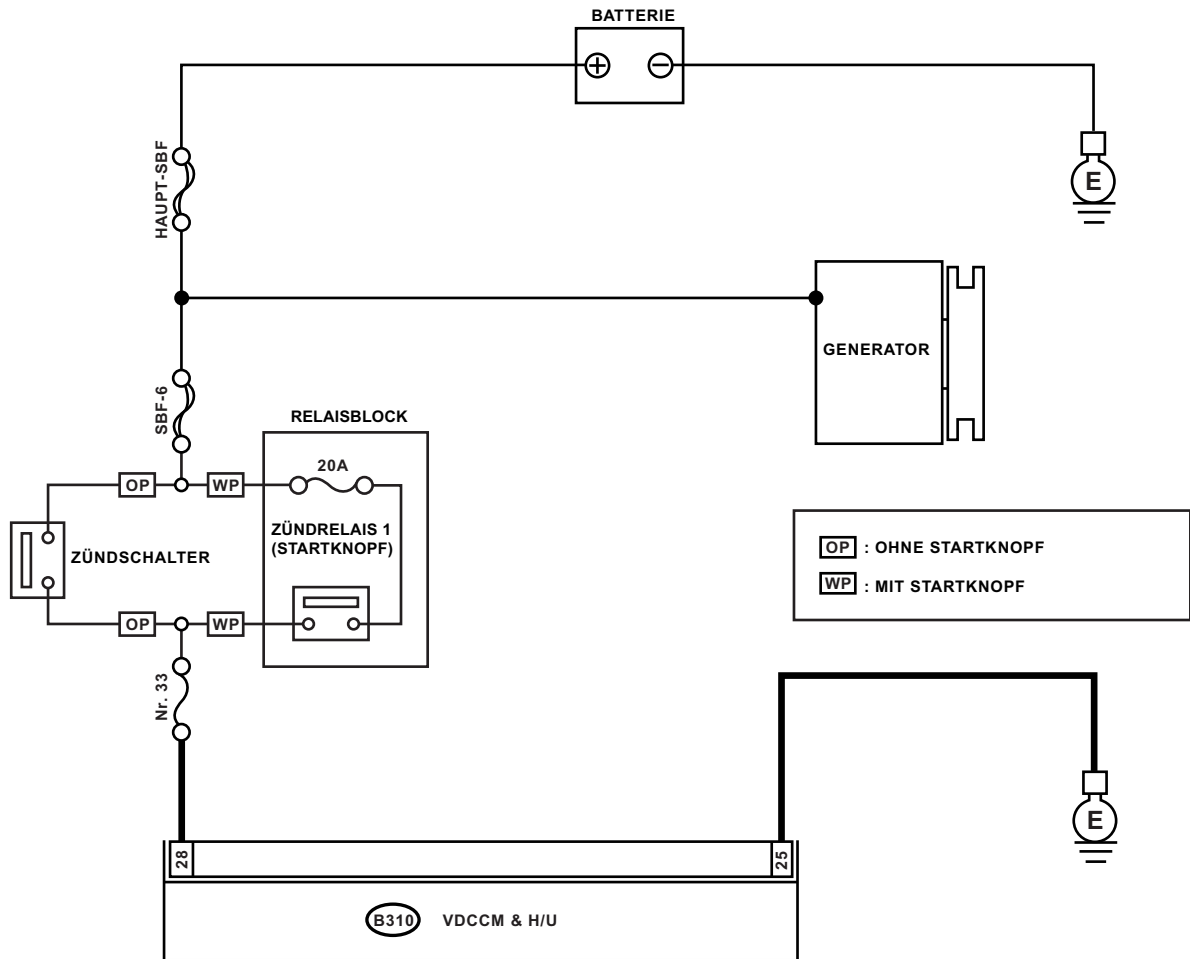

B310

22	23	24	25	1	2	3	4	5	6	7	8	9	10	11	12	13	14	15	16	17	18	19	20	21
				26	27	28	29	30	31	32	33	34	35	36	37	38	39	40	41	42	43	44	45	46

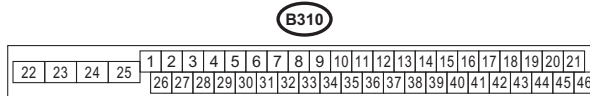
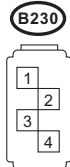
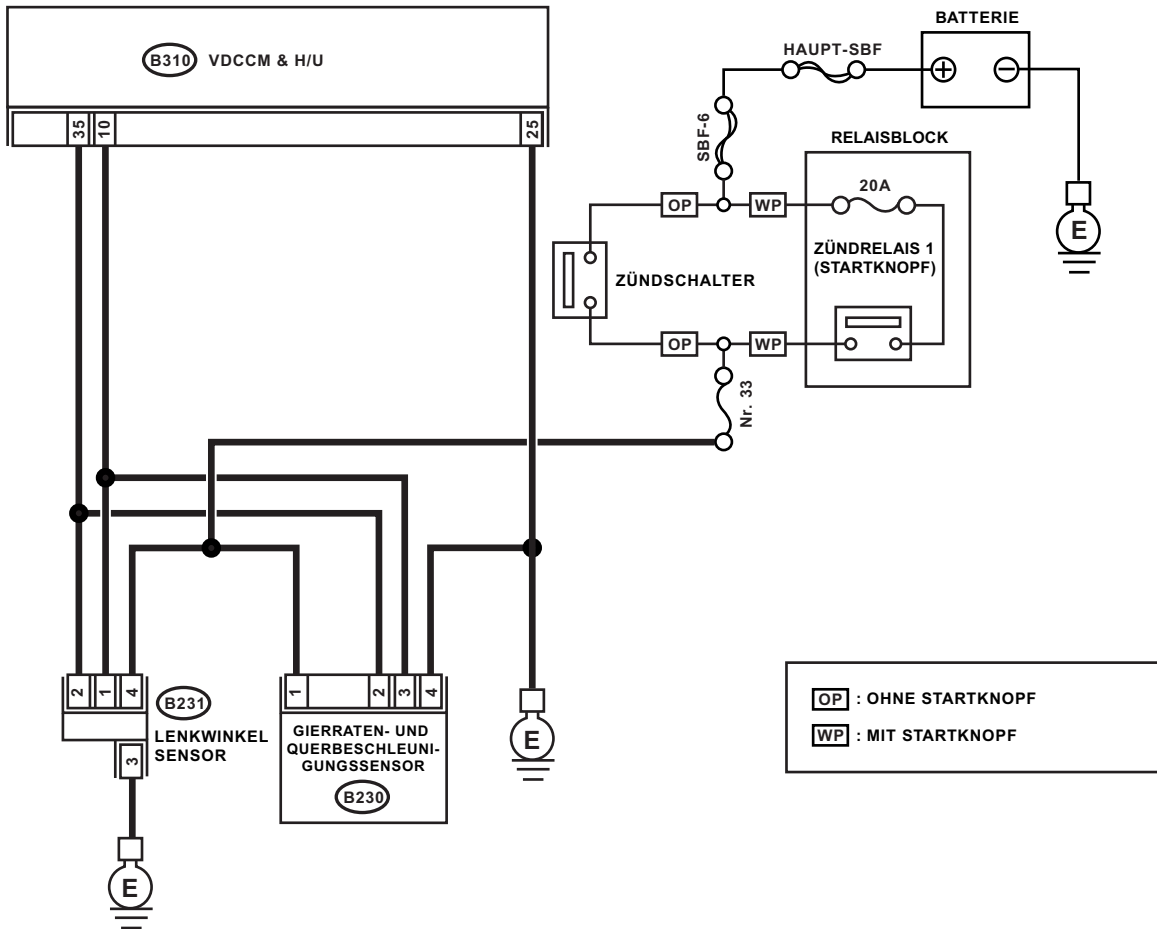

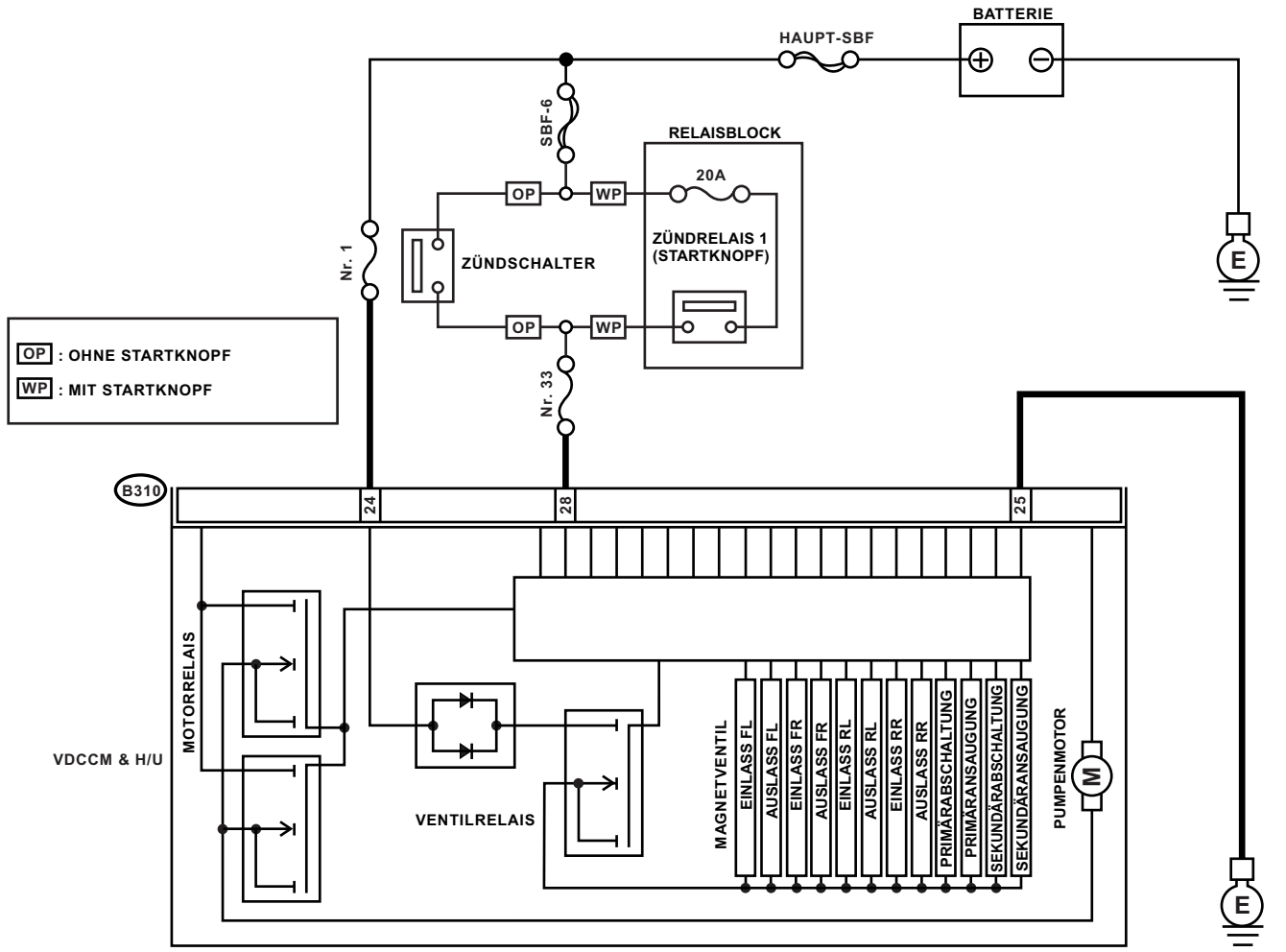

B310

22	23	24	25	1	2	3	4	5	6	7	8	9	10	11	12	13	14	15	16	17	18	19	20	21
				26	27	28	29	30	31	32	33	34	35	36	37	38	39	40	41	42	43	44	45	46

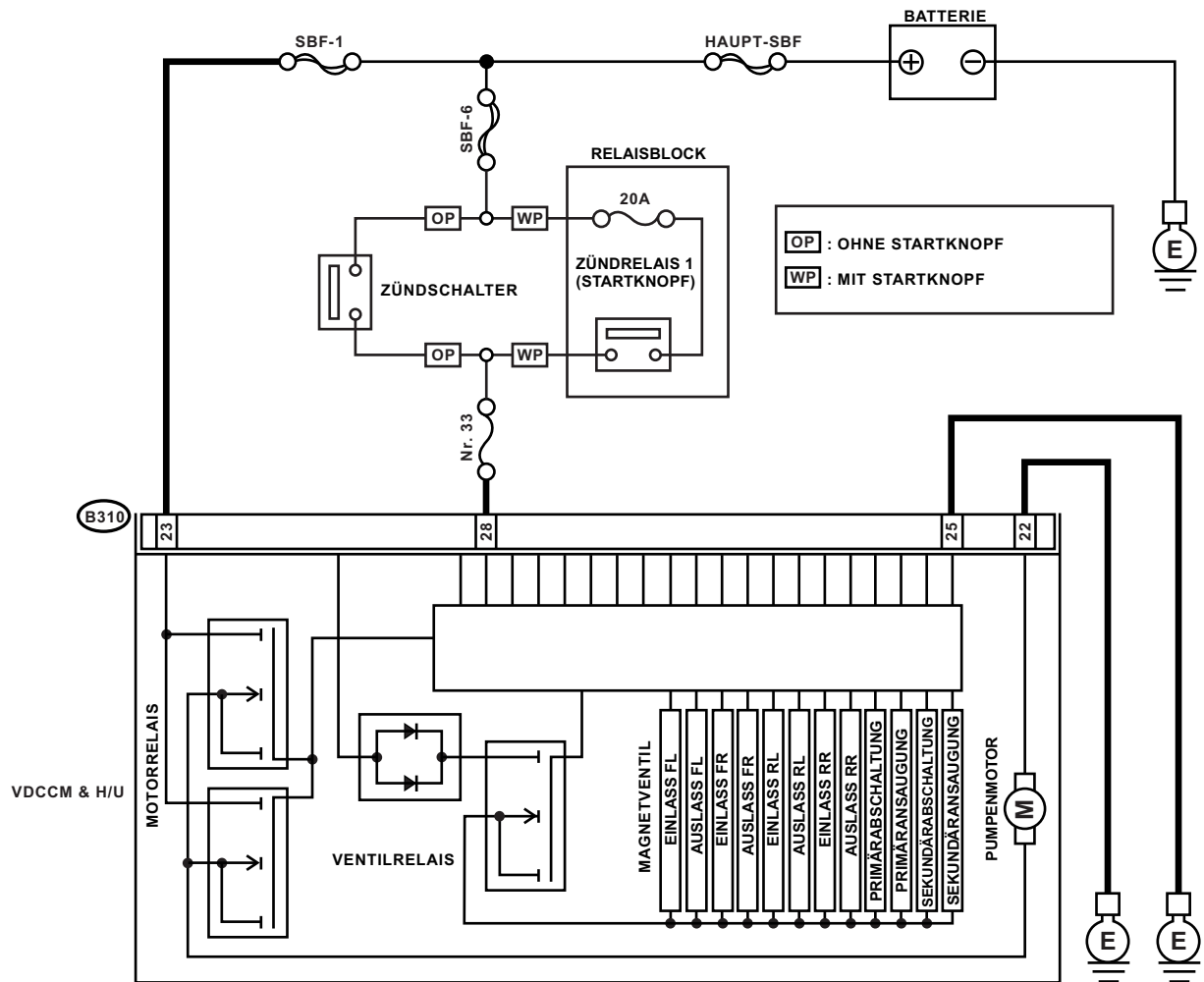

B310

22	23	24	25	1	2	3	4	5	6	7	8	9	10	11	12	13	14	15	16	17	18	19	20	21
				26	27	28	29	30	31	32	33	34	35	36	37	38	39	40	41	42	43	44	45	46

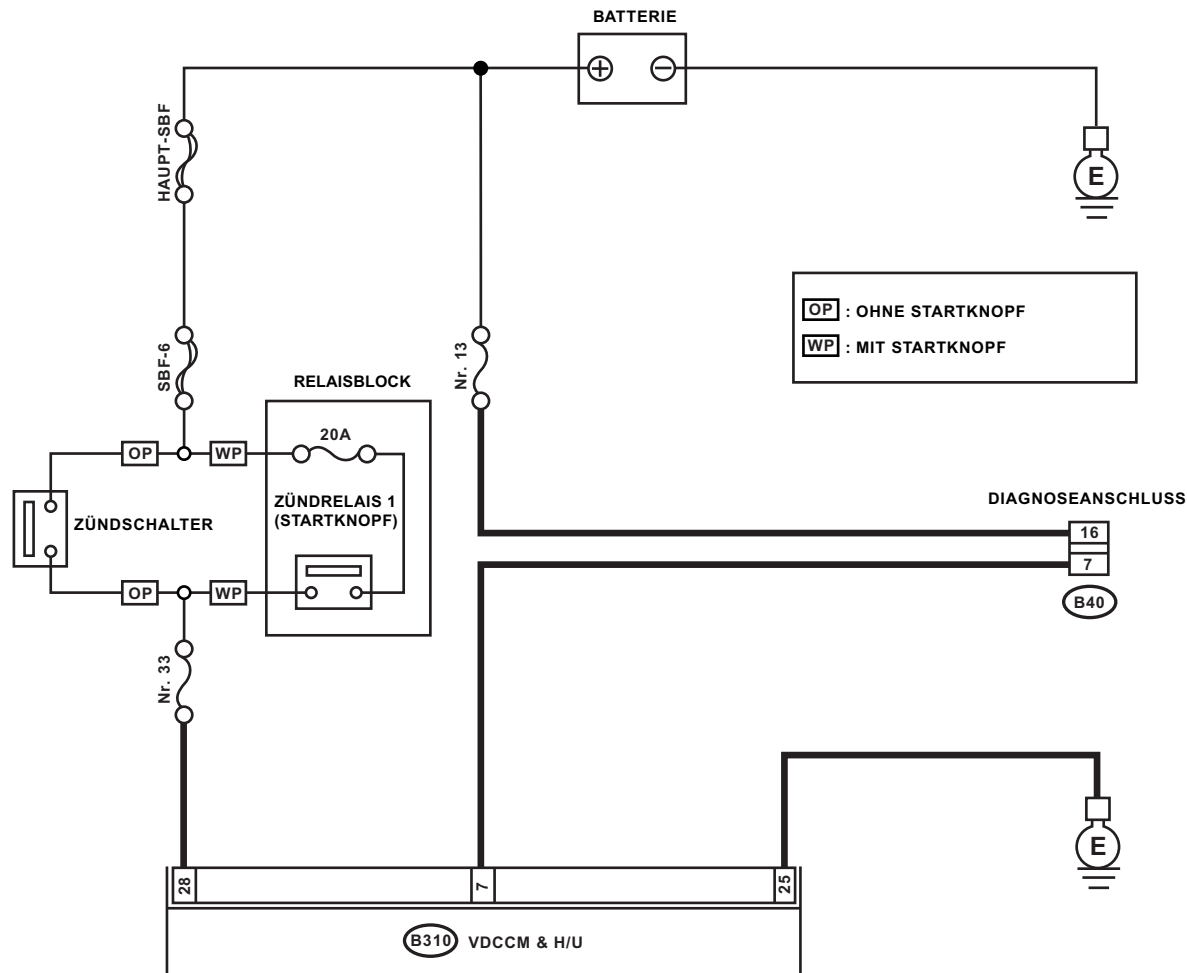

B40

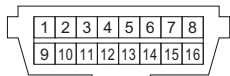

B310

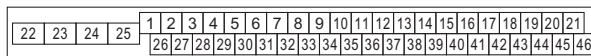

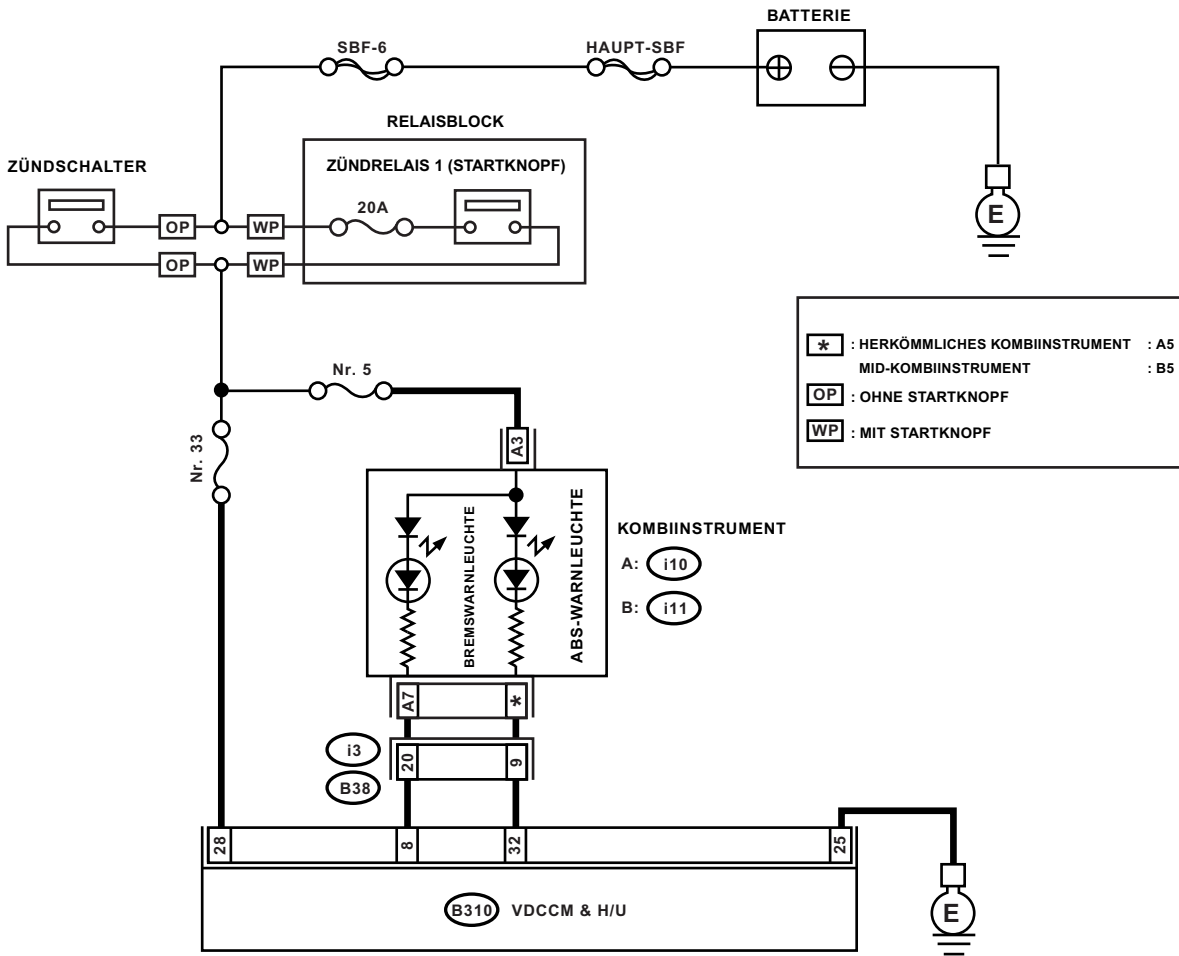

A: i10

B: i11

B38

B310

1	2	3	4	5	6	7	8	9	10
11	12	13	14	15	16	17	18	19	20
21	22								

1	2	3	4	5	6
7	8	9	10	11	12
13	14				

1	2	3	4	5	6	7	8	9
10	11	12	13	14	15	16	17	18
19	20							

22	23	24	25	1	2	3	4	5	6	7	8	9	10	11	12	13	14	15	16	17	18	19	20	21
				26	27	28	29	30	31	32	33	34	35	36	37	38	39	40	41	42	43	44	45	46

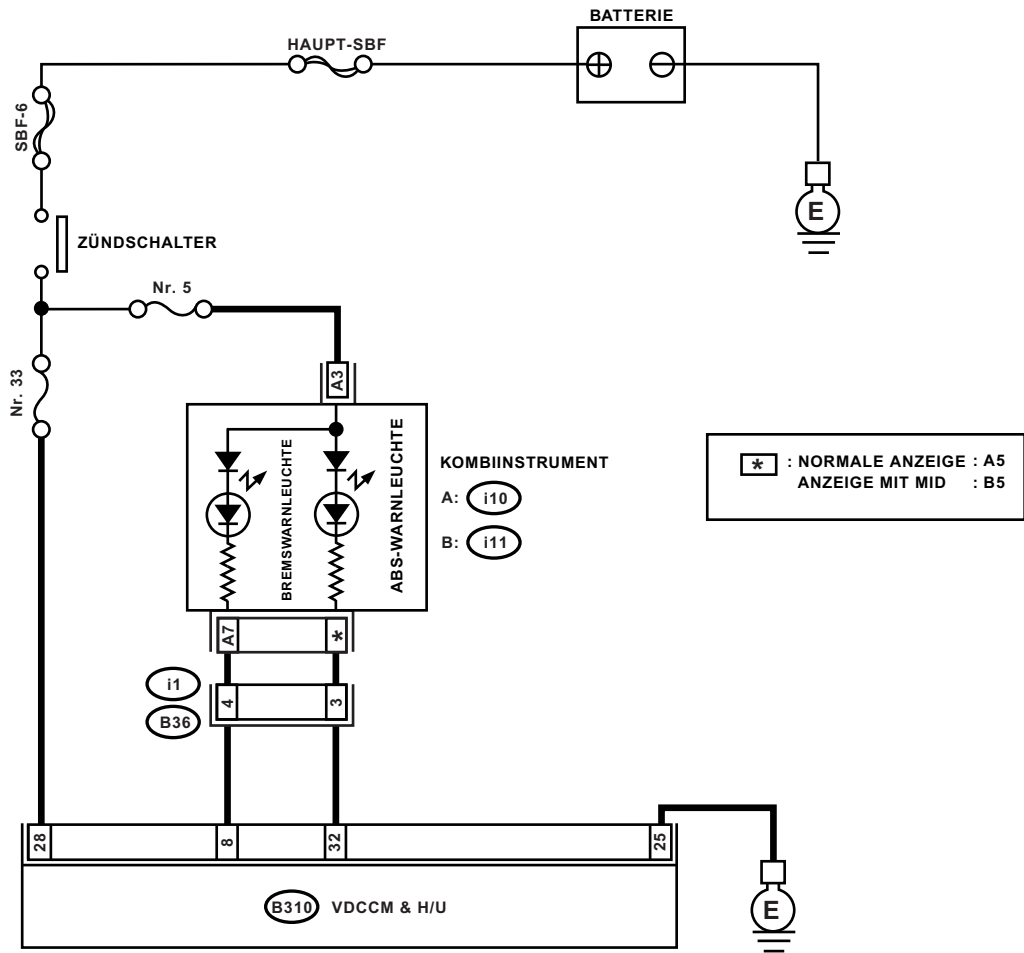

A: i10

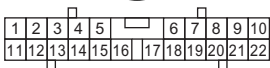

B: i11

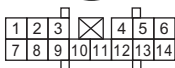

i1

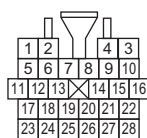

B310

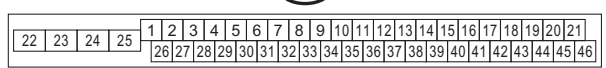

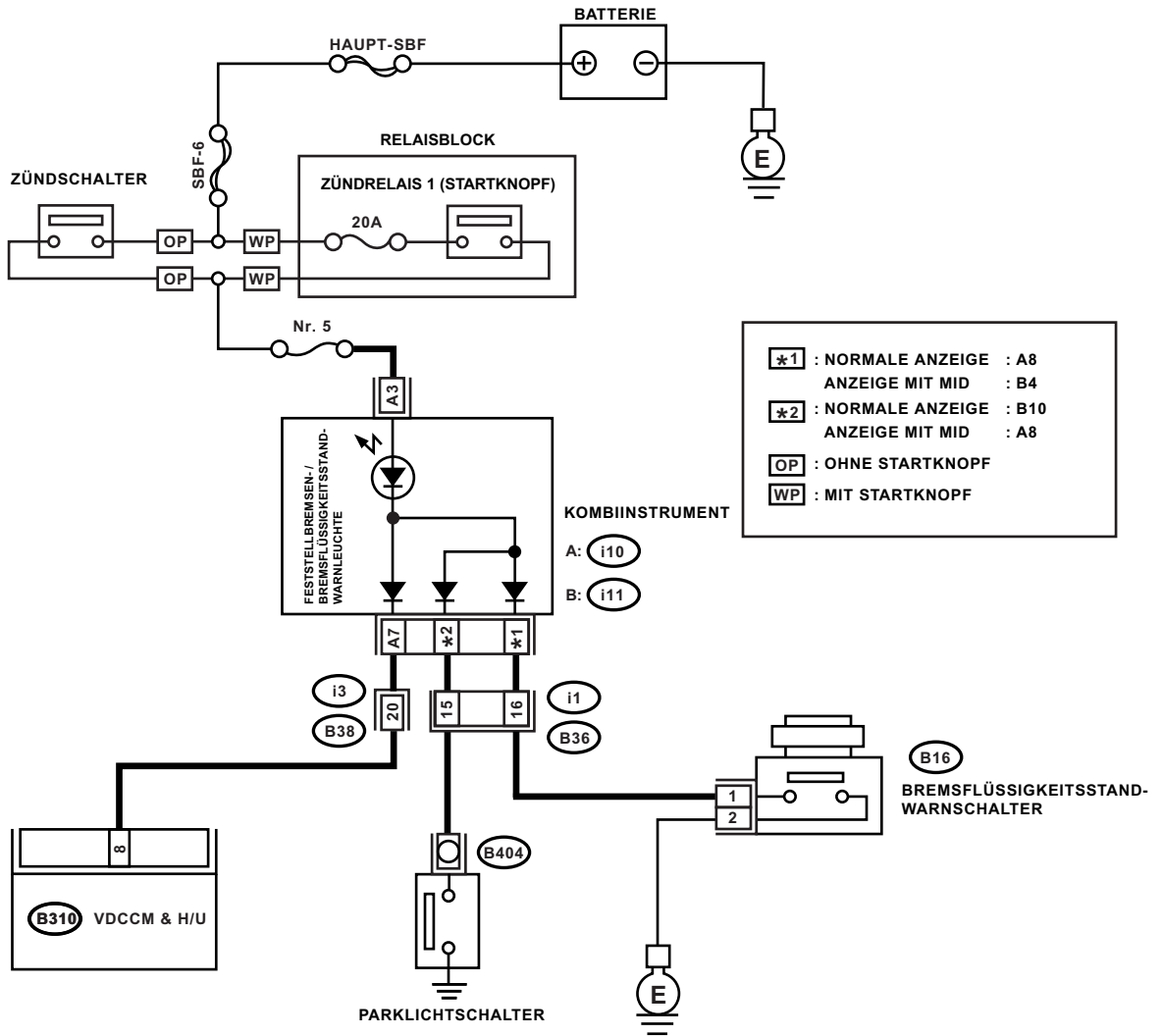

- *1** : NORMALE ANZEIGE : A8
- ANZEIGE MIT MID : B4
- *2** : NORMALE ANZEIGE : B10
- ANZEIGE MIT MID : A8
- OP** : OHNE STARTKNOFF
- WP** : MIT STARTKNOFF

B16



i1

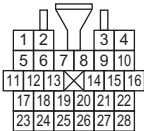

B310

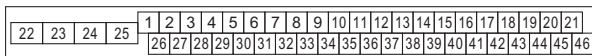

A: i10

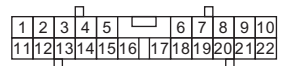

B38

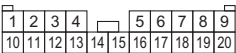

B: i11

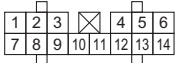

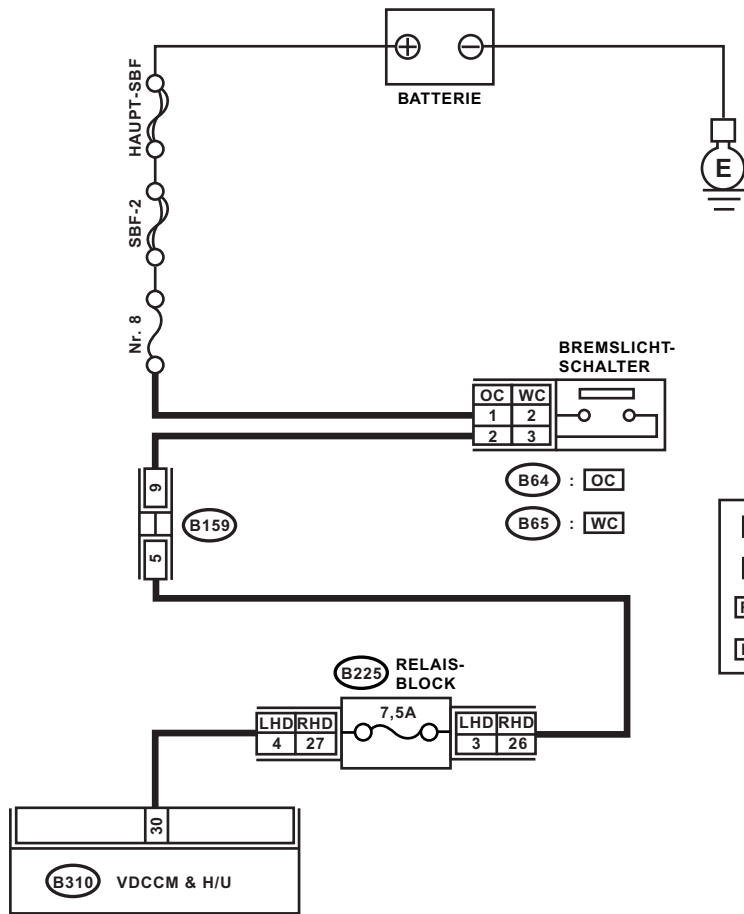

- WC** : MIT GESCHWINDIGKEITSREGELUNG
- OC** : OHNE GESCHWINDIGKEITSREGELUNG
- RHD** : RHD-MODELL
- LHD** : LHD-MODELL

B64



B65



B159

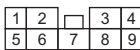

B310

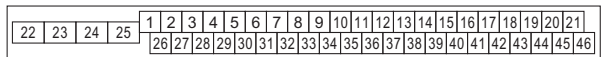

RHD : **B225**

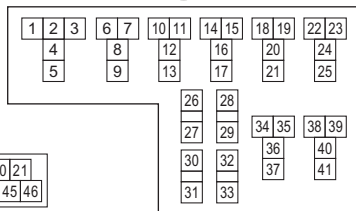

LHD : **B225**

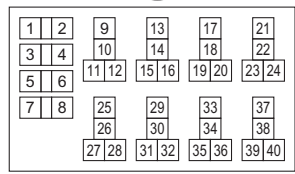

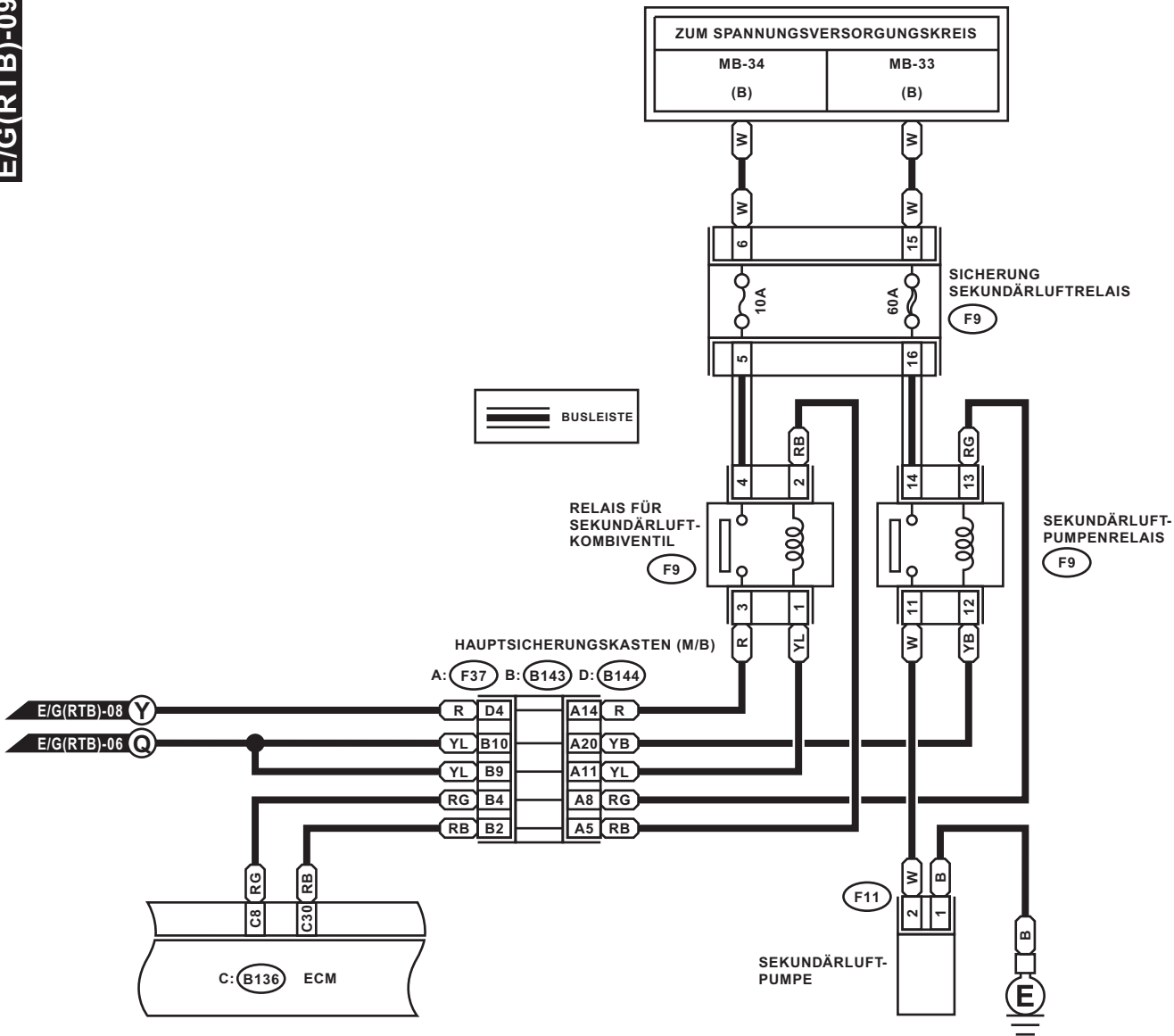

F11 (GRAU)

D: (B144) (BRAUN)

F9 (SCHWARZ)

B: (B143)

A: (F37)

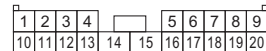
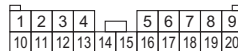
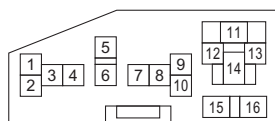

C: (B136)

HALTERUNG SEKUNDÄRLUFTRELAIS

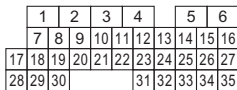

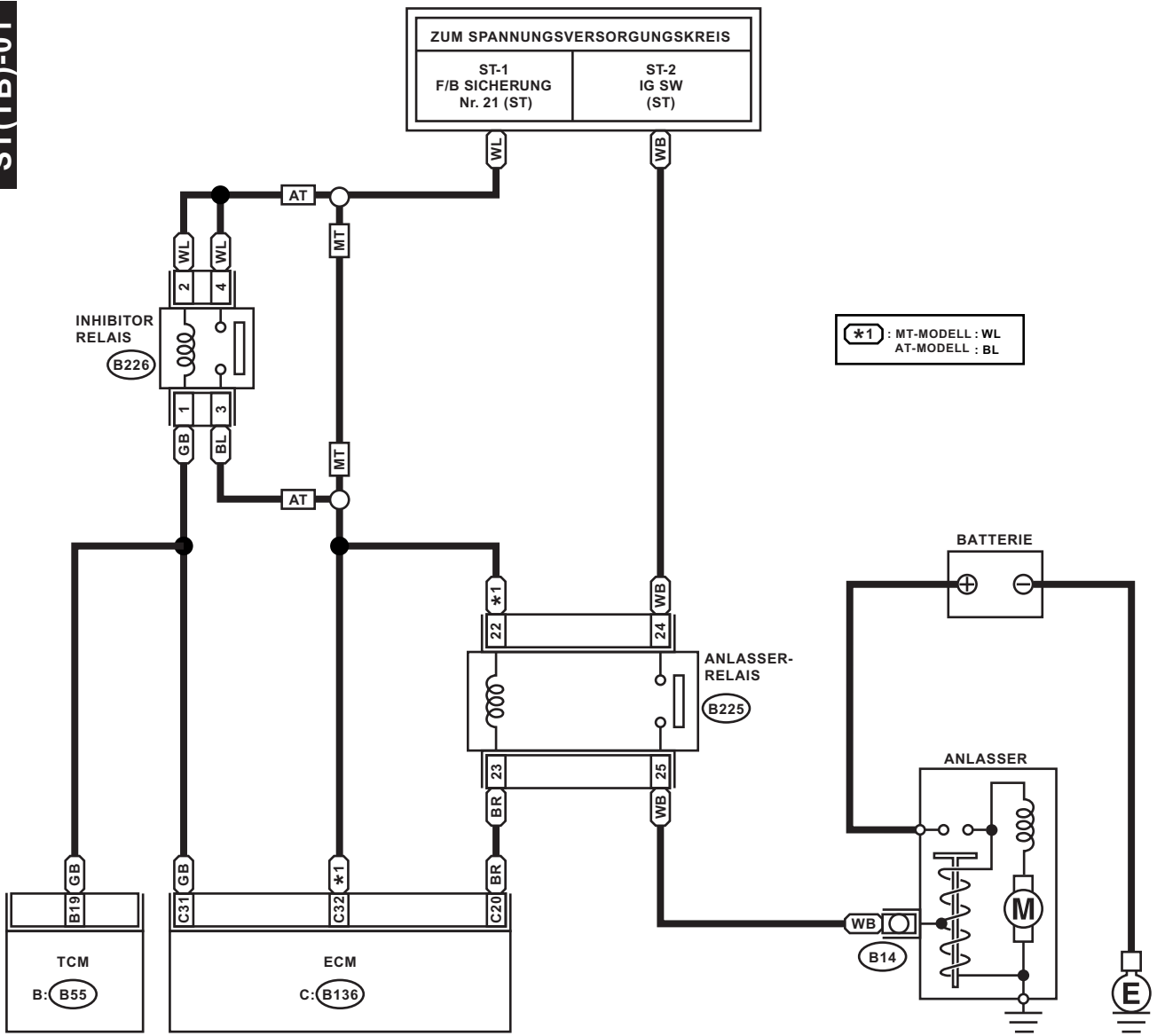

*1 : MT-MODELL : WL
AT-MODELL : BL

B226 (SCHWARZ)



B: B55 (GRAU)

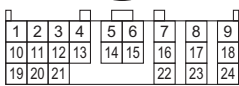

C: B136

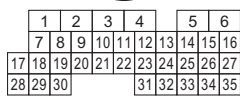

B225 (SCHWARZ)

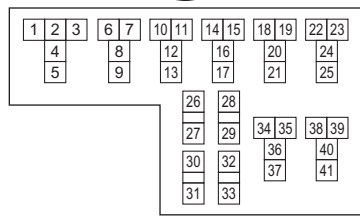

RELAISBLOCK

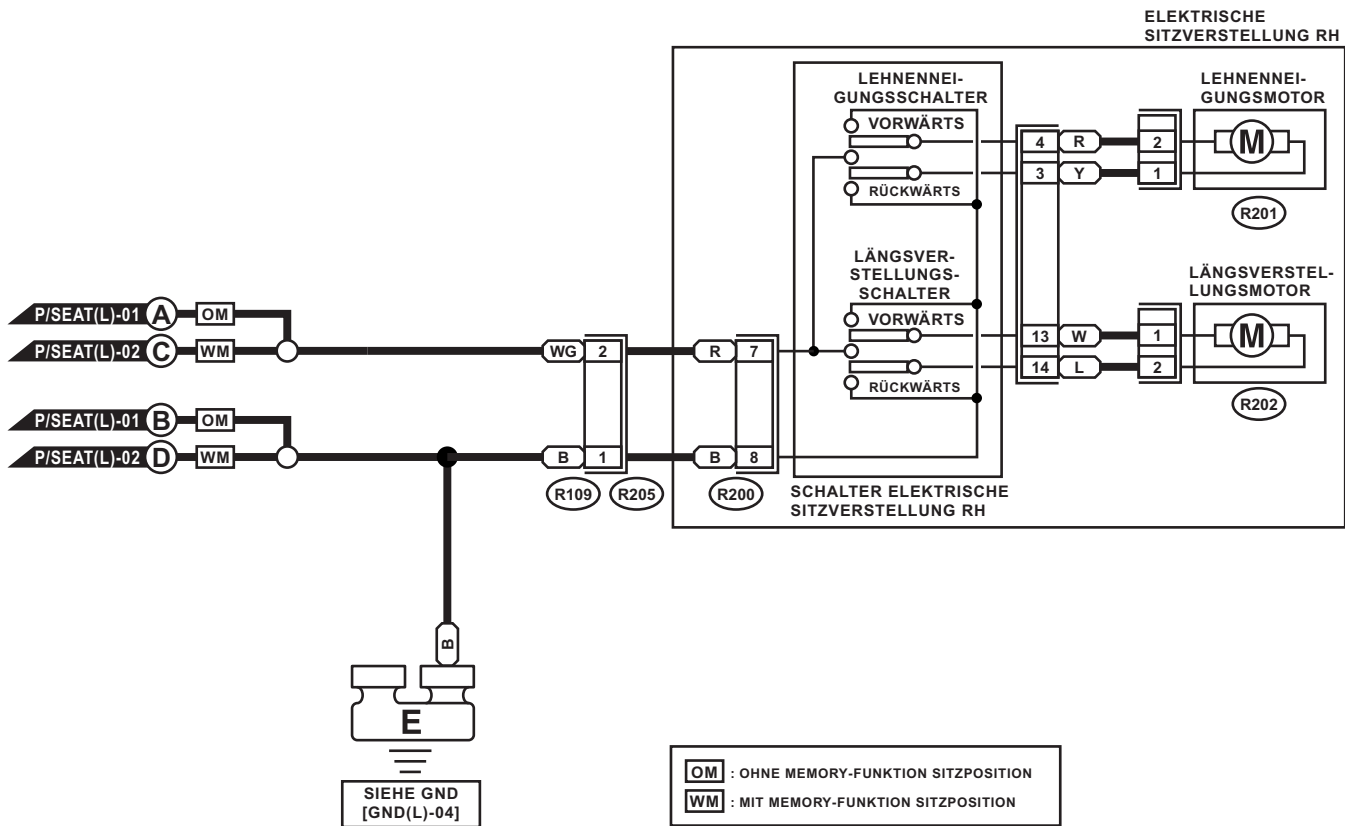

R109 (SCHWARZ)

R200

1	2
3	4

1	2	3	4	5	6
7	8	9	10	11	12
					13
					14

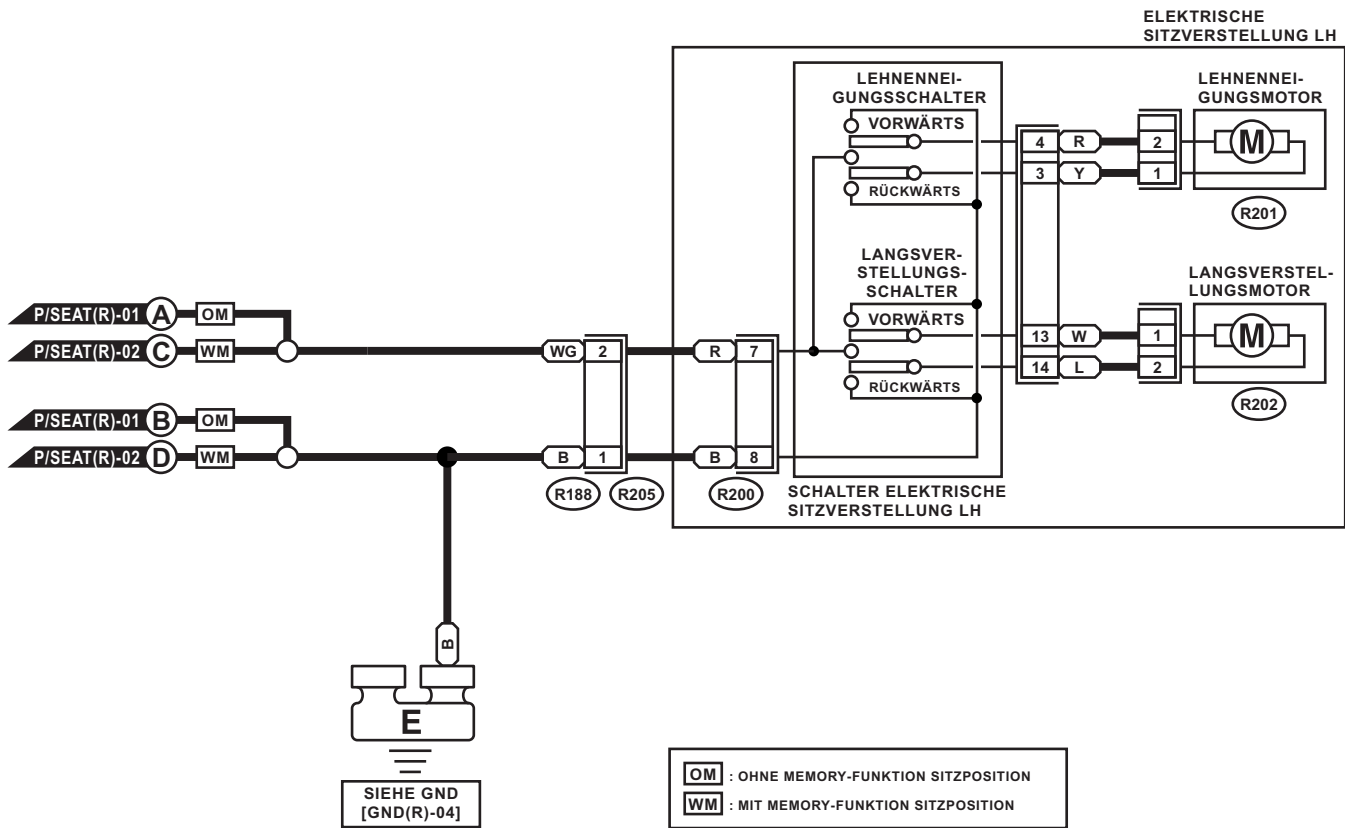

R188 (SCHWARZ)

R200

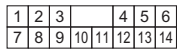

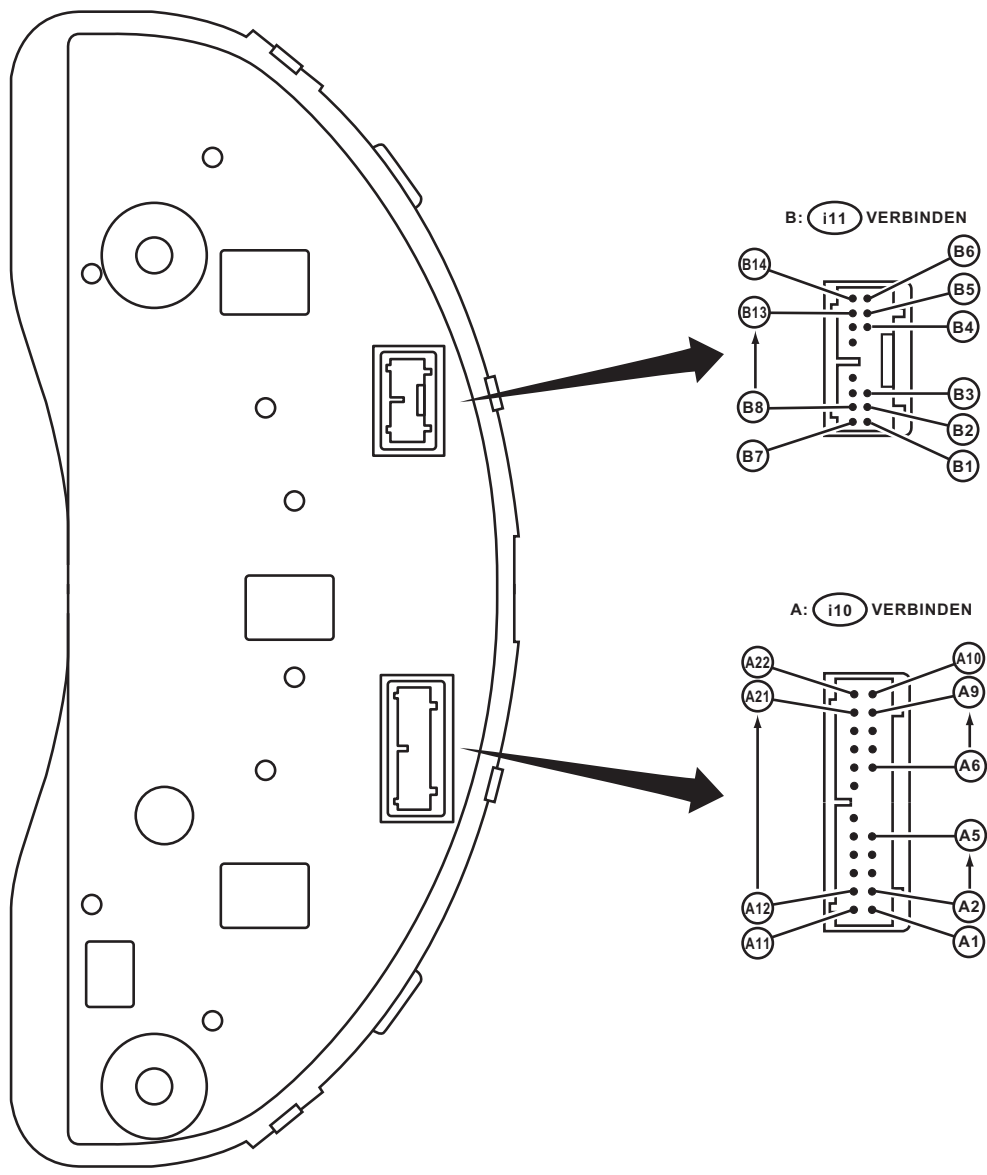

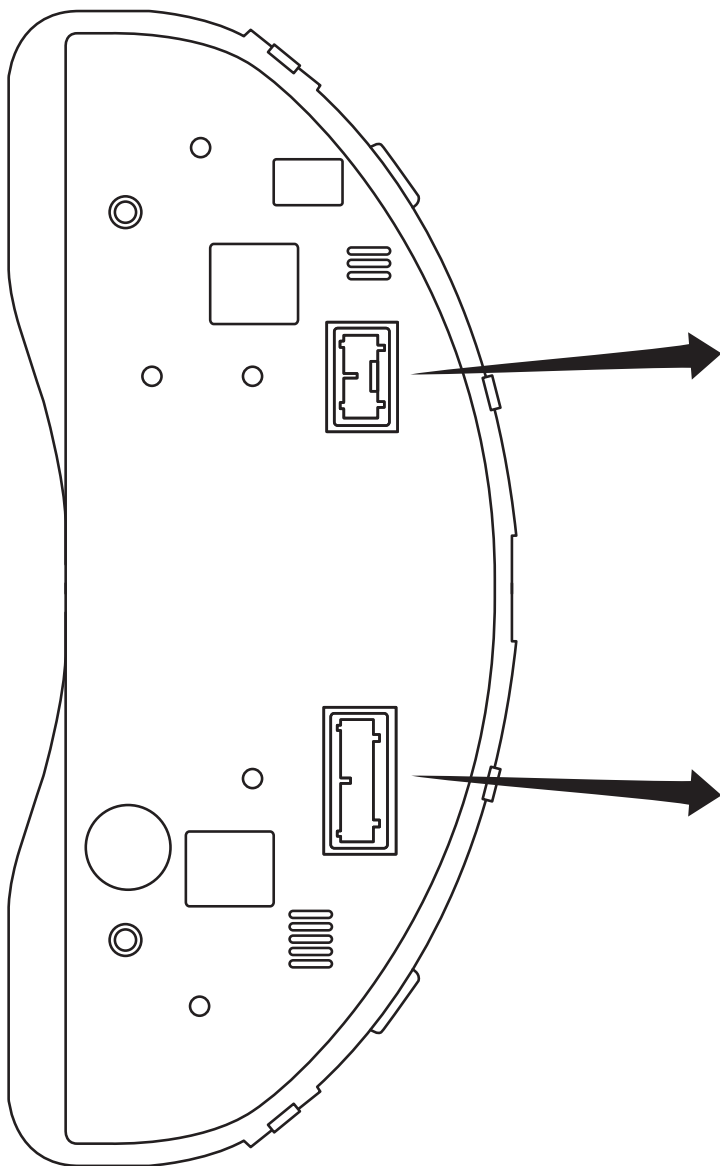

B: i11 VERBINDEN

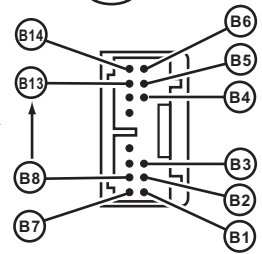

A: i10 VERBINDEN

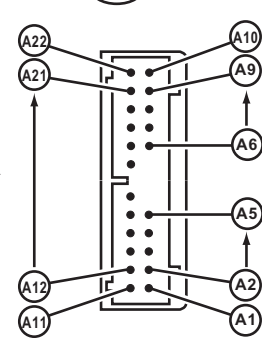

HAUPTSICHERUNGSKASTEN (M/B)

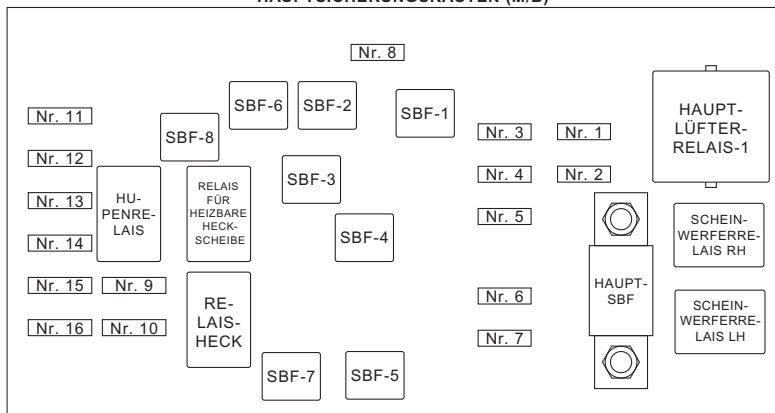

SEKUNDÄRLUFT-SICHERUNG UND RELAIKASTEN

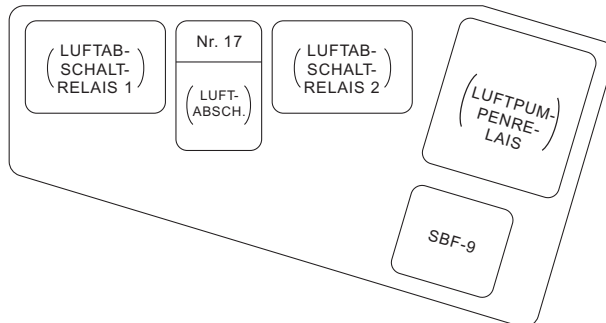

SICHERUNGS- UND RELAIKASTEN (F/B)

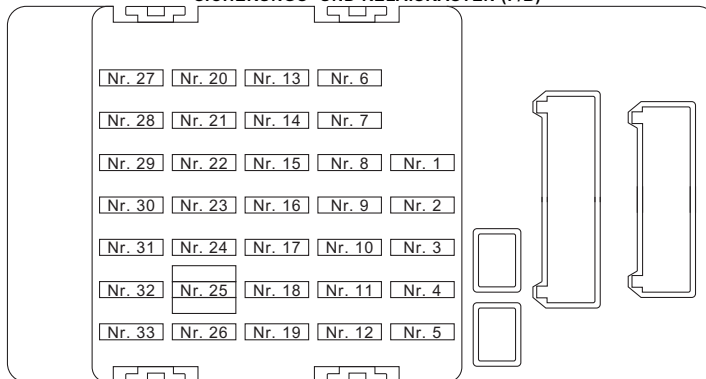

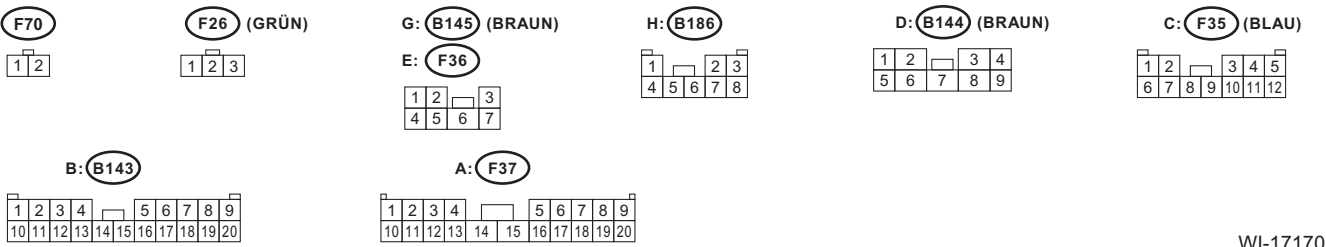
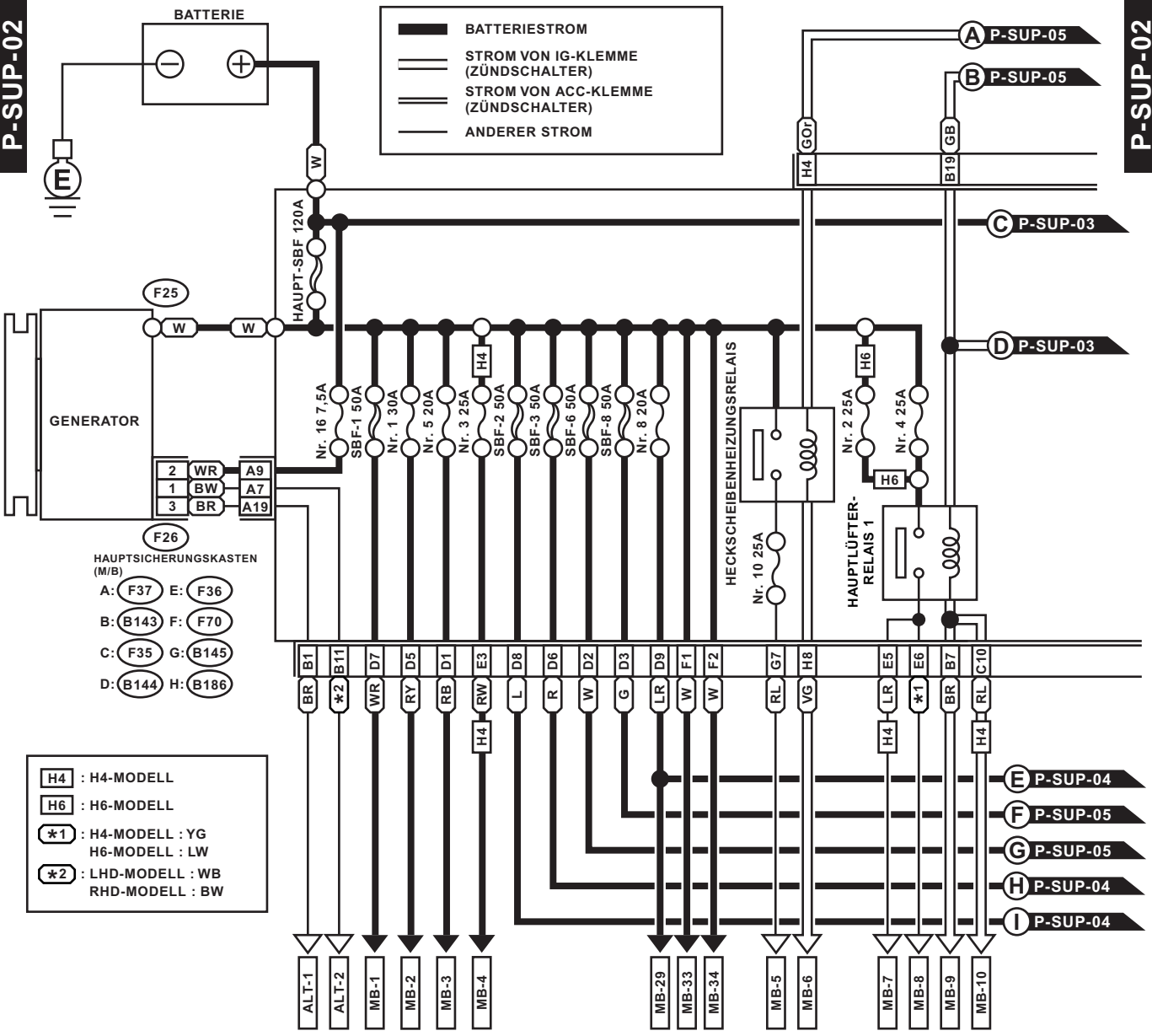

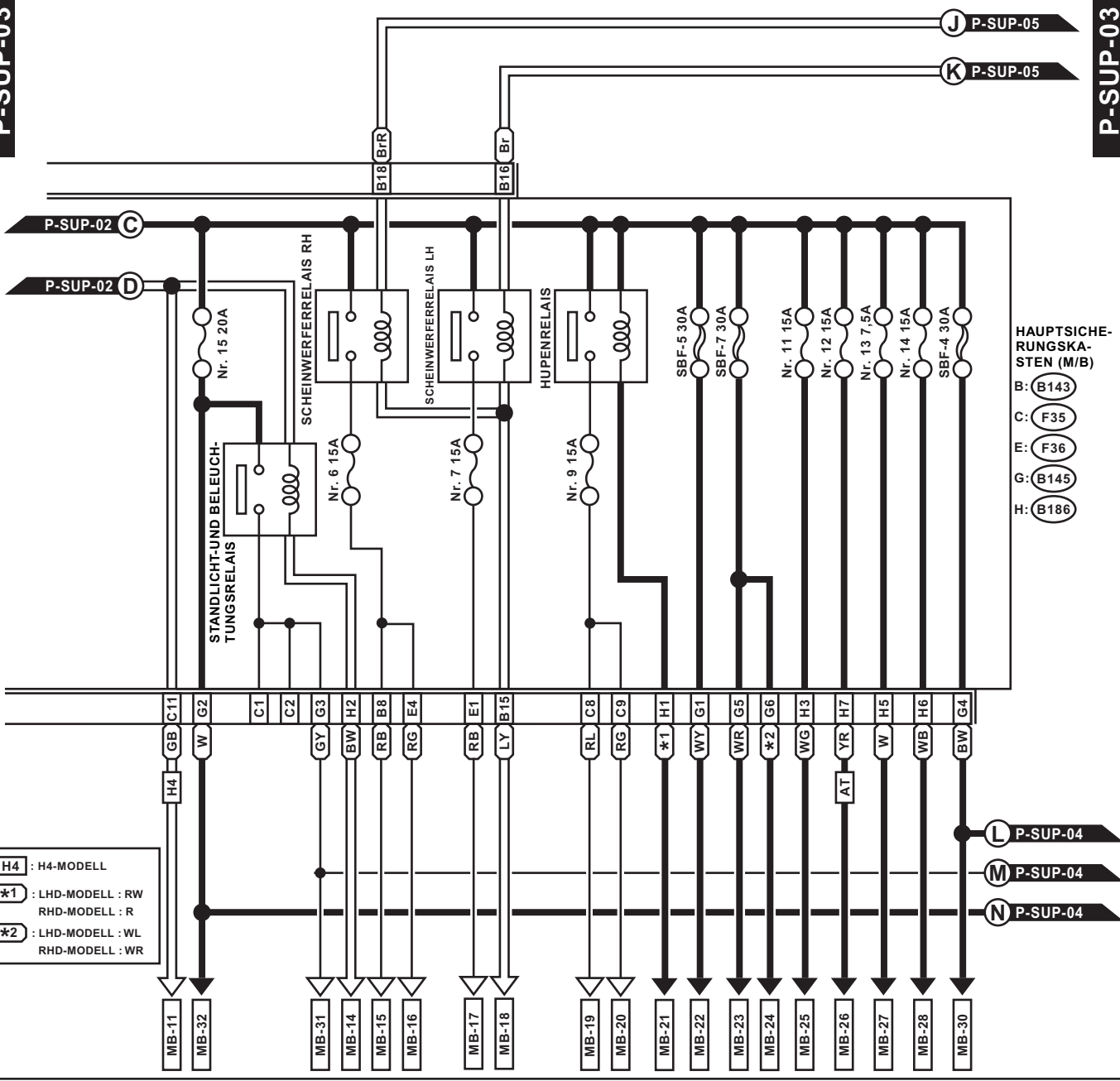

HAUPTSICHERUNGSKASTEN (M/B)

B: (B143)
 C: (F35)
 E: (F36)
 G: (B145)
 H: (B186)

H4 : H4-MODELL
 *1 : LHD-MODELL : RW
 RHD-MODELL : R
 *2 : LHD-MODELL : WL
 RHD-MODELL : WR

G: (B145) (BRAUN) H: (B186)

1	2	3
4	5	6
7	8	9

C: (F35) (BLAU)

1	2	3	4	5
6	7	8	9	10
11	12			

B: (B143)

1	2	3	4	5	6	7	8	9
10	11	12	13	14	15	16	17	18
19	20							

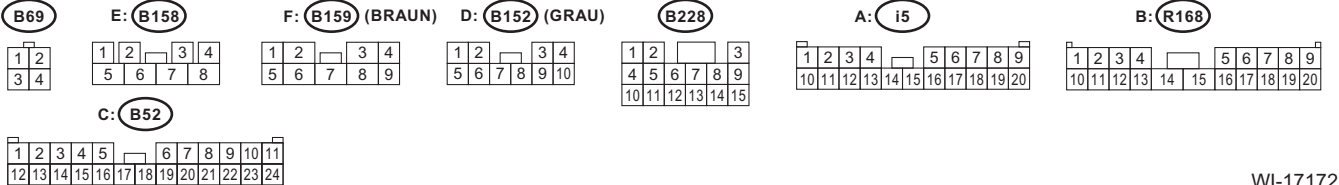
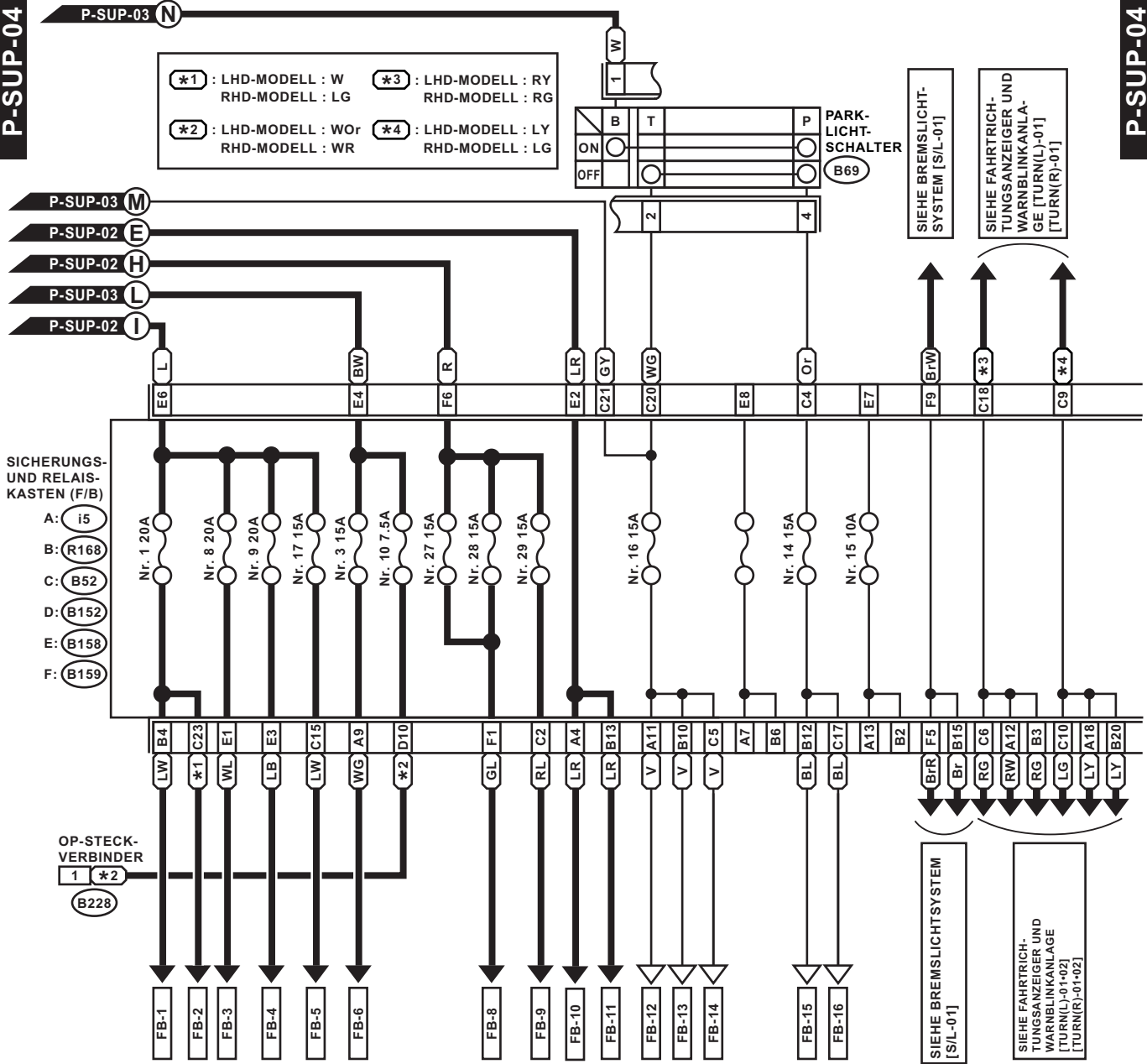

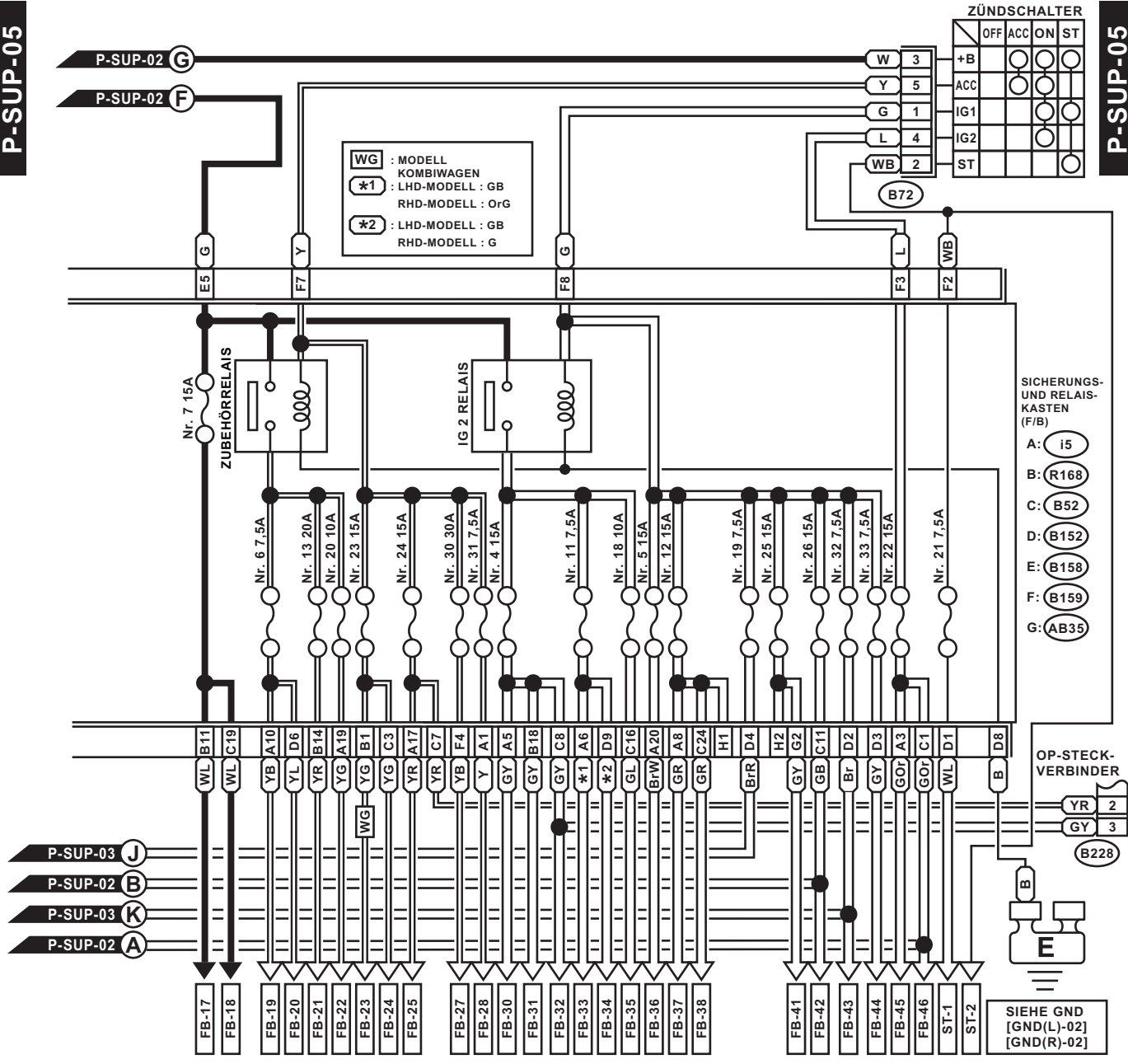

G: AB35



B72



E: B158

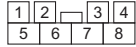

F: B159 (BRAUN)



D: B152 (GRAU)

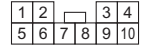

B228

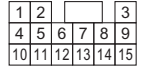

A: i5

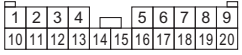

B: R168

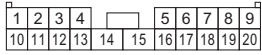

C: B52

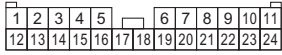

HAUPTSICHERUNGSKASTEN (M/B)

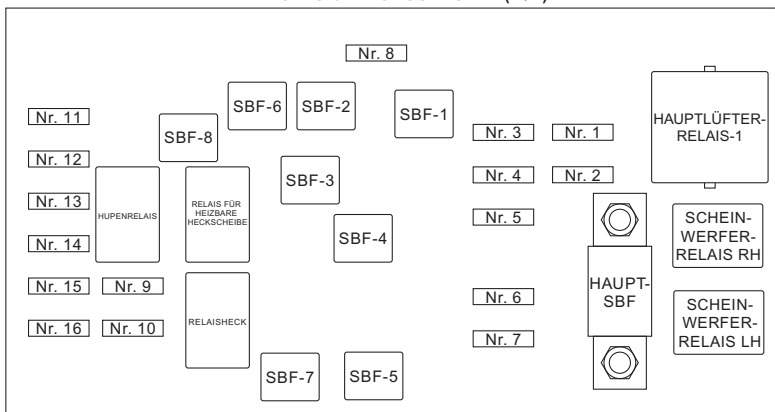

RELAISBLOCK (STARTKNOPF)

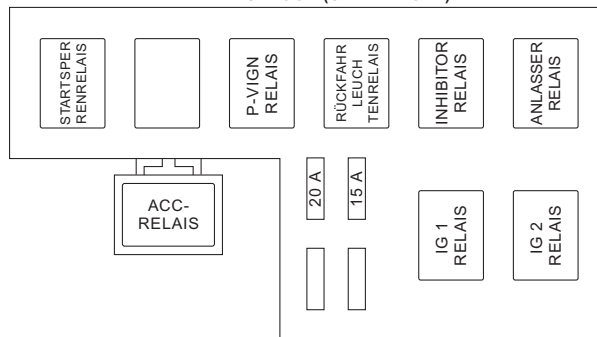

SICHERUNGS- UND RELAIKASTEN (F/B)

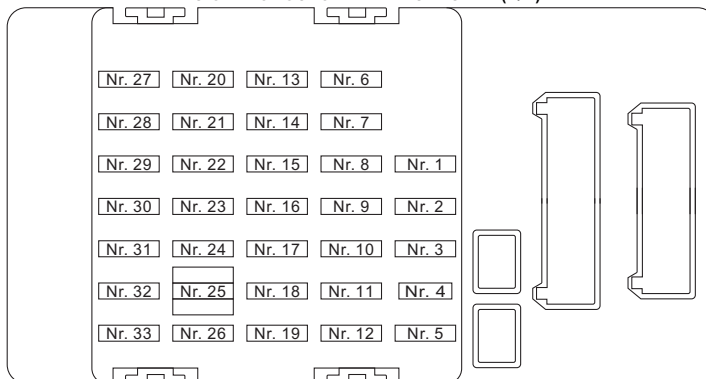

P-SUP(P)-02

P-SUP(P)-02

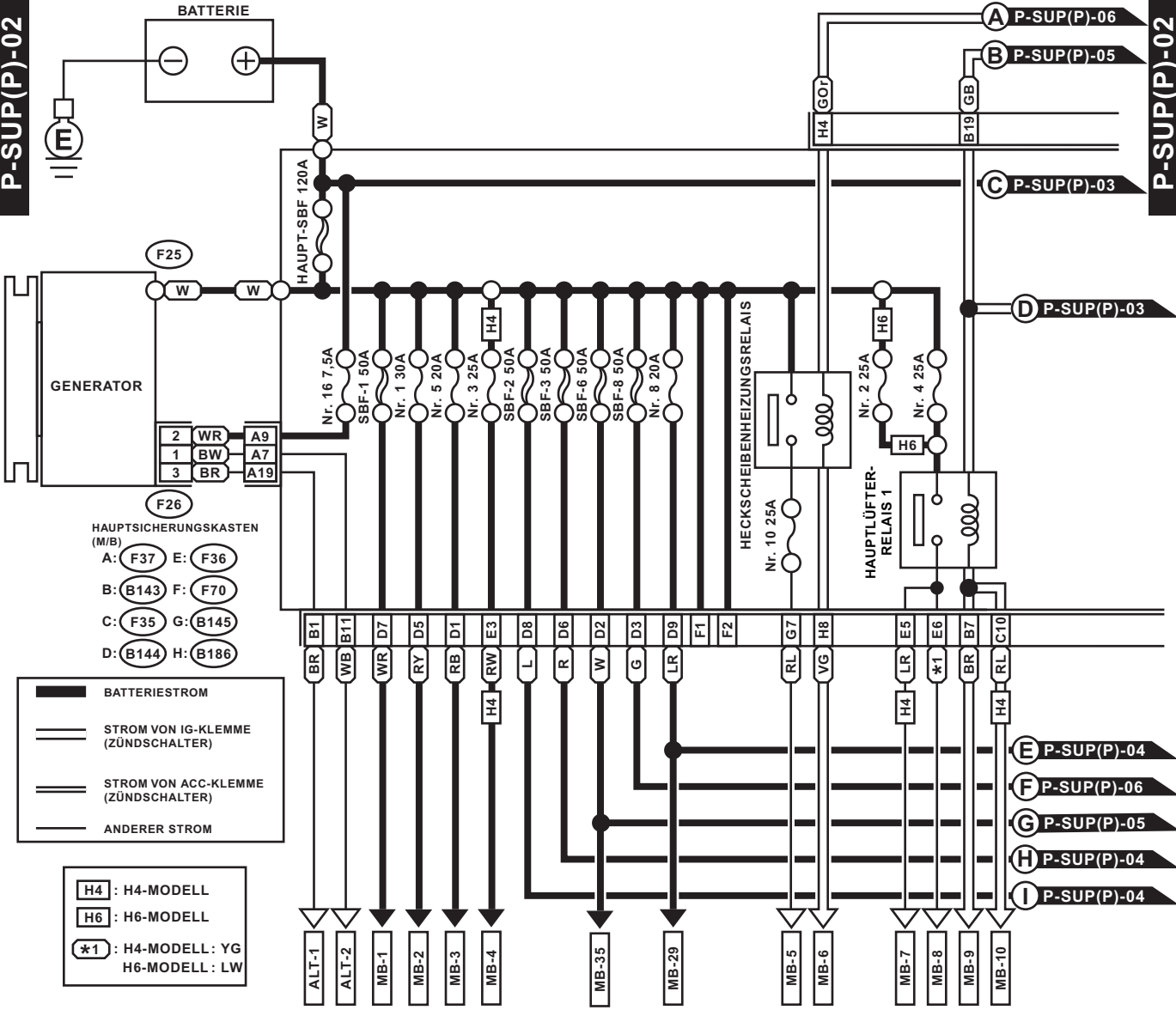

- F: **F70**

1	2
---	---
- F26 (GRÜN)

1	2	3
---	---	---
- G: **B145** (BRAUN)

1	2	3	
4	5	6	7
- H: **B186**

1	2	3		
4	5	6	7	8
- D: **B144** (BRAUN)

1	2	3	4	
5	6	7	8	9
- C: **F35** (BLAU)

1	2	3	4	5		
6	7	8	9	10	11	12
- B: **B143**

1	2	3	4	5	6	7	8	9		
10	11	12	13	14	15	16	17	18	19	20

A: **F37**

1	2	3	4	5	6	7	8	9		
10	11	12	13	14	15	16	17	18	19	20

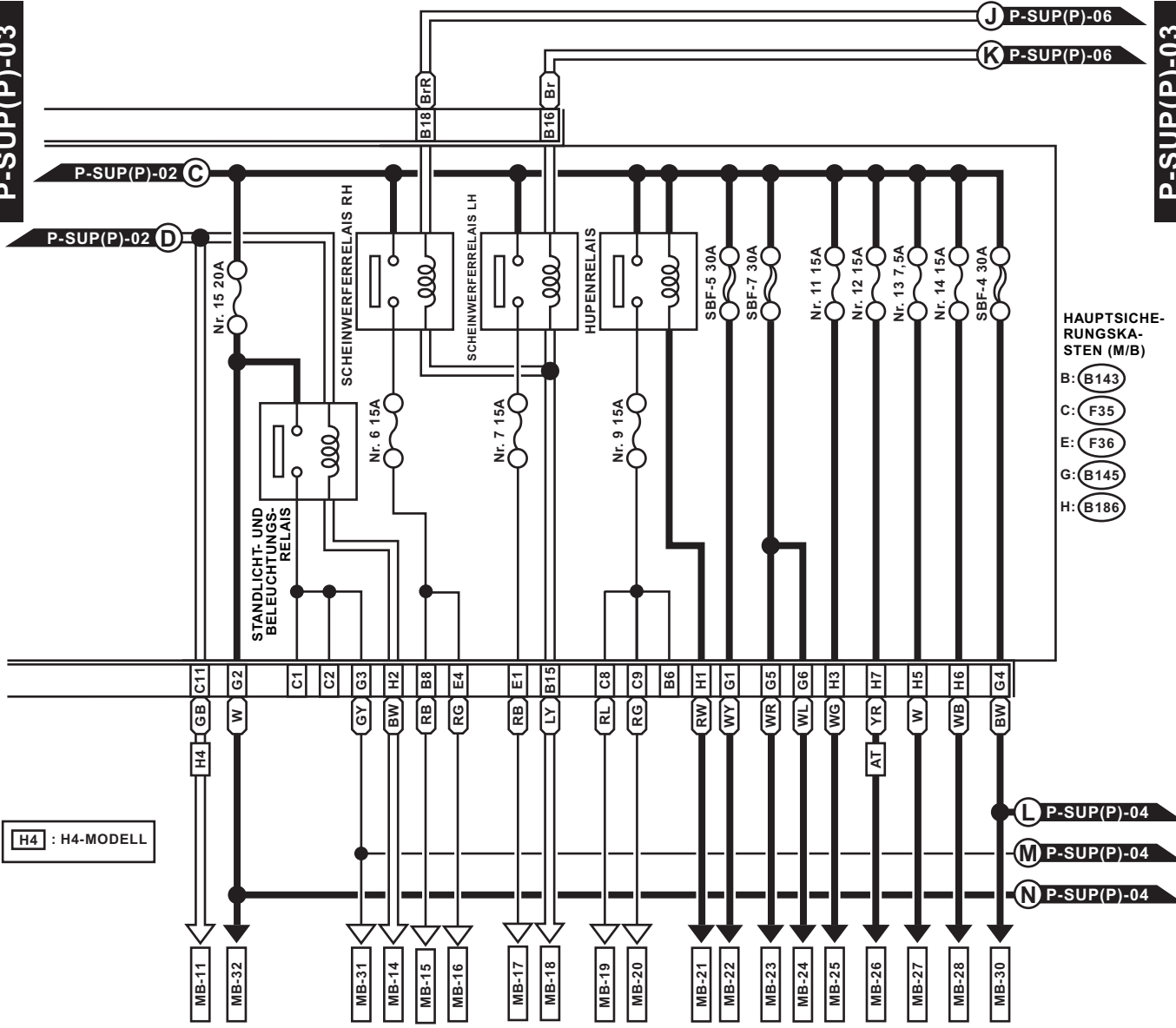

- HAUPTSICHERUNGSKASTEN (M/B)
- B: (B143)
 - C: (F35)
 - E: (F36)
 - G: (B145)
 - H: (B186)

H4 : H4-MODELL

G: (B145) (BRAUN)

H: (B186)

C: (F35) (BLAU)

B: (B143)

E: (F36)

1	2	3
4	5	6
7		

1		2	3
4	5	6	7
8			

1	2		3	4	5
6	7	8	9	10	11
12					

1	2	3	4		5	6	7	8	9
10	11	12	13	14	15	16	17	18	19
20									

P-SUP(P)-04

P-SUP(P)-03 (N)

P-SUP(P)-03 (M)

P-SUP(P)-02 (E)

P-SUP(P)-02 (H)

P-SUP(P)-03 (L)

P-SUP(P)-02 (I)

SICHERUNGS- UND RELAIS-KASTEN (F/B)

- A: (i5)
- B: (R168)
- C: (B52)
- D: (B152)
- E: (B158)
- F: (B159)

OP-STECK-VERBINDER

1 (WOP) (B228)

1 W

B T P

ON OFF

PARKLICHT-SCHALTER (B69)

2 4

SIEHE BREMSLICHT-SYSTEM [S/L-01]

SIEHE FAHRT-RICHTUNGSANZEIGER UND WARNBLINKANLAGE [TURN(L)-01]

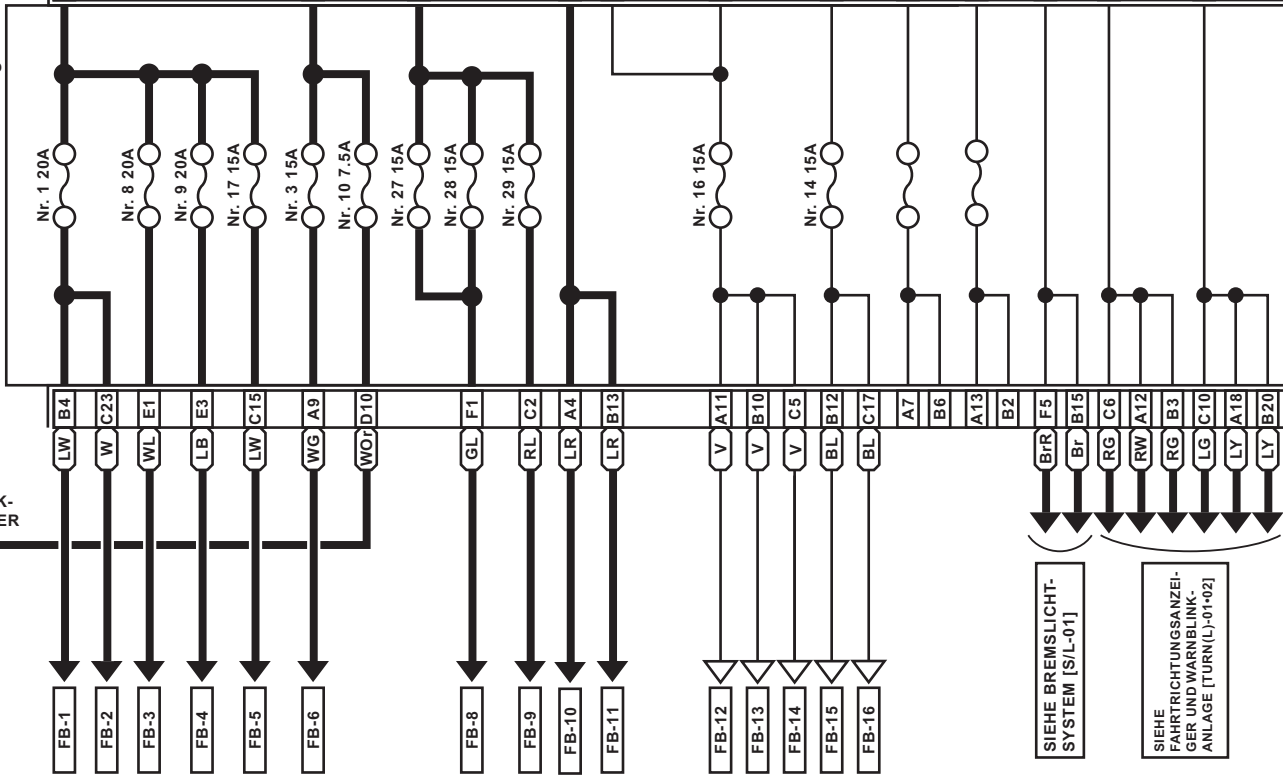
P-SUP(P)-04

(B69)

E: (B158)

F: (B159) (BRAUN)

D: (B152) (GRAU)

(B228)

A: (i5)

B: (R168)

1	2		
3	4		

1	2		3	4
5	6	7	8	9

1	2		3	4
5	6	7	8	9

1	2		3	4	
5	6	7	8	9	10

1	2			3	
4	5	6	7	8	9
10	11	12	13	14	15

1	2	3	4		5	6	7	8	9	
10	11	12	13	14	15	16	17	18	19	20

1	2	3	4		5	6	7	8	9	
10	11	12	13	14	15	16	17	18	19	20

C: (B52)

1	2	3	4	5		6	7	8	9	10	11	
12	13	14	15	16	17	18	19	20	21	22	23	24

SIEHE BREMSLICHT-SYSTEM [S/L-01]

SIEHE FAHRT-RICHTUNGSANZEIGER UND WARNBLINKANLAGE [TURN(L)-01+02]

P-SUP(P)-06

- P-SUP(P)-05 P
- P-SUP(P)-05 Q
- P-SUP(P)-02 F
- P-SUP(P)-05 R
- P-SUP(P)-05 S
- P-SUP(P)-05 T

WG : MODELL
KOMBIWAGEN
*1 : MT-MODELL : W
AT-MODELL : WB

P-SUP(P)-06

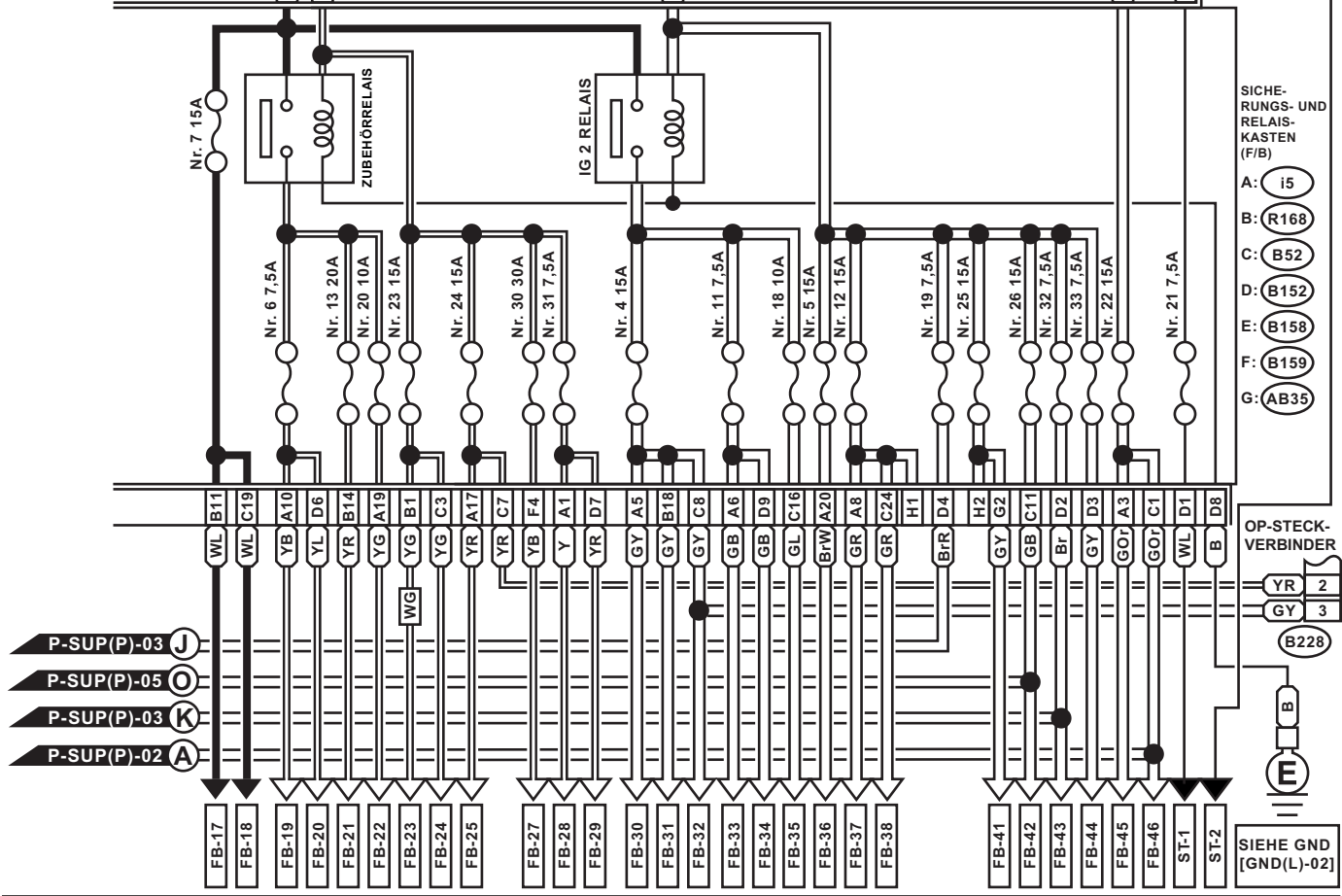

- SICHERUNGS- UND RELAIS-KASTEN (F/B)
- A: i5
 - B: R168
 - C: B52
 - D: B152
 - E: B158
 - F: B159
 - G: AB35

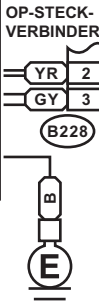

G: AB35



E: B158

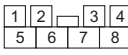

F: B159 (BRAUN)

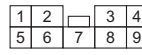

D: B152 (GRAU)

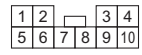

B228

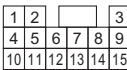

A: i5

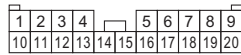

B: R168

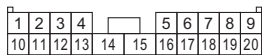

C: B52

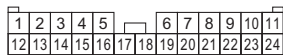

GND(L)-01

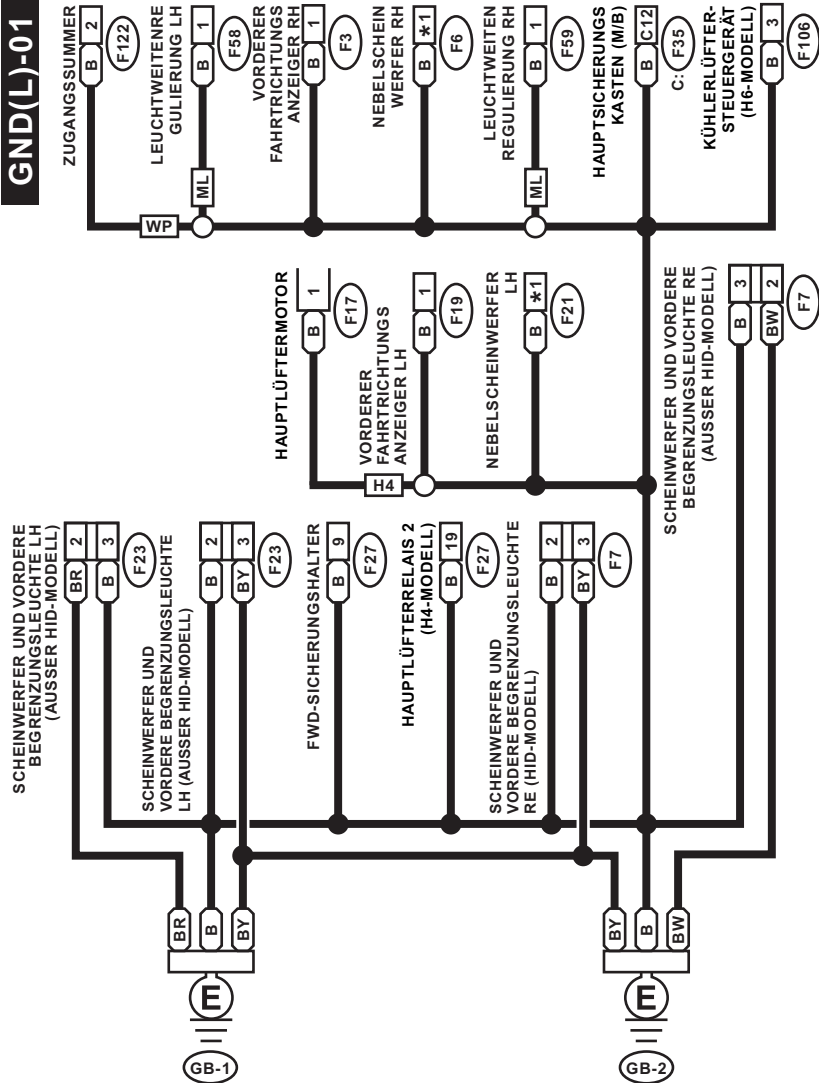

- *1** : OUTBACK-MODELL : 2
AUSSER
OUTBACK-MODELL : 1
- OB** : OUTBACK-MODELL
- OT** : AUSSER OUTBACK-MODELL
- SD** : MODELL LIMOUSINE
- WH** : HID-MODELL
- OH** : AUSSER HID-MODELL
- H4** : H4-MODELL
- WP** : MIT STARTKNOPF
- ML** : MANUELLE RHGULIERUNG

GND(L)-01

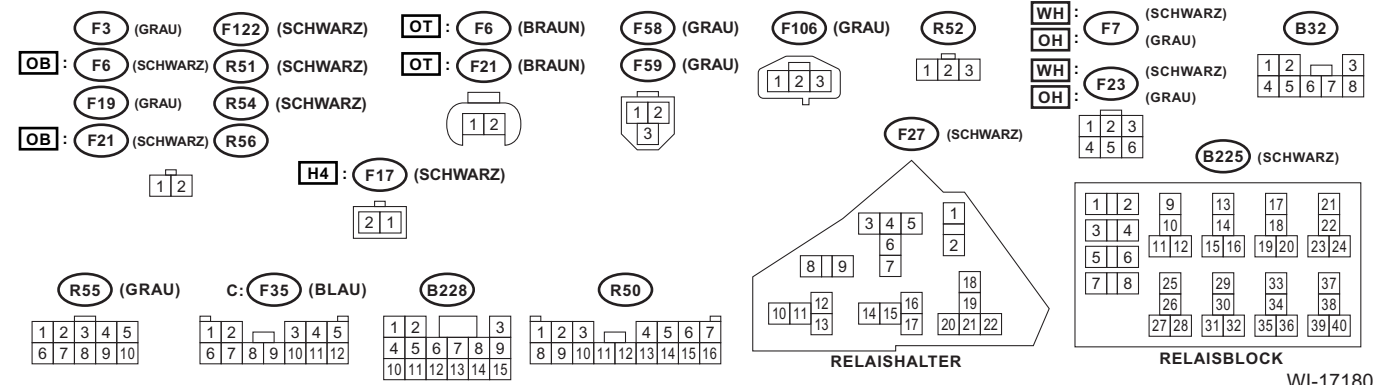

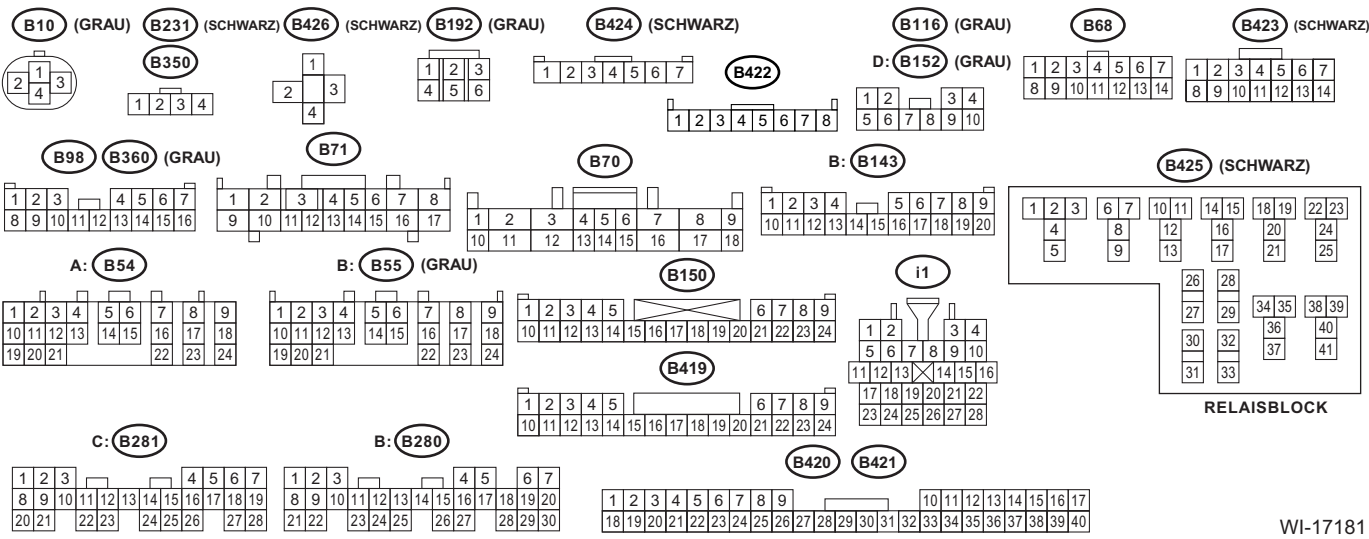
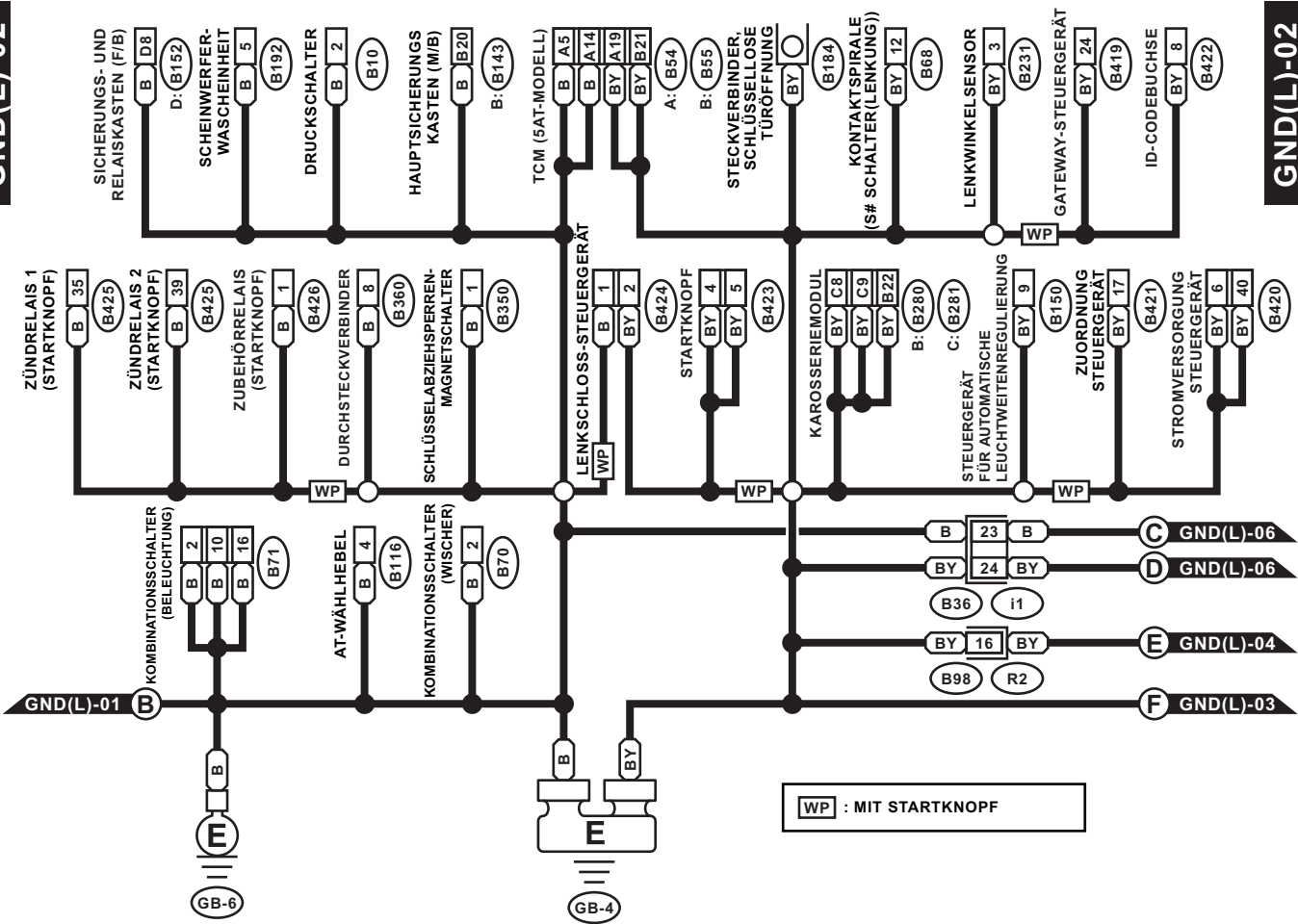

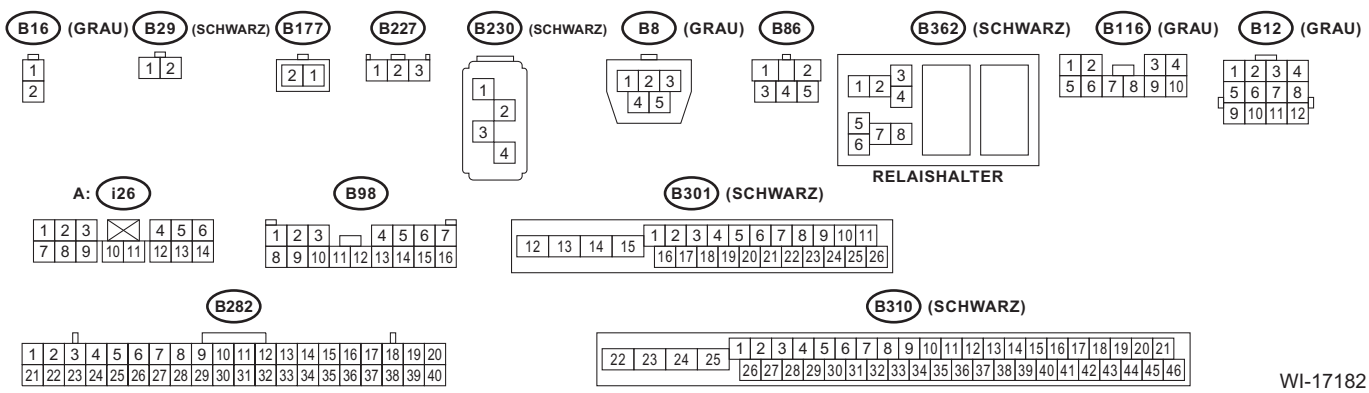
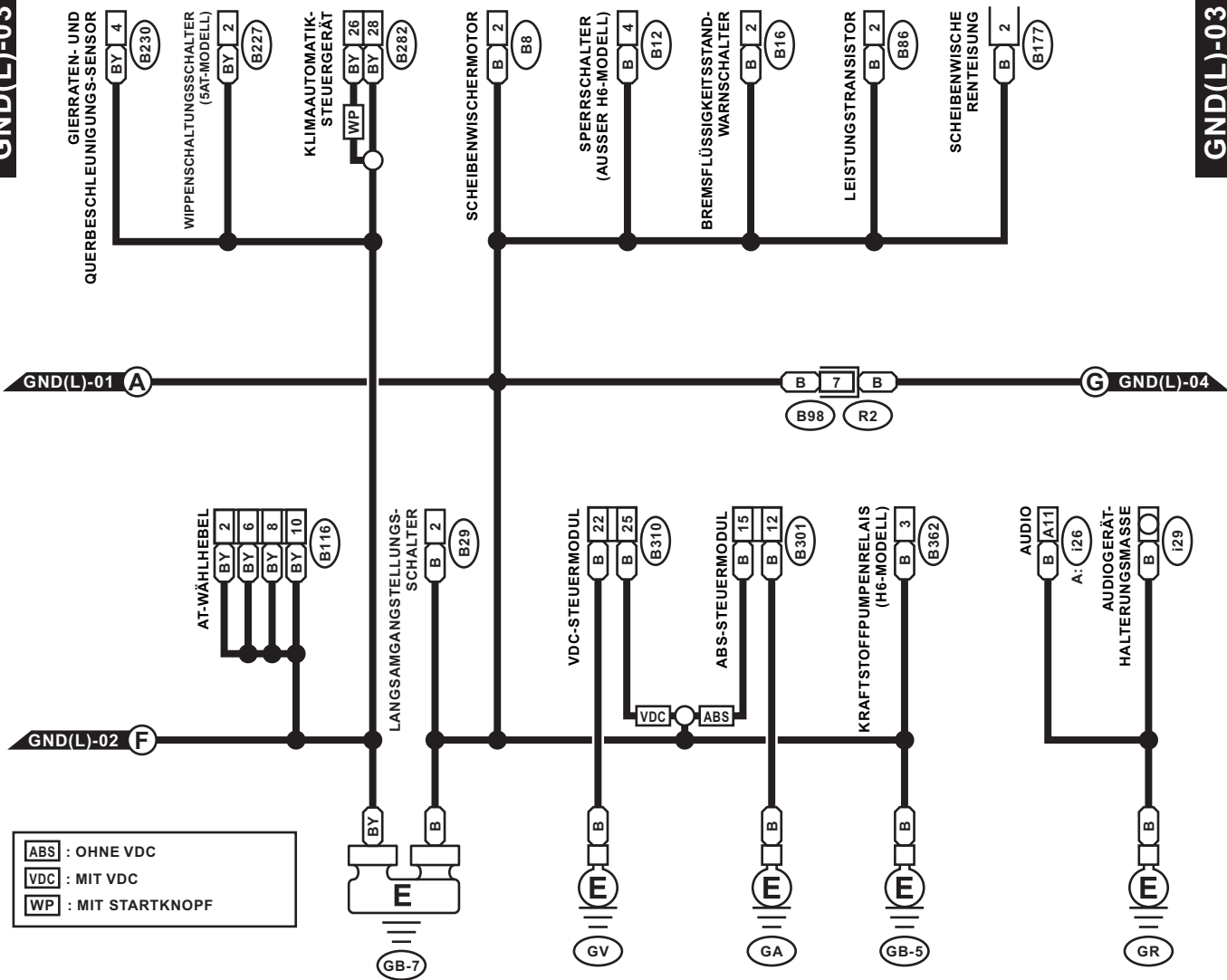

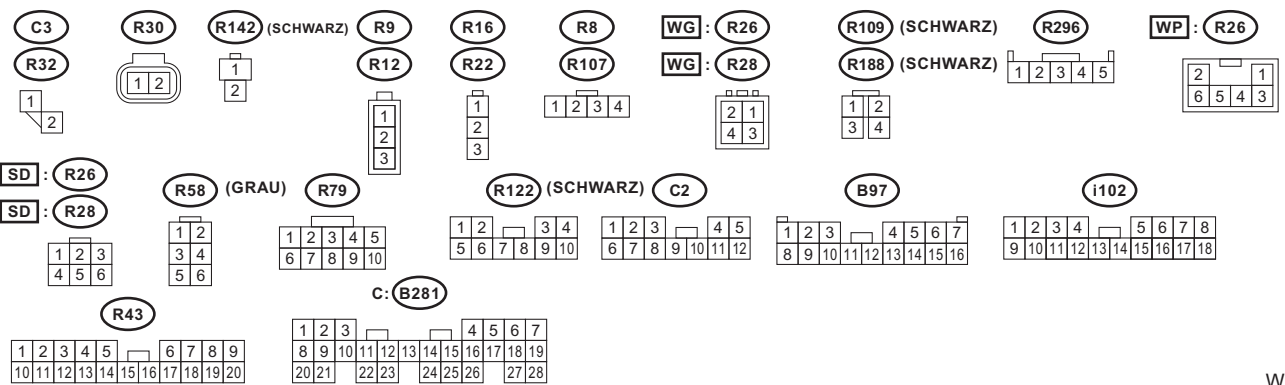
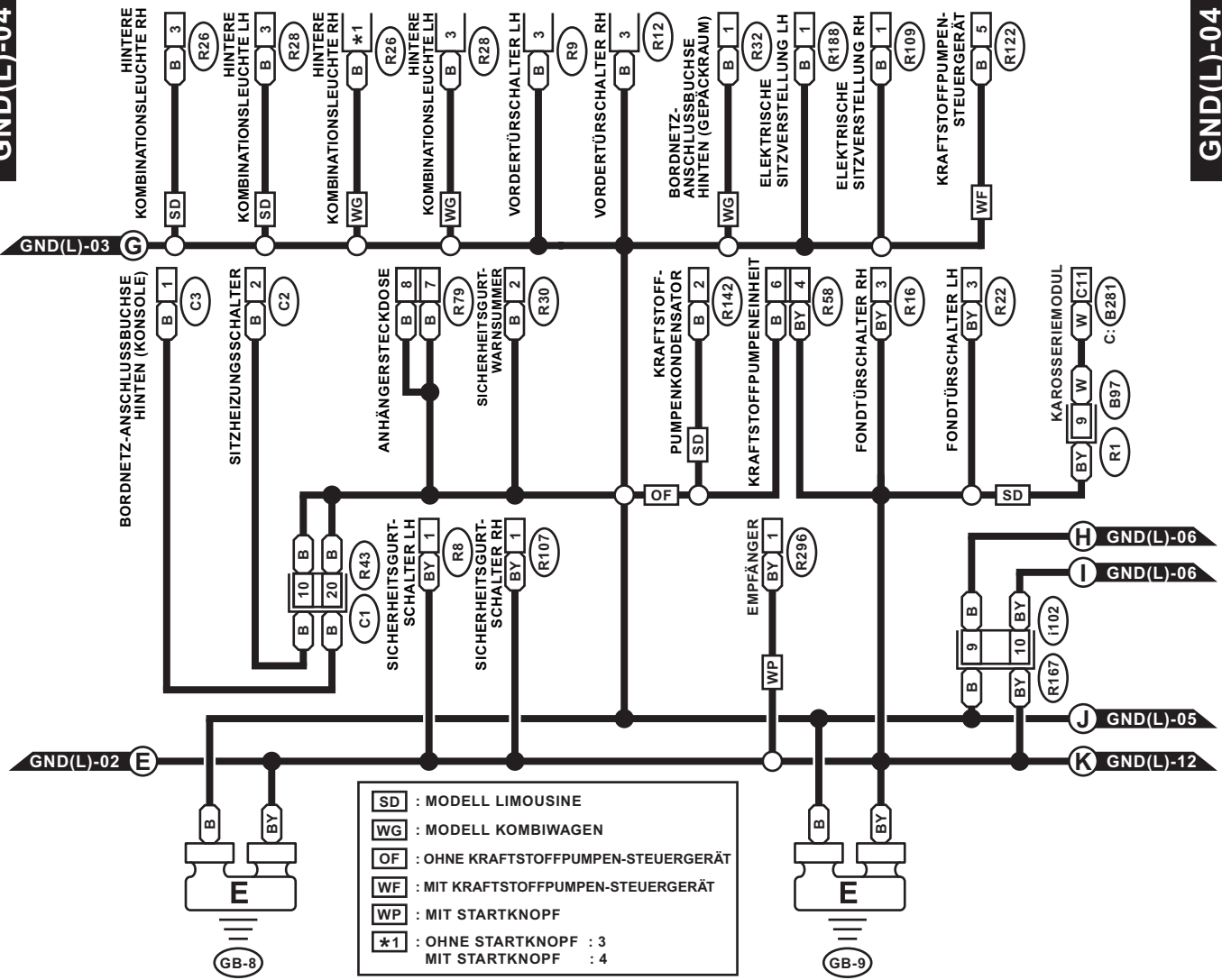

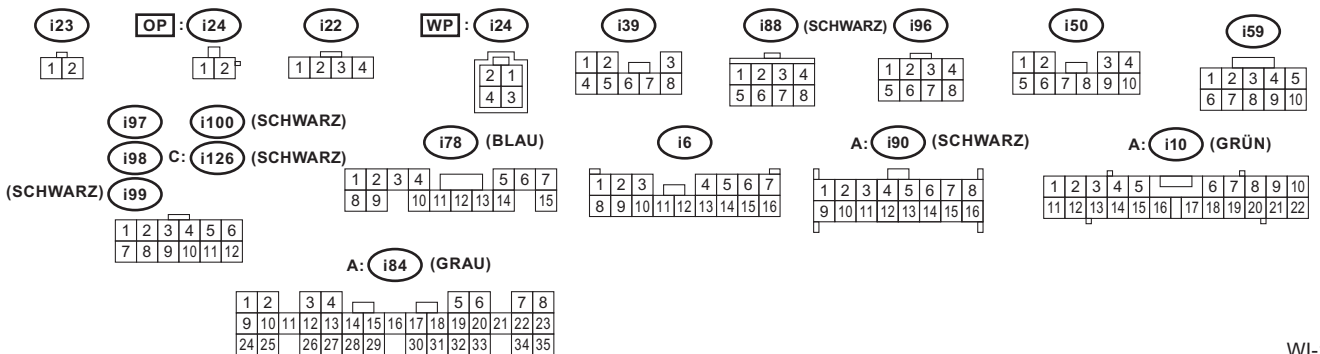
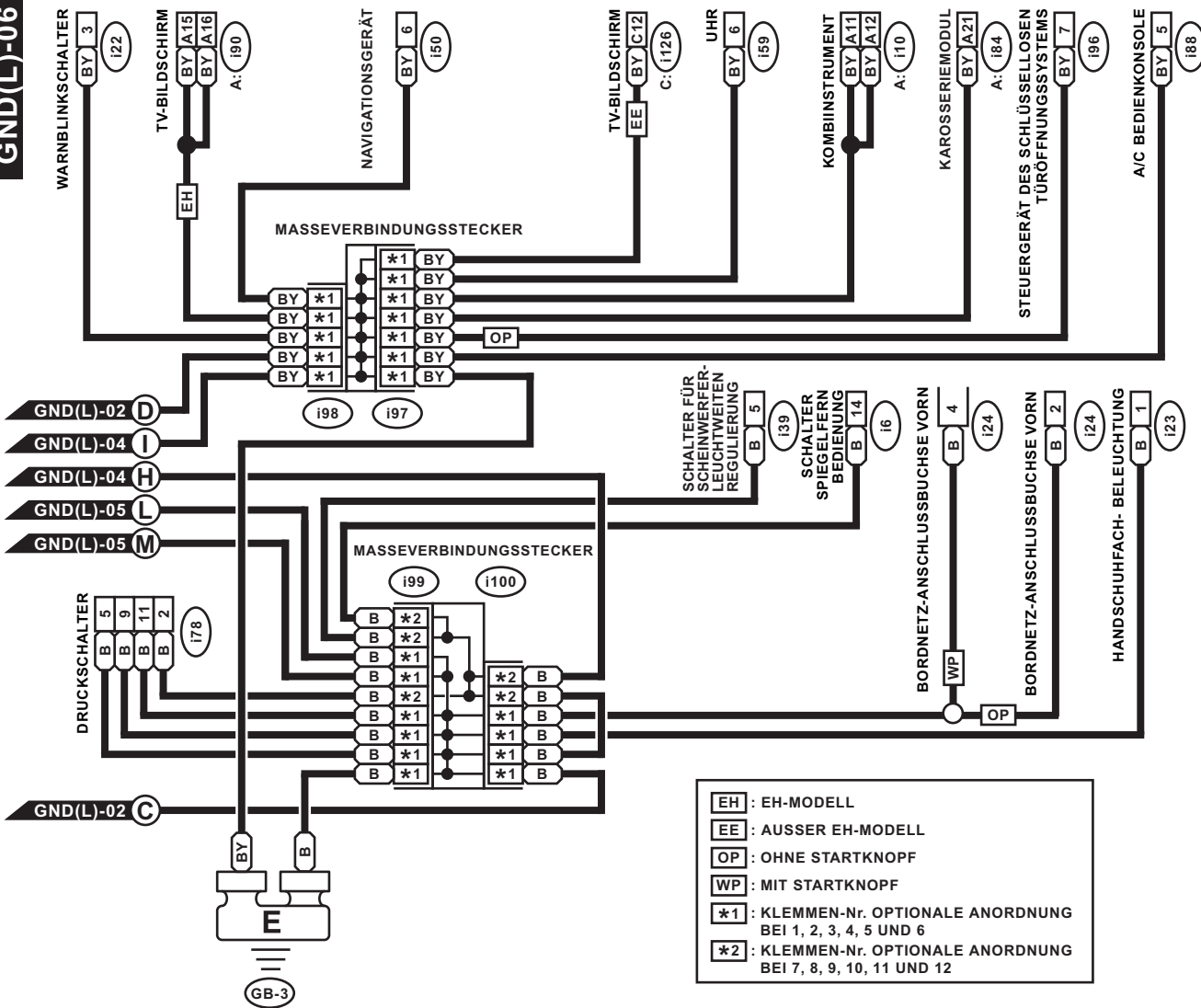

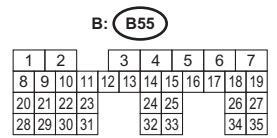
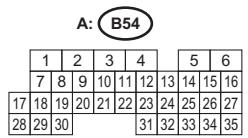
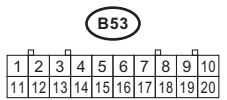
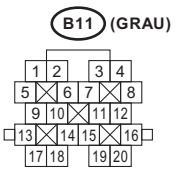
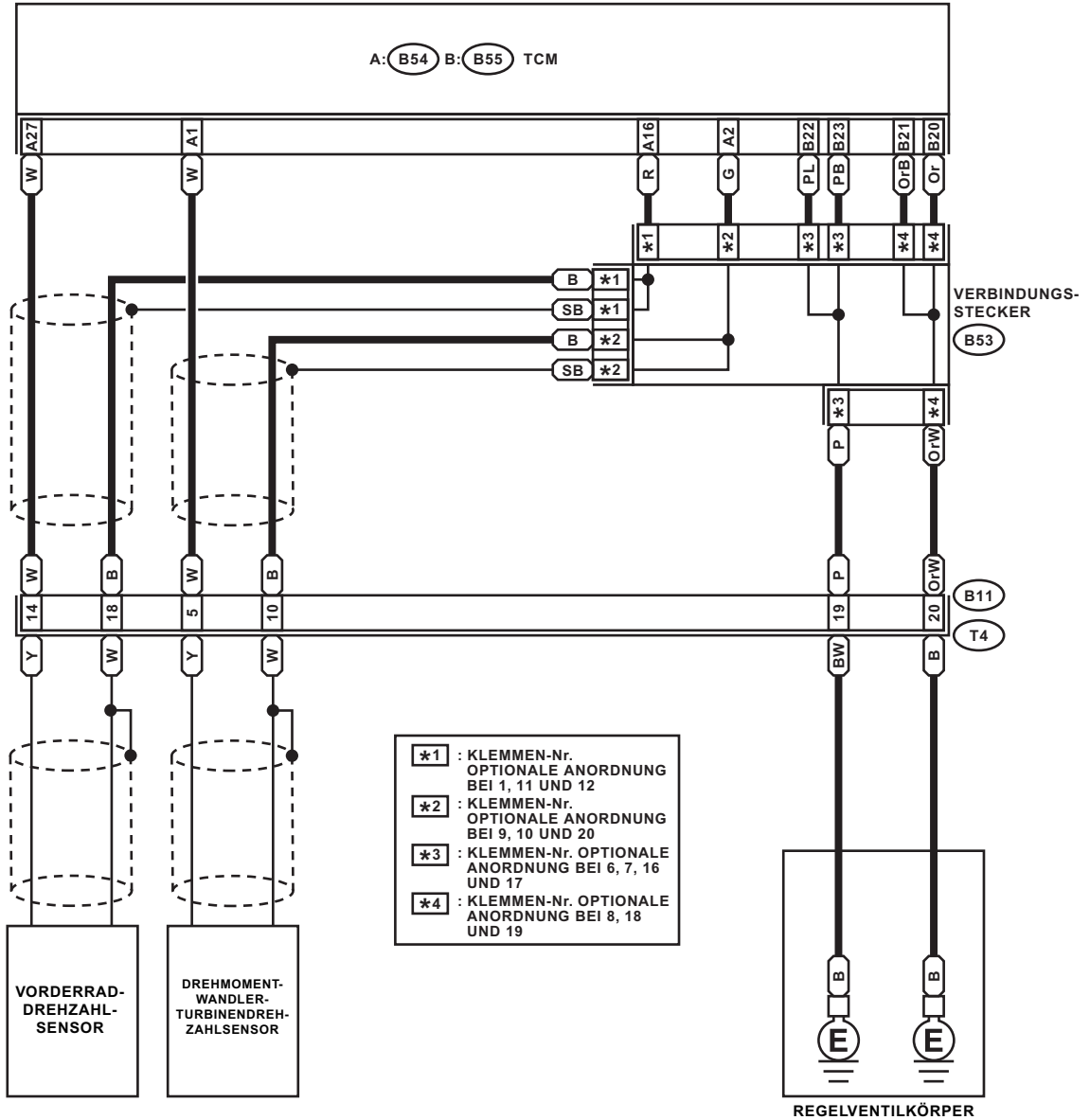

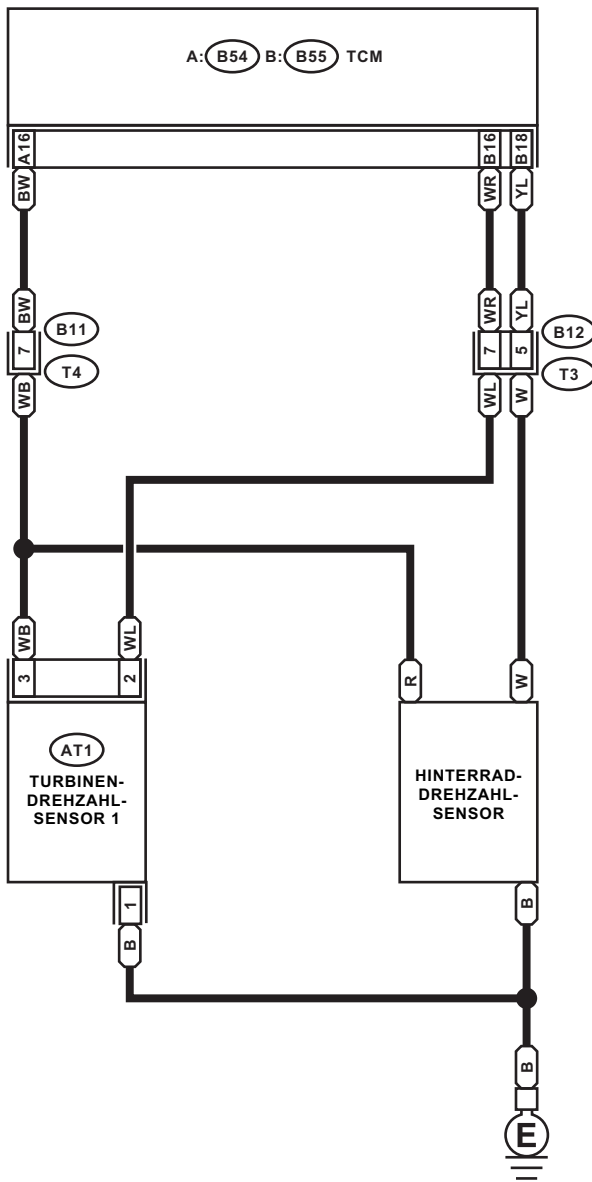

AT1



B12 (BRAUN)



B11 (GRAU)

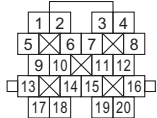

A: B54

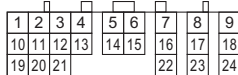

B: B55 (GRAU)

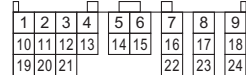

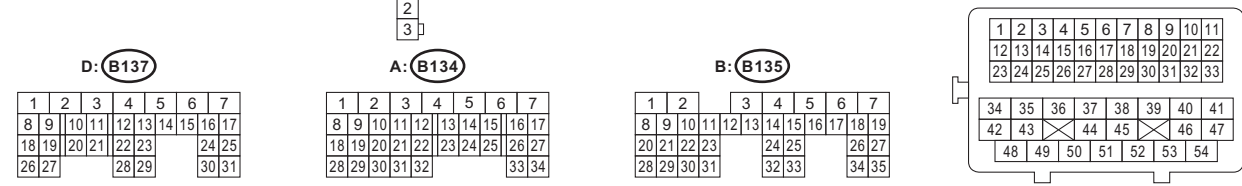
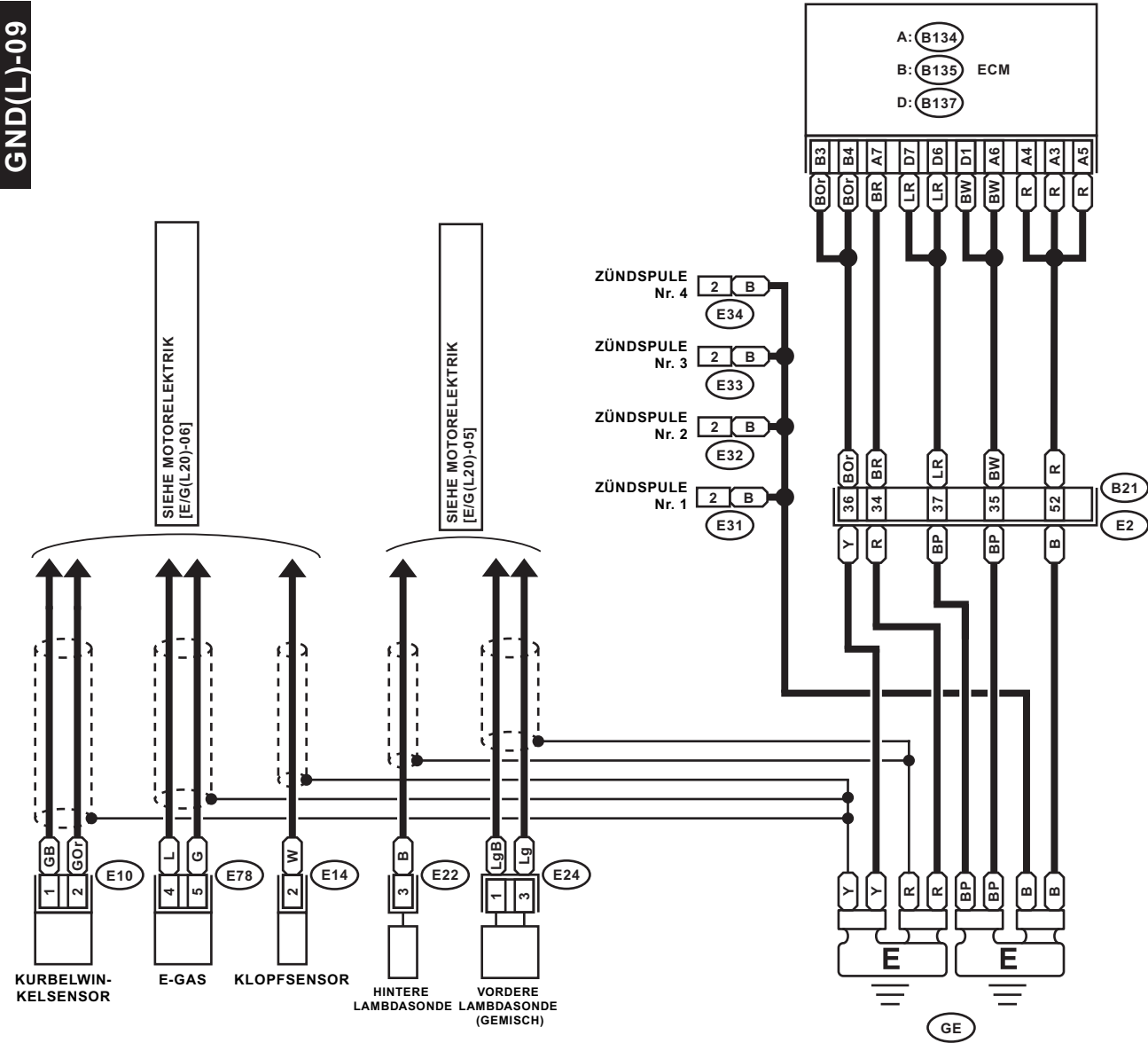

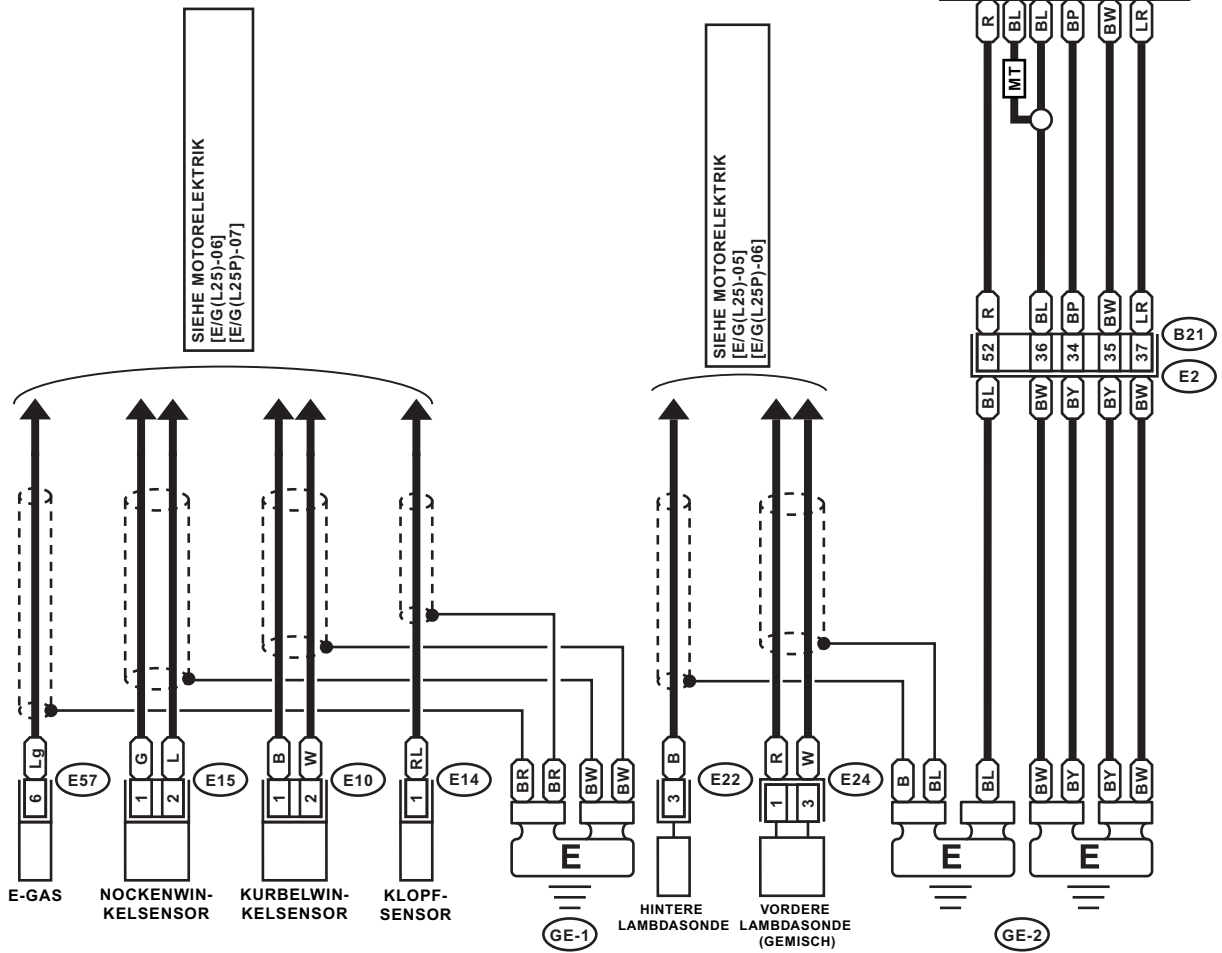

- (E10) (HELLGRAU)
- (E14) (BRAUN)
- (E22) (DUNKELGRAU)
- (E24) (SCHWARZ)
- (E57) (SCHWARZ)
- (E15) (SCHWARZ)
- (1 2)
- (1 2, 3 4)
- (3 2 1, 6 5 4)
- (1 2 3 4 5 6)

- (B21) (SCHWARZ)

D: (B137)

1	2	3	4	5	6	7
8	9	10	11	12	13	14
15	16	17	18	19	20	21
22	23	24	25	26	27	28
29	30	31				

A: (B134)

1	2	3	4	5	6	7
8	9	10	11	12	13	14
15	16	17	18	19	20	21
22	23	24	25	26	27	28
29	30	31	32	33	34	

C: (B136)

1	2	3	4	5	6
7	8	9	10	11	12
13	14	15	16	17	18
19	20	21	22	23	24
25	26	27	28	29	30
31	32	33	34	35	

1	2	3	4	5	6	7	8	9	10	11
12	13	14	15	16	17	18	19	20	21	22
23	24	25	26	27	28	29	30	31	32	33
34	35	36	37	38	39	40	41			
42	43	44	45	46	47					
48	49	50	51	52	53	54				

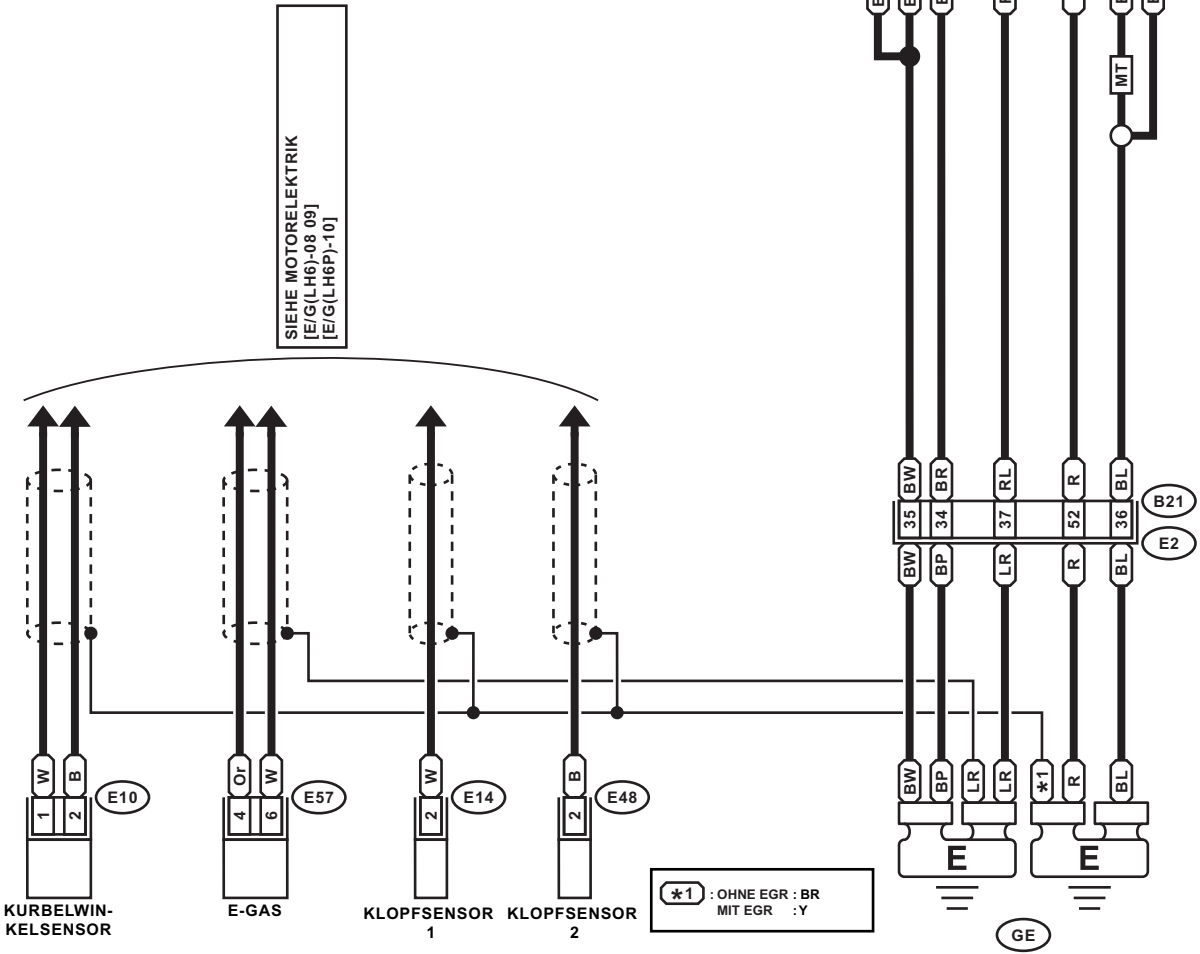

SIEHE MOTORELEKTRIK
[E/G(L-H6)-08 09]
[E/G(L-H6P)-10]

- A: B134
- C: B136 ECM
- D: B137

*1 : OHNE EGR : BR
MIT EGR : Y

E10 (HELLGRAU)	E57 (SCHWARZ)	D: B137	A: B134	C: B136	B21 (SCHWARZ)
E14 (BLAU)					
E48 (BLAU)					
1 2	1 2 3 4 5 6	1 2 3 4 5 6 7 8 9 10 11 12 13 14 15 16 17 18 19 20 21 22 23 24 25 26 27 28 29 30 31	1 2 3 4 5 6 7 8 9 10 11 12 13 14 15 16 17 18 19 20 21 22 23 24 25 26 27 28 29 30 31 32 33 34	1 2 3 4 5 6 7 8 9 10 11 12 13 14 15 16 17 18 19 20 21 22 23 24 25 26 27 28 29 30 31 32 33 34 35	1 2 3 4 5 6 7 8 9 10 11 12 13 14 15 16 17 18 19 20 21 22 23 24 25 26 27 28 29 30 31 32 33 34 35 36 37 38 39 40 41 42 43 44 45 46 47 48 49 50 51 52 53 54

AIRBAG-STEUERGERÄT

SATELLITEN-SICHERHEITSSENSOR

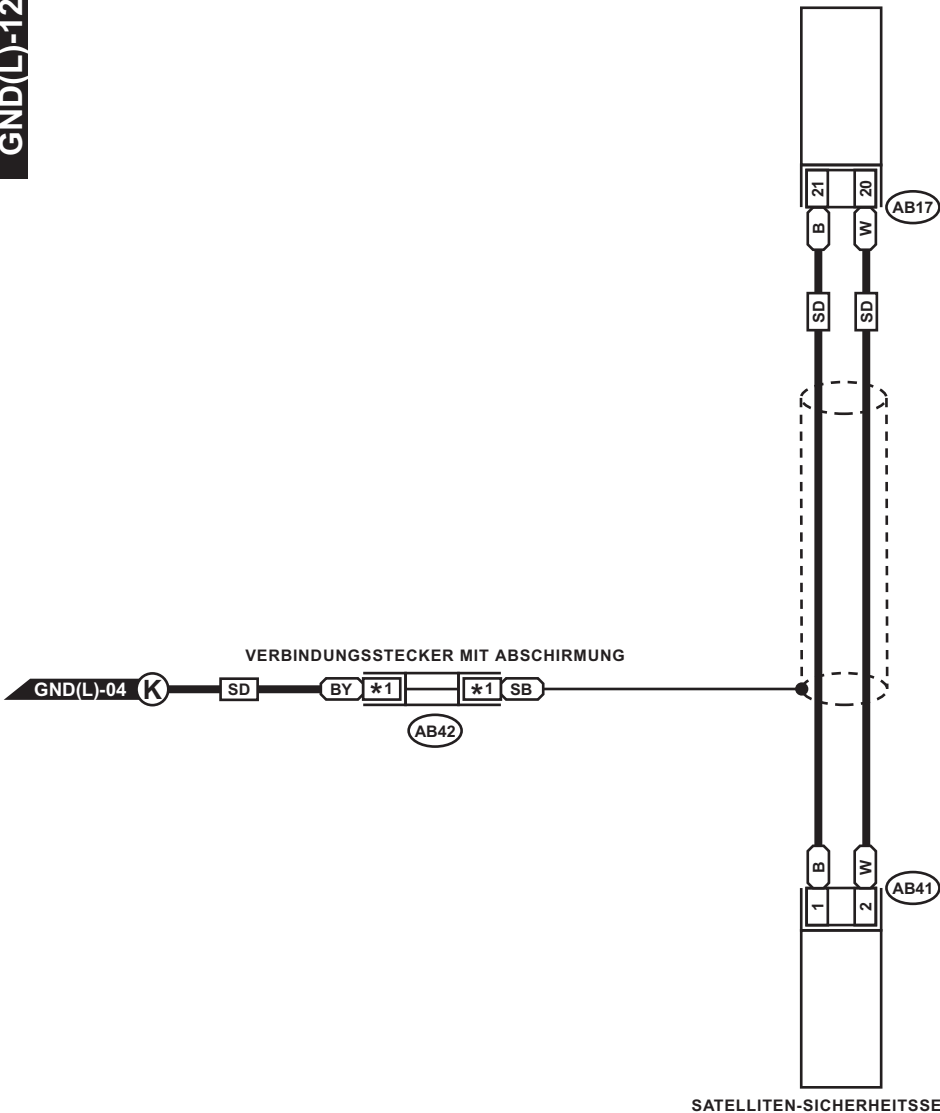

*1 : KLEMMEN-Nr.
OPTIONALE
ANORDNUNG
SD : MODELL
LIMOUSINE

AB41 (GELB)



AB42



AB17 (GELB)



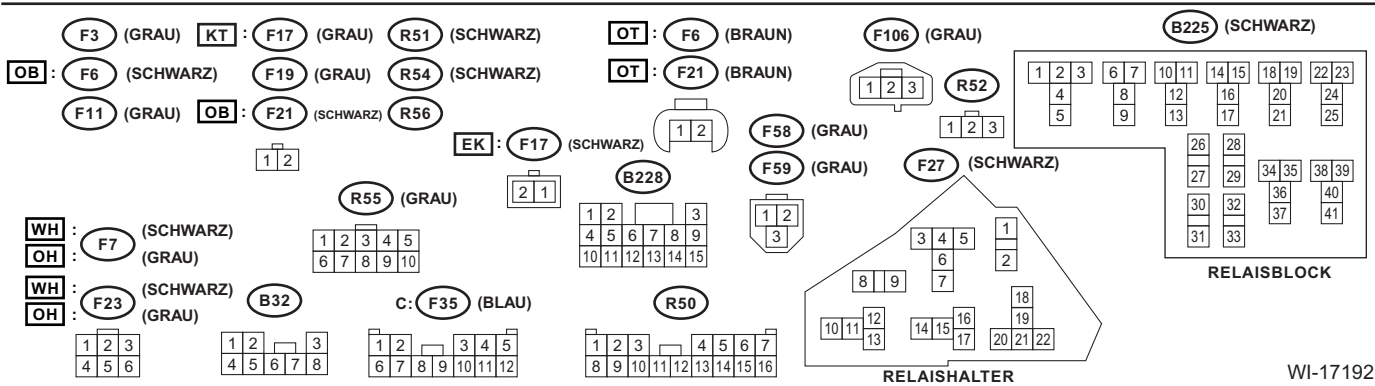
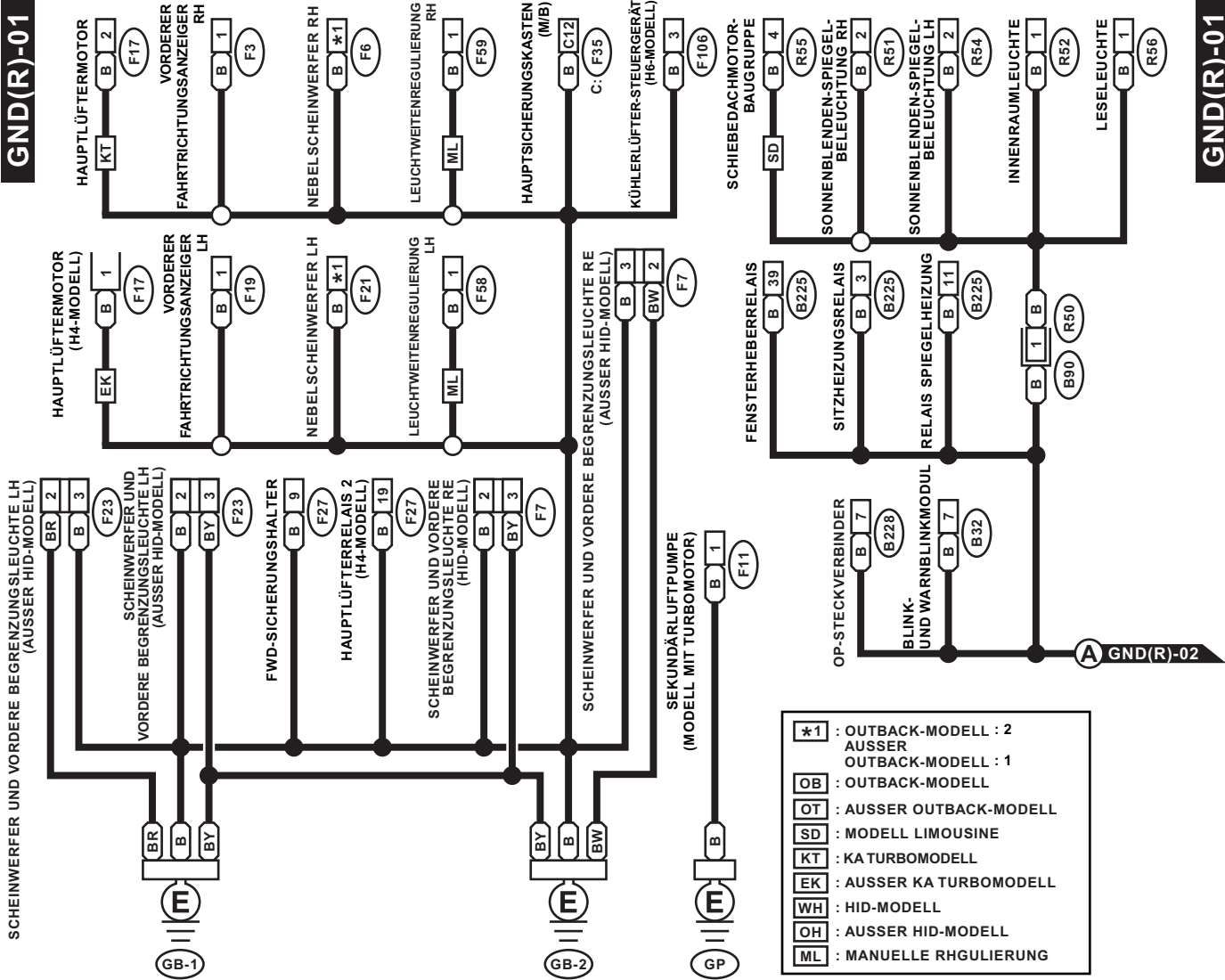

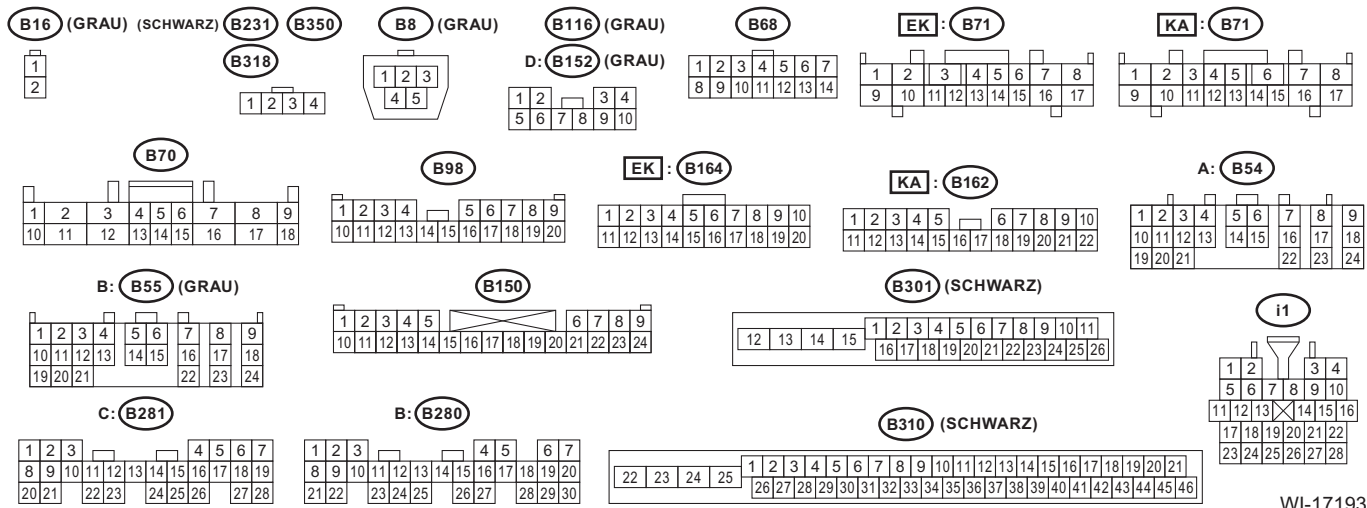
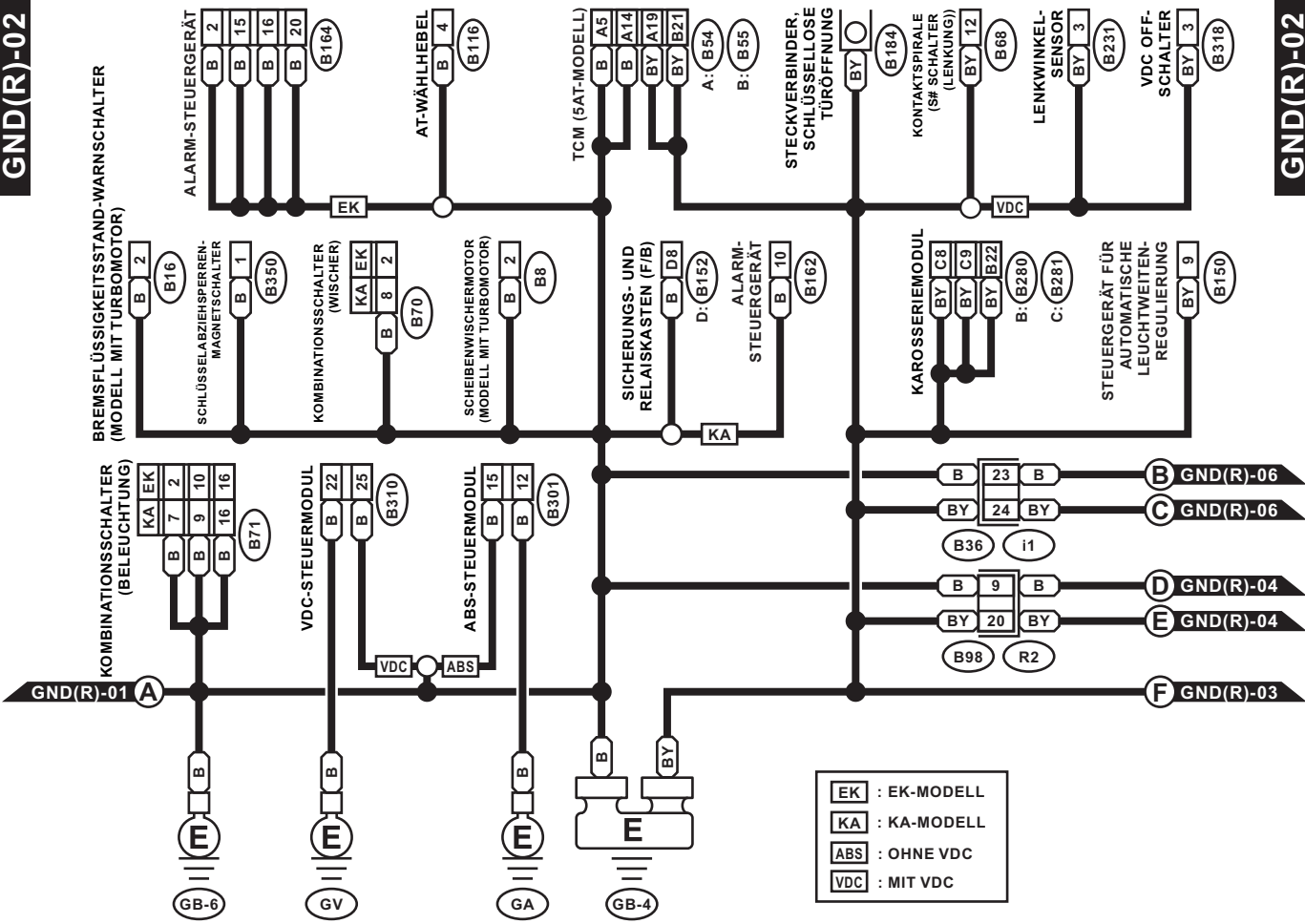

- OA** : OHNE KLIMAANLAGE HINTEN
- WA** : MIT KLIMAANLAGE HINTEN
- VDC** : MIT VDC
- *1** : OHNE GETRENNTEN TEMPERATURREGLER LI/RE : 1
MIT GETRENNTEM TEMPERATURREGLER LI/RE : 2

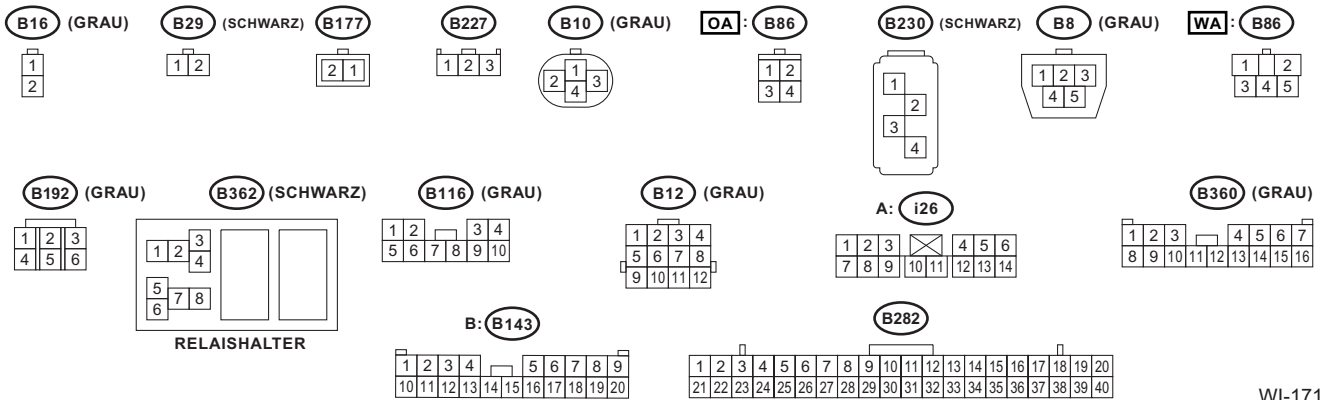
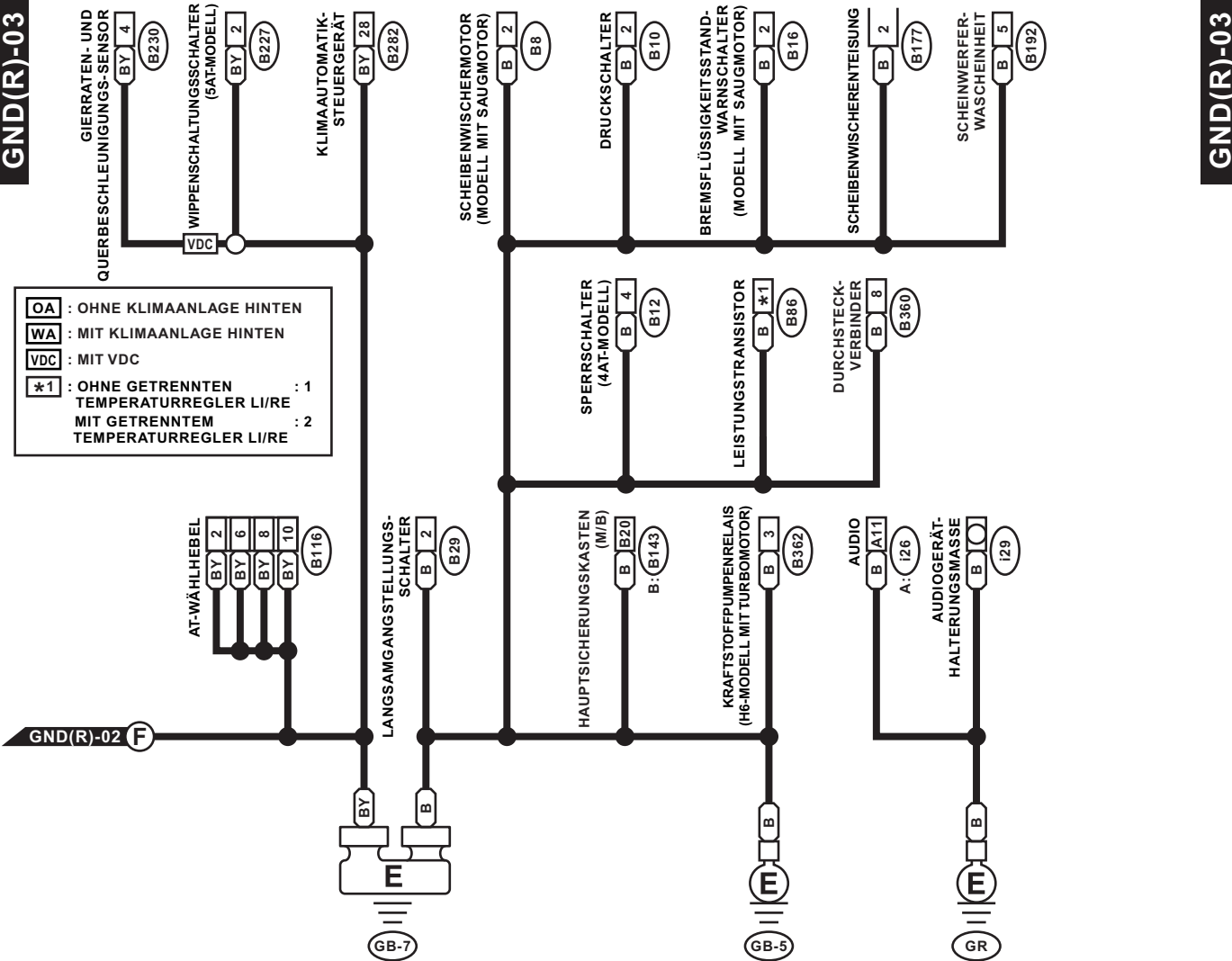

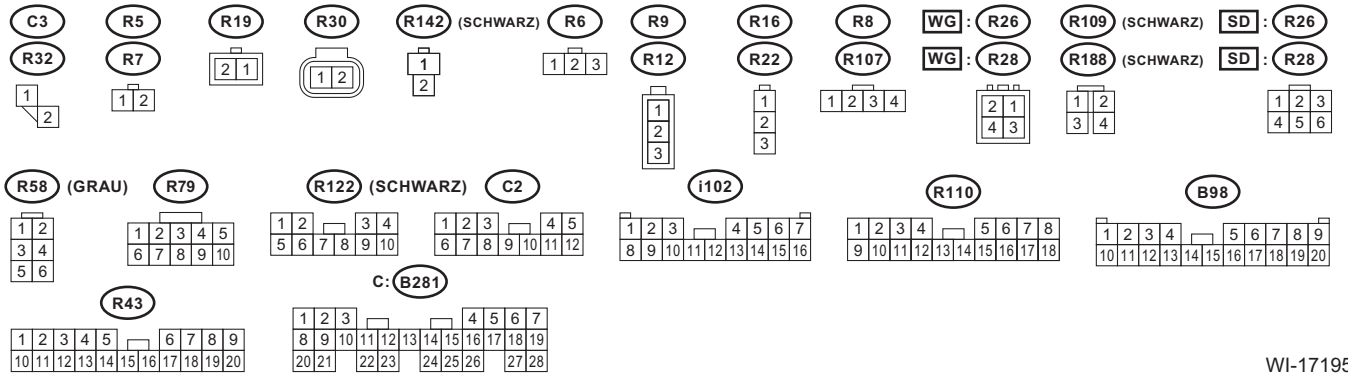
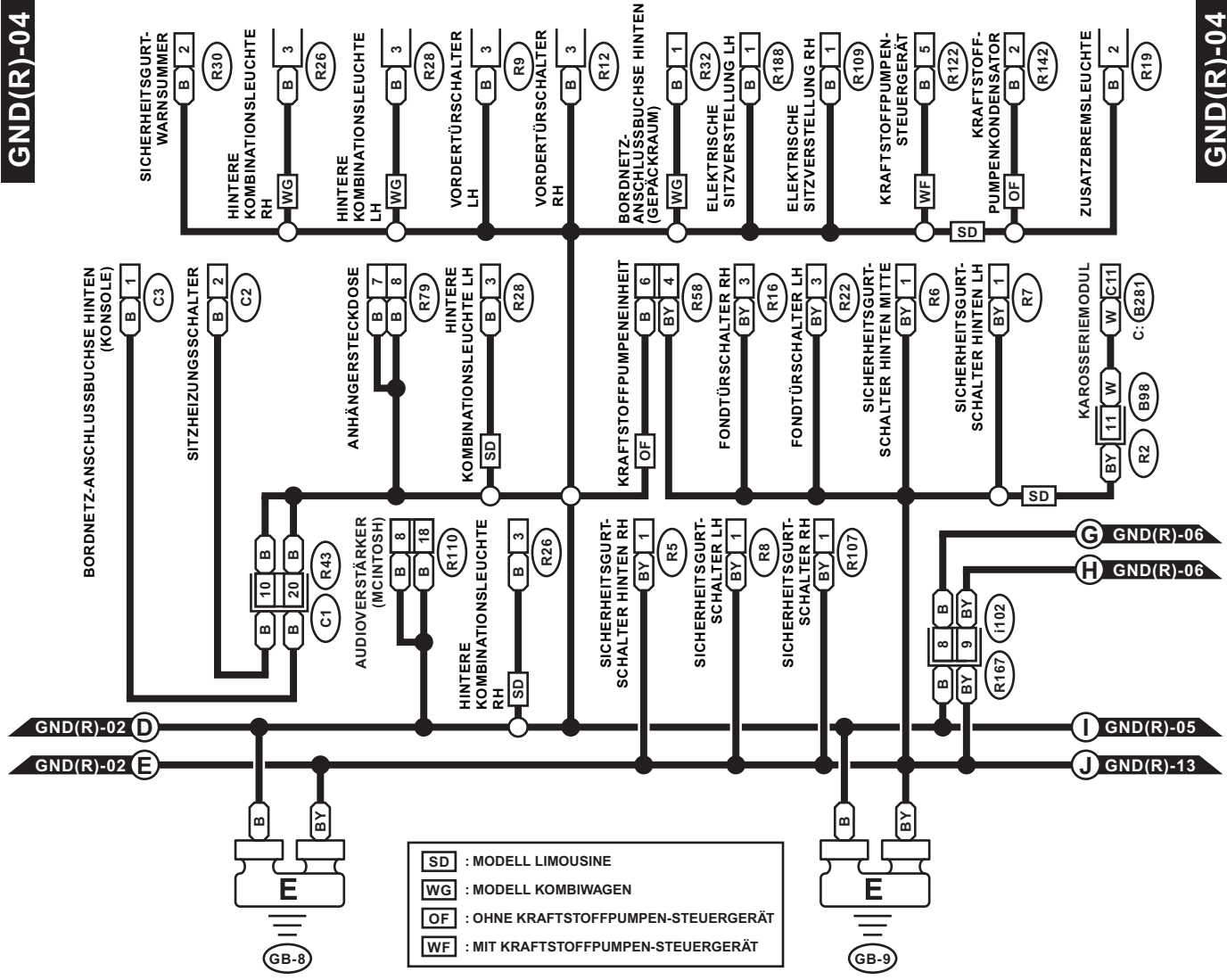

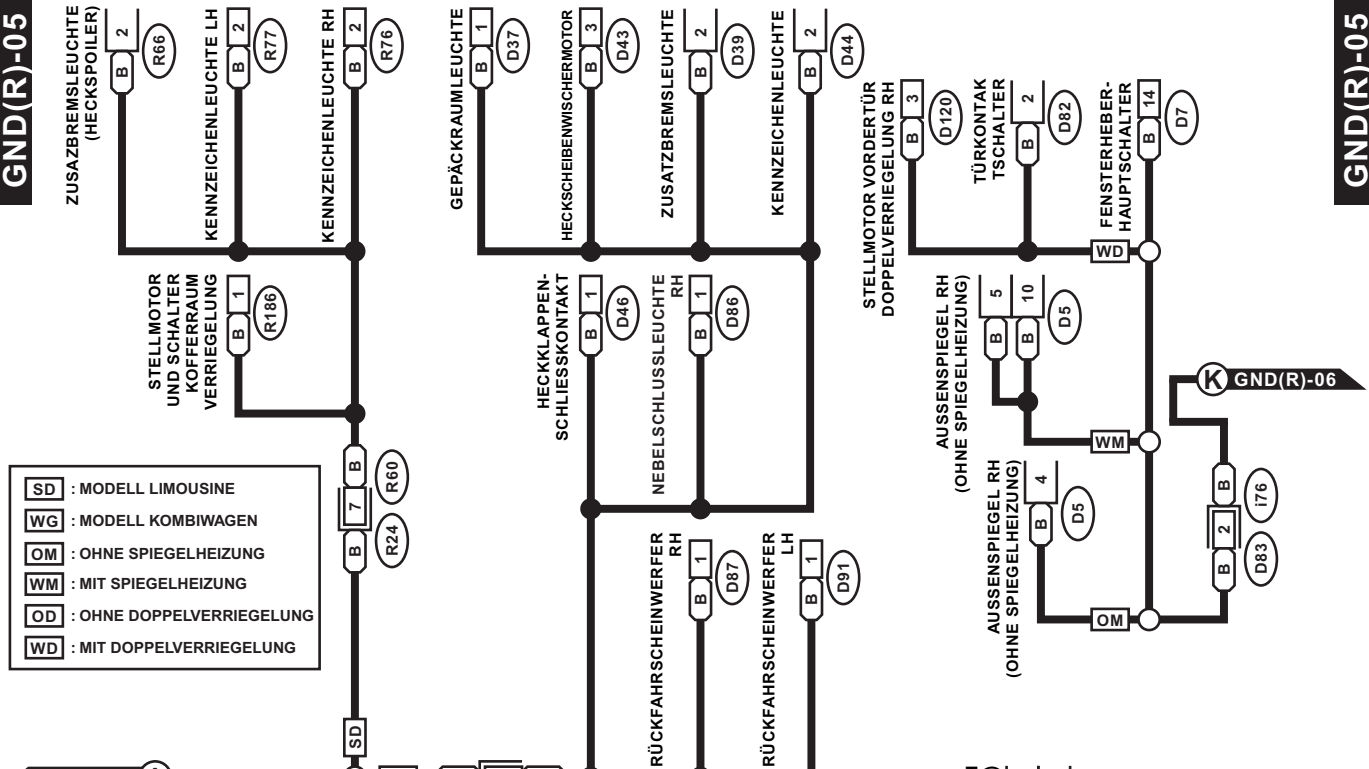

- SD** : MODELL LIMOUSINE
- WG** : MODELL KOMBIWAGEN
- OM** : OHNE SPIEGELHEIZUNG
- WM** : MIT SPIEGELHEIZUNG
- OD** : OHNE DOPPELVERRIEGELUNG
- WD** : MIT DOPPELVERRIEGELUNG

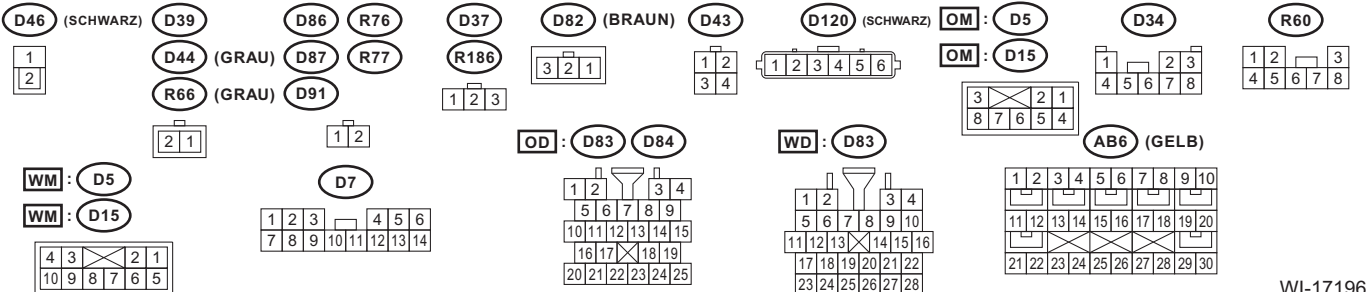
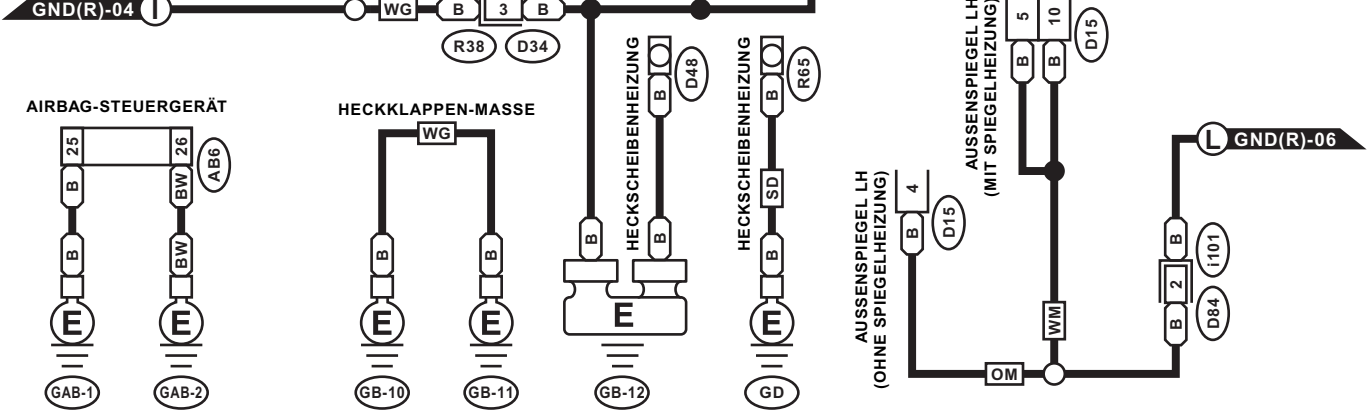

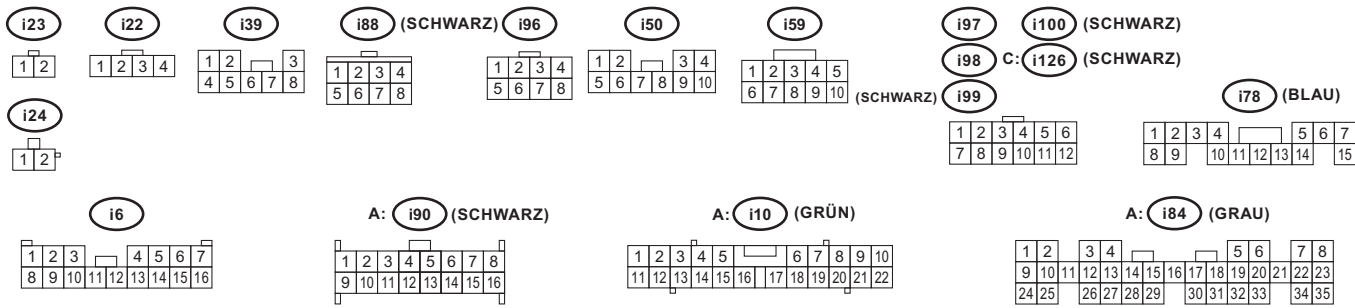
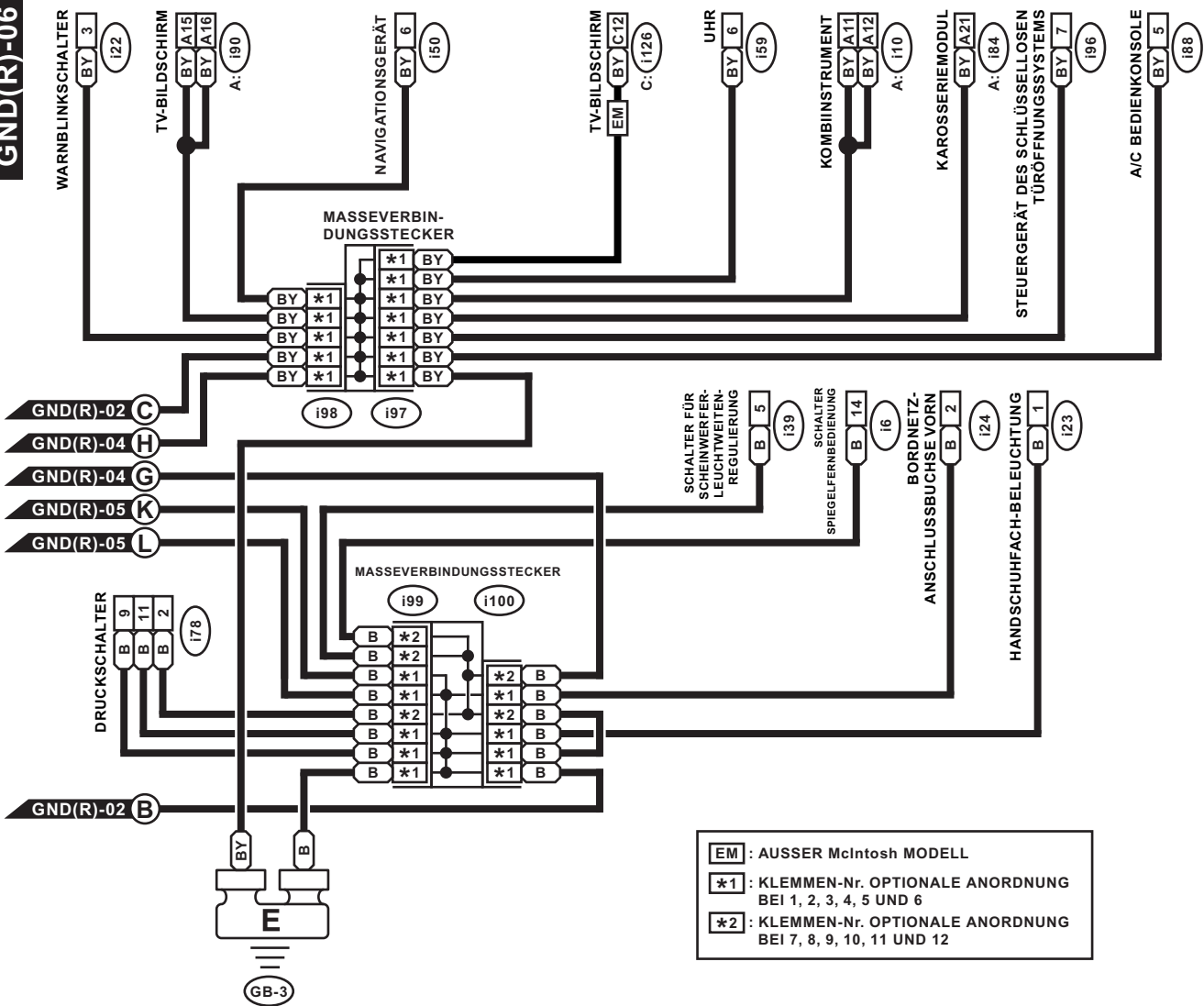

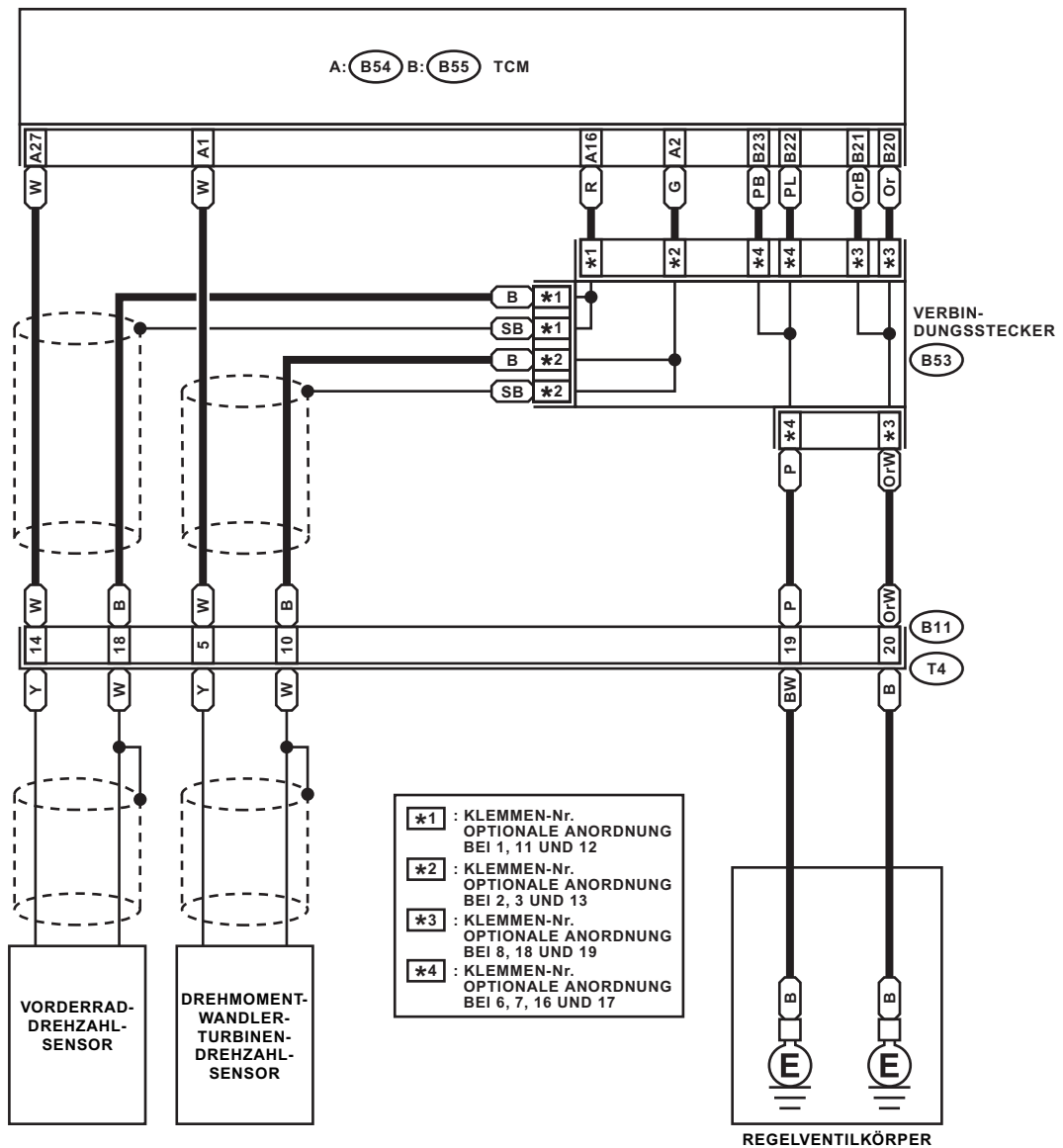

B11 (GRAU)

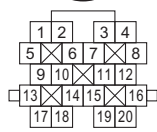

B53



A: B54

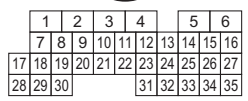

B: B55

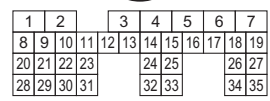

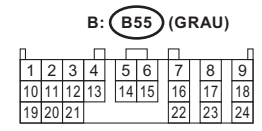
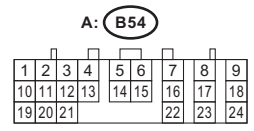
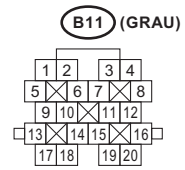
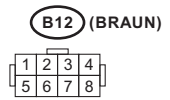
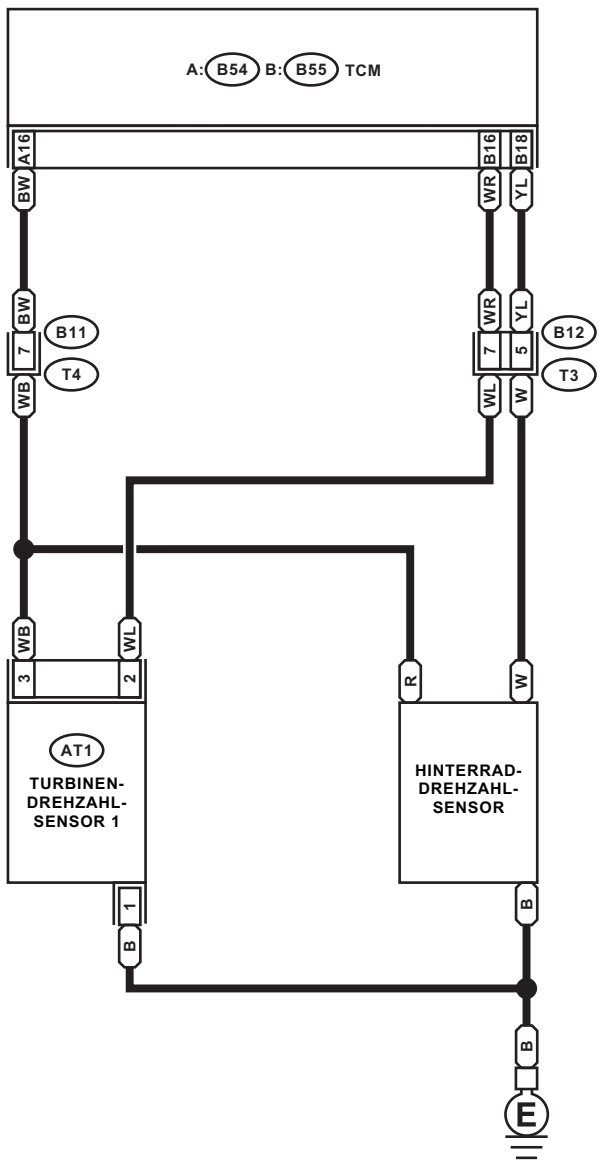

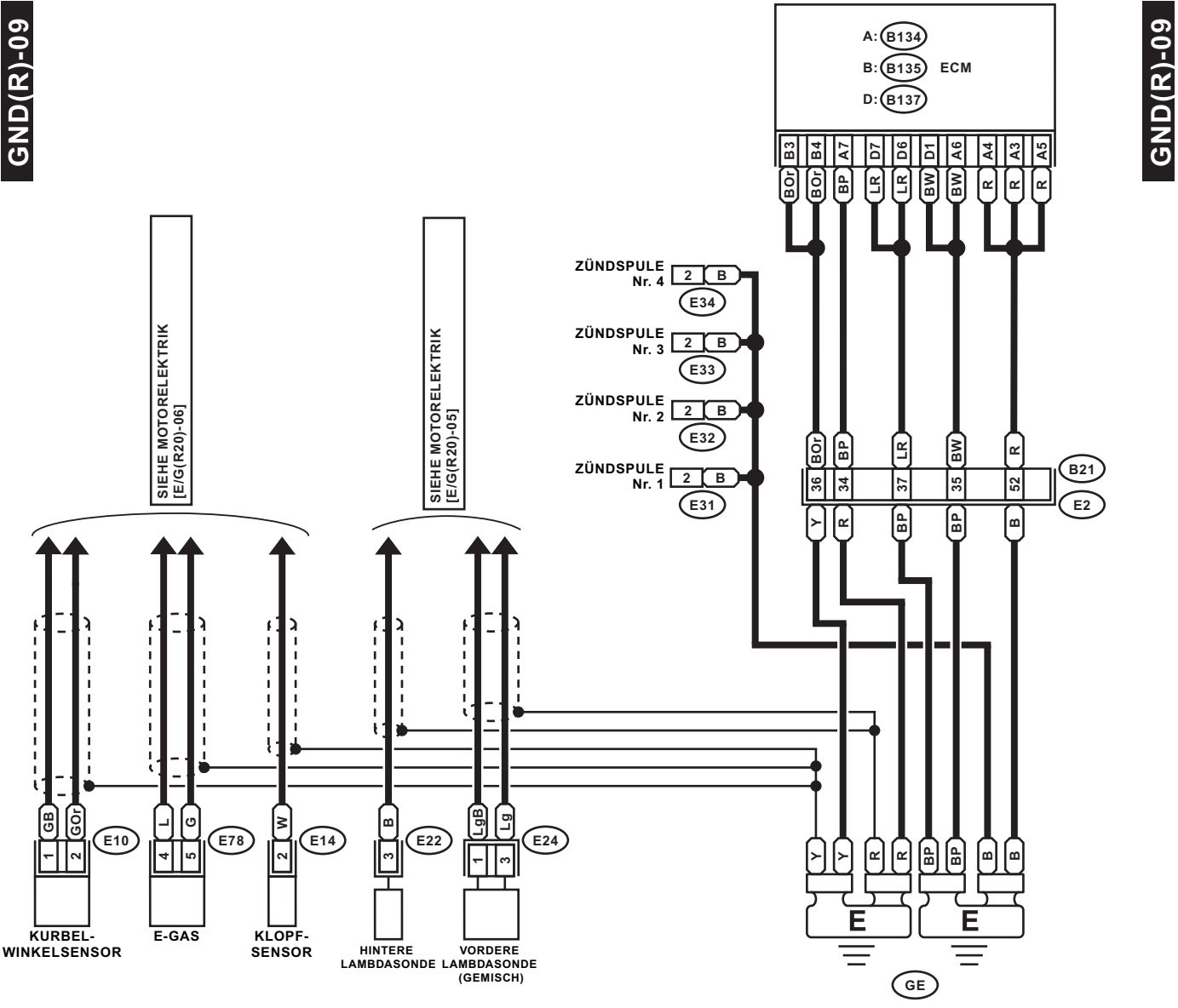

E10 (HELLGRAU) **E14 (GRAU)** **E31 E33 (SCHWARZ)** **E22 (DUNKELGRAU)** **E24 (SCHWARZ)** **E78 (SCHWARZ)**

E32 E34 (SCHWARZ)

D: (B137) **A: (B134)** **B: (B135)** **(B21) (SCHWARZ)**

1	2	3	4	5	6	7
8	9	10	11	12	13	14
15	16	17	18	19	20	21
22	23	24	25	26	27	28
29	30	31	32	33	34	35

1	2	3	4	5	6	7
8	9	10	11	12	13	14
15	16	17	18	19	20	21
22	23	24	25	26	27	28
29	30	31	32	33	34	35

1	2	3	4	5	6	7
8	9	10	11	12	13	14
15	16	17	18	19	20	21
22	23	24	25	26	27	28
29	30	31	32	33	34	35

1	2	3	4	5	6	7	8	9	10	11
12	13	14	15	16	17	18	19	20	21	22
23	24	25	26	27	28	29	30	31	32	33
34	35	36	37	38	39	40	41	42	43	44
45	46	47	48	49	50	51	52	53	54	55

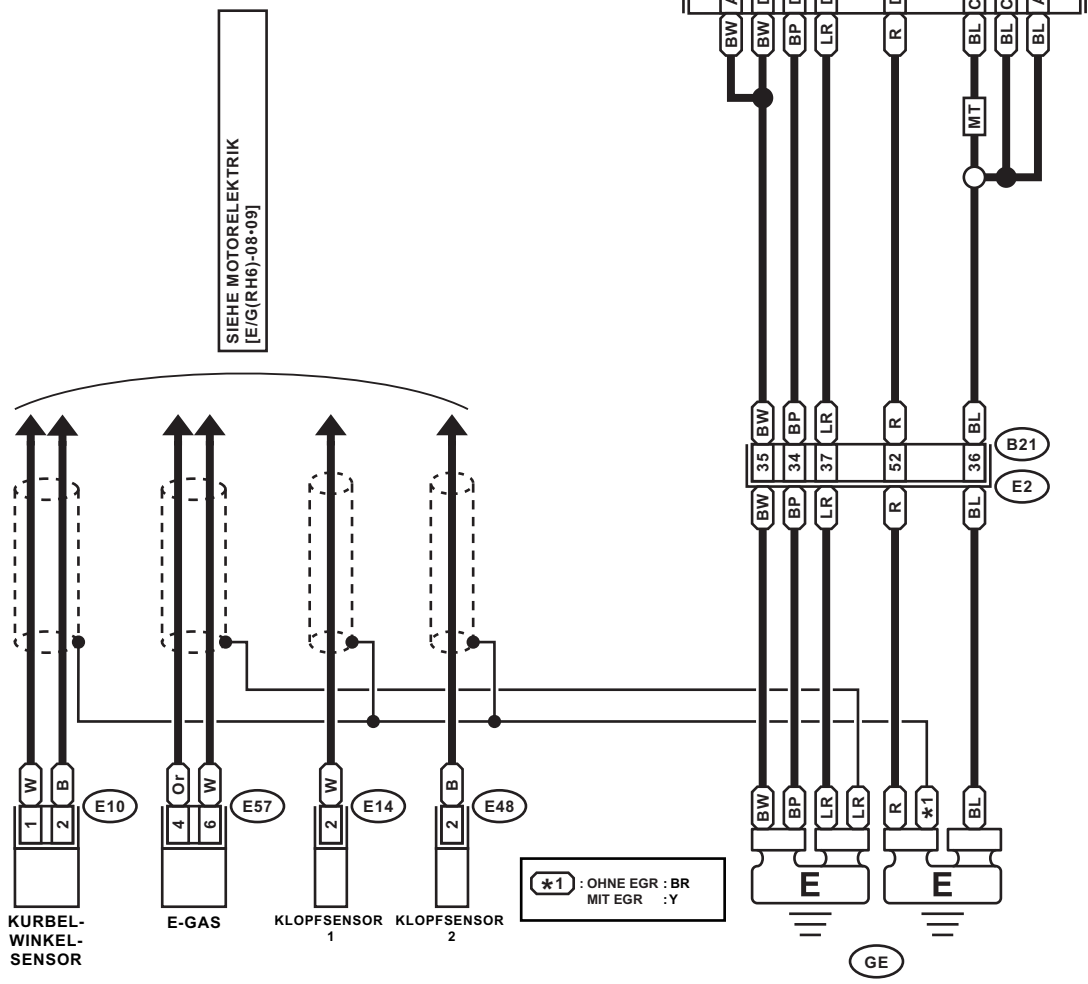

E10 (HELLGRAU)

E14 (BLAU)

E48 (BLAU)



E57 (SCHWARZ)

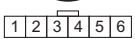

D: B137

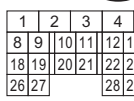

A: B134

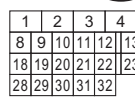

C: B136

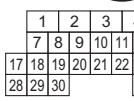

B21 (SCHWARZ)

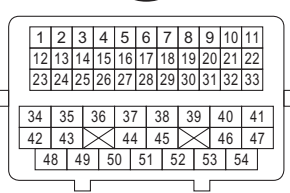

AIRBAG-STEUERGERÄT

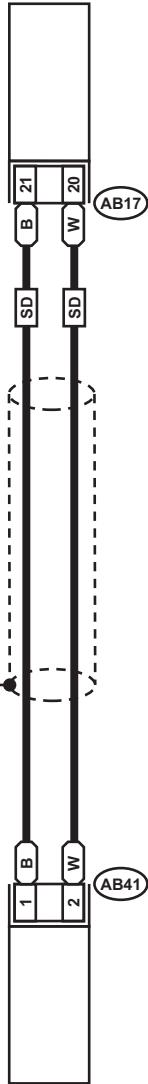

VERBINDUNGSSTECKER MIT ABSCHIRMUNG



*1 : KLEMMEN-Nr.
OPTIONALE
ANORDNUNG
SD : MODELL
LIMOUSINE

SATELLITEN-SICHERHEITSSENSOR

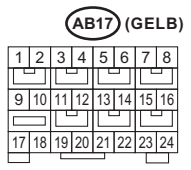

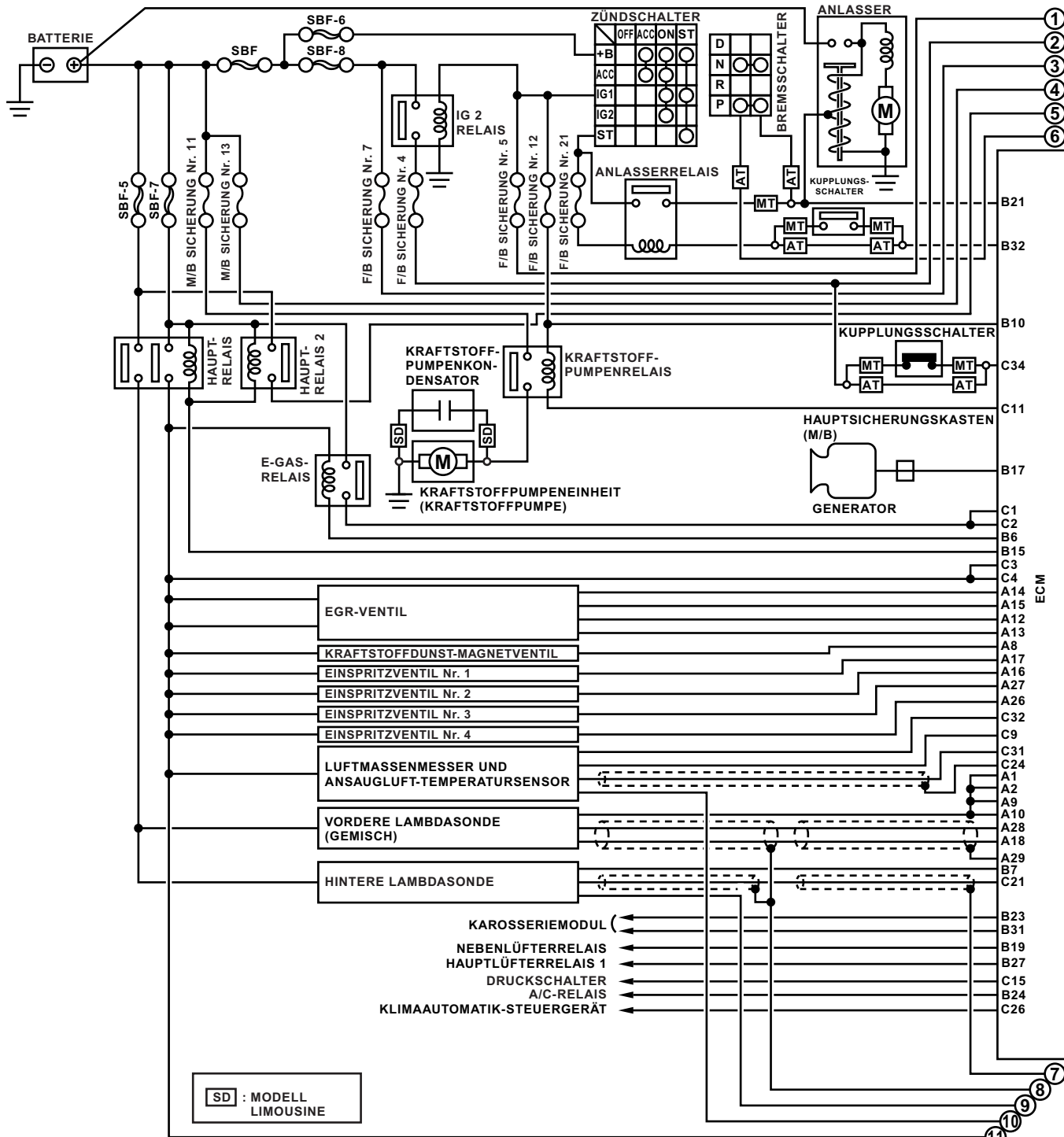

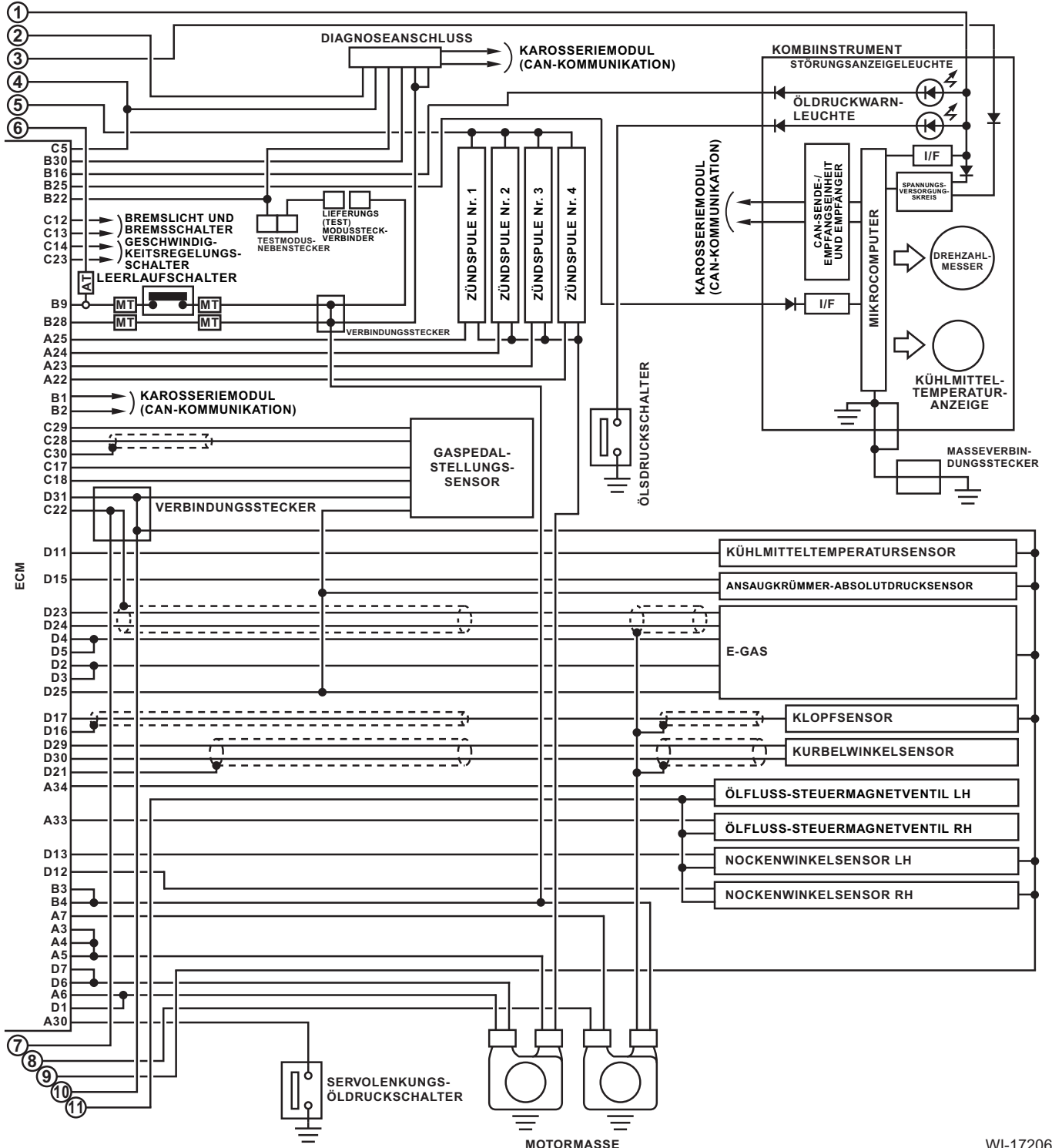

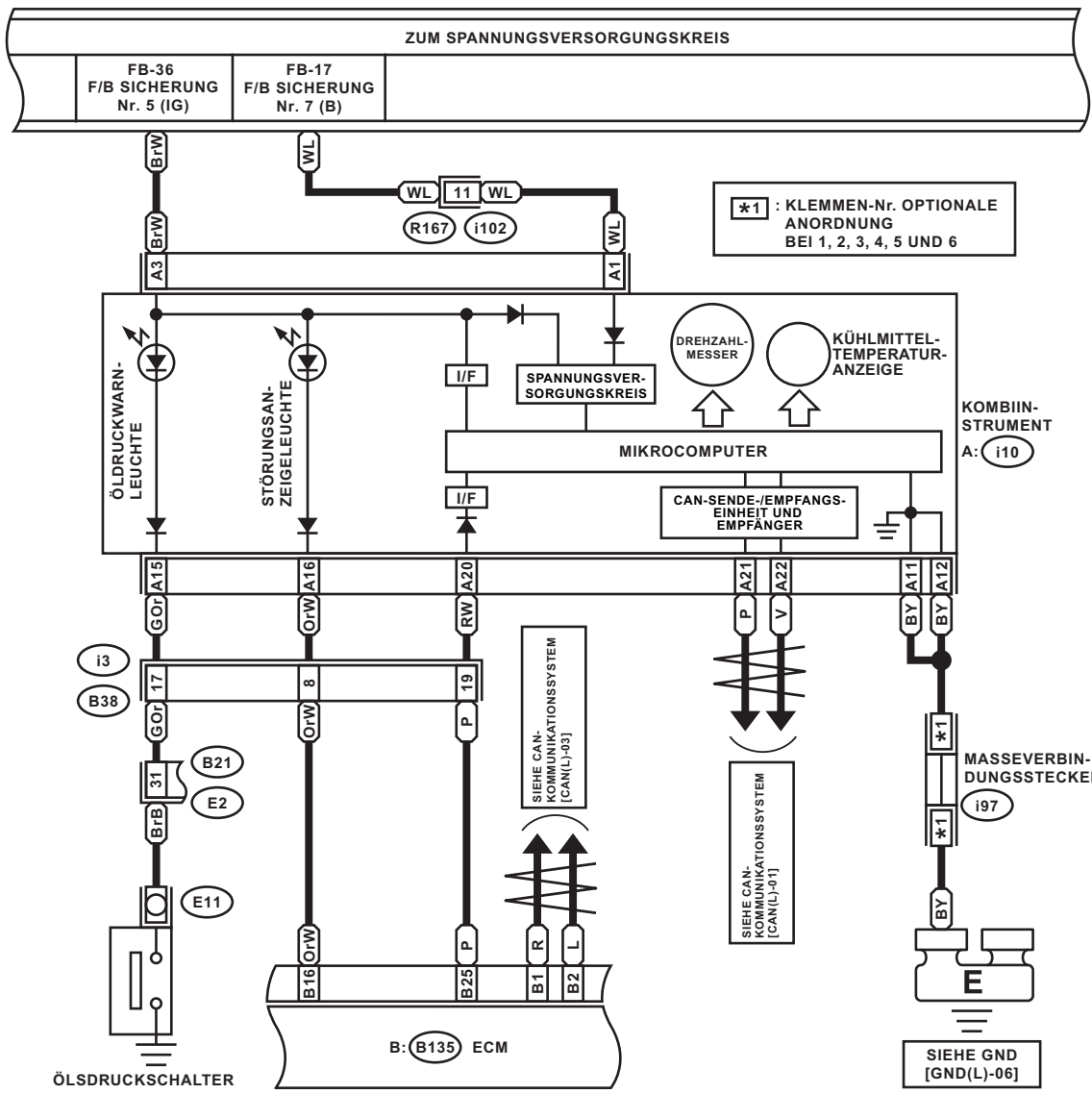

i97

1	2	3	4	5	6
7	8	9	10	11	12

i102

1	2	3	4		5	6	7	8	
9	10	11	12	13	14	15	16	17	18

B38

1	2	3	4		5	6	7	8	9	
10	11	12	13	14	15	16	17	18	19	20

B21 (SCHWARZ)

1	2	3	4	5	6	7	8	9	10	11
12	13	14	15	16	17	18	19	20	21	22
23	24	25	26	27	28	29	30	31	32	33
34	35	36	37	38	39	40	41			
42	43	44	45	46	47					
48	49	50	51	52	53	54				

A: i10 (GRÜN)

1	2	3	4	5		6	7	8	9	10	
11	12	13	14	15	16	17	18	19	20	21	22

B: B135

1	2		3	4	5	6	7				
8	9	10	11	12	13	14	15	16	17	18	19
20	21	22	23		24	25		26	27		
28	29	30	31		32	33		34	35		

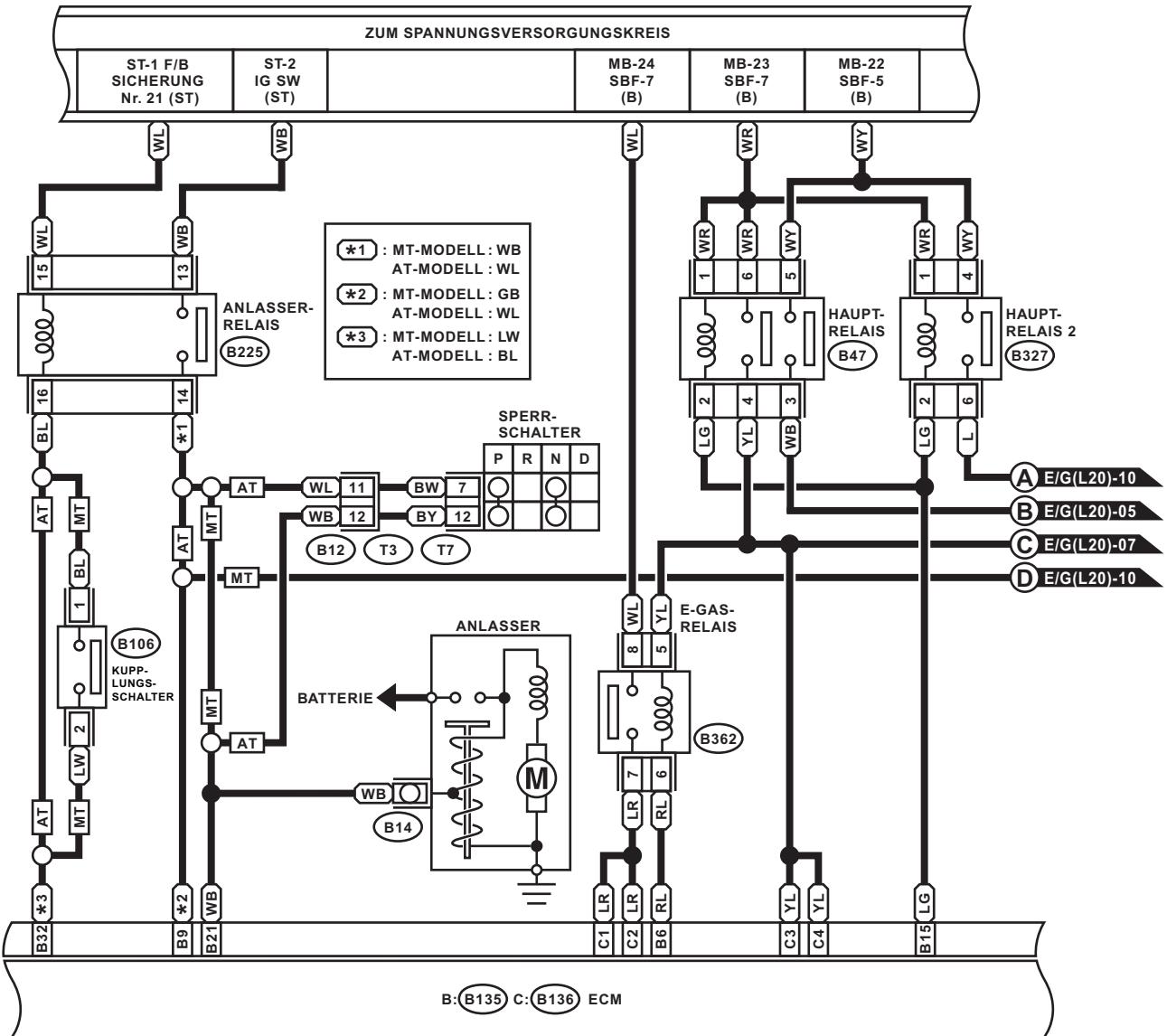

B106



B47 (BRAUN)

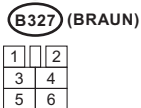

B362 (SCHWARZ)

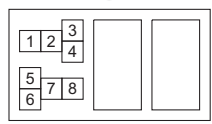

RELAISHALTER

B12 (GRAU)

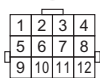

T7 (SCHWARZ)

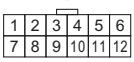

B: B135

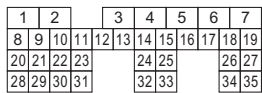

C: B136

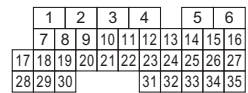

B225 (SCHWARZ)

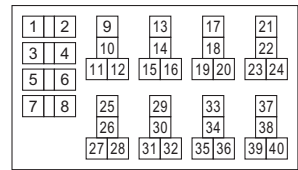

RELAISBLOCK

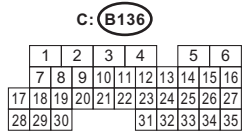
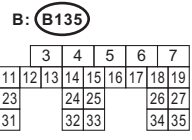
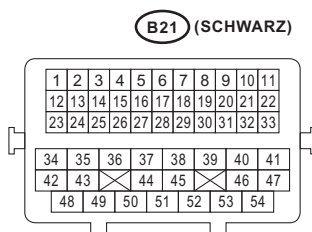
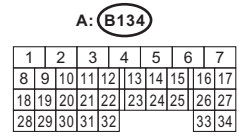
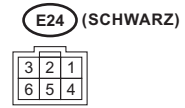
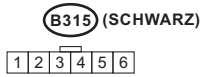
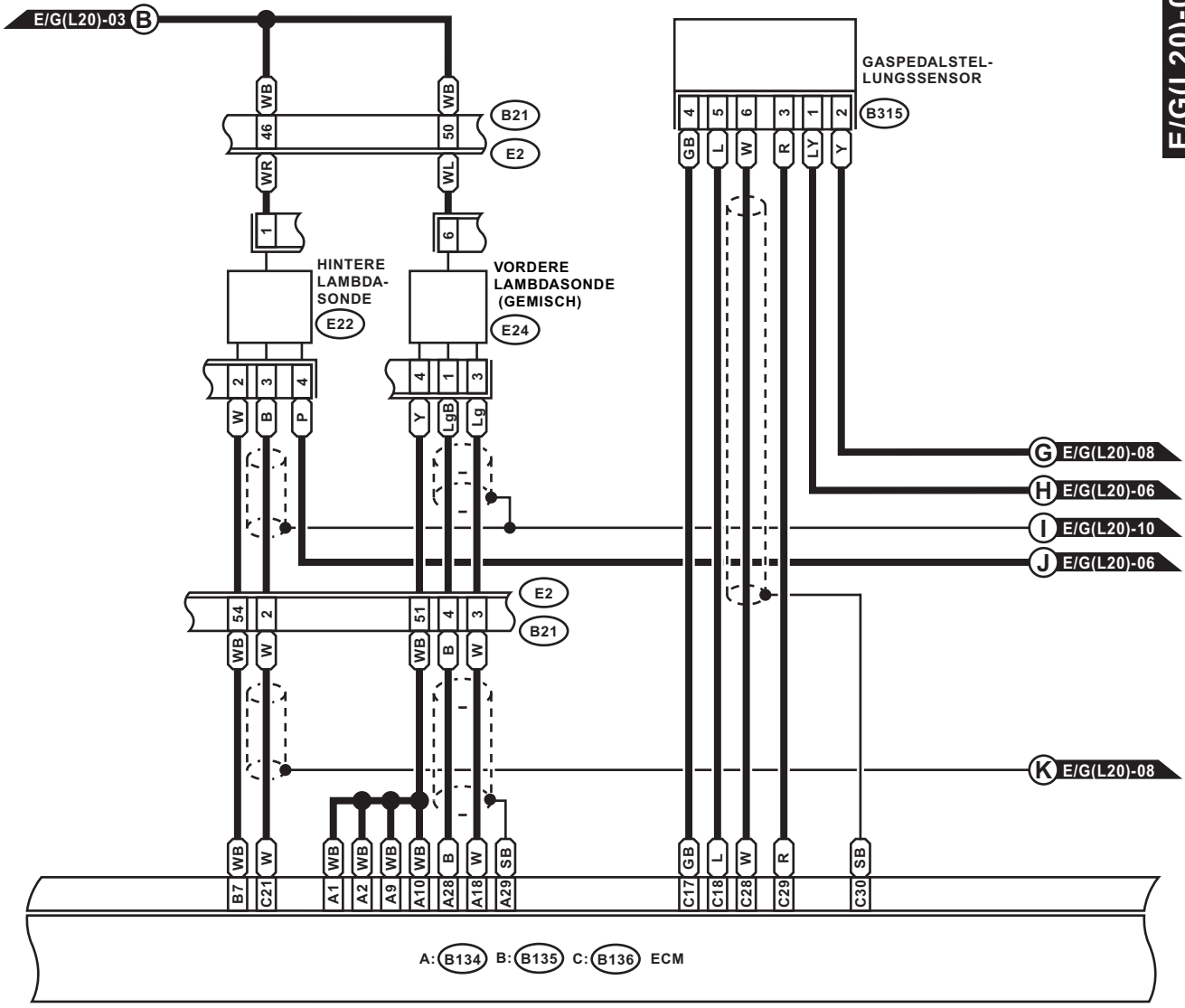

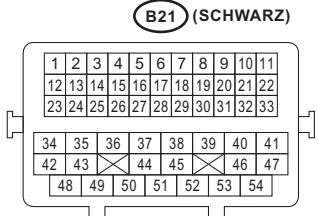
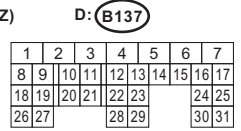
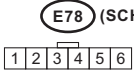
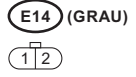
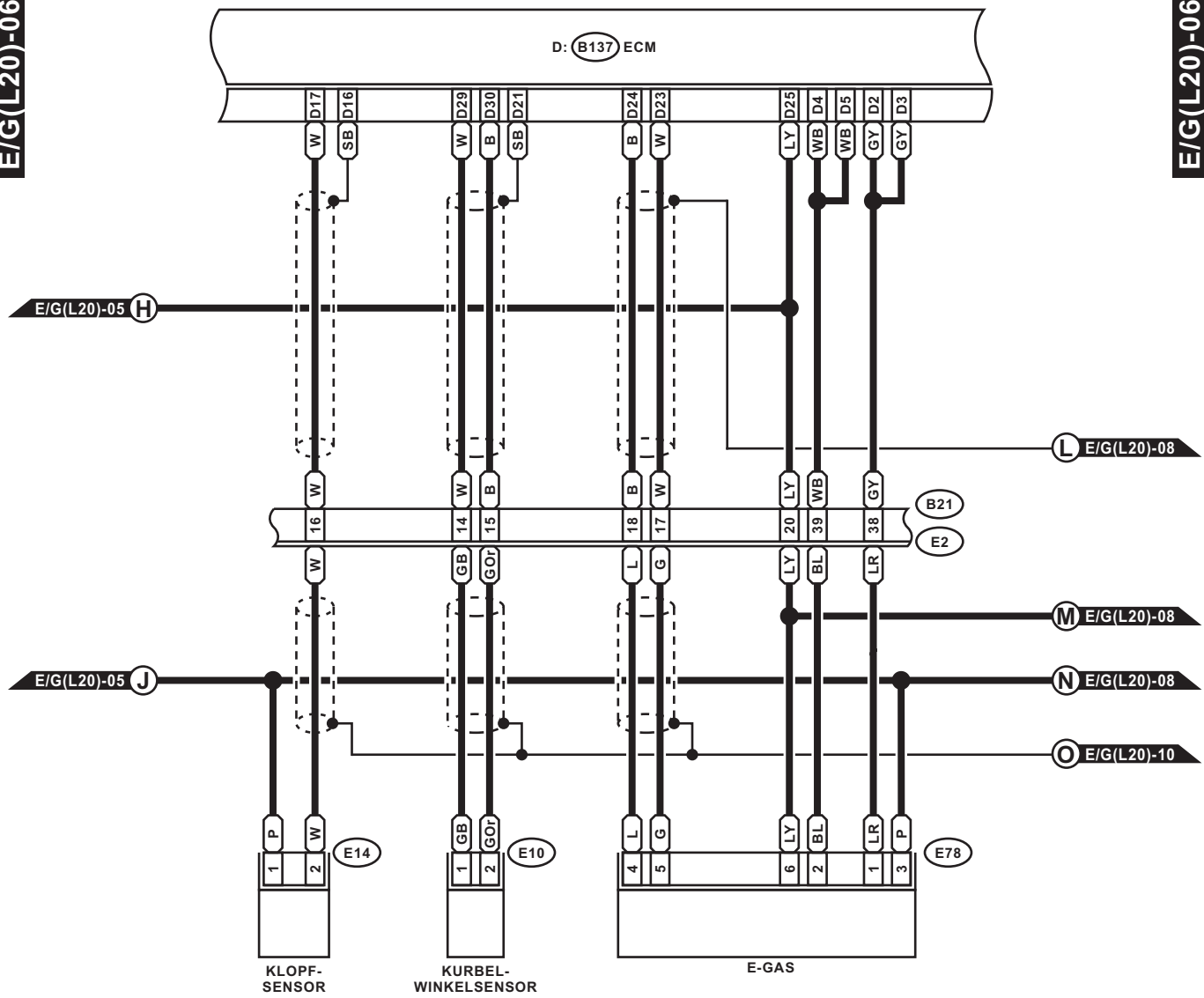

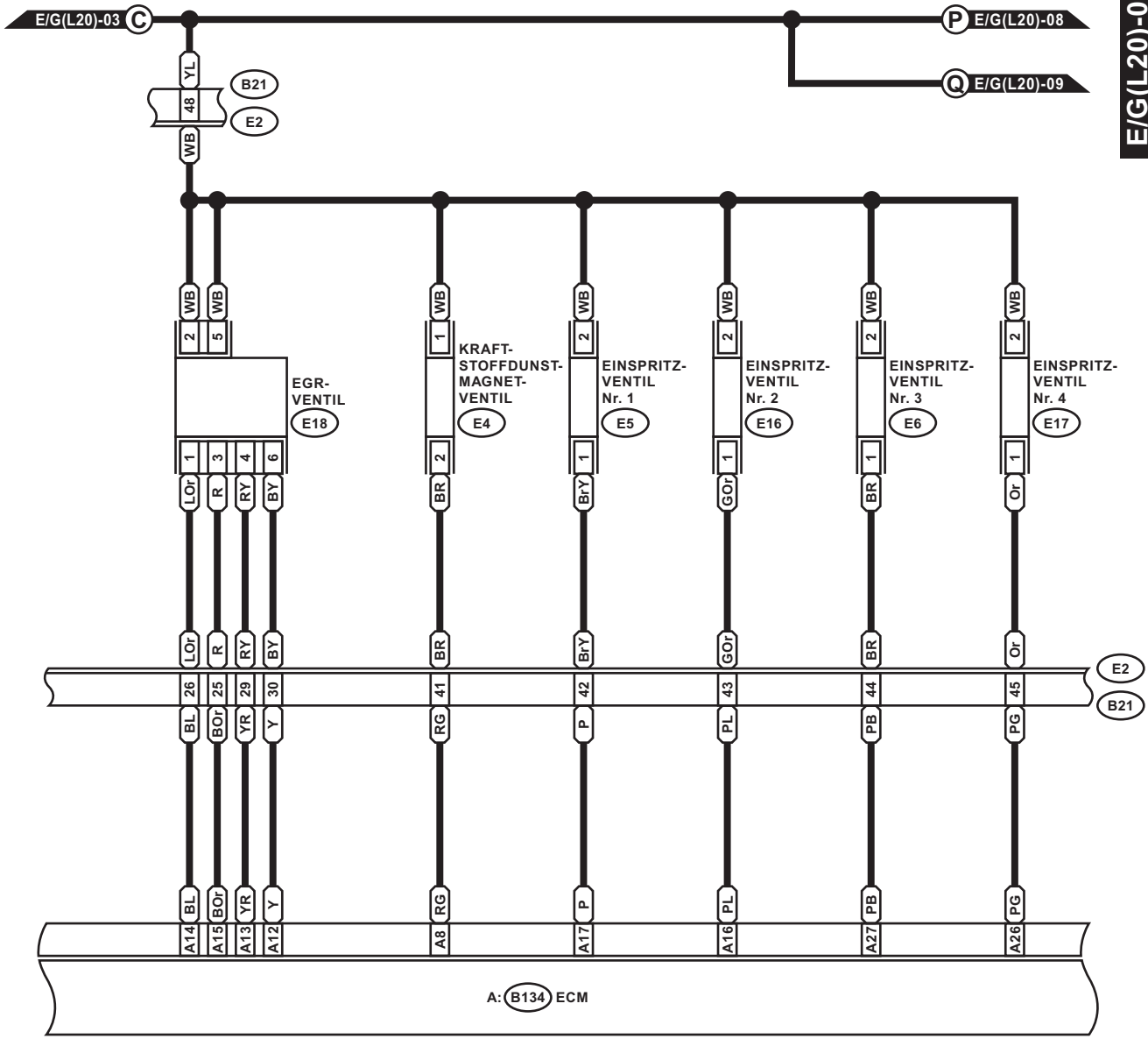

- E4** (SCHWARZ)
- E5** (HELLGRAU)
- E6** (HELLGRAU)
- E16** (HELLGRAU)
- E17** (HELLGRAU)

- E18** (DUNKELGRAU)
- | | | |
|---|---|---|
| 1 | 2 | 3 |
| 4 | 5 | 6 |

- A: B134**
- | | | | | | | | | | |
|----|----|----|----|----|----|----|----|----|----|
| 1 | 2 | 3 | 4 | 5 | 6 | 7 | | | |
| 8 | 9 | 10 | 11 | 12 | 13 | 14 | 15 | 16 | 17 |
| 18 | 19 | 20 | 21 | 22 | 23 | 24 | 25 | 26 | 27 |
| 28 | 29 | 30 | 31 | 32 | | | | 33 | 34 |

- B21** (SCHWARZ)
- | | | | | | | | | | | |
|----|----|----|----|----|----|----|----|----|----|----|
| 1 | 2 | 3 | 4 | 5 | 6 | 7 | 8 | 9 | 10 | 11 |
| 12 | 13 | 14 | 15 | 16 | 17 | 18 | 19 | 20 | 21 | 22 |
| 23 | 24 | 25 | 26 | 27 | 28 | 29 | 30 | 31 | 32 | 33 |
| 34 | 35 | 36 | 37 | 38 | 39 | 40 | 41 | | | |
| 42 | 43 | 44 | 45 | 46 | 47 | | | | | |
| 48 | 49 | 50 | 51 | 52 | 53 | 54 | | | | |

A: B134 C: B136 D: B137 ECM

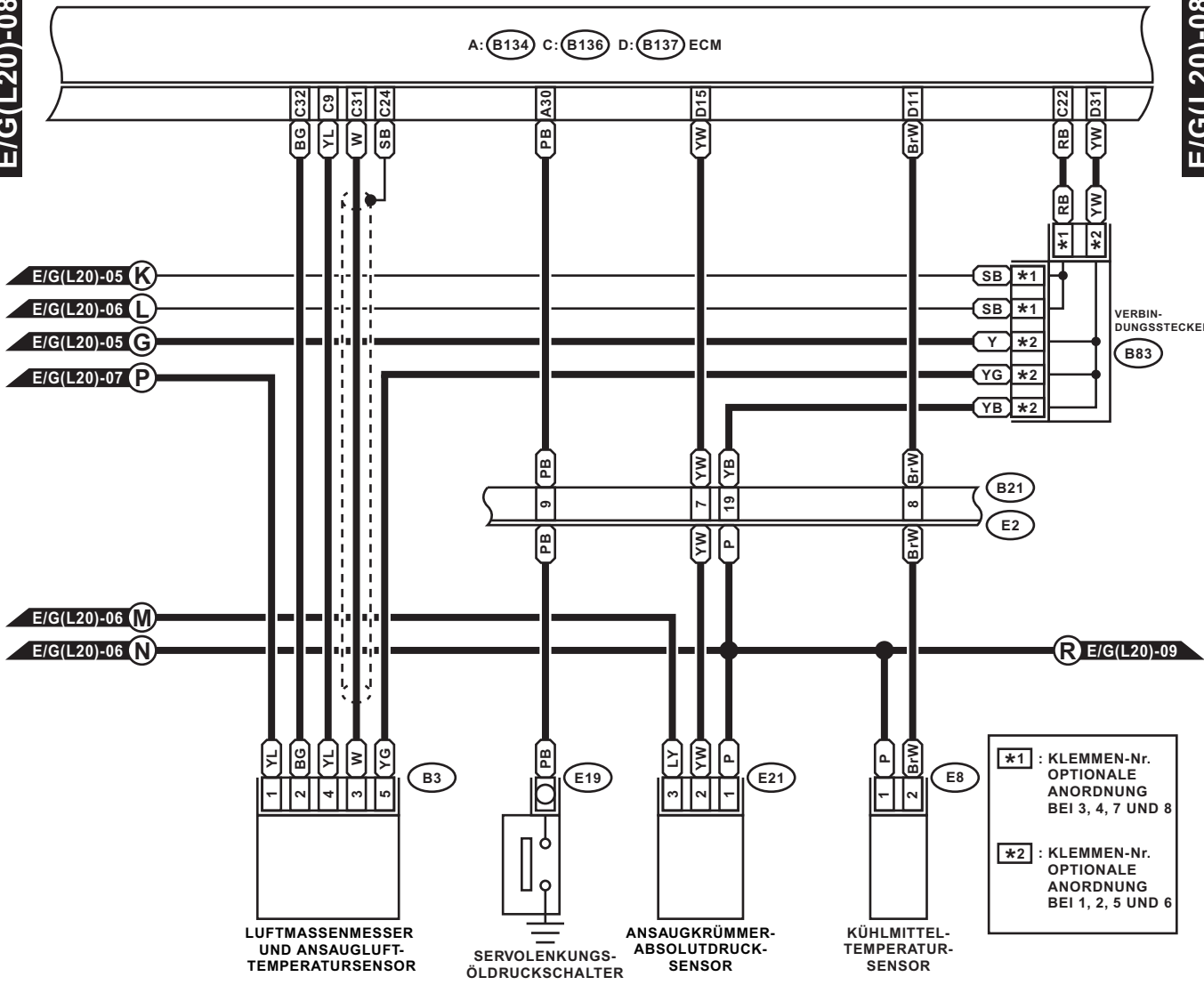

*1 : KLEMMEN-Nr. OPTIONALE ANORDNUNG BEI 3, 4, 7 UND 8
 *2 : KLEMMEN-Nr. OPTIONALE ANORDNUNG BEI 1, 2, 5 UND 6

E8 (SCHWARZ)

1	2
---	---

E21 (SCHWARZ)

1	2	3
---	---	---

B3 (SCHWARZ)

1	2	3	4	5
---	---	---	---	---

B83

1	2	3	4
5	6	7	8

D: B137

1	2	3	4	5	6	7
8	9	10	11	12	13	14
15	16	17	18	19	20	21
22	23	24	25	26	27	28
29	30	31	32	33	34	35

A: B134

1	2	3	4	5	6	7
8	9	10	11	12	13	14
15	16	17	18	19	20	21
22	23	24	25	26	27	28
29	30	31	32	33	34	35

C: B136

1	2	3	4	5	6
7	8	9	10	11	12
13	14	15	16	17	18
19	20	21	22	23	24
25	26	27	28	29	30
31	32	33	34	35	

B21 (SCHWARZ)

1	2	3	4	5	6	7	8	9	10	11
12	13	14	15	16	17	18	19	20	21	22
23	24	25	26	27	28	29	30	31	32	33
34	35	36	37	38	39	40	41			
42	43	44	45	46	47					
48	49	50	51	52	53	54				

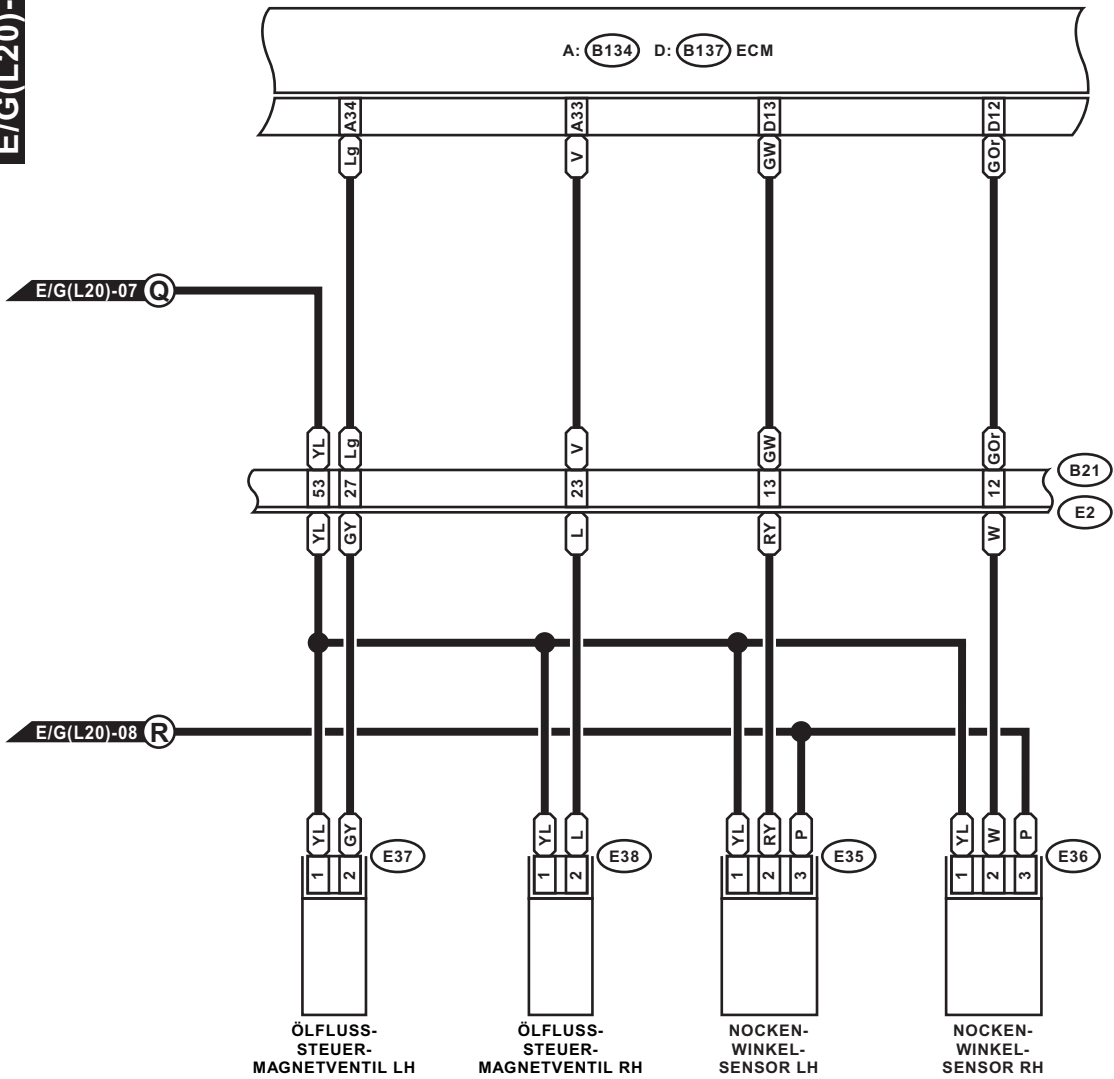

E37 (BLAU)

E35 (GRAU)

D: B137

A: B134

B21 (SCHWARZ)

E38 (BLAU)

E36 (GRAU)

1	2	3	4	5	6	7
8	9	10	11	12	13	14
15	16	17	18	19	20	21
22	23	24	25	26	27	28
29	30	31	32	33	34	

1	2	3	4	5	6	7
8	9	10	11	12	13	14
15	16	17	18	19	20	21
22	23	24	25	26	27	28
29	30	31	32	33	34	

1	2	3	4	5	6	7	8	9	10	11
12	13	14	15	16	17	18	19	20	21	22
23	24	25	26	27	28	29	30	31	32	33
34	35	36	37	38	39	40	41			
42	43	44	45	46	47					
48	49	50	51	52	53	54				

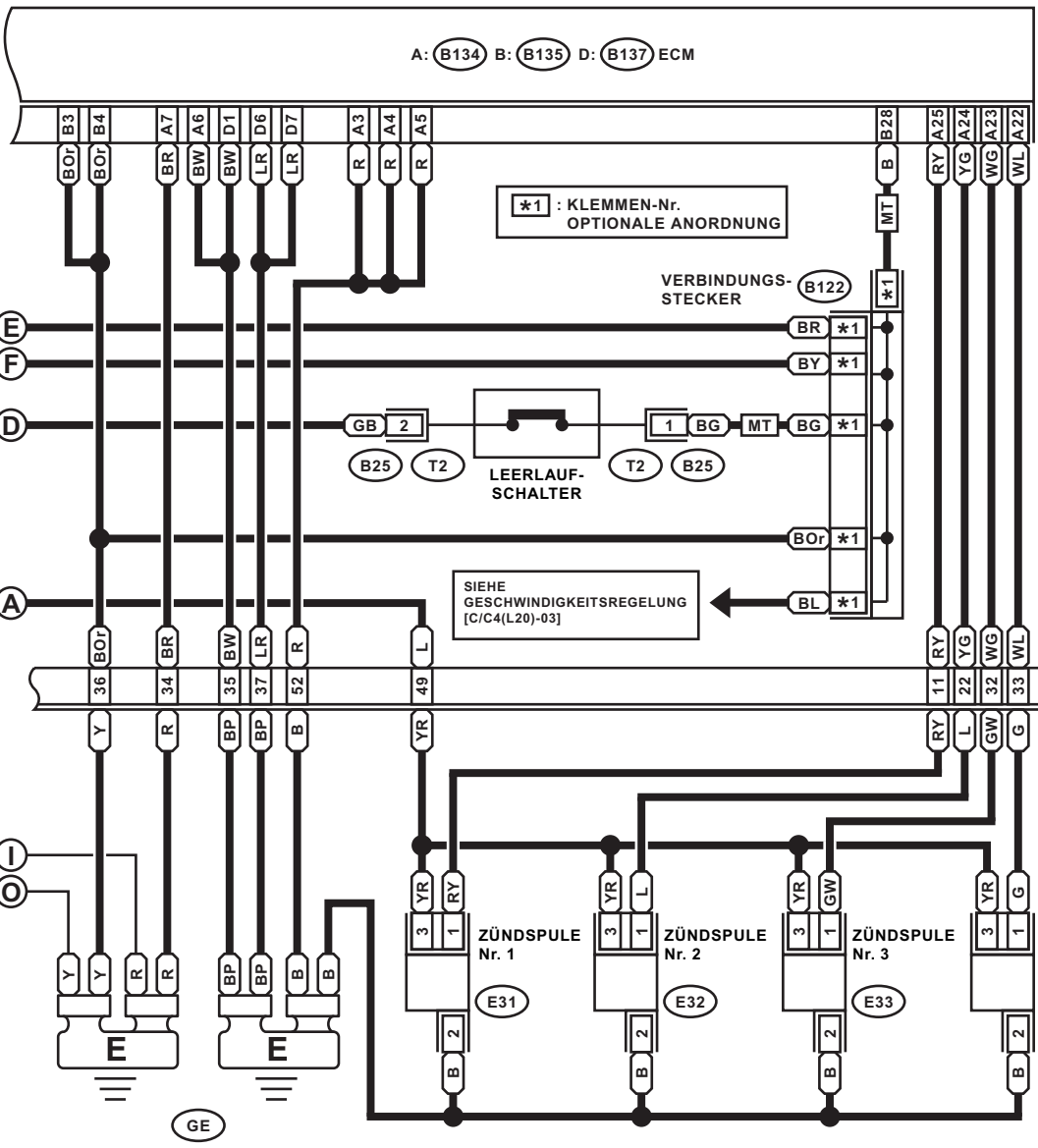

B25 (BRAUN)

1	2
---	---

E31 (SCHWARZ) E33 (SCHWARZ)

1	2	3	4
5	6	7	8

B122

1	2	3	4
5	6	7	8

D: (B137)

1	2	3	4	5	6	7
8	9	10	11	12	13	14
15	16	17	18	19	20	21
22	23	24	25	26	27	28
29	30	31	32	33	34	35

B21 (SCHWARZ)

1	2	3	4	5	6	7	8	9	10	11
12	13	14	15	16	17	18	19	20	21	22
23	24	25	26	27	28	29	30	31	32	33
34	35	36	37	38	39	40	41	42	43	44
45	46	47	48	49	50	51	52	53	54	55

A: (B134)

1	2	3	4	5	6	7
8	9	10	11	12	13	14
15	16	17	18	19	20	21
22	23	24	25	26	27	28
29	30	31	32	33	34	35

B: (B135)

1	2	3	4	5	6	7
8	9	10	11	12	13	14
15	16	17	18	19	20	21
22	23	24	25	26	27	28
29	30	31	32	33	34	35

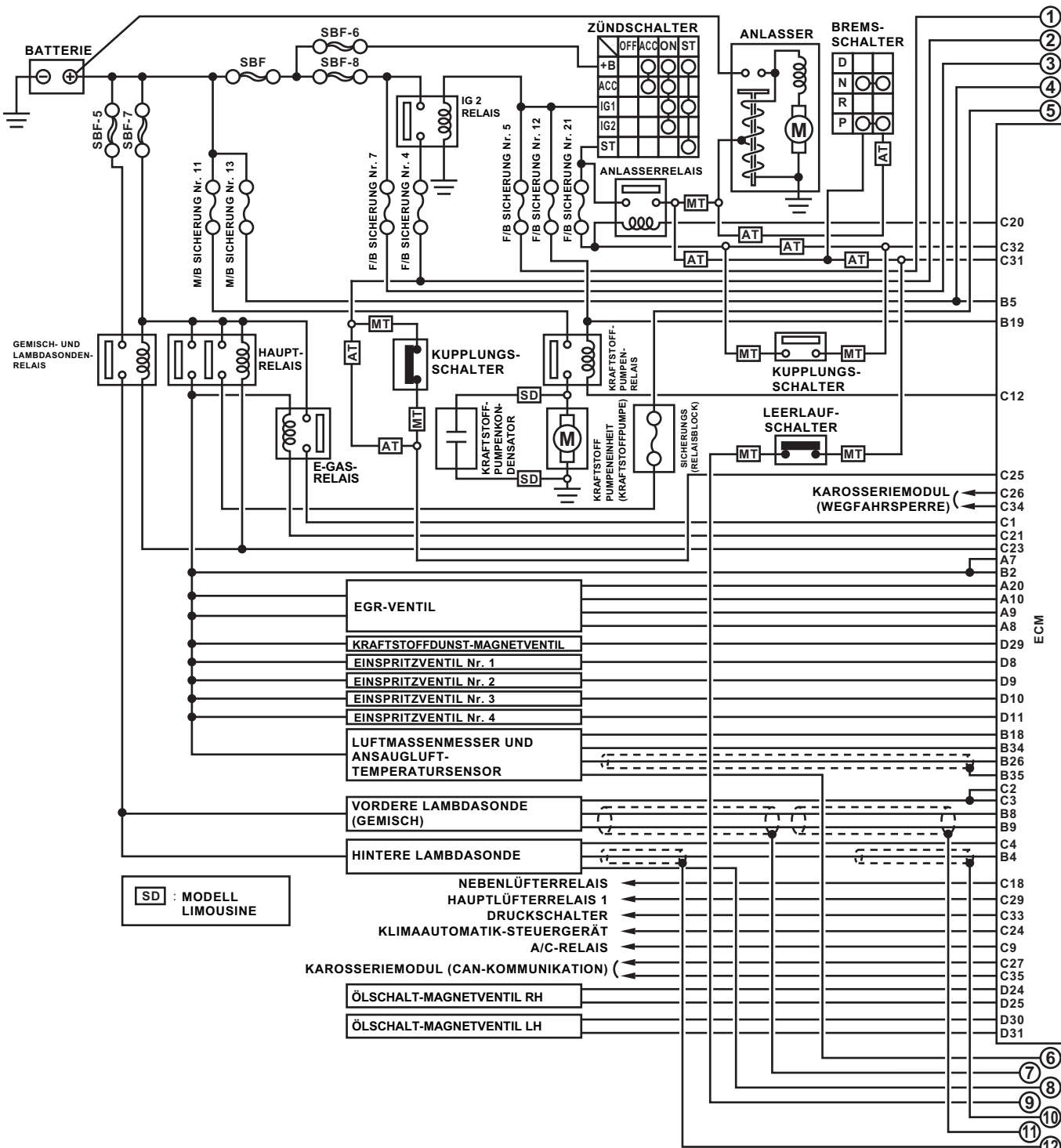

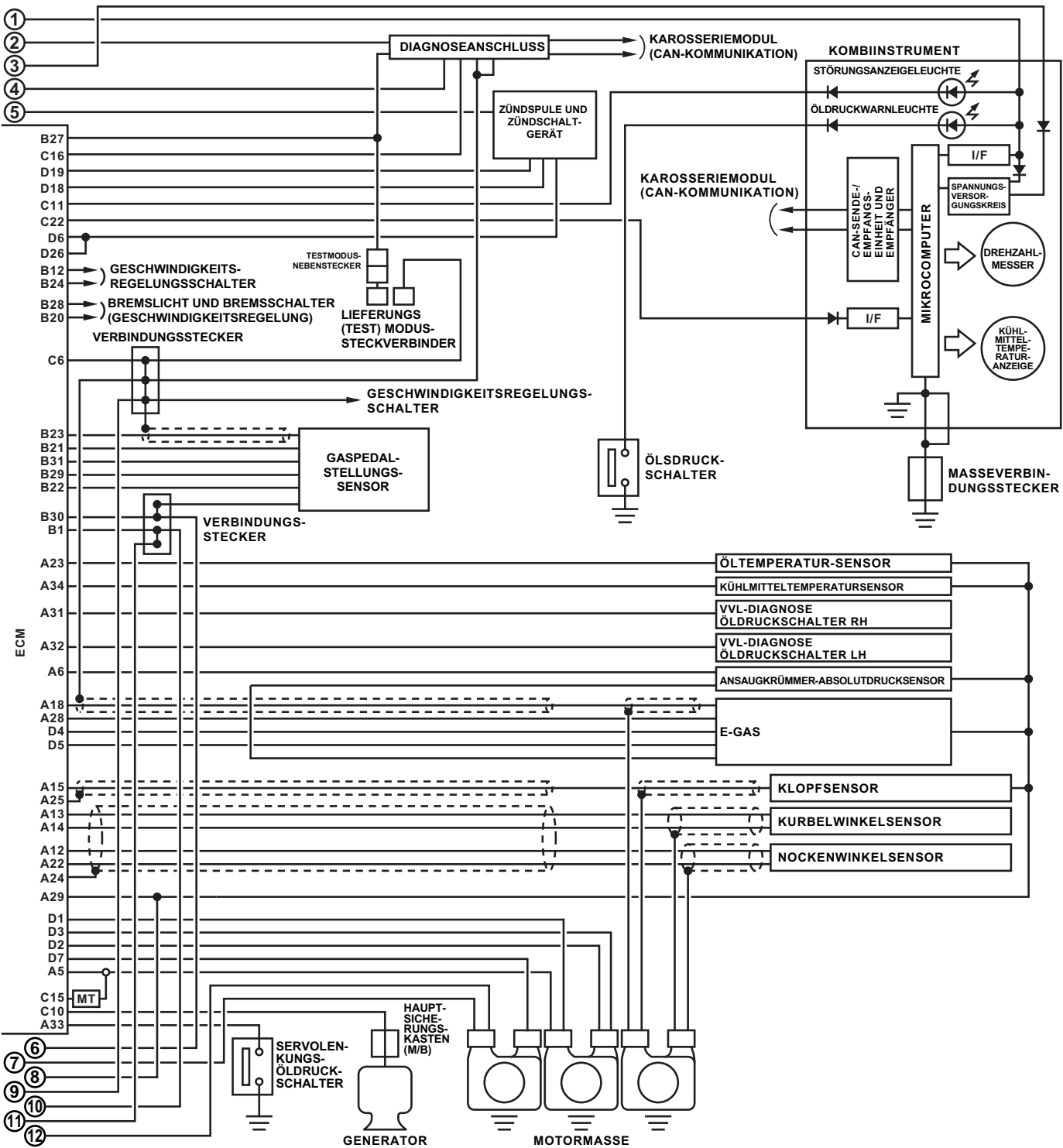

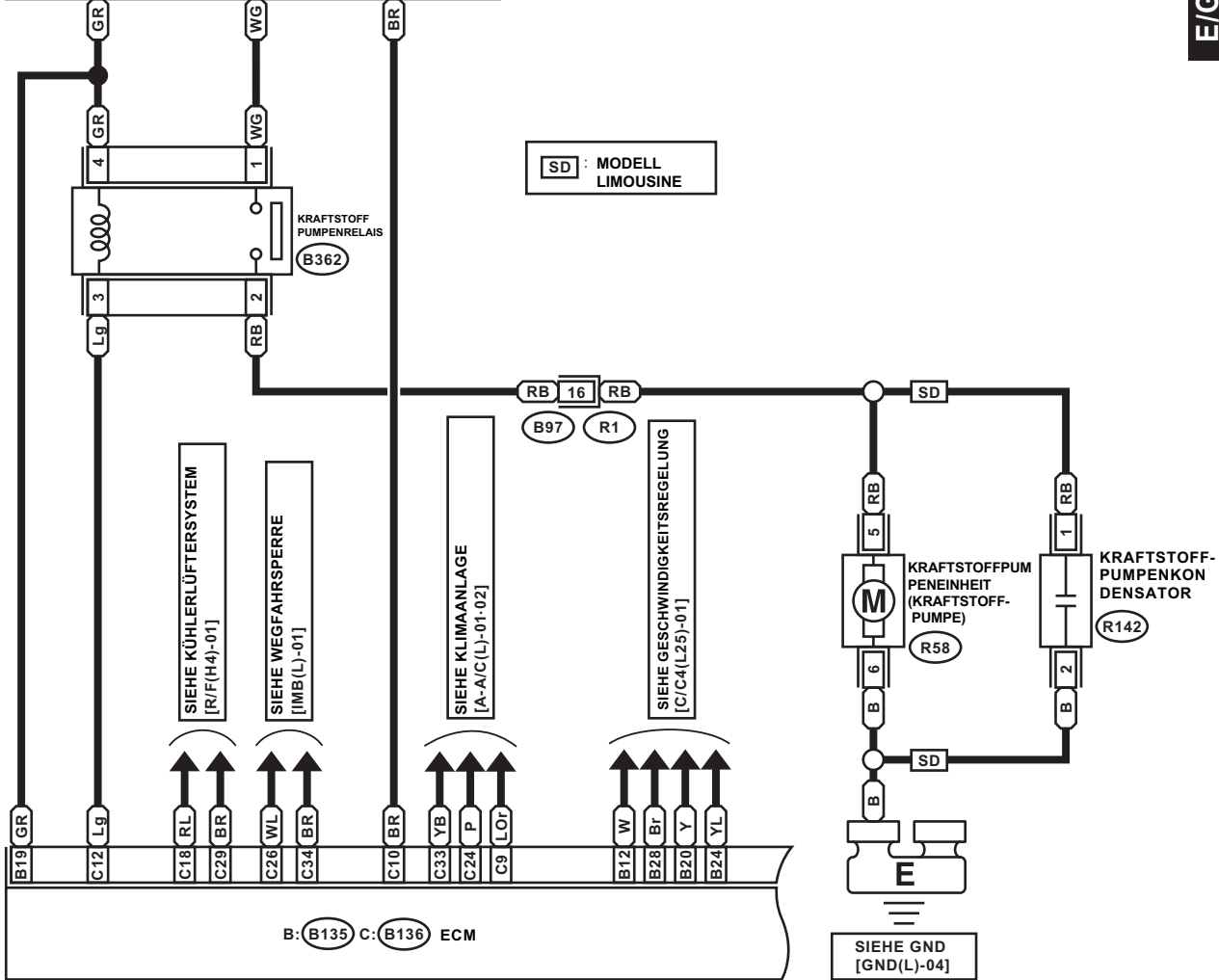
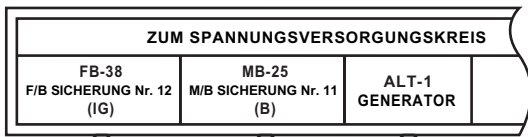

- R142 (SCHWARZ)
- R58 (GRAU)
- B362 (SCHWARZ)
- B97
- B: B135
- C: B136

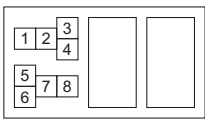

RELAISHALTER

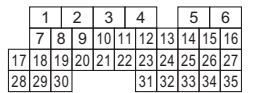
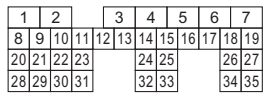
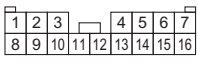

ZUM SPANNUNGSVERSORGUNGSKREIS

ST-1
F/B SICHERUNG
Nr. 21 (ST)

ST-2
IG SW
(ST)

MB-24
SBF-7
(B)

MB-23
SBF-7
(B)

MB-22
SBF-5
(B)

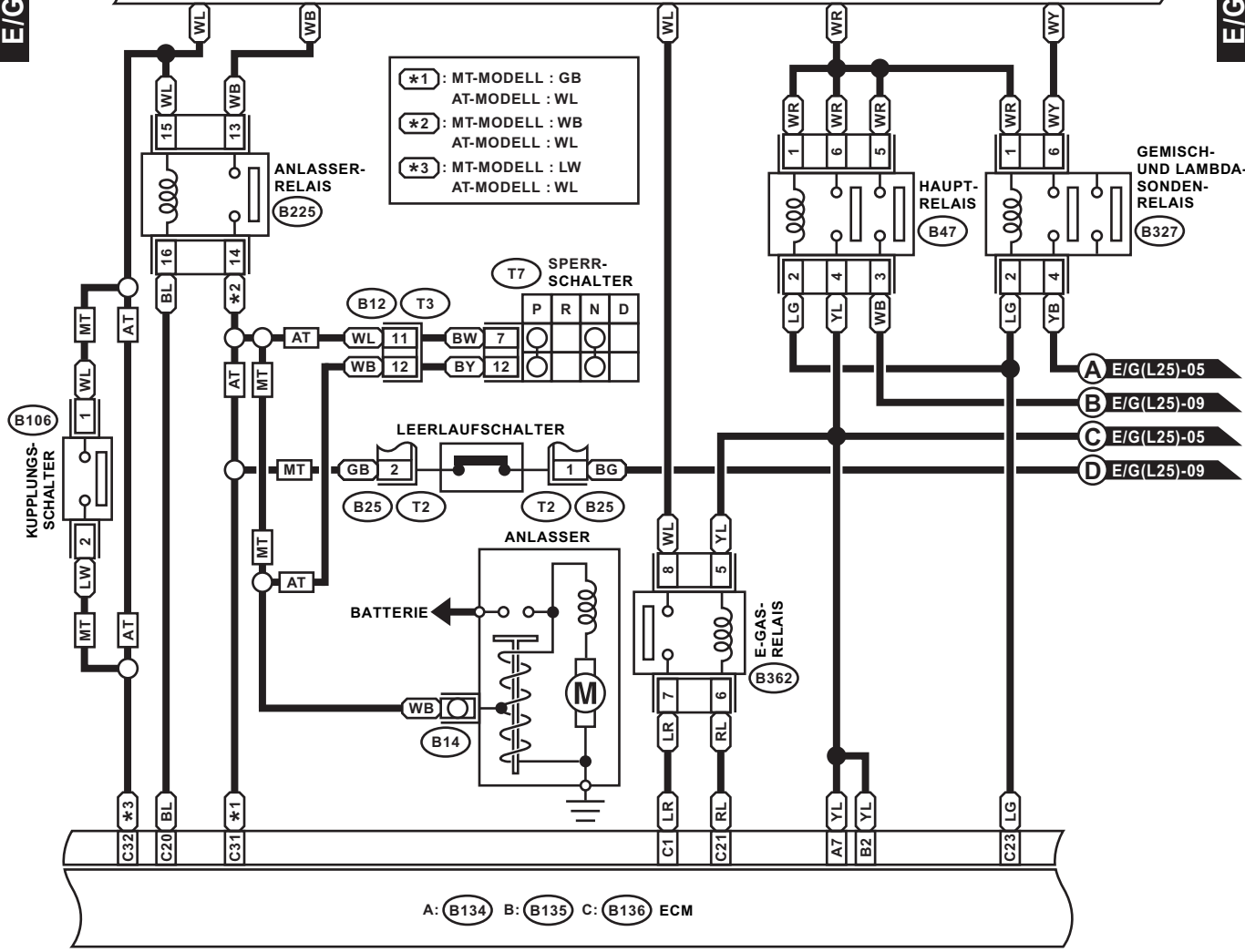

Component Pinouts:

- B25 (BRAUN):** 1 2
- B106:** 1 2
- B47 (BRAUN):** 1 2
- B327 (BRAUN):** 1 2, 3 4, 5 6
- B362 (SCHWARZ):** 1 2 3, 4, 5 6 7 8
- B12 (GRAU):** 1 2 3 4, 5 6 7 8, 9 10 11 12
- T7 (SCHWARZ):** 1 2 3 4 5 6, 7 8 9 10 11 12
- B225 (SCHWARZ):** 1 2, 3 4, 5 6, 7 8, 9 10, 11 12, 13 14, 15 16, 17 18, 19 20, 21 22, 23 24, 25 26, 27 28, 29 30, 31 32, 33 34, 35 36, 37 38, 39 40

Relay Blocks:

- A: B134:** 1 2 3 4 5 6 7, 8 9 10 11 12, 13 14 15 16 17 18 19 20 21 22 23, 24 25 26 27, 28 29 30 31 32, 33 34
- B: B135:** 1 2, 3 4 5 6 7, 8 9 10 11 12, 13 14 15 16 17 18 19 20 21 22 23, 24 25 26 27, 28 29 30 31, 32 33, 34 35
- C: B136:** 1 2 3 4, 5 6, 7 8 9 10 11 12, 13 14 15 16, 17 18 19 20 21 22 23 24 25 26 27, 28 29 30, 31 32 33 34 35

RELAISHALTER: 1 2 3, 4, 5 6 7 8

RELAISBLOCK: 1 2, 3 4, 5 6, 7 8, 9 10, 11 12, 13 14, 15 16, 17 18, 19 20, 21 22, 23 24, 25 26, 27 28, 29 30, 31 32, 33 34, 35 36, 37 38, 39 40

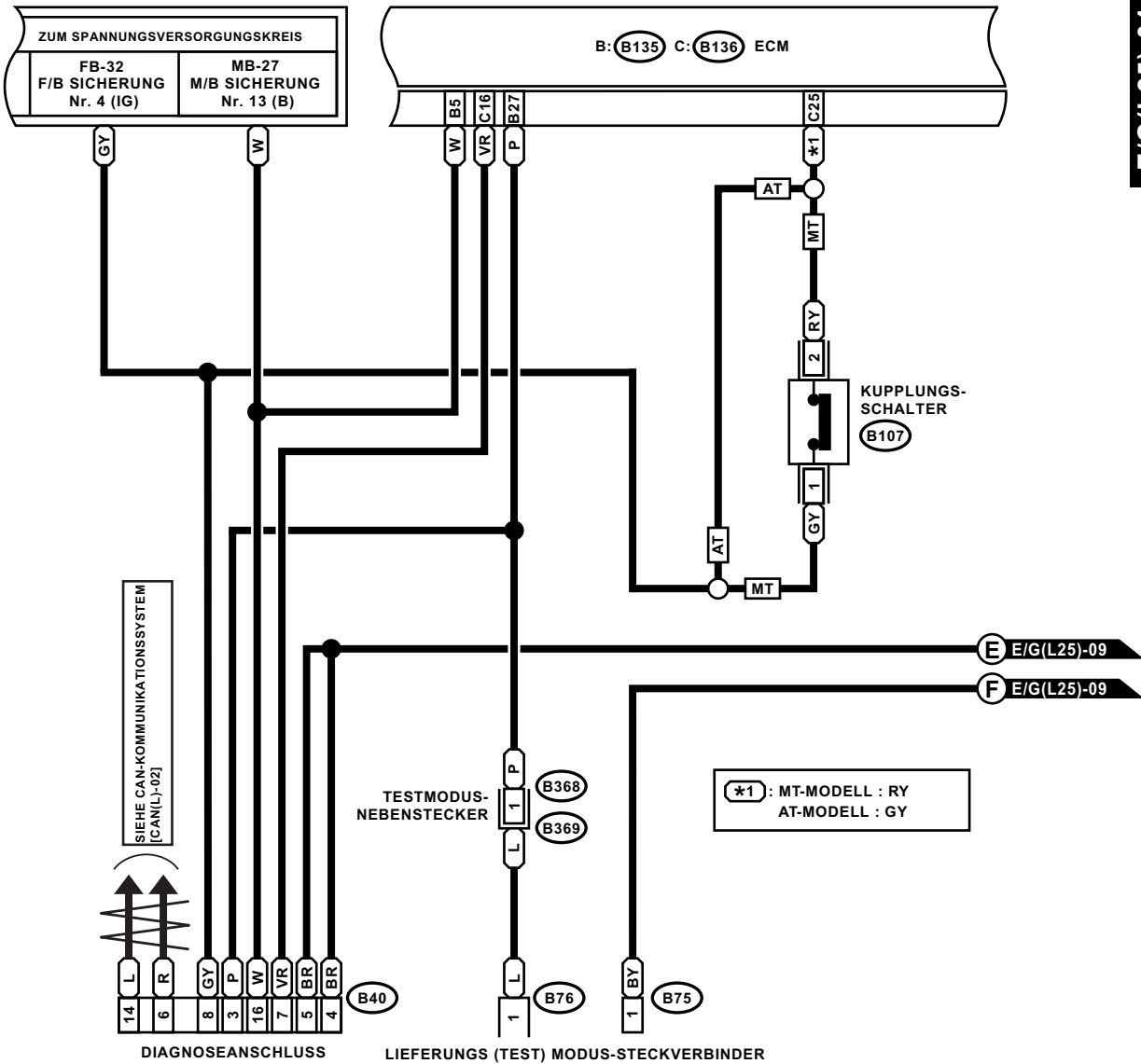

(B75) (GRÜN)

(B76) (GRÜN)

(B107) (BLAU)

(B40) (SCHWARZ)

B: (B135)

C: (B136)

(B368) (GRÜN)

(B369) (GRÜN)

1 2

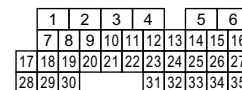
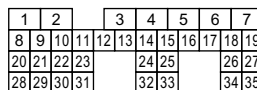
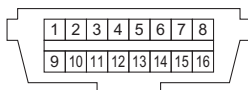

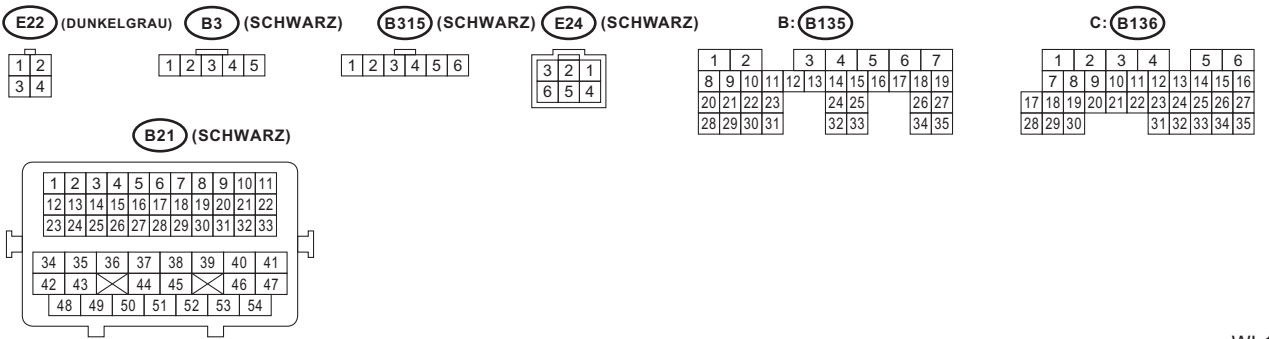
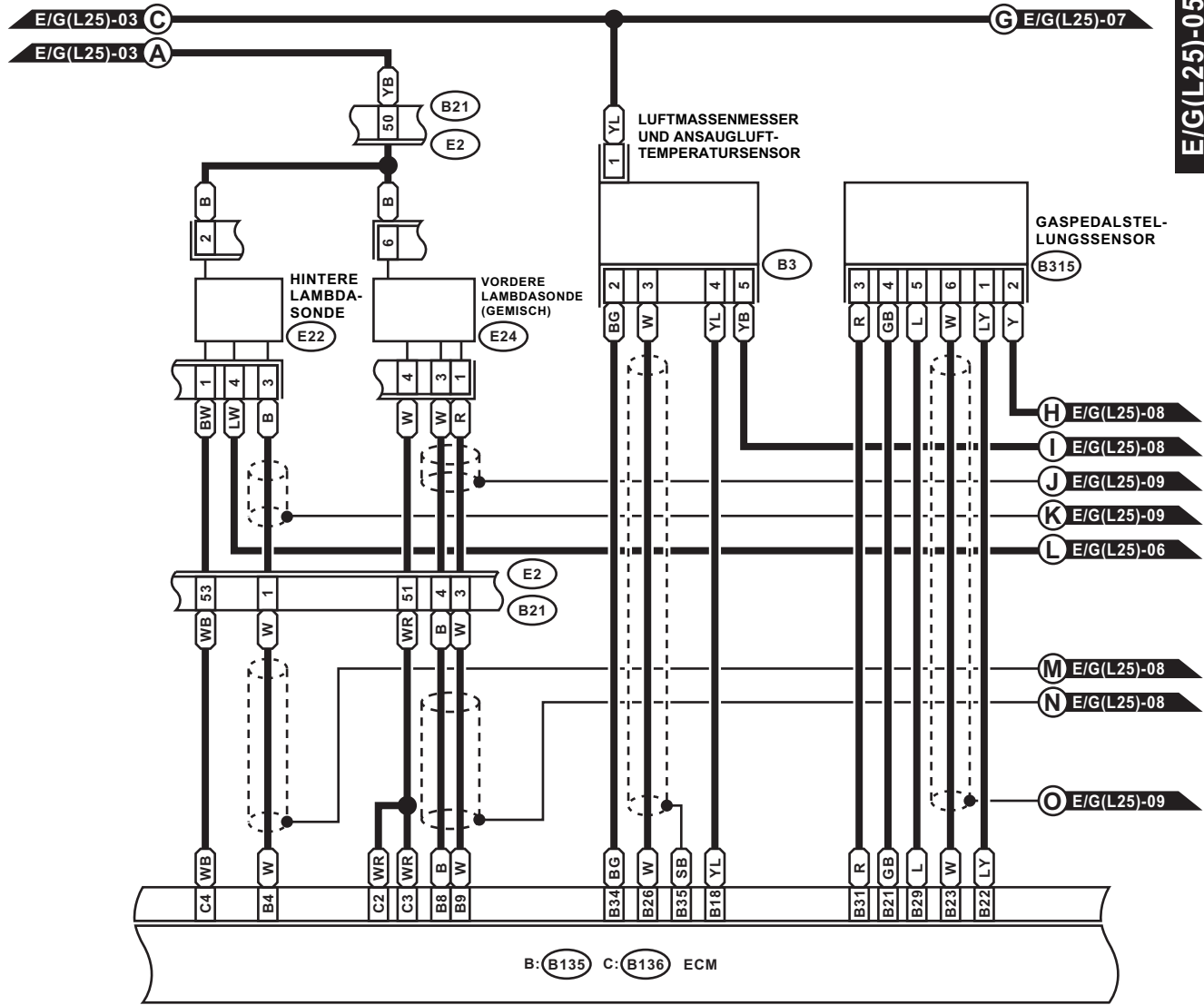

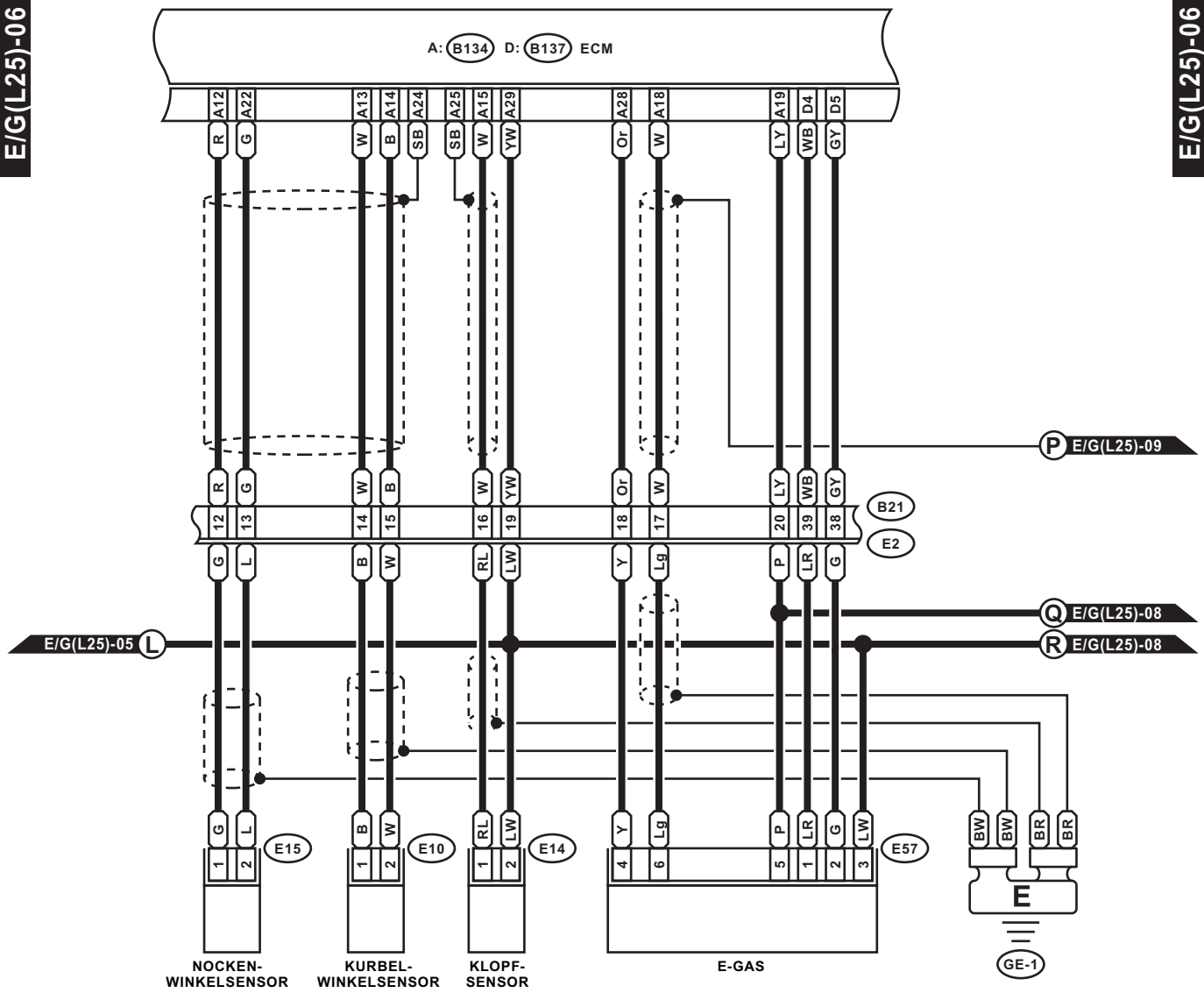

E10 (HELLGRAU)

E57 (SCHWARZ)

D: **B137**

A: **B134**

E14 (GRAU)

1	2	3	4	5	6
---	---	---	---	---	---

1	2	3	4	5	6	7
8	9	10	11	12	13	14
15	16	17	18	19	20	21
22	23	24	25	26	27	
		28	29	30	31	

1	2	3	4	5	6	7
8	9	10	11	12	13	14
15	16	17	18	19	20	21
22	23	24	25	26	27	
		28	29	30	31	
				32	33	34

E15 (GRAU)

1	2
---	---

B21 (SCHWARZ)

1	2	3	4	5	6	7	8	9	10	11
12	13	14	15	16	17	18	19	20	21	22
23	24	25	26	27	28	29	30	31	32	33
34	35	36	37	38	39	40	41			
42	43	44	45	46	47					
48	49	50	51	52	53	54				

E/G(L25)-05

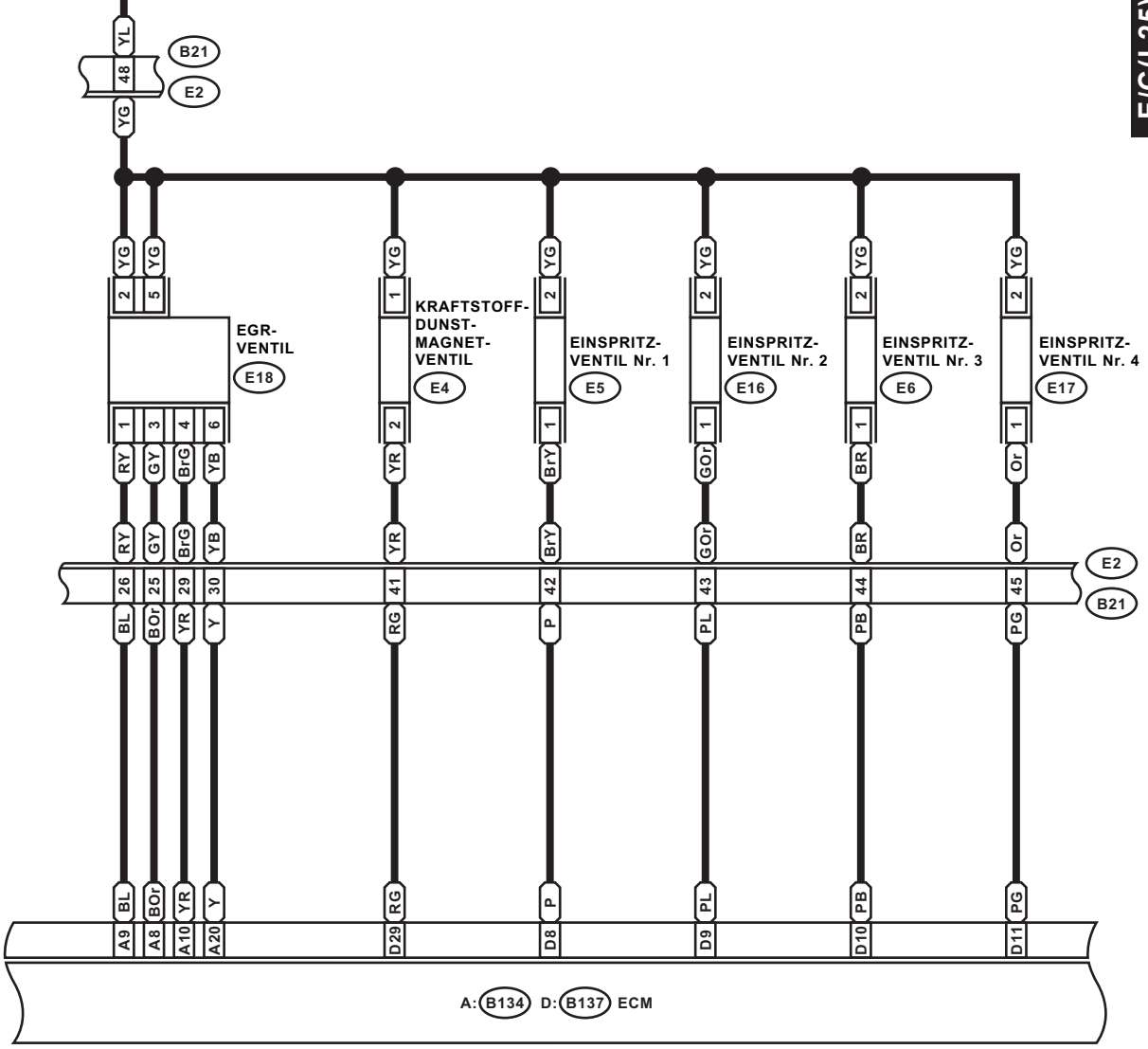

E4 (SCHWARZ) (DUNKELGRAU) E5 (DUNKELGRAU) E16 (DUNKELGRAU) E18 (DUNKELGRAU) D: B137 B21 (SCHWARZ)



A: B134

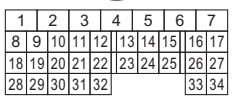

A: B134 B: B135 D: B137 ECM

E/G(L25)-05 **H**
 E/G(L25)-05 **I**
 E/G(L25)-05 **M**
 E/G(L25)-05 **N**

E/G(L25)-06 **Q**
 E/G(L25)-06 **R**

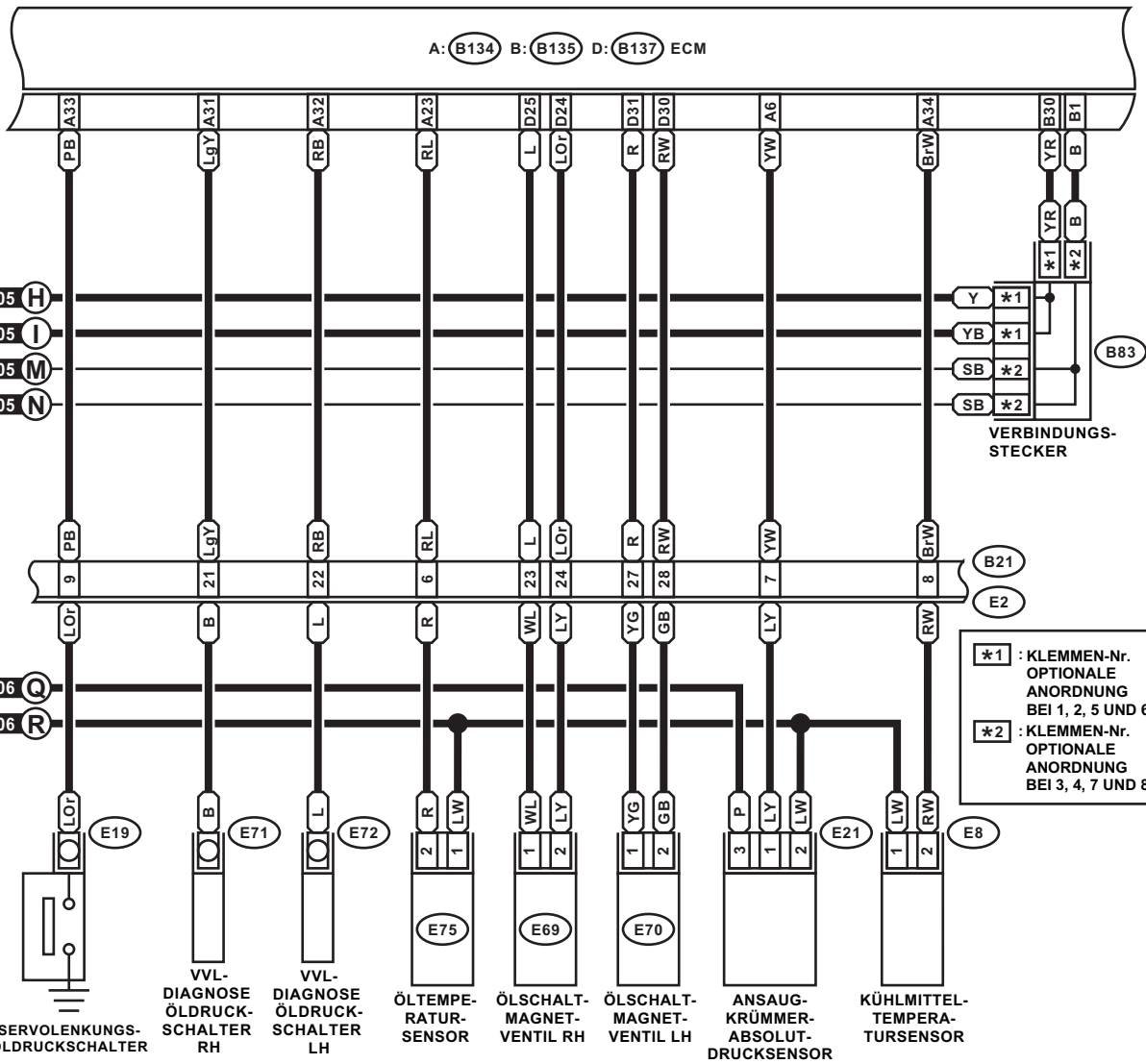

***1** : KLEMMEN-Nr. OPTIONALE ANORDNUNG BEI 1, 2, 5 UND 6
***2** : KLEMMEN-Nr. OPTIONALE ANORDNUNG BEI 3, 4, 7 UND 8

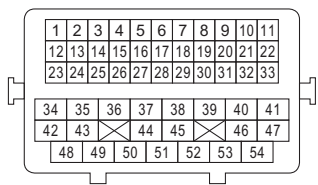
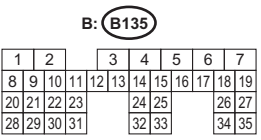
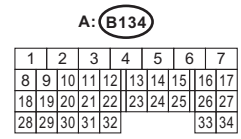
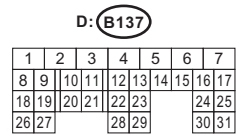
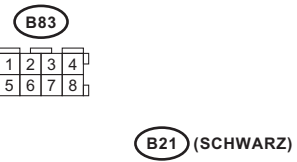
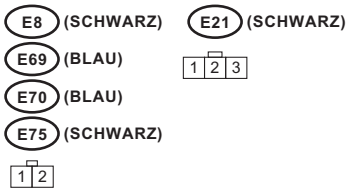
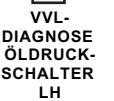

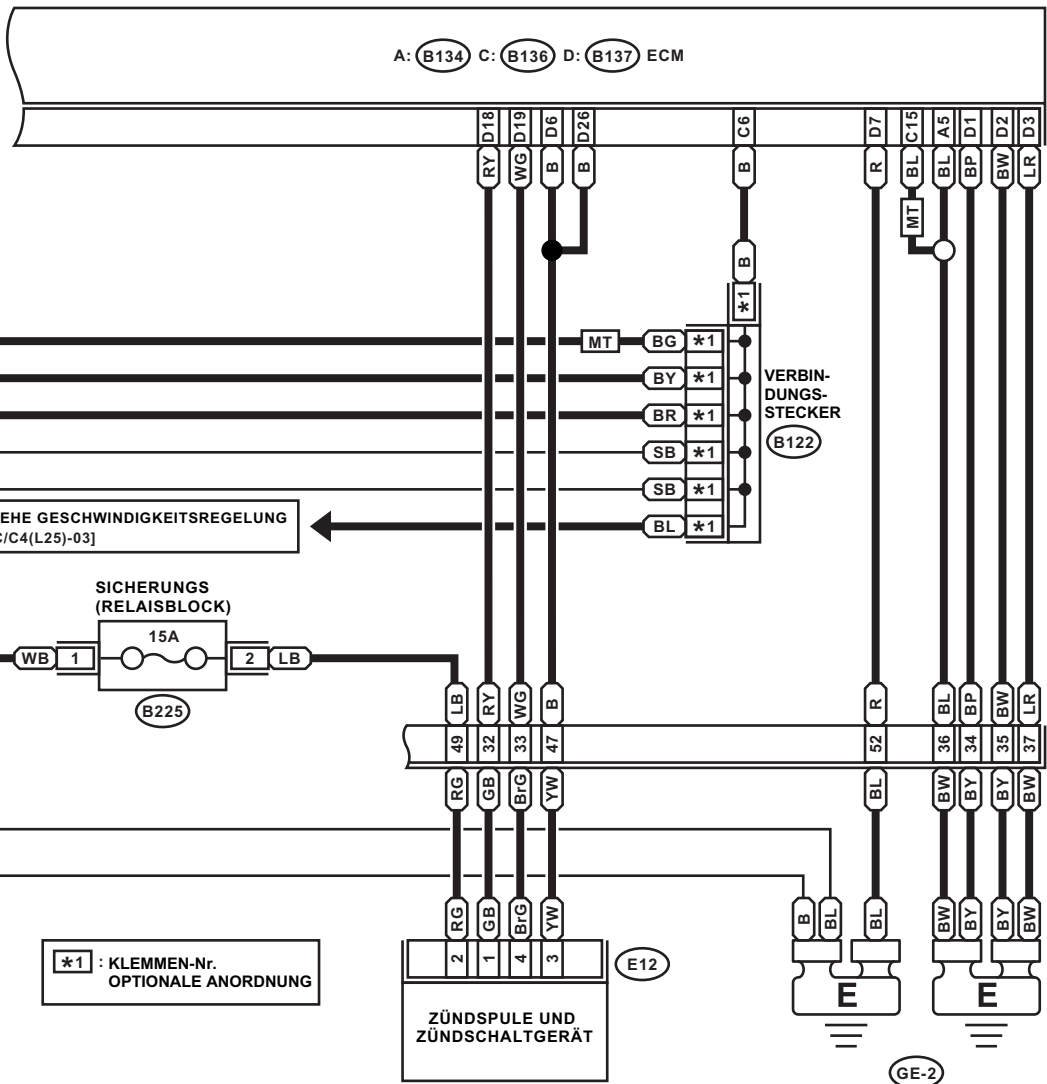

SIEHE GESCHWINDIGKEITSREGELUNG
[C/C4(L25)-03]

*1 : KLEMMEN-Nr.
OPTIONALE ANORDNUNG

E12 (DUNKELGRAU) B122

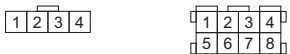

D: B137

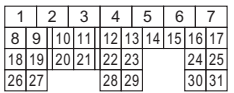

A: B134

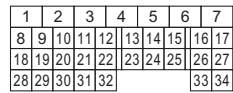

B21 (SCHWARZ)

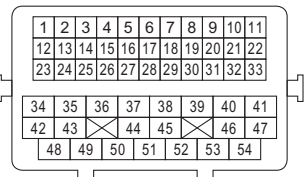

B225 (SCHWARZ)

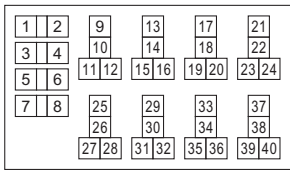

C: B136

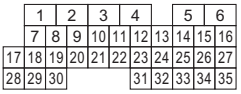

RELAISBLOCK

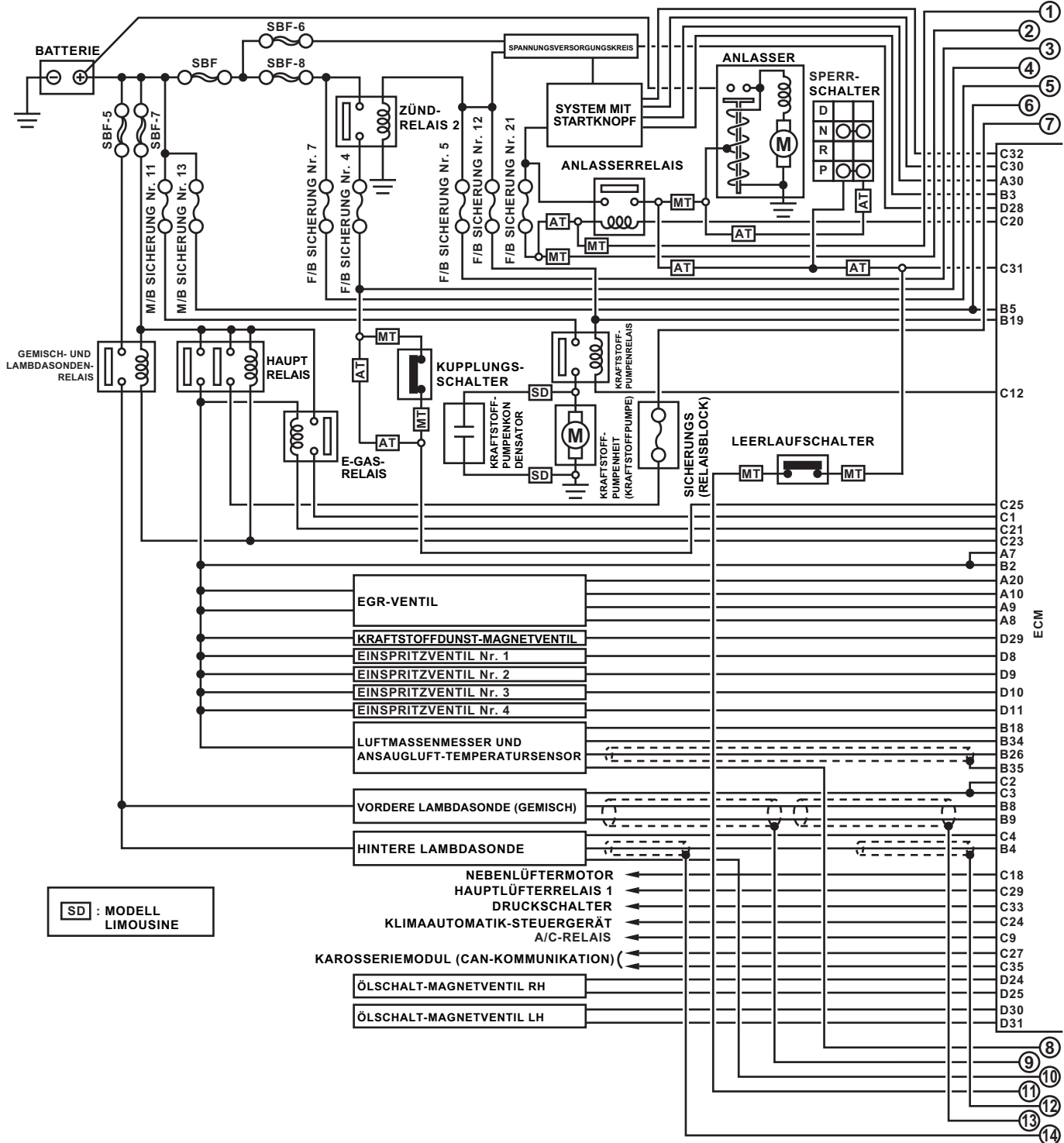

SD : MODELL LIMOUSINE

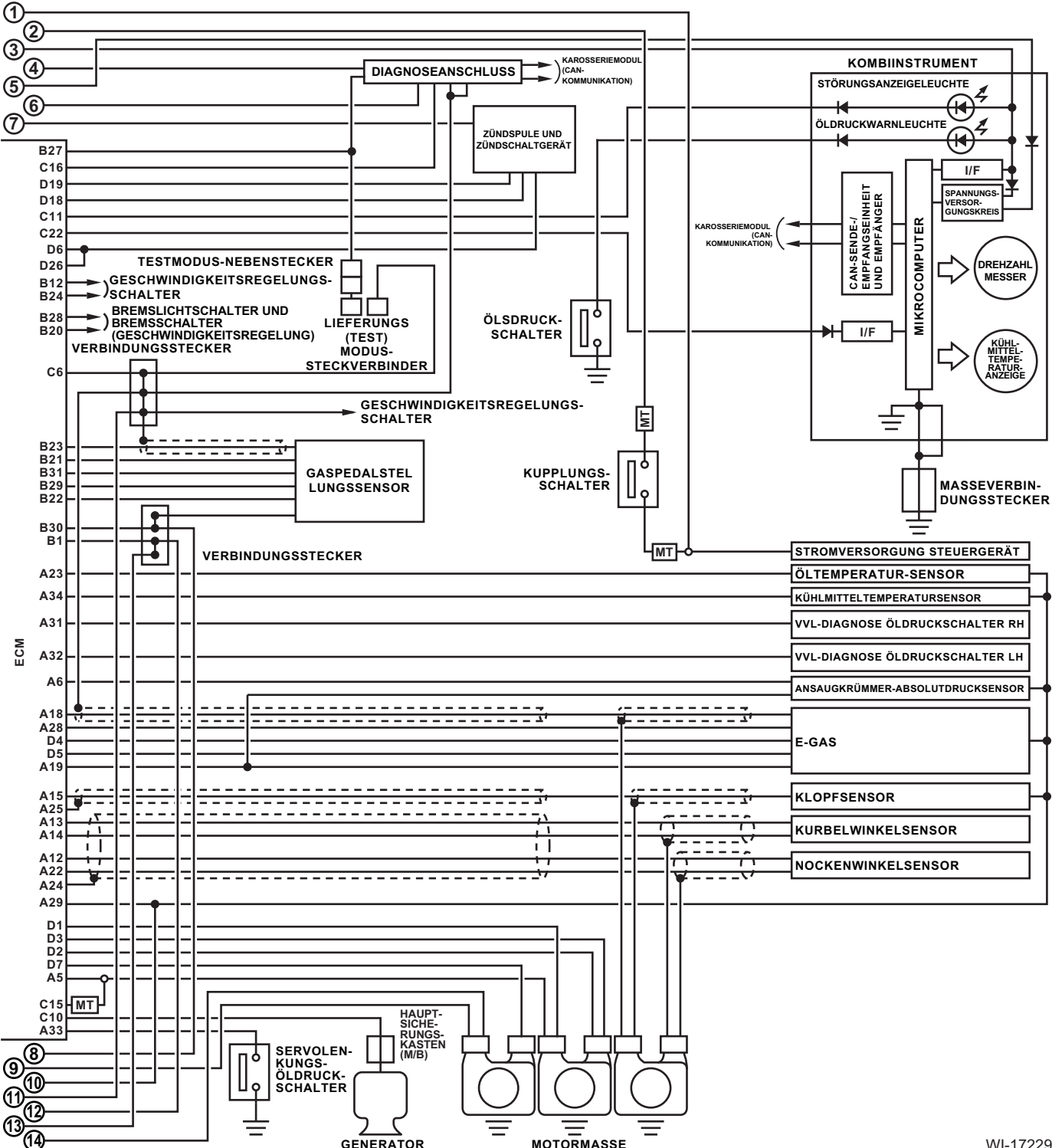

- ①
- ②
- ③
- ④
- ⑤
- ⑥
- ⑦
- B27
- C16
- D18
- C11
- C22
- D6
- D26
- B12
- B24
- B28
- B20
- C6
- B23
- B21
- B31
- B29
- B22
- B30
- B1
- A23
- A34
- A31
- A32
- A6
- A18
- A28
- D4
- D5
- A19
- A15
- A25
- A13
- A14
- A12
- A22
- A24
- A29
- D1
- D3
- D2
- D7
- A5
- C15
- C10
- A33
- ⑧
- ⑨
- ⑩
- ⑪
- ⑫
- ⑬
- ⑭

DIAGNOSEANSCHLUSS

KAROSSERIEMODUL (CAN-KOMMUNIKATION)

ZÜNDSPULE UND ZÜNDSCHALTGERÄT

KOMBIINSTRUMENT

STÖRUNGSANZEIGELEUCHE

ÖLDRUCKWARNLEUCHE

I/F

SPANNUNGSVERSORGUNGSKREIS

CAN-SENDE-/EMPFANGSEINHEIT UND EMPFÄNGER

MIKROCOMPUTER

I/F

DREHZAHLMESSER

KÜHLMITTELTEMPERATURANZEIGE

MASSEVERBINDUNGSSTECKER

KAROSSERIEMODUL (CAN-KOMMUNIKATION)

TESTMODUS-NEBENSTECKER

GESCHWINDIGKEITSREGELUNGS-SCHALTER

BREMSSCHALTER UND BREMSSCHALTER (GESCHWINDIGKEITSREGELUNG) VERBINDUNGSSTECKER

LIEFERUNGS (TEST) MODUS-STECKERVERBINDER

ÖLDRUCK-SCHALTER

GESCHWINDIGKEITSREGELUNGS-SCHALTER

GASPEDALSTEL LUNGSSENSOR

KUPPLUNGS-SCHALTER

VERBINDUNGSSTECKER

STROMVERSORGUNG STEUERGERÄT

ÖLTEMPERATUR-SENSOR

KÜHLMITTELTEMPERATURSENSOR

VVL-DIAGNOSE ÖLDRUCKSCHALTER RH

VVL-DIAGNOSE ÖLDRUCKSCHALTER LH

ANSAUGKRÜMMER-ABSOLUTDRUCKSENSOR

E-GAS

KLOPFSENSOR

KURBELWINKELSENSOR

NOCKENWINKELSENSOR

SERVOLENKUNGS-ÖLDRUCK-SCHALTER

HAUPT-SICHERUNGS-KASTEN (M/B)

GENERATOR

MOTORMASSE

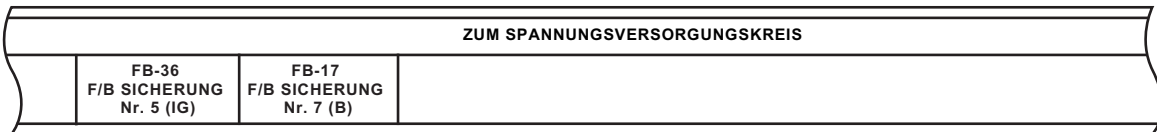

*1 : KLEMMEN-Nr. OPTIONALE ANORDNUNG BEI 1, 2, 3, 4, 5 UND 6

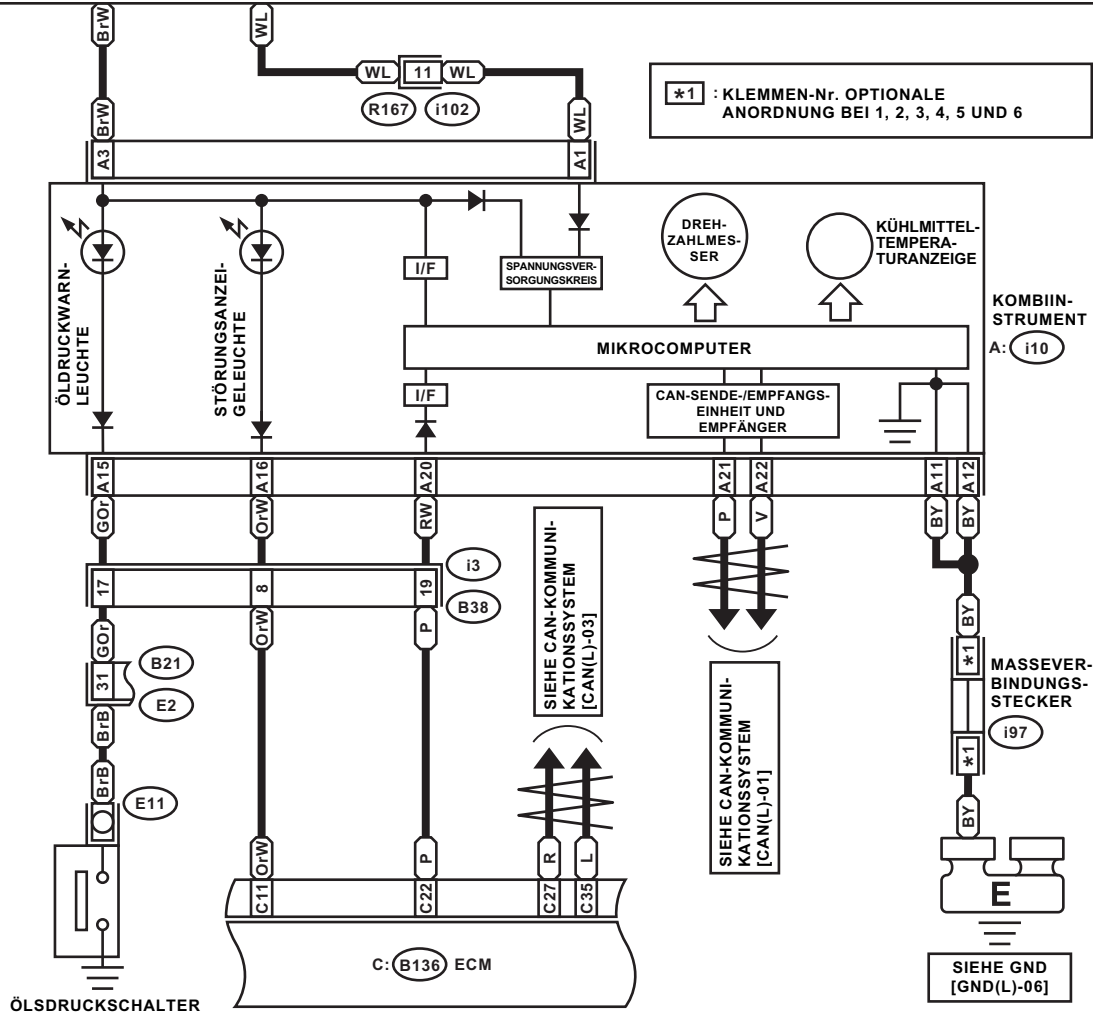

KOMBIN-STRUMENT
A: i10

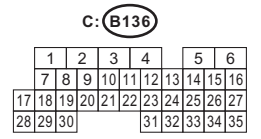
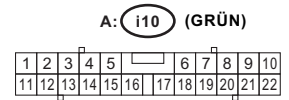
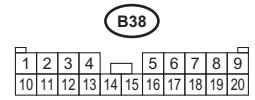
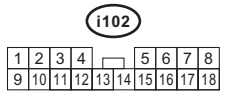
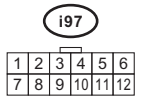

B21 (SCHWARZ)

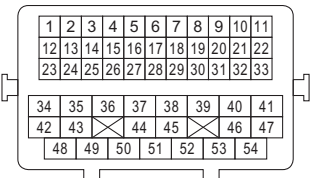

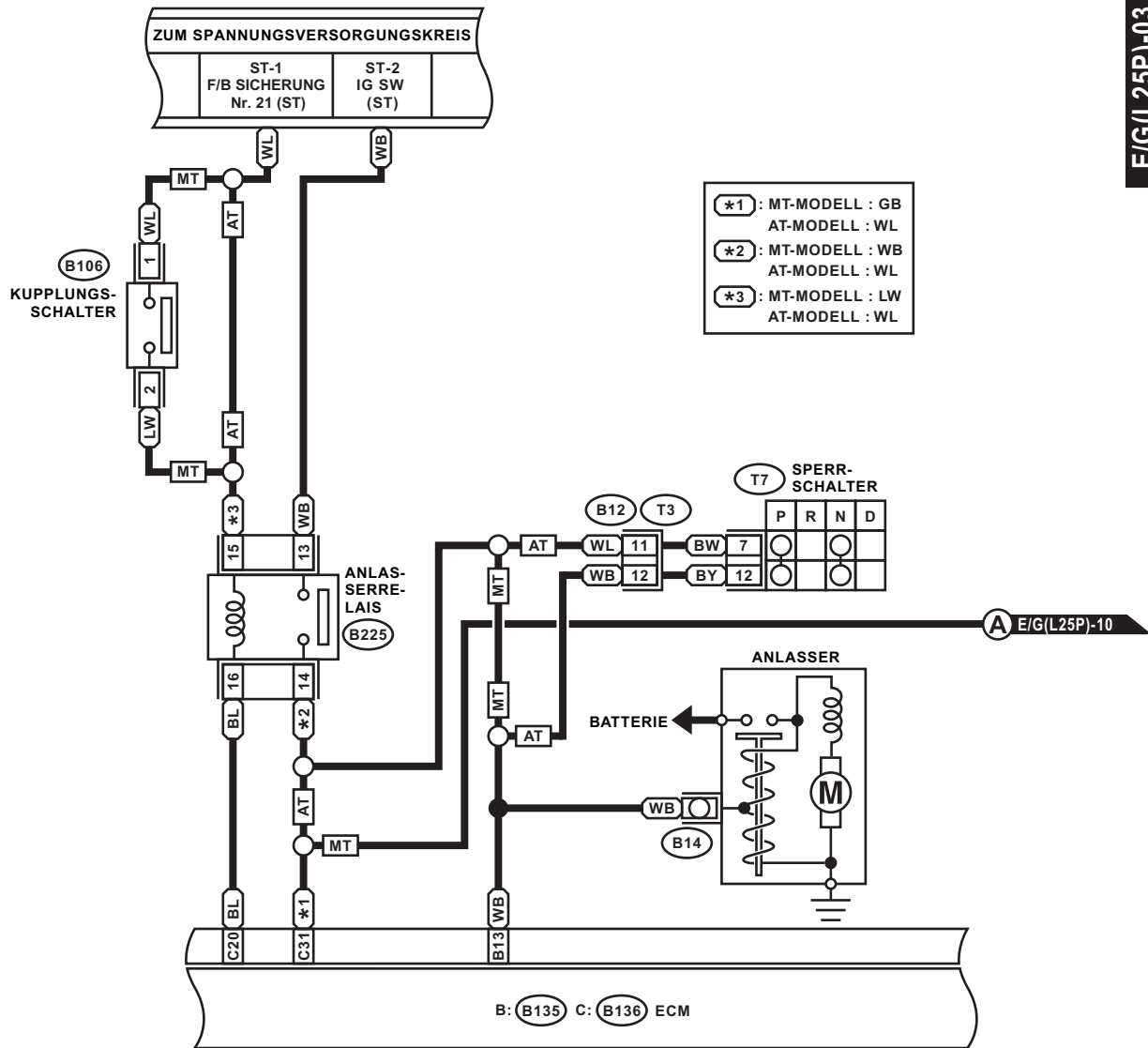

B106



B12 (GRAU)



T7 (SCHWARZ)



B: B135

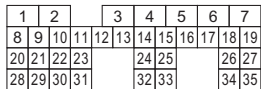

C: B136

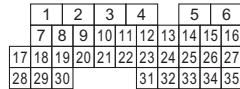

B225 (SCHWARZ)

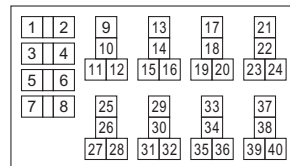

RELAISBLOCK

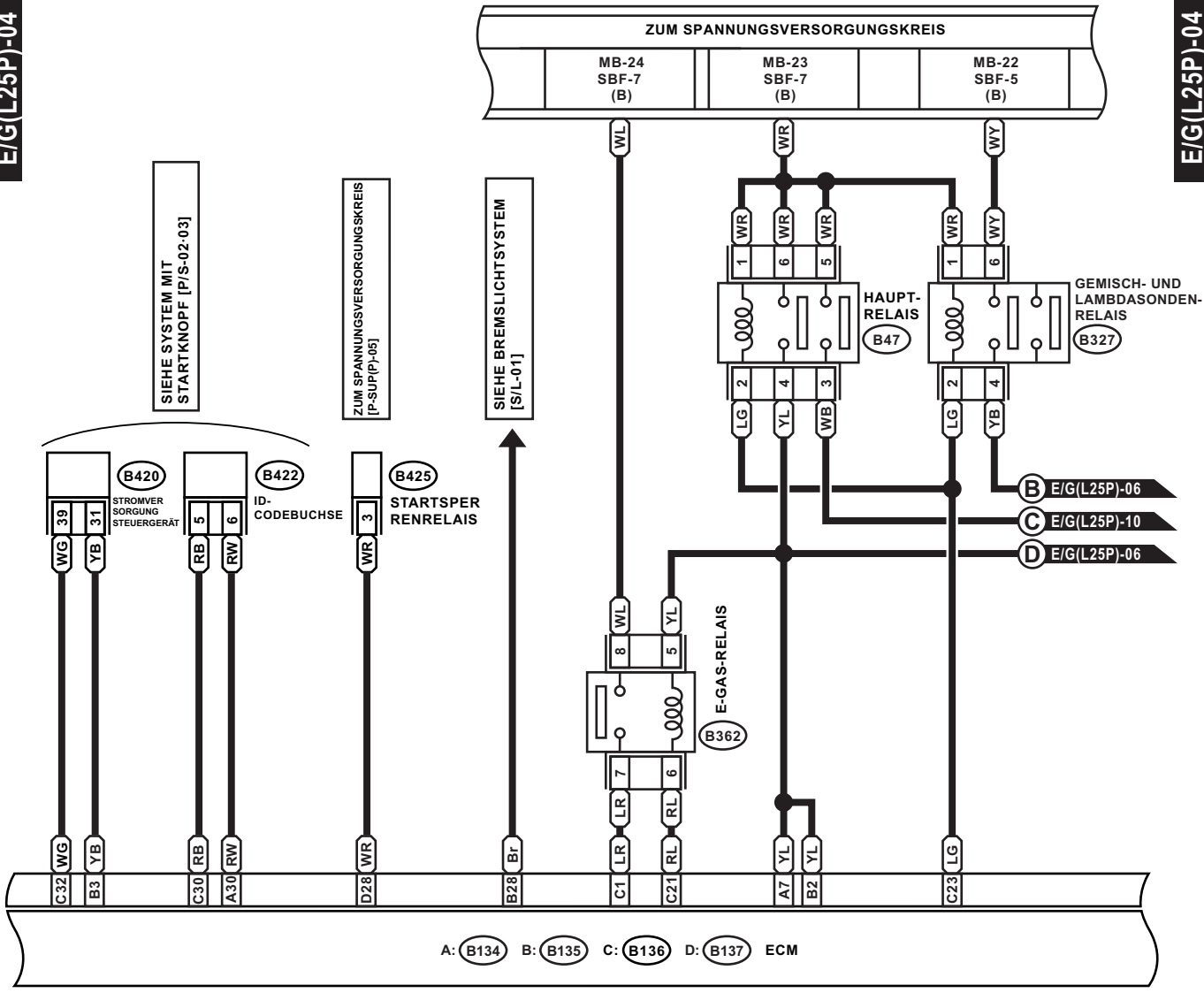

A: (B134) B: (B135) C: (B136) D: (B137) ECM

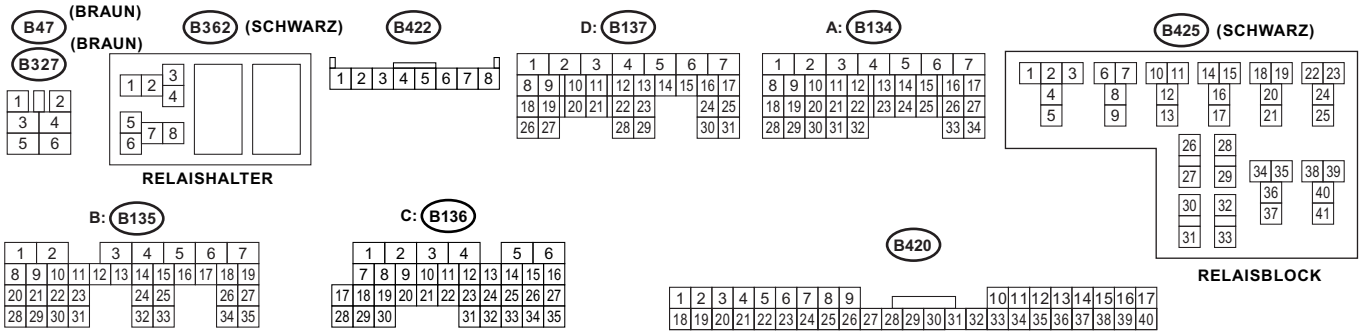

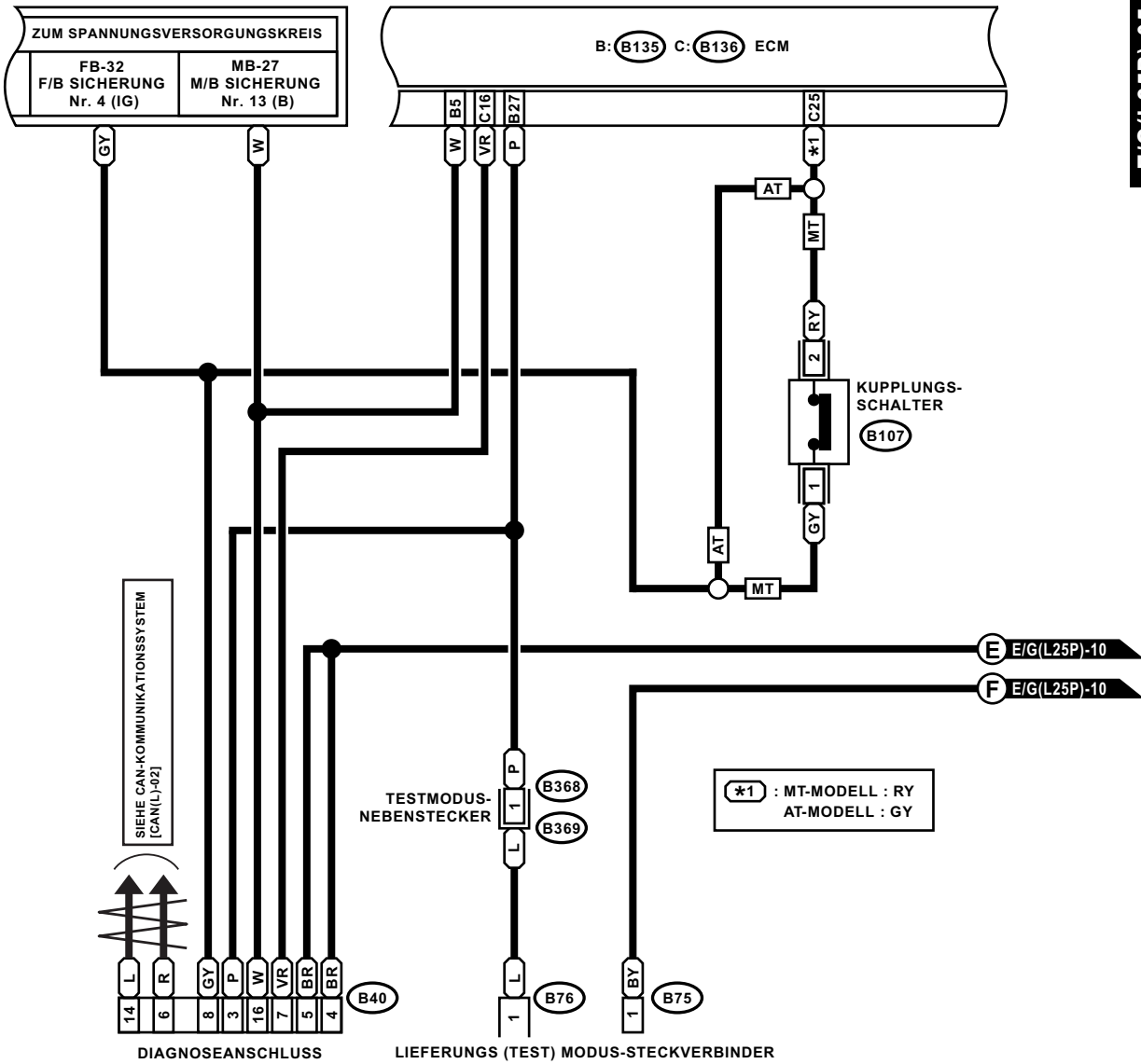

(B75) (GRÜN)

(B76) (GRÜN)

(B107) (BLAU)

(B40) (SCHWARZ)

B: (B135)

C: (B136)

(B368) (GRÜN)

(B369) (GRÜN)

1 2

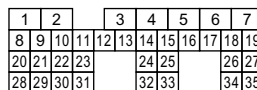
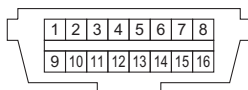

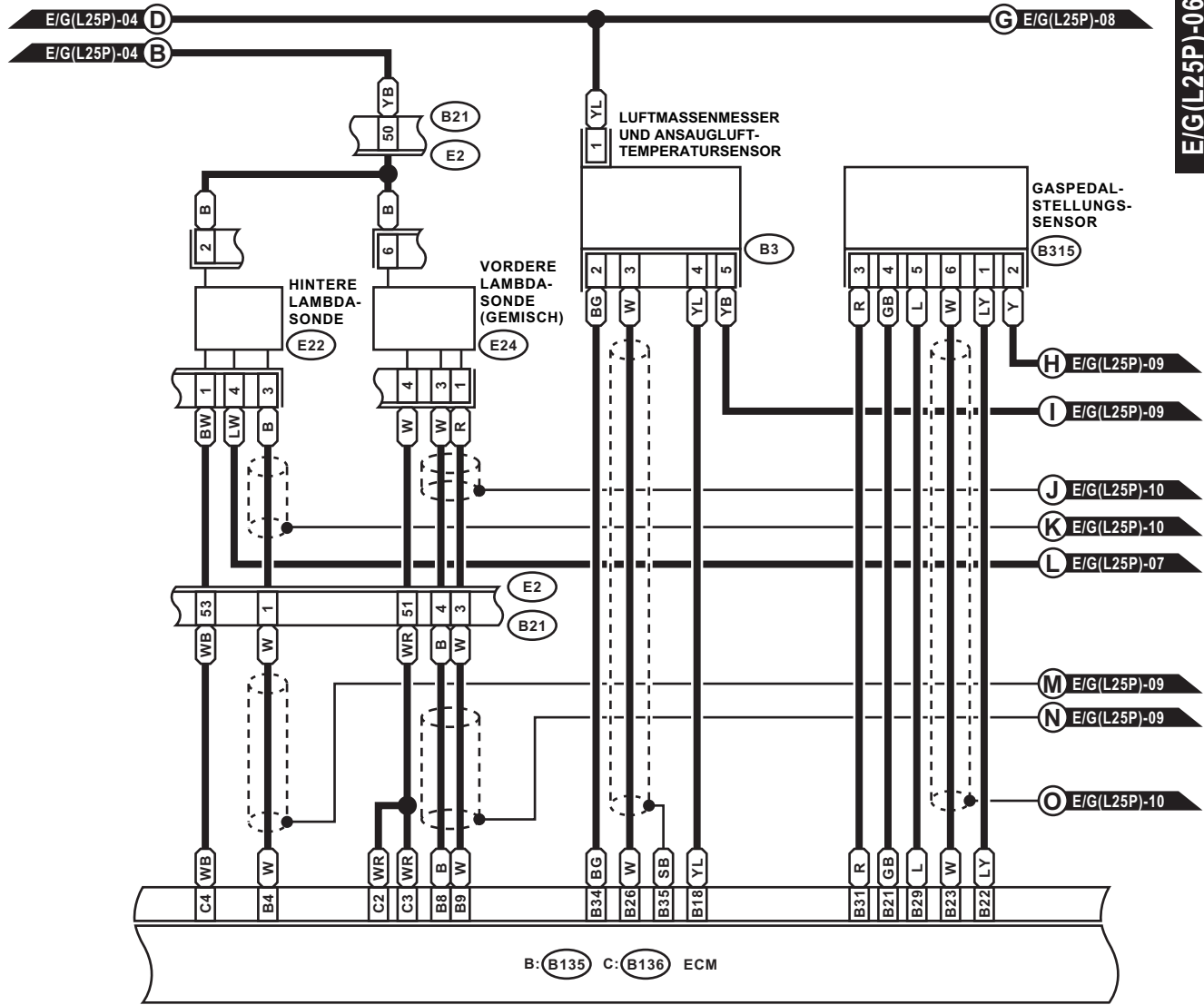

- E22 (DUNKELGRAU)
- B3 (SCHWARZ)
- B315 (SCHWARZ)
- E24 (SCHWARZ)
- B: (B135)
- C: (B136)

1	2
3	4

1	2	3	4	5
---	---	---	---	---

1	2	3	4	5	6
---	---	---	---	---	---

3	2	1
6	5	4

1	2	3	4	5	6	7					
8	9	10	11	12	13	14	15	16	17	18	19
20	21	22	23	24	25	26	27				
28	29	30	31	32	33	34	35				

1	2	3	4	5	6					
7	8	9	10	11	12	13	14	15	16	
17	18	19	20	21	22	23	24	25	26	27
28	29	30				31	32	33	34	35

- B21 (SCHWARZ)

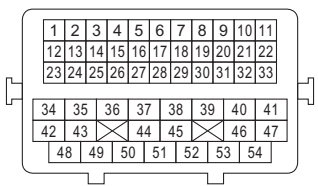

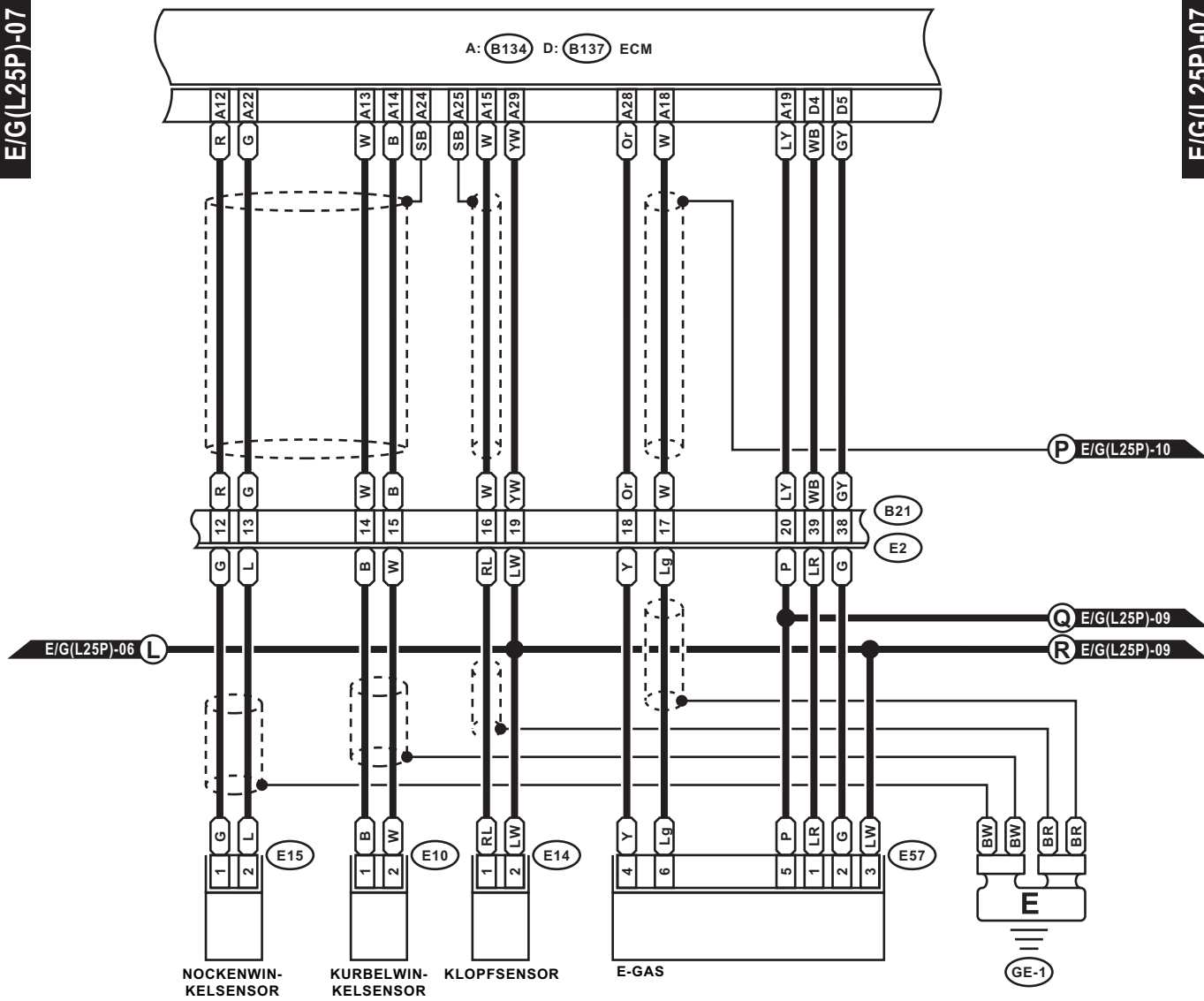

E10 (HELLGRAU)

E57 (SCHWARZ)

D: B137

A: B134

E14 (GRAU)

1	2	3	4	5	6
---	---	---	---	---	---

1	2	3	4	5	6	7
8	9	10	11	12	13	14
15	16	17	18	19	20	21
22	23	24	25	26	27	28
29	30	31	32	33	34	

1	2	3	4	5	6	7
8	9	10	11	12	13	14
15	16	17	18	19	20	21
22	23	24	25	26	27	28
29	30	31	32	33	34	

E15 (GRAU)

1	2
---	---

B21 (SCHWARZ)

1	2	3	4	5	6	7	8	9	10	11
12	13	14	15	16	17	18	19	20	21	22
23	24	25	26	27	28	29	30	31	32	33
34	35	36	37	38	39	40	41			
42	43	44	45	46	47					
48	49	50	51	52	53	54				

E/G(L25P)-06 **G**

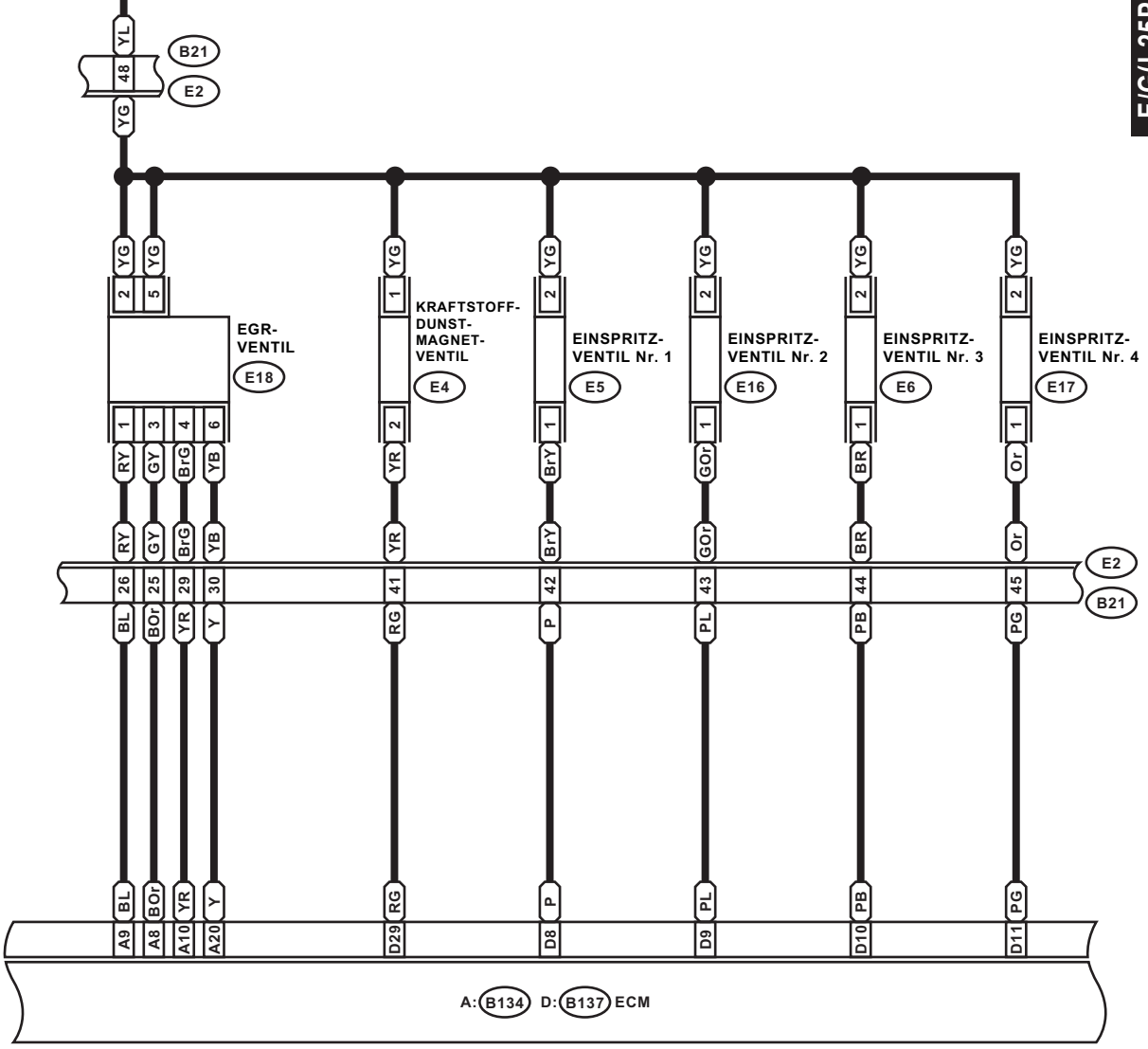

A: (B134) D: (B137) ECM

E4 (SCHWARZ) (DUNKELGRAU) **E5** (DUNKELGRAU) **E16** (DUNKELGRAU) **E18** (DUNKELGRAU) **D: (B137)** **B21** (SCHWARZ)

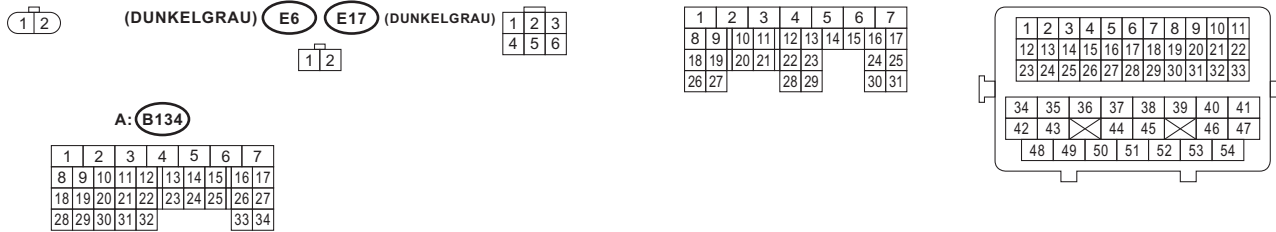

A: B134 B: B135 D: B137 ECM

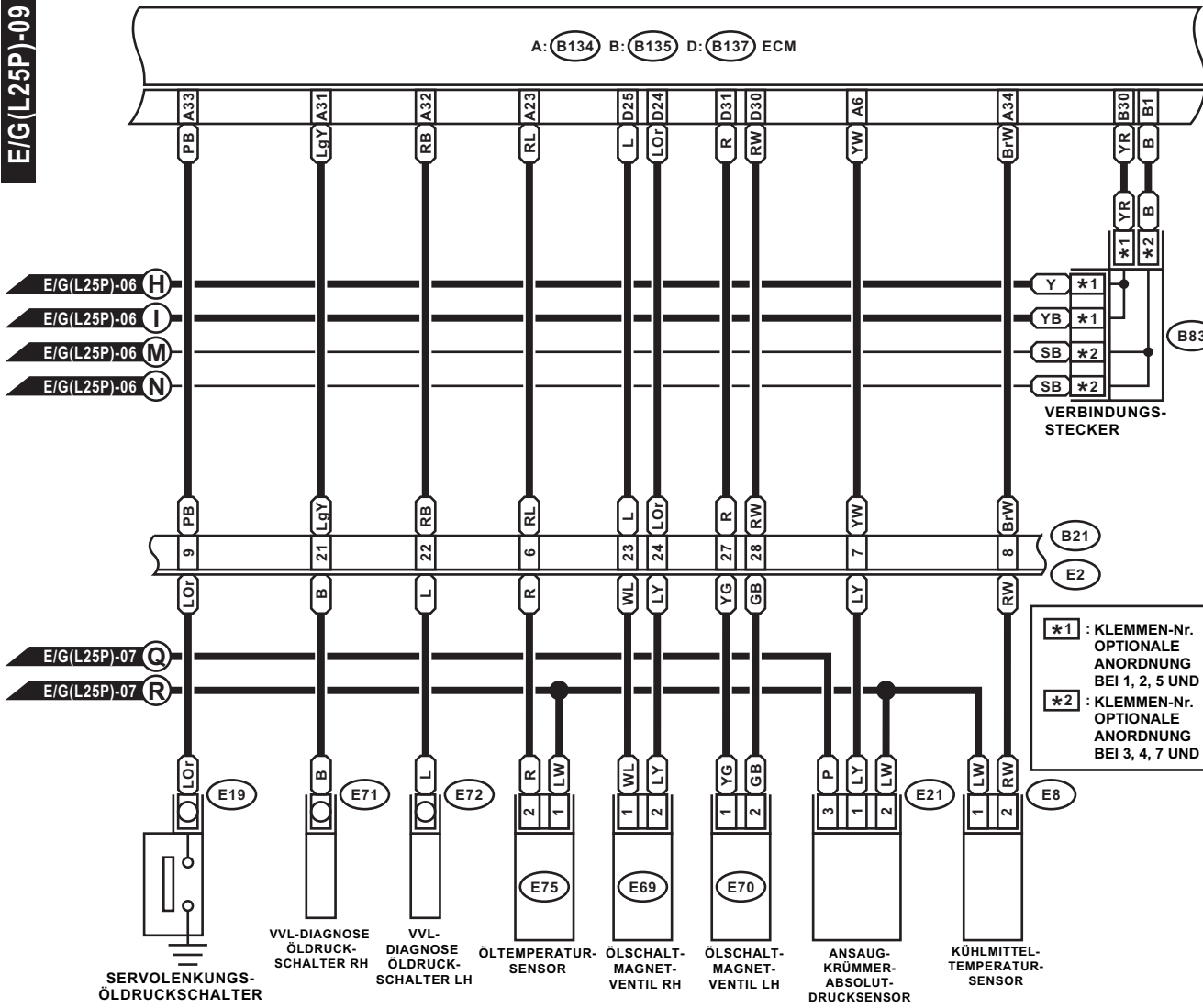

*1 : KLEMMEN-Nr. OPTIONALE ANORDNUNG BEI 1, 2, 5 UND 6
 *2 : KLEMMEN-Nr. OPTIONALE ANORDNUNG BEI 3, 4, 7 UND 8

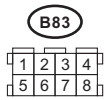
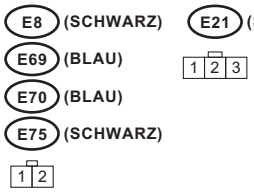

D: B137

1	2	3	4	5	6	7
8	9	10	11	12	13	14
15	16	17	18	19	20	21
22	23	24	25	26	27	
		28	29	30	31	

A: B134

1	2	3	4	5	6	7
8	9	10	11	12	13	14
15	16	17	18	19	20	21
22	23	24	25	26	27	
		28	29	30	31	32
						33
						34

B: B135

1	2	3	4	5	6	7
8	9	10	11	12	13	14
15	16	17	18	19	20	21
22	23	24	25	26	27	
		28	29	30	31	
			32	33		
						34
						35

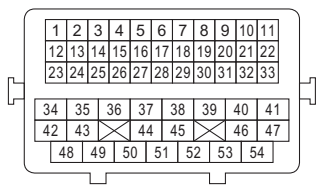

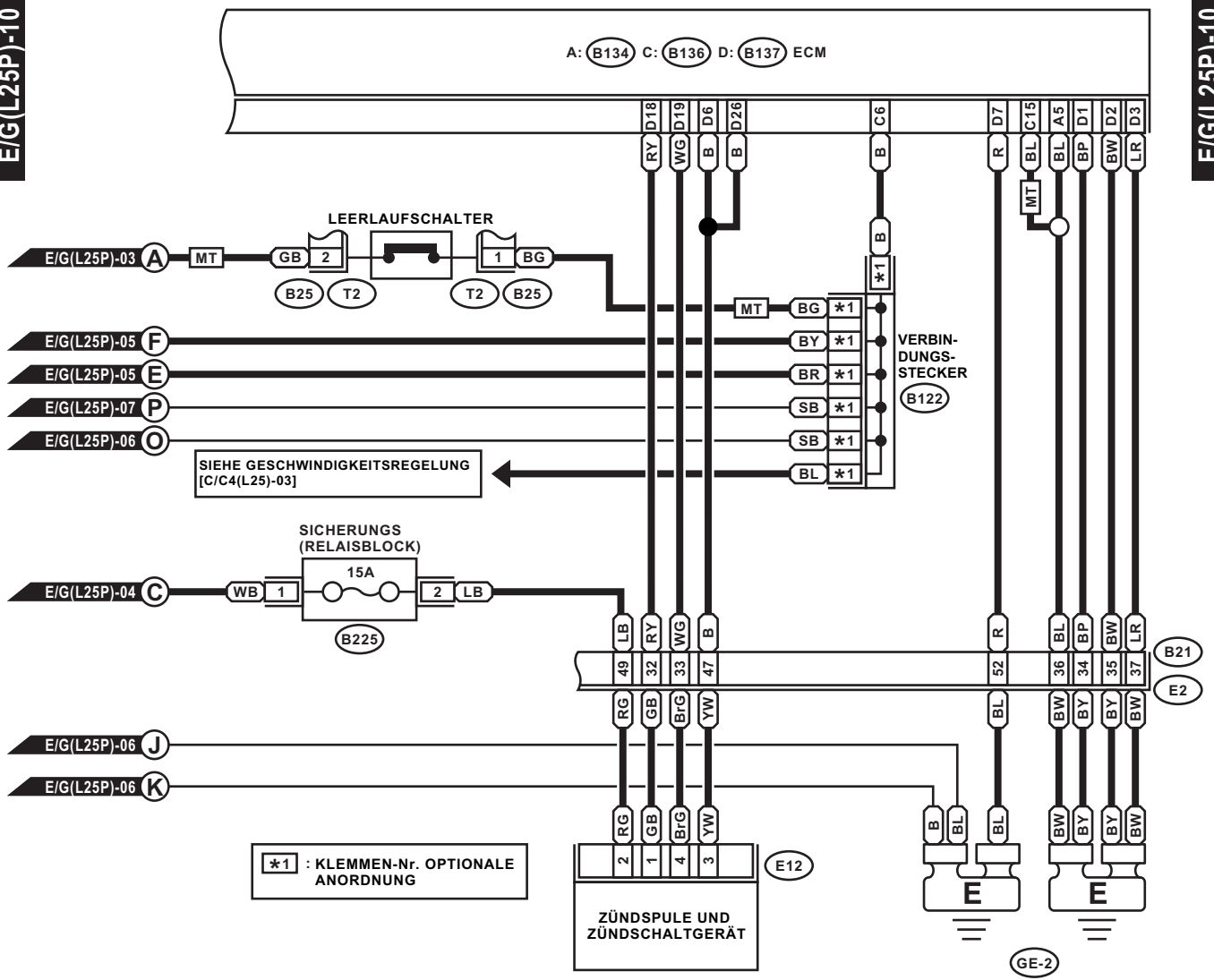

*1 : KLEMMEN-Nr. OPTIONALE ANORDNUNG

B25 (BRAUN)

E12 (DUNKELGRAU)

B122

D: B137

A: B134

B21 (SCHWARZ)

1	2
---	---

1	2	3	4
---	---	---	---

1	2	3	4
5	6	7	8

1	2	3	4	5	6	7			
8	9	10	11	12	13	14	15	16	17
18	19	20	21	22	23	24	25		
26	27		28	29		30	31		

1	2	3	4	5	6	7			
8	9	10	11	12	13	14	15	16	17
18	19	20	21	22	23	24	25	26	27
28	29	30	31	32		33	34		

1	2	3	4	5	6	7	8	9	10	11
12	13	14	15	16	17	18	19	20	21	22
23	24	25	26	27	28	29	30	31	32	33
34	35	36	37	38	39	40	41			
42	43	44	45	46	47					
48	49	50	51	52	53	54				

B225 (SCHWARZ)

C: B136

1	2	3	4	5	6					
7	8	9	10	11	12	13	14	15	16	
17	18	19	20	21	22	23	24	25	26	27
28	29	30		31	32	33	34	35		

1	2	9	13	17	21				
		10	14	18	22				
3	4	11	12	15	16	19	20	23	24
5	6								
7	8	25	29	33	37				
		26	30	34	38				
27	28	31	32	35	36	39	40		

RELAISBLOCK

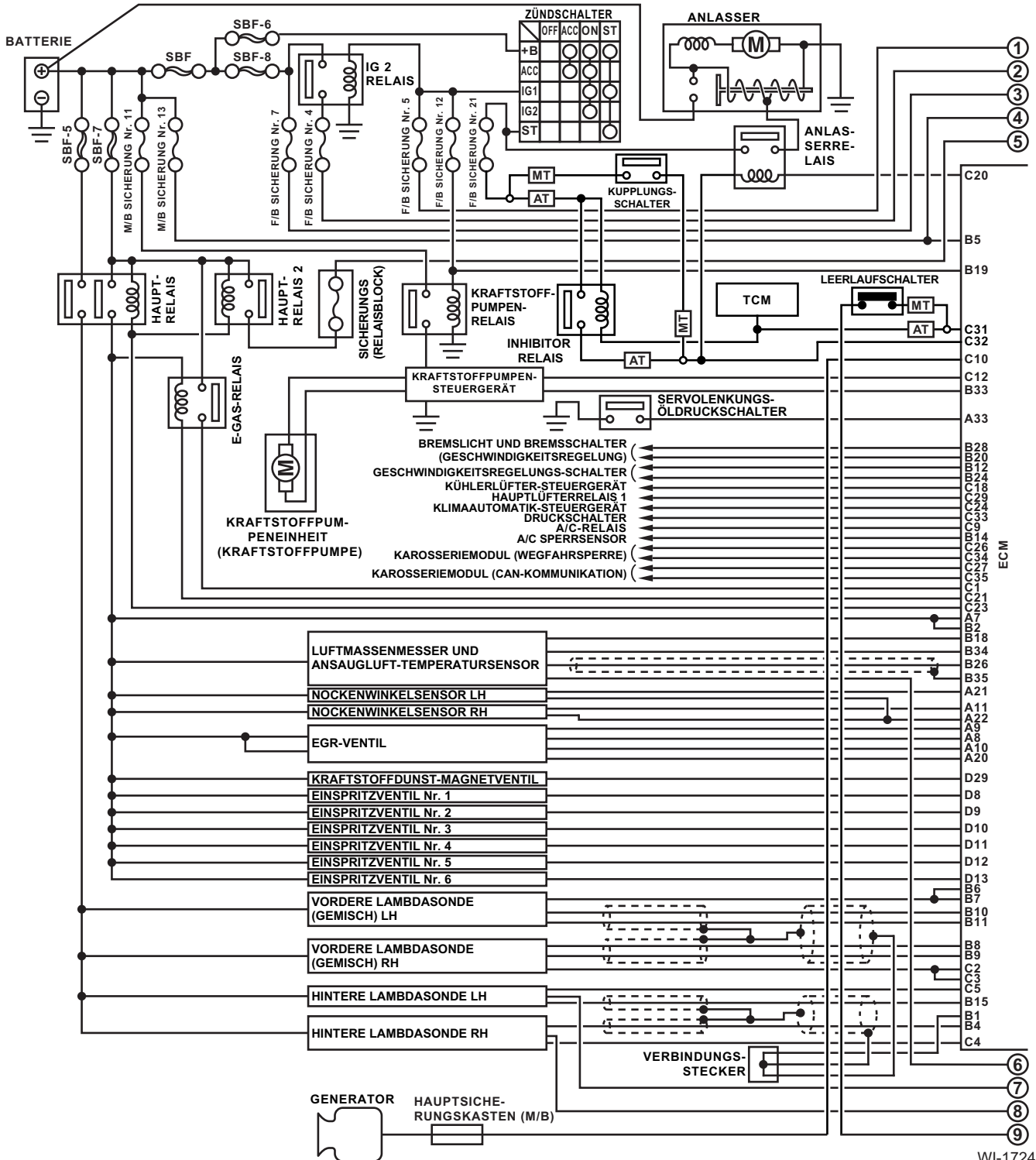

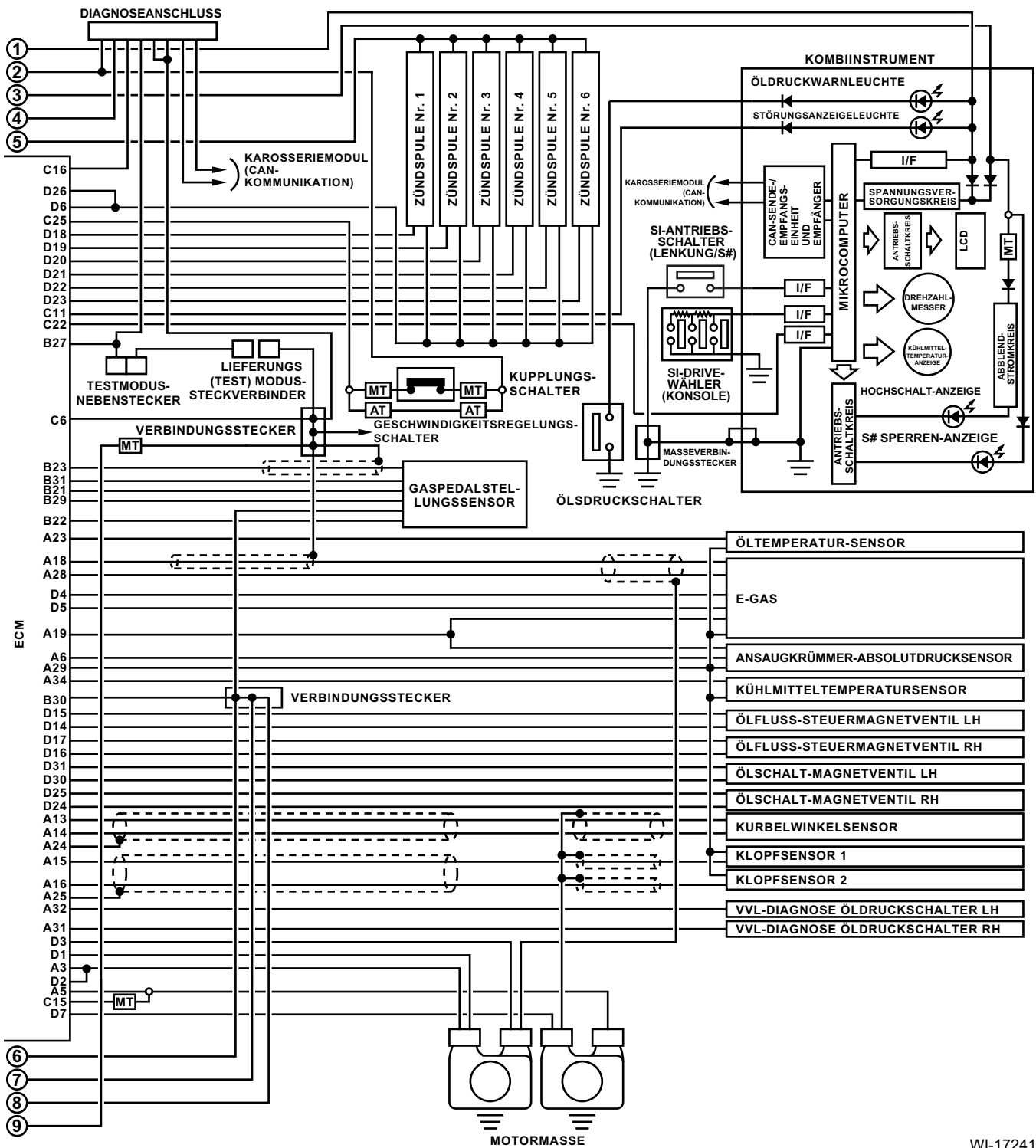

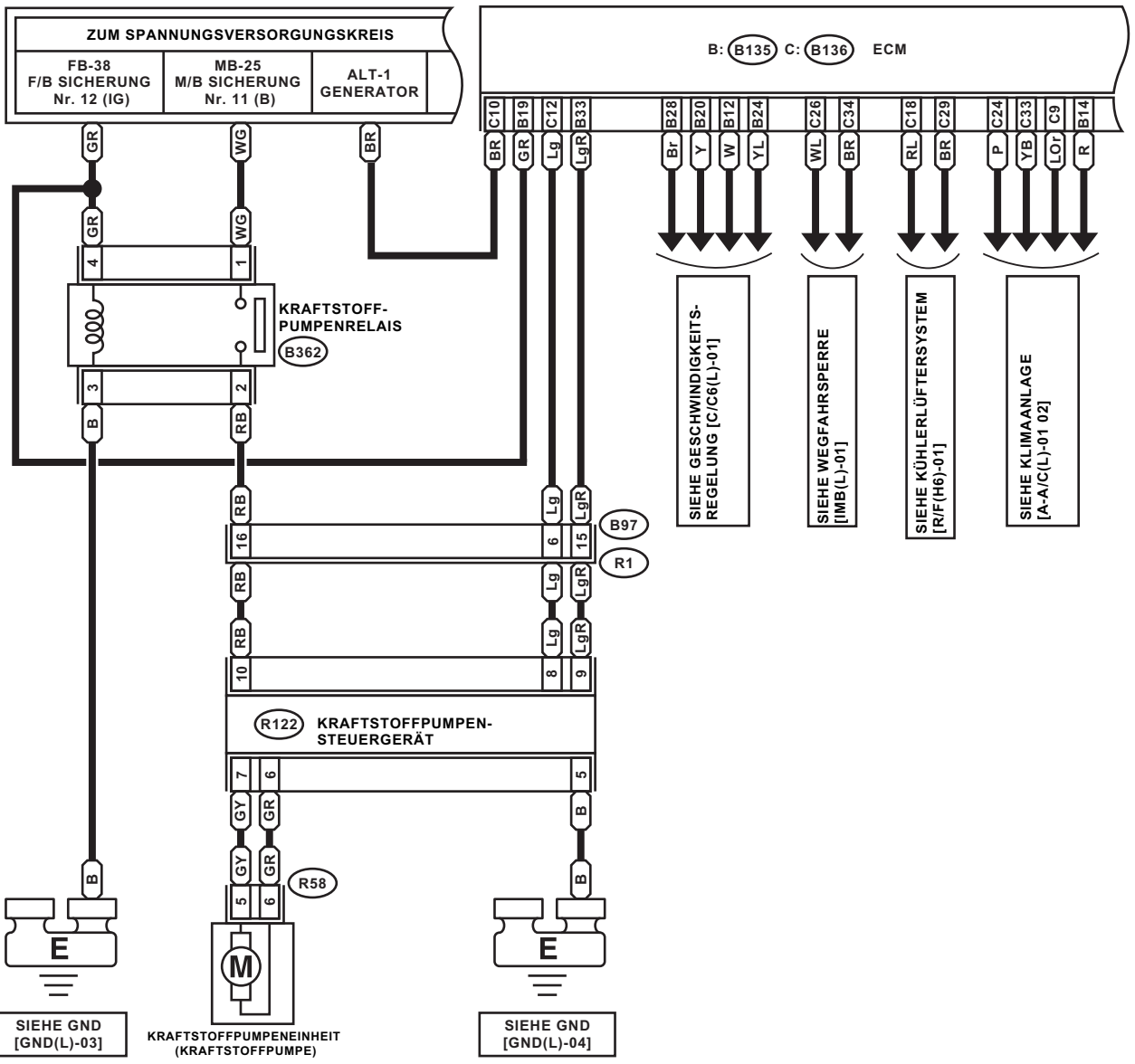

R58



B362 (SCHWARZ)

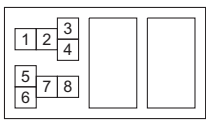

RELAISHALTER

R122 (SCHWARZ)

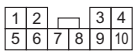

B97

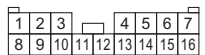

B: B135

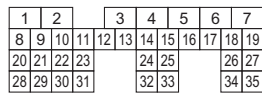

C: B136

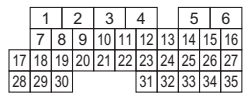

ZUM SPANNUNGSVERSORGUNGSKREIS

FB-36 F/B SICHERUNG Nr. 5 (IG)

FB-17 F/B SICHERUNG Nr. 7 (B)

*1 : KLEMMEN-Nr. OPTIONALE ANORDNUNG BEI 1, 2, 3, 4, 5 UND 6

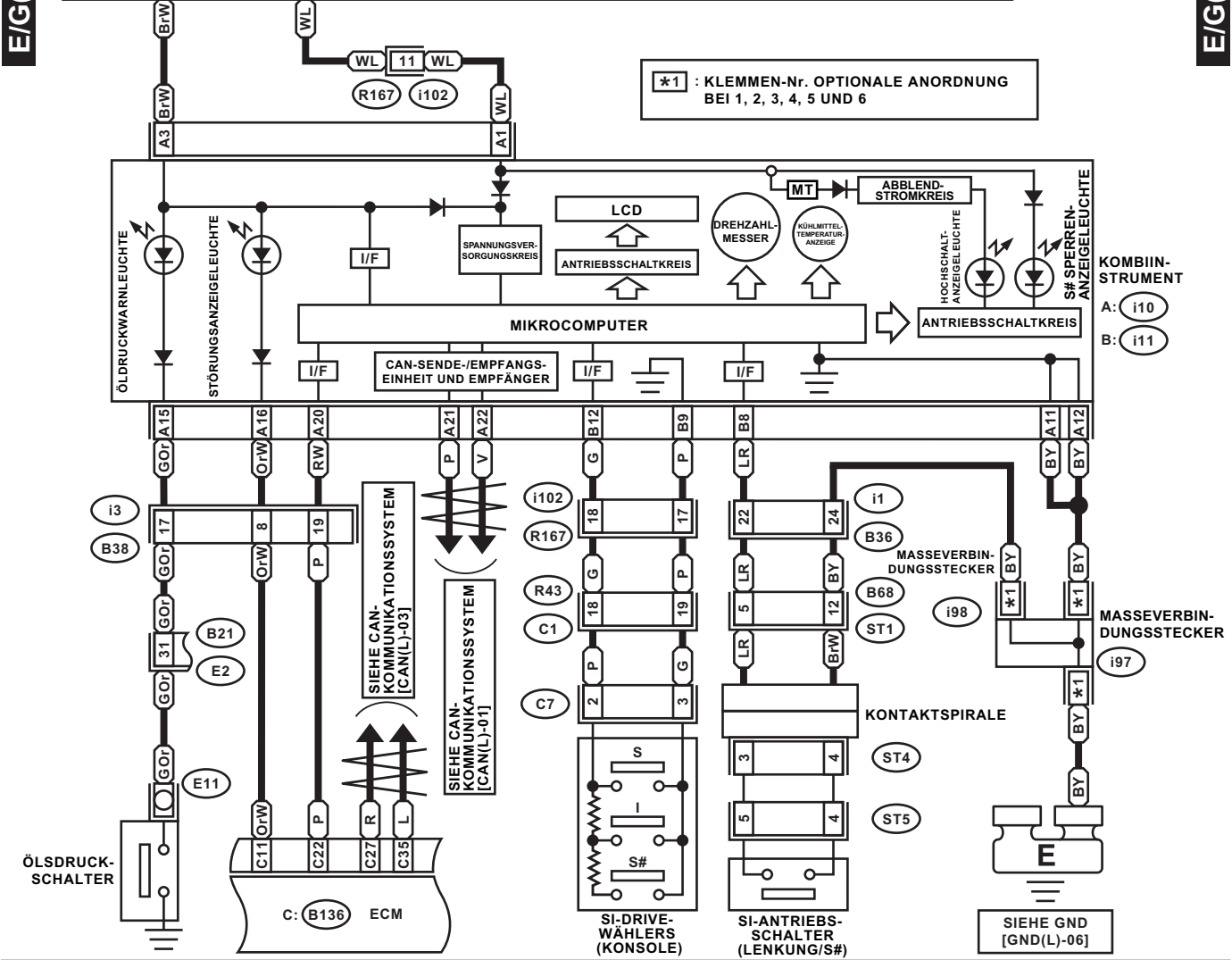

KOMBI-STRUMENT
A: i10
B: i11

MASSEVERBINDUNGSSTECCKER
i98
i97

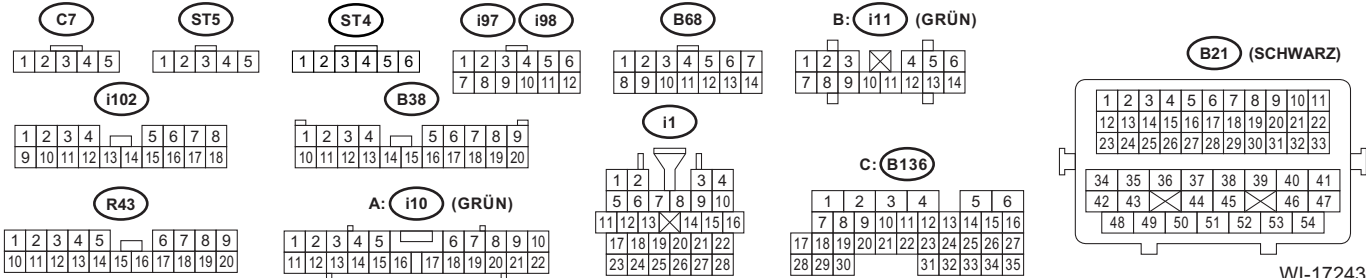

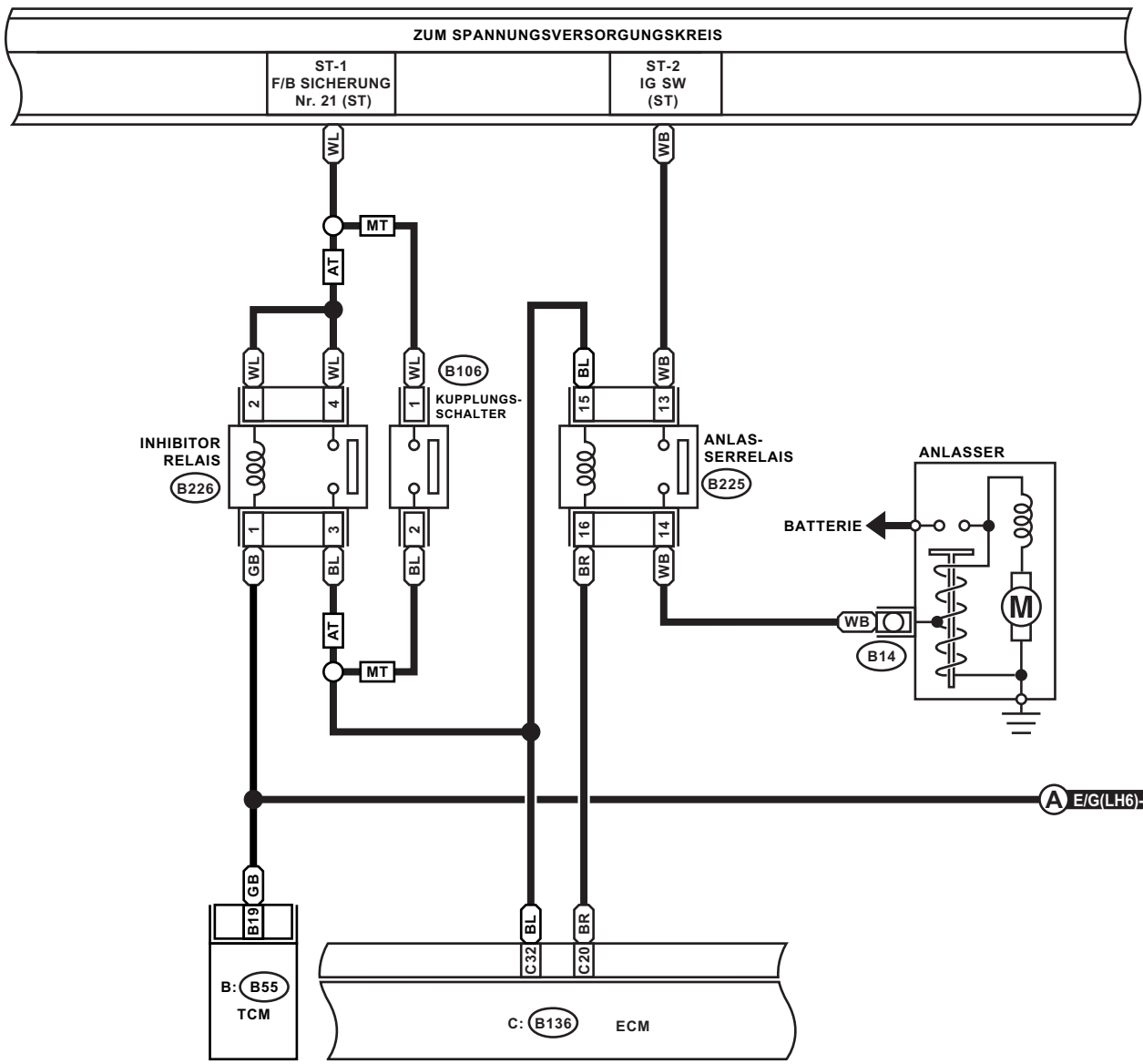

B106



B226 (SCHWARZ)



B: B55 (GRAU)

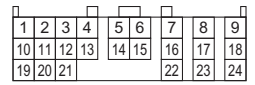

C: B136

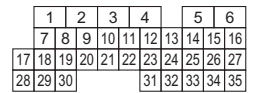

B225 (SCHWARZ)

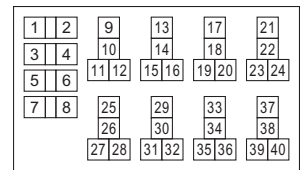

RELAISBLOCK

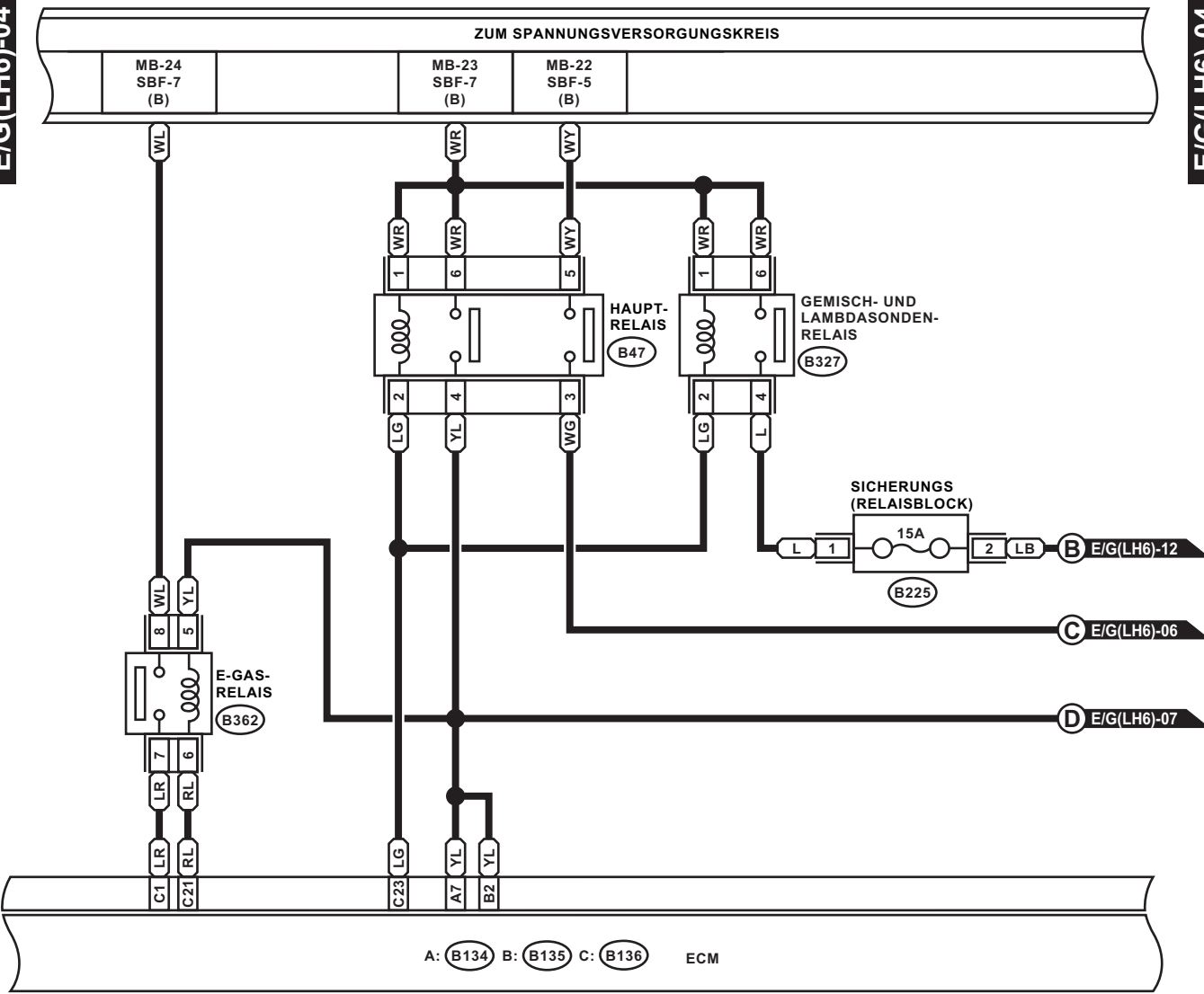

(B47) (BRAUN)

(B327) (BRAUN)

1	2
3	4
5	6

(B362) (SCHWARZ)

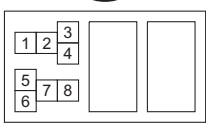

RELAISHALTER

A: (B134)

1	2	3	4	5	6	7
8	9	10	11	12	13	14
15	16	17	18	19	20	21
22	23	24	25	26	27	28
29	30	31	32	33	34	35

(B225) (SCHWARZ)

1	2	9	13	17	21
3	4	10	14	18	22
5	6	11	12	15	16
7	8	19	20	23	24
25	29	33	37		
26	30	34	38		
27	28	31	32	35	36
39	40				

RELAISBLOCK

B: (B135)

1	2	3	4	5	6	7
8	9	10	11	12	13	14
15	16	17	18	19	20	21
22	23	24	25	26	27	28
29	30	31	32	33	34	35

C: (B136)

1	2	3	4	5	6
7	8	9	10	11	12
13	14	15	16	17	18
19	20	21	22	23	24
25	26	27	28	29	30
31	32	33	34	35	

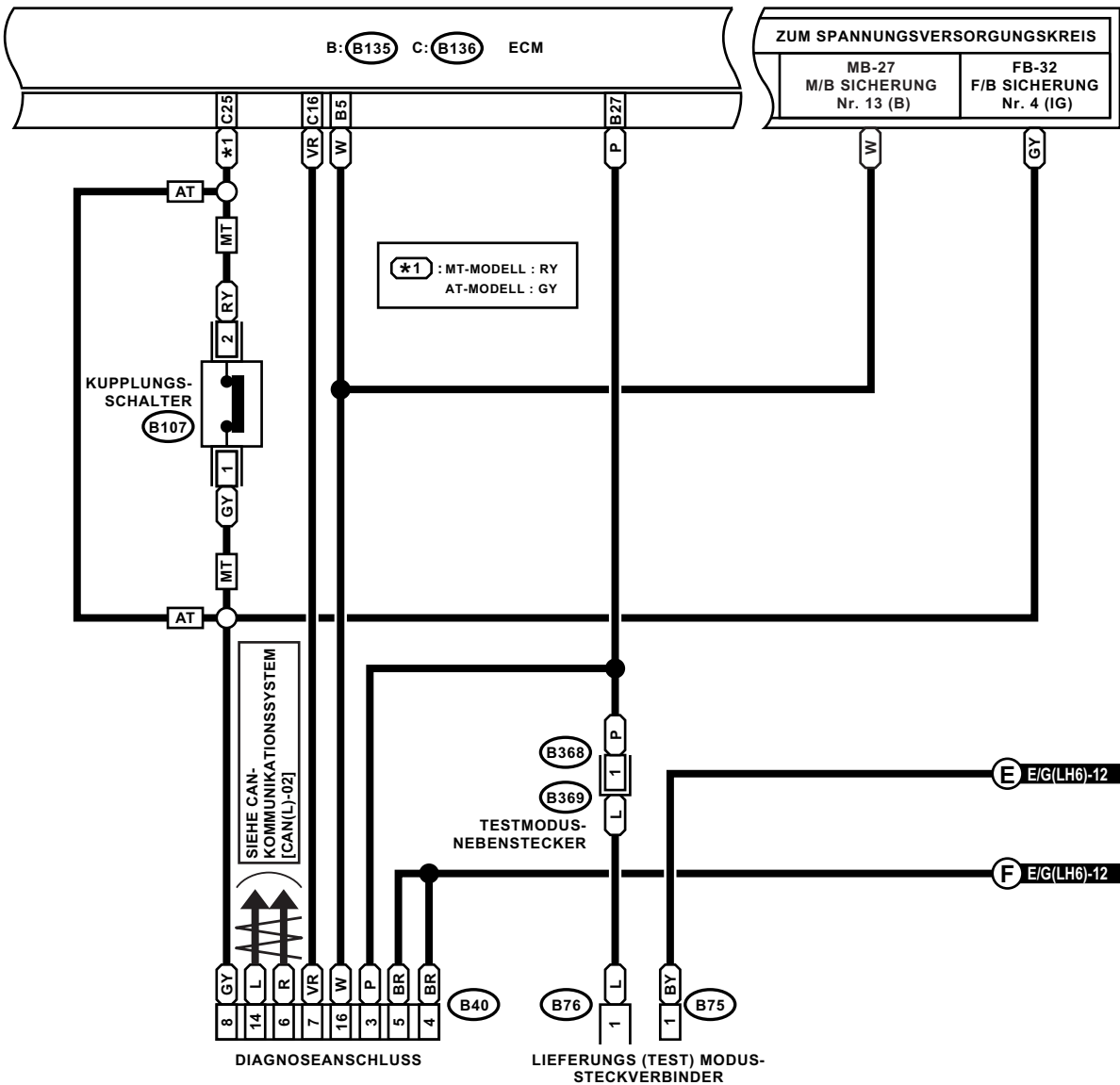

B75 (GRÜN)

B76 (GRÜN)

B107 (BLAU)

B40 (SCHWARZ)

B: B135

C: B136

B368 (GRÜN)

B369 (GRÜN)

1 2

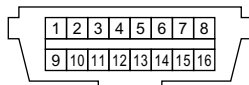

1	2	3	4	5	6	7
8	9	10	11	12	13	14
15	16	17	18	19	20	21
22	23	24	25	26	27	28
29	30	31	32	33	34	35

1	2	3	4	5	6
7	8	9	10	11	12
13	14	15	16	17	18
19	20	21	22	23	24
25	26	27	28	29	30
31	32	33	34	35	

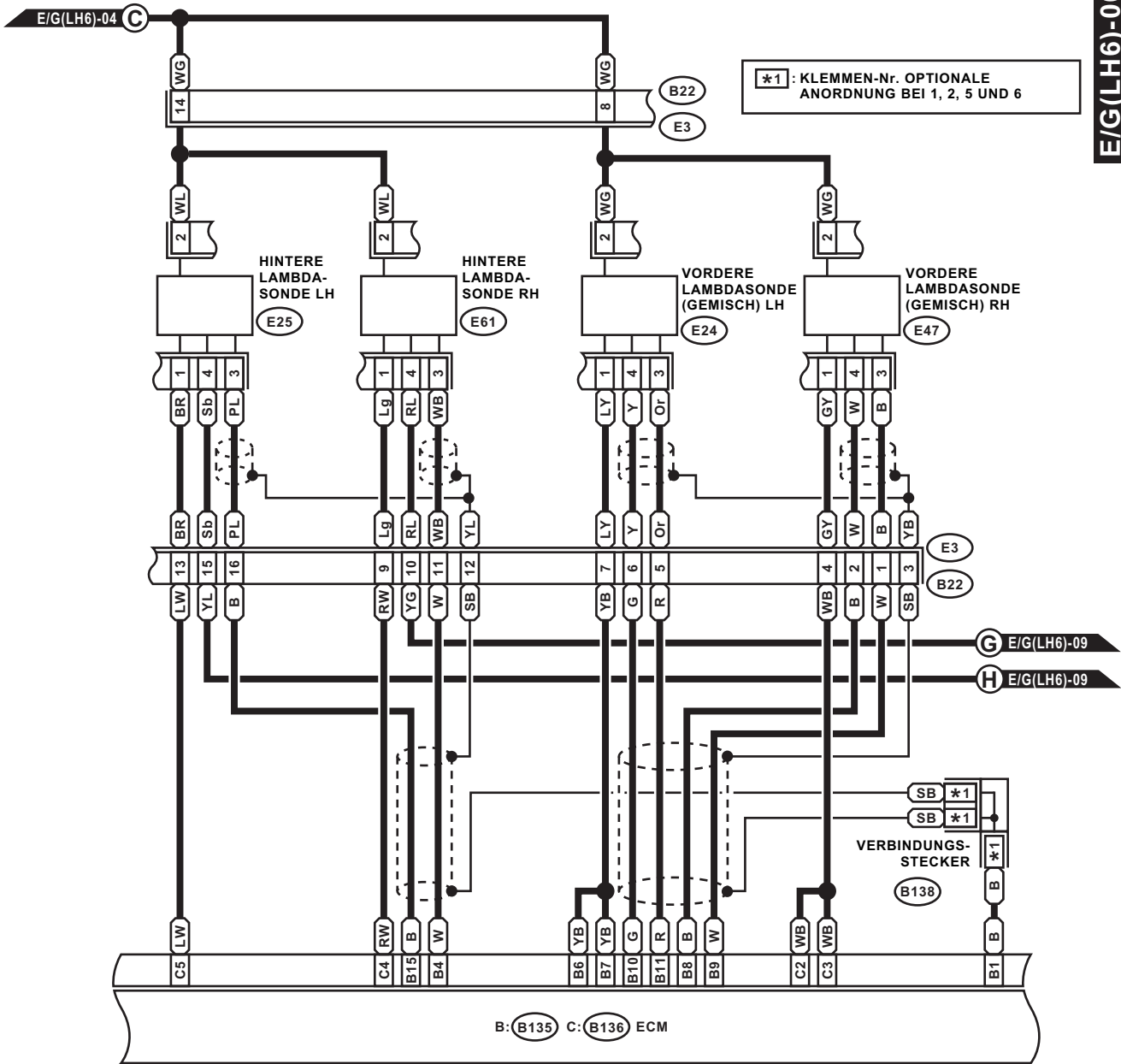

E24 (HELLGRAU)	B138	B22 (BRAUN)	B: B135	C: B136																																																																																															
E25 (DUNKELGRAU)	<table border="1"><tr><td>1</td><td>2</td><td>3</td><td>4</td></tr><tr><td>5</td><td>6</td><td>7</td><td>8</td></tr></table>	1	2	3	4	5	6	7	8	<table border="1"><tr><td>1</td><td>2</td><td>3</td><td>4</td></tr><tr><td>5</td><td>6</td><td>7</td><td>8</td></tr><tr><td>9</td><td>10</td><td>11</td><td>12</td></tr><tr><td>13</td><td>14</td><td>15</td><td>16</td></tr></table>	1	2	3	4	5	6	7	8	9	10	11	12	13	14	15	16	<table border="1"><tr><td>1</td><td>2</td><td>3</td><td>4</td><td>5</td><td>6</td><td>7</td></tr><tr><td>8</td><td>9</td><td>10</td><td>11</td><td>12</td><td>13</td><td>14</td></tr><tr><td>15</td><td>16</td><td>17</td><td>18</td><td>19</td><td>20</td><td>21</td></tr><tr><td>22</td><td>23</td><td>24</td><td>25</td><td>26</td><td>27</td><td>28</td></tr><tr><td>29</td><td>30</td><td>31</td><td>32</td><td>33</td><td>34</td><td>35</td></tr></table>	1	2	3	4	5	6	7	8	9	10	11	12	13	14	15	16	17	18	19	20	21	22	23	24	25	26	27	28	29	30	31	32	33	34	35	<table border="1"><tr><td>1</td><td>2</td><td>3</td><td>4</td><td>5</td><td>6</td></tr><tr><td>7</td><td>8</td><td>9</td><td>10</td><td>11</td><td>12</td></tr><tr><td>13</td><td>14</td><td>15</td><td>16</td><td>17</td><td>18</td></tr><tr><td>19</td><td>20</td><td>21</td><td>22</td><td>23</td><td>24</td></tr><tr><td>25</td><td>26</td><td>27</td><td>28</td><td>29</td><td>30</td></tr><tr><td>31</td><td>32</td><td>33</td><td>34</td><td>35</td><td></td></tr></table>	1	2	3	4	5	6	7	8	9	10	11	12	13	14	15	16	17	18	19	20	21	22	23	24	25	26	27	28	29	30	31	32	33	34	35	
1	2	3	4																																																																																																
5	6	7	8																																																																																																
1	2	3	4																																																																																																
5	6	7	8																																																																																																
9	10	11	12																																																																																																
13	14	15	16																																																																																																
1	2	3	4	5	6	7																																																																																													
8	9	10	11	12	13	14																																																																																													
15	16	17	18	19	20	21																																																																																													
22	23	24	25	26	27	28																																																																																													
29	30	31	32	33	34	35																																																																																													
1	2	3	4	5	6																																																																																														
7	8	9	10	11	12																																																																																														
13	14	15	16	17	18																																																																																														
19	20	21	22	23	24																																																																																														
25	26	27	28	29	30																																																																																														
31	32	33	34	35																																																																																															

1	2
3	4

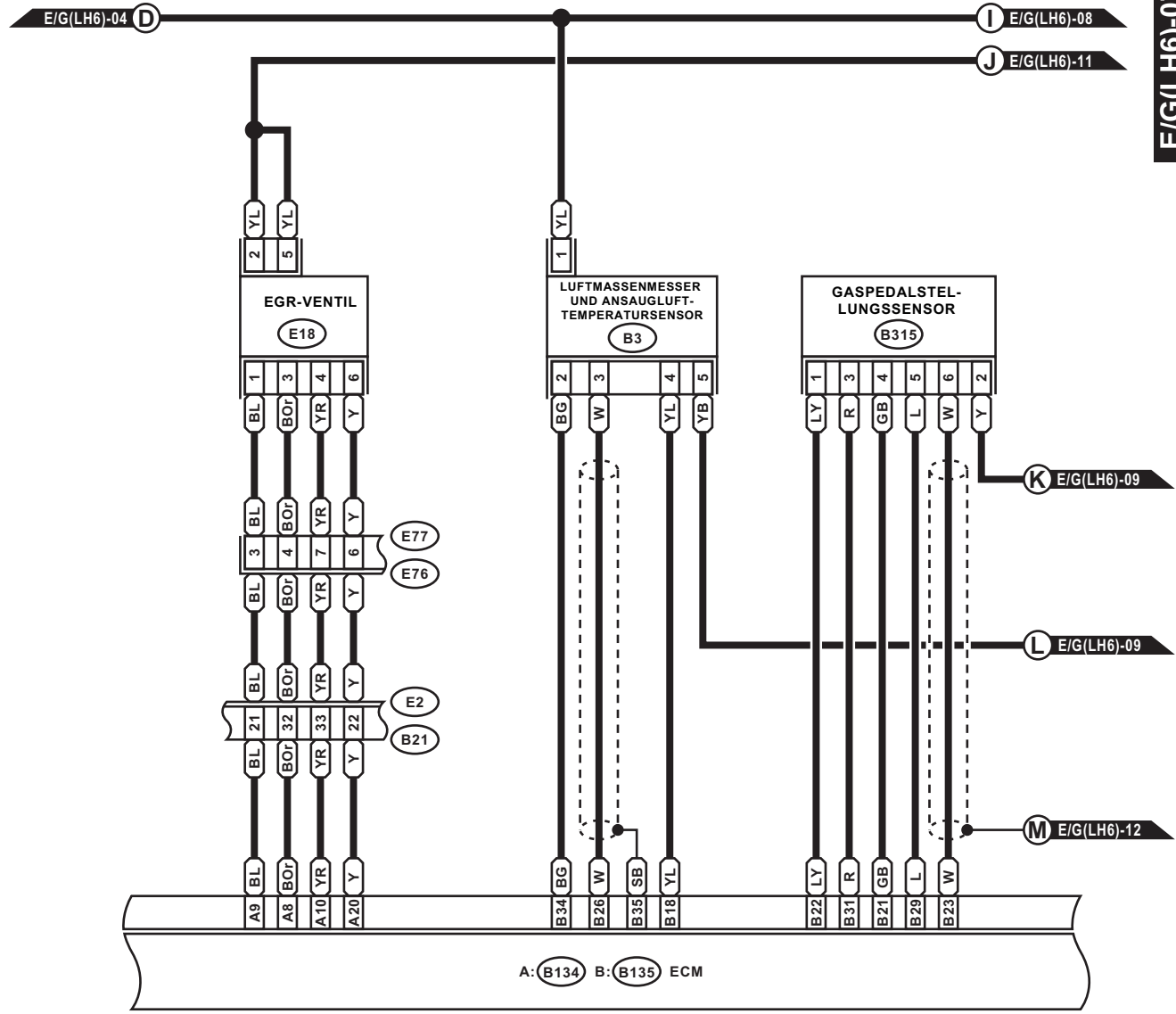

A: B134 B: B135 ECM

B3 (SCHWARZ)

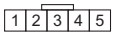

B315 (SCHWARZ)

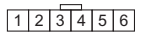

E18 (DUNKELGRAU)



E77 (GRAU)

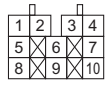

B21 (SCHWARZ)

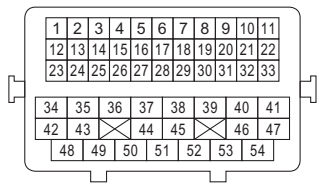

A: B134

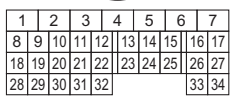

B: B135

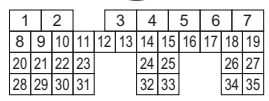

A: B134 ECM

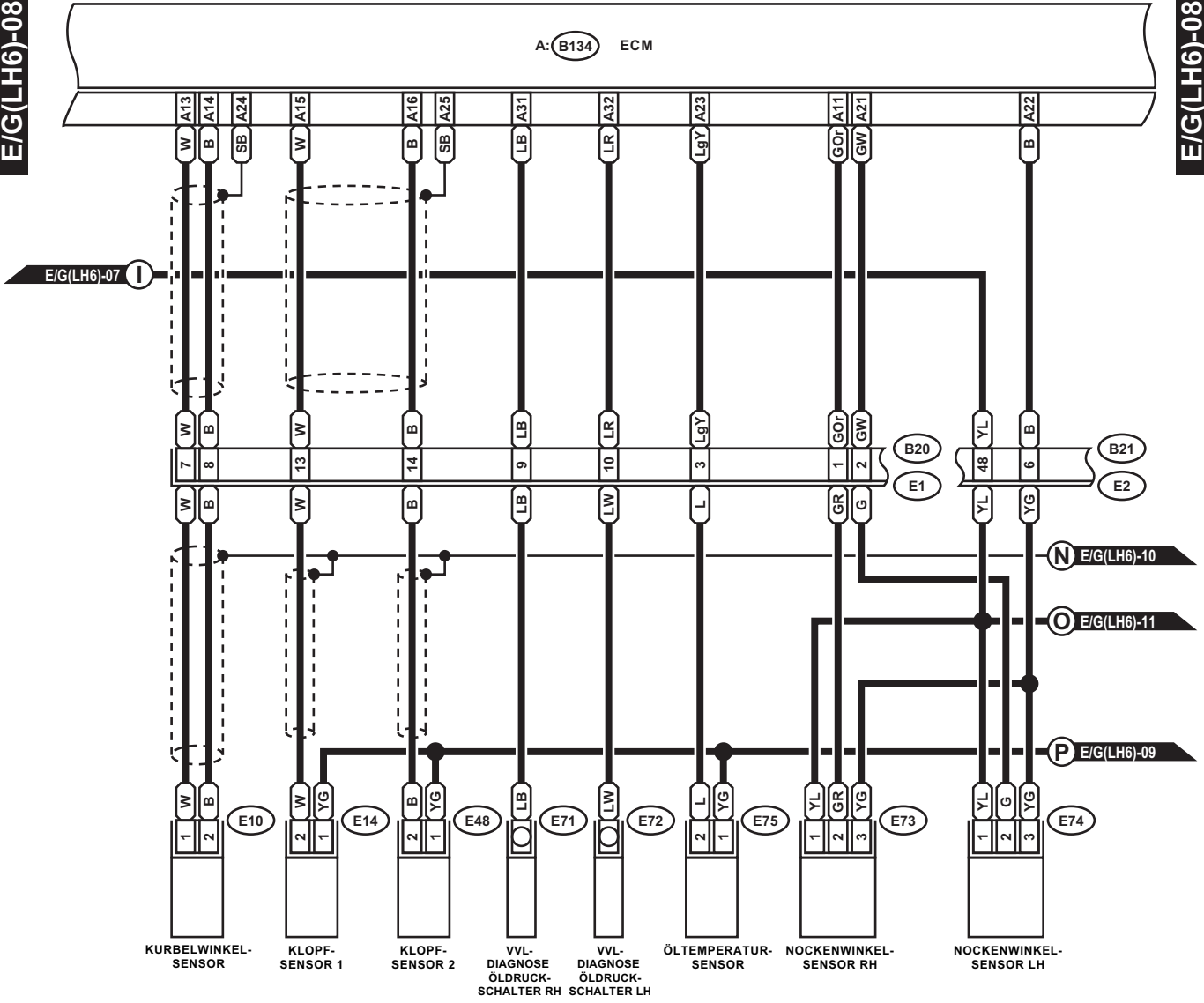

E10 (HELLGRAU)

E73 (GRAU)

B20 (BRAUN)

A: B134

B21 (SCHWARZ)

E14 (BLAU)

E74 (GRAU)

E48 (BLAU)

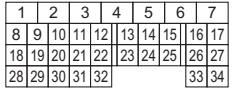
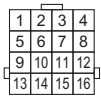

E75 (SCHWARZ)

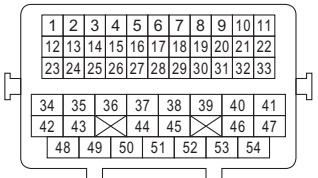

A: B134 B: B135 D: B137 ECM

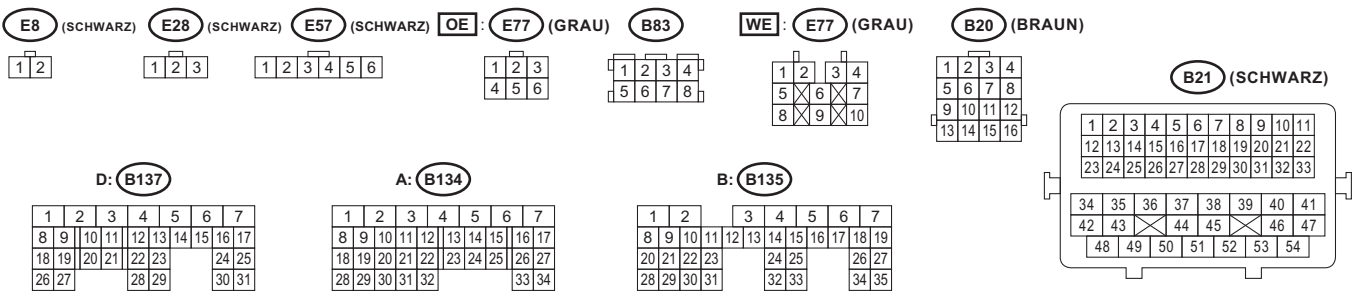
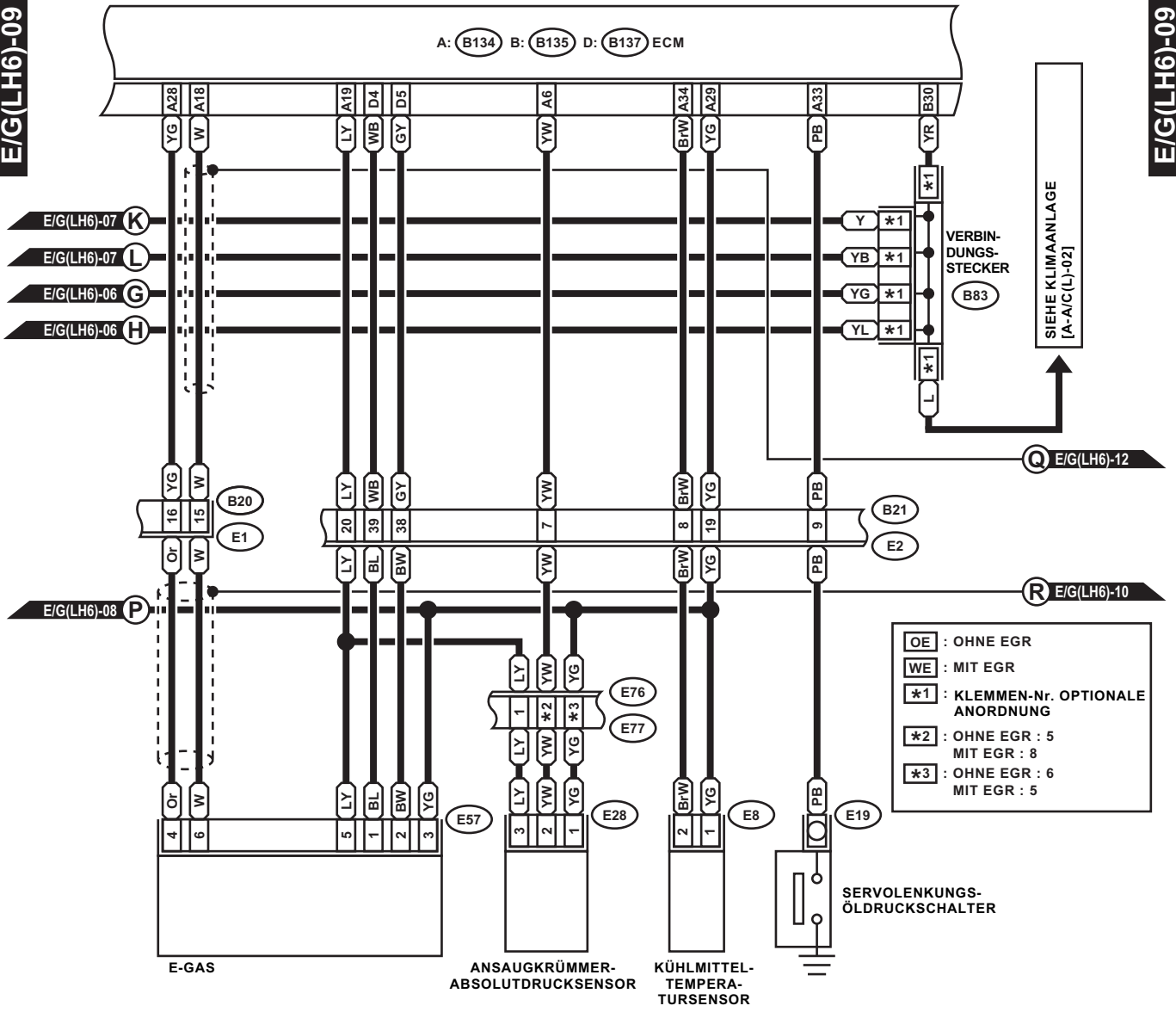

A: B134 C: B136 D: B137 ECM

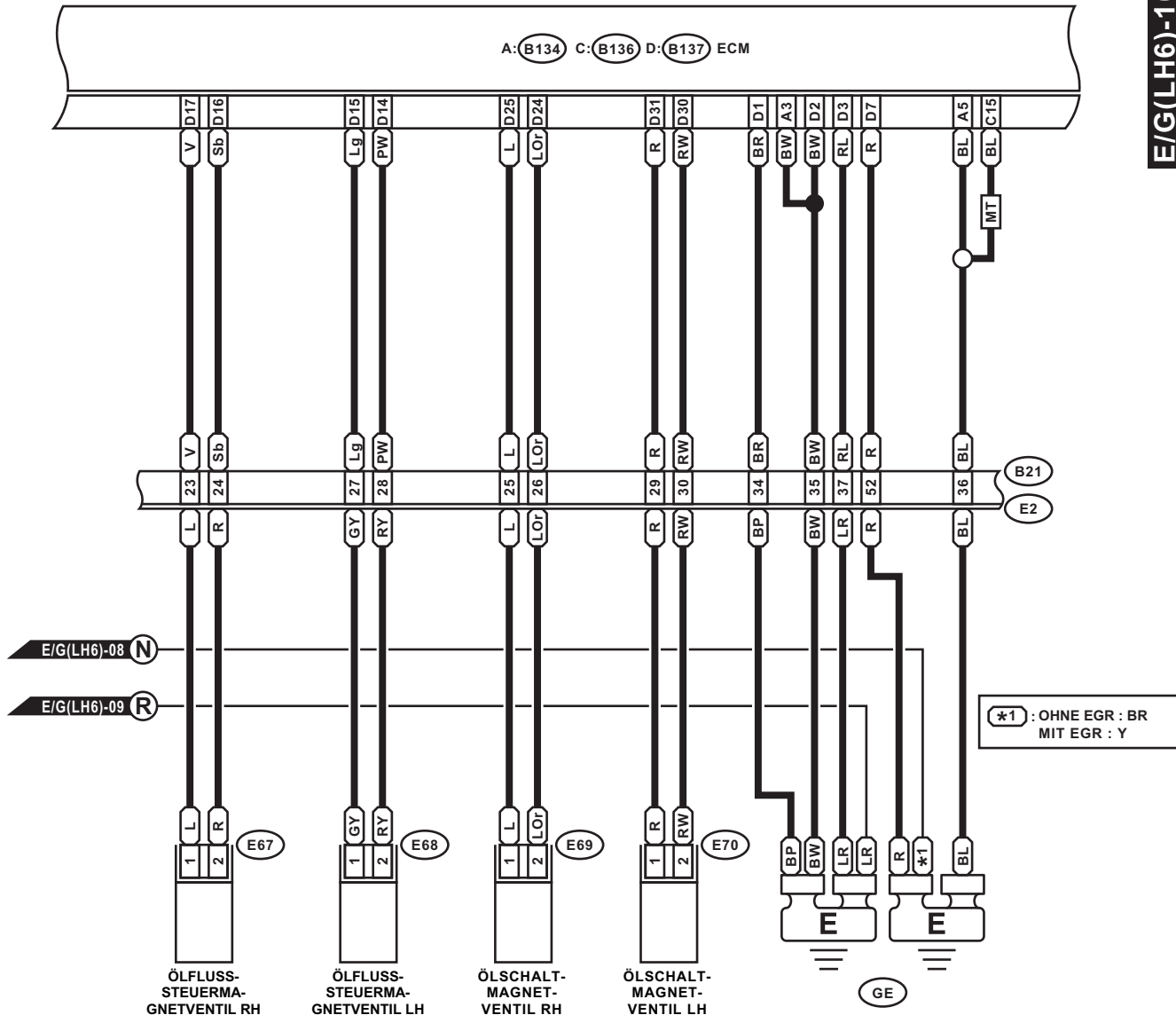

*1 : OHNE EGR : BR
MIT EGR : Y

(SCHWARZ) E67 E69 (BLAU)

D: B137

A: B134

C: B136

B21 (SCHWARZ)

(SCHWARZ) E68 E70 (BLAU)



1	2	3	4	5	6	7
8	9	10	11	12	13	14
15	16	17	18	19	20	21
22	23	24	25	26	27	28
29	30	31	32	33	34	35

1	2	3	4	5	6	7
8	9	10	11	12	13	14
15	16	17	18	19	20	21
22	23	24	25	26	27	28
29	30	31	32	33	34	35

1	2	3	4	5	6
7	8	9	10	11	12
13	14	15	16	17	18
19	20	21	22	23	24
25	26	27	28	29	30
31	32	33	34	35	36

1	2	3	4	5	6	7	8	9	10	11
12	13	14	15	16	17	18	19	20	21	22
23	24	25	26	27	28	29	30	31	32	33
34	35	36	37	38	39	40	41	42	43	44
45	46	47	48	49	50	51	52	53	54	55

- OE** : OHNE EGR
- WE** : MIT EGR
- *1** : OHNE EGR : 3
MIT EGR : 10
- *2** : OHNE EGR : P
MIT EGR : Lg
- *3** : OHNE EGR : PL
MIT EGR : LR
- *4** : OHNE EGR : PB
MIT EGR : GOr
- *5** : OHNE EGR : PG
MIT EGR : RG
- *6** : OHNE EGR : V
MIT EGR : Br
- *7** : OHNE EGR : VW
MIT EGR : GW

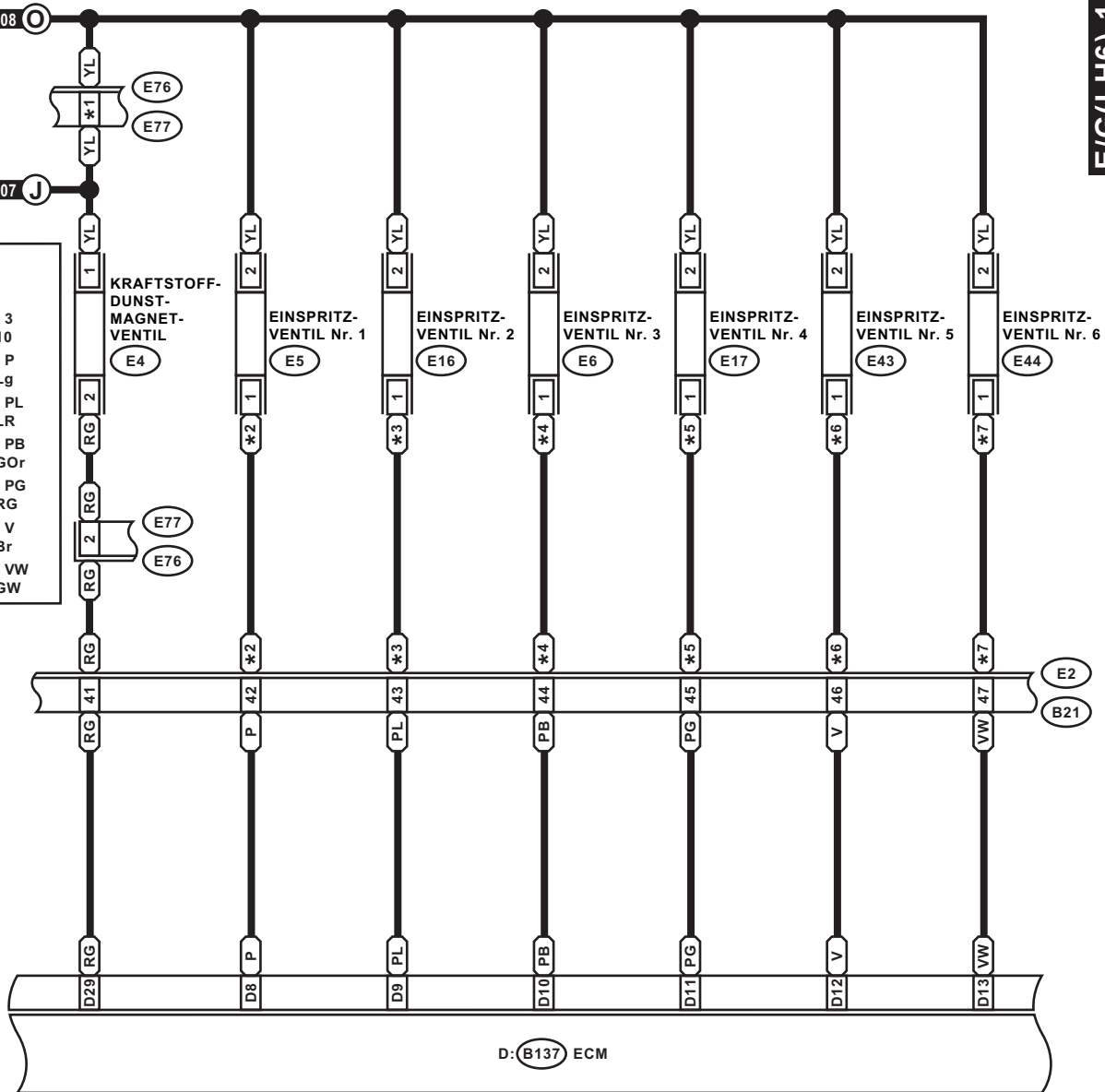

(E4) (BLAU)

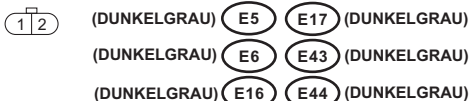

OE : (E77) (GRAU) **WE** : (E77) (GRAU)

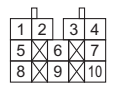

D: (B137)

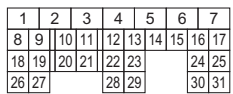

(B21) (SCHWARZ)

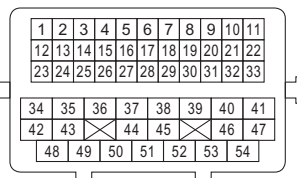

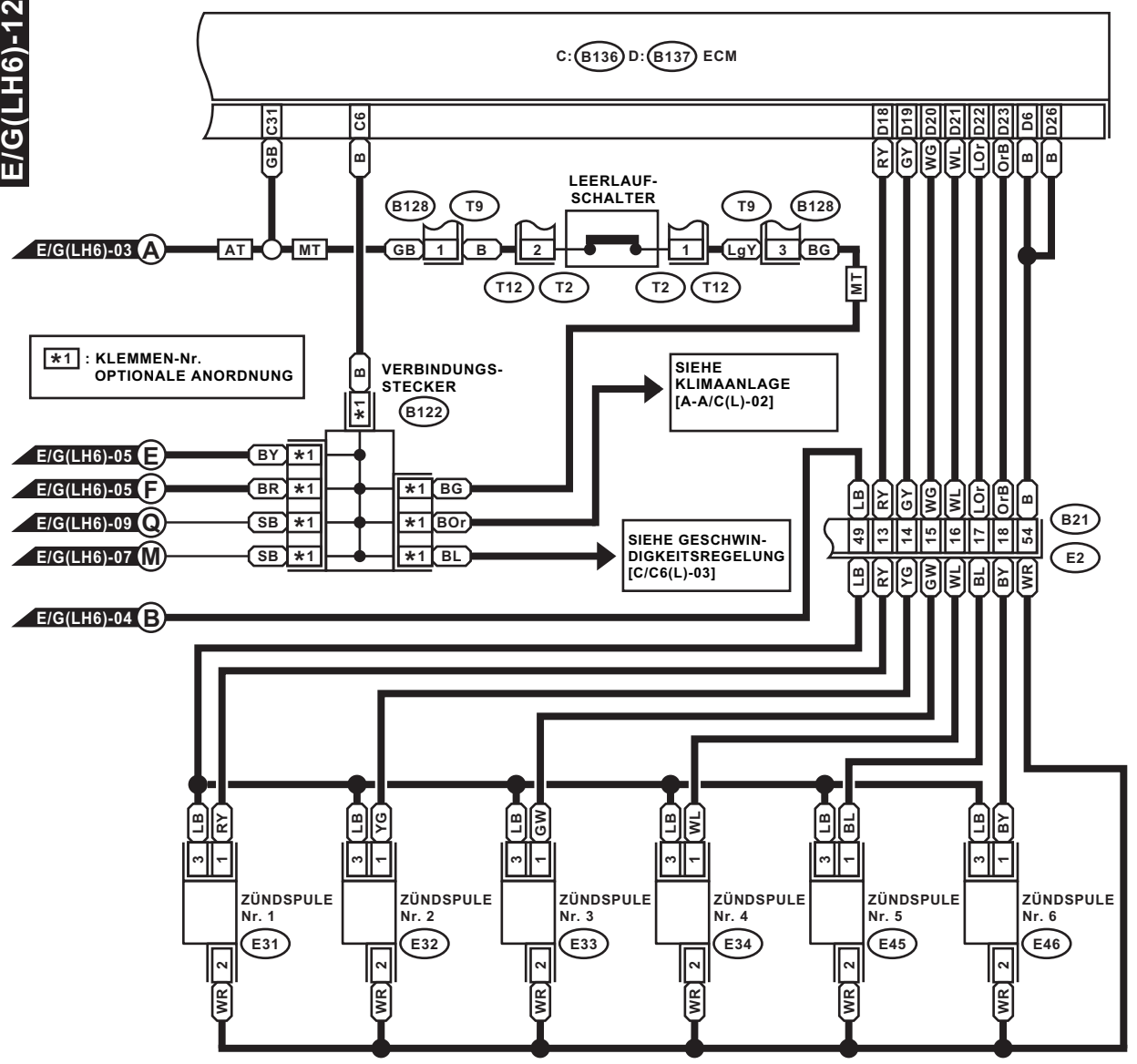

*1 : KLEMMEN-Nr. OPTIONALE ANORDNUNG

SIEHE KLIMAANLAGE [A-A/C(L)-02]

SIEHE GESCHWINDIGKEITSREGELUNG [C/C6(L)-03]

T2 (SCHWARZ)



- (SCHWARZ) E31 E34
- (SCHWARZ) E32 E45 (SCHWARZ)
- E33 E46 (SCHWARZ)



B128 (GRAU)



B122

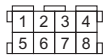

D: B137

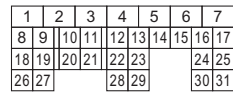

C: B136

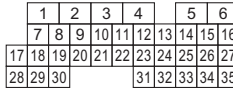

B21 (SCHWARZ)

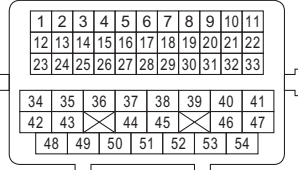

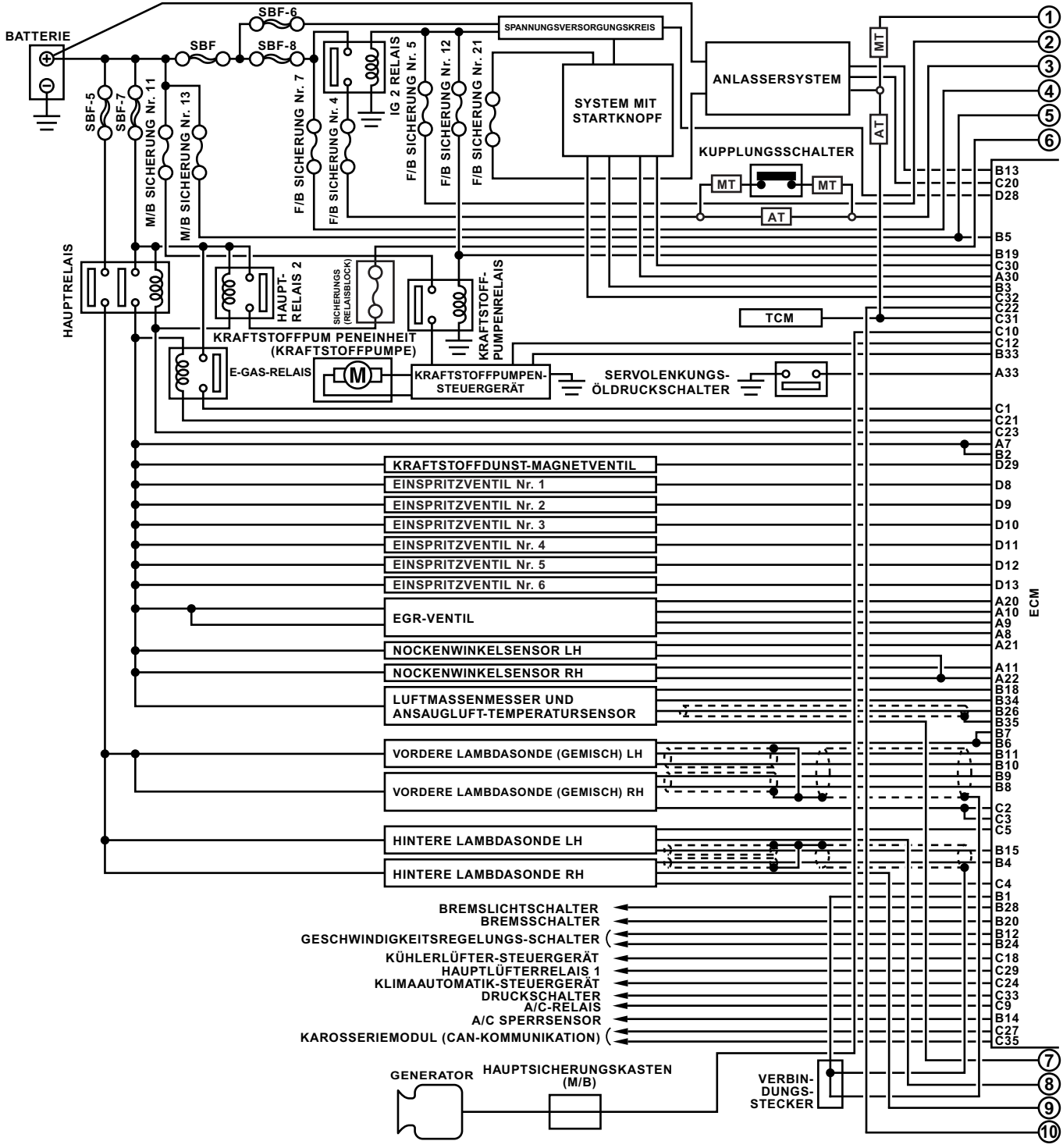

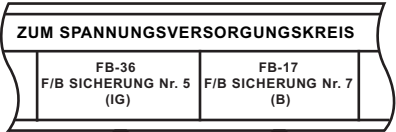

*1 : KLEMMEN-Nr. OPTIONALE ANORDNUNG
BEI 1, 2, 3, 4, 5 UND 6

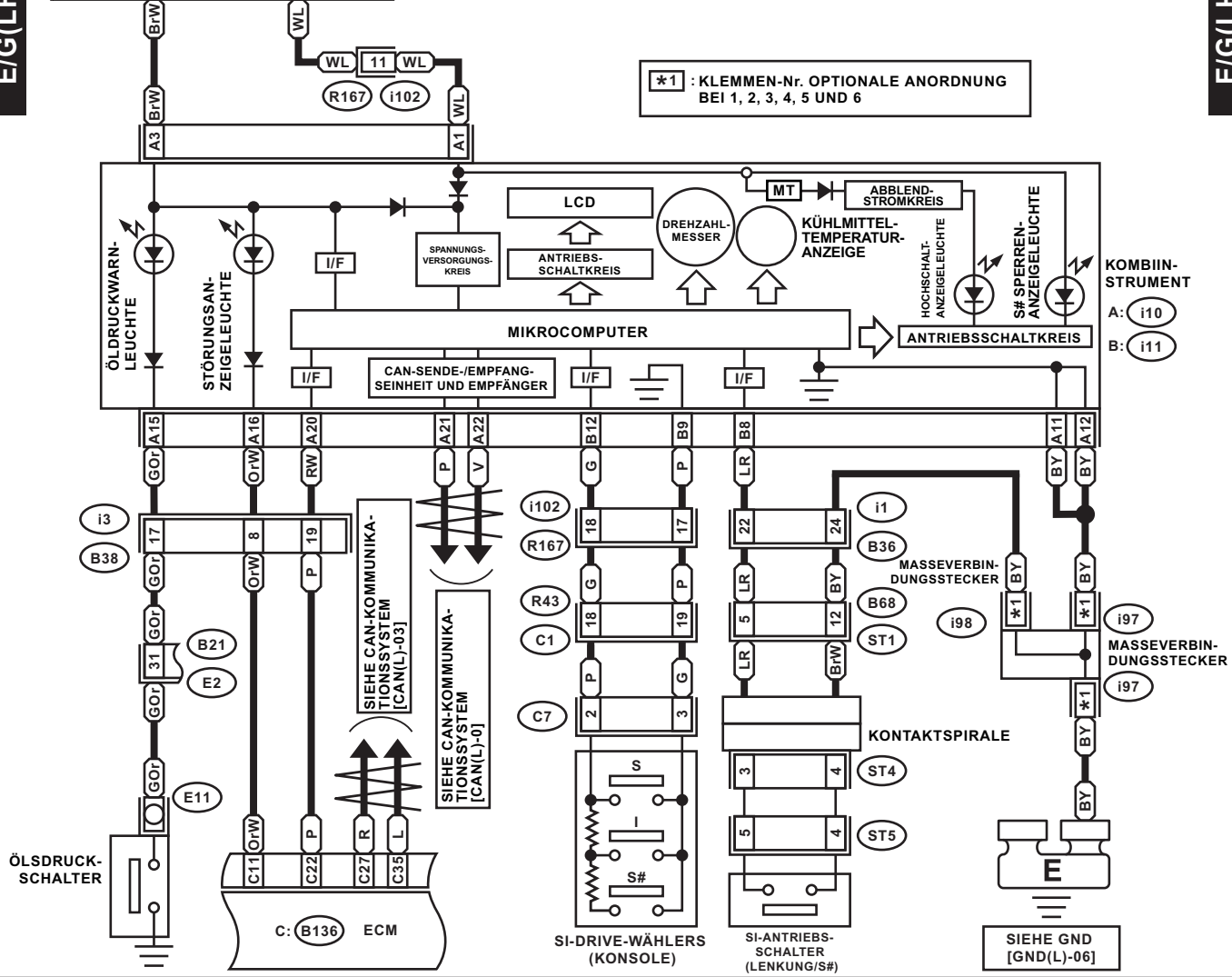

KOMBINSTRUMENT
A: i10
B: i11

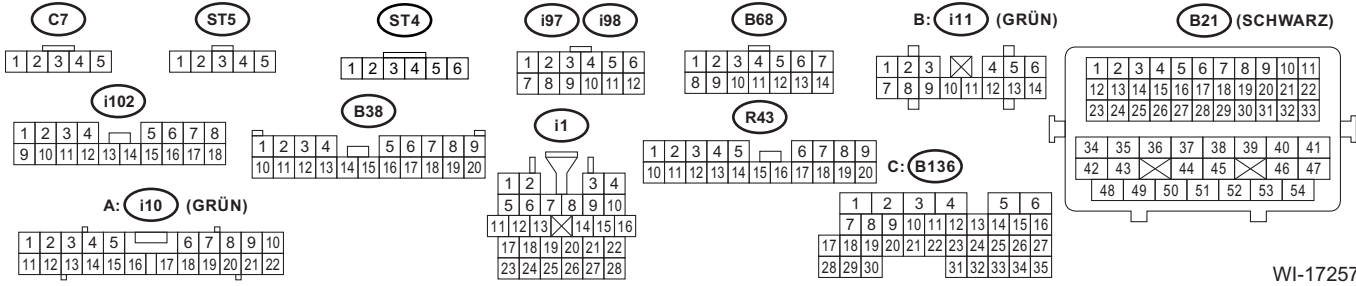

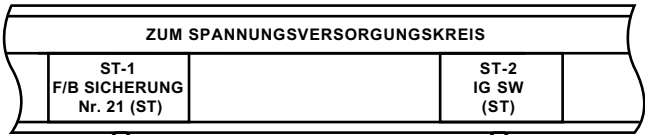

*1 : MT-MODELL : LW
AT-MODELL : BL

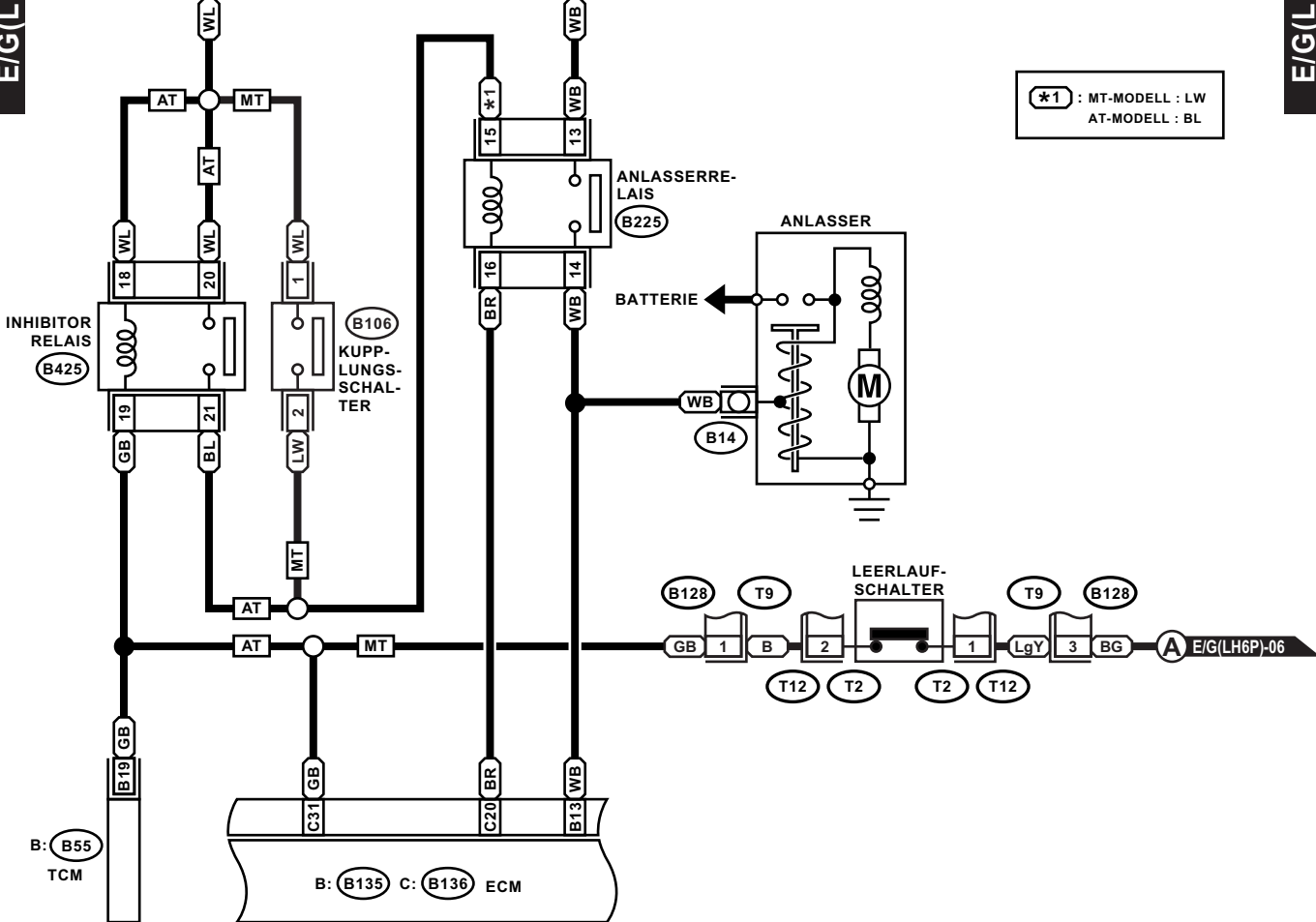

B106



T2 (SCHWARZ) B128 (GRAU)



B: B55 (GRAU)

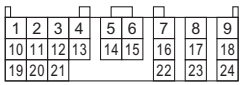

B: B135

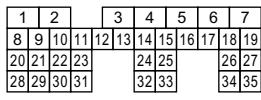

C: B136

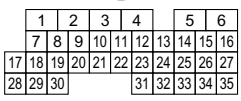

B225 (SCHWARZ)

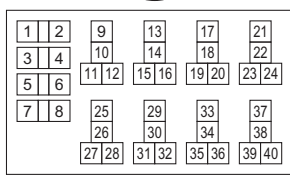

B425 (SCHWARZ)

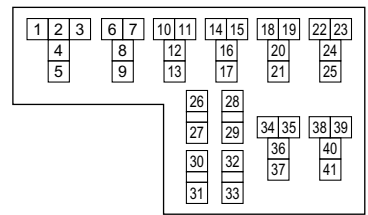

RELAISBLOCK

RELAISBLOCK

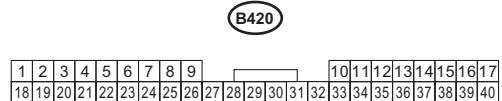
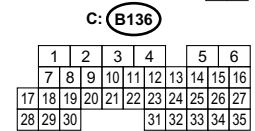
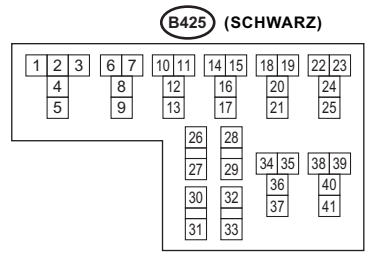
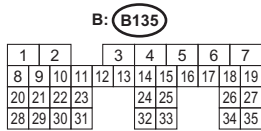
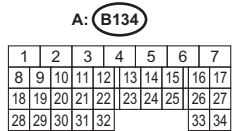
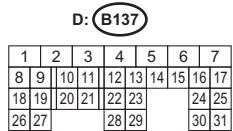
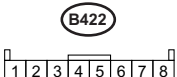
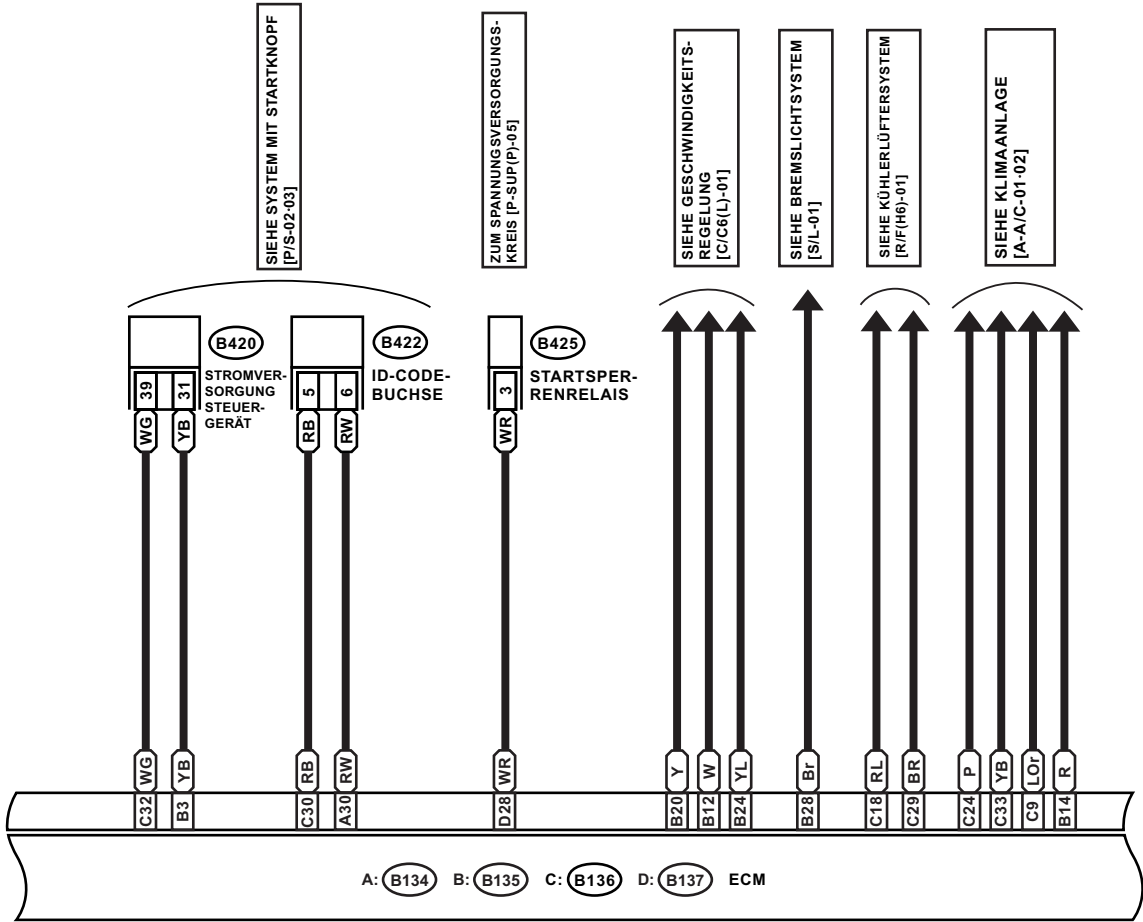

RELAISBLOCK

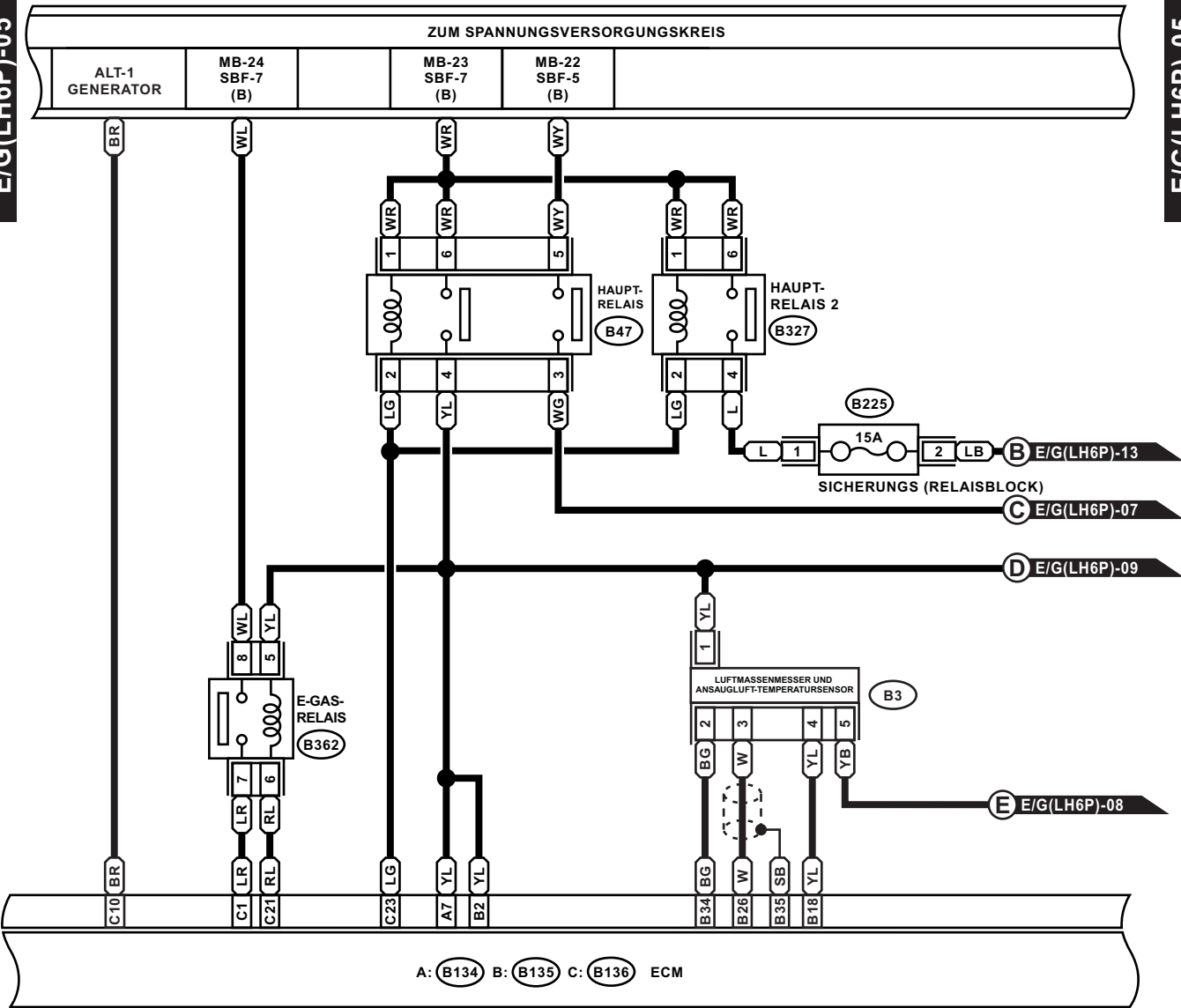

(B3) (SCHWARZ)

1	2	3	4	5
---	---	---	---	---

(B47) (BRAUN) (B327) (BRAUN)

1	2
3	4
5	6

(B362) (SCHWARZ)

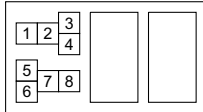

(B225) (SCHWARZ)

1	2	9	13	17	21				
3	4	10	14	18	22				
5	6	11	12	15	16	19	20	23	24
7	8	25	29	33	37				
		26	30	34	38				
		27	28	31	32	35	36	39	40

RELAISBLOCK

A: (B134)

1	2	3	4	5	6	7			
8	9	10	11	12	13	14	15	16	17
18	19	20	21	22	23	24	25	26	27
28	29	30	31	32				33	34

B: (B135)

1	2	3	4	5	6	7					
8	9	10	11	12	13	14	15	16	17	18	19
20	21	22	23	24	25	26	27				
28	29	30	31	32	33	34	35				

C: (B136)

1	2	3	4	5	6					
7	8	9	10	11	12	13	14	15	16	
17	18	19	20	21	22	23	24	25	26	27
28	29	30		31	32	33	34	35		

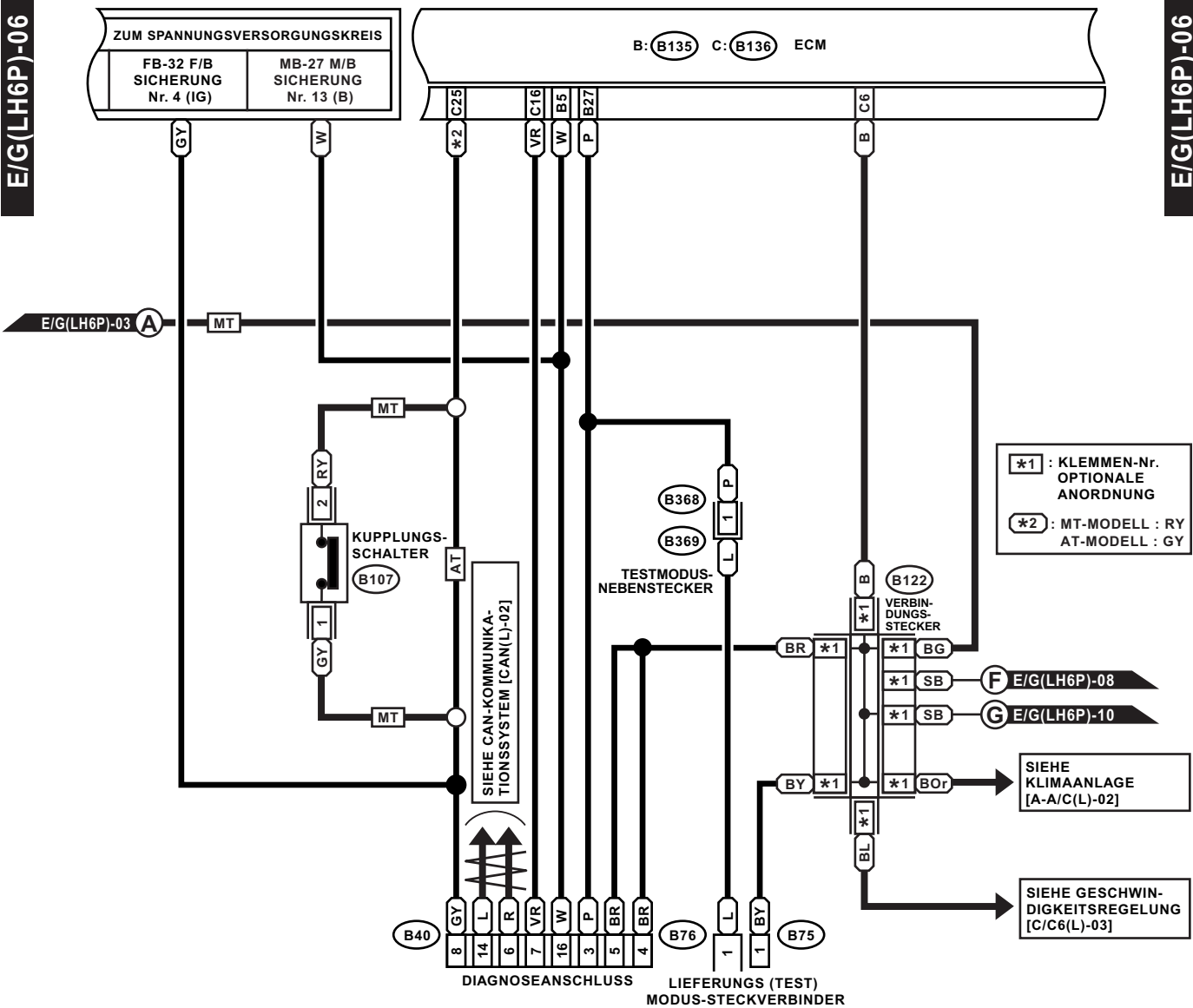

*1 : KLEMMEN-Nr. OPTIONALE ANORDNUNG

*2 : MT-MODELL : RY AT-MODELL : GY

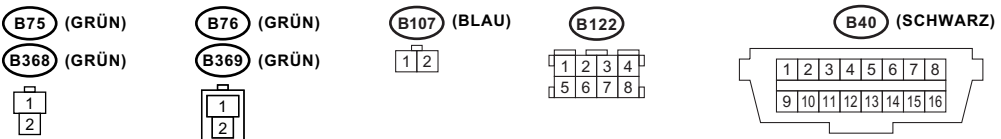

B: B135

C: B136

1	2	3	4	5	6	7					
8	9	10	11	12	13	14	15	16	17	18	19
20	21	22	23	24	25	26	27				
28	29	30	31	32	33	34	35				

1	2	3	4	5	6					
7	8	9	10	11	12	13	14	15	16	
17	18	19	20	21	22	23	24	25	26	27
28	29	30	31	32	33	34	35			

E/G(LH6P)-05 C

*1 : KLEMMEN-Nr. OPTIONALE ANORDNUNG BEI 1, 2, 5 UND 6

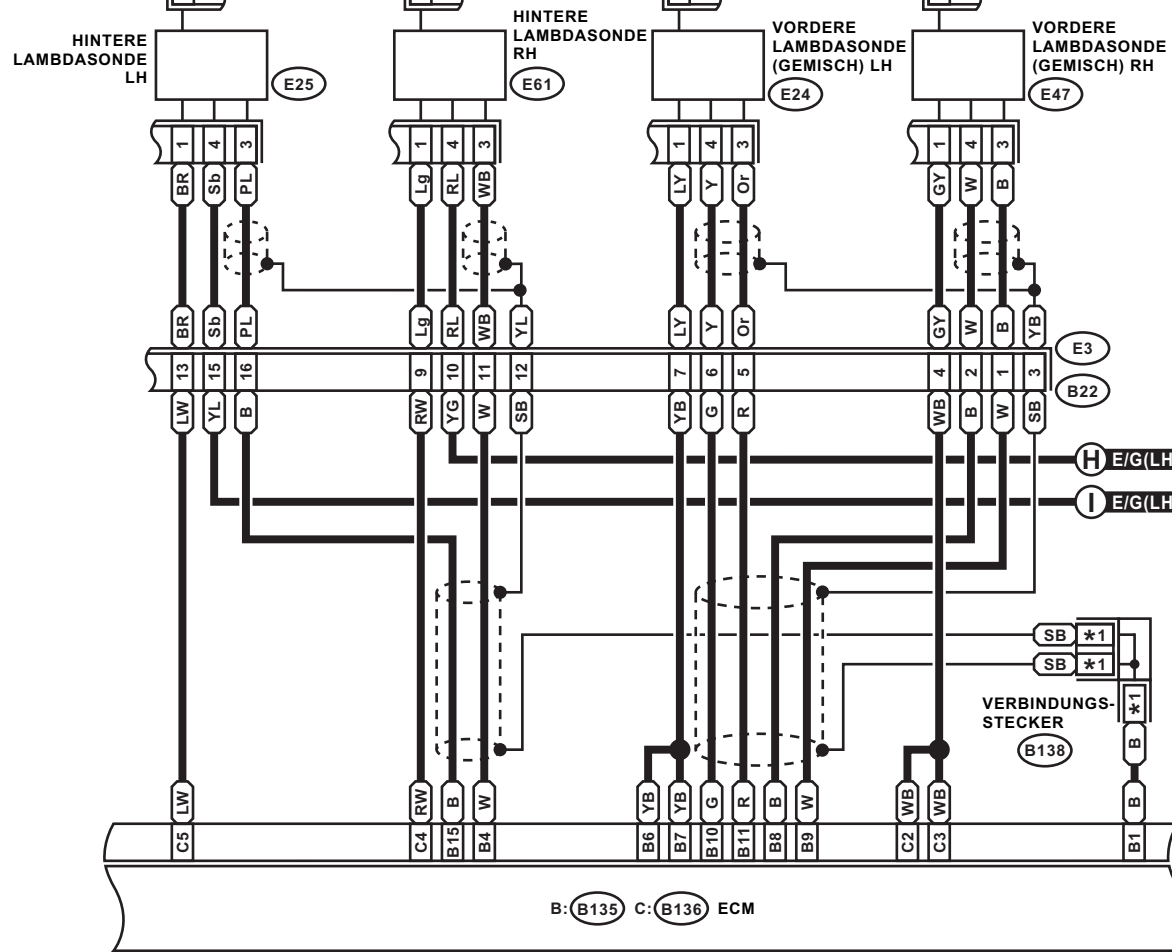

- E24 (HELLGRAU)
- E25 (DUNKELGRAU)
- E47 (HELLGRAU)
- E61 (DUNKELGRAU)

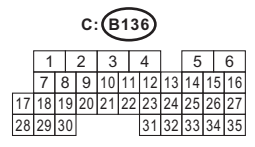
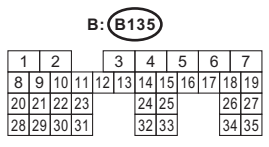
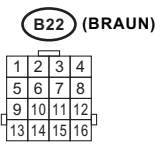
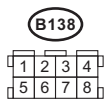

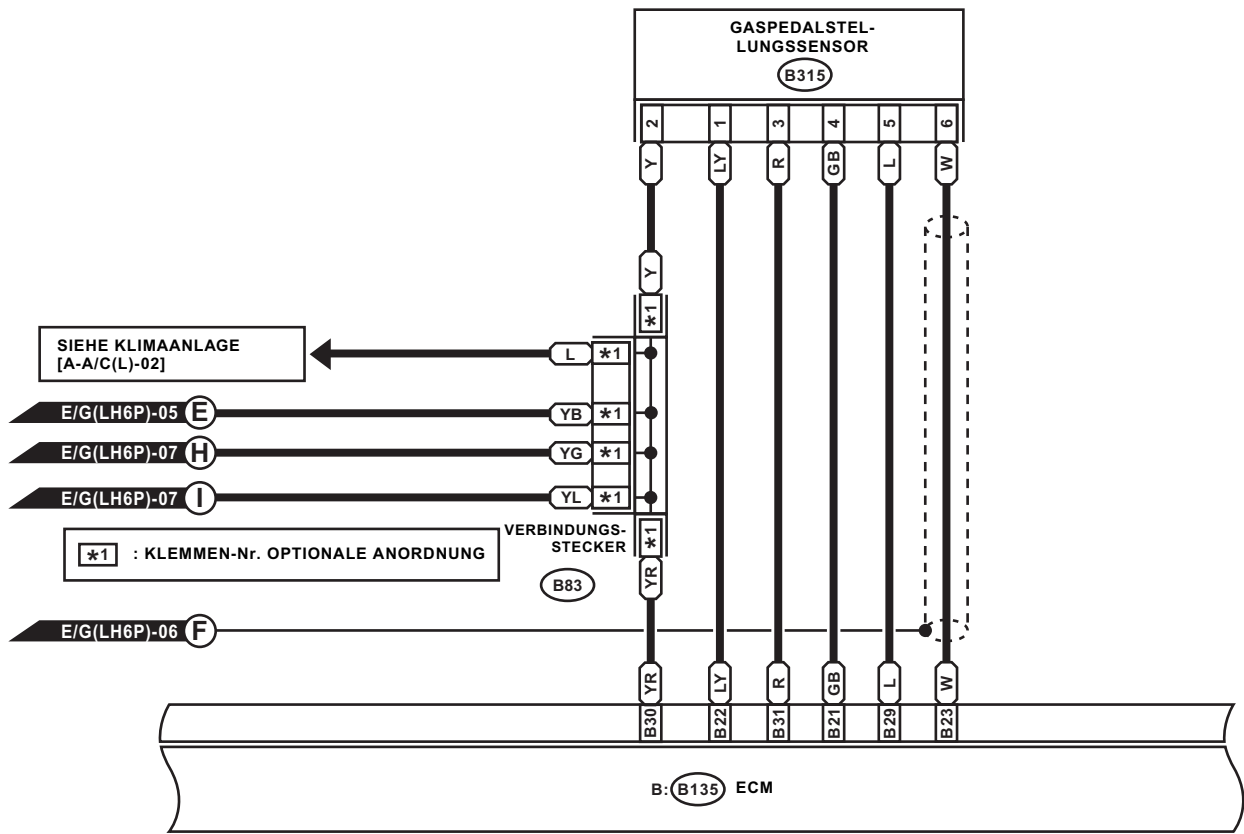

B315 (SCHWARZ)

B83

B: B135

1	2	3	4	5	6
---	---	---	---	---	---

1	2	3	4
5	6	7	8

1	2	3	4	5	6	7
8	9	10	11	12	13	14
15	16	17	18	19	20	21
22	23	24	25	26	27	28
29	30	31	32	33	34	35

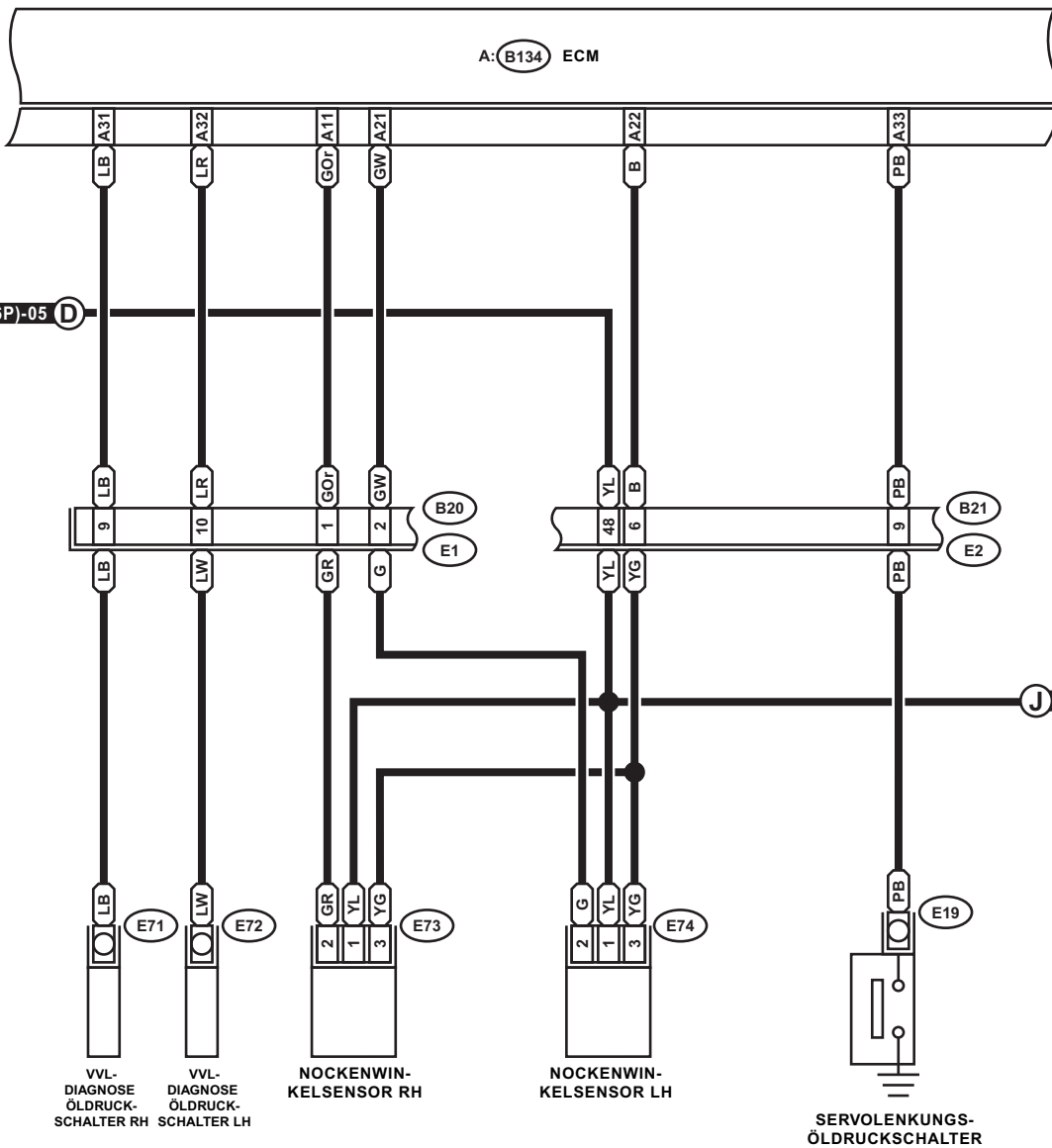

E73 (GRAU)

B20 (BRAUN)

A: B134

B21 (SCHWARZ)



E74 (GRAU)

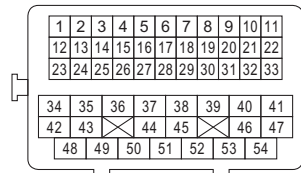
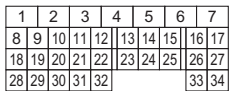

A: (B134) D: (B137) ECM

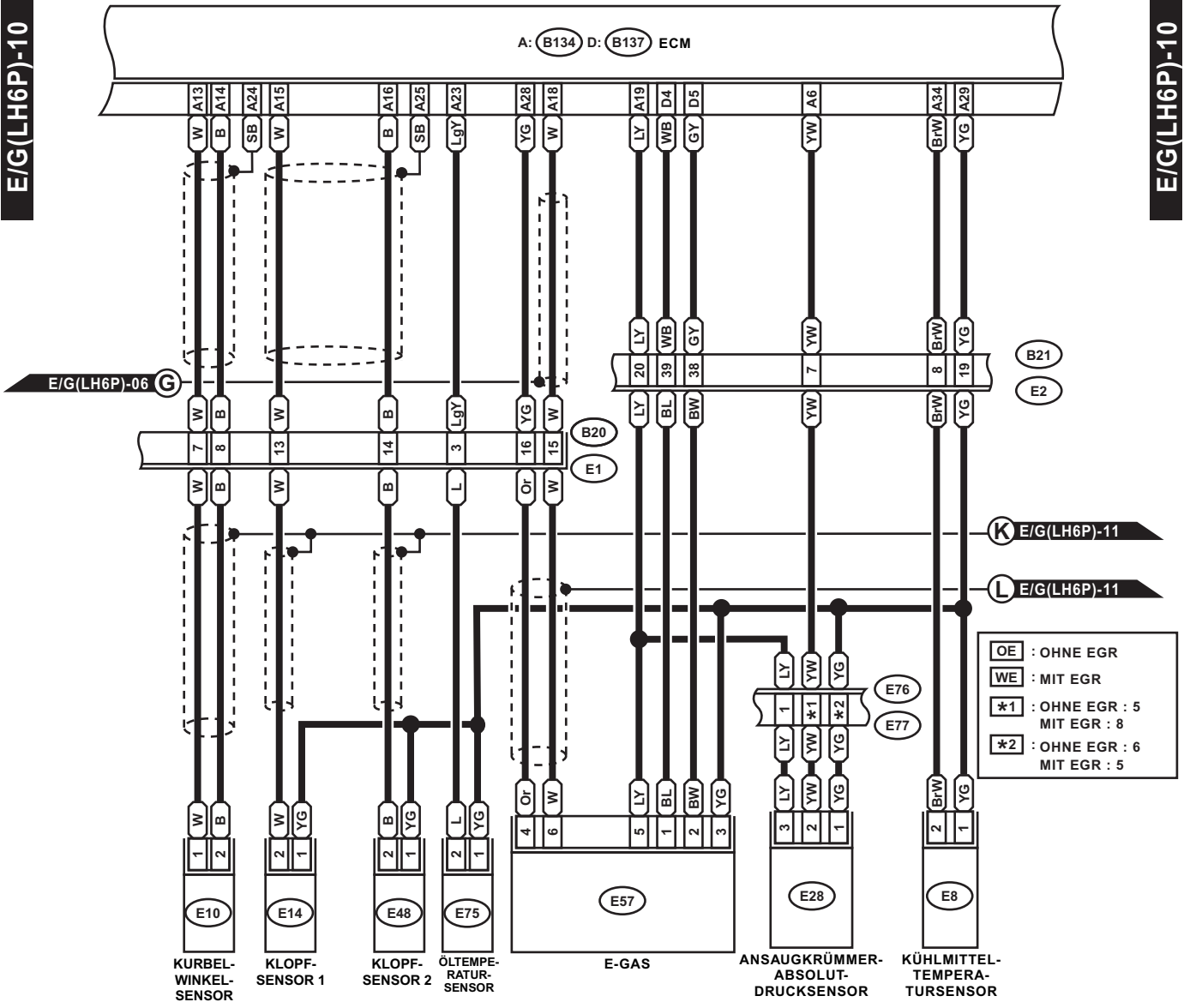

OE : OHNE EGR
WE : MIT EGR
***1** : OHNE EGR : 5
 MIT EGR : 8
***2** : OHNE EGR : 6
 MIT EGR : 5

E8 (SCHWARZ) **E48** (BLAU) **E28** (SCHWARZ) **OE** : **E77** (GRAU) **WE** : **E77** (GRAU) **B20** (BRAUN)

E10 (HELLGRAU) **E75** (SCHWARZ) **E57** (SCHWARZ) **B21** (SCHWARZ)

E14 (BLAU)

D: (B137)

1	2	3	4	5	6	7
8	9	10	11	12	13	14
15	16	17	24	25	26	27
28	29	30	31			

A: (B134)

1	2	3	4	5	6	7
8	9	10	11	12	13	14
15	16	17	23	24	25	26
27	28	29	30	31	32	33
34						

1	2	3
4	5	6

1	2	3	4
5	6	7	8
9	10	11	12

1	2	3	4
5	6	7	8
9	10	11	12
13	14	15	16

1	2	3	4	5	6	7	8	9	10	11	12
13	14	15	16	17	18	19	20	21	22	23	24
25	26	27	28	29	30	31	32	33			

A: B134 C: B136 D: B137 ECM

*1 : OHNE EGR : BR
: MIT EGR : Y

E/G(LH6P)-10 K
E/G(LH6P)-10 L

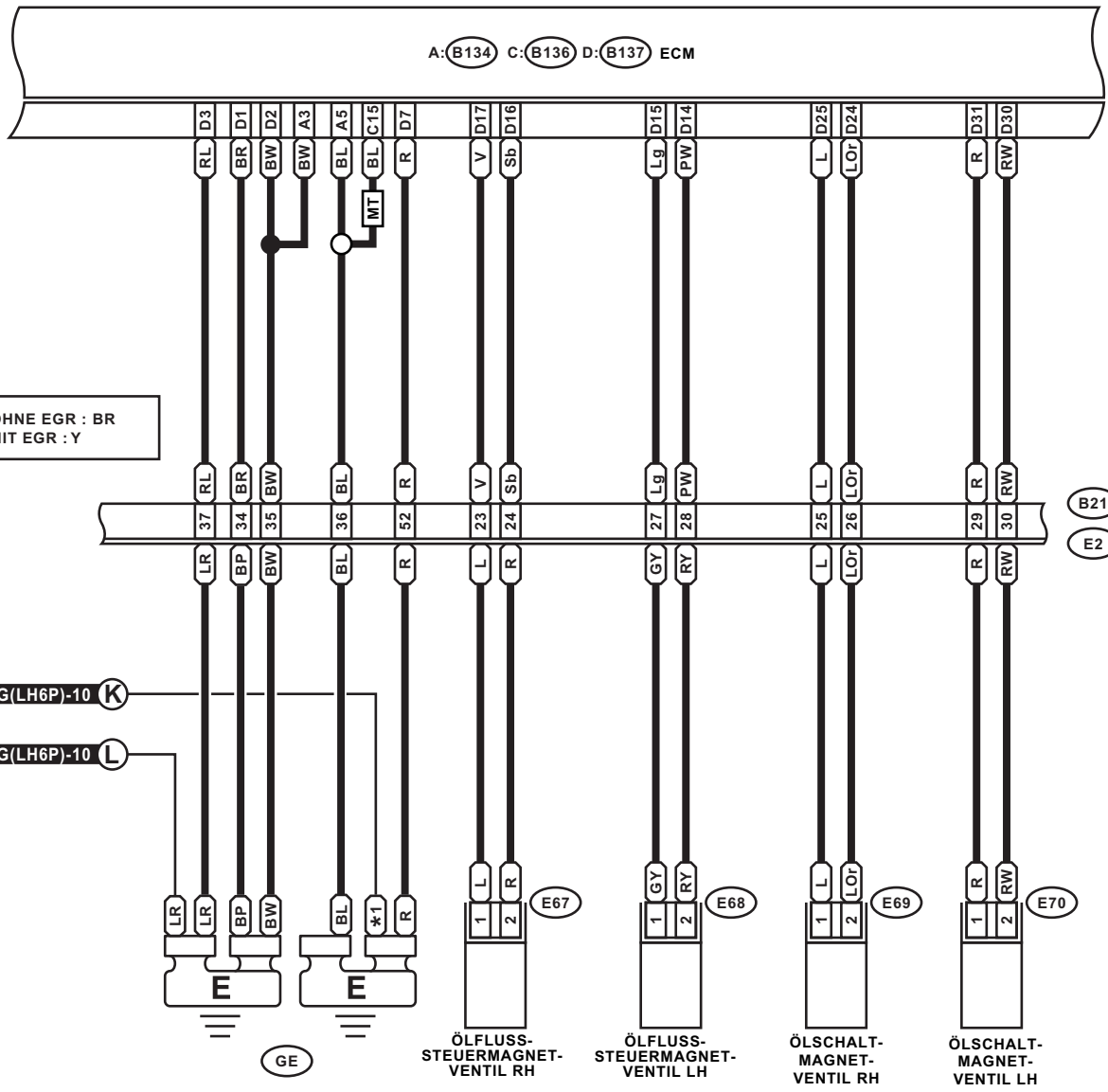

(SCHWARZ) E67 E69 (BLAU)

D: B137

A: B134

C: B136

B21 (SCHWARZ)

(SCHWARZ) E68 E70 (BLAU)



1	2	3	4	5	6	7
8	9	10	11	12	13	14
15	16	17	18	19	20	21
22	23	24	25	26	27	28
29	30	31				

1	2	3	4	5	6	7
8	9	10	11	12	13	14
15	16	17	18	19	20	21
22	23	24	25	26	27	28
29	30	31	32	33	34	

1	2	3	4	5	6
7	8	9	10	11	12
13	14	15	16	17	18
19	20	21	22	23	24
25	26	27	28	29	30
31	32	33	34	35	

1	2	3	4	5	6	7	8	9	10	11
12	13	14	15	16	17	18	19	20	21	22
23	24	25	26	27	28	29	30	31	32	33
34	35	36	37	38	39	40	41			
42	43	44	45	46	47					
48	49	50	51	52	53	54				

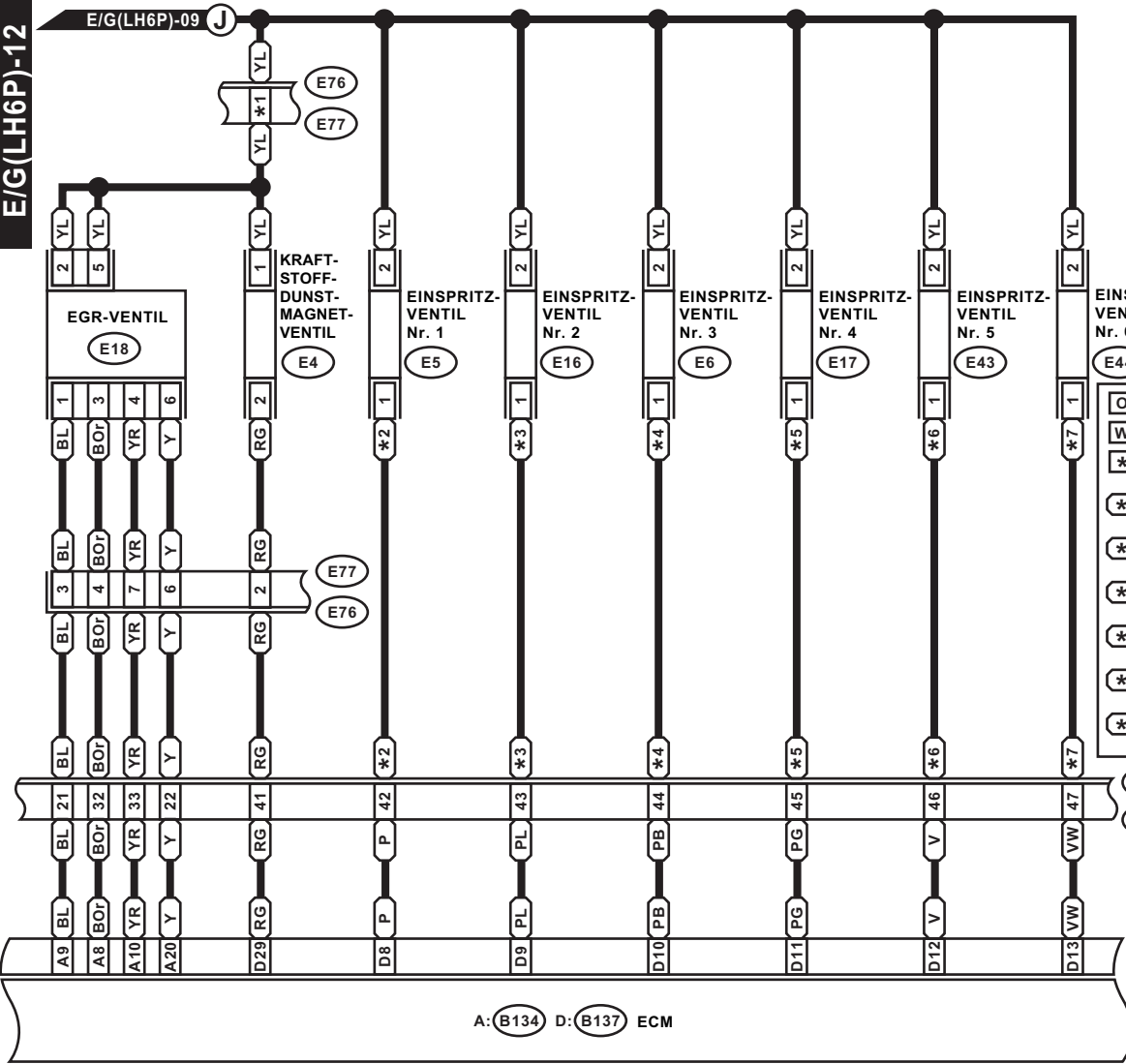

- OE** : OHNE EGR
- WE** : MIT EGR
- *1** : OHNE EGR : 3
MIT EGR : 10
- *2** : OHNE EGR : P
MIT EGR : Lg
- *3** : OHNE EGR : PL
MIT EGR : LR
- *4** : OHNE EGR : PB
MIT EGR : GO
- *5** : OHNE EGR : PG
MIT EGR : RG
- *6** : OHNE EGR : V
MIT EGR : Br
- *7** : OHNE EGR : VW
MIT EGR : GW

A: B134 D: B137 ECM

E4 (BLAU)

(DUNKELGRAU) E5 E17 (DUNKELGRAU)

E18 (DUNKELGRAU)

WE : E77 (GRAU)

D: B137

1 2

(DUNKELGRAU) E6 E43 (DUNKELGRAU)

OE : E77 (GRAU)

1	2	3	4
5	X	6	X
8	X	9	X
			10

1	2	3	4	5	6	7
8	9	10	11	12	13	14
15	16	17				
18	19	20	21	22	23	24
25	26	27		28	29	30
						31
						32
						33
						34

(DUNKELGRAU) E16 E44 (DUNKELGRAU)

1 2

1	2	3
4	5	6

B21 (SCHWARZ)

A: B134

1	2	3	4	5	6	7
8	9	10	11	12	13	14
15	16	17				
18	19	20	21	22	23	24
25	26	27				
28	29	30	31	32		33
						34

1	2	3	4	5	6	7	8	9	10	11
12	13	14	15	16	17	18	19	20	21	22
23	24	25	26	27	28	29	30	31	32	33
34	35	36	37	38	39	40	41			
42	43	X	44	45	X	46	47			
48	49	50	51	52	53	54				

D: B137 ECM

E/G(LH6P)-05 B

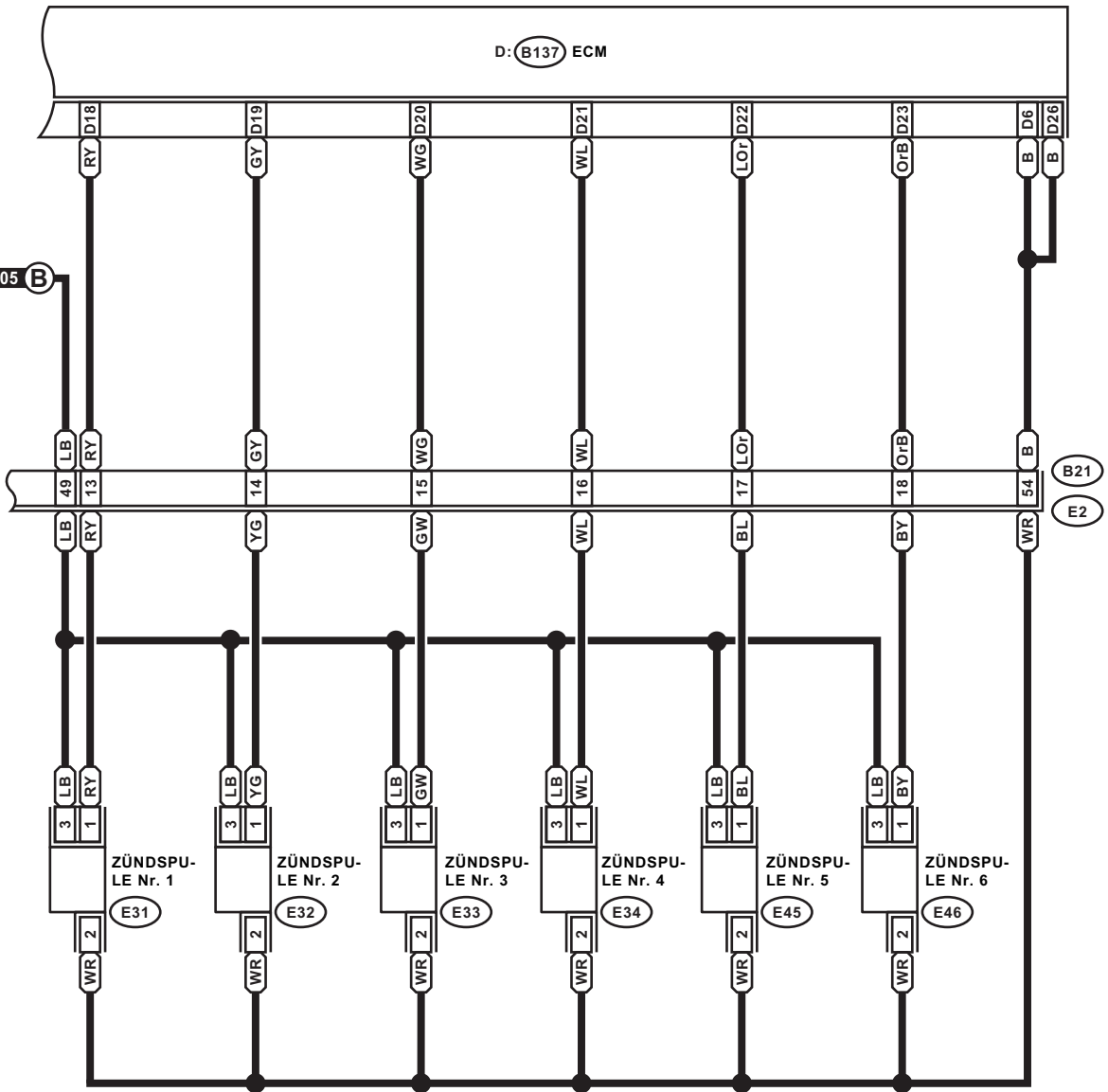

- (SCHWARZ) E31 E34
- (SCHWARZ) E32 E45 (SCHWARZ)
- E33 E46 (SCHWARZ)



D: B137

1	2	3	4	5	6	7			
8	9	10	11	12	13	14	15	16	17
18	19	20	21	22	23	24	25	26	27
28	29	30	31						

B21 (SCHWARZ)

1	2	3	4	5	6	7	8	9	10	11
12	13	14	15	16	17	18	19	20	21	22
23	24	25	26	27	28	29	30	31	32	33
34	35	36	37	38	39	40	41			
42	43	X	44	45	X	46	47			
48	49	50	51	52	53	54				

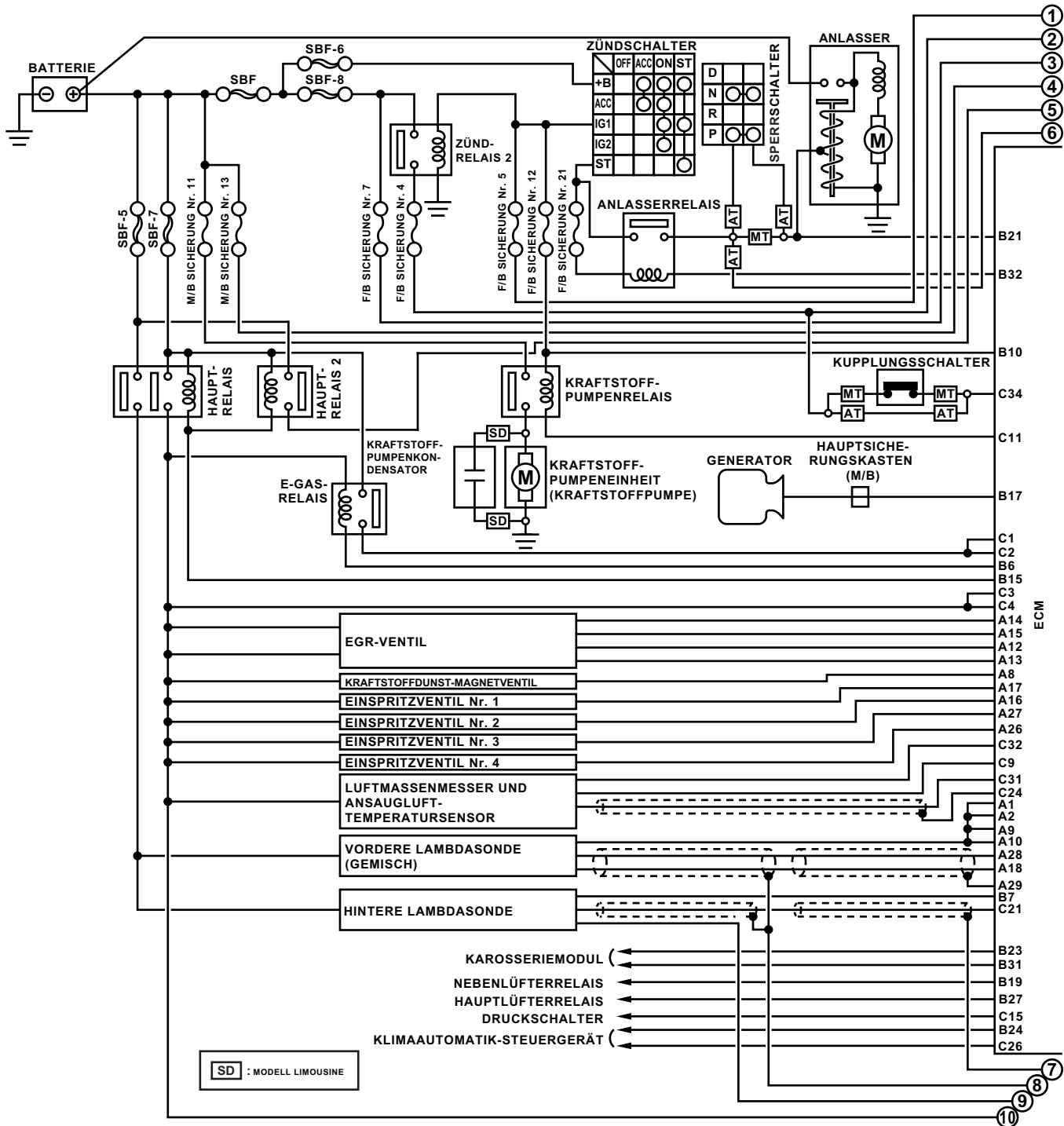

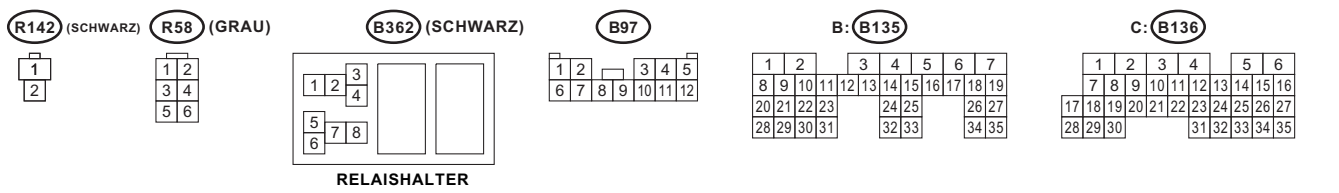
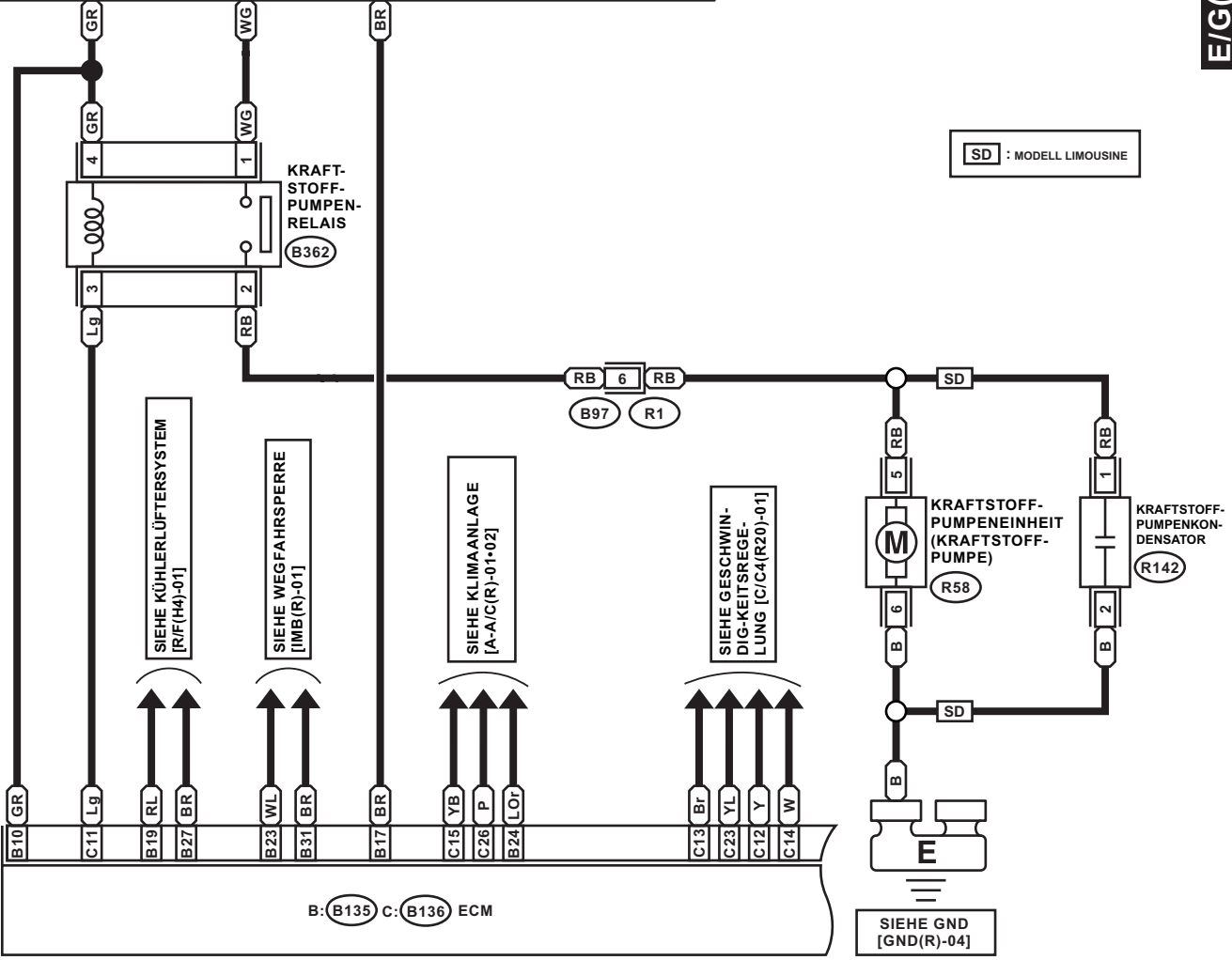
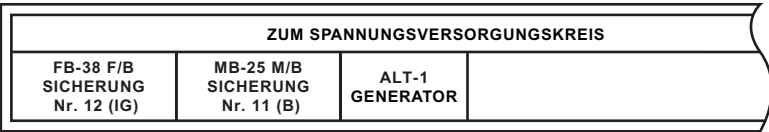

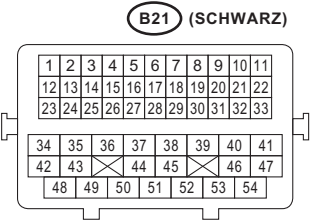
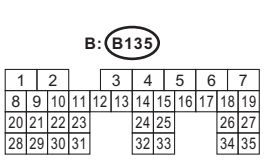
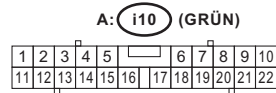
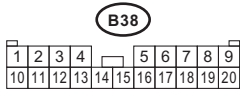
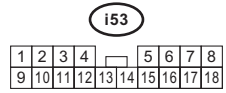
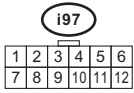
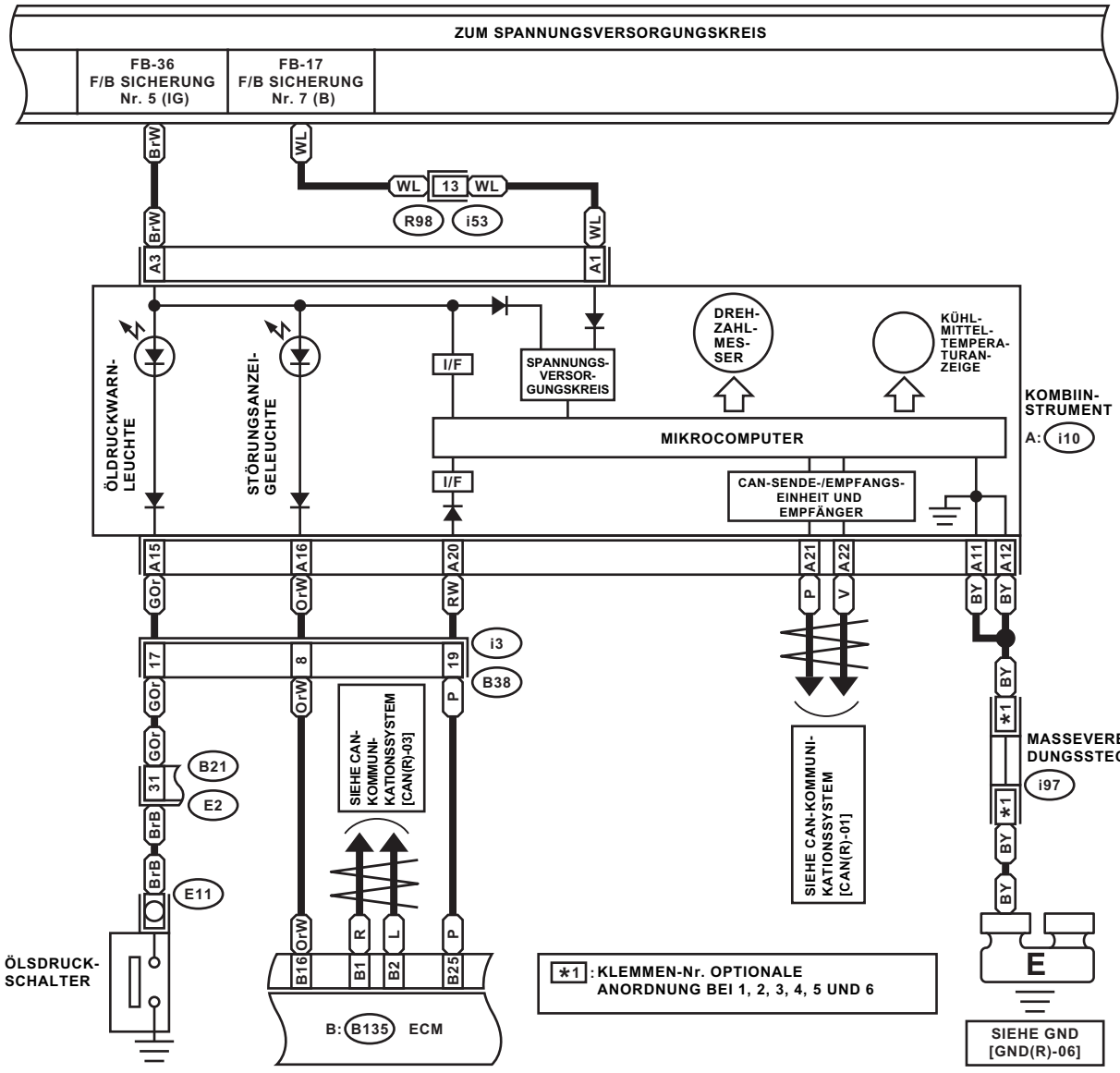

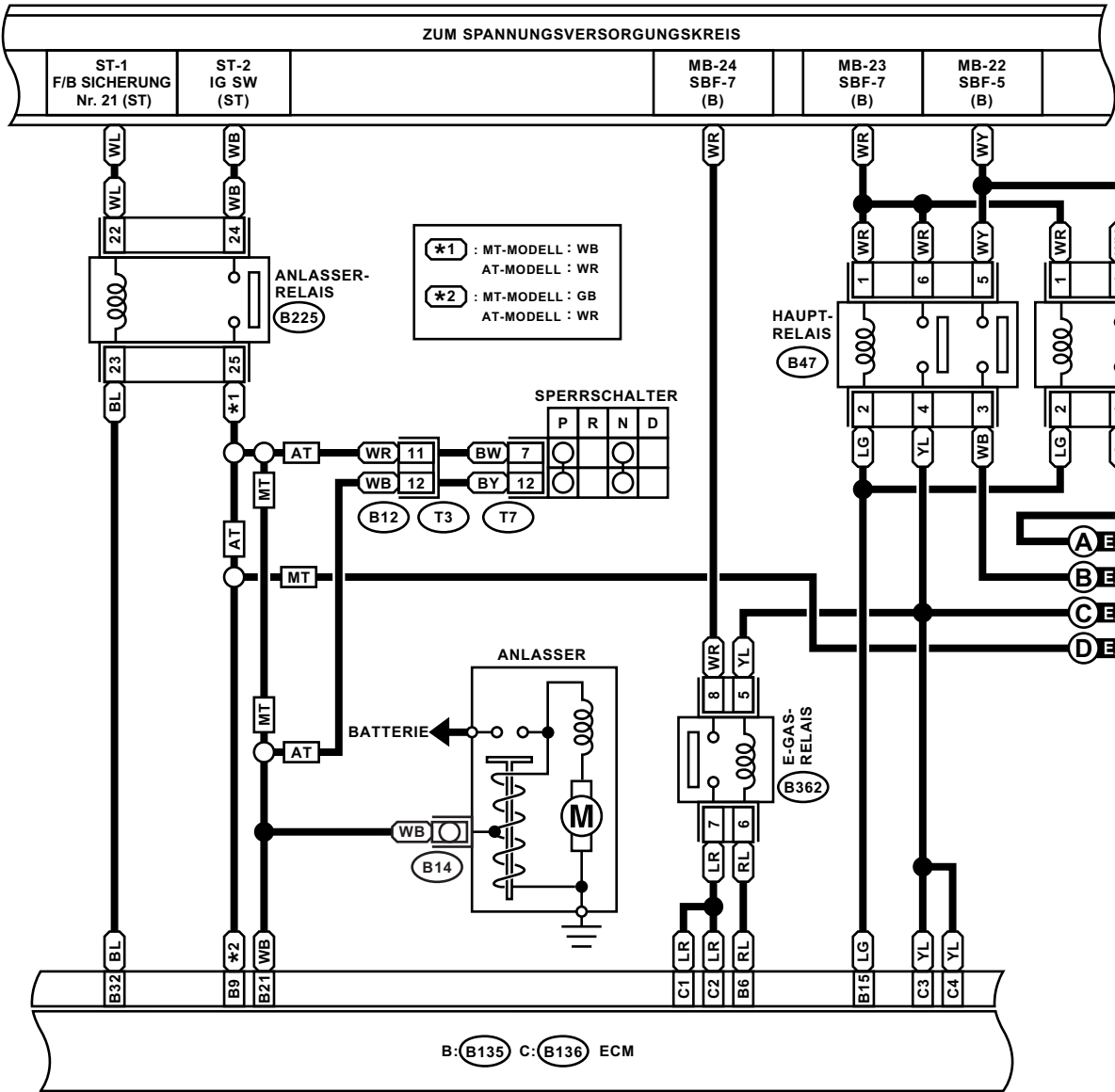

B47 (BRAUN)



B362 (SCHWARZ)

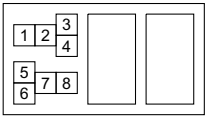

B12 (GRAU)

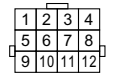

T7 (SCHWARZ)

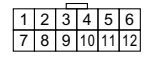

B225 (SCHWARZ)

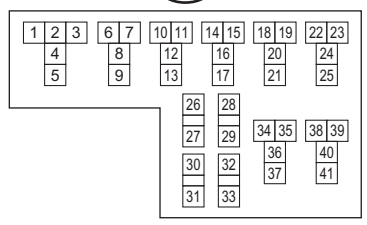

B: B135

RELAISHALTER

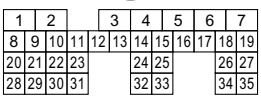

C: B136

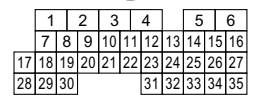

RELAISBLOCK

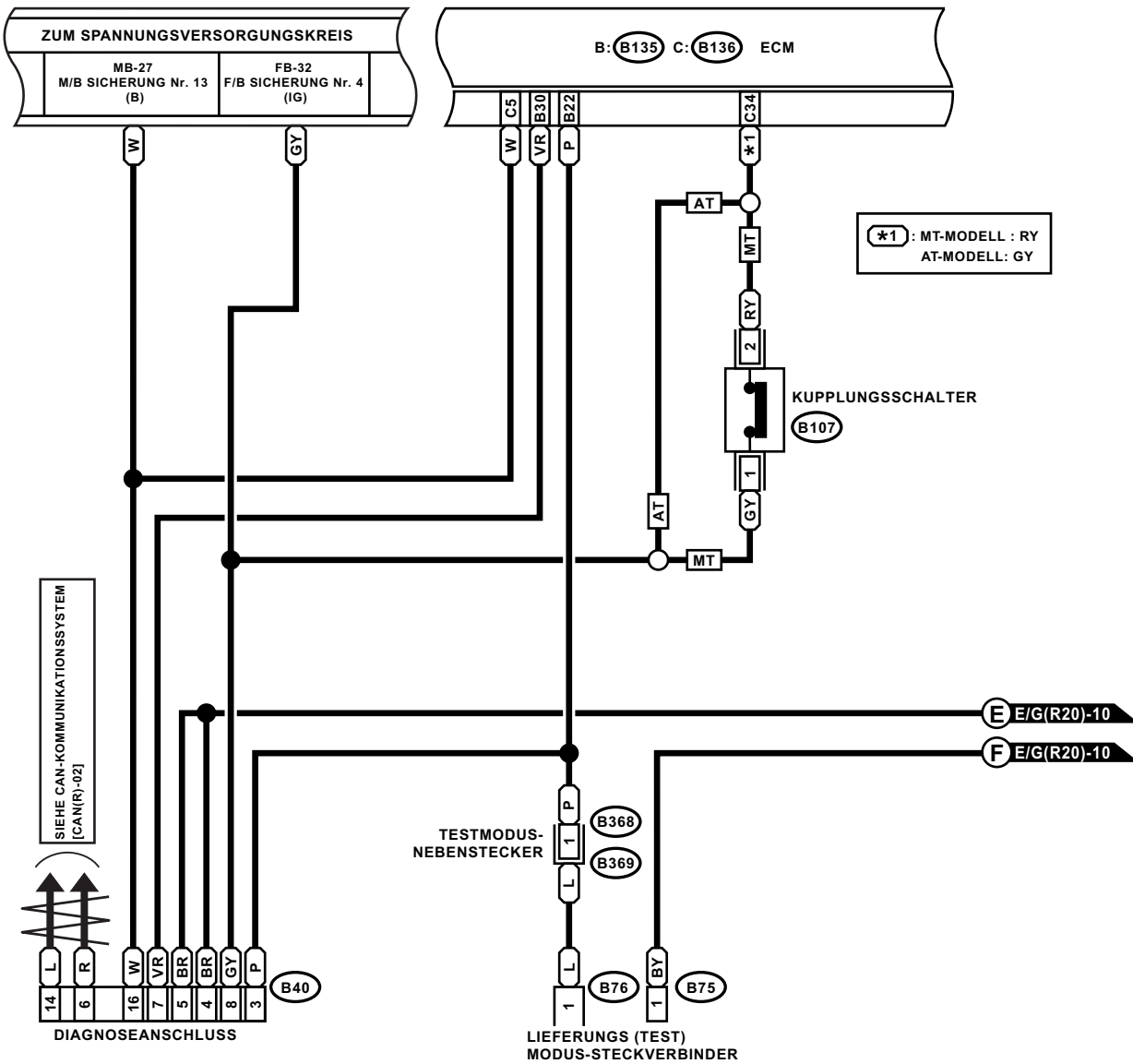

(B75) (GRÜN)

(B76) (GRÜN)

(B107) (BLAU)

(B40) (SCHWARZ)

B: (B135)

C: (B136)

(B368) (GRÜN)

(B369) (GRÜN)

1 2

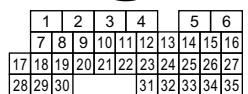

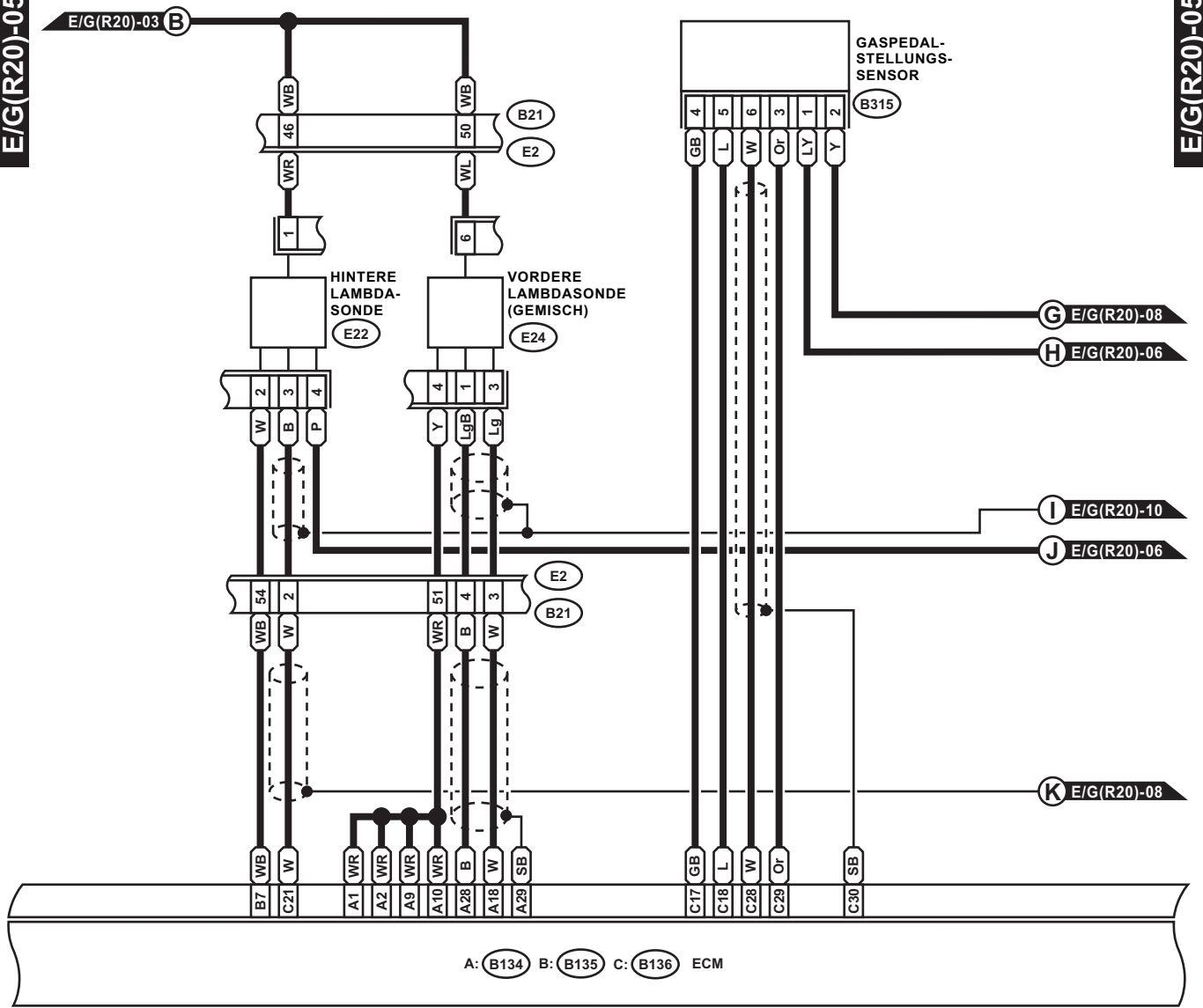

E22 (DUNKELGRAU) **B315** (SCHWARZ)

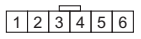

E24 (SCHWARZ)



A: B134

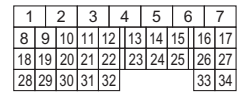

B21 (SCHWARZ)

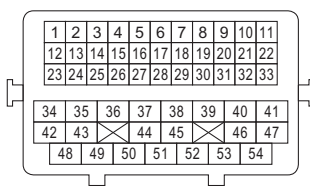

B: B135

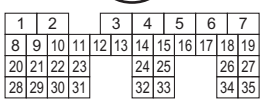

C: B136



D: B137 ECM

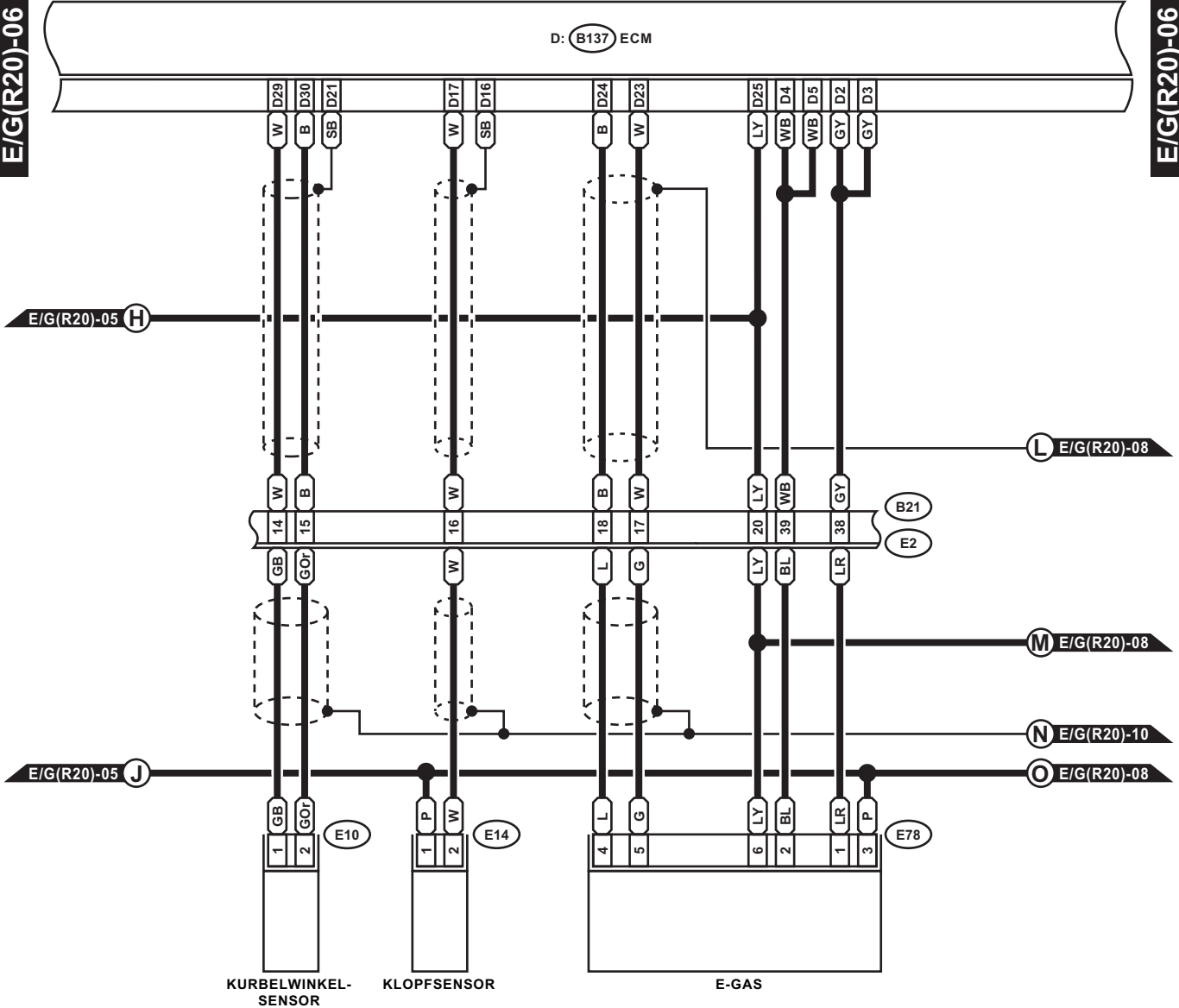

E10 (HELLGRAU)

E14 (GRAU)

E78 (SCHWARZ)

D: B137

B21 (SCHWARZ)

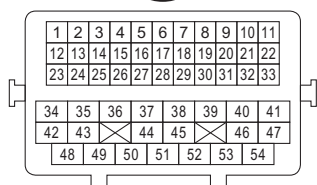
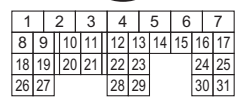

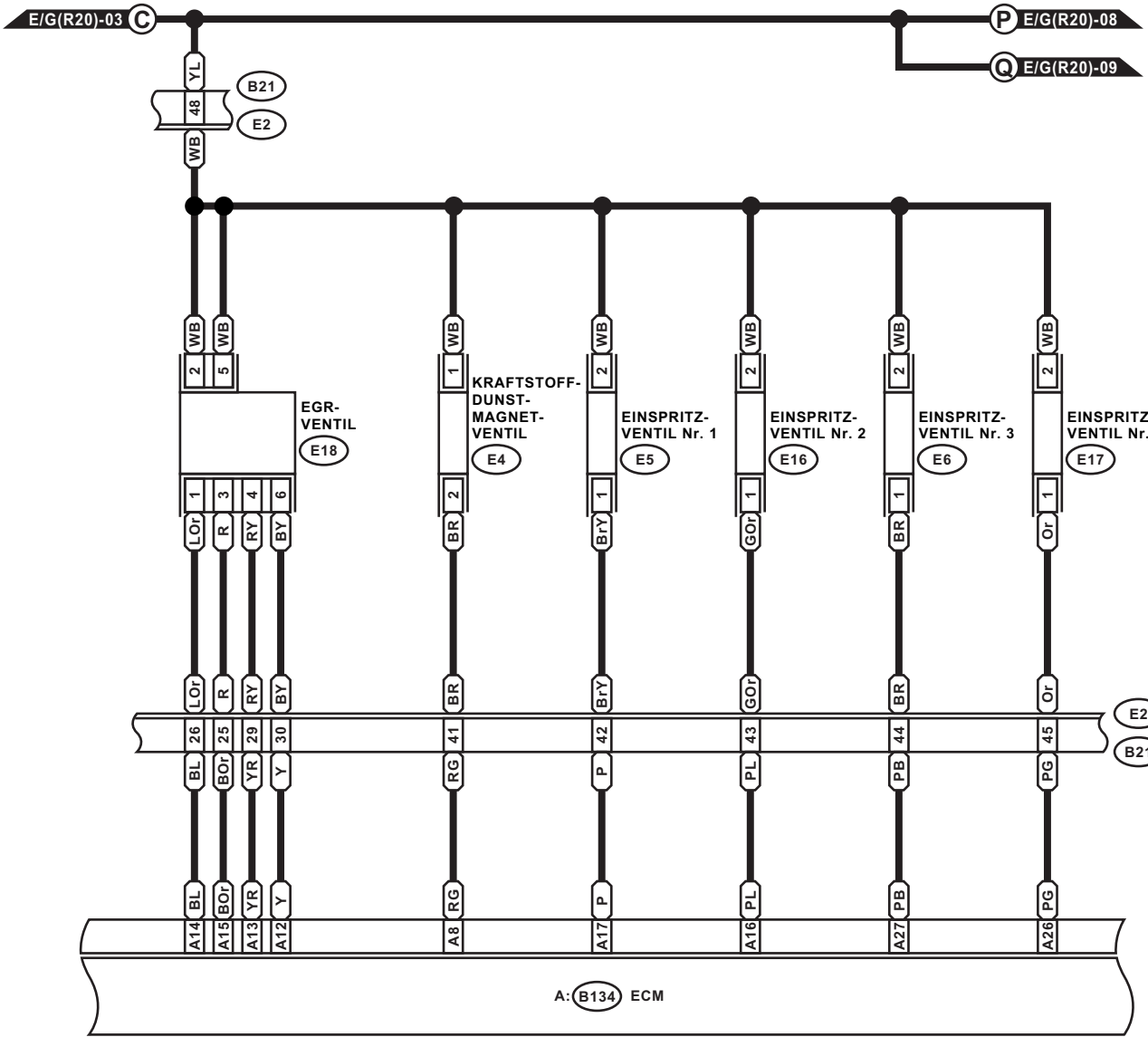

- E4** (SCHWARZ)
 - E5** (HELLGRAU)
 - E6** (HELLGRAU)
 - E16** (HELLGRAU)
 - E17** (HELLGRAU)
- | | |
|---|---|
| 1 | 2 |
|---|---|

- E18** (DUNKELGRAU)
- | | | |
|---|---|---|
| 1 | 2 | 3 |
| 4 | 5 | 6 |

A: B134

1	2	3	4	5	6	7			
8	9	10	11	12	13	14	15	16	17
18	19	20	21	22	23	24	25	26	27
28	29	30	31	32		33	34		

B21 (SCHWARZ)

1	2	3	4	5	6	7	8	9	10	11
12	13	14	15	16	17	18	19	20	21	22
23	24	25	26	27	28	29	30	31	32	33
34	35	36	37	38	39	40	41			
42	43	⊗	44	45	⊗	46	47			
48	49	50	51	52	53	54				

A: (B134) C: (B136) D: (B137) ECM

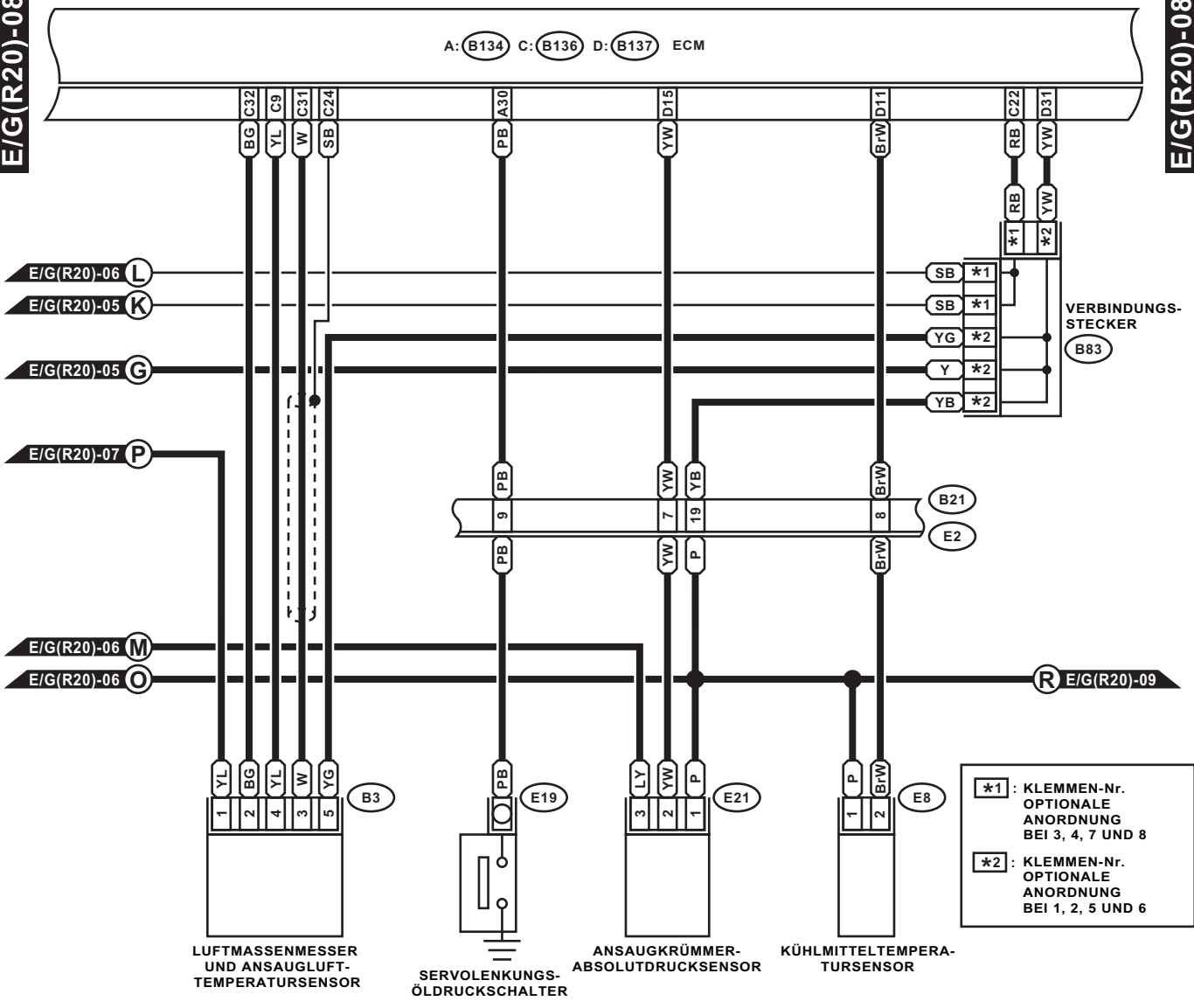

*1 : KLEMMEN-Nr. OPTIONALE ANORDNUNG BEI 3, 4, 7 UND 8
 *2 : KLEMMEN-Nr. OPTIONALE ANORDNUNG BEI 1, 2, 5 UND 6

E8 (SCHWARZ)



E21 (GRAU)



B3 (SCHWARZ)

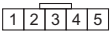

B21 (SCHWARZ)

B83

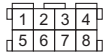

D: (B137)

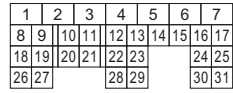

A: (B134)

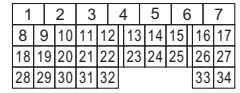

C: (B136)

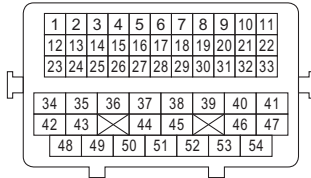
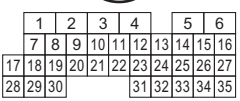

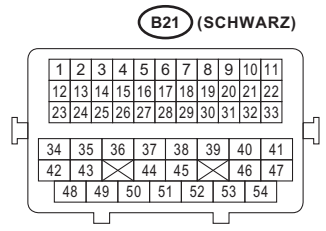
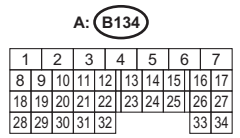
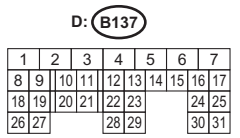
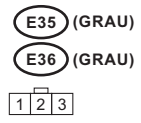
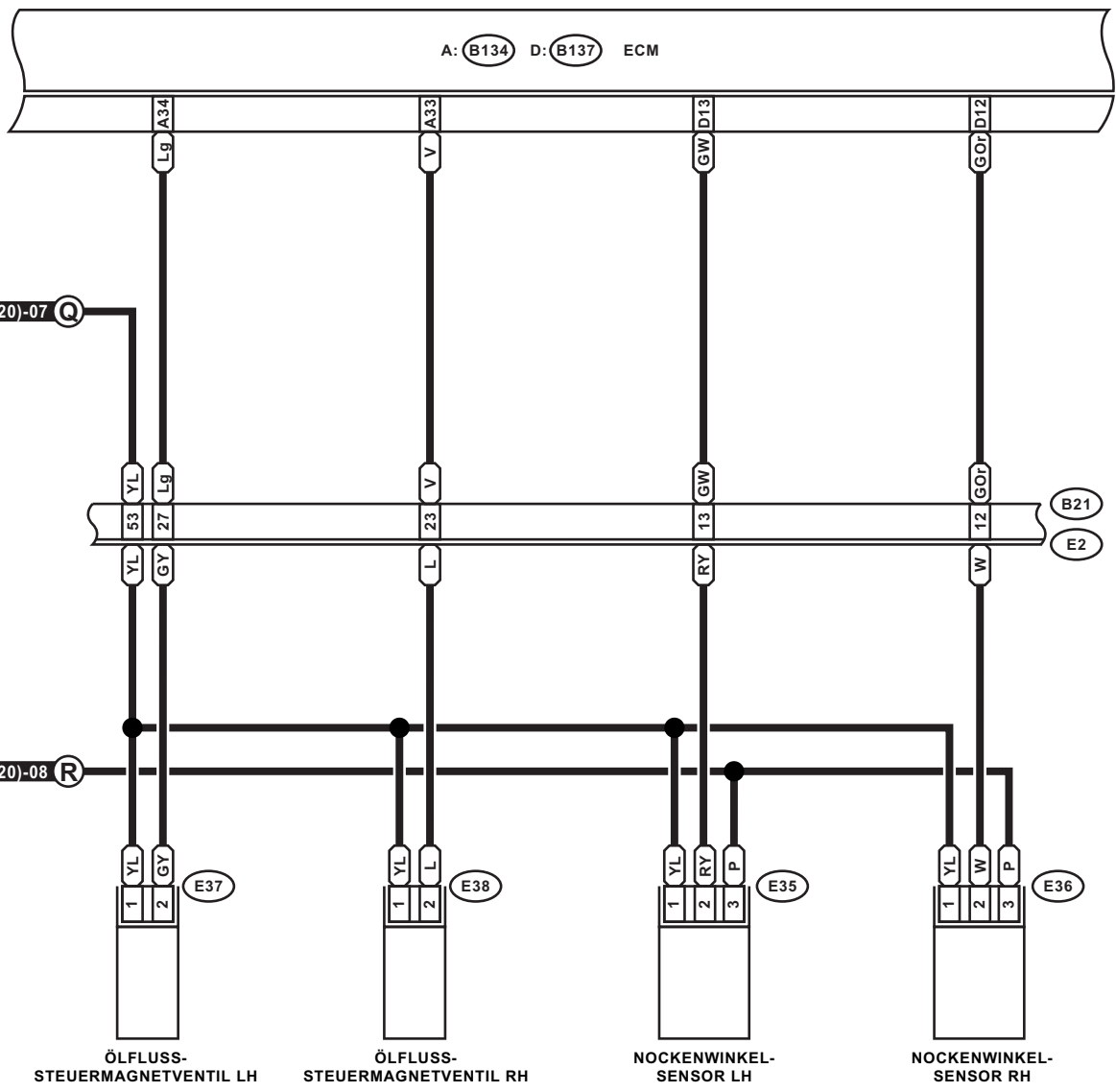

A: B134 B: B135 C: B136 D: B137 ECM

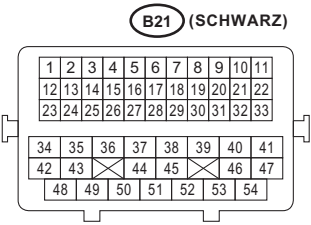
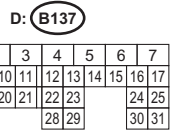
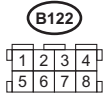
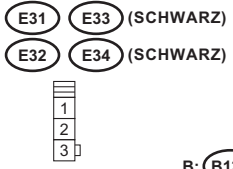
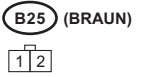
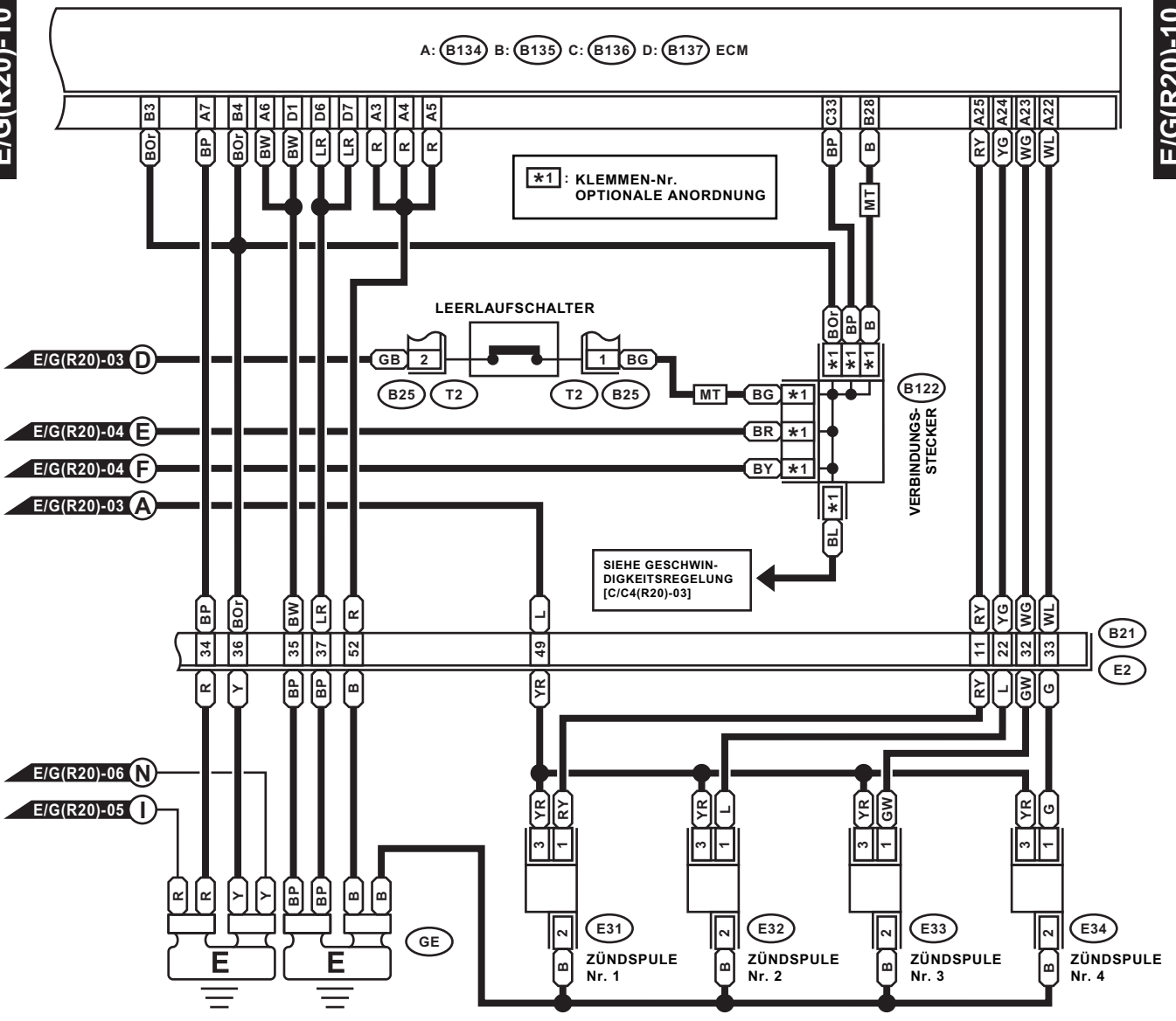

A: B134

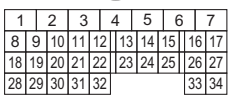

B: B135

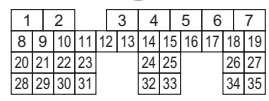

C: B136

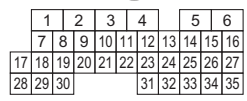

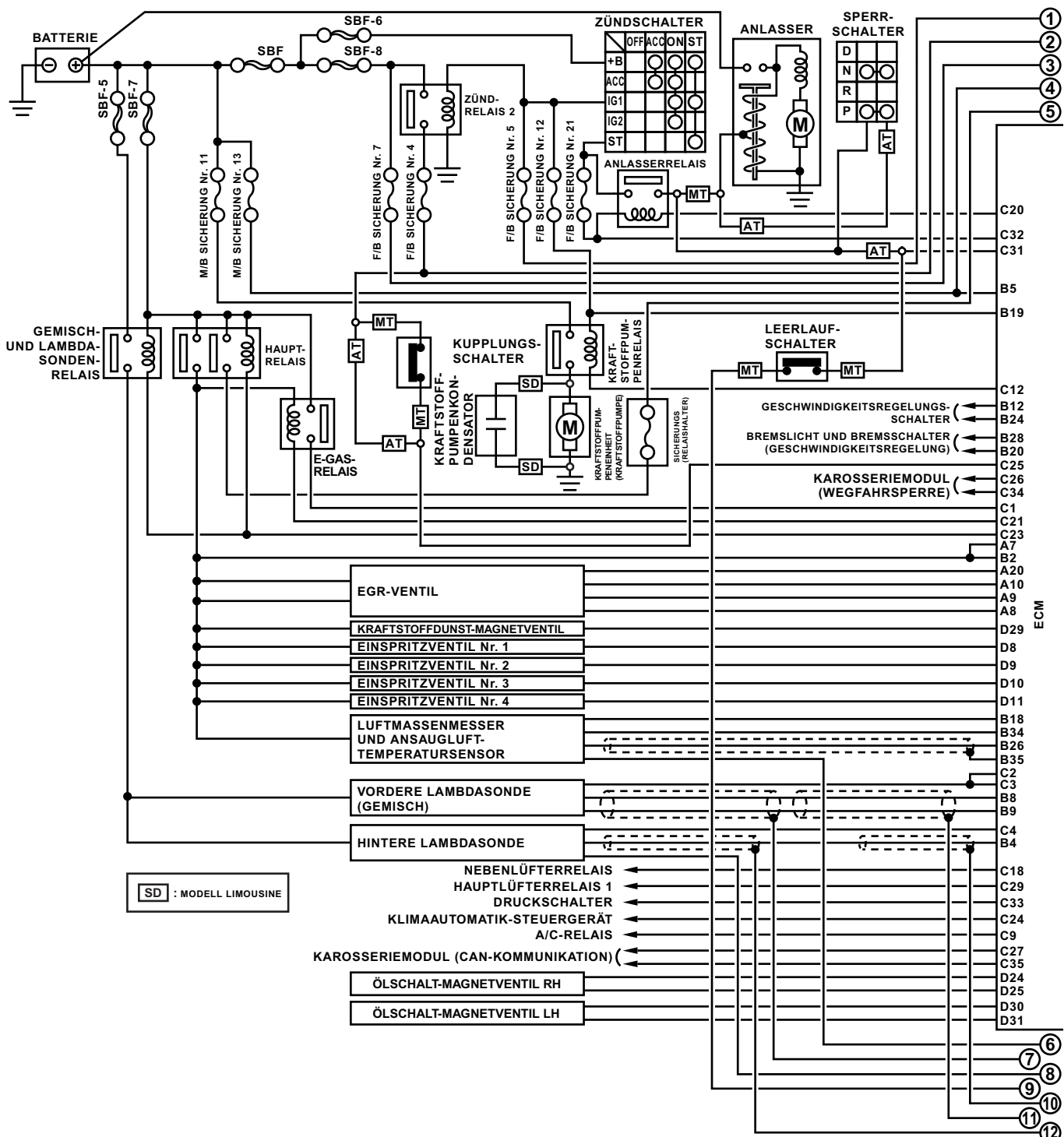

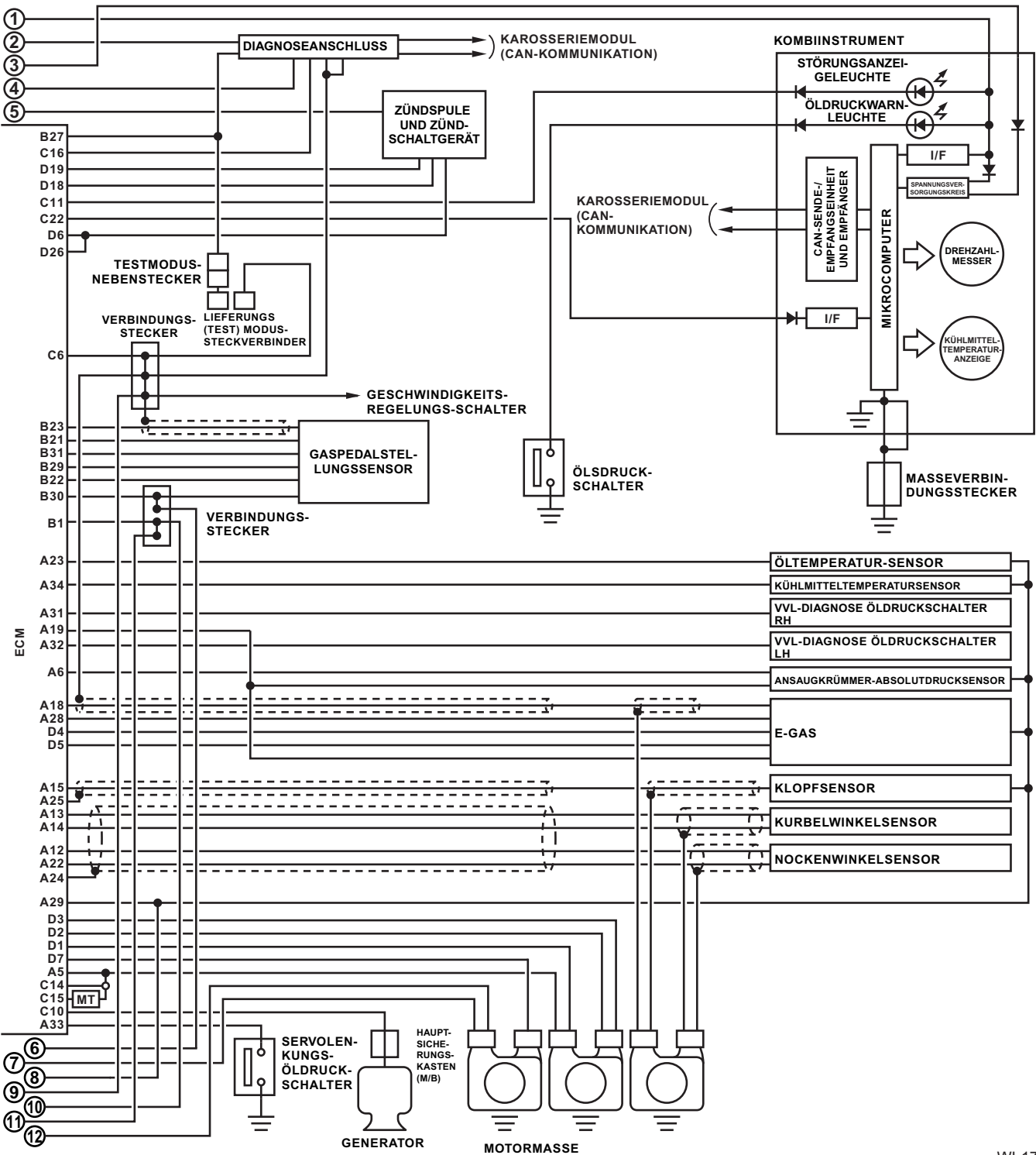

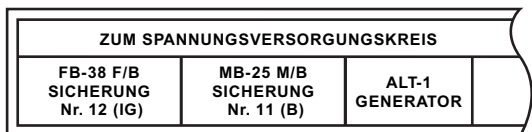

SD : MODELL LIMOUSINE

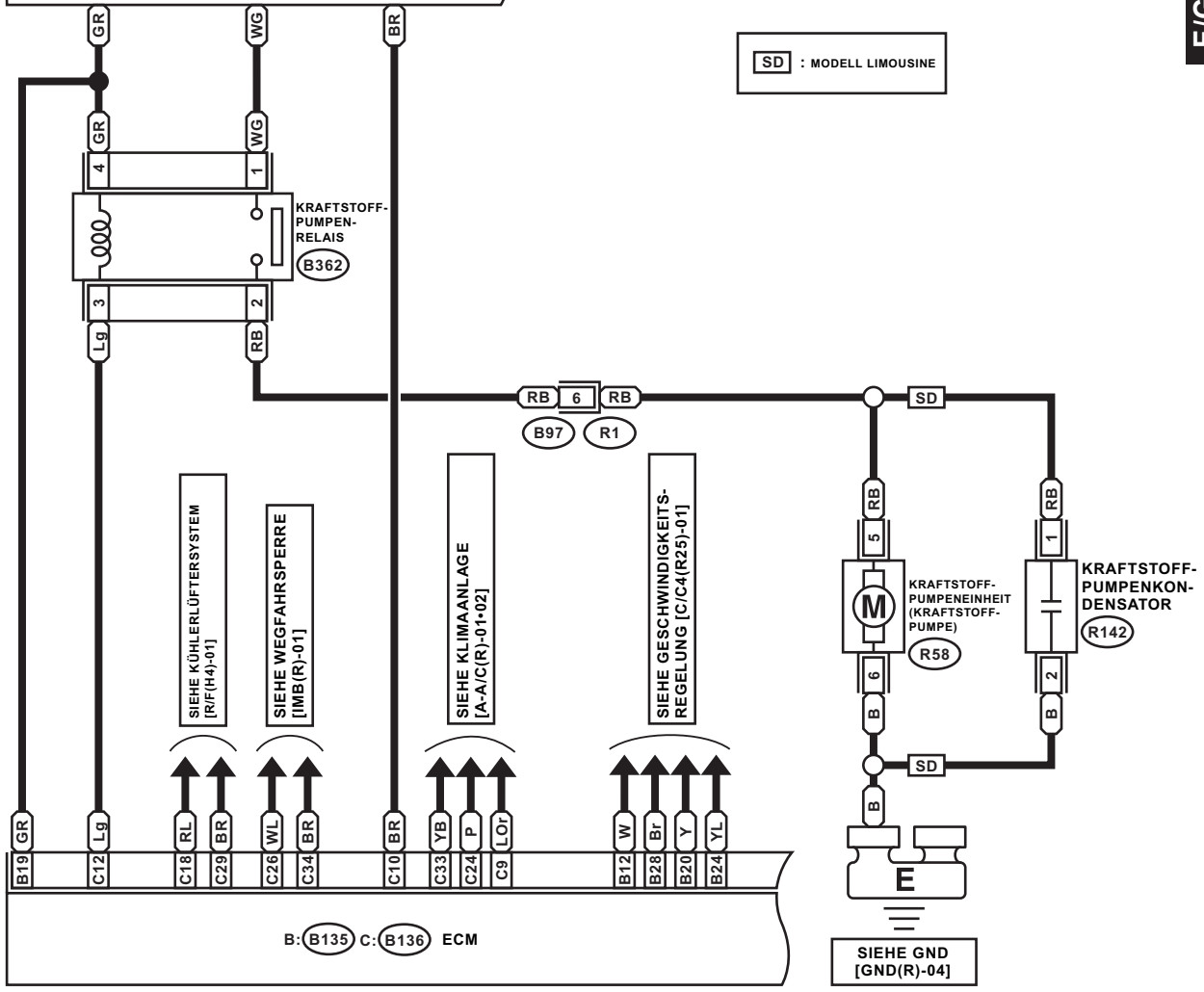

B: B135 C: B136 ECM

SIEHE GND [GND(R)-04]

R142 (SCHWARZ)

R58 (GRAU)

B362 (SCHWARZ)

B97

B: B135

C: B136

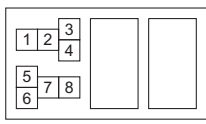

RELAISHALTER

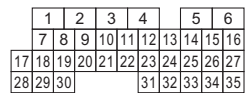
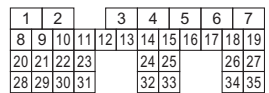
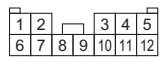

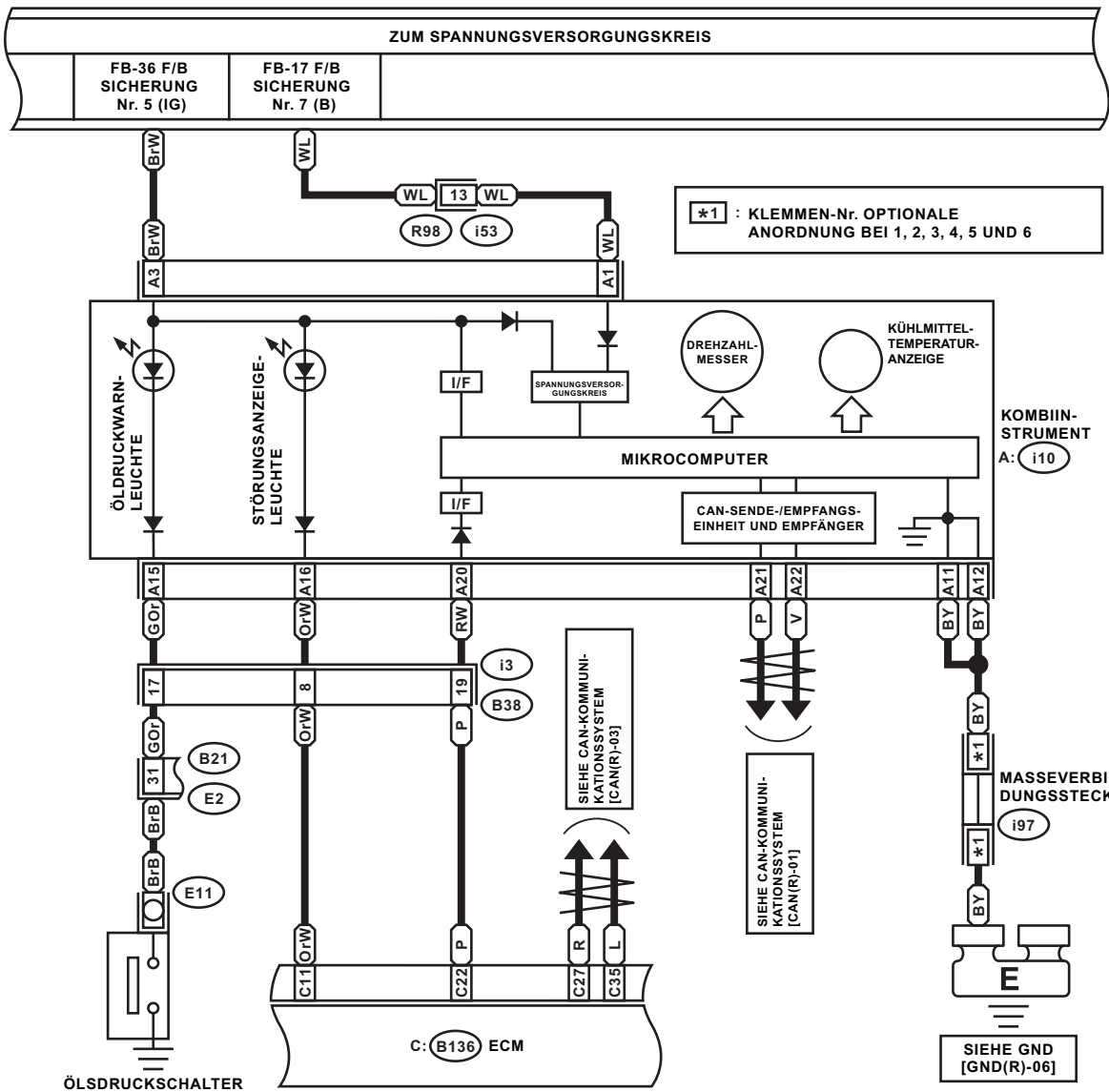

ZUM SPANNUNGSVERSORUNGSKREIS

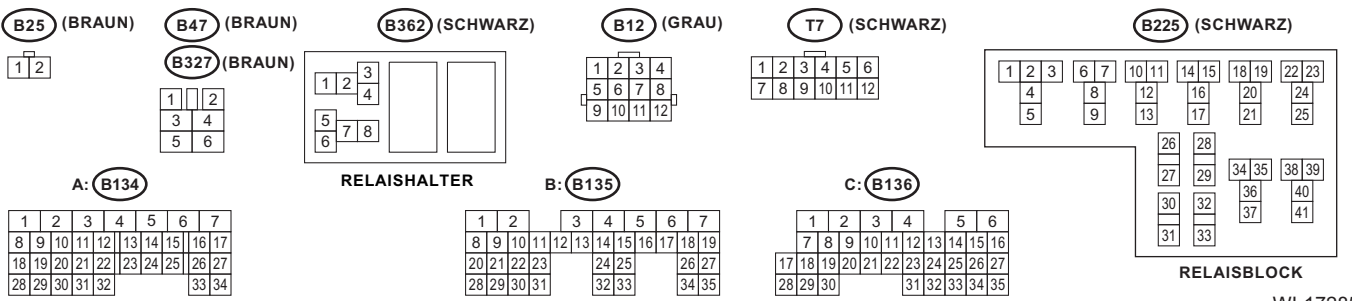
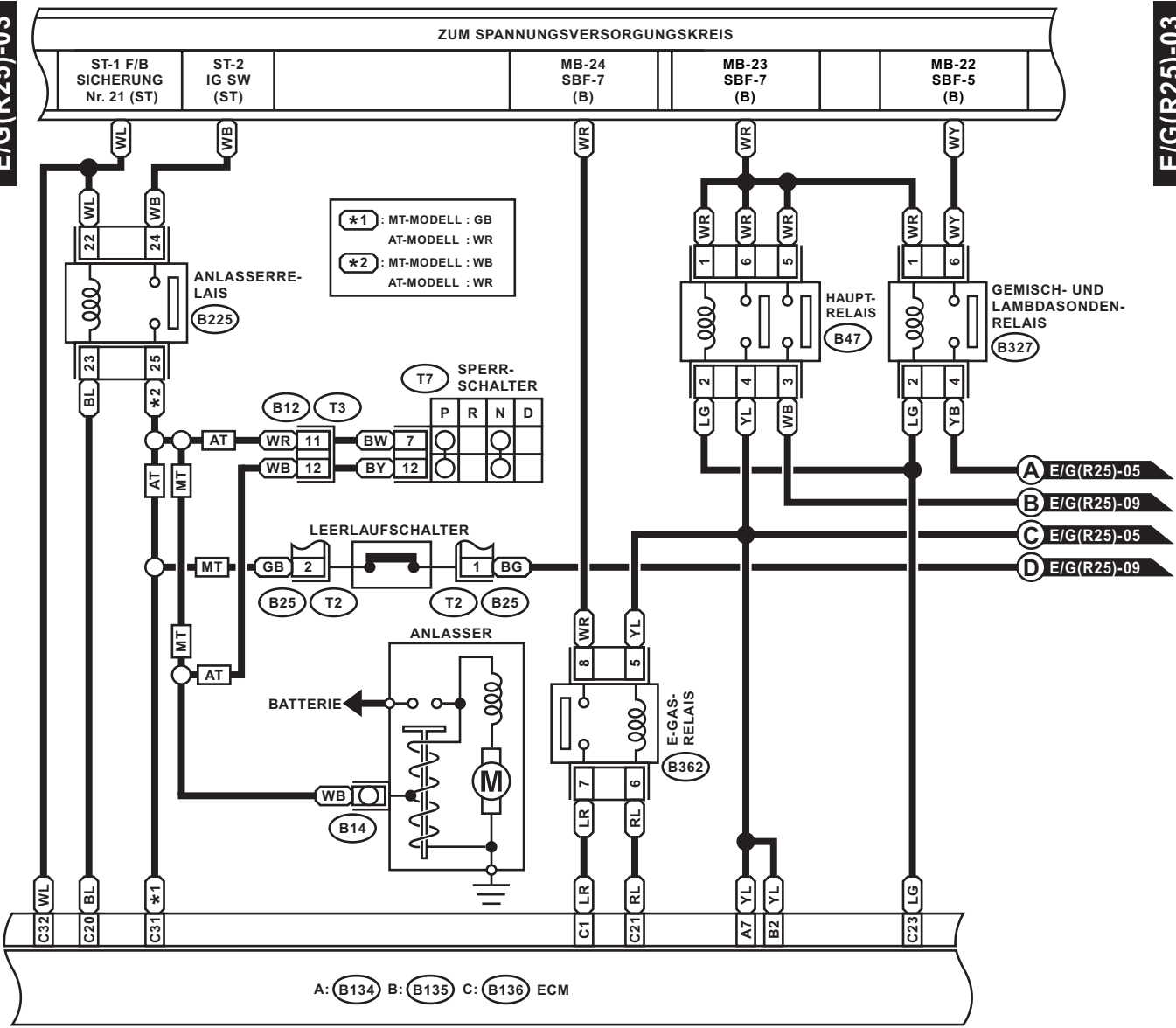

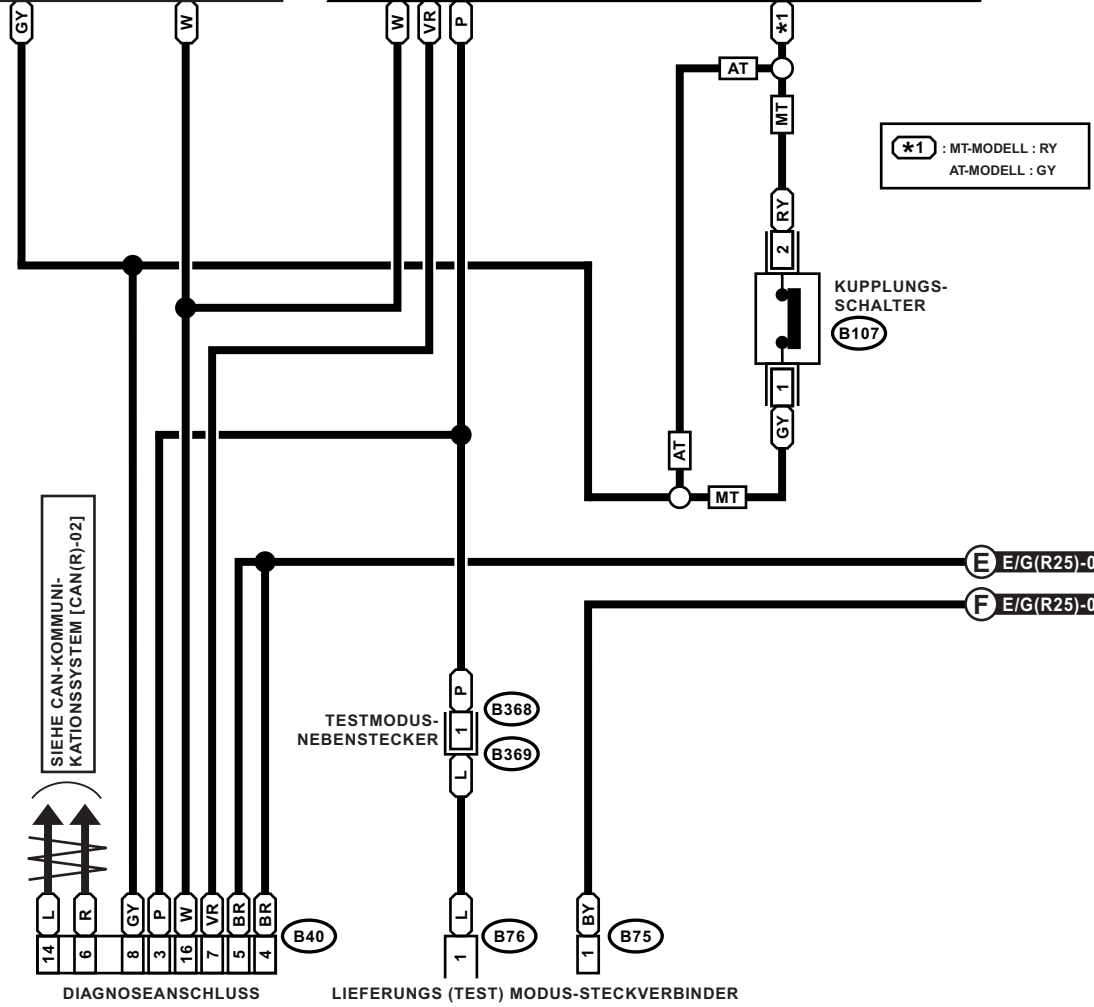
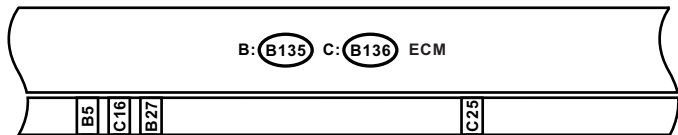
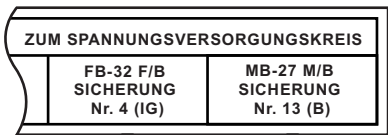

SIEHE CAN-KOMMUNIKATIONSSYSTEM [CAN (R)-02]

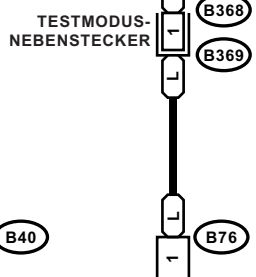
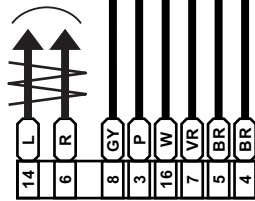

*1 : MT-MODELL : RY
AT-MODELL : GY

KUPPLUNGS-SCHALTER (B107)

E E/G(R25)-09
F E/G(R25)-09

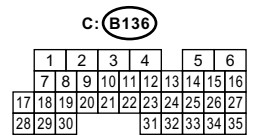
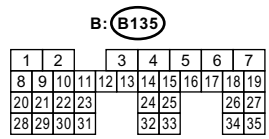
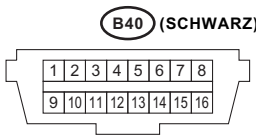
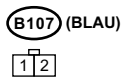
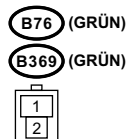
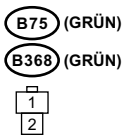

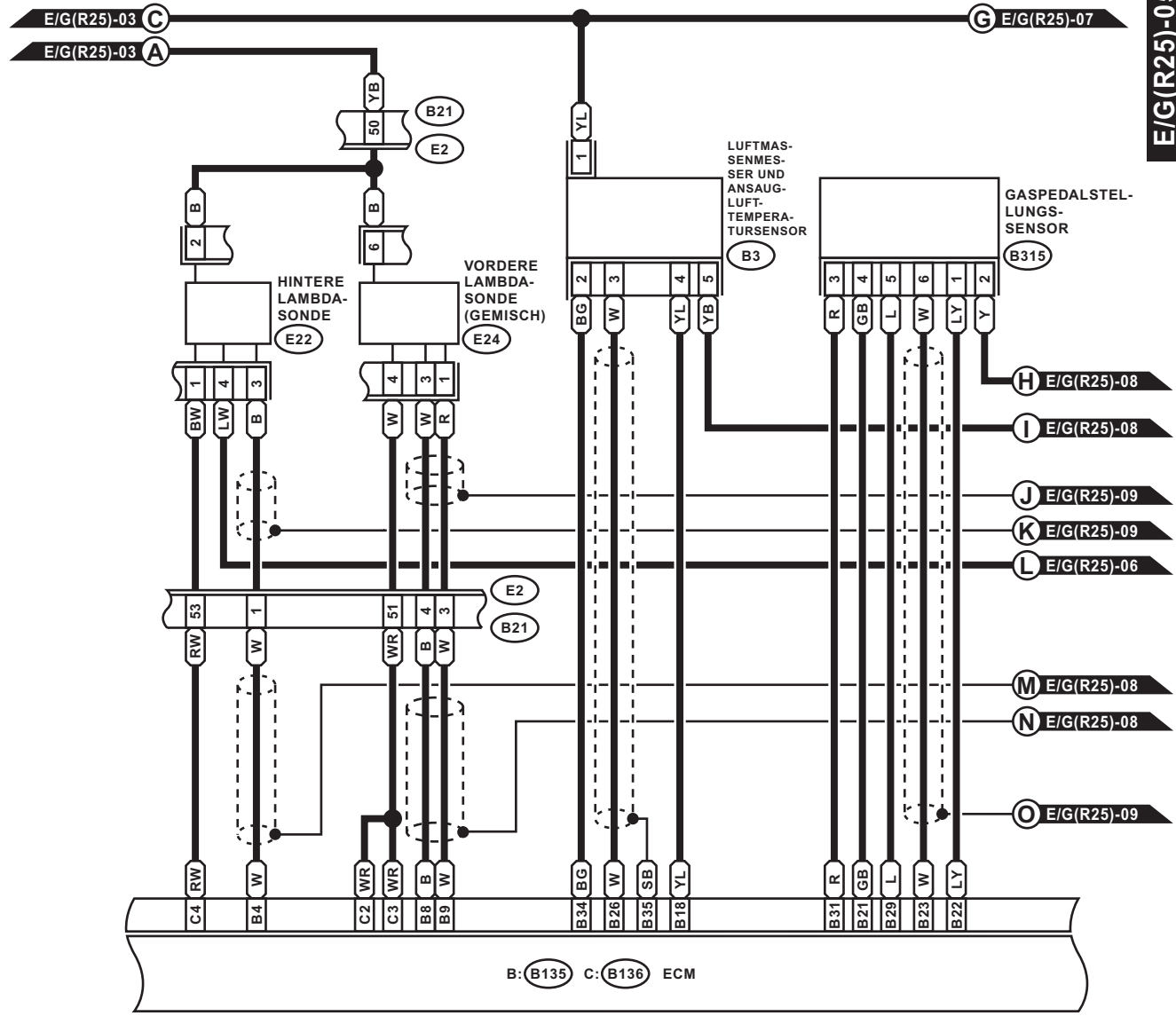

E22 (DUNKELGRAU)

1	2
3	4

B3 (SCHWARZ)

1	2	3	4	5
---	---	---	---	---

B315 (SCHWARZ)

1	2	3	4	5	6
---	---	---	---	---	---

B: B135

1	2	3	4	5	6	7					
8	9	10	11	12	13	14	15	16	17	18	19
20	21	22	23	24	25	26	27				
28	29	30	31	32	33	34	35				

C: B136

1	2	3	4	5	6					
7	8	9	10	11	12	13	14	15	16	
17	18	19	20	21	22	23	24	25	26	27
28	29	30				31	32	33	34	35

B21 (SCHWARZ)

1	2	3	4	5	6	7	8	9	10	11
12	13	14	15	16	17	18	19	20	21	22
23	24	25	26	27	28	29	30	31	32	33
34	35	36	37	38	39	40	41			
42	43	44	45	46	47					
48	49	50	51	52	53	54				

E24 (SCHWARZ)

3	2	1
6	5	4

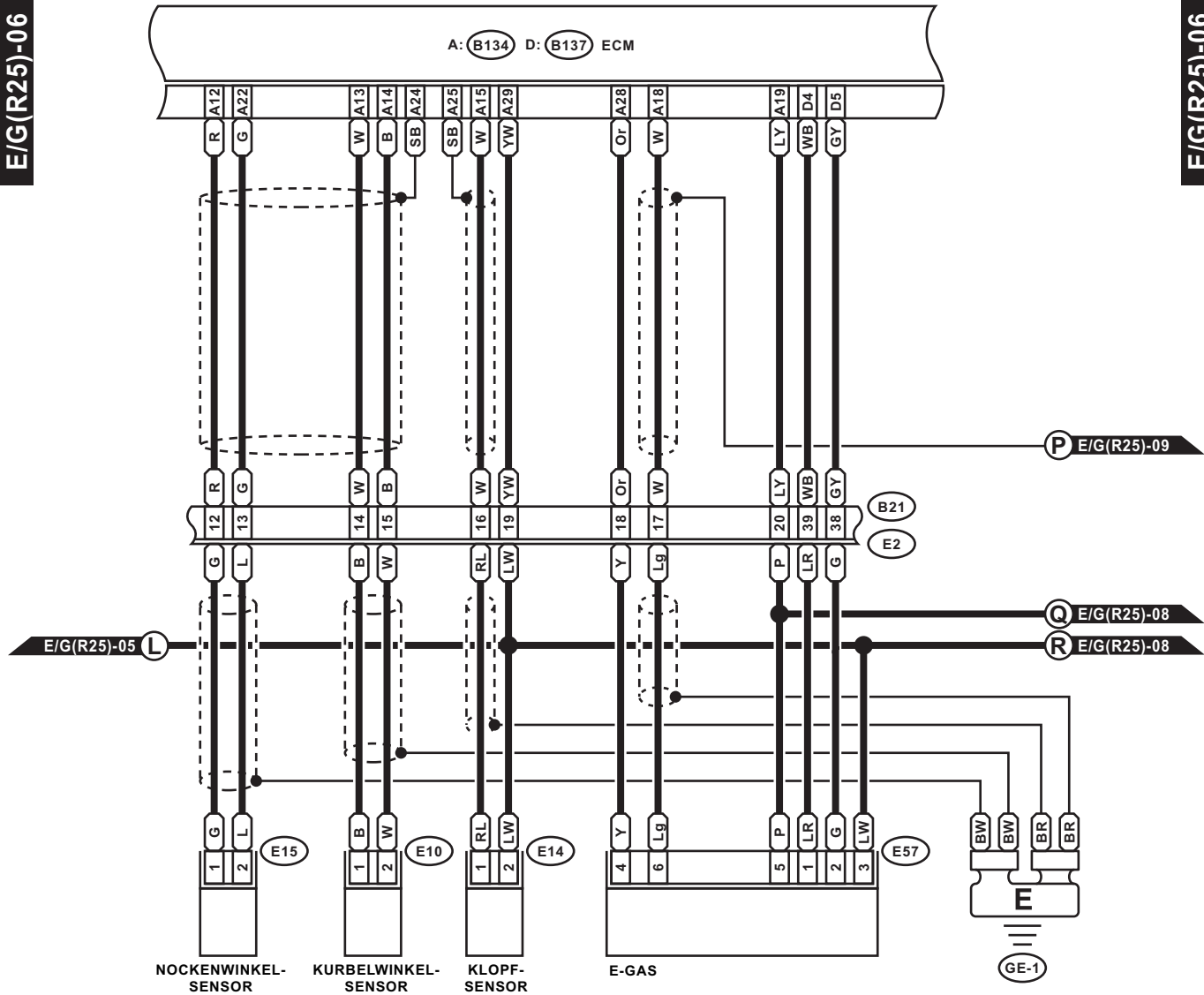

(E10) (HELLGRAU)

(E57) (SCHWARZ)

D: (B137)

A: (B134)

(E14) (GRAU)

1	2	3	4	5	6
---	---	---	---	---	---

1	2	3	4	5	6	7
8	9	10	11	12	13	14
15	16	17	18	19	20	21
22	23	24	25	26	27	28
29	30	31	32	33	34	35

1	2	3	4	5	6	7
8	9	10	11	12	13	14
15	16	17	18	19	20	21
22	23	24	25	26	27	28
29	30	31	32	33	34	35

(E15) (GRAU)

(B21) (SCHWARZ)

1	2
---	---

1	2	3	4	5	6	7	8	9	10	11
12	13	14	15	16	17	18	19	20	21	22
23	24	25	26	27	28	29	30	31	32	33
34	35	36	37	38	39	40	41	42	43	44
45	46	47	48	49	50	51	52	53	54	55

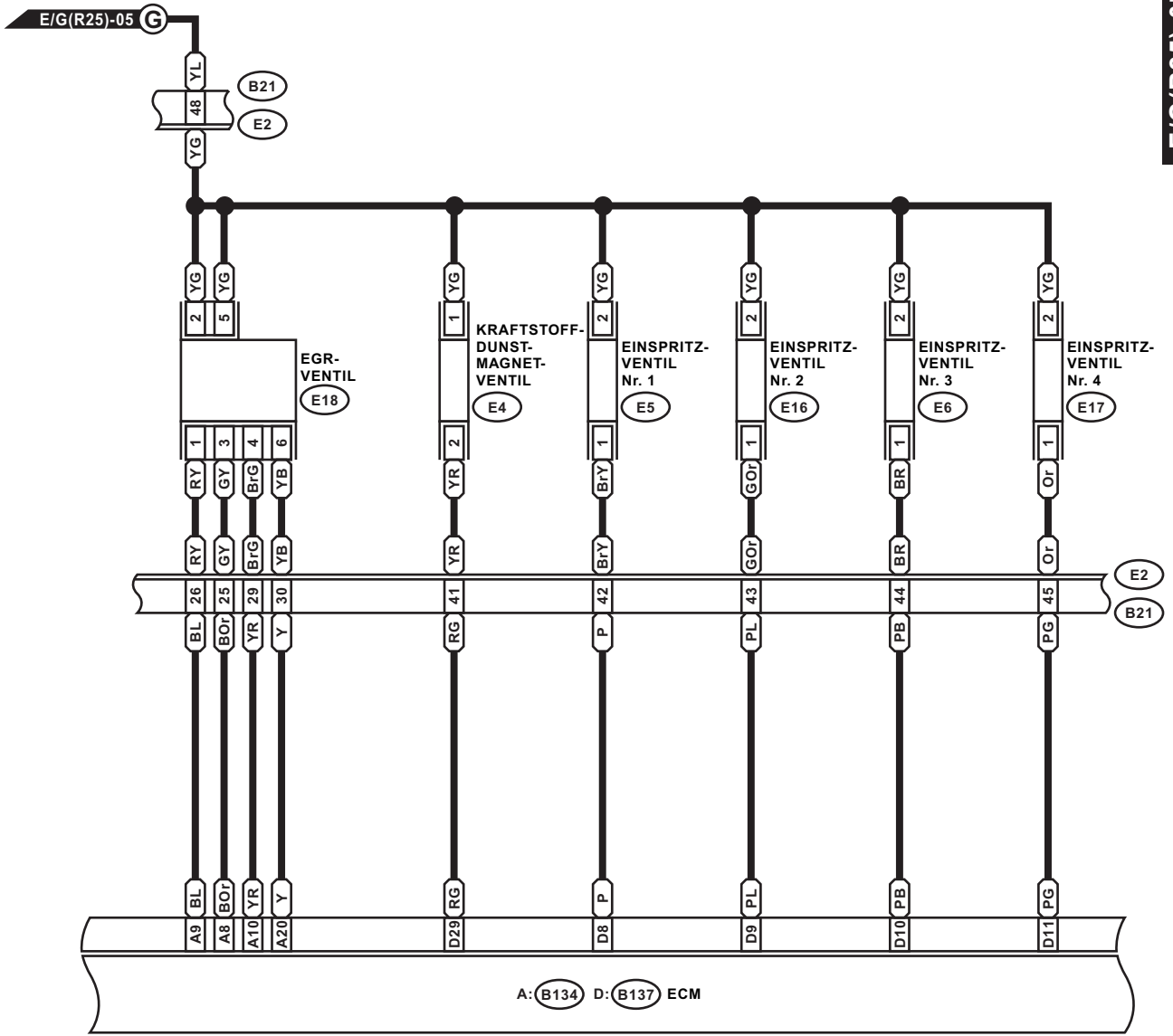

E4 (SCHWARZ)



E5 (DUNKELGRAU) **E16** (DUNKELGRAU)
E6 (DUNKELGRAU) **E17** (DUNKELGRAU)



E18 (DUNKELGRAU)



D: B137

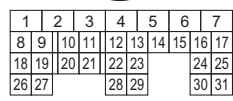

B21 (SCHWARZ)

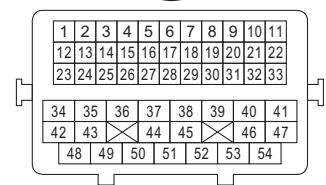

A: B134

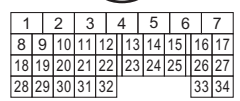

A: (B134) B: (B135) D: (B137) ECM

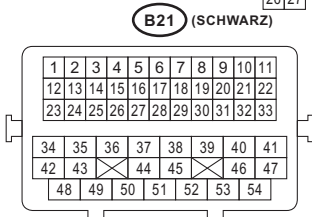
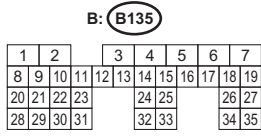
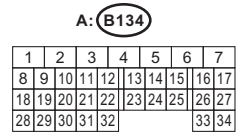
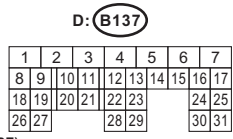
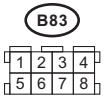
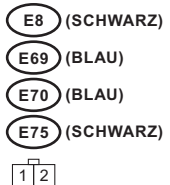
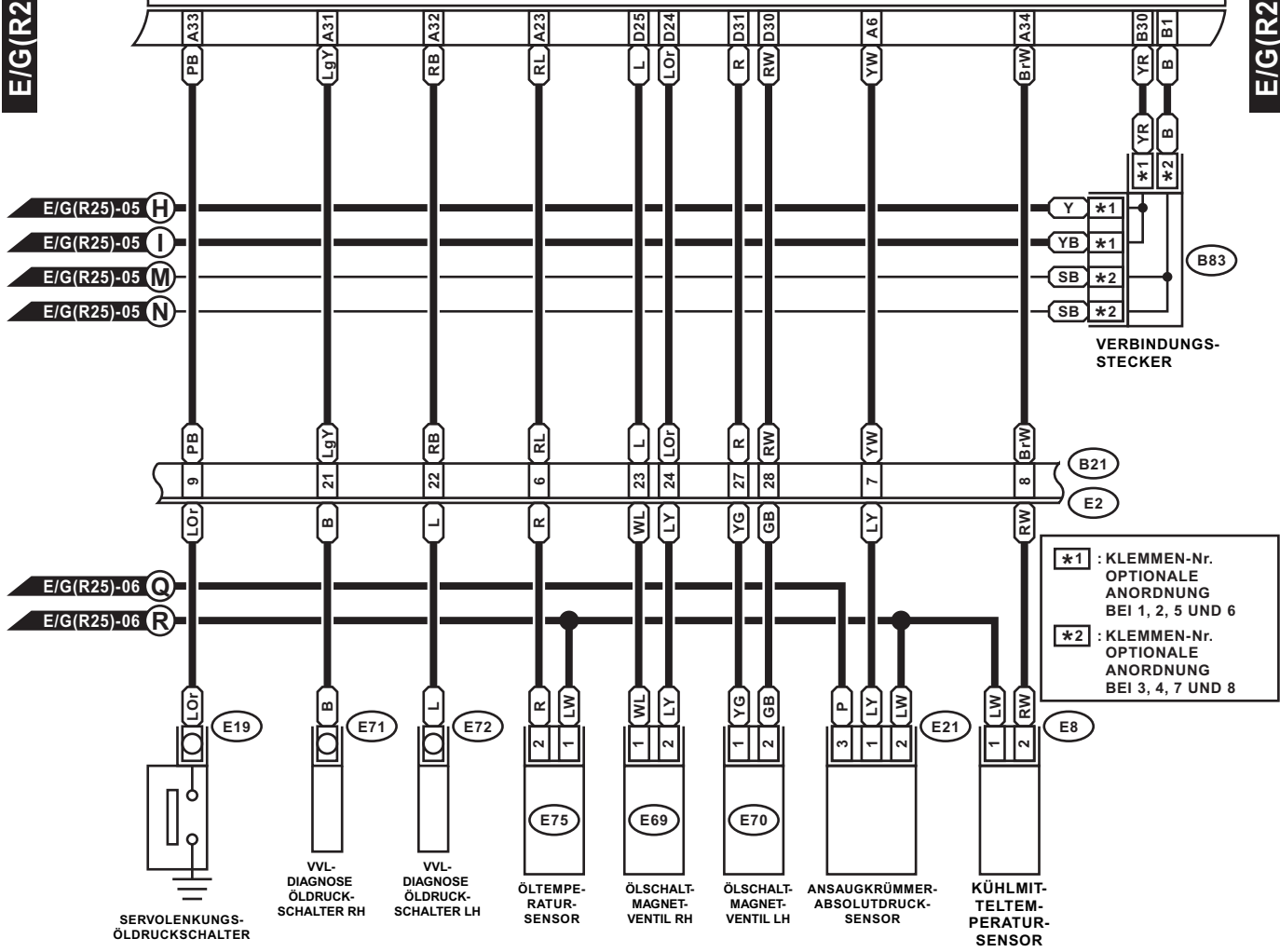

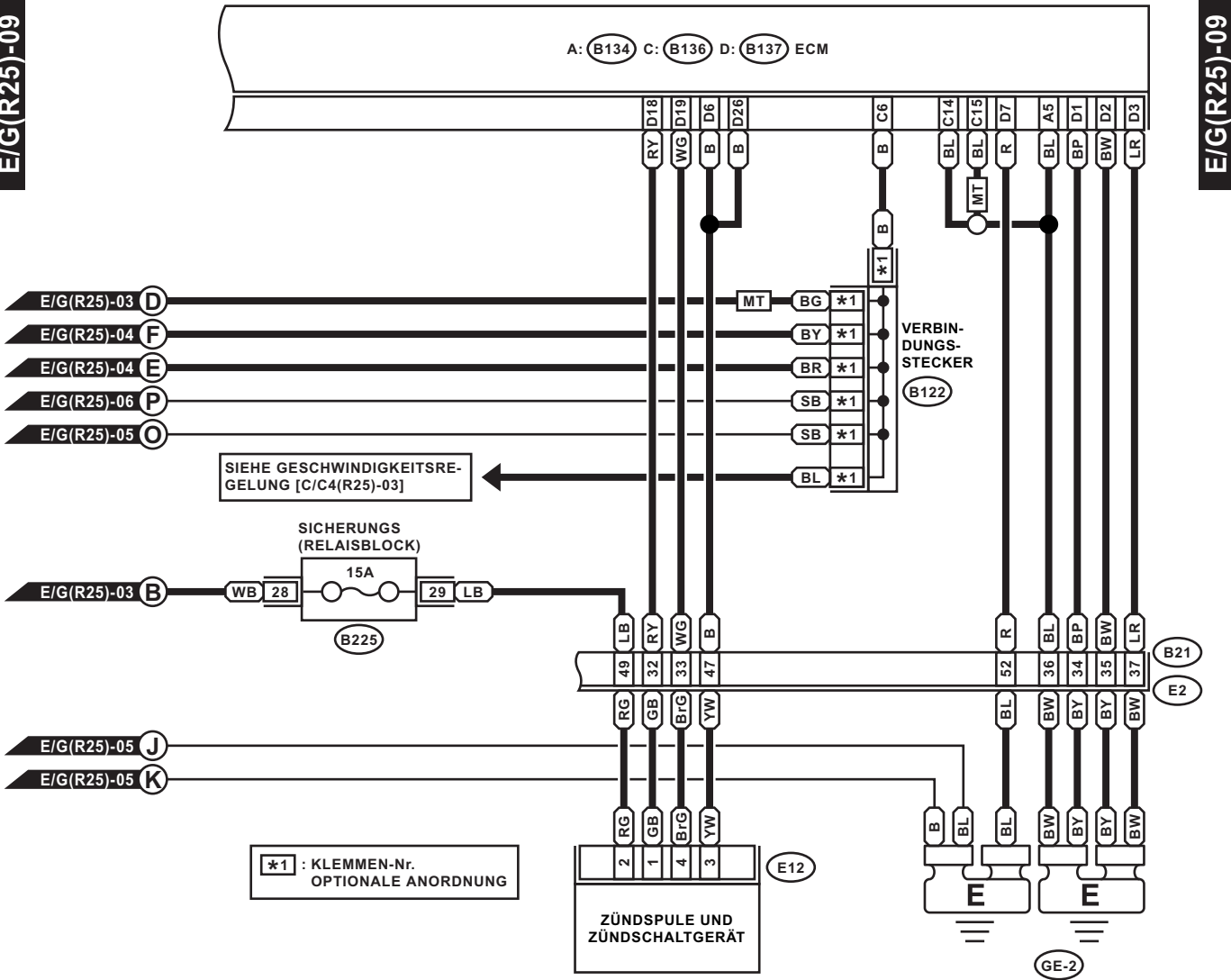

SIEHE GESCHWINDIGKEITSREGELUNG [C/C4(R25)-03]

*1 : KLEMMEN-Nr. OPTIONALE ANORDNUNG

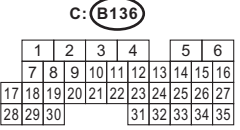
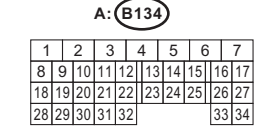
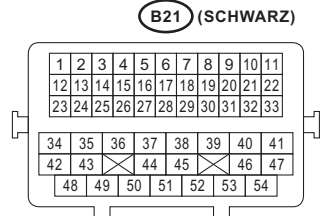
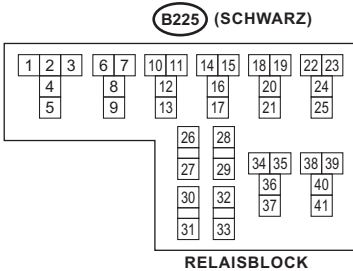
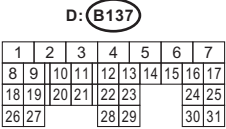
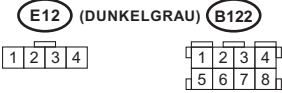

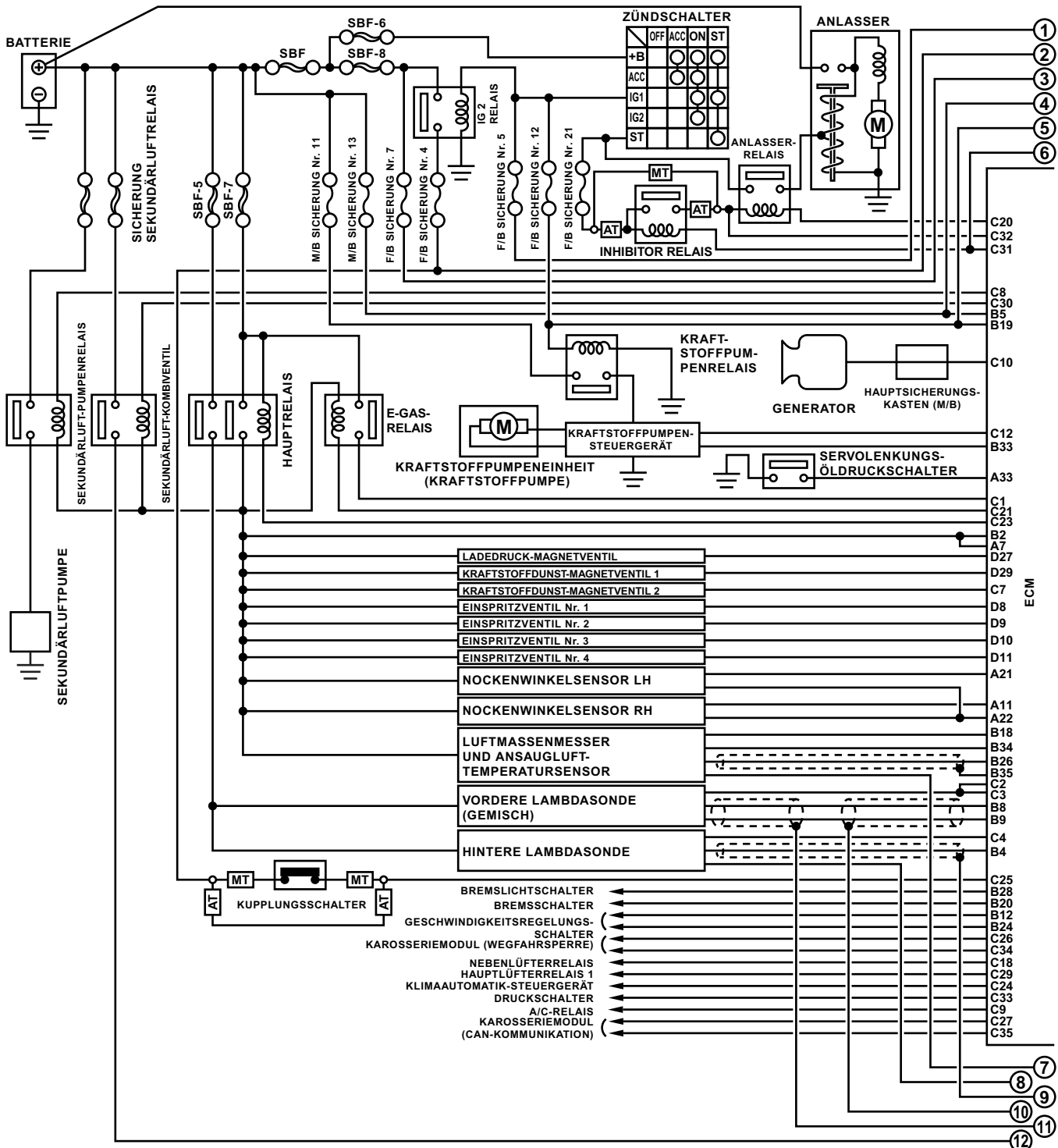

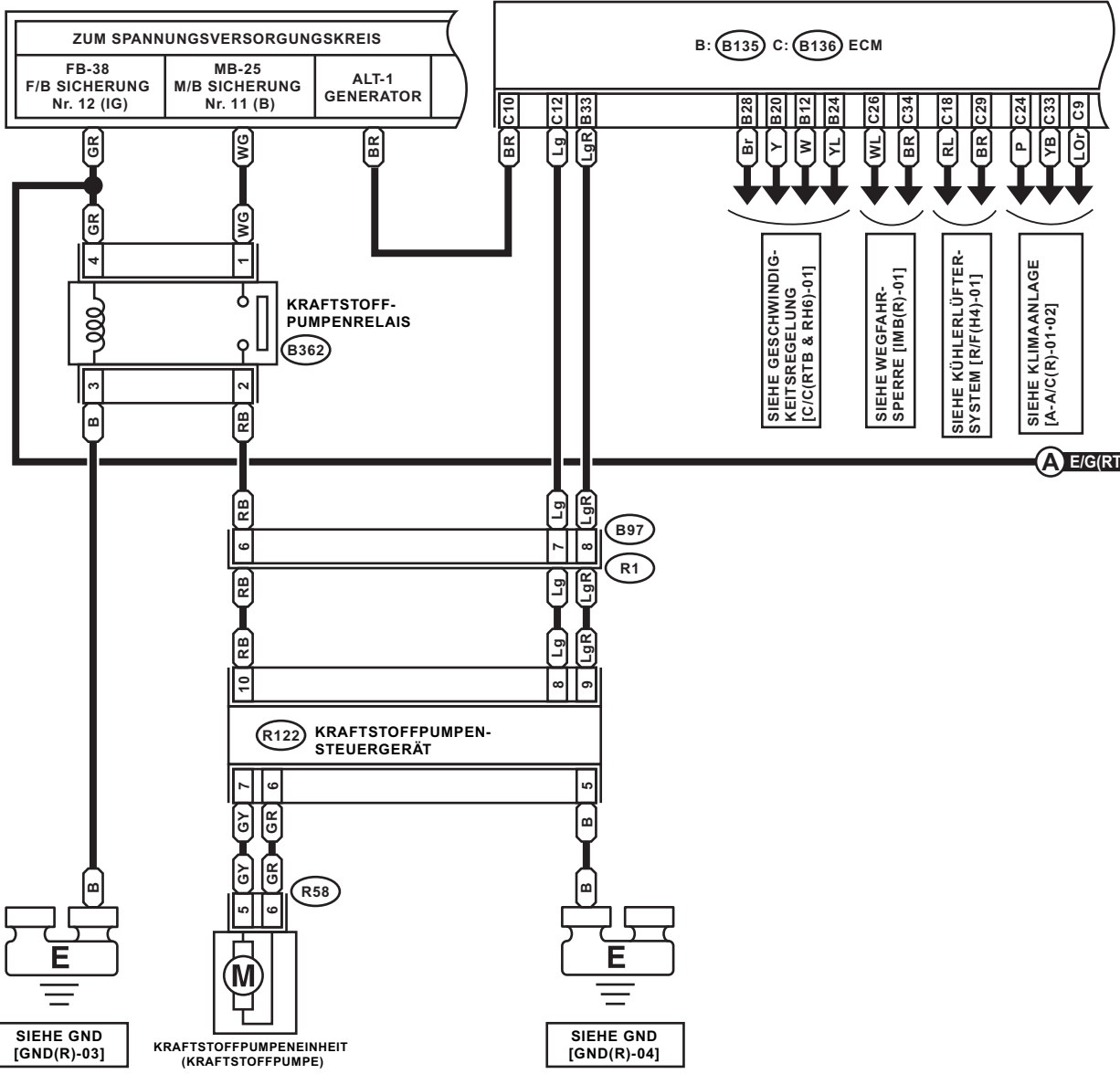

A E/G(RTB)-03

(R58) (GRAU)



(B362) (SCHWARZ)

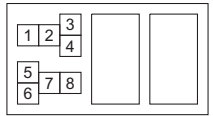

RELAISHALTER

(R122) (SCHWARZ)

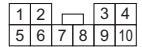

(B97)

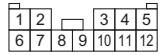

B: (B135)

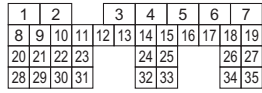

C: (B136)

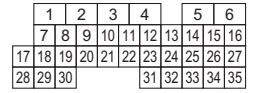

ZUM SPANNUNGSVERSORUNGSKREIS

FB-36 F/B SICHERUNG Nr. 5 (G) FB-17 F/B SICHERUNG Nr. 7 (B)

*1 : KLEMMEN-Nr. OPTIONALE ANORDNUNG BEI 1, 2, 3, 4, 5 UND 6

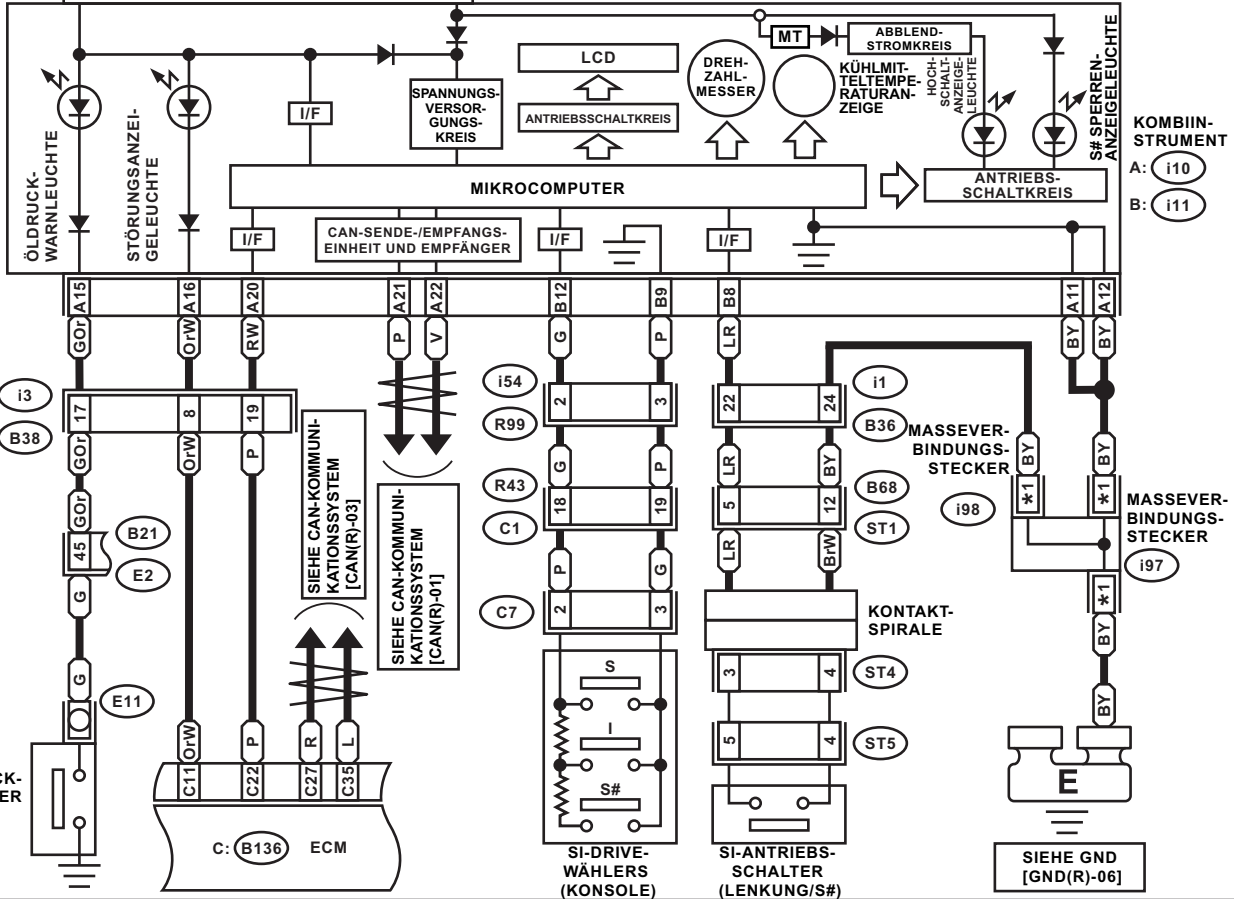

KOMBI-INSTRUMENT
A: i10
B: i11

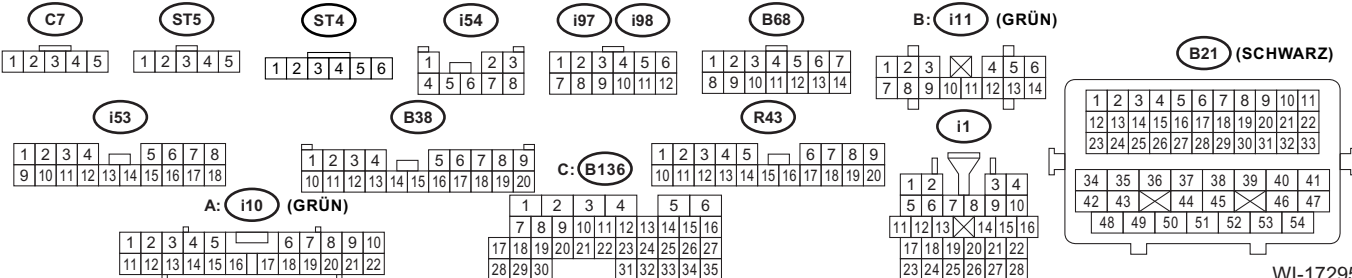

ZUM SPANNUNGSVERSORUNGSKREIS

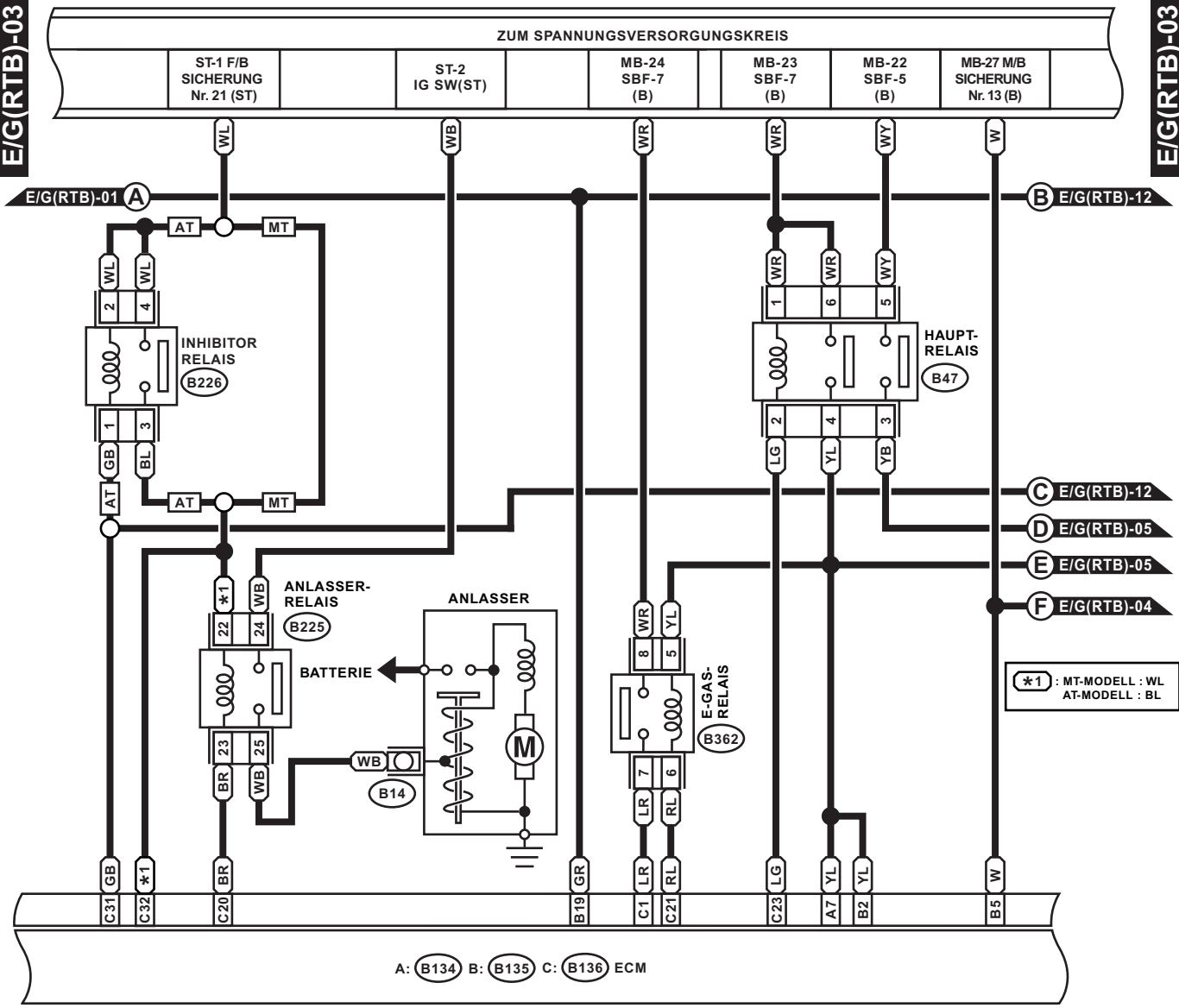

A: (B134) B: (B135) C: (B136) ECM

*1 : MT-MODELL : WL
AT-MODELL : BL

B226 (SCHWARZ) B47 (BRAUN)

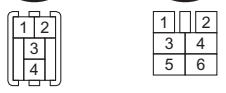

B362 (SCHWARZ)

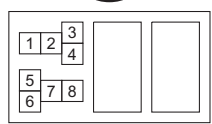

RELAISHALTER

A: B134

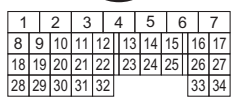

C: B136

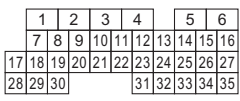

B225 (SCHWARZ)

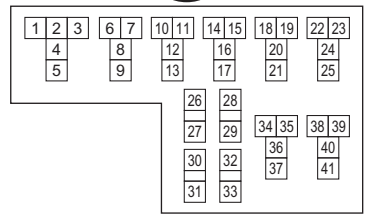

RELAISBLOCK

B: B135

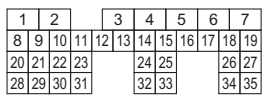

ZUM SPANNUNGSVERSORGUNGSKREIS
 FB-32
 F/B SICHERUNG
 Nr. 4 (IG)

B: (B135) C: (B136) ECM

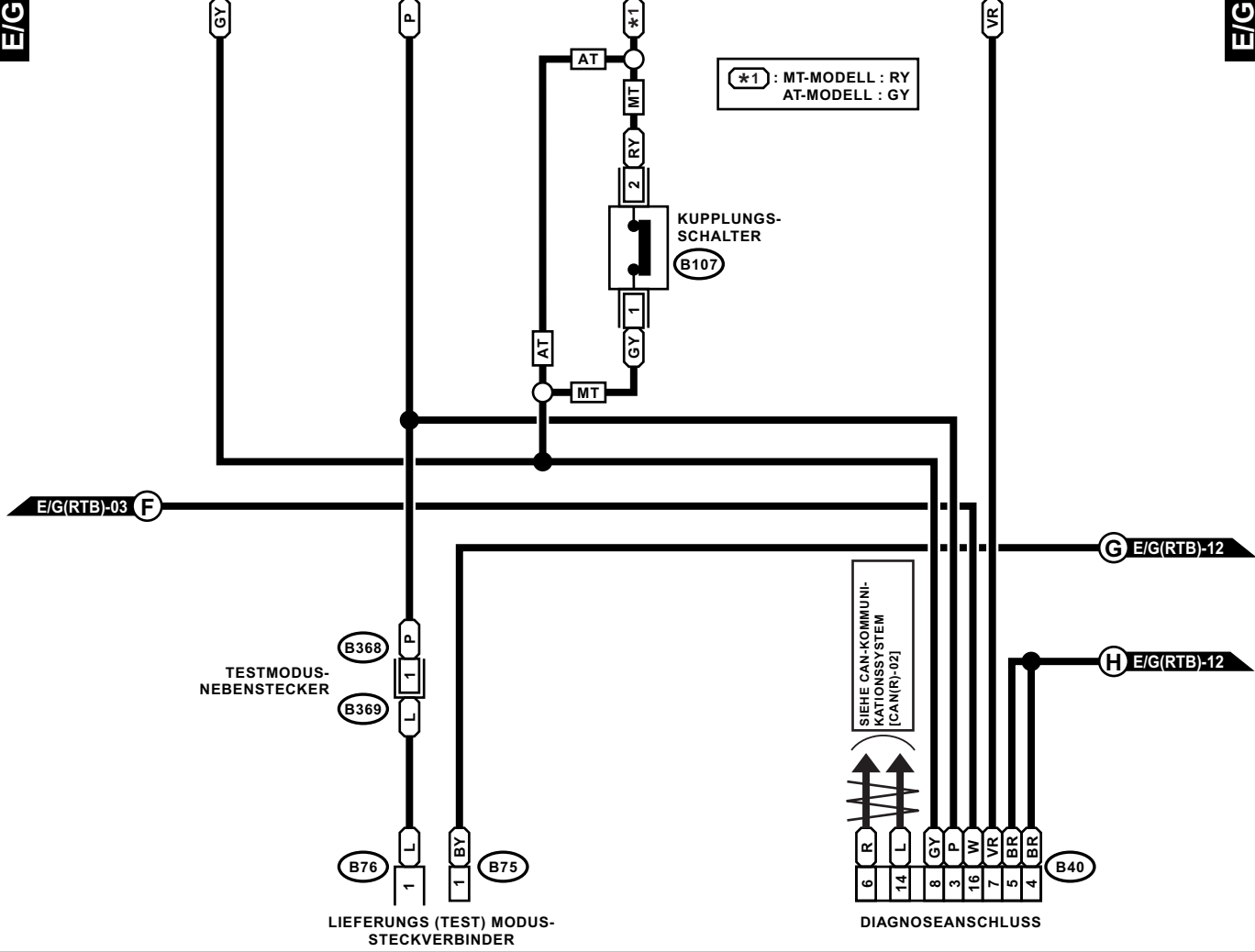

*1 : MT-MODELL : RY
 AT-MODELL : GY

KUPPLUNGS-SCHALTER
 (B107)

TESTMODUS-NEBENSTECKER

SIEHE CAN-KOMMUNIKATIONSSYSTEM [CAN(R)-02]

LIEFERUNGS (TEST) MODUS-STECKERVERBINDER

DIAGNOSEANSCHLUSS

(B75) (GRÜN)

(B76) (GRÜN)

(B107) (BLAU)

(B40) (SCHWARZ)

B: (B135)

C: (B136)

(B368) (GRÜN)

(B369) (GRÜN)

1 2



1	2	3	4	5	6	7
8	9	10	11	12	13	14
15	16	17	18	19	20	21
22	23	24	25	26	27	28
29	30	31	32	33	34	35

1	2	3	4	5	6
7	8	9	10	11	12
13	14	15	16	17	18
19	20	21	22	23	24
25	26	27	28	29	30
31	32	33	34	35	



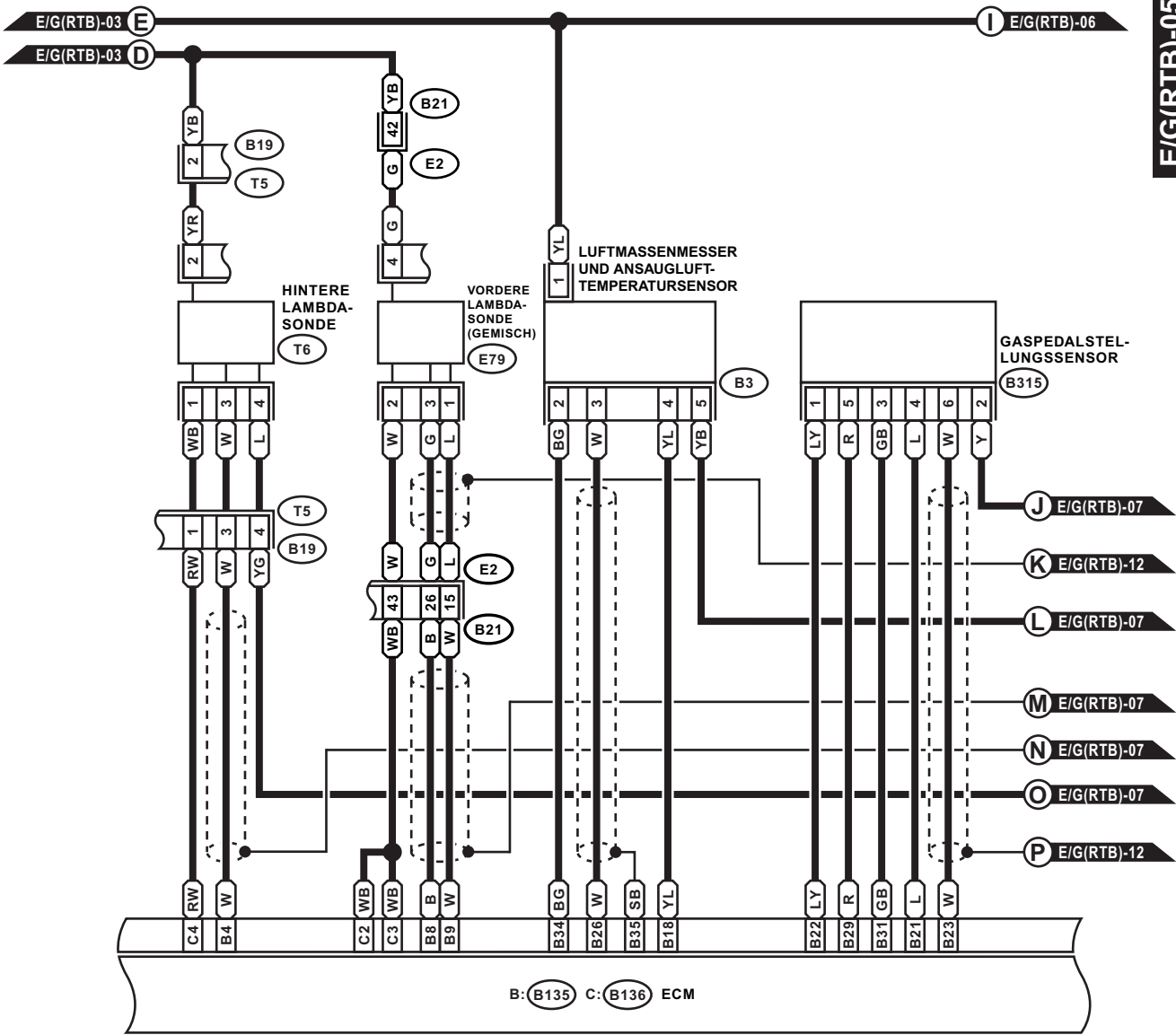

B19 (GRAU) : MT
(GRÜN) : AT

E79 (DUNKELGRAU)

T6 (DUNKELGRAU)



B3 (SCHWARZ)

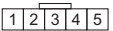

B315 (SCHWARZ)

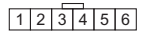

B: B135

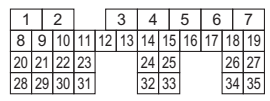

C: B136

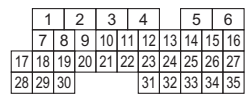

B21 (SCHWARZ)

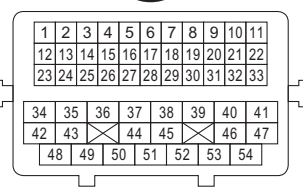

A: B134 ECM

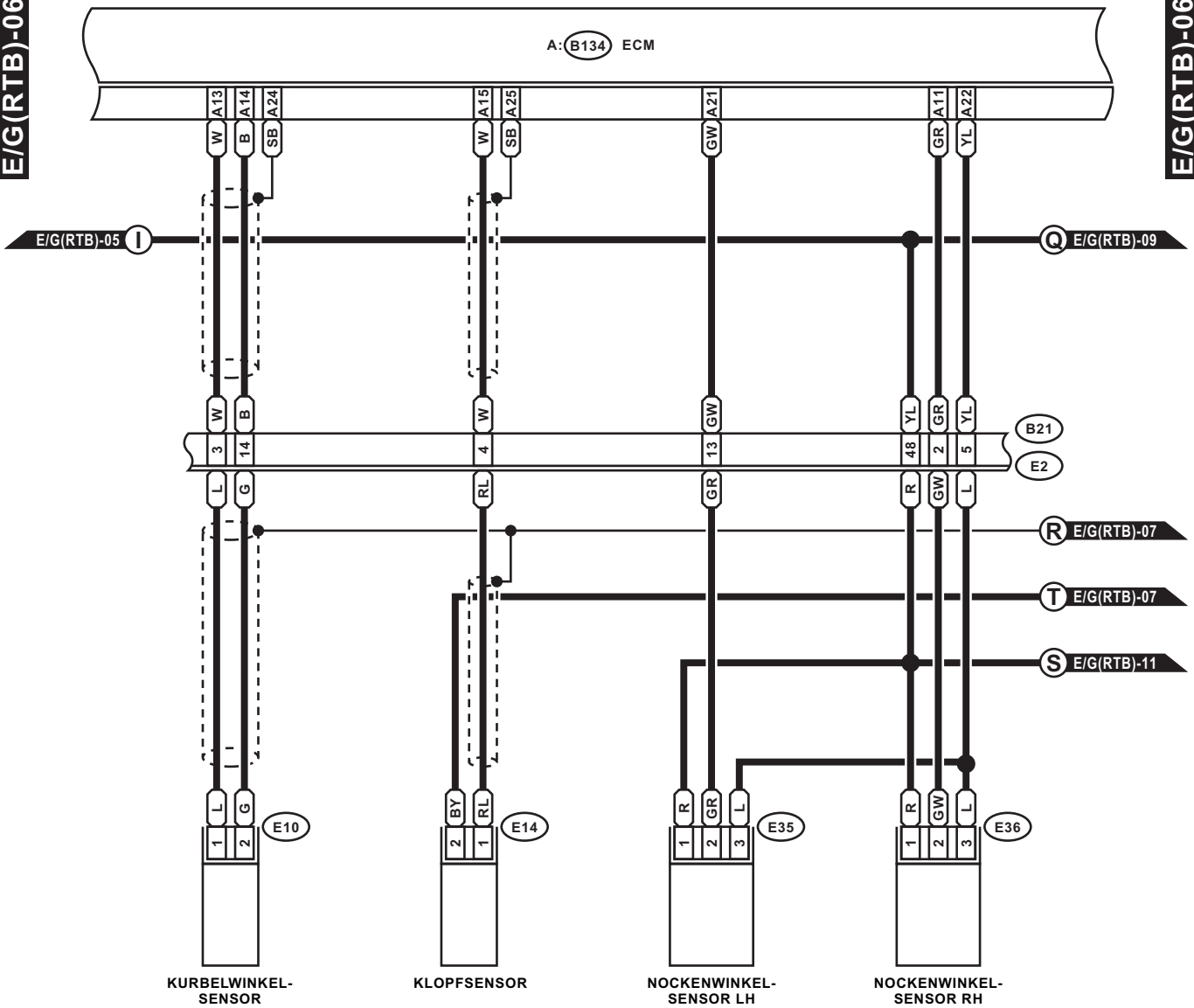

E10 (HELLGRAU)

E35 (HELLGRAU)

A: B134

B21 (SCHWARZ)

E14 (HELLGRAU)

E36 (HELLGRAU)

1	2	3	4	5	6	7
8	9	10	11	12	13	14
15	16	17	18	19	20	21
22	23	24	25	26	27	
28	29	30	31	32	33	34

1	2	3	4	5	6	7	8	9	10	11
12	13	14	15	16	17	18	19	20	21	22
23	24	25	26	27	28	29	30	31	32	33
34	35	36	37	38	39	40	41			
42	43	44	45	46	47					
48	49	50	51	52	53	54				

A: (B134) B: (B135) D: (B137) ECM

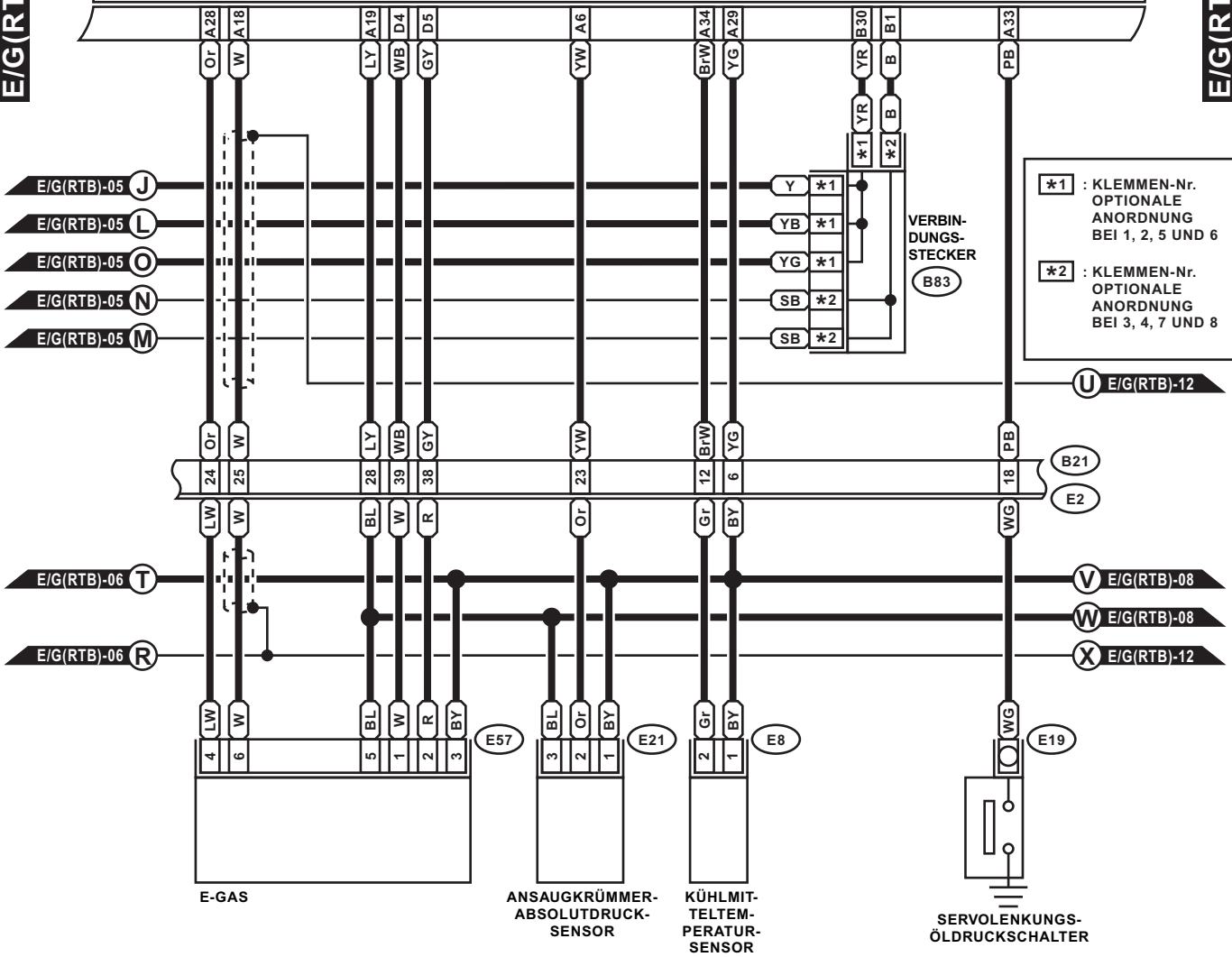

***1** : KLEMMEN-Nr. OPTIONALE ANORDNUNG BEI 1, 2, 5 UND 6

***2** : KLEMMEN-Nr. OPTIONALE ANORDNUNG BEI 3, 4, 7 UND 8

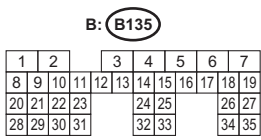
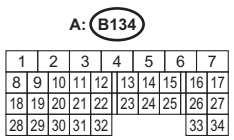
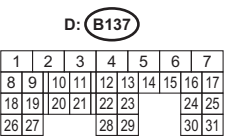
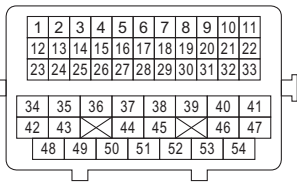
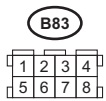
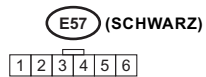
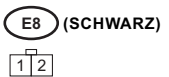

A: B134 D: B137 ECM

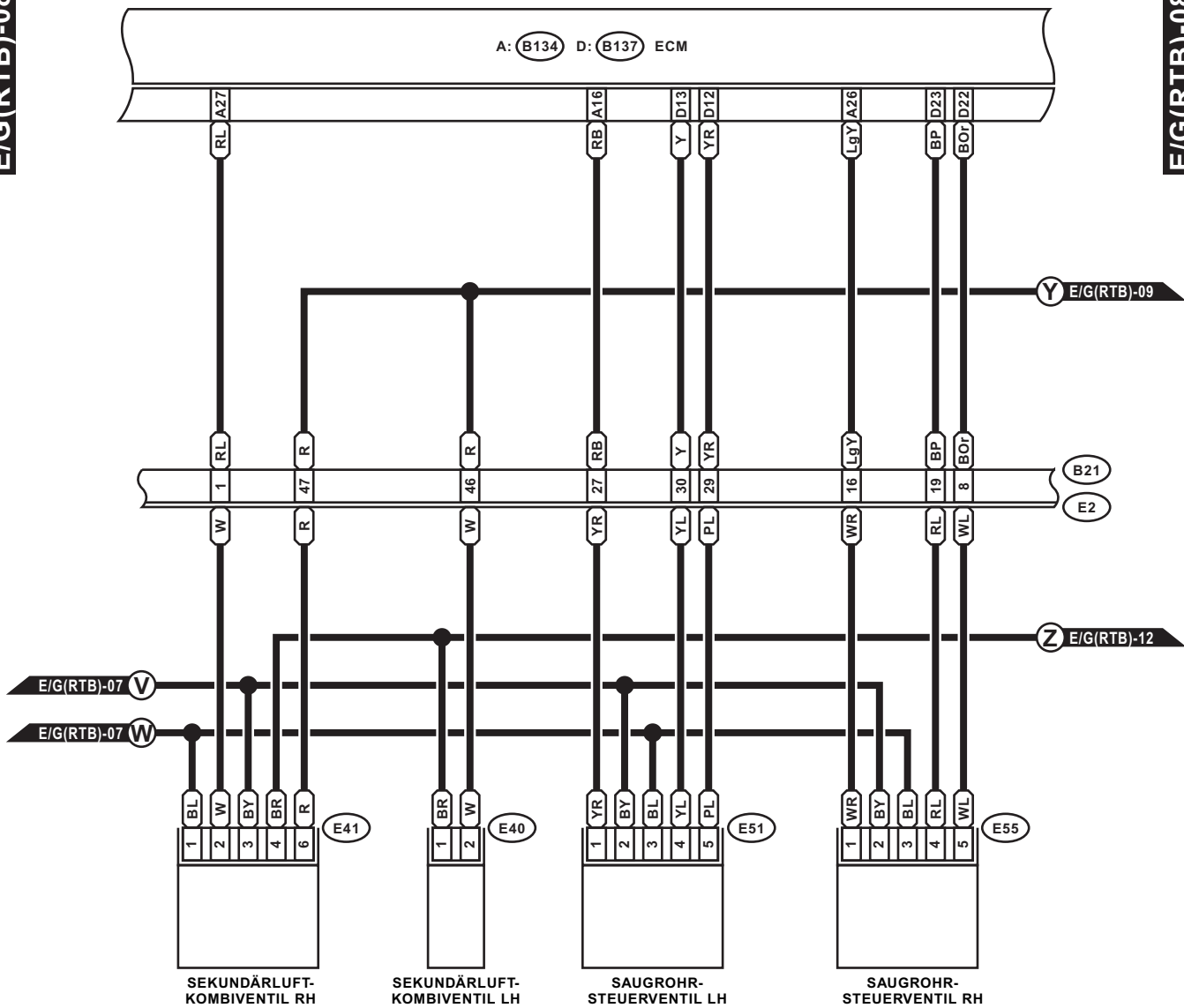

E40 (SCHWARZ)

1	2
---	---

E41 (SCHWARZ) D: B137

1	2	3
4	5	6

A: B134

1	2	3	4	5	6	7			
8	9	10	11	12	13	14	15	16	17
18	19	20	21	22	23	24	25		
26	27		28	29	30	31			

1	2	3	4	5	6	7			
8	9	10	11	12	13	14	15	16	17
18	19	20	21	22	23	24	25	26	27
28	29	30	31	32			33	34	

B21 (SCHWARZ)

1	2	3	4	5	6	7	8	9	10	11
12	13	14	15	16	17	18	19	20	21	22
23	24	25	26	27	28	29	30	31	32	33
34	35	36	37	38	39	40	41			
42	43	44	45	46	47					
48	49	50	51	52	53	54				

E51 (HELLGRAU)

E55 (HELLGRAU)

1	2	3
4	5	

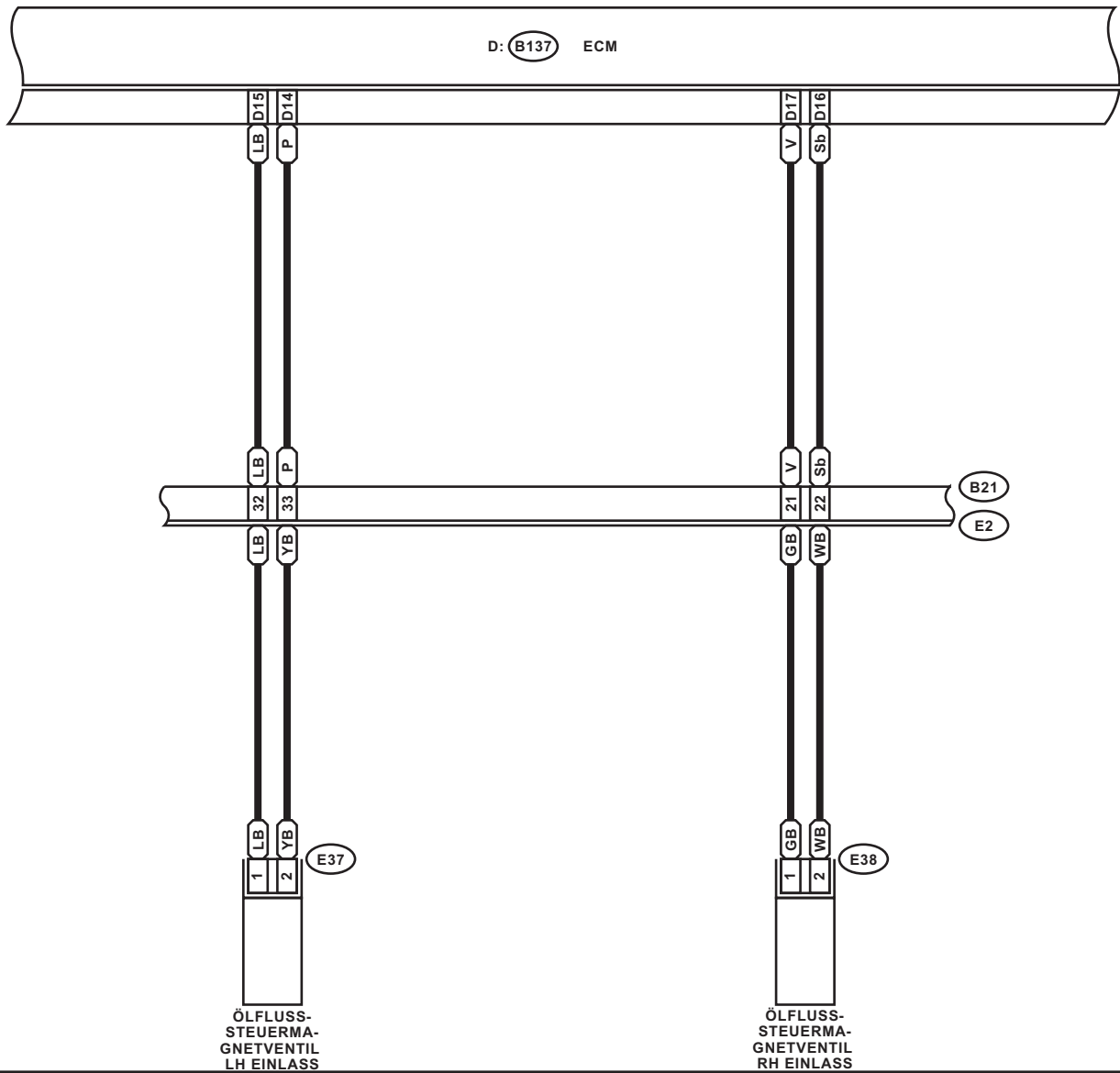

E37 (BLAU)

D: B137

B21 (SCHWARZ)

E38 (BLAU)

1	2	3	4	5	6	7
8	9	10	11	12	13	14
15	16	17	18	19	20	21
22	23	24	25	26	27	28
29	30	31				

1	2	3	4	5	6	7	8	9	10	11
12	13	14	15	16	17	18	19	20	21	22
23	24	25	26	27	28	29	30	31	32	33
34	35	36	37	38	39	40	41			
42	43	44	45	46	47					
48	49	50	51	52	53	54				

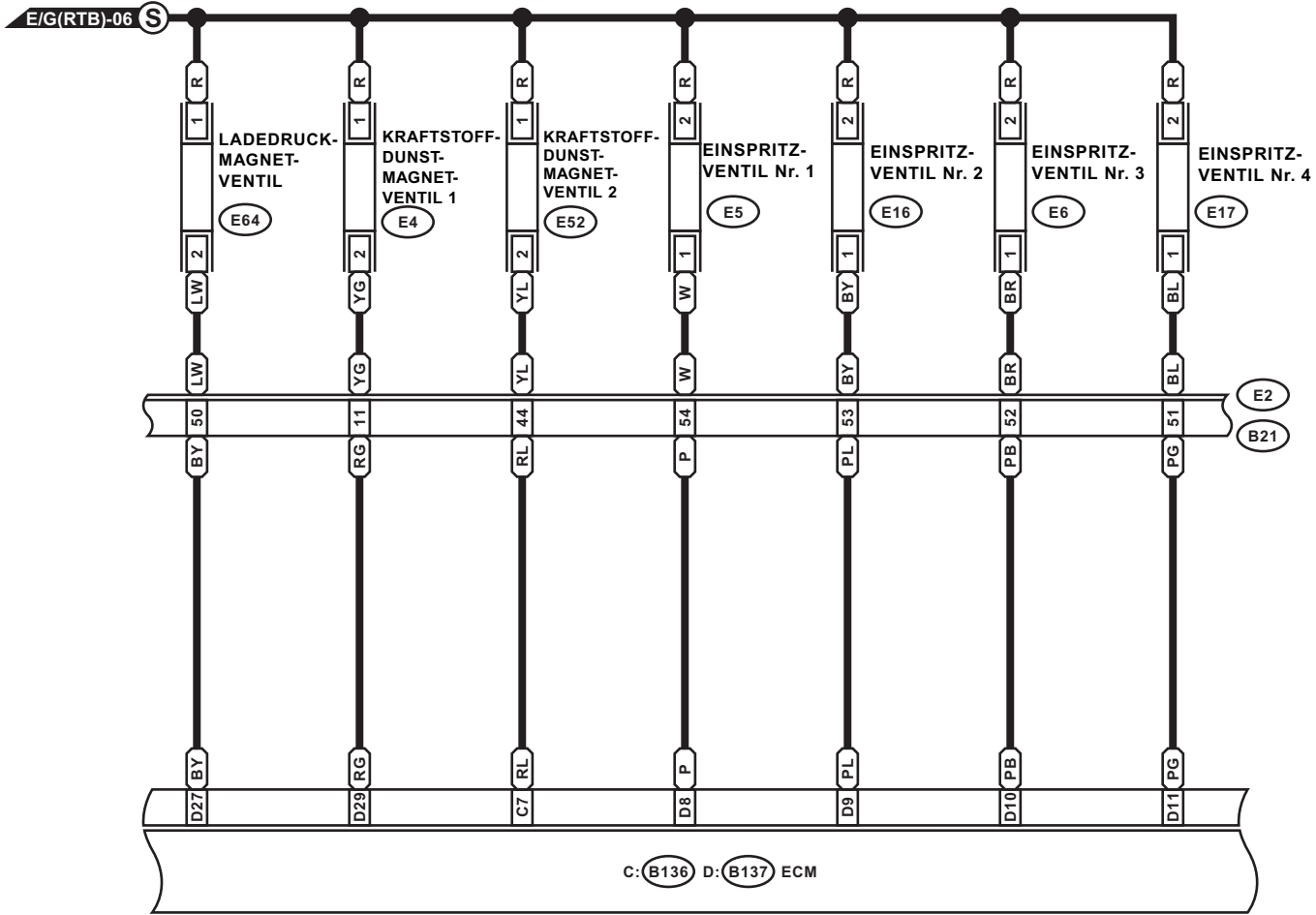

- E4 (SCHWARZ)
- E5 (DUNKELGRAU)
- E52
- E6 (DUNKELGRAU)
- E64 (BLAU)
- E16 (DUNKELGRAU)
- E17 (DUNKELGRAU)

D: B137

1	2	3	4	5	6	7
8	9	10	11	12	13	14
15	16	17	18	19	20	21
22	23	24	25	26	27	28
29	30	31				

C: B136

1	2	3	4	5	6
7	8	9	10	11	12
13	14	15	16	17	18
19	20	21	22	23	24
25	26	27	28	29	30
31	32	33	34	35	

B21 (SCHWARZ)

1	2	3	4	5	6	7	8	9	10	11
12	13	14	15	16	17	18	19	20	21	22
23	24	25	26	27	28	29	30	31	32	33
34	35	36	37	38	39	40	41			
42	43	44	45	46	47					
48	49	50	51	52	53	54				

A: B134 C: B136 D: B137 ECM

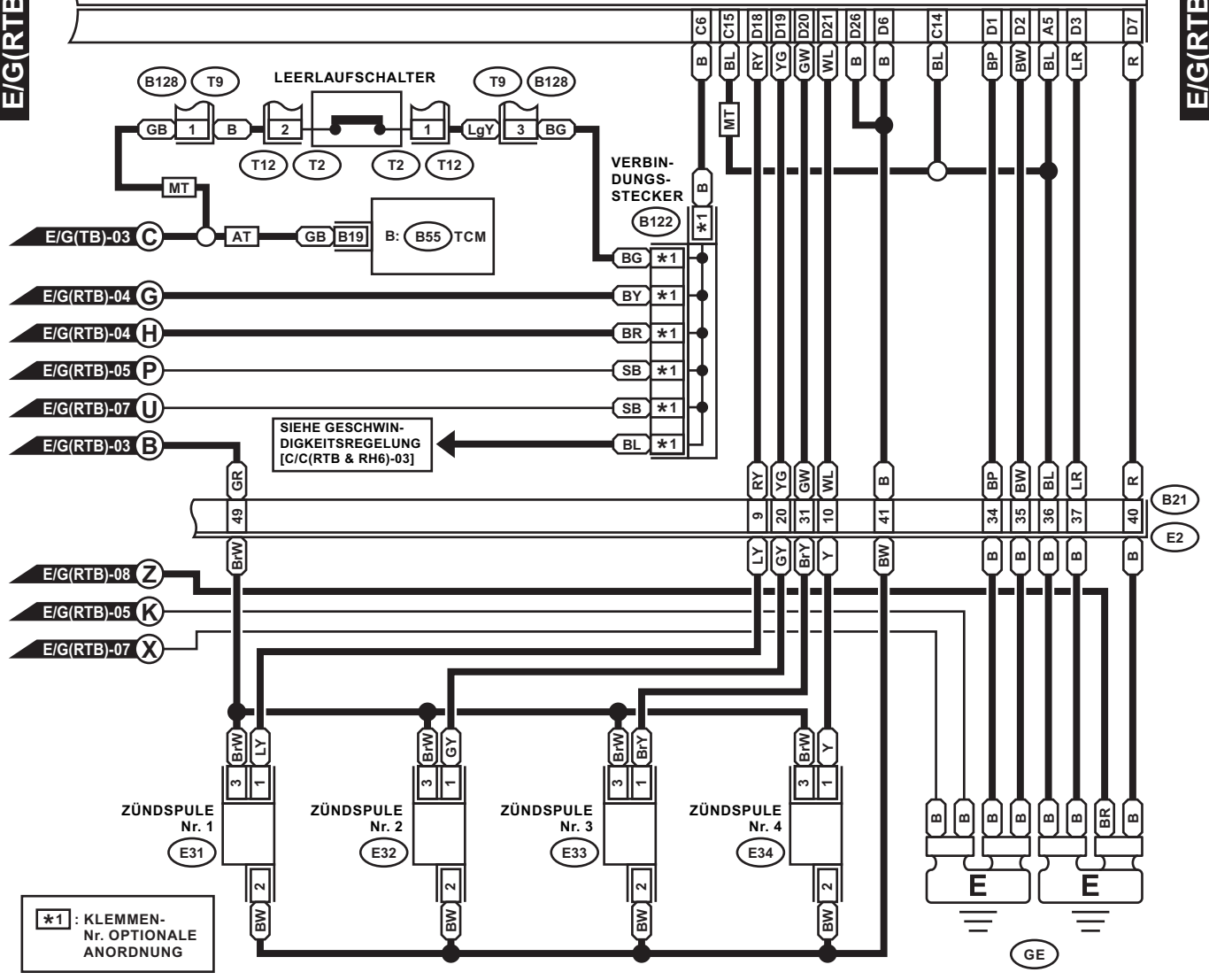

*1 : KLEMMEN-Nr. OPTIONALE ANORDNUNG

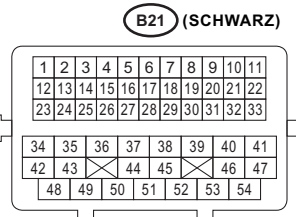
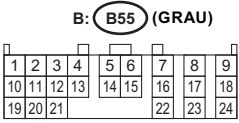
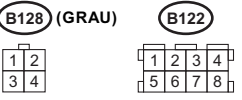
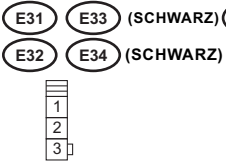

D: B137

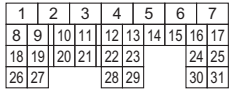

A: B134

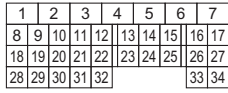

C: B136

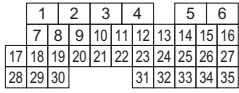

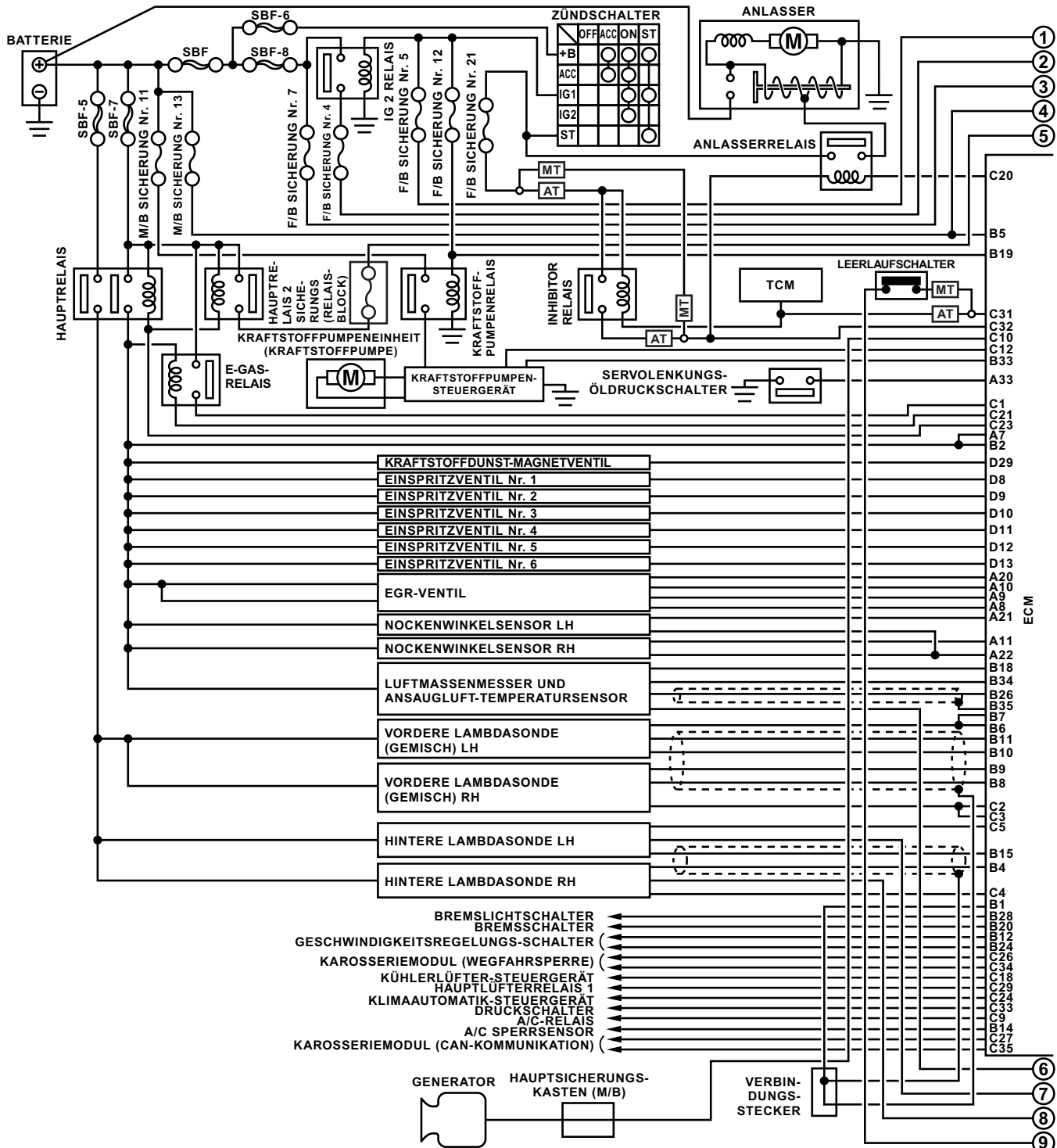

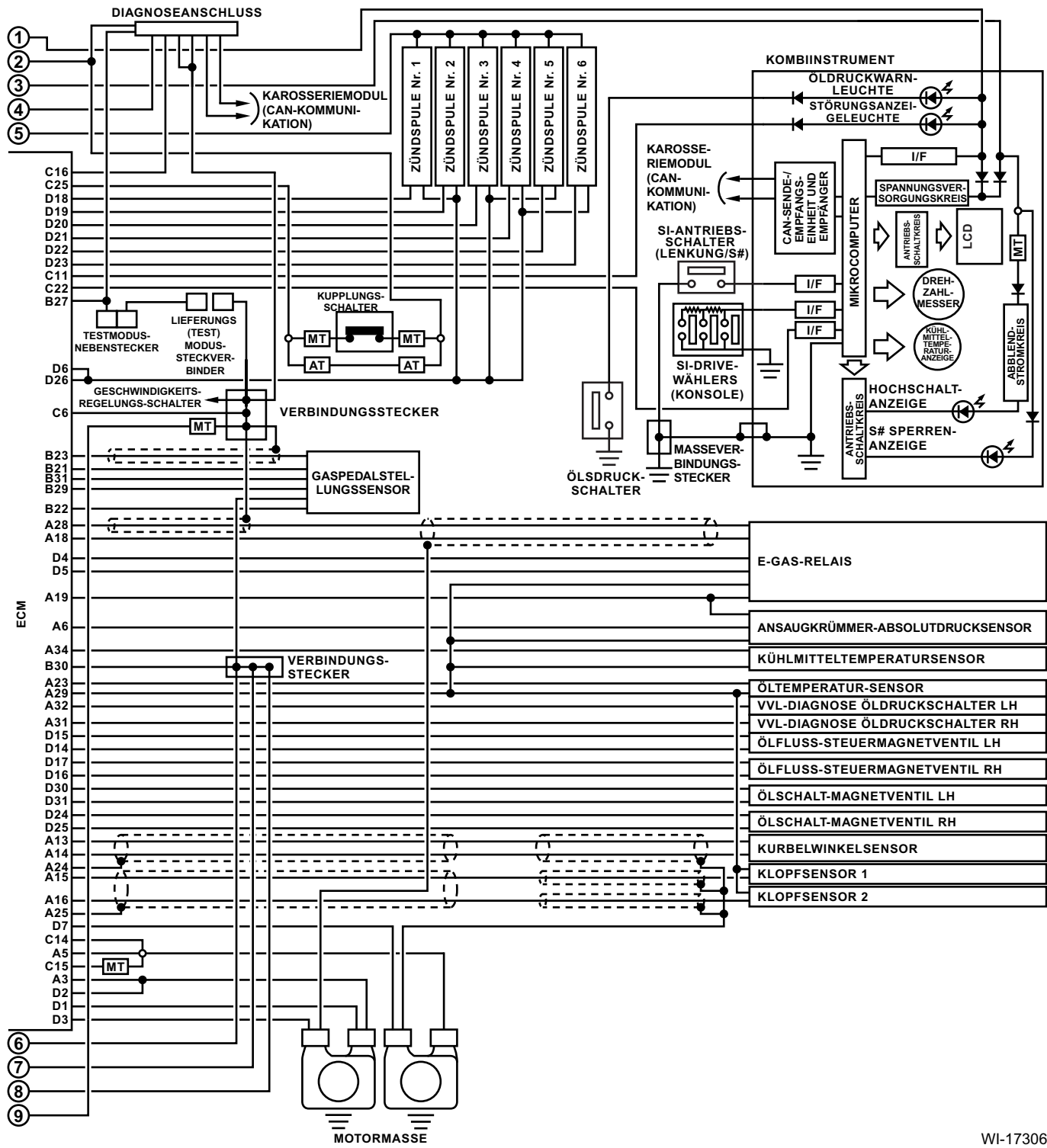

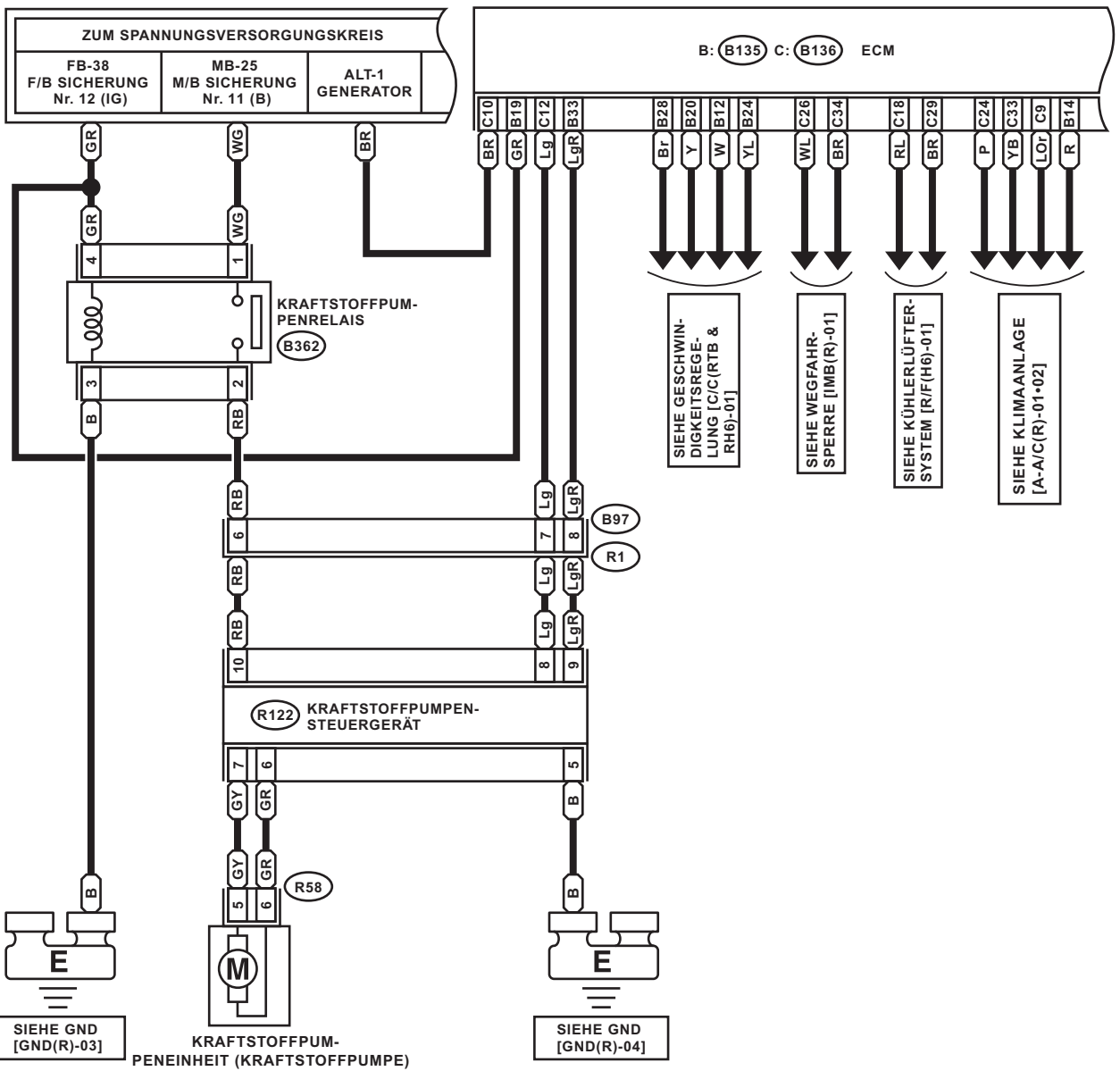

R58 (GRAU)



B362 (SCHWARZ)

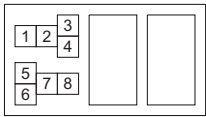

RELAISHALTER

R122 (SCHWARZ)

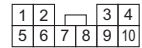

B97

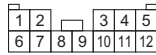

B: B135

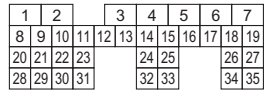

C: B136

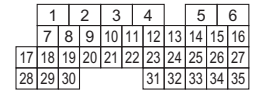

ZUM SPANNUNGSVERSORUNGSKREIS

FB-36
F/B SICHERUNG Nr. 5
(G)

FB-17
F/B SICHERUNG Nr. 7
(B)

*1 : KLEMMEN-Nr. OPTIONALE ANORDNUNG
BEI 1, 2, 3, 4, 5 UND 6

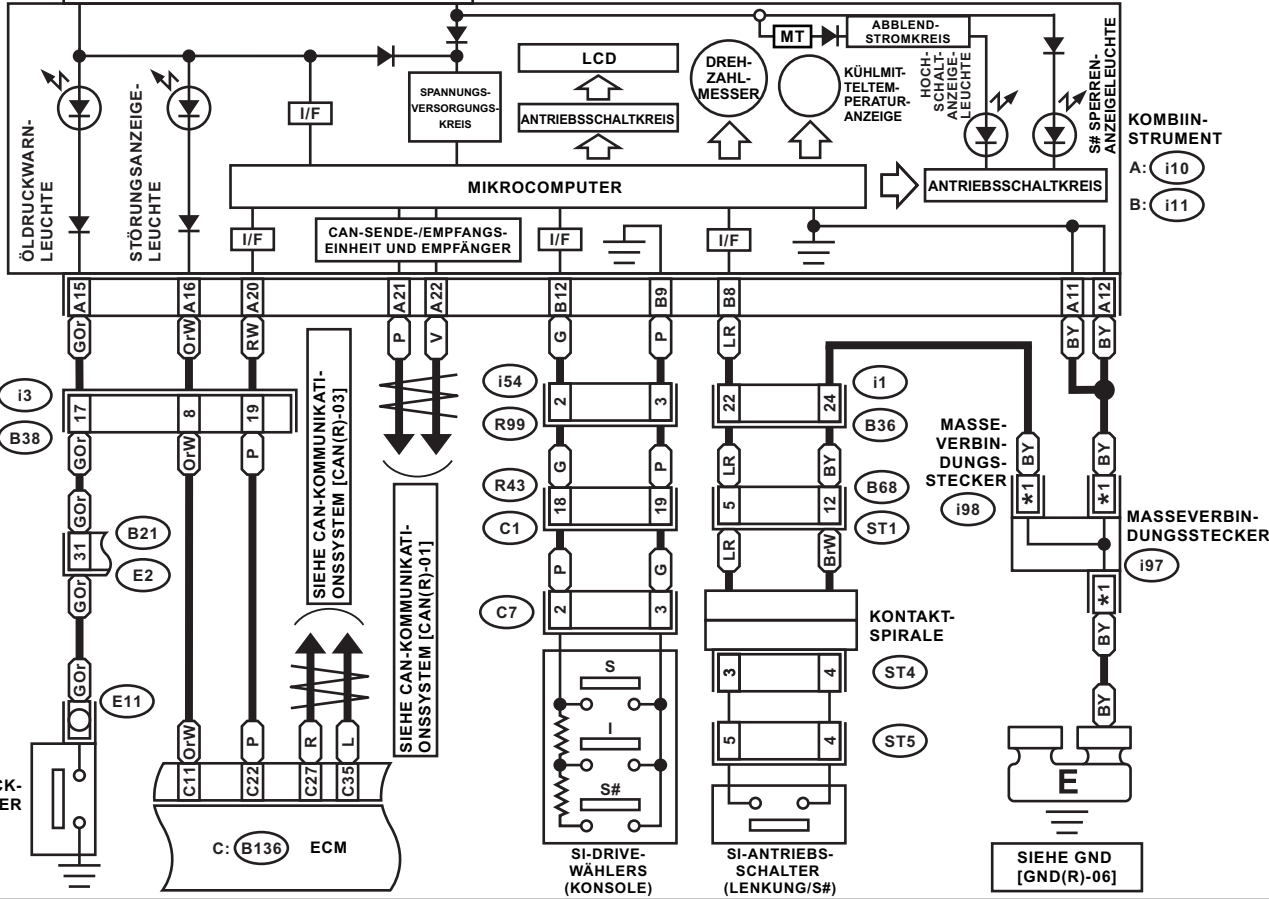

KOMBIINSTRUMENT
A: (i10)
B: (i11)

MASSEVERBINDUNGSSTECKER
i98
MASSEVERBINDUNGSSTECKER
i97

SIEHE GND [GND(R)-06]

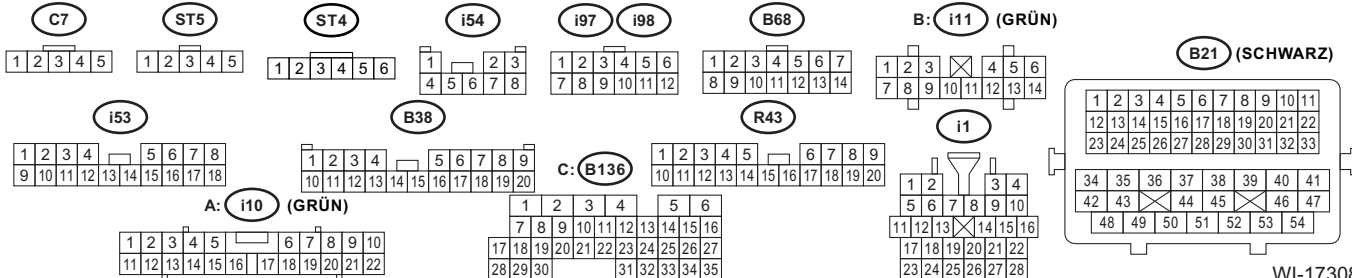

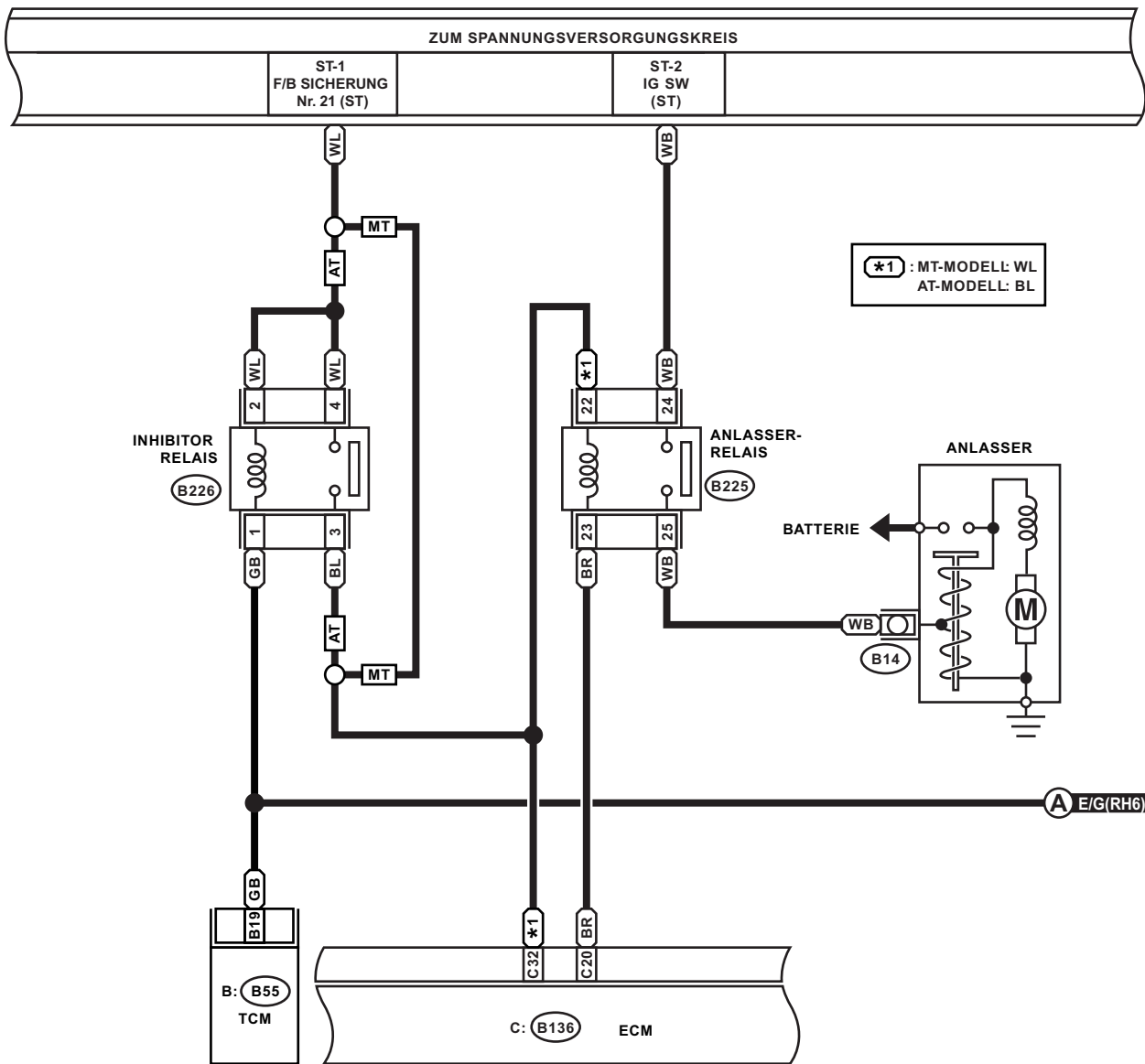

B226 (SCHWARZ)



B: B55 (GRAU)

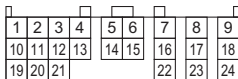

C: B136

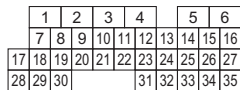

B225 (SCHWARZ)

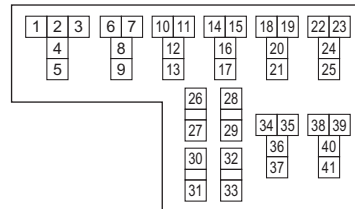

RELAISBLOCK

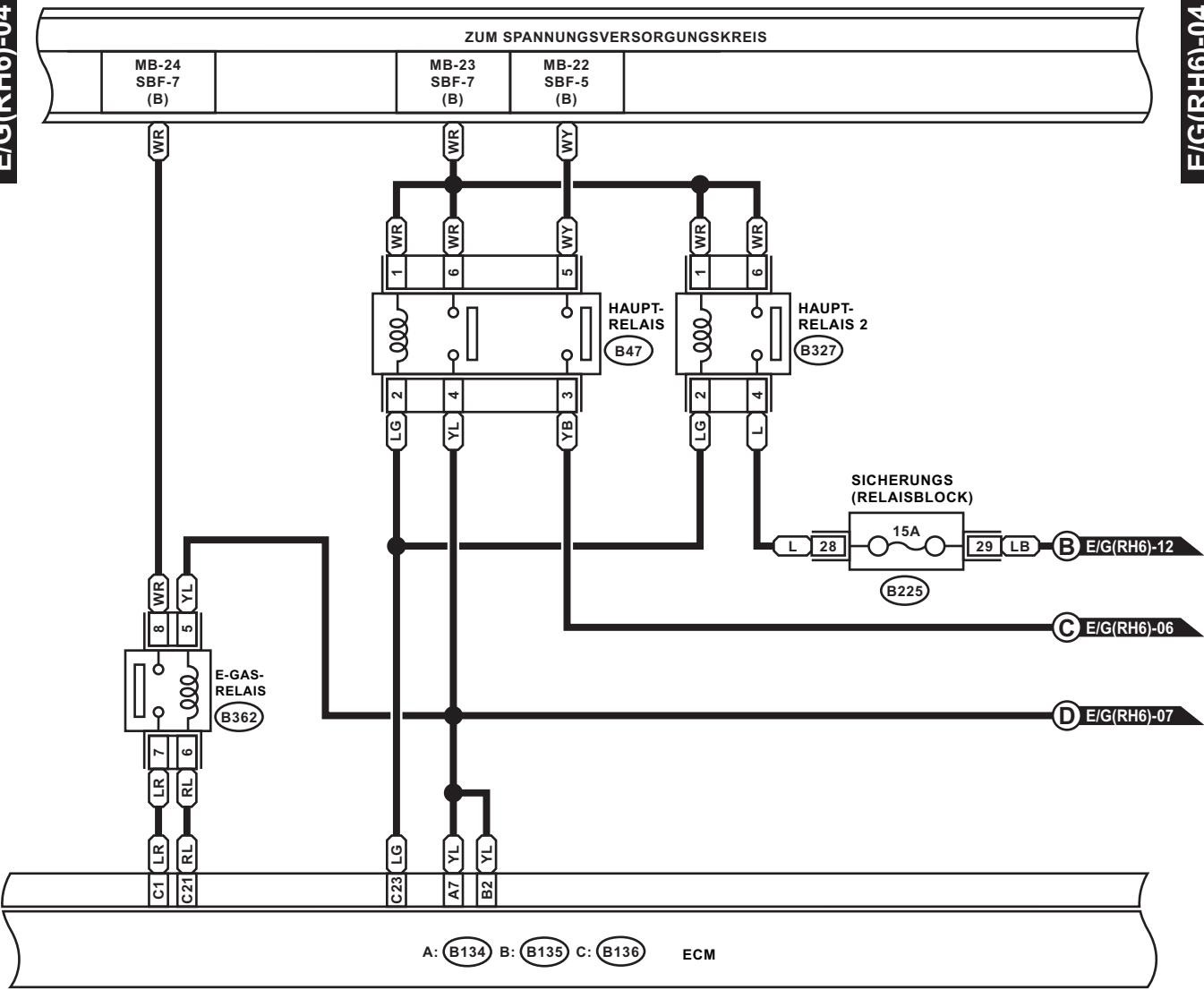

(B47) (BRAUN)

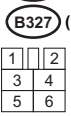

(B362) (SCHWARZ)

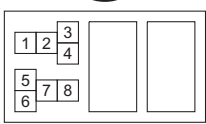

A: (B134)

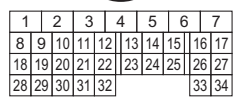

(B225) (SCHWARZ)

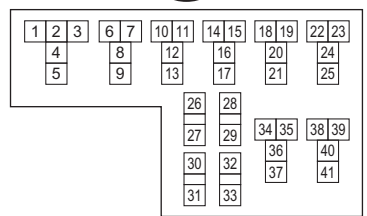

B: (B135)

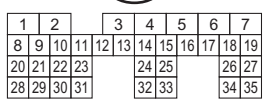

C: (B136)

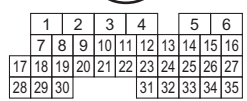

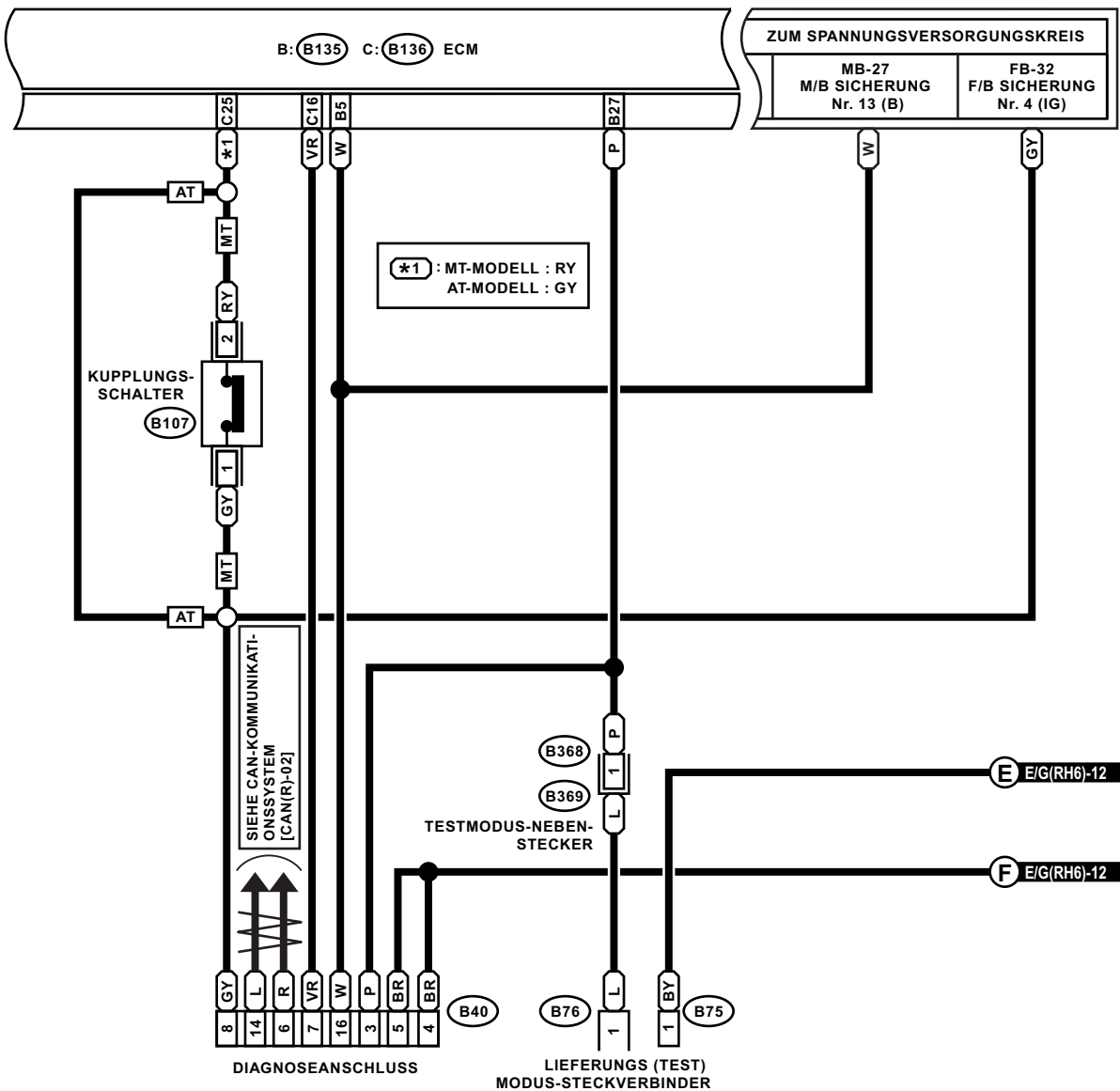

*1 : MT-MODELL : RY
AT-MODELL : GY

DIAGNOSEANSCHLUSS

LIEFERUNGS (TEST) MODUS-STECKVERBINDER

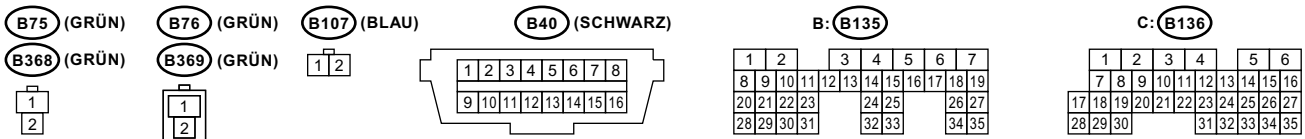

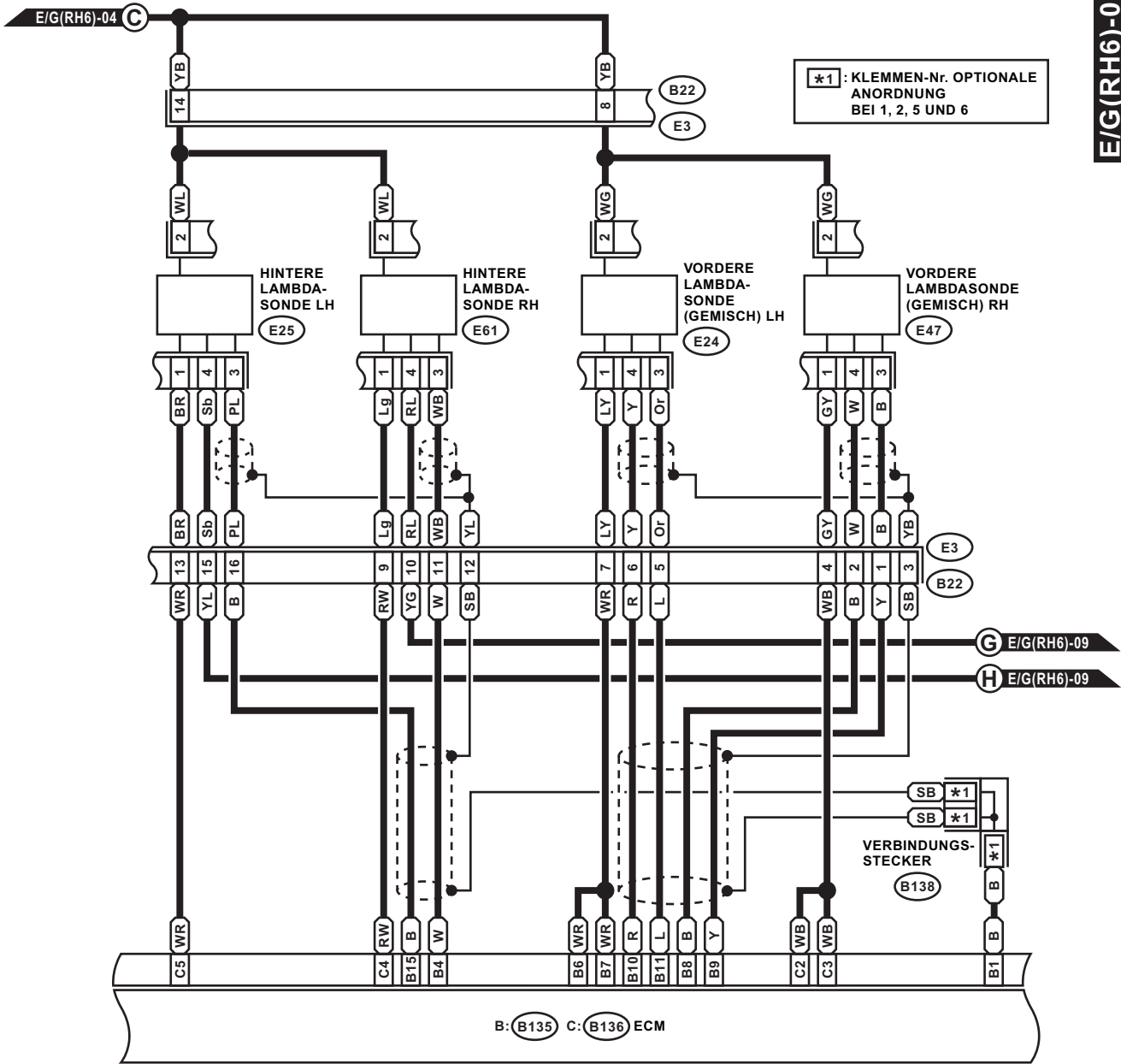

E24 (HELLGRAU)

B138

B22 (BRAUN)

B: B135

C: B136

E25 (DUNKELGRAU)



E47 (HELLGRAU)

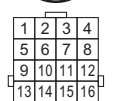

E61 (DUNKELGRAU)

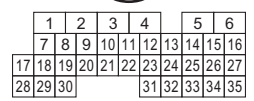
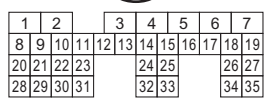

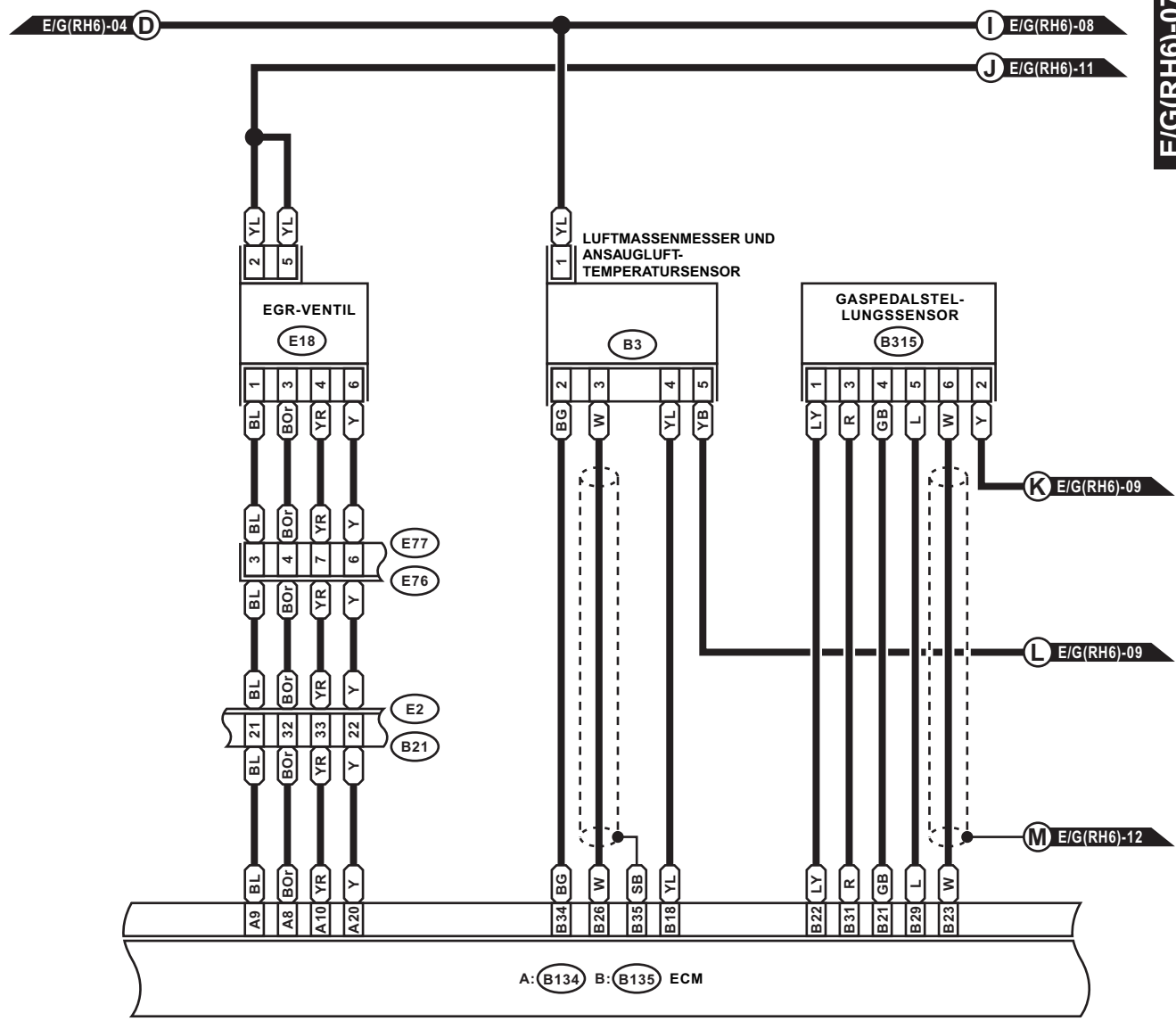

B3 (SCHWARZ) **B315 (SCHWARZ)** **E18 (DUNKELGRAU)** **E77 (GRAU)**

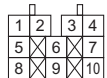
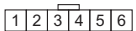
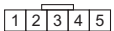

B21 (SCHWARZ)

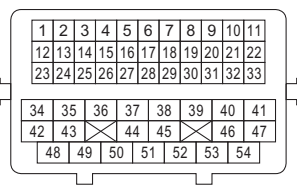

A: B134

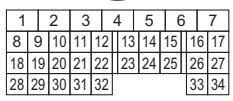

B: B135

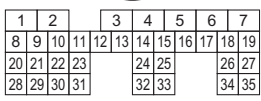

A: B134 ECM

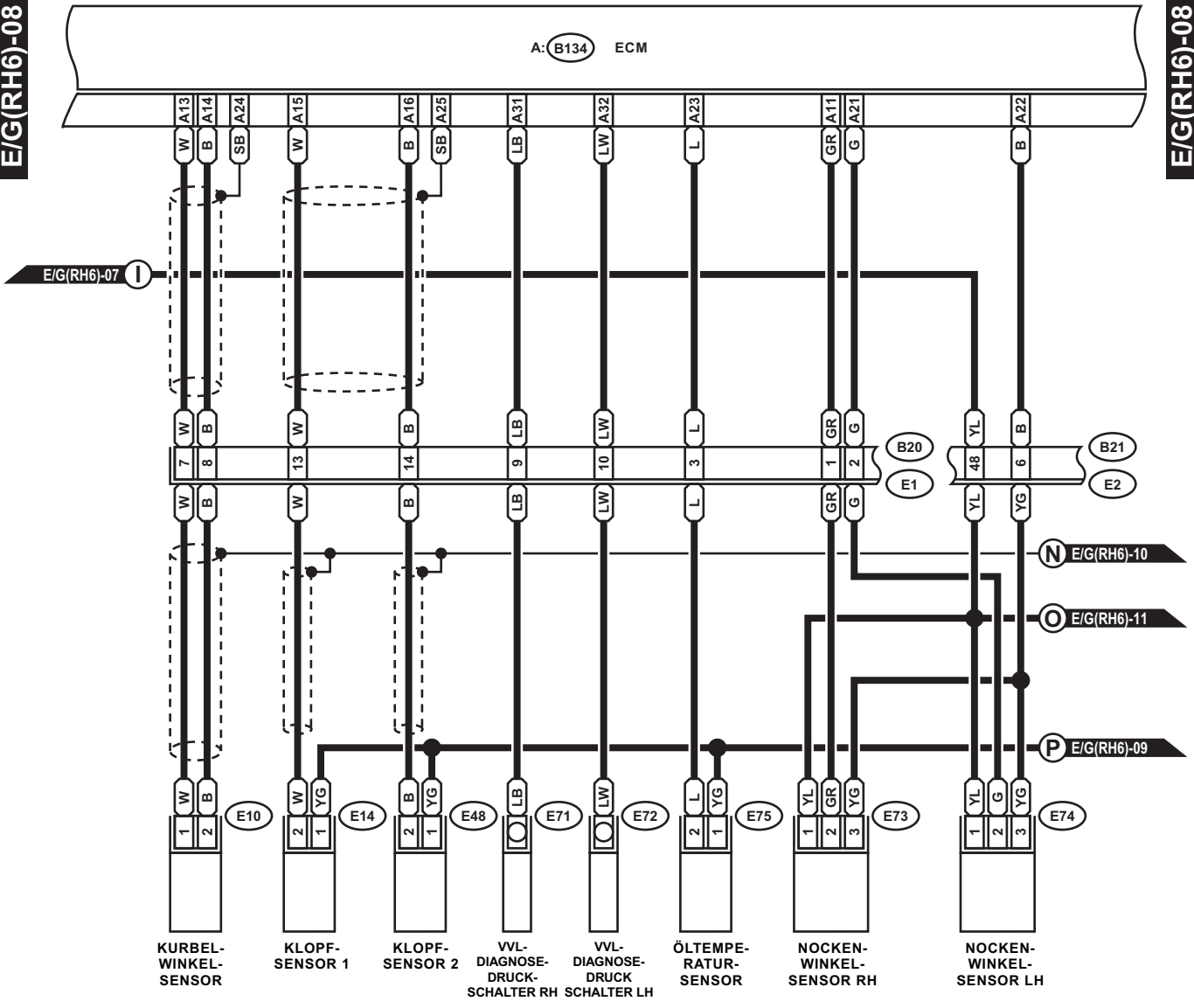

- E10 (HELLGRAU)
- E14 (BLAU)
- E48 (BLAU)
- E75 (SCHWARZ)
- E73 (GRAU)
- E74 (GRAU)

B20 (BRAUN)

1	2	3	4
5	6	7	8
9	10	11	12
13	14	15	16

A: B134

1	2	3	4	5	6	7
8	9	10	11	12	13	14
15	16	17	18	19	20	21
22	23	24	25	26	27	28
29	30	31	32	33	34	

B21 (SCHWARZ)

1	2	3	4	5	6	7	8	9	10	11
12	13	14	15	16	17	18	19	20	21	22
23	24	25	26	27	28	29	30	31	32	33
34	35	36	37	38	39	40	41			
42	43	44	45	46	47					
48	49	50	51	52	53	54				

A: B134 B: B135 D: B137 ECM

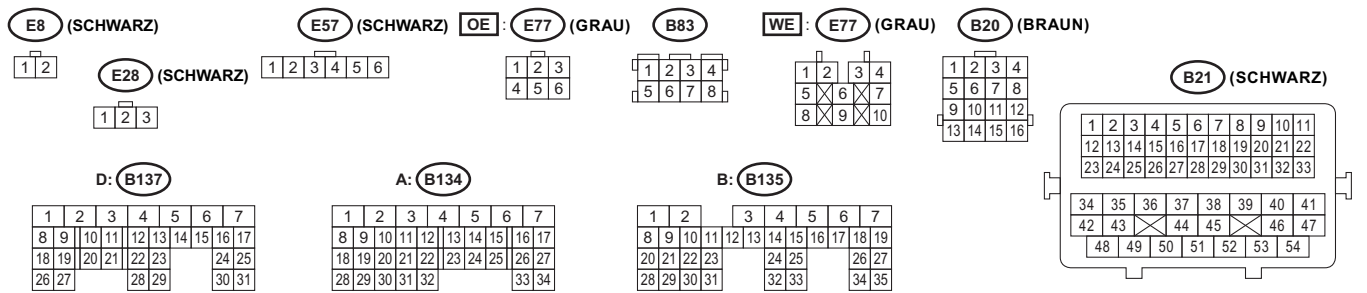
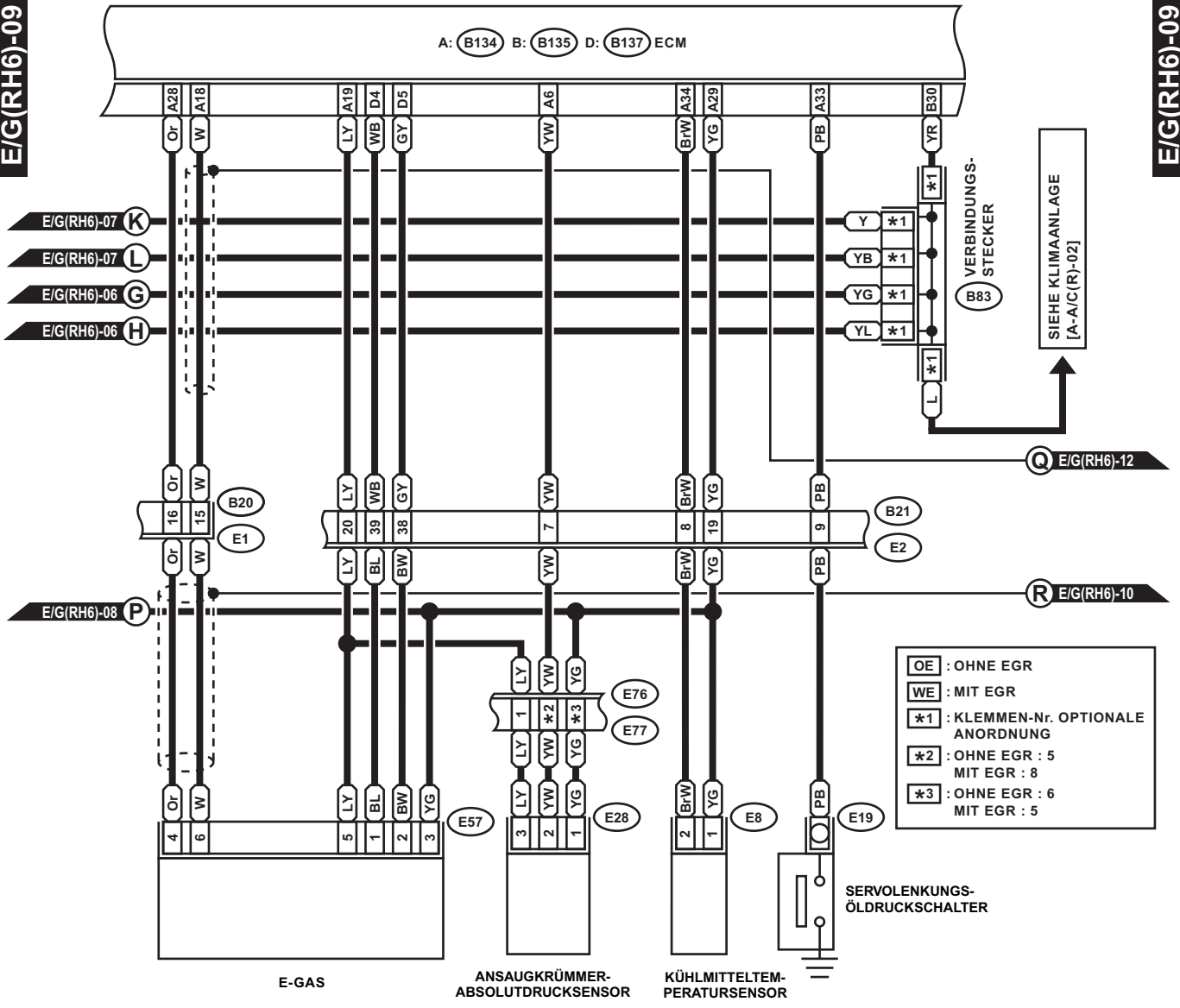

A: B134 C: B136 D: B137 ECM

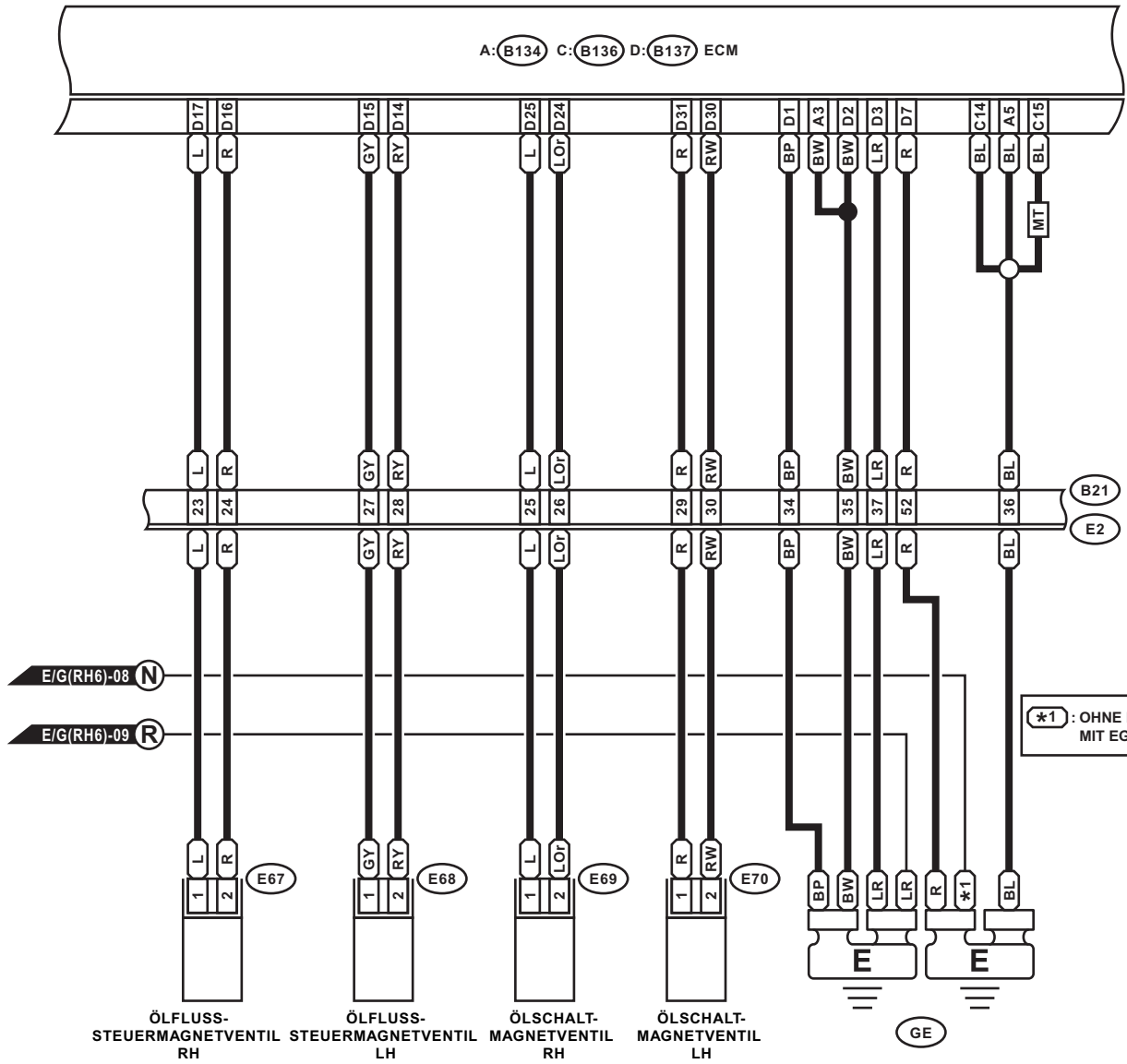

(SCHWARZ) E67 (BLAU) E69

D: B137

A: B134

C: B136

B21 (SCHWARZ)

(SCHWARZ) E68 (BLAU) E70



1	2	3	4	5	6	7
8	9	10	11	12	13	14
15	16	17	18	19	20	21
22	23	24	25	26	27	28
29	30	31	32			

1	2	3	4	5	6	7
8	9	10	11	12	13	14
15	16	17	18	19	20	21
22	23	24	25	26	27	28
29	30	31	32	33	34	

1	2	3	4	5	6
7	8	9	10	11	12
13	14	15	16	17	18
19	20	21	22	23	24
25	26	27	28	29	30
31	32	33	34	35	

1	2	3	4	5	6	7	8	9	10	11
12	13	14	15	16	17	18	19	20	21	22
23	24	25	26	27	28	29	30	31	32	33
34	35	36	37	38	39	40	41			
42	43	44	45	46	47					
48	49	50	51	52	53	54				

- OE** : OHNE EGR
- WE** : MIT EGR
- *1** : OHNE EGR : 3
MIT EGR : 10
- *2** : OHNE EGR : P
EGR : Lg
- *3** : OHNE EGR : PL
MIT EGR : LR
- *4** : OHNE EGR : PB
MIT EGR : GOr
- *5** : OHNE EGR : PG
MIT EGR : RG
- *6** : OHNE EGR : V
MIT EGR : Br
- *7** : OHNE EGR : VW
MIT EGR : GW

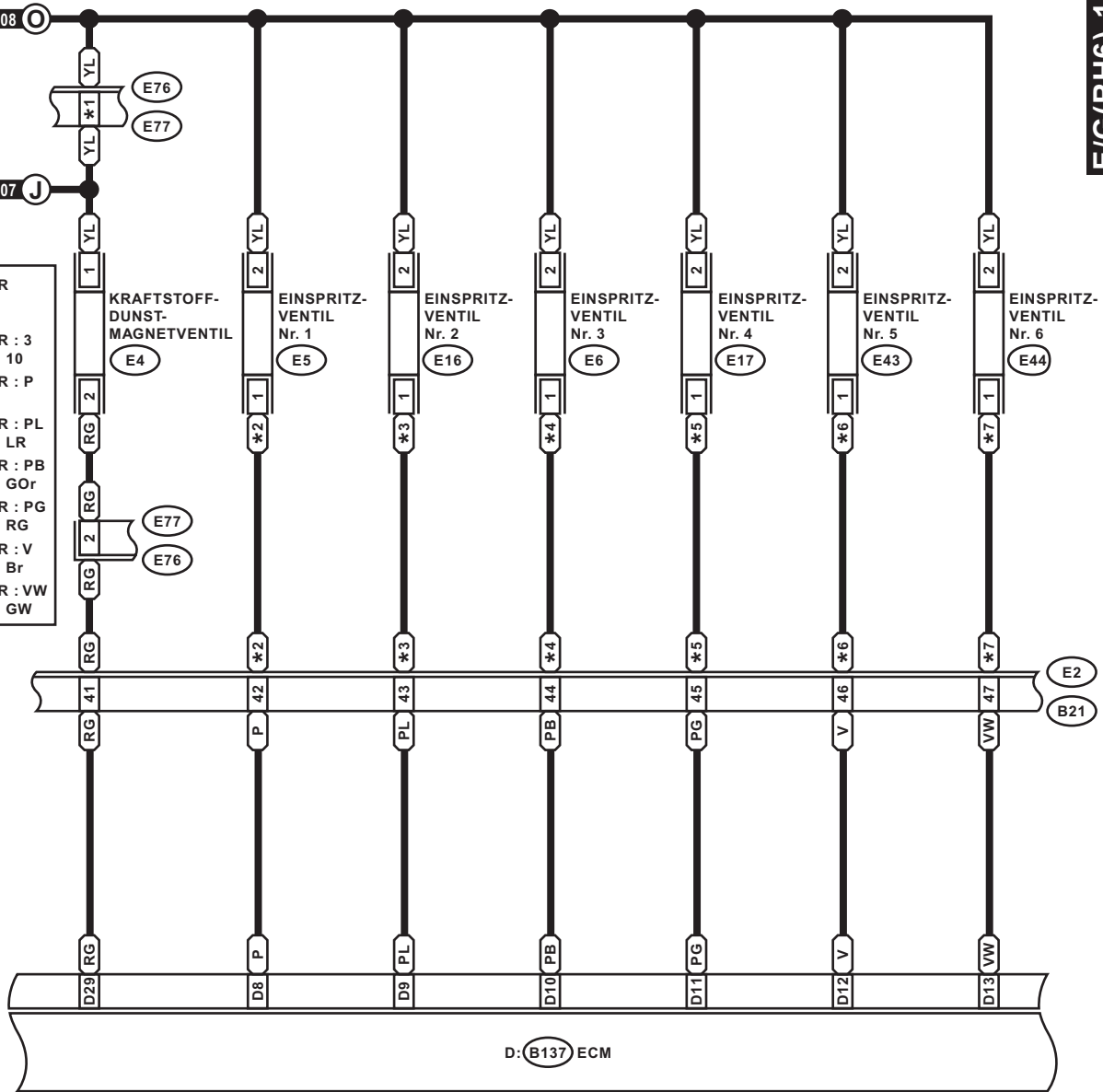

E4 (BLAU) (DUNKELGRAU) **E5** (DUNKELGRAU) **E17** (DUNKELGRAU) **OE** : **E77** (GRAU) **WE** : **E77** (GRAU) **D: B137** **B21** (SCHWARZ)

1	2	3
4	5	6

1	2	3	4
5	6	7	8
9	10	11	12

1	2	3	4	5	6	7
8	9	10	11	12	13	14
15	16	17	18	19	20	21
22	23	24	25	26	27	28
29	30	31	32	33	34	35

1	2	3	4	5	6	7	8	9	10	11
12	13	14	15	16	17	18	19	20	21	22
23	24	25	26	27	28	29	30	31	32	33
34	35	36	37	38	39	40	41	42	43	44
45	46	47	48	49	50	51	52	53	54	55

C: (B136) D: (B137) ECM

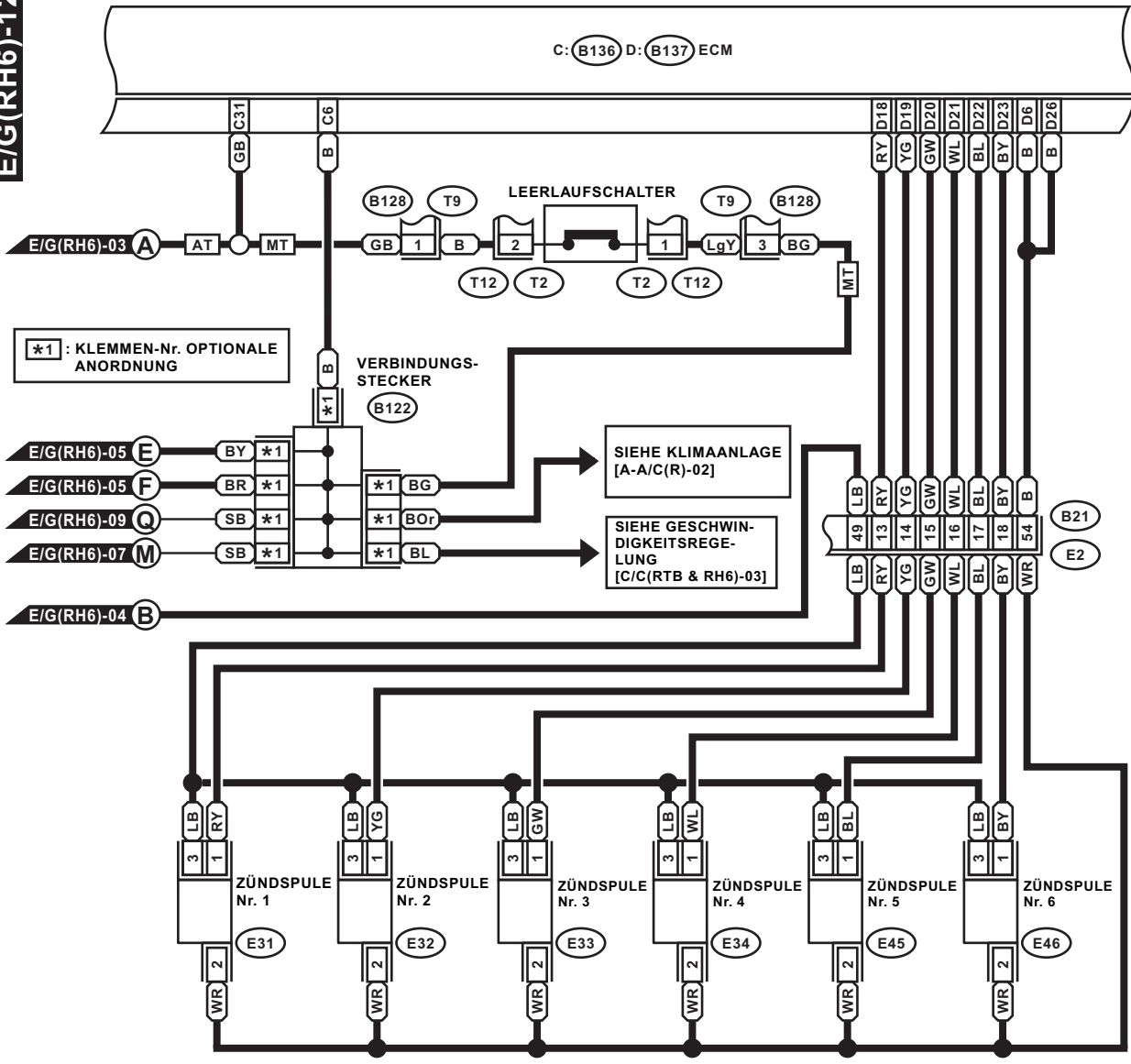

*1 : KLEMMEN-Nr. OPTIONALE ANORDNUNG

SIEHE KLIMAANLAGE [A-A/C(R)-02]

SIEHE GESCHWINDIGKEITSREGELUNG [C/C(RTB & RH6)-03]

- (T2) (SCHWARZ) (SCHWARZ) (E31) (E34) (B128) (GRAU) (B122)
- (SCHWARZ) (E32) (E45) (SCHWARZ) (1 2) (1 2 3 4)
- (E33) (E46) (SCHWARZ) (3 4) (5 6 7 8)
- (B21) (SCHWARZ)

D: (B137)

1	2	3	4	5	6	7
8	9	10	11	12	13	14
15	16	17	18	19	20	21
22	23	24	25	26	27	
28	29	30	31			

1
2
3

C: (B136)

1	2	3	4	5	6
7	8	9	10	11	12
13	14	15	16	17	18
19	20	21	22	23	24
25	26	27	28	29	30
31	32	33	34	35	

1	2	3	4	5	6	7	8	9	10	11
12	13	14	15	16	17	18	19	20	21	22
23	24	25	26	27	28	29	30	31	32	33
34	35	36	37	38	39	40	41			
42	43	44	45	46	47					
48	49	50	51	52	53	54				

ZUM SPANNUNGSVERSORUNGSKREIS

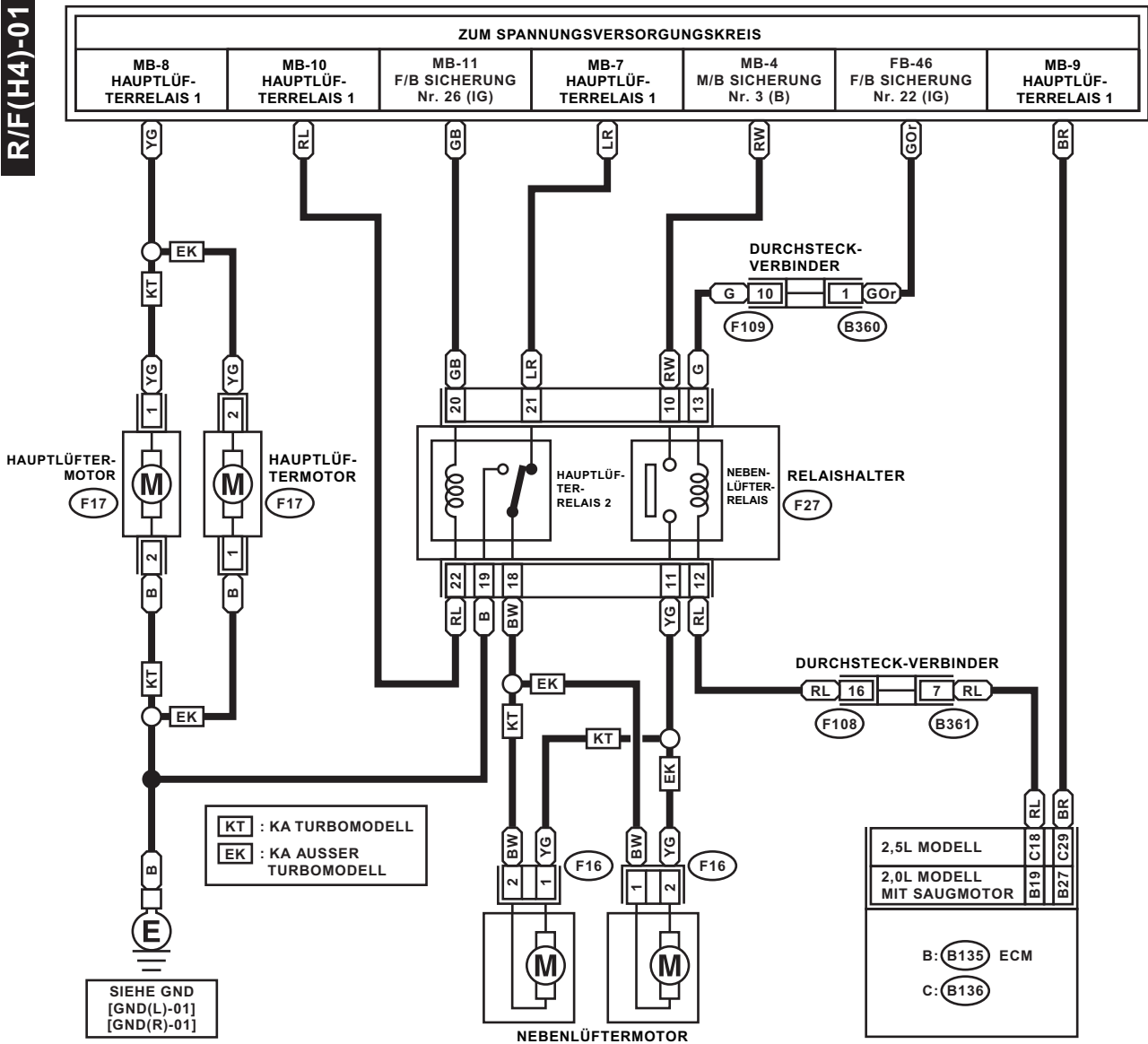

EK : F16 (SCHWARZ) **KT** : F16 (GRAU)

B361 (GRAU)

B360 (GRAU)

F108

F27 (SCHWARZ)

EK : F17 (SCHWARZ) **KT** : F17 (GRAU)

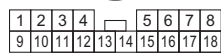
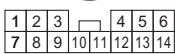

F109

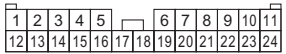

B: B135

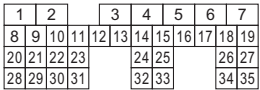

C: B136

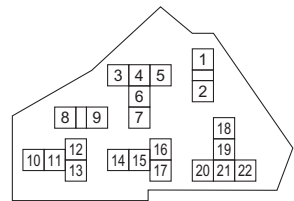
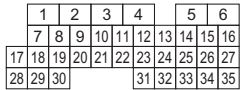

RELAISHALTER

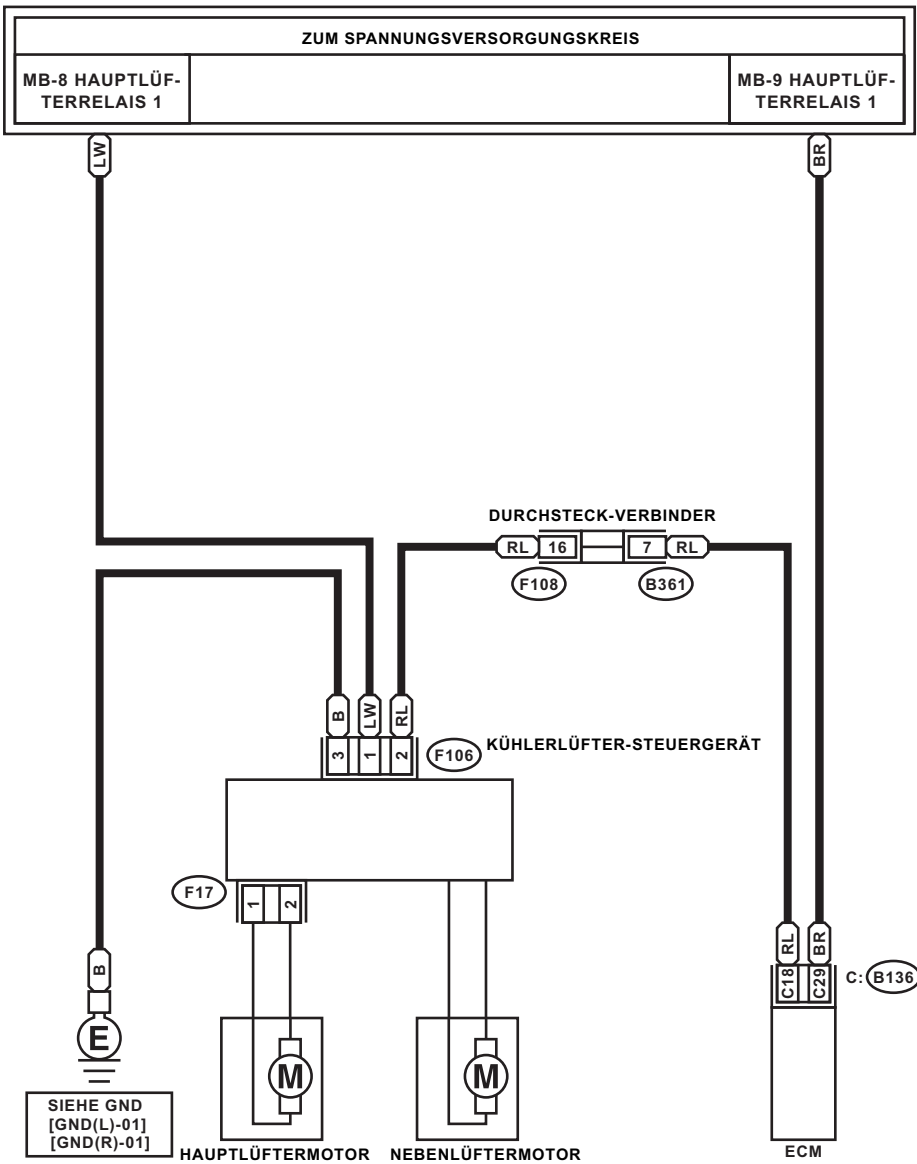

F17 (SCHWARZ) F106 (GRAU)



B361 (GRAU)



F108

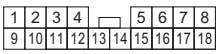

C: B136

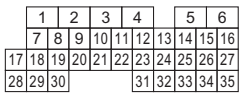

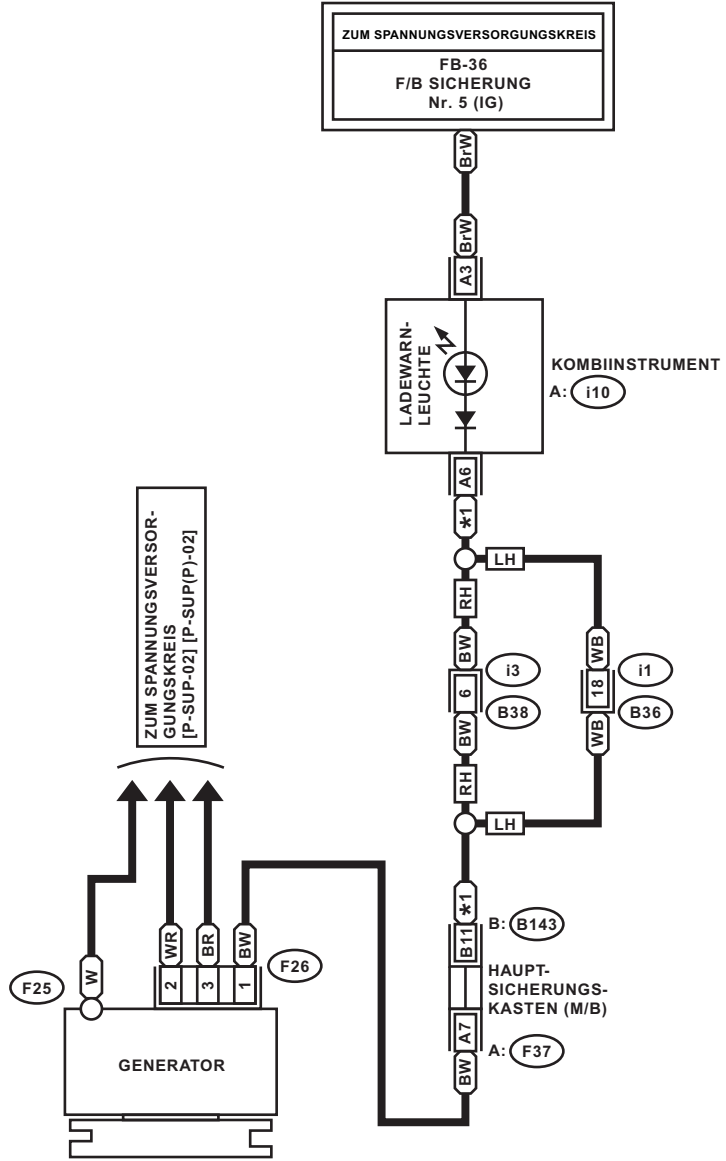

LH : LHD-MODELL
 RH : RHD-MODELL
 *1 : LHD-MODELL : WB
 RHD-MODELL : BW

F26 (GRÜN)



B38

B: B143

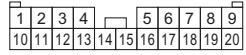

A: F37

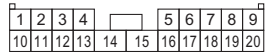

A: i10 (GRÜN)

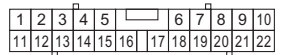

i1

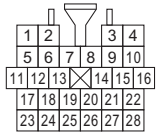

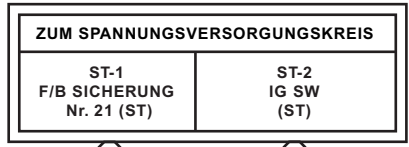

- LH** : LHD-MODELL
- RH** : RHD-MODELL
- LM** : LHD-MODELL MIT MT
- EM** : LHD AUSSER MT-MODELL
- *1** : LHD-MODELL : 15
RHD-MODELL : 22
- *2** : LHD-MODELL : 16
RHD-MODELL : 23
- *3** : LHD-MODELL : 13
RHD-MODELL : 24
- *4** : LHD-MODELL : 14
RHD-MODELL : 25
- *5** : MT-MODELL : WB
LHD-MODELL MIT AT : WL
RHD-MODELL MIT AT : WR
- *6** : LHD-MODELL : WL
RHD-MODELL : WR
- *7** : LHD-MODELL MIT MT : LW
LHD AUSSER
MT-MODELL : BL

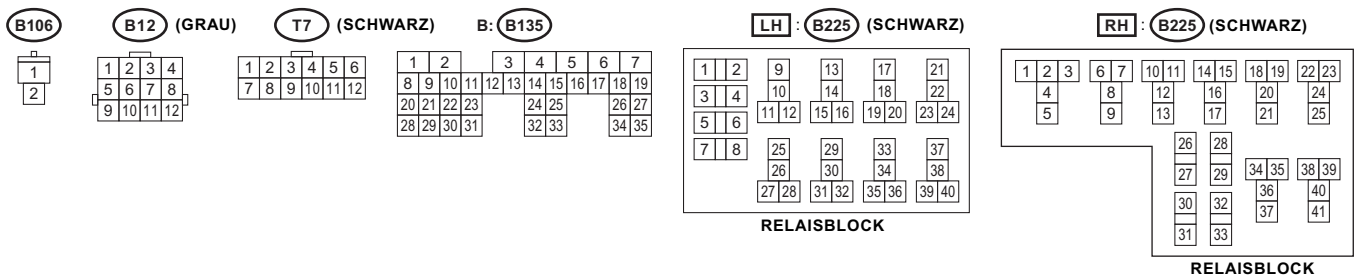
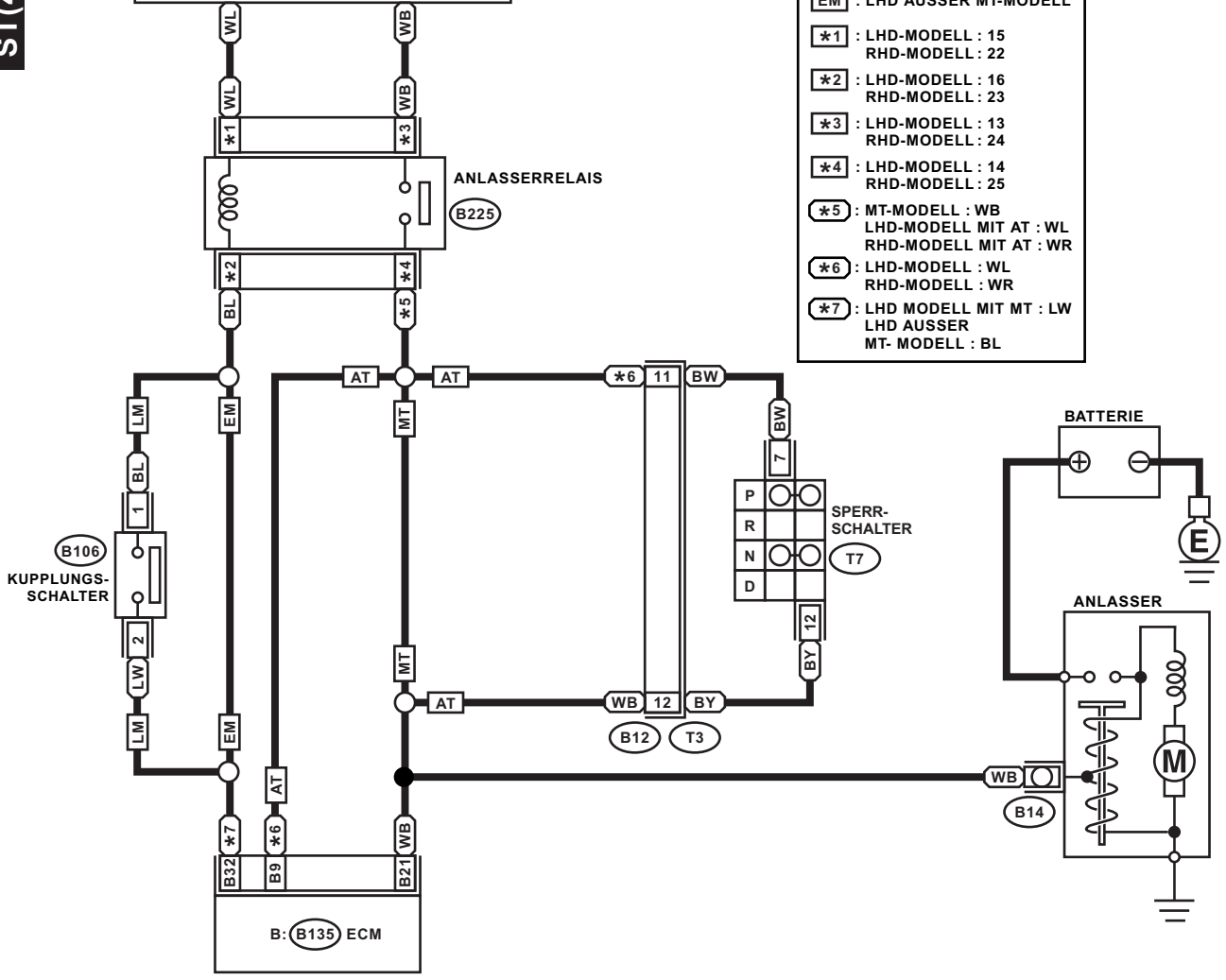

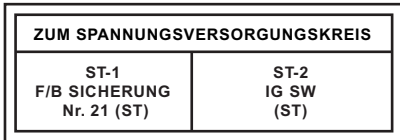

- LH** : LHD-MODELL
- RH** : RHD-MODELL
- LM** : LHD-MODELL MIT MT
- EM** : LHD AUSSER MT-MODELL
- *1** : LHD-MODELL : 15
RHD-MODELL : 22
- *2** : LHD-MODELL : 16
RHD-MODELL : 23
- *3** : LHD-MODELL : 13
RHD-MODELL : 24
- *4** : LHD-MODELL : 14
RHD-MODELL : 25
- *5** : MT-MODELL : WB
LHD-MODELL MIT AT : WL
RHD-MODELL MIT AT : WR
- *6** : MT-MODELL : GB
LHD-MODELL MIT AT : WL
RHD-MODELL MIT AT : WR
- *7** : LHD-MODELL MIT MT : WL
LHD AUSSER
MT-MODELL : WL

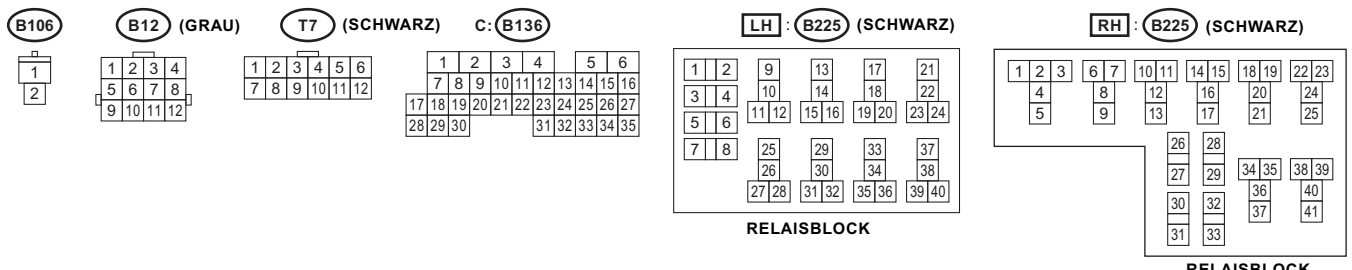
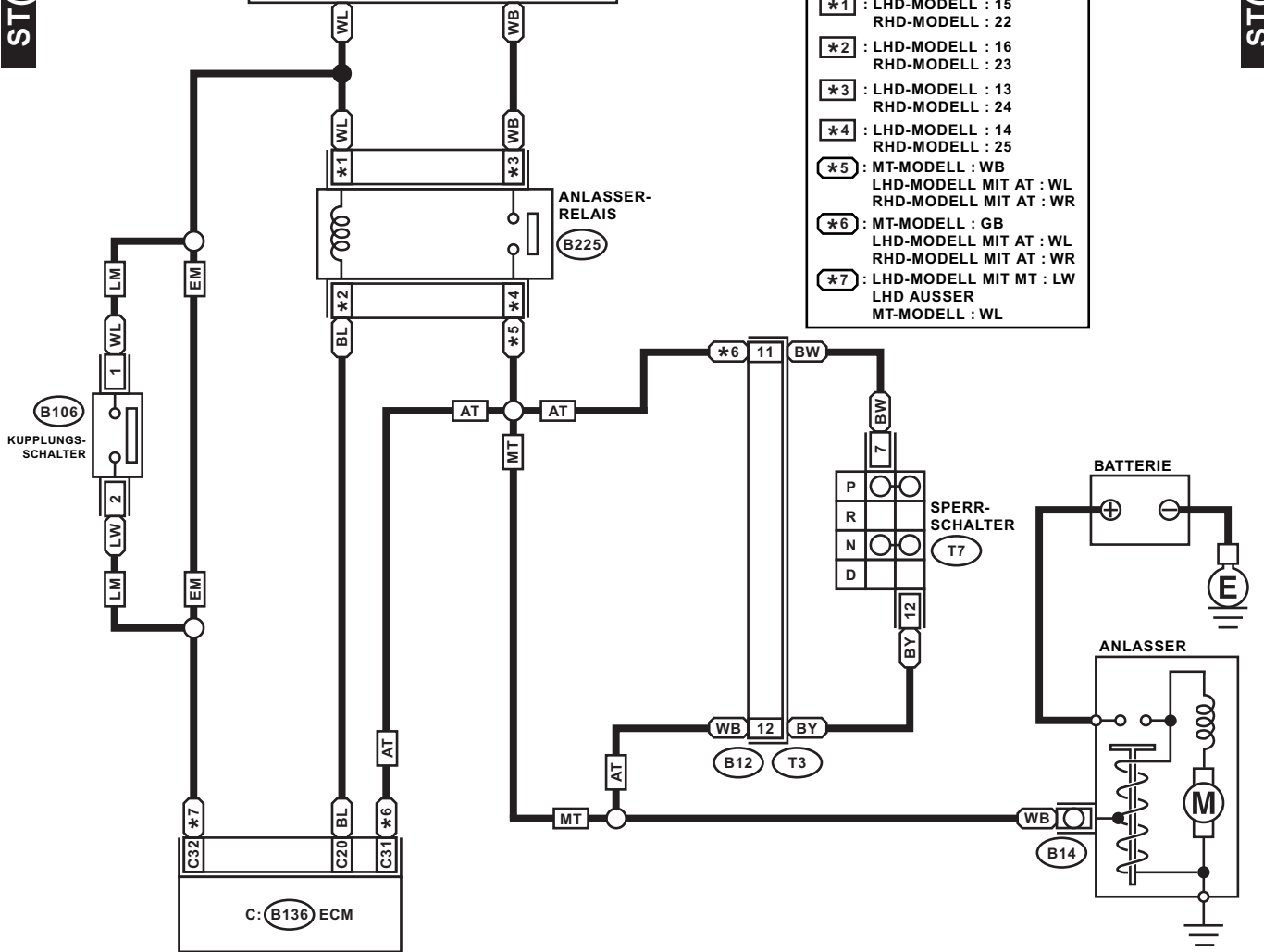

RELAISBLOCK

RELAISBLOCK

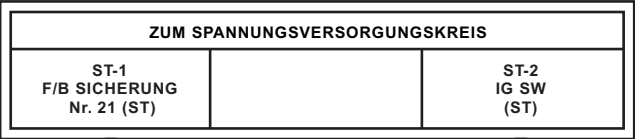

- LH** : LHD-MODELL
- RH** : RHD-MODELL
- LM** : LHD-MODELL MIT MT
- RM** : RHD-MODELL MIT MT
- *1** : LHD-MODELL : 15
RHD-MODELL : 22
- *2** : LHD-MODELL : 16
RHD-MODELL : 23
- *3** : LHD-MODELL : 13
RHD-MODELL : 24
- *4** : LHD-MODELL : 14
RHD-MODELL : 25
- *5** : RHD-MODELL MIT MT : WL
RHD-MODELL MIT AT : BL
LHD-MODELL : BL

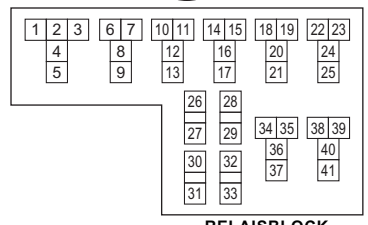
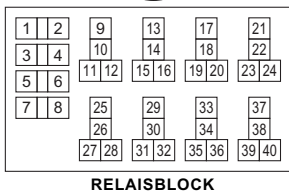
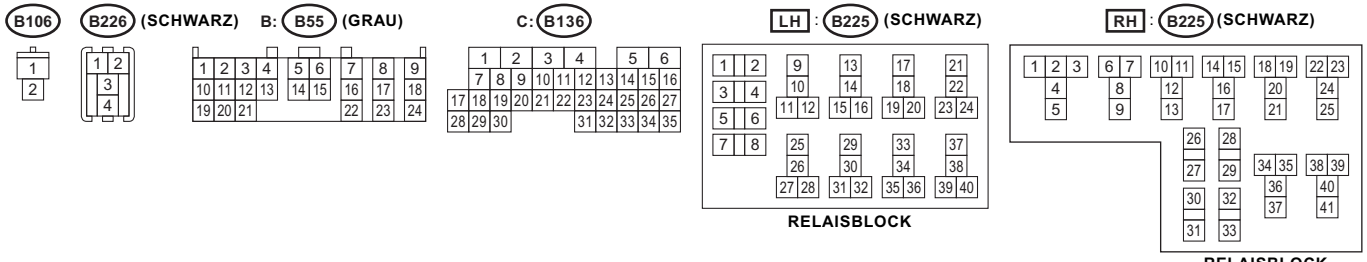
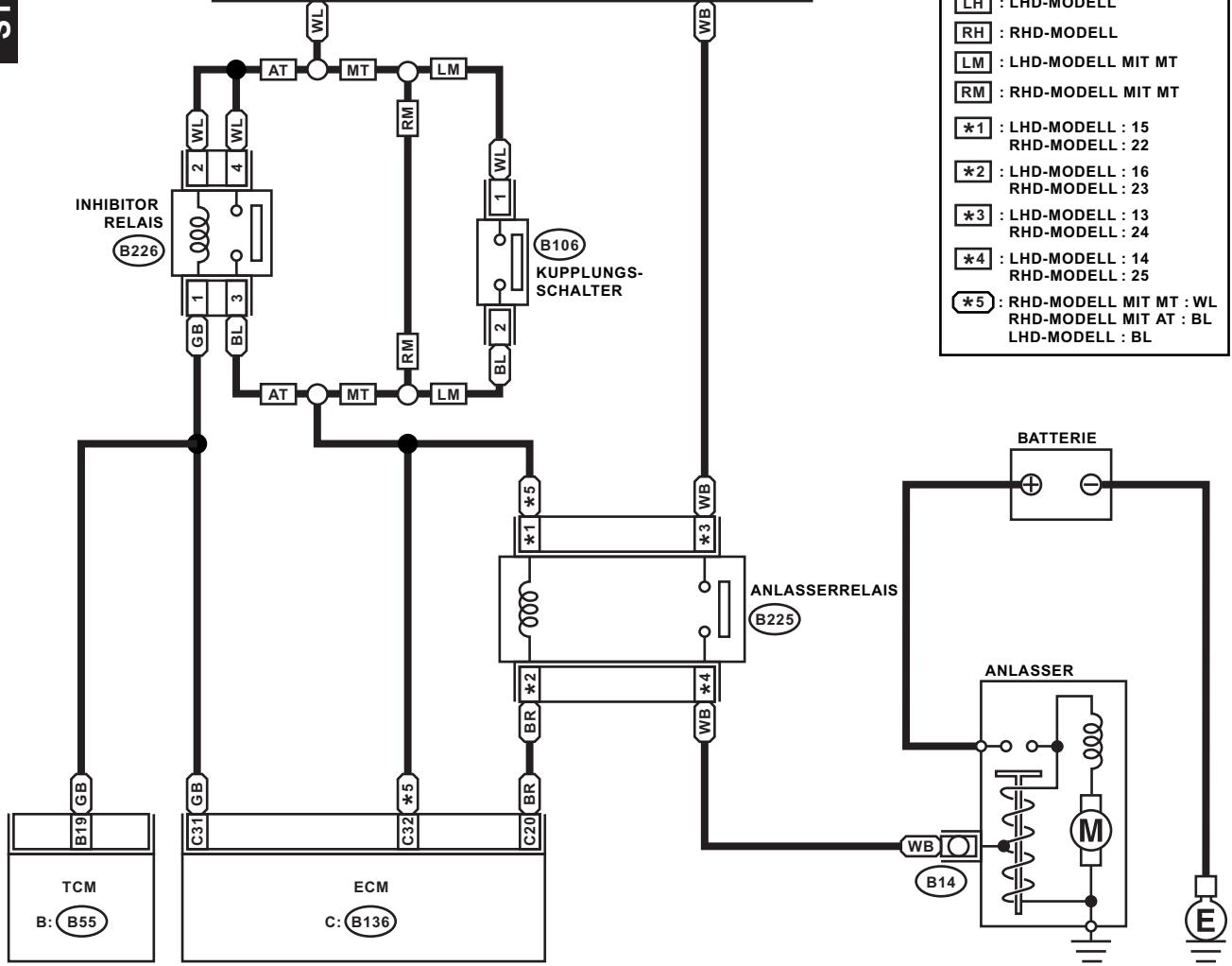

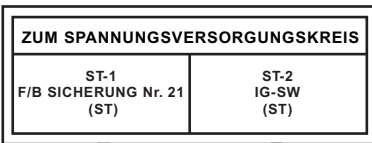

*1 : MT-MODELL : LW
AT-MODELL : BL

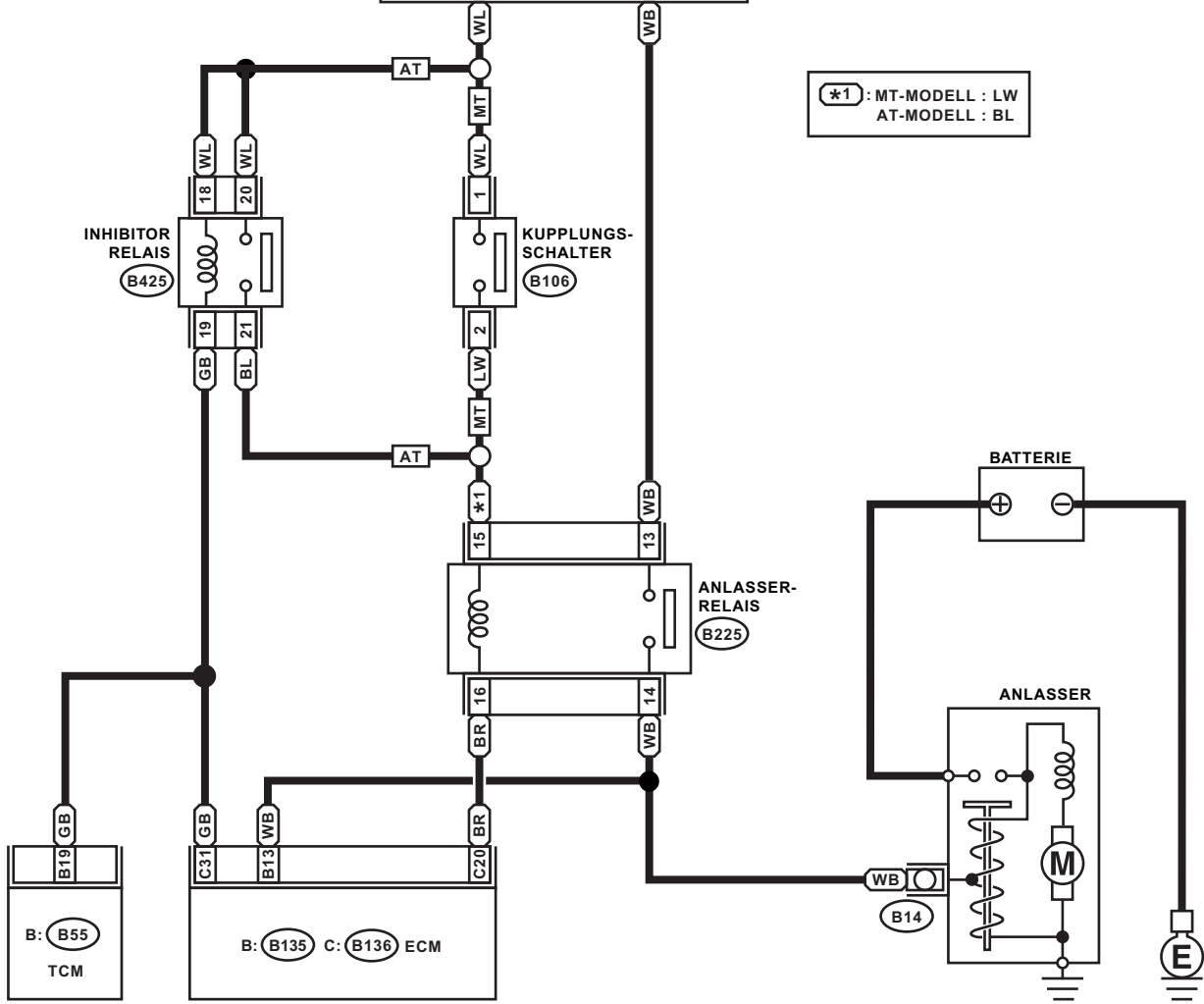

B106



B: B55 (GRAU)

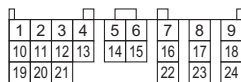

B225 (SCHWARZ)

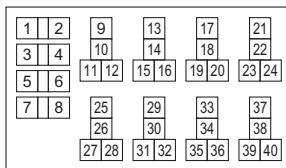

RELAISBLOCK

B425 (SCHWARZ)

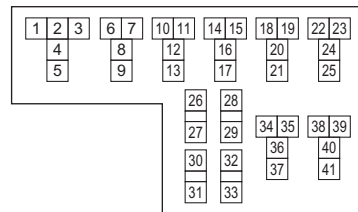

RELAISBLOCK

B: B135

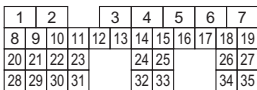

C: B136

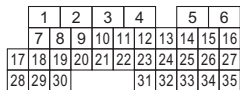

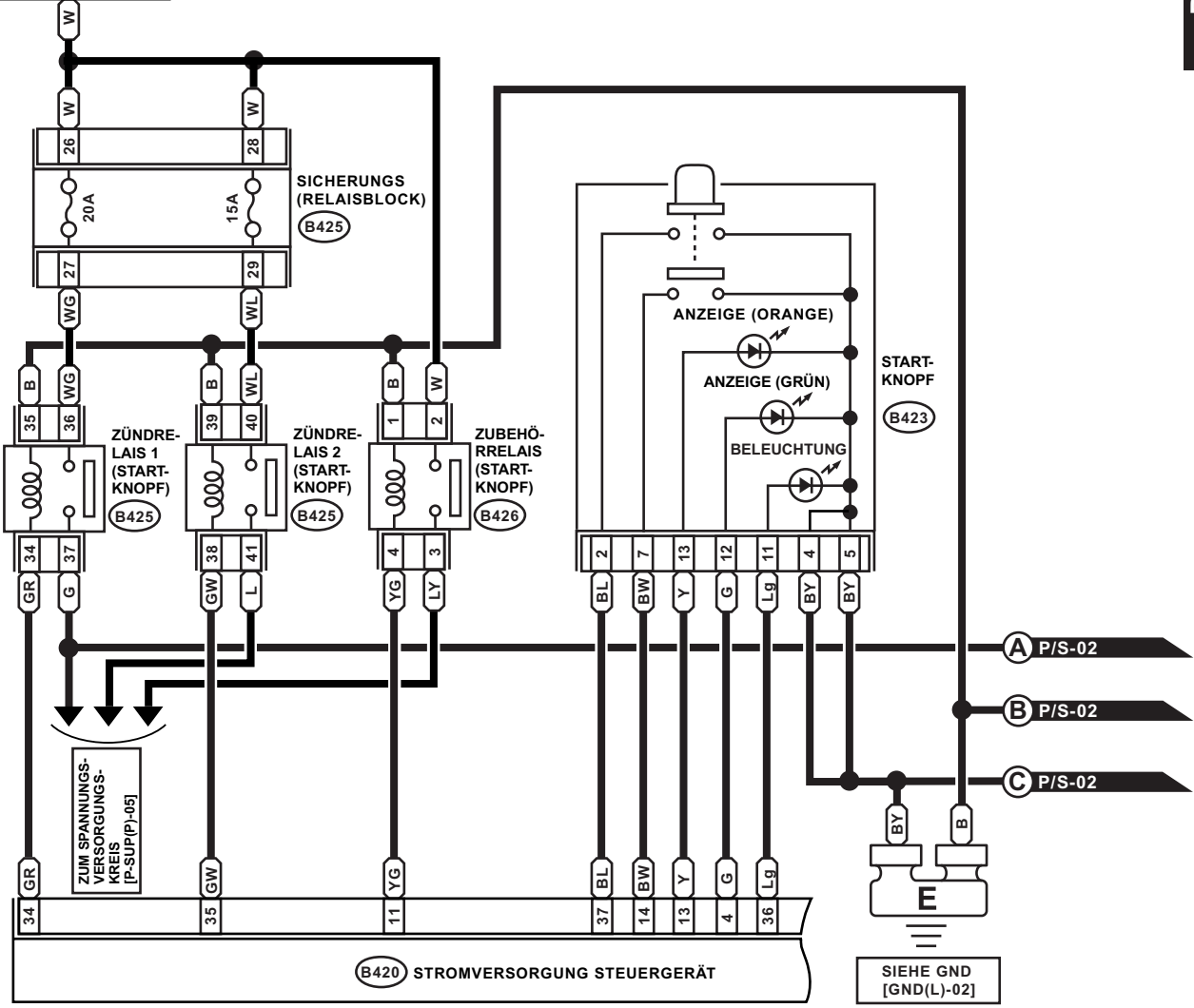
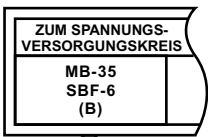

(B426) (SCHWARZ)

(B423) (SCHWARZ)

(B420)

(B425) (SCHWARZ)

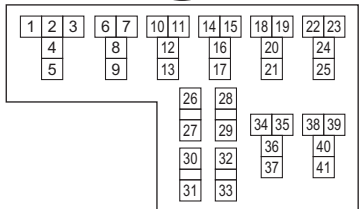
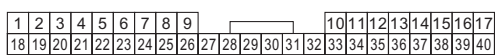
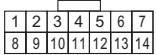

RELAISBLOCK

ZUM SPANNUNGS-
VERSORUNGSKREIS
FB-18
F/B SICHERUNG Nr. 7
(B)

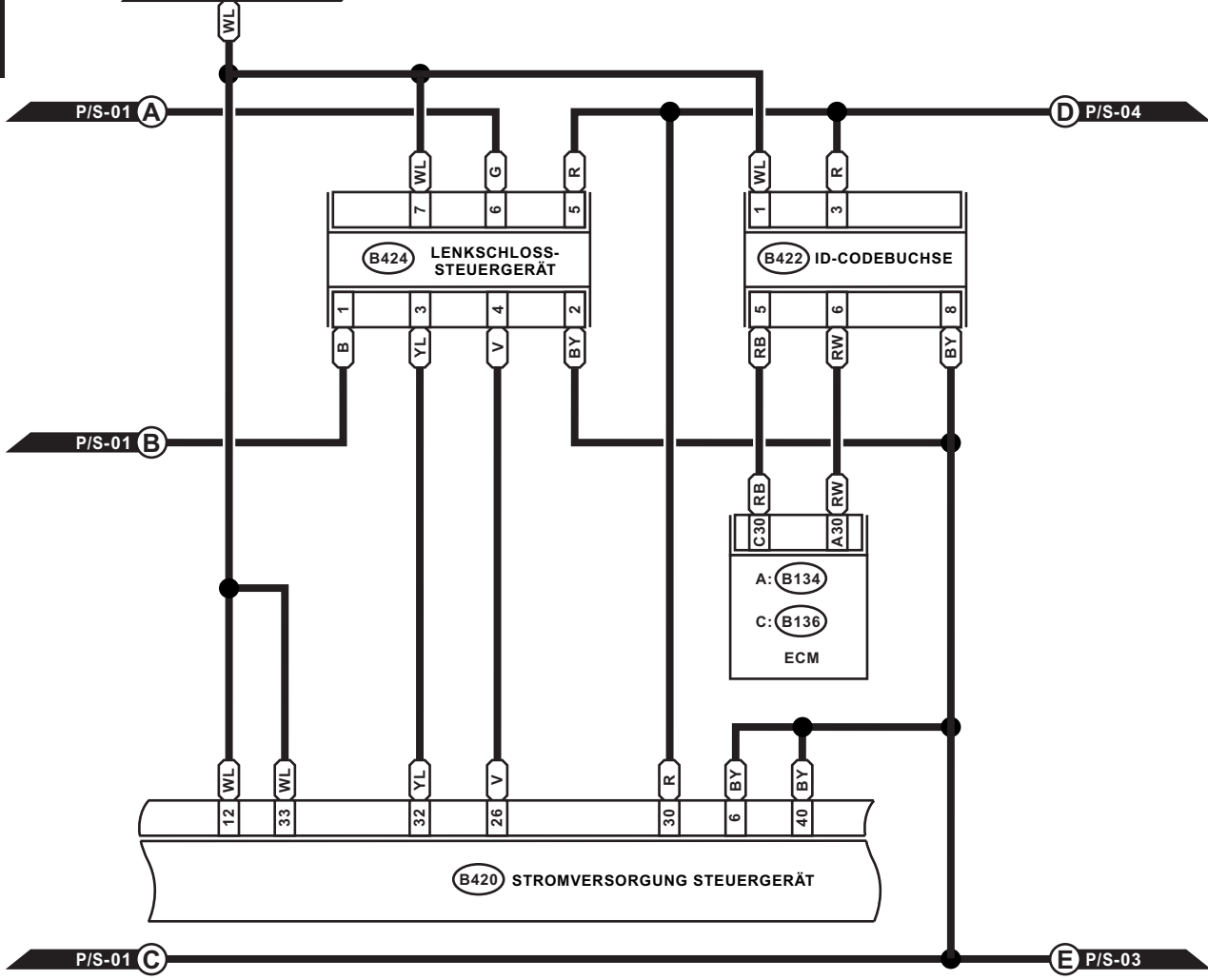

B424 (SCHWARZ)

B422

A: B134

C: B136

B420

1	2	3	4	5	6	7
---	---	---	---	---	---	---

1	2	3	4	5	6	7	8
---	---	---	---	---	---	---	---

1	2	3	4	5	6	7			
8	9	10	11	12	13	14	15	16	17
18	19	20	21	22	23	24	25	26	27
28	29	30	31	32	33	34			

1	2	3	4	5	6					
7	8	9	10	11	12	13	14	15	16	
17	18	19	20	21	22	23	24	25	26	27
28	29	30	31	32	33	34	35			

1	2	3	4	5	6	7	8	9	10	11	12	13	14	15	16	17						
18	19	20	21	22	23	24	25	26	27	28	29	30	31	32	33	34	35	36	37	38	39	40

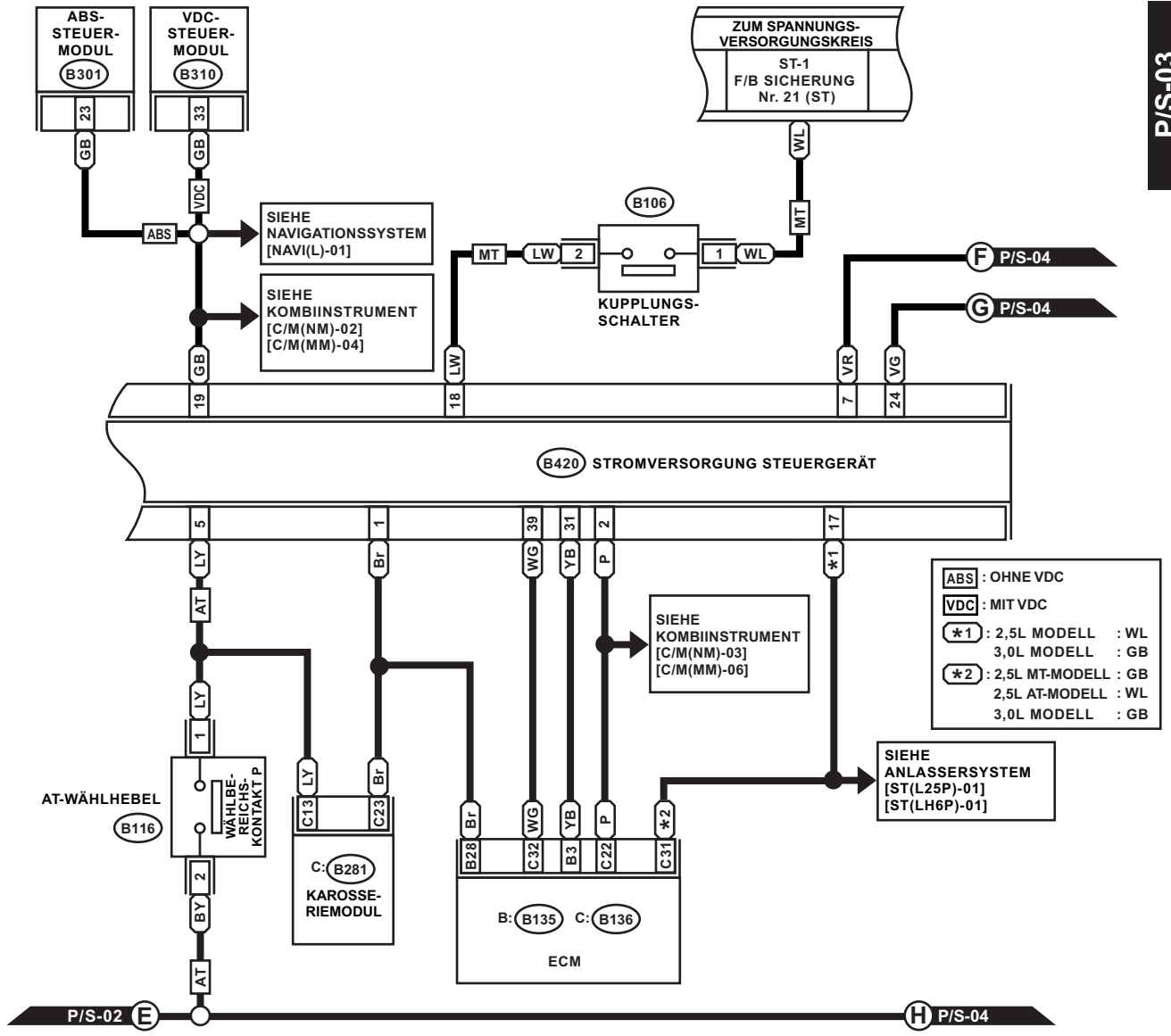

B106

1
2

B116 (GRAU)

1	2	3	4
5	6	7	8
9	10		

B301 (SCHWARZ)

12	13	14	15	1	2	3	4	5	6	7	8	9	10	11
16	17	18	19	20	21	22	23	24	25	26				

C: (B281)

1	2	3			4	5	6	7
8	9	10	11	12	13	14	15	16
17	18	19						
20	21	22	23	24	25	26	27	28

B: (B135)

1	2		3	4	5	6	7
8	9	10	11	12	13	14	15
16	17	18	19	20	21	22	23
24	25	26	27	28	29	30	31
			32	33			
							34
							35

C: (B136)

1	2	3	4		5	6
7	8	9	10	11	12	13
14	15	16	17	18	19	20
21	22	23	24	25	26	27
28	29	30				
			31	32	33	34
						35

B420

1	2	3	4	5	6	7	8	9						
18	19	20	21	22	23	24	25	26	27	28	29	30	31	32
33	34	35	36	37	38	39	40							

B310 (SCHWARZ)

22	23	24	25	1	2	3	4	5	6	7	8	9	10	11	12	13	14	15	16	17	18	19	20	21
				26	27	28	29	30	31	32	33	34	35	36	37	38	39	40	41	42	43	44	45	46

ZUM SPANNUNGSVERSORUNGSKREIS		
FB-29 F/B SICHERUNG Nr. 31 (ACC)	FB-38 F/B SICHERUNG Nr. 12 (IG)	FB-18 F/B SICHERUNG Nr. 7 (B)

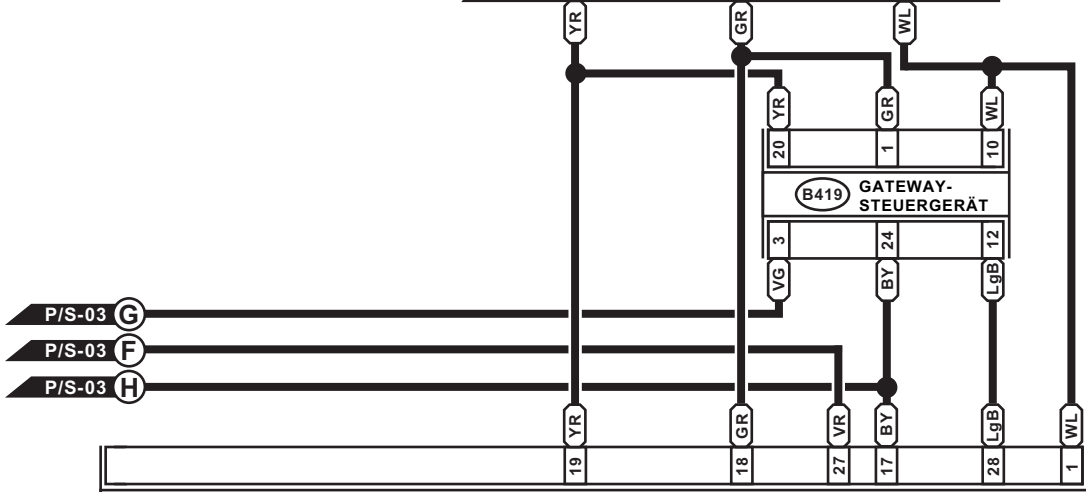

B421 ZUORDNUNG STEUERGERÄT									
10	11	12	13	14	29	38	39	1	

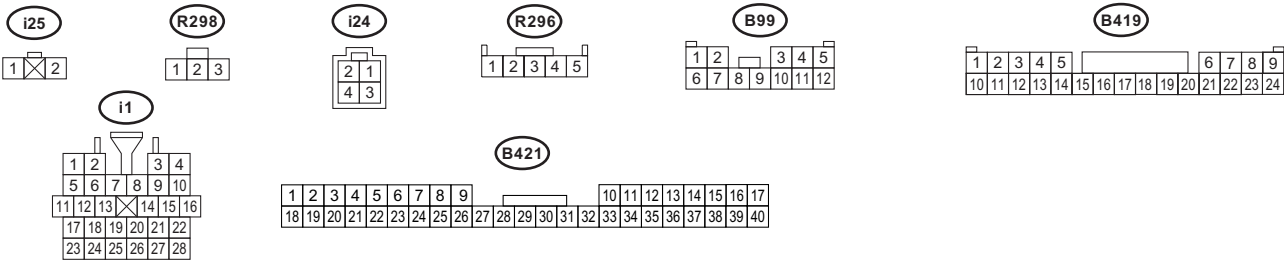
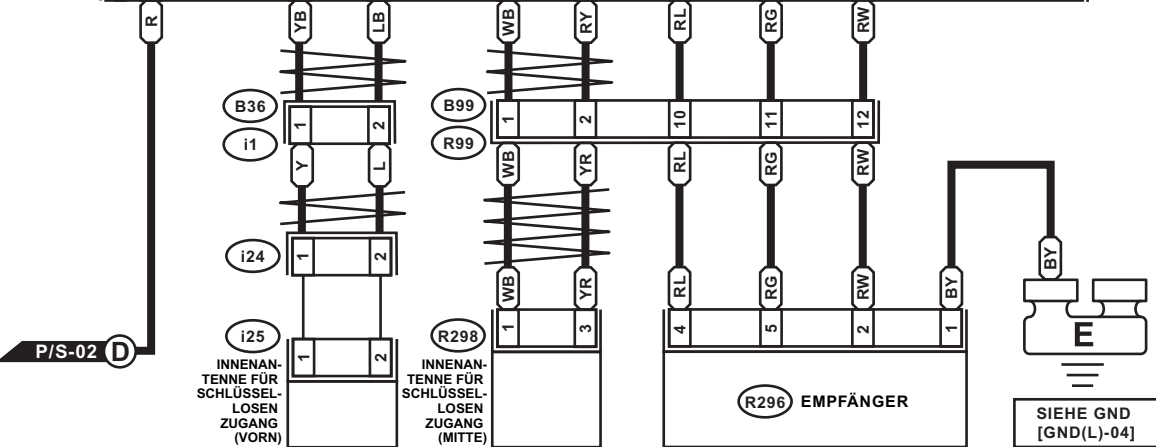

SIEHE GND [GND(L)-04]

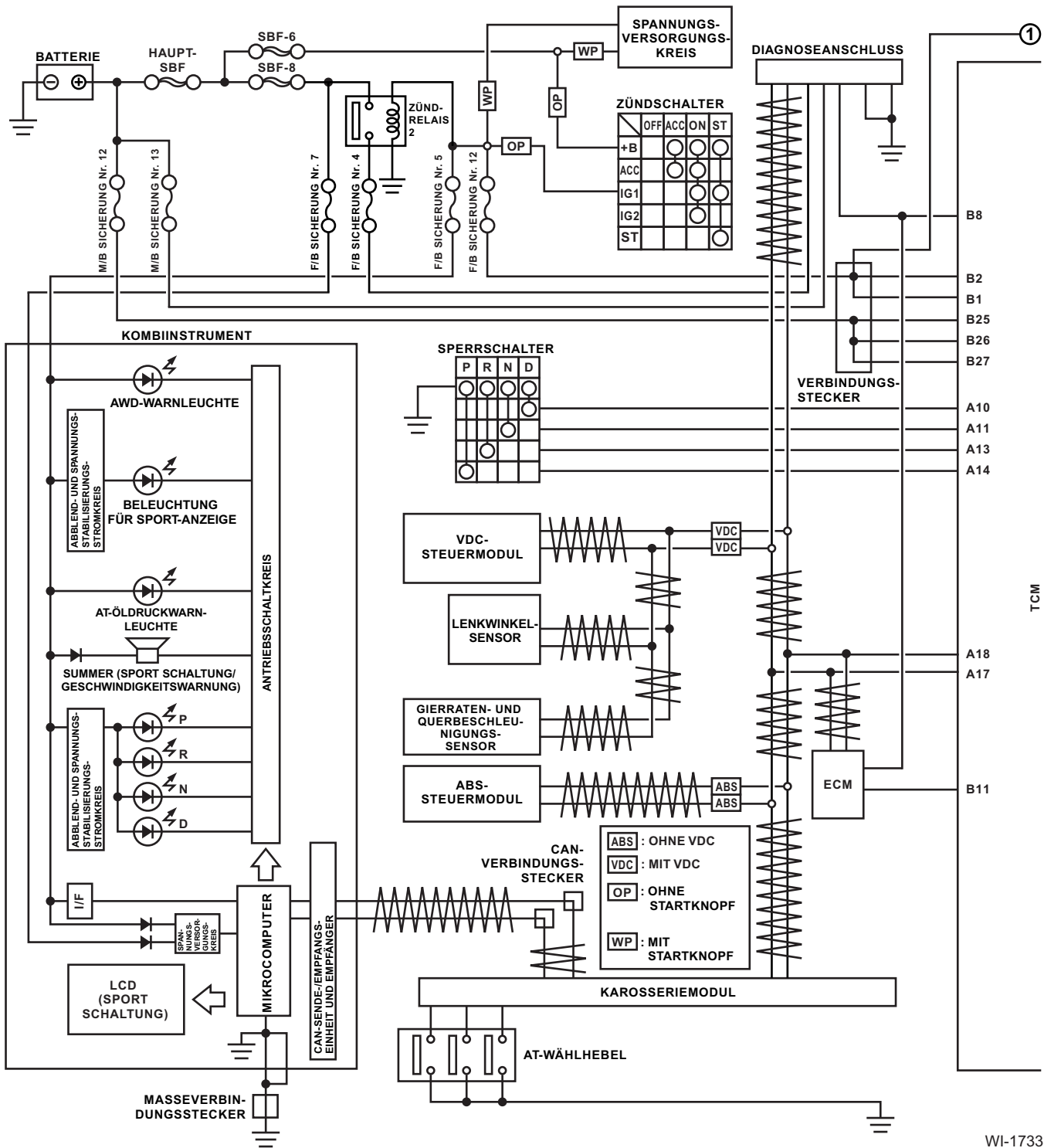

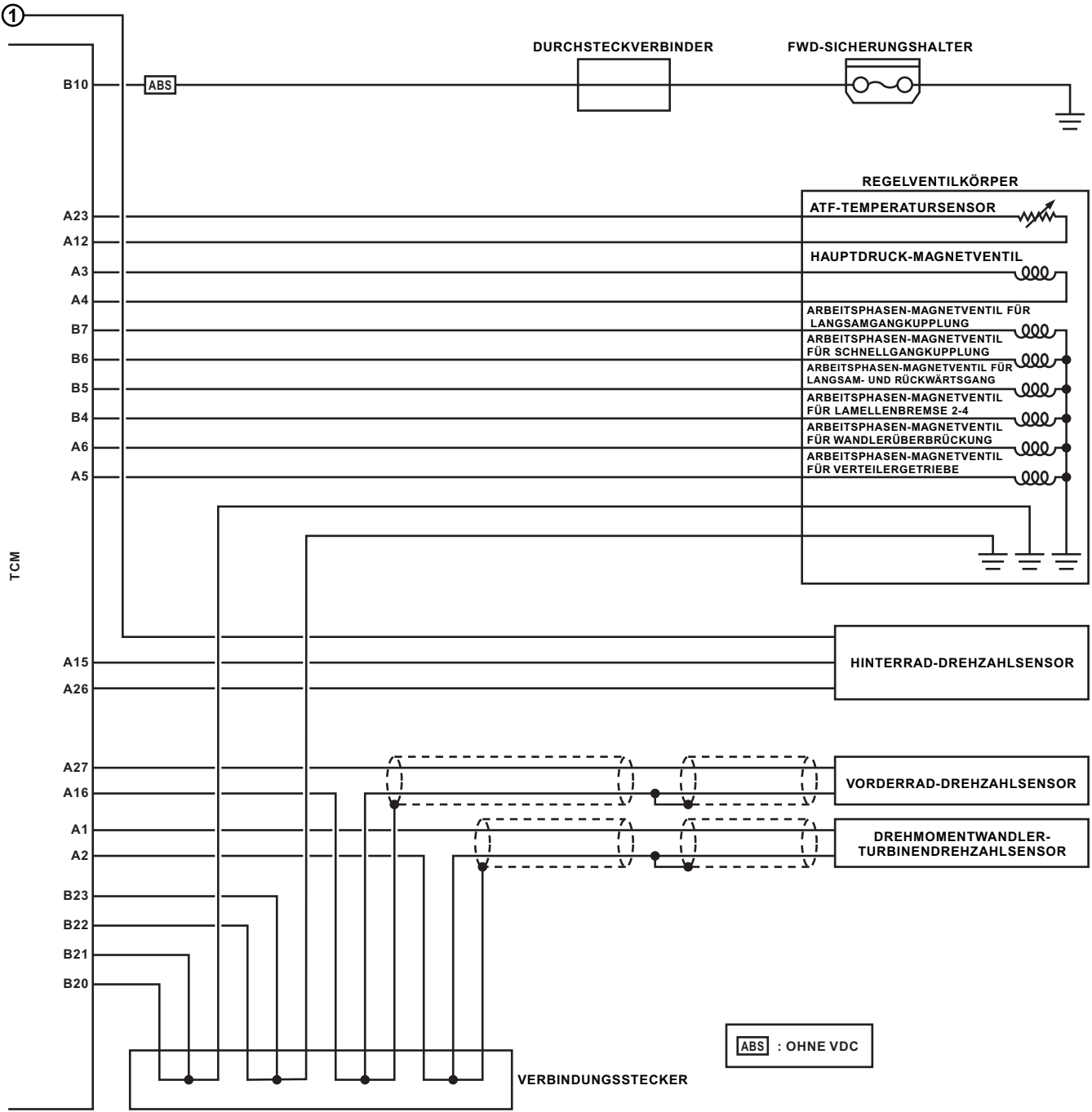

*1 : KLEMMEN-Nr. OPTIONALE ANORDNUNG BEI 1, 2, 3, 4, 5 UND 6
 *2 : KLEMMEN-Nr. OPTIONALE ANORDNUNG BEI 1, 2, 3 UND 4

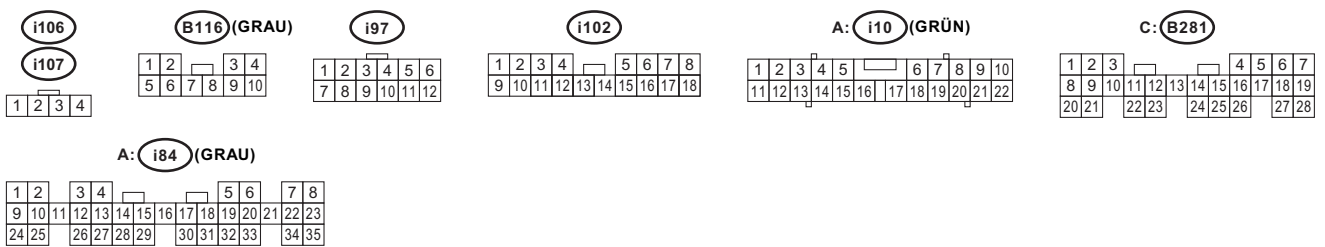
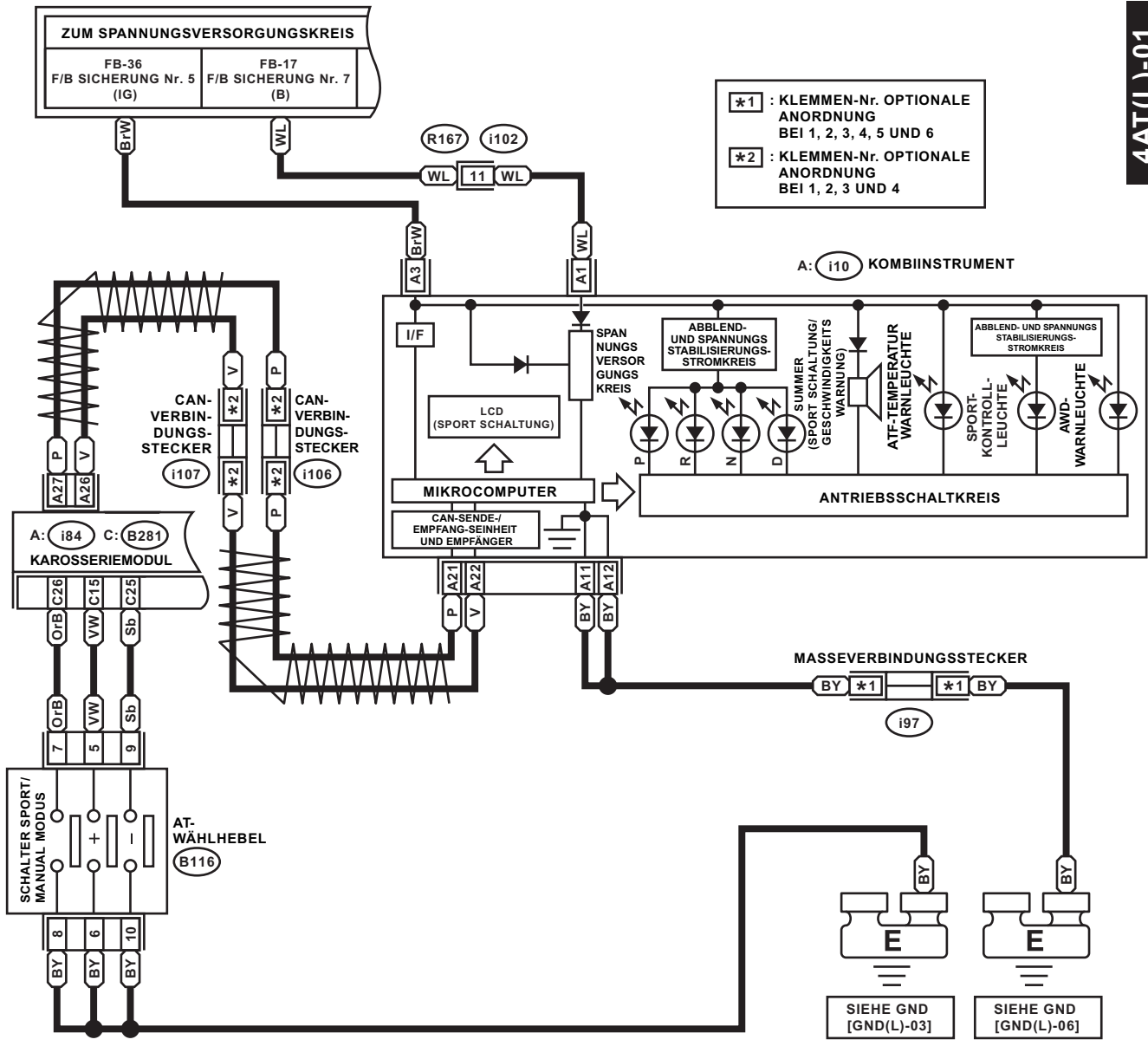

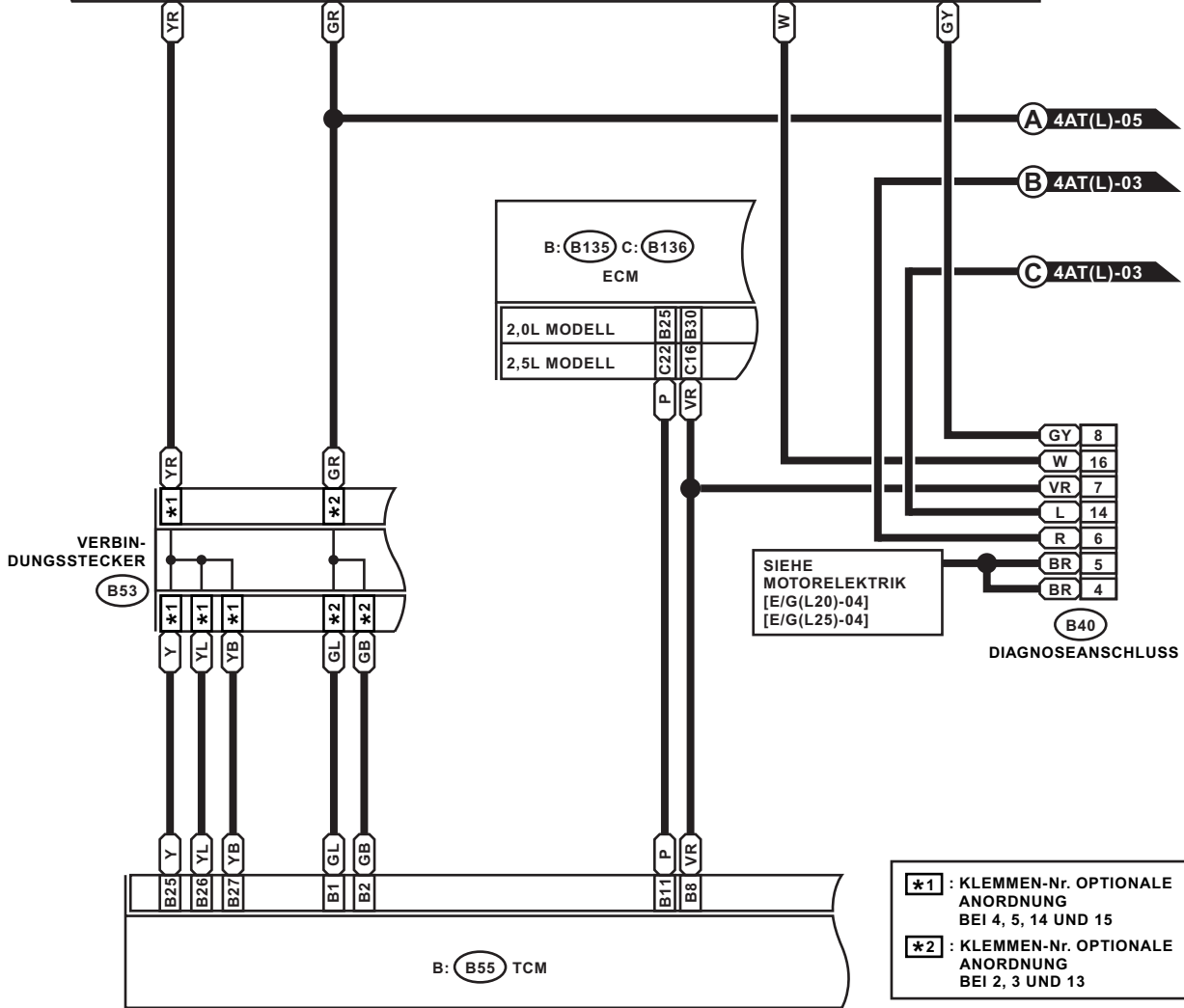
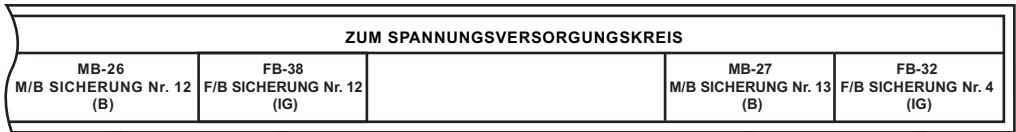

***1** : KLEMMEN-Nr. OPTIONALE ANORDNUNG BEI 4, 5, 14 UND 15

***2** : KLEMMEN-Nr. OPTIONALE ANORDNUNG BEI 2, 3 UND 13

B40 (SCHWARZ)

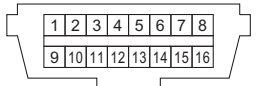

B53

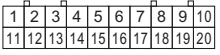

B: (B55) B: (B135)

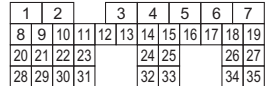

C: (B136)

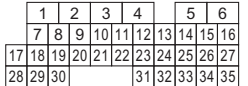

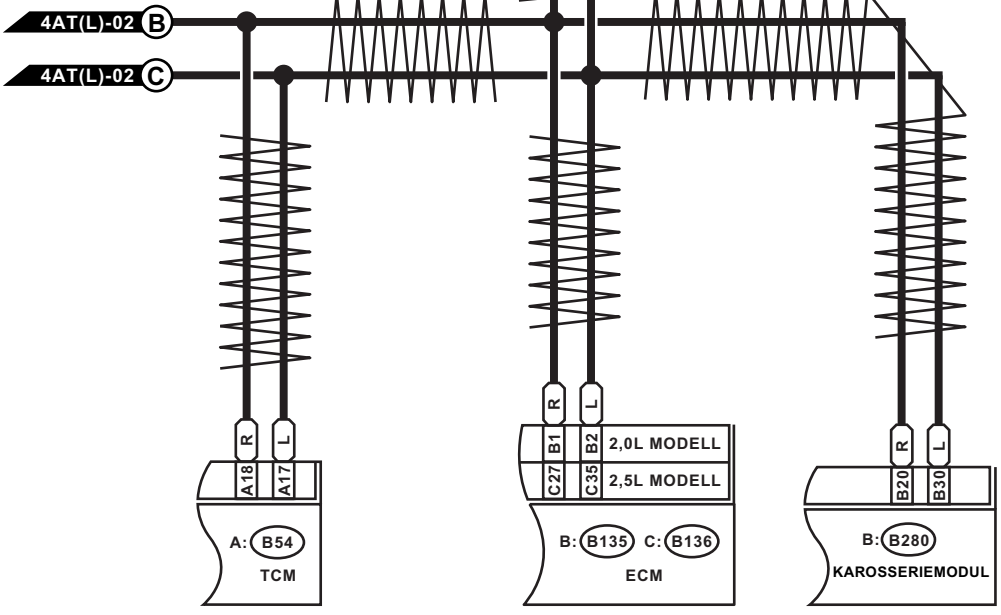
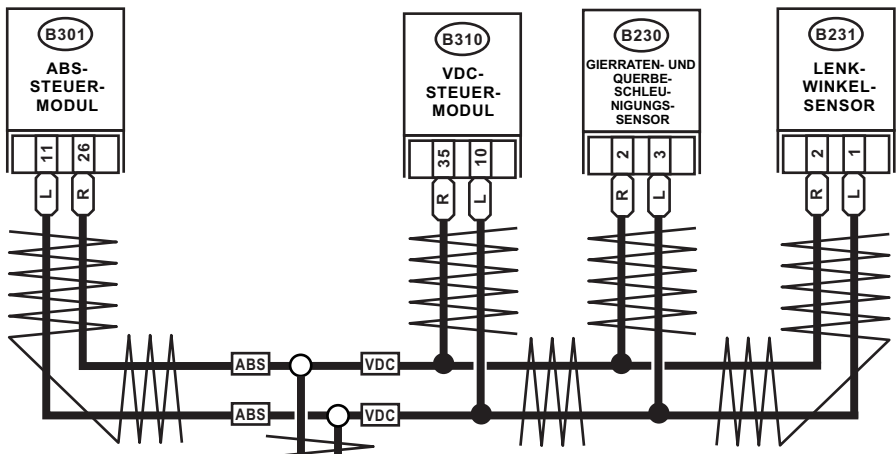

ABS : OHNE VDC
VDC : MIT VDC

B230 (SCHWARZ) B231 (SCHWARZ)

B301 (SCHWARZ)

B: B280

A: B54 C: B136

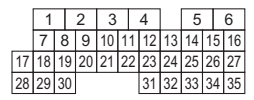
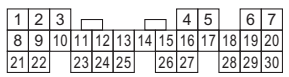
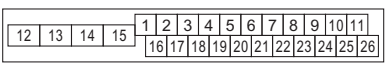
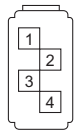

B: B135

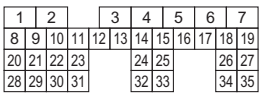

B310 (SCHWARZ)

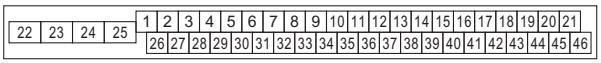

A: B54 B: B55 TCM

4AT(L)-02 A

- *1 : KLEMMEN-Nr. OPTIONALE ANORDNUNG BEI 1, 11 UND 12
- *2 : KLEMMEN-Nr. OPTIONALE ANORDNUNG BEI 9, 10 UND 20
- *3 : KLEMMEN-Nr. OPTIONALE ANORDNUNG BEI 6, 7, 16 UND 17
- *4 : KLEMMEN-Nr. OPTIONALE ANORDNUNG BEI 8, 18 UND 19

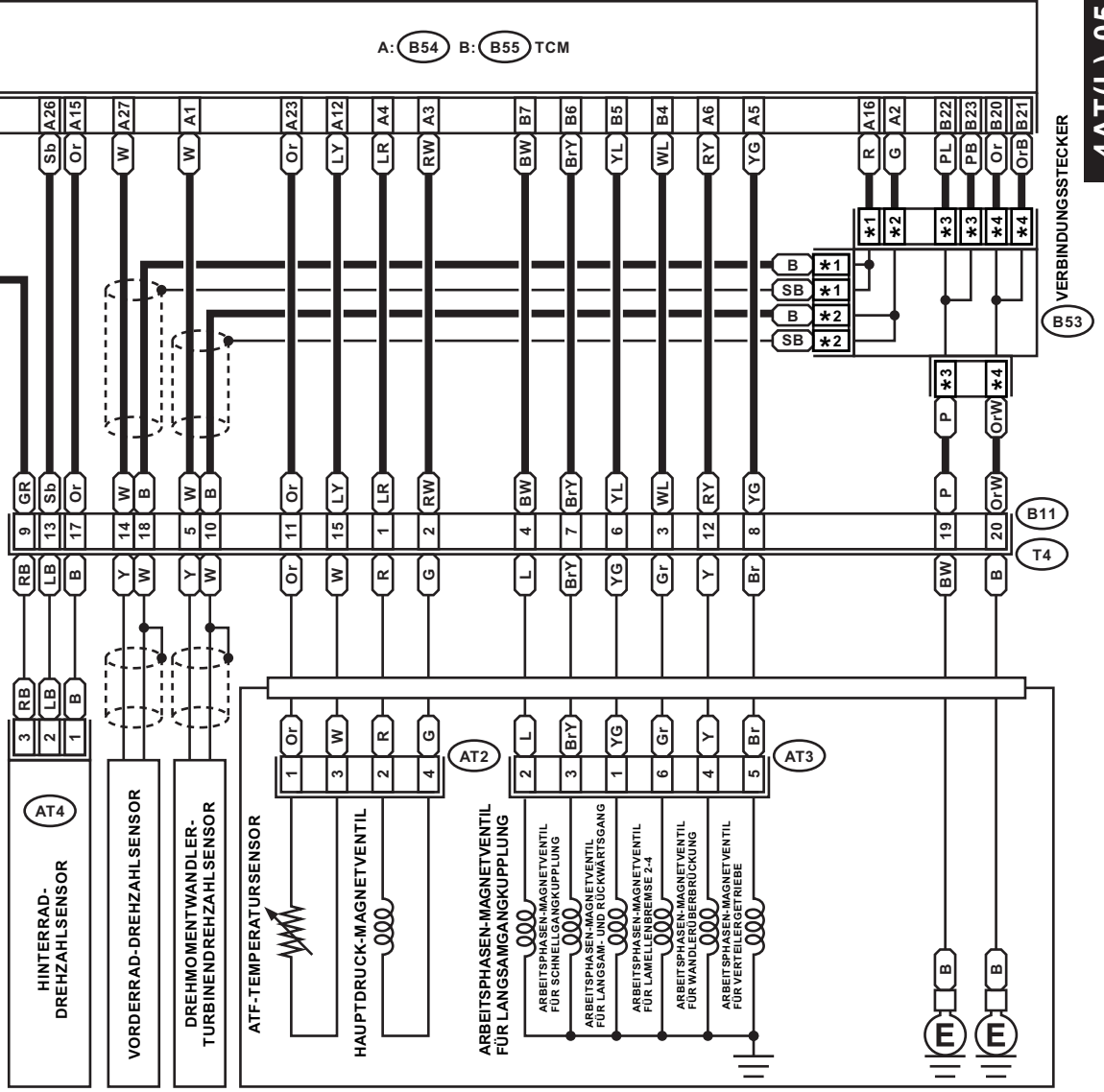

REGELVENTILKÖRPER

AT4



AT2



AT3



B11 (GRAU)

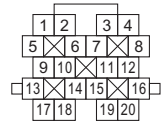

B53

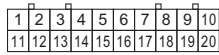

A: B54

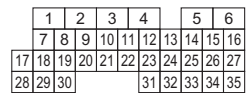

B: B55

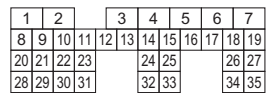

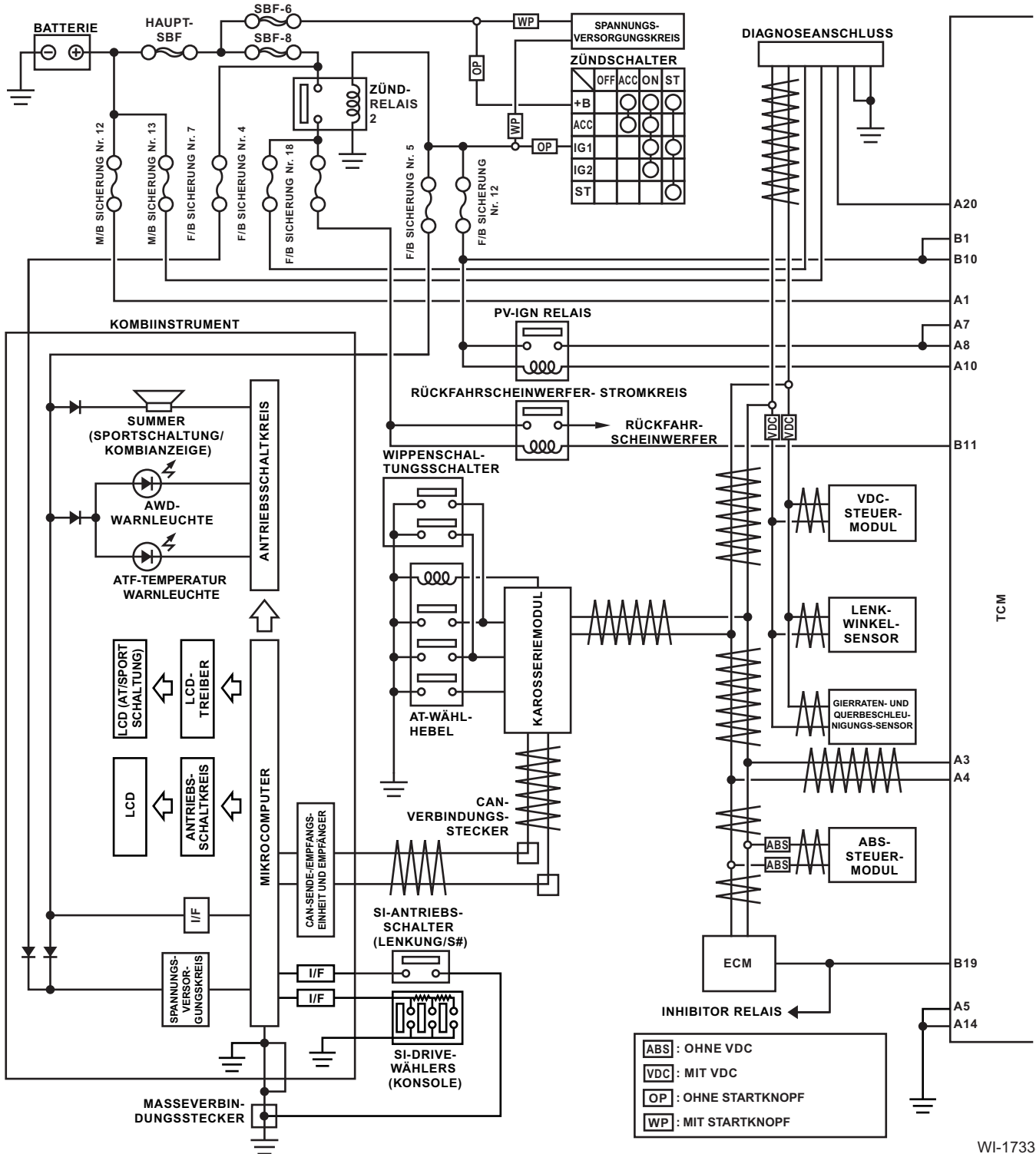

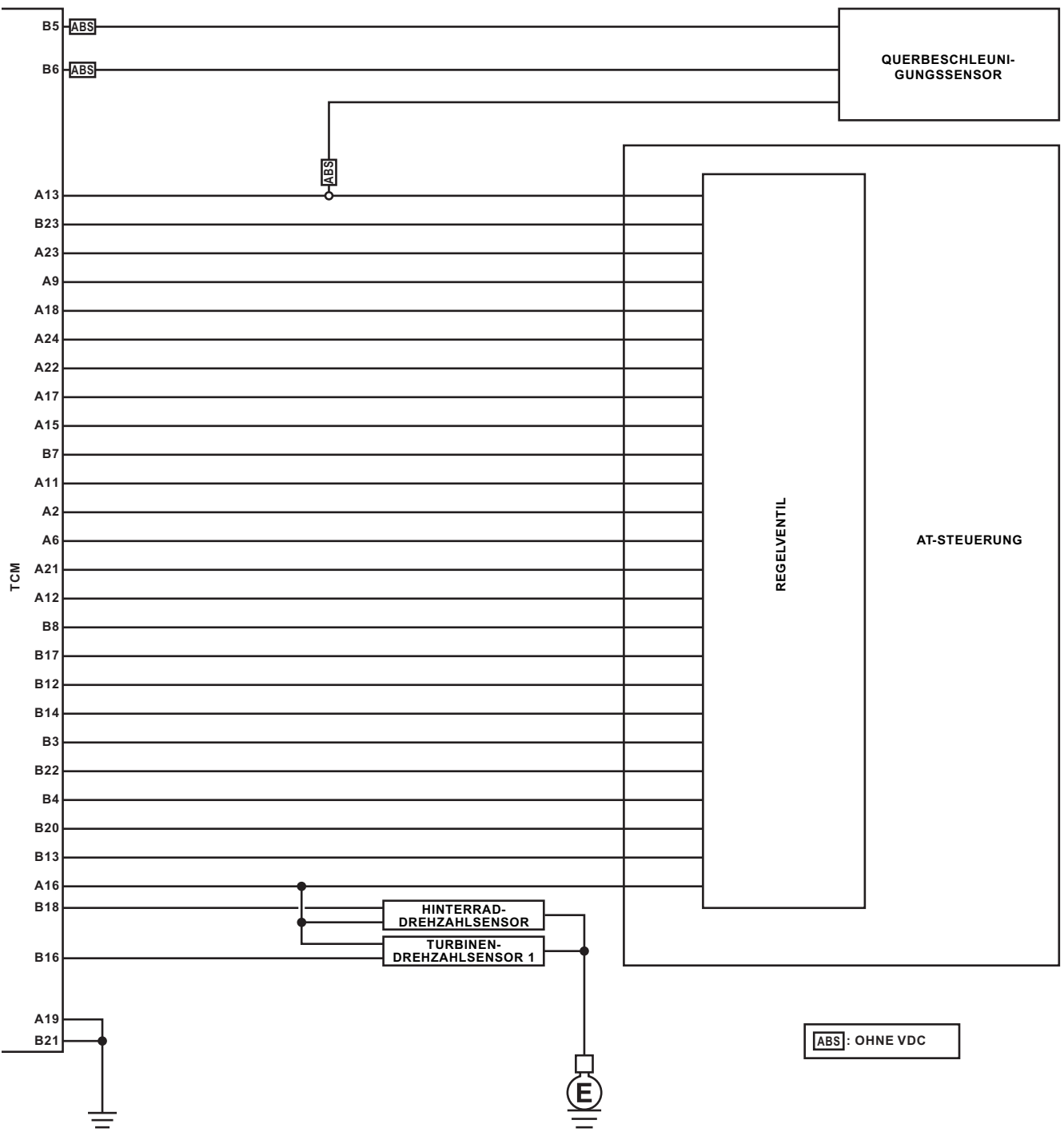

ZUM SPANNUNGSVERSORUNGSKREIS

FB-36 F/B SICHERUNG Nr. 5 (IG)	FB-17 F/B SICHERUNG Nr. 7 (B)
--------------------------------------	-------------------------------------

- *1 : KLEMMEN-Nr. OPTIONALE ANORDNUNG BEI 1, 2, 3, 4, 5 UND 6
- *2 : KLEMMEN-Nr. OPTIONALE ANORDNUNG BEI 1, 2, 3 UND 4

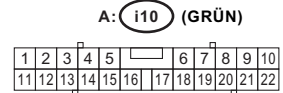
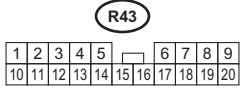
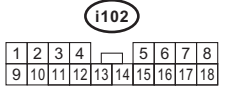
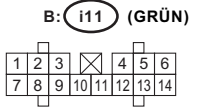
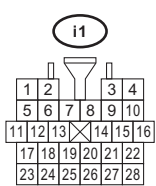
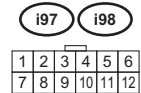
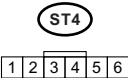
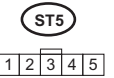
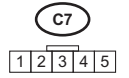
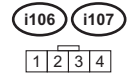
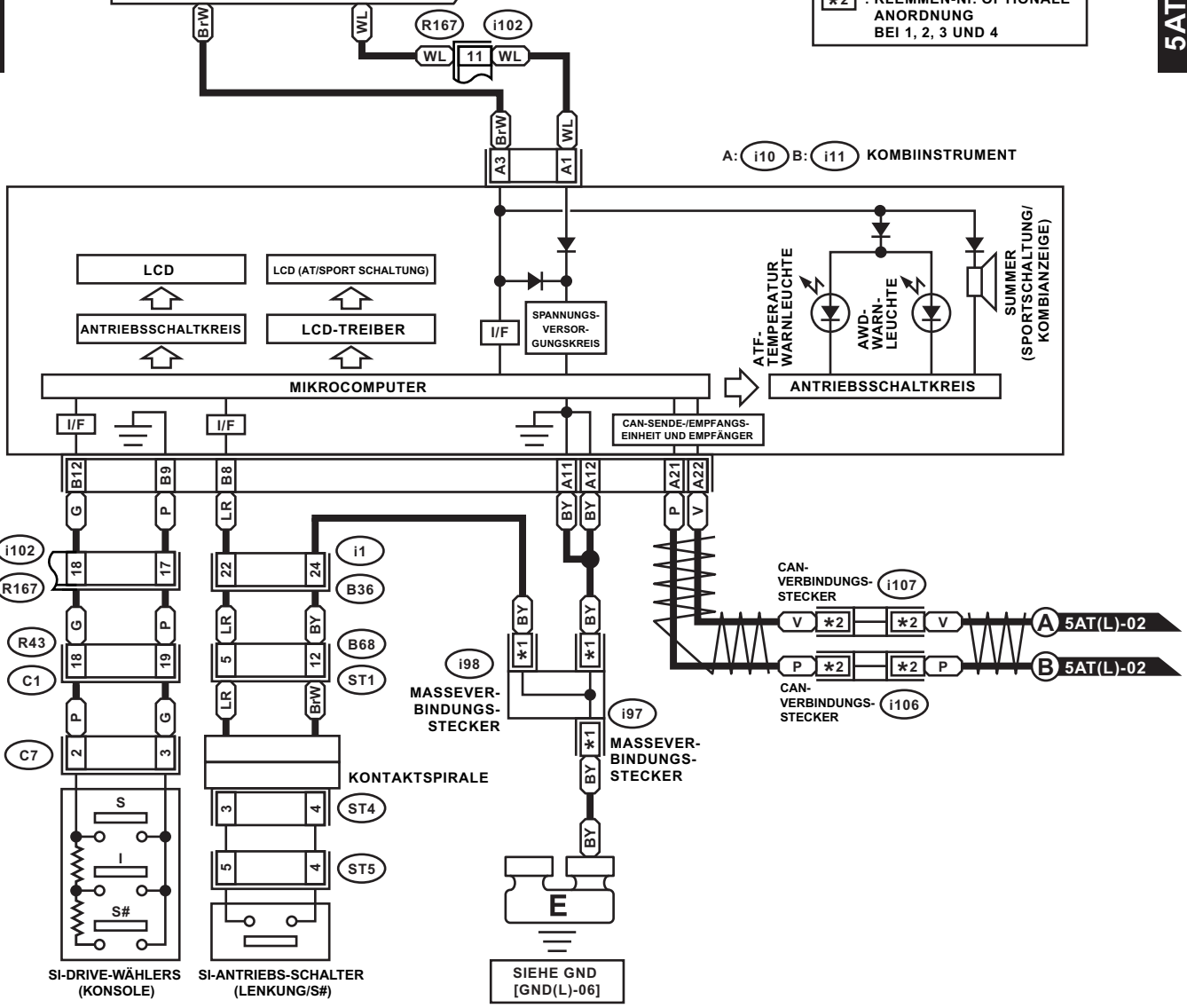

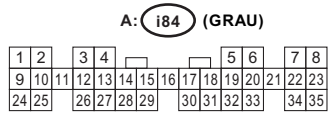
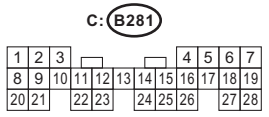
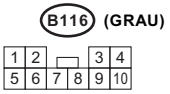
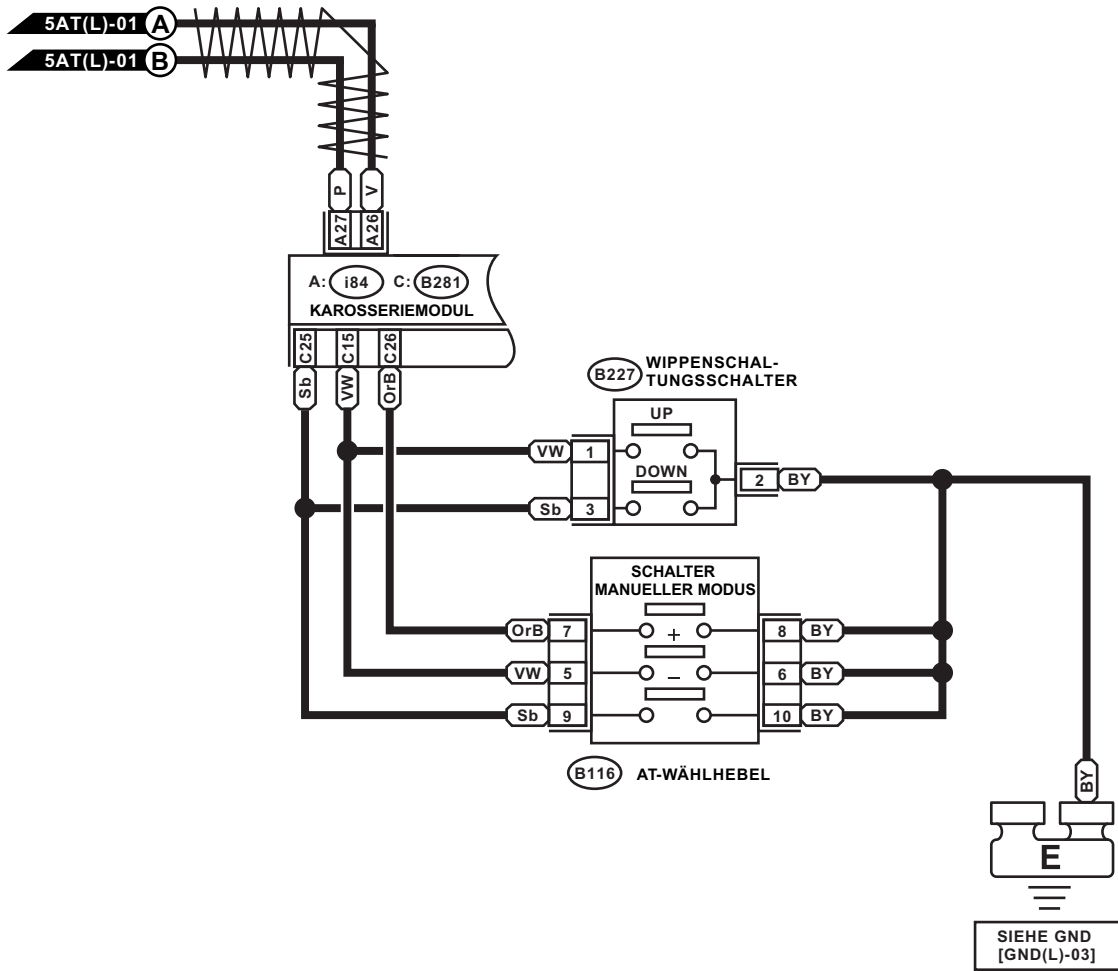

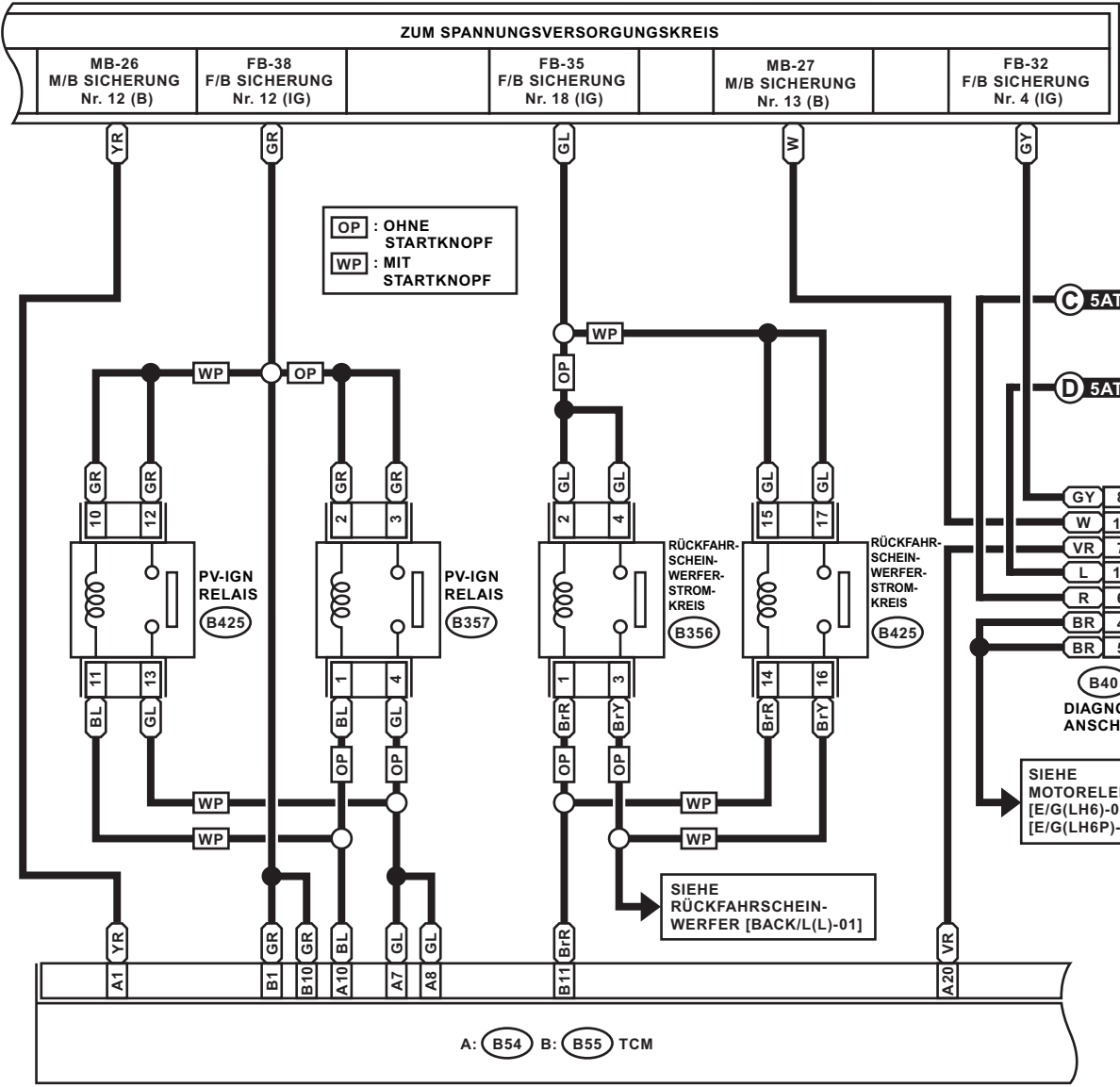

B356 (SCHWARZ)

B40 (SCHWARZ)

A: **B54**

B: **B55** (GRAU)

B425 (SCHWARZ)

B357 (SCHWARZ)

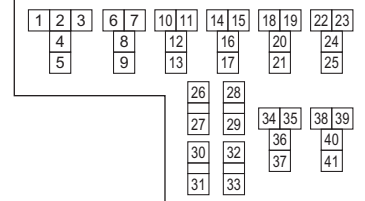
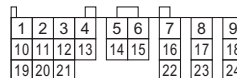
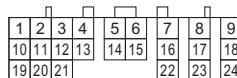

RELAISBLOCK

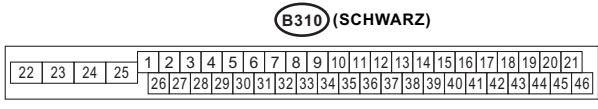
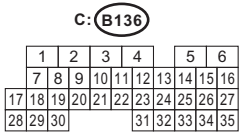
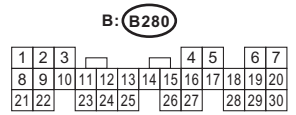
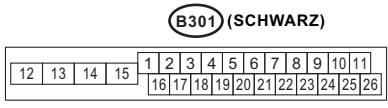
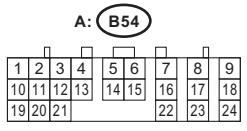
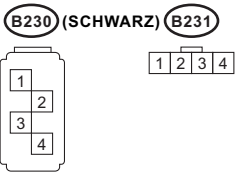
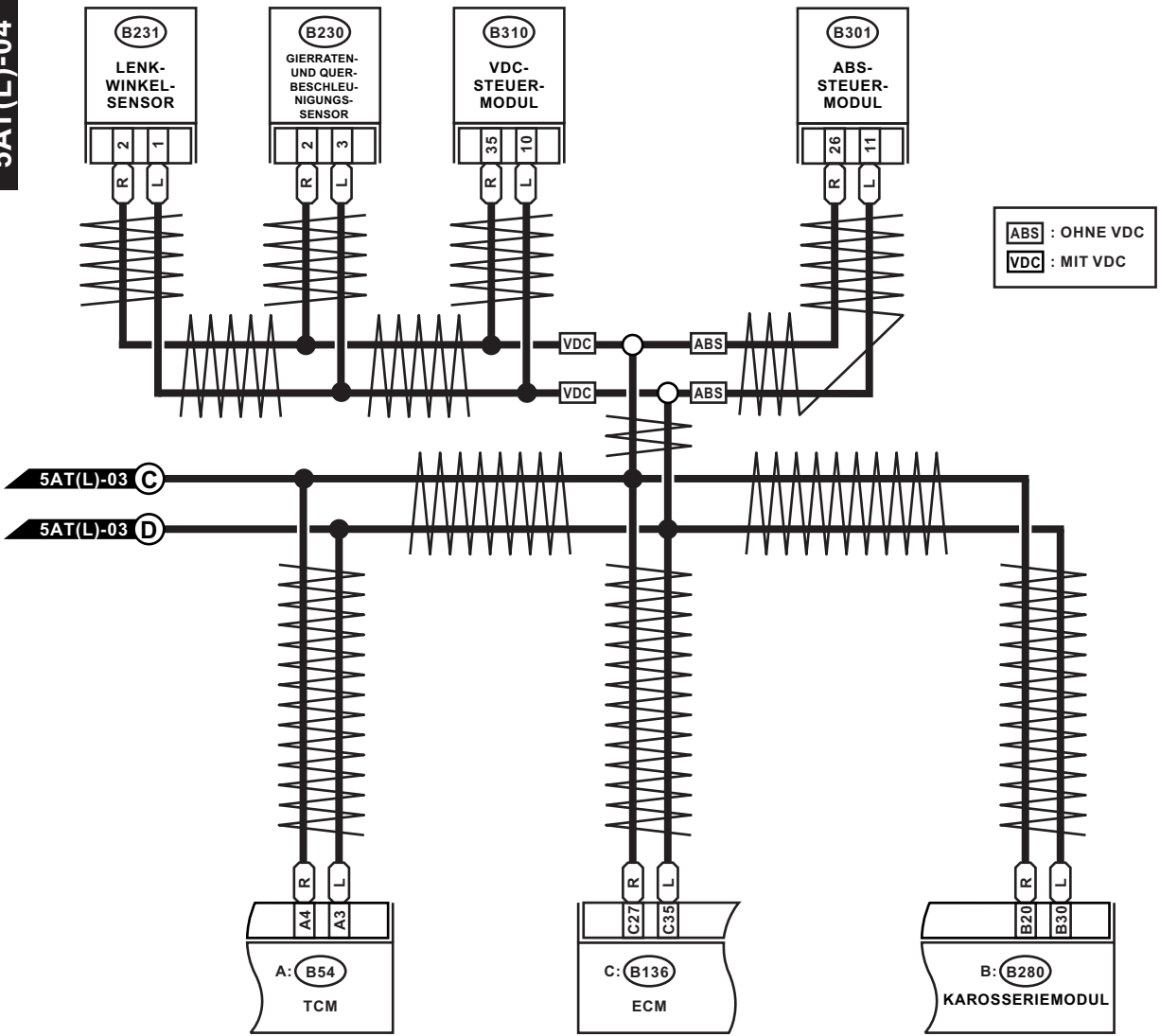

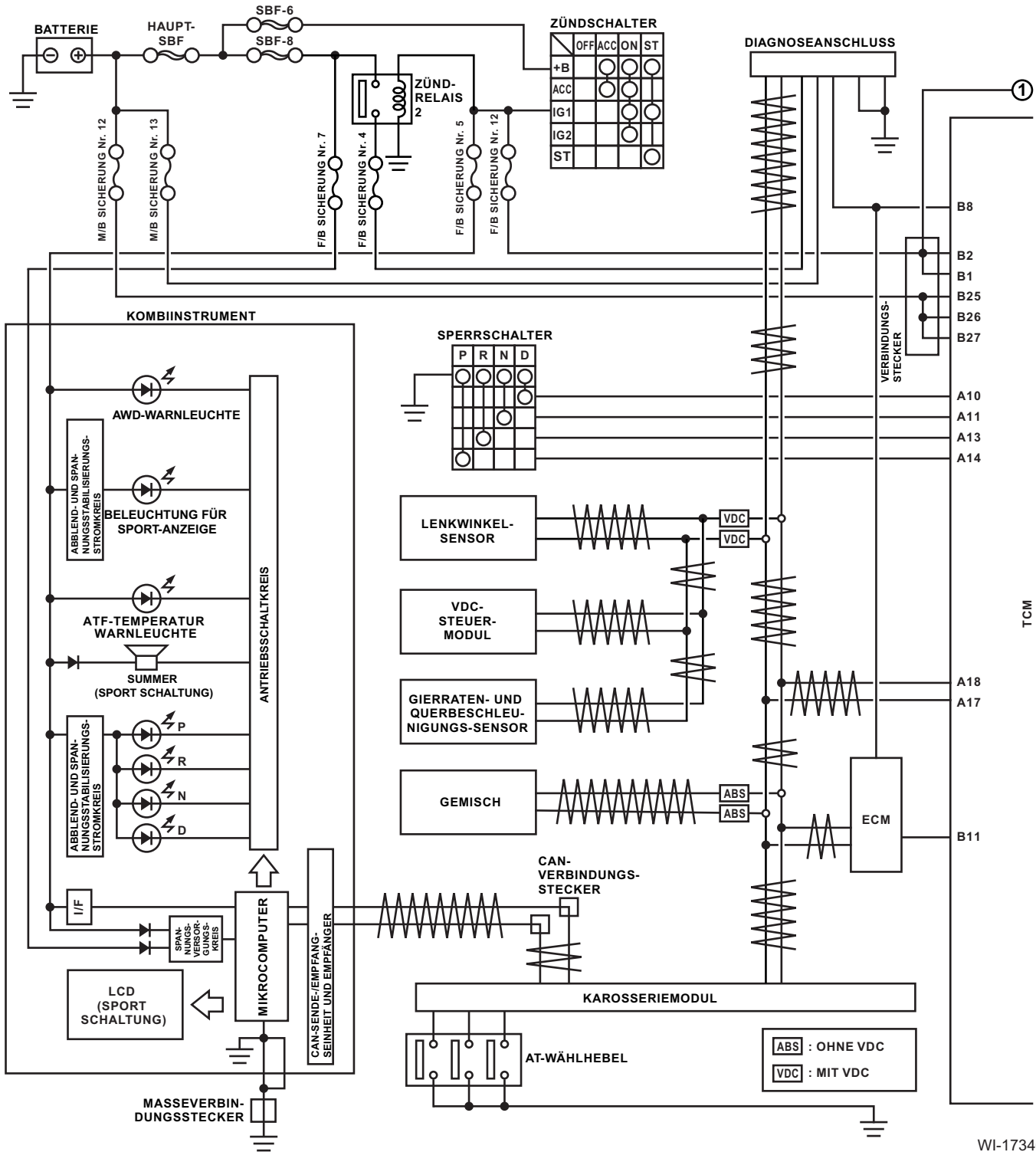

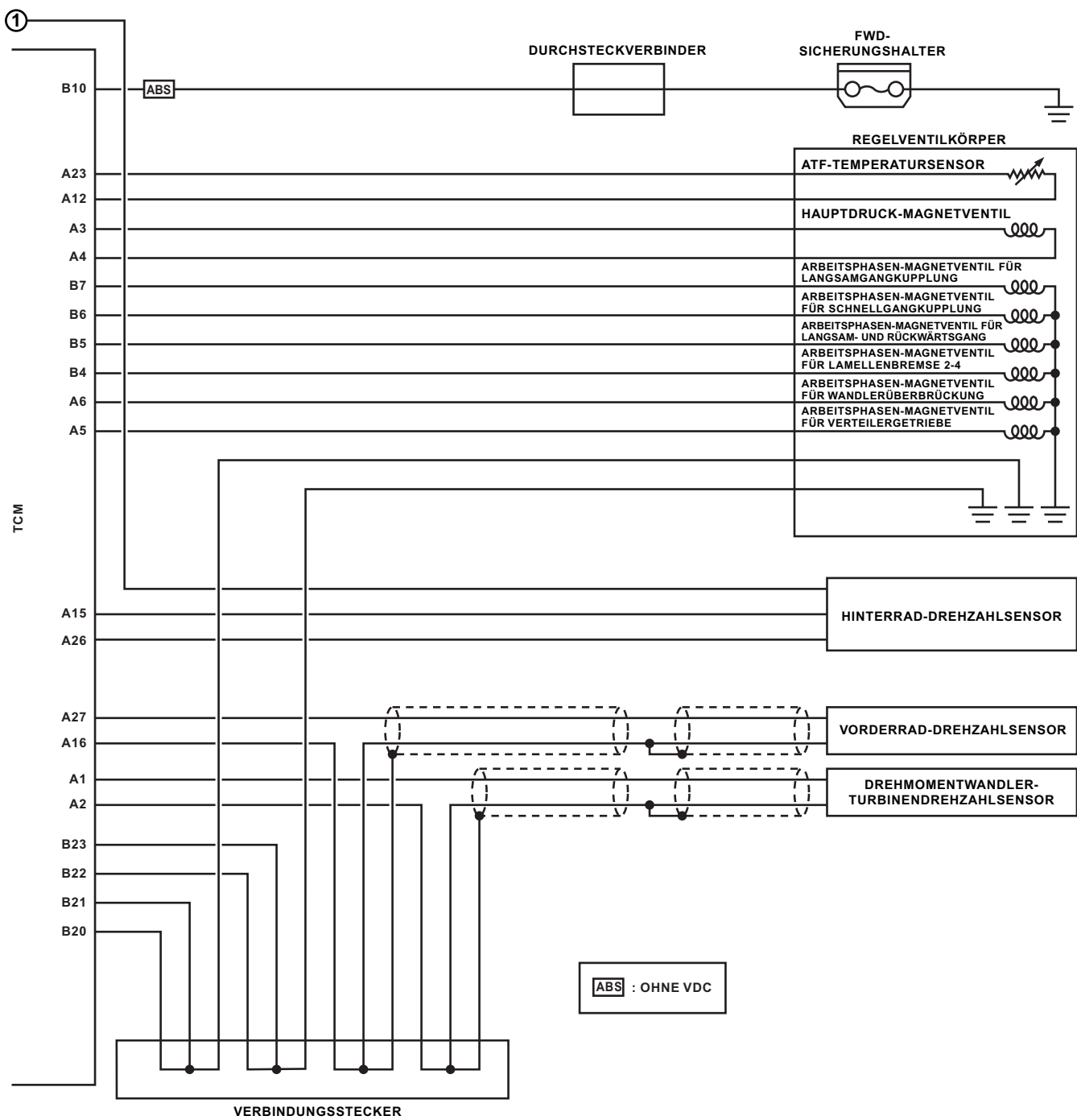

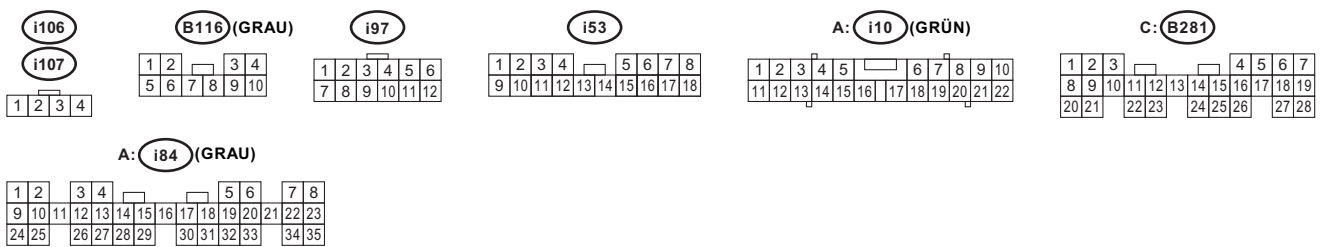
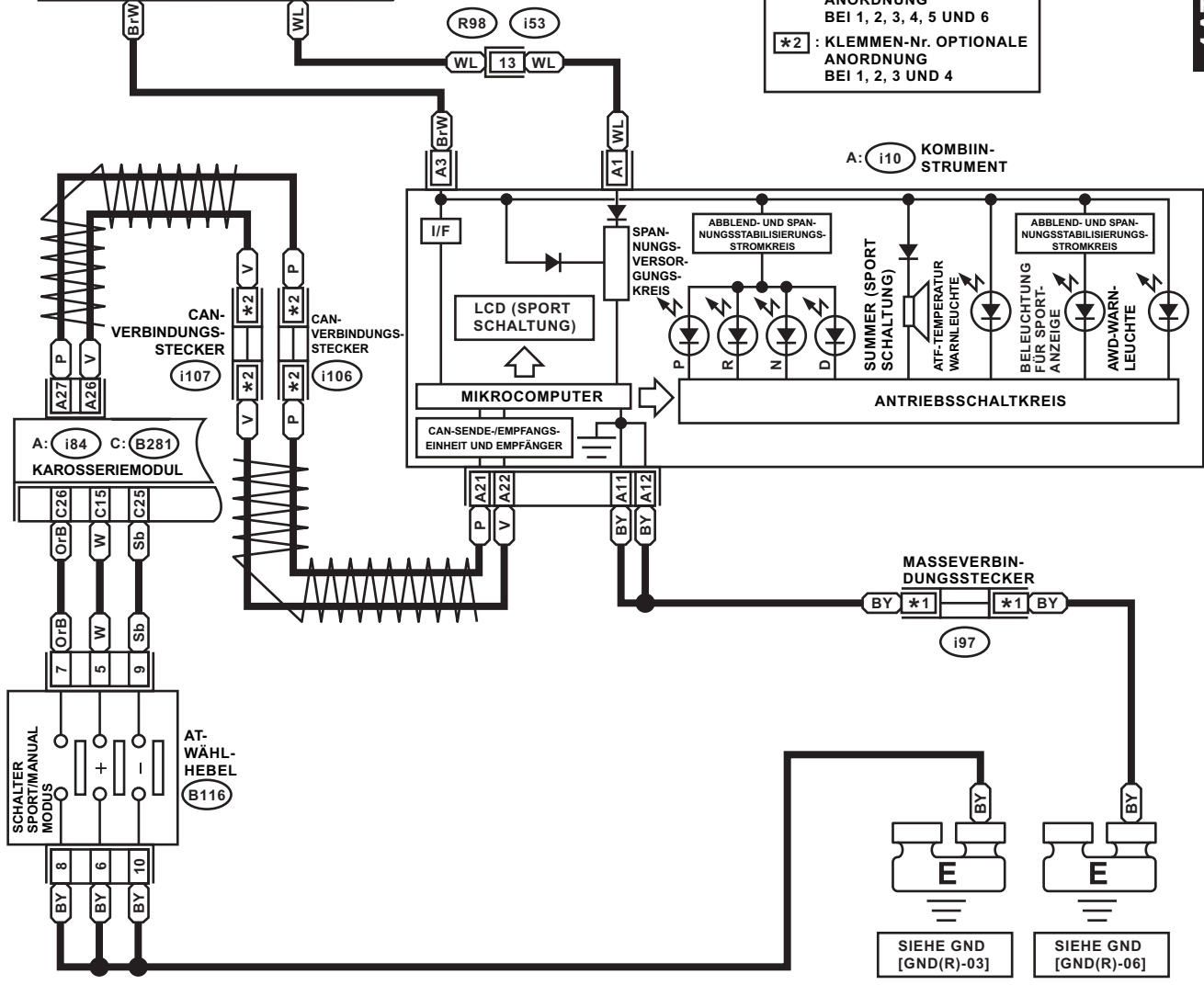
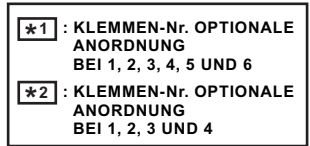
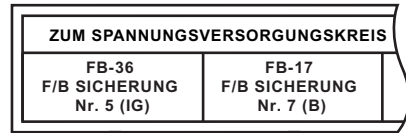

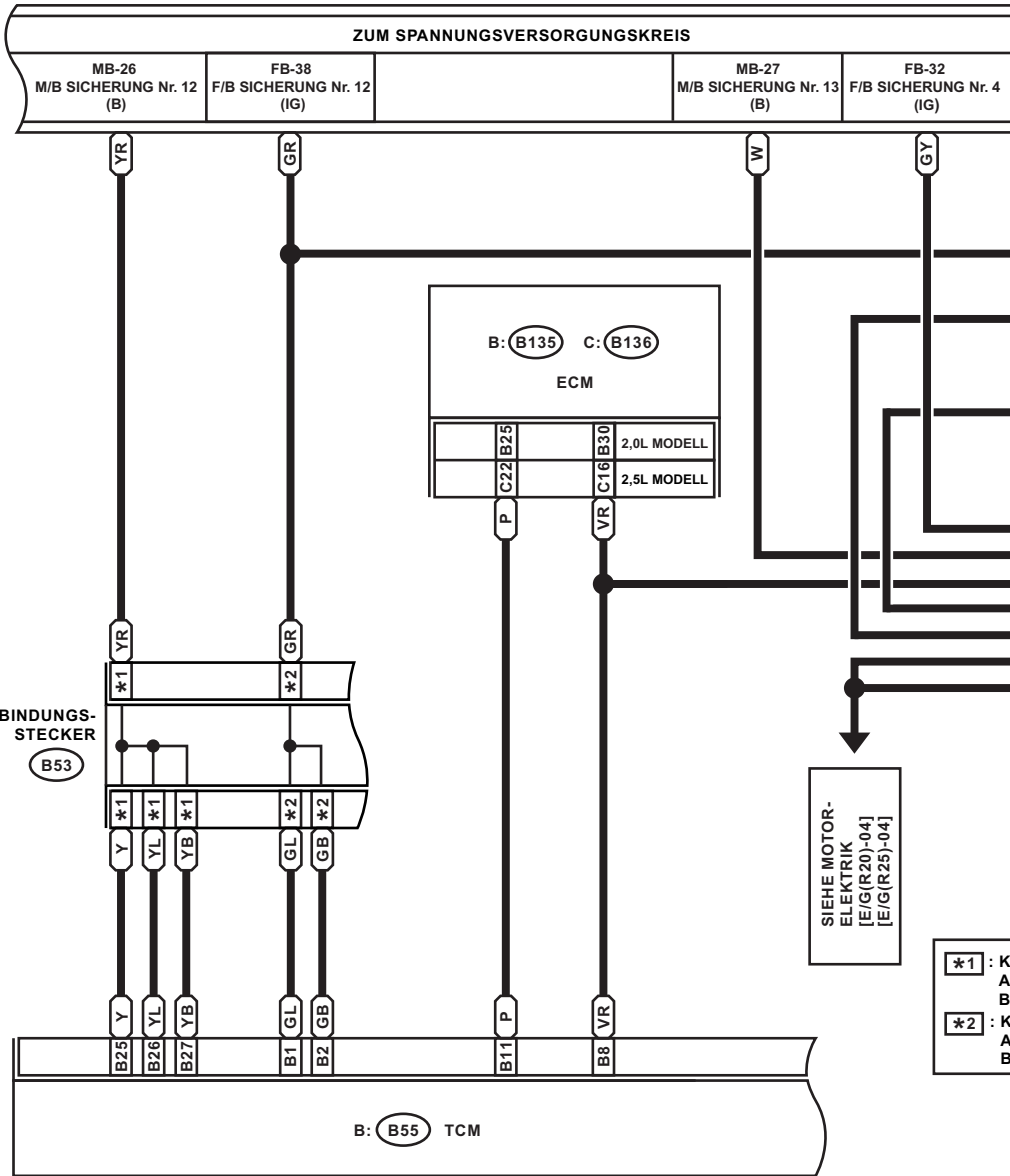

B40 (SCHWARZ)

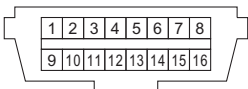

B53

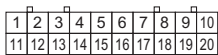

B: (B55) B: (B135)



C: (B136)

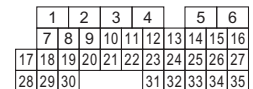

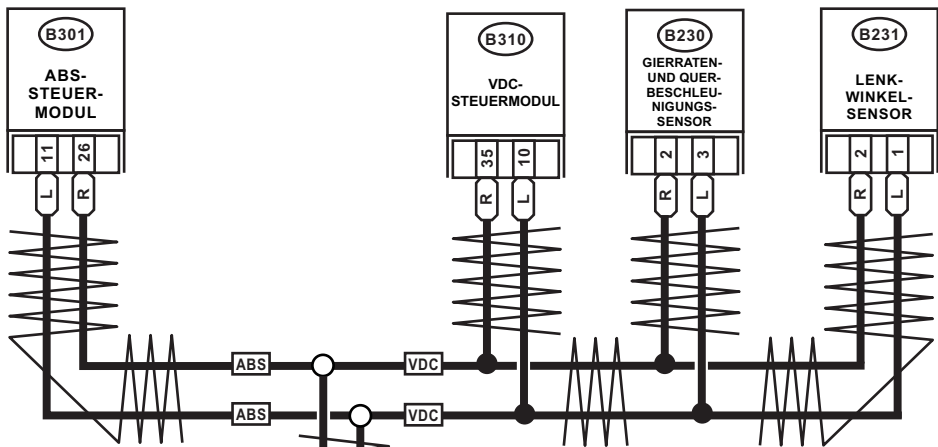

4AT(R)-02 **B**
 4AT(R)-02 **C**

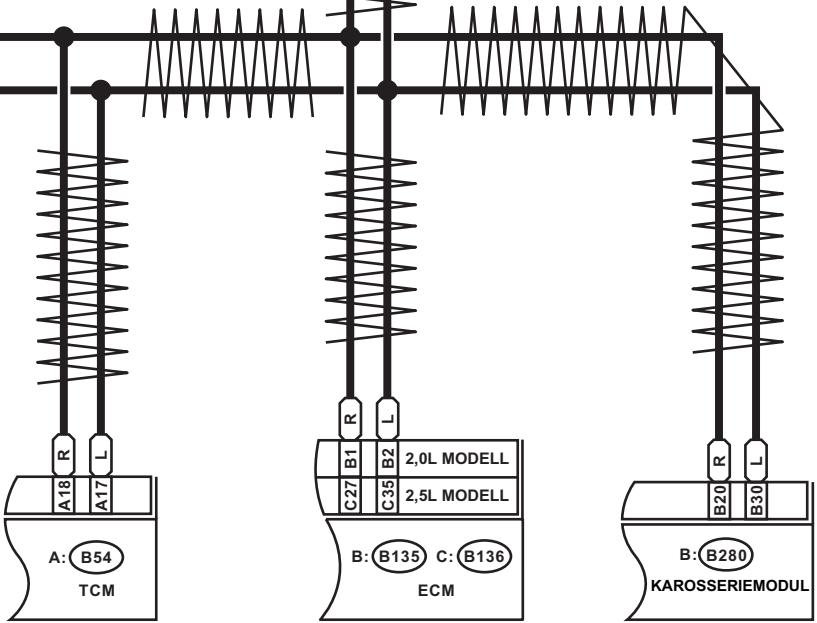

ABS : OHNE VDC
VDC : MIT VDC

B230 (SCHWARZ) **B231** (SCHWARZ)

B301 (SCHWARZ)

B: B280

A: B54 C: B136

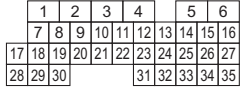
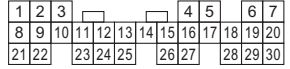
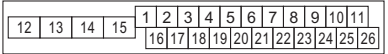
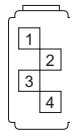

B: B135

B310 (SCHWARZ)

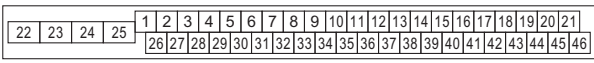
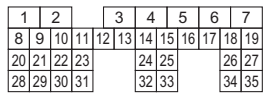

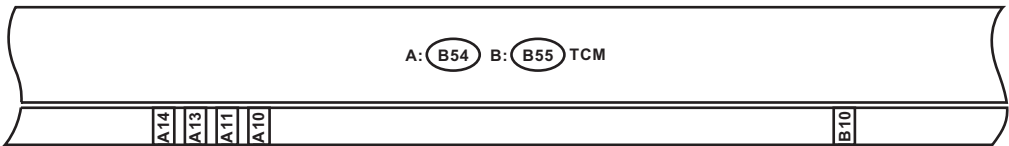

SIEHE ANLASSERSYSTEM
[ST(4ND)-01]
[ST(NS)-01]

SIEHE RÜCKFAHR
SCHEINWERFER
[BACK(L/R)-01]

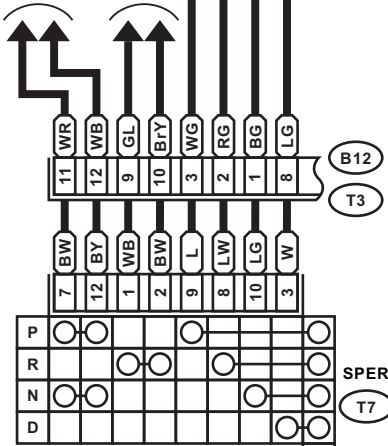

ABS : OHNE VDC

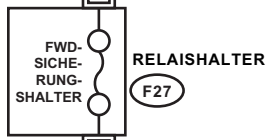
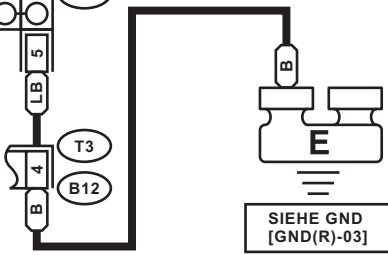

SIEHE GND [GND(R)-01]

B12 (GRAU)

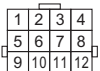

T7 (SCHWARZ)

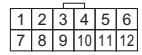

B361 (GRAU)

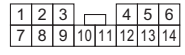

F108

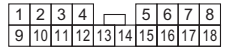

F27 (SCHWARZ)

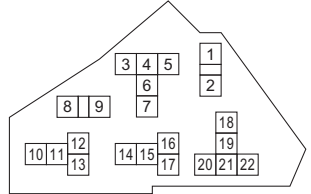

RELAIHALTER

A: B54

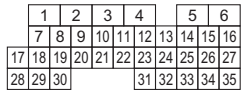

B: B55

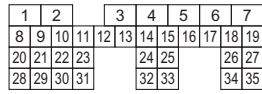

A: B54 B: B55 TCM

- 4AT(R)-02** **A**
- *1** : KLEMMEN-Nr. OPTIONALE ANORDNUNG BEI 1, 11 UND 12
 - *2** : KLEMMEN-Nr. OPTIONALE ANORDNUNG BEI 2, 3 UND 13
 - *3** : KLEMMEN-Nr. OPTIONALE ANORDNUNG BEI 8, 18 UND 19
 - *4** : KLEMMEN-Nr. OPTIONALE ANORDNUNG BEI 6, 7, 16 UND 17

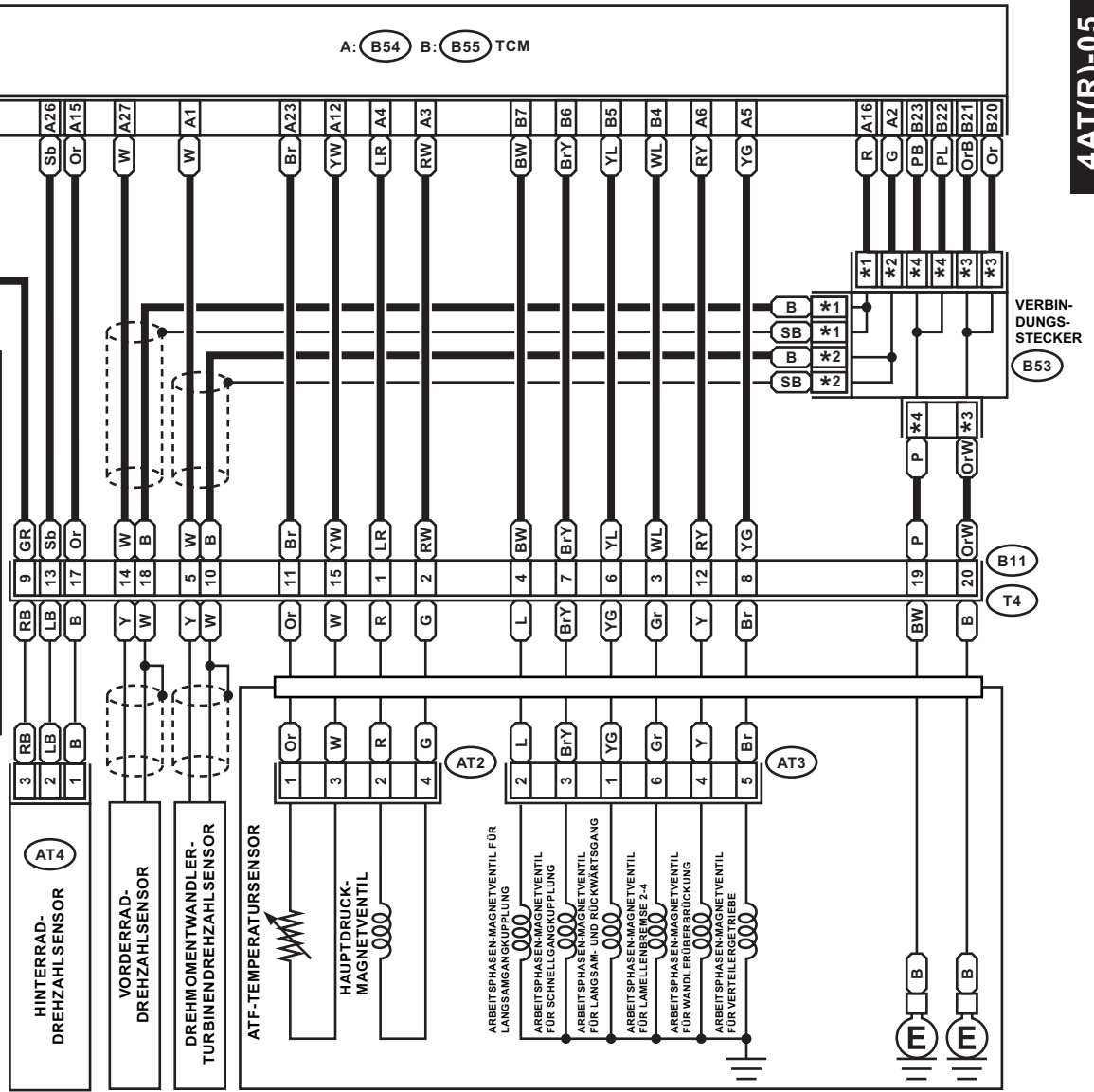

B: B55

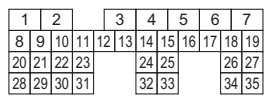

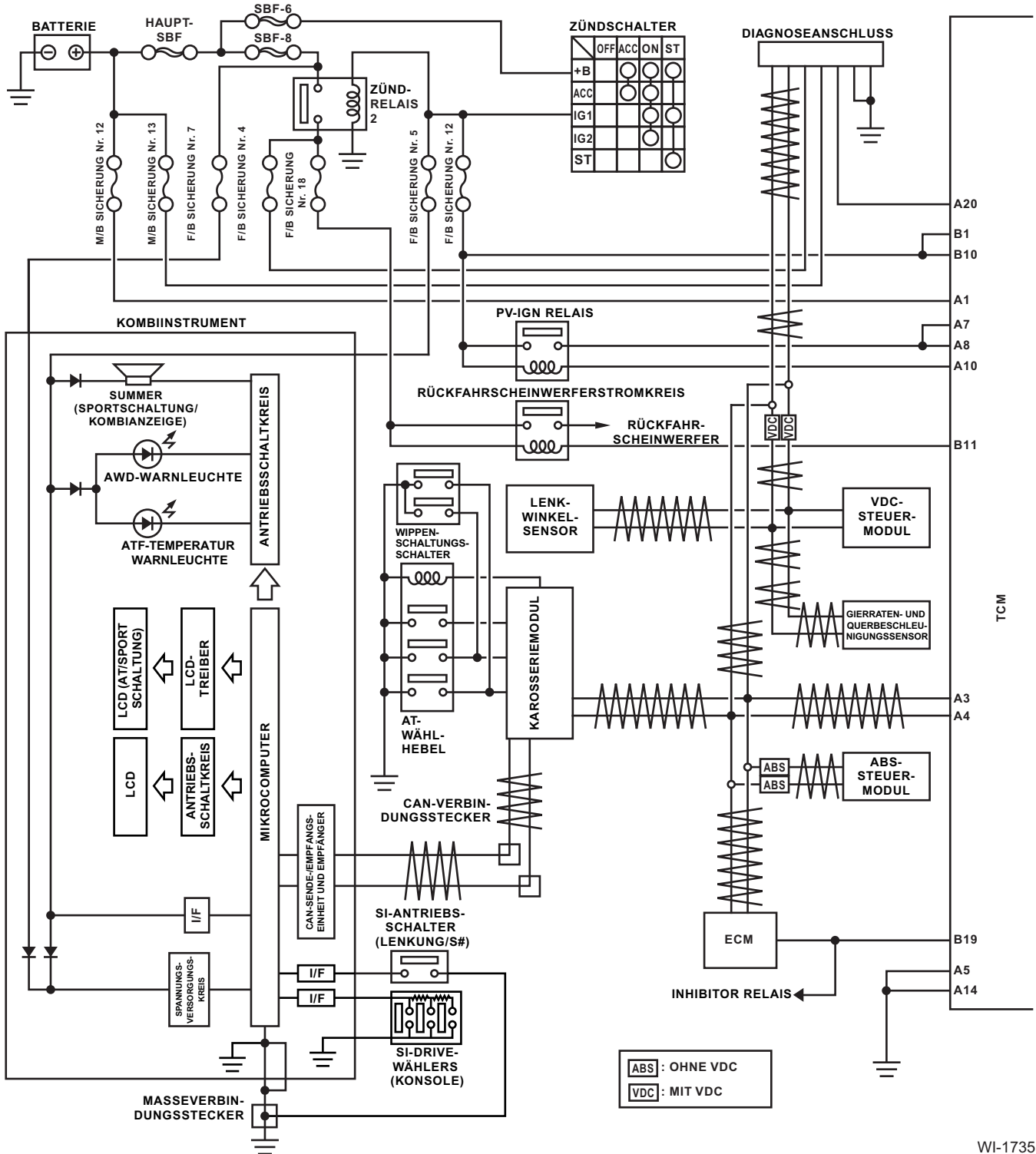

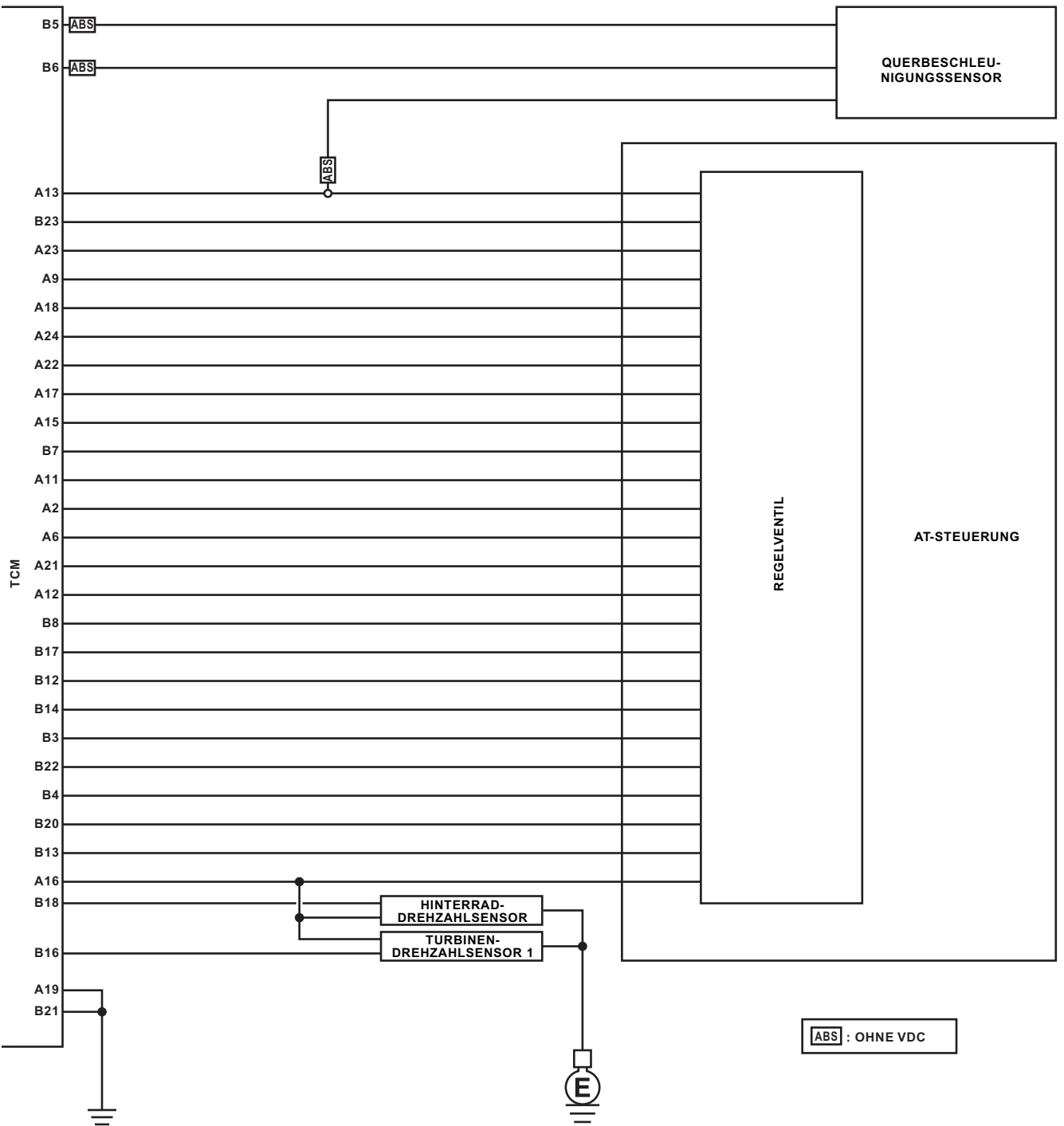

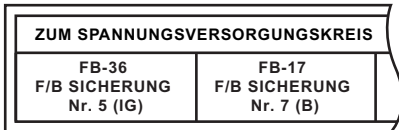

- *1 : KLEMMEN-Nr. OPTIONALE ANORDNUNG BEI 1, 2, 3, 4, 5 UND 6
- *2 : KLEMMEN-Nr. OPTIONALE ANORDNUNG BEI 1, 2, 3 UND 4

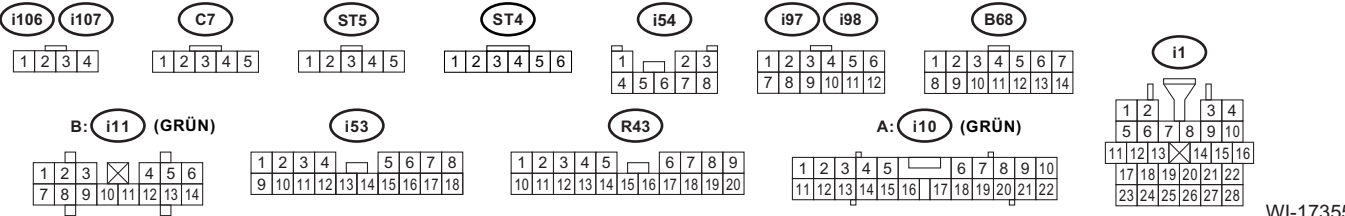
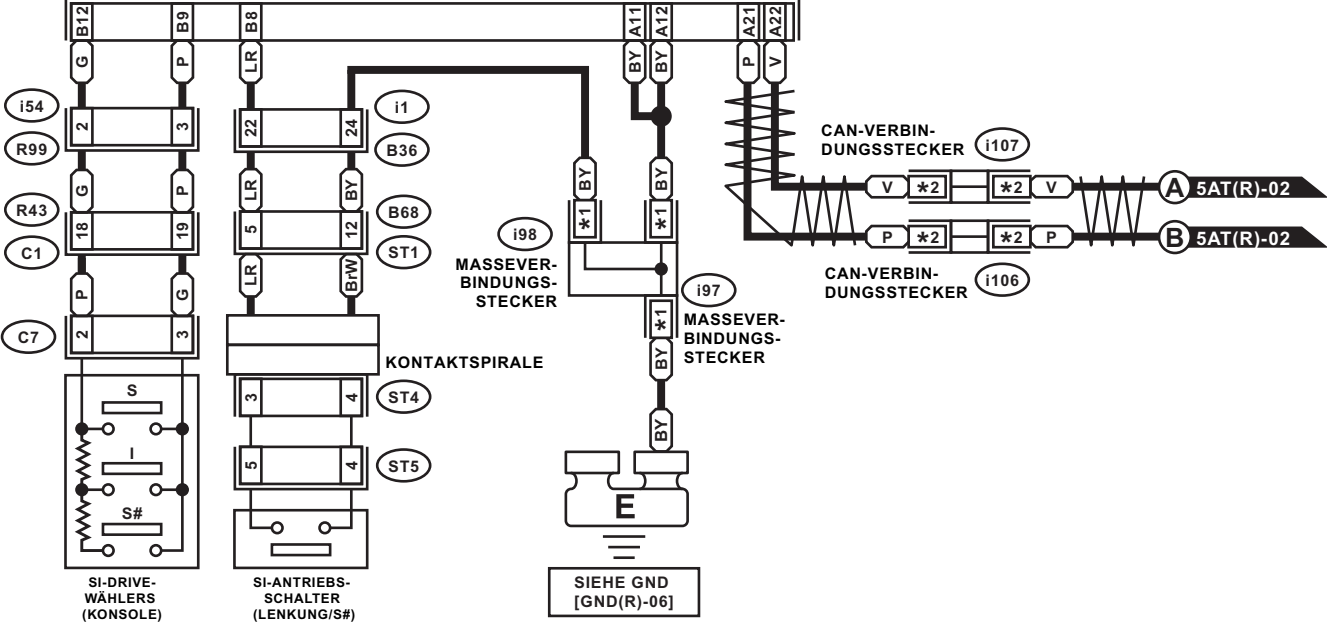
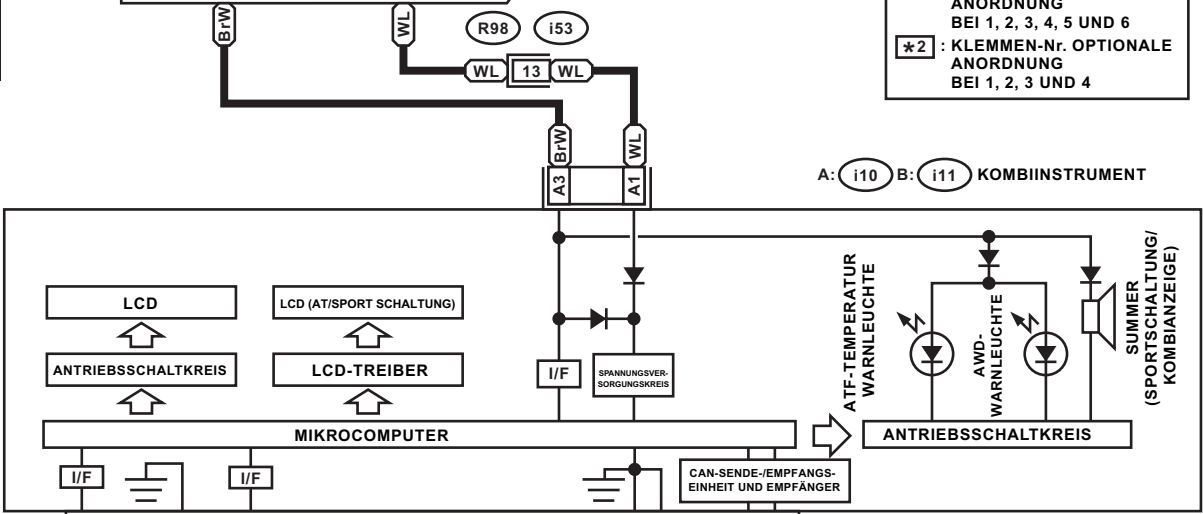

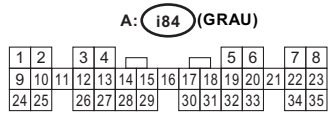
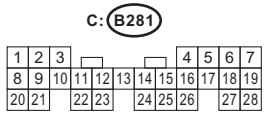
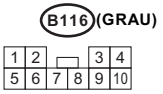
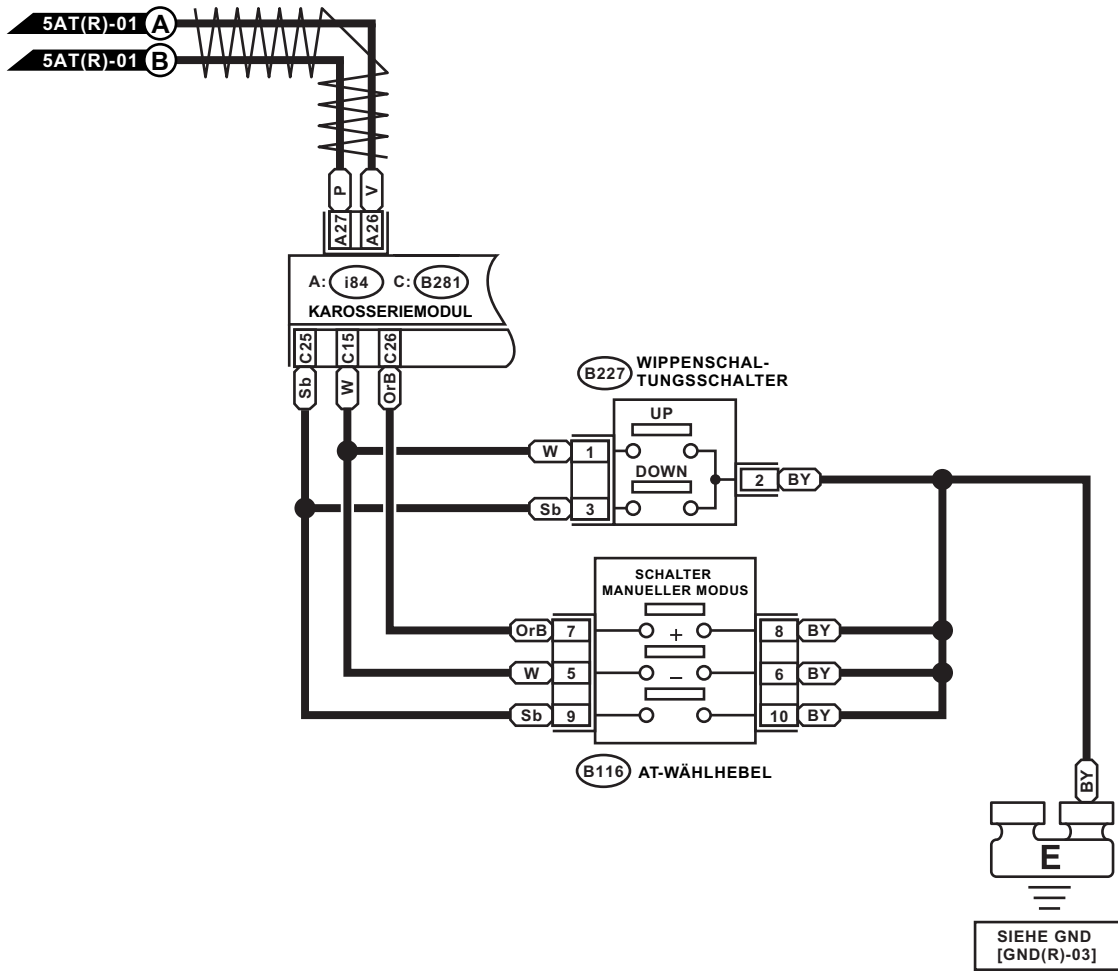

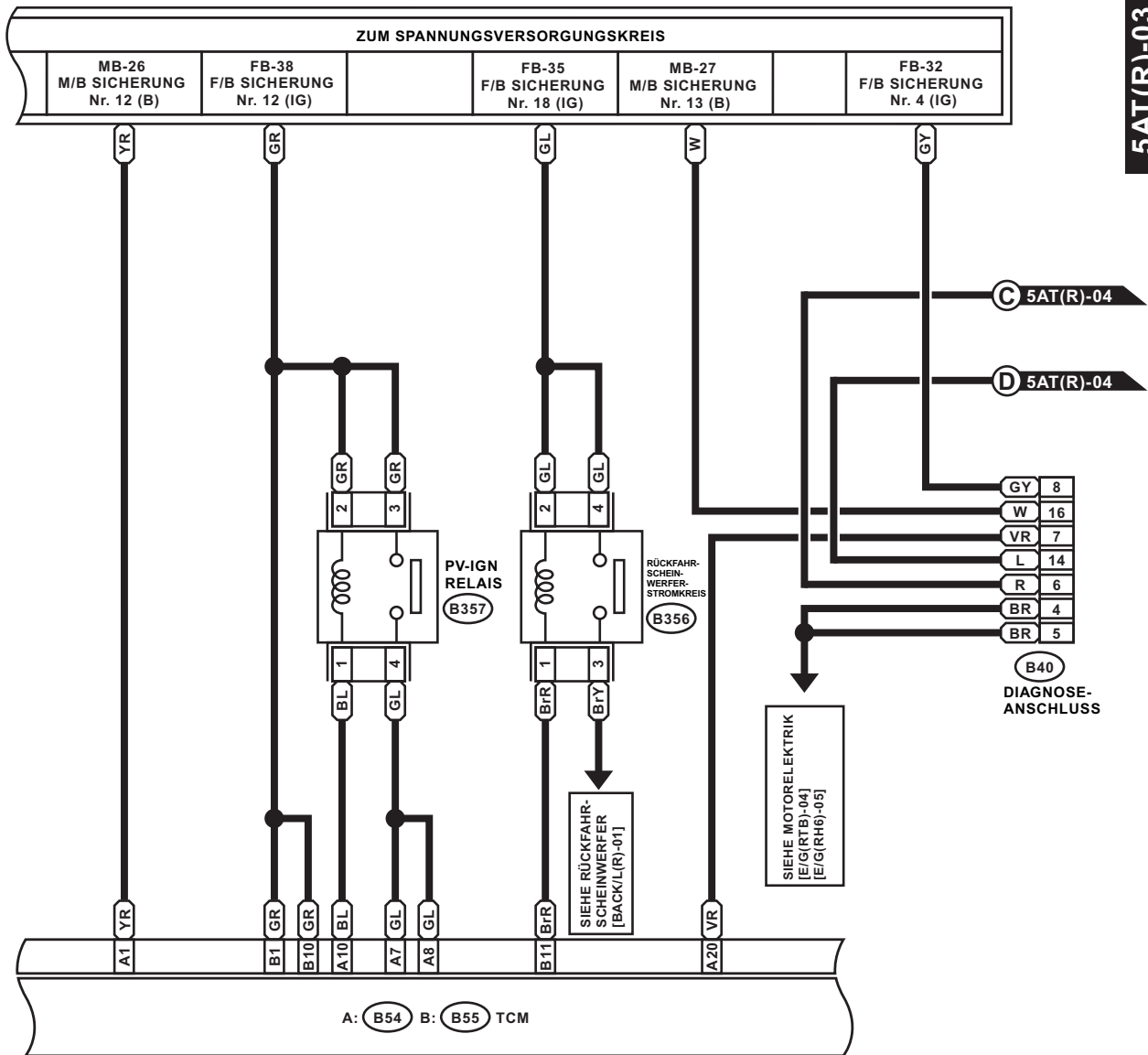

B356 (SCHWARZ)

B40 (SCHWARZ)

A: B54

B: B55 (GRAU)

B357 (SCHWARZ)

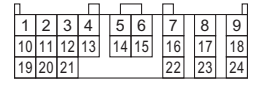
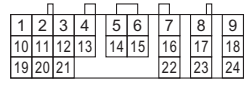
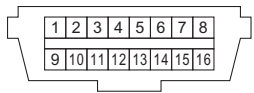

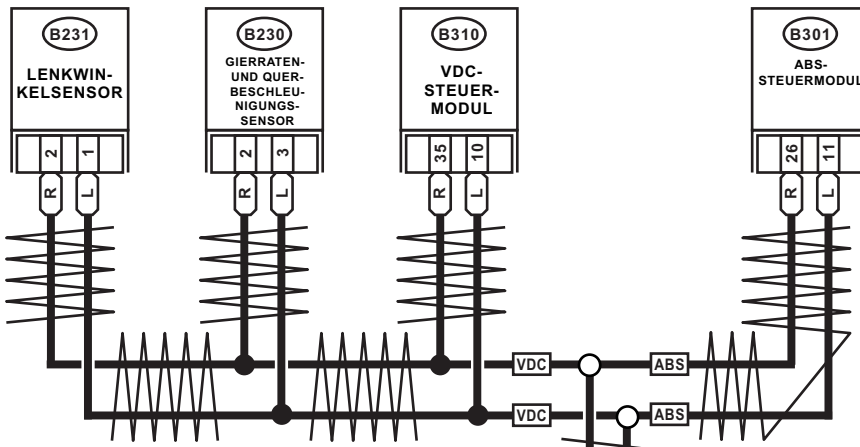

ABS : OHNE VDC
 VDC : MIT VDC

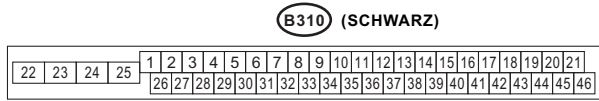
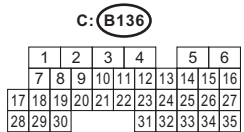
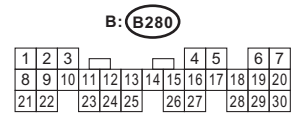
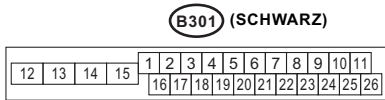
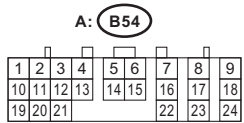
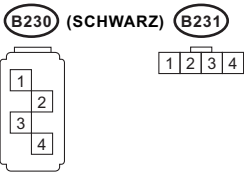
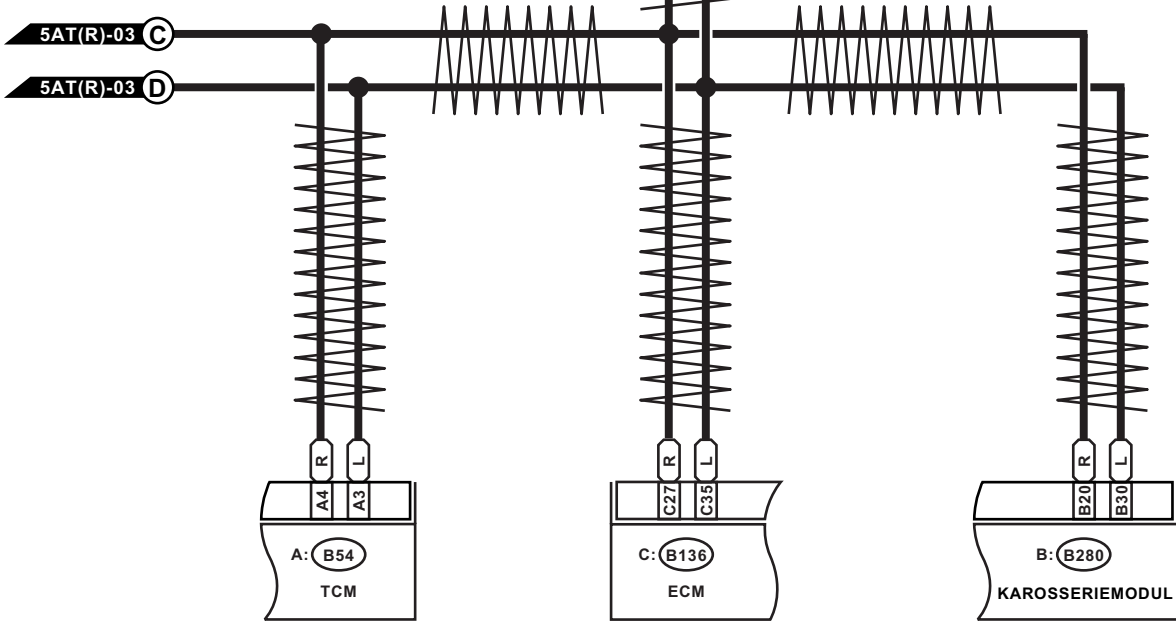

A: B54 B: B55 TCM

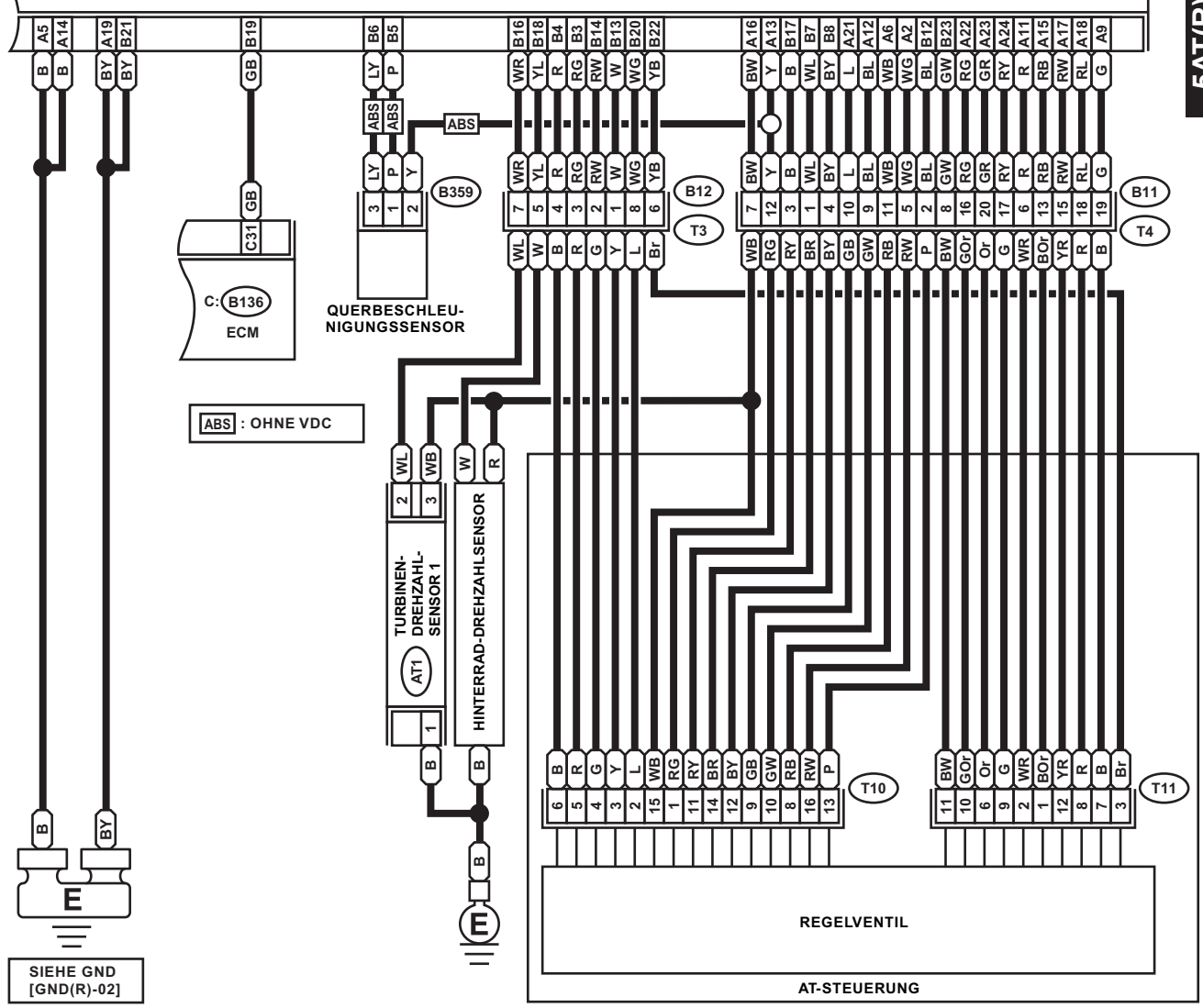

ABS : OHNE VDC

SIEHE GND [GND(R)-02]

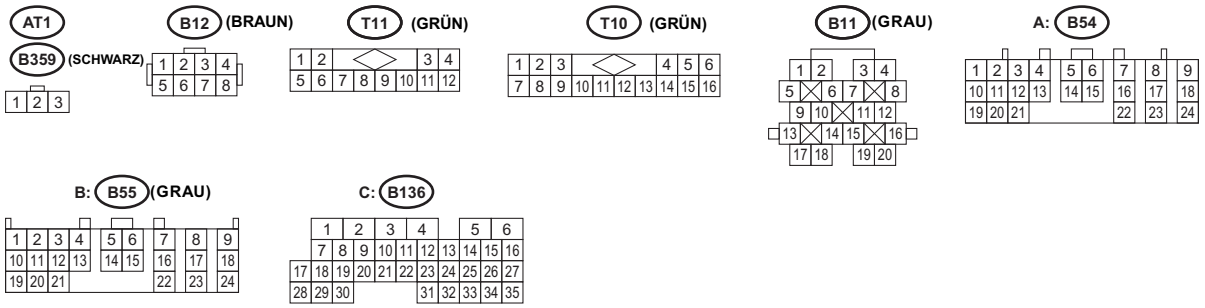

ZUM SPANNUNGSVERSORNGSKREIS

FB-28 F/B SICHERUNG Nr. 31 (ACC)	FB-37 F/B SICHERUNG Nr. 12 (IG)	MB-28 M/B SICHERUNG Nr. 14 (B)	FB-18 F/B SICHERUNG Nr. 7 (B)	FB-3 F/B SICHERUNG Nr. 8 (B)
--	---------------------------------------	--------------------------------------	-------------------------------------	------------------------------------

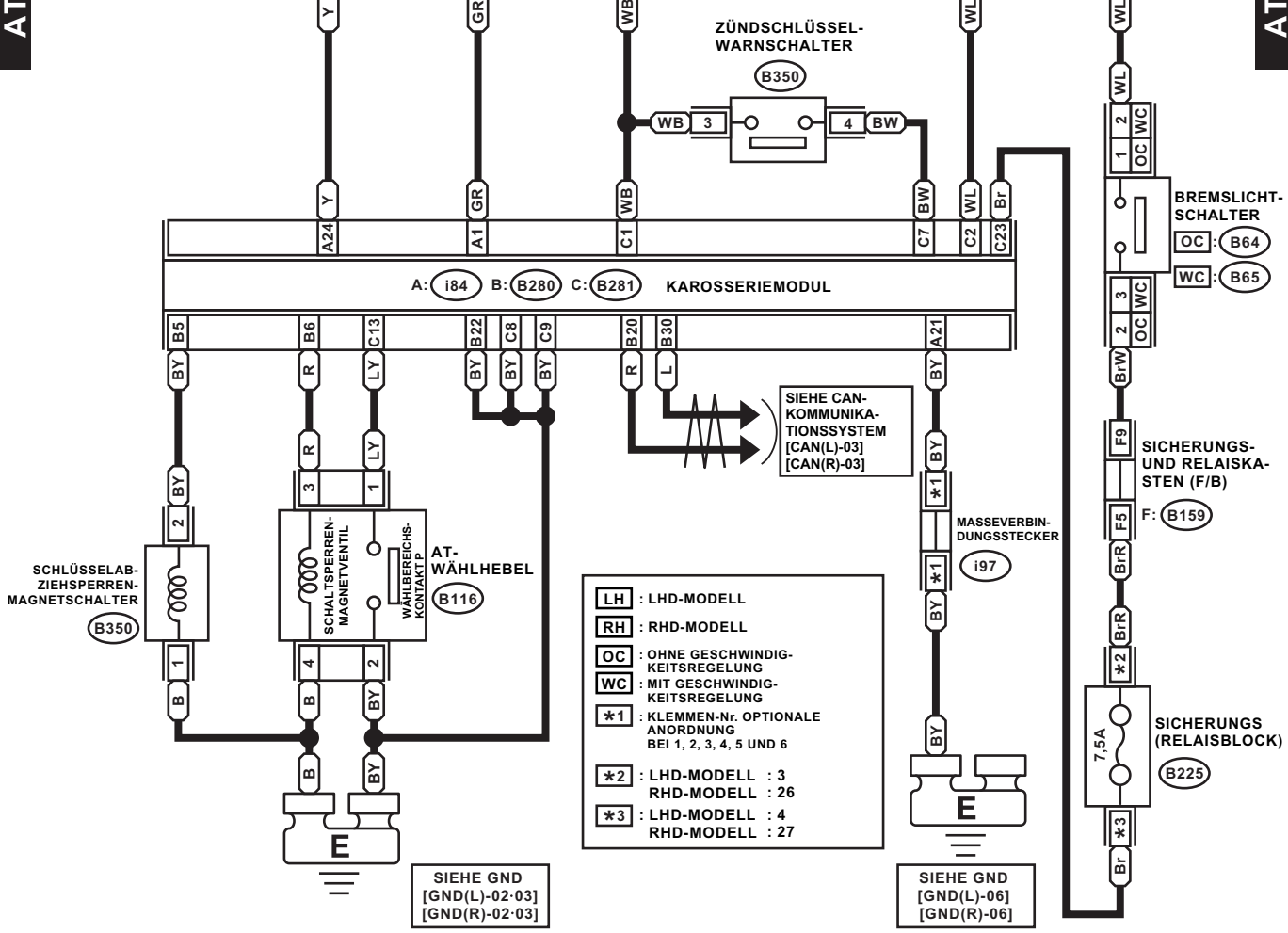

- LH** : LHD-MODELL
- RH** : RHD-MODELL
- OC** : OHNE GESCHWINDIGKEITSREGELUNG
- WC** : MIT GESCHWINDIGKEITSREGELUNG
- *1** : KLEMMEN-Nr. OPTIONALE ANORDNUNG BEI 1, 2, 3, 4, 5 UND 6
- *2** : LHD-MODELL : 3
RHD-MODELL : 26
- *3** : LHD-MODELL : 4
RHD-MODELL : 27

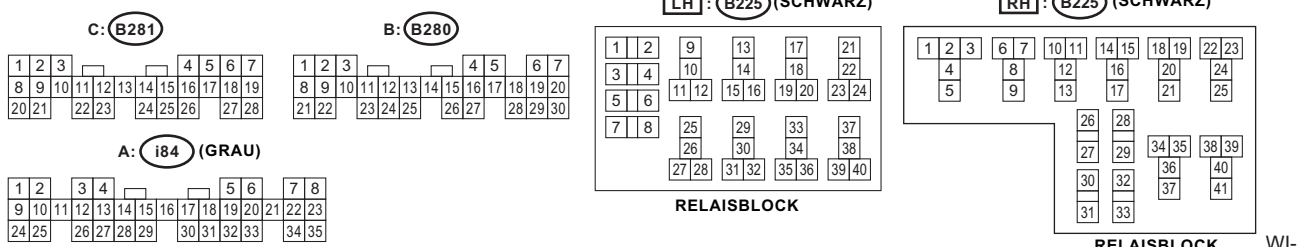
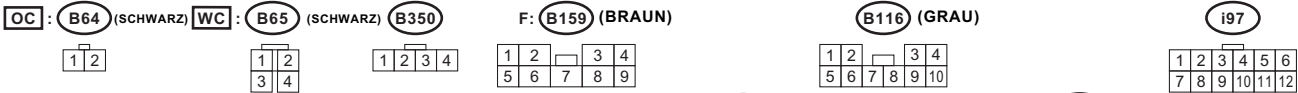

*1 : KLEMMEN-Nr. OPTIONALE ANORDNUNG BEI 1, 2, 3, 4, 5 UND 6

SIEHE SYSTEM MIT STARTKNOPF [P/S-03]

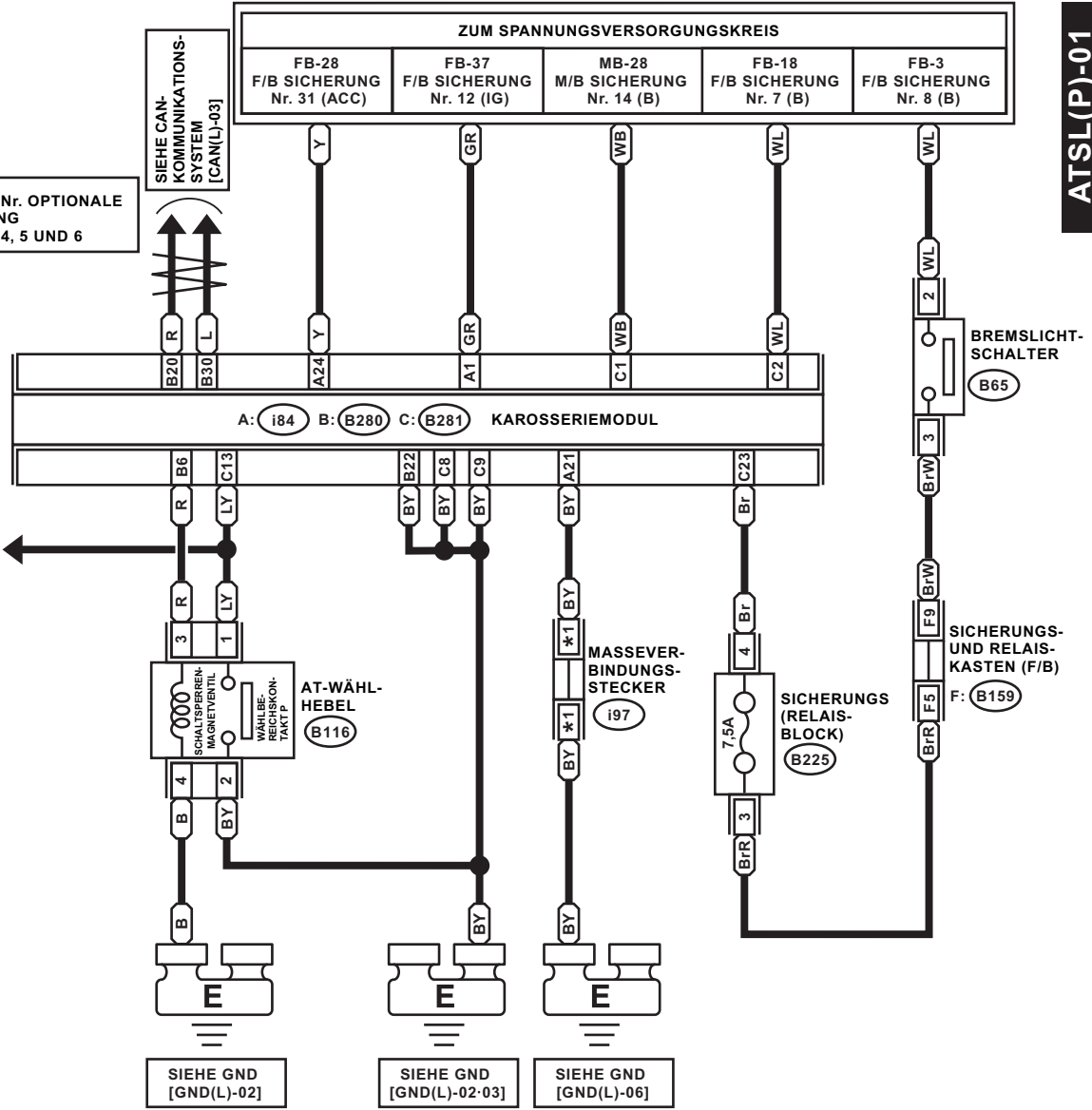

B65 (SCHWARZ)



F: (B159) (BRAUN)

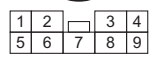

B116 (GRAU)

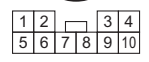

197

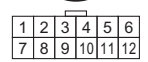

B225 (SCHWARZ)

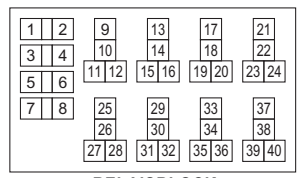

C: (B281)

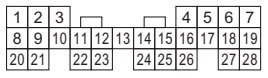

B: (B280)

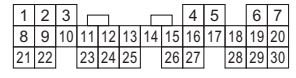

A: (i84) (GRAU)

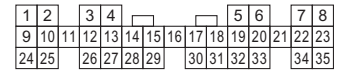

ZUM SPANNUNGSVERSORGUNGSKREIS

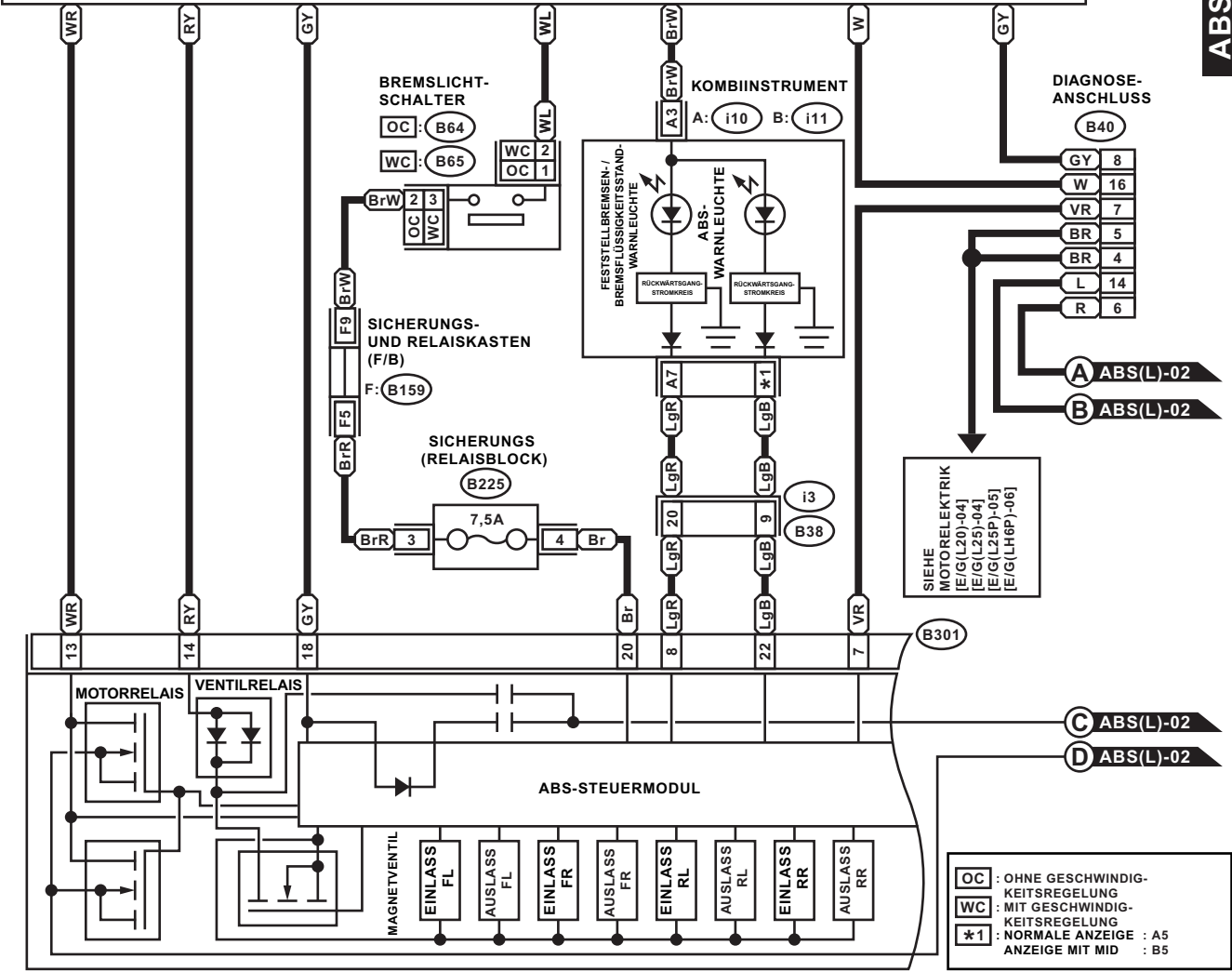

OC : OHNE GESCHWINDIGKEITSREGELUNG
 WC : MIT GESCHWINDIGKEITSREGELUNG
 *1 : NORMALE ANZEIGE : A5
 ANZEIGE MIT MID : B5

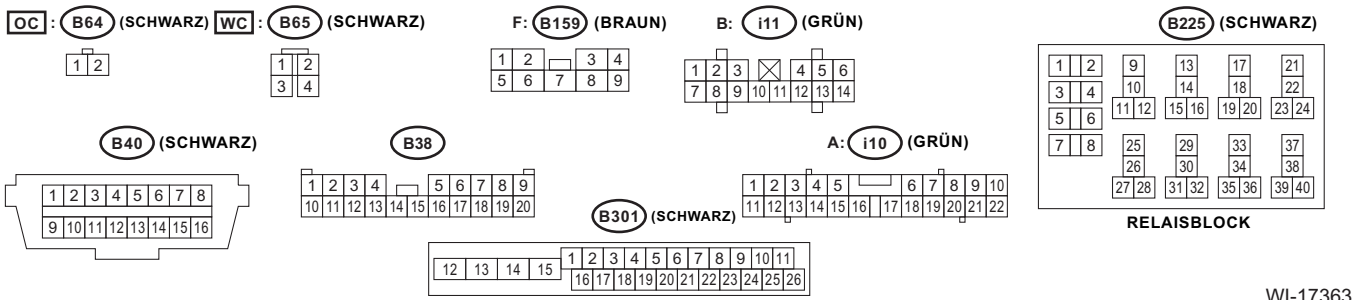

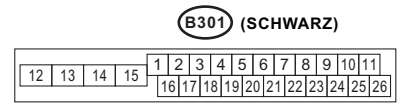
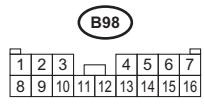
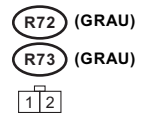
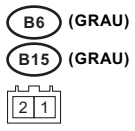
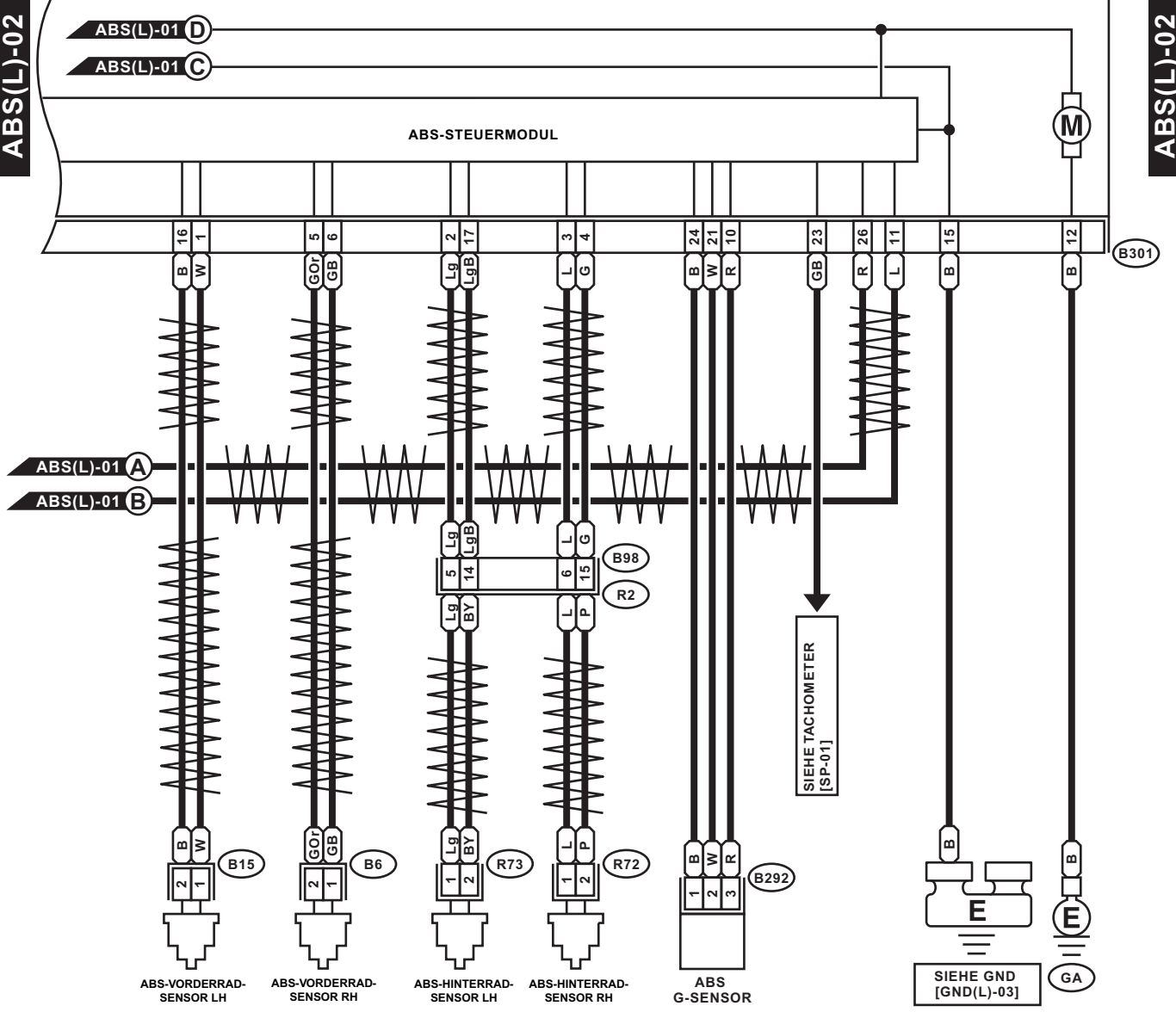

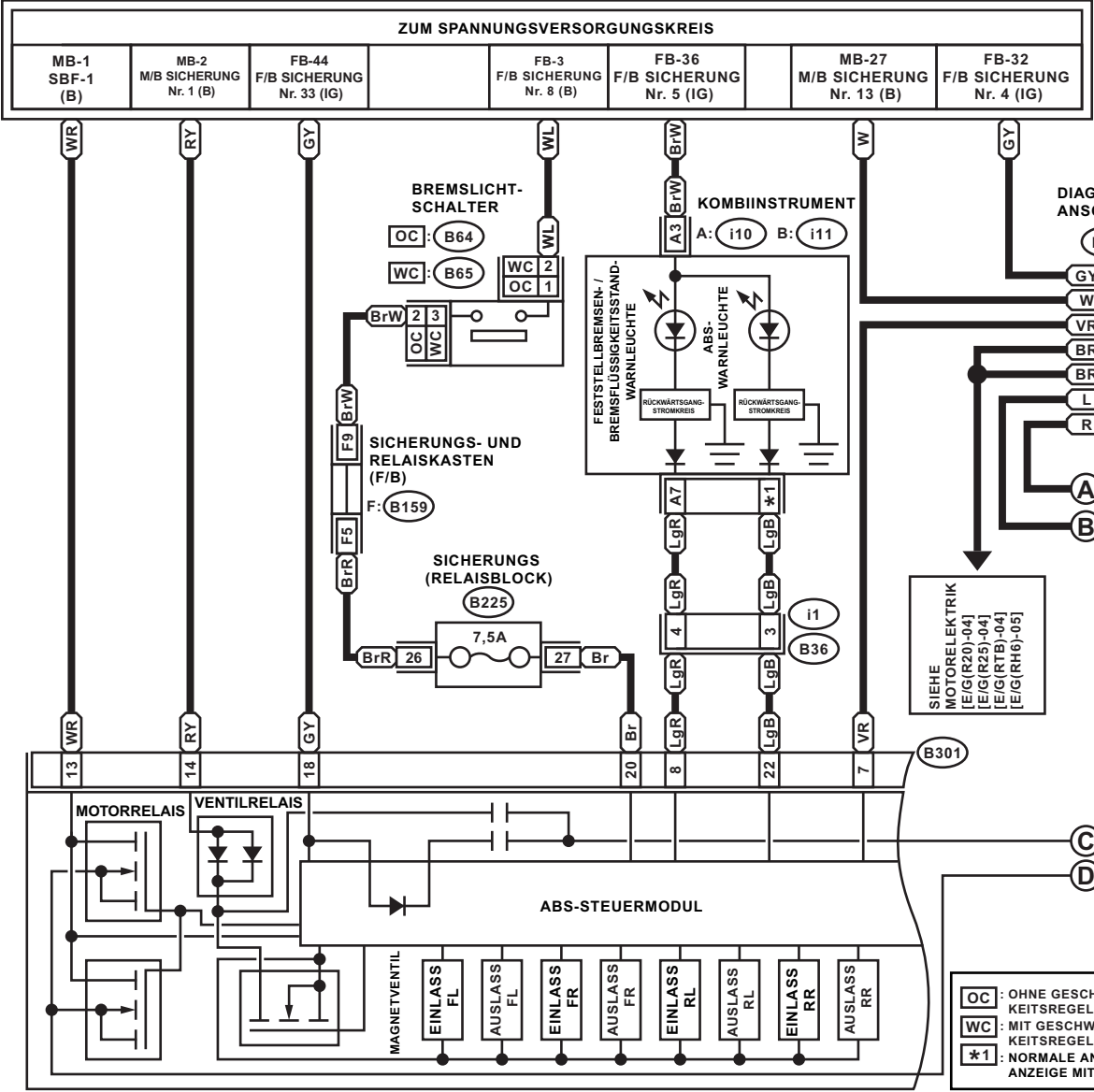

OC : B64 (SCHWARZ) WC : B65 (SCHWARZ)

F: B159 (BRAUN) B: i11 (GRÜN)

B225 (SCHWARZ)

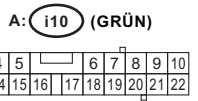
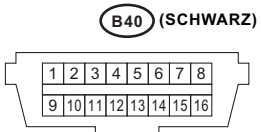
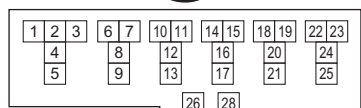
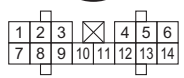
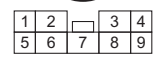

B301 (SCHWARZ)

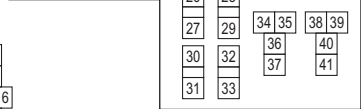
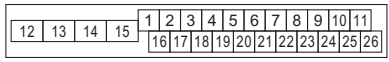
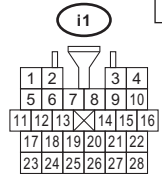

RELAISBLOCK

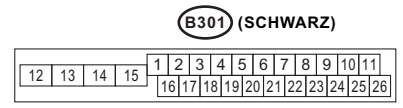
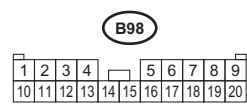
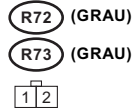
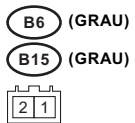
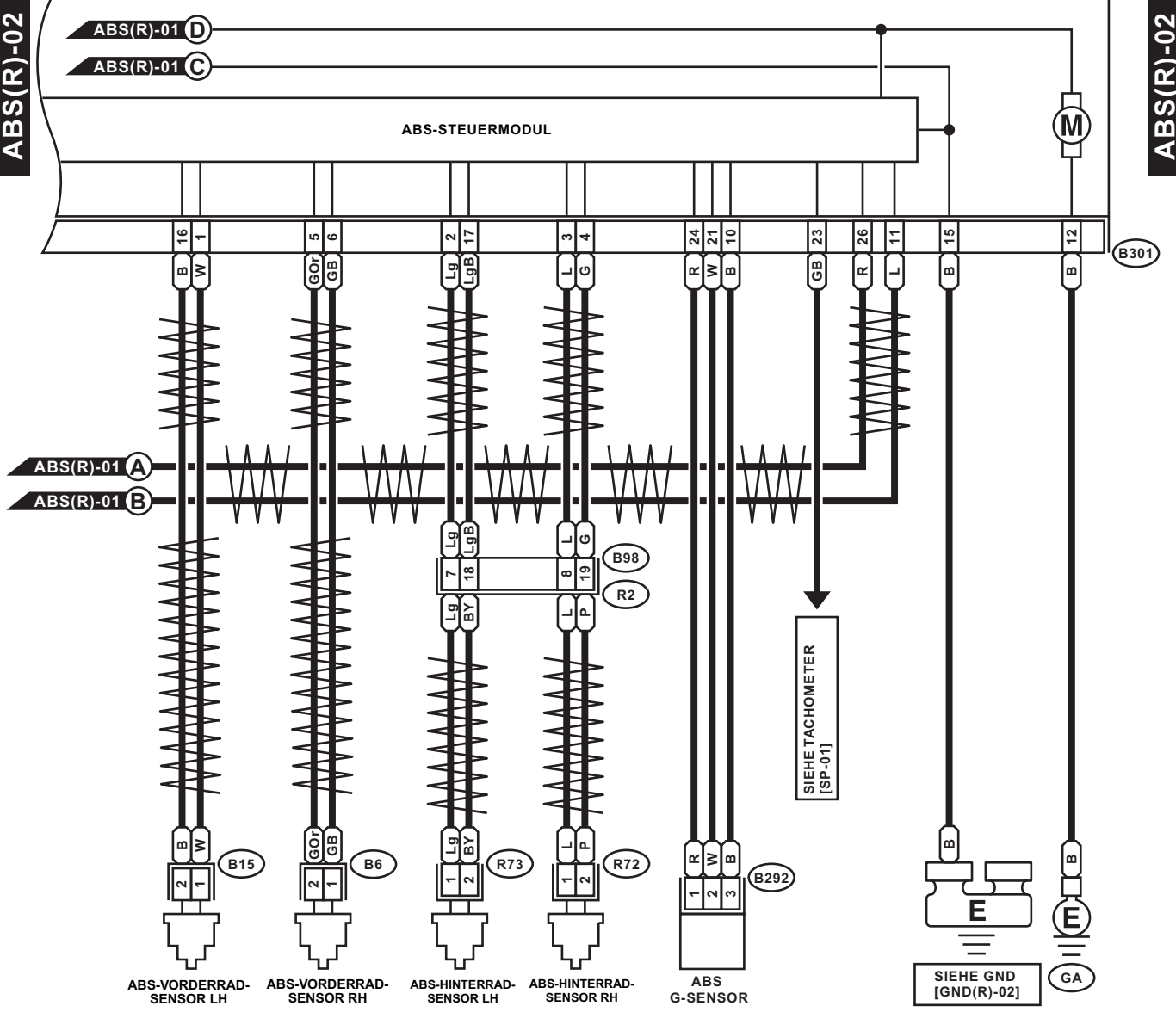

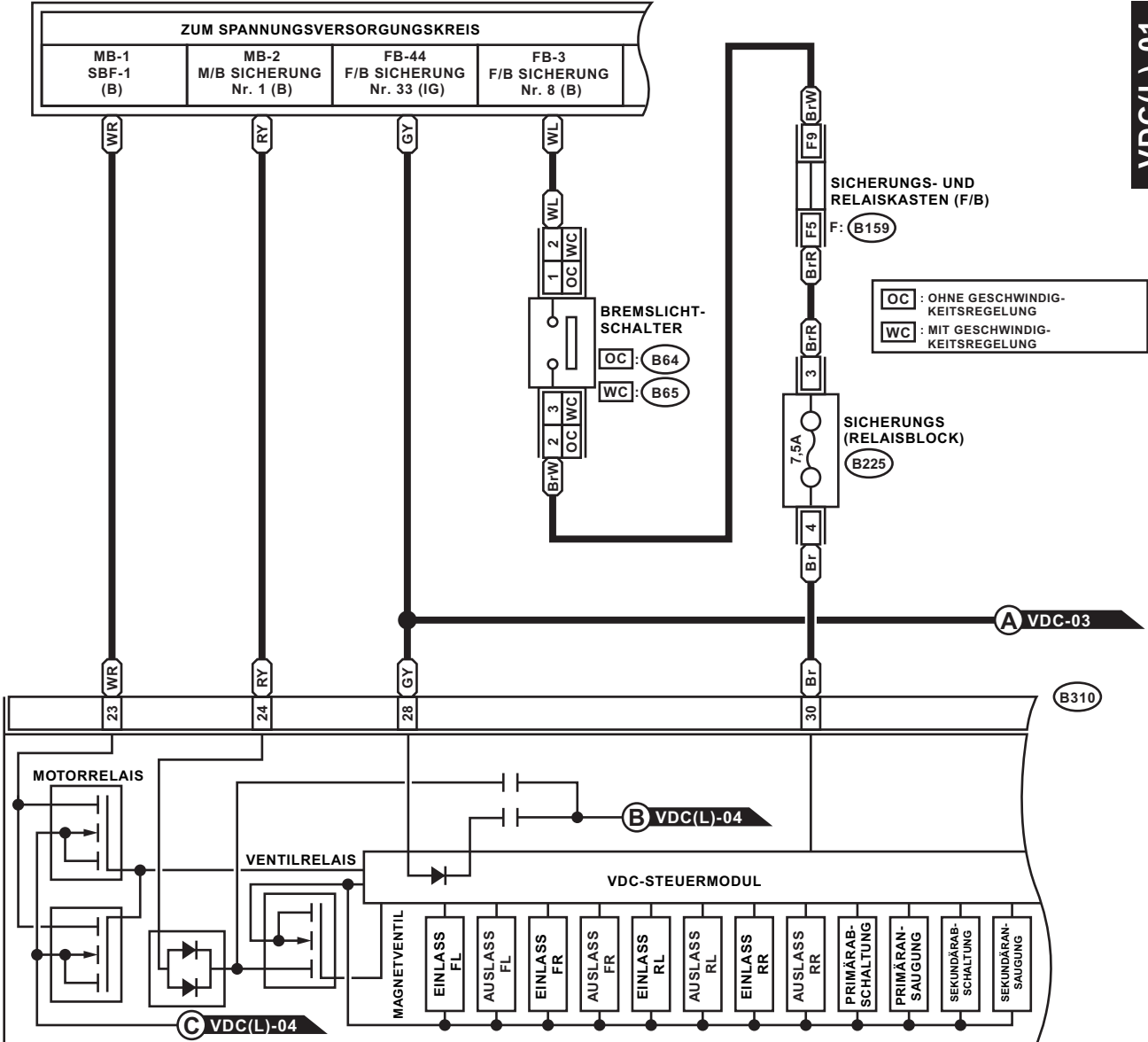

OC : B64 (SCHWARZ) WC : B65 (SCHWARZ) F: B159 (BRAUN)

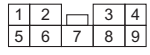

B225 (SCHWARZ)

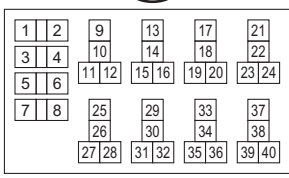

RELAISBLOCK

B310 (SCHWARZ)

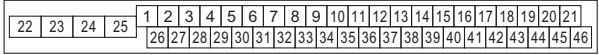

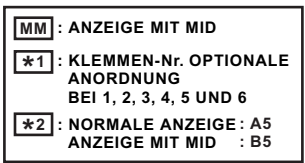
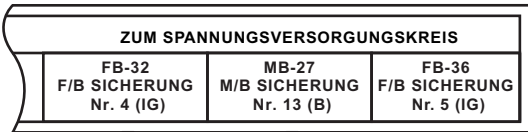

DIAGNOSE-ANSCHLUSS

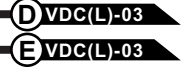
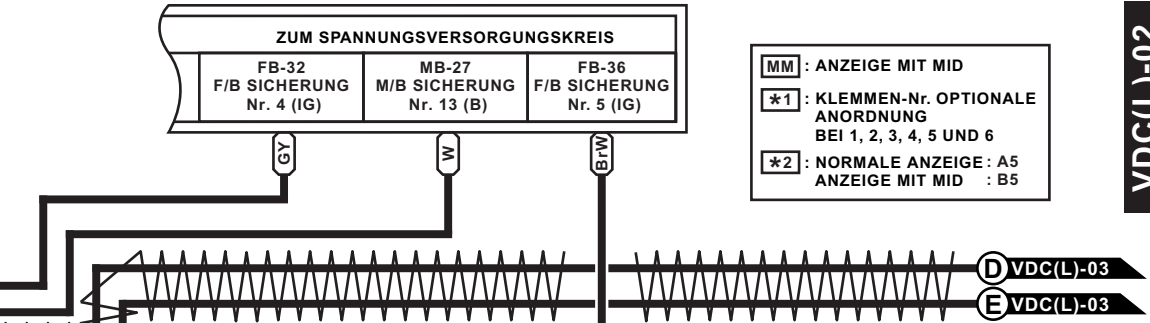
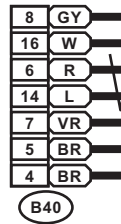

KOMBIINSTRUMENT A: i10 B: i11

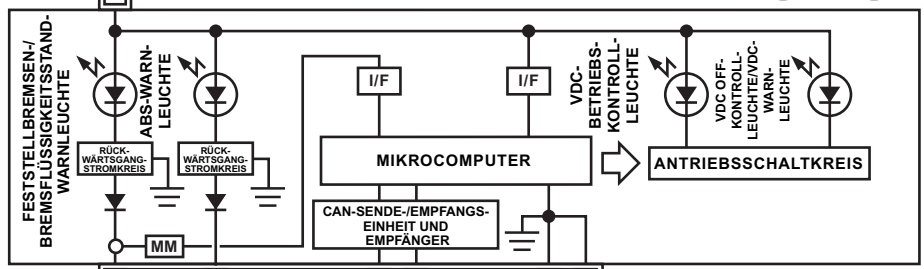

SIEHE MOTORELEKTRIK
[E/G(L20)-04]
[E/G(L25S)-04]
[E/G(L25P)-05]
[E/G(LH6)-05]
[E/G(LH6P)-06]

SIEHE TACHOMETER
[SP-01]

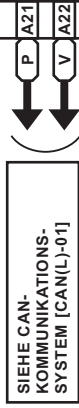
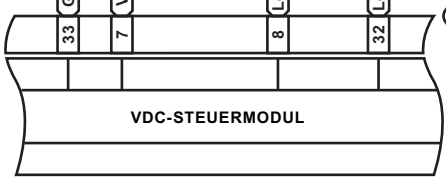

MASSEVERBINDUNGSSTECKER

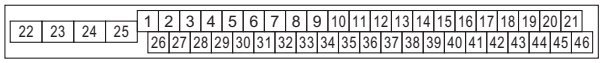
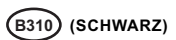
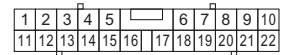
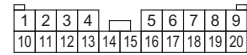
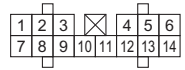
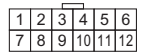
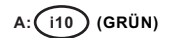
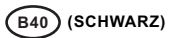
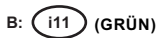
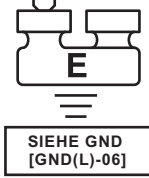
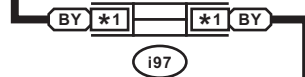

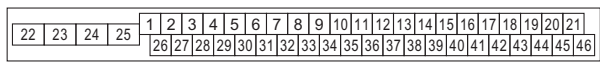
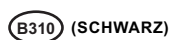
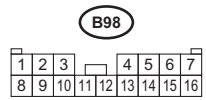
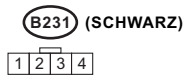
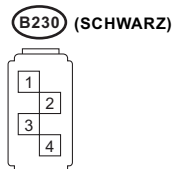
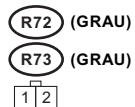
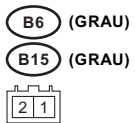
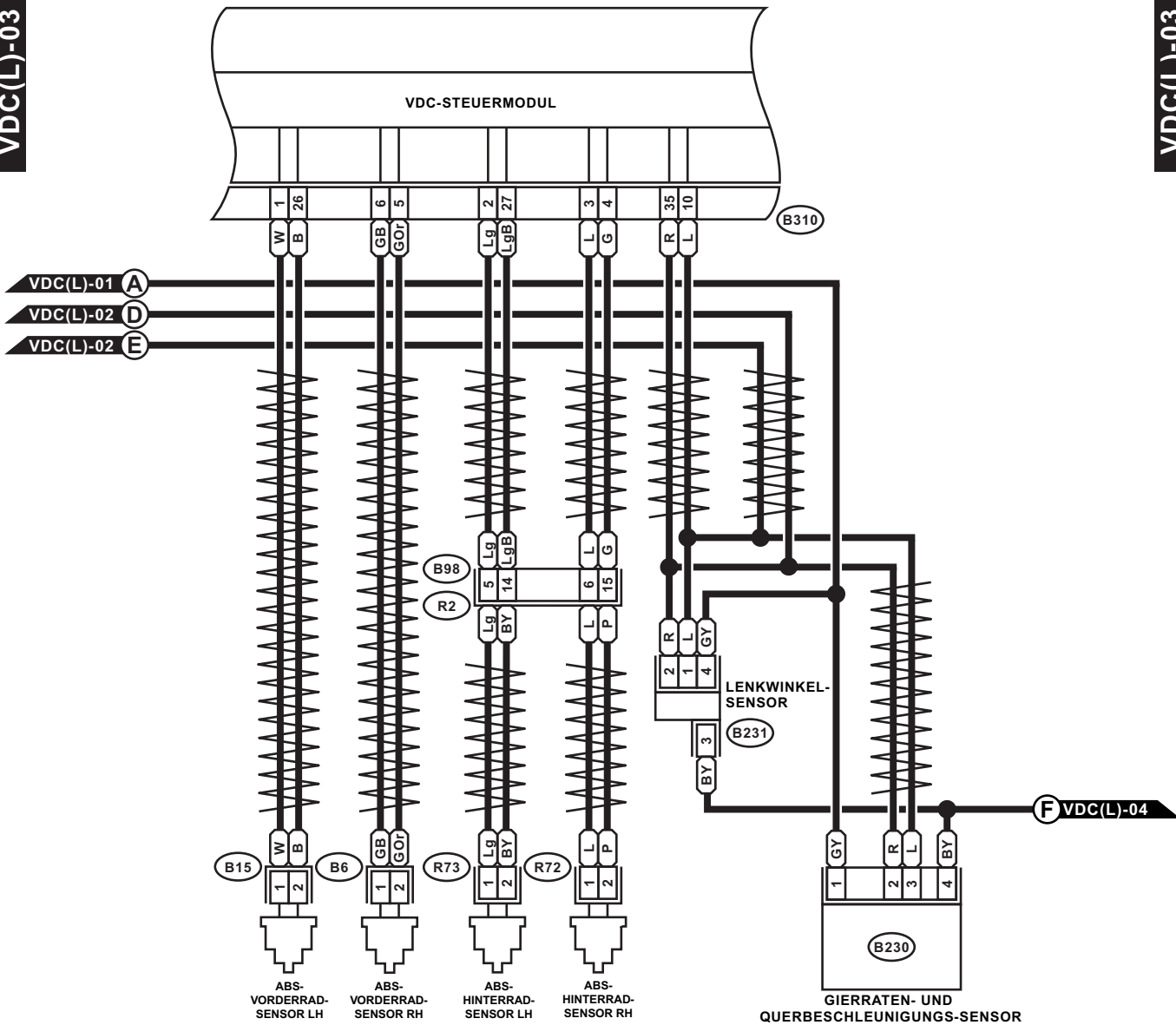

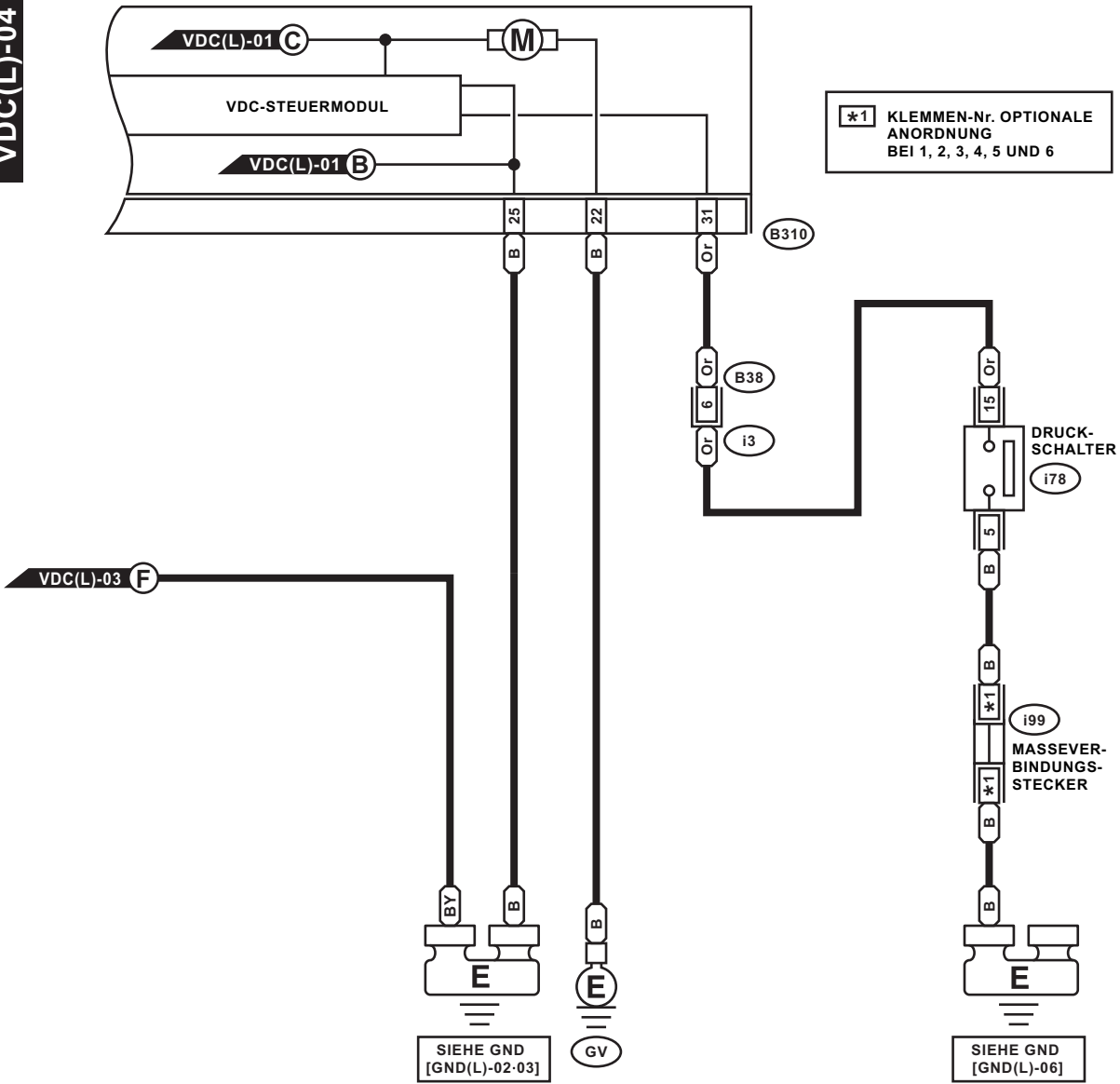

i99 (SCHWARZ)

1	2	3	4	5	6
7	8	9	10	11	12

i78 (BLAU)

1	2	3	4		5	6	7
8	9	10	11	12	13	14	15

B38

1	2	3	4		5	6	7	8	9	
10	11	12	13	14	15	16	17	18	19	20

B310 (SCHWARZ)

22	23	24	25	1	2	3	4	5	6	7	8	9	10	11	12	13	14	15	16	17	18	19	20	21
				26	27	28	29	30	31	32	33	34	35	36	37	38	39	40	41	42	43	44	45	46

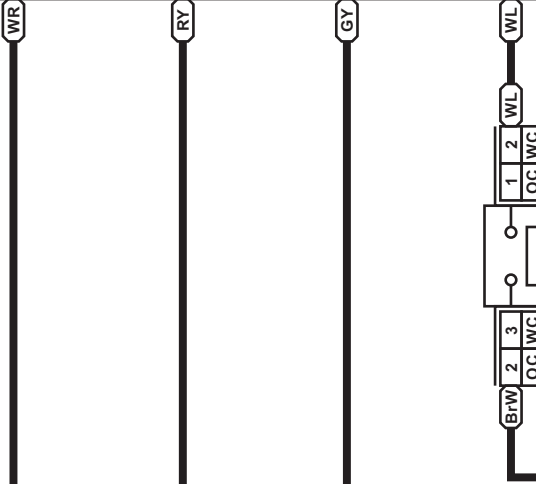
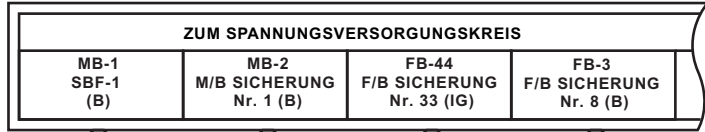

SICHERUNGS- UND
RELAISKASTEN (F/B)

F: B159

OC : OHNE GESCHWINDIG-
KEITSREGELUNG
WC : MIT GESCHWINDIG-
KEITSREGELUNG

BREMSLICHT-
SCHALTER

OC : B64

WC : B65

SICHERUNGS
(RELAISBLOCK)

B225

A VDC(R)-03

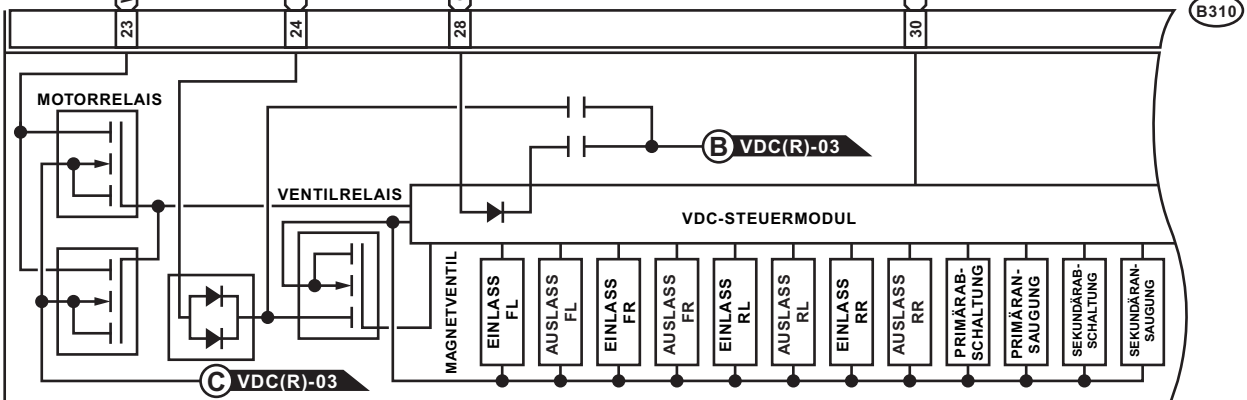

C VDC(R)-03

B VDC(R)-03

OC : B64 (SCHWARZ) WC : B65 (SCHWARZ) F: B159 (BRAUN)

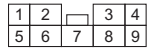

B310 (SCHWARZ)

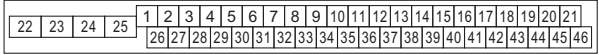

B225 (SCHWARZ)

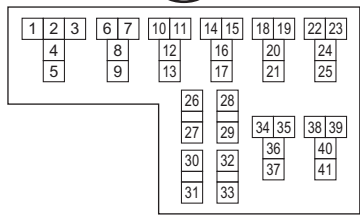

RELAISBLOCK

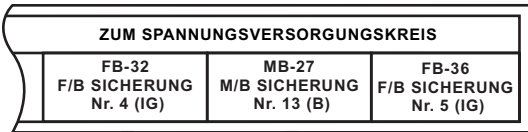

MM : ANZEIGE MIT MID
***1** : KLEMMEN-Nr. OPTIONALE ANORDNUNG BEI 1, 2, 3, 4, 5 UND 6
***2** : NORMALE ANZEIGE : A5 ANZEIGE MIT MID : B5

DIAGNOSEANSCHLUSS

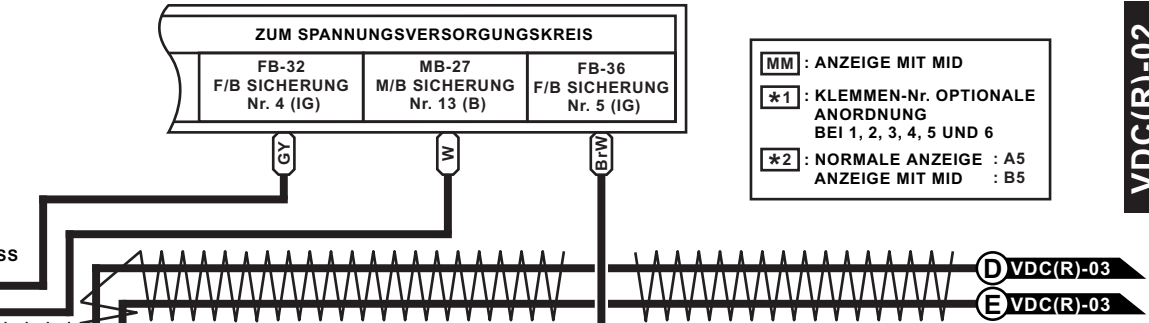

KOMBIINSTRUMENT A: i10 B: i11

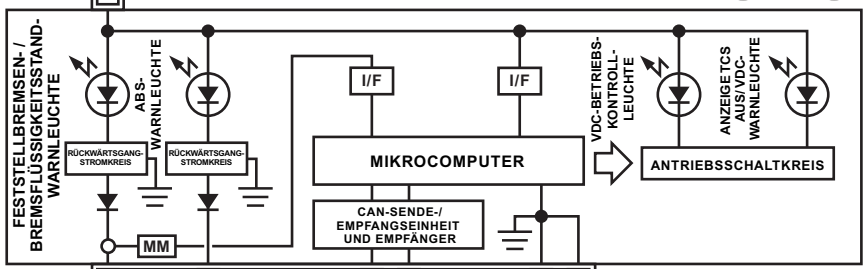

SIEHE MOTORELEKTRIK [E/G(R25)-04] [E/G(RTB)-04] [E/G(RH6)-05]

SIEHE TACHOMETER [SP-01]

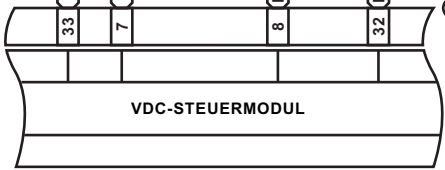

SIEHE CAN-KOMMUNIKATIONSSYSTEM [CAN(R)-01]

MASSEVERBINDUNGS-STECKER

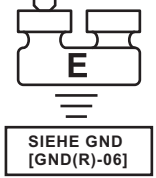

(i97)

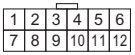

B: (i11) (GRÜN)

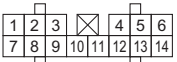

(B40) (SCHWARZ)

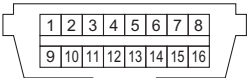

A: (i10) (GRÜN)

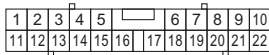

(i1)

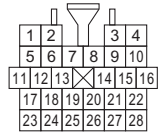

(B310) (SCHWARZ)

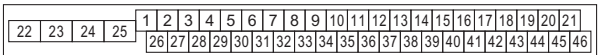

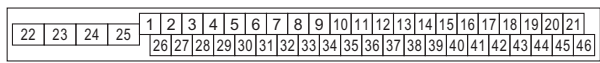
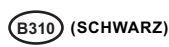
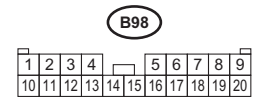
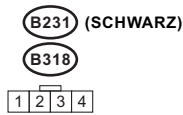
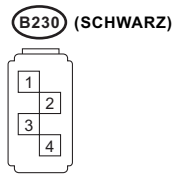
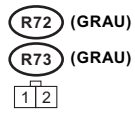
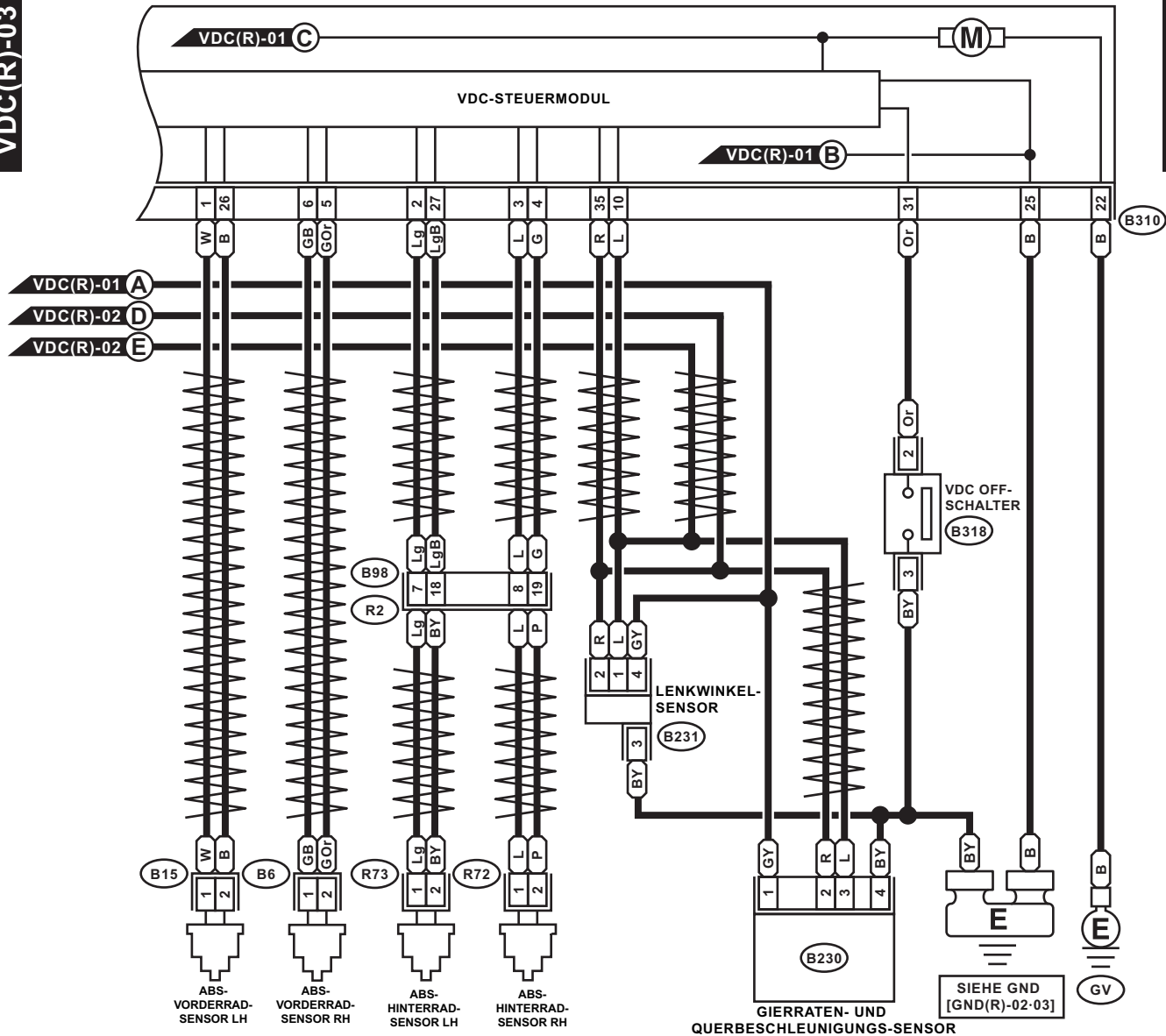

ZUM SPANNUNGSVERSORGUNGSKREIS
 FB-18
 F/B SICHERUNG
 Nr. 7 (B)

A-A/C(L)-01 **A** **B** A-A/C(L)-03

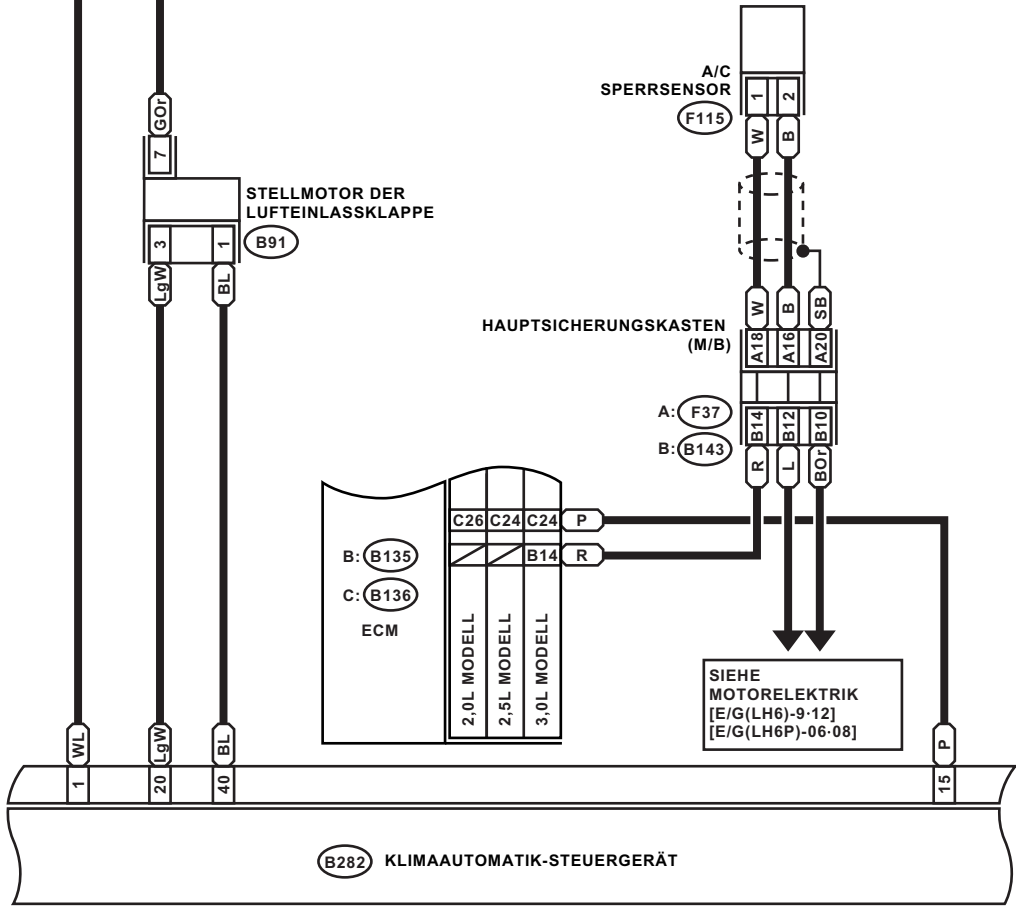

F115 (GRAU)



B91 (GRÜN)

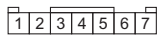

B: (B143)

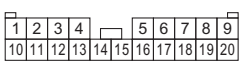

A: (F37)

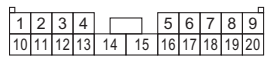

B: (B135)

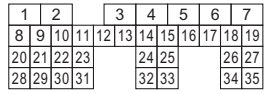

C: (B136)

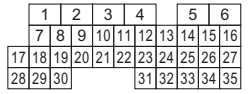

(B282)

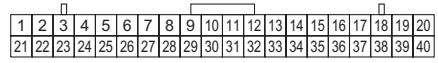



A-A/C(L)-02 B

*1	: AUSSER 3,0L MODELL	: 21
	3,0L MODELL	: 1
*2	: AUSSER 3,0L MODELL	: 23
	3,0L MODELL	: 2
*3	: AUSSER 3,0L MODELL	: 24
	3,0L MODELL	: 4
*4	: AUSSER 3,0L MODELL	: 22
	3,0L MODELL	: 5
*5	: AUSSER 3,0L MODELL	: B225
	3,0L MODELL	: B89

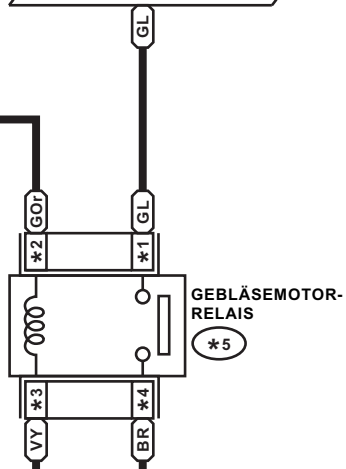

GEBLÄSEMOTOR

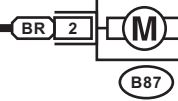

LEISTUNGSTRANSISTOR

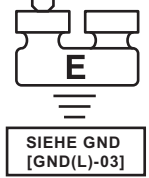
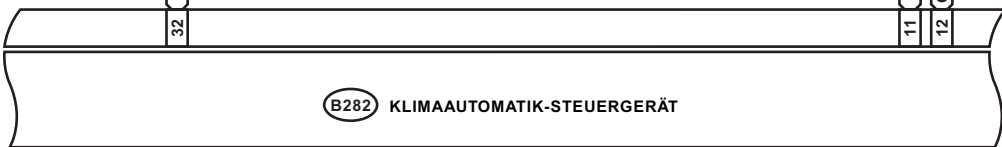
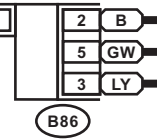

B87



B86



B89

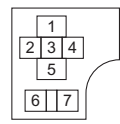

B225 (SCHWARZ)

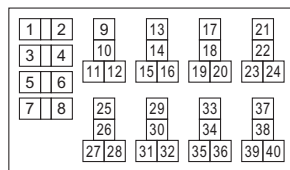

RELAISBLOCK

B282

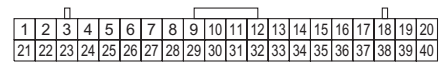

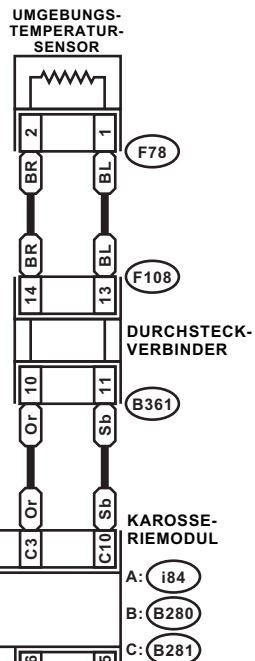
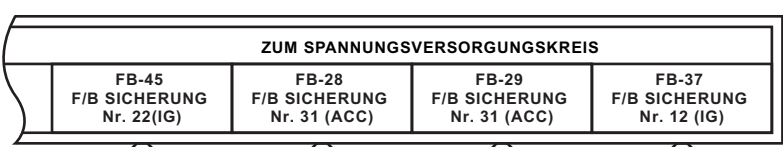

WP : MIT STARTKNOPF
***1** : KLEMMEN-Nr. OPTIONALE ANORDNUNG BEI 1, 2, 3, 4, 5 UND 6

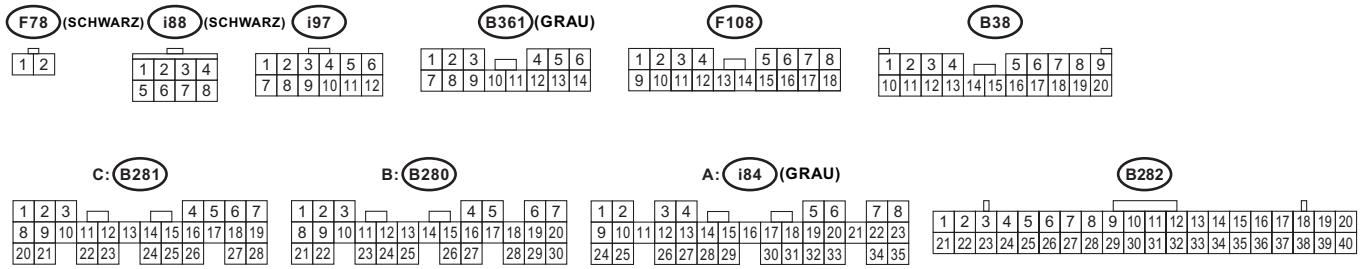
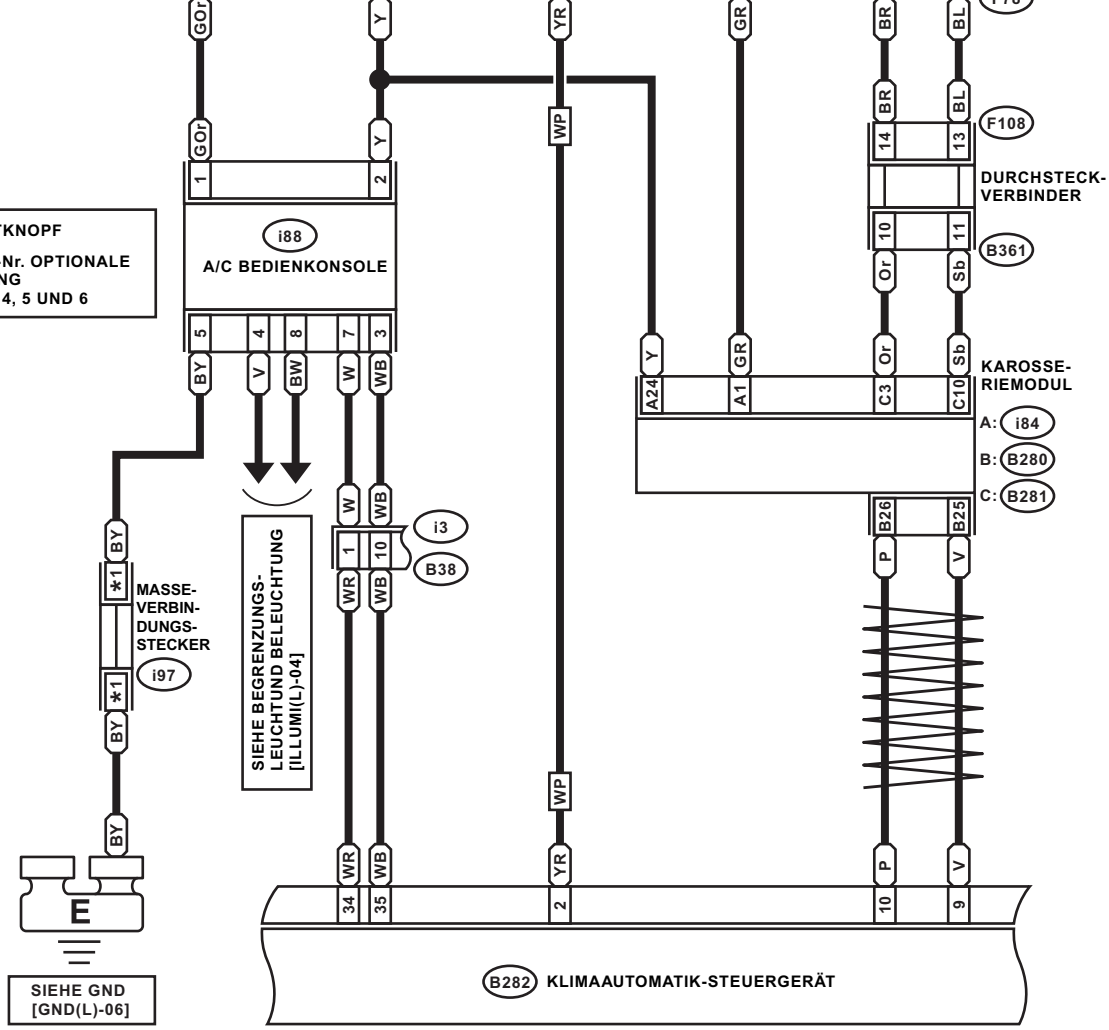

B282 KLIMAAUTOMATIK-STEUERGERÄT

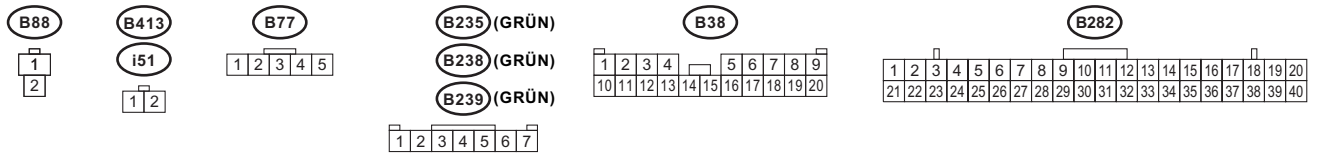
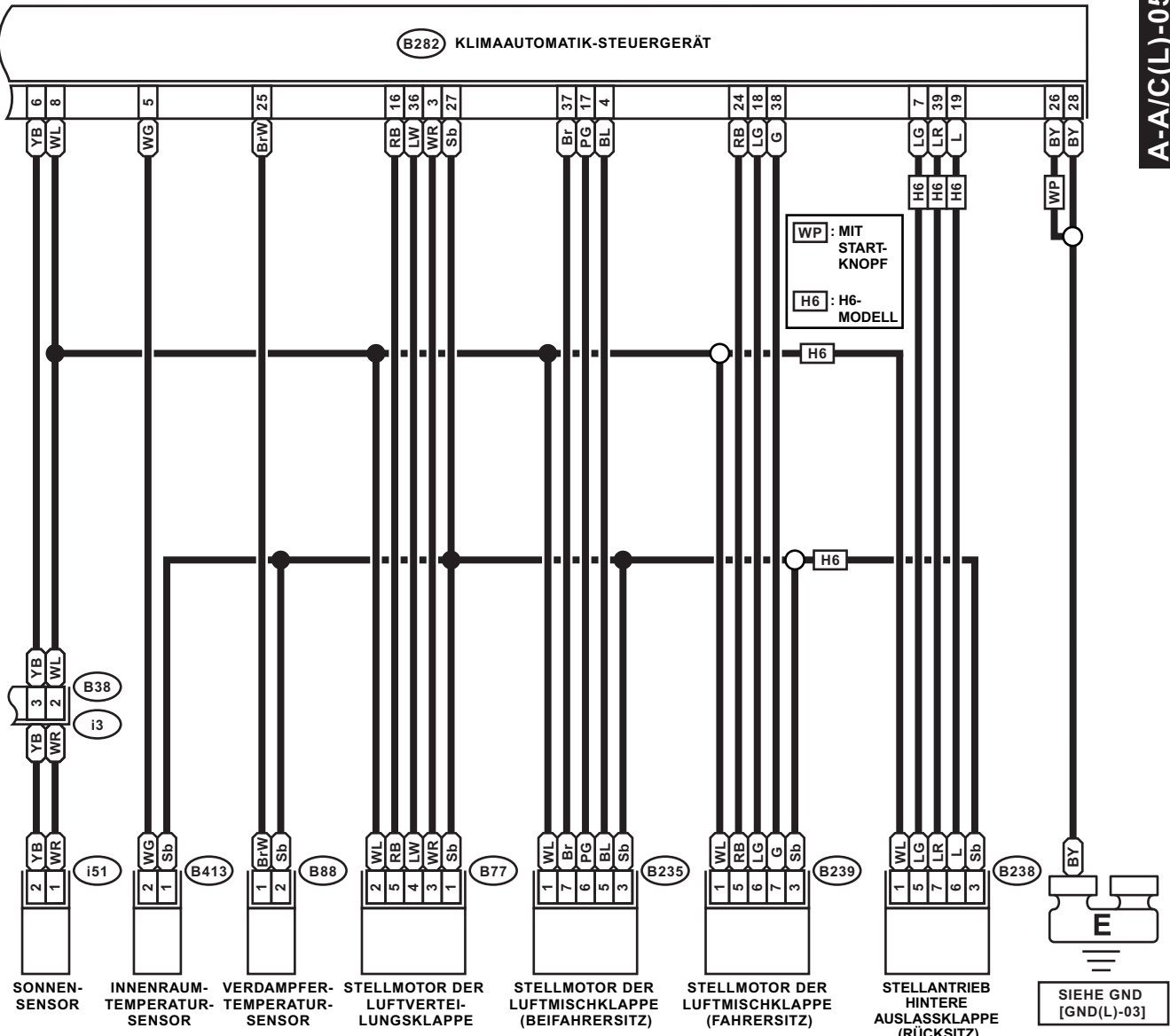

ZUM
SPANNUNGSVERSORUNGSKREIS
FB-46
F/B SICHERUNG
Nr. 22 (IG)

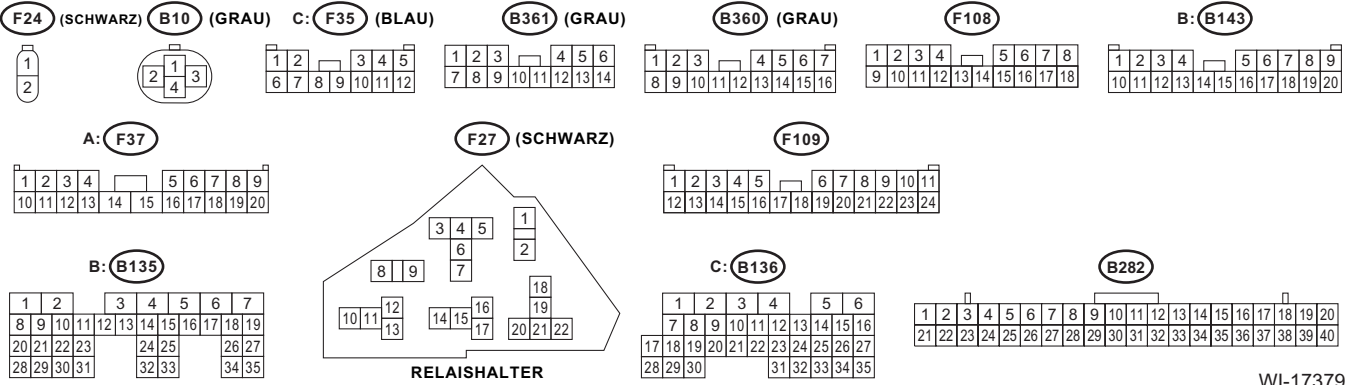
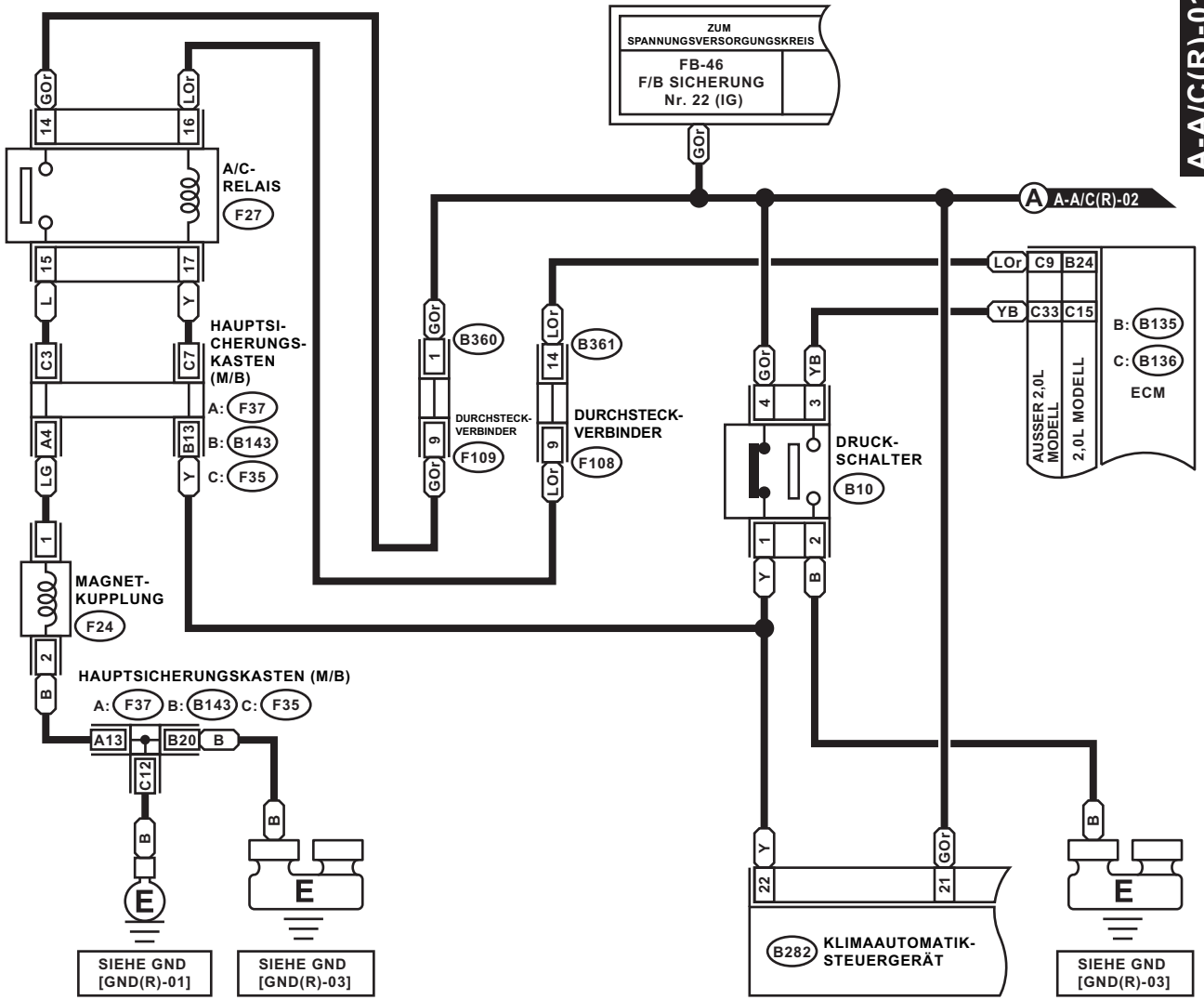

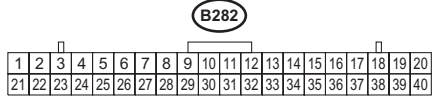
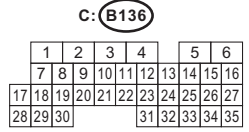
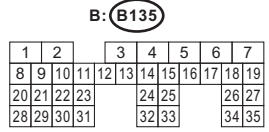
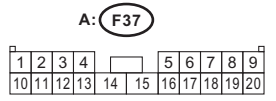
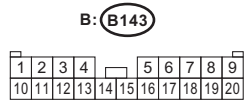
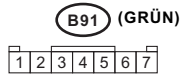
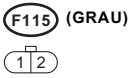
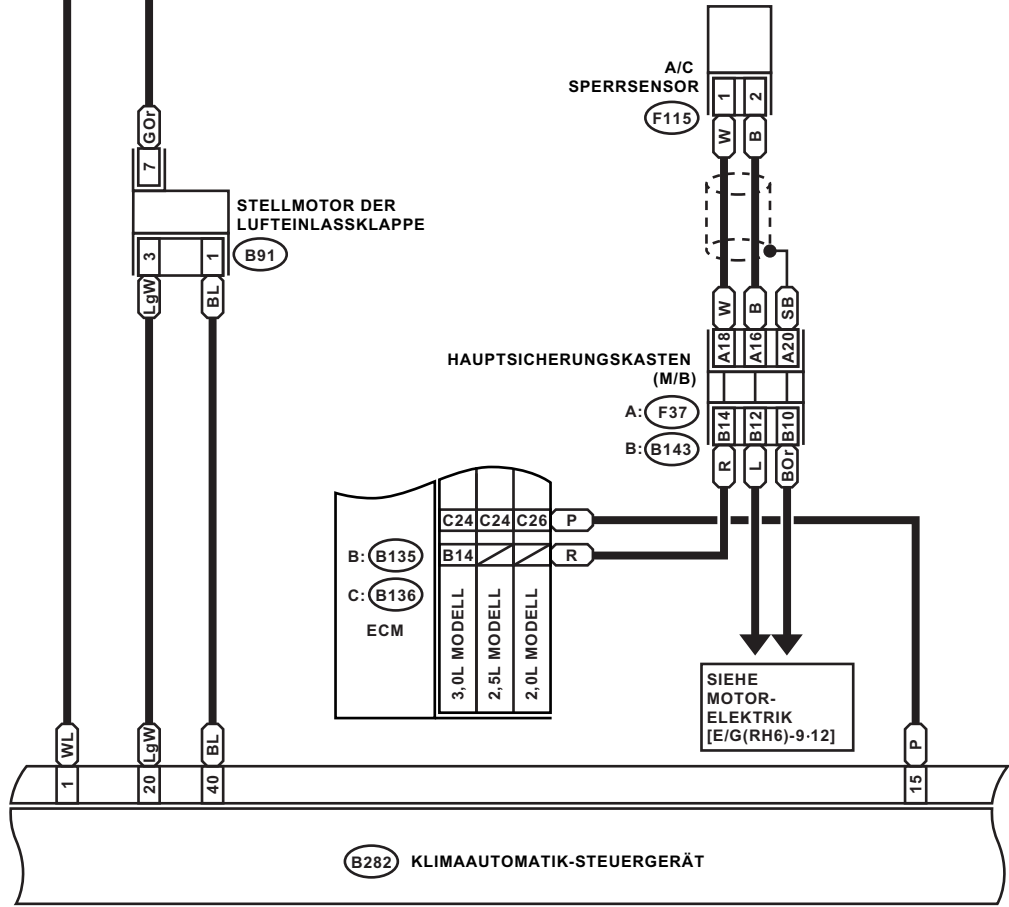
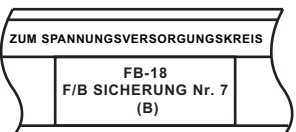

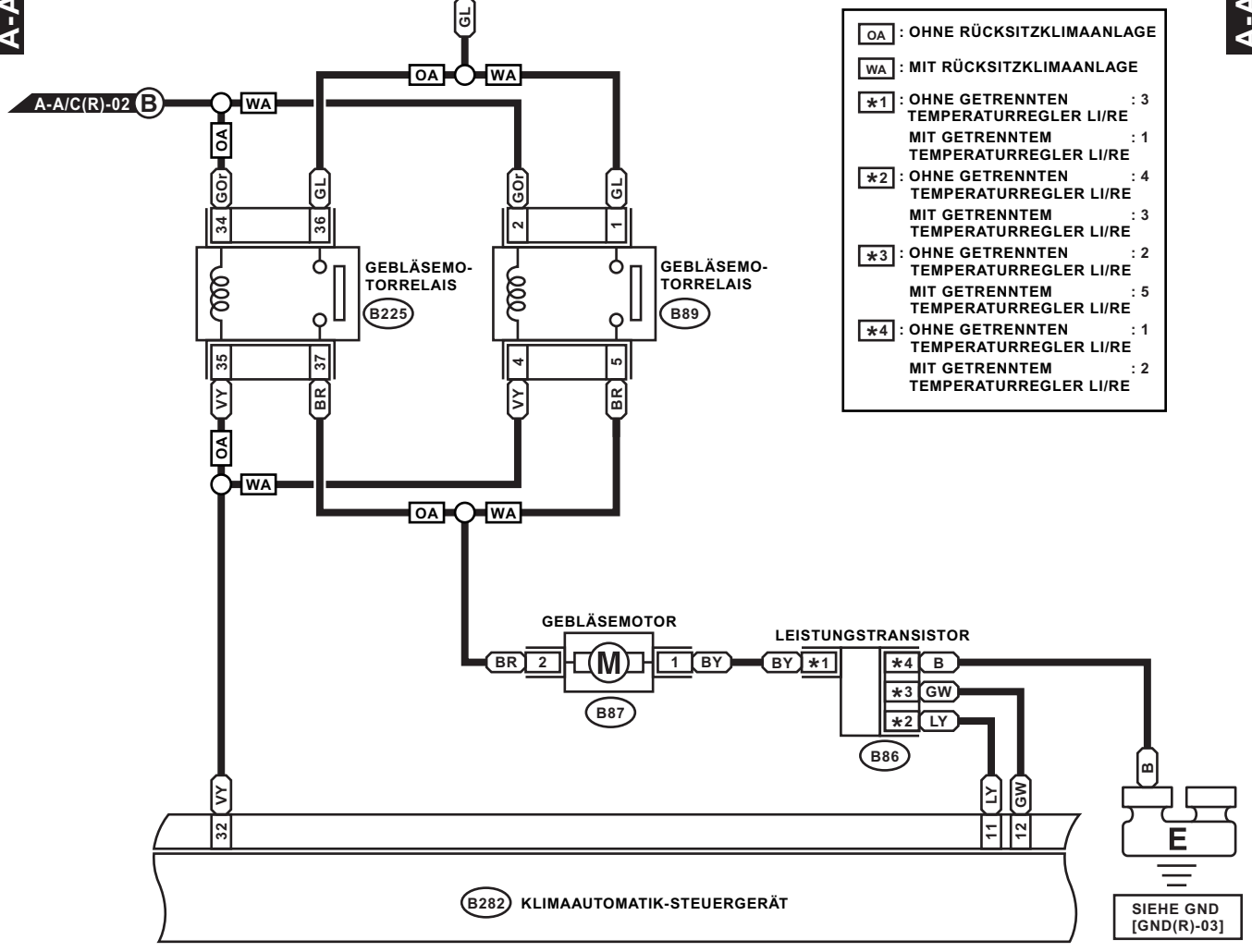

- OA** : OHNE RÜCKSITZKLIMAANLAGE
- WA** : MIT RÜCKSITZKLIMAANLAGE
- *1** : OHNE GETRENNTEN TEMPERATURREGLER LI/RE : 3
MIT GETRENNTEM TEMPERATURREGLER LI/RE : 1
- *2** : OHNE GETRENNTEN TEMPERATURREGLER LI/RE : 4
MIT GETRENNTEM TEMPERATURREGLER LI/RE : 3
- *3** : OHNE GETRENNTEN TEMPERATURREGLER LI/RE : 2
MIT GETRENNTEM TEMPERATURREGLER LI/RE : 5
- *4** : OHNE GETRENNTEN TEMPERATURREGLER LI/RE : 1
MIT GETRENNTEM TEMPERATURREGLER LI/RE : 2

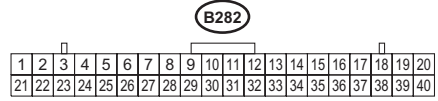
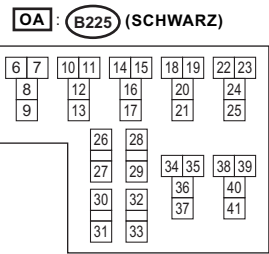
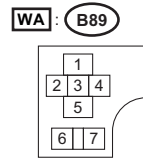
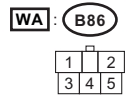
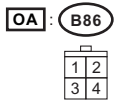

RELAISBLOCK

SIEHE GND [GND(R)-03]

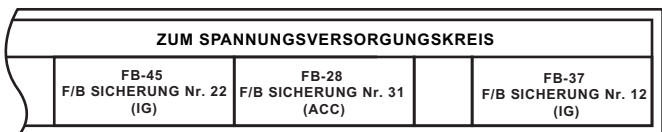

*1: KLEMMEN-Nr. OPTIONALE ANORDNUNG BEI 1, 2, 3, 4, 5 UND 6

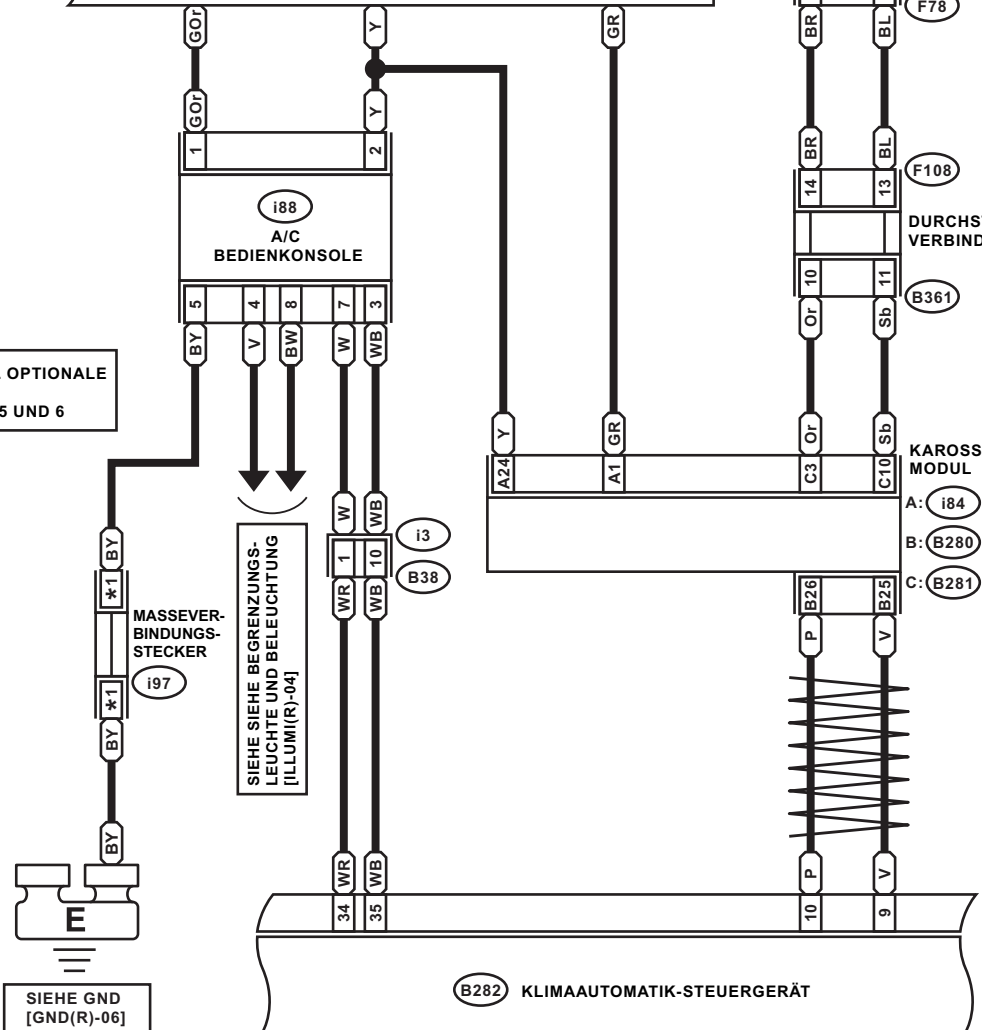

SIEHE GND [GND(R)-06]

SIEHE SIEHE BEGRENZUNGS-LEUCHTE UND BELEUCHTUNG [ILLUM(R)-04]

MASSEVER-BINDUNGS-STECKER

DURCHSTECK-VERBINDER

KAROSSERIE-MODUL

- A: i84
- B: B280
- C: B281

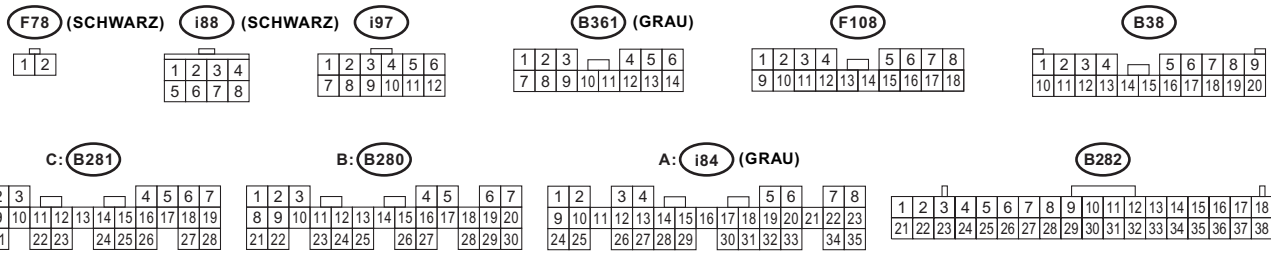

B282 KLIMAAUTOMATIK-STEUERGERÄT

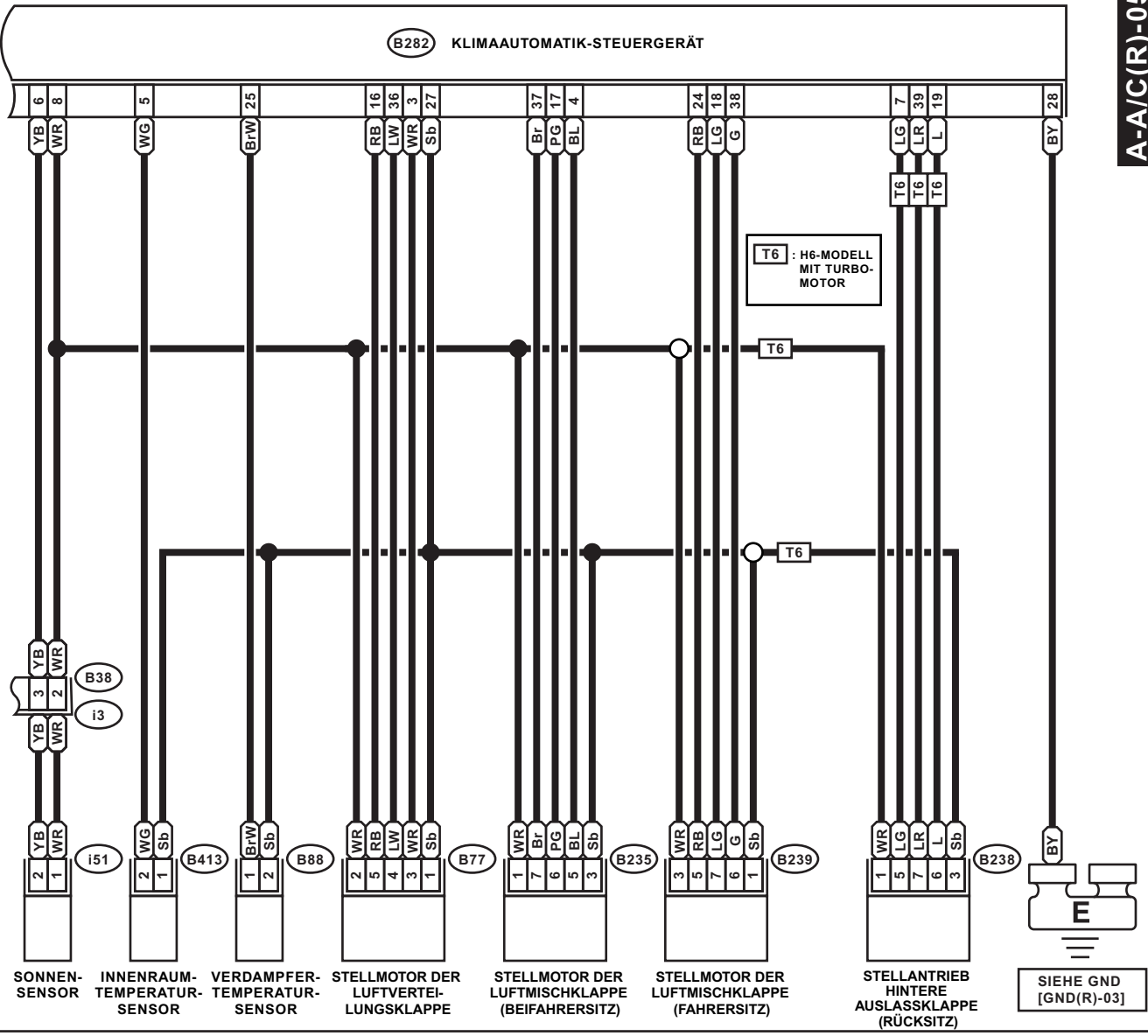

T6 : H6-MODELL
MIT TURBO-
MOTOR

SIEHE GND
[GND(R)-03]

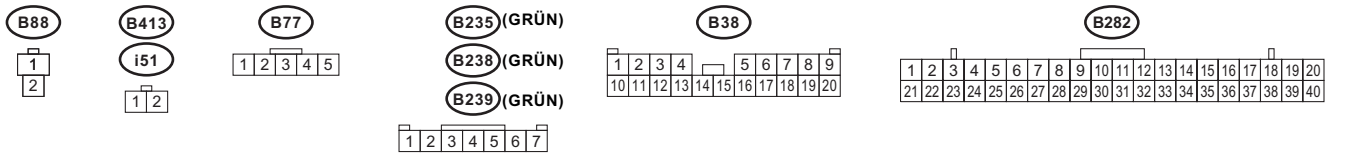

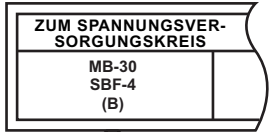

ELEKTRISCHE SITZVERSTELLUNG LH
(OHNE MEMORY-FUNKTION SITZPOSITION)

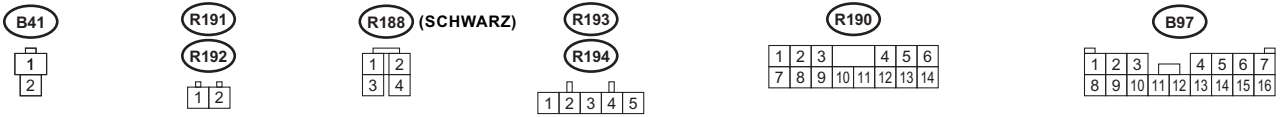
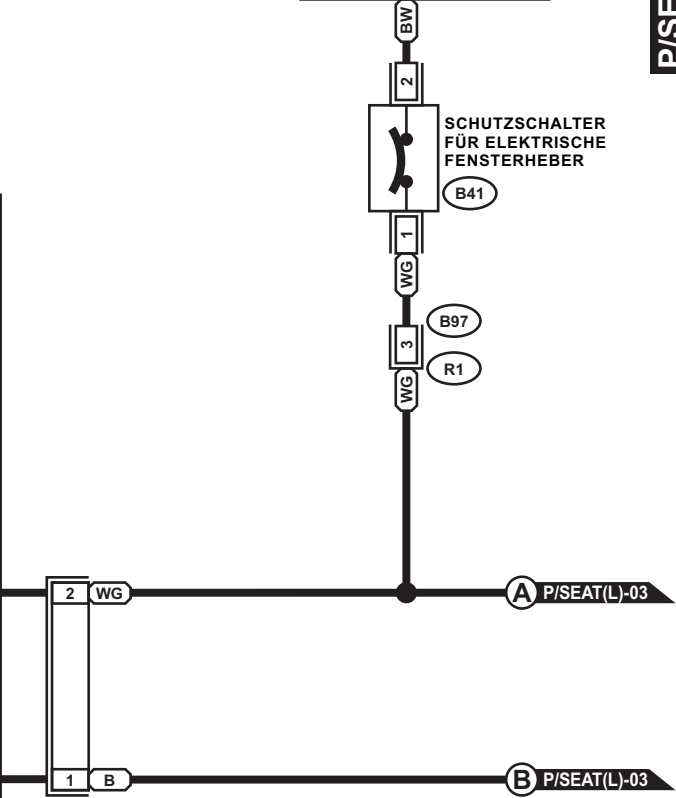
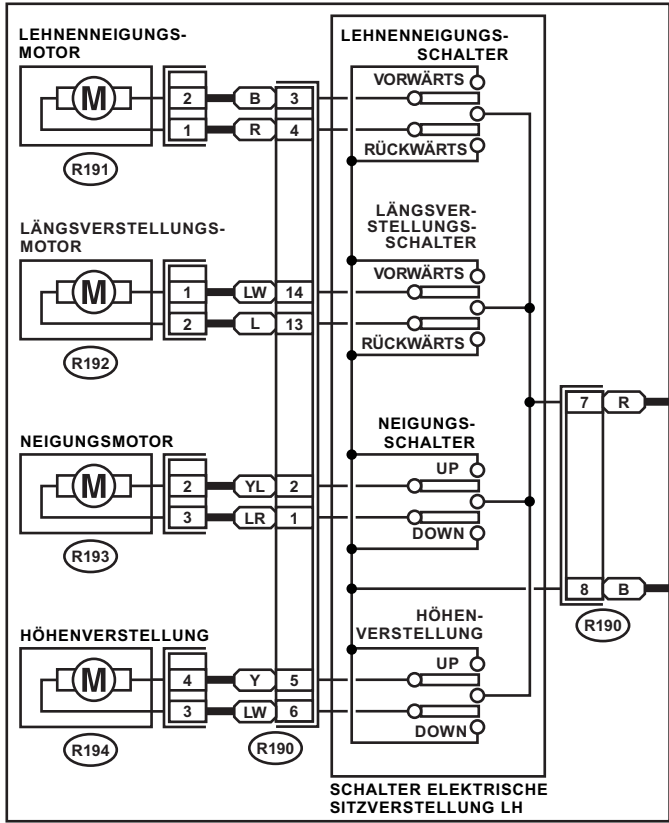

*1 : MT-MODELL : Gr
AT-MODELL : LY

ZUM SPANNUNGSVERSORGUNGSKREIS	
FB-31 F/B SICHERUNG Nr. 4 (IG)	MB-30 SBF-4 (B)

ELEKTRISCHE SITZVERSTELLUNG LH
(MIT MEMORY-FUNKTION SITZPOSITION)

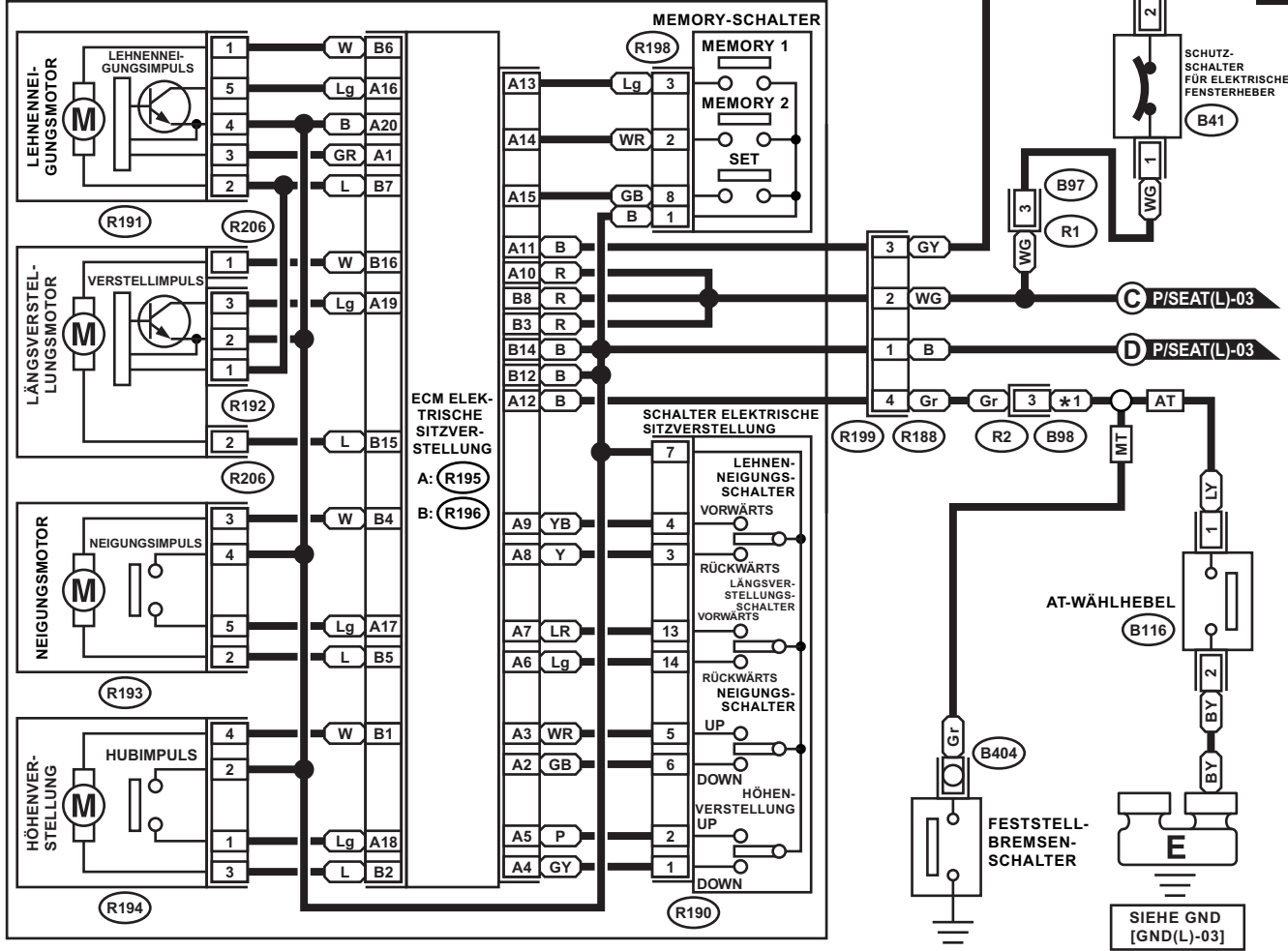

B41 1 2	R188 (SCHWARZ) 1 2 3 4	R192 1 2 3 4 5	R194 1 2 3 4 5	R191 1 2 3 4 5 6	R198 1 2 3 4 5 6 7 8	B116 (GRAU) 1 2 3 4 5 6 7 8 9 10	R190 R206 1 2 3 4 5 6 7 8 9 10 11 12 13 14
B97 B98	B: R196 1 2 3 4 5 6 7 8 9 10 11 12 13 14 15 16	A: R195 1 2 3 4 5 6 7 8 9 10 11 12 13 14 15 16 17 18 19 20					

ELEKTRISCHE SITZVERSTELLUNG RH
(OHNE MEMORY-FUNKTION SITZPOSITION)

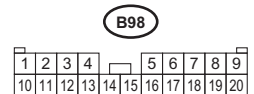
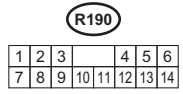
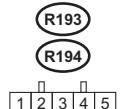
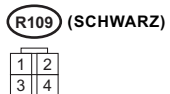
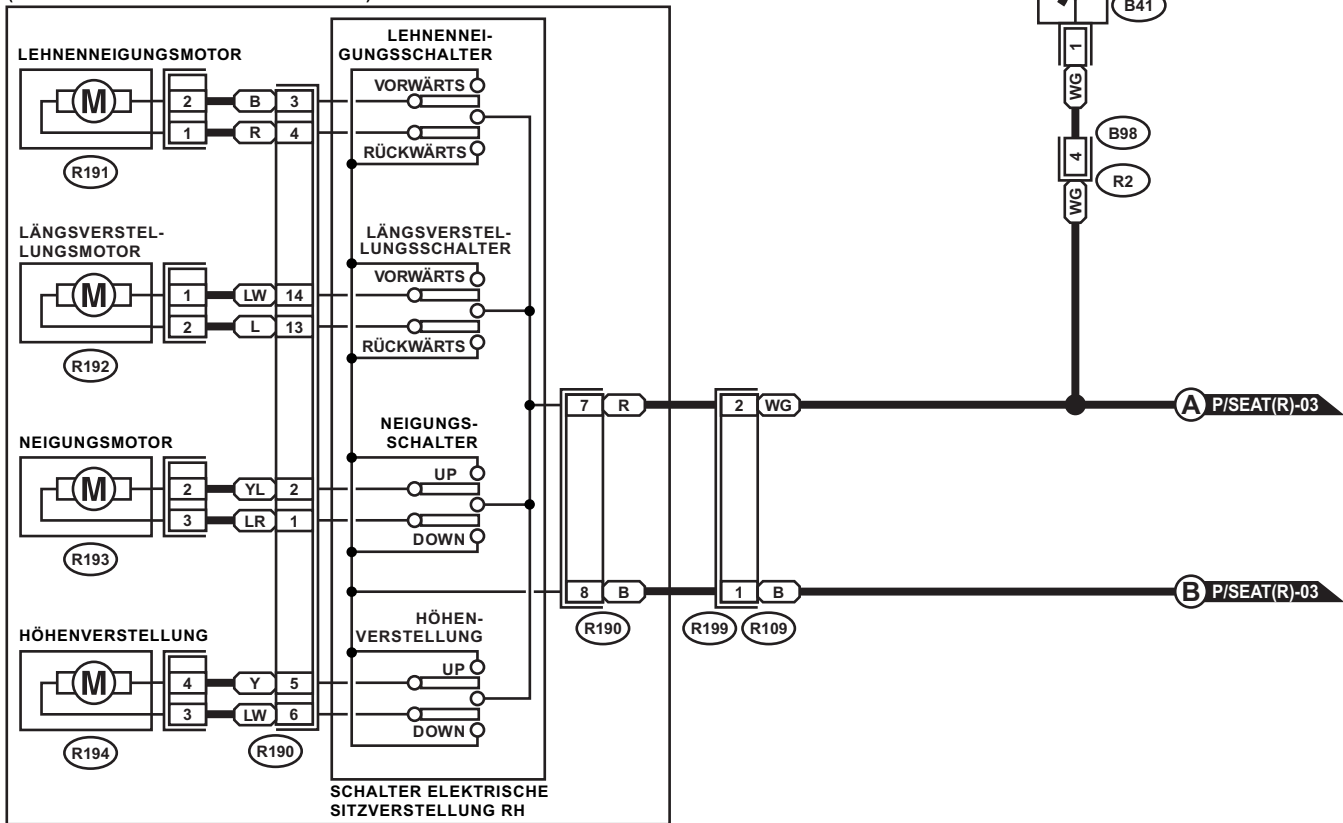

★1 : MT-MODELL : Gr
AT-MODELL : LY



ELEKTRISCHE SITZVERSTELLUNG RH
(MIT MEMORY-FUNKTION SITZPOSITION)

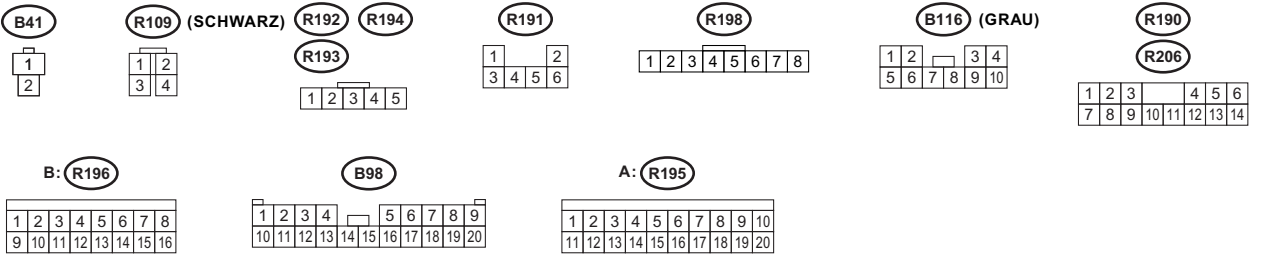
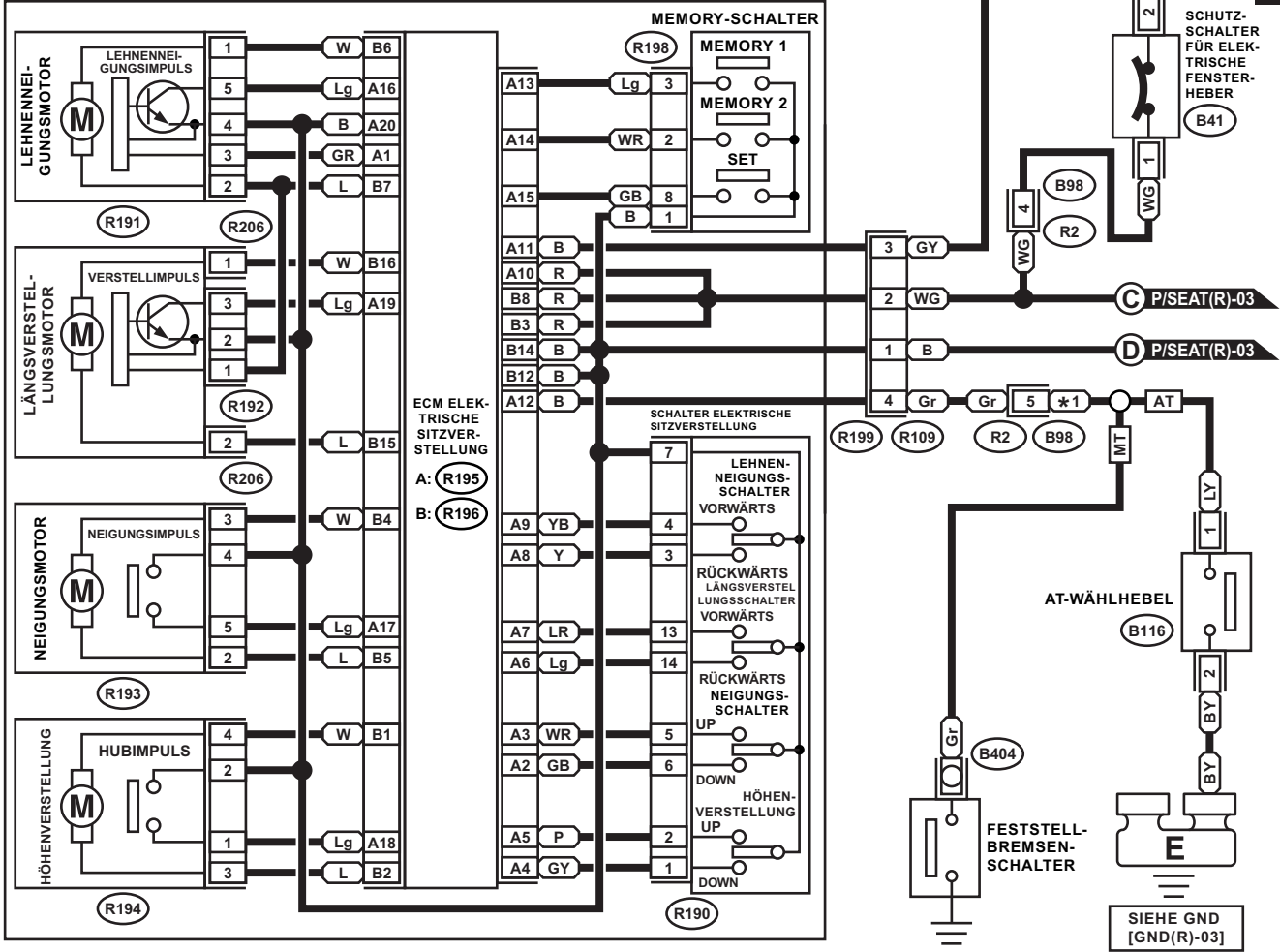

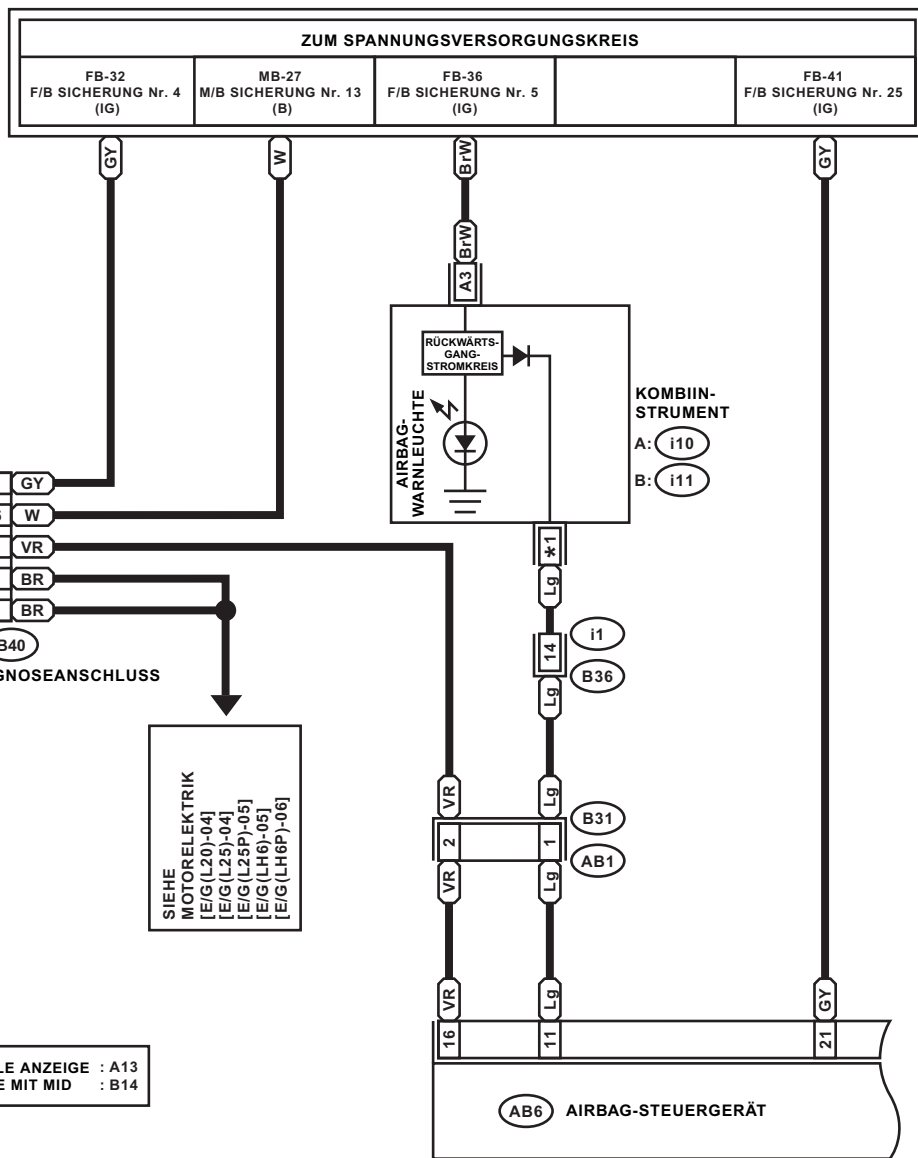

AB1

B: i11 (GRÜN)

B40 (SCHWARZ)

A: i10 (GRÜN)

i1

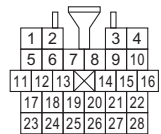
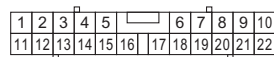
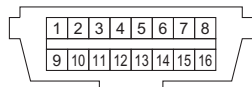
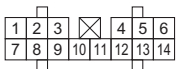

AB6 (GELB)



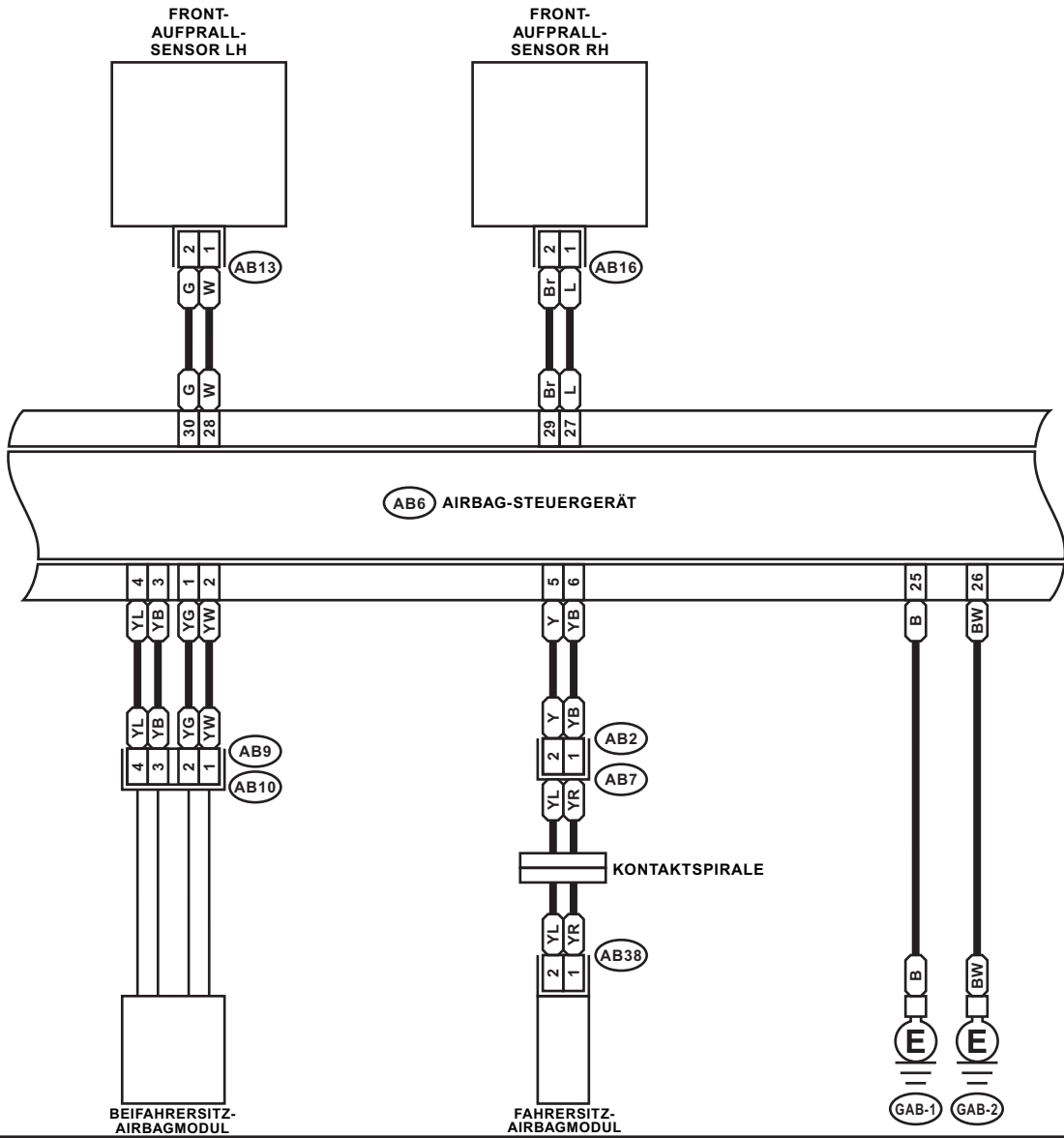

AB13 (GELB)

AB16 (GELB)

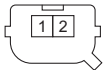

AB38 (SCHWARZ)



AB2 (GELB)

AB9 (GELB)



AB6 (GELB)

1	2	3	4	5	6	7	8	9	10
11	12	13	14	15	16	17	18	19	20
21	22	23	24	25	26	27	28	29	30

AB17 AIRBAG-STEUERGERÄT

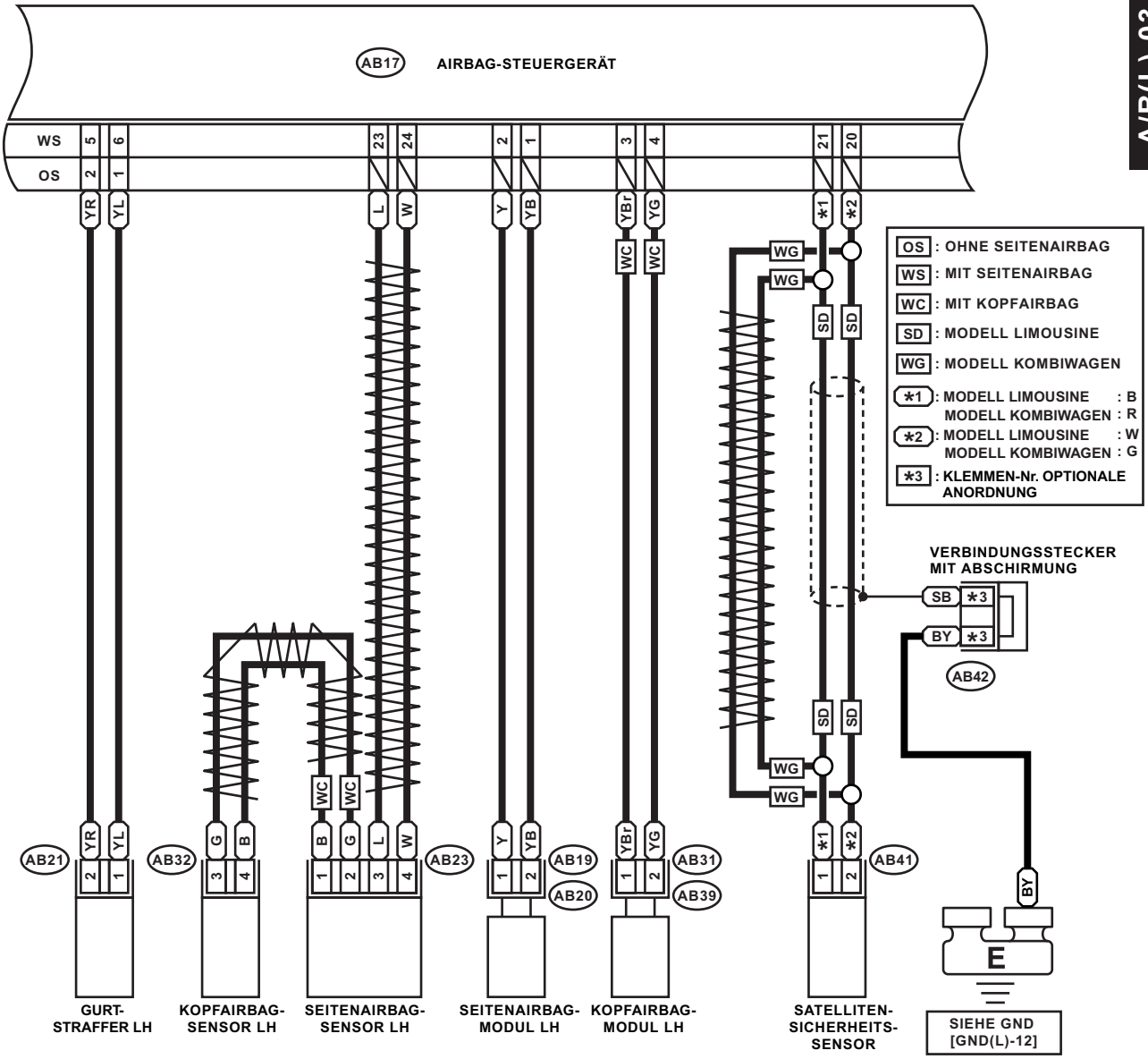

- OS : OHNE SEITENAIRBAG
- WS : MIT SEITENAIRBAG
- WC : MIT KOPFAIRBAG
- SD : MODELL LIMOUSINE
- WG : MODELL KOMBIWAGEN
- *1 : MODELL LIMOUSINE : B
MODELL KOMBIWAGEN : R
- *2 : MODELL LIMOUSINE : W
MODELL KOMBIWAGEN : G
- *3 : KLEMMEN-Nr. OPTIONALE ANORDNUNG

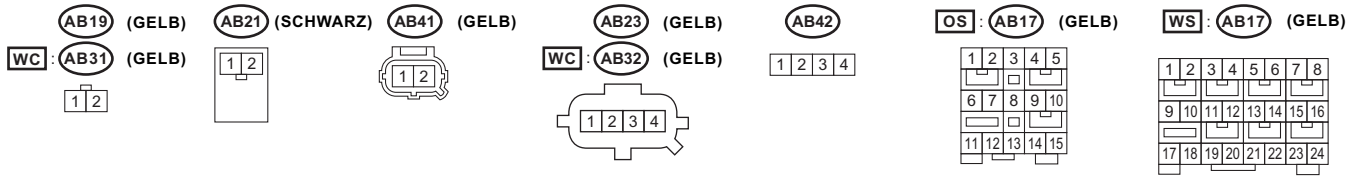

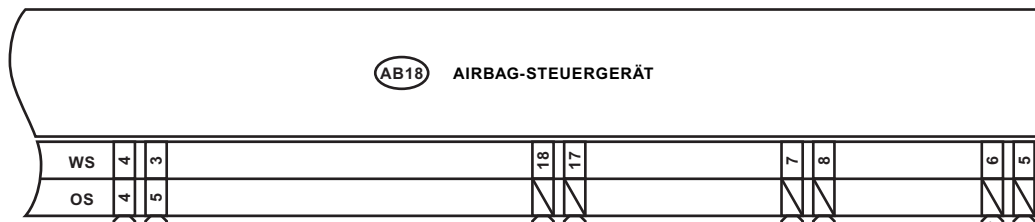

OS : OHNE SEITENAIRBAG
WS : MIT SEITENAIRBAG
WC : MIT KOPFAIRBAG

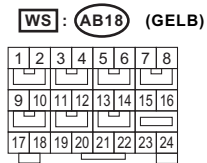
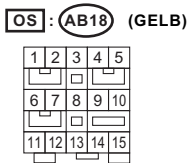
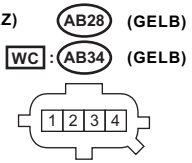
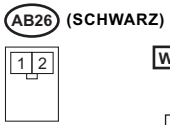
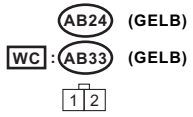
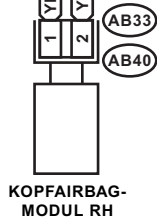
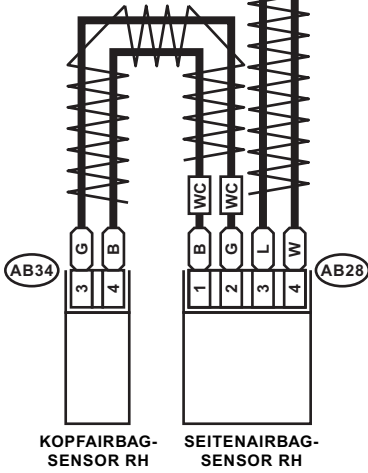
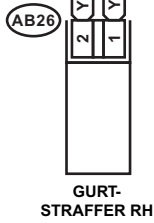

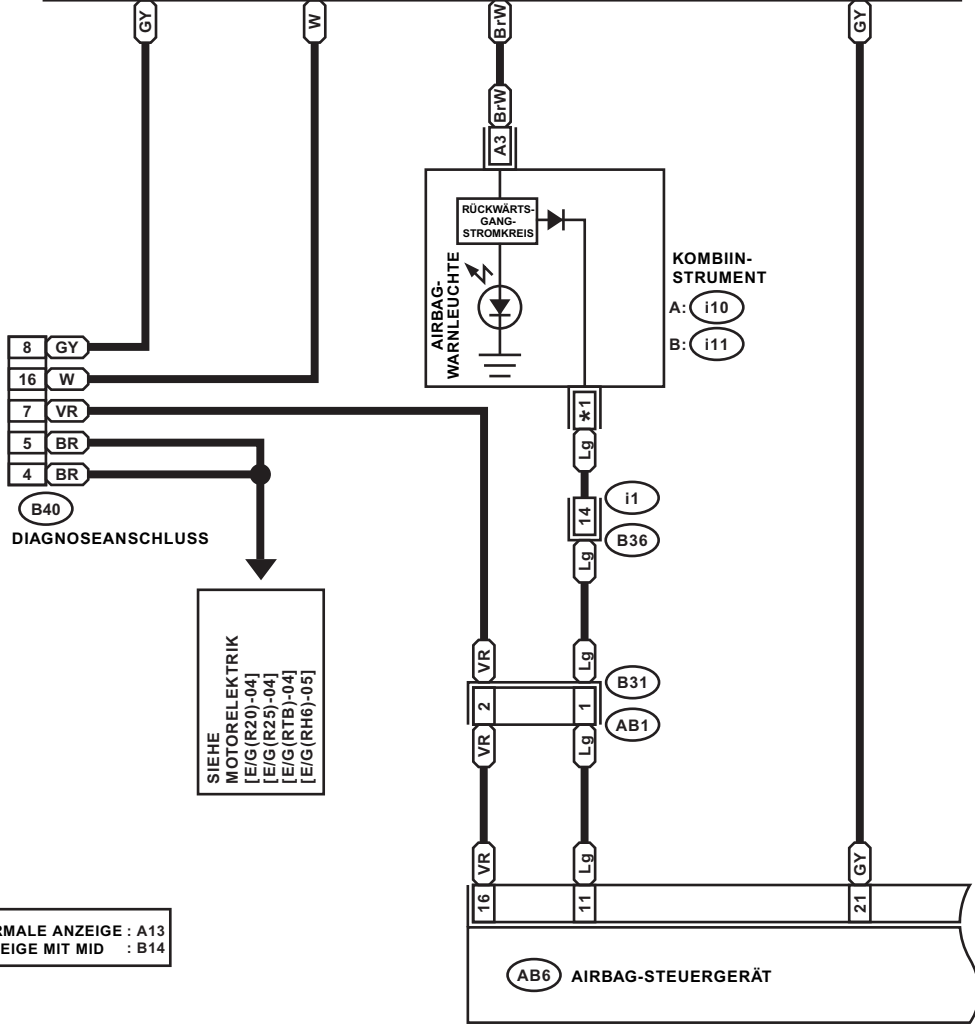

*1 : NORMALE ANZEIGE : A13
ANZEIGE MIT MID : B14

AB1



B: i11 (GRÜN)

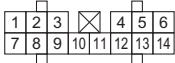

B40 (SCHWARZ)

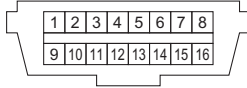

A: i10 (GRÜN)

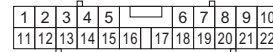

i1

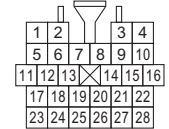

AB6 (GELB)

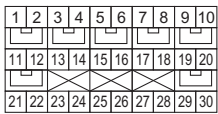

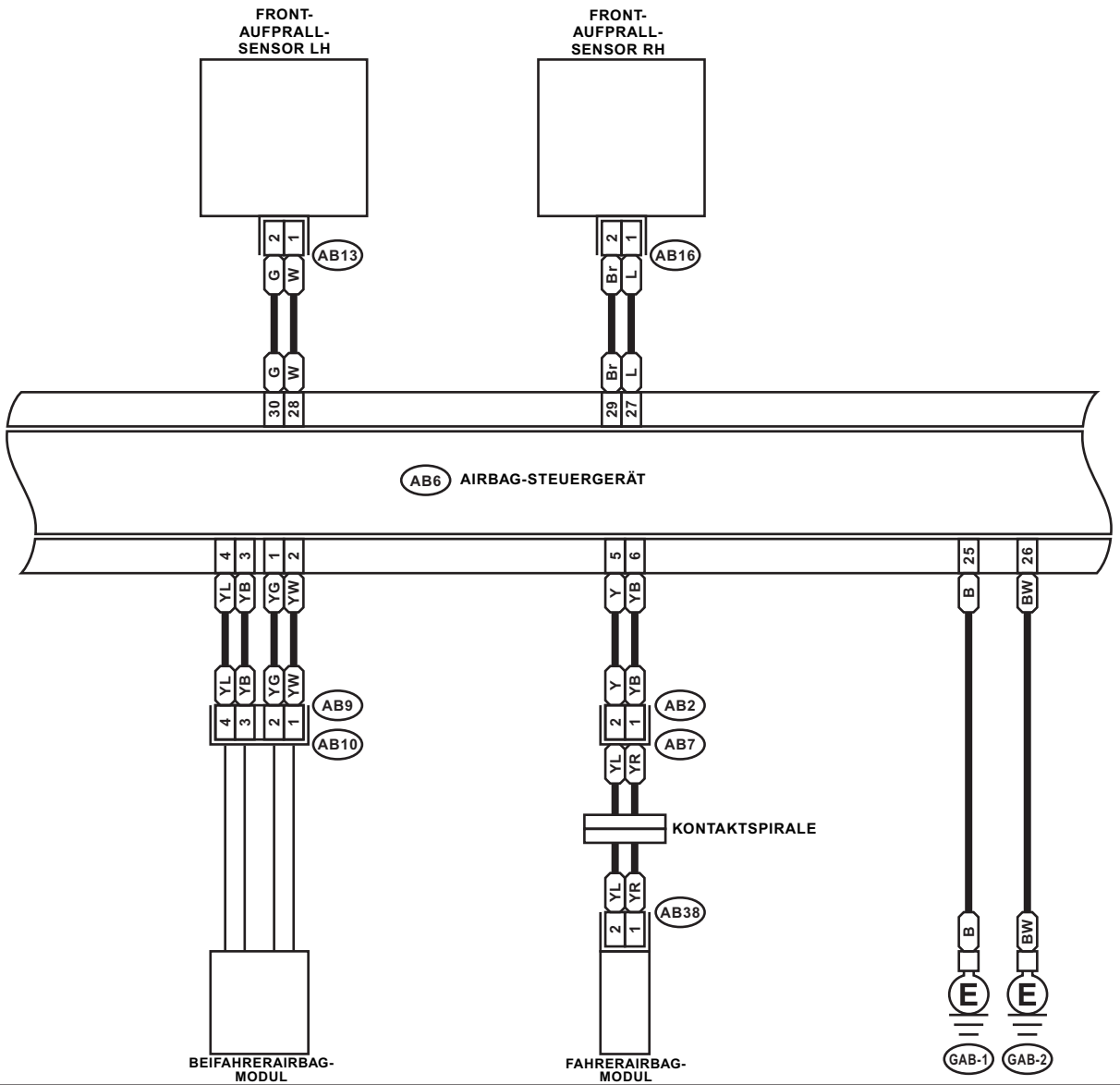

AB13 (GELB)

AB16 (GELB)

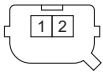

AB38 (SCHWARZ)



AB2 (GELB)

AB9 (GELB)



AB6 (GELB)

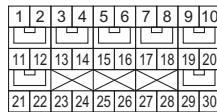

AB17 AIRBAG-STEUERGERÄT

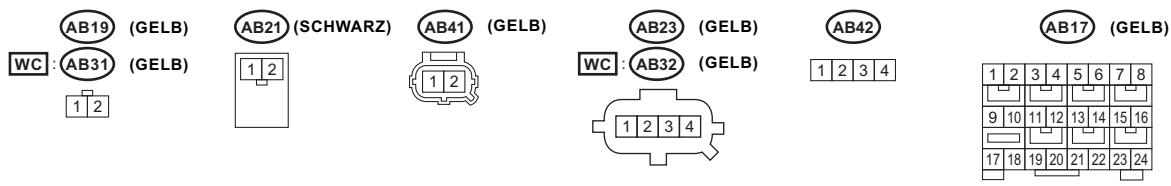
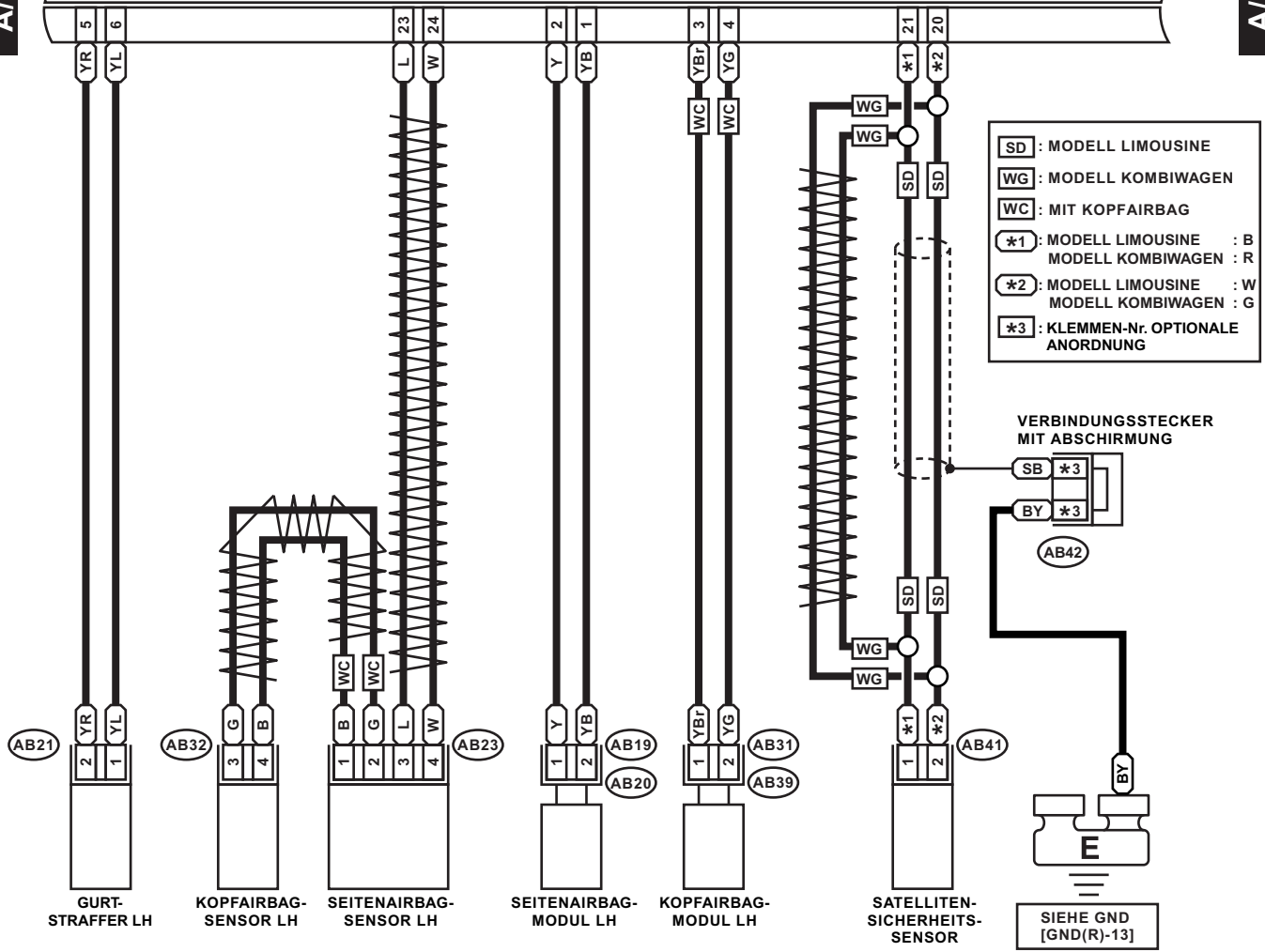

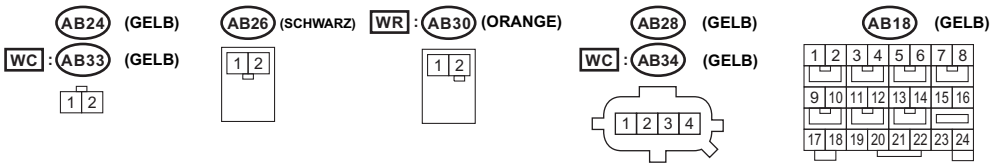
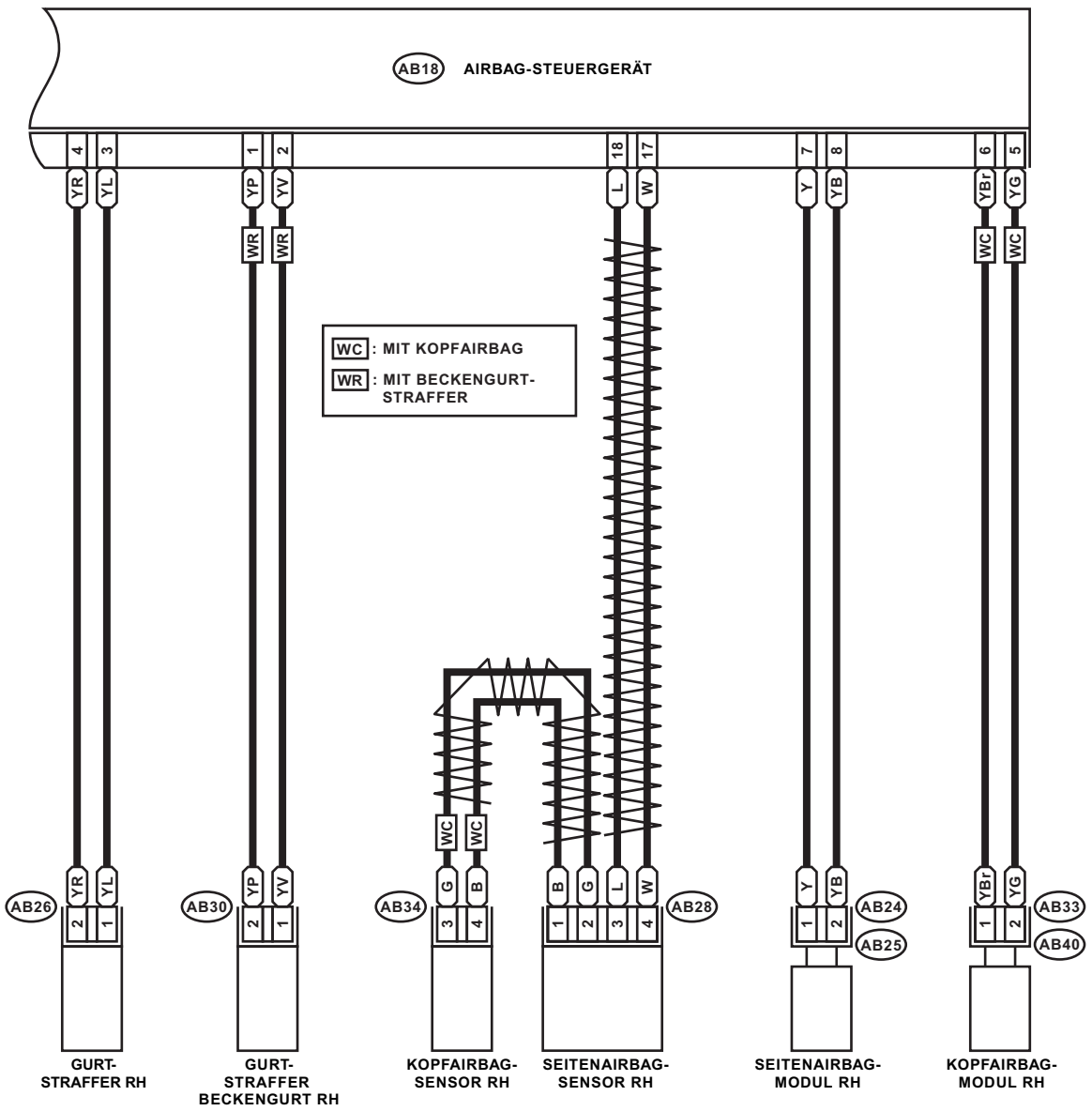

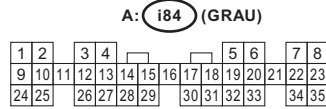
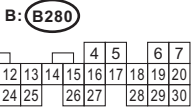
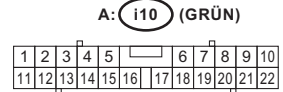
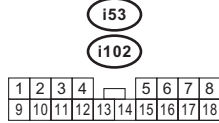
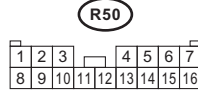
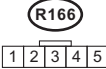
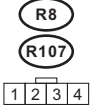
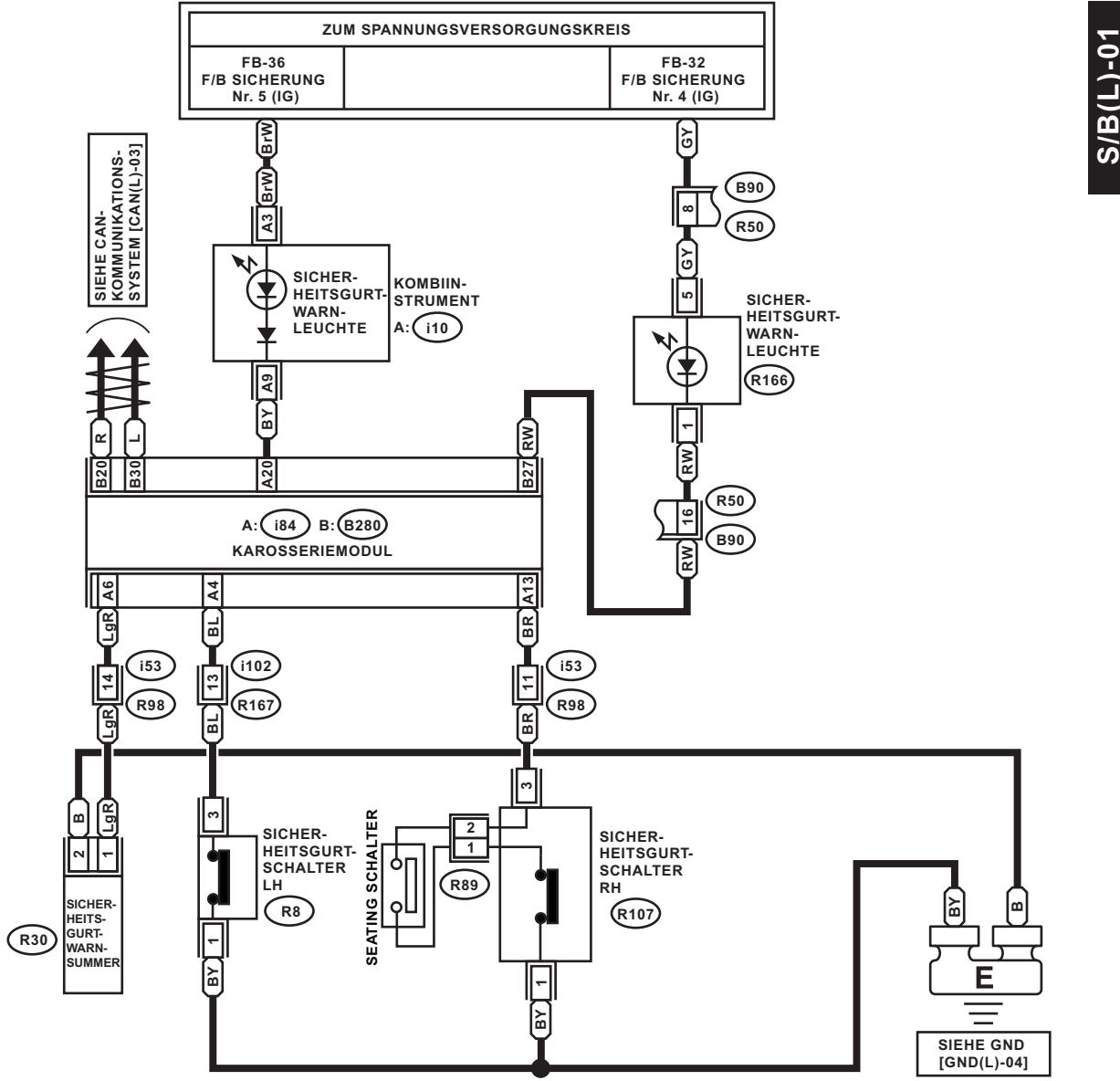

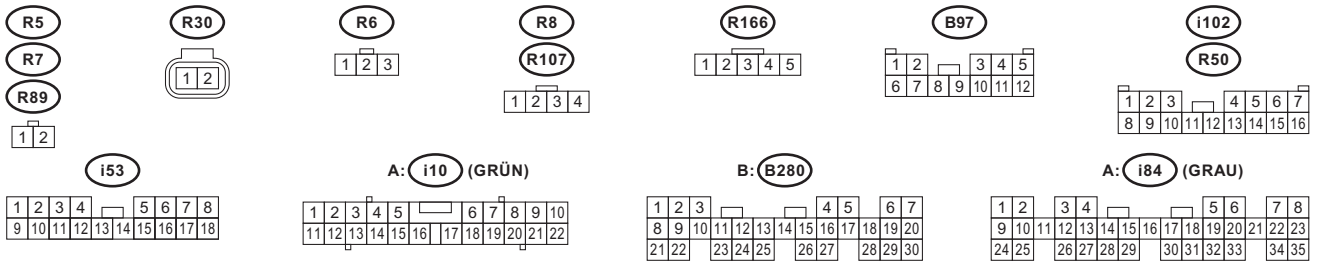
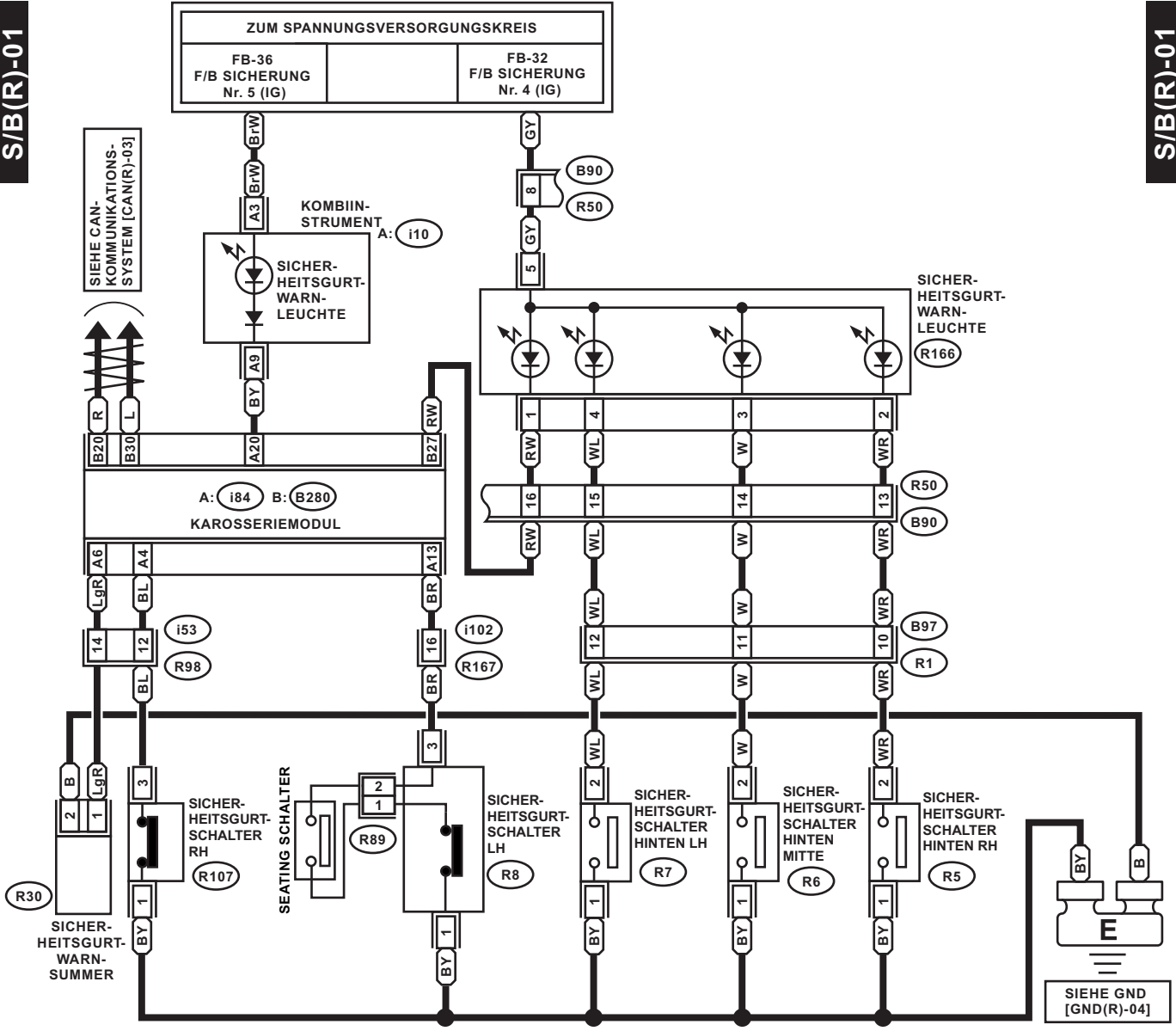



- | | |
|----|-------------------------------------|
| LH | : LHD-MODELL |
| RH | : RHD-MODELL |
| *1 | : LHD-MODELL : 37
RHD-MODELL : 4 |
| *2 | : LHD-MODELL : 39
RHD-MODELL : 1 |
| *3 | : LHD-MODELL : 38
RHD-MODELL : 5 |
| *4 | : LHD-MODELL : 40
RHD-MODELL : 3 |

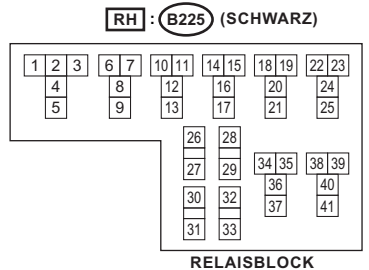
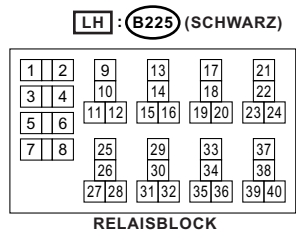
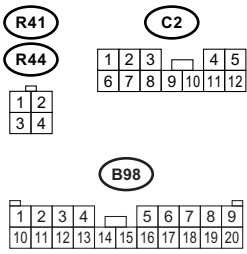
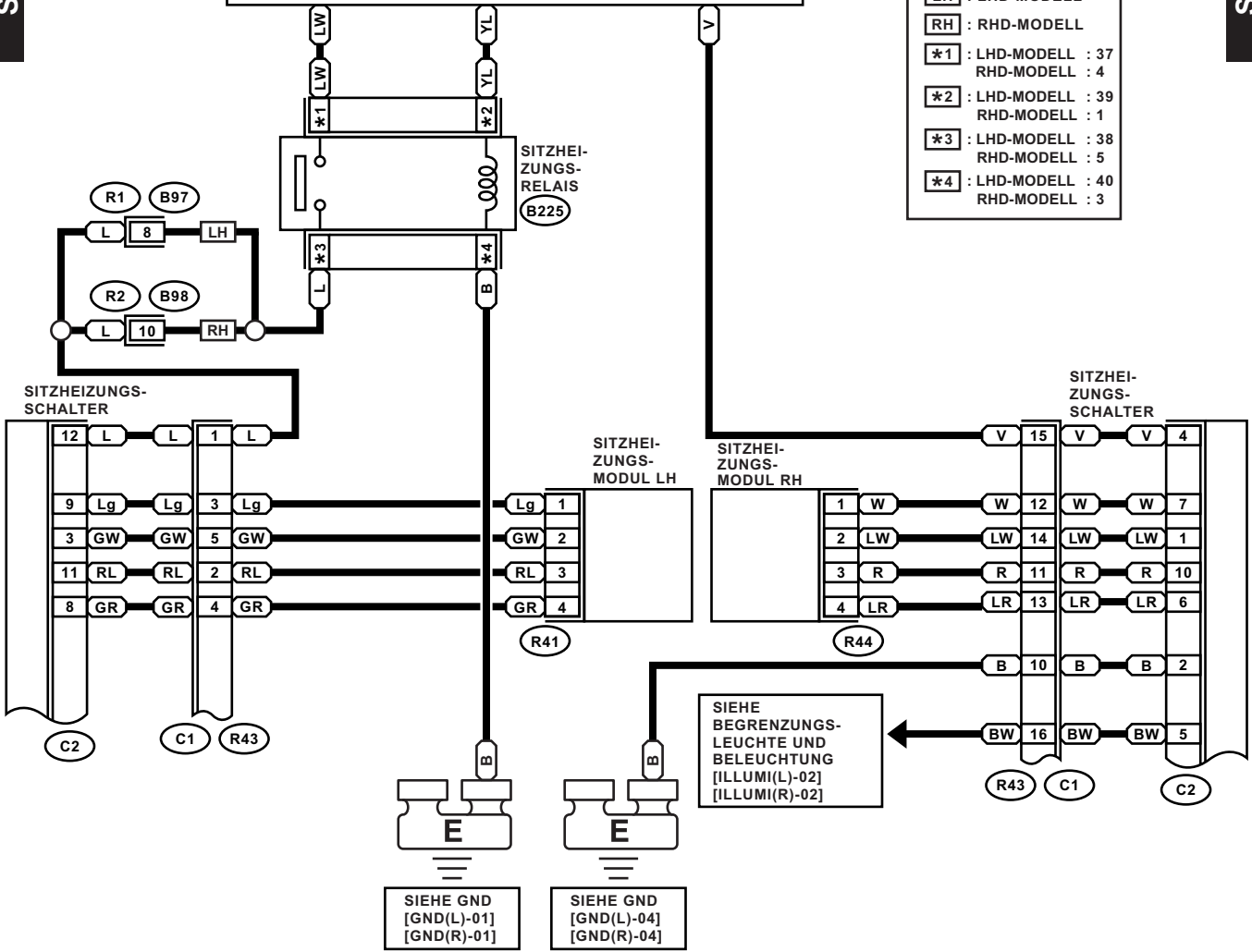

ZUM SPANNUNGSVERSORUNGSKREIS

MB-17 M/B SICHERUNG Nr. 7	MB-16 M/B SICHERUNG Nr. 6	MB-15 M/B SICHERUNG r. 6	MB-18 SCHEINWERFER RELAIS
---------------------------------	---------------------------------	--------------------------------	---------------------------------

OP : OHNE STARTKNOPF
WP : MIT STARTKNOPF

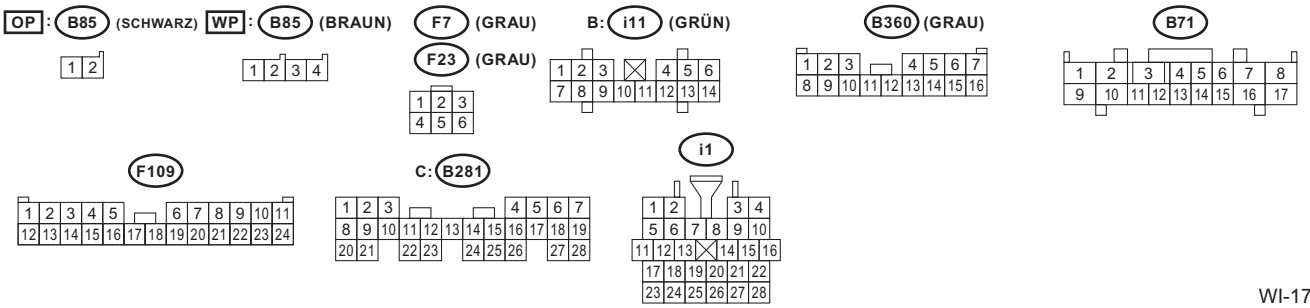
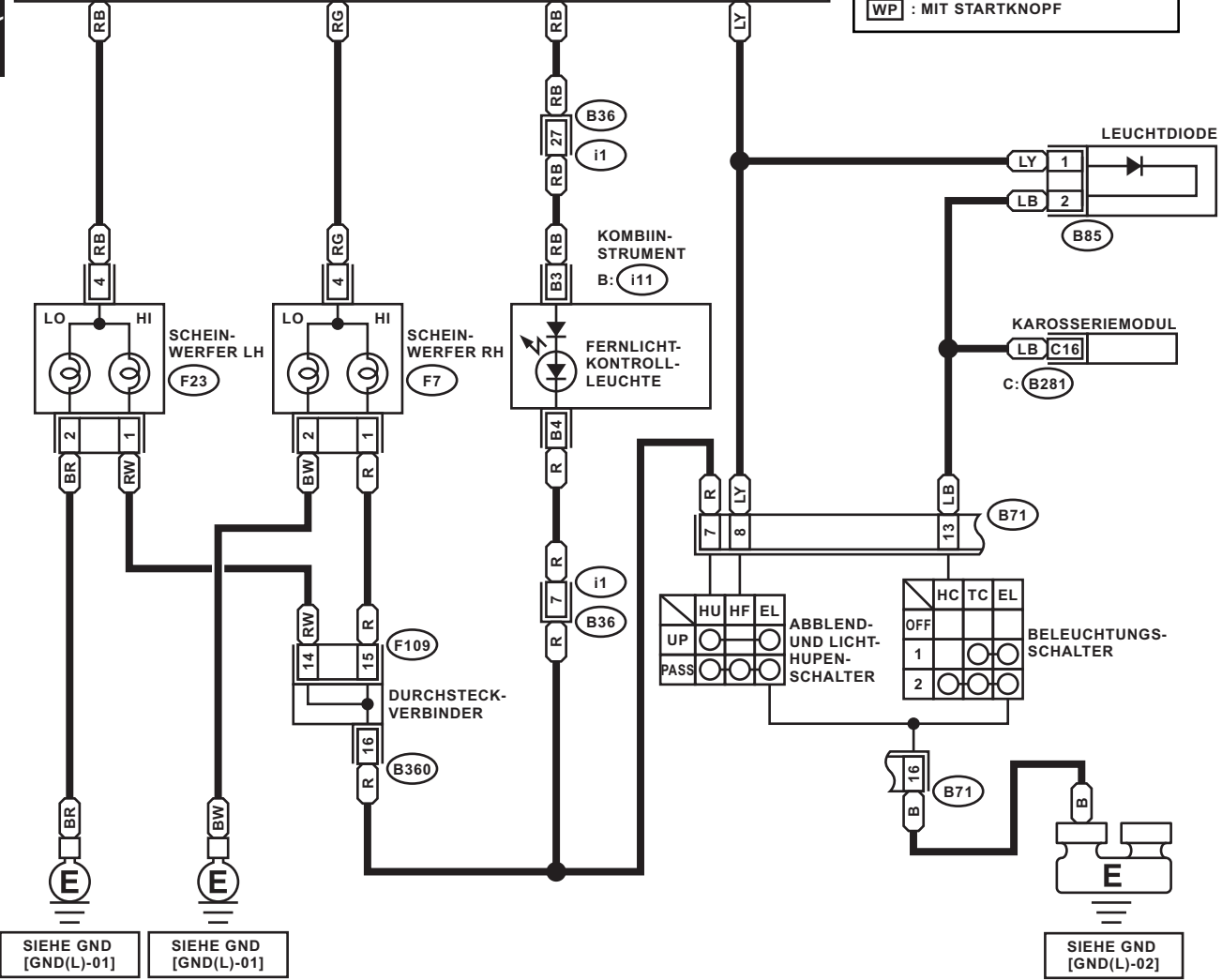

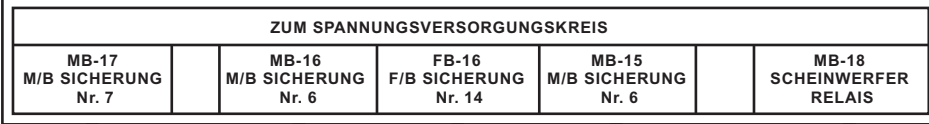

- OP : OHNE STARTKNOPF
- WP : MIT STARTKNOPF
- *1 : KLEMMEN-Nr. OPTIONALE ANORDNUNG BEI 4, 5 UND 6
- *2 : KLEMMEN-Nr. OPTIONALE ANORDNUNG BEI 1, 2 UND 3

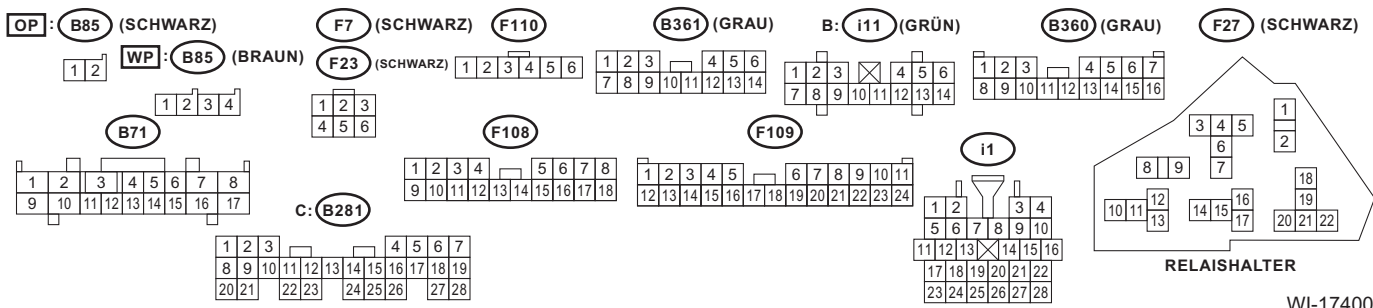
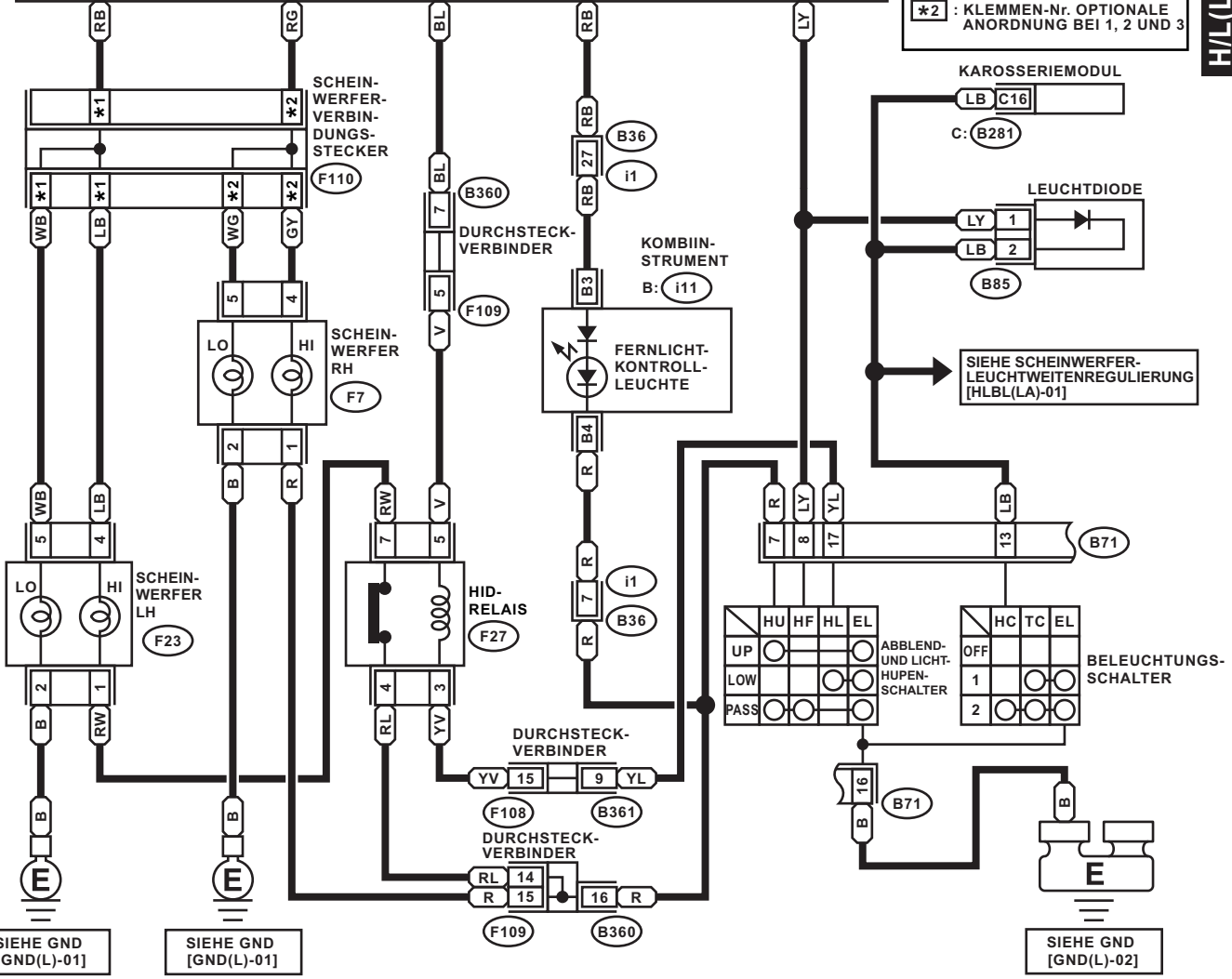

ZUM SPANNUNGSVERSORUNGSKREIS

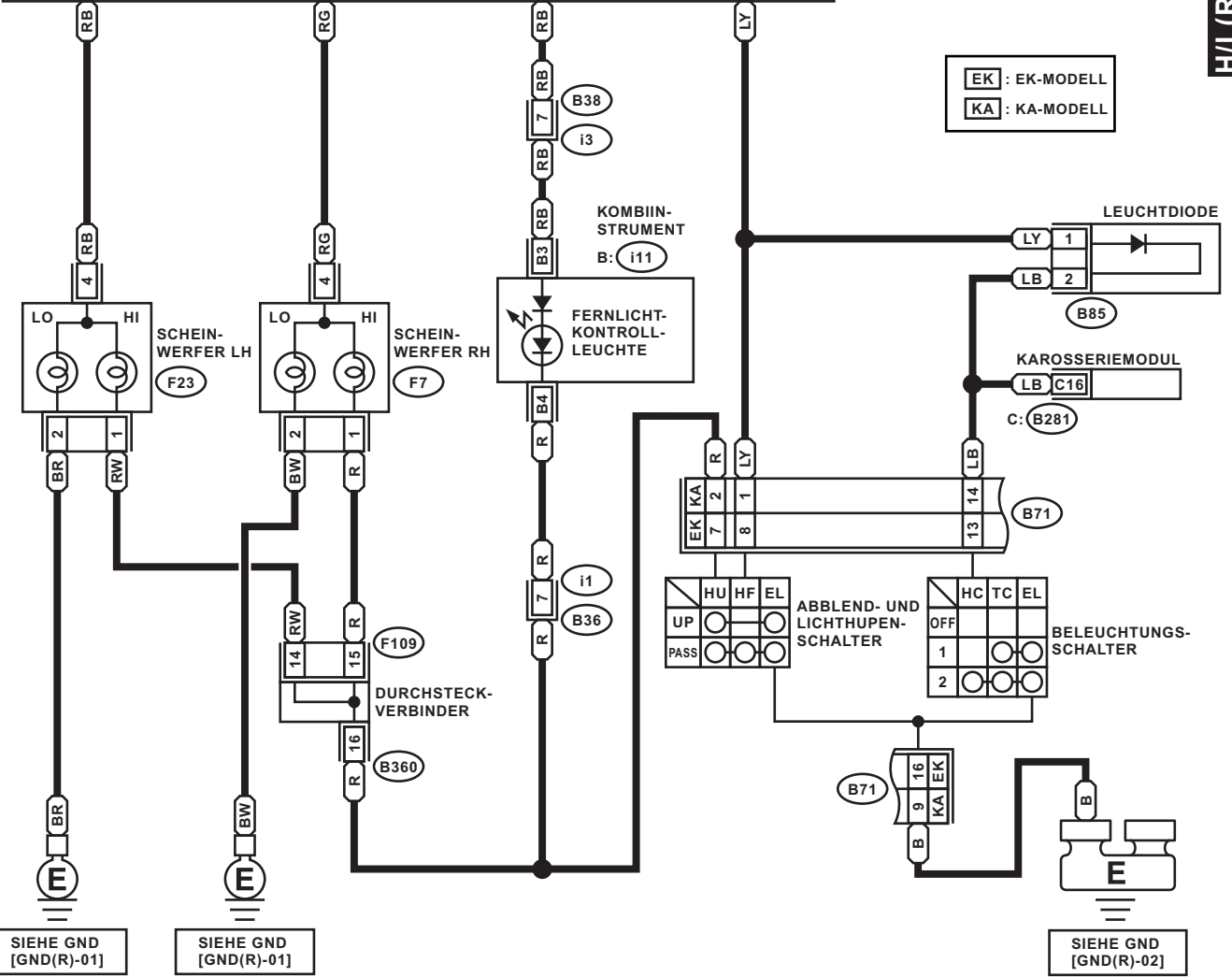

EK : EK-MODELL
 KA : KA-MODELL

SIEHE GND [GND(R)-01]

SIEHE GND [GND(R)-01]

SIEHE GND [GND(R)-02]

B85 (SCHWARZ)

F7 (GRAU)

B: i11

B360 (GRAU)

KA : B71

EK : B71

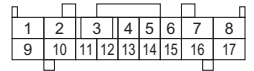
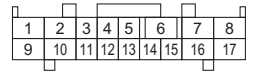
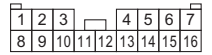
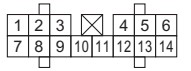

B38

F109

c: B281

i1

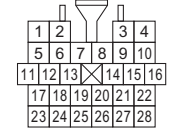
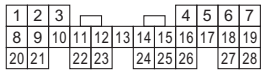
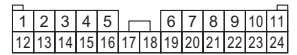
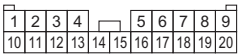

ZUM SPANNUNGSVERSORGUNGSKREIS

MB-17 M/B SICHERUNG Nr. 7	MB-16 M/B SICHERUNG Nr. 6	FB-16 F/B SICHERUNG Nr. 14	MB-15 M/B SICHERUNG Nr. 6	MB-18 SCHEINWERFER RELAIS
---------------------------------	---------------------------------	----------------------------------	---------------------------------	---------------------------------

- EK** : EK-MODELL
- KA** : KA-MODELL
- *1** : KLEMMEN-NR. OPTIONALE ANORDNUNG BEI 4, 5 UND 6
- *2** : KLEMMEN-NR. OPTIONALE ANORDNUNG BEI 1, 2 UND 3

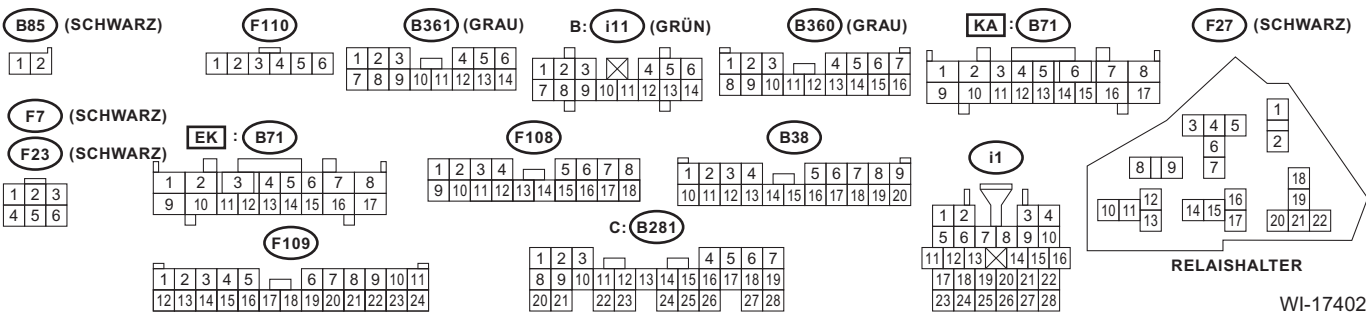
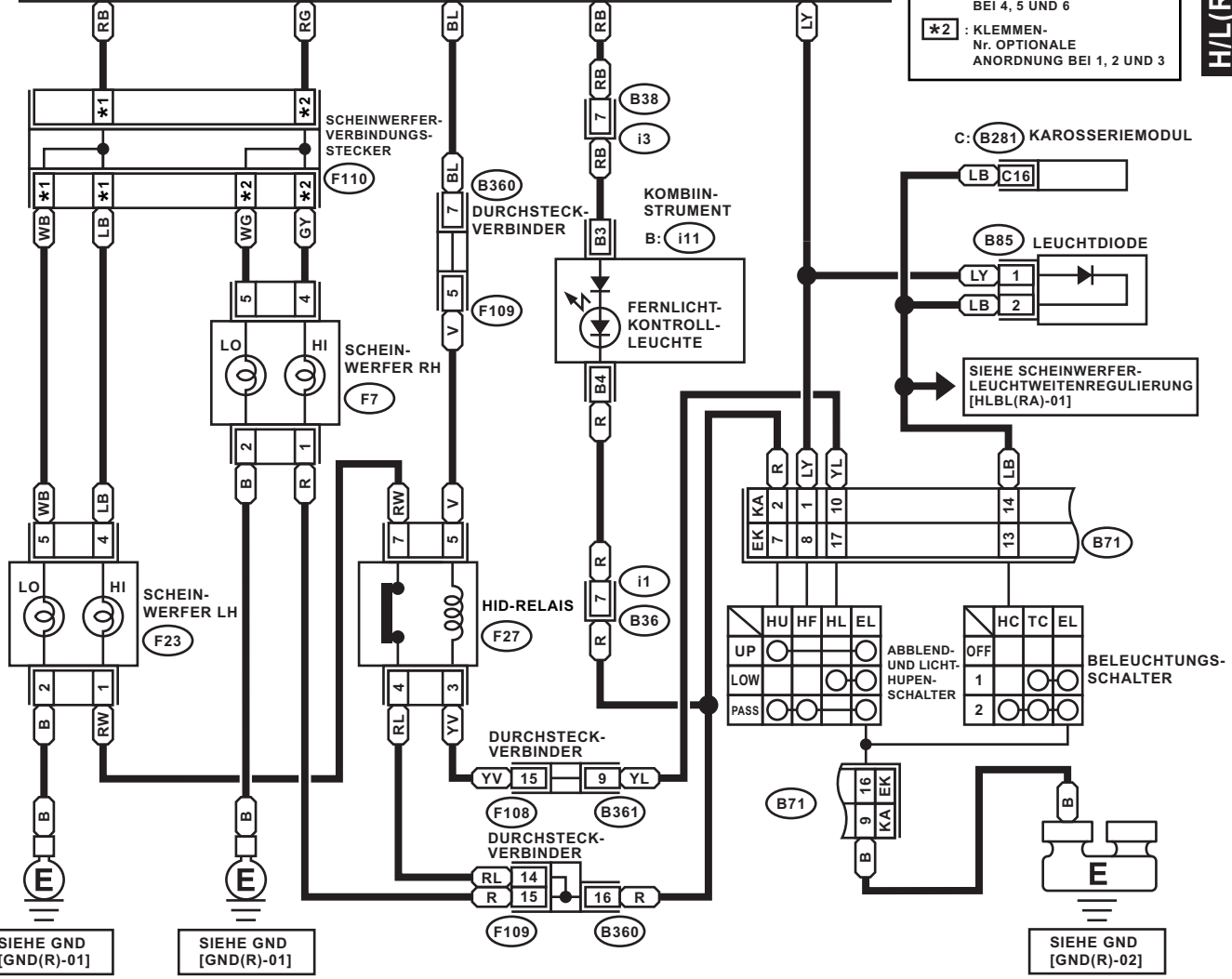



*1 : KLEMMEN-Nr. OPTIONALE ANORDNUNG
BEI 1, 2, 3, 4, 5 UND 6

*2 : KLEMMEN-Nr. OPTIONALE ANORDNUNG
BEI 7, 8, 9, 10, 11 UND 12

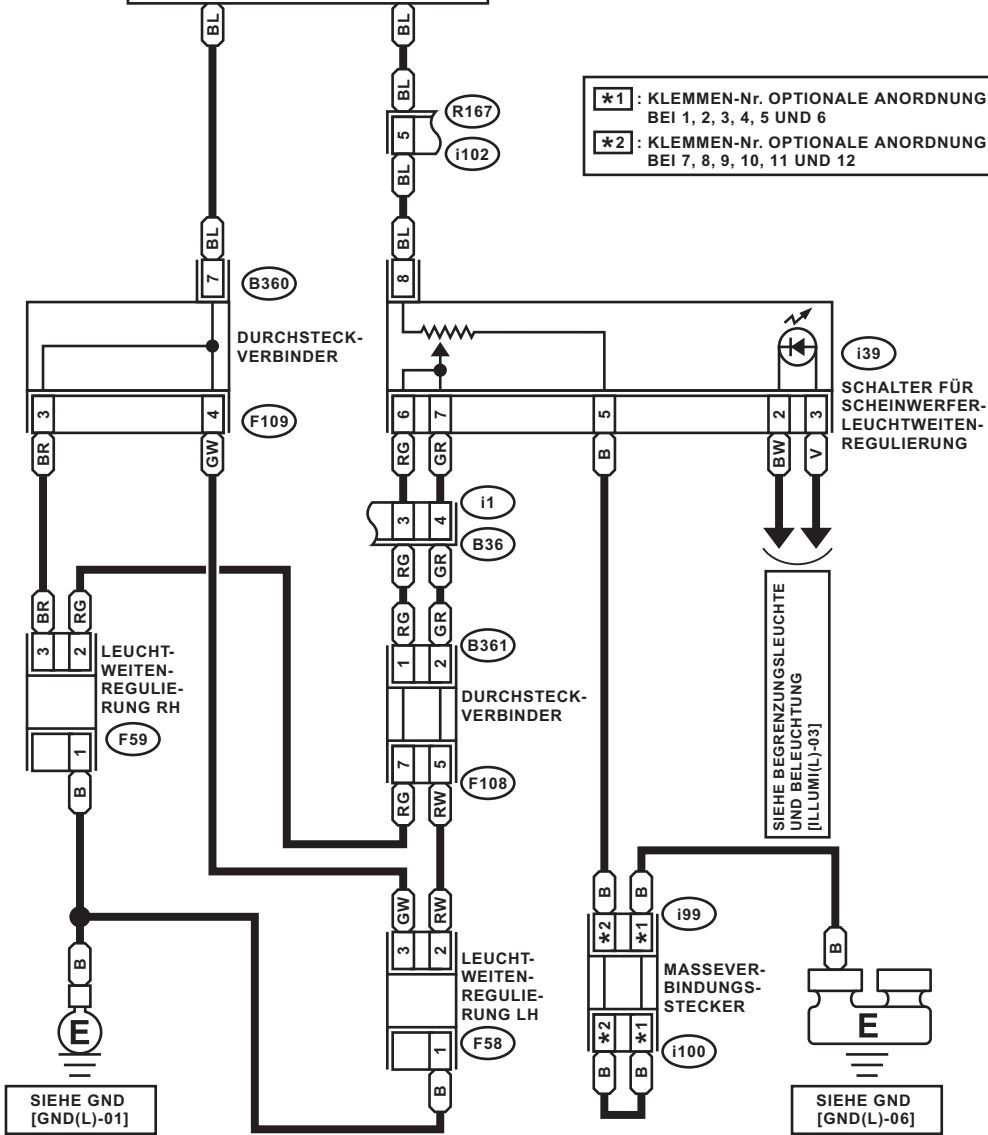

F58 (GRAU)

i39

i99 (SCHWARZ)

B361 (GRAU)

B360 (GRAU)

F108

F59 (GRAU)

i100 (SCHWARZ)

1	2	3	4	5	6		
7	8	9	10	11	12	13	14

1	2	3	4	5	6	7		
8	9	10	11	12	13	14	15	16

1	2	3	4	5	6	7	8		
9	10	11	12	13	14	15	16	17	18

i102

i1

F109

1	2	3	4	5	6	7	8	9	10	11		
12	13	14	15	16	17	18	19	20	21	22	23	24

1	2	3	4		
5	6	7	8	9	10
11	12	13	14	15	16
17	18	19	20	21	22
23	24	25	26	27	28

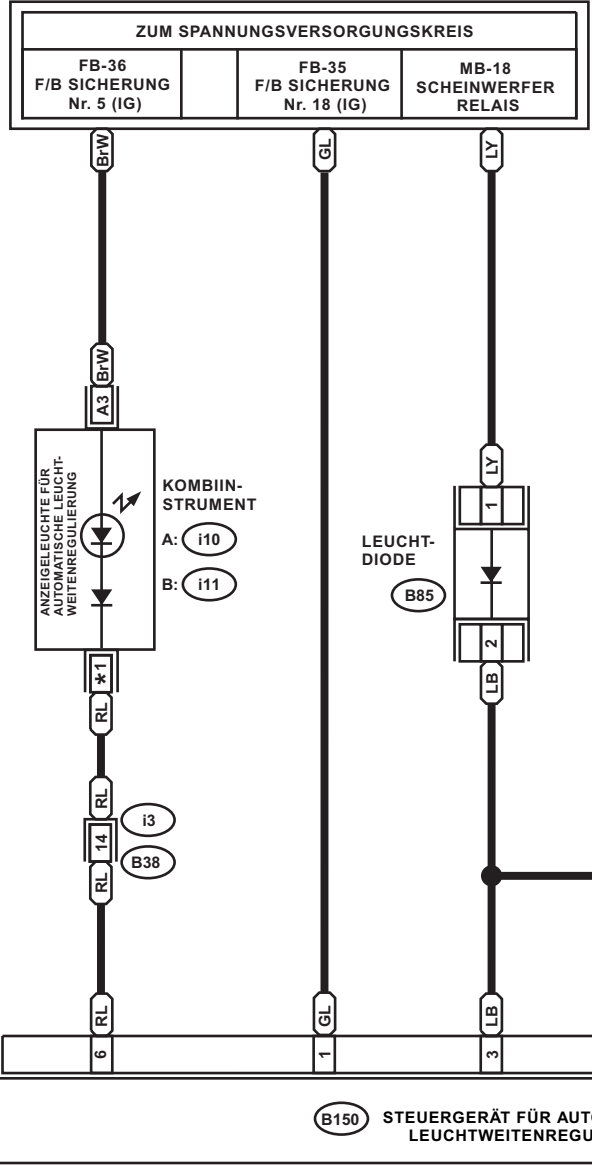

OP : OHNE STARTKNOPF
WP : MIT STARTKNOPF
ABS : OHNE VDC
VDC : MIT VDC
***1** : NORMALE ANZEIGE : B14
 ANZEIGE MIT MID : A2

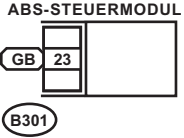
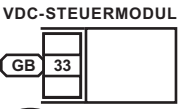

SIEHE SCHEINWERFER [H/L(LHID)-01]

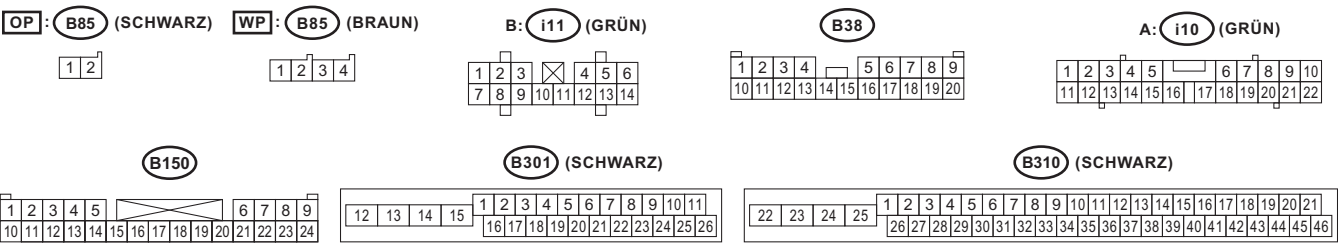

B150 STEUERGERÄT FÜR AUTOMATISCHE LEUCHTWEITENREGULIERUNG

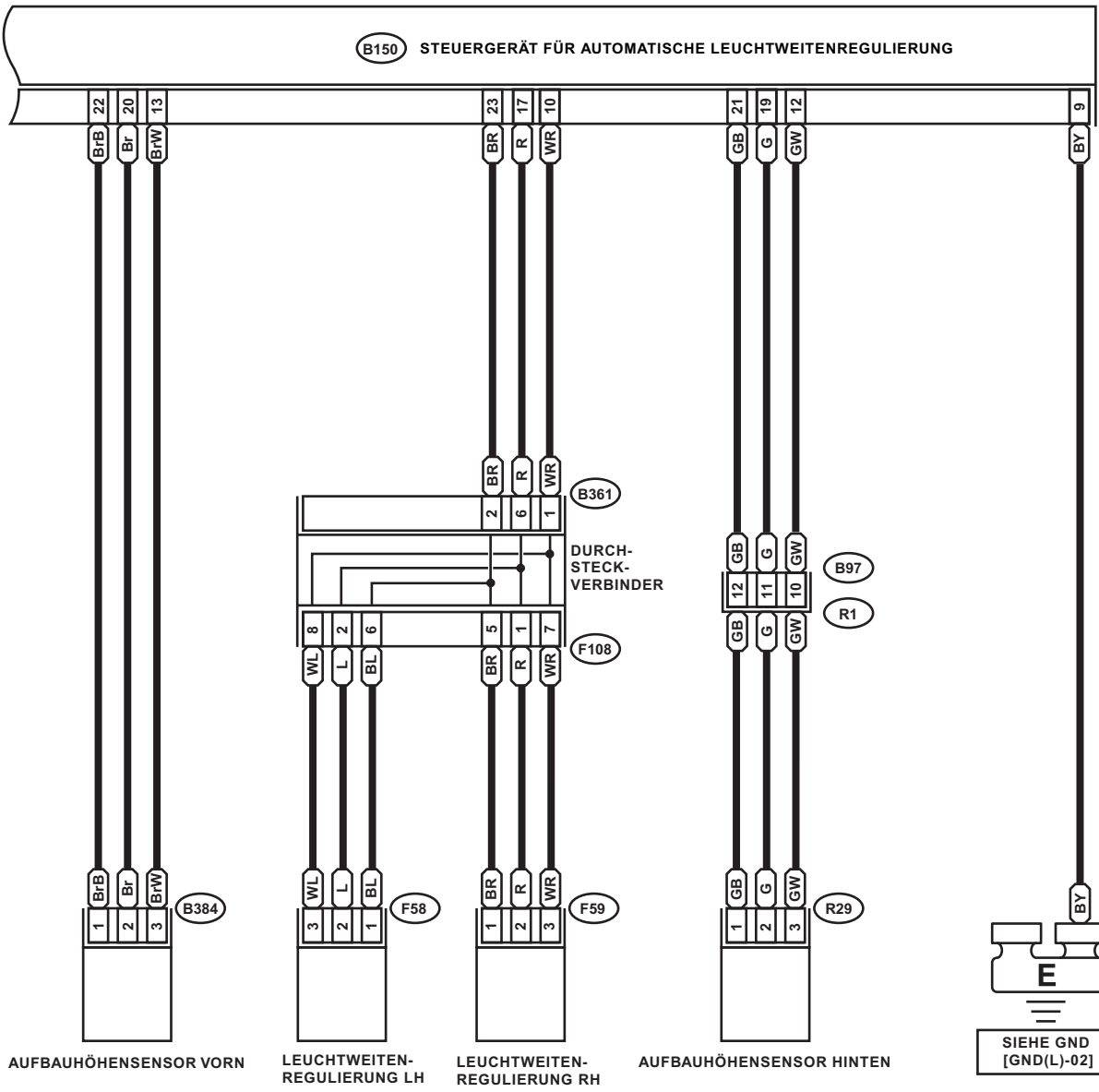

AUFBAUHÖHENSENSOR VORN

LEUCHTWEITEN-REGULIERUNG LH

LEUCHTWEITEN-REGULIERUNG RH

AUFBAUHÖHENSENSOR HINTEN

SIEHE GND [GND(L)-02]

- B384 (SCHWARZ)
- R29 (SCHWARZ)
- F58 (GRAU)
- F59 (GRAU)

- B361 (GRAU)

- B97

- F108

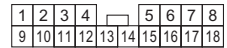
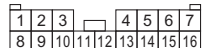
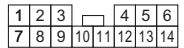
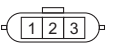

B150

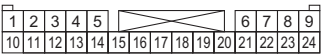



*1 : KLEMMEN-Nr. OPTIONALE ANORDNUNG BEI 1, 2, 3, 4, 5 UND 6
 *2 : KLEMMEN-Nr. OPTIONALE ANORDNUNG BEI 7, 8, 9, 10, 11 UND 12

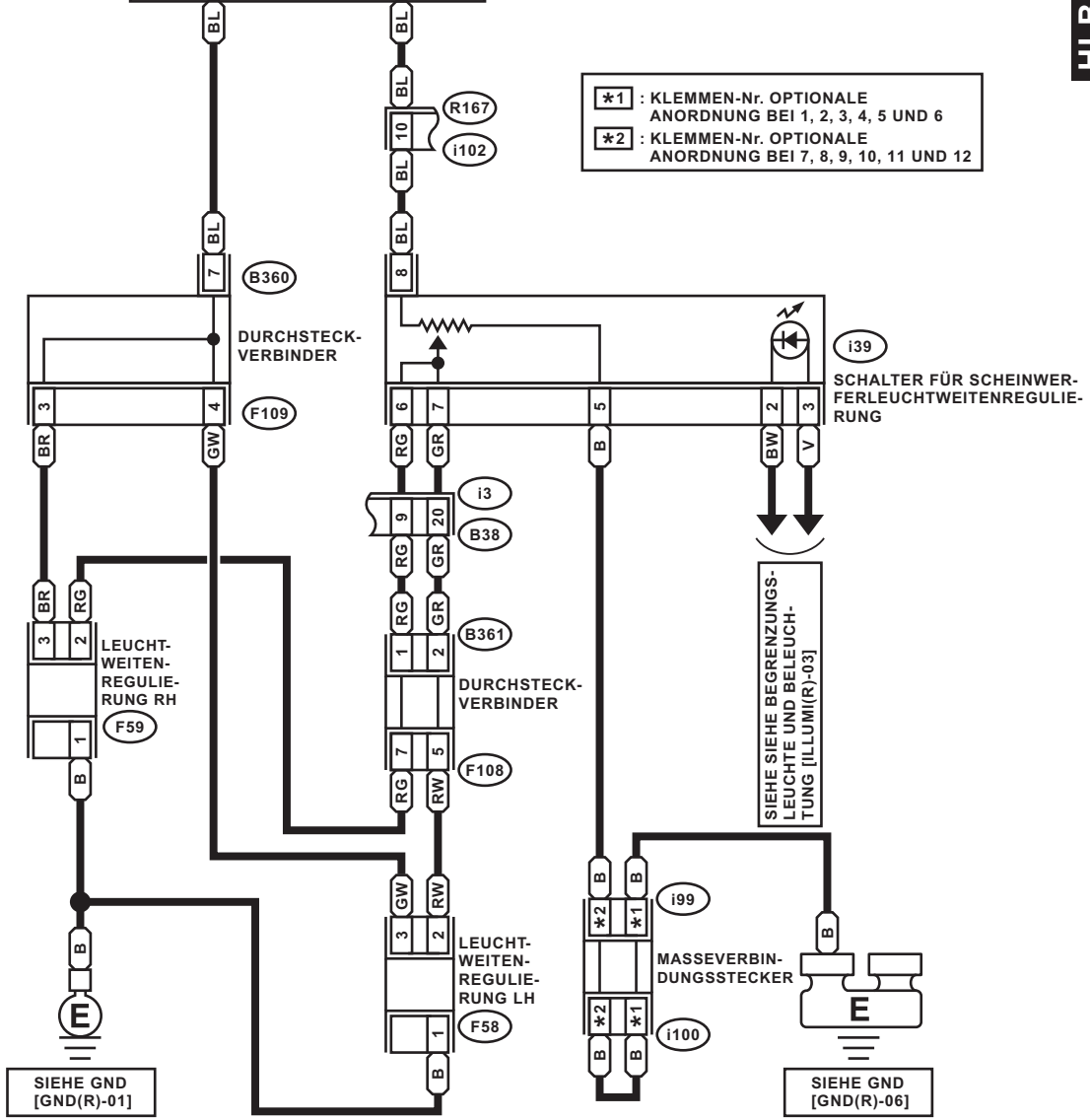

F58 (GRAU)

i39

i99 (SCHWARZ)

B361 (GRAU)

B360 (GRAU)

F108

F59 (GRAU)

i100 (SCHWARZ)

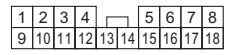
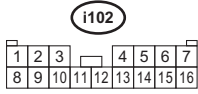
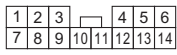

B38

F109

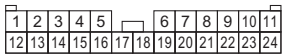
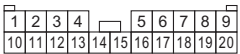

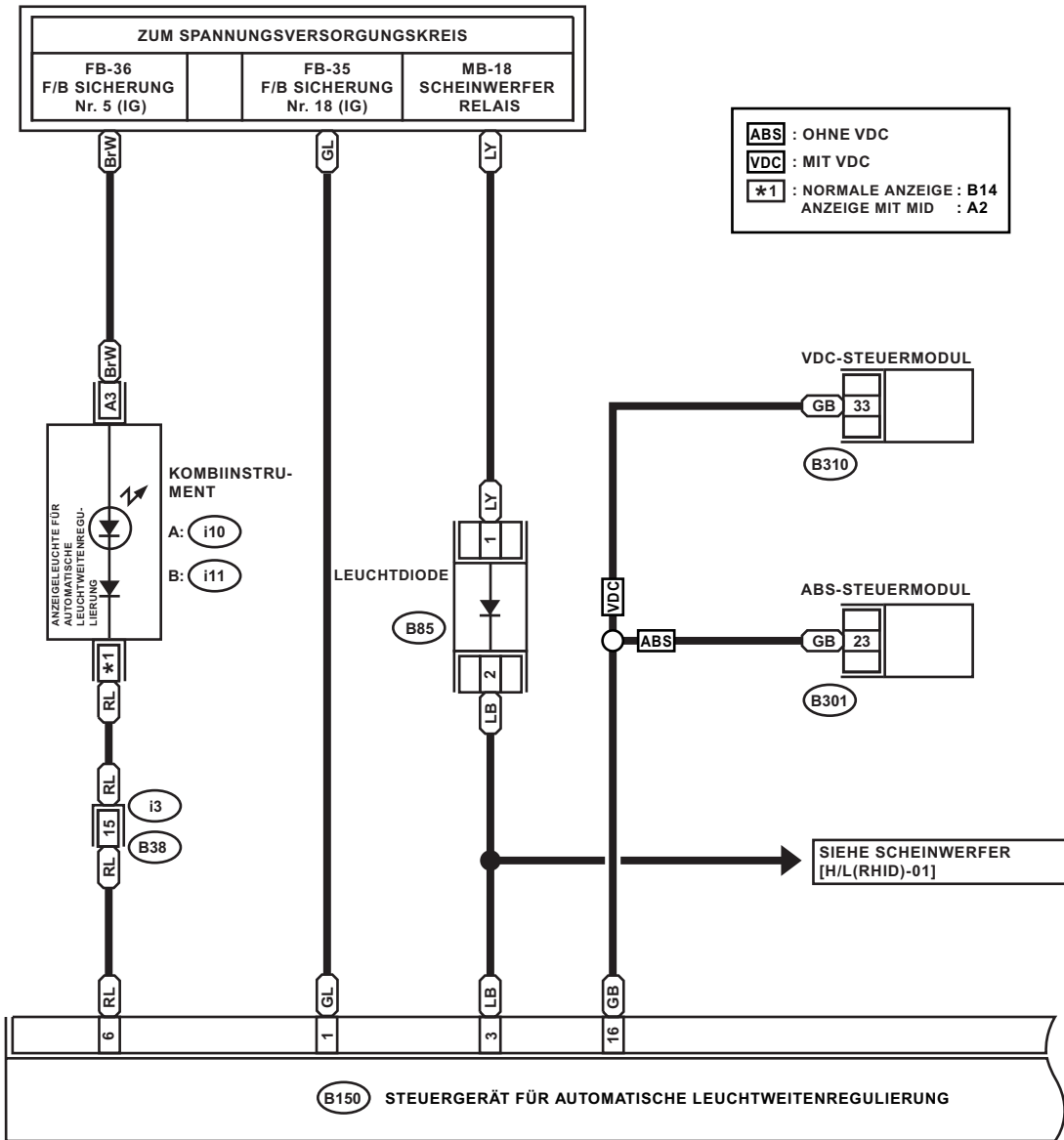

B85 (SCHWARZ) B: i11 (GRÜN)

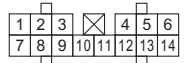

B38

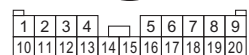

A: i10 (GRÜN)

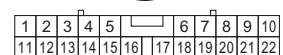

B150

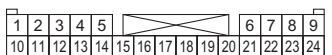

B301 (SCHWARZ)

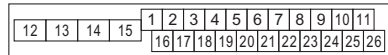

B310 (SCHWARZ)

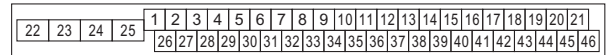

B150 STEUERGERÄT FÜR AUTOMATISCHE LEUCHTWEITENREGULIERUNG

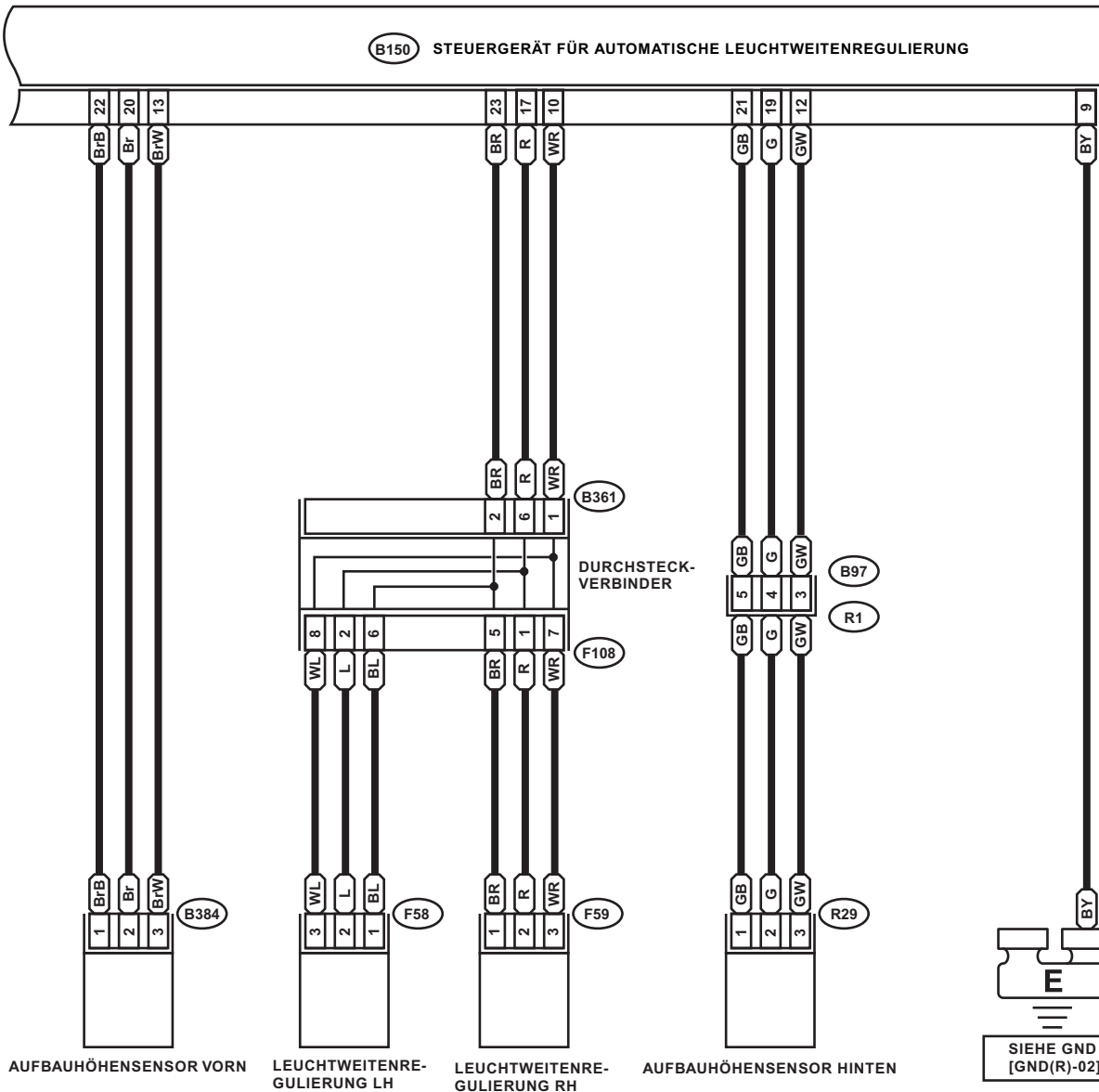

AUFBAUHÖHENSENSOR VORN

LEUCHTWEITENREGULIERUNG LH

LEUCHTWEITENREGULIERUNG RH

AUFBAUHÖHENSENSOR HINTEN

SIEHE GND [GND(R)-02]

- B384 (SCHWARZ)
- R29 (SCHWARZ)
- F58 (GRAU)
- F59 (GRAU)

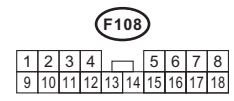
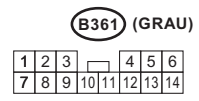
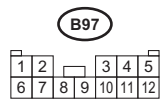
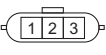

B150

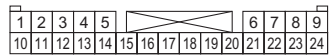



- *1 : KLEMMEN-Nr. OPTIONALE ANORDNUNG BEI 1, 2, 3, 4, 5 UND 6
 - *2 : KLEMMEN-Nr. OPTIONALE ANORDNUNG BEI 1, 2, 3 UND 4
 - *3 : OUTBACK-MODELL : 1
AUSSER OUTBACK-MODELL : 2
 - *4 : OUTBACK-MODELL : 2
AUSSER OUTBACK-MODELL : 1
- OB : OUTBACK-MODELL
 - OT : AUSSER OUTBACK-MODELL
 - EK : EK-MODELL
 - KA : KA-MODELL

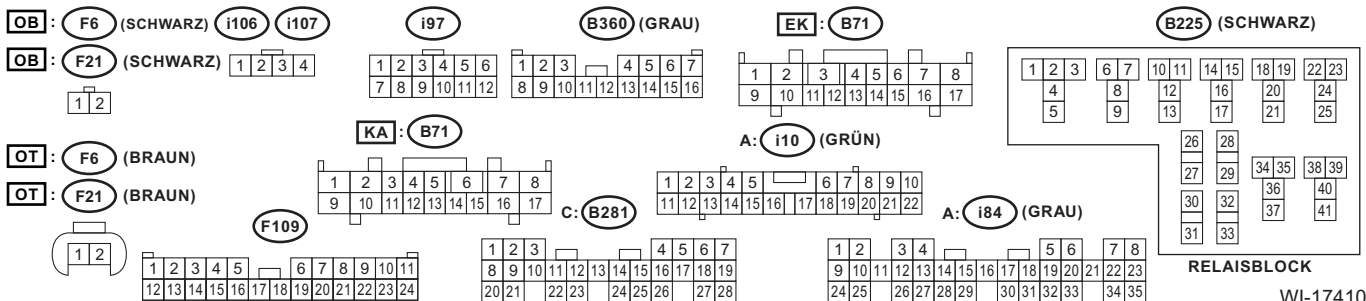
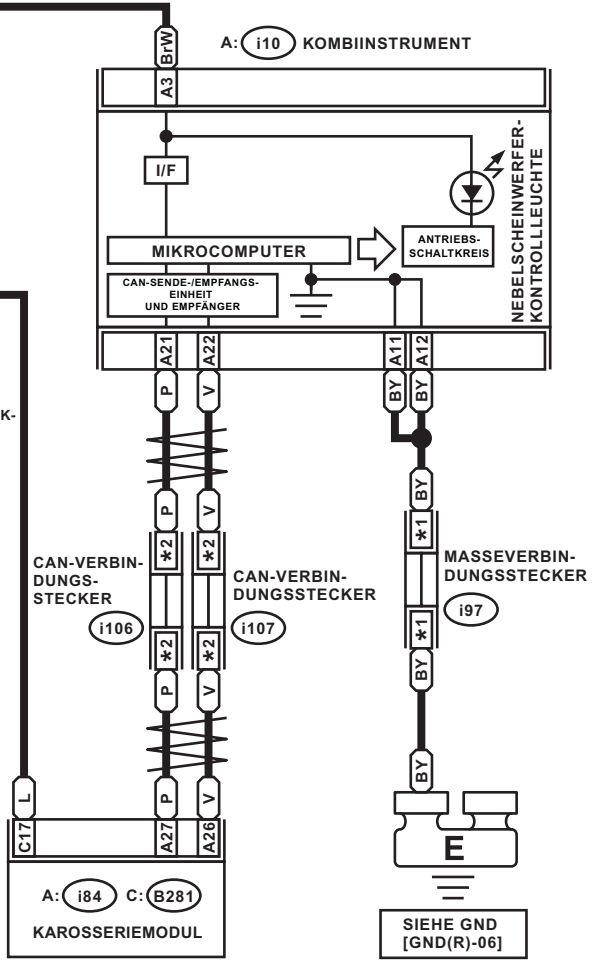
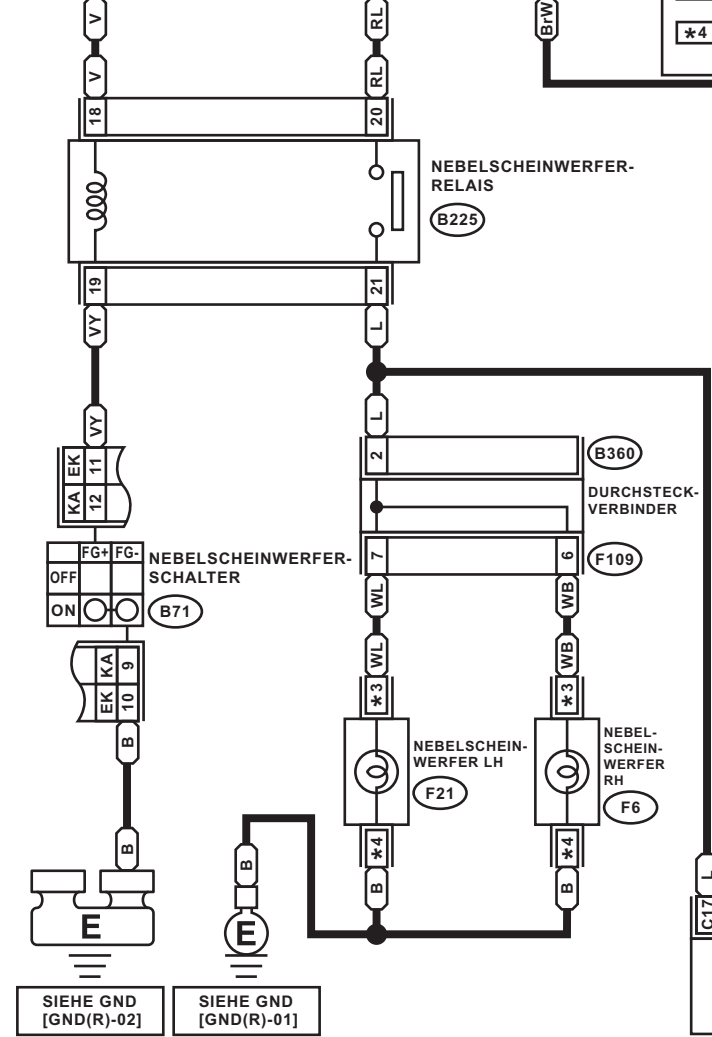



A: i10 KOMBIINSTRUMENT

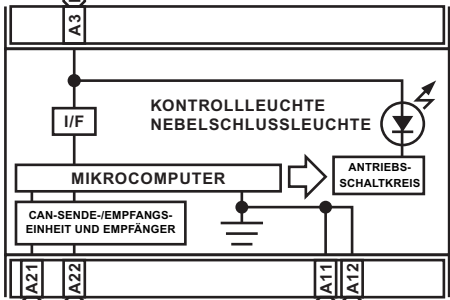

- *1 : KLEMMEN-Nr. OPTIONALE ANORDNUNG BEI 1, 2, 3, 4, 5 UND 6
- *2 : KLEMMEN-Nr. OPTIONALE ANORDNUNG BEI 1, 2, 3 UND 4

SIEHE NEBELSCHLEINWERFER [FOG(L)-01]

CAN-VERBINDUNGS-STECKER

CAN-VERBINDUNGS-STECKER

MASSEVERBINDUNGS-STECKER

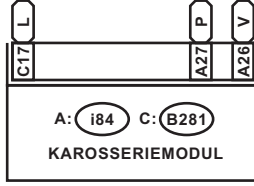

i106 i107

i97

A: i10 (GRÜN)

C: B281

A: i84 (GRAU)

1	2	3	4
---	---	---	---

1	2	3	4	5	6
7	8	9	10	11	12

1	2	3	4	5	6	7	8	9	10		
11	12	13	14	15	16	17	18	19	20	21	22

1	2	3	4	5	6	7					
8	9	10	11	12	13	14	15	16	17	18	19
20	21	22	23	24	25	26	27	28			

1	2	3	4	5	6	7	8							
9	10	11	12	13	14	15	16	17	18	19	20	21	22	23
24	25	26	27	28	29	30	31	32	33	34	35			

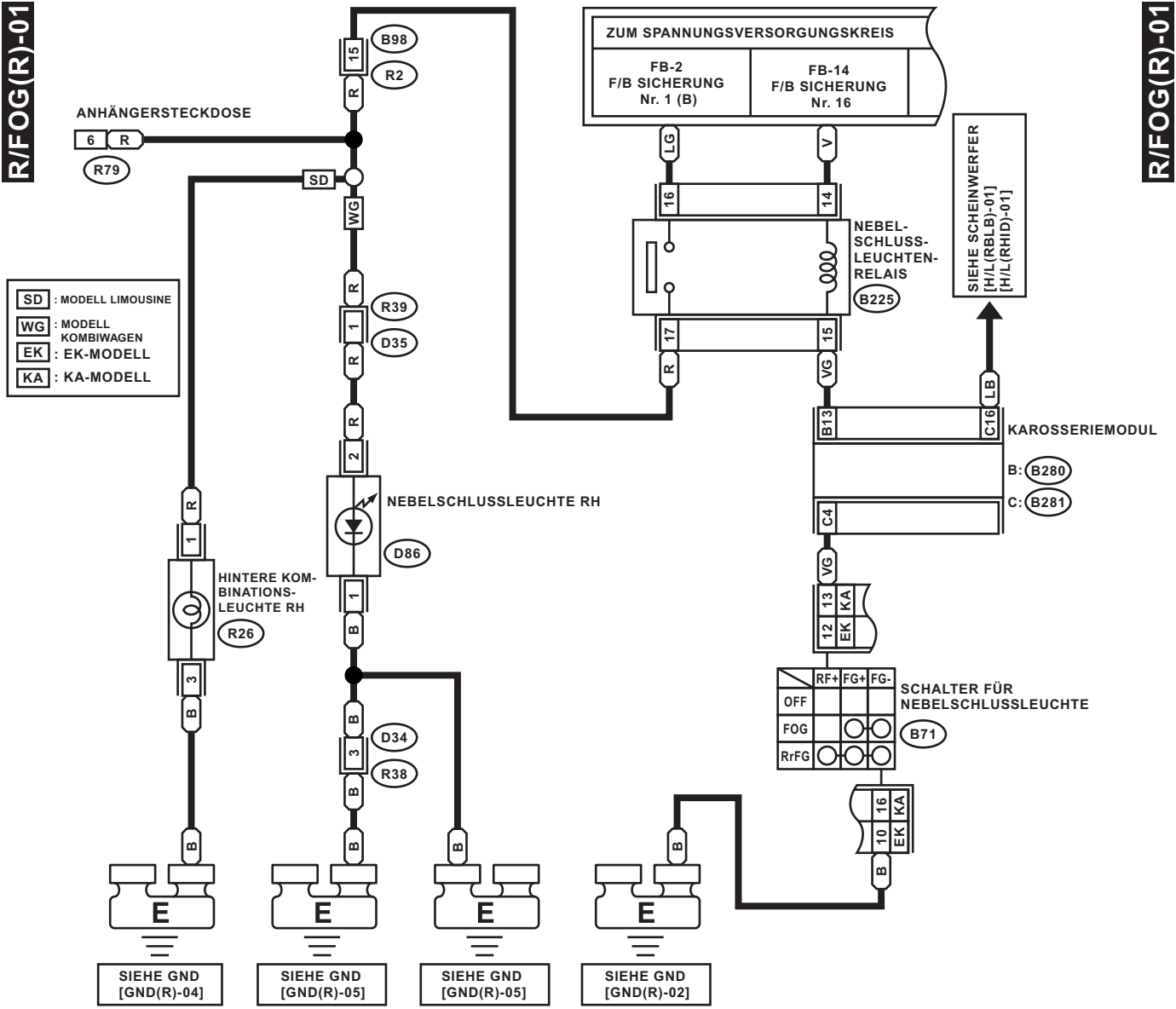

- SD** : MODELL LIMOUSINE
- WG** : MODELL KOMBIWAGEN
- EK** : EK-MODELL
- KA** : KA-MODELL

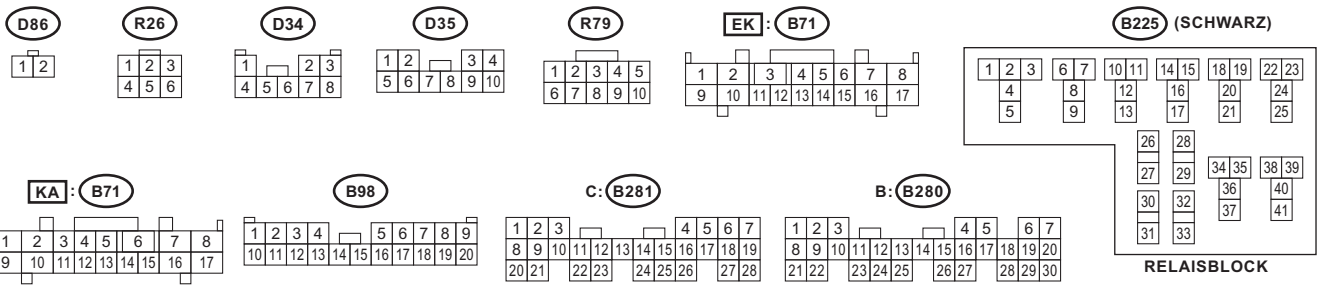



A: i10 KOMBIINSTRUMENT

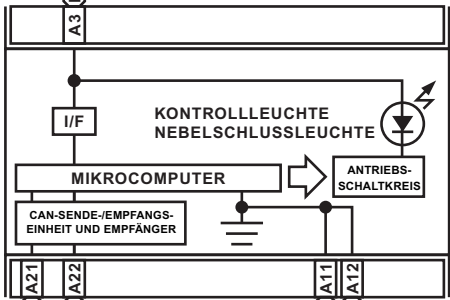

*1 : KLEMMEN-Nr. OPTIONALE ANORDNUNG BEI 1, 2, 3, 4, 5 UND 6
 *2 : KLEMMEN-Nr. OPTIONALE ANORDNUNG BEI 1, 2, 3 UND 4

SIEHE NEBELSCHEINWERFER [FOG(R)-01]

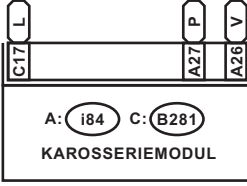
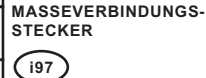
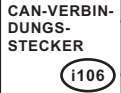

i106 i107



i97



A: i10 (GRÜN)

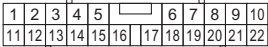

C: B281

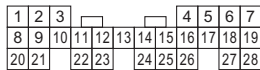

A: i84 (GRAU)

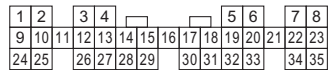

ZUM SPANNUNGSVERSORGUNGSKREIS
 FB-35
 F/B SICHERUNG Nr. 18
 (IG)

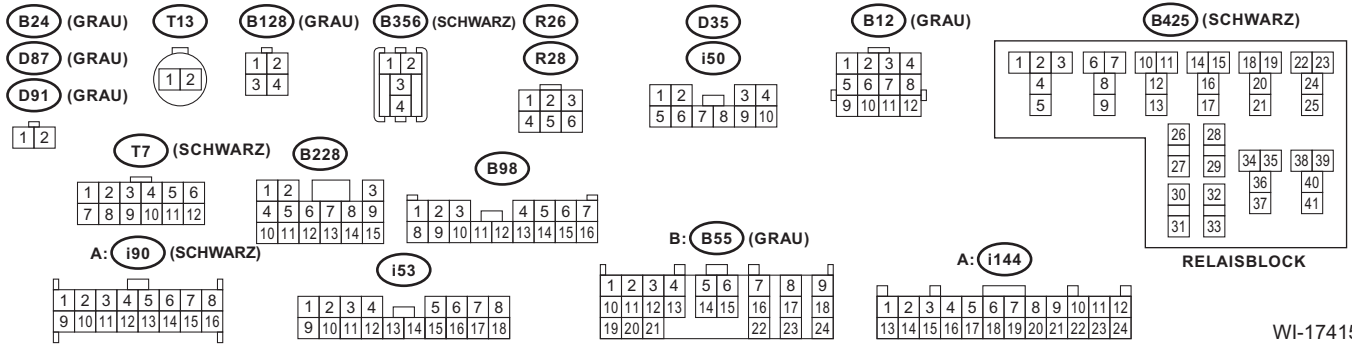
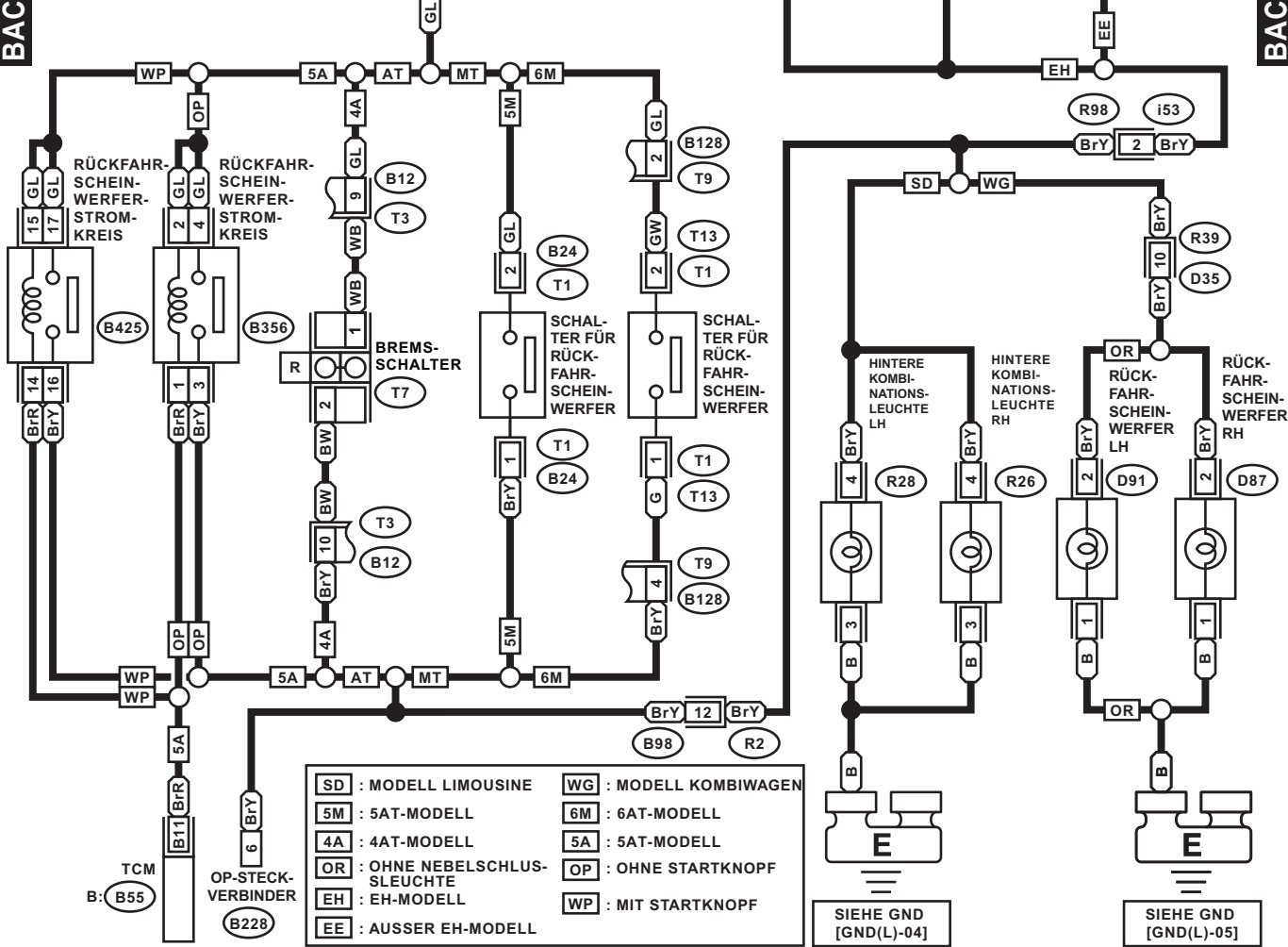

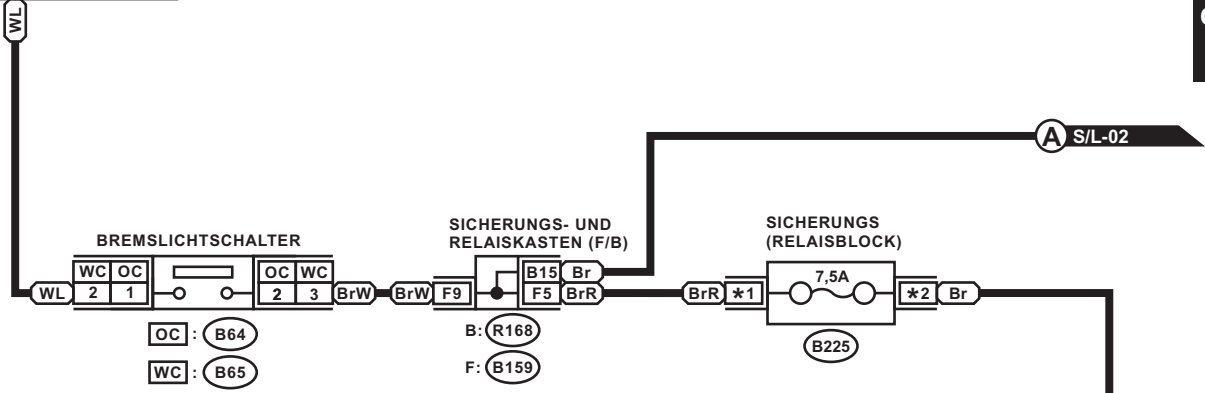

- LH** : LHD-MODELL
- RH** : RHD-MODELL
- ABS** : OHNE VDC
- VDC** : MIT VDC
- OC** : OHNE GESCHWINDIGKEITS-REGELUNG
- WC** : MIT GESCHWINDIGKEITSREGELUNG
- ND** : 2,0L MODELL
- OT** : AUSSER 2,0L MODELL
- *1** : LHD-MODELL : 3
RHD-MODELL : 26
- *2** : LHD-MODELL : 4
RHD-MODELL : 27

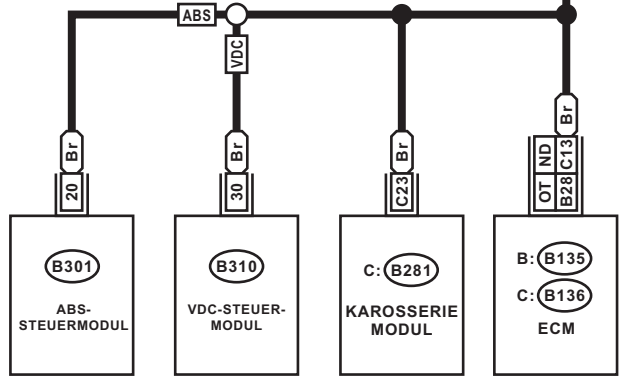

OC : B64 (SCHWARZ) WC : B65 (SCHWARZ) F: B159 (BRAUN) B: R168

B301 (SCHWARZ)

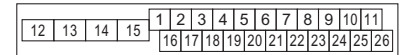
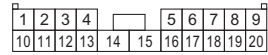
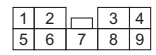

C: B281

B: B135

LH : B225 (SCHWARZ)

RH : B225 (SCHWARZ)

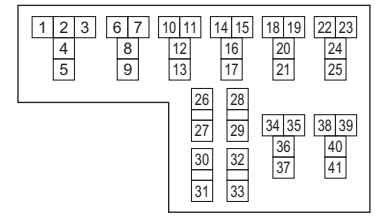
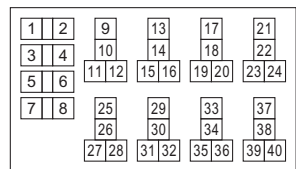
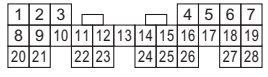

C: B136

B310 (SCHWARZ)

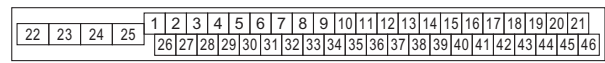
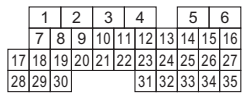

RELAISSCHWELB

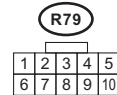
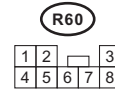
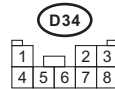
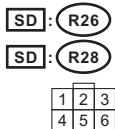
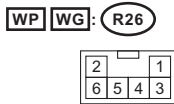
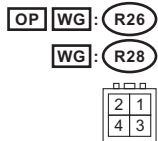
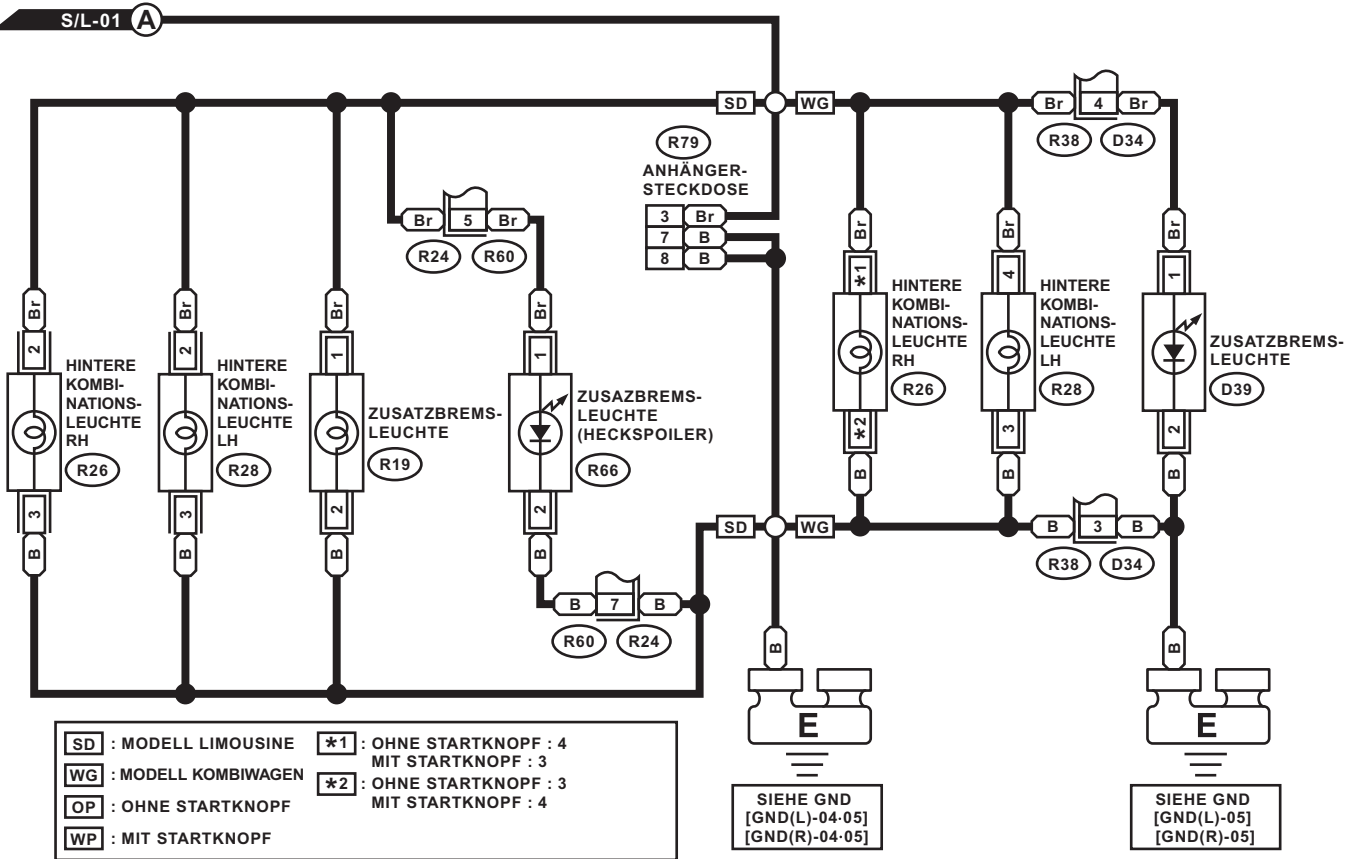
S/L-01 **A**

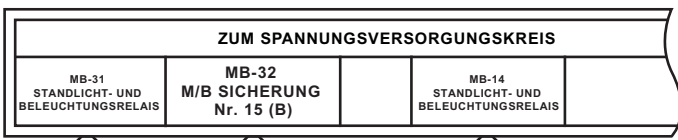

5A : 5AT-MODELL

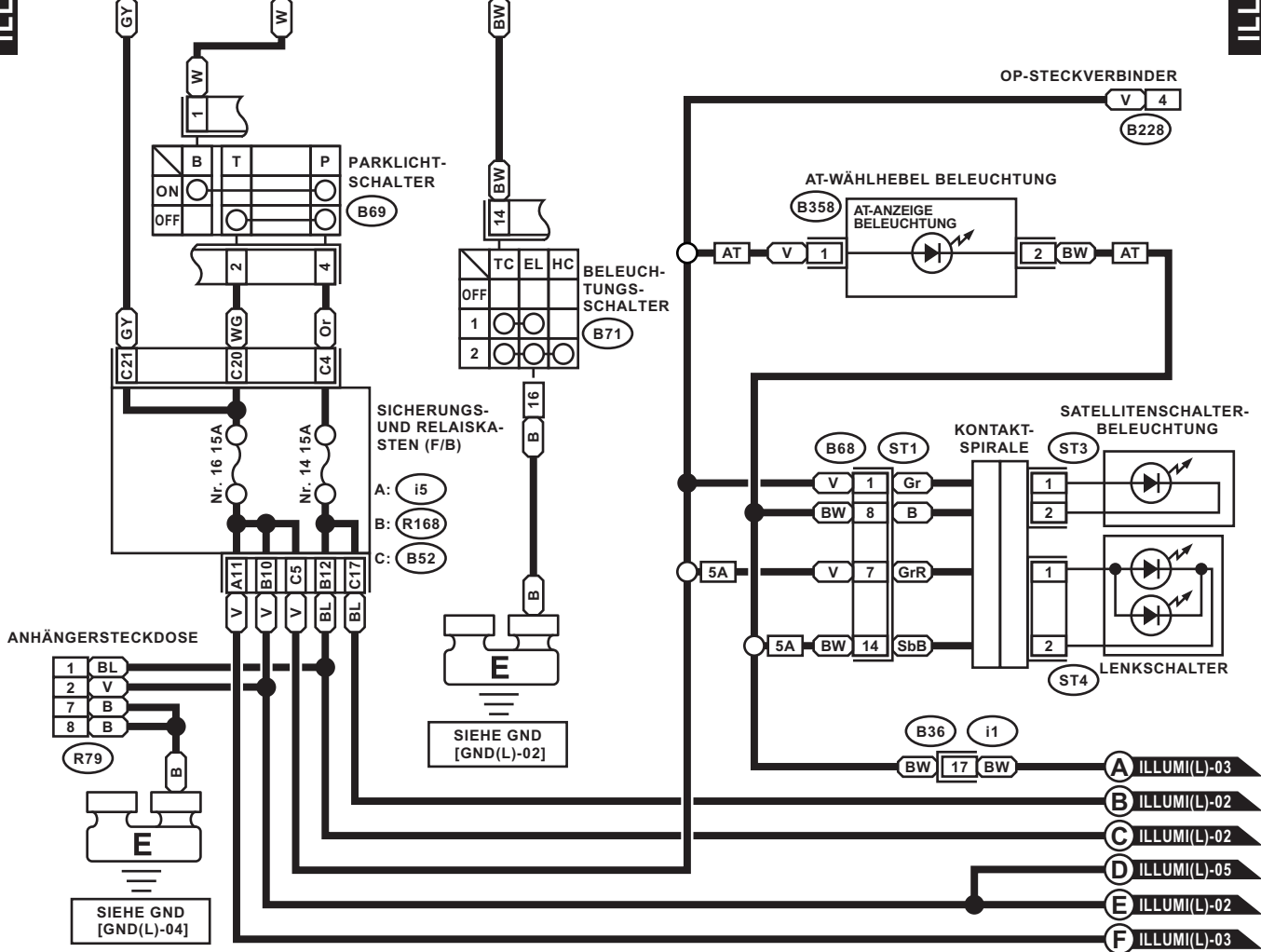

- A** ILLUMI(L)-03
- B** ILLUMI(L)-02
- C** ILLUMI(L)-02
- D** ILLUMI(L)-05
- E** ILLUMI(L)-02
- F** ILLUMI(L)-03

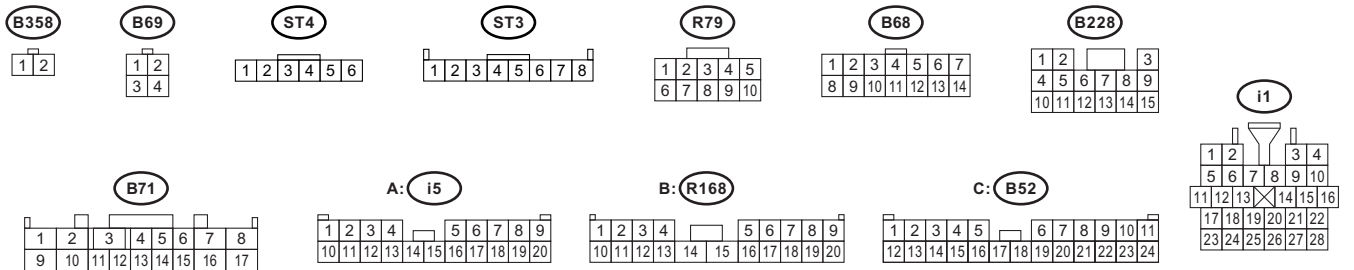

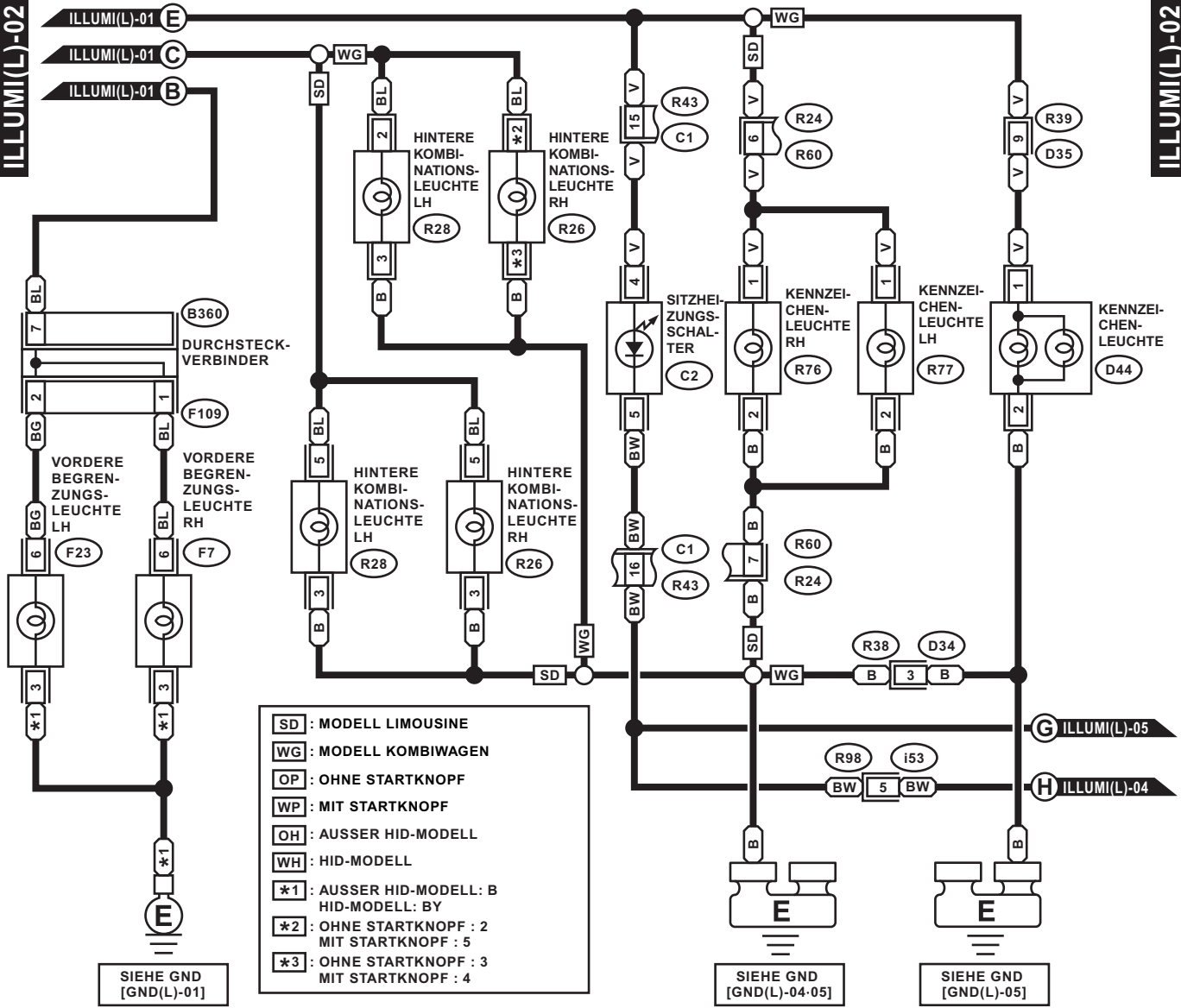

- SD** : MODELL LIMOUSINE
- WG** : MODELL KOMBIWAGEN
- OP** : OHNE STARTKNOPF
- WP** : MIT STARTKNOPF
- OH** : AUSSER HID-MODELL
- WH** : HID-MODELL
- *1** : AUSSER HID-MODELL : B
HID-MODELL : BY
- *2** : OHNE STARTKNOPF : 2
MIT STARTKNOPF : 5
- *3** : OHNE STARTKNOPF : 3
MIT STARTKNOPF : 4

SIEHE GND [GND(L)-01]

SIEHE GND [GND(L)-04-05]

SIEHE GND [GND(L)-05]

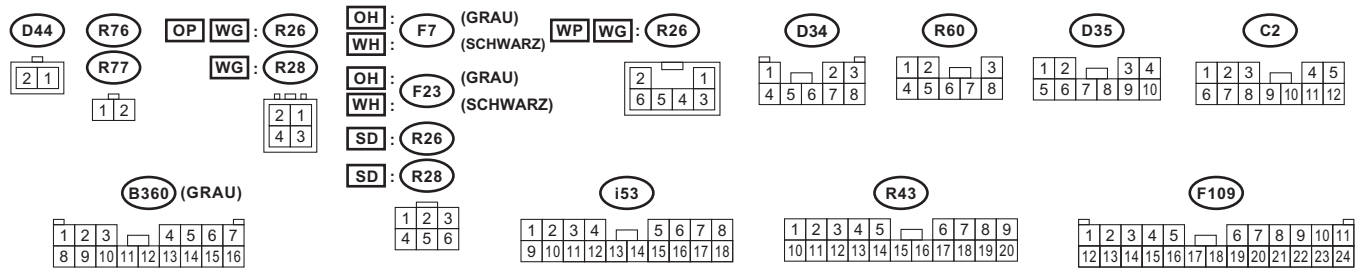

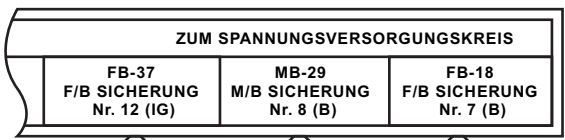

- *1 : KLEMMEN-Nr. OPTIONALE ANORDNUNG BEI 7, 8, 9, 10, 11 UND 12
- *2 : KLEMMEN-Nr. OPTIONALE ANORDNUNG BEI 1, 2, 3, 4, 5 UND 6
- VDC : MIT VDC
- ML : MODELL MIT MANUELLER LEUCHTWEITENREGULIERUNG
- NM : NORMALE ANZEIGE
- MM : ANZEIGE MIT MID

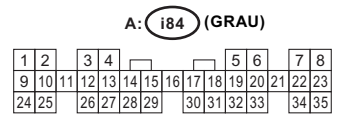
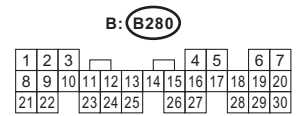
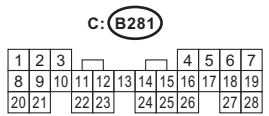
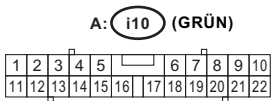
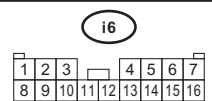
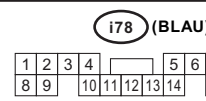
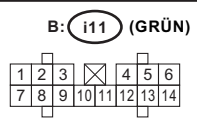
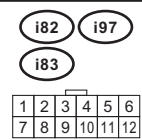
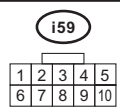
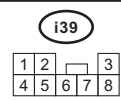
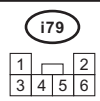
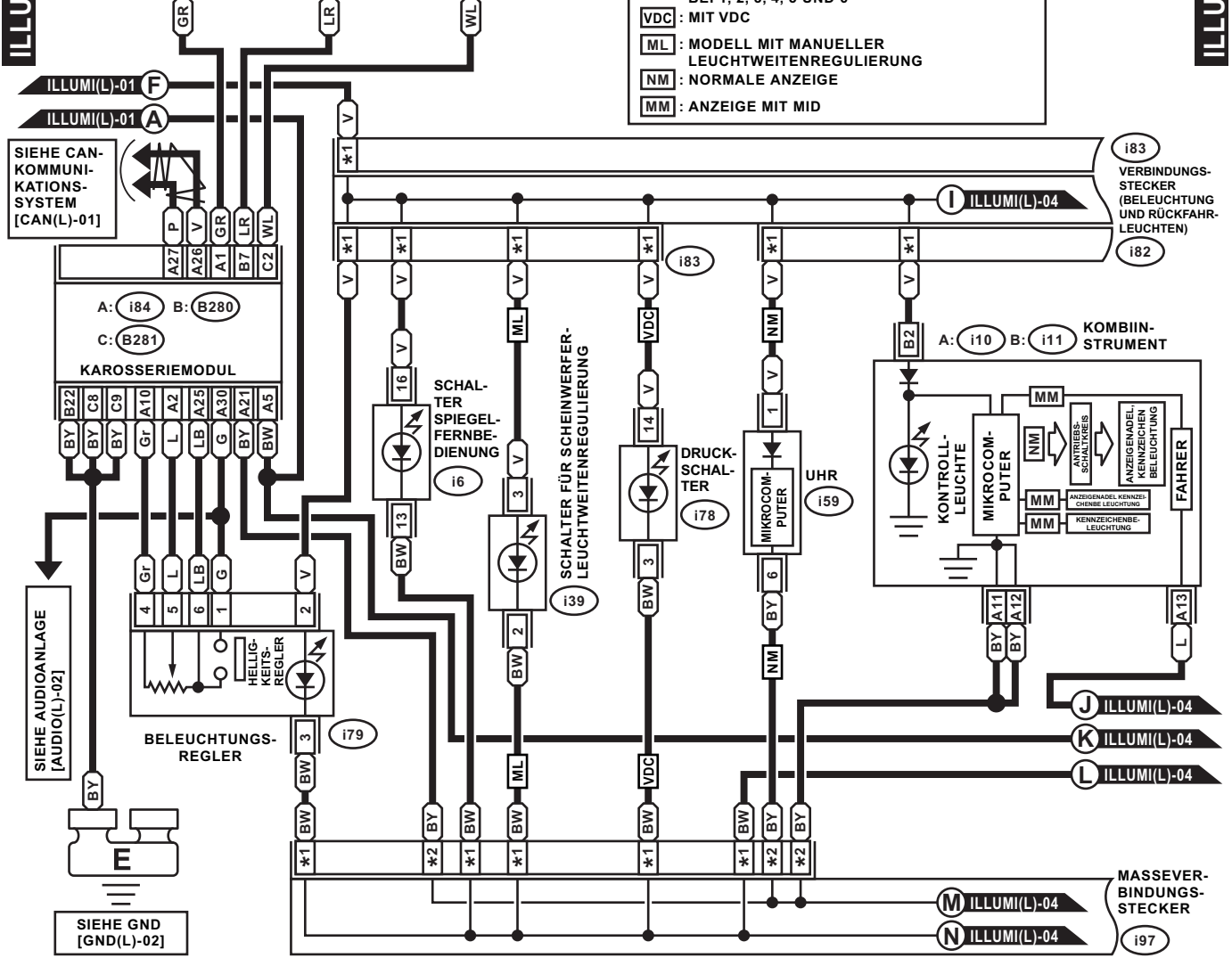

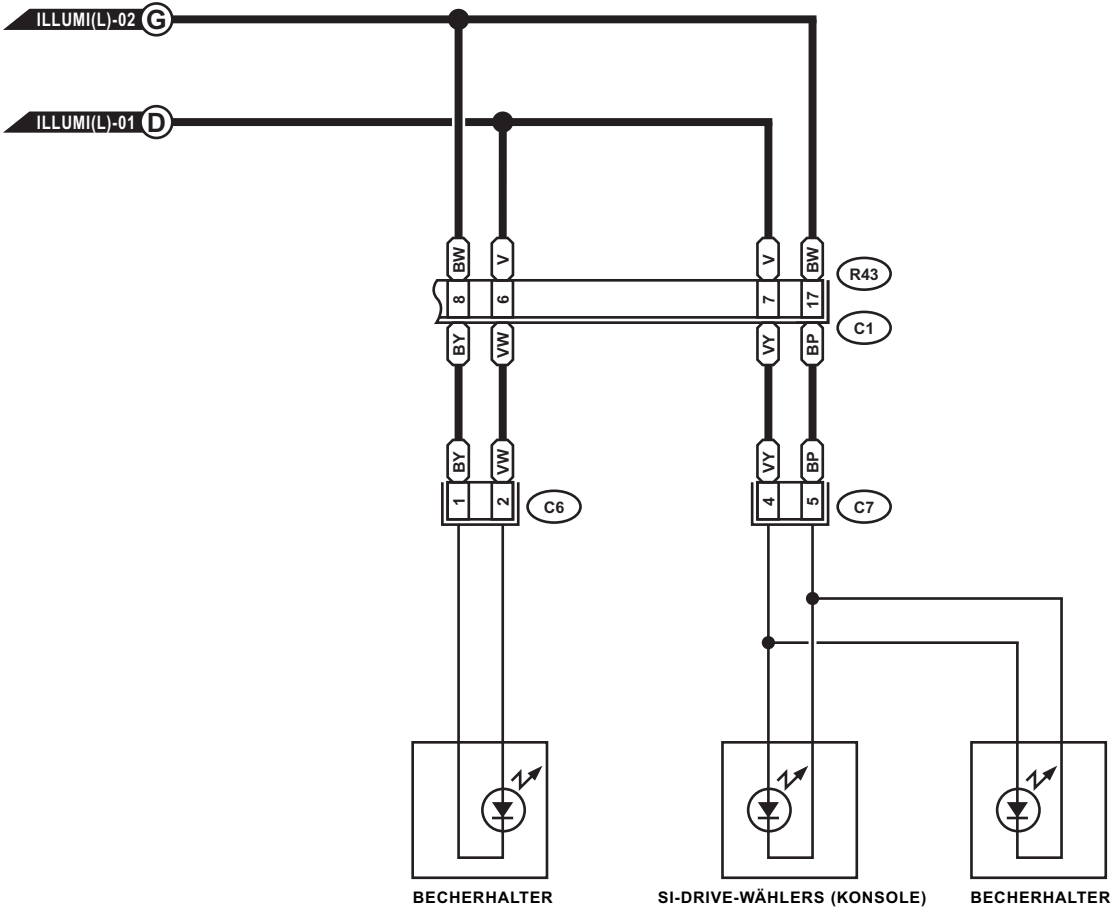

C6



C7

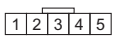

R43

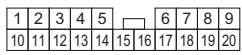

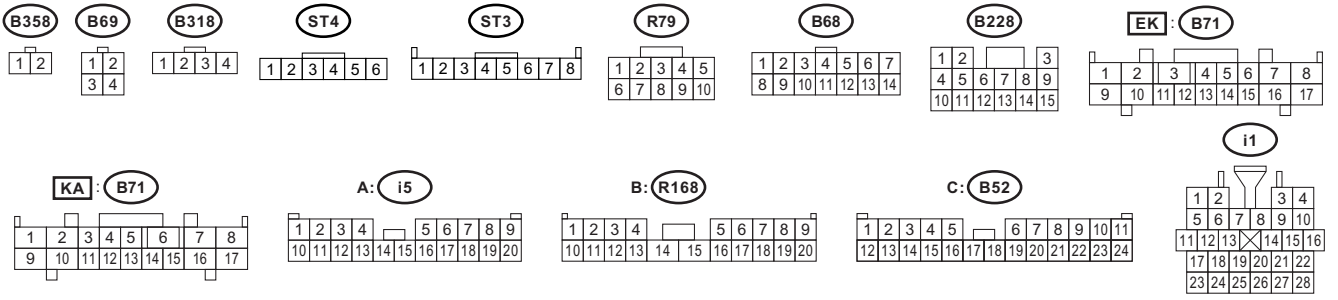
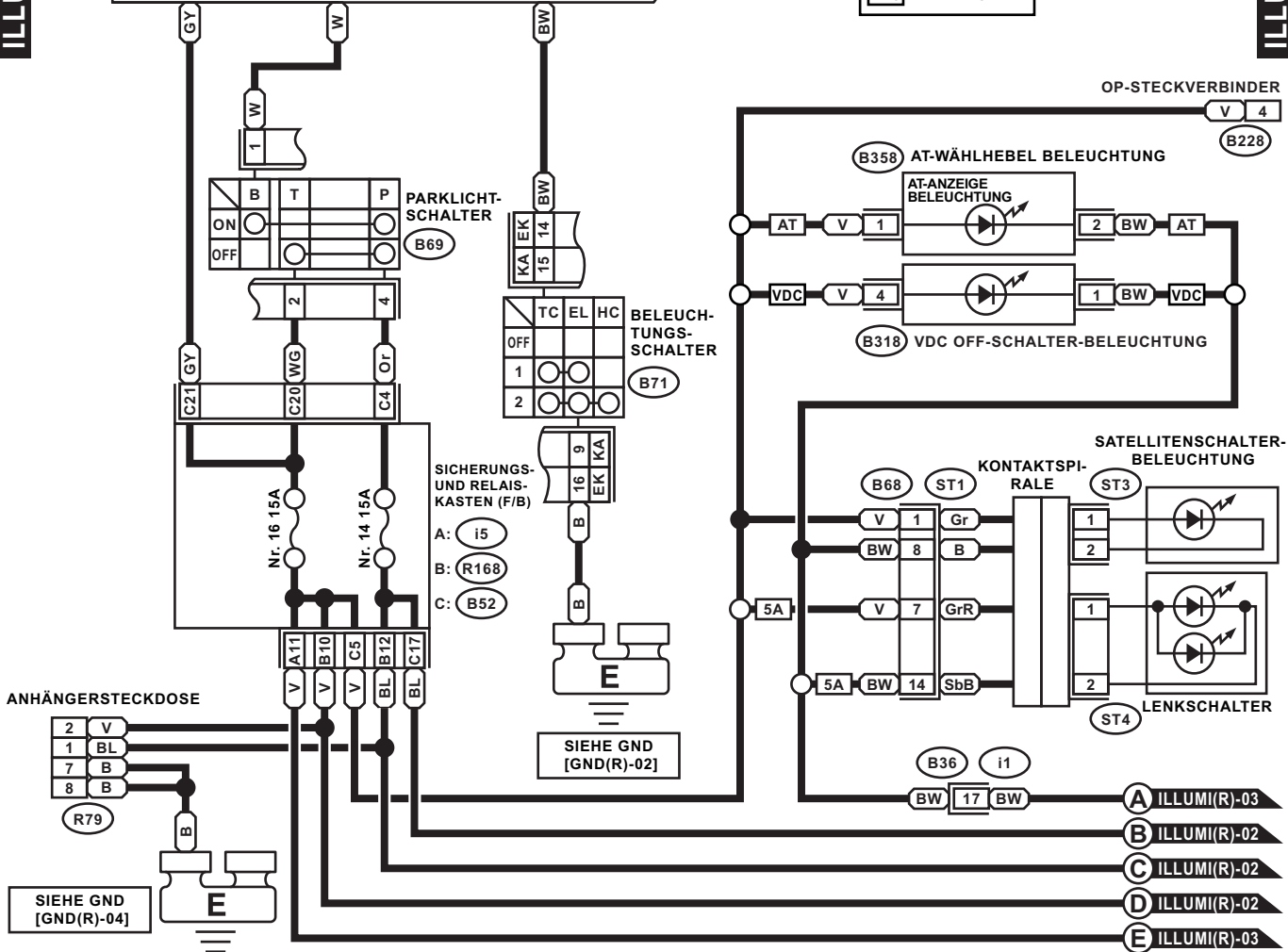
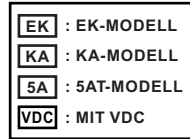
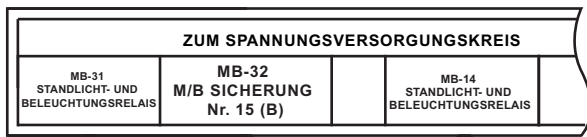

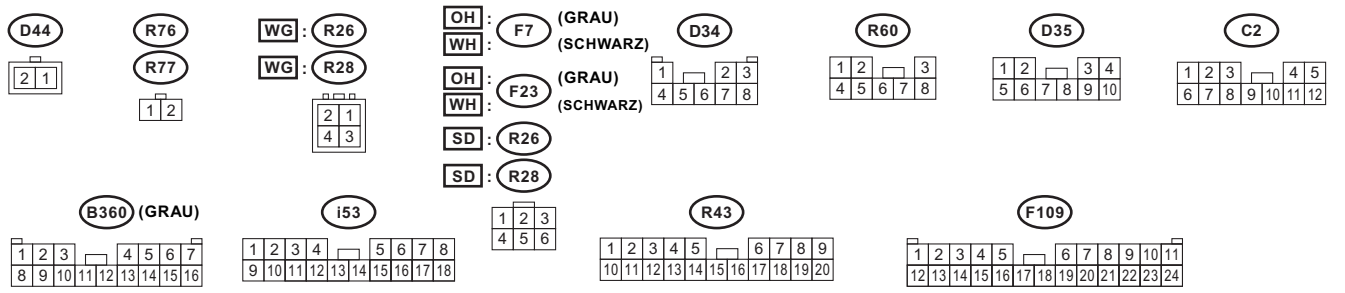
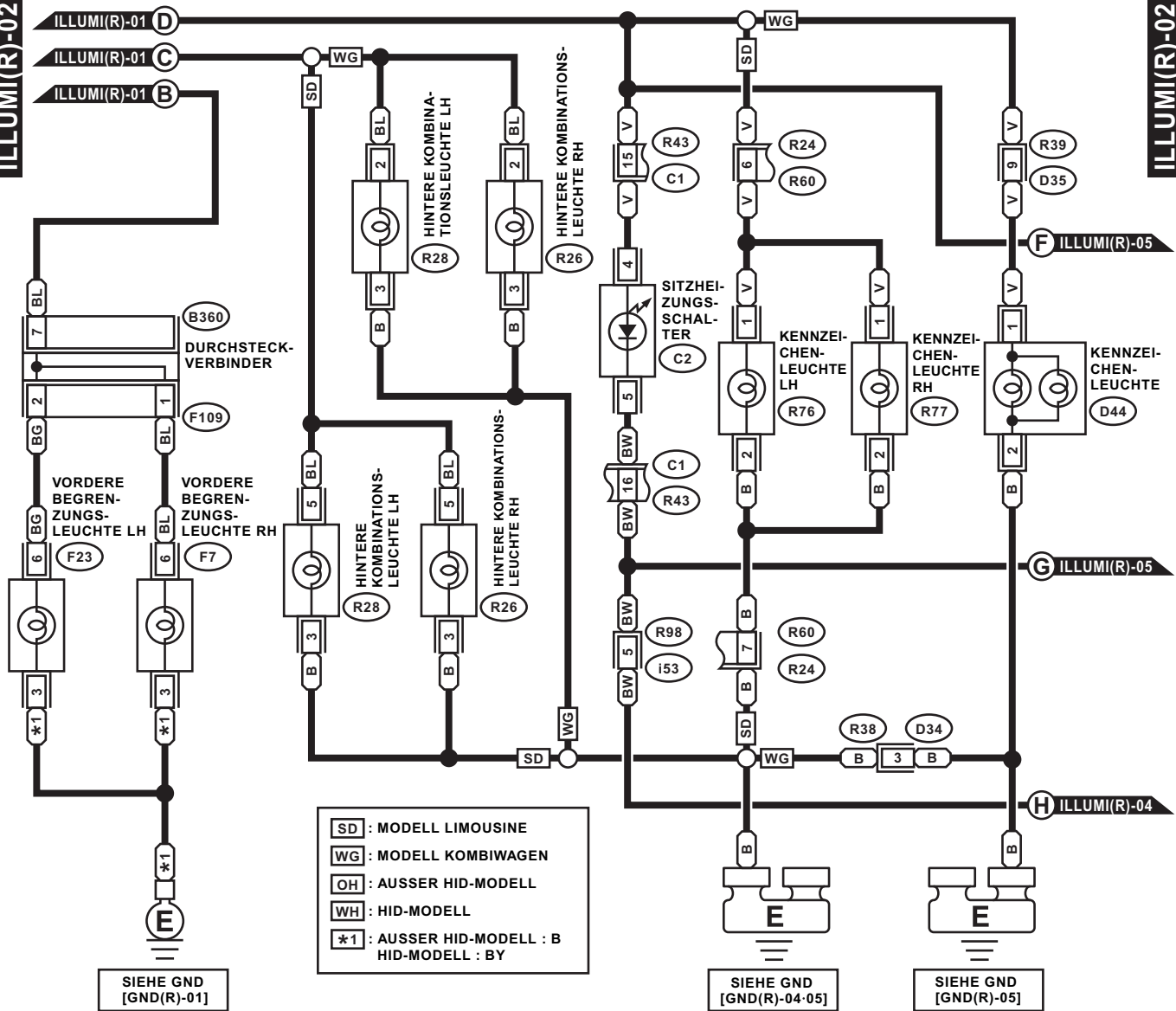

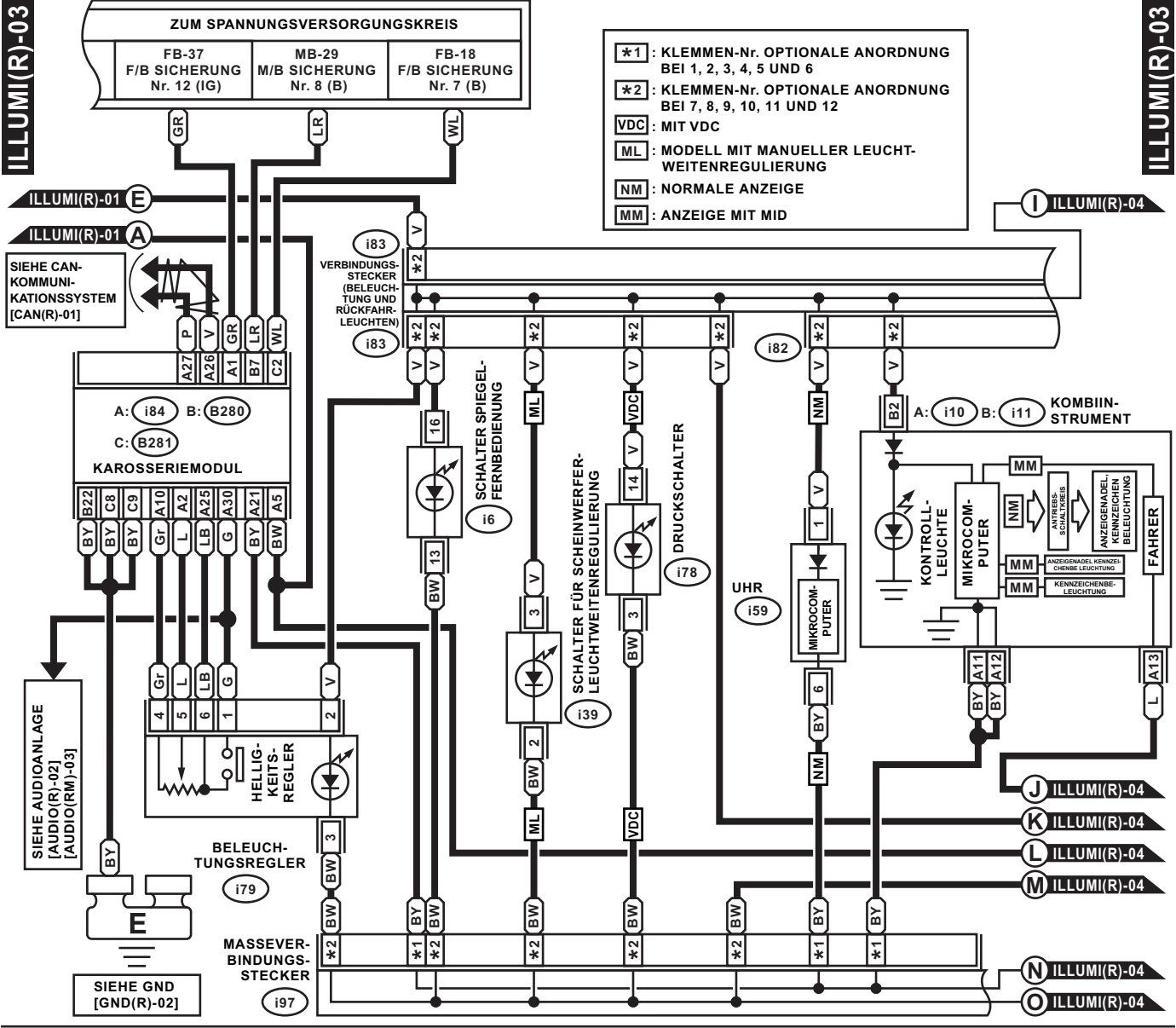

- *1 : KLEMMEN-Nr. OPTIONALE ANORDNUNG BEI 1, 2, 3, 4, 5 UND 6
- *2 : KLEMMEN-Nr. OPTIONALE ANORDNUNG BEI 7, 8, 9, 10, 11 UND 12
- VDC : MIT VDC
- ML : MODELL MIT MANUELLER LEUCHTWEITENREGULIERUNG
- NM : NORMALE ANZEIGE
- MM : ANZEIGE MIT MID

ILLUMI(R)-01 (E)
ILLUMI(R)-01 (A)

SIEHE CAN-KOMMUNIKATIONSSYSTEM [CAN(R)-01]

I ILLUMI(R)-04

SIEHE AUDIOANLAGE [AUDIO(R)-02] [AUDIO(RM)-03]

SIEHE GND [GND(R)-02]

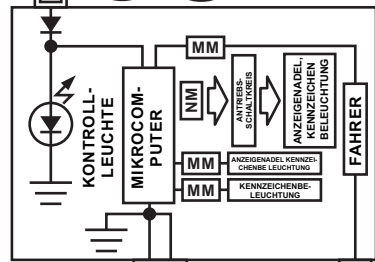

J ILLUMI(R)-04
K ILLUMI(R)-04
L ILLUMI(R)-04
M ILLUMI(R)-04
N ILLUMI(R)-04
O ILLUMI(R)-04

i79



i39

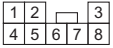

i59

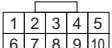

i82



B: i11 (GRÜN)



i78 (BLAU)

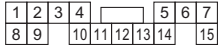

i6

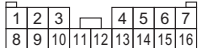

A: i10 (GRÜN)

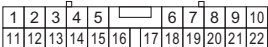

C: B281

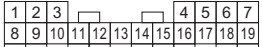

B: B280

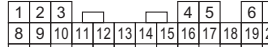

A: i84 (GRAU)

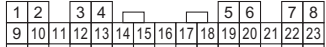

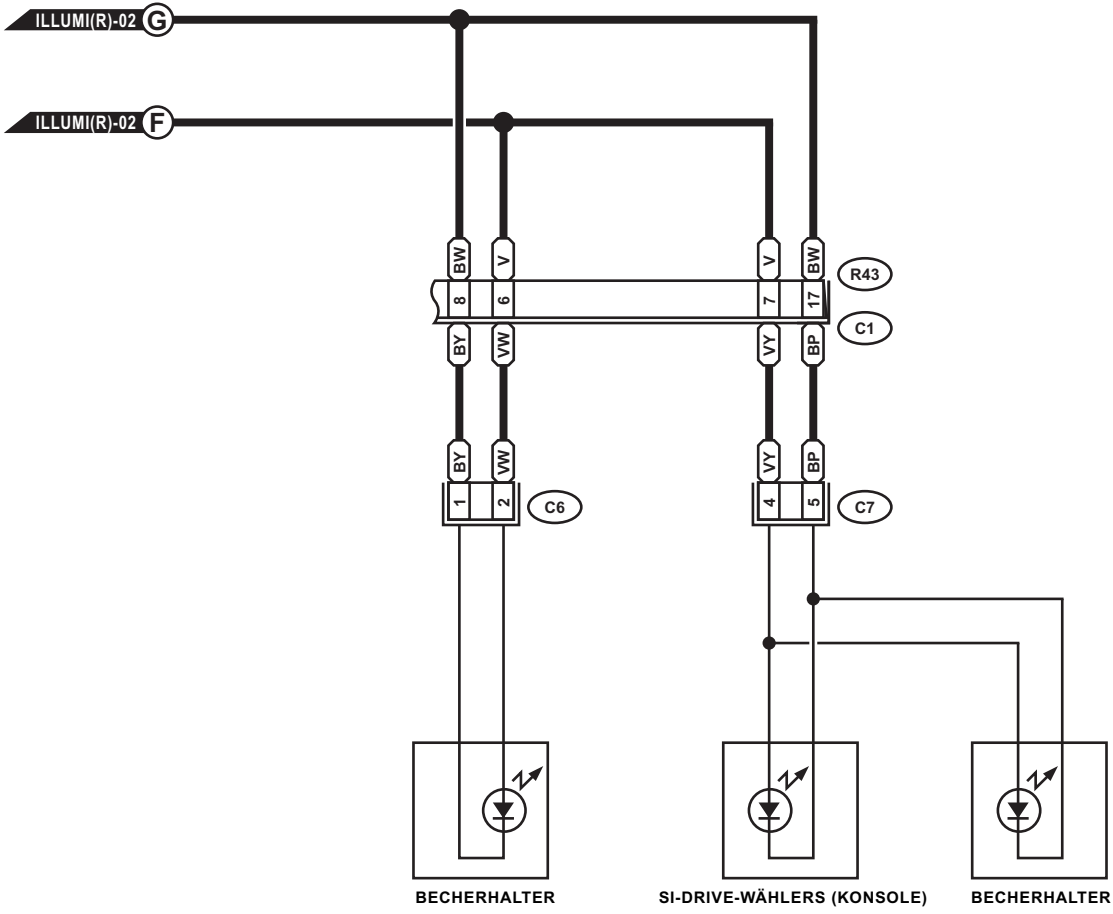

C6



C7

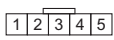

R43

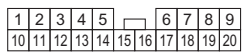

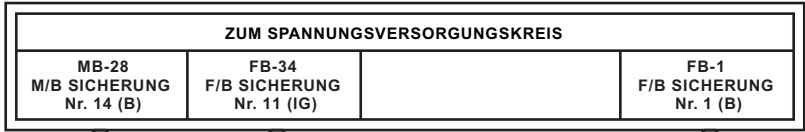

C TURN(L)-02

B32 BLINK- UND WARNBLINKMODUL

OM : OHNE SPIEGELHEIZUNG NM : NORMALE ANZEIGE
 WM : MIT SPIEGELHEIZUNG
 *1 : KLEMMEN-Nr. OPTIONALE ANORDNUNG BEI 1, 2, 3, 4, 5 UND 6

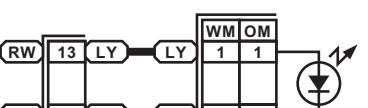
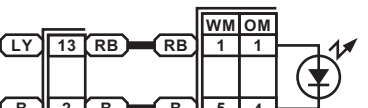
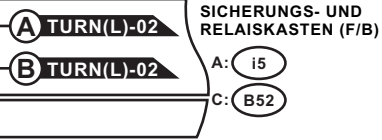
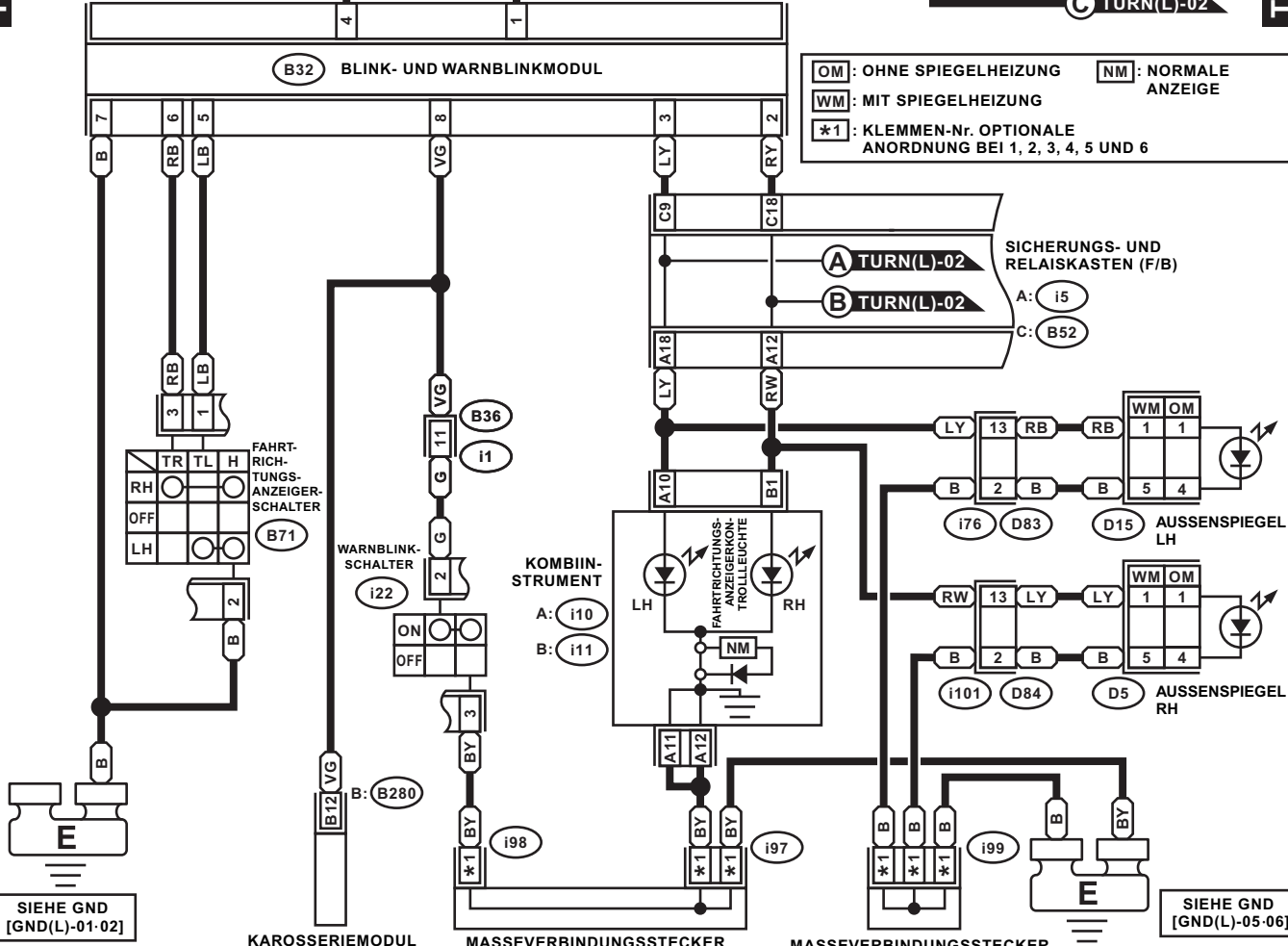

SIEHE GND [GND(L)-01-02]

SIEHE GND [GND(L)-05-06]

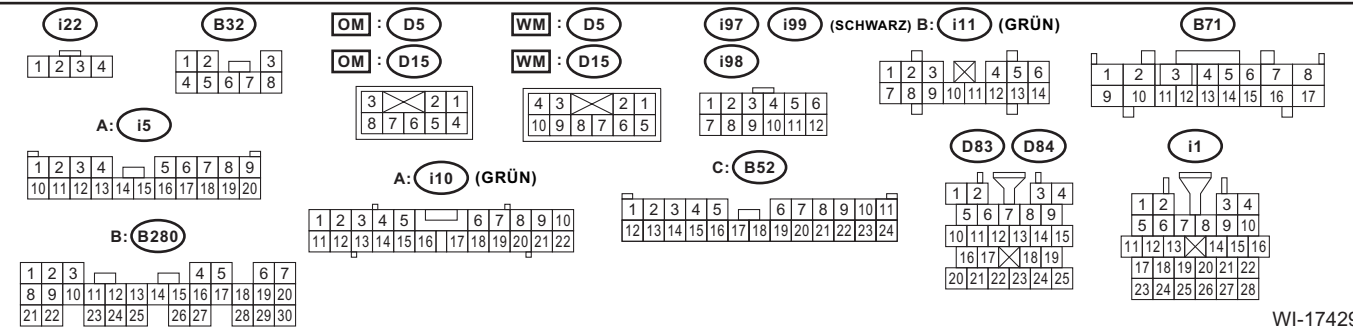

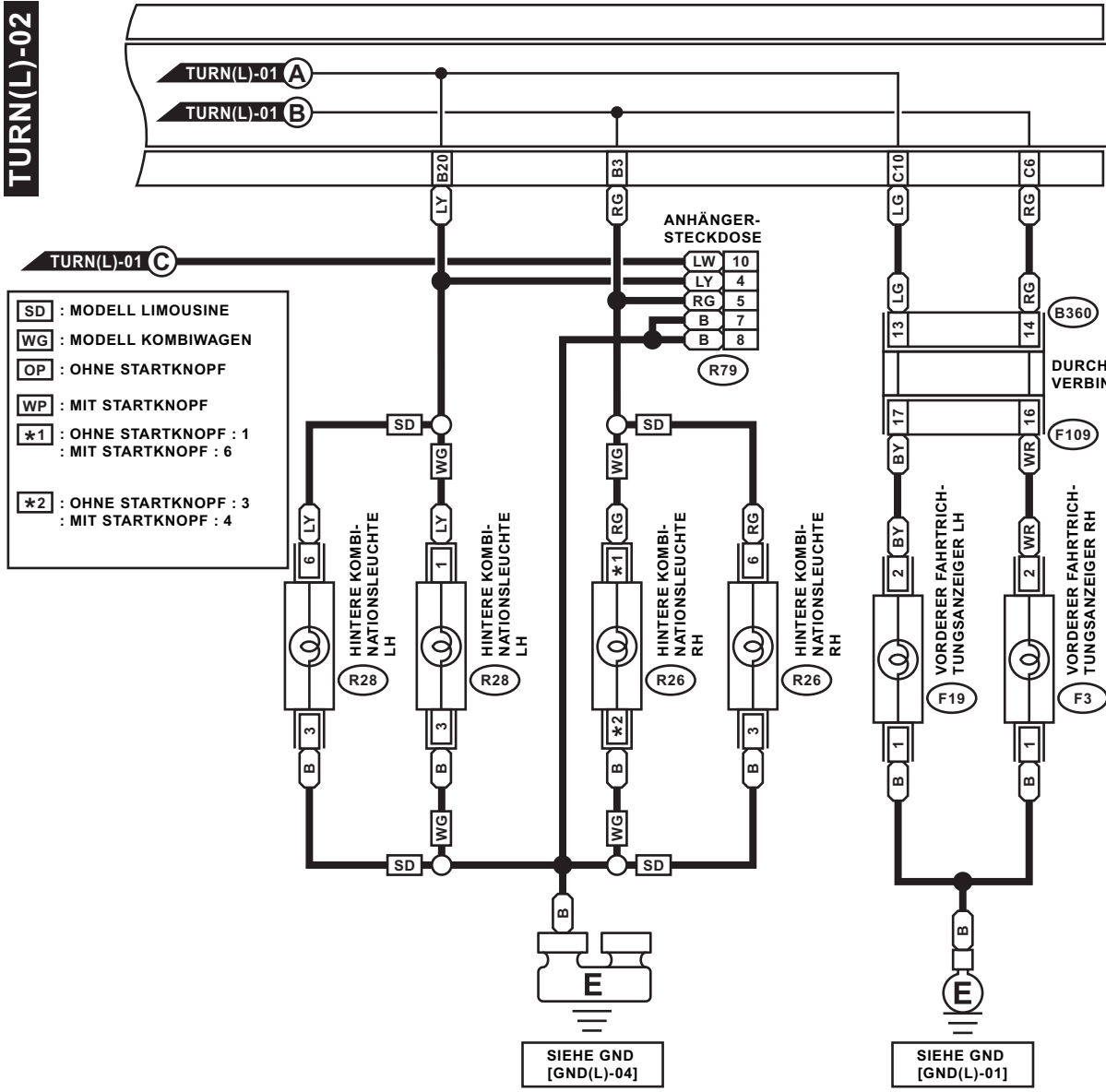

SICHERUNGS- UND RELAIS-KASTEN (F/B)

B: R168
C: B52

- SD : MODELL LIMOUSINE
- WG : MODELL KOMBIWAGEN
- OP : OHNE STARTKNOPF
- WP : MIT STARTKNOPF
- *1 : OHNE STARTKNOPF : 1
: MIT STARTKNOPF : 6
- *2 : OHNE STARTKNOPF : 3
: MIT STARTKNOPF : 4

ANHÄNGER-STECKDOSE

LW	10
LY	4
RG	5
B	7
B	8

B360

DURCHSTECK-VERBINDER

F109

VORDERER FAHRTRICHTUNGSANZEIGER LH

VORDERER FAHRTRICHTUNGSANZEIGER RH

SIEHE GND [GND(L)-04]

SIEHE GND [GND(L)-01]

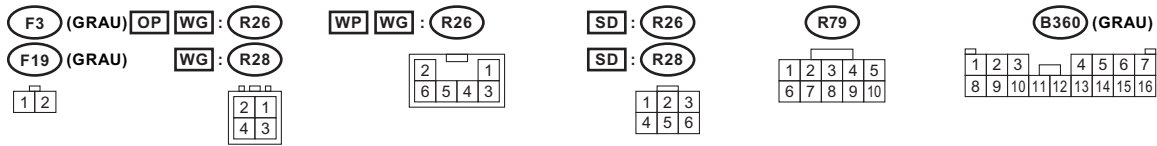

C: B52

F109

B: R168

1	2	3	4		5	6	7	8	9	
10	11	12	13	14	15	16	17	18	19	20

1	2	3	4	5		6	7	8	9	10	11	
12	13	14	15	16	17	18	19	20	21	22	23	24

- OD** : OHNE DOPPELVERRIEGELUNG **OM** : OHNE SPIEGELHEIZUNG **NM** : NORMALE ANZEIGE
- WD** : MIT DOPPELVERRIEGELUNG **WM** : MIT SPIEGELHEIZUNG
- KA** : KA-MODELL ***1** : KLEMMEN-Nr. OPTIONALE ANORDNUNG BEI 1, 2, 3, 4, 5 UND 6
- EK** : EK-MODELL

ZUM SPANNUNGSVERSORGENSKREIS		
MB-28 M/B SICHERUNG Nr. 14 (B)	FB-34 F/B SICHERUNG Nr. 11 (IG)	FB-1 F/B SICHERUNG Nr. 1 (B)

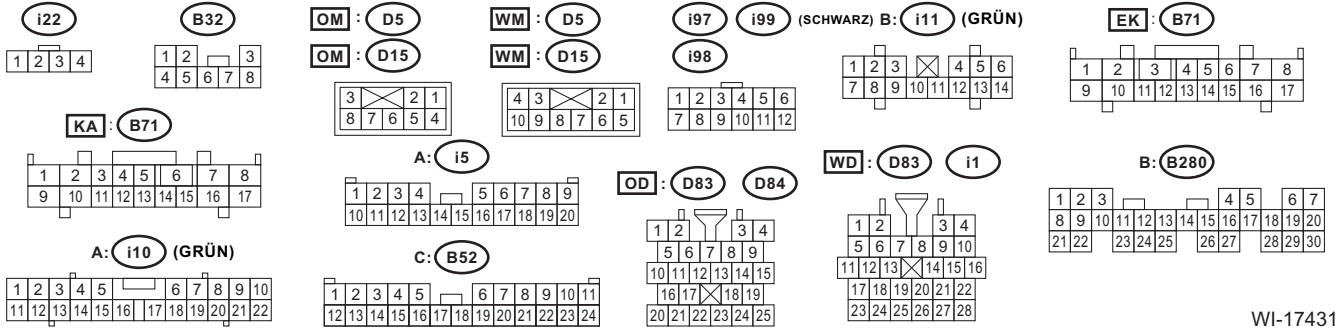
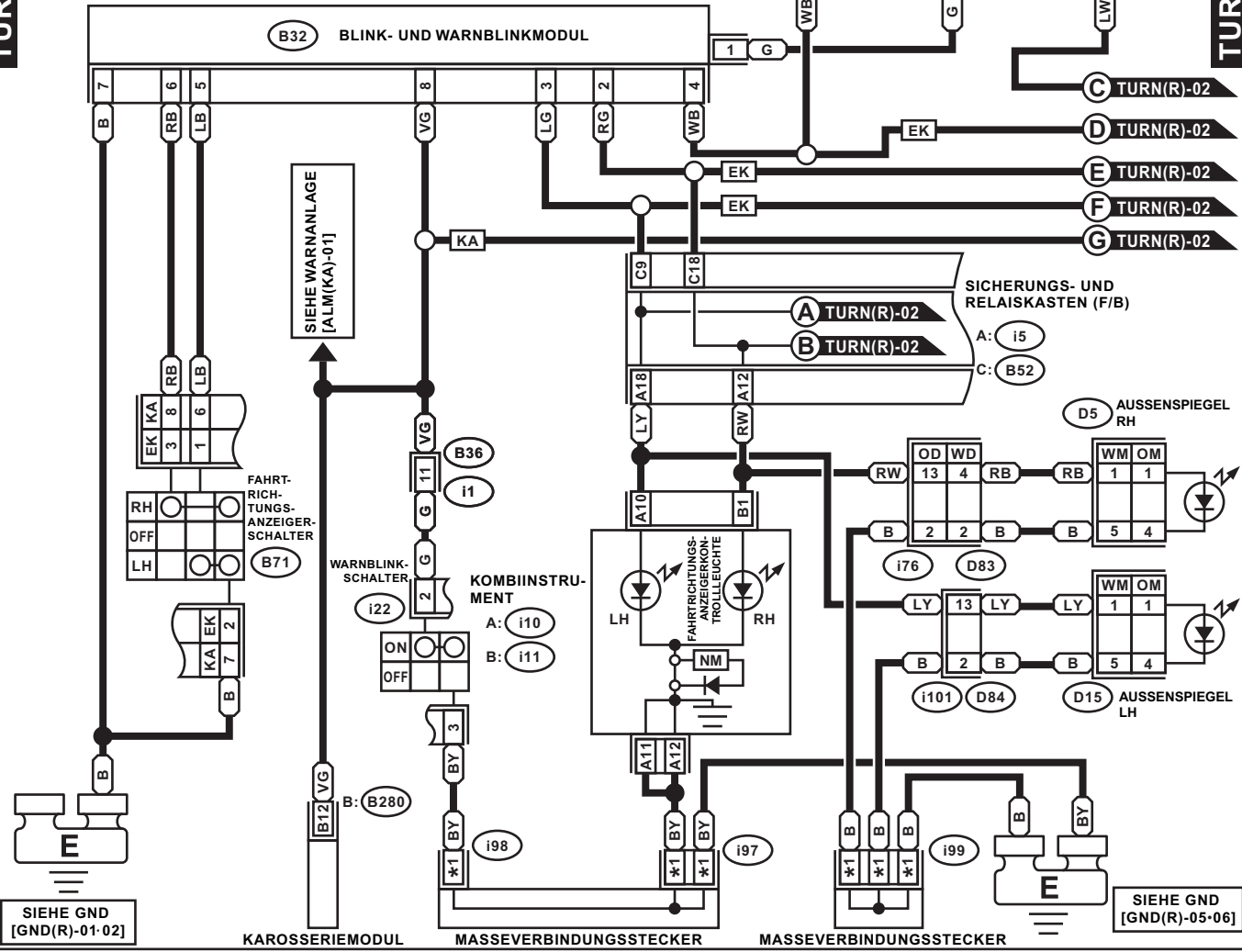

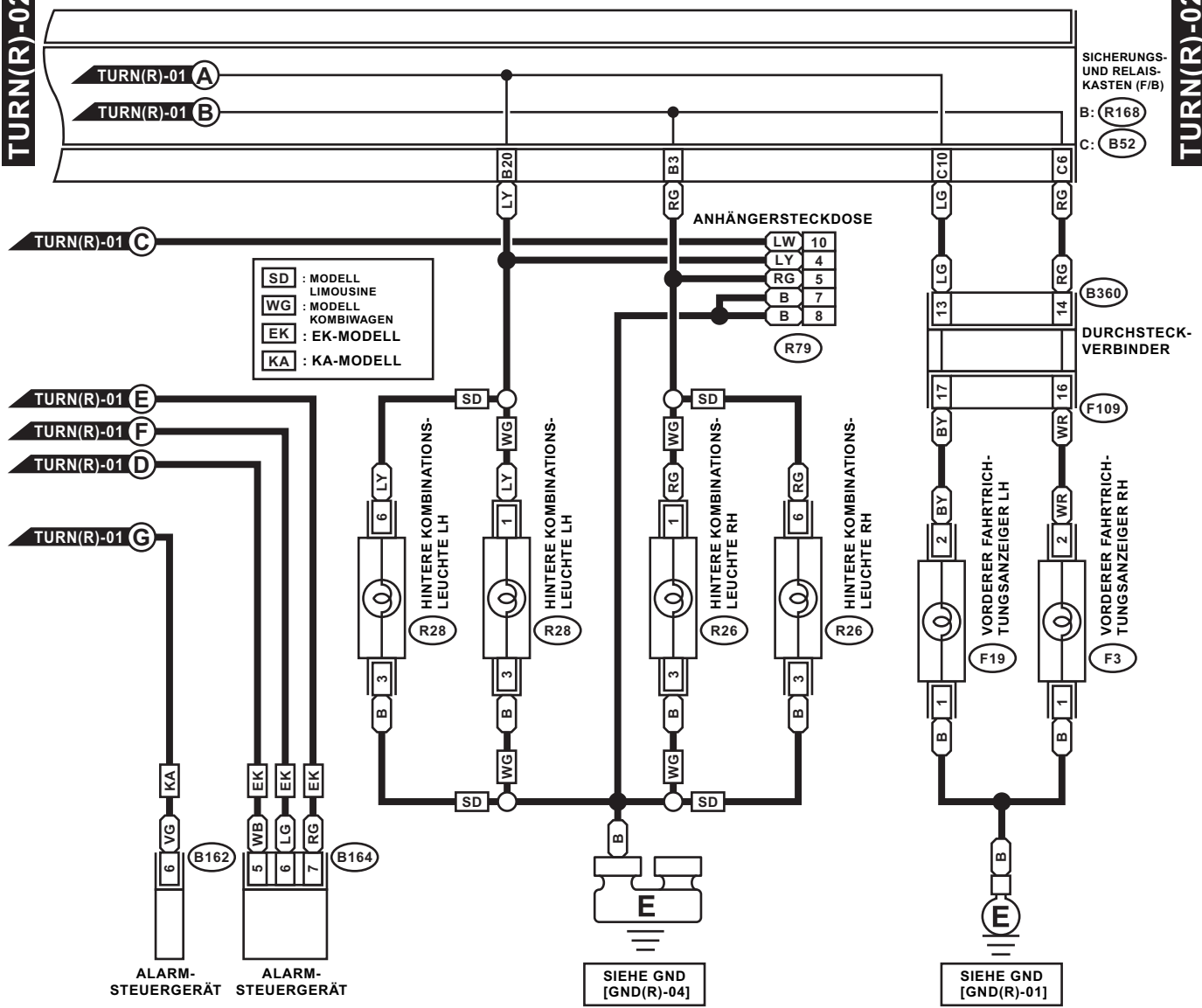

SICHERUNGS- UND RELAIS-KASTEN (FB)

B: R168
C: B52

B360

DURCHSTECK-VERBINDER

F109

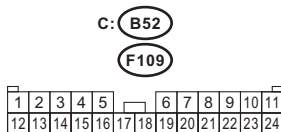
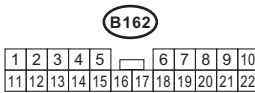
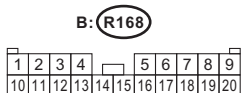
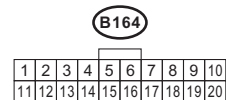
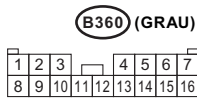
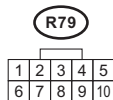
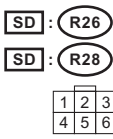
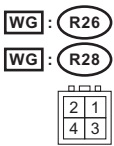

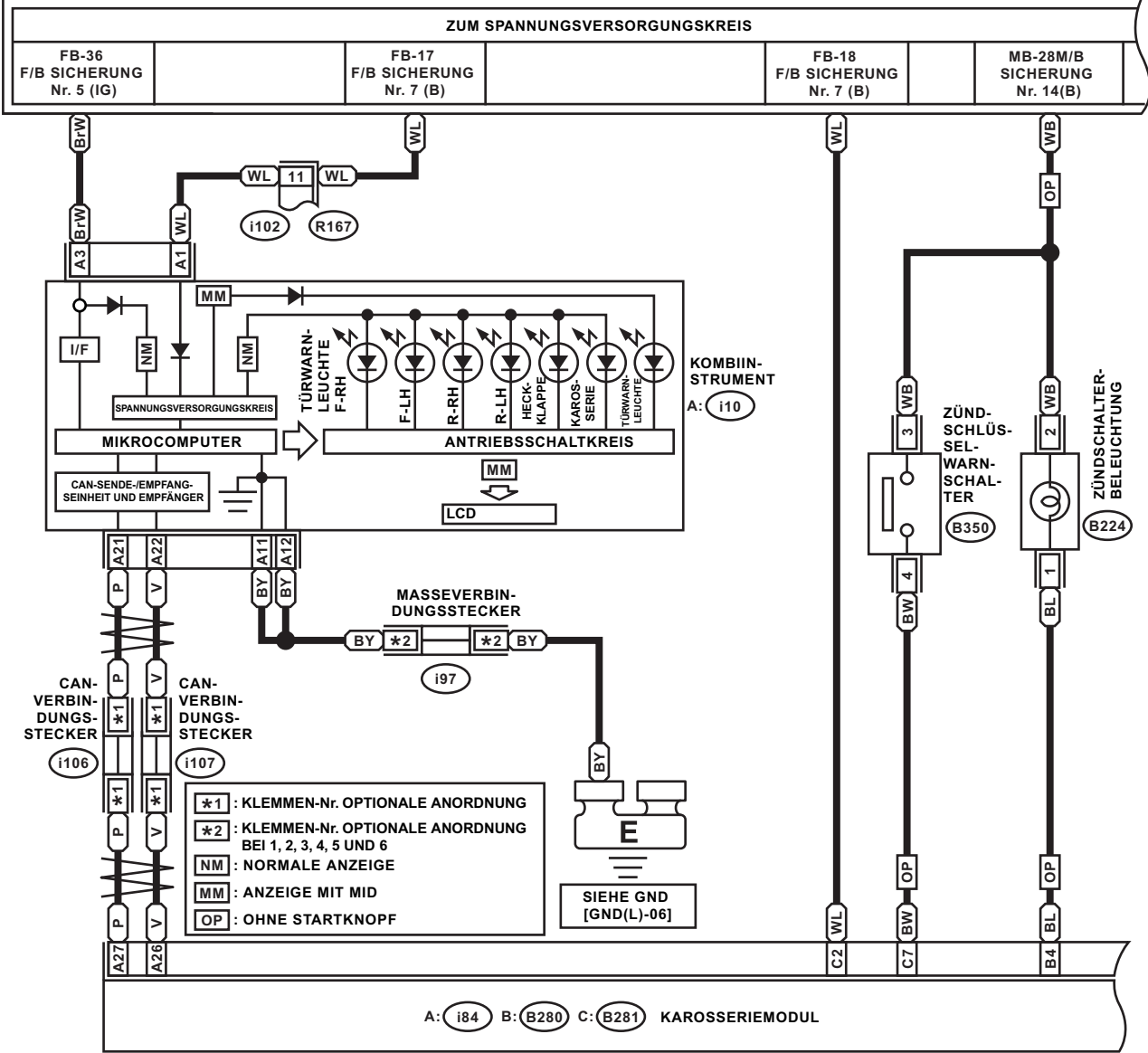

B224

1	2
---	---

B350

1	2	3	4
---	---	---	---

i106

1	2	3	4
---	---	---	---

i107

i97

1	2	3	4	5	6
7	8	9	10	11	12

i102

1	2	3	4	5	6	7	8		
9	10	11	12	13	14	15	16	17	18

A: i10 (GRÜN)

1	2	3	4	5	6	7	8	9	10		
11	12	13	14	15	16	17	18	19	20	21	22

C: B281

1	2	3	4	5	6	7					
8	9	10	11	12	13	14	15	16	17	18	19
20	21	22	23	24	25	26	27	28			

B: B280

1	2	3	4	5	6	7						
8	9	10	11	12	13	14	15	16	17	18	19	20
21	22	23	24	25	26	27	28	29	30			

A: i84 (GRAU)

1	2	3	4	5	6	7	8							
9	10	11	12	13	14	15	16	17	18	19	20	21	22	23
24	25	26	27	28	29	30	31	32	33	34	35			

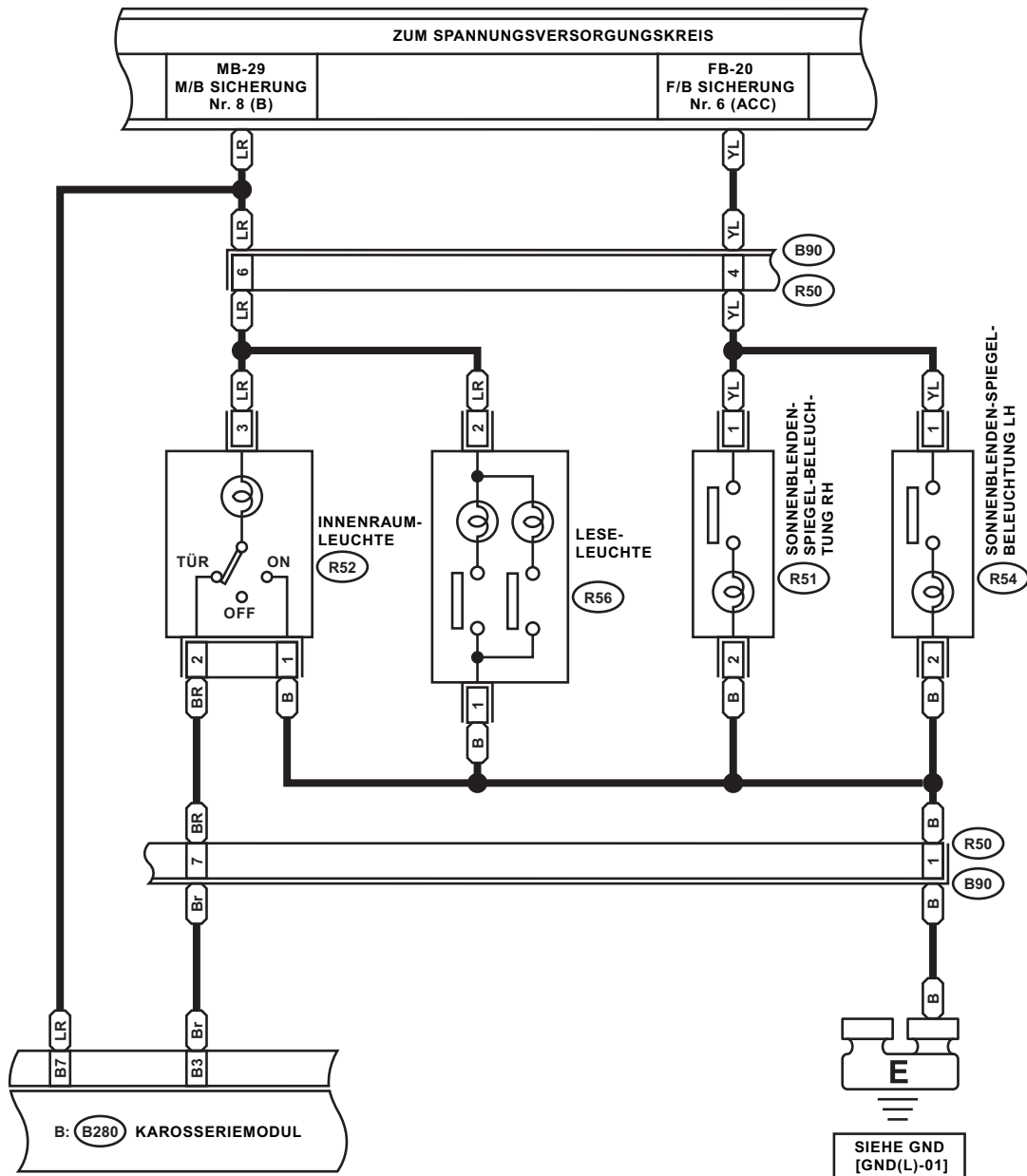

R51 (SCHWARZ)

R52

R50

B: B280

R54 (SCHWARZ)



ZUM SPANNUNGSVERSORUNGSKREIS

FB-11
M/B SICHERUNG
Nr. 8 (B)

FB-10
M/B SICHERUNG
Nr. 8 (B)

- SD : MODELL LIMOUSINE
- WG : MODELL KOMBIWAGEN
- OP : OHNE STARTKNOPF
- WP : MIT STARTKNOPF
- *1 : KLEMMEN-Nr. OPTIONALE ANORDNUNG BEI 1, 2, 3, 4, 5 UND 6
- *2 : OHNE STARTKNOPF : LW MIT STARTKNOPF : LOR

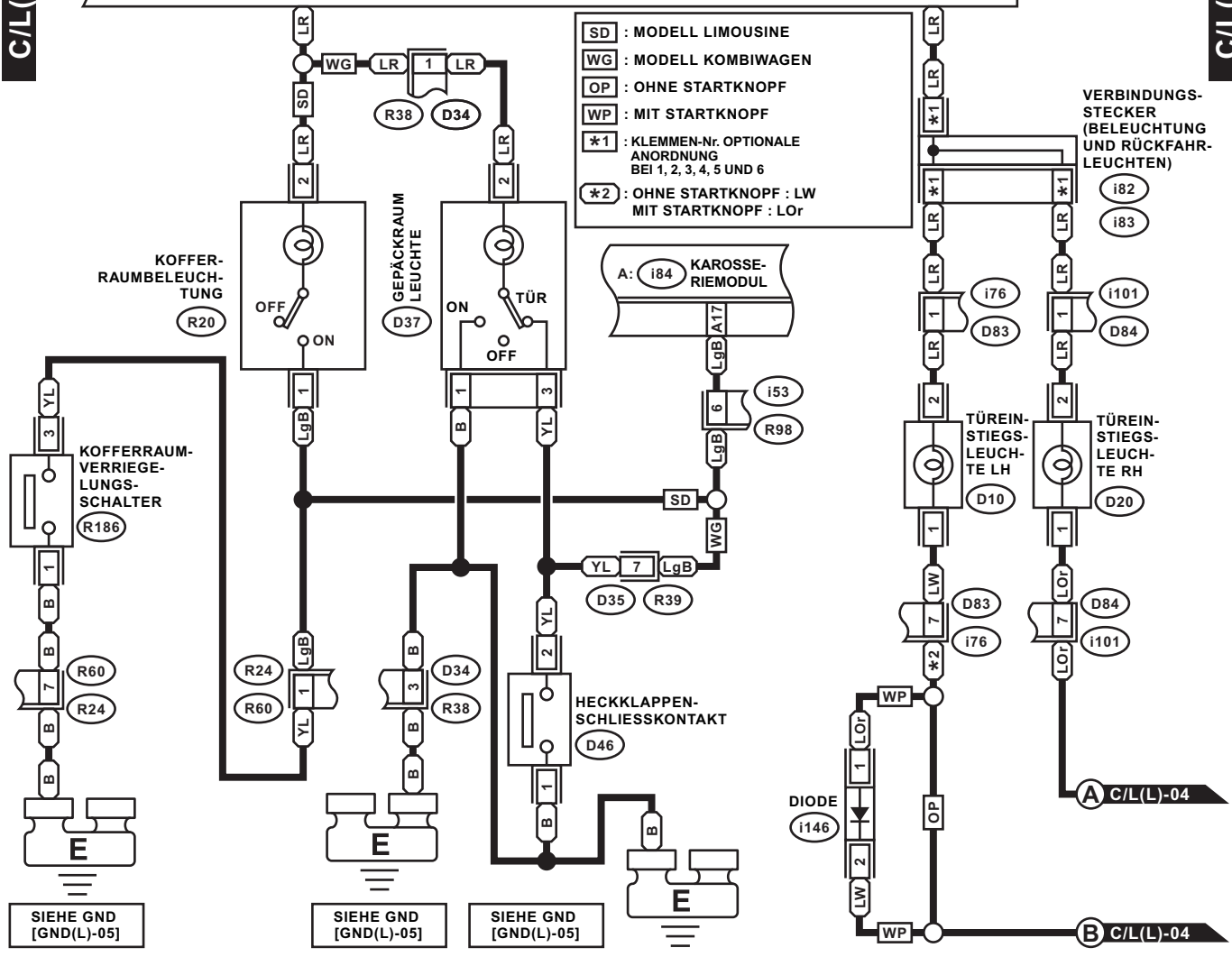

VERBINDUNGS-
STECKER
(BELEUCHTUNG
UND RÜCKFAHR-
LEUCHTEN)



A C/L(L)-04

B C/L(L)-04

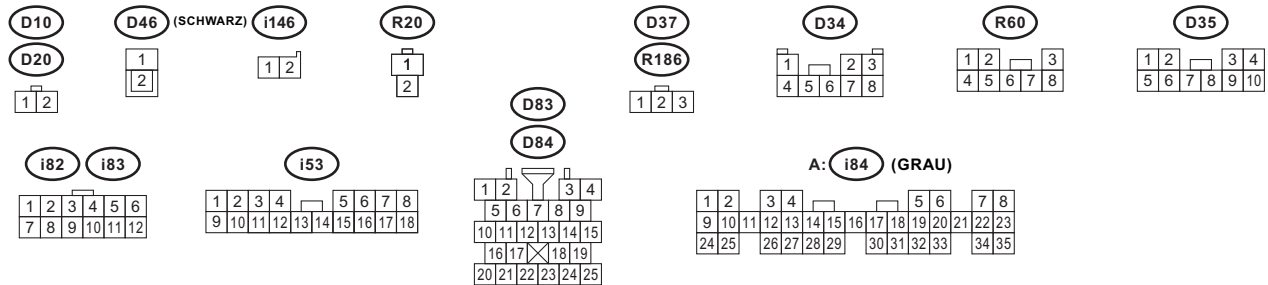

A: i84 B: B280 C: B281 KAROSSERIEMODUL

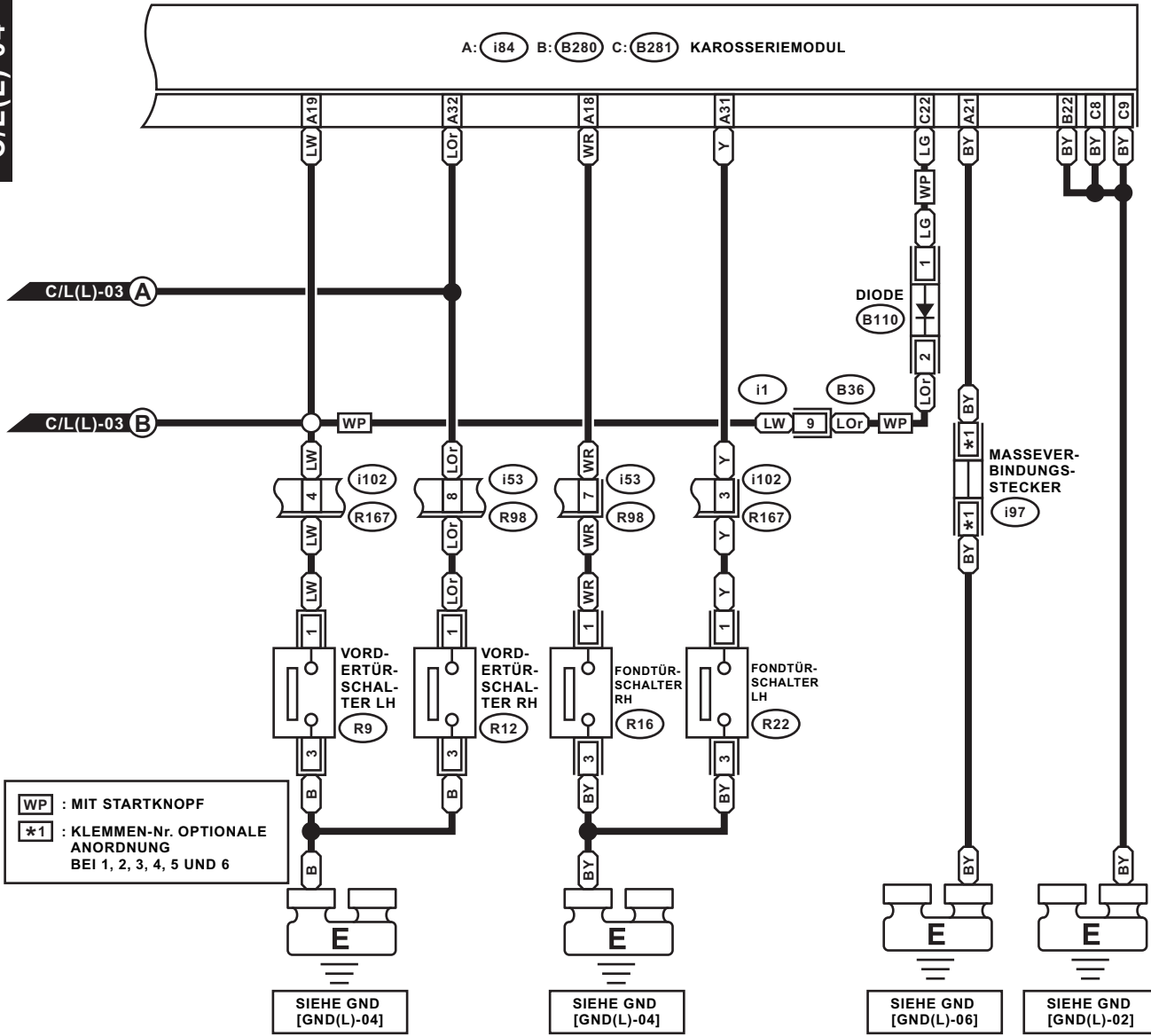

WP : MIT STARTKNOPF
 *1 : KLEMMEN-Nr. OPTIONALE ANORDNUNG BEI 1, 2, 3, 4, 5 UND 6

SIEHE GND [GND(L)-04]

SIEHE GND [GND(L)-04]

SIEHE GND [GND(L)-06]

SIEHE GND [GND(L)-02]

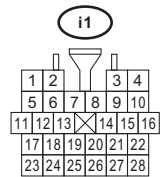
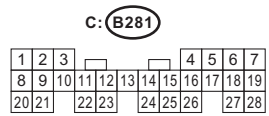
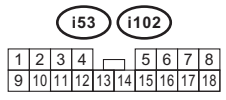
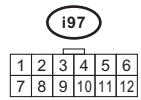
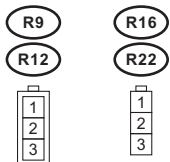
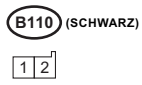

B: B280



A: i84 (GRAU)

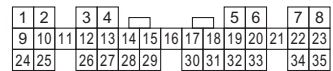

ZUM SPANNUNGSVERSORUNGSKREIS

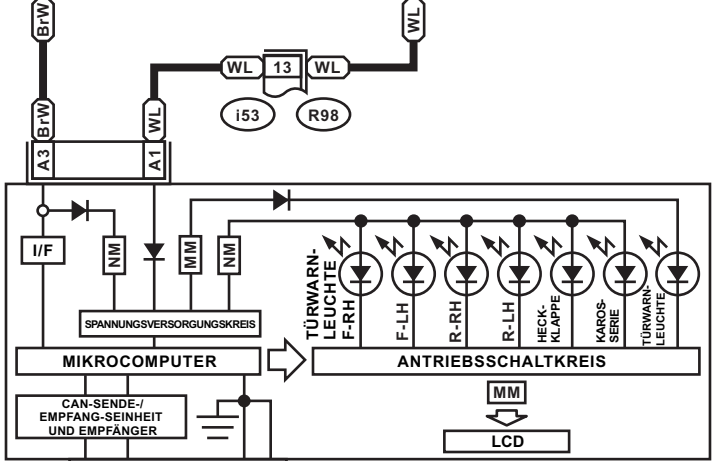
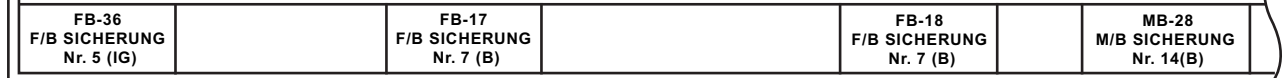

KOMBI-STRUMENT
A: (i10)

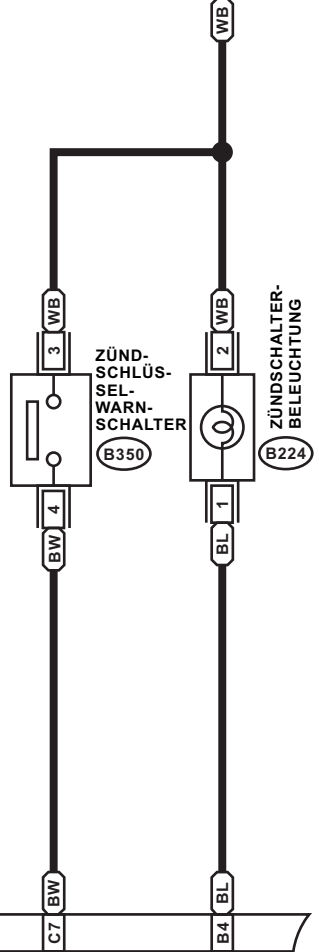

- *1 : KLEMMEN-Nr. OPTIONALE ANORDNUNG BEI 1, 2, 3 UND 4
- *2 : KLEMMEN-Nr. OPTIONALE ANORDNUNG BEI 1, 2, 3, 4, 5 UND 6
- NM : NORMALE ANZEIGE
- MM : ANZEIGE MIT MID

SIEHE GND [GND(R)-06]

A: (i84) B: (B280) C: (B281) KAROSSERIEMODUL

B224

B350

i106

i107

i97

i53

A: (i10) (GRÜN)

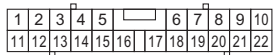
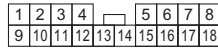
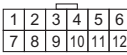

C: (B281)

B: (B280)

A: (i84) (GRAU)

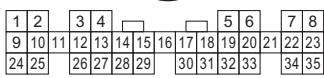
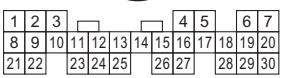
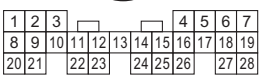

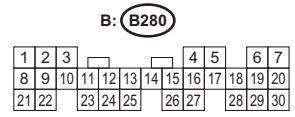
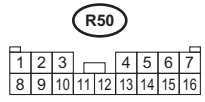
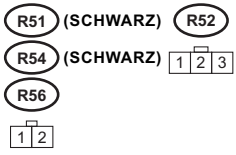
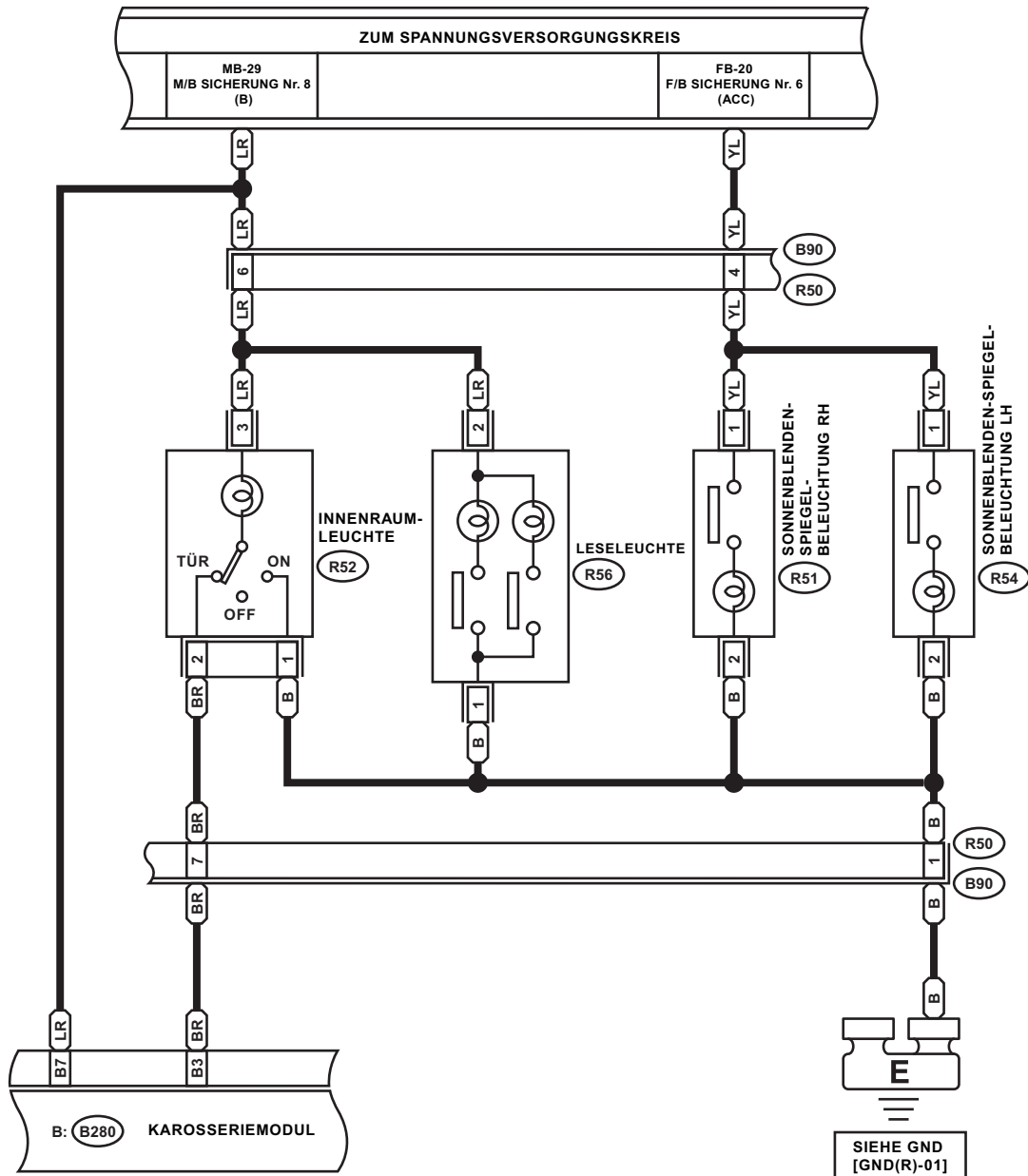

ZUM SPANNUNGSVERSORUNGSKREIS

FB-11
M/B SICHERUNG
Nr. 8 (B)

FB-10
M/B SICHERUNG
Nr. 8 (B)

- KA : KA-MODELL
- EK : EK-MODELL
- OD : OHNE DOPPELVERRIEGELUNG
- WD : MIT DOPPELVERRIEGELUNG
- *1 : KLEMMEN-Nr. OPTIONALE ANORDNUNG BEI 1, 2, 3, 4, 5 UND 6
- SD : MODELL LIMOUSINE
- WG : MODELL KOMBIWAGEN
- *2 : KA-MODELL: 20
EK-MODELL: 12

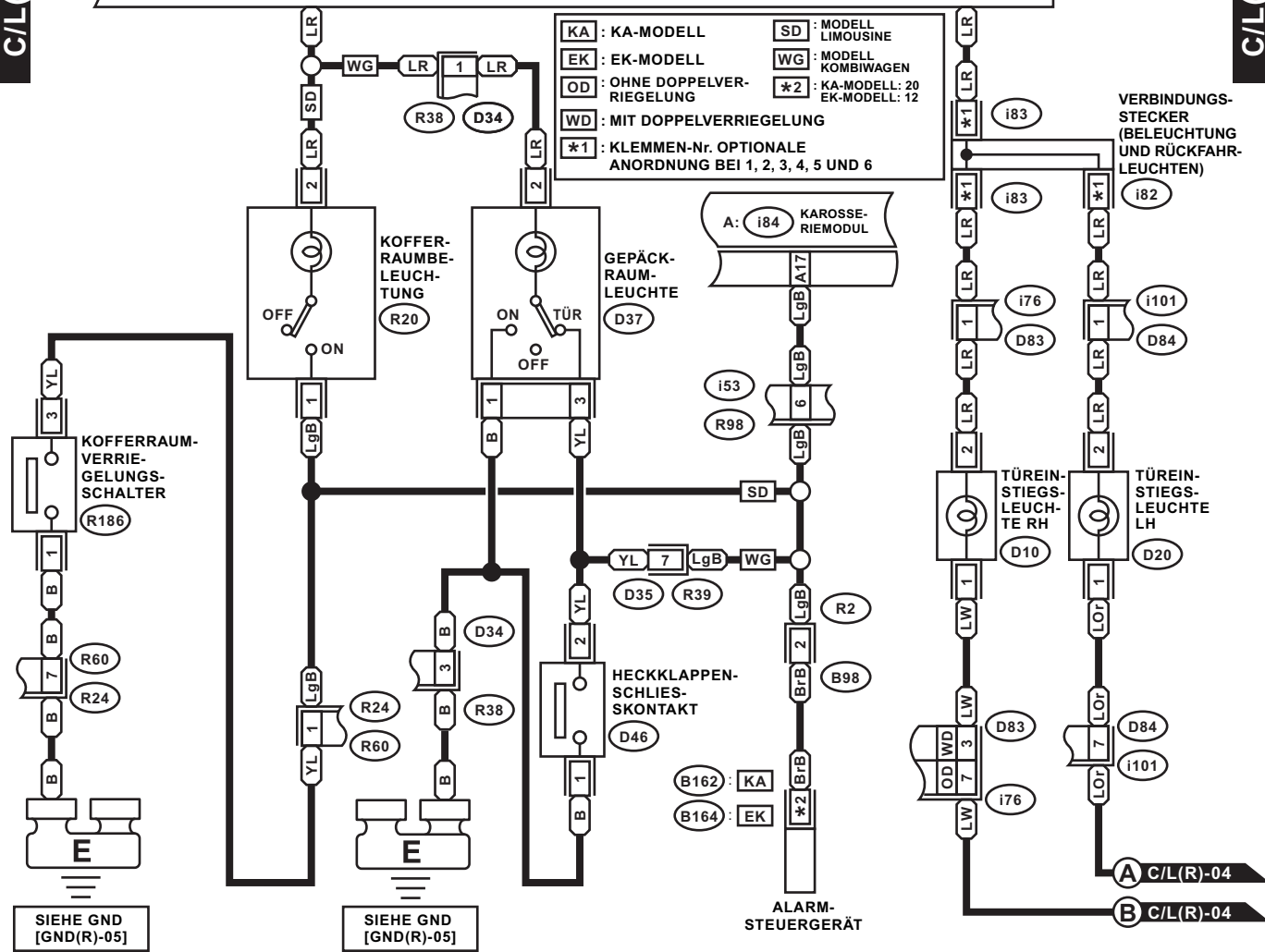

VERBINDUNGS-
STECKER
(BELEUCHTUNG
UND RÜCKFAHR-
LEUCHTEN)

A: i84 KAROSSE-
RIEMODUL

TÜREIN-
STIEGS-
LEUCHTE
RH

TÜREIN-
STIEGS-
LEUCHTE
LH

ALARM-
STEUERGERÄT

SIEHE GND
[GND(R)-05]

SIEHE GND
[GND(R)-05]

A C/L(R)-04

B C/L(R)-04

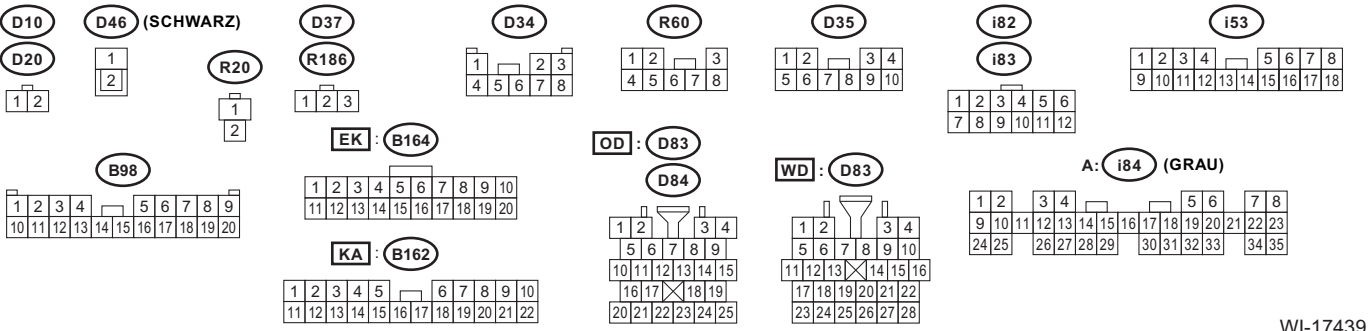

A: i84 B: B280 C: B281 KAROSSERIEMODUL



*1 : KLEMMEN-Nr. OPTIONALE ANORDNUNG BEI 1, 2, 3, 4, 5 UND 6

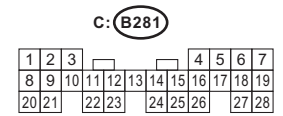
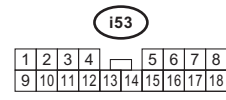
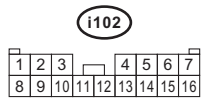
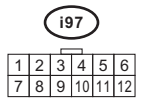
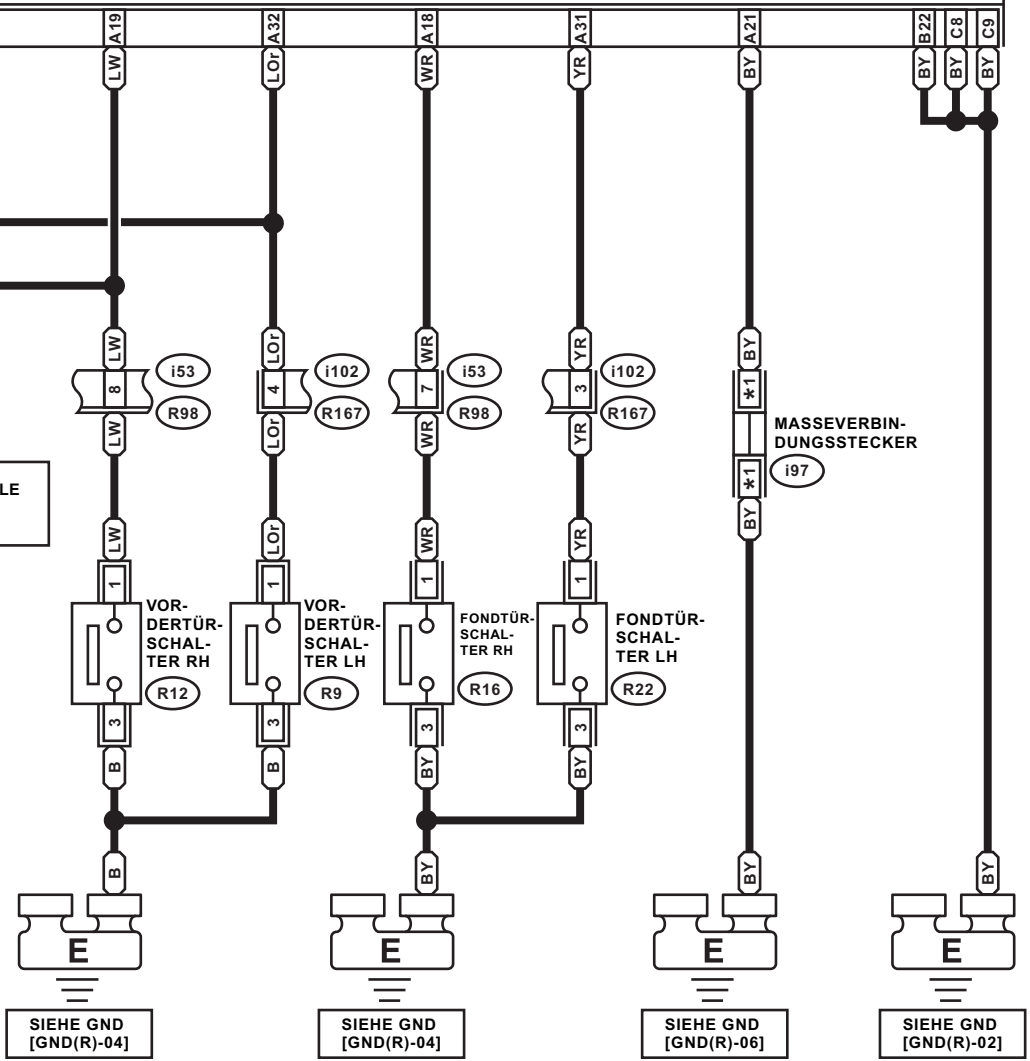

B: B280



A: i84 (GRAU)

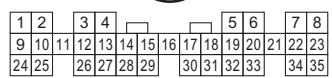

ZUM SPANNUNGS-
VERSORGUNGSKREIS
FB-27
F/B SICHERUNG Nr. 30
(ACC)

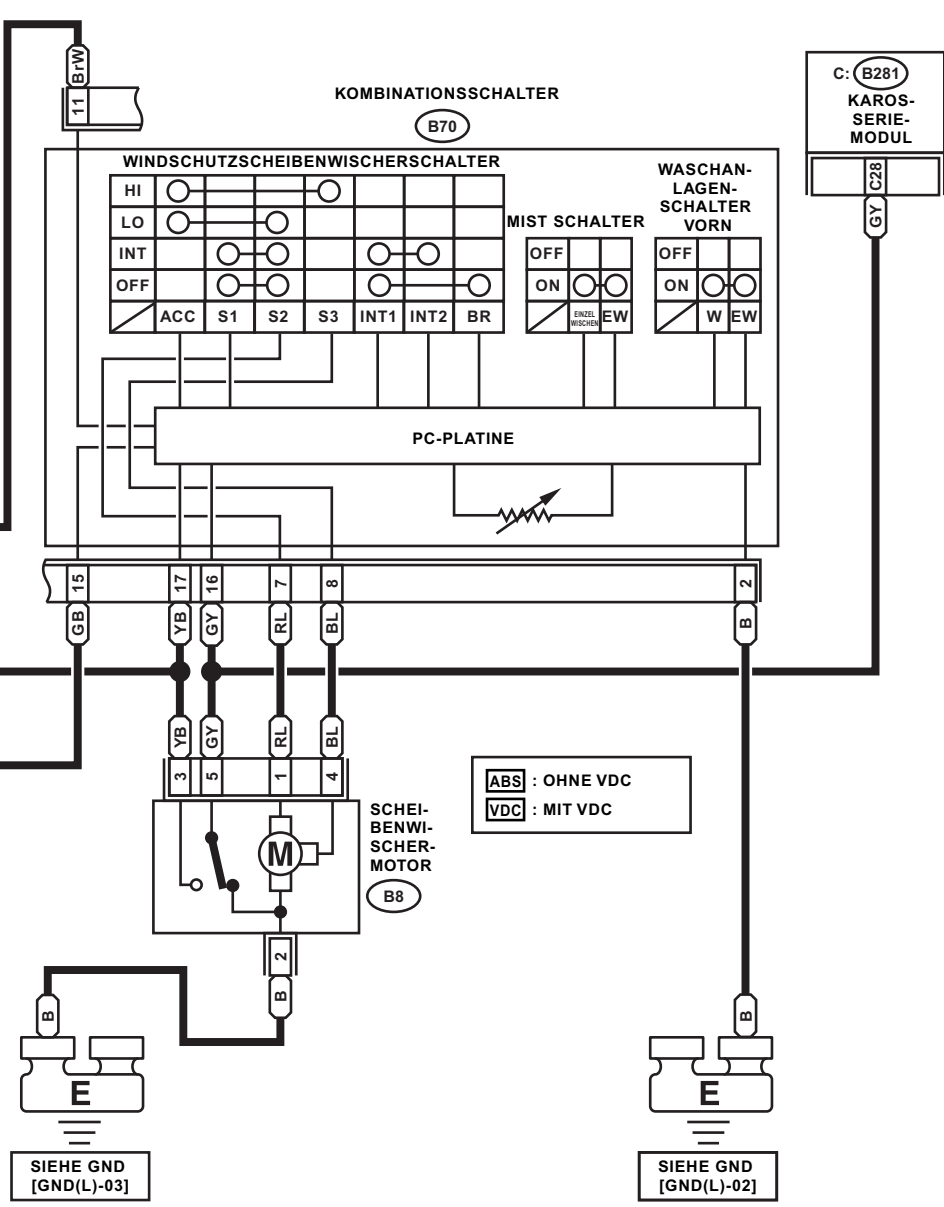
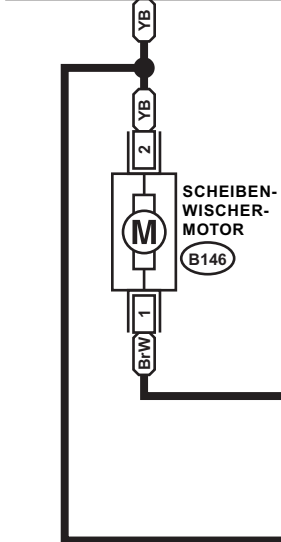

ABS : OHNE VDC
VDC : MIT VDC

VDC-STEUER-
MODUL

ABS-
STEUERMODUL

SIEHE GND
[GND(L)-03]

SIEHE GND
[GND(L)-02]

(B146) (GRAU)



(B8) (GRAU)



(B70)

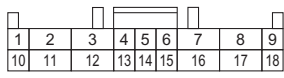

(B301) (SCHWARZ)

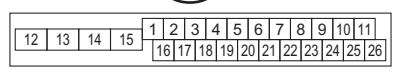

C: (B281)

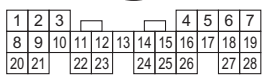

(B310) (SCHWARZ)

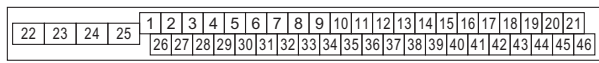

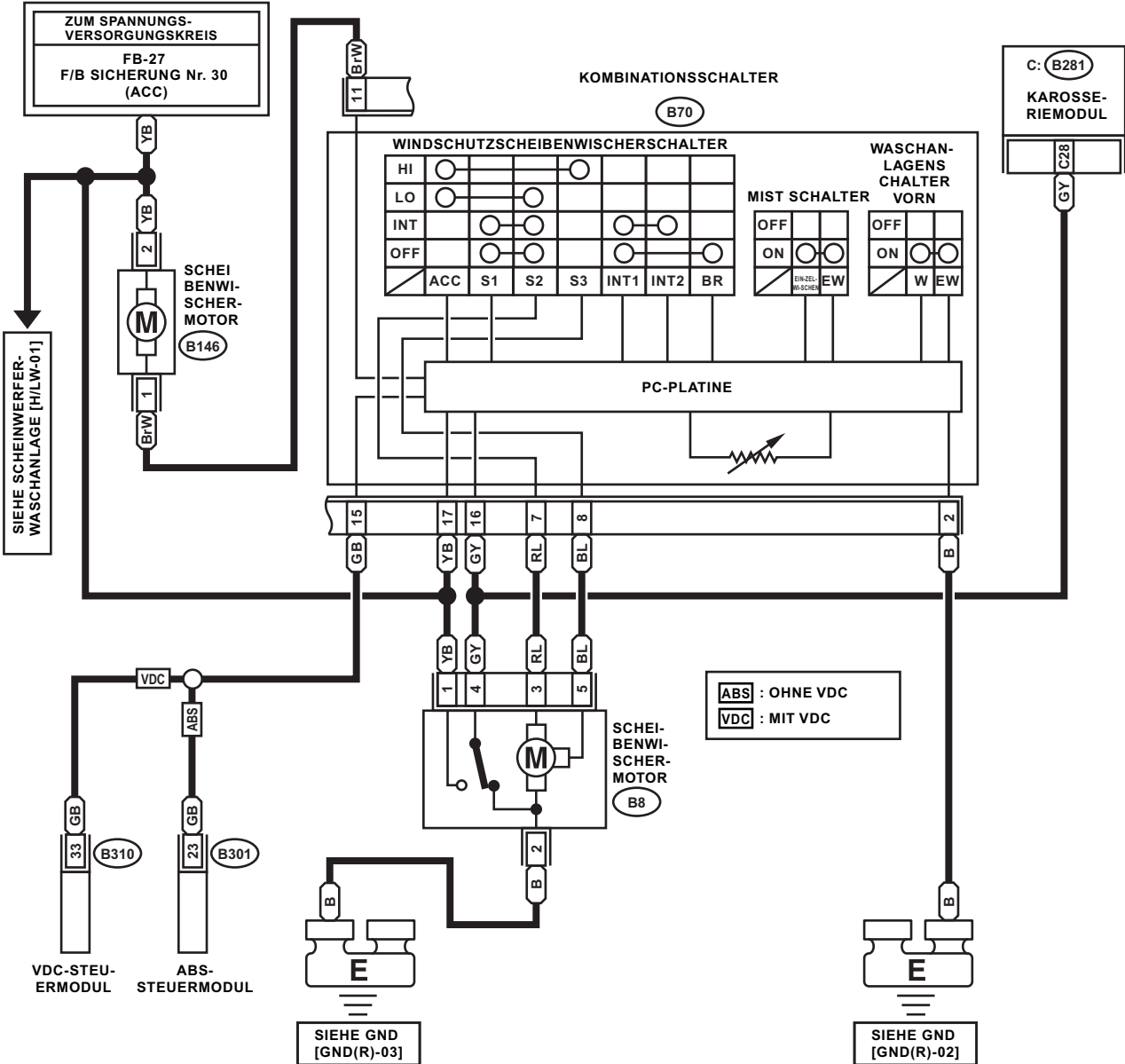

(B146) (GRAU)



(B8) (GRAU)



(B70)

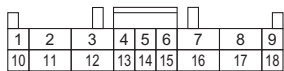

(B301) (SCHWARZ)

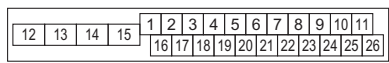

C: (B281)



(B310) (SCHWARZ)

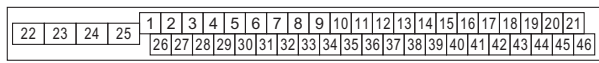

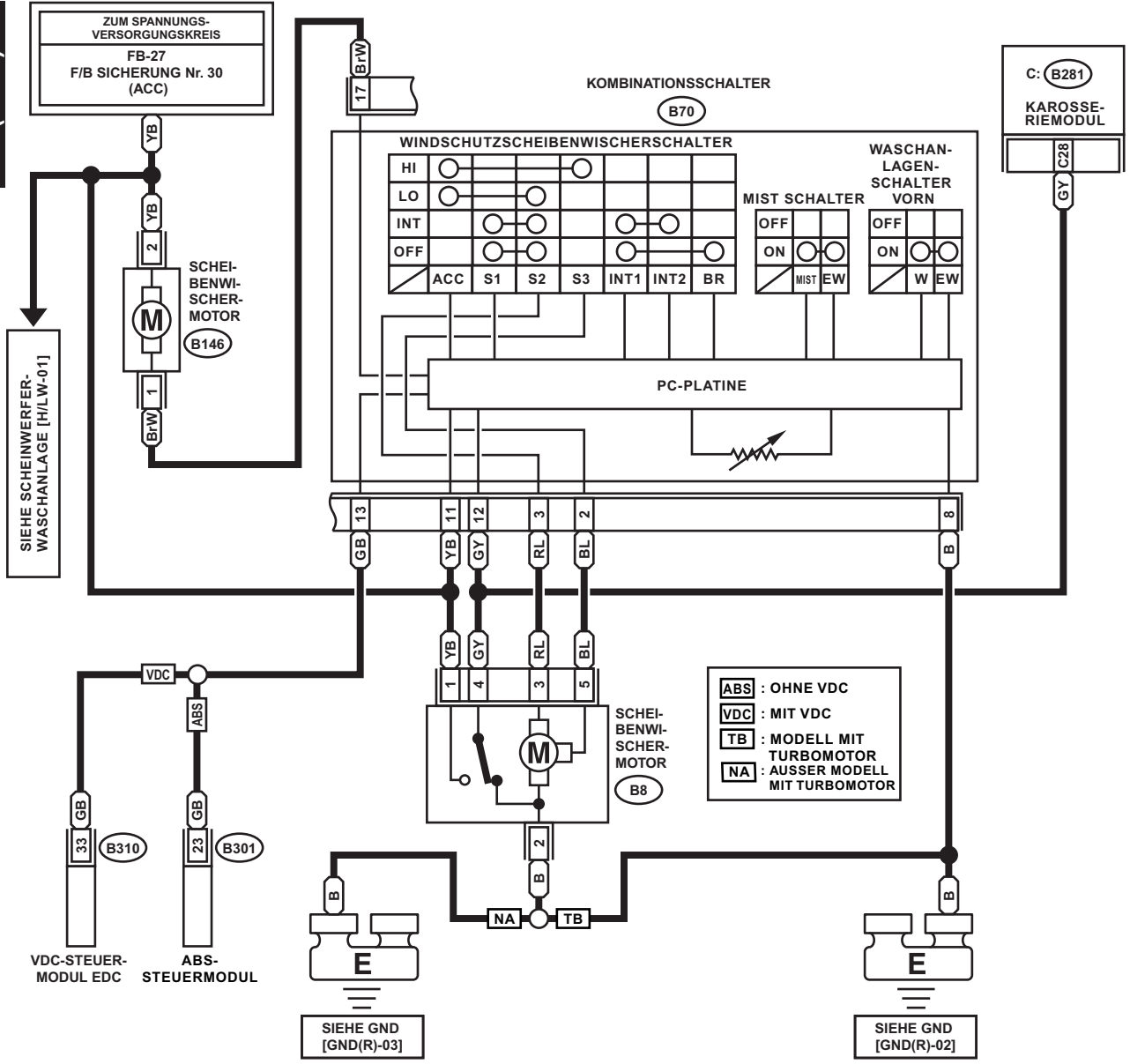

B146 (GRAU)



B8 (GRAU)



B70

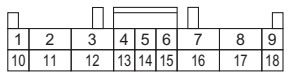

B301 (SCHWARZ)

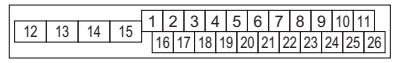

C: B281

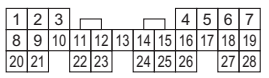

B310 (SCHWARZ)

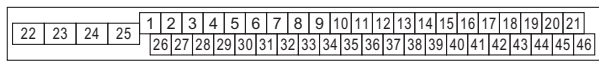

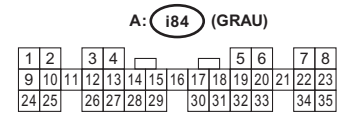
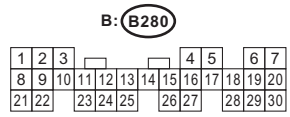
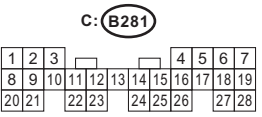
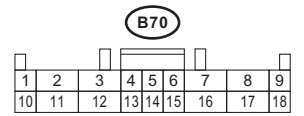
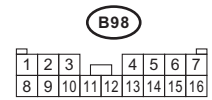
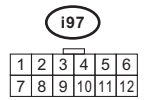
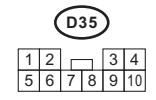
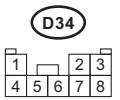
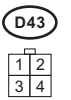
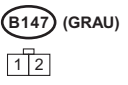
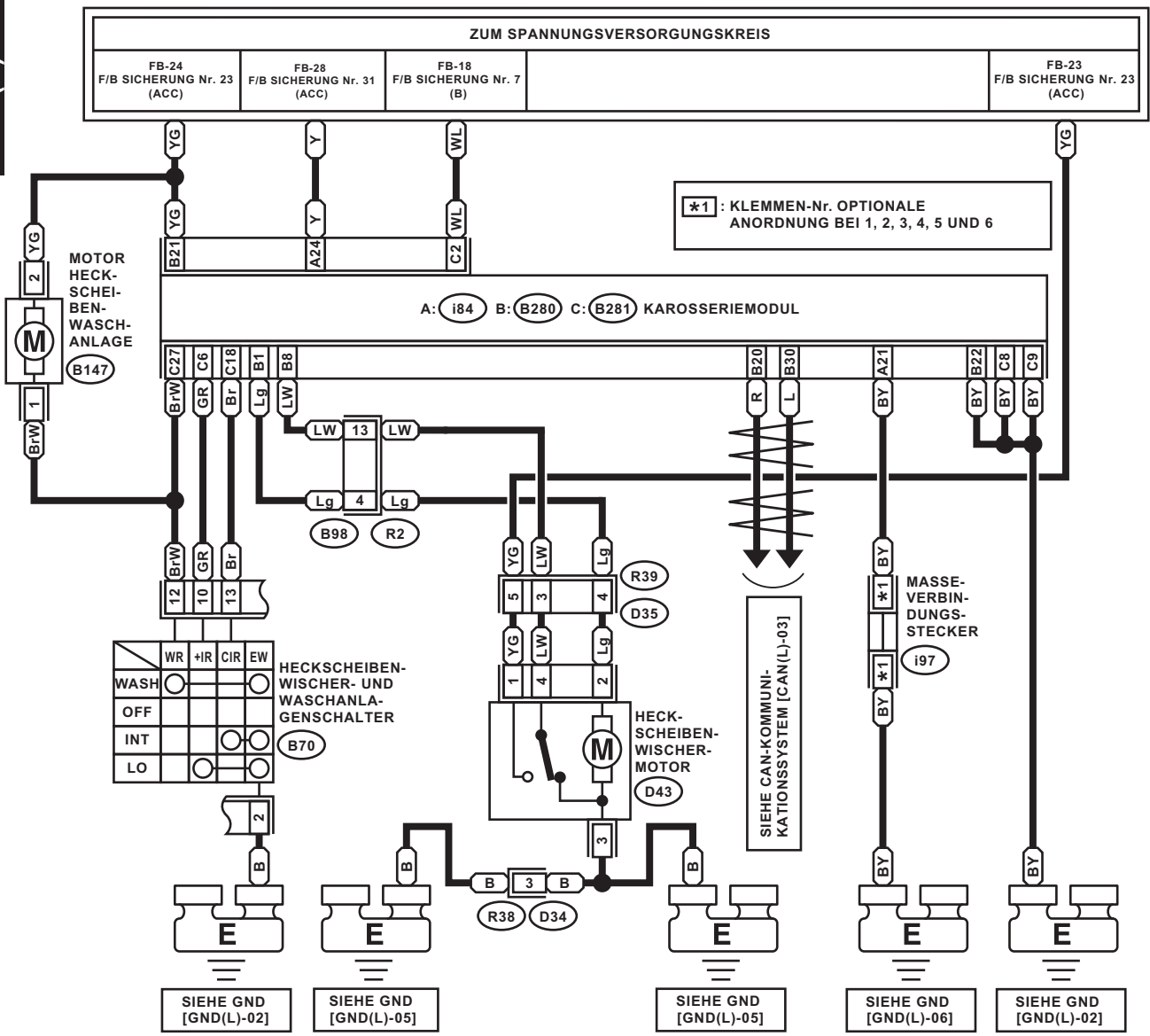



KA : KA-MODELL
EK : AUSSER KA-MODELL
***1** : KLEMMEN-Nr. OPTIONALE ANORDNUNG BEI 1, 2, 3, 4, 5 UND 6
***2** : EK-MODELL: YL
 AUSSER EK-MODELL: YG

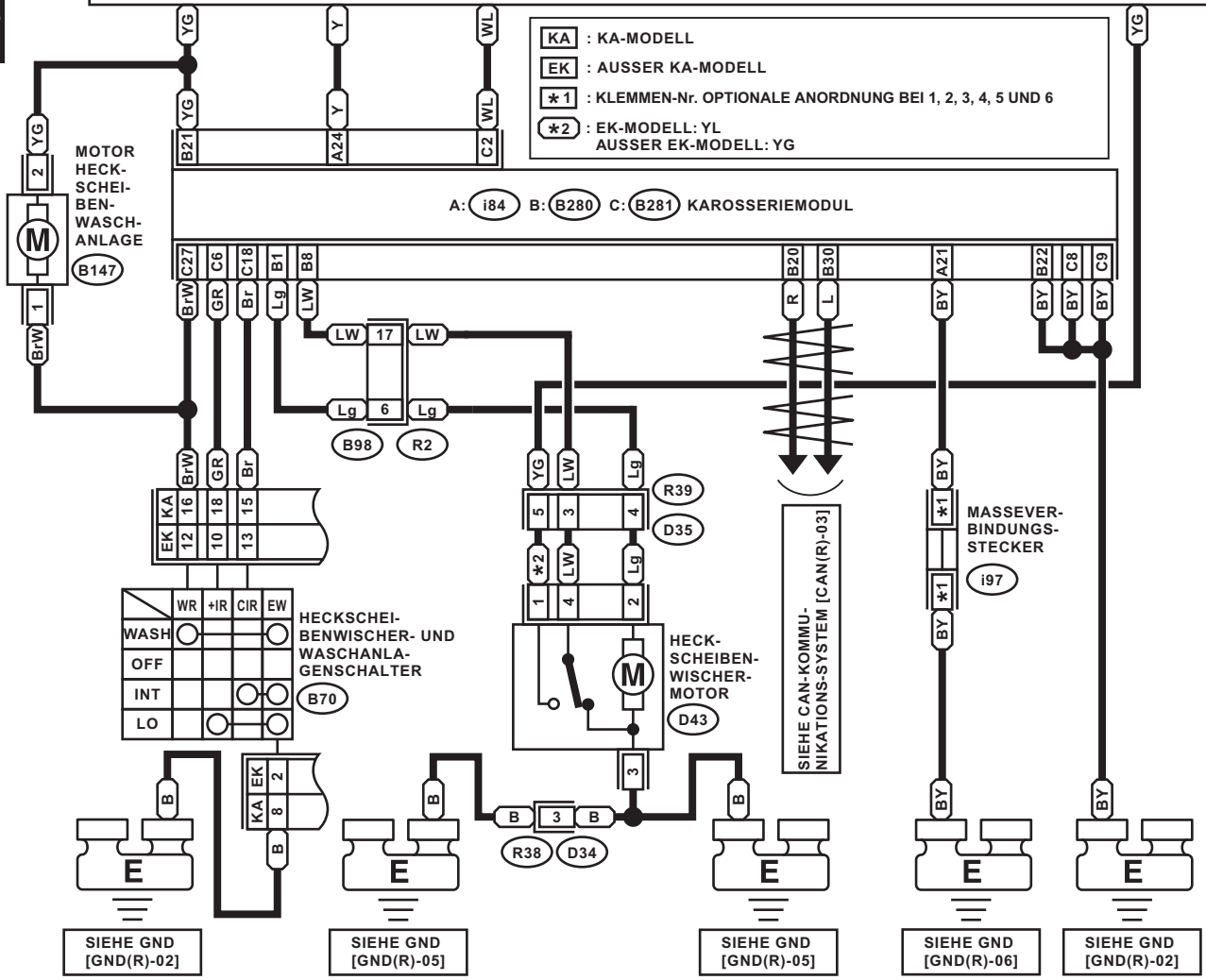

B147 (GRAU)



D43



D34

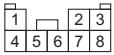

D35

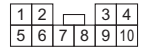

i97

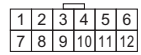

B70

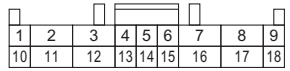

B98

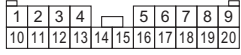

C: B281

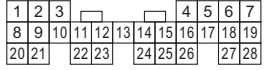

B: B280

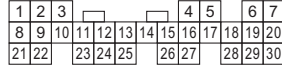

A: i84 (GRAU)

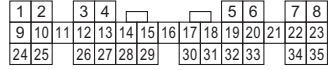

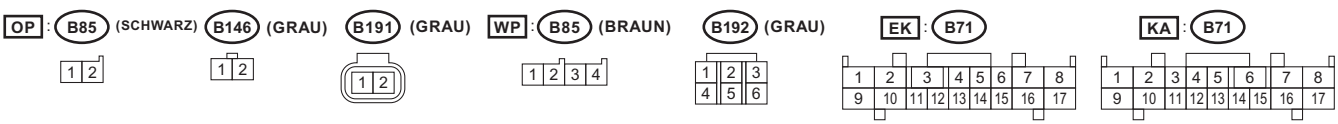
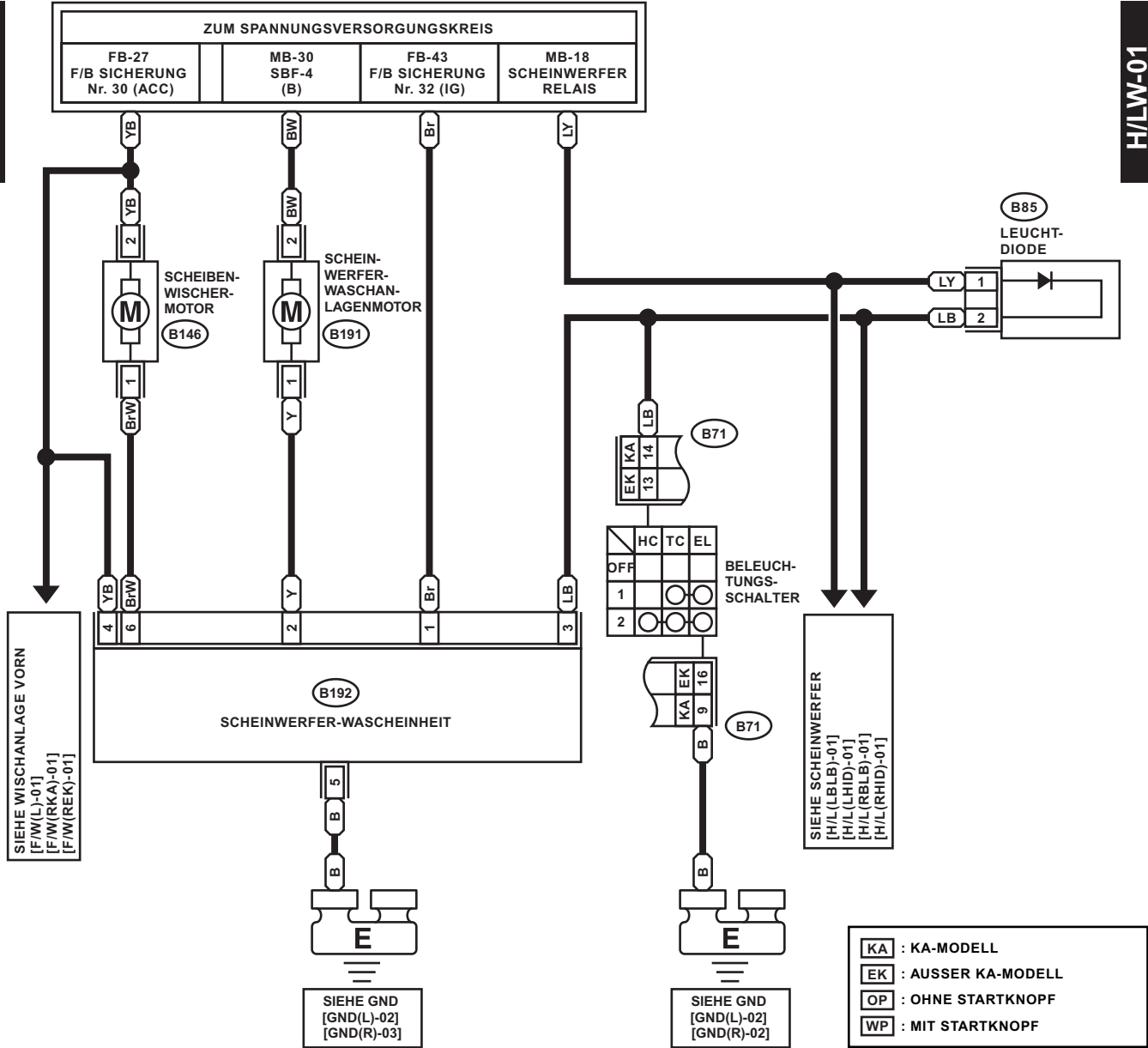

ZUM SPANNUNGSVERSORUNGSKREIS		
FB-4 F/B SICHERUNG Nr. 9 (B)	FB-32 F/B SICHERUNG Nr. 4 (IG)	FB-37 F/B SICHERUNG Nr. 12 (IG)

- *1 : KLEMMEN-Nr. OPTIONALE ANORDNUNG BEI 7, 8, 9, 10, 11 UND 12
- *2 : KLEMMEN-Nr. OPTIONALE ANORDNUNG BEI 1, 2, 3, 4, 5 UND 6

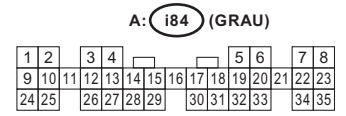
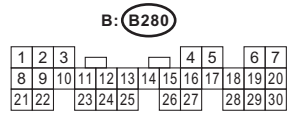
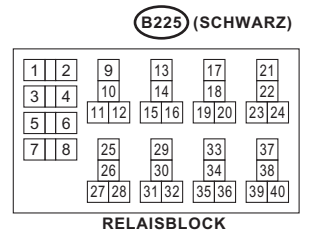
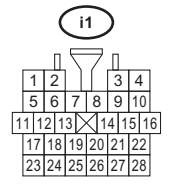
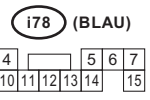
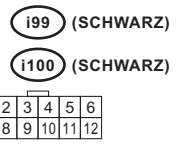
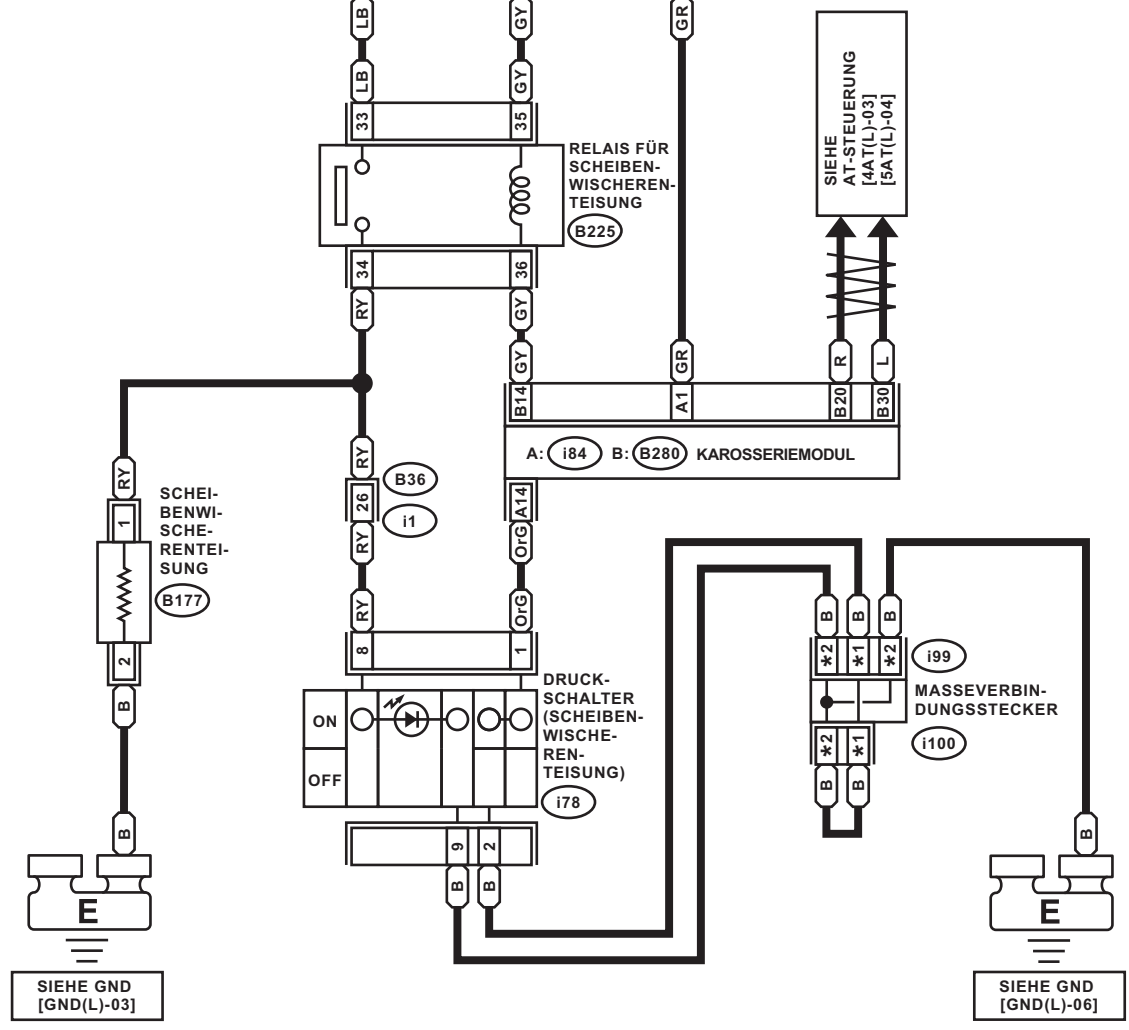

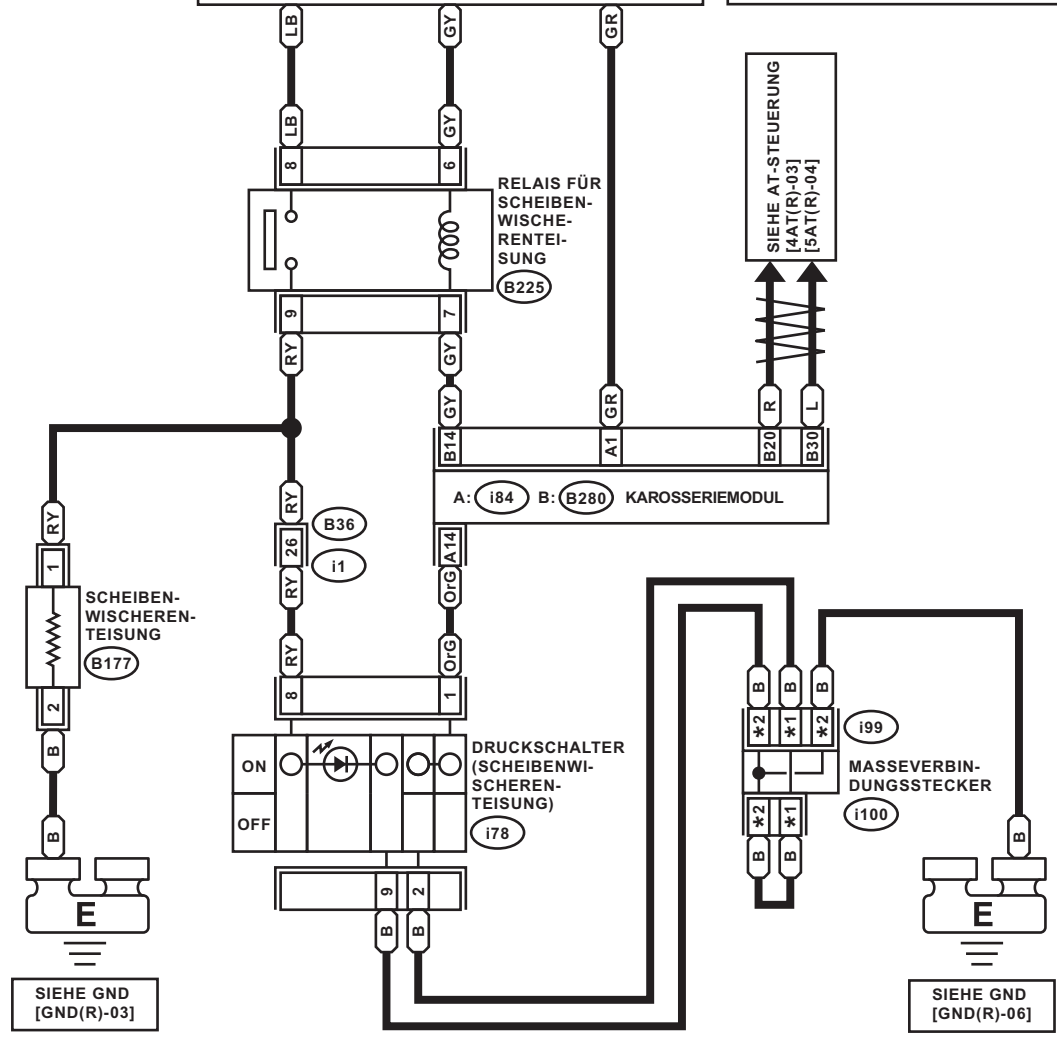
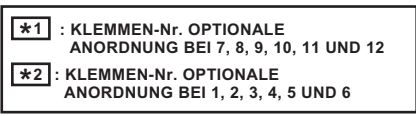

B177



i199 (SCHWARZ)

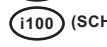

i78 (BLAU)

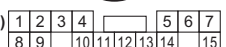

i1

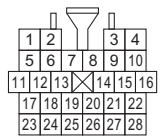

B225 (SCHWARZ)

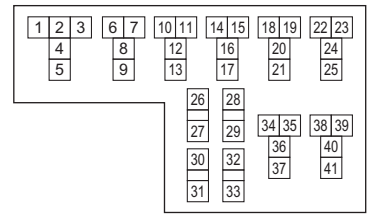

B: B280

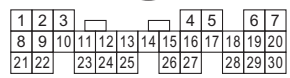

A: i84 (GRAU)

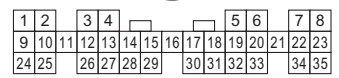

RELAISBLOCK

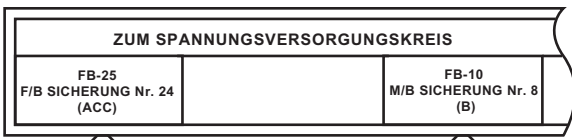

VERBINDUNGSSTECKER
(BELEUCHTUNG UND
RÜCKFAHRLEUCHTEN)

*1 : KLEMMEN-Nr. OPTIONALE
ANORDNUNG BEI 1, 2, 3, 4, 5 UND 6

SIEHE BEGREN-
ZUNGSLEUCHE UND
BELEUCHTUNG
[ILLUM(L)-04]

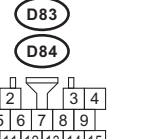
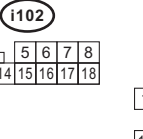
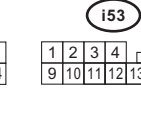
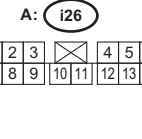
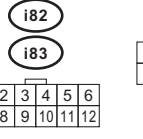
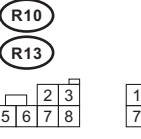
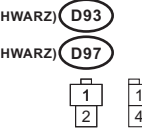
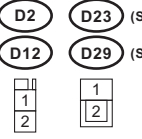
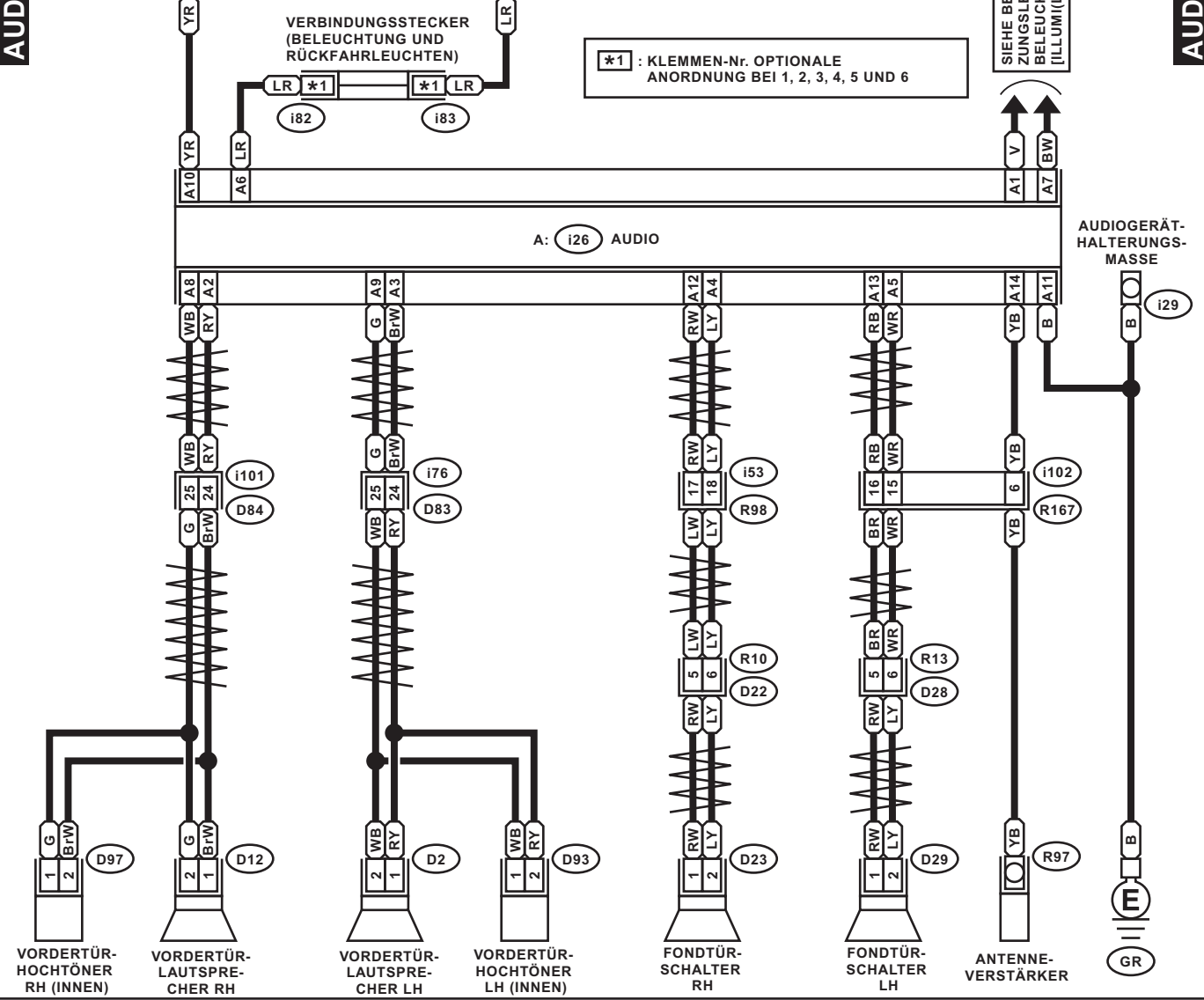

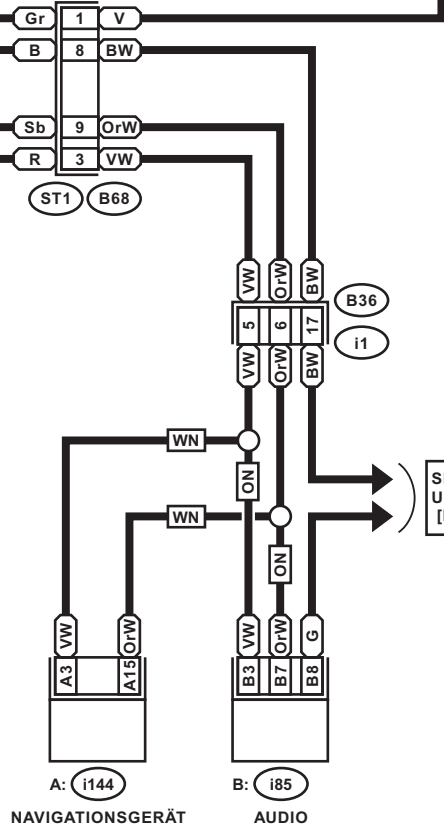
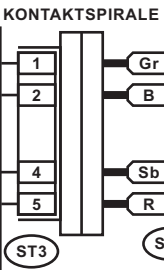
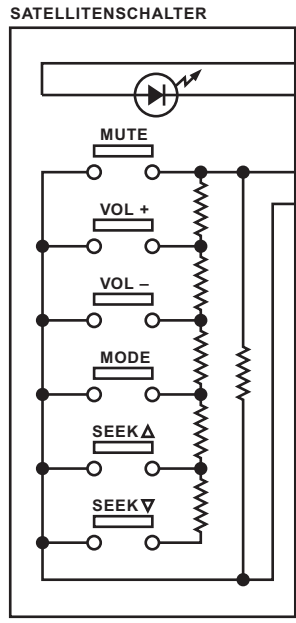
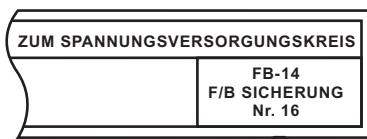

ON : OHNE NAVIGATIONSSYSTEM (AUSSER EH-MODELL) EH-MODELL

WN : MIT NAVIGATIONSSYSTEM (AUSSER EH-MODELL)

SIEHE BEGRENZUNGSLEUCHE UND BELEUCHTUNG [ILLUMI(L)-01-03]

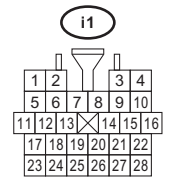
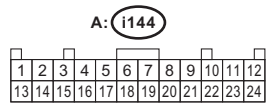
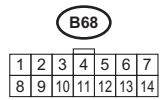
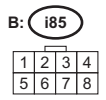
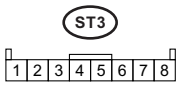

ZUM SPANNUNGSVERSORUNGSKREIS
 FB-14
 F/B SICHERUNG Nr. 16

SATELLITENSCHALTER

KONTAKTSPIRALE

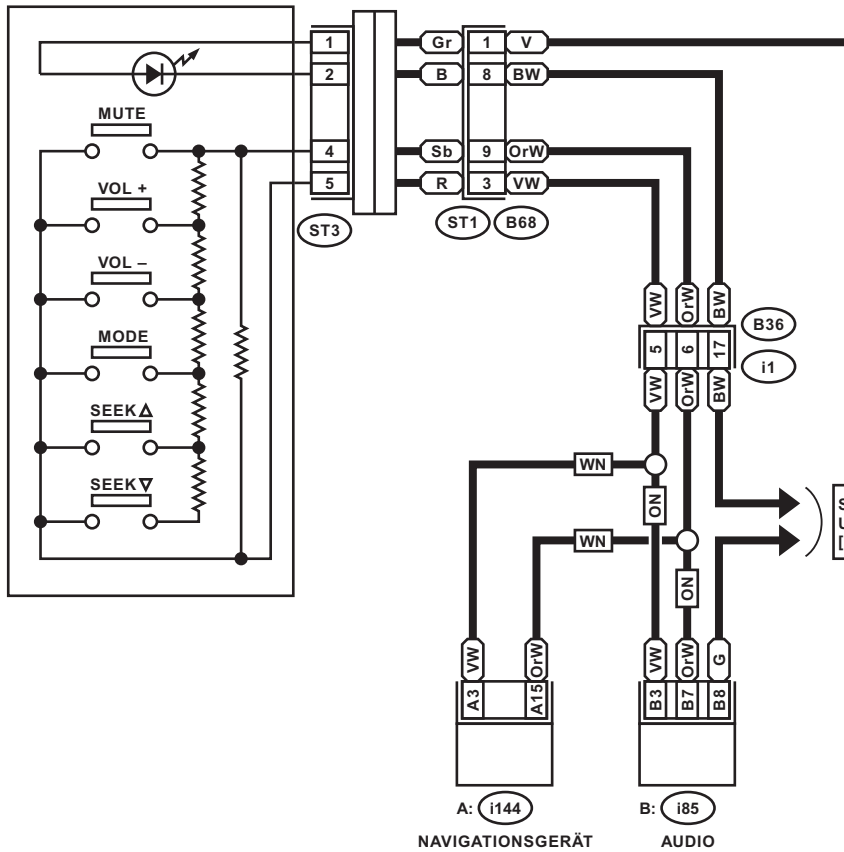

ON : OHNE NAVIGATIONSSYSTEM
WN : MIT NAVIGATIONSSYSTEM

SIEHE BEGRENZUNGSLEUCHE UND BELEUCHTUNG [ILLUMI(R)-01-03]

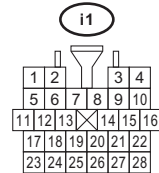
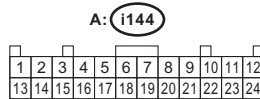
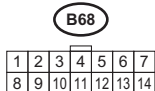
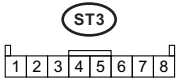

R110 AUDIOVERSTÄRKER

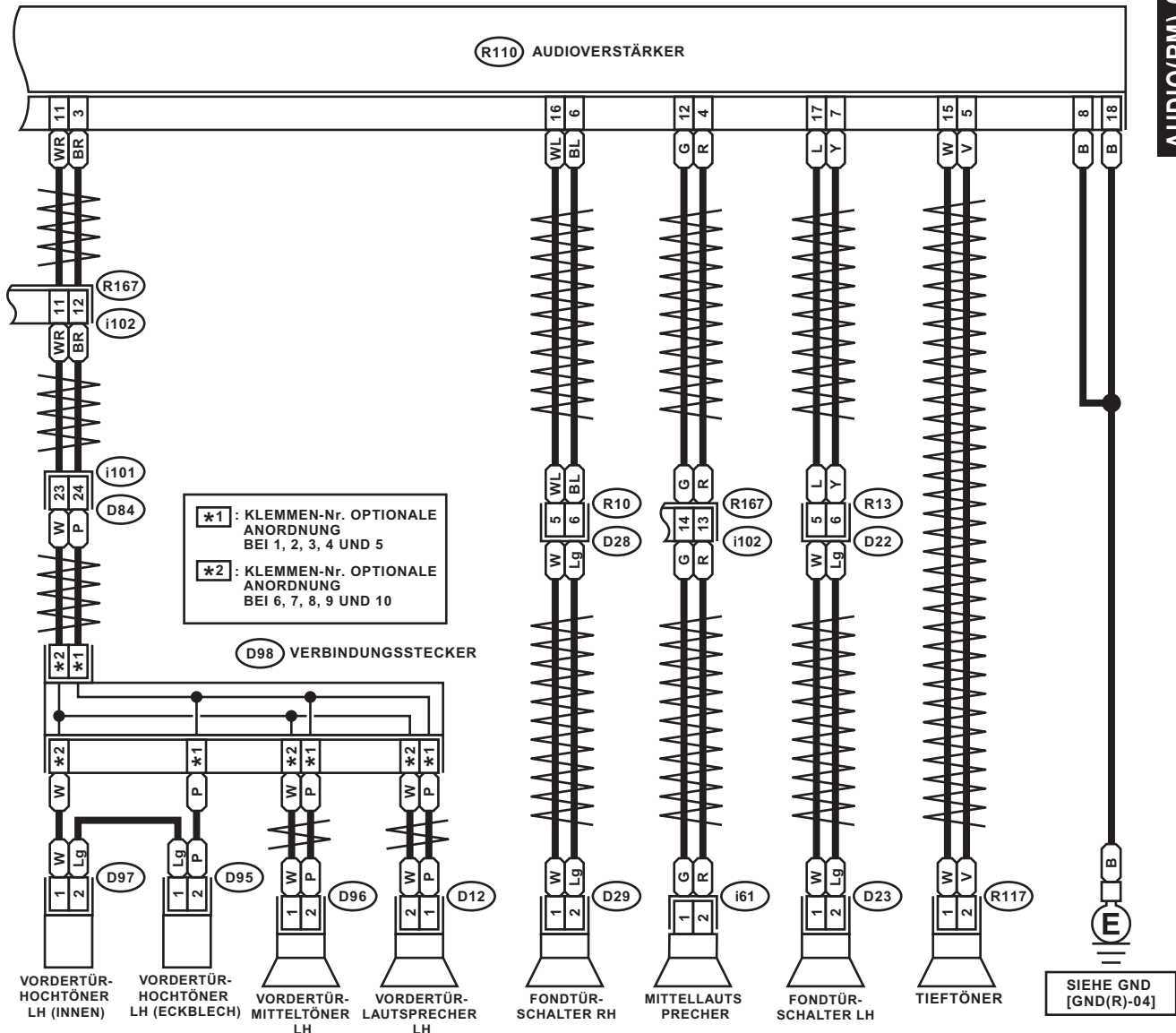

*1 : KLEMMEN-Nr. OPTIONALE ANORDNUNG BEI 1, 2, 3, 4 UND 5
 *2 : KLEMMEN-Nr. OPTIONALE ANORDNUNG BEI 6, 7, 8, 9 UND 10

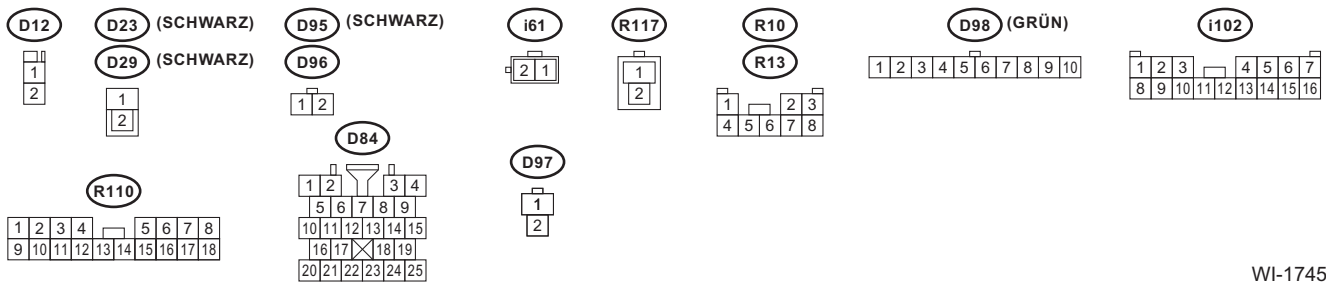

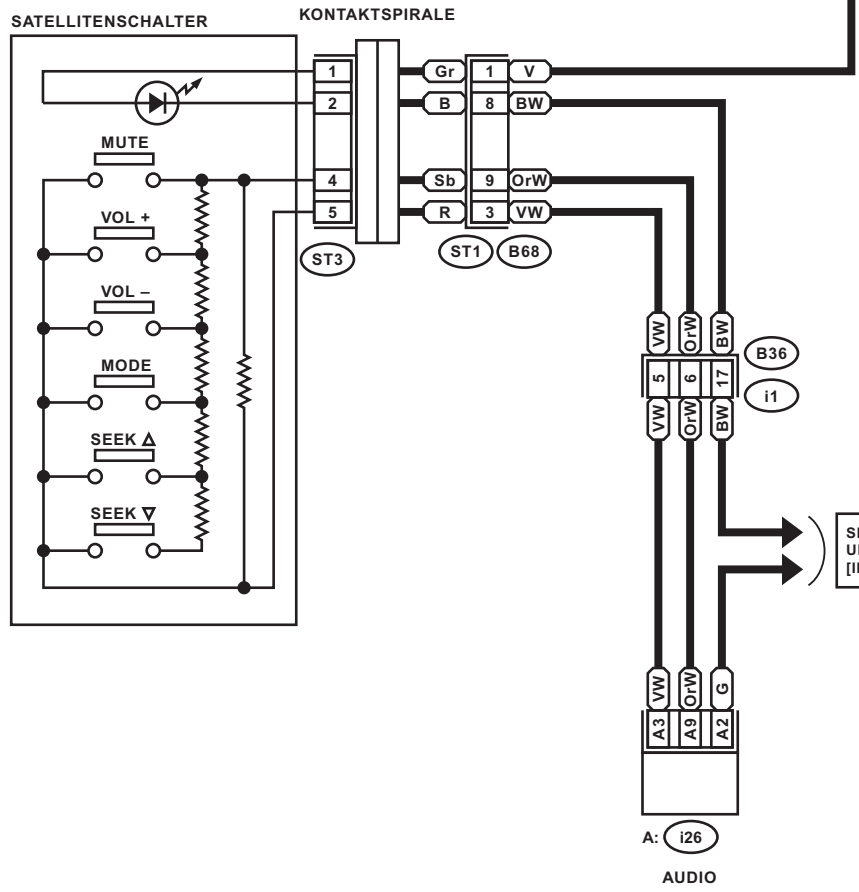
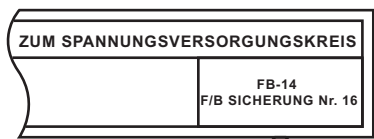

SIEHE BEGRENZUNGSLEUCHE UND BELEUCHTUNG [ILLUMI(R)-01-03]

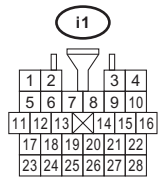
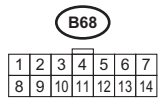
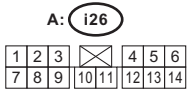
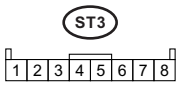

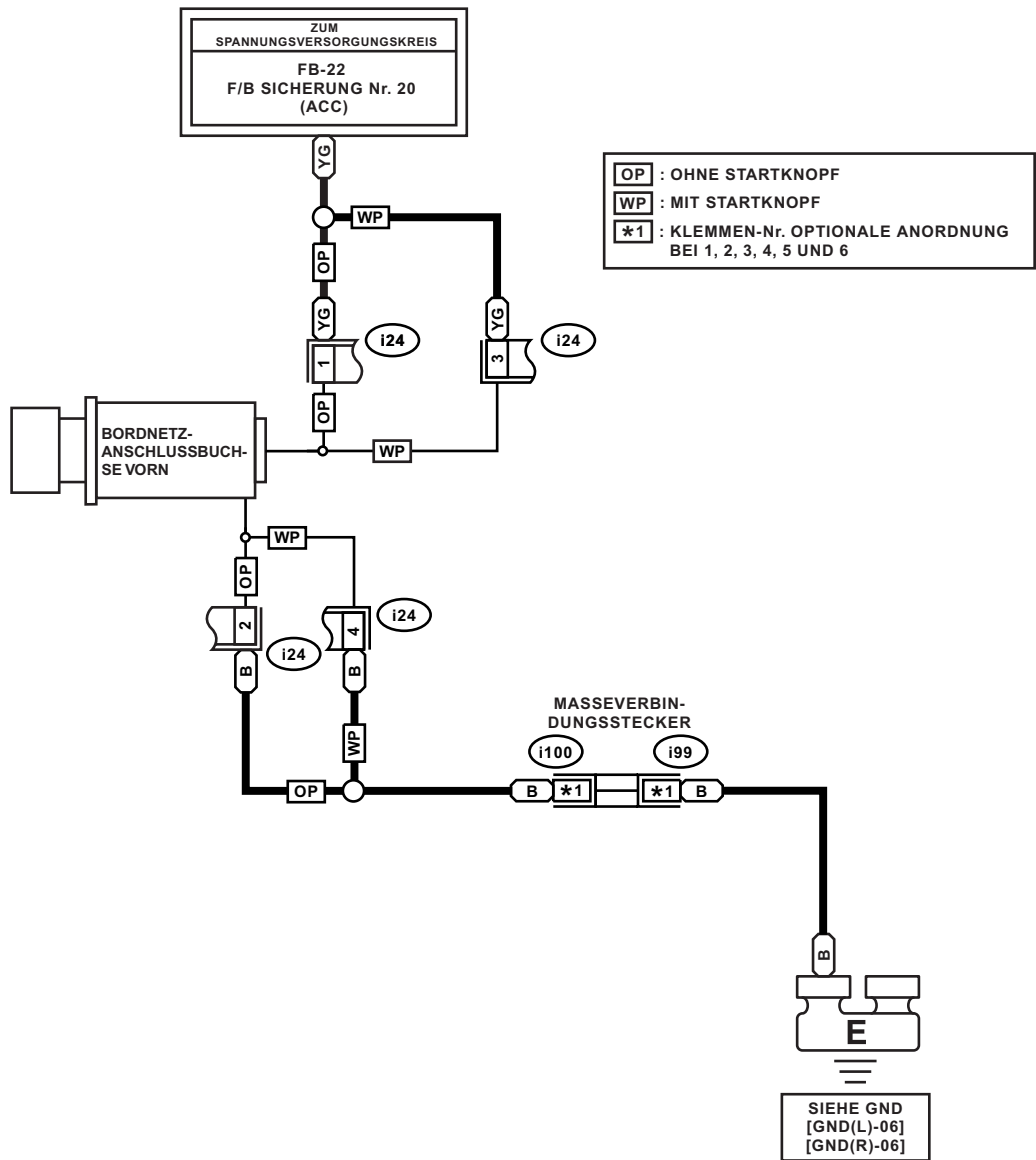

OP : OHNE STARTKNOPF
WP : MIT STARTKNOPF
***1** : KLEMMEN-Nr. OPTIONALE ANORDNUNG BEI 1, 2, 3, 4, 5 UND 6

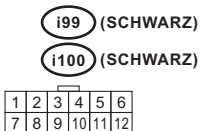
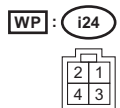
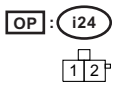

SIEHE GND
[GND(L)-06]
[GND(R)-06]

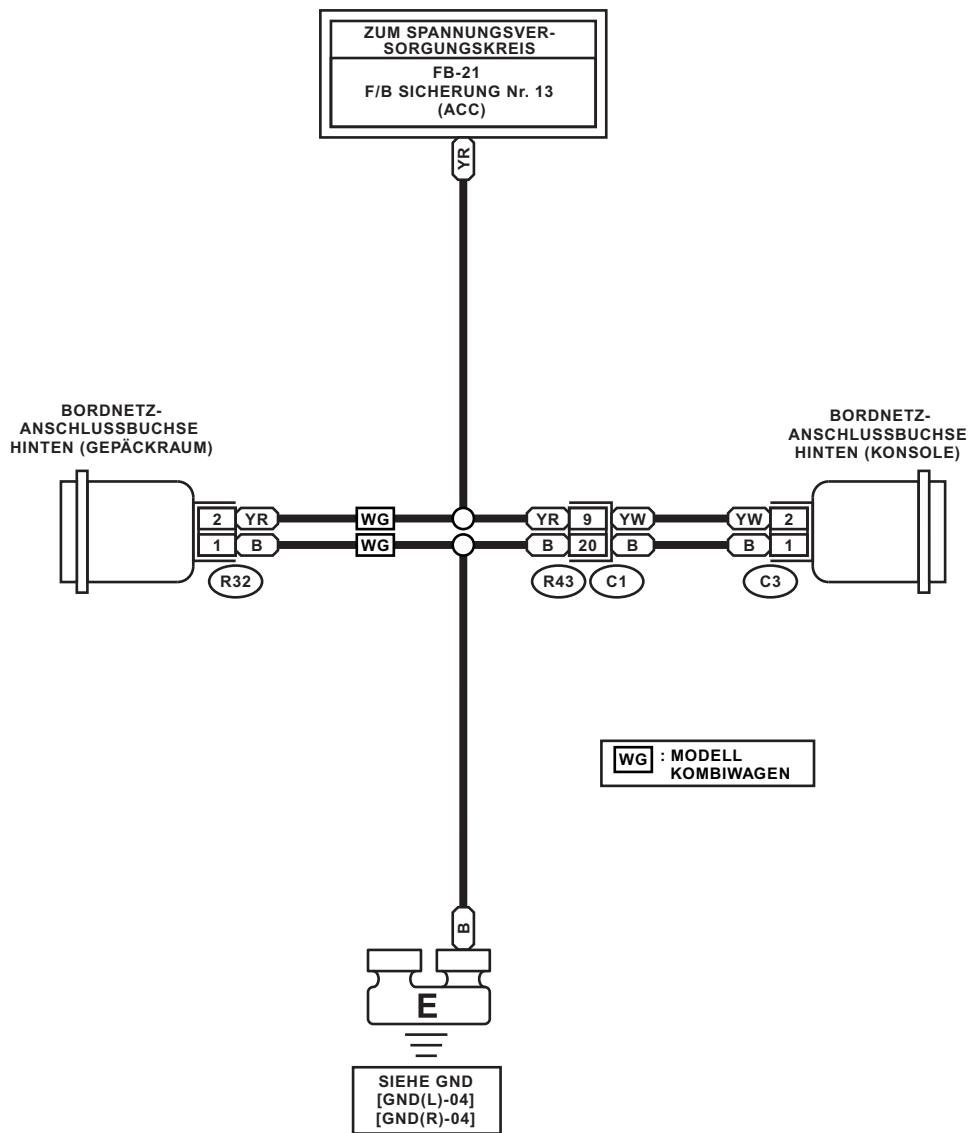

WG : MODELL
KOMBIWAGEN

SIEHE GND
[GND(L)-04]
[GND(R)-04]

R32

R43

C3

1	2	3	4	5	6	7	8	9		
10	11	12	13	14	15	16	17	18	19	20

1
2

ZUM SPANNUNGSVERSORUNGSKREIS		
FB-25 F/B SICHERUNG Nr. 24 (ACC)	FB-10 M/B SICHERUNG Nr. 8 (B)	FB-30 F/B SICHERUNG Nr. 4 (IG)

A: i84
KAROSSE RIEMODUL
P A27
V A26

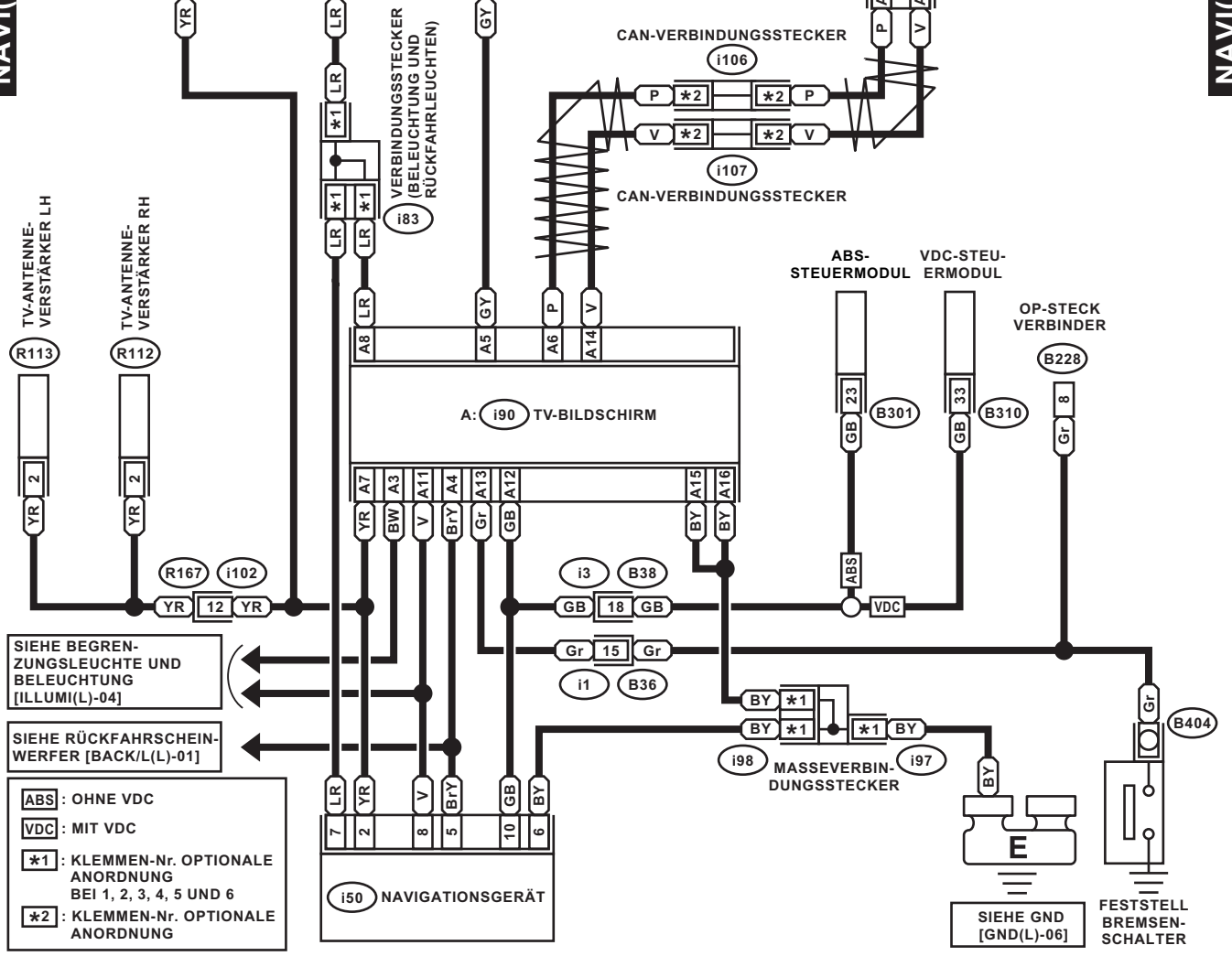

- SIEHE BEGRENZUNGSLEUCHE UND BELEUCHTUNG [ILLUM(L)-04]
- SIEHE RÜCKFAHRSCHWIFER [BACK/L(L)-01]
- ABS** : OHNE VDC
 - VDC** : MIT VDC
 - *1** : KLEMMEN-Nr. OPTIONALE ANORDNUNG BEI 1, 2, 3, 4, 5 UND 6
 - *2** : KLEMMEN-Nr. OPTIONALE ANORDNUNG

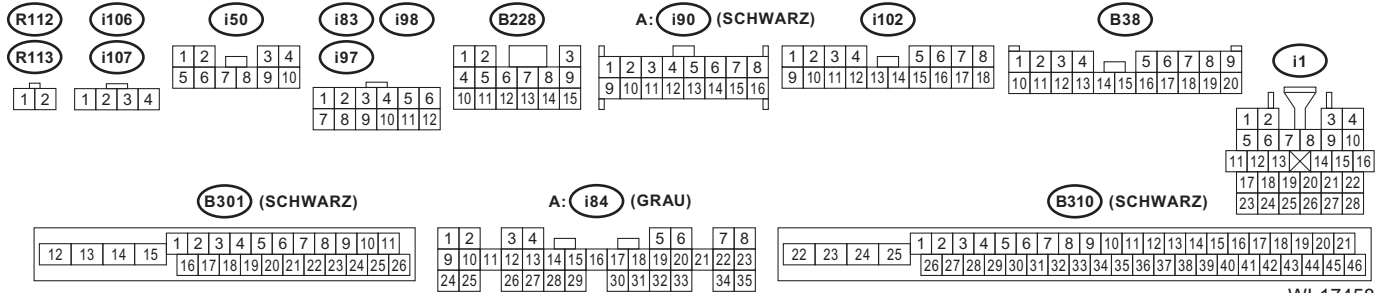

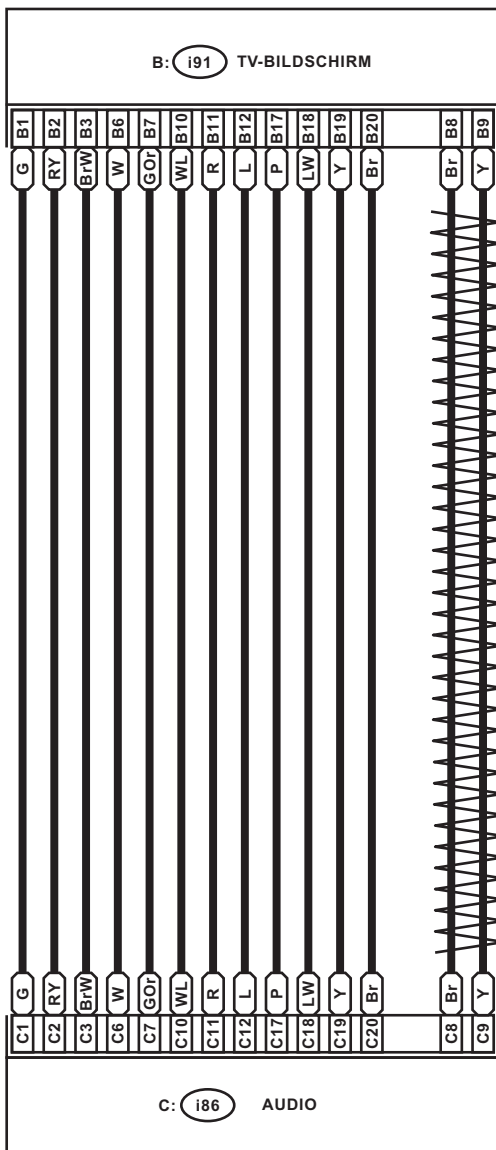

C: i86 (SCHWARZ)

B: i91 (SCHWARZ)

1	2	3	4	5	6	7	8	9	10
11	12	13	14	15	16	17	18	19	20

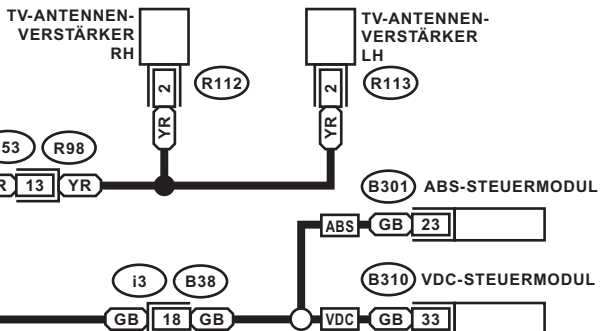

VERBINDUNGS-STECKER (BELEUCHTUNG UND RÜCKFAHR-LEUCHTEN)

SIEHE BEGRENZUNGS-LEUCHTE UND BELEUCHTUNG [ILLUM(L)-04]

ABS : OHNE VDC
VDC : MIT VDC
*1 : KLEMMEN-Nr. OPTIONALE ANORDNUNG BEI 1, 2, 3, 4, 5 UND 6
*2 : KLEMMEN-Nr. OPTIONALE ANORDNUNG

SIEHE AUDIOANLAGE [AUDIO(L)-02]
SIEHE RÜCKFAHRSCHEINWERFER [BACK(L)-01]

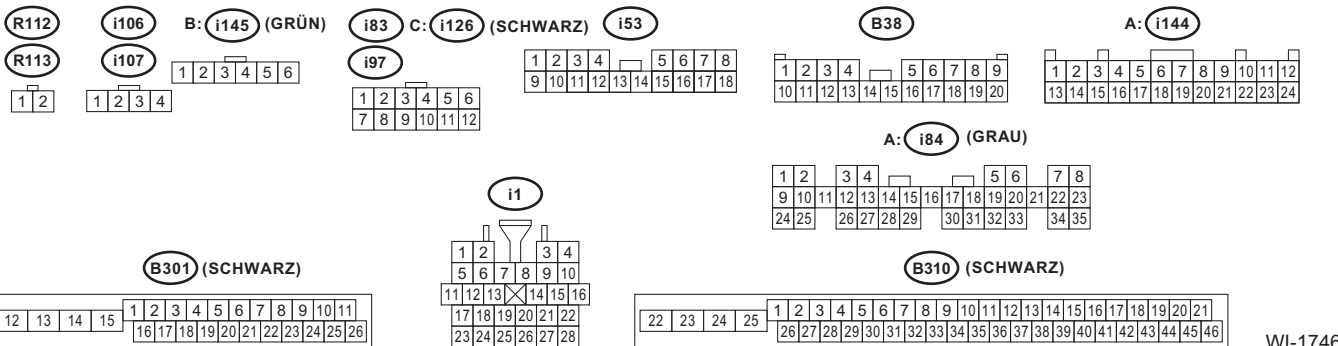
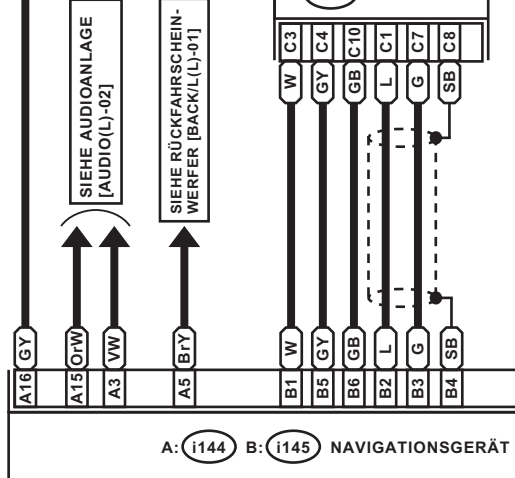
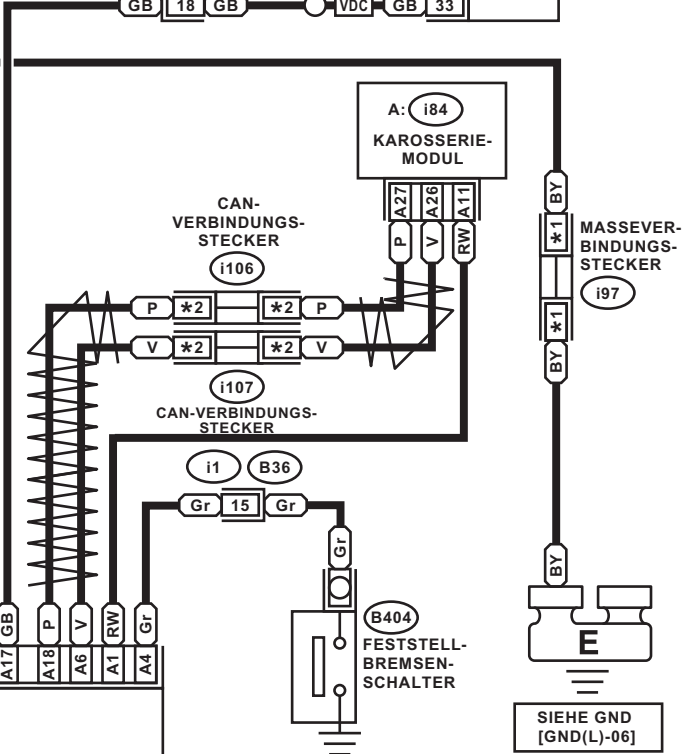
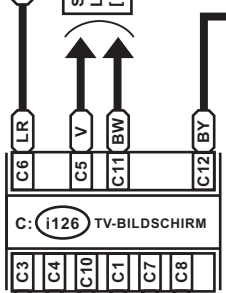

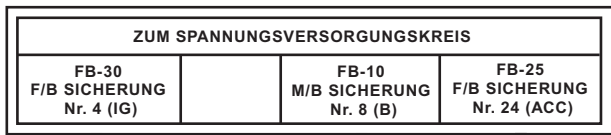

VERBINDUNGS-
STECCKER
(BELEUCHTUNG
UND RÜCKFAHR-
LEUCHTEN)

- ABS : OHNE VDC
- VDC : MIT VDC
- *1 : KLEMMEN-Nr. OPTIONALE ANORDNUNG BEI 1, 2, 3, 4, 5 UND 6
- *2 : KLEMMEN-Nr. OPTIONALE ANORDNUNG

SIEHE AUDIOANLAGE
[AUDIO(R)-02]

SIEHE RÜCKFAHRSCHEIN-
WERFER [BACK/L(R)-01]

SIEHE SIEHE
BEGRENZUNGSLEUCHTE UND
BELEUCHTUNG [ILLUMI(R)-04]

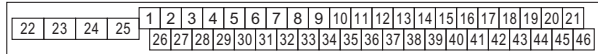
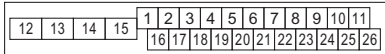
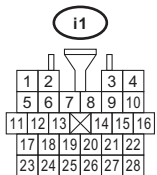
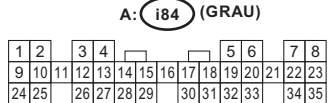
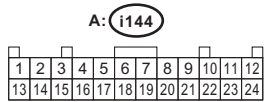
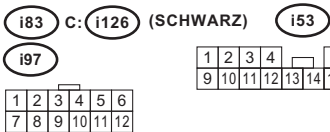
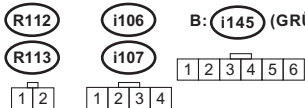
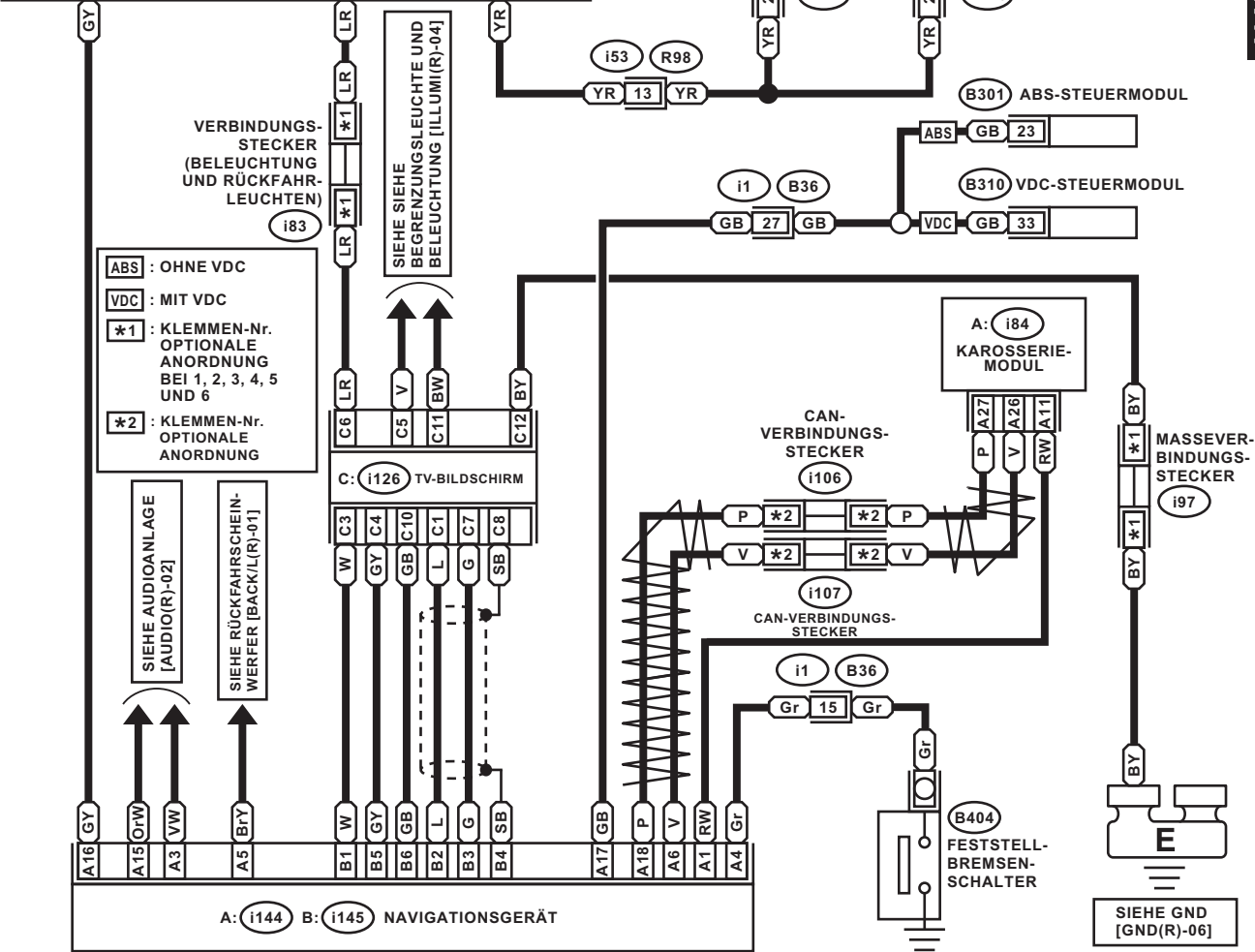

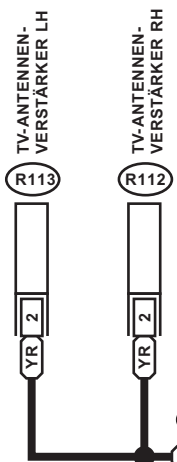
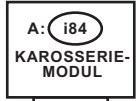
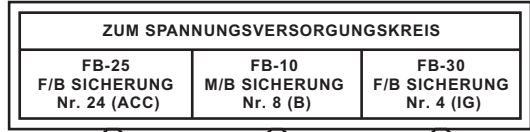

- SIEHE SIEHE BEGRENZUNGSLEUCHTE UND BELEUCHTUNG [ILLUMI(R)-04]
- SIEHE RÜCKFAHRSCHWEIFER [BACK/L(R)-01]
- ABS : OHNE VDC
 - VDC : MIT VDC
 - *1 : KLEMMEN-Nr. OPTIONALE ANORDNUNG BEI 1, 2, 3, 4, 5 UND 6
 - *2 : KLEMMEN-Nr. OPTIONALE ANORDNUNG

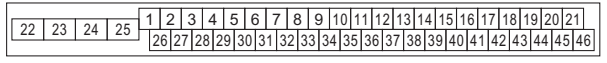
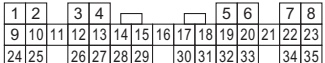
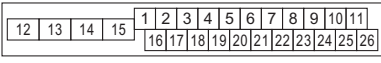
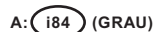
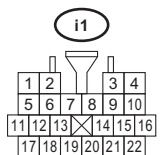
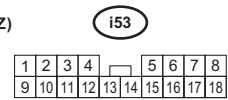
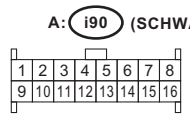
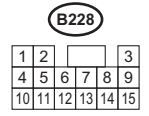
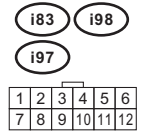
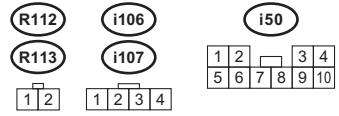
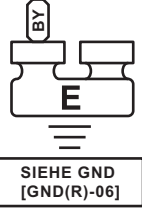
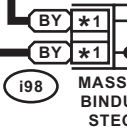
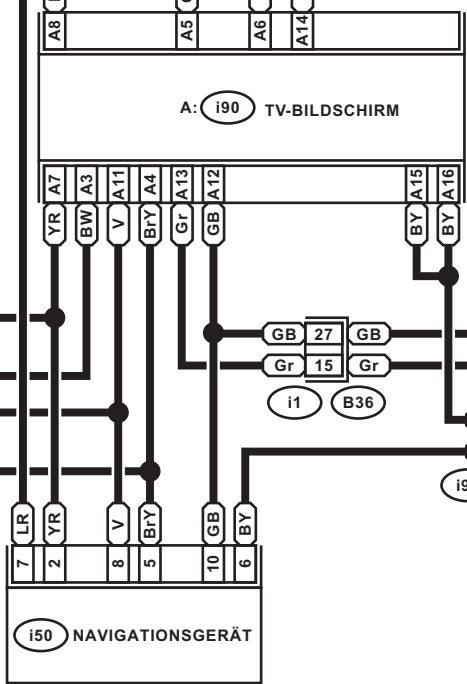
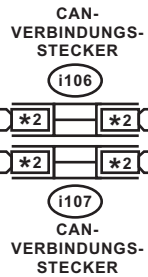
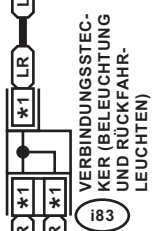

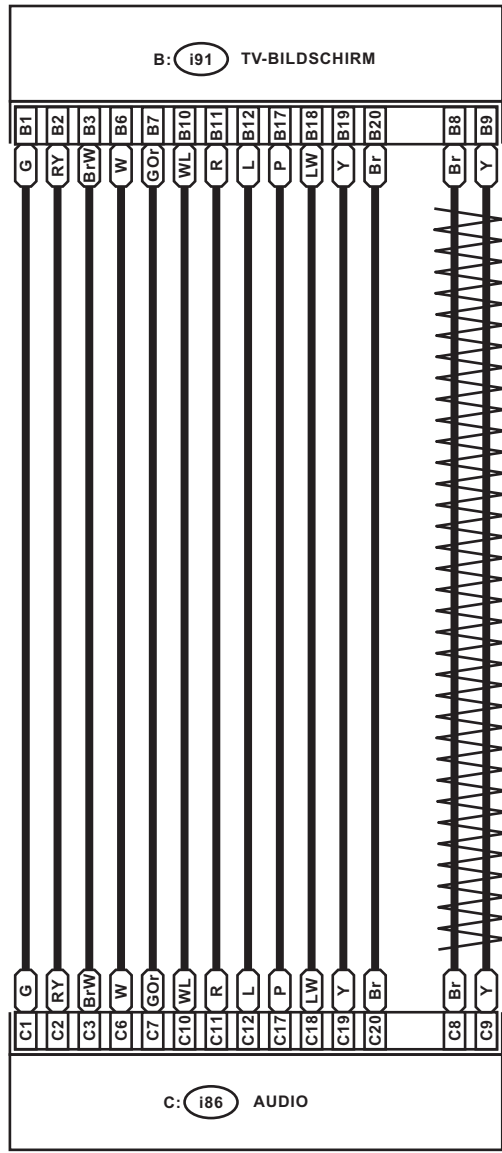

C: **i86** (SCHWARZ)

B: **i91** (SCHWARZ)

1	2	3	4	5	6	7	8	9	10
11	12	13	14	15	16	17	18	19	20

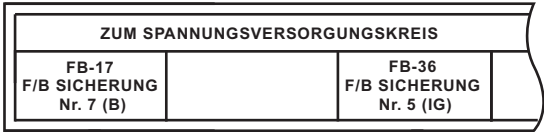

KOMBIINSTRUMENT
A: (i10) B: (i11)

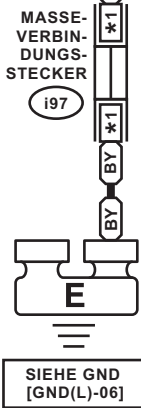
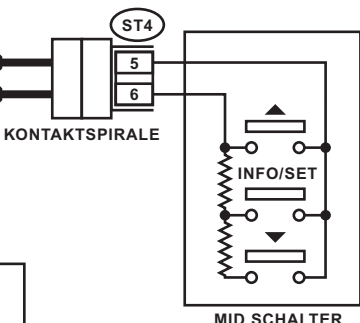
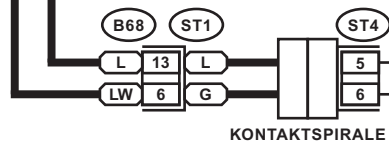
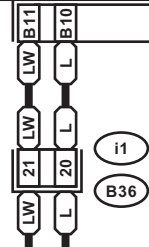
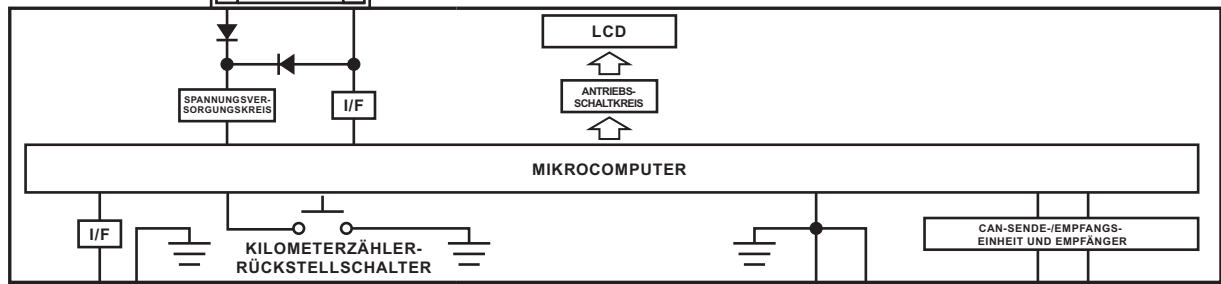

*1: KLEMMEN-Nr. OPTIONALE ANORDNUNG BEI 1, 2, 3, 4, 5 UND 6

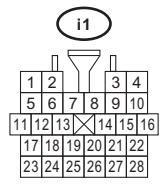
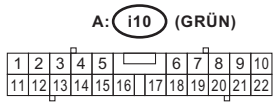
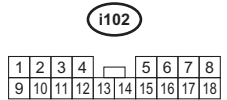
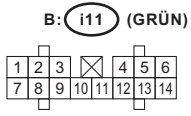
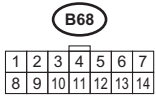
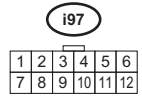
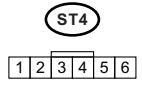

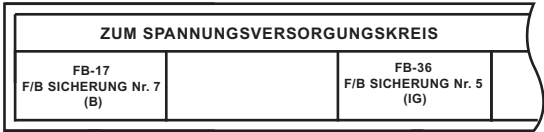

KOMBIINSTRUMENT

A: (i10) B: (i11)

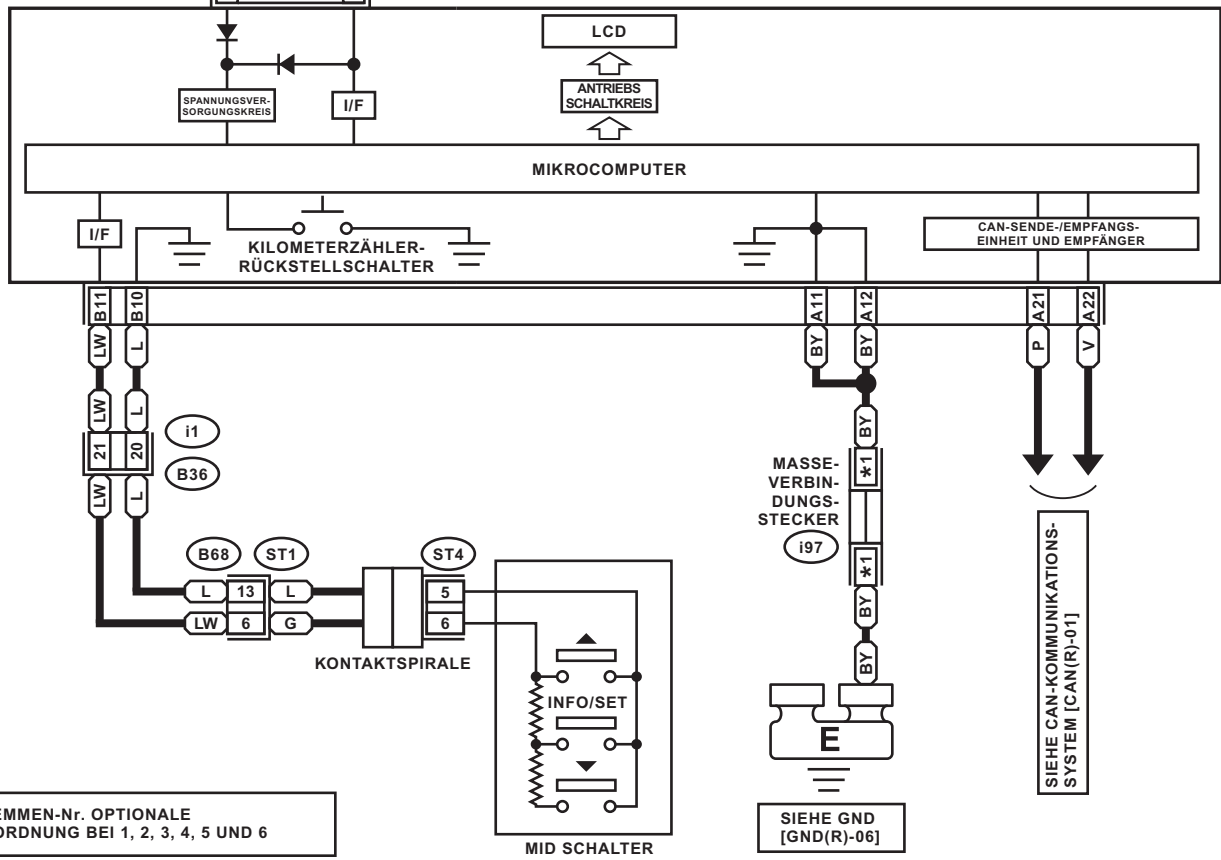

*1 : KLEMMEN-Nr. OPTIONALE ANORDNUNG BEI 1, 2, 3, 4, 5 UND 6

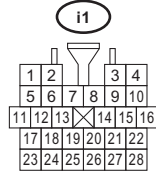
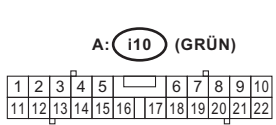
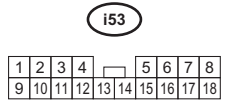
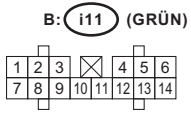
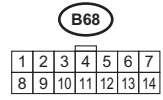
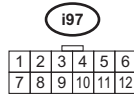
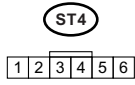

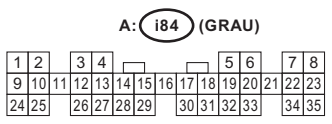
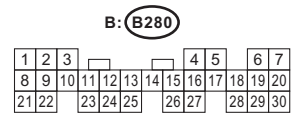
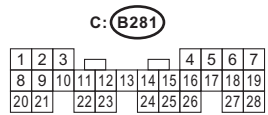
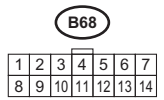
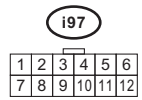
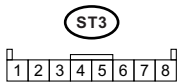
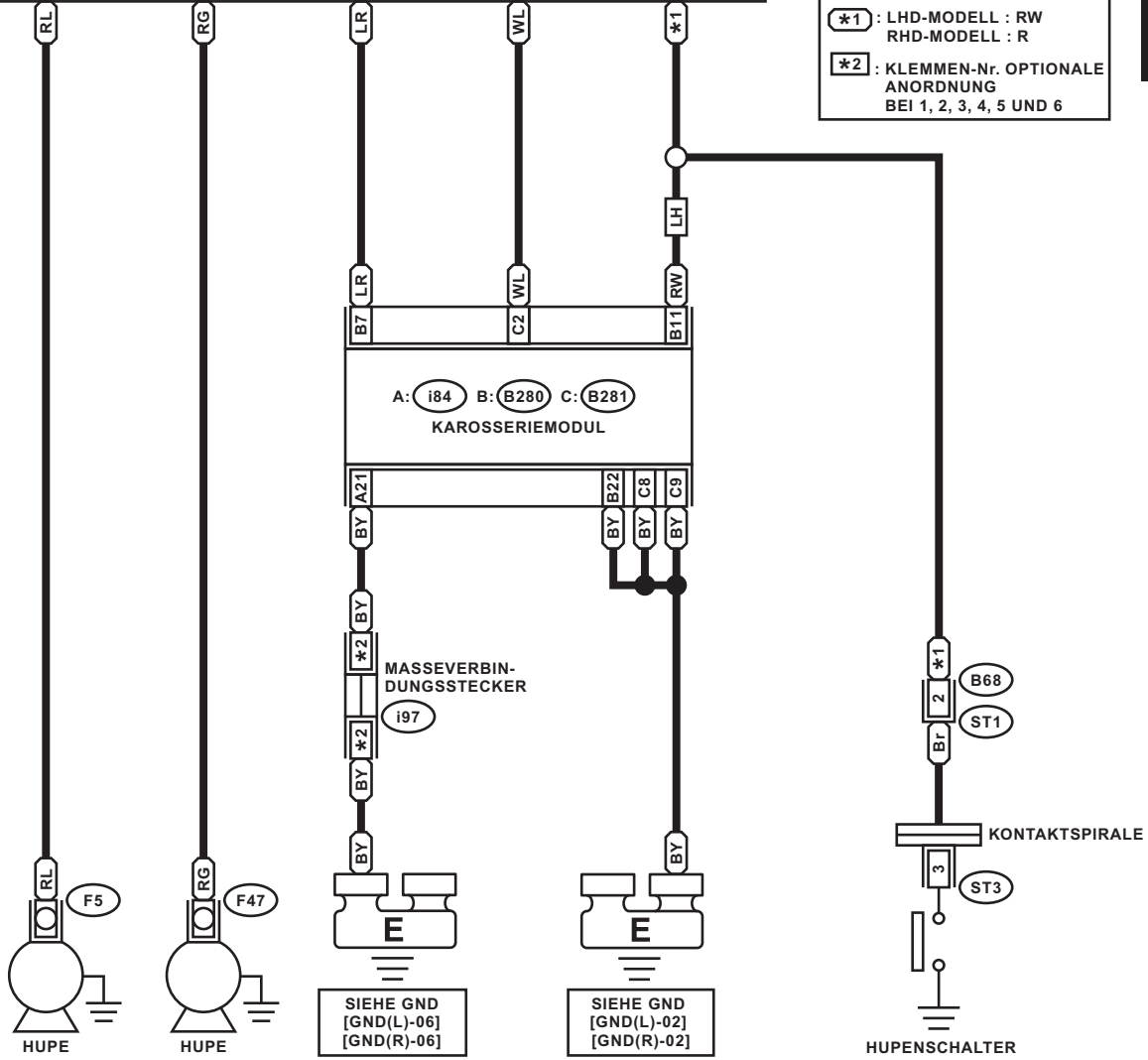
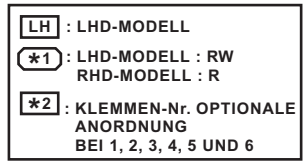
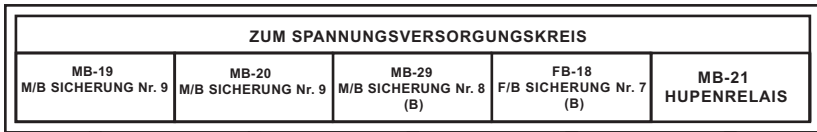

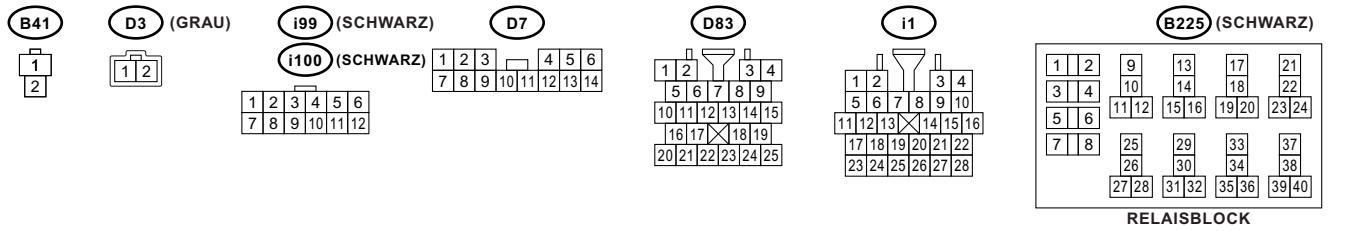
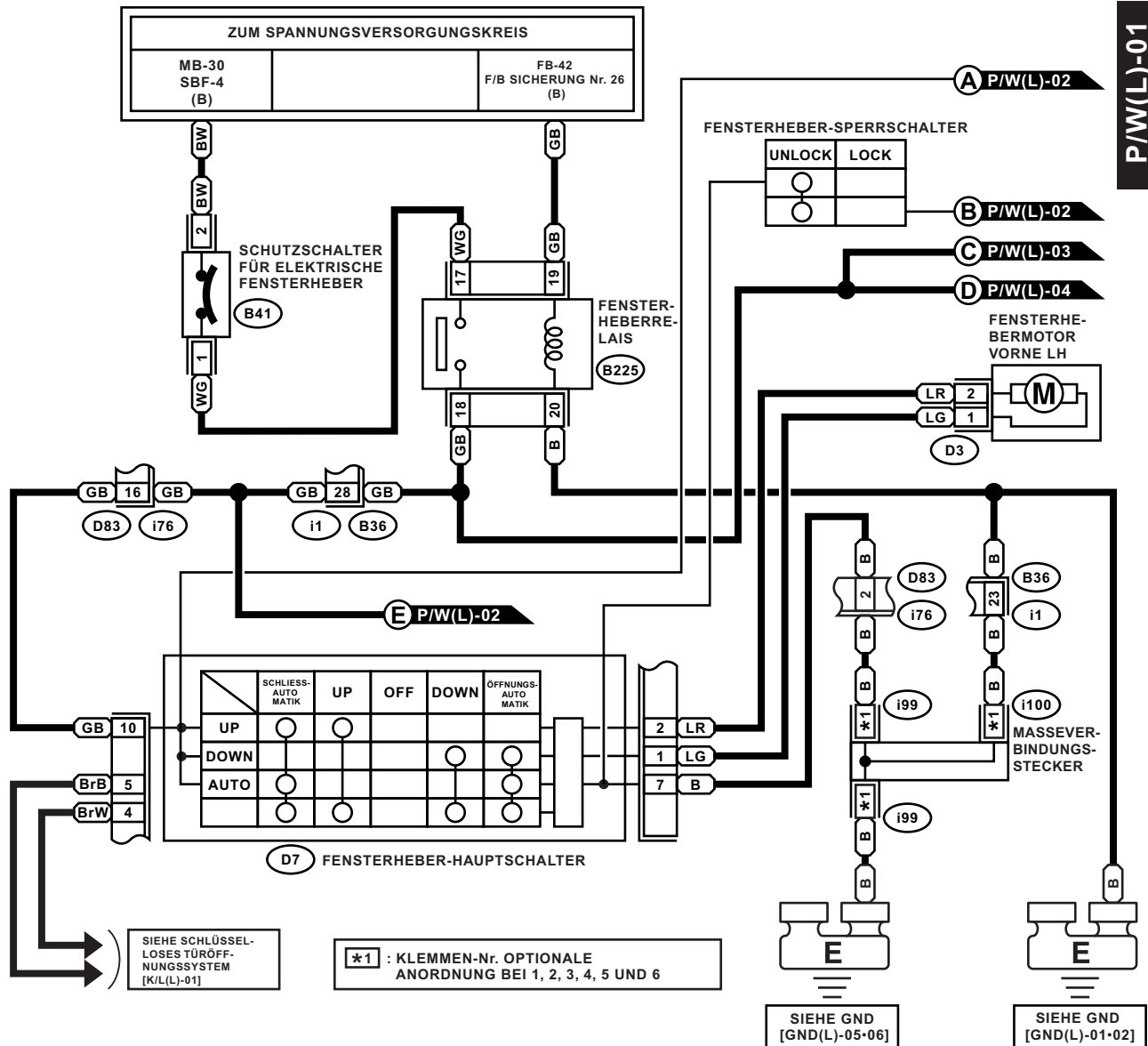

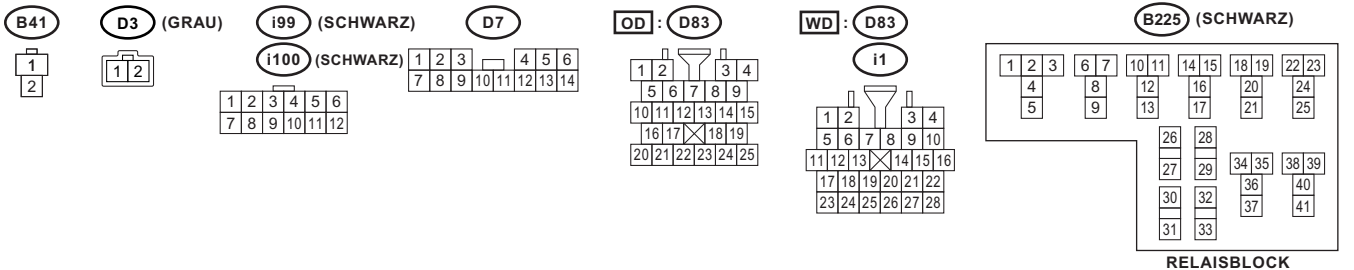
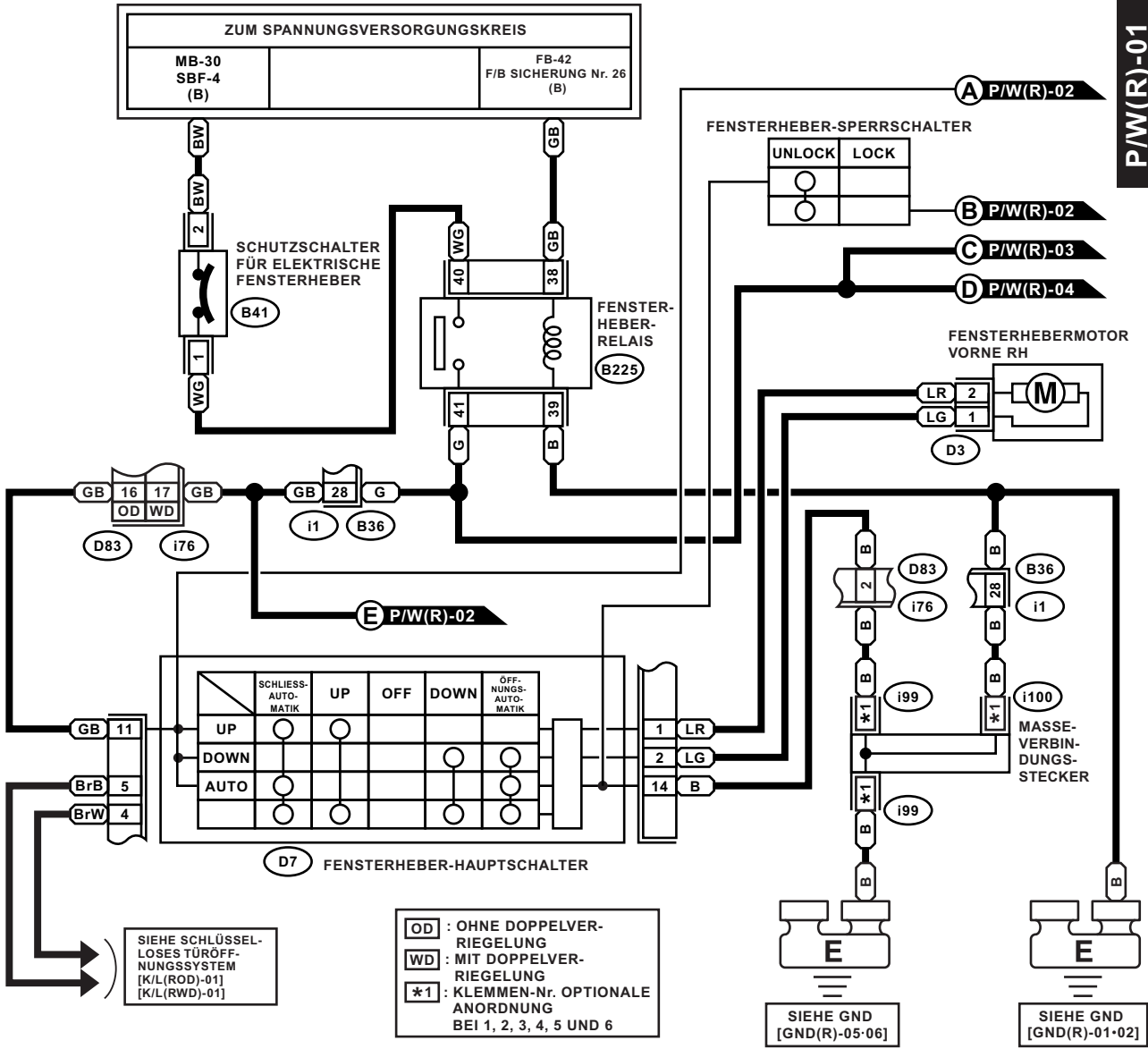

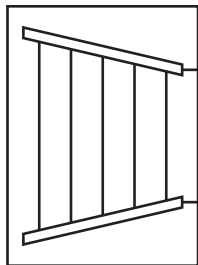
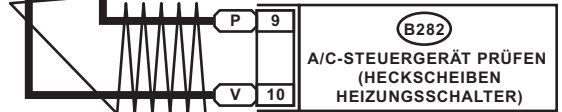
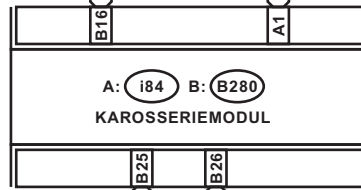
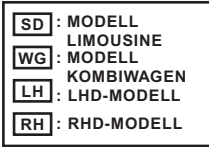

HECKSCHEIBENHEIZUNG

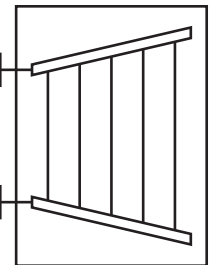

HECKSCHEIBENHEIZUNG

SIEHE GND
[GND(L)-05]
[GND(R)-05]

SIEHE GND
[GND(L)-05]
[GND(R)-05]

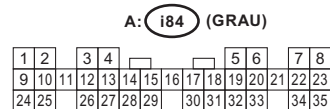
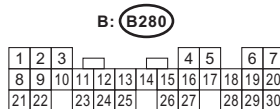
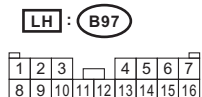
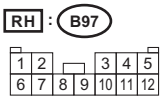
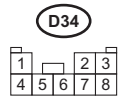

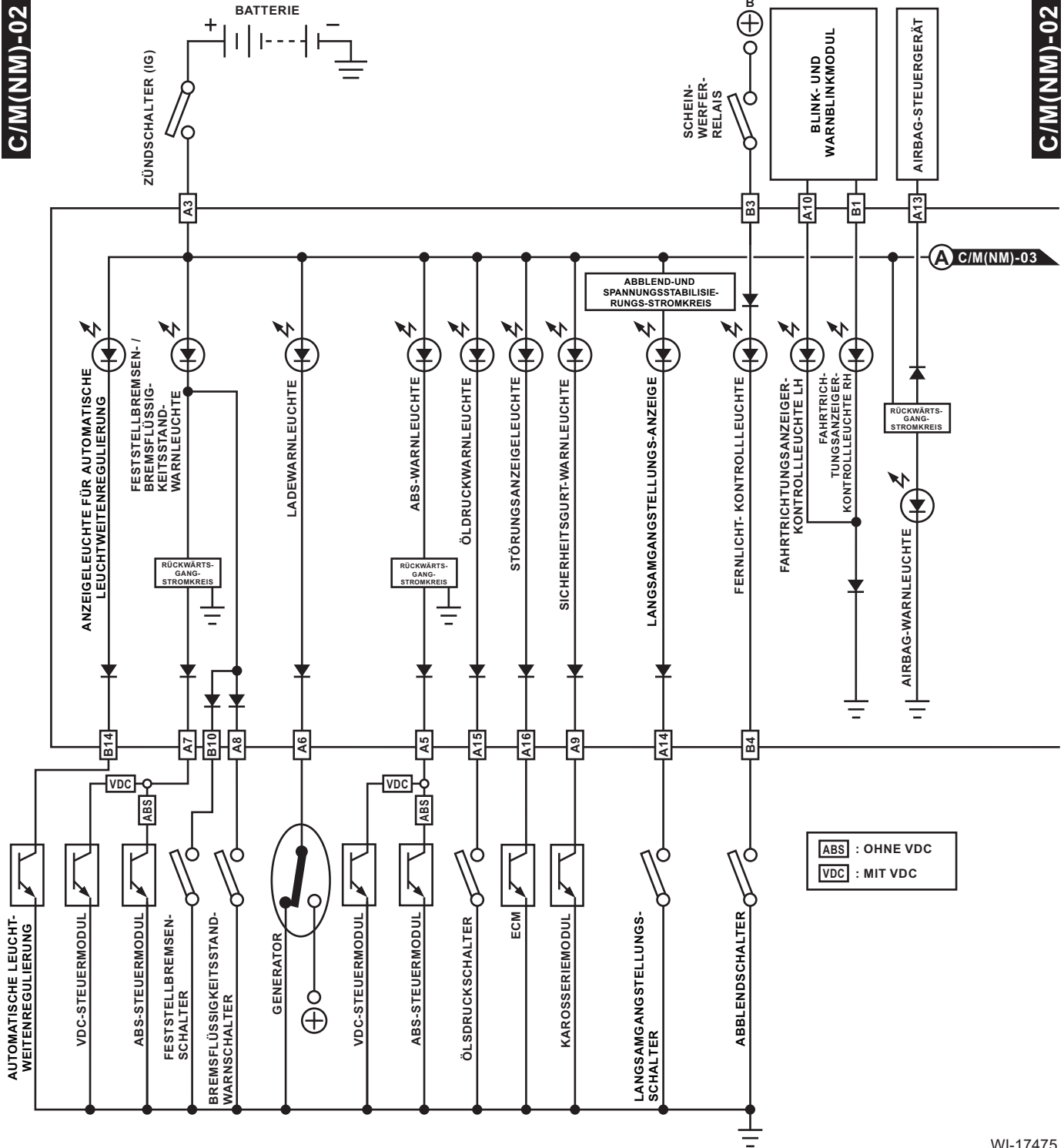

ABS : OHNE VDC
 VDC : MIT VDC

A C/M(NM)-03

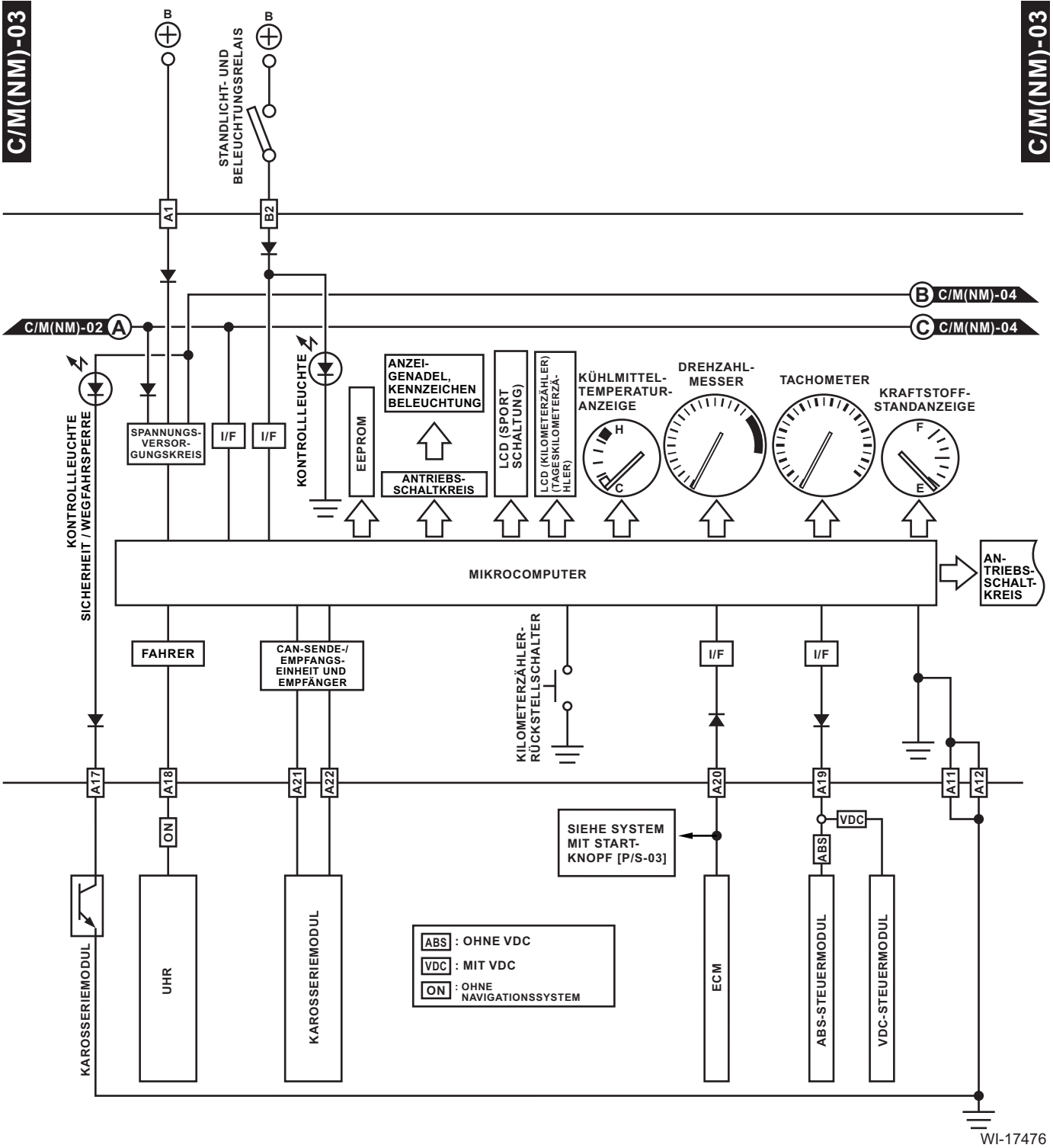

B C/M(NM)-04

C C/M(NM)-04

SIEHE SYSTEM MIT START-KNOPF [P/S-03]

ABS : OHNE VDC
 VDC : MIT VDC
 ON : OHNE NAVIGATIONSSYSTEM

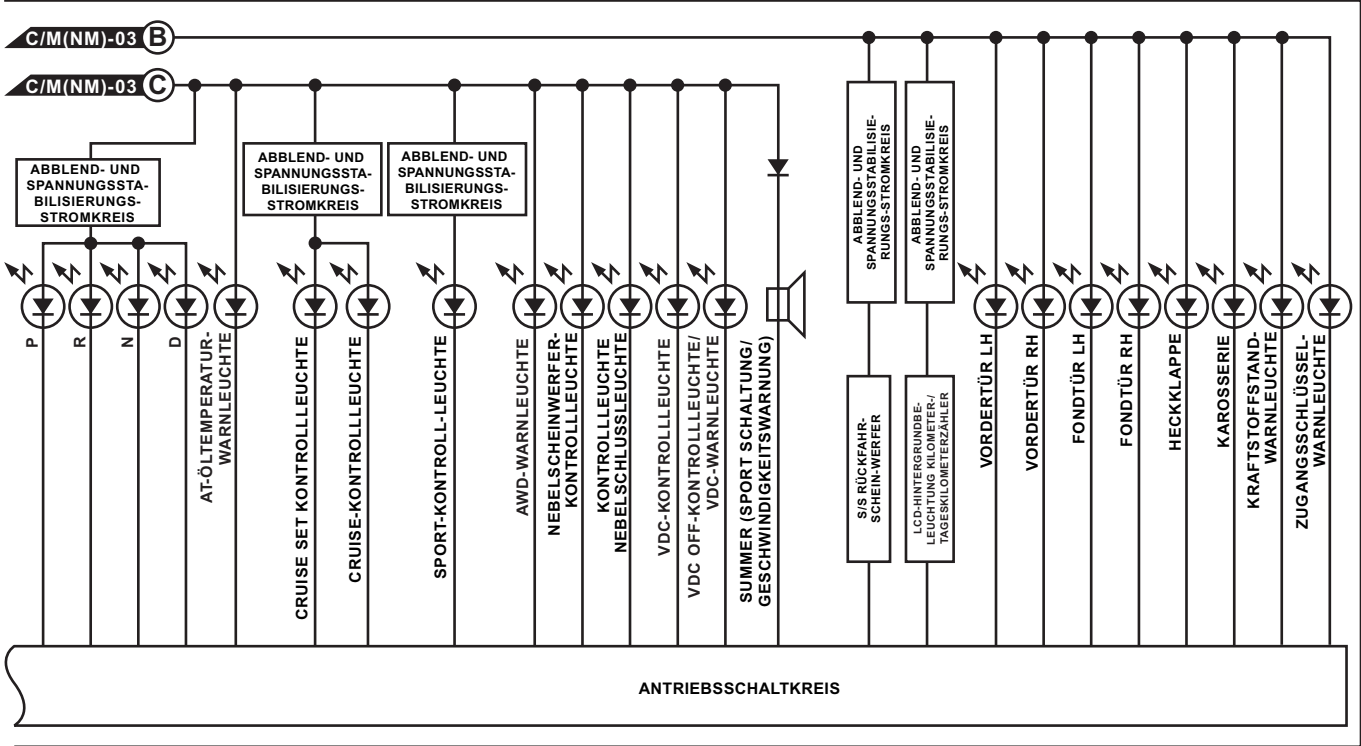

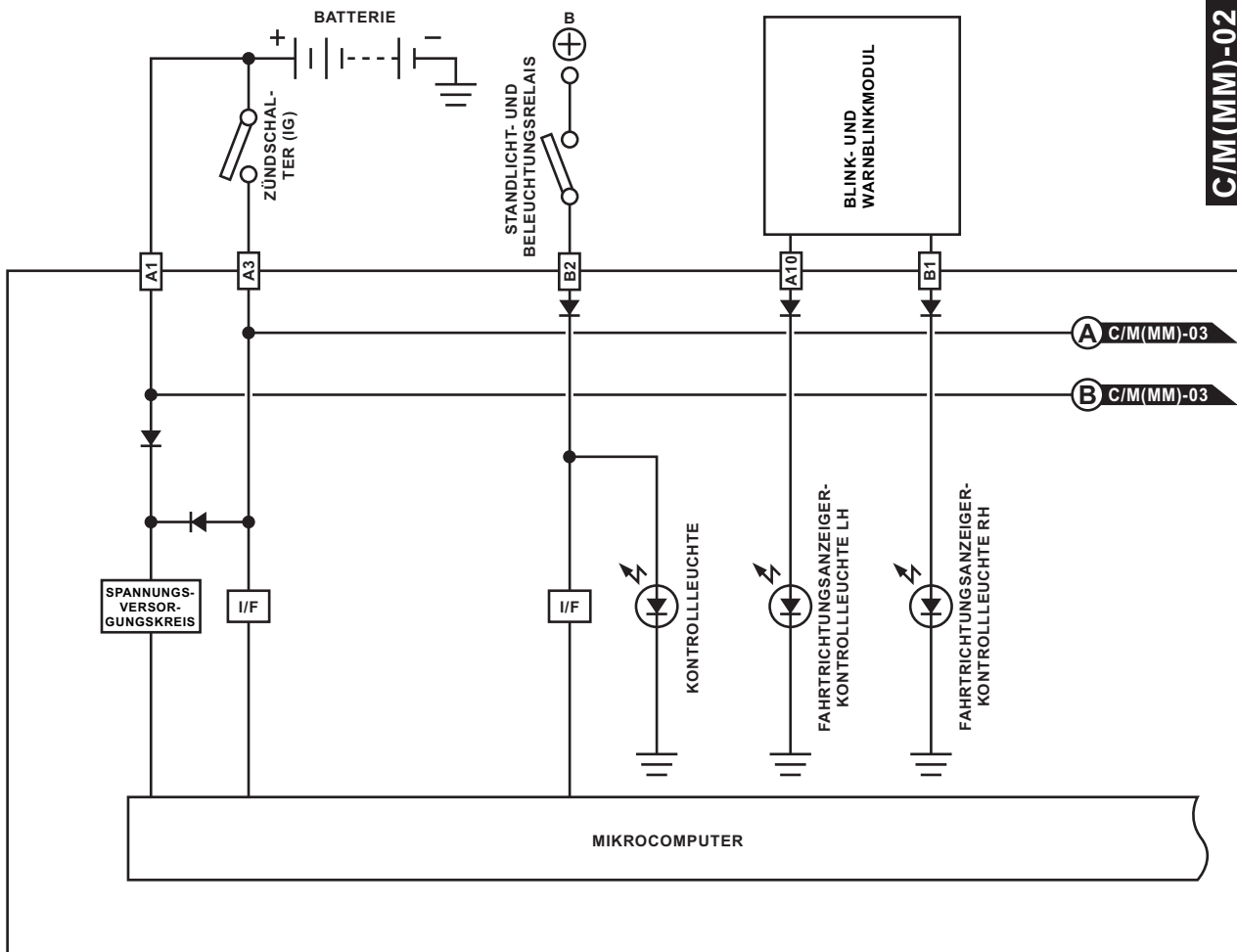

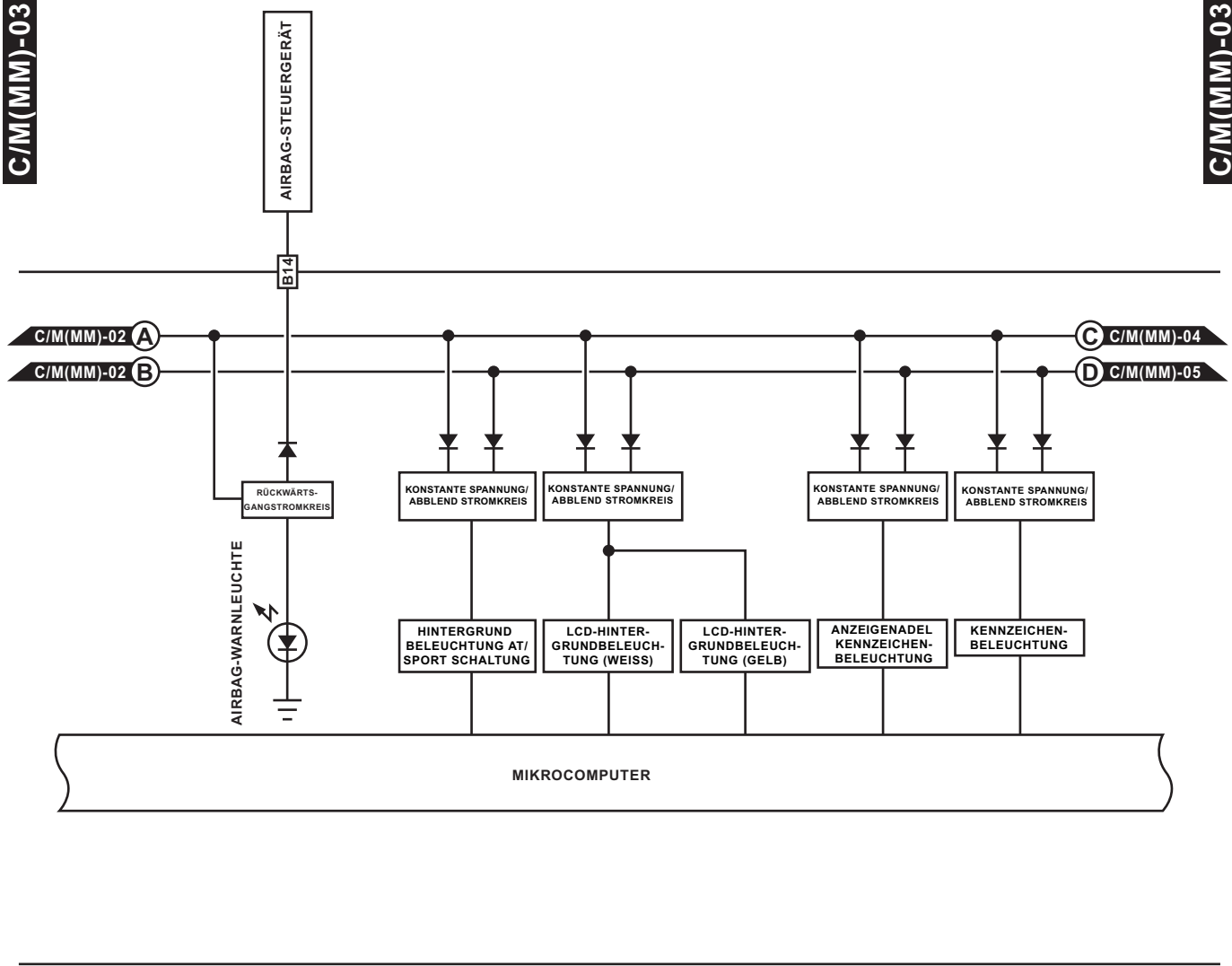

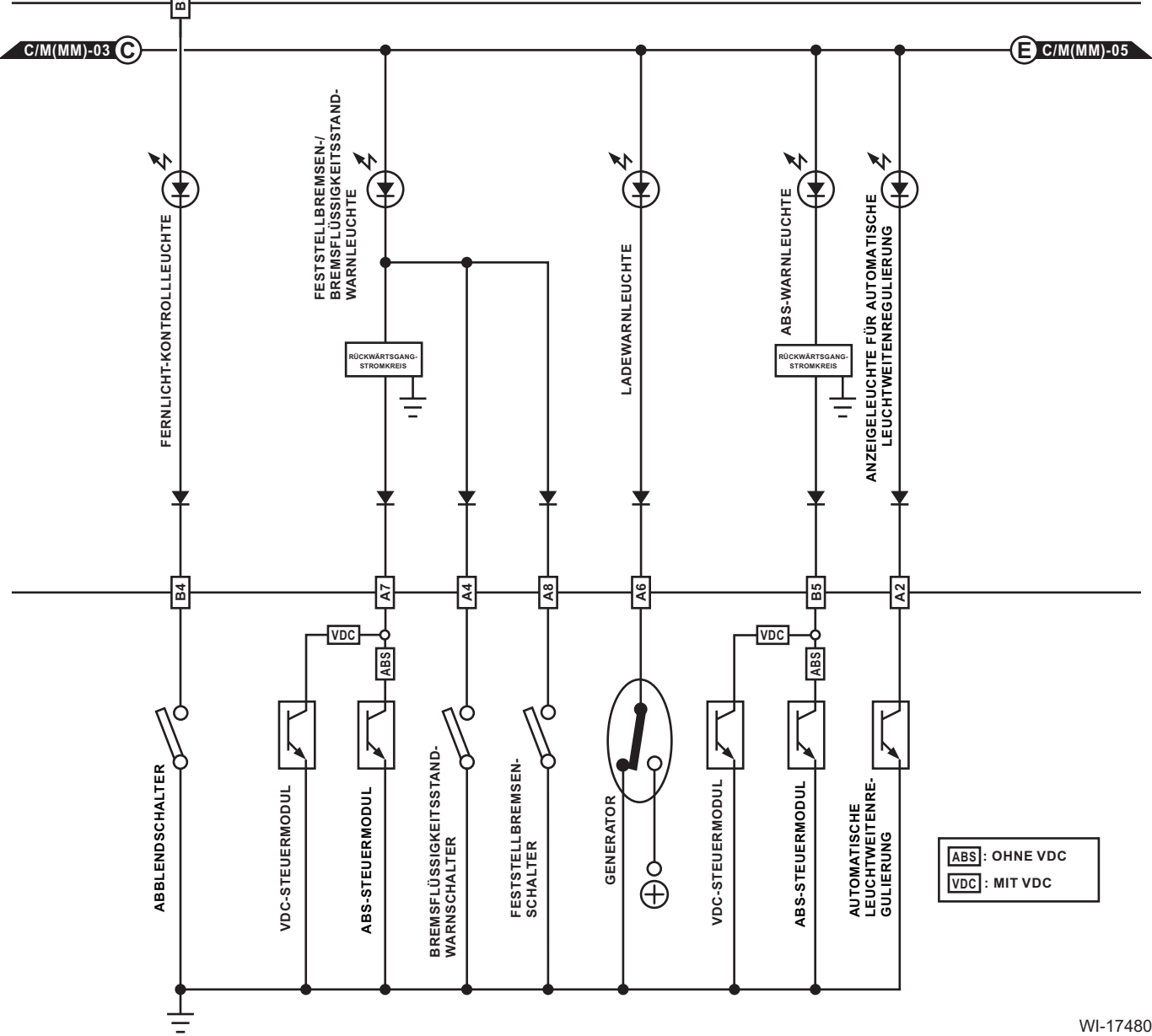

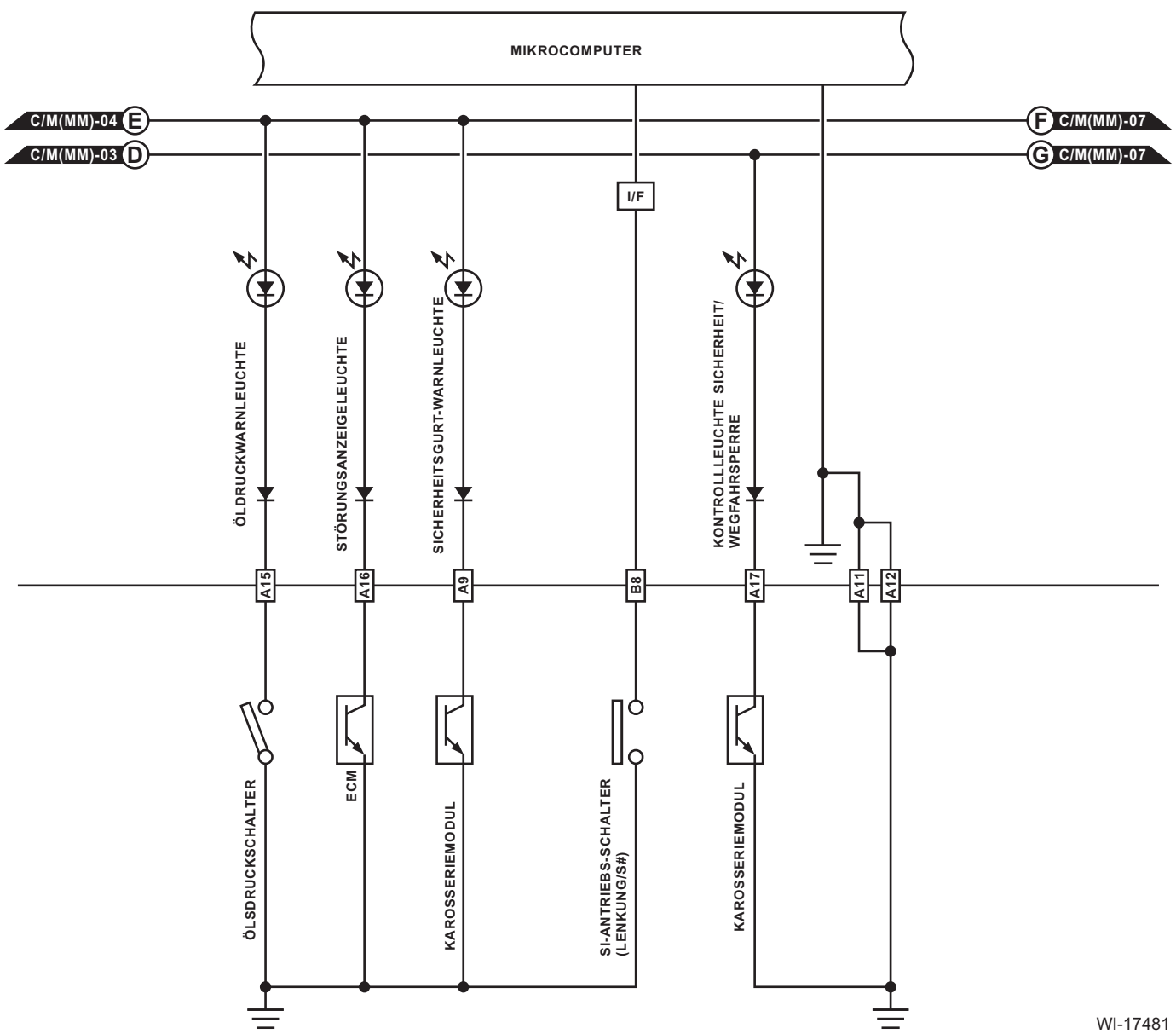

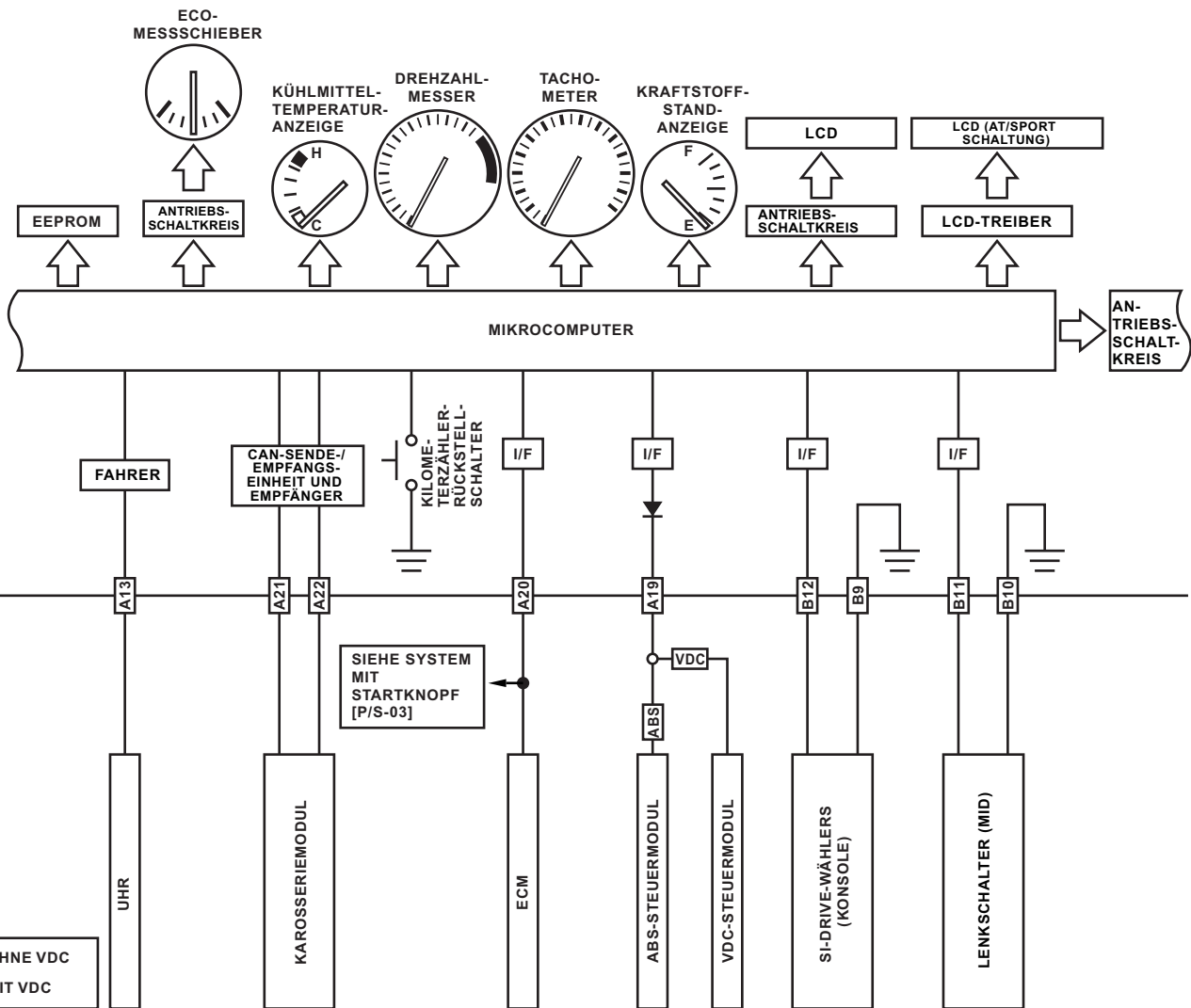

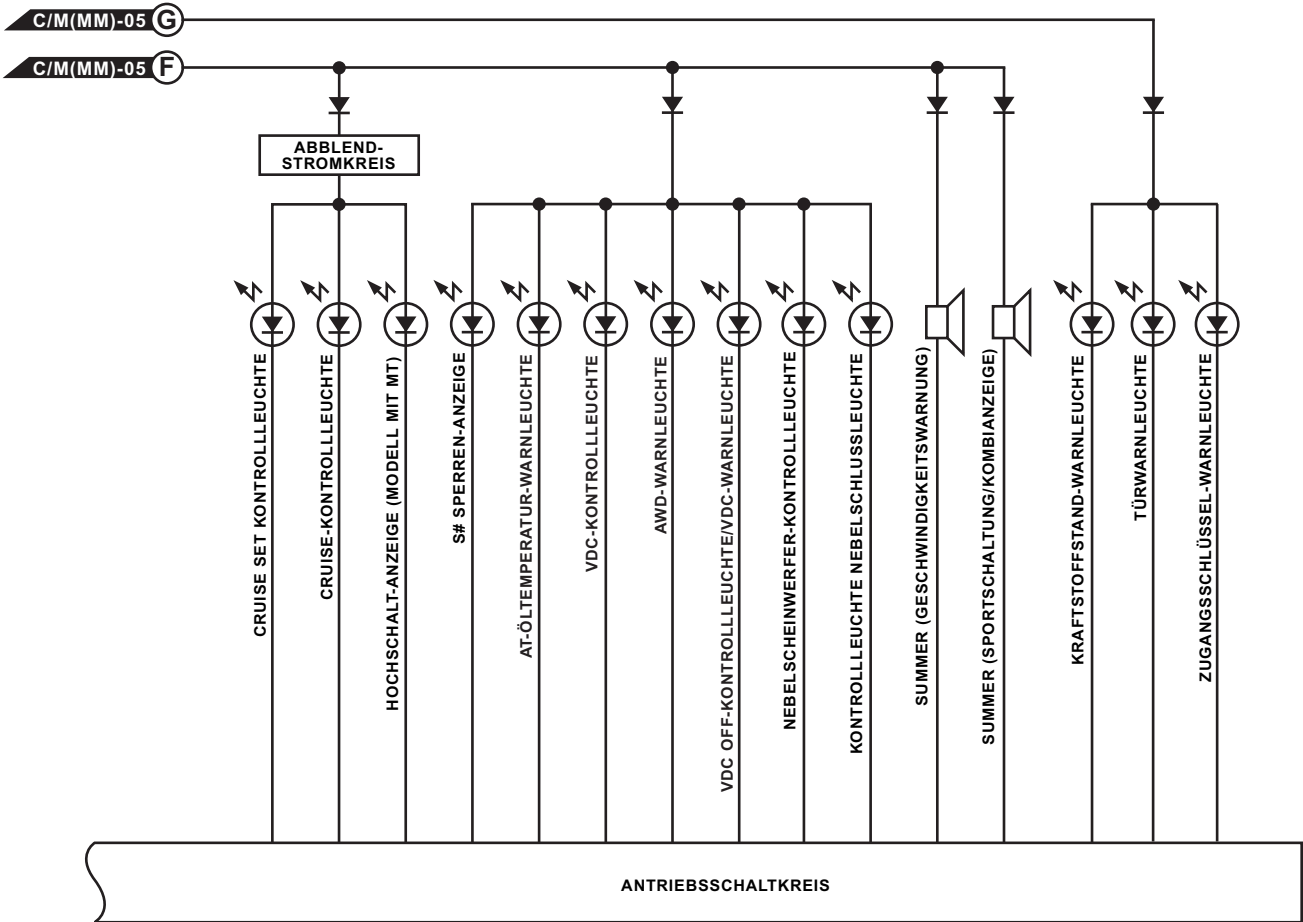

ZUM SPANNUNGSVERSORUNGSKREIS		
FB-10 M/B SICHERUNG Nr. 8 (B)	FB-25 F/B SICHERUNG Nr. 24 (ACC)	FB-36 F/B SICHERUNG Nr. 5 (IG)

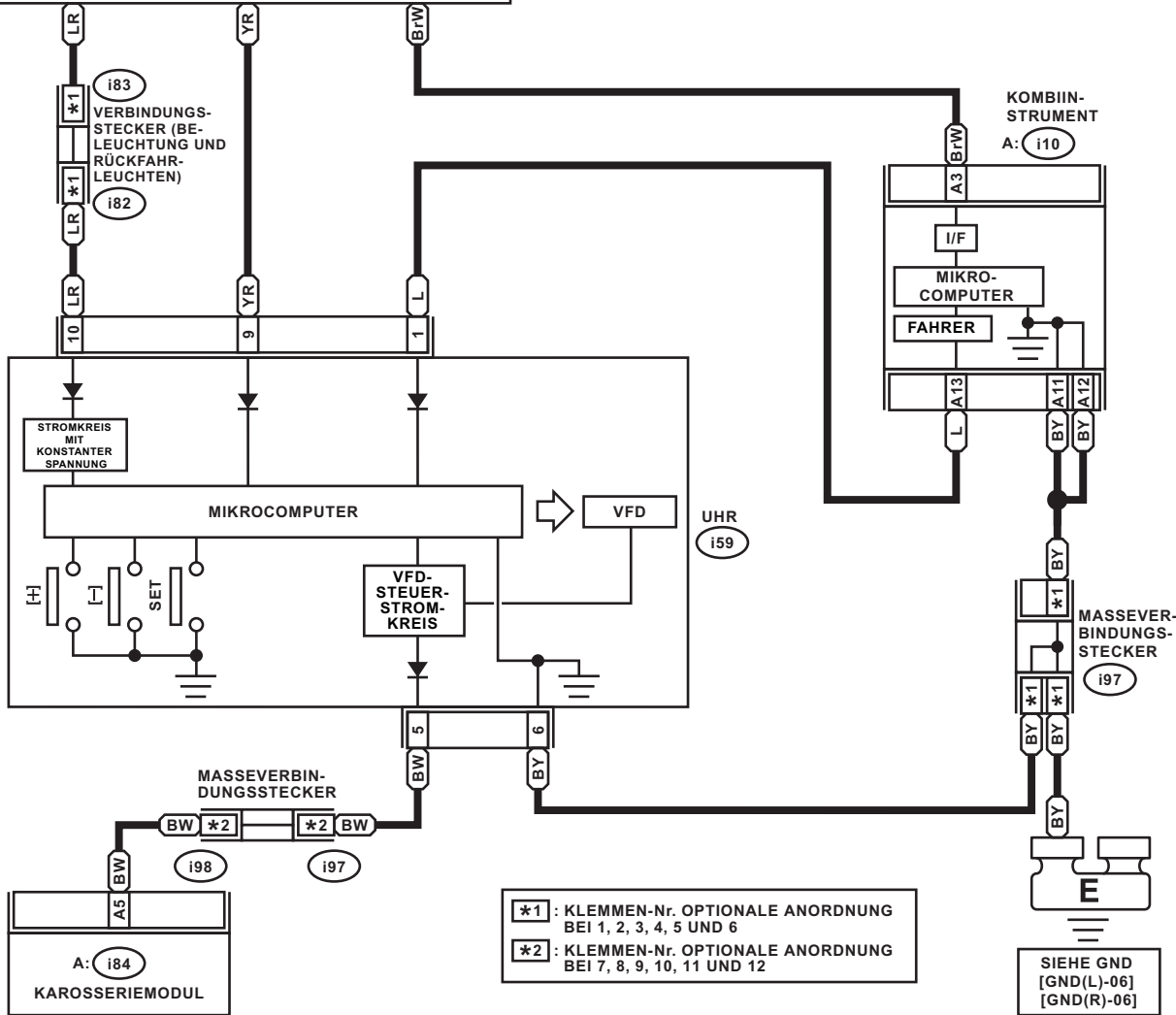

*1 : KLEMMEN-Nr. OPTIONALE ANORDNUNG BEI 1, 2, 3, 4, 5 UND 6
 *2 : KLEMMEN-Nr. OPTIONALE ANORDNUNG BEI 7, 8, 9, 10, 11 UND 12

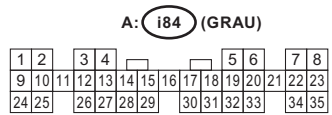
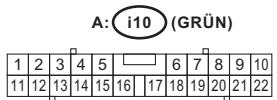
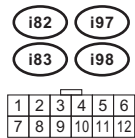
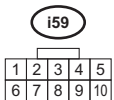

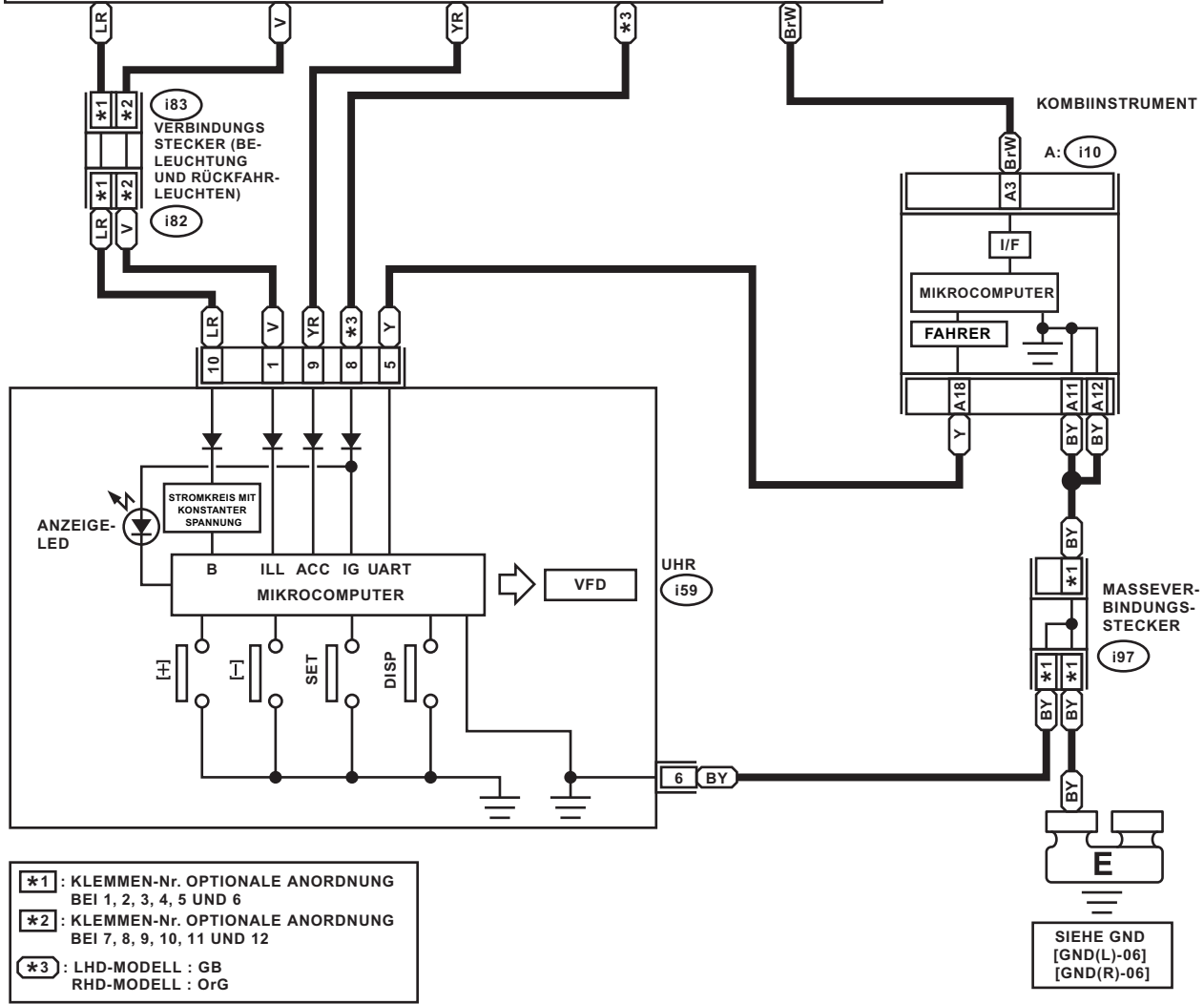

- *1 : KLEMMEN-Nr. OPTIONALE ANORDNUNG BEI 1, 2, 3, 4, 5 UND 6
- *2 : KLEMMEN-Nr. OPTIONALE ANORDNUNG BEI 7, 8, 9, 10, 11 UND 12
- *3 : LHD-MODELL : GB
RHD-MODELL : 0rg

SIEHE GND
[GND(L)-06]
[GND(R)-06]

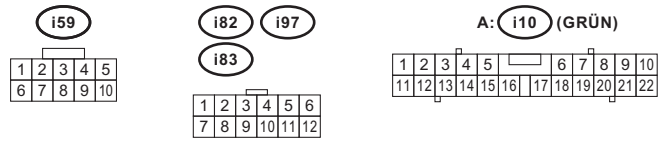

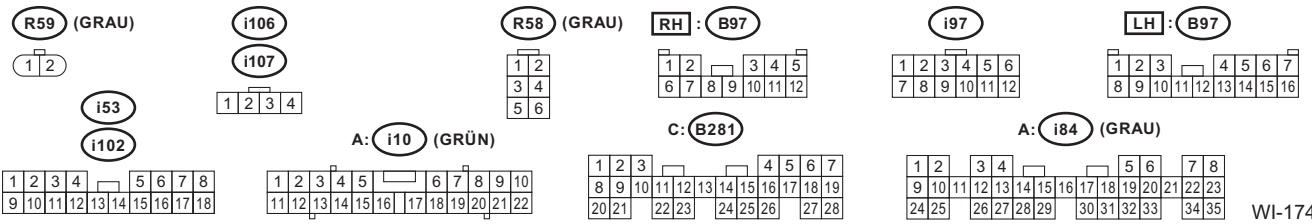
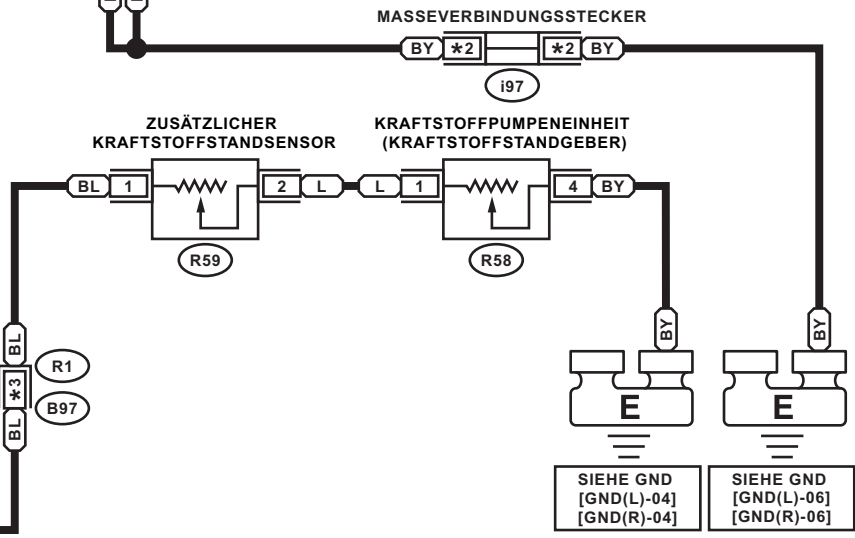
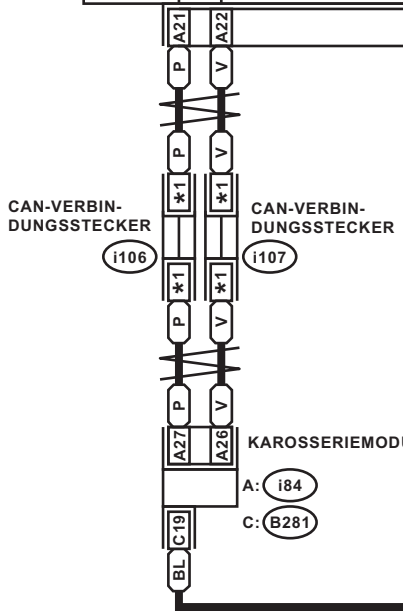
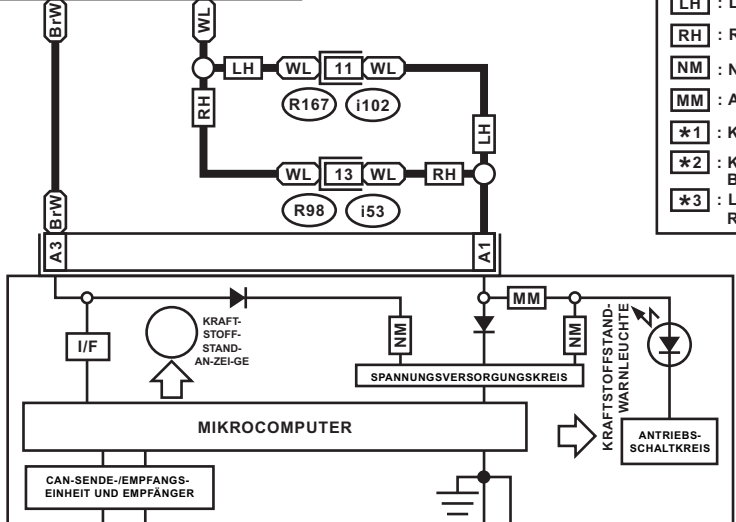
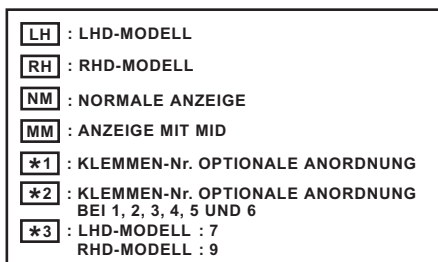

ZUM SPANNUNGSVERSORGUNGSKREIS
 FB-36
 F/B SICHERUNG
 Nr. 5 (IG)

- *1 : KLEMMEN-Nr. OPTIONALE ANORDNUNG BEI 1, 2, 3 UND 4
- *2 : KLEMMEN-Nr. OPTIONALE ANORDNUNG BEI 1, 2, 3, 4, 5 UND 6
- *3 : KLEMMEN-Nr. OPTIONALE ANORDNUNG BEI 1, 2, 5 UND 6

KÜHLMITTELTEMPERATURSENSOR (H6-MODELL)

KÜHLMITTELTEMPERATURSENSOR (2,5L MODELL)

KÜHLMITTELTEMPERATURSENSOR (H4 MIT SAUGMOTOR DOHC-MODELL)

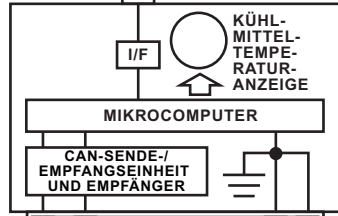

KOMBINSTRUMENT
 A: i10

CAN-VERBINDUNGS-STECKER
 i106

CAN-VERBINDUNGS-STECKER
 i107

MASSEVERBINDUNGS-STECKER
 i97

KAROSRIEMODUL
 A: i84
 B: B280

SIEHE GND [GND(L)-06]

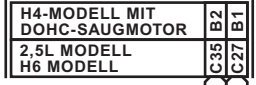
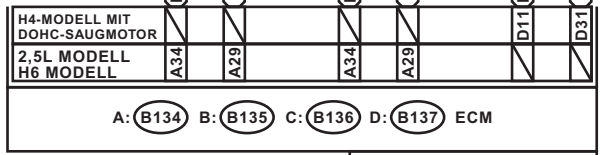

VERBINDUNGS-STECKER
 B83

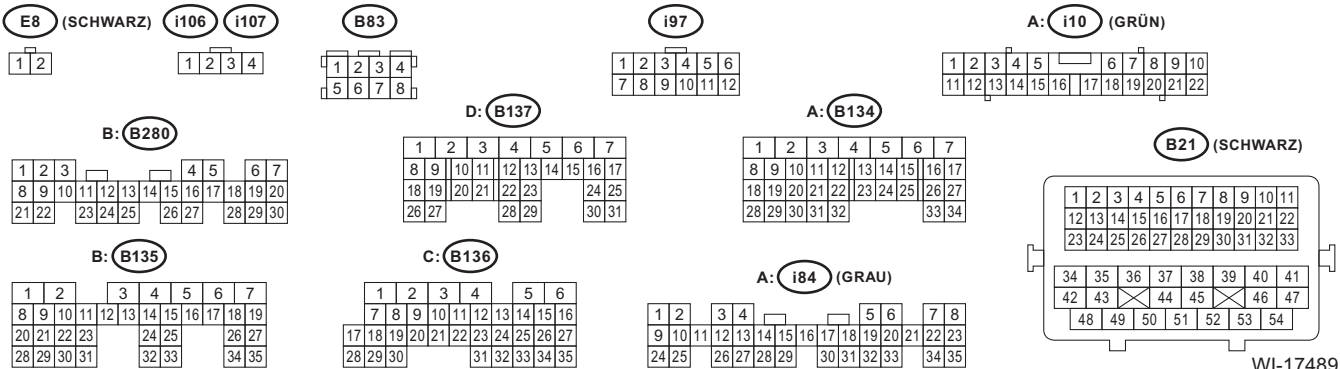

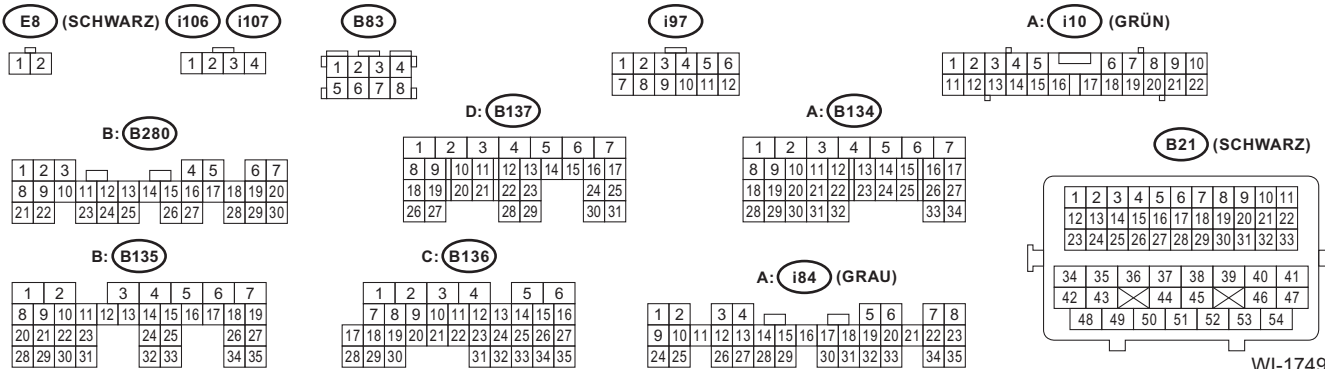
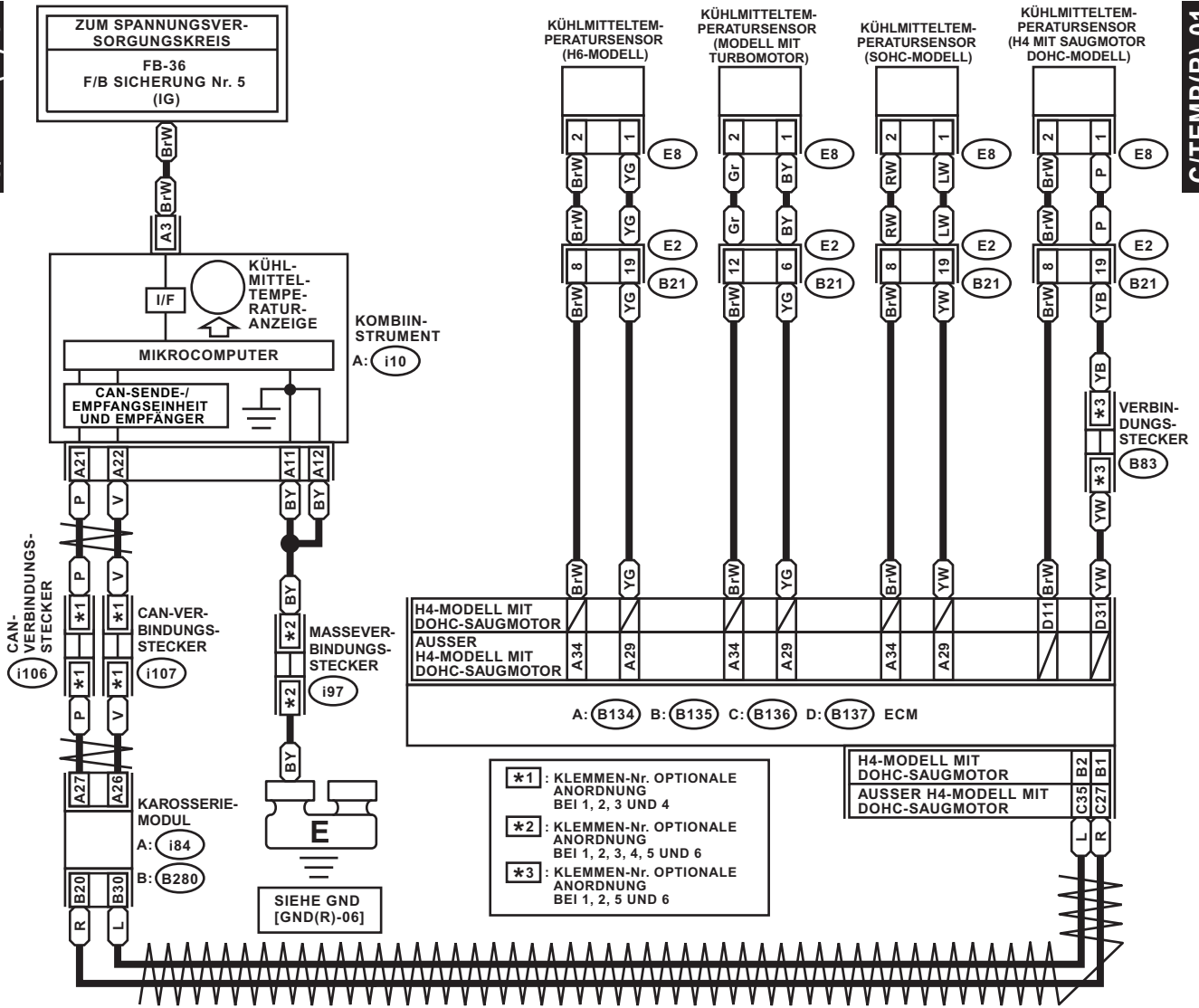

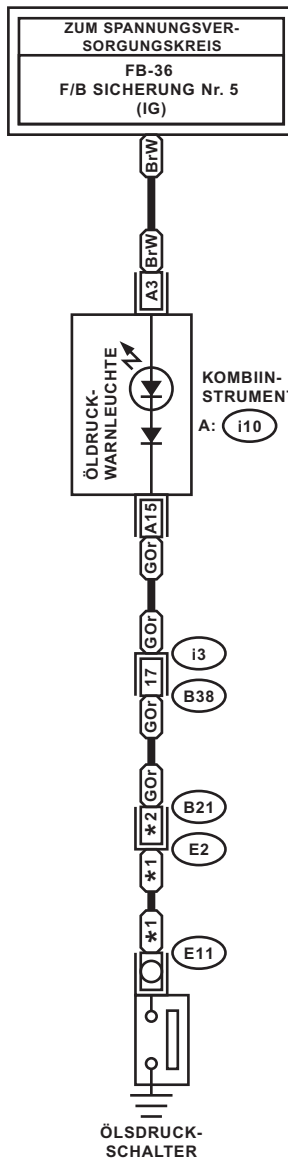

***1** : 2.0L UND 2.5L MODELL : BrB
 3.0L MODELL : GOr
 MODELL MIT TURBOMOTOR : G

***2** : MODELL MIT TURBOMOTOR : 45
 AUSSER :
 MODELL MIT TURBOMOTOR : 31

B38

1	2	3	4	5	6	7	8	9		
10	11	12	13	14	15	16	17	18	19	20

A: i10 (GRÜN)

1	2	3	4	5	6	7	8	9	10		
11	12	13	14	15	16	17	18	19	20	21	22

B21 (SCHWARZ)

1	2	3	4	5	6	7	8	9	10	11
12	13	14	15	16	17	18	19	20	21	22
23	24	25	26	27	28	29	30	31	32	33
34	35	36	37	38	39	40	41			
42	43	44	45	46	47					
48	49	50	51	52	53	54				

ZUM SPANNUNGSVER-
SORGUNGSKREIS
FB-36
F/B SICHERUNG Nr. 5
(IG)

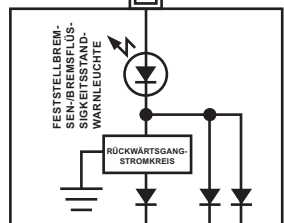

- ABS** : OHNE VDC
- VDC** : MIT VDC
- *1** : NORMALE ANZEIGE: A8
ANZEIGE MIT MID : A4
- *2** : NORMALE ANZEIGE : B10
ANZEIGE MIT MID : A8

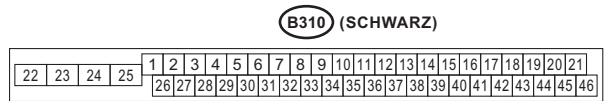
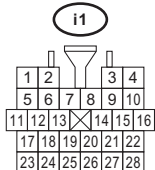
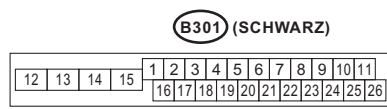
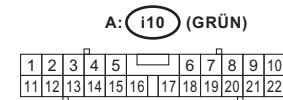
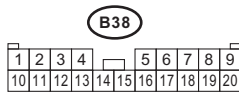
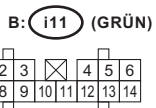
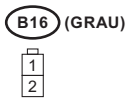
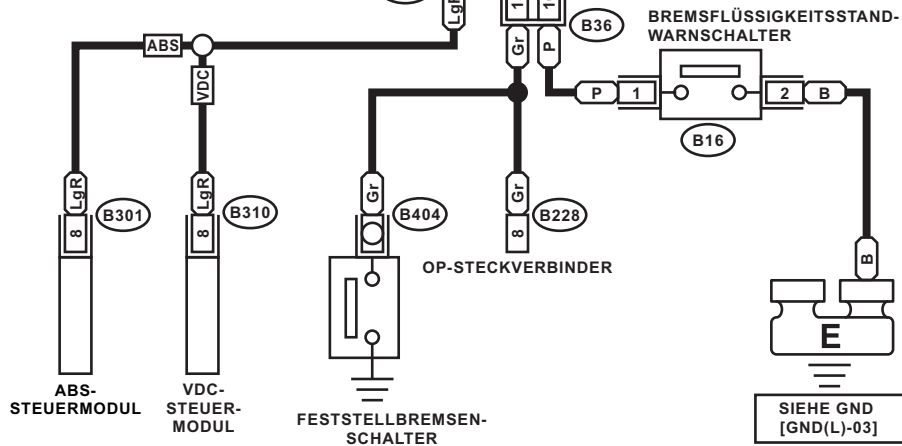

ZUM SPANNUNGSVER-
SORGUNGSKREIS
FB-36
F/B SICHERUNG Nr. 5
(IG)

- TB** : MODELL MIT TURBOMOTOR
- NA** : AUSSER MODELL MIT TURBOMOTOR
- ABS** : OHNE VDC
- VDC** : MIT VDC
- *1** : NORMALE ANZEIGE : A8 ANZEIGE MIT MID : A4
- *2** : NORMALE ANZEIGE : B10 ANZEIGE MIT MID : A8

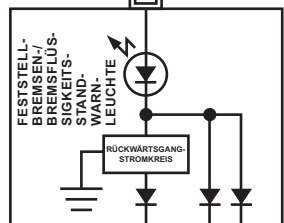

KOMBIINSTRUMENT

A: i10
B: i11

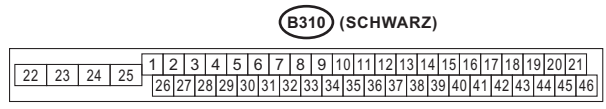
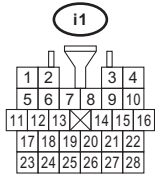
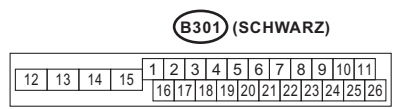
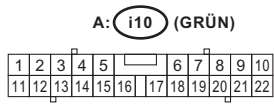
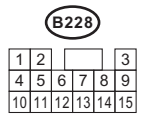
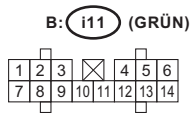
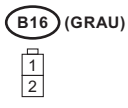
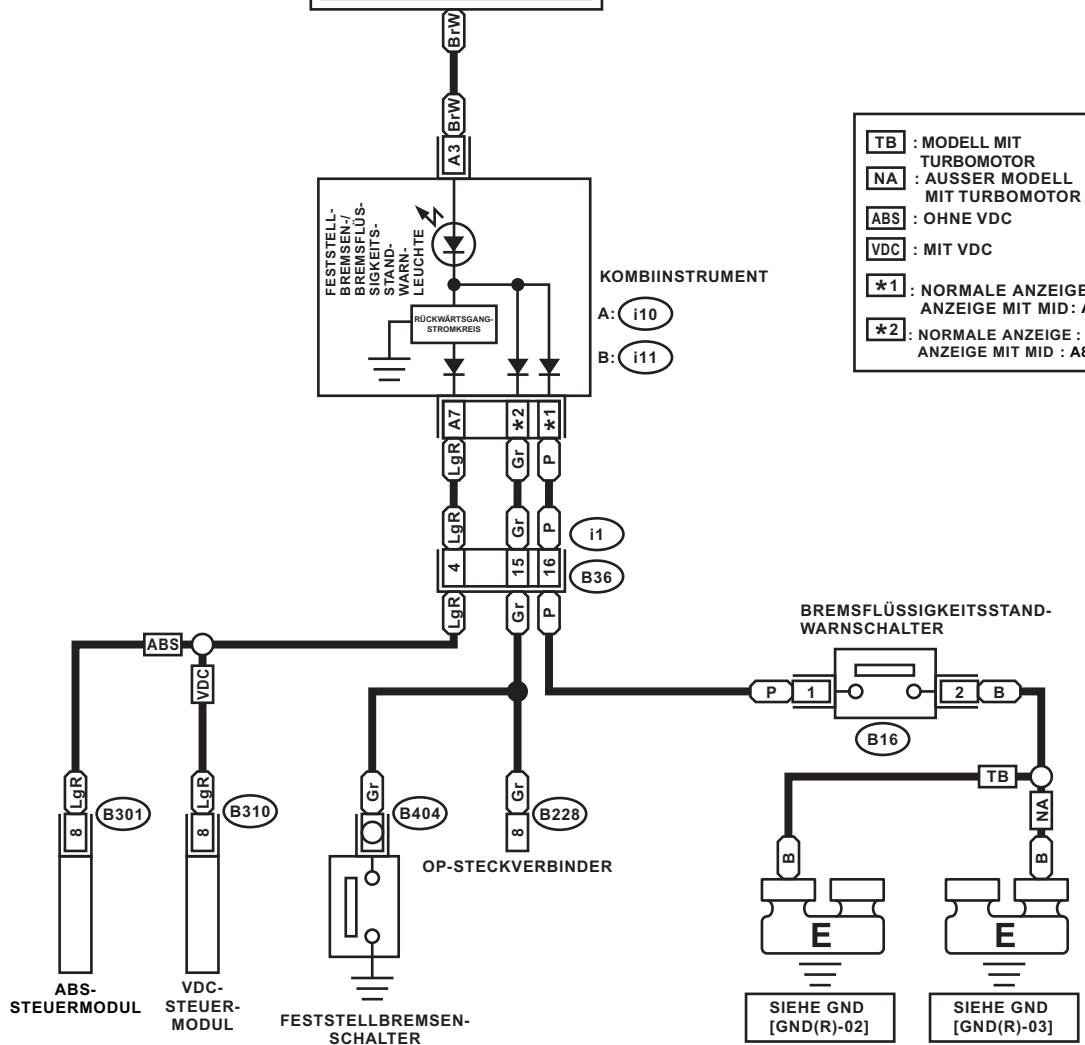

ZUM SPANNUNGSVERSORUNGSKREIS	
MB-30 SBF-4 (B)	FB-32 F/B SICHERUNG Nr. 4 (IG)

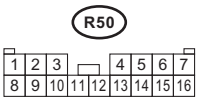
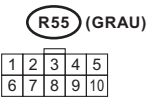
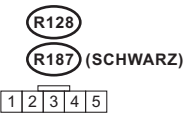
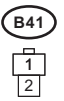
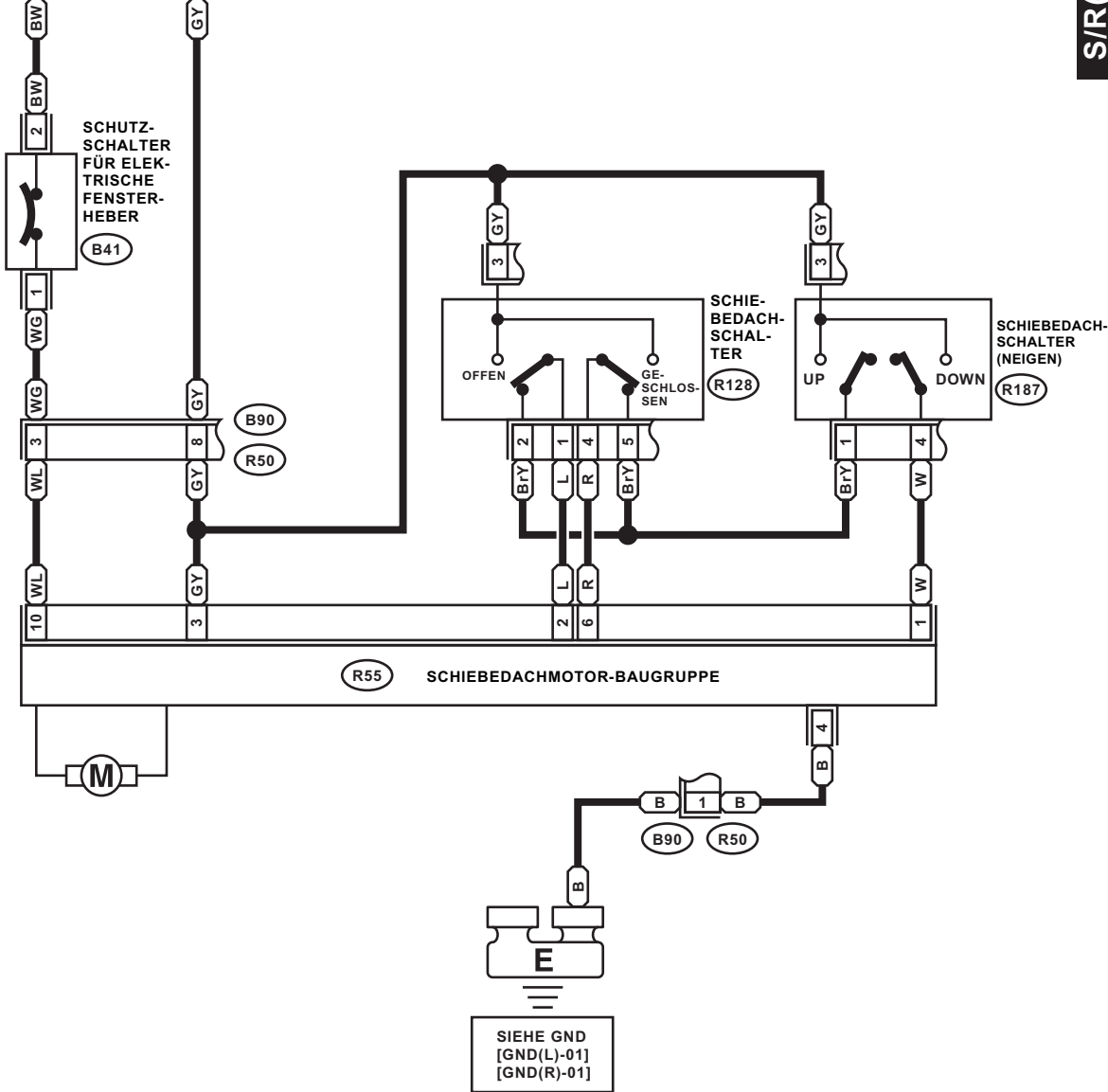



- ABS** : OHNE VDC
- VDC** : MIT VDC
- LH** : LHD-MODELL
- RH** : RHD-MODELL
- *1** : LHD-MODELL : GB
RHD-MODELL : G
- *2** : LHD-MODELL : 18
RHD-MODELL : 41
- *3** : LHD-MODELL : 17
RHD-MODELL : 40
- *4** : LHD-MODELL : 20
RHD-MODELL : 39
- *5** : LHD-MODELL : 19
RHD-MODELL : 38

VDC-
STEUERMODUL ABS-
STEUERMODUL

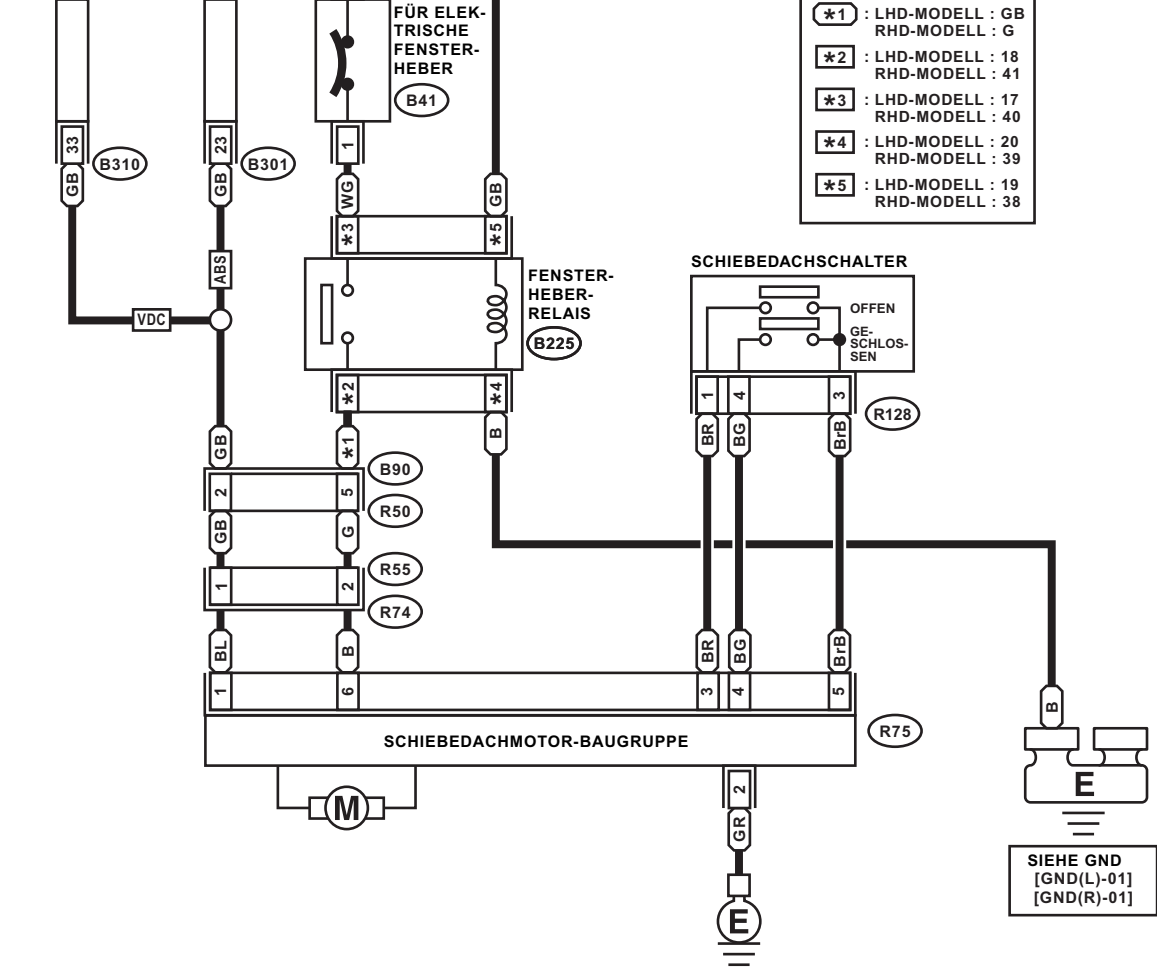

SIEHE GND
[GND(L)-01]
[GND(R)-01]

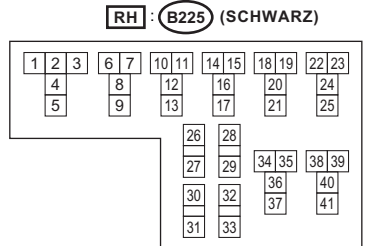
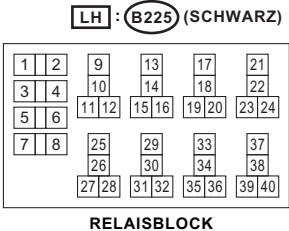
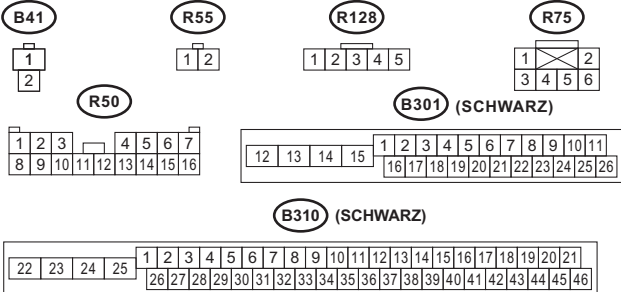

A: (i84) B: (B280) C: (B281) KAROSSERIEMODUL

- OD** : OHNE DOPPELVERRIEGELUNG
- WD** : MIT DOPPELVERRIEGELUNG
- WP** : MIT STARTKNOPF
- *1** : OHNE DOPPELVERRIEGELUNG : 3
MIT DOPPELVERRIEGELUNG : 14
- *2** : OHNE DOPPELVERRIEGELUNG : 4
MIT DOPPELVERRIEGELUNG : 15
- *3** : LHD-MODELL : 7
RHD-MODELL : 14
- *4** : KLEMMEN-Nr. OPTIONALE ANORDNUNG BEI 1, 2, 3, 4, 5 UND 6

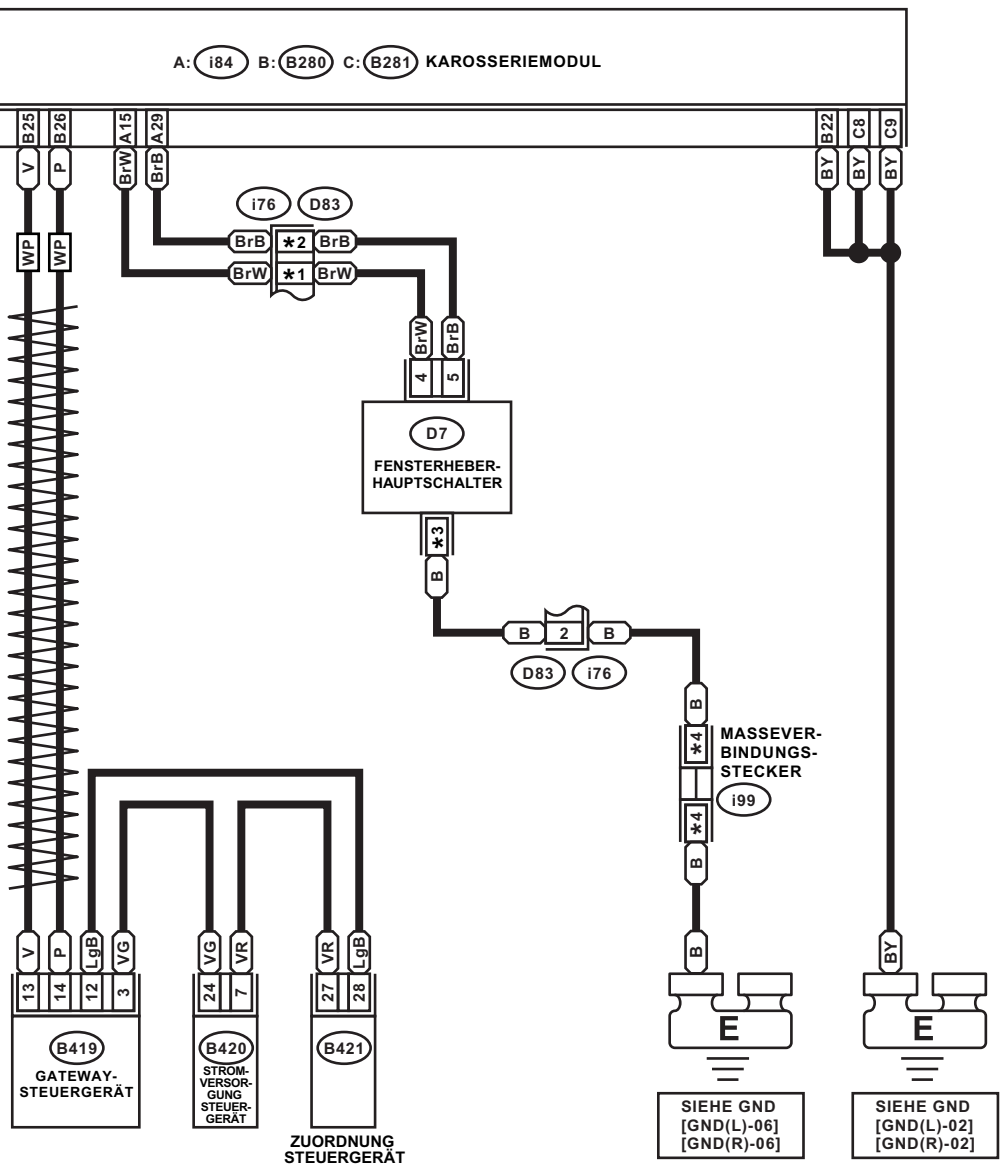

(i99) (SCHWARZ) (D7)

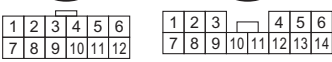

(B419)

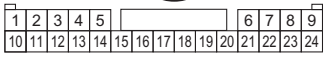

OD : (D83)

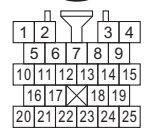

C: (B281)



WD : (D83)

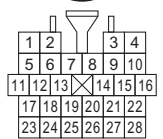

B: (B280)

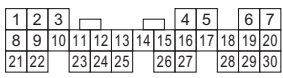

A: (i84) (GRAU)

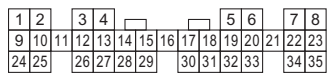

(B420) (B421)

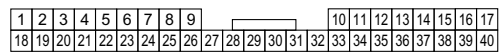

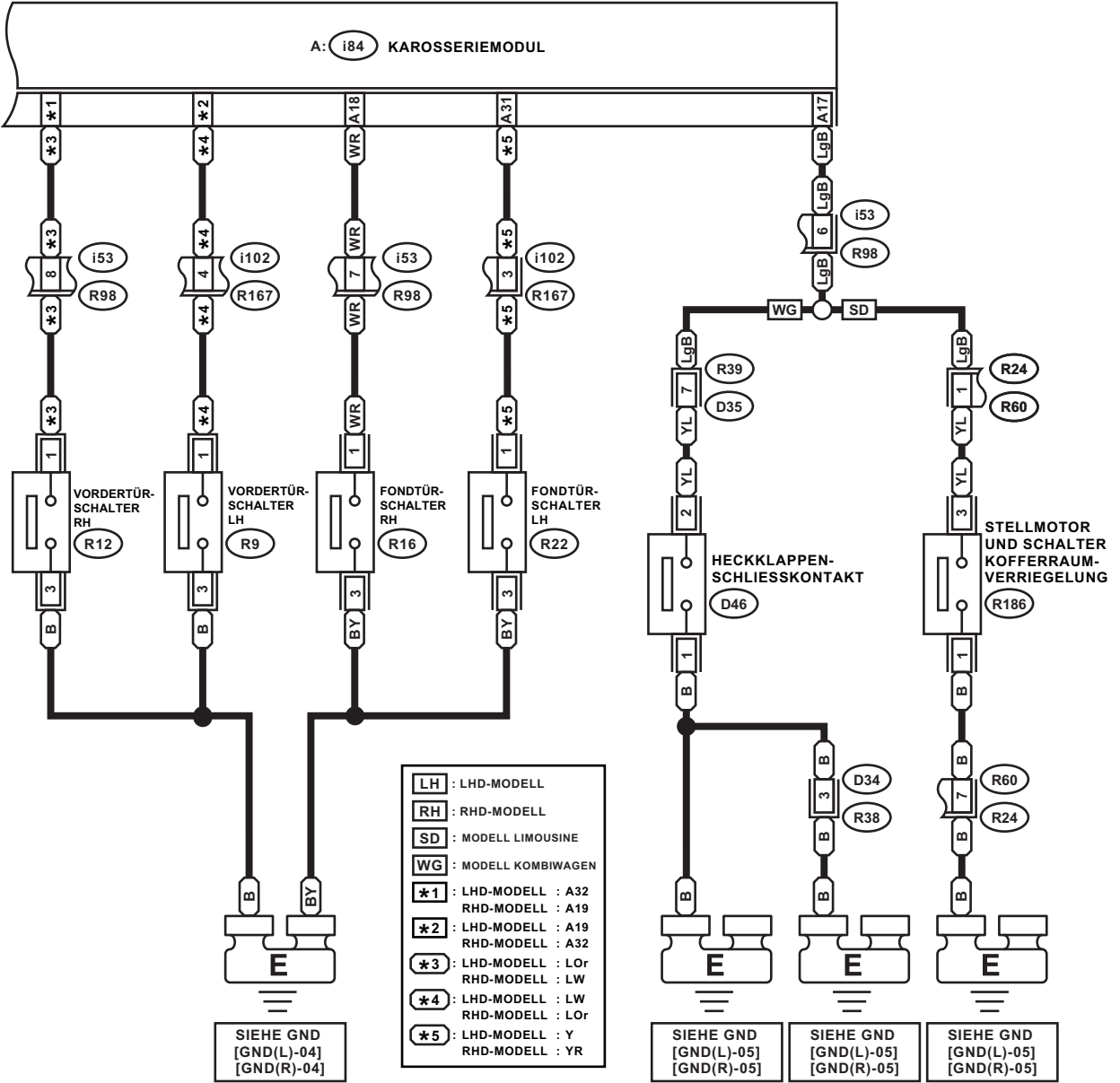

D46 (SCHWARZ)



R9



R16

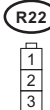

R186



D34

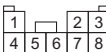

R60

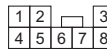

D35

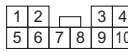

RH : i102

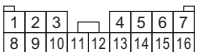

i53

LH : i102

A: i84 (GRAU)

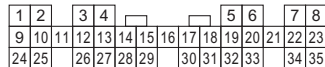
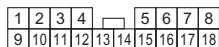

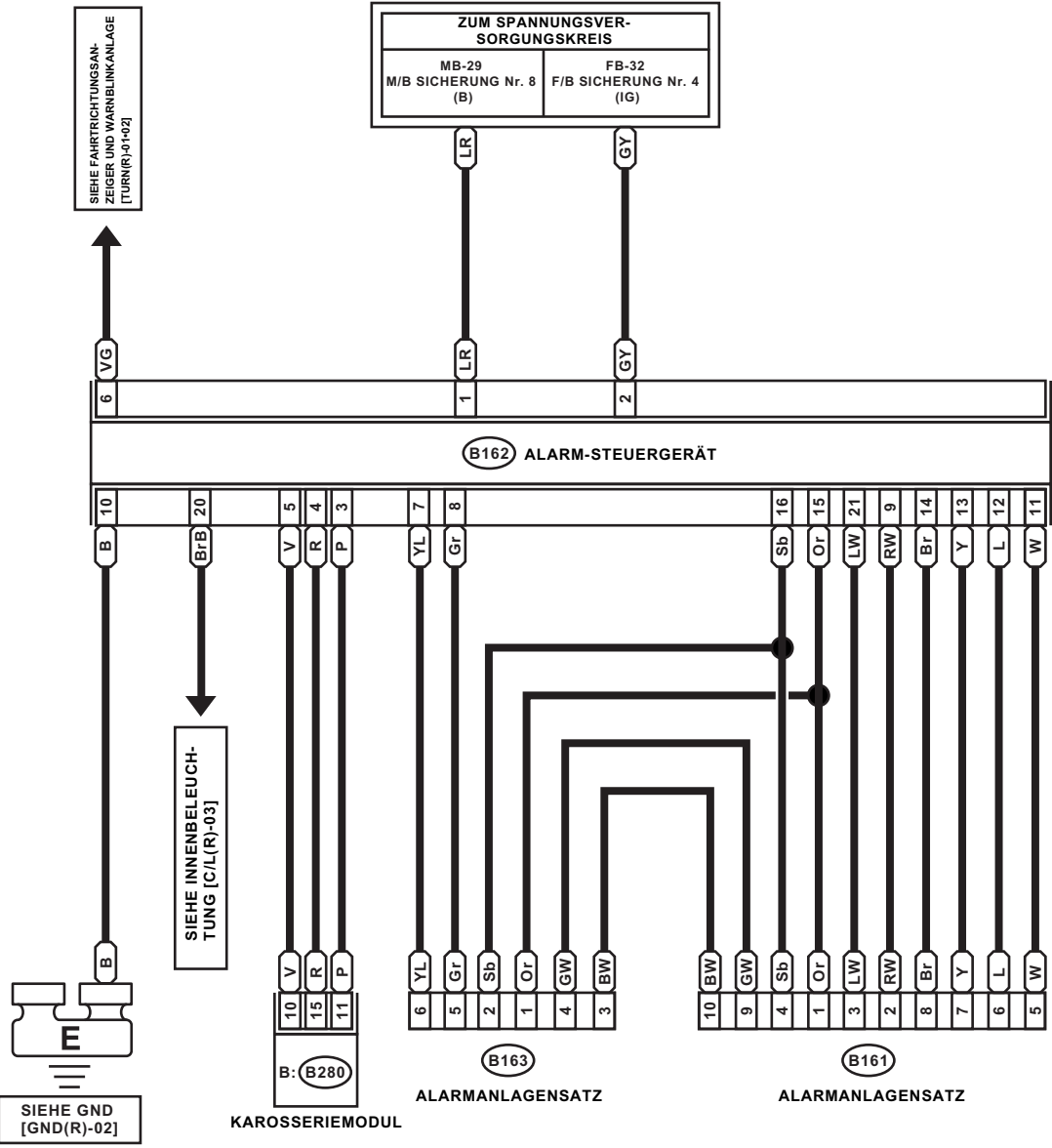

(B163) (SCHWARZ)

(B161)

(B162)

B: (B280)

1		2
3	4	5
6		

1	2		3	4
5	6	7	8	9
10				

1	2	3	4	5		6	7	8	9	10	
11	12	13	14	15	16	17	18	19	20	21	22

1	2	3			4	5	6	7				
8	9	10	11	12	13	14	15	16	17	18	19	20
21	22	23	24	25	26	27	28	29	30			

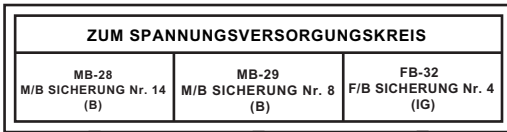

SIEHE FAHRRICHTUNGSANZEIGER UND WARNBLINKANLAGE [TURN(R)-01-02]



*1 : KLEMMEN-Nr. OPTIONALE ANORDNUNG BEI 1, 2, 3, 4, 5 UND 6

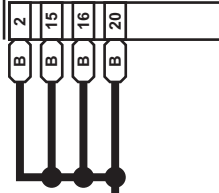
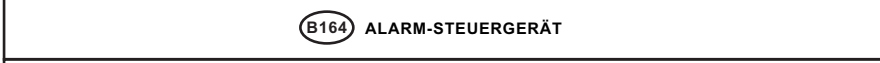

SIEHE INNENBELEUCHTUNG [C/L(R)-03]



SIEHE GND [GND(R)-02]



SICHERHEITS-STECKER



KAROSSE-RIEMODUL

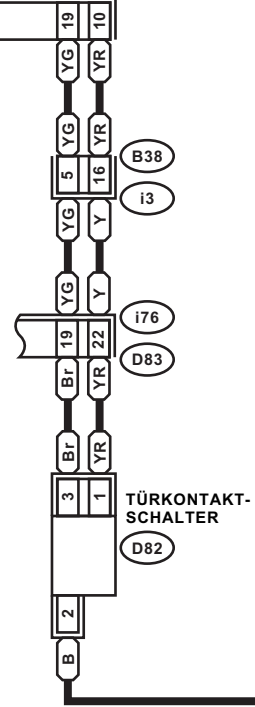

TÜRKONTAKT-SCHALTER

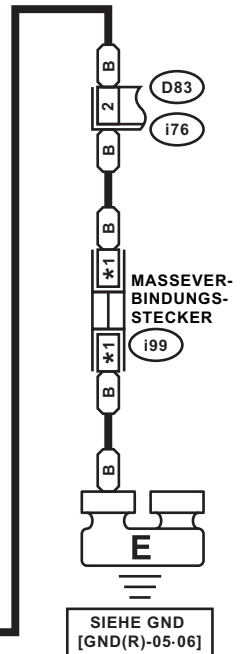

MASSEVERBINDUNGS-STECKER

SIEHE GND [GND(R)-05-06]

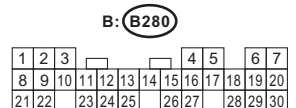
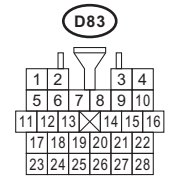
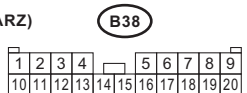
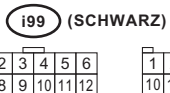
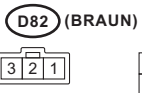

ZUM SPANNUNGSVERSORUNGSKREIS

FB-18 F/B SICHERUNG Nr. 7 (B)	FB-37 F/B SICHERUNG Nr. 12 (IG)	MB-28 M/B SICHERUNG Nr. 14 (B)	MB-29 M/B SICHERUNG Nr. 8 (B)		FB-17 F/B SICHERUNG Nr. 7 (B)
-------------------------------------	---------------------------------------	--------------------------------------	-------------------------------------	--	-------------------------------------

ECM

B: (B135) C: (B136)

2,0 L MODELL	C26 B23
AUSSER 2,0L MODELL	C34 B31

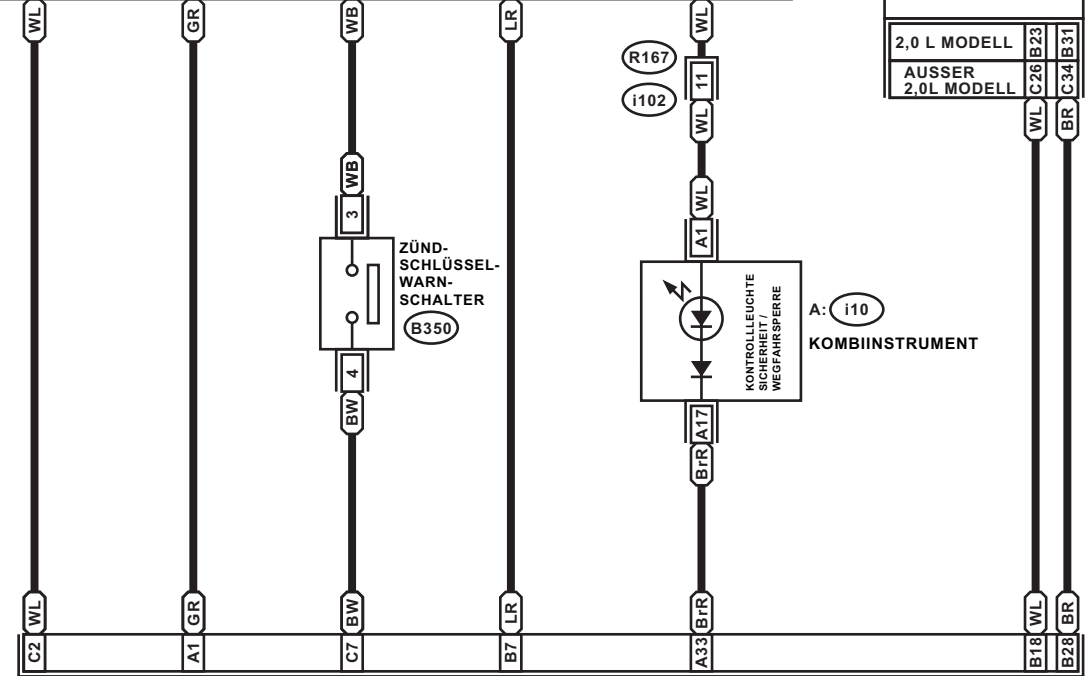

A: (i84) B: (B280) C: (B281) **KAROSSEMODUL**

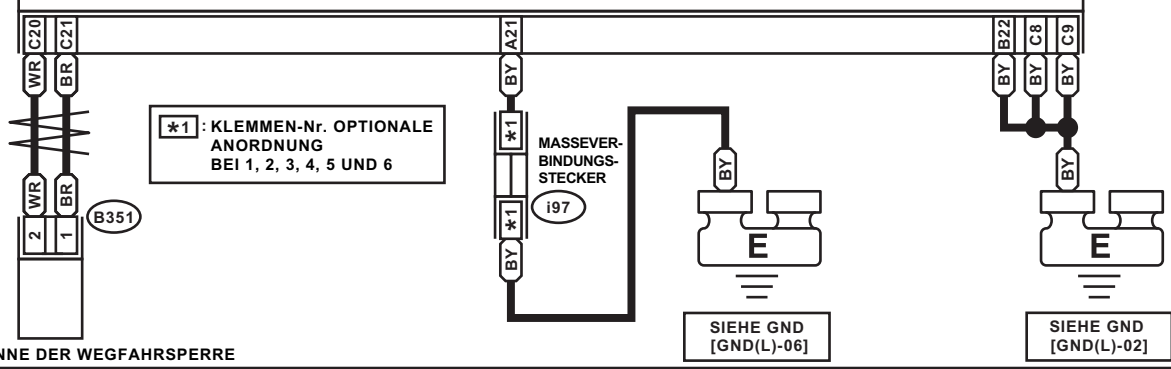

*1 : KLEMMEN-Nr. OPTIONALE ANORDNUNG BEI 1, 2, 3, 4, 5 UND 6

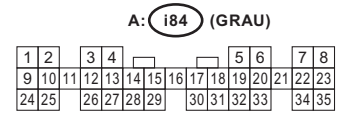
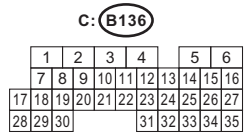
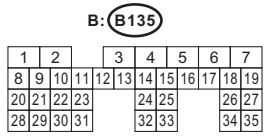
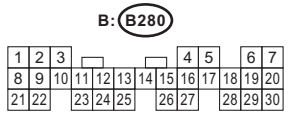
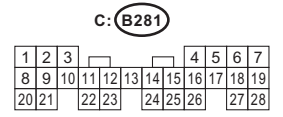
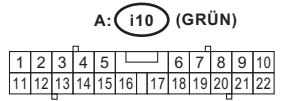
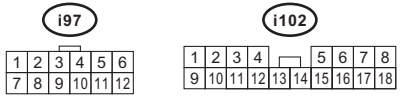
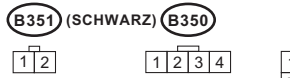

ZUM SPANNUNGSVERSORGUNGSKREIS
 FB-29
 F/B SICHERUNG
 Nr. 31 (ACC)

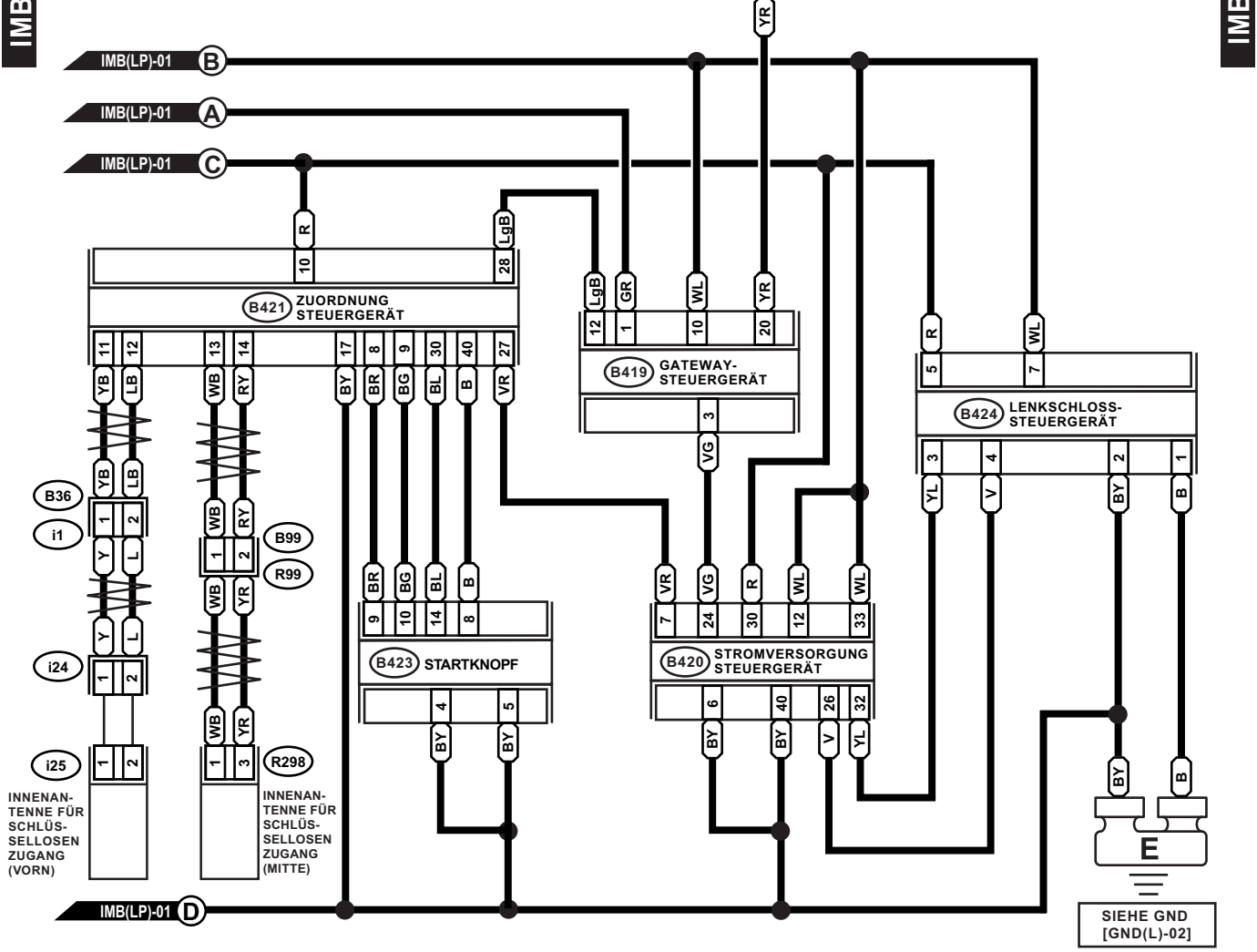

INNENANTENNE FÜR SCHLÜSSELLOSEN ZUGANG (VORN)

INNENANTENNE FÜR SCHLÜSSELLOSEN ZUGANG (MITTE)

SIEHE GND [GND(L)-02]

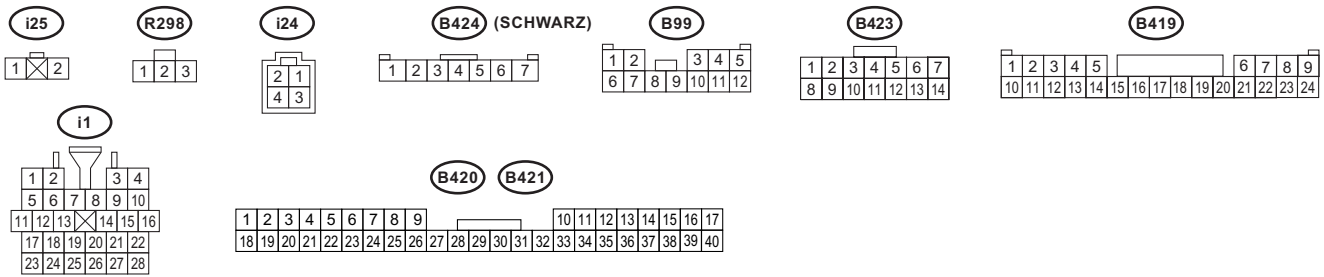

ZUM SPANNUNGSVERSORGUNGSKREIS				
FB-18 F/B SICHERUNG Nr. 7 (B)	FB-37 F/B SICHERUNG Nr. 12 (IG)	MB-28 M/B SICHERUNG Nr. 14 (B)	MB-29 M/B SICHERUNG Nr. 8 (B)	FB-17 F/B SICHERUNG Nr. 7 (B)

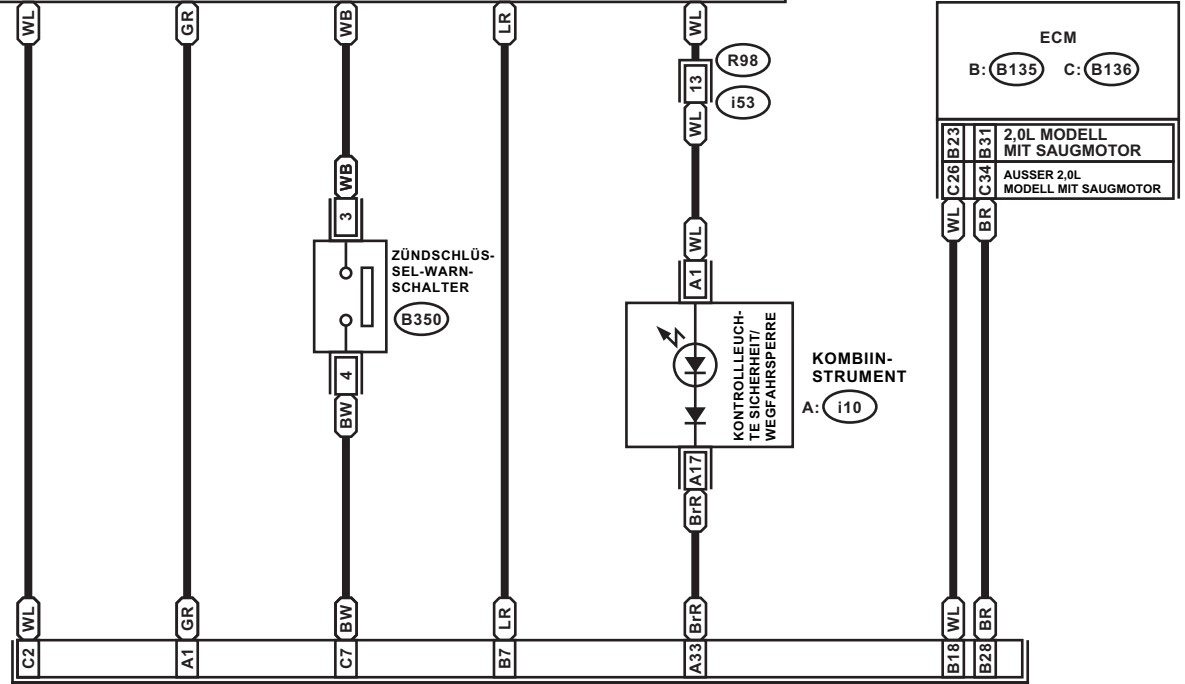

A: i84			B: B280			C: B281		
KAROSSERIEMODUL								

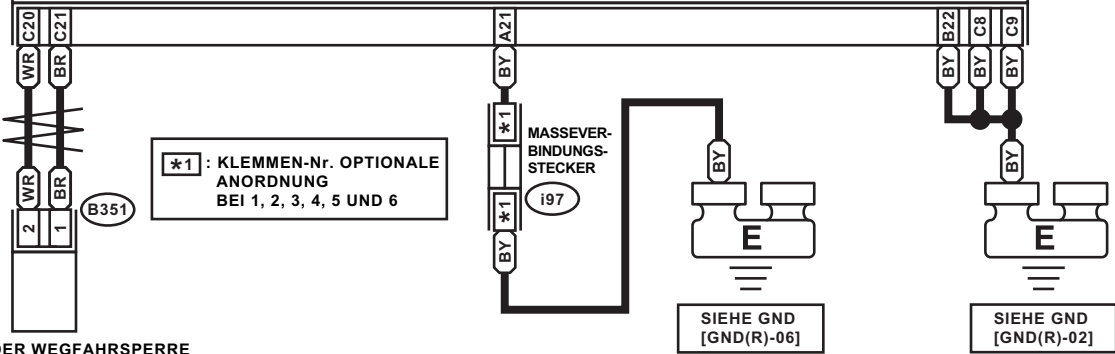

ANTENNE DER WEGFAHRSPERRE

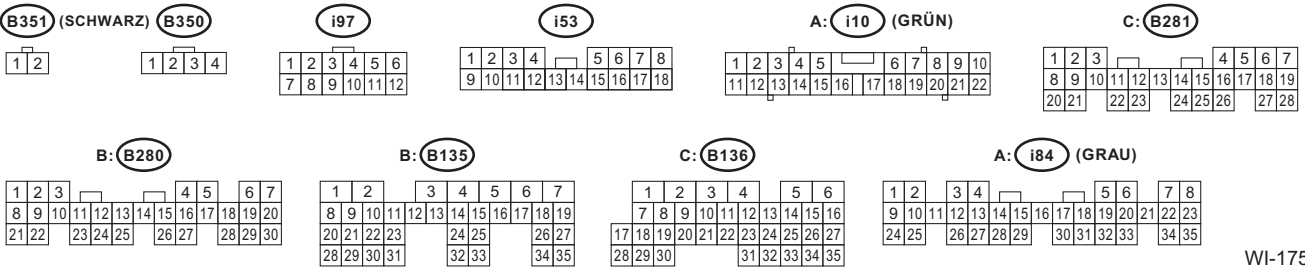

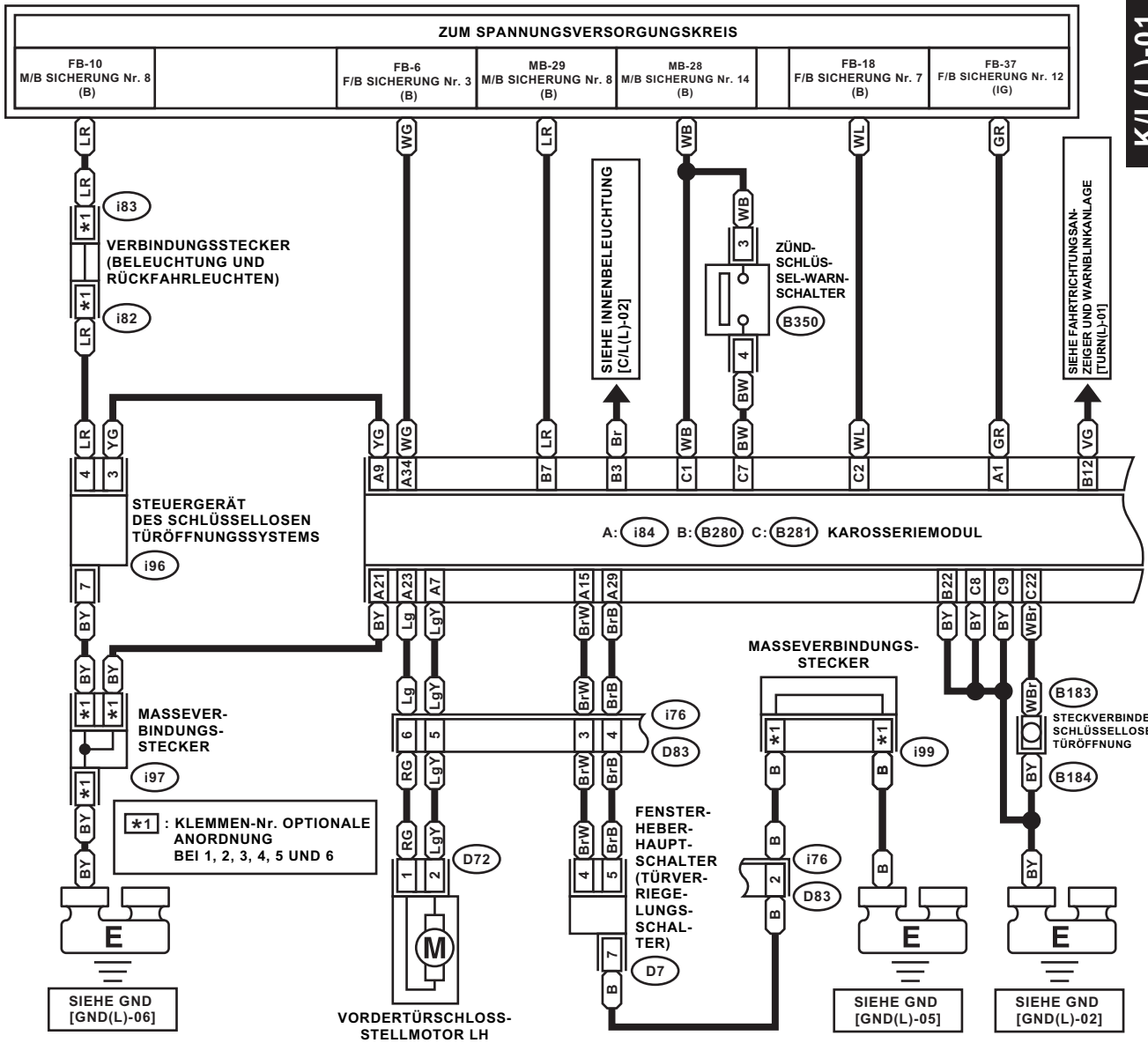

D72 (GRAU)



B350



i96



i82 i97
i83 i99 (SCHWARZ)

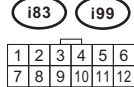

D7

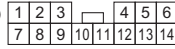

D83

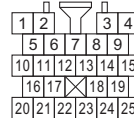

C: B281

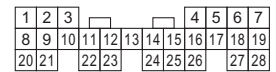

B: B280



A: i84 (GRAU)

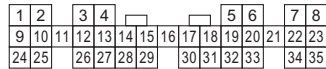

A: 184 KAROSSERIEMODUL

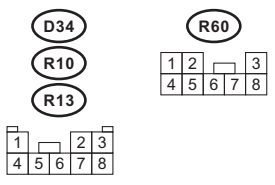
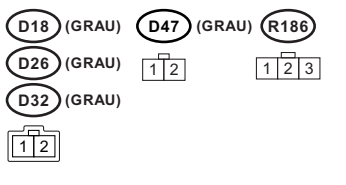
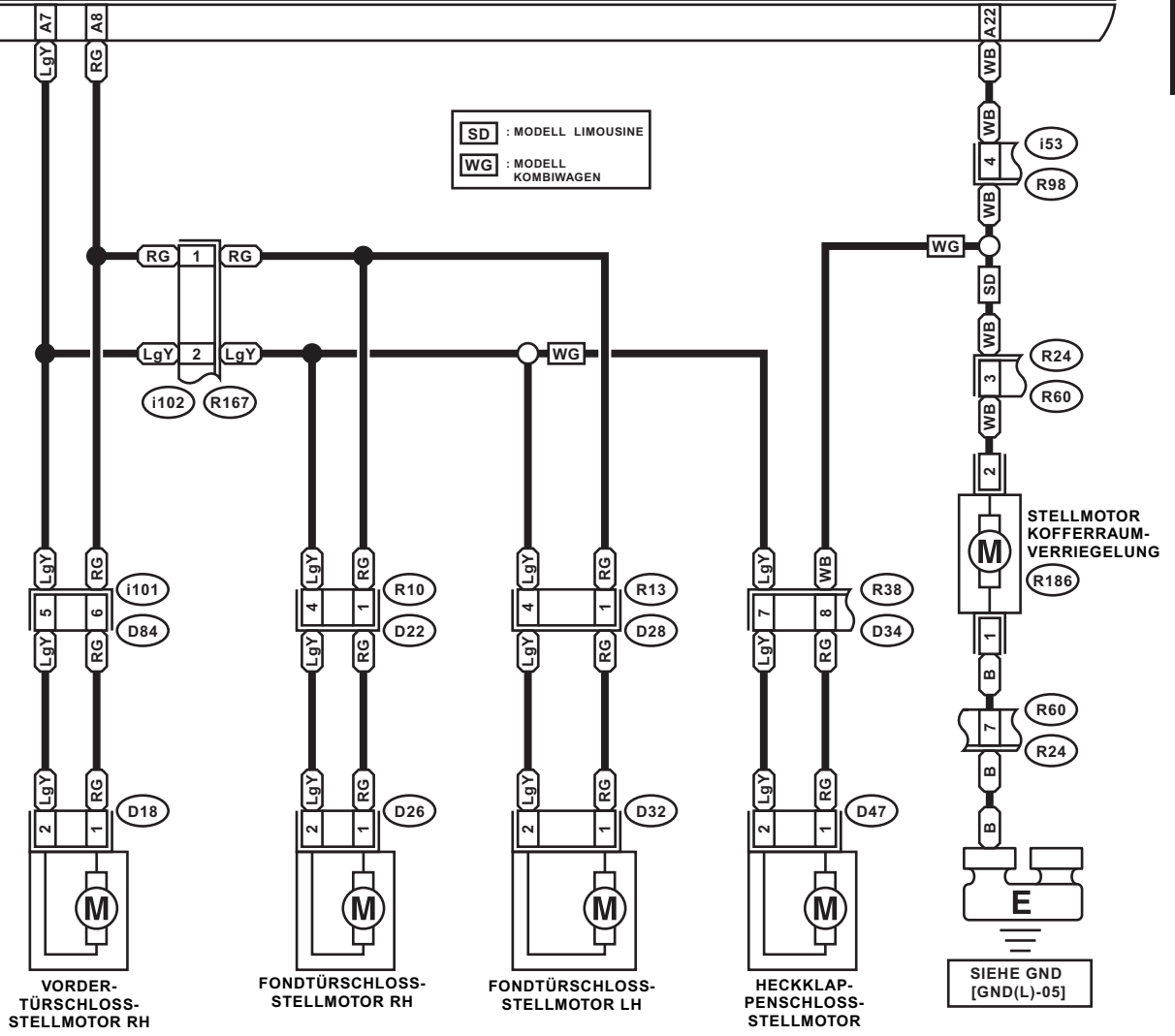

A: 184 (GRAU)

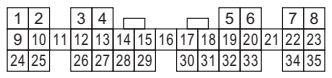

A: i84 KAROSSERIEMODUL

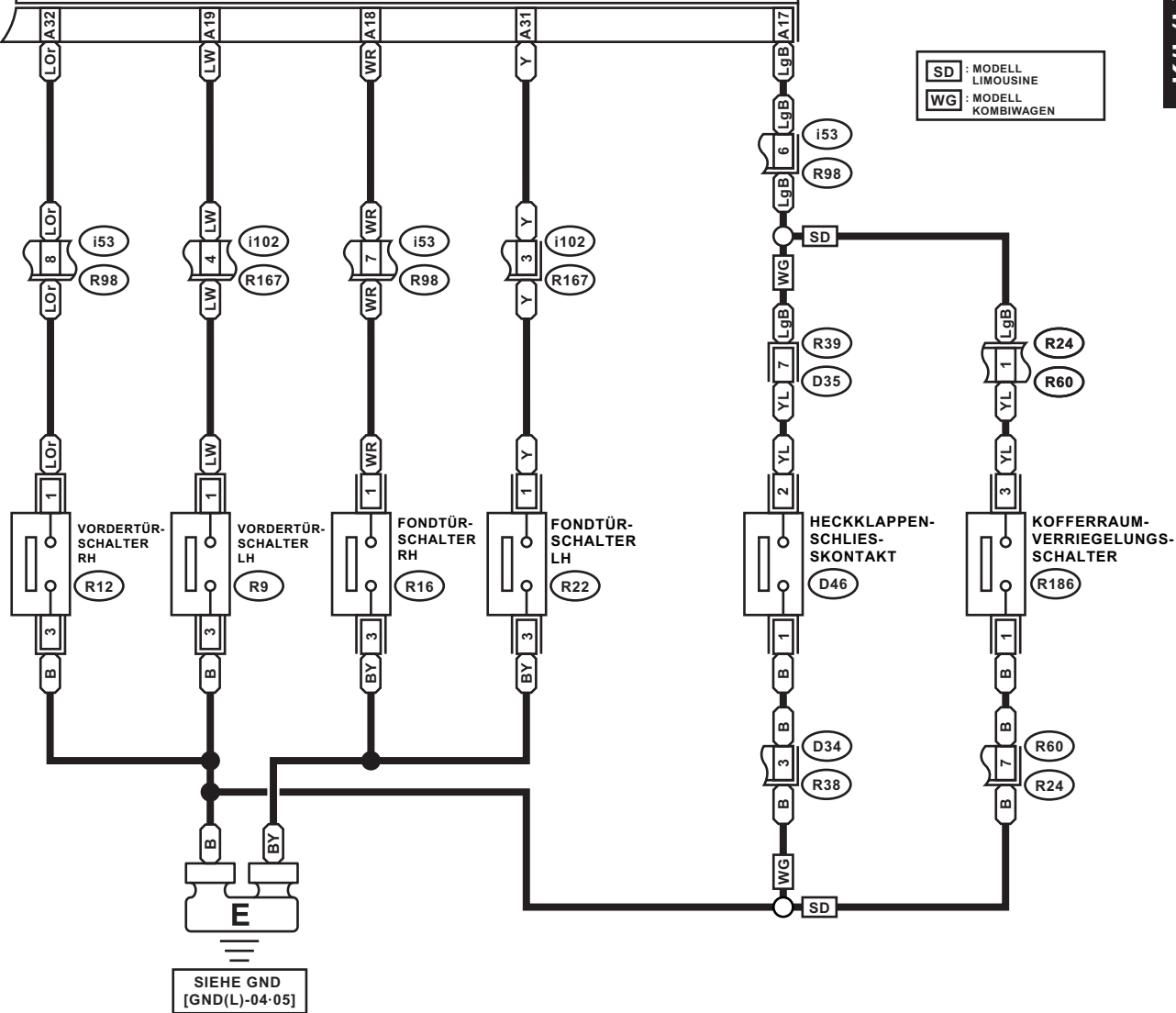

SD : MODELL LIMOUSINE
WG : MODELL KOMBIWAGEN

SIEHE GND [GND(L)-04-05]

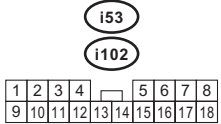
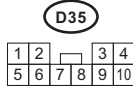
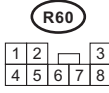
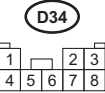
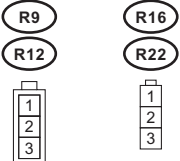

A: i84 (GRAU)

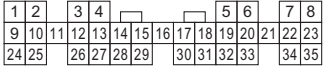

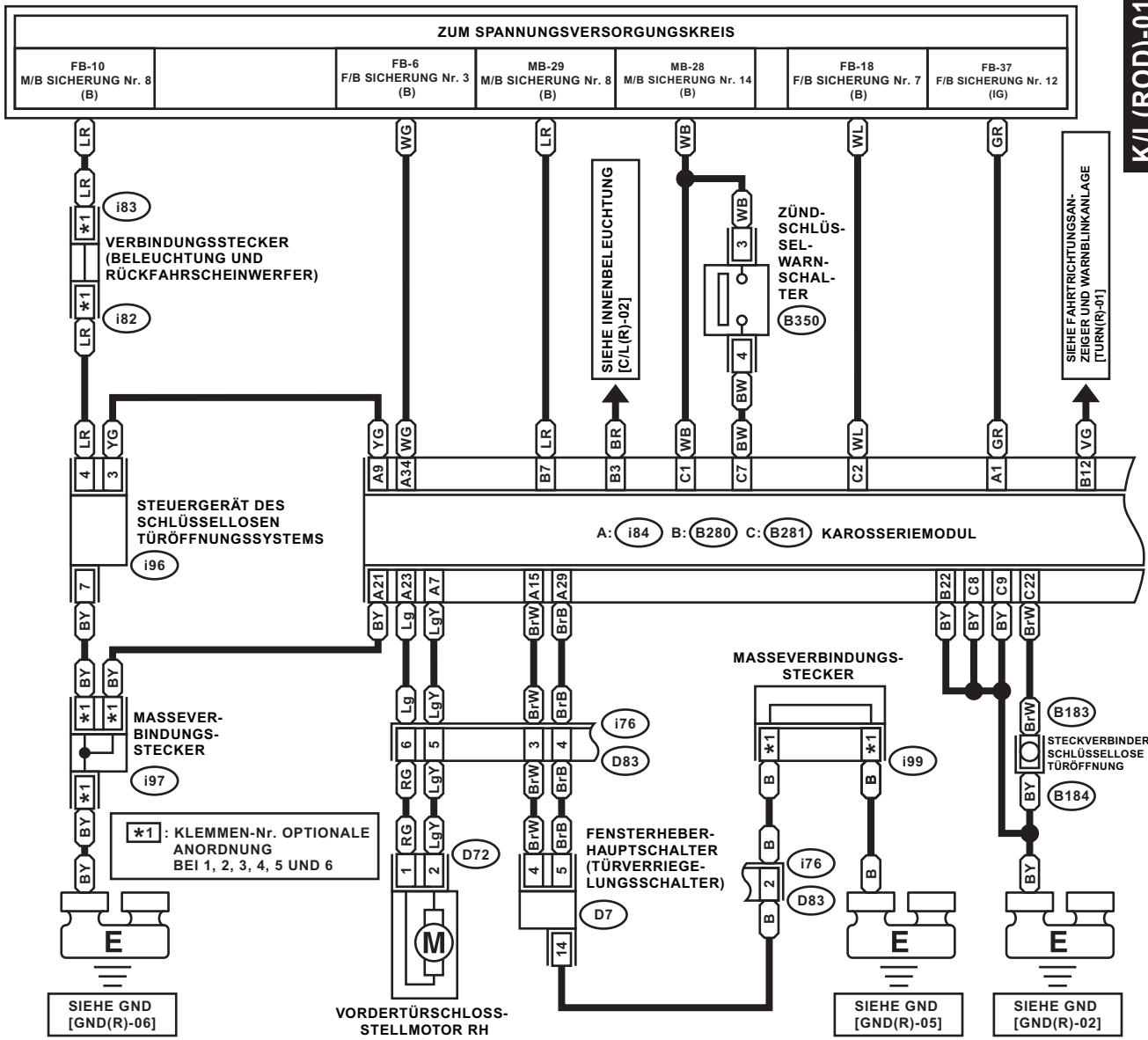

D72 (GRAU)



B350



i96



i82 i97
i83 i99 (SCHWARZ)

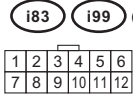

D7



D83

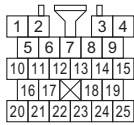

C: B281

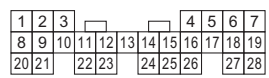

B: B280



A: i84 (GRAU)

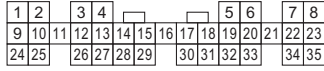

A: i84 KAROSSERIEMODUL

- SD** : MODELL LIMOUSINE
- WG** : MODELL KOMBIWAGEN
- *1** : EK-MODELL : YL
AUSSER EK-MODELL : RG
- *2** : EK-MODELL : YL
AUSSER EK-MODELL : LgY

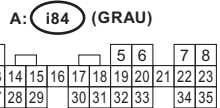
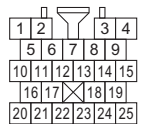
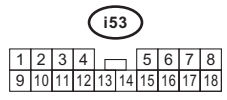
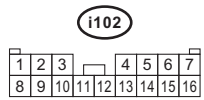
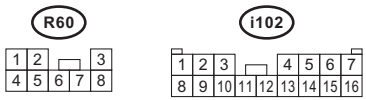
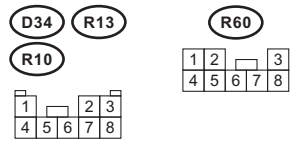
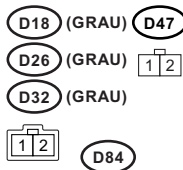
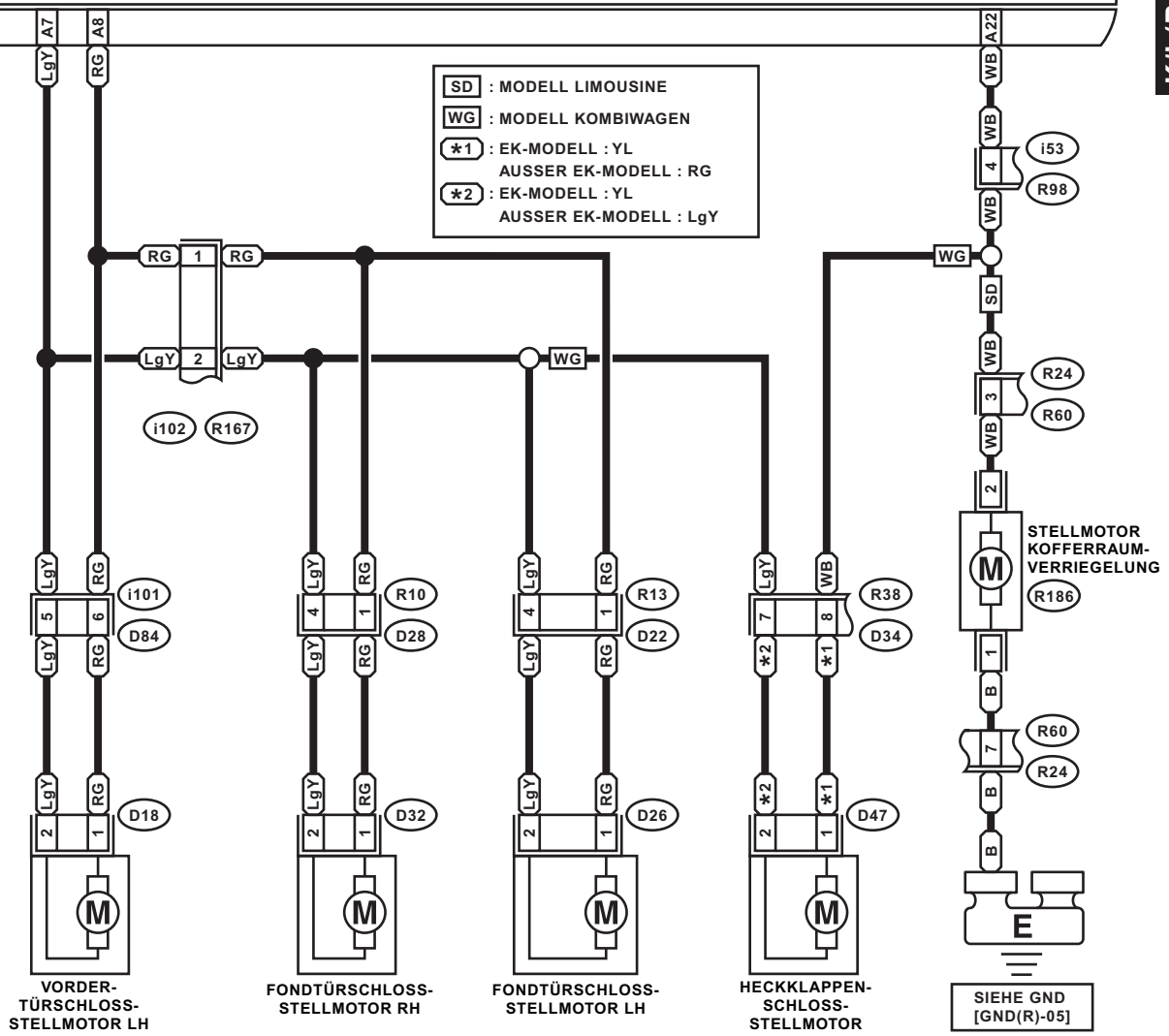

A: i84 KAROSSERIEMODUL

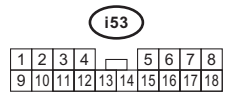
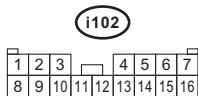
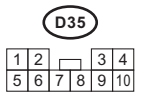
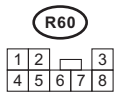
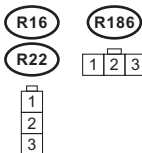
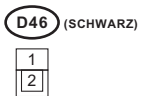
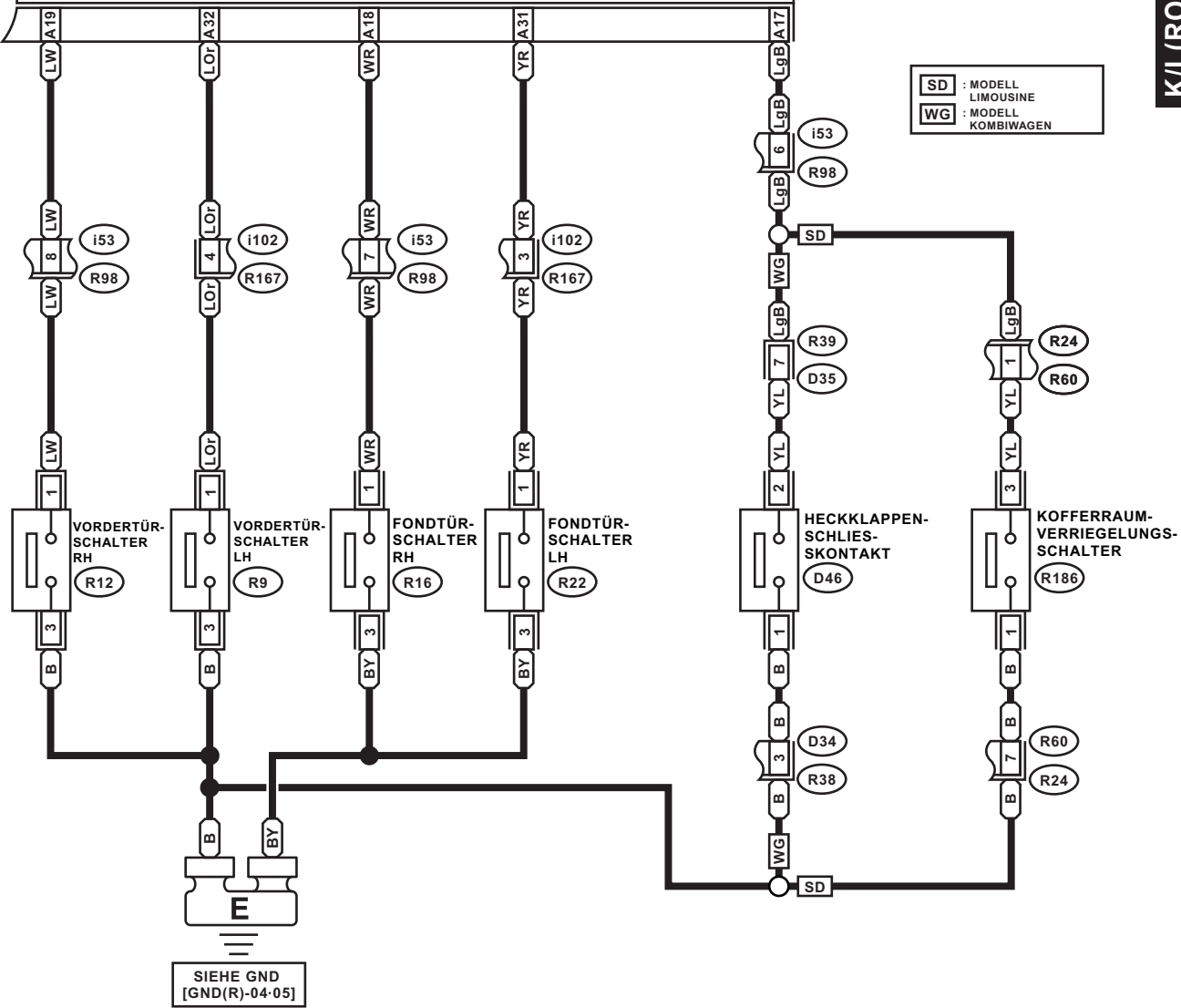

A: i84 (GRAU)

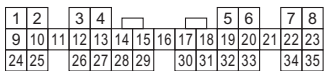

ZUM SPANNUNGSVERSORUNGSKREIS

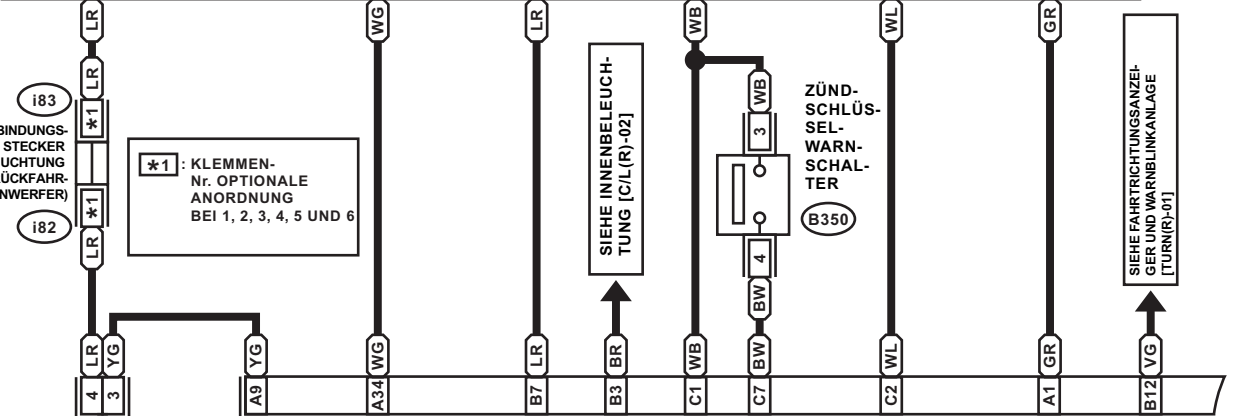

*1 : KLEMMEN-Nr. OPTIONALE ANORDNUNG BEI 1, 2, 3, 4, 5 UND 6

A: i84 B: B280 C: B281 KAROSSIEREMODUL

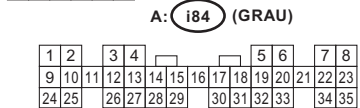
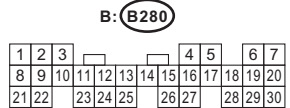
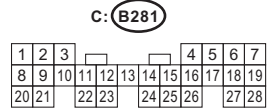
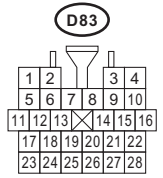
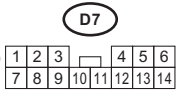
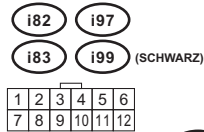
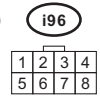
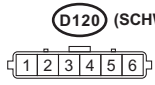
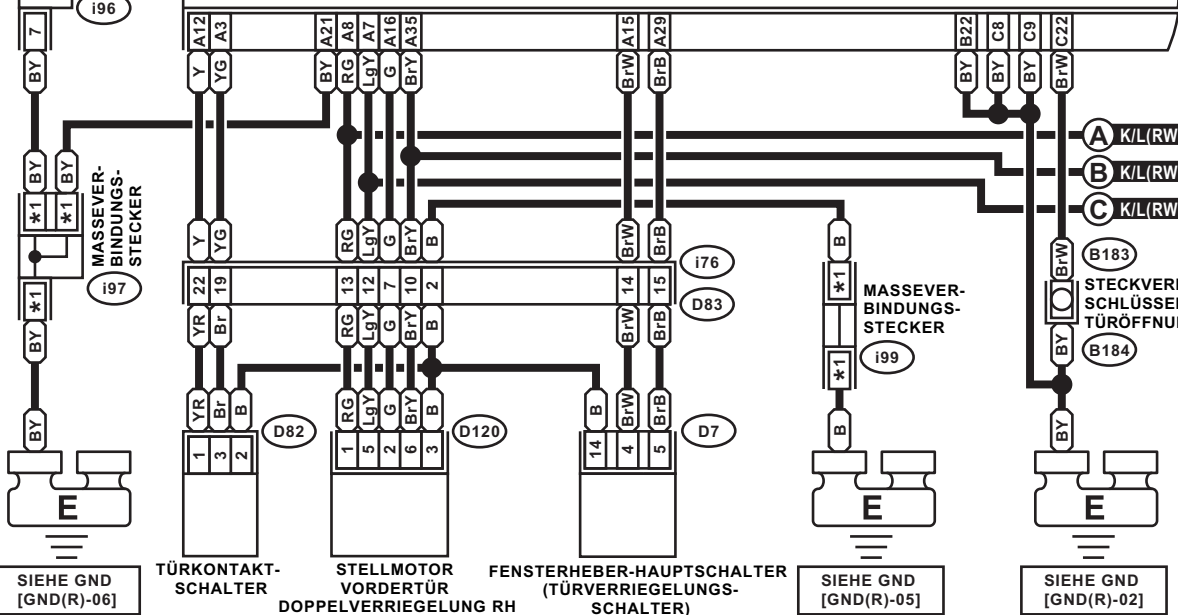

A: i84 KAROSSERIEMODUL

SD : MODELL LIMOUSINE
 WG : MODELL KOMBIWAGEN

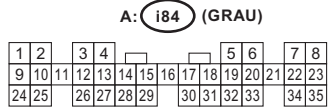
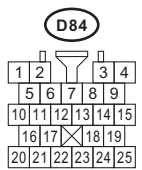
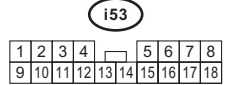
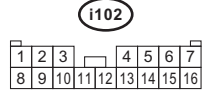
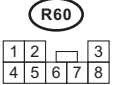
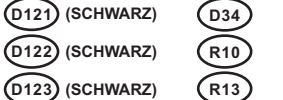
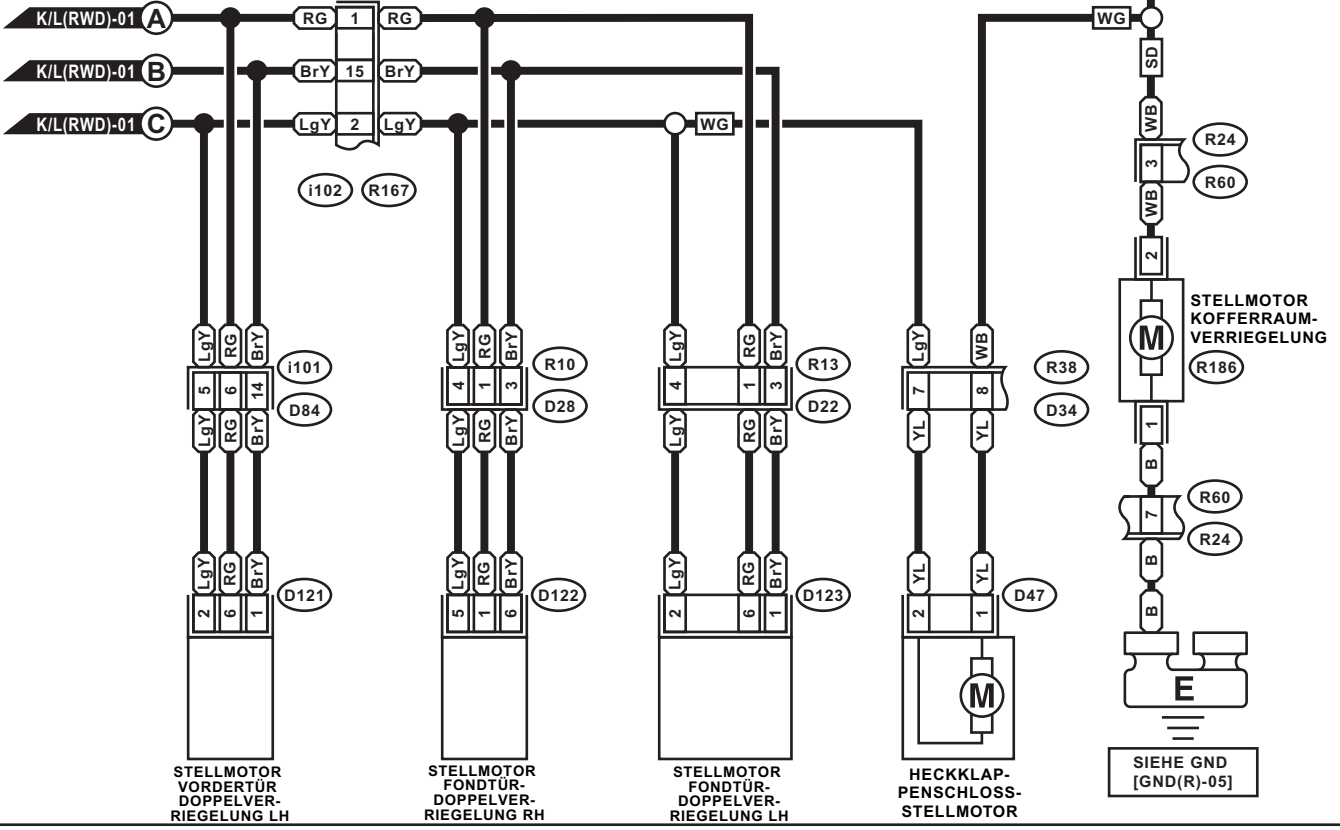

A: i84 KAROSSERIEMODUL

SD : MODELL LIMOUSINE
 WG : MODELL KOMBIWAGEN

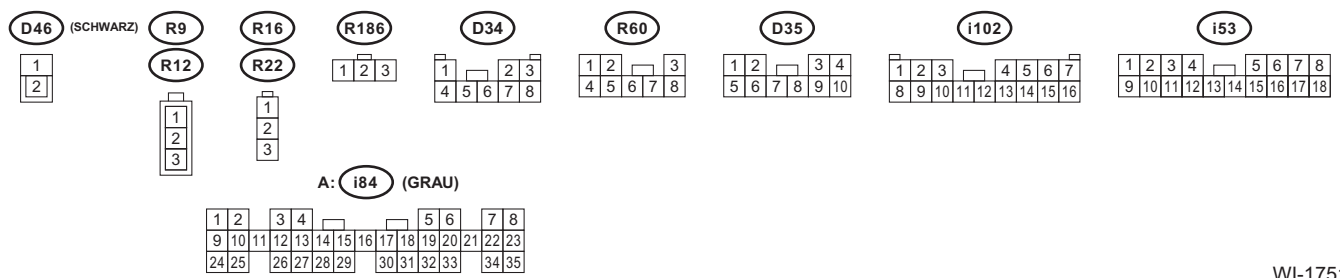
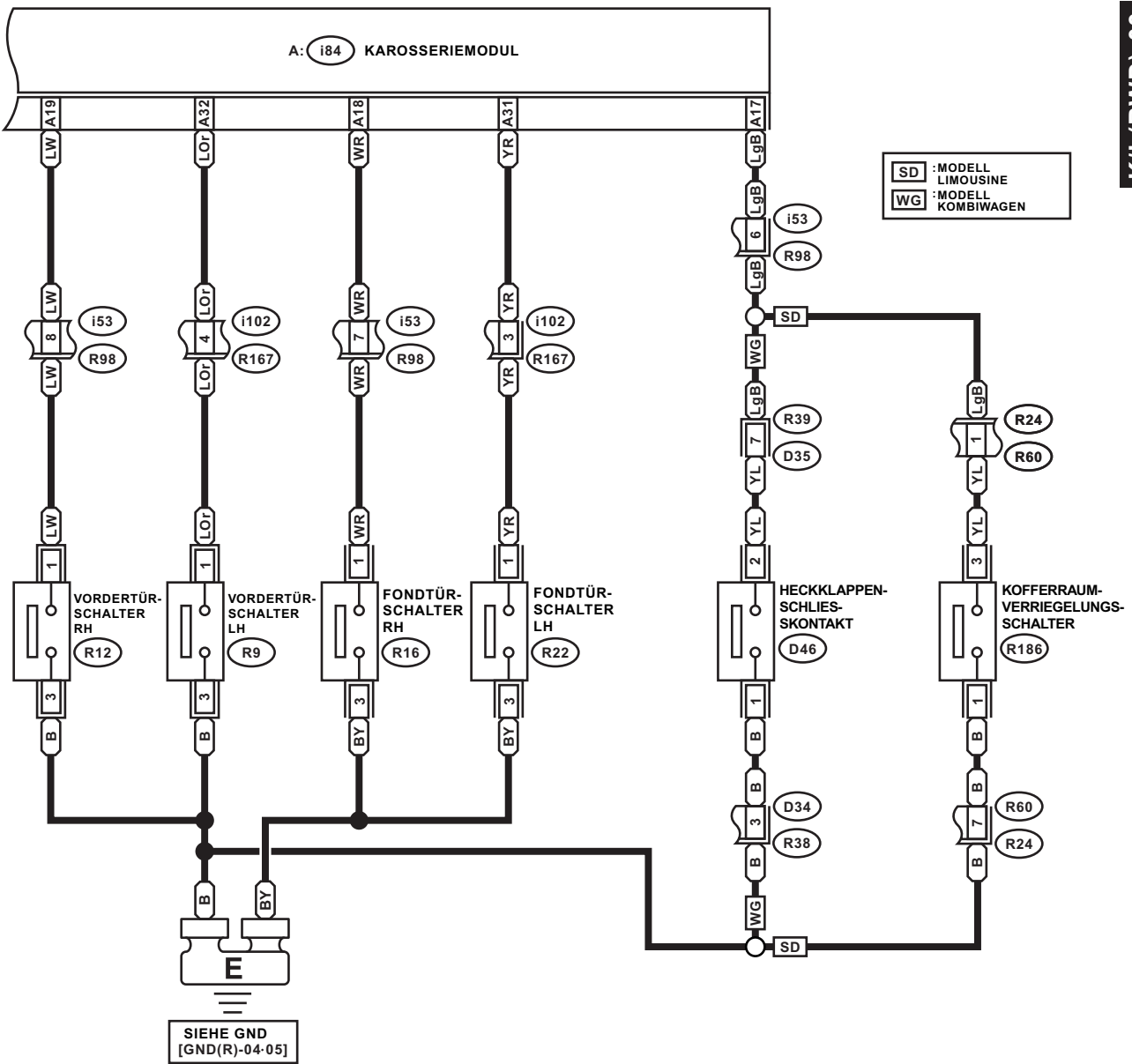

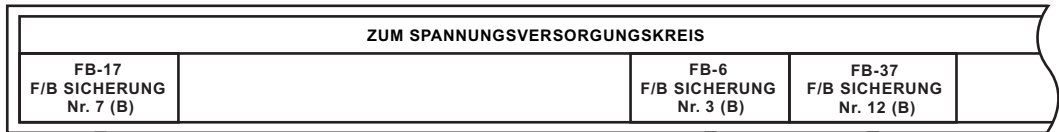

- *1 : KLEMMEN-Nr. OPTIONALE ANORDNUNG BEI 1, 2, 3, 4, 5 UND 6
- *2 : KLEMMEN-Nr. OPTIONALE ANORDNUNG

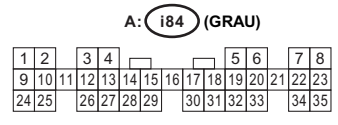
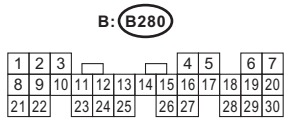
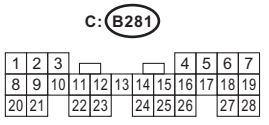
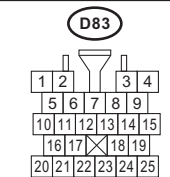
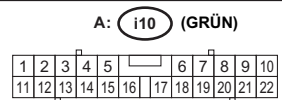
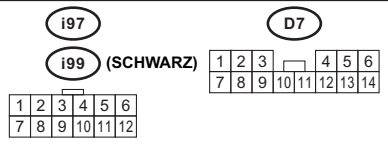
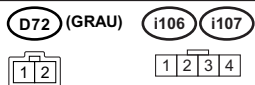
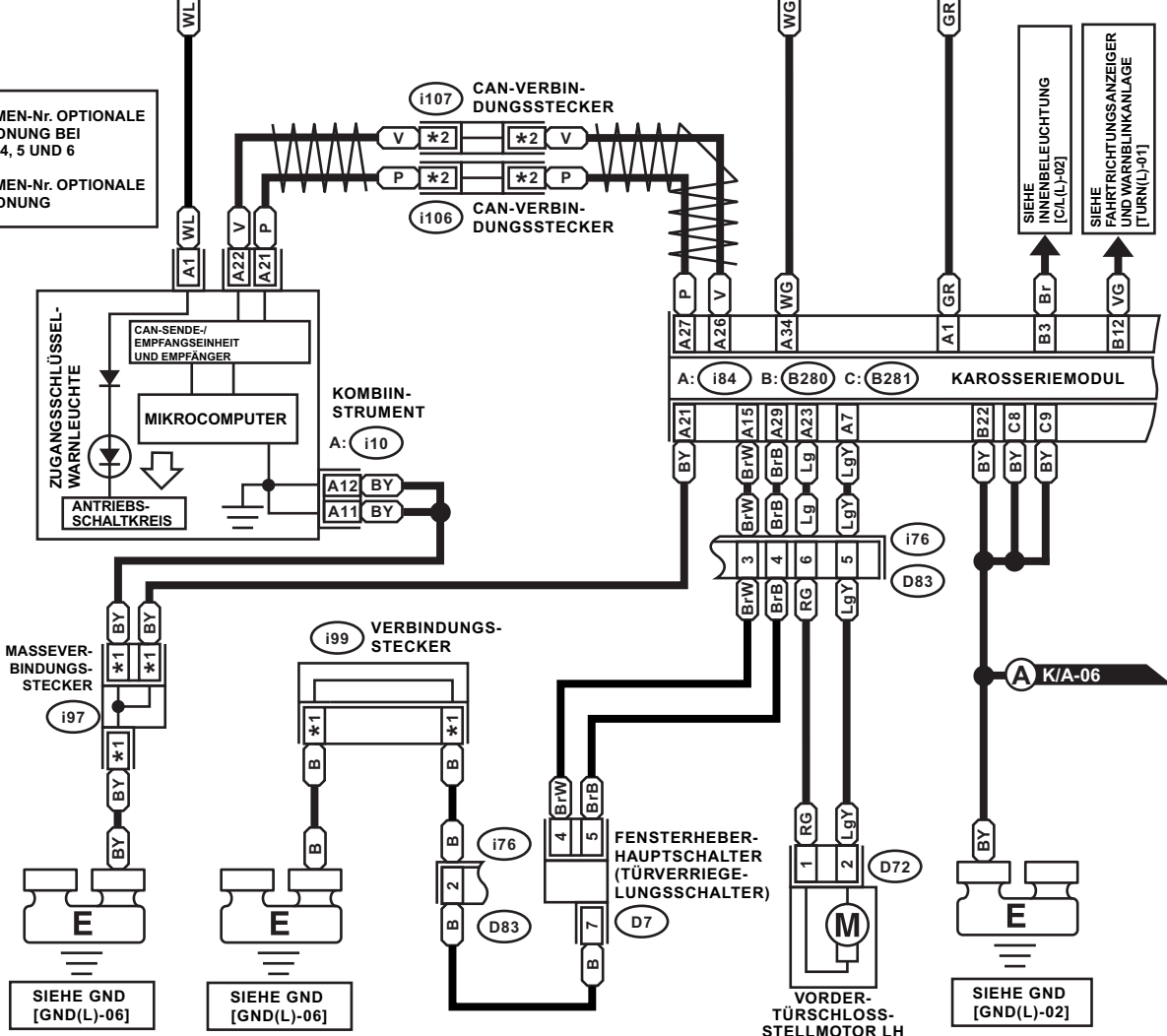

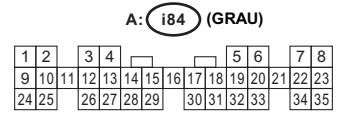
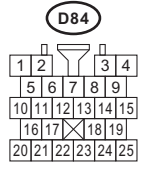
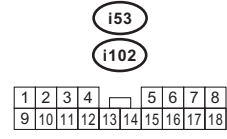
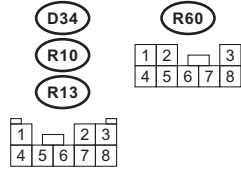
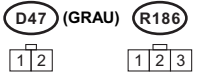
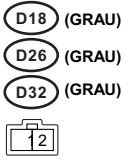
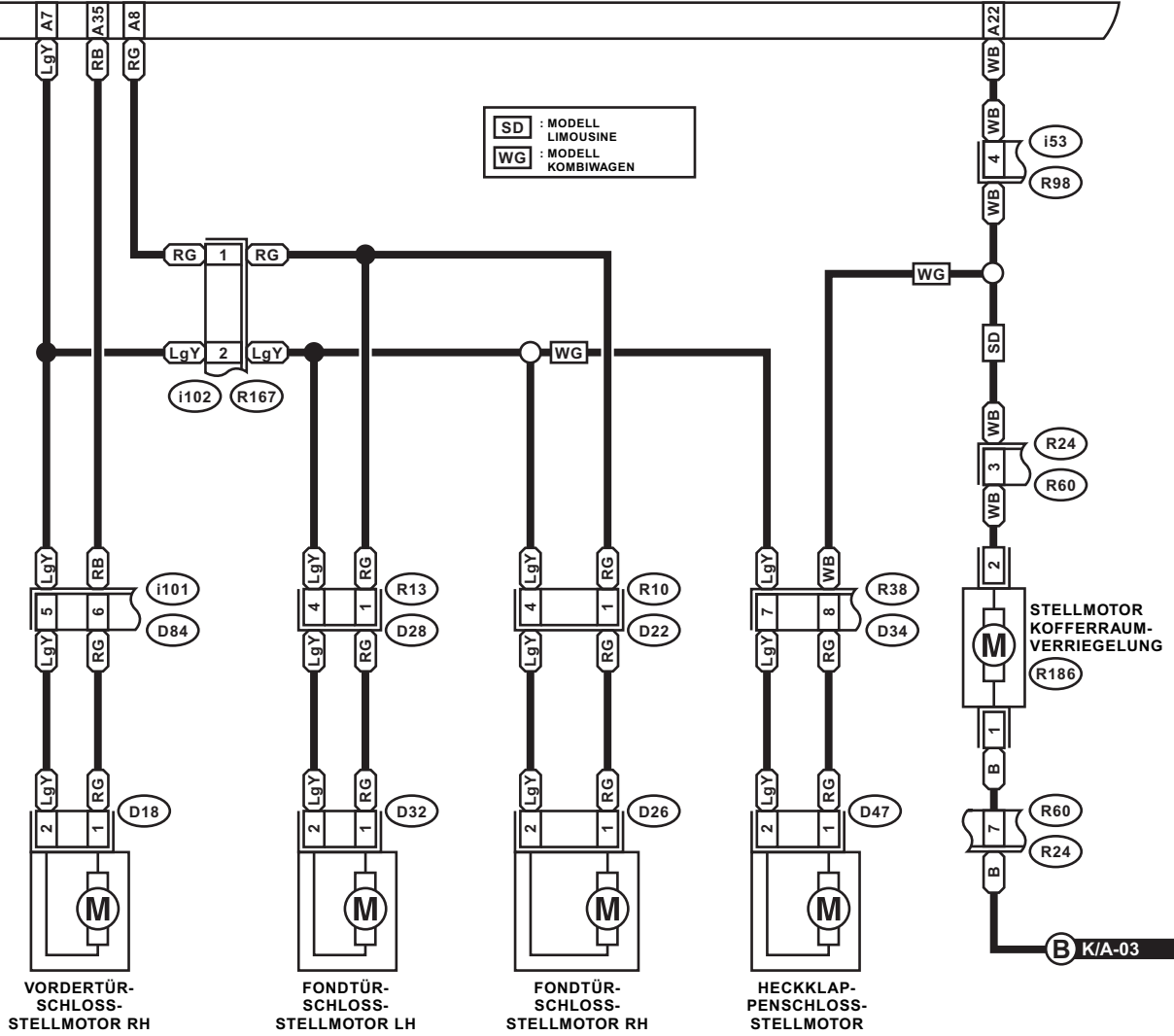

B K/A-03

A: i84 KAROSSERIEMODUL

SD : MODELL LIMOUSINE
 WG : MODELL KOMBIWAGEN

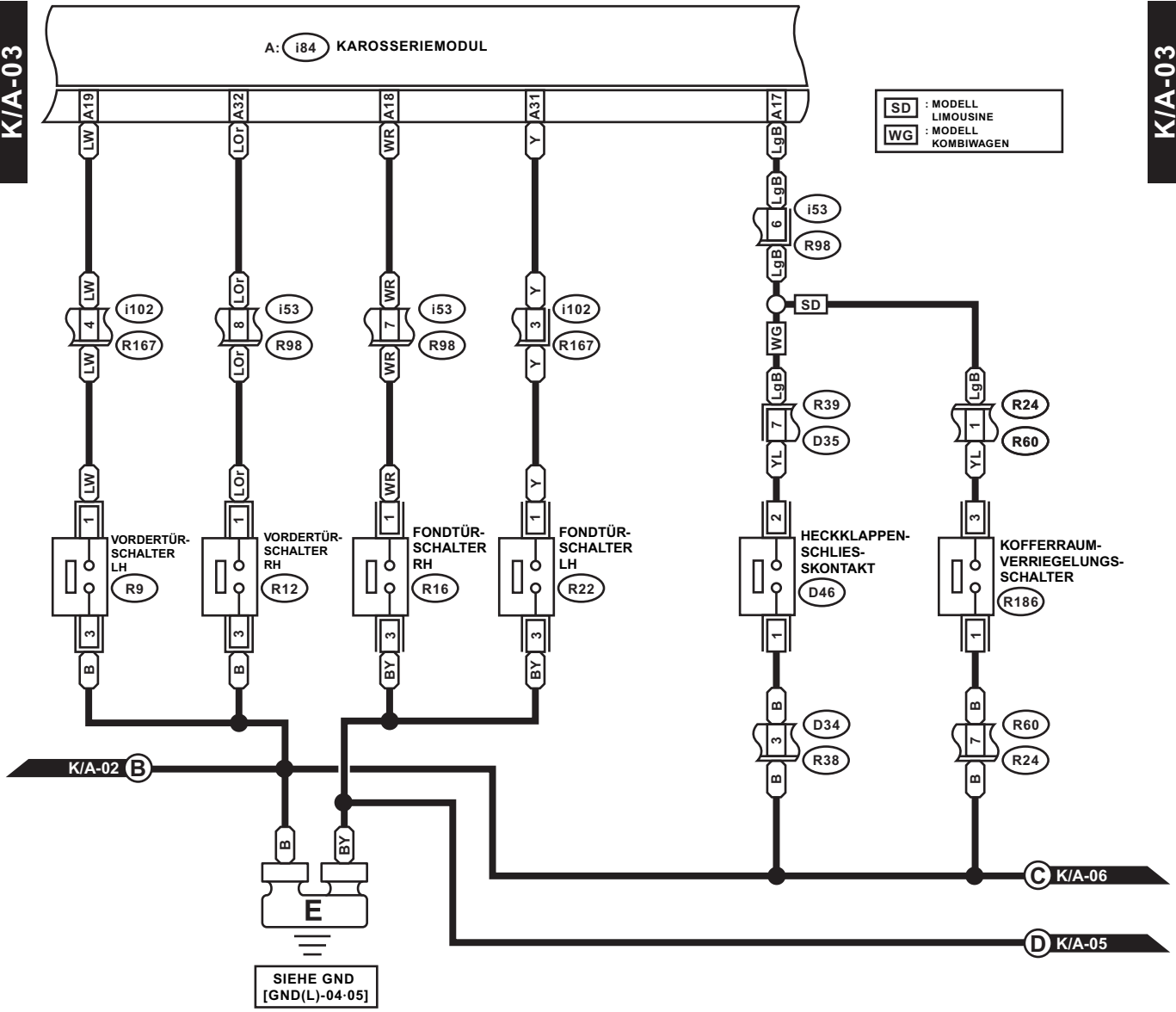

SIEHE GND [GND(L)-04-05]

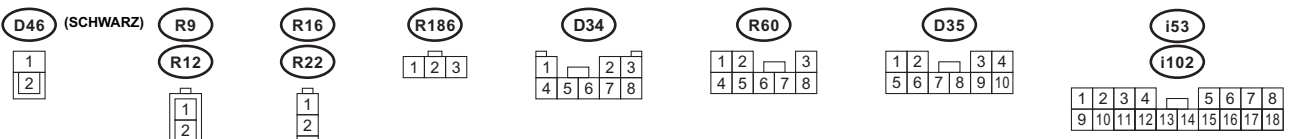

A: i84 (GRAU)

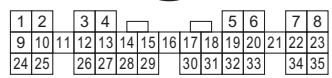

ZUM SPANNUNGSVERSORGUNGSKREIS
 FB-10
 M/B SICHERUNG
 Nr. 8 (B)

*1 : KLEMMEN-Nr. OPTIONALE ANORDNUNG BEI 1, 2, 3, 4, 5 UND 6

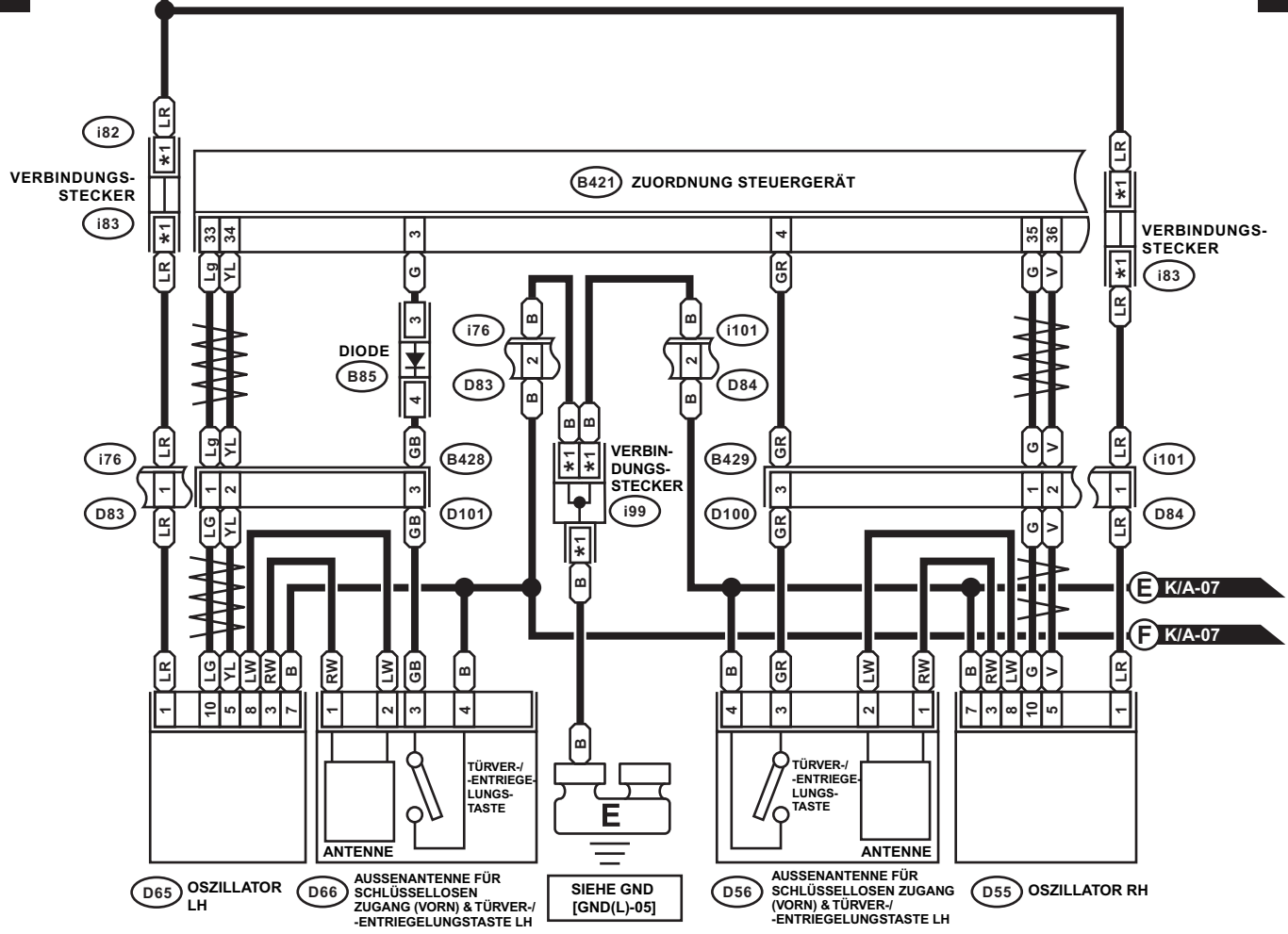

E K/A-07
 F K/A-07

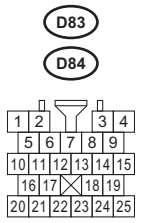
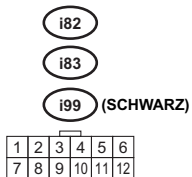
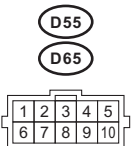
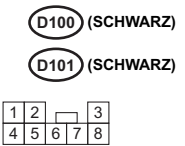
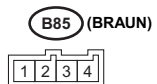

B421

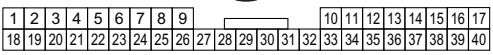

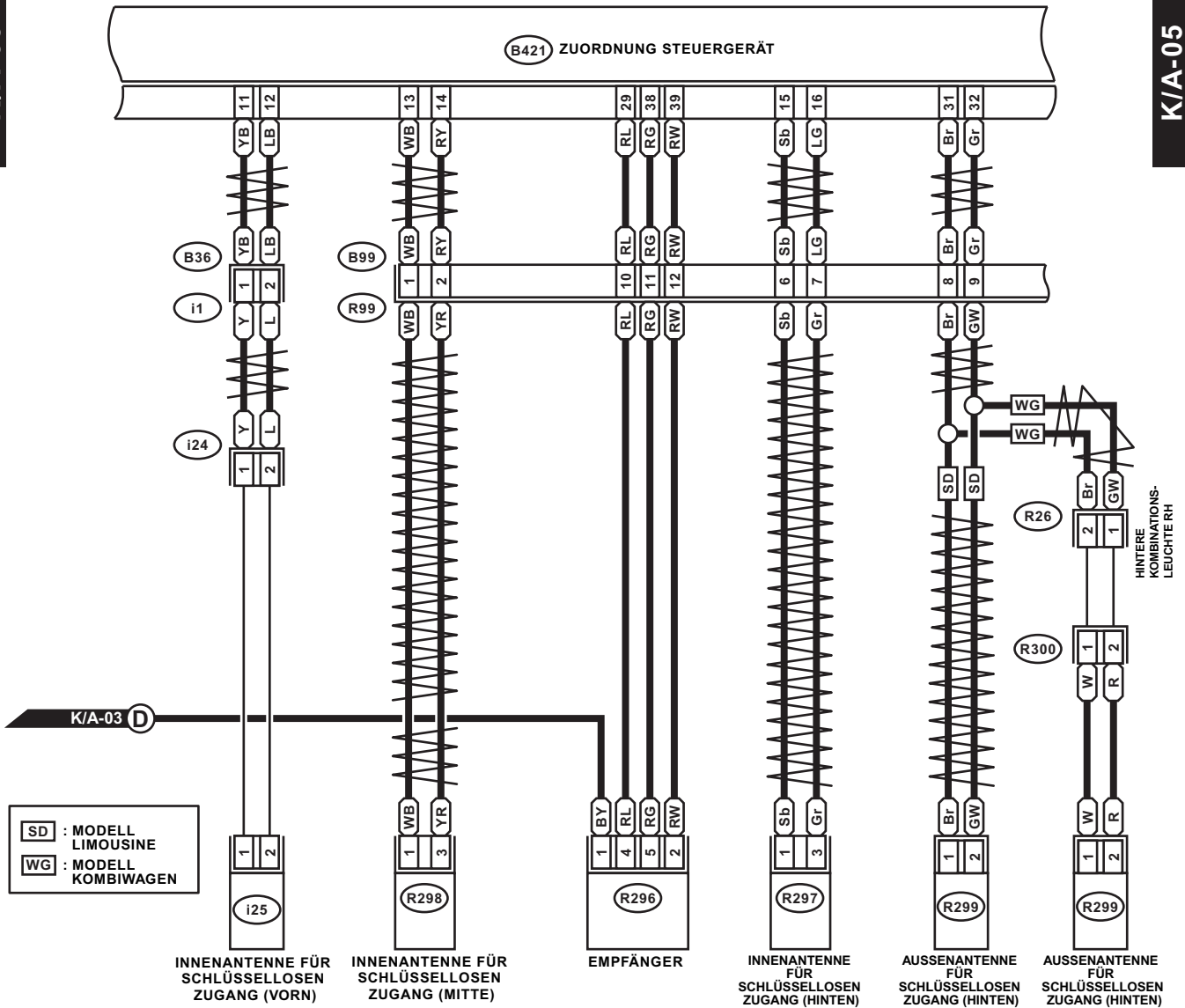

HINTERE
KOMBINATIONSLAUCHLEUCHTE RH

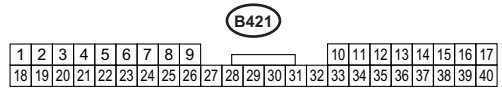
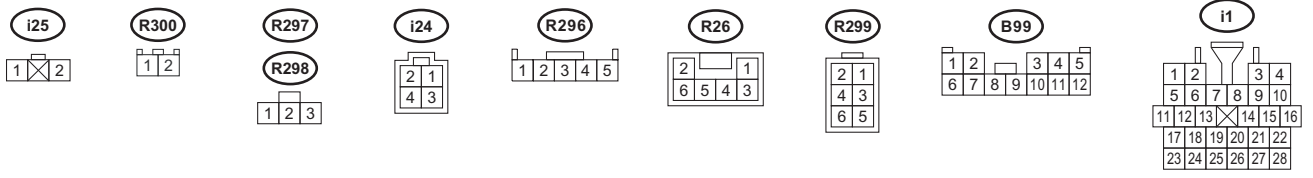

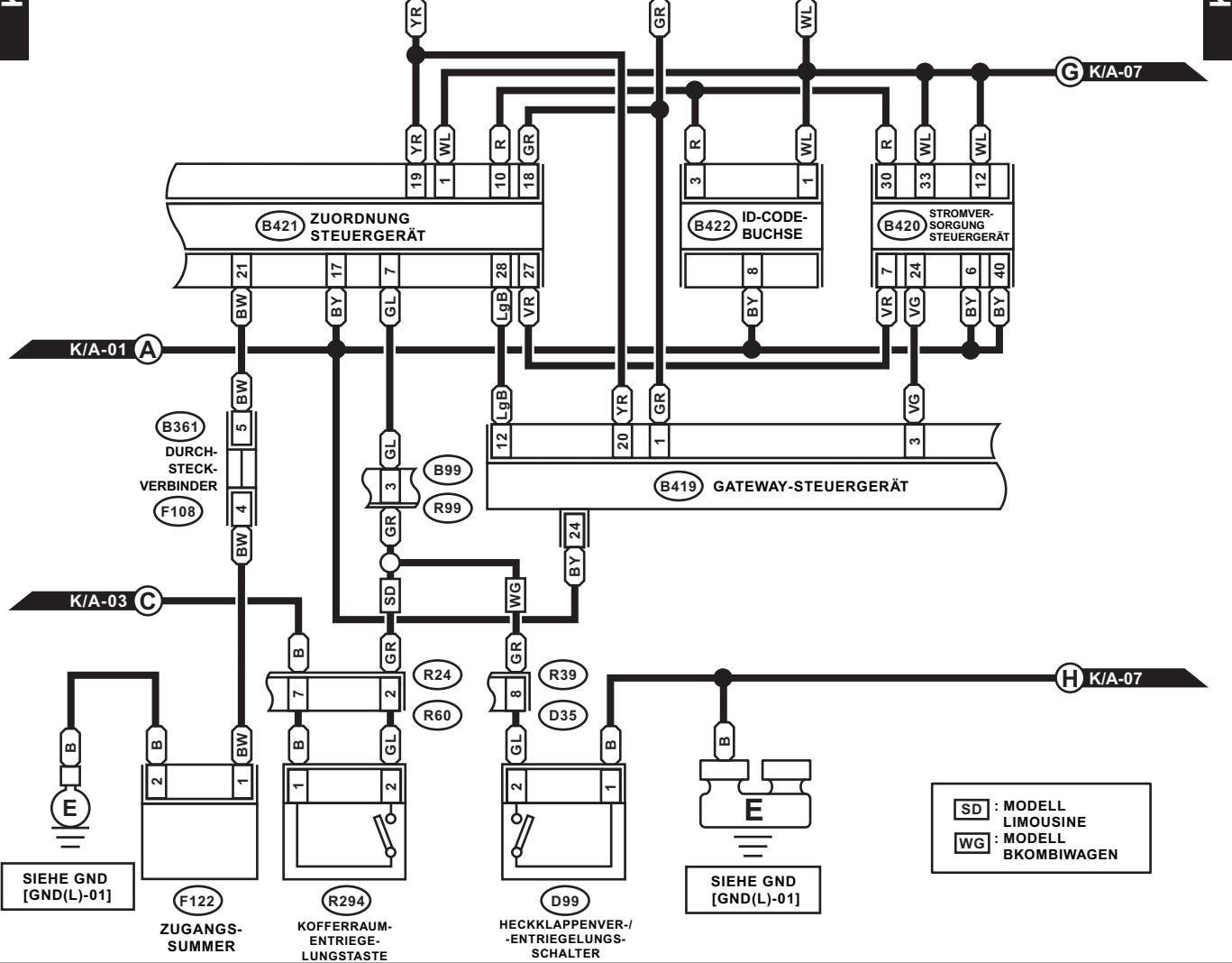

SIEHE GND [GND(L)-01]

SIEHE GND [GND(L)-01]

SD : MODELL LIMOUSINE
WG : MODELL BKOMBIWAGEN

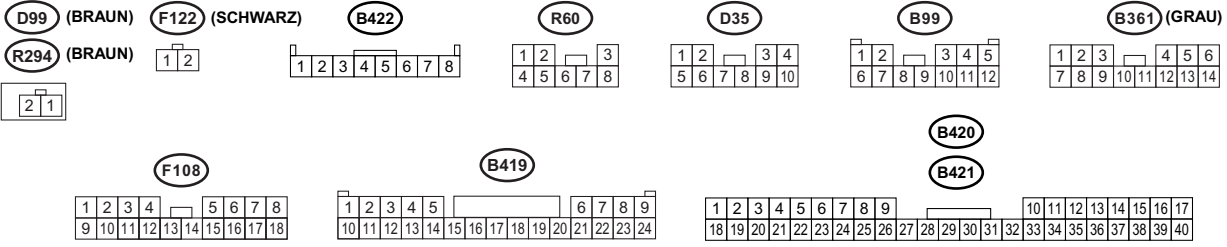

WG : MODELL
KOMBIWAGEN

ZUM SPANNUNGSVER-
SORGUNGSKREIS
MB-29
M/B SICHERUNG
Nr. 8 (B)

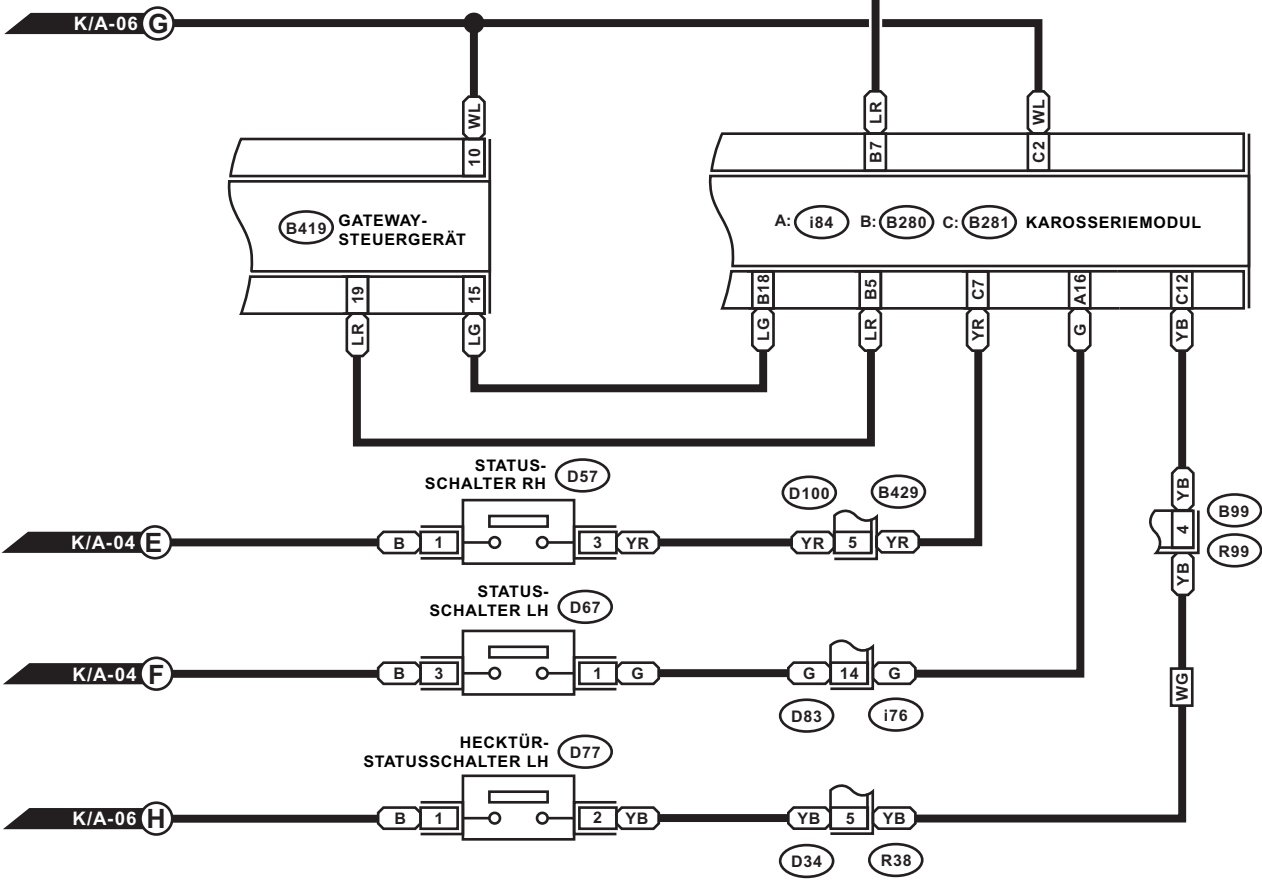

D57 (GRAU)

D77

D34

D100 (SCHWARZ)

B99

B419

D83

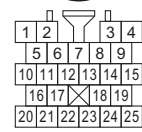
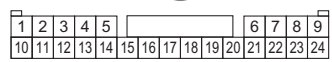
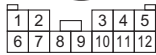
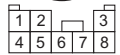
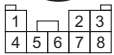

C: B281

B: B280

A: i84 (GRAU)

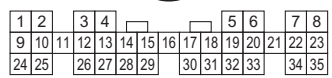
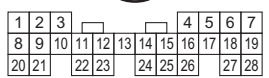



*1 : MT-MODELL : GB
AT-MODELL : WL

*2 : MT-MODELL : RY
AT-MODELL : GY

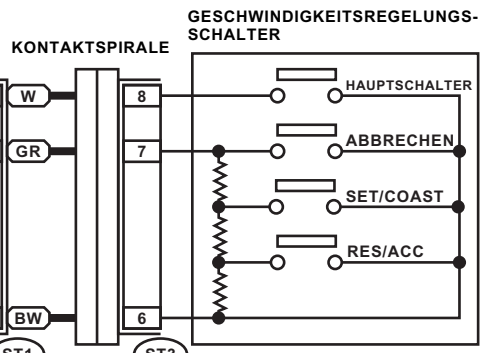
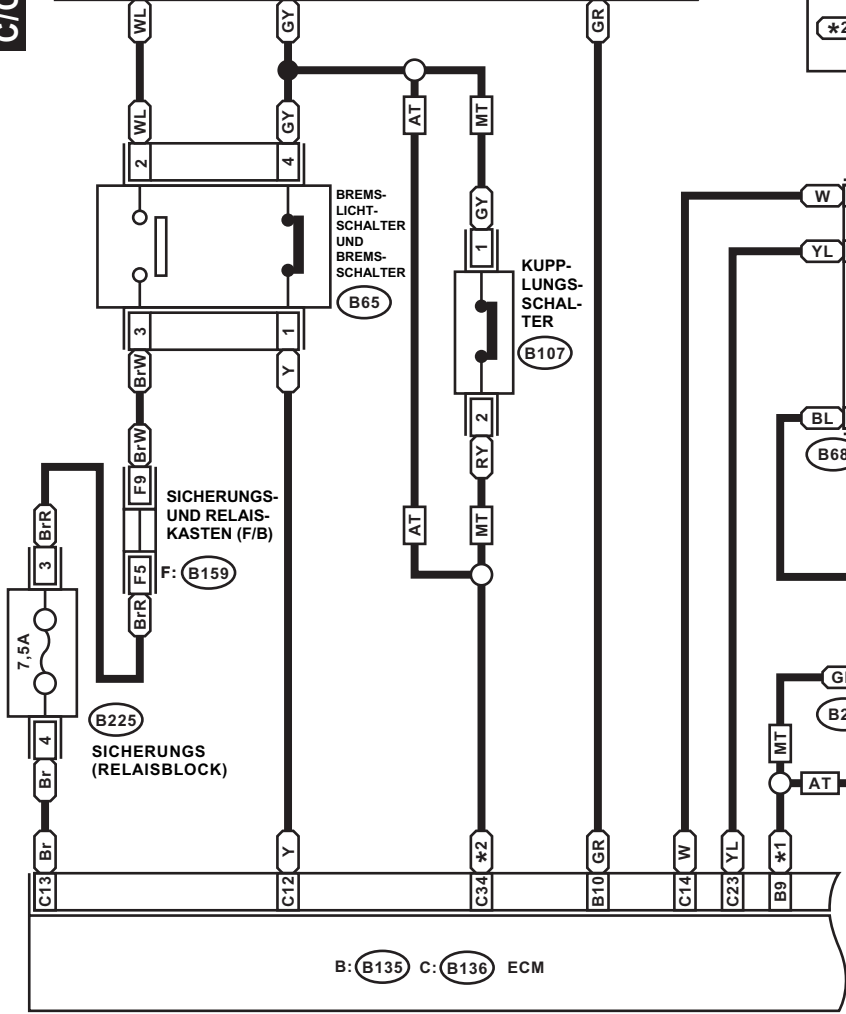

A C/C4(L20)-03

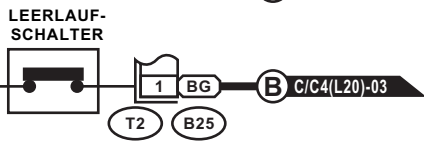

C C/C4(L20)-03

B: (B135) C: (B136) ECM

B25 (BRAUN)

B65 (SCHWARZ)

ST3

F: B159 (BRAUN)

B68

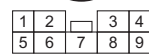
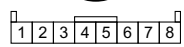
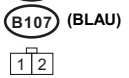

B225 (SCHWARZ)

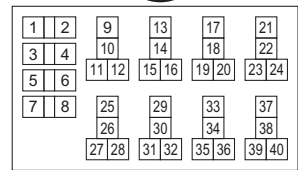

B: (B135)

C: (B136)

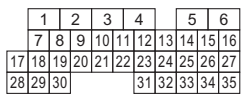
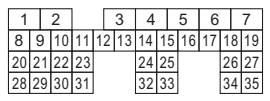

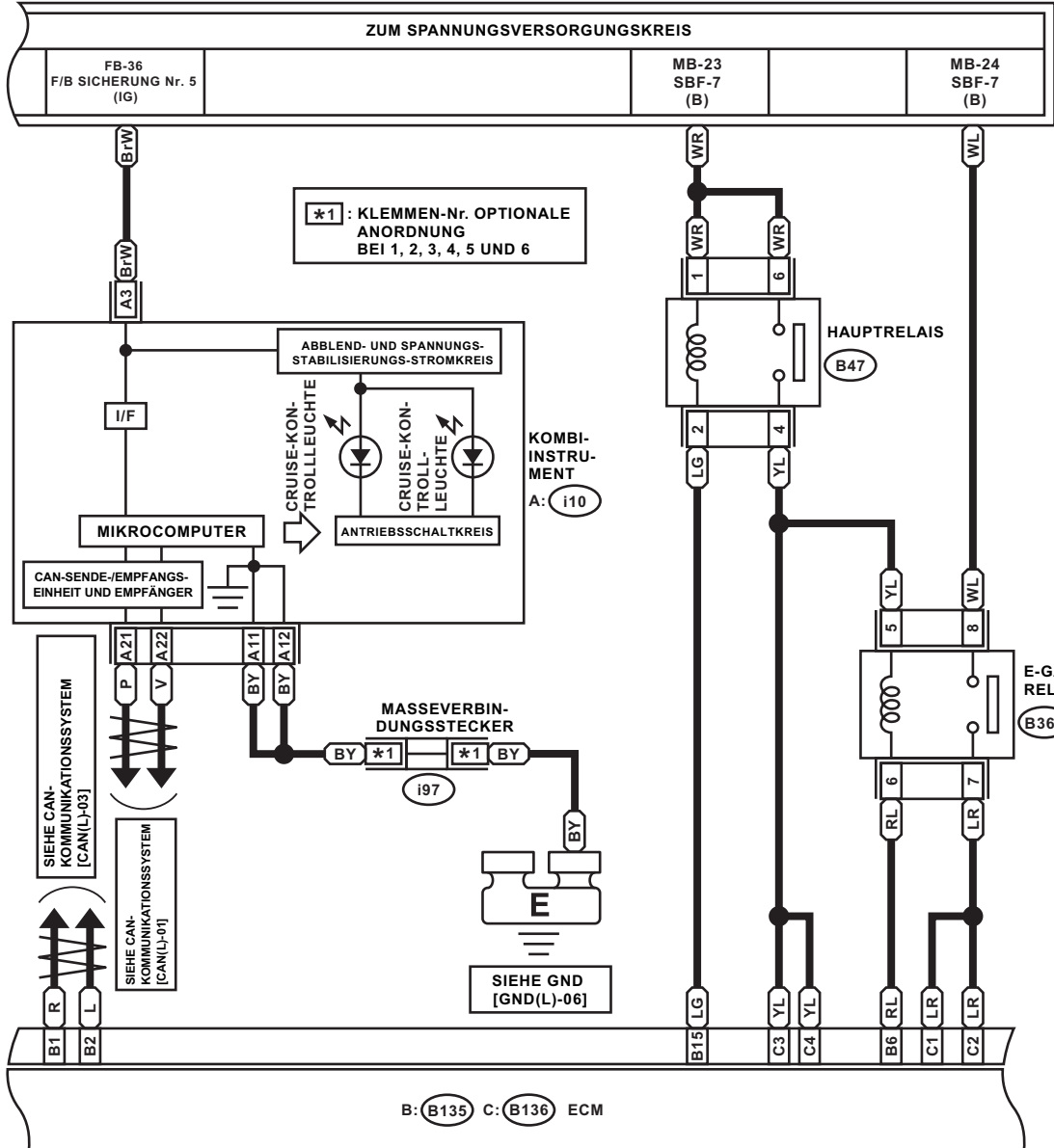

(B47) (BRAUN)



(B362) (SCHWARZ)

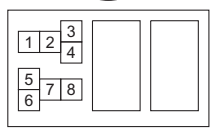

(i97)

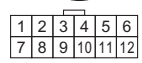

A: (i10) (GRÜN)

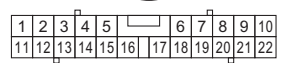

B: (B135)

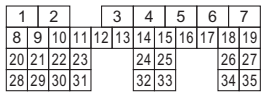

C: (B136)

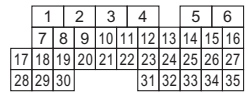

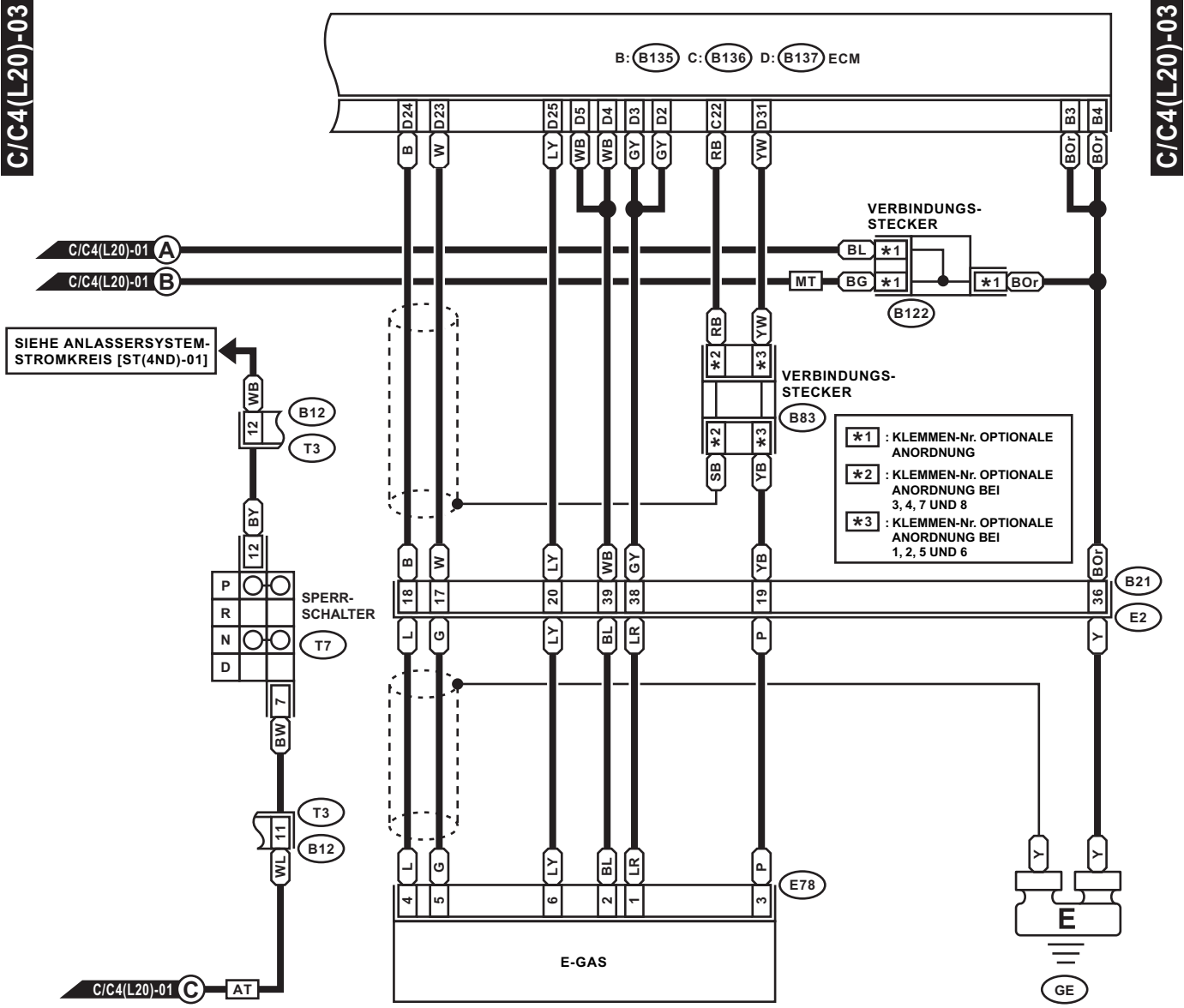

E78 (SCHWARZ) B83 B122

1	2	3	4	5	6
---	---	---	---	---	---

1	2	3	4
5	6	7	8

B12 (GRAU)

1	2	3	4
5	6	7	8
9	10	11	12

T7 (SCHWARZ)

1	2	3	4	5	6
7	8	9	10	11	12

D: B137

1	2	3	4	5	6	7
8	9	10	11	12	13	14
15	16	17	18	19	20	21
22	23	24	25	26	27	28
29	30	31	32	33	34	35

B: B135

1	2	3	4	5	6	7
8	9	10	11	12	13	14
15	16	17	18	19	20	21
22	23	24	25	26	27	28
29	30	31	32	33	34	35

C: B136

1	2	3	4	5	6
7	8	9	10	11	12
13	14	15	16	17	18
19	20	21	22	23	24
25	26	27	28	29	30
31	32	33	34	35	

B21 (SCHWARZ)

1	2	3	4	5	6	7	8	9	10	11
12	13	14	15	16	17	18	19	20	21	22
23	24	25	26	27	28	29	30	31	32	33
34	35	36	37	38	39	40	41	42	43	44
45	46	47	48	49	50	51	52	53	54	



*1 : MT-MODELL : GB
AT-MODELL : WL

*2 : MT-MODELL : RY
AT-MODELL : GY

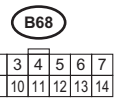
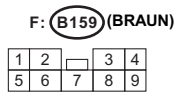
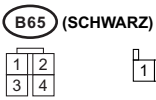
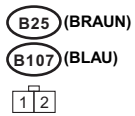
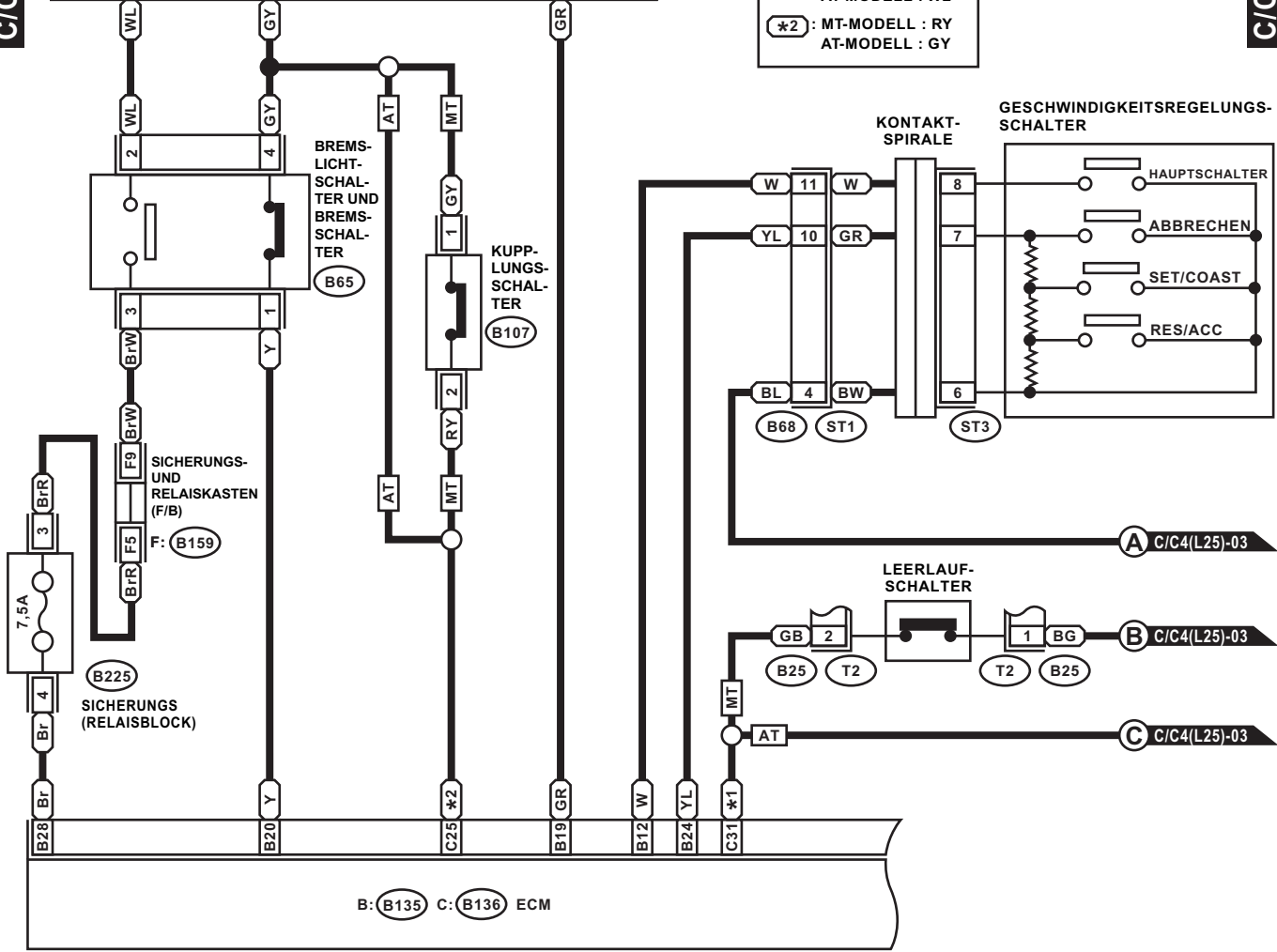

B: (B135)

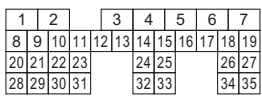

C: (B136)

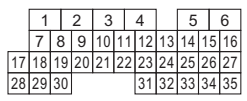

(B225) (SCHWARZ)

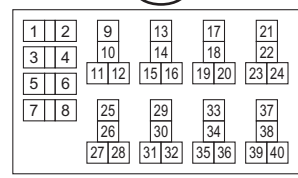

RELAISBLOCK

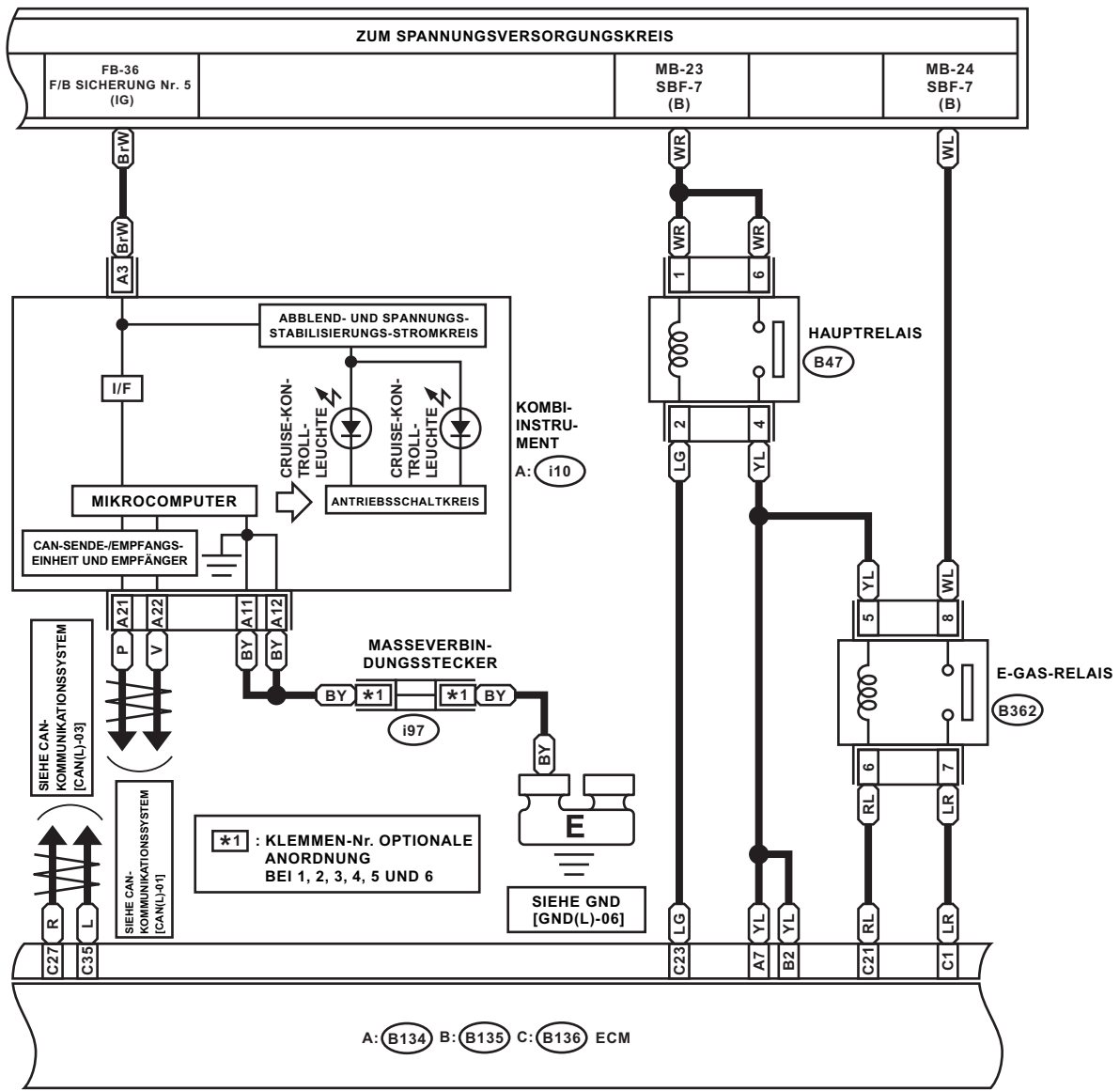

B47 (BRAUN)

1	2
3	4
5	6

B362 (SCHWARZ)

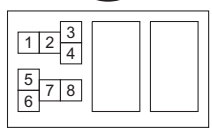

i97

1	2	3	4	5	6
7	8	9	10	11	12

A: i10 (GRÜN)

1	2	3	4	5	6	7	8	9	10		
11	12	13	14	15	16	17	18	19	20	21	22

A: B134

1	2	3	4	5	6	7			
8	9	10	11	12	13	14	15	16	17
18	19	20	21	22	23	24	25	26	27
28	29	30	31	32				33	34

B: B135

RELAISHALTER

C: B136

1	2	3	4	5	6	7					
8	9	10	11	12	13	14	15	16	17	18	19
20	21	22	23	24	25	26	27				
28	29	30	31	32	33	34	35				

1	2	3	4	5	6						
7	8	9	10	11	12	13	14	15	16		
17	18	19	20	21	22	23	24	25	26	27	
28	29	30	31	32	33	34	35				

A: (B134) C: (B136) D: (B137) ECM

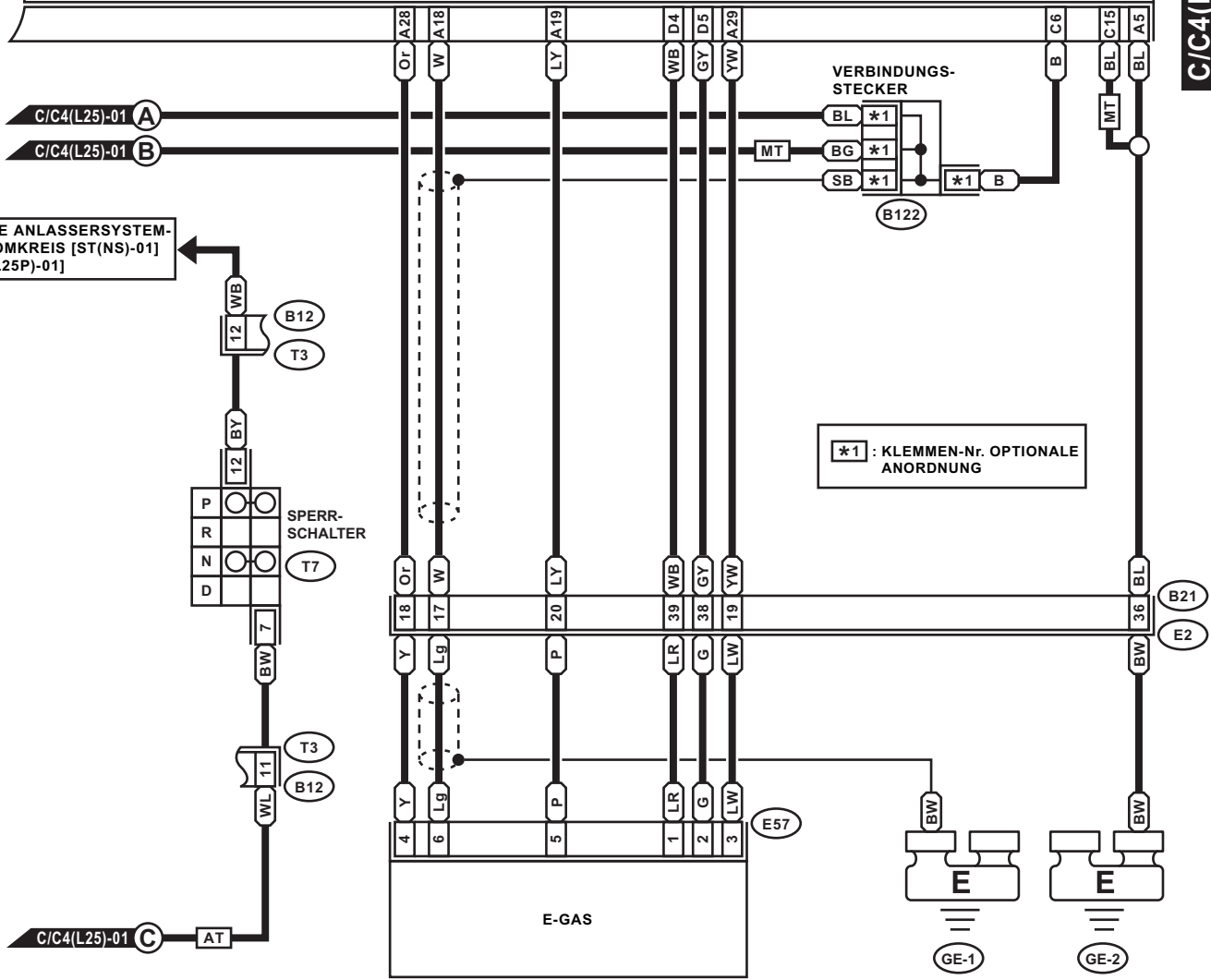

SIEHE ANLASSERSYSTEM-STROMKREIS [ST(NS)-01] [ST(L25P)-01]

*1 : KLEMMEN-Nr. OPTIONALE ANORDNUNG

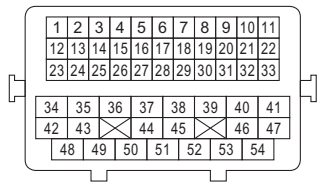
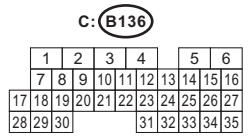
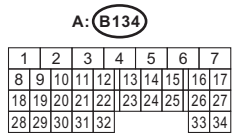
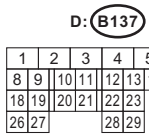
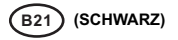
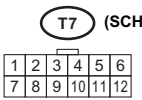
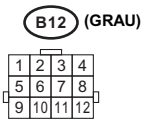
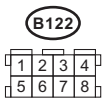
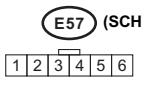

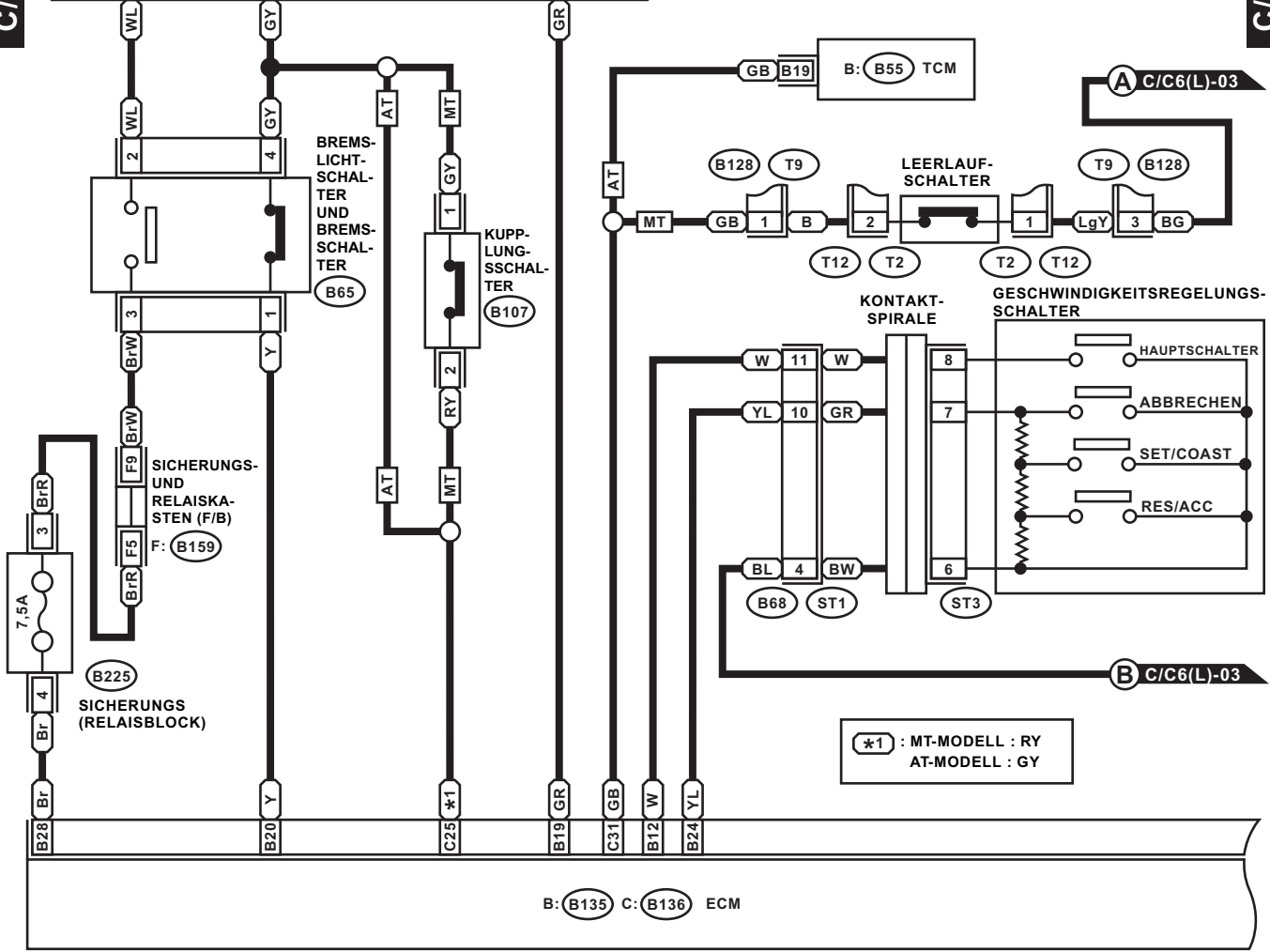
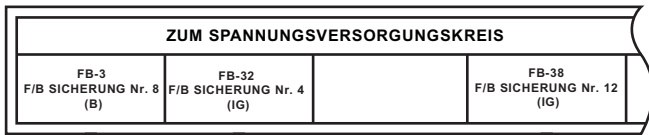

*1 : MT-MODELL : RY
AT-MODELL : GY

B: B135 C: B136 ECM

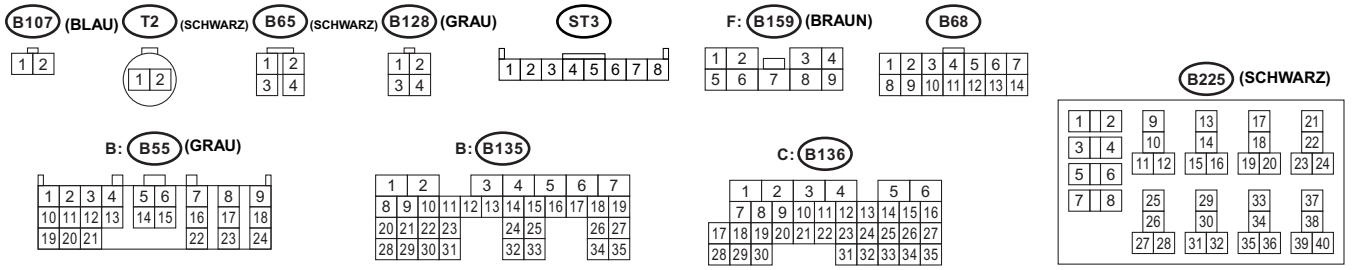

RELAISBLOCK

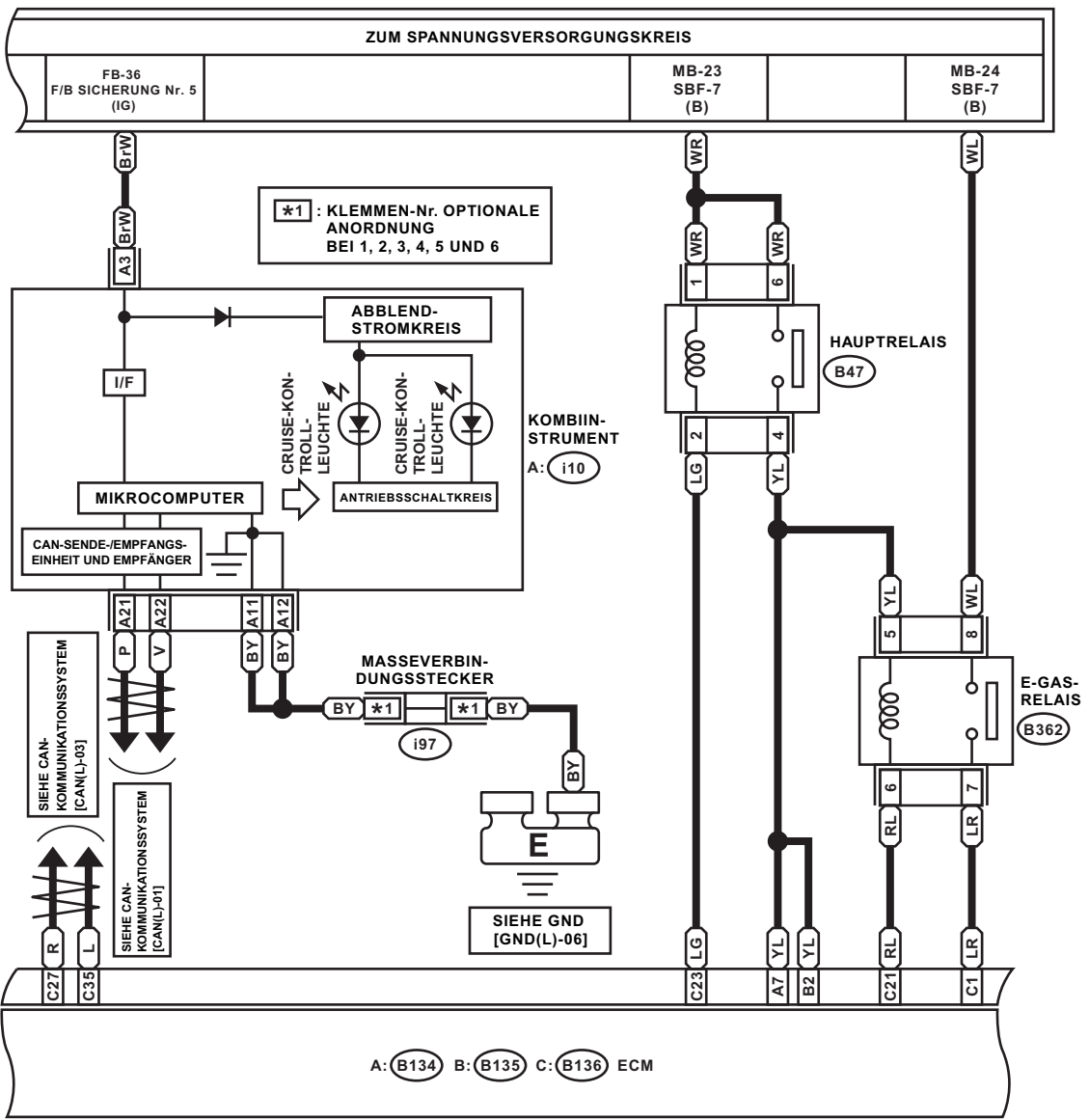

B47 (BRAUN)



B362 (SCHWARZ)

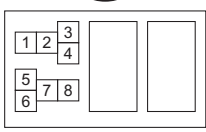

197



A: i10 (GRÜN)

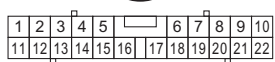

A: B134

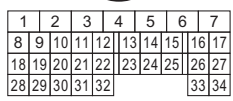

B: B135

RELAISHALTER

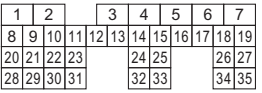

C: B136

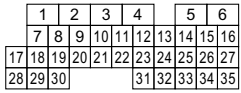

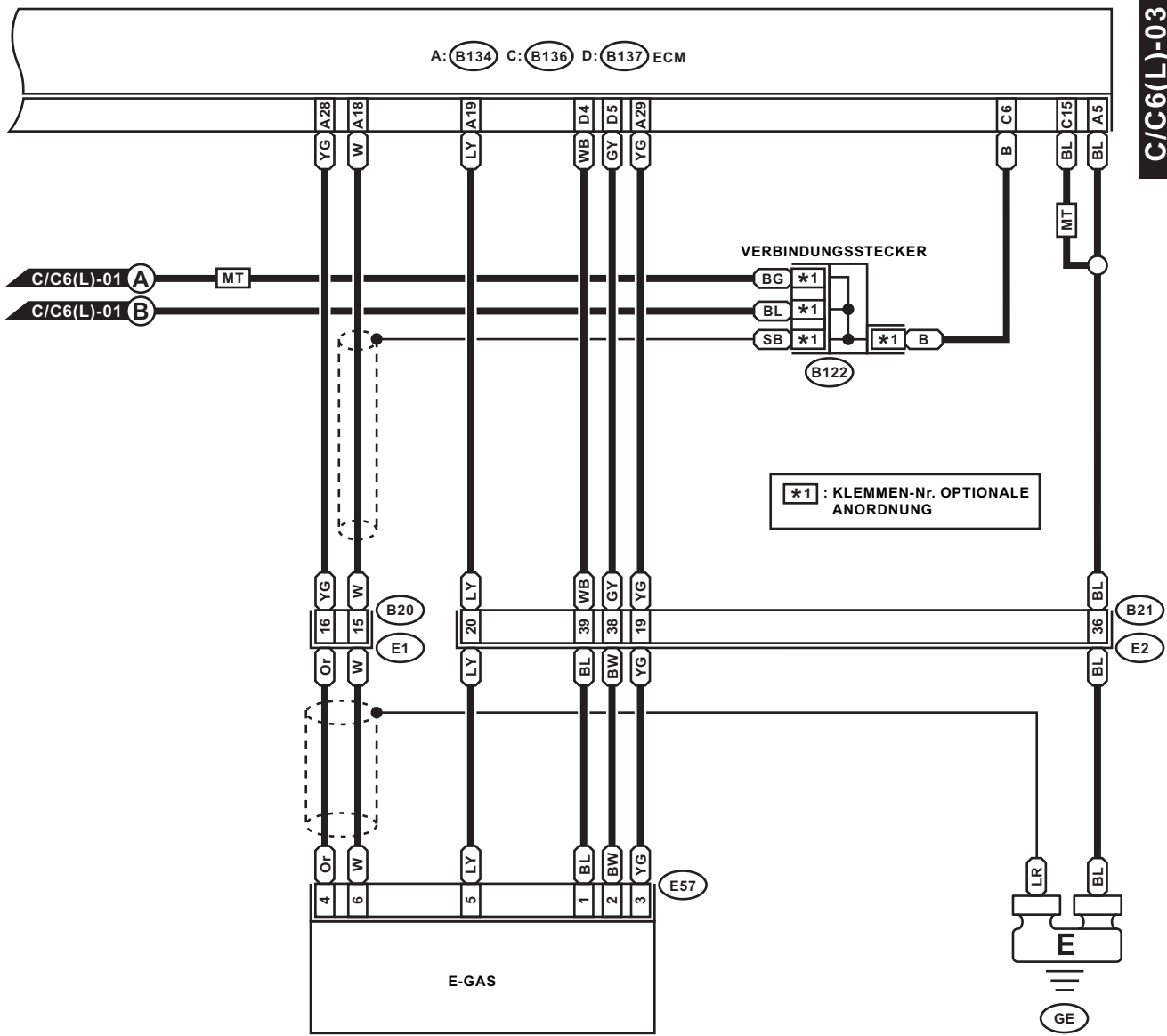

E57 (SCHWARZ)

1	2	3	4	5	6
---	---	---	---	---	---

B122

1	2	3	4
5	6	7	8

B20 (BRAUN)

1	2	3	4
5	6	7	8
9	10	11	12
13	14	15	16

D: B137

1	2	3	4	5	6	7
8	9	10	11	12	13	14
15	16	17	18	19	20	21
22	23	24	25	26	27	28
29	30	31	32	33	34	35

A: B134

1	2	3	4	5	6	7
8	9	10	11	12	13	14
15	16	17	18	19	20	21
22	23	24	25	26	27	28
29	30	31	32	33	34	35

C: B136

1	2	3	4	5	6
7	8	9	10	11	12
13	14	15	16	17	18
19	20	21	22	23	24
25	26	27	28	29	30
31	32	33	34	35	

1	2	3	4	5	6	7	8	9	10	11
12	13	14	15	16	17	18	19	20	21	22
23	24	25	26	27	28	29	30	31	32	33
34	35	36	37	38	39	40	41			
42	43	44	45	46	47					
48	49	50	51	52	53	54				

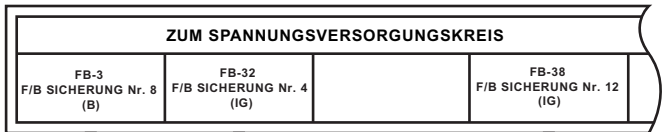

*1 : MT-MODELL : GB
AT-MODELL : WR

*2 : MT-MODELL : RY
AT-MODELL : GY

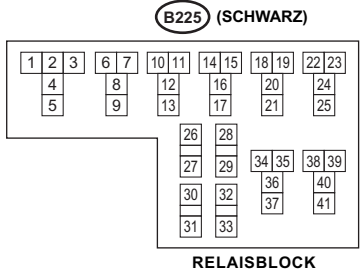
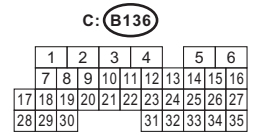
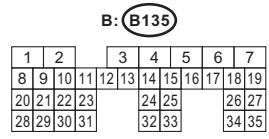
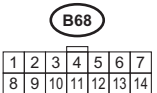
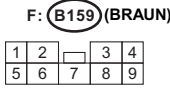
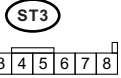
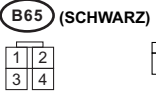
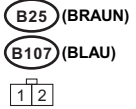
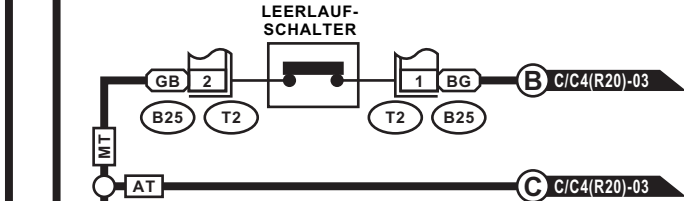
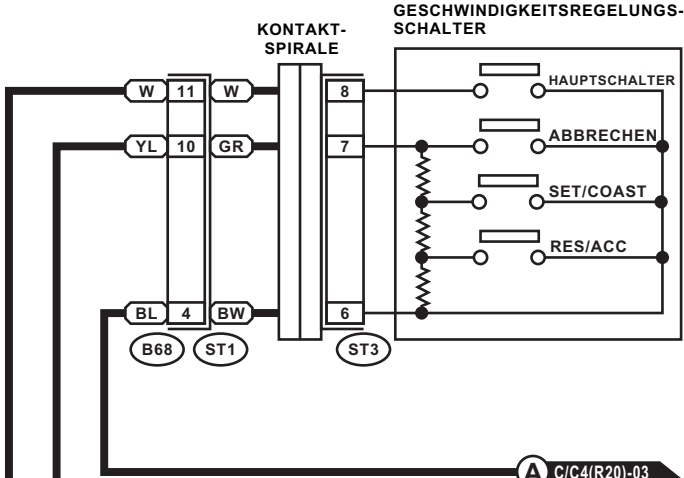
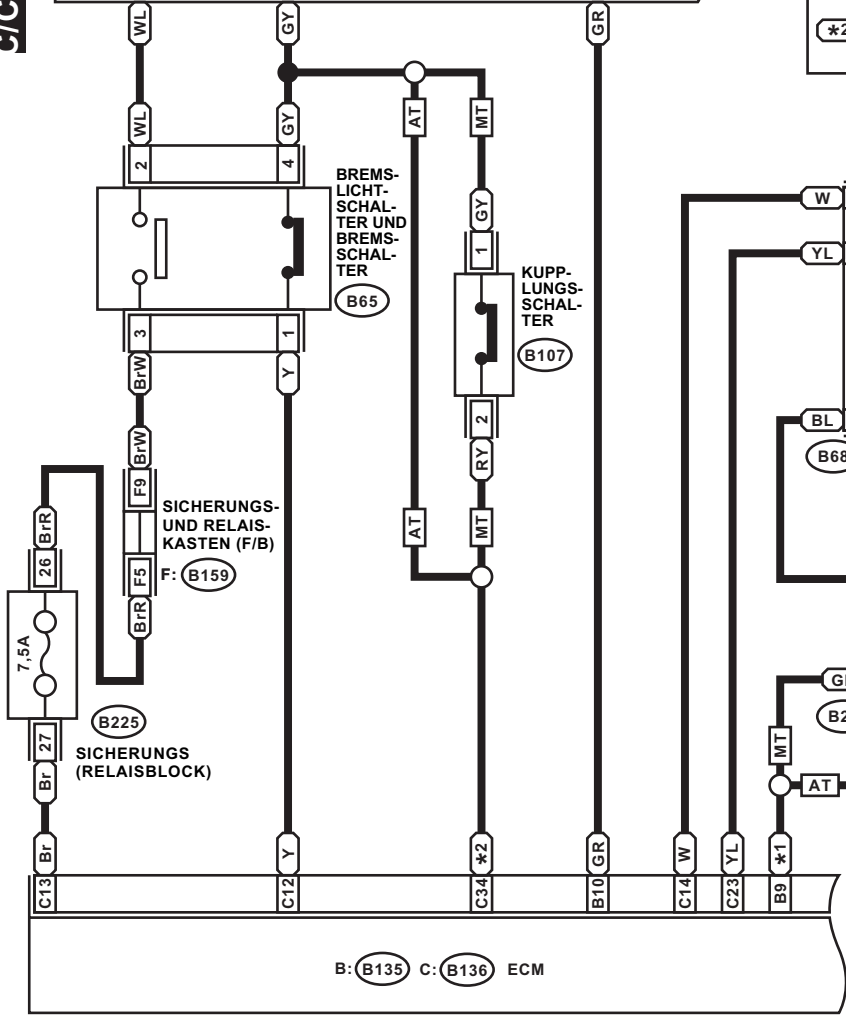

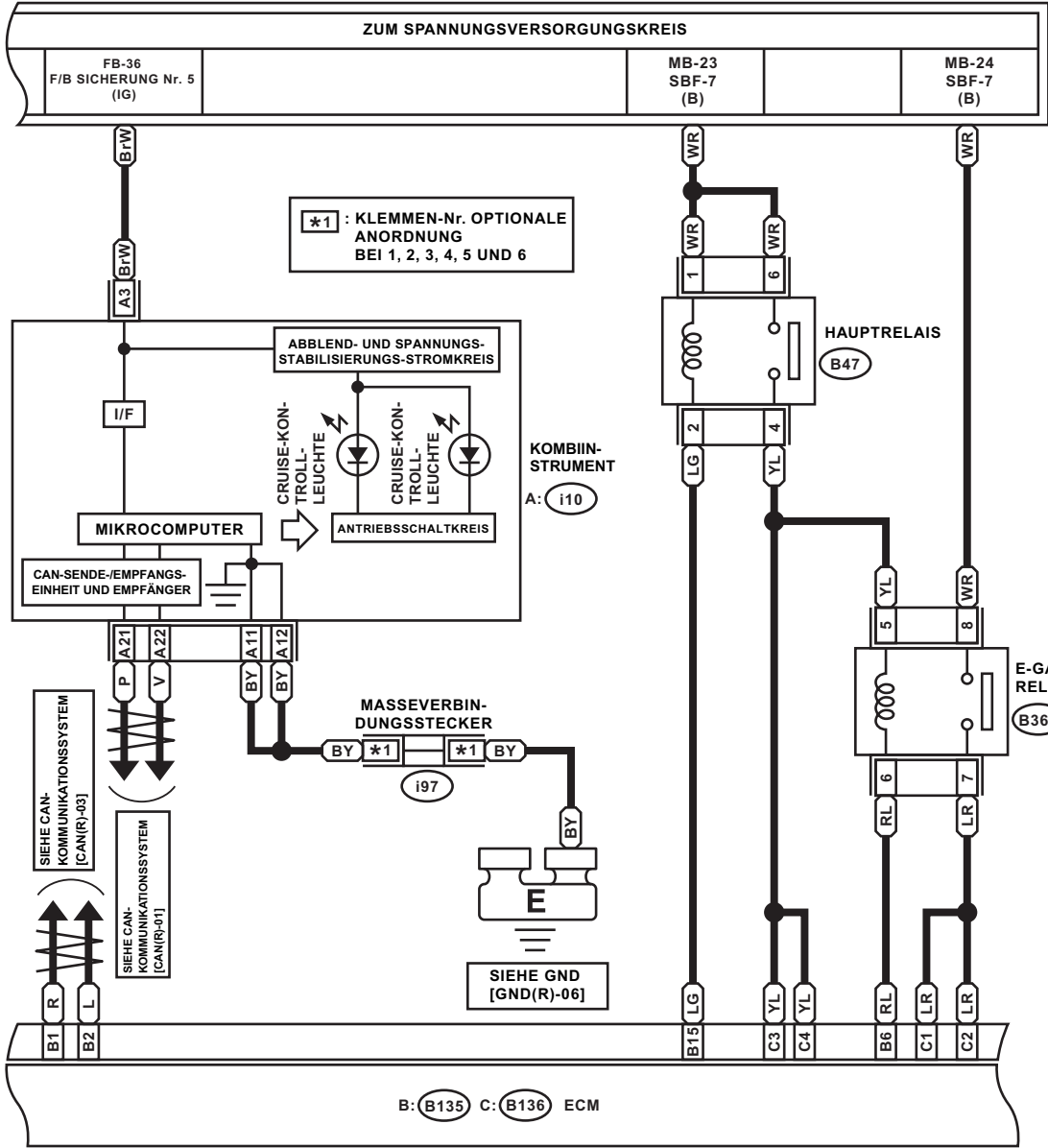

B47 (BRAUN)



B362 (SCHWARZ)

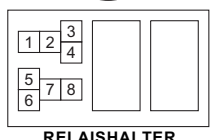

i97

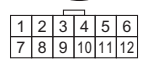

A: i10 (GRÜN)

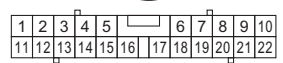

B: B135

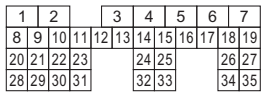

C: B136

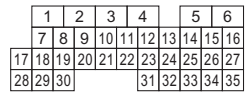

B: (B135) C: (B136) D: (B137) ECM

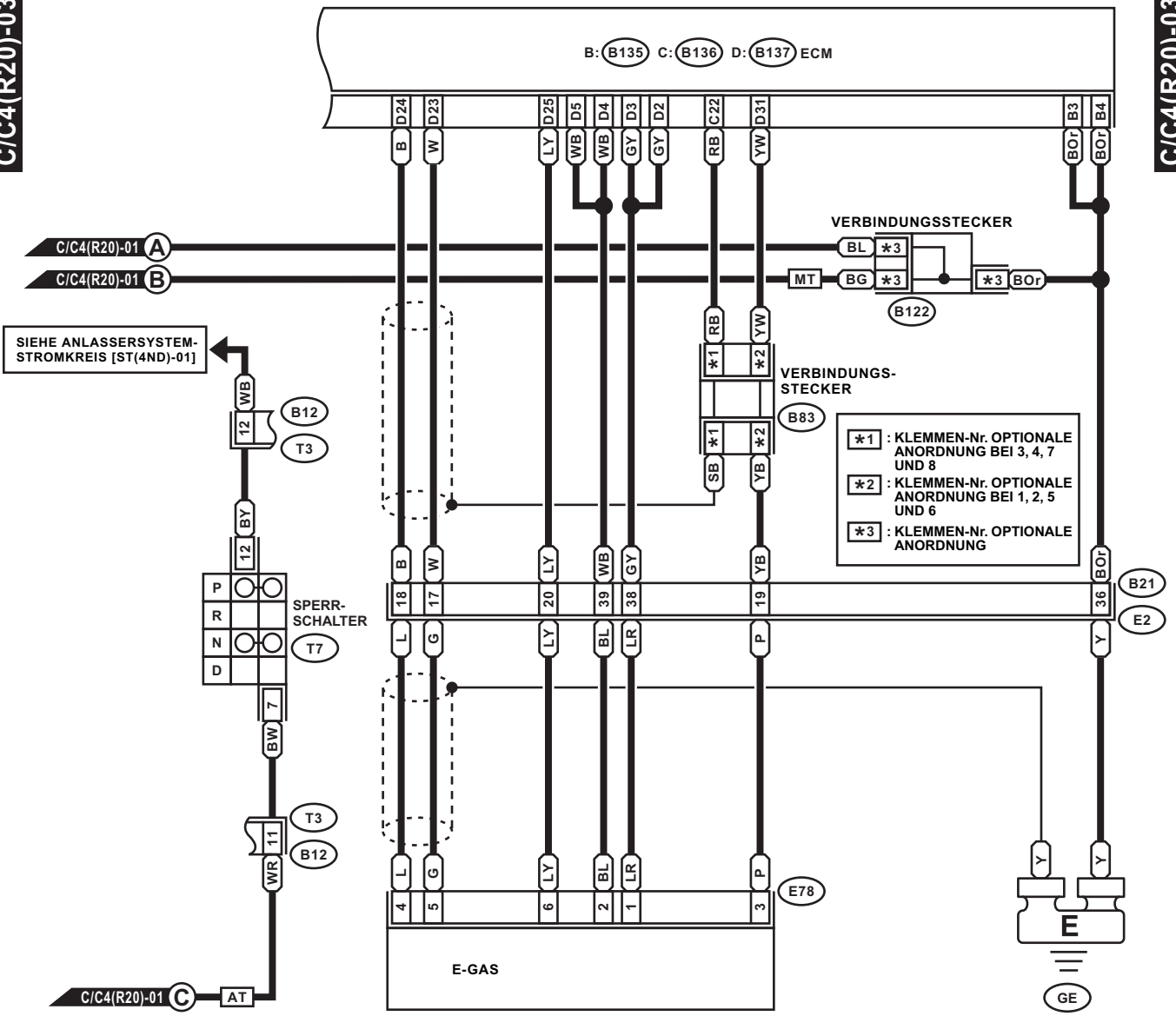

SIEHE ANLASSERSYSTEM-STROMKREIS [ST(4ND)-01]



C/C4(R20)-01 C AT

E78 (SCHWARZ)

1	2	3	4	5	6
---	---	---	---	---	---

B83 (SCHWARZ)

1	2	3	4
5	6	7	8

B12 (GRAU)

1	2	3	4
5	6	7	8
9	10	11	12

T7 (SCHWARZ)

1	2	3	4	5	6
7	8	9	10	11	12

D: (B137)

1	2	3	4	5	6	7
8	9	10	11	12	13	14
15	16	17	18	19	20	21
22	23	24	25	26	27	28
29	30	31	32	33	34	35

B: (B135)

1	2	3	4	5	6	7
8	9	10	11	12	13	14
15	16	17	18	19	20	21
22	23	24	25	26	27	28
29	30	31	32	33	34	35

C: (B136)

1	2	3	4	5	6
7	8	9	10	11	12
13	14	15	16	17	18
19	20	21	22	23	24
25	26	27	28	29	30
31	32	33	34	35	36

B21 (SCHWARZ)

1	2	3	4	5	6	7	8	9	10	11
12	13	14	15	16	17	18	19	20	21	22
23	24	25	26	27	28	29	30	31	32	33
34	35	36	37	38	39	40	41	42	43	44
45	46	47	48	49	50	51	52	53	54	55

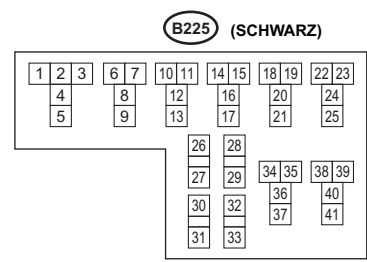
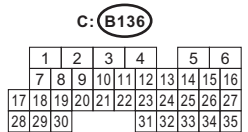
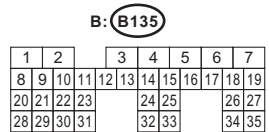
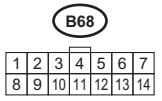
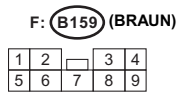
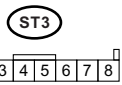
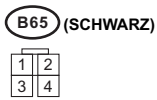
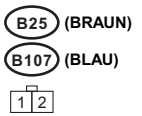
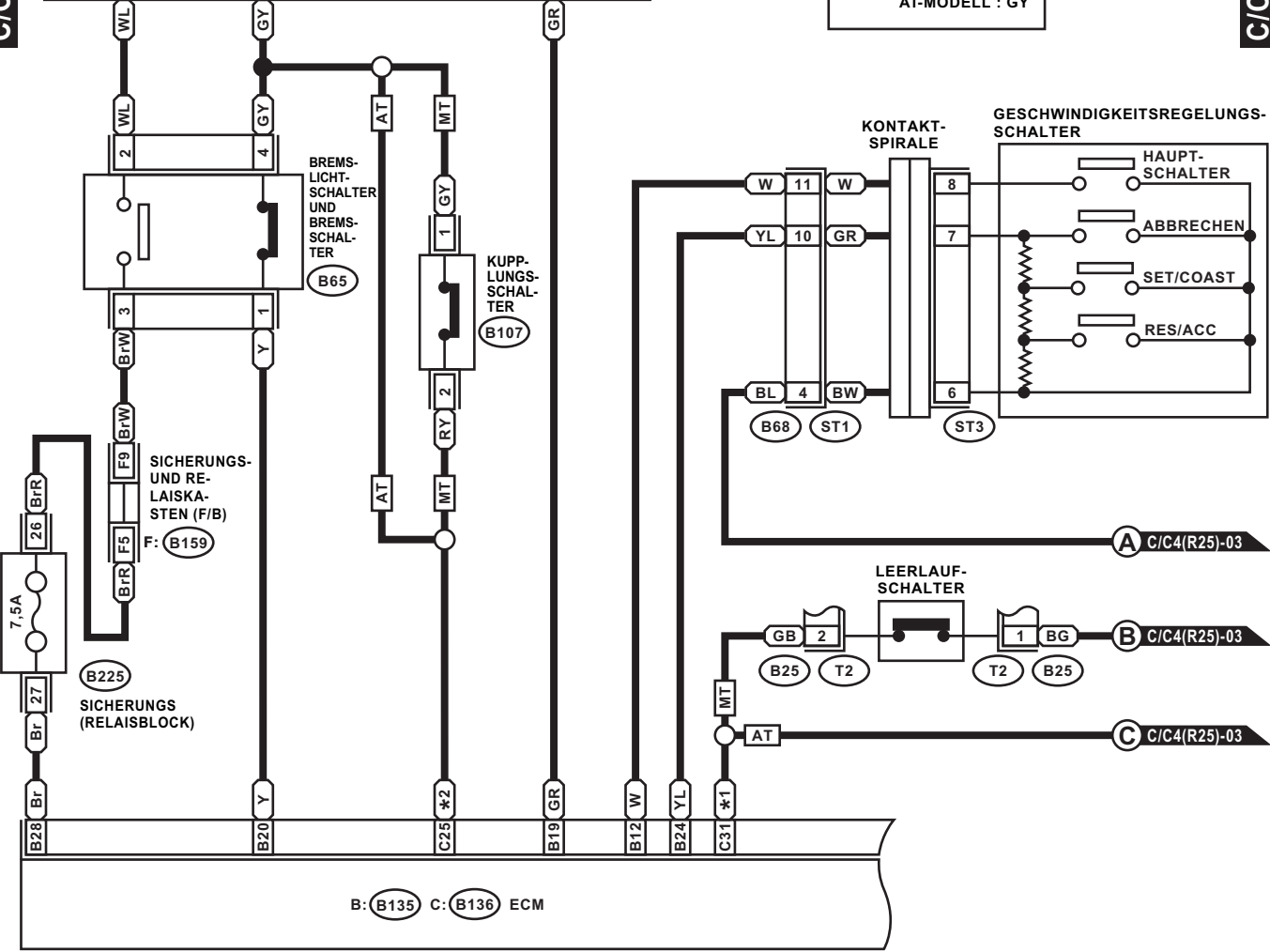
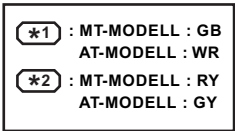
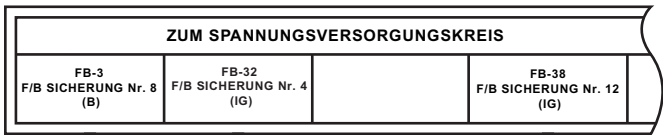

RELAISBLOCK

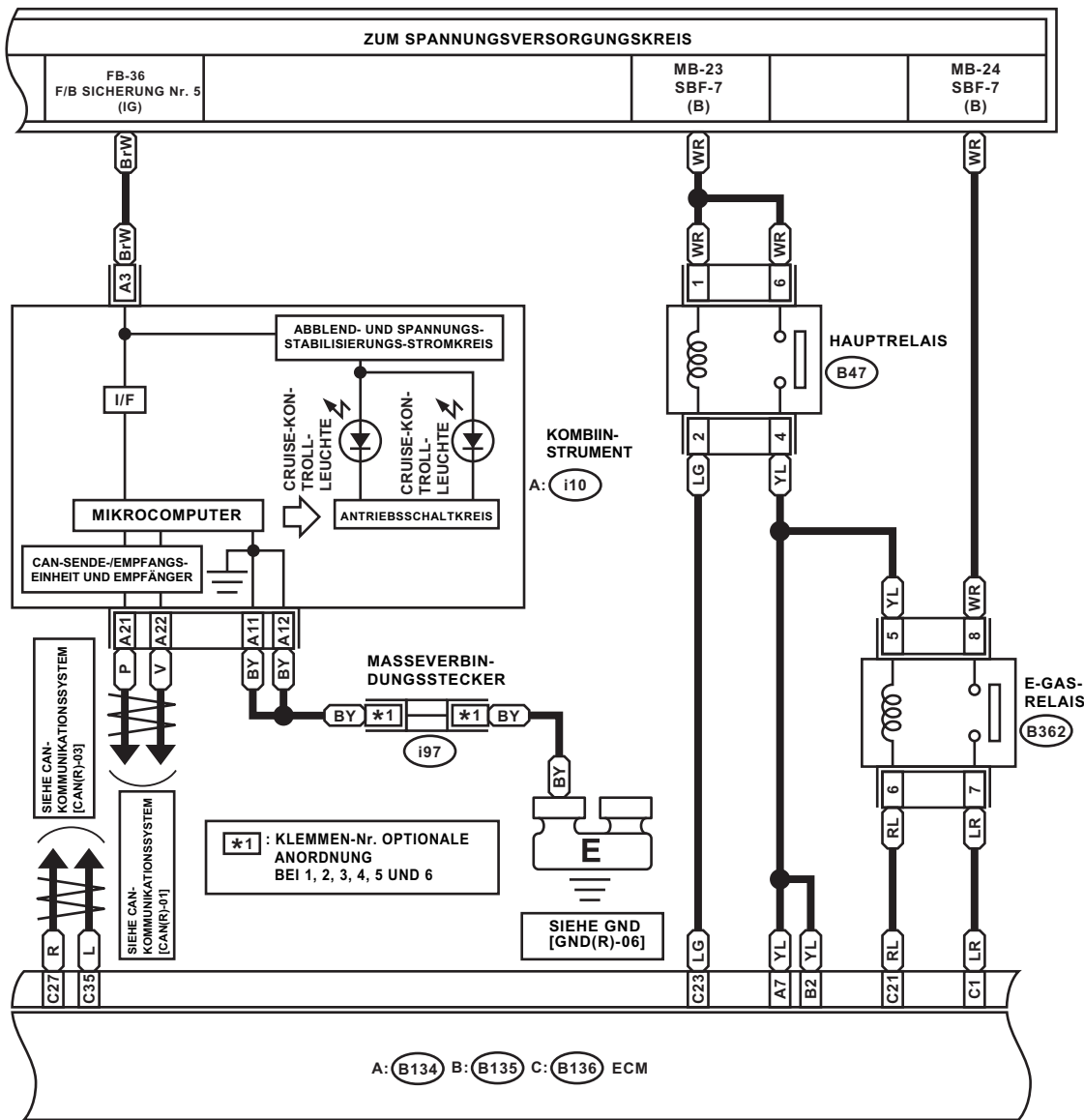

(B47) (BRAUN)

1	2
3	4
5	6

(B362) (SCHWARZ)

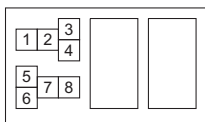

(i97)

1	2	3	4	5	6
7	8	9	10	11	12

A: (i10) (GRÜN)

1	2	3	4	5	6	7	8	9	10		
11	12	13	14	15	16	17	18	19	20	21	22

A: (B134)

1	2	3	4	5	6	7			
8	9	10	11	12	13	14	15	16	17
18	19	20	21	22	23	24	25	26	27
28	29	30	31	32				33	34

B: (B135)

RELAISHALTER

C: (B136)

1	2	3	4	5	6	7					
8	9	10	11	12	13	14	15	16	17	18	19
20	21	22	23	24	25	26	27				
28	29	30	31	32	33	34	35				

1	2	3	4	5	6						
7	8	9	10	11	12	13	14	15	16		
17	18	19	20	21	22	23	24	25	26	27	
28	29	30	31	32	33	34	35				

A: (B134) C: (B136) D: (B137) ECM

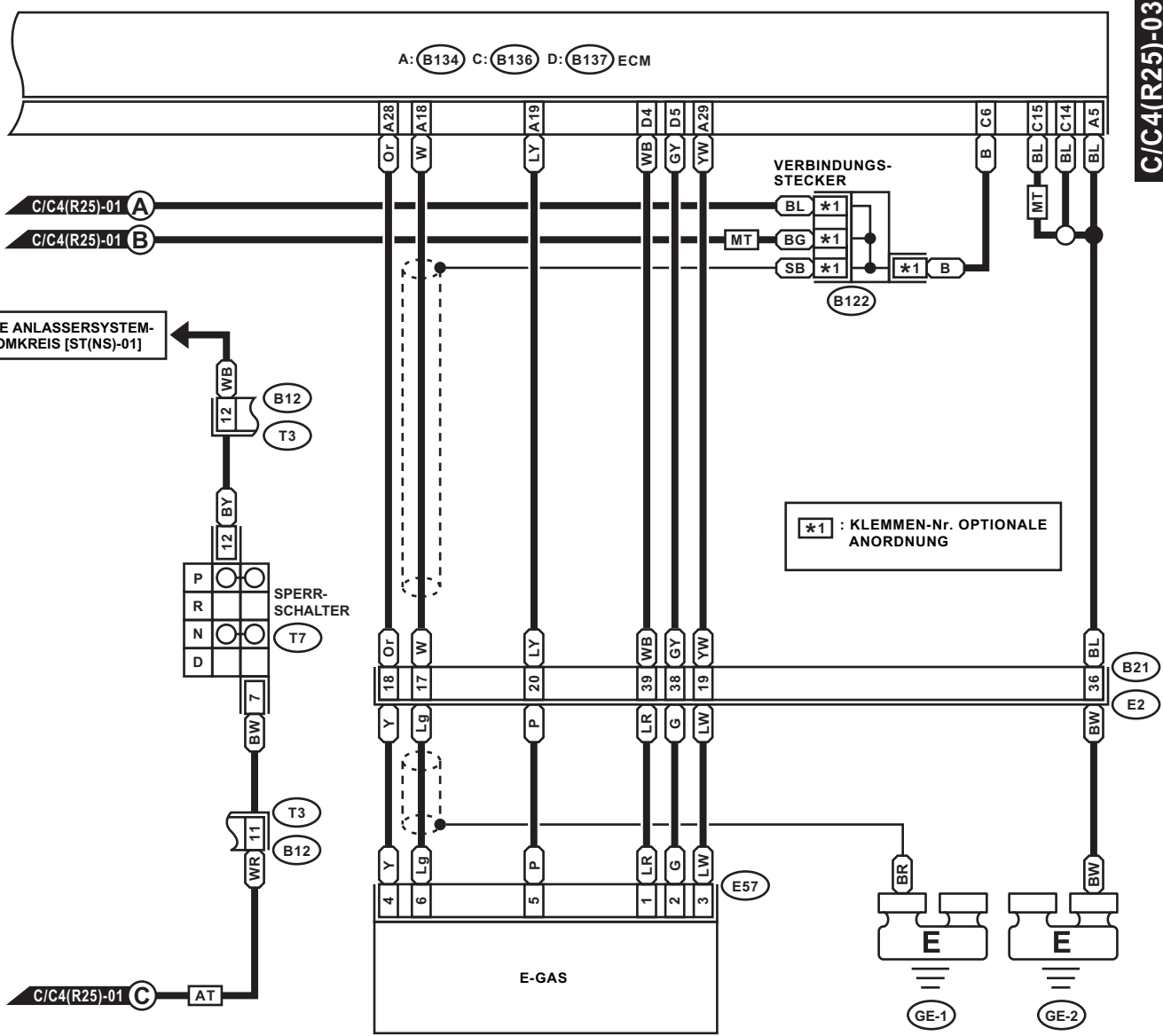

(E57) (SCHWARZ)

1	2	3	4	5	6
---	---	---	---	---	---

(B122)

1	2	3	4
5	6	7	8

(B12) (GRAU)

1	2	3	4
5	6	7	8
9	10	11	12

(T7) (SCHWARZ)

1	2	3	4	5	6
7	8	9	10	11	12

(B21) (SCHWARZ)

1	2	3	4	5	6	7	8	9	10	11
12	13	14	15	16	17	18	19	20	21	22
23	24	25	26	27	28	29	30	31	32	33
34	35	36	37	38	39	40	41			
42	43	44	45	46	47					
48	49	50	51	52	53	54				

D: (B137)

1	2	3	4	5	6	7
8	9	10	11	12	13	14
15	16	17	18	19	20	21
22	23	24	25	26	27	28
29	30	31				

A: (B134)

1	2	3	4	5	6	7
8	9	10	11	12	13	14
15	16	17	18	19	20	21
22	23	24	25	26	27	28
29	30	31	32	33	34	

C: (B136)

1	2	3	4	5	6
7	8	9	10	11	12
13	14	15	16	17	18
19	20	21	22	23	24
25	26	27	28	29	30
31	32	33	34	35	

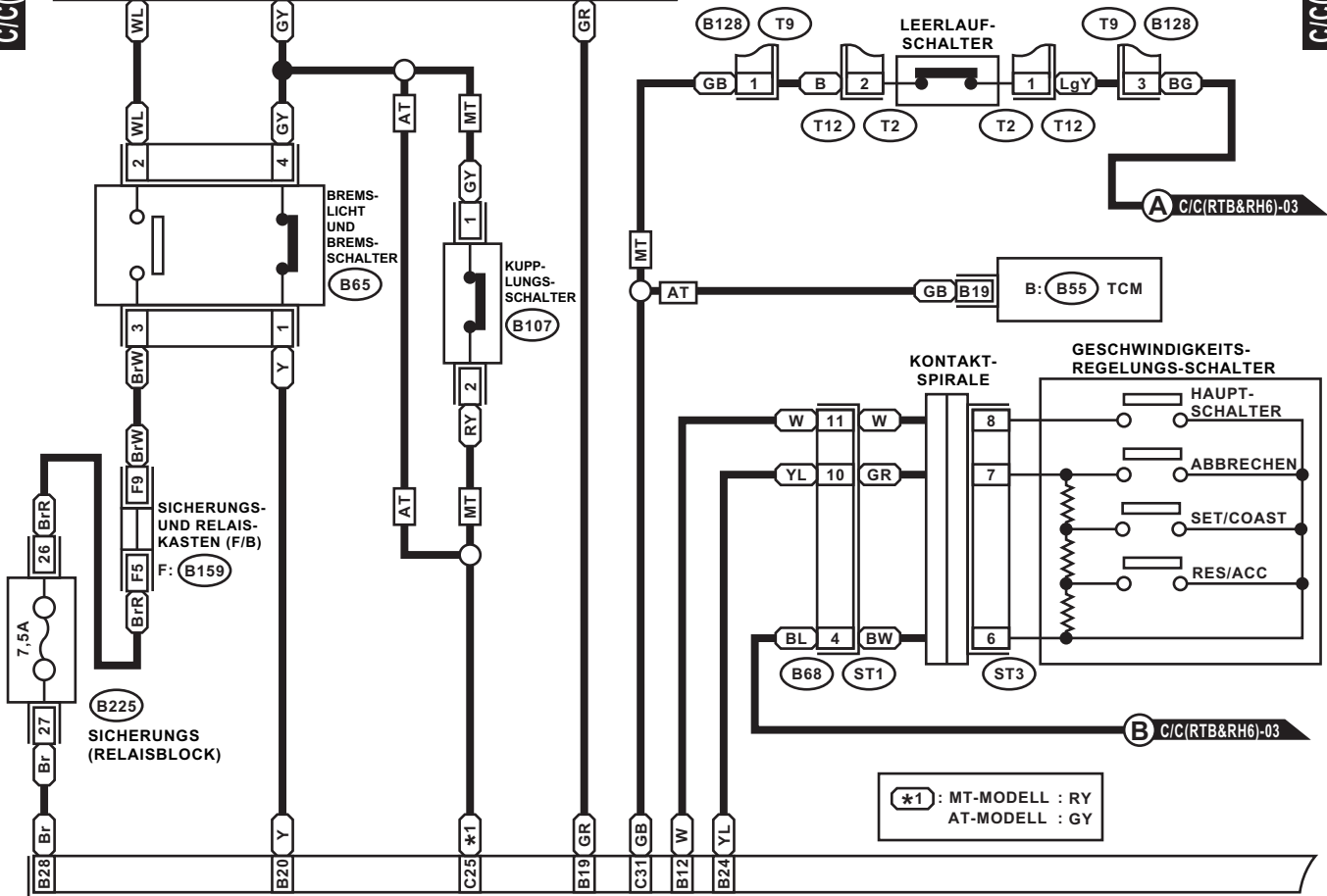
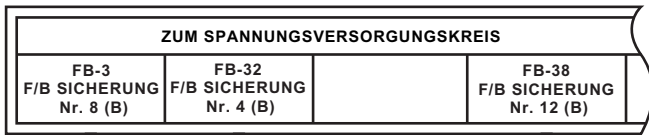

B: B135 C: B136 ECM

*1: MT-MODELL : RY
AT-MODELL : GY

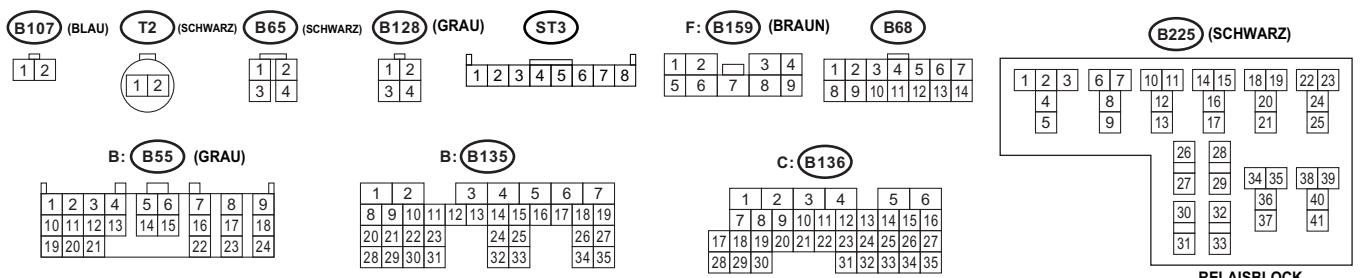

RELAISBLOCK

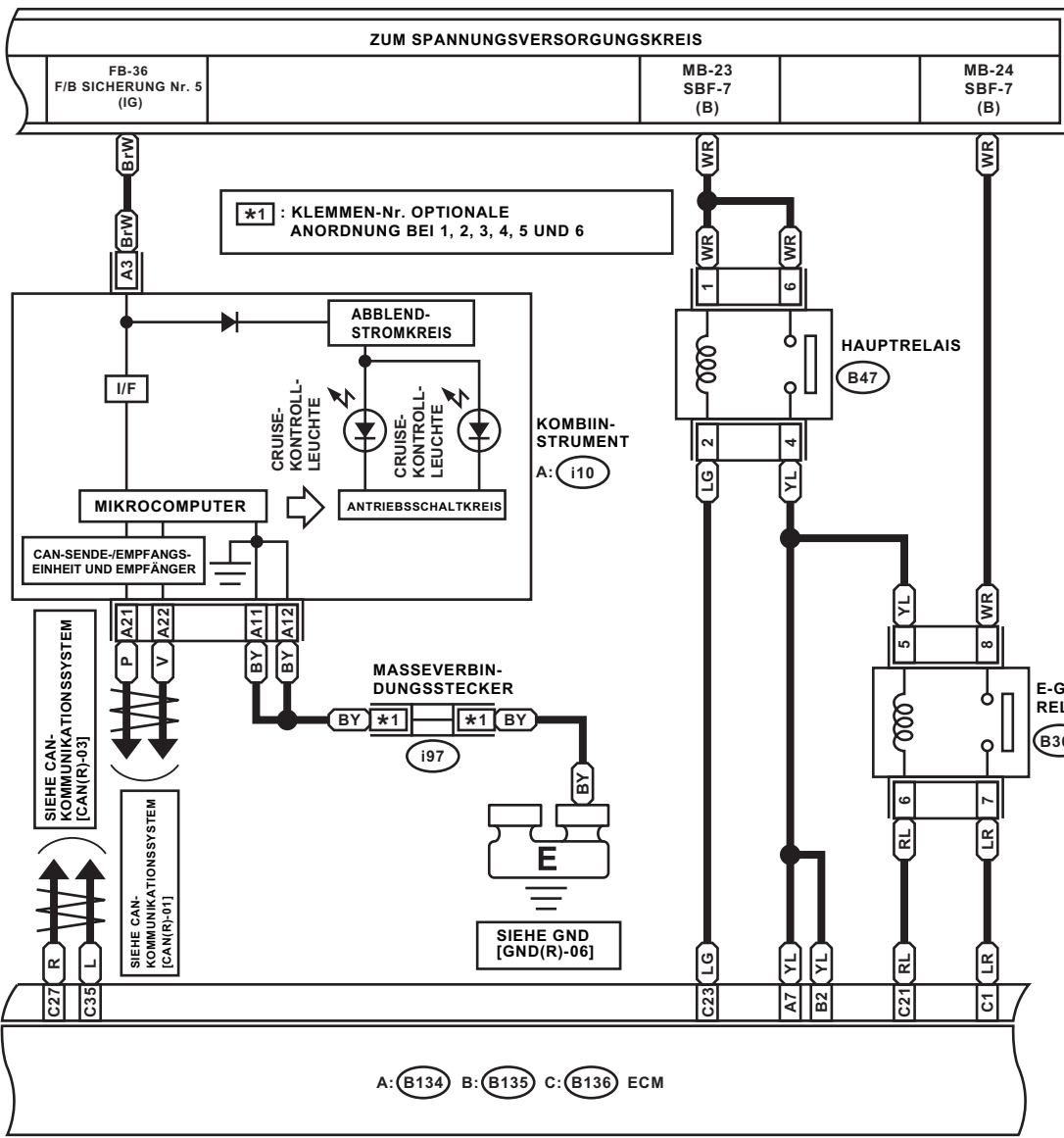

B47 (BRAUN)



B362 (SCHWARZ)

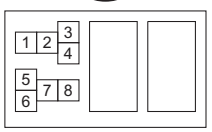

i97



A: **i10** (GRÜN)

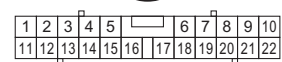

A: **B134**

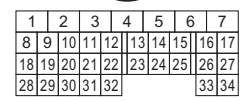

B: B135 **RELAISHALTER**

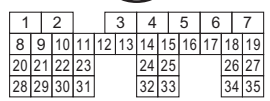

C: B136

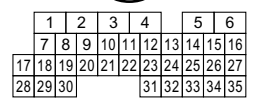

A: (B134) C: (B136) D: (B137) ECM

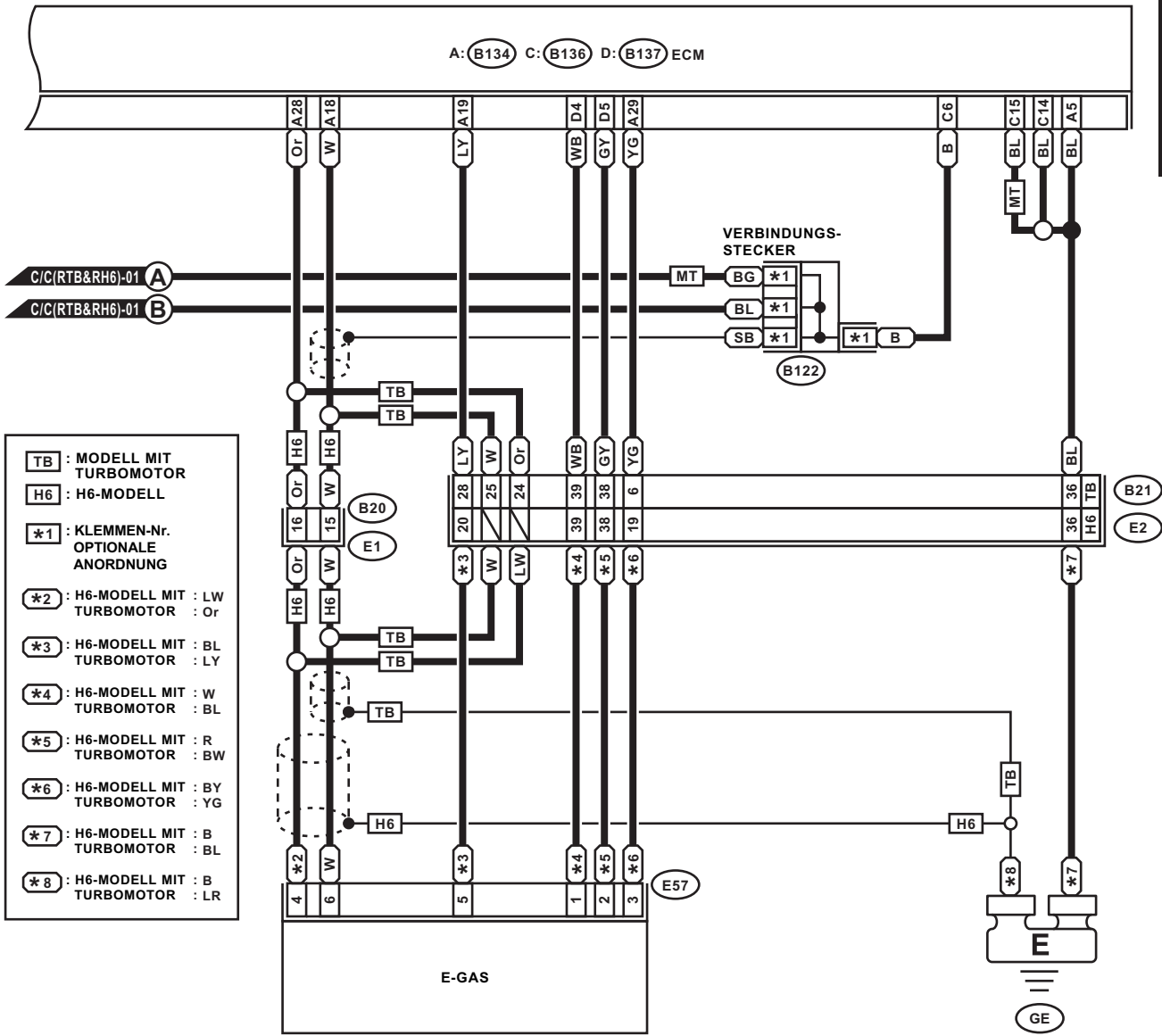

- TB** : MODELL MIT TURBOMOTOR
- H6** : H6-MODELL
- *1** : KLEMMEN-Nr. OPTIONALE ANORDNUNG
- *2** : H6-MODELL MIT : LW
TURBOMOTOR : Or
- *3** : H6-MODELL MIT : BL
TURBOMOTOR : LY
- *4** : H6-MODELL MIT : W
TURBOMOTOR : BL
- *5** : H6-MODELL MIT : R
TURBOMOTOR : BW
- *6** : H6-MODELL MIT : BY
TURBOMOTOR : YG
- *7** : H6-MODELL MIT : B
TURBOMOTOR : BL
- *8** : H6-MODELL MIT : B
TURBOMOTOR : LR

E57 (SCHWARZ)

1	2	3	4	5	6
---	---	---	---	---	---

B122

1	2	3	4
5	6	7	8

B21 (SCHWARZ)

1	2	3	4	5	6	7	8	9	10	11
12	13	14	15	16	17	18	19	20	21	22
23	24	25	26	27	28	29	30	31	32	33
34	35	36	37	38	39	40	41			
42	43	44	45	46	47					
48	49	50	51	52	53	54				

C: (B136)

1	2	3	4	5	6
7	8	9	10	11	12
13	14	15	16	17	18
19	20	21	22	23	24
25	26	27	28	29	30
		31	32	33	34
				35	

B20 (BRAUN)

1	2	3	4
5	6	7	8
9	10	11	12
13	14	15	16

D: (B137)

1	2	3	4	5	6	7
8	9	10	11	12	13	14
15	16	17	18	19	20	21
22	23	24	25	26	27	28
29	30	31				

A: (B134)

1	2	3	4	5	6	7
8	9	10	11	12	13	14
15	16	17	18	19	20	21
22	23	24	25	26	27	28
29	30	31	32	33	34	

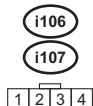
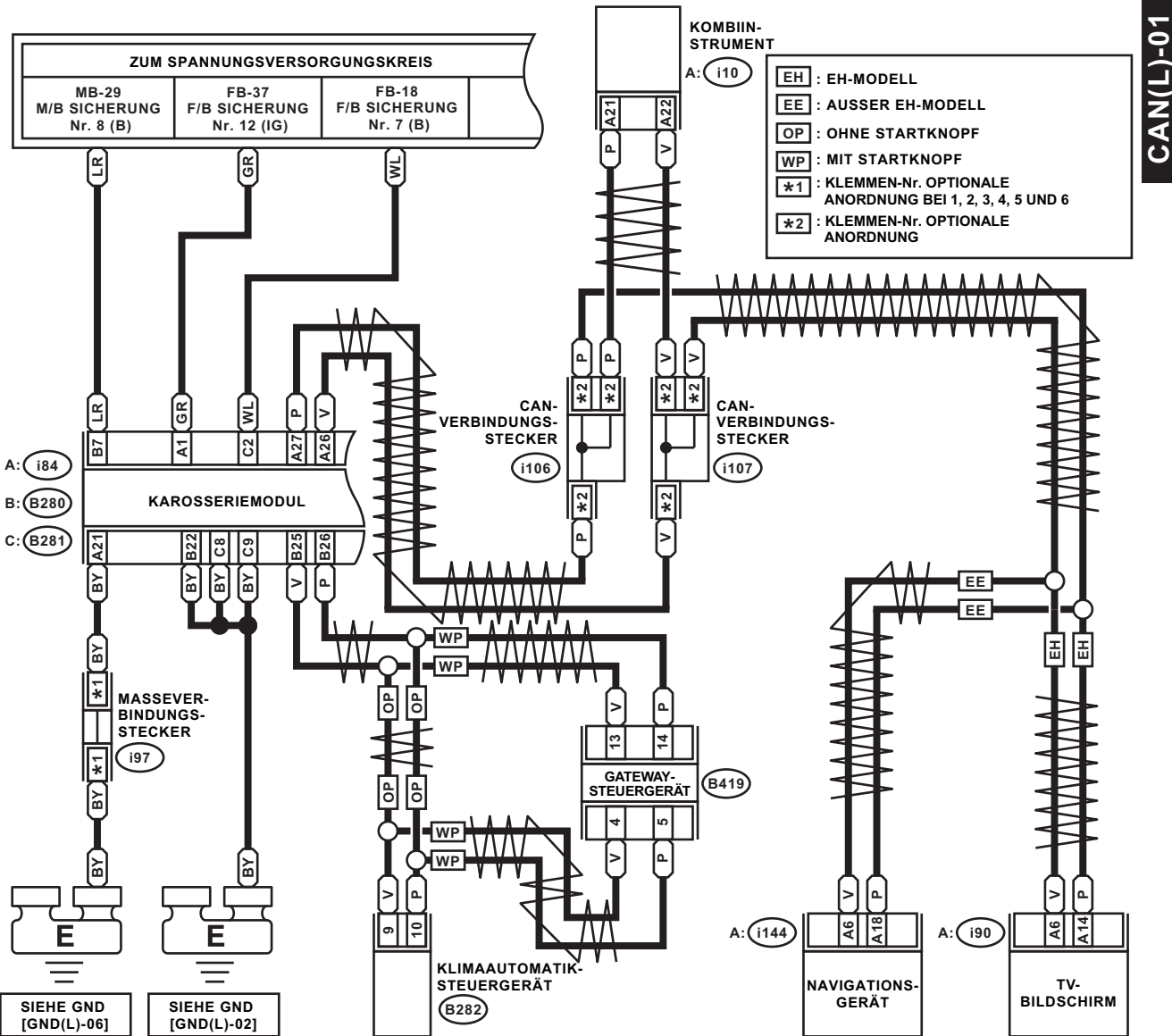

i97



A: i90

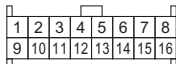

A: i10 (GRÜN)

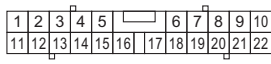

B419

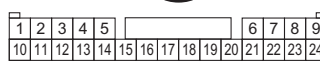

A: i144



C: B281



B: B280



A: i84 (GRAU)

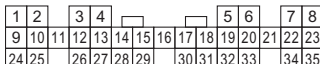

B282

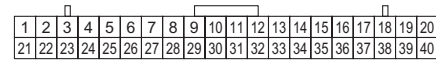

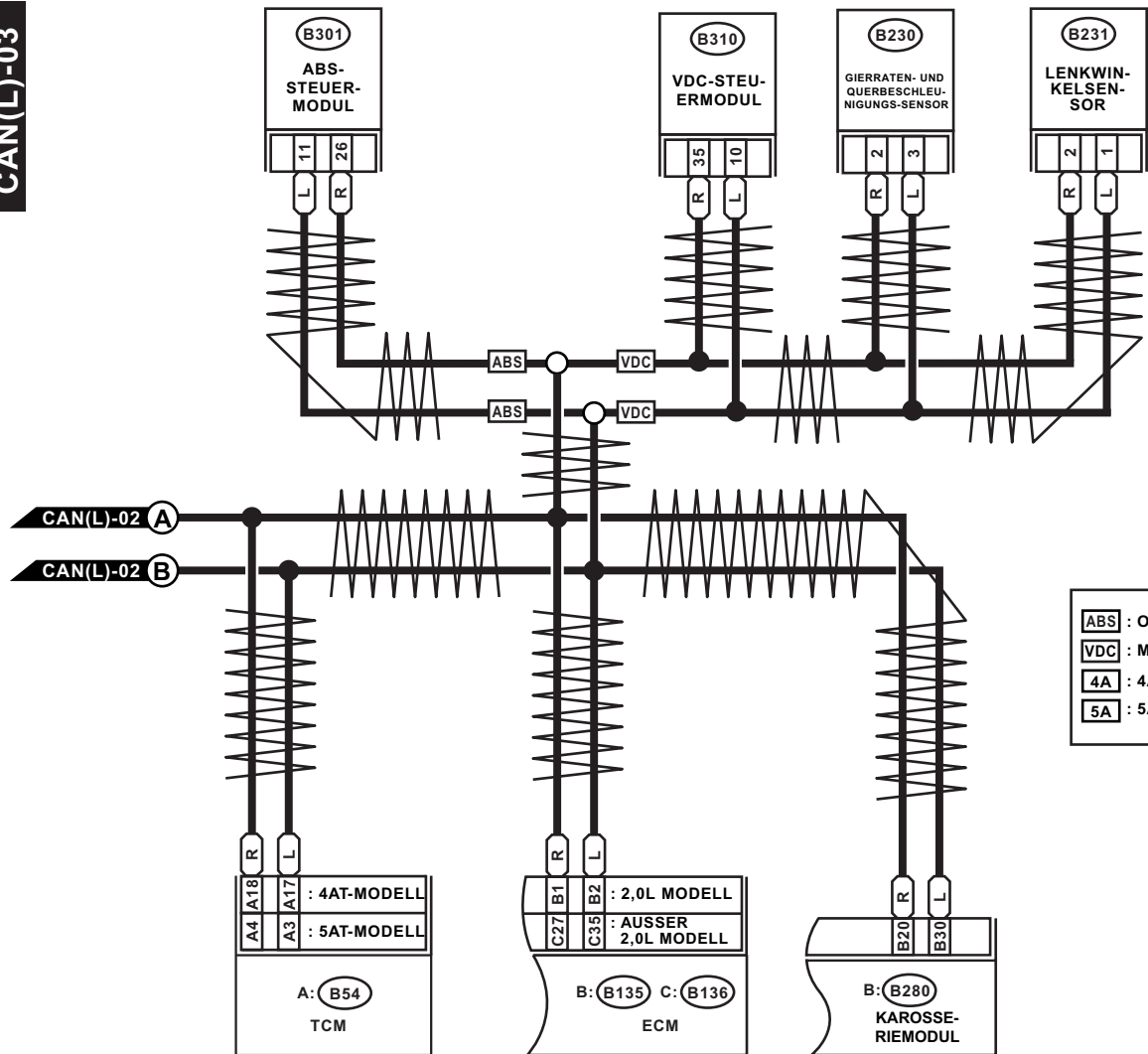

ABS : OHNE VDC
VDC : MIT VDC
4A : 4AT-MODELL
5A : 5AT-MODELL

A4 A18 : 4AT-MODELL
 A3 A17 : 5AT-MODELL

C27 B1 : 2,0L MODELL
 C35 B2 : AUSSER 2,0L MODELL

B: B280
 KAROSSE-RIEMODUL

B230 (SCHWARZ) B231 (SCHWARZ)

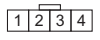
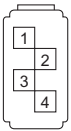

5A A: B54

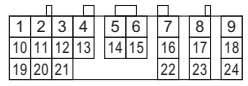

B301 (SCHWARZ)

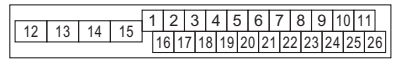

B: B280

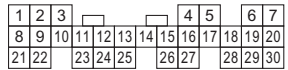

4A A: B54

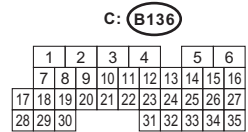

C: B136

B: B135

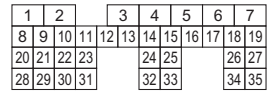

B310 (SCHWARZ)

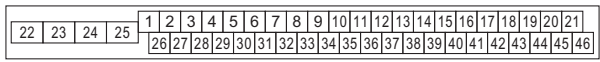



KOMBIINSTRUMENT

A: i10

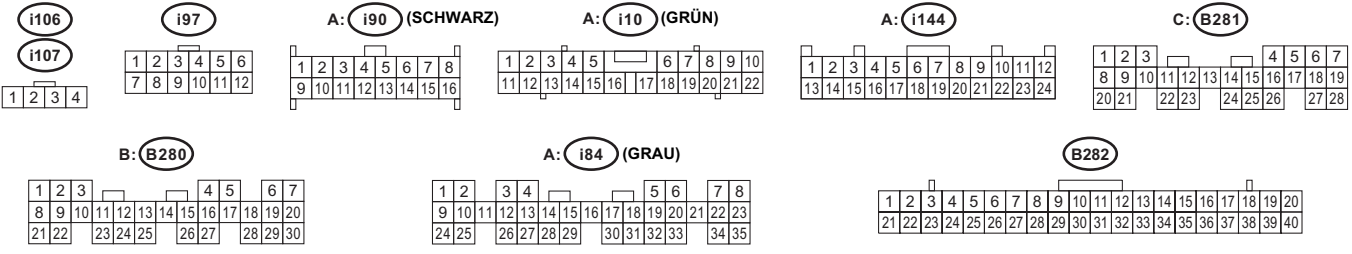
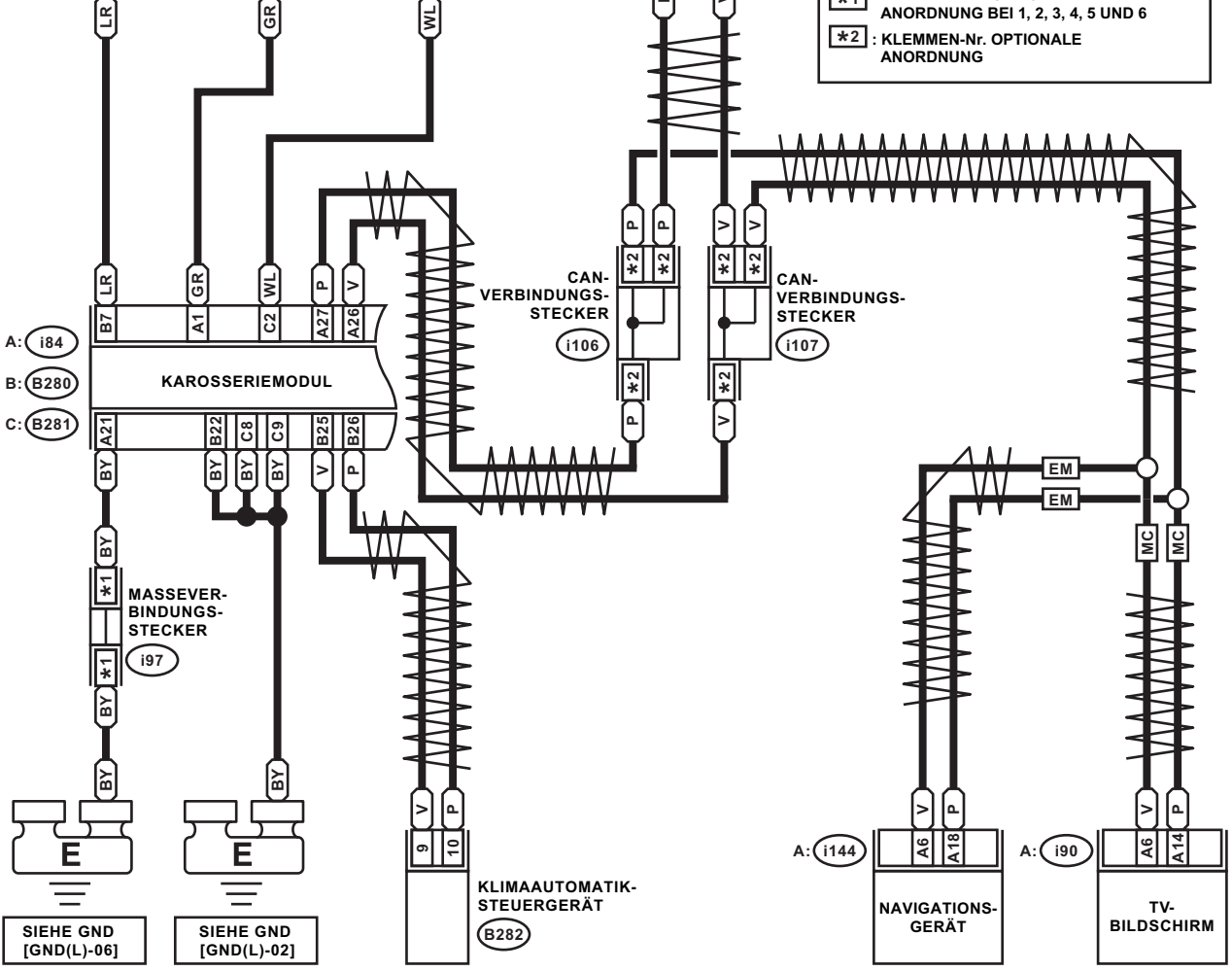
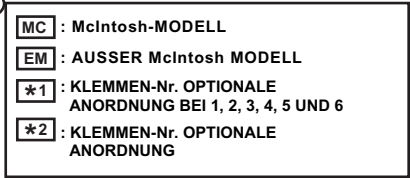

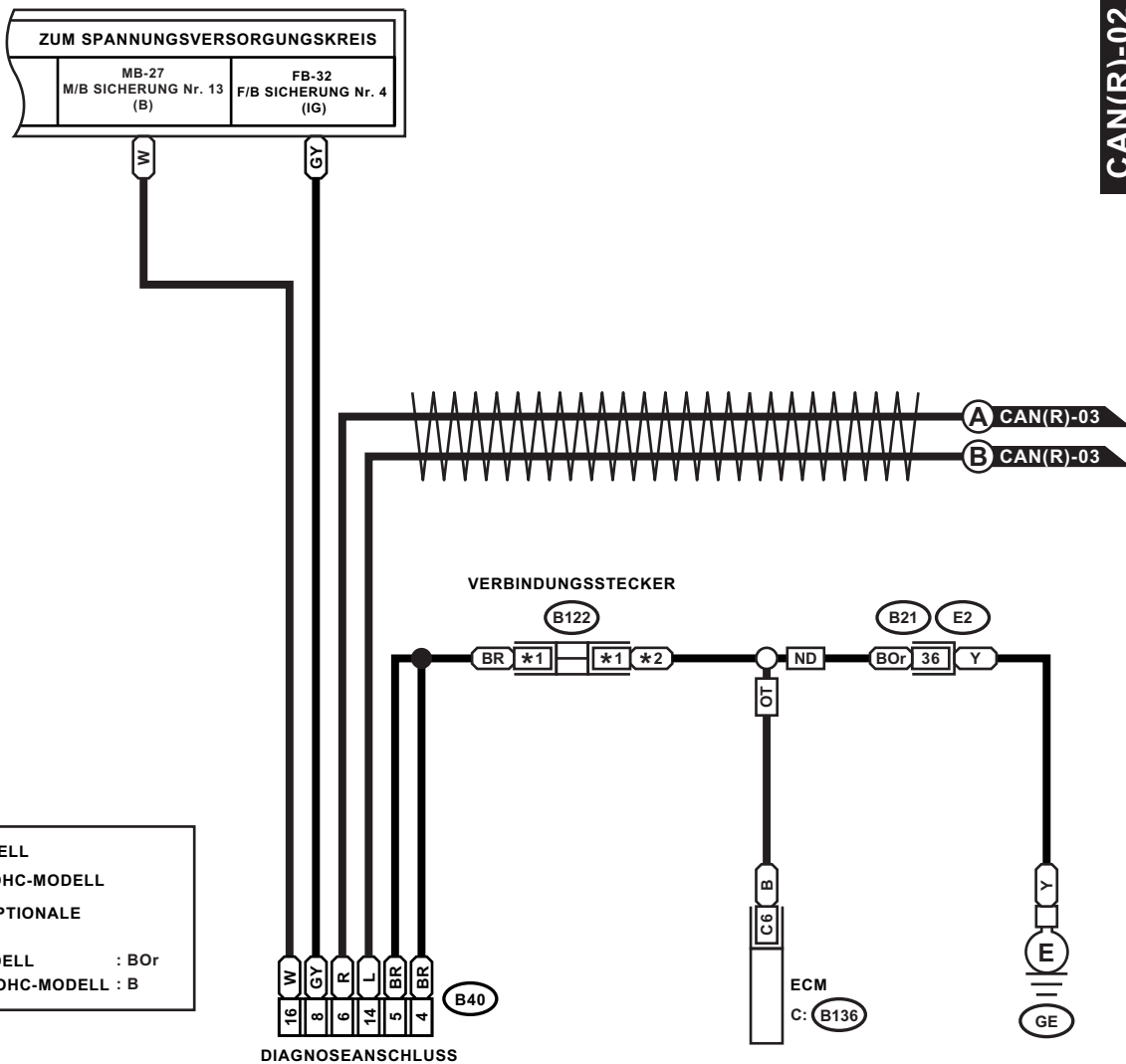

B122

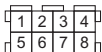

B40 (SCHWARZ)

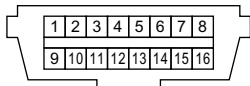

C: B136

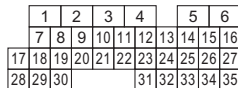

B21 (SCHWARZ)

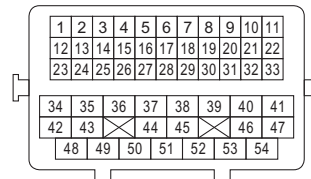

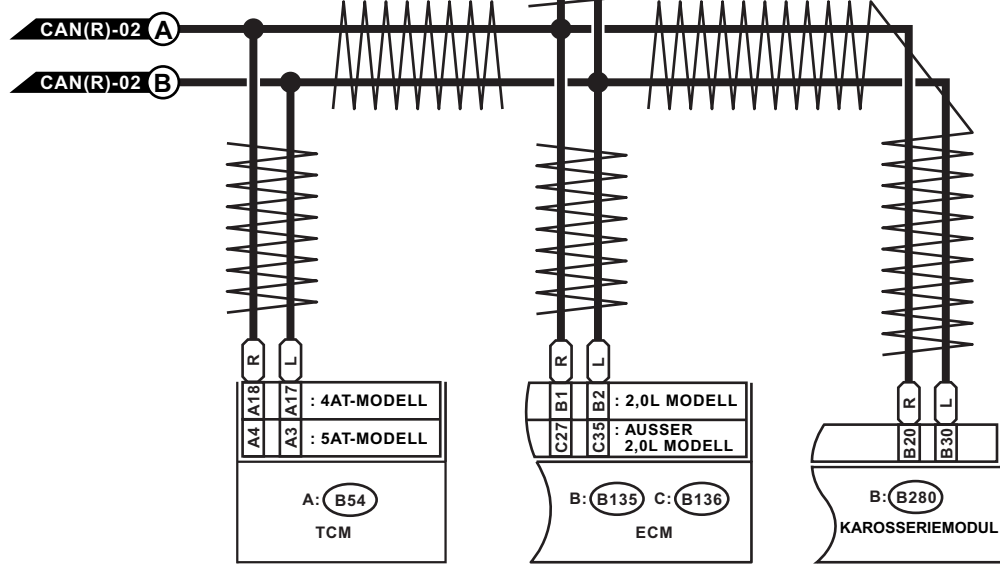
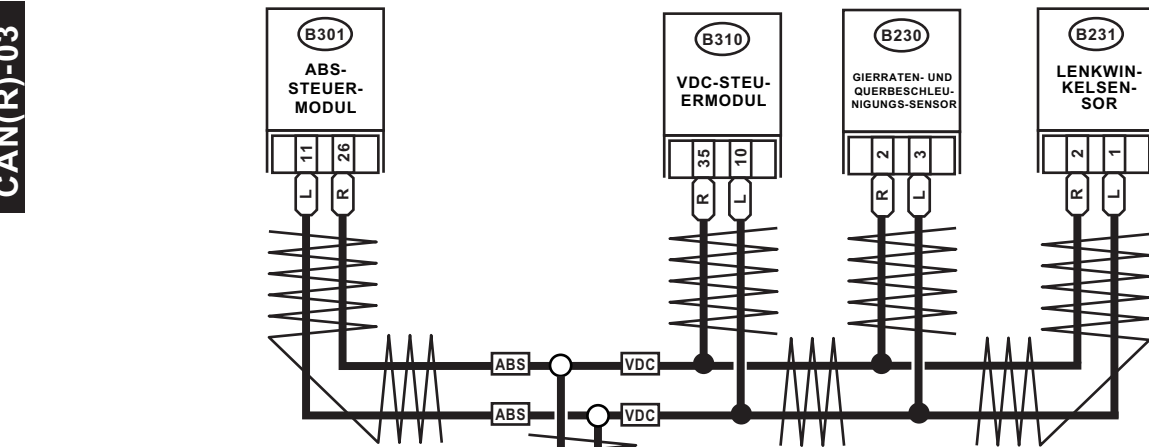

ABS : OHNE VDC
VDC : MIT VDC
4A : 4AT-MODELL
5A : 5AT-MODELL

B230 (SCHWARZ) B231 (SCHWARZ)

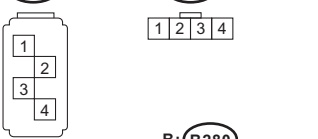

5A A: B54

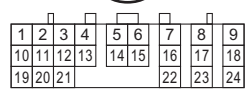

B310 (SCHWARZ)

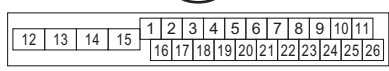

B: B280



4A A: B54

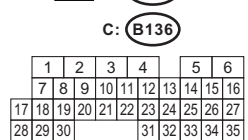

C: B136

B: B135

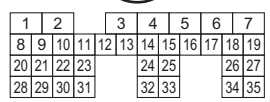

B310 (SCHWARZ)

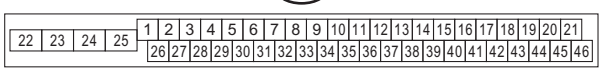

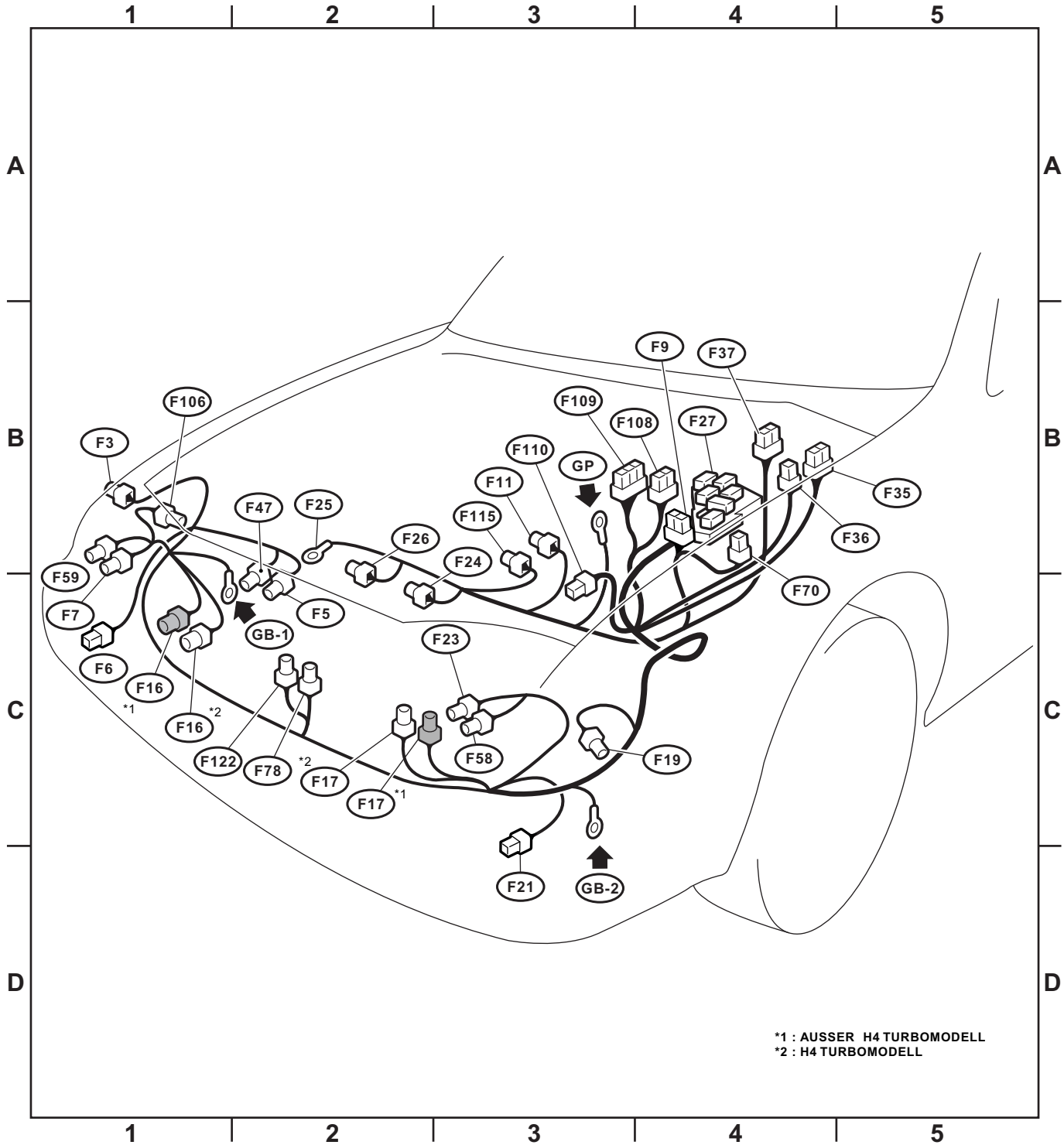

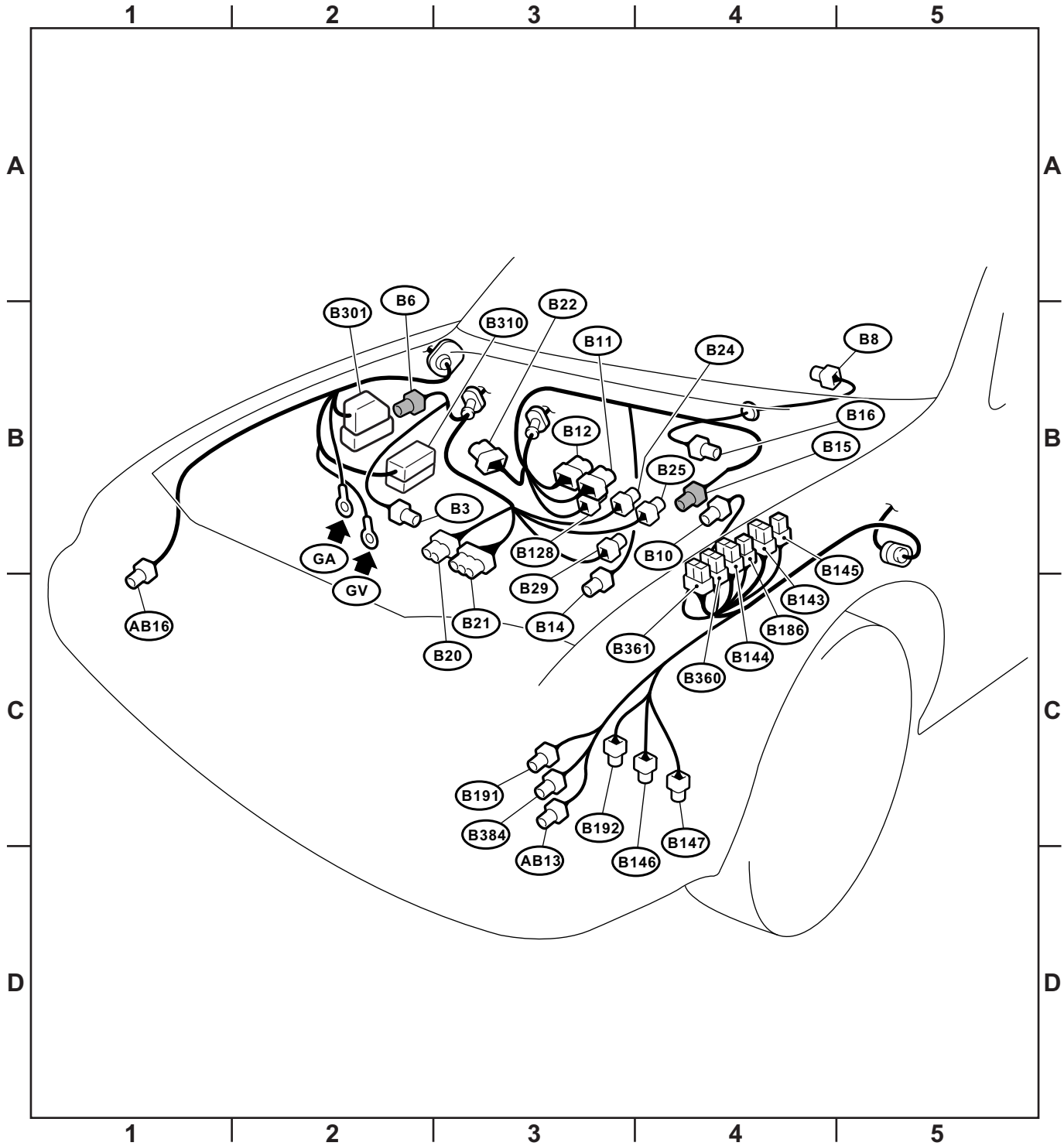

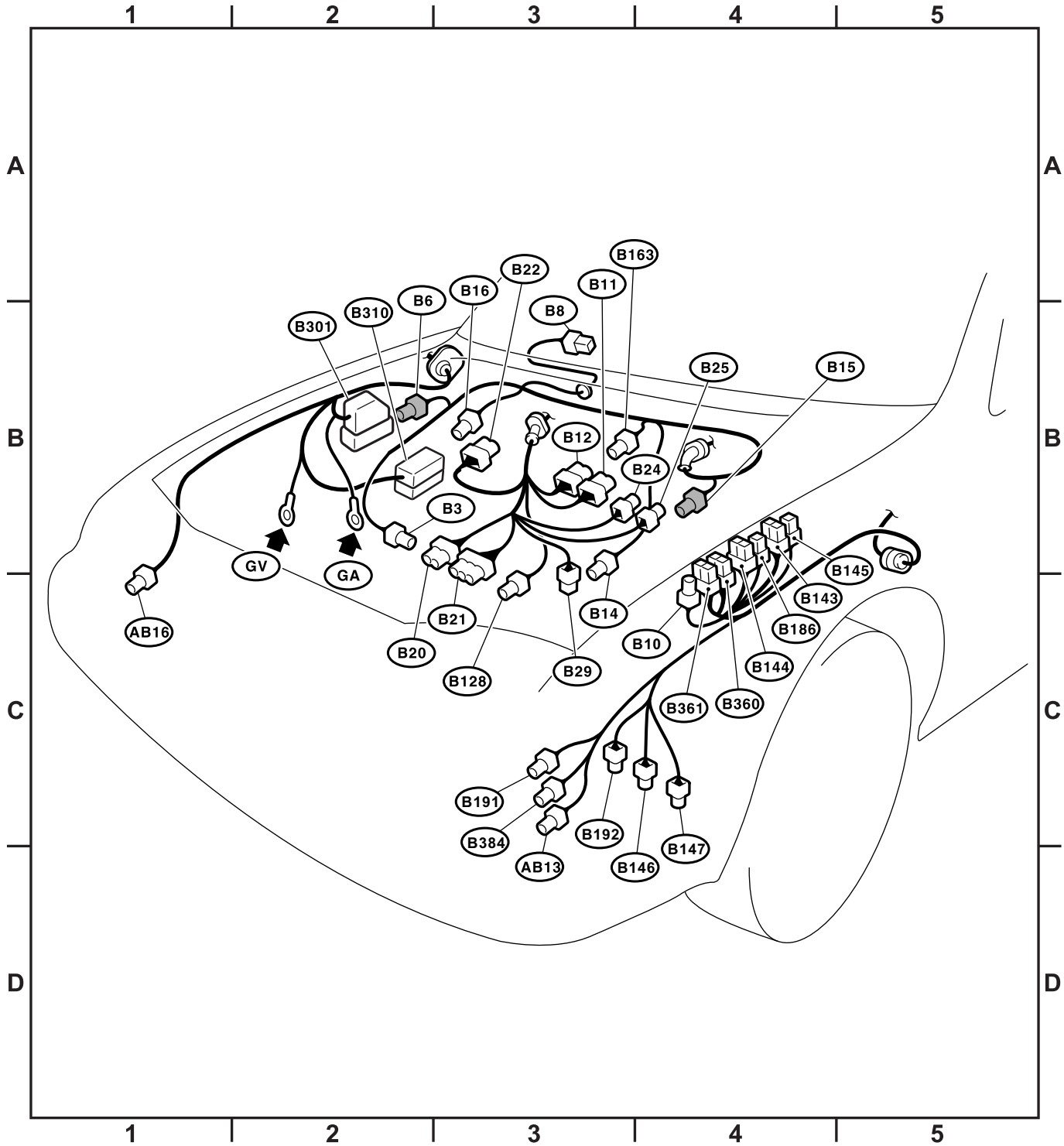

1

2

3

4

5

A

A

B

B

C

C

D

D

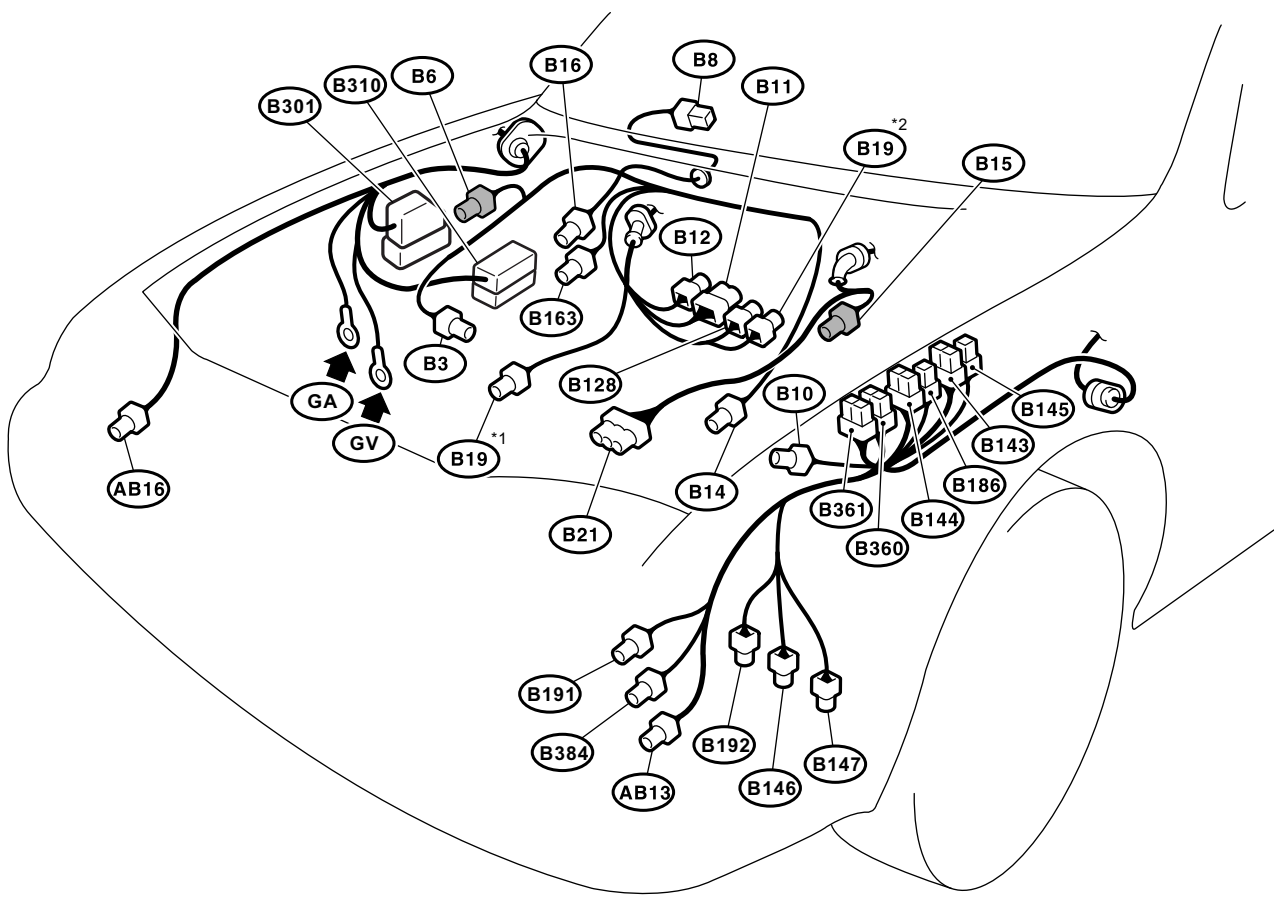

*1 : AT-MODELL
 *2 : MT-MODELL

1

2

3

4

5

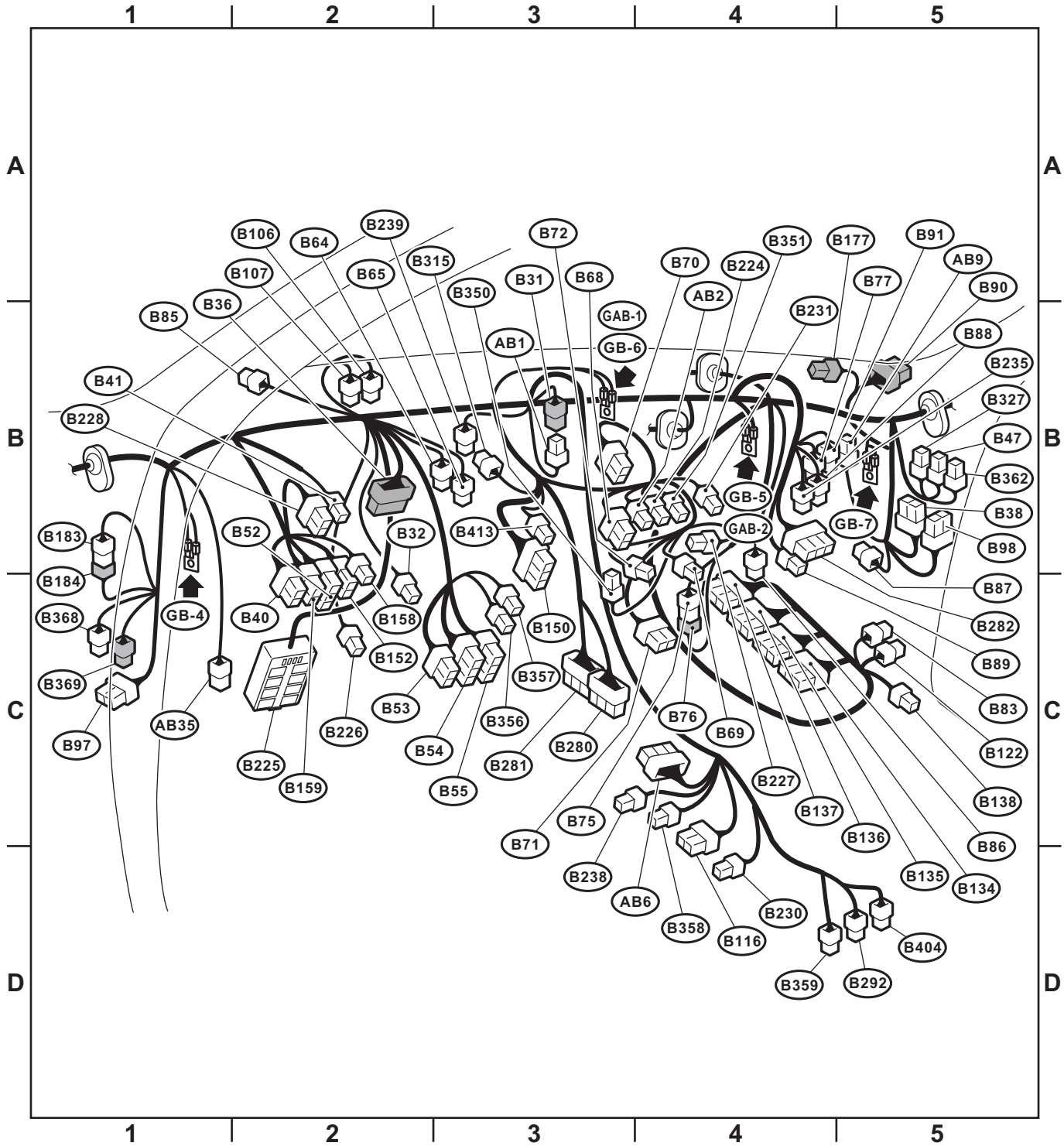

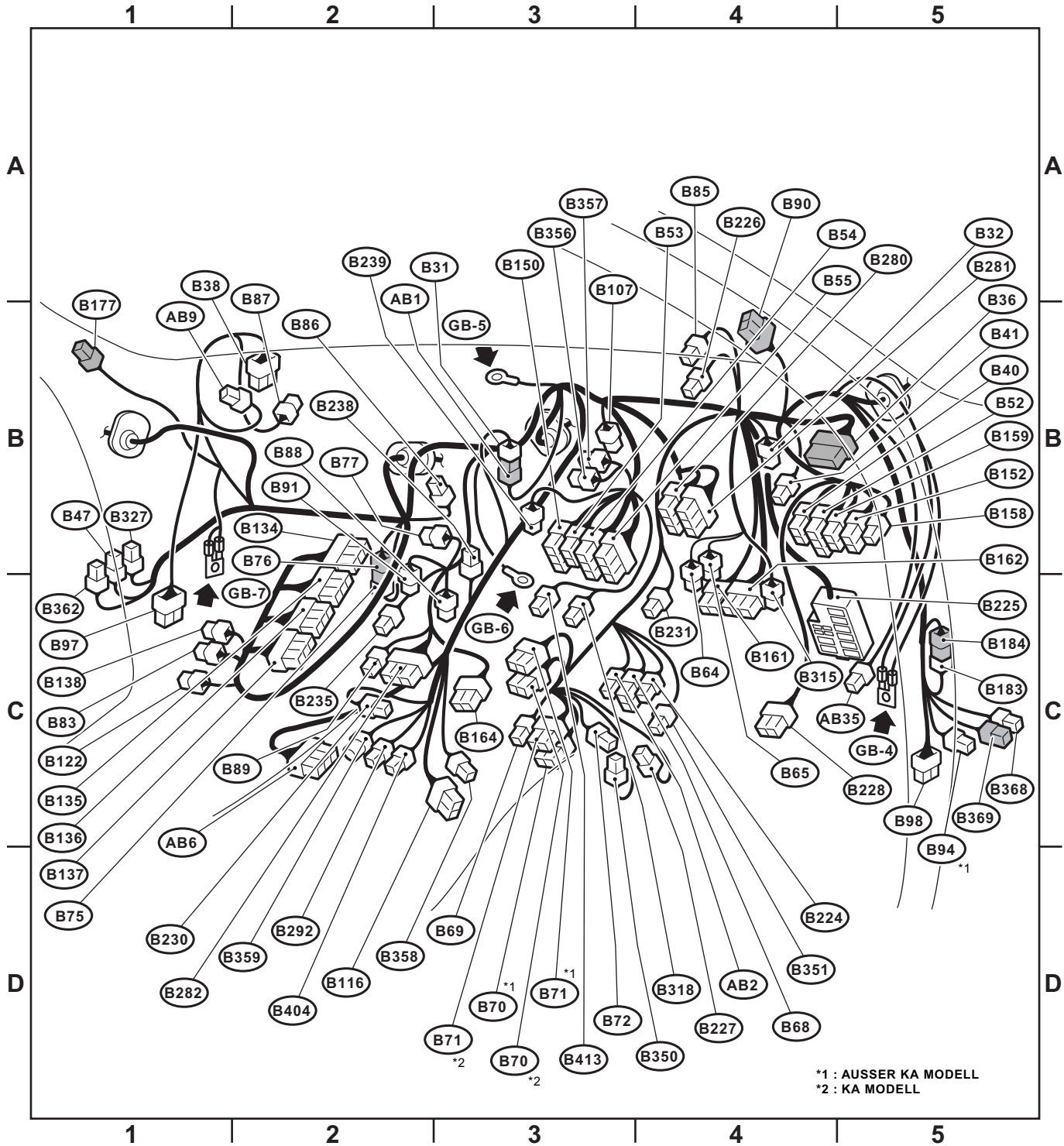

1

2

3

4

5

A

A

B

B

C

C

D

D

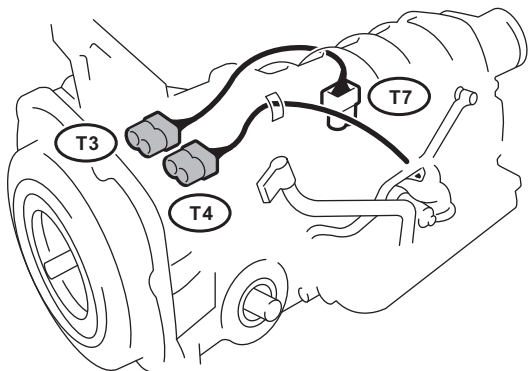
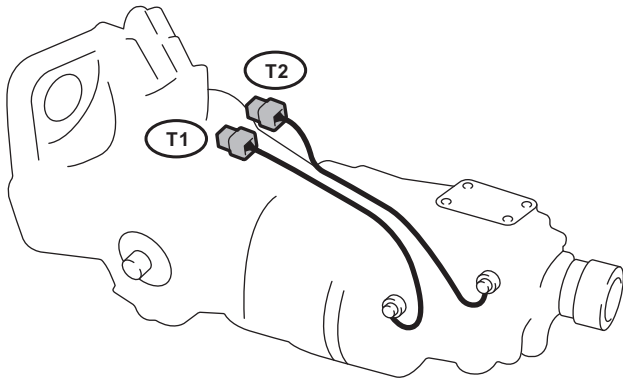
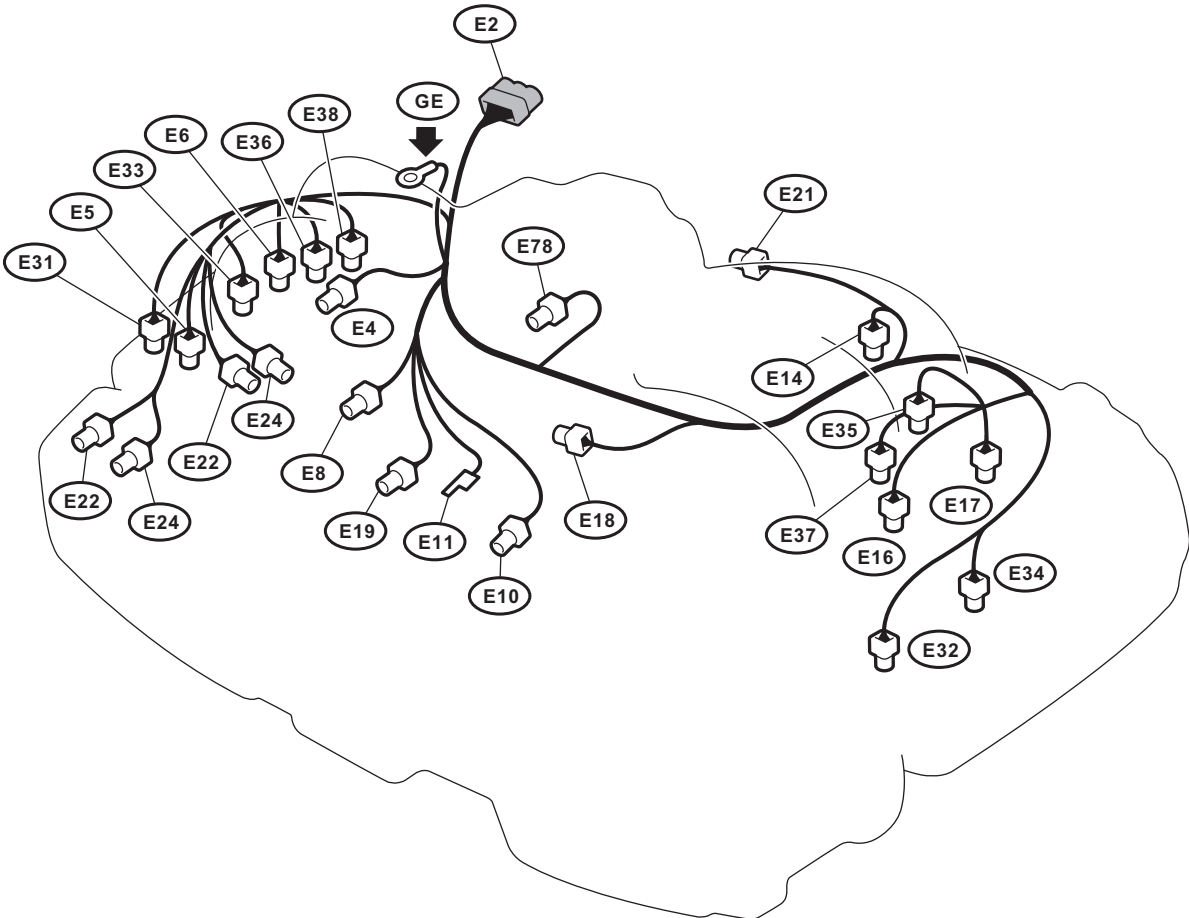

1

2

3

4

5

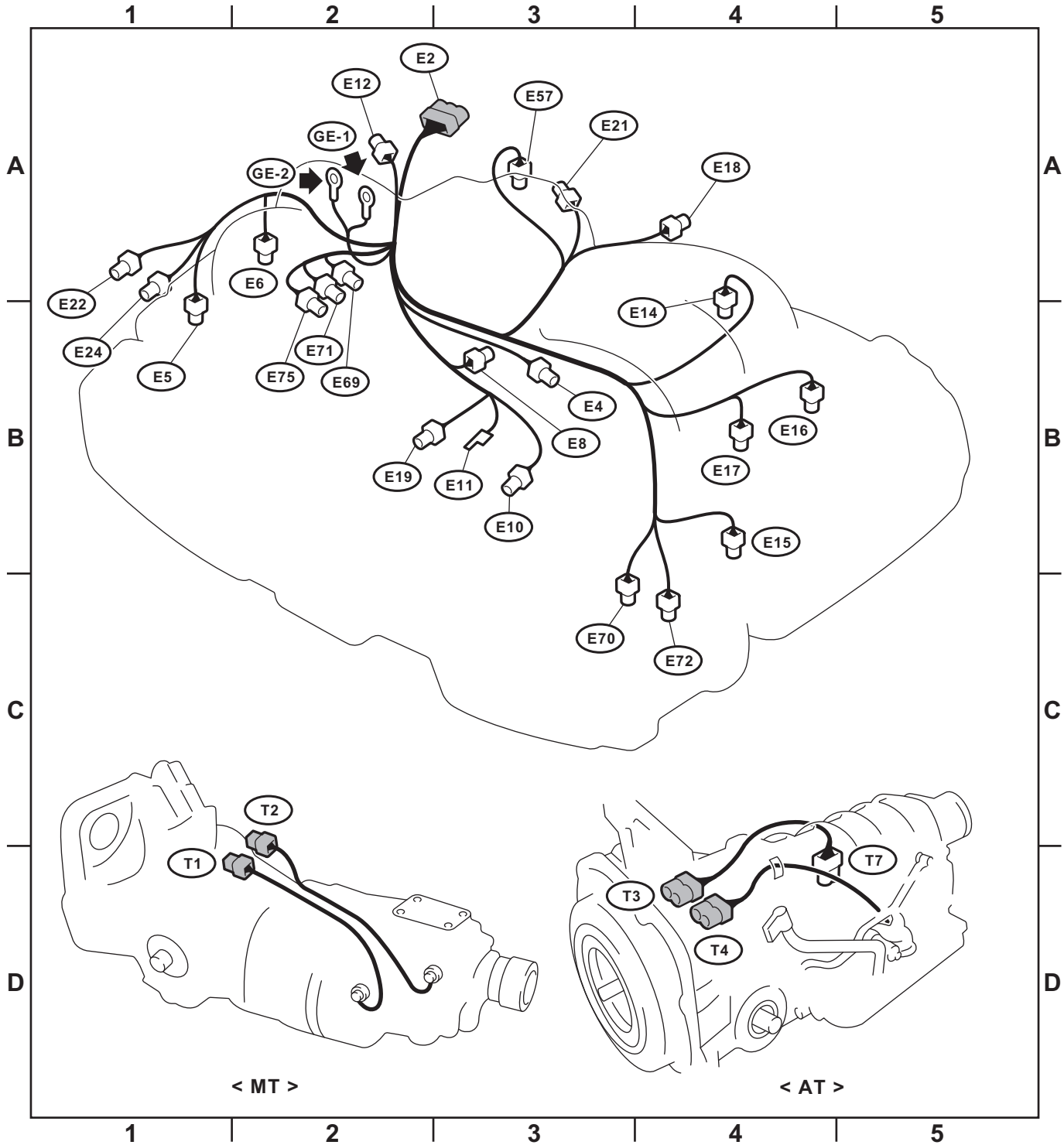

1

2

3

4

5

A

A

B

B

C

C

D

D

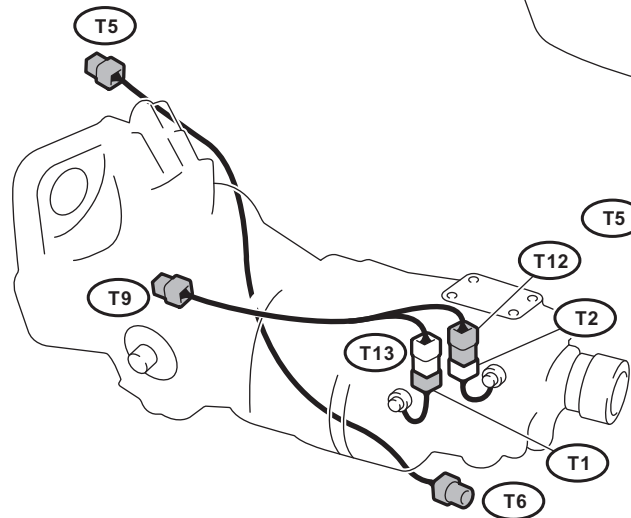
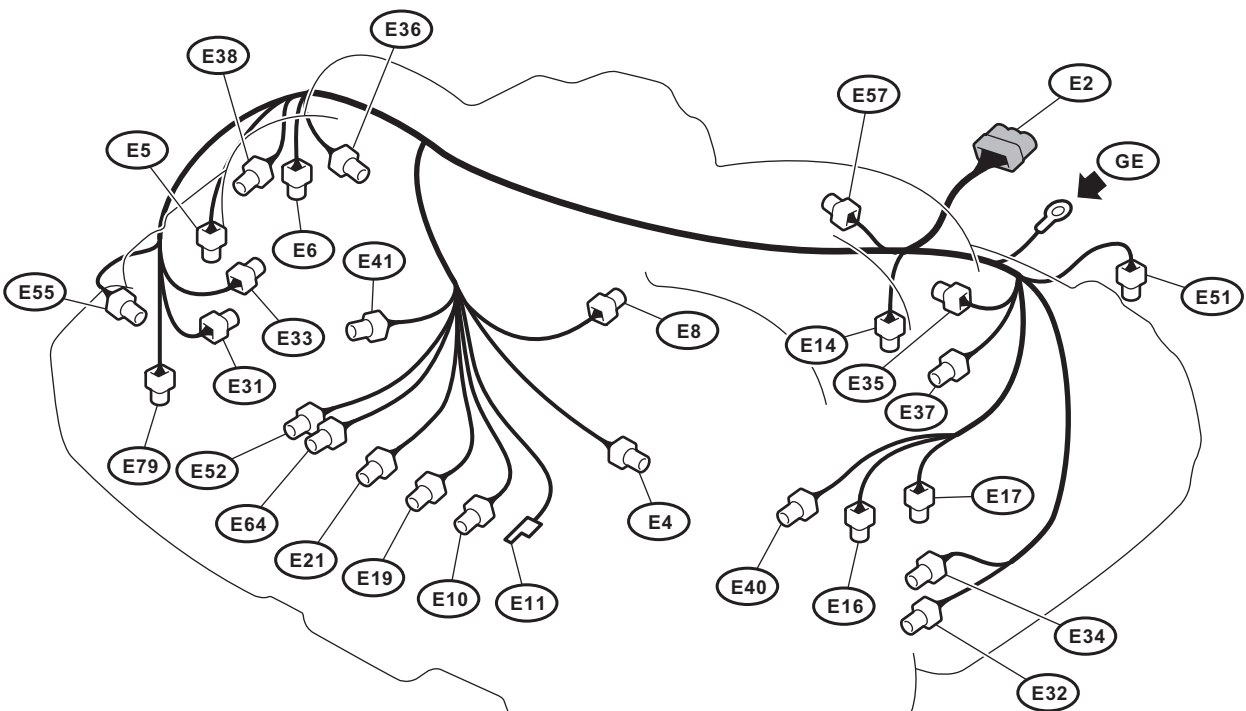

< MT >

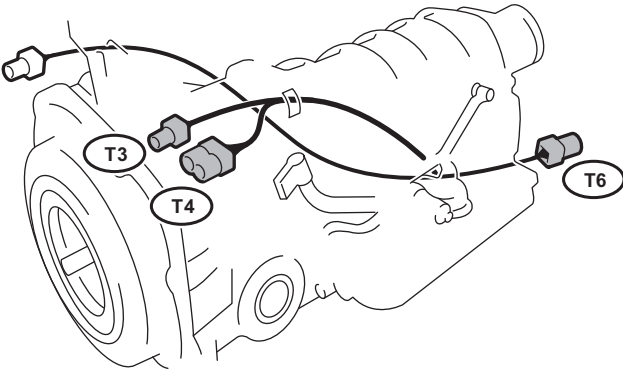

< AT >

1

2

3

4

5

1

2

3

4

5

A

A

B

B

C

C

D

D

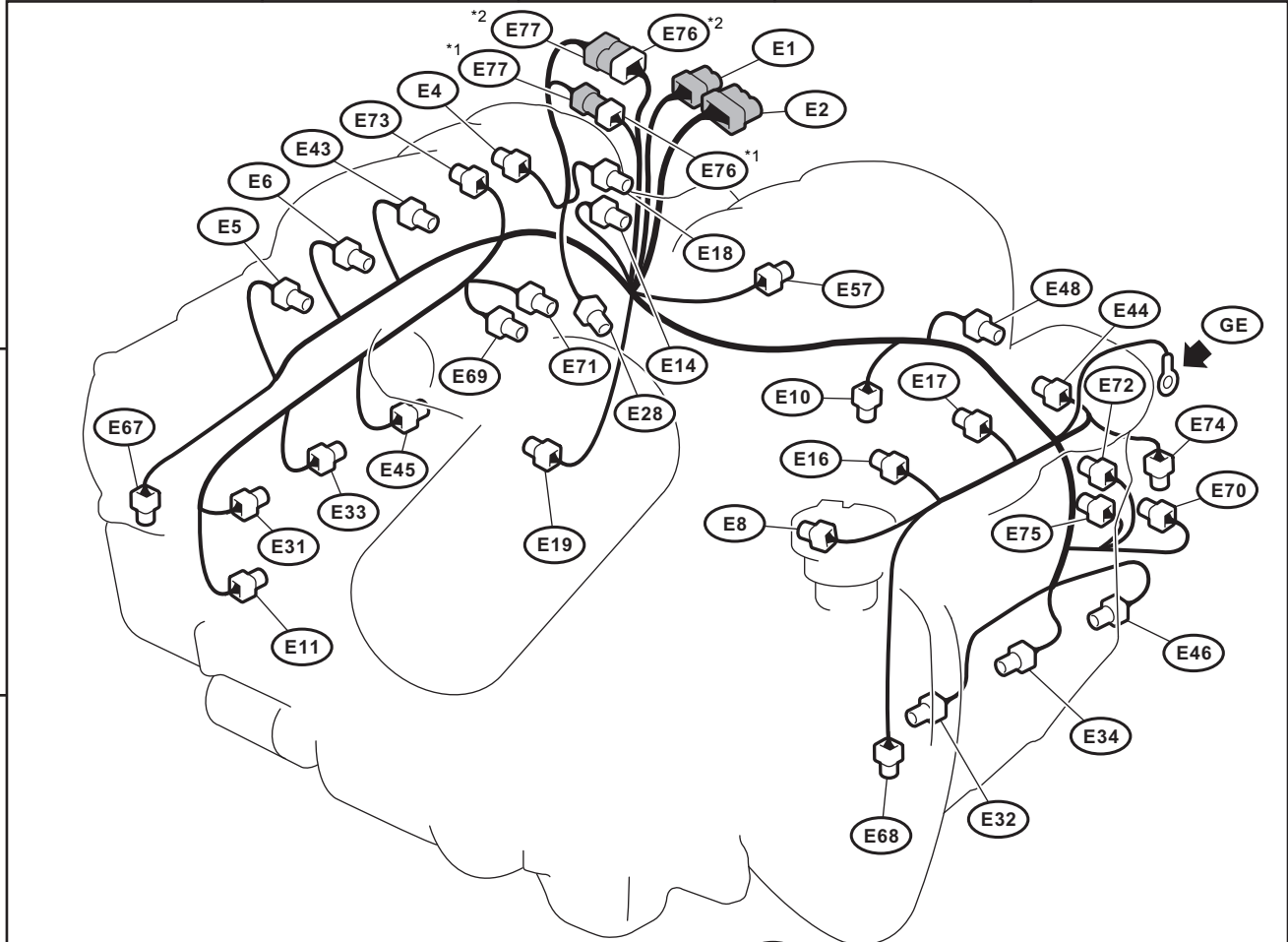

*1 : OHNE EGR
 *2 : MIT EGR

< MT >

< AT >

1

2

3

4

5

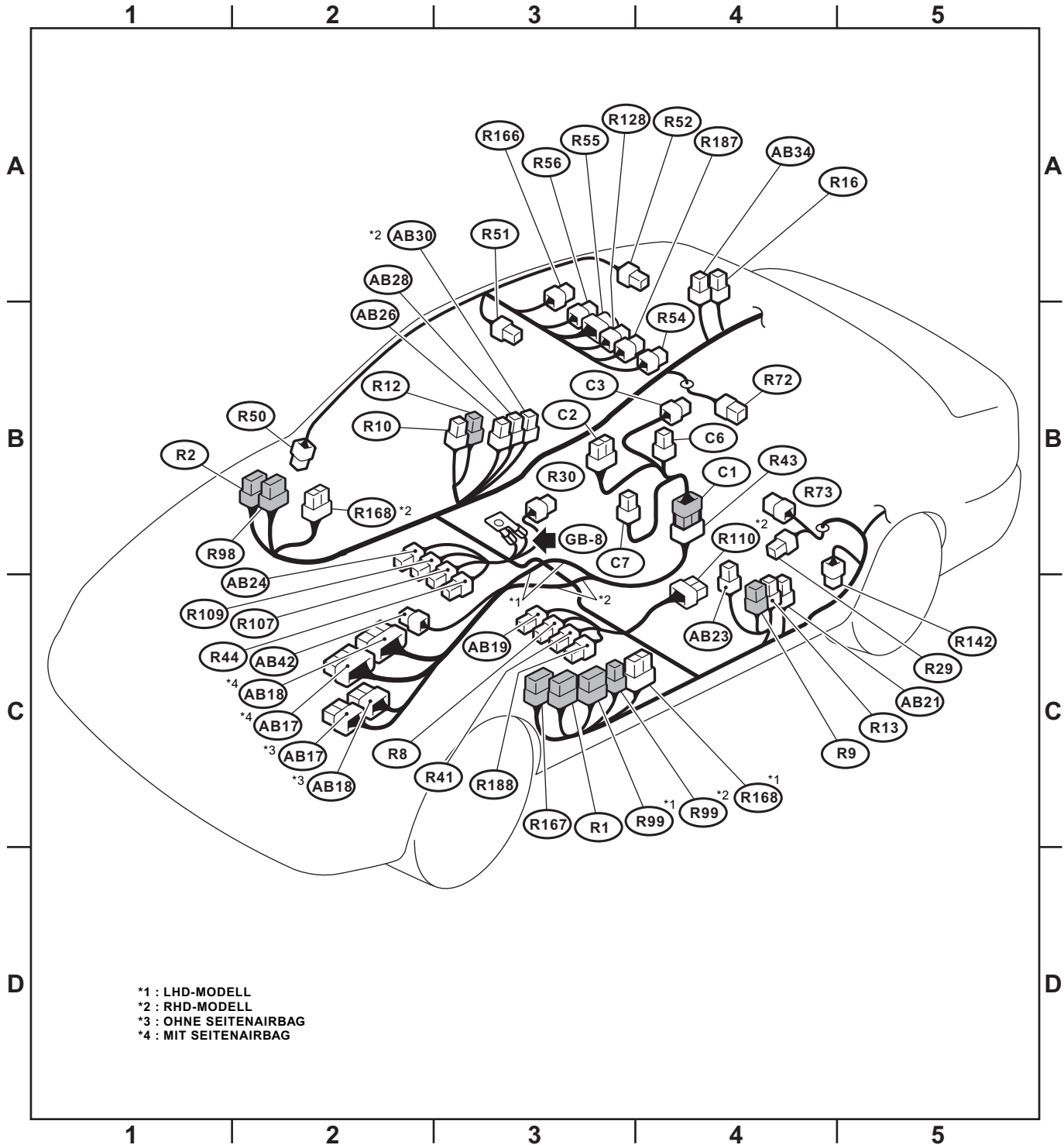

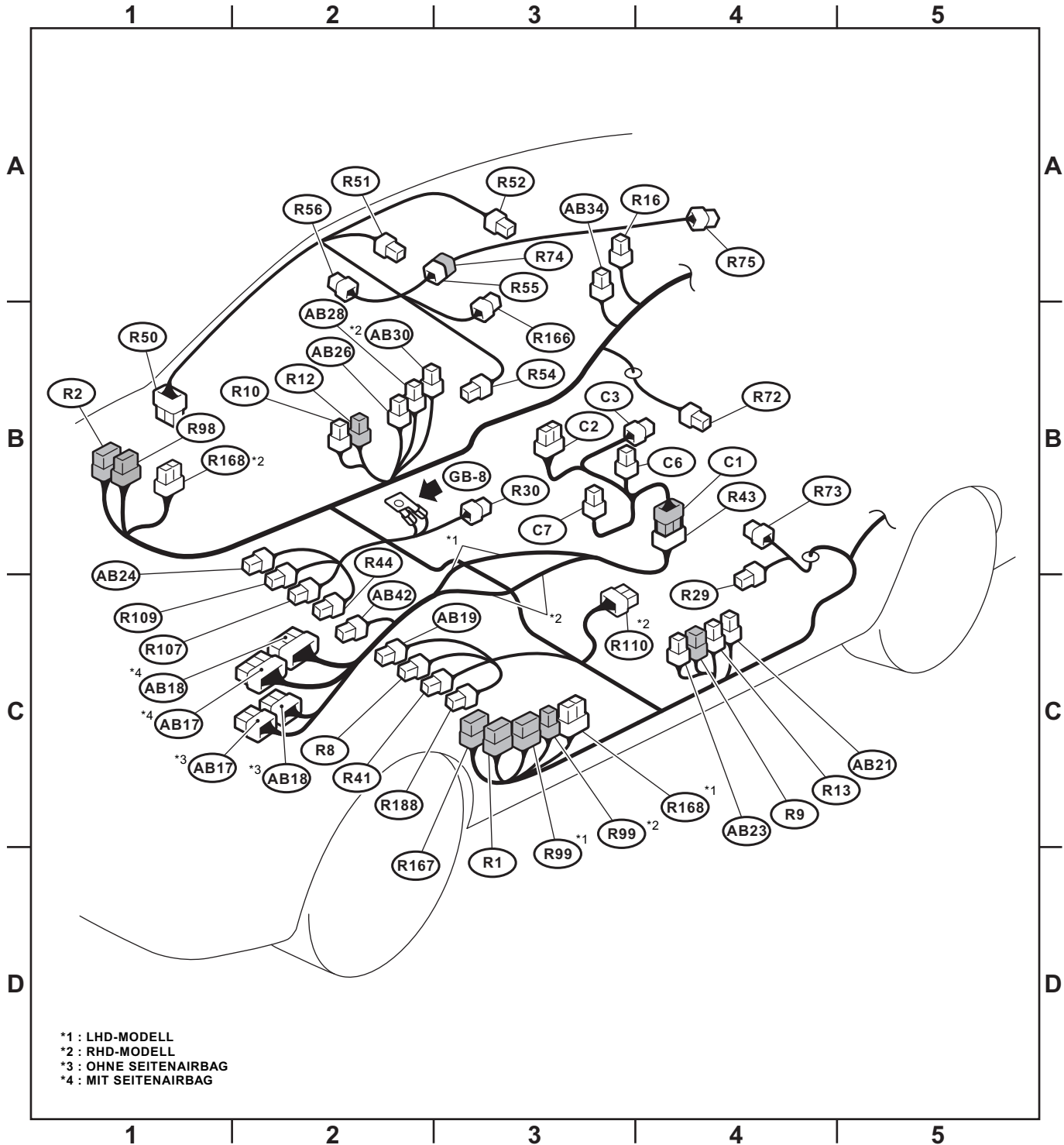

1

2

3

4

5

A

A

B

B

C

C

D

D

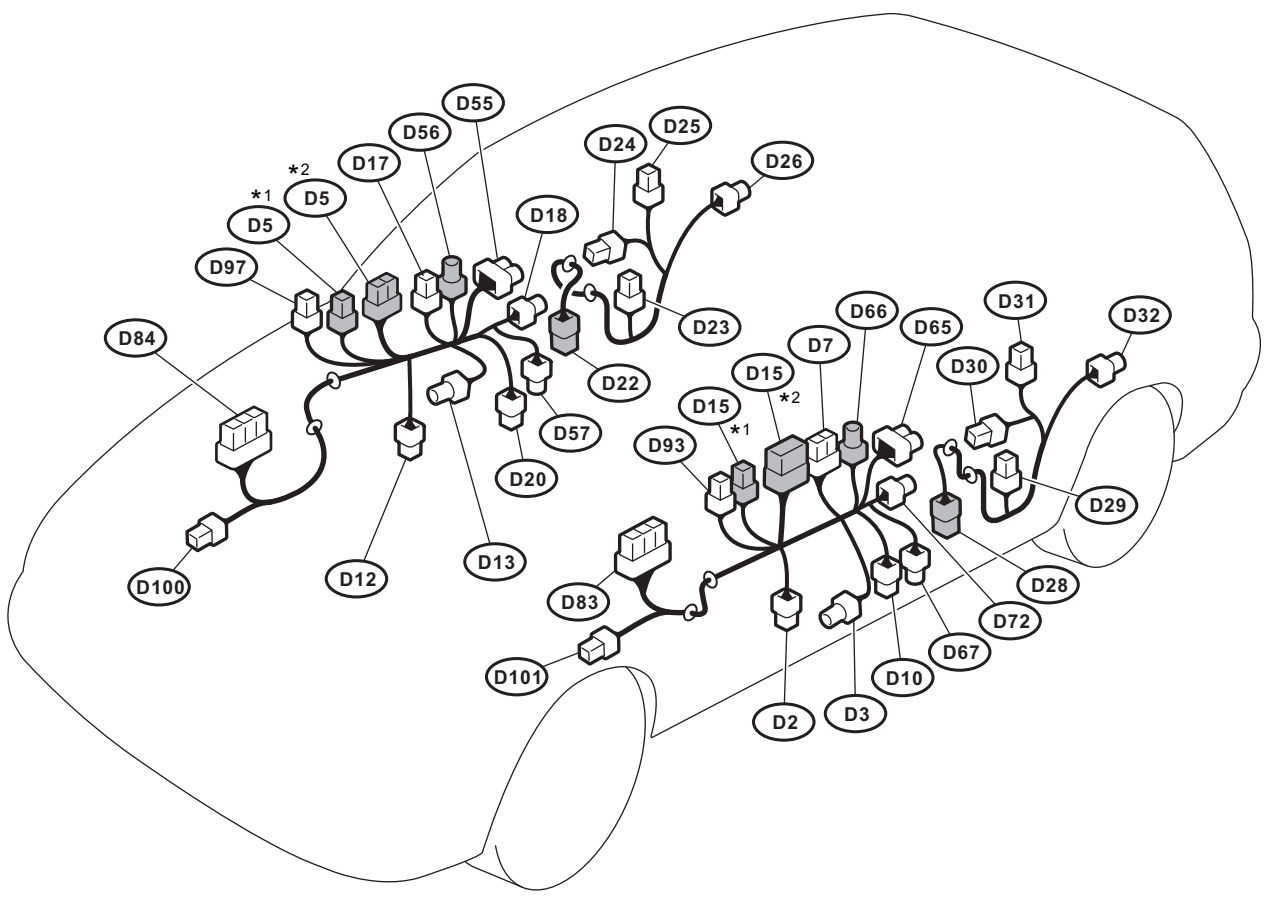

*1 : OHNE SPIEGELHEIZUNG
 *2 : MIT SPIEGELHEIZUNG

1

2

3

4

5

1

2

3

4

5

A

A

B

B

C

C

D

D

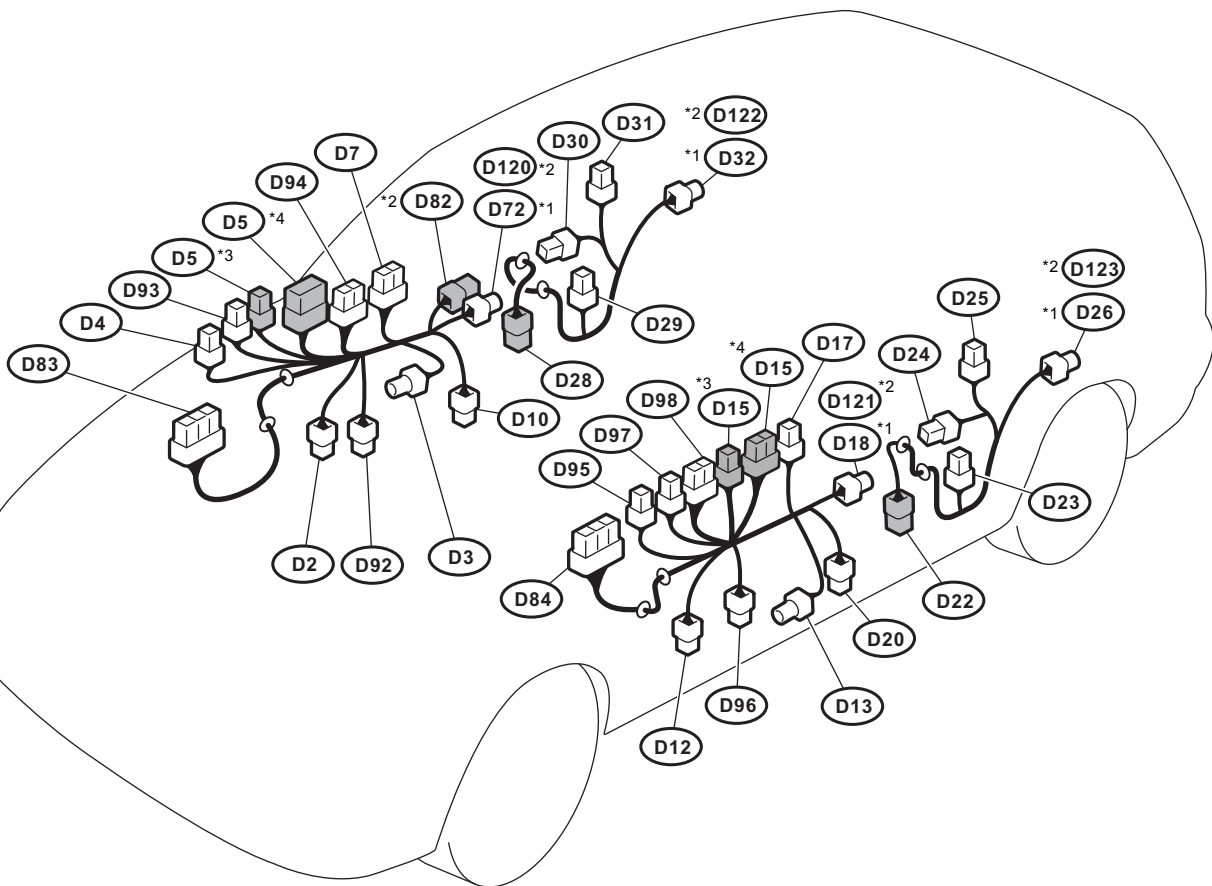

- *1 : OHNE DOPPELVERRIEGLUNG
- *2 : MIT DOPPELVERRIEGLUNG
- *3 : OHNE SPIEGELHEIZUNG
- *4 : MIT SPIEGELHEIZUNG

1

2

3

4

5

1

2

3

4

5

A

A

B

B

C

C

D

D

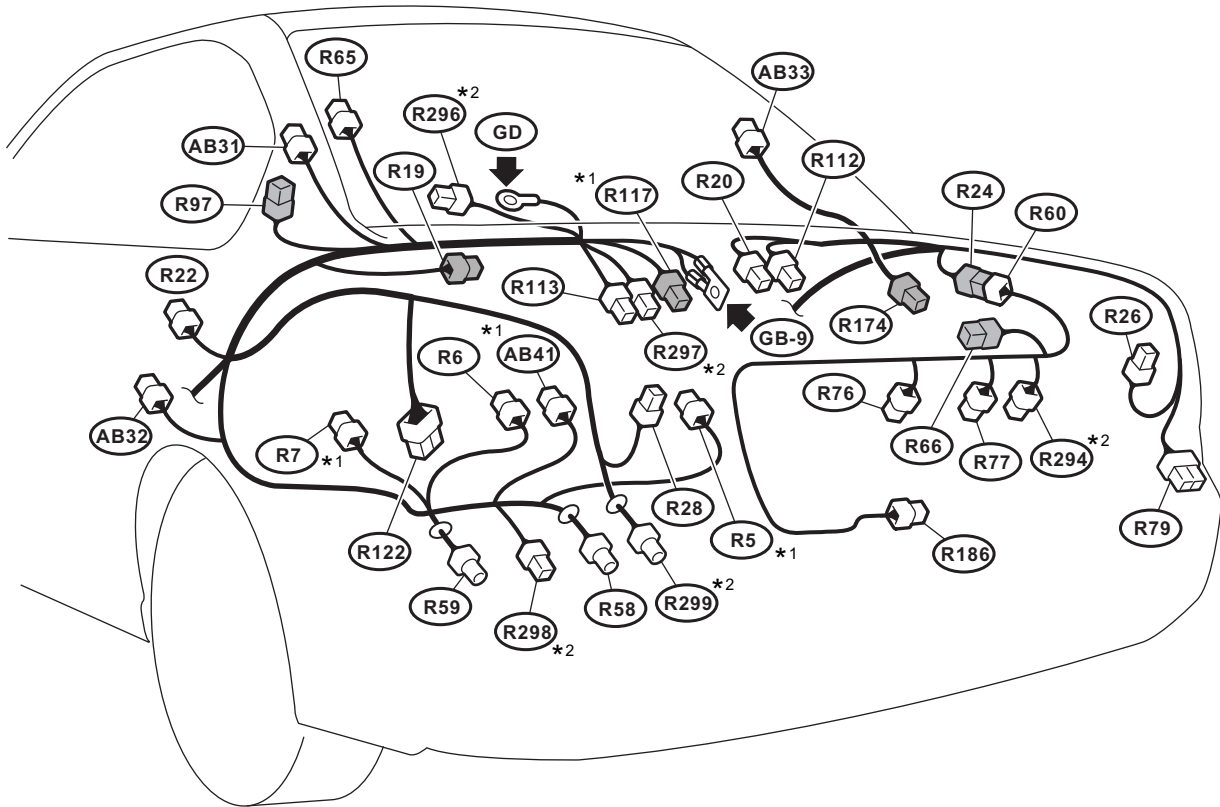

*1 : RHD-MODELL
 *2 : MIT STARTKNOPF

1

2

3

4

5

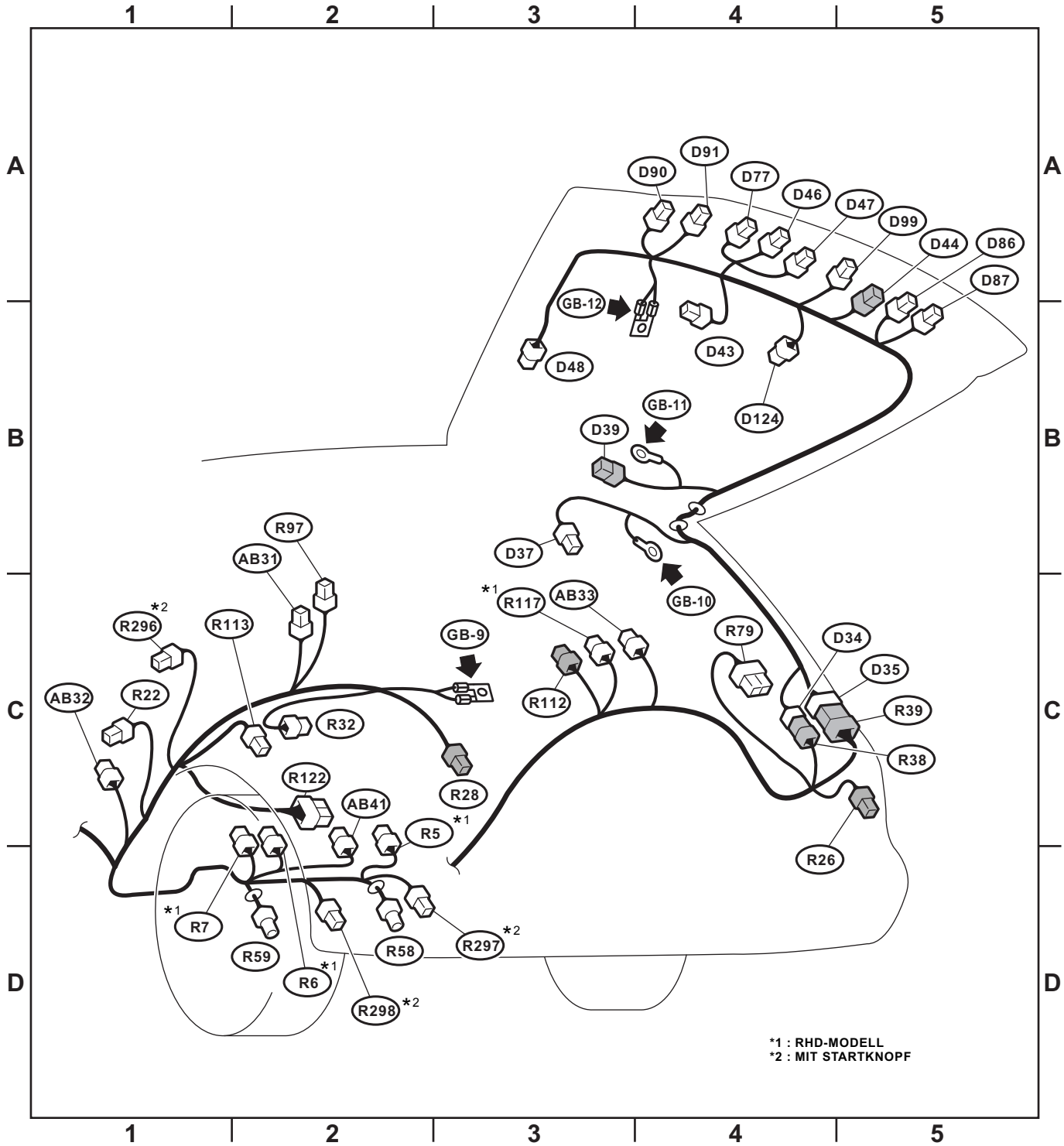

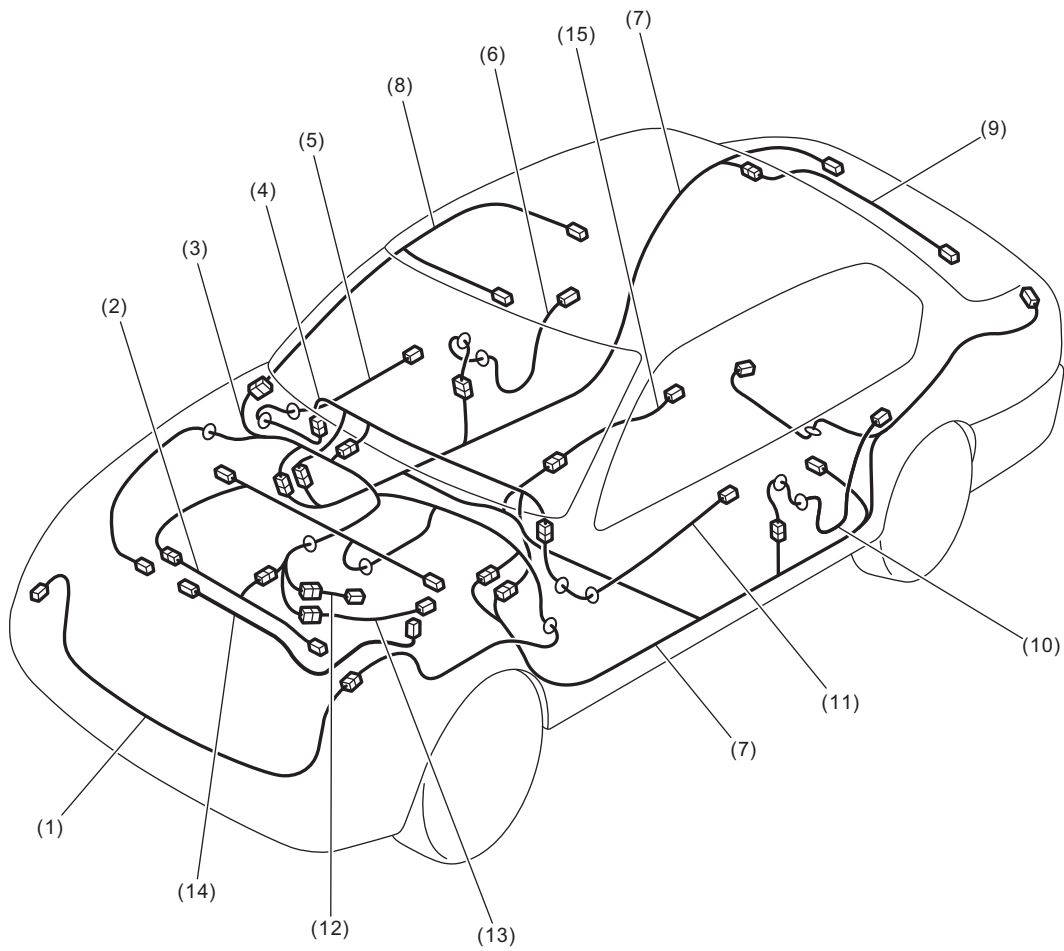

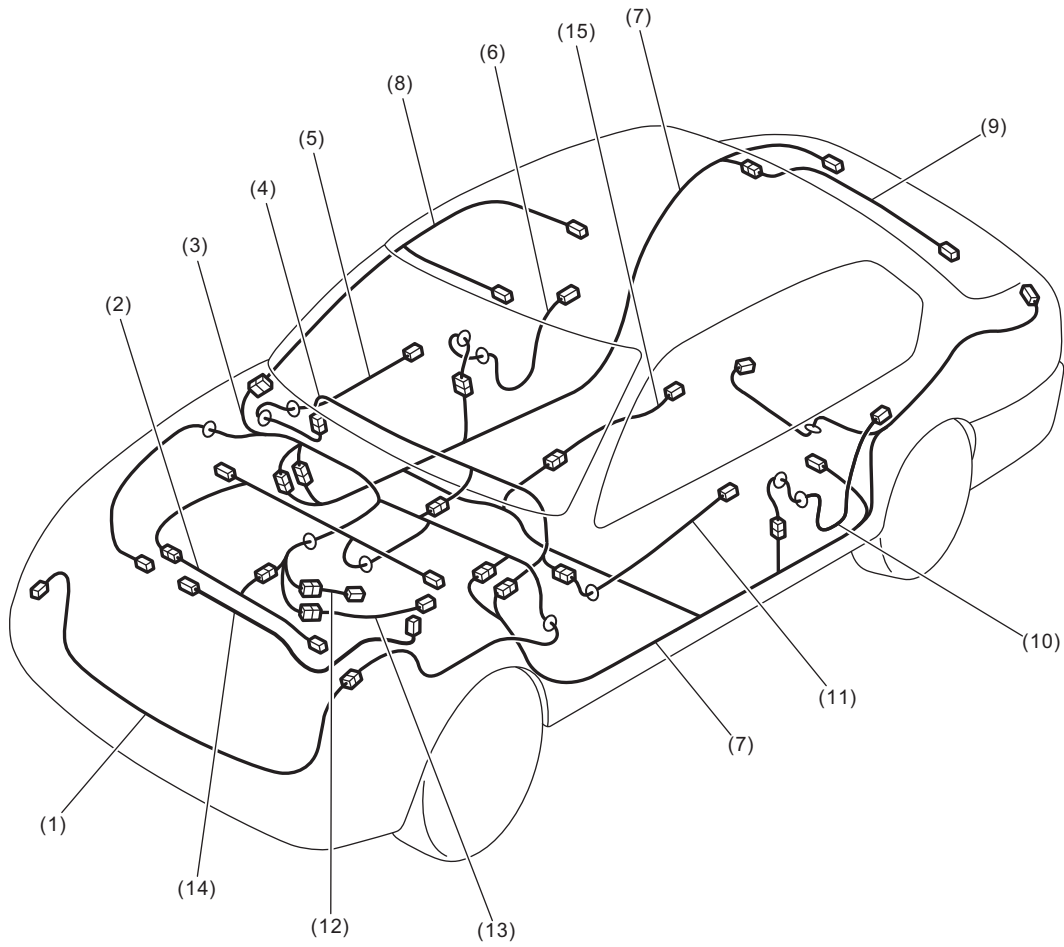

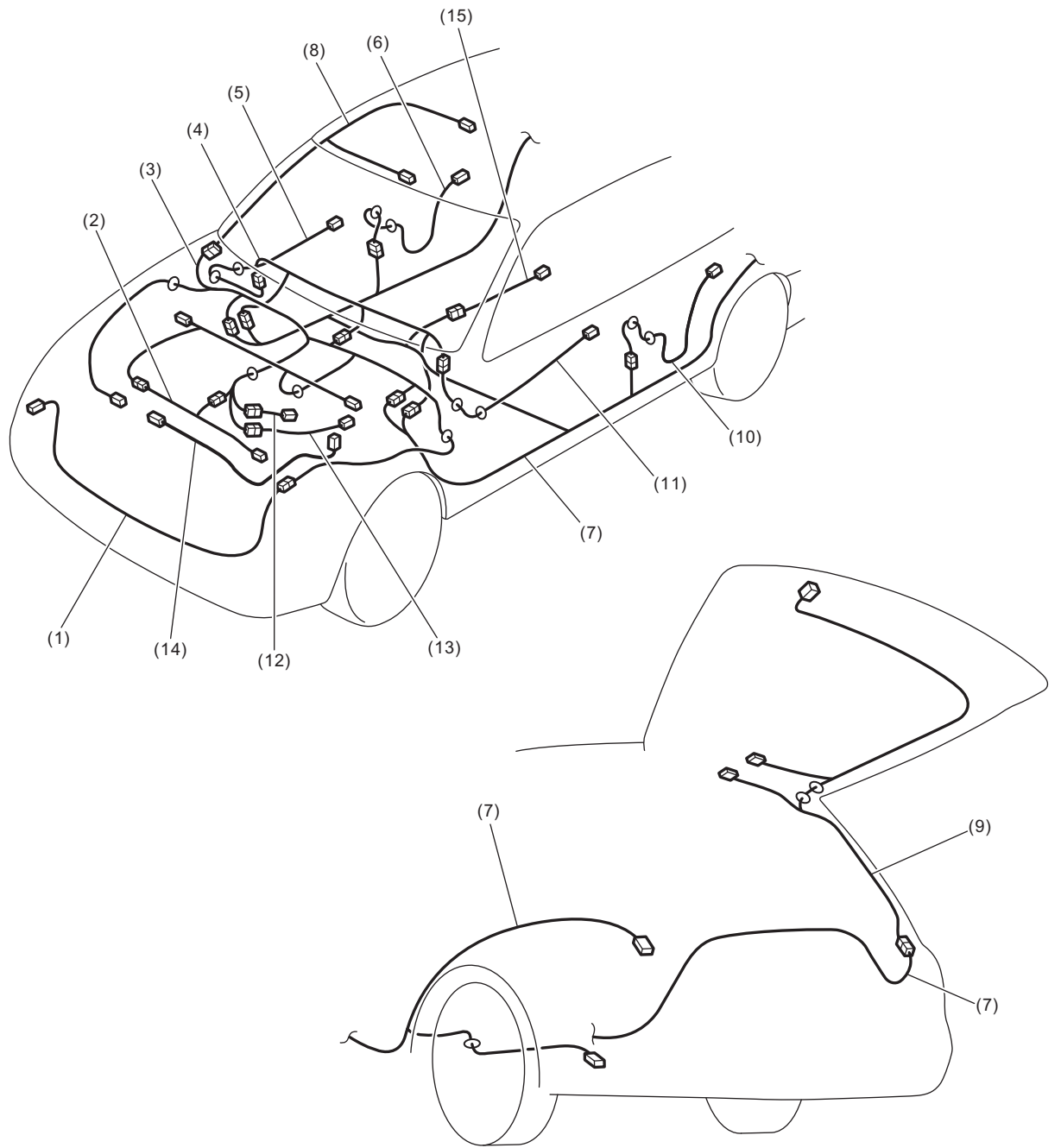

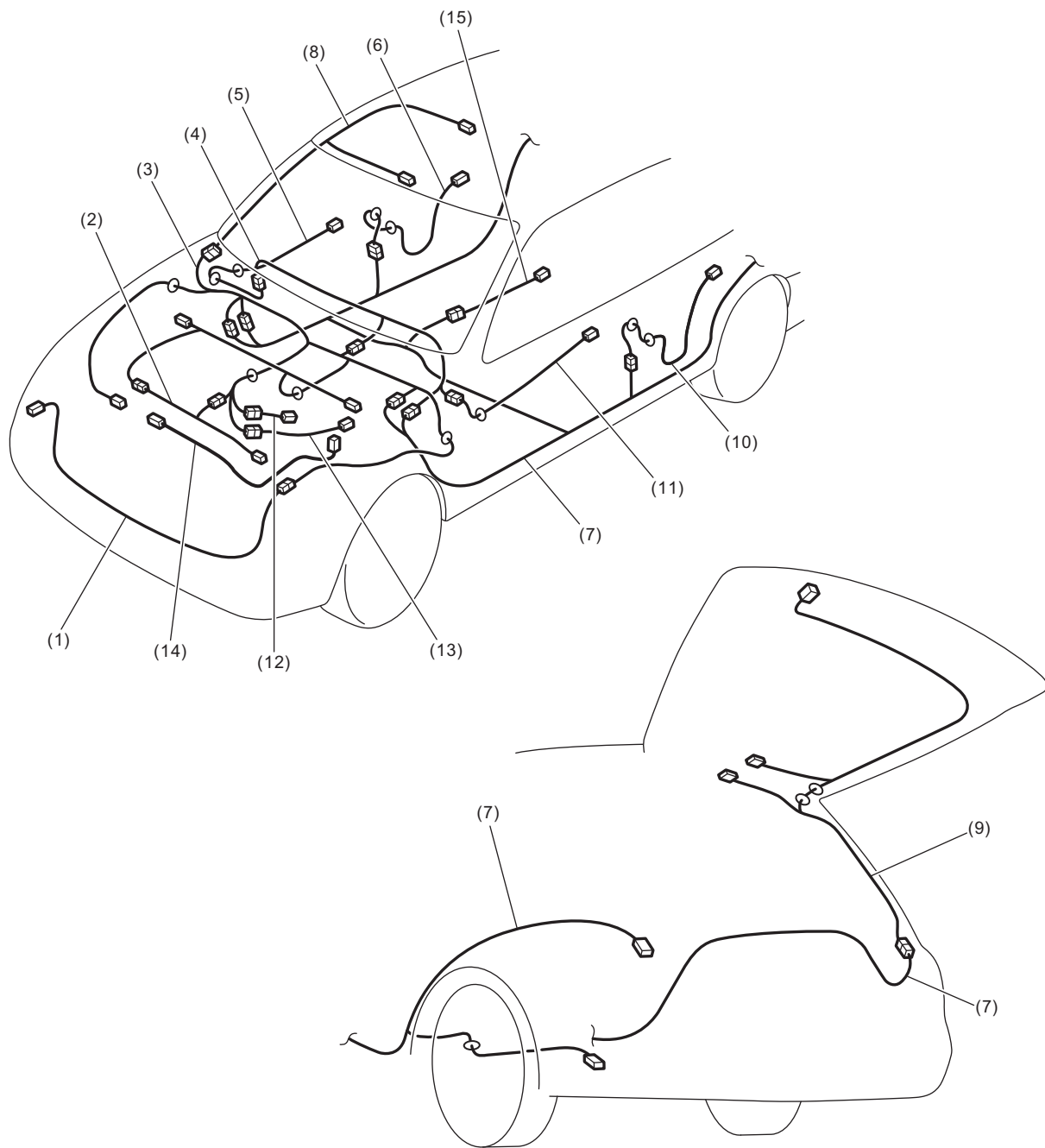

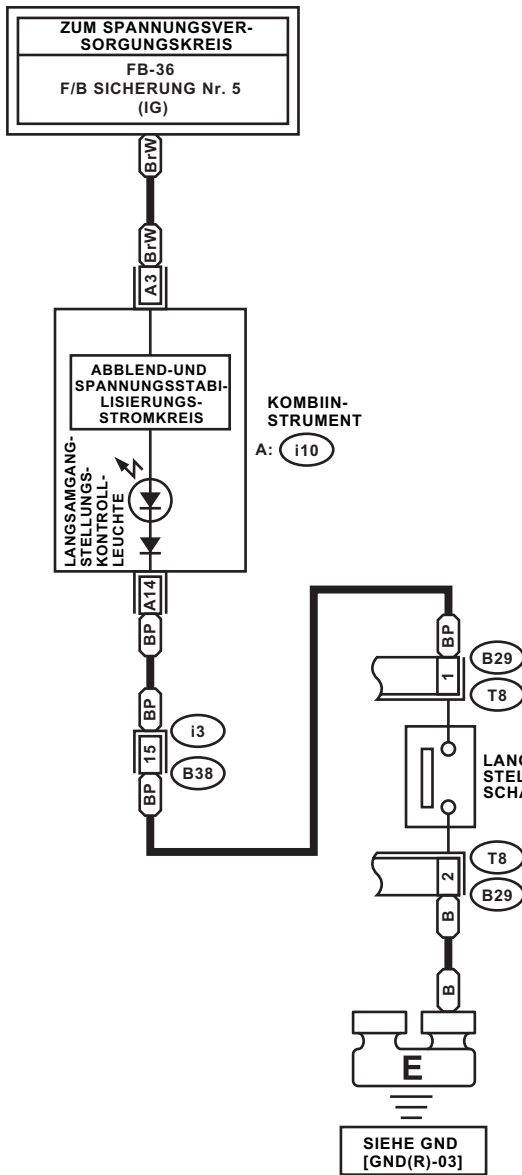

B29 (SCHWARZ)



B38

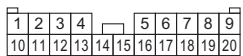

A: i10 (GRÜN)

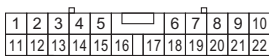

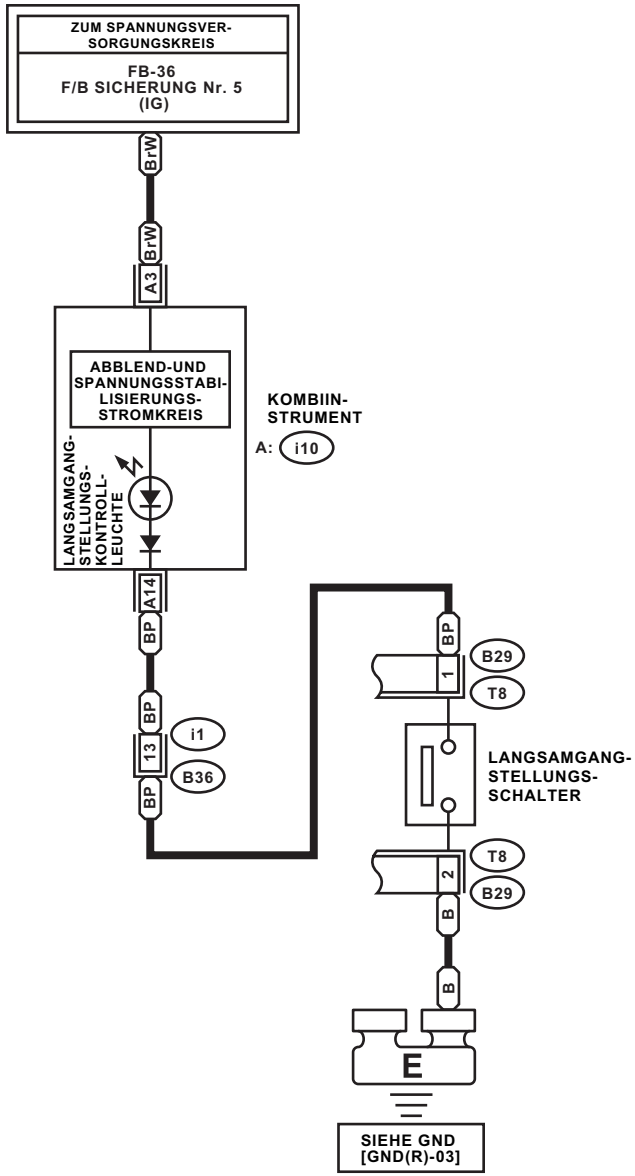

B29 (SCHWARZ)



A: i10 (GRÜN)

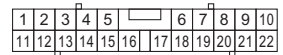

i1

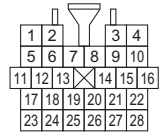

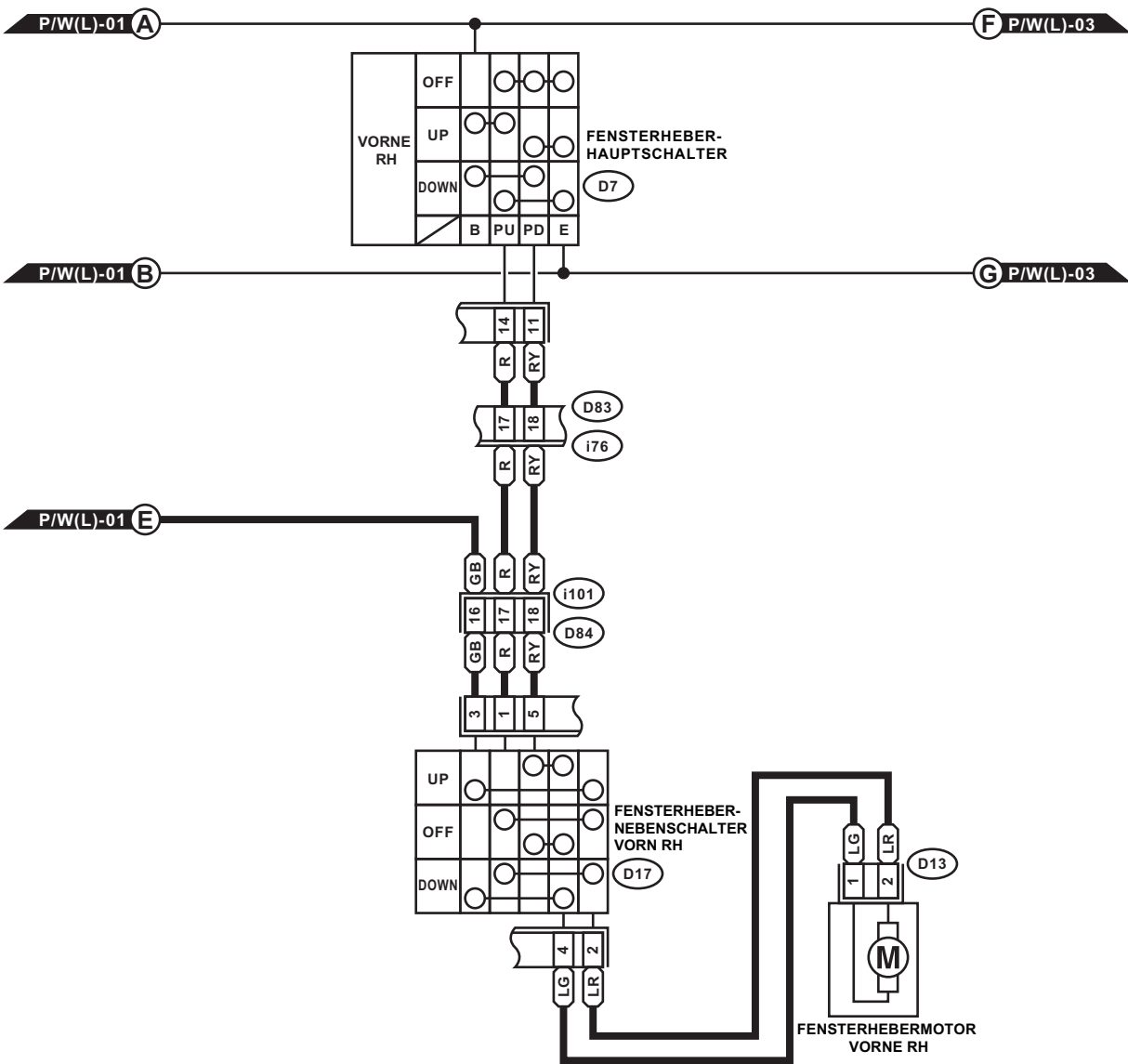

D13 (GRAU)



D17

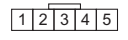

D7

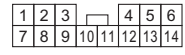

D83

D84

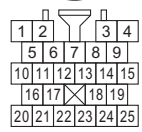

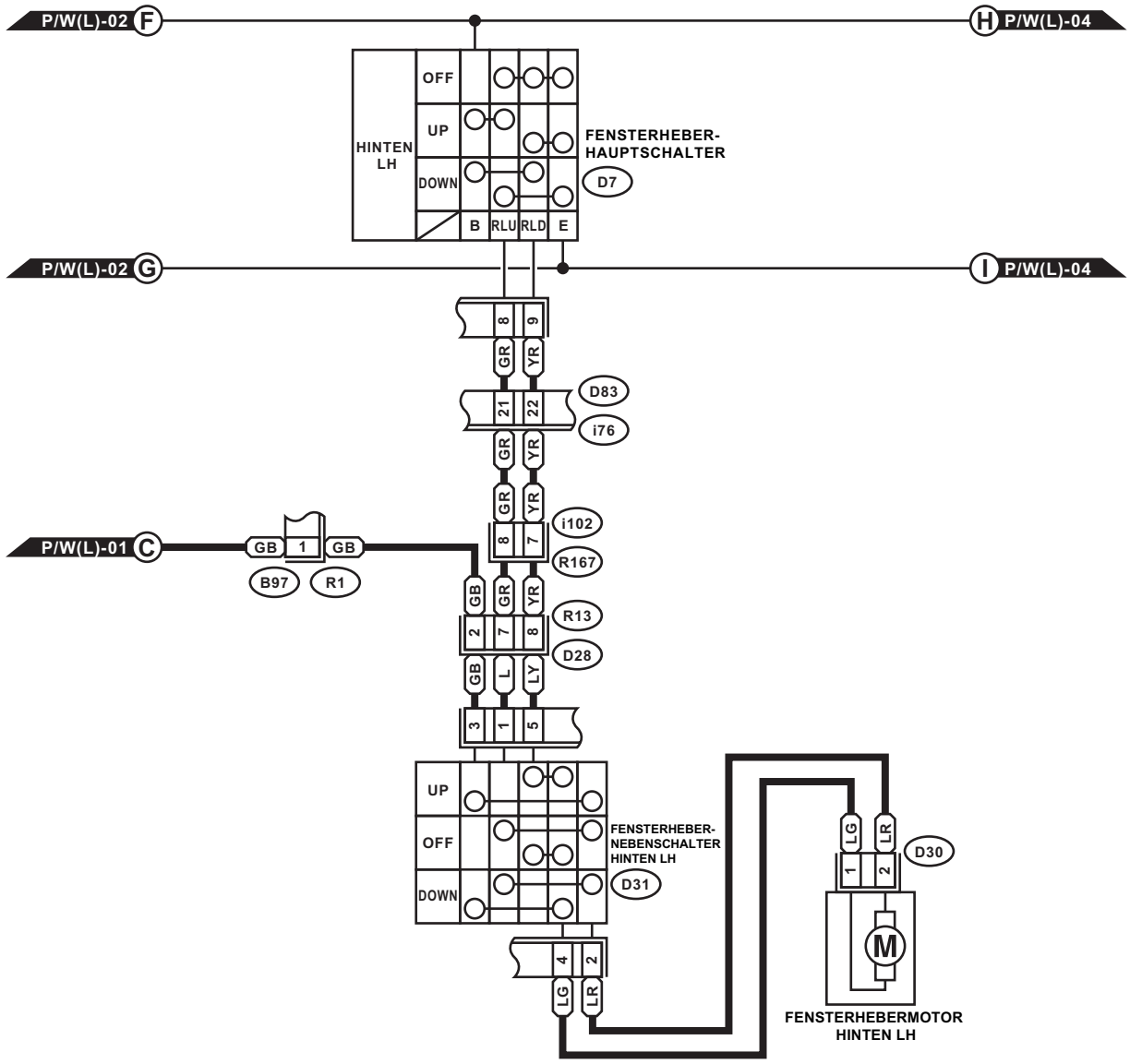

D30 (GRÜN)



D31

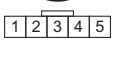

R13

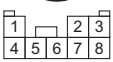

D7

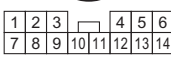

B97

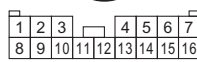

i102

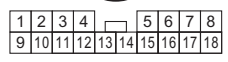

D83

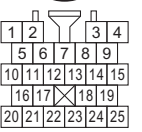

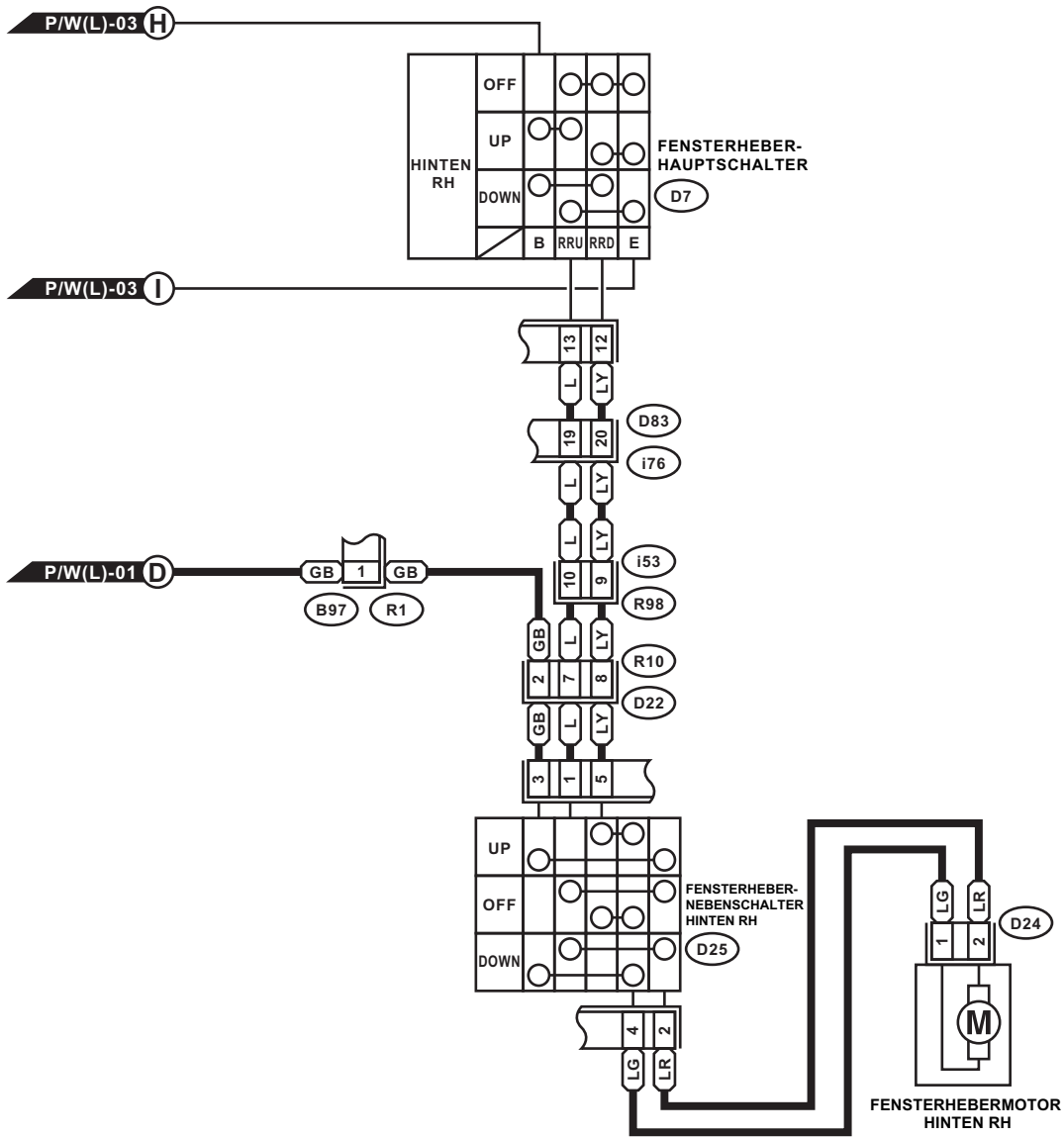

D24 (GRÜN)



D25

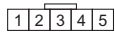

R10

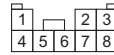

D7

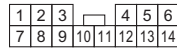

B97

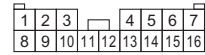

i53

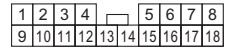

D83

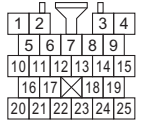

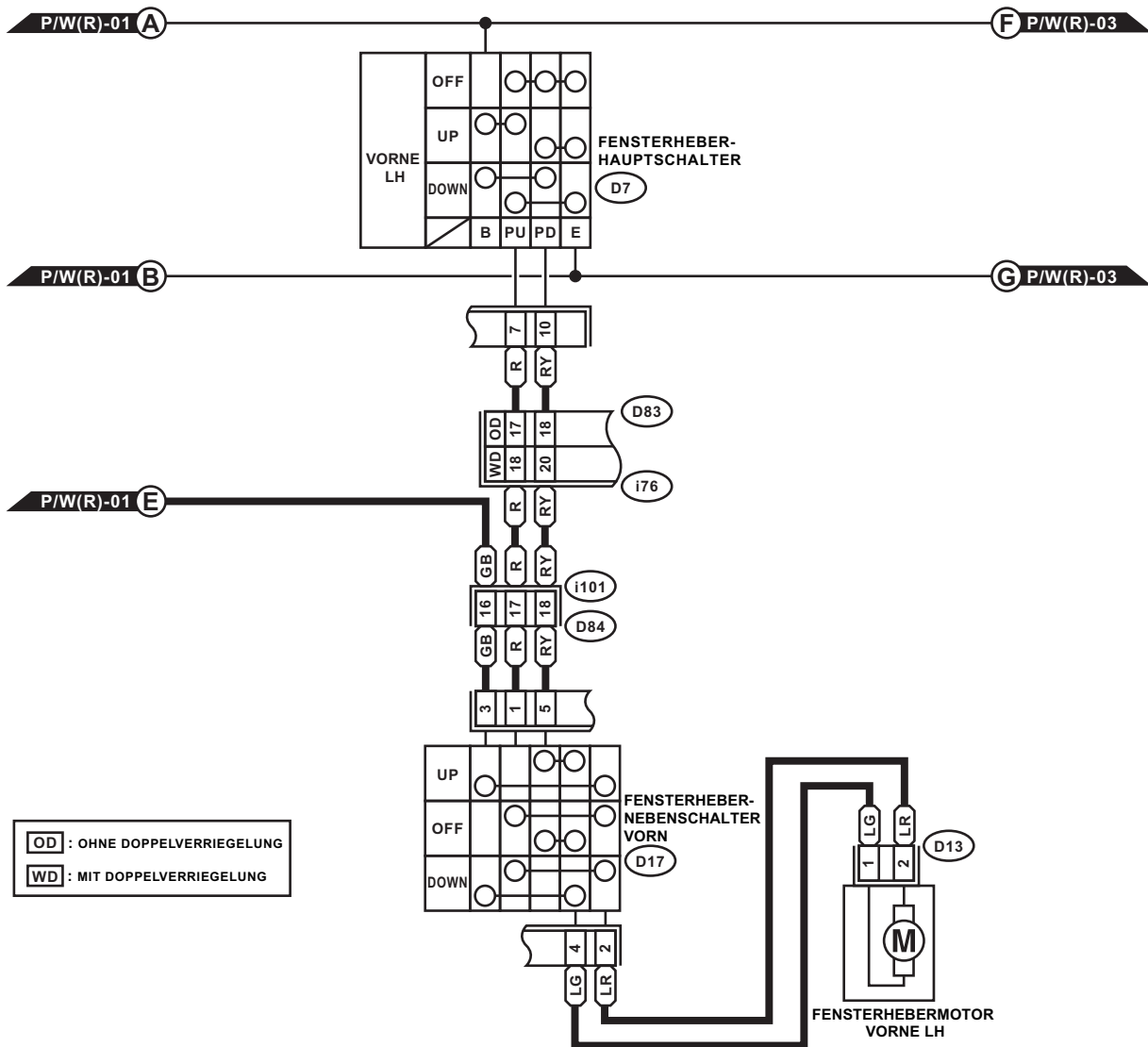

OD : OHNE DOPPELVERRIEGLUNG
WD : MIT DOPPELVERRIEGLUNG

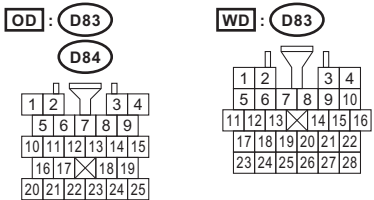
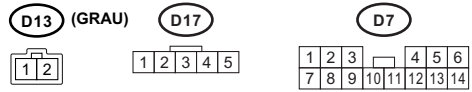

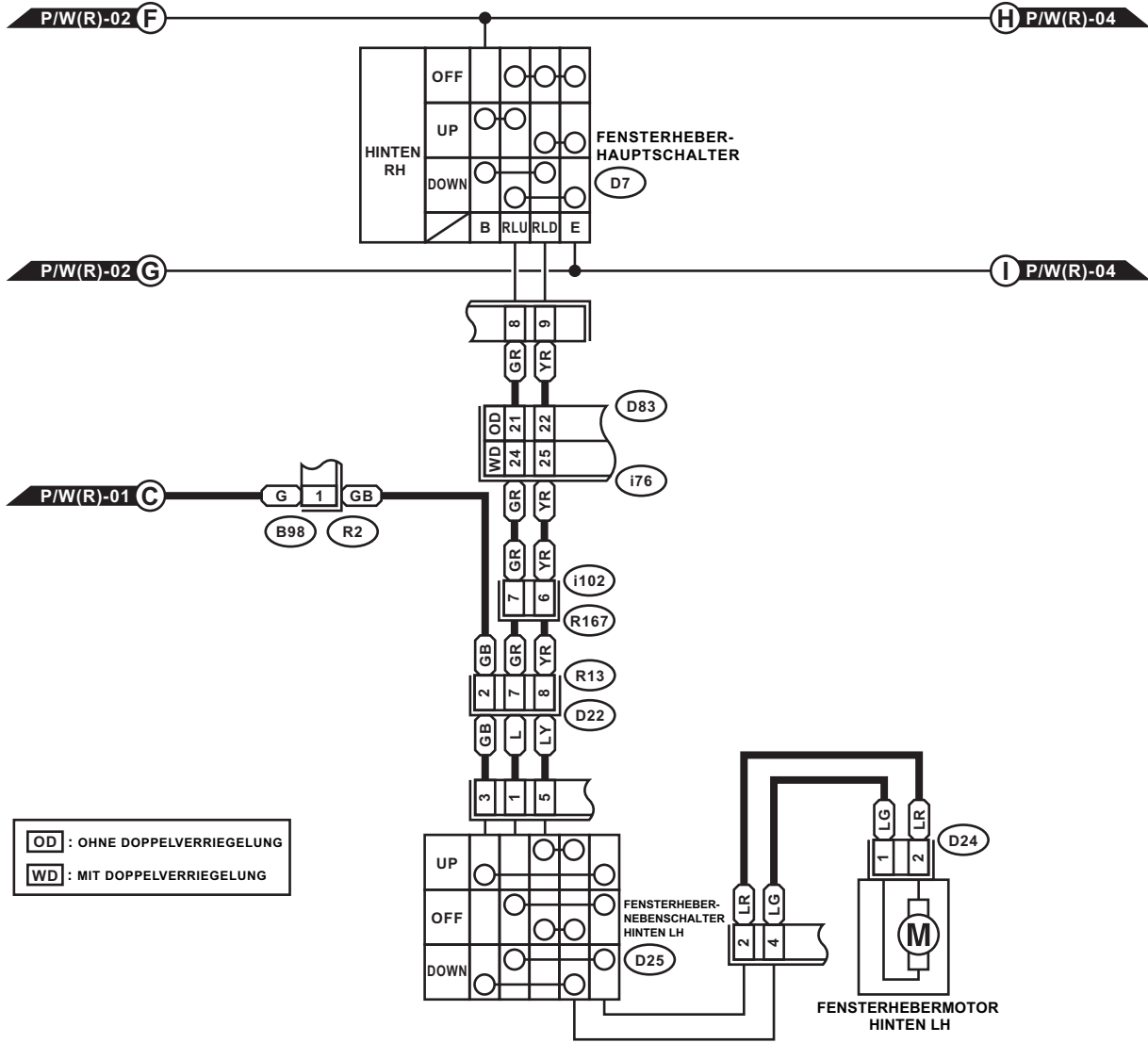

OD : OHNE DOPPELVERRIEGLUNG
WD : MIT DOPPELVERRIEGLUNG

D24 (GRÜN)



D25

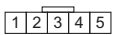

R13

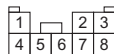

D7

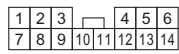

i102

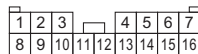

B98

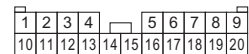

OD : D83

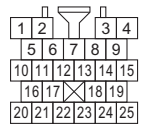

WD : D83

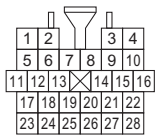

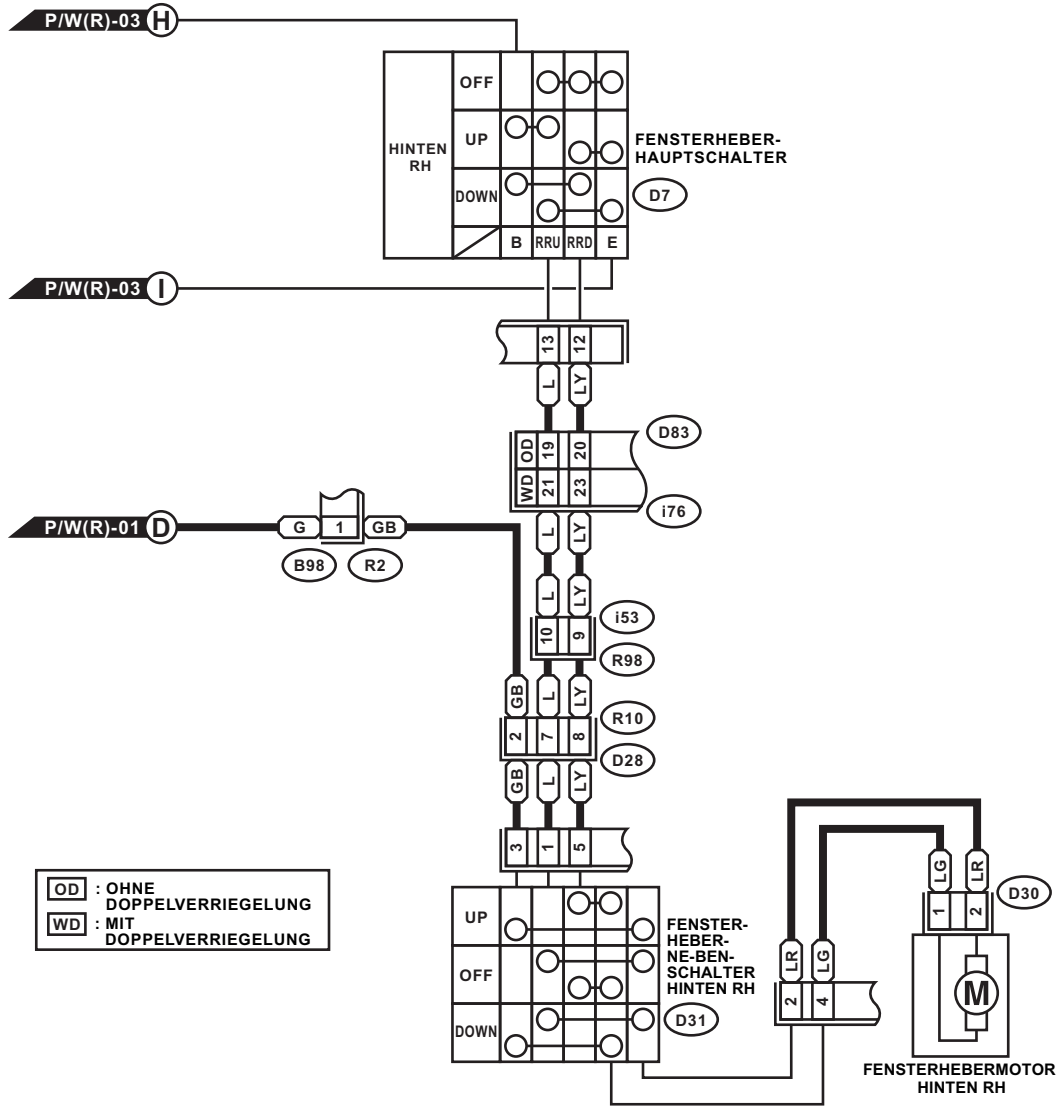

OD : OHNE
DOPPELVERRIEGLUNG
WD : MIT
DOPPELVERRIEGLUNG

D30 (GRÜN)



D31

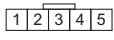

R10

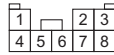

D7

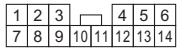

i53

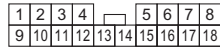

B98

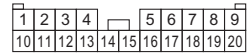

OD : D83

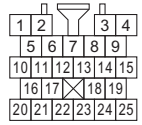

WD : D83

