



# The Remington 1100 Exotic Weapon System

J.M. Ramos



# **The Remington 1100 Exotic Weapon System**

**J. M. Ramos**

**A Paladin Press Book  
Boulder, Colorado**

**Donations & contact:**

**[kommandobooks@mail.com](mailto:kommandobooks@mail.com)**

***/K/'s Book Guy***



The author and publisher will not be responsible for the use or misuse of the information presented in this book. It is intended for historical and reference purposes only.

*The Remington 1100 Exotic Weapon System*  
Copyright 1983 by Paladin Press

Published by Paladin Press, a division of  
Paladin Enterprises Inc., P.O. Box 1307,  
Boulder, Colorado, USA 80306.

All rights reserved. No portion of this publication may be reproduced in any form without the written consent of the author and publisher.

Printed in the United States of America

ISBN 0-87364-262-7



# Warning

It is against the law to manufacture a restricted or prohibited firearm without an appropriate license from the federal government. There are also state and local laws prohibiting the possession of such devices in many areas. Severe penalties are prescribed for violations of these laws. Be warned!



# Notice

Be advised that I have applied for a patent on the automatic tripper device described in this book.

While I hereby grant permission to use this selective-fire mechanism in the reader's personal 1100, no commercial application is permitted.

J. M. Ramos



# Contents

Publisher's Forward . . . . .	vii
Introduction . . . . .	1
1. The 1100 Selective-Fire Conversion System . . . . .	5
2. Automatic Tripping Device . . . . .	28
3. Replacement Safety/Selector . . . . .	31
4. Trigger Modification Procedure . . . . .	33
5. Sear Modification Procedure . . . . .	35
6. Bolt Carrier Link Modification . . . . .	37
7. Test Firing Preparations . . . . .	39
8. Shotgun Compensator Design . . . . .	42
9. Parts and Accessories Directory . . . . .	45
10. Machinist's Drawings and Templates . . . . .	46
Appendix . . . . .	83



# Publisher's Foreword

As we approach the close of the twentieth century, the topic of the electronic battlefield grows more popular among military theorists and tacticians. Truly, we are about to enter an age of advanced weaponry hardly dreamed of even five decades ago. Both the East and West have committed huge sums of money to the development of what were once called "Buck Rogers" type weapons. But no longer are such weapons the mere fancy of a science fiction writer.

Both the United States and the USSR have reportedly already downed aircraft with atomic particle beam weapons. Also underway is development of satellites armed with multiple reentry nuclear warheads, against which there is no currently available defense. Likewise, the neutron bomb is now a reality. Other sophisticated weapons of war currently in production include disposable laser-guided antiaircraft and antitank rockets, plus a variety of ghoulis chemical and biological contaminants in use by Warsaw Pact nations. Not to mention the family of intelligence gathering systems based on high-flying satellites, AWAC, night vision amplification units, and so on. The list grows by the day.

Yet when scanning the daily papers for new reports on military conflicts around the world, seldom do we see a reference to these new wave weapon systems. In El Salvador, Afghanistan, Lebanon, and other Third World hotspots, we see a recurring theme: infantrymen, armed with conventional

weapons and using time-honored small unit tactics, are still doing most of the fighting. The relative importance of these brushfire actions should not be slighted. For after all, have we not entered an era of war by proxy? Are not the minions of the West fighting the minions of the East in these brushfire wars, using conventional arms—all because the superpowers are *afraid* to use the terrible space-age weapons they have developed over the past decade?

If we accept the above war-by-proxy premise, we begin to see the importance of the work herein. For instead of concerning itself with weapons so terrifying in their effects that world leaders are fearful of their use, it is predicated on a new breed of small arm meant especially for today's infantryman: the selective-fire shotgun.

America has had a long and enduring love affair with the fighting shotgun. No other nation can make this claim. From the time the Pilgrims landed, they found that the blunderbuss was an ideal weapon for fighting Indians in the dense New England forests.

Interestingly, to this day, one of the most ideal applications of the combat shotgun remains the same as then. For use in ambush and counterambush situations where the nature of the terrain limits observation, there is no better weapon. Studies conducted by the British during the Malayan insurgency of 1948–1958 prove this. It was found that the

semiautomatic shotgun was superior to both the rifle and submachine gun during jungle firefights. Rifles produced one hit for every eleven shots fired, and submachine guns needed eight shots to effect each hit. Yet the Brits' fighting shotguns (primarily Browning semiautos and Remington 870 pumps) scored a hit for each 5.5 shots fired. Further study showed that the semiauto scatterguns were more effective than pump models. Eventually, the British armed their jungle patrols with one fighting shotgun per every four men, approximately.

Note that the superiority of the shotgun diminished considerably outside a range of seventy-five yards. Beyond this distance, assault-type rifles were more efficient than other small arms.

Just a few short years later, during our own jungle war in Vietnam, America's ground troops experienced a similar challenge. Much of the conflict took the form of ambush/counterambush actions in confined jungle trails. Night raids, where aimed fire was especially difficult, were common. Here the fighting shotgun proved its worth again and again. The U.S. Marines were the heaviest users of these weapons, mainly in the form of cut-down 870s with extended magazines.

It is noteworthy that the selective-fire design which follows in this work is based on the same shotgun which military planners felt might work well in the jungles of Vietnam: the Remington 1100. Designated the 7188 during extensive testing in the early 1960s, this weapon closely resembled the project shotgun presented in this book. Its primary characteristics are: selective-fire capability, extended ten-shot magazine, and shortened barrel.

The designer and other experts as well feel that such a weapon, loaded with 00 buckshot, can equal the firepower of three or four calibre 9mm submachine guns. The merits of this 1100 variant are obvious, particularly in close-quarter situations such as jungle patrolling, trench raids, night scouting, and ambush/counterambush.

Composing the intended audience for *The Remington 1100 Exotic Weapon System* are police and military armorers, survivalists, and weapons buffs. Once converted, the 1100 machinestrongun will particularly fill the needs of survivalists, who have already made the combat shotgun one of their primary weapons of choice. It is hard to imagine a more devastating long gun, given current arms technology.

At last, the fighting man's weapon of tomorrow is here today.



# Introduction

After searching out the most suitable sporting-type semi-automatic shotgun for our next *Exotic Weapons* project, the Remington 1100 was finally selected. It is one of the most reliable and well-made shotguns currently manufactured in the U.S. and is very popular here as well as abroad. The U.S. Marine testing of the selective-fire Remington shotgun in 1960 also proved that its conversion is far more workable than any other shotgun submitted for testing. The full auto Remington shotgun tested was developed from the standard 1100 model and was later designated as the model 7188. Various limited production-prototype models were also built in several configurations, differing in magazine capacity, with some small external changes, but being otherwise internally the same.

The selective-fire conversion system described in this book has been well thought out. For example, the original factory semiautomatic trigger mechanism components are completely interchangeable with the conversion replacement parts. The conversion process requires only minor alterations to its nonvital components, leaving the receiver and housing virtually untouched. Only the original push-button safety is discarded, being replaced by a three-position safety/selector lever. Otherwise, all small parts are retained.

Perhaps the most ingenious feature of the conversion

system employed in this project is the ability to convert the 1100 to the selective-fire mode and then switch back to the original semiauto configuration by simply removing the automatic tripping device that is retained by the trigger pin itself. Once this small part is removed from the gun, the weapon will fire in the normal semiauto mode only, whether the selector is set to full auto or not. In this sense, the conversion system is quite similar to the infamous "AR-15 drop-in sear." In the case of this 1100 conversion, it could be termed as the "drop-in tripper."

The automatic tripping device utilized in the conversion process has its own independent spring and guide rod and can be removed as a unit once the trigger housing plate is removed from the receiver frame. This simply requires pushing out the trigger pin. The tripper device and its spring is then easily lifted out from its seat on the right side of the trigger. The automatic tripping device is solely actuated by the bolt carrier link shoulder just before the carrier comes to a full stop on its forward recoil. The link shoulder will push down the auto tripper on contact, thereby depressing a replacement sear extension, which in turn automatically releases the hammer to fire the weapon. This full auto function will only repeat itself if the trigger is held down and the selector is set to the full auto index. On the semiauto setting,

the tripping device will not make any contact with the sear and will therefore function in the normal semiauto fashion only, as in the original system.

As noted earlier, other than the slightly modified trigger mechanism with a few new, small parts, all components remain virtually the same. If your 1100 works well prior to its conversion, it should work just as well after converting it to the selective-fire system.

Although your 1100 may work reliably when shoulder fired (as it was designed to), some feeding problems may occur when the weapon is fired from unconventional positions. Older models particularly are more likely to experience this problem. For this reason, a patent relating to the improvement and correction of feeding malfunction is included at the end of this book for you to study. If possible, the specified changes as noted in the patent must be undertaken. A qualified gunsmith can easily do this modification. Once it has been done, your machinesthotgun will perform reliably in any firing position that you may require. This is a definite advantage, especially in a combat situation where the weapon may be fired from an unorthodox position.

The low cyclic rate of fire on full auto functioning (about 400 rounds per minute) combined with its low impulse of recoil, make the 1100 the ideal, all-purpose defense and survival weapon, particularly in close-quarter situations. It has the equivalent firepower of four or five submachine guns fired at the same time. It may therefore be the ultimate small arm for the lone man guarding his home against superior forces.

As a reminder to the reader, you must fully understand all of the drawings and instructions detailed in this book before starting work on your project. Also, before attempting any full auto conversion, you must first secure a valid government license to modify and possess such a restricted or prohibited device. This book is written strictly for reference purposes only. Be warned!



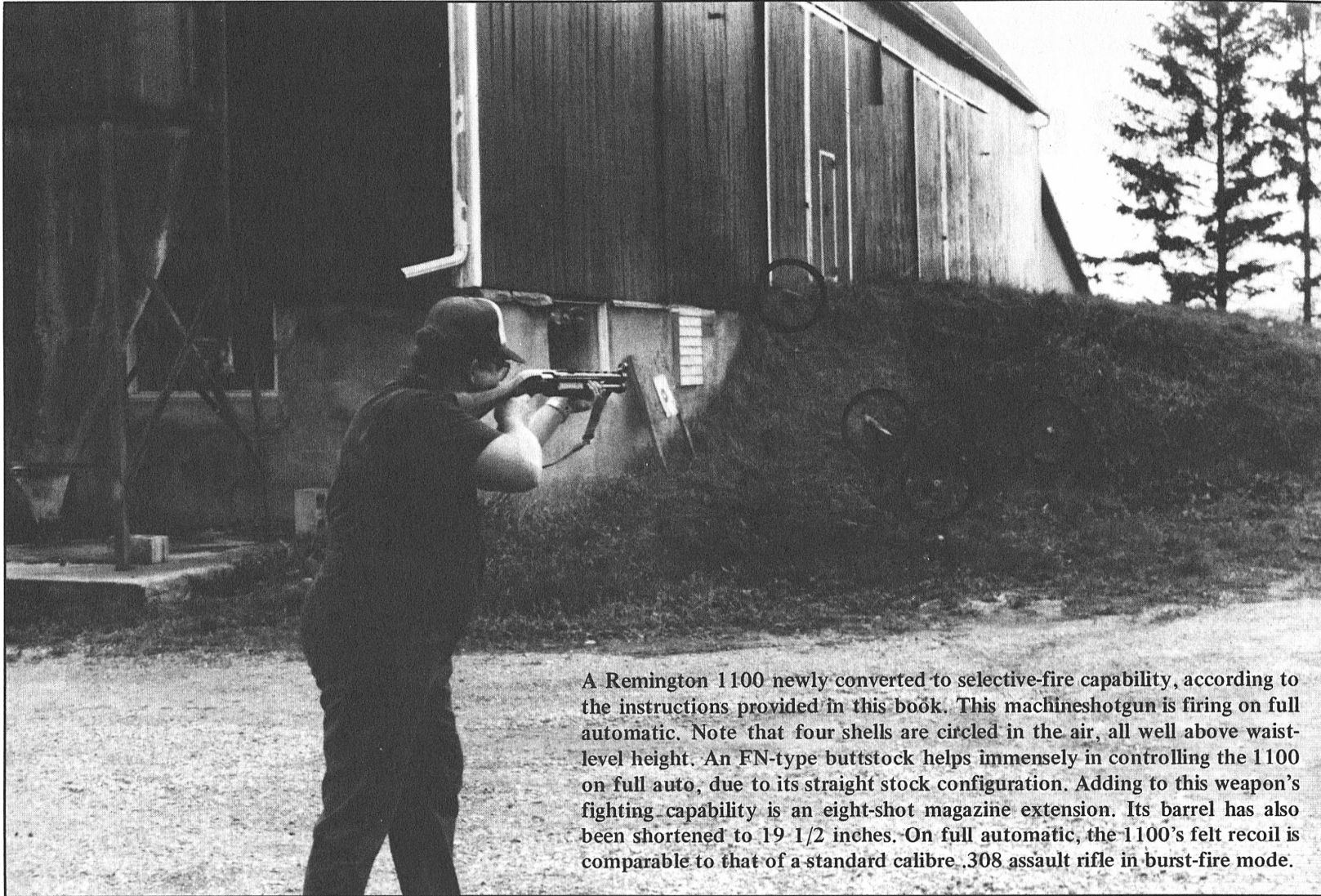

A Remington 1100 newly converted to selective-fire capability, according to the instructions provided in this book. This machinesthgun is firing on full automatic. Note that four shells are circled in the air, all well above waist-level height. An FN-type buttstock helps immensely in controlling the 1100 on full auto, due to its straight stock configuration. Adding to this weapon's fighting capability is an eight-shot magazine extension. Its barrel has also been shortened to 19 1/2 inches. On full automatic, the 1100's felt recoil is comparable to that of a standard calibre .308 assault rifle in burst-fire mode.

# 1. The 1100 Selective-Fire Conversion System

The first phase in the development of the selective-fire conversion for the Remington 1100 semiautomatic shotgun proved to be a difficult task. This can be attributed to the complicated loading system employed in tubular magazines as compared to the simple detachable box type. Another factor that contributed to the conversion system puzzle is the bolt group arrangement, as well as the unique trigger mechanism, which is universally used on most of the Remington pump and semiautomatic rifles.

Several experimental variations of the selective-fire conversion procedure for the Remington 1100 were tested prior to the perfection of the system featured in this book. The first prototypes required extensive modification and replacement of the trigger group, whereas the perfected conversion system utilizes the entire trigger group with very few add-on parts. The only original factory part that is not used is the push-button-type safety. This system ensures that all components are original and therefore sturdy enough for heavy-duty use. Furthermore, with the utilization of all original components except for the safety, the weapon will function as well as it did before it was converted. The conversion system also ensures that all components are usable in the semiautomatic mode by simply removing the automatic tripping device. With the automatic tripping device removed, the wea-

pon will fire semiautomatic only, even when the selector is set to the full auto position.

The best way to ensure a quick changeover from semiauto only to selective-fire mode is to order a separate replacement trigger housing frame complete with trigger group and loading mechanism. This will enable you to switch back and forth from semi only to selective-fire capability in a matter of seconds, by simply removing the two pins that retain the trigger housing frame and taking out the trigger group. Now snap the other substitute trigger group back inside the receiver frame, assemble the two pins back, and you are in business again. Having reserve components will also benefit you in the long run, since parts are getting more expensive by the month. Buy all the parts that you need now while they are still affordable, and of course, while they are available.

# CONVERSION PARTS GROUP

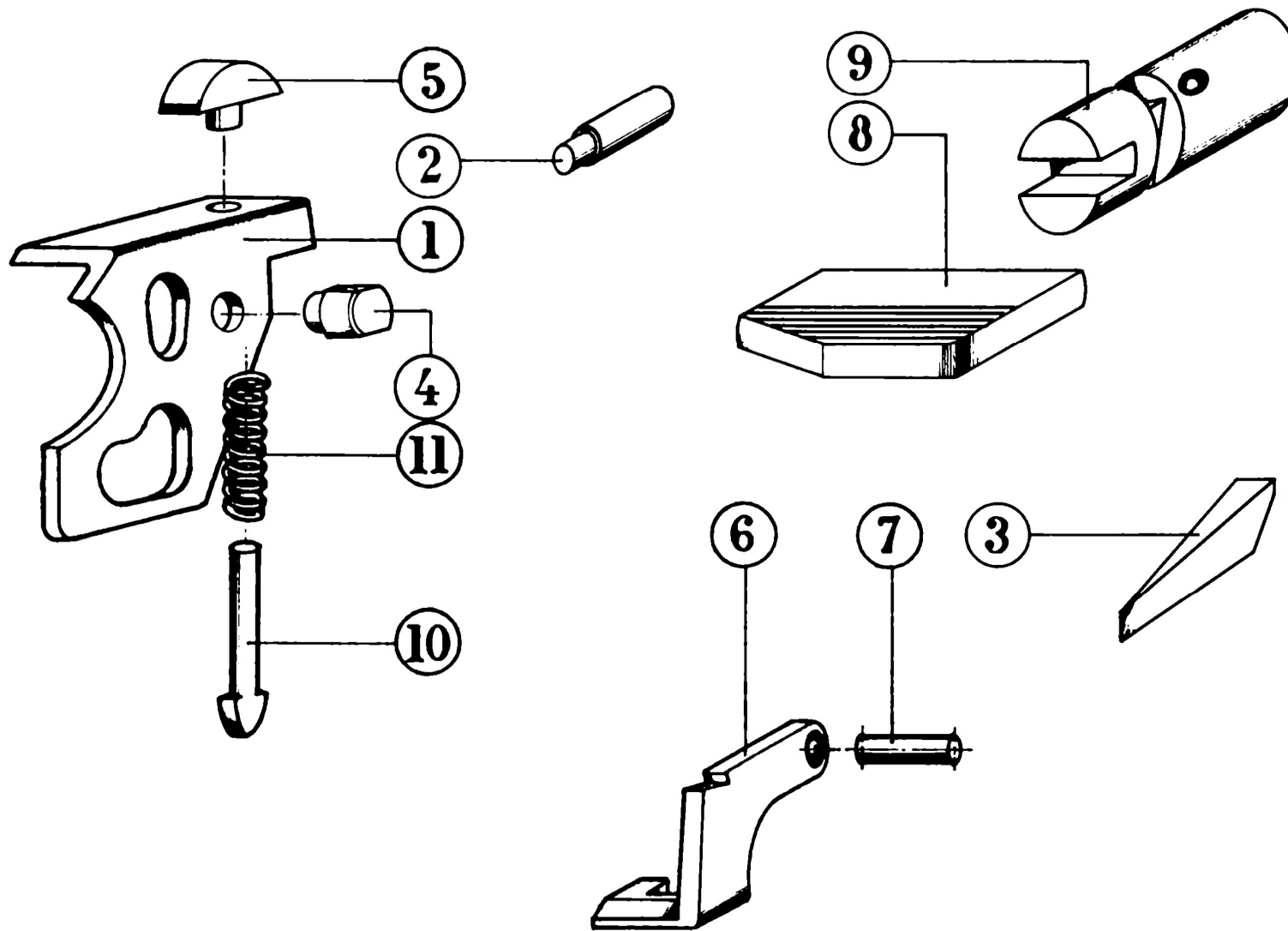



**REMINGTON 1100 CONVERSION PARTS FUNCTIONS**

1. *Automatic Tripper*—Acts as a connecting bridge between the bolt carrier link and sear extension for mechanical hammer release during full automatic operation.
2. *Replacement Trigger Connector Pin*—Acts as a cam for the tripper in bringing it forward at a controlled distance, depending on the amount of trigger pull permitted by the selector switch. The short pull results in semiauto functioning, while the long pull results in full automatic fire.
3. *Bolt Carrier Link Tripping Shoulder*—This is an 1/8 inch thick plate soldered on the rear end of the link prongs. It acts as a mechanical trigger, depressing the tripper downward each time the bolt group fully closes and locks. The tripping action of the tripper and sear will result in automatic hammer release only when switched to full auto. Otherwise, contact between the sear and tripper is restricted due to the amount of trigger pull needed to engage these two parts.
4. *Trip Spring Assembly Support*—This is a 3/16 inch diameter steel rod riveted to the right side of the tripper. Its sole function is to support and retain the upper end of the trip spring guide while the tripper is assembled in place to the trigger housing frame. A small hole slightly larger than the diameter of the tripper spring guide is drilled so the end of the guide can be inserted into it. Although this rod is riveted in place, it must be free to pivot forward and backward as the tripper is cammed into action by the trigger connector pin while the trigger is being pulled or released.
5. *Trip Contact Lug*—This is an 1/8 inch thick steel plate riveted to the top of the bent portion of the tripper. It has a circular shape for smooth tripping action with the link shoulder. The final height of this contact lug must be precisely adjusted during final fitting to properly time the hammer release. The bolt must be fully locked before the hammer hits the firing pin on full auto operation.
6. *Sear Extension*—This part is added to assist the sear for proper tripping action of the automatic tripping device during semiauto firing. Without this piece added to the sear, the sear is difficult to trip from the top without using an excessive amount of force. In this case, the tripper will not have enough force to depress the sear without jamming the link before the bolt fully closes.
7. *Sear Extension Rivet*—A 1/16 inch diameter drill rod used to rivet the sear extension to upper front end of sear. The sear extension, although permanently in place, must be free to pivot for smoother action.
8. *Selector Pin Lever*—The sheet metal extension permitting the selector pin to be rotated in any index position as desired by the shooter for the type of firing required. The lever is 1/8 inch thick plate steel permanently soldered to pin.
9. *Selector Pin*—Acts as a fire control mechanism for the weapon. Its solid part blocks the trigger on “safe” position, its shallower notch permits full auto firing, and its deep notch allows semiauto firing.
10. *Trip Spring Guide*—This small part retains the connection of the trip spring in assembled manner to the trigger housing frame and the trip spring assembly support.
11. *Trip Spring*—Powers the upward action of the automatic tripper during the cycle of operation.

## SEMIAUTOMATIC OPERATION

The new replacement safety selector mechanism has been designed so that it can be rotated to three index positions. These are "safe" (rear horizontal position), "semiautomatic" (center vertical position), and "full automatic" (forward horizontal position). On the "safe" position, the solid portion of the selector pin blocks any movement of the trigger, preventing it from being pulled.

The weapon is loaded in normal procedure. With the bolt group held open by the bolt lock, the first round is inserted in the chamber. The bolt lock is then disengaged by pressing the square button underneath the carrier latch to release the bolt forward. This functions the first round into the chamber, preparing it for the first shot. The next rounds can be loaded into the port underneath the gun, by inserting them one by one through the magazine tube until fully loaded. *Always make it a practice to put the selector mechanism on the "safe" position during loading and unloading operation to prevent accidental discharge.*

Once you are ready to shoot the weapon, move the selector lever to the middle horizontal position for semiauto firing. *Make very sure you have a safe backstop.* Squeezing the trigger will fire the first shot. After the projectiles have left the muzzle, the gas piston will activate the bolt carrier to unlock the bolt mechanism from the barrel extension locking shoulder. Once the bolt locking piece (L) has unlocked, the bolt group (K) will recoil rearward to accomplish the extraction and ejection of the empty shell, as well as recocking the hammer (H) for the next shot.

During the rearward recoil of the bolt group (K), the automatic tripper unit will rise upward since the bolt carrier link gap where the hammer pivots on battery will now permit the trip lug (D) to bounce up inside the said link gap. Note that while the selector is set on semiauto mode, the trigger pull is strictly controlled by the shallow notch of the selector pin. The pull is just enough to trip the sear in order to release

the hammer to fire the gun, but it is not long enough to permit contact between the trip nose (E) and sear extension step (F) for automatic hammer release.

After the full rearward recoil is accomplished by the bolt group (K), it will now move forward again under recoil spring tension provided by the spring follower (A) to complete its cycle of operation. The disconnecter is operated by the hammer plunger (R) each time the hammer (H) is released to fire the gun. The bolt group (K), during its forward recoil, will activate the shell lifter mechanism and carrier group, automatically functioning another round from the magazine tube into the chamber mechanically as it closes the breech.

During the last eighth-inch of its forward recoil, the bolt group carrier link tripping shoulder (C) will make contact with the trip lug (D), forcing it down to its normal position. Since the trigger pull is limited, it is not possible for the trigger (N) to bring the tripper nose (E) to make contact with the sear extension step (F), thus not allowing the hammer (H) to be released even though the link tripping shoulder (C) has pushed down the trip lug (D). The hammer (H) is held in the full cocked position by the sear during this cycle of operation. In order to fire the next shot, it is necessary to release the pull on the trigger (N) so that the trigger sear connector (P) can reengage with the sear tripping shoulder (Q) for the next shot. The bolt group will be held in open position after the last round is fired.

The sequence of operation in the semiautomatic mode is the same as an 1100 coming direct from the factory. The automatic tripper does not perform any function during semiauto firing. It merely bounces up and down when actuated by the bolt carrier link shoulder (C) during battery.

# SEMI AUTOMATIC OPERATION

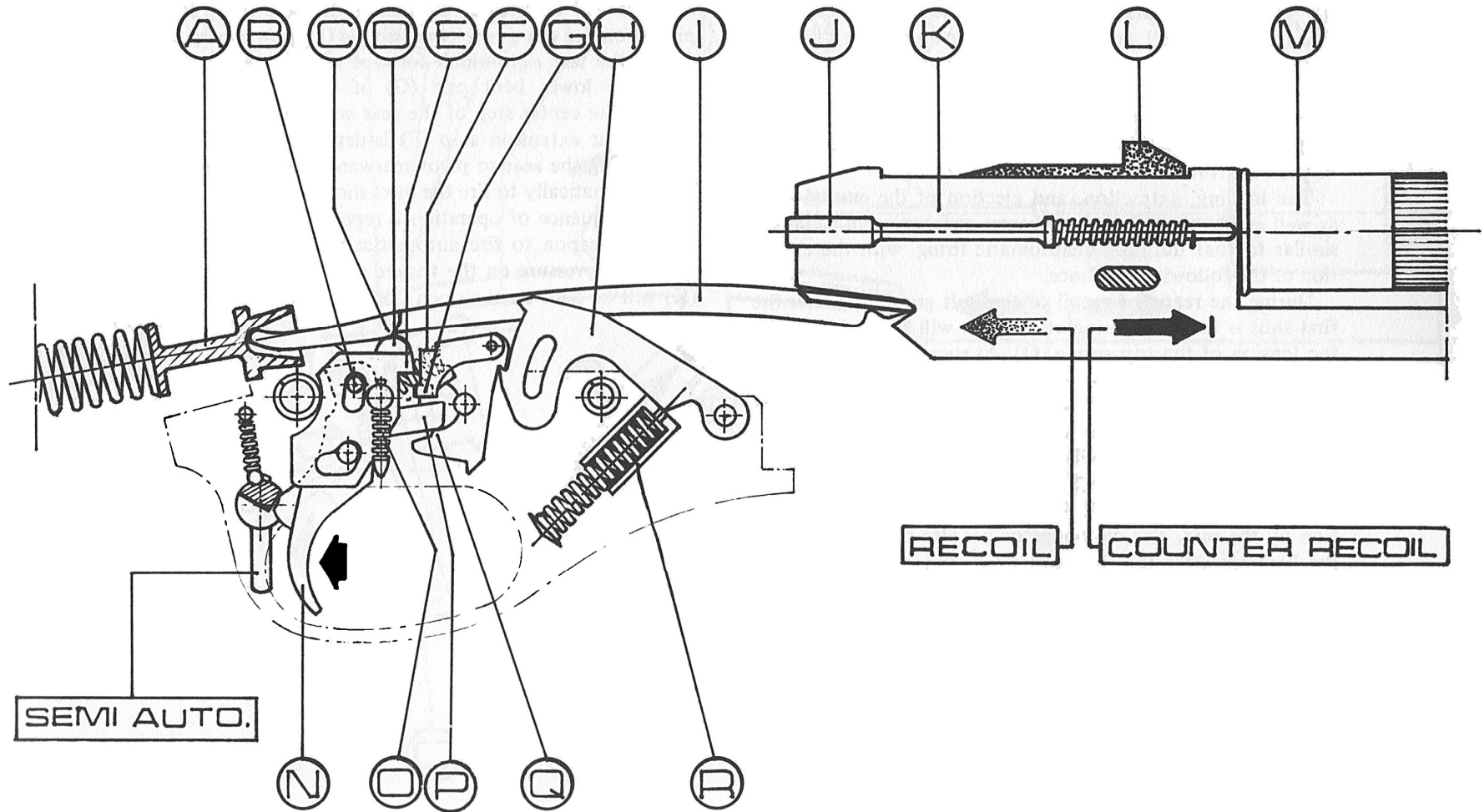

## FULL AUTOMATIC OPERATION

Assuming that the chamber and magazine tube are loaded, switch the selector lever to the "full auto" position all the way to the horizontal front position. The weapon is now ready for full automatic firing. *Never press the trigger while you are moving the selector mechanism to any index position.*

Squeezing the trigger will fire the first shot. Note that the deep notch of the selector pin will now permit the trigger to be pulled farther than on the semiauto setting.

The loading, extraction, and ejection of the empty shell, as well as the recocking of the hammer, function in a manner similar to that during semiautomatic firing, with the exception of the following sequence.

During the rearward recoil of the bolt group (K) after the first shot is fired, the automatic tripper will bounce up under the tension of the trip spring (O). As soon as the bolt carrier link tripping shoulder (C) clears its contact with the trip nose (E), it will automatically bounce up inside the link gap where the hammer (H) pivots during battery. As soon as the tripper moves up, its nose (E) will automatically ride over the sear extension step. Note that during rearward recoil of the bolt group (K), the hammer will be recocked and held in this position by the sear. The disconnecter has also been actuated by the hammer after the shot was fired. Therefore the trigger connectors are now completely disconnected from their usual function, while maintaining the pressure on the trigger (N).

As mentioned earlier, a long pull is required on the trigger (N) to fire the weapon on full automatic in order to connect the trip nose (E) to sear extension step (F). These two parts are activated by the bolt carrier link tripping shoulder (C) in order to release the hammer (H) mechanically each time the bolt group (K) fully closes and locks to the barrel extension.

The small protrusion of the trigger connector pin (B) on the upper right side of the trigger (N) will hook and force the

tripper on its top slot to move farther to the front to make engagement with sear extension step (F) when the trigger is pulled via the long pull on the "full auto" setting. Once the trip nose (E) rides over the sear extension step (F), the hammer will be released as soon as the bolt group link tripping shoulder (C) pushes the trip lug (D) down upon contact during the last eighth-inch forward recoil of the bolt group (K). The lower bent part (G) of the sear extension will depress the center step of the sear where it is resting as soon as the sear extension step (F) is depressed by the trip nose (E) causing the sear to pivot rearward and releasing the hammer automatically to fire the next shot.

This sequence of operation is repeated mechanically, causing the weapon to fire automatically until the magazine is empty or pressure on the trigger is released. The bolt group (K) will be held on the open position after the last round is fired.



# FULL AUTOMATIC OPERATION

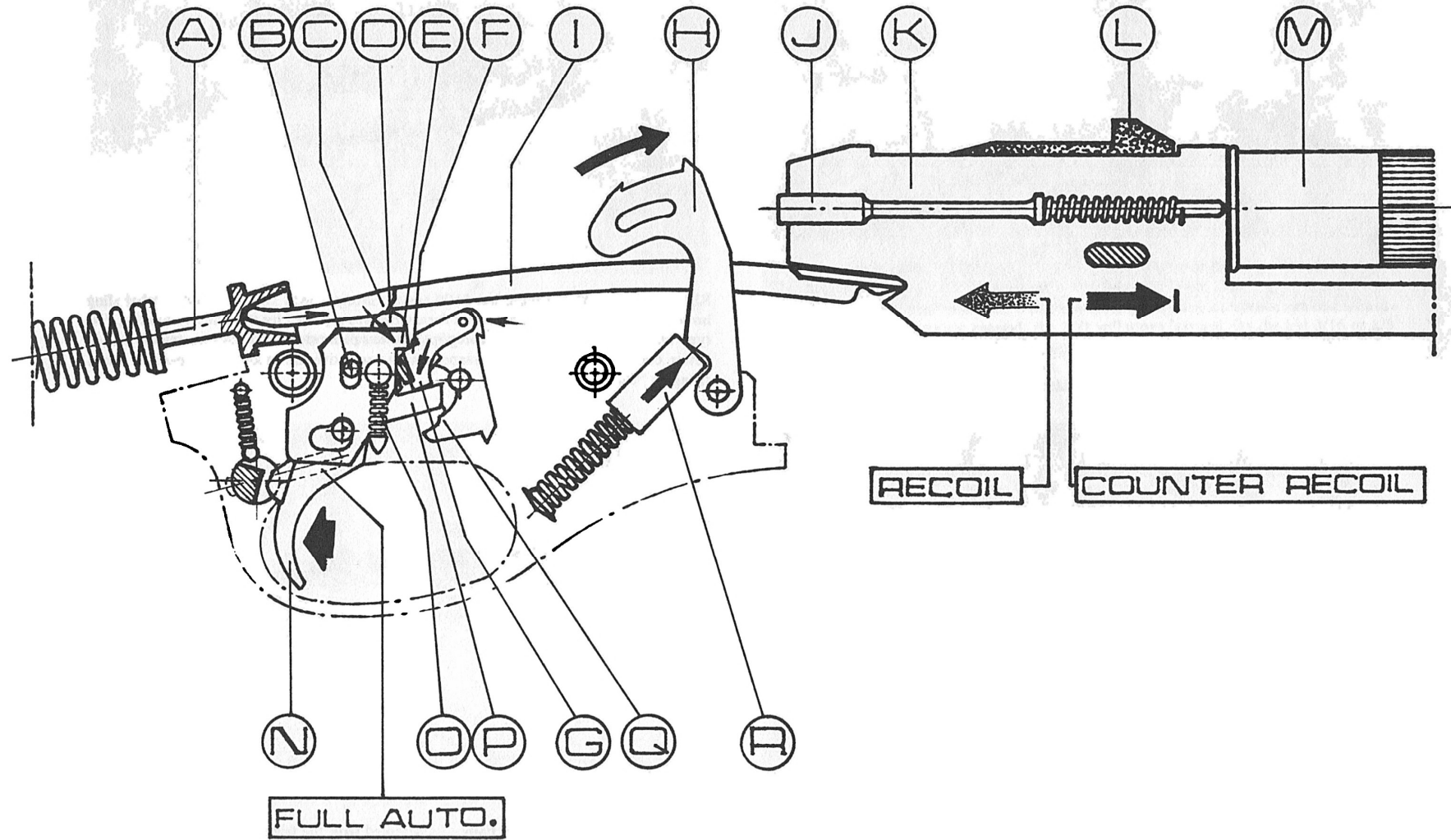



The original configuration of the now-converted, selective-fire shotgun as it comes from the factory. This one has a ventilated barrel and sports a 28-inch barrel.

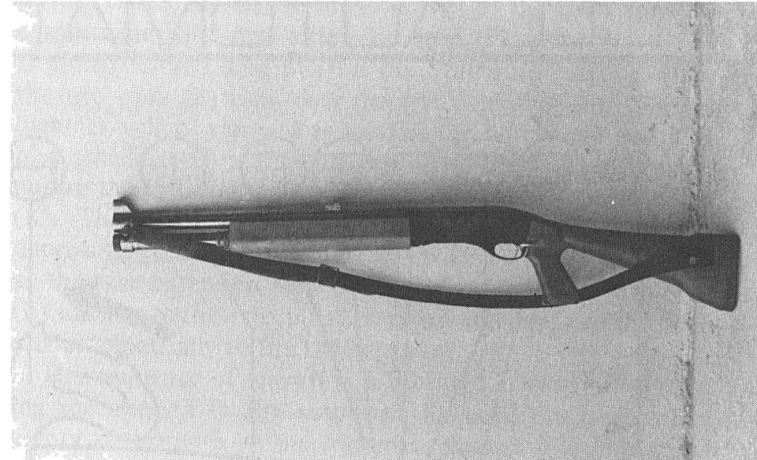

Right side view of the modified 1100 assault shotgun with side-mounted combat sling installed in place. The original wood furnishing was replaced by the military-looking FN-type buttstock and a matching foregrip. The excellent stock and foregrip are a must for better control when using the weapon in the selective-fire mode, and especially when firing on "full auto."



A left side view of the same weapon with its side-mounted sling removed. Note that this still has the original wooden foregrip. The buttstock is an indestructible FN-type plastic material.



View showing the weapon partially disassembled with the trigger plate assembly and the long magazine spring removed. Note the magazine tube end cap unscrewed for removal of the spring. The original magazine extension was modified so that a custom front sight and end cap can be installed for more sophisticated and faster field stripping.



Close-up view of the field-stripped trigger mechanism assembly.



The proper procedure in testing the mechanism for functioning during fitting procedure. The trigger is pressed with the selector in the full auto mode. The sequence starts with the bolt held in "open" position. When the rectangular knob at the bottom of the loading port and the trigger are pressed, the bolt will move forward. On the last 3/16 or 1/8 inch of bolt travel, the sear will be tripped, releasing the hammer to fire the weapon. By the time the hammer hits the firing pin, the bolt lock is fully seated. The action of the mechanism can easily be seen on the cocking handle slot behind the bolt.

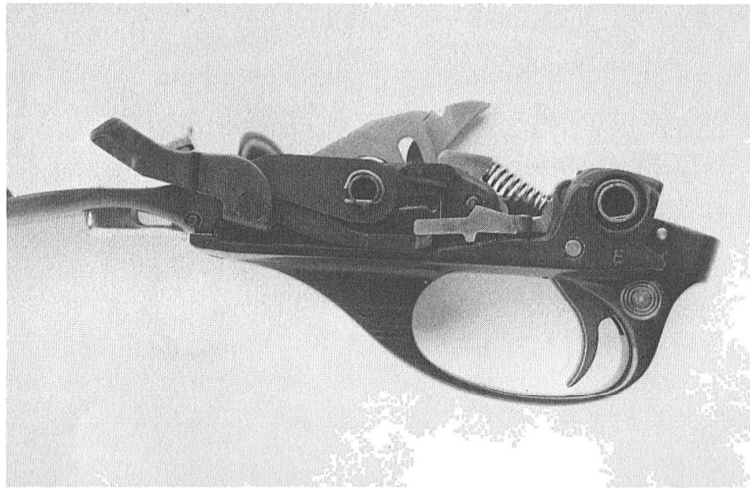

Left side view showing the original components of the trigger plate assembly prior to conversion to selective-fire. Hammer is in cocked position and ready to fire. Note proper assembly of components.

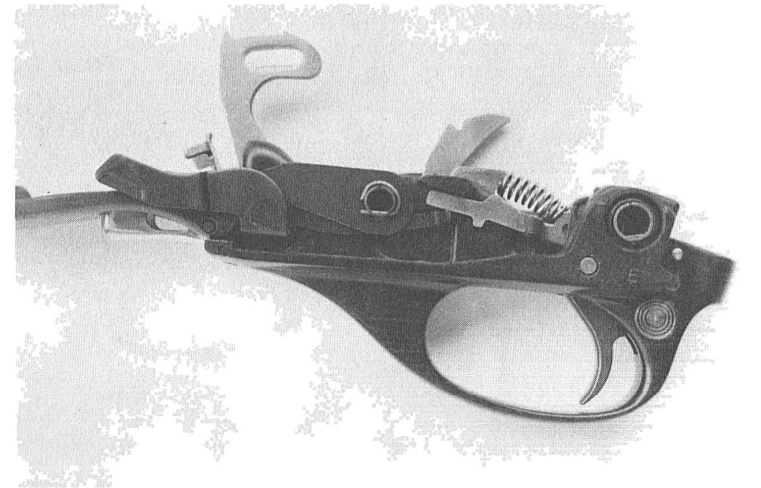

Same left side view showing the hammer in "fired" position.

## REMINGTON 1100 EXOTIC WEAPON SYSTEM

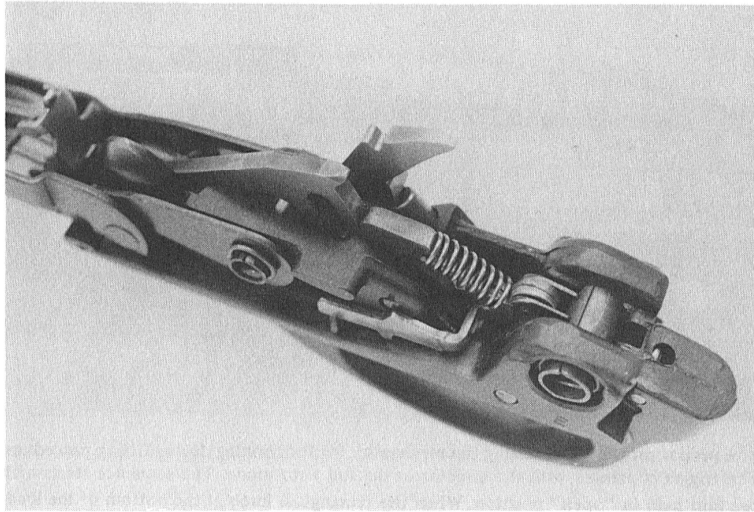

Perspective top view showing the original factory mechanism.

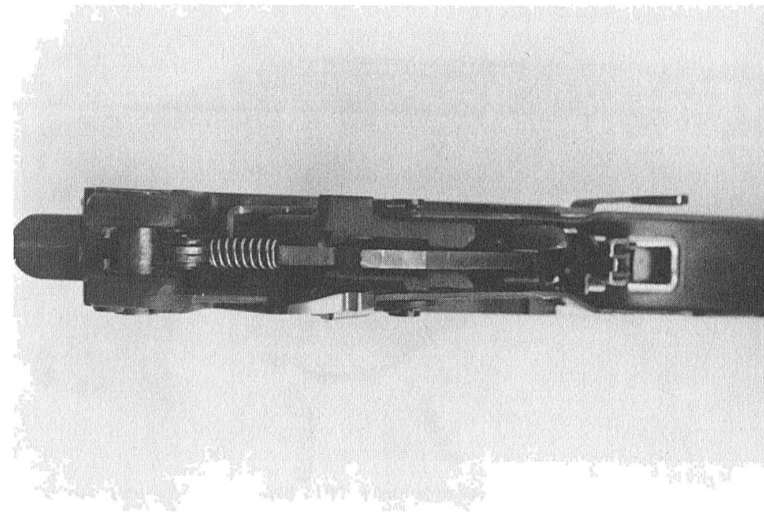

Top view showing the original factory trigger mechanism assembly.

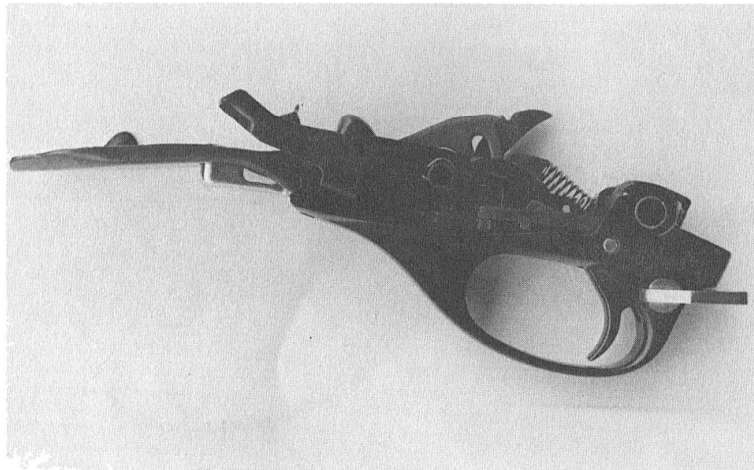

View showing the original trigger mechanism assembly with the new replacement safety selector mechanism. The weapon will not fire selective even when the new selector device is installed with the original factory mechanism still assembled. Selector is in "safe" position.

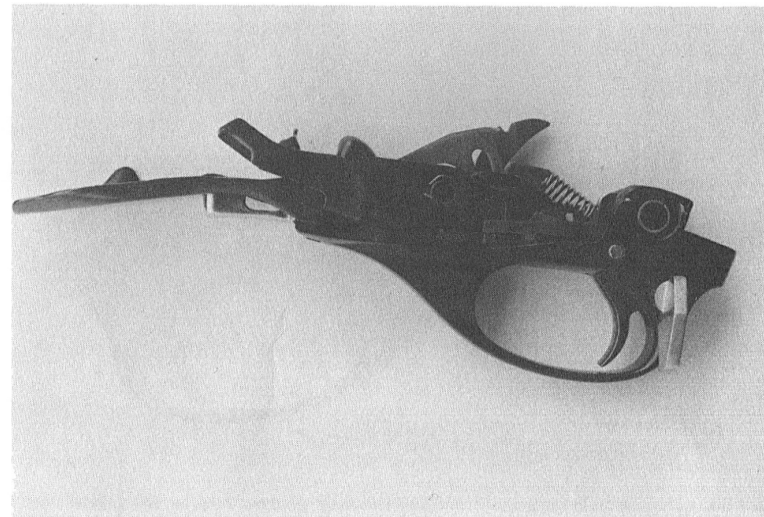

Left side view of selector in "semiau to" position.



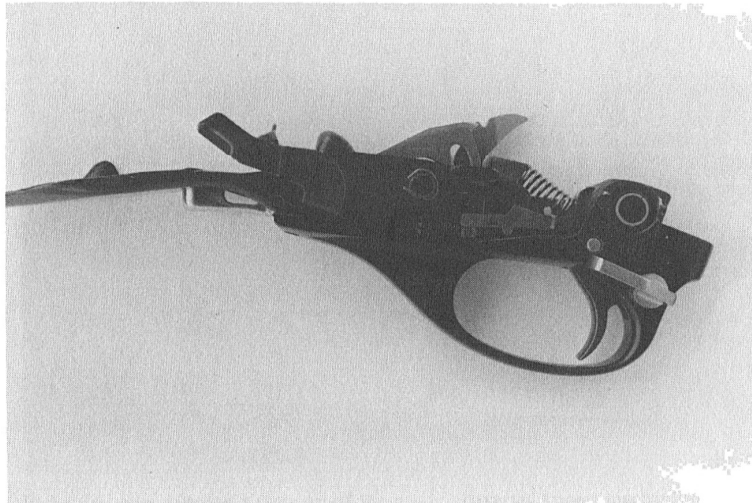

Left side view of the selector in "full auto" position.

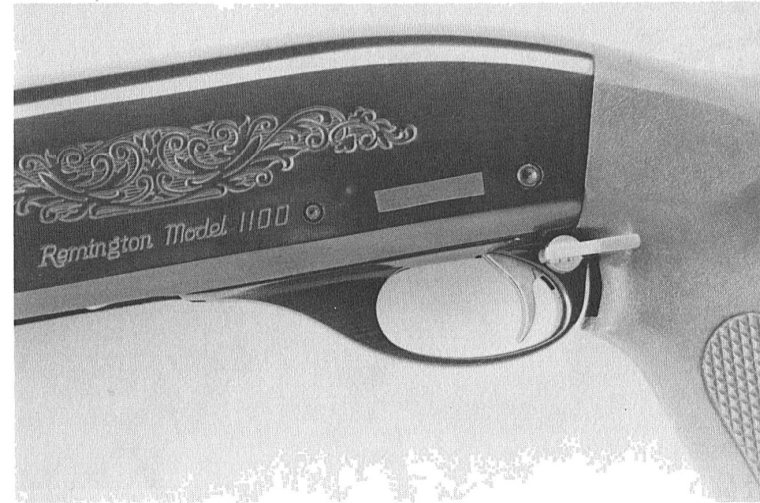

View showing the selector lever mechanism set on "safe" position with the shotgun fully assembled.



Another left side view showing selector lever on "semiauto" position.



View showing selector at "full auto" position.

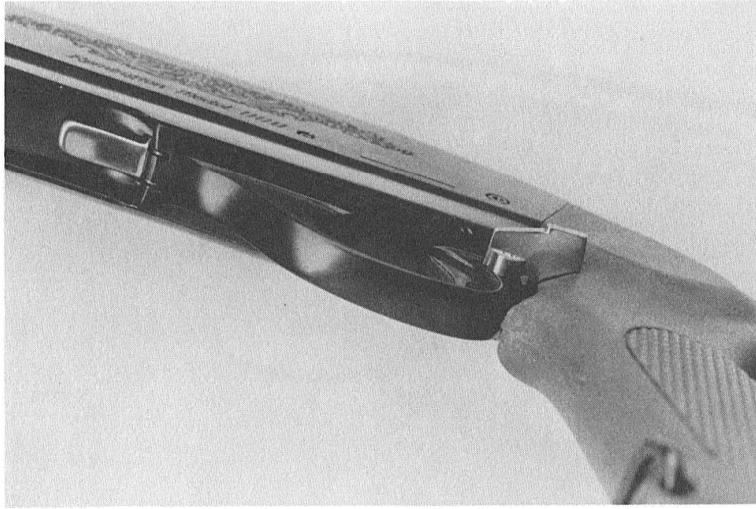

The selector lever viewed from the bottom. Note the angled clearance on the rear part of the lever to accommodate the contour of the FN-type grip. Cutting this clearance is not necessary if standard factory stocks are used.

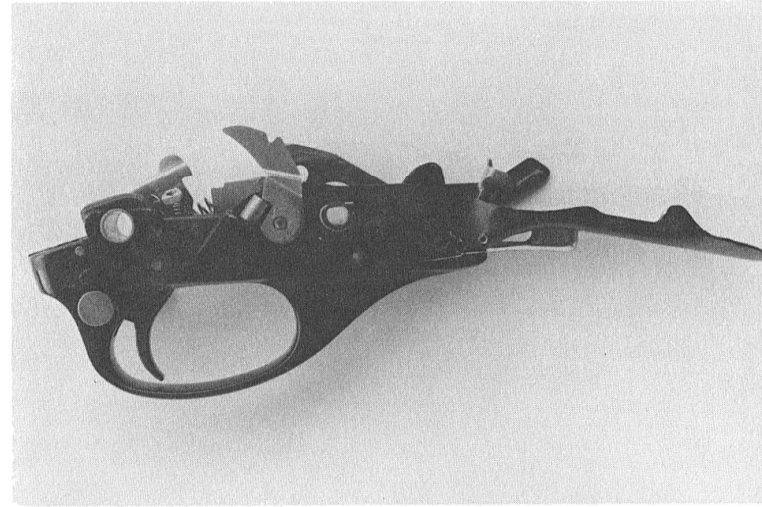

Right side view of the newly converted trigger mechanism assembly.

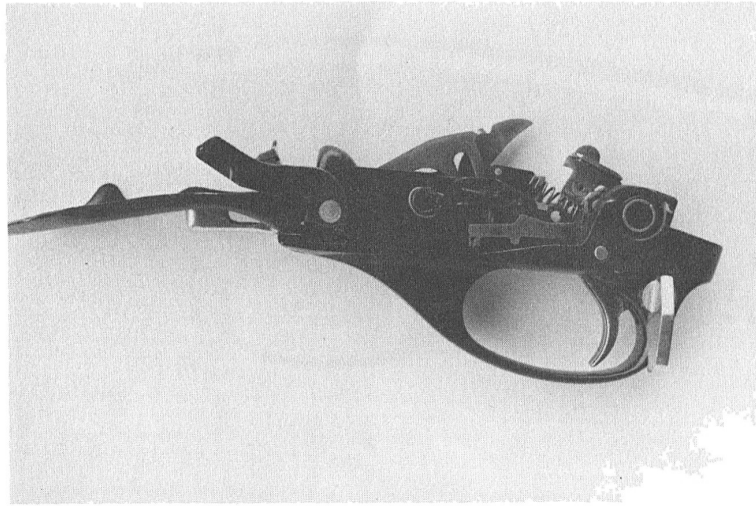

Same trigger mechanism assemblies viewed from the left. Selector is at "semiauto."

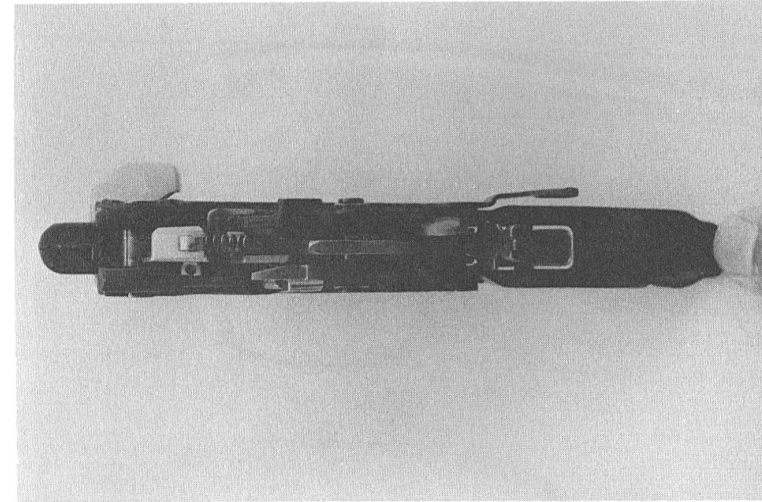

Same trigger mechanism assembly viewed from the top. Selector is set at "full auto."

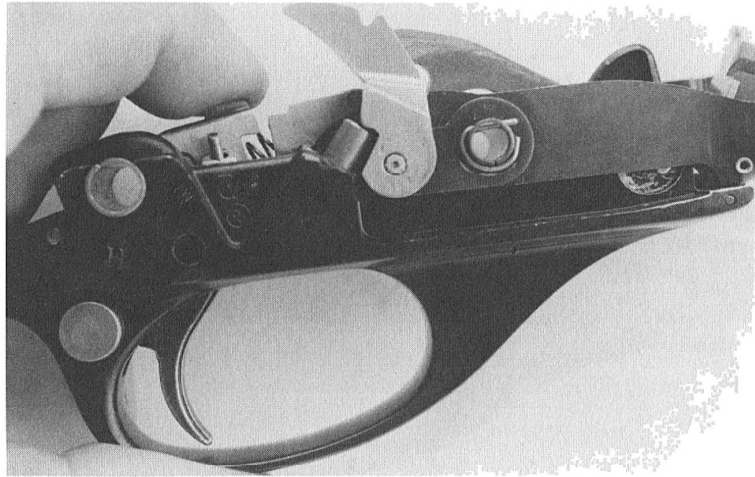

Right side view showing a close-up of the newly converted trigger mechanism. Selector is set on "semiauto." Photo shows the automatic tripper being depressed but not pulling the trigger. To prevent accidental discharge, make sure that the hammer is not tripped which may be caused by heavy rubbing of the automatic tripper and the trigger when assembled together in the frame.

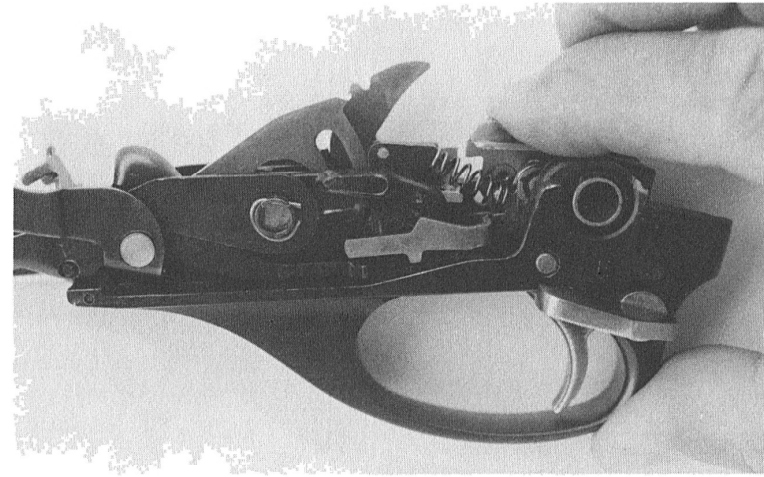

Another view showing the tripper being depressed without tripping the hammer sear. The trigger is not pressed and the selector is set on "full auto." This is the relationship of parts during the loading process without the trigger being pulled and with the selector being set on any index. For maximum safety, the shooter must make it a habit to set the selector on "safe" each time he loads the weapon or when he is not ready to fire.

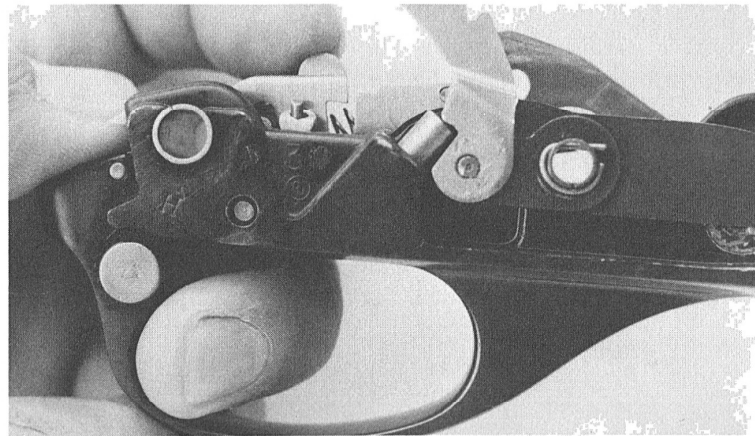

A view showing the relationship of the mechanism on semiauto functioning. Assuming that the first round has been fired, by maintaining pressure on the trigger, the hammer will be recocked (as shown in photo) and the tripper will be depressed by the link tripping shoulder on its full forward position. The depressed tripper did not reach the sear extension step to trip the sear since the shallow notch of the selector pin restricted trigger pull.

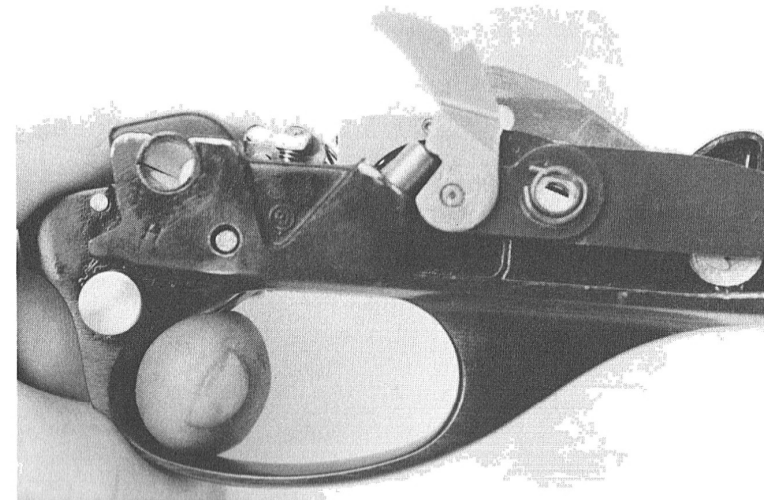

View showing the relationship of parts after the first shot is fired, the hammer recocked, and the link shoulder not pressing the tripper on rearward recoil. Note how the trip nose slightly parallels and rides well above the sear extension step ready for reengagement.



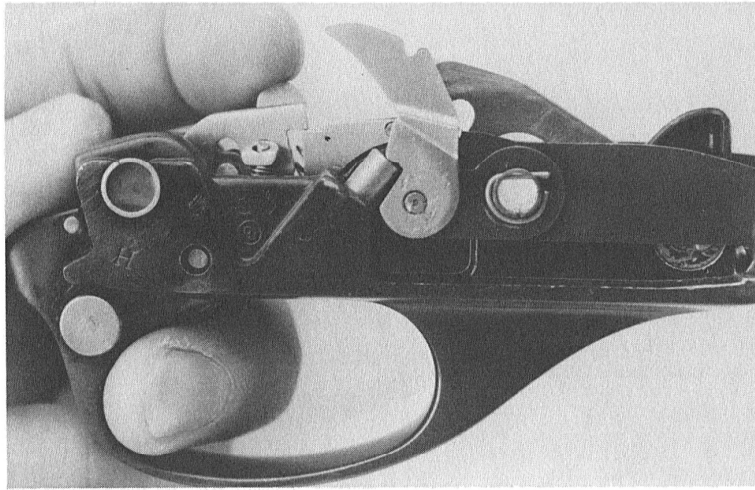
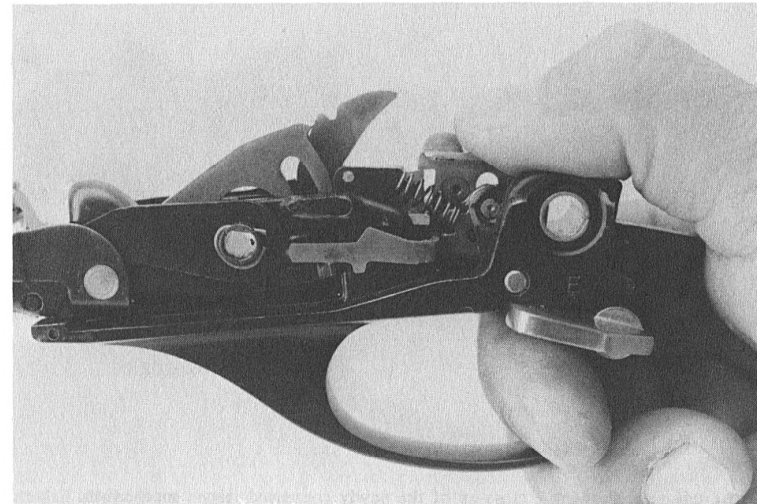
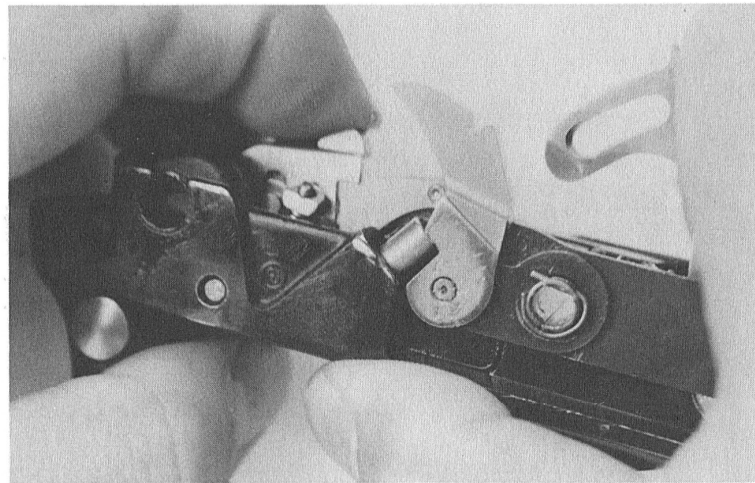

Photo showing the tripper being slightly depressed while maintaining pressure on the trigger. Note that the trip nose now begins to make contact with the sear extension step. In this sequence of action, the link tripping shoulder started to make contact with the trip top lug.



Same action viewed on the left side of frame.



The final contact. Here the trip top lug was fully depressed forcing the sear extension downward, releasing the sear's contact with the hammer to fire the weapon. Note that the hammer was restrained after release so it will not damage the disconnecter if not fully assembled to weapon.

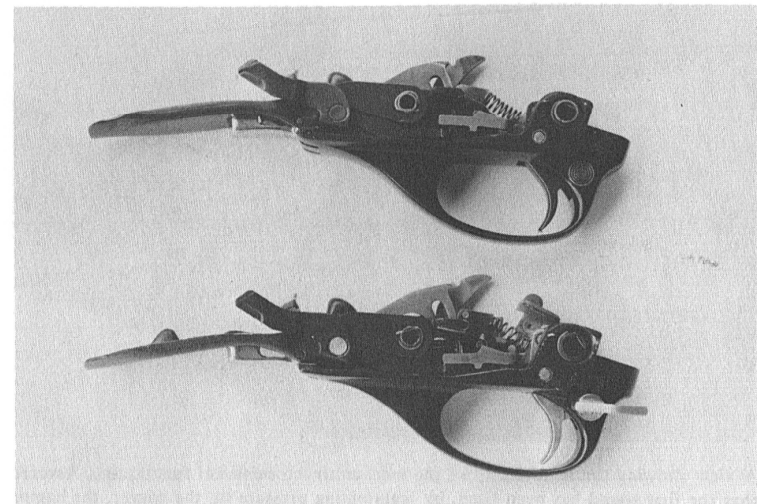

Left side view showing comparison of the original, unaltered trigger mechanism assembly (top) and the modified, converted selective-fire trigger mechanism assembly (bottom). Hammers are in cocked position.

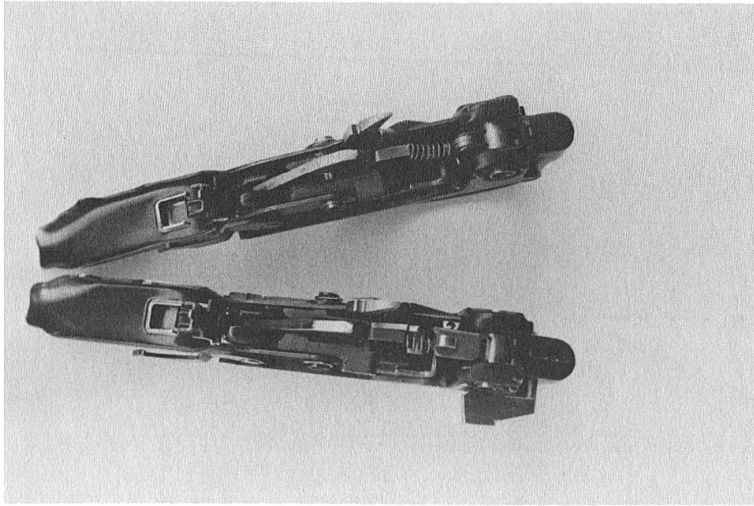

Same trigger mechanism assemblies showing respective top views.

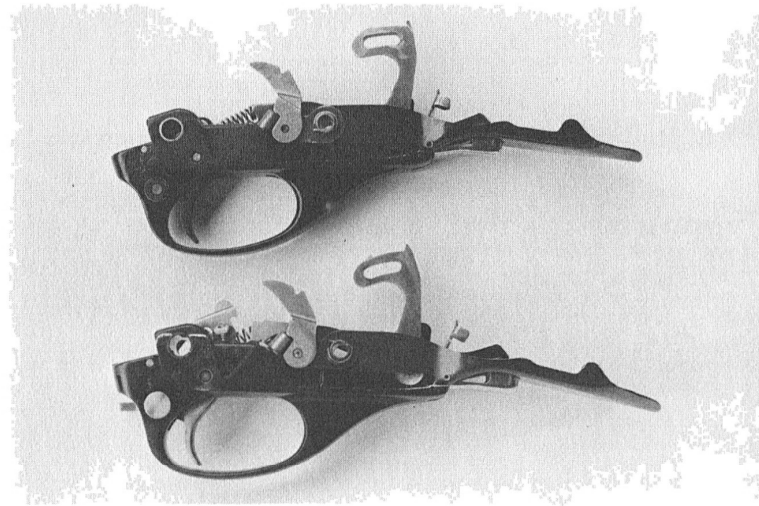

Same trigger plate assemblies viewed from the right. Hammers are in "fired" position.

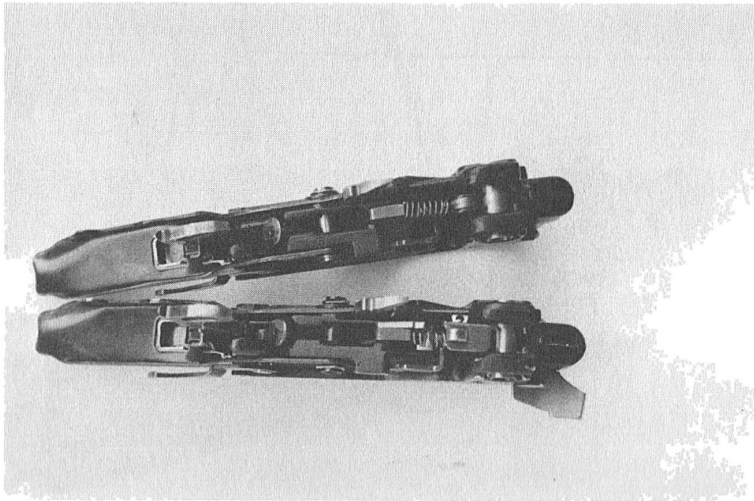

Same trigger mechanism assemblies viewed from the top.

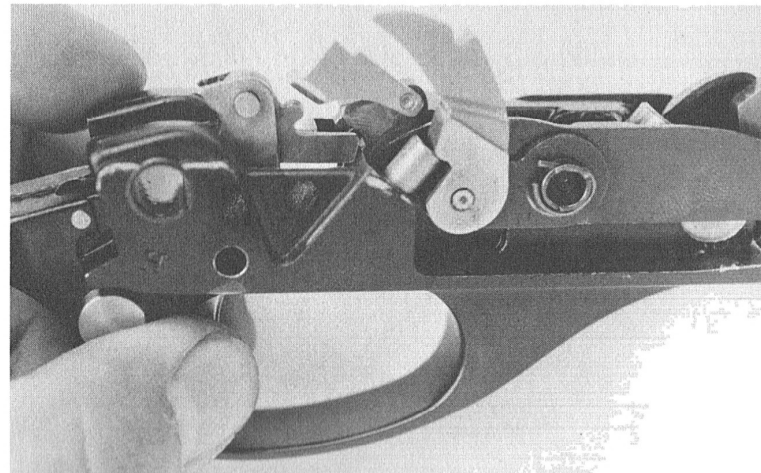

View of the proper assembly of the trigger unit with the modified sear and sear extension unit in place. The sear extension must be pivoted upward so that the sear connector can be inserted in its usual position. Push the sear extension back down as soon as the connector is seated.



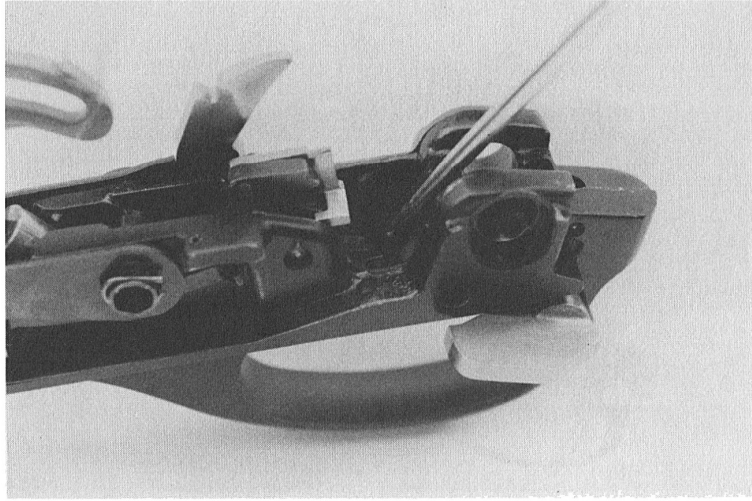

Here the scribe points to the bottom of the triangular cutout inside the right frame wall of the trigger housing plate. A small, shallow hole about .050 deep must be drilled by a 3/32 inch diameter drill to support the lower part of the trip spring unit when assembled in place.

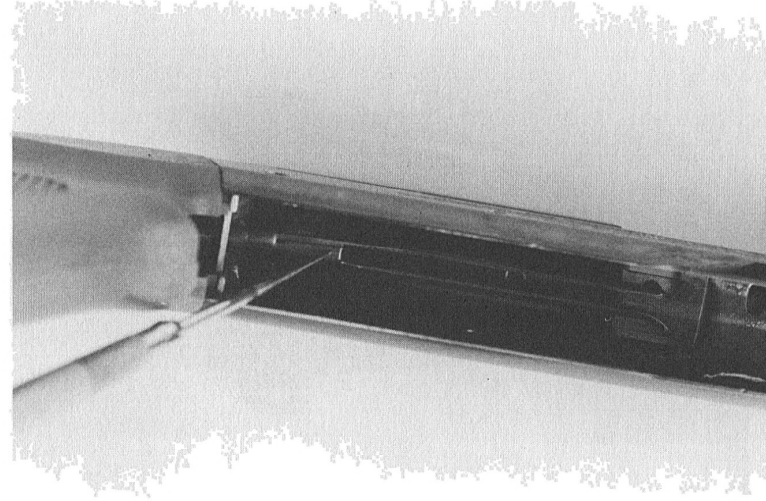

The scribe points to the tripping shoulder of the bolt group link as assembled to the receiver. This small plate was soldered permanently with one of the link prongs to act as a mechanical trigger during full automatic operation.

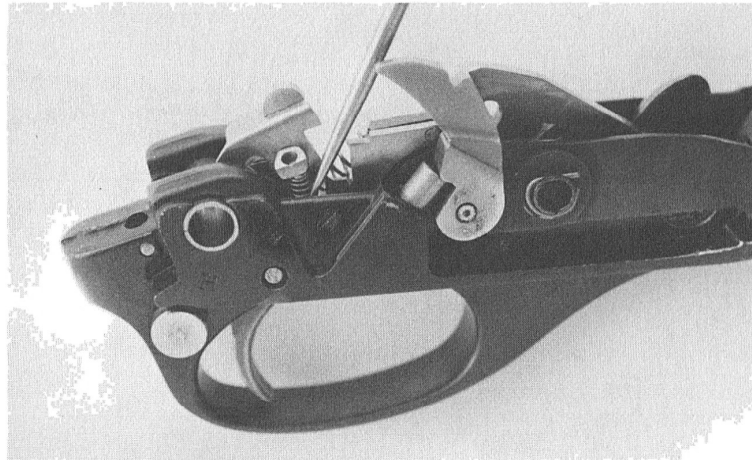

Scribe points to the trip spring. Note that the spring guide was not riveted on the end, and as a result, the automatic tripper unit is clumsily assembled in place. But the rivet-mounted system for securing the trip spring unit in place (described in the text) makes it possible to quickly insert or remove the trip spring unit without tools.

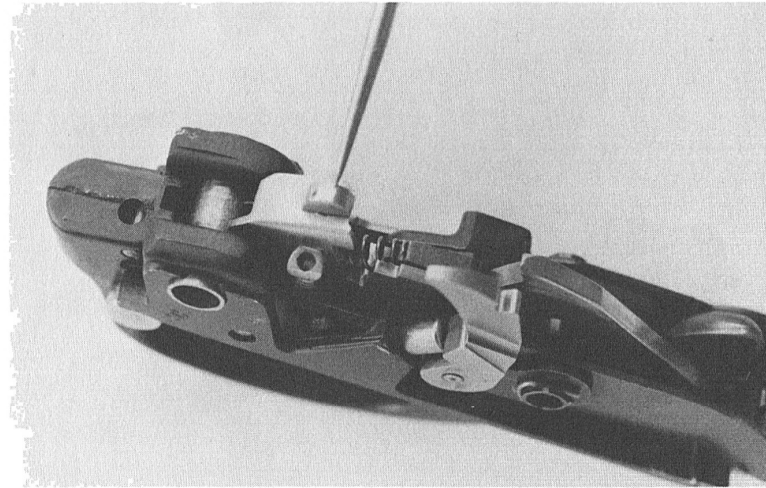

Scribe points to the top lug of the tripper. It is necessary to highly polish this lug for smooth operation during the tripping process. Adjustment for perfect hammer release timing can best be done by gradually trimming this lug.

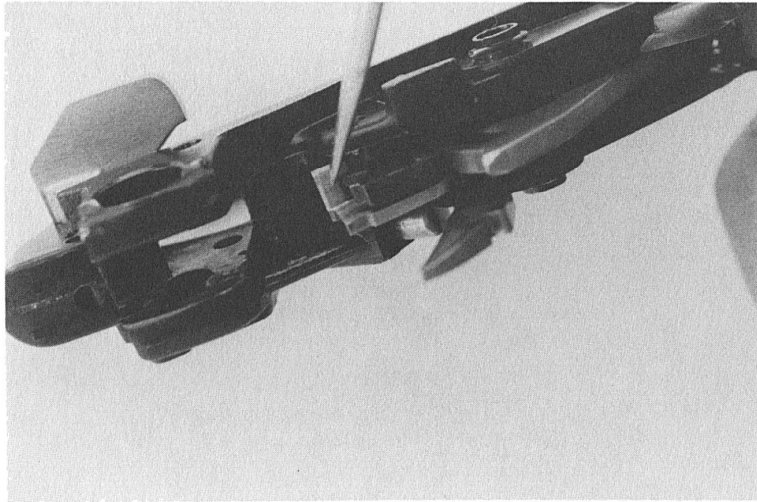

Scribe points to the lower bent part of the sear extension. This portion of the extension rides over the center step of the modified sear. When the sear extension step is depressed by the tripper, this bent part of the extension will depress the sear causing the hammer to be released, thus firing the weapon.

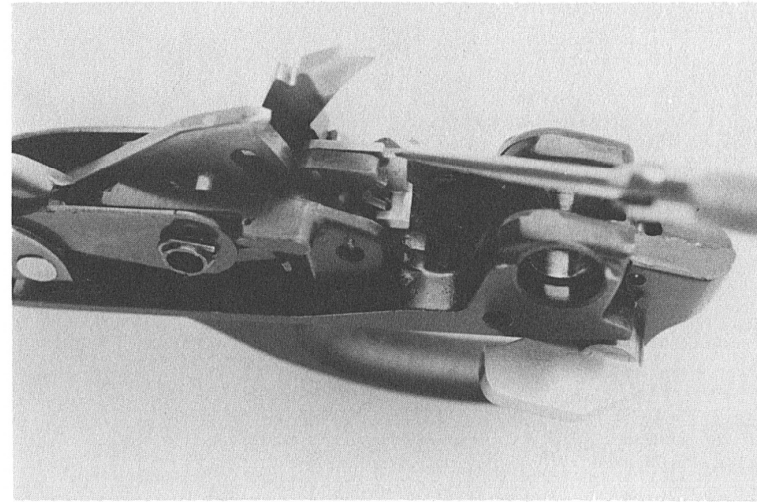

The sear extension in its normal position as viewed from the left.

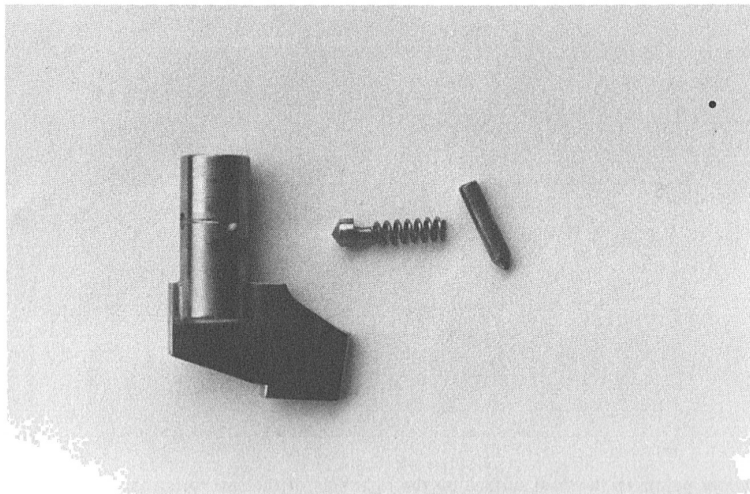

The new selector lever mechanism viewed from the top with the selector set on "safe." The original safety mechanism incorporates an index ball. Here the index ball was replaced with a spring-loaded plunger which does not get lost easily as does the ball.

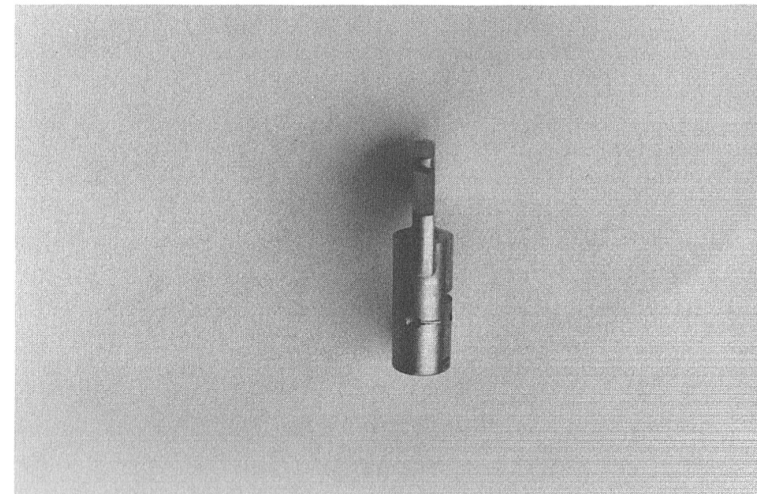

Same selector viewed from the top. The selector is set on "semiauto."

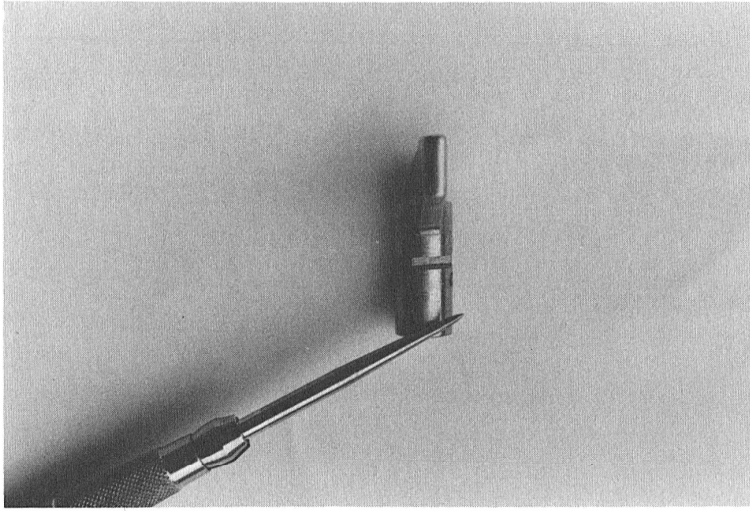

Selector viewed from bottom in "semiauto" setting. Note the shallow notch facing trigger safety lug.

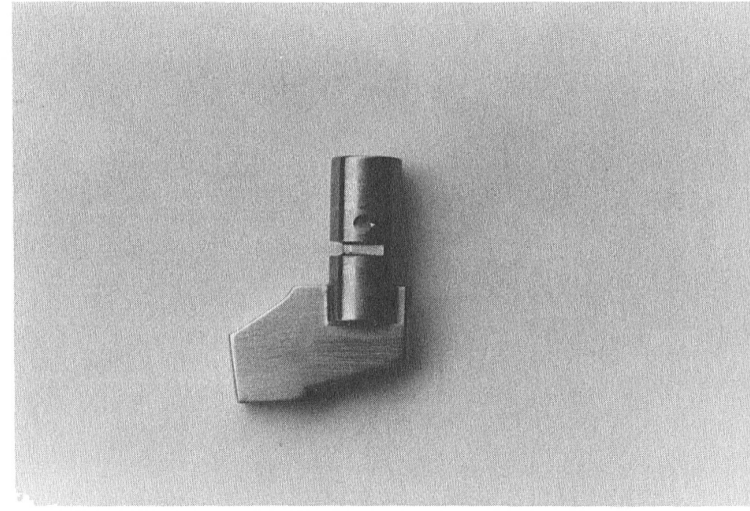

Selector viewed from top in "full auto" Note the deeper notch facing trigger.

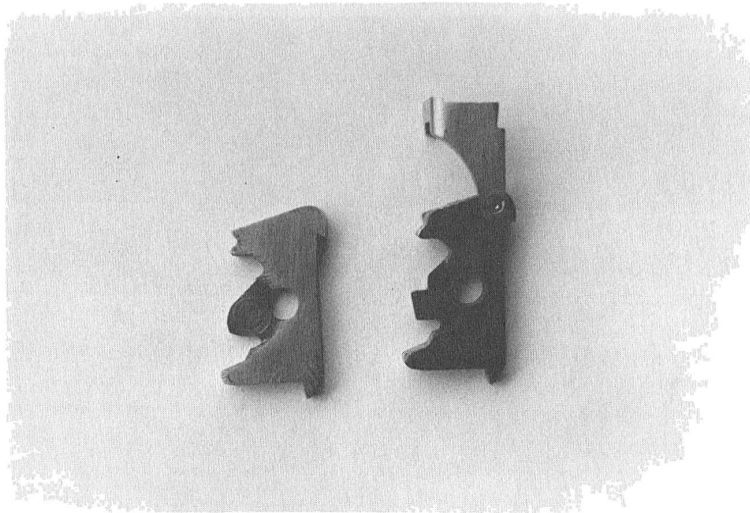

Comparison between the original sear (left) and the modified sear with the extension riveted in place (right).

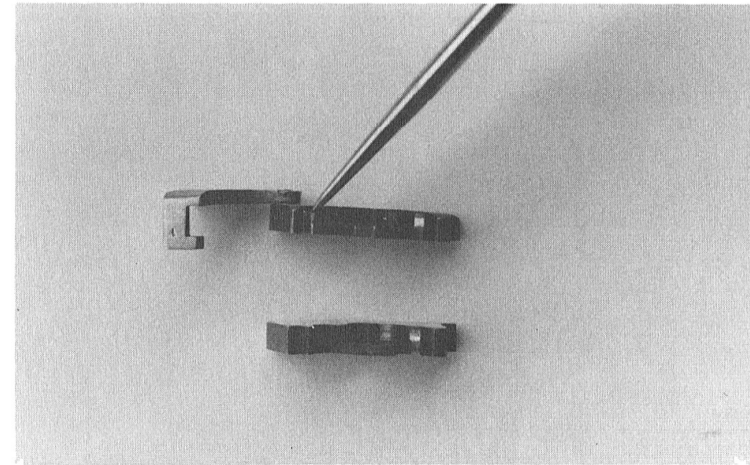

Scriber points to the filed surface on the right side of the sear spring base. This filing is necessary so the sear spring can move slightly to the left to give clearance for the extension. Without filing clearance on this part of the sear, the spring cannot be inserted once the extension is riveted in place. Filing will prevent the spring from rubbing tightly against the extension.



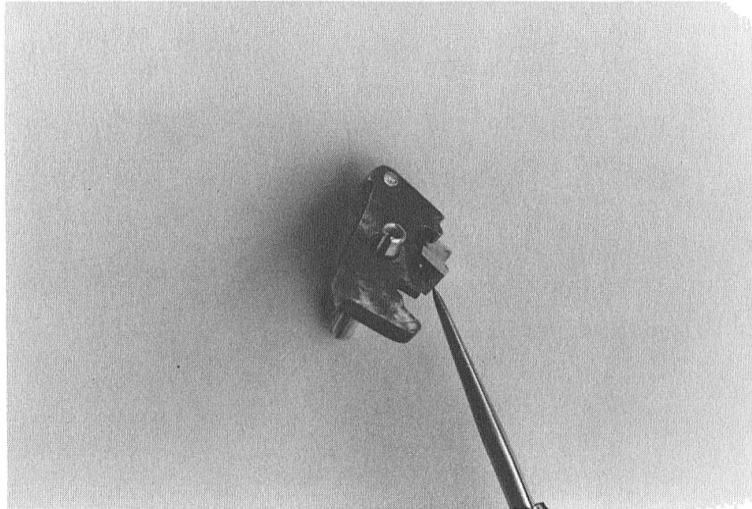

Scriber points to the lower portion of the sear extension bent part. This portion is shown riding on top of the sear center step.

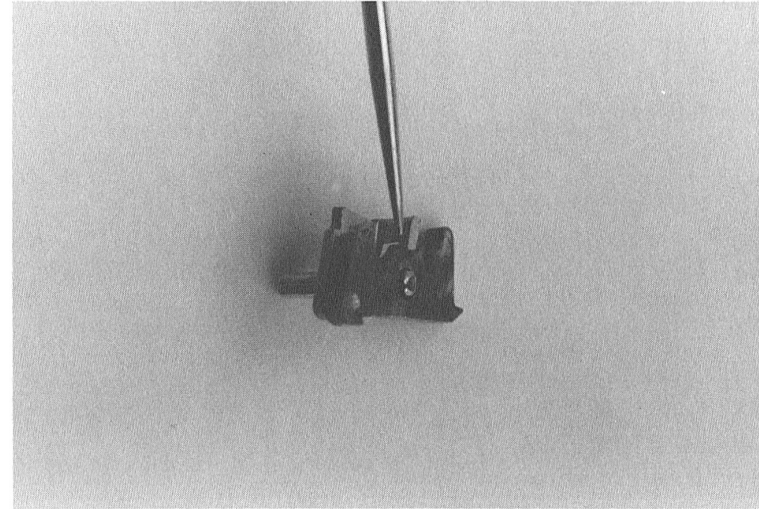

Scriber points to the left side hook of the bent part of the extension. This hook secures and prevents the extension from shifting during operation. This part should snugly fit the sear to achieve a uniform and parallel contact of the trip nose and sear end step.

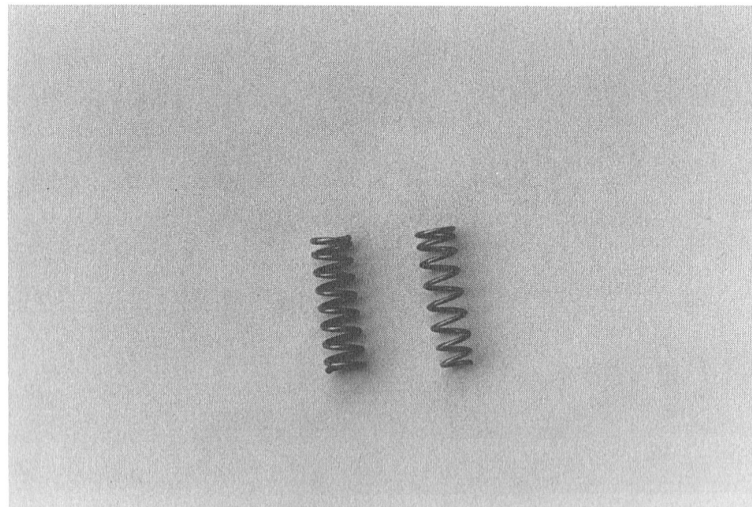

The optional, lighter sear spring compared to the original factory one. The lighter spring gives better performance during full auto functioning since it is easier for the tripper to operate than the heavier factory spring.

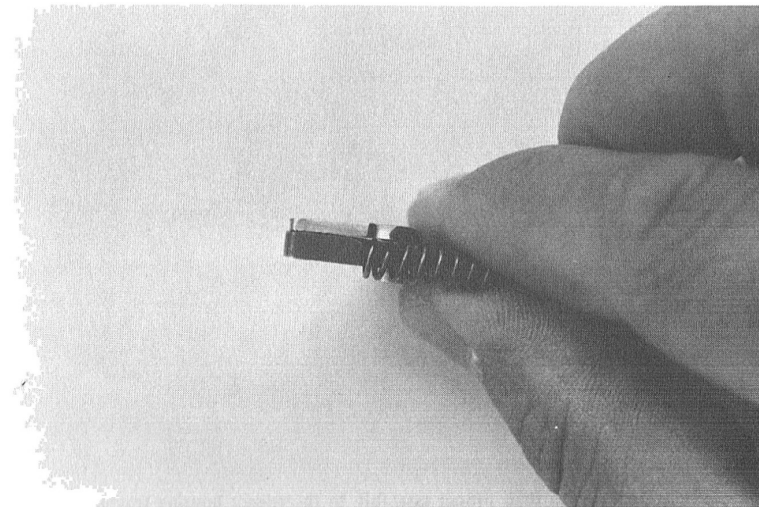

The optional sear spring assembled in place. Note that the filed clearance of the sear spring base makes way for the unimpeded insertion of the spring. There is no heavy rubbing on the sear extension surface.

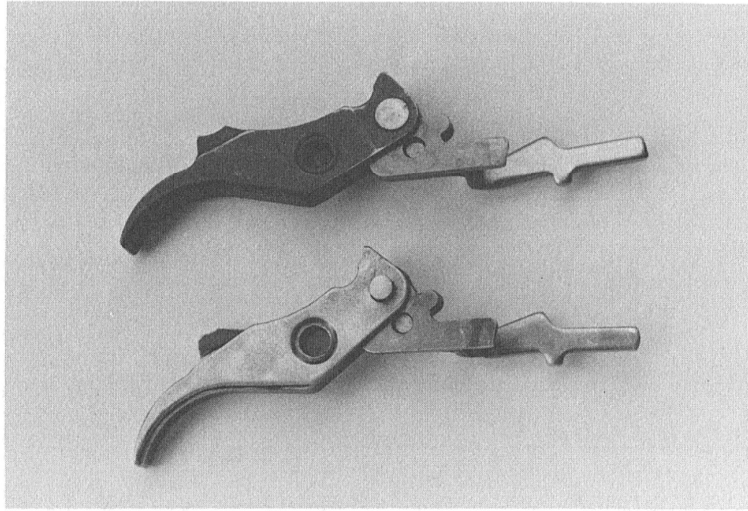

The original, unaltered trigger assembly (top) compared with the modified trigger assembly (bottom). Note the smaller diameter pinhead acting as cam for the tripper during trigger pull movement.

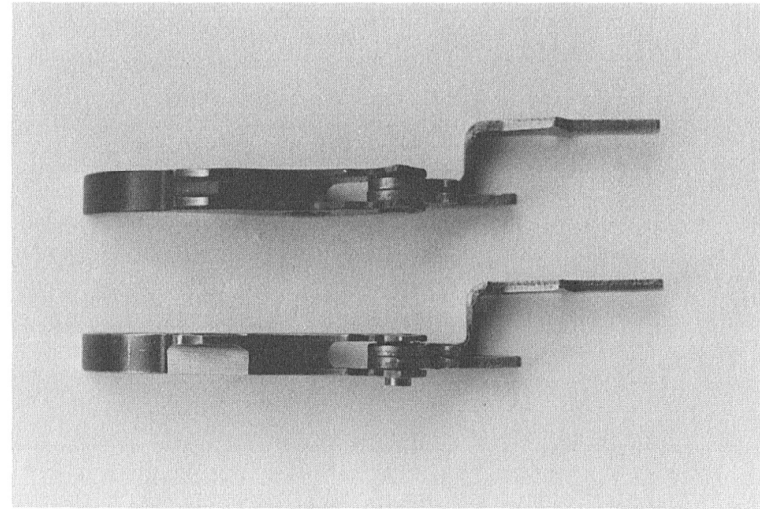

Same trigger assembly viewed from the back. The safety lug on the right side of the modified trigger (bottom) has been filed off completely to mate with the replacement safety selector notches. Note the protrusion on the new trigger connector pin on the right side acting as cam for the tripper.

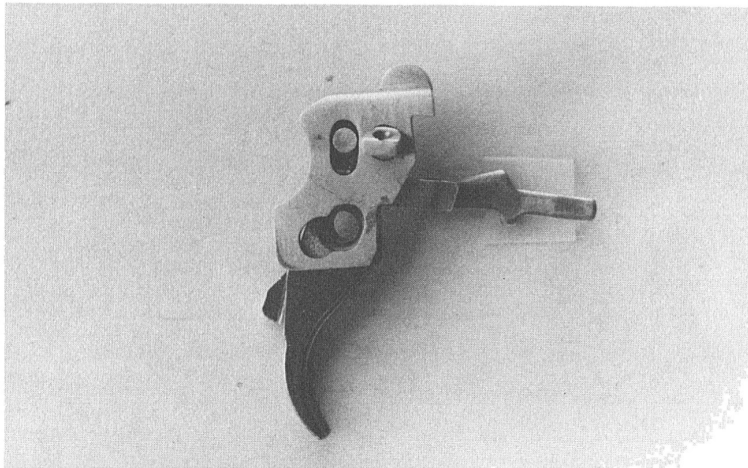

The trigger and tripper in their proper assembly to the trigger housing frame. Both the tripper and trigger unit are retained in place by the trigger pin. The upper slot of the tripper is operated by the trigger connector pin (cam). The lower slot of the tripper is controlled by the trigger pin.

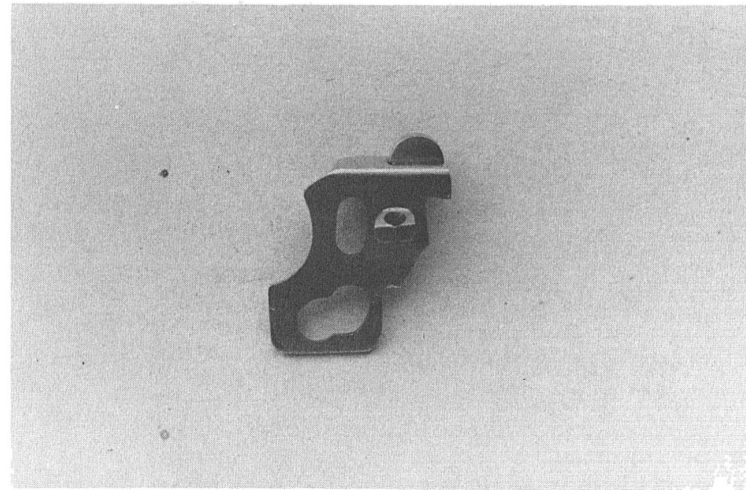

Detailed right side view of the automatic tripper without its spring and guide rod.



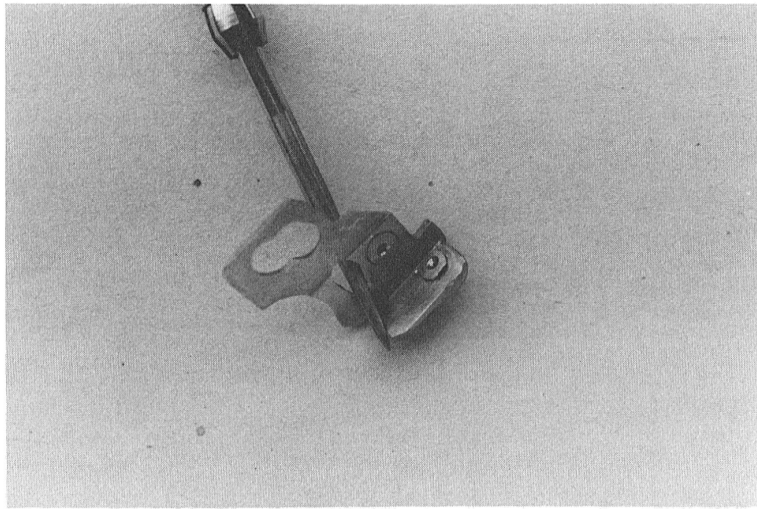

The tripper viewed from the inside. The rivet heads of the top lug and trip spring unit base are filed flush to the inside surface of the tripper.

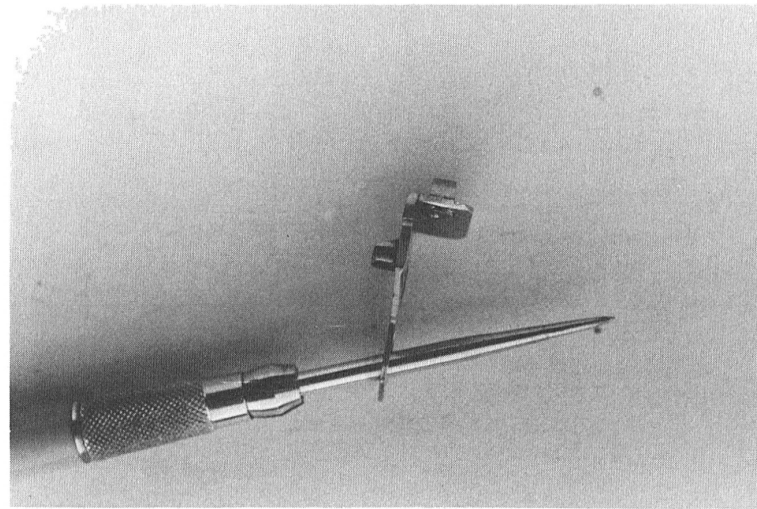

Front view showing the side and top lug of the tripper. Note that the reduced, trimmed thickness on the lower part of the tripper side wall is for the mark 2 model.

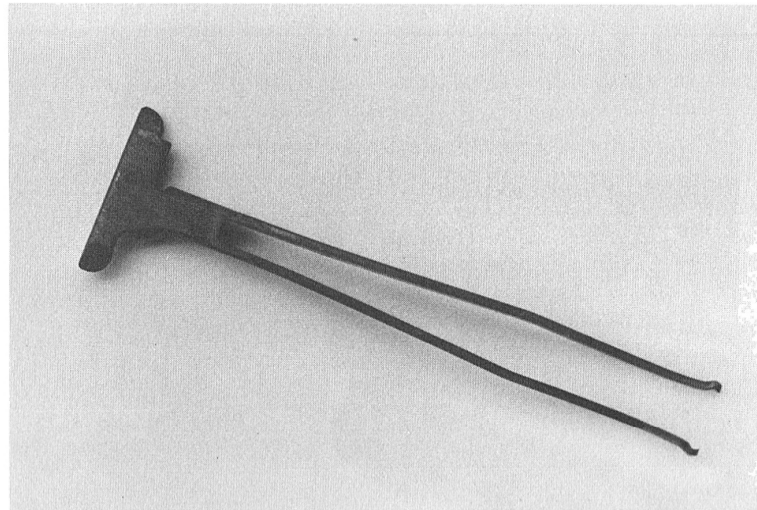

The original bolt group link viewed from top.

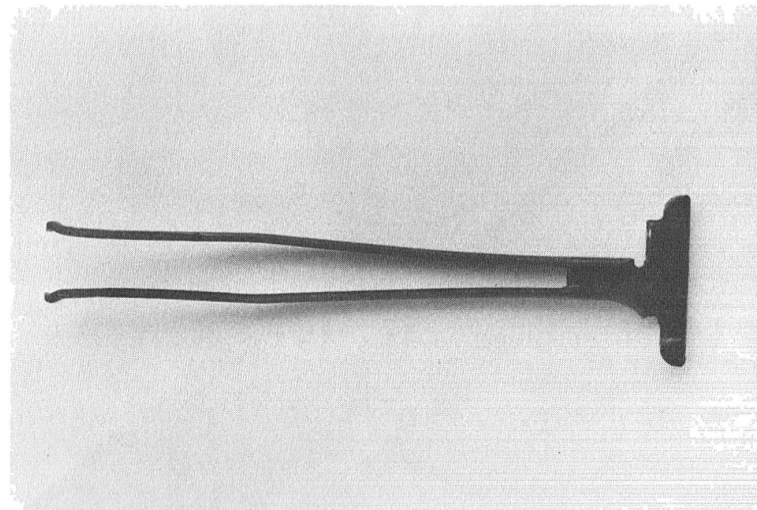

Same link viewed from the bottom before brazing the tripping shoulder plate in place.

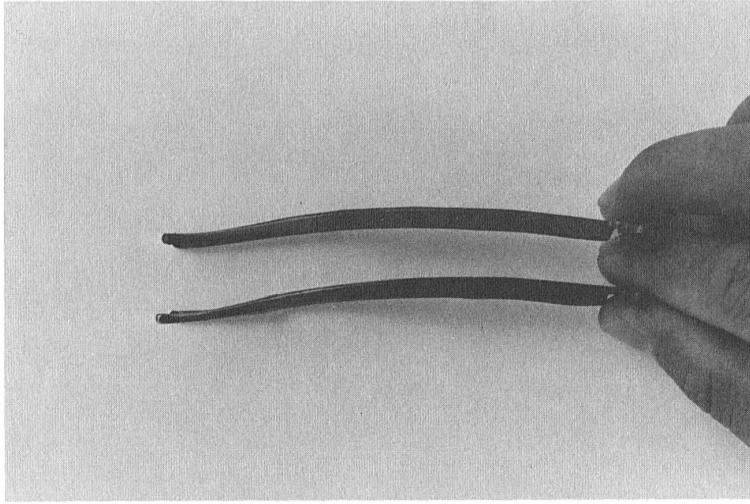

Side view comparison of the original unaltered link (top) and the modified link (bottom).

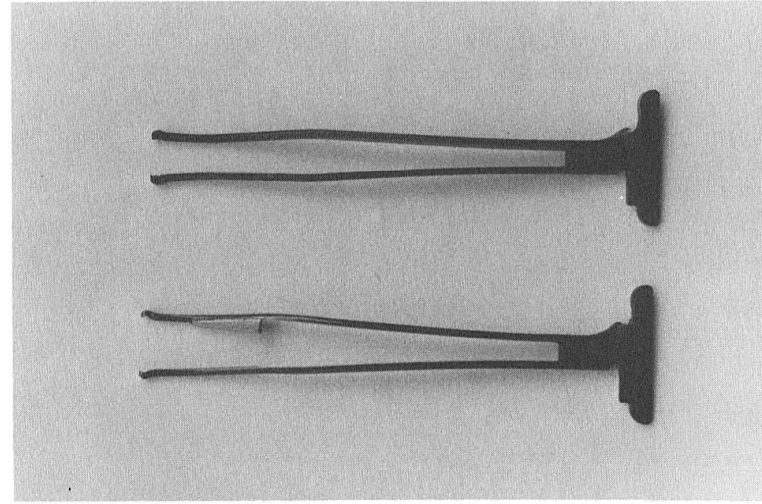

Top view showing the same two links. Note that the modified link below has the tripping shoulder plate brazed on the left side prong. Braze and/or solder the plate as you prefer, but make sure that all unnecessary protrusion of the plate is filed off and polished after it is in place.

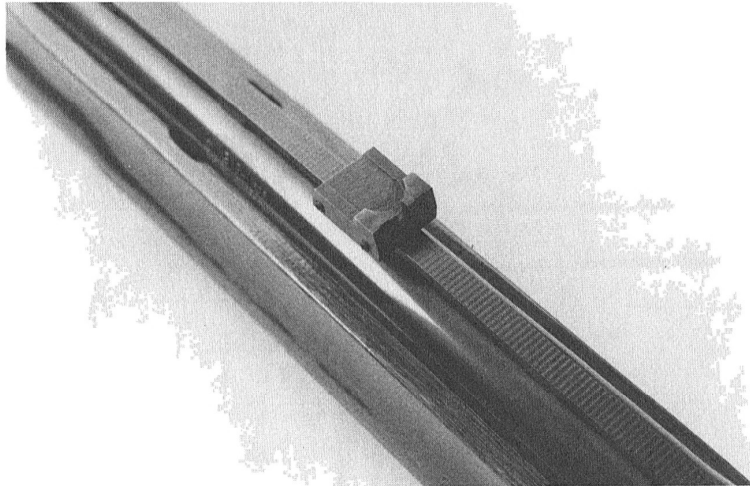

Top perspective view showing the customized rear sight for quick and accurate shooting with slugs. Sight has dual grooves which should be painted white for more accurate alignment in low-light condition.

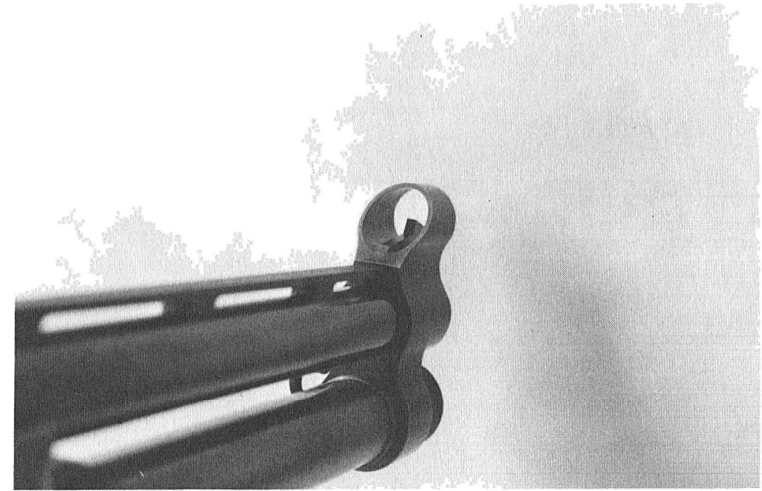

View of the front sight. The custom-built sight has a provision for fluorescent dot on its sight blade and is fully protected by a one-piece, machined-tool steel block.

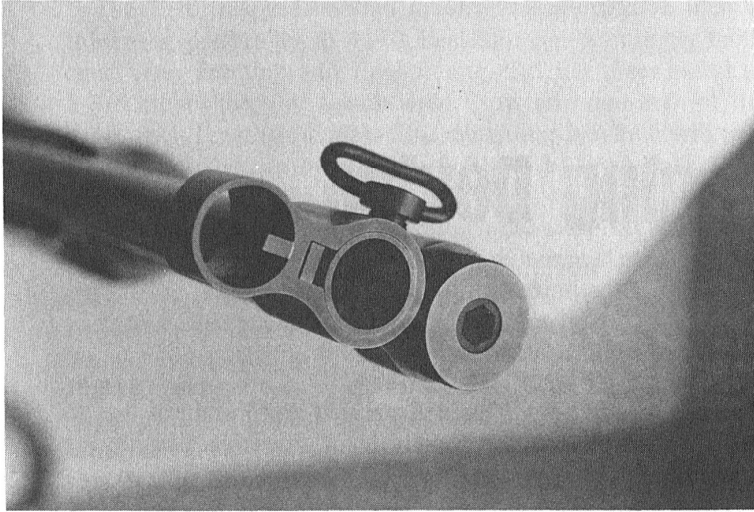

The custom-built front sight viewed from the muzzle. Note the side-mounted sling swivel loop.

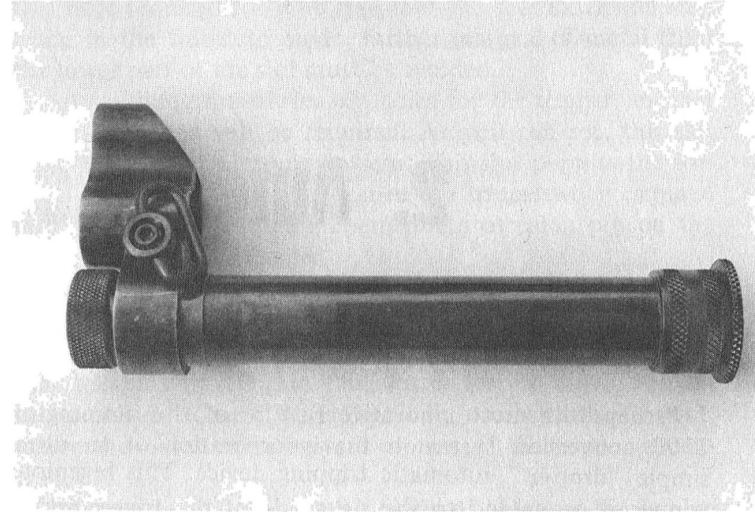

View of the eight-shot extension tubing specially modified to mate with the custom-made front sight base. The modified extension has incorporated an end cap for easier disassembly of the magazine spring unit during field stripping.

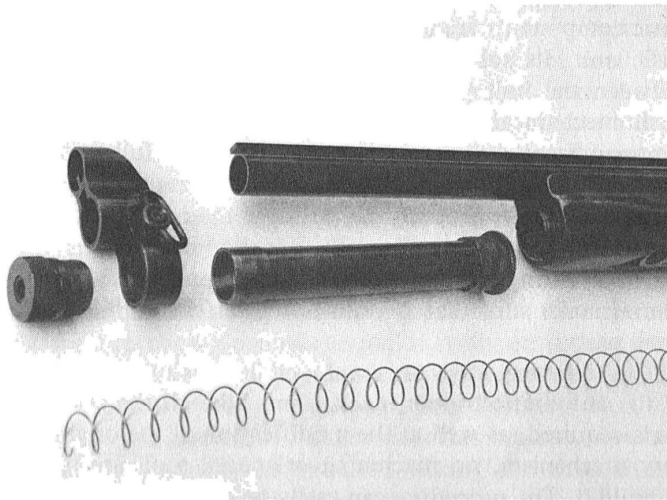

Here the front sight and magazine extension are fully disassembled to show the proper relationship of the components.

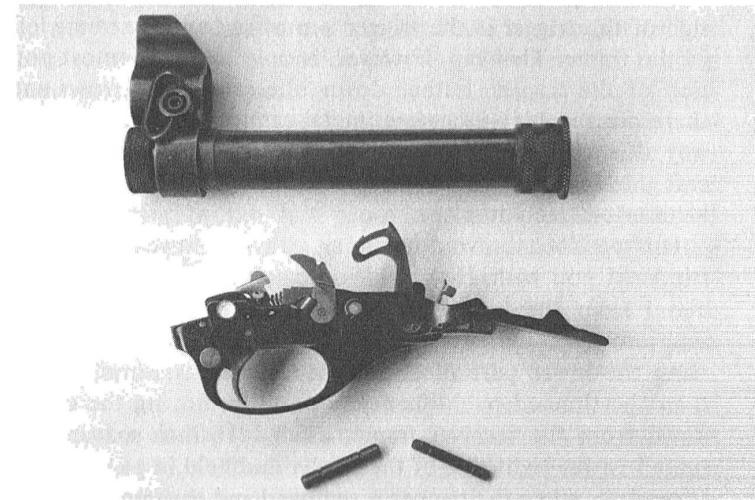

View of the magazine extension unit and the selective-fire trigger plate assembly—the basic ingredients for making a superlative yet affordable, ultimate combat shotgun.

## 2. Automatic Tripping Device

Perhaps the most innovative feature of this Remington 1100 conversion system is the incorporation of an ultra-simple “drop-in” automatic tripping device. This ingenious tripper is assembled to the right side of the trigger and is retained in place by the trigger pin itself. If you will look at the gaps on both sides of the trigger while assembling it within the trigger housing frame, you will note that it is possible to insert a piece of 1/16 inch thick sheet metal on the right side of the trigger if the trigger is pushed to the extreme left of the frame. This gap, however, is only at the topmost portion of the trigger. Further down, the said gap narrows and therefore the 1/16 inch sheet metal cannot be inserted all the way down to the bottom of the trigger guard area. In this case, the lower part of the tripper must be trimmed so it can be inserted freely in place.

It is possible to avoid trimming away the lower part of the tripper if you wish. However, you may have to file off excess metal from the lower part of the trigger housing frame's interior where the fit of the part is tight. If you avoid trimming the lower part of the tripper, it can take more stress than the thinned one. When you prefer removing the excess metal from the receiver frame, use a 1/16 inch spacer positioned to the right side of the trigger and held in place by the trigger pin when the tripper is removed and the gun is used in

semiauto mode only. This will prevent any looseness due to the enlarged gap on the right side of the trigger inside the housing.

### FABRICATING THE AUTOMATIC TRIPPING DEVICE

The automatic tripping device consists of three basic parts: the tripper itself, its spring, and the spring guide. These three basic components are built separately and will perform as one basic unit. Its sole function is to act as a connecting bridge between the bolt group link and sear extension, to accomplish mechanical tripping action of the sear to release the hammer from full cocked position during full automatic mode of firing. It is very important that these three parts are fitted and built properly to perform their individual functions properly, ensuring smooth operation of the device. During final fitting and assembly of the tripper to the receiver frame, make sure that it does not interfere with any other small parts.

The following steps are employed in the simple fabrication of the automatic tripper mechanism. Like all the conversion parts required, as well as the modification of the original factory mechanism, no machining or special tools are required to build it. The procedure can easily be done by hand.



The first step is to obtain sheet metal about .055 inch in thickness, preferably of 4140 steel so it can be suitably hardened after forming and final fitting. Cut the sheet metal to 1 3/8 inches long by 1 inch wide. Now grip one inch of the 1 3/8 inch length in a vise. The remaining 3/8 inch will protrude from the top of the vise and is to be bent to the left. Make sure that when bending this top part that you use at least 3/8 inch or 1/2 inch diameter mild steel rod as a buffer against the part to be bent to eliminate hammer marks on the part to be bent. This mild steel rod is hammered against the part to be bent. Do not hammer the part itself. After bending the top part, file the surface smooth of any blow marks to give clean surface.

After the top part is bent and marks filed off, slightly raise the part in the vise about an eighth-inch. Now locate the spot where you will be drilling the hole for the top lug of the tripper. Refer to the drawing dimension and drill diameter for the location and size of the hole required here.

After drilling the top hole in the bent part, remove the part from the vise and locate the trip spring assembly support pin hole, trigger pin hole, and trigger connector pin hole. Again, refer to the drawing specifications for the exact locations of these holes as well as the drill sizes to be used. It is advisable to make a cardboard template traced from the full scale templates in the book to mark the exact locations of these holes on the right side of the tripper. Simply put the cardboard template on the side of the unfinished tripper and mark with a punch exactly where the center of the pin holes are, as located in the cardboard template.

After the center pin locations have been marked, drill the specified holes in their locations. Note that the top hole for the trigger connector pin is really an oblong vertical slot. The length of the slot must be adjusted gradually during the final fitting. Therefore, it is advisable that you start with an undersize length for this oblong slot and lengthen it gradually as required during the final fitting. Once you have achieved the exact topmost position of the

trip nose required for it to ride over the sear extension step while in the full auto mode, further removal of metal from the lower part of the slot must be avoided.

After drilling the trigger pin holes for the tripper, another slot in this area will be required. As you can see, this slot design will be a cam-type pattern. This slot permits the forward as well as upward motion of the tripper when cammed into action by the trigger connector protrusion pin on the top right side of the trigger.

This slot pattern can be accomplished by drilling a series of holes in the required shape and then finished up using a round needle file for the final form. It is of prime importance that the pins traveling in this slot be free to move, yet not be excessively loose. This is especially true with the top slot, where the elevation or upward motion of the tripper is controlled.

After primary slotting and drilling of holes for the top lug and trip spring assembly support pin, prepare a piece of 1/8 inch thick steel (preferably 4140) for the top lug. Cut the 1/8 inch thick plate to the dimensions specified in the drawing. Now the lower rounded part of the plate will be riveted to the top bent part of the tripper. Make sure to put a slight countersink in the underside of the hole where the top lug is to be riveted. If possible, the rivet head must flush to the underside surface of the bent part. This part can also be soldered in place as required for maximum strength. The final height and shape of the top lug will be calculated during final fitting. Refer to the test procedure sequence as described later in the book for tips on the proper and gradual trimming of this part for reliable performance.

Once the top lug is riveted and shaped in the proper circular pattern as specified, the only remaining part to be added to the tripper is the side base for the trip spring guide. For this part a 3/16 inch diameter rod is required. A piece of drill rod is usable for this purpose. First cut the rod to about two inches in length. Trim about 1/16 inch of one end down to about 1/8 inch diameter. This smaller trimmed diameter

will be assembled and riveted to the right side of the tripper. The left side wall of the hole where this rod will be riveted must be countersunk, as we want to have the rivet head completely flush with the trip surface so it will not rub against the sear spring when assembled in place. After riveting the trimmed end of the rod to the tripper, grip the long end of the rod in a vise and mark the location where the small hole will be drilled for the trip spring guide rod assembly. Drill the rod as specified, then remove it from the vice and grip it again in the vertical position with the tripper on top. Rotate the tripper in a pivoting fashion so that the rivet loosens up. This is necessary since we want the trip assembly support to pivot during operation. After the rivet loosens up, file off any excess head of the rivet flush with the trip surface. Now cut the excess length of the rod to the specified length in the drawing and refit it during final assembly. Make sure that its end is not rubbing tightly against the trigger housing frame where it is assembled, so that the trigger group will function smoothly without undue binding when operated.

After the tripper add-ons and slotting are done, the final contour and required shape of the tripper can now be cut. First, cut close to the pattern with a hacksaw, then finish it up with the appropriate size and shape file. The part is now ready for fitting and adjustment.

As noted, the lower portion of the tripper is thinner as required by the underside gap between the trigger and trigger housing frame. The trimming on the lower portion of the tripper is done gradually, depending on the gap remaining where the tripper is inserted. Make sure to insert both the tripper and the trigger in assembled manner during this process to ensure that proper allowance and fit is achieved.

Heat treat the part after final fitting and polishing.

#### **ASSEMBLY OF THE AUTOMATIC TRIPPING DEVICE WITHIN THE TRIGGER GROUP**

The assembly of the automatic tripping device to the

trigger group is quite simple, since the device comes as one unit. All you have to do is remove the sear spring and then the trigger pin. Now lift the trigger halfway and fit the tripper top slot to the trigger's protruding connector cam pin and assemble the tripper with the trigger in its normal seat. Make sure that the lower end of the trip spring guide is resting inside the shallow hole below the triangular cutout inside the trigger housing frame. It is also best to slightly pivot up the sear extension while fitting the tripper to the trigger cam pin so you will be able to see and make sure that the trigger connectors are in their normal positions during the assembly process. After assembly of the trigger, slightly depress the tripper and realign the lower slot to the trigger pin hole. Push in the trigger pin to retain both parts in the assembled manner.

Push back down the sear extension to its normal position and reassemble the sear spring. The automatic tripper is now assembled and ready for action.



# 3. Replacement Safety/Selector

The original safety mechanism on the Remington 1100 automatic shotgun is of the push-button type. To put the weapon on “safe” position, the button must be depressed to the left. To put the weapon on the “fire” position, the button is pushed back from the right. This safety provision only blocks the trigger from being accidentally pulled. It will *not* render the weapon totally safe since the sear and hammer may still disengage, especially if the weapon is jarred or dropped. A good safety should block at least the hammer or sear, preferably both.

Since we want to eliminate building any unnecessary components, we will settle for the original safety design. This will also allow us to use the original detent ball and spring of the push-button safety for the new replacement one. For shooters who are not familiar with the push-button type safety, the operation of it is quite slow and confusing, especially in the event of an emergency. The replacement safety lever is much easier to manipulate in the dark.

The safety/selector mechanism replacing the original factory push-button safety has three provisional indexes for selective firing operation. When the selector lever is at the rear horizontal position, it is on “safe.” On the middle vertical position it is on “semiauto” and on the full forward horizontal position, “full auto” functioning is achieved.

When the selector is on the “safe” position, its solid shoul-

der blocks the trigger’s back shoulder, preventing it from being pulled. Moving the selector to the semiauto position, the shallower notch will allow just enough clearance for the trigger to be pulled halfway or less, as compared to the full maximum pull on the full auto setting. The semiautomatic notch must be cut gradually while testing the trigger pull until just enough pull is achieved to release the hammer. Avoid excessive deepening of this notch as you may have to trim the front part of the tripper unnecessarily in order to prevent contact with the sear.

If excessive trimming is done to the top part of the tripper where it makes contact with the sear, the tripper may no longer have enough length to reach the sear extension even when the selector is set to the full auto setting.

With the selector lever set at the full auto index, the deepest notch will be facing the trigger back shoulder. This deep notch will permit the trigger to be pressed all the way until its back part is resting against the rear of the trigger guard. This extra long pull on the trigger will push the tripping device far enough so that the front part of it will ride and connect with the top rear end of the sear extension for mechanical tripping of the bolt group link.

Note that the replacement safety selector mechanism is usable whether or not the automatic tripping device is installed to the gun. Without the tripper installed, the weapon

will function in the usual semiauto fashion only, even if the selector is set to the full automatic position. The new safety also offers a definite advantage over the factory safety since it is easier to manipulate.

# 4. Trigger Modification Procedure

The original factory trigger of the 1100 requires only two minor modification procedures, which are easily done using a file and a drill. The first modification requires that the original connector pin riveted to the top part of the trigger be replaced with the same type and diameter pin, with the exception that the replacement pin will have an extra 1/16 inch protrusion on its right side. This small protrusion will act as a cam with the trigger in order to connect it with the scar extension when the trigger is pulled to its maximum length. In this case, the selector is set to a full auto index. The protrusion of the pin (cam) will also act as a guide and stopper for the automatic trigger on its upward and downward actions during operation.

To remove the original riveted connector pin, first drill a small hole in the center of the riveted end. Follow it up with a drill the same diameter as the pin until the rivet head is cleared. Now you can push the original pin out.

In making a replacement pin, make sure you measure the dimension of the original pin, including its neck portion where it was originally riveted. Always add about 1/16 inch to its overall length for riveting purposes. Add about 1/8 inch on the other end where the 1/16 inch protrusion is required on the right side of the trigger. After the two connectors (left and right) are riveted back to the trigger, make

sure that you file the rivet head of the pin flush with the surface of the trigger so it will not rub against the trigger housing frame.

After filing the rivet head flush with the left side surface of the trigger, you can now proceed to trim the pin protrusion on the right side of the trigger. The final length of the protrusion of the pin will depend on the gap that you have on the right side of the trigger, with the trigger assembled in position in the trigger housing. By inserting the trigger into the housing frame, you can actually see how much gap you have as clearance for the pin protrusion. Cut the excess length you see protruding beyond the gap between the right side of the trigger to the inside surface of the housing frame where the trigger is assembled. Make sure that the protrusion of the pin does not bind against the housing frame so that the trigger can operate freely when the trigger is pulled and released.

The second modification required for the trigger is filing off the right lug that makes contact with the selector pin. The right lug must be filed off till it reaches the back arch of the trigger so that the trigger can be pulled longer when the selector is set to full automatic. This clearance will also allow for the necessary indexes for the steel ball of the original safety detent. Note that even though the right lug of the trigger acting with safety block is filed off, the safety is still 100

percent usable since the left lug remains intact and is more than sufficient for functioning the safety. The modified trigger is usable for both the selective-fire selector mechanism or the original push-button-type safety.

# 5. Sear Modification Procedure

The conversion technique requires that the original factory sear be fitted with a rear-end extension to facilitate contact with the connector, as well as perform a tripping action with the automatic tripping device. The original factory sear configuration cannot be depressed from its top rear while the hammer is engaged without exerting tremendous downward pressure. This is due to the position of its pivot pin. In this case, we simply make the front nose of the tripper depress the top rear of the original sear. This arrangement will not trip the sear. Instead, it will lock the link pushing the bolt group as soon as the link shoulder hits the top lug of the tripper before the bolt fully closes. This results in the failure of the link to depress the tripper completely. It is therefore imperative that the sear extension must incorporate a bend in its lower rear end portion to depress the center shoulder of the sear so that the tripping action of the weapon is smooth, without the need for undue force.

The sear extension is easily fabricated from 1/16 inch sheet metal, preferably 4140 gauge steel, so that it can be tempered after forming and fitting. The extension must be riveted to the upper front portion on the right side of the sear. For the proper location of the extension assembly, refer to the drawing and assembly procedures later in the book.

As you should know, the factory sear as well as its major mechanism are heat treated at the factory. It is therefore

necessary that you must first anneal (soften) the sear before you can drill the small hole in which the extension is to be riveted in place. To anneal the part, use a portable propane torch to heat the part to a dull red. Let the part cool down by itself before drilling it.

Before drilling the sear, first build the extension. As you can see, the lower part on the rear end of its extension has been bent. This will rest on the top shoulder on the center part of the sear. First, drill a 1/16 inch diameter hole in the front end of the extension as specified in the drawing, after the part is bent and roughly cut in a semifinished pattern. Now assemble the sear extension to the sear with its rear end bent part resting on the center notched shoulder of the sear. Make sure that the bent part is positioned and seated directly on the rear end of the shoulder without falling off. While gripping these two small parts in the assembled manner, insert a 1/16 inch drill in the front hole of the extension and turn it while pressing it in at the same time so that the drill tip will make a mark on the sear. Remove the extension from the sear. Use a center punch pin to punch the location of the spot where the drill made a mark. Drill a 1/16 inch diameter hole in this location.

Prepare a temporary rivet pin about 1/16 inch in diameter to connect the two parts together while you are making the adjustments for the extension with the tripper. As soon as



the extension is properly adjusted, remove the temporary rivet. Sand, heat treat, and polish the sear extension before riveting it permanently to the sear.

*It is of primary importance that you leave a little looseness in the riveting so that the extension part can pivot slightly during operation. However, do not allow too much gap, for the tripper nose may hit only the edge of the sear extension during tripper engagement, thus disengaging itself, causing malfunction during operation.*

# 6. Bolt Carrier Link Modification

Along with the automatic tripping device, the tripping shoulder added to the bolt carrier link is another major factor in the selective-fire capability of the converted 1100. Without the tripping shoulder added to the link, nothing would activate the automatic tripper to push down the sear extension when the selector is on "full auto." Therefore, without this important modification to the link, the weapon will only fire in the conventional semiautomatic fashion.

The modification required for the link is quite simple. You will, however, need a propane gas torch for silver soldering the shoulder between the two prongs of the link on its rear end. After cutting the shoulder to the required size (refer to the drawing dimensions), it is then attached to either one of the prongs of the link, using a small clamp. Make sure that the part areas to be soldered are clean and free from oil and dirt. Use a new emery cloth to abrade the area to be soldered before cleaning it to ensure a good bond. Apply heat only to the part areas that will be soldered in order not to affect the temper of the extension part of the link. You may wish to wrap a wet cloth around the bolt carrier prong length that is not brazed to retain its original hardness. Make sure that the brazing or solder melts and flows evenly within the seam that you are soldering to ensure maximum strength.

After soldering the shoulder to the carrier prong, allow it to cool down. Trim the inside part of the shoulder into the

designated triangular pattern, which thins out at the rear end. It is necessary that the original dimensional pattern of the two bolt carrier prongs be maintained while trimming the shape of the shoulder. Once you have removed the exact amount of metal from the remaining inside surface of the shoulder, the carrier's original shape must be adhered to.

As soon as the inside trimming of the shoulder is accomplished, the next step is to file off any surface protruding from the top and underside of the prong where the part was soldered. In order to achieve even filing of this excess metal, the rear 1/8 inch ends of the link prongs must be gripped in a wood-padded vise. The part should be positioned in a semi-horizontal manner, exposing the upper back of the prong on the top of the vise. Support the front extension of the link while filing off the excess metal protruding from top of the prongs. The same procedure must be done on the underside. After removing all excess metal from the specified areas, polish all filed areas with emery cloth. Start with the rough type and work gradually up to a smoother one till the surface is highly polished. This will ensure smooth performance during battery.

After the inside and out of the modified areas are polished, measure the distance of the tripping shoulder starting from the rear end of the prongs to the specified dimension. Note that the shoulder is trimmed and adjusted gradually until it

mates perfectly with the automatic tripping device's top lug. It is better to leave excess allowance for this purpose as you can always trim it during the final fitting process. Also make sure that the tripping shoulder is inclined or slanted so that it will depress the rounded nose of the trip top lug smoothly during engagement. Polish the tripping shoulder of the link smoothly after final adjustment is done. Reblue parts only after final filing and polishing.

# 7. Test Firing Preparations

It is advisable never to fire the weapon until you are positively certain that you will not accidentally trip the trigger when you release the bolt into the forward position after you have loaded the first round in the chamber. As a general rule, always put the selector on “safe” position during the loading and unloading process. The following test must be conducted and any deficiency corrected before firing any live round.

1. With the trigger housing unit fully assembled and the selector set on “safe” position, cock the hammer manually. (The trigger group is not assembled to the receiver.)
2. Depress the top lug of the tripper down slowly, feeling any noticeable hesitation or rubbing between the tripper, the trigger, and the sear spring. A slight rubbing of the tripper and sear spring is permissible as long as it does not cause the sear to release the hammer when the tripper is pressed downward. However, operation of the tripper and trigger must be absolutely smooth and without friction. Any surface on either of these two parts that is rubbing hard and causing both to operate in one action when the tripper is pressed down must be completely eliminated or accidental discharge may occur while the bolt is released forward during loading process.
3. All surfaces including the slot where the pin retaining the tripper must be highly polished after fitting is accomplished. This will make the part operate smoothly during battery. Make sure that there is enough play between the trigger, tripper, and sear spring to ensure positive mechanical function of all parts.
4. If possible, heat treat the tripper unit, particularly all contact areas, the stress points (which are the lower thinner part), and the top bent portion where the lug is riveted in place. Buff the part as desired after heat treating to attain smoothness prior to bluing.
5. Reassemble the part after bluing. Check the final fitting and action of the tripper by following the same sequence prior to final adjustments.
6. With the hammer cocked and the selector on “safety” position, depress the top lug of the tripper. Note any hesitation and smoothness. With a pencil or pen, tap the

top portion of the tripper as hard and as fast as you can to simulate a rapid tripping action of the link when the weapon is in battery. The sear or trigger must not be operated during this test so that the hammer is not released accidentally.

7. If everything goes well on the above test, move the selector to "semiauto" position (middle index). The hammer is on cocked position. Place your left thumb on the front of the cocked hammer, and with the rest of your left hand, grasp the trigger housing frame. Press the trigger in normal fashion. The hammer will be released by the sear. Support the forward action of the hammer with your left thumb so the disconnecter will not be affected. Remember not to snap the hammer without supporting it while it is being disassembled from the receiver or breakage or deformation of the disconnecter bend will eventually occur.
8. Now the hammer has snapped forward to "fired" position. Maintain constant pressure on the trigger and recock the hammer. Observe that the front portion of the tripper must not engage with the rear end extension of the sear when the tripper is depressed in this sequence of action. If the front portion of the tripper is touching the end extension of the sear, file it until it clears in order to achieve positive semiauto functioning. *Do not overcut the selector pin notch* on the semiauto position as excessive removal on the front portion of the tripper will create too little length when the trigger is pulled on full auto setting. Remove just enough metal to permit the trigger to be pulled only enough to trip the sear to release the hammer.
9. While the trigger is pressed and the hammer is fully cocked, maintain trigger pressure with your left hand in order to test the tripping action with your right hand

(or vice versa if you are lefthanded). With your right hand, tap the top portion of the tripper with a pencil as hard and as fast as you can. The hammer must not be released accidentally during the process.

10. If everything goes well, repeat procedure with the selector set on "full auto" (full forward position). The only difference is that the front end of the tripper must ride on top of the rear end extension of the sear when the trigger is totally pulled. If you must let the hammer trip onto "fired" position, place a wooden block in between the hammer and the disconnecter bend so the hammer will not hit and damage the disconnecter bend. The wooden block can also be used as a shoulder for automatic recocking of the hammer during the process by pressing the hammer against it each time the tripper trips the sear.

*Note: The above testing procedure for the positive operation of the automatic tripper must first be accomplished and perfectly adjusted before firing the weapon with live rounds. It is also very important to observe the timing of the hammer release by the tripper once the trigger group is fully assembled to the receiver group. The hammer must hit the firing pin only after the bolt group has stopped and the locking mechanism of the bolt has locked itself fully on its seating recess on the barrel extension. If the hammer drops too soon, the weapon is dangerous to fire as the locking process will not have been fully completed. To adjust the timing of the hammer blow or release, file the top part of the tripper lug gradually until the timing is perfected. The filing must be done in a circular shape so that the link tripping shoulder will operate smoothly. Overfiling the top lug may cause miscalculation which will soon prevent the tripper from being pressed down far enough to trip the sear and release the cocked hammer. Polish both the circular contact point of the trip top lug and the link shoulder to ensure smooth contact.*



To further ensure positive and safe operation of your newly converted 1100 prior to firing it with live rounds, test fire it with a primed empty shell. You will need at least ten empty shells, preferably ones which have been fired only once. Remove the fired primer and reload with a live one. Do not load any powder or shots in the shell. Be sure that no live round is mixed in with the primed empty shells. *Double check these empty shells before using them for test purposes.*

To start the test, assemble your gun completely. Put the selector in "safe" position. Pull the cocking handle all the way to the rear. The bolt will be held in the "open" position by the bolt lock. Insert one primed empty shell halfway into the chamber. Make sure the muzzle is pointed in a safe direction, and keep the gun level so the shell will stay in its half-loaded position. Now move the selector lever to full auto position. Press the trigger all the way and depress the square button underneath the loading carrier to release the bolt forward. The bolt will move forward and shove the shell into the chamber in normal loading fashion. While maintaining the trigger pull in this action, note that on the last eighth inch before the bolt comes to a full stop, the hammer will be released by the sear. Do not release your pull on the trigger when the primer is fired. Observe the ejection slot to see if the bolt locking block is fully seated.

If the bolt locking block is not fully seated and the primer is fired, your weapon fired in an unlocked or semilocked position. This must be corrected as the weapon is absolutely unsafe in its present condition to fire live rounds.

In this case, trim the top part of the tripper top lug a little bit more then polish it after filing. Reassemble the whole gun, and repeat the same firing technique as described above until the hammer fall and ignition are properly adjusted: that is, until the locking block is fully seated in its locked position.

# 8. Shotgun Compensator Design

The recoil of the Remington 1100 on full auto can be compared to the .308 Browning BAR automatic rifle. If a real straight stock configuration similar to that of the M16 assault rifle is used on the 1100, it is quite controllable on full automatic mode.

To further reduce the heavy recoil and muzzle climb of this weapon when fired on full automatic, a simple compensator design is included in the book for the benefit of those who are not familiar with shotgun recoil.

The compensator design is installed permanently to the barrel end and is silver soldered in place. A thread-on type system is also adoptable if you will not be using slugs. The threading is done inside the barrel end.

The dimensions for the compensator design are measured 28 inches from the barrel end. If your barrel is shorter or has a different diameter, make the necessary revision of figures. The compensator design system is adaptable to any shotgun using slugs or shot.

# ASSEMBLY - MUZZLE BRAKE

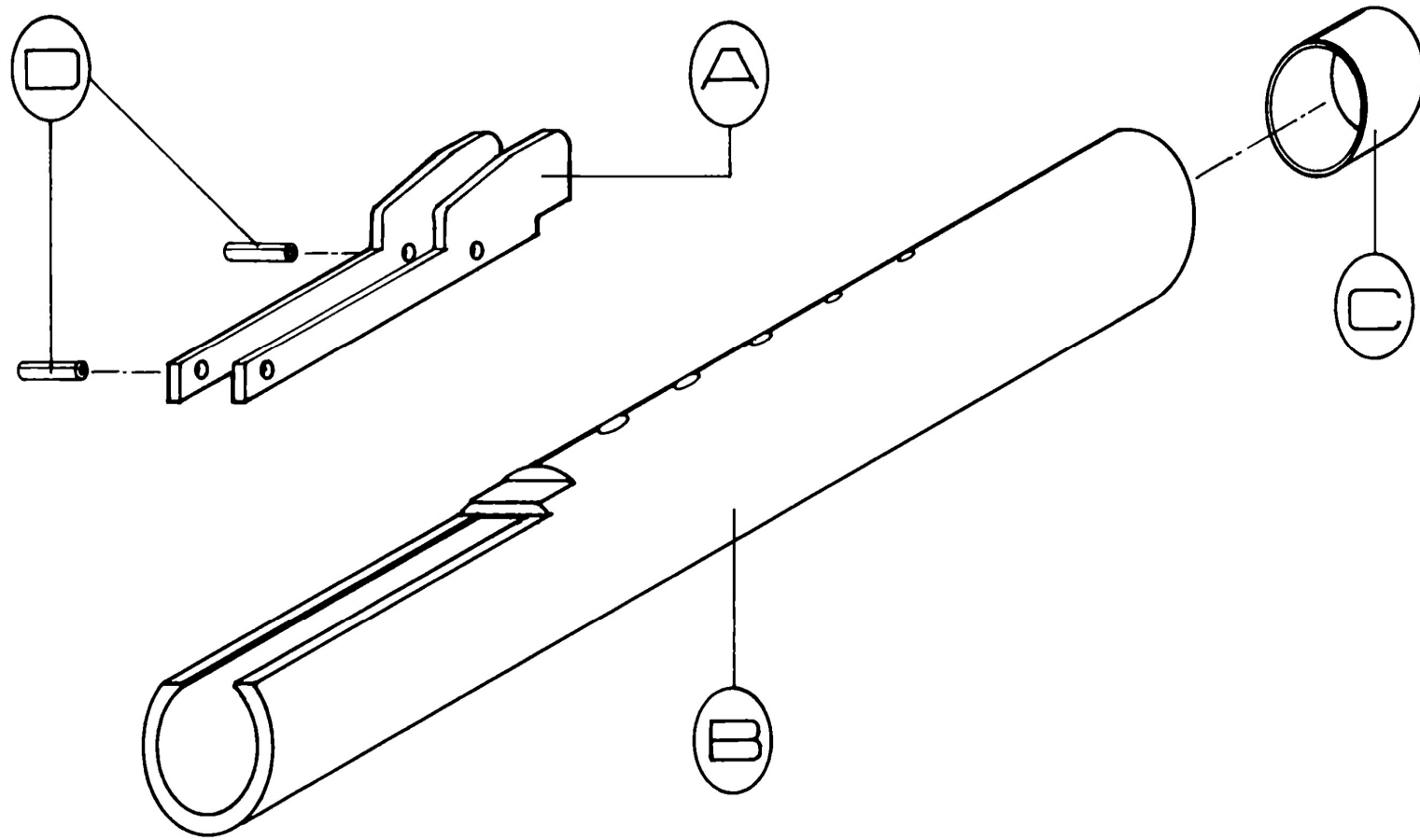

### SHOTGUN COMPENSATOR PARTS AND SPECIFICATIONS

- A. *Mount Base*—Formed sheet metal about 1/8 inch thick. The base is first formed in a square “U” shape, then cut to the specified dimensions. After the part is completed, it is then brazed permanently on the top rear end of the tubing where the long slot is cut. The clearance of the prong will be in line with the slotted end of the tubing during welding of the two parts. The slot and clearance of the base prongs will accommodate the barrel rib of the shotgun.
- B. *Compensator Tube*—Seamless tubing with an inside diameter of 13/16 inch and a maximum thickness of 1/8 inch. The barrel end of the shotgun has an outside diameter of .830 inch. The 13/16 inch inside diameter of the compensator tubing is slightly undersize. The I.D. of the tubing can be easily resized to .825 inch diameter by simply using a rough emery cloth wrapped around a wood dowel slightly smaller in diameter than the inside diameter of the tubing. A series of holes and elongated slots are also incorporated in the tubing. The holes are drilled on top of the tubing and the slots are positioned at about forty degrees in the topmost left-hand side of the tubing. No slots are cut on the right-hand side. The main purpose of the offset slotting is to control the left and upward tendency of the barrel to rise during burst firing. It is best to cut the holes and slots after welding the mount base and before press-fitting the tube end reducer. Debur the inside of the tubing after drilling and slotting by using emery cloth wrapped on the dowel. Better still, cut the long slot in the rear end for rib clearance, and drill the holes and vent slots *before* resizing the inside diameter of the tubing for complete and clean removal of burrs.
- C. *Tube End Reducer*—Seamless tubing with an outside diameter not exceeding .835. The inside can have a maximum diameter of .700 inch so that both slugs and shots can be used. The rear end of the reducer has been tapered to prevent any shaving of slugs when passing through the tubing end. This inside surface of the end reducer must be polished smoothly for optimum performance and less friction. The reducer is to be press-fitted at the front end of the compensator tubing, then brazed or silver-soldered permanently around the seam joining both parts permanently.
- D. *Compensator Mount Pins*—Two roll pins for the 5/64 inch diameter holes are preferred. These pins retain the compensator in place. The barrel end is first inserted inside the compensator, aligning the slotted portion with the barrel rib. Then slightly tap the compensator with a rubber or wooden mallet to force-fit the barrel to the compensator tube. It is important that the barrel be slightly tight when assembling the compensator to it, thus preventing any looseness and gas escape which could affect its muzzle control function during automatic firing. The length of the roll pins is no less than 5/8 inch.

For a shotgun without a rib, using a deer barrel with front sight, the mount base must correspond with the length of the barrel's front sight. The width must be the same for the compensator tubing rear slot. The compensator mount pins can be assembled to the front sight blade itself. For a shotgun with a plain top post front sight, a small slot must be cut in the same manner to pass the front post sight. At least 1 1/2 inches of the compensator's rear end must be soldered to the barrel if this type of barrel is used.



# 9. Parts and Accessories Directory

The following is a list of independent manufacturers and dealers currently marketing parts and accessories for the Remington 1100 shotgun that you may find useful for your individual requirements. It is best to drop a line to these firms and request their catalogs and current price listings. You can also order these parts and accessories through your local gun dealers.

Company	Accessories for Sale
<p>QUARTERMASTER SALES 7201 Avenida La Costa N.E. Albuquerque, NM 87109</p>	<ul style="list-style-type: none"> <li>• Magazine extensions for seven, eight, and ten shots.</li> <li>• Steel spring mag. follower</li> <li>• High visibility shell follower</li> <li>• Sling swivel base clamp</li> <li>• Pistol grip buttstocks and matching foregrip FN-FAL assault rifle-- pattern in olive drab or black colors.</li> </ul>
<p>SAGE INTERNATIONAL LTD. 2271 Star Court Auburn Heights, MI 48057</p>	<p>Folding stocks.</p>

PARELLEX CORPORATION  
P.O. Box "F"  
Chicago Ridge, IL 60415

Magazine extensions for seven, eight, and ten shots.

COBRA  
P.O. Box 30035  
Midwest City, OK 73110

Assault stocks, magazine extensions, and slings.

LA FRANCE SPECIALTIES  
P.O. Box 178211  
San Diego, CA 92117

Specializing in "pistolized" conversions of the 1100 shotgun.

# 10. Machinist's Drawings and Templates

## NOTES ON DIMENSION AND TOLERANCES

Several trigger units were examined to determine the uniformity of the gap between the trigger and trigger housing wall, to which the automatic tripper will be assembled. It was found that some of the units had a gap wide enough to accept the dimension specified in the book. However, the other units examined had a tighter gap which required minor filing on the inside surface of the trigger housing frame where the tripper is inserted during assembly.

When filing the inside housing surface to enlarge the gap, make sure that the tripper will move freely when assembled in place. This is necessary so that the trigger and tripper will not bind against each other when the weapon is in operation. The builder must see to it that this is done properly to prevent accidental discharge. The automatic tripper may accidentally push down the trigger if both parts bind during loading of the first round, if the selector is not set to the "safe" position during the loading process.

The filed portion inside the trigger housing frame as well as the shallow hole drilled in the bottom of the triangle cut-out inside the frame can easily be touched up by using aluminum black to blend with its original finish. Make sure that you clean the surface of the areas to be touched up with

cleaner degreaser or alcohol before applying the aluminum black. It is best to put the aluminum black container in hot water (not boiling) to warm the solution before application so that the solution can penetrate the metal easily.

## 2 TYPES OF "DROP IN" AUTOMATIC TRIPPER

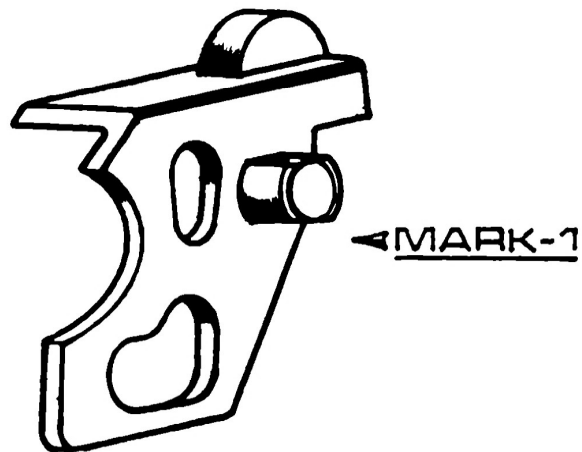

The Mark 1 model is designed primarily for heavy duty use. The original thickness of the material used in its construction is retained. It is, however, necessary that you file the right inside wall of the trigger housing frame to enlarge the gap between the trigger and housing wall to accommodate this part. When removing the tripper unit for non-selective firing, a 3/8 inch diameter by 1/16 inch thick metal spacer must be used and retained in place by the trigger pin. The spacer will prevent the trigger from loosening and shifting. This model is ideal for police and military conversion application.



The Mark 2 model automatic tripper is designed exclusively for light-duty use. It is primarily constructed so that no modification or filing enlargement of the trigger housing frame gap is required. About three-fourths of its lower portion has to be reduced in thickness to compensate for the narrower gap in the trigger assembly pocket. A good tempering throughout is a must for this model.

SCALE: 2X

**MATERIAL SPECIFICATION—  
CONVERSION PARTS COMPONENTS**

1. *Automatic Tripper*—.055 inch thick metal, preferably 4140C steel. Part must be heat treated after all additional lugs are added and required fitting is done.
2. *Replacement Trigger Connector Pin*—1/8 inch diameter drill rod. See riveting specifications and length of pin protrusion on drawing.
3. *Bolt Carrier Link Tripping Shoulder*—1/8 inch thick metal, preferably 4140C steel. Part is to be brazed or soldered to one of the prong ends of the link.
4. *Trip Spring Unit Support Base*—3/16 inch diameter drill rod. A mild steel rod is usable. It is best to leave enough length allowance for the rod end (not the end to be riveted) so the rod can be gripped in a vise by this extension during riveting and drilling.
5. *Automatic Tripper Top Lug*—1/8 inch thick metal, preferably 4140C steel so it can be tempered after final fitting and riveting. Installation of this part to the tripper is like riveting a front sight on pistol.
6. *Sear Extension*—5/64 inch (.078) thick sheet metal, preferably 4140C steel. Part must be heat treated with sear after riveting and final fitting.
7. *Sear Extension Assembly Rivet*—1/16 inch diameter drill rod. See specifications.
8. *Selector Lever*—1/8 inch thick metal plate. Mild steel is usable. Lever is to be brazed or soldered permanently to pin.
9. *Selector Lever Pin*—.340 inch diameter drill rod. Note that the diameter of the pin is nonstandard. The closest standard diameter drill rod size that you can get is 11/32 inch diameter drill rod. Lathe turn or file the 11/32 inch (.344) diameter rod to .340 to match the diameter of the original push-button-type factory safety.
10. *Tripper Spring Guide*—5/64 inch (.078) sheet metal, preferably 4140C steel. The bottom end of this part is in oval-pointed shape. The part which will be inserted to guide the spring is rounded to .070 inch diameter.
11. *Tripper Spring*—.018 inch to .020 inch diameter music wire spring. Maximum O.D. of coil is .117 inch. Maximum number of coils is 12. The overall length with spring expanded (normal) is 9/16 inch. The AR-15 front sight post detent spring can be used if you cannot make your own spring. Order this spring through your dealer or any Colt distributor.

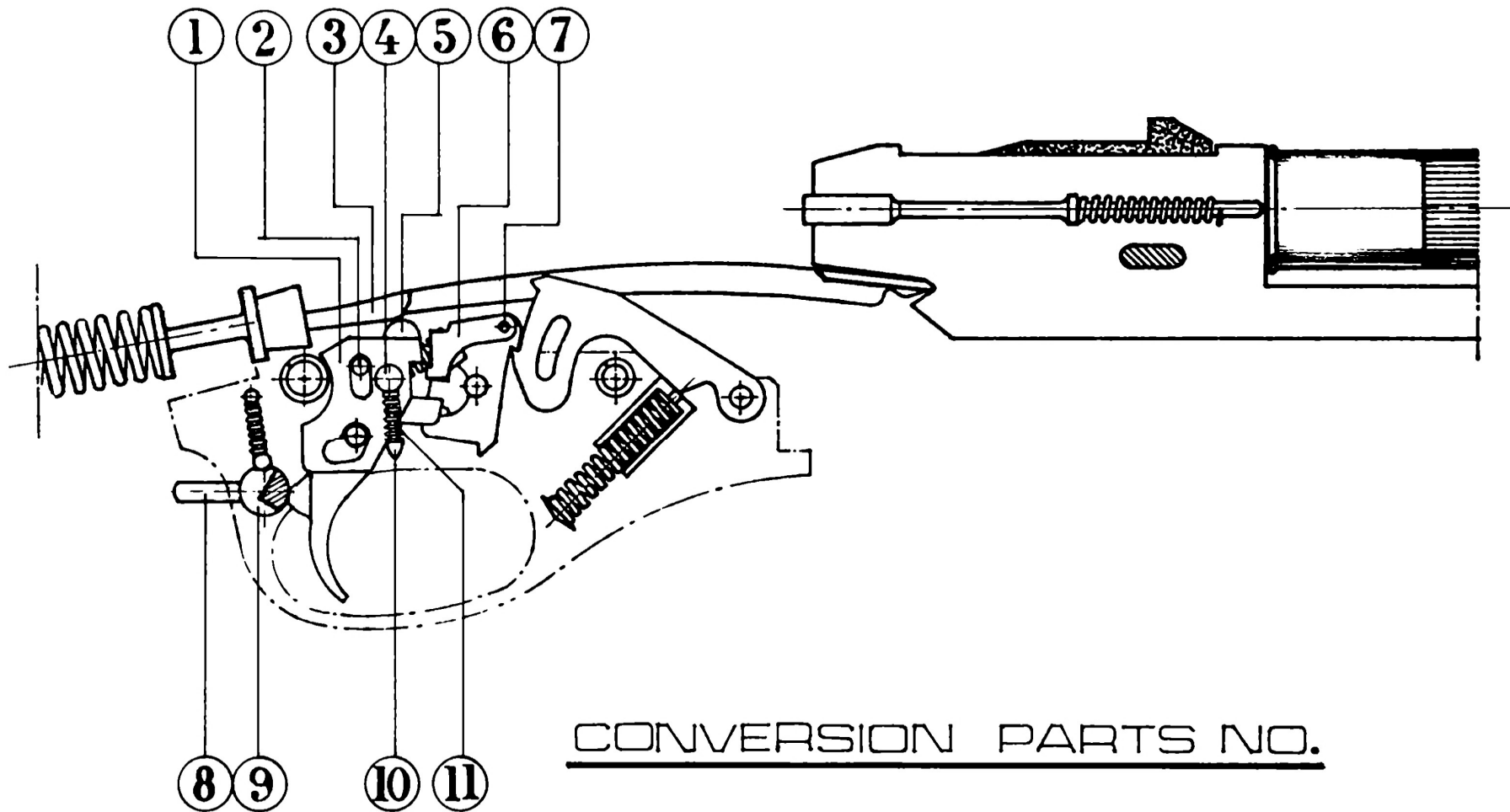



# FULL SCALE TEMPLATES

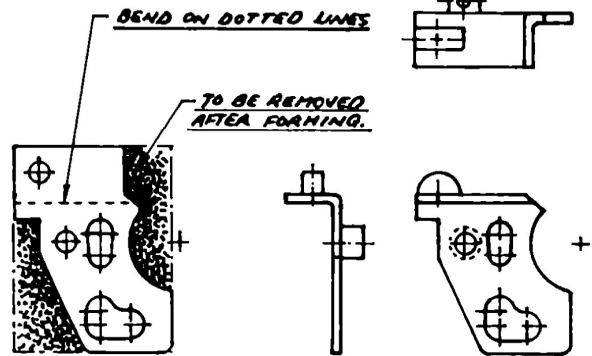

AUTO. TRIPPER

PART COMPLETED  
READY FOR FITTING.

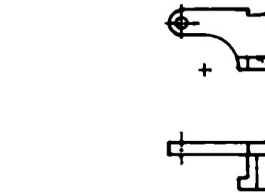

SEAR EXTENSION

## ORIG. TRIGGER MODIF.

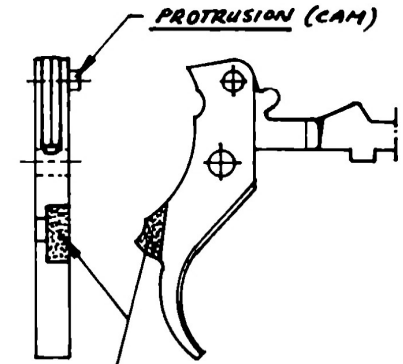

SHADED AREA TO BE REMOVED

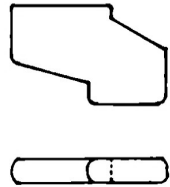

SELECTOR LEVER

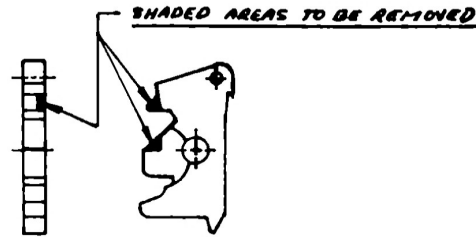

ORIGINAL MODIFIED SEAR

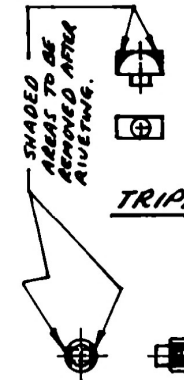

TRIPPER TOP LUG

NOTE:  
SELECTOR NOTCHES & INDEX SETTING  
TO BE DONE AFTER PIN & LEVER ARE  
BRAZED TOGETHER. SEE ASSEMBLY DRAWINGS.

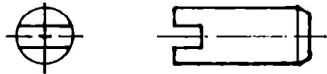

SELECTOR LEVER PIN



SEAR SPRING



TRIPPER SPRING  
GUIDE



TRIPPER SPR.



REPLACEMENT  
CONNECTOR PIN

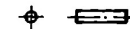

SEAR EXTENSION  
RIVET.

TRIPPER SPRING SUPPORT BASE

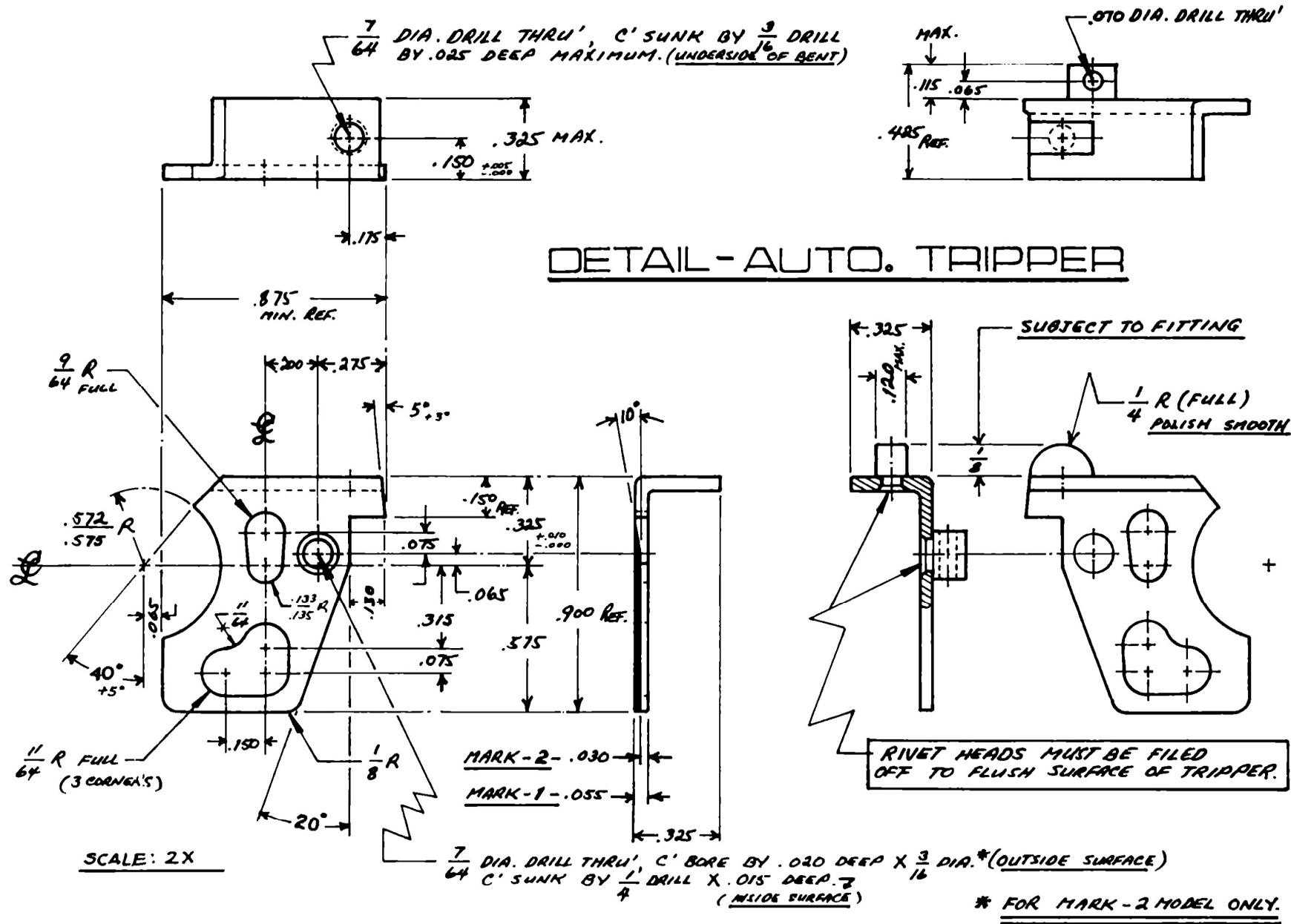

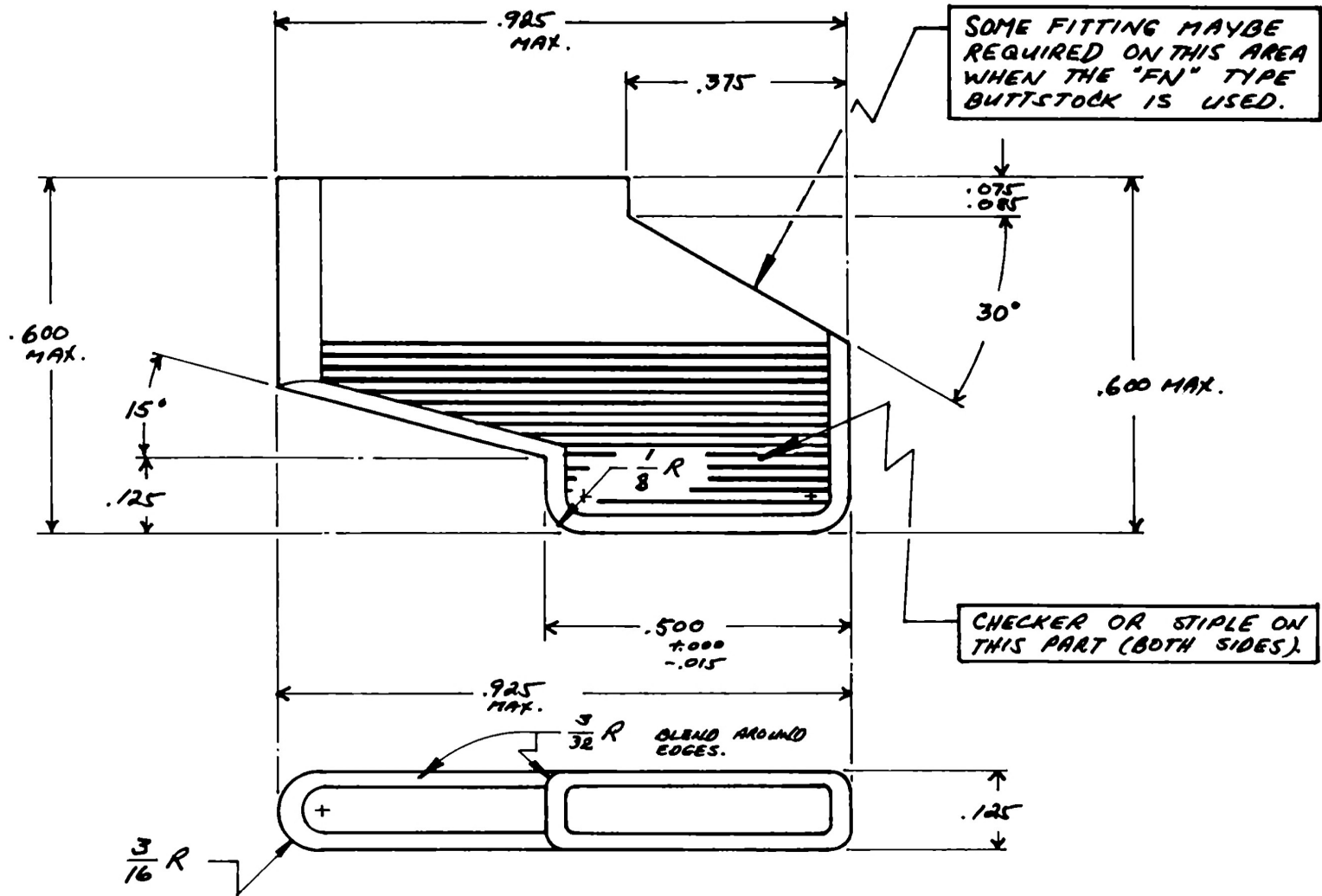

SCALE: 4X

DETAIL - SELECTOR LEVER

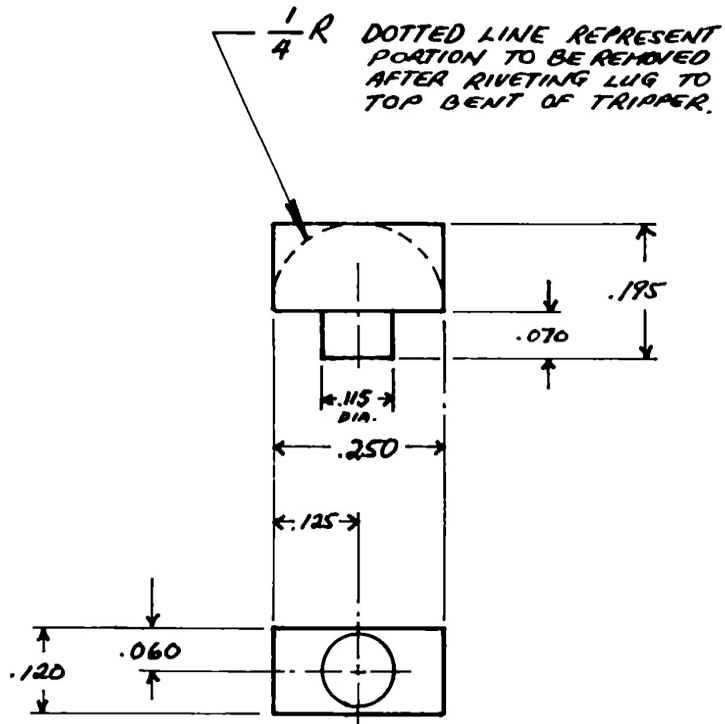

Scale: 4X

DETAIL-TRIPPER TOP LUG

DETAIL-REPLACEMENT CONNECTOR PIN.

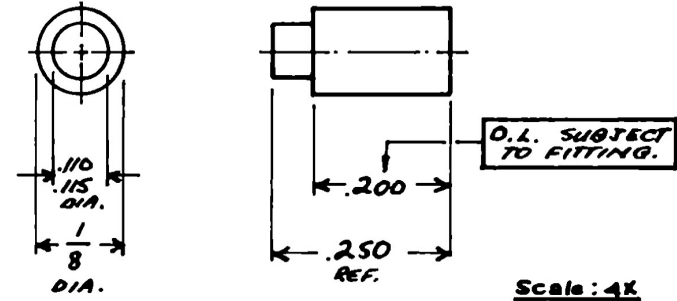

Scale: 4X

DETAIL TRIPPER SPRING BASE

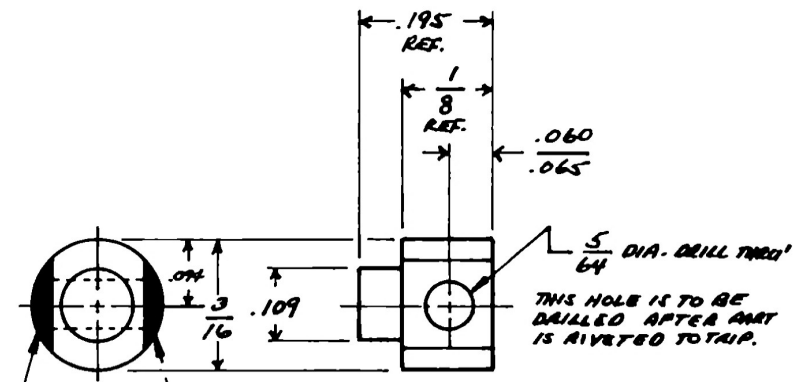

Scale: 4X

SHADED AREAS TO BE REMOVED AFTER RIVETING & LOOSENING RIVET HEAD FOR FREE ROTATIONAL MOTION OF ROD.

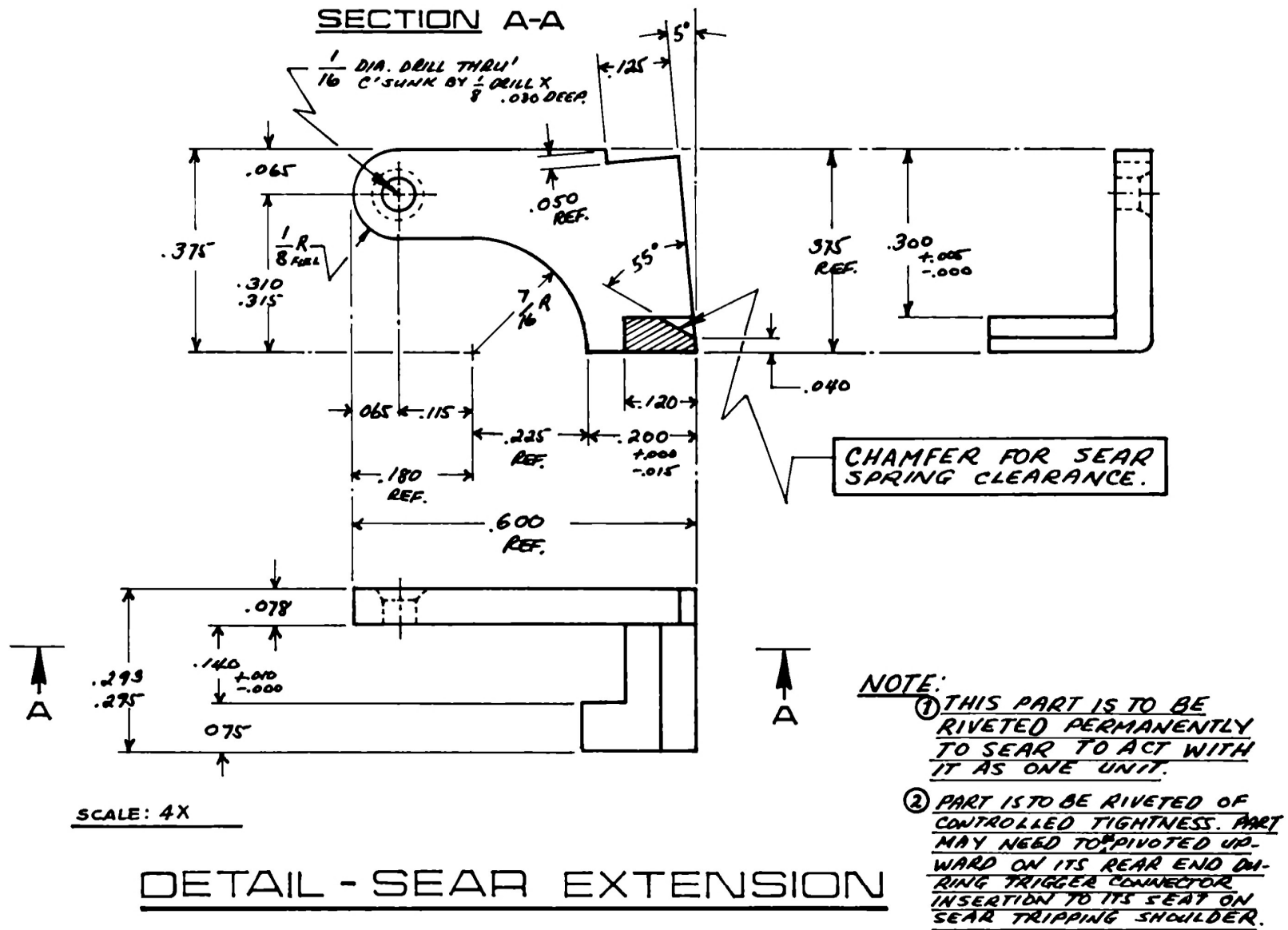



# DETAIL-TRIP SPRING

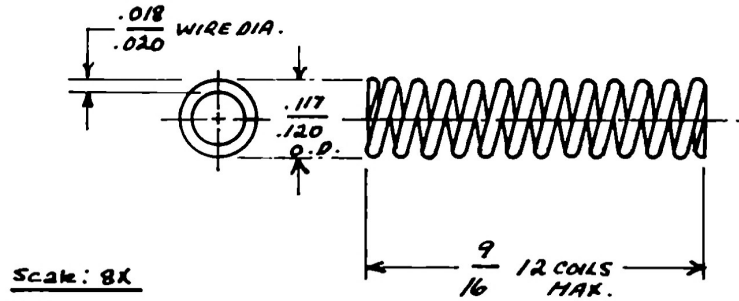

SPRING STRESS RELIEVED AFTER FORMING.

# MODIFICATION ORIGINAL SEAR SPR.

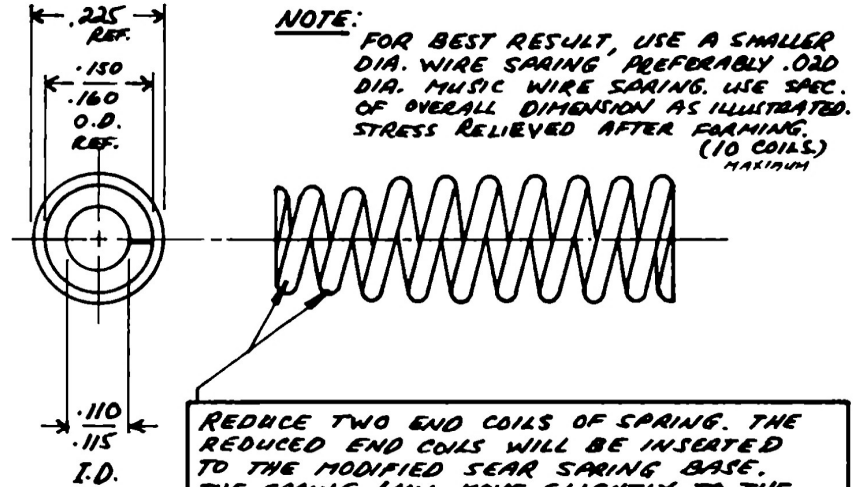

**NOTE:** FOR BEST RESULT, USE A SMALLER DIA. WIRE SPRING, PREFERABLY .020 DIA. MUSIC WIRE SPRING. USE SPEC. OF OVERALL DIMENSION AS ILLUSTRATED. STRESS RELIEVED AFTER FORMING. (10 COILS.) MAXIMUM

REDUCE TWO END COILS OF SPRING. THE REDUCED END COILS WILL BE INSERTED TO THE MODIFIED SEAR SPRING BASE. THE SPRING WILL MOVE SLIGHTLY TO THE LEFT DURING ASSEMBLY TO PREVENT IT FROM RUBBING AGAINST THE SEAR EXTENSION.

Scale: 4X

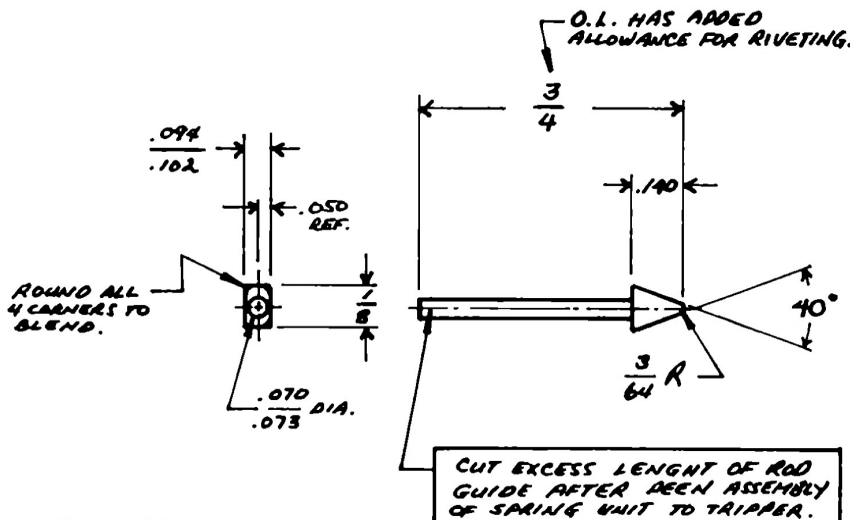

# DETAIL-TRIP SPRING GUIDE

# DETAIL-SEAR EXTENSION PIN

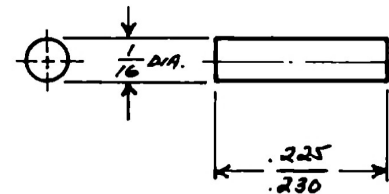

**NOTE:** BOTH ENDS TO BE RIVETED WHEN ASSEMBLING SEAR & SEAR EXTENSION UNIT.

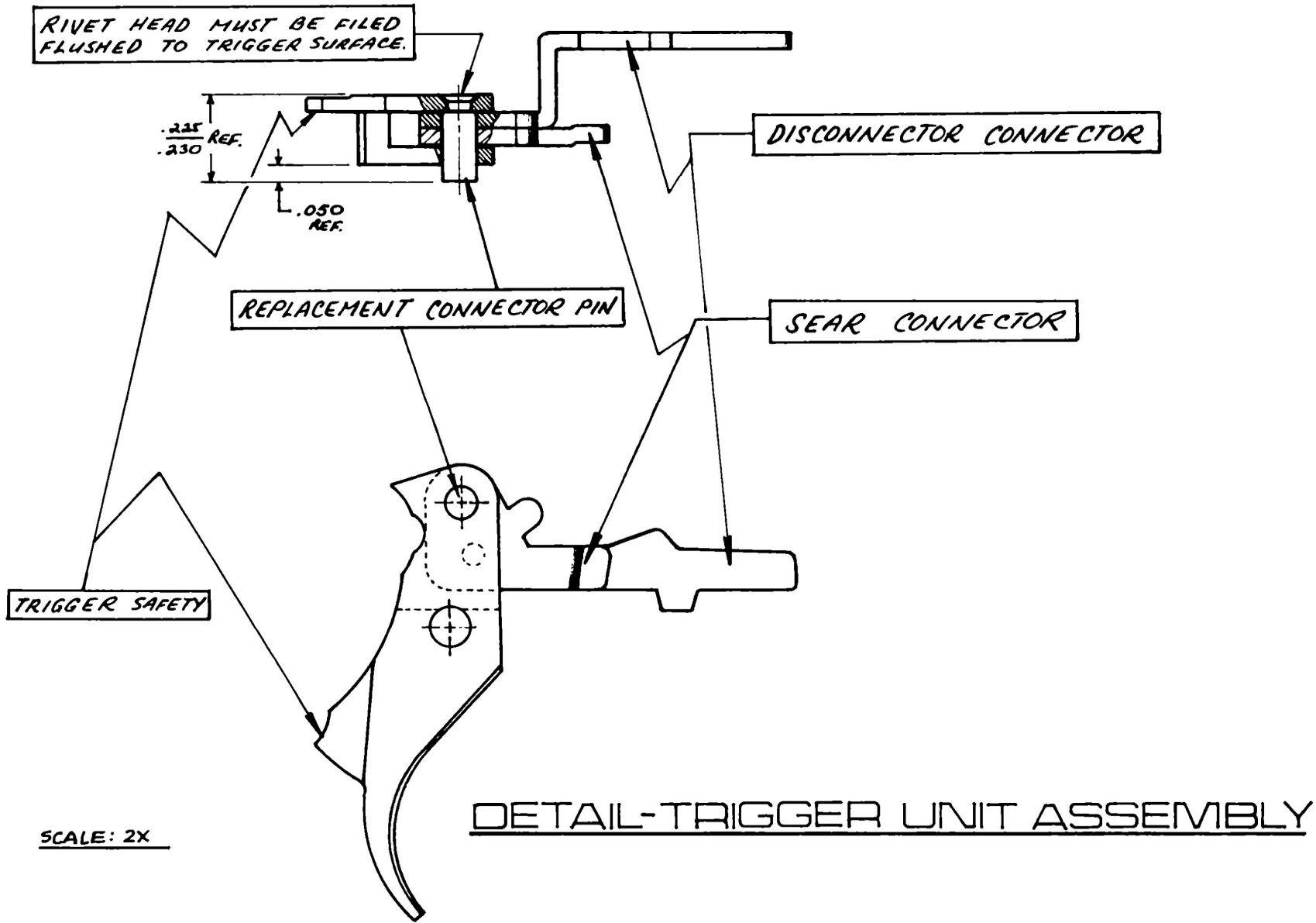

# DETAIL-SELECTOR LEVER PIN

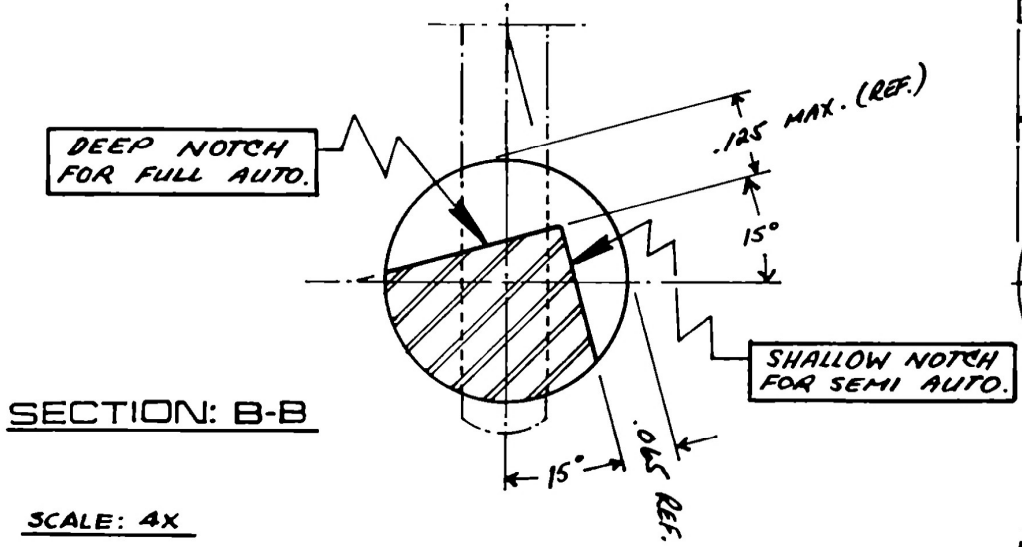
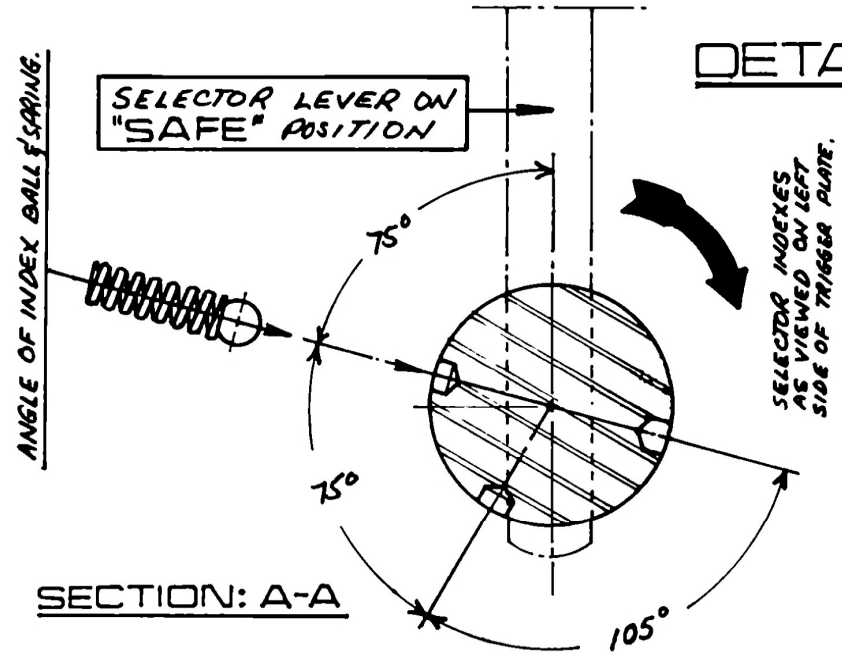

SCALE: 4X

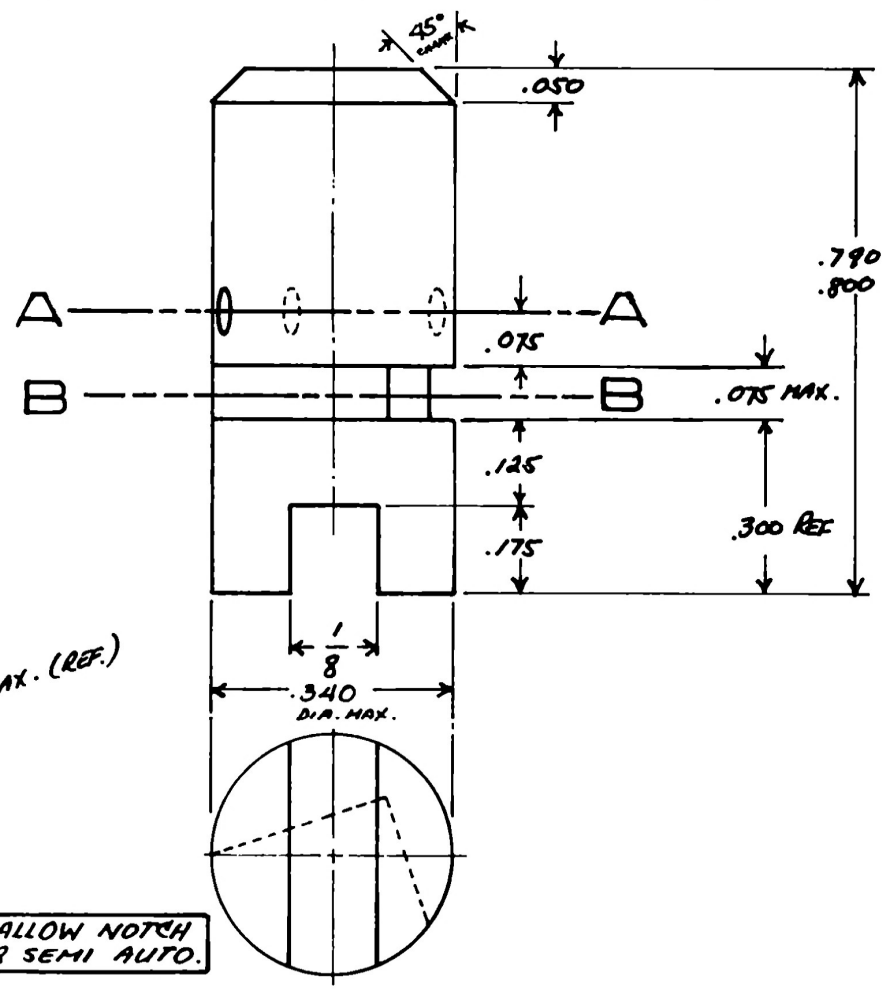

**IMPORTANT:**  
SEE NOTES FOR ACCURATE INDEX & TRIGGER PULL CONTROL NOTCHES.

ORIGINAL SEAR

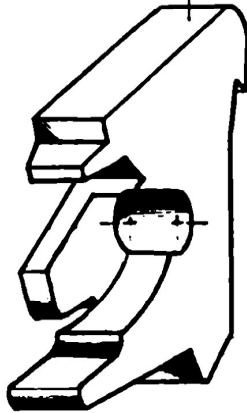

MODIFIED SEAR

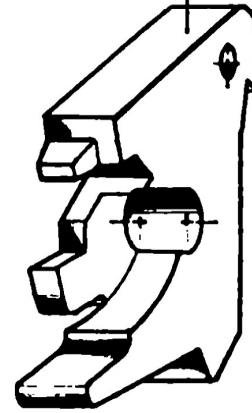

SCALE: 2X

SEAR COMPARISON-ORIGINAL & MODIFIED

ORIGINAL

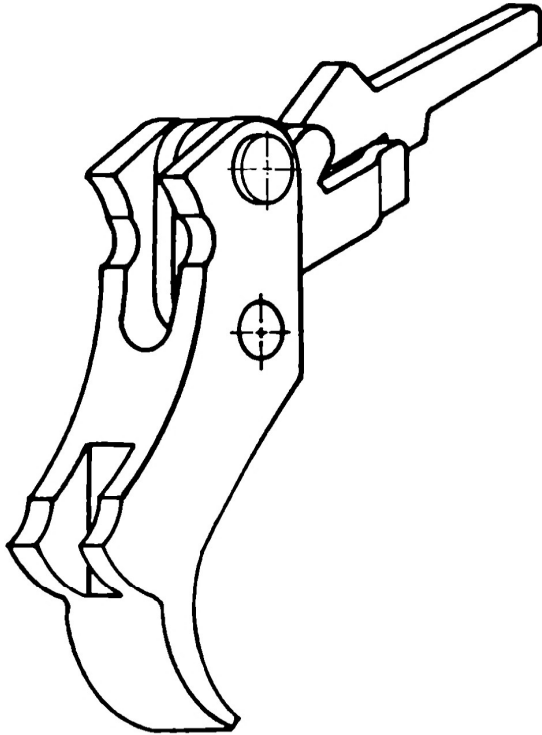

MODIFIED

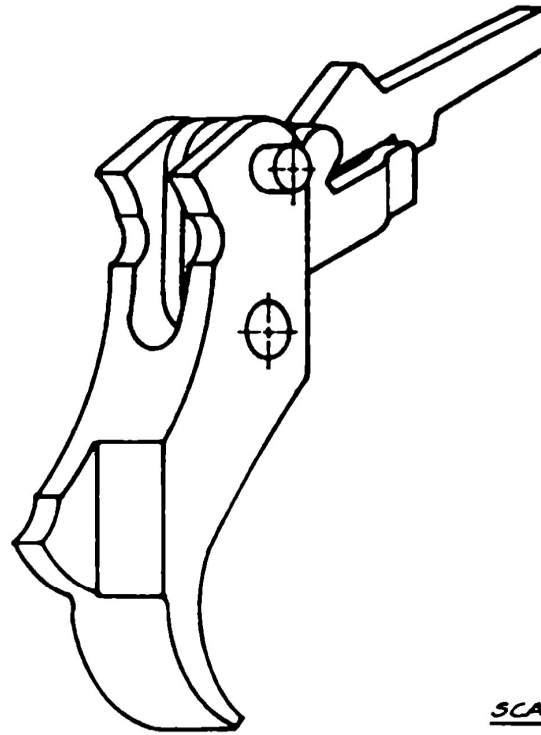

SCALE: 2X

COMPARISON-TRIGGER ASSEMBLY



## STEP BY STEP PROCEDURES IN SIMPLIFIED AUTOMATIC TRIPPER MANUFACTURE.

1. Cut a 7/8 inch wide by 1 3/16 inch long piece from .055 inch thick sheet metal. Good quality steel of known analysis is preferred here so it can be properly heat-treated.
2. Trace the cardboard full-scale template onto the sheet metal. Make sure you use metal ink or a permanent-type felt marker if metal ink is not available. Gun blue can also be used for this purpose.
3. Mark the center locations of the holes and slots for drilling. If possible, also mark the full outlines of the slots for later filing purposes.
4. Bend the top portion of the metal as indicated by the dotted lines. The larger portion (lower part) of the metal can be gripped in a vise during bending.
5. Using the appropriate drill size that matches the specified hole diameters, drill the marked center areas of slots and rivet holes.
6. Using a small round needle file, remove shaded areas to join holes to form the slots.
7. Countersink the underside hole for the tripper top lug rivet head.
8. Counterbore a 3/16 inch diameter by .020 inch deep hole for the trip spring unit base rod. Counterboring is necessary only for the Mark 2 model to level it off with its trimmed portion. The Mark 1 model need not be counterbored. The other side of this hole must also be lightly countersunk to accommodate the rivet head of the base rod.
9. Using a hacksaw, cut the shaded areas as closely as you can. Finish to final shape with appropriate files.
10. Trim by filing off the lower portion (outside surface) of the tripper for Mark 2 model to fit the gap between the trigger and frame wall to where this part is to be assembled. The maximum thickness must not exceed .030 inch so that the lower part will have enough strength for heavy-duty use. If your frame and trigger gap will not permit the insertion for the maximum thickness allowance for the Mark 2 model, a slight filing will be needed on the inside surface of your housing frame at the location where this part is inserted. Slight allowance for this purpose will not affect the performance of your weapon.
11. Rivet the top lug on top of the bent portion of the tripper. It is best to start with a rectangular head, then round it after riveting. Good quality steel plate is preferred so it will not wear easily, as this part serves as a contact point for the bolt carrier link tripping shoulder each time the bolt closes to fire the weapon. Tight riveting is necessary to prevent the lug from shifting during operation. The lug can also be soldered or brazed in place if required. Make sure to file off the protruding rivet head from tripper surface.
12. Rivet the trip spring base to the right side hole of the tripper. It is best to add about 1/2 inch length allowance to the specified overall length of the base. This extension part can be gripped vertically in a vise while riveting the part into place. The same procedure applies to the top lug. A mild steel 3/16 inch diameter drill rod is suitable for this part.
13. File off shaded areas. The top lug must be rounded to shape then polished smoothly. The base rod must be filed flat on top and bottom, making a flat width not

# AUTOMATIC TRIPPER MANUFACTURE

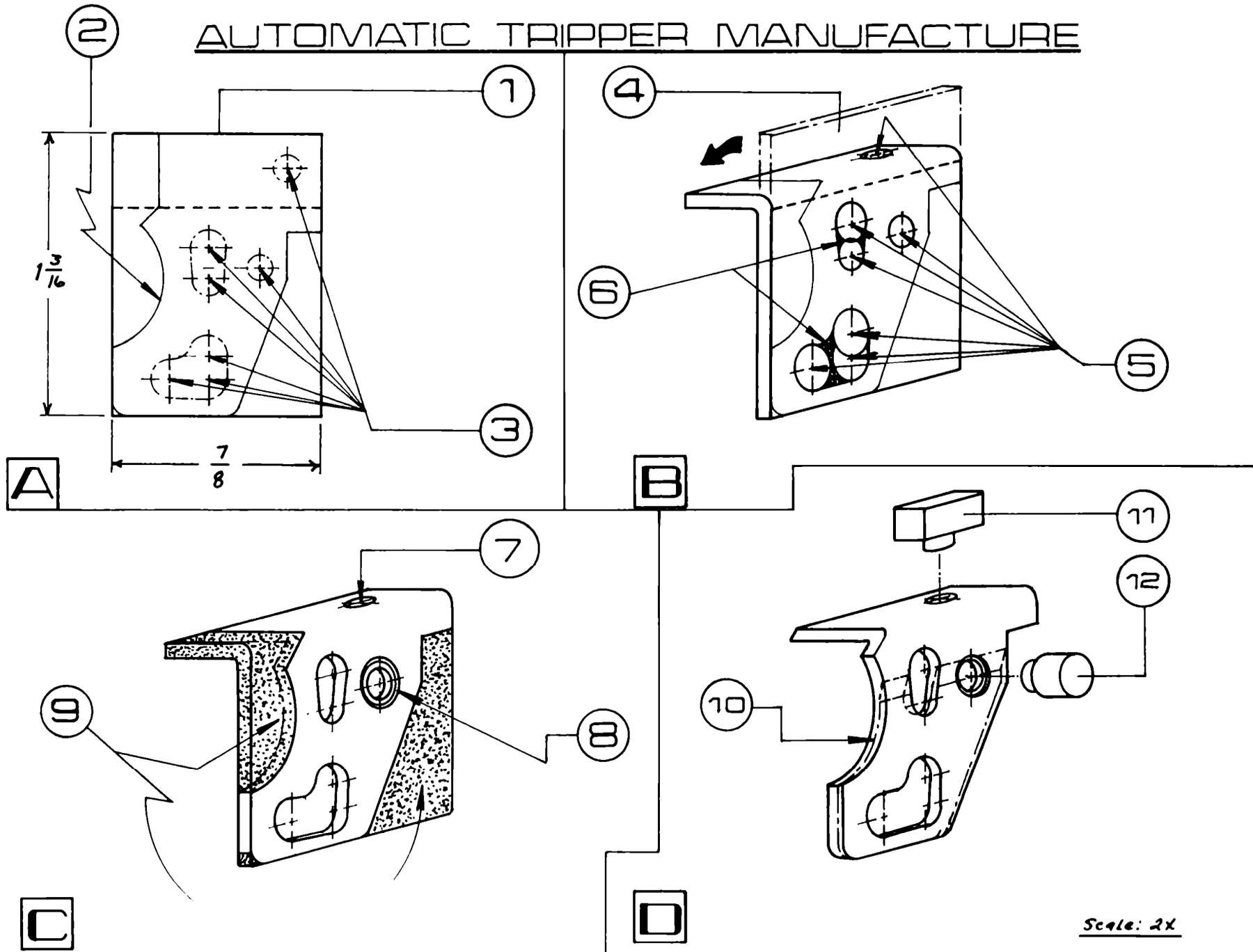

Scale: 2X

E

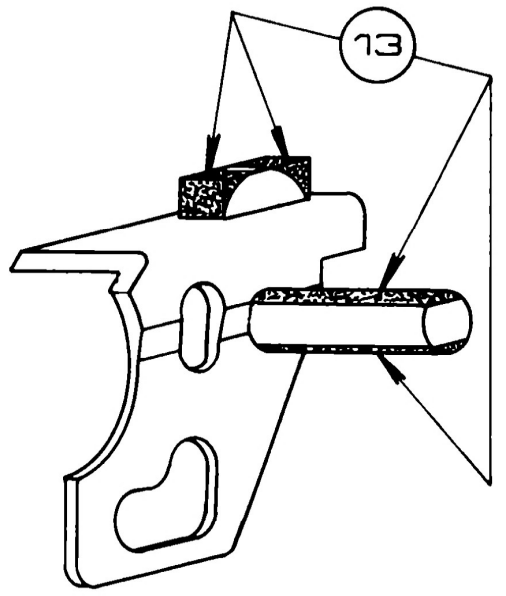

F

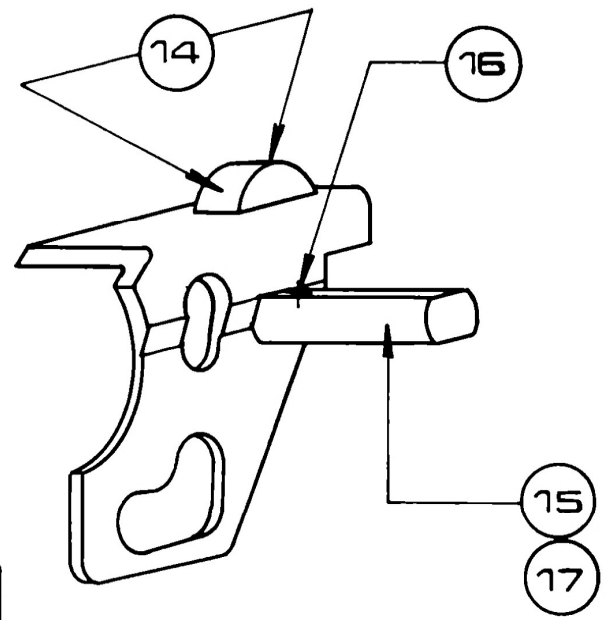

G

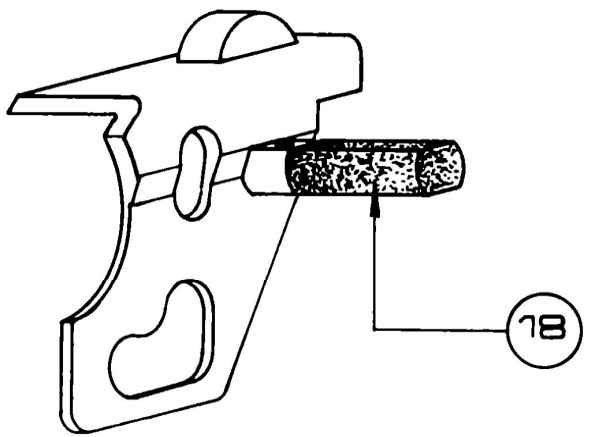

I

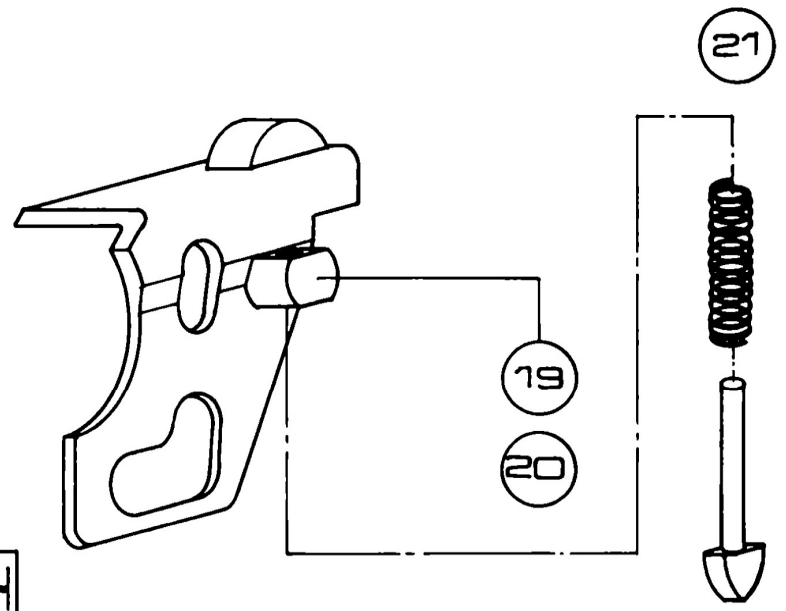

exceeding 1/8 inch in thickness.

14. Polish smooth the top lug and check for proper tightness.
15. Grip the base extension part in a vise horizontally with its top portion facing up.
16. Mark the location for the trip spring guide assembly hole with a center punch. After marking the location of the hole with a punch, drill a 5/64 inch diameter hole through. Lightly countersink both ends of the hole to remove burrs on the hole edges.
17. Remove the rod extension and regrip it in the vise in a vertical position with the tripper on top. Now rotate the tripper clockwise as well as counterclockwise until the rivet head loosens up to permit the trip to rotate freely during operation. After the rivet loosens up, file any protruding surface of the rivet flush to the tripper's inside surface so it will not rub against the sear spring when the part is assembled in place.
18. Remove the base extension by cutting it with a hacksaw and square off the face to specified overall length. Note that the overall length of the base rod is subject to fitting during final assembly. If the protrusion is rubbing tightly on the side wall of the trigger housing frame, it must be reduced till it can move freely during operation.
19. Check the fitting of the overall length of the base rod.
20. The automatic tripper is now ready for final fitting. After the part is fitted properly, make sure to polish smoothly all contact surfaces, including the slot edges for smooth action.
21. Trip spring and its guide can now be assembled permanently (spring guide top end must be expanded or flared up to prevent the spring unit from coming off) with the automatic tripper.

*Note: To determine the exact location of the spring rod that needs to be expanded in order to retain spring unit in place, the tripper with the spring and guide rod must be fully assembled in place with the trigger. The tripper will be forced upward by its spring unit. Mark the top edge of the guide rod where the spring guide levels up. Just above the marked line, expand the end by peening it with a center punch till it has enough width to prevent the spring unit from coming off. Any excess length above the peened end must be trimmed.*

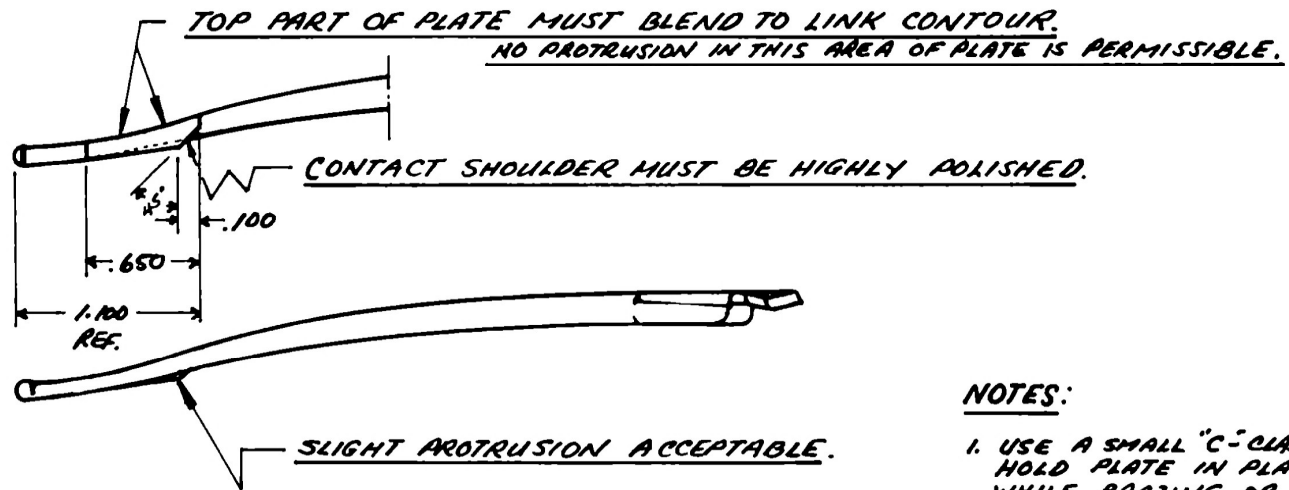
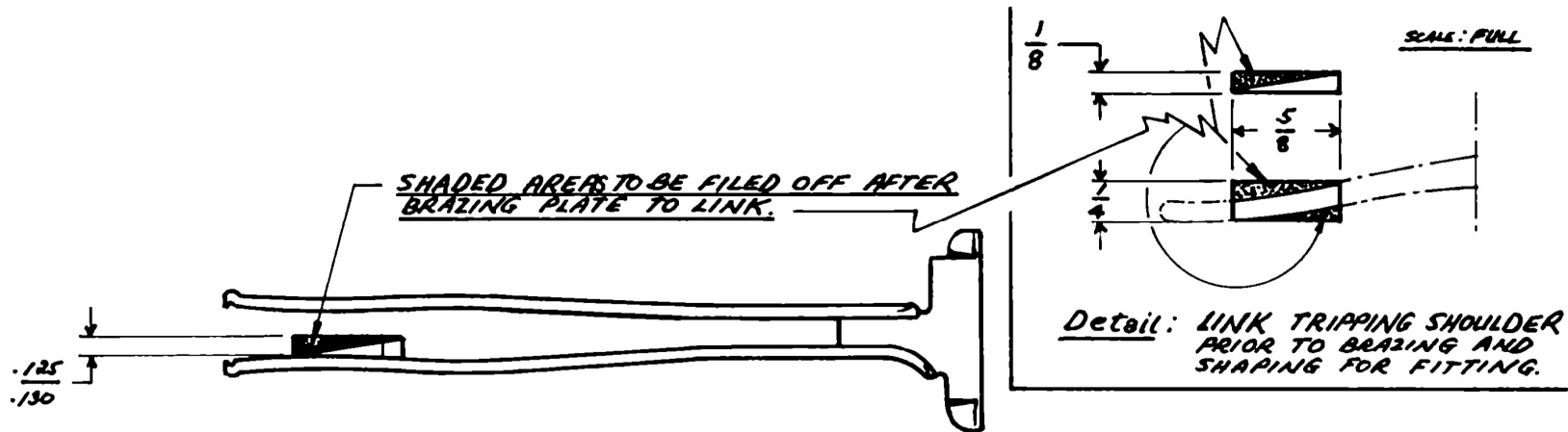

SCALE: FULL

## MODIFICATION-BOLT CARRIER LINK

### NOTES:

1. USE A SMALL "C"-CLAMP TO HOLD PLATE IN PLACE WHILE BRAZING OR SOLDERING. A LONG NOSE VISE GRIP OR SIMILAR TOOL WILL DO SAME.
2. CONTACT SHOULDER OF PLATE MUST ONLY BE REMOVED GRADUALLY DURING FINAL FITTING.
3. POLISH ALL SURFACES OF PLATE AFTER FINAL FITTING.

MODIFIED SEAR

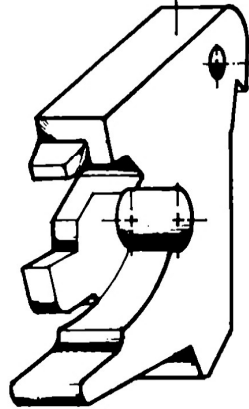

6

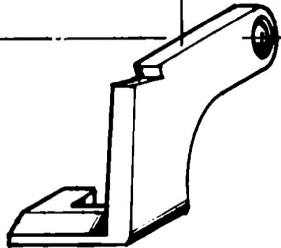

7

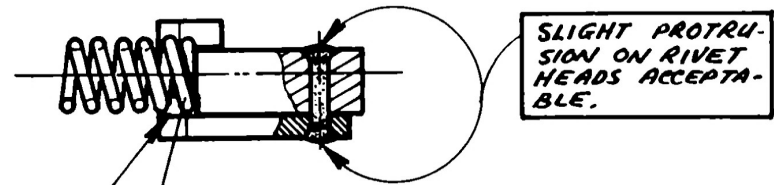
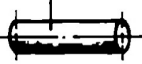

SLIGHT PROTRU-  
SION ON RIVET  
HEADS ACCEPTA-  
BLE.

SEAR SPRING MUST NOT  
RUB AGAINST SEAR EXTEN-  
SION INSIDE SURFACE (X)

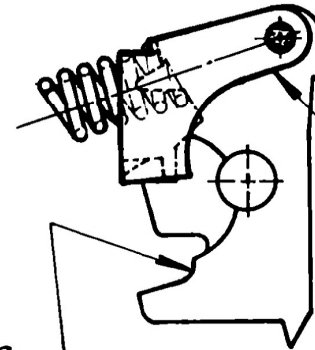

CHECK THIS AREA OF  
EXTENSION PART DU-  
RING ASSEMBLY OF  
SEAR UNIT TO TRIGGER  
HOUSING FRAME. MAKE  
SURE THAT IT IS NOT RU-  
BBING AGAINST HOUSING.

SEAR TRIPPING SHOULDER

SCALE: 2X

RIVET ASSEMBLY - SEAR & EXTENSION UNIT

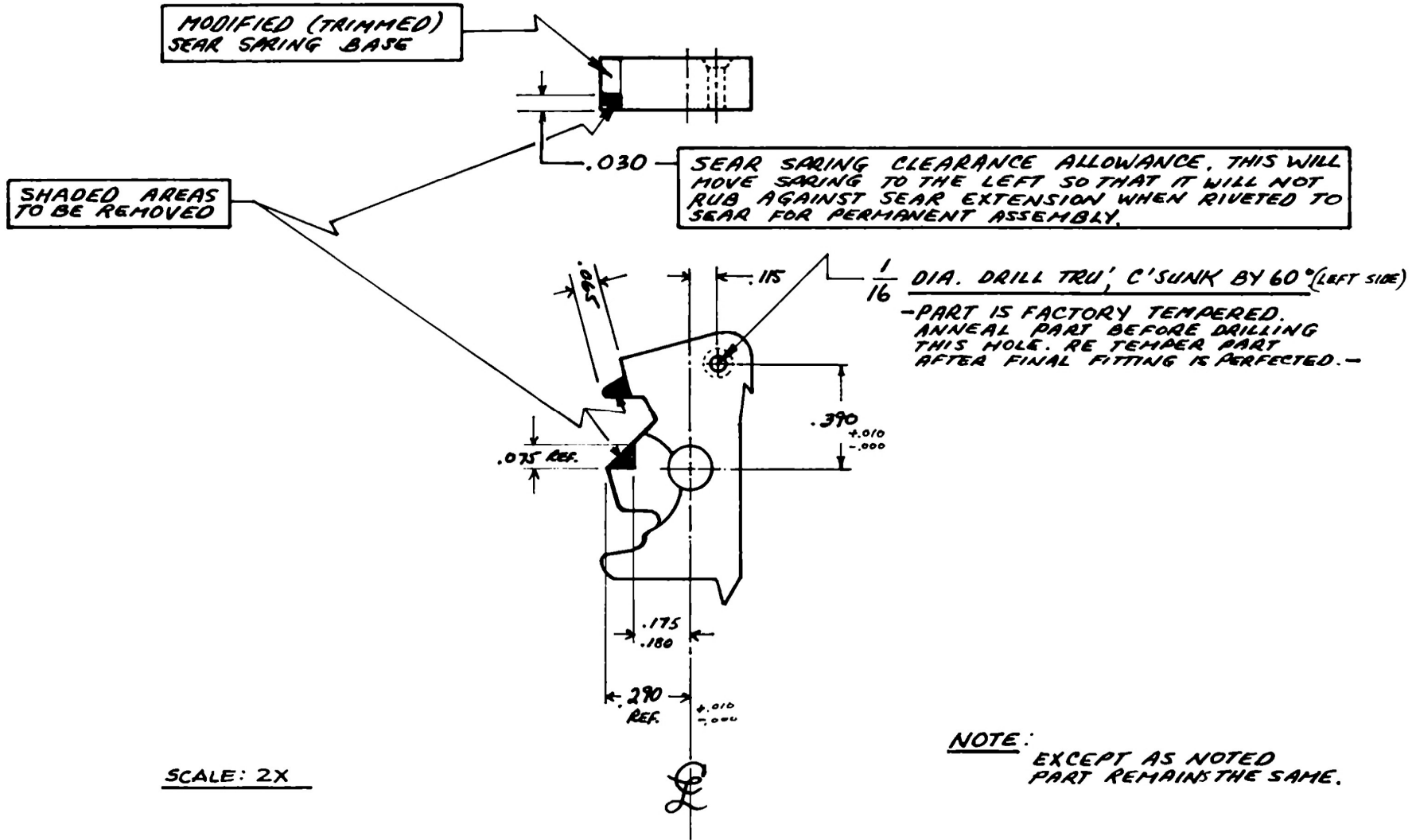

MODIFICATION - ORIGINAL SEAR



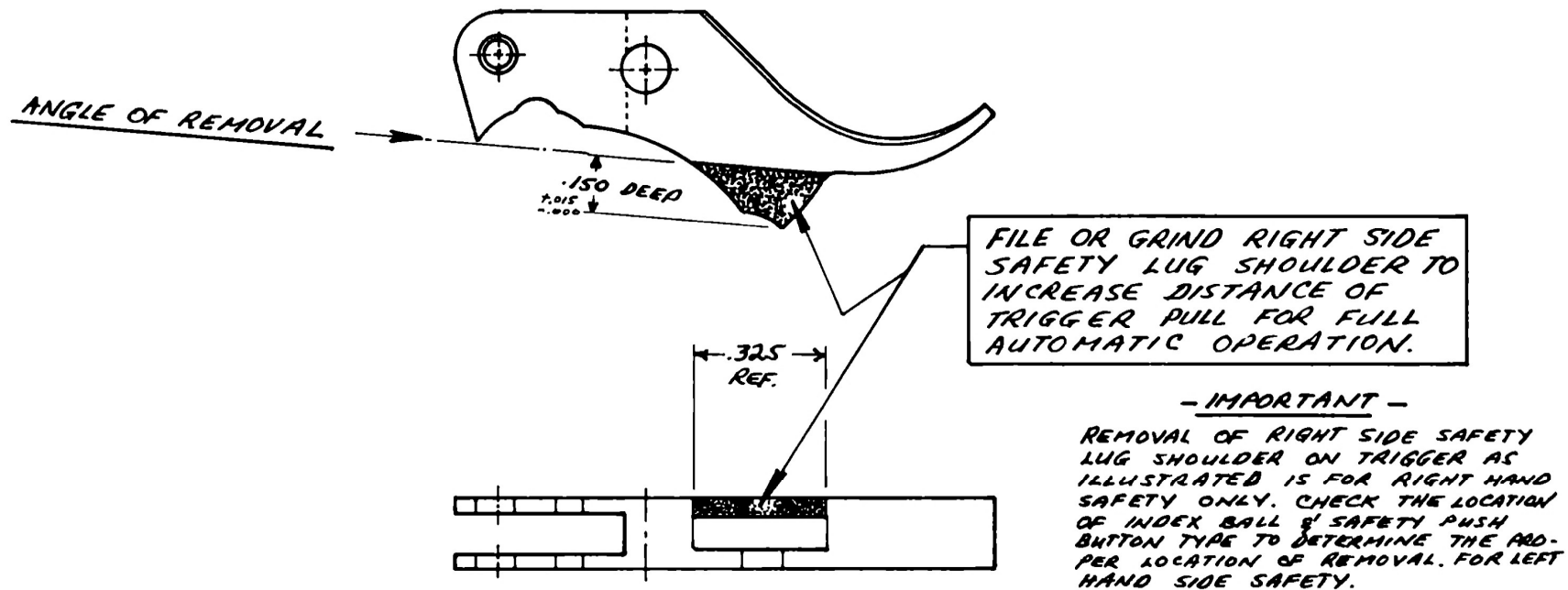

## MODIFICATION-ORIGINAL TRIGGER

SCALE: 2X

NOTE:  
EXCEPT AS NOTED,  
PART REMAIN THE SAME.

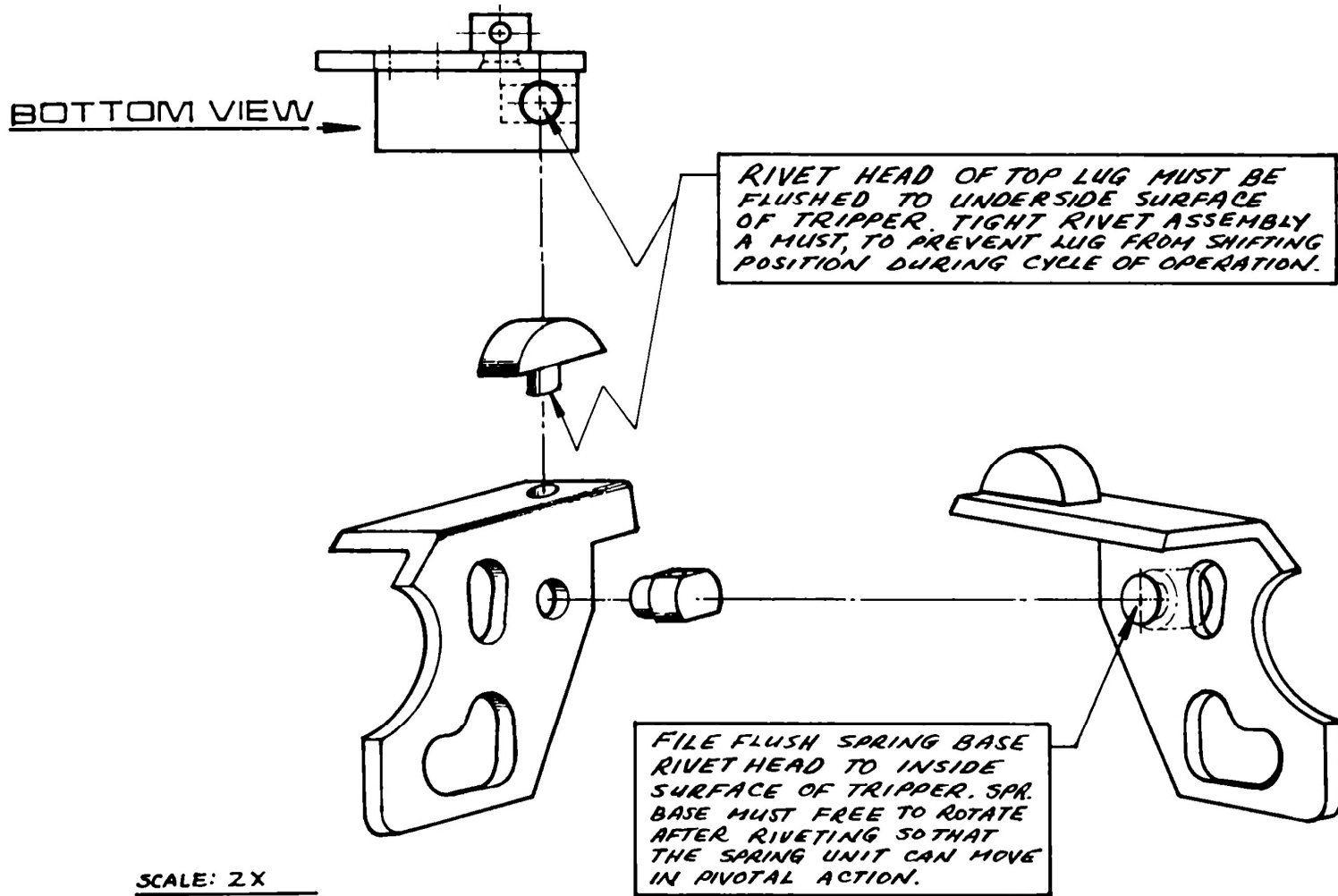

ASSEMBLY- TRIP TOP LUG & SPRING BASE

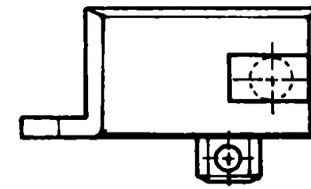
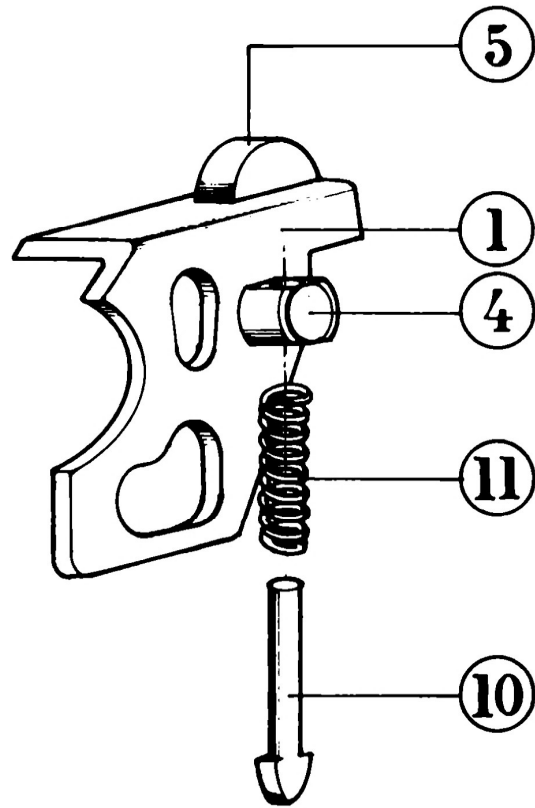

USE PRICK PUNCH TO PEEN THE  
END OF SPRING GUIDE TO SECURE  
PERMANENT ASSEMBLY OF SPRING  
UNIT TO TRIPPER.

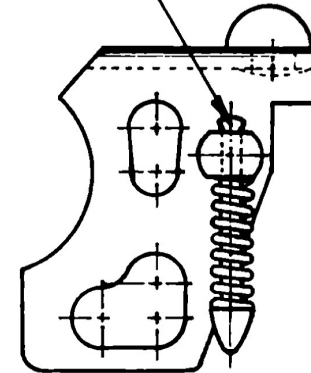

SCALE: 2X

ASSEMBLY "DROP IN" AUTO. TRIPPER UNIT

**LOCATING AND CUTTING THE TRIGGER  
PULL CONTROL NOTCHES FOR SEMI AND  
FULL AUTO POSITIONS.**

1. Before inserting the selector pin into the frame for locating the trigger pull notches, apply a metal ink or rub a permanent marker on the pin surface.
2. Insert the pin into the trigger housing frame in the usual manner and assemble the steel ball index and its spring, securing it in place by the stop pin. Check the proper position of the lever by pivoting the selector lever from index to index.
3. Now move the selector index to the "semiauto" position. To mark the proper location of the semiauto notch, look under the trigger guard and you will see exactly where the trigger safety shoulder is pressing against the safety lever pin.
4. Use a small scribe to mark the portion of the pin that is directly blocking the trigger lug shoulder.
5. Same procedure is followed in calculating the "full auto" index notch setting. After both notch locations have been marked, remove the selector lever from frame. Make sure you disassemble the index ball and spring group first.
6. After removing the selector mechanism from frame, clearly mark with a scribe the portion which will be removed for the trigger pull allowance.
7. By using a small flat file with a 5/64 inch (.078) width, you can cut the notch with enough clearance for the thickness of the trigger safety lug. It is imperative that the notches be cut gradually so that unnecessary depth is avoided, especially for the semiauto notch.
8. The semiauto mode requires a notch with just enough depth to trip the sear for releasing the hammer. The full auto notch requires a depth enough to reconnect the tripper nose to the sear extension rear end.

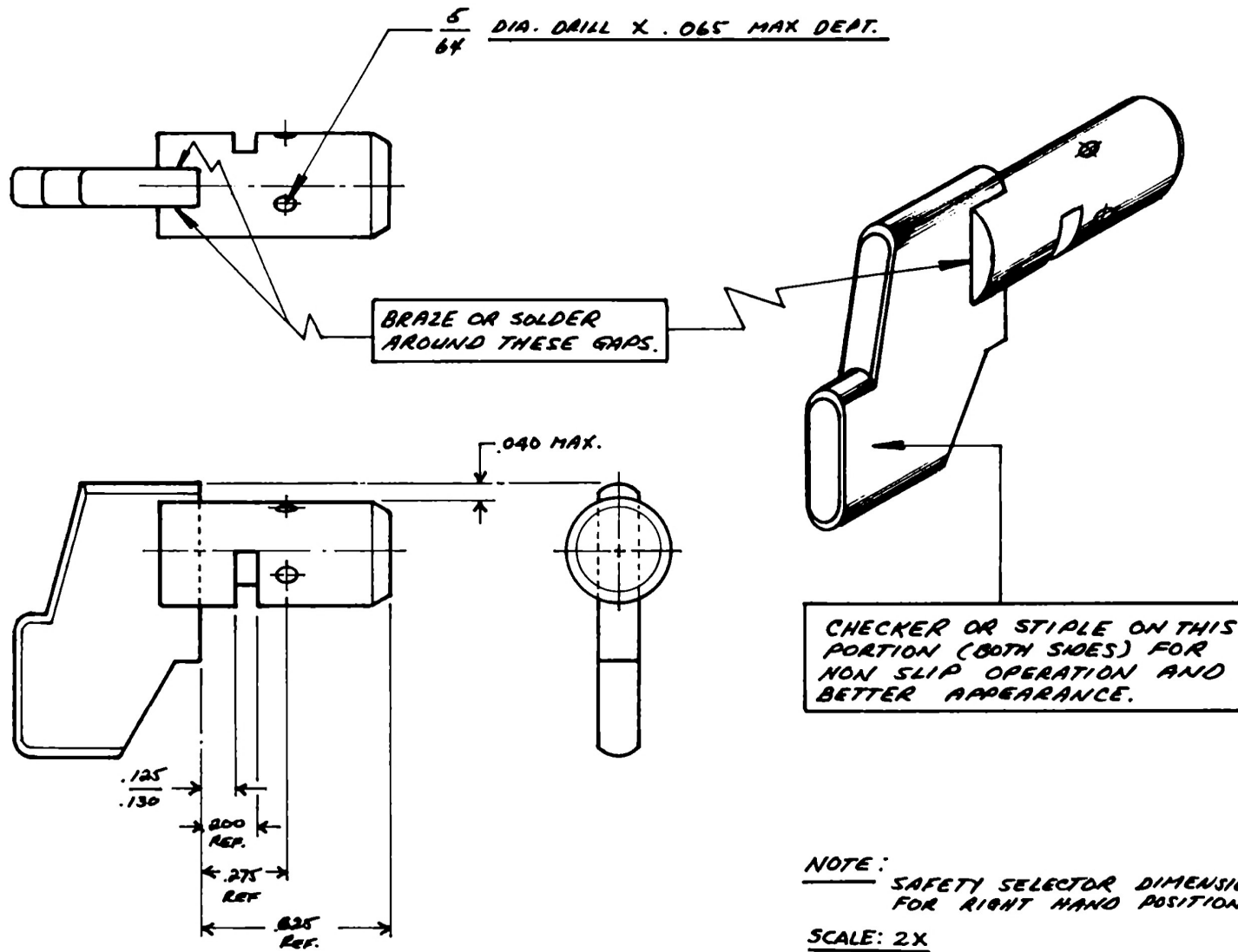

ASSEMBLY SELECTOR LEVER & PIN

# LOCATING SELECTOR INDEXES PRECISELY

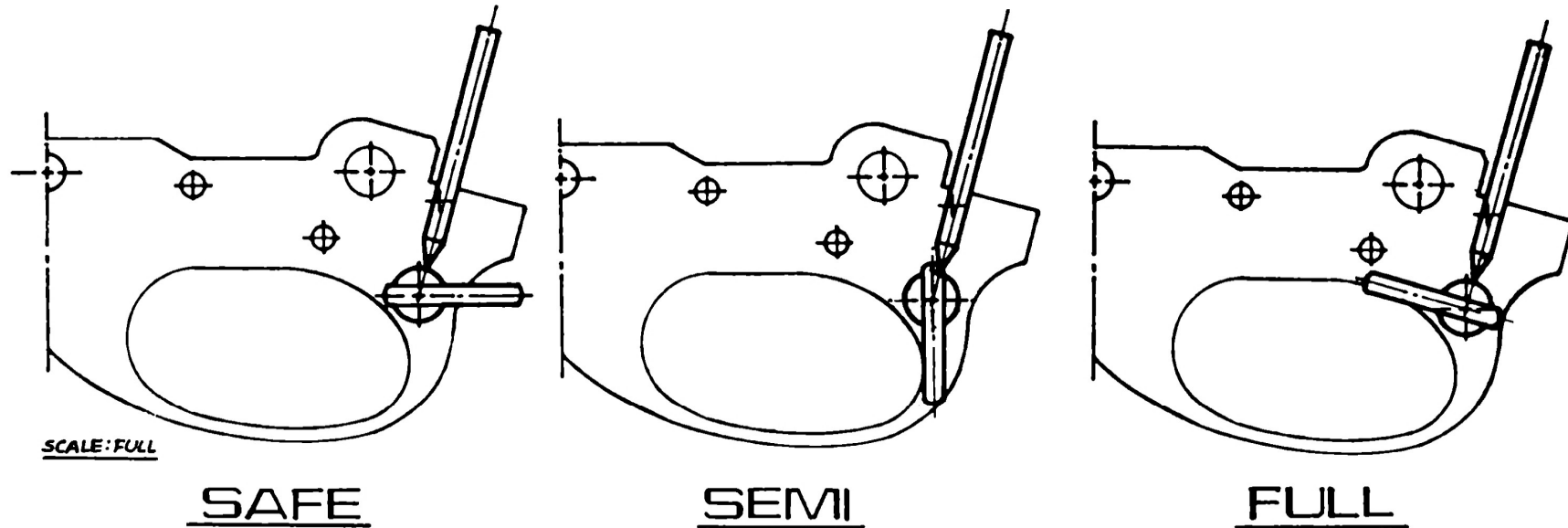

## **SIMPLE STEPS ON HOW TO LOCATE SELECTOR INDEXES PRECISELY.**

1. Prepare a pointed drill rod with a  $9/64$  inch diameter. A drill with the same diameter will do as well for this purpose.
2. Assemble the finished selector lever mechanism in its usual position in the trigger housing.
3. Insert the drill rod in the top hole where the selector index ball and spring are assembled. Position the selector lever in the rear horizontal position for "safe" and hold it there. Make sure that the safety lever is pressed in tight against the frame. While on this position, tap the rod or drill lightly so its pointed end will make a mark on the selector pin.
4. Move the selector next to "semiauto" and repeat the same procedure, only this time with the selector lever in the down vertical position. Repeat the same on the "full auto" position, moving the selector all the way to the front as far as it can pivot with the lever resting on the frame edge.
5. After all three index positions have been marked, remove the selector lever mechanism from the frame housing. Mark the slightly dented selector pin indexes deeper with a center punch so you can accurately drill the center.
6. Use  $5/64$  inch diameter drill for the index holes. Maximum depth for the index holes is .065 inch.
7. Repolish the drilled surface of the pin to level it so that it can be inserted freely into the frame.

**TIPS ON THE PROPER FITTING OF THE AUTOMATIC TRIPPER, SEAR EXTENSION, AND LINK TRIPPING SHOULDER DURING FINAL ASSEMBLY.**

With the complete trigger mechanism assembly group fully assembled but not installed, the following test for proper functioning of parts must be undertaken.

1. For semiautomatic functioning, set the selector on "semiauto." Cock the hammer. Press the trigger to trip the sear, and the hammer should release forward into "fired" position. Support the hammer during the process so it will not snap against the disconnecter. Always ease the hammer forward everytime you squeeze the trigger to release it into "fired" position.
2. While holding the trigger after the hammer has snapped forward, recock the hammer. In the semiautomatic position, the automatic tripper's front nose must not rub against the rear end of the sear extension when recocking the hammer. With the hammer cocked and trigger pressure maintained, depress the top of the tripper forward and down, simulating the action of the link shoulder making contact with the tripper's top lug. Note that the top of the upper slot of the tripper where the connector pin cams with the tripper is slightly larger in radius than its lower portion. Therefore, to get the actual maximum reach of the tripper towards the rear end of the sear extension, the tripper must be pushed forward and downward to see if it will trip the sear extension when the selector is set on "semiauto."
3. Any areas of the trip front nose and sear extension rear end which bind when the tripper is pushed down with the hammer on full cocked position must be filed off and polished. Do not attempt to remove excessive metal from these surfaces as the tripper may not have enough reach to engage the sear extension step if excessive metal is removed. A very slight rubbing is permissible between these two parts during the cocking of the hammer while the trigger is pressed fully on the semi-auto mode.
4. On the full auto mode, the system of fitting is the same. Once you have adjusted the mechanism to work properly in the semiauto mode, the full auto adjustment is quite simple. Moving the selector lever into the forward horizontal position for full auto functioning, press the trigger and let the hammer ease forward into "fired" position. Now, while maintaining the trigger pull, recock the hammer.
5. While the hammer is in the full cocked position and the trigger pull is maintained, check that the tripper's front nose is riding on top of the sear extension step. The lower part of the trip nose should be .025 inches above the sear extension step. This gap is necessary so that the sear extension can have enough space to bounce back to its normal position during recocking of the hammer. Note also that by slightly depressing the tripper just to make it ride on top of the sear extension step, only about .050 inches of the trip nose will make contact with the sear extension step.
6. While depressing the tripper forward and downward and maintaining the trigger pull with the hammer cocked, the sear extension will be tripped and will move downward and rearward to release the hammer. Note that on the fully depressed position of the tripper, the sear extension moved slightly *rearward* to release the hammer. A full contact of the trip nose and sear extension is thus accomplished. This must be the proper relationship of the automatic tripper device during fitting.



NOTE: ALL ACTION ILLUSTRATION DEPICTS FIRST SHOT FIRED  
AND TRIGGER PULL MAINTAINED.

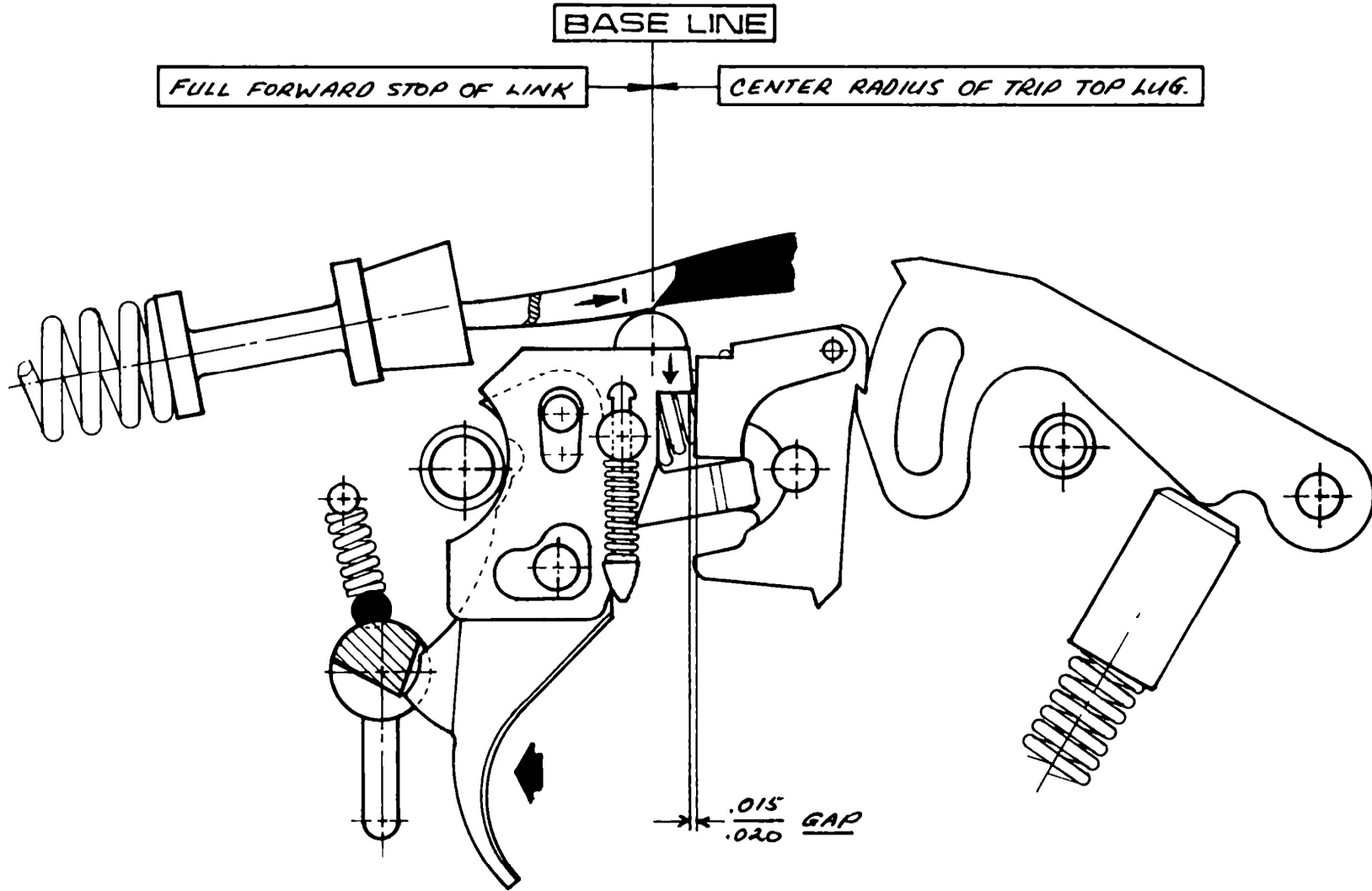

**FIG. A** SEMI AUTO. OPERATION

7. After the trigger mechanism assembly has been fully fitted to functional order, the next critical part that must be fitted is the link tripping shoulder. Note that this shoulder of the link acts as your mechanical trigger. It is also your key factor in adjustment of the hammer release timing during full auto operation. Assemble the complete trigger assembly to the receiver group to test the link tripping shoulder for proper adjustment.
8. If the link tripping shoulder hits the trip top lug early, the hammer release is too soon. This is a dangerous situation since the weapon may be firing from semilocked bolt. The link shoulder in this case may also prevent the bolt from moving rearward freely without hesitation. This is due to the trip nose and sear extension rear ends rubbing tightly together as caused by excessive length of the link tripping shoulder in the front. In case this happens, trim the front portion of the link tripping shoulder at the front, making contact with the trip top lug gradually until the bolt hesitation to move to the rear is corrected. Make sure that the inclined surface of the link tripping shoulder is maintained during the trimming process to ensure positive action. This contact surface must be smooth-polished.
9. Alternately, the tripper's top lug can also be trimmed gradually together with the link tripping shoulder during this process. It is imperative that the tripping action of the link and tripper which releases the hammer during full auto be given the greatest consideration while adjusting the link and trip contact shoulder. It is best to do the fitting and trimming of these two parts in the full auto mode only. Once you have perfected the timing of the hammer release and eliminated any hesitation in the movement of the bolt, the weapon will fire in either mode the operator may desire. It is therefore advisable that the selector stay on the "full auto" position with the trigger pressed each time you release the bolt group to slam forward.
10. During the final phase of fitting, to ensure that you have correctly fitted the gun prior to testing it with the blank shell test, press the trigger and depress the bolt lock to release the bolt forward. While depressing the bolt lock, hold the cocking handle and allow the bolt to slowly move forward. Note that during the last eighth inch, a very slight hesitation can be felt in the cocking handle before it fully closes. This is the time when the link tripping shoulder and tripper top lug start to make contact. Your bolt locking block in this position, as viewed from the top of the ejection port, is almost completely seated in its locking recess. Once you push the cocking handle forward till it stops, the hammer will release, hitting the firing pin. The bolt locking block is fully locked before the hammer hits the firing pin.

Repeat this same procedure until you are satisfied with the hammer timing for release. This is the only way you can be sure that your weapon is safe to fire, as well as reliable. Note that the gun will not fire most of the time if the bolt is not fully closed and locked.

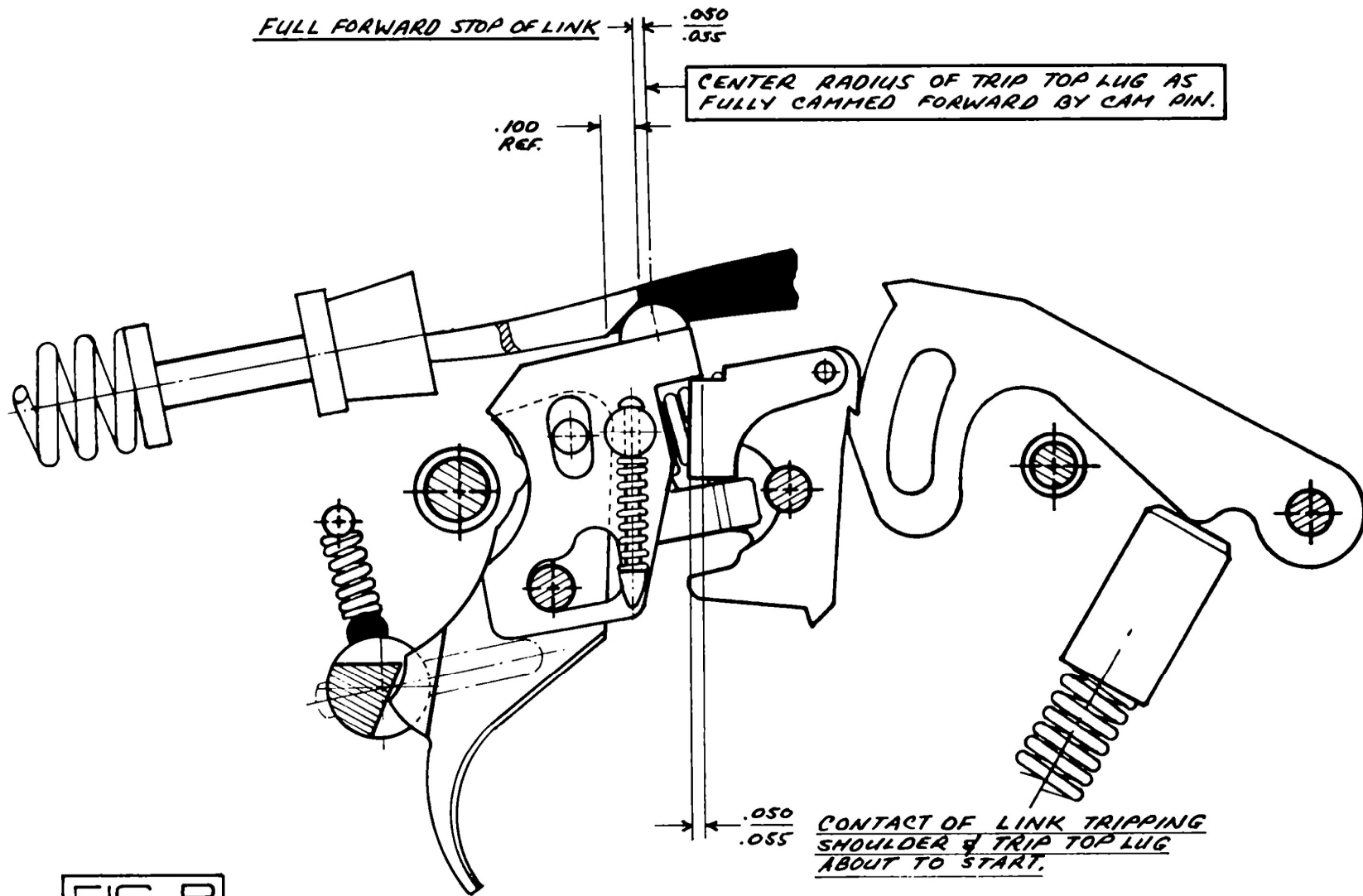
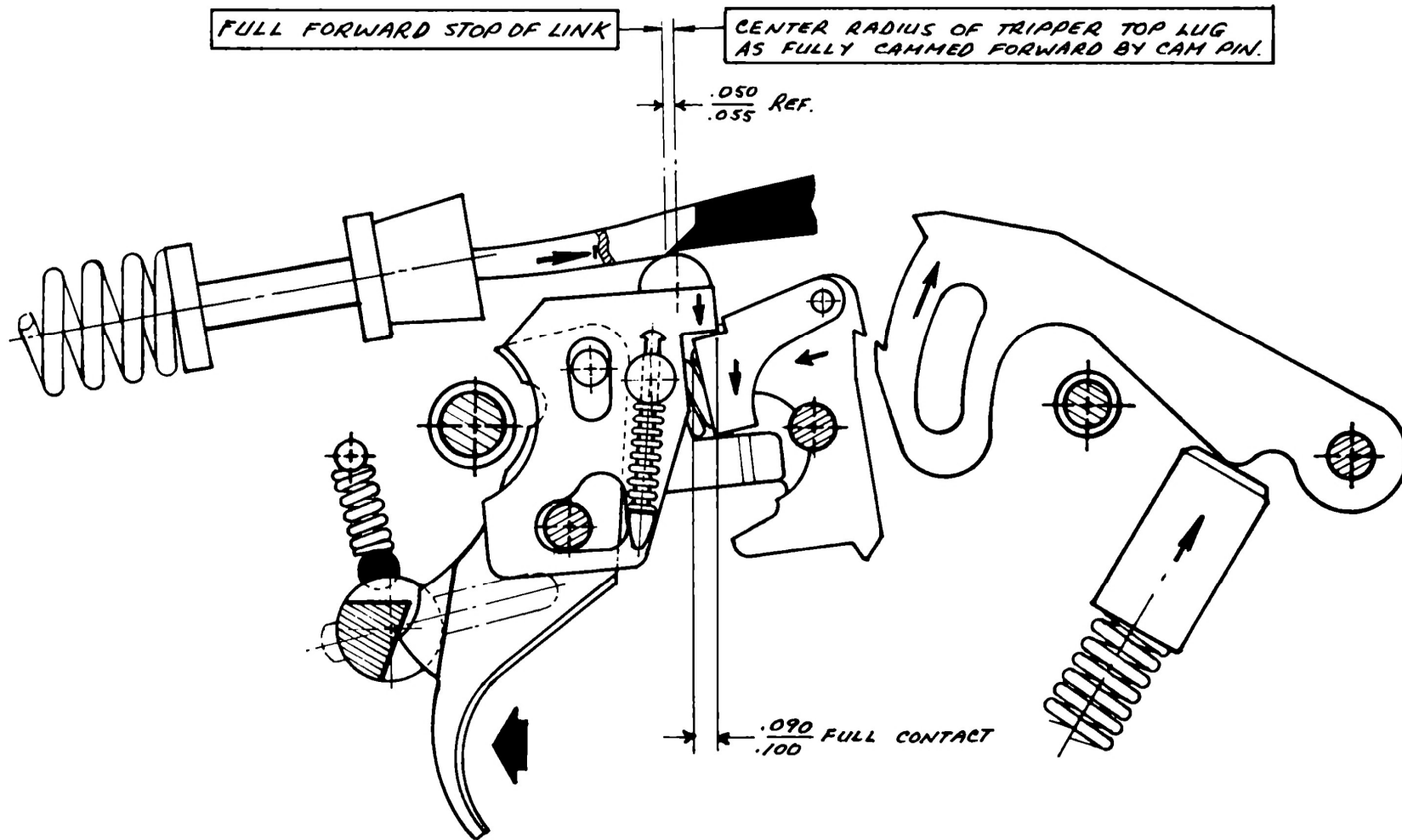

FIG. B

FULL AUTO FUNCTION BEFORE FULL CONTACT OF TRIPPER

**FIG.C FULL AUTO. OPERATION**



**PROPERLY FITTED TRIGGER COMPONENTS**

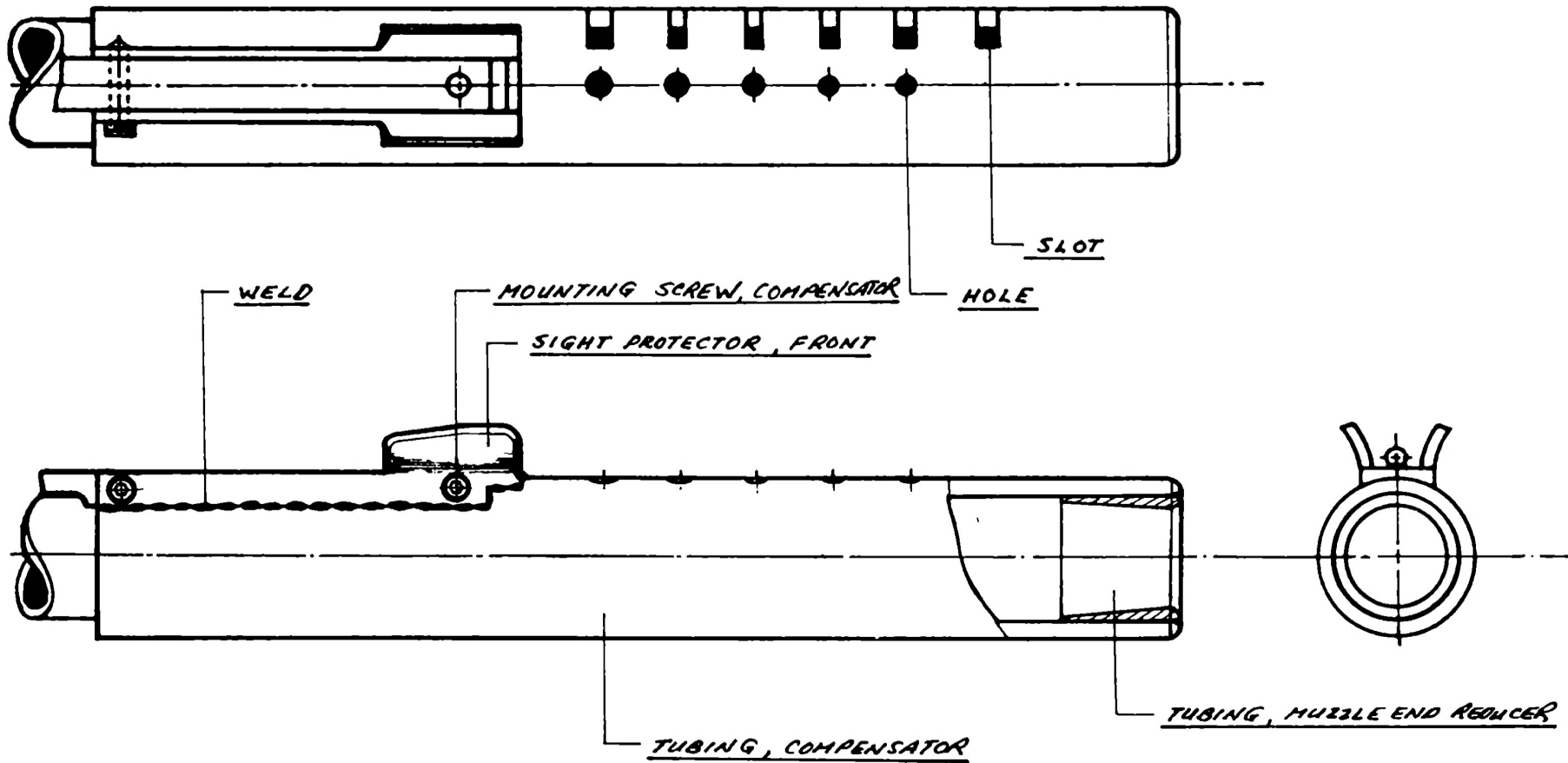

DETAIL-MUZZLE STABILIZER / COMPENSATOR

SCALE : FULL

NOTE: FULL SIZE SHOW IS FOR 12 GAUGE  
WITH VENTILATED RIB BARREL.

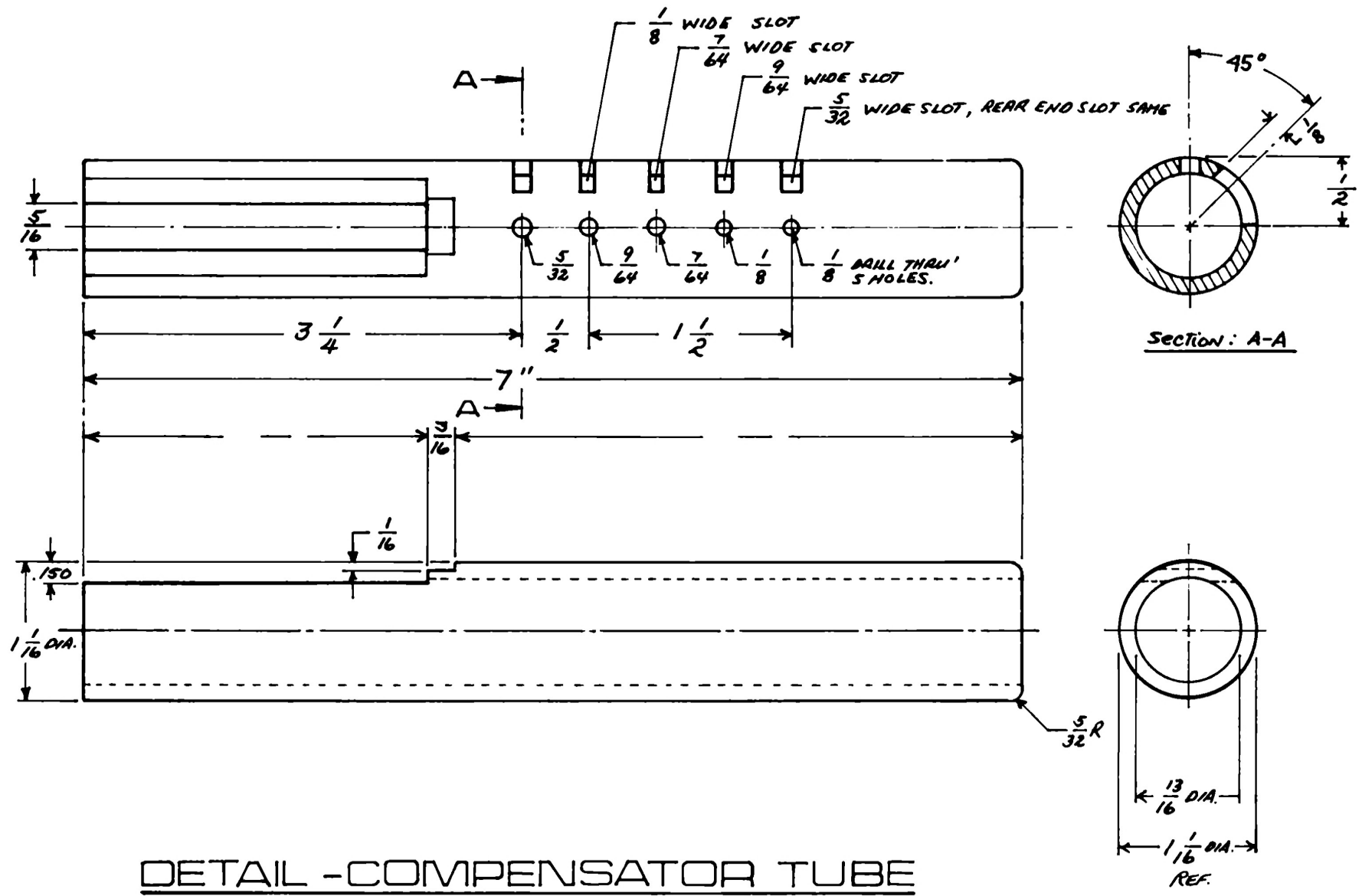

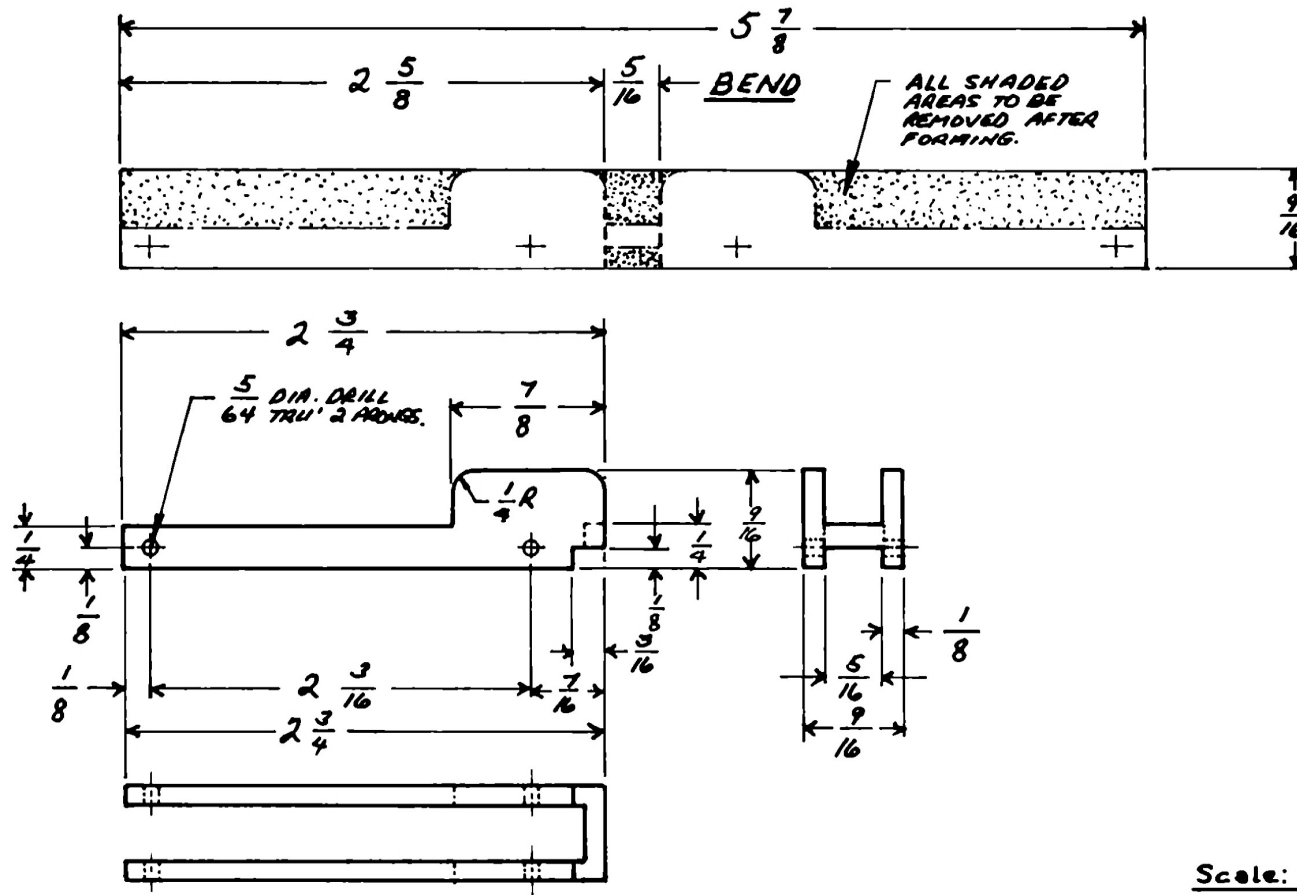

Scale: FULL

DETAIL-COMPENSATOR MOUNT BASE



# DETAIL-TUBE END REDUCER

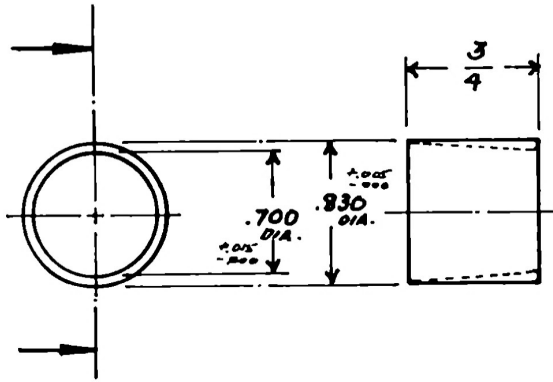

Scale: FULL

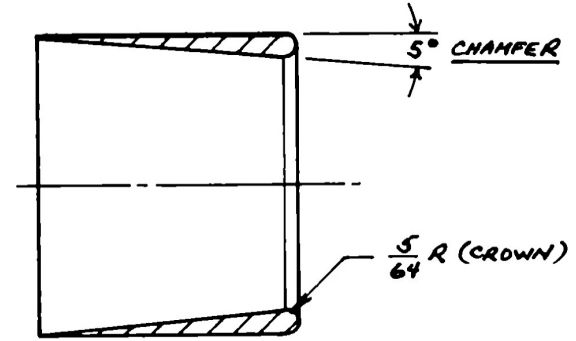

Scale: 2X

ASSEMBLY - MUZZLE BRAKE  
TO VENTILATED RIB BARREL

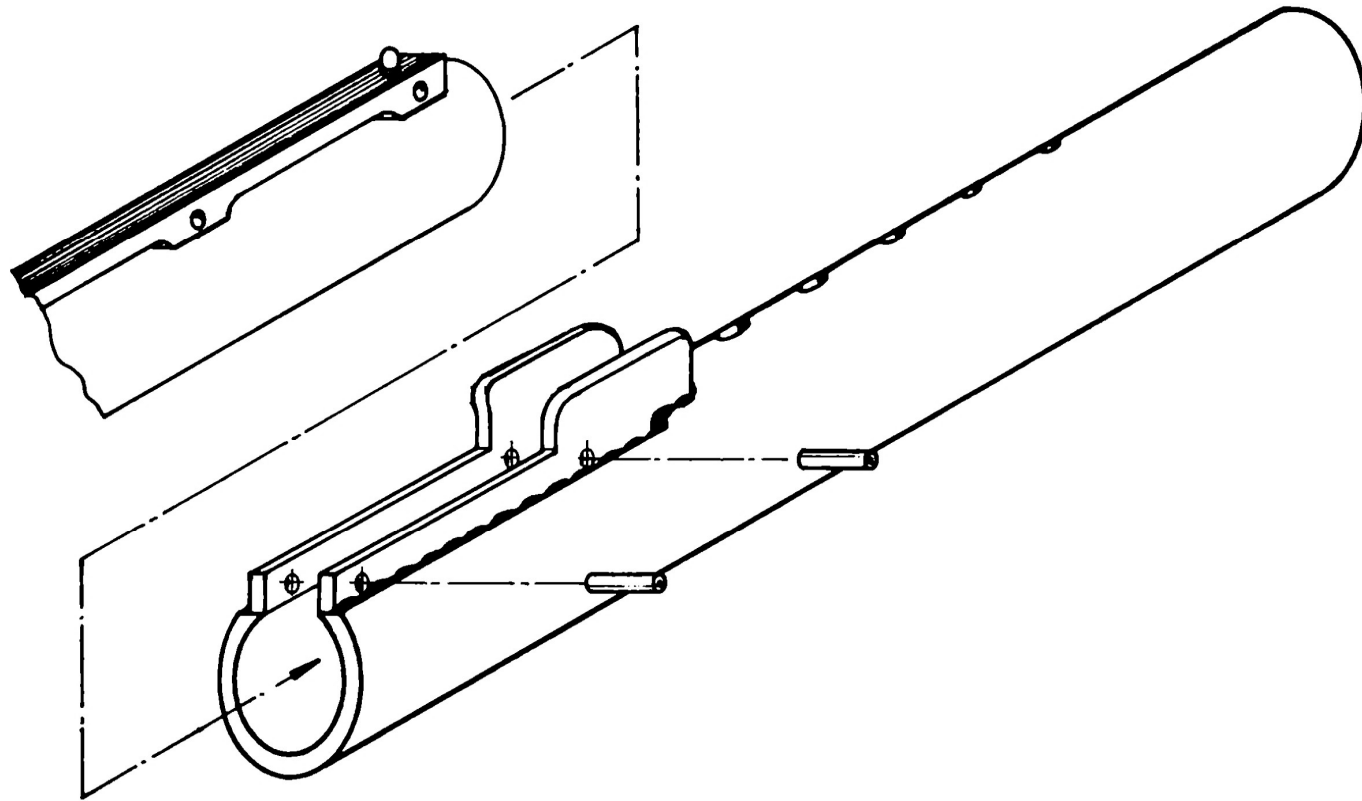

# Appendix

In order to achieve maximum reliability on full automatic mode of fire, the following patented modification to the latch device of the 1100 model must be accomplished. This improvement will also enable the operator to fire the weapon reliably in any unconventional shooting position, especially in a combat situation.

**1**

**3,373,519**  
**CARRIER LATCH RETAINER FOR**  
**AUTOLOADING FIREARMS**

**Walter L. Dahl, Herkimer, and James S. Martin, Mohawk,**  
**N.Y., assignors to Remington Arms Company, Inc.,**  
**Bridgeport, Conn., a corporation of Delaware**  
**Filed Apr. 3, 1967, Ser. No. 627,785**  
**7 Claims. (Cl. 42—17)**

**ABSTRACT OF THE DISCLOSURE**

A fire control mechanism for autoloading firearms including a shell carrier arranged to transfer shells from the magazine to the chamber of the firearm. A carrier latch is arranged to hold the shell carrier in a position

to receive shells from the magazine. Shells fed from the magazine move the carrier latch out of engagement with the carrier to allow the shell to be fed to the chamber. A retainer is formed on the carrier to prevent the carrier latch from relatching the carrier prior to the shell being fed to the chamber.

---

*Background of the invention*

This invention relates to a fire control mechanism for the type of autoloading firearm having a tubular magazine positioned beneath and parallel to the barrel. In particular, the invention relates to a retainer for a carrier latch in that type of fire control which includes a pivoted shell carrier to feed shells fed from the magazine to the chamber. This type of fire control is usually found in autoloading shotguns.

A firearm of the above type is shown in United States Patent No. 3,200,710 issued Aug. 17, 1965, to R. P. Kelly et al. One fire control for use with such a gun is shown in United States Patent No. 2,887,808 issued May 26, 1959 to S. K. Janson et al. This fire control has a hinged shell carrier and fails to make any provision to retain the carrier latch out of engagement with the shell carrier during cycling of the firearm. Failure to provide the carrier latch retainer of the subject invention can result

March 19, 1968

W. L. DAHL ET AL

3,373,519

CARRIER LATCH RETAINER FOR AUTOLOADING FIREARMS

Filed April 3, 1967

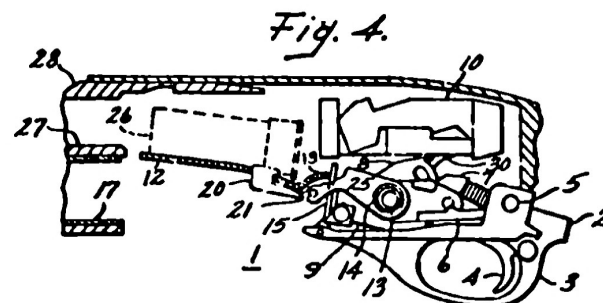
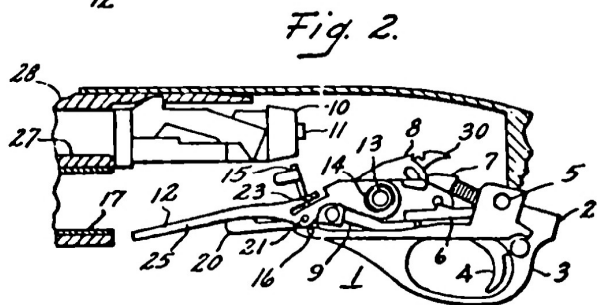
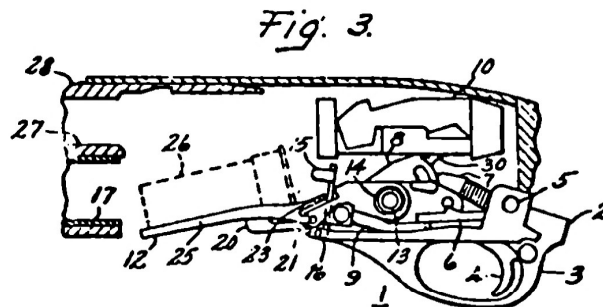
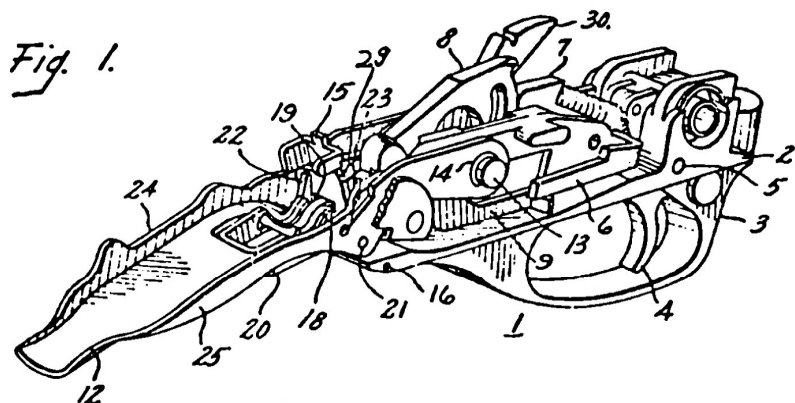

Inventors:  
Walter L. Dahl,  
James S. Martin.

John H. Lewis Jr.  
John W. Rappi  
Nicholas Skovran  
Attorneys

in malfunctions due to failure to feed shells to the chamber.

#### *Summary*

The subject invention contemplates the provision of a spring detent or retainer formed from a portion of the shell carrier of a fire control for autoloading shotguns. The retainer is positioned so that a feeding shotshell tripping the carrier latch forces the latch to deflect the retainer and snap in behind it. The latch once tripped and held by the retainer cannot rebound or relatch the carrier until the carrier rises and falls during the gun cycle. When the carrier rises it releases the engagement of the latch and retainer allowing the latch to return to its normal position latching the carrier after the carrier falls to its normal position.

It has been found that malfunctions can occur in autoloading shotguns not equipped with the subject invention. In a shotgun such as the one shown in Patent No. 3,200,710, mentioned above, equipped with a fire control described below but without the inclusion of the carrier latch retainer malfunctions can occur, particularly, if the gun is not held to the shooter's shoulder.

When shooting the gun from the hip or in other unconventional attitudes, malfunctions may occur from an apparent failure to trip the carrier latch. It has been found that in such instances the shell being fed from the magazine under the impetus of the magazine spring, actually trips the carrier latch releasing the carrier so it can feed the shell to the chamber. In these unconventional attitudes, it is possible for the shell to rebound from the latch so rapidly that the latch re-engages the carrier instead of remaining clear of the carrier. When this happens, the shell cannot be fed to the chamber and the gun fails to function. The incorporation of a latch retainer on the carrier positively locks the latch rearward so that the carrier will be free to rise with the shell to be fed to the chamber no matter what attitude the gun is fired from.

The timing of an autoloading shotgun is extremely critical. Firing from unconventional attitudes affects the

timing and leads to the malfunction which appears to be a failure of tripping of the carrier latch. The subject invention insures that this apparent malfunction cannot occur. The inclusion of the carrier latch retainer infallibly times the gun regardless of firing attitude.

It can, therefore, be seen that the primary object of this invention is to provide means to positively disengage the latch from the carrier during cycling of the gun regardless of the firing attitude. Normally, these guns are fired in a conventional attitude but for law enforcement and military use the ability to be fired from an unconventional attitude becomes extremely important.

An additional advantage of the carrier latch retainer is to provide space in a standard receiver for  $2\frac{3}{4}$  inch shotshells so that 3 inch shotshells may be used. The retainer prevents rebounding of the latch and thus provides sufficient space to allow feeding of the longer shells.

The carrier latch retainer further provides a means to produce a full automatic shotgun free from the malfunction problems set forth above.

#### *Brief description of the drawings*

FIGURE 1, is a perspective view of a fire control mechanism including the carrier latch retainer with some of the parts broken away for clarity;

FIGURE 2, is a fragmentary sectional side elevation of the receiver section of a firearm incorporating this invention showing the firearm ready to fire with some of the parts broken away for clarity;

FIGURE 3, is a fragmentary sectional side elevation of the receiver section of a firearm incorporating this invention showing the feeding shell acting upon the carrier latch so that the carrier latch is engaged by the carrier latch retainer with some of the parts broken away for clarity; and

FIGURE 4, is a fragmentary sectional side elevation of the receiver section of a firearm incorporating this invention showing the carrier delivering the feeding shell to the chamber with some of the parts broken away for clarity.

*Description of the preferred embodiment*

The drawings illustrate a fire control 1 including a trigger plate 2 upon which the remaining components of fire control 1 are mounted. Formed integrally at the bottom of plate 2 is a trigger guard 3. A trigger 4 is positioned to extend in trigger guard 3 and upward through plate 2. Trigger 4 is mounted on pivots on trigger pin 5.

Attached to trigger 4 is a connector 6 which is arranged to contact the sear 7 and disengage sear 7 from the hammer 8 for firing. A disconnecter 9 is provided to disengage connector 6 from sear 7 except when the firearm is in the closed position ready to fire as shown in FIGURE 2. In this figure the bolt 10 is in the battery or ready-to-fire position with the firing pin 11 cocked and positioned to be struck by hammer 8.

The carrier 12 is pivotally mounted on plate 2 about hollow pin 13. Carrier 12 is retained on pin 13 by clip 14 and is locked in its normal position as shown in FIGURE 2 by carrier latch 15. Latch 15 is pivotally mounted on pin 16 which is in turn secured to plate 2. Latch 15 is biased toward magazine tube 17 by means of a spring and plunger not shown. A portion of carrier 12 is bent upward to form a projection 18 so that the end of projection 18 extends into an opening 19 in latch 15 whereby latch 15 locks carrier 12 in its normal position.

A carrier release 20 is pivotally mounted on a pin 21 which is secured to carrier 12. Release 20 projects below carrier 12 for manual depression and has an arm 22 projecting upward to engage latch 15. Depressing release 20 disengages carrier projection 18 from latch 15 so that carrier 12 can be raised to allow shells to be fed to magazine tube 17.

As originally conceived the carrier latch retainer 23 was formed in the right leg 24 of carrier 12. In this version retainer 23 was formed by making a single vertical cut in leg 24 and a triangle of metal was bent in to be positioned behind latch 15. When latch 15 was forced rearward, leg 24 would spring outward allowing latch 15 to move behind retainer 23. Latch 15 would, therefore, be latched

behind retainer 23, until carrier 12 was lifted to clear the engagement of latch 15 and retainer 23.

In the preferred embodiment shown, retainer 23 is formed in the left leg 25 of carrier 12. This is done by making a long cut substantially parallel to the top of leg 25 and bending the end of the spring leaf thus formed in behind latch 15. Upon rearward movement of latch 15, retainer 23 will spring outward by the camming action of latch 15. As soon as latch 15 has cleared retainer 23 the end will spring in to engage latch 15 and maintain out of engagement with carrier 12. It can, therefore, be seen that retainer 23 renders the firearm insensitive to variations in feeding shell velocities.

Reference may now be made to FIGURES 3 and 4, wherein, the operation of retainer 23 is shown. In FIGURE 3, a feeding shell 26 is shown on carrier 12 after being delivered from magazine tube 17. When shell 26 is transferred from magazine 17 to carrier 12 its momentum will cause it to move latch 15 rearwardly until it has cleared retainer 23 and is maintained in the rearward position by retainer 23. This relationship will be maintained until carrier 12 rises to deliver shell 26 to the chamber 27 formed in the barrel 28 and falls once again to its normal position. This motion takes place during each cycle of the firearm.

In FIGURE 4, carrier 12 is shown in position to feed shell 26 to chamber 27. Carrier 12 holds shell 26 in a position where it will be moved into chamber 27 by bolt 10 returning to the battery or ready-to-fire position. As carrier 12 rises retainer 23 rides upward on latch 15 until it reaches the cutout 29 at which time latch 15 is no longer engaged by retainer 23 and is forced forward to its normal position by the biasing spring and plunger not shown. Once carrier 12 has returned to its normal position by the force of the carrier dog 30, the firearm is ready to fire once again. Dog 30 pivotally mounted on plate 2 is forced forward by a spring and plunger not shown after bolt 10 returns to battery position. The movement of bolt 10 rearward during cycling of the fire-

arm cams ~~dog~~ 30 rearward out of engagement with carrier 12.

It can thus be seen that provision of retainer 23 provides positive retention of latch 15 during shell feeding so that feeding malfunctions by failure to release carrier 12 are eliminated.

We claim:

1. A fire control mechanism for autoloading firearms comprising a trigger plate, a shell carrier pivotally mounted on said trigger plate and positioned to receive shells fed from a magazine, a spring finger retainer formed in one side of said carrier, a carrier latch pivotally mounted on said trigger plate and passing through an opening in said carrier adjacent said finger, said finger positioned with its free end behind said latch.

2. The device as set forth in claim 1, wherein, said carrier has an arm formed therein positioned to engage said latch so that said latch prevents movement of said carrier, said latch is moved rearward by the motion of a feeding shell to free said carrier, said rearward movement of said latch positions said latch behind said retainer, whereby, said retainer maintains said latch free of said carrier until said carrier rises during the firearm cycle releasing said latch from said retainer.

3. The device as set forth in claim 1, wherein, said retainer is formed in the right leg of said carrier.

4. The device as set forth in claim 1, wherein, said retainer is formed in the left leg of said carrier.

5. The device as set forth in claim 2, wherein, a latch release is pivotally mounted on said carrier, said release having an upright arm engaging said latch, whereby, manual depression of said release disengages said latch and said carrier.

6. The device as set forth in claim 5, wherein, said retainer is formed in the right leg of said carrier.

7. The device as set forth in claim 5, wherein, said retainer is formed in the left leg of said carrier.

No references cited.

BENJAMIN A. BORCHELT, *Primary Examiner.*