

2003-1T2003

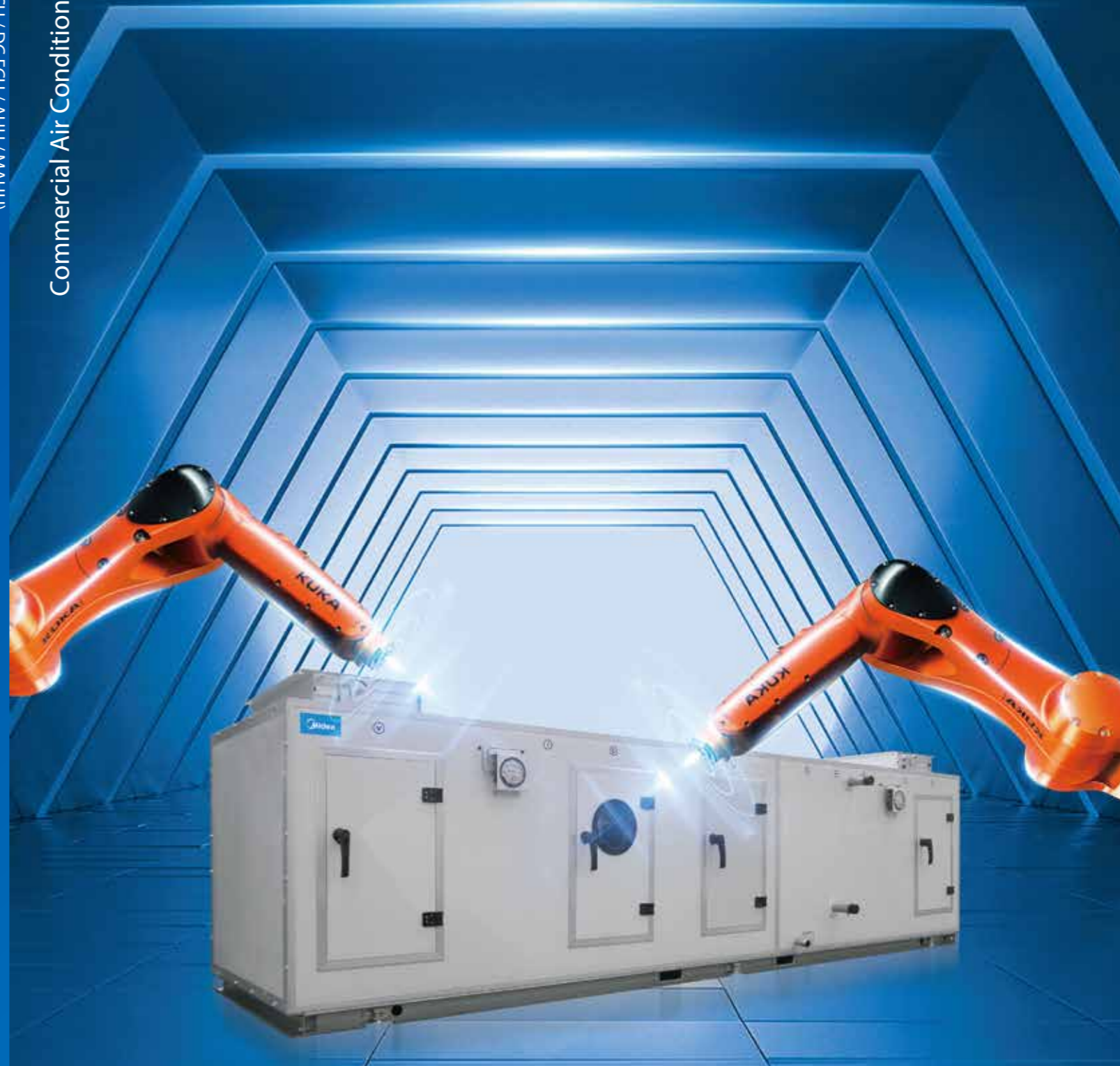

FCU&AHU (AC FCU / DC FCU / AHU / MAHU)

Commercial Air Conditioners 2020



Commercial Air Conditioner Division
Midea Group

Add.: Midea Headquarters Building, 6 Midea Avenue, Shunde, Foshan, Guangdong, China

Postal code: 528311

cac.midea.com www.midea-group.com



Note: Product specifications change from time to time as product improvements and developments are released and may vary from those in this document.

Midea FCU & AHU

AC FCU / DC FCU / AHU / MAHU



Midea CAC

Midea CAC is a key division of the Midea Group, a leading producer of consumer appliances and provider of heating, ventilation and air conditioning solutions. Midea CAC has continued with the tradition of innovation upon which it was founded, and emerged as a global leader in the HVAC industry. A strong drive for advancement has created a groundbreaking R&D department that has placed Midea CAC at the forefront of a competitive field. Through these independent efforts and joint cooperation with other global enterprises, Midea has supplied thousands of innovative solutions to customers worldwide. There are four production bases: Shunde, Chongqing, Hefei and Italy.

MCAC Shunde: 38 product lines focusing on VRF, Split Products, Heat Pump Water Heaters, and AHU/FCU.

MCAC Chongqing: 14 product lines focusing on Water Cooled Centrifugal/Screw/Scroll Chillers, Air Cooled Screw/Scroll Chillers and AHU/FCU.

MCAC Hefei: 11 product lines focusing on VRF, Chillers and Heat Pump Water Heaters.

Clivet S.p.A: 50,000m² workshop in Feltre and Verona, covering products such as ELFO system, hydronic, WHLP, packaged, split and close control and so on.

- 2019 >> Launched the new generation of Ceiling & Floor.
- 2017 >> Developed the large capacity air cooled scroll chiller.
Launched the new generation of R410A Aqua Tempo Super II Series DC Inverter Air-cooled Chiller.
- 2016 >> Acquire an 80% stake in Clivet.
- 2014 >> Launched the first wall-mounted series of DC fan coil unit and entered the DC FCU field.
- 2013 >> Launched the super high efficiency centrifugal chiller with dual-stage compressor and full falling film evaporator.
- 2010 >> Developed and launched the first generation of air handling unit
- 2007 >> Won the first Midea centrifugal chiller project overseas.
- 2006 >> Launched the first VFD (Variable Frequency Drive) centrifugal chiller.
- 2004 >> Acquired MGRE entered the chiller industry.
Launched the first generation of AC fan coil unit.
- 2001 >> The R134a (LC) series centrifugal chiller was named as a key national product.
- 1999 >> Entered the CAC field.

MCAC Learning Academy



Objective

Midea CAC Learning Academy aims to provide training to the sales personnel as well as technical personnel in order to increase the utilization for your Midea CAC equipment. Once you have purchased equipment from Midea CAC, taking care of the equipment is topmost priority. Midea CAC Learning Academy offers training courses to learn firsthand from the manufacturer what it takes to get the best out of your Midea CAC product. The goal of Midea CAC Learning Academy is to provide product specific training, safe work procedures and expertise in carrying out the installation and maintenance of Midea CAC products as well as teaching the main selling points in order to help the sales people sell the Midea CAC products with ease.

Training Centers

Our world class training centers provide knowledge and skills necessary to efficiently deploy Midea CAC technologies. The training centers include dedicated laboratories to provide hands-on experiences with various systems, components and controls to refresh and enhance the skills of your sales, design and installation and service teams. Right now we operate our trainings from the below two locations:

1. Midea CAC Training Center

Address: Midea CAC Training Center, 2nd Floor, Building 6, Midea Global Innovation Center, Beijiao, Shunde, Foshan, China
Pin- 528311

The Midea CAC Training Center is situated 70 kilometers from Baiyun Guangzhou International Airport.

Products: VRF, M-Thermal

2. Chongqing Midea Training Center

Address: No. 15, Qiangwei Road, Nan'an District, Chongqing, China

Chongqing Midea Training Center is 35 kilometers from Chongqing International Airport.

Products: Centrifugal Chiller, Screw/Scroll Chiller and Terminals



VRF training



M-Thermal training



Chiller training

Global Technical Trainings

The training courses by Midea CAC Learning Academy are divided into the following two categories with different targeted audiences for each.

Design and Application Trainings: The design and application trainings for various products are basically for the sales personnel selling Midea CAC products in order to give them basic understanding about the main features. The trainings are conducted on a global level inviting sales engineers, technical engineers, consultants and project designers from different parts of the world.

Main Courses Offered:

1. Introduction to main Selling points and Features
2. Installation and Commissioning
3. Control Systems
4. Selection Software



Products: VRF, M-Thermal, Chillers and Terminals

After Sales- Service Trainings: These trainings are dedicated for the After Sales/ Service personnel in order for them to better carry out the installation, commissioning and maintenance of Midea CAC products. Technical person and engineers from different parts of the world are invited to take part in these trainings.

Main Courses Offered:

1. Product Electric Control and Refrigerant System
2. Control Systems
3. Installation and Commissioning Demonstration
4. Troubleshooting and Maintenance

Products: VRF, M-Thermal, Chillers and Terminals

Highly Skilled Trainers: The trainers for various courses by Midea CAC Learning Academy are expert people with vast experiences in their field. Most of them have a deep insight about the global HVAC market and help the attendees to better understand the CAC products.

Training Certificates:

The attendees for Global trainings are provided a training certificate highlighting the courses discussed in the training, signed by Mr. Jason Zhao, General Manager of Midea CAC Overseas Sales Company.

Registration:

You can contact your respective Midea contact point to provide you with the complete schedule about the global technical trainings as well as how to register for these trainings.



Introduction

Midea fan coil units are divided to ceiling exposed type, ceiling concealed type, wall-mounted type and floor-standing type according to their structure design and installation method. The air volume ranges from 150CFM to 2200CFM (255m³/h~3740m³/h). It is a highly versatile product suitable for hospitals, office buildings, hotels, airports and various other applications.

Midea (Modular) air handling units (AHUs/MAHUs) have been designed and manufactured to meet the requirements of all kinds of space cooling and heating, such as office buildings, shopping malls, exhibition halls, airports, railway stations, hotels, factories and any other central air-conditioning systems.

Contents

- ▶ 11 AC Fan Coil Units
- ▶ 42 DC Fan Coil Units
- ▶ 68 Control Soltions
- ▶ 77 Air Handing Unit
- ▶ 95 Modular Air Handling Unit

Reference Projects

2018 Russia World Cup Stadiums Nizhny Novgorod Stadium

- City: Nizhny Novgorod
- Product: Water-cooled Screw Chiller; Fan Coil Units



2018 Russia World Cup Stadiums Volgograd Arena

- City: Volgograd
- Product: Water-cooled Screw Chiller; Fan Coil Units



The 27th Southeast Asian Games Stadium

- Country: Myanmar
- City: Nay Pyi Taw
- Outdoor Units: Water-cooled screw chiller
- Indoor Units: MAHU
- Total Capacity: 4,100RT



Beijing New International Airport

- Country: China
- City: Beijing
- Outdoor Units: Centrifugal chiller
- Indoor Units: FCU & MAHU
- Total Capacity: 10,000RT



Hilton Hotel in Foshan(Five Star)

- 🌐 Country: China
- 📍 City: Foshan
- 🏢 Outdoor Units: Centrifugal chiller & Water-cooled screw chiller
- 🏠 Indoor Units: FCU & AHU
- 📊 Total Capacity: 4,500RT



Top Glove in Malaysia

- 🌐 Country: Malaysia
- 📍 City: Klang
- 🏢 Outdoor Units: Water-cooled screw chiller
- 🏠 Indoor Units: FCU & AHU
- 📊 Total Capacity: 3,400RT



Major Platinum Cineplex Laos

- 🌐 Country: Laos
- 📍 City: Vientiane
- 🏢 Outdoor Units: Centrifugal chiller & Water-cooled screw chiller
- 🏠 Indoor Units: FCU & AHU
- 📊 Total Capacity: 2,000RT



The Prime Minister Office Building

- 🌐 Country: Tajikistan
- 📍 City: Dushanbe
- 🏢 Outdoor Units: Water-cooled screw chiller
- 🏠 Indoor Units: FCU & AHU
- 📊 Total Capacity: 2,880kW





AC Fan Coil Units



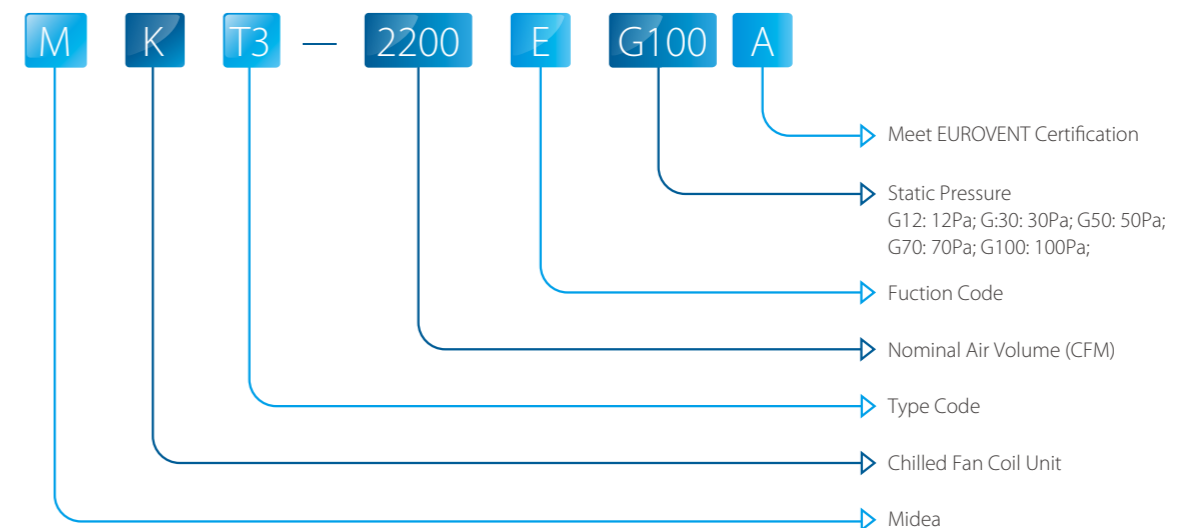

Midea Fan Coil Units have ceiling exposed type, ceiling concealed type, wall-mounted type and floor-standing type. The air volume ranges from 150CFM to 2200CFM. It is a highly versatile product suitable for hospitals, office buildings, hotels, airports and various other applications.

Nomenclature





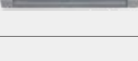

Product Lineup

2-Pipe FCUs

Air volume (CFM)		150	200	250	300	350	400	450	500	600		700	750	800	850	900	950	1000	1200	1400	1500	1600	1800	2000	2200	
1-way cassette					■		■																			
4-way cassette										■		■		■		■		■		■		■				
Compact 4-way cassette					■		■		■																	
Duct			■		■		■		■	■				■				■	■							
High static pressure Duct														■			■	■				■			■	
Wall mounted				■				■	■																	
2 nd generation Ceiling&floor		■		■		■			■			■		■												

4-Pipe FCUs

Air volume (CFM)		100	150	200	250	300	350	400	450		500	600	700	750	800	850	900	950	1000	1200	1400	1500		
Compact 4-way cassette						■		■			■													
4-way cassette												■		■		■		■		■		■		■
Duct				■		■		■			■	■			■				■	■				
2 nd generation Ceiling&floor			■		■		■				■		■		■									

Notes:
 The standard power supply for all fan coil units is 220V-240V/50Hz; 208-230V/60Hz can be customized for some series of fan coil units, for further information, please contact with our salesmen.



1-way Cassette



Compact 4-way Cassette



4-way Cassette



1-way Cassette

Min. 153mm Thickness

- Compact design, ultra slim body with a minimum thickness of 153mm, especially suitable for narrow ceiling, such as in lobbies and small meeting rooms.

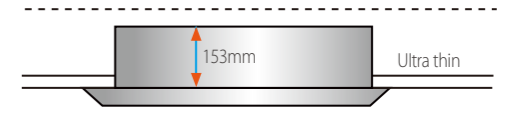

High-lift Pump

- Standard built-in drain pump with 750mm pump head.

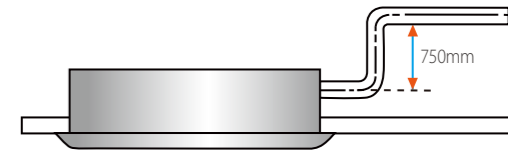

One Direction Air Flow

- One direction air flow guarantees quick cooling, flexible installation positioning.

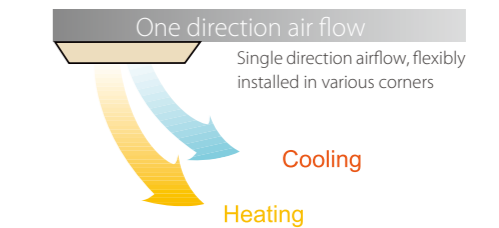

Specifications

Model			MKC-300R-BA
Air flow	H/M/L	m ³ /h	472/360/297
	H/M/L	CFM	278/212/175
Cooling	Capacity	H/M/L	2.55/1.96/1.63
	Water flow rate	H/M/L	0.46/0.35/0.29
	Water pressure drop	H/M/L	14.3/8.7/6.3
	Power input	H/M/L	45/42/41
Heating	Capacity	H/M/L	3.1/2.62/2.26
	Water flow rate	H/M/L	0.56/0.47/0.41
	Water pressure drop	H/M/L	18/13.2/9.9
	Power input	H/M/L	37/34/33
Power supply		V/Ph/Hz	220-240/1/50
Current input	H	A	0.15
Electric heater capacity		W	750
Sound power level	H/M/L	dB(A)	58/53/49
Fan motor	Type		Low noise 4-speed fan motor
	Quantity		1
Fan	Type		Cross fan
	Quantity		1
Coil	Row		2
	Max. Working pressure	MPa	1.6
	Diameter	mm	Φ7
Panel	Dimensions	WxHxD	1180x25x465
	Packing	WxHxD	1232x107x517
	Net weight	kg	3.5
	Gross weight	kg	5.2
Body	Dimensions	WxHxD	1054x155x428
	Net weight	*A	12.8/13.1
	Packing	WxHxD	1155x245x490
	Gross weight	*A	16.6/17.1
Pipe connection	Water inlet/outlet pipe	inch	G1/2
	Drain pipe	mm	ODΦ25

Notes:

1. H: High fan speed; M: Medium fan speed; L: Low fan speed.
2. Cooling conditions: Entering water 7°C, leaving water 12°C, Entering air temperature 27°C DB/19°C WB.
Heating conditions: Entering water 45°C, leaving water 40°C, Entering air temperature 20°C DB.
3. Noise is tested in a reverberation chamber test room.

Various Selections

- Versions for 2/4 pipe systems.
- Versions for compact/normal size.



Stylish Panel with Large Airflow Outlet

- 4-way air supply panel is standard for 4-way cassette.
- 360° air supply panel is standard for compact 4-way cassette.

Compact Design, Easy Installation

- For Compact Four-way Cassette: Extremely compact casing suits any room's decor and requires little space for installation on a low ceiling.
- Due to compact body and light weight, all models can be installed without a hoist.

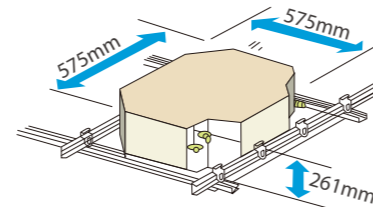

Various Accessories Selections

- Safe factory-installed electric heater is optional.
- Extended drainage pan is optional.
- Wireless controller is standard, and wired controller is optional.

High-lift Drain Pump

- Standard built-in drain pump with 750mm pump head for normal size and 500mm for compact size.

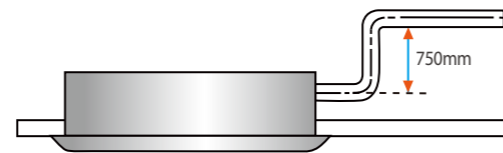

Fresh Air Intake

- Fresh air can enter through the cassette unit so you can enjoy even fresher air in a room.



2-Pipe 4-Way Cassette



Model		MKA-600RA	MKA-750RA	MKA-850RA
Power supply		V/ph/Hz		220-240/1/50
Air flow (H/M/L)		m³/h		1017/807/639
		CFM		358/275/217
Cooling	Capacity (H/M/L)	kW		5.58/4.87/4.09
	Water flow rate(H/M/L)	m³/h		1/0.88/0.74
	Water pressure drop(H/M/L)	kPa		30/20.1/15
Heating	Capacity (H/M/L)	kW		6.67/5.95/5.03
	Water flow rate(H/M/L)	m³/h		1.21/1.07/0.91
	Water pressure drop(H/M/L)	kPa		37.2/23.4/18
Power input (H/M/L)		W		140/121/108
Auxiliary electric heater (AEH)		W		2100
Sound Power level (H/M/L)		dB(A)		58/54/48
Fan motor	Type	Low noise 4-speed fan motor		
	Quantity	1		
Fan	Type	Centrifugal, forward-curved blades		
	Quantity	1		
Coil	Row	2		
	Max. working pressure	MPa		1.6
	Diameter	mm		Φ7
Panel	Net dimensions (WxHxD)	mm		950x45x950
	Packing size (WxHxD)	mm		1035x90x1035
	Net weight	kg		6
Body	Gross weight	kg		9
	Net dimensions (WxHxD)	mm		840x230x840
	Packing size (WxHxD)	mm		900x260x900
Pipe connections	Water inlet/outlet pipe	inch		RC3/4
	Drain pipe	mm		ODΦ32

Model		MKA-950RA	MKA-1200RA	MKA-1500RA
Power supply		V/ph/Hz		220-240/1/50
Air flow (H/M/L)		m³/h		1562/1183/1013
		CFM		548/422/358
Cooling	Capacity (H/M/L)	kW		6.09/6.21/5.78
	Water flow rate(H/M/L)	m³/h		1.1/1.12/1.04
	Water pressure drop(H/M/L)	kPa		27.1/22/18.1
Heating	Capacity (H/M/L)	kW		7.92/7.35/6.63
	Water flow rate(H/M/L)	m³/h		1.44/1.34/1.21
	Water pressure drop(H/M/L)	kPa		31.7/26.2/22.1
Power input (H/M/L)		W		190/160/130
Auxiliary electric heater (AEH)		W		2850
Sound Power level (H/M/L)		dB(A)		65/63/57
Fan motor	Type	Low noise 4-speed fan motor		
	Quantity	1		
Fan	Type	Centrifugal, forward-curved blades		
	Quantity	1		
Coil	Row	2		
	Max. working pressure	MPa		1.6
	Diameter	mm		Φ7
Panel	Net dimensions (WxHxD)	mm		950x45x950
	Packing size (WxHxD)	mm		1035x90x1035
	Net weight	kg		6
Body	Gross weight	kg		9
	Net dimensions (WxHxD)	mm		840x300x840
	Packing size (WxHxD)	mm		900x330x900
Pipe connections	Water inlet/outlet pipe	inch		RC3/4
	Drain pipe	mm		ODΦ32

Notes:

1. H: High fan speed; M: Medium fan speed; L: Low fan speed.
2. Cooling conditions: Entering water 7°C, leaving water 12°C, Entering air temperature 27°C DB/19°C WB.
Heating conditions: Entering water 45°C, leaving water 40°C, Entering air temperature 20°C DB.
3. Noise is tested in a reverberation chamber test room.

4-Pipe 4-Way Cassette



Model			MKA-600FA	MKA-750FA	MKA-850FA
Power supply		V/Ph/Hz	220-240/1/50		
Air flow (H/M/L)		m ³ /h	1123/749/587	1249/853/671	1304/1041/934
		CFM	661/441/345	735/502/395	767/612/549
Cooling	Capacity (H/M/L)	kW	4.14/3.63/2.97	4.43/3.72/3.07	4.73/3.97/3.61
	Water flow rate(H/M/L)	m ³ /h	0.74/0.65/0.53	0.8/0.67/0.55	0.85/0.71/0.65
	Water pressure drop(H/M/L)	kPa	20/13/10	20.4/15/15	25/20/15
Heating	Capacity (H/M/L)	kW	5.99/4.56/3.77	6.14/4.64/3.93	6.21/5.2/4.8
	Water flow rate(H/M/L)	m ³ /h	0.55/0.42/0.35	0.56/0.43/0.36	0.57/0.48/0.44
	Water pressure drop(H/M/L)	kPa	25/20/16	40/25/20	45/35/28.1
Power input (H/M/L)		W	124/89/68	172/86/63	187/161/144
Sound power level (H/M/L)		dB(A)	56/45/43	63/51/45	64/52/51
Fan motor	Type	Low noise 4-speed fan motor			
	Quantity	1			
Fan	Type	Centrifugal, forward-curved Blades			
	Quantity	1			
Coil	Row	2			
	Max. working pressure	MPa	1.6	1.6	1.6
	Diameter	mm	Φ7	Φ7	Φ7
	Panel	Net dimensions (WxHxD)	mm	950x45x950	950x45x950
Panel	Packing size (WxHxD)	mm	1035x90x1035	1035x90x1035	1035x90x1035
	Net weight	kg	6	6	6
	Gross weight	kg	9	9	9
	Body	Net dimensions (WxHxD)	mm	840x300x840	840x300x840
Packing size (WxHxD)		mm	900x330x900	900x330x900	900x330x900
Net weight		kg	35	35	35
Gross weight		kg	41	41	41
Pipe connections	Water inlet/outlet pipe	inch	Cold water: RC3/4; Hot water: RC1/2		
	Drain pipe	mm	ODΦ32	ODΦ32	ODΦ32

Model			MKA-950FA	MKA-1200FA	MKA-1500FA
Power supply		V/Ph/Hz	220-240/1/50		
Air flow (H/M/L)		m ³ /h	1339/1112/1001	1618/1359/1053	1681/1457/1117
		CFM	787/654/589	952/800/620	989/857/657
Cooling	Capacity (H/M/L)	kW	4.96/4.25/3.88	7.32/6.36/5.48	8.86/7.29/6.37
	Water flow rate(H/M/L)	m ³ /h	0.89/0.76/0.7	1.32/1.14/0.99	1.6/1.31/1.15
	Water pressure drop(H/M/L)	kPa	35/20/15	40/35/30	45.2/35/29.5
Heating	Capacity (H/M/L)	kW	6.5/5.34/4.96	8.76/7.76/6.98	10.34/7.91/7.5
	Water flow rate(H/M/L)	m ³ /h	0.6/0.49/0.46	0.8/0.71/0.64	0.95/0.73/0.69
	Water pressure drop(H/M/L)	kPa	43.9/33.6/29.4	52.9/42.4/36	53.4/40.9/33.7
Power input (H/M/L)		W	190/155/141	197/155/130	267/231/184
Sound power level (H/M/L)		dB(A)	65/56/52	67/59/54	69/59/52
Fan motor	Type	Low noise 4-speed fan motor			
	Quantity	1			
Fan	Type	Centrifugal, forward-curved Blades			
	Quantity	1			
Coil	Row	2			
	Max. working pressure	MPa	1.6	1.6	1.6
	Diameter	mm	Φ7	Φ7	Φ7
	Panel	Net dimensions (WxHxD)	mm	950x45x950	950x45x950
Panel	Packing size (WxHxD)	mm	1035x90x1035	1035x90x1035	1035x90x1035
	Net weight	kg	6	6	6
	Gross weight	kg	9	9	9
	Body	Net dimensions (WxHxD)	mm	840x300x840	840x300x840
Packing size (WxHxD)		mm	900x330x900	900x330x900	900x330x900
Net weight		kg	35	38	38
Gross weight		kg	41	44	44
Pipe connections	Water inlet/outlet pipe	inch	Cold water: RC3/4; Hot water: RC1/2		
	Drain pipe	mm	ODΦ32	ODΦ32	ODΦ32

Notes:

1. H: High fan speed; M: Medium fan speed; L: Low fan speed.
2. Cooling conditions: Entering water 7°C, leaving water 12°C, Entering air temperature 27°C DB/19°C WB.
Heating conditions: Entering water 65°C, leaving water 55°C, Entering air temperature 20°C DB.
3. Noise is tested in a reverberation chamber test room."

2-Pipe Compact 4-Way Cassette



Model			MKD-300A	MKD-400A	MKD-500A
Power supply		V/Ph/Hz	220-240/1/50		
Air flow (H/M/L)		m ³ /h	478/375/283	625/499/392	756/535/423
		CFM	281/221/167	368/294/231	445/315/249
Cooling	Capacity (H/M/L)	kW	2.5/2.02/1.61	3.09/2.52/2.08	4.06/3.2/2.52
	Water flow rate(H/M/L)	L/h	0.45/0.36/0.29	0.56/0.45/0.37	0.73/0.58/0.45
	Water pressure drop(H/M/L)	kPa	15/15/10	15/15/10	20/15/10
Heating	Capacity (H/M/L)	kW	2.92/2.41/1.9	3.59/2.98/2.51	4.57/3.48/2.73
	Water flow rate(H/M/L)	m ³ /h	0.53/0.44/0.34	0.65/0.54/0.46	0.83/0.63/0.5
	Water pressure drop(H/M/L)	kPa	15.4/15/10	20/15/10	20/15/15
Power input (H/M/L)		W	50/40/32	70/52/40	92/56/41
Sound power level (H/M/L)		dB(A)	54/47/41	59/52/46	63/56/48
Fan motor	Type	Low noise 4-speed fan motor			
	Quantity	1			
Fan	Type	Centrifugal, forward-curved Blades			
	Quantity	1			
Coil	Row	2			
	Max. working pressure	MPa	1.6	1.6	1.6
	Diameter	mm	Φ7	Φ7	Φ7
	Panel	Net dimensions (WxHxD)	mm	647x50x647	647x50x647
Panel	Packing size (WxHxD)	mm	715x123x715	715x123x715	715x123x715
	Net weight	kg	2.5	2.5	2.5
	Gross weight	kg	4.5	4.5	4.5
	Body	Net dimensions (WxHxD)	mm	575x261x575	575x261x575
Packing size (WxHxD)		mm	670x290x670	670x290x670	670x290x670
Net weight		kg	16.5	16.5	16.5
Gross weight		kg	20	20	20
Pipe connections	Water inlet/outlet pipe	inch	G3/4	G3/4	G3/4
	Drain pipe	mm	ODΦ25	ODΦ25	ODΦ25

4-Pipe Compact 4-Way Cassette

Model			MKD-300SA	MKD-400SA	MKD-500SA
Power supply		V/Ph/Hz	220-240/1/50		
Air flow (H/M/L)		m ³ /h	493/385/295	608/475/375	724/542/430
		CFM	290/226/174	358/279/221	426/319/253
Cooling	Capacity (H/M/L)	kW	2.18/1.78/1.48	2.39/2.2/1.61	2.59/2.26/1.81
	Water flow rate(H/M/L)	m ³ /h	0.39/0.32/0.27	0.43/0.4/0.29	0.47/0.41/0.33
	Water pressure drop(H/M/L)	kPa	25/20/20	20/20/13	25/20/15
Heating	Capacity (H/M/L)	kW	2.91/2.42/1.97	3.5/2.91/2.43	3.96/3.17/2.73
	Water flow rate(H/M/L)	m ³ /h	0.27/0.22/0.18	0.32/0.27/0.22	0.36/0.29/0.25
	Water pressure drop(H/M/L)	kPa	25/20/15	30/25/20	30/30/25
Power input (H/M/L)		W	50/40/32	70/50/35	93/56/41
Sound power level (H/M/L)		dB(A)	54/47/41	59/52/46	63/56/48
Fan motor	Type	Low noise 4-speed fan motor			
	Quantity	1			
Fan	Type	Centrifugal, forward-curved Blades			
	Quantity	1			
Coil	Row	2			
	Max. working pressure	MPa	1.6	1.6	1.6
	Diameter	mm	Φ7	Φ7	Φ7
	Panel	Net dimensions (WxHxD)	mm	647x50x647	647x50x647
Panel	Packing size (WxHxD)	mm	715x123x715	715x123x715	715x123x715
	Net weight	kg	2.5	2.5	2.5
	Gross weight	kg	4.5	4.5	4.5
	Body	Net dimensions (WxHxD)	mm	575x261x575	575x261x575
Packing size (WxHxD)		mm	670x290x670	670x290x670	670x290x670
Net weight		kg	16.5	16.5	16.5
Gross weight		kg	20	20	20
Pipe connections	Water inlet/outlet pipe	inch	Cold water: G3/4; Hot water: G1/2		
	Drain pipe	mm	ODΦ25	ODΦ25	ODΦ25

Notes:

1. H: High fan speed; M: Medium fan speed; L: Low fan speed.
2. Cooling conditions: Entering water 7°C, leaving water 12°C, Entering air temperature 27°C DB/19°C WB.
Heating conditions: Entering water 65°C, leaving water 55°C, Entering air temperature 20°C DB.
3. Noise is tested in a reverberation chamber test room."

Duct Series



Duct



High Static Pressure Duct



District Cooling Duct



Various Selections

- Versions for 2/4 pipe systems.
- Versions for normal/large temperature difference systems.
- 2, 3 or 4 rows coil for 2-pipe systems.
- Large range of available static pressure.
- Wired controller is optional.
- Four fan speeds are available: low, medium, high and one reserved for more choice.

High Efficiency

- Highly efficient heat exchange for complete counterflow.

Flexible Installation

- Left and right hand piping connections are optional, flexible installation.

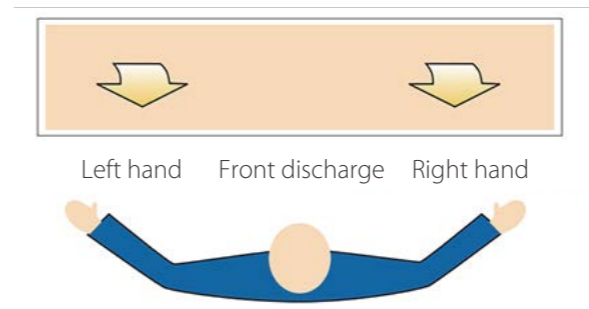

Standard Return Air Plenum and Filter

- Standard return air plenum and filter guarantees clean air supply and stable air flow rate.

Fresh Air Intake

- Fresh air can enter through the duct unit so you can enjoy even fresher air in a room.



2-Row Duct



Model		MKT2-200G30A MKT2-200EG30A	MKT2-300G30A MKT2-300EG30A	MKT2-400G30A MKT2-400EG30A	MKT2-500G30A MKT2-500EG30A	MKT2-600G30A MKT2-600EG30A
Power supply	V/Ph/Hz	220-240/1/50				
Air flow (H/M/L)	m³/h	434/354/264	632/483/366	802/648/512	960/775/582	1166/906/703
	CFM	255/208/155	372/284/215	472/381/301	565/456/342	686/533/414
Standard external static pressure	Pa	G30 models: 30				
Cooling	Capacity (H/M/L)	kW 2.03/1.7/1.4 2.82/2.29/1.89 3.2/2.72/2.34 3.9/3.44/2.88 4.92/4.14/3.52				
	Water flow rate(H/M/L)	m³/h 0.36/0.31/0.25 0.51/0.41/0.34 0.58/0.49/0.42 0.7/0.62/0.52 0.89/0.75/0.63				
	Water pressure drop(H/M/L)	kPa 11.9/11.1/9.2 19.8/14.5/10.5 26/20.3/15.7 34.3/27.4/20.5 18.5/14.8/11.2				
Heating	Capacity (H/M/L)	kW 2.55/2.09/1.67 3.39/2.76/2.25 4.02/3.41/2.9 4.79/4.06/3.35 6.13/5.13/4.19				
	Water flow rate(H/M/L)	m³/h 0.46/0.38/0.3 0.62/0.5/0.41 0.73/0.62/0.53 0.87/0.74/0.61 1.12/0.93/0.76				
	Water pressure drop(H/M/L)	kPa 9.5/7/4.8 21.8/15.9/10.9 29.9/23.3/17.3 39.7/31.4/22.4 25.3/19.4/14.2				
Power input	W	55/51/45 79/64/53 92/80/69 119/96/76 141/119/103				
Auxiliary electric heater (AEH)	W	550 650 1100 1100 1600				
Sound power level(H/M/L)	dB(A)	58/55/50 58/54/48 57/52/50 65/59/52 64/60/53				
Fan motor	Type	Low noise 4-speed fan motor				
	Quantity	1 1 1 1 1				
Fan	Type	Centrifugal, forward-curved Blades				
	Quantity	1 2 2 2 2				
Coil	Row	2 2 2 2 2				
	Max. working pressure	MPa 1.6 1.6 1.6 1.6 1.6				
	Diameter	mm Ø9.52 Ø9.52 Ø9.52 Ø9.52 Ø9.52				
Net dimensions (WxHxD)	mm	741x241x522 841x241x522 941x241x522 941x241x522 1161x241x522				
Packing size (WxHxD)	mm	790x260x550 890x260x550 990x260x550 990x260x550 1210x260x550				
Net weight (non-AEH/with-AEH)	kg	13.9/15.4 16.5/18 19.2/20.7 19.2/20.7 22/24				
Gross weight (non-AEH/with-AEH)	kg	16.2/17.7 19/20.5 21.6/23.1 21.6/23.1 25/27				
Water inlet/outlet pipe	inch	RC3/4 RC3/4 RC3/4 RC3/4 RC3/4				
Drain pipe	inch	ZG3/4 ZG3/4 ZG3/4 ZG3/4 ZG3/4				

Model		MKT2-800G30A MKT2-800EG30A	MKT2-1000G30A MKT2-1000EG30A	MKT2-1200G30A MKT2-1200EG30A	MKT2-1400G30A MKT2-1400EG30A
Power supply	V/Ph/Hz	220-240/1/50			
Air flow (H/M/L)	m³/h	1463/1128/859	1800/1374/997	2271/1642/1089	2327/1767/1190
	CFM	860/664/506	1059/808/587	1336/966/641	1369/1039/700
Standard external static pressure	Pa	G30 models: 30			
Cooling	Capacity (H/M/L)	kW 6.6/5.47/4.45 7.82/6.44/5.34 9.85/8.67/6.13 10.89/9.49/7.49			
	Water flow rate(H/M/L)	m³/h 1.19/0.98/0.8 1.41/1.16/0.96 1.77/1.56/1.1 1.96/1.71/1.35			
	Water pressure drop(H/M/L)	kPa 19.8/14.5/10.7 30.5/22.4/16.1 59.6/48.5/26.4 60.9/47.8/31.9			
Heating	Capacity (H/M/L)	kW 7.95/6.58/5.32 9.36/7.76/6.21 12.04/9.89/6.84 12.66/10.92/8.14			
	Water flow rate(H/M/L)	m³/h 1.44/1.2/0.97 1.7/1.41/1.13 2.19/1.8/1.24 2.3/1.99/1.48			
	Water pressure drop(H/M/L)	kPa 23.6/15.6/12.8 33/24.8/17.5 75.2/60.3/31.6 58.2/45.2/27.5			
Power input	W	167/134/113 231/191/168 278/229/176 304/233/195			
Auxiliary electric heater (AEH)	W	2200 2200 3200 3200			
Sound power level(H/M/L)	dB(A)	62/57/51 65/60/54 67/61/57 70/65/59			
Fan motor	Type	Low noise 4-speed fan motor			
	Quantity	2 2 2 2			
Fan	Type	Centrifugal, forward-curved Blades			
	Quantity	4 4 4 4			
Coil	Row	2 2 2 2			
	Max. working pressure	MPa 1.6 1.6 1.6 1.6			
	Diameter	mm Ø9.52 Ø9.52 Ø9.52 Ø9.52			
Net dimensions (WxHxD)	mm	1461x241x522 1566x241x522 1856x241x522 2022x241x522			
Packing size (WxHxD)	mm	1510x260x550 1615x260x550 1905x260x550 2070x260x550			
Net weight (non-AEH/with-AEH)	kg	30.9/33.4 33.4/36.4 38.5/42 42.1/46.1			
Gross weight (non-AEH/with-AEH)	kg	34.5/37 37/40 42/45.5 47.5/51.5			
Water inlet/outlet pipe	inch	RC3/4 RC3/4 RC3/4 RC3/4			
Drain pipe	inch	ZG3/4 ZG3/4 ZG3/4 ZG3/4			

- *Notes:
1. H: High fan speed; M: Medium fan speed; L: Low fan speed.
 2. Cooling conditions: Entering water 7°C, leaving water 12°C, Entering air temperature 27°C DB/19°C WB. Heating conditions: Entering water 45°C, leaving water 40°C, Entering air temperature 20°C DB.
 3. Noise is tested in a reverberation chamber test room."
 4. The external static pressure test condition is 0 Pa.

3-Row Duct



Model		MKT3-200G12A MKT3-200EG12A	MKT3-300G12A MKT3-300EG12A	MKT3-400G12A MKT3-400EG12A	MKT3-500G12A MKT3-500EG12A	MKT3-600G12A MKT3-600EG12A	MKT3-800G12A MKT3-800EG12A	MKT3-1000G12A MKT3-1000EG12A	MKT3-1200G12A MKT3-1200EG12A	MKT3-1400G12A MKT3-1400EG12A	
Power supply	V/Ph/Hz	220-240/1/50									
Air flow (H/M/L)	m³/h	401/363/300	576/467/391	707/532/404	898/652/419	1046/759/513	1362/1031/724	1697/1232/844	2121/1471/972	2541/1965/1123	
	CFM	236/213/176	339/274/230	416/313/237	528/384/246	615/446/302	801/607/426	998/725/496	1248/865/572	1495/1156/661	
Standard external static pressure	Pa	G12 models: 12									
Cooling	Capacity (H/M/L)	kW 1.97/1.84/1.57 2.93/2.51/2.21 3.62/2.92/2.34 4.39/3.51/2.73 5.77/4.57/3.36 7.99/6.68/4.8 8.45/6.74/4.99 10.66/8.23/5.94 13.18/11.36/7.77									
	Water flow rate(H/M/L)	m³/h 0.35/0.33/0.28 0.53/0.45/0.4 0.71/0.61/0.44 0.79/0.63/0.49 1.04/0.82/0.61 1.44/1.2/0.86 1.52/1.21/0.9 1.92/1.48/1.07 2.37/2.04/1.4									
	Water pressure drop(H/M/L)	kPa 17.7/15.9/11.9 41/31.6/25.5 23.67/16.29/11.05 32/20.7/11.3 67/44.3/25.8 38.8/27.8/18.1 46/30.9/18 48/30.6/17 57.1/45.2/22.4									
Heating	Capacity (H/M/L)	kW 2.39/2.23/1.74 3.45/2.94/2.57 4.17/3.37/2.71 4.9/3.89/2.78 6.13/4.86/3.56 8.88/7.24/5.48 9.29/7.41/5.56 11.35/8.77/6.42 15.36/12.72/8.29									
	Water flow rate(H/M/L)	m³/h 0.43/0.41/0.32 0.63/0.53/0.47 0.82/0.67/0.48 0.89/0.71/0.5 1.11/0.88/0.65 1.61/1.32/1 1.69/1.35/1.01 2.06/1.59/1.17 2.79/2.31/1.51									
	Water pressure drop(H/M/L)	kPa 20.6/18.8/13.9 46.7/33.7/26.7 26.2/18.02/12.19 35.3/20.1/11.3 60.7/40.2/22.7 37.3/26/15.7 45.3/30.5/17.9 44.5/28/16.1 60.9/46.7/20.7									
Power input	12Pa (H/M/L) W	40/37/33 63/52/45 85/66/55 101/85/70 124/101/83 154/120/98 202/168/141 250/197/163 273/224/175									
Auxiliary electric heater (AEH)	W	550 600 1100 1100 1600 2000 2200 3200 3200									
Sound power level	12Pa (H/M/L) dB(A)	53/51/45 54/50/43 55/52/47 60/54/46 62/56/46 62/56/48 66/58/48 64/56/46 68/64/58									
Fan motor	Type	Low noise 4-speed fan motor									
	Quantity	1 1 1 1 1 2 2 2 2									
Fan	Type	Centrifugal, forward-curved Blades									
	Quantity	1 2 2 2 2 4 4 4 4									
Coil	Row	3 3 3 3 3 4 4 4 4									
	Max. working pressure	MPa 1.6 1.6 1.6 1.6 1.6 1.6 1.6 1.6									
	Diameter	mm Ø9.52 Ø9.52 Ø9.52 Ø9.52 Ø9.52 Ø9.52 Ø9.52 Ø9.52									
Net dimensions (WxHxD)	mm	741x241x522 841x241x522 941x241x522 941x241x522 1161x241x522 1461x241x522 1566x241x522 1856x241x522 2022x241x522									
Packing size (WxHxD)	mm	790x260x550 890x260x550 990x260x550 990x260x550 1210x260x550 1510x260x550 1615x260x550 1905x260x550 2070x260x550									
Net weight (non-AEH/with-AEH)	kg	14.6/16.1 17/18.5 20.2/21.7 20.2/21.7 23/25 31.9/34.4 34.4/37.4 39.5/43 43.1/47.1									
Gross weight (non-AEH/with-AEH)	kg	16.9/18.4 19.5/21 22.6/24.1 22.6/24.1 26/28 35.5/38 38.1/41.1 43/46.5 48.4/52.4									
Water inlet/outlet pipe	inch	RC3/4 RC3/4 RC3/4 RC3/4 RC3/4 RC3/4 RC3/4 RC3/4 RC3/4 RC3/4									
Drain pipe	inch	ZG3/4 ZG3/4 ZG3/4 ZG3/4 ZG3/4 ZG3/4 ZG3/4 ZG3/4 ZG3/4 ZG3/4									

Model		MKT3-200G30A MKT3-200EG30A	MKT3-300G30A MKT3-300EG30A	MKT3-400G30A MKT3-400EG30A	MKT3-500G30A MKT3-500EG30A	MKT3-600G30A MKT3-600EG30A	MKT3-800G30A MKT3-800EG30A	MKT3-1000G30A MKT3-1000EG30A	MKT3-1200G30A MKT3-1200EG30A	MKT3-1400G30A MKT3-1400EG30A	
Power supply	V/Ph/Hz	220-240/1/50									
Air flow (H/M/L)	m³/h	472/375/294	575/455/338	787/648/469	1014/764/552	1191/971/763	1454/1166/861	1865/1454/1062	2272/1840/1160	2680/1975/1192	
	CFM	278/221/173	338/268/199	463/381/276	596/450/325	701/571/449	855/686/506	1097/855/625	1336/1082/682	1577/1162/701	
Standard external static pressure	Pa	G30 models: 30									
Cooling	Capacity (H/M/L)	kW 2.21/1.86/1.55 2.92/2.49/1.97 4.05/3.52/2.72 5.12/4.37/3.55 6.49/5.68/4.74 8.31/7.1/5.66 8.84/7.49/5.96 10.98/9.5/7.19 13.53/11.38/7.83									
	Water flow rate(H/M/L)	m³/h 0.4/0.34/0.28 0.53/0.45/0.36 0.73/0.63/0.49 0.92/0.79/0.64 1.17/1.02/0.85 1.5/1.28/1.02 1.59/1.35/1.07 1.98/1.71/1.29 2.44/2.05/1.41									
	Water pressure drop(H/M/L)	kPa 21.4/15.9/11.9 41/31.6/21 29.2/23/14.6 23.2/17.8/12.2 80.5/64.6/46.2 76.8/57.5/38.6 48.2/36.1/24.3 48.9/38/23.5 58.9/44.5/21.7									
Heating	Capacity (H/M/L)	kW 2.68/2.27/1.9 3.45/2.89/2.3 4.6/3.99/3.11 6.12/4.98/3.9 6.97/6.05/5.05 8.53/7.31/5.85 9.88/8.34/6.63 11.89/10.32/7.8 15.7/12.53/8.2									
	Water flow rate(H/M/L)	m³/h 0.49/0.41/0.35 0.63/0.52/0.42 0.84/0.73/0.57 1.11/0.9/0.71 1.27/1.1/0.92 1.55/1.33/1.06 1.8/1.52/1.21 2.16/1.88/1.42 2.85/2.28/1.49									
	Water pressure drop(H/M/L)	kPa 25.3/18.8/13.9 46.7/33.7/22.5 30.3/24.3/15.1 26.5/18.2/11.8 75.4/59.7/42.8 65/51.5/33.7 50.3/38/24.8 48.5/38.6/23.2 62.2/43.4/21.6									
Power input	30Pa (H/M/L) W	63/54/47 84/72/62 97/90/80 142/90/77 135/120/108 178/163/145 220/179/153 267/222/180 319/222/174									
Auxiliary electric heater (AEH)	W	550 600 1100 1100 1600 2000 2200 3200 3200									
Sound power level	30Pa (H/M/L) dB(A)	56/51/44 55/50/43 59/55/49 62/58/52 63/59/52 61/56/50 65/59/54 65/61/55 69/63/57									
Fan motor	Type	Low noise 4-speed fan motor									
	Quantity	1 1 1 1 1 2 2 2 2									
Fan	Type	Centrifugal, forward-curved Blades									
	Quantity	1 2 2 2 2 4 4 4 4									
Coil	Row	3 3 3 3 3 4 4 4 4									
	Max. working pressure	MPa 1.6 1.6 1.6 1.6 1.6 1.6 1.6 1.6									
	Diameter	mm Ø9.52 Ø9.52 Ø9.52 Ø9.52 Ø9.52 Ø9.52 Ø9.52 Ø9.52									
Net dimensions (WxHxD)	mm	741x241x522 841x241x522 941x241x522 941x241x522 1161x241x522 1461x241x522 1566x241x522 1856x241x522 2022x241x522									
Packing size (WxHxD)	mm	790x260x550 890x260x550 990x260x550 990x260x550 1210x260x550 1510x260x550 1615x260x550 1905x260x550 2070x260x550									
Net weight (non-AEH/with-AEH)	kg	14.6/16.1 17/18.5 20.2/21.7 20.2/21.7 23/25 31.9/34.4 34.4/37.4 39.5/43 43.1/47.1									
Gross weight (non-AEH/with-AEH)	kg	16.9/18.4 19.5/21 22.6/24.1 22.6/24.1 26/28 35.5/38 38.1/41.1 43/46.5 48.4/52.4									
Water inlet/outlet pipe	inch	RC3/4 RC3/4 RC3/4 RC3/4 RC3/4 RC3/4 RC3/4 RC3/4 RC3/4 RC3/4									
Drain pipe	inch	ZG3/4 ZG3/4 ZG3/4 ZG3/4 ZG3/4 ZG3/4 ZG3/4 ZG3/4 ZG3/4 ZG3/4									

- *Notes:
1. H: High fan speed; M: Medium fan speed; L: Low fan speed.
 2. Cooling conditions: Entering water 7°C, leaving water 12°C, Entering air temperature 27°C DB/19°C WB. Heating conditions: Entering water 45°C, leaving water 40°C, Entering air temperature 20°C DB.
 3. Noise is tested in a reverberation chamber test room."
 4. The external static pressure test condition is 0 Pa.

4-Row Duct



Model		MKT4-200G30A	MKT4-300G30A	MKT4-400G30A	MKT4-500G30A	MKT4-600G30A	
Power supply	V/Ph/Hz	220-240/1/50					
Air flow (H/M/L)	m³/h	452/369/275	639/494/373	784/634/500	948/766/578	1124/875/682	
	CFM	266/217/162	376/290/220	461/373/294	557/451/340	661/515/401	
Standard external static pressure	Pa	30	30	30	30	30	
Cooling	Capacity (H/M/L)	kW	2.22/1.67/1.2	3.04/2.58/1.87	3.71/3.17/2.62	4.49/3.87/3.07	6.18/4.95/3.78
	Water flow rate(H/M/L)	m³/h	0.4/0.3/0.22	0.55/0.46/0.34	0.67/0.57/0.47	0.81/0.7/0.55	1.11/0.89/0.68
	Water pressure drop(H/M/L)	kPa	5/5/5	10/5.4/3	15/9/8	20/16/15	30/22/16
Heating	Capacity (H/M/L)	kW	2.81/2.23/1.54	3.58/3.09/2.35	4.56/3.89/3.08	5.44/4.66/3.58	6.94/5.75/4.58
	Water flow rate(H/M/L)	m³/h	0.51/0.41/0.28	0.65/0.56/0.43	0.83/0.71/0.56	0.99/0.85/0.65	1.26/1.04/0.83
	Water pressure drop(H/M/L)	kPa	5/3.5/5	10/5.5/3.5	15/9.5/8	22.6/20/15	28/20/15
Power input (H/M/L)	W	92/50/43	76/62/52	90/78/68	110/90/77	142/124/109	
Sound power level	dB(A)	56/52/47	56/52/44	62/58/50	63/59/53	65/60/54	
Fan motor	Type	Low noise 4-speed fan motor					
	Quantity	1	1	1	1	1	
Fan	Type	Centrifugal, forward-curved Blades					
	Quantity	1	2	2	2	2	
Coil	Row	4	4	4	4	4	
	Max. working pressure	MPa	1.6	1.6	1.6	1.6	
	Diameter	mm	Φ9.52	Φ9.52	Φ9.52	Φ9.52	Φ9.52
Net dimensions (WxHxD)	mm	741x241x522	841x241x522	941x241x522	941x241x522	1161x241x522	
Packing size (WxHxD)	mm	790x260x550	890x260x550	990x260x550	990x260x550	1210x260x550	
Net weight	kg	15.3	17.5	20.7	20.7	23.5	
Gross weight	kg	17.6	20	23.1	23.1	26.5	
Water inlet/outlet pipe	inch	RC3/4	RC3/4	RC3/4	RC3/4	RC3/4	
Drain pipe	inch	ZG3/4	ZG3/4	ZG3/4	ZG3/4	ZG3/4	

Model		MKT4-800G30A	MKT4-1000G30A	MKT4-1200G30A	MKT4-1400G30A	
Power supply	V/Ph/Hz	220-240/1/50				
Air flow (H/M/L)	m³/h	1447/1119/857	1868/1397/1026	2213/1692/1074	2311/1756/1095	
	CFM	851/658/504	1099/822/603	1302/995/632	1359/1033/644	
Standard external static pressure	Pa	30	30	30	30	
Cooling	Capacity (H/M/L)	kW	6.31/5.1/4.14	7.79/6.13/4.87	10.17/8.57/5.44	11.7/9.43/6.47
	Water flow rate(H/M/L)	m³/h	1.14/0.92/0.75	1.4/1.1/0.88	1.83/1.54/0.98	2.11/1.7/1.16
	Water pressure drop(H/M/L)	kPa	15/7.5/5	18.3/12.1/8	33/24.8/11.4	35/23.9/15
Heating	Capacity (H/M/L)	kW	7.78/6.4/4.9	9.86/7.73/6.01	11.76/10.31/6.76	13.55/10.96/7.12
	Water flow rate(H/M/L)	m³/h	1.41/1.16/0.89	1.79/1.4/1.09	2.14/1.87/1.23	2.46/1.99/1.29
	Water pressure drop(H/M/L)	kPa	15/10/6	20.6/13.9/8.2	36.1/20.9/13.2	37/26/17
Power input (H/M/L)	W	166/134/113	223/164/139	277/228/174	325/240/193	
Sound power level	dB(A)	62/57/51	66/61/55	68/63/56	69/63/57	
Fan motor	Type	Low noise 4-speed fan motor				
	Quantity	2	2	2	2	
Fan	Type	Centrifugal, forward-curved Blades				
	Quantity	4	4	4	4	
Coil	Row	4	4	4	4	
	Max. working pressure	MPa	1.6	1.6	1.6	1.6
	Diameter	mm	Φ9.52	Φ9.52	Φ9.52	Φ9.52
Net dimensions (WxHxD)	mm	1461x241x522	1566x241x522	1856x241x522	2022x241x522	
Packing size (WxHxD)	mm	1510x260x550	1615x260x550	1905x260x550	2070x260x550	
Net weight	kg	32.9	35.4	40.5	44.1	
Gross weight	kg	36.5	39.1	44	49.4	
Water inlet/outlet pipe	inch	RC3/4	RC3/4	RC3/4	RC3/4	
Drain pipe	inch	ZG3/4	ZG3/4	ZG3/4	ZG3/4	

Notes:

1. H: High fan speed; M: Medium fan speed; L: Low fan speed.
2. Cooling conditions: Entering water 7°C, leaving water 12°C, Entering air temperature 27°C DB/19°C WB. Heating conditions: Entering water 45°C, leaving water 40°C, Entering air temperature 20°C DB.
3. Noise is tested in a reverberation chamber test room."
4. The external static pressure test condition is 0 Pa.

A4 Type Duct



Model MKT4-		800G50-A4A	1000G50-A4A	1200G50-A4A	1400G50-A4A		
Air flow	H/M/L	m³/h	1922/1862/1672	2137/2047/1931	2311/2123/1951	2480/1939/1777	
	H/M/L	CFM	1130/1096/984	1257/1204/1136	1359/1249/1147	1459/1141/1045	
External Static pressure		Pa	50	50	50	50	
Cooling	Capacity	H/M/L	kW	9.59/9.35/8.92	9.84/9.66/9.37	11.5/10.65/10.02	12.6/10.88/10.28
	Water flow rate	H/M/L	m³/h	1.73/1.68/1.61	1.77/1.74/1.69	2.07/1.92/1.8	2.27/1.96/1.85
	Water pressure drop	H/M/L	kPa	79.5/73.7/67.5	42.1/39.2/36.4	62/52.5/47.6	42.6/32.3/28.8
Heating	Capacity	H/M/L	kW	10.96/10.68/10.01	11.56/11.24/10.81	12.22/11.51/10.78	13.51/11.32/10.69
	Water flow rate	H/M/L	m³/h	1.97/1.92/1.8	2.08/2.02/1.95	2.2/2.07/1.94	2.43/2.04/1.92
	Water pressure drop	H/M/L	kPa	79.1/76.9/69.2	46.1/44.6/41.5	52/47.8/41.8	39.8/28.7/25.5
Power input	H/M/L	W	208/194/172	224/206/193	455/389/347	469/331/290	
Power supply		V/Ph/Hz	220-240/1/50	220-240/1/50	220-240/1/50	220-240/1/50	
Sound pressure level		H/M/L	dB(A)	48.4/47.9/46.6	49.5/48.1/47.3	50.9/50/48.5	51.7/50/49.5
Fan motor	Type	Low noise 4-speed fan motor					
	Model	YSK105-65C	YSK150-65C	YSK230-45C	YSK230-45C		
Fan	Type	Centrifugal, forward-curved Blades					
	Quantity	1	1	1	1		
Coil	Row	4	4	4	4		
	Max. Working pressure	MPa	1.6	1.6	1.6	1.6	
	Coil length x height	mm	885x305	885x305	1085x305	1085x305	
Body	Fin spacing	mm	2.2	2.2	2.2	2.2	
	Fin type	Hydrophilic aluminum					
	Number of circuits		4	6	8	8	
Pipe connection	Diameter	mm	Φ9.52	Φ9.52	Φ9.52	Φ9.52	
	Dimensions	WxHxD	mm	1180x340x612	1180x340x612	1369x340x612	1369x340x612
	Packing	WxHxD	mm	1310x380x693	1310x380x693	1490x380x693	1490x380x693
Body	Net weight	kg	39.3	40.8	46.3	46.3	
	Gross weight	kg	47	49.6	56.4	56.4	
	Water inlet/outlet pipe	inch	RC3/4	RC3/4	RC3/4	RC3/4	
Pipe connection	Drain pipe	mm	ODΦ24	ODΦ24	ODΦ24	ODΦ24	

Model MKT4-		1600G50-A4A	1800G50-A4A	2000G50-A4A		
Air flow	H/M/L	m³/h	2695/2164/1997	3490/2641/2310	3686/2780/2307	
	H/M/L	CFM	1585/1273/1175	2053/1554/1359	2168/1635/1357	
External Static pressure		Pa	50	50	50	
Cooling	Capacity	H/M/L	kW	13.16/11.24/10.61	16.51/12.59/11.07	19.15/15.64/13.67
	Water flow rate	H/M/L	m³/h	2.37/2.02/1.91	2.97/2.27/1.99	3.45/2.83/2.46
	Water pressure drop	H/M/L	kPa	70.9/54.1/49.1	239.6/150.4/117.8	283.3/199.2/159.7
Heating	Capacity	H/M/L	kW	14.66/11.46/10.76	17.54/13.21/11.67	19.31/15.69/13.63
	Water flow rate	H/M/L	m³/h	2.64/2.06/1.94	3.16/2.38/2.1	3.48/2.83/2.45
	Water pressure drop	H/M/L	kPa	65.5/49.8/43.7	241.9/146.1/115.5	283/193.9/151.5
Power input	H/M/L	W	573/391/341	637/416/358	696/444/384	
Power supply		V/Ph/Hz	220-240/1/50	220-240/1/50	220-240/1/50	
Sound pressure level		H/M/L	dB(A)	52.9/50.7/50	53.6/51.1/50.2	54.4/52.7/51.6
Fan motor	Type	Low noise 4-speed fan motor				
	Model	YSK230-45C	YSK360-45C	YSK360-45C		
Fan	Type	Centrifugal, forward-curved Blades				
	Quantity	1	1	1		
Coil	Row	4	4	4		
	Max. Working pressure	MPa	1.6	1.6	1.6	
	Coil length x height	mm	1085x305	1277x305	1277x305	
Body	Fin spacing	mm	2.2	2.2	2.2	
	Fin type	Hydrophilic aluminum				
	Number of circuits		8	8	8	
Pipe connection	Diameter	mm	Φ9.52	Φ9.52	Φ9.52	
	Dimensions	WxHxD	mm	1369x340x612	1500x340x612	1500x340x612
	Packing	WxHxD	mm	1490x380x693	1620x380x693	1620x380x693
Body	Net weight	kg	46.3	54.8	54.8	
	Gross weight	kg	56.4	64.6	64.6	
	Water inlet/outlet pipe	inch	RC3/4	RC3/4	RC3/4	
Pipe connection	Drain pipe	mm	ODΦ24	ODΦ24	ODΦ24	

Note:

- 1.H: high fan speed; M: medium fan speed; L: low fan speed.
- 2.Cooling conditions: Entering water 7°C, temperature rise 5°C, entering air temperature 27°C DB,19°C WB. Heating conditions: Entering water 45°C, leaving water 40°C,enter air temperature 20°C.
- 3.Noise is tested in semi-anechoic test room.
4. The external static pressure test condition is 0 Pa.

High Static Pressure Duct



Model		MKT3H-800G70A MKT3H-800EG70A	MKT3H-1000G70A MKT3H-1000EG70A	MKT3H-1200G70A MKT3H-1200EG70A	MKT3H-1400G70A MKT3H-1400EG70A	
Power supply	V/Ph/Hz	220-240/1/50				
Air flow (H/M/L)	m³/h	1464/1453/1408	1507/1491/1397	1601/1557/1500	1659/1590/1501	
	CFM	861/855/828	887/877/822	942/916/882	976/935/883	
Standard external static pressure	Pa	70	70	70	70	
Cooling	Capacity (H/M/L)	kW	5.4/5.27/5.08	7.75/7.56/6.98	8.03/7.8/7.49	10.41/10.11/9.69
	Water flow rate(H/M/L)	m³/h	0.97/0.95/0.91	1.39/1.36/1.26	1.45/1.4/1.35	1.87/1.82/1.74
	Water pressure drop(H/M/L)	kPa	14.5/11.7/13.2	35.1/34/30.8	35.3/33.5/31.4	52.1/48.1/44.3
Heating	Capacity (H/M/L)	kW	8.09/7.82/7.42	9.62/9.28/8.85	10.33/10.02/9.17	11.15/10.46/9.65
	Water flow rate(H/M/L)	m³/h	1.47/1.42/1.35	1.75/1.69/1.61	1.88/1.82/1.67	2.03/1.9/1.75
	Water pressure drop(H/M/L)	kPa	25.5/24.2/22.8	42.8/40.8/36.5	55.5/52.8/48.1	47.3/45.5/41.9
Power input (H/M/L)	W	391/375/348	382/363/343	386/372/355	380/364/347	
Auxiliary electric heater (AEH)	W	5000	5000	5000	5000	
Sound power level	Inlet	dB(A)	74/73/71	72/71/70	73/71/70	73/71/70
	Outlet	dB(A)	72/71/69	70/70/69	71/70/69	71/70/69
Fan motor	Type	Low noise 4-speed fan motor				
	Quantity	1	1	1	1	
Fan	Type	Centrifugal, forward-curved Blades				
	Quantity	1	1	1	1	
Coil	Row	2	3	3	4	
	Max. working pressure	MPa	1.6	1.6	1.6	1.6
	Diameter	mm	Ø9.52	Ø9.52	Ø9.52	Ø9.52
Net dimensions(WxHxD)	mm	946x400x816	946x400x816	946x400x816	946x400x816	
Packing size (non-AEH/with-AEH) (WxHxD)	mm	Left connection: 1075x480x857/1075x480x925 Right connection: 1015x480x857/1015x480x925				
Net weight (non-AEH/with-AEH)	kg	50/53	52/55	52/55	54/57	
Gross weight (non-AEH/with-AEH)	kg	55/58	57/60	57/60	59/62	
Water inlet/outlet pipe	inch	RC3/4	RC3/4	RC3/4	RC3/4	
Drain pipe	inch	ZG3/4	ZG3/4	ZG3/4	ZG3/4	

Model		MKT3H-1600G100A MKT3H-1600EG100A	MKT3H-1800G100A MKT3H-1800EG100A	MKT3H-2200G100A MKT3H-2200EG100A	
Power supply	V/Ph/Hz	220-240/1/50			
Air flow (H/M/L)	m³/h	2272/2126/1911	3177/2983/2327	3411/3034/2588	
	CFM	1336/1251/1124	1869/1755/1369	2007/1785/1522	
Standard external static pressure	Pa	100	100	100	
Cooling	Capacity (H/M/L)	kW	12.99/12.02/11.04	15.25/13.42/12.38	16.71/15.15/13.58
	Water flow rate(H/M/L)	m³/h	2.34/2.16/1.99	2.74/2.42/2.23	3.01/2.73/2.44
	Water pressure drop(H/M/L)	kPa	86/73.4/60.7	129/113/100.1	147.9/124.2/98.6
Heating	Capacity (H/M/L)	kW	14.07/12.91/11.78	18.23/16.84/14.76	19.94/17.26/15.25
	Water flow rate(H/M/L)	m³/h	2.56/2.35/2.14	3.31/3.06/2.68	3.62/3.14/2.77
	Water pressure drop(H/M/L)	kPa	87.8/75.1/63	168/147/127.2	163.7/130.9/102
Power input (H/M/L)	W	546/475/415	782/683/606	887/755/628	
Auxiliary electric heater (AEH)	W	9500	9500	9500	
Sound power level	Inlet	dB(A)	68/67/65	74/72/70	75/72/69
	Outlet	dB(A)	66/65/62	72/70/68	73/70/67
Fan motor	Type	Low noise 4-speed fan motor			
	Quantity	1	1	1	
Fan	Type	Centrifugal, forward-curved Blades			
	Quantity	2	2	2	
Coil	Row	3	3	3	
	Max. working pressure	MPa	1.6	1.6	1.6
	Diameter	mm	Ø9.52	Ø9.52	Ø9.52
Net dimensions(WxHxD)	mm	1290x400x809	1290x400x809	1290x400x809	
Packing size (non-AEH/with-AEH) (WxHxD)	mm	Left connection: 1448x460x877/1448x460x950 Right connection: 1383x422x877/1368x460x950			
Net weight (non-AEH/with-AEH)	kg	76/82	76/82	76/82	
Gross weight (non-AEH/with-AEH)	kg	83/89	83/89	83/89	
Water inlet/outlet pipe	inch	RC3/4	RC3/4	RC3/4	
Drain pipe	inch	ZG3/4	ZG3/4	ZG3/4	

Notes:

- H: High fan speed; M: Medium fan speed; L: Low fan speed.
- Cooling conditions: Entering water 7°C, leaving water 12°C, Entering air temperature 27°C DB/19°C WB.
Heating conditions: Entering water 45°C, leaving water 40°C, Entering air temperature 20°C DB.
- Noise is tested in a reverberation chamber test room."
- The external static pressure test condition is the same as Eurovent conditions (External static pressure is different for each models).

District Cooling Duct



Model		MKS4-200G30	MKS4-300G30	MKS4-400G30	MKS4-500G30	MKS4-600G30	MKS4-800G50-A4	
Power supply	V/Ph/Hz	220-240/1/50						
Air flow (H/M/L)	m³/h	430/380/340	600/540/480	700/630/520	900/810/720	1160/1040/930	1400/1342/1200	
	CFM	253/224/200	353/318/282	412/370/305	530/476/424	682/612/547	824/789/705	
Standard external static pressure	Pa	30	30	30	30	30	50	
Cooling	Capacity (H/M/L)	kW	2.05/1.742/1.55	2.61/2.21/1.98	4.03/3.42/3.06	4.57/3.88/3.47	6.39/5.43/4.85	6.93/5.89/5.26
	Water flow rate	L/h	196	249	385	437	610.6	662
	Water pressure drop	kPa	10	10	21	25	53.8	13.3
Power input (H/M/L)	W	47/38/33	65/52/46	78/62/55	92/74/64	116/93/81	144/115/101	
Sound pressure level	dB(A)	38/33/27	39/34/28	39/35/29	41/35/30	42/36/31	48/47/46	
Fan motor	Type	Low noise 3-speed fan motor						
	Quantity	1						
Fan	Type	Centrifugal, forward-curved blades						
	Quantity	1	2	2	2	2	2	
Coil	Row	4						
	Max. working pressure	MPa	1.6					
	Diameter	mm	Ø9.52					
Net dimensions (WxHxD)	mm	741x241x522	841x241x522	941x241x522	941x241x522	1161x241x522	1180x340x612	
Packing size (WxHxD)	mm	790x260x550	890x260x550	990x260x550	990x260x550	1210x260x550	1310x380x693	
Net weight	kg	15.3	17.5	20.7	20.7	23.5	39.3	
Gross weight	kg	17.6	20	23.1	23.1	26.5	47	
Water inlet/outlet pipe	inch	RC3/4						
Drain pipe	inch	ZG3/4						

Model		MKS4-1000G50-A4	MKS4-1200G50-A4	MKS4-1400G50-A4	MKS4-1600G50-A4	MKS4-1800G50-A4	MKS4-2000G50-A4	
Power supply	V/Ph/Hz	220-240/1/50						
Air flow (H/M/L)	m³/h	1650/1527/1405	2040/1851/1666	2420/1850/1657	2430/1917/1742	3380/2239/1878	3660/2544/2199	
	CFM	970/898/826	1200/1089/980	1424/1088/975	1431/1128/1025	1988/1317/1105	2153/1496/1295	
Standard external static pressure	Pa	50	50	50	50	50	50	
Cooling	Capacity (H/M/L)	kW	7.57/6.43/5.75	10.11/8.59/7.68	11.5/9.7/8.74	11.74/9.97/8.92	14.74/12.52/11.2	16.1/13.68/12.23
	Water flow rate	L/h	723	966	1099	1122	1408	1538
	Water pressure drop	kPa	16.3	21	25.3	27.8	37.9	48.1
Power input (H/M/L)	W	176/141/123	320/256/224	392/314/274	482/386/337	538/430/376	583/466/408	
Sound pressure level	dB(A)	49/48/47	51/50/48	52/50/49	53/51/50	54/51/50	54/52/51	
Fan motor	Type	Low noise 3-speed fan motor						
	Quantity	1						
Fan	Type	Centrifugal, forward-curved blades						
	Quantity	2	2	2	2	3	3	
Coil	Row	4						
	Max. working pressure	MPa	1.6					
	Diameter	mm	Ø9.52					
Net dimensions (WxHxD)	mm	1180x340x612	1369x340x612	1369x340x612	1369x340x612	1500x340x612	1500x340x612	
Packing size (WxHxD)	mm	1310x380x693	1490x380x693	1490x380x693	1490x380x693	1620x380x693	1620x380x693	
Net weight	kg	40.8	46.3	46.3	46.3	54.8	54.8	
Gross weight	kg	49.6	56.4	56.4	56.4	64.6	64.6	
Water inlet/outlet pipe	inch	RC3/4						
Drain pipe	inch	ZG3/4						

Notes:

- H: High fan speed; M: Medium fan speed; L: Low fan speed.
- The data are test under standard external static pressure.
- Cooling conditions: entering water 5.5°C, temperature rise 9°C, entering air temperature 27°C DB/19°C WB.
- Noise is tested in a semi-anechoic test room.
- The external static pressure test condition is 0 Pa.

4-Pipe Duct



Model		MKT3-200FG30A	MKT3-300FG30A	MKT3-400FG30A	MKT3-500FG30A	MKT3-600FG30A	
Power supply		V/Ph/Hz 220-240/1/50					
Air flow (H/M/L)		m³/h	470/382/285	639/493/374	751/628/457	955/779/589	1204/955/719
		CFM	200/150/100	300/225/150	400/300/200	500/375/250	600/450/300
Standard external static pressure		Pa G30 models: 30					
Cooling	Capacity (H/M/L)	kW	2.01/1.76/1.44	2.76/2.34/1.97	3.37/3.03/2.33	3.49/3.1/2.53	4.82/4.29/3.61
	Water flow rate(H/M/L)	m³/h	0.36/0.32/0.26	0.5/0.42/0.35	0.61/0.55/0.42	0.63/0.56/0.46	0.87/0.77/0.65
	Water pressure drop(H/M/L)	kPa	11/9/6.5	23/17.3/12.7	58.7/55.2/51	142.2/113.4/79.7	24.7/19.9/14.8
Heating	Capacity (H/M/L)	kW	2.33/2.1/1.79	3.07/2.72/2.37	3.8/3.49/2.98	4.51/4.03/3.43	5.5/4.99/4.35
	Water flow rate(H/M/L)	m³/h	0.21/0.19/0.16	0.28/0.25/0.22	0.35/0.32/0.27	0.41/0.37/0.32	0.5/0.46/0.4
	Water pressure drop(H/M/L)	kPa	8.5/7.2/5.8	13.8/11.3/9	18.4/16.2/12.3	31/22.7/17.8	50/42.2/33
Power input	30Pa (H/M/L)	W	61/53/47	76/65/57	88/81/72	108/89/77	136/121/106
Sound power level	30Pa (H/M/L)	dB(A)	60/55/46	56/51/44	59/55/48	62/58/52	63/58/52
Fan motor	Type	Low noise 4-speed fan motor					
	Quantity	1	1	1	1	1	
Fan	Type	Centrifugal, forward-curved Blades					
	Quantity	1	2	2	2	2	
Coil	Row	3	3	3	3	3	
	Max. working pressure	MPa	1.6	1.6	1.6	1.6	
	Diameter	mm	Φ9.52	Φ9.52	Φ9.52	Φ9.52	
Net dimensions (WxHxD)	mm	741x241x522	841x241x522	941x241x522	941x241x522	1161x241x522	
Packing size (WxHxD)	mm	790x260x555	890x260x555	990x260x555	990x260x555	1210x260x555	
Net weight	kg	15.1	17.5	20.7	20.7	23.5	
Gross weight	kg	17.4	20	23.1	23.1	26.5	
Water inlet/outlet pipe	inch	RC3/4	RC3/4	RC3/4	RC3/4	RC3/4	
Drain pipe	inch	ZG3/4	ZG3/4	ZG3/4	ZG3/4	ZG3/4	

Notes:

1. H: High fan speed; M: Medium fan speed; L: Low fan speed.
2. Cooling conditions: Entering water 7°C, leaving water 12°C, Entering air temperature 27°C DB/19°C WB.
Heating conditions: Entering water 65°C, leaving water 55°C, Entering air temperature 20°C DB.
3. Noise is tested in a reverberation chamber test room."
4. The external static pressure test condition is 0 Pa.

4-Pipe Duct



Model		MKT3-800FG30A	MKT3-1000FG30A	MKT3-1200FG30A	MKT3-1400FG30A	
Power supply		V/Ph/Hz 220-240/1/50				
Air flow (H/M/L)		m³/h	1349/1062/820	1749/1350/1006	2099/1698/1145	2226/1720/1173
		CFM	800/600/400	1000/750/500	1200/900/600	1400/1050/700
Standard external static pressure		Pa G30 models: 30				
Cooling	Capacity (H/M/L)	kW	6.16/5.38/4.55	7.15/6.17/5.21	7.36/6.72/5.54	10.16/8.85/7.02
	Water flow rate(H/M/L)	m³/h	1.11/0.97/0.82	1.29/1.11/0.94	1.32/1.21/1	1.83/1.59/1.26
	Water pressure drop(H/M/L)	kPa	26.3/20.6/15.5	32/24.4/18.1	41.3/34.9/24.7	74.8/58.3/39
Heating	Capacity (H/M/L)	kW	6.04/5.41/4.73	7.22/6.43/5.62	8.89/8.09/6.73	9.84/8.78/7.28
	Water flow rate(H/M/L)	m³/h	0.55/0.5/0.43	0.66/0.59/0.52	0.82/0.74/0.62	0.9/0.81/0.67
	Water pressure drop(H/M/L)	kPa	11/8.9/10.4	17.3/14.2/11	27.6/23.3/16.9	33.6/27.6/20
Power input	30Pa (H/M/L)	W	169/144/127	224/197/177	270/234/195	308/238/197
Sound power level	30Pa (H/M/L)	dB(A)	62/57/50	66/60/54	66/62/56	66/62/57
Fan motor	Type	Low noise 4-speed fan motor				
	Quantity	2	2	2	2	
Fan	Type	Centrifugal, forward-curved Blades				
	Quantity	4	4	4	4	
Coil	Row	3	3	3	3	
	Max. working pressure	MPa	1.6	1.6	1.6	
	Diameter	mm	Φ9.52	Φ9.52	Φ9.52	
Net dimensions (WxHxD)	mm	1461x241x522	1566x241x522	1856x241x522	2022x241x522	
Packing size (WxHxD)	mm	1510x260x555	1615x260x555	1905x260x555	2070x260x555	
Net weight	kg	32.4	34.9	40	43.6	
Gross weight	kg	36	38.6	43.5	48.9	
Water inlet/outlet pipe	inch	RC3/4	RC3/4	RC3/4	RC3/4	
Drain pipe	inch	ZG3/4	ZG3/4	ZG3/4	ZG3/4	

Notes:

1. H: High fan speed; M: Medium fan speed; L: Low fan speed.
2. Cooling conditions: Entering water 7°C, leaving water 12°C, Entering air temperature 27°C DB/19°C WB.
Heating conditions: Entering water 65°C, leaving water 55°C, Entering air temperature 20°C DB.
3. Noise is tested in a reverberation chamber test room."
4. The external static pressure test condition is 0 Pa.

Wall Mounted Series

C Type



S Type



Stylish Panel

- Stylish front panel blends easily within any interior décor, ideal for use in shops, restaurants or offices with no or narrow false ceilings.

Convenient Installation

- Multi-directional outlet pipe feature: left/right/rear, to meet the needs of different rooms.

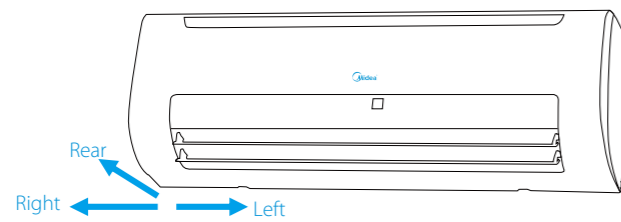

Built-in 3-Way Electromagnetic Valve

Auto Swing Louver

- The Auto Swing Louver function ensures that the air direction corresponds to the mode selected.

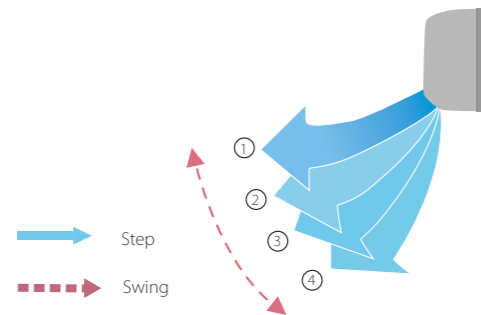

Easy Maintenance

- Removable front panel making maintenance convenient.

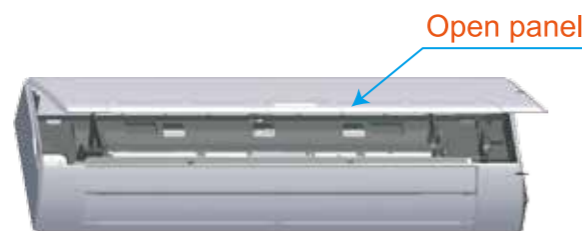

Wall Mounted (C Type)



Model		MKG-250A	MKG-300A	MKG-400A	MKG-500A	MKG-600A	
Power supply	V/Ph/Hz	220-240/1/50					
Air flow (H/M/L)	m ³ /h	435/396/342	523/426/351	660/534/480	841/723/594	915/836/714	
	CFM	256/233/201	308/251/206	388/314/282	495/425/349	538/492/420	
Cooling	Capacity (H/M/L)	kW	1.94/1.84/1.68	2.64/2.4/1.99	2.94/2.58/2.34	4.01/3.61/3.1	4.61/4.33/3.84
	Water flow rate(H/M/L)	m ³ /h	0.35/0.33/0.3	0.47/0.43/0.36	0.53/0.46/0.42	0.72/0.65/0.56	0.83/0.78/0.69
	Water pressure drop(H/M/L)	kPa	31.6/28.6/25.2	37.5/30/24	57.2/47.6/38.7	47.1/33.5/29.7	51/39.5/34
Heating	Capacity (H/M/L)	kW	2.34/2.15/1.94	2.9/2.6/2.22	3.46/2.75/2.52	4.39/3.8/3.27	4.55/4.2/3.82
	Water flow rate(H/M/L)	m ³ /h	0.43/0.39/0.35	0.53/0.47/0.4	0.63/0.5/0.46	0.8/0.69/0.6	0.83/0.76/0.69
	Water pressure drop(H/M/L)	kPa	35.2/34.9/30	39.3/31.5/25	70.8/55.1/46.2	48.6/40.8/31.7	48/43/33
Power input (H/M/L)	W	35/32/31	47/43/39	50/51/47	60/54/48	72/60/55	
Sound power level	dB(A)	44/42/40	48/43/39	57/51/47	54/50/45	59/55/50	
Fan motor	Type	Low noise 4-speed fan motor					
	Quantity	1	1	1	1	1	
Fan	Type	Tangential fan	Tangential fan	Tangential fan	Tangential fan	Tangential fan	
	Quantity	1	1	1	1	1	
Coil	Row	2	2	2	2	2	
	Max. working pressure	MPa	1.6	1.6	1.6	1.6	1.6
	Diameter	mm	Φ7	Φ7	Φ7	Φ7	Φ7
Net dimensions (WxHxD)	mm	915x290x210	915x290x210	915x290x210	1070x315x210	1070x315x210	
Packing size (WxHxD)	mm	1020x385x300	1020x385x300	1020x385x300	1180x410x300	1180x410x300	
Net weight	kg	12	12	12	15	15	
Gross weight	kg	16	16.7	16.7	19	19	
Water inlet/outlet pipe	inch	G3/4	G3/4	G3/4	G3/4	G3/4	
Drain pipe	mm	ODΦ20	ODΦ20	ODΦ20	ODΦ20	ODΦ20	

Wall Mounted (S Type)



Model		MKG-250-BA	MKG-300-BA	MKG-400-BA	MKG-500-BA	MKG-600-BA	
Power supply	V/Ph/Hz	220-240/1/50					
Air flow (H/M/L)	m ³ /h	435/396/342	523/426/351	660/534/480	841/723/594	915/836/714	
	CFM	256/233/201	308/251/206	388/314/282	495/425/349	538/492/420	
Cooling	Capacity (H/M/L)	kW	1.94/1.84/1.68	2.64/2.4/1.99	2.94/2.58/2.34	4.01/3.61/3.1	4.61/4.33/3.84
	Water flow rate(H/M/L)	m ³ /h	0.35/0.33/0.3	0.47/0.43/0.36	0.53/0.46/0.42	0.72/0.65/0.56	0.83/0.78/0.69
	Water pressure drop(H/M/L)	kPa	31.6/28.6/25.2	37.5/30/24	57.2/47.6/38.7	47.1/33.5/29.7	51/39.5/34
Heating	Capacity (H/M/L)	kW	2.34/2.15/1.94	2.9/2.6/2.22	3.46/2.75/2.52	4.39/3.8/3.27	4.55/4.2/3.82
	Water flow rate(H/M/L)	m ³ /h	0.43/0.39/0.35	0.53/0.47/0.4	0.63/0.5/0.46	0.8/0.69/0.6	0.83/0.76/0.69
	Water pressure drop(H/M/L)	kPa	35.2/34.9/30	39.3/31.5/25	70.8/55.1/46.2	48.6/40.8/31.7	48/43/33
Power input (H/M/L)	W	35/32/31	47/43/39	50/51/47	60/54/48	72/60/55	
Sound power level	dB(A)	44/42/40	48/43/39	57/51/47	54/50/45	59/55/50	
Fan motor	Type	Low noise 4-speed fan motor					
	Quantity	1	1	1	1	1	
Fan	Type	Tangential fan	Tangential fan	Tangential fan	Tangential fan	Tangential fan	
	Quantity	1	1	1	1	1	
Coil	Row	2	2	2	2	2	
	Max. working pressure	MPa	1.6	1.6	1.6	1.6	1.6
	Diameter	mm	Φ7	Φ7	Φ7	Φ7	Φ7
Net dimensions (WxHxD)	mm	915x290x230	915x290x230	915x290x230	1072x315x230	1072x315x230	
Packing size (WxHxD)	mm	1020x390x315	1020x390x315	1020x390x315	1180x415x315	1180x415x315	
Net weight	kg	13	13	13.3	15.8	15.8	
Gross weight	kg	16.3	16.3	16.7	19.4	19.4	
Water inlet/outlet pipe	inch	G3/4	G3/4	G3/4	G3/4	G3/4	
Drain pipe	mm	ODΦ20	ODΦ20	ODΦ20	ODΦ20	ODΦ20	

Notes:

1. H: High fan speed; M: Medium fan speed; L: Low fan speed.
2. Cooling conditions: Entering water 7 °C, leaving water 12 °C, Entering air temperature 27 °C DB/19 °C WB.
Heating conditions: Entering water 45 °C, leaving water 40 °C, Entering air temperature 20 °C DB.
3. Noise is tested in a reverberation chamber test room."

2nd Generation Ceiling&Floor series

Concealed Type
H3 Series



Exposed Type
(air return from bottom)
H2 Series



Note : The footing need to purchase separately

High Efficiency and Low Sound Operation

- Due to the AC brushless fan motor, the unit operates in high efficiency and low sound level.

Flexible Installation

- Cabinet and concealed versions meet various installation requirements.
- Horizontal or vertical installation.



Feature

- Ultra-thin, the thickness is only 200mm.

2- Pipe 2nd Generation Ceiling&Floor

Model		MKH2-150-R3	MKH2-150-R4	MKH2-250-R3	MKH2-250-R4	MKH2-350-R3	MKH2-350-R4	
Power supply	V/Ph/Hz	220-240/1/50						
Air flow (H/M/L)	m ³ /h	255/165/142	255/192/139	400/273/180	425/284/184	595/447/319	595/450/319	
	CFM	150/97/84	150/113/82	235/161/106	250/167/109	350/263/188	350/265/188	
External static pressure	Pa	0						
Cooling	Total Capacity (H/M/L)	kW	1.65/1.22/1.09	2.25/1.85/1.40	2.65/2.02/1.40	3.05/2.26/1.58	3.85/3.19/2.46	4.20/3.38/2.48
	Water flow rate (H/M/L)	L/h	283/209/186	386/317/241	454/346/240	523/387/272	660/546/422	720/580/425
	Water pressure drop (H/M/L)	kPa	15.75/9.33/7.37	33.19/22.37/14.64	18.03/11.18/5.48	26.71/15.66/8.42	38.23/27.11/16.96	41.15/27.07/15.71
Heating	Capacity (H/M/L)	kW	1.85/1.29/1.13	2.35/1.87/1.42	3.05/2.24/1.52	3.15/2.28/1.60	4.10/3.30/2.48	4.30/3.43/2.52
	Water flow rate (H/M/L)	L/h	317/222/194	403/320/244	523/384/260	540/392/275	705/568/427	740/590/433
	Water pressure drop (H/M/L)	kPa	15.13/8.22/6.64	33.19/22.37/14.64	17.56/10.28/5.43	23.31/12.57/6.11	35.52/24.83/14.91	37.20/24.50/13.75
Power input (H/M/L)	W	35/17/14	40/24/15	47/26/14	47/26/14	51/32/19	51/32/19	
Sound power level	(H/M/L) dB(A)	47/35/34	53/47/39	46/37/31	47/38/32	52/44/36	52/45/37	
Fan motor	Type	AC fan motor						
	Quantity	1	1	1	1	1	1	
Fan	Type	Centrifugal, forward-curved Blades						
	Quantity	1	1	2	2	2	2	
Coil	Row	3	4	3	4	3	4	
	Max. working pressure	MPa	1.6	1.6	1.6	1.6	1.6	
	Diameter	mm	Φ7.94	Φ7.94	Φ7.94	Φ7.94	Φ7.94	
Body	Net dimensions (W×H×D)	mm	495×200×790	495×200×790	495×200×1020	495×200×1020	495×200×1240	495×200×1240
	Packing size (W×H×D)	mm	595×300×895	595×300×895	595×300×1125	595×300×1125	595×300×1345	595×300×1345
	Net weight	kg	16.3	16.7	20.0	20.8	24.0	25.4
	Gross weight	kg	21.8	22.7	26.8	26.8	31.0	32.4
Water inlet/outlet pipe	inch	G3/4	G3/4	G3/4	G3/4	G3/4	G3/4	
Drain pipe	mm	ODΦ18.5	ODΦ18.5	ODΦ18.5	ODΦ18.5	ODΦ18.5	ODΦ18.5	

Model		MKH2-500-R3	MKH2-500-R4	MKH2-700-R3	MKH2-700-R4	MKH2-800-R3	MKH2-800-R4	
Power supply	V/Ph/Hz	220-240/1/50						
Air flow (H/M/L)	m ³ /h	790/560/392	800/574/404	1190/855/555	1150/885/591	1300/1088/782	1300/1132/836	
	CFM	465/330/231	471/338/238	700/503/327	677/521/348	766/641/461	766/667/492	
External static pressure	Pa	0						
Cooling	Total Capacity (H/M/L)	kW	4.65/3.80/2.92	5.35/4.25/3.31	6.00/5.03/3.71	6.75/5.80/4.24	7.35/6.51/5.15	8.25/7.52/5.87
	Water flow rate (H/M/L)	L/h	797/652/500	917/729/567	1029/862/636	1157/995/727	1260/1116/884	1414/1289/1007
	Water pressure drop (H/M/L)	kPa	56.85/40.02/25.31	61.48/41.44/26.62	53.79/36.96/21.16	40.26/29.20/16.15	45.43/37.06/23.29	64.72/55.03/34.88
Heating	Capacity (H/M/L)	kW	5.20/3.95/3.00	5.70/4.36/3.31	6.15/5.10/3.80	7.15/5.81/4.30	8.20/7.09/5.46	8.50/7.60/5.90
	Water flow rate (H/M/L)	L/h	894/679/516	977/747/569	1054/877/654	1226/996/740	1406/1216/937	1457/1302/1015
	Water pressure drop (H/M/L)	kPa	56.68/37.31/23.25	60.89/37.73/21.79	57.85/38.53/21.1	42.16/28.68/14.66	44.60/34.09/19.98	61.96/47.46/28.84
Power input (H/M/L)	W	91/54/34	91/54/35	123/98/68	110/89/64	123/109/83	118/104/82	
Sound power level	(H/M/L) dB(A)	59/51/43	59/51/43	/5645	62/56/46	/56250	/56250	
Fan motor	Type	AC fan motor						
	Quantity	1	1	1	1	1	1	
Fan	Type	Centrifugal, forward-curved Blades						
	Quantity	2	2	3	3	3	3	
Coil	Row	3	4	3	4	3	4	
	Max. working pressure	MPa	1.6	1.6	1.6	1.6	1.6	
	Diameter	mm	Φ7.94	Φ7.94	Φ7.94	Φ7.94	Φ7.94	
Body	Net dimensions (W×H×D)	mm	495×200×1240	495×200×1240	495×200×1360	495×200×1360	591×200×1360	591×200×1360
	Packing size (W×H×D)	mm	595×300×1345	595×300×1345	595×300×1465	595×300×1465	695×300×1465	695×300×1465
	Net weight	kg	25.5	26.3	27.3	28.5	31.7	34.0
	Gross weight	kg	32.0	33.4	34.8	36.0	40.2	42.0
Water inlet/outlet pipe	inch	G3/4	G3/4	G3/4	G3/4	G3/4	G3/4	
Drain pipe	mm	ODΦ18.5	ODΦ18.5	ODΦ18.5	ODΦ18.5	ODΦ18.5	ODΦ18.5	

Notes:

1. H: High fan speed; M: Medium fan speed; L: Low fan speed.
2. Cooling conditions: Entering water 7 C., leaving water 12 C., Entering air temperature 27 C. DB/19 C. WB.
Heating conditions: Entering water 45 C., leaving water 40 C., Entering air temperature 20 C. DB/15 C. WB.
3. Noise is tested in a reverberation chamber.

Model		MKH3-150-R3	MKH3-150-R4	MKH3-250-R3	MKH3-250-R4	MKH3-350-R3	MKH3-350-R4	
Power supply	V/Ph/Hz	220-240/1/50						
Air flow (H/M/L)	m³/h	255/165/142	255/192/139	400/273/180	425/284/184	595/447/319	595/450/319	
	CFM	150/97/84	150/113/82	235/161/106	250/167/109	350/263/188	350/265/188	
External static pressure	Pa	12						
Cooling	Total Capacity (H/M/L)	kW	1.65/1.22/1.09	2.25/1.85/1.40	2.65/2.02/1.40	3.05/2.26/1.58	3.85/3.19/2.46	4.20/3.38/2.48
	Water flow rate (H/M/L)	L/h	283/209/186	386/317/241	454/346/240	523/387/272	660/546/422	720/580/425
	Water pressure drop (H/M/L)	kPa	15.75/9.33/7.37	33.19/22.37/14.64	18.03/11.18/5.48	26.71/15.66/8.42	38.23/27.11/16.96	41.15/27.07/15.71
Heating	Capacity (H/M/L)	kW	1.85/1.29/1.13	2.35/1.87/1.42	3.05/2.24/1.52	3.15/2.28/1.60	4.10/3.30/2.48	4.30/3.43/2.52
	Water flow rate (H/M/L)	L/h	317/222/194	403/320/244	523/384/260	540/392/275	705/568/427	740/590/433
	Water pressure drop (H/M/L)	kPa	15.13/8.22/6.64	33.19/22.37/14.64	17.56/10.28/5.43	23.31/12.57/6.11	35.52/24.83/14.91	37.20/24.50/13.75
Power input (H/M/L)	W	35/17/14	40/24/15	47/26/14	47/26/14	51/32/19	51/32/19	
Sound power level	(H/M/L) dB(A)	47/35/34	53/47/39	46/37/31	47/38/32	52/44/36	52/45/37	
Fan motor	Type	AC fan motor						
	Quantity	1	1	1	1	1	1	
Fan	Type	Centrifugal, forward-curved Blades						
	Quantity	1	1	2	2	2	2	
Coil	Row	3	4	3	4	3	4	
	Max. working pressure	MPa	1.6	1.6	1.6	1.6	1.6	
	Diameter	mm	Ø7.94	Ø7.94	Ø7.94	Ø7.94	Ø7.94	
Body	Net dimensions (WxHxD)	mm	455x200x607	455x200x607	455x200x837	455x200x837	455x200x1057	455x200x1057
	Packing size (WxHxD)	mm	555x255x755	555x255x755	555x255x985	555x255x985	555x255x1205	555x255x1205
	Net weight	kg	11.6	12.0	13.9	14.8	17.3	18.2
	Gross weight	kg	15.9	16.3	19.4	20.3	24.0	24.9
Water inlet/outlet pipe	inch	G3/4	G3/4	G3/4	G3/4	G3/4	G3/4	
	mm	ODØ18.5	ODØ18.5	ODØ18.5	ODØ18.5	ODØ18.5	ODØ18.5	

Model		MKH3-500-R3	MKH3-500-R4	MKH3-700-R3	MKH3-700-R4	MKH3-800-R3	MKH3-800-R4	
Power supply	V/Ph/Hz	220-240/1/50						
Air flow (H/M/L)	m³/h	790/560/392	800/574/404	1190/855/555	1150/885/591	1300/1088/782	1300/1132/836	
	CFM	465/330/231	471/338/238	700/503/327	677/521/348	766/641/461	766/667/492	
External static pressure	Pa	12						
Cooling	Total Capacity (H/M/L)	kW	4.65/3.80/2.92	5.35/4.25/3.31	6.00/5.03/3.71	6.75/5.80/4.24	7.35/6.51/5.15	8.25/7.52/5.87
	Water flow rate (H/M/L)	L/h	797/652/500	917/729/567	1029/862/636	1157/995/727	1260/1116/884	1414/1289/1007
	Water pressure drop (H/M/L)	kPa	56.85/40.02/25.31	61.48/41.44/26.62	53.79/36.96/21.16	40.26/29.20/16.15	45.43/37.06/23.29	64.72/55.03/34.88
Heating	Capacity (H/M/L)	kW	5.20/3.95/3.00	5.70/4.36/3.31	6.15/5.10/3.80	7.15/5.81/4.30	8.20/7.09/5.46	8.50/7.60/5.90
	Water flow rate (H/M/L)	L/h	894/679/516	977/747/569	1054/877/654	1226/996/740	1406/1216/937	1457/1302/1015
	Water pressure drop (H/M/L)	kPa	56.68/37.31/23.25	60.89/37.73/21.79	57.85/38.53/21.1	42.16/28.68/14.66	44.60/34.09/19.98	61.96/47.46/28.84
Power input (H/M/L)	W	91/54/34	91/54/35	123/98/68	110/89/64	123/109/83	118/104/82	
Sound power level	(H/M/L) dB(A)	59/51/43	59/51/43	64/56/45	62/56/46	63/58/50	63/58/50	
Fan motor	Type	AC fan motor						
	Quantity	1	1	1	1	1	1	
Fan	Type	Centrifugal, forward-curved Blades						
	Quantity	2	2	3	3	3	3	
Coil	Row	3	4	3	4	3	4	
	Max. working pressure	MPa	1.6	1.6	1.6	1.6	1.6	
	Diameter	mm	Ø7.94	Ø7.94	Ø7.94	Ø7.94	Ø7.94	
Body	Net dimensions (WxHxD)	mm	455x200x1057	455x200x1057	455x200x1177	455x200x1177	550x200x1177	550x200x1177
	Packing size (WxHxD)	mm	555x255x1205	555x255x1205	555x255x1325	555x255x1325	650x255x1325	650x255x1325
	Net weight	kg	17.9	18.8	20.5	21.7	24.0	25.2
	Gross weight	kg	24.6	25.5	27.3	28.5	31.1	32.3
Water inlet/outlet pipe	inch	G3/4	G3/4	G3/4	G3/4	G3/4	G3/4	
	mm	ODØ18.5	ODØ18.5	ODØ18.5	ODØ18.5	ODØ18.5	ODØ18.5	

- Notes:
1. H: High fan speed; M: Medium fan speed; L: Low fan speed.
 2. Cooling conditions: Entering water 7°C, leaving water 12°C, Entering air temperature 27°C DB/19°C WB. Heating conditions: Entering water 45°C, leaving water 40°C, Entering air temperature 20°C DB/15°C WB.
 3. Noise is tested in a reverberation chamber.
 4. H3 series test with concealed tooling.

4-Pipe 2nd Generation Ceiling&Floor

Model		MKH2-150F-R4	MKH2-250F-R4	MKH2-350F-R4	MKH2-500F-R4	MKH2-700F-R4	MKH2-800F-R4	
Power supply	V/Ph/Hz	220-240/1/50						
Air flow (H/M/L)	m³/h	255/192/139	425/284/184	595/450/319	800/574/404	1150/885/591	1300/1132/836	
	CFM	150/113/82	250/167/109	350/265/188	471/338/238	677/521/348	766/667/492	
External static pressure	Pa	0						
Cooling	Sensible Capacity (H/M/L)	kW	1.50/1.20/0.78	2.05/1.39/0.84	2.94/2.38/1.60	3.80/2.95/2.25	4.90/4.25/2.95	5.85/5.28/4.05
	Total Capacity (H/M/L)	kW	1.95/1.60/1.15	2.89/2.05/1.25	4.09/3.35/2.35	5.05/4.05/3.20	6.40/5.59/4.00	7.65/7.00/5.50
	Water flow rate (H/M/L)	m³/h	0.33/0.28/0.20	0.50/0.35/0.21	0.70/0.57/0.40	0.87/0.69/0.55	1.10/0.96/0.69	1.31/1.20/0.94
	Water pressure drop (H/M/L)	kPa	27.47/19.63/12.54	21.38/11.95/4.99	47.7/33.04/18.22	71.09/47.81/31.95	63.05/48.47/27.23	50.47/43.72/28.23
Heating	Capacity (H/M/L)	kW	1.69/1.40/1.15	2.45/1.70/1.19	2.95/2.50/2.00	3.64/3.05/2.50	4.65/4.09/3.19	7.30/7.19/6.25
	Water flow rate (H/M/L)	m³/h	0.14/0.12/0.10	0.21/0.15/0.10	0.25/0.21/0.17	0.31/0.26/0.21	0.40/0.35/0.27	0.63/0.62/0.54
	Water pressure drop (H/M/L)	kPa	15.60/11.01/8.04	31.95/16.83/9.52	58.17/43.35/29.20	82.01/61.29/42.87	135.21/111.75/70.91	67.86/65.78/53.61
Power input (H/M/L)	W	40/24/15	47/26/14	51/32/19	91/54/35	110/89/64	118/104/82	
Rated current	A	0.17/0.10/0.07	0.20/0.11/0.06	0.22/0.14/0.08	0.40/0.24/0.15	0.48/0.39/0.28	0.51/0.45/0.36	
Sound power level	(H/M/L) dB(A)	53/47/39	47/38/32	52/45/37	59/51/43	62/56/46	63/58/50	
Fan motor	Type	AC fan motor						
	Quantity	1	1	1	1	1	1	
Fan	Type	Centrifugal, forward-curved Blades						
	Quantity	1	2	2	2	3	3	
Coil	Row	4	4	4	4	4	4	
	Max. working pressure	MPa	1.6	1.6	1.6	1.6	1.6	
	Diameter	mm	Ø7.94	Ø7.94	Ø7.94	Ø7.94	Ø7.94	
Body	Net dimensions (WxHxD)	mm	495x200x790	495x200x1020	495x200x1240	495x200x1240	495x200x1360	591x200x1360
	Packing size (WxHxD)	mm	595x300x895	595x300x1125	595x300x1345	595x300x1345	595x300x1465	695x300x1465
	Net weight	kg	17.2	21.3	25.9	26.8	29.0	34.5
	Gross weight	kg	23.2	27.3	32.9	33.9	36.5	42.5
Water inlet/outlet pipe	inch	G3/4	G3/4	G3/4	G3/4	G3/4	G3/4	
Drain pipe	mm	ODØ18.5	ODØ18.5	ODØ18.5	ODØ18.5	ODØ18.5	ODØ18.5	

Model		MKH3-150F-R4	MKH3-250F-R4	MKH3-350F-R4	MKH3-500F-R4	MKH3-700F-R4	MKH3-800F-R4	
Power supply	V/Ph/Hz	220-240/1/50						
Air flow (H/M/L)	m³/h	255/192/139	425/284/184	595/450/319	800/574/404	1150/885/591	1300/1132/836	
	CFM	150/113/82	250/167/109	350/265/188	471/338/238	677/521/348	766/667/492	
External static pressure	Pa	12						
Cooling	Sensible Capacity (H/M/L)	kW	1.50/1.20/0.78	2.05/1.39/0.84	2.94/2.38/1.60	3.80/2.95/2.25	4.90/4.25/2.95	5.85/5.28/4.05
	Total Capacity (H/M/L)	kW	1.95/1.60/1.15	2.89/2.05/1.25	4.09/3.35/2.35	5.05/4.05/3.20	6.40/5.59/4.00	7.65/7.00/5.50
	Water flow rate (H/M/L)	m³/h	0.33/0.28/0.20	0.50/0.35/0.21	0.70/0.57/0.40	0.87/0.69/0.55	1.10/0.96/0.69	1.31/1.20/0.94
	Water pressure drop (H/M/L)	kPa	27.47/19.63/12.54	21.38/11.95/4.99	47.7/33.04/18.22	71.09/47.81/31.95	63.05/48.47/27.23	50.47/43.72/28.23
Heating	Capacity (H/M/L)	kW	1.69/1.40/1.15	2.45/1.70/1.19	2.95/2.50/2.00	3.64/3.05/2.50	4.65/4.09/3.19	7.30/7.19/6.25
	Water flow rate (H/M/L)	m³/h	0.14/0.12/0.10	0.21/0.15/0.10	0.25/0.21/0.17	0.31/0.26/0.21	0.40/0.35/0.27	0.63/0.62/0.54
	Water pressure drop (H/M/L)	kPa	15.60/11.01/8.04	31.95/16.83/9.52	58.17/43.35/29.20	82.01/61.29/42.87	135.21/111.75/70.91	67.86/65.78/53.61
Power input (H/M/L)	W	40/24/15	47/26/14	51/32/19	91/54/35	110/89/64	118/104/82	
Rated current	A	0.17/0.10/0.07	0.20/0.11/0.06	0.22/0.14/0.08	0.40/0.24/0.15	0.48/0.39/0.28	0.51/0.45/0.36	
Sound power level	(H/M/L) dB(A)	53/47/39	47/38/32	52/45/37	59/51/43	62/56/46	63/58/50	
Fan motor	Type	AC fan motor						
	Quantity	1	1	1	1	1	1	
Fan	Type	Centrifugal, forward-curved Blades						
	Quantity	1	2	2	2	3	3	
Coil	Row	4	4	4	4	4	4	
	Max. working pressure	MPa	1.6	1.6	1.6	1.6	1.6	
	Diameter	mm	Ø7.94	Ø7.94	Ø7.94	Ø7.94	Ø7.94	
Body	Net dimensions (WxHxD)	mm	455x200x607	455x200x837	455x200x1057	455x200x1057	455x200x1177	550x200x1177
	Packing size (WxHxD)	mm	595x300x895	595x300x1125	595x300x1345	595x300x1345	595x300x1465	695x300x1465
	Net weight	kg	12.5	15.3	18.7	19.3	22.2	25.7
	Gross weight	kg	16.8	20.8	25.4	26.0	29.0	32.8
Water inlet/outlet pipe	inch	Cold water: G3/4; Hot water: G1/2						
Drain pipe	mm	ODØ18.5						

- Notes:
1. H: High fan speed; M: Medium fan speed; L: Low fan speed.
 2. Cooling conditions: Entering water 7°C, leaving water 12°C, Entering air temperature 27°C DB/19°C WB. Heating conditions: Entering water 65°C, leaving water 55°C, Entering air temperature 20°C DB/15°C WB.
 3. Noise is tested in a reverberation chamber.
 4. H3 series test with concealed tooling.

4-way cassette

2-pipe 4-way cassette
Dimensions (unit:mm)

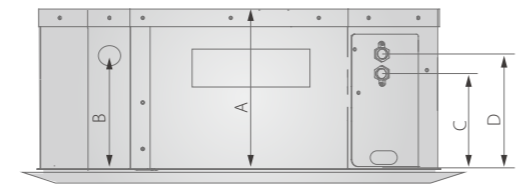
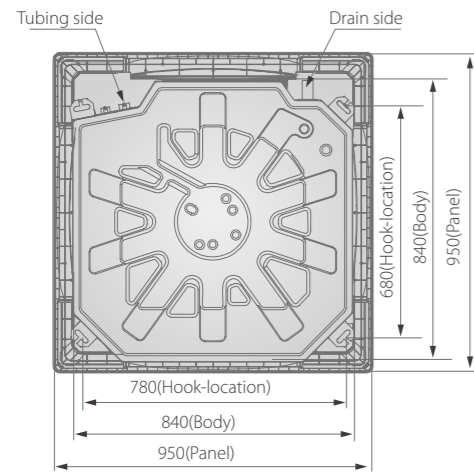

Model	A	B	C	D
MKA-600RA	230	170	135	185
MKA-750RA				
MKA-950RA				
MKA-1200RA	300	190	145	195
MAK-1500RA				

4-Pipe 4-way cassette
Dimensions (unit:mm)

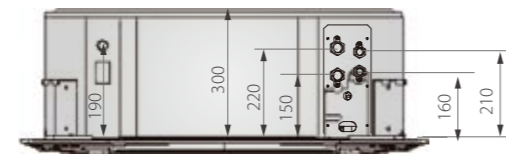
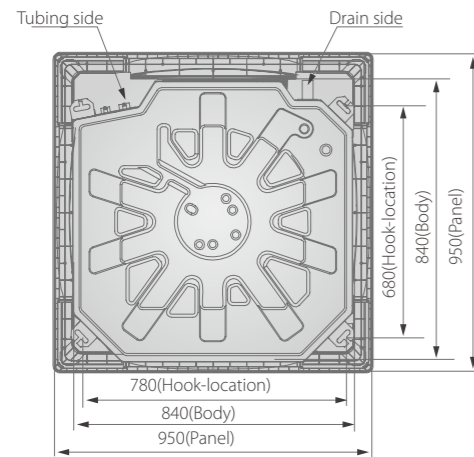

Service Spaces (unit:mm)

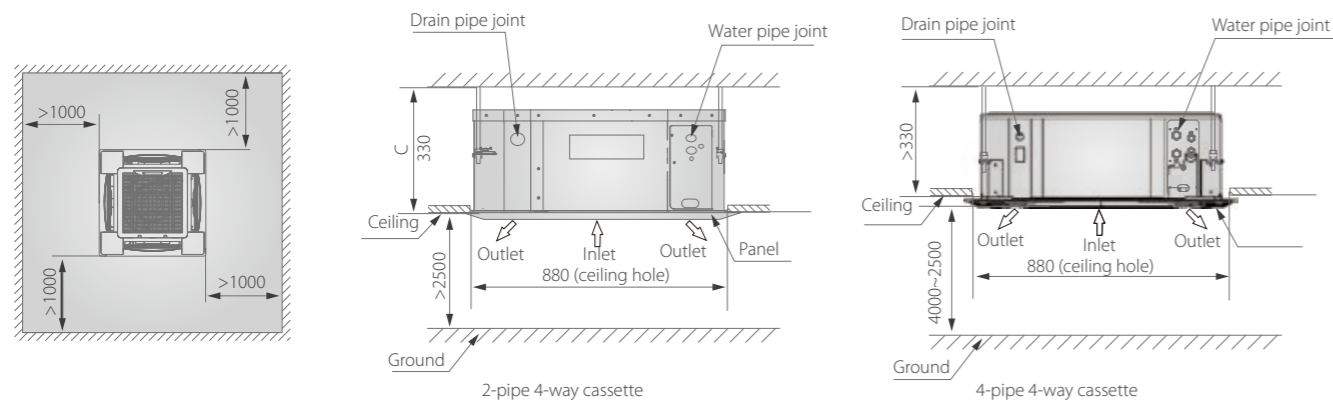

Compact 4-way cassette

2-pipe compact 4-way cassette
Dimensions (unit: mm)

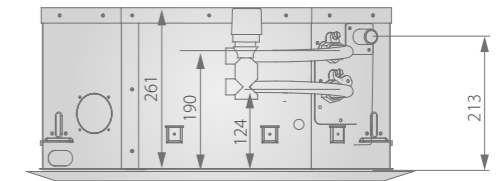
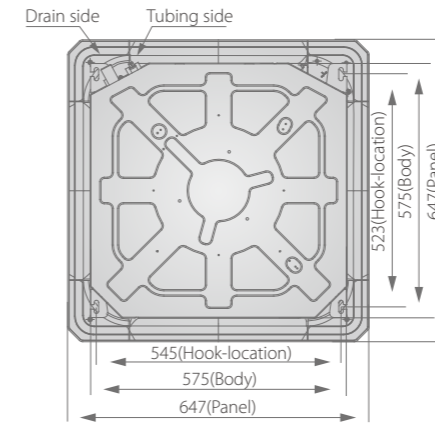

4-pipe compact 4-way cassette
Dimensions (unit: mm)

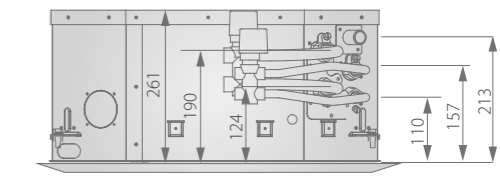
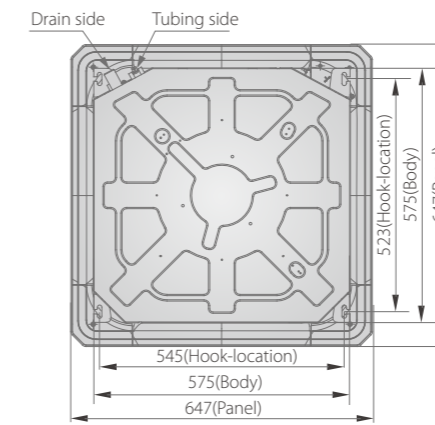

Service Space (unit: mm)

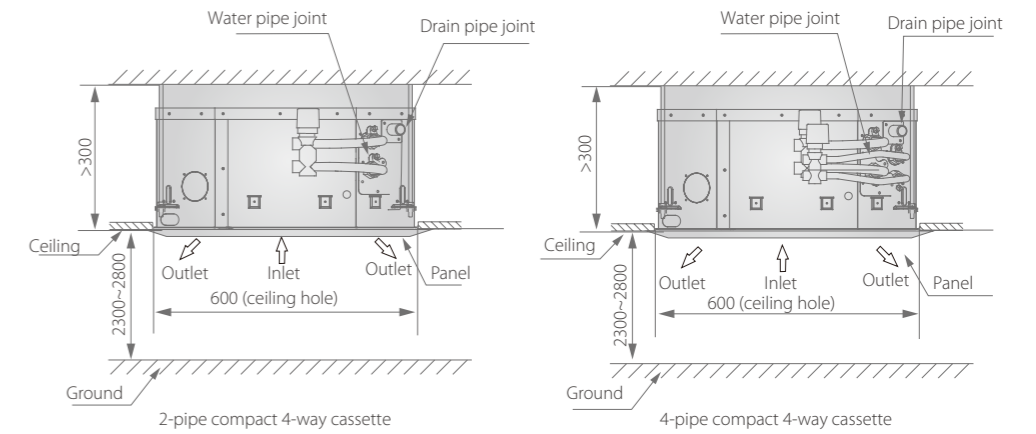
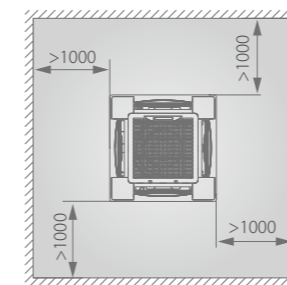

Thickness of the front panel

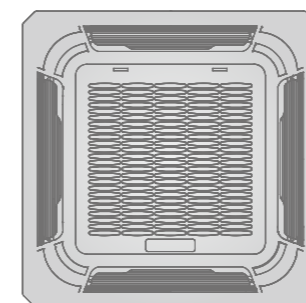

Type	H (mm)
4-way cassette	45
Compact 4-way cassette	50

1-way cassette

Dimensions (unit: mm)
MKC-300R-BA MKC-400R-B

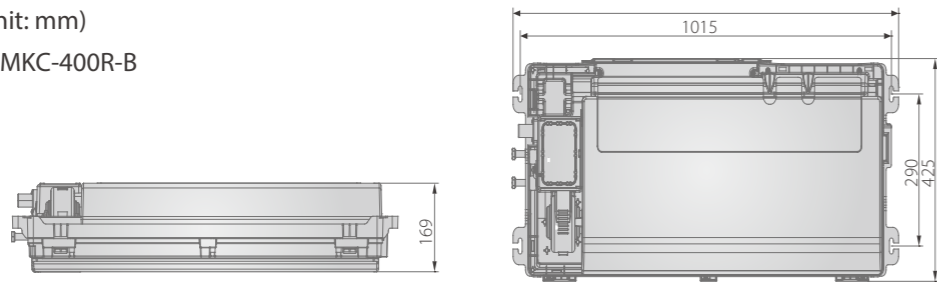

Wall mounted - S type

Dimensions (unit: mm)

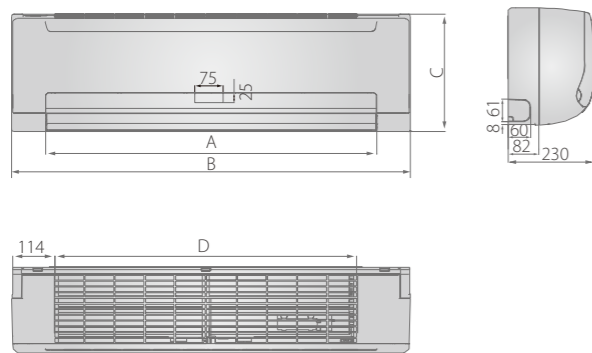

Model	MKG-250-BA MKG-300-BA MKG-400-BA	MKG-500-BA MKG-600-BA
A	732	892
B	915	1072
C	290	315
D	663	813

Wall mounted - C type

Dimensions (unit: mm)

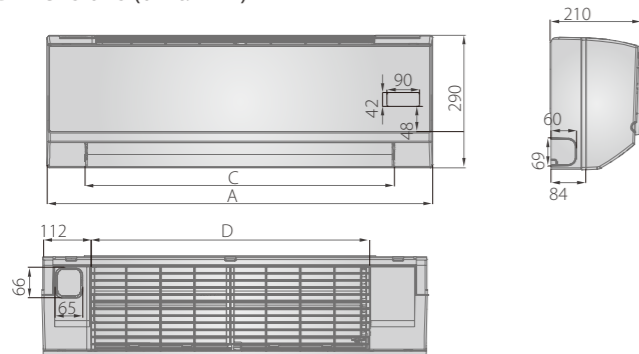

Model	MKG-250A MKG-300A MKG-400A	MKG-500A MKG-600A
A	915	1070
B	290	315
C	725	885
D	670	815

Duct

Dimensions (unit: mm)

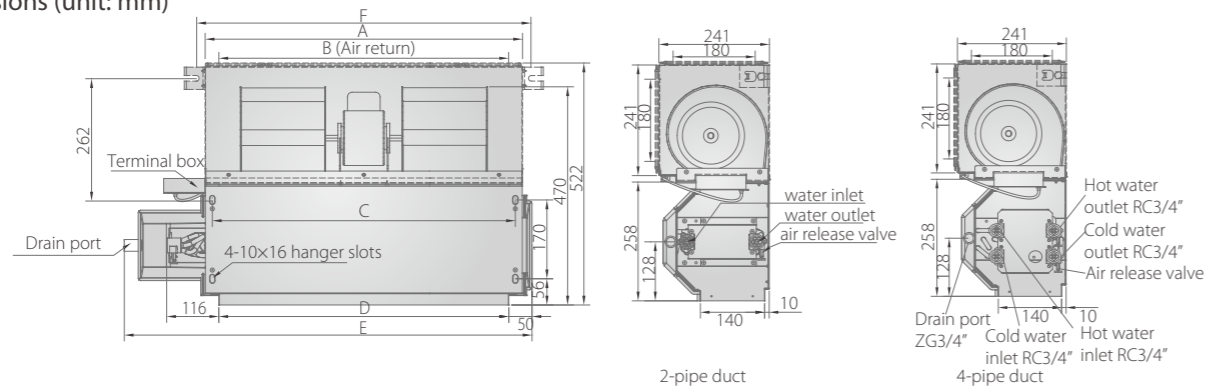

Size	A	B	C	D	E	F
200CFM	545	485	513	485	741	583
300CFM	645	585	613	585	841	683
400CFM	745	685	713	685	941	783
500CFM	745	685	713	685	941	783
600CFM	965	905	933	905	1161	1003
800CFM	1265	1205	1233	1205	1461	1303
1000CFM	1370	1310	1338	1310	1566	1408
1200CFM	1660	1600	1628	1600	1856	1698
1400CFM	1826	1766	1794	1766	2022	1864

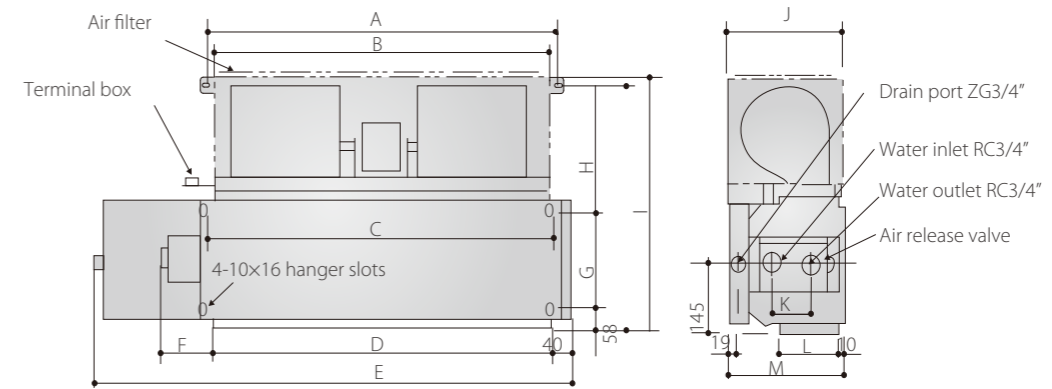

Notes:
This figure is for reference only, actual product may differ.
The dotted line in the figure is the dimension for air return plenum.
Units with air return plenum is standard, units without air return plenum can be customized.

Model	MKT3-800/1000G50-A4A MKT4-800/1000G50-A4A	MKT4-1200/1400/ 1500/1600G50-A4A	MKT4-1800/ 2000G50-A4A
A	960	1085	1277
B	900	1135	1327
C	910	1112	1308
D	885	1085	1277
E	1180	1369	1500
F	150	160	160
G	195	195	195
H	335	335	335
I	612	612	612
J	342	342	342
K	231	231	231
L	230	230	230
M	340	340	340

High static pressure duct

Dimensions (unit:mm)

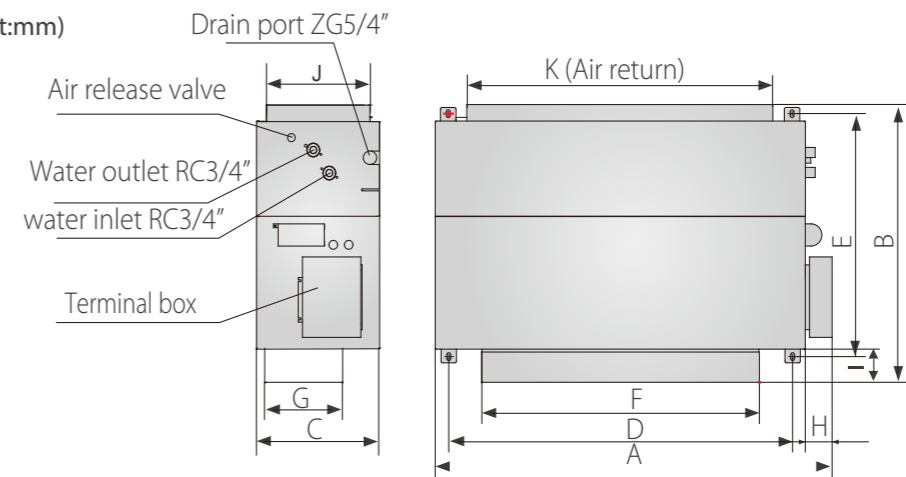

Model	MKT3H-800G70A MKT3H-1000G70A MKT3H-1200G70A MKT3H-1400G70A	MKT3H-800EG70A MKT3H-1000EG70A MKT3H-1200EG70A MKT3H-1400EG70A	MKT3H-1600G100A MKT3H-1800G100A MKT3H-2200G100A	MKT3H-1600EG100A MKT3H-1800EG100A MKT3H-2200EG100A
A	946	946	1290	1290
B	816	876	809	874
C	400	400	400	400
D	778	778	1118	1118
E	767	767	765	765
F	306	306	900	900
G	219	219	249	249
H	88	88	88	88
I	37	97	39	104
J	338	338	320	320
K	512	512	995	995

Dimensions (unit: mm)

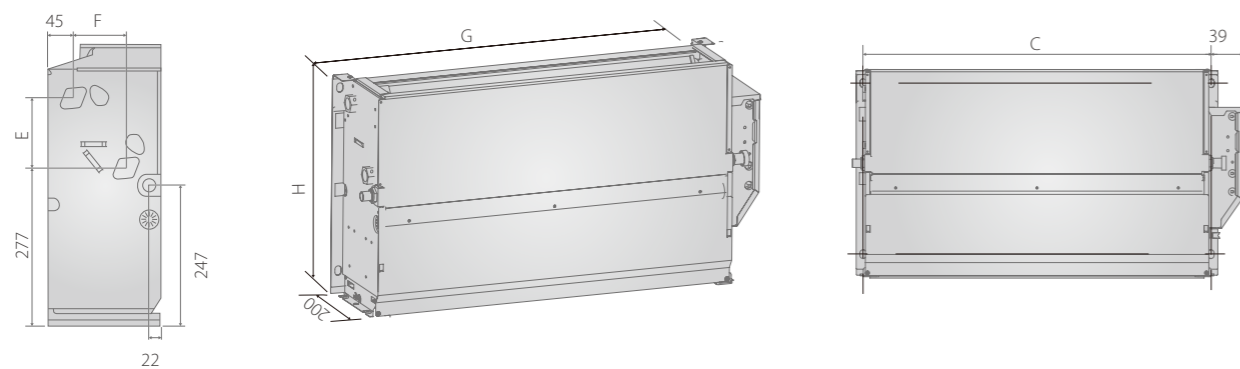
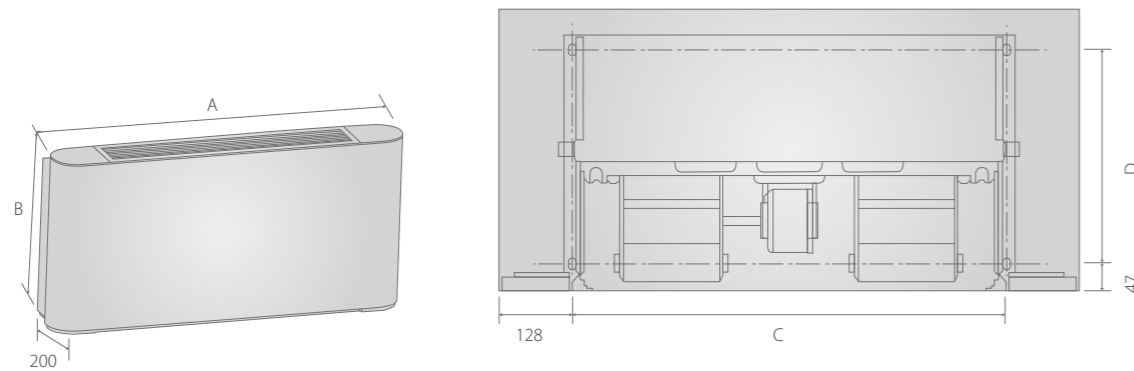

Model	150	250	300	500	700	800
A(mm)	790	1020	1240	1240	1360	1360
B(mm)	495	495	495	495	495	591
C(mm)	534	764	984	984	1104	1104
D(mm)	375	375	375	375	375	319
E(mm)	123	123	123	123	123	219
F(mm)	93	93	93	93	93	102
G(mm)	628	858	1078	1078	1198	1198
H(mm)	455	455	455	455	455	551



DC Fan Coil Units

Midea DC Fan Coil Units operate in high efficiency and low sound level due to the DC brushless fan motor. It contains cassette units, ceiling & floor units with or without cabinet, wall-mounted units and duct units. The air volume ranges from 150CFM to 1500CFM. It is a highly versatile product suitable for hospitals, office buildings, hotels, airports and various other applications.



Nomenclature

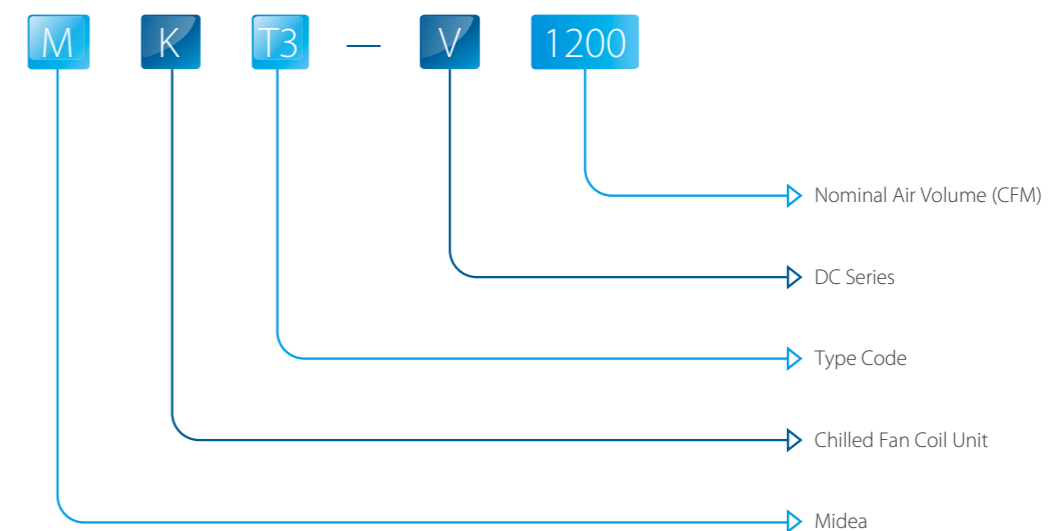

Advantage of Fan Coil Units with

DC Brushless Fan Motor

The DC fan coil units are the new energy saving products improved with advanced DC driven technology. The DC fan coil units have advanced technology of high energy efficiency, low noise operation and precision temperature control, so are ideal for hospitals, office building, hotels, airports and various other applications.

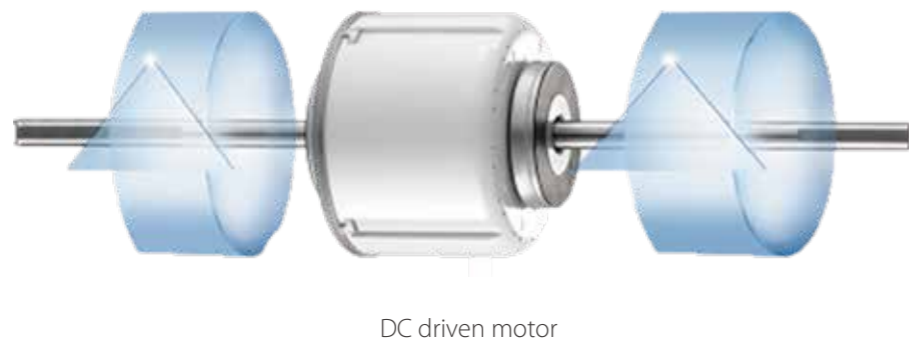

Energy Efficiency, Comply with CE Regulation

The power consumption of DC driven fan coil units can be reduced up to 30% in comparison to corresponding AC type.

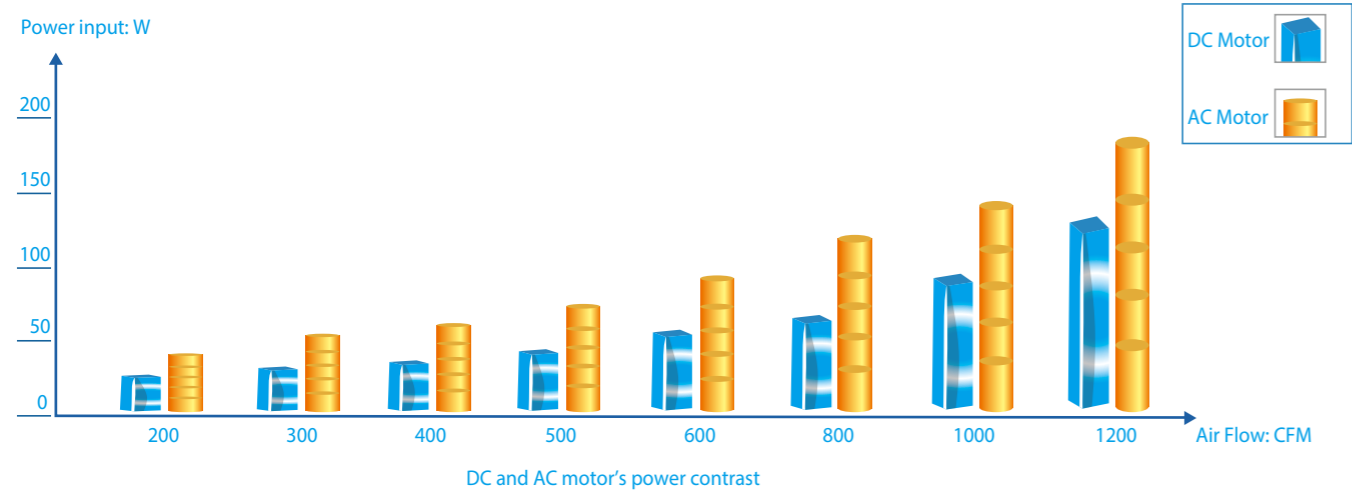

Quiet Operation

Unit noise is 2-5dB(A) lower compared to an AC motor fan coil unit, creating a quiet living environment.



Constant Level of Air Temperature and Humidity

The DC Inverter fan motor adjusts of air flow based on thermal load instantly providing less temperature fluctuation and an improved living environment.

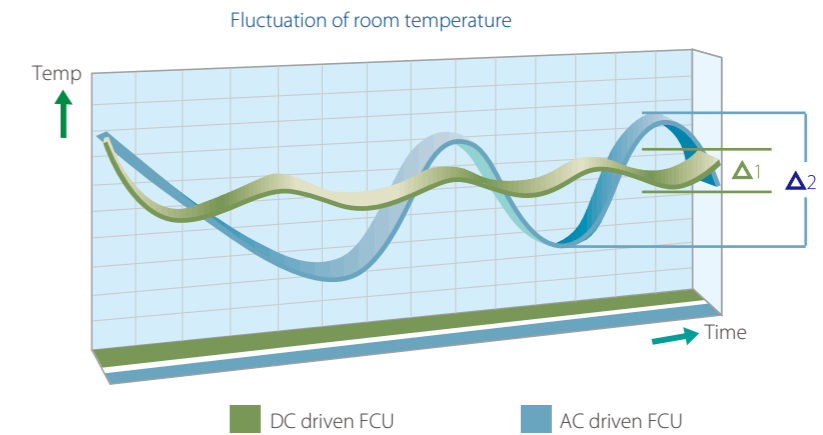







Versatile Selection

Midea DC Fan Coil Units contain cassette units, ceiling & floor units with or without cabinet, wall-mounted units and duct units. The air volume ranges from 150CFM to 1500CFM. It is a highly versatile product suitable for hospitals, office buildings, hotels, airports and various other applications.





Product Lineup

2-Pipe FCUs

Air volume (CFM)		150	200	250	300	350	400	450	500		600	700	750	800	850	900	950	1000	1200	1500	
1-way cassette					■		■				■										
4-way cassette											■		■		■		■		■		■
Compact 4-way cassette					■		■		■												
Duct			■		■		■		■		■			■					■		■
Wall mounted				■	■		■		■		■										
2 nd generation Ceiling&floor		■		■		■			■			■		■							

4-Pipe FCUs

Air volume (CFM)		150	200	250	300	350	400	500		600	700	750	800	850	950	1000	1200	1500			
4-way cassette										■	■	■		■	■		■	■		■	
Compact 4-way cassette					■	■	■	■													
2 nd generation Ceiling&floor		■		■		■		■			■		■								

Notes:
The standard power supply for all fan coil units is 220V-240V/50Hz; 208-230V/60Hz can be customized for some series fan coil units. For further information, please contact with our salesmen.



300/400/600CFM

Features

- Auto mode and seven speed fan motor.
- Ultra-thin, the thickness is only 200mm.
- Hysteresis temperature can be set in heating and cooling mode by PCB switch, field adjustable.
- With/without forced fan on can be set by PCB switch, field adjustable.
- The centralized control function can be connected through the customization XYE port.
- The Gateway(Modbus) can be connected through the customization PQE port.
- Wired controller KJR-75A is optional.
- 0-10V wired control is optional.

Notes: Centralized control function and Gateway(Modbus) can only choose one.

1-way Cassette

Min. 153mm Thickness

- Compact design, ultra slim body with a minimum thickness of 153mm, especially suitable for narrow ceiling, such as in lobbies and small meeting rooms.

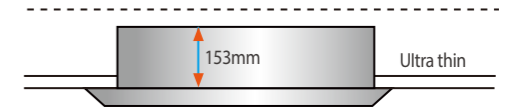

High-lift Pump

- Standard built-in drain pump with 750mm pump head.

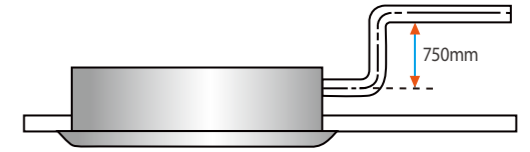

One Direction Air Flow

- One direction air flow guarantees quick cooling, flexible installation positioning.

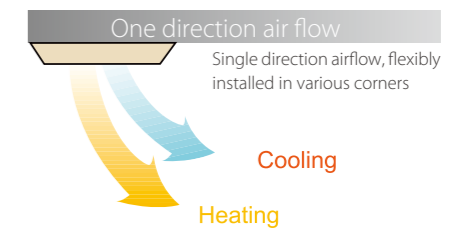

Specifications

Model		MKC-V300R-B	MKC-V400R-B	MKC-V600R-B	
Power supply	V/Ph/Hz		220-240/1/50		
Air flow (H/M/L)	m ³ /h	510/432/330	630/509/428	1000/786/583	
	CFM	300/254/194	371/299/252	588/462/343	
Cooling	Capacity (H/M/L)	kW	2.64/2.23/1.68	3.94/3.43/3.07	
	Water flow rate(H/M/L)	m ³ /h	0.49/0.42/0.33	0.6/0.52/0.45	
	Water pressure drop(H/M/L)	kPa	8.63/6.26/3.69	23.85/18.07/14.8	38.22/28.95/19.41
	Power input(H/M/L)	W	22/18/14	23/19/17	38/27/19
Heating	Capacity (H/M/L)	kW	3.85/3.27/2.53	4.86/3.94/3.24	6.49/5.3/4.01
	Water flow rate(H/M/L)	m ³ /h	0.5/0.42/0.32	0.59/0.49/0.42	0.86/0.67/0.48
	Water pressure drop(H/M/L)	kPa	7.72/5.75/3.28	20.12/15.50/12.42	32.36/24.57/16.37
	Power input(H/M/L)	W	16/11/8	16/12/10	31/20/12
Sound pressure level (H/M/L)	dB(A)	44.3/40.6/33.5	36.6/32.6/30.4	44.6/38.6/33.1	
Fan motor	Type		DC motor	DC motor	
	Quantity		1	1	
Fan	Type		Centrifugal, forward-curved Blades		
	Quantity		1	1	
Coil	Row		2	2	
	Max. working pressure	MPa	1.6	1.6	
	Diameter	mm	Ø7	Ø7	
Panel	Net dimensions (WxHxD)	mm	1181x466x60	1350x505x25	
	Packing size (WxHxD)	mm	1232x517x107	1410x560x95	
	Net weight	kg	3.5	4	
Body	Gross weight	kg	5.2	5.4	
	Net dimensions (WxHxD)	mm	1055x425x169	1275x452x206	
	Packing size (WxHxD)	mm	1155x490x245	1400x505x295	
	Net weight	kg	12.5	17.5	
Pipe connections	Gross weight	kg	16.5	23.5	
	Water inlet/outlet pipe	inch	G1/2	G1/2	
	Drain pipe	mm	ODØ25	ODØ25	

Notes:

1. H: High fan speed; M: Medium fan speed; L: Low fan speed.
2. Cooling conditions: Entering water 7°C, leaving water 12°C, Entering air temperature 27°C DB/19°C WB.
Heating conditions: Entering water 45°C, leaving water 40°C, Entering air temperature 20°C DB.
3. Noise is tested in a semi-anechoic test room.

4-way Cassette



Compact 4-way Cassette



Various Selections

- Versions for 2/4 pipe system.
- Versions for compact/normal size.

Stylish Panel with Large Airflow Outlet

- 4-way air supply panel is standard for 4-way cassette.
- 360° air supply panel is standard for compact 4-way cassette.

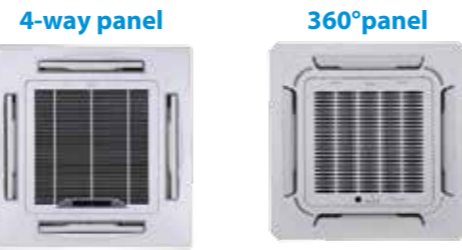

Compact Design, Easy Installation

- For Compact Four-way Cassette: Extremely compact casing suits any room's decor and requires little space for installation on a low ceiling. Due to compact body and light weight, all models can be installed without a hoist.

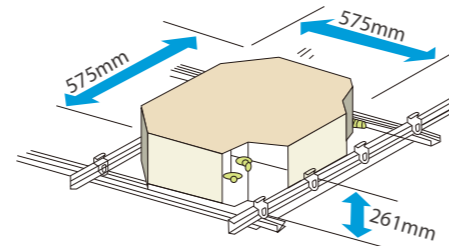

High Efficiency and Low Sound Operation

Various Accessories Selections

- Thanks to the DC brushless fan motor, the unit operates in high efficiency and low sound level.
- Extended drainage pan for better ceiling protection is optional.

High-lift Drain Pump

- Standard built-in drain pump with 750mm pump head for normal size and 500mm for compact size.

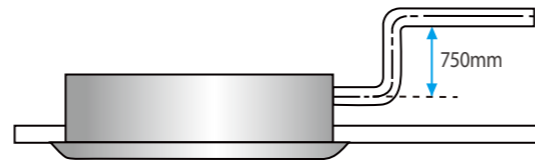

Fresh Air Intake

- Fresh air can enter through the cassette unit so you can enjoy even fresher air in a room.



2-Pipe 4-Way Cassette



Model			MKA-V600R	MKA-V750R	MKA-V850R
Power supply		V/Ph/Hz	220-240/1/50	220-240/1/50	220-240/1/50
Air flow (H/M/L)		m ³ /h	1175/987/768	1229/1020/810	1451/1146/1012
		CFM	691/580/451	722/600/476	853/674/595
Cooling ¹	Capacity (H/M/L)	kW	5.93/5.3/4.4	6.12/5.45/4.6	7.52/6.46/5.89
	Water flow rate(H/M/L)	m ³ /h	1.06/0.92/0.77	1.10/0.96/0.81	1.37/1.18/1.07
	Water pressure drop(H/M/L)	kPa	19.2/15.4/11	21.3/21.3/12.4	20.1/15.3/12.6
	Power input(H/M/L)	W	41/27/17	49/31/20	68/37/30
	Capacity (H/M/L)	kW	6.06/5.72/5.32	6.27/5.88/5.43	7.88/7.48/6.76
Heating ²	Water flow rate(H/M/L)	m ³ /h	1.30/1.14/1.13	1.39/1.20/1.00	1.66/1.39/1.25
	Water pressure drop(H/M/L)	kPa	25.9/20.1/19.9	30/22.7/16.3	26.7/18.8/15.6
	Power input(H/M/L)	W	42/28/17	44/32/21	66/37/28
	Capacity (H/M/L)	kW	8.42/7.37/6.06	8.62/7.49/6.27	10.37/8.72/7.88
	Water flow rate(H/M/L)	m ³ /h	1.06/0.92/0.77	1.10/0.96/0.81	1.37/1.18/1.07
Heating ³	Water pressure drop(H/M/L)	kPa	16.9/12.7/8.6	19.1/14.8/10.6	18.2/13.6/11.1
	Power input(H/M/L)	W	42/28/17	49/31/19	67/37/28
	Power input(H/M/L)	W	43/39/33	44/40/34	45/40/37
Sound pressure level (H/M/L)		dB(A)	43/39/33	44/40/34	45/40/37
Fan motor		Type	DC Motor	DC Motor	DC Motor
Fan		Quantity	1	1	1
		Type	Centrifugal, forward-curved Blades		
		Quantity	1	1	1
		Row	2	2	2
Coil	Max. Working pressure	MPa	1.6	1.6	1.6
	Diameter	mm	Ø7	Ø7	Ø7
Panel	Net dimensions (W×H×D)	mm	950×45×950	950×45×950	950×45×950
	Packing size (W×H×D)	mm	1035×90×1035	1035×90×1035	1035×90×1035
	Net weight	kg	6	6	6
Body	Gross weight	kg	9	9	9
	Net dimensions (W×H×D)	mm	840×230×840	840×230×840	840×300×840
	Packing size (W×H×D)	mm	900×237×900	900×237×900	900×330×900
Pipe connections	Water inlet/outlet pipe	inch	RC3/4	RC3/4	RC3/4
	Drain pipe	mm	ODØ82	ODØ82	ODØ82

Model			MKA-V950R	MKA-V1200R	MKA-V1500R
Power supply		V/Ph/Hz	220-240/1/50	220-240/1/50	220-240/1/50
Air flow (H/M/L)		m ³ /h	1530/1224/1101	1581/1371/1236	1871/1415/1198
		CFM	900/720/647	930/806/727	1100/832/704
Cooling ¹	Capacity (H/M/L)	kW	7.84/6.84/6.35	7.87/7.12/6.67	11.19/8.82/7.48
	Water flow rate(H/M/L)	m ³ /h	1.43/1.24/1.13	1.44/1.28/1.22	1.96/1.53/1.28
	Water pressure drop(H/M/L)	kPa	22/17/14.1	22.3/18.1/16.3	36.6/22.7/16.4
	Power input(H/M/L)	W	75/42/34	85/59/45	126/58/39
	Capacity (H/M/L)	kW	8.49/8/7.35	9.16/8.54/7.9	10.07/9.37/8.68
Heating ²	Water flow rate(H/M/L)	m ³ /h	1.71/1.45/1.33	1.73/1.57/1.46	2.35/1.86/1.59
	Water pressure drop(H/M/L)	kPa	28.1/20.7/17.4	28.8/24/20.7	49.2/31.2/23.3
	Power input(H/M/L)	W	76/43/33	86/59/45	128/58/38
	Capacity (H/M/L)	kW	10.86/9.24/8.49	10.92/9.84/9.16	14.92/11.73/10.07
	Water flow rate(H/M/L)	m ³ /h	1.43/1.24/1.13	1.44/1.28/1.22	1.96/1.53/1.28
Heating ³	Water pressure drop(H/M/L)	kPa	19.9/15.2/12.6	20/16.2/14.7	34.3/21.3/15
	Power input(H/M/L)	W	76/42/33	85/58/45	127/58/39
	Power input(H/M/L)	W	46/42/39	48/44/41	49/43/39
Sound pressure level (H/M/L)		dB(A)	46/42/39	48/44/41	49/43/39
Fan motor		Type	DC Motor	DC Motor	DC Motor
Fan		Quantity	1	1	1
		Type	Centrifugal, forward-curved Blades		
		Quantity	1	1	1
		Row	2	2	3
Coil	Max. Working pressure	MPa	1.6	1.6	1.6
	Diameter	mm	Ø7	Ø7	Ø7
Panel	Net dimensions (W×H×D)	mm	950×45×950	950×45×950	950×45×950
	Packing size (W×H×D)	mm	1035×90×1035	1035×90×1035	1035×90×1035
	Net weight	kg	6	6	6
Body	Gross weight	kg	9	9	9
	Net dimensions (W×H×D)	mm	840×300×840	840×300×840	840×300×840
	Packing size (W×H×D)	mm	900×330×900	900×330×900	900×330×900
Pipe connections	Water inlet/outlet pipe	inch	RC3/4	RC3/4	RC3/4
	Drain pipe	mm	ODØ82	ODØ82	ODØ82

Notes:

H:High fan speed; M: Medium fan speed; L: Low fan speed.

1: Cooling mode (2 and 4-pipe coil): entering air temperature 27°C DB/19°C WB, entering/leaving water temperature 7°C /12°C.

2: Heating mode(1): (2-pipe coil): entering air temperature 20°C DB, entering/leaving water temperature 45/40°C.

3: Heating mode(2): (2-pipe coil): entering air temperature 20°C DB, enter water teperature/water flow 50°C/°(same water flow as in standard rating condition in cooling)

4: Noise is tested in a semi-anechoic test room.

4-Pipe 4-Way Cassette



Model			MKA-V600FA	MKA-V750FA	MKA-V850FA
Power supply		V/Ph/Hz	220-240/1/50		
Air flow (H/M/L)		m ³ /h	1184/997/783	1278/1057/855	1328/1052/927
		CFM	696/586/460	751/621/502	780/618/545
Cooling ¹	Capacity (H/M/L)	kW	4.96/4.383/3.642	5.178/4.563/3.875	5.129/4.413/4.06
	Water flow rate(H/M/L)	m ³ /h	0.9/0.8/0.67	0.94/0.83/0.71	0.93/0.81/0.75
	Water pressure drop(H/M/L)	kPa	14.8/11.5/8.1	15.9/12.4/9	16/14.2/10.4
	Power input(H/M/L)	W	62/44/30	72/50/35	80/49/40
Heating ²	Capacity (H/M/L)	kW	6.148/5.43/4.614	6.519/5.785/4.944	6.684/5.748/5.283
	Water flow rate(H/M/L)	m ³ /h	0.58/0.52/0.45	0.61/0.55/0.47	0.62/0.54/0.50
	Water pressure drop(H/M/L)	kPa	25.3/20.5/14.5	32/25.7/19.1	32.6/24.7/21.2
	Power input(H/M/L)	W	56/36/21	67/42/25	75/41/31
Heating ³	Capacity (H/M/L)	kW	6.94/6.217/5.266	7.374/6.533/5.6	7.657/6.584/6.033
	Water flow rate(H/M/L)	m ³ /h	0.64/0.58/0.50	0.68/0.61/0.53	0.71/0.61/0.57
	Water pressure drop(H/M/L)	kPa	37.2/26.1/19.3	39.5/32.5/23.8	41.6/31.5/26.8
	Power input(H/M/L)	W	55/36/21	68/43/25	76/42/31
Sound power level	(H/M/L)	dB(A)	54/49/43	56/51/45	57/51/48
Sound pressure level	(H/M/L)	dB(A)	42/37/33	44/39/33	45/39/36
Rated current		A	0.48	0.6	0.72
Fan motor	Type		7	DC motor	DC motor
	Quantity		1	1	1
Fan	Type		Centrifugal, forward-curved Blades		
	Quantity		1	1	1
Coil	Row		2	2	2
	Max. working pressure	MPa	1.6	1.6	1.6
Panel	Diameter	mm	Ø7	Ø7	Ø7
	Net dimensions (WxHxD)	mm	950x45x950	950x45x950	950x45x950
	Packing size (WxHxD)	mm	1035x90x1035	1035x90x1035	1035x90x1035
	Net weight	kg	6	6	6
	Gross weight	kg	9	9	9
	Body	Net dimensions (WxHxD)	mm	840x300x840	840x300x840
Packing size (WxHxD)		mm	900x330x900	900x330x900	900x330x900
Net weight		kg	27.5	27.5	27.5
Gross weight		kg	33.5	33.5	33.5
Pipe connections	Water inlet/outlet pipe	inch	Cold water: RC3/4; Hot water: RC1/2		
	Drain pipe	mm	ODØ32	ODØ32	ODØ32

Model			MKA-V950FA	MKA-V1200FA	MKA-V1500FA
Power supply		V/Ph/Hz	220-240/1/50		
Air flow (H/M/L)		m ³ /h	1403/1115/1001	1642/1421/1285	1708/1297/1096
		CFM	824/655/588	965/835/755	1004/762/644
Cooling ¹	Capacity (H/M/L)	kW	5.306/4.593/4.279	7.984/7.245/6.697	8.038/6.623/5.837
	Water flow rate(H/M/L)	m ³ /h	0.96/0.84/0.78	1.42/1.29/1.2	1.43/1.19/1.05
	Water pressure drop(H/M/L)	kPa	16.4/12.6/10.9	33.9/30/24	33/22.6/17.7
	Power input(H/M/L)	W	90/54/43	121/83/66	139/70/49
Heating ²	Capacity (H/M/L)	kW	6.736/5.833/5.442	9.746/8.962/8.422	9.93/8.326/7.512
	Water flow rate(H/M/L)	m ³ /h	0.63/0.55/0.52	0.89/0.82/0.77	0.90/0.76/0.69
	Water pressure drop(H/M/L)	kPa	34/26.6/23.5	42.4/36.6/32.6	48.7/32.5/27
	Power input(H/M/L)	W	84/46/35	118/79/61	125/64/42
Heating ³	Capacity (H/M/L)	kW	7.659/6.646/6.204	11.045/10.149/9.527	11.342/9.596/8.683
	Water flow rate(H/M/L)	m ³ /h	0.71/0.62/0.58	1.0/0.92/0.87	1.02/0.87/0.79
	Water pressure drop(H/M/L)	kPa	43.8/33.5/29.3	52.1/44.9/40.6	62.1/45.7/38.3
	Power input(H/M/L)	W	84/45/35	118/79/61	125/64/42
Sound power level	(H/M/L)	dB(A)	58/53/50	60/56/54	61/55/50
Sound pressure level	(H/M/L)	dB(A)	46/41/38	48/44/42	49/43/38
Rated current		A	0.72	1.08	1.32
Fan motor	Type		DC motor	DC motor	DC motor
	Quantity		1	1	1
Fan	Type		Centrifugal, forward-curved Blades		
	Quantity		1	1	1
Coil	Row		2	3	3
	Max. working pressure	MPa	1.6	1.6	1.6
Panel	Diameter	mm	Ø7	Ø7	Ø7
	Net dimensions (WxHxD)	mm	950x45x950	950x45x950	950x45x950
	Packing size (WxHxD)	mm	1035x90x1035	1035x90x1035	1035x90x1035
	Net weight	kg	6	6	6
	Gross weight	kg	9	9	9
	Body	Net dimensions (WxHxD)	mm	840x300x840	840x300x840
Packing size (WxHxD)		mm	900x330x900	900x330x900	900x330x900
Net weight		kg	27.5	30	30
Gross weight		kg	32.4	35	35
Pipe connections	Water inlet/outlet pipe	inch	Cold water: RC3/4; Hot water: RC1/2		
	Drain pipe	mm	ODØ32	ODØ32	ODØ32

Notes:

H: High fan speed; M: Medium fan speed; L: Low fan speed.

1: Cooling mode (2 and 4-pipe coil): entering air temperature 27°C DB/1 9°C WB, entering/leaving water temperature 7°C /12°C.

2: Heating mode(1): (4-pipe coil): entering air temperature 20°C DB, entering/leaving water temperature 65/55°C.

3: Heating mode(2): (4-pipe coil): entering air temperature 20°C DB, entering/leaving water temperature 70/60°C.

4.Sound pressure level is tested in a semi-anechoic test room.

5.Sound power level is tested in a reverberation chamber.

2-Pipe Compact 4-Way Cassette



Model			MKD-V300	MKD-V400	MKD-V500
Power supply		V/Ph/Hz	220-240/1/50		
Air flow (H/M/L)		m ³ /h	535/429/322	610/477/381	781/611/494
		CFM	314/252/189	359/281/224	459/359/290
Cooling ¹	Capacity (H/M/L)	kW	2.98/2.53/2	3.96/3.26/2.76	4.2/3.48/3.01
	Water flow rate(H/M/L)	m ³ /h	0.53/0.45/0.35	0.7/0.58/0.51	0.75/0.61/0.54
	Water pressure drop(H/M/L)	kPa	10/7/5	11.48/8.2/6.54	12.32/8.62/7.4
	Power input(H/M/L)	W	15/9/5	28/15/9	43/28/21
Heating ²	Capacity (H/M/L)	kW	2.61/2.31/2.24	4.08/3.34/2.73	4.95/3.99/3.26
	Water flow rate(H/M/L)	m ³ /h	0.64/0.54/0.42	0.83/0.67/0.56	0.87/0.70/0.58
	Water pressure drop(H/M/L)	kPa	12.1/8.5/5.3	9.2/8.6/6	9.4/8.23/6.1
	Power input(H/M/L)	W	15/9/5	28/16/10	33/18/11
Heating ³	Capacity (H/M/L)	kW	4.01/3.35/2.61	4.78/3.84/3.18	5.76/4.69/3.84
	Water flow rate(H/M/L)	m ³ /h	0.53/0.45/0.35	0.7/0.58/0.51	0.75/0.61/0.54
	Water pressure drop(H/M/L)	kPa	8.2/6/3.8	12.68/6.4/4.92	11.41/6.5/5.41
	Power input(H/M/L)	W	14/9/5	28/16/10	33/18/11
Sound pressure level	(H/M/L)	dB(A)	39/33/27	42/36/30	43/38/32
Fan motor	Type		DC Motor	DC Motor	DC Motor
	Quantity		1	1	1
Fan	Type		Centrifugal, forward-curved Blades		
	Quantity		1	1	1
Coil	Row		2	2	2
	Max. working pressure	MPa	1.6	1.6	1.6
Panel	Diameter	mm	Ø7	Ø7	Ø7
	Net dimensions (WxHxD)	mm	647x50x647	647x50x647	647x50x647
	Packing size (WxHxD)	mm	715x123x715	715x123x715	715x123x715
	Net weight	kg	2.5	2.5	2.5
	Gross weight	kg	4.5	4.5	4.5
	Body	Net dimensions (WxHxD)	mm	575x261x575	575x261x575
Packing size (WxHxD)		mm	670x290x670	670x290x670	670x290x670
Net weight		kg	16.5	16.5	16.5
Gross weight		kg	22.5	22.5	22.5
Pipe connections	Water inlet/outlet pipe	inch	G3/4	G3/4	G3/4
	Drain pipe	mm	ODØ25	ODØ25	ODØ25

4-Pipe Compact 4-Way Cassette

Model			MKD-V300FA	MKD-V400FA	MKD-V500FA
Power supply		V/Ph/Hz	220-240/1/50		
Air flow (H/M/L)		m ³ /h	493/395/295	669/523/415	673/526/425
		CFM	290/232/173	393/307/244	395/309/250
Cooling ¹	Capacity (H/M/L)	kW	2.161/1.861/1.485	2.777/2.375/2.045	2.771/2.382/2.069
	Water flow rate(H/M/L)	m ³ /h	0.42/0.37/0.3	0.53/0.46/0.4	0.56/0.49/0.43
	Water pressure drop(H/M/L)	kPa	17.4/13.5/9.3	13.15/9.4/7	16.8/13.1/10.3
	Power input(H/M/L)	W	15/10/6	30/26/21	35/19/12
Heating ²	Capacity (H/M/L)	kW	3.131/2.628/2.077	3.711/3.138/2.65	3.942/3.296/2.826
	Water flow rate(H/M/L)	m ³ /h	0.32/0.28/0.23	0.37/0.32/0.28	0.42/0.36/0.32
	Water pressure drop(H/M/L)	kPa	23.5/17.1/11.3	24.1/17.9/13.1	26.8/19.2/14.5
	Power input(H/M/L)	W	17/10/6	32/18/11	35/18/11
Heating ³	Capacity (H/M/L)	kW	3.564/2.989/2.356	4.251/3.584/3.023	4.508/3.789/3.222
	Water flow rate(H/M/L)	m ³ /h	0.36/0.31/0.25	0.41/0.36/0.31	0.47/0.40/0.36
	Water pressure drop(H/M/L)	kPa	29.8/21.7/14.3	30.4/22.2/16.7	36.1/25.9/19
	Power input(H/M/L)	W	17/10/6	31/18/11	35/19/11
Sound power level	(H/M/L)	dB(A)	51/45/39	54/47/42	56/51/43
Sound pressure level	(H/M/L)	dB(A)	39/33/27	42/35/30	44/39/31
Rated current		A	0.24	0.36	0.48
Fan motor	Type		DC motor	DC motor	DC motor
	Quantity		1	1	1
Fan	Type		Centrifugal, forward-curved Blades		
	Quantity		1	1	1
Coil	Row		2	2	2
	Max. working pressure	MPa	1.6	1.6	1.6
Panel	Diameter	mm	Ø7	Ø7	Ø7
	Net dimensions (WxHxD)	mm	647x50x647	647x50x647	647x50x647
	Packing size (WxHxD)	mm	715x123x715	715x123x715	715x123x715
	Net weight	kg	2.5	2.5	2.5
	Gross weight	kg	4.5	4.5	4.5
	Body	Net dimensions (WxHxD)	mm	575x261x575	575x261x575
Packing size (WxHxD)		mm	675x320x675	675x320x675	675x320x675
Net weight		kg	16.7	16.7	16.7
Gross weight		kg	22.7	22.7	22.7
Pipe connections	Water inlet/outlet pipe	inch	Cold water: G3/4; Hot water: G1/2		
	Drain pipe	mm	ODØ25	ODØ25	ODØ25

Notes:

H: High fan speed; M: Medium fan speed; L: Low fan speed.

1: Cooling mode (2 and 4-pipe coil): entering air temperature 27°C DB/1 9°C WB, entering/leaving water temperature 7°C /12°C.

2: Heating mode(1): (4-pipe coil): entering air temperature 20°C DB, entering/leaving water temperature 65/55°C.

3: Heating mode(2): (4-pipe coil): entering air temperature 20°C DB, entering/leaving water temperature 70/60°C.

4.Sound pressure level is tested in a semi-anechoic test room.

5.Sound power level is tested in a reverberation chamber.

Duct Series

2-Pipe Duct



Various Selections

- 2, 3 or 4 row coils for 2-pipe system.
- 3 row coils for 4-pipe system is customizable.
- Large range of available static pressure.

High Efficiency and Low Sound Operation

- Due to the DC brushless fan motor, the unit operates in high efficiency and low sound level.

Flexible Installation

- Left and right hand piping connections are optional, flexible installation.

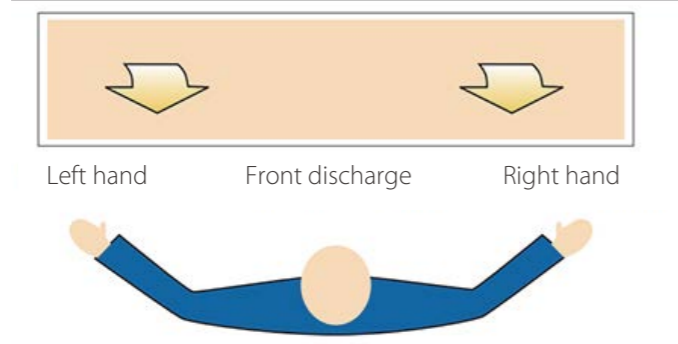

Standard Return Air Plenum and Filter

- Standard return air plenum and filter guarantees clean air supply and stable air flow rate.

Fresh Air Intake

- Fresh air can enter through the duct unit so you can enjoy even fresher air in the room.



2-Pipe 2-Row Duct



Model		MKT2-V200	MKT2-V300	MKT2-V400	MKT2-V500	
Power supply	V/Ph/Hz	220-240/1/50				
Air flow (H/M/L)	m ³ /h	439/295/221	615/439/310	792/622/413	887/620/443	
	CFM	258/173/130	361/258/182	465/365/242	521/364/260	
Standard external static pressure	Pa	12Pa (default); 30/50Pa can be set through dial switch on PCB				
Cooling ¹	Capacity (H/M/L)	kW	2.02/1.52/1.17	2.82/2.33/1.79	3.31/2.78/2.14	3.83/3.16/2.55
	Water flow rate(H/M/L)	m ³ /h	0.37/0.28/0.22	0.51/0.41/0.32	0.59/0.50/0.38	0.68/0.56/0.46
	Water pressure drop(H/M/L)	kPa	6.3/3.62/2.17	14.16/10.5/7.33	19.37/14.79/9.57	23.7/17.1/11.9
	Power input(H/M/L)	W	18/9/6	25/15/11	29/16/9	42/20/11
Heating ²	Capacity (H/M/L)	kW	2.57/1.89/1.47	3.56/2.8/2.08	4.19/3.42/2.49	4.84/3.9/3.01
	Water flow rate(H/M/L)	m ³ /h	0.47/0.34/0.27	0.62/0.50/0.37	0.72/0.6/0.45	0.84/0.69/0.53
	Water pressure drop(H/M/L)	kPa	5.64/4.5/2.9	10.54/10.3/6.3	16.20/16.6/10	30.8/32.4/20
	Power input(H/M/L)	W	19/9/7	25/15/11	32/17/9	45/22/12
Heating ³	Capacity (H/M/L)	kW	2.98/2.22/1.73	4.12/3.26/2.39	4.91/4.1/3.02	5.6/4.49/3.45
	Water flow rate(H/M/L)	m ³ /h	0.37/0.28/0.22	0.51/0.41/0.32	0.59/0.50/0.38	0.68/0.56/0.46
	Water pressure drop(H/M/L)	kPa	7.91/3.5/2.3	15.39/7.41/4.83	23/12.09/7.81	29.04/17.16/9.71
	Power input(H/M/L)	W	19/9/7	25/15/11	31/18/9	45/21/11
Sound pressure level	0Pa (H/M/L)	dB(A)	37.5/27.4/24.0	40.3/33.1/26.7	41.1/34.7/26.8	44.6/36.8/29.4
Fan motor	Type	DC Motor				
	Quantity	1				
Fan	Type	Centrifugal, forward-curved Blades				
	Quantity	2				
Coil	Row	2				
	Max. working pressure	MPa	1.6			
	Diameter	mm	Ø9.52			
Net dimensions (WxHxD)	mm	741x241x522	841x241x522	941x241x522	941x241x522	
Packing size (WxHxD)	mm	790x260x555	890x260x560	990x260x560	990x260x560	
Net weight	kg	16.5	18.5	20	20	
Gross weight	kg	19	21.4	23.2	23.2	
Water inlet/outlet pipe	inch	RC3/4				
Drain pipe	inch	ZG3/4				

Model		MKT2-V600	MKT2-V800	MKT2-V1000	MKT2-V1200	
Power supply	V/Ph/Hz	220-240/1/50				
Air flow (H/M/L)	m ³ /h	1081/821/586	1492/1071/797	1824/1332/906	2327/1669/1135	
	CFM	635/482/344	877/630/468	1072/783/532	1368/981/667	
Standard external static pressure	Pa	12Pa (default); 30/50Pa can be set through dial switch on PCB				
Cooling ¹	Capacity (H/M/L)	kW	4.78/4.01/3.09	6.7/5.49/4.45	7.92/6.62/5.15	9.83/8.5/6.46
	Water flow rate(H/M/L)	m ³ /h	0.85/0.69/0.54	1.19/0.96/0.80	1.43/1.17/0.91	1.74/1.42/1.12
	Water pressure drop(H/M/L)	kPa	14.2/9.8/6.1	15.1/10.89/7.82	23.2/16.44/10.94	50.33/30.4/21.71
	Power input(H/M/L)	W	53/25/12	62/28/16	93/42/19	111/53/24
Heating ²	Capacity (H/M/L)	kW	6.25/5.17/4.03	8.39/6.64/5.2	9.92/7.94/5.86	12.58/10.24/7.57
	Water flow rate(H/M/L)	m ³ /h	1.10/0.91/0.7	1.46/1.17/0.91	1.69/1.38/1.01	2.17/1.79/1.34
	Water pressure drop(H/M/L)	kPa	12.36/14.2/8.9	13.26/13.1/8.28	19.72/18.87/11.07	38.30/41.81/26.5
	Power input(H/M/L)	W	58/27/13	66/30/16	100/44/19	118/55/24
Heating ³	Capacity (H/M/L)	kW	7.19/5.92/4.55	9.87/7.83/6.29	11.63/9.37/6.96	14.58/11.82/8.83
	Water flow rate(H/M/L)	m ³ /h	0.85/0.69/0.54	1.19/0.96/0.80	1.43/1.17/0.91	1.74/1.42/1.12
	Water pressure drop(H/M/L)	kPa	19.88/8.56/5.4	19.36/9.03/6.4	26.68/13.96/9.1	60.7/26.5/17.8
	Power input(H/M/L)	W	58/27/13	66/30/17	99/45/19	119/55/24
Sound pressure level	0Pa (H/M/L)	dB(A)	46.1/38.9/29.9	47.7/39.4/31.1	50.2/43.0/33.0	50.9/44.0/33.8
Fan motor	Type	DC Motor				
	Quantity	1				
Fan	Type	Centrifugal, forward-curved Blades				
	Quantity	2				
Coil	Row	2				
	Max. working pressure	MPa	1.6			
	Diameter	mm	Ø9.52			
Net dimensions (WxHxD)	mm	1161x241x522	1461x241x522	1566x241x522	1856x241x522	
Packing size (WxHxD)	mm	1210x260x560	1510x260x560	1615x260x560	1905x260x560	
Net weight	kg	22.2	31.4	32.5	37.5	
Gross weight	kg	26	35.8	37.2	42.8	
Water inlet/outlet pipe	inch	RC3/4				
Drain pipe	inch	ZG3/4				

Notes:

H: High fan speed; M: Medium fan speed; L: Low fan speed.

1. Cooling mode (2 and 4-pipe coil): entering air temperature 27°C DB/19°C WB, entering/leaving water temperature 7°C /12°C.

2. Heating mode (1) : (2-pipe coil): entering air temperature 20°C DB, entering/leaving water temperature 45/40°C.

3. Heating mode (2) : (2-pipe coil): entering air temperature 20°C DB, enter water teperature/water flow 50°C/*(same water flow as in standard rating condition in cooling)

4. Sound pressure level is tested in a semi-anechoic test room.

5. The external static pressure test condition is 0 Pa.

2-Pipe 3-Row Duct



Model		MKT3-V200	MKT3-V300	MKT3-V400	MKT3-V500	
Power supply		220-240/1/50				
Air flow (H/M/L)		m³/h 411/273/171	531/442/311	734/564/389	865/626/441	
		CFM 241/160/100	312/260/182	431/331/228	508/368/259	
Standard external static pressure		12Pa (default); 30/50Pa can be set through dial switch on PCB				
Cooling ¹	Capacity (H/M/L)	kW	2.35/1.72/1.32	3.12/2.72/2.1	3.99/3.26/2.5	4.46/3.59/2.83
	Water flow rate(H/M/L)	m³/h	0.43/0.31/0.25	0.6/0.48/0.37	0.69/0.57/0.43	0.79/0.63/0.50
	Water pressure drop(H/M/L)	kPa	13.6/8.6/6.3	23.8/16.4/11.3	13/9.3/5.8	16.4/11.3/7.6
	Power input(H/M/L)	W	17/9/7	23/15/10	26/15/9	39/19/11
Heating ²	Capacity (H/M/L)	kW	2.68/1.99/1.42	3.82/3.08/2.28	4.7/3.85/2.77	5.27/4.21/3.21
	Water flow rate(H/M/L)	m³/h	0.49/0.35/0.26	0.67/0.54/0.41	0.82/0.67/0.50	0.92/0.73/0.57
	Water pressure drop(H/M/L)	kPa	12.6/7.6/4.9	25/17.6/11.3	13/10.5/6.2	18.4/12.4/8.1
	Power input(H/M/L)	W	18/9/7	23/15/10	26/16/9	43/21/11
Heating ³	Capacity (H/M/L)	kW	3.17/2.27/1.75	4.51/3.61/2.71	5.52/4.55/3.27	6.26/4.99/3.81
	Water flow rate(H/M/L)	m³/h	0.43/0.31/0.25	0.60/0.48/0.37	0.69/0.57/0.43	0.79/0.63/0.50
	Water pressure drop(H/M/L)	kPa	10.3/6.1/4.2	19.2/12.9/8.5	10.8/7.7/4.8	13.7/9.5/6.3
	Power input(H/M/L)	W	18/9/7	23/15/10	28/16/9	43/21/11
Sound pressure level	0Pa (H/M/L)	dB(A)	38.1/28.4/23.4	36.4/29.5/20.7	38.4/32.2/24.0	44.3/36.3/27.9
Fan motor	Type	DC Motor				
	Quantity	1				
Fan	Type	Centrifugal, forward-curved Blades				
	Quantity	1				
Coil	Row	3				
	Max. working pressure	MPa	1.6			
Coil	Diameter	mm	Ø9.52			
	Net dimensions (WxHxD)	mm	741x241x522	841x241x522	941x241x522	941x241x522
Packing size (WxHxD)	mm	790x260x555	890x260x560	990x260x560	990x260x560	
Net weight	kg	16.7	19	21	21	
Gross weight	kg	19.7	22	24	24	
Water inlet/outlet pipe	inch	RC3/4				
Drain pipe	inch	ZG3/4				

Model		MKT3-V600	MKT3-V800	MKT3-V1000	MKT3-V1200	
Power supply		220-240/1/50				
Air flow (H/M/L)		m³/h 1022/760/544	1452/1038/781	1824/1332/906	2134/1581/1083	
		CFM 601/447/320	854/610/459	1072/783/532	1255/930/637	
Standard external static pressure		12Pa (default); 30/50Pa can be set through dial switch on PCB				
Cooling ¹	Capacity (H/M/L)	kW	5.85/4.82/3.78	8.02/6.36/5.08	8.96/7.37/5.66	10.79/8.86/6.79
	Water flow rate(H/M/L)	m³/h	1.05/0.85/0.65	1.42/1.11/0.89	1.59/1.29/0.98	1.93/1.57/1.20
	Water pressure drop(H/M/L)	kPa	31.4/22/14.2	31.6/20.5/13.9	24.1/16.9/10.8	26.3/18.8/12.8
	Power input(H/M/L)	W	49/24/12	60/28/16	60/43/19	106/49/24
Heating ²	Capacity (H/M/L)	kW	6.62/5.38/4	9.15/7.08/5.58	10.74/8.55/6.35	12.62/10.15/7.47
	Water flow rate(H/M/L)	m³/h	1.15/0.94/0.71	1.59/1.26/0.98	1.88/1.51/1.13	2.23/1.78/1.31
	Water pressure drop(H/M/L)	kPa	31.7/22.2/13.6	32.9/21.6/13.9	28.3/19.4/12	29.4/20/11.9
	Power input(H/M/L)	W	53/26/12	65/30/17	100/45/20	115/52/22
Heating ³	Capacity (H/M/L)	kW	7.84/6.35/4.81	10.88/8.46/6.68	12.61/10.04/7.35	14.9/11.92/8.89
	Water flow rate(H/M/L)	m³/h	1.05/0.85/0.65	1.42/1.11/0.89	1.59/1.29/0.98	1.93/1.57/1.20
	Water pressure drop(H/M/L)	kPa	26.4/18.2/11.4	26.3/16.9/11.5	21.1/14.8/9.5	22.6/16/10.2
	Power input(H/M/L)	W	52/25/13	65/30/17	99/44/19	114/51/22
Sound pressure level	0Pa (H/M/L)	dB(A)	46.1/39.0/30.3	44.9/36.1/27.7	47.8/40.7/30.7	48.9/41.8/31.7
Fan motor	Type	DC Motor				
	Quantity	1				
Fan	Type	Centrifugal, forward-curved Blades				
	Quantity	2				
Coil	Row	3				
	Max. working pressure	MPa	1.6			
Coil	Diameter	mm	Ø9.52			
	Net dimensions (WxHxD)	mm	1161x241x522	1461x241x522	1566x241x522	1856x241x522
Packing size (WxHxD)	mm	1210x260x560	1510x260x560	1615x260x560	1905x260x560	
Net weight	kg	23.7	33	34.7	39.2	
Gross weight	kg	27.2	37.2	39.2	44.4	
Water inlet/outlet pipe	inch	RC3/4				
Drain pipe	inch	ZG3/4				

Notes:

H: High fan speed; M: Medium fan speed; L: Low fan speed.

1. Cooling mode (2 and 4-pipe coil): entering air temperature 27°C DB/19°C WB, entering/leaving water temperature 7°C /12°C.

2. Heating mode (1) : (2-pipe coil): entering air temperature 20°C DB, entering/leaving water temperature 45/40°C.

3. Heating mode (2) : (2-pipe coil): entering air temperature 20°C DB, enter water teperature/water flow 50°C/*(same water flow as in standard rating condition in cooling)

4. Sound pressure level is tested in a semi-anechoic test room.

5. The external static pressure test condition is 0 Pa.

2-Pipe 4-Row Duct

Model		MKT4-V200	MKT4-V300	MKT4-V400	MKT4-V500	
Power supply		220-240/1/50				
Air flow (H/M/L)		m³/h 441/297/227	627/468/338	778/537/349	884/642/461	
		CFM 259/174/133	368/275/198	458/316/205	520/377/271	
Standard external static pressure		12Pa (default); 30/50Pa can be set through dial switch on PCB				
Cooling ¹	Capacity (H/M/L)	kW	2.22/1.59/1.2	3.19/2.58/1.87	4.06/3.26/2.41	4.46/3.56/2.78
	Water flow rate(H/M/L)	m³/h	0.40/0.30/0.23	0.57/0.47/0.34	0.72/0.59/0.43	0.80/0.63/0.50
	Water pressure drop(H/M/L)	kPa	2.44/1.52/1	5.24/3.61/2.36	8.4/5.9/3.49	11.6/8.1/5.6
	Power input(H/M/L)	W	17/9/6	21/12/7	29/16/9	43/23/14
Heating ²	Capacity (H/M/L)	kW	2.81/2.154	3.88/3.09/2.35	4.19/3.42/2.49	5.44/4.23/3.23
	Water flow rate(H/M/L)	m³/h	0.51/0.37/0.29	0.67/0.56/0.42	0.84/0.68/0.51	0.96/0.76/0.57
	Water pressure drop(H/M/L)	kPa	2/1.76/1.2	4.3/4.29/2.8	6.99/6.4/3.8	10.64/9.83/6.68
	Power input(H/M/L)	W	18/9/7	23/13/8	32/18/10	41/22/12
Heating ³	Capacity (H/M/L)	kW	3.23/2.32/1.75	4.5/3.6/2.68	5.6/4.59/3.36	6.25/4.88/3.74
	Water flow rate(H/M/L)	m³/h	0.40/0.30/0.23	0.57/0.47/0.34	0.72/0.59/0.43	0.80/0.63/0.50
	Water pressure drop(H/M/L)	kPa	2.99/1.2/0.71	5.85/3.1/1.9	9.1/4.9/2.8	14.06/7.6/5.5
	Power input(H/M/L)	W	19/9/6	23/13/8	32/18/10	42/21/11
Sound pressure level	0Pa (H/M/L)	dB(A)	37.3/27.4/22.2	39.6/32.5/25.0	41.1/34.5/26.4	44.8/37.2/29.8
Fan motor	Type	DC Motor				
	Quantity	1				
Fan	Type	Centrifugal, forward-curved Blades				
	Quantity	1				
Coil	Row	4				
	Max. working pressure	MPa	1.6			
Coil	Diameter	mm	Ø9.52			
	Net dimensions (WxHxD)	mm	741x241x522	841x241x522	941x241x522	941x241x522
Packing size (WxHxD)	mm	790x260x555	890x260x560	990x260x560	990x260x560	
Net weight	kg	17.8	20	21.9	21.9	
Gross weight	kg	20.4	22.9	25.1	25.1	
Water inlet/outlet pipe	inch	RC3/4				
Drain pipe	inch	ZG3/4				

Model		MKT4-V600	MKT4-V800	MKT4-V1000	MKT4-V1200	
Power supply		220-240/1/50				
Air flow (H/M/L)		m³/h 1056/793/575	1506/1084/822	1813/1341/932	2134/1617/1119	
		CFM 621/466/338	885/637/483	1066/788/548	1255/951/658	
Standard external static pressure		12Pa (default); 30/50Pa can be set through dial switch on PCB				
Cooling ¹	Capacity (H/M/L)	kW	5.87/4.78/3.68	6.65/5.04/3.61	7.98/6.19/4.37	9.76/7.81/5.72
	Water flow rate(H/M/L)	m³/h	1.06/0.86/0.65	1.19/0.88/0.64	1.47/1.12/0.78	1.78/1.41/1.02
	Water pressure drop(H/M/L)	kPa	19.4/13.6/8.5	8.8/5.09/2.8	13.81/8.63/4.75	22.31/15/8.98
	Power input(H/M/L)	W	51/25/12	61/27/16	93/49/21	109/50/22
Heating ²	Capacity (H/M/L)	kW	6.47/5.18/3.91	8.36/6.32/4.77	9.92/7.94/5.86	11.76/9.32/6.76
	Water flow rate(H/M/L)	m³/h	1.11/0.90/0.67	1.43/1.12/0.86	1.68/1.35/1.00	2.01/1.60/1.15
	Water pressure drop(H/M/L)	kPa	16.31/12.6/7.41	7.7/6.97/4.3	19.72/18.9/11.1	20.04/16.93/9.62
	Power input(H/M/L)	W	56/27/13	66/30/16	102/46/20	119/55/24
Heating ³	Capacity (H/M/L)	kW	7.72/6.19/4.68	9.55/7.14/5.23	11.55/9/6.46	14.34/11.31/8.3
	Water flow rate(H/M/L)	m³/h	1.06/0.86/0.65	1.19/0.88/0.64	1.47/1.12/0.78	1.78/1.41/1.02
	Water pressure drop(H/M/L)	kPa	17.92/11.31/7	10.9/4.49/2.5	15.42/7.5/4.1	24.94/13.46/13.48
	Power input(H/M/L)	W	56/27/13	67/29/16	103/46/20	121/54/23
Sound pressure level	0Pa (H/M/L)	dB(A)	46.1/39.4/30.7	47.4/39.1/32.1	50.4/42.7/33.1	50.7/43.8/34.5
Fan motor	Type	DC Motor				
	Quantity	1				
Fan	Type	Centrifugal, forward-curved Blades				
	Quantity	2				
Coil	Row	4				
	Max. working pressure	MPa	1.6			
Coil	Diameter	mm	Ø9.52			
	Net dimensions (WxHxD)	mm	1161x241x522	1461x241x522	1566x241x522	1856x241x522
Packing size (WxHxD)	mm	1210x260x560	1510x260x560	1615x260x560	1905x260x560	
Net weight	kg	25	34.8	36.4	41.9	
Gross weight	kg	28.8	39.2	41.9	47.2	
Water inlet/outlet pipe	inch	RC3/4				
Drain pipe	inch	ZG3/4				

Notes:

H: High fan speed; M: Medium fan speed; L: Low fan speed.

1. Cooling mode (2 and 4-pipe coil): entering air temperature 27°C DB/19°C WB, entering/leaving water temperature 7°C /12°C.

2. Heating mode (1) : (2-pipe coil): entering air temperature 20°C DB, entering/leaving water temperature 45/40°C.

3. Heating mode (2) : (2-pipe coil): entering air temperature 20°C DB, enter water teperature/water flow 50°C/*(same water flow as in standard rating condition in cooling)

4. Sound pressure level is tested in a semi-anechoic test room.

5. The external static pressure test condition is 0 Pa.

Wall Mounted Series



C Type

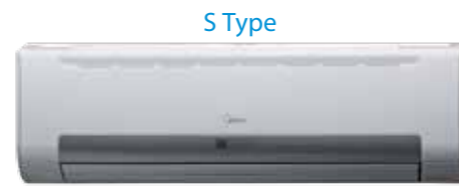

S Type

Stylish Panel

- Stylish front panel blends easily within any interior décor, ideal for use in shops, restaurants or offices with no or narrow false ceilings.

Convenient Installation

- Multi-directional outlet pipe feature: left/right/rear, to meet the needs of different rooms.

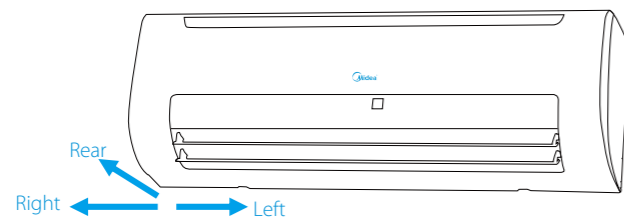

Built-in 3-Way Electromagnetic Valve

Auto Swing Louver

- The Auto Swing Louver function ensures that the air direction corresponds to the mode selected.

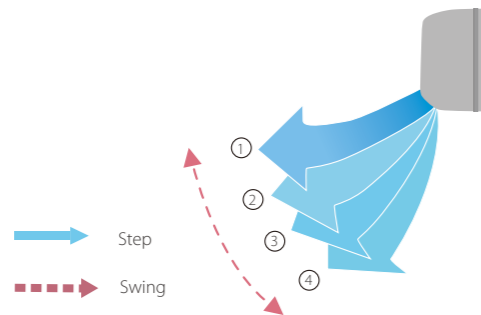

Easy Maintenance

- Removable front panel making maintenance convenient.



Wall Mounted (S Type)



Model		MKG-V250B	MKG-V300B	MKG-V400B	MKG-V500B	MKG-V600B	
Power supply	V/Ph/Hz	220-240/1/50					
Air flow (H/M/L)	m ³ /h	492/454/400	585/485/413	825/689/590	862/741/634	979/849/717	
	CFM	289/267/235	344/285/242	485/405/347	507/435/372	575/499/421	
Cooling ¹	Capacity (H/M/L)	kW	2.7/2.59/2.39	2.91/2.54/2.19	3.81/3.3/2.88	4.47/3.98/3.48	4.87/4.26/3.79
	Water flow rate(H/M/L)	m ³ /h	0.48/0.46/0.42	0.51/0.45/0.38	0.67/0.57/0.51	0.77/0.68/0.61	0.85/0.72/0.65
	Water pressure drop(H/M/L)	kPa	31.61/28.63/25.36	37.2/29.73/23.36	56.75/41.23/33.02	41.17/33.54/27.05	50.68/39.47/33.66
	Power input(H/M/L)	W	13/11/10	15/11/9	34/22/15	26/18/13	38/26/18
Heating ²	Capacity (H/M/L)	kW	2.94/2.8/2.58	3.23/2.77/2.42	4.3/3.65/3.09	4.84/4.23/3.62	5.26/4.68/3.96
	Water flow rate(H/M/L)	m ³ /h	0.51/0.49/0.46	0.56/0.49/0.42	0.73/0.64/0.56	0.84/0.73/0.64	0.89/0.80/0.68
	Water pressure drop(H/M/L)	kPa	32.66/34.89/30.24	34.12/31.53/25.1	51.86/47.53/35.69	36.82/33.83/26.26	47.12/42.75/32.95
	Power input(H/M/L)	W	11/11/9	14/10/8	31/20/14	22/16/12	33/23/16
Heating ³	Capacity (H/M/L)	kW	3.29/3.03/2.63	3.76/3.22/2.77	5.08/4.33/3.77	5.68/4.94/4.24	6.31/5.57/4.77
	Water flow rate(H/M/L)	m ³ /h	0.48/0.46/0.42	0.51/0.45/0.38	0.67/0.57/0.51	0.77/0.68/0.61	0.85/0.72/0.65
	Water pressure drop(H/M/L)	kPa	37.49/30.25/26.53	40.64/27.03/20.98	61.94/37.88/30.34	43.74/29.69/23.98	51.65/36.3/30.3
	Power input(H/M/L)	W	12/10/8	14/10/8	31/20/14	23/16/12	33/23/16
Sound pressure level (H/M/L)	dB(A)	32/30/27	32/27/23	45/39/35	38/34/30	44/40/35	
Fan motor	Type	DC Motor					
	Quantity	1					
Fan	Type	Tangential fan					
	Quantity	1					
Coil	Row	2					
	Max. working pressure	MPa	1.6				
	Diameter	mm	Ø7				
Net dimensions (WxHxD)	mm	915x290x230	915x290x230	915x290x230	1072x315x230	1072x315x230	
Packing size (WxHxD)	mm	1020x390x315	1020x390x315	1020x390x315	1180x415x315	1180x415x315	
Net weight	kg	12.7	12.7	12.7	15.1	14.9	
Gross weight	kg	17.3	17.6	16.3	19	18.6	
Water inlet/outlet pipe	inch	G3/4					
Drain pipe	mm	ODØ20					

Wall Mounted (C Type)

Model MKG-		V250	V300	V400	V500	V600	
Air flow	H/M/L	m ³ /h	425/410/320	510/427/349	680/550/504	850/692/586	1020/820/670
	H/M/L	CFM	250/241/188	300/251/205	400/324/297	500/407/345	600/483/394
Cooling	Capacity	kW	2.2/2.2/1.97	2.64/2.48/2.06	3.08/2.90/2.66	4.07/3.78/3.05	4.45/3.95/3.21
	Water flow rate	L/h	378	454	530	700	765
	Water pressure drop	kPa	23.1	33.6	42	34.9	36.3
Heating	Capacity	kW	3.02/2.85/2.35	3.69/2.92/2.49	4.34/3.77/3.35	5.69/4.14/3.63	6.30/5.17/4.18
	Water pressure drop	kPa	22	31.4	40	29.7	32.8
Power supply	V/Ph/Hz	220-240/1/50					
Power input	H	W	10.7	14.3	33	28	37.5
Sound pressure level	H/M/L	dB(A)	30/26/23	32/28/25	36/32/29	38/34/30	40/36/31
Fan motor	Type	DC Motor					
	Quantity	1					
Fan	Type	Tangential fan					
	Quantity	1					
Coil	Row	2					
	Max. Working pressure	MPa	1.6				
	Coil length x height	mm	635x26.74	635x26.74	635x26.74	785x26.74	785x26.74
	Fin spacing	mm	1.5				
	Fin type	Hydrophilic aluminium					
	Number of circuits		5	5	5	7	7
	Diameter	mm	Ø7				
Body	Dimensions	WxHxD	915x290x210	915x290x210	915x290x210	1070x315x210	1070x315x210
	Packing	WxHxD	1020x385x300	1020x385x300	1020x385x300	1180x410x300	1180x410x300
	Net weight	kg	12	12	12	14.7	14.8
	Gross weight	kg	15.6	15.6	15.6	18.6	18.8
Pipe connection	Water inlet/outlet pipe	inch	G3/4				
	Drain pipe	mm	ODØ20				

Note:

Based on Eurovent conditions:

H :High fan speed; M: Medium fan speed; L: Low fan speed.

1 :Cooling mode: entering air temperature 27°C DB/1 9°C WB, entering/leaving water temperature 7°C /12°C, high fan speed.

2 :Heating mode:entering air temperature 20°C DB, enter water teperature/water flow 50°C/*(same water flow as in standard rating condition in cooling)

3 :Noise is tested in a semi-anechoic test room.

2nd Generation Ceiling&Floor series

Concealed Type
H3 Series



Exposed Type
(air return from bottom)
H2 Series



Note : The footing need to purchase separately

High Efficiency and Low Sound Operation

- Due to the DC brushless fan motor, the unit operates in high efficiency and low sound level.

Flexible Installation

- Cabinet and concealed versions meet various installation requirements.
- Horizontal or vertical installation.



Feature

- Auto mode and seven speed fan motor
- Ultra-thin, the thickness is only 200mm.
- Hysteresis temperature can be set in heating and cooling mode by PCB switch, field adjustable.
- With/without forced fan on can be set by PCB switch, field adjustable.
- The centralized control function can be connected through the customization XYE port.
- The Gateway(Modbus) can be connected through the customization PQE port.
- Wired controller KJR-75A is optional.
- 0-10V wired control is optional.

Notes: Centralized control function and Gateway(Modbus) can only choose one.

2- Pipe 2nd Generation Ceiling&Floor

Model		MKH2-V150-R3	MKH2-V150-R4	MKH2-V250-R3	MKH2-V250-R4	MKH2-V350-R3	MKH2-V350-R4	
Power supply	V/Ph/Hz	220-240/1/50						
Air flow (H/M/L)	m ³ /h	255/170/150	255/210/150	400/315/190	425/300/190	595/470/340	595/450/310	
	CFM	150/100/88	150/124/88	235/185/112	250/176/112	350/276/200	350/265/182	
External static pressure	Pa	0						
Cooling	Capacity (H/M/L)	kW	1.50/1.06/0.92	1.95/1.66/1.21	2.35/1.94/1.19	2.85/2.13/1.41	3.50/2.89/2.22	3.90/3.20/2.43
	Water flow rate(H/M/L)	m ³ /h	0.26/0.18/0.16	0.33/0.28/0.21	0.40/0.34/0.21	0.49/0.37/0.24	0.60/0.50/0.38	0.67/0.55/0.42
	Water pressure drop(H/M/L)	kPa	13.9/8.21/6.16	27.2/20.88/12.2	13.3/9.98/4.59	26/15.06/7.41	34.1/24.63/15.39	37.4/25.91/15.37
Heating	Capacity (H/M/L)	kW	1.57/1.07/0.92	2.05/1.75/1.25	2.60/2.11/1.34	2.95/2.15/1.42	3.80/3.10/2.35	4.00/3.22/2.50
	Water flow rate(H/M/L)	m ³ /h	0.27/0.19/0.16	0.35/0.30/0.22	0.45/0.37/0.23	0.51/0.37/0.24	0.65/0.53/0.40	0.70/0.56/0.43
	Water pressure drop(H/M/L)	kPa	15.1/7.63/5.84	25.3/19.65/10.25	14.3/10.33/4.5	24.4/13.65/6.64	35.1/24.41/14.82	36.5/25.34/14.22
Power input (H/M/L)	W	15/9/8	20/14/9	17/12/7	20/11/8	26/17/10	29/17/11	
Sound power level (H/M/L)	dB(A)	47/36/34	52/46/38	43/37/29	46/37/29	52/44/36	52/45/36	
Fan motor	Type	Low noise DC fan motor						
	Quantity	1	1	1	1	1	1	
Fan	Type	Centrifugal, forward-curved Blades						
	Quantity	1	1	2	2	2	2	
Coil	Row	3	4	3	4	3	4	
	Max. working pressure	MPa	1.6	1.6	1.6	1.6	1.6	
	Diameter	mm	Φ7.94	Φ7.94	Φ7.94	Φ7.94	Φ7.94	
Body	Net dimensions (WxHxD)	mm	495x200x790	495x200x790	495x200x1020	495x200x1020	495x200x1240	495x200x1240
	Packing size (WxHxD)	mm	595x300x895	595x300x895	595x300x1125	595x300x1125	595x300x1345	595x300x1345
	Net weight	kg	18.0	18.5	21.5	22.0	25.5	26.5
	Gross weight	kg	23.5	24.0	27.5	28.0	32.5	33.5
Water inlet/outlet pipe	inch	G3/4	G3/4	G3/4	G3/4	G3/4	G3/4	
Drain pipe	mm	ODΦ18.5	ODΦ18.5	ODΦ18.5	ODΦ18.5	ODΦ18.5	ODΦ18.5	

Model		MKH2-V500-R3	MKH2-V500-R4	MKH2-V700-R3	MKH2-V700-R4	MKH2-V800-R3	MKH2-V800-R4	
Power supply	V/Ph/Hz	220-240/1/50						
Air flow (H/M/L)	m ³ /h	790/580/410	800/600/420	1190/855/505	1190/875/530	1360/1015/685	1300/980/680	
	CFM	488/359/253	471/353/247	700/503/297	700/515/312	800/597/403	765/576/400	
External static pressure	Pa	0						
Cooling	Capacity (H/M/L)	kW	4.30/3.48/2.71	4.85/3.92/2.93	5.60/4.47/3.14	6.35/5.19/3.62	7.35/6.12/4.57	8.25/6.65/4.84
	Water flow rate(H/M/L)	m ³ /h	0.74/0.60/0.47	0.83/0.67/0.51	0.96/0.77/0.54	1.09/0.90/0.63	1.27/1.05/0.79	1.43/1.14/0.83
	Water pressure drop(H/M/L)	kPa	54.2/36.22/22.78	54.3/36.81/21.77	50.7/33.38/17.73	32.8/21.75/11.43	44.1/33.7/19.41	71.4/46.17/25.39
Heating	Capacity (H/M/L)	kW	4.70/3.70/2.81	5.25/4.09/3.04	6.00/4.77/3.36	7.05/5.61/3.83	8.05/6.46/4.71	8.70/6.81/4.85
	Water flow rate(H/M/L)	m ³ /h	0.81/0.64/0.48	0.91/0.71/0.53	1.04/0.83/0.59	1.22/0.98/0.67	1.39/1.12/0.82	1.51/1.18/0.83
	Water pressure drop(H/M/L)	kPa	54.3/36.87/22.32	53.4/36.54/20.47	55.5/37.66/19.27	37.6/25.47/12.5	46.9/31.9/18.16	62.6/41.06/21.68
Power input (H/M/L)	W	50/25/14	52/28/15	96/44/17	92/46/19	113/53/22	102/49/22	
Sound power level (H/M/L)	dB(A)	59/51/43	59/51/43	64/56/45	62/56/46	63/58/49	63/57/47	
Fan motor	Type	Low noise DC fan motor						
	Quantity	1	1	1	1	1	1	
Fan	Type	Centrifugal, forward-curved Blades						
	Quantity	2	2	3	3	3	3	
Coil	Row	3	4	3	4	3	4	
	Max. working pressure	MPa	1.6	1.6	1.6	1.6	1.6	
	Diameter	mm	Φ7.94	Φ7.94	Φ7.94	Φ7.94	Φ7.94	
Body	Net dimensions (WxHxD)	mm	495x200x1240	495x200x1240	495x200x1360	495x200x1360	591x200x1360	591x200x1360
	Packing size (WxHxD)	mm	595x300x1345	595x300x1345	595x300x1465	595x300x1465	695x300x1465	695x300x1465
	Net weight	kg	25.5	26.5	28.5	29.5	32.5	34.5
	Gross weight	kg	32.5	33.5	36.0	37.0	41.0	42.5
Water inlet/outlet pipe	inch	G3/4	G3/4	G3/4	G3/4	G3/4	G3/4	
Drain pipe	mm	ODΦ18.5	ODΦ18.5	ODΦ18.5	ODΦ18.5	ODΦ18.5	ODΦ18.5	

Notes:

1. H: High fan speed; M: Medium fan speed; L: Low fan speed.

2. Cooling conditions: Entering water 7°C, leaving water 12°C, Entering air temperature 27°C DB/19°C WB.

Heating conditions: Entering water 45°C, leaving water 40°C, Entering air temperature 20°C DB/15°C WB.

3. Noise is tested in a reverberation chamber.

Model		MKH3-V150-R3	MKH3-V150-R4	MKH3-V250-R3	MKH3-V250-R4	MKH3-V350-R3	MKH3-V350-R4
Power supply		V/Ph/Hz 220-240/1/50					
Air flow (H/M/L)		m³/h 255/170/150	255/210/150	400/315/190	425/300/190	595/470/340	595/450/310
		CFM 150/100/88	150/124/88	235/185/112	250/176/112	350/276/200	350/265/182
External static pressure		Pa 12					
Cooling	Capacity (H/M/L)	kW 1.50/1.06/0.92	1.95/1.66/1.21	2.35/1.94/1.19	2.85/2.13/1.41	3.50/2.89/2.22	3.90/3.20/2.43
	Water flow rate(H/M/L)	m³/h 0.26/0.18/0.16	0.33/0.28/0.21	0.40/0.34/0.21	0.49/0.37/0.24	0.60/0.50/0.38	0.67/0.55/0.42
	Water pressure drop(H/M/L)	kPa 13.9/8.21/6.16	27.2/20.88/12.2	13.3/9.98/4.59	26/15.06/7.41	34.1/24.63/15.39	37.4/25.91/15.37
Heating	Capacity (H/M/L)	kW 1.57/1.07/0.92	2.05/1.75/1.25	2.60/2.11/1.34	2.95/2.15/1.42	3.80/3.10/2.35	4.00/3.22/2.50
	Water flow rate(H/M/L)	m³/h 0.27/0.19/0.16	0.35/0.30/0.22	0.45/0.37/0.23	0.51/0.37/0.24	0.65/0.53/0.40	0.70/0.56/0.43
	Water pressure drop(H/M/L)	kPa 15.1/7.63/5.84	25.3/19.65/10.25	14.3/10.33/4.5	24.4/13.65/6.64	35.1/24.41/14.82	36.5/25.34/14.22
Power input (H/M/L)		W 15/9/8	20/14/9	17/12/7	20/11/8	26/17/10	29/17/11
Sound power level (H/M/L)		dB(A) 47/36/34	52/46/38	43/37/29	46/37/29	52/44/36	52/45/36
Fan motor	Type	Low noise DC fan motor					
	Quantity	1	1	1	1	1	1
Fan	Type	Centrifugal, forward-curved Blades					
	Quantity	1	1	2	2	2	2
Coil	Row	3	4	3	4	3	4
	Max. working pressure	MPa 1.6	1.6	1.6	1.6	1.6	1.6
	Diameter	mm Ø7.94	Ø7.94	Ø7.94	Ø7.94	Ø7.94	Ø7.94
Body	Net dimensions (WxHxD)	mm 455x200x637	455x200x637	455x200x867	455x200x867	455x200x1087	455x200x1087
	Packing size (WxHxD)	mm 555x255x755	555x255x755	555x255x985	555x255x985	555x255x1205	555x255x1205
	Net weight	kg 11.8	12.1	13.9	14.8	17.3	18.2
	Gross weight	kg 16.1	16.4	19.4	20.3	24.0	24.9
Water inlet/outlet pipe		inch G3/4	G3/4	G3/4	G3/4	G3/4	G3/4
Drain pipe		mm ODØ18.5	ODØ18.5	ODØ18.5	ODØ18.5	ODØ18.5	ODØ18.5

Model		MKH3-V500-R3	MKH3-V500-R4	MKH3-V700-R3	MKH3-V700-R4	MKH3-V800-R3	MKH3-V800-R4
Power supply		V/Ph/Hz 220-240/1/50					
Air flow (H/M/L)		m³/h 790/580/410	800/600/420	1190/855/505	1190/875/530	1360/1015/685	1300/980/680
		CFM 488/359/253	471/353/247	700/503/297	700/515/312	800/597/403	765/576/400
External static pressure		Pa 12					
Cooling	Capacity (H/M/L)	kW 4.30/3.48/2.71	4.85/3.92/2.93	5.60/4.47/3.14	6.35/5.19/3.62	7.35/6.12/4.57	8.25/6.65/4.84
	Water flow rate(H/M/L)	m³/h 0.74/0.60/0.47	0.83/0.67/0.51	0.96/0.77/0.54	1.09/0.90/0.63	1.27/1.05/0.79	1.43/1.14/0.83
	Water pressure drop(H/M/L)	kPa 54.2/36.22/22.78	54.3/36.81/21.77	50.7/33.38/17.73	32.8/21.75/11.43	44.1/33.7/19.41	71.4/46.17/25.39
Heating	Capacity (H/M/L)	kW 4.70/3.70/2.81	5.25/4.09/3.04	6.00/4.77/3.36	7.05/5.61/3.83	8.05/6.46/4.71	8.70/6.81/4.85
	Water flow rate(H/M/L)	m³/h 0.81/0.64/0.48	0.91/0.71/0.53	1.04/0.83/0.59	1.22/0.98/0.67	1.39/1.12/0.82	1.51/1.18/0.83
	Water pressure drop(H/M/L)	kPa 54.3/36.87/22.32	53.4/36.54/20.47	55.5/37.66/19.27	37.6/25.47/12.5	46.9/31.9/18.16	62.6/41.06/21.68
Power input (H/M/L)		W 50/25/14	52/28/15	96/44/17	92/46/19	113/53/22	102/49/22
Sound power level (H/M/L)		dB(A) 59/51/43	59/51/43	64/56/45	62/56/46	63/58/49	63/57/47
Fan motor	Type	Low noise DC fan motor					
	Quantity	1	1	1	1	1	1
Fan	Type	Centrifugal, forward-curved Blades					
	Quantity	2	2	3	3	3	3
Coil	Row	3	4	3	4	3	4
	Max. working pressure	MPa 1.6	1.6	1.6	1.6	1.6	1.6
	Diameter	mm Ø7.94	Ø7.94	Ø7.94	Ø7.94	Ø7.94	Ø7.94
Body	Net dimensions (WxHxD)	mm 455x200x1087	455x200x1087	455x200x1207	455x200x1207	550x200x1207	550x200x1207
	Packing size (WxHxD)	mm 555x255x1205	555x255x1205	555x255x1325	555x255x1325	650x255x1325	650x255x1325
	Net weight	kg 17.3	18.2	19.6	20.8	23.1	24.3
	Gross weight	kg 24.0	24.9	26.4	27.6	30.2	31.4
Water inlet/outlet pipe		inch G3/4	G3/4	G3/4	G3/4	G3/4	G3/4
Drain pipe		mm ODØ18.5	ODØ18.5	ODØ18.5	ODØ18.5	ODØ18.5	ODØ18.5

Notes:

- H: High fan speed; M: Medium fan speed; L: Low fan speed.
- Cooling conditions: Entering water 7°C, leaving water 12°C, Entering air temperature 27°C DB/19°C WB. Heating conditions: Entering water 45°C, leaving water 40°C, Entering air temperature 20°C DB/15°C WB.
- Noise is tested in a reverberation chamber.
- H3 series test with concealed tooling.

4- Pipe 2nd Generation Ceiling&Floor

Model		MKH2-V150F-R4	MKH2-V250F-R4	MKH2-V350F-R4	MKH2-V500F-R4	MKH2-V700F-R4	MKH2-V800F-R4
Power supply		V/Ph/Hz 220-240/1/50					
Air flow (H/M/L)		m³/h 255/206/134	425/280/158	595/461/324	800/595/417	1190/887/564	1300/969/661
		CFM 150/121/79	250/165/93	350/271/191	471/350/245	700/522/332	765/570/389
External static pressure		Pa 0					
Cooling	Sensible Capacity(H/M/L)	kW 1.30/1.07/0.64	1.90/1.30/0.70	2.80/2.30/1.61	3.50/2.75/2.01	4.80/3.88/2.53	5.90/4.60/3.30
	Capacity (H/M/L)	kW 1.70/1.44/0.95	2.70/1.94/1.10	3.80/3.18/2.32	4.60/3.75/2.83	6.05/5.00/3.43	7.65/6.19/4.54
	Water flow rate	m³/h 0.29/0.25/0.16	0.46/0.33/0.19	0.65/0.55/0.40	0.79/0.64/0.49	1.04/0.86/0.59	1.31/1.06/0.78
Heating	Water pressure drop	kPa 18.16/13.74/7.50	16.97/9.73/3.51	39.17/28.35/16.91	56.18/39.04/23.84	53.66/36.96/19.07	48.07/32.56/18.32
	Capacity (H/M/L)	kW 1.40/1.23/0.95	2.30/1.78/1.22	2.88/2.49/2.00	3.35/2.88/2.36	4.60/3.95/3.02	7.50/6.44/5.22
	Water flow rate	m³/h 0.12/0.11/0.08	0.20/0.15/0.10	0.25/0.21/0.17	0.29/0.25/0.20	0.39/0.34/0.26	0.64/0.55/0.45
Power input (H/M/L)	Water pressure drop	kPa 10.74/8.50/5.49	28.16/18.45/10.08	55.37/43.00/29.20	69.57/54.65/38.21	132.32/104.19/63.73	71.63/56.17/37.44
	W 20/14/9	20/11/8	29/17/11	52/28/15	92/46/19	102/49/22	
Rated current		A 0.21	0.22	0.28	0.51	0.79	0.87
Sound power level (H/M/L)		dB(A) 52/46/38	46/37/29	52/45/36	59/52/43	63/58/46	64/57/47
Fan motor	Type	Low noise DC fan motor					
	Quantity	1	1	1	1	1	1
Fan	Type	Centrifugal, forward-curved Blades					
	Quantity	1	2	2	3	3	
Coil	Row	4	4	4	4	4	
	Max. working pressure	MPa 1.6	1.6	1.6	1.6	1.6	
	Diameter	mm Ø7.94	Ø7.94	Ø7.94	Ø7.94	Ø7.94	
Body	Net dimensions (WxHxD)	mm 495x200x790	495x200x1020	495x200x1240	495x200x1240	495x200x1360	591x200x1360
	Packing size (WxHxD)	mm 595x300x895	595x300x1125	595x300x1345	595x300x1345	595x300x1465	695x300x1465
	Net weight	kg 19.0	22.5	27.0	27.0	30.0	35.0
	Gross weight	kg 24.5	28.5	34.0	34.0	37.5	43.0
Water inlet/outlet pipe		inch Cold water: G3/4; Hot water: G1/2					
Drain pipe		mm ODØ18.5					

Model		MKH3-V150F-R4	MKH3-V250F-R4	MKH3-V350F-R4	MKH3-V500F-R4	MKH3-V700F-R4	MKH3-V800F-R4
Power supply		V/Ph/Hz 220-240/1/50					
Air flow (H/M/L)		m³/h 255/206/134	425/280/158	595/461/324	800/595/417	1190/887/564	1300/969/661
		CFM 150/121/79	250/165/93	350/271/191	471/350/245	700/522/332	765/570/389
External static pressure		Pa 12					
Cooling	Sensible Capacity(H/M/L)	kW 1.30/1.07/0.64	1.90/1.30/0.70	2.80/2.30/1.61	3.50/2.75/2.01	4.80/3.88/2.53	5.90/4.60/3.30
	Capacity (H/M/L)	kW 1.70/1.44/0.95	2.70/1.94/1.10	3.80/3.18/2.32	4.60/3.75/2.83	6.05/5.00/3.43	7.65/6.19/4.54
	Water flow rate	m³/h 0.29/0.25/0.16	0.46/0.33/0.19	0.65/0.55/0.40	0.79/0.64/0.49	1.04/0.86/0.59	1.31/1.06/0.78
Heating	Water pressure drop	kPa 18.16/13.74/7.50	16.97/9.73/3.51	39.17/28.35/16.91	56.18/39.04/23.84	53.66/36.96/19.07	48.07/32.56/18.32
	Capacity (H/M/L)	kW 1.40/1.23/0.95	2.30/1.78/1.22	2.88/2.49/2.00	3.35/2.88/2.36	4.60/3.95/3.02	7.50/6.44/5.22
	Water flow rate	m³/h 0.12/0.11/0.08	0.20/0.15/0.10	0.25/0.21/0.17	0.29/0.25/0.20	0.39/0.34/0.26	0.64/0.55/0.45
Power input (H/M/L)	Water pressure drop	kPa 10.74/8.50/5.49	28.16/18.45/10.08	55.37/43.00/29.20	69.57/54.65/38.21	132.32/104.19/63.73	71.63/56.17/37.44
	W 20/14/9	20/11/8	29/17/11	52/28/15	92/46/19	102/49/22	
Rated current		A 0.21	0.22	0.28	0.51	0.79	0.87
Sound power level (H/M/L)		dB(A) 52/46/38	46/37/29	52/45/36	59/51/43	62/56/46	63/57/47
Fan motor	Type	Low noise DC fan motor					
	Quantity	1	1	1	1	1	1
Fan	Type	Centrifugal, forward-curved Blades					
	Quantity	1	2	2	3	3	
Coil	Row	4	4	4	4	4	
	Max. working pressure	MPa 1.6	1.6	1.6	1.6	1.6	
	Diameter	mm Ø7.94	Ø7.94	Ø7.94	Ø7.94	Ø7.94	
Body	Net dimensions (WxHxD)	mm 455x200x637	455x200x867	455x200x1087	455x200x1087	455x200x1207	550x200x1207
	Packing size (WxHxD)	mm 595x300x895	595x300x1125	595x300x1345	595x300x1345	595x300x1465	695x300x1465
	Net weight	kg 12.6	15.3	18.7	18.7	21.3	24.8
	Gross weight	kg 16.9	20.8	25.4	25.4	28.1	31.9
Water inlet/outlet pipe		inch Cold water: G3/4; Hot water: G1/2					
Drain pipe		mm ODØ18.5					

Notes:

- H: High fan speed; M: Medium fan speed; L: Low fan speed.
- Cooling conditions: Entering water 7°C, leaving water 12°C, Entering air temperature 27°C DB/19°C WB. Heating conditions: Entering water 65°C, leaving water 55°C, Entering air temperature 20°C DB/15°C WB.
- Noise is tested in a reverberation chamber.
- H3 series test with concealed tooling.

Dimensions

1-way cassette

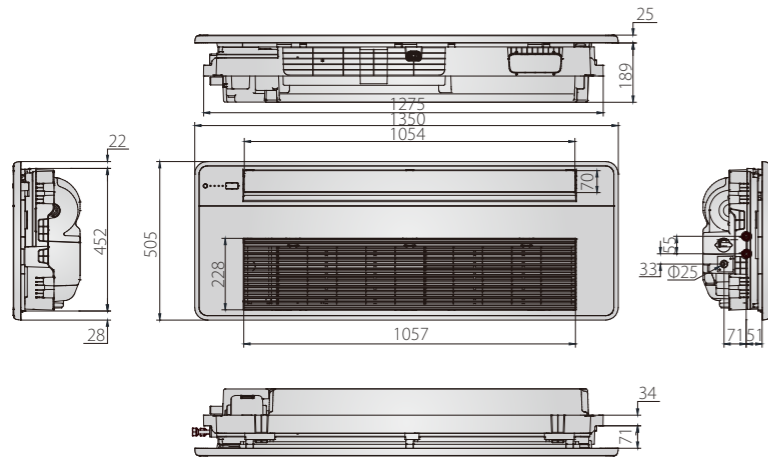

MKC-V400R-B
MKC-V600R-B

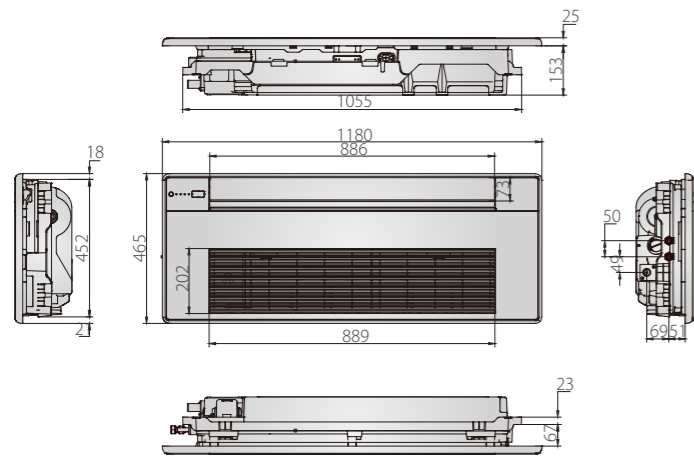

MKC-V300R-B

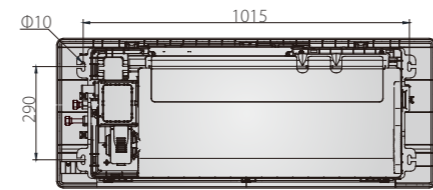
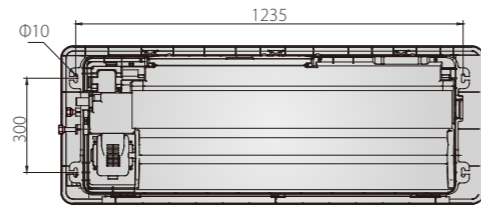

4-way cassette

2-pipe 4-way cassette
Dimensions (unit:mm)

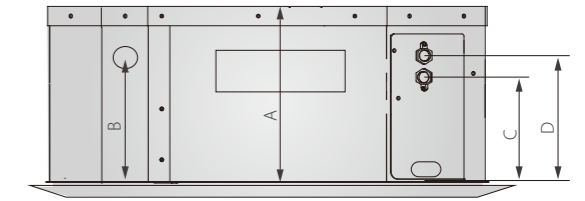
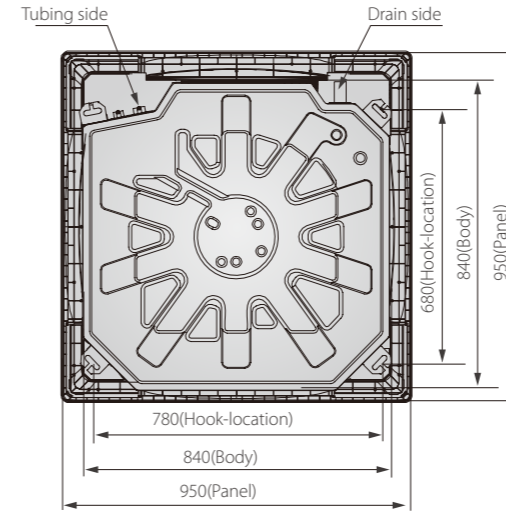

Model	Size	A	B	C	D
MKA-V600R		230	170	135	185
MKA-V750R					
MKA-V950R		300	190	145	195
MKA-V1200R					
MAK-V1500R					

4-Pipe 4-way cassette
Dimensions (unit:mm)

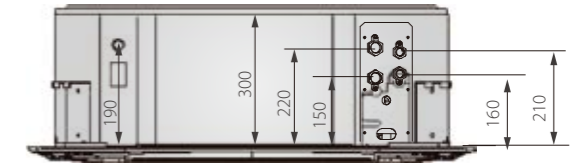
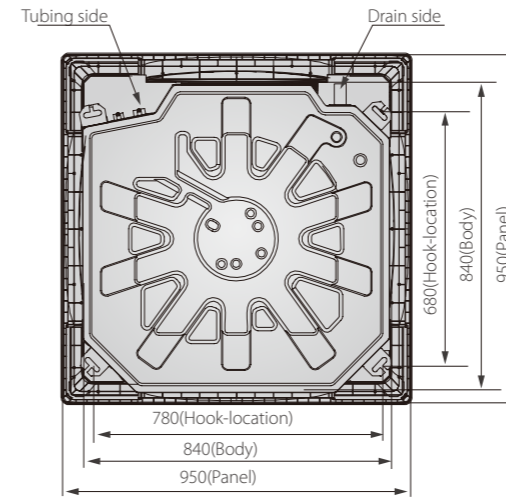

Service Spaces (unit:mm)

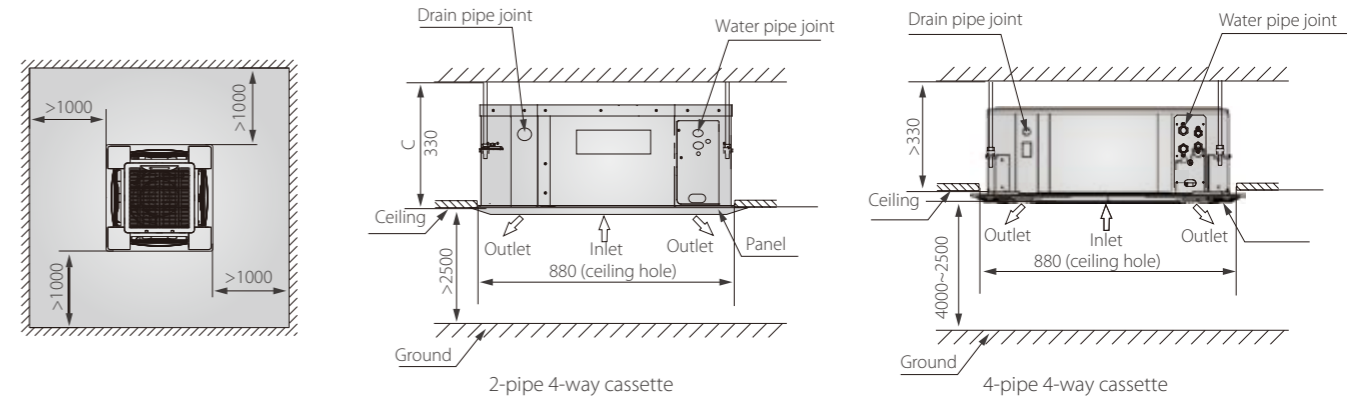

Compact 4-way cassette

2-pipe compact 4-way cassette
Dimensions (unit: mm)

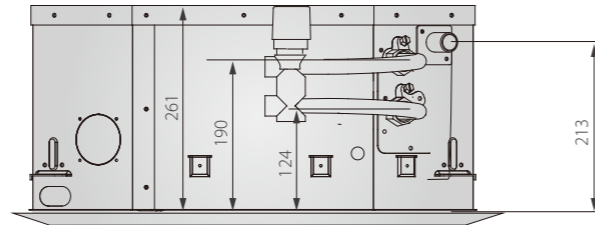
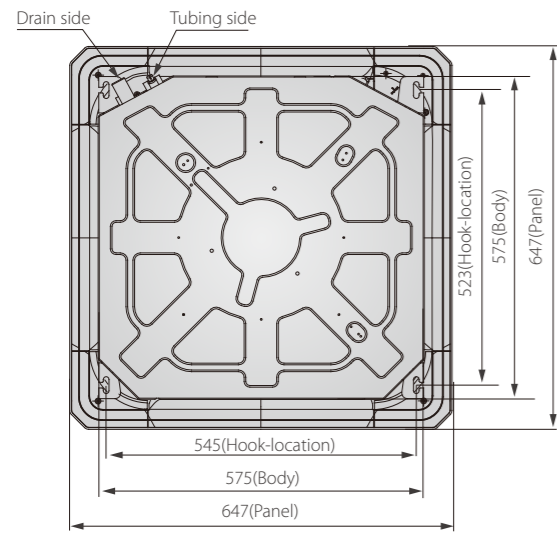

4-pipe compact 4-way cassette
Dimensions (unit: mm)

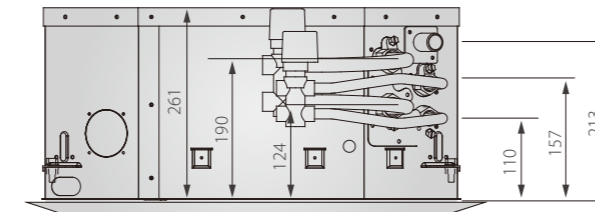
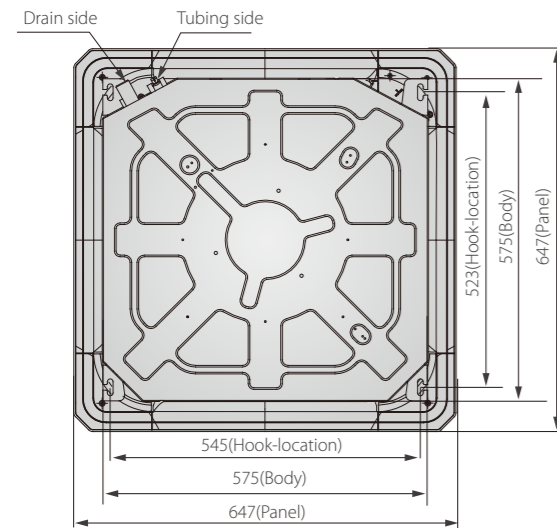

Service Spaces (unit: mm)

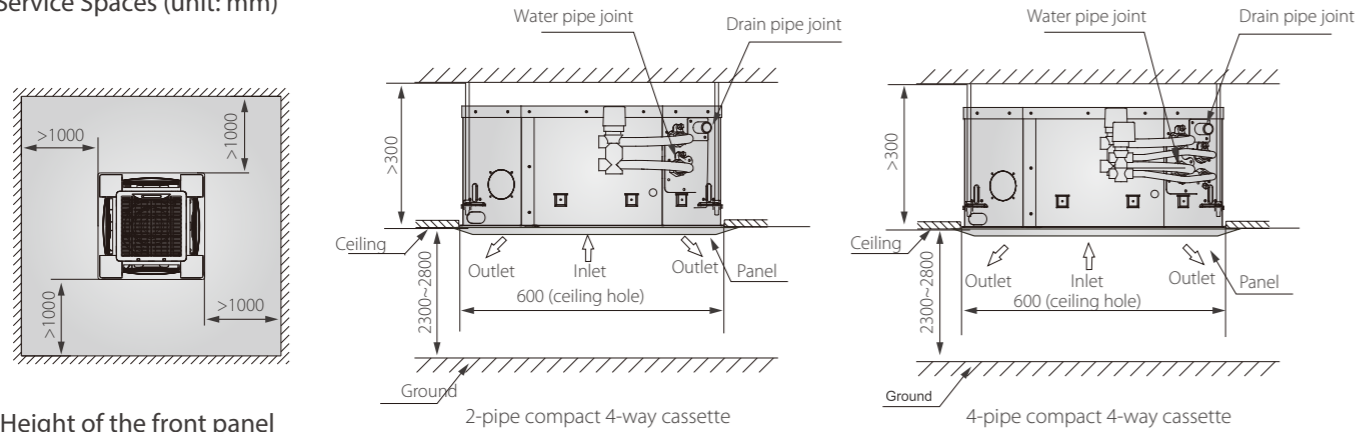

Height of the front panel

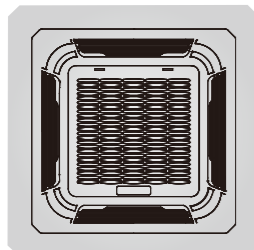

Type	H (mm)
4-way cassette	45
Compact 4-way cassette	50

Wall mounted - S type

Dimensions (unit: mm)

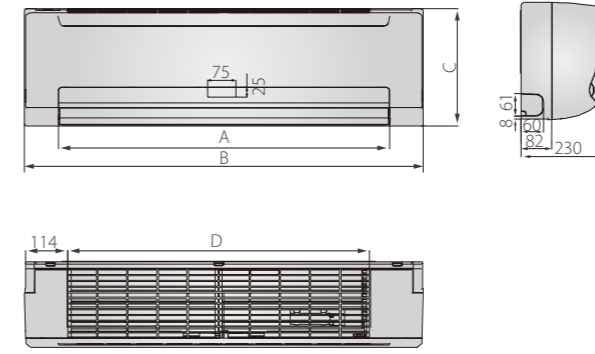

Model	MKG-V250-B MKG-V300-B MKG-V400-B	MKG-V500-B MKG-V600-B
A	732	892
B	915	1072
C	290	315
D	663	813

Wall mounted - C type

Dimensions (unit: mm)

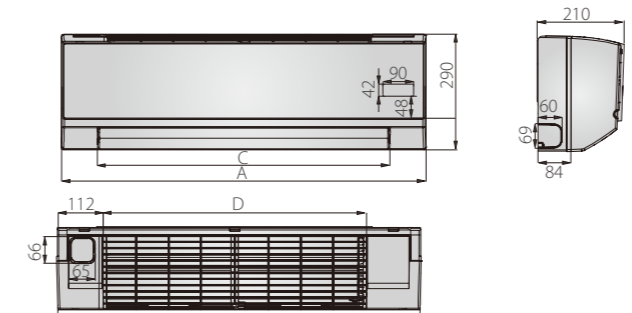

Model	MKG-V250 MKG-V300 MKG-V400	MKG-V500 MKG-V600
A	915	1070
B	290	315
C	725	885
D	670	815

Duct

Dimensions (unit: mm)

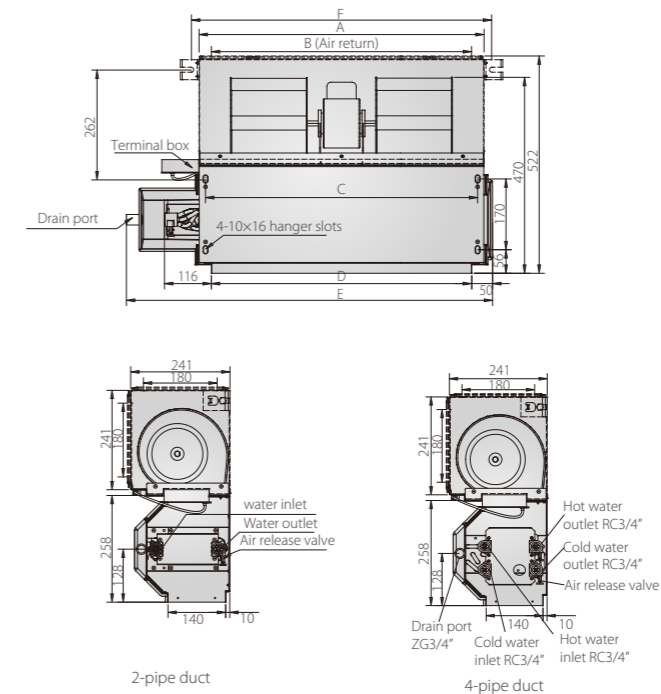

(continued: duct units dimensions)

Size	A	B	C	D	E	F
200CFM	545	485	513	485	741	583
300CFM	645	585	613	585	841	683
400CFM	745	685	713	685	941	783
500CFM	745	685	713	685	941	783
600CFM	965	905	933	905	1161	1003
800CFM	1265	1205	1233	1205	1461	1303
1000CFM	1370	1310	1338	1310	1566	1408
1200CFM	1660	1600	1628	1600	1856	1698

2nd generation Ceiling&Floor

Dimensions (unit: mm)

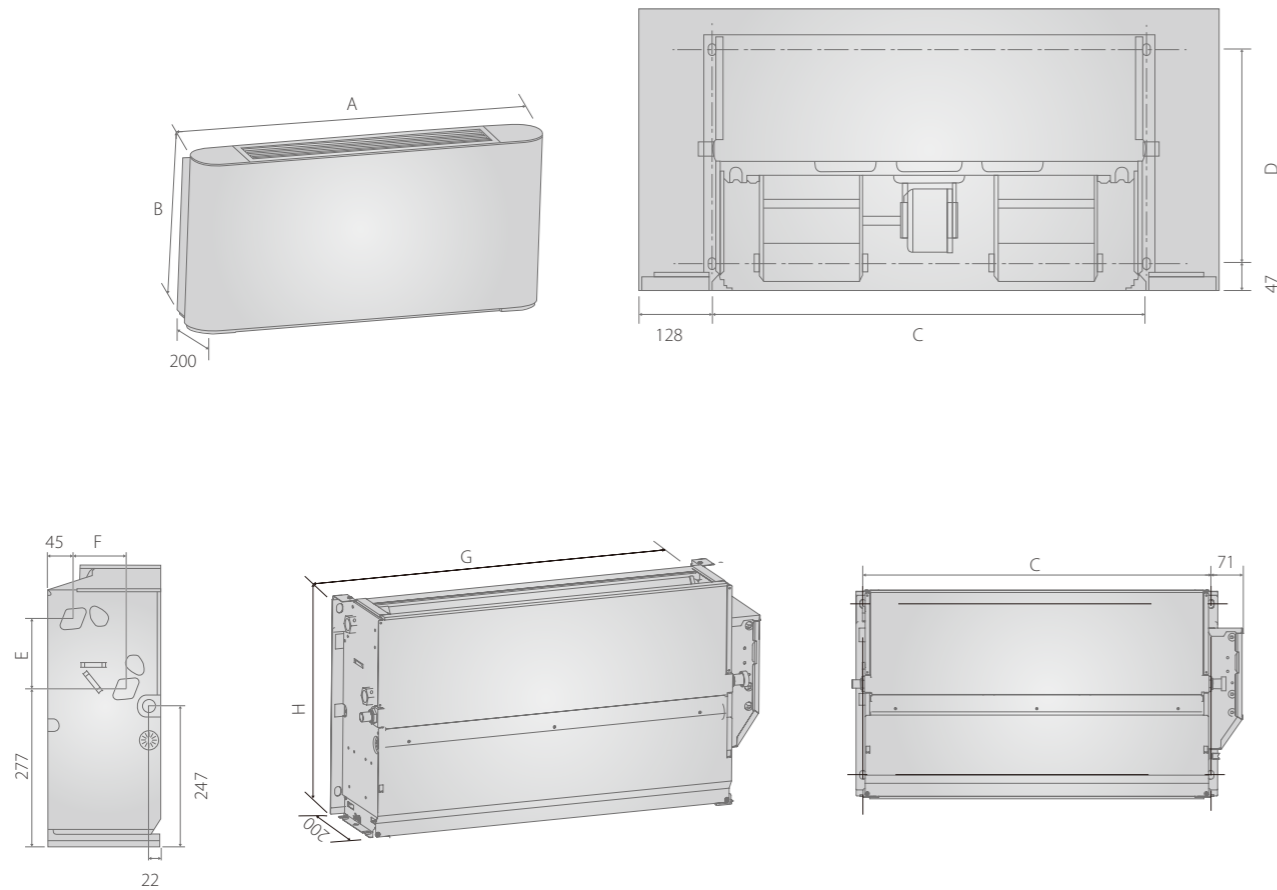

Model	150	250	300	500	700	800
A(mm)	790	1020	1240	1240	1360	1360
B(mm)	495	495	495	495	495	591
C(mm)	534	764	984	984	1104	1104
D(mm)	375	375	375	375	375	319
E(mm)	123	123	123	123	123	219
F(mm)	93	93	93	93	93	102
G(mm)	628	858	1078	1078	1198	1198
H(mm)	455	455	455	455	455	551

CONTROL SOLUTIONS

Midea CAC provides a variety of control schemes:

Embedded wall-mounted comes with standard remote controller. Similarly the other models have their respective series of controllers. The units can also be made to connect with BMS systems by undergoing some customizations.

▶ Control Devices

▶ Accessories



▶ Application of Central Control & BMS Control

▶ AC Selection Software







▶ DC Selection Software

Control Devices



Wireless Remote Controllers

Model	Appearance	Function Descriptions	Applicable FCUs
R05/BGE		<ul style="list-style-type: none"> ● LCD display screen ● Mode control ● Fan speeds control 	4-way Cassette (standard) 1-way Cassette (standard)
R51/E		<ul style="list-style-type: none"> ● Time setting / Temp. setting / Swing setting 	Compact 4-way cassette (standard) Wall-mounted (standard)

Wired Controllers

Model	Appearance	Function Descriptions	Applicable FCUs
KJRP-86A1-E		<ul style="list-style-type: none"> ● LCD display screen ● Mode control ● Fan speeds control ● Timer setting / Temp. setting 	AC Ceiling& Floor and Duct without electric heater (optional)
KJR-18B/E		<ul style="list-style-type: none"> ● Mechanical thermostat ● Mode control ● Fan speeds control ● Temp. setting 	AC Ceiling& Floor and Duct without electric heater (optional)
KJR-29B		<ul style="list-style-type: none"> ● Receiving remote signal ● Mode control ● Fan speeds control ● Temp. setting 	Cassette / Wall-mounted (optional)
KJR-75A/BK		<ul style="list-style-type: none"> ● LED display screen ● Mode control ● Seven speed fan control ● Temp. setting 	2 nd generation Ceiling&Floor(optional) DC one-way cassette (optional)
KJRP-861/MFK-E		<ul style="list-style-type: none"> ● LCD display screen ● Mode control ● Fan speeds control ● Timer / Temp. setting ● ECO setting/reminder 	AC Ceiling& Floor and AC&DC Duct without electric heater (optional)
KJRP-86A/BMFNvKD-E		<ul style="list-style-type: none"> ● LCD display screen ● Mode/Electric heater control ● Fan speeds control ● Timer / Temp. setting ● ECO setting/reminder ● Compatible with Modbus 	AC Ceiling& Floor and AC&DC Duct (optional)

Centralized Controllers

Model	Appearance	Function Descriptions	Applicable FCUs
CCM09		<ul style="list-style-type: none"> ● Weekly schedule function ● Large LCD display screen ● Max. of 64 FCUs can be controlled by a CCM09 ● Mode control / fan speed control ● Time setting / temp. setting / swing setting 	All FCUs (AC 1-way cassette FCUs need adding NIM01 module, non-PCB FCUs need adding PC board control kit)
CCM30		<ul style="list-style-type: none"> ● Touch-style keys ● Large LCD display screen ● Max. of 64 FCUs can be controlled by a CCM30 ● Mode control / fan speed control ● Time setting / temp. setting / swing setting 	

Accessories

PC Board Control Kit for FCU



- Available for all non-PCB FCUs.
- Flexibility installation: can be attached to the unit, mounted on a wall or hung under a ceiling.
- External installation making maintenance more convenient.
- Functions: three fan speeds control, Water pump control, Long-distance ON/OFF control, ALARM function, electric heater control.
- Operating status can be displayed by wired controller lamp indicator.
- Centralized control function.
- BMS control function through Modbus protocol.

Centralized control

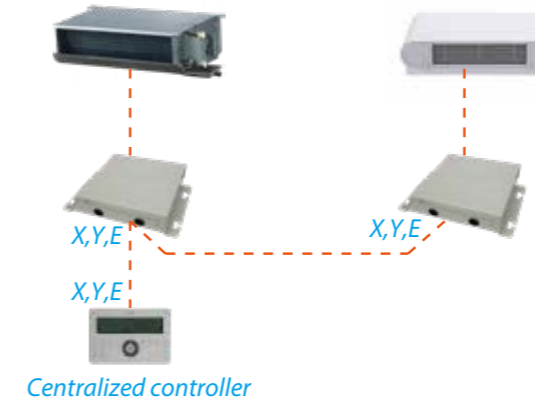

Note: The ceiling&floor of AC and duct series of AC and DC need PCB kit to connect Centralized controller.

Model	CE-FCUKZ-03	CE-FCUKZ-04	
Applicable appliance	2-pipe FCUs	4-pipe FCUs	
Power supply	V-Ph-Hz	220~240-1-50/60	
Operation range	Room temp.	°C	17-30
	Inlet water temp.	°C	3-75
Temp. controlling precision	°C	±1	
Net dimension	WxHxD	mm	296x66x212
Packing size	WxHxD	mm	410x115x262
Net weight	kg		1.4
Gross weight	kg		2.5

Network Module

- Achieve centralized control through XYE connection;
- Only available for one way Cassette of AC;
- Address setting should be same as connecting FCU;
- There LEDs display: operation indicator lamp, communication indicator lamp and malfunction indicator lamp.



Centralized wiring

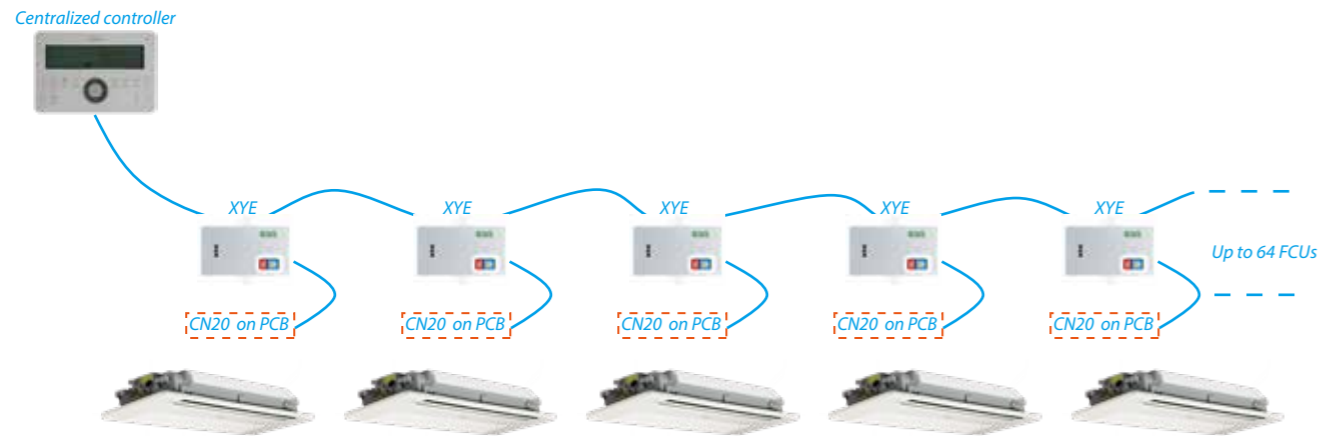

Valve kit

DN(mm)	Inner Screw Thread	Applicable Appliance
15	1/2"	For 4-pipe cassette and ceiling&floor (for cold water),
20	3/4"	For 2-pipe FCU,4-pipe duct, 4-pipe cassette and ceiling&floor (for cold water).



Note:
The valve kit includes valve, actuator and connecting pipe. For different model of units, the models of valve kit are difference.

Application of Central Control & BMS Control



Notice: Please note that the PCB kit and Wired Controller (KJR-18B / KJR-86A) can not be connected with an Indoor Unit at the same time

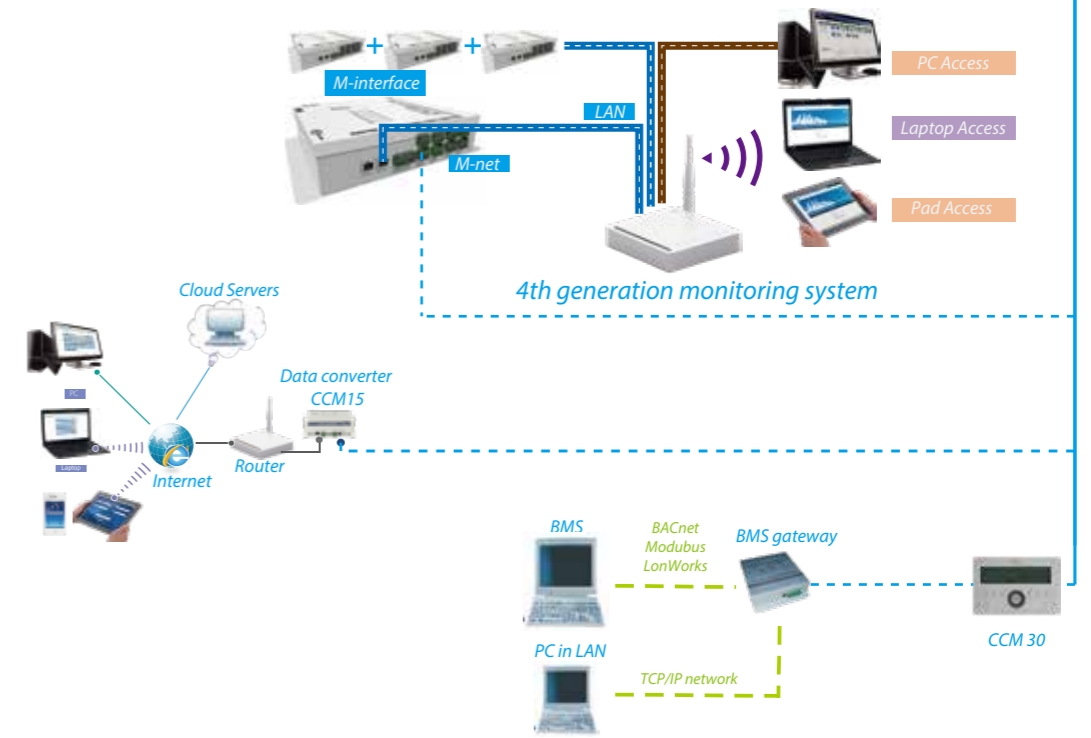

Note: When connecting to BMS through the BACnet protocol, a custom version of CCM30 was required.

DC Selection Software

Features

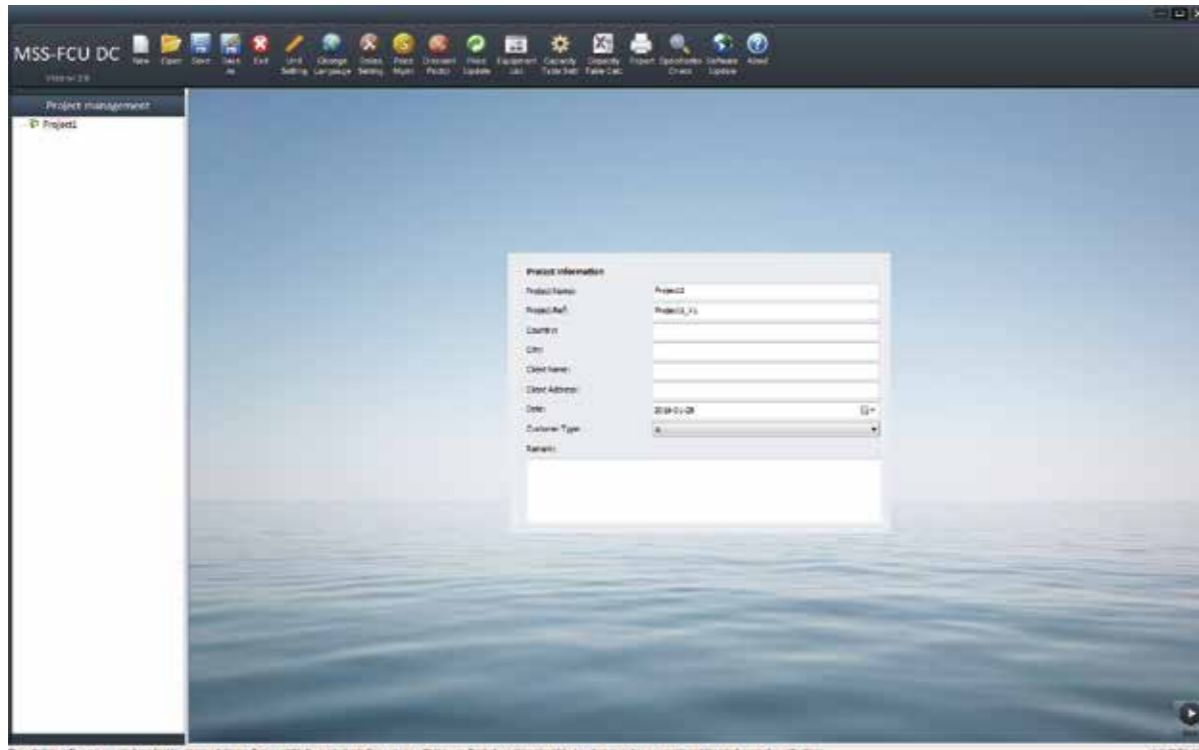

- Select by entering air and water conditions as well as fan speed.
- Easy to operate interface and visual display.
- Powerful project management function.

Main Interface

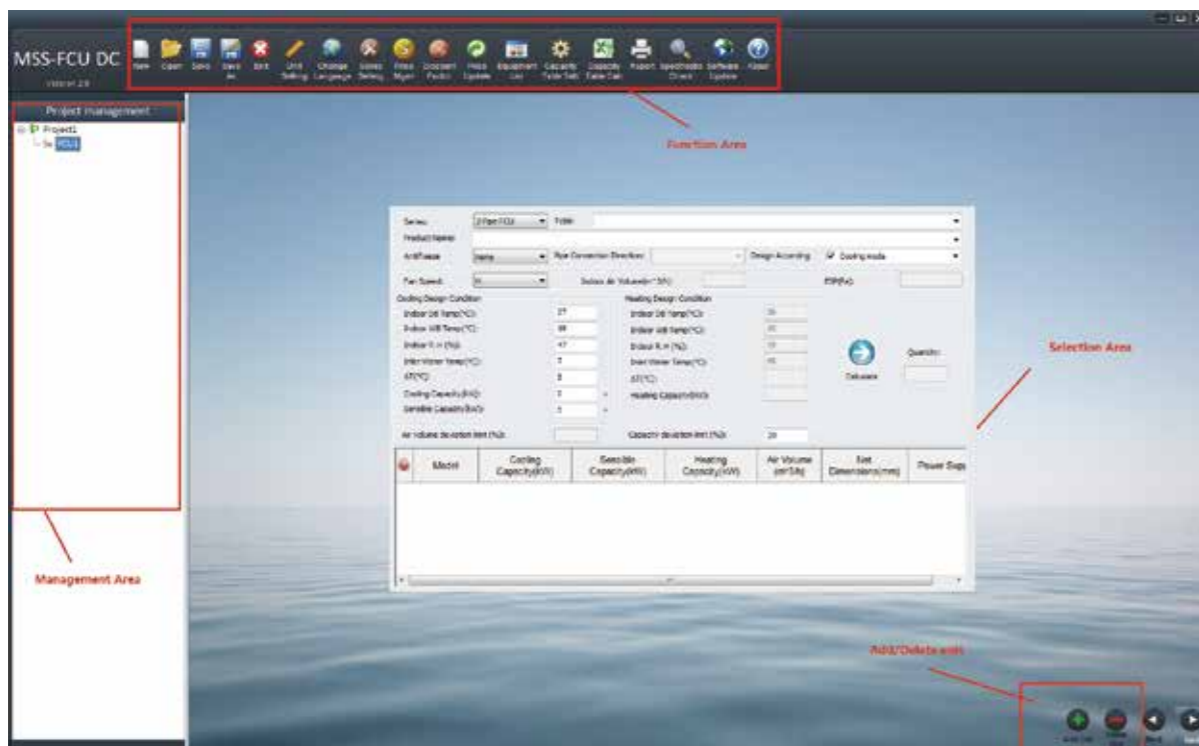

Selection Interface

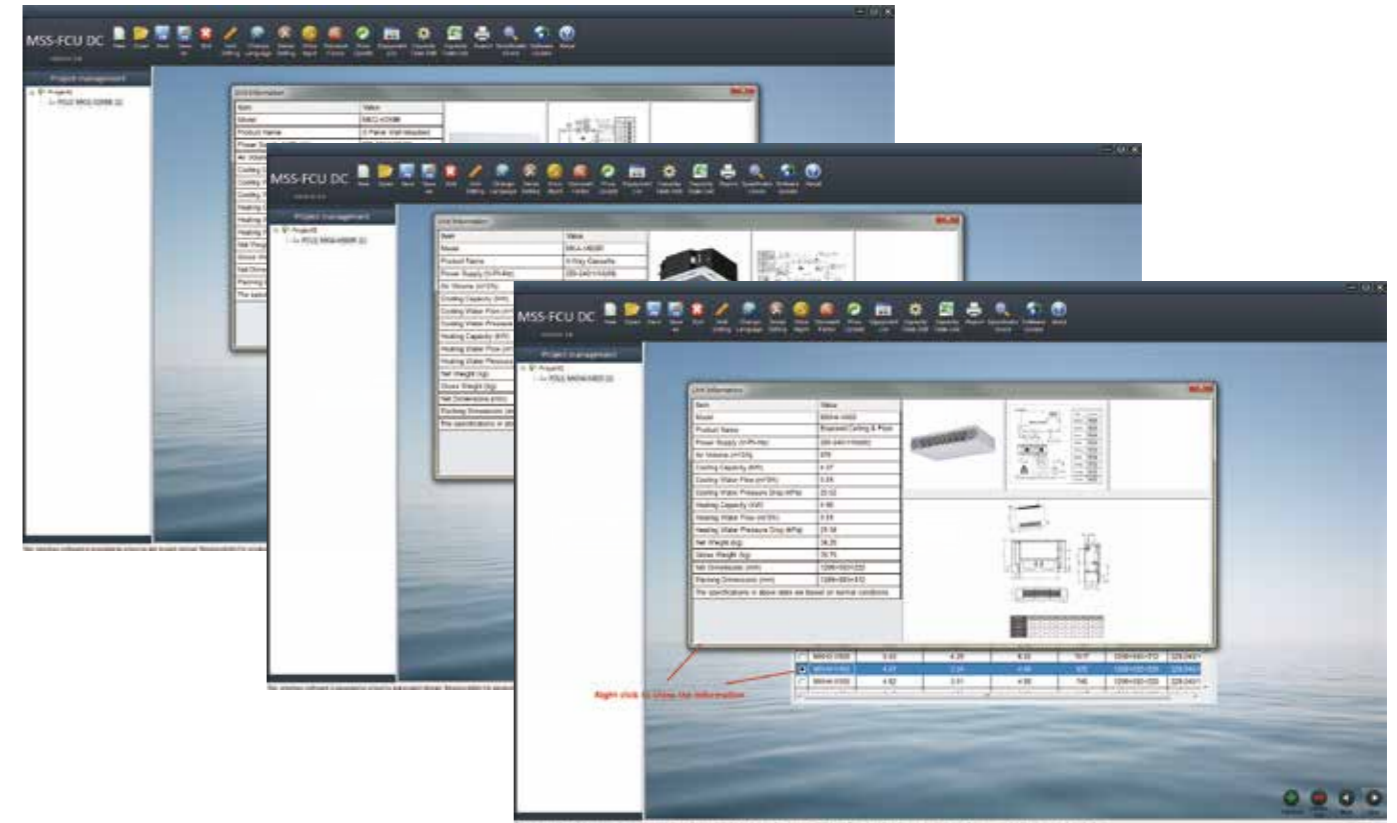

Report Data Interface

DWT	ΔT	Indoor Temp (air) (WB, I)	MCO-V2590																		
			21				22				25				27						
			TC	SC	WF	WFO	TC	SC	WF	WFO	TC	SC	WF	WFO	TC	SC	WF	WFO			
3	15	2.26	1.82	0.64	87.62	2.26	1.86	0.64	96.89	2.26	2.17	0.66	88.72	2.52	2.62	0.72	68.40	2.76	2.76	0.78	80.37
6	17	3.01	1.85	0.69	92.78	2.99	1.88	0.65	91.99	2.98	2.10	0.65	91.20	2.36	2.33	0.84	90.41	2.56	2.56	0.84	89.63
	19	3.80	1.67	1.08	139.24	3.79	1.90	1.08	138.10	3.77	2.13	1.07	136.97	3.75	2.36	1.67	135.85	3.73	2.68	1.08	134.74
	20.5	-	-	-	-	4.21	1.92	1.20	165.71	4.19	2.15	1.19	164.56	4.17	2.38	1.19	163.44	4.15	2.60	1.18	161.76
	20.5	-	-	-	-	4.42	1.93	1.26	188.75	4.40	2.16	1.26	175.32	4.39	2.39	1.25	177.90	4.36	2.61	1.24	176.45
9	15	1.99	1.50	0.43	28.18	2.01	1.77	0.43	28.55	2.16	2.11	0.46	32.40	2.41	2.41	0.52	36.08	2.66	2.66	0.57	45.99
	17	2.75	1.53	0.59	48.75	2.74	1.76	0.59	48.35	2.72	1.95	0.58	47.91	2.71	2.22	0.58	47.40	2.74	2.52	0.55	48.55
	19	3.56	1.58	0.75	75.68	3.54	1.89	0.76	75.92	3.52	2.02	0.76	74.39	3.51	2.25	0.75	72.77	3.49	2.47	0.75	73.15
	20.5	-	-	-	-	3.96	1.81	0.85	91.97	3.94	2.04	0.85	90.32	3.93	2.27	0.84	89.58	3.91	2.49	0.84	88.85
12	15	1.72	1.83	0.43	16.18	1.83	1.72	0.48	16.33	2.03	2.02	0.50	19.89	2.29	2.29	0.59	21.41	2.56	2.56	0.64	29.15
	17	2.47	1.81	0.42	27.68	2.46	1.84	0.42	27.41	2.61	1.97	0.42	27.14	2.45	2.14	0.42	27.38	2.58	2.46	0.64	29.88
	19	3.29	1.85	0.58	45.69	3.28	1.88	0.58	44.70	3.26	1.91	0.58	44.30	3.24	2.14	0.56	43.91	3.23	2.34	0.56	43.53
	20.5	-	-	-	-	3.70	1.70	0.64	55.10	3.68	1.93	0.63	54.63	3.67	2.16	0.63	54.17	3.65	2.36	0.63	53.71
15	15	1.40	1.34	0.48	4.99	1.62	1.59	0.23	6.62	1.90	1.90	0.27	11.27	2.17	2.17	0.31	15.04	2.43	2.43	0.35	19.63
	17	2.14	1.27	0.31	15.43	2.15	1.52	0.48	15.52	2.15	1.75	0.30	15.23	2.27	2.09	0.32	17.55	2.44	2.36	0.35	19.79
	19	3.01	1.33	0.43	28.26	2.99	1.56	0.43	27.93	2.97	1.70	0.42	27.67	2.96	2.01	0.42	27.41	2.94	2.24	0.42	27.16
	20.5	-	-	-	-	3.43	1.68	0.49	36.21	3.41	1.81	0.49	34.90	3.39	2.04	0.48	34.68	3.27	2.26	0.48	34.29
18	15	1.70	1.37	0.49	34.61	1.78	1.69	0.61	37.44	2.01	2.01	0.68	46.21	2.26	2.26	0.66	46.61	2.61	2.61	0.72	67.67
	17	2.45	1.40	0.70	64.68	2.44	1.63	0.70	64.06	2.42	1.88	0.69	63.45	2.41	2.18	0.69	63.03	2.63	2.48	0.72	68.78
	19	3.25	1.43	0.93	136.22	3.23	1.66	0.93	134.29	3.22	1.89	0.92	133.97	3.20	2.12	0.92	132.45	3.18	2.34	0.91	131.66
	20.5	-	-	-	-	3.66	1.68	1.05	128.64	3.64	1.91	1.04	127.74	3.62	2.13	1.04	126.85	3.60	2.36	1.03	125.17
21	15	1.40	1.31	0.31	16.22	1.64	1.61	0.25	20.35	1.90	1.90	0.41	25.02	2.15	2.15	0.45	31.71	2.41	2.41	0.52	38.24
	17	2.17	1.29	0.47	32.09	2.16	1.62	0.46	31.75	2.14	1.74	0.46	31.42	2.22	2.06	0.48	33.33	2.41	2.39	0.52	38.35
	19	2.99	1.32	0.64	56.23	2.97	1.55	0.64	54.73	2.96	1.76	0.63	54.22	2.94	2.01	0.63	53.72	2.92	2.23	0.63	53.23
	20.5	-	-	-	-	3.49	1.67	0.73	68.83	3.48	1.90	0.73	68.22	3.46	2.02	0.72	67.61	3.24	2.25	0.72	67.82
24	15	1.23	1.18	0.21	5.23	1.51	1.51	0.26	10.35	1.78	1.78	0.31	15.44	2.04	2.04	0.35	19.71	2.30	2.30	0.38	24.89
	17	1.94	1.25	0.33	18.06	1.95	1.48	0.32	18.59	1.89	1.87	0.48	17.52	2.04	1.98	0.34	20.09	2.38	2.38	0.38	24.14
	19	2.70	1.30	0.46	31.64	2.68	1.43	0.46	31.33	2.67	1.66	0.45	31.02	2.70	2.15	0.48	31.61	2.64	2.11	0.45	30.41
	20.5	-	-	-	-	3.07	1.68	0.11	542.05	3.05	1.91	1.10	141.15	3.04	2.14	1.10	139.96	3.02	2.37	1.05	128.76



Air Handling Unit

Midea AHUs have been widely used in most part of the world for a couple of years. Now, the 3rd generation AHU has been launched to provide you with more comfortable and convenient. It adapts unitary structure design, more outstanding cold-bridge free performance, lower air leakage and more elegant appearance. There are 3 types - suspended type, horizontal type and vertical type, including 66 standard models, and the air flow rate is available from 2,000m³/h to 40,000m³/h. Different external static pressure (ESP) can be customized to meet different kinds of applications.

Nomenclature

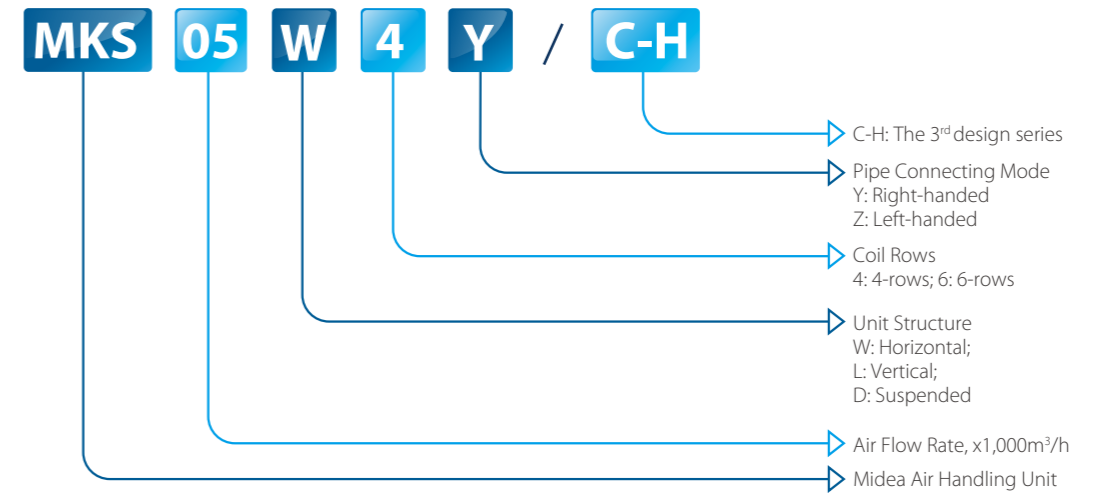

Orientation

Unit handling orientation is determined by location of pipe connection while facing unit in the direction of air flow. The unit below is left-handed connection unit, otherwise is right-handed connection unit.

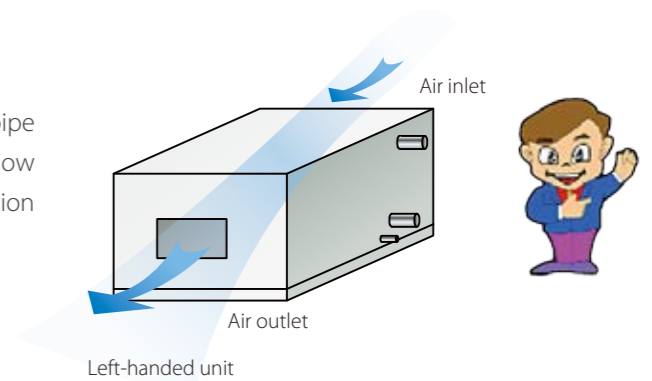

Features

High strength, high reliability

Panels are double-skin with injection of high density polyurethane. The outer skin is anti-corrosion color-coated steel sheet, the inner skin is galvanized steel sheet. The unit cabinet consists of panels attaching to each other by combining with male and female aluminum alloy cards and sealing strip, tighten with concealed bolts.

Outstanding cold-bridge free structure

The density of polyurethane injection is $50\text{kg}/\text{m}^3$ (thermal conductivity factor $K \leq 0.0224\text{W}/\text{m}^2\cdot\text{K}$). Unit cabinet is constructed by panels with male and female aluminum alloy cards and sealing strip. The service door (or service panel) is plastic-steel frame with polyurethane injection panel and rubber sealing strip.

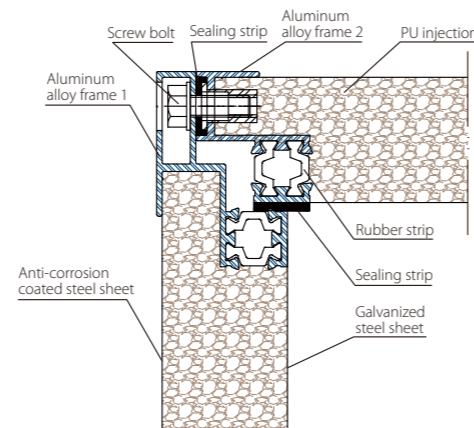

Low air leakage rate

Double skin panel, unitary structure design, less connecting joints, multi sealing strips in the contact surfaces, around sealing service door/ panel, all ensure almost total air can be supplied to the air-conditioned room. The air leakage rate is less than 0.29%. Units will not sweat when exterior room temperature is 27°C , relative humidity is 90%.

- Simple structural components
- Less at-site work

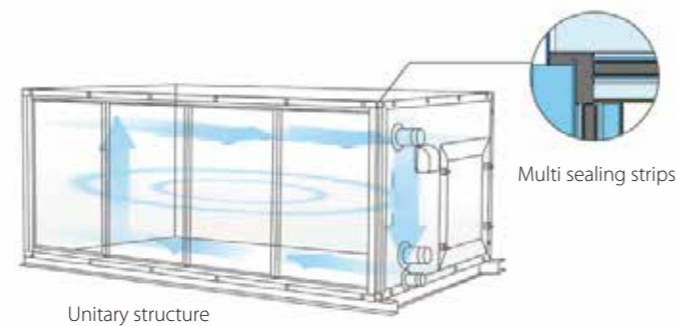

High performance heat exchanger



- Copper pipe and aluminum fin type heat exchanger, optimal choice of fin spacing and number of rows.
- Fins are coated with anticorrosive layers, assure longer coil life and lower maintenance cost.
- Optimal water circuits design, increased heat exchange efficiency and decreased water resistance, improving unit performance efficiency.

Stable air supply fan assembly

- Yilida brand centrifugal fan, high performance efficiency, 3-phase, class "F" insulation and IP54 protection AC motor.
- Belt drive, optimal selection of drive ratio, increase fan/motor assembly efficiency, easy for maintenance.
- Service door or service panel is equipped for inspection of motor and fan.



Low noise design

- Optimal fan selection, excellent working condition, efficient operation.
- Flexible connection at air outlet, minimizes vibration transmission.
- Equip with shock absorbers, decreases vibration, low noise. Tighten cabinet, secure against noise leakage.

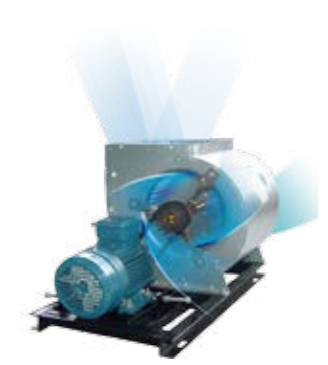

Improved indoor air quality

- Aluminum alloy frame plate type filter, stable and durable.
- Cover the whole return air inlet, large filter surface, higher inlet air quality.
- Filter can be extracted in leftward and rightward way, easy for maintenance.



State-of-the-art design

The outer skin is colored steel sheet with anti-corrosion coat and is cleanable; the fastening bolts are concealed by plastic caps. The outer layer of film prevents panels from scratching during unit assembling and transportation. Clear, smooth and color coordination appearance make the outlook attractive.

Wide usage

- Three structure design: horizontal type, vertical type and suspended type.
- Two pipe connecting mode: right-handed and left handed.
- Air flow rate ranging from $2,000\text{m}^3/\text{h}$ to $40,000\text{m}^3/\text{h}$.
- Different ESP can be customized.

Midea AHU can be widely used in hotels, restaurants, factories, hospitals, airports, railway stations, exhibition halls, office buildings, shopping malls, laboratories and other central air-conditioning systems.



School

Factory

Hotel

Hospital

Office

Mechanical specifications

Base frame

Unit sections are mounted on galvanized steel or channel steel base frame for easy shipment and handling. The frames provide holes for section connection, and holes for fork-lift truck. Guard rail cross the bottom in the holes prevents unit damage. The base frame can be used in lieu of concrete plinths or other additional bases that are used on site. However, for high static pressure application, additional concrete plinths or other additional bases are required at site to raise the AHU for drain pan's U-trap.

Double skin panel

Standard panels are 25mm thick double skin type with injected polyurethane foam insulation. The outer skin is anti-corrosion color-coated steel sheet with a layer of film and the inner skin is galvanized steel sheet. The panel insulation is moistureproof and anti-corrosive. The insulation material is totally enclosed in the panel to avoid any possibility of insulation being exposed to air stream.

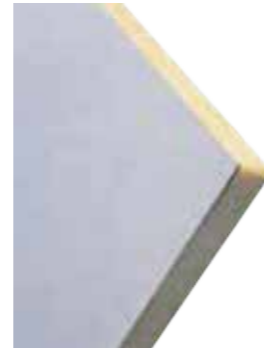

Coil

Coil used in Midea AHU is AHRI certified. It is consisted of copper tubes and aluminum fins. The fins are sine-wave design with slits for better heat transfer efficiency and moisture carry-over limit performance. Coil is leak tested at 1.6MPa at the factory. Coil is mounted over a drain pan. The coil rests on U-shape supporter locating over the drain pan. The drain pan extends beyond the leaving side of the coil to recover condensate water. Coil connections always extend through out of the unit cabinet, allowing for easy connection of valves and piping. Air discharge valve is on the top of water outlet pipe and is located outside the cabinet.

Drain pan

The cooling coil is installed on reversed U-shaped support plate. Standard galvanized drain pan is coated to inhibit the growth of algae and fungi. 10mm insulation is provided between the drain pan and the bottom panel. Stainless steel drain pan is optional.

Filter

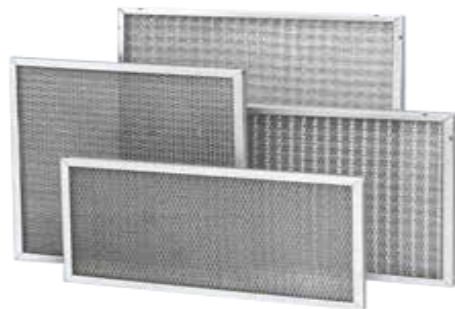

Filter is aluminum alloy frame structure. Primary efficiency plate type filter is designed as standard. The structure of filters are stable and firm, high strength and intensity, washable and easy changing. Filter can be unloaded and loaded from both left and right side.

Fan and motor assembly

The fan is made of high grade hot galvanized steel sheet. It is designed to a special configuration according to aerodynamics. It is coated in order to be anti-corrosive. Fan connection is isolated from unit casing by a flexible canvas duct mounted at fan discharge outlet. Fan and motor assembly is internally isolated from unit casing with rubber pad, furnished and installed in the factory.

Motors are mounted on slide rails with provision for V-belt tensioning. Motor can be moved freely in four directions to reach the correct point. Installation and maintenance of motor, belt and pulley are time saving jobs. Fan and motor assembly is mounted on a rigid base frame which is supported by effective rubber shock absorber. Discharge fan is provided with a fire retardant flexible connection.

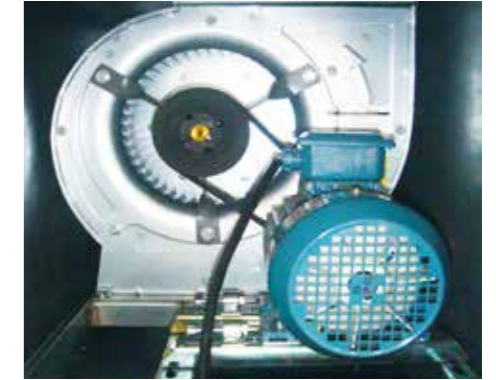

Fan and motor assembly

Access panel



Inside



Outside

Access panel is double skins with injected polyurethane foam insulation. The outer skin is anti-corrosion coated steel sheet, the inner skin is galvanized steel sheet. The polyurethane foam insulation is heat resistance and totally enclosed. 4 hinges are used to fixed the access panel, convenient for installation and maintenance. A durable rubber seal is around the panel's frame and a 10mm thick insulation seal is stucked around the back side frame of the panel to prevent air leakage.

Air dampers

Air dampers in AHUs are optional. Aerodynamically designed damper blades have built in high quality bearings. Blade edges are lined with sealing strip to restrict leakage to an absolute minimum. Air damper blades are either linked to give parallel turning operation or gear set to give opposing direction. The dampers are tested to yield linear control characteristic.



Suspended type

● Return air condition

Model	Air volume	Rated cooling capacity	Rated heating capacity	Water flow rate	External static pressure	Fan motor input	Water pressure drop	Chilled water pipe	Drain pipe	Sound level	Net weight	Net dimension	Package dimension	Power supply
MKSxxxY(orZ)/C-H	m ³ /h	kW	kW	L/s	Pa	kW	kPa	DN	DN	dB(A)	kg	WxDxH (mm)	WxDxH (mm)	V-Ph-Hz
02D	4	2000	11.2	18.6	0.54	67	0.37	19	40	58.0	90	870×750×555	1066×914×702	380~415V -3-50Hz
	6		14.6	22.6	0.70	227	0.75	32	40	58.9	95			
03D	4	3000	17.1	26.7	0.82	52	0.55	35	40	58.0	120	1020×830×605	1216×994×752	
	6		22.0	33.8	1.05	212	0.75	57	40	58.1	125			
04D	4	4000	22.8	39.9	1.09	70	0.75	52	40	60.0	145	1300×830×605	1496×994×752	
	6		29.3	45.1	1.40	230	1.10	62	40	61.9	155			
05D	4	5000	28.5	31.4	1.36	42	1.10	20	40	62.0	160	1390×830×605	1586×994×752	
	6		36.6	56.4	1.75	202	1.50	40	40	63.0	170			
06D	4	6000	34.1	57.5	1.63	92	1.10	25	40	62.0	180	1590×830×605	1786×994×752	
	6		44.1	67.7	2.11	252	2.20	54	40	63.3	190			
07D	4	7000	39.1	66.0	1.90	98	1.10	44	40	64.0	190	1590×830×705	1786×994×852	
	6		51.7	79.0	2.47	258	2.20	61	40	65.4	205			
08D	4	8000	45.5	73.1	2.17	79	1.50	31	50	64.0	205	1700×830×705	1896×994×852	
	6		59.1	90.2	2.82	239	2.20	42	50	65.5	220			
09D	4	9000	51.2	83.0	2.45	116	2.20	34	50	66.0	235	1700×920×755	1896×1084×902	
	6		67.1	100.8	3.21	286	3.00	59	50	67.0	250			
10D	4	10000	58.9	99.3	2.81	136	2.20	30	50	66.0	260	1940×920×755	2136×1084×902	
	6		74.6	112.0	3.56	306	3.00	58	50	67.8	280			
12D	4	12000	68.3	113.5	3.26	108	3.00	52	50	68.0	270	1940×920×860	2136×1084×1007	
	6		85.6	135.2	4.09	278	4.00	57	50	69.6	290			
15D	4	15000	85.3	142.1	4.08	125	4.00	36	50	70.0	350	2240×1000×905	2436×1164×1052	
	6		107.0	169.0	5.11	305	5.50	33	50	71.8	380			

1. Cooling capacity is based in the following condition

a) Water temperature: 7°C (inlet)/12°C (outlet) b) Air entering condition: 27°C DB/19.5°C WB

2. Heating capacity is based on the following condition

a) Water temperature: 60°C (inlet) / same water flow as in standard rating condition in cooling(outlet) b) Air entering condition: 21°C DB

● Fresh air condition

Model	Air volume	Rated cooling capacity	Rated heating capacity	Water flow rate	External static pressure	Fan motor input	Water pressure drop	Chilled water pipe	Drain pipe	Sound level	Net weight	Net dimension	Package dimension	Power supply
MKSxxxY(orZ)/C-H	m ³ /h	kW	kW	L/s	Pa	kW	kPa	DN	DN	dB(A)	kg	WxDxH (mm)	WxDxH (mm)	V-Ph-Hz
02D	4	2000	23.5	27.3	1.12	67	0.37	38	40	58.0	90	870×750×555	1066×914×702	380~415V -3-50Hz
	6		28.4	33.0	1.35	227	0.75	54	40	58.9	95			
03D	4	3000	32.0	35.6	1.53	52	0.55	55	40	58.0	120	1020×830×605	1216×994×752	
	6		42.5	49.4	2.03	212	0.75	77	40	58.1	125			
04D	4	4000	45.5	52.0	2.17	70	0.75	52	40	60.0	145	1300×830×605	1496×994×752	
	6		56.7	65.9	2.71	230	1.10	58	40	61.9	155			
05D	4	5000	57.1	72.6	2.73	42	1.10	61	40	62.0	160	1390×830×605	1586×994×752	
	6		70.9	82.4	3.39	202	1.50	58	40	63.0	170			
06D	4	6000	64.9	84.0	3.10	92	1.10	37	40	62.0	180	1590×830×605	1786×994×752	
	6		84.5	97.0	4.04	252	2.20	62	40	63.3	190			
07D	4	7000	83.8	97.2	4.00	98	1.10	36	40	64.0	190	1590×830×705	1786×994×852	
	6		98.9	115.5	4.72	258	2.20	59	40	65.4	205			
08D	4	8000	87.6	112.0	4.19	79	1.50	73	50	64.0	205	1700×830×705	1896×994×852	
	6		113.0	132.0	5.40	239	2.20	46	50	65.5	220			
09D	4	9000	106.1	123.1	5.07	116	2.20	39	50	66.0	235	1700×920×755	1896×1084×902	
	6		126.9	148.5	6.06	286	3.00	46	50	67.0	250			
10D	4	10000	113.0	140.0	5.40	136	2.20	79	50	66.0	260	1940×920×755	2136×1084×902	
	6		141.0	165.0	6.74	306	3.00	69	50	67.8	280			
12D	4	12000	139.1	161.4	6.65	108	3.00	41	50	68.0	270	1940×920×860	2136×1084×1007	
	6		170.4	197.6	8.14	278	4.00	57	50	69.6	290			
15D	4	15000	170.0	210.0	8.12	125	4.00	73	50	70.0	350	2240×1000×905	2436×1164×1052	
	6		213.0	247.0	10.18	305	5.50	76	50	71.8	380			

1. Cooling capacity is based in the following condition

a) Water temperature: 7°C (inlet)/12°C (outlet) b) Air entering condition: 35°C DB/28°C WB

2. Heating capacity is based on the following condition

a) Water temperature: 60°C (inlet) / same water flow as in standard rating condition in cooling(outlet) b) Air entering condition: 7°C DB

Horizontal type

● Return air condition

Model	Air volume	Rated cooling capacity	Rated heating capacity	Water flow rate	External static pressure	Fan motor input	Water pressure drop	Chilled water pipe	Drain pipe	Sound level	Net weight	Net dimension	Package dimension	Power supply
MKSxxxY(orZ)/-H	m ³ /h	kW	kW	L/s	Pa	kW	kPa	DN	DN	dB(A)	kg	WxDxH (mm)	WxDxH (mm)	V-Ph-Hz
05W	4R	5000	28.3	47.5	1.35	96	1.1	20.2	40	59.5	220	1100×1120×840	1294×1264×980	380~415V-3-50Hz
	6R		36.6	56.4	1.75	256	1.5	39.5	40	61.2	260			
06W	4R	6000	34.6	58.8	1.65	68	1.1	25	40	60.3	240	1200×1120×840	1394×1264×980	
	6R		44.1	67.7	2.11	228	2.2	54	40	61.4	300			
08W	4R	8000	50.8	73.1	2.43	78	1.5	30.7	50	63.1	290	1450×1170×945	1646×1314×1092	
	6R		59.1	90.2	2.82	198	2.2	42.3	50	63.5	315			
10W	4R	10000	63.2	91.3	3.02	112	3	30	50	63.5	340	1650×1200×965	1864×1344×1112	
	6R		74.6	112	3.56	152	3	58	50	65.2	365			
15W	4R	15000	91	131.3	4.35	125	4	35.5	50	66.1	440	1940×1220×1195	2134×1364×1338	
	6R		107	169	5.11	305	5.5	33	50	68.2	530			
20W	4R	20000	119.3	183.4	5.70	210	7.5	28.1	65	70.4	580	2440×1350×1310	2642×1502×1462	
	6R		149	224	7.12	210	7.5	59	65	71.6	700			
25W	4R	25000	149.3	248.9	7.13	318	7.5	34	65	70.2	660	2590×1400×1510	2792×1552×1662	
	6R		187	279	8.93	318	7.5	64	65	71.5	765			
30W	4R	30000	179.2	298.7	8.56	273	11	53.3	65	73.3	750	2790×1450×1580	2992×1602×1727	
	6R		225	335	10.75	273	11	69	65	73.5	865			
35W	4R	35000	209.1	348.4	9.99	432	5.5	40	2*65	73.8	1000	2790×1880×1930	3042×2028×2082	
	6R		265	391	12.66	432	7.5	67	2*65	74.2	1070			
40W	4R	40000	238.9	398.2	11.41	405	7.5	41.2	2*65	76.2	1040	2790×1880×2060	3042×2028×2212	
	6R		300	447	14.33	405	7.5	68	2*65	77.5	1270			

1. Cooling capacity is based in the following

a) Water temperature: 7°C (inlet)/12°C (outlet) b) Air entering condition: 27°C DB/19.5°C WB

2. Heating capacity is based on the following

a) Water temperature: 60°C (inlet) / same water flow as in standard rating condition in cooling(outlet) b) Air entering condition: 21°C DB

● Fresh air condition

Model	Air volume	Rated cooling capacity	Rated heating capacity	Water flow rate	External static pressure	Fan motor input	Water pressure drop	Chilled water pipe	Drain pipe	Sound level	Net weight	Net dimension	Package dimension	Power supply
MKSxxxY(orZ)/-H	m ³ /h	kW	kW	L/s	Pa	kW	kPa	DN	DN	dB(A)	kg	WxDxH (mm)	WxDxH (mm)	V-Ph-Hz
05W	4R	5000	57.1	72.6	2.7	96	1.1	61	40	59.5	190	1100×1120×840	1294×1264×980	380~415V-3-50Hz
	6R		70.9	82.4	3.4	256	1.5	58	40	61.2	230			
06W	4R	6000	64.9	84.0	3.1	68	1.1	37	40	60.3	210	1200×1120×840	1394×1264×980	
	6R		84.5	97.0	4.0	228	2.2	62	40	61.4	270			
08W	4R	8000	87.6	112.0	4.2	78	1.5	73	50	63.1	250	1450×1170×945	1646×1314×1092	
	6R		113.0	132.0	5.4	198	2.2	46	50	63.5	273			
10W	4R	10000	113.0	140.0	5.4	112	3	79	50	63.5	300	1650×1200×965	1864×1344×1112	
	6R		141.0	165.0	6.7	152	3	69	50	65.2	325			
15W	4R	15000	170.0	210.0	8.1	125	4	73	50	66.1	390	1940×1220×1195	2134×1364×1338	
	6R		213.0	247.0	10.2	305	5.5	76	50	68.2	480			
20W	4R	20000	222.0	280.0	10.6	210	7.5	69	65	70.4	500			

● Return air condition

Model	Air volume	Rated cooling capacity	Rated heating capacity	Water flow rate	External static pressure	Fan motor input	Water pressure drop	Chilled water pipe	Cooling water pipe	Sound level	Net weight	Net dimension	Package dimension	Power supply	
MKSxxxY(orZ)/C-H	m³/h	kW	kW	L/s	Pa	kW	kPa	DN	DN	dB(A)	kg	WxDxH (mm)	WxDxH (mm)	V-Ph-Hz	
03L	4	3000	17.1	26.7	0.82	52	0.75	35	40	25	57.1	130	1010x580x1100	1260x730x1290	380~415V-3-50Hz
	6		22.0	33.8	1.05	212	1.1	57	40	57.5	140				
04L	4	4000	22.8	39.9	1.09	79	1.1	52	40	25	58.2	150	1050x580x1250	1300x730x1440	
	6		29.3	45.1	1.40	239	1.5	62	40	60.3	162				
05L	4	5000	28.3	47.5	1.4	96	1.1	20	40	25	60.5	170	1110x630x1420	1360x780x1610	
	6		36.6	56.4	1.7	256	2.2	40	40	61.2	185				
06L	4	6000	34.6	58.8	1.7	68	1.5	25	40	25	61.4	190	1200x630x1470	1450x780x1660	
	6		44.1	67.7	2.1	228	2.2	54	40	61.9	210				
08L	4	8000	50.8	73.1	2.4	118	2.2	31	40	25	63.2	230	1350x740x1650	1600x890x1840	
	6		59.1	90.2	2.8	288	3.0	42	40	63.6	255				
10L	4	10000	58.9	99.3	2.81	112	3.0	30	50	25	64.5	250	1410x740x1800	1660x890x1990	
	6		74.6	112.0	3.6	292	4.0	58	50	65.4	290				
15L	4	15000	91	131.3	4.3	125	5.5	36	50	25	67.6	360	1940x740x1880	2190x960x2070	
	6		107.0	169.0	5.1	205	5.5	33	50	68.4	410				
20L	4	20000	113.7	183.4	5.4	152	7.5	28	50	25	70.5	480	2420x860x1980	2670x1080x2170	
	6		149.0	224.0	7.1	152	7.5	59	50	71.2	540				
25L	4	25000	149.3	248.9	7.1	218	7.5	34	65	25	70.7	620	2790x960x2160	3040x1180x2350	
	6		187.0	279.0	8.9	218	7.5	64	65	71.3	680				
30L	4	30000	179.2	298.7	8.6	173	11.0	53	65	25	73.1	690	2790x960x2360	3040x1180x2540	
	6		225.0	335.0	10.8	173	11.0	69	65	73.5	760				
35L	4	35000	209.1	348.4	10.0	235	11.0	40	80	25	73.6	780	3200x1000x2360	3450x1220x2540	
	6		265.0	391.0	12.7	235	15.0	67	80	74.2	860				
40L	4	40000	238.9	398.2	11.4	193	15.0	41	80	25	76.2	850	3400x1000x2360	3650x1220x2540	
	6		300.0	447.0	14.3	193	15.0	68	80	77.5	940				

1.Cooling capacity is based in the following

a)Water temperature:7 C (inlet)/12 C (outlet) b)Air entering condition:27 C DB/19.5 C WB

2.Heating capacity is based on the following:

a)Water temperature:60 C (inlet) /same water flow as in standard rating condition in cooling(outlet) b)Air entering condition:21 C DB

● Fresh air condition

Model	Air volume	Rated cooling capacity	Rated heating capacity	Water flow rate	External static pressure	Fan motor input	Water pressure drop	Chilled water pipe	Cooling water pipe	Sound level	Net weight	Net dimension	Package dimension	Power supply	
MKSxxxY(orZ)/C-H	m³/h	kW	kW	L/s	Pa	kW	kPa	DN	DN	dB(A)	kg	WxDxH (mm)	WxDxH (mm)	V-Ph-Hz	
03L	4	3000	32.0	35.6	1.53	52	0.75	46	40	25	57.1	130	1010x580x1100	1260x730x1290	380~415V-3-50Hz
	6		42.5	49.4	2.03	212	1.1	47	40	57.5	140				
04L	4	4000	45.5	46.0	2.17	79	1.1	13	40	25	58.2	150	1050x580x1250	1300x730x1440	
	6		56.7	65.9	2.71	239	1.5	24	40	60.3	162				
05L	4	5000	57.1	72.6	2.73	96	1.1	61	40	25	60.5	170	1110x630x1420	1360x780x1610	
	6		70.9	82.4	3.39	256	2.2	58	40	61.2	185				
06L	4	6000	64.9	84.0	3.10	68	1.5	37	40	25	61.4	190	1200x630x1470	1450x780x1660	
	6		84.5	97.0	4.04	228	2.2	62	40	61.9	210				
08L	4	8000	87.6	112.0	4.19	118	2.2	73	40	25	63.2	230	1350x740x1650	1600x890x1840	
	6		113.0	132.0	5.40	288	3.0	46	40	63.6	255				
10L	4	10000	113.0	140.0	5.40	112	3.0	79	50	25	64.5	250	1410x740x1800	1660x890x1990	
	6		141.0	165.0	6.74	292	4.0	69	50	65.4	290				
15L	4	15000	170.0	210.0	8.12	125	5.5	73	50	25	67.6	360	1940x740x1880	2190x960x2070	
	6		213.0	247.0	10.18	205	5.5	76	50	68.4	410				
20L	4	20000	222.0	280.0	10.61	152	7.5	69	50	25	70.5	480	2420x860x1980	2670x1080x2170	
	6		279.0	323.0	13.33	152	7.5	66	50	71.2	540				
25L	4	25000	279.0	350.0	13.3	218	7.5	71	65	25	70.7	620	2790x960x2160	3040x1180x2350	
	6		350.0	404.0	16.7	218	7.5	83	65	71.3	680				
30L	4	30000	322.0	412.0	15.38	173	11.0	36	65	25	73.1	690	2790x960x2360	3040x1180x2540	
	6		418.0	485.0	19.97	173	11.0	77	65	73.5	760				
35L	4	35000	382.0	490.0	18.25	235	11.0	32	80	25	73.6	780	3200x1000x2360	3450x1220x2540	
	6		494.0	566.0	23.60	235	15.0	67	80	74.2	860				
40L	4	40000	430.0	560.0	20.54	193	15.0	35	80	25	76.2	850	3400x1000x2360	3650x1220x2540	
	6		557.0	647.0	26.61	193	15.0	77	80	77.5	940				

1.Cooling capacity is based in the following:

a)Water temperature:7 C (inlet)/12 C (outlet) b)Air entering condition:35 C DB/28 C WB

2.Heating capacity is based on the following:

a)Water temperature:60 C (inlet) /same water flow as in standard rating condition in cooling(outlet) b)Air entering condition:7 C DB

Dimensions

Suspended type

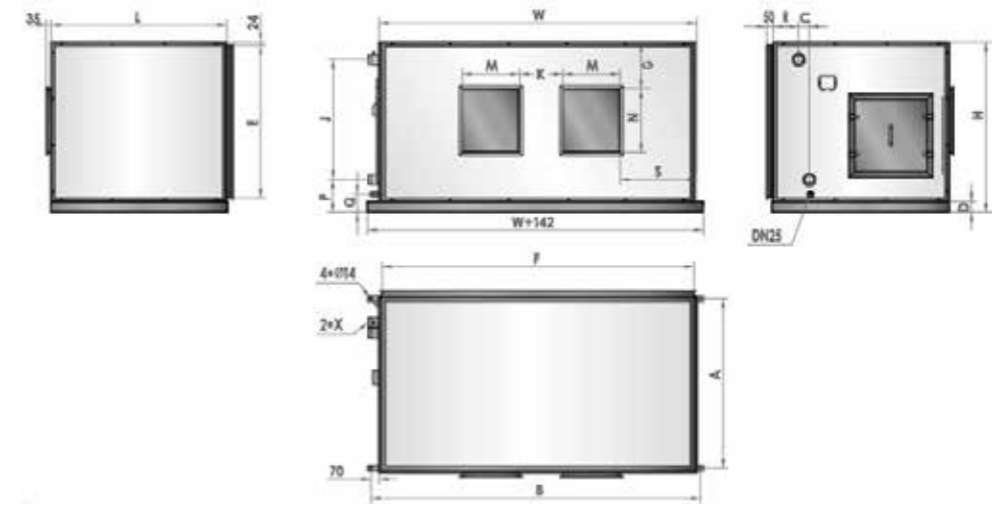

(unit:mm)

MODEL (MKS-H)		02D/C	03D/C	04D/C	05D/C	06D/C	07D/C	08D/C	09D/C	10D/C	12D/C	15D/C
Outside dimension	L	750	830	830	830	830	830	830	920	920	920	1000
	W	870	1020	1300	1390	1590	1590	1700	1700	1940	1940	2240
	H	555	605	605	605	605	705	705	755	755	860	905
C	4R	66	66	66	66	66	66	66	66	66	66	66
	6R	110	110	110	110	110	110	110	110	110	110	110
D		25	25	25	25	25	25	25	25	25	25	25
Inlet flange	E	465	510	510	525	525	625	625	675	675	680	825
	F	820	970	1250	1340	1540	1540	1650	1650	1890	1890	2190
G		141	166	166	166	166	211	211	211	211	316	306
J		195	245	245	295	295	400	400	445	445	550	595
K		/	/	172	172	232	202	252	234	314	312	282
Outlet flange	M	271	310	244	244	310	277	343	319	405	407	385
	N	238	274	274	274	274	301	301	351	351	353	416
P		170	170	170	170	170	170	170	170	170	170	170
Q		71	71	71	71	71	71	71	71	71	71	71
R		115	115	115	115	115	115	115	115	115	115	115
Diameter of connection pipe X	4R	DN40	DN40	DN40	DN40	DN40	DN40	DN50	DN50	DN50	DN50	DN50
	6R	DN40	DN40	DN40	DN40	DN40	DN40	DN50	DN50	DN50	DN50	DN50

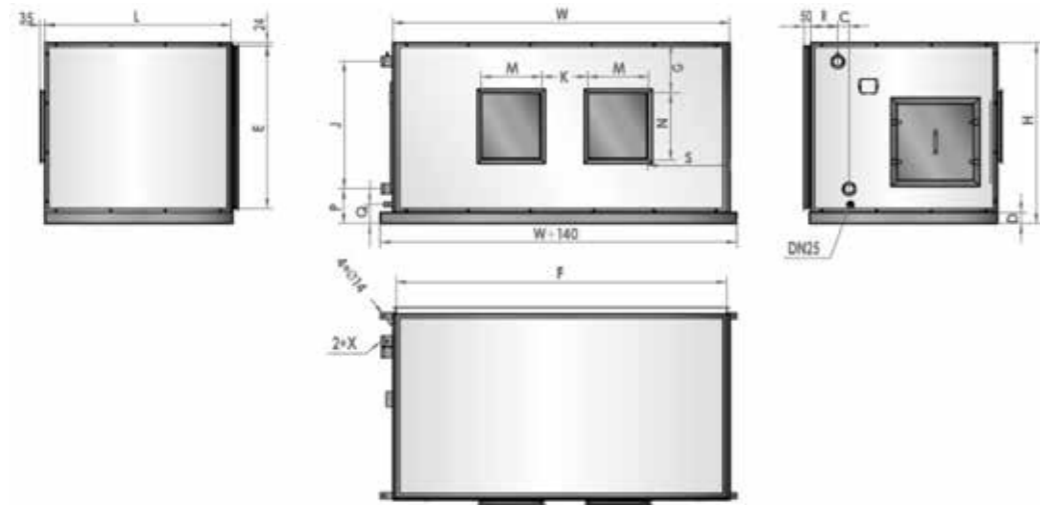

(unit:mm)

MODEL(MKS-H)		05W/C	06W/C	08W/C	10W/C	15W/C	20W/C	25W/C	30W/C	35W/C	40W/C
Outside dimension	L	1120	1120	1170	1200	1220	1350	1400	1450	1880	1880
	W	1100	1200	1450	1650	1940	2440	2590	2790	2790	2790
	H	840	840	945	965	1195	1310	1510	1580	1930	2060
C	4R	66	66	66	66	66	82.5	82.5	82.5	82.5	82.5
	6R	110	110	110	110	110	137.5	137.5	137.5	137.5	137.5
D		25	25	25	25	25	80	80	80	80	80
Inlet flange	E	762	762	865	890	1115	1175	1375	1440	1795	1925
	F	1050	1140	1390	1600	1880	2390	2540	2740	2740	2740
G		157	157	177	195	422	349	533	593	797	924
J		498	498	599	599	853	923	1114	1177	669	733
K		/	/	/	/	282	335	446	446	666	666
Outlet flange	M	405	405	460	460	373	430	557	557	638	638
	N	350	350	408	408	404	478	478	478	638	638
P		172	172	172	172	172	224	224	224	224	224
Q		71	71	71	71	71	126	126	126	126	126
R		156	156	156	156	156	195	195	195	186	186
Diameter of connection pipe X	4R	DN40	DN40	DN50	DN50	DN50	DN65	DN65	DN65	2xDN65	2xDN65
	6R	DN40	DN40	DN50	DN50	DN65	DN65	DN80	DN80	2xDN65	2xDN65

note:code 2x representative two coil.

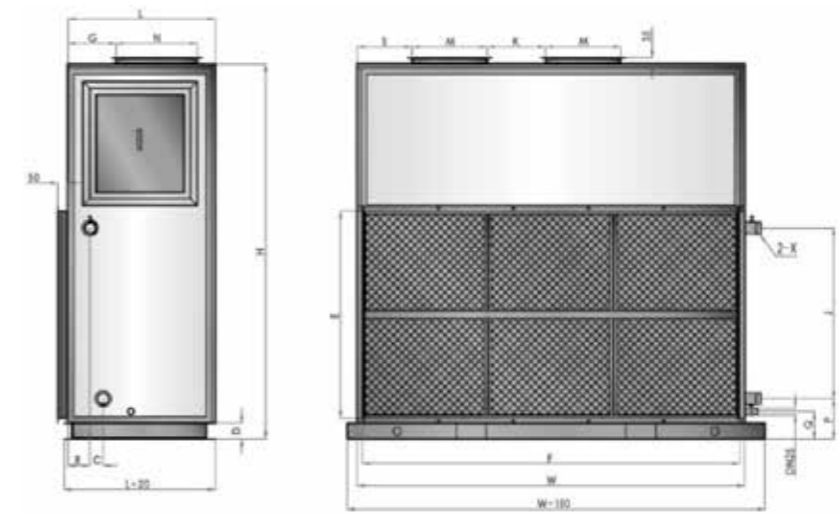

(unit:mm)

MODEL(MKS-H)		03L/C	04L/C	05L/C	06L/C	08L/C	10L/C	15L/C	20L/C	25L/C	30L/C	35L/C	40L/C
Outside dimension	L	580	580	630	630	740	740	740	860	960	960	1000	1000
	W	1010	1050	1110	1200	1350	1410	1940	2420	2790	2790	3200	3400
	H	1100	1250	1420	1470	1650	1800	1880	1980	2160	2360	2360	2360
C	4R	66	66	66	66	66	66	66	83	83	83	118	118
	6R	110	110	110	110	110	110	110	138	138	138	138	138
D		50	50	50	50	50	50	80	80	80	80	80	80
Inlet flange	E	474	575	677	728	830	982	1038	1026	1090	1280	1280	1280
	F	960	1000	1060	1150	1300	1360	1890	2370	2740	2740	3150	3350
J		304	405	507	558	660	805	856	839	918	1108	1098	1098
K		/	/	/	/	/	/	282	373	448	448	438	438
Outlet flange	M	298	331	405	405	471	471	373	471	557	557	569	569
	N	262	289	350	350	404	404	404	404	478	478	569	569
G		188	202	205	205	249	249	233	247	309	309	303	307
S		212	207	232	271	307	347	266	290	348	348	616	854
P		161	161	161	161	161	168	203	206	211	211	214	214
Q		101	101	101	101	101	101	131	134	134	134	134	134
R		102	102	102	102	102	102	111	111	111	111	111	111
Diameter of connection pipe X	4R	DN40	DN40	DN40	DN40	DN40	DN50	DN50	DN50	DN65	DN65	DN80	DN80
	6R	DN40	DN40	DN40	DN40	DN40	DN50	DN50	DN50	DN65	DN65	DN80	DN80

note:code 2x representative two coil.

Options

Customizable ESP

● Suspended type

MKSxxY (Z)/C-H	Air volume (m³/h)	Rows of cooling coil	External static pressure(Pa)					
			P1	P2	P3	P4	P5	P6
02D	2000	4	27	67	107	147	187	227
		6	27	67	107	147	187	227
03D	3000	4	12	52	92	132	172	212
		6	12	52	92	132	172	212
04D	4000	4	30	70	110	150	190	230
		6	30	70	110	150	190	230
05D	5000	4	2	42	82	122	162	202
		6	2	42	82	122	162	202
06D	6000	4	52	92	132	172	212	252
		6	52	92	132	172	212	252
07D	7000	4	58	98	138	178	218	258
		6	58	98	138	178	218	258
08D	8000	4	39	79	119	159	199	239
		6	39	79	119	159	199	239
09D	9000	4	76	116	156	196	236	286
		6	76	116	156	196	236	286
10D	10000	4	96	136	176	216	256	306
		6	96	136	176	216	256	306
12D	12000	4	68	108	148	188	228	278
		6	68	108	148	188	228	278
15D	15000	4	85	125	165	205	255	305
		6	85	125	165	205	255	305

MKSxxY (Z)/C-H	Air volume (m³/h)	Rows of cooling coil	Motor power(kW) corresponding to external static pressure					
			P1	P2	P3	P4	P5	P6
02D	2000	4	0.37	0.37	0.37	0.55	0.55	0.55
		6	0.37	0.37	0.55	0.55	0.55	0.75
03D	3000	4	0.55	0.55	0.55	0.75	0.75	0.75
		6	0.55	0.55	0.75	0.75	0.75	0.75
04D	4000	4	0.55	0.75	0.75	1.1	1.1	1.1
		6	0.75	0.75	1.1	1.1	1.1	1.1
05D	5000	4	1.1	1.1	1.1	1.5	1.5	1.5
		6	1.1	1.1	1.5	1.5	1.5	1.5
06D	6000	4	1.1	1.1	1.5	1.5	1.5	2.2
		6	1.1	1.5	1.5	1.5	2.2	2.2
07D	7000	4	1.1	1.1	1.1	1.5	1.5	1.5
		6	1.1	1.1	1.5	1.5	1.5	2.2
08D	8000	4	1.5	1.5	1.5	2.2	2.2	2.2
		6	1.5	1.5	2.2	2.2	2.2	2.2
09D	9000	4	2.2	2.2	2.2	2.2	3	3
		6	2.2	2.2	2.2	2.2	3	3
10D	10000	4	2.2	2.2	2.2	3	3	3
		6	2.2	2.2	3	3	3	3
12D	12000	4	3	3	3	3	4	4
		6	3	3	3	3	4	4
15D	15000	4	4	4	4	4	5.5	5.5
		6	4	4	4	4	5.5	5.5

● Horizontal type

MKSxxY (Z)/C-H	Air volume (m³/h)	Rows of cooling coil	External static pressure(Pa)					
			P1	P2	P3	P4	P5	P6
05W	5000	4	56	96	136	176	216	256
		6	56	96	136	176	216	256
06W	6000	4	28	68	108	148	188	228
		6	28	68	108	148	188	228
08W	8000	4	38	78	118	158	198	238
		6	38	78	118	158	198	238
10W	10000	4	72	112	152	192	242	292
		6	72	112	152	192	242	292
15W	15000	4	85	125	165	205	255	305
		6	85	125	165	205	255	305
20W	20000	4	170	210	260	310	360	410
		6	170	210	260	310	360	410
25W	25000	4	268	318	368	418	468	518
		6	268	318	368	418	468	518
30W	30000	4	223	273	323	373	423	473
		6	223	273	323	373	423	473
35W	35000	4	382	432	482	532	582	632
		6	382	432	482	532	582	632
40W	40000	4	355	405	455	505	555	605
		6	355	405	455	505	555	605

MKSxxY (Z)/C-H	Air volume (m³/h)	Rows of cooling coil	Motor power(kW) corresponding to external static pressure					
			P1	P2	P3	P4	P5	P6
05W	5000	4	1.1	1.1	1.1	1.1	1.5	1.5
		6	1.1	1.1	1.1	1.5	1.5	1.5
06W	6000	4	1.1	1.5	1.5	1.5	2.2	2.2
		6	1.1	1.5	1.5	1.5	2.2	2.2
08W	8000	4	1.5	1.5	1.5	2.2	2.2	2.2
		6	1.5	1.5	2.2	2.2	2.2	2.2
10W	10000	4	2.2	3	3	3	/	/
		6	3	3	3	/	/	/
15W	15000	4	3	4	4	4	4	5.5
		6	3	4	4	4	4	5.5
20W	20000	4	5.5	7.5	7.5	7.5	7.5	11
		6	7.5	7.5	7.5	7.5	7.5	11
25W	25000	4	5.5	7.5	7.5	7.5	7.5	11
		6	7.5	7.5	7.5	7.5	11	11
30W	30000	4	11	11	11	11	11	11
		6	11	11	11	11	11	15
35W	35000	4	5.5	5.5	7.5	7.5	7.5	7.5
		6	7.5	7.5	7.5	7.5	7.5	11
40W	40000	4	7.5	7.5	7.5	11	11	11
		6	7.5	7.5	11	11	11	11

● Vertical type

MKSxxY (Z)/C-H	Air volume (m³/h)	Rows of cooling coil	External static pressure(Pa)					
			P1	P2	P3	P4	P5	P6
03L	3000	4	12	52	92	132	172	212
		6	12	52	92	132	172	212
04L	4000	4	39	79	119	159	199	239
		6	39	79	119	159	199	239
05L	5000	4	56	96	136	176	216	256
		6	56	96	136	176	216	256
06L	6000	4	28	68	108	148	188	228
		6	28	68	108	148	188	228
08L	8000	4	78	118	158	198	238	288
		6	78	118	158	198	238	288
10L	10000	4	72	112	152	192	242	292
		6	72	112	152	192	242	292
15L	15000	4	85	125	165	205	255	305
		6	85	125	165	205	255	305
20L	20000	4	112	152	192	242	292	342
		6	112	152	192	242	292	342
25L	25000	4	178	218	268	318	368	418
		6	178	218	268	318	368	418
30L	30000	4	133	173	223	273	323	373
		6	133	173	223	273	323	373
35L	35000	4	185	235	285	335	385	435
		6	185	235	285	335	385	435
40L	40000	4	143	193	243	293	343	393
		6	143	193	243	293	343	393

MKSxxY (Z)/C-H	Air volume (m³/h)	Rows of cooling coil	Motor power(kW) corresponding to external static pressure					
			P1	P2	P3	P4	P5	P6
03L	3000	4	0.75	0.75	0.75	1.1	1.1	1.1
		6	0.75	0.75	1.1	1.1	1.1	1.1
04L	4000	4	1.1	1.1	1.1	1.1	1.1	1.5
		6	1.1	1.1	1.1	1.1	1.5	1.5
05L	5000	4	1.1	1.1	1.5	1.5	1.5	1.5
		6	1.1	1.5	1.5	1.5	1.5	2.2
06L	6000	4	1.1	1.5	1.5	1.5	2.2	2.2
		6	1.5	1.5	1.5	2.2	2.2	2.2
08L	8000	4	1.5	2.2	2.2	2.2	3	3
		6	2.2	2.2	2.2	2.2	3	3
10L	10000	4	3	3	3	3	4	4
		6	3	3	3	3	4	4
15L	15000	4	5.5	5.5	5.5	5.5	5.5	7.5
		6	5.5	5.5	5.5	5.5	7.5	7.5
20L	20000	4	7.5	7.5	7.5	7.5	7.5	11
		6	7.5	7.5	7.5	7.5	11	11
25L	25000	4	7.5	7.5	7.5	11	11	11
		6	7.5	7.5	11	11	11	11
30L	30000	4	11	11	11	11	15	15
		6	11	11	11	11	15	15
35L	35000	4	11	11	15	15	15	15
		6	11	15	15	15	15	15
40L	40000	4	15	15	15	18.5	18.5	18.5
		6	15	15	18.5	18.5	18.5	18.5

Note :
 1.Character in red are standard motor power input in standard ESP, others ESP must be customized.
 2.Character in red are standard motor power input in standard ESP, others power input correspondence others customized ESP.

Air outlet directions

● Suspended type

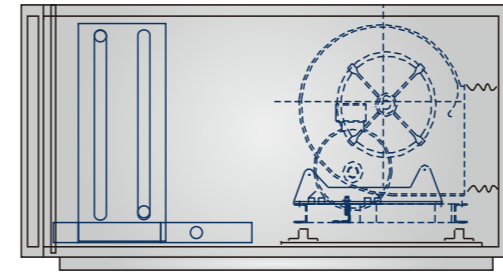

Standard: Front below

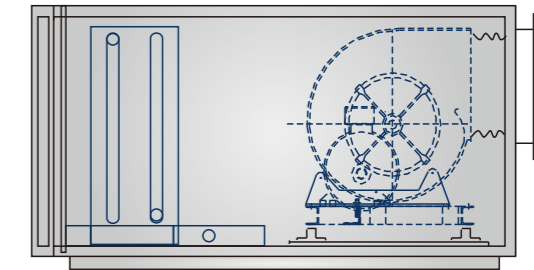

Option: Front up

● Horizontal type

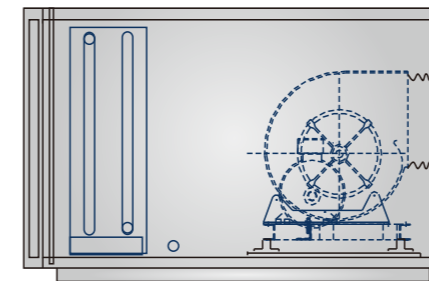

Standard: Front up

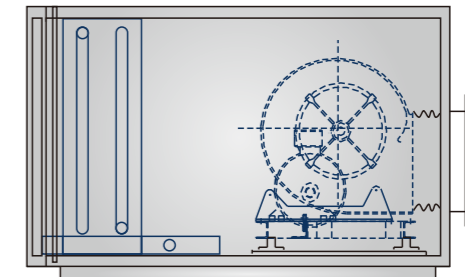

Option: Front below

● Vertical type

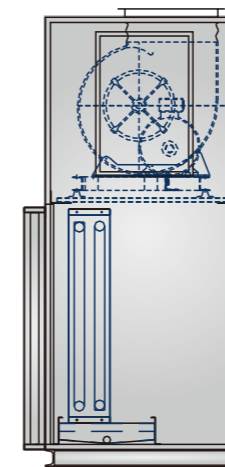

Standard: Up front

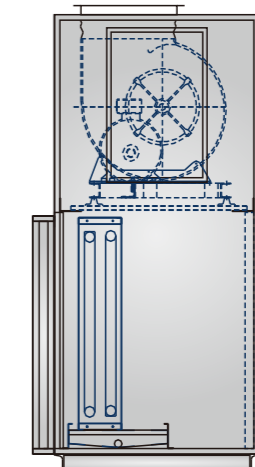

Option: Up rear

Name	Standard	Customized
Panel	Thickness: 25mm	35mm 50mm
Fan	Yilida	Kruger
Motor	Power supply: 380V/3N/50Hz; 400V/3N/50Hz	Other power supply: 220V/3N/60Hz; 440V/3N/60Hz; 460V/3N/60Hz
Cooling coil	4-rows and 6-rows; Aluminum fins; Seamless steel connecting water pipes; Galvanized steel drain pan	8-rows Hydrophilic aluminum fins; Copper connecting water pipes; Stainless steel drain pan
Heating coil	-	1-row heating coil; 2-rows heating coil
Air filter	14mm nylon plate type air filter; Side drawn	14/25mm aluminum alloy plate type filter
Humidifier	-	Wet film humidifier
Service light	-	Can be customized to meet the requirement
UV germicidal lamp	-	Can be customized to meet the requirement
Service window	-	Can be customized to meet the requirement
Electrical control box	-	Can be customized to meet the requirement



Motor



Coil



Air filter



Humidifier



Service light



UV germicidal lamp

Selection

Selection procedures

● Step 1:

Determine the airflow (m³/h), inlet air condition, total cooling capacity (kW), or total heating capacity (kW). If the inlet air condition is beyond the standard condition of the above specifications, please check to the following formula:

$$Q = F1 \times F2 \times F3 \times Q0$$

Note:

Q0—cooling capacity of standard cooling condition, refer to the unit specifications;

F1—temperature correction coefficient of cooling coil, refer to table A;

F2—temperature difference correction coefficient of water, refer to figure 1;

F3—water velocity correction coefficient, refer to figure 2

Table A Temperature correction coefficient of cooling coil F1

EWB	EWT	Entering water temperature °C						
		4	5	6	7	8	9	10
Entering air WB temperature °C	17	0.978	0.890	0.801	0.711	0.626	0.523	0.423
	18	1.093	1.001	0.915	0.823	0.731	0.635	0.538
	19	1.213	1.124	1.032	0.940	0.846	0.750	0.652
	19.5	1.274	1.184	1.093	1.000	0.906	0.809	0.711
	20	1.337	1.246	1.155	1.061	0.967	0.869	0.770
	21	1.464	1.373	1.281	1.186	1.090	0.993	0.893
	22	1.597	1.504	1.411	1.316	1.219	1.121	1.020
	23	1.733	1.641	1.547	1.450	1.352	1.252	1.151
	24	1.874	1.781	1.685	1.589	1.490	1.389	1.287
	26	2.172	2.076	1.978	1.879	1.779	1.676	1.571
	28	2.489	2.391	2.291	2.189	2.086	1.981	1.874
	30	2.824	2.725	2.623	2.519	2.414	2.306	2.196

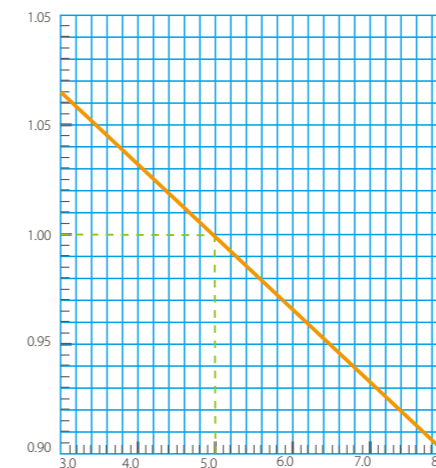

Figure 1 Temperature difference correction coefficient of water F2

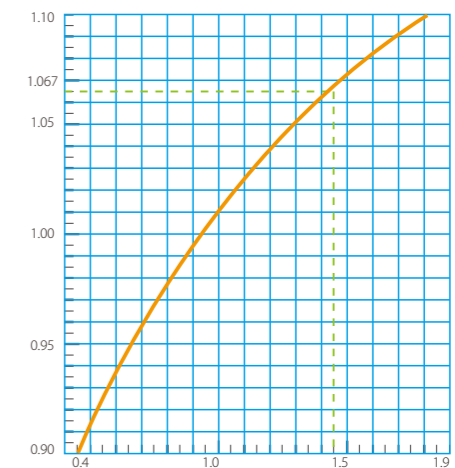

Figure 2 Water velocity correction coefficient F3

● Step 2:

Determine the external static pressure (Pa). If the ESP is beyond the standard value of the above specifications, please indicate the required ESP when you take the order. Take table B as a reference to estimate the air pressure in the duct.

Table B Air resistance of duct

Air speed(m/s)	Total air pressure of the duct (Pto)				
	On-way resistance (Pa/m)	Local resistance (Pa/pcs)			
		Straight pipe	Damper	Diffuser	Bend
10	1.35	30	20(air outlet speed ≤5m/s)	30	20
9	1	25		25	18
8	0.7	20		20	15
7	0.55	15		15	12
6	0.4	12		12	10

Note:
 1. Pto= on-way resistance+ local resistance, Pa.
 2. ESP≈ Pto.

- **Step 3:**
Determine the unit structure: horizontal type (W), vertical type (L) and suspended type (D).
- **Step 4:**
Determine the pipe connecting mode: right-handed (Y), left-handed (Z).

Selection software

- You can make selections under varies entering air conditions, entering water conditions, different air volume, and different cooling capacity or heating capacity.
- User friendly interface make selection visual and easy.
- Powerful project managemakes functions.
- Selection interface

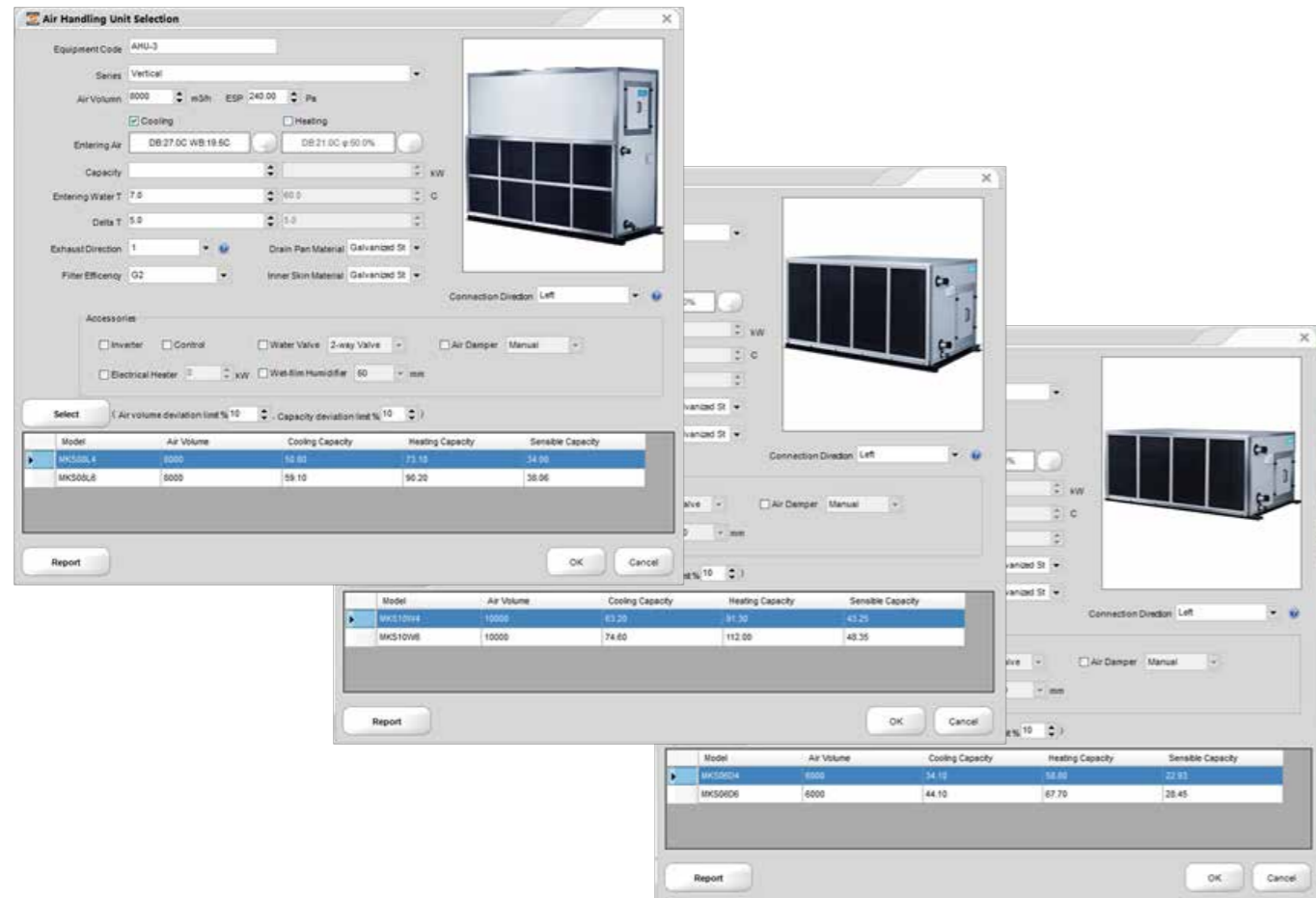

- Main interface

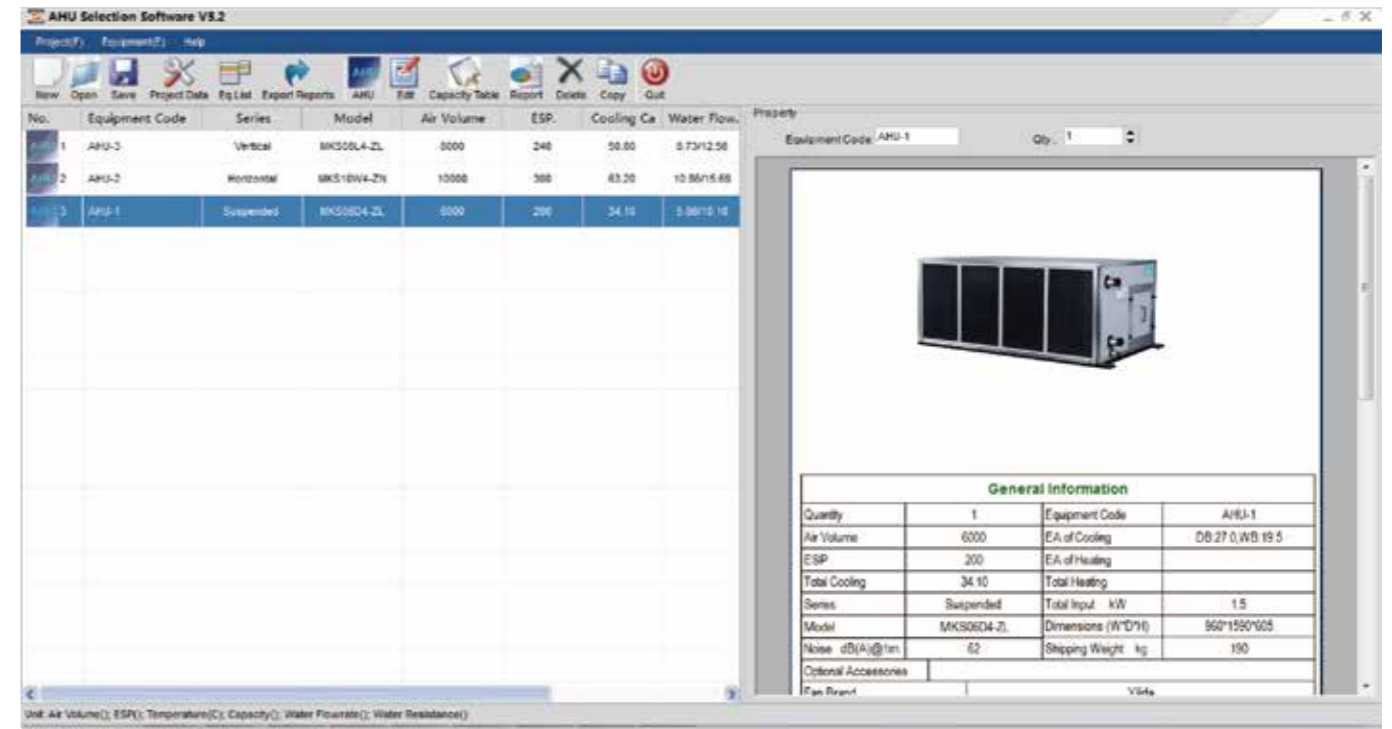

- Report data interface

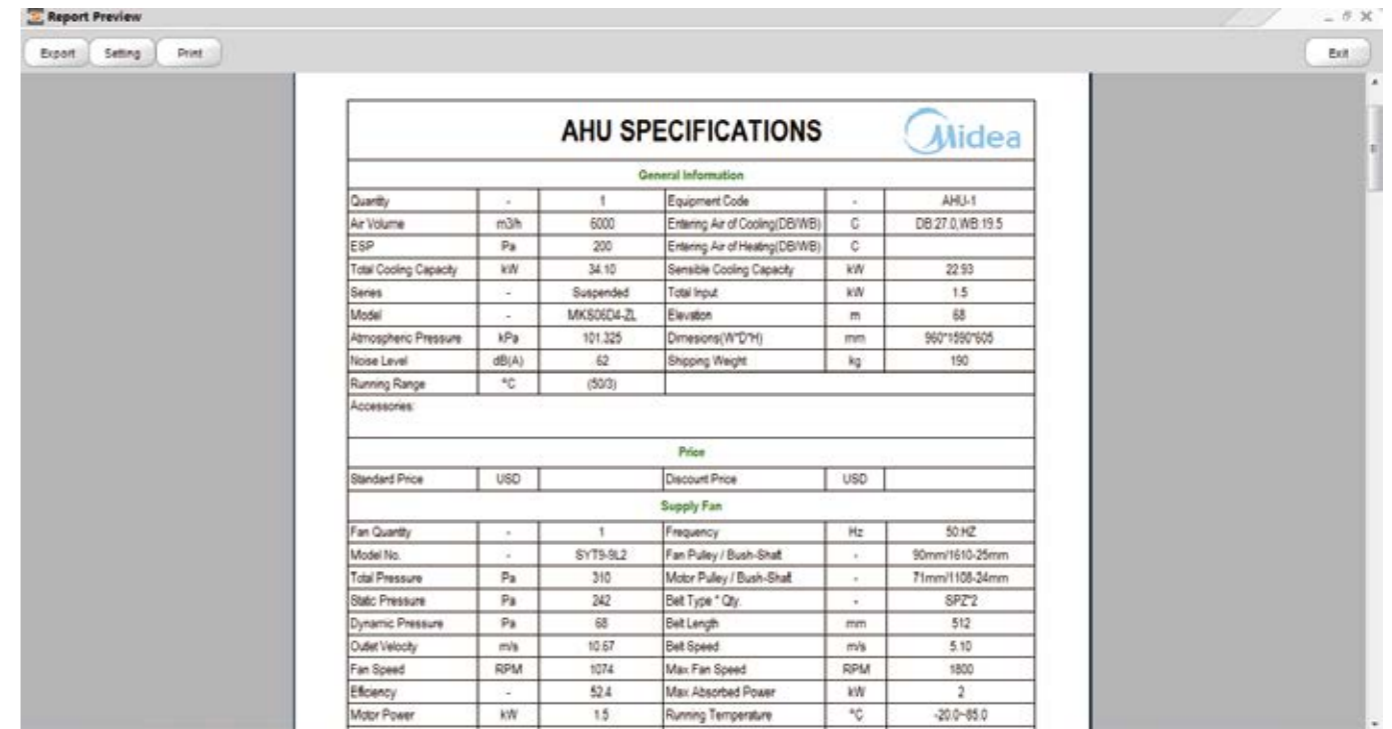



Modular Air Handling Unit

MAHUs are modular so that they have the flexibility to add components as required. The 3rd generation Midea MAHU adapts unitary structure design, more outstanding cold-bridge free performance, lower air leakage and more elegant appearance. It realizes a variety of functions: cooling, heating, humidification, dehumidification, air purification, noise elimination, and so on. The air flow rate is available from 1,500m³/h to 200,000m³/h. Total pressure (TP) exceeds 2000Pa to adapt to different kinds of applications, such as office buildings, shopping malls, exhibition halls, airports, railway stations, hotels, chemical fibres, electronics industries, textile mills, tobaccos, hospitals, printers, automobile factories and any other central air-conditioning systems.

Nomenclature

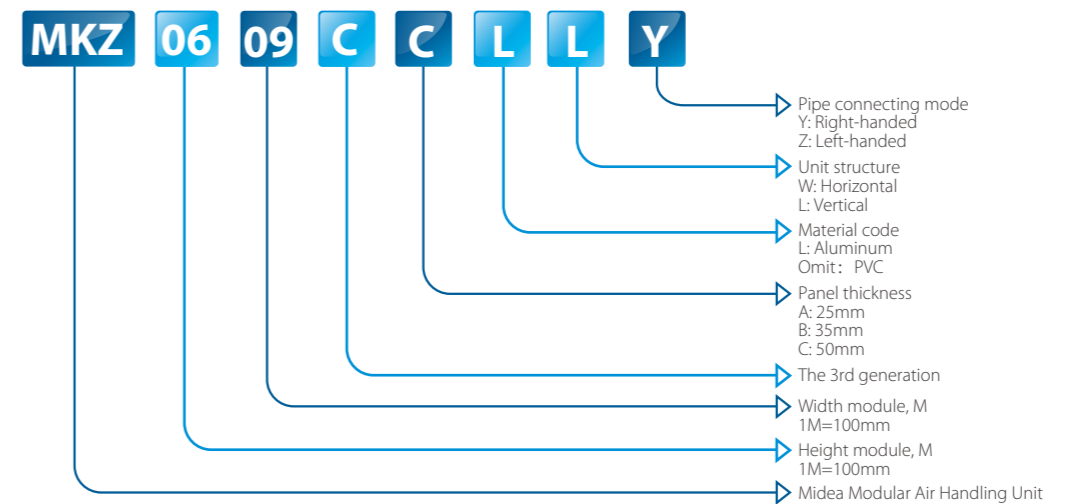

Orientation

Unit handling orientation is determined by location of pipe connection while facing unit in the direction of air flow. The unit below is left-handed connection unit, otherwise is the right-handed connection unit.

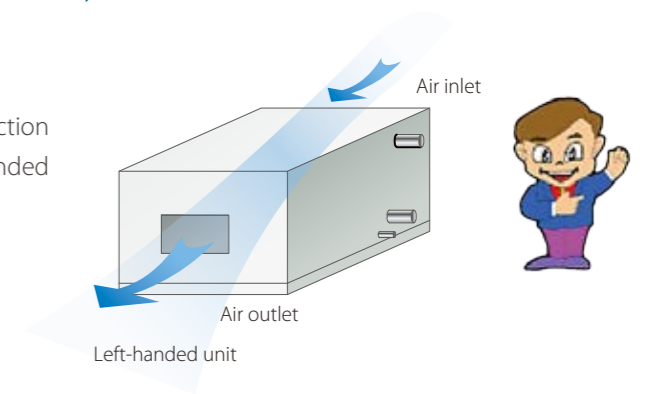

Reliable quality

For the 3rd generation of Midea MAHUs, reinforced frame is built in the section connection gap to enhance the structure for large air flow volume and high air pressure. The MAHUs' construction provides unequalled thermal efficiencies and low leak rates. In addition, the MAHUs offers tremendous flexibility in sizing, component options, and unit arrangements to meet the indoor air quality, operating efficiency, sound and installation requirements for today's extensive commercial and custom markets.

Also, Midea combines comprehensive performance certifications with thorough laboratory testing and manufacturing methods. These assure that each MAHU operates predictably and reliably throughout the life of the unit.



Modular design

The MAHUs adopt modulus design. Usually including mixing section, primary efficiency filter section, medium efficiency filter section, high efficiency filter section, cooling coil section, heating section, humidifier section, sound attenuator section, service section, heat recovery section, fan section and so on. Function sections can be combined freely. Different function sections can be selected according to the specific applications.

The MAHUs can be shipped in divided sections. Each section is wholly completed at manufacturer's work place, and only connection of sections can be done at site. Oversized units cannot be fitted in normal container shipment or cannot be delivered through access at site can be considered shipment in complete knock down form, but reassembling works must be done by engineers of the manufacturer.

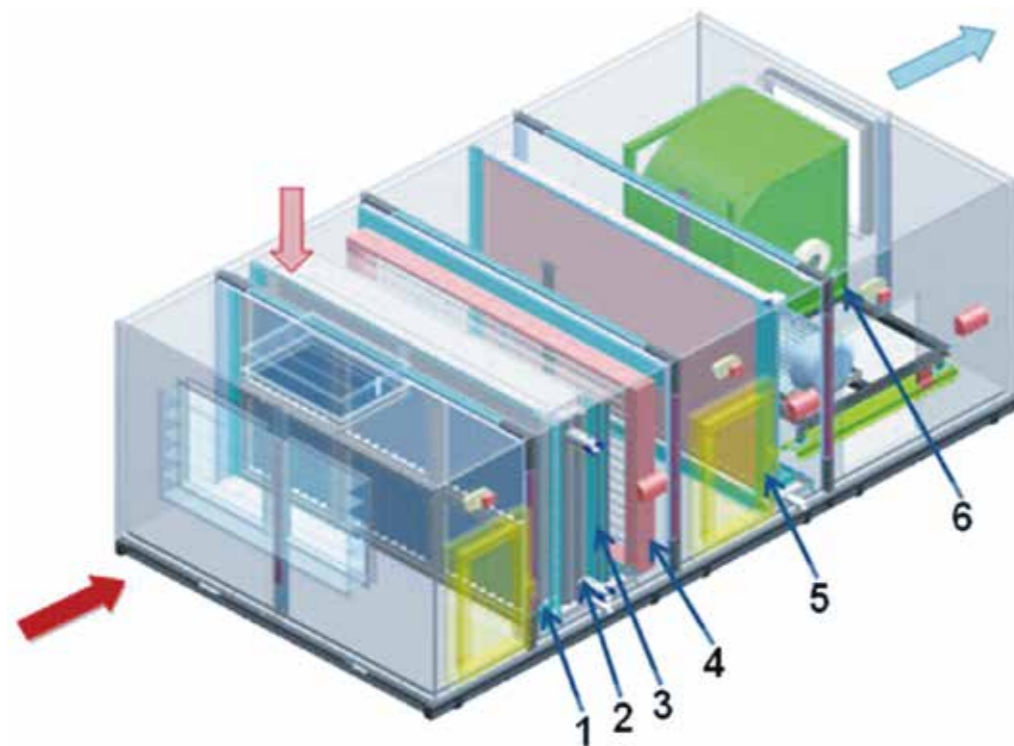

- 1.Pre-filter
- 2.Chilled water coil
- 3.Eliminator
- 4.Eletric heater
- 5.Wet film humidifier
- 6.Fan

Cold bridge free structure

Unitary structure design and module panel design. Panels are double-skin with injection of high density polyurethane. The outer skin is anti-corrosion color-coated steel sheet, the inner skin is galvanized steel sheet, the density of polyurethane is more than 50kg/m³, and the thermal conductivity is 0.0224W/m²·K. The unit cabinet is constructed by panels with male and female aluminum alloy cards and sealing strip. The air leakage rate is less than 0.29%. Units will not sweat when exterior room temperature is 27°C, relative humidity is 90%.

State-of-the-art design

The MAHUs adopt unitary structure design and the insert fastening bolts are covered by haps which are in accordance with the color of the outer skin, and clear, smooth appearance make the outlook attractive.

Serviceability

The Midea MAHUs are designed to provide easy access to interior components for routine maintenance and service. The easy-to-move panels and access doors of the units provide complete access to the unit interior and components.

Wide usage

Midea MAHUs can be widely used in chemical fibres, electronics industries, textile mills, tobaccos, hospitals, printers, automobile factories and any other central air-conditioning systems, especially these have special requirements of environment space.



Selection software

A user-friendly software selection program has been provided to help the customer easily define their product requirements.



Base frame

Unit sections are mounted on galvanized steel or channel steel base frame for ease of shipment and handling. The frames provide holes for section connection, and holes for fork-lifting truck. There is a guard rail cross the bottom in the holes to prevent unit damage by trucks.

The base frame can be used in lieu of concrete plinths or other additional bases that are used on site. However, for high static pressure application, additional concrete plinths or other additional bases are required at site to raise the MAHUs for drain pan's U-trap.

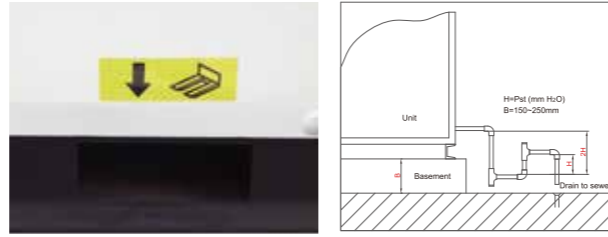

Double skin panel

The outer skin is color-coated steel sheet that is resistant to scratch and nicks and shall allow for easy cleaning. The inner skin is galvanized steel sheet.

The panels are double skin type with injected polyurethane foam insulation. The panel is moisture proof and anti-corrosive. The insulation material is totally enclosed in the panel to avoid any possibility of insulation being exposed to air stream.

The panel is sturdy and, in its standard design, unit sections of the same width can be stacked on the top of one another, without additional reinforcement.

Drain pan

Cooling coil and humidifier are installed on reversed U-shaped supporters. A U-shaped channel is pressed in the middle of drain pan to promote proper condensate removal. Standard drain pan is galvanized steel, fully insulated on the outside with 10mm foam insulation. Stainless steel drain pan is optional. Connecting pipe is located at bottom of drain pan to allow complete drainage. The drain pipe exits from the same side as coil header.

Access door

Access section, fan section, humidifier section and heat-exchanged coil sections usually equipped with access doors. The access doors are equipped with locking handle which is controllable internally and externally. A durable seal is around the full perimeter of the door's frame to prevent air leakage. Light is fixed above access door, and quipped with a weather-resistant plastic box.



Vibration protector

The fan motors are mounted on a rigid base frame which is supported by effective spring shock absorber. Shipping brackets are equipped at the base frame to protect fans, motors and spring shock absorber during transportation.



Fan assembly

The vibration levels of the complete fan assembly (fan wheel, motor and drives assembled as a whole system) is checked and dynamically balanced in the factory.

Fans are mainly consisted of scroll, impeller, frame, bearing and shaft. The scroll is made of hot galvanized steel sheet. Its side plate has an outline complying with aerodynamics. The impeller is made of high grade hot galvanizing steel sheet and is designed to a special configuration according to aerodynamics to make the efficiency highest and the noise lowest. The high quality ball bearings are air-sealed, with preset lubricating oil, and of automatically alignment. The shafts are made of 40 Cr or C45 carbon steel bars. They are coated after assembly in order to provide corrosion resistance. Fan connection is isolated from unit casing by a flexible canvas duct mounted at fan discharge outlet. Fan and motor assembly is internally isolated from the unit casing with spring isolators, furnished and installed by the unit manufacturer.

The drive assembly is consist of belt pulley and motor. The belt type is oil and heat resistant, antistatic and avoiding electric discharges. Motor is mounted on a sliding base to permit adjustment of drive belt tension. Standard motor is horizontal foot mounting, induction motor, and totally enclosed.

Unit is provided with a painted metal sheet belt guard. The belt guard is rigidly attached to the fan base support structure.

Fan assembly section is equipped with an access door with window on the drive side of the fan.

Motor

Totally enclosed fan cooled motors, with class F insulation, are mounted on slide rails with provision for V-belt tensioning. Fan and motor are mounted on a common base frame fitted with anti-vibration mountings and the fan discharge is provided with a fire retardant flexible connection to completely isolate the fan and motor assembly from the unit casing.

Fan motor is mounted on a horizontal flat plate and can't be supported by the fan or its structural members. Motor is mounted within the fan section casing on slide rails equipped with adjusting screws. So motor can be moved freely in the horizontal direction to reach the correct point then fasten bolts. Installation and maintenance are time saving.



Coil

In Midea MAHUs, there are three typical types of coils: chilled water coils, hot water coils and steam heater coils. All coils are AHRI certified and provided to meet the scheduled performance. Coils are consisted of copper-tubes and aluminum fins. The fins are sine-wave design with slits for better heat transfer efficiency and moisture carry-over limit performance.



All coils are installed with space between each component for cleaning and mounting of controls.

All cooling coils are mounted over a drain pan. The drain pan extends beyond the leaving side of the coil to help recover condensate.

Coil connections always extend through out of the unit cabinet, allowing for the easy connection of valves and piping. Vents are located outside the cabinet.



The coil can be customized with fluorine coil, and the refrigerant can choose R22 or R410A.

Humidifier

Usually, there is no humidifier installed in the MAHUs for comfort air conditioning systems; but the outdoor climate is very cold in winter so that if a humidifier is not employed, the winter indoor relative humidity may be too low. Humidifiers are necessary for health care facilities and processing systems in pharmaceutical, semiconductor, textile, communication centers, and computer rooms.

In Midea MAHUs, wet film vaporization, dry steam, electrode boiler, and water spray humidifiers are widely used. Wet film vaporization humidifier is a type of enthalpy humidifier or evaporation gasification humidifier. Through the principle of exchange of heat and moisture, the air is humidified and cooled. The medium is inorganic material which is high-life, high reliability, clean, good heat conduction and bacteria resistance. Dry steam or electrode boiler humidifiers are widely used in where a warm air supply and humidity control are needed in winter.



Wet film vaporization humidifier



Dry steam humidifier



Electrode boiler humidifier



Water spray humidifier

Filter

Air filtration is an important component to achieve an acceptable indoor air quality. In MAHUs, earlier low-efficiency filters of the panel type are giving way to the medium- and high-efficiency bag type and cartridge type of filters.

Filter section is consisted of galvanized steel filter frame structure and an access door for filter maintenance. Low efficiency plate filter is designed as standard. Bag, cartridge and other high efficiency filters is optional. The structure of filters are stable and firm, high strength and intensity, and easy changing. Filter can be loaded from both left and right side. Front loaded is optional. The filters efficiency is up to 95%.

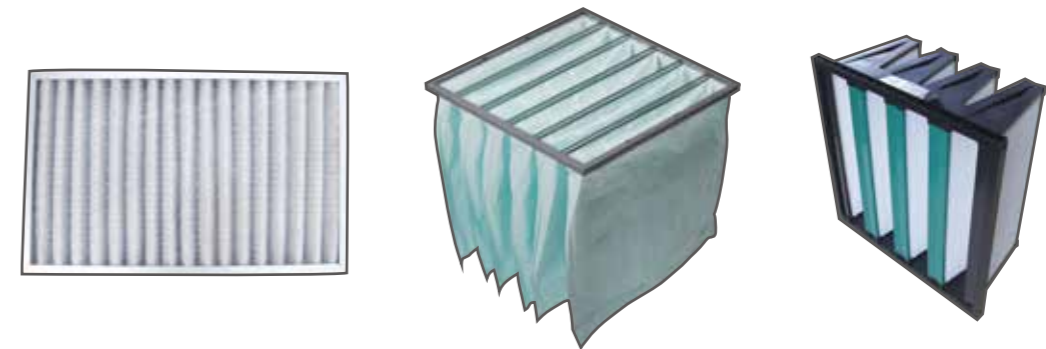

Filter efficiency table







Partical diameter	≥5μm			≥1μm		≥1μm			≥0.5μm				≥0.3μm
	G1 E<65	G2 65≤E<80	G3 80≤E<90	G4 90≤E	F5 40≤E<60	F6 60≤E<80	F7 80≤E<90	F8 90≤E<95	F9 95≤E	H10 85≤E<95	H11 95≤E<99.5	H12 99.5≤E<99.95	H13 99.95≤E<99.995
Testing method	Arrestance				Dust-spot				Particle-counting				
Filter Type	Plate		Plate/bag		bag			Dense pleated			HEPA		

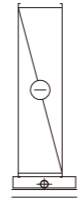

Air dampers

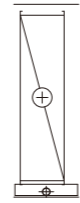
Air dampers in MAHUs are optional. Aerodynamically designed damper blades have built in high quality bearings. Blade edges are lined with sealing strip to restrict leakage to an absolute minimum. Air damper blades are either linked to give parallel turning operation or gear set to give opposing direction. The dampers are tested to yield linear control characteristic. Mixing dampers working in pairs and can be coupled in such a way that if one is 75% open the other is 25% open.

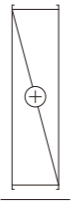

Name	Sketch	Description	
		Unit model	Length (mm)
Mixing Box		0609~1821	600
		1824~3342	700
		3636~3663	800
Inlet Section		0609~1821	600
		1824~3342	700
		3636~3663	800
Outlet Section		Without access door	L=400mm
		With access door	L=600mm
Plate Filter		L= 100mm, can be fixed in mixing box.	
Bag Filter		Bag of 381mm: L=500mm	
Supply Fan		L=700~3900mm, depending on the unit model and air volume	

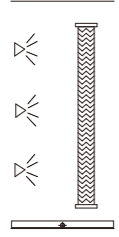
Name	Sketch	Description		
		Rows	Width(mm)	Length(mm)
Chilled Water Coil		4	W≤3300	600
			W>3300	900
		6	W≤3300	700
			W>3300	1000
		8	W≤3300	700
		W>3300	1100	
Chilled Water Coil		P≤15	L=500	L=700
		20≤P≤50	L=600	L=800
		75≤P	L=800	/
Hot Water Coil		1~3 rows	L=300mm	
		4 rows	L=400mm	
Electric Heater		L=300mm		
Steam Heater Coil		1~3 rows	L=300mm	
		4 rows	L=400mm	
Dry Steam Humidifier		L=700mm		
Electrode Boiler Humidifier		L=700mm		

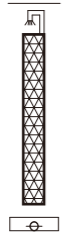
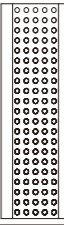
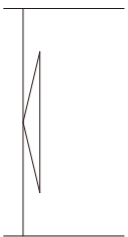
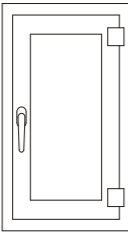
Name	Sketch	Description		
Water Spray Humidifier		L=700mm, eliminator is needed		
Eliminator		Can be fixed in water spray humidifier.		
Wet-film Humidifier		Water Supply	Thickness (mm)	Length (mm)
		Direct water supply	50/100	300
			150/200	400
		Circular water supply	100 /150/ 200	600/700/800
250/300	700/800/900			
Silencer		Three options:L=600mm,L=900mm,L=1200mm		
Diffuser		L=700mm		
Access Door		L=600mm		

Quick selection table

Unit model	Air volume	Face area	Air flow			External static pressure	Fan impeller diameter	Motor input
	m ³ /h		2.25m/s	2.5m/s	2.75m/s			
MKZ0609	2680	0.30	2412	2680	2948	200	180	1.1
MKZ0612	3760	0.42	3384	3760	4137	200	225	1.1
MKZ0909	4595	0.51	4135	4595	5054	210	250	1.5
MKZ0912	6447	0.72	5802	6447	7091	220	280	2.2
MKZ0915	8298	0.92	7468	8298	9128	220	315	2.2
MKZ1212	9133	1.01	8219	9133	10046	260	335	2.2
MKZ1215	11756	1.31	10580	11756	12931	260	400	3.0
MKZ1218	14670	1.63	13203	14670	16137	280	450	4.0
MKZ1221	17585	1.95	15827	17585	19344	300	500	5.5
MKZ1518	18122	2.01	16310	18122	19934	320	500	5.5
MKZ1524	25083	2.79	22575	25083	27591	360	560	7.5
MKZ1821	26895	2.99	24205	26895	29584	380	560	11.0
MKZ1827	35513	3.95	31962	35513	39064	420	710	11.0
MKZ2124	35833	3.98	32250	35833	39416	440	710	11.0
MKZ2127	40977	4.55	36879	40977	45074	460	710	15.0
MKZ2427	46440	5.16	41796	46440	51084	500	800	15.0
MKZ2433	58099	6.46	52289	58099	63909	560	900	22.0
MKZ2733	68351	7.59	61516	68351	75187	620	900	30.0
MKZ2736	74524	8.28	67071	74524	81976	680	1000	30.0
MKZ3036	81976	9.11	73778	81976	90174	740	1000	37.0
MKZ3042	97064	10.78	87357	97064	106770	800	1120	55.0
MKZ3342	105888	11.77	95299	105888	116476	840	1120	55.0
MKZ3645	124187	13.80	111768	124187	136606	880	1250	75.0
MKZ3654	151448	16.83	136303	151448	166592	920	1400	75.0
MKZ3663	178708	19.86	160837	178708	196579	960	1400	90.0

Notes:

1. Larger modular air handing units up to 200,000 m³/h air volume can be customized by Midea.
2. It is suggested that air flow rate do not exceed 3m/s.
3. The above performance are for reference only, and may deviate from latest development. Please contact your local Midea sales representative for detail and updated selections.

Standard combination

Horizontal STD combination 1: Prefilter + Cooling coil + Supply air fan

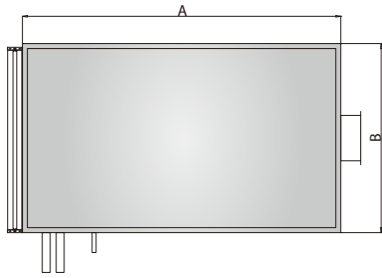
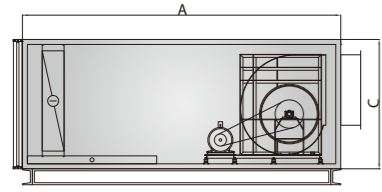

Unit model	A	B	C	Net weight
	mm	mm	mm	kg
MKZ0609	1500	950	650	295
MKZ0612	1600	1250	650	342
MKZ0909	1600	950	950	369
MKZ0912	1700	1250	950	432
MKZ0915	1800	1550	950	491
MKZ1212	1900	1250	1250	542
MKZ1215	2000	1550	1250	618
MKZ1218	2100	1850	1250	715
MKZ1221	2200	2150	1250	813
MKZ1518	2200	1850	1550	838
MKZ1524	2400	2450	1550	1068
MKZ1821	2400	2150	1850	1174

Horizontal STD combination 2: Mixing chamber + Prefilter + Cooling coil + Supply air fan

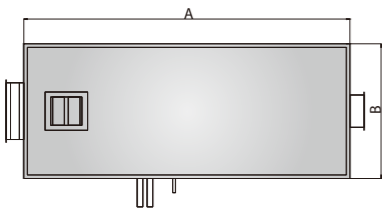
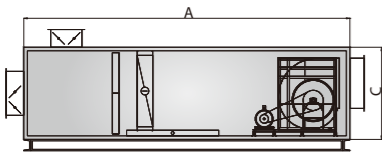

Unit model	A	B	C	Net weight
	mm	mm	mm	kg
MKZ0609	2200	950	650	386
MKZ0612	2300	1250	650	441
MKZ0909	2300	950	950	471
MKZ0912	2400	1250	950	544
MKZ0915	2500	1550	950	610
MKZ1212	2600	1250	1250	671
MKZ1215	2700	1550	1250	763
MKZ1218	2800	1850	1250	876
MKZ1221	2900	2150	1250	966
MKZ1518	2900	1850	1550	995
MKZ1524	3100	2450	1550	1244
MKZ1821	3100	2150	1850	1355

Horizontal STD combination 3: Mixing chamber + Prefilter +Dense pleated filter + Cooling coil + Supply air fan

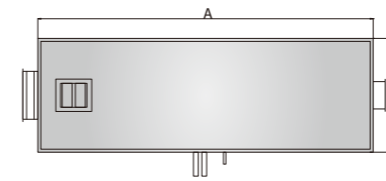
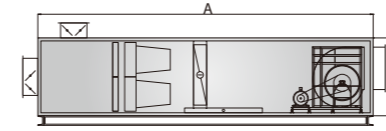

Unit model	A	B	C	Net weight
	mm	mm	mm	kg
MKZ0609	2700	950	650	452
MKZ0612	2800	1250	650	516
MKZ0909	2800	950	950	550
MKZ0912	2900	1250	950	624
MKZ0915	3000	1550	950	706
MKZ1212	3100	1250	1250	762
MKZ1215	3200	1550	1250	864
MKZ1218	3300	1850	1250	1007
MKZ1221	3400	2150	1250	1104
MKZ1518	3400	1850	1550	1135
MKZ1524	3600	2450	1550	1447
MKZ1821	3600	2150	1850	1502

Horizontal STD combination 4: Mixing chamber + Prefilter +Dense pleated filter + Cooling coil + Humidifier + Supply air fan

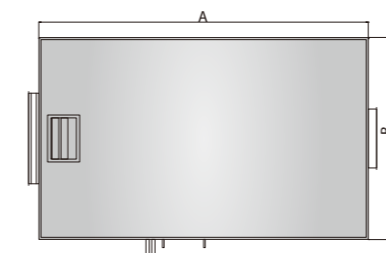
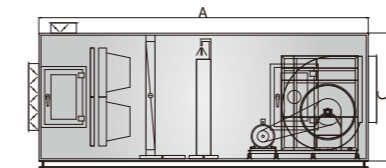

Unit model	A	B	C	Net weight
	mm	mm	mm	kg
MKZ0609	3100	950	650	545
MKZ0612	3200	1250	650	637
MKZ0909	3200	950	950	671
MKZ0912	3300	1250	950	777
MKZ0915	3400	1550	950	881
MKZ1212	3500	1250	1250	957
MKZ1215	3600	1550	1250	1101
MKZ1218	3700	1850	1250	1266
MKZ1221	3800	2150	1250	1395
MKZ1518	3800	1850	1550	1437
MKZ1524	4000	2450	1550	1782
MKZ1821	4000	2150	1850	1910

Notes:

1. Height of unit = C + Height of base.
2. Two kinds of base height can be optioned: 80mm and 100mm.
3. Section should be CKD transported if a. The divided section's length is over 4000mm. or b. Divided section's length and width is over 2300mm at the same time.
4. The above data are for reference only, and may deviate from latest development. Please contact your local Midea sales representative for detail and updated data.

Vertical STD combination 1: Prefilter + Cooling coil + Supply air fan

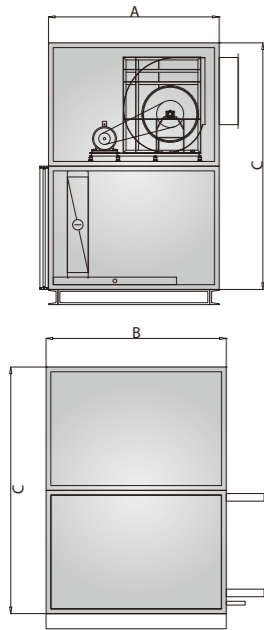

Unit model	A	B	C	Net weight
	mm	mm	mm	kg
MKZ0609	900	950	1300	305
MKZ0612	1000	1250	1300	363
MKZ0909	1000	950	1900	385
MKZ0912	1100	1250	1900	461
MKZ0915	1200	1550	1900	534
MKZ1212	1300	1250	2500	257+332
MKZ1215	1400	1550	2500	300+383
MKZ1218	1500	1850	2500	352+445
MKZ1221	1600	2150	2500	414+500
MKZ1518	1600	1850	3100	418+517
MKZ1524	1800	2450	3100	568+639
MKZ1821	1800	2150	3700	625+677
MKZ1827	2200	2750	3700	830+984

Vertical STD combination 2: Mixing chamber + Prefilter + Cooling coil + Humidifier + Supply air fan

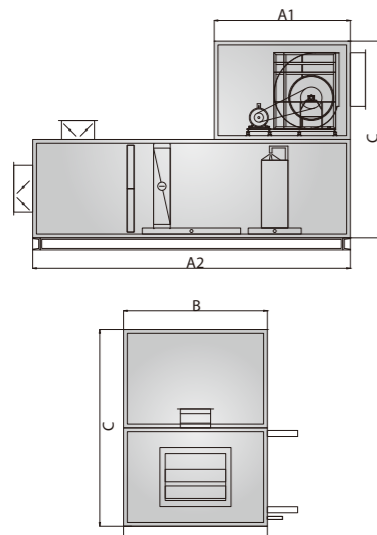

Unit model	A1	A2	B	C	Net weight A1+A2
	mm	mm	mm	mm	kg
MKZ0609	900	2000	950	1300	136+357
MKZ0612	1000	2000	1250	1300	157+412
MKZ0909	1000	2000	950	1900	171+436
MKZ0912	1100	2000	1250	1900	197+504
MKZ0915	1200	2000	1550	1900	230+570
MKZ1212	1300	2000	1250	2500	262+597
MKZ1215	1400	2100	1550	2500	310+692
MKZ1218	1500	2100	1850	2500	352+796
MKZ1221	1600	2100	2150	2500	414+867
MKZ1518	1600	2100	1850	3100	418+899
MKZ1524	1800	2300	2450	3100	622+1065
MKZ1821	1800	2300	2150	3700	625+1181
MKZ1827	2200	2700	2750	3700	888+1579

Vertical STD combination 3: Mixing chamber + Prefilter + Dense pleated filter + Cooling coil + Humidifier + Supply air fan

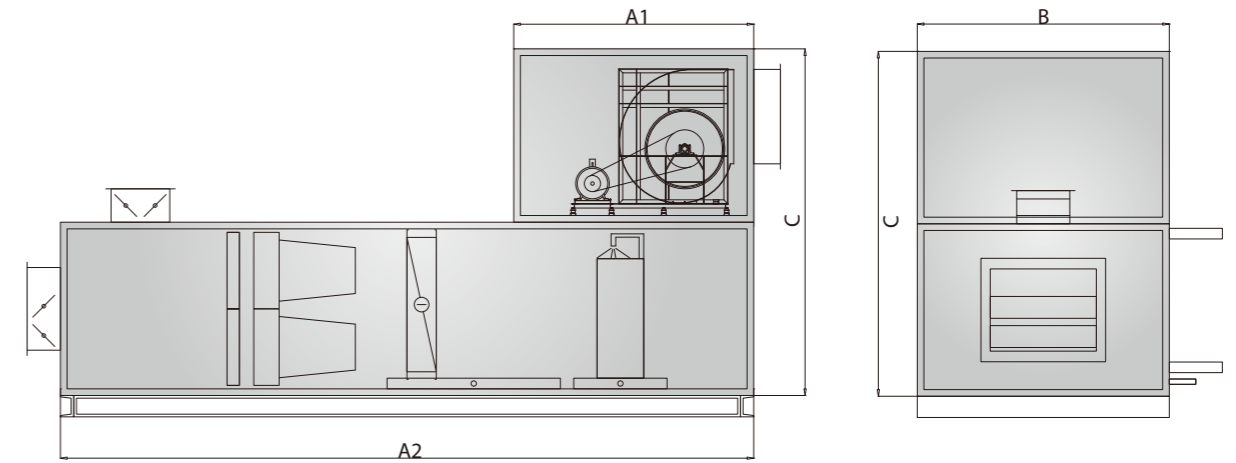

Unit model	A1	A2	B	C	Net weight A1+A2
	mm	mm	mm	mm	kg
MKZ0609	900	2500	950	1300	136+418
MKZ0612	1000	2500	1250	1300	165+483
MKZ0909	1000	2500	950	1900	171+507
MKZ0912	1100	2500	1250	1900	202+584
MKZ0915	1200	2500	1550	1900	230+661
MKZ1212	1300	2500	1250	2500	273+688
MKZ1215	1400	2600	1550	2500	328+792
MKZ1218	1500	2600	1850	2500	369+907
MKZ1221	1600	2600	2150	2500	429+990
MKZ1518	1600	2600	1850	3100	433+1024
MKZ1524	1800	2800	2450	3100	622+1214
MKZ1821	1800	2800	2150	3700	625+1328
MKZ1827	2200	3000	2750	3700	841+1787

Notes:

1. Height of unit = C + Height of base.
2. Two kinds of base height can be optioned: 80mm and 100mm.
3. Section should be CKD transported if a. The divided section's length is over 4000mm. or b. Divided section's length and width is over 2300mm at the same time.
4. The above data are for reference only, and may deviate from latest development. Please contact your local Midea sales representative for detail and updated data.

Horizontal STD combination 1:
Prefilter + Cooling coil + Supply air fan

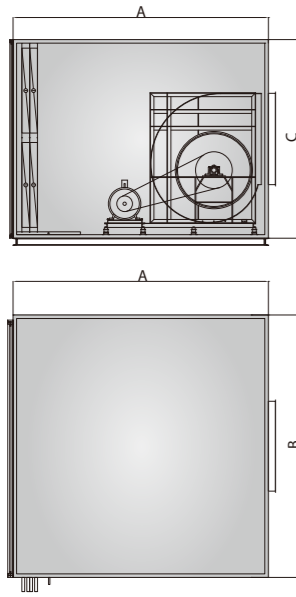

Unit model	A	B	C	Net weight
	mm	mm	mm	kg
MKZ1827	2700	2750	1850	1603
MKZ2124	2700	2450	2150	1642
MKZ2127	2700	2750	2150	1779
MKZ2427	2800	2770	2470	2078
MKZ2433	3000	3370	2470	2537
MKZ2733	3000	3400	2800	2854
MKZ2736	3500	3700	2800	3292
MKZ3036	3500	3700	3100	3556
MKZ3042	3800	4100	3100	3542
MKZ3342	3800	4300	3400	4372
MKZ3645	900+3200	4600	3700	1786+3314
MKZ3654	900+3500	5500	3700	2088+4159
MKZ3663	900+3500	6400	3700	2369+4310

Horizontal STD combination 2:
Mixing chamber + Prefilter + Cooling coil + Supply air fan

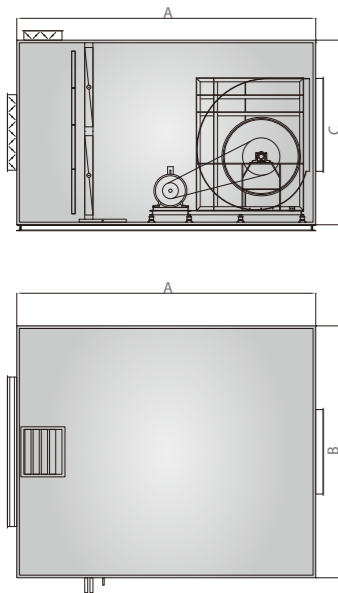

Unit model	A	B	C	Net weight
	mm	mm	mm	kg
MKZ1827	3600	2750	1850	1878
MKZ2124	3600	2450	2150	1954
MKZ2127	3600	2750	2150	2057
MKZ2427	3700	2770	2470	2489
MKZ2433	3900	3370	2470	2878
MKZ2733	3900	3400	2800	3263
MKZ2736	1700+2600	3700	2800	1620+2159
MKZ3036	1700+2600	3700	3100	1769+2208
MKZ3042	1700+2900	4300	3100	2042+2574
MKZ3342	1700+3000	4300	3400	2026+2014
MKZ3645	1800+3200	4600	3700	2268+2370
MKZ3654	1800+3500	5500	3700	2600+4159
MKZ3663	1800+3500	6400	3700	2920+4310

Horizontal STD combination 3:
Mixing chamber + Prefilter +Dense pleated filter + Cooling coil + Supply air fan

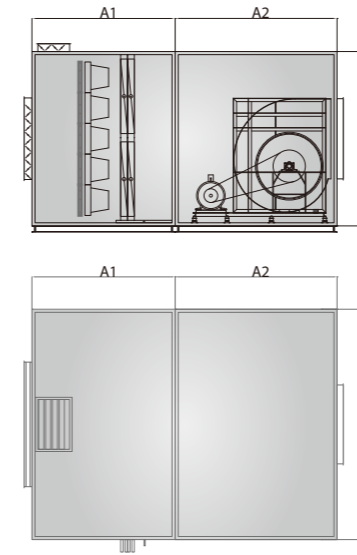

Unit model	A1	A2	B	C	Net weight A1+A2
	mm	mm	mm	mm	kg
MKZ1827	1900	2200	2750	1850	1094+1034
MKZ2124	1900	2200	2450	2150	1120+1003
MKZ2127	1900	2200	2750	2150	1204+1095
MKZ2427	1900	2300	2770	2470	1348+1420
MKZ2433	1900	2500	3370	2470	1532+1704
MKZ2733	1900	2500	3400	2800	1755+1929
MKZ2736	2200	2600	3700	2800	1975+2159
MKZ3036	2200	2600	3700	3100	2145+2318
MKZ3042	2200	2900	4300	3100	2345+2709
MKZ3342	2200	2900	4300	3400	2466+2014
MKZ3645	2300	3200	4600	3700	2750+2370
MKZ3654	2300	3500	5500	3700	3154+4159
MKZ3663	2300	3500	6400	3700	3549+4319

Horizontal STD combination 4:
Mixing chamber + Prefilter +Dense pleated filter + Cooling coil + Humidifier + Supply air fan

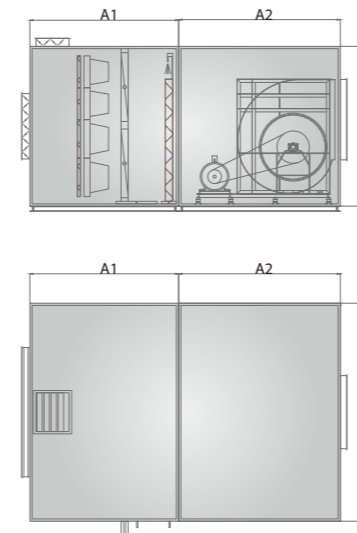

Unit model	A1	A2	B	C	Net weight A1+A2
	mm	mm	mm	mm	kg
MKZ1827	2300	2200	2750	1850	1562+987
MKZ2124	2300	2200	2450	2150	1599+1003
MKZ2127	2300	2200	2750	2150	1731+1095
MKZ2427	2300	2300	2770	2470	1946+1420
MKZ2433	2200	2500	3370	2470	2102+1704
MKZ2733	2600	2500	3400	2800	2273+1929
MKZ2736	2900	2600	3700	2800	2523+2269
MKZ3036	2900	2600	3700	3100	2735+2318
MKZ3042	2900	2900	4300	3100	2901+1953
MKZ3342	2900	3000	4300	3400	3155+2162
MKZ3645	3000	3200	4600	3700	3511+2370
MKZ3654	3000	3500	5500	3700	4007+4159
MKZ3663	3000	3500	6400	3700	4505+4319

Notes:

1. Height of unit = C + Height of base.
2. Two kinds of base height can be optioned: 80mm and 100mm.
3. Section should be CKD transported if a. The divided section's length is over 4000mm. or b. Divided section's length and width is over 2300mm at the same time.
4. The above data are for reference only, and may deviate from latest development. Please contact your local Midea sales representative for detail and updated data.

Cooling coil—Fresh air condition

Unit model	Entering air: 35°C WB / 28°C DB, entering water: 7°C								
	Air volume	4-rows					6-rows		
		Cooling capacity	Sensible cooling capacity	Air resistance	Water flow	Water pressure drop	Cooling capacity	Sensible cooling capacity	Air resistance
	m ³ /h	kW	kW	Pa	L/s	kPa	kW	kW	Pa
MKZ0609	2680	32.9	14.27	88	1.6	46.45	41.37	17.54	132
MKZ0612	3760	46.82	20.24	88	2.2	47.88	60.01	25.34	132
MKZ0909	4595	56.42	24.47	88	2.7	44.95	70.12	29.77	132
MKZ0912	6447	80.29	34.71	88	3.8	44.55	102.34	43.25	132
MKZ0915	8298	104.79	45.17	88	4.6	73.65	130.99	55.39	132
MKZ1212	9133	113.73	49.17	88	5.4	51.87	145.77	61.56	132
MKZ1215	11756	142.28	61.88	88	6.8	30.32	185.58	78.48	132
MKZ1218	14670	182.69	78.96	88	8.7	54.15	226.43	96.00	132
MKZ1221	17585	222.07	95.71	88	9.9	75.80	277.59	117.36	132
MKZ1518	18122	225.68	97.54	88	10.7	51.15	279.71	118.59	132
MKZ1524	25083	312.36	135.05	88	12.2	79.40	391.55	165.78	132
MKZ1821	26895	311.34	136.88	88	14.8	13.37	424.56	179.49	132
MKZ1827	35513	429.79	186.98	88	20.5	28.15	535.68	227.89	132
MKZ2124	35833	427.38	186.50	88	20.4	21.57	527.94	225.36	132
MKZ2127	40977	495.92	215.75	88	23.6	30.43	618.10	262.95	132
MKZ2427	46440	562.03	244.52	88	26.8	33.34	700.51	298.01	132
MKZ2433	58099	723.52	312.78	88	34.5	59.58	896.75	380.25	132
MKZ2733	68351	851.19	367.97	88	40.5	69.36	1054.99	447.35	132
MKZ2736	74524	941.13	405.59	88	44.8	62.32	1163.34	492.57	132
MKZ3036	81976	1035.24	446.21	90	49.3	64.60	1279.67	541.68	135
MKZ3042	97064	1123.63	493.80	90	53.5	16.92	1532.22	647.87	135
MKZ3342	105888	1300.07	563.68	88	62.10	37.06	1690.09	713.74	132
MKZ3645	124187	1524.74	660.95	90	72.83	44.65	1938.60	820.63	134
MKZ3654	151448	1912.15	824.39	90	91.31	76.09	2390.71	1010.93	134
MKZ3663	178708	2225.48	961.90	90	160.30	60.22	2789.69	1180.86	134

Notes:

- Totally fresh air cooling condition: Entering air: 35°C WB / 28°C DB, entering water: 7°C, leaving water: 12°C.
- Coil is copper tube and aluminum fin type, the water velocity is 0.8~2.0 m/s.
- The above performance are for reference only, and may deviate from latest development.
Please contact your local Midea sales representative for detail and updated selections.

Unit model	Entering air: 35°C WB / 28°C DB, entering water: 7°C							
	Air volume	6-rows			8-rows			
		Water flow	Water pressure drop	Cooling capacity	Sensible cooling capacity	Air resistance	Water flow	Water pressure drop
	m ³ /h	L/s	kPa	kW	kW	Pa	L/s	kPa
MKZ0609	2680	2	33.72	48.18	20.22	176	2.3	72.37
MKZ0612	3760	2.9	79.61	67.27	28.24	176	3.2	59.85
MKZ0909	4595	3.3	30.15	82.21	34.51	176	3.9	66.97
MKZ0912	6447	4.9	72.01	115.34	48.41	176	5.5	58.27
MKZ0915	8298	6.2	68.54	147.00	61.73	176	7.0	47.47
MKZ1212	9133	6.9	73.15	163.39	68.59	176	7.8	56.01
MKZ1215	11756	8.8	65.65	208.26	87.46	176	9.9	47.61
MKZ1218	14670	10.8	38.92	257.31	108.12	176	12.3	33.82
MKZ1221	17585	13.2	62.80	313.06	131.42	176	14.9	53.38
MKZ1518	18122	13.3	42.93	317.85	133.56	176	15.1	40.60
MKZ1524	25083	18.7	59.51	417.95	176.38	176	19.9	40.68
MKZ1821	26895	20.2	58.04	478.81	201.00	176	22.8	46.94
MKZ1827	35513	25.5	27.08	604.20	254.44	176	28.8	27.63
MKZ2124	35833	25.1	22.41	641.07	269.10	176	30.5	71.11
MKZ2127	40977	29.4	31.71	697.16	293.58	176	33.2	33.52
MKZ2427	46440	33.4	36.99	790.11	332.72	176	37.6	40.24
MKZ2433	58099	42.7	63.79	1013.94	426.09	176	48.3	68.65
MKZ2733	68351	50.3	78.81	1192.86	501.27	176	56.8	87.86
MKZ2736	74524	55.4	51.25	1320.20	554.48	176	62.9	47.15
MKZ3036	81976	61.0	47.00	1437.83	604.26	180	68.5	37.86
MKZ3042	97064	73.0	72.55	1728.01	725.45	180	82.3	58.45
MKZ3342	105888	80.73	73.36	1894.39	795.21	176	90.49	60.43
MKZ3645	124187	92.60	48.99	2221.76	932.33	179	106.13	75.28
MKZ3654	151448	114.20	80.05	2682.91	1126.42	179	128.15	85.71
MKZ3663	178708	133.25	83.71	3131.40	1304.84	179	149.58	93.73

Unit model	Entering air: 27°C WB / 19.5°C DB, entering water: 7°C								
	Air volume at 2.5m/s	4-rows					6-rows		
		Cooling capacity	Sensible cooling capacity	Air resistance	Water flow	Water pressure drop	Cooling capacity	Sensible cooling capacity	Air resistance
m ³ /h	kW	kW	Pa	L/s	kPa	kW	kW	Pa	
MKZ0609	2680	13.39	10.44	88	0.6	9.35	18.24	12.90	132
MKZ0612	3760	20.08	15.15	88	1.0	23.32	26.56	18.49	132
MKZ0909	4595	22.96	17.91	88	1.1	9.11	31.27	22.12	132
MKZ0912	6447	34.43	25.97	88	1.6	22.77	45.54	31.71	132
MKZ0915	8298	45.74	33.98	88	2.2	44.23	57.89	40.52	132
MKZ1212	9133	48.77	36.80	88	2.3	21.46	64.51	44.92	132
MKZ1215	11756	64.81	48.17	88	3.1	41.92	82.02	57.40	132
MKZ1218	14670	83.40	61.09	88	4.0	76.43	105.51	72.94	132
MKZ1221	17585	99.21	72.95	88	4.7	62.01	124.20	86.50	132
MKZ1518	18122	103.02	75.46	88	4.9	79.38	130.34	90.11	132
MKZ1524	25083	143.68	104.92	88	6.8	82.68	180.40	124.74	132
MKZ1821	26895	151.74	111.58	88	7.2	57.76	189.96	132.29	132
MKZ1827	35513	195.77	145.45	88	9.3	37.15	247.77	173.42	132
MKZ2124	35833	205.25	149.88	88	9.8	84.62	257.72	178.20	132
MKZ2127	40977	225.89	167.83	88	10.8	38.16	285.89	200.10	132
MKZ2427	46440	256.01	190.21	88	12.2	39.31	324.01	226.78	132
MKZ2433	58099	330.29	241.98	88	15.7	72.72	415.36	287.79	132
MKZ2733	68351	388.57	284.68	88	18.5	69.70	488.66	338.58	132
MKZ2736	74524	410.83	305.27	88	19.6	42.88	539.21	371.81	132
MKZ3036	81976	451.91	335.55	90	21.5	44.34	593.13	408.95	135
MKZ3042	97064	551.80	404.01	90	26.3	71.23	685.57	477.36	135
MKZ3342	105888	601.91	441.07	88	28.75	71.11	747.90	520.81	132
MKZ3645	124187	663.21	500.11	90	31.68	26.04	887.84	615.18	134
MKZ3654	151448	834.88	619.94	90	39.88	45.06	1056.65	739.54	134
MKZ3663	178708	1015.94	743.90	90	48.53	71.99	1277.63	885.22	134

Notes:

1. Return air cooling condition: Entering air: 27°C WB / 19.5°C DB, entering water: 7°C, leaving water: 12°C.
2. Coil is copper tube and aluminum fin type, the water velocity is 0.8~2.0 m/s.
3. The above performance are for reference only, and may deviate from latest development.
Please contact your local Midea sales representative for detail and updated selections.

Unit model	Entering air: 27°C WB / 19.5°C DB, entering water: 7°C							
	Air volume at 2.5m/s	6-rows		8-rows				
		Water flow	Water pressure drop	Cooling capacity	Sensible cooling capacity	Air resistance	Water flow	Water pressure drop
m ³ /h	L/s	kPa	kW	kW	Pa	L/s	kPa	
MKZ0609	2680	0.9	22.25	21.58	14.49	176	1.0	37.99
MKZ0612	3760	1.3	53.01	30.61	20.46	176	1.5	41.00
MKZ0909	4595	1.5	21.79	37.01	24.84	176	1.8	37.35
MKZ0912	6447	2.2	52.05	52.20	34.97	176	2.5	38.00
MKZ0915	8298	2.8	31.47	68.62	45.62	176	3.3	73.23
MKZ1212	9133	3.1	49.75	74.34	49.70	176	3.5	42.48
MKZ1215	11756	3.9	31.90	97.21	64.63	176	4.6	80.70
MKZ1218	14670	5.0	58.22	119.41	79.82	176	5.7	44.42
MKZ1221	17585	5.9	42.54	146.17	96.98	176	7.0	72.30
MKZ1518	18122	6.2	59.72	147.51	98.60	176	7.0	43.14
MKZ1524	25083	8.6	60.92	205.25	136.99	176	9.8	48.98
MKZ1821	26895	9.0	40.51	223.55	148.32	176	10.6	69.49
MKZ1827	35513	11.8	27.75	295.19	195.84	176	14.1	70.93
MKZ2124	35833	12.3	61.34	293.22	195.70	176	14.0	45.91
MKZ2127	40977	13.6	28.51	340.60	225.97	176	16.2	66.25
MKZ2427	46440	15.4	29.37	386.01	256.09	176	18.4	68.27
MKZ2433	58099	19.8	53.74	472.91	316.14	176	22.5	44.62
MKZ2733	68351	23.3	56.21	556.36	371.93	176	26.5	48.80
MKZ2736	74524	25.7	70.58	616.24	409.74	176	29.4	53.29
MKZ3036	81976	28.3	78.08	670.80	447.55	180	32.0	53.80
MKZ3042	97064	32.7	49.36	802.62	533.46	180	38.2	83.70
MKZ3342	105888	35.72	49.27	861.91	576.20	176	41.17	38.54
MKZ3645	124187	42.41	60.64	1016.20	678.02	179	48.54	46.62
MKZ3654	151448	50.47	34.16	1252.32	832.37	179	59.82	78.29
MKZ3663	178708	61.03	53.97	1446.95	969.14	179	69.12	44.11

Unit model	Air volume at 2.5m/s	1-row					
		Return air condition (15°C)			Fresh air condition (7°C)		
		Heating capacity	Water flow	Water pressure drop	Heating capacity	Water flow	Water pressure drop
		m ³ /h	kW	L/s	kPa	kW	L/s
MKZ0609	2680	8.4	0.2	9	10.1	0.24	13
MKZ0612	3760	11.5	0.28	17	13.8	0.33	24
MKZ0909	4595	14.4	0.34	9	17.3	0.41	13
MKZ0912	6447	19.4	0.46	17	23.3	0.56	23
MKZ0915	8298	26.6	0.64	30	32	0.76	43
MKZ1212	9133	30.2	0.72	20	36.3	0.87	28
MKZ1215	11756	39.6	0.95	33	47.5	1.14	47
MKZ1218	14670	50.4	1.2	81	60.5	1.44	74
MKZ1221	17585	63.4	1.51	15	76	1.82	115
MKZ1518	18122	63.4	1.51	25	76	1.82	35
MKZ1524	25083	90.0	2.15	49	108	2.58	69
MKZ1821	26895	93.6	2.24	35	112.3	2.68	50
MKZ1827	35513	126.7	3.03	63	152.1	3.63	89
MKZ2124	35833	126.7	3.03	48	152.1	3.63	67
MKZ2127	40977	143.3	3.42	60	171.9	4.11	85
MKZ2427	46440	165.6	3.96	62	198.7	4.75	89
MKZ2433	58099	208.8	4.99	97	250.6	5.99	138
MKZ2733	68351	244.8	5.85	97	293.8	7.02	137
MKZ2736	74524	259.2	6.19	29	311	7.43	41
MKZ3036	81976	288.0	6.88	29	345.6	8.26	41
MKZ3042	97064	352.8	8.43	43	423.4	10.11	61
MKZ3342	105888	381.6	9.12	42	457.9	10.94	60
MKZ3645	124187	439.2	10.49	46	527.0	12.59	65
MKZ3654	151448	540.0	12.90	68	648.0	15.48	96
MKZ3663	178708	619.2	14.79	88	743.0	17.75	125

Notes:

- Return air heating condition: Entering air:15°C DB, entering water: 60°C, leaving water:50°C.
- Fresh air heating condition: Entering air:7°C DB, entering water: 60°C, leaving water:50°C.
- Coil is copper tube and aluminum fin type, the water velocity is 0.8~2.0 m/s.
- The above performance are for reference only, and may deviate from latest development.
Please contact your local Midea sales representative for detail and updated selections.

Unit model	Air volume at 2.5m/s	2-rows					
		Return air condition (15°C)			Fresh air condition (7°C)		
		Heating capacity	Water flow	Water pressure drop	Heating capacity	Water flow	Water pressure drop
		m ³ /h	kW	L/s	kPa	kW	L/s
MKZ0609	2680	14.0	0.33	25	17.9	0.43	40
MKZ0612	3760	19.1	0.46	45	24.5	0.59	72
MKZ0909	4595	23.9	0.57	25	30.7	0.73	40
MKZ0912	6447	32.3	0.77	44	41.4	0.99	70
MKZ0915	8298	44.2	1.06	37	56.7	1.36	59
MKZ1212	9133	50.2	1.2	24	64.4	1.54	39
MKZ1215	11756	65.7	1.57	40	84.3	2.01	65
MKZ1218	14670	83.7	2	17	107.4	2.56	27
MKZ1221	17585	105.2	2.51	26	135	3.22	42
MKZ1518	18122	105.2	2.51	18	135	3.22	28
MKZ1524	25083	149.4	3.57	34	191.7	4.58	55
MKZ1821	26895	155.4	3.71	25	199.4	4.76	40
MKZ1827	35513	210.4	5.03	44	269.9	6.45	71
MKZ2124	35833	210.4	5.03	33	269.9	6.45	54
MKZ2127	40977	237.8	5.68	42	305.2	7.29	68
MKZ2427	46440	274.9	6.57	44	352.7	8.43	70
MKZ2433	58099	346.6	8.28	68	444.7	10.62	110
MKZ2733	68351	406.4	9.71	68	444.7	10.62	110
MKZ2736	74524	430.3	10.28	20	552.1	13.19	32
MKZ3036	81976	478.1	11.42	20	613.4	14.65	33
MKZ3042	97064	585.6	13.99	30	751.5	17.95	49
MKZ3342	105888	633.5	15.13	30	812.8	19.42	48
MKZ3645	124187	729.1	17.42	32	935.5	22.35	54
MKZ3654	151448	896.4	21.41	48	1150.2	27.48	77
MKZ3663	178708	1027.9	24.55	62	1318.9	31.51	100

Selection software

To help customers define their product requirements easily, a user-friendly software selection program is provided. The program leads the user through the selection process by pertinent input data for all components required. Component sections are selected by placing them on a configure screen. Once the unit layout is defined, the options and accessories are identified. The program gives immediate feedback about fan and coil selection, offering serial options based on the performance inputs. Once final component selections have been made, the program provides all output needed, including unit specification, dimension, weights, fan curves and so on.



● Main interface

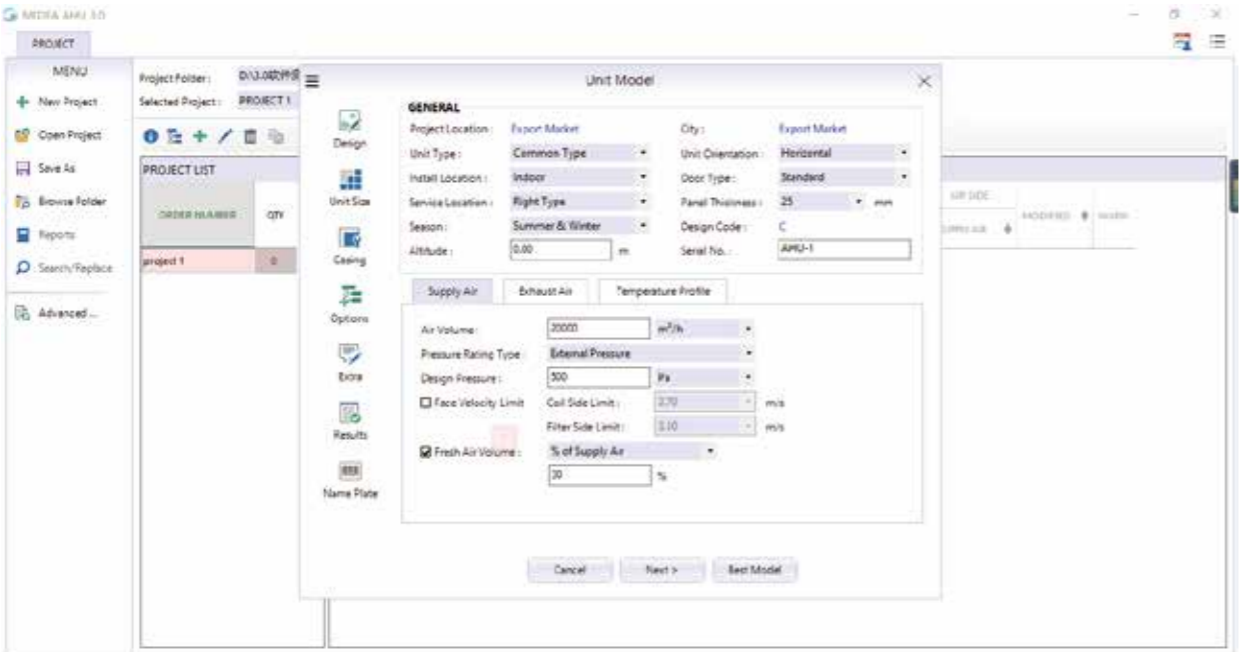

● Selection interface

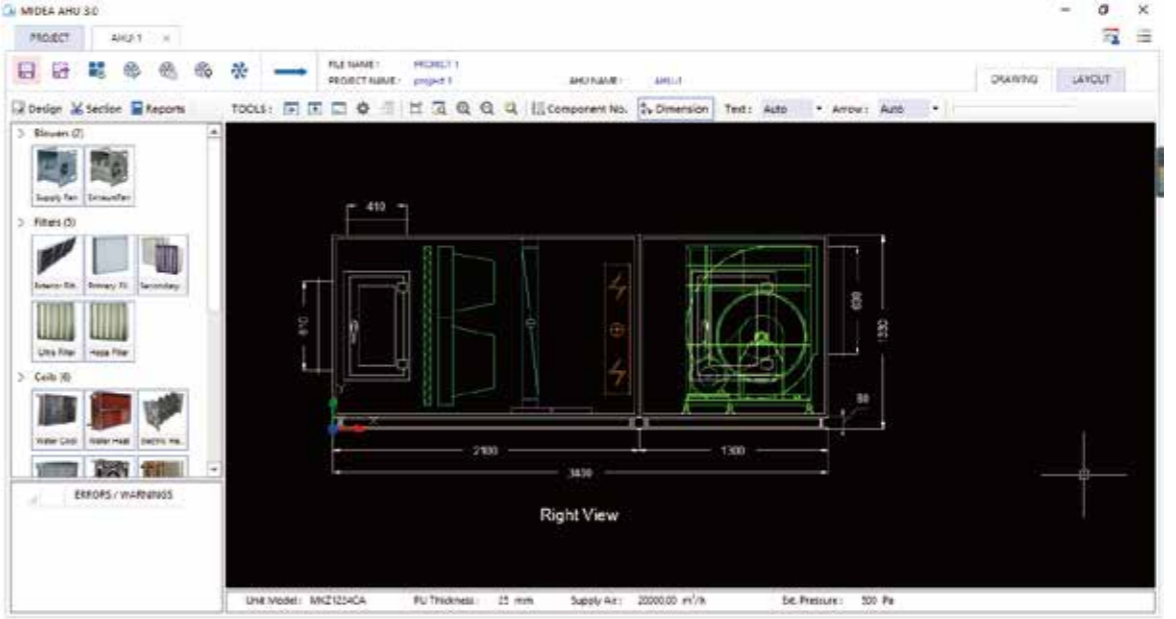

● Report interface

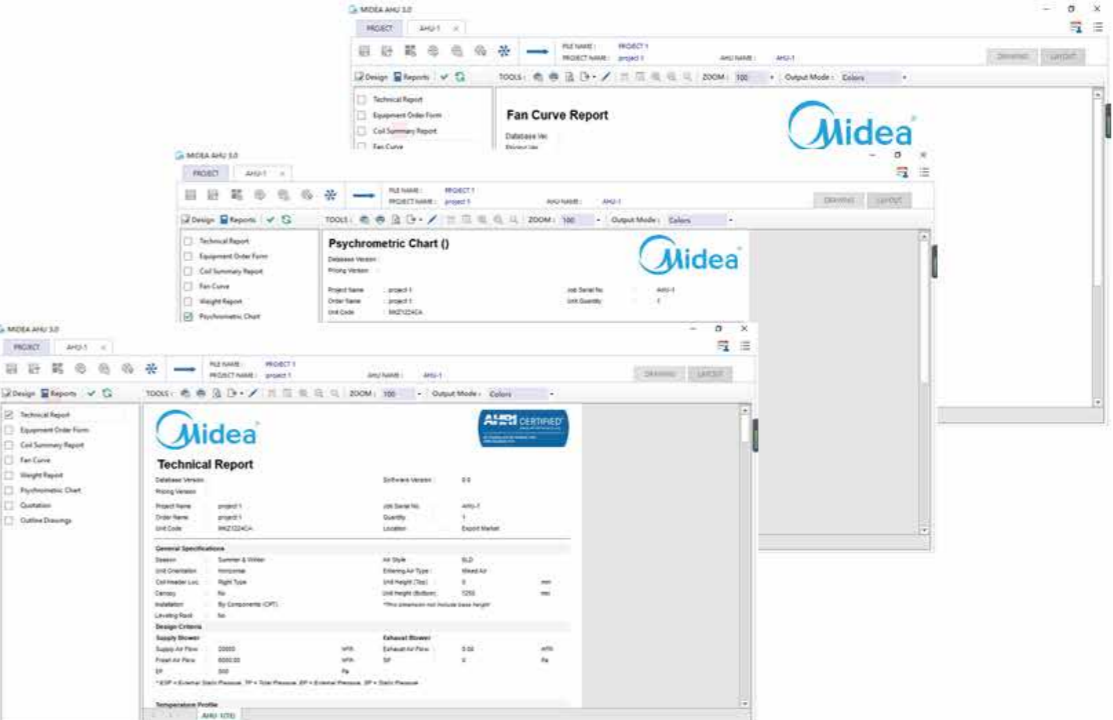

Installation

- Unit should be installed on a horizontal foundation to avoid running noise and keep the condensing water draining smoothly.
- Allow sufficient space for maintenance. At least 1m width should be reserved in the direction of setting up the accesses door as shown in figure installation space.

Piping

- Flexible fittings should be used in water piping to absorb thermal expansion and contraction strains.
- Drainage pipe should be equipped a U shape water seal to keep water draining fluently as shown in figure draining pipe.

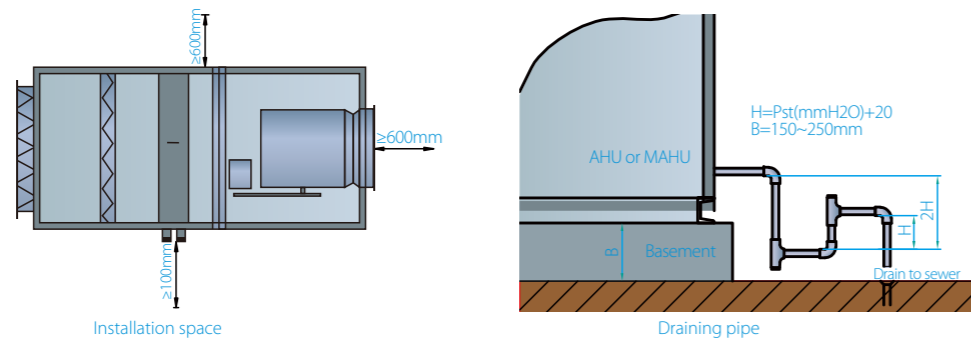

Wiring

- Wiring according to electric diagram as shown in the right picture.
- Unit shell must have reliable earthing.
- One motor one protection switch.
- During unit running time, the power voltage fluctuate value must less than 10%, frequency fluctuate value less than 2%.

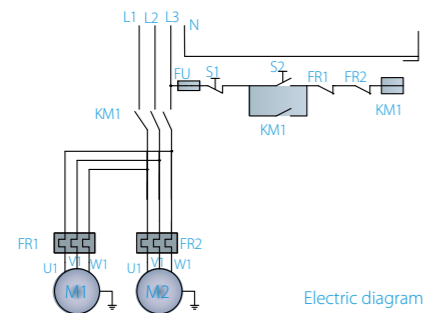

Water supply

- The water supplied in the water system should be soft, clean water. Before water supply, the water system should be washed to clean away all the scraps and patches compounds first. At last, exhaust the air in the coil by discharge valve on the top of the water outlet pipe.
- If unit is running in winter season and is planning to stop for some time, the following steps should be taken to avoid damage on the coil: keep the water in coil circulating continuously; added in some antifreeze; close the fresh air inlet damper.
- If unit stop running in winter season, water in the coil must be drained out completely to keep the coil dry.

Start-up requirements

- Before start-up the units, do make sure that ductwork is clean, filters are in place, bearings lubricated, condensate properly trapped, piping connections verified and leak tested, belts aligned and tensioned, all shipping braces have been removed, and fan has been test run under observation.

Maintenance

- Check and make sure valves in water pipe and air duct are in normal working condition before unit running.
 - Check the lubrication of fan bearings and tension of belts regularly.
 - Check and adjust the connection, operation and transmission of fan, motor and other moving parts regularly.
 - Wash the air filters once a month.
 - Exhaust the water in the coil if the unit stops using for a long period.
 - In winter, keep the water in the coil circulating when stop the unit for a short time.
 - The water in the coil should be softened water. Clear away scale in the coil and dirty thing among the fins once a year.
- For the detail information about installation, usage and maintenance, please refer to the 'installation manual', or consult Midea company.