

F1 TEST LATEST McLAREN'S HIDDEN PACE

AUTOSPORT

11-PAGE NEW CAR SPECIAL

FEBRUARY 14 2013 • £3.50 • autosport.com

FERRARI

Test verdict: "We're on a different planet to 2012"



Edd Straw watches trackside at first test run **p26**

The hits & misses of the car's evolution **p30**

Alonso & Massa set their targets for 2013 **p32**

Full analysis of its technical secrets **p36**



F1 is back on track
All the news from Jerez

Rally Sweden shock
Loeb trumped by landmark VW win

One-hit wonders
Formula 1's most random winners





"Provides the things that customers really want in a car, at a price they can afford"

- Neil Lyndon, Daily Telegraph, 26th August 2012

"SUV space for Supermini money"

- What Car?, August 2012

"Never has so little cash bought you such a roomy, adventurous vehicle"

- Nick Gibbs, Auto Express, April 2010

"A no nonsense machine that wears its bargain price tag like a badge of honour"

- Autocar, September 2012



Better than your
average quote.
From **£8,995***

You do the maths

"Actually you don't need to, because the answer is obvious"

- Richard Hammond, Daily Mirror, 29th June 2012



DACIA
GROUPE RENAULT

*Car shown is a Dacia Duster Laureate dCi 110 4x2 at £12,995 with optional front chrome bar at £235 and optional metallic paint at £470. Prices correct at time of print.

Dacia Duster | [To find a dealer visit dacia.co.uk](http://dacia.co.uk)

The official fuel consumption figures in mpg (l/100km) for the Dacia Duster dCi 110 4x2 are: Urban 49.6 (5.7); Extra Urban 61.4 (4.6); Combined 56.5 (5.0). The official CO₂ emission is 130g/km.

5 Year Warranty: Standard HP offer: Cash Price £8995, customer deposit £744, 60 monthly payments of £169, Representative APR 9.9%; 5yr Warranty for £5 offer: Cash Price £9390. £395 charge for cash customers or £300 charge (equivalent to just £5 a month over the 5 year term) for finance customers. Customer deposit £744, 60 monthly payments of £174, Representative APR 9.0%. On all agreements a £99 arrangement fee is payable with the first monthly payment plus a £149 Option to Purchase fee is payable with the final payment. Subject to status. Guarantees or indemnities may be required. You must be at least 18 years old and a UK resident (excluding Isle of Man and Channel Islands) to apply. Finance provided by RCI Financial Services Ltd., PO Box 149, Watford WD17 1F). At participating dealers only.

CONTENTS

February 14 2013 - vol 211 no 7



AUTOSPORT.COM

Up-to-the-minute news and reports from F1, WRC and more. Subscribe for must-read opinion, stats and images

"I was on my limit. I pushed hard and tried my best all the time, but he did a great race"
RALLY KING LOEB ADMITS HE HAD NO ANSWER IN SWEDEN FOR OGIER

COVER IMAGE: FERRARI INSETS: STALEY/LAT LAT ARCHIVE MCKLEIN.DE



FEATURES & REPORTS

- 26 Ferrari: ready to fight at the front**
Famous squad's new F1 car has hit the track at Jerez. Massa was fastest, but does this mean a title attack's on the cards?
- 30 Ferrari evolution**
Plotting how Scuderia's cars have changed over five years
- 32 Time heals wounds for Alonso and Massa**
How Ferrari's duo is shaping up after recent disappointments
- 36 Ferrari technical analysis**
Taking a look at Prancing Horse's new challenger, the F138
- 38 Timo Glock**
Interview with the man who went from Marussia to the DTM
- 42 Introducing...**
Formula Renault king and FR3.5 recruit Stoffel Vandoorne
- 47 World of Sport**
Bathurst 12 Hours, Toyota Racing Series, MRF Challenge
- 48 F1's kings for a day**
The stories behind those one-time grand prix winners
- 52 Rally Sweden**
A dominant win for Sebastien. But this time it's Ogier in a VW
- 56 The downfall of British F3**
How UK's top single-seater series ended up in a sorry state
- 60 Senna at Aston Martin**
How the F1 refugee is looking ahead to life in the WEC

NEWS

- 8 Gary Anderson's trackside view on new racers**
Assessing how the cars are performing, based on the opening four-day test of the pre-season at Jerez...
- 10 Drawing board: early developments on F1 class of 2013**
...and our technical expert casts his eye over what the teams did between launch and the first track runout at Jerez
- 12 Van der Garde: Caterham's slow-burner**
Dutchman reflects on career to date and his new opportunity
- 14 Razia gets his GP break at last**
GP2 veteran tells all on his graduation with Marussia
- 16 This week in F1**
What else has been going on while they were testing?
- 20 Pau Grand Prix looks to the future**
Organiser meets with FIA man Gerhard Berger to secure F3 European Championship date for 2014
- 22 Kobayashi closes on Ferrari deal - but it's GTs**
Japan's F1 podium hero joins Chandhok in tryout for new recruits to AF Corse's World Endurance line-up
- 24 Volkswagen reckons Polo's not the 'hole' deal yet**
German manufacturer claims Rally Sweden win was all down to Ogier as it plays down expectations of a WRC title

REGULARS

- 5 From the editor**
- 6 Snapshot**
- 19 Mark Hughes column**
- 76 Subscribe for a free gift**
- 80 Final drive**
Letters and latest gear
- 82 On track/on screen**
The best action in the next week
- 85 From the archive**
Volkswagen's first WRC win, Ivory Coast Rally, 1987
- 86 Race of my life**
Didier Artzet, Monaco F3 Grand Prix, 1987

SPORTS EXTRA

- 73 Stoneman flies in Carrera Cup test**
Ex-F2 champ could race Porsche as he recovers from illness
- 74 Ginetta ace moves team to Supercup**
Nicoll-Jones to campaign G55 with his own Academy squad
- 78 Legends to Daytona**
Club-racing ace Lawrence Davey makes most of prize drive

One-hit F1 wonders

Single grand prix winners who have never returned to the top of the grid

Jean Pierre Beltoise
The 1970 Formula 1 season was a rollercoaster for Jean Pierre Beltoise. He won the Monaco Grand Prix in a Ferrari 312B1, but then spent the rest of the season in the shadows. He never returned to the top of the grid.

Alessandro Nannini
Alessandro Nannini won the 1992 Italian Grand Prix in a Benetton B192. He was the only driver to win a race in a Benetton car. He never returned to the top of the grid.

Amnes Ireland
Amnes Ireland won the 1992 British Grand Prix in a Williams FW18C. He was the only driver to win a race in a Williams car. He never returned to the top of the grid.

ONE-HIT WONDERS

SOLO WINNERS

Amnes Ireland
Amnes Ireland won the 1992 British Grand Prix in a Williams FW18C. He was the only driver to win a race in a Williams car. He never returned to the top of the grid.

Amnes Ireland
Amnes Ireland won the 1992 British Grand Prix in a Williams FW18C. He was the only driver to win a race in a Williams car. He never returned to the top of the grid.

Trackside view from Jerez test

GARY ANDERSON offers his verdict on the 10 new machines that ran at the Jerez test last week, showing that the order on the timesheets is leading doesn't always reflect which cars are the most impressive

RED BULL RACING
Red Bull Racing's RB8 was the fastest car in the test. It was also the most consistent. It was also the most impressive.

LOTUS F1
Lotus F1's E23 was the second fastest car in the test. It was also the most consistent. It was also the most impressive.

WILLIAMS F1
Williams F1's FW35 was the third fastest car in the test. It was also the most consistent. It was also the most impressive.

NEWS

PIT & PADDOCK

GET AUTOSPORT ON THE MOVE

INTERVIEW

THE OTHER BRIT ABROAD

Trading paint and places

Legends champion Lawrence Davey won the chance to race at the world's greatest Daytona Supercup in support of the 24 Hours

From this...
Lawrence Davey won the chance to race at the world's greatest Daytona Supercup in support of the 24 Hours.

...to this
Lawrence Davey won the chance to race at the world's greatest Daytona Supercup in support of the 24 Hours.

SENATE
GRAND PRIX
.....
EXCLUSIVE HOSPITALITY

Monaco Grand Prix 2013

The finest selection of accommodation, race-viewing and exclusive hospitality packages.

Senate Grand Prix specialises in providing the F1™ teams, drivers, sponsors, as well as a vast array of corporate and private clients with the finest hotel accommodation and race viewing hospitality for the worlds most glamorous race.

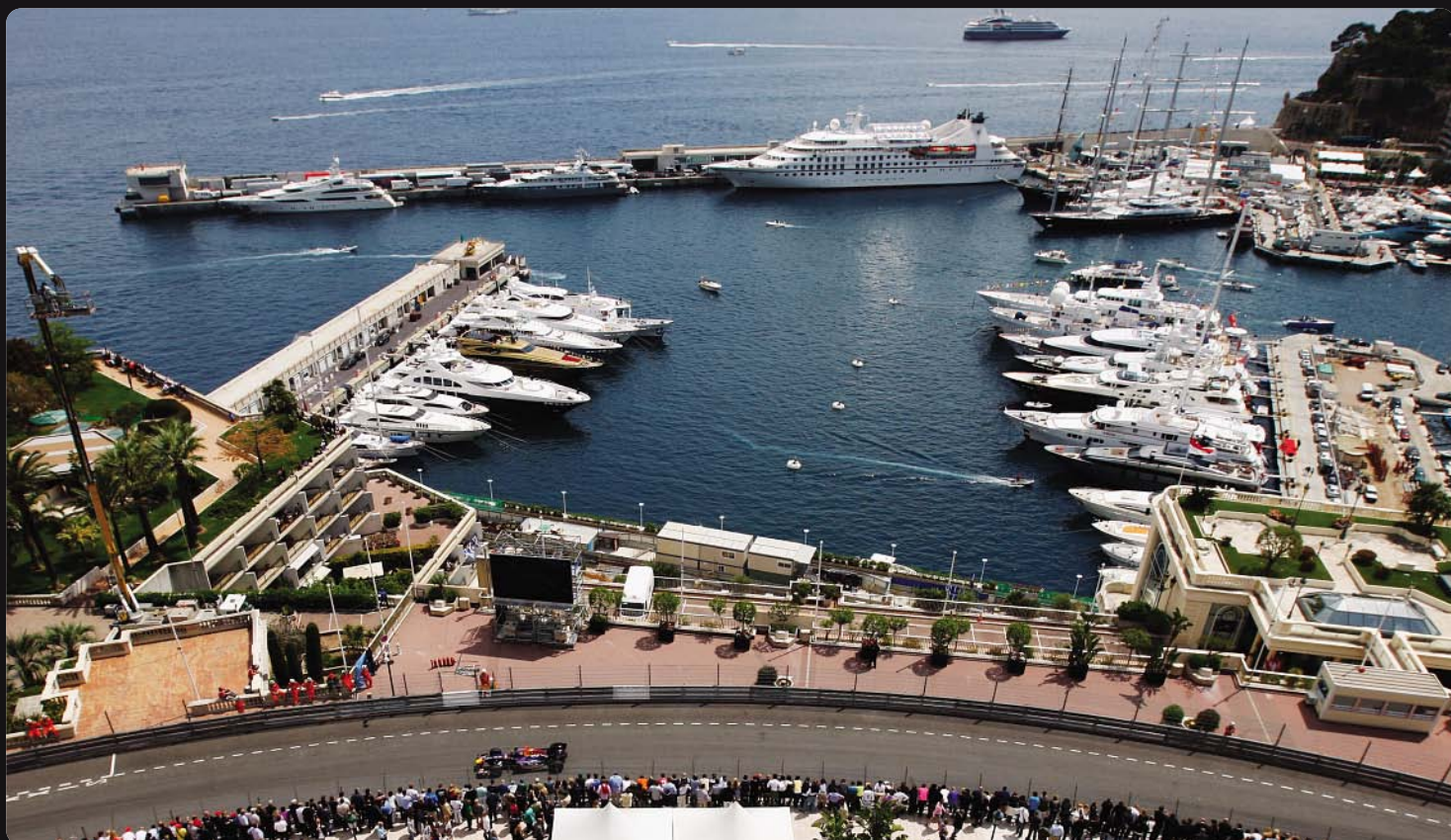

ACCOMMODATION

We have the largest range of accommodation options in Monaco and the surrounding area:

- Over 800 rooms to choose from
- Trackside hotels available
- Multiple Nice hotel options
- Transport to Monaco available



RACE VIEWING

Watch the race from the best locations around the circuit with VIP hospitality:

- 10+ locations to choose from
- Exclusive Hotel de Paris suites
- Shared or private facilities
- Fully catered VIP hospitality



EXCLUSIVE EVENTS

Senate Grand Prix has the contacts and know how to open all doors to you in Monaco:

- Meeting drivers and teams
- Exclusive party access
- Dinner at the best restaurants
- Senate Concierge service

Please call us now or visit our website for more details of the packages we offer for the 2013 Monaco Grand Prix

Tel: +44 (0) 1342 830495
f1racing@senategrandprix.com
www.senategrandprix.com/f1racing



EDITOR-IN-CHIEF

Andrew van de Burt
andrew.vandeburg@haymarket.com ext.5974

EDITOR

Charles Bradley
charles.bradley@haymarket.com ext.5889

GROUP F1 EDITOR

Jonathan Noble ext.5810
jonathan.noble@haymarket.com

F1 EDITOR

Edd Straw ext.5887
edd.straw@haymarket.com

FEATURES EDITOR

Kevin Turner ext.5432
kevin.turner@haymarket.com

NEWS EDITOR

Glenn Freeman ext.5309
glenn.freeman@haymarket.com

REPORTS EDITOR

Jamie O'Leary ext.5811
jamie.oleary@haymarket.com

MANAGING EDITOR

Peter Hodges ext.5903
peter.hodges@haymarket.com

RALLIES EDITOR

David Evans
david.evans@haymarket.com

DEPUTY NEWS EDITOR

Sam Tremayne ext.5952
sam.tremayne@haymarket.com

SPECIAL CONTRIBUTORS

Mark Hughes
Gary Watkins
Marcus Pye
Mark Glendenning

ART EDITOR

Aubrey Smith ext.5914
aubrey.smith@haymarket.com

PRESENTER/SUB-EDITOR

Henry Hope-Frost ext.5835
henry.hope-frost@haymarket.com

CHIEF SUB-EDITOR

Marcus Simmons ext.5807
marcus.simmons@haymarket.com

NATIONAL EDITOR

Ben Anderson ext.5425
ben.anderson@haymarket.com

SENIOR DESIGNER

Michael Cavalli

PICTURE EDITOR

Peter Mills ext.5918
peter.mills@haymarket.com

AUTOSPORT.COM

TECHNICAL TEAM LEADER

Geoff Creighton
geoff.creighton@haymarket.com

AUTOSPORT.COM USER

INTERFACE DEVELOPER

Pete Holmes
peter.holmes@haymarket.com

SECRETARY

Joanne Grove
joanne.grove@haymarket.com ext.5804

PHOTOGRAPHS

LAT Photographic

Jim Bamber
Pablo Eizalde
Matt Beer

CORRESPONDENTS

ARGENTINA

Tony Watson

AUSTRALIA

Phil Branagan

AUSTRIA

Gerdhard Kuntzsch

BELGIUM

Gordon McKay

BRAZIL

Lito Cavalcanti

FINLAND

Esa Iiloinen

GERMANY

Rene de Boer

GREECE

Dimitris Papadopoulos

ITALY

Roberto Chinchero

JAPAN

Jiro Takahashi, Len Clarke

NEW ZEALAND

Bernard Garpinter

RUSSIA

Gregory Golyshev

SOUTH AFRICA

Richard Asher

SPAIN

Raimon Duran

SWEDEN

Tege Formwall

USA

Jonathan Ingram, Bruce

Martin, David Phillips,

Diego Mejia, Robin Miller,

Jeremy Shaw.

UK & EIRE

David Addison,

Dave Candier, Jonathan

Crawford, Kerry Dunlop,

Leanne Fahy, Paul Healy,

Paul Judd, Paul Lawrence,

Stephen Lickorish,

Marc Orme, Graham

Read, Peter Scherer, Ian

Sowman, Oliver Timson,

Jan Tschichansky, Matt

Upton, Eddie Walder, Tim

Whittington, Richard Young

ADVERTISING

Tel: +44 (0) 20 8267 5820
Fax: +44 (0) 20 8267 5850
E-mail: autosport.ads@haymarket.com

COMMERCIAL

MANAGER

Rachel Brock,
ext: 5820
rachel.brock@haymarket.com

DISPLAY ADVERTISING

Peter De Vries,
ext: 5961
peter.devries@haymarket.com

GARY-LEE HOEBECK

ext: 5876
garylee.hoebek@haymarket.com

ALEX NEWBERRY

ext: 5244
alex.newberry@haymarket.com

CLASSIFIED

ADVERTISING

Matt Simpkin,
ext: 5560
matt.simpkin@haymarket.com

LUKE RICKETTS

ext: 5992
luke.ricketts@haymarket.com

EMILY CLARK

ext: 5865
emily.clark@haymarket.com

ONLINE ADVERTISING

Leanne Foley,
ext: 5846
leanne.foley@haymarket.com

BILLY JONES

ext: 5367
billy.jones@haymarket.com

AD PRODUCTION

Tel: +44 (0) 20 8267 5740 Fax: +44 (0) 20 8267 5320

ADVERTISING

DIRECTOR

Matthew Witham

SPECIAL PROJECTS

Derek Nielsen

LICENSING DIRECTOR

Jim James

PRODUCTION MANAGER

Ailsa Donovan, ext: 5639
ailsa.donovan@haymarket.com

SENIOR DISPLAY

PRODUCTION CONTROLLER

Roxy Agius, ext: 5740
roxy.agius@haymarket.com

PRODUCTION CONTROLLER

Marc Baker, ext: 5563
marc.baker@haymarket.com

SUBSCRIPTIONS

UK 0844 8488817

OVERSEAS +44 (0)1795 592 974

EMAIL

autosport@servicehelpline.co.uk

US & CANADA 1-866-918-1445

US & CANADA EMAIL

haymarket@usnews.com

AUTOSPORT, ISSN number 0269946X,

is published weekly by Haymarket Media

Group, Teddington Studios, Broom

Road, Teddington TW11 9BE, United

Kingdom. The US annual subscription

price is \$235. Airfreight and mailing in

the USA by agent named Air Business Ltd, c/o Worldnet Shipping Inc, 156-15, 146th Avenue, 2nd Floor, Jamaica, NY 11434, USA. Periodicals postage paid at Jamaica NY 11434. Subscription records are maintained at Haymarket Media Group, Teddington Studios, Broom Road, Teddington TW11 9BE. Air Business Ltd is acting as our mailing agent.

BACK ISSUES

Tel: 0844 8488817

DIRECT MARKETING EXECUTIVE

Karen McCarthy, ext: 5658
karen.mccarthy@haymarket.com

MANAGEMENT

GROUP PUBLISHER

Rob Aherne

PUBLISHING MANAGER

Samantha Tompson

SPECIAL EVENTS MANAGER

Laura Coppin

DIGITAL SPECIAL PROJECT

MANAGER

Simon Strang, ext: 5093
simon.strang@haymarket.com

DIGITAL PRODUCT MANAGER

Simon Grayson, ext: 5345
simon.grayson@haymarket.com

© 2013, HAYMARKET MEDIA

GROUP LTD

Publishing, trade and further subscription

details on www.autosport.com. Whilst due

care is taken to ensure the contents of

AUTOSPORT are accurate, the publishers

and printers cannot accept liability for

errors and omissions. Advertisements are

accepted for publication in AUTOSPORT

only upon Haymarket Media Group Ltd's

Standard Terms of Acceptance of

Advertising, copies of which are available

from the Advertising Sales Department of

AUTOSPORT.

EDITORIAL DIRECTOR

Mark Payton

CREATIVE DIRECTOR

Paul Harpin

STRATEGY AND

PLANNING DIRECTOR

Bob McDowell

PUBLISHING

DIRECTOR

Patrick Fuller

MANAGING

DIRECTOR

David Proctor

CHIEF EXECUTIVE

Kevin Costello

Haymarket is certified by

BSI to environmental

standard ISO14001

POLE POSITION

So far, so good for Alonso's new Ferrari



ONLY A FOOL WOULD READ TOO MUCH into last week's opening Formula 1 test of 2013 at Jerez, but there were some general conclusions we can reach from it.

For a start, this week's cover star – Ferrari's new F138 – isn't the pig (both aesthetically and handling-wise) its predecessor was at first. It's easy to forget just how bad the pre-season version of last year's Ferrari was, after all it powered Fernando Alonso to a close runner-up spot in the title race. That goes to show how the fortunes of these ultimate expressions of automotive rapid prototyping can turn around.

What the F2012 was good at – and we have little idea how the class of 2013 fare in this regard – was tyre management, both in terms of turning the Pirellis on and keeping them in their operating zone for the duration of a stint.

So far, so good: Red Bull, McLaren, Ferrari and Lotus appear on the money, and we can expect a battle royal between them this season. Meantime, Lewis Hamilton now knows just how much work he and Mercedes has on its hands to catch them up.

Charles Bradley

CHARLES BRADLEY EDITOR
charles.bradley@haymarket.com

Find us on



BAMBER'S WEEK



PEFC Certified

This product is from sustainably

managed forests and controlled sources

www.pefc.co.uk



WRC

Ogier blazes a trail for VW in Sweden

Volkswagen's all-new Polo R WRC finished second on its debut in Monte Carlo last month and then, last weekend, went one better in Sweden. Sebastien Ogier beat fellow Frenchman Sebastien Loeb for VW's first win for a quarter of a century. Rally report, p52.

Pic: McKlein





Trackside view from Jerez test

GARY ANDERSON offers his verdict on the 10 new machines that ran at the Jerez test last week, showing that the order on the timesheets in testing doesn't always reflect which cars are the most impressive

RED BULL RB9

It's hard to conclude anything other than Red Bull was running a lot of fuel for much of the test. The car seems to have a lot of grip, the drivers can get back on the throttle and the rear doesn't step out like it does with the other cars. There is a bit of understeer and with Mark Webber, in particular, if he braked just a metre later the front end would wash out. This didn't happen with Vettel.

FERRARI F138

It appears the rear of the Ferrari gives up a little on corner exit as the drivers feed in the throttle. It also seemed to struggle over the bump before the chicane, snapping at the rear. This suggests the rear end has a problem. But, in general, the car looks OK.

MCLAREN MP4-28

Even though the lap times in isolation don't look as dramatic as others, overall the McLaren looked very good. It has a secure rear end but, oddly, there was a bit of medium-speed

understeer, which is something that the team needs to address. Perhaps it's because the car appears to have a slightly longer wheelbase. But the signs are that McLaren, which had (on average) the fastest car last year, has built on those foundations.

LOTUS E21

The Lotus looks very consistent on track. What's most impressive is that the front end seems very strong and the drivers can place the car where they want. Having watched it over long runs it doesn't appear that the car has any understeer, which potentially could hurt over a stint on a set of tyres. Lotus has a good little car that is working well.

MERCEDES F1 W04

For both Nico Rosberg and Lewis Hamilton, the Mercedes seemed to have understeer. The rear would sometimes snap, but it wasn't so much of a problem as it was for Sauber or Toro Rosso. When the drivers tried to push mid corner

and get on the power earlier, the understeer was just magnified. That seems to be the characteristic that dictates the car's outright pace.

SAUBER C32

The Sauber didn't look far away from the Lotus and the Force India in terms of driveability, but the rear end does have its moments. If the rear doesn't misbehave, then the car has a bit of understeer. It's either one or the other, which suggests the car has a rear-end issue that needs sorting.

FORCE INDIA VJM06

It's a similar story to Lotus here. It was possible to place the car where the driver wanted to in the corners without the understeer that some have. If you were to pick out the two most consistent cars, you would say it was the Lotus and the Force India.

TORO ROSSO STR8

The two drivers have different styles. Jean-Eric Vergne is more aggressive, while Daniel Ricciardo tends to carry

a bit more speed into corners. The rear of the car is a little bit nervous and, much like the Sauber, if it's not doing this then there's understeer. That shows that STR still needs to find some more downforce at the rear.

CATERHAM CT03

The Caterham drivers both struggled to be precise with this car. It seems highly strung and if things go wrong, you are just a passenger until you get out of the corner. It's not a compliant car but, without simulator technology, track time might help improve this.

MARUSSIA MR02

The Marussia looked to be on a very similar pace to the Caterham. It's a more simple car than the Caterham, which has more aero detailing, so there is room to improve. But as you'd expect with a back of the grid car at this early stage of the year, it just lacks downforce.

 **P19 MARK HUGHES'S VIEW**

McLaren pace went under the radar



Vettel looked happy in RB9



Lotus showed consistency



Merc made up for lost time



Solid start for Force India

2013 CAR MILEAGE

1	Sauber	1183
2	Red Bull	1024
3	Force India	982
4	Toro Rosso	908
5	Mercedes	886
6	Caterham	875
7	McLaren	823
8	Ferrari	765
9	Lotus	749
10	Marussia	605

AUTOSPORT SAYS...

EDD STRAW
F1 EDITOR

@eddstrawF1



So who will be world champion? Admit it, that's the question that you want answered isn't it? Frankly, all the evidence from Jerez points to two things: firstly, that it's very close, perhaps closer than last year. Secondly, that the competitive order doesn't appear to have changed much from 2012.

That's no surprise. With no significant rule changes this year, few of the cars have changed dramatically. As demonstrated by the lap-time ranking of the cars, which places probably the most impressive team of the test, McLaren, down in eighth, headline times mean nothing. Even reading much into the long runs at a circuit like Jerez is extremely dicey because of the abrasive track surface and relatively early stage of testing. Look to the Barcelona tests to start seeing those patterns emerging.

Instead, we're left to use a confluence of factors upon which to base our judgements.

The McLaren was certainly impressive, but the Red Bull, particularly in Sebastian Vettel's hands on days three and four, looked extremely well-balanced and seemed to have grip where others didn't. At least, it did once you factor in the fuel load that the team appeared to be running.

Right now, you could make a case for any of the top four in last year's constructors' championship having the strongest car. But whatever you were to plump for, it's so tight that the upgrades that will appear between now and Melbourne are sure to change the picture drastically.

Frustrating business, testing.

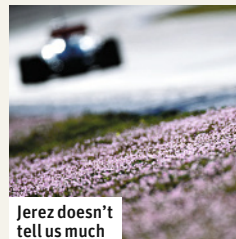

Jerez doesn't tell us much

JEREZ F1 TEST, FEBRUARY 5-8

POS	DRIVER	CAR	TUESDAY	WEDNESDAY	THURSDAY	FRIDAY	*2012 CAR
1	Felipe Massa (BR)	Ferrari F138	1m20.536s	1m19.914s	1m17.879s	-	-
2	Kimi Raikkonen (FIN)	Lotus-Renault E21	-	-	1m19.200s	1m18.148s	-
3	Jules Bianchi (F)	Force India-Mercedes	-	-	-	1m18.175s	-
4	Romain Grosjean (F)	Lotus-Renault E21	1m19.796s	1m18.218s	-	-	-
5	Sebastian Vettel (D)	Red Bull-Renault RB9	-	-	1m19.052s	1m18.565s	-
6	Esteban Gutierrez (MEX)	Sauber-Ferrari C32	-	-	1m19.934s	1m18.669s	-
7	Jean-Eric Vergne (F)	Toro Rosso-Ferrari STR8	-	-	1m19.247s	1m18.760s	-
8	Nico Rosberg (D)	Mercedes F1 W04	1m20.846s	-	1m18.766s	-	-
9	Jenson Button (GB)	McLaren-Mercedes MP4-28	1m18.861s	-	1m19.603s	-	-
10	Lewis Hamilton (GB)	Mercedes F1 W04	-	1m19.519s	-	1m18.905s	-
11	Sergio Perez (MEX)	McLaren-Mercedes MP4-28	-	1m19.572s	-	1m18.944s	-
12	Paul di Resta (GB)	Force India-Mercedes	1m20.343s	1m19.003s	1m23.729s	1m23.435s	-
13	Daniel Ricciardo (AUS)	Toro Rosso-Ferrari STR8	1m20.401s	1m19.134s	-	-	-
14	James Rossiter (GB)	Force India-Mercedes	-	1m21.273s	1m19.303s	-	-
15	Mark Webber (AUS)	Red Bull-Renault RB9	1m19.709s	1m19.338s	-	-	-
16	Nico Hulkenberg (D)	Sauber-Ferrari C32	1m20.699s	1m19.502s	-	-	-
17	Valtteri Bottas (FIN)	Williams-Renault FW34*	-	-	1m21.575s	1m19.851s	-
18	Pedro de la Rosa (E)	Ferrari F138	-	-	-	1m20.316s	-
19	Pastor Maldonado (UYV)	Williams-Renault FW34*	1m20.864s	1m20.693s	-	-	-
20	Charles Pic (F)	Caterham-Renault CT03	-	-	1m22.352s	1m21.105s	-
21	Luiz Razia (BR)	Marussia-Cosworth MRO2	-	1m23.537s	-	1m21.226s	-
22	Max Chilton (GB)	Marussia-Cosworth MRO2	1m24.176s	-	1m21.269s	-	-
23	Giedo van der Garde (NL)	Caterham-Renault CT03	1m21.915s	1m21.311s	-	-	-

GET AUTOSPORT ON THE MOVE

DIGITAL EDITION NOW AVAILABLE FOR iPad

STUNNING HI-DEFINITION VIDEO CONTENT

ON SALE ALL OVER THE WORLD FOR ONLY £2.99



Download it now from the Apple Newsstand **AUTOSPORT**

Drawing board



After the flurry of car launches, GARY ANDERSON and GIORGIO PIOLA took a closer look at the new cars and some of the development parts when they ran for the first time in the Jerez test

MERCEDES GETS NEW FRONT WING

➔ Mercedes introduced a different front wing to the one that first appeared on its 2013 car, with a step forward in detailing of the outboard/endplates section and an increase from three to five main wing elements.

The outboard part of the front wing works in front of the front tyre, which creates a lot of blockage. So when you're braking and the wheels are straight, you need the wing to produce as much downforce as possible to give the grip required for braking. Once there is steering lock on the car in a second or third gear corner, that part of the wing will have a lot less blockage and probably have stalled, giving understeer.

Having four slot gaps (arrow 1) abates that a bit because if one part stalls, it's a smaller overall percentage of lost downforce. Arrow 2 shows the addition of a small turning vane to assist the airflow.

Inboard of that part, it's a different deal. There, it's all about creating downforce and directing the airflow well to give the whole car downforce. Last season, Red Bull, Ferrari and McLaren all developed in a similar direction to each other and it's surprising that Mercedes hasn't followed their lead.

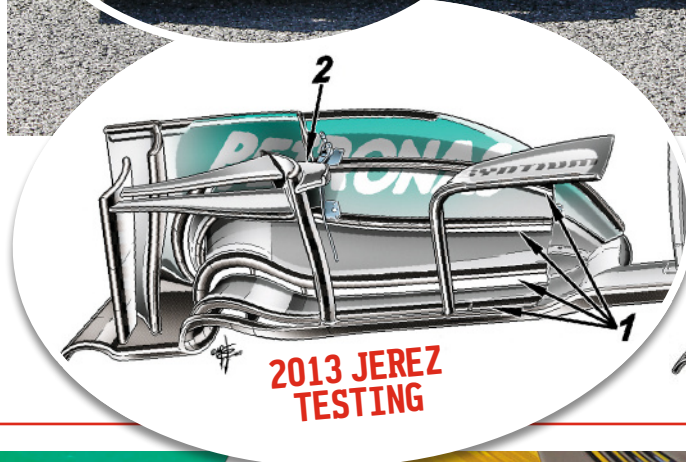
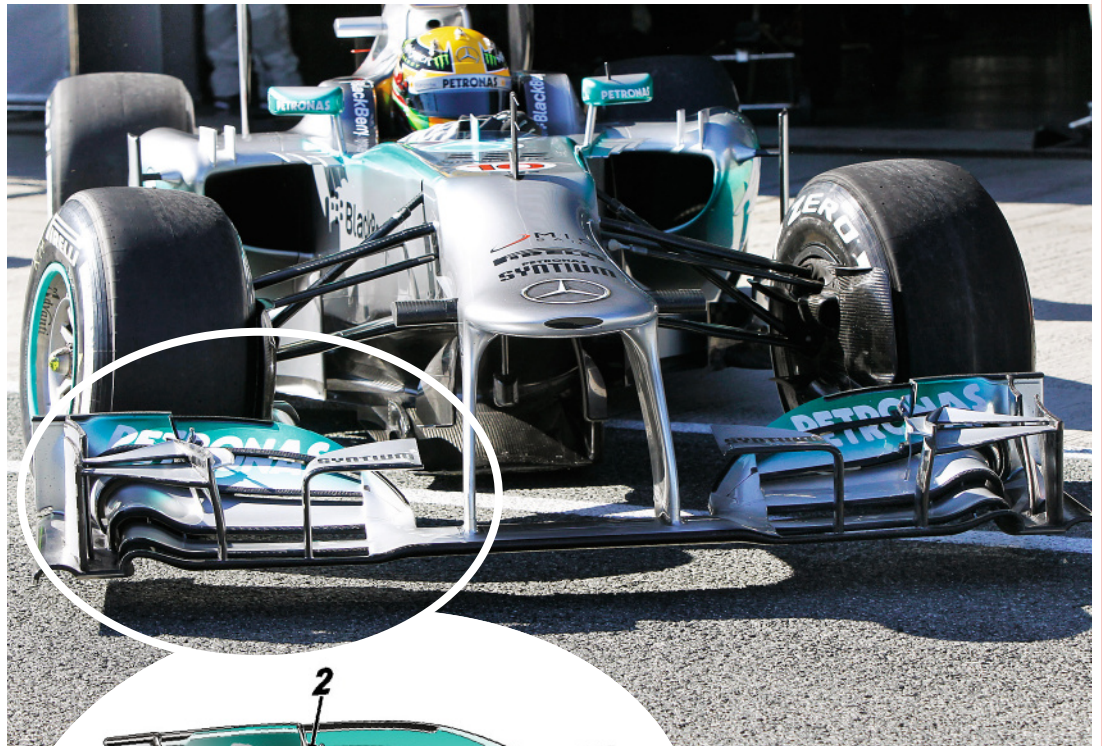

CATERHAM'S CONTROVERSIAL VANE

➔ A few years ago there was a push to tidy up the side of the car, which is why the flick-ups and vanes disappeared. There are certain radiuses and profiles that are not allowed in set areas of the bodywork. The exhaust regulations also stipulate a cone shape at the exit of the exhaust pipes that can't have bodywork within. The vane in the exhaust-exit channel on the Caterham appears to contravene both rules, not to mention last year's technical directive prohibiting the reingestion of exhaust gases. Whether or not it's illegal is secondary to the fact that, with the way that the exhaust gases rotate, it will serve to break up the flow and reduce their energy by the time they do get to the brake ducts.

ELEMENTARY, DEAR McLAREN

➔ The McLaren is the first car to have a three-element turning vane under the nose. Effectively, together they form a three-element vertically-mounted wing. If you didn't have the slot gaps between them then the airflow wouldn't stay attached to the inner surface, hence the three parts. The aim here is to take as much of the airflow off the front wing as possible and direct it inside the front wheels. Then you have to pick that airflow up and turn it back outside again where it approaches the chassis. That's what these vanes are doing and they are a natural step forward for the team, which has a higher front of chassis than it did last year.

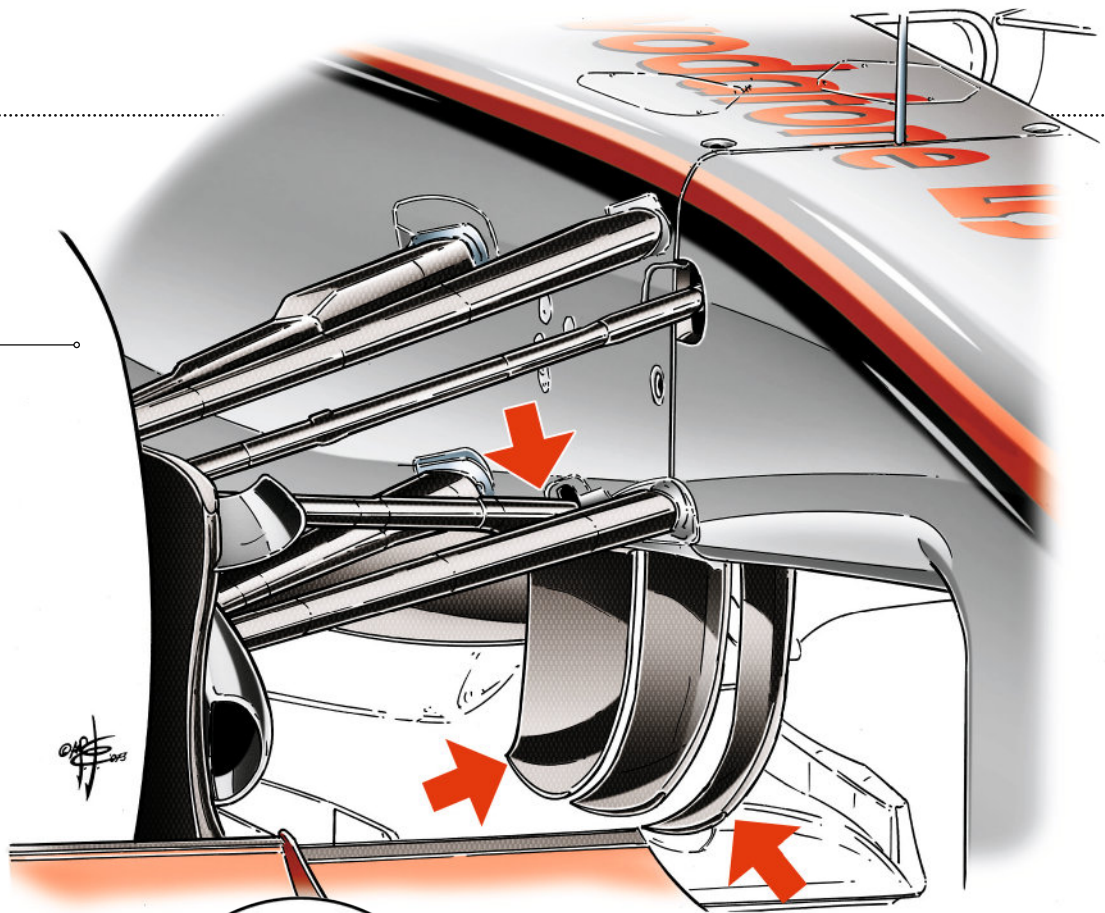

SAUBER 2012

RED BULL SLOTS IN

➔ Last year Red Bull had a front-facing letterbox in the step of the nose for electrical cooling etc, whereas Sauber (right) had a rearward-facing duct. Red Bull has now adopted this approach (below). The slot is attached to a duct that runs to a hole in the chassis under the nose. The low pressure at the letterbox sucks air from under the chassis through the duct and onto the top of the nose, accelerating airflow off the front wing and raising the potential for creating downforce under the car.

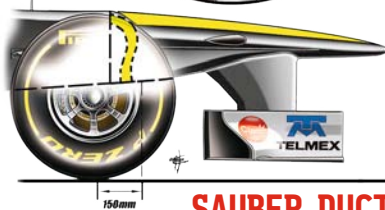

SAUBER DUCT

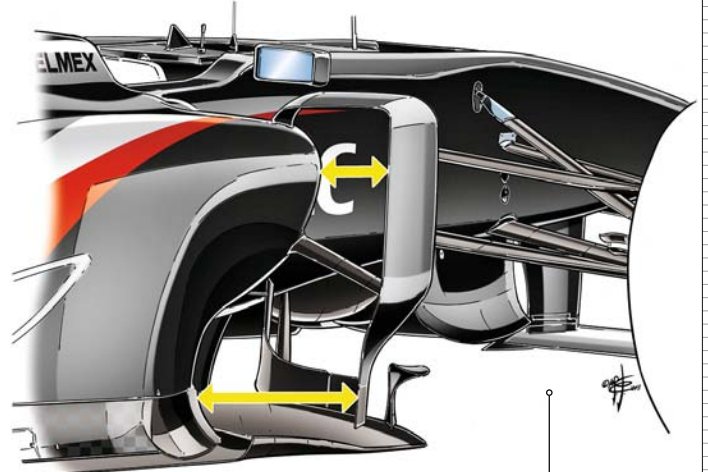

SAUBER NARROWS OPTIONS

➔ The regulations state that the maximum bodywork width of the car is 1400mm. You want the floor area to be as big as you can and everybody has the undercut section in the sidepod, through which the Coke bottle sucks the air. Sauber, in adopting these new narrow sidepods to reduce the cross-section area of the car, makes the undercut more or less vertical. The top of the sidepod is approximately 120mm from the maximum width. This reduces drag, but you will lose out in the acceleration of the airflow around the sidepod.

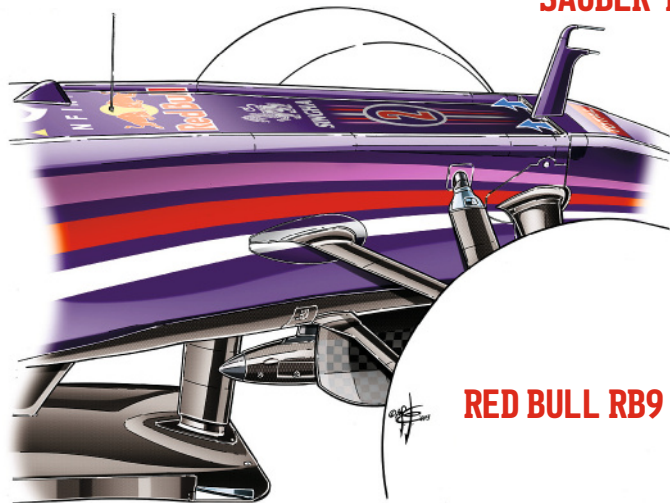

RED BULL RB9



UNDER THE SKIN OF THE
NEW FERRARI F138 P36

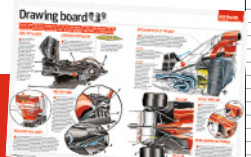



Van der Garde – better late than never

He was racing against Nico Rosberg and Lewis Hamilton in 2004, but Giedo van der Garde has only just joined them in Formula 1 this year



New Caterham signing Giedo van der Garde believes that he will be making his Formula 1 debut at his peak after taking nine years to climb from Formula 3 to the top level.

The Dutchman made his Formula 3 debut in 2004 and his F1 test bow with Super Aguri in January 2007. He has come close to graduating to a race seat with Williams and HRT in recent years, but after driving for Caterham on six Fridays in 2012, as well as for the marque's GP2 outfit, he feels that he is stepping up to F1 in time for the optimum years of his career.

"The best experience I had in Formula 1 was last year," van der Garde, who has also tested for Spyker and Renault, told AUTOSPORT. "The team was really open and they taught me everything; how the procedures go, the way of working. Last year, I learned a lot on the Fridays and you saw a big improvement from me in the car.

"Now, I know more or less the whole team. Because the deal was quite late, you lose a bit of preparation but I feel at home. I feel strong and in the strength of my life. As they say, from 27 to 33 is your best and I'm happy and mentally ready. In Holland we always say 'laat bloeier' – it's like every step is always a bit later than everybody [a late bloomer], but I'm ready for it."

"In the beginning we know we will be a bit slow, but I'm sure we can take steps in the right direction"

Giedo van der Garde

Van der Garde sealed the deal thanks to significant sponsorship from Dutch fashion brand McGregor. But despite the need to raise funding to seal the drive, the Dutchman isn't worried about being written off as a pay driver.

"I have to say I've always been up there and in 2008 I had a really good season in World Series [Formula Renault 3.5] and was flying," he said. "It has been a little bit up and down but I'm sure that the speed has always been there. I don't mind [the pay driver tag] but the reality is that you need to bring to the team some sponsors and some money to race in F1. I'm happy with mine, so what can you do?"

Van der Garde is bringing a realistic mindset to his first F1 season. Team principal Cyril Abiteboul is already on record as doubting that Caterham will score points on merit and van der Garde accepts that top-10 finishes could well be beyond him.

But the Dutchman, whose contract is only for this season, and includes options on both sides for 2014, is confident that the team can make progress in the long term.



Caterham in for another tough year

GIEDO VAN DER GARDE CV

- Age 27**
- Nationality Dutch**
- 2012** 6th in GP2 (2 wins), F1 tests/
Friday outings for Caterham
- 2011** 5th in GP2, 3rd in GP2 Asia
- 2010** 7th in GP2
- 2009** 7th in GP2 with iSport (3 wins),
Renault F1 tests
- 2008** Formula Renault 3.5 champion
(5 wins), 12th in GP2 Asia
- 2007** 6th in Formula Renault 3.5,
F1 tests for Super Aguri and Spyker
- 2006** 6th in F3 Euro Series (1 win)
- 2005** 9th in F3 Euro Series
- 2004** 9th in F3 Euro Series
- 2003** 6th in Formula Renault Eurocup

"My mindset is that it is a bit like last year," he said. "But don't forget that we've got Cyril on board and he's a really good guy. He has started to put the right people in the right spots and we will push this year.

"I know [team-mate] Charles Pic well because we worked together in 2011 [in GP2]. He's a good guy and he's had one year of experience so I can learn from him. He had a good season last year and he learned a lot from Timo Glock. My target is to learn as much as possible from him and then towards the middle we have to start to fight each other.

"In the beginning, we know we will be a bit slow but I'm sure we can take the right steps in the right direction."

While van der Garde is anticipating a tough season, with Caterham unlikely to make a major stride forward from the 10th position that it secured last year, he is hoping that his presence on the grid will act as a boost for Dutch motorsport.

He is the first Dutch driver on the grid since Christijan Albers raced for Minardi and Spyker from 2005-2007. The last time that a driver from the Netherlands stood on the podium was in 1994 when Jos Verstappen, whose arrival in F1 helped to inspire van der Garde to race karts, was driving for Benetton.

"The interest is coming," he said.

"Motorsport in Holland has dropped down over the last few years but after my announcement, you saw it everywhere. We had a big press conference with the team and everybody and it was mega, with a lot of interest. All of the TV channels and people are really excited. Motorsport has to grow up a bit in Holland and that's my aim.

"I started in karts because of Jos Verstappen, who did well in F1. It was something nice to watch and the whole country got behind it. If I can generate this in Holland, it would be mega."



Verstappen was an inspiration to VdG

GIEDO'S RACING RIVALS

Giedo van der Garde has already crossed swords with over half of the F1 grid during his junior career



Sebastian Vettel
F3 ('05-6), FR3.5 ('07)



Sergio Perez
GP2 ('08-10)



Lewis Hamilton
FR2.0 ('03), F3 ('04-5)



Romain Grosjean
F3 ('06), GP2 ('09-11)



Nico Rosberg
F3 ('04)



Paul di Resta
F3 ('05-6)



Esteban Gutierrez
GP2 ('11-12)



Nico Hulkenberg
GP2 ('08-9)



Charles Pic
FR3.5 ('08), GP2 ('10-11)



Luiz Razia
GP2 ('08-12)



Max Chilton
GP2 ('10-12)



Pastor Maldonado
FR2.0 ('03), GP2 ('08-10)

“I’ve finished one dream, now I’m starting another”

New Marussia driver Luiz Razia tells *GLENN FREEMAN* how he feels after making it to Formula 1 this year

Luiz Razia was announced as the latest newcomer to the Formula 1 grid with Marussia during last week’s opening test at Jerez. Just hours after the confirmation, he was driving the team’s new MR02 for the first time, splitting the duties over the course of the week with fellow GP2 graduate Max Chilton.

While the Briton was driving, Razia sat down with *AUTOSPORT* to talk about making the step up to the pinnacle of the sport.



Razia ingratiate himself with team

Luiz Razia, Formula 1 driver. How does that sound?

It sounds really good. It’s an achievement. It’s quite difficult to get to this point, you need to have a lot of backing – which is not news for anybody – and you need to deliver good results. Without the results, the people who can give you the backing don’t give you any attention. When you finish one dream you start another one, and for me that is growing inside this category, which is even harder than getting here.

Your deal was only announced on the second day of testing. Has



First F1 mileage came at Jerez...



... during which he learned about tyres

that late start hampered you at all?

No, not much. We’ve been talking about getting together for a long time, and I know the team from working with them in 2010 [as reserve driver]. The team is quite similar to last time, so I could catch up quite quickly.

You made a step forward as a driver in 2012, fighting for the GP2 title. Was there a reason for that?

To be honest I think I got to GP2 at the wrong time. If I had to go back in my life, I would do some things different. In 2008 I was fighting for the Euro 3000 title and leading the championship when I decided to do GP2 Asia. For me, GP2 was like F1 so I wanted to do it, but I regretted it later because I lost my championship. It meant I didn’t have a championship in Europe yet which was difficult for me psychologically. Then I was too early in GP2 and that burned me a little bit. But in 2012 I was with a team that was low on the grid the year before, and we worked hard together to end up fighting for the championship. That was just awesome.

You beat your new team-mate Max Chilton in GP2. Do you expect the same now you’re both in F1?

That’s the goal, isn’t it? I’m sure he’s got the same goal and it’s good to have this competition between team-mates. We should share as much information as we can to lift the areas of the car that need improving, but that doesn’t stop us being competitive on track.

Is it difficult being in a team with two rookie drivers?

It is a big challenge. I think the team is aware of this environment and I do believe that everybody will grow during the season. If we are patient with each other, explain how everything works and push each other, I don’t think it’s going to be a big issue.

Your rival, Caterham, also has an inexperienced line-up. Is that good?

Yeah it’s a good opportunity for us. There are a lot of drivers from GP2 on the grid and that’s good because I know those guys, and I know their strengths and weaknesses. I’m sure it’s going to

LUIZ RAZIA CV

Razia lost 2012 GP2 title to Valsecchi (l)...



... but won four times for Arden



Age 23

Nationality Brazilian

2013 Formula 1, Marussia

2012 2nd in GP2 (4 wins),

F1 tests (Toro Rosso, Force India)

2011 12th in GP2

2010 11th in GP2, F1 tests (Virgin),

3 starts in British F3 National class

2009 19th in GP2 (1 win), 0 points

in GP2 Asia

2008 13th in GP2 Asia (1 win),

4th in Euro 3000 (2 wins), 4th

in Italian F3000

2007 3rd in Euro 3000, 4th in

Italian F3000, four starts in

Formula Renault 3.5

2006 Sudam F3 champion

(7 wins), 8th in F3000 Masters

(3 wins)

2005 6th in Sudam

F3 (2 wins), 10th in

F.Renault Brazil

make a difference for me knowing that I'm in an environment where I know most of the people.

What have you learned from the test?

It's been a good learning curve, especially with how the tyres work. There are some differences from GP2 in how you work with the tyres, when you push, when you don't, and how you get the most out of the temperature range. The range is much bigger in GP2 because we don't use tyre warmers, so it's not a problem if you lose some temperature. But in F1 this is a big issue so we have to work on that because it's new for me. Even when Max was in the car it showed me the areas we need to work on and what we can do with the car. So yes, my first week as a Formula 1 driver has been a good week for learning. ☺



Timo Glock
interview P38

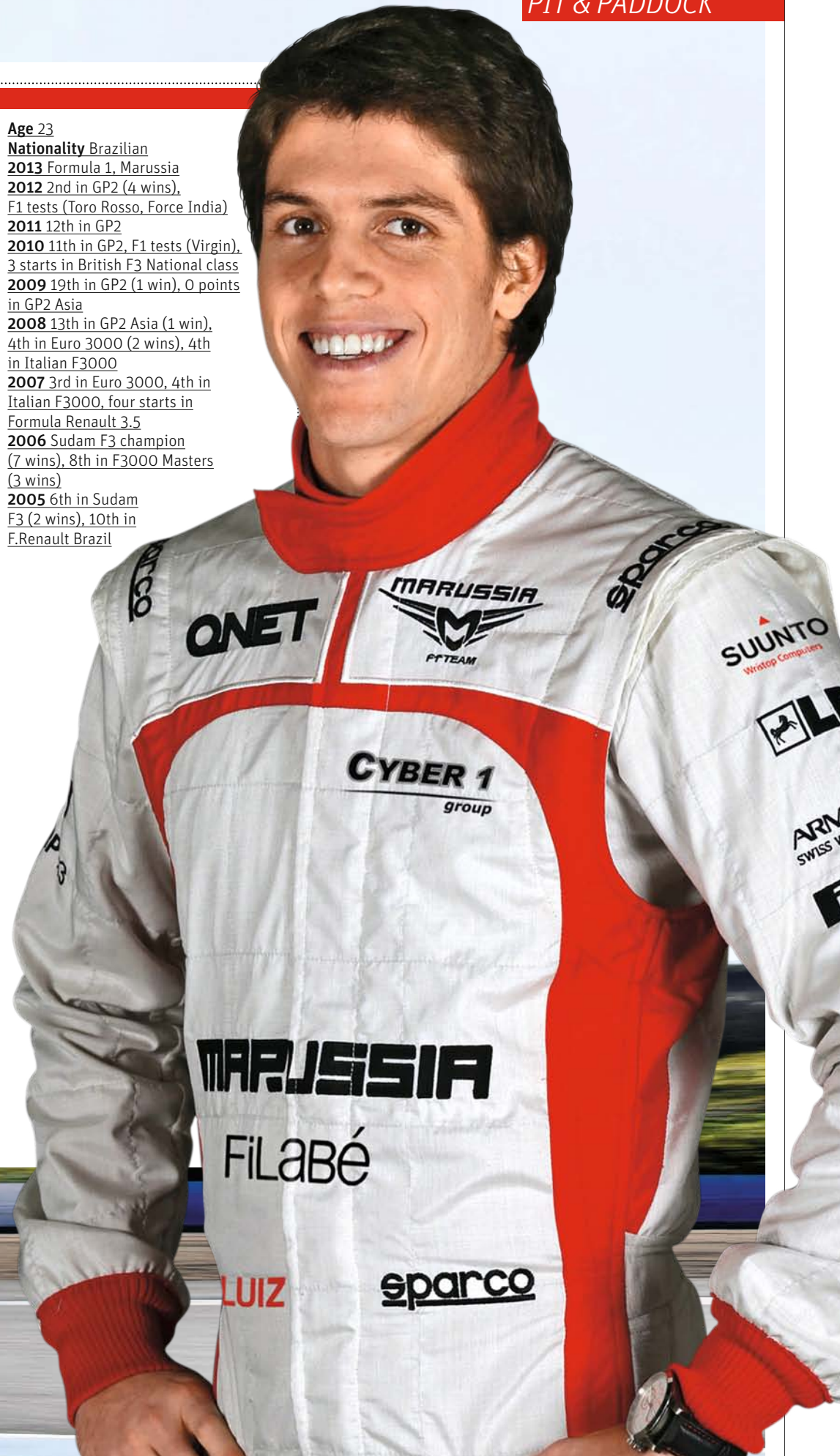

THIS WEEK IN F1

Mercedes bounces back

Mercedes recovered from a troubled start to last week's Jerez test to complete 322 laps, the majority of them on the final two days. Nico Rosberg's day-one run was curtailed by a wiring-loom problem, while Lewis Hamilton shunted at Dry Sack, hitting the tyrewall at 35mph (below) after suffering a rear-brake problem that necessitated a tweak to the specification of a brake line.



Marussia revises rear suspension after crash

Marussia was forced to make changes to a component in its rear suspension after Max Chilton crashed on the first day of the Jerez test. AUTOSPORT understands that the team reverted to a 2012-specification part for the rest of its running.



Pirelli slates Jerez's 'abrasive' surface

Pirelli motorsport director Paul Hembery has criticised the Jerez track surface. "It's rather abrasive and is substantially worse than last year," he said of the asphalt, which suffers from a lack of bitumen.



Byrne working on 2014 Ferrari

Leading designer Rory Byrne, who has acted as a Ferrari consultant since leaving its Formula 1 team at the end of 2006, is assisting with development work of the team's 2014 challenger. Byrne (below) was one of the architects of the Scuderia's dominance in the early years of this century.



Sutil favourite for Force India drive

Ex-Force India racer Adrian Sutil is favourite for the team's vacant seat alongside Paul di Resta. AUTOSPORT understands that Sutil's sponsorship package is strong, but the team is keen to run Jules Bianchi – third fastest in last week's Jerez test – if the Frenchman and his Ferrari mentors can come up with an improved financial package.



Toro Rosso eyes Renault power

Scuderia Toro Rosso is close to securing a Renault engine/gearbox supply deal for 2014. Team principal Franz Tost said it was a logical move for STR to switch to the same supplier as sister team Red Bull. Toro Rosso currently uses Ferrari engines and makes its own gearbox.

The regulations haven't changed much, so we now have a Brazil car at Jerez.



This is the 21st grand prix for this car. Red Bull's Mark Webber sums up how most teams feel about their new cars

Williams on target

The new Williams-Renault FW35 will as planned make its track debut on February 19, the first day of the Barcelona test, after passing the last of its mandatory crash tests last week.

3531

Total number of laps of the 2.752-mile Jerez circuit completed in last week's four-day F1 test

PICS: GILHAM, THOMPSON/GETTY, GRIFFITHS, COATES/LAT



CHEVRON GT CARS • COM

Chevron Cars Limited / +44 (0)1270 581 508 / info@chevronGTcars.com / @ChevronGTCars
CHEVRON GT / GT3 / GT4 information available on request



Trident
Racing Supplies



MS NAS AN

Unit 31 Silverstone Circuit Northants NN12 8TL UK
Tel: +44 (0)1327 857822 Fax: +44 (0)1327 858096
sales@tridentracing.co.uk www.tridentracing.co.uk

Think motorsport insurance.

Motorsport insurance for race cars, equipment and teams whether they are on or off track.

Our new and improved scheme for 2013 gives you great flexibility and the chance to receive no claims discounts.

We also have a range of additional covers so you can choose the package that's right for you.

Talk to us today or visit us online.

01638 608062
motorsport@bluefingroup.co.uk
insuremotorsport.com

Think Bluefin.



The Finest Collection of Motor Sports Holidays Worldwide

INCLUDING: F1, LE MANS 24HRS, INDY CAR, HISTORIC CAR RACES, CLASSIC MOTORING EVENTS, MOTOGP, WORLD SUPERBIKES



MALAYSIAN F1 GRAND PRIX 24 MARCH

It's always summer in Malaysia and the Grand Prix is a great excuse to combine a race weekend with a holiday. Stay in Kuala Lumpur where ornate temples, modern skyscrapers, hawker markets and shopping malls can all be found on a typical street. Extend your stay on one of Malaysia's idyllic beach resorts and recharge the batteries.



CANADIAN F1 GRAND PRIX 9 JUNE

Montréal is a lively multi-cultural city perfect for hosting a Grand Prix weekend. Often referred to as the most eclectic of Canada's cities, there really is something for everyone. Visit Mount Royal, the landmark where Montréal gets her name, enjoy a picnic in a local park, indulge in a spot of shopping or head down to the Old Port to sample Quebec's finest ales.



SINGAPORE F1 GRAND PRIX 22 SEPTEMBER

The Singaporeans really go out their way to ensure you have a fantastic racing experience - with great entertainment and a wide selection of eateries, the whole weekend is extremely organised. During the day, take a pleasant stroll along the marina, visit Chinatown and Little India or hop on the metro to Sentosa Island and enjoy a day on the beach.

Tailor-made tours to suit you with a choice of flights, hotels, race tickets and hospitality.

Call us now to discuss your plans or to reserve a copy of our 2013 brochure:

0845 375 0300
www.grandstandmotorsports.co.uk





MARK HUGHES GRAND PRIX EDITOR

The first F1 test at Jerez suggests that the top four teams' cars have closed up amid theories that Red Bull has been pegged back. Could that mean an ultra-close 2013 season ahead?

Jerez testing gave us our first glimpse of the 2013 competitive order – and if it doesn't look night-and-day different to 2012 in terms of which teams are going to be fielding the quick cars, it does suggest an exceptionally close Formula 1 season ahead.

With the new formula on the horizon for 2014 and only small tweaks to this year's technical regulations, it figures that those teams with quick cars last year will not have tried to reinvent the wheel for one season. Even a new concept that an aerodynamicist knows will ultimately have more potential than the existing one can often take half a season or more to actually become quicker. That would normally be a change worth making as it's an investment that will carry into the future, but that's not the case this time.

So the cars of – in particular – Red Bull and Lotus, but also McLaren and Ferrari are not so different from last year. The Ferrari is more tightly packaged around the rear, the McLaren has its new suspension and enhanced sidepod

undercut, but they are still visibly related to their race-winning machines of 2012. All the evidence from Jerez suggests that they are the four teams that will be contenders going into the season and that the differences may be even smaller than last year, as all four designs have been refined and had their inherent weak points eased.

Looking at the two significant tweaks that *have* been made – new Pirelli tyre specs and a ban on double DRS – may even suggest a further levelling of the competitive order. Last year the difficulty of getting the front tyres up to their operating temperature was often a cause of problems for Lotus and occasionally for Jenson Button's McLaren. If conditions were at all cool for the combination of track and tyre compound, they tended to qualify badly.

This year's tyre – with more of a true radial construction rather than the radial/crossply hybrid of before – will flex more. With stronger bracing from the carcass itself, the sidewall no longer needs to be so domineeringly strong and

its flexure can contribute to the heating process. Such movement helps the rubber to reach its operating temperature easier. A key bugbear for both Lotus and Button would appear to have been wiped away at a stroke.

Last year's Red Bull took a major leap forward after its double-DRS feature was introduced at September's Singapore Grand Prix. In itself the system gave maybe a couple of tenths of qualifying pace, but in the way the car responded to the change there was more. Because the Red Bull had a wide range of ride heights over which it worked it could carry more rear wing (it worked well at low speed/high rear-ride heights owing to its Coanda effect, and was also strong at high speed/low rear-ride heights because the diffuser could suck on those tunnel inlets rather than stalling). Double DRS then got rid of more drag than it would have done if the car hadn't been able to carry that much wing in the first place.

So for a crucial period of four or five races – the period where Sebastian Vettel took control of the championship – the Red Bull was the absolute class of the field. But double DRS is banned for this year.

So with the peaks of the title-winning car and the dips of two of its close rivals rounded off, and everyone in addition tending to their own weaknesses, we just may be set for a yet-closer season.

If any one car was marginally quicker than the others at Jerez last week, it was probably the McLaren. As the car with the most fundamental reworking compared to last year, could that prove to be decisive? ❧



Button was quick out of the box in new McLaren

“A key bugbear for Lotus and Button appears wiped away”



V8 SUPERCARS
NISSAN DOUBLES UP
 Nissan Motorsport unveiled its definitive Kelly Racing-run Altima V8 Supercars this week and announced that Michael Caruso and James Moffat (far right) will join team co-owners Todd and Rick (far left) Kelly in the driver line-up.

EUROPEAN F3

F3 set for Pau return in 2014

Organisers and FIA say European Championship likely to take space freed up by British F3 downscaling

The Formula 3 European Championship looks certain to incorporate the Pau Grand Prix from 2014.

Pau event promoter Patrick Peter was due to meet with FIA single-seater commission president Gerhard Berger this week to discuss the future of F3 at the French street track. Ahead of the meeting, there appeared to be intent from both sides for the European championship to take the place of the cancelled British F3 round from next season.

Peter, whose eponymous organisation took over the running of the Pau GP meeting for 2011, told AUTOSPORT: "It is a pity that there will be no British F3 at Pau this year, but we will be discussing with the FIA about having the European championship next year."

"We hope to have the European championship in the future; it would be good for everyone. I will do my best to try to achieve that." Former grand prix driver Berger



Marciello won Pau GP last year

echoed Peter's comments. "Certainly it would be great to get it on the calendar for next year, because F3 has a good history at Pau in the last decade. We will talk to the promoter and hopefully come to an arrangement."

Peter and Berger ruled out an 11th-hour calendar change to bring the European championship onto the Pau bill this year, following the downscaling of the British series to

just four weekends. The Pau event on May 18-20 clashes with the European championship round at Brands Hatch.

Berger said: "There's not enough time to do it this year. The calendar is set already."

The prospect of the European championship racing at Pau from next year was welcomed by Rene Rosin, whose Prema Powerteam squad won the event last year

with driver Raffaele Marciello. "Pau, like Macau, is a real challenge for the drivers, something a young driver needs at this stage of their career," he said. "It would be a pity to lose Pau and the Masters [which has yet to be confirmed for 2013 — see AUTOSPORT January 3] from the calendar."

"It's easy to be quick at Hockenheim because you can simulate a track like that. But you can't simulate skimming a barrier."

Peter said that there would be no headline race carrying the Pau GP title this year. Two Formula Renault races, which were due to form an ALPS round, will now become non-points encounters that will run under the Formula Renault Pau Trophy banner, with teams from the Eurocup and NEC also invited.

Last year's Pau F3 event was a round of the British series, which also counted for the European championship. The GP title was awarded to the winner of the second of two races.



High costs led to low BF3 grids

BRITISH F3

Teams: UK focus would revive BF3

BRITISH FORMULA 3 TEAMS

Carlin and Double R Racing both believe that the championship could be revived for 2014 and beyond by returning to its UK roots.

British F3 has been forced to slim down to four race weekends in 2013, with organisers hoping to attract teams from the F3 European Championship, German F3 Cup and European F3 Open.

Both Carlin chief Trevor Carlin and Double R boss Anthony Hieatt think drivers could be enticed again if costs reduce to the £350-425,000 level.

Hieatt said: "We probably got a

bit big for our boots with these races abroad. The meetings are too long and too far away.

"We should do more racing, because we have to employ our staff and keep our building anyway, so it doesn't matter if it's eight weekends or 28. It's all about better value for money – not paying £5000 per weekend for hotels."

Carlin added: "Drivers have nothing against racing on the British tracks. If it was OK for Senna, Sato, Ricciardo and Vergne, it's all right for them."

Regarding European F3, BF3 series promoter Stephane Ratel said: "There

is no intention to compete; there is a wish to complement."

Ratel added that, in the long term, he is hopeful that some competitors could be tempted from European F3, which looks set to boast grids of up to 30 cars this season.

"I think a good balance is 18 cars," he said. "More than that, and there are too many losers, and the dads don't want to pay for their sons to be at the back."

➔ P56 BF3 ANALYSIS

AUTOSPORT SAYS...

JAMIE O'LEARY
REPORTS EDITOR

@mrjamieoleary



Formula 3 and the Pau Grand Prix. In the modern age of motorsport, they belong together.

Sure, the event's history largely revolves around the great F2 encounters of the past, but with its natural successor GP2 (and no, I haven't forgotten about the interim F3000 period before you ask), having grown just too fast for the Armco-lined 1.714 miles of twisting asphalt around Parc Beaumont, there is no better fit than F3.

Now I've got nothing against Brands Hatch; I love the place, in fact. But the thought of 56 laps of F3 cars bombing around on May 18-19 trying – and failing – to overtake isn't especially inspiring. I'd far rather watch 30 laps of cars failing to overtake at Pau on the same weekend. At least they'll have to work out how to skim the barriers as much as possible without taking a corner off!

The challenge has helped forge many a driver's reputation over the past decade and last year introduced the world to many a young talent. How many of you, dare I ask, had never heard of Raffaele Marciello prior to his double domination on the French streets last year?

It's not going to happen this year, that I've accepted. But come 2014, with a high-quality European F3 line-up on-track, Pau should be restored to its former glory once more. I can't wait...

Greats like Clark have won Pau GP



ALMS/WEC

Rebellion may run extra cars

REBELLION RACING HAS NOT

ruled out running extra cars in either the World Endurance Championship or the American Le Mans Series this year.

Rebellion is planning to run one Lola-Toyota B12/60 in the full WEC, as well as an extra car at the first three rounds, and one in at least the majority of the ALMS. It has revealed that it could increase its programme in either championship after the Le Mans 24 Hours in June.

Team manager Bart Hayden said: "Depending on how things go, we could revise the programme later in the season. We won't want to make a commitment at this stage, because it depends on what happens in the races up to and including Le Mans."



Rebellion runs Lolas

Fast Fred is off to race in Japan



SUPER GT

Makowiecki's Honda deal

FRENCH SPORTSCAR STAR

Frederic Makowiecki will combine his Aston Martin World Endurance Championship assault with a Super GT campaign with Honda.

Makowiecki, 32, who was revealed as part of Aston's factory team last week, was unveiled as a Honda works driver on Monday. He will share the Dome team's HSV-010 GT500 contender with Naoki Yamamoto, who has moved over from the Kunimitsu squad.

Makowiecki said: "At the end of 2012 my target was to have a factory deal. Now I have two works deals, and both will give me the chance of winning.

"Super GT is a big series and Dome is a good team, so I am very happy to be here."

Dome boss Hiroshi Fushida explained that Makowiecki had been recommended by veteran engineer Ricardo Divila, with whom the French driver worked while developing the Ligier JS51 Group CN prototype for the Springbox squad.

"Fred came on Ricardo's recommendation and that was good enough for me," admitted Fushida.

Makowiecki and Yamamoto replace Carlo van Dam and Takashi Kogure in the Dome entry.

BIG NUMBER



The number of times the Pau GP has not been run since its inception in 1933. The longest gap was from 1940-46.



ALMS

NEW BMW REVEALED

The wraps came off BMW's new ALMS challenger at Daytona on Tuesday this week. The Z4 GTE, developed from the V8-powered GT3 car, tested for the first time in mid-January ahead of its debut with the factory RLL team at Sebring.

WEC

Kobayashi in Ferrari WEC frame

Japanese ex-F1 driver joined by Chandhok and Filippi at AF Corse's Aragon GT test. By GARY WATKINS

Formula 1 refugee Kamui Kobayashi is in line to land a Ferrari factory GT deal to race in this season's World Endurance Championship.

The Japanese driver, who was not retained by the Sauber F1 squad at the end of last season, was one of a number of new drivers tried out by the works AF Corse Ferrari team at Aragon in Spain at the start of this week. It is understood by AUTOSPORT that 26-year-old

Kobayashi has already signed or is close to signing to join Gianmaria Bruni, Giancarlo Fisichella and Andrea Bertolini on Ferrari's roster of factory sports-car drivers.

AF Corse boss Amato Ferrari would only confirm on Monday that Kobayashi was taking part in the three-day test at Aragon along with fellow ex-F1 driver Karun Chandhok and GP2 racewinner Luca Filippi.

"There are some guys we are testing, including Kobayashi and

Chandhok," he said. "We are just gaining some information and after that we will see what happens."

Ferrari stressed that the test was not a form of shoot-out for any vacant seats with AF Corse in the WEC.

"We had the possibility to test some drivers, so that is what we are doing," he continued. "Nothing depends on what happens in the test. We will decide our drivers at the end of February."

No comment was available from Kobayashi ahead of the end of the test on Wednesday. Davide Rigon, who drove Beijing Guoan's car to the inaugural Superleague Formula crown in 2008, was also driving one of two 2012-specification GTE-class 458 Italias at Aragon, along with 19-year-old Ferrari Driver Academy member Brandon Maisano. Rigon raced for the Kessel team in last year's Blancpain Endurance Series as part of a Ferrari deal that encompasses test and simulator duties with the F1 team.

There is at least one seat with AF Corse up for grabs in the WEC for the coming season. Olivier Beretta, who joined Ferrari after parting company with Chevrolet a year ago, will race with the Risi Competizione squad in the American Le Mans Series rather than continuing in the WEC with AF, despite being listed on the WEC entry.

Bruni, Fisichella and Bertolini were sharing the driving of two revised 2013-spec cars in Spain. It is expected that Bruni and Fisichella will drive AF's lead GTE Pro-class entry in the WEC this year as Ferrari seeks to defend its manufacturers' and teams' titles while at the same time chasing the new-for-2013 World Cup for drivers.

Updates on the 2013-spec 458 are focused on aerodynamics with the aim of reducing drag to increase straightline speed and reduce fuel consumption. Ferrari's fuel-tank size was reduced by mandate at the end of last season.



Kobayashi tested 458 at Aragon

ALMS

DeltaWing set for Bridgestone switch

THE DELTAWING LOOKS SET TO RACE on Bridgestone tyres when it competes in the American Le Mans Series this season.

The move follows Michelin's announcement that it will no longer support the programme after it emerged last week that Dan Panoz, one of the prime movers in the DeltaWing project, was on course to field a Mazda-engined version of the car in the ALMS-opening Sebring 12 Hours next month. Panoz hoped to begin the season using Michelins left over from last year's assault on the Le Mans 24 Hours and the Petit Le Mans ALMS round at Road Atlanta.

Veteran sportscar team manager Dave Price, who has been brought in to run the DeltaWing team by Panoz, said: "We will be at Sebring, but we won't be on Michelins because they have withdrawn with immediate effect.

"We have examined our options and will make an announcement soon."

Bridgestone is known to have produced



No more Nissan or Michelin support

tooling for the DeltaWing's bespoke tyres, which includes four-inch wide fronts, when the car was designed for IndyCar racing.

The DeltaWing that will race at Sebring will be the car that competed last year, which is built around an Aston Martin AMR-One monocoque. A revised version

with a new monocoque is expected to come on stream during the summer.

The DeltaWing team, which will run out of Panoz's Elan Motorsports Technologies facility near Road Atlanta, plans to contest all the ALMS races bar the Long Beach and Baltimore street events.

IN BRIEF



Jakes has IndyCar seat

JAKES JOINS RLL FOR INDYCAR

British IndyCar racer James Jakes has joined Rahal Letterman Lanigan Racing for the coming season and will partner Graham Rahal. Jakes was 22nd in last year's series for Dale Coyne Racing.

AUTO GP'S SILVERSTONE DATE

Auto GP has replaced its scheduled Moscow round with an event on Silverstone's Blancpain Endurance Series bill on June 1-2. Meanwhile a new team, Ibiza Racing, created by Giuseppe Cipriani, Modesto Benegiamo and Ferdinando Ravarotto, will enter the series.

PHIL REMINGTON 1921-2013

Phil Remington, who worked for Dan Gurney's All-American Racers squad as a designer and engineer for 43 years, died aged 92 last week. He also played a pivotal role in the development of the AC Cobra and Ford GT40 plus the Scarab F1 car.

KOIRANEN SIGNS GP3 TRIO

Kevin Korjus, Aaro Vainio and Patrick Kujala will form the line-up for GP3 newcomer Koiranen GP this year. Carlin, meanwhile, has signed Luis Sa Silva.

ZETA COMPLETES RENAULT 3.5

Renault has confirmed that Zeta Corse has taken the 13th and final slot on the Formula Renault 3.5 grid after it took over BVM Target during the winter. Rival team Draco has retained driver Nico Muller.

BIG ELMS ENTRY LIST

A total of 29 entries have been received for the relaunched European Le Mans Series. The tally includes 11 LMP2 prototypes in the top class, one of which – the Sebastian Loeb Racing ORECA-Nissan – will be driven by former Peugeot ace Franck Montagny.

AJR SWAPS LOTUS FOR FERRARI

Multiple ALMS champion team Alex Job Racing is swapping from Lotus to Ferrari for this year's series. AJR will field a solo GT 458 Italia, entered in conjunction with the Mexican West Racing squad, for Townsend Bell and Bill Sweedler.

AJR has ditched Evoras



BLANCPAIN

Luhr makes JRM return

LUCAS LUHR IS RETURNING TO THE JRM Racing squad with which he won the 2011 FIA GT1 World Championship.

Luhr will contest the Blancpain Endurance Series in one of JRM's Nissan GT-R NISMO GT3s alongside the defence of his American Le Mans Series title with the Pickett HPD squad. The German will share the team's Pro-class car with Peter Dumbreck, who remains on board for a fourth straight season, and a third driver who is yet to be determined.

Luhr, 33, said: "I saw how many cars from different manufacturers and how many top drivers there were in the BES,

so when the chance to go back to JRM came up, it was easy to say yes."



Luhr will race GT-R

MEC

Aston Martin creates new junior squad



Team launched last week

ASTON MARTIN RACING HAS INITIATED

a young-driver programme aimed at producing its next generation of stars.

AMR has revealed that British GT Championship race winner Jonny Adam and ex-Formula 2 and 3 racer Daniel McKenzie will be the first Aston Martin Young Drivers. They will act as reserves for Aston's four-car World Endurance Championship squad and race for the AMR-run Beechdean squad this year.

AMR team principal John Gaw said: "We need to find the Darren Turners of the future and, with four cars, we also need reserves for this season."

It is expected that Adam and McKenzie

will take part in the Le Mans Test Day in order that they can race in the 24 Hours if the need arises.

Adam will again compete in British GTs with Beechdean boss Andrew Howard, while the pair will share the same Vantage V12 GT3 with McKenzie in the Blancpain Endurance Series.

McKenzie, 24, said: "There wasn't the money to continue in single-seaters and the plan is to eventually start earning a living from driving. The dream would be to end up in one of the GTE Astons."

P60 SENNA AT ASTON

GLOBAL RALLYCROSS

MEGA RALLYCROSS FORD

Ford launched its new Fiesta ST rallycross car at last week's Chicago Auto Show. The first three cars to be built by OMSE will be driven in the Global Rallycross Championship by Tanner Foust, Brian Deegan and Ken Block.



WRC

VW: win down to Ogier, not car

Volkswagen motorsport chief says his French star, not Polo, was key to Swedish victory. By DAVID EVANS

Volkswagen motorsport director Jost Capito believes that Sebastien Ogier's Rally Sweden victory was more down to him than the new Polo R WRC.

Ogier's win on the Karlstad-based event – his eighth success in the WRC – was VW's first since Kenneth Eriksson's success with a Golf GTi on the 1987 Ivory Coast Rally (see page 85). And Capito says much of that is down to the Frenchman's ability rather than the car's performance.

Ogier had contested Rally Sweden three times before, but had never finished on the podium in the all-snow event. He ended the event 41.8 seconds ahead of his countryman and arch-rival, nine-time world champion Sebastien Loeb.

After watching Ogier's first win



Ogier made the difference

in VW colours, Capito said that January's Monte Carlo Rally, on which Ogier finished second, gave a great indication of where he was as a driver.

Capito said: "I am quite surprised with this result. The Monte Carlo Rally is 80 to 90 per cent the driver and here it's 70 to 80 per cent. We

have shown with Ogier and with Jari-Matti Latvala that we have two of the fastest drivers. At the rallies where the majority of the performance is with the drivers, it's only important that the car is reliable. Then the drivers can get good results.

"Sebastien has done an incredible job for us here, we know with him we can win; he has nothing to prove. But for the car, we still don't know and won't know where we are until Portugal, when the regular season starts."

Despite Ogier leading the championship after the second round, Capito refuses to make predictions for VW's rookie season with a World Rally Car.

"I won't get over-excited. This is not an indication of what way the season will go," said Capito.

"We will know more and we will have a good idea of what will be happening from Portugal."

Ogier added: "Words can't describe this moment. It's just incredible. I had the perfect car this weekend. When I needed to make the time, when Loeb was giving more pressure to me, then I could do it and I felt comfortable doing it. It's amazing."

Loeb paid tribute to Ogier's victory saying: "He made no mistakes, the perfect rally and I couldn't beat him."

Ogier's team-mate Latvala finished fourth in Sweden, the Finn feeling increasingly confident with the car as he spends more time in it this season.



P52 SWEDEN REPORT

IN BRIEF

Solbergs' Escort took historic win



SOLBERGS WIN IN SWEDEN

Petter Solberg, co-driven by his wife Pernilla,

dominated the Historic Rally Sweden last weekend in his Ford Escort MkII. The Solbergs won the event without a reverse gear.

TIDEMAND WANTS WRC RETURN

Pontus Tidemand hopes to return to a World Rally Car on two occasions later this year. The Swede ran as high as fourth in a Ford Fiesta on his home WRC round, before its engine failed on SS9. He also hopes to contest the Junior WRC again this season.

SKY IN LINE FOR WRC TV DEAL

Sky is being tipped as the British broadcaster most likely to show the WRC in the UK. A deal has still not been confirmed, but it is hoped it will be in place for round three, Rally Mexico, next month.

NIKARA TO DRIVE MINI AGAIN

Jarkko Nikara will drive a Prodrive Mini WRC on the fourth round of the world championship in Portugal. The 26-year-old Finn finished fifth

in Spain last year on his World Rally Car debut with the British squad.



Nikara will drive Mini



HVM ran on its own in 2012 and may do again

INDYCAR

HVM could ditch collaboration for 2014

HVM RACING BOSS KEITH WIGGINS IS

keeping an open mind regarding his team's future as an independent IndyCar entrant after joining forces with two teams for the 2013 season.

The formerly Lotus-affiliated team was left stranded when the engine supplier pulled the plug on its IndyCar programme after a disastrous inaugural season in 2012.

Wiggins announced last December that the team will move into the World Endurance Championship, running an LMP2 Lola with Status Grand Prix. HVM retains an IndyCar

involvement this year via a commercial partnership with Andretti Autosport that will help field EJ Viso's entry, and an engineering relationship with an undisclosed entry, believed to be the second Dragon Racing car.

Last week's announcement of the Andretti/HVM tie-up hinted that it could be a step toward a full-time return to IndyCar by HVM next year, but Wiggins told AUTOSPORT that he has not made a decision yet.

"Coming off last year, we're in no rush to jump back in with half-budgets and struggle at the back," he said.

"People have always said, 'oh, you'll get it together somehow', but now has come the time where resilience is a nice thing to be attributed with; if it doesn't make business sense then there is no point. You get to a point where you say, 'if it's not getting better then you need to make a responsible decision'. We're just going to sit back and see where things land."

HVM has retained the requisite hardware to run a car at the Indianapolis 500 if a deal becomes viable, although Wiggins said that this would also likely be a joint effort.

IN BRIEF



Graf drove new HPD

NEW HPD HITS THE TRACK

The 2013-spec HPD LMP1 contender, which runs the now *de rigueur* wide front tyre, made its first public appearance at last week's official American Le Mans Series test at Sebring. Pickett Racing's ARX-01c topped the times with Klaus Graf driving.

BERRO LEAVES LOTUS

Claudio Berro left his role as motorsport director at Lotus at the end of January. His duties in the British manufacturer's downscaled motorsport department have been taken over by Rupert Manwaring.

LEITZINGER BACK WITH DYSON

Butch Leitzinger will return to Dyson Racing for the Sebring 12 Hours after a year's absence. The American, who was part of its regular line-up from 1995-2009, will share the Dyson Lola-Mazda B12/60 with Guy Smith and Chris Dyson.

PIQUET STEPS UP A LEVEL

Ex-F1 driver Nelson Piquet Jr will race full-time in the NASCAR Nationwide Series this year. The Brazilian remains with Turner Scott Motorsports, with which he finished seventh in the NASCAR Truck Series last year.

MURPHY'S HRT BATHURST DRIVE

Four-time Bathurst 1000 winner Greg Murphy has joined Holden Racing Team for this year's enduros at Mount Panorama and Sandown. He replaces Cameron McConville, who last week became V8 Supercars' driving-standards officer.

O'YOUNG SWITCHES TEAMS

Darryl O'Young will partner Tom Coronel at ROAL Motorsport outfit in the World Touring Car Championship this year. Rival BMW squad Proteam, meanwhile, has retained Moroccan driver Mehdi Bennani.

MOTORBASE RETAINS PAIR

Mat Jackson and Aron Smith will continue with David Bartrum's Motorbase squad in the British Touring Car Championship this year. Irishman Smith, 23, will step up to an NGTC Ford Focus alongside Jackson.



Smith (l) with Bartrum and Jackson

WTCC

MacDowall stays at Bamboo

ALEX MacDOWALL WILL STAY WITH leading independent squad Bamboo-Engineering for his second season in the World Touring Car Championship.

MacDowall, who made his WTCC debut in 2012 after spending two years in British touring cars with Chevrolet, took a pair of Yokohama Trophy victories and finished 11th in the overall championship standings.

"Coming into the WTCC from the BTCC obviously meant I had experience of touring cars, but the world championship is a whole different level," said MacDowall, who finished fifth in the Independent standings.

"I would have liked a few more indie

wins last year, but overall I think we did a really good job. The experience I've got going into this season will be invaluable. I'm confident we've got a great chance to arrive in Macau, at the end of the year, in the mix for the title."

The 22-year-old Briton will partner former Arena Ford Focus driver James Nash, who was confirmed at Bamboo last December.

Bamboo team principal Richard Coleman added: "Alex had an especially strong second half to the season, so we're delighted to keep him this year and will build on that experience."

Bamboo still hopes to expand to a three-car line-up for the coming season.



Neal tested soft Dunlops

BTCC

Neal tests new BTCC rubber

THREE-TIME BRITISH TOURING CAR

champion Matt Neal believes the series' new option tyre will provide a tough driving challenge this season.

The Honda driver tested the new soft-compound Dunlop, which drivers will have to use in one race per meeting in 2013, at Rockingham last week.

"It's not overly different [to the old tyre] and didn't affect the balance - you just get a little more grip," he told AUTOSPORT.

"Tyre wear will definitely be an issue this year. People will have to use their heads rather than their right feet. Getting the power down will be an issue in the second half of races."

AUTOSPORT understands the compound will be assessed after the first two rounds at Brands Hatch and Donington Park and tweaked if required.



MacDowall raced for Bamboo in 2012

Massa set the fastest time in Jerez test



Ready to fight

Ferrari produced a dubious car for 2012 and had to spend much of the year playing catch-up.

One thing is beyond doubt: Ferrari is in better shape than it was this time last year, when it emerged during the first test at Jerez that all was not well with the F2012. Then, the car was, as Fernando Alonso later admitted, “two seconds off the pace”, and talk both inside the paddock and in the watching world was of Ferrari being in the proverbial. Its successor, the F138, does not look anything like as troublesome on the track.

“If you compare to last year, it’s a completely different planet,” said Felipe Massa after his first taste of the new car. “Last year, I remember we were struggling a lot to drive the car. It was tricky to keep the car on track, so this year the base is completely different.”

Alonso was absent from the Jerez test, and Massa was the only driver to dip under the 1m18s barrier during last week’s four days of running. The Brazilian’s mark of



Massa with his race engineer Rob Smedley

1m17.879s was quick no doubt, and the car was unquestionably capable of lapping even quicker. But Massa himself pointed out that McLaren driver Jenson Button’s fastest time of the first day, on a green track in an unsorted car on hard Pirellis, was more impressive, even if it was around a second slower than his own headline best. He wasn’t the only one to have noted the implications of that time as,

by general consensus, the tenuous evidence of the first test pointed to the Working squad being in the strongest position. Just... maybe.

But if that is the case – and this is based on brittle evidence, and with the caveat that there will be plenty of car developments to come between now and the first race in Melbourne – then Ferrari certainly isn’t far off. Massa’s aggression means that, from trackside, the driver-friendliness of a new car will be laid bare. The F138 didn’t appear to be particularly difficult to drive at Jerez, although there were tell-tale signs that it didn’t quite have as much rear grip on the power as the drivers wanted. On longer runs it looked competitive, although it’s a waste of time to look deeply at such patterns until pre-season testing gets to Barcelona, given the number of variables at Jerez and the unhelpful track surface.

But Ferrari merrily worked through its programme, experimenting with some tweaks to its exhaust-blown brake ducts and a so-called double DRS. With



from the start

EDD STRAW saw the new F138 in action in Jerez testing, and investigates its potential

windtunnel work based at the ex-Toyota F1 facility in Cologne, there were no sign of the correlation problems that blighted Ferrari's 2012 campaign. But that's just one half of the equation the team must solve if it is to take the step from second to first in the championship. With the foundations there, it's now down to Ferrari to have a better hit rate with its upgrades, particularly as some of the parts that were added to Alonso's car late last year were of questionable benefit.

The most revealing of all Ferrari's activities at Jerez came on the last day, when new development driver Pedro de la Rosa took over. The 41-year-old hasn't been recruited by Ferrari as an experienced stand-in or even for his track-testing abilities, formidable as they are. Instead, he is there (at Alonso's insistence) to help Ferrari haul itself back onto the cutting edge of grand prix car technology by accelerating the development of its driver-in-loop simulator.

His day of running, which was

“The point of being here is to accelerate our simulator process. We have to work flat-out”

Ferrari recruit de la Rosa

interrupted for three and a half hours by a gearbox failure early on, was focused on getting a feel for the car and gathering as much data as he could to help develop the simulator. He was an obvious choice for this role because of his experience with McLaren's simulator programme during his years as test driver from 2003-09 and in '11. The Woking team's experiments in this field date back to 1996, so it's no surprise that it has a big advantage over the rest. How it compares to Red Bull's top-secret simulator (which runs in tandem with a slightly less formidable one that sometimes appears in the public domain) is a matter for debate, with some arguing that the Milton Keynes team has made giant



De la Rosa joined at Alonso's behest

CARRY ALL THE GOOD MEMORIES... STAY TUNED FOR MORE FUN...

www.pettersolberg.com

CANNON RUN EUROPE

Experience the Cannonrun European Road Trip.

28th June 2013

-6 days away driving some of the best roads around Europe.

JUST £795.00 per person based on two sharing a car. Includes hotels, breakfast and return ferry.

Have the time of your life!

www.topgearcannonrun.co.uk
Contact T: 01227 371801 M: 07780 564255

onpole
.com

#1 for MOTORSPORT FANS

WINTER SALE – Massive range of diecast models, F1 and MotoGP merchandise.
Up to 50% off! Strictly while stock lasts. A treasure trove for diehard F1 and MotoGP fans.



Vodafone McLaren Mercedes | Red Bull Racing | Mercedes AMG Petronas | Lotus F1 | Ferrari | Force India | Rossi VR46 | Simoncelli Sic58

+44 (0) 870 241 2829 | www.onpole.com | sales@onpole.com



Breakdown cost de la Rosa time

◀ strides since its technology was compared with a PlayStation a few years ago by one of its drivers!

“The whole point of being here [at Jerez] is to accelerate this process,” says de la Rosa. “We are not sure if it will take six months, one year or two years [to catch up]. We just have to work flat-out because there is no testing and this is a handicap for all the teams that don’t have a very developed simulator.”

The simulator disadvantage is symptomatic of Ferrari’s game of technological catch-up. During the Michael Schumacher era, it took full advantage of its Fiorano test track and founded its development work on testing, testing and more testing. In that situation, it didn’t matter so much why something worked, given that it could use the empirical method to work through countless designs and stay ahead of the game. At the same time McLaren – which did not have its own test track, after a putative plan to develop the Lydden circuit in Kent failed – invested heavily in pioneering technology such as the simulator.

This is at the heart of the question of whether the Italian squad really can win the championship this year. In 2012, Alonso came desperately close to taking the crown, more through circumstances and his own relentlessness than through Ferrari’s brilliance. The car improved, certainly, but over the balance of the season it was, at best, the third-best car – only the topsy-turvy nature of the first half of the season, McLaren’s points squandered to unreliability and pitstop blunders, and Red Bull’s erratic campaign kept it in the game. This shrouded the extent to which Ferrari was playing catch-up.

Inroads have been made under technical director Pat Fry, but with major rule changes coming in 2014 it may be beyond Maranello to produce a car that this year is able to start, and stay, ahead of the game.

“I know when it’s a good car, but it doesn’t really matter because the most important thing is how much it will develop until Australia [scene of the first race],” says de la Rosa. “It doesn’t really matter where you are today. But we have good pace, that’s all I can say. The car is sensitive to changes, the car has a good front-to-rear-end balance and we just have to work to improve it by Australia. Obviously, this is very different from last year.”

So Ferrari has the baseline. What it needs to prove now is that – in a season likely to be so close that parts producing hundredths of a second rather than the traditional tenths will make the difference – it has the technology to go toe-to-toe with Red Bull and McLaren rather than simply hanging on. ☞



Pedro can take real-time info back to the simulator

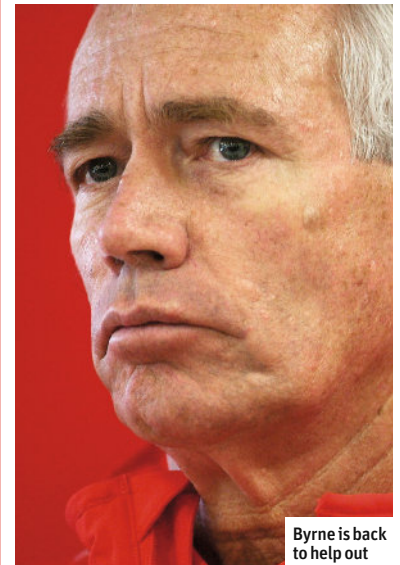

Byrne is back to help out

FERRARI'S SECRET WEAPON

Ferrari is not alone in having made overtures to poach Red Bull design chief Adrian Newey, but with F1’s leading technical mind shrugging away any such approaches, the Scuderia has pulled off its own masterstroke. It emerged last week that Rory Byrne will have some involvement in the team’s 2014 machine, when the new 1.6-litre turbocharged V6 power units will transform the cars.

Since retiring at the end of 2006, Byrne has been retained by Ferrari as a consultant, spending around a third of the year at Maranello and the rest in his home at Phuket in Thailand. Much of that time has been spent on road-car projects, although he has occasionally drifted into the sphere of the F1 team. Officially, his main focus in his consultancy role is on the Ferrari Enzo project, although he is available for “operational support” for the F1 team, according to a spokesman.

At the very least, that means that he’s available to offer advice and direction to chief designer Nikolas Tombazis and 2014 car project leader Fabio Montecchi, and sources indicate that Byrne has been playing an active role. This could prove invaluable to concepts and design directions at a time when clarity of thinking will play a key role in whether teams hit the ground running next year.

Byrne generally had a lower profile than Newey, but the South African is the man whose cars have most consistently been responsible for bumping Red Bull’s chief technical officer off his perch in the past 20 years. Byrne was central to all seven of Michael Schumacher’s world championships, at Benetton in the mid-1990s and with Ferrari in the early years of the 21st century.

That’s a man who Ferrari’s technical department will be very pleased to have in their corner.

RACING EV

In the final year of the current rules cycle, *CHARLES BRADLEY* takes an overview of Ferraris, from the F60 to the

2009

F60
Constructors' position: 4th
Wins: 1 (Belgium)
Poles: 0
Fastest laps: 1 (Monaco)

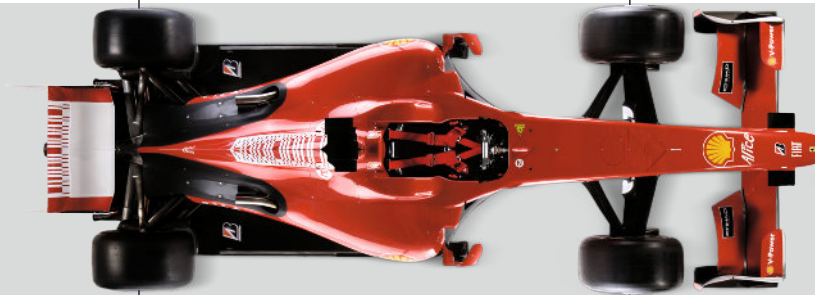

Overconservative car misses boat on the double diffuser, not aided by unhelpful shape of gearbox casing. Lack of downforce means it's hard to drive, leading to worst season in team's history since 1993. Kimi Raikkonen's Belgian GP success is the highlight of a troubled campaign.

2010

F10
Constructors' position: 3rd
Wins: 5 (Bahrain, Germany, Italy, Singapore, Korea)
Poles: 2 (Italy, Singapore)
Fastest laps: 5 (Bahrain, Great Britain, Italy, Singapore, Korea)

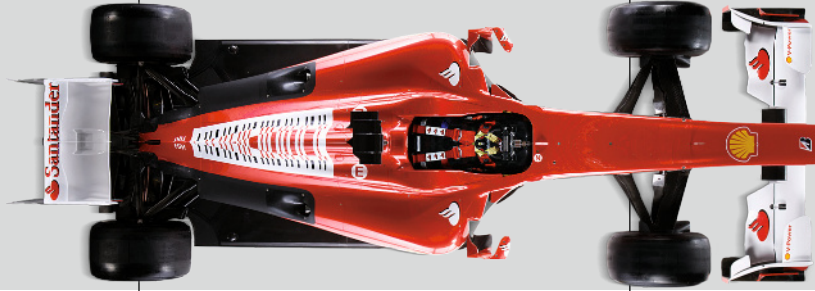

Fernando Alonso wins on Ferrari debut in Bahrain. Cleverly tilted engine/gearbox, but team isn't helped by playing catch-up on blown diffuser and f-duct. Alonso wins four more races, however, and is set to win title in Abu Dhabi decider when strategy error hands it to Vettel.

2011

150 Italia
Constructors' position: 3rd
Wins: 1 (Great Britain)
Poles: 0
Fastest laps: 3 (Australia, Great Britain, Hungary)

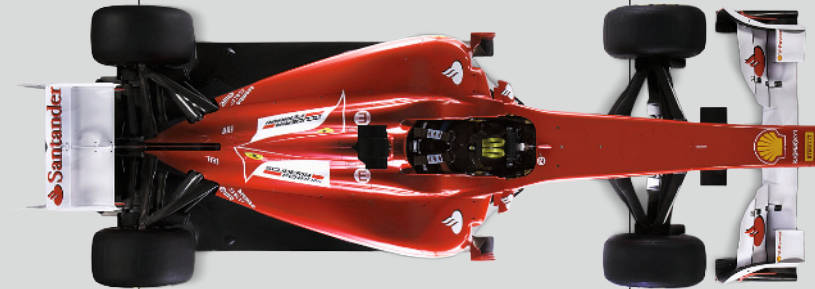

Hilarious pre-season spat with Ford over the use of original model name 'F150'. Car is again too conservative. Lack of off-throttle blown-diffuser technology hinders first half of the season but, when that is briefly banned at Silverstone, Alonso wins. Windtunnel problems are identified.

2012

F2012
Constructors' position: 2nd
Wins: 3 (Malaysia, Europe, Germany)
Poles: 2 (Great Britain, Germany)
Fastest laps: 0

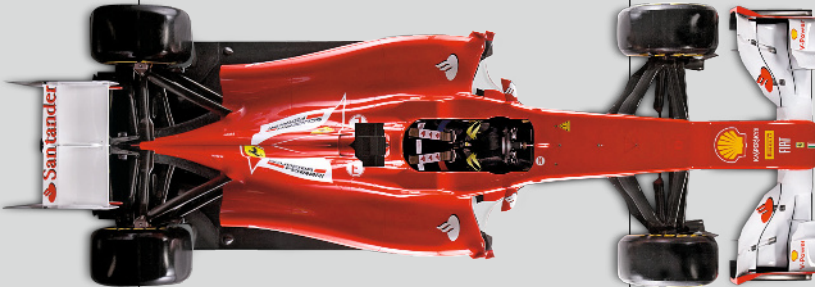

Aggressive concept leads to major rear-end instability, and car struggles in early races - although Alonso claims inspired victory in Malaysia. Upgrade at Barcelona improves matters, and a reversion to initial Coanda exhaust in Canada also helps his strong, but unsuccessful, title bid.

2013

F138

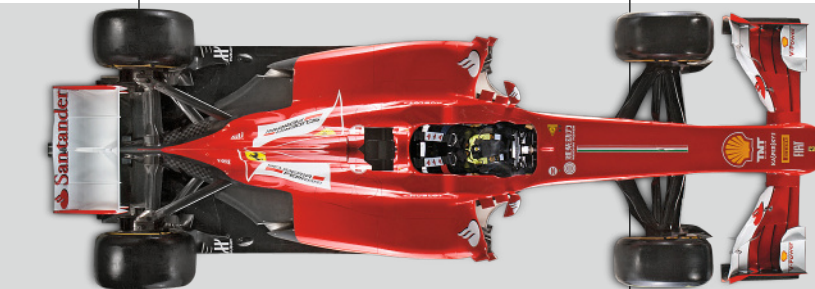

Launched at Maranello on Feb 1, car retains pullrod front suspension. Its hindmost rear wishbone has shifted forwards, to incorporate the driveshaft, and a new, tightly packaged gearbox has been integrated. Aerodynamics now developed in Toyota's windtunnel.

EVOLUTION

brand-new F138. Can it bring the drivers' world championship back to Maranello after a five-year drought?





Alonso: calm
and impassive



Lost points part one: victim at Spa



Lost points part two: beaten by Maldonado in Spain



Lost points part three: crash in Japanese GP

SHAKEN

but not stirred

For different reasons, Fernando Alonso and Felipe Massa had tricky times during 2012, but both Ferrari stars are confident of a strong challenge this year. By *JONATHAN NOBLE*

To lose a championship by the smallest of margins at the final hurdle because of a simple mistake may be hard to accept at the time – but it at least enables you to find closure in the long term. All you need to do is work out what went wrong, change things to make sure it doesn't happen again, and move on.

But to lose a championship at the eleventh hour, when you've dug deep and done everything you can, is much harder to deal with. The frustration of reflection burns deeper; you're forced to pore over not just one race but a whole season of circumstance to ponder where the crown was lost.

That's the very feeling that Ferrari faced in the weeks after the 2012 Formula 1 season drew to a close.

Losing the title for Fernando Alonso in Abu Dhabi in 2010 through the strategy blunder, or in '11 through being no match for Sebastian Vettel, was one thing. But for an Alonso who was near-flawless throughout '12, and for a Ferrari team that made the most of

every opportunity thrown its way with a car that was fastest, at best, for just two weekends, last season proved more of a challenge to accept.

A lot of time can be spent looking back at where that ultimate three-point deficit to Vettel was conceded.

The incidents at Spa and Suzuka were obvious moments, but what if Alonso had beaten Pastor Maldonado at Barcelona, or held off Mark Webber for a few more laps at Silverstone? What if the team hadn't tried to make a one-stop strategy work in Montreal? Or what if it had checked the rear suspension just one more time at Monza before qualifying?

After the supreme effort that Alonso and the Ferrari crew put in last year to recover from that awful first test at Jerez, how did they once again not come away with a crown that had, until the autumn, appeared to be theirs?

Only time was going to answer those lingering questions.

Yet while such a scenario may have caused huge internal politicking at Ferrari years ago, for Alonso and Ferrari

the lessons of last year appear to have perhaps unified them even more.

There was no witch hunt to show the world that those who slipped up no longer deserved their place, no finger pointing or shifting of blame for the small errors that proved costly in the end. Instead, the focus was on even more determination to knuckle down and get things right in 2013.

That's very much the strength of the Alonso-era Ferrari – the acceptance that achieving the dominance of the Michael Schumacher years is unlikely. And this has helped galvanise the team.

It's time to accept the way the sport is; that an exclusive tyre partnership and a return to unlimited testing is not going to happen – so it's time to wake up and play the game, the same high-tech simulation game as everyone else.

But for all the lessons that Ferrari took on board about not getting to grips with its exhaust concept last winter, you can't help but wonder whether Alonso is starting to feel a sense of anxiety that the crown has not come his way. ▶



◀ He joined Ferrari for 2010 not just because of the legendary status of the team but because he wanted to win. And not just races.

The Spaniard might have been just nine points – five in 2010 and four last year – from having secured two crowns for Ferrari, but the gap may as well have been 900. Championships are all Alonso really cares about.

But for all the opportunities for frustration, Alonso is adamant that there is no desperation sneaking in. He is completely dismissive of there being a burden for him and Ferrari to get it right this time out.

“There is never a must in terms of winning,” he says. “This is a sport – sport means sacrifice, it means determination, it means to like what one is doing – to find pleasure in what one does.”

“In the last three years I’ve been able to fight for something very important. There are 24 drivers out there and not all of them have the luck of being on the podium and fighting for the championship.”

“I had the possibility of winning the title in the last few seasons, which is a target for both myself and Ferrari. But when sport is involved obligations become superficial.”

Don’t imagine for a second, however, that Alonso’s philosophical approach means he isn’t hungry to win. The job he did on track last season might have earned almost universal praise – including the F1 team principals voting him in as driver of the year in AUTOSPORT’s annual poll – but he’d rather take home some proper silverware.

“It’s simple,” he says. “In all the voting and on many websites they considered me the best driver.”

“OK, this pays for the sacrifice and training I did, the dedication that we gave to the sport, but the goal is of course to win.”



Brazil 2012: Alonso lost title, but Massa joined him on podium

With his feet on the ground, there’s no griping from Alonso about the windtunnel issues that proved so costly when Ferrari needed successful updates in 2012. Rather, there’s an acceptance that he trusts the team has everything in hand.

The area in which he thinks Ferrari perhaps needs to lift itself is in being aggressive with car designs; perhaps taking things a bit more to the limit than the team has in the past. A stronger start to the season is essential too.

“If you’re fighting for a championship then podiums can be enough, but during the first races [in 2012] we came ninth in China and seventh in Bahrain,” he says. “These were the results that did not allow us to fight for the championship.”

“But things turned around. And, due to mechanical problems of our rivals, we were ahead and fought until the end. In the first four or five races though, our level was not enough to fight for the championships.”

If there’s one area where Alonso can look to progress this year, it’s in what’s going on in the other red car.

Felipe Massa appears to have got his house in order. After coming close to being dropped by Ferrari on the back of early-season frustrations last year, a new mindset helped the Brazilian come on strongly in the second half of the season.

His transformation boiled down to confidence and an acceptance of the speed of the man he lines up alongside. That renewed mental strength certainly

Drawing board



Ferrari promised major changes for its new car and there are clear steps forward with the packaging, particularly around the rear. By GARY ANDERSON, EDD STRAW and GIORGIO PIOLA

SMALLER GEARBOX

→ This is very different from its rivals. It mounts the rear suspension on a subframe on the back of the engine, and that means that it doesn't put such high loads through the gearbox, although it still carries the wishbones. The subframe supports the rockers, the torsion bars and the anti-rollbars. The carbonfibre gearbox casing can be shallower as it doesn't take any of the bending load. That's an effective way of reducing the cross-section of the gearbox for aerodynamic reasons, like Williams has done, but without getting too elaborate.

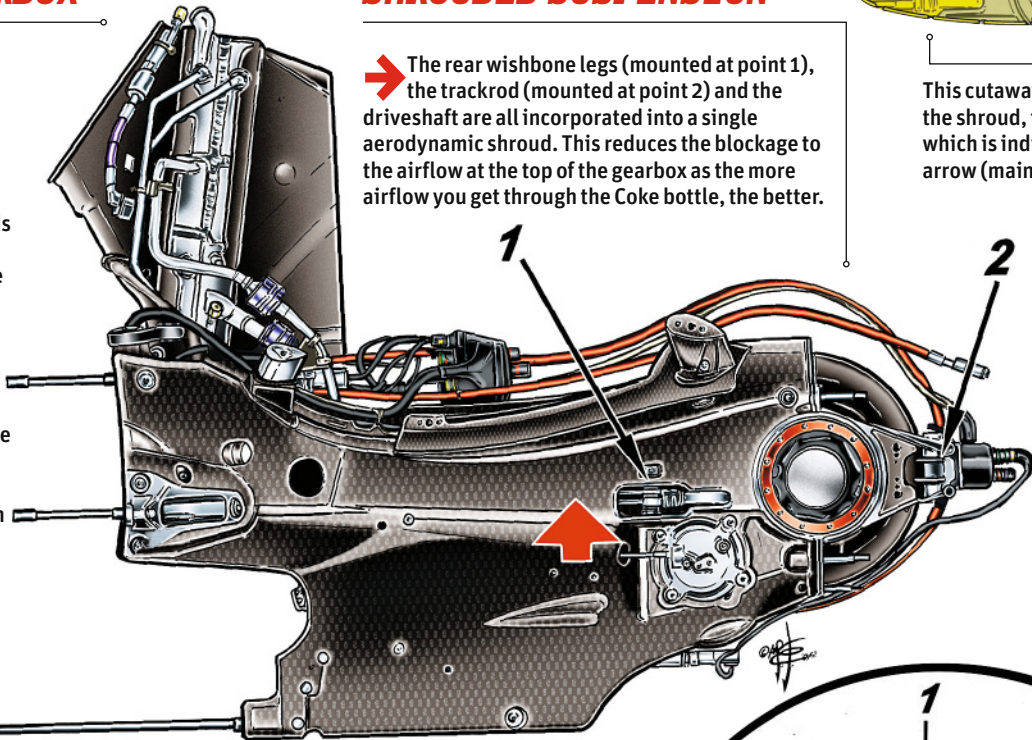

SHROUDED SUSPENSION

→ The rear wishbone legs (mounted at point 1), the trackrod (mounted at point 2) and the driveshaft are all incorporated into a single aerodynamic shroud. This reduces the blockage to the airflow at the top of the gearbox as the more airflow you get through the Coke bottle, the better.



This cutaway shows what's inside the shroud, the actual location of which is indicated by the red arrow (main image, below)

DUCTED FLOOR

→ The extra space created by the gearbox allows the addition of small vertical turning vanes, as Red Bull had last year (3). It has also incorporated a duct on the top surface of the floor similar to last year's Red Bull (inset, 4). The duct starts when the sidepod's vertical wall goes inside the vertical surface joining the reference to the step plane; this allows them to get more airflow (blue arrows) into the centre of the diffuser area to reduce problems with airflow separation and improve reattachment. (2) shows brake-duct detailing, with (1) showing the wishbone.

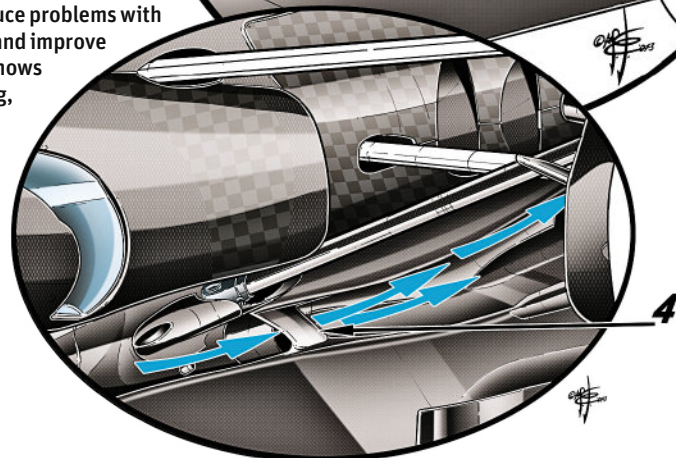
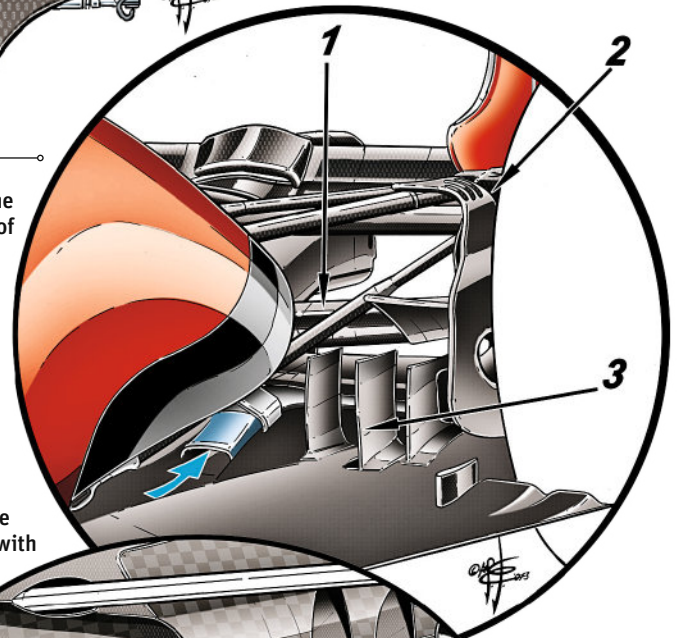

REAR WING GETS VANES

→ The rear wing is similar in concept to last year's, but with more detail work. There are curved fins mounted on the outer surface of the endplates to try to redirect the airflow to a more aerodynamically advantageous place. But the trailing edge is most interesting. The long turning vanes are trying to create low and high-pressure areas to turn the airflow around the back. In 2012, Ferrari just had a gurney flap to do this, but what it has done here is more efficient. It's probably only a small return, but worth doing if you have the resources.

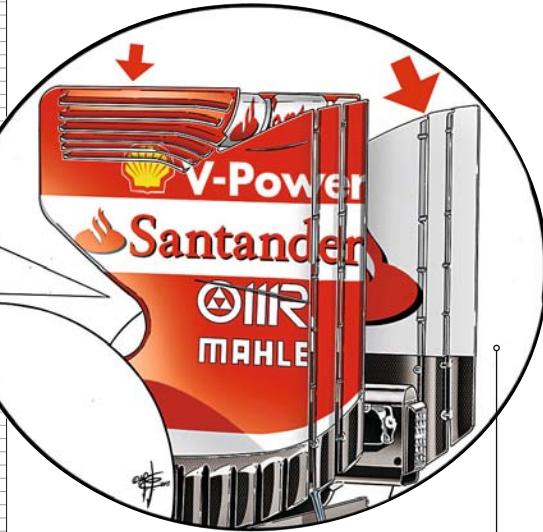

RADIATORS KEEP UP THE HEAT

➔ The vertical radiators from 2012 are retained. This is for packaging reasons, to allow the undercut and the sidepods to work the Coke bottle harder. But you can't cheat the cooling demands, so by having these radiators – rather than conventional ones at around 20 degrees to the horizontal – requires a thicker cord for the elements in the radiator. It's not the most efficient way of doing that, but Ferrari clearly feels there is a net gain.

RED ARROW

This strut was on the 2012 car but has been dropped for the F138. It ran from the front of the gearbox to the back of the monocoque to deal with the vertical bending moment under load.

BLUE ARROW

This indicates the airflow that runs through the secondary inlet just behind the main airbox. It directs the air into a cooler, probably for hydraulics, and out of the back of the car. At high speed there's a lot of spillage from the main airbox intake, so this takes some of that turbulent air and redirects it, giving a cleaner flow to the rear wing.

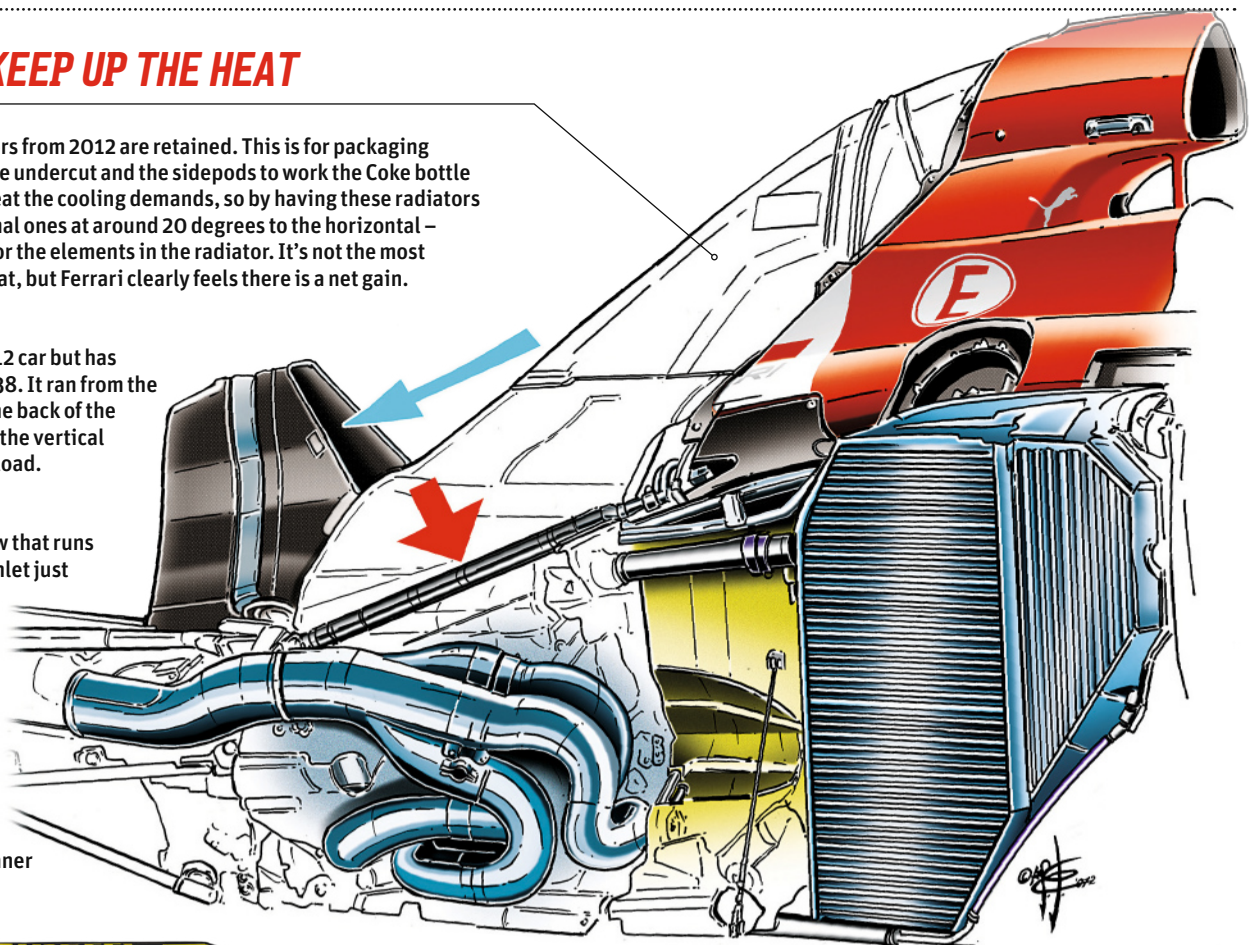

2012 CAR



LATEST NOSE JOB

➔ The front-wing pillars are tapered inboard at the back and outboard at the front to divert more airflow into the middle of the car. The front-wing pillars are exaggerated and finish further forward than they did last year to get more airflow through below the nose.

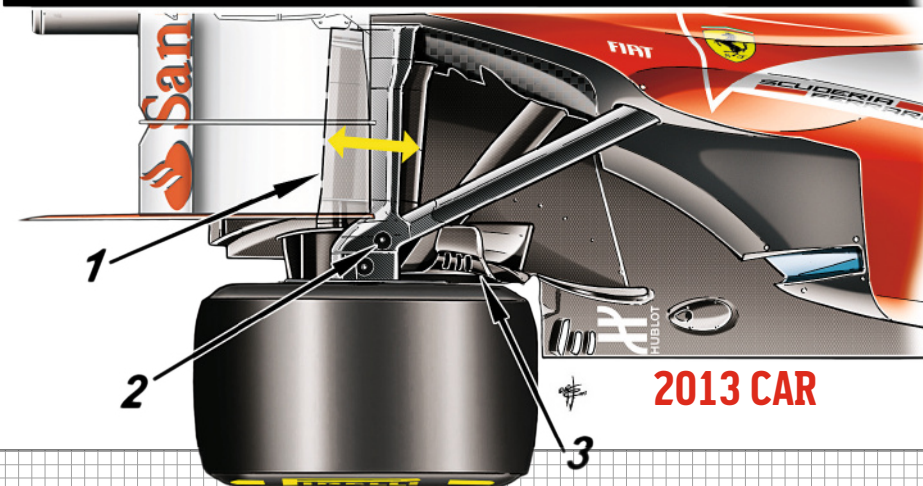
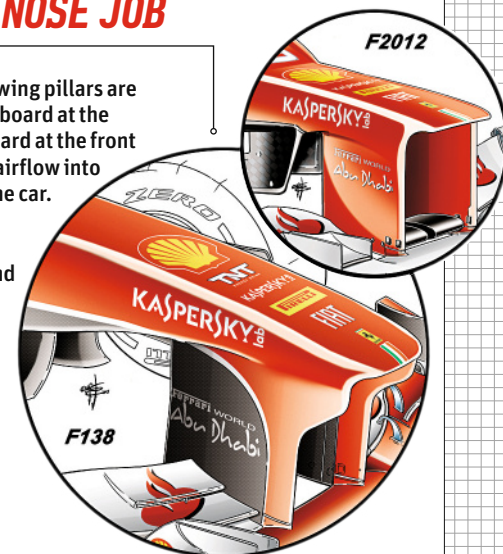

2013 CAR

REAR SUSPENSION TWEAKED

➔ Arrow (1) is the rear leg of the wishbone and this, the driveshaft and the trackrod are all in line with each other. (2) is the upright pickup point. Normally, this point would be the other bolt that you can see a little closer to the wheel, but by moving it forward and inboard there is more potential for camber change. (3) is an extension of the brake duct – a top fin and three little vanes – to help with producing downforce using the exhaust gases.

“I always thought DTM was more interesting than F1”

Timo Glock might be out of F1, but as a long-term DTM fan he is not too upset about where he's ended up. BMW's latest star signing spoke to *JAMIE O'LEARY*





The next few years could be very good for Timo Glock. Sure, no Formula 1 driver likes being turfed out of his team for reasons not to do with performance (although an increasing number are experiencing it), but the German has, at least, taken a constructive view on the matter.

Now he's setting about readying himself for an assault on the DTM, arguably the only series in the world in which you can't buy a drive. With three F1 podiums to his name and a BMW M3 just like the one Bruno Spengler drove to last year's title at his disposal, there's no reason to think that Glock can't go on to become a multiple champion and add his name to a list of BMW touring car legends that includes Ravaglia, Soper, Cecotto and a lot more besides.

AUTOSPORT caught up with him after his maiden outing for BMW at Valencia...

How difficult was it to be dropped by Marussia with a year of your F1 contract still to run?

It wasn't easy. We had a pretty open talk just before Christmas and came to the conclusion that this should be the result. It's the only way the team could move forward and survive. It's the reason we split and on reflection it seems to have been the right decision for the team and for me.

How quickly was BMW on the phone once the news broke?

I'd been in contact with BMW over the past few years and I know a couple of people there pretty well. That contact never stopped and probably helped a bit at the end, but it all came about very quickly. There was no masterplan put together over many months; it happened very quickly. And it was definitely positive for me that there was a free seat and a test coming up at Valencia. It all worked out very well.

You built up a strong relationship with Jens Marquardt when you drove for Toyota in F1. Was this move inevitable once he became BMW motorsport director?

Jens and I had a very good relationship at Toyota and that never really stopped between 2009 – when Toyota pulled out of F1 – and now, and if you know someone well it helps. But if I'd been three seconds off the pace at the Valencia test, he'd never have signed me. I'm pretty sure of that.

There was very little German involvement in Formula 1 between Zakspeed's departure and the arrival of Michael Schumacher in 1991. Did ▶

BMW was swift to sign up Glock



Glock in Tomczyk's car at Valencia test

◀ **you have an interest in the series or ever aspire to be a DTM driver?**

I was nine years old when Michael came into F1 and it wasn't big on TV. That changed, of course, and I took a lot more interest in it after that. The DTM was another matter. It was on TV every Sunday and I always watched it with my dad. I followed it closely, and I did so again when the series returned in 2000. I always thought it was more interesting than F1. Dad was a big BMW supporter and my heroes were Johnny Cecotto and Steve Soper – fantastic drivers and great fun to watch.

What were your first impressions of the BMW M3 DTM machine when you drove it at Valencia?

It was a bit more similar to a Formula 1 car than I expected. You think, 'OK it has a roof so it should be slower to react with direction change, acceleration, etc, etc'. But the car felt good and importantly gave very good feedback. So I felt quite at home reasonably quickly. These cars are a step in the right direction, definitely much closer to an F1 car than the older-spec cars. I'd driven an Opel DTM car in a test in 2002 when I was using their engines in Formula 3, and that was much further away from a single-seater than the BMW.

You'd finished third in German F3 when you had that Opel test. Was there an opportunity to step up to the DTM at the time?

Not really. When I was an Opel driver



Glock must now learn tin-top art

in 2002, it was pretty certain that I'd be doing another year of Formula 3 [in 2003], in what became the Euro Series, and then at the end of that year came my opportunity in Formula 1 with Jordan, so nothing serious ever happened with DTM.

What are a realistic set of aims for your rookie DTM season?

I want to be competitive pretty quickly and fight for points, and then be on the podium at least once before the end of the year. I've followed the DTM for the last couple of years and all the ex-F1 drivers have struggled to get up to speed. It's not impossible though. It should be possible to be at least in the points and maybe get that podium.

What makes you think you will succeed where David Coulthard

and Ralf Schumacher – both grand prix winners – have struggled?

Good question. I've only had one-and-a-half days in the car. I will just have to try hard and do my best. The good thing is there are still a couple of tests ahead of the first race, which should give me enough time to get used to the car. Still it's different to Formula 1. You have to drive these cars differently to a grand prix car. It's a different system.

Also the race weekends won't be that easy because a lot has been changed in terms of the format. In particular the reduction in track time. The game is all about finding these last two or three tenths of a second. That's the point at which you need to really understand how to extract that final bit of performance. That's what makes the difference.



GLOCK CV

2012 20th in F1 with Marussia
2011 25th in F1 with Virgin
2010 25th in F1 with Virgin
2009 10th in F1 with Toyota
2008 10th in F1 with Toyota
2007 GP2 champion with iSport (5 wins)
2006 4th in GP2 with iSport/BCN (2 wins)
2005 8th in Champ Car with Rocketsports
2004 19th in F1 with Jordan
2003 5th in F3 Euro Series with KMS (3 wins)
2002 3rd in German F3 with KMS (3 wins)
2001 1st in FBMW ADAC
2000 1st in FBMW ADAC Rookie Cup
1998-1999 Karting

in the DTM who are on a very high level – nearly all of them. That’s especially true of the guys with a lot of experience like Gary Paffett, Bruno Spengler, Martin Tomczyk, Timo Scheider, Mattias Ekstrom, Mike Rockenfeller... They are all super-quick in touring cars. If any of those are having one of their better days then they are easy race winners. That’s the reason the DTM is so mixed-up every time and so tight in qualifying. Watch qualifying and you can see how small the gaps are.

You’re going to race for BMW’s newest team, MTEK, alongside Marco Wittmann. Would you have preferred a team-mate with DTM experience?

I don’t think it will make a massive difference because within BMW we all share data and can see what the other drivers and teams are doing. But it goes without saying that if you have an experienced guy like Tomczyk, with 13 years in the DTM behind him, you maybe have a closer chat with him and get some more information.

Do you see the DTM as a series in which you can spend the next decade, winning races and titles, or a way of making it back to F1 with your reputation further enhanced?

Could be either. Paul di Resta showed you can still go to F1 via the DTM. But all my focus now is on the DTM and BMW. There’s no point focusing on anything else because it won’t help me. It’s a big challenge ahead. My time in the DTM could run for 10 years and I’d have no problem with that. I’m not looking five years down the line; I’m looking at this year and concentrating on the job I’ve got to do. ☺

P60

Bruno Senna on surprise Aston move

A 2013 rule change is the scrapping of the 90-minute practice session on Fridays, leaving just 90 minutes on Saturday before qualifying. How crucial will this be for a rookie?

I think it’s the wrong way to go; not because I – as a rookie – only have 90 minutes of track time, but because it’s bad for the fans too. They will see the cars less on the track, so I just don’t understand this. We have a proper Friday in every other major series. I don’t know why the rule-makers have shortened it, but that’s the way it is. We just have to get on with it and make the best of the 90

minutes we do have. It does make it difficult for me. The guys with more experience will be less disadvantaged than me, but we’ll just see what we can get out of it.

Have your season’s expectations been reduced as a result?

Maybe. If I can get some proper results then that’s definitely going to be something positive for myself.

How highly do you rate the drivers in the DTM? Are the top guys on a par with high-level F1 drivers?

I think there are quite a lot of drivers

HOW GOOD WAS GLOCK IN F1?

Timo Glock wasn’t destined to be world champion, but he was a very effective grand prix driver who wouldn’t have looked out of place on the top step of the podium. Of all the drivers to have lost out in the off-season game of musical chairs, the 30-year-old is arguably the most unfortunate.

Glock was just what a team like Marussia needed. Quick in qualifying, albeit not stellar except on slower tracks like Monaco, where he excelled, but a tenacious racer who kept the team in the hunt in its on/off battle with Caterham from 2010-2012. He also shone in low-grip conditions, be it in the wet or in on a dusty, green track.

Things could have gone very

differently for Glock in his F1 career. He was on his way out of Toyota even before the Japanese manufacturer decided to pull the plug on its team in 2009, and was offered a drive by Renault. Amid uncertainty about its future thanks to the fallout from the Singapore GP scandal, he opted for a Marussia (then Virgin) drive rather than a place alongside Robert Kubica in what was a strong top-10 car.

That same year, he was also on McLaren’s list, albeit a few notches below the likes of Kimi Raikkonen and eventual signing Jenson Button.

But don’t feel too sorry for Glock. He has started 91 world championship grands prix, had a shot with a megabucks works team and stood on the podium three times. That



Glock took trio of F1 podiums

puts him in the top 15 per cent or so of drivers ever to have raced at the highest level.

And he has been well paid for

five years before landing on his feet in the DTM with a car capable of letting him fight for wins.

Edd Straw

INTRODUCING STOFFEL VANDOORNE

The young Belgian has joined FRenault 3.5 champion Fortec and is expected to shine

“That was another attractive point about Fortec - they believe that a driver can win FR3.5 as a rookie”



Vandoorne has stepped up to FR3.5 with Fortec

Stoffel Vandoorne is accustomed to earning coveted championship-winning seats. The Belgian sprang into Robin Frijns' vacated cockpit at Josef Kaufmann Racing to triumph in last year's Formula Renault 2.0 Eurocup, and further aims to emulate the Sauber F1 reserve driver's meteoric career.

A deal to race with Fortec in the forthcoming Formula Renault 3.5 season mirrors Frijns' choice of teams, and has fuelled Vandoorne's belief that championship success in his rookie year is attainable.

Fastest in the final collective test of 2012 at Motorland Aragon, Vandoorne will reacquaint himself with Fortec at an extended private test at Monza on Thursday. Fortec engineer Jamie Dye, who heads an unchanged technical line-up, is encouraged by the early signs from his new charge.

“Stoffel is a very mature driver,” says Dye. “He drives in a similar way to Robin Frijns – both came from Kaufmann – and he seems to be fast in the same sort of car. Nothing is taken for granted, but we think we can go out there and fight hard with Kevin Magnussen, who is in his second year and is blindingly quick, and [Felix] da Costa – who obviously had a mega second half of 2012. I am fairly sure it will be between those three.”

The driving bug started when Stoffel's father was commissioned to design a restaurant at an indoor karting track in Flanders, 15-20 minutes away from the family home in the medieval town of Rumbeke. The six-year-old Vandoorne was soon allowed to drive at his leisure by the facility's generous boss.

“I started enjoying it and always wanted to go back,” recounts Vandoorne. “Then the owner bought me a little

go-kart and, whenever I wanted to drive, I could always go.”

In 2008, at the age of 16, Vandoorne was crowned Belgian national champion in his first year of KF2. The runner-up spot in the world championship came the following year, in which he also emerged as winner of the Royal Automobile Club of Belgium's influential ‘Steering Wheel’ competition, which inaugurates young drivers into its national team.

The prize was around half the budget, €45,000, towards a season in the Auto Sport Academy's, nee Campus, F4 1.6 Eurocup. Reflecting on his subsequent domination of the Academy series, Vandoorne admits: “The most difficult thing was actually making the choice to take up the prize. When you are not successful in cars, it is hard to continue unless you have a lot of money, which I didn't have. I almost had to win the Auto Sport Academy to get the prize money to go into FR2.0.”

The 20-year-old describes the Eurocup's €500,000 scholarship as “the key” to his entry into FR3.5 and motivation is high thanks to Frijns' presence at the recent Sauber F1 launch.

“It is crazy,” agrees Vandoorne. “Only two years ago I was racing against Robin in two litres and now he is in F1, so things can go really, really quick. That was another attractive point about Fortec – unlike other teams they believe that a driver can win FR3.5 as a rookie.”

VANDOORNE CV



Born: March 26, '92
From: Kortrijk, Belgium
2012 FR Eurocup champion (four wins); Ninth in FR2.0 NEC, seven races
2011 Third in FR2.0 NEC (8 podiums); Fifth in FR Eurocup (1 podium)
2010 F4 Eurocup 1.6 champion (6 wins)
1998 to 2009 Karting: 2009 CIA-FIA World Cup vice-champion KF2; 2008 Belgian KF2 champion

Winning in Hungary en route to FR2.0 title





YOU CAN'T TRUST EVERYONE SELLING CARS ON THE INTERNET



You don't necessarily know who's behind selling a car when you buy online. You also need to be assured that what they say they are selling and what they are selling are the same thing. Buying from **Trusted Dealers** is the safest and most reliable way to buy a used car online. Owned by its members with hundreds of **franchised dealerships across the UK**, we can offer standards that other classified websites can't guarantee and that's why **What Car?** endorse our Ten Points of Difference.



Don't just buy from anyone. Search for trusted dealers.



OUR TRUSTED DEALERS INCLUDE ARNOLD CLARK · BEADLES · BRAYLEY · BRISTOL STREET MOTORS · CAFFYNS · CAMBRIA · CHAMBERS · CLEMO · COLLIERS · CO-OPERATIVE MOTOR GROUP · CURRIE MOTORS · DM KEITH · DRIVE MOTOR GROUP · EASTERN WESTERN HOLDINGS LTD · FG BARNES · FORD RETAIL · FROSTS CARS · GK GROUP · HARTWELL · HENDY · HOLDCROFT · HWM GROUP · INCHCAPE · JARDINE MOTORS · JCT600 · JOHNSONS · KINEHOLME GARAGE · LIFESTYLE EUROPE · LLOYD MOTOR GROUP · LOOKERS · MACKLIN MOTORS · MARSHALL · NIDD VALE · PENTAGON · PERRYS MOTOR SALES · PHOENIX · RIDGEWAY GROUP · RINGWAYS GARAGES · ROBINSONS · RON BROOKS · ROYCE ROBERTS SKODA · RYBROOK · SANDICLIFFE · SG SMITH · SHIELDS AUTOMOTIVE · SKY FORD · SNOWS · SPEEDWELL HONDA · STURGESS · SWANSWAY · TAGGARTS · TRIDENT · TRUST GROUP UK · WAYSIDE GROUP · WESTONS



View our full lot listing of more than 25
Race, Rally & Competition Cars at
www.silverstoneauctions.com

CLASSIC CARS >> MODERN CARS >> RACING CARS >> RALLY CARS >> MOTORBIKES >> AUTOMOBILIA



Race Retro & Classic Car Sale

23rd February 2013

Stoneleigh Park
Coventry



DAYTONA
MOTORSPORT

24 Hours

The Daytona 24 Hours 2013

What

Daytona Motorsport are delighted to confirm details of the 2013 Daytona 24 Hour Race. Teams of up to 12 drivers are invited to register for "The Race Of The Year".

When

Saturday 4th May – Sunday 5th May 2013 - Driver Sign on at 0900hrs.

Race Start/Finish at 1400hrs

Where

Daytona Milton Keynes, Danstead Way, Milton Keynes, MK13 8NP

How Much

Dmax Team: £2195 inc VAT

Prokart Team: £1695 inc VAT

Pay by 28/02/13 to save £100 per team

Call Mark Wimblett on
Tel: 0845 644 5504
to reserve your space

www.daytona.co.uk



Trophy Championship 2013

Looking for **cost effective** racing where **sealed engines** create a **level playing field**? The MG Trophy Championship is **as fast as it gets for entry-level money**. With classes for full Slicks or Treaded race tyres, drivers often progress through the Championship onto bigger series, like current Renault Clio Cup Champion and **2013 BTCC driver Jack Goff**.

Visit mgcc.co.uk/trophy now for more info | Contact Pete Macwaters: 01280 821442



...the friendly one-make championship



BATHURST 12 HOURS MOUNT PANORAMA (AUS), FEBRUARY 10

Mercedes wins scintillating enduro

MERCEDES WON A DRAMATIC Bathurst 12 Hours as Erebus Racing trio Bernd Schneider, Thomas Jager and Alexander Roloff kept their heads through tricky conditions in the final stages and their chief rivals lost theirs.

With the safety car appearing 15 times – on some occasions due to sudden and torrential storms on the mountain section of the track – strategy was all-important. Clever tactics put Erebus on course for a one-two finish, but hopes of this came to an end when the second SLS AMG GT3 was crashed by Lee Holdsworth in wet conditions with an hour to go. The car, shared with Tim Slade and Peter Hackett, was repaired, and finished sixth.

The Clearwater Racing Ferrari of Craig Baird/Matt Griffin/Mok Weng Sun

finished second, a mere six seconds behind the lead Mercedes. Its winning hopes were dashed when a front splitter broke, possibly as a consequence of Mok striking another car earlier in the race. Third was the Porsche 911 GT3-R of Shane van Gisbergen/Klark Quinn/Matt Kingsley, with Quinn taking the maximum points for the opening round of the Australian GT Championship, which was determined by positions at the one-hour mark.

Audi's best chance of making it three straight Bathurst enduro victories ended when V8 Supercar legend Craig Lowndes had a rear wheelhub fail on his R8 LMS ultra, spinning him at The Dipper.

The Peter Conroy Motorsport Audi, which featured two Britons at the



Merc was victorious

wheel – World Touring Car title winner Rob Huff and Australian Formula 3 champion James Winslow – finished eighth.

● Phil Branagan

RESULTS

1 Bernd Schneider/Thomas Jager/Alexander Roloff (Mercedes SLS AMG GT3), 268

laps in 12h03m04.519s; 2 Craig Baird/Matt Griffin/Mok Weng Sun (Ferrari 458 Italia GT3), +6.381s; 3 Shane van Gisbergen/Klark Quinn/Matt Kingsley (Porsche 911 GT3-R); 4 Johan Kristoffersson/Harold Primat/Andreas Simonsen (Audi R8 LMS ultra); 5 Mark Eddy/Marc Cini/Dean Grant/Christopher Mies (Audi); 6 Tim Slade/Lee Holdsworth/Peter Hackett (Mercedes).

IN BRIEF



'Bargs' won twice

NEW ZEALAND V8s

Points leader Jason Bargwanna took a double win at Manfeild, but was denied a third victory when a mysterious electrical glitch caused his Tulloch Holden to cut-out mid-race and hand victory to fellow Holden man Nick Ross.

USF2000 WINTERFEST

Ex-British Formula Ford racer Neil Alberico took the title by winning five times in his Cape Motorsports/WTR car. The US driver won all three Sebring races, but lost his chance of a 100 per cent record when team-mate Scott Hargrove took the first victory at Palm Beach. Briton James Fletcher, also in a Cape car, took a trio of third places.

TOYOTA RACING SERIES MANFEILD (NZ), FEBRUARY 9-10, RD 5/5

Cassidy nicks Toyota title at NZ GP

NICK CASSIDY WON New Zealand's most prestigious race – its Grand Prix – at Manfeild last weekend, and in doing so wrapped up the Toyota Racing Series title.

The 18-year-old Kiwi's successes were repeats of 2012, and came after he shot into the lead from the outside of the front row, outdragging M2 Competition team-mate and title rival Alex Lynn, who had started from pole.

Steijn Schothorst, whose brother Pieter made his TRS debut at Manfeild, reacted by taking his first win in race one in another M2 car, ahead of Cassidy, Pipo Derani and Bruno Bonifacio.

Brazilian Bonifacio took victory in the reversed-grid race two, but only after on-the-road winner Lucas Auer – the third of the pre-event title contenders – was given a 50s penalty for forcing Steijn Schothorst off the road.

That loss of position for the Austrian dropped him to third in the points behind Lynn.

Fellow Briton Jann Mardenborough was sixth in race one and claimed the top rookie award in the series, finishing 10th in the points.

● Bernard Carpinter

RESULTS

Race 1 1 Steijn Schothorst, 17 laps in 20m17.102s; 2 Nick Cassidy, +0.702s; 3 Alex Lynn; 4 Lucas Auer; 5 Pieter Schothorst; 6 Pipo Derani. **Race 2 1 Bruno Bonifacio**, 15 laps in 18m52.536s; 2 Cassidy, +0.639s; 3 Ignazio d'Agosto; 4 S Schothorst; 5 Dennis Olsen; 6 Jann Mardenborough. **Race 3 1 Cassidy**, 35 laps in 43m03.743s; 2 Lynn, +0.711s; 3 S Schothorst; 4 Derani; 5 Bonifacio; 6 Auer. **Points** 1 Cassidy, 915; 2 Lynn, 803; 3 Auer, 797; 4 S Schothorst, 754; 5 Bonifacio, 650; 6 Felix Serralles, 646.



Cassidy with the NZ GP Cup

MRF CHALLENGE IRUNGATTUKOTTAI (IND), FEBRUARY 9-10, RD 3/3

Daly dethrones King

CONOR DALY BEAT JORDAN King to the MRF Challenge title in the final race of a dramatic round in Chennai.

The American struggled to 13th spot in qualifying for race one, but climbed to sixth and won the reversed-grid race two from pole to take the points lead.

King dominated race three to put himself back in front, but the Briton ran wide at Turn 1 at the start of the final encounter and dropped to the tail of the field, handing the title to his rival, who took the lead as those ahead made errors.

Series debutant Josh Hill started second and took victory in the first race after beating polesitter

Jon Lancaster off the line, with Luciano Bacheta completing a British 1-2-3. Hill added two more podiums to his tally.

● Jack Nicholls

RESULTS

Race 1 1 Josh Hill, 15 laps in 23m46s; 2 Jon Lancaster, +6.470s; 3 Luciano Bacheta; 4 Jordan King; 5 Sam Dejonghe; 6 Conor Daly. **Race 2 1 Daly**, 20 laps in 31m47s; 2 Dejonghe, +11.181s; 3 King; 4 Bacheta; 5 Lancaster; 6 Hill. **Race 3 1 King**, 13 laps in 20m41s; 2 Lancaster, +1.263s; 3 Hill; 4 Dejonghe; 5 Daly; 6 Alice Powell. **Race 4 1 Daly**, 20 laps in 31m51s; 2 Lancaster, +1.382s; 3 Hill; 4 Shinya Michimi; 5 Vicky Piria; 6 Bacheta. **Points** 1 Daly, 164; 2 King, 159; 3 Bacheta, 102; 4 Lancaster, 91; 5 Powell, 79; 6 Dejonghe, 77.



Daly took title

One-hit F1 wonders

Forget record breakers like Schumacher and Vettel, F1 history is full of drivers who had just one day in the sun. In the first of a three-part series, *KEVIN TURNER* looks at the one-time F1 winners



Jean Alesi

Ferrari 412T2
1995 Canadian GP

Qualified: 5th

He burst onto the Formula 1 scene with Tyrrell in 1989 and memorably battled Ayrton Senna for the lead in Phoenix the following season. Jean Alesi looked set to be a multiple winner, but a move to Ferrari and some appalling luck kept him off the top step of the podium.

That was until the 1995 Canadian Grand Prix and the Frenchman's 31st birthday. Alesi qualified fifth and moved past Ferrari team-mate Gerhard Berger just as the Williams

of David Coulthard spun off in front of them.

With Michael Schumacher's Benetton streaking away in front, the Ferraris closed on Damon Hill, struggling with his Williams. Alesi made it by at the hairpin on lap 17 and left Berger to battle his way past Hill.

After the stops, Schumacher was around half a minute clear and Alesi had settled for yet another second place. Then, with a little over 11 of the 69 laps to go, Schumacher hit gearbox trouble. Alesi swept by and cruised home to finally record his first F1 victory in his 91st GP.

"It felt unbelievable to win; I finished second 16 times," Alesi told *AUTOSPORT* years later. "OK, I won, but it was more of a relief than anything.

"It was a tough weekend, I had to overtake a lot of people to run second to Michael. And then his car stopped and I thought: 'Finally!' Then I was worried about the fuel, because Gerhard had run out before his pitstop. I ran out on the slowing-down lap!"

Many more near misses and 16 further podiums followed, but Alesi's luck would never hold like it did that day in Montreal.

Alesi celebrates his one F1 victory





Beltoise was in a class of his own in wet Monaco race

Jean-Pierre Beltoise

BRM P160B
1972 Monaco GP

Qualified: 4th

His Monaco success wasn't just one of the best one-off victories, it was one of the great F1 drives of all time. Jean-Pierre Beltoise had arrived in grand prix racing in 1967, won the '68 European F2 title, and had scored six F1 podiums with Matra by the time he arrived in Monte Carlo with BRM.

Beltoise qualified fourth before torrential rain hit on race day. After an extra practice session to allow drivers to acclimatise to the conditions, the field set off. Beltoise immediately shot by front-row men Emerson Fittipaldi (Lotus 72) and Jacky Ickx (Ferrari 312B2) to lead up the hill towards Casino. After three laps he was five seconds clear of Clay Regazzoni's Ferrari and his lead grew further when 'Regga' slid down a

slip road and took Fittipaldi with him.

In his AUTOSPORT report, Patrick McNally said: "Beltoise drove with inspired confidence. Any thoughts that it was a sprayless road that enabled him to pull away were quickly dispelled by the way he handled traffic. He passed people on the left, right and centre and wasn't above putting a wheel on the pavement if the situation demanded it."

Ickx, an established wet-weather ace who had taken his first championship victory by almost two minutes in the rainy 1968 French GP, took up the chase. But he was powerless to stop Beltoise, who set fastest lap by over half a second. He eventually came home almost 40 seconds clear, with Fittipaldi a lap behind in third.

Beltoise scored no other points in 1972 and would only record one more podium, but on that day in Monaco he had defeated the best in the world.



No Innes, you were first...

Innes Ireland

Lotus 21
1961 United States GP

Qualified: 8th

Stirling Moss might have given Lotus its first world championship wins as a constructor – in privateer Rob Walker entries – but it was Innes Ireland who gave Colin Chapman's Team Lotus its breakthrough.

Ireland's 1961 season had not been good and he only qualified eighth at Watkins Glen, despite the absence of the pacesetter Ferraris. His practice efforts had not been helped by a steering failure that sent him flying into trees at 100mph...

Jack Brabham's Cooper and the Lotus of Moss put on a fierce battle at the front of the field, pulling clear of Ireland, who engaged Bruce McLaren (Cooper), Graham Hill (BRM) and Dan Gurney's Porsche in a battle for third.

Ireland moved to the front of the group, which became the lead when both Brabham and Moss hit trouble.

The Ireland-Hill battle "was as good as the Moss-Brabham one had been" claimed AUTOSPORT's report, but the BRM then had to pit with a loose magnet.

Ireland was left to beat Gurney by just over four seconds. It would be his last world championship outing for Team Lotus, Colin Chapman rewarding Ireland by firing him ahead of 1962.



Nannini inherited Suzuka victory

Alessandro Nannini

Benetton B189
1989 Japanese GP

Qualified: 6th

The 1989 Japanese GP is remembered for the infamous clash between Ayrton Senna and Alain Prost, Senna's recovery to victory and subsequent exclusion. But it also gave Alessandro Nannini an F1 win before his helicopter crash in '90.

The Benetton driver qualified sixth and immediately rose to fourth, behind Prost, Senna and the Ferrari of Gerhard Berger. Just after half-distance, Berger hit gearbox trouble and the challenging Nigel Mansell dropped out 10 laps later, leaving Nannini well clear in third.

With such a big gap to the McLarens he backed off. "It was a prudent course to take, but later we were all, Sandro included, to wish he had kept up the pace," wrote AUTOSPORT's Nigel Roebuck. "It would have prevented a great deal of controversy."

Thus, when the McLarens clashed and Senna toured around to the pits for a new nosecone, Nannini inherited a lead that was not as big as it could have been. Senna charged back and overtook Nannini with just over two laps to go.

But Nannini still got to stand on the top of the Suzuka podium, as Senna was disqualified for not returning to the track where he had left it.

Richie Ginther

Honda RA272
1965 Mexican GP

Qualified: 3rd

He was an experienced hand when he joined the fledgling Honda operation, having taken podiums for Ferrari and BRM, and had finished second in the 1963 F1 standings despite not winning.

Richie Ginther's 1965 season was one of improvement with the Japanese firm, and the American had already qualified the RA272 third three times before the season finale in Mexico City.

Honda had tested at the circuit in the days before practice and the car was on the pace straight away, Ginther qualifying third again behind Jim Clark's Lotus and Dan Gurney (Brabham).

His start wasn't the best, but he still led at the end of the opening lap, helped by Clark suffering with a sick engine. Clark retired and by the time Gurney had worked his way by the other Lotus of Mike Spence to run second, Ginther was seven seconds clear. "The Honda was using less road than most in the esses, and despite the fact that Gurney was in an inspired mood, no change seemed imminent," wrote Bill Gavin in *AUTOSPORT*.

And so it proved. Gurney lapped faster than his qualifying effort, but Ginther held on by 2.89s to win the last race of the 1.5-litre formula.



Ginther takes a well-earned drink in Mexico

The trio of 1975

In the 1970s the almost ubiquitous Cosworth DFV engine allowed a number of F1 teams to build competitive racers, and three different drivers took their only world championship successes during 1975.

The Brabham BT44B was one of the best chassis at the start of the season and allowed rising Brazilian star Carlos Pace a chance to shine. He qualified second in the opening round in Argentina and took his only F1 world championship pole at Kyalami, outpacing team-mate Carlos Reutemann by just 0.07s. In between he also scored his one race victory, on home turf at Interlagos.

When the dominant Shadow of Jean-Pierre Jarier, which had built up a lead of half a minute, was struck by fuel-metering problems, Pace moved to the front. Emerson Fittipaldi's McLaren kept the pressure on, but Pace kept him at arm's length and took a popular home win by six seconds.

Jochen Mass's win in Spain was not greeted with the same level of enthusiasm, but that was not the McLaren driver's fault. The Montjuich Park race was controversial before practice, the safety provisions being considered inadequate.

Mass's team-mate Fittipaldi refused



Mass won tragic 1975 Spanish GP

to start and there were a number of accidents before the leading Hill of Rolf Stommelen suffered a rear-wing failure. He hit the barriers hard, took off and killed four spectators.

There was a delay before the chequered flag was thrown, and future sportscar star and Le Mans 24 Hours victor Mass was a none-too-happy winner of a chaotic half-points race.

Vittoria Brambilla's Austrian GP also came in a shortened event, but the end result was more comic than tragic. The

March driver qualified eighth and moved up to sixth on the opening lap of the wet race. He then "rapidly overtook five more men to arrive in the lead on the 19th lap", reported *AUTOSPORT*'s Pete Lyons. "He simply drove away from everyone and was ahead by 24 seconds" when the race was stopped as conditions worsened.

Surprised at the premature end, Brambilla backed off, lost control of the car and crashed. A memorable way to take your only win.

Sharing the joy

Two of the one-time winners owe their successes to the car-sharing that was a part of racing in the 1950s.

Italian Luigi Fangio was one of the top drivers of the pre-war era, but younger racers had come to the fore by the time he lined his Alfa Romeo 159 up seventh for a one-off 1951 outing in the French GP.

While team-mate Juan Manuel Fangio fought the Ferrari of Alberto Ascari for the lead, Fangio ran further back in the top six. But when Fangio's Alfa hit ignition trouble, the Argentinian was switched to Fangio's fourth-placed machine, with Fangio eventually taking over his team-mate's repaired 159.

Fangio brought that car home 11th, but Fangio began a charge, going after the Ferraris and reigning world champion team-mate Giuseppe Farina. When Farina hit tyre problems, Fangio was left to fight the Ferraris and he

went on to win by almost a minute, making Fangio – then 53 – the oldest driver to win a points-paying F1 race.

Fangio played a key role in Luigi Musso's 1956 Argentinian GP success too. Musso was an up-and-coming talent who had already won the non-championship Pescara GP in '54. He qualified on the front row in Buenos Aires and took an initial lead before Froilan Gonzalez (Maserati) went by. Musso gradually fell back to fifth, but that was still better than Fangio, who struggled from the start with his problematic Lancia-Ferrari.

Musso was fourth when he was brought in to hand his car over to Fangio, who charged up to second. When Stirling Moss's Maserati lapsed onto five cylinders, Fangio was left to complete another victory.

Musso would be an F1 frontrunner over the next couple of years, but was killed at the 1958 French GP before he could add to his singleton success.

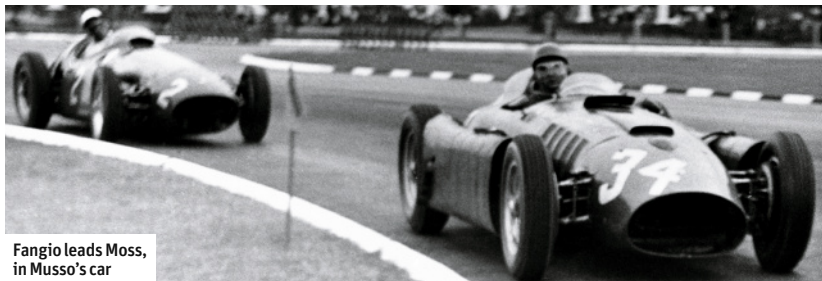

Fangio leads Moss, in Musso's car

THE COMPLETE LIST

Excluding the Indy 500, which counted for the world championship between 1950 and 1960, 24 drivers have tasted success just once...

Luigi Fangio Alfa Romeo 159
1951 French GP (Reims)

Piero Taruffi Ferrari 500
1952 Swiss GP (Bremgarten)

Luigi Musso Lancia-Ferrari D50
1956 Argentinian GP (Buenos Aires)

Jo Bonnier BRM P25
1959 Dutch GP (Zandvoort)

Giancarlo Baghetti Ferrari 156
1961 French GP (Reims)

Innes Ireland Lotus 21
1961 United States GP (Watkins Glen)

Lorenzo Bandini Ferrari 156
1964 Austrian GP (Zeltweg)

Richie Ginther Honda RA272
1965 Mexican GP (Mexico City)

Ludovico Scarfiotti Ferrari 312
1966 Italian GP (Monza)

Peter Gethin BRM P160
1971 Italian GP (Monza)

Francois Cevert Tyrrell 002
1971 United States GP (Watkins Glen)

Jean-Pierre Beltoise BRM P160B
1972 Monaco GP (Monte Carlo)

Carlos Pace Brabham BT44B
1975 Brazilian GP (Interlagos)

Jochen Mass McLaren M23
1975 Spanish GP (Montjuich Park)

Vittorio Brambilla March 751
1975 Austrian GP (Osterreichring)

Gunnar Nilsson Lotus 78
1977 Belgian GP (Zolder)

Alessandro Nannini Benetton B189
1989 Japanese GP (Suzuka)

Jean Alesi Ferrari 412T2
1995 Canadian GP (Montreal)

Olivier Panis Ligier JS43
1996 Monaco GP (Monte Carlo)

Jarno Trulli Renault R24
2004 Monaco GP (Monte Carlo)

Robert Kubica BMW Sauber F1.08
2008 Canadian GP (Montreal)

Heikki Kovalainen McLaren MP4-23
2008 Hungarian GP (Hungaroring)

Nico Rosberg Mercedes F1 W03
2012 Chinese GP (Shanghai)

Pastor Maldonado Williams FW34
2012 Spanish GP (Barcelona)

Can they add more?

The four most recent one-time winners are still active, but have varying chances of winning again.

Robert Kubica would surely have racked up more wins and perhaps a title or two beyond his 2008 Canadian Grand Prix victory had it not been for his rally crash at the start of '11. Although many hope he can return, his injuries seem set to restrict him to competition cars with roofs.

The loss of his Caterham drive has pushed Heikki Kovalainen further away from backing up his sole win for McLaren at Budapest in 2008, but Nico Rosberg and Pastor Maldonado could move off the list if their respective Mercedes and Williams teams can produce the goods.



Might Maldonado add to Spanish win?

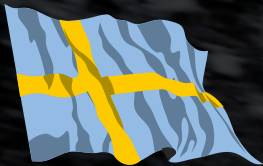

SWEDEN

Hagfors

ROUND 2/13

WINNER

Sebastien Ogier/Julien Ingrassia, 3h11m41.9s

STAGE MILEAGE

209.977 miles

QUALY STAGE WINNER

Ogier

POWERSTAGE WINNER

Ogier

RALLY RATING

★★★★☆

Exceptional first win for untouchable Ogier and VW Polo R WRC

DRIVERS' STANDINGS

Ogier	46pts
Loeb	43pts
Ostberg	24pts

MILESTONES

● First WRC win for Volkswagen since 1987 Ivory Coast Rally

DAVID EVANS reports



Ogier's mint victory in Volkswagen Polo

The German firm blitzed its second rally since joining the modern-day WRC, thanks to Sebastien Ogier - who saw off his Citroen namesake Loeb



A SEBASTIEN WENT TO

Sweden last week to settle a score. Mission accomplished. Another Sebastien went to Sweden last week to settle a score. And went home disappointed. The Ogier Sebastien routinely laughs off discussions of scores to be settled with the Loeb Sebastien, but there's absolutely no doubt he loved putting one over his Citroen nemesis from two years ago. Loeb's score, with Sweden itself, remains frustratingly unsettled, but what a fight he provided in trying to take his first 'real' Rally Sweden win.

LEG ONE (81.15 miles)

SNOW - AMBIENT TEMP RANGE: -1 TO -5C

On Thursday night, honours were pretty much even. Ogier had spanked Loeb through the qualifying stage, but then the champion won their head-to-head duel around the Karlstad superspecial, helped in no small part when the VW Polo smacked a bank hard enough to damage a tyre.

When he went to bed, Loeb knew that his hopes of retaining the rally lead faded with every white flake that fell from the sky. He wasn't in the worst position, not by a long stretch. The #1 Citroen driver had nine cars running ahead of it and sweeping the loose snow from the surface, but Ogier had 16 cars ahead of him. And that would

make a real difference.

Ogier duly hit the front with fastest time in the first real stage on Friday morning. And moved further clear on SS3. While Jari-Matti Latvala moved into second place on SS2, ensuring the double-dream start for VW, Citroen suffered a Mikko Hirvonen-based nightmare as the Finn

roofed his DS3 WRC in Lesjofors. Twenty-four minutes - and any hope of featuring on an event he was tipped to win - were lost digging the car out.

"We slid wide on a fast right-hander," explained the disconsolate Hirvonen, "and dropped a wheel into the ditch. There had been a snowbank

there, but somebody had already knocked it down. We spun across the road and rolled really quickly. We got out and the snow was so deep. We started digging..."

Friday was not a morning for the favourites as M-Sport's Mads Ostberg hit engine problems in SS2. His Fiesta RS WRC sprung a water leak. As the water pressure went south, the temperature gauge headed north - as far north as 140C. There were ominous deposits and smells on the stop line, but the team and Ostberg did a superb job to contain the problem. The contents of the crew's Camelbaks and a deal of melted snow were poured into the unexpectedly thirsty



Latvala salvaged fourth in #7 Polo



Second Swedish win still elusive for Loeb

Ogier led from SS2 for historic victory

Ostberg was top Ford man again, in third



Anything and everything, he assured the listening world, was still possible. The world, however, was sceptical, with a pair of on-fire Frenchmen and a Finn ahead. Ogier made the perfect loop through the afternoon, with fastest time on all three stages. Hirvonen was fastest on the Karlstad dash in the evening, but the leader was happy to cede the city's applause, sitting 31.4s out front at close of play on Friday night. Pulling into parc ferme, Ogier flicked the switch to turn off the Polo. And put his head back. What a day. For him and for the Polo. "It's been unbelievable," he said, quietly. "When we did

Ford motor, with a temporary fix made to the leak. Having remained calm in SS2, Ostberg was livid in stage three, when padding from the side of his seat came loose and dropped into the footwell. "It was nice," he said, with a degree of sarcasm. "I was

playing football in the middle of the stage." Fastest on the fourth stage was exceptional under the circumstances. He incurred 20 seconds of road penalties working on the car, but remained fourth, half a minute off the front.

the test last week, the car felt good and you start to think, 'How good is it?' And now we know: it's perfect. Today hasn't been easy, look how many people had problems, but so far... we have won nothing. We must keep up the concentration." After watching Ogier triple his 10s lead through the afternoon, Loeb was adamant his final Swedish Rally wouldn't be the success he hoped for. "There are two Sebastiens at the front of this field," he said with a wry smile. "But one has gone and the other one is fighting a Finn. It's impossible to catch him [Ogier] now, it's enough to try to stay ahead of Jari-Matti." As the afternoon progressed, it became increasingly important to stay on the line and out of the soft snow either side of the line. And the ruts, the dreaded ruts – the *bête noire* of our champion – appeared to rattle the Citroen. Despite a brace of Michelins with the full compliment of studs at the front of the car, Loeb still complained of understeer at the end of the day. "I can't find the balance," he said. "We could make the changes, but it's not always a change in the good way." Latvala had made changes. The Finn likes his rally cars stiff with plenty of precision, but he had to do something to contain his Polo's apparent ambition to dive into a snowbank every time it hit soft snow. He moved a step closer to Ogier's softer-sprung VW in the afternoon and the times improved. Unfortunately, losing the intercom for the

first six miles of Vargasen 2 dropped him back behind Loeb at the end of the day. "It was not nice driving with no notes," said Latvala. "I pulled the wire out and put it back in and it worked. It's a shame." Ostberg was consistently second quickest through the woods in the afternoon, slashing the gap to Loeb and Latvala. He'd set his sights on third place at the end of the day and – briefly – managed it. "Mid-way through the last long stage we were five up on Jari-Matti," said Ostberg, "but I pushed too hard in the first part of the stage and we lost some studs, which made the second half quite tough. OK, we're fourth, but we're close. I want them both tomorrow." Evgeny Novikov was fifth in the second factory Fiesta, but it was sixth-placed Pontus Tidemand who shared Ogier's day-one limelight. The 22-year-old Swede enjoyed a staggering World Rally Car debut in his Fiesta, just 10.4s off the celebrated Russian on Friday night. Juho Hanninen was a rather subdued seventh in another Cocker mouth car, with Thierry Neuville eighth and a returning Henning Solberg running in ninth.

POSITIONS AFTER DAY ONE

1 Ogier/Ingrassia	1h16m00.1s
2 Loeb/Elena	+31.4s
3 Latvala/Anttila	+33.1s
4 Ostberg/Andersson	+42.3s
5 Novikov/Minor	+1m11.7s
6 Tidemand/Floene	+1m22.1s

LEG TWO (70.85 miles)
CLEAR - AMBIENT TEMP RANGE ON STAGES
-12 TO -2C ▶



Hirvonen went off early and fought back to P17

STAGE TIMES

SS1 KARLSTAD SUPER SPECIAL 1 (1.18 MILES)

Fastest: Loeb 1m34.5s
Leader: Loeb

SS2 LESJOFORS 1 (9.32 MILES)

Fastest: Ogier 9m15.8s
Leader: Ogier

SS3 VARMULLSASEN 1 (14.77 MILES)

Fastest: Ogier 13m48.0s
Leader: Ogier

SS4 VARGASEN 1 (15.30 MILES)

Fastest: Ostberg 13m45.1s
Leader: Ogier

SS5 LESJOFORS 2 (9.32 MILES)

Fastest: Ogier 8m59.1s
Leader: Ogier

SS6 VARMULLSASEN 2 (14.77 MILES)

Fastest: Ogier 13m33.6s
Leader: Ogier

SS7 VARGASEN 2 (15.30 MILES)

Fastest: Ogier 13m24.4s
Leader: Ogier

SS8 KARLSTAD SUPER SPECIAL 2 (1.18 MILES)

Fastest: Hirvonen 1m35.9s
Leader: Ogier

SS9 SAGEN 1 (8.84 MILES)

Fastest: Ogier 7m07.4s
Leader: Ogier

SS10 FREDRIKSBERG 1 (11.27 MILES)

Fastest: Latvala 10m24.6s
Leader: Ogier

SS11 RAMMEN 1 (14.14 MILES)

Fastest: Loeb 11m42.6s
Leader: Ogier

SS12 HAGFORS SPRINT 1 (1.16 MILES)

Fastest: Hirvonen 1m55.8s
Leader: Ogier

SS13 SAGEN 2 (8.84 MILES)

Fastest: Loeb 7m00.2s
Leader: Ogier

SS14 FREDRIKSBERG 1 (11.27 MILES)

Fastest: Ogier 10m16.6s
Leader: Ogier

SS15 RAMMEN 1 (14.14 MILES)

Fastest: Ogier 11m42.9s
Leader: Ogier

SS16 HAGFORS SPRINT 1 (1.16 MILES)

Fastest: Loeb 2m00.7s
Leader: Ogier

SS17 MITANDERSFORS (16.82 MILES)

Fastest: Loeb 14m00.1s
Leader: Ogier

SS18 FINNSKOGEN 1 (10.45 MILES)

Fastest: Loeb 9m00.0s
Leader: Ogier

SS19 KIRKENER 1 (4.44 MILES)

Fastest: Loeb 5m42.7s
Leader: Ogier

SS20 KIRKENER 2 (4.44 MILES)

Fastest: Ogier 5m38.9s
Leader: Ogier

SS21 FINNSKOGEN 2 (10.45 MILES)

Fastest: Ostberg 8m55.8s
Leader: Ogier

SS22 TORSBY (11.26 MILES)

Fastest: Ogier 9m54.1s
Leader: Ogier

Engine woe hobbled superb Tidemand run



◀ For two minutes, Saturday morning was good for Loeb. Fastest on the Sagen stage, the superstar blew out his cheeks and smiled.

"The conditions were better for me in that stage," he said. "I pushed and it felt good. We worked on the car last night to get rid of the understeer and it worked. I'm happy."

And then Ogier arrived and lowered Loeb's benchmark to the tune of 2.1s. Drivers just don't do that to Loeb. Any time that Loeb's under the cosh, he comes out fighting and usually flattens the rest of the field. Not this time. Fire was fought with fire. "Good start to the day," said Ogier with a wink. "I like that."

Fourth-placed Ostberg was also happy with his weekend opener. Not a fan of the Sagen stage, he took a further 3.3s out of Latvala. There was some respite for Latvala in Fredriksberg, as he scored his first fastest time of the event, beating Loeb by two-tenths and Ostberg by three-tenths.

"I feel the confidence coming a little bit more now," he said at the finish. "It felt good, but the car is still not exactly right."

Having seen Ogier back off for the second half of SS10 and sensing that the leader might be looking at controlling the pace from the front, Loeb piled on the coals and went fastest in Rammen.

"I am trying," he promised, "trying my best." Returning to service after a dash through the Hagfors Sprint, Loeb had cut the lead to 25.2s.

"I can only do my race," he said, "he must do his and we will see what happens. But at the same time, I must think also of Jari-Matti and Ostberg."

Ogier laughed off suggestions that he was messing with Loeb's mind in his talk of a controlled approach.

"You can't," he said, "play with a nine-time world champion."

The overtone was clear — he wouldn't be poking any tigers in the immediate future either.

Ostberg returned to the stages just 1.5s behind the podium place he so badly wanted. And he landed it on the second run through Fredriksberg. He then beat Latvala on the next two stages to end the day 6.1s up. Now he could go home to Norway on Sunday in a provisional podium slot.

"It's good for the fans," said Ostberg, "and I'm sure their support will be worth a second per kilometre or something for me. We could have had even more time, but I had a big moment in a very fast corner in Rammen and I dropped two or three second sorting it out."

With Latvala done, Ostberg now set his sights on the two tricolored Sebastiens ahead.

"We can't have a French one-two on the winter rally, can we?" he smiled.

Own backyard or not, the half-minute gap between him and Loeb would be near impossible for the Qatar M-Sport driver, however.

Frustration was writ large across Latvala's face as he strode into VW's mission control on the airfield in Hagfors.

Emerging a while later, he pulled his woolly hat as far down as it would come.

"I need to drive," the two-time Swedish winner said. "I need to stop thinking what I have with the car. I need to drive. It has been a tough day. I can really feel my inexperience with the car here. I don't know the limit of the car."

Elsewhere in VW, the smiles were miles wide. Leader Ogier said: "Today, it was about finding the rhythm to drive at, so I wasn't taking to much risk. I think I managed that and still we have a comfortable lead. I like this rally!"

Loeb hadn't given up. He was still pushing like hell. He out-braked himself into the last hairpin in Rammen, ploughing the snowbank, but coming out the other side. He wouldn't give up.

"But 20 seconds is too much, eh?" he said. Nobody was willing to remind the master of our world that it was actually 26.9 seconds...

Novikov was now running in a comfortable fifth — especially after the heart-breaking retirement of Tidemand. The local hero started the day just 10 seconds behind the Russian in sixth, but that was as close as he would get through Saturday as his engine detonated on the first shot at Sagen.

Neuville moved up to sixth when Hanninen put his Fiesta in a snowbank on the day's final dash around the Hagfors Sprint.

"Stupid!" shouted Hanninen at the end of the day, "So stupid."

He dropped a minute to the bespectacled Belgian who continued to impress with a sensible run on an event quite alien to him.

Solberg, Prokop and Dani Sordo rounded out the top 10 — the Spaniard recovering from time spent in a snowbank on day one.



Brit Matthew Wilson had a tough return



Ogier performed a podium reign dance

POSITIONS AFTER DAY TWO

1 Ogier/Ingrassia	2h18m22.8s
2 Loeb/Elena	+26.9s
3 Ostberg/Andersson	+57.7s
4 Latvala/Anttila	+1m03.8s
5 Novikov/Minor	+1m43.5s
6 Neuville/Gilsoul	+3m16.2s

LEG THREE (58.59 miles)

SNOW FLURRIES - AMBIENT TEMP RANGE ON STAGES -7 TO -3C

And so to Norway. Clearly, Loeb likes Norway. A string of three fastest times on Sunday morning were testament to the fact that the Frenchman certainly had not given up on victory.

Unfortunately for him, Ogier was never too far away. Arriving at the end of the border-crossing Mitsandersfors stage, Loeb was 15s faster than anybody.

"I won't be 15 seconds faster than the guy behind," Loeb smiled thinly. He wasn't, but he did take three off the leader.

That was the start of Loeb's best run in the event as he made scratch times on the next two as well.

Coming out of the first run at Kirkener and heading into a regroup in the centre of the two, Loeb had reduced Ogier's lead to 20.7s, the lowest it had been for two days.

Was it possible? "I'll keep giving pressure to him," said Loeb, "Let's see what happens. I'm pushing as hard as I can. I like the last stage, I made a good time and the drive was good."

But, with just 26 miles left, Loeb was realistic.

Ogier had made a small mistake in Kirkener, dicing with death as he scuffed the Polo against a snowbank. Momentarily, the chipper smile that he'd worn for pretty much the past three days slipped. He realised just how quickly the dream could be lost.

Returning to Kirkener, Loeb found the road a little more rutted and elected to settle for second.

"It was not easy in there," said Loeb.

Conversely, Ogier was upbeat again, saying: "I really enjoyed it!"

Psychology or not. The deal was pretty much done. Ogier throttled back in Finnskogen, but once back in Sweden, he let rip with a Powerstage win.

Across the line, he and co-driver Julien Ingrassia were out of the car and on the roof. Dancing.

"It's just incredible," said Ogier. "I don't know the words..."

Ingrassia smiled adding: "I don't even know the words in French!"

Loeb was entirely magnanimous, saying: "We lost our chance at the qualifying stage, but Sebastien Ogier has driven the perfect rally."

Ostberg's hopes of maintaining third on home ground didn't look good as he crossed the border.

"My driving was horrible

in there," he grimaced. Ostberg couldn't get comfortable in the Fiesta in Norway. Latvala nibbled, cutting the difference to 5s, before Ostberg took the bull by the horns and charged through Finnskogen the second time around. Quickest. And eight ahead going into the final stage. The home hero kept his head, went back to Sweden and finished third.

"On Friday, I knew the chance of winning had gone," said Ostberg. "To be honest, I didn't know if this was possible. But to beat Jari-Matti is an incredible feeling."

Latvala was a crestfallen fourth, pleased to have bagged more miles and made the finish. Novikov

repeated his final-day shunt of the Monte, rolling in Kirkener 2. This time, he made it out and finished ninth, moving Neuville up to fifth, Hanninen sixth, Prokop seventh and Henning Solberg eighth.

Saudi Arabian driver Yazeed Al-Rajhi rounded out the top 10 and celebrated his maiden win at the World Rally Championship level, when he took the WRC 2 class last week. The Ford Fiesta RRC driver hit the front of the field on Sunday morning after hassling leader Anders Grondal for much of the rally. Grondal suffered a spin on the first stage of the final day – ironically the stage that

took him from Sweden into his Norwegian homeland. Understandably, Al-Rajhi and his British co-driver Michael Orr were delighted at the finish.

"I didn't drive so much on snow," he said, "so I treated it like white sand and went flat-out!"

Much as Al-Rajhi smiled, he couldn't quite match the mile-wide grins being sported across the board at Volkswagen.

With Loeb stepping down for the next two WRC rounds in Mexico and Portugal the best of the rest had better pick up the pace if they're hoping to challenge the Ogier Polo. The Tricolore looks like it might be flying high for some time to come. ❁

RESULTS

Swedish Rally, Hagfors, February 7-10

22 SPECIAL STAGES, 209.977 MILES

POS	NO	DRIVER/NAVIGATOR	CAR	TIME
1	8	Sebastien Ogier/Julien Ingrassia	Volkswagen Polo R WRC	3h11m41.9s
2	1	Sebastien Loeb/Daniel Elena	Citroen DS3 WRC	+41.8s
3	4	Mads Ostberg/Jonas Andersson	Ford Fiesta RS WRC	+1m24.5s
4	7	Jari-Matti Latvala/Mikka Anttila	Volkswagen Polo R WRC	+1m30.6s
5	11	Thierry Neuville/Nicolas Gilsoul	Ford Fiesta RS WRC	+5m06.4s
6	15	Juho Hanninen/Tomi Tuominen	Ford Fiesta RS WRC	+5m43.1s
7	21	Martin Prokop/Michael Ernst	Ford Fiesta RS WRC	+11m25.4s
8	16	Henning Solberg/Emil Axelsson	Ford Fiesta RS WRC	+11m42.7s
9	5	Evgeny Novikov/Ilka Minor	Ford Fiesta RS WRC	+13m04.7s
10	35	Yazeed Al-Rajhi/Michael Orr	Ford Fiesta RRC	+16m27.0s

OTHERS

14	5	Michał Kosciuszko/Maciej Szczepaniak	Mini John Cooper WRC	3h36m50.8s
17	6	Mikko Hirvonen/Jarmo Lehtinen	Citroen DS3 WRC	3h39m00.9s
25	34	Jarkko Nikara/Jarkko Kalliolepo	Mini John Cooper WRC	4h02.27.0s
27	26	Matthew Wilson/Giovanni Bernacchini	Ford Fiesta RS WRC	4h07.29.2s

Starters/finishers: 43/35
Leaders: SS1 Loeb; SS2-22 Ogier
WRC2 winner: Al-Rajhi/Orr
WRC3 winner: N/A

CHAMPIONSHIP TABLE

POS	DRIVER	PTS
1	Sebastien Ogier	46
2	Sebastien Loeb	43
3	Mads Ostberg	24
4	Dani Sordo	15
5	Jari-Matti Latvala	14
6	Mikko Hirvonen	12
7	Martin Prokop	12
8	Thierry Neuville	10
9	Bryan Bouffier	10
10	Juho Hanninen	8

MANUFACTURERS' POINTS

1	Citroen Total	57
2	VW Motorsport	55
3	Qatar M-Sport Ford	31

RALLY ROUTE The usual mixture of Swedish and Norwegian stages – although the event didn't cross the border until the final day. The rally was based in Hagfors with a remote service on Sunday in Torsby ahead of the Powerstage.



British Formula 3's state of emergency

Its rich heritage wasn't enough: now it's effectively a tournament hoping to entice competitors from other series for extra races. *MARCUS SIMMONS* talks to British F3's major players to find out what went wrong

With only half a dozen drivers signed up for the 2013 British Formula 3 International Series it was inevitable: series promoter the Stephane Ratel Organisation slashed the calendar from 10 to four race weekends, with only two of them in the UK.

How has it come to this? There are a number of tangled threads, and to start unravelling them we need to go way back, to 1979...

That was the year when the British Automobile Racing Club and British Racing Drivers' Club merged their F3 championships, gaining the right to call their new series the 'British Formula 3 Championship'. This gave rise to inconsistencies in organisation and administration by the two clubs, so in the 1980s the teams formed a new body – the Formula 3 Association (FOTA for short). Long-time team boss Dave Price was chairman and brought in his lawyer friend, ex-racer Jeremy Lord, to write FOTA's constitution and run it on a

day-to-day basis as secretary, while the body raised the profile of F3 by securing BBC TV coverage.

The BRDC took over full commercial rights for 2000, when the series became a headline act on the club's PowerTour. Amid the Brands Hatch-v-Silverstone battle for the British Grand Prix, one part of the fallout was sports-marketing company Octagon acquiring PowerTour. This was making a huge loss, so the plug was pulled partway into '01. British F3 carried on under BRDC administration, but the club – its vision tunnelled into securing the future of the British GP – closed down its competitions department at the end of '03.

This is where SRO came in. Talking of the transfer from Octagon, Ratel jokes: "Nobody gives you something if it's worth anything!"

In the meantime, the German and French F3 championships had joined for 2003 to form the Euro Series. As a reaction, for 2005 British F3's continental rounds were upped from one to three.

FOTA wanted more 'Formula 1' tracks to encourage drivers to its series, and SRO went along with it. "The teams wanted more and more races on the continent and I have always been happy to provide them what they want," says Ratel.

BACKING DOWN FROM TOCA

But the teams didn't stay unanimous in their thinking. In late 2007, veteran team boss and then-FOTA chairman Alan Docking (Price was off the BF3 scene by now) set up a new company called FOTA GB Limited, with himself as director and Carlin Motorsport chief Trevor Carlin as secretary. They opened negotiations with British Touring Car Championship supremo Alan Gow to join his TOCA package, to leave SRO and promote the 'breakaway' series themselves.

"It was fairly obvious that one big event [as part of TOCA] was better than us running apart," remembers Docking.

Subsequent meetings were held between all FOTA members and Gow, who needed a replacement on the TOCA

First season of British F3 Championship was 1979



PIC: EBREVILAT, LAT ARCHIVE



Drivers out of cars, and no one to fill the seats



Ratel allowed the teams autonomy

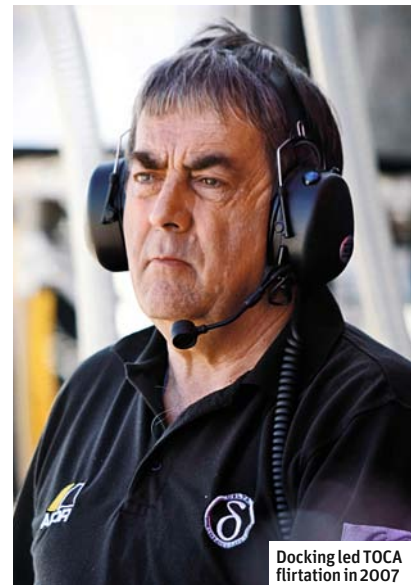

Docking led TOCA flirtation in 2007



bill for Formula BMW. But a new offer from SRO, and a spreadsheet produced by T-Sport chief Russell Eacott incorporating extra costs beyond the £125,000 start-up TOCA fee, brought matters to a head at the Snetterton round in June 2008. To Gow's fury, the teams signed up for SRO's new deal.

"I used my contacts to get them

sponsorship deals," says Gow. "The whole thing was a ridiculous waste of my time and energy. I couldn't be bothered with them anymore. At the end of the day they were the losers, not TOCA."

Docking's team was heading for the exit gates anyway. "Perhaps my focus was diminishing a little," he admits. "I was taking opportunities in other areas [A1GP and then Superleague Formula] for new business. Possibly F3 was suffering because of competition from other categories."

"They [the other teams] didn't have the balls to do it. But it was risky – and it could have turned into a mess!"

To go the TOCA route would have meant the teams abandoning their continental quest and keeping British F3 at 'rustic' venues such as Knockhill, Thruxton and Croft. That would have clashed with accepted wisdom at the time, but Carlin looks upon it as a turning point. "That was possibly the beginning of the end in a way," he reflects. "BTCC is a big event – there's

"They didn't have the balls to join TOCA. But it was risky – and it could have turned into a mess!"

Alan Docking

a buzz about it. And everyone banged on about tub damage at places like Knockhill, but it was never that bad."

Meanwhile, Lord was increasingly feeling like a pawn between SRO and the teams. He left FOTA and was replaced by Peter Briggs, whose Edenbridge Racing team had run Oliver Gavin to the 1995 title. The teams were generally a united collective, allowed autonomy in their government by SRO, but there would be disagreement at the end of 2011.

The Carlin team, taken over in late 2009 by Capsicum Motorsport (led by Grahame Chilton, father of '09 Carlin F3 driver Max, and Rupert Swallow), had pulled out of the F3 Euro Series at the end of '09. The existing generation of ▶



Foreign quest has taken British F3 to tracks such as Nurburging

◀ chassis would be granted a shelf life by the FIA until the end of '11, and FOTA waived its four-cars-per-team gentlemen's agreement to allow Carlin to field its two ex-Euro Series Dallaras alongside its four British cars. "We let him use them," says Double R Racing head Anthony 'Boyo' Hieatt. "But the problem for us was that by now drivers reckoned you could only win with Carlin."

For the new-generation chassis in 2012, FOTA wanted SRO to enshrine the four-car gentlemen's agreement in the sporting regulations. Amid the threat of legal action from Capsicum over restriction of trade, a compromise of five was reached.

It's a difficult subject, and many would point out that, in a pure sporting meritocracy, there should be no such limit. Besides, Trevor Carlin himself worked hard on bringing two of single-seater racing's biggest junior-talent schemes – Red Bull and the Racing Steps Foundation – into British

F3. He believes that his drivers would have been lost to BF3 entirely if they could not join his squad. There were only 12 cars in the top class of BF3 in 2012. "There'd have been one more car on the grid if we could have run six," continues Carlin. "If we'd run four it would have been even weaker."

In the meantime, the FIA, while delaying the new chassis until 2012, had postponed F3's new-engine rules (along with new electronics) until '13. New gearbox regulations gave teams a massive hit too. It was enough to force the departure of Hitech Racing.

"It was a huge expense to buy the new cars," says Hitech boss Ryan Sharp. "You couldn't sell your 2011 cars because you wanted to use the electronics [worth £35,000 per car] from them for the extra year before the new engines. Also, we had £93,000 of lightweight gear ratios we'd machined and manufactured ourselves and had to throw them in the bin when the FIA mandated heavy-duty ones for '12. It was supposed to be cost-saving, but it would have taken us 16 years to recover the cost!"

With the new engines now effectively postponed again until at least this year's Macau Grand Prix, Sharp says Hitech could have carried on in F3 had he known there would be a two-year overlap between new chassis and engines. But it likely would not have been in British F3 due to his anger over the Capsicum/SRO situation regarding the four-car limit. "I don't blame Trevor," he stresses, "but that was the final nail in the coffin for us."

It left British F3 with just four major

teams. As Hieatt says: "A championship with only three or four teams isn't a championship. It's a club."

THE DEATH OF FORMULA RENAULT UK

A big problem was looming: the demise of Formula Renault UK on the eve of the 2012 season. All of a sudden, a British F3 series costing £5-700,000 to contest now had no clear-cut feeder series. Teams were seeking drivers who had raced internationally in karting and FRenault, and trying to sell them deals to race at unfashionable UK circuits.

"If you've raced in Europe in Renault, the natural thing when you move to F3 is to stay in Europe," says Fortec Motorsport head Richard Dutton, the current FOTA chairman whose squad straddles both categories. "Without a doubt losing FRUK had a massive impact on British F3. Oulton is a beautiful track, but F3 has outgrown the Oultons and Snettertons of this world, and drivers want big crowds."

Perhaps an even bigger issue than this was ex-F1 star Gerhard Berger taking over as president of the FIA Single-Seater Commission. One of the Austrian's first acts, on the eve of the 2012 season, was to give the FIA title to a new European F3 Championship, which would comprise eight Euro Series events and two from British F3. At the Norisring event in late June, alarm bells rang in British F3 when Berger pledged that FIA European F3 should be supported by national series that stay within their own borders. Later that year it emerged that Mercedes and VW, which had missed the March 31 2012 cut-off date



Carlin: BF3 got too big for its boots



F3 at Thruxton: does the series need 'small' tracks?



Briggs has headed FOTA since 2009



Gow says there's no silver bullet

to apply to the FIA for tenders to supply new engines for '13, would be allowed to use their old powerplants for one more year, in return for striking a deal to build new engines for '14.

Ratel held discussions with DMSB chief Christian Schacht, with a view to putting to the FIA a suggestion that the European championship could consist of an equal split between British and Euro Series rounds. But *fait accompli* emerged at the Macau GP in November, when it was announced that the Euro Series title was dead and that it would be reborn as the European championship.

As Ratel puts it: "As much as I'm in

"We've always been led by teams and heritage. We ran out of steam, but only by a tiny bit"

Trevor Carlin

the driving seat in GT racing, with F3 I could only go back and forth and say to the teams, 'What do you want to do?' The only thing I would say is it took the FIA far too long – it should have been wrapped up by the summer. But it was natural it would move that way. It was always clear that the Euro Series would become the FIA championship."

British teams point to the lack of support from the MSA. "The DMSB are all over it [European F3]," Carlin says. "They're into it massively, but they've got manufacturer cash funding it."

With Gow also acting as chairman of

the MSA, he called a round-table meeting last spring to discuss the state of single-seaters in the UK. "We wanted to work out a landscape for the good of open-wheeler racing," he says. "Peter Briggs said F3 didn't have an issue – it [the small field in 2012] was a blip and it would be fine going forward. They read that wrong. I said at the time it was like drug addiction: to fix a problem you have to admit to it."

Briggs points out that he was justified at the time, as this was before Berger's push for European F3 and the manufacturers' negotiations that effectively stalled the new-engine rules. So could the MSA have helped, had those in British F3 realised how it would play out? "There's no silver bullet, but we could have worked further forward," says Gow. "My personal opinion is that British F3 lost its way. Once it started pulling itself away to Europe it lost its USP."

FACING UP TO REALITY

Three weeks ago, FOTA met with Ratel and agreed that the only way for British F3 to survive was through (hopefully temporarily) slimming to four rounds.

"British F3 has always been led by its drivers and teams and heritage, and eventually we ran out of steam, but only by a tiny bit," says Carlin. "We wanted 12 cars [for the top class], with 10 definites and four maybes. We were only four drivers away from that."

But there's no escaping the fact that British F3, with four rounds abroad on its provisional calendar for 2013, was more expensive than European F3 – thanks in

part to manufacturer backing from the Germans, and possibly partly due to the strength of the pound against the euro.

And there are considerably cheaper alternatives. Team West-Tec chief John Miller says that to race with his squad in European F3 Open – which features five current grand prix tracks among its eight rounds, has a pre-season Winter Series and 22 test days – costs £350,000. And if you're one of the top junior talents around, you can probably pick up a drive in the Formula 1-supporting GP3 Series for that sort of money.

F3, as an open formula with many development opportunities, is unquestionably the best proving ground for drivers, engineers and mechanics. Its proponents call it the 'university of motorsport', but that's not much good if no one can afford to the tuition fees.

In the case of British F3, it may not have priced itself out of the market as much as the market priced itself below British F3.

While Dutton and Eacott reckon the drivers want F1-grade circuits, Heatt and Carlin believe it's time to go back to basics, and back to Britain. "Berger had a mission and he's delivering on it," says Carlin. "I don't think he's really screwed anyone over. He's looking at a two-tier system of F3 and that's not a bad idea. The onus is now on us to put a new, cheaper British F3 'formula' together. Drivers have to realise we can't have F1-style hospitality, chefs, trainers, data engineers, PR... We've all been guilty of providing it for them. We've created our own monster." ❧



Senna: excited about new start

PIC-DUNBAR/LAT

“Winning is underrated by some people in motor racing”

Aston Martin Racing's new recruit Bruno Senna explains to *GARY WATKINS* that he'd rather fight for victory in a sportscar than make up the numbers on the F1 grid

This was a deal that surprised everyone. Bruno Senna was still being tipped for a Force India Formula 1 seat at the very moment that he was putting pen to paper on his contract for 2013. The Silverstone-based F1 team and his new employer are only 15 or so miles distant geographically, but in the landscape of world motor racing they are worlds apart. The Brazilian will be competing in the World Endurance Championship for Aston Martin Racing this year.

Not in a lithe prototype at the sharp end of the WEC grid, of course, rather in a road-based GT car shooting for class honours somewhere towards the back. But that doesn't matter to Senna. He has put his F1 aspirations to one side, temporarily or otherwise, because he wants to start winning races again. And AMR proved that its Vantage GTE is capable of that over the final events of last year's WEC.

“I want to get back to winning races,” says Senna. “The opportunities weren't there to do that in F1. There is no

secret that every F1 driver wants to be a world champion or a race winner, but there are relatively few who have a chance to achieve that. At the end of the day, I am in racing to win races. Winning is underrated by some people in motor racing, but in the end, that's what it's all about.”

The time, he says, was right to “make a few decisions about the future”.

“I want to broaden my horizons,” continues the 29-year-old, who will share his Vantage GTE with Frederic Makowiecki and, at the Spa round and the Le Mans 24 Hours, Rob Bell. “I am going to diversify my driving activities and my portfolio.”

Senna points out that it wasn't a case of his F1 hopes coming to an end one day and the quest to race something else starting the next. But he does admit that by the time he and his management team started to focus on life outside F1, his options were narrowing.

“I'm lucky to get such a good

opportunity so late in the day,” says Senna, who only started talking to AMR six days before he was unveiled as one of its drivers. “This was one of those opportunities that was difficult to turn down. When these guys called me I thought, ‘That's really good.’”

Senna didn't need any explaining about sportscars and just how competitive GTE Pro is going to be in the WEC and, even more so, at the Le Mans 24 Hours.

“I'm not one of those drivers who ignores what's going on outside F1,” he says. “I'm passionate about motor racing, not only F1; I read about a lot of other stuff. I knew the GTE class is very competitive and that it has a very high level of driver. That's why I was so excited about this opportunity.”

This isn't Senna's first foray into the world of sportscars. He contested four races, including Le Mans, in his gap year between GP2 and F1 in 2009. The previous year's GP2 runner-up was brought into the ORECA team to drive one of its own AIM-powered ▶

◀ LMP1 chassis that season.

His fortunes were mixed. He ended up claiming a couple of podiums in the Le Mans Series, while never challenging for wins, and also had a massive shunt at Spa. Perhaps, most significantly, he never looked entirely happy with his lot in 2009.

"It was a tough year: I learned so much, but, of course, my mind was on F1," he says. "I thought it would be good experience, but I really wanted to be in F1.

"For sure I have grown up as a driver and as a man. This time I'm very focused on the programme, doing a good job and winning races."

The part-season with the French ORECA squad was a useful experience for Senna, however. Some of the tricks he learned served him well in F1. "Last year I started a few races with 10kg less fuel in my car than my team-mate because I know how to save fuel," he points out.

Senna insists he isn't saying that he'll never race in F1 again. Not quite anyway. "You never say never to F1," he says. "You never close the door, but the time was right to look elsewhere."

If he never starts another grand prix, would there be a sense of regret?

"I took a massive gamble in trying to come from nowhere and get to F1 and be successful," he says. "My first full year of racing was the season [2005] Fernando Alonso won his first title."

Senna reckons he didn't do too badly

Last F1 start ended in shunt with Vettel

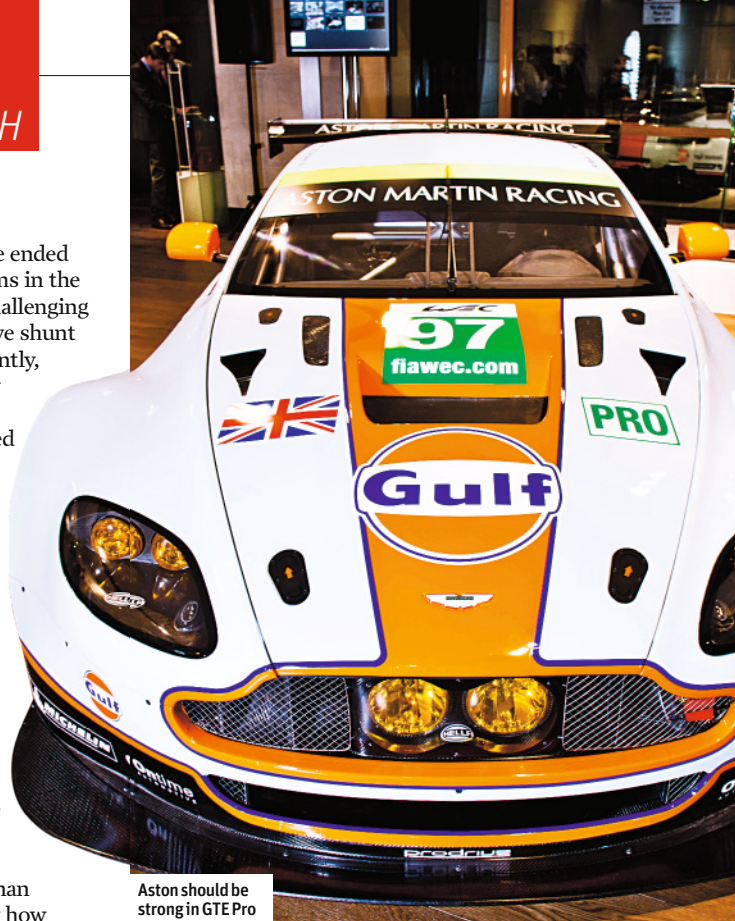

Aston should be strong in GTE Pro

for someone who didn't start racing until he had already celebrated his 20th birthday. "From 2005 to 2008, I was able to get to the point where I finished second in GP2, but after that it was a bit more rocky," he says. "I wouldn't say I'm satisfied, but it's been a good run."

There is clearly a sense of dissatisfaction that he didn't achieve more in 2012 with Williams, which was meant to be his breakthrough year following a rookie season with HRT in '10 and eight races with Renault in '11.

"I would have loved to have fulfilled my potential," he says. "I had a good car, but not the full programme to give me the same chances as the other guys."

That's a reference to the presence of Valtteri Bottas – then Williams test driver and now his replacement in the race team – in the cockpit of the #19 FW34 in first free practice at 15 of the 20 races.

"When you're looking at a tenth or half a tenth being the difference between P10 and P15, you realise that missing that track time puts you on the back foot," he says. "I was always one step behind, or rather one session behind, when it came to qualifying.

"Not doing Friday mornings meant I had no reference of how the track changed for qualifying on Saturday afternoon. Sometimes I overdrove, sometimes I didn't have the right car under me. It was really frustrating, because I have qualified pretty well in the past."

Senna reckons his performances in the races prove that the potential was there and could have been unlocked in a second full season with a decent team.

"I was always strong in the races, so it's clear to me that the second year, a proper full year, would have been much better. That's life."

Life now is all about racing in the WEC with AMR, but there's also a plan to add to his programme, which includes an outing with the team in the Sebring 12 Hours American Le Mans Series opener next month. "Racing just once a month is a bit lazy, so I'm looking for some more opportunities," he says. "We've been looking in the States; I'd like to do some races out there."

Senna doesn't really want to discuss his future beyond this season. "I guess it all depends on what I achieve and how much I enjoy it. It would be awesome to be champion, which is something I've never achieved. That's my goal: win races and championships, and to have a nice long career.

"I haven't stayed with the same team for two seasons since F3, so I'm interested to see what that feels like again." ❄

MAKOWIECKI: ASTON'S TARGET MAN

If you don't ask, you don't get. That was Aston Martin Racing boss John Gaw's philosophy when it came to assembling the driver line-up for the team's expanded World Endurance Series assault in 2013.

Gaw explains that he and his team came up with a list of 100 potential drivers. They were split into four groups, including those with recent GT experience who were already proven to be quick. Out of this list came Frederic Makowiecki, who over the past two or three seasons has come to be regarded as one of the best GT drivers in the world.

"Fred was top of our list along with Maxime Martin, and why wouldn't they be?" explains Gaw. "I'm pretty sure that if Maxime hadn't gone to BMW for this year, he would have been with us."

Signing 'Mako' is a coup in itself, because there was competition for his signature. His starring performances in a Luxury Racing Ferrari 458 Italia in the first half of last year – including pole ahead of the works AF Corse cars at the Le Mans 24 Hours – made him a target for the Italian manufacturer, while he had also impressed the right

people at McLaren while driving a Hexis Racing MP4-12C in the FIA GT1 World Championship.

Thirty-two-year-old Makowiecki chose Aston for two reasons. First, there was his long-standing links with the marque stretching back to 2007; and second, it offered the chance to chase the WEC title.

"I wanted to be in the WEC, because we will have three big brands [Ferrari, Porsche and Aston] racing each other over the full season," he says. "It is the most competitive championship and I want to win it."



Makowiecki: wanted man

WEB DIRECTORY

CAR BROKERAGE

RACING CARS FOR SALE
ALAN CORNOCK FCS
BUYING - SELLING - BROKERAGE
www.racingcarsforsale.co.uk
TEL: 01480 891212

DRIVER DEVELOPMENT

eugene **O'BRIEN**.co.uk
DRIVER DEVELOPMENT
Tel: 0775 383 5629

EXHAUSTS

Inconel & Stainless Steel Specialists
SIMPSON
Race Exhausts
Tel: 01753 532222
www.simpsonraceexhausts.com

GEARBOXES

eLITE transmissions
Rally & Race Gearboxes,
GearKits, LSD's and Driveshafts
Tel: 01782 280136 Fax: 01782 269113
Email: sales@eliteracingtransmissions.com
www.eliteracingtransmissions.com

GEARBOXES

Gearboxman.com
COMPETITION TRANSMISSION SERVICES
Gearboxes and Axles for Road, Race, Rally, and more
Telephone: 01582 840008, Fax: 01582 840007

HELMET GRAPHICS

Mike Fairholme Designs
Sole approved painter of Arai helmets.
Silver Birches, Corby Birkholme, Nr Grantham, Lincs NG33 4LE.
Tel: 01476 550630, Fax: 01476 550029.
email: fairholmedesigns@btconnect.com
www.fairholmedesigns.co.uk

MEMORABILIA

FINAL LAP
For Everything Formula One
www.finallap.net WE BUY AND SELL
+44 (0)1246 287588 / 07771 920345

JMJ AUTOMOBILIA America's #1 supplier
of CART and Formula
One Racing memorabilia. Large selection of signed
original collectables. See our ad under marketplace
Memorabilia. Call or fax or a mail listing at (609) 575 1143
or visit our website @ www.JMJAuto.com

MERCHANDISE

F1 Merchandise bought and sold.
Meadowhall, Sheffield
Tel: 0114 256 9835
www.theformula1shopandmore.co.uk

MODELS

HISTORIC SPORTS RACERS
For a new range of 1/43 scale hand
built 1950's Sports Racing Models visit
www.modelgarage.co.uk
and follow the Online Shop link.

RACE PARTS

ARE DRY SUMP SYSTEMS
ARMSTRONG RACE ENGINEERING INC.
WWW.DRYSUMP.COM (916) 652-5282

RACE PRODUCTS

demon tweeks
MOTORSPORT Direct
www.demon-tweeks.co.uk

RACE PRODUCTS

msar LONDON
MOTORSPORT
SHOWROOM
www.msar.co.uk

PIPER
www.pipercams.co.uk

SCHROTH
RACING
www.schroth.com

www.porscheshop.co.uk
PORSCHESHOP
+44 (0) 121 585 6088

RACE PRODUCTS

TEKNOFIBRA
HEAT RESISTENT MATERIAL
Protection to 1000°C
web: www.walkersgarage.com
tel: 0044 (0) 1609 777221

RACE RADIO

Pit to Car Autotel
Radio solutions
0044(0)1508 528837
Digital Race Radio
www.raceradio.co.uk

RACEWEAR

JJC race and rally
PASSIONATE ABOUT MOTORSPORT
www.jjraceandrally.com

GPR sparcos livex omp
SCHROTH hans seat Arai BELL
RACEWEAR | KARTWEAR | SIMULATION
WWW.GPRDIRECT.COM

RACING OILS

WWW.ROYALPURPLE.CO.UK
ROYAL PURPLE
SYNTHETIC RACE OILS
01209 216 666

TRAILERS AND TRANSPORTERS

BRIAN JAMES TRAILERS
CLUBMAN
Tel. 01327 308833
Web. www.brianjames.co.uk

PRG TRAILERS
www.prgtrailers.co.uk
Phone no: +44 (0) 1270 812402

WHEELS

Image Manufacturers of bespoke
split rim alloy wheels
www.imagewheels.co.uk
IMAGE WHEELS INTERNATIONAL LTD

AUTOSPORT.COM

TO ADVERTISE IN THE WEB DIRECTORY PLEASE CALL
020 8267 5560 OR EMAIL: autosport.ads@haymarket.com

TRAILERS & TRANSPORTERS

WOODFORD TRAILERS

Call Us Now! tel. 01327 263 384

www.woodfordtrailers.com sales@woodfordtrailers.com



RL 5000
£7,300 + vat



RL 6000
£9,500 + vat

PRG Trailers

All trailers now come with European COC certificate



optional colour finishes shown

PRG Trailers | Cheshire | UK | Tel: +44 (0) 1270 812402
Web: www.prgtrailers.co.uk | Email: info@prgtrailers.co.uk

ABL LOGISTICS

Specialising in car movements and race support offering tractor units, an 18 ton two-car transporter, with moveable deck to hold 2 cars, large external lockers and an enclosed race shuttle. For long/short term hire. Also able to supply drivers/truckies.



For hire for the 2013 season

Contact- James on 07973 746025
or email: james.goodwin5@yahoo.co.uk
or Sean on 07766101845
or email: weeman.smg@hotmail.co.uk

STARHOME



FREE UK DELIVERY & COLLECTION*



Luxury trackside accommodation

Hire the ultimate motorhomes sleeping up to 18 people in centrally heated, air conditioned luxury for events in UK / Europe.

For reservations please call Heidi Crawford on 07711 665 622 or the office 0161 452 3630

www.starhomehire.com

*For bookings during February & March 2013

BRIAN JAMES TRAILERS

» Connected to you



Endurance & Efficiency

www.brianjames.co.uk

Race Transporter trailers demonstrate all the capability you require. Our passion for continual development underpins everything we do. The results are available for you.

RACE TRANSPORTER

T +44 (0)1327 308 833

For more information and details of your local BJT dealer please call or visit our website.

RACE & RALLY CARS

FOR SALE!



2x SEAT LEON WTCC

- Car n° 07 with 460 hp 2000cc Lehmann turbo engine and central fixing nut.
- Both cars: Hewland EGT 6 speed, AP brakes, Sachs dampers, PIDatalogging system, Loads of spares.
- Car n° 16 with 400 hp Lehmann turbo engine.
- The car with the big turbo: £70,000
The car with the small turbo: £54,000

Contact: pierre@proconceptliege.be



Race support services 2013

2012 championship winning team offer a range of Professional race support services for Customer owned cars from our Midlands based workshops just off M40. We will be supporting the BTCC,MSVR and Masters Championships.

In2Racing have a drive available in Radical SR3 Challenge and opportunities available in our Championship winning Porsche Carrera Cup GB & Porsche GT3 Challenge team.

Contact: Nick Dudfield Tel: 01789750567 or 07768548774
nick@in2racing.co.uk www.in2racing.co.uk



How much
FASTER
can you go?

Racing Driver
1-to-1 Tuition
with Eugene O'Brien

any car, any driver... results guaranteed!

Tel: 07753 835629

www.eugeneO'Brien.co.uk

2012 MSA British Endurance Championship (Britcar) winning car for sale:



2012 Lotus Evora GTC developed throughout last year by Lotus Motorsport. 7 fastest laps and 5 race wins in 8 rounds including overall race win at Oulton Park.

Spec includes:

- Max Power 440 bhp
- Max Torque 460 Nm
- Dry Weight 1160 kg
- Cosworth SQ6 ECU with Variable Traction Control
- Cosworth Omega dash, PI D3 Dash with Full Data Logging
- XTRAC Sequential 6-speed with Pneumatic Paddle Shift
- 4 way Ohlins TTX36 dampers,
- Alcon Endurance Brakes with Variable Race ABS
- Centre Lock Hubs,
- 120 litre Fuel tank, FIA FT3 approved
- ATL Quick Filler Dry Break System
- Air Jack System

A proven race winner that could be utilised in various GT championships. Car is in perfect condition.

There is no VAT to pay on purchase price.

Comprehensive spares package is available separately.

£135,000

Please contact David Green for further details on:
07889707005 or
david@giantfilm.tv



New for 2013 French Trophy Racing Series citroen/peugeot/Renault

A series dedicated to French Cars only, and about time too some might say. 14 races all around the UK, with media support from Performance French Cars Magazine, who will cover all events with possible TV coverage of some events, make it a winning package. Five classes to choose from and an even cost of registering and becoming a club member is taken care of with Performance French Cars magazine paying for it if you carry their logos through the season. See our website for more details.

**CANT AFFORD TO RACE?
YES YOU CAN!**

Ask about our all inclusive deals Just £5990 gets you a turn key newly built race car for any of our series including all race entry fees, reg and club membership fees.

Nippon Challenge, Hyundai Coupe Cup, Toyota Mr2 Racing, French Trophy racing.

www.trackattackraceclub.com
Or call Steve Vince 01646 601908
Stephenezbra@aol.com

New for 2013

Ferrari 458 Challenge Upgrade

The E2M Phase II kit comprises of:

- 1 New Anhedral Rear Wing
- 2 Billet Alloy Rear Wing Support
- 3 Carbon Ultra - Lite Doors - uses factory window and locks
- 4 Carbon Aero Vented Carbon Rear Bumper
- 5 Carbon Rear Diffusor
- 6 Carbon Aero Vented Front Wings
- 7 Carbon Aero Vented Louvered Bonnet
- 8 Carbon Aero Vented Front Bumper
- 9 Carbon Dive Planes
- 10 Carbon 100mm Front Splitter with Integral Carbon Floor and Strengthened Carrier
- 11 Power Upgrade to 625 BHP
- 12 4 Way Adjustable Suspension

Evolution 2 Motorsport now offers an all new for 2013 ultra lite performance aerokit, to both reduce weight and improve aerodynamic performance. With over 25 years of race winning experience, the aerokit has been designed and manufactured to factory standards. All parts use existing mounting points, with excellent fit, quality and finish.



Visit the new Evolution 2 Motorsport website or call us for pricing and delivery times. Dealers wanted in USA

Evolution 2
MOTORSPORT

Email info@evolution2motorsport.com
Telephone +44 (0) 1753 885 453
www.evolution2motorsport.com

MARKETPLACE

AUTOMOBILIA

F1 COLLECTORS .COM



#1 FOR F1 MEMORABILIA
 We buy and sell F1 items
AYRTON SENNA specialists
 Call CHRIS GRINT **01763 274448**
 email: sales@f1collectors.com

JMJ Automobilia
 SUPPLIERS OF RACE
 MEMORIBILIA SINCE 1992

Florida, USA (609) 575-1143

email: JMJO@JMJAUTO.COM
WWW.JMJAUTO.COM

CAR TYRES

FOR ALL YOUR

AVON
 TYRES
MOTORSPORT

RACING TYRES
 Inc. ACB 10 Formula Ford
 Contact

BMTR LTD

Tel: 0121 331 1122
 Fax: 0121 331 1144
 email: sales@bmtr.co.uk
 see our new web site at www.bmtr.co.uk

**TO ADVERTISE IN
 THIS SECTION OF**

AUTOSPORT

**PLEASE CALL
 0208 267 5560**

AUTOSPORT.COM

FLOORING

Kiwi Tiles
 Interlocking Plastic Floor Tiles, as used by leading
 race teams throughout Europe.

- Easy installation & removal
- Many colours
- Lightweight
- Strong and durable
- Compact & easy to store
- Top quality
- Value for money

Stock Colours:
 Red, Blue, Green,
 Yellow, Silver, Orange,
 Grey, Black, White,
 Dayglo Red

Ralt Engineering
 Tel: 01865 883354 Fax: 01865 883789
 Email: enquiries@kiwilitiles.com
www.kiwilitiles.com

FRANCHISES

Mac Tools
 GREAT TO WORK WITH

Business for sale:

Mac Tools is part of StanleyBlack & Decker, an \$11+ billion global organisation and owner of the world famous Stanley Black & Decker and DeWalt brands. If you have the desire and passion to work for yourself, available cash of £15,000 and the ability to build relationships, our franchise businesses give you the power to drive your future with our training and support.



Call us on: 08450 6000 60
 Email: franchise@mactools.co.uk
www.mactools.co.uk

GEARBOXES

RACING
 TRANSMISSIONS

**SPECIALISING IN
 GEARBOX REBUILD,
 REPAIR AND SERVICING
 FOR GT, LMP, F3
 AND MORE...**

Hewland Specialist

Call 07976 877 612
jono@racing-transmissions.co.uk
www.racing-transmissions.co.uk

FOR RENT





PCM are pleased to offer a newly vacant business unit on their Long Buckby Site. Located 250 yards from the A5 and 10 minutes from J16 or 18 of the M1 Motorway, it is strategically located at the heart of the South Midlands. The accommodation has an existing trade counter and fully racked stores, workshop and offices. The total area including mezzanine being 5250 sq ft. It has car parking for up to 10 vehicles and for one large HGV. The building could be reconfigured and refurbished to your specification or let "as is" at a reduced rent. The overall site contains 8 other units and is fully security fenced. PCM are the site owners and therefore able to negotiate directly and quickly with potential clients.

Contact John Plant on: 01327 842808
 or email: accounts@pcmfluidpower.co.uk

MOTORSPORT PREPARATION

MARDI GRAS
MOTORSPORT
 Saloon Car Preparation



Unit 45, Silverstone Circuit
 Towcester
 Northampton NN12 8TL

tel: 01327 858006 fax: 01327 858800
 email: info@mardigras.co.uk
 web: www.performanceclutch.co.uk
 buy online at www.mardigras.co.uk

Distributors and agents for:



















RACE PRODUCTS

WWW.REIGERSUSPENSION.COM

The best suspension for:

- Rally
- Rallycross
- Autocross
- MotoCross
- Quads
- Sidecar Cross
- Rallye Raid
- Trial



Reiger Suspension BV
Molenenk 5a
NL-7255 AX Hengelo Gld.
Tel.: +31 (0)575-462077 Fax: +31 (0)575-463316
Info@reigersuspension.com

CARTEK **NEW** MOTORSPORT ELECTRONICS Wireless Steering Wheel Pushbutton Controls



CARTEK now offer a quick and easy solution to installing 8 pushbutton controls to detachable racing steering wheels.

This wireless system is fully configurable incorporating momentary, latching and flashing functions for uses such as: radio, pit limiter, dash, lights, wipers, etc...



£499
+vat



CARTEK AUTOMOTIVE ELECTRONICS Ltd
www.CARTEKMOTORSPORT.com

Available from: Demon Tweaks, Competition Supplies
Powervamp, Rallynuts, Pandamonium, Interex

Professional Quality...
...Clubman Price

Analysis Software Now Compatible with GoPro HD Video



Data + Video

- Data analysis with synchronised video
- Create videos with graphical data overlays
- Complete integrated systems, or import videos - optimised for GoPro HD video
- VIDEO4 systems - record from multiple cameras. Video and data perfectly synchronised to a single card for fast loading and analysis



Data Loggers

- High accuracy GPS data loggers
- GPS track maps, lap/sector timing
- Integrated accelerometers for grip use measurement
- Expandable with external sensors & enhancement options



Data Displays

- Fully configurable multiple screens of data & configurable shiftlights
- DASH2 road/race ready display
- Range of auxiliary data displays to suit your application



Race Technology
www.race-technology.com

Race Technology Ltd (UK) 01773 537620
(US) 804 358 7289
sales@race-technology.com

MARKETPLACE

RACE PRODUCTS

SCHROTH RACING

HARNESS THE POWER TO WIN



www.schroth.com

ETA APPROVED

• EXPERT ADVICE • MASSIVE STOCKS • RAPID DELIVERY



www.demon-tweeks.co.uk **QZ252A**

DON'T DELAY, CALL TODAY **demon tweeks** MOTORSPORT *Direct*

0844 375 2196 LOW CALL RATE CALLS MAY BE RECORDED FOR TRAINING PURPOSES

London Motorsport Showroom

www.msar.co.uk



MSAR UK agent for **SCHROTH RACING**

ORDER HOTLINE: 020 8655 7877

WILLANS

LEADERS IN DRIVER SAFETY SINCE 1967

When only the best will do...



www.willans.com

Tel: 01488 669001

Fax: 01488 668141

sales@willans.com

RACEWEAR

Grand Prix Racewear

WWW.GPRDIRECT.COM

2013 CATALOGUE

AVAILABLE NOW

REQUEST YOUR COPY GO ONLINE OR CALL US ON:

08435 070 858

RACEWEAR | KARTWEAR | SIMULATION



Race Wear • Kart Wear • Leisure Wear • Helmets • HANS • Sim

DRIVEN BY PASSION

Grand Prix Racewear

2013 Catalogue

QR code: Scan code to view it online now

MOTORSPORT JOBS

PUBLICATION DATE EVERY THURSDAY

CALL 020 8267 5820

FOR ALL AVAILABLE VACANCIES PLEASE GO TO THE JOBS SECTION OF AUTOSPORT.COM

BOOKING DEADLINE MIDDAY MONDAY PRIOR TO PUBLICATION
COPY DEADLINE MONDAY 5PM PRIOR TO PUBLICATION
ALL ADVERTS PLACED FEATURE IN THE APPOINTMENTS SECTION OF AUTOSPORT.COM FOR ONE WEEK

RACHEL.BROCK@HAYMARKET.COM

BJR
BRAD JONES RACING

838 Hope Court
Albury NSW 2640
Australia

Number One Mechanic

You will be responsible for carrying out preparation and maintenance on one of our V8 super cars ensuring that it is presented to the highest standards. It is essential that you are an excellent technical problem-solver under pressure and a team player, with a strong mechanical background in Formula One or another motorsport environment. A flexible approach to work is essential due to the significant amount of national and international travel required of this role.

We also require:

Motorsport TIG Welder / Fabricator

Fabricator you will be responsible for fully fabricating components from drawings, ensuring they are of the highest quality and delivered on time.

Experience in Chrome molly and aluminum is a must, with the ability to TIG weld light gauge materials. Motorsport experience is essential with a preference given to previous work in touring car and cage fabrication. To apply for the roles listed, please simply send your CV and a covering letter via email to Chris Clark.

APPLICATIONS TO: chris.clark@bradjonesracing.com.au
PHONE: + 61 2 6049 4600

LOOKING TO RECRUIT FOR 2013?

CHECK OUT OUR NEW MOTORSPORT JOBS WEBSITE

- The Motorsport Jobs page of the website receives on average 200,000 page impressions per month
- The magazine you are looking at has a readership of 144,000 (Source: NRS Survey Q3)
- All job adverts placed in Autosport magazine are listed on the website.

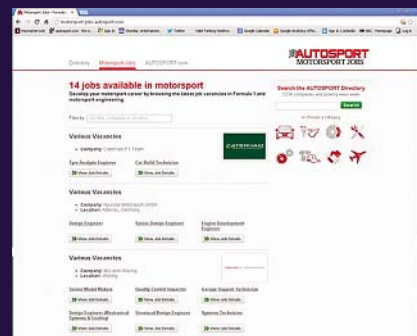

<http://motorsport-jobs.autosport.com/>

AUTOSPORT

WHERE ARE YOU ADVERTISING YOUR MOTORSPORT JOB VACANCIES?

“At Flybrid Systems we have used Autosport as a single source to advertise a range of jobs from design and development engineering roles to assembly technicians and administrators. We have always had a strong response and on the last occasion we received over 200 applications for 6 posts.”

Jon Hilton FIMechE CEng, Managing Partner, Flybrid Systems LLP

“The decision to advertise for staff in Autosport was easy as the magazine is one of the most widely read motorsport publications in the world. The resulting response also met our expectations providing us with a large number of high quality candidates. What exceeded our expectations was the friendly and helpful nature of the Autosport staff who helped us with the timing and preparation of our advertisement. I would recommend the use of Autosport to any organization looking to recruit staff in our business.”

Steve Hallam, Director of Competition, Michael Waltrip Racing



WE ARE CURRENTLY LOOKING TO RECRUIT THE FOLLOWING POSITIONS WITHIN RED BULL TECHNOLOGY:

HR869 – SENIOR ELECTRICAL TECHNICIAN

We have an exciting opportunity for a Senior Electrical Technician to join our Electronics Team.

You will be responsible for the production of high quality Electrical and Electronic components, looms and assemblies within the time scales set, to required specifications using Autosport or Aerospace connectors, MIL spec wiring, and heat shrink moulded parts. In this role you will also work closely with the Electronics Production Team Leader assisting with day-to-day task planning while providing leadership, mentoring and technical support to the Electrical Technicians.

It is essential for the successful applicant to have strong leadership and organisational skills, with the ability to work closely with other team members, and enjoy the challenge of working in a high pressured, time sensitive environment. As a requirement for this position you will need previous experience in a Motorsport (ideally Formula One) build environment, with a BTEC NC in Electrical or Electronic Engineering (or equivalent).

HR27111201 – ELECTRICAL TECHNICIAN

We are currently seeking an Electrical Technician to maintain and develop our on-car wiring systems and garage based Electrical equipment.

Ideally you will have experience in a Motorsport or Aerospace environment, and you will be able to demonstrate a high level of commitment, coupled with excellent interpersonal skills. You will work to exceptional standards whilst under pressure, using your thorough knowledge of cutting edge Electrical/Electronic installations, Autosport or Aerospace connectors, MIL spec wiring and heat shrink moulded parts.

To apply, please email recruitment@redbullracing.com quoting the above reference number and attaching your CV and covering letter including details of your current salary.

Closing date for applications – 28th February 2013

For details of available opportunities at Red Bull Technology and Red Bull Racing, please visit the recruitment page on our website www.infiniti-redbullracing.com

PLEASE NOTE: No Agencies please.



Mercedes-Benz has been setting the standard in racing for over 100 years. The MERCEDES AMG PETRONAS Formula One™ Team continues the proud history of the legendary Silver Arrows with the clear ambition of winning the FIA Formula One™ World Championships. Based in Brackley, UK, we are recruiting highly motivated, talented new members of our team. If you would like more information about one of our roles then please see the 'Join our team' area of our website.

AERODYNAMICS PRODUCTION PLANNER
SW514/1102

Reporting to the Aerodynamics Planning Manager, you will be responsible for the short-term management of wind tunnel sessions and projects from CAD release to delivery. This will be achieved through reviewing, scheduling, sourcing and progressing of parts and assemblies through all procurement, manufacturing and build processes culminating in delivery to the wind tunnel. A hands-on and busy role, you'll possess at least 3 years experience gained in a fast-moving and highly-dynamic environment.

AERODYNAMIC MACHINISTS - ALL SHIFTS
SW510/1102

With a proven capability in the production of high-quality machined components within a time-pressured environment, you will form part of a dedicated team responsible for programming, setting and operating CNC and manual machinery as required to meet the daily production schedule. We are looking for candidates from a motorsport, aerospace or similar high-precision environment confident in running multiple CNC machines and with a good working knowledge of modern CAD/CAM systems, preferably CATIA or UG.

WIND TUNNEL SYSTEMS ENGINEER
SW498/2801

Providing technical support to those operating the wind tunnel, you'll actively develop and support wind tunnel programmes enhancing overall test capabilities. Other responsibilities will include the development of off-line testing, system checks and simulations to minimise tunnel downtime as well as investigating and resolving issues and faults as they occur, continuously looking for opportunities to implement improvements. Capable of providing flexible out-of-hours cover and emergency assistance, you will be educated to HNC level or above and possess at least 3 years experience in a test cell environment

SENIOR AERODYNAMICIST
SW478/1101

Reporting to the team leader, your primary focus will be to add aerodynamic performance to the race car. Responsible for aerodynamic development projects from initial concept, through CFD analysis, to design and wind tunnel testing, you will work on some of the more challenging projects. A minimum of 3 years experience in top level motorsport aerodynamics is required together with education to degree level in aerospace or aeronautical engineering.

TRACK AERODYNAMICIST
SW441/2611

A role involving travel, you will be able to deliver the highest standards of work whilst operating in a high-pressure environment. You'll have a strong aerodynamics background and a highly-analytical nature, able to generate innovative solutions to the challenges which confront the track aerodynamics group on a day-to-day basis. Candidates require a minimum Bachelor of Engineering (Aerospace or Aeronautical).

AERODYNAMICS GROUP LEADER
SW523/1102

Responsible for adding aerodynamic performance to the race car, you will lead a development team of Aerodynamic engineers and oversee wind tunnel tests, CFD simulations and other forms of research used to define aerodynamic directions for race car developments. Working on challenging projects, you'll possess a minimum of 5 years experience in top level motorsport aerodynamics and be educated to degree level in aerospace or aeronautical engineering. You'll be able to demonstrate excellent interpersonal, motivational and leadership skills.

QUALITIES THAT WE ARE LOOKING FOR IN ALL CANDIDATES ARE:

- Flexibility in hours and approach
- Ability to communicate effectively at all levels
- Methodical with good organisation skills
- Ability to work under minimal supervision, to strict deadlines
- "Can do" and "team player" attitude

In return for your work and commitment, we offer a competitive package including bonus, 25 days holiday, subsidised restaurant and on-site gym facilities. If you wish to apply for a position please see our website and then forward your CV and letter of application with current remuneration details/salary expectations, quoting the job title/reference and where you saw the advertisement to recruitment@mercedes-amg-f1.com

NO AGENCIES PLEASE
Closing Date: 28 February 2013

Sports Extra

NATIONAL RACING • HISTORICS • CLUB • RALLY • RALLYCROSS • HILLCLIMB

Stoneman eyes Porsche drive

Ex-F2 champ tests for leading Carrera Cup squad at Brands



Stoneman was on the pace for Redline at Brands Hatch

» **EX-SINGLE-SEATER STAR** Dean Stoneman is eyeing a return to racing in the Porsche Carrera Cup GB this season.

The 22-year-old, who won the FIA Formula 2 title in 2010, aborted a move into Formula Renault 3.5 for '11 after being diagnosed with testicular cancer. He returned to competition in powerboats, winning the P1 SuperStock UK crown last year.

Stoneman completed over 100 laps of the Brands Hatch Indy Circuit with leading Porsche team Redline Racing last Thursday. "It was good fun – very different to what I'm used to," he told AUTOSPORT.

"I raced a Radical last April so it's been nearly a year since I've driven anything. I'm nowhere near as fit as I was when I was driving F2 but I didn't struggle with the Porsche."

Stoneman said he was still looking at options in single-seaters and

due to meet with Redline again this week to discuss a race deal. He is likely to test for the team again at Thruxton next week as he evaluates his options.

"Porsche looks attractive with the Supercup route and finding the money is not a problem, but how long do you keep paying for?" added Stoneman, who is working to find a route to a professional drive. "The only way you'll get into F1 is if you've got 10 million quid, and you'll only be there for a year – unless you've got another 10 million!"

Double Carrera Cup GB champion Tim Harvey oversaw Stoneman's Porsche test and is keen to help the 2008 McLaren AUTOSPORT BRDC Award finalist back into racing.

"The test really came about through the BRDC Superstars programme," said Harvey. "He's been on that for a few years, even when he

wasn't racing because of the cancer; we hoped to play a part in his recovery. The initial thought was single-seaters, but things have dragged on and the opportunities were getting fewer and fewer.

"Porsches is a good way to go to get into GT racing, which is probably the strongest category in motorsport at the moment. I was able to give some help and guidance. I thought the test was just to see what it was like, but his adjustment was so fast. After a couple of runs he was asking for changes. He was a true professional and it was fantastic to work with him.

"He ran very competitively. The conditions weren't ideal and he was on old tyres, but he was able to beat [2012 race winner] Ben Barker's time when he went out. We came away impressed and confident that if he chose to do the Carrera Cup he'd be incredibly competitive. It would be perfect for him, and it'd be great for Porsche and British motorsport. He's an absolute star."

DEAN STONEMAN CV

2010 1st in FIA Formula 2 (6 wins), Williams F1 test (Abu Dhabi)

2009 4th in Formula Renault UK (1 win)

2008 4th in Formula Renault UK (3 wins), McLaren AUTOSPORT BRDC Award finalist

2007 2nd in Formula Renault BARC (1 win)

AUTOSPORT SAYS...

BEN ANDERSON
NATIONAL
EDITOR

ben.anderson
@haymarket.com



I CAN'T PROFES TO BE AN

expert in recovering from cancer but I can say with some certainty that it cannot be easy. This terrible affliction struck Dean Stoneman down at a time when his career momentum was building nicely.

He'd just won the second season of Jonathan Palmer's FIA Formula 2 category, tested a Williams F1 car at the young-driver test in Abu Dhabi, and was set to partner Red Bull rising star Daniel Ricciardo at ISR in Formula Renault 3.5 for the 2011 campaign.

That he's fought his way back to health, let alone to a point at which he may return to racing, is a testament to his personal strength and willpower – as well as the quality of healthcare he has no doubt received during his battle.

Although Dean is still considering a return to single-seater action, there are two significant obstacles in his way. First, can he regain the level of fitness necessary to compete at the highest level? By his own admission he is "nowhere near" as fit as he was in F2, and the levels of exertion required are only greater the further up you go. The second obstacle is Stoneman's desire to make his talent pay. Forking out for single-seater budgets is all well and good, but only if you can see financial light at the end of that tunnel. He is not convinced he can.

So that leaves sportscars and tin-tops. Stoneman is not a fan of the idea of sharing driving duties, but would happily fall into line if it were to become his job. As Tim Harvey says, GT racing is in vogue right now and the Carrera Cup GB is a fine place to start. Whatever the future holds, it will be good to see Dean Stoneman racing regularly again.

Extra contact details

Kevin Turner, features editor
kevin.turner@haymarket.com

CONTENTS

p78 INTERVIEW
LAWRENCE DAVEY

PICS: HAWKINS, DUNBAR/LAT

Stoneman tested F1 Williams in 2010





Ginetta GT Supercup

Nicoll-Jones to Ginetta Supercup

Double G20 champion to race a G55 in TOCA support series for his own team in 2013

Nicoll-Jones raced a G55 in British GT3 in 2011

FORMER BRITISH GT4 and double Ginetta G20 champion Matt Nicoll-Jones will return to regular racing this season in the Ginetta GT Supercup.

The 27-year-old will drive a G55 for his own Academy Motorsport team, which will also run a G50 in the TOCA support series for reigning Ginetta GT5 Challenge champion Sean Huyton.

Nicoll-Jones, whose team will continue to run G40s for Matt Flowers and Will Burns in the GT5 Challenge, said: "The Supercup grid looks immensely strong this year, which is part of the attraction for me, and we feel that, as a company, Ginetta provides unrivalled opportunities to teams and drivers for sensible money.

"Our previous success is proof

enough of what we are capable of. Combined with our already immensely strong GT5 Challenge squad, we are expecting another good year in 2013."

Huyton, who won the lease of a G50 for the year as his prize for lifting last season's GT5 title, added: "The prize has certainly given me the opportunity to progress, and our plan is to repeat the process and move up

the Ginetta ladder again next year with Academy."

Leading Ginetta Junior squad Douglas Motorsport will also join the GT Supercup grid this season.

The team, run by the racing arm of Wayne Douglas's renowned driver development operation, will run a G55 for Andrew Watson, who won a race and finished fifth for the squad in Ginetta Junior last year.

Fun Cup

Indy racer joins Fun Cup field

FORMER ASIAN F3, INDY LIGHTS race winner and one-time IndyCar racer Dillon Battistini will compete in selected Fun Cup races this season.

Battistini, runner-up in the 2003 Caterham R400 Superlight Challenge, will race for a new team - Mid Life Crisis - alongside ex-Caterham racer Richard Webb, Julian Bricknell, Colin Kingsnorth and novice Edd Horder.

The team is describing Battistini, who will complete the line-up for selected events, as its "ace in the hole".

Battistini said: "I did get the opportunity to try out one of these cars for several laps last year at Oulton Park



Battistini has been a race winner in Indy Lights

and was surprised at how much fun it was behind the wheel.

"When Colin asked whether I would drive with him it was an easy decision to make. I may even be able to offer some advice on his driving - but I can't promise help with his mid-life crisis."

Ginetta Junior

Kart ace Mills to Ginetta Junior

BRITISH KARTING CHAMPION Connor Mills will graduate to car racing this season in Ginetta Junior.

The teenager enjoyed the most successful season of his career to date in 2012, winning the British and London Cup championships in the MiniMax class, the ABKC 'O' Plate, the British Open title, and finishing second in Formula Kart Stars.

He will race as a privateer in Ginettas, run by his father Steve. They plan to race in the series for two seasons.

Mills, 16, said: "The Ginetta Junior Championship has attracted us, firstly because it means my father

will be able to run the car, which obviously keeps costs down, and secondly it seems to be a very fair championship, with the driver's ability being the key component."



Kart champ Mills will race as a privateer

IN BRIEF

TOP BTCC SQUAD

Triple Eight rolled out the new BMW Z4 GT3 it will run

Triple Eight tested BMW Z4



in British GT this season. Series race winner Joe Osborne and his 2013 co-driver Lee Mowle both got their first taste of the car, which they will race under the 888Optimum banner, at Snetterton last week.

FORMER BRITISH GT

racer Freddy Nordstrom will return to the Euro Racecar NASCAR Touring Series this season. Nordstrom, who finished ninth in the standings last year, will drive for Eric Helary's STILL Racing team.

SCOTTISH TIN-TOP

racers Finlay Crocker and Ronnie Klos will both return to the Renault Clio Cup this season with top squad Scuderia Vittoria. Crocker finished 19th and Klos 25th in the standings last season.

EX-SINGLE-SEATER

racer James Nutbrown will return to racing this season in the Renault Clio Cup. The former InterSteps racer will drive for leading squad Team Pyro and tested with Mark Hunt's squad at Donington Park last week.

Rotax Max karting ace Ash Hand also tested with Pyro at Donington.

Nutbrown will race in Clio5



Clio Cup

SWB targets Clio Cup expansion after committing to new series

SINGLE-SEATER SQUAD SWB

Motorsport hopes to expand into the Clio Cup UK after becoming the first team to commit to running cars in the BARC's new club series for Clios.

The BARC has launched the new series to give existing Clio Cup UK cars a place to continue racing when they are replaced by a new model in 2014, as well as offering a lower-cost way into Clios for drivers who cannot afford the TOCA package.



SWB has its eye on joining the Clio Cup

SWB, which will also run cars in Formula Renault BARC and the revised Formula Ford EcoBoost 200 formula, will run karting ace Sam Rindt in the Roadcar (non-slick tyres) class of the four-round Clio series.

SWB team principal Simon Baldry said: "The cost-effectiveness of the Clio Cup Series is the main draw for us as a team. We've already got our academy structure in place from karting to single-seaters. Now this will give us a route from karts into tin-tops for those who want to go down that road.

"The longer-term plan is to run in the Clio Cup on the TOCA package as well. Being in the Clio Cup Series this year will enable us to test the water under the radar. We're looking forward to working with Sam, we all know him from karting and this is a great way for him to start out in cars."

MARCUS PYE

HUMBLE PYE

The voice of club motor racing



Rindt took the first of his Thruxton F2 wins in '68

The British Automobile Racing Club's agreement to loan its splendid Jochen Rindt Memorial Trophy for the Historic Formula 2 feature at Thruxton's exciting new HSCC-organised Easter Revival meeting (March 30/31) will delight fanatics of his era of motorsport.

Rindt was the undisputed king of Thruxton, unbeaten in the BARC's colourful Easter Monday F2 internationals from 1968 (when the Hampshire airfield venue reopened to cars, using its perimeter track rather than the '53-'54 layout) to '70, the year in which the Lotus 72 racer lost his life during practice for the Italian Grand Prix at Monza.

He was also an incredibly nice bloke, agree all who knew him. HSCC chief Grahame White, a BARC staffer back then, was a big fan and instrumental in inaugurating the Rindt trophy for the F2 race, won by stars such as Graham Hill, Ronnie Peterson, Jacques Laffite, Brian Henton, Bruno Giacomelli - and also 1979 European champion Marc Surer in '93's 25th Anniversary Historic F2 event!

Despite German-born Jochen's prodigious ability and record of success (he won six F1 GPs, the 1965 Le Mans 24 hours for Ferrari, and the inaugural Trans-Am race at Sebring in '66, famously soloing after Roberto Bussinello rolled their Alfa Romeo GTA in practice),

he remained shy and diffident, almost incredulous at fans' interest in him.

Much of this was deep-rooted. Orphaned as a child, Rindt was brought up by grandparents in Austria, under whose flag he raced. Married to Nina Lincoln, daughter of top Finnish racer Curt, he saw many contemporaries and friends die in accidents and resolved to quit if he lifted the F1 crown. He remains its only posthumous champion.

The tragically truncated era in which he was at the peak of his powers was largely in a 'racing shadow' for me, so I never saw him in a decent F1 car, or an F2 event. I do, however, vividly remember him lugging an ungainly barge of a Cooper-Maserati around Silverstone in the 1967 British GP.

With Team Lotus's Ford Cosworth DFV V8 engines in the ascendant, and Jim Clark and Graham Hill making hay in 49s, Rindt's thirsty V12 was largely impotent. The previous season, the faltering first of the three-litre F1, the Rindt/Cooper combo had finished third in the table, behind quadruple race winner Jack Brabham's supposedly underpowered Repco-engined Brabham, and John Surtees, who had won the Belgian GP for Ferrari and Mexico's finale as Jochen's team-mate.

Jochen Rindt was the undisputed king of Thruxton. He was also an incredibly nice bloke"



USF2000

Fletcher shines on US race debut

EX-FORMULA RENAULT RACER James Fletcher took a trio of podiums during his USF2000 debut last week.

Fletcher, who finished seventh in FR BARC last year, warmed up for the main 2013 USF2000 series by contesting the six-race 'Winterfest' mini-series at Sebring and Palm Beach.

He finished third overall for the Cape Motorsports with Wayne Taylor Racing team, behind team-mates Neil Alberico and Scott Hargrove.

"I learned loads and I've done more racing in the last week than I've ever done in the UK in that



Fletcher took third in USF2000 'Winterfest'

period of time," said Fletcher. "The reason I moved here is because there are big grids, it's really competitive, the weather's nice and there are good locations, so I'm really enjoying it. We struggled a little for pace at Palm Beach but I'm really happy."

Mini Challenge

Legend Davey heads for Minis

REIGNING UK LEGENDS CHAMPION

Lawrence Davey will switch to the Mini Challenge this season.

Davey, who also won the Sunoco 200 Challenge prize drive in the GT support race to this year's Daytona 24 Hours, will run the Mini with his father

Martin under the Lawrence Davey Racing banner.

Davey, who has raced in Legends for 12 years, said: "After racing Legends for many years, I feel it's time to move up to a championship that can push my career further.

"My goal is to be in the BTCC so, after looking at various championships, the Mini Challenge made perfect sense to get involved in."

Davey hopes to run a second car on an arrive-and-drive basis.



Davey has starred in Legends for many years

P78 DAVEY AT DAYTONA

MO213P

AUTOSPORT

FREE KIMI RAIKKONEN T-SHIRT

WHEN YOU SUBSCRIBE TO AUTOSPORT



**SAVE
23%
ON THE
COVER
PRICE**



**JUST
~~£3.50~~
£2.69
AN ISSUE**

Subscribe online at:

www.themagazineshop.com/ASPO/MO213P

Offer closes March 7 2013

GREAT REASONS TO SUBSCRIBE:

- **FREE KIMI RAIKKONEN T-SHIRT**
- **SAVE 23%** on the cover price
- **SPREAD THE COST** - just £34.99 every 13 issues with easy direct debit instalments
- **FREE P&P** - every issue delivered direct to your door

Yes

AUTOSPORT

Yes, please start my subscription to AUTOSPORT paying just £34.99 every 13 issues. Please send me my FREE Kimi Raikkonen T-Shirt in the following size (one choice only):

Medium Large X-Large

YOUR DETAILS - must be completed
(BLOCK CAPITALS PLEASE)

Title: Name:

Surname:

Address:

Postcode:

Telephone:

Mobile:

Email:

DIRECT DEBIT PAYMENT (UK ONLY)

To the manager, bank name:

Address:

Postcode:

Name of account holder(s):

Bank sort code -

Bank/building society account number

Please pay Haymarket Media Group direct debits from the account detailed on this instruction subject to the standards assured by the direct debit guarantee. I understand that this instruction may remain with Haymarket Media Group and, if so, details will be passed electronically to my bank/building society.

Signature(s):

Date:

Please return this form to:

**AUTOSPORT
FREEPOST RSBY-ZLLA-SZZS
PO Box 326
Sittingbourne ME9 8FA**

Terms and conditions: This offer is open to UK residents only. Overseas rates are available on *44 (0) 1753592 974 and residents of USA and Canada should call 1-866-918-1446 or visit www.imsnews.com for rates. Please allow 36 days for delivery of your gift and first issue. The gift will be sent under separate cover from the magazine. Should we run out of gifts, you may be offered an alternative gift - there is no cash alternative. Direct Debit rates are valid for one year after which they are subject to change - should prices change we will inform you in writing. We ask that you enter into a Direct Debit agreement with the intention that your subscription will continue for a minimum period of 12 months even if the frequency of payment is for a shorter period, however, you will still have the right to cancel your Direct Debit in accordance with Direct Debit Guarantee. Should you wish to cancel your subscription it will be cancelled on expiry of the current term which will not be refundable other than in exceptional circumstances. If a gift is included as part of the subscription offer we reserve the right to request the return of the gift. Details of the Direct Debit Guarantee are available on request. Savings are based on the standard UK cover price of £3.50. Offer ends March 7 2013. Haymarket Media Group Ltd uses a best-practice layered Privacy Policy to provide you with details about how we would like to use your personal information. To read the full privacy policy please visit our website www.haymarket.com/privacy or call us on 08448 482 800. Please ask if you have any questions as submitting your personal information indicates your consent for the time being that we and our partners may contact you about products and services that will be of interest to you via post, phone, e-mail and SMS. You can opt-out at ANY time by emailing datacontroller@haymarket.com or by calling 08448 482 800.



Wallace gave the new RXC its first proper run

Radical Sportscars

New Radical hits the tracks

Le Mans winner Andy Wallace conducts shakedown of its first roofed car

THE NEW RADICAL RXC COUPE has successfully come through its first shakedown tests in the UK ahead of the start of its test programme in Spain this week.

The British constructor's first coupe briefly ran at Bedford Autodrome at the beginning of this month with company boss Phil Abbott driving, before taking to a racetrack for the first time at Brands Hatch last week.

Former Le Mans 24 Hours winner and Radical test driver Andy Wallace put approximately 12 laps on the car around the Indy Circuit before it was shipped to the Aragon track.

Wallace said: "It was freezing cold and the track was never properly dry, but we did just enough to find out that everything was working properly."

"The visibility is good, the engine has a good bunch of torque and

the traction is pretty good.

"I was running on slicks, so it wasn't about pushing. We need to take it somewhere warm so we can properly start putting it through its paces and generating some forces on the car."

The RXC is due to begin a four-day test at Aragon today (Thursday). Wallace, Abbott and his 19-year-old Radical-racing son James are scheduled to split the driving.

Aston Centenary

Modern GT racers for Aston 100



Aston wants top GT cars to be at Brands

A RACE FOR MODERN ASTON Martin GT cars will be part of the marque's centenary celebrations at Brands Hatch in July.

The Aston Martin Owners Club and MotorSport Vision Racing will run a two-day meeting on the Kent venue's Grand Prix circuit to mark Aston's 100th birthday, with the date now moving to July 6-7.

The 100-minute race is one of a number of planned events at the meeting. Astons from the mid-1960s through to modern GT1, GTE, GT3 and GT4 machines will all be eligible to participate.

There will also be a special race for earlier Aston Martins, as well as grids for AMOC Intermarque, 50s Sports Cars, Equipe GTS and HRDC Touring Greats.

Organisers hope to display examples of most types of Aston, and provide on-track demonstrations of key racers.

Aston Martin Lagonda chairman David Richards said: "Brands is a fitting venue for one of the key events in our year of centenary celebrations."

"It will provide a wonderful arena for our competition and road cars to participate in a superb weekend."

Rallying

New Fiesta R5 to make debut

THE NEW FORD FIESTA R5 RALLY car will break cover on next month's Malcolm Wilson Rally.

Matthew Wilson, whose father Malcolm's M-Sport concern has designed and built the car to replace S2000 machines in European and WRC2 competition, is expected to drive the R5 on the Cocker-mouth-based event on March 2. It has not yet been decided whether the car will run competitively or as a zero car through the Lake District stages.

Wilson Sr said: "It makes sense to run the car for the first time on the Malcolm Wilson Rally. It's the week before [Rally] Mexico, so we're all here and we can make some good promotion on the rally. It's a good place to show the car off. Everybody's really excited about this car."



New Fiesta R5 will contest Malcolm Wilson Rally

IN BRIEF



Fans can now go over the circuit at Cadwell

CADWELL PARK HAS INSTALLED a new footbridge to improve access for spectators at the Lincolnshire venue. The 40-metre steel bridge links the paddock with the pit straight, spanning two sections of the circuit at the run to Coppice and the return leg between Mansfield and the Mountain.

BRITISH GT BOSS BENJAMIN

Franassovici claimed the BRSCC's John Nicol Memorial Trophy at the club's 2012 awards presentation last weekend. Franassovici was recognised for working to turn the flagship series around after poor grids in '09. FF1600 coordinator Ian Smith was commended for his service to the category, as was John Baker for his many seasons of service as a marshal.

EX-GINETTA JUNIOR RACER

Struan Moore will contest the new BRDC Formula 4 Championship this season with Hillspeed. Moore contested the final two Formula Renault BARC events of 2012 with the team, after skipping most of the season to focus on school.

FORMER 750MC TOYOTA MR2

champion James Cross will return to the F3 Cup this season with AW Tracksport. Cross, whose debut season in single-seaters was plagued by engine problems, will be joined by Tony Bishop, who switches from 2012 teams' champion Omicron Motorsport.

FOUR-TIME AUSTRALIAN

Formula 5000 champion Alfredo Costanzo, 70, will return to the category at the Phillip Island Classic on March 8-10. Italian-born Costanzo, who has not raced since contesting Australian GTs in 1998, will make his historic debut in one of Alan Hamilton's McLaren M10Bs.

PETE ALEXANDER TESTED HIS

newly-rebuilt ex-Rod Birley Ford Anglia 1500 at Brands Hatch last week. It was the 1995 Champion of Brands and Historic FF1600 team boss's first ever drive in a racing tin-top.



Fford ace Alexander is going tin-top racing

From this...



Trading paint and places



...to this

It's been an unusual start to 2013 for Lawrence Davey. In between a couple of trips to Florida to test and then race a Mitchum Motorsports Chevrolet Camaro at Daytona, he found himself a bystander to one of London's most terrifying transport incidents.

Heading towards the Vauxhall office where he works as an IT engineer, the 2012 Legends champion was an eye-witness as a helicopter made contact with a roof-top crane and burst into flames. In fact, the building hit was the office block where Davey works, and debris from the stricken craft fell just metres away from him as he looked on in horror. It was part of a surreal chapter in Davey's life as he embarked upon the Sunoco-backed journey to race in the Continental GT support race to January's Daytona 24 Hours.

Having shown well by lapping within a couple of seconds of team-mate Mike Skeen during a damp initiation test, Davey returned to Daytona optimistic of a competitive showing in the two-and-a-half-hour race.

With over 60 cars entered, finding a clear lap in qualifying was always going to be crucial and, unsurprisingly with



Impressive '12 earned Davey Sunoco prize

PICS: HOYEBREY, GARY HAWKINS



Legends champion Lawrence Davey won the chance to race at the world-famous Daytona Speedway in support of the 24 Hours. ANDREW VAN DE BURGT caught up with him after the experience



Davey (6) on famous banking and top (2) leading Legends



Jordan enjoyed Daytona run

THE OTHER BRIT ABROAD

Lawrence Davey wasn't the only Brit enjoying a busman's holiday in the Continental GT race, as BTCC race winner Andrew Jordan headed Stateside too.

Through his Honda contacts, the 32-year-old found a place among the multi-car Honda Civic entry of Compass360 Racing in the near-standard ST class, where he finished seventh.

"People asked me how it compared to Rockingham," he says. "There's no comparison at all!"

With 250bhp, the ST-class Civic has a lot less horsepower than Jordan's NGTC BTCC version, but even so he was reaching 153mph heading into Turn 1.

"That's quicker than our top speed at Thruxton in the BTCC," he says. "We were four-wide at some stage too, which was an interesting experience."

Jordan is keen to continue to broaden his racing horizons: "I'd love to do something with dad [BTCC race winner Mike]. I think if we built a GT car to race here we could be a really strong team."

only one actual flying lap, Davey struggled to set a representative time.

Not that it stopped him from feeling bullish at the start. "On the two warm-up laps I was talking to the team – the first time I've used team radio – and it was nothing like I'm used to," he recalls. "My spotter told me what to watch out for; we had some very quick cars around us who also didn't make the best of their one lap in qualifying.

"All the lights went out and I said, 'Don't worry, I've got my elbows out ready'. Heading into the first corner I went round the outside and made up five places, and they came on the radio saying, 'Yeah, you're looking pretty good out there!'"

Davey used his Legends experience, where random grids are commonplace and overtaking is taken for granted rather than seen as some sacred cow, to continue to muscle his way up the order. He'd already cracked the top six when he made light contact with another car.

He initially pushed on, but the car soon became undrivable. A rear wheel had been knocked out of line and shredded the tyre to the canvas. The driver change took place as he

pitted for the new rubber but Skeen was uncomfortable with the car's behaviour. Laps were lost as the problem was fixed.

Despite the setback, Davey loved the experience. While he's open to the offer of making a return, a very different animal waits for him this season: after 12 years and two titles, Davey has put his Legends car up for sale and is set to embark on a Mini Challenge attack.

"My main goal is to get to British Touring Cars," says Davey, who was a karting rival to Lewis Hamilton in his formative years. "So we thought the Mini would be the next step up without spending silly money. Turbocharged engine, 215bhp on slicks; it makes perfect sense."

Davey's family ran him in Legends, and helped wrap up three titles in 2012 (the teams' title and rookie honours also went to the Nathan Anthony Racing squad, of which they are part). Davey signed up to Sunoco's challenge at the season's start, and five wins and a second place in the first two rounds of the series took him to the top of both Legends and the Sunoco standings.

Having opened up a 1200-point lead at one stage in the Legends title race



Mitchum team was impressed

(that's equivalent to 150 points under the F1 scoring system), Davey was able to concentrate on securing the Sunoco prize in the final round, although it proved to be more nerve-racking than he expected at a sodden Brands Hatch.

"The heavens opened and I was very doubtful of even racing because the track was waterlogged," he recalls. "I talked to the guys about the Challenge and they said they'd knock the three races off and I would still win. Then the races were on and I was starting at the very back. I just thought I had to finish, but we came through to finish second and that was the Challenge! It was amazing." ❄

YOUR SAY

What you think of the motorsport news of the past week



Four points for pole, reckons Sir Stirling

Reward drivers for being quickest

Do any other readers agree with me that Formula 1 drivers should receive at least four points for pole and the same for fastest lap?

Sir Stirling Moss OBE
London

EDITORIAL CONTACT mail@autosport.com

I'm sure I speak for the

majority of BTCC fans when I admit the excitement about the impending 2013 season has been slightly tempered by the news that once again Paul O'Neill has failed to find a budget to join a grid he belongs on!

The return of Colin Turkington and the continued influx of NGTC models show the championship continues to go from strength to strength.

However, when drivers as popular and high profile as Paul cannot get a drive, long term this is a worry –

surely Alan Gow and his team need to look at this.

The BTCC was built on personalities like Cleland, Harvey, Soper and so on. Neal and Plato won't be around forever and it seems the new generation are being frozen out by the wealthy amateurs!

Darren Timms
Hinckley, Leicestershire

Congratulations to the organisers of Rally Sweden! It's been the best I've ever seen – lots of fans, great entertainment all weekend and a fantastic atmosphere.

Keep on working like this, because I've loved being a marshal at 'TC Out' in Hagfors Service Park all weekend: 13 hours of sleep and 46 hours of fulltime job from Thursday to Sunday! It's been great!

Patrik Knoos
Saffle, Sweden

The continued stabilisation of F1 regulations into 2013 means it has never been easier for a team to be competitive. This will guarantee unpredictability at the front of the field.

However, it is more than predictable that Caterham

and Marussia will continue to languish at the back of the grid. The disappearance of HRT only heightens concerns over their long-term future.

Will their owners and Bernie tolerate another pointless season or end their involvement at the end of 2013?

Also, the rule changes in 2014 may be a challenge too far for the smaller teams.

F1 is at a crossroads and should be considering the best way to manage, or avoid, a further reduction in teams.

Adrian King
Rushden, Northants

AUTOSPORT.COM

TOP FIVE ON OUR WEBSITE

1. **MERCEDES' NEW W04 MAKES DEBUT**
2. **BUTTON FASTEST ON FIRST JEREZ TEST DAY**
3. **RAIKKONEN ENDS FINAL DAY OF TEST ON TOP**
4. **MASSA STILL WOWED BY BUTTON'S TIME**
5. **MASSA STAYS ON TOP AT JEREZ TEST**

AUTOSPORT+

TOP STORY ONLINE

WHAT WE LEARNED FROM THE FIRST F1 TEST

To read this exclusive feature and many others like it, log on to autosport.com/plus and choose which package you'd like. A month will cost £5.50, a year £46. Includes access to Forix – the ultimate stats website.

WIN!



ROAD ANGEL VANTAGE

This week's star letter will receive a Road Angel Vantage – a dedicated safety camera and blackspot locator that displays the legal speed limit of every road you drive, automatically and wirelessly updating its database every few minutes as you drive. For more details on Road Angel visit www.roadangelgroup.com Please ensure that your full address is included on all correspondence.

FROM THE FORUM - forums.autosport.com

WHAT OUR READERS ARE TALKING ABOUT RIGHT NOW

- Rally NEEDS fierce cars again
- Genuinely Excited for 2013

CORRECTIONS AND CLARIFICATIONS

It is the policy of AUTOSPORT to correct significant errors as soon as possible. Please note the issue date and page number when contacting us on autosport.editorial@haynet.com

THE LATEST GEAR

Desirable new releases for motor racing fans: books, DVDs, models, art and gifts



SIGNED VETTEL RED BULL MODELS

£174.99 each
autosport.com/shop

Three stunning 1:18-scale diecast models form the Sebastian Vettel Signature Collection, all of them hand-signed by the triple F1 champion. The Toro Rosso STR3, in which he scored his breakthrough victory at Monza in 2008, is joined by the Red Bull RB6 and RB7 from the German's first two championship-winning seasons in 2010 and '11 respectively.



AMG HISTORY BOOK
£55
autosport.com/shop

A lavishly illustrated book that celebrates 45 years of AMG – the Mercedes tuner and race-prep firm started by former Stuttgart factory engineers Hans-Werner Aufrecht and Erhard Melcher. Details of all 117 AMG road cars are here, along with stories and pics from decades of on-track milestones and successes.



REVELL DAKAR KITS
£14.99 each
revell.eu

Revell's 1:32-scale EasyKit models of two Dakar Rally-winning icons – the Mitsubishi Pajero of Stephane Peterhansel and the Volkswagen Race Touareg of Jutta Kleinschmidt – are pre-painted and just click together, so there's no need for any mess. Perfect for young modellers.

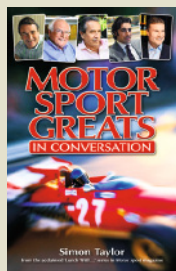

MOTORSPORT GREATS BOOK
£19.99 (978 0857 332 509)
haynes.co.uk

A collection of 24 of former AUTOSPORT editor Simon Taylor's engaging 'Lunch with...' interviews conducted with some of the biggest names in the sport. And the common thread? They were all grilled in the perfect place to tease out all the best reminiscences: a restaurant or watering hole.

HOT ON THE WEB THIS WEEK

YOUTUBE: COLIN CHAPMAN DOCUMENTARY FROM 1968



SEARCH FOR: Colin Chapman Team Lotus 1968 (35:18)
Superb film following the exploits of Colin Chapman and the Lotus team in 1968, with amazing access to the design genius and Lotus chief – at the factory, at home and in the pitlane – following the post-Jim Clark regroup that season.

WHAT'S ON...

Your guide to the week ahead, including TV listings and online – plus opinion columns



NASCAR elite to race in three-segment warm-up

NASCAR SPRINT UNLIMITED

Daytona, Florida, USA
February 16
nascar.com

EURO F3 OPEN WINTER SERIES

Rd 1/2
Paul Ricard, France
February 16
f3open.net

INT'L GT OPEN WINTER SERIES

Rd 1/2
Paul Ricard, France
February 16, gtopen.net

AUTOSPORT SOAPBOX



We've looked at the best in F1, but what about the worst? By EDD STRAW

During AUTOSPORT's live website coverage of last week's Jerez test, a debate erupted on the topic of the worst grand prix driver of the past 20 years. Eventually, ex-Arrows and Simtek racer Taki Inoue prevailed in a vote among readers of our live testing commentary, aided by the man himself mounting his own Twitter campaign to take an award that he appeared to covet!

Inoue was a pretty poor grand prix driver, but the prevailing opinion that he is the most catastrophic contender during this period is based as much on his cult status, thanks to being run over by a rescue vehicle while retrieving a fire extinguisher in Hungary 1995, as his speed. That, and sitting in his car when it flipped while it was being recovered in Monaco, after being clouted by a Renault Clio course car driven by Jean Ragnotti (on a serious note, a chunk was taken out of Inoue's helmet when he landed upside down and what would have happened had he already taken it off doesn't bear thinking about).

Inoue certainly ticked the boxes of a classic pay driver: uncompetitive, unproven in any other category and clearly out of his depth. But he wasn't quite as woeful as some have made out. OK, he had a propensity for comedy mishaps, but in his 18 starts in 1994 and '95 his average qualifying deficit to three handy team-



Inoue: not one of the GP greats, but really the worst?

mates (David Brabham, Gianni Morbidelli and Max Papis) was 2.056s. He even managed to outqualify Papis twice and Morbidelli once.

And as much as he struggled, there have been worse. Jean-Denis Deletraz, who finished second in the vote, was, on average, one second worse off in qualifying during

his outings for Larrousse and Pacific. Granted, Deletraz didn't have the benefit of a full season, but it shows that a case can at least be made for Inoue not being the worst.

After all, even those famous mishaps were largely out of his hands. While the footage of the Japanese getting mown down while grabbing a fire extinguisher

in Hungary makes him look foolish, he was very conscious of the fact that the team had already lost one chassis that weekend to a Papis shunt and didn't want to risk costing the Arrows squad another.

@eddstrawF1



Television

THURSDAY FEBRUARY 14

1115-1145 ESPN

NASCAR Now

1545-1620 Motors TV

Arctic Lapland Rally

2130-2230 Premier Sports

NASCAR Sprint Cup:

2012 Season Review

FRIDAY FEBRUARY 15

0000-0030, 1300-1330 ESPN

NASCAR Now

0500-0530 Premier Sports

NASCAR Sprint Cup:

2012 Season Review

0530-0600 Premier Sports

NASCAR Nationwide:

2012 Season Review

1830-1930 Sky Sports F1 LIVE

The F1 Show

1830-1930 Sky Sports 1 LIVE

The F1 Show

2100-2235, 2305-0040 Motors TV

Roger Albert Clark Rally

SATURDAY FEBRUARY 16

0355-0410 Channel 5

Motorsport Mundial

0745-0840 Premier Sports

NASCAR Sprint Cup:

2012 Season Review

1000-1100, 1500-1600,

1800-1900 Sky Sports F1

The F1 Show

1140-1300 Motors TV LIVE

Legend Boucles De Spa: Bilstain Stage

SUNDAY FEBRUARY 17

0100-0330 Premier Sports LIVE

NASCAR Daytona Sprint Unlimited



Catch up with F1 latest on Sky Sports

0340-0505, 1545-1720 Motors TV

Legend Boucles De Spa:

Bilstain Highlights

0430-0530 Sky Sports 3

Max Power

0900-1000 ESPN

NASCAR Daytona Sprint Unlimited

1100-1200, 1300-1400,

1900-2000 Sky Sports F1

The F1 Show

1210-1515 Motors TV

Roger Albert Clark Rally

1600-1700 Sky Sports 4

Racemax

MONDAY FEBRUARY 18

0010-0145, 0935-1105 Motors TV

Legend Boucles De Spa:

Bilstain Highlights

0500-0600, 1500-1600 ESPN

NASCAR Daytona Sprint Unlimited

1700-1800 Sky Sports F1

The F1 Show

1800-1830 ITV4

GT Academy

1830-1900 ITV4

TT Legends

Online

AUTOSPORT+

Coming up in our premium web content this week

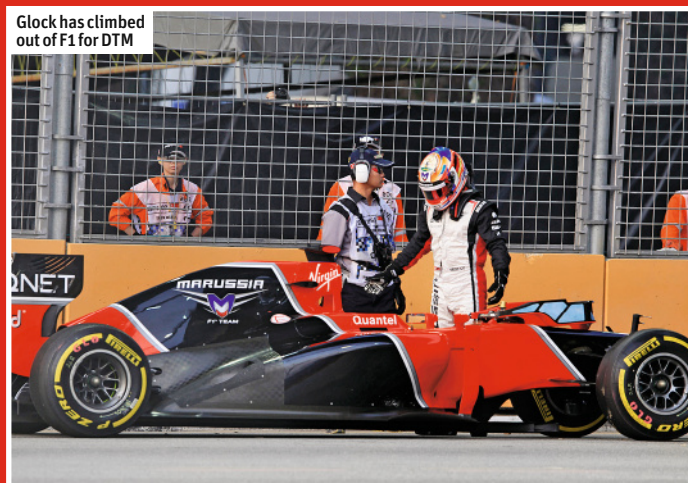

Glock has climbed out of F1 for DTM

F1 DRIVERS WHO DESERVED TO STAY

With Timo Glock's move to the DTM confirmed after he lost his Marussia seat, Edd Straw looks at the German's career and considers a few other recent Formula 1 drivers who perhaps didn't get the chances they deserved.

THE REAL ISSUES WITH F1 IN 2014

Dieter Rencken on a potential problem few have considered for F1 in 2014.



THE WRC IS ALIVE, BUT LOEB LEAVES

David Evans ponders the Swedish rally and a duel we won't see this season.



REVVED UP OVER WHAT'S ON THE BOX

We cast a critical eye over the best and worst of this week's TV coverage

Hamilton gets familiar with the Kravitz mic



F1 PRE-SEASON TESTING: the equivalent pre-season football matches. As much as you can't tell how your expensive new South American signing will fare during a cold, wet evening in Stoke as he dances between defenders on a billiard-smooth pitch in the height of summer, so trying to work out the F1 form in winter testing is a fool's errand.

But there's bugger-all else going on to fill Sky's F1 channel, so action-starved fans were treated to the sound of racing cars in the background as the usual suspects trotted out the

well-worn answers to the ubiquitous questions.

In fairness, the 15-minute test wraps did a pretty good job of summing up the day's action, but it was Ted Kravitz's notebook that held the real gems.

Bounding around like Anika Rice, Ted and cameraman Pete stuck themselves and their mic in places they clearly weren't welcome to illustrate whatever point Ted had scribbled on his tiny pad.

He likes the McLaren ("adventurous") and the Red Bull ducting, but he's unimpressed by the Toro Rosso ("there's nothing

new") and worries about Marussia's budget ("no big sponsors on the car").

Day two saw Ted swap the pitlane for the deserted paddock, pointing out Nico Rosberg's scooter, adding an 'n' to the phrase 'my other car is a RB9' on the back of a Lexus SUV as 15 minutes plodded by.

We got a view of the media centre on day three, but not before he finally got to the end of his Alonso

story... but no mention of

Fred's injured rib rumour!

The interview pen was the setting for day four, where a Spanish toddler was Ted's first victim. "Hola!" was the beginning and end of proceedings.

It was like watching a one-man 'pin the tail on the Lotus' in the knowledge that the best he can do is limit the amount of times he's proved wrong. Futile. *Revved Up*

"Ted and his cameraman Pete stuck themselves and their mic in places they clearly weren't welcome"

THE WEEK IN PICTURES

Our lensmen pounding the beat, from Sweden to Australia, via Spain and the USA



THIERRY GETS A BIT HAIRY IN SWEDEN
Qatar M-Sport Ford Fiesta WRC driver Thierry Neuville gives it plenty of air en route to fifth overall



ENJOYING THE VIEW BACK THERE?
Ex-V8 Supercar star Cam McConville drives a two-seater F1 car along Australia's lush Great Ocean Road



I'D BETTER DROP FERNANDO A TEXT ABOUT THIS...
Ferrari's new test driver Pedro de la Rosa was three laps into his new job when this happened at Jerez. See the brilliant *Bamber's Week* for Alonso's reaction!

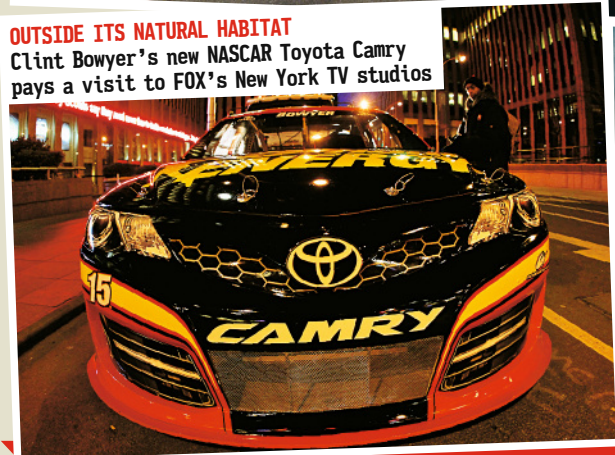

OUTSIDE ITS NATURAL HABITAT
Clint Bowyer's new NASCAR Toyota Camry pays a visit to FOX's New York TV studios

PICS: GILHAM, PREZIOSO, STOBE, GETTY, MCKLEIN, DE

FROM THE ARCHIVE

Volkswagen's first WRC win, Ivory Coast 1987



"Eriksson arrived in a village that had not been warned of the rally's arrival and narrowly avoided a herd of cows"

Eriksson charges to VW's first WRC win

SEBASTIEN OGIER DOMINATED RALLY SWEDEN

proceedings last weekend, pulling away on Friday and then resisting an attempted fight back from nine-time champion Sebastien Loeb to eventually triumph by 41.8 seconds.

As he did so, he also claimed only the second World Rally Championship victory in Volkswagen's history. The first came 26 years ago, and in very different conditions to the snowy Swedish climes.

While VW had been represented in rallying for decades through privateer efforts, it wasn't until the 1980s that factory involvement began to take off. The Pierburg and Rheila Mk1 Golfs were followed by the Mk2, and in 1986 Kenneth Eriksson and co-driver Peter Diekmann earned VW the Group A title.

The pair would deliver the first outright WRC win less than a year later, in the 1987 Ivory Coast Rally.

The rally itself was not without complications. In addition to extremely heavy rains in the preceding weeks, there was the fact that marshals would mistakenly try to penalise entrants for permitted early arrivals – an issue exacerbated by crews jumping out of their cars to get their timecards signed. Those drawbacks aside, the road book and the event route were well received, while a three-way fight between Toyota, Nissan and VW added to expectations.

It was VW, with Eriksson at the wheel, that made the best start, the Swede taking an immediate lead on the opening stage of the event. Toyota fared less well, but frustration turned to horror when it was revealed on the second morning that the team's radio communications plane had crashed, killing the four onboard including top former WRC co-drivers Henry Liddon and Nigel Harris. The team immediately withdrew from the rally.

The following morning Eriksson, still in the lead, arrived in a village that had not been warned of the rally's impending arrival and he narrowly avoided a herd of cows crossing the road.

Eriksson managed to stay out of trouble for the rest of the event and it was a water hole that would seal his historic victory. Nissan's chasing pack, comprising Shekhar Mehta, Alain Ambrosino and Mike Kirkland, all hit trouble, with only Mehta escaping intact.

Former Safari Rally ace Mehta remained in the hunt but Eriksson drove faultlessly through the Tai forest and started the final leg with a 10-minute advantage. He still had to contend with gearbox issues and another wrongly-enforced early-arrival penalty from the official, but eventually he reached Abidjan to book his and VW's place in the WRC record books. 🏆

THIS WEEK IN...

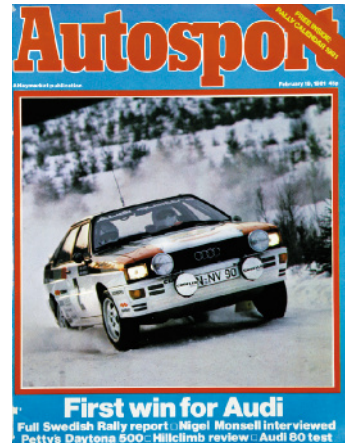

FEBRUARY 19 1981

IN A NEAT BIT OF SYMMETRY

AUTOSPORT also celebrated another marque's World Rally breakthrough this week in 1981, as Hannu Mikkola guided the Audi Quattro to victory in Rally Sweden – in the process becoming the first non-Swede to win the event.

As Mikkola rewrote the record books, Nigel Mansell celebrated the advent of his career as a permanent Formula 1 driver with a promising drive in the non-championship South African Grand Prix.

From eighth on the grid in the Lotus, Mansell made rapid progress and was third by the end of the fourth lap, only to suffer contact with John Watson that spoiled his race and restricted him to 10th. He didn't have to wait long for a podium though: just four races into the season he climbed from 10th to third in the Belgian GP at Zolder.



PICTURE ARCHIVE

NEXT WEEK

NEW WILLIAMS FW35 DON'T MISS IT!
UNDER THE SKIN OF FINAL 2013 CHALLENGER;
PASTOR MALDONADO: SAINT OR SINNER?

DIDIER ARTZET

■ Monaco F3 Grand Prix ■ Monte Carlo ■ May 30, 1987 ■ Ralt RT30-Volkswagen ■ Street fight with Jean Alesi



Artzet withstood race-long pressure from Alesi to win

THE 1987 MONACO F3 RACE was a huge breakthrough for me. Of course there were all the F1 bosses watching on the Saturday afternoon and I felt sure that I would have a chance in F1 after that weekend. As it turned out that was not to be but there are a thousand stories like that in racing!

The weekend was very intense because the previous year I had qualified on the front row and unbelievably it was only my second ever race in an F3 car. In fact I had only been racing in anything at all for less than a year. It seemed to come so easy and naturally on the streets of Monaco for me. I loved it.

My team was called Monaco Sponsoring but really it was KTR (Keerbergs Transport Racing) and had lots of local Cote d'Azur companies helping with the budget. I was born and raised in Nice so there was a lot of interest because it was the home race for people that invested in the team. The pressure was really big, especially as Jean Alesi was on my arse all weekend!

The big boost for the team was that Jacky Eeckelaert was leading the engineering on our Ralt and he was a very strong guy when it came to understanding what I needed

"Alesi and I were over the limit, touching the barriers every lap. On one occasion I remember laughing in my helmet when I saw him sideways coming out of Mirabeau"

from the car. I ended up qualifying on pole by two-tenths but there was a big psychological battle with Alesi because, as everyone knows, he was very quick at street circuits and just about everywhere else too. But I was good as well and had great results at Monaco, Pau and also at Birmingham in F3000.

Even all those years ago the Monaco F3 race was still all about

the start and how you got off the line. I was concentrating like crazy on the perfect clutch release but it was not perfect and Alesi got a slightly better start. At Saint Devote he was very close. We may have touched slightly but I shut the door and led up the hill. From then, every corner of every lap it was me and Jean together, doing crazy qualifying laps all the way to the

chequered flag. We were at, and over, the limit by a big margin and touching the barriers every lap at Casino and Rascasse. On one occasion I remember laughing in my helmet when I saw him sideways coming out of Mirabeau.

Really good drivers like Herbert, Larini, Bernard and Schneider were also there that year but may as well have been in a different race to Jean and me. After the race I spoke with Jean and it turned out that we had quite different set-ups because he had a slight amount of oversteer, whereas I was more comfortable with a small amount of understeer. I did the fastest lap on the last tour and by the end I won by just over a second. On the podium our eyes were bulging and we were still in the moment. Great times.

The team was delighted and we had a big party, but I was focused on trying to get to F1 and spoke with a few team bosses. Ken Tyrrell was especially interested, but of course he needed money and I just didn't have any. Looking back I feel a small amount of disappointment but not many people can say they won at Monaco and beat a future Ferrari driver at the same time. ✪ *Didier Artzet was talking to Sam Smith*

IN PROFILE



A LATE STARTER TO MOTORSPORT, Frenchman Didier Artzet had a stellar start to his professional career, finishing second in the 1986 Monaco F3 race. A year later he went one better by winning before graduating to F3000 in 1988. His best result – third – came at Birmingham in '90. He also made two starts in the Le Mans 24 Hours. Despite his acknowledged natural talent he retired from racing in 1992. Now aged 50, he lives on the Pacific island of New Caledonia.

RFX™ Wireless Scale Systems

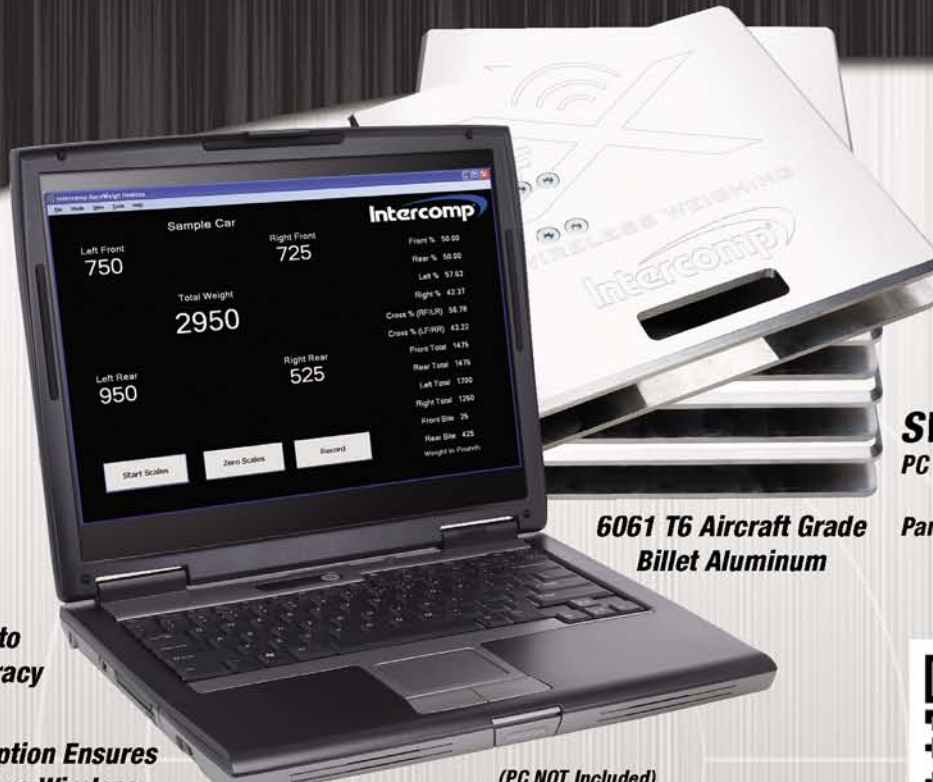

SW787RFX™
PC Wireless Scale System

6061 T6 Aircraft Grade
Billet Aluminum

Part # 170154-PC

**Certified to
0.1% Accuracy**

**Encryption Ensures
Secure Wireless
Communication**

(PC NOT Included)



*Want to learn more
Use your smart phone to scan
this code or visit us online at
www.intercompracing.com*



Intercomp offers you the most comprehensive line of indicator options

Intercomp's industry leading RFX™ Wireless Weighing Technology is the most widely used advanced weighing technology of it's kind and is used by champions in all forms of motorsports.



SW500™
Cabled Scale System
Part # 170125



SW650RFX™
Wireless Scale System
Part # 170126-W



SW777RFX™
Wireless Scale System
Part # 170127-WPC



Call to request our 2013 Racing Products Catalog or log on to:

+44 (0) 118 932 0578 EUROPE **intercompracing.com** Worldwide **+1 763-476-2531**

European Sales & Service

DEMON TWEAKS
Wrexham, Clwyd
Tel: 44(0) 1978 664466
Fax: 44(0) 1978 664467

ROLLECENTRE RACING
St. Ives, Cambs
Tel: 44(0) 1480 464052
Fax: 44(0) 1480 461454

RACE HARDWARE
The Netherlands
Tel: 30(0) 36 537 0689
Fax: 30(0) 36 537 1797

DANIELSON
Magny-Cours, France
Tel: 33(0) 3 86 21 22 55
Fax: 33(0) 3 86 21 22 65

GIEFFE SRL
Castelceriolo, (AL) Italia
Tel: 39(0) 131 216505
Fax: 39(0) 131 216506

ISA RACING
Kottenheim, Germany
Tel: 49(0) 2651 96250
Fax: 49(0) 2651 962510

NIMEX
Monheim, Germany
Tel: 49(0) 2173 54253
Fax: 49(0) 2173 51089

RYAN

MOTORSPORT INSURANCE



On Track

We provide comprehensive cover for accident damage to vehicles whilst testing and competing in the UK or Worldwide. Cover is based on your requested levels of sum insured and excess. Single events covered, discounts available for multiple event policies. All levels covered – Sprints, Hillclimbs, Club, Hatchbacks, Sportscar, GT, Single Seaters.



Personal Accident

In the event of a big accident, Personal Accident insurance could be the most important insurance product you have purchased. Sums insured can include Mortgage loan amount and weekly wage protection, race contract instalments, and medical expenses if racing overseas. Cover available for any type of motorsport.



Track Days

Our specialist product is available to insure road going and track prepared cars for accident damage occurring on track days. All circuits in the UK and Europe can be covered, including Spa and Nurburgring Nordschleife. Discounts available to track day operators and organisations.

Log on for a quotation at: www.ryanmi.com

Or call: +44 (0) 1799 524202

Email: info@ryanmi.com