

# Rear Mud Flap Guard Package Installation (Instruction ID: 84263460)

## [Installation Instructions Part Number](#)

84263460

**Note:** Please read instructions thoroughly before starting.

### Tools Required

- Socket wrench
- 7 mm Socket
- Plastic Trim Removal Tool
- Clean Cloth/Rag

### Kit Contents

Qty	Description
1	Left Hand Mud Flap Guard
1	Right Hand Mud Flap Guard
1	Instruction Sheet

### Procedure

**Note:** Do not use power tools to install splash guard fasteners

1. Clean and degrease body panel where mud flap guards are to be located.

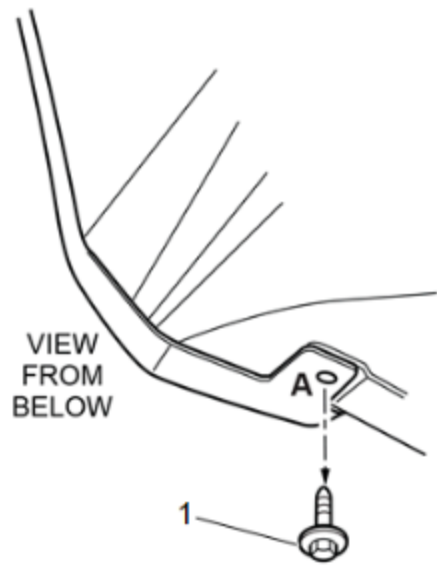

2. Use 7 mm Socket to remove screw (1) in location (A). Retain screw.

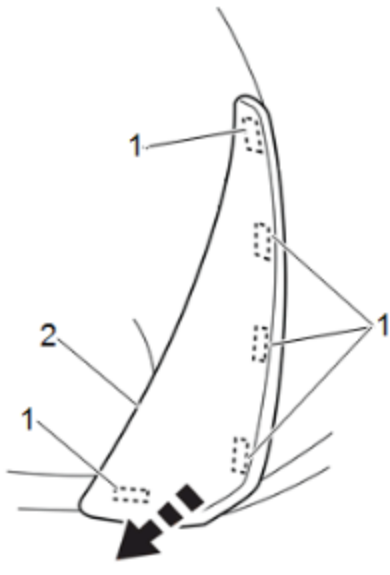

3. Use plastic trim removal tool to dislodge clips (1) from rear fascia and remove existing stone protector (2). Take care not to damage paint.

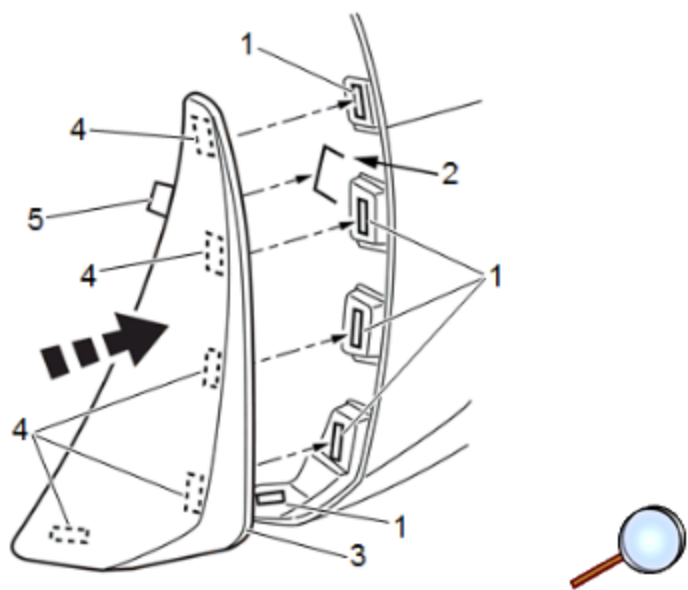

4. Align and then insert the mud flap guard tab (5) to the wheel liner slit (2).
5. Align mud flap guard clips (4) with clip insertion holes (1) and snap mud flap guard (3) in place.

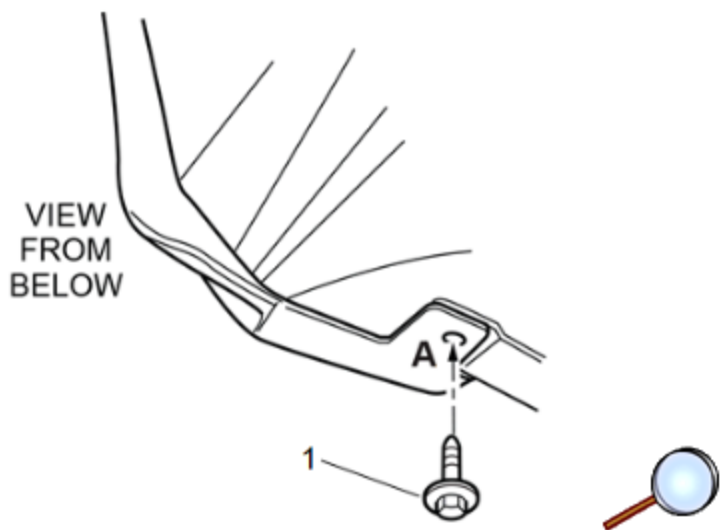

**Caution:** Use the correct fastener in the correct location. Replacement fasteners must be the correct part number for that application. Fasteners requiring replacement or fasteners requiring the use of thread locking compound or sealant are identified in the service procedure. Do not use paints, lubricants, or corrosion inhibitors on fasteners or fastener joint surfaces unless specified. These coatings affect fastener torque and joint clamping force and may damage the fastener. Use the correct tightening sequence and specifications when installing fasteners in order to avoid damage to parts and systems.

6. Reinstall the screw (1) at locations **A**.

**Note:** Max torque on M4.2 screw is 3.0 Nm.

7. Repeat procedure for the other side.

