

F1 SHOWTIME IN MELBOURNE

AUTOSPORT

WORLD EXCLUSIVE!

www.autosport.com • MARCH 13 2014 • £3.60

LEWIS V NICO

**FIGHTING TALK
FROM MERC'S
TITLE FAVOURITES**

**"The most skilful driver
is the one who adapts
the quickest"**

**"We want to beat each
other – the fans want
to see us racing"**

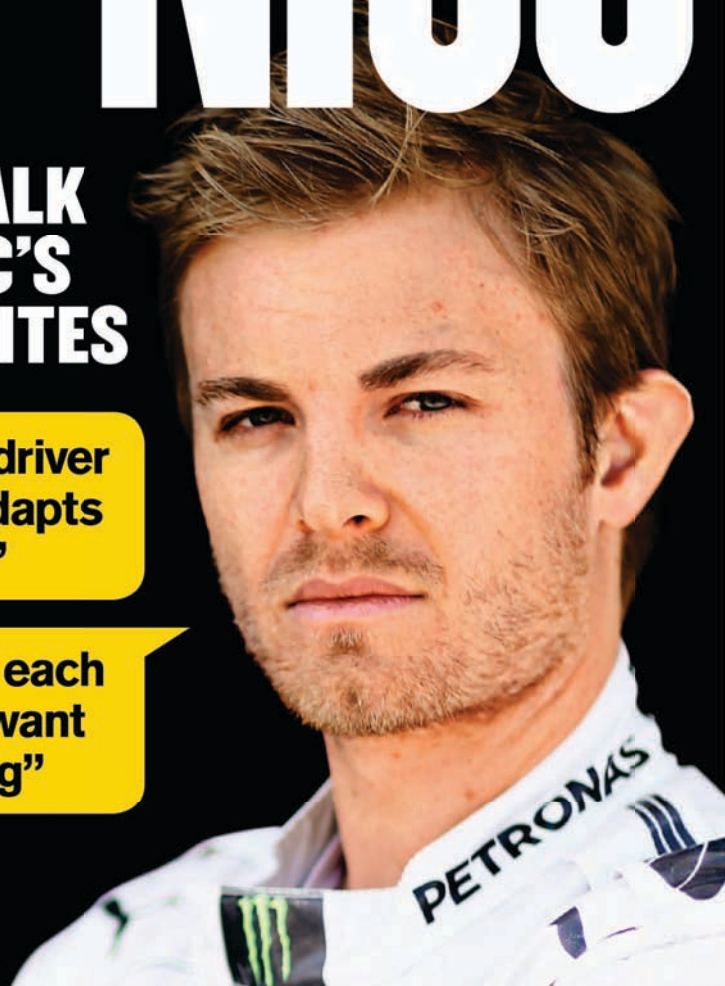

PLUS

**WEBBER'S NEW
LE MANS PORSCHE**

**Technical secrets of hybrid
prototype racer revealed**



haymarket



C\$8.99



Innovation
that excites



THE ALL NEW NISSAN NOTE WITH SAFETY SHIELD FROM £149 PER MONTH



The all new Nissan Note keeps you protected with Safety Shield technologies, including Blind Spot Warning, Lane Departure Warning and Moving Object Detection, and also comes with NissanConnect 5.8" touch screen navigation, Bluetooth® and 360° Around View Monitor.

nissan.co.uk/newnote

- ▶ 1 year free insurance*
- ▶ 3 years servicing for £199
- ▶ 3 years Pan-European Nissan Roadside Assistance

Price includes customer saving. Offer valid until 31 March 2014 at participating dealers only. Finance is available subject to status on eligible new vehicles in the UK. Guarantees and indemnities may be required. You must be at least 18 and a UK resident (excluding Isle of Man and Channel Islands) to apply. Rental stated is for Nissan Lease. Comparable payments are available on our personal contract purchase product, ask your dealer for details. Note 1.2 Acenta Premium with AVM Advance Rental £5,350 followed by 36 monthly rentals of £149, final rental £5,648. All figures are inclusive of VAT. Once you have paid the final rentals you can keep using the car by paying an annual rental of £50+VAT; if you choose Nissan Lease then you will never own the car. Offer available at participating dealers only and is not available in conjunction with any scheme or other offers. Finance provided by RCI Financial Services Limited, PO Box 149, Watford WD17 1EJ. Breakdown services provided by RAC Motoring Services and/or RAC Insurance Ltd. All prices include first registration fee and 12 months' road fund licence. Information correct at time of going to press. Model shots shown are for illustration purposes only. Models subject to availability. Model shown has pearlescent paint at £450 inc VAT. Nissan Motor (GB) Ltd, The Rivers Office Park, Denham Way, Rickmansworth, Hertfordshire WD3 9YS. MPG figures are obtained from laboratory testing, in accordance with 2004/3/EC and intended for comparisons between vehicles and may not reflect real driving results. (Optional equipment, maintenance, driving behaviour, road and weather conditions may affect the official results.) *One year's free insurance is available on all qualifying New Micra and New Note grades excluding Visia grade. Free insurance is only available on selected Nissan Finance PCP and lease finance plans - offer not available to cash or HP finance customers. Offer available on vehicles ordered from 1 January - 31 March 2014 and delivered no later than 30 April 2014. Only available for residents of the UK excluding Northern Ireland. Minimum age of 21 to a maximum age of 74 at the start of the policy. Other key terms, eligibility and acceptance criteria apply, for full details visit www.nissan-offers.co.uk/termsandconditions

New Note Range £12,100 - £17,100. URBAN 45.6-67.3mpg (6.2-4.2L/100km), EXTRA URBAN 62.8-88.3mpg (4.5-3.2L/100km), COMBINED 55.4-78.5mpg (5.1-3.6 L/100km), CO₂ emissions 119-92g/km.



Cover Images: Thompson/Getty

POLE POSITION

Williams-Martini deal adds to the excitement

IT'S SHOWTIME IN MELBOURNE! AND IF THERE wasn't enough to get excited about ahead of this weekend's season-opening Australian GP, the prospect of a Martini-liveried Williams gunning for glory is the cherry on the cake.

Hark back to all the legendary machines that have benefited from those famous stripes, and how they helped awesome Porsches, Lancias, Brabhams and Lotuses look even more luscious than before. It genuinely is an iconic colour scheme.

Williams has cannily exploited this deal, which is not fiscally groundshaking by any means, to ensure that many more eyeballs will be glued to its machines – surely those empty white sidepods will get filled by some shrewd operator soon... The switch to Mercedes power has come at just the right time to allow Felipe Massa and Valtteri Bottas to run with the hounds and maybe, just maybe, take the fight to the works Merc team.

Speaking of which, Lewis Hamilton and Nico Rosberg are in bullish form ahead of Sunday's race, for which they're the odds-on favourites. Read Edd Straw's exclusive interview with them both on page 14.

Here's to a classic F1 season!

CHARLES BRADLEY EDITOR
charles.bradley@haymarket.com
@Autosport_Ed



PRIVATE EAR



FIND US ON



PIT & PADDOCK

- 6 **THIS WEEK IN F1**
- 9 **JONATHAN NOBLE: F1 NEWSHOUND**
- 10 **THIS WEEK IN MOTORSPORT**
- 13 **MARTIN BRUNDLE: THE INSIDE LINE**

FEATURES

- 14 **HAMILTON AND ROSBERG UP CLOSE**
The two Mercedes stars and pre-season title favourites talk of the challenges in new-era F1
- 22 **MERCEDES' SUPPORTING CAST**
How it looks for McLaren, Williams and Force India
- 28 **AUSTRALIAN GP PREVIEW**
- 34 **PORSCHE 919 HYBRID**
The critical details of sportscar icon's new LMP1 car
- 36 **BACK WHERE IT BELONGS**
The story behind Porsche's return to top-level racing as it bids for outright honours in Le Mans 24 Hours
- 42 **DAVID COULTHARD**
Candid interview with the Scot as he talks of what differentiates the great drivers from the good
- 52 **MARTINI: EARNING ITS STRIPES**
Wallow in nostalgia of drinks brand's best racers
- 56 **1974 RACE OF CHAMPIONS**
Looking back on a famous Ickx win at Brands
- 64 **LOEB ON HIS NEW STAGE**
Rally king settles in for Citroen's WTCC campaign
- 70 **RACING IN THE MRF CHALLENGE**
Journo goes to India – and nearly wins!

DEBRIEF

- 30 **RON SPEAKS OF McLAREN PLAN**
Returning boss Dennis on reviving F1 sleeping giant
- 32 **EUROPEAN F3 IS GO FOR 2014**
FIA releases entry – and Rosenqvist is on it

RACE CENTRE

- 51 **NASCAR LAS VEGAS**
Earnhardt runs dry, so Keselowski wins the jackpot
- 60 **RALLY MEXICO**
Ogier back on top with win as Kubica rolls – twice

CLUB AUTOSPORT

- 83 **FORD FAVOURITE FOR F4 DEAL**
MSA confirms formal negotiations with Blue Oval
- 84 **HUGHES SWITCHES TO TRACKSPEED**
Geordie veteran to join Firth in Brit GT Porsche
- 87 **WERNER GETS F1 SEAT – AT LAST!**
But Audi favourite has to buy an old Tyrrell to do it
- 88 **PORSCHE'S NEW CARRERA CUP BABY**
How the 991-shape racer can revitalise GB series

SUBSCRIBE FOR A FREE GIFT

- 86 **FREE ADIDAS RUCKSACK**
Subscribe for a great free gift and digital package

THE BACK STRAIGHT

- 90 **THIS WEEK**
Readers' letters; best pictures; product reviews
- 92 **WHAT'S ON**
The best track and TV action in the coming week
- 94 **RACE OF MY LIFE: JO RAMIREZ**

THE BIG PICTURE

Andreas Mikkelsen nosedives his VW Polo R WRC during Rally Mexico. The Norwegian had a tough event, finishing 19th, while his team-mates took a one-two

 P60 FULL REPORT





This week in F1

LONG BEACH LOOKING AT FORMULA 1 RETURN

Long Beach officials are considering dropping their IndyCar race to allow Formula 1 to return to the Californian street track.

IndyCar's current deal expires in 2015 and the city council met in a closed session on March 4 to discuss the plans. AUTOSPORT understands the meeting was inconclusive, with council members instructed to gather additional information.

Key to any possible F1 return is finances, with F1's sanction fee expected to greatly exceed the estimated \$2million demanded by IndyCar.

The venue would also require upgrades to reach the required F1 standard.



2013

LONG BEACH F1 WINNERS

YEAR	DRIVER	TEAM
1976	Clay Regazzoni	Ferrari
1977	Mario Andretti	Lotus
1978	Carlos Reutemann	Ferrari
1979	Gilles Villeneuve	Ferrari
1980	Nelson Piquet	Brabham
1981	Alan Jones	Williams
1982	Niki Lauda	McLaren
1983	John Watson	McLaren



1980

POWELL/GETTY; INSET: LEVITZ/CAR

Maldonado's 'best decision'

Pastor Maldonado believes he made the right decision to switch from Williams to Lotus for 2014, despite his new team's disastrous performance in pre-season testing.

"In my opinion it's the best decision ever. I think they've done a really good job in terms of design," he said.

PIRELLI ANNOUNCES TYRE-TEST SCHEDULE



Pirelli has announced the schedule of dedicated days that each F1 team will devote to tyre testing in 2014.

Teams and Pirelli have agreed to each use one of their allocated days of in-season testing for tyre work. The Italian manufacturer will also supply all teams with prototype rubber in preparation for the 2015 campaign during the Abu Dhabi test on November 25-26, which follows the season finale at the Yas Marina track.

PIRELLI 2014 TEST SCHEDULE

BAHRAIN (APRIL 8-9)

Day 1	Caterham
Day 2	Mercedes, Williams

BARCELONA (MAY 13-14)

Day 1	Sauber, Toro Rosso
Day 2	McLaren, Force India

SILVERSTONE (JULY 8-9)

Day 1	Ferrari, Lotus
Day 2	Red Bull, Marussia

For all the breaking news, visit **AUTOSPORT.COM**



Haas waiting for F1 answer

Formula 1 team candidate Gene Haas is hoping a final decision on whether he gets an entry for 2015 will be made within the next week. It is understood the American outfit is up against a Romanian-backed effort, although it is possible both teams could be granted an entry if the FIA deems them both financially viable.



Williams: test pace is real

Williams chief technical officer Pat Symonds believes the pace teams showed during testing will prove a stronger guide to form than it has in previous seasons, given the challenges of the new regulations. "Over the last few years there has been a lot of sandbagging, but this year people really needed to see what they were doing," said Symonds. "We have run a very genuine winter test programme and I suspect that is true for most people."

McLAREN COULD REBRAND DURING SEASON

Ron Dennis has hinted McLaren's cars could be rebranded mid-season, once the team has signed a new title sponsor. The Woking outfit's deal with Vodafone ended last season and plans to announce a new title sponsor before the start of this campaign were delayed. "We've turned away stop-gaps," said Dennis. "Because of the depth of the company, we are not stressed by that and I am certain this will change over the course of the next few months."



P30 DENNIS ON McLAREN'S F1 FUTURE

REMEMBER WHEN



McLaren last raced without a title sponsor in 2006, which fell between the conclusion of its deal with West and the start of its seven-year tie-up with Vodafone.

RON DENNIS on...



Cost-capping in F1

"In the end, it is a simple thing in Formula 1: people spend what they have. If you cannot afford to be in F1, don't be in F1. There are lots of other categories that you can go motor racing in."

McLaren's lack of title sponsor

"Our cars will not feature a title sponsor at the first event. Why? Because I strongly believe we are Manchester United. Inevitably when you have a run of poor results people push the ratecard down. I won't accept that."

Martin Whitmarsh

"I appointed Martin to this company 20-odd years ago. He has always been a friend. This is 100 per cent between him and me until its resolution."

Alonso: racing won't change

Fernando Alonso does not expect the style of racing in Formula 1 to be different in 2014, despite the major changes to the technical regulations for this season. "We were saving the tyres from lap one of the

stints last year and we are saving the tyres from lap one this year, [so] that's no different," he said. "I don't think things will change that much, but obviously the cars are slower."



We have seen cars struggle to do a race distance in pre-season then finish the first race on the podium. I really don't know how it is going to unfold



Andy Cowell, Mercedes engine chief on what to expect this weekend in Australia

P52 MARTINI CARS



Williams unveils Martini livery

Williams unveiled its new Martini livery at a special launch event last week. The title-sponsorship deal with the drinks firm revives the white and striped colour-scheme last seen on Brabham's cars in 1975.

Castrol GRAND PRIX EDGE PREDICTOR

The Castrol EDGE Grand Prix Predictor returns for 2014 with new prizes and new functions. Free and easy to play, all you have to do is predict the top 10 and more ahead of each grand prix. Now you can also track your progress through race-by-race league histories and join driver fan leagues. Race-by-race prizes are back too and the highest scorer after Australia could win a PlayStation 4. To play just log-in or sign-up at www.gppredictor.com

BIG NUMBER

7 The number of season-opening F1 world championship races a Mercedes engine has won in 21 attempts.

TAKING **SERIOUS FUN** TO ANOTHER LEVEL

Be part of the fastest growing and most exciting single make series in the UK, as **Atom Cup** enters its second season. 16 races over 8 weekends at the UK's top tracks, in the sensational Ariel Atom.

**FULL SEASONS
RACING FROM
£25,600+VAT**



- HONDA RELIABILITY
- F1 HOSPITALITY
- TELEVISED COVERAGE
- AFFORDABLE PACKAGES
- TRACKSIDE ASSISTANCE

For further details visit:
www.atomcup.co.uk

16 RACES, 8 RACE WEEKENDS



Silverstone GP



Rockingham



Donington GP



Cadwell Park



Oulton Park



Brands Hatch GP



Silverstone National

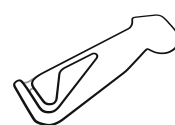

Snetterton 300



SIGN UP TODAY!

Call 01926 258028 or e-mail: info@atomcup.co.uk to secure your place on the grid



Jonathan Noble

F1's newshound

Domination from Mercedes in Melbourne is predictable, but don't be fooled into thinking that will set the tone for the 2014 season

There's a little bit of irony to the fact that Formula 1's most unpredictable of seasons may well deliver us a completely predictable outcome in Australia's opening round this weekend.

But even if Lewis Hamilton and Nico Rosberg power the Silver Arrows in Melbourne to their first one-two since the 1955 Italian Grand Prix, don't believe for one second that the die is cast for an era of Red Bull F1 dominance to be followed by a Mercedes whitewash.

In fact, the one thing that no one must do after this weekend is write off new-era F1 as a lost cause, even if Australia does not deliver us a complete thriller with wheel-to-wheel battles from start to finish, and a race with strategic nuances to keep fans on the edges of their seats for two hours.

Indeed, it may well be the exact opposite. Teams may well be regimented in performance order, reliability fears are likely to produce conservative strategies, and uncertainty about the ebb-and-flow of the racing may lead to a lack of aggression on track.

Plus there is probably little anyone can do to stop that Mercedes steamroller, and no one is under any illusions about that.

From the statement of intent in making sure its car was the first out on the track at 9am on the opening day of testing at Jerez, through to the near 5000 kilometres of running it did before the chequered flag came out at the

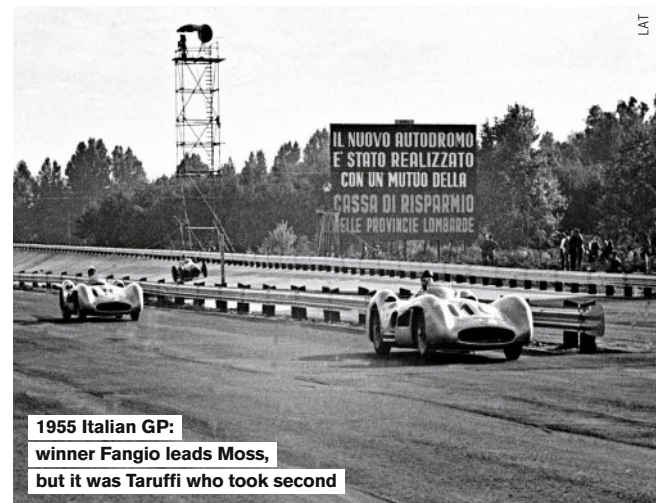

1955 Italian GP:
winner Fangio leads Moss,
but it was Taruffi who took second

stable and there's little scope to find areas in the regulations that deliver major performance benefits. But with a new rules cycle just beginning, the rate of the teams' current development is pretty aggressive, which means that form could vary dramatically.

If the teams were climbing Mount Everest, they wouldn't even have packed for base camp yet. Teams'

“What's good for Melbourne may not be good for Monaco's confines or the blasts of Monza”

end of the final session in Bahrain, Mercedes has been singled out as everyone's tip for the top.

Yes, there may be some challenges ahead for the Brackley boys – and reliability is going to be a big talking point over these first few flyaways – but all the indications are that it will be Hamilton and Rosberg in the clear, with Williams duo Valtteri Bottas and Felipe Massa breathing down their necks and hoping that their reliability trump card pays off big time.

And should it pan out that way this weekend, with the biggest intrigue being Red Bull's competitiveness at the start of the campaign, is that reason to switch off and give up on the new 2014 rules as a lost cause? Of course not.

Anyone who has followed F1 over recent years knows that it's rare for a performance advantage eked out at the start of the season to stay in place until the very end of the campaign.

Yes it can happen, most notably when regulations are

knowledge of how the races will actually pan out is zero. No one knows if it's better to have a fast-and-thirsty car or a slower-and-more-economical one. Do you want the tortoise or the hare? And what's good for winning in Melbourne may not necessarily be good for victory in the tight confines of Monaco, the swoops of Silverstone or the flat-out blasts of Monza.

It also doesn't take into account the fact that Red Bull's rivals are very wary about what Milton Keynes has produced, aside from the issues it has with engine supplier Renault. Data from testing shows the RB10 is phenomenally strong in corners, with enough downforce to have left its opposition with furrowed brows.

F1 remains completely wide open this year, and the spectacle for the fans is going to evolve as quickly as the cars. So for the doubters out there: give it time, and don't judge the sport on the first race.

F1 in 2014 is going to be great. 🏁

This week in motorsport



10

Formula E to race around Bird's Nest

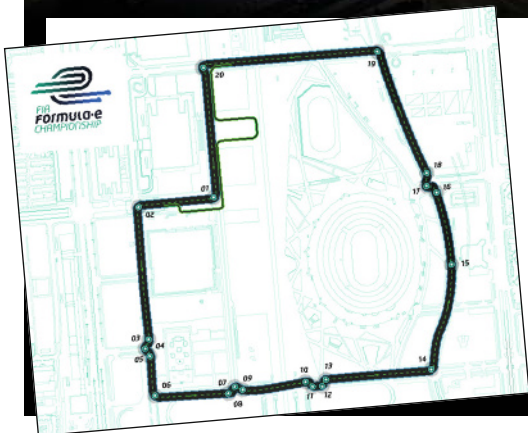

Formula E's inaugural race will be held on a circuit surrounding Beijing's Bird's Nest Olympic Stadium.

The temporary track, the first of the new city-centre venues to be unveiled, will be 2.14 miles long, comprise 20 turns and include a U-shaped pitlane.

While the track remains subject to final FIA homologation, designer Rodrigo Nunes has worked in close cooperation with the governing body and various Chinese motoring and governmental authorities.

Series CEO Alejandro Agag said: "Now people can visualise where Formula E will come together. The track looks fantastic; we're sure it'll be an amazing spectacle."

Battersea hope

Battersea Park is the latest site earmarked to host the London round of the Formula E Championship in June 2015. Series organisers are known to be working on plans to run the final event of the inaugural 2014/15 championship, set for June 27, on a temporary circuit laid out around the 200-acre riverside park in the Borough of Wandsworth.



Ganassi's silver celebrations

Chip Ganassi Racing will celebrate its 25th anniversary with a silver livery in the Indianapolis 500 and the 600-mile NASCAR round at Charlotte on the same day. Indy stars Tony Kanaan (left) and Scott Dixon are pictured.



Piquet Jr heads for Blancpain

Ex-grand prix driver Nelson Piquet Jr will contest selected rounds of the Blancpain Sprint Series with BMW Team Brazil this year. The 28-year-old could miss as many as three events due to commitments in the US-based Global Rallycross series.

NEW REBELLION TO MISS TEST

Rebellion will not take its new Toyota-powered LMP1 contender to the official World Endurance Championship test at Paul Ricard at the end of March. The Anglo-Swiss

team opted not to rush the first Rebellion R-One, and will instead take a pair of Toyota-powered Lolas in the specification in which they completed last year's WEC.

For all the breaking news, visit AUTOSPORT.COM

I am completely focused on the championship; I know what I'm capable of



Ferrari protege and 2013 Euro F3 champion Raffaele Marciello aims for the top three in rookie GP2 season



DUNGAN/EBREV/LAT

ON SLOW-COLE LEAVES BTCC

British Touring Car race winner Tom Onslow-Cole has quit the championship to pursue a career in sportscar racing. The 26-year-old, who first raced in the BTCC in 2007, has seven wins to his name. He had been looking for a seat, but has now decided to search elsewhere. "It's been increasingly difficult to raise the budget," he said, "and GTs provide good opportunities."



Lexus unveils GT3 contender

Lexus took the wraps off a GT3 concept, based on its RC F Sport coupe, at last week's Geneva motor show. The Toyota brand, active in Super GT, intends to deliver the first cars in time for the start of 2015.



MATT REEVES

Ecurie Ecosse begins testing

The Barwell Motorsport-run Ecurie Ecosse BMW Z4 tested at Silverstone last week ahead of its Blancpain Endurance Series campaign this season.

Oliver Bryant, Alasdair McCaig and Andrew Smith will race the GT3 machine, and will be joined by Joe Twyman for July's Spa 24 Hours.



ZEOD MAKES TRACK DEBUT

Nissan's ZEOD RC Le Mans 24 Hours racer is running for the first time on a racetrack with its full petrol-electric powertrain this week. Nissan GT Academy winner Wolfgang Reip has been tasked

with driving duties over the course of the three-day Snetterton test. The car has so far only run on the Bruntingthorpe proving ground with both its three-cylinder turbo petrol engine and electric motor.

Nasr stays at Carlin for GP2

Williams Formula 1 test driver Felipe Nasr will stay with Carlin for his third season in GP2. The Brazilian, who finished fourth in last year's standings, will combine his efforts with five F1 Friday-practice outings for Williams.



In brief



INDY RECORD PLAN

IndyCar wants Arie Luyendyk's 18-year-old track record at Indianapolis Motor Speedway to be broken by 2016. Mark Miles, CEO of IndyCar parent company Hulman & Co, hopes to see Luyendyk's 1996 236.986mph four-lap average speed beaten by the race's 100th edition.

COLETTI SWITCHES

GP2 veteran Stefano Coletti will stay in the series for a fourth season after switching from Rapax to Racing Engineering for 2014. The 24-year-old won three races in 2013 and led the championship for the majority of the campaign, but tumbled to fifth after a torrid second half of the year.

BRDC SUPERSTARS

Adrian Quaife-Hobbs and Jack Hawksworth have been added to this year's BRDC SuperStars programme. Both Hawksworth, who steps up into a full-time IndyCar drive this year, and GP2 race winner Quaife-Hobbs were part of last year's development scheme.

BAUMGARTNER RACES

Skydiver Felix Baumgartner will compete in this year's Nurburgring 24 Hours in an Audi R8 LMS ultra. The Austrian gained worldwide repute in 2012 when he completed a jump from the edge of space, breaking the sound barrier during his 24-mile descent.

F3 DISPUTE RESOLVED

The FIA has found a compromise that will enable the British Formula 3 International Series to continue using the 'F3' name. National ASNs, including the MSA, can use the F3 moniker provided they run to the FIA regulations that were in place when the cars were built.

AUTO GP CALENDAR

Auto GP has finalised its 2014 calendar, with a return to Imola and a maiden trip to Estoril completing the eight rounds. The Portuguese circuit will host the finale on October 18-19, in conjunction with the ELMS round.



Almo Coppelli...

NO	PAIN
NO	GAIN





Martin Brundle

The inside line

The former grand prix racer, Sky Sports F1 presenter and commentator looks forward to a pulsating Australian Grand Prix

For me, this is easily the biggest change I've ever seen in F1, even compared to switching away from turbo engines at the end of the 1980s. I think the aerodynamic changes alone would have challenged most teams, but added to that you have a step change with the tyres and, of course, the massive complexity of the new power units.

Normally in testing we see teams pound round and fine tune one element, but this year it's all changed and, as impressive as F1 teams are, they've struggled. It's a huge challenge, although I've no doubt they will all rise to it sooner rather than later.

Clearly reliability is the major issue, particularly early on – even Mercedes is far from bulletproof. If we get 10 finishers in Australia I'll be impressed. It's highly likely that not everyone scoring points will actually see the chequered flag.

I think the uncertainty – the calamity – we're going to get will be fun for a while. It will be a bit like an egg and spoon race; you could be way ahead, but drop the egg before the line and Mr Steady will take the victory.

We might have half a dozen races of that kind of craziness before teams start to get on top of it, which is good because the novelty will wear off. The bottom line is it should be about the drivers, so we need that to be the case.

I think the issue of fuel saving is being overhyped.

can't just floor the throttle, and that brings back a core skill. We're going to see them making mistakes, getting sideways, which is really good.

That said, I do have concerns. One that I voiced last year was that I hope we don't have three classes develop within the championship: one for Mercedes, one for Ferrari and one for Renault.

Another concern is having enough information to know what is going on. No-one will feel sorry for the commentators, but there is nothing worse for us or the fans than someone coming from nowhere to grab a podium, even a victory, and not being able to explain it.

There is a lot of complex information that teams don't want to give their competitors, but you still need some information or the fans get confused. As a good car dealer, I know that confused customers don't buy.

But the way that we report on it will evolve as the season does. Whether you're a fan, part of Sky F1 or in a team, we're all in that same zone of beginning to understand what is a wildly new era for the sport. We might spend the whole year working it out, but it's going to be fascinating.

Will we need DRS, for example? There is so much spare power, so much latent horsepower through the boost and electronic systems, that one driver could piss by another if they aren't harvesting power that lap. Will cars overheat during pitstops? What will

“I won't be surprised if Williams or Force India win a race, or if Caterham and Marussia score”

Ever since Colin Chapman and his ilk realised that weight is God, managing fuel has always been a concern. Teams have always been light on fuel: if you carry 5kg that you don't need, you might as well not bother.

Concerns about cars not being quicker than GP2 are also nonsense. Felipe Massa was less than one second off Nico Rosberg's 2013 pole time in Bahrain, and that's before teams have optimised everything.

I'm absolutely convinced F1 had to make these changes; it has to be cutting-edge. We might have some growing pains, but it couldn't plod along with a dinosaur engine. I had no affection for that engine – it might have sounded good, but it wouldn't pull the skin off a rice pudding. I've driven the V8 cars, and I thought they became guided missiles.

Now, with the huge amount of extra torque and power, drivers will have to control the power much more – they

be an optimal strategy?

What we can say is that it looks like Mercedes-powered cars are ahead, led by the works team. I'd expect them to be the strongest, along with Ferrari, over the year. If a Mercedes-powered car doesn't win the first few races I'll be surprised. I will not be at all surprised if Williams or Force India win a race, or if Caterham and Marussia score some points.

It's a terrible thing to say, but everyone is thinking, 'Well at least Sebastian Vettel won't win'. That's really cruel, because all the bloke has done – all Red Bull has done – is be brilliant for four years. But I'm afraid that's the way it is; people are ready for a change.

And that's precisely why I can't wait – because I'll be getting on that plane with no idea what will happen. ❧

■ *Sky Sports F1 is the only place to watch all 19 grand prix weekends live on TV, Sky Go and Now TV.*



MERCE DYNAM

They enter the 2014 Formula 1 season do Lewis Hamilton and Nico Rosberg exclusive interview, they reveal one or

Last year, Lewis Hamilton and Nico Rosberg ended the season separated by just 18 points. That's less than a point's difference on average per grand prix between the old karting team-mates in their first season together at Mercedes. The pair head into the 2014 as favourites for the world championship, so how do you choose between them?

The contrast between the artist and the artisan has long been drawn between grand prix drivers. In the 1960s, Jim Clark was the so-called 'natural' talent and Graham Hill the one who used diligence and determination to make up the deficit. Both won two world titles. Later, Alain Prost was the professor to Ayrton Senna's maestro. Between them, they won seven championships. Today, Hamilton and Rosberg are cast in similar terms, with the Briton as the gloriously 'pure' driver and the German working hard to compensate for his.

Both characterisations are very broad brushstrokes, designed to be a shorthand rather than a final judgement on their respective abilities. Rosberg is the artisan, Hamilton the artist. But it is a false dichotomy to conclude that therefore this means Rosberg is slow or Hamilton is stupid. Far from it. At the elite level of any professional sport, the differences between the athletes are tiny.

So, it is essential to play to your strengths. Rosberg always had an engineering mindset, and came close to studying for an engineering degree before racing got in the way. He has always been a fast driver but, once you get to the top level, even if you give away a tenth of a second that's enough to make the difference. It's in his character to immerse himself in the detail of the car and it helps to make him a formidable competitor.

As for Hamilton, he has always been seriously fast, that's why McLaren signed him all those years ago. But while sheer speed can get you so far in motorsport, it doesn't get you to the top and it must be fused with application and understanding of the car. McLaren set stunningly high standards for Hamilton, who had to win at

THOMPSON/GETTY

DES' IC DUO

as overwhelming favourites, but what really think of their chances? In this two home truths to **EDD STRAW**

every level, so he had to work incredibly hard even to earn his place in F1.

In a way, he's exactly the driver fans want to see, someone who earned his opportunities through success. His McLaren silver spoon could have been withdrawn at the drop of a hat and he had plenty of opportunities to fall off the ladder, but he always fought his way through. He has 22 grand prix wins to his name across a variety of cars and regulations. During the Pirelli era, he's also made significant progress in terms of dealing with the demands of fuel and tyre management. He's far from one-dimensional and the idea he hops out of the car after a session and is unwilling to put in the hard graft is misleading, even though the depths he goes to might not match Rosberg. The bottom line is that he's one of the very best.

While Rosberg and Hamilton do have different biases in their approaches, their end results were remarkably similar last year. The question in 2014 is whether the shift in regulations to an ever-more engineering-led approach will move the dial a little in favour of Rosberg? Or will Hamilton, as he has always done, adapt to these new challenges? Even those in the team don't really know who will thrive. And that's what makes this intra-team rivalry more fascinating even than Fernando Alonso versus Kimi Raikkonen at Ferrari.

So what better way to get a deeper understanding of the way Hamilton and Rosberg work than asking them about the challenges of F1 in 2014 and their own strengths.

There are massive changes in Formula 1 this year. From what you have seen in testing, what do you make of this new kind of racing?

Lewis Hamilton: It's even more technical than it has been in the past. But it's a step further forward into the future.

Nico Rosberg: It's a very exciting time in the sport and I enjoy it. After four years of Red Bull and Sebastian Vettel dominance, change is a great thing for the sport, a great thing for everybody involved, a new challenge. It's refreshing even for me as a driver. I'm excited about the current ▶



ETHERINGTON/LAT



Rosberg's focus is on getting to grips with new-look F1

16

ROSBERG IT'S BEEN A HARD SLOG TO THE TOP IN F1

It's been a long hard slog to the top for Nico Rosberg. Still only 28, he will start his 150th grand prix this season and his journey has gone from driver who flattered to deceive by setting fastest lap and scoring points on his debut to many people's tip for 2014 world title glory. While Williams was only very sporadically competitive during Rosberg's four seasons there, serious doubts did arise in the team

about his ability to nail it when it mattered.

At the 2009 Hungarian GP, for example, Williams considered a punt for pole position with Rosberg on a light fuel load. But his scrappy lap to set 10th fastest time in Q2 made them think again for fear of a mistake leaving him down the grid. The raw material was there, but he wasn't seen as a driver to rely on. He proved that again in Singapore when he had the car

to win and was hassling Lewis Hamilton, only to run wide over the white line at pit exit and incur a penalty.

The move from Williams to Mercedes, where Rosberg benefitted from the tutelage of Ross Brawn, and he could watch Michael Schumacher at work, was key. Rosberg started to become more convincing. He dialled out some of the softness in wheel-to-wheel battle from his game and started to win the odd race. Even when Hamilton seemed to take the initiative within Mercedes mid-season last year after settling in, Rosberg managed to fight back in the closing stages of the campaign.

This is what is so impressive about Rosberg. Just when he seems to have plateaued, he finds a way to rise further. This is not a case of a driver who was always a racewinner but hobbled by mediocre machinery. He has constantly evolved.

"I like to question myself and question the norm to get that next step," says Rosberg.

"Because it's only by re-evaluating that you're going to be able to see where you can improve.

"It's something that I try to do at all times, really question what I can do better as a person to continually develop. Not just in racing, everywhere. That's my approach."

Four-year stint at Williams left some in doubt about Nico



THOMPSON/GETTY



DUNBAR/LAT

German's speed is
complemented by
his racing brain

“I like the challenge and the complications. Whether it suits me, we’ll see...” ROSBERG

► period because there are so many new things; the technology, progressing with it, optimising it. It’s about possibilities. At the moment, as a driver I can have so much influence on where it is going because they need the driver input. I’m the one driving the car out there and I’m the only one who can tell them where the main problems are. So it’s an extremely interesting time. With the V8s, you were at the limit and you could play around a little bit here and there and that’s it. But now everything is open and you can just do whatever you want. So I find it a cool challenge.

People talk a lot about the change in demands on drivers. Is this as significant as some claim?

LH: It’s huge. People watching will never ever know [how demanding it is], not just for the driver but also what the team does in the garage and what the factory does. I’m pretty sure that at least 70 per cent of those who watch it on TV don’t realise that all of the components on the car are built by the team, or the trials and tribulations you go through in testing, the failures and improvements. This year, as a driver, it has taken a good step up in terms of the technical side for us to understand. But it’s cool. As drivers, we grow and we get stronger mentally each year to be able to do so.

NR: Last year, there was enough technology that I could use for my benefit inside and outside the car and now there are just a few variables that have come in like the ERS, how it deploys, where

it deploys. A big one is also the brake-by-wire. It’s all electronic now and you can play around so much that it’s such a big part of the balance and the handling of the car and what it does under braking. Braking is now all the way to mid-corner so it’s like half of every corner that you are taking is braking and you can have such a big influence on the balance with the brake-by-wire. You can shape it as you want. In the first part of braking, when you are straight ahead you can have a lot of rear brakes, then the middle part you can shape it the other way. Then you have different corners which require different things. It’s so powerful, so that’s a new area where you can play around more than before. I like the challenge and the complications. As to whether it suits me, we will see from the results. Also, tyres, we were expecting them to be rock solid one-stop tyres but actually it’s quite the contrary: it’s a similar story to last year with a lot of tyre degradation. That’s another challenge that we didn’t see coming.

How much of an impact does the 100kg-per-race fuel limit have and do you enjoy that challenge? Or is it frustrating not to be able to drive at 100 per cent?

LH: “Years ago, in 2007 and 2008, you could be pretty much flat out the whole time because they were flat-out stints. You might have to do the smallest amount of lift and coast to save fuel, but that was cool back then. Now it’s a lot more strategic from a team’s and driver’s point of view. In the past it was ‘the driver drives and the team

does the strategy’ but now it’s team and driver. Lift and coast is going to be a huge player this year. And also, how you manage your fuel, how you use it because in the 70 laps you have, you could use it more in 10 laps flat out and then save it for five laps or 20 laps and use it later. Or use it in the first 20 laps, push and then save it for the rest, or save it off the start. It can be moved around and you have to decide how you do that with the team.”

NR: It’s more extreme but it’s not completely new. Fuel has always been a big thing, especially in recent years with the 150kg start fuel. We have always been trying to optimise fuel because if you saved a little bit you could leave the grid with 3kg less fuel. And 3kg was one-and-a-half or two-tenths per lap or something crazy like that. So it’s not a completely new world, it’s just more extreme and it’s going to have an impact on racing even more than it used to in the past. It’s something that needs a lot of attention this year.

What does fuel-saving actually involve? Obviously it’s about more than simply driving slowly, as some believe...

LH: As a driver you have to short-shift the gears quite often and it’s lifting several metres before the braking zone. It’s being less aggressive with the throttle, riding the throttle less, coasting into a lot of places instead of having to use the fuel. That’s generally all we can do and then it’s just managing the switches. ►

ETHERINGTON/LAT



The spotlight is on Hamilton, many folks' tip for the 2014 title

► **NR:** One of the most efficient ways of saving fuel is lifting off the throttle 50 metres before you get to the braking point for the corner. By coasting for that short period of time, you hardly lose any laptime. But at the same time, because it's the period with the highest wind resistance the fuel consumption [when flat out] is massive in that point because the resistance is so big. You are saving fuel by lifting off the throttle but you're not losing laptime, so that's the most efficient way. That's one of the key things that I need to play around with.

Lewis, you are often portrayed as an incredibly fast driver but not as technically-minded as someone like Nico. Is that fair?

LH: Firstly, anyone from the outside has never actually sat in a debrief with me or in the garage or heard how I set up my car, or how Nico or any of the other drivers do, so it's almost impossible to say one does it better than the other. But naturally every driver does it differently and every driver uses more time for one thing than he does another thing. What's most important is how those two drivers come together and push the team forward using constructive criticism, getting the results, using that enthusiasm and energy to push the team forward.

But do people underestimate your strategic and technical skills? You adapted well to tyre management in recent years so does that get overlooked?

LH: I don't really know. I don't read what people are writing or take any notice of it. If people talk about it it's OK – people will say what they are going to say. As long as I know what I do, as long as I'm sitting with my engineers studying data to see how I can improve the car. I never thought that I would have such a good understanding of my car. If only people knew what I knew, I think they would be surprised. The results that I have had have never, ever, just come from pure driving, they have always been about me setting my car up. No-one sets the car up for me. No-one has ever set my car up for me in my whole F1 career. They do simulations and they come up with a baseline set-up but I can do one lap and tell them where it's wrong and come in. They might send me out after five laps and I'll come in every two and say we've got to change this, change that.

Nico, you're regarded as an intelligent driver, an 'engineering' driver, but not always seen as the absolute fastest over a single lap. Is that a fair characterisation?

NR: I don't know. I haven't really paid attention to how people see me – I'm focused on my own thing. I could go against you and say that my team-mate is renowned as one of the fastest and it was only 11-8 [to him] in qualifying last year, so that's the only thing I could say against that. Then the rest is up to you.

Following the huge changes in F1 for this year there's been a lot of talk about its direction.

If you had a clean sheet of paper to say what F1 should be, what would it be?

LH: If I was to talk about it, it would all be bull. What difference does it make because it's not going to happen. I'm happy with the way it is. I'm enjoying driving, I love F1 because it changes every year. It's a challenge for me every year with my team to put the car together to get it to be as quick as it can be and to get myself in the right shape, learn the changes, learn the tyres. I like doing that every year.

NR: F1 should be about the best race drivers battling it out among each other in the most technologically advanced cars in the world. That should be F1. And that's what it seems to be this year. The only downside to that is that sometimes the best drivers don't battle each other because we are so dependent on our teams. And again this year it seems that the teams play a bigger role than ever before.

You and Mercedes go into the season-opening Australian Grand Prix as favourites. How does that feel?

LH: I don't think it really changes things. Within the team, it's positive to know that we don't have this negative pressure that some teams have about not making it [on performance] by race one. So we don't have that dragging us back or stressing us out. Now we can put all of our focus on getting these results and doing it well. ►

“It’s positive to know we don’t have this negative pressure that some of the teams have” HAMILTON



The Brit looked good in pre-season tests aboard the new W05

DUJIBAR/LAT

19

HAMILTON SECOND TITLE A LONG TIME COMING

Had you told anyone on that November afternoon at Interlagos in 2008 when Lewis Hamilton secured the world championship that he would go through the following five seasons without even breaking into the top three in the points, you would have been laughed out of Sao Paulo. Yet that is exactly what has happened.

It's far from all Hamilton's fault. In 2009, McLaren started the season dreadfully and the following year he was putting together a superb run only for the team to slip back late on. The 2011 campaign

was his worst season, when a litany of cack-handed mistakes betrayed the fact that off-track issues were affecting him, as he confirmed late in the season. But even then he drove superbly at times and won three races. In 2012 he drove well enough to be champion, but other people's blunders (mostly McLaren's) cost him four wins, while 2013 was all about settling in at Mercedes. At 29, he goes into 2014 seemingly with everything he needs to win the title.

His decision to join Mercedes was all about two things. Forget about the money, that's a red herring,

Hamilton desperately needed to get out of McLaren and have a fresh start. But the other big selling point was that Mercedes was, on paper, best equipped to take on the challenges of 2014. Last year was a year of transition, but one that, by his own admission, exceeded expectations both in terms of how well he settled in and how well the team evolved.

“Definitely,” he said when asked if the success of 2013 was a bonus. “And also the progression through the year. In previous years, it looked like Mercedes would come to a halt while everyone kept developing. But to see the developments kept coming is a really good step.

“I thought [2013] would be a foundation-building year, but I didn't realise that the foundation would be so good.”

For all his speed, there were a few negatives. By drifting over on Valtteri Bottas's lapped Williams at Interlagos, he ruined his own race and earned a penalty, showing the potential for needless errors remains. There were also a few times when he frustrated the team with his reaction, particular to tyre management issues, over the radio. But overall, the good far outweighed the bad.

If he can build on the work already done during the winter, Hamilton's long wait for a second world title could well be about to end.



Hamilton suffered a needless collision with Bottas in Brazil

HONE/LAT

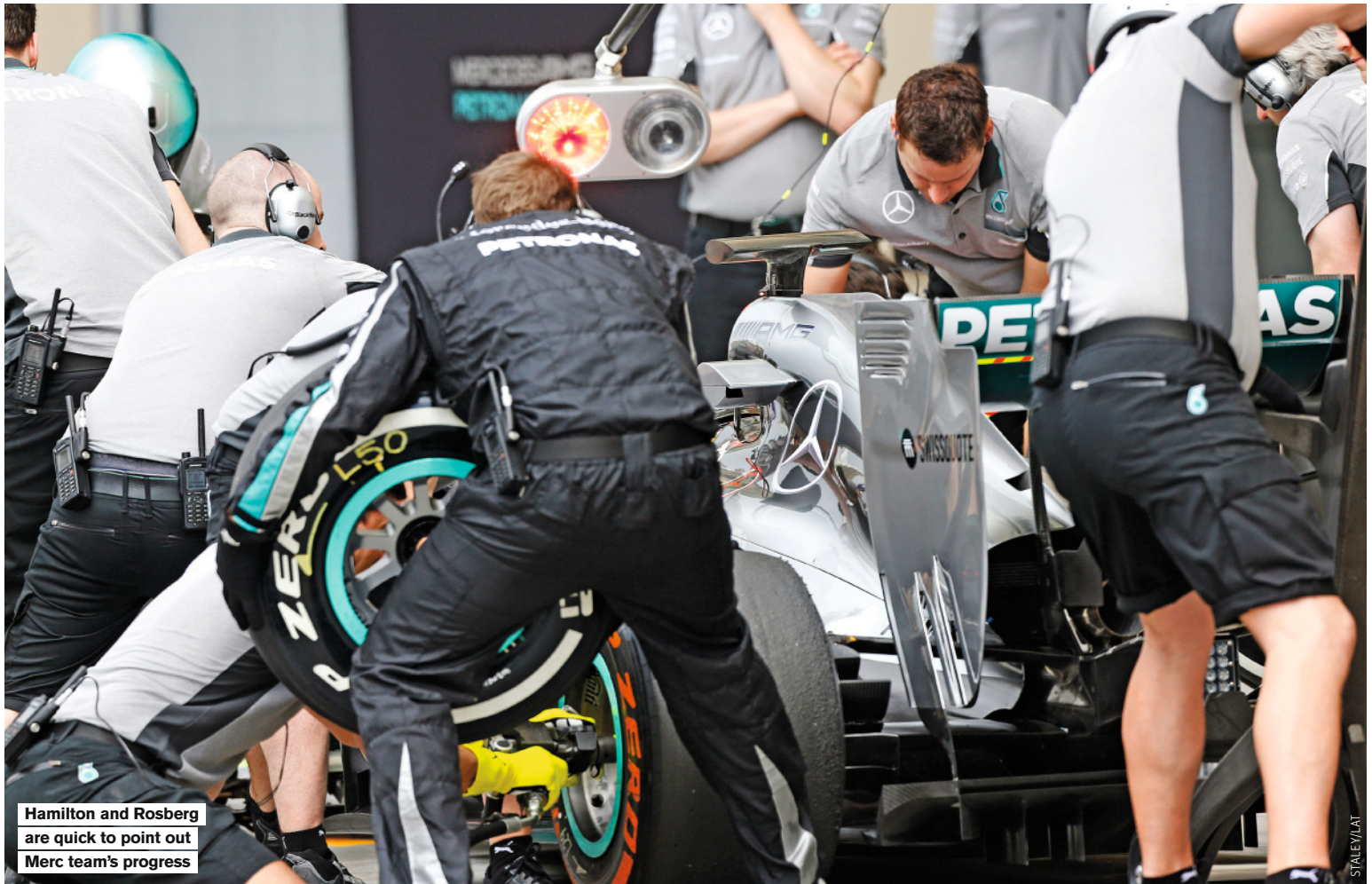

Hamilton and Rosberg are quick to point out Merc team's progress

20

► The guys have worked so hard and now we are carrying the momentum that we had last year, which is a real positive.

NR: That's the opinion of other people but I'm fully in the moment with my team, extracting the maximum from what we have in testing. That's where my focus is. So the opinion of other people doesn't occupy much of my capacity! So how does it feel? We have a great team spirit, that's what I feel. I feel how far we have come as a team and the momentum that we have as a team of moving on our way to becoming the best in the sport. I believe in this possibility. That's what I feel. There's an optimism. I'm not saying that for Melbourne, but soon.

The battle between you and your team-mate is one of the most interesting as you are two established, experienced drivers. How do you go about beating the other?

LH: It's very difficult in F1 nowadays to have an edge on someone and it has probably been the same for quite some time. You get in the car, you go and do a lap. It's a fantastic lap. Your team-mate does a lap and it's not so good and then he compares that lap through data on the screen or on a printout and can say, 'shoot, that guy is braking five metres later than me in Turn 1, or he's on the power earlier than me or he's using a different gear to me'. Any advantage through your skill that you bring to the table is immediately

taken away, or inherited. It's the same with all drivers. It's the same with Nico. He'll go out and go faster and I'll see he's using third instead of second gear, so I'll do the same and I'll find that time. So it's a constant evolution. The most skilful driver, I would assume, is one who is able to adapt to that most quickly, to really get his car to the place where he wants to in the short amount of time we have. So then it becomes more technical than just driving. Then when you drive you have to get that extra five per cent.

NR: It's tough. It's a difficult subject. You have the one side that you are a team and you are driving to win the constructors' championship for the team because that is where the money is. And that's what the team is in the sport for, to win the constructors' championship. But at the same time you want to race each other and beat each other and that's what the fans want to see – racing. There's always going to be that compromise because there are teams and then there are drivers in the team fighting it out. It's always difficult, especially if you are fighting for race wins, that's where it gets difficult. We are so competitive, massively competitive. The faster our car gets the more difficult it will become.

Sebastian Vettel is struggling in the Red Bull and even though the car fundamentally looks good, it will start the season on the back foot. You've started seasons in bad cars. What's it like in that situation?

LH: Sebastian has a great car and if he had our engine, they would be very hard to beat. But who knows? Maybe Renault will flick a switch and they will be on it suddenly in the first race.

HAMILTON versus ROSBERG 2013

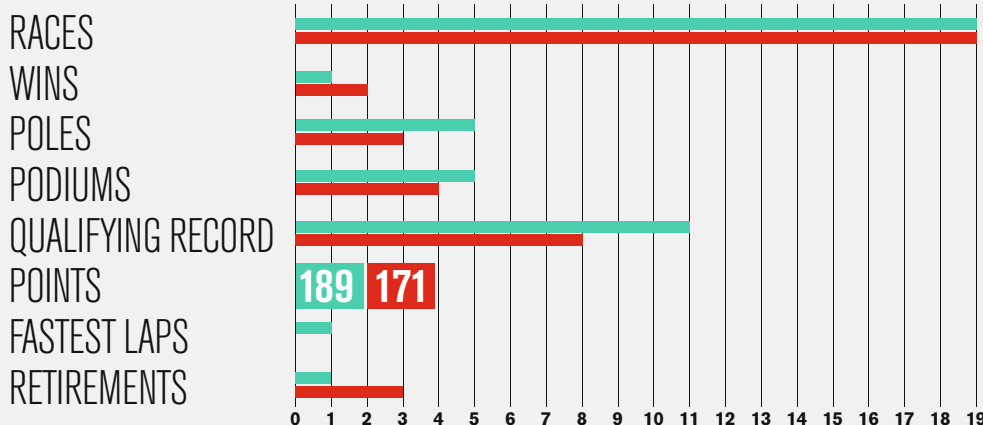



Both drivers are aware of the need to drive the team forward

“You are driving to win the constructors’ title for the team, but I want to beat Lewis” ROSBERG

Maybe they are fooling us? Who knows what’s going on. But when you are in a team and you’ve had success, just constant praise from people, positive races for a year, two years, especially for Sebastian after so many years, to then have a year where you’re not fighting at the top and you’re not having good things said about yourself, generally that is an opportunity for people to talk you or the team down. So you can easily be drawn to the negativity. But they are a world championship-winning team. And the other

teams are doing it, McLaren are bouncing back this year, they are on it and having a positive year so far. That’s what every team does, they just bounce back.

NR: For me, it was a steady progression [up the grid] so it’s probably tougher for someone like Sebastian now. If he starts the season on the back foot, which we don’t know but certainly there is the possibility that will happen given the way Red Bull’s testing has gone, that could be

tough for him because you are so used to winning and everything. To suddenly not have the machinery to do it is surely tough for a driver. For me, I got in and there was a steady progress going up. But I’m just motivated by the moment, wherever my car is. I prefer having a great car, that makes it even more enjoyable, but even having a mediocre car, the challenge of getting the most out of it and doing a great race with what I have is always there and that’s where I take my motivation from. ❧

THE CUSTOMERS WHO ARE GETTING IT RIGHT

Mercedes isn't the only team in good shape heading to Melbourne – it has three customer squads using the same engine snapping at its heels. **BEN ANDERSON** assesses their chances

Much of the pre-season talk in Formula 1 has centred on the speed of the new Mercedes engine. The general consensus is that it's lighter and more powerful than the Ferrari motor, and quicker and more reliable than Renault's troublesome unit.

No one is sure of the figures, but it's clear that the Three-Pointed Star has an edge. Naturally that propels the Mercedes factory team – and star drivers Lewis Hamilton and Nico Rosberg – to pre-season-favourite status.

But there are three other outfits using the same 1.6-litre V6 turbo 'power units' as the silver machines, six other cars benefiting from the good work done over the winter by Mercedes High Performance Powertrains in Brixworth.

McLaren, Williams and Force India all plan to use that propulsive edge to bring glory to their respective camps at the season-opening Australian Grand Prix in Melbourne this Sunday.

McLAREN NOT UP TO SPEED YET

McLaren looked to be a serious contender during the first eight days of pre-season testing in Jerez and Bahrain, but the MP4-29 fell off the pace and started to look fragile during the final test in the Middle East.

Jenson Button endured a particularly rough time, suffering drive issues and an engine failure that severely limited his last two days of running.

The Brit surged to the 2009 world title on the knowledge that the Brawn was quick enough to win after his first few laps in the seat. This season, all his talk has been of a car that is decent and driveable, but needs to be faster.

Rookie team-mate Kevin Magnussen – the reigning Formula Renault 3.5 champion, of whom the team has high hopes – enjoyed a much smoother pre-season than Button, but the McLaren looked only solid rather than spectacular in his hands.

It would be no surprise if McLaren has played on the conservative side with this new design. Attempts at producing a radical car to take the fight to Red Bull last season backfired

spectacularly, as the team endured arguably its worst season since 1980 – the year it last failed to score a podium during an F1 campaign.

Better to play it safe, build something fundamentally sound, and go from there. But that naturally exposes you to the risk of being upstaged by more confident contenders, certainly until McLaren flexes its considerable technical muscle.

Button is pinning his hopes for a strong result this weekend on a set of planned upgrades. If these developments translate well onto the Albert Park street circuit, then McLaren could be Mercedes' nearest challenger for victory. If not, the Woking squad could find itself fighting to feed on scraps once again.

"We're definitely happy to be with Mercedes in terms of mileage, but as I've always said we've got to build a quick enough car around it to win races," says Button. "Driveability is something we definitely didn't have last year. We've got that and now we've got to build on it."

"Last year, if you bounced into the right place in a corner you could be quick, but it was so inconsistent. Now we can do consistent laps and the pace is reasonably good, but there are areas we can improve. At the moment we've got a good base, but there's a lot of work needed still to be competitive. We need more downforce. But that's coming, and the guys are working flat-out to make it happen for the first race."

Amid the backdrop of a realigned relationship with its engine supplier (a natural consequence of McLaren's decision to jump into bed with Honda for 2015), McLaren could be in for another tough season. Not that Eric Boullier, the team's new racing director signed from Lotus over the winter, is worried.

"It's more complex than the other years, because downforce will bring pace, but driveability of the car, the power train, and power-unit management is going to also give you pace, at least until everyone is up to speed," argues Boullier. "The other parameter is the fuel situation, where you have to adjust settings and driving style to make sure you match numbers."

"This makes it a little bit more complex understanding the pace of everybody. We are not bad. We have some advantage in the driveability of the car, and we have a lot of different performance packages coming. I think a good season for McLaren is to win the ▶



Button is happy that new car is more consistent than old

"We're happy to be with Mercedes on mileage, but we need a car quick enough to win" **JENSON BUTTON**

McLAREN



WILLIAMS



FORCE INDIA



Castrol **EDGE** GRAND PRIX **PREDICTOR**

The pack has been shuffled... **LET'S PLAY!**

**SIGN UP
NOW!**

The F1 grid has been shaken up, but do you know who'll come out on top?

- Register today and pick the Top 10 drivers at each Grand Prix
- Create mini-leagues with mates

WIN **A PLAYSTATION 4**

The highest score at the Australian Grand Prix wins



Subject to terms and conditions



START PLAYING TODAY:
GPPREDICTOR.COM





Bottas is confident ahead of sophomore F1 season at Williams

► world championship, but realistically if we are back in the race-winning mode that will be a decent season.”

WILLIAMS

THE WORKS TEAM'S BIGGEST THREAT

Countless times we have tipped Williams to make a surge along the comeback trail to the front of the grid. And countless times (Pastor Maldonado's stunning victory in the 2012 Spanish GP aside) we have been proved wrong. But this season Williams really could be a dark horse for success.

The FW36 set the fastest outright lap across the final two pre-season tests (just), and certainly showed the best reliability. There's a feeling that Mercedes hasn't shown its true potential so far, where Williams may have left nothing in the tank, so it could be a stretch to expect the Grove squad to take the fight to the factory full-on. But Felipe Massa and Valtteri Bottas look better placed than most if Mercedes drops the ball in Melbourne.

Of course Mercedes won't say it's looking over its shoulder at the now Martini-liveried cars, sweating profusely and pulling at its collar with a grimace, but the Brackley squad is known to be impressed with the job Williams has done

“All the changes in the team have finally started to turn into performance” VALTTERI BOTTAS

dealing with the hefty cooling demands of these new powerplants. If Williams is the leading light in this regard, it will pay enormous dividends over a race distance, particularly in the hotter climes of Malaysia (round two on the calendar).

“It has been a very successful pre-season,” says chief technical officer Pat Symonds. “We have done every bit of homework that we can do, and more, so we have to go to Melbourne with some confidence. We have run a very genuine winter-test programme and what you see is what you get from that.

“I have to say, the performance we are getting is above my expectations. That shows what a damned good structure there was here to start with, and what good people we had. It was just a question of refocusing in some areas and it's really coming together. It has exceeded my hopes.”

Both drivers look delighted with the work Williams has done over the winter, and each carries an air of quiet confidence (particularly

Bottas) heading into the new season. “The feeling is different and more positive than last year,” says the Finn. “A lot of it is down to the engine. We definitely have the right one at this time of the year.

“All the changes that have happened in the team have finally started to turn into performance, and that's just been a matter of time. For us, it's definitely possible to do a full race distance and finish the first few races, and that should be our target. Not only that but, of course, we need to do it as quickly as possible!”

One of the key questions for Williams will be whether it can keep pace with the traditional big players in F1's development war. It found itself sorely lacking in this area last season, bamboozled by exhaust-blown downforce in particular. The regulations have effectively removed much of that disadvantage this year, and Bottas is confident the team can do a better job.

“Development this season will be very ►



Massa: first Brazilian to wear these stripes in F1 since Carlos Pace



Two 1970s F1 logos: Martini and, for obscurati fans, Wihuri (backed Kinnunen in '74)

25



IMPERIAL RANGE



METRIC RANGE



TENDER | HELPER



OFF ROAD



COIL SLEEVE



BUMP STOPS

DOMINATE THE TRACK. RULE THE STREET.

ERS | Eibach Race Spring System

- Over 1,300 single components - main and tender springs - metric and imperial, various auxiliary race suspension accessories, ready and in stock on 5 continents
- Comprehensive Program of single components
- Single Main Springs with highest rate-linearity and lowest rate tolerance
- Progressive Characteristics via set-up of different springs serially - double or even triple spring combinations
- Extreme Low Weights achieved through Super Hi-Ten materials and manufacturing technology
- Smallest Solid heights, maximized spring travels and higher maximum loads
- Spring Surface Stabilization through specialized shot peening
- Every ERS Spring preset to block
- Block and Sag Resistant
- Smallest Tolerances and precise plane parallelism of spring ends
- High Dynamic Durability - under Motorsports conditions
- High quality corrosion protection by phosphating and epoxy coating
- Springs Printed with part-number (speaking code = rate and dimensions)
- Individual protective single box packaging



eibach.com



Hulkenberg: top driver. Does he have a top car?

► important and maybe more important than any other season for many years,” he adds. “We must make sure we are in that race, not just that we’re good in the first few races. I’m confident we can keep up. We have a stronger team than last year so I really hope so.”

FORCE INDIA
TIME TO BREAK OUT OF MIDFIELD

Force India makes no bones about the fact that it is the perennial midfield team trying to break into the big league. But Vijay Mallya’s squad has been stealthily climbing the grid over the past few seasons with smart spending and a highly focused technical approach.

The lack of willingness among F1’s bigger fish to take a punt on the obvious talents of Nico Hulkenberg means Force India has recaptured one of the best drivers on the grid to lead its charge. Alongside rapid (if a little erratic) Mexican McLaren refugee Sergio Perez, Force India looks to be in great shape to spring some surprise results.

The VJM07 looked decently quick in pre-season and its race simulations during the final test in Bahrain were impressive, suggesting Force India may finally be in a position to transition from what deputy team principal Bob Fernley



Perez has made switch to Force India

describes as “a team of podium potential” to podium contenders.

“We’re arrogant enough to believe that we’re a Q3 team every season and in most cases that’s been correct,” he asserts. “We’ve proved that over the last three seasons.

“We’re certainly not doubting our ability to be Q3 for 2014. What we’re looking to be is a podium contender. That’s the next step for Force India.

“I think it would have happened last year, but the tyre change [whereby Pirelli reverted to harder compounds in the face of repeated tyre failures] derailed the whole programme.”

Force India switched focus early to its 2014 car, and its technical partnership with Mercedes looks set to bear serious fruit on the engine side. The team used the last major rules change in 2009 to vault from the back of the grid to regular midfielder (and occasional big points scorer). Perhaps history will repeat itself this season...

“We tend to work in five-year plans,” says Fernley. “If you look at the five-year plan that was introduced in 2009, it had very clear objectives in trying to take the team from the back into becoming the best of the rest below the top five. We achieved that.

“In our mandate we were also expected to be getting podium opportunities in the latter part of it, and realistically that was the only bit we’ve missed out on.

“When we signed with Mercedes in March of last year that was part of the next five-year programme, starting in ‘14. That has to take us from being best of the rest to hopefully being a podium contender in the future, including this year.

“Coincidentally, we introduced the Force India livery in 2009 for five years and we’ve introduced a slightly more aggressive livery for this year. It’s a purposeful statement of intent. What we’re trying to do is send the message that we are trying to up our game to the next level.”

If the work it has done so well in pre-season can continue into the first few races, Force India has every chance of making good on that promise. ❧



Can Alonso fight Mercedes, or just its customer teams?

BOTTERILL/GETTY

FERRARI THE CAT AMONG THE MERCEDES PIGEONS

Ferrari looks to be the nearest challenger to Mercedes heading into the new season, but it’s likely the Scuderia will be fighting with all the Mercedes teams, not just the factory squad.

Its engine is reckoned to be heavier and slower, which will make it much harder for Fernando Alonso and Kimi Raikkonen to deliver the world title craved by the management in Italy.

Team principal Stefano Domenicali suggested in Bahrain that Ferrari still has work to do to get the most out of its power unit. “I know what the situation is on our side but I can guarantee I heard numbers that are like throwing dice in the air because it’s like a chain: one, two, three and by the time it comes back to us it is already 100!” he quipped when asked by AUTOSPORT if the engine was too heavy and too slow to take on Mercedes.

“I think the most important thing to understand on our side is how to manage the balance between electrical power, the ERS, the MGU-K, the battery – all these things have an effect in terms of horsepower.”

Ferrari suffered a number of issues that delayed its pre-season programme, but it recovered enough ground to attempt race simulations with both drivers during the final pre-season test, and what looked like a ‘let’s take fuel out, put sticky tyres on, and see how quick we are’ run with Alonso on the final day.

There was bad news on both counts for Ferrari fans. Both drivers’ race runs were pretty evenly matched, but some way off the average pace of the Mercedes cars. Alonso’s fastest lap during that short stint on the final day also left him a second adrift of Lewis Hamilton’s test-topping effort, suggesting the F14 T lacks outright speed too.

“We know that we have big competitors in front of us, but we are here for that,” adds Domenicali. “We have seen Mercedes acting very well so far, but they are a monster, we are smaller, and we want to show that even though we are smaller we can do a fantastic job.”

The jury is still out on Ferrari’s prospects, but it looks as though the Scuderia already has serious work to do.



AUSTRALIAN GP PREVIEW

The return of turbo F1 cars

After 25 seasons of exclusively normally-aspirated engines, turbochargers are back in F1. On the eve of the Australian GP, **CRAIG SCARBOROUGH** explains the science behind the turbo

For the first time since 1988, a grid featuring turbocharged Formula 1 cars will line up this Sunday to compete around the Albert Park circuit. The new 1.6-litre V6 engines dictate a single turbo can be fitted to the engine, which must be placed in-line along the car's centreline, meaning all teams have mounted it low down behind the engine.

A turbocharger is simply an air pump driven by exhaust gases. The more air that can be fed into an engine, the more fuel that can be injected, allowing more power to be created. But in 2014, F1 is a fuel-efficiency formula

thanks to the 100kg-per-race rule, so these will not be the fire-breathing high-boost turbos of the 1980s. Instead, these will be more moderately boosted designs, bringing the output of the internal-combustion engine itself to well over 600bhp, with the electrical ERS (energy-recovery system) adding more on top of that.

A turbo is made up of two sections: a turbine and a compressor. The exhaust pipes are routed together to blow a fan inside the turbine housing. The exhaust gases then exit through the centre of the unit. This fan is linked by a shaft to another fan inside the compressor housing. The fan

sucks in air from the centre of the housing and compresses it to exit around its outside.

When engine revs rise, so does pressure inside the compressor as the exhaust gases spin the turbine faster. It's possible for the boost to rise too high, risking blowing up the turbo or the pipework downstream. F1 engines have a wastegate for emergency use, but in normal running the motor-generator unit (MGU-H) that is part of the ERS will slow the turbo down to prevent overboost.

To feed the compressor with air, there is an airbox with an air filter. Current bodywork rules and the

central location of the turbo engine prevent the snorkel-like inlets projecting from the sidepods.

Spinning at up to 125,000rpm, the turbo requires oil cooling to keep the shaft's bearing cool and friction free. Coming from such short exhaust pipes, gas temperatures inside the compressor will exceed 900C, while the action of pressurising the air inside the compressor will increase the air going back into the engine too.

To deal with this, the turbine housing will be made in steel, while the slightly lower temperatures inside the compressor allow it to be made from aluminium.

2014 TURBO ENGINE

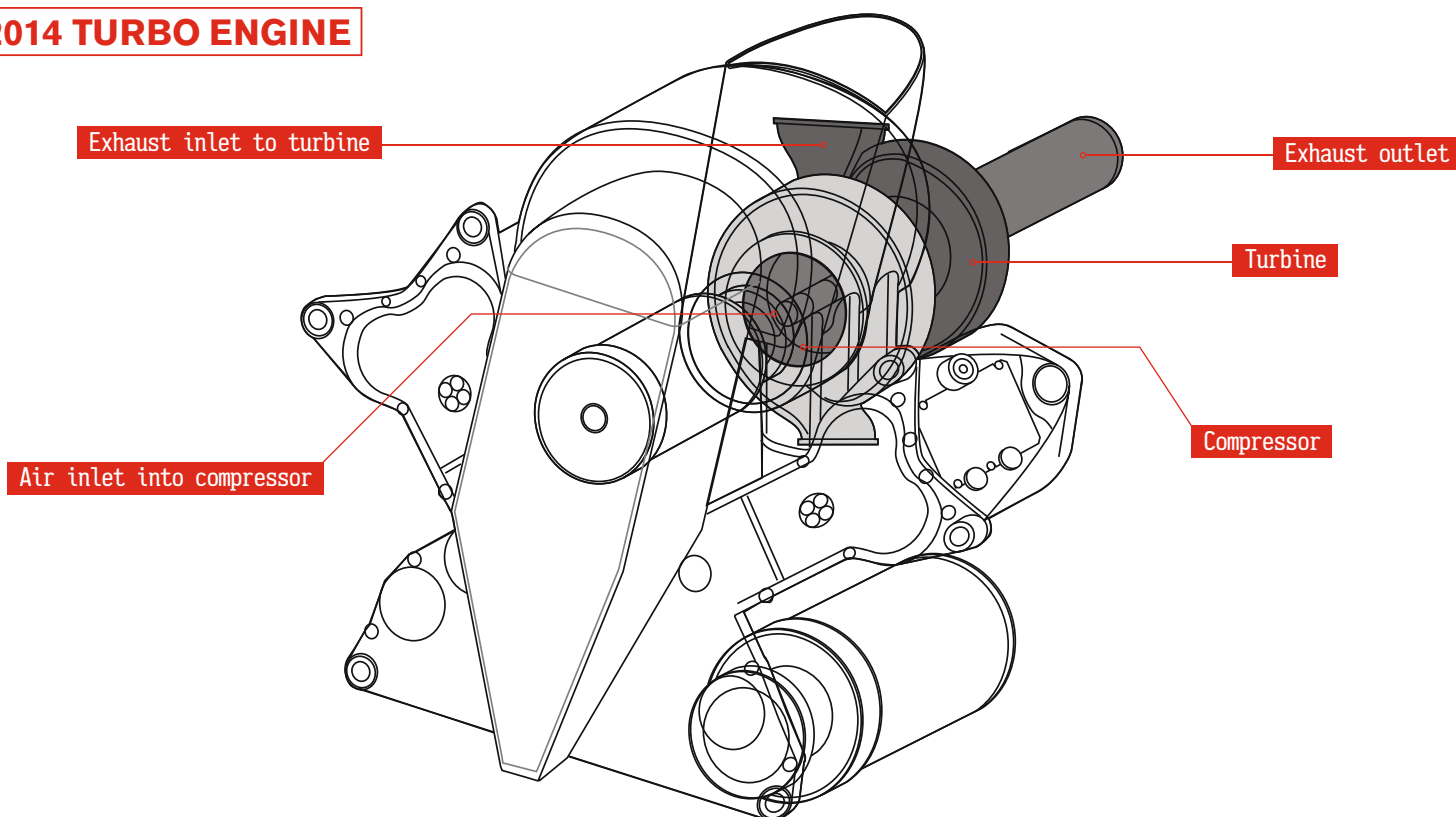

WHAT TO WATCH OUT FOR

Cars breaking down

The massive change in technical regulations for this season has fundamentally altered the way F1 cars are propelled around a racetrack. The new 1.6-litre turbo engines (and their associated energy-recovery systems) are pioneering and thus little-understood yet, so expect plenty of fireworks in Melbourne.



Red Bull struggling

The familiar sight of energy-drinks branding at the front of the grid will likely be a thing of the past this weekend. The reigning world champion team endured a disastrous pre-season, as the RB10 proved slow and unreliable. Time to see what four-time title winner Sebastian Vettel is truly made of...



Williams springing a surprise

Lewis Hamilton and Nico Rosberg rightly head to Australia as the favourites, after a fine performance in pre-season testing. But there's every chance that Mercedes customer team Williams (left) could be snapping at their heels. The FW36 cools better than the F1 W05 and is very quick too, so expect Valtteri Bottas and Felipe Massa to be right in the mix.



STATS

2013 winner
Kimi Raikkonen (Lotus)

2013 pole
Sebastian Vettel (Red Bull) 1m27.407s

UK start times
FP1: 0130
FP2: 0530
FP3: 0300
Qualifying: 0600
Race: 0600

Live TV
Sky Sports F1

CLASSIC RACE

Jenson Button and Rubens Barrichello led a Brawn one-two in 2009, the first grand prix of the previous F1 rules cycle. Ross Brawn's team, raised from the ashes following Honda's withdrawal from the sport, stole a march on some rivals by running a controversial 'double diffuser' that gave it a downforce advantage. Button led from start to finish, while Barrichello recovered from a poor start and two

collisions to finish second, after Sebastian Vettel and Robert Kubica came together in the closing stages. Lewis Hamilton finished third on the road, but was later disqualified after McLaren misled officials over an overtaking incident concerning Toyota's Jarno Trulli under safety car conditions. The incident also cost Dave Ryan, then McLaren sporting director, his job after 35 years with the team.



THOMPSON/GETTY

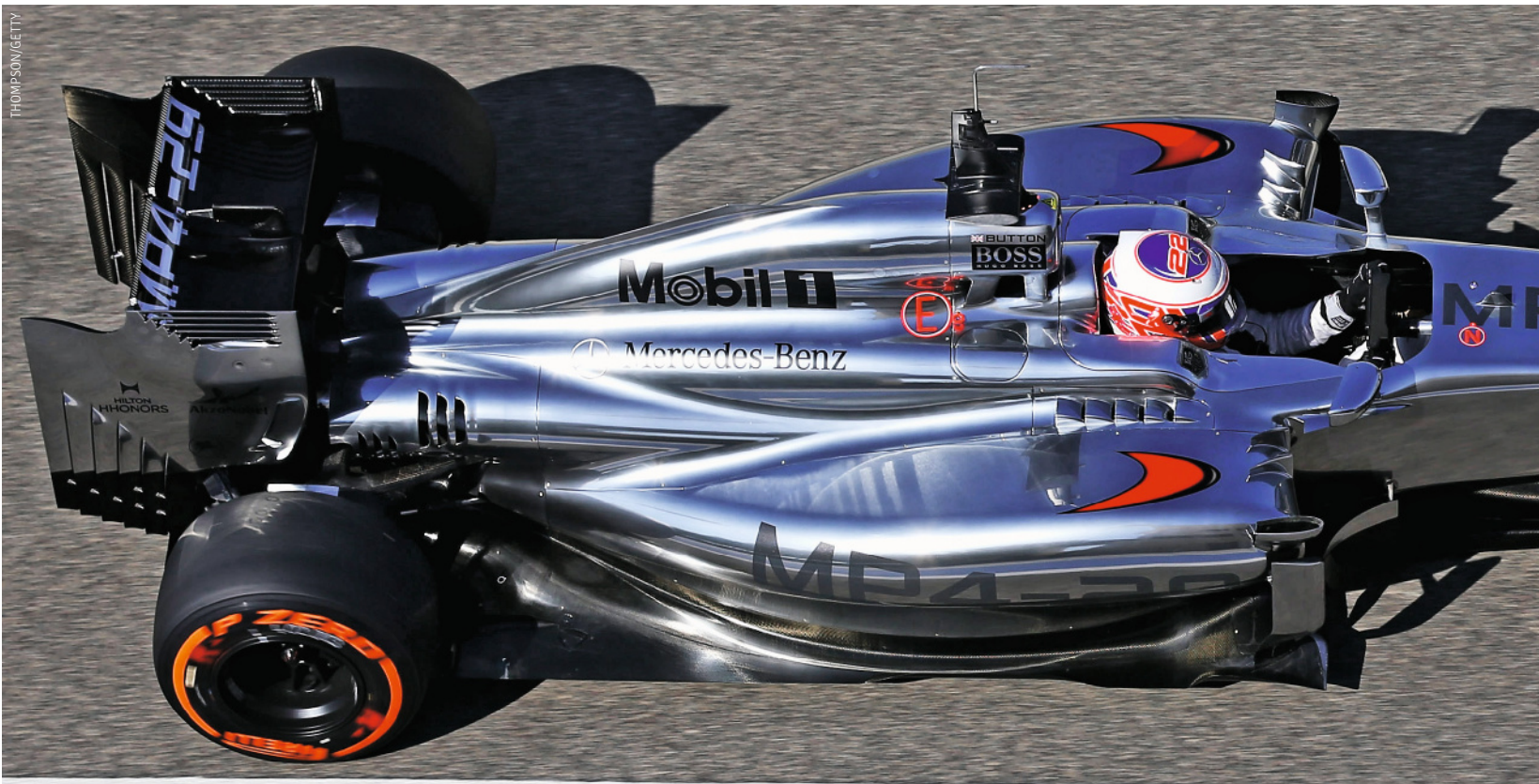

30

Dennis's McLaren vision

Ron Dennis revealed the first details of his plans to rebuild McLaren at its factory last week.

JONATHAN NOBLE was there to find out what's in store for the Woking-based outfit from now on

After its lacklustre 2013 campaign, McLaren has been pretty honest about the mountain it needs to climb to get itself back to the top of Formula 1.

But although it heads in to the new season admitting it does not have the fastest car, the returning Ron Dennis is convinced that it is on course to surprise with its rate of progress.

"We will do it much faster than people think," said Dennis, talking for

the first time since being appointed as Group CEO. "We know where we are. We know where the weaknesses are. We are about winning."

But on the back of the team's first season without a podium finish since 1980, is Dennis's stance will optimism or a realistic assessment of the new McLaren era?

WHAT HAD GONE WRONG?

Dennis had sought the backing of McLaren's board since the middle

of last year to return to a position of influence to help turn things around, for he felt the team had taken a wrong turn. He finally won their support in January.

Rather than there having been a single defining moment, or a key decision, that had put McLaren on the back foot, Dennis reckoned the decline had been caused more gradually and had resulted in team members getting distracted from their F1 efforts.

"What happens in life, there is evolution and revolution," said Dennis. "And very often when companies evolve they don't always evolve in a positive way. So when they go down this path, small things go wrong and the focus gets lost."

Although he declined to elaborate on the specific aspects of where these distractions were, AUTOSPORT understands that one example was that McLaren's GT racing project was using resources and personnel from the F1 operation.

He also believed the team's

DENNIS: "I cannot believe anyone will look and say, 'this is not the right way'"

on-track performance was weakened by the fact that team principal Martin Whitmarsh had responsibilities as then-Group CEO that stretched beyond running the F1 operation as best he could.

"Martin inherited the position as chief executive of the group and that carries with it a lot of responsibilities of the grand prix team," said Dennis. "I was partially responsible for that process. It was a distraction."

Whitmarsh's future remains unclear, but it is unlikely he will have any role in the F1 team's future.

THE TEAM PRINCIPAL ROLE

Dennis's perception of too much distraction and a lack of focus has resulted in the imposition of more clearly defined roles for everyone at



Dennis had been pushing for power behind the scenes



2014 is a fresh start for McLaren



Current drivers are highly rated

DRIVERS NO CONCERN

While Ron Dennis is still getting his teeth in to an overhaul of the McLaren infrastructure, one thing he is not worried about is the driver line-up.

In Jenson Button and Kevin Magnussen, Dennis believes the team has a strong pairing.

"In many ways there are similarities between Ayrton [Senna] and Jenson Button," said Dennis. "The way he conducts his life and the way he conducts his relationship with this team is right up there with some of

the great drivers who've been with us.

"He is quick. He is capable of winning races and world championships. I am extremely optimistic and he is an incredible mentor to Kevin."

On Magnussen Dennis added: "I think he has exceeded everyone's expectations. There is something special about him.

"He will have an exceptional debut. He has a steely determination and he will certainly keep Jenson honest."



GT project has been considered a distraction

CHANGING FACE OF THE F1 CALENDAR

How the balance of the schedule has shifted during Ron Dennis's time in the sport

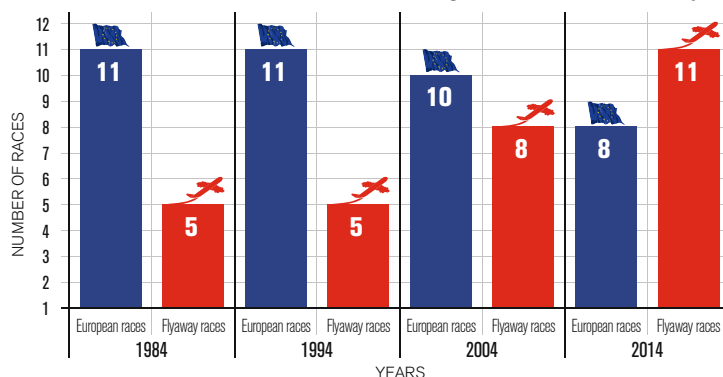

McLaren, and the end of the traditional team principal position.

The shift of F1's calendar towards more flyaway events (see graph) means that team principals are absent from the factory for longer spells than had been the case during previous eras.

"You cannot run a large organisation if you are outside the organisation four months a year," said Dennis. "This [the factory] is where the power has to be. This is where the development of the car has to be. Making a car go faster happens in this building – it doesn't happen at a grand prix circuit."

That is why Dennis has split up the previous responsibilities that were held by the team principal. New racing director Eric Boullier will focus

entirely on the operation of the team at the race track, while the new position of F1 CEO, currently filled by Jonathan Neale, will focus on driving factory improvements, infrastructure issues and longer-term strategy.

Dennis said: "I cannot believe anyone will look at it and say this is not the right way. F1 has changed now. Completely changed. You have to react."

RING-FENCING THE F1 TEAM

Dennis has been working on his vision for a revamped McLaren for several months, and his action plan has forced through a sharpening up of responsibilities for all F1 staff.

There will also be clearer lines of divisions and a ring-fencing of the F1 team's resources to ensure it is never

compromised. AUTOSPORT understands that McLaren's booming Applied Technologies division will soon have its own bespoke windtunnel rather than having to use the F1 team's.

"The new model for our F1 team is that it is completely propagated by people who have no other objective than winning in F1," he said.

The determination to focus on the F1 team also means that Dennis and McLaren representatives will no longer get dragged in to politicking for the wider interests of the sport. Previously, Whitmarsh was heavily involved in the recently defunct FOTA as its chairman, with Boullier acting as his deputy.

"We have sacrificed enough over the past 10-20 years for the benefit

of the whole," Dennis said. "It doesn't mean we are going to be selfish but we will stand by our principles and we will be supportive of what is right. But we won't lead."

MORE UPHEAVAL TO COME

Dennis is adamant that changes he has already implemented are enough to set McLaren on its way.

However, this is clearly just the start of a rebirth. A decision will be taken later this year on a full-time appointment for the F1 team CEO role, and Dennis has talked of both fresh appointments and a parting of ways for those who do not buy in to his vision.

"If everybody matches my passion and commitment and focus, we will most definitely win," he said.

How is European F3 holding up?

Following fears over the winter that the F3 European Championship would find it tough to maintain its momentum, **MARCUS SIMMONS** assesses how the series is looking for this year



32

The Formula 3 European Championship appears to have retained momentum from 2013, with 30 cars on this season's entry list, which was made official by the FIA last Friday.

Although two of these are for drivers yet to be nominated, and one of the confirmed pilots cannot appear until the fifth round at Spa in June, the entry list has assuaged concerns that last year's grid size would not be sustained into 2014.

Thirty drivers appeared for last season's opener at Monza, but the field had been artificially boosted by around half a dozen cars thanks to British F3 organiser SRO's late decision to slash the number of rounds of its UK-based series from 10 to four.

While some predicted in January that this year's entry would fall into the low twenties, a late spate of deals means the championship is on a par with 2013.

Series architect Gerhard Berger, who as FIA Single-Seater Commission president brought what was formerly the F3 Euro

Series under FIA control in 2013, said: "We've filled all the slots and this confirms that F3 is now back in the vanguard of promotional formulas. It's the best training school and every driver should go through it. The entry list looks fantastic with experienced drivers and a dozen or so rookies whose performance will be highlighted by a separate classification."

THE FAVOURITE

Felix Rosenqvist, runner-up in '13, returns for a fourth successive season with Mücke Motorsport at this level, his fifth year in total of F3.

The Swede openly wanted a move up to GP2 or Formula Renault 3.5, but could not raise a budget. He will therefore retain Mercedes backing as he remains with the Berlin-based Mücke team.

Rosenqvist, 22, downplayed talk that anything short of a decisive title win would be disastrous for one of his experience.

"I rather see it as I didn't have any choice but to drive F3 again," he told AUTOSPORT.

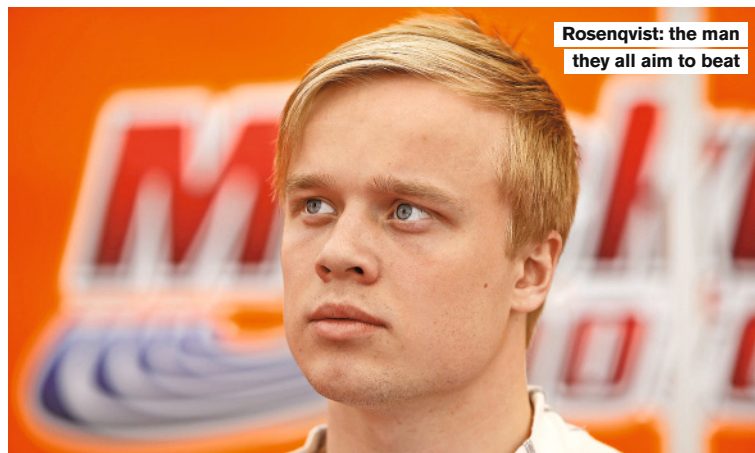

Rosenqvist: the man they all aim to beat

FIA F3/SUER

"It's not that bad. It's quite common for drivers to have pressure to move on quickly, but for some reason it's not always possible and I can only do what I can. You can't expect to win championships – OK I can say I expect to be in the top three, but things can always happen."

Rosenqvist has not driven an F3 car since retiring from last November's Macau Grand Prix, so will not get his first taste of the

new-rules, HWA-built Mercedes powerplant until a private test at Lausitz on March 20-21.

"It's always a bit difficult when they change things," he said. "There is always something different – new chassis, new tyres or new engines. It can set you back quite a lot, which it has at the beginning of every year for us [Mücke]. I really hope we have learned, because it always seems as though we have lost the



BRITISH TEAMS STAY ON BOARD

A clutch of late deals has enabled UK-based Formula 3 loyalists Fortec Motorsport and Double R Racing to stay in European F3.

The two teams, which will split their efforts this year between European and British F3, are both confident of strong showings.

Swede John Bryant-Meisner remains with Fortec, after stepping up from German F3 for some late-season outings in 2013, while Australian Mitch Gilbert switches

from Mucke to return to the team with which he raced in Formula Renault UK in 2011.

Meanwhile, Brazilian Felipe Guimaraes leaves Fortec, with which he scored two reversed-grid wins in British F3 last season, to line up as Double R's only registered competitor. Guimaraes, who also won the South American F3 title last year, is supported by Brazilian ex-F1 racers Emerson Fittipaldi and Alex Ribeiro.

“As soon as I saw Max in an F3 car I could tell it suited him more than a Formula Renault”

JOS VERSTAPPEN



championship in the first couple of race weekends.”

This year Rosenqvist joins Lucas Auer, who has moved to Mucke after finishing fourth in last year's series with Prema Powerteam.

“It's good to have a driver you know is quick from the beginning alongside you,” he said. “Pascal Wehrlein had to leave after the first round last year [when he switched to the DTM], and that was a difference between us and Prema in 2013

– they had experienced and quick drivers while my team-mates lacked experience. That will help this year, and also Roy Nissany [Mucke's other

driver] has taken steps forward.”

Apart from Auer, Rosenqvist tips a handful of rivals to push him this season. “Lucas, Jordan King and Tom Blomqvist [both of whom are at Carlin] are very quick,” he said, “and Prema have a couple of very fast new guys, like Esteban Ocon. And you never know what will happen with Signature [which returns to F3 with Renault power].”

VERSTAPPEN JR'S F3 LEAP

The other big story of the past few days is the deal for 16-year-old Max Verstappen, son of Dutch folk hero and ex-Formula 1 racer Jos, to race

for Van Amersfoort Racing – the team with which his father won the 1992 Dutch Opel Lotus title.

Verstappen Jr, whose first car races came in a race-winning campaign in the Florida Winter Series early this year, starred in his maiden F3 test at Valencia last December with the German-spec car of Motopark.

Verstappen Sr said: “Max did most of his testing in Formula Renault. I must say that it all went very well, but he did one test in F3 and straight away it felt very good.

“The way it handles, the downforce, the brakes and the grip level suited Max very well, and

that's why we made the decision to do this to prepare for the year after.

“Maybe an F3 car is more difficult to adapt to, but as soon as I saw him in one I could tell it suited him more than a Formula Renault.

“Van Amersfoort Racing can prepare him very well for the year after, and better to do that year of learning in an F3 car.”

Verstappen is not the youngest driver in the series – American Santino Ferrucci, aged 15 and a winner in Skip Barber series races, will make his first appearance for EuroInternational after his 16th birthday, which is at the end of May.

2014 ENTRY LIST

PREMA POWERTEAM (MERCEDES)

Nicholas Latifi (CDN), Esteban Ocon (F), Antonio Fuoco (I), Dennis van de Laar (NL)

MUCKE MOTORSPORT (MERCEDES)

Lucas Auer (A), Roy Nissany (IL), Felix Rosenqvist (S)

CARLIN (VOLKSWAGEN)

Jordan King (GB), Ed Jones (UAE), Antonio Giovinazzi (I), Sean Gelael (RI), Jake Dennis (GB), Tom Blomqvist (GB)

EUROINTERNATIONAL (MERCEDES)

Riccardo Agostini (I), Michele Beretta (I), Santino Ferrucci (USA)

FORTEC MOTORSPORT (MERCEDES)

Mitch Gilbert (AUS), John Bryant-Meisner (S)

T-SPORT (NBE)

Spike Goddard (AUS), Alexander Toril (E)

DOUBLE R RACING (MERCEDES)

Felipe Guimaraes (BR)

VAN AMERSFOORT RACING (VW)

Jules Szymkowiak (NL), Gustavo Menezes (USA), Max Verstappen (NL)

JO ZELLER RACING (MERCEDES)

Sandro Zeller (CH), TBA

TEAM WEST-TEC (MERCEDES)

Felix Serralles (USA), TBA

SIGNATURE (RENAULT)

Oscar Tunjo (CO), Tatiana Calderon (CO)

Quick and competitive Track Day Insurance

The first online "quote and buy" system solely for the track day user, supplied by established track day and motorsport insurance provider - Ryan Motorsport Insurance

- Damage to your car on a track day, regardless of fault.
- Any circuit in Europe, including Spa and Nürburgring Nordschleife.
- Inclusive cover for barrier damage at the Nordschleife.
- Vehicle recovery available for circuits in Great Britain.
- Organisers and Clubs - promotional rates and discounts
- Storage and transit for vehicles and trailers

Log on to www.InsureMyTrackday.com to obtain your online quote today

Ryan Motorsport Insurance Limited is an appointed representative (557405) of Independent Broking Solutions Limited who are authorised and regulated by the Financial Conduct Authority. Its Financial Services Register number is 312026

The power behind Porsche's new LMP1 racer

The hopes of one of sportscars' iconic marques rest on the new 919 Hybrid.

CRAIG SCARBOROUGH takes a look at the technology behind the new Porsche

PORSCHE 919 HYBRID

Porsche's build-up to its return to Le Mans and the premier LMP1 category has resulted in its new 919. Externally a contemporary LMP1 design, albeit built to the new narrower-chassis rules, the 919 exhibits innovation mainly in its powertrain, with approximately 750bhp coming from a tiny V4 turbo engine and two Energy Recovery Systems (ERS). One of those is a unique exhaust-driven generator that charges the car's central battery.

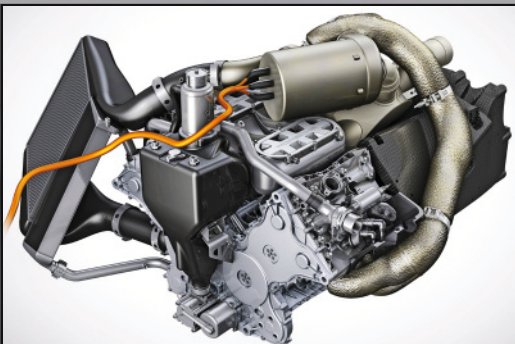

HYBRID TURBO

A unique means of recovering energy from the petrol engine is the exhaust-driven generator. This can create AC power to be sent via the power-control electronics for converting to DC power for storage in the battery. The exhaust pipes split to feed both the turbocharger and the turbo-hybrid generator. On the end of the generator is a turbo-like turbine, and the energy from the exhaust

gases spins the turbine and thus the generator. The exhaust outlet from the generator joins that of the turbocharger to exit off-centre from the back of the car. Notionally similar to F1's new ERS-H, this system does not provide for the stored energy to be fed back into the generator to provide an exhaust flow when off throttle, as energy flows purely one way from the generator to the battery.



GEARBOX

As energy-recovery systems add weight, any opportunity is taken to reduce weight around the car. For the gearbox, this means the seven-speed semi-automatic cluster is mounted inside a composite gear case. This uses a carbonfibre casing, with titanium inserts for highly stressed areas.

OFFSET EXHAUST

The exhaust outlet is off-centre, exiting on one side of the dorsal fin on the engine cover. This is due to the complex exhaust routing feeding both the generator and turbo. As clever exhaust blown-floor solutions are banned this year, this is a simple way to dump the exhaust gases and the asymmetric set-up probably has little aero effect.

V4 ENGINE

As the WEC continues to downsize engines and upscale energy-recovery systems, the 919 is fitted with a two-litre V4 engine running on petrol. Increasing its efficiency is a single turbocharger and direct injection, allowing the engine to produce around 500hp. A V4 is structurally more efficient than straight-four, meaning the engine can be fully stressed, being bolted between the monocoque and gearbox without external supports.

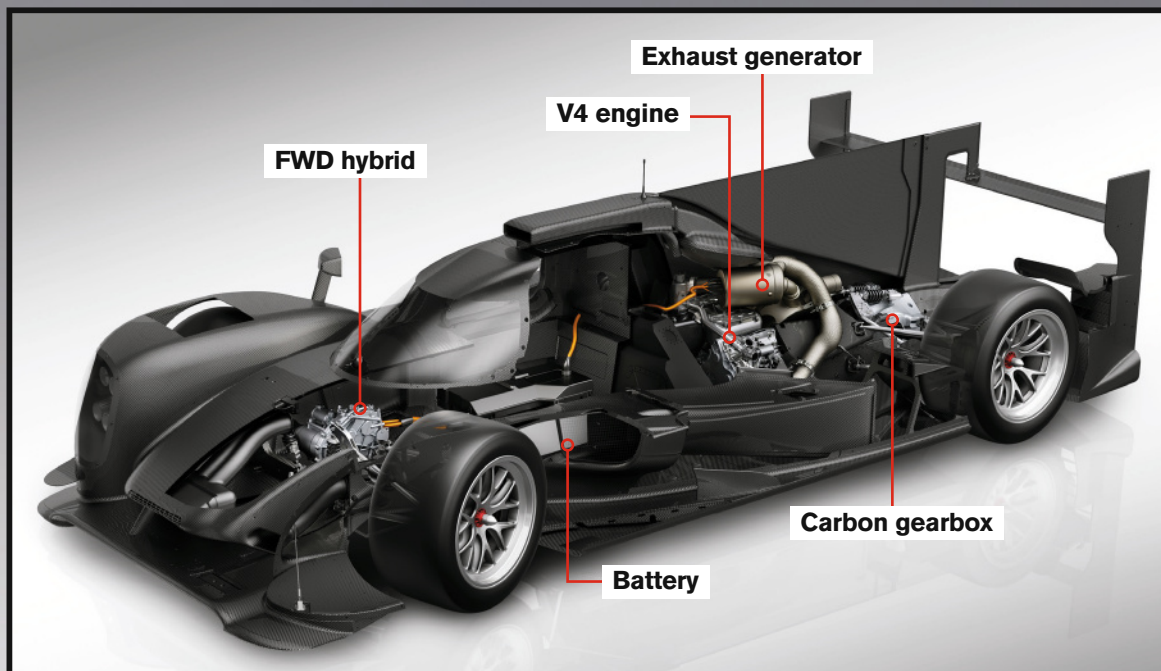

BATTERY

Similar to F1, but in contrast to Porsche's competitors Audi and Toyota, the battery system uses an array of lithium-ion cells. These are protected within a housing and sit in the passenger side of the cockpit. Energy recovered from both the front MGU and the turbo generator is stored within the battery and all the power is released through the front-wheel-drive MGU.

FWD HYBRID

A motor generator unit (MGU) is linked with driveshafts to the front wheels. Under braking this will act as a generator to harvest energy and store the power in the hybrid system's battery. Under acceleration, power from the battery will be redirected to power the MGU's motor. In this mode the car becomes four-wheel drive and the MGU will provide an estimated extra 250bhp.

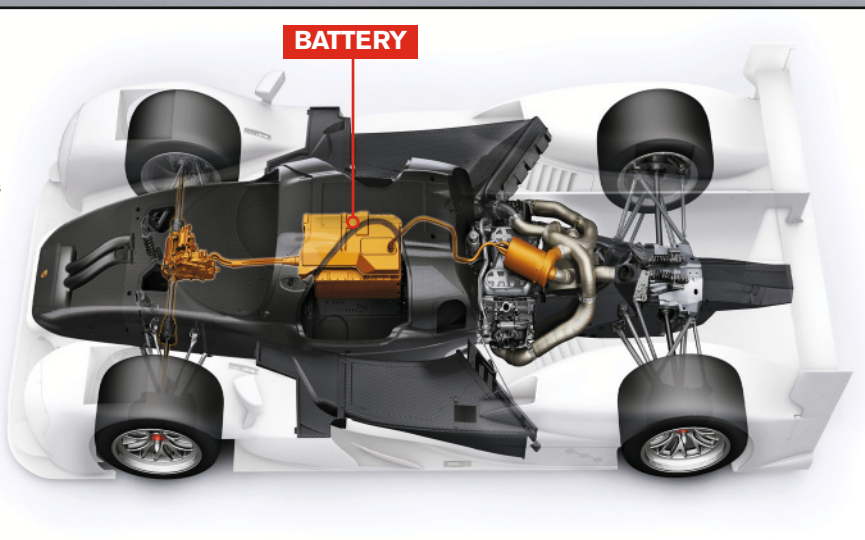





About time too

It's been a lengthy absence from frontline sportscar racing for Porsche, but now the discipline's most celebrated marque is back. **GARY WATKINS** spoke to the key players about the 919 Hybrid

That Porsche has been away too long is probably how most sportscar aficionados regard the German marque's return to frontline motorsport after more than 15 years. And it's a view shared by the architect of the new 919 Hybrid challenger for World Endurance Championship and Le Mans 24 Hours honours, Porsche research and development boss Wolfgang Hatz. "Yes," he says, "it was probably about time."

The time was right, but the stars have aligned to bring Porsche, a very different company now to the one that notched up the last of its 16 Le Mans victories in 1998, back to its rightful place at the top of the sportscar racing tree. The dust had settled after the company was incorporated into the Volkswagen Group in 2009, Hatz returned to take up the role once filled by Porsche legends Ferdinand Piech and Helmuth Bott, and Matthias Muller came in as company chairman to replace Wendelin Wiedeking, a man known for his ambivalent attitude towards motorsport. And over in France a radical set of regulations was being formulated by the Automobile Club de l'Ouest at Le Mans and the FIA, rules that were manna from heaven for any manufacturer looking

to showcase its environmental credentials.

"We had to return, but the fit with 2014 was perfect," explains Hatz, whose first stint at Porsche in 1989-93 included an involvement in the unsuccessful V12 Formula 1 engine used by Footwork. "We knew in which direction the regulations would go. The objective was that they should very much have road relevance and that very much fitted our strategies."

The fit with the new LMP1 rulebook, which puts an emphasis on efficiency and new technologies, came at a time when it was already developing its 918 plug-in hybrid supercar. But there was an elephant in the room during the early discussions about a return to what Porsche has alternatively called "big motorsport" or "high-level motorsport" – another category by the name of Formula 1. Muller made hints about F1 on his first day in his new job at the Paris motor show in October 2010, which were elaborated upon by the man it was already decided Hatz would replace, Wolfgang Durheimer, a couple of days later during the Petit Le Mans weekend at Road Atlanta.

Hatz insists that prototype sportscar racing and Le Mans was always the first priority. "There were only two options – F1 or LMP, but Le Mans is our second home; for me, we had to return there because I am an old Porsche man," he explains,

referencing his first stint in Porsche's motorsport department. "What could have influenced it was if someone in the group had said, 'Yes, but Audi is there and you cannot compete with Audi. If someone from senior management had said this is not possible, we would have had no other alternative [but F1].'"

The suggestion has always been that talk of F1 by Porsche senior management was part of a game of politicking as it tried to stake its claim on Le Mans and the prototype arena within the Volkswagen Group.

Hatz insists it was much simpler than that. "I presented it to my board colleagues," he explains. "They said, 'good idea', now we have to discuss it with the supervisory board [of VW]. And then they said, 'OK'. For me, it was surprisingly easy."

THE ROAD BACK

If the decision to return, made in the summer of 2011, was relatively simple, the task of putting it into practice wasn't. Porsche had to set up what is effectively a second motorsport department – new building and a fully-functioning race team included – alongside the home of its long-standing programmes in the GT racing arena.

When Alex Hitzinger joined on December 1 2011 from Red Bull Racing to become technical ▶

Conseil général
Sarthe



PORSCHE



**CLASSIC
BRITISH WELCOME**
S A I N T S A T U R N I N

13 juin 2014
9h00 - 17h00



www.classicbw.org

Thème 2014 : Porsche

Invité d'honneur : Jürgen BARTH

Création : agence archimède.com



JUERGEN TAP/PORSCHE

New weapon first did a 1000km run in Bahrain

► director of the LMP1 programme there were, he says, “just a few people looking at ergonomic studies and stuff”. The total staff working on the 919 project now exceeds 200.

“We had to build a completely new team from scratch and we even had to build the infrastructure of the buildings,” says Hitzinger. “We have brought in people from all over the place and from very different horizons, so we have a very young team.”

Key decisions about the technology that the car we now know as the 919 Hybrid – which is correctly written with a capital H, although the signage on the car retains the original low-case letter – would employ had to be made. That was a job made all the more difficult by the fact that there weren’t firm regulations in place at the time.

“At the very beginning, there was only a rough idea about the regulations,” explains Hitzinger, whose job at Red Bull had been head of advanced technologies.

“We have done a lot of concept studies in the beginning when we were looking at different technologies potentially available and in parallel talking to the regulators, the FIA and the ACO.

“It took us into the second quarter of 2012 to do more-defined concept studies. It then became clear what directions to go. In the middle of 2012 we started the proper design phase.”

THE TECHNOLOGY

The choice of configuration for what was always going to be a petrol-powered engine was one of the earliest decisions. Porsche, unlike petrol rival Toyota, has opted for a small-capacity turbocharged unit.

“The regulations are all about efficiency and weight. Nobody talks so much about the weight. But the weight is extremely important in these regulations,” explains Hitzinger. “There is an incentive built into the regulation to have a very big hybrid system [there are four levels of energy return allowed under the rules and the Porsche will run in the highest ‘class’ that allows for eight megajoules per lap of Le Mans].

“To be able to fit a big hybrid system, you have to have a very light base car. And in order to have weight to spare to invest in the hybrid system, a lighter base car is an advantage. We think you want a light and compact, very highly-efficient engine. One way to achieve this is to downsize.”

A four-cylinder configuration was chosen because it is the most efficient. Hitzinger points out that the reasons F1 went the six-cylinder route have nothing to do with efficiency. “At Porsche, the reasons for the four-cylinder engine choice was the pure drive for efficiency because of the thermo dynamic advantages,” he explains.

The engine is of two litres capacity, which Hitzinger describes as a “compromise” and a “sensible decision”. He says: “There is no point to go too much to the low side of the capacity.”

A ‘V’ was favoured over an in-line set-up, again

in the interests of weight saving. It allows the engine to be a structural component. “If you went for an in-line four, you would have to have some kind of spaceframe around [the engine] and that is obviously additional weight and complexity,” continues Hitzinger.

When Hitzinger arrived from Red Bull, the idea was to use a flywheel energy-storage system *a la* Audi rather than the batteries it eventually went for. Porsche, don’t forget, had been developing the technology together with Williams Hybrid Power on its experimental 911 GT3-R Hybrid Nurburgring 24 Hours racer of 2010-11 at the same time as Audi was independently forging a link with the British company.

“When I arrived, we looked at the whole spectrum of technologies again and we did a proper in-depth analysis, and then we changed course,” explains Hitzinger.

That resulted in the choice of lithium-ion batteries, which, according to Hitzinger, offer the best compromise between energy density and power density. In layman’s terms that’s the amount of energy that can be stored and the rate at which it can be stored and released.

Hitzinger suggests that the differences ►

“Nobody talks much about weight, but it’s extremely important in these regulations”
ALEX HITZINGER



Porsche reckons it still has work to do before challenging for wins

JUERGEN TAP/PORSCHE

AUTOSPORT.COM

FANTASY LEAGUE GP
IS LIVE FOR 2014!

\$100M TO BUILD YOUR
ULTIMATE TEAM OF 6 DRIVERS!



WHO'S IN YOUR TEAM?

autosport.fantasyleaguegp.com

 **fantasy**
league **GP**
THE ORIGINAL

Porsche has opened the doors for LMP1 comeback

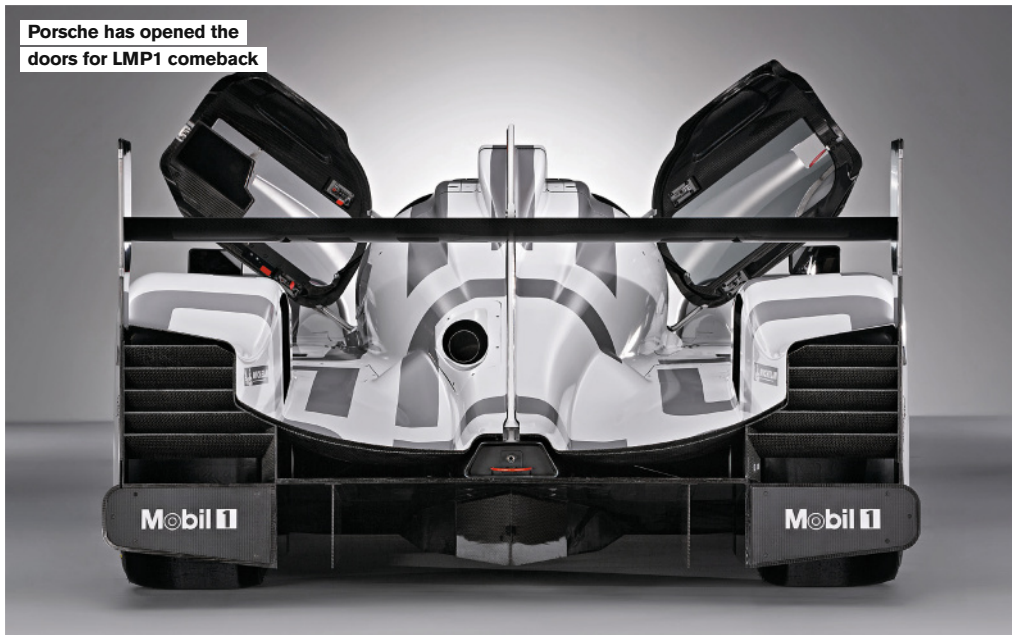

► between the different energy-storage solutions chosen by the three LMP1 manufacturers – batteries (Porsche), a flywheel (Audi) and a supercapacitor (Toyota) – might not be that large. He also points out that it's difficult to make a comparison without knowing all the details of the respective systems.

"Maybe Toyota doesn't have access to the technology we have, or maybe we don't have the technology that they have," he explains.

The new LMP1 rulebook allows for two hybrid systems. Porsche has chosen front-axle kinetic energy recovery and an exhaust-driven system. The abolition of the so-called '120 Rule', which prevented Audi from using retrieved energy below 120km/h (75mph), means that the benefit of four-wheel drive has been dramatically increased and has made energy-retrieval via the front axle *de rigueur*.

Porsche's exhaust system is distinct from that used by Audi and on the latest breed of F1 car. They retrieve energy from the spinning turbo, whereas Porsche has a separate turbine in parallel, which is driven by exhaust gases that would otherwise be lost through the wastegate.

The Audi and F1 systems allow for the possibility of the hybrid system to use retrieved

energy to spin up the turbo to overcome lag. Porsche believes it doesn't need this.

"If you have a problem with the turbo lag it is nice to have a possibility to overcome that with a different system," says Hitzinger. "If you don't have a problem, you don't need it. I guess we will see if our system is better."

THE TEST PROGRAMME

The new Porsche LMP1 hit the track at the firm's Weissach test facility just ahead of Le Mans last June. That gave it a headstart on Audi of approximately three months and nearly six on Toyota, yet the car was beset by a major engine vibration from the moment it first ran in anger.

Porsche hasn't gone into detail on the problem, though it has admitted there was a long lead time on solving the issue. That goes some way to confirming that it involved the crankshaft.

"We recognised it straight at the rollout and we reacted," explains Hitzinger. "It was a big call, but we did the right thing."

The crucial parts to revise the engine weren't ready until the end of November, which meant Porsche managed only one test, at the Algarve circuit the following month, without the vibration in its first six months of testing. It

was a major breakthrough that coincided with star signing Mark Webber's first run in the car. He managed to complete two grand prix distances on just one day during the test.

Hitzinger dismisses the idea that the first months of development – and no fewer than nine separate tests – with the 919 were wasted courtesy of this problem.

"There was a lot that we learnt all over the place on the car," he explains. "For sure we didn't do much performance testing in the beginning last year, but then that was never going to be the priority with a brand-new car and concept."

The progress continued after Christmas with two tests in Bahrain with the second 919 to be built. At the second of these tests, the Porsche completed 1000km (620 miles) in a day for the first time.

Porsche has two Le Mans simulations scheduled before the 24 Hours, one at French track Paul Ricard at the beginning of April and a second at an undisclosed venue between the Spa WEC round at the start of May and the Le Mans Test Day a month later.

EXPECTATIONS AND THE FUTURE

There's clearly a company crib sheet when it comes to talking about aspirations for 2014. Put the question to anyone involved in the programme and they will trot out the same line.

Finishing races is priority number one and being competitive is the second. There's a vague target of achieving a podium, or, as Webber puts it, "getting some bubbles here and there".

No one at Porsche is underestimating the task at hand. Team principal Andreas Seidel, who is running the in-house LMP1 race team operationally, suggests that the marque has to be modest for its frontline motorsport comeback. "You have to remember that this is our return," he says. "We have to be realistic about our opposition and all the experience that they have."

But project boss Fritz Enzinger, vice-president of LMP1 at Porsche, is under no illusions that the company has to start notching up the victories in year two of the programme. "Winning in 2015 is something we have to do," he says. "We want another Le Mans victory." ❧

THE MEN BEHIND THE WHEEL

The driver combinations in the two 919 Hybrids, which were finally announced earlier this month, were decided upon to try to create two equal cars. The starting point was the decision to split Porsche's two outright Le Mans 24 Hours winners, Timo Bernhard and Romain Dumas.

Bernhard will share the #20 Porsche with Mark Webber and Brendon Hartley, while Dumas teams up with Neel Jani and Marc Lieb in the #14 entry. It seems like a strange decision given the success they have achieved together with both the RS Spyder LMP2 car in the American Le Mans Series and in the 24 Hours while on loan to Audi [they won together in 2010].

"Timo and Romain have the most prototype experience of our drivers, so we decided to split them," explains Porsche LMP1 vice-president Fritz Enzinger. "We have two newcomers to Porsche in Neel [Jani] and Brendon [Hartley], and decided to put one in each car.

"The other factor was weight. We looked at the weight of the drivers and have tried to equalise that across the two cars because we want to be absolutely fair to give both cars an equal chance."

The decision on the combinations was made as long ago as last December, but it was set in stone after seat fittings in the first race 919s at the factory in early February.



Bernhard (centre) and Dumas (right) won Le Mans 2010 with Mike Rockenfeller (left)

What separates the great from the good?

Thirty-two drivers have won the F1 World Championship, and many more tried and failed.

One is David Coulthard; CHARLES BRADLEY asks him why he, and so many others, fell short



42

There aren't too many Formula 1 drivers who end their careers without an overinflated opinion of their own ability. David Coulthard, who drove at the top level from 1994 to 2008, is one of the few who didn't.

In his second career, in the media, Coulthard is very honest – to the point of self-deprecation – about his skills during his first metier.

During that 15-year career at the sport's pinnacle, he went wheel to wheel with great champions such as Michael Schumacher, Mika Hakkinen, Sebastian Vettel, Fernando Alonso, Damon Hill, Jacques Villeneuve, Kimi Raikkonen and Lewis Hamilton.

From his 246 starts with Williams, McLaren and Red Bull, he won 13 times with 12 pole positions and 18 fastest laps. DC finished second in the world championship to Schumacher in 2001, and scored 535 points in total. That's pretty much top-of-the-heap good, but he admits that he wasn't in the league of the great. So who better to ask?

What makes the difference between the great and the good?

DC: "It's certainly not application because I worked hard. I put my training hours in, I worked with my engineers, I did everything that was asked of me and a lot of things that were not. That's why I was able to retire, comfortable in my mind, not having a problem acknowledging the great drivers as opposed to the good ones.

"I've got some buddies who are ex-drivers who find it hard to acknowledge, who are not as good as they like to imagine they were, but we're all different and that's the journey of life."

You enjoyed taking on Hakkinen and Schumacher, you proved you could overtake them and, on your day, could come out on top. How could you not do that across a period of time in terms of putting a title together?

"That's what makes these guys the greats of the sport. The highly talented probably wouldn't be able to explain to you why they're so consistent, they just are. I know it's not linked to how you feel, because I remember winning at Spa, where

Mika and I just touched at the first corner and then I pissed off into the distance... I'd been up all night coughing blood and went to the track in a misery!

"But it didn't affect my ability to drive the car in the zone, and there were other days I'd come in feeling like a million dollars and I've wanted to just hide when I've seen my lap times.

"So it's a very difficult thing to understand, but it didn't seem to be attached to emotion. Sometimes you see Lewis doesn't look that happy but he's on pole position. It's because something else in his life is not making him happy but it doesn't affect his ability to drive. I remember Gerhard Berger winning at Hockenheim just a week after he'd come back from an illness and his father had been killed, yet he put a performance in like he hadn't done all year."

We're currently in a golden period of hugely impressive drivers. How do you think they stack up against the all-time greats?

"I know we're talking different eras but I have the simple view, which is if you had Fangio,



Great pass on Schumacher to win 2000 French GP



DC accepts 'number-two' role to Häkkinen

RONDEAU/GETTY

“If you had Fangio, Clark, Prost and Senna trained today as professionals, it would be like how we compare Hamilton, Alonso, Vettel and Raikkonen”



Scott's retirement came as Vettel joined Red Bull

TEE/LAT

THOMPSON/GETTY

Clark, Prost and Senna being brought up today, fed the proper things, so they were trained and focused on becoming professional drivers, as a group it would be just like how we compare Hamilton, Alonso, Vettel and Raikkonen today. They're my top four – and just below that you have Jenson and the emerging talents that can join that elite group in the future or else they'll be just very good racing drivers.

“You race whatever you have. Those guys won in karting, and what is the relationship between a go-kart and a Formula 1 car? Four wheels and an engine, that's it. No suspension, no aerodynamics, it's just the pure vehicle, man and machine. The vehicle interaction, the dynamics and how the driver sets the car up become a whole new technical aspect of the game that wasn't there in karting. But the good were good there, and the good are still good here – but it's the greats that somehow manage to get the maximum out of it.”

When did you realise Vettel would be a great?
“Although I was never his team-mate within the Red Bull/Toro Rosso alliance, in my last year,

2008, in the pre-season, I tweaked my neck on a kerb. I phoned Christian [Horner] and said, ‘Seb's here testing the Toro Rosso, you should get him in the car because you're looking at him anyway.’ So we got Seb out of the Toro Rosso and stuck him in the Red Bull that I had driven already so I got to see differences in driving. The quicker driver is not just quick everywhere – it's not like he goes out of the pitlane 1km/h faster. There will be areas in any good driver, anyone who's in F1, with particular styles of driving a corner that suit them better than others.”

When you were team-mates with Häkkinen at McLaren, was there an area where you were actually better than him?

“I tended to always be better on the brakes than Mika. Part of that was I was a right-foot braker for most of my career. I went very late to left-foot braking, the last four or five years. The benefit of right-foot braking is you don't overlap on fuelling so you could run less fuel, because you were either on the throttle or on the brake – it was very difficult to do both! ▶

► “In the time you go, ‘I think I’ll brake now,’ from that mental decision, the couple of milliseconds you’ve physically got your lump of meat off one pedal onto the other, you’ve gone another 10 metres. You gain lap time on the way in and it’s very difficult to outaccelerate your team-mate when you’ve got the same horsepower and drag level, so where can you go quicker than your team-mate? By entry speed and apex speed.

“Any fool can go barrelling into a corner and never make the apex and gain half a second on your lap delta and then you’ll lose six tenths coming out, so there’s a net loss. The exceptional drivers, the simple answer is they have a God-given, or whatever you want to believe, ability to feel the limit of adhesion.

“On straights we can all go as quickly as each other, there’s no skill set at that. I don’t think it’s that they’re particularly good at braking from my experience, but it’s rolling off the brake and that transitional phase. People talk a lot about lines and that sort of thing, and all of that’s relevant stuff, but it’s very difficult to know from the outside whether someone is still feeling the brake or whether they’re off the brake.

“The thing for me seems to be they’re able to carry a little bit more speed at the key phase, which is the last part of braking, because the first part is all much of a muchness as long as you don’t lock up. The first part of throttle application, you can be a bit earlier but if you’re late to full power it hasn’t gained you anything. It’s not about how early you’re on the power, it’s about at what point you can release the maximum amount of power for the right amount of grip before the car’s left the corner.

“They just have great skills in that area. It has to be a feel thing. I felt comfortable on street circuits, which some drivers feel uncomfortable with. I was not particularly good on these wide, open circuits where it was difficult to judge where the limit was. When I knew the limits I could operate well within them because you know you can’t go any further than that.

“Places like Turn 8 in Turkey, I’d be like ‘where’s the limit?’ I could take the corner as quickly as my team-mate, but it didn’t have the same emotion of control. These guys take the best bits of everything and put it together. Who knows why Nadal or Federer is so strong? There are such small differences in these guys.”

Your former manager Martin Brundle told us recently that he thought there ‘wasn’t enough bastard in you’ – that you essentially lacked that ruthless streak. Do you agree with that?

“It would be easy to agree... but I don’t think Mika was a bastard. Mika was very straightforward, he knows what he wants. He’s actually quite risk-averse and, in the end, he stopped racing in F1 because he got a little bit of a scare.

“Kimi’s not a bastard; he’s just annoyingly quick. When we were team-mates he’d be sleeping in the back of a truck, wake up, go in the car and – bam! – lap time. You hear stories of Berger testing all winter at McLaren and Senna turns up and within five laps he’s gone as fast as him. They just have speed.

“Was Prost a bastard? He won four world titles



On the way to satisfying second Monaco win in '02

“Ron Dennis blanks me, sits down and goes, ‘What are we doing?’ Then, ‘What are they doing?’ ‘They’ meant me and my engineer”



Schuey celebrates his fifth title; DC never got one



Brundle played strong role in Coulthard career

and he might not have been to everyone's taste but I worked with him as a test driver, I've spent time with him – he's not got a bad bone in his body. Did he ever do the Michael/Rubens pitwall incident in Budapest? He got pushed into the pitwall [at Estoril by Senna], so he might have done the turn-in a bit shallower at Suzuka...

"Did Nigel Mansell ever do anything 'bastard' on track? I don't think so. Nigel had an innate ability to be the ultimate underdog and fighter and deliver. So I wouldn't agree that you have to be a bastard because there's enough evidence that these people weren't bastards. Was Fangio ever seen as a bastard, or was he just seen as being extremely talented?"

What about the psychology of the situation, because you were in a position at McLaren where you were made to feel a clear number two. Martin said he got you to write him letter about how you felt. What did it say about how you felt at that time?

"It's very difficult to live the experience – even if you're the driver manager you're not living the experience. Martin wasn't at every test, he wasn't in the meetings. He did the contracts and had driven for the team, but he wasn't in the debriefs so he had to take my word for it.

"I went through certain examples like in Melbourne 1996 when I first raced for the team. I sat in the debrief with Steve Hallam, Mark Slade, Mika, Pat Fry, myself and Dave Redding. Ron Dennis comes in and I instinctively stood up to shake his hand because he's the governor, he's my new boss. He blanks me, sits down and goes, 'What are we doing?' Steve Hallam explained what 'we' were doing and then he goes, 'What are they doing?' They was 'us' – there was no one else in the room.

"I had to explain that to Martin so I said, 'Explain this to me, I don't understand this 'us' and 'them'. But then I found out that Ron was affiliated more to Steve and Mika, and Dave Ryan was on my side. It inevitably played out like that. It was good for me because Dave was a good team manager, so I had that strength of personality, but I never captured Ron right from the word go.

"As time has played out, Mika was an exceptional talent, very quick and had performance for quite a short period because after his accident it focused him on delivering and then retiring. He should have kept going for longer but he ran out of energy and commitment, but it was the right decision for McLaren to do that.

"But equally, I am comfortable with the fact that I was there for nine seasons. I know that team intimately and they didn't give me nine seasons because I'm Ron's lovechild! They did it because I kept working hard every year to try to overcome and to try to make the system work for me.

"I've got no regrets from that period and I'm comfortable with the fact that, occasionally, I was able to genuinely beat someone who won a couple of world titles in the same car. It's more difficult to compare when you beat someone in a different car, but I had some good battles with Michael and some cheeky little passes here and there – which didn't happen because I missed my braking point! They happened because they were planned and I could see a weakness and I took the opportunity." ▶

DC: THE BEST AND THE WORST



Spa '98 prompted flashpoint with 'never-wrong' Schuey

BONGOTS/GETTY



DC picks 2000 British GP win as one of his best



Great effort in Williams at Monza '95. Then disaster...

LAT

Who was your biggest rival?

"Michael Schumacher's amazing success and rewriting of the history books gave my career credibility. I did the best I could, but finishing second in a world championship to the most successful driver in the history of the sport gives me some comfort. Would I rather be Keke Rosberg, winning one grand prix and a world championship or would I rather be second having been up against someone who you can say was pretty damn hot?"

What's your favourite win?

"I enjoyed all the wins but especially the ones where you really had to work hard for it at places like Spa, Silverstone and Monaco. It's probably the second Monaco [2002] or the second British one [2000]."

Best qualifying lap?

"My best-ever weekend of qualifying was Monza 1995. Jock Clear was my engineer at Williams and we were on pole position on Friday and Saturday. You could argue I was only beating Damon Hill [Schumacher was actually second, with Hill fourth over a second slower – Ed] but I felt in such a zone with that particular car on that weekend. I then went on to spin on the parade lap..."

What about your biggest crash?

"All my crashes were in winter testing. I hit the sleepers at Club Corner at Silverstone in my Williams in '95, cracked my helmet on the chassis and got knocked out. I rolled the McLaren at

Barcelona in a private test when there was a tyre failure. The rear suspension failed in a winter test at Valencia, just as I braked into the first corner – I was doing 190mph on the wooden plank and did one skip over the gravel and got embedded into the Armco. That was a pretty big impact and it hurt my middle back."

What was your best argument?

"Michael at Spa [1998]. But the best part of that argument was not that, it was sitting in Bernie's motorhome at Monza afterwards. I went to the test the week after and the crowd were booing every time I came out, 'killer Coulthard' banners, and Bernie organised for us to go and sit down, just the two of us, and we discussed who was at fault.

"I said, 'I was slowing down to let you past, I didn't brake-test you. I accept I should have pulled off line because, with hindsight, I realise driving into spray you don't know where I am and there's an assumption, down the straights, everyone is going flat-out. You have to be able to look in my eyes and trust me that it's just a set of circumstances which appears much bigger than it is, it's not a conspiracy against you.'

"That got me to the point of saying, 'Surely you've been wrong at times in your life' and he went, 'Not that I remember.' And then I was exasperated and said, 'When you're at home with your wife, you can't always be right?' He just shrugged and said, 'No'. So how can you negotiate with someone who's not prepared to even give you anything?"



On the brakes against Schumacher, Spa '04

ETHERINGTON/LAT

“At Melbourne '98, Ron asked why I didn't let Mika past somewhere more quietly than in front of the pits. I said, ‘It's my career as well’”

46

► **If you had a reset button, is there any time to which you would go back to and do something a bit differently?**

“You can't change your personality. In Jerez '97, Ron had made that deal with Frank [Williams], which none of us knew anything about, that if we helped Williams in their quest to beat Ferrari they wouldn't get in the way of helping McLaren. Ron would probably still deny it today. That's what happened, then they asked me to move over.

“Apparently, I was running behind Mika and they told him to come in to clear the way for Jacques Villeneuve but that meant I jumped in at the pitstop. I see it differently because I was right with him and they wanted him to be realigned for 20 laps and then tell me to move over. Eventually Dave Ryan, who was on my side, said, ‘Look, you're compromising your position within the team’, which I saw as another way of saying ‘you'll get fired’ so I moved over and Mika won the race.

“Then there was that ridiculous finish where I let him past and Berger almost overtakes as Jacques slows down. I remember explaining immediately afterwards to Heidi, my girlfriend at the time, and Peter Windsor was standing there. Ron walks up and says we can't say anything, and Heidi turned around to Ron and said, ‘You're a f**king asshole.’ And then Ron just walked off, he didn't react.

“There were all sorts of fun and games that went on at that time. And it took energy, time and emotion. I could have ignored that instruction, but they were paying me to do a job and I needed the opportunity to do the job.

“Then there was Melbourne '98 where the car was unreliable and we agreed a format where it was initially suggested for qualifying, but Mika was pretty handy at that so I said it should be the first corner because I figured even if I'd been outqualified I still had a fighting chance down to the first corner.

“As it happened, we were first and second by [over] half a second, I didn't manage to outrun him and that was it. Then Mika did his pitstop because Mark Slade said ‘cool your brakes’, and because he was deaf in one ear he claims he thought he said ‘pit now’. So I ended up in front and they wanted me to change around and I chose to do that in front of the pits. Ron said, ‘Why didn't you do it more quietly somewhere else?’ And I said, ‘It's my career as well. It needs to be known I'm moving over otherwise it looks like I'm being beaten.’”

Was it hard to deal with the fact that Mika was that bit quicker over a single lap?

“It was difficult. You could see what you needed from the car that would give you that time, but the difference was you needed a car change to deliver that time. The cars are not exactly the same. There were days he wasn't performing even though he was exceptional, and I would outqualify him, but he was more often able to deal with the compromise of what he had and deliver the lap.

“When I had everything aligned I was able to be on pole. But he had that ability to accept a compromise – that made a big difference.”



Contentious conceding of 1997 European GP

LAT



Freeview
CHANNEL 240

THE HOME OF LIVE MOTOR SPORT IS NOW **SUBSCRIPTION FREE**



Freeview CHANNEL 240

From around **midday on February 27** Motors TV will be available on Freeview. Anyone with a compatible internet-enabled Freeview HD or Freeview+HD product can enjoy **subscription free access** to the High Speed Television Channel.

That means more motor sport fans than ever before can watch **live coverage** of the FIA World Endurance Championship, V8 Supercars, TUSC, ELMS, Blancpain GT Series, NASCAR Nationwide Series, FIA Formula 3 European Championship, FIM MXGP and FIM Endurance World Championship, plus daily FIA WRC highlights and so much more besides.

Available on selected products only. For more information visit www.motorstv.co.uk

www.MotorsTV.co.uk

/MotorsTVInternational

@MotorsTV

Celebrating 15 years of



OUR GOAL

To give you excellent technical advice, to keep a vast range of fuels, oils and consumables in stock, and to deliver quickly. Our aim is to be your "one stop fuel and lube shop". We distribute directly in the UK and through our distributors in Europe and the Middle East. We are really looking forward to what the next 15 years have in store. Please call us for special offers throughout 2014 to celebrate our anniversary.

Distributor of



Proud supplier to



+44 (0)1929 551557 info@aaoil.co.uk www.aaoil.co.uk

fuelling racing!



BORN FROM JOE GIBBS RACING

DRIVEN

DRIVEN TO WIN RACING OIL®

SUNOCO RACE FUELS

Sunoco is the largest supplier of racing fuels in the world and we are proud to represent them in the UK, Europe and the Middle East. We keep a vast range of unleaded, leaded, E85, methanol, GTL diesel and specially blended 99 to 119 octane racing fuels in stock for immediate dispatch to your door. We also stock accessories such as pumps and cleaning products.



DRIVEN RACING OIL

Born from Joe Gibbs Racing and although only 10 years old, Driven Racing Oil are specially developed for racing. What started as one running in oil and one race oil have now grown into one of the widest ranges of racing engine, gearbox and transmission oils available today. Driven is quickly becoming the must have race oil for serious racers.



We deliver to your door!



WELCOME TO THE **TW STEEL** DMAX CHAMPIONSHIPS



NEW Weight Classes for 2014
 Lights Min 70Kgs
 Inters Min 85Kgs
 Heavies Min 100Kgs

Prices are £190* per Endurance Round and £165* per Heats Round
£295* to enter both

Cumulative Loyalty Discount of 2.5% for each round entered.

A full season of Heats Racing for £1476* or Enduro Racing for £1699*

16 February 2014	Daytona Milton Keynes
16 March 2014	Daytona Sandown Park
20 April 2014	Whilton Mill
18 May 2014	Rye House
15 June 2014	Daytona Milton Keynes
20 July 2014	PF International
17 August 2014	Clay Pigeon
21 September 2014	Whilton Mill
19 October 2014	Daytona Milton Keynes
16 November 2014	Daytona Sandown Park

Tel: 0845 644 5504
www.daytonamax.co.uk



*all prices include VAT



6 HOURS OF SILVERSTONE

18-20 APRIL 2014

FIA WORLD ENDURANCE CHAMPIONSHIP

The FIA World Endurance Championship returns to Silverstone for their opening round in what will be another action packed weekend here at the circuit.

There will be fresh competition for Toyota and Audi with former F1® ace Mark Webber signing for Porsche. The racing is sure to have you sitting on the edge of your seat!

With an exciting program packed full of Le Mans endurance racing and entertainment, there is no better reason to visit Silverstone for the ultimate Easter weekend of motorsport.

BOOK NOW ON FIAWEC.COM
FROM £20 & FREE UNDER 15

THEY ARE READY,

WHAT ABOUT YOU?
 ASTON MARTIN
 AUDI | FERRARI
 PORSCHE | TOYOTA





Keselowski moved in front on final lap of the race

NASCAR SPRINT CUP LAS VEGAS (USA), MARCH 9, RD 3/36

Keselowski denies Dale Jr

BRAD KESELOWSKI SCOOPED THE NASCAR Sprint Cup jackpot in Las Vegas after Dale Earnhardt Jr's luck resembled his Chevrolet's fuel tank in Nevada – it ran out.

Earnhardt's gamble on fuel was appropriate given the location, and his decision not to pit with 45 laps to go under the final caution set up a grandstand finish with the crowd – and Earnhardt's Hendrick team – watching nervously to see if his Chevrolet would make the finish.

The Daytona 500 winner held the aces at the restart, bolting clear as Keselowski's Ford recovered lost ground having emerged from the pits outside the top six.

Penske's 2012 champion had rocketed to second through Turn 1 but was delayed as Carl Edwards regained the runner-up spot briefly. By the time Keselowski had made the place his own, a process that took a dozen laps, he was 2.8s behind Earnhardt.

That gradually ticked down, and with just over 10 laps to go the race leader got the message he was

expecting, but dreading. "We're three quarters of a lap short, at best half," radioed crew chief Steve Letarte.

"Just run hard right now, run hard."

Keselowski reduced Earnhardt's remaining gap to nothing and piled on the pressure, hauling himself alongside the leader before the #88 fought back to lead on the final lap.

With the tension at breaking point in the Hendrick camp, the team's driver confirmed the worst.

"Run out, run out," was the message as Earnhardt moved aside on the back straight, allowing Keselowski by. He managed to hold onto second just ahead of Paul Menard, who charged through the field in the final third of the race.

Before the final caution, Keselowski had led Menard, Jimmie Johnson, Kyle Busch and Earnhardt, who then rolled the dice.

Earnhardt's team made it clear that the strategy was a long shot – and the half-a-lap-short prediction proved spot-on when Keselowski roared past as they powered down the back straight for the final time.

Behind the limping Earnhardt and delighted Menard, whose Childress Chevy led before the final round of green-flag stops, was Joey Logano, who vaulted up the order during the final pair of pitstops to clinch fourth.

Logano had spent two thirds of the race outside the top 10 struggling with his Ford's handling in traffic, after he'd started from pole and shrugged off a challenge from Penske team-mate Keselowski into Turn 1 at the green flag. As Keselowski slid wide and dropped to seventh, Logano drove imperiously to lead the first 44 laps almost uninterrupted, and headed the field until the second caution, when he fell out of the top 10.

Among the other race leaders were Johnson, Kyle Busch and Kevin Harvick, but the last-named fell out of the fray when he dived into the pits and retired with brake issues at three-quarters distance.

Edwards and Johnson completed the top six, but Busch tumbled down the field after the final stop, eventually finishing 11th.

● Connell Sanders Jr

NASCAR NATIONWIDE

Brad Keselowski not only won the Sprint Cup round in Las Vegas – he took Saturday's Nationwide event after shrugging off low-battery-voltage worries to hold off Kyle Busch. Kyle Larson completed the top three, with Dale Earnhardt Jr fourth and Chase Elliott the top series regular in fifth. Technical checks mean Keselowski and Elliott will have to wait on possible post-event penalties.

NZ V8 TOURING CARS

Jason Bargwanna was denied a win in the first race of the series' penultimate round at Taupo, but made up for it by winning the other two. His Toyota nudged leader Nick Ross's Holden off the road in race one, Bargwanna taking a drivethrough penalty that gave victory to Ross. The spoils in the third and final race were decided when points leader Bargwanna undercut Ross during the compulsory pitstops.

NEW ZEALAND FFORD

Jamie Conroy won all three races in the final round at Taupo to clinch the championship with 16 victories from 18 races in his Mygale. The 22-year-old, in his rookie season of car racing, is run by Wal Willmott (below, with Conroy), the first employee of McLaren Racing who worked at the team until returning down under in 1968. Michael Collins finished as championship runner-up.



Earnhardt ran dry but made it home second

RESULTS

1 Brad Keselowski (Ford Fusion), 267 laps in 2h35m24s; 2 Dale Earnhardt Jr (Chevrolet SS), +1.530s; 3 Paul Menard (Chevy); 4 Joey Logano (Ford); 5 Carl Edwards (Ford); 6 Jimmie Johnson (Chevy); 7 Ryan Newman (Chevy); 8 Kasey Kahne (Chevy); 9 Jeff Gordon (Chevy); 10 Matt Kenseth (Toyota Camry). **POINTS**

1 Earnhardt, 133; 2 Keselowski, 132; 3 Johnson, 117; 4 Logano, 116; 5 Gordon, 115; 6 Edwards, 105; 7 Kenseth, 105; 8 Denny Hamlin, 101; 9 Newman, 97; 10 Kyle Busch, 95.



GEOFF RIDDER

MARTINI

STARS IN STRIPES

Williams last week announced Martini as its lead sponsor in F1, so **HENRY HOPE-FROST** takes a look back at some of the most iconic cars to have worn the colours of the famous drinks brand

The Martini racing stripes, and the different varieties in which they have appeared, have provided some of the most recognisable sponsorship colours in motorsport history. Martini has appeared on successful cars in sportscars, touring cars and the World Rally Championship, as well as Formula 1. With Williams bringing the famous name back to motorsport, we thought it was a good excuse to pick out, in chronological order, the coolest cars from Martini's history.

PORSCHE 917

SPORTSCAR LEGEND

Martini's successful collaboration with Porsche began in 1968 when the famous stripes appeared on the three-litre 908 sports-racer.

The relationship continued in 1971 with the formidable 917. Highlights were victory in the Sebring 12 Hours for Vic Elford and Gerard Larrousse in the silver Martini car and a Le Mans win for Helmut Marko and Gijs van Lennep in the white version.

The #22 917 (below)

set a distance record in the French classic that would not be broken for almost 40 years.

At the end of the year, the Martini squad and the similarly factory-backed Gulf JWA team had helped Porsche secure its third consecutive manufacturers' title.

CAR Porsche 917 (Martini)

HIGHLIGHTS

2 wins

1971 Sebring 12 Hours
1971 Le Mans 24 Hours

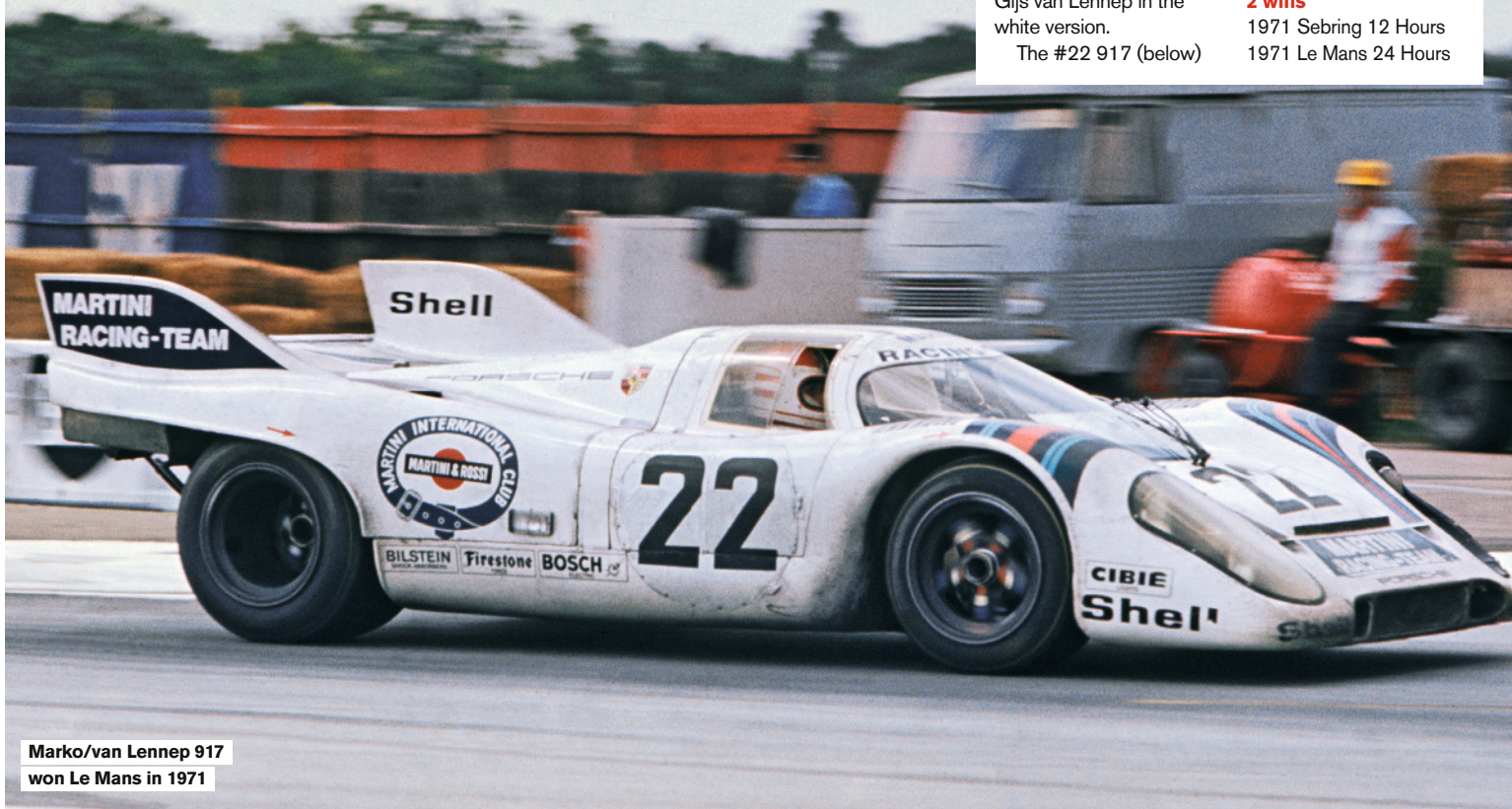

Marko/van Lennep 917
won Le Mans in 1971

BRABHAM BT44B

F1 BEAUTY

After an unsuccessful tie-up with Italian Formula 1 minnow Tecno in 1972-73, Martini returned to F1 for an altogether more high-profile and fruitful partnership with the Brabham team.

The plain-white BT44 of 1974 was upgraded to B-spec at the start of '75 and was blessed with those stripes.

South American heroes Carlos Reutemann and Carlos Pace helped the team to second in the constructors' world

championship, thanks to nine podium finishes, including a win apiece for the two Carloses.

Surely one of the finest-looking grand prix cars of all time.

CAR Brabham BT44B

HIGHLIGHTS

2 wins

1975 Brazilian GP

1975 German GP

7 other podiums

Reutemann 5

Pace 2

1 pole

1 fastest lap



Pace hustles the BT44B at Montjuich Park in '75



Ickx anchored '77 Le Mans win in factory Porsche 936

PORSCHE 936

ENDURANCE DOMINATOR

So called because it used the 930 turbo powerplant and was devised to contest the Group 6 category of international sportscar racing, the 936 arrived in 1976.

The open-cockpit prototype, with a 2.1-litre, flat-six turbo motor won the World Championship for Sports Cars (its Group 5-spec cousin won the concurrent World Championship for Makes) and Le Mans in year one.

The 936 continued its winning run in 1977, still in Martini colours, with another Le Mans victory, once again anchored by

factory ace Jacky Ickx.

Porsche didn't encourage customer teams to run the 936, although did offer unofficial support to some – notably Reinhold Joest – so most of its success came in factory-entered, Martini-liveried guise.

CAR Porsche 936 (Martini)

HIGHLIGHTS

7 wins

1976 Le Mans

1977 Le Mans

1976 Monza, Imola, Enna-Pergusa, Dijon and Salzburgring World Championship for Sports Cars

BRABHAM BT45B

RED ROCKET LACKING LUCK

The Alfa Romeo-powered BT45 of 1976 didn't produce the goods in the same way its Cosworth-powered predecessor had done; its best result, second, came in the Argentinian GP of the following season while Bernie Ecclestone's team readied the 45B.

The replacement car appeared for the fourth race of '77 at Long Beach, still resplendent in the red Martini livery.

John Watson was unlucky not to win several races that year; second place in the French GP for the Irishman was complemented by two third-place finishes for his team-mate Hans Stuck in this sensational-looking car.

CAR Brabham BT45B

HIGHLIGHTS

3 podium finishes

Stuck two, Watson one

1 pole

1 fastest lap



Watson led the first 49 laps of the '77 British GP



Waldegaard made 911SC dance in the African dirt

PORSCHE 911SC

MARATHON RALLY RAIDER

Four years before Martini began one of the longest and most profitable partnerships in motorsport sponsorship – a decade with Lancia in rallying – its colours adorned the Porsche 911SCs used by Bjorn Waldegaard and his African team-mate Vic Preston for the 1978

Safari Rally.

Local hero Preston went on to finish second, with Swede Waldegaard taking fourth in the 5000km, five-day marathon.

CAR Porsche 911SC
HIGHLIGHTS
Second place
 1978 Safari Rally

PORSCHE 935-78

PROTOTYPE EATER

Dubbed affectionately 'Moby Dick' in deference to its aerodynamic whale tail, Porsche's final evolution of the venerable 935 moved the Group 5 goalposts off the pitch.

The 3.2-litre machine was built for Le Mans but made its bow in the World Championship for Makes-qualifying Silverstone 6 Hours in May, with Jacky Ickx and Jochen Mass beating the older 935/77 of Bob Wollek and Henri Pescarolo by seven laps!

Things didn't go as well at Le Mans, however. The car qualified third with drivers Manfred Schurti and Rolf Stommelen and its 235mph top speed enabled it to steam past the open prototypes on the Mulsanne Straight. But engine problems in the race limited the monster to eighth place, 43 laps off the winning distance.

CAR Porsche 935-78
HIGHLIGHTS
Victory
 1978 Silverstone 6 Hours



Ickx and Mass (in car) blitzed '78 Silverstone 6hr

LANCIA LC1 AND LC2

TAKING ON THE MIGHT OF PORSCHE

Lancia lifted the up-to-two-litre crown in the 1979 and '80 World Championship for Makes with its Group 5 Beta Monte Carlo, but shifted its programme to the ageing Group 6 formula

for 1982, bucking the trend to go with an all-new Group C machine to circumvent fuel-limit rules.

The slippery-shaped, open-top, Dallara-built LC1 prototype took pole

on its debut at Monza in 1982 with F1 star Riccardo Patrese, then won three times. It was piloted by a roster of single-seater aces, including Patrese, Michele Alboreto, Teo Fabi and Piercarlo Ghinzani.

When Lancia did commit to Group C –

and thereby qualify to score points in the makes' championship – the exquisite LC2 racer was born.

Pole on its debut, at Monza in 1983, came courtesy of Ghinzani, but the car was no match for Porsche's 956.

The first win came in a

European Endurance Championship round at Imola, although the first World Sportscar Championship victory didn't arrive until the end of 1984.

There was one further win – in 1985 – before Martini chose to focus its efforts on rallying.

CARS Lancia LC1 and LC2
HIGHLIGHTS
LC1: 3 World Sportscar Championship wins
 1982 Silverstone, Nurburgring, Mugello
LC2: 1 European Endurance win
 1983 Imola
2 World Sportscar wins
 1984 Kyalami, 1985 Spa



The Baldi/Patrese/Wollek LC2 won '85 Spa 1000km

LANCIA 037

LAST HURRAH FOR REAR-WHEEL DRIVE



Alen gives it large in 037 during '84 Sanremo Rally

MCLLENDE

The two-seat Lancia 037 was conceived for the FIA's Group B rallying regulations for cars that only needed limited-number production models to satisfy entry criteria.

The car was a collaboration between styling house Pininfarina, tuning wizard Abarth and chassis guru Dallara. It made its debut in a European championship round in Italy in 1982 before appearing for the first time in the WRC in Corsica that year.

Five wins for Markku Alen and Walter Rohrl gave Lancia the manufacturers' crown the following season

and the 037 remains the last two-wheel-drive car to win the title.

Alen won in Corsica the following year, before the 037 was vanquished by the four-wheel-drive cars from Audi and Peugeot in 1985, necessitating a move by the Italian firm to create a car to take the fight to the Quattro and 205T16 (see below)...

CAR Lancia 037
HIGHLIGHTS

Six WRC victories
1983 Monte Carlo, Corsica, Acropolis, New Zealand and Sanremo; 1984 Corsica; winner of 1983 manufacturers' WRC

LANCIA DELTA S4

ULTIMATE GROUP B MONSTER?

Not even the most passionate Lancia fans, the ones who'd spent almost four years having their knees clipped during the heroics of Markku Alen, Miki Biasion, Walter Rohrl and Henri Toivonen in the two-wheel-drive 037s, could have prepared themselves for the Group B S4 that appeared for the first time in the World Rally Championship on the 1985 RAC Rally.

The turbocharged and supercharged monsters of Toivonen and Alen romped

to an easy debut one-two in the British forests.

Further success in 1986 was overshadowed by Toivonen's death in Corsica, with the sport's most dangerous cars then outlawed at the end of that year.

Martini and Lancia continued to dominate the sport with the advent of Group A, taking the manufacturers' crown every year between 1987 and '92 with the Martini Delta HF Turbo and Integrale models.



Toivonen gave the wild S4 a debut win on the '85 RAC

CAR Lancia Delta S4
HIGHLIGHTS

Four wins
1985 RAC
1986 Monte Carlo, Argentina and Olympus.

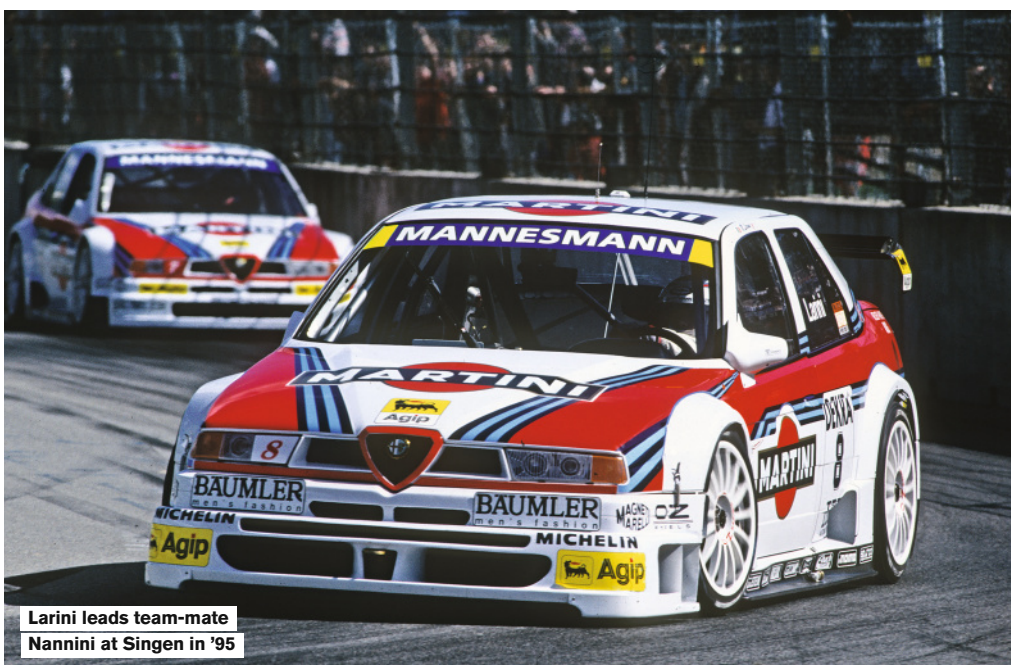

Larini leads team-mate Nannini at Singen in '95

ALFA ROMEO 155 DTM

TECHNOLOGICAL TIN-TOP

British Touring Car Championship fans will recall fondly the Alfa 155 making an instant mark on the series in 1994, but a more muscly, bewinged version of the car had already made a huge impact on the German-based DTM.

Italian Nicola Larini secured the drivers' title in 1993, winning 11 of the 22 races. His team-mate Alessandro Nannini also won twice. The duo repeated its winning ways in '94, racking up nine further victories.

The 1995 season heralded the advent of the

concurrent ITC, an attempt to give the DTM a global reach, and with it came Martini sponsorship for the factory Alfa Corse 155s. Larini and Nannini won 10 races across the balance of the '95 DTM/ITC and '96 ITC campaigns in what were arguably the most distinctive tin-top machines of all time.

CAR Alfa Romeo 155 (Martini)

HIGHLIGHTS
10 ITC wins

1995 Helsinki; 1996 Estoril x2, Nurburgring x2, Mugello, Interlagos x2

Race of Champions

1974
RETRO

It's 40 years since Jacky Ickx sensationally won Brands Hatch's curtain raiser to Europe's F1 season. CHAS PARKER looks back

You could argue that Jacky Ickx has reason to be grateful to the National Union of Mineworkers. Without the organisation's unintentional intervention in 1974, he might never have won what was to be his last-ever Formula 1 victory, or pull off one of the great overtaking moves of all time.

It had been a bleak winter for UK motorsport fans, with a worldwide fuel crisis causing a blanket 50mph speed limit to be imposed across the country, and even threatening the start of the new season. In addition, industrial action by the miners meant that coal to fuel power stations was in short supply and so, from January 1 until March 7, the government brought in a three-day working week in order to conserve electricity.

For the F1 teams, almost all of which were based in Britain, the reduced manufacturing capability meant that spare parts and engines were in short supply. Nevertheless, the season had kicked off in Argentina in mid-January, with Denny Hulme taking victory in his McLaren ahead of the two Ferraris of Niki Lauda and Clay Regazzoni. A fortnight later, at Interlagos in Brazil, home hero Fittipaldi made it a second victory for the McLaren team, followed home by Regazzoni and Ickx in a Lotus.

There was now a two-month break before the

next grand prix, the South African race having been moved from the beginning to the end of March due to a temporary ban on racing in that country, but sandwiched in between were two non-championship events: the Grande Premio Presidente Emilio Medici at the Brasilia circuit in Brazil, which was won by Fittipaldi, and the Race of Champions at Brands Hatch on March 17.

Britain used to host a number of non-championship F1 races – the International Trophy at Silverstone and the Gold Cup at Oulton Park being the other main events – and the Race of Champions provided a precursor to the European F1 season. If it was an even-numbered year, it was also a taster for things to come at the British Grand Prix in July, this event alternating between Brands and Silverstone from 1964 to '86.

This year marks the 40th anniversary of that 1974 event, one of the last of those traditional season-opening F1 races to feature a really strong field, and which has gone down in motor racing folklore for one of the greatest wet-weather overtaking manoeuvres ever seen.

Heading the original entry was a pair of the new Lotus 76s for Ickx and Ronnie Peterson, but instead the team substituted a single 72E for Ickx. They had been testing the new car at Jarama in Spain and, with engines and spares in short supply, team boss Colin Chapman decided it was better to concentrate on the South African GP in a fortnight's time, and to ship the cars directly there.

Reports at the time say that Ickx and Peterson tossed a coin to see who would drive at Brands, but the Belgian denies this. "No, it's not true," he says. "I think the decision was made by Colin Chapman. We had two races, one at Silverstone, and he decided to put Ronnie into one race and me into the other. We had two races but not the possibility to have two cars in every race, and they decided I would do Brands Hatch and Ronnie had to do Silverstone."

Ickx was a newcomer to the JPS-liveried Lotus team, having spent the previous four seasons with Ferrari, but leaving part-way through the previous year. "I had to discover the team and discover the people around me, and it was a new story starting for me. It was not an easy period," he explains.

His type 72E included a revised saddle-style oil

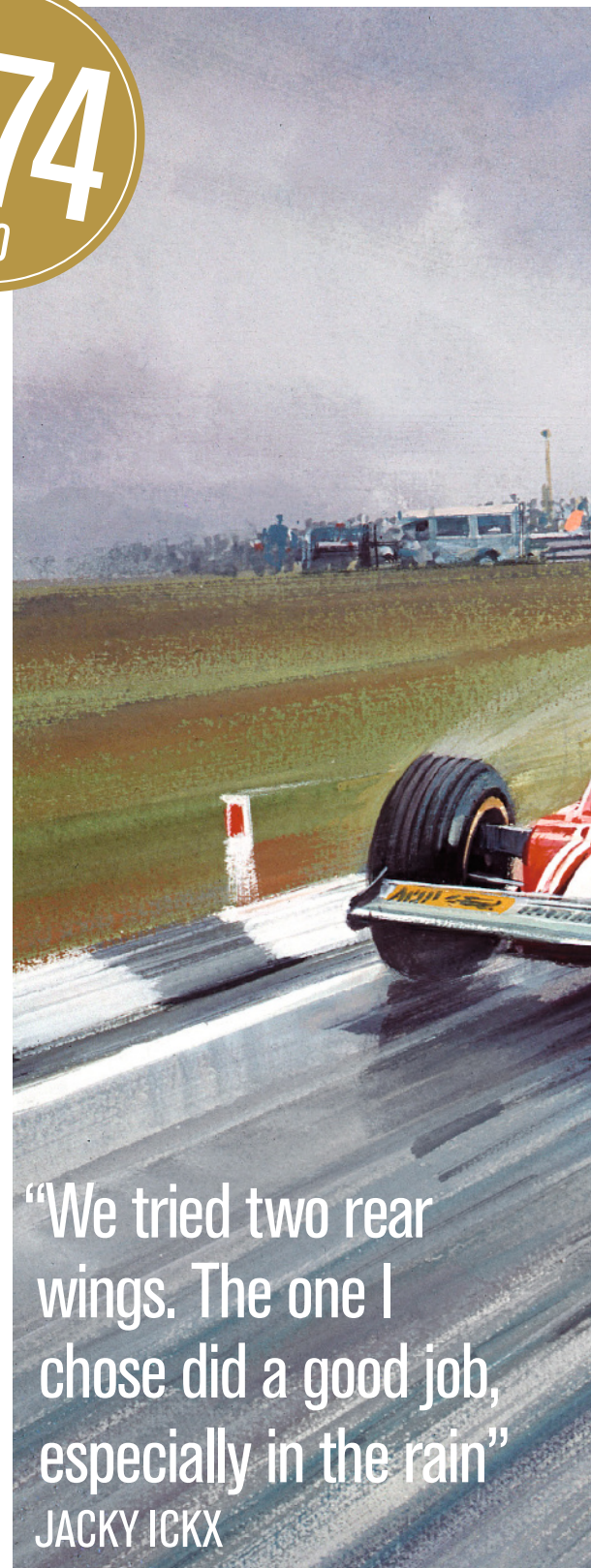

tank, straddling the gearbox, to improve airflow to the rear wing, and a new 'banana'-shaped rear aerofoil. "I think we had some practice a week or two before," he recalls. "We tried two different types of rear wing, if I remember well. I chose one of these wings and I think that wing was doing a good job, especially because it was raining."

Ferrari sent two 312-B3/74s for Lauda and Regazzoni, while McLaren fielded three of its M23s – two Texaco-Marlboro-backed examples for new signing Fittipaldi and Hulme, with a Yardley-supported car for Mike Hailwood, all three sporting a narrow 'winkle-picker' nose, which was only subsequently seen during practice for that year's Monaco Grand Prix but never raced again. There was a brace of Shadow DN3s for Peter Revson and



Jean-Pierre Jarier, while Brabham fielded a BT44 for Carlos Reutemann and a BT42 for Richard Robarts.

All of these were running on Goodyear tyres, while the rest of the field sported Firestones and comprised the new Harvey Postlethwaite-designed Hesketh 308 for James Hunt, which was making its race debut, a new Embassy-backed Lola T370 for Graham Hill, Henri Pescarolo in a BRM P160E, a Surtees TS16 for Jochen Mass, an Ensign N174 for Rikky von Opel and the Lyncar of John Nicholson. Chris Amon's new Amon AF101 had also been entered, but suffered an accident during testing at Goodwood and was withdrawn.

Augmenting the entry were the top runners in the Rothmans Formula 5000 Championship, including the outright winner of the previous year's

race, Peter Gethin, in a Chevron B28.

Practice consisted of a pair of two-hour sessions on the Friday and Saturday. Revson's Shadow had been quickest in Friday's cold, windy and wet conditions but, right at the end of the session, Lauda put in a time one and a half seconds better than anyone else, earning himself 100 bottles of champagne from the *Evening News* in the process.

Saturday defied the weather forecasts with blue skies, albeit still very cold – conditions that suited the Firestone runners. Thus, to everyone's surprise, including the Hesketh team itself, Hunt put his new 308 on pole at its debut race, with Regazzoni alongside him. Lauda and Reutemann occupied row two, ahead of Pescarolo and Fittipaldi. Hailwood and Mass were next, followed by Revson and

Hulme, with Ickx and Hill back on row six. Jarier crashed on his first flying lap on Saturday and would not start, while von Opel withdrew, unhappy with the handling of his car.

Around 41,000 people turned out on race day, which was wet – very wet. During the morning warm-up session, Mass crashed his Surtees and so non-started, while Ickx's engine blew up, necessitating a change. The Belgian's lowly grid position had been partly a result of a down-on-power engine, the team not wanting to use a new one, but when his DFV expired one of those intended for South Africa had to be installed instead.

Hold-ups from previous races meant the start was delayed by half an hour, by which time a ▶

It's narrow, it's twisty... Can you drive it flat out?

Try the challenge of Speed Hillclimbing at the **Gurston Down Hillclimb Drivers School**

- No experience necessary
 - Qualified, MSA-licensed Instructors
 - Helmets provided (if required)
 - Superb lunch and refreshments included
 - Full day's activities just £165
 - "Gurston grin" guaranteed!!
 - Competition Licence upgrade option available
- Year's top student receives a free day at the Thruxton Motorsport Centre!

Available dates in 2014:

April 8th, May 6th, June 10th, July 8th
BOOK NOW!

Contact Andrew Hext on 07971 989517

GIFT
VOUCHERS
AVAILABLE



Supported by Car & Commercial Services
Member of the Association of Hillclimb and Sprint Schools

Gurston Down is located in superb surroundings, 9 miles south west of Salisbury, Wiltshire. Full details at www.gurstondown.org
Voted Best British Hillclimb Championship event organiser a record 9 times



Xtreme range

Xtreme alloy touch up Xtreme alloy repair kit
Xtreme windscreen chip repair Xtreme bond
Xtreme glass scratch repair



+44(0)1903 750355

www.simply-brands.com

sales@jrpdistribution.co.uk

Simply

Professional wheel cleaning by

Valet PRO[®]
PROFESSIONAL VALETING SUPPLIES



BILBERRY WHEEL CLEANER

This is our best selling wheel cleaner and it's perfect for everyday use. Simply spray on rinse off for dazzling results every time.

DRAGON'S BREATH

Designed for use on custom wheels, chrome, anodised, polished and split rims. This product is extremely powerful but it's pH neutral so it's safe for all wheel finishes. Dragon's Breath reacts and dissolves iron particles, so baked on brake dust becomes water soluble. You can see the product working with the naked eye as the clear gel turns red when activated.

BLUE GEL WHEEL CLEANER

Professional acid based wheel cleaner is the first choice for those really tough jobs, or for wheels that have a high build up of dirt and road grime. The gel formula means the product can be applied precisely and accurately with no wastage, with cleaning power that's second to none.

Find a stockist at valetpro.co.uk
or call us on **01323 287980**

**Auto
Windscreens
MOTORSPORT**

**Proud patron of the
2014 BRDC RISING STAR PROGRAMME.**

To celebrate our patronage and continued support of British racing we have launched AUTO WINDSCREENS MOTORSPORT!

Visit Auto Windscreens Motorsport today and enter our new fantasy challenge to win fantastic prizes.

Register at www.autowindscreenmotorsport.co.uk





Hunt's Hesketh loses pole advantage to Regazzoni and Reutemann

► steady drizzle was falling as the cars lined up for 40 laps. No starting lights in those days – it was an up-and-down of the Union flag that sent the cars on their way, Hunt and Regazzoni both spinning their wheels in a mass of tyre smoke as Reutemann took advantage and swept to the left of them and into the lead. Lauda was boxed in by his team-mate as Fittipaldi went by into second.

Up at Druids on the first lap it was Reutemann from Fittipaldi, Regazzoni and Lauda, this trio side-by-side through the hairpin. Ickx, meanwhile, was already up to fifth and poleman Hunt down to sixth. The following lap he spun at the exit of the corner, dropping almost to the back of the field, and retired a short while later, the handling of the Hesketh having become unmanageable.

With the white Brabham out in front, Lauda took second from Fittipaldi. Reutemann's front brakes were beginning to lock intermittently and he was passed by the Ferrari on lap seven, then on lap 14 by Fittipaldi and Ickx, who was flying. Soon afterwards the Argentinian was caught out when

the right-front brake locked at Druids, pitching him into the barrier and out of the race.

Lauda now seemed to have everything under control as the leading trio lapped backmarkers, a factor that aided Ickx in closing on Fittipaldi's McLaren. He took second place from the Brazilian on lap 16, saying after the race that he hadn't even seen him when he went past – conditions were that bad – and set off after Lauda, who was now struggling with a faulty shock absorber. He caught the Austrian with a dozen laps to go and planned his move. The pair appeared through the spray down the main straight and onlookers in the Paddock Hill Bend grandstand thought for a moment that Ickx's throttle must have jammed. They jumped to their feet as the Lotus pulled out and simply drove past the Ferrari, around the outside of the plunging downhill corner, Ickx somehow finding enough grip to stay on track.

"In reality I made two attempts," he explains. "The first one I was just a little bit too far away, but luckily for me he didn't see me doing this attempt. And the second one the next lap was just fine."

A few laps later the black-and-gold car crossed the line and Chapman's cap flew in the air in traditional celebratory style. Along the way, Ickx also set fastest lap and took great satisfaction from beating his old team.

"Obviously I did like Brands Hatch and my car went very well in the wet," he says. "As you know, when it's raining I am usually fairly under control, and I was always good in the rain, so without any doubt that helped me a lot. You can say I'm one of the very few people who attempted overtaking

ICKX'S AFFINITY WITH BRANDS

Brands Hatch was a good track for Jacky Ickx, the Belgian enjoying a number of other successes on the Kent circuit.

"I always went fairly well there," he says, "because with the Ferrari in '72 at the Grand Prix I was in the lead before I had to retire, and I won the endurance championship at Brands in '82, [co-driven by Derek Bell] against the Lancia. I also won the BOAC 500 in '68 with the GT40 [sharing with Brian Redman] in front of the Porsche."

He fails to mention that he also won the 1972 BOAC 1000 in a Ferrari 312PB sharing with Mario Andretti, the 1977 6-hour event, also in the wet, in a Martini Porsche 935-77 with Jochen Mass, and that 1982 title success was taken with victory in the 1000Km in a Rothmans Porsche 956.

"Sometimes some tracks are more favourable for you than others, like the Nurburgring and Brands Hatch for me," he says.

around the outside of Paddock Bend. And to overtake Niki Lauda on the outside of Paddock Bend, it was nice, yes it was nice."

The race was expected to be the last run for a Lotus 72 but problems with the 76, it being neither competitive nor reliable, meant it was brought back into service again, providing Peterson with victories in Monaco, France and Italy. Ickx's best result was a third back at Brands Hatch in July.

"It was also my last win in Formula 1, so it left a special taste, because the rest of the season with Lotus was for me a total disaster for a lot of reasons," continues Ickx. "And you know, life is like that sometimes – you have a lucky choice, sometimes less lucky. But it's a very good memory."

And maybe it was lucky for Ickx that the situation in Britain had caused that shortage of spares, which meant the old 72 was brought into use. It's highly unlikely he would have had the same success in the recalcitrant type 76.

Less lucky was the person who was probably closer than anyone else to Ickx's overtaking manoeuvre, yet never actually saw it. Photographer Jeff Bloxham was halfway through the tunnel that runs underneath the track at Paddock Bend and heard the roar of the crowd above him... ❧

"I made two attempts. The first was from too far away, but luckily Niki didn't see it" JACKY ICKX

SORRIER TALE FROM THE F5000s

One person for whom an overtaking attempt around the outside of a corner didn't work was Formula 5000 driver Mike Wilds. He had finished second the day before in the opening round of the European F5000 championship but started the Race of Champions on the last row of the grid in his March-Chevrolet 74A.

"I made a reasonable start and got as far as Druids without any incident," he explains. "Teddy Pilette in the VDS Chevron was in front of me and he tucked in on a tight line, a dry line at Druids where the surface is more polished, and in the wet I always went up around the outside. So I left my braking a little bit late, and just went straight up and then turned to go round the outside of Druids and started to overtake Teddy around the outside. Of course, he had quite a lot of power from his five-litre Chevy and he gave it a big bootful to try and get out of the corner in front of me and spun.

"Unfortunately, because I was on the outside, as he started the slide and spin, his left rear hit my right front and punched the suspension through the monocoque, luckily missing my legs. But of course it ended my race.

"It was an awesome day for me because it was my first really big motor race. It was a shame I only managed two corners because I won a few thousand pounds for finishing second in the European F5000 race on the Saturday, and I think the repairs on the car, almost to the penny, cost the same amount as I'd won the day before.

"It was my decision to go round the outside at Druids. There was always more grip around the outside, but you always run that risk that the guy on the inside might lose control, as happened with me with Teddy Pilette, but you also have to trust in the guy on the inside, and obviously Jacky and Niki were fast drivers, so I think it's credit to Niki as well that he didn't force Jacky into the outside



Wilds had shone in points-counting race

of the track on the exit at Paddock.

"But that was one of the best overtaking manoeuvres around Paddock of all time, when Jacky went round the outside. It was very controlled and a very, very good bit of motor racing."

Rally Mexico



Leon (MEX) March 6-9
World Rally Championship
Round 3/13

RESULTS

22 STAGES, 248.517 MILES

1	SEBASTIEN OGIER (F)/JULIEN INGRASSIA (F)	
	VW Motorsport Volkswagen Polo R WRC #1	4h27m41.8s
2	JARI-MATTI LATVALA (FIN)/MIIKKA ANTTILA (FIN)	
	VW Motorsport Volkswagen Polo R WRC #2	+1m12.6s
3	THIERRY NEUVILLE (B)/NICOLAS GILSOUL (B)	
	Hyundai Motorsport Hyundai i20 WRC #7	+5m28.6s
4	ELFYN EVANS (GB)/DANIEL BARRITT (GB)	
	M-Sport Ford Fiesta RS WRC #6	+6m49.3s
5	MARTIN PROKOP (CZ)/JAN TOMANEK (CZ)	
	Jipocar Czech National Team Ford Fiesta RS WRC #21	+9m54.4s
6	BENITO GUERRA (MEX)/BORJA ROZADA (E)	
	M-Sport Ford Fiesta RS WRC #11	+12m57.6s
7	CHRIS ATKINSON (AUS)/STEPHANE PREVOT (B)	
	Hyundai Motorsport Hyundai i20 WRC #8	+15m15.4s
8	MIKKO HIRVONEN (FIN)/JARMO LEHTINEN (FIN)	
	M-Sport Ford Fiesta RS WRC #5	+17m06.8s
9	MADS OSTBERG (N)/JONAS ANDERSSON (S)	
	Citroen Total Abu Dhabi Citroen DS3 WRC #4	+25m41.6s
10	YURIY PROTASOV (UA)/PAVEL CHEREPIN (UA)	
	Darnitsa Motorsport Ford Fiesta RS #32	+28m18.2s

OTHERS

15	OTT TANAK (EST)/RAIGO MOLDER (EST)	
	Drive DMACK Ford Fiesta RS #35	+54m37.4s
19	ANDREAS MIKKELSEN (N)/MIKKO MARKKULA (FIN)	
	VW Motorsport Volkswagen Polo R WRC #9	+1h05m56.8s
R	KRIS MEEKE (GB)/PAUL NAGLE (IRL)	
	Citroen Total Abu Dhabi Citroen DS3 WRC #3	SS22-accident
R	ROBERT KUBICA (PL)/MACIEK SZCZEPANIAK (PL)	
	RK M-Sport Ford Fiesta RS WRC #10	SS13-accident

DRIVERS' CHAMPIONSHIP

1	OGIER	63	6	BOUFFIER	18
2	LATVALA	60	7	HIRVONEN	18
3	OSTBERG	32	8	MEEKE	17
4	MIKKELSEN	24	9	NEUVILLE	15
5	EVANS	20	10	TANAK	10

MANUFACTURERS' CHAMPIONSHIP

1	VW MOTORSPORT	115	3	M-SPORT	40
2	CITROEN TOTAL	60	4	HYUNDAI	31

STAGE TIMES

SS1 MONSTER STREET STAGE

GUANAJUATO (0.82 miles)

FASTEST: Ogier 0:52.9s LEADER: Ogier

SS2 LOS MEXICANOS 1 (6.13 miles)

FASTEST: Ogier 7m40.2s LEADER: Ogier

SS3 EL CHOCOLATE 1 (27.36 miles)

FASTEST: Ostberg 30m04.8s LEADER: Ostberg

SS4 LAS MINAS 1 (9.88 miles)

FASTEST: Ostberg 11m18.2s LEADER: Ostberg

SS5 PARQUE BICENTENARIO 1 (1.61 miles)

FASTEST: Ogier 2m23.3s LEADER: Ostberg

SS6 LOS MEXICANOS 2 (6.13 miles)

FASTEST: Ogier 7m33.7s LEADER: Ostberg

SS7 EL CHOCOLATE 2 (27.36 miles)

FASTEST: Ogier 29m29.0s LEADER: Ogier

SS8 LAS MINAS 2 (9.88 miles)

FASTEST: Ogier 11m06.1s LEADER: Ogier

SS9 PARQUE BICENTENARIO 2 (1.61 miles)

FASTEST: Latvala 2m22.2s LEADER: Ogier

SS10 SUPERSPECIAL 1 (1.37 miles)

FASTEST: Ogier 1m42.1s LEADER: Ogier

SS11 SUPERSPECIAL 2 (1.37 miles)

FASTEST: Ostberg 1m42.5s LEADER: Ogier

SS12 IBARILLA 1 (18.84 miles)

FASTEST: Ogier 17m44.3s LEADER: Ogier

SS13 OTATES (33.36 miles)

FASTEST: Ogier 36m40.1s LEADER: Ogier

SS14 IBARILLA 2 (18.84 miles)

FASTEST: Ogier 17m30.0s LEADER: Ogier

SS15 OTATITOS (26.75 miles)

FASTEST: Ogier 30m19.8s LEADER: Ogier

SS16 EL BRINCO 1 (5.12 miles)

FASTEST: Ogier 4m40.2s LEADER: Ogier

SS17 SUPERSPECIAL 3 (1.37 miles)

FASTEST: Latvala 1m40.0s LEADER: Ogier

SS18 SUPERSPECIAL 4 (1.37 miles)

FASTEST: Meeke 1m41.2s LEADER: Ogier

SS19 SUPERSPECIAL 5 (1.37 miles)

FASTEST: Ogier 3m22.0s LEADER: Ogier

SS20 GUANAJUATITO (34.74 miles)

FASTEST: Ostberg 35m45.8s LEADER: Ostberg

SS21 DERRAMADERO (7.22 miles)

FASTEST: Ostberg 7m07.5s LEADER: Ogier

SS22 EL BRINCO 2 (5.12 miles)

FASTEST: Ogier 4m34.2s LEADER: Ogier

RALLY ROUTE

Rally Mexico remained long on competition and short on liaison this year. No significant changes on the route from previous years, with the final day livened up with the 35-miler through Guanajuatito. Big change this year involved taking the service park outside for the first time.

FOR IN-DEPTH RESULTS
forix.autosport.com



Ogier leaps back into the points lead

The world champion vanquished rivals to regain the title-race advantage and lead team-mate Jari-Matti Latvala to a VW one-two. **DAVID EVANS** reports



SEBASTIEN OGIER SMILED, PAUSED AND delivered the line that sent a chill through his fellow drivers at Rally Mexico's pre-event press conference. "My mistake in Sweden made me more angry for this rally..." That anger was further fuelled by Friday frustration at being first on the road, but as soon as he passed Mads Ostberg with a stunning run through El Chocolate 2, he was away. He couldn't and wouldn't be touched. Having set himself the target of returning home to Europe in the lead of the championship, he did just that as he swapped places with team-mate Jari-Matti Latvala, who took second. Thierry Neuville made history for Hyundai with third, benefitting from a high rate of attrition on the first gravel rally of the year.

LEG ONE (92.98 miles)

Sunny - ambient temperature range on stages 22-30C

After a cheery wave to the massed ranks of Mexicans waiting to watch the WRC go

underground, Ogier took his anger out on the streets of Guanajuato. Fastest on the opener, he was ready to spend the next morning sideways and struggling for grip. He would be second over the loose surfaces and, while he accepted his position wasn't great, he quickly pointed out that it was better than that of his championship-leading Volkswagen team-mate Latvala.

Conventional wisdom, according to Latvala, meant he could lose as much as 40 seconds across the first morning. That same conventional wisdom would probably hit Ogier for half a minute. Ogier's not one for conventional wisdom; he went fastest again on the first shot at Los Mexicanos, six tenths up on Citroen driver Ostberg. The cleaning effect was there, but slightly negated by the dust hanging over the windless dirt roads. And when there's dust around, self-confidence comes to the fore. And Ogier goes quickest.

Ostberg had been the man both Ogier and



Neuville and Hyundai took superb podium

MCKEIN/DE



Win #18 for Ogier gave him back the series lead

Latvala had mentioned as the one to watch. Behind them on the road and with real Mexican pedigree, having led this event before, the Norwegian justified that concern by winning the longest – and highest – stage of the day, El Chocolate. A fraction more than half an hour after he started the test in third place, Ostberg ended it in the lead.

"I'm pleased with the performance in there," he said. "The car was perfect." He wasn't bad either.

Latvala's worst fears were realised in this one. "It was really tough near the start," he said. "The surface was like powder and when we were going uphill we couldn't find any traction."

Asked if the powder was a new addition from last year, Latvala smiled.

"I don't know," he said, "I didn't get that far."

While Latvala dropped 13.9s to Ostberg, Ogier contained the time loss to three seconds and was accepting of the situation.

"What's the point of talking about the rules?" he said, "we just have to get on with it."

The Frenchman was slightly more irritated at the end of SS4 when Ostberg and Mikko Hirvonen beat him. "What strategy can we use?" he asked rhetorically. "We just have to push hard."

Conversely, Ostberg was having fun. "I always have fun," he admitted, "when things are going well in the car."

And opening a six-second lead over the driver who utterly dominated this event last year was the Citroen driver's idea of big fun. The fun was finished on the very next stage, when his co-driver Jonas Andersson forgot to take the radiator blanking plate out. Used to keep heat in the engine on road sections, it had to be removed for fear of cooking the motor in stage mode.

"Jonas told me just before the start of the stage," said Ostberg, "Without so much experience of the car, I didn't know what would happen, so I took it steady."

He emerged without any warning lights, but half of the lead he'd spent the previous 37 miles building was gone in a 1.5-mile spectator-pleasing dash around the Bicentenary Park.

Hirvonen was third, but admitted fortune had favoured the Finn through the morning. He'd punctured on SS2 and then clouted the front-left just after the start of SS3.

"The wheel was knocked out of my hand," said Hirvonen, "I really thought it would go down."

But it didn't. Stoically, the Michelin held its pressure for the remainder of the morning despite a sizeable gash in the sidewall. Hirvonen was 11.3 down on the leader with countryman Latvala a further 7.9s back. Kris Meeke led a trio of Mexican debutants with Robert Kubica and Elfyn Evans behind. Kubica's morning had been the most fraught as the hydraulic pump that works the paddleshift on his Fiesta failed as temperatures rose towards 30C. He was forced to use the manual shift with his weaker right arm.

"It was not so nice," said Kubica, "the problem came when I was downshifting and the gear didn't change – we almost went off."

M-Sport's finest sorted the problem over lunch in readiness for what was going to be a scorcher of an afternoon.

After just six miles of Los Mexicanos, the drivers were reporting a significant rise in in-car temperatures. Ogier coped best and took 2.1s out of Ostberg – it would have been more had he not made a hash of the first hairpin. Coming out of El

Evans took career-best of P4 in M-Sport Fiesta



Chocolate, the exertions were clear.

As were the frustrations for Ostberg. His lead had disappeared.

"I am very disappointed," he said, "we had a lot of oversteer and it wasn't so perfect. Not far after the start, I knew it was going to be a long stage..."

Ogier landed the lead, mopped his brow and said: "Very hard stage; it was very hot in the car and very hot for the car."

Meeke had been flying for much of the stage, posting some super-quick splits to end the test second fastest. He'd found his rhythm and moved past Latvala for fourth. Unfortunately, he found a rock on the very next stage. He was out. But totally bemused.

"I didn't see anything and didn't feel anything," he said. "We came over a crest into a second gear corner, maybe I was a couple of inches wide and then I felt the wheel shaking. We carried on and the wheel popped off 500 metres before the finish."

After a quiet morning, Mexico was beginning to show its teeth. Hirvonen was another victim of SS8, after alternator failure halted his Fiesta.

By the end of Las Minas, the day's final gravel action, Ogier had built a 20s lead over Ostberg. Three spectator stages later and that gap stood at 26s, with Latvala 16s further down on the Citroen.

Kubica headed back towards Leon in an exceptional fourth place, but lost that when he rolled on the first of two stages at a nearby kart track. That left Evans running fourth after a very smart day for the Welshman. Neville was fifth, but struggling more than most for power from a lethargic Hyundai motor. His team-mate Chris Atkinson was down in eighth after all manner of issues that included switches falling off, wheels almost falling off and an electrical glitch.

"I've had worst days," said the returning Queenslander, philosophically.

POSITIONS AFTER DAY ONE

1 Ogier/Ingrassia	1h46m25.3s
2 Ostberg/Andersson	+26.1s
3 Latvala/Anttila	+42.5s
4 Evans/Barritt	+2m28.7s
5 Neuville/Gilsoul	+2m30.2s
6 Prokop/Tomanek	+3m31.1s

LEG TWO (105.68 miles)

Sunny ambient temperature range on stages 23-32C

The longest day was the perfect day for Ogier. At least on the gravel it was. Only Latvala and Meeke could get the better of the flying Frenchman on Saturday and only on the day-ending Superspecial.

Already running at high altitude, Ogier took himself to a higher plane as he reeled off fastest time after fastest time to dominate day two and move a minute clear at the front of the field.

"Nothing special," was his modest assessment ▶

Latvala took second but lost points lead to Ogier



MCKLEIN/DE

► of Saturday. “It was a good day, we kept a good rhythm.”

One place back and Latvala grimaced. “He just keeps on with the fastest times...”

J-MI’s day had started well as he took a 10.8s chunk out of Ostberg’s second place, but any illusions of a day-long scrap went out of the window on the road section to the next stage.

Spookily, for the second year in succession, Ostberg retired from second place on the second morning on the way to the Otates test. Last year he was 41.2s behind Ogier when he exited with a failed alternator, this time he was 41.4s off the lead when damaged rear suspension ruled him out.

He’d thumped the left-rear of the DS3 late in the stage and, despite working on the car for as long as possible before the next stage, he had to call it a day. Even if he had affected repairs, a 33-miler lay in wait.

“I was too fast,” said Ostberg. “The pacenote wasn’t right and I couldn’t slow the car enough.”

Latvala was left alone and when Ostberg failed to start SS13, Evans moved into a theoretical podium place. Neuville spoiled that theory when he nicked third in Otates. The Belgian had taken his i20 WRC to its extreme suspension settings in search of more traction and it worked. He felt more comfortable as he sought to pull away from Evans.

Evans stuck to his plan. “I don’t want to get drawn into a fight,” he said. “Of course it would be nice to think about a podium, but there’s still a good result there for us.”

A loss of confidence in the looser, twistier sections of the afternoon – allied to a couple of big stones rattling the Fiesta’s underside – was enough to convince Evans that discretion remained the better part of valour.



MCKLEIN/DE

Meeke had a torrid rally and didn't score

Top privateer Martin Prokop was fifth with local hero Benito Guerra sixth and a road-sweeping Atkinson holding down seventh.

POSITIONS AFTER DAY TWO

1 Ogier/Ingrassia	3h36.42.2s
2 Latvala/Anttila	+1m00.3s
3 Neuville/Gilsoul	+4m37.0s
4 Evans/Barritt	+5m24.0s
5 Prokop/Tomanek	+8m02.5s
6 Guerra/Rozada	+10m33.6s

LEG THREE (49.84 miles)

Sunny – ambient temperature range on stages 23-32C

Much as the other three stages were interesting, Sunday was really only about Guanajuatito – the 34-mile sting in this rally’s tail. After the chaos of the previous two days, nothing could be taken for granted as the cars lined up at the start of the longest test, having warmed up with a fifth and final run around the Superspecial (Ogier was again quickest around that one).

But, in the end, there was very little to report after 35 minutes of flat-chat driving. There was too much to risk in every direction, heroes were not going to be made on that stage. Apart from Ostberg and Tanak. Both had tripped up early in the event and both were making amends with awesome Sunday speed. Ostberg was quickest on both gravel stages, but not the Powerstage. An odd new-for-2014 regulation meant drivers Superallying on Sunday weren’t eligible for the three bonus points. Ostberg’s desire to charge was probably further blunted by the news that his team-mate Meeke, first on the road on the final day, had retired in El Brinco with broken steering.

The Powerstage points were taken by Ogier to complete the perfect rally ahead of Latvala. Neuville delivered Hyundai’s dream in third, despite a very late drama when his i20 developed a water leak on the final run into Leon. Fortunately, the organisers had armed every finisher with a big bottle of Corona (a slightly odd drink-driving message, but there you are) and the Hyundai slugged most of it down and made it home.

Evans completed a brilliant drive to a career-best fourth, with Prokop and Guerra rounding out the top six, while Atkinson was a satisfied, if a little frustrated, seventh.

For the second year in succession, it was Ogier who pulled on the traditional winner’s cowboy boots at the finish. He admitted he hadn’t really worn last year’s, but said: “Somebody told me this year’s were more beautiful and I had to have them.”

Those boots are made for winnin’. And Ogier did just that. Again. ☘

IN THE SERVICE PARK

David Evans



LOOKS LIKE I WAS WRONG. LOOKS LIKE THE WRC might still have an endurance element beyond the loss of the Acropolis Rally. The rate of attrition on last week’s Rally Mexico was astonishing – particularly in these days of supposedly bomb-proof cars.

Friday morning cost us Ott Tanak and Andreas Mikkelsen, but it was from lunchtime on day one that things really started to toughen up as car after car crashed, pinged suspension parts or hit mechanical trouble. The heat and the rocks, allied to endless surface changes and tightening corners, took their toll.

Out front, Sebastien Ogier and Jari-Matti Latvala predictably delivered another VW one-two. Behind the pair of Polos, massive credit must go to Thierry Neuville and the Hyundai team for taking a podium on only their third outing – a better result than the Korean outfit managed in 75 WRC starts in its previous guise.

And the same recognition must go to Elfyn Evans on his career-best fourth place. It looked for a while on Saturday afternoon as though a podium might be on the cards, but the top three can wait – although probably not too long at this rate. Evans’ approach drew praise from all quarters. Neuville and Evans were well aware of the gap between them and the VWs, but they weren’t going let that spoil Sunday night.



MCKLEIN/DE

Rally took its toll. This is Bertelli's Fiesta

“I’m an Eskimo coming from winter to summer”

Latvala on his arrival in Mexico.



MCKLEIN/DE

Neuville: only here for the beer

BRITAIN'S ELFYN EVANS CAME WITHIN A

bottle of beer of claiming his maiden World Rally Championship podium on last week's Rally Mexico.

The M-Sport driver was poised to move from fourth to third in central America after a late overheating problem struck Thierry Neuville's Hyundai i20 WRC. Neuville kept the car running and remained on the bottom step of the podium by filling the radiator from a bottle of beer that had been given to him following the final stage in Leon.

The Belgian made it to the finish to deliver a dream result for the Korean team whose i20 WRC only turned a wheel in testing for the first time 235 days ago.

Having calmed down after the late drama, Hyundai team principal Michel Nandan said: "I can't believe it! This is an unbelievable result for us. When we came here we knew where we were because of the tests and we knew that we hadn't done a lot of work at high altitude. The best we were hoping for was fifth place. It's incredible to think where we have come from 12 months ago."

Neuville added: "The team has achieved a lot. It's great that my car had no problems here in Mexico and I am really happy for everybody – we are really coming together now."

Both Neuville and Nandan admitted they would not be getting carried away with the Mexican podium, however.

"We have some more steps to make," said Neuville. "Yes, we are third here, but we have to be realistic and understand that we are not on the pace. We have seen a lot of retirements and without them we would be fifth, but we



Hyundai's P3 was saved by a bottle of Corona

are working and we have more developments coming."

Evans was magnanimous in fourth, saying: "I wouldn't want to take third that way, Thierry has driven well and deserves the place."

Talking about his own career-best WRC finish – on only his fourth event in a World Rally Car – Evans added: "I knew if we kept out of trouble then we could make a strong result, but I didn't think it would be fourth. I think we can be pleased with our weekend's work. The result has come as a result of lot of others tripping-up, but this rally is renowned for that and we kept out of trouble."

"This has to be the biggest result of my career. A top-four finish at this level is a big result, regardless of what the gap is to the leader."



Wilson (r) wants to solve alternator woes

M-SPORT'S ALTERNATOR ANGST

M-Sport's team principal Malcolm Wilson travelled back to Britain with Mikko Hirvonen's alternator packed in his suitcase. The unit failed in Mexico and Wilson wanted to get it back to supplier McLaren as soon as possible. This is the second alternator-related failure for Hirvonen in three rallies.

FISHER FOR NEW-LOOK JWRC

Britain's Alastair Fisher will be among 14 drivers starting the first round of a new-look Junior WRC on next month's Rally of Portugal. Fisher and his fellow JWRC runners will use Citroen DS3 R3s for the first time instead of M-Sport's Fiesta R2. Fisher is well used to the DS3, however, having contested WRC3 in his last year.

PROTASOV TAKES WRC2 GLORY

Ukrainian driver Yuriy Protasov romped to an easy WRC2 win in Mexico. The Fiesta R5 driver was 24 minutes ahead of his closest rival Max Rendina. Much-fancied WRC2 runner Ott Tanak crashed on the first morning having run as high as second overall in his DMACK Drive Fiesta R5.

AL-ATTIYAH BACK FOR PORTUGAL

Former Dakar winner Nasser Al-Attiyah is scheduled to make his first WRC appearance of the season in Portugal, driving a brand new Autotek-run Fiesta RRC car.

208 T16 FOR IL CIOCCO DEBUT

Peugeot's 208 T16 is expected to be homologated this week, with the world's second R5 car being given its debut by Paolo Andreucci on Rally Il Ciocco in Italy this weekend. Citroen's DS3 R5 should be homologated early in April.

JRM SUBARU FOR YPRES DEBUT

British team JRM has announced a three-round European Rally Championship programme for its new saloon-based Group N Subaru Impreza. The car is scheduled to make its competitive debut on the Ypres Rally in June.

GUERRA WANTS MORE RALLIES

Mexican driver Benito Guerra is hoping his career-best sixth place on his home round of the WRC will be enough to land him a Fiesta RS WRC return on May's Rally Argentina – and possibly three further European WRC outings later in the year.



Guerra wants more Fiesta WRC outings

Kubica to revise his approach



Kubica will take steps to keep his car upright

ROBERT KUBICA WILL MAKE SIGNIFICANT

changes to his approach to the WRC in an bid to stop crashing and start finishing some rallies.

Kubica's tally of World Rally Car shunts rose to eight in four starts when he inverted his Fiesta RS WRC twice on Rally Mexico last week. The Pole admits he has identified the problem and will work on it ahead of Rally Portugal next month.

"I know what I have to do: work on my notes in the narrow sections of stages," he said. "This is where my notes are not ideal." Kubica's second accident in

Guanajuato came in just such a section.

"I came over a crest into a narrow place," he said, "I had the wrong pacenotes into a blind corner. I slid, we hit the rock and the car rolled – the roof hit another rock, which was what damaged the rollcage."

"My notes work well on Tarmac, but not so well on gravel. We will make changes to make me feel more comfortable and I will adjust my driving style, which is not easy. I don't have so much experience of this kind of road. Before the stupid accident [his first roll at the day-one Superspecial], this event was going very well."

THE KING'S NEW CODE

Nine-time world rally champion Sebastien Loeb needed a new career focus so opted for racing in the WTCC with Citroen. The Frenchman shares a few thoughts during testing with **PETER MILLS**



When AUTOSPORT convenes at Paul Ricard in February for its first glimpse of the new generation of TC1-spec World Touring Cars, the occasion marks not only the first time that championship favourites Honda and Citroen have tested together, but the 40th birthday of the man arguably responsible for Citroen's entry into the series: Sebastien Loeb.

The nine-time world rally champion hinted heavily in his biography that, so strong was his desire for a new challenge after an astounding run of WRC titles with Citroen, a switch to incoming manufacturer VW had all but been agreed. The genesis of Citroen's WTCC programme can be traced back to a determination to keep Loeb in the 'family'. Citroen's subsequent entry into the touring car arena persuaded one of France's most popular sportsmen to remain part of a team that has been integral to his success.

"One day you have to decide when to stop," explains Loeb, who multi-tasks between answering questions thoughtfully and scrolling through smart-phone content – presumably of which there is rather more than usual. "I wanted to do something after rallying, and if I stopped rallying at 45 it would be too late to start a new project. I needed something different, a new challenge, and to go into the WTCC with Citroen was the best choice. The championship is very different on the driving side. It gives me new motivation. I enjoyed my experience when I did some racing over these last years, so I said, 'why not go into a new discipline like this?'"

The plush Le Castellet pit garage where Loeb and assorted media are gathered is deliberately positioned at an opposing end of the pitlane to rival Honda. Neither the new Civic nor the C-Elysee models are homologated at the time of interview, leading to a state of heightened sensitivity among each camp over security and prying cameras.

For Honda team principal Alessandro Mariani, just being on track with a single car is described as a "miracle". In contrast, Citroen has conducted intensive preparations as both team and Loeb adapt to circuit racing. Monza, Abu Dhabi, the Hungaroring, Valencia and Sevilla Monteblando



Citroen's C-Elysee gets set-up tweaks at Ricard

formed the venues on a relentless testing schedule embarked on last July.

Honda's elder-statesman racer Gabriele Tarquini, a touring car devotee since the late '80s, struggles to compare the lightened and more muscular TC1 machinery to other categories: "It's not like formula cars, not like prototypes and it's far away from last year, so really I can't use my experience to guide the team until I've had more kilometres of testing."

Loeb concedes any potential competitive disadvantage relative to a touring car specialist could be lessened thanks to the rebooting of the championship regulations.

"I needed something different to do, a new challenge. The WTCC gives me motivation"

SEBASTIEN LOEB

"I start from zero, but the others don't start from 100 per cent like last year," admits Loeb. "They have all sorts of things to discover about the cars, so maybe it's a good time to come in."

Loeb's transition to tin-top racing should be assisted by the presence of Yvan Muller on Citroen's driving strength. The unfolding relationship between the pair promises to be fascinating. While in many ways Citroen can be viewed as Loeb's team, the WTCC has frequently been under a Muller-controlled grip – his status as one of the benchmark drivers in the business being earned through four WTCC crowns.

Extracting clues as to which man has been quicker in testing, and by what margin, has proved difficult, not least because of differences in the development machinery. Citroen initiated its programme by building a test-bed C-Elysee using a DS3 rally car as a starting point and Xsara kit-car suspension geometry. At Paul Ricard, different induction treatment of the two C-Elysees points to a discrepancy in their ages.

"For sure I have some improvement to do [relative to Yvan], but we never really worked to compare because we're driving two different cars," relates Loeb. "Each one is on a different setting, so we are not very often using the same configuration of car."

Both natives of Alsace, although from ▶

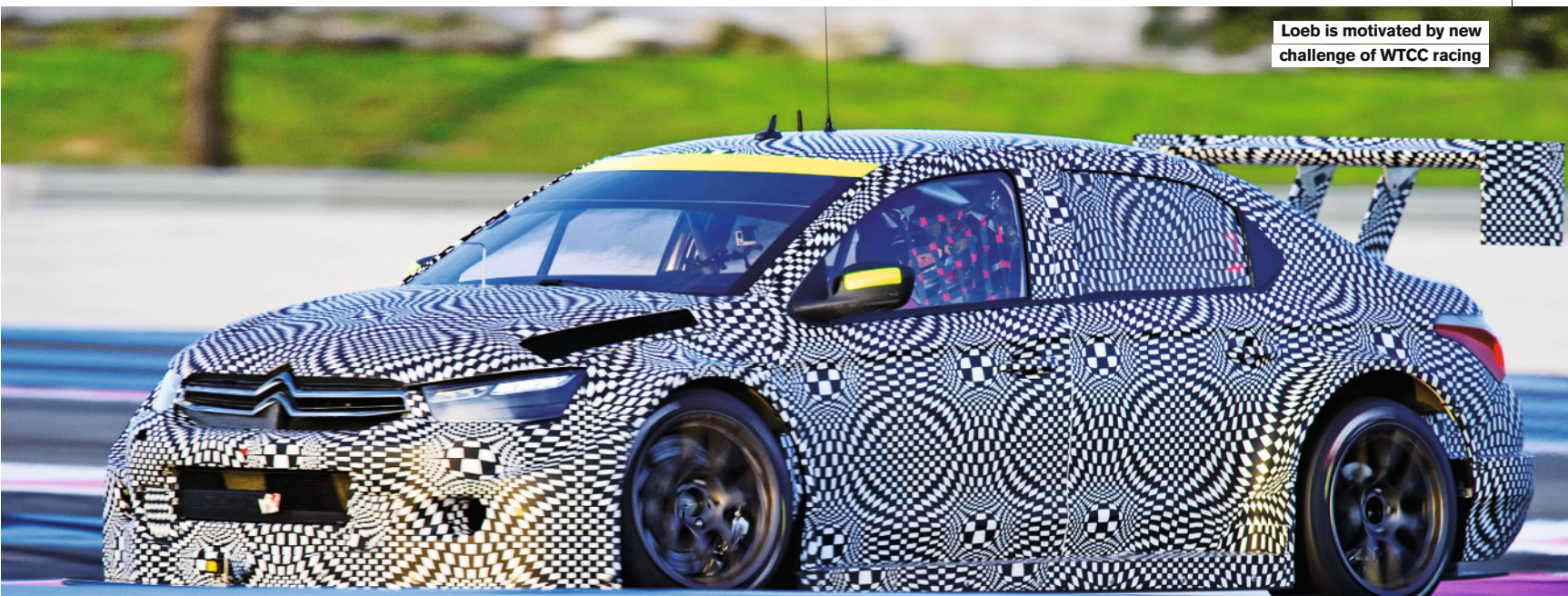

Loeb is motivated by new challenge of WTCC racing

8 EVENTS// 16 RACES

ALL EVENTS LIVE ON EUROSPORT IN 87 COUNTRIES

ALL PARTNERING, 550 BHP ZYTEK V8 POWER

PRIZE MONEY PER EVENT

FIRST PLACED DRIVER €20,000

SECOND PLACED DRIVER €10,000

THIRD PLACED DRIVER €5,000



THE BEST SCHOOL FOR F1

- Double compound KUMHO TYRES
- Qualifying is like F1: Qualifying 1 (20 min) - 10 min break - Qualifying 2 (10 min) for the first ten placed in Qualifying 1 - Race 1 // 100 Kms - Race 2 // 85 kms - Both races have mandatory Pit Stops



Auto GP 2014 Calendar:

01-02 April - Valencia (official Test)

12-13 April - Marrakech (with the FIA WTCC)

19-20 April - Paul Ricard (with the FIA WTCC)

03-04 May - Hungaroring (with the FIA WTCC)

31-01 June - Monza

28-29 June - Imola

19-20 July - Red Bull Ring (with the FIA ELMS)

16-17 August - Nurburgring (with the DTM)

18-19 October - Estoril (with the FIA ELMS)

► different *departmental arrondissements*, Loeb stresses his relationship with Muller has not centred on being mentored, rather they work in tandem to provide engineers with analysis and direction: "The data is shared by the engineers. When I do something better they tell him, when he is doing something better they tell me. If I have any questions I can check how he is doing in a certain corner, for example, if I don't feel well. But the main thing is not [working] on



Citroën has racked up many miles with C-Elysee

"Seb has a lot, and I mean a lot, of talent. He has been quick from the beginning"

CITROËN TEAM-MATE JOSE MARIA LOPEZ

my driving, it's more working for the team developing the car."

Third driver Jose Maria Lopez, a former double Argentine TC2000 champion, is in no doubt of his team-mate's abilities.

"I have more experience than Seb in touring car series," he says. "Even if someone is saying he will take a while [to get up to speed] because he is coming from a completely different discipline, he is a nine-time world champion. He has a lot, and I mean a lot, of talent and he has been really quick right from the beginning."

Can the WTCC capture Loeb's imagination in the way offered by his previous career; contorting behind the controls of dancing Xsara, C4 and DS3 rally cars across spectacular backdrops and varied driving conditions? While Loeb admits there is an element of repetition involved in his new pursuit, the 100kg weight reduction of the TC1 cars over their 2013 predecessors, hugely increased aero and extra power should prevent adrenaline levels from dipping too low.

"I didn't really have any experience of front-wheel drive on a track and I didn't know how it was going to be, but with these new regulations it is quite exciting to drive," counters Loeb. "The car is fast, you brake late and can carry a lot of speed in the corners, so it's not bad. I like it. It has a good balance. For me it's something exciting to discover, really different from rally driving. I enjoyed a lot driving in rallies, where it's more up to you to improvise. Here, you have to repeat the same thing all the time, so it's another approach, another kind of concentration. You need to develop some different skills."

Enthusiasm begins to surface as Loeb relays his early impressions of the varying approaches and techniques required for driving in the WRC and the WTCC.

"In rally, when you have a setting it is OK nearly everywhere. Here if the car is not perfect you cannot do the time, because you have too much oversteer or understeer. If the temperature of the track changes, you have to adjust the balance immediately or the car picks up [an imbalance]. Oversteer and you cannot do the

JML ON CHANCES

Jose Maria Lopez faces the daunting task of taking on team-mates boasting 13 world titles between them. The Argentinian racer owes his place not to marketing men keen to push the C-Elysee in its target emerging markets, but through winning over the team in a series of evaluations.



"I tested twice last year, but it was to see if I could stay in the team," says Lopez. "So it was really a test for me as well as testing the car. One test was at Valencia and one at Monza."

"This year I did the official test in Abu Dhabi for a day and a half, then Sevilla Montebanico and now Paul Ricard. We are going to do a couple of days more. I did less running than Loeb and Muller, of course, but since my first test I felt quite comfortable with the car, because I drove quite similar cars in Argentina. The Super TC2000 cars are quite similar in terms of grip and power, the only thing is today maybe the WTCC car has more downforce and the tyres are a bit different – and then there's the turbo, of course."

Honda race winner Norbert Michelisz who watched the Le Castellet test with interest from trackside, tips Lopez to spring a surprise. "I think he is going to be good. He has been spectacular in testing, particularly in the wet." Is that just spectacular or fast? "Spectacular and fast," comes the instant response.

Lopez is more modest on his prospects: "My team-mates are two of the best drivers in the world. So I see it is an advantage because I am learning, and I think I can bring experience as I raced for many years in Argentina with front-wheel-drive cars. We'll see in Marrakech, and how we are against the others."



Loeb is focussed on turning Citroën into a race winner

times. If you understeer you destroy your tyres, so it is always playing around. That is something different that you have to get to used to. It's very complicated, much more complicated on the setting than being in the rally."

Tyre degradation has been a watchword in past WTCC seasons, as the fastest cars grow faster and are invariably laden with success ballast. Muller believes the situation should be alleviated by the use of wider wheels, new Yokohama slicks and weight reduction for 2014. But in any case, racing convert Loeb feels being kind on rubber is one skill-set he might possess.





"In rally I was not bad at this when we were driving with soft tyres. I was not bad at saving the tyres, not so much in asphalt rallies because we had quite a hard compound tyre to cope with it. Also, here it's everything on the front so for sure it's important to manage it. I used to have four-wheel drive, where the four wheels started to go down at the same time. This shouldn't be the worst [thing for me to manage] but we'll see."

Last year's FIA GT programme in his own Sebastien Loeb Racing McLaren served to increase Loeb's familiarity to racing with other cars around him. The McLarens have been replaced by a pair of Audi R8s, but Loeb has no immediate plans to add additional race outings to his WTCC commitments.

"This is something very new to me, so I think ►



Germany just got quicker with our 48 hour pallet delivery service

-  Daily **Express** pallet service for Exports & Imports
-  Fastest transit times, **48 hours** door-to-door
-  Easy to use through any one of our 180 UK/German depots
-  Fully tracked & traced online
-  Single pallet to multi-pallet consignments



alnet
the alliance of networks



Muller leads Loeb in testing but will he prevail in races?



► I have enough to concentrate on, but we'll look at the situation again during the season."

Only Slovakia Ring from the 2013 FIA GT calendar will feature as a stop on the WTCC tour, but Loeb has knowledge of a number of other circuits including Macau, where he raced a Porsche last year, and the Autodromo Termas de Rio Hondo. The foray to Argentina came about after Lopez made introductions between Citroën and his former TC2000 team, which provided a local car to test. The effort could reap rewards given there are only two 30-minute practice sessions for most races.

Asked to cast his mind back over the past 10 months, and the major developments the car has gone through, Loeb says: "We started from zero and we discovered a lot of things, the geometry, the suspension, the aerodynamics and still we are looking for other solutions. We just try to understand how the car is working and how the tyres are working. For sure the car changed."

To that end, how satisfied and content does Loeb feel about the preparations and the challenge ahead given the clean sheet of paper that the project started from last year?

"I'm really looking forward to certain places, like Spa, everyone says it's a very beautiful track. I think the car was well born, the feeling from the first days has not changed, but there's still more to do." ❧

MULLER THE MAIN MAN

New father Yvan Muller appeared to suppress some satisfaction in welcoming Loeb to the over 40s club. The RML Chevrolet refugee's 20 years of amassed experience in touring car racing is valued highly by Citroën technical chief Yves Matton.

"We have experience of motorsport but this is totally new for us," said Matton. "We look to Yvan to help us."

Muller's views are not only prized by his team, but were sought after by the FIA when the TC1 regulations were being formulated. So what does Muller think of the final product?

"After two years of discussion with the FIA, where I was sort of consultant, we finally have the result of all these discussions," says Muller, excited to be working with a French

manufacturer for the first time.

Of course, the result is not perfect, it can never be perfect, but [to have] this speed for this cost, we did something pretty good. One important thing is that the car has 40-50 per cent more downforce than in the past. That is something new to manage, and it's not easy."

Will the racing therefore match the rough and tumble provided by the outgoing S2000 cars?

"I think side-by-side touching will not be possible, but with the bumpers yes. As you can see, the wheels are wider than the doors. Before, the doors were touching, here it would be the wheels. Ah, but we are never touching..." says Muller with trademark Gallic accent.

"The target is to win some races and for me to deliver as much information that I have.



Of course Citroën has a lot to learn but all the engineers are very good engineers. We just need some time."

Finally, have he and Loeb been on the same wavelength when it comes to development direction with the C-Elysee?

"In motor racing you have not to do a car how you want to do it, you make a car to go fast"



Enjoying an Indian winter

The MRF Challenge is still in its infancy, but is gaining traction as a way for young single-seater racers to keep busy in the off-season. **BEN ANDERSON** joined them on the grid for the 2013/14 finale

The current two-litre Indian MRF Challenge only started in 2012, but is gaining popularity among foreign racers keen on quality track time during the European winter. And earning themselves a bit of pocket money if they do well.

This is one thing that sets the MRF Challenge apart. Thanks to the generous backing of the Madras Rubber Factory (India's oldest, biggest and wealthiest tyre company), there is genuine prize money on offer, to the tune of 2.5 million Indian rupees (around £24,000) for the champion, plus 100,000 INR (£10,000) for each race winner (there were 13 races in all last season).

That's non-existent in many championships. When you also consider that you can race 'all expenses paid' (the drive, insurance for the car, flights, accommodation and transport) for less than £50,000, MRF F2000 looks a seriously competitive proposition.

The concept of Europeans heading to India for some winter motorsport is nothing new. The seeds of this venture were sown as far back as the 1990s, when British Formula 3 teams would head to Chennai to run a fleet of old cars for locals to take on their own up-and-comers in the Madras Grand Prix.

It was during this period that Indian racing driver



Winners: (l-r) Ellinas, Svendsen-Cook, Dejonghe

J Anand (whose JA Motorsport concern builds the Renault-engined Dallara Formulinos used in MRF F2000) got to know Anthony Hieatt. The Double R Racing boss (who runs Dallara's spares business) is a technical delegate for the series, and an advisor to the 'Brits on tour' running the cars at races and developing the skills of local drivers and mechanics as they go.

"We want to develop another generation of Indian racing drivers," says Hieatt. "Anand's done an amazing

job. There's talent here, we just need it to emerge, and having the European drivers helps with that."

It is this sea of familiar faces that greets me when I arrive in the Irungattukottai circuit's Macau-esque makeshift paddock to participate in the final round of the 2013/14 season for AUTOSPORT. Before taking to the track, I take some tips from British F3 race winner Rupert Svendsen-Cook, a development driver for MRF.

"It's the most difficult car I've driven," says RS-C.



Brits to the fore as Oscar King (11) and Svendsen-Cook lead the way



Our bloke: a British hunter who brought no trophies home from India

MRF CHALLENGE TECH SPEC

CHASSIS Dallara Formolino carbon monocoque
SUSPENSION double wishbones with pushrods
BRAKES Brembo two-piston calipers
TYRES bespoke MRF ZLO slicks, OZ Racing wheels

ENGINE 1998cc Renault F4R 832, four-cylinder
POWER 210bhp
GEARBOX Hewland FTR six-speed sequential
WEIGHT 610kg



Karthikeyan a huge draw in home city



Defensive Anderson frustrates the field

IRUNGATTUKOTTAI

Distance 2,310 miles
Pole time Tio Ellinas, 1m33.086s

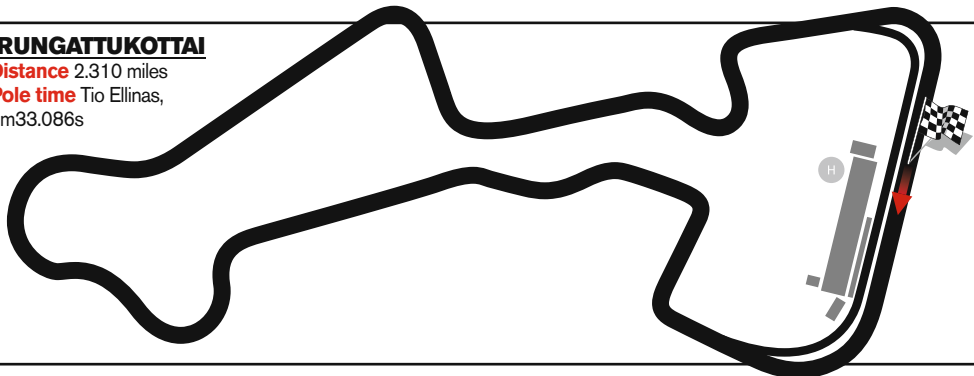

"Because the sidewalls of the tyres are so stiff there's hardly any lateral grip. You feel like you've got oversteer the whole time.

"You have to drive with fingertips to avoid overloading the fronts. The steering is quite light so it's easy to put on more lock than you need. But if you scrub the fronts you start a vicious cycle of understeer, and once the tyres grain you can't get them back."

"It's a proper driver's circuit," adds Hieatt. "Like Oulton Park without the gravel traps! Just edge your way up." I have little choice but to heed his advice, because first practice (one of 10 sessions – four practice, one qualifying and five races! – across the event) is a little overwhelming as I get used to the car. It gives a peculiar lack of feel through the brake pedal, and the F3-style gearchanging system requires the driver to counterintuitively release the 'radio' button on the steering wheel to cut the engine for every upshift.

I am five seconds off the pace in FP1 and FP2, but an engine problem is discovered overnight so the organisers swap my car. I will now drive the one developed by Indian F1 hero Narain Karthikeyan, who is also racing this weekend.

We all get new tyres for FP3 (drivers are given five sets to use from FP3 onwards) and things get better as we make small adjustments to the car and I gain

confidence, eventually qualifying 11th out of 17.

The racing proves wild and unpredictable on a narrow, technical and bumpy track. My fortunes fluctuate like a sine wave. I mess up my first start entirely and plummet to the back, then fall off the road at Turn 2 trying to make up ground. One to forget.

The next race is much better, as I make use of a new set of tyres to climb to sixth and earn reversed-grid pole. Before making a complete hash of the start again...

What's more, on the same set of tyres as the previous race, the car transforms into an oversteering beast. This confuses me and I fall down the order, spooked by the handling and also hampered by an electrical misfire. I end up 12th. And to top it off, I commit birdslaughter by accidentally running over what looks like an innocent sparrow at Turn 2. Bad karma.

To my amazement, I manage to repeat my race-two trick in race four: dodge the chaos and climb to sixth to score another reversed-grid pole. Determined not to make a mess this time, I sit down with my engineer and work out how to get the car off the line properly.

It works, and I make it through Turns 1 and 2 in the lead. Before the race, I reckoned leading for a lap would be a good result in a field that includes Svendsen-Cook, Karthikeyan, GP3 ace Tio Ellinas and F3 race winners Harry Tincknell and Sam Dejonghe. But as

the race goes on I find myself increasingly in control, basically because I defend for all I'm worth!

This gameplan causes chaos behind, as the faster drivers trip over one another. RS-C understeers off at the long double-apex right-hander at the far end of the circuit (booking himself a date with the officials when he allegedly forces title rival Ellinas off the road as he rejoins), leaving Dejonghe second. The Belgian puts me under pressure, but can't find a way past, and as the count ticks down I feel sure I'm going to win...

Then the safety car appears (Karthikeyan and Tincknell have come together). 'Great!' I think. 'More laps ticked off and a moment to relax.' Then I spot a black flag with my race number next to it...

It transpires I've been had for a jumped start. After the race, I twice review video with the clerk of the course, who tells me I moved fractionally as the second start light came on. We have to view it in slow-motion and zoom in to see what he's on about.

"How the hell did you spot that in real time?!" I exclaim. "I've watched a lot of races over the years," he responds. "If it's any consolation, I was very impressed with the way you held them back for so long."

"A tiny consolation," I say despondently, having seen the biggest win of my career slip away. But I soon feel better as we head off to the post-season after-party!

On the flight home Tincknell obtains a copy of the *Hindu Times*, one of India's biggest newspapers, which carries a half-page report of the previous day's race. Then it dawns on me what a big deal the MRF Challenge is in India.

It would be easy for European motorsport to look down its nose at this concept, with its quirky car and inconsistent tyres. But it's great fun and the racing is highly competitive. Everyone has to start somewhere, and you have to admire the Indians for making the effort.

As one driver said to me when I arrived: "You'll enjoy it if you don't take it too seriously."

He was absolutely right. ❧

WEB DIRECTORY

CAR BROKERAGE

RACING CARS FOR SALE
ALAN CORNOCK FCS
BUYING - SELLING - BROKERAGE
www.racingcarsforsale.co.uk
TEL: 01480 891212

ENGINES

JULIAN GODFREY
ENGINEERING
visit our new online shop www.racetuners.com

EXHAUSTS

Inconel & Stainless Steel Specialists
SIMPSON
Race Exhausts
Tel: 01753 532222
www.simpsonraceexhausts.com

GEARBOXES

Gearboxman.com
COMPETITION TRANSMISSION SERVICES
Gearboxes & Axles for Road, Race, Rally and more
Telephone: 01582 840008 Fax: 01582 840007

eLITE RACING TRANSMISSIONS
Rally & Race Gearboxes, GearKits, LSDs and Driveshafts
Tel: 01782 280136 Fax: 01782 269913
Email: sales@eliteracingtransmissions.com
www.eliteracingtransmissions.com

HELMET GRAPHICS

Mike Fairholme Designs
Sole approved painter of Arai helmets.
Silver Birches, Corby Birkholme, Nr Grantham, Lincs NG33 4LE.
Tel: 01476 550630. Fax: 01476 550029.
email: fairholmedesigns@btconnect.com
www.fairholmedesigns.co.uk

MEMORABILIA

FINAL LAP
For Everything Formula One
www.finallap.net **WE BUY AND SELL**
+44 (0) 1245 287588 / 07771 920345

GRANDPRIXGRAPHICS
SPECIALISTS IN MOTORSPORT GRAPHICS
RACE CARS, SUPPORT VEHICLES,
F1 TYPE BOTTLES, SIGNS.
07902061423 or 01992 666913
www.grandprixgraphics.co.uk

RACE CAR MANUFACTURERS

MANUFACTURERS OF PROTOTYPE SPORTS RACING CARS
NEW AND SECOND HAND MCV'S
ARRIVE & DRIVE PACKAGES
WWW.MCRRACECARS.CO.UK phone: 07771 762145

RACE PARTS

ARE DRY SUMP SYSTEMS
ARMSTRONG RACE ENGINEERING INC.
WWW.DRYSUMP.COM (916) 652-5282

FLAT-SIX.CO.UK
MARTINI
Gulf
CLASSIC CLOTHING & LIFESTYLE

RACE RADIO

Pit to Car Radio solutions
0044(0)1508 528837
Autotel Digital Race Radio
www.raceradio.co.uk

RACE PRODUCTS

PIPER
www.pipercams.co.uk

JJC race and rally
PASSIONATE ABOUT MOTORSPORT
www.jjcraceandrally.com

MARDI GRAS MOTORSPORT
www.mardigras.co.uk

RACEWEAR

demon tweeks MOTORSPORT Direct
www.demon-tweeks.co.uk

Grand Prix Racewear THE RACEWEAR EMPORIUM
WWW.GPRDIRECT.COM
08435 070 858
sparco, uvex, OMP, Arai, BELL, SCHRITTE, HANS

AUTHORISED DISTRIBUTOR
OMP **YBRACING**
MOTORSPORT & PERFORMANCE
WWW.YBRACING.COM

RACEWEAR

CROYDON RACE & RALLY CENTRE
www.croydonraceandrally.co.uk
220-222 Portland Road South Norwood London SE25 4QB
For Racewear & Motorsport equipment
FORECOURT PARKING Tel: 020 8656 7031

OLD HALL PERFORMANCE LTD T: 02476 717 100
RED LINE SYNTHETIC OIL
sales@redlineoil-europe.com www.redlineoil-europe.com

at power
www.atpower.co.uk
+44 (0)1953 857800

TRAILERS & TRANSPORTERS

BRIAN JAMES TRAILERS
» Connected to you
www.brianjames.co.uk

PRG TRAILERS
www.prgtrailers.co.uk
Phone no: +44 (0) 1270 812402

WHEELS

Image Manufacturers of bespoke split rim alloy wheels
www.imagewheels.co.uk
IMAGE WHEELS INTERNATIONAL LTD.

BRIAN JAMES TRAILERS

»» Connected to you



www.brianjames.co.uk

Established in the present

Carefully crafted, finely honed enclosed designs offer discreet, safe and efficient vehicle transportation. Style is always important, never more so than when in such illustrious company.

The latest Race Transporter models are testimony to the technology, craft and designs our dedicated engineers have developed.

Main photograph, Race Transporter 5 with high level tyre rack and work bench combination, Interior LED lighting pack and 'style 1' Alloy wheels.

Race Transporter range from £ 7,099 (excl. VAT).



T +44 (0)1327 308 833

For more information and details of your local BJT dealer please call or visit our website.

RACE TRANSPORTER

TRAILERS & TRANSPORTERS

WOODFORD TRAILERS



www.WOODFORDTRAILERS.com
HIGH QUALITY TRAILERS FOR CLUB, PRIVATE AND PRO MOTORSPORTS

Email: sales@woodfordtrailers.com



CALL US NOW

01327 263 384



Why rent with us:

- Competitive pricing
- Pick-Up and return depot
- All maintenance included
- 24/7 tire breakdown service
- Flexible rental periods
- Biggest fleet in Europe

RENT-A-RACETRILER.COM

PRG TRAILERS

Finest Built British Trailers.



PRG Trailers | Cheshire | UK | Tel: +44 (0) 1270812402
Web: www.prgtrailers.co.uk | Email: info@prgtrailers.co.uk

OSC OXFORD SPECIALIST COACHBUILDERS

Oxford Specialist Coachbuilders Have the following Trailers Available for Sale or Hire.

Merchandising/Vending Trailer:



5.0mt demountable merchandising/vending trailer, electro-hydraulic demount system, onboard generator, hot and cold water system, slide-out pod, canopy flaps to o/s & n/s, 3 tall fridge units.

Race Trailer:



13.6mt tri-axle trailer under going internally and externally refurbishment including new 2500kgs Dollandia Tailift, belly locker system. Office area to the front with seating, table, storage units, TV, fridge & air conditioning.

Two full length car deck in the rear section suitable for sports cars or single seaters.

For further details please contact Iain Fraser on **01865 300999**



TRAILER - Race Transporter 40ft 2005/6 Unfinished project. All coach work done. Front office /bedroom 5MT x 4MT. Middle bedroom for crew 1 bunk bed, fitter room for 1 more. Back open shell ready to kit for bikes, karts or cars. Trailer cost me £8500+VAT, Coach work cost £6000+VAT, Spent approx £2000 inside. All electric wire in fuse box. Just 200 miles since last MOT. When sold I will MOT it for 12 months. **£13500**

tzracer8@gmail.com 01530446436

Boarding Screen Background

Free standing awning background in white. Little use from new. Approx 15 x 2.5 MT

Cost me £4500

For Sale

£1650

Plastic Flooring

Yellow and Gold approx 70 MT

In very gold order

£450

HOSPITALITY UNIT FOR SALE

- Articulated Unit, currently white, with low mileage Renault Premium truck 16mtr total length.
- Commercial kitchen, central office, rear horseshoe lounge. Main 5 mtr awning and secondary 4 mtr.
- In built generator. Tables, chairs, flooring included.

Price **£35,000** ono.

For further details;

Email: studispires@hotmail.com
or call: **44 7768 256524**



MARKETPLACE

ART

PAUL DOVE ART



HUNT v LAUDA
www.pauldoveart.co.uk
paul@pauldoveart.co.uk

CAR TYRES

FOR ALL YOUR
AVON
 TYRES
MOTORSPORT
 RACING TYRES
 Inc. ACB 10 Formula Ford
 Contact

BMTR LTD

Tel: 0121 331 1122
 Fax: 0121 331 1144
 email: sales@bmtr.co.uk
 see our new website at www.bmtr.co.uk

ENGINES

V8 RACING ENGINES

- 289 GT40 Engine
 Original C6FE heads;
 Italian 48IDAs Fresh Dyno
 Tested
£25,000 + VAT
- 289 COBRA FIA
 Compliant/446 bhp
- 289 MUSTANG/
 FALCON/405 bhp
- 5 Ltr T70/F5000
 New High Spec -
 Can be seen on Dyno/520 bhp

Phone: 01630 638712 (T)

FLOORING

Kiwi Tiles

Interlocking Plastic Floor Tiles, as used by leading
 race teams throughout Europe.

- Easy installation & removal
 - Many colours
 - Lightweight
 - Strong and durable
 - Compact & easy to store
 - Top quality
 - Value for money
- Stock Colours:
 Red, Blue, Green,
 Yellow, Silver, Orange,
 Grey, Black, White,
 Dayglo Red

Ralt Engineering
 Tel: 01865 883354 Fax: 01865 883789
 Email: enquiries@kiwitiles.com
www.kiwitiles.com

AUTOMOBILIA

F1 COLLECTORS .COM



#1 FOR F1 MEMORABILIA & AUTOGRAPHS

We buy and sell F1 items
 AYRTON SENNA specialists
 Call CHRIS GRINT **01763 274448**
 email: sales@f1collectors.com

CORPORATE FLOWERS

THE *White* ROOM FLORAL DESIGN LTD

t: 01625 615880

enquiries@whiteroomfloraldesign.co.uk

Bespoke Florist with both
 Motorsport Hospitality
 and Product Launch Experience.
 Prepared to travel throughout UK
 and Europe, leaving your team to do
 what they do best.

Contact Julie on **01625 615880** or
 email enquiries@whiteroomfloraldesign.co.uk
www.whiteroomfloraldesign.co.uk



BUSINESS OPPORTUNITY

BUSINESS FOR SALE



SUPERCAR DRIVING EXPERIENCES



A unique opportunity to acquire a highly profitable, cash
 flow positive, DRIVES & DRIVE VOUCHERS business.

Based in North of England, est 6 years, t/o £167k,
 aNP £37k from 8 weekends per year, exclusive track,
 3 web sites, instructors in place, much scope to expand,
 confidential retirement sale.

Goodwill, customerbase, websites etc £195k
 F360, DB9, EvoX, Sti & Evoque £150k

info@a2zBusinessBrokers.com **0844 247 0 247**

GEARBOXES

Hewland Series 5, Formula 3 Gears. 1 1/3 Layshaft

18/34 - 19/24 - 24/26 - 24/28 - 18/32 - 22/28 -
 21/31 - 16/24 - 16/35 - 16/24 - 21/28

£60 each +VAT (All Good)

12/31 Mk 9, First Gear (5 Speed)
 £60 +VAT

Woodcote Racing, Silverstone
Phone: 01327 858074
Fax: 01327 858235

RACE PRODUCTS

- EXPERT ADVICE
- MASSIVE STOCK
- RAPID DELIVERY

demon tweeks
 MOTORSPORT Direct

sparco



CALL TODAY **0844 375 2196**

LOW CALL RATE CALLS MAY BE
 RECORDED FOR TRAINING PURPOSES
 MEDIA CODE: PZ252A

www.demon-tweeks.co.uk

80% OFF car insurance



If you have 8 years or more No Claim Discount

Chat to churchill™
0800 917 7626

churchill.com

Applies to new customers for the first year. Minimum premium applies. Excludes N.I. Underwritten by U K Insurance Limited.

One discount, two discount, three discount, more...

Insure your cars with Admiral MultiCar, and each car receives a great discount. More cars equals more discounts!



Admiral.com

0800 600 880



MARKETPLACE

RACE PRODUCTS



**MARDI GRAS
MOTORSPORT**
Saloon Car Preparation



Unit 45, Silverstone Circuit
Towcester
Northampton NN12 8TL

tel: 01327 858006 fax: 01327 858800
email: info@mardigras.co.uk
web: www.performanceclutch.co.uk
buy online at www.mardigras.co.uk

Distributors and agents for:

AVUL
RACING FUEL CELLS



**STACK
STACK
STACK**

HELIX
AUTOSPORT

VDO
Performance Instruments

HYPERCOILS

VARLEY RED TOP™
THE ORIGINAL RACING BATTERIES

FERODO RACING

Setrab
Pro Line

AP
RACING

LifeLine
Fire & Safety Systems Ltd.

VEVO

PERFORMANCE
FRICTION
BRAKES

Eibach
SPRINGS

EARL'S
PERFORMANCE PRODUCTS

Castrol

HONDA

K&N
THE WORLD'S BEST AIR FILTER

SCHRICK

CARTEK
MOTORSPORT ELECTRONICS

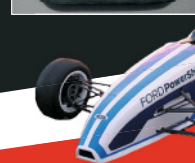

Innovative products:

- Solid State Battery Isolators
- Power Distribution Modules
- Wireless Steering Wheel Controls
- Coolant Sensors
- FIA Rain Lights
- Shift Lights



www.CARTEKMOTORSPORT.com

CARTEK AUTOMOTIVE ELECTRONICS Ltd

44 (0)2380 637600

info@cartekmotorsport.com



UK Distributor / Warehouse

Tel: +44 (0)1784 493 555

Fax: +44 (0)1784 493 222

Email: sales@glencoeltd.co.uk

Made in the USA

"Fuel Pumps for the Professionals":-
Original Equipment
Formula One
Race Teams
Rally Teams
Military



FAST ROAD

'IN TANK PUMP'
UPGRADES

From **£56.08**

Pump kits..... **£60.40**

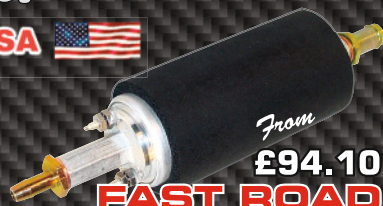

From **£94.10**
FAST ROAD
'OUT OF TANK'
(3 BAR) REPLACEMENT PUMPS

**400
450** LITRES / HR

**2 YEAR
WARRANTY**

EXTREME FUEL

For
**EXTREME
POWER**

**190
255** LITRES / HR

MOTORSPORT
'IN TANK PUMP'

From **350 BHP £65.80**

From **500 BHP £74.64**

Kit prices From **£75.90**



325 LITRES / HR
MOTORSPORT
'OUT OF TANK'

325 LTR / HR
5 BAR FUEL PUMP
(180 LTR / HR @ 3 BAR)

From **£99.50**

MOTORSPORT
400 LTR/HR

Upto 600 BHP

Pt.No. GST400 (PUMP ONLY)

GST400K (PUMP KIT)

From **£92.40**



MOTORSPORT
450 LTR/HR

Upto 750 BHP

Pt.No. GST450 (PUMP ONLY)

GST450K (PUMP KIT)

From **£112.00**



Prices exclude VAT @ 20%

www.glencoeltd.co.uk

MARKETPLACE



WWW.REIGERSUSPENSION.COM



The best suspension for:

- Rally
- RallyCross
- AutoCross
- MotoCross
- Trial
- Quads
- Sidecar Cross
- Rally Raid



Reiger Suspension BV
Molenek 5a
NL-7255 AX Hengelo Gld.
Tel.: +31 (0)575-462077 info@reigersuspension.com



MOTORSPORT JOBS



Primary Designs are leaders in the designs and manufacture of racing car exhaust systems and are proud of our associations with world championship winning F1 teams, other leading race series manufacturers and supercar manufacturers. Primary Designs are a very successful and proactive organisation and are recognised as being at the forefront of innovation in exhaust technology and manufacturing. As part of our ongoing expansion plans we are recruiting self-motivated people to join our highly skilled engineering team.

We wish to recruit for the following position:-

Skilled Fabricators - TIG Welders (Racing car exhaust systems)

We are looking for Skilled Fabricator /TIG Welders, suitable applicants must have experience with exotic materials such as Nickel Alloys (Inconel), Titanium and Stainless steel.

You will preferably have Motorsport experience, but candidates from the Scientific, Aerospace or any other precision welding industry may have the necessary qualifications and experience required.

Previous exhaust fabrication and manufacturing experience is preferred but training will be given to self-motivated candidates who can demonstrate their adaptability to this kind of highly skilled work.

If you wish to apply for this position please forward your CV to the following:-

Primary Designs Ltd
Unit 10, Thame Park Business Centre,
Wenman Road, Thame, Oxon OX9 3XA
patbarrett@primarydesigns.co.uk

Recent business expansion within the UK's leading electrical connector distributor/ assembler and stockist has resulted in an exciting opportunity for an experienced:

Business Development Manager (Motorsport)

Location flexible -
Competitive salary + bonus + car

To be predominantly responsible for selling electrical connectors and associated products to the motorsport electronics industry as well as other interconnection products from the Lane portfolio as opportunities arise.

Extensive experience of motorsport connector sales/markets is essential as will be a proven track record in increasing sales, combined with the ability to develop and maintain long-term relationships not only with existing and new customers but also suppliers and manufacturers as required.

FOR FURTHER INFORMATION PLEASE VISIT THE VACANCIES SECTION ON OUR WEBSITE:

www.fclane.com



F/T Aero Engine Mechanic/Licensed Engineer

We are seeking to appoint a highly skilled and dedicated individual to join our engine workshop team. The successful candidate will ideally have a minimum of six years' experience in maintenance and overhaul of aircraft piston engines. A licensed engineer with a BCAR 'D' Licence or equivalent is ideal but not essential. Essential qualities are: versatility, a willingness to learn new skills and broaden knowledge, the ability to adhere to a high standard of quality and workmanship and, to work as part of a close-knit team.

Closing date 31.03.2014; Apply by visiting
www.shuttleworth.org or call 01767 627927

Registered charity no. 307534.



BRISTOL CARS SERVICES LTD

would like to recruit a full-time

Parts Sales/Purchase Person

to work from their Brentford service and restoration facility

Applicants must:

- have a minimum of ten years' experience with classic or historic vehicles
- be computer literate with Sage or similar
- have experience in purchasing good quality parts in low volumes
- be able to work as part of a close team
- maintain excellent working conditions and work to a very high standard.

This role is a fantastic opportunity for the applicant to expand the retail parts department and to grow with a recently reinvigorated historic British Company. We are in the process of expanding our Service Department and have just opened our new Parts Department office.

Please contact the Service Manager **Mr Martin Sutherland** on 0208 560 33 00 or email martin@bristolcars.co.uk

Bristol Cars Services Ltd, Units 17-19, Shield Drive, West Cross Industrial Park, Brentford TW8 9EX

MOTORSPORT JOBS



Wirth Research is a group of innovative engineering companies specialising in research, development, design and manufacture for the motor racing industry and other sectors including commercial vehicles and architecture.

We are currently looking for a talented individual to join us in the following role:

Senior Vehicle Dynamics Modelling Engineer

We are looking for a Vehicle Dynamics Modelling Engineer with at least 5 years experience in the field to lead a team responsible for vehicle and sub-system modelling and analysis.

The role will offer you the opportunity to work on a range of different motorsport formulas developing vehicle models for our DIL simulators and offline simulation tools. Working as part of a small team you will be involved in all aspects of the team's work.

Responsibilities will include:

- Developing whole vehicle and sub-system models from first principles
- Integrating sub-system models into existing vehicle models
- Validating vehicle and sub-system models against rig and track data
- Ensuring effective use of vehicle modelling tools by departments and customers

Essential experience and qualifications required for the role:

- Educated to degree level in an engineering discipline; ideally 2:1 or above with a broad based education in physics and mathematics
- Solid grasp of first principle vehicle dynamics
- Capable of innovative vehicle model design, optimisation and validation against real world data
- Proven experience of working with C++, Matlab and Simulink with sound understanding of programming principles. Experience of Matlab & Simulink Coder/Real-time workshop would be an advantage
- Experience in development of models for real time simulation
- Experience in analysis of car and simulation data using packages such as Atlas, Wintax or Pi Toolbox
- Experience in development of multi-body models would be an advantage

How to apply

If you are interested in joining the company in Bicester, enjoy working in a team environment and are highly motivated please contact us on the email below stating the role you are interested in and attaching your CV

Email address for applications: vacancy@wirthresearch.com

For more information about the company please visit our website www.wirthresearch.com

Toyota Motorsport GmbH (TMG) is a supplier of high-performance engineering services to the automotive industry and beyond, located in the friendly and international city of Cologne, Germany. With an extensive experience of World Rally, sports car racing and Formula 1, two state-of-the-art wind tunnels, unique R&D testing facilities and extensive production departments as well as impressive design and simulation capabilities, TMG is at the forefront of engineering services supply to the motorsport and automotive industries.

MECHANICAL DESIGN ENGINEER ELECTRIC/ELECTRONIC (M / F)

For our Electric/Electronic Department we are seeking a Mechanical Design Engineer who will be responsible for the design of mechanical hardware and its integration in cooperation with other departments. These tasks include 3D model design of components in CATIA V5 and of 2D drawings for manufacturing as well as creation and controlling of part and assembly lists in ENOVIA VPM. The follow-up of car build, test and race, analysis of problems and design improvement are also part of your job. Furthermore you will be in charge of the coordination of special development projects.

We are looking for specialists in the following areas:

- Electrical Wire Harness Design
- Motorsport Parts Layout
- High Performance Parts

We offer an attractive package including competitive remuneration, 30 days annual holiday (plus public holidays), relocation assistance and discounted insurance. In addition, TMG's modern, dynamic working environment provides training and career development opportunities as well as free on-site gym and subsidised restaurant.

**FOR FURTHER INFORMATION AND QUALIFICATIONS REQUIRED
PLEASE VISIT THE CAREER SECTION ON OUR WEBSITE:
www.toyota-motorsport.com**



Toyota Motorsport GmbH, Human Resources, Toyota Allee 7, 50858 Köln, Germany
job-opportunities@toyota-motorsport.com



MERCEDES AMG
PETRONAS FORMULA ONE™ TEAM

Right team.
Right time.

Opportunities in Aerodynamics, Engineering Software, Composites, Quality and more...

You don't need to be in the cockpit to race in F1. At MERCEDES AMG PETRONAS, everybody leads and everybody's contribution is valued. We all take responsibility for our tenth of a second – and that's what drives our performance. Our people are our greatest strength and you will have the investment, facilities and leadership you need to do a world-class job. At the dawn of a new era in Formula One, MERCEDES AMG PETRONAS is the right team. And for you, this could be the right time.

Visit careers.mercedesf1.com to search and apply for our exciting opportunities.

MOTORSPORT JOBS



For more than 30 years our Team AMG-Mercedes stands for fascination and success in international motorsport. We have been just as successful in recent years with the development and production of highly exclusive Mercedes-Benz road cars.



In order to stay right at the top, we would like to fill the following positions:

Vehicle dynamics engineer (m/f)

You prepare and validate calculation models in the area of driving dynamics. After carrying out the calculations, you check the results to ensure correlation with data from the racetrack and the test stand. For this, the data will need to be evaluated and processed using data analysis programs. A good theoretical knowledge in the area of driving dynamics and tyre modelling is assumed. In addition, you will also be experienced in the use of Matlab, C/C++ and Simulink.

Performance engineer (m/f)

You are a member of our operation team and responsible for data analysis in the area of tyres and chassis dynamics. This includes firstly the evaluation and processing of the data and also looking after the measuring equipment on the track.

Technical manager (m/f)

In this position, you are responsible for the technical sector for racing and test events in the DTM. This includes preparing for and following up the events. You work closely with management and the specialist divisions such as aerodynamics, simulation and design team.

For these tasks you be a graduate of engineering, automotive engineering or a similar field of study as well as having several years of professional experience in motorsport.

In addition to the fascination of motor sports, you will also have the opportunity to achieve extraordinary successes in an enthusiastic team.

If you wish to apply for one of these positions please forward your CV and letter of application with current remuneration details / salary expectations and your available start date to:

HWA AG | Human Resources Department | Benzstrasse 8 | 71563 Affalterbach, Germany

You can find more information about the company on www.hwaag.com



HR05031401 – FACTORY & HOSPITALITY SALES COORDINATOR

We are currently looking for a Factory & Hospitality Sales Coordinator to support, grow and enhance our unique hospitality offering at the Infiniti Red Bull Racing Factory and Test events.

The primary function of the role will be to drive ticket sales in all hospitality areas as well as oversee all Factory Hospitality events and Formula One Test guest programmes.

The successful candidate will have experience in sporting hospitality (ideally Formula One), be knowledgeable in conferencing and event sales and have a drive to achieve beyond targets. The ideal candidate will have excellent interpersonal skills, be proactive in making contacts, achieving sales and be able to negotiate confidently. Demonstrating a high level of commitment, an ability to present to an audience and the capacity to work in a pressured environment is paramount in a Team which expects excellence as standard. Applicants should be degree qualified or equivalent.

This role will occasionally be asked to support trackside hospitality and minimal race travel will be required.

Fixed Term contract until 31st December 2014

To apply for positions at Red Bull Racing and Red Bull Technology, please visit the jobs link on our website www.infiniti-redbullracing.com.

CLOSING DATE FOR APPLICATIONS – 20TH MARCH 2014

PLEASE NOTE: No Agencies please.



At McLaren we believe that winning matters most. We know what it takes to win and we achieve this by working together and encouraging innovation in an extraordinary high performance environment.

We currently have the following exciting opportunities:

- MRL - 210/318 X2 CNC MACHINIST ROLES - ON SHIFT BASIS
- MRL - 260 ELECTRICAL ENGINEER
- MRL - 324 SENIOR MODEL MAKER
- MRL - 361 CNC MACHINIST - 4 DAY WEEK
- MRL - 367 SENIOR MECHANICAL DESIGN ENGINEER - AERODYNAMICS
- MRL - 372 POWER TRAIN QUALITY ENGINEER

For further information on the above roles and details of how to apply, please visit www.mclaren-jobs.com Please quote Autosport when applying for the above vacancies.





Mission 2014. Our return.

Your chance.

Porsche is returning to Le Mans. And you can be part of this. Help us to write the next chapter of our successful motorsports history – as part of the Porsche LMP1 team in Weissach.

Interested?
We are looking for you as

Head (f/m) of Suspension LMP1

Vacancy: 267-2037966

Teamleader (f/m) Cockpit Interior & Fuel System LMP1

Vacancy: 4794-2101811

Specialist (f/m) Transmission Design LMP1

Vacancy: 4738-2002845

Engineer (f/m) Development Transmission LMP1

Vacancy: 4742-2100443

Engineer (f/m) Development Hydraulic LMP1

Vacancy: 4739-2100444

Your profile:

- Bachelor's or Master's degree in Mechanical Engineering, Automotive Engineering or an equivalent education
- Work experience in motorsports development in Formula 1 or LMP1
- Proficiency in German and English
- Excellent team and interpersonal skills
- Independent and structured working attitude

Please use our online application form or send your complete application documents to:

Dr. Ing. h.c. F. Porsche AG
Personalmarketing
Porscheplatz 1
70435 Stuttgart
Germany

You will find further information about Porsche and our job openings at www.porsche.com/careers or www.facebook.com/porschekarriere



PORSCHE

QUALITY MOTORSPORT LOOMS FROM A PROVEN MOTORSPORT MANUFACTURER

- Looms manufactured to Tyco System 25 and IPC-620 standards
- Fully automated CNC and semi auto tooling
- ISO9000, ISO:14001 and OHSAS:18001 approved

*Quality is key to our success
- and yours!*



scan for more info

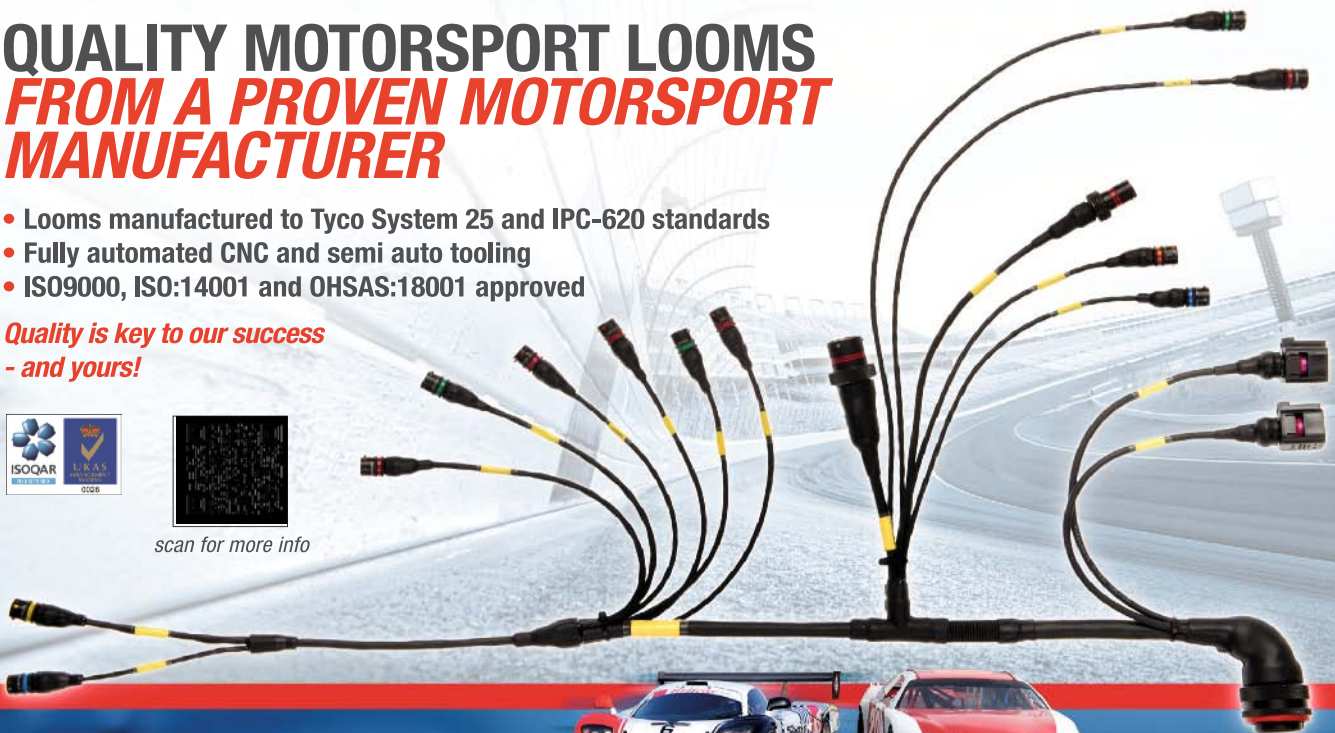

Contact us now with your requirements.

UNIT 14 MOUNT PLEASANT INDUSTRIAL PARK,
SOUTHAMPTON, SO14 0SP, ENGLAND

TEL: +44 23 8022 7636

EMAIL: sales@st-cross-electronics.co.uk



St. Cross Electronics

Established 30 Years 1983 - 2013



RACING4mnd

racehut?

highR

Racing4mnd support research into Motor Neurone Disease, which also advances the prospect of treatments for Alzheimer's, Parkinson's, Huntington's Disease and MS. Support us by purchasing one of the items in our race shop. Visit racing4mnd.org to see the full range!



2013 WSR Ebay Motors BTCC BMW 125i.
Acrylic on canvas by Gallery of Speed.
120cm wide by 40cm high.
£450 ONO



Pirtek Racing toolkit by Teng Tools.
Includes Andrew Jordan autograph,
plus goodie bag and two VIP tickets
to a 2014 BTCC round.
£1,000 ONO



FreeM made-to-measure FIA
approved race suit, provided
by m2d, the leading supplier
to British motorsport.
£750 ONO



Ragus®



info@m2d.biz

racing4mnd.org

Heaton-Ellis Trust Charity no: 1126534.

CLUB AUTOSPORT

NATIONAL RACING • HISTORICS • RALLYCROSS • HILLCLIMB • TRACK TESTS



Ford is favourite to become FIA's British F4 series

SCOTT MITCHELL
EDITORIAL ASSISTANT

scott.mitchell@haymarket.com

@ScottMitchell89



ONE THING THAT PERPLEXES

me is the attitude among some that the Motor Sports Association has not done anything to 'fix' Britain's current junior single-seater problem.

The perception in a few circles is that the sport's governing body in this country has been lazy, and I've heard people criticise the MSA for allegedly resting on its laurels as young drivers face an ever-tougher task to establish a professional motorsport career.

It's a tough, if not impossible, problem to solve. The sport's financial dependency is its pervasive issue in modern times and for a driver to even move out of the UK will set them back hundreds of thousands of pounds. The cost of running and repairing cars takes its toll over the course of a season – even more so when a series has been around a while and spares become harder to source.

In stepping in with his own BRDC Formula 4 concept last year, Jonathan Palmer showed there is still a strong appetite among young drivers to race single-seaters. Formula Renault BARC and British Formula Ford grids should number between 12 and 15 this season, and in the current climate that's a very respectable tally. It's just made to look worse by the 20-plus grids that BRDC F4 attracts.

Where British Formula 4 will feature on the popularity scale remains to be seen, and its viability depends entirely on a car being produced within the FIA's requisite price cap and then the series being managed in the correct fashion. There's little danger of Ford tripping up on the latter, as getting British F4 onto the TOCA package proves. The next issue, of course, will be how FIA F4 fares in competition with its similarly named equivalent...

Ford closes on British F4 deal

MSA enters formal negotiations with the Blue Oval over UK FIA series

FORMULA FORD HAS MOVED nearer to becoming the new British Formula 4 championship next season.

The Motor Sports Association, Britain's governing body, has confirmed its selection of Ford's tender to organise and promote the new single-seater series in 2015 to go through to the formal-negotiation stage.

The marque first expressed its intent to be the basis of the new championship, which will run in line with the FIA's universal F4 proposal, last year (see AUTOSPORT August 8).

Its original vision was to migrate British Formula Ford to the FIA's sporting and technical regulations, a plan that was boosted late last year when the FIA relented on its original requirement for normally-aspirated engines. That move cleared the path for Ford to tender with its EcoBoost turbo powerplant before Christmas.

No specific details have been revealed about the tender, nor whether Ford would continue to

contract organiser RacingLine to manage the running of the series, but AUTOSPORT understands it contained multiple chassis options.

Ford Europe head of motor racing Gerard Quinn told AUTOSPORT: "We're pleased to be involved. We have tendered for the organisation and the promotion, similar to what we do with British Formula Ford now.

"If that [contracting RacingLine] is what we wanted to do, we could. It wouldn't be fair to comment on the specific requirements of the tender. What I can say is we offered a good proposal with a number of options and that's maybe what made it attractive.

"There's a series of discussions that have to take place now. The important thing from a championship perspective is that due diligence is done."

While transitioning British F4 into the the UK's FIA F4 championship is Ford's long-term goal, Quinn believes the upcoming season could be crucial to its success and hopes a grid of 13-15 will line up for the opening round at Brands

Hatch on March 29-30.

Champion team JTR has confirmed Max Marshall, bringing its entry up to three cars, while Jamun Racing is still expected to field two Mygales despite losing the previously confirmed Juan Rosso to Radical. Karter Samuel Oram-Jones tested with James Mundy's team last week.

Three cars have been declared by Falcon Motorsport, with Radical set to run two. A two-car Meridian Motorsport line-up plus lone entries from Richardson Racing and SWB Motorsport have also been mooted.

"Thirteen to 15 cars is the target and I think we're moving towards that," Quinn added. "I would hope people recognise the commitment [Ford is making with its F4 plans].

"Anyone making a decision now or for next year, this is probably the championship to look at."

The MSA will not release further information until a final decision has been reached, but has not imposed a formal deadline for that to be taken.

NEW 2014 COLLECTION AVAILABLE



CIRCUIT



OFF-ROAD

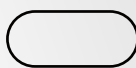

OVAL



08435 070 858 | WWW.GPRDIRECT.COM



Hughes and Firth will renew their successful partnership

British GT

Hughes and Firth join Trackspeed

BRITISH GT FRONTRUNNER

Warren Hughes will switch to a Trackspeed-run Porsche 911 GT3 this season, partnering Jody Firth.

Hughes and Firth have combined to win SPEED titles in the UK and in Europe, and have contested World Endurance Championship rounds and the Le Mans 24 Hours together.

The team will again run race-winning pair Phil Keen and Jon Minshaw in a second car. A third Porsche is also a possibility.

Gold-rated Hughes moves to the team after a disjointed M-Sport/WRT Audi R8 LMS ultra campaign in 2013, while silver-ranked Firth is a United Autosports convert. They will have to run with 75kg of ballast, but team boss Keith Cheetham believes his new duo will be in the title fight.

"They will carry extra weight but should be a good pairing," said Cheetham. "I think it's worth it."

"We stand a great chance of taking the title again this year as long as the

Balance of Performance is fair.

"We have two great driver line-ups in Jon, Phil, Warren and Jody and the whole team has gelled already. I have a special feeling about this year and I'm greatly looking forward to it."

Firth is confident the rapport he and Hughes have built up stands them out as title candidates.

"This kind of repeat success doesn't come by accident," he said. "Sometimes you just find team-mates who click. Warren and I are an example."

While his team-mate agrees they will be strong, he is fearful that the weight penalty could hurt their chances. "I think we're the strongest overall combination, but the 75kg we are forced to carry will make things harder," Hughes added.

● Ginetta GT5 Challenge champion Oliver Basey-Fisher will make his British GT debut. He will contest the GT4 division with former class champion Matt Nicoll-Jones in an Academy Motorsport Ginetta G55.

Formula Renault ALPS

Russell adds Prema Renault attack to BRDC F4 programme

HIGHLY RATED BRITON GEORGE

Russell will dovetail his BRDC Formula 4 campaign with a Formula Renault 2.0 ALPS programme for his first season racing in single-seaters.

Russell, European karting champion in 2011 and '12, will join the crack Prema Powerteam squad that ran Antonio Fuoco to last year's ALPS title.

The car racing rookie, who will race with Lanar Racing in BRDC F4, joins third-year ALPS driver Alex Bosak at Prema.

"I'm delighted to have signed with Prema as I feel this is the perfect place for me to learn and develop as a driver," said Russell, whose new team won every ALPS race last season.

"Hopefully we can pick up where they left off last year by winning the title."



Russell has busy schedule

Team principal Angelo Rosin believes that the 16-year-old, who shone on his FRenault testing debut in late 2013, will adapt well to car racing.

"Russell is a young British talent," he said. "He proved his ability in kart racing and we're sure he will repeat with open-wheelers."

Goodwood Members' Meeting

Ex-BTCC champion Gravett to race Dolomite at Goodwood

FORMER BRITISH TOURING CAR

champion Robb Gravett will compete in this month's Goodwood Members' Meeting in a Triumph Dolomite Sprint.

The Briton, who beat Frank Sytner and Andy Rouse to the 1990 BTCC crown, will drive the 1973 machine in the Group 1 Touring Car race with owner Anthony Robinson.

He says it could be part of a "bigger picture" this year as he also has an offer to return full-time to the BTCC.

"It's a really nimble car, and while we might be up against more powerful models, I'll give it a good go," Gravett told AUTOSPORT.

"I'm doing it for fun but it might form

part of a bigger programme for me, as I have also been courted about returning to the BTCC with a frontrunning team.

"I've never felt an urge to return before, but there are so many ex-champions it would be nice to add one more. It's a strong possibility."



Gravett won '90 BTCC title

Comprehensive motorsport insurance products to keep you on track;

- 🔵 Worldwide On Track
- 🔵 Personal Accident
- 🔵 Storage and transit
- 🔵 Track day
- 🔵 Liability
- 🔵 Commercial

Please complete an online quote request form at – www.ryanmi.com

Email – info@ryanmi.com Tel – +44 (0)1799 524202

Ryan Motorsport Insurance Limited is an appointed representative (557405) of Independent Broking Solutions Limited who are authorised and regulated by the Financial Services Authority, registration number 312026



BRDC F4

Barrichello protege to BRDC F4 as part of new Brazilian set-up

EX-FORMULA 1 STAR RUBENS

Barrichello will advise Brazilian youngster Gaetano di Mauro in the BRDC Formula 4 Championship this season.

The former Ferrari driver will work with di Mauro, a karting champion in his native Brazil, and could accompany him to several races. Di Mauro, 17, contested a bit-part South American Formula 3 campaign in 2013 and is the first signing of the new Petroball Racing team, which will field a two-car entry.

"I'm still dreaming about it all," he said. "Everything moved very fast in 2013, and 2014 has started in the same way. I couldn't be happier and am looking forward



Brazilian team is serious about F4

HAWKINS

to repaying the faith they have in me."

The Petroball team has set up a base in Milton Keynes and is purchasing a house in the same area for drivers to stay in.

Jake Hughes, the inaugural BRDC F4 champion, will work as a driver coach and test the second car until a team-mate for di Mauro is confirmed, while Andy Miller has been drafted in as a race engineer.

Team principal Jose Roberto Sabathe told AUTOSPORT he had originally considered a British Formula Ford entry before deciding on BRDC F4.

"Britain is the top place to be in motorsport," he said. "I didn't want to go to Italy or Germany. If you want a career in motorsport you need to be in Britain.

"It took five minutes to convince me about F4. The costs, the car, the whole package – it's very nice. I'm very excited."

Another Latin-American, Telmex-backed Mexican karter Rodrigo Fonseca, has joined Douglas Motorsport.

This year's F4 champion will receive an end-of-season GP3 Series test with the race-winning Arden Motorsport squad.

Formula Renault BARC

McLaren youngster Barnicoat for Rockingham FR BARC opener

McLAREN FORMULA 1 JUNIOR

Ben Barnicoat will contest the first round of the Formula Renault BARC series.

The Racing Steps Foundation-backed ace, whose main programme in 2014 is a Formula Renault Northern European Cup campaign with Fortec Motorsport, won the category's Autumn Cup title on his single-seater debut last November.

Former European karting champion Barnicoat, 17, will stick with Fortec for the FR BARC opener at Rockingham on April 5-6 and team manager Dominic Stott believes he will be the favourite.

"It's great to have Ben in the car for the first round at Rockingham," he said. "He'll be the driver everyone wants to beat and

we'll be looking to carry on from where we finished 2013."

Briton Alex Gill and Finnish car racing rookie Niklas Tiuhonen are the latest drivers to commit to a full FR BARC campaign. Sixteen-year-old Gill is Fortec's first full-time signing while Tiuhonen, 18, will run as a privateer.



Barnicoat won on debut in FR BARC

EBREY

Historics

Legendary BTCC machines to be celebrated at Donington festival

A SPECIAL CELEBRATION RACE

for iconic cars from the British Touring Car Championship will be held at the Donington Historic Festival.

The Historic Racing Drivers Club is organising the 45-minute pitstop race, to be held on May 3, for specially selected

replicas of historic cars from the formative years of the BTCC.

Among the roster of models will be the Austin Westminster, Jaguar Mk1 and Austin A40 and a quintet of Ford classics including the Zephyr, Galaxie, Cortina, Mustang and Anglia.

HRDC race director Julius Thurgood said: "This unique race will literally be a dynamic celebration of the emerging years of British Touring Car history that is sure to thrill any race fan attending this spectacular historic festival at Donington."

A litany of sub-class replicas will also be present, including the Riley 1.5, MG Magnette and Borgward Isabella.



Tin-top replicas will star at event

EBREY

HUMBLE PYE

The voice of club racing



Lydden rallycross circuit is UK's finest

Picturesque Kent venues will shine during fabulous 2014

Working in eastern Kent last Wednesday, and with momentum building towards the circuit's first FIA World Rallycross Championship round in May, I could not resist dropping in at Lydden Hill for a peek at the pretty Canterbury venue. It was there that the sport was born for television, in February 1967, but regrettably I've not visited for a race meeting in more than 25 years.

Lydden's compact amphitheatrical layout mirrors Brands Hatch Indy circuit's in that it was overlaid (in 1965) on a motorcycle grass track. Its hairpin extension also came later. The plunge down Hairy Hill to Paddock Bend is as exciting as the long right at Chesson's Drift that immortalises founder Bill Chesson.

I attended the Thames Estuary AC's first Castrol International in November '77. The entry was not a full European affair, but Norway's Martin Schanche (Ford Escort), Swede Per Eklund (Saab 96) and Dutchman Cees Teurlings (Porsche 911) faced Britain's best: RAC champion-elect John Taylor and John Welch in Escort-BDAs.

The weather was grim, which stymied the favourites – including local emerging powerhouse Will Gollop (Saab 99) and future Historic Formula 1 Tyrrell 008 racer Trevor Reeves (1500cc Mini), plus National Hot Rod aces Barry Lee and Mick Collard (BTCC star Rob's

dad) in Escorts – and gave skilled clubmen a real moment of glory.

Gordon Rogers was unbeatable in his Mini, seeing off Eklund in the final. Hampshire tuning wizard Tom Airey (Mini) bagged third, ahead of Welch and Dave Potter (Mini). Rogers triumphed again the next day, winning the RAC championship finale from Reeves and Barry Hathaway, also Mini-mounted.

I didn't stay, for Sunday's choice was the BRSCC Formula Ford Festival at Brands Hatch. Brazilian Chico Serra starred, the works Van Diemen RF77 driver winning the first of Saturday's six heats, then his semi-final and the final on day two. David Leslie (Royale RP24) led the chase, with Trevor van Rooyen (RP24) third by a whisker from Mike Blanchet (Lola T540), Donald MacLeod (RF77) and Kenny Acheson (Crossle 32F).

Repeating my 1977 trip, I caught the afternoon of Brands's MSVR media day en route home last week. I can't wait for the action-packed 750MC event on the 1.2-mile course (April 26-27) and Masters Festival (May 24-25 – no World Rallycross at Lydden for me) and HSCC Super Prix (July 12-13) historic showcases on the GP circuit.

Marcus Pye

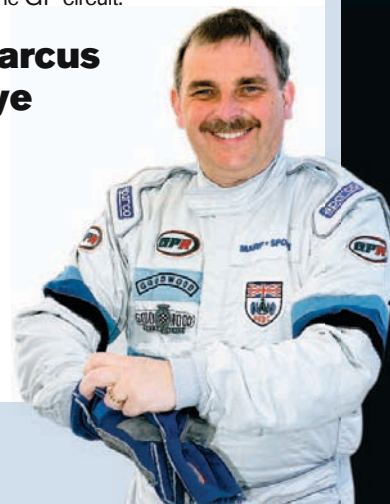

"The weather was grim, which stymied the favourites and gave skilled clubmen a moment of glory"

SUBSCRIBE TO AUTOSPORT AND GET... A FREE ADIDAS RUCKSACK

+PLUS+

**FREE DIGITAL EDITION
SUBSCRIPTION & UNLIMITED
ACCESS TO AUTOSPORT.COM**



FREE GIFTS

- ✓ Free Adidas rucksack worth £29.99! Features include side mesh pockets and padded laptop compartment. Size: 32x18x44cm
- ✓ Free subscription to the AUTOSPORT Digital Edition and unlimited access to AUTOSPORT.com

SUBSCRIBE NOW!



- ✓ Save 25% on the cover price
- ✓ Pay just £34.99 every 13 issues by Direct Debit

Visit: www.themagazineshop.com/aspo/m0314p

08448 488 817

Or call and quote **M0314P**
Please have your bank details ready.
Offer ends April 3, 2014.

themagazineshop.com

THE BENEFITS OF SUBSCRIBING!

- ✓ Never miss an issue
- ✓ Free delivery direct to your door
- ✓ Unlimited access to news and views from the paddock
- ✓ Access to subscriber-only analysis and comment

This offer is open to UK residents only. Overseas rates are available on +44 (0) 1795592 972. Please allow 35 days for delivery of your gift and first issue. The gift will be sent under separate cover from the magazine. Should we run out of gifts, you may be offered an alternative gift – there is no cash alternative. To activate your AUTOSPORT online account visit <https://secure.autosport.com/subs/activate.php> and enter your activation code (your personal magazine subscriber number which will be included in your welcome email/letter) along with your email address to access your extra AUTOSPORT content. Direct Debit rates are valid for one year after which they are subject to change – should prices change we will inform you in writing. We ask that you enter into a Direct Debit agreement with the intention that your subscription will continue for a minimum period of 12 months, even if the frequency of payment is for a shorter period, however, you will still have the right to cancel your Direct Debit in accordance with Direct Debit Guarantee. Should you wish to cancel your subscription it will be cancelled on expiry of the current term which will not be refundable, other than in exceptional circumstances. If a gift is included as part of the subscription offer we reserve the right to request the return of the gift. Details of the Direct Debit Guarantee are available on request. Savings are based on the standard UK cover price of £3.60. Offer ends April 3, 2014. Haymarket Media Group Ltd uses a best-practice layered Privacy Policy to provide you with details about how we would like to use your personal information. To read the full privacy policy please visit our website www.haymarket.com/privacy or call us on 08448 482 800. Please ask if you have any questions as submitting your personal information indicates your consent, for the time being, that we and our partners may contact you about products and services that will be of interest to you via post, phone, e-mail and SMS. You can opt out at ANY time by emailing the datacontroller@haymarket.com or by calling 08448 482 800.



Werner has bought ex-Bailey Tyrrell 017

BOSS GP

Werner eyes BOSS F1 outings in '88 Tyrrell

THREE-TIME LE MANS 24 HOURS winner Marco Werner has purchased a 1988 Formula 1 Tyrrell 017 that he hopes to race in BOSS GP.

Audi ambassador Werner, who won the French endurance classic in 2005-'07 and who will race an R8 LMS ultra in the Nurburgring 24 Hours in June, has bought the Cosworth DFZ-engined 017, chassis #2, raced by Julian Bailey in

'88. He explained that he expected to test the car soon and that he has his eye on the odd race outing in BOSS GP (which has replaced EuroBOSS).

"When I was a young guy, it was my dream to drive a F1 car," Werner told AUTOSPORT. "I didn't make it, but now I'm going to get the chance.

"I'm just a big fan of racing. I've read all the books, so I'm very excited to own this

car. I'm going to do some trackdays in it, but I would love to race it."

Werner has also purchased the Ralt RT36 he drove to second in the 1992 German Formula 3 Championship. The car came with a Volkswagen engine, but he is having it converted to the Spiess-Opel unit in which he raced it in period by some of his former mechanics from Siggie Muller's GM team.



Ian Ashley tried to qualify Warner's Brabham in '74

GRAHAM WARNER 1929-2014

GRAHAM WARNER, THE FOUNDER of the illustrious Chequered Flag team, passed away last weekend aged 84.

Warner founded the Chequered Flag garage in 1956 and first raced in '58 with an Austin-Healey 100S, but would enjoy most success as a driver with the famous Lotus Elite 'LOV1'.

The team turned constructor when it acquired the rights to the Formula Junior Moorland design, reworking it and producing a run of Gemini racers, the first of which gave Jim Clark his debut

race in a single-seater.

The Chequered Flag would go on to run works teams in Formula 3 for Brabham and McLaren, and produce the Lotus Elan 26R variant, in which Jackie Stewart would star. A great talent nurturer, Warner was also instrumental in the career of Chris Irwin.

After a sabbatical from racing, the team attempted in vain to qualify a Brabham BT42 for the Canadian and US GPs in 1974 and moved into rallying with a fleet of Lancia Stratos cars.

Rallycross

Reborn RX series begins

VAUXHALL CORSA DRIVER ALLAN Tapscott won the opening round of the revived BTRDA Clubmans Rallycross Championship at Blyton Park last weekend.

Run on a new rallycross circuit at the venue, 42 drivers took part in the first of six rounds for the series, the revival of which had been postponed by heavy rain at the same venue last month.

Tapscott was hounded throughout the Super Modified final by Gary Dixon and Gary Cook. Victory in the Production category was claimed by reigning British Hot Hatch rallycross champion John Lyne.



Tapscott won main event



Donnellys will share Elise

Lotus Cup UK

Donnellys in Lotus Elise tie-up

FORMER TEAM LOTUS FORMULA 1 driver Martin Donnelly will partner his son Stefan in the Lotus Cup UK this season for the 20-year-old's racing debut.

Donnelly Sr, who has contested the Lotus on-Track Racing Drivers Club-run category before, will mentor his son in Elise Trophy and Speed events as well.

They will drive a Production class-spec Lotus Elise previously raced by world land speed record holder-turned-Radical SR1 Cup racer Andy Green.

"This is my first year of car racing, and I have to be realistic with my ambitions for the season," said Donnelly Jr. "Hopefully I can try to keep dad on his toes."

In brief



Webster joins Redline

Porsche Carrera Cup GB scholar Josh Webster will partner double champion Michael Meadows at Redline Racing this season. Webster (above, right) is excited about joining the multiple teams' champion. "I think we've made a good choice and now I'm really looking forward to getting going," he said.

MSA appoints Jones

The Motor Sports Association has confirmed that general secretary Rob Jones has become full-time MSA chief executive. Jones has held the position of acting chief executive of the governing body for UK motorsport since October. He is also president of the ethics commission of the world governing body, the FIA.

Winstanley award

Motorsport TV film maker and producer David Winstanley, who died of natural causes last month, will be remembered by an annual award in the RAC Rally Championship. Competitors, marshals and fans will be invited to cast their votes for the award, which will be given to the driver judged to have delivered the championship's best TV moment of the season in or out of the car.

Bumper retro F1 entry

A 29-car entry has been confirmed for the opening round of the FIA Masters Historic Formula 1 Championship. Held as part of the Catalan Classic Festival at Barcelona on April 4-6, reigning Post-'78 champion Greg Thornton heads the entry in his ex-Nigel Mansell Lotus 92/5. Williams, McLaren and Brabham and more marques will be represented.

Pattison back in Clios

Renault Clio Cup UK race winner Lee Pattison will return to the category this season with JHR Developments. Team boss Steven Hunter, who ran Pattison last season, believes the 2010 runner-up (pictured below) will be a title challenger in the new model. Jordan Stip will also return with 20Ten Racing.





Not just another 911

Porsche Carrera Cup GB grids suffered a dramatic decline in 2013. SCOTT MITCHELL looks at whether the new 991 will change the series' fortunes, and finds out what makes it so different

Last year was a tough one for the Porsche Carrera Cup GB. Grids were poor throughout the season and a low of seven at Rockingham inevitably raised questions among those outside of Porsche Great Britain's Reading headquarters.

Would the series continue? Did it deserve to be on the British Touring Car Championship support package? And wouldn't a more-expensive new car make it even harder to get those numbers up?

Despite a difficult winter – at the end of which teams have not been able to test the new cars properly before the first round of the season at the end of March – Porsche is optimistic about its grid for the coming season.

"It's been a bit harder than we anticipated bringing in the new model," says Porsche GB motorsport manager Marion Barnaby, who wants 18 cars on the grid.

"The biggest thing for us – and it's why we have new teams and

new drivers – is it's a level playing field. Coming into the latter years of an existing model the old hands know it inside-out, so new guys are at a disadvantage. The new model is completely new, for everybody."

That word 'new' unsurprisingly crops up a lot as Porsche GB gives its teams (and AUTOSPORT) an intensive crash course in working with the car. So what's different?

Yes, the 991, which will replace the 997 GT3 Cup car in the Porsche Carrera Cup GB this season, is a 911, and yes, it's that shape, but the car has little in common thereafter.

It costs just over 10 grand more than the old car at £120,000 plus VAT, but boasts 12 months' worth of development in the Formula 1-supporting Porsche Supercup and a raft of changes from the 997.

Bigger wheels, tyres and brakes (now made by Performance Friction) are part of the package, with new shock absorbers and suspension geometry leading onto a completely new chassis sporting a gearbox that is now controlled by a paddleshift.

The engine is similar but it's

been tuned to deliver an extra 10bhp, and the management system is new. There's a totally different data-logging package and, internally, a new seat and safety system. It's longer than the previous model – by about 10cm – and its brand new chassis is now 60 per cent aluminium rather than all-steel, and much stiffer.

The Michelin tyres have grown two centimetres to 27cm at the front and by 10mm at the rear (now 31cm), so there's more grip there now too.

"There are so many areas on the car that are different, so many aspects," explains Carrera Cup GB project manager Robert Boakes. "You can start at a wheelnut and work your way to the glue that holds the chassis together. Every corner and every aspect is new."

The core of the 991 – the chassis – is where the largest change can be found. In Boakes's words, it's the biggest development, "from a design perspective all the way through to a repair perspective", and it's easy to see why.

Its mixed-metal composition



Porsche will assist teams in working on new cars...



EXPERT VIEW

NICK TANDY (Porsche factory driver)



The new car is faster, and it is consistently faster. It's much more like a proper GT racecar and it's easier to do a race distance.

Every aspect of the car, whether it's the driving position, the way the power is delivered or the paddleshift, is further developed and further optimised. Overall, it's a much more advanced racing car.

With the longer wheelbase it gives the new car more stability when you're on the edge. The paddleshift system makes it more consistent and allows the driver to concentrate more on driving. You flat-shift on the way up and it has the auto-blip system for the downshift. It's how every racing car will be in the future.

One of the big steps is the driver ergonomics and the way the driver interacts with every aspect of the car. There's more learning to do, but at the end of the day it's a Porsche.

I think it will enable guys with less experience to progress with the car a lot quicker. You still have to have everything perfect from a set-up point of view and a driving point of view to pull a fast lap out in qualifying. There's still a big skill involved, but I think it will be easier for drivers to get on top of.

Every part of the car is better. There isn't a single aspect that hasn't been improved, which is naturally what you would expect from the next-generation Porsche.



Tandy has been a big part of the 991's development

"Every corner and

aspect is new.

It's a ground-up

refresh for everyone"

Robert Boakes

"You kind of have to cut yourself in half, there's been no backing off. From driving it to engineering it, it really is a ground-up refresh for everyone and a new learning process."

Porsche GB remained calm in 2013. With a new car coming onto the scene, it would have been foolish to expect new customers when the model in use would become ineligible for that championship the next season.

So for Barnaby the speculation was just hearsay. Touring car and GT racing is booming in Britain at the moment, so it's inevitable that the spread across championships gets a little thin sometimes.

The important thing for Porsche is the optimism is back, and that's largely thanks to the new car and the renewed interest it has brought.

"The thing you've got to remember is however many cars are on the grid, they are still our customers paying a lot of money to go racing Porsches," Barnaby argues.

"Motorsport in the UK is such a massive stretch, you're fighting your corner all the time.

"So the future has never been in doubt, we just needed to keep our confidence. Everyone's having a struggle at the moment, but now we're getting there."

had in the Supercup, which means there should be no unpleasant surprises for the teams when the season gets underway. And it's unfair to describe it just as a Supercup hand-me-down, because it's been in constant development. The gearbox, for example, is very similar to the ultra-aggressive Porsche 991 RSR that made its World Endurance Championship debut in 2013.

But while the 991 was out being developed, tested and raced, Porsche GB was busy trying to keep the UK series afloat. It was a tough logistical ask, especially with the arrival of the new car coinciding with the outgoing model still being raced.

"There's been no compromise," says Boakes when asked if the phasing out of an old car and introduction of a new one resulted in a need to find a few shortcuts.



...which are almost ready to hit the track

means this 911 is much less pliable, which in turn makes the car handle better. The rear quarter is still made of steel, as are some other panels, but where parts were welded together before they are now mostly held in place by glue. The front and rear can also now be cut away in the event of a serious crash.

This should allow better, more permanent solutions to heavy damage, with the possibility of completing a front-end change in six hours and the rear in a shorter period of time. Porsche is also supplying a specialist bodyshop at every race up to the Le Mans 24 Hours supporter to help teams if these repairs need to be carried out.

The electronics are different too. Porsche has an all-new data system to log every electronic pulse that emanates from the 991. The Cosworth programme and the upgraded Bosch ECU offer the teams much more detail in terms of what can be read and understood within the car's engine and electric systems. "It's a huge technological step forward, the way it manages the diagnostics and power systems," Boakes explains.

"It's something we've never experienced in the Carrera Cup so it's a big step for us and the teams to move the technology on."

One key benefit they've got is the year's worth of running the car has

Teddington Studios, Broom Road, Teddington, Middlesex TW11 9BE, UK.
Tel: +44 (0) 20 8267 5804 Fax: +44 (0) 20 8267 5922
E-mail: mail@autosport.com Website: www.autosport.com

EDITOR
Charles Bradley ext.5889
charles.bradley@haymarket.com

GROUP F1 EDITOR
Jonathan Noble ext.5810
jonathan.noble@haymarket.com

F1 EDITOR
Edd Straw ext.5877
edd.straw@haymarket.com

FEATURES EDITOR
Kevin Turner ext.5432
kevin.turner@haymarket.com

NEWS EDITOR
Glenn Freeman ext.5309
glenn.freeman@haymarket.com

MANAGING EDITOR
Peter Hodges ext.5903
peter.hodges@haymarket.com

RALLIES EDITOR
David Evans
david.evans@haymarket.com

DEPUTY NEWS EDITOR
Sam Tremayne ext.5952
sam.tremayne@haymarket.com

ART EDITOR
Lynsey Row ext.5914
lynsey.row@haymarket.com

PHOTOGRAPHS
LAT Photographic

CHIEF SUB-EDITOR
Marcus Simmons ext.5807
marcus.simmons@haymarket.com

PRESENTER/SUB-EDITOR
Henry Hope-Frost ext.5835
henry.hope-frost@haymarket.com

NATIONAL EDITOR
Ben Anderson ext.5425
ben.anderson@haymarket.com

EDITORIAL ASSISTANT
Scott Mitchell ext.5370
scott.mitchell@haymarket.com

SENIOR DESIGNER
Michael Cavalli

PICTURE EDITOR
Peter Mills ext.5918
peter.mills@haymarket.com

AUTOSPORT.COM TECHNICAL TEAM LEADER
Geoff Creighton
geoff.creighton@haymarket.com

AUTOSPORT.COM DEVELOPER
Tomasz Trznadel
tomasz.trznadel@haymarket.com

AUTOSPORT.COM USER INTERFACE DEVELOPER
Theo Pape
theo.pape@haymarket.com

OFFICE MANAGER
Joanne Grove
joanne.grove@haymarket.com
ext.5804

SPECIAL CONTRIBUTORS

Gary Watkins	Dieter Rencken	Alan Eldridge
Marcus Pye	Gary Anderson	Pablo Elizalde
Mark Glendenning	Giorgio Piola	Matt Beer

CORRESPONDENTS

ARGENTINA Tony Watson	ITALY Roberto Chinchero	Martin, David Phillips, Diego Mejia, Robin Miller, Jeremy Shaw
AUSTRALIA Phil Branagan	JAPAN Jiro Takahashi, Len Clarke	UK & EIRE Jonathan Crawford, Dan Cross, Kerry Dunlop, Leanne Fahy, Paul Healy, Paul Jurd, Linda Keen, Mark Libbeter, Stephen Lickorish, Marc Orme, Graham Read, Hal Ridge,
AUSTRIA Gerhard Kuntzsch	NEW ZEALAND Bernard Carpenter	Peter Scherer, Ian Sowman, Timson, Ian Titchmarsh, Matt Upton, Eddie Walder, Richard Young
BELGIUM Gordon McKay	RUSSIA Gregory Golyshv	
BRAZIL Lito Cavalcanti	SOUTH AFRICA Richard Asher	
FINLAND Esa Iloninen	SPAIN Raimon Duran	
GERMANY René de Boer	SWEDEN Tege Tornvall	
GREECE Dimitris Papadopoulos	USA Jonathan Ingram, Bruce	

ADVERTISING
Tel: +44 (0) 20 8267 5820
Fax: +44 (0) 20 8267 5850
E-mail: autosport.ads@haymarket.com

DISPLAY SALES MANAGER
Martin Lee,
ext: 5389
martin.lee@haymarket.com

DISPLAY ADVERTISING
Gary Lee Hoebbeck,
ext: 5276
garylee.hoebbeck@haymarket.com

LUKE RICKETTS
ext: 5961
luke.ricketts@haymarket.com

DON RUPAL
ext: 5244
don.rupal@haymarket.com

CLASSIFIED SALES MANAGER
Jonathan Whitehead,
ext: 5908
jonathan.whitehead@haymarket.com

SUBSCRIPTIONS
UK 0844 8488817
OVERSEAS +44 (0)1795 592 974
EMAIL
autosport@servicehelpline.co.uk

MARKETING MANAGER
Karen McCarthy, ext: 5658
karen.mccarthy@haymarket.com

MANAGING DIRECTOR
Patrick Fuller

CHIEF EXECUTIVE
Kevin Costello

EDITORIAL DIRECTOR
Mark Payton

CREATIVE DIRECTOR
Paul Harpin

STRATEGY AND PLANNING DIRECTOR
Bob McDowell

haymarket

Haymarket is certified by BSI to environmental standard ISO14001

PEFC
PEFC Certified
This product is from sustainably managed forests and controlled sources.
www.pefc.co.uk

THIS WEEK

LETTERS • BEST PICS • LATEST GEAR • ON TRACK & SCREEN • ONLINE

What you think of the motorsport news of the past week



That's right – point the camera at the car, not the driver's girlfriend

Action happens on the track

A plea from one of the silent majority. Bernie, can you please ensure the following for those of us locked into paying a fortune for our F1 viewing.

A single expert director at all races: the action happens on the track, even during pitstops. Please can we get away from seeing girlfriends, celebs and pitcrew in the garage watching TV. No more watching the pitwall and bouncing feet as nervous people who

may as well be in the motorhome worry about things they can do nothing about.

And a plea for a more balanced view of qualifying, as TV crews pick up drivers on their wind-down lap and miss the one major run by a driver. Better direction, use the technology you have (put the pitstops in a quarter of the frame) and remember the action happens on the track. Thanks.

Kevin Ryder, London

Edd Straw is right to say that mechanical unreliability used to spice up the outcome of grands prix. But it is interesting that he cites 1984 as the low point for reliability, as I remember it as the season where we saw the first signs of the level of reliability that we now expect.

If, prior to the British Grand Prix (round 10/16) you had said that nothing other than a McLaren would win for the rest of the season, you would have been laughed out of the room, as this level of reliability was simply unheard of.

But a few years later the same team won all bar one race of the whole season.

Bruce Carlin
By email

I thought it might be time for some alternative predictions

for the coming Formula 1 season:

Highest speed recorded
Mercedes W05 at Monza.
Honourable mention: high-profile driver agents heading into Mercedes-engined teams' hospitality units.

Most precise technology in F1
Turbo bearings running at 125,000rpm.
Honourable mention: alignment of pencils on Ron Dennis's desk.

Loudest scream across the start/finish line
Fernando Alonso upon realising radio button no longer moves team-mate out of the way.
Honourable mention: Pastor Maldonado's radio after being lapped by Massa and Bottas.

Highest in-car temperature recorded
Red Bull energy store between

completing its sixth flying lap and the outbreak of fire.
Honourable mention: Fernando Alonso's helmet just after release of loudest scream.

Rule that a team wants to revive
Red Bull lobbying for reintroduction of ride-along mechanic.

New F1 facet wearing out quickest
Drivers moaning about fuel saving/tyres/brake-by-wire/being in a black Renault-powered car and not a white Mercedes-powered car.

F1 figure starting first race of the season with a non-frontrunning car for the first time
Sebastian Vettel: Toro Rosso 2008.

Most creative application of the rules and regulations
FIA (winner every year!).

Paul Irwin
Bexleyheath

In pictures

Images around the globe, from the middle of London to Australian parks



WILL IT GO AS WELL AS IT LOOKS?
One last shot of the Williams FW36 this week, resplendent in its new Martini livery. We'll soon find out if 2014 will bring more success to two of motorsport's iconic names

In the shops

Desirable new releases

WRC 2013 REVIEW DVD

£16.99 – dukevideo.com

The 472-minute (that's almost eight hours' worth!) WRC 2013 official review DVD brings all the best bits from last season's world championship, with plenty of onboard action and an interview with retiring world champion Sebastien Loeb. Exciting stuff, with value to match.



SIGNED SURTEES FERRARI

£399 – autosport.com/shop

Revival's fabulous 1:20-scale NART-entered Ferrari 158 is a replica of the car driven to second place in the 1964 Mexican GP by John Surtees – a result that secured the Briton the world title. The only man to take the crown on two and four wheels has signed just 50 of these models – the perfect item of Surtees memorabilia in this, the 50th anniversary year of his unique efforts.



MOTOGP '13 OFFICIAL ANNUAL

£30 – haynes.co.uk

Now in its 10th year, Haynes's official MotoGP annual recounts in superb detail – with photos and statistics to go with the expert prose – the full story of the 2013 MotoGP season. Edited by television commentator Julian Ryder, with technical analysis from Neil Spalding, there's nowhere better to relive a historic year of premier-class bike racing than here.



MELBOURNE PREPARATION PART ONE...
Aussie rules football star Shaun Higgins and Force India's Nico Hulkenberg look on as Sergio Perez attempts to get the ball off Will Minson. Best stick to F1, Sergio!

EX-F3 CHAMP'S NEW COLOURS
British Touring Car rookie Marc Hynes launched the Quantel Bifold Racing team, which will be run by Triple Eight, at Horse Guards Parade last week



...AND PART TWO
Model and Australian GP ambassador Georgia Geminder helped to get Melbourne ready for this weekend's F1 encounter with a street demo in this two-seater



WHAT'S ON

ON TRACK AROUND THE WORLD

AUSTRALIAN GRAND PRIX

Formula 1 World Championship
Rd 1/19
Albert Park, Melbourne, Australia
March 16
formula1.com

SEBRING 12 HOURS

United SportsCar Championship
Rd 2/13
Sebring, Florida, USA
March 15
imsa.com

NASCAR SPRINT CUP

Round 4/36
Bristol, Tennessee, USA
March 16
nascar.com

NASCAR NATIONWIDE

Rd 4/33
Bristol, Tennessee, USA

March 15
nascar.com

V8 SUPERCARS

Non-championship
Albert Park, Melbourne, Australia
March 14-16
v8supercars.com.au

NATIONAL LISTINGS

Mondello Park MPSC
March 16
Irish Formula Vee, Touring Cars and GT rounds plus the Champion of Mondello Formula Ford 1600 opener.

AUTOSPORT

Room 101

Imagine you had the chance to banish your worst nightmares, what would they be? Picture editor **PETER MILLS** gives his arguments to get rid of his pet hates to motorsport's Room 101

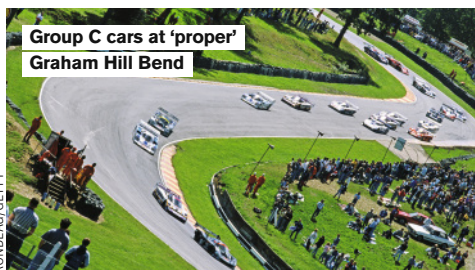

Group C cars at 'proper' Graham Hill Bend

RONDEAU/GETTY

THE POST-1998 GRAHAM HILL BEND

You'd really think I ought to have come to terms with it by now, but I've always felt the post-1998 revisions to Graham Hill Bend did rather more than just break up the flow at my local circuit Brands Hatch.

Alterations to other circuits down the years have never caused so much of an affront to my sensitivities, almost certainly because I never held such affection for them in the first place.

Work at AUTOSPORT may have provided numerous opportunities to travel to classic circuits across the world, but few can arouse the same emotion as simply turning off the A20 and entering the gates to the leafy Kent speedbowl for a race meeting.

Perhaps a touch of sentimentality could be detected in even Bernie Ecclestone when he said, 'There's some magic about Brands! It's just that with a tight second-gear corner nestling at the foot of Druids in place of the old sweeper, a piece of that magic has been taken away. Would it really be so difficult to revert it to its former glory?'

SAME POINTS FOR REVERSED-GRID AS CONVENTIONAL RACES

This means you, the World Touring Car Championship. No disrespect to the efforts of those who have used the system to take victory—they're almost certainly in less-than-competitive machinery—but why should,

for example, Pepe Oriola be awarded the same points for holding the chasing pack at bay in the reversed-grid race on the Marrakech street circuit last year as Michel Nykjaer did for winning the feature event?

The reasoning behind the points system is baffling. Don't want to take my word for it? Well, here's four-time World Touring Car Champion Yvan Muller on the subject (which has been his constant bugbear): "I don't agree with using this points system. It's really illogical, but [sounding exasperated] it has been like this for many years." At least Yvan can look forward to revisions to the WTCC's qualifying system this season and a return to a factory-backed team.

CONTRACT LAWYERS FOR FORMULA 1 RESERVE DRIVERS

Davide Valsecchi got a vote of sympathy from many observers last year. The genial chap slaves away for five years in GP2, having persuaded his backers to fork out countless millions, lands a deal at Lotus, which may well have required additional funding, and then fails to land a call-up when a vacancy materialises. For any driver deliberating whether to stump up the heady budgets required for FR3.5 or GP2 this year, perhaps there's a danger they'll now look at Valsecchi and his successor Fabio Leimer's predicaments and think, 'What's the point?'

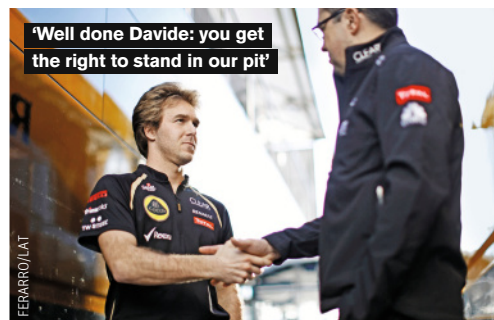

FERRARO/LAT

Teams need freedom to choose the best stand-ins possible, and if they're held to account to use only nominated reserve drivers perhaps we would miss out on the future equivalents of Mario Andretti popping up in a Ferrari at Monza in 1982. But then again, maybe it would have been future sportscar stalwart Oscar Larrauri in a Ferrari. Was Valsecchi deserving of the drive over Heikki Kovalainen. Who knows? But perhaps we'd have found out, and that, surely, might have been one justification for giving the Italian the nod.

FAILURE TO NURTURE MOTORSPORT'S GRASSROOTS

A couple of years ago, Marcello Lotti, then promoter of the WTCC, recounted a conversation with FIA president Jean Todt in which he'd argued for the importance of nourishing grassroots in motorsport. One of the larger-than-life Italian's remarks has stuck in the head: "I said, 'Jean, it's no good having all of this froth at the top without having anything underneath.'"

It's difficult to identify anyone, or any single factor, responsible for the erosion of strength in depth of domestic single-seater racing since the boom 1990s years of Formula Vauxhall Junior, Formula Ford, Formula Vauxhall Lotus and Formula Renault.

Of the potential culprits, today's current 'villain' for many F1 journo's, CVC Capital Partners, probably isn't one of them. CVC is regularly accused of taking the sport's wealth, but how much did Formula One Management ever support national feeder categories?

However, when F1 is in rude health, there is usually some sort of trickle-down—recall manufacturers' driver programmes that greased the wheels of racing and bolstered grids at the end of the noughties. If there was a more generous distribution of funds to F1 teams today, is it not unreasonable to imagine there could be more spillover for lower levels? So who to put in Room 101? Oh, go on then, CVC Capital Partners.

Your guide to the best events taking place in the UK and around the world – plus TV and online

ON TELEVISION

THURSDAY MARCH 13

1430-1530 **BT Sport 1**

WRC: Rally Mexico Review

2000-2045 **Sky Sports F1**

Australian GP: Drivers' Press Conference

2100-2230 **Sky Sports F1**

F1 Classics: Australian GP 1989

FRIDAY MARCH 14

0100-0320 **Sky Sports F1 LIVE**

Australian GP: Free Practice 1

0515-0730 **Sky Sports F1 LIVE**

Australian GP: Free Practice 2

0730-0815 **Sky Sports F1 LIVE**

Australian GP: Team Principals' Press Conference

0800-0830 **ESPN**

NASCAR Now

1030-1130, 1900-2000

Sky Sports F1

Horse Power: Ferrari's 2014 preparations

2100-2145 **Sky Sports F1**

F1 Classics: Australian GP 1996

2235-2340 **Motors TV**

WRC: Rally Mexico Highlights

SATURDAY MARCH 15

0245-0415 **Sky Sports F1 LIVE**

Australian GP: Free Practice 3

0500-0745 **Sky Sports F1 LIVE**

Australian GP: Qualifying

0900-1145, 1430-1715, 1800-2045

Sky Sports F1

Australian GP: Qualifying Replay

1055-1155 **ITV4**

WRC: Rally Mexico Review

1230-1300 **Motors TV**

Inside the Australian GP

1400-1800, 2030-0235

Motors TV LIVE

Sebring 12 Hours

1455-1625 **BBC2**

Australian GP: Qualifying Highlights

1800-2030 **Motors TV LIVE**

NASCAR Nationwide: Bristol

2100-2200 **Sky Sports F1**

F1 Classics: Australian GP 1994

SUNDAY MARCH 16

0500-0915 **Sky Sports F1 LIVE**

F1 Australian Grand Prix

0505-0530 **Channel 4**

Mobil 1 The Grid

1035-1340 **Motors TV**

Sebring 12 Hours Highlights

1100-1200, 1800-1900

Sky Sports F1

Australian GP Highlights

1230-1600 **Sky Sports F1**

Australian GP Replay

1400-1600 **BBC1**

F1 Australian Grand Prix Highlights

1630-2100 **Premier Sports LIVE**

NASCAR Sprint Cup: Bristol

MONDAY MARCH 17

1200-1300, 2100-2200 **ESPN**

NASCAR Sprint Cup: Bristol Highlights

1855-2100 **Motors TV**

NASCAR Nationwide: Bristol Highlights

2100-2345 **Sky Sports F1**

F1 Classics: Japanese GP 1998

2100-0010 **Motors TV**

Sebring 12 Hours Highlights

2345-0045 **Sky Sports F1**

Australian GP Highlights

ONLINE

HOT ON THE WEB THIS WEEK

YouTube **BAHRAIN F1 PRE-SEASON F1 TEST FOOTAGE**



SEARCH FOR: F1 2014 Bahrain Test Day 4 HD (6:25)

Can't wait just a few more hours to see and hear 2014-spec Formula 1 cars in action? Well here's some footage from the final day of last month's first Bahrain test, including Kimi Raikkonen's shunt. If anything, the VT proves the new V6 turbos sound great.

AUTOSPORT+

Exclusive content coming up in our premium website this week

It's finally here. The eagerly anticipated new Formula 1 era kicks off in Australia this weekend and AUTOSPORT's team will be there to bring you the latest breakthroughs and disasters. GARY ANDERSON will also be on hand to assess how all the squads are getting on in the first clash of 2014.

GET AUTOSPORT ON THE MOVE

- IN THE IPAD ISSUE THIS WEEK
- SOME MARTINI MOTORSPORT MOMENTS AND WRC HIGHLIGHTS
- ON SALE ALL OVER THE WORLD FOR ONLY £2.99

Download it now from autosport.com



Revved up over what's on the box

Michael Waltrip's natural ebullience drained from his eyes as sudden self-awareness washed over him. As part of its Daytona 500 rain-delay filler, Fox Sports replayed the racer/pundit/team boss's grid walk, with the twist of a studio camera on Waltrip as he watched himself in action. 'Wow...' came his stunned expression, 'I come across pretty ludicrous...'

The grid walk has become a staple of motorsport TV since Martin Brundle first popularised it in ITV's first F1 season – but it's also grown into rather an albatross. Initially rolled out by ITV for the marquee events (British GP and the Jerez title-decider), its modern regularity means its golden moments are drowned among vacant celebrity trawls and shoulder-

clashes with rival broadcasters.

But as a relative newcomer to the genre, Waltrip brings a refreshing innocence. Watching his grid walk is like watching a much-loved regular stride into



Waltrip didn't teach us anything, but it was fun

his local bar on a Friday night. The odd yelled 'Hi Danica!' greeting, a few high fives, 'wow, he's famous!' reactions to celebs, an occasional semi-conversation, some compliments for the drivers' wives and kids, and quite a few looks of fond concern from his interviewees. All helped by the air of Big Friendly Giant his six foot five height gives him as he swaggers chaotically through the pre-race crowd. Does Waltrip provide any in-depth analysis of how the race might unfold? Not in the slightest. Do you get a genuine taste of the atmosphere, camaraderie and excitement of a NASCAR build-up? Without a doubt. Did his Daytona epiphany prompt a style rethink? None whatsoever – his ruminations obviously ended on a 'what

the hell, I'll stick to what I know' conclusion. And so at Las Vegas last Sunday, he was back to his best with Dale Earnhardt Jr..

MW: "Hey Junior! Juuunnnoorr! How are you doing buddy? You won the Daytona 500, how's your year going?"

DEJ: "My year's going good, Michael."

MW: "You're succinct and to the point. With all that money you won at Daytona, were there any questionable purchases?"

DEJ: "I ain't got my cheque yet. NASCAR still has it. Gonna put it in the bank, I guess."

MW: "Looove that. I love that man."

And Revved Up loves your grid walk, Michael. A lot more than we loved your team manipulating race outcomes to influence the Chase, that's for sure.

Revved Up

Jo Ramirez

“It was a super but sad weekend. I have Ayrton’s suit, boots and gloves”

■ Australian GP, Adelaide ■ November 7, 1993 ■ McLaren MP4/8 ■ Ayrton Senna’s last F1 victory



Senna leads from pole ahead of Prost, Hill, Schumacher and Berger

I REMEMBER FONDLY THE Daytona 24 Hours back in 1971, when my friend Pedro Rodriguez won the race with Jackie Oliver in the JWA Porsche 917, but the event that really stands out for me is Ayrton Senna’s final race for McLaren, in Adelaide in 1993.

I was working at the team and I recall it was such a significant event as it was not only his last race with us after six years, but it would prove to be his 41st and last victory in F1.

The other thing is his great rival Alain Prost was retiring. I tried, but failed, to get them together to make up at the Japanese GP. I had always been close to Prost too, but Ayrton was difficult about it – if he hadn’t thought of it he didn’t want to do it.

As it was Ayrton’s last race there was lots going on. Marlboro had created a collage of photos from many of his races and asked me to present it to him at a team BBQ before practice. Of course I obliged!

There was so much anticipation before the race. McLaren and Ferrari

were tied on 103 wins, so if either won that day they would become the most successful team in the history of F1. It started well for us, as Ayrton had taken pole position ahead of Prost and Damon Hill in the Williams cars. It was also the first pole for a Cosworth engine for over 10 years – since Rosberg in ’83.

Before the start on the grid Ayrton called me over – he wanted to talk

to me, but not on the radio. He said, ‘It’s strange for me to be doing this for the last time in a McLaren’. And I replied, ‘Imagine what it’s like for us! I don’t need to remind you how important this win is for us. If you win I will love you forever’.

Ayrton grabbed my arm very hard and I saw tears in his eyes. I was worried I had made him too emotional before the start.

Well, as history has recorded, Ayrton won the race by just under 10 seconds from Prost. And I got my wish as the two of them were on the podium together. They shook hands and smiled and posed for photos – I think at that moment they made up for all the problems when they had been team-mates at McLaren.

Obviously Ayrton was going to Williams for 1994 in place of Prost so I said to him, ‘If you think you can do better then go ahead, but you’ll be back’. At the time, the Williams was the better car so he wanted to drive it. Sadly, we’ll never know if I was right about him one day returning.

We had a big party afterwards, but beforehand we’d been to the Tina Turner concert inside the circuit and she had dragged him up on stage to sing ‘Simply the best’ to him.

It was a super weekend, but a sad one, too. I still have Ayrton’s suit, boots and gloves from that race which I treasure. ❖

Jo Ramirez was talking to Henry Hope-Frost

PROFILE



MEXICAN JO RAMIREZ CAME to Europe with compatriot Ricardo Rodriguez in 1961. After his friend’s death in ’62, Ramirez soon joined Dan Gurney’s Eagle F1 team. He also worked as chief mechanic at the JWA Porsche sportscar team, but returned to F1 with Tyrrell in ’72. Stints at Copersucar, Shadow, ATS and Theodore preceded a 1983 move to McLaren as team co-ordinator. He retired in ’01 and lives in Spain.

NEXT WEEK AUSTRALIAN GP REPORT
Plus: Brits to watch in ’14; Berger’s narrow escape

Fancy a wee Double?



Join us to raise a glass, as we toast 40 years of Knockhill at this year's British Superbike and Touring Car events!

Come and see Britain's best racers go head-to-head on the twisty and technical Knockhill track - excitement, drama and action are always guaranteed. Fantastic feature races, starring alongside equally competitive support classes; makes this year's BSB and BTCC events an absolute MUST for any motorsport fan!



27/28/29 JUNE 2014



23/24 AUGUST 2014

Book Tickets Now - 01383 723337 or online at
KNOCKHILL.COM

Event Features

- + Knockhill 40th Anniversary marquee showcasing special exhibits from the four decades of Knockhill
- + 3 big screen TVs to see all the racing LIVE at the Hairpin, Duffus Dip & Clark's
- + FREE parking, kids under 12 go FREE and early bird ticket offers (see web for details)
- + Trackside VIP Hospitality and weekend camping available (limited spaces/pre-book only)
- + Plus a special Jim Clark tribute at BTCC



BY APPOINTMENT TO
HER MAJESTY THE QUEEN
SUPPLIER OF CAR CARE PRODUCTS
AUTOGLYM, LETCHWORTH, ENGLAND



BY APPOINTMENT TO
H.R.H. THE PRINCE OF WALES
SUPPLIER OF CAR CARE PRODUCTS
AUTOGLYM, LETCHWORTH, ENGLAND



OFTEN IMITATED, NEVER RIVALLED.



It's not until you've experienced an inferior product that you realise only the original will do. If you take car care seriously, like we do, you'll appreciate how important authenticity and quality is. After all, there will only ever be one king.

Find out more about why the finest marques insist on Autoglym Super Resin Polish, visit autoglym.com

Join the conversation: [#superresinpolish](https://twitter.com/superresinpolish)



Made in Great Britain

PASSION for PERFECTION

