

Keeping you On Track.....



Insurance products available

- ✓ Accident damage On Track
- ✓ Rally damage On Event
- ✓ Storage and transit
- ✓ Liability
- ✓ Personal accident
- ✓ Track day



- ✓ Competitive premiums
- ✓ A-Rated Insurers
- ✓ Fast claim payments
- ✓ Simple quote form
- ✓ Bespoke cover
- ✓ Knowledgeable staff

Complete an online quote request form at

www.ryanmi.com

Email us: info@ryanmi.com Call us: +44 (0) 1799 524202

Ryan Motorsport Insurance Limited is an appointed representative (557405) of Independent Broking Solutions Limited who are authorised and regulated by the Financial Conduct Authority. Its Financial Services registration number is 312026.

BTCC PREVIEW Who will be on top in 2019?



AUTOSPORT

BRITAIN'S BEST MOTORSPORT WEEKLY

4 APRIL 2019

AN F1 STAR IS BORN

Leclerc
outshines
Vettel as
Hamilton
wins

'He's got
lots of wins
coming'

LEWIS
HAMILTON

PLUS

F1
Alonso already in
McLaren return

WRC
Evans denied win
on final stage

MotoGP
Marquez is master
in Argentina





A PODIUM AS BEAUTIFUL AS THE SCENERY.

APPARENTLY.

**Citroën on the podium
For the 250th time at Rally Corsica.***

Congratulations and thank you to Sébastien Ogier and Julien Ingrassia,
and to the entire Citroën racing team.

Inspired by Seb.



Leclerc becomes a major player and Vettel's headache gets worse

We all expected Charles Leclerc to demonstrate his star quality at Ferrari in 2019, but to put in such a fine performance in just his second race with the team was remarkable. As Lewis Hamilton pointed out, Leclerc really deserved to win the Bahrain Grand Prix.

Although Leclerc was cruelly denied, there were lots of positives from last weekend. First of all, the racing was much better than in Melbourne – the DRS was too strong on the main straight, but there was some great battling into Turn 4. Secondly, Ferrari showed that testing pace was no fluke and that it *will* be in the championship fight with Mercedes this season. And, finally, Leclerc's performance demonstrates that we'll have an interesting dynamic to watch at Ferrari.

Sebastian Vettel is in quite an uncomfortable position. During the very same weekend that he once *again* lost out in a wheel-to-wheel battle with Hamilton, the potential challenge he faces from within his own team became a reality. If Leclerc can maintain that sort of form then Ferrari's stated position of Vettel being its lead man in the championship challenge may need to be revised.

Vettel's next chance to strike back will be at the Chinese GP on 14 April, which will also be the 1000th world championship event. To help celebrate the milestone, our track tester Ben Anderson will talk about four very special Formula 1 cars he got to drive recently in next week's issue. We'll also take a look at some milestone events and key statistics from the first 69 years of the world championship.



Kevin Turner
Editor

kevin.turner@autosport.com

NEXT WEEK
11 APRIL

We celebrate (nearly) 1000 world championship races with a very special F1 track test



COVER IMAGES

Motorsport Images/Zak Mauger

PIT & PADDOCK

- 4 Progress made on F1 2021 regulations
- 6 Lynn replaces Piquet at Jaguar
- 9 W Series picks its final 18 drivers
- 10 Shedden and Tordoff lead tin-top tests
- 11 F1 technical focus
- 15 Opinion: Edd Straw
- 16 Opinion: Adam Cooper
- 17 Feedback: your letters

RACE CENTRE

- 18 Bahrain GP report and analysis
- 32 Evans denied on Tour de Corse
- 38 World of Sport: Formula 2; Intercontinental GT Challenge; NASCAR Cup; MotoGP

INSIGHT

- 44 BTCC preview: Turkington's new BMW
- 46 BTCC preview: Toyota's challenge
- 48 BTCC preview: eight things to watch
- 52 WTCR preview: Monteiro's comeback
- 56 10 reasons to go to Goodwood MM

CLUB AUTOSPORT

- 70 Mazda plans new MX-5 Mk4 series
- 72 MG Live cancelled for 2019
- 74 'Old Nail' goes under the hammer
- 75 Opinion: Stephen Lickorish
- 76 National reports: Donington Park; Kirkistown; Silverstone
- 80 BTCC supports preview

FINISHING STRAIGHT

- 84 What's on this week
- 87 Top five stillborn racing cars
- 88 From the archive: 1990 Spanish GP
- 90 Pit your wits against our quiz

SUBSCRIPTION OFFER

- 91 Try six issues for £1 each

VISIT AUTOSPORT.COM

For other ways to read Britain's best motorsport weekly



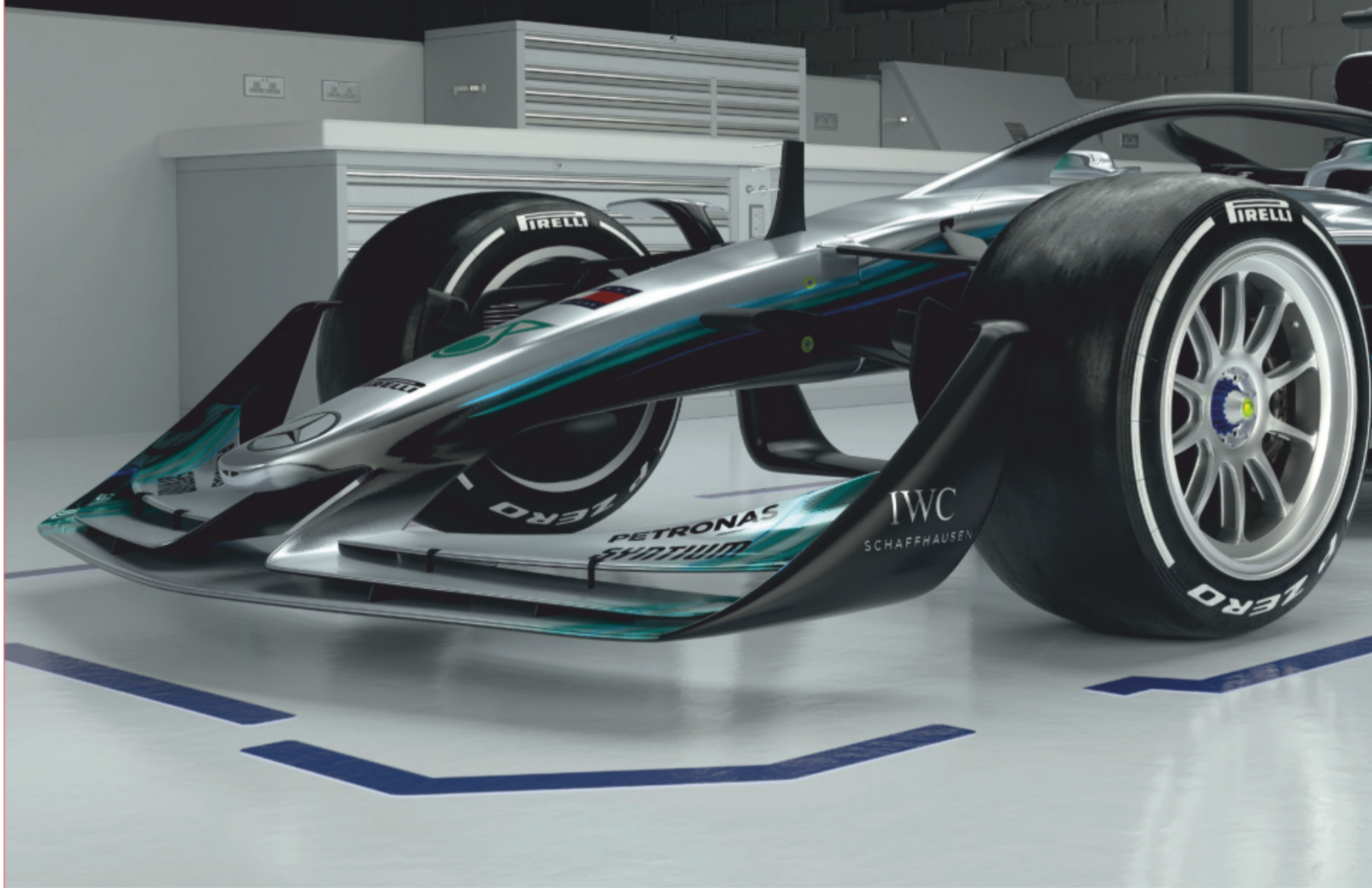

F1 MAKES PROGRESS ON MAJOR

FORMULA 1

Formula 1's planned 2021 rules overhaul took a step forward at a key meeting between the rulemakers and its stakeholders last week, with several details emerging over the Bahrain Grand Prix weekend.

One year has passed since F1 presented its first idea for a technical, sporting and financial revolution, and the championship's participating teams and manufacturers have finally been presented with their first look at the full framework.

This occurred at a meeting of the Strategy Group and the F1 Commission in London last Tuesday (March 26). Those present will now have the chance to consider the details before continuing discussions over the coming weeks.

Possible intentional chassis rules delay

Details such as a cost cap and new revenue distribution need to be finalised, but several team bosses have indicated they are positive about the direction and that there are no major causes for concern.

However, there is pressure on F1 because, under the terms of the FIA's International Sporting Code that governs all its championships, regulations for 2021 need to be sorted by 30 June.

While that timetable seems plausible for financial, regularity and engine rules, sources have revealed that teams have discussed delaying an agreement on the sign-off of the chassis rules until the end of 2019 to help smaller outfits.

The majority of teams support the delay, but

it is understood that clarification is now being sought to ensure that this does not breach the ISC.

Stronger listed-parts stance from 2020

While most eyes are on 2021, there are also significant changes on the immediate horizon. One concerns the listed-parts debate that has split the grid between big/small teams forming alliances – like Ferrari/Haas – and the likes of Renault, McLaren and Williams, which stick to a more traditional model.

Listed parts are the components teams must make themselves. They are currently limited to the survival cell, the front impact structure, the roll structures and bodywork with the exception of airboxes, engine exhausts and any prescribed bodywork geometries.

The issue was discussed in last week's London meeting, and one of the key battlegrounds was related to suspension. There had been calls for it to be added to the listed parts rules, but it is understood that the basic suspension set-up will remain purchasable and the aerodynamic elements around it need to be designed by each team.

That means brake ducts look set to become a listed part for 2020. Although they are a relatively small part of the car, they have often been utilised by teams for aerodynamic benefits.

Qualifying tweak back on for 2020

Plans for a switch to a four-session qualifying format in 2020 are back on the table. No vote was held or firm conclusion reached, but



➔ P16 OPINION

2021 REVAMP

sources suggest that the idea is gathering momentum and is likely to be agreed in some form. The new format would mean four cars are eliminated after Q1, Q2 and Q3, leaving eight to contest Q4.

The hope is that it would create extra uncertainty and the discussion now focuses on how many tyres drivers will have to use to get through all the sessions and what tyre the Q4 qualifiers will be obliged to start on. Pirelli is reluctant to provide any extra sets.

Four bidders for control gearbox

The FIA is understood to have received four bids from companies interested in fulfilling the tender to supply a gearbox cassette to all teams for the 2021-24 seasons.

The governing body launched the tender on 18 February, with an initial deadline of 15 March. That was subsequently extended by four extra days to 19 March to give potential bidders extra time.

Xtrac is the only bidder to have publicly declared its interest. It is believed that the other bidders include the partner companies of at least one current F1 team, and that one of them might have made a bid in co-operation with a third party.

The logical candidates are Williams and McLaren, both of whom have separate technology divisions with manufacturing capability and have experience of fulfilling FIA tenders either in F1 or Formula E. Williams and McLaren declined to comment on their sister companies' intentions.

SCOTT MITCHELL



Why Alonso was driving the 2019 McLaren in Bahrain

FORMULA 1

Fernando Alonso has been back driving a contemporary Formula 1 car for the first time since the 2018 Abu Dhabi Grand Prix.

The two-time world champion participated in Pirelli's tyre testing programme for McLaren at the Bahrain circuit this week.

Alonso's testing opportunity has arisen through a new ambassadorial and advisory role he has taken on for McLaren after stepping away from F1 at the end of last year.

He hopes to understand the "limitations" of the 2019 car, even though the team might have "more interest than myself" in the run.

Alonso drove an older, Mercedes-powered McLaren during a car swap

with NASCAR star Jimmie Johnson in Bahrain the day after the Abu Dhabi finale, but the Pirelli test will give Alonso genuine on-track development work to do.

However, he has made it clear that sampling McLaren's current MCL34 for the first time is not part of a plan to return to F1 next year.

"In my case obviously it's more a test for myself to go back to this driving style, to understand the car a little bit," said Alonso. "And the limitations of the car, if the tyres allow me to feel the limitation [and] what the limitation is – which part of the corner are we strong, which part of the corner are we weak."

SCOTT MITCHELL AND JONATHAN NOBLE

Co-founder Heads returns to unpick Williams mess

FORMULA 1

Patrick Head is to return to duty with the Williams Formula 1 team he co-founded for the first time in eight years.

Head will take on a part-time consultancy role, as the team undergoes a wider reshuffle in the wake of Paddy Lowe's departure last month.

Adam Carter has taken on the role of head of design, while Dave Robson is now

the acting chief race engineer.

Head's decades of experience should allow him to assess the reasons behind Williams's late start to pre-season testing, and the fundamental problem with what is comfortably F1's slowest car at present.

Now 72 years old, Head has remained a minority shareholder in Williams and last had a hands-on role as engineering director in 2011.

ADAM COOPER

Jaguar gives Piquet his marching orders



FORMULA E

The Nelson Piquet Jr and Jaguar relationship is over. It began as a high-profile move for 2017/18, in which the inaugural Formula E champion joined Jaguar after its disastrous first campaign in the series.

To begin with, the new partnership started well. Leaving the 2017/18 season's fifth round in Mexico, Piquet was fifth in the standings and not far from the title fight. But when the championship returned to Europe things started to unravel. He ended up ninth – behind team-mate Mitch Evans, who finished seventh and took Jaguar's first podium and pole.

The slump continued into the Gen2 era. Evans has scored 36 points from the opening six races – with a best finish of

fourth – and has taken points at every round. Piquet has just one point, and crashed out in Mexico City and at Sanya.

It was in Hong Kong that rumours first emerged in the paddock that Piquet might not see out the season. But at what turned out to be his final race, in Sanya, he denied that a mid-campaign seat-change was a possibility, and said that he was “not worried about” his future with Jaguar.

“There are bigger problems on their plates at the moment [than] about choosing drivers,” he said.

But then the news broke last week that the two parties had “mutually agreed” to split, and that former Virgin Racing driver Alex Lynn had been drafted in.

On the face of it, such a change is understandable – Piquet has not lived up

to the expectations of his past FE success. But what of Jaguar? Yes, Evans has scored many more points and decent results, but there is still yet to be a second podium or pole. The team has not looked like a pacesetter at any point this season.

Ultimately, this is a case of what might have been for both. Had Piquet made fewer mistakes he might have kept his drive. Had Jaguar produced a better car he might have been able to shine more often.

The 2014/15 season finale was 40 races ago. It's been quite a rapid fall for Formula E's first champion.

In other news, Maximilian Gunther will return to Dragon Racing for the Rome round in place of Felipe Nasr, who is racing in IMSA at Long Beach.

ALEX KALINAUCKAS

WRX plans electric support series

WORLD RALLYCROSS

World Rallycross has announced a new electric support series after plans to switch WRX to electric cars for 2021 fell through.

The new championship will be called Projekt E

WRX had been due to become EWRX, racing silhouette-style cars with a single-supplier carbon monocoque chassis and batteries. A manufacturer vote held on the 29 March

deadline for the EWRX concept failed to get the required three marques to sign up, though. Initially, nine brands were said to be in talks with series promotor IMG and the FIA.

“It's obviously been our intention together with the FIA to have an electric element of the sport,” said World Rallycross managing director Torben Olsen. “We've come together, put plans on the table and worked very closely with

the manufacturers. This [EWRX not happening] is just a result of them not being ready for 2021, which is obviously a shame.”

Projekt E is expected to join WRX events at selected European-based rounds.

“Our aim is to showcase future mobility and relevant technologies in the tough, competitive environment of rallycross with production-based vehicles consumers can relate to,” said Olsen.

HAL RIDGE





Honda bikes grow wings

MOTOGP

Honda has managed to get its own version of the controversial Ducati winglet homologated after the FIM ruled the Italian manufacturer's device legal.

Last week the FIM responded to an appeal lodged by Honda, Suzuki, Aprilia and KTM after their protest against the controversial appendage was thrown out by Qatar race stewards. The FIM backed the stewards' verdict.

Andrea Dovizioso's Qatar victory was declared final and Ducati was given clearance to use the winglet (below), which it claims is to cool the rear tyre. Ducati's rivals are adamant the piece's true purpose is to generate downforce.

Since this decision, Honda submitted a design of its own in Argentina last

weekend to MotoGP technical director Danny Aldridge, the person who first gave the Ducati winglet the all-clear.

Aldridge refused to approve the device for homologation on the grounds that the stated purpose of the Honda winglet was to create downforce.

The next day, the Japanese manufacturer submitted the exact same design for approval, only this time it declared the winglet's purpose was cooling, not to generate downforce, leading Aldridge to approve its use.

It remains to be seen when the Honda winglet will first be used, but it succeeded in its main aim of highlighting the flaws in MotoGP's current rule-making process with regards to aerodynamics.

JAMIE KLEIN



IN THE HEADLINES

AHMED FINDS JAPANESE F3 REFUGE

Formula 3 European Championship race winner Enaam Ahmed has switched to the B-Max with Motopark squad for his move into Japanese F3. He had signed a deal with ThreeBond Racing but it was dependent on Ahmed providing a budget that he had secured from a sponsor. That arrangement fell through after the Suzuka test, which he finished 1.5 seconds off the pace.

NEW-LOOK 2020 CUP CALENDAR

The NASCAR Cup Series calendar has undergone a vast shuffle for the 2020 season. The finale will be two weeks earlier (8 November) and move to Phoenix, having been at Homestead every year since 2001. Other changes during the 26-race regular season include the moving of the first race at Martinsville Speedway from March to 9 May and Indianapolis from September to 4 July.

GARAGE 59 REVEALS DRIVERS

The Garage 59 team has revealed its Blancpain GT Series Endurance Cup line-up, having swapped from McLaren machinery to running a pair of Aston Martin Vantage GT3s in 2019. Factory racer Jonny Adam will share the team's pro class entry with Andrew Watson and Come Ledogar. *Top Gear* presenter Chris Harris will share the amateur entry along with Chris Goodwin and team owner Alexander West – the same trio that finished second in the 2018 Am class points.

SUPERCARS SHUFFLES BALLAST

Supercars has confirmed that the Ford Mustang and Holden Commodore will undergo a centre of gravity change to narrow their advantage over the Nissan Altima. Roof line ballast will now be mandated ahead of the upcoming Symmons Plains round.

RALLY GB MOVES TO THE SEASIDE

Rally GB will move its base from Deeside to the seaside town of Llandudno to further boost the profile of Britain's round of the World Rally Championship. Hopes of competitive action in Liverpool have faded, but sources suggest the city could still host a ceremonial start on Thursday 3 October.

WTGR SCORES BBC BROADCASTING

The opening round of the 2019 World Touring Car Cup season will be shown by the BBC. As with the BBC's Formula E coverage, the tin-tops will be available to watch via its interactive services. It will be the first time World Touring Cars have appeared on free-to-air TV in the UK for 11 years, and also ends the BBC's 18-year touring car drought. It ended its coverage of the British championship in 2001.

F1
FORMULA 1
SINGAPORE AIRLINES
SINGAPORE GRAND PRIX
2019
MARINA BAY STREET CIRCUIT
20-22 SEPTEMBER



2019
EARLY BIRD
TICKETS
NOW ON
SALE UP TO 28%
SAVINGS

3 DAYS OF NON-STOP RACE ACTION
+ PERFORMANCES BY

FRI

SAT

SUN

SWEDISH
HOUSE MAFIA

MUSE

RED HOT
CHILI PEPPERS

FRI & SUN

SAT

SAT & SUN

SUN

TOOTS &
THE MAYTALS

CARDI B

FATBOY
SLIM

HANS
ZIMMER

DJ LIZZY • FFION • GLEN WEE • GYM AND SWIM • J.S. ONDARA • JUPITER & OKWESS
LARKIN POE • MANTRAVINE • NJWA • PAREKH & SINGH • RAJA KUMARI
SWOON! • TEXAS • TROY • WOLFGANG FLÜR (EX-KRAFTWERK)

OFFICIAL WEBSITE

WWW.SINGAPOREGP.SG

AVAILABLE THROUGH ALL AUTHORISED
TICKETING PARTNERS

PHONE BOOKING

+65 6738 6738

HOSPITALITY ENQUIRIES

+65 6731 5900
HOSPITALITY@SINGAPOREGP.SG

*Artiste line-up subject to change. Visit the official website for artiste performance timings, zones and stages. The F1 FORMULA 1 logo, F1 logo, F1, FORMULA 1, FIA FORMULA ONE WORLD CHAMPIONSHIP, GRAND PRIX and related marks are trademarks of Formula One Licensing BV, a Formula 1 company. All rights reserved.



W Series selects final 18 for inaugural season



FINAL LINE-UP

DRIVER	EXPERIENCE
Jamie Chadwick	British F3
Sabre Cook	USF2000
Marta Garcia	Spanish F4
Megan Gilkes	US Formula Vee
Esmee Hawkey	Porsche Carrera Cup GB
Jessica Hawkins	Minis/VW Cup
Shea Holbrook	Lamborghini Trofeo
Emma Kimilainen	STCC
Miki Koyama	Japanese F4
Sarah Moore	Britcar
Tasmin Pepper	South African Polo Cup
Vicky Piria	GP3
Alice Powell	GP3
Gosia Rdest	European GT4
Naomi Schiff	GT4
Beitske Visser	Formula Renault 3.5/GT4
Fabienne Wohlwend	Ferrari Challenge
Caitlin Wood	GT
RESERVES	
Sarah Bovy	GT
Vivien Keszthelyi	Audi R8 Cup
Stephane Kox	Asian Le Mans Series
Francesca Linossi	Lamborghini Super Trofeo

W SERIES

The all-female W Series championship has announced its final line-up of 18 drivers after an intensive four-day final selection process at Almeria Circuit.

The 18 drivers, plus four reserves, who will make up the grid were chosen from the 28 who made it through the initial selection process in late January.

High-profile British names such as MRF Challenge champion Jamie Chadwick and former GP3 racer Alice Powell are among those joining the grid. Other drivers to

watch include Emma Kimilainen, Sarah Moore, Vicky Piria and Beitske Visser.

The Almeria test was more race-focused than the previous outing and provided the first opportunity for the qualifiers to drive the Tatuus F-318 Formula 3 car – operated by Hitech GP – which will be used in the inaugural season. A comprehensive fitness programme also formed a significant part of the assessment.

The first 12 successful drivers were selected by the end of three days of running, leaving the remaining six full-time and four reserve slots to be decided by a shootout

on the final day of the assessment.

“It’s been tough on a few of the women, but the ones that have gone through have done a really good job over the four days in Almeria,” said racing director Dave Ryan, who oversaw the process.

“Obviously a couple of the entrants are disappointed, but that’s sadly how it is and they have just got to keep trying.”

W Series pre-season testing takes place at the Lausitzring from 14-16 April, before the season gets underway at Hockenheim as part of the DTM support bill in May.

LUCY MORSON

Three Super GT cars to join the DTM finale

DTM

Three Super GT cars will race in the 2019 DTM finale at Hockenheim as a precursor to the first joint race of the two series at Fuji in November.

The Japanese and German championships have long been working on a collaborative rules package in the hope that it would allow both to add more manufacturers to their grids.

Autosport revealed in February that the likelihood was that there would be just one joint race in Japan in 2019. But the hope was for some Super GT involvement at a DTM event, and that plan was

confirmed by the two series on Friday. Three Super GT cars will enter the 5-6 October DTM final round, before teams from both series combine for a joint race at Fuji on 23-24 November.

Super GT manufacturers Nissan, Lexus and Toyota will each send one car to Germany to join Audi, BMW and Aston Martin on the DTM grid.

Twelve DTM cars will race at Fuji and the event will run to the DTM format of two races without driver swaps – unlike the usual two-driver Super GT format. All cars will run on control tyres from DTM supplier Hankook.

MATT BEER



ISHIHARA
motorsport
IMAGES

Shedden tops WTCR testing

WTCR

Three-time British Touring Car champion Gordon Shedden was fastest in the World Touring Car Cup's two-day Barcelona test.

He set a best time of 1m54.434s in his WRT Audi RS3 LMS on the second day, outpacing the Munnich Motorsport Honda Civic Type R of Nestor Girolami by 0.074 seconds.

WRT and Munnich locked out the top four positions in the combined order, with Girolami's team-mate Esteban Guerrieri and the second WRT Audi of Jean-Karl Vernay next up.

Team Mulsanne pair Ma Qing Hua and Kevin Ceccon, driving new Alfa Romeo Giulietta Veloce cars built by the Romeo Ferraris team over the winter, were fifth and sixth.

The test gave squads one last chance to add to what for most has been a winter of significant mileage, but it was overshadowed to an extent by the first complaints about TCR's Balance of Performance emerging.

The BRC Racing outfit that will carry Hyundai's hopes issued a statement blasting the calculations, saying it was "surprised and disappointed" by many teams receiving a break compared to the end of 2018, while the i30 N's engine power remained at 97.5%.

BRC's lead driver Gabriele Tarquini was a lowly 19th in the combined times, while Yann Ehrlacher was the fastest of Cyan Racing's new Lynk & Co 03s in 10th.

JACK COZENS

[➔ P52 WTCR PREVIEW](#)



GUILLAUMOT/DPPI

WTCR BARCELONA TEST TOP 10 TIMES

POS	DRIVER (CAR)	TIME
1	Gordon Shedden (Audi RS3 LMS)	1m54.434s
2	Nestor Girolami (Honda Civic Type R)	+0.074s
3	Esteban Guerrieri (Honda Civic Type R)	+0.097s
4	Jean-Karl Vernay (Audi RS3 LMS)	+0.405s
5	Ma Qing Hua (Alfa Romeo Giulietta)	+0.492s
6	Kevin Ceccon (Alfa Romeo Giulietta)	+0.810s
7	Niels Langeveld (Audi RS3 LMS)	+1.181s
8	Attila Tassi (Honda Civic Type R)	+1.673s
9	Daniel Haglof (Cupra)	+1.686s
10	Yann Ehrlacher (Lynk & Co 03)	+1.778s



JEP

Tordoff surprises as BTCC pacesetter

BTCC

Just one day of official pre-season testing for the British Touring Car Championship meant all eyes were on WSR and its box-fresh BMW 330i M Sport, plus the return of Toyota GB and the Corolla name badge.

New packages for title hopefuls Colin Turkington (the defending champion) and Tom Ingram (holder of the independents' crown) made them the centre of attention. But

Sam Tordoff stole the headlines with his metronomic pace at Brands Hatch.

Having switched from Motorbase last season, Tordoff will drive one of the oldest packages on the grid in the form of AmD Tuning's FK2-generation Honda Civic Type R. But the 2016 runner-up rolled back the years to break the Indy circuit series lap record. He was the only person to dip below 48 seconds, ending the day with a 47.927s.

He said: "We changed

the set-up a little bit, but the great thing about this car is it's almost perfect straight out of the truck. It's the best touring car I've ever driven."

Tordoff's former Motorbase team-mate Tom Chilton piloted his Ford Focus RS to second – 0.110s shy and 38 laps down on Tordoff's unmatched count of 170.

After a year to develop the newer FK8 Civic, the Team Dynamics assault was headed by Dan Cammish, a title favourite for his second BTCC season. Team-

mate Matt Neal was sixth in the morning running, but made an exit for a sponsor commitment in Leeds and so fell to ninth.

The outgoing BMW 1 Series racked up more than 100 podiums for WSR, and the 3 Series looks to have picked up the baton as Andrew Jordan finished fourth and fastest rear-wheel-drive car. Jordan – the 2013 champion – set a 48.063s lap, 0.14s faster than Turkington in seventh and 0.25s ahead of Oliphant in 12th.

Tordoff's team-mate Rory Butcher and Ingram in the Corolla completed the top six. Although there were no red flags throughout the day, the Speedworks driver had

to sit out the final hour after running wide at Paddock Hill Bend and losing a sill.

Team BMR stablemates Ashley Sutton and Senna Proctor could only manage 19th and 20th in their Subaru Levorg GTs. The build on 2017 champion Sutton's car was only just finished the night before.

Two-time BTCC champion and Vauxhall returnee Jason Plato was 21st in his Astra. And ex-Formula 1 driver and 1992 Le Mans winner Mark Blundell ended the day 24th in his Audi S3, 0.6s off team-mate Jake Hill.

MATT KEW

[➔ P44 BTCC PREVIEW](#)

BTCC BRANDS HATCH TEST TOP 10 TIMES

POS	DRIVER (CAR)	TIME
1	Sam Tordoff (Honda Civic Type R FK2)	47.927s
2	Tom Chilton (Ford Focus RS)	+0.110s
3	Dan Cammish (Honda Civic Type R FK8)	+0.126s
4	Andrew Jordan (BMW 330i M Sport)	+0.136s
5	Rory Butcher (Honda Civic Type R FK2)	+0.186s
6	Tom Ingram (Toyota Corolla)	+0.264s
7	Colin Turkington (BMW 330i M Sport)	+0.280s
8	Stephen Jelley (BMW 125i M Sport)	+0.292s
9	Matt Neal (Honda Civic Type R FK8)	+0.344s
10	Jake Hill (Audi S3)	+0.355s

DRAWING BOARD

GIORGIO PIOLA

McLAREN PUSHES ON WITH BARGEBOARD DETAILS

The absence of the massively complex front wing furniture has given much more of a role in this year's aerodynamics package to the bargeboards. It's an area in which the bulk of the teams are pouring vast amounts of resources to shave off fractions of a second.

McLaren, en route to its best result since Fernando Alonso's fifth

place in Australia last year, emerged in Bahrain with a revised bargeboard concept aimed at better controlling the wake from the front wheels.

Featuring a more detailed leading edge compared with the original specification, there are seven horizontal slots at the very front, paired up with six cascading

fins that form a mini-bargeboard. This is a hugely aggressive attitude to turning around the airflow emanating from the front of the car.

The large horizontal element looping from the top of the main bargeboard has also been reprofiled slightly. The aim is to angle the airflow towards the undercut of the sidepod inlet.

The front of the bargeboards also now feature wave-shaped cuts along the front, sculpted to better manage the wave kicked up from the wheel in contact with the road. This is designed to work with the wheel at a range of angles, cleaning up the turbulence and washing it around the bargeboard.

JAKE BOXALL-LEGG

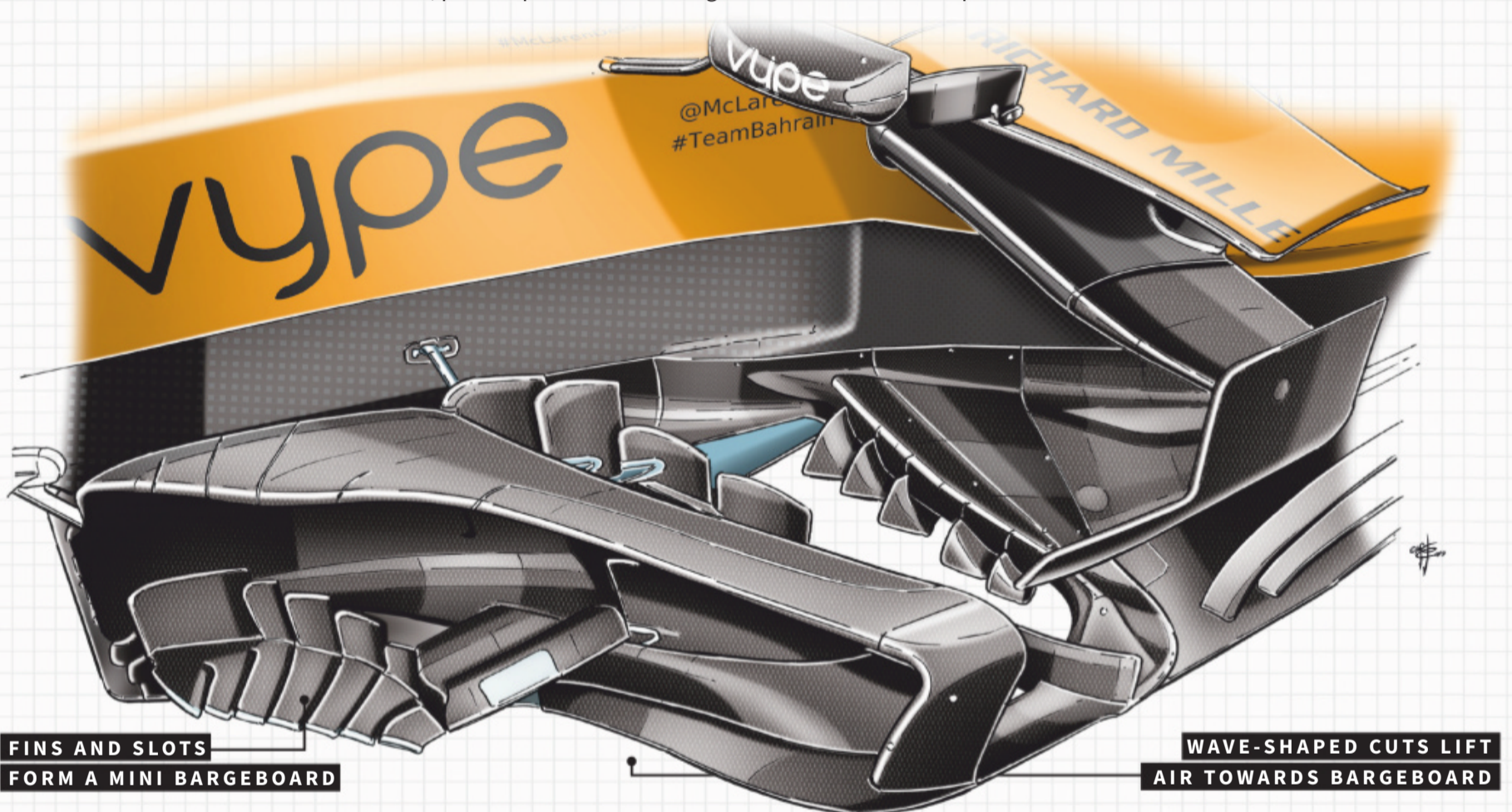

MERCEDES REFINES COOLING SOLUTIONS

Bahrain was the first of the 'conventional' circuits on the calendar, where teams can begin to get a proper handle on their cars' performance on a purpose-built

track. Where it differs from the norm is the sweltering desert heat, which often prompts a need for more aggressive cooling solutions to keep the highly complex powertrains from overheating.

Mercedes was off the pace of Ferrari throughout the weekend, despite taking a few tweaks to Bahrain to find a little more performance.

One of them was a slight adaptation of its cooling package, discarding the outlet behind the halo mounting for an extension with the gill-like vent by it.

The radiators are mounted diagonally within the sidepod

and, once the air passes through it, that air is expelled by the vent. A low-pressure zone behind the vent creates a suction effect to draw the hot air out, which can then fall down the sidepod – trimming the boundary layer slightly to keep airflow attached over the bodywork.

Mercedes also made a change to its rear wing endplates, opting for an extra strake at the back. There's plenty of wake to clean up in this area, and the airflow coming between the endplates is given the chance to expand slightly by creating those strakes. That's going to improve the effect of the suction surface of the rear wing,



and also clean up the air that begins to rotate from the flared endplate area.

Those are only minor tweaks, most likely to accommodate the Bahrain track characteristics. But Ferrari is finally showing its hand, meaning that Mercedes has more performance to find.

JAKE BOXALL-LEGG

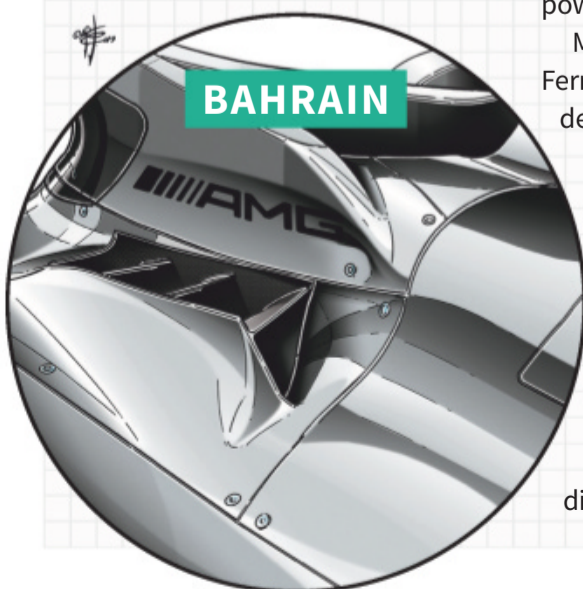

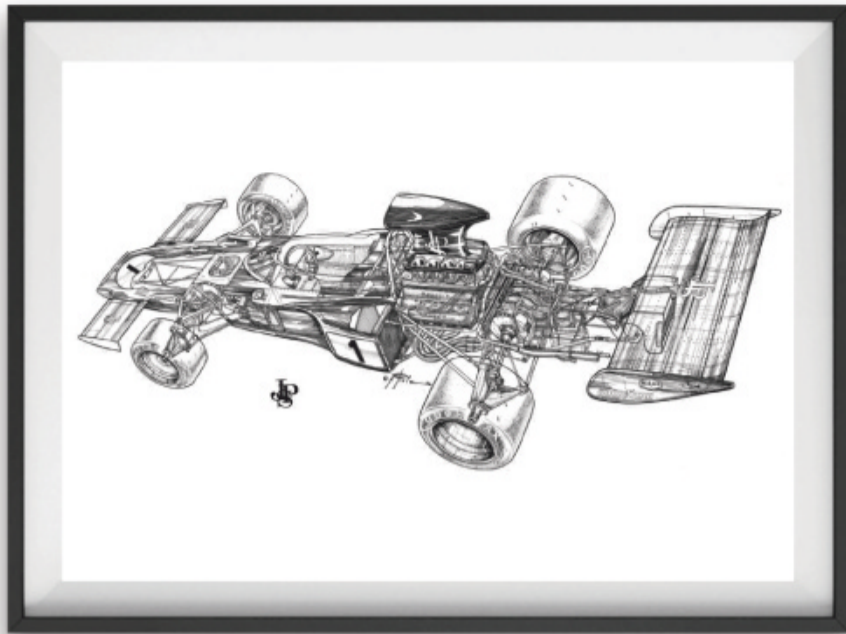

LOTUS 72 - 1971

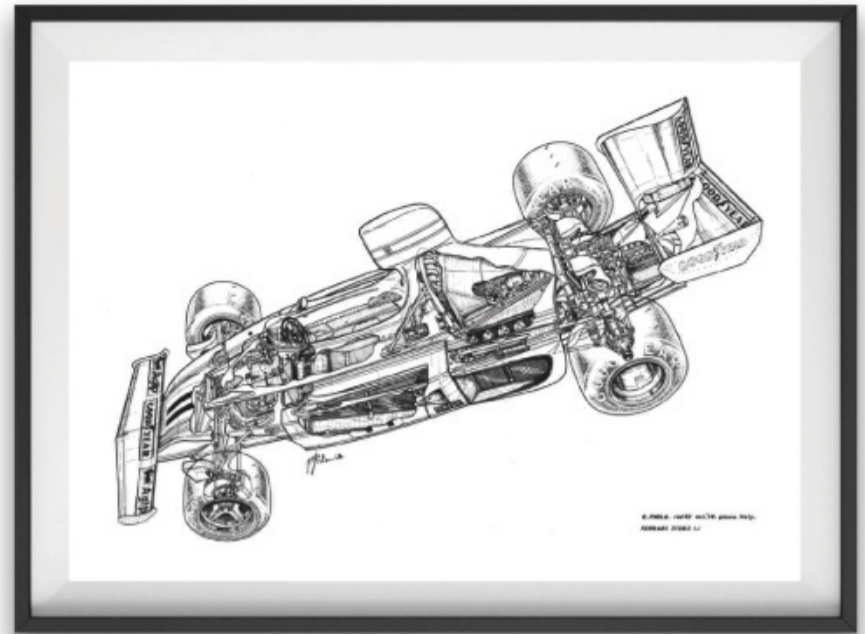

FERRARI 312B3 - 1974

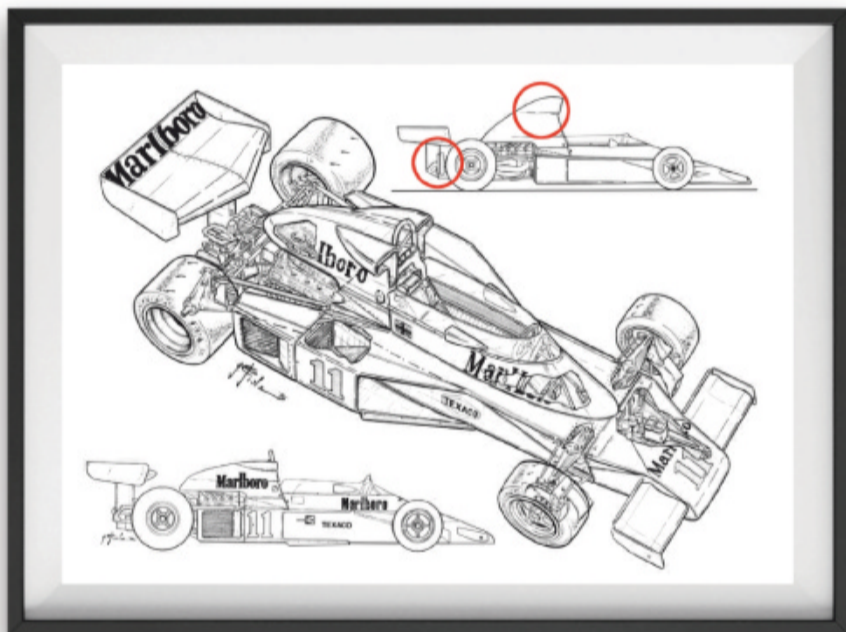

McLAREN M23 - 1976

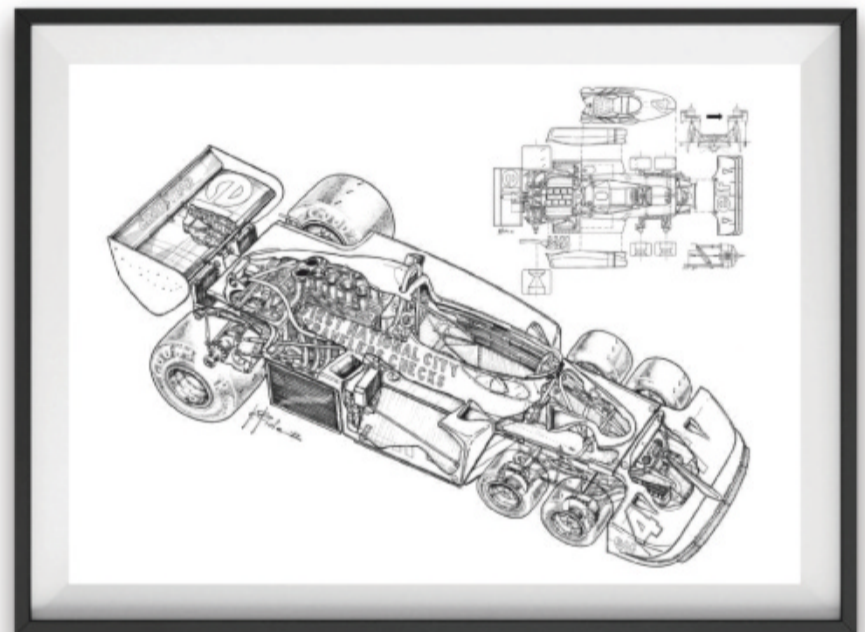

TYRRELL P34 - 1977

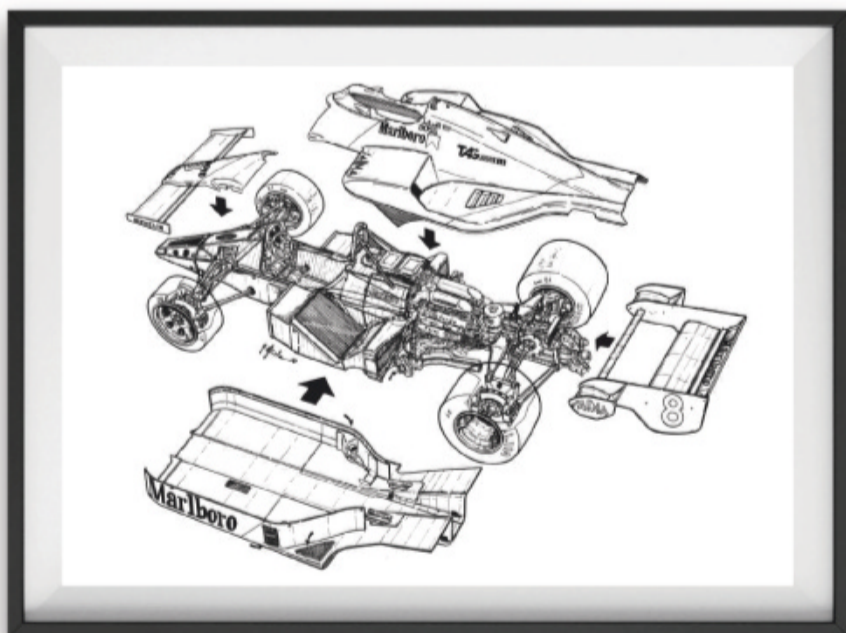

McLAREN MP4/2 - 1984

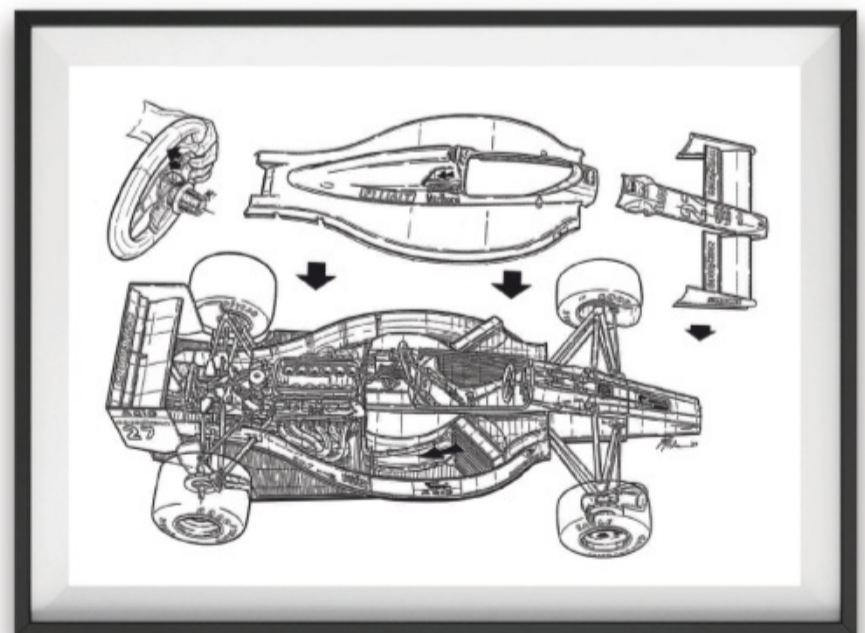

FERRARI 640 - 1989

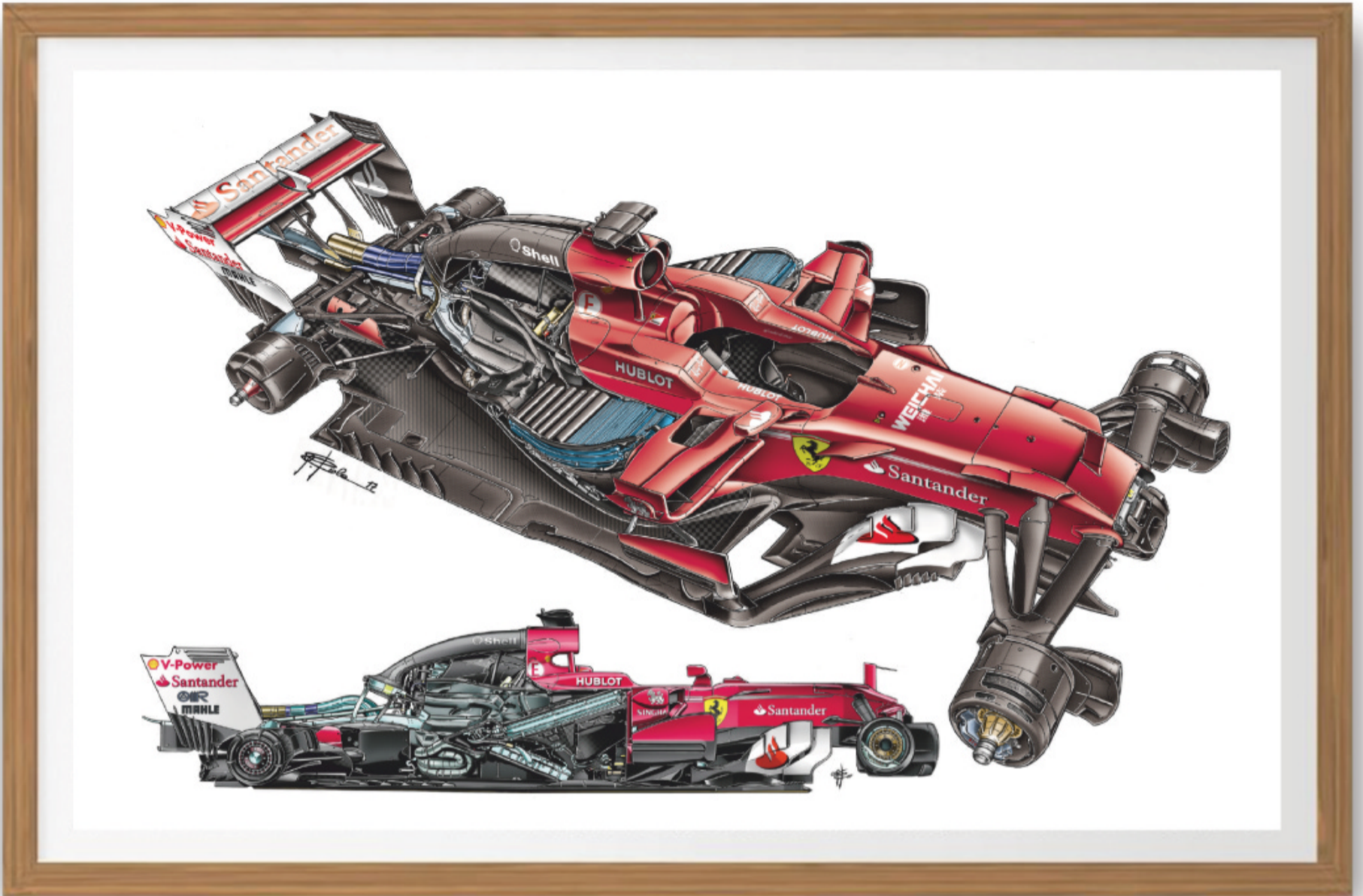

FERRARI SF70H

THE ART OF



RACING



GOODWOOD REVIVAL

"A magical step back in time"

13 • 14 • 15 SEPTEMBER



Ricciardo's midfield reality check sinks in

The seven-time grand prix winner's switch to Renault made a lot of sense, but he's now discovering the full implications of stepping back in the hope of moving forward

EDD STRAW

After qualifying for the Bahrain Grand Prix, Nico Hulkenberg said that Renault team-mate Daniel Ricciardo's feedback comes from a "spoiled, a kind of better car" starting point. It was a light-hearted comment rather than a dig, made in response to a question about Ricciardo feeling the car wasn't perfect over the bumps, but Hulkenberg's words encapsulate an irrefutable truth.

Ricciardo's shock decision to sign for midfield Renault meant turning his back on a series of Red Bulls that were, at times, the class of the chassis field. The evidence so far suggests adapting to life in the midfield has been more difficult than anticipated, hence the decision to participate in this week's Bahrain test.

Ricciardo is no fool and went into this with his eyes open. But knowing you are moving into – hopefully temporarily – disadvantageous circumstances before the event is one thing. Living it minute by minute is another entirely. Two pre-season tests and a pair of troubled GPs have been a reality check. In Bahrain, Ricciardo's underlying pace was two or three tenths off Hulkenberg's and he has struggled to adapt to a more limited car than he is used to.

"I knew it would take time, but in my heart I guess I just

"I knew it would take time, but in my heart I guess I expected to jump in and it'd all be sweet"

expected to jump right in the car and it'd all be sweet," said Ricciardo when asked if it has been more challenging than expected. "It's no secret that we're not on the same pace as the car I had last year and that's something I need to figure out a bit.

"I guess in Charles [Leclerc]'s situation, coming up to the seat he has this year, it's a bit like me when I came from Toro Rosso to Red Bull. You just have more grip and it's like, 'Wow!' So I'm trying to come back and figure out the best way."

Put it to Ricciardo that he's effectively faster than the car he is driving and it's clear he understands the meaning. He is a classical stylist behind the wheel and wants to carry in huge speed. That demands rear stability in the entry phase and grip in the corner, both areas where the Renault lacks compared to the Red Bull. He's trying to drive a car that's better than the one he is in, and the result

is messy. In effect, Ricciardo has to relearn what an F1 car can and cannot do, a task that's tougher than it sounds.

Ricciardo hasn't always been "spoiled" by his machinery in F1, having raced for HRT and Toro Rosso. But as he alludes to with his comment about Leclerc, jumping into a better car is an easier direction than the one he has gone in. The Ferrari Leclerc is racing this year has more of everything than his 2018 Sauber. What Ricciardo has is less of everything (except, presumably, power).

Ricciardo knew what he was getting into. He desperately needed to get out of Red Bull after five seasons and, when Mercedes and Ferrari shunned him, his only option was to buy into Project Renault. It was not a ridiculous idea. Renault is a manufacturer team with big investment and legitimate aspirations to fight for championships – and in its various guises the Enstone squad has been tremendously successful. But there's a long way to go.

Ricciardo hasn't lost hope, but the reality of the situation will now be very clear to him. And given that the Renault doesn't have the balance he needs, who knows when he will next pull off one of those trademark late-lunge overtaking manoeuvres?

Driving is just one side of the coin and, actually, the far easier one to fix for a driver of Ricciardo's calibre. We can be sure he will adapt; he's too sharp not to. But there are other dimensions to his new situation. Firstly, although the car's overall performance level is better than qualifying has suggested, Renault is not where it needs to be – not just at the front of the midfield but clear of it.

Secondly, the reason the performance level has been shrouded is that things keep going wrong. In four attempts at qualifying so far this season, only one hasn't been affected by problems. Then there was the double retirement in the race in Bahrain.

So Ricciardo finds himself in a car he's struggling to get on top of, in a team that still has some growing to do, powered by an engine package that has always had problems during the V6 turbo hybrid era. He signed up for two years, hopeful of climbing to the front with the team. But victories must feel a very long way off right now.

He's a wonderful driver, a great ambassador for F1 and a genuinely likeable character whose perma-grin shrouds a ruthless competitive instinct. He deserves a shot at the championship. Let's hope Renault delivers on its potential long term.

Taking one step back to go two forwards down the line sounds great before you do it, but once you're living that battle it's far harder. It's a task he will be equal to and it was clearly the right move for him personally, but that doesn't mean it's going to be easy. The past six weeks have proved that. ❄



The clock is ticking

One year after Formula 1 unveiled its plan for transformation in 2021, the details are yet to be confirmed. Is there enough time to get all the teams on board?

ADAM COOPER

It was a year ago that Chase Carey and his Formula 1 colleagues unveiled their 2021 vision in a presentation to the teams in Bahrain. After 12 months of discussions, mainly on an individual team-by-team basis, the first comprehensive update came at a meeting in London last week.

Such a gathering didn't necessarily have to take place within the formal framework of the Strategy Group, especially since no voting was scheduled to take place. However, the fact that it did was an indication that plans are finally beginning to gather momentum, and also that Liberty is serious – especially in terms of its stance on the two key pieces of financial business, namely a more equitable revenue distribution and a cost cap that pegs back the three top teams.

“It's been arrived at with a lot of discussion,” Ross Brawn told Martin Brundle on Sky F1. “Everyone's view has been heard.

“We've made massive progress since this time a year ago, and we're very close to saying, ‘This is it now. This is where we want to be.’ There is still some room for discussion, but I think the picture is clear.”

The consensus among the team principals was that progress has indeed been made over the past 12 months.

“It was a good meeting,” said Mercedes boss Toto Wolff, “because Liberty and the FIA were very clear; they presented

“It was clear after the London meeting that everybody still had something to be unhappy about”

us their view on cost caps, prize fund distribution, on the technical regulations, on the sporting regulations. Now we are able to digest, comment, and come back to them.”

A busy year of shuttle diplomacy by Carey has got things to this stage, and it's now a question of pushing on and getting what is a hugely complex global package agreed and signed off in the form of a new Concorde Agreement.

In theory the deadline, as set out in the FIA's International Sporting Code, is June. But the big (and contentious) question mark on timing concerns the technical regulations, which could be postponed until December.

There now will be discussions within the individual teams as the Liberty blueprint is properly assessed, and those teams will then decide whether or not to sign up.

“There has definitely been progress in that we now have a deal in front of us to react to,” said McLaren's Zak Brown. “I think it's been well thought out. We've all been consulted and we'd just emphasise timing now is of the essence so we can all get prepared – but the ball's really in our court for that.”

“It's a big thing, and we've got until the middle of June to get it done, so there's still time,” noted Racing Point's Otmar Szafnauer. “The good news is that in F1 we're used to working quickly.

“There's a lot of consultation of all the teams and the stakeholders that has happened leading up to this, so it's not just that they are off in a vacuum coming up with rules, cost cap, money distribution, take or leave it. That's not how it happened. It's gone through churn, process, feedback, change for the last year. So one year of doing that, and now we've got until June. Another three months is enough time.”

Ferrari's Mattia Binotto, a relative newcomer to the high-stakes poker game of F1 politics to which the likes of Wolff and Christian Horner are well attuned, stressed that any deal has to be right for his team. “I think that we are collaborating well with both FIA and F1,” he said. “The process is still ongoing. There are still points where there is some distance compared with their position and what we believe should be the right Ferrari position, but we are still discussing.

“For us it is more important to make sure we've got the right agreements, and we should not be caught by time.”

Aside from timing, the other buzz word is compromise. Every team has a different financial structure, a different business model and different priorities, even if they all share the basic aim of producing a competitive car and going racing.

One team boss suggested privately that Liberty still doesn't fully understand the nuances of those differences, while others made it clear that, after the London meeting, everyone still had something to be unhappy about.

There's still plenty of arm wrestling to come, but the intention is that we emerge with a stronger sport in 2021.

“This is going to end up being a compromise,” said Szafnauer. “A lot of people have said with every good compromise no one's really happy, and I can see that. From our perspective I think the FIA and FOM are trying to do the right thing.

“They're trying to bring the field closer together, trying to make the sport less costly, introducing a cost cap so that if we do really well on revenue and sponsorship there's a bit of profit at the end, and the sport is sustainable.

“And the other underlying thing is it's got to stay at the pinnacle of motorsport, which is great. What's wrong with that? It's just how do you do it. The ‘how do you do it’ bit will inevitably upset somebody.” ❄

YOUR SAY

The answer to this conundrum for 2021 is staring everyone in the face – shorten the wheelbase to something comparable to IndyCar

GUY DORMEHL

Short answer to making F1 better

The comparisons between Formula 1 cars and IndyCars at Austin make for fascinating reading. Sure, IndyCars are ‘too slow’ for some F1 folk, but they look great and are spectacular, as Edd Straw so eloquently put it in his column last week.

The answer to this conundrum for 2021 is staring everyone in the face – shorten the wheelbase to something comparable to IndyCar (and what F1 had since the year dot, before the stupidity of aero overtook the situation!). The Mercedes F1 car is nearly 25% longer – just plain daft...

Lewis Hamilton has often said that shorter cars would be more fun, and spectacular, to drive – and watch. Why, oh why the hesitation to make the change (I don’t even read about it being discussed as an option)?

Guy Dormehl

Afrika (where we need an F1 GP)

IndyCar’s gladiatorial aspect appeals

With regards to the column comparing F1 and IndyCar, the halo is a big reason F1 looks dull. The in-car view is now awful with the halo, and sticking a graphic overlay achieves nothing as nobody is interested in it.

The element of danger is massively reduced with the halo, as an IndyCar looks genuinely terrifying and keeps the gladiatorial aspect.

I was going to get rid of Sky F1, but will now keep it for the IndyCars.

Paul Stewart

Hartford, Cheshire

The greatest show on earth

To Messrs Brawn, Chase & Todt, I have been following Formula 1 since 1986. My first live experience of an F1 race was at Silverstone in 2000 and I was blown away by the noise, the smell and the violent thunder of 20-plus V10 engines screaming down the straight at near 200mph.

That, sirs, I contend is the show that most if not all F1 fans yearn for and I fear if you continue down the current



path of road relevant hybrid engines, or even worse electrification, F1 is doomed.

Fans want the noise, the speed and the smell of petrol in their nostrils while paying homage to their favourite team and/or driver – that has been the attraction of F1 since 1950.

Pandering to manufacturers who will leave F1 when their respective boards decide to is not helpful. F1 is a show first and a business second, and if you have the greatest show on earth, everyone will want to be a part of it. No show equals no fans, no sponsors, no manufacturers, no money, the end...

Colin Fox

Dublin, Ireland

Flight or fright?

Can anyone in the F1 cosmos confirm that the FIA got its front-wing specifications from the Ministry of Defence, because all the cars on track are carrying copies of the HMS Queen Elizabeth’s flight deck. That begs the question, will the ‘halo’ save the driver from a monstrous piece of flight deck when it, as it will, flies off?

C Nash

Byemail

HAVE YOUR SAY, GET IN TOUCH

Autosport editorial
Autosport Media UK Ltd
1 Eton Street
Richmond
TW9 1AG

@
E-mail
autosport@
autosport.com

Visit our website
autosport.com

Twitter
twitter.com/
autosport

Facebook
facebook.com/
autosport

Instagram
instagram.com/
autosport

YouTube
youtube.com/
AUTOSPORTdotcom

RACE CENTRE

BAHRAIN GRAND PRIX • TOUR DE CORSE • WORLD OF SPORT





HAMILTON WINS BUT LECLERC MAKES HIS POINT

Ferrari's 21-year-old rising star deserved more than the final podium place in Bahrain. He showed he's got a genuine claim to the F1 crown

EDD STRAW

PHOTOGRAPHY



motorsport
IMAGES



Wheelspin off the line squandered Leclerc's pole-position start

History will record the 2019 Bahrain Grand Prix as another victory for Lewis Hamilton, his 74th. Considering he was in the second-fastest car and forced Sebastian Vettel into a mistake in battle to ensure he inherited the lead late in the race, it was a fine win. But what the record books won't reflect is that this was the moment a star was born in Charles Leclerc, whose maiden Formula 1 podium deserved to be a victory of consummate skill worthy of Hamilton at his best. That Hamilton magnanimously raised his hand as he apologetically passed the stricken Ferrari tells you everything you need to know.

The agonisingly slow death of Leclerc's race was thanks to his V6 engine dropping a cylinder on lap 46. Associated problems, such as not being able to use the MGU-H, costing him 40km/h (25mph) on the straights, condemned him to limp home. The only consolation was that a late safety car, triggered by the expiry of the works Renaults within a few hundred metres of each other, stemmed the bleeding and allowed Leclerc to stay ahead of Max Verstappen and hold onto third place behind Hamilton and his Mercedes team-mate Valtteri Bottas.

The quality of Leclerc's performance, even in what was clearly the fastest car in Bahrain, cannot be understated. With Ferrari back on the kind of form it showed in testing, primarily thanks to gaining almost 0.5 seconds on Mercedes on the straights in qualifying trim, it was Leclerc who led the charge. Fastest in two out of three practice sessions, then all three segments of qualifying, you might expect an ordinary 21-year-old not possessed of extraordinary mental fortitude to fold,

given what happened on the first lap. Instead, he used first-lap setbacks to show just how strong he is.

Wheelspin off the line meant Leclerc instantly dropped behind nominal team leader Vettel, before Bottas went around the outside of him for second into the Turn 4 right-hander. Hamilton, who had been passed by Bottas through Turn 2, then attacked Leclerc into the Turn 8 right-hander, with Leclerc staying ahead but only after his front-left rubbed with Hamilton's front wing and a quick front-right lock-up. Leclerc ended a bruising first lap third, but what followed demonstrated rare star quality.

Bottas went wide into Turn 1 on the second lap and Leclerc pounced up the inside. It didn't just cost Bottas one position, as it also allowed Hamilton to make a move for third place into Turn 4.

"I had a great start to the race, I managed to get into P2 but then on lap two into Turn 1 I think the wind caught me up a bit," said Bottas. "I braked a bit too late, trying to keep my position, and I lost two places – so back to fourth place."

Leclerc's two-second gap to Vettel rapidly closed and Leclerc was soon pointing out over the radio that he was faster. By lap five, Leclerc was hassling Vettel. On lap six, with an advantage that peaked at around 35km/h (22mph) thanks to the use of the DRS, he forced Vettel to defend and went to the outside after braking later for the Turn 1 hairpin. On the wider line, he didn't get too greedy, ensuring he was still there to hang Vettel out to dry on the outside



“IT’S ALWAYS A TRICKY SITUATION WHEN YOU GET TO FIGHT YOUR TEAM-MATE. I HAD AN OPPORTUNITY ON THE OUTSIDE AND I WENT FOR IT. IT WAS SUCCESSFUL THE FIRST TIME I TRIED, SO I’M HAPPY WITH THAT”

line into the left-hander that followed.

But his illustrious team-mate had fallen just behind by the time they reached the detection line for the second DRS zone at the entry to Turn 1, meaning Vettel had a speed advantage on the squirt from Turn 3 to Turn 4. Leclerc defended, Vettel thought better of a risky move around the outside and the lead was in the hands of nominally Ferrari’s junior driver.

“It’s always a tricky situation when you get to fight your team-mate because the risks are very high and in every team they will warn you before that it’s your team-mate,” said Leclerc. “I had an opportunity on the outside and I went for it. It was successful the first time I tried, so I’m happy with that.”

In the six laps that followed, Leclerc outpaced Vettel by 0.363s per lap to establish a comfortable advantage before diving into the pits at the end of lap 13 to switch from soft to medium Pirellis. With Verstappen (lap 11), Bottas (12) and Hamilton (13) all having made their first stops, Leclerc breezed past the long-running Daniel Ricciardo’s Renault to retake the

lead on the start/finish straight on lap 15. That should have been the last anyone saw of him. Leclerc made his final stop under no pressure on lap 36 and seemed certain to cruise serenely to a first grand prix victory.

At the end of lap 42 of the 57-lapper, Leclerc had an advantage of 10.441s over Hamilton and, having set fastest lap already, had no need to do anything too aggressive. But soon Leclerc reported to Ferrari that “there is something strange with the engine”. Hamilton had closed on Leclerc by six tenths on lap 43, then another four tenths on lap 44, then by nine tenths on lap 45. But it was on the following lap that it became clear that Leclerc was in serious trouble, his pace dropping into the 1m38s bracket, three seconds slower than a few laps earlier, and allowing Hamilton to close to just 6.835s behind. Soon his lap times had dropped to 1m40s— and on one lap as slow as a 1m42.317s. Hamilton was already ahead by then, breezing past apologetically on the run to the last corner on lap 48.

Leclerc was given a target time of 1m38.7s to hang onto second place, but this was impossible. Bottas, 40s behind before Leclerc’s problem, took the position effortlessly on lap 54 on the run to the first corner, and Max Verstappen was on course to follow him through. Only the serendipitous double Renault retirement, which cost Nico Hulkenberg sixth place and Daniel Ricciardo 10th, saved Leclerc’s podium by triggering a safety car.

This was a tortuous way for Leclerc to lose what should have been a famous breakthrough win. A maiden podium, even with the >>

“TODAY WAS NOT OUR DAY. IT’S SAD, BECAUSE I WAS SO CLOSE TO REALISING A DREAM THAT YOU HAVE SINCE CHILDHOOD, WHICH IS YOUR FIRST WIN IN F1”

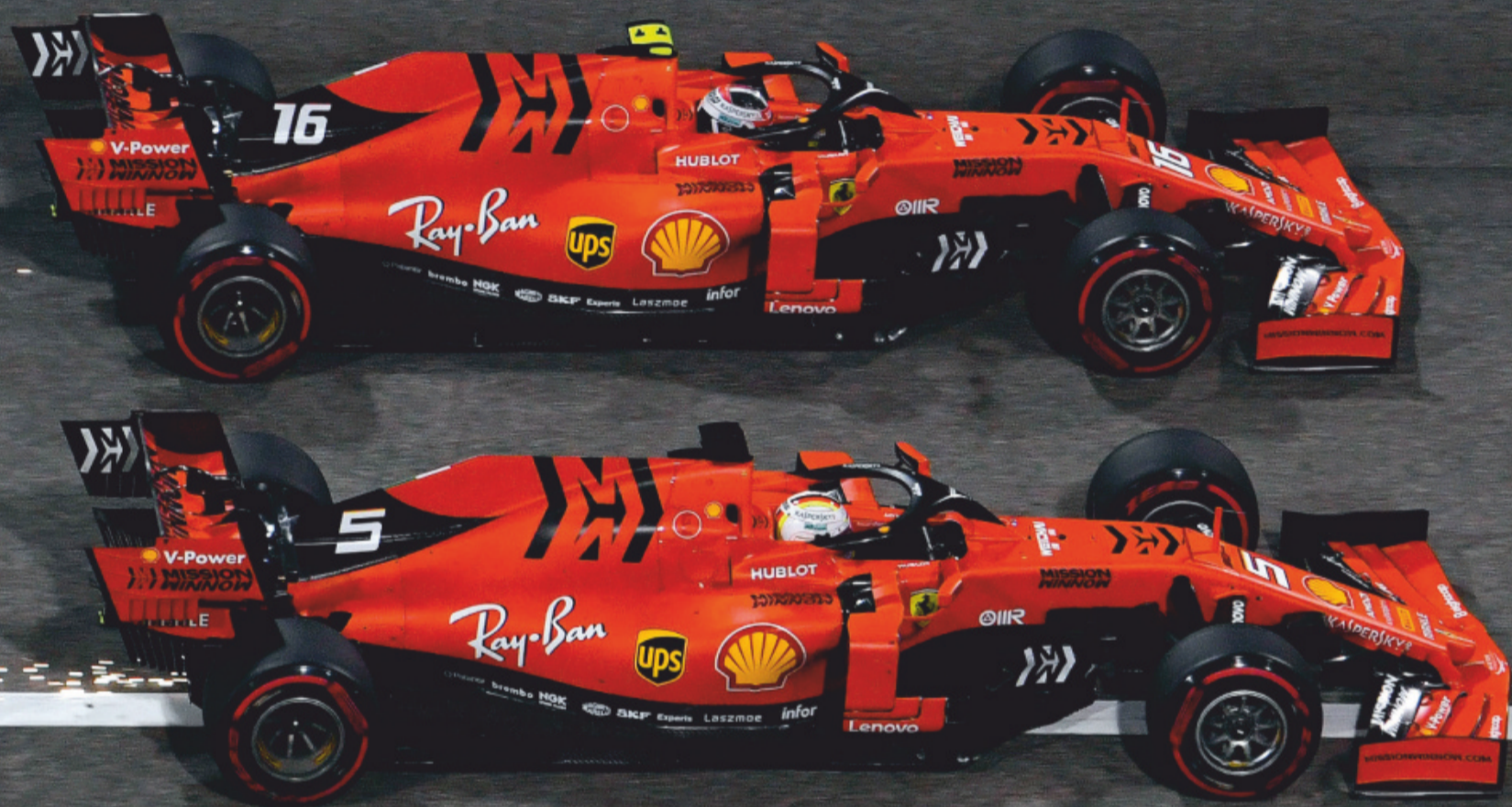

Leclerc is nominally Ferrari's junior driver, but his move on Vettel (5) belied that status

bonus point for fastest lap, was little consolation. But Leclerc had made his point, emphatically.

“From the whole weekend there are a lot of positives to take,” he said. “After Australia we were quite a lot far off. I think we found some answers – not all of them – but we found some. We came here, front row lock-out, which was very positive for the team, and we showed that they have done an amazing job. That doesn’t mean we’ll stay there for the rest of the season, but that just shows off how good of a job they’ve done between the two races.

“And then I think we’ve shown also that we had very strong pace during the race. Probably we were the strongest today. Unfortunately the issues stopped us winning – but, on the other hand, issues always happen in a season and, if any time I have an issue, I finish third, then I think we could be quite happy.

“Today was not our day. It’s sad, because obviously I was so close to realising a dream that you have since childhood, which is your first win in Formula 1, but hopefully this day will come in the future. I’ll work for that, and I’m pretty sure the team will work for this but they should be proud about what they’ve done this weekend, and we’ll come back stronger.”

Leclerc’s fate was just one side of the Bahrain Grand Prix coin. To understand the other we have to wind back to the moment he took the lead from Vettel. Given Ferrari’s pace advantage, Leclerc’s

problems shouldn’t have handed a 1-2 to Mercedes, but instead given victory to Vettel. That he wasn’t there to perform a salvage job was a consequence of the irresistible attacking ability of Hamilton, and Vettel’s propensity to make key errors in pressure situations.

With the undercut so powerful in the high-degradation track conditions, Hamilton jumped Vettel for third place by making his first stop a lap earlier. With Vettel switching to mediums and Hamilton on another set of softs, the expectation was that, early in the stint at least, Hamilton would consolidate what was initially an advantage of three seconds. But Vettel was faster, and on lap 23 claimed second place by using the DRS to close on the run to Turn 4 before completing the pass around the outside.

Mercedes took the initiative at the second round of pitstops, with Hamilton stopping on lap 34 and Vettel one lap later. Vettel held onto the position this time, but with both on fresh mediums Hamilton came back at him. On lap 37, the attack came. In a reversal of the earlier pass, Hamilton used the DRS on the run to Turn 4 and went around the outside of Vettel. The Ferrari then spun at the exit of the corner. Not for the first time, Vettel had crossed swords with Hamilton and emerged worse off. And while the windy conditions that made life particularly difficult at Turn 4 contributed to the spin, Vettel was happy to own the mistake.

“When I was fighting with Lewis, the target was to stay ahead,”



Vibrations from flat-spotted tyres broke Vettel's front wing

GALLOWAY



McLaren man Sainz was able to battle Red Bull of Verstappen on merit

HONEY

“WHEN I WAS FIGHTING WITH LEWIS, I GOT SURPRISED WHEN I LOST THE REAR THAT SUDDENLY. IT WAS MY MISTAKE, SO I NEED TO DIGEST THAT. PLENTY OF HOMEWORK ON MY SIDE”

SUTTON

said Vettel. “I got surprised when I lost the rear that suddenly. It was my mistake, so I need to digest that. Obviously our race could have been a bit better without that spin, nevertheless it was a difficult race so plenty of homework on my side, not having the feel for the car.”

Worse was to come. Vettel had instantly radioed in to say he had to pit for fresh rubber thanks to flatspots caused by the spin – particularly to the left-rear. But on the back straight, the resulting vibration led to the front wing supports breaking under increasing load, and the Ferrari bounced over its own discarded wing amid a shower of sparks. He made it back to the pits, but significant time had been lost.

Vettel returned to the track in ninth place, picking up one position when Red Bull driver Pierre Gasly made his pitstop. He then dispatched Ricciardo, McLaren's Lando Norris – who was on his way to an excellent sixth place – and Hulkenberg to move up to fifth. But even if the safety car hadn't intervened, he'd lost so much time that he wasn't close enough to pass the hobbled Leclerc.

Hamilton, meanwhile, simply had to cruise to the finish. Although he crossed the line only 2.980s ahead of Bottas, his advantage had been 21.7s at the moment the safety car was deployed. To that we must add the caveat that Bottas lost some performance to a plastic bag that became stuck in his front wing and cost him after strong pace early on. Leclerc had been brilliant, but so too had Hamilton to get the better of Vettel. Without his attacking surge after the second pitstops, Vettel would >>

QUALIFYING



SUTTON

Coming into the 2019 Formula 1 season, one of the few question marks hanging over Charles Leclerc was whether he could nail a perfect lap in the intense pressure of Q3. He proved he can in Bahrain, becoming the second-youngest driver (after Sebastian Vettel) to take an F1 pole position at the age of 21 years, five months and 15 days.

Fastest in FP1, FP3 and all three segments of qualifying, Leclerc always had the underlying pace to pull this off. While he didn't quite string together his best three sectors and was just 0.002s off his best in the final sector on his pole lap, it was enough to take pole by 0.294s from Ferrari team-mate Vettel.

The only asterisk against Leclerc's performance was that Vettel couldn't make it an even fight in Q3. While Leclerc had two runs on fresh soft Pirellis, Vettel only had one thanks to his first Q2 run being compromised by traffic and having to go again. But given that Leclerc set two times good enough for pole position, that hardly devalues his achievement.

Mercedes reckoned Ferrari was gaining “almost half a second” on the straights, which was telling given the gap to third-placed Lewis Hamilton was just over 0.3s. Hamilton failed to improve on his second Q3 run, with Bottas ending up 0.066s down on his team-mate.

Red Bull struggled to get the best out of the softs, with Max Verstappen complaining the team hasn't found the set-up sweet spot. While he did take fifth place by stringing all his best sectors together, it was only 0.005s faster than the Haas of Kevin Magnussen. But that was better than team-mate Pierre Gasly fared, falling in Q2 in 13th place after finding that the rear end stepped out every time he applied the throttle.

McLaren executed qualifying superbly, with Carlos Sainz Jr seventh and Lando Norris 10th. Norris, along with Kimi Raikkonen and 11th-fastest Daniel Ricciardo, picked up a place when Romain Grosjean lost eighth to a three-place grid penalty for impeding Norris badly in the final turn in Q1.

It was another disappointing qualifying for Renault. Ricciardo and Q1 victim Nico Hulkenberg both lost out on straightline speed to an engine mapping problem; a second, unspecified “mechanical” problem also hurting the German.

EDD STRAW

“CHARLES LECLERC BECAME THE SECOND-YOUNGEST DRIVER TO TAKE AN F1 POLE POSITION”



TRACKSIDE VIEW

Friday afternoon in Bahrain, free practice one, and it's hot – blisteringly so. The air temperature is 'only' 28C but it feels far hotter in the sun, as the track surface that is baked to 50C proves. While the ambient temperature might not be much lower during the serious sessions, the track surface is – about half what it is in FP1. But taking shelter in the shadow of a handy bus shelter used to give some of the trackside workers by Turn 11 much-needed protection when they aren't on post at least makes it more comfortable to watch the drivers in action in this sweltering session.

What draws the attention isn't so much the rapid, uphill left-hander at Turn 11, but the end of the straight where it's easy to compare the DRS-closing strategies of drivers. As you'd expect, the strongest teams tend to close that little bit later, only by a few metres, to give the airflow time to re-attach. Most team-mates shut at a similar moment, but Sebastian Vettel is the latest of all, with Charles Leclerc, who favours a manually operated closure, visibly shutting it earlier. Perhaps that plays a part in a moment Vettel has when the rear gives way a little on turn-in and means he misses the apex, delaying the



application of the throttle.

Turn 11 is one of those corners that offers a true three-dimensional challenge to the cars. You need the front end to be strong enough to get the nose in, but then the rear to grip when you feed in the power. When it comes to getting onto the power it's Mercedes, in particular Valtteri Bottas – always superb at picking up grip levels early on a green track – that impresses. The Red Bull

drivers carry in formidable speed, but can't feed in the power as aggressively. As the weekend progresses, this becomes a very limiting trait for the car, particularly in Pierre Gasly's case.

There is a temptation for some drivers to get the nose in that bit too much at this corner. Lando Norris, never afraid to experiment early on, finds himself taking a little too much kerb and unsettling the car on the more aggressive

part of the apex kerb. Others occasionally find themselves wide, while the two Williams drivers appear to be giving the kerbing a wide berth.

As for Leclerc, who goes on to have a stellar weekend, his slightly more composed approach to the corner seems to pay dividends by making the car do the work. He looks the part, even this early in the weekend.

EDD STRAW



Turn 11 poses a true three-dimensional challenge to F1 cars

Hamilton acknowledged this win was a gift, and that there's lots of work to do

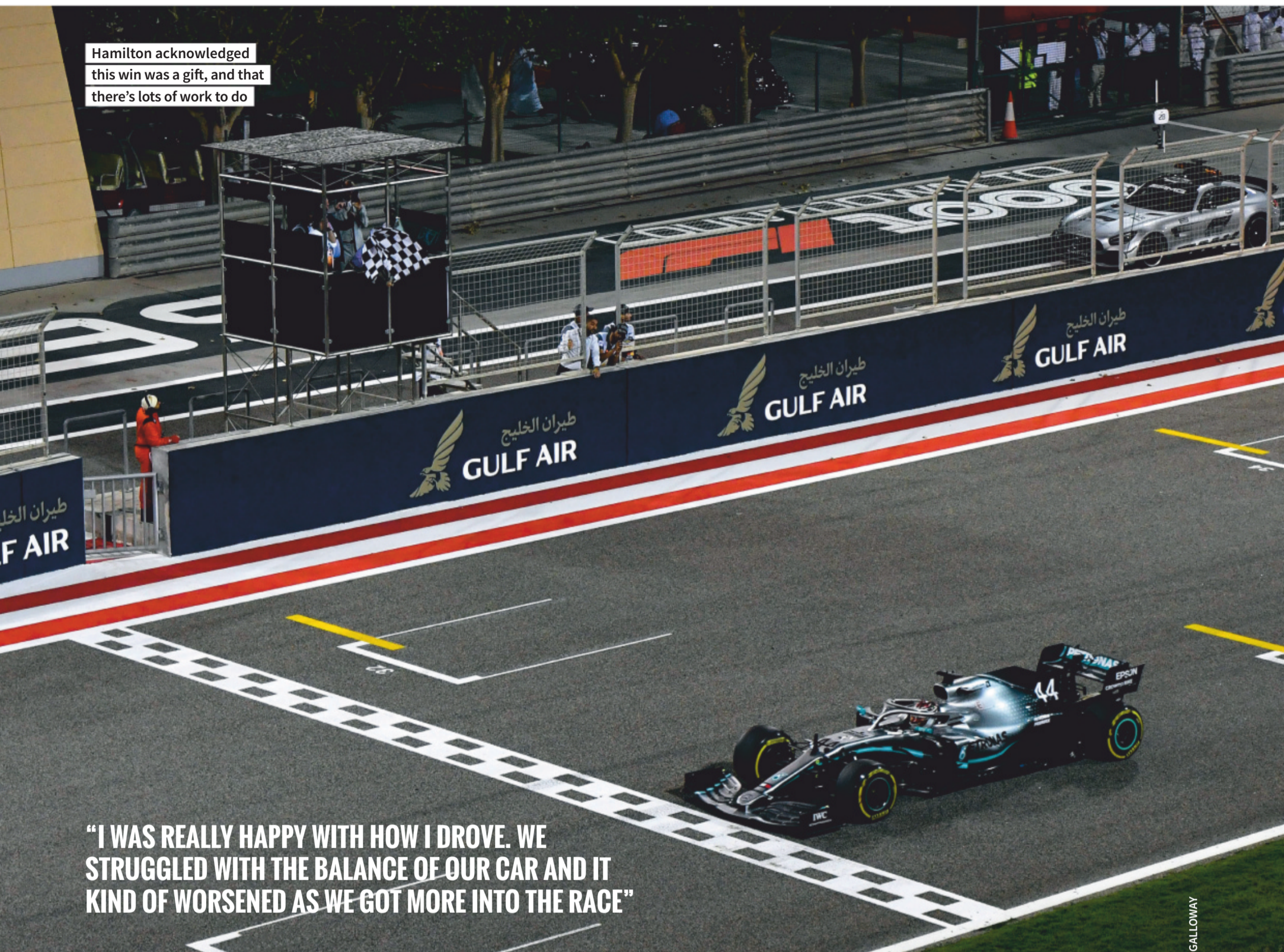

“I WAS REALLY HAPPY WITH HOW I DROVE. WE STRUGGLED WITH THE BALANCE OF OUR CAR AND IT KIND OF WORSENERD AS WE GOT MORE INTO THE RACE”

GALLOWAY

probably have been there to pick up the pieces.

Once again, Hamilton had forced the issue and made his own luck – and managed to show his class by expressing genuine respect for the fact that this was a race Leclerc had won. But this wasn't like Baku 2018, when Hamilton had to apologise repeatedly for taking a win that should have gone to Bottas, for Hamilton had maximised his machinery and was in the right position – ahead of one of the faster Ferraris – when Leclerc hit trouble. And all this at a track where Hamilton is not very at home, despite this being his third win here.

“I was really happy with how I drove in the race,” said Hamilton. “We struggled with the balance of our car throughout and it kind of worsened as we got more into the race. I can't express to you how hard I've been working on my starts, and the start really wasn't good. I'm just going to keep working on it. Basically you stumble and you fall and you get back up. So I just keep pushing.

“Fortunately I was still within the mix and got past Valtteri. I was happy with that manoeuvre, and then had that battle with Sebastian, which was awesome. We worked really hard and made some really good steps with the set-up through the weekend, moving in the right direction. As I said this is a track where I struggle, probably one of the most out of the lot of them, so to come out ahead, I was really happy with that.”

Verstappen had to settle for fourth place after a fairly lonely race, but only after seeing off McLaren driver Carlos Sainz Jr. The Spaniard briefly got ahead of the Red Bull man at the start, then attempted to

pass him four laps in around the outside of Turn 4. Verstappen defended to the inside, but made contact with Sainz as they ran side by side into the corner. The resulting puncture ruined what was a very promising race for Sainz and for McLaren, which for the first time in a long time was able to battle on merit with a Red Bull. Sainz was always doomed to lose out given that a gearbox problem later set in, but at least Norris came through with sixth for McLaren, his first points in F1 on what was a day for the new guard.

While this was a victory lost for Leclerc, he proved beyond doubt that he's a gold-standard driver by outclassing Vettel and doing everything but win the race. Given that Vettel once again came off second best in a scrap with Hamilton, you have to wonder which Ferrari driver the five-time world champion needs to worry about more for the rest of the season...

What happened in Bahrain has only delayed what nobody doubts will be the first of many victories for Leclerc. While he didn't get the winner's trophy, this might go down in history as a very significant race in the rise of a driver who should be a major force in F1 for a decade or more. ❧

NEXT F1 REPORT

CHINESE GRAND PRIX 18 APRIL ISSUE

Ferrari looks to have reasserted the pecking order from pre-season testing, but can Vettel quell the challenge from young charger Leclerc?



PORTLOCK



No action on Sainz/Verstappen clash

Max Verstappen and Carlos Sainz Jr's clash while battling for fifth place on the fourth lap of the race was investigated by stewards, who took no action because neither driver was "wholly or predominantly to blame" for the collision.

Sainz attempted to go around the outside of Verstappen at the Turn 4

right-hander. The Red Bull driver made contact with him and caused a front-right puncture. Sainz limped back to the pits, but later retired with a gearbox problem.

Sainz labelled his clash with Verstappen as "racing", but said the Dutchman had hit him very hard.

"It's racing, it's incidents,"

he said. "All I can say is that I started well, I did all I had to do and tried everything I had to try and I ended up worse off. It was my turn to get [a] puncture thanks to how hard he hit me.

"The normal thing would have been that we both got a puncture and to be both out of the race. He was lucky to continue, but he hit me really

hard and that was it."

Verstappen said Sainz had probably not seen him. "He tried to go around the outside and braked late. I guess he didn't see me," he said. "In these cars you are blind to what is happening next to you. I braked late and saw him turn into the corner, so I had to take avoiding action."

Norris and Albon bag their first points

McLaren driver Lando Norris and Toro Rosso's Alex Albon (right) bagged their first Formula 1 points finishes in the Bahrain Grand Prix.

Norris started 10th, slipping to 14th on the first lap after an off-track moment at Turn 7 following a clash with Nico Hulkenberg. He then passed Albon on lap two before picking up 12th place when Carlos Sainz Jr got a puncture, then passed Red Bull driver Pierre Gasly around the outside at Turn 4.

After the first round of pitstops he overcame Sergio Perez's Racing Point machine, before passing Kevin Magnussen, then overtaking Kimi Raikkonen and finally Daniel Ricciardo. He moved up to sixth when Nico Hulkenberg's Renault retired.

"We did get a bit lucky with the Renaults, I passed one of them but the other DNF'd with

a couple of laps to go," said Norris. "It kind of saved me a bit as well because I was under quite a bit of pressure from Kimi the last 10-15 laps."

It was an unexpectedly strong weekend for McLaren, with both drivers making Q3 and Sainz only prevented from scoring points by a clash with Max Verstappen and then a gearbox problem.

London-born Thai driver Albon missed out on a place in Q3 to a wide moment at the final corner. From 12th on the grid he ran 13th on the first lap before being bumped to 14th by Norris.

He moved up to 13th when Sainz hit trouble, then passed Magnussen in the second stint and later the Alfa Romeo of Antonio Giovinazzi. When the two Renaults expired late on, Albon moved up to ninth. He was under pressure from Perez late on when the safety car was deployed, which ensured he held on to the position.



ANDRE



Double retirement hits Renault hard

Nico Hulkenberg and Daniel Ricciardo both retired from points positions at the start of the 54th lap of the race with engine-related problems.

Hulkenberg started 17th after a combination of an engine mapping problem and a second, mechanical issue meant he fell in Q1. But after climbing to 11th on the first lap he was running sixth when he pulled off the track just after Turn 1 with four laps remaining thanks to a loss of power.

Simultaneously, Ricciardo pulled off at the entry to Turn 2 with smoke coming from the back of his car after an MGU-K failure. The MGU-K has been a weak point in terms of reliability for Renault this year, with a similar problem putting McLaren driver Carlos Sainz Jr out of the Australian Grand Prix and causing several issues in testing.

“It is a hard one to swallow, not just on me but everyone,” said Hulkenberg. “This is when you realise that F1 is about a team sport. The engine guys in Viry and everyone will be devastated. So there is no point hammering on them. We need to work as a unit and help each other.”

Ricciardo had briefly led the race after extending his first stint on a one-stop strategy, but had slid to 10th by the time he retired. Along the way, the pair made contact at Turn 1 and Hulkenberg drove over the end of Ricciardo’s wing despite leaving plenty of room for the Australian.

Ricciardo was scheduled to take part in the post-Bahrain GP test in order to get on top of the car, having struggled to match Hulkenberg’s underlying pace so far this season.

Q & A

PIERRE GASLY RED BULL DRIVER

Gasly scored his first Red Bull points for eighth place on a difficult weekend during which he struggled with rear grip on the throttle and failed to reach Q3 for the second race in succession. Max Verstappen had similar problems, admitting that Red Bull struggled to find the set-up “sweet spot”, although he handled the difficulties better.



help me to make it more suitable to my driving and to see what I can improve.

Did you get the maximum out of the race?

No, I still feel like I can’t really do what I want inside the car. There

was more potential, but I feel at the moment that I cannot really push and the car does not react how I would expect. There is more potential but we need to unlock it.

What was the problem in qualifying?

Since the beginning of the weekend, we struggled – especially on my car – with the rear. We tried many, many things, but just didn’t really improve. It’s fair to say – especially this weekend, in Melbourne it was OK – I didn’t really feel comfortable, especially with the rear. It’s wheelspinning a lot and quite unpredictable. I didn’t really put everything together, and when it’s so tight like this – I think we missed out [on Q3] by six hundredths, it cost quite a lot.”



Kubica a ‘passenger’

Robert Kubica says the ongoing problems with his Williams Formula 1 car were “exaggerated” by windy conditions that left him a “passenger” in the Bahrain Grand Prix.

Williams data suggested Kubica’s repaired car was displaying different aerodynamic behaviour despite running the same set-up as rookie team-mate George Russell in Bahrain.

“You can do whatever you want – you can put rear tyres on the front! It will be dominated by the characteristics we are having,” said Kubica, who described his race as “survival” after finishing two laps down in 16th.

“We need to find out what’s going on because I have no margin and I have no window in the car where actually I can drive it. I am a passenger.”

20 Kubica #88 1m31.799s	18 Stroll #18 1m30.217s	16 Giovinazzi #99 1m30.026s	14 Perez #11 1m29.756s	12 Albon #23 1m29.513s
19 Russell #63 1m31.759s	17 Hulkenberg #27 1m30.034s	15 Kvyat #26 1m29.854s	13 Gasly #10 1m29.526s	11 Grosjean #8 1m29.015s

FREE PRACTICE 1

POS	DRIVER	TIME
1	Leclerc	1m30.354s
2	Vettel	1m30.617s
3	Bottas	1m31.328s
4	Hamilton	1m31.601s
5	Verstappen	1m31.673s
6	Gasly	1m31.815s
7	Sainz	1m31.952s
8	Hulkenberg	1m32.040s
9	Kvyat	1m32.339s
10	Raikkonen	1m32.385s
11	Ricciardo	1m32.401s
12	Magnussen	1m32.602s
13	Albon	1m32.874s
14	Perez	1m32.885s
15	Norris	1m32.945s
16	Giovinazzi	1m32.949s
17	Grosjean	1m32.994s
18	Stroll	1m33.518s
19	Russell	1m34.188s
20	Kubica	1m34.253s

WEATHER 28C, sunny

FREE PRACTICE 2

POS	DRIVER	TIME
1	Vettel	1m28.846s
2	Leclerc	1m28.881s
3	Hamilton	1m29.449s
4	Bottas	1m29.557s
5	Hulkenberg	1m29.669s
6	Verstappen	1m29.725s
7	Magnussen	1m30.000s
8	Norris	1m30.017s
9	Grosjean	1m30.068s
10	Kvyat	1m30.093s
11	Sainz	1m30.192s
12	Gasly	1m30.429s
13	Albon	1m30.458s
14	Perez	1m30.716s
15	Ricciardo	1m30.848s
16	Raikkonen	1m31.088s
17	Stroll	1m31.129s
18	Giovinazzi	1m31.144s
19	Russell	1m31.904s
20	Kubica	1m32.932s

WEATHER 24C, dark

FREE PRACTICE 3

POS	DRIVER	TIME
1	Leclerc	1m29.569s
2	Vettel	1m29.738s
3	Hamilton	1m30.334s
4	Bottas	1m30.389s
5	Grosjean	1m30.818s
6	Hulkenberg	1m30.910s
7	Norris	1m30.955s
8	Verstappen	1m30.959s
9	Sainz	1m30.965s
10	Kvyat	1m31.173s
11	Raikkonen	1m31.333s
12	Gasly	1m31.392s
13	Magnussen	1m31.540s
14	Stroll	1m31.618s
15	Perez	1m31.638s
16	Ricciardo	1m31.643s
17	Albon	1m31.679s
18	Giovinazzi	1m32.132s
19	Russell	1m33.387s
20	Kubica	1m33.525s

WEATHER 25C, sunny

SEASON STATS

DRIVERS' CHAMPIONSHIP	PTS	BEST FINISH	BEST QUAL
1 Bottas	44	1	2
2 Hamilton	43	1	1
3 Verstappen	27	3	4
4 Leclerc	26	3	1
5 Vettel	22	4	2
6 Raikkonen	10	7	9
7 Norris	8	6	8
8 Magnussen	8	6	6
9 Hulkenberg	6	7	11
10 Gasly	4	8	13
11 Albon	2	9	12
11 Stroll	2	9	16
13 Kvyat	1	10	15
14 Perez	1	10	10
15 Giovinazzi	0	11	14
16 Russell	0	15	19
17 Kubica	0	16	20
18 Ricciardo	0	18	11
19 Sainz	0	19	7
20 Grosjean	0	-	6

CONSTRUCTORS' CHAMPIONSHIP

1 Mercedes	87
2 Ferrari	48
3 Red Bull	31
4 Alfa Romeo	10
5 McLaren	8
6 Haas	8
7 Renault	6
8 Toro Rosso	3
9 Racing Point	3
10 Williams	0

QUALIFYING BATTLE

Hamilton	2	0	Bottas
Vettel	1	1	Leclerc
Gasly	0	2	Verstappen
Ricciardo	1	1	Hulkenberg
Grosjean	1	1	Magnussen
Norris	1	1	Sainz
Perez	2	0	Stroll
Raikkonen	2	0	Giovinazzi
Albon	2	0	Kvyat
Russell	2	0	Kubica

Scores ignore sessions if a driver didn't participate in qualifying or had a serious technical problem

WINS

Bottas	1
Hamilton	1

POLE POSITIONS

Hamilton	1
Leclerc	1

FASTEST LAPS

Bottas	1
Leclerc	1

SPEED TRAP

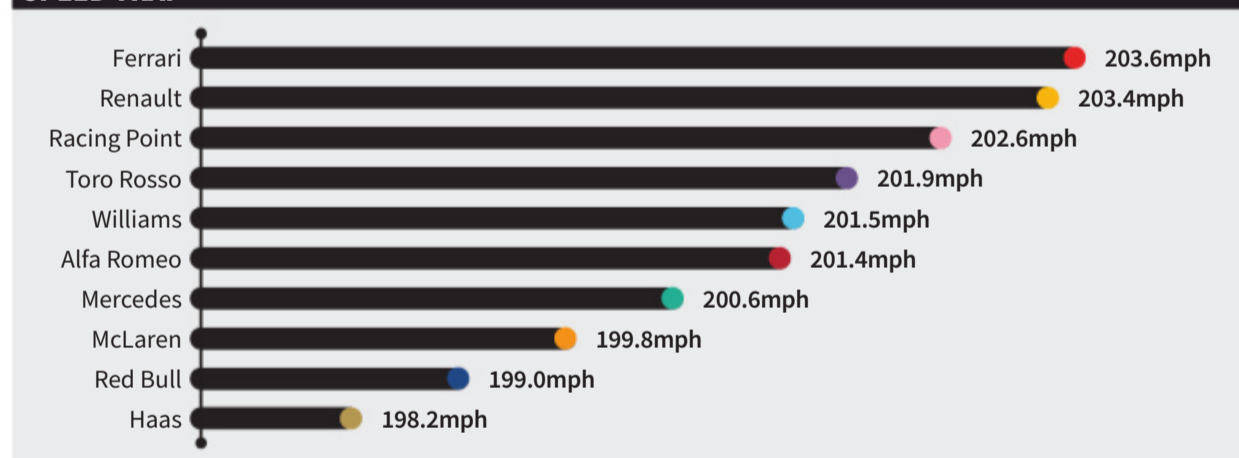

QUALIFYING 1

POS	DRIVER	TIME
1	Leclerc	1m28.495s
2	Vettel	1m28.733s
3	Hamilton	1m29.262s
4	Norris	1m29.381s
5	Bottas	1m29.498s
6	Albon	1m29.514s
7	Sainz	1m29.528s
8	Magnussen	1m29.532s
9	Verstappen	1m29.579s
10	Grosjean	1m29.688s
11	Ricciardo	1m29.859s
12	Kvyat	1m29.876s
13	Perez	1m29.893s
14	Gasly	1m29.900s
15	Raikkonen	1m29.959s
16	Giovinazzi	1m30.026s
17	Hulkenberg	1m30.034s
18	Stroll	1m30.217s
19	Russell	1m31.759s
20	Kubica	1m31.799s

QUALIFYING 2

POS	DRIVER	TIME
1	Leclerc	1m28.046s
2	Vettel	1m28.356s
3	Hamilton	1m28.578s
4	Bottas	1m28.830s
5	Magnussen	1m29.017s
6	Sainz	1m29.055s
7	Verstappen	1m29.109s
8	Grosjean	1m29.249s
9	Norris	1m29.258s
10	Raikkonen	1m29.471s
11	Ricciardo	1m29.488s
12	Albon	1m29.513s
13	Gasly	1m29.526s
14	Perez	1m29.756s
15	Kvyat	1m29.854s

QUALIFYING 3

POS	DRIVER	TIME
1	Leclerc	1m27.866s
2	Vettel	1m28.160s
3	Hamilton	1m28.190s
4	Bottas	1m28.256s
5	Verstappen	1m28.752s
6	Magnussen	1m28.757s
7	Sainz	1m28.813s
8	Grosjean	1m29.015s
9	Raikkonen	1m29.022s
10	Norris	1m29.043s

WEATHER 25C, dark





POWERED BY

motorsport
STATS

Motorsport Stats is the pre-eminent provider of motorsport data to media owners, rights-holders, bookmakers and sponsors. Its data services are founded on the world's largest repository of racing results dating back to 1897. **For more information contact sales@motorsportstats.com**

STARTING GRID



RACE RESULTS ROUND 2/21, 57 LAPS - 191.54 MILES

POS	DRIVER	TEAM	FINISHTIME	LED	TYRES
1	Lewis Hamilton (GBR)	Mercedes	1h34m21.295s	10	Su, Sn, Mn
2	Valtteri Bottas (FIN)	Mercedes	+2.980s		Su, Mn, Su
3	Charles Leclerc (MCO)	Ferrari	+6.131s	41	Su, Mn, Mn
4	Max Verstappen (NLD)	Red Bull-Honda	+6.408s		Su, Mn, Mn
5	Sebastian Vettel (DEU)	Ferrari	+36.068s	6	Su, Mn, Mn, Su
6	Lando Norris (GBR)	McLaren-Renault	+45.754s		Su, Mn, Su
7	Kimi Raikkonen (FIN)	Alfa Romeo-Ferrari	+47.470s		Su, Mn, Su
8	Pierre Gasly (FRA)	Red Bull-Honda	+58.094s		Su, Sn, Mn
9	Alexander Albon (THA)	Toro Rosso-Honda	+1m02.697s		Su, Sn, Mn
10	Sergio Perez (MEX)	Racing Point-Mercedes	+1m03.696s		Sn, Mn, Mn
11	Antonio Giovinazzi (ITA)	Alfa Romeo-Ferrari	+1m04.599s		Sn, Mn, Sn
12	Daniil Kvyat (RUS)	Toro Rosso-Honda	-1 lap		Sn, Mn, Sn
13	Kevin Magnussen (DNK)	Haas-Ferrari	-1 lap		Su, Mn, Su
14	Lance Stroll (CAN)	Racing Point-Mercedes	-1 lap		Sn, Mn, Mn
15	George Russell (GBR)	Williams-Mercedes	-1 lap		Sn, Mn, Mn
16	Robert Kubica (POL)	Williams-Mercedes	-2 laps		Mn, Sn, Mu
17	Nico Hulkenberg (DEU)	Renault	-4 laps		Sn, Sn, Mn
18	Daniel Ricciardo (AUS)	Renault	-4 laps		Sn, Mn
19	Carlos Sainz Jr (ESP)	McLaren-Renault	-4 laps		Su, Mn, Hu, Su
R	Romain Grosjean (FRA)	Haas-Ferrari	16 laps-acc damage		Su, Mn

FASTEST LAPS

POS	DRIVER	TIME	GAP	LAP
1	Leclerc	1m33.411s	-	38
2	Hamilton	1m33.528s	+0.117s	36
3	Bottas	1m34.209s	+0.798s	42
4	Vettel	1m34.895s	+1.484s	43
5	Kvyat	1m34.934s	+1.523s	40
6	Hulkenberg	1m35.215s	+1.804s	14
7	Giovinazzi	1m35.237s	+1.826s	42
8	Gasly	1m35.291s	+1.880s	42
9	Verstappen	1m35.311s	+1.900s	47
10	Sainz	1m35.586s	+2.175s	42
11	Raikkonen	1m35.589s	+2.178s	45
12	Norris	1m35.777s	+2.366s	14
13	Magnussen	1m35.892s	+2.481s	41
14	Perez	1m36.330s	+2.919s	51
15	Ricciardo	1m36.697s	+3.286s	42
16	Albon	1m36.752s	+3.341s	39
17	Stroll	1m37.037s	+3.626s	31
18	Grosjean	1m37.262s	+3.851s	3
19	Russell	1m37.313s	+3.902s	14
20	Kubica	1m37.903s	+4.492s	13

WEATHER 26C, dark

WINNER'S AVERAGE SPEED 121.80mph. FASTEST LAP AVERAGE SPEED 129.61mph.

TYRES

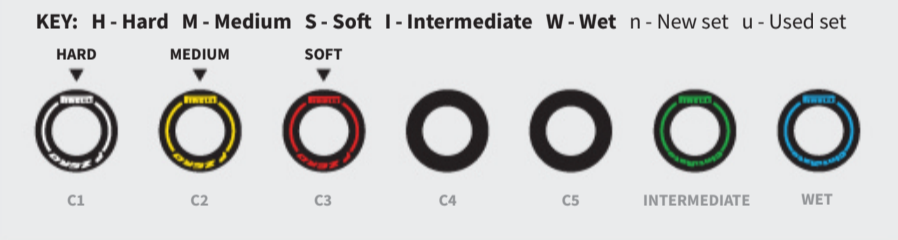

RACE BRIEFING

QUALIFYING GROSJEAN

Three-place penalty and one licence point for impeding Norris

RACE PENALTIES

KVYAT Five-second penalty for pitlane speeding



MOTORSPORTIMAGES/HONE

LAP CHART What happened, when

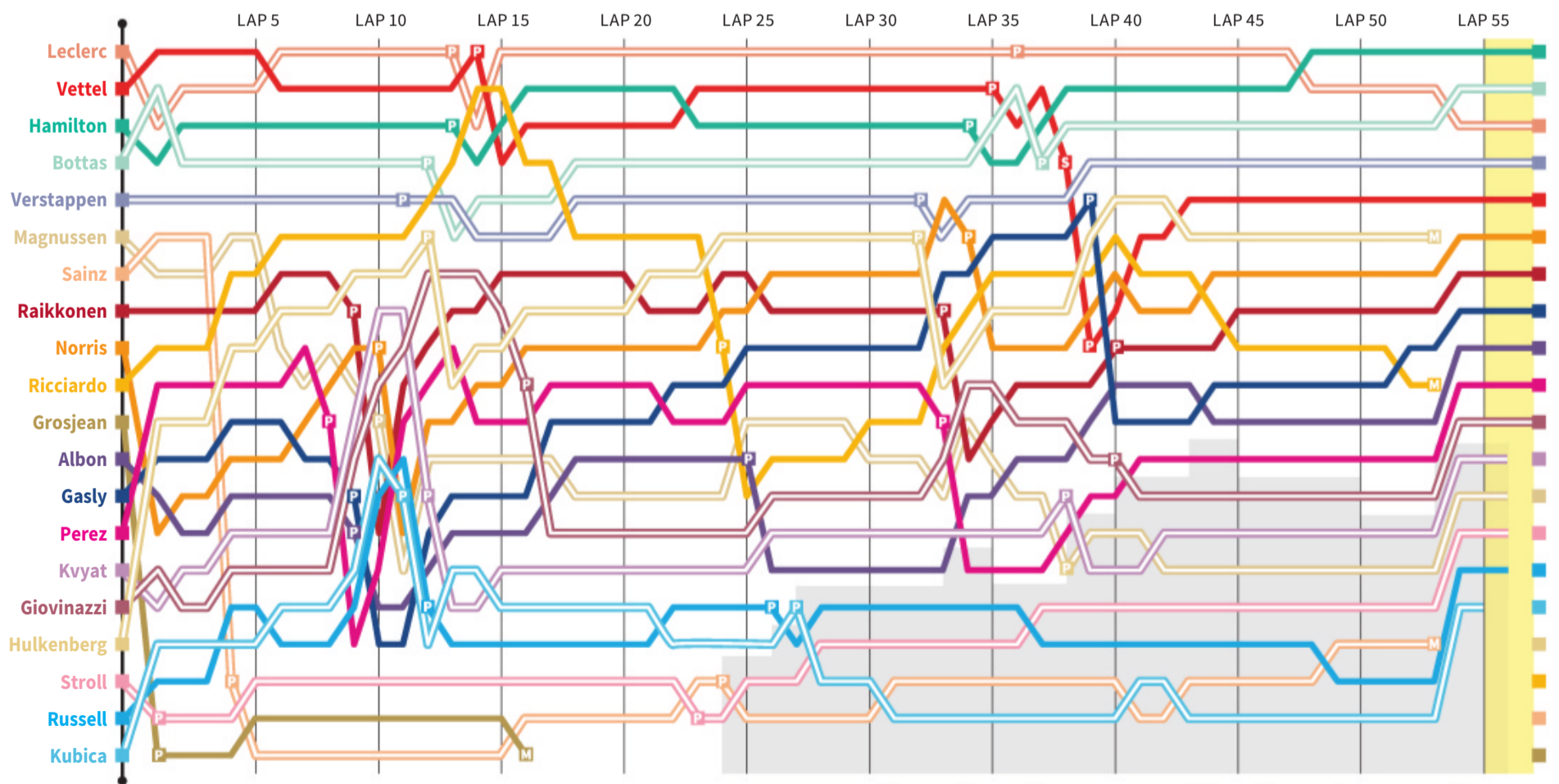

P Pitstop C Crash M Mechanical failure S Spin + Penalty Car lapped Safety car

THE ONE THAT GOT AWAY FOR LECLERC

Charles Leclerc laid down a vivid marker in Bahrain and was one of three aces to score 10 in our traditional driver ratings

EDD STRAW

MERCEDES



LEWIS HAMILTON

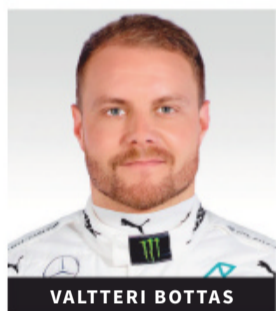

VALTTERI BOTTAS

10 Shaded Bottas by 0.066s in qualifying. The Mercedes wasn't as quick as the Ferrari but, while he couldn't keep Vettel behind after undercutting him at the first stops, Hamilton's attack after the second stops earned him second, which became first when Leclerc slowed.

8 Bottas was close to Hamilton in qualifying, and the race started well before he lost two places as a result of misjudging the wind into Turn 1. He was 22s behind Hamilton in second when the safety car was deployed, but the gap was partly explained by a plastic bag lodged in his front wing.

FERRARI



SEBASTIAN VETTEL



CHARLES LECLERC

4 Vettel only occasionally looked to have the same speed as Leclerc, and never when it mattered. Although he did ace the start to jump into the lead, he couldn't hold it. Spinning at Turn 4 while battling with Hamilton caused flat spots and wing failure that dropped him to fifth.

10 Fastest in two out of three practice sessions, all three segments of qualifying – by 0.294s over Vettel in the one that really counted – then the class of the field in the race, passing Vettel in the process. Leclerc was outstanding and had it in the bag before his engine faltered.

RED BULL

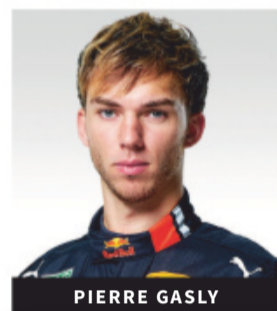

PIERRE GASLY

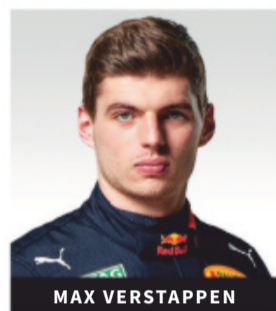

MAX VERSTAPPEN

4 Gasly looked all at sea in a Red Bull that he found pushed the rear end away every time he touched the throttle, and couldn't match what Verstappen did with the car in qualifying before falling in Q2. But he stuck at it in the race and was rewarded with his first Red Bull points.

8 Verstappen struggled for pace over a single lap on the softs, and failing to hit the set-up sweet spot meant it was tough to beat the midfield in qualifying. He had a lonely race after his early clash with Sainz, and would have been third but for the safety car saving the ailing Leclerc.

RENAULT



DANIEL RICCIARDO

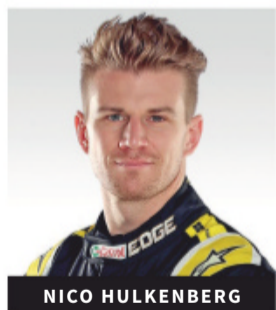

NICO HULKENBERG

6 Ricciardo had a horrendous time in practice but was much happier in qualifying despite an engine mapping problem that he reckoned cost him a Q3 place. Made the best of a bad job on a one-stopper in the race and was hanging on to 10th place when his Renault engine shut down.

10 An engine mapping problem and a second “mechanical” issue led to him falling in Q1. But he climbed to 11th at the start, which was the foundation of a race drive that should have netted sixth after passing Raikkonen along the way. An engine shutdown late on cost him the points.

HAAS

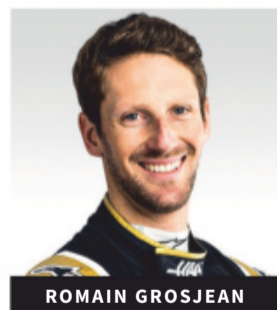

ROMAIN GROSJEAN

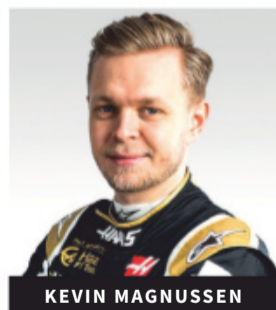

KEVIN MAGNUSSEN

5 Qualified a quarter of a second behind team-mate Magnussen, which was broadly in line with the pace gap between the pair all weekend, but was dropped three grid positions for impeding. His race was effectively over at Turn 2 when contact with Stroll pushed him off the track.

8 Magnussen came within five thousandths of outqualifying a Red Bull on merit in securing sixth on the grid. He fell to seventh on the opening lap, and it soon became clear the Haas was struggling with the tyres on race stints. An attempt to do a one-stop race made things worse.

MCLAREN

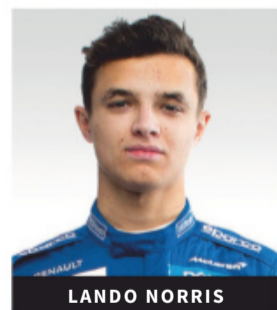

LANDO NORRIS

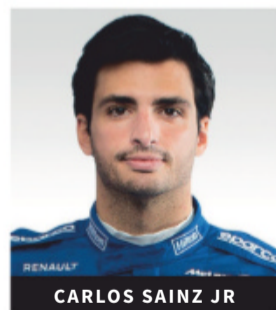

CARLOS SAINZ JR

8 Norris made Q3 again, qualifying 10th and 0.230s behind Sainz. His race could have unravelled after a difficult first lap, but after dropping to 14th he drove a strong race, making key passes on the likes of Magnussen, Raikkonen and Ricciardo to take a deserved sixth.

9 Sainz was one of the stars of qualifying, putting his McLaren seventh, and went on the attack in the early stages. After briefly getting ahead of Verstappen, he fell behind before clashing with him at Turn 4 while attempting to go around the outside. Gearbox problems prevented a recovery.



RACING POINT



SERGIO PEREZ

8 Traction troubles and a lack of downforce put Perez deep in the midfield. But he did what he could in qualifying and was three tenths ahead of Stroll. Capitalised on Renault's problems in the race to take 10th, harrying Albon while under pressure from the closing Giovinazzi late on.



LANCE STROLL

5 Qualifying went poorly for Stroll, who ended up three tenths behind his team-mate and out in Q1 after a scruffy couple of runs in which he didn't get the best out of the car. His race was ruined by the first-lap contact with Grosjean, which was a racing accident, condemning him to the lower midfield.

ALFA ROMEO



KIMI RAIKKONEN

8 Advanced by the skin of his teeth in both Q1 and Q2, and his reward was eighth on the grid. He didn't put a foot wrong in the race, although he came close to beating Norris and would probably have been one place better off with a perfect race. Even so, he banked good points.



ANTONIO GIOVINAZZI

6 Giovinazzi fell in Q1, but the gap to Raikkonen was just 0.067s. From 16th on the grid he was always up against it, but in the crowded midfield he acquitted himself solidly and was closing on Perez at an average of 0.960s per lap when the safety car was deployed, costing a possible shot at 11th.

TORO ROSSO



ALEXANDER ALBON

7 Albon claimed his first F1 points with a good race drive under late pressure from Perez, who might have passed him but for the safety car. He did a good job in qualifying, coming agonisingly close to Q3 and could have advanced with a perfect run as he continues his tough learning curve.



DANIIL KVYAT

6 Kvyat was baffled to be sent out in Q2 on used softs, the consequence of a mistake over which tyre set to put on the car, which led to him having no chance of reaching Q3 despite good underlying pace. Hitting Giovinazzi at Turn 11 ruined his race and left him out of touch with the points.

WILLIAMS

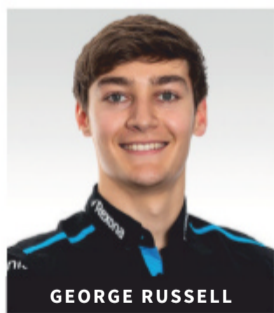

GEORGE RUSSELL

7 Russell struggled to find the grip in the car during qualifying and was potentially 0.5-0.7s faster than the lap time he did achieve in Q1. While the windy race conditions made life difficult, he fought hard and ultimately got ahead of Kubica after being outfoxed by him.

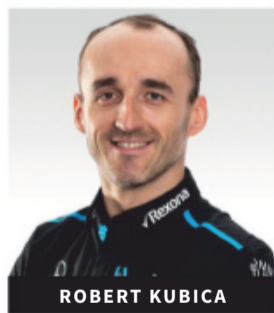

ROBERT KUBICA

7 Still struggling with car issues, beyond the fact that the Williams is slow, thanks to a shortage of parts. His qualifying showing, just behind Russell, wasn't representative of the deficit, although it's clear that his Williams is the weaker of the two. Did what he could in the race and battled hard.

TOP 10 AVERAGE RATINGS

AUTOSPORT'S RATING AFTER ROUND 2

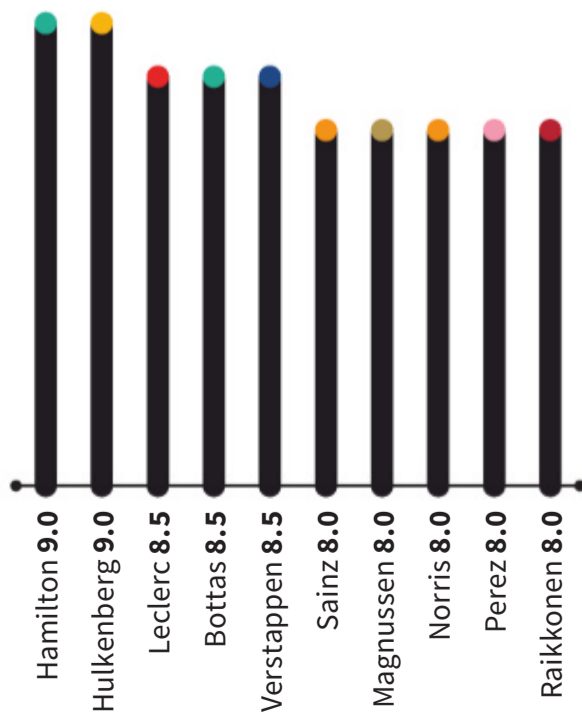

READERS' RATING AFTER ROUND 2

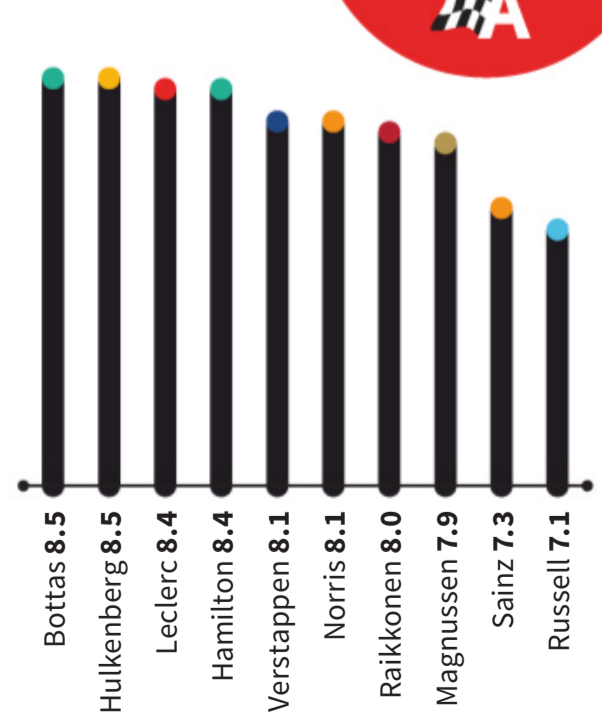

GIVE YOUR DRIVER RATINGS
[AUTOSPORT.COM/F1/DRIVER-RATINGS](https://www.autosport.com/f1/driver-ratings)



Evans heartbreak hands Neuville an escape route

A front-left puncture in the final stage meant Elfyn Evans lost out to Thierry Neuville – who vaulted from third to first in the championship

DAVID EVANS
PHOTOGRAPHY MCKLEIN



Second-guessing rallies is a dangerous business. Formbooks, like scripts, can be tossed aside in an instant. So much for Sebastien Ogier and Citroen, or for Ott Tanak and Toyota.

Instead, it was a Belgian who topped the podium. The same one who'd been blown away in the final stage, turning the air blue with a particularly expletive-laden analysis of his own time. And the Hyundai – the one which was nowhere last time out in Mexico, was fully expected to be embarrassed on asphalt, and which understeered its way through shakedown? Yes, that one. It won.

And Thierry Neuville, third in the table and staring down the barrel ahead of last week's Tour of Corsica? Championship leader. Same for his Korean employer. Third to first in three days.

But Hyundai didn't win this one. M-Sport, Elfyn Evans and Scott Martin lost it. Or rather, they were robbed.

Evans deserved to win. He'd earned it with a breathtaking and brilliant drive through the first stage on the final morning. That run through the 20-mile Eaux de Zilia test won him back all 16 seconds he'd lost to Neuville when his rival finally hooked his Hyundai up in a similarly merit-worthy effort on the last Saturday night stage.

Evans started the 14th and final stage with 11 seconds in hand for the final 12 twisting and turning miles that stood between him and a second world championship success.

And how that run into the Calvi finish would twist, turn and ultimately torment.

The weather was the chief talking point in the days leading up to round four, because the mountain roads were covered in more snow than Monte Carlo managed in January. Brief (very brief) crew concerns about a lack of suitable footwear disappeared once spring returned to clear the roads.

Snow or no snow, the roads remained very much in the pre-event spotlight courtesy of a route that was 75% new. In such circumstances, the rally is won or lost on the recce – it's where experience really comes into play. Which made Jari-Matti Latvala's lack of pace even more surprising; he's the most experienced full-time driver



Evans was faster than Neuville (inset) for much of the rally

in the World Rally Championship, but he was caught out on his two practice runs.

"The notes weren't good enough," he said. "Just not good enough. The first stage was bad, but the second stage – this one we did in 2015, but the conditions were so different with all the rain... I should have made new notes. My mistake."

He wasn't the only one. Kris Meeke's event was spoiled by a Monday morning blunder. The Northern Irishman clipped a kerb stone that wasn't marked in his notes while negotiating a left-hander.

"I had a 'hug' in the notes," he said. "This doesn't mean cut, it means hug the corner. I did that and we hit something. It's not good enough. I need to open my eyes."

The process of making new pacenotes was further complicated by the nature of the stages – these wider, less typically Corsican tests offered more variety in terms of lines.

As much as these elements expose a lack of experience, they can also showcase the effectiveness of a new partnership, such as Evans and Martin, who got together at the start of the season.

M-Sport team principal Rich Millener said: "They put in an awful lot of work in the winter, really working together on the notes – how they make them, how to refine them, everything."

Fastest times in Sweden and a podium in Mexico meant Evans arrived at round four in good shape. And confident. Oddly overlooked by the masses, Evans has genuine form on the French island. He overcame some of the wettest and toughest conditions to lead before finishing second in 2015 and won WRC 2 a year later.

"I like this place," he explained on the eve of the rally. "The key is to find the rhythm and not force it."

He found that rhythm in stage one. Then forced it in stage two. Fastest in SS1 became fifth quickest on the next one. He learned.

"I got a sniff in the first one," he said. "Then I was just trying to take more time on the next one. I wasn't so smooth and not so fluid."

A day later and Evans was still working on the theory. He led overnight, but slipped to second after tickling the right-rear against something solid early in the 30-mile Castagniccia stage.

"It didn't feel like the kind of knock that would give us a puncture," he said, "but I had to be careful just to find out what it had done. There was something



Sheer number of new stages made the recce particularly important



“Fastest times in Sweden and a podium in Mexico meant Evans arrived in good shape”

odd with the geometry and that caused the car to understeer in left-handers. Once I understood that and I knew what to expect then I was happy and I could push again.

“It is difficult. The road in the long one was mega dirty and slippery and you’ve just got to know when to grab the thing by the scruff of the neck and really force it. We had to do some of that in the long one, but in the first two the road was more like a race track and there you need to bring it back a tiny step, carry the speed and be neat and tidy. That’s when you need to... finesse it a bit more.”

A quick enquiry about finesse levels after he was just fourth fastest in SS8 drew a wry smile from the Welshman. “Yeah,” he grinned, “maybe I gave that one a bit too much finesse!”

Across the service park, Autosport took that principle up with Meeke. The Toyota man agreed with Evans completely.

“The trouble is,” said Meeke, “you see this wide road and the temptation is to carry more speed into the corner because you have more room. Then you start to

slide and you think, ‘We must be really quick’. But actually...”

At that point Toyota’s resident four-time world champion, team boss Tommi Makinen, arrived and completed Meeke’s sentence for him: “...You’re not so quick. Because the energy and the speed is going sideways and not forwards. And you are stressing the tyre more. I remember when I was fighting with Didier [Auriol] in Sanremo one year. I was in the Mitsubishi and the stage went really high into the mountains and the stage was 35 kilometres.

“At the start I told myself, ‘Stay calm and drive calm’. I didn’t slide, I didn’t lock the wheel, and I told myself 1000 times, ‘You are not losing time; you are not slow’. I could have driven for 100 more kilometres at that speed with no problem, the temperature in the tyre was perfect. I was fastest. I won the rally.”

Reminded of that conversation following Evans’s SS13 stunner, Makinen demonstrated a love for the sport that goes beyond his commitment to Toyota.

“I hope he does it,” he said. “He deserves it. And so does M-Sport. It was only our car and their car at the race this weekend, but Elfyn – this one should be for him. His time this morning... an incredible time.”

Nobody could argue with that. Just as nobody could argue with Neuville’s effort the night before.

Evans had been right at the sharp end since his stage one scratch time, but he’d succumbed to Ott Tanak’s Toyota before Tanak’s rally was wrecked by a puncture >>

IN THE HEADLINES

CITROEN OFF FORM

Ahead of the rally, Citroen made much of Esapekka Lappi’s karting background. He had, the French firm’s PR machine reckoned, developed a special relationship with asphalt while growing up. That affinity seemed to have been put on hold because he struggled to get his C3 WRC under his control. “I can’t make the car turn,” he said. “All we have is understeer. Just understeer.” Five places and 80 seconds ahead on the leaderboard, his team-mate Sebastien Ogier told the same story. A French rally to forget for the French company.

KOREAN PREDATOR

Hyundai’s return to the top of the table marked the Koreans out as ‘predators’, according to team principal Andrea Adamo. He candidly admitted that the fastest car and driver hadn’t won, but he made no apology for his squad’s smash-and-grab approach that placed Dani Sordo fourth and Sebastien Loeb eighth. Local hero and nine-time champion Loeb’s rally was effectively run when he damaged the suspension aboard his i20 on the opening stage. There were flashes of the speed that carried him to four successive victories on the island in years past, but this wasn’t the sort of return Loeb had been hoping for.

LATVALA’S WOES

Another former winner struggling to hit their stride was Toyota man Jari-Matti Latvala, who was adrift in 10th place, having stopped to change two punctures. His team-mate Kris Meeke suffered deflations and damaged rims of his own, but Meeke’s outing was improved immeasurably by a second stunning powerstage win in four rallies. Ott Tanak was top Toyota in sixth, having pushed for the win before he stopped to change a puncture. Tanak had hoped to catch and pass M-Sport’s Teemu Suninen for fifth on Sunday, but Suninen recovered from a throttle problem – not to mention a shoddy start and a third crash in three rallies – to hold on to the place.





on Saturday afternoon. That left Evans 11s up on Neuville and seemingly in control.

Or as much in control as possible ahead of the second run at the horribly messy Castagniccia. That 30-miler had been tricky – or, to use British WRC 2 charger Rhys Yates’s description, ‘sketchy’ – first time through, and was expected to yield many punctures at the second attempt.

But with risk came huge potential reward. And Neuville went all out to secure those gains. He took three seconds out of Ogier, 10s out of Tanak and 16s out of Evans.

Neuville was all smiles. Historically, the Hyundai has been better suited to the narrower, bumpier sections and that was the case on Saturday.

“I didn’t want to make a mistake,” said Neuville, “but I found a good rhythm and the speed was there. I found the confidence with the car. We are on the edge, for sure. I don’t know how the other drivers are – I can only compare with my team-mates and we can see that I’m much faster than

Dani [Sordo] and Seb [Loeb] also. We keep pushing. We have to.”

Understeer-free, he would lead the field by 4.5s into the final day.

Evans, by contrast, was baffled – but not beaten. Looking at the times, he blinked. “I’d have been disappointed to lose five seconds,” he said. “But that much...”

He’d led the event for seven of the 12 stages so far, and run first or second for all of them. But now, more than ever, he wanted two to become one on Sunday.

But could it? Could he overcome Neuville’s psychological blow from the night before? The gap was ‘only’ 4.5s, but the wind that had filled Evans’s sails for two days had dropped and turned in the direction of the #11 i20.

Final-day fights haven’t always been Evans’s forte. Earlier last month we’d seen him lose out to Tanak on a Mexican Sunday. What now?

Arriving at Sunday morning service after a short trip from parc ferme in the

“With risk came potential reward. And Neuville went all out to secure those gains”

centre of Bastia, the rest of the crews emerged from their cars to chew the fat. Evans and Martin stayed where they were. There was a wave, but little more. This wasn’t the time for questions. This was their time. And they used it well.

M-Sport’s chief rally engineer confirmed that Evans’s Ford Fiesta WRC would be as light as it had ever been when it headed for Sunday’s two stages. “We’ve done absolutely everything,” said Chris Williams. “We’ve taken everything possible out and put as much new stuff – new dampers, new brakes – as we can. I don’t think the engine guy or the chassis guy would have slept much last night.”

By the time they left service, there was nothing more to be said. “We just need to get on with it now,” said Millener.

With Malcolm Wilson on Bentley duty in the USA, Millener was flying solo as team principal for the first time. Delivering this result would be the perfect payback for Wilson’s confidence in making him the sport’s youngest ever factory team principal.

Split one, SS13 and Evans was 7s up; 12s; 14s and finally 16s. He’d repaid the favour.

Now to ice the cake, with the potential of a five-point cherry on top. There was





Last-stage heartbreak for Evans handed victory to Neuville



RESULTS ROUND 4/14, TOUR DE CORSE (FRA), 28-31 MARCH

POS	DRIVER / CO-DRIVER	TEAM / CAR	TIME
1	Thierry Neuville (BEL) Nicolas Gilsoul (BEL)	Hyundai Shell Mobis WRT / Hyundai i20 Coupe WRC	3h22m59.0s
2	Sebastien Ogier (FRA) Julien Ingrassia (FRA)	Citroen Total WRT / Citroen C3 WRC	+40.3s
3	Elfyn Evans (GBR) Scott Martin (GBR)	M-Sport Ford WRT / Ford Fiesta WRC	+1m06.6s
4	Dani Sordo (ESP) Carlos del Barrio (ESP)	Hyundai Shell Mobis WRT / Hyundai i20 Coupe WRC	+1m18.4s
5	Teemu Suninen (FIN) Marko Salminen (FIN)	M-Sport Ford WRT / Ford Fiesta WRC	+1m24.6s
6	Ott Tanak (EST) Martin Jarveoja (EST)	Toyota Gazoo Racing WRT / Toyota Yaris WRC	+1m40.0s
7	Esapekka Lappi (FIN) Janne Ferm (FIN)	Citroen Total WRT / Citroen C3 WRC	+2m09.1s
8	Sebastien Loeb (FRA) Daniel Elena (MCO)	Hyundai Shell Mobis WRT / Hyundai i20 Coupe WRC	+3m39.2s
9	Kris Meeke (GBR) Sebastian Marshall (GBR)	Toyota Gazoo Racing WRT / Toyota Yaris WRC	+5m06.3s
10	Jari-Matti Latvala (FIN) Miikka Anttila (FIN)	Toyota Gazoo Racing WRT / Toyota Yaris WRC	+6m44.6s

OTHERS

23	Jean-Charles Beaubelique (FRA) Julien Pesenti (FRA)	Jean-Charles Beaubelique / Citroen DS3 WRC	+28m56.8s
29	Armando Pereira (FRA) Remi Tutelaire (FRA)	Armando Pereira / Ford Fiesta RS WRC	+34m52.3s
37	Alain Vauthier (FRA) Gilbert Dini (FRA)	Alain Vauthier / Ford Fiesta RS WRC	+37m32.4s
63	Robert Simonetti (FRA) Celia Simonetti (FRA)	Robert Simonetti / Citroen DS3 WRC	+1h14m23.2s

STAGE TIMES

STAGE	FASTEST	LEADER	SECOND
SS1 Bavella 1 (10.94 miles)	Evans 10m20.6s	Evans	Neuville +2.9s
SS2 Valinco 1 (16.12 miles)	Meeke 14m23.6s	Tanak	Evans +0.6s
SS3 Alta-Rocca 1 (10.79 miles)	Tanak 10m05.2s	Tanak	Evans +1.3s
SS4 Bavella 2 (10.94 miles)	Evans 10m17.5s	Evans	Tanak +1.4s
SS5 Valinco 2 (16.12 miles)	Evans 14m23.2s	Evans	Tanak +4.5s
SS6 Alta-Rocca 2 (10.79 miles)	Neuville 10m02.3s	Evans	Tanak +4.5s
SS7 Cap Corse 1 (15.92 miles)	Tanak 15m50.6s	Evans	Tanak +3.9s
SS8 Desert des Agriates 1 (8.98 miles)	Tanak 7m55.8s	Evans	Tanak +0.2s
SS9 Castagniccia 1 (29.32 miles)	Sordo 29m45.0s	Tanak	Evans +2.3s
SS10 Cap Corse 2 (15.92 miles)	Meeke 15m52.3s	Tanak	Evans +1.6s
SS11 Desert des Agriates 2 (8.98 miles)	Neuville 7m57.6s	Evans	Neuville +11.5s
SS12 Castagniccia 2 (29.32 miles)	Neuville 29m24.4s	Neuville	Evans +4.5s
SS13 Eaux de Zilia (19.79 miles)	Evans 15m47.2s	Evans	Neuville +11.5s
SS14 Calvi (powerstage) (12.02 miles)	Meeke 9m54.0s	Neuville	Ogier +40.3s

DRIVERS' CHAMPIONSHIP

POS	DRIVER	PTS
1	Neuville	82
2	Ogier	80
3	Tanak	77
4	Evans	43
5	Meeke	42
6	Lappi	26
7	Loeb	22
8	Sordo	16
9	Latvala	15
10	Suninen	14

MANUFACTURERS' CHAMPIONSHIP

POS	DRIVER	PTS
1	Hyundai Shell Mobis WRT	114
2	Citroen Total WRT	102
3	Toyota Gazoo Racing WRT	98
4	M-Sport Ford WRT	70

NEXT EVENT

RALLY ARGENTINA 2 MAY ISSUE

It's back onto the gravel as the WRC heads to Cordoba, won last year by Ott Tanak in the Toyota. Fastest over 10 of the 18 stages, Tanak was on unbeatable form.

some speculation about a brake problem for Neuville, but Evans wasn't buying it.

"I had to push in there," said the leader following what was now readily and repeatedly being called the stage of his life. "It all worked. But nothing's done yet..."

Off the line and the countdown began to a result that should have eclipsed anything Evans had achieved before. On a level playing field, he and the Fiesta were ready to show themselves as a genuine force in the 2019 title race.

Then, disaster. A stone, a hole? It mattered little. The result was the same: front-left puncture and heartbreak as first turned to third. Nobody was more surprised than Neuville. And the winner was quick to pay tribute to the loser.

"Elfyn was faster than us this weekend," he said. "I'm sorry for him."

But still, he'd won the rally, moved Hyundai into the manufacturers' lead, and risen to the head of the drivers' standings. Ogier was another beneficiary in second place, but that wasn't cause for much celebration in an event that had been expected to yield a French winner.

The emotional dynamic on the podium was fascinating. Neuville couldn't get enough of a champagne-soaked top step, while Ogier held the bottle still, fired the cork and watched impassively as the fizz fell in front of him. Evans and Martin looked like men who'd rather have been elsewhere. Undoubtedly, that was the one that got away for M-Sport and Evans.

It might not have been the Corsica the wider world – and France in particular – expected, but round four delivered an improvised script of its own. ❧



Ghiotto follows in the wake of Bahrain star Leclerc

FORMULA 2
SAKHIR (BHR)
30-31 MARCH
ROUND 1/12

Most of the pre-event attention might have been lavished upon Mick Schumacher, but it was another Ferrari-backed driver with Prema Racing pedigree who led the way in Bahrain. While Charles Leclerc was busy writing a new chapter in his career by taking pole position for the grand prix, one of his former rivals was imitating his F2 race-winning strategy from two years ago.

Back in 2017, Leclerc opened the F2 season with a stunning sprint race win in Bahrain after pitting – a counter-intuitive tactic in the shorter reversed-grid race. The man he beat that day, Luca Ghiotto, had to watch the young Monegasque breeze by with fresher tyres. But Ghiotto put that pain to good use by pulling off the same move to cap a weekend in which he starred.

Ghiotto opened his account with pole position in the feature race. After struggling for pace in 2018, he left Campos Racing and has joined the Virtuosi Racing team (which ran Russian Time when Ghiotto drove there in 2017) for his fourth season in GP2/F2.

Back in familiar surroundings, Ghiotto flew. There were many names bandied around as pre-season title favourites and he was among them, but few expected him to be quite as quick as he was in Bahrain. Sadly, disaster struck. A clutch-related

issue (unrelated to last year's poor reliability since Ghiotto was one of only two stallers across the two races) hindered his getaway and the result was a poor start.

He fought back strongly, driving all the way up to second. But the feature race belonged to a resurgent Nicholas Latifi, who looked every bit as impressive as Ghiotto throughout the weekend.

The Canadian was awful in the first half of last year, which he attributed to an illness that limited his pre-season testing. But in 2019 he completed more testing laps than anyone, and looks right at home in his fourth season with DAMS.

Once past Carlin's Louis Deletraz on lap nine of 32, he looked unstoppable. There was a wheelgun fault in his pitstop and

he lost four or five seconds, but passing three cars in as many laps put him back into a dominant lead.

Behind Ghiotto, Sergio Sette Camara was resurgent. A lock-up in qualifying consigned him to a disappointing eighth on the grid. He came back strongly to take a podium in the race, and made it four F2 podiums in four races in Bahrain the following day. That meant he kicked off the year with 27 points, having stated pre-season that he'd set himself a target of 20 points per round.

Just behind him in the feature race, reigning GP3 champion Anthoine Hubert delivered an incredible fourth for Arden in his first race with a planned pitstop – and with no radio – having started 11th. He made a double pass on Deletraz and



Latifi came through to win feature race after Ghiotto's poor start

ALL PICS: PORTLOCK
motorsport
 IMAGES



2017 loss to Leclerc inspired strong Ghiotto racecraft



GP3 champion Hubert impressed on his F2 debut

Nobuharu Matsushita at Turn 1 in the closing stages, before overtaking the limping Nyck de Vries, who was also jumped by Deletraz. De Vries topped all but two days of pre-season testing but he managed only a sixth and a seventh, although his ART predecessor George Russell also had a tough weekend in Bahrain last year.

Schumacher saved his tyres nicely to overcome Matsushita and take a storybook pole position, even if it was for the reversed-grid race. He failed to convert that pole and fell back on Sunday, jumped in the process by a number of drivers, including his ex-European Formula 3 team-mate Guan Yu Zhou, Ghiotto's stablemate at Virtuosi. But it was a sensible drive by Schumacher, who stuck to his own pace to take sixth.

Ghiotto took four laps to go from seventh to the lead and stretched a gap of five seconds over Sette Camara and Latifi.

After pitting on lap 12, the DAMS drivers committed to staying out and Ghiotto would have 10 laps to claw back over 20 seconds. By the time he reached the quibbling DAMS drivers with a few laps in hand they had no hope, and he took a glorious win ahead of Sette Camara and Latifi.

Lando Norris was the star of Bahrain last season and won the feature race from pole. It would be his only win and pole in 2018 and he took second in the championship, so take caution in writing anyone off after what is always a tricky weekend in Bahrain.

JACK BENYON

RESULTS ROUND 1/12, BAHRAIN, 30-31 MARCH, RACE 1 (32 LAPS - 107.459 MILES)

POS	DRIVER	TEAM	TIME
1	Nicholas Latifi (CAN)	DAMS	59m19.517s
2	Luca Ghiotto (ITA)	Virtuosi Racing	+8.744s
3	Sergio Sette Camara (BRA)	DAMS	+14.826s
4	Anthoine Hubert (FRA)	Arden	+17.273s
5	Louis Deletraz (CHE)	Carlin	+26.686s
6	Nyck de Vries (NLD)	ART Grand Prix	+28.497s
7	Jack Aitken (GBR)	Campos Racing	+31.545s
8	Mick Schumacher (DEU)	Prema Racing	+34.708s
9	Nobuharu Matsushita (JPN)	Carlin	+37.395s
10	Guan Yu Zhou (CHN)	Virtuosi Racing	+41.131s
11	Ralph Boschung (CHE)	Trident	+42.092s
12	Giuliano Alesi (FRA)	Trident	+47.711s
13	Tatiana Calderon (COL)	Arden	+55.775s
14	Callum Ilott (GBR)	Sauber Junior Team by Charouz	+56.293s
15	Dorian Boccia (FRA)	Campos Racing	+1m14.247s
16	Juan Manuel Correa (USA)	Sauber Junior Team by Charouz	+1m24.988s
17	Jordan King (GBR)	MP Motorsport	+1m26.511s
18	Mahaveer Raghunathan (IND)	MP Motorsport	+1m33.150s
19	Nikita Mazepin (RUS)	ART Grand Prix	+1m37.568s
R	Sean Gelael (IDN)	Prema Racing	4 laps-DRS failure

Winner's average speed 108.680mph. **Fastest lap** Zhou 1m47.645s, 112.465mph.

QUALIFYING 1 Ghiotto 1m40.504s; 2 Deletraz 1m40.871s; 3 de Vries 1m40.889s; 4 Latifi 1m40.964s; 5 Aitken 1m41.115s; 6 Matsushita 1m41.137s; 7 Gelael 1m41.254s; 8 Camara 1m41.310s; 9 Boschung 1m41.505s; 10 Schumacher 1m41.583s; 11 Hubert 1m41.596s; 12 Correa 1m41.722s; 13 Mazepin 1m41.848s; 14 King 1m41.857s; 15 Alesi 1m41.864s; 16 Boccia 1m41.918s; 17 Zhou 1m42.123s; 18 Ilott 1m42.280s; 19 Calderon 1m42.810s; 20 Raghunathan 1m43.343s.

RACE 2 (23 LAPS - 77.193 MILES)

1 Ghiotto 42m36.192s; 2 Camara +5.474s; 3 Latifi +6.867s; 4 Zhou +18.240s; 5 Deletraz +21.939s; 6 Schumacher +24.679s; 7 de Vries +25.154s; 8 King +25.520s; 9 Hubert +30.514s; 10 Gelael +30.532s; 11 Aitken +32.224s; 12 Matsushita +35.980s; 13 Mazepin +40.541s; 14 Boschung +43.074s; 15 Calderon +46.006s; 16 Ilott +56.487s; 17 Boccia +1m00.048s; 18 Correa +1m32.585s; 19 Raghunathan -1 lap; EX Alesi +1m21.115s-tyres.

Winner's average speed 108.714mph. **Fastest lap** de Vries 1m47.145s, 112.989mph.

GRID FOR RACE 2

Decided by result of Race 1, with top eight finishers reversed.

CHAMPIONSHIP

1 Ghiotto 37; 2 Latifi 35; 3 Camara 27; 4 Deletraz 16; 5 Hubert 12; 6 de Vries 12; 7 Zhou 11; 8 Schumacher 8; 9 Aitken 6; 10 Matsushita 2.



Schumacher (9) failed to convert sprint race pole into victory



"Cataclean has long been the go-to fuel and exhaust system cleaner in my workshop – it really works!"

*Daniel Rowbottom
BTCC driver / Auto technician*



CATAACLEAN®

Liquid science for the life of your vehicle

cataclean.com

Available from:



and most leading UK motor factors

HubAuto Corsa Ferrari takes enduro victory

**INTERCONTINENTAL GT CHALLENGE
LAGUNA SECA (USA)
30 MARCH
ROUND 2/5**

The HubAuto Corsa Ferrari 488 GT3 won the second round of the Intercontinental GT Challenge at Laguna Seca as Nick Foster, Tim Slade and Miguel Molina beat the GruppeM Mercedes-AMG of Maxi Buhk, Maxi Goetz and Raffaele Marciello by 12.5 seconds.

Remarkably, there were no cautions in the entire eight hours, but the Balance of Performance ensured the race still swung back and forth between different cars.

The KCMG Nissan GT-R of Alex Buncombe, Katsumasa Chiyo and Joshua Burdon passed the polesitting Acura NSX of Mario Farnbacher on the opening lap to head the first hour, while Molina's Ferrari 488 then also passed Farnbacher, and assumed the lead when Buncombe pitted.

Thanks to a slow stop from KCMG, the Ferrari retained its lead – until it too had a tardy service, which allowed the Park Place Motorsports Porsche 911 GT3 R of Romain Dumas, Mathieu Jaminet and Sven Muller to hit the front. The similar car of Wright Motorsports would take command at half-distance, until Dirk Werner pitted the 911 with terminal gearbox problems.



Ferrari set a distance record of 732 miles for the famous track

That left the Schnitzer BMW M6 of Augusto Farfus, Chaz Mostert and Martin Tomczyk in the lead, but a drivethrough penalty for Mostert after contact with the Land Motorsport Audi R8 LMS dropped it back to fifth at the chequered flag, one lap down on the winner.

Park Place managed to score a podium ahead of the Audi Sport Team WRT R8 of Dries Vanthoor, Frederic Vervisch and Christopher Haase, which was the last car on the lead lap.

DAVID MALSHER

Penalty brace fails to halt Hamlin's Texan charge

**NASCAR CUP
TEXAS (USA)
31 MARCH
ROUND 7/36**

Denny Hamlin took his second win of the NASCAR Cup season in Texas after battling back from two penalties.

Hamlin was penalised for pitlane speeding in the first stage, then for an errant wheel in the pitlane just after he won the second stage.

For much of the race it looked like Hamlin's Joe Gibbs Racing team-mate Kyle Busch would win. Following victories in the Truck and Xfinity series earlier in the weekend, Busch led a race-high 66 laps out of 334 but contact with the Turn 2 wall late on ended all

chances of an unprecedented third career triple-header sweep.

Ford took second and third, with Clint Bowyer and a strong Daniel Suarez.

Erik Jones recovered from a spin to finish fourth, while polesitter Jimmie Johnson had his best race in almost a year, finishing as top Chevrolet in fifth after leading 61 laps. William Byron equalled his career-best with sixth.

Joey Logano was the winner of the first stage but finished a lap down in 17th. His Penske Ford team-mate Ryan Blaney led 45 laps but retired with engine failure, while the third Penske entry of Brad Keselowski was also halted by transmission issues, which cost him 55 laps.

DOMINIK WILDE

WEEKEND WINNERS

INTERCONTINENTAL GT CHALLENGE

LAGUNA SECA (USA)

Nick Foster/Tim Slade/Miguel Molina
HubAuto Corsa (Ferrari 488 GT3)

NASCAR CUP

TEXAS (USA)

Denny Hamlin (below)
Joe Gibbs Racing (Toyota Camry)

NASCAR XFINITY SERIES

TEXAS (USA)

Kyle Busch
Joe Gibbs Racing (Toyota Supra)

NASCAR TRUCK SERIES

TEXAS (USA)

Kyle Busch
Kyle Busch Motorsports (Toyota Tundra)



POWERED BY
**motorsport
STATS**

For full results visit motorsportstats.com



What a difference a year makes as Marquez

MOTOGP
RIO HONDO (ARG)
31 MARCH
ROUND 2/19

Marc Marquez opened his 2019 MotoGP win account in emphatic style last weekend in Argentina, banishing memories of his Termas de Rio Hondo meltdown last year by taking one of the most dominant victories of his entire grand prix career.

The contrast with 2018 – when Marquez stalled on the grid, earning himself a ridethrough penalty that precipitated his infamous clash with Valentino Rossi – couldn't have been greater. The Honda

rider made the perfect getaway from pole and simple rode into the distance, pulling clear by as much as one second per lap in the early stages.

“Honestly, after last year I wanted to do a race like that; I wanted to show my speed and my precision,” said Marquez. He crossed the line almost 10 seconds ahead of second-place Rossi for his third Argentinian MotoGP victory in six attempts.

Marquez's supremacy meant attention turned to the fight for second, which was essentially a race-long battle between Rossi and Ducati's Andrea Dovizioso.

Qatar winner Dovizioso looked to have the upper hand for much of the second

half of the race, but 40-year-old Rossi fought back to grab the runner-up spot on the last lap to mark his best finish since last July's Sachsenring race.

That move also effectively handed Marquez a four-point lead in the standings.

Best of the rest was Jack Miller, who reckoned he was on a lap good enough for pole on Saturday before suffering a “big old highside moment” that dropped him to fifth. He was then left to regret his choice of medium front tyre, meaning he had to focus on fighting Danilo Petrucci and Alex Rins instead of getting in the mix with Rossi and Dovizioso ahead.

In the end, Pramac Ducati rider Miller was content enough with fourth – critically, ahead of factory Ducati rider Petrucci, who was sixth – while Rins completed a strong comeback on his Suzuki in fifth after qualifying well down in 16th place.

Yamaha's Maverick Vinales looked to have made a step forward after qualifying second behind Marquez, but again failed to get off the line well and within two laps found himself mired down in eighth place.

The fact that Vinales didn't seem too angry to have been taken out by Franco Morbidelli on the Petronas Yamaha at Turn 7 on the final lap perhaps speaks volumes about his race. That entanglement promoted Takaaki Nakagami to seventh, giving the him his best dry-weather finish in MotoGP to date.

Nakagami's LCR Honda team-mate



Lorenzo has yet to find form since moving to Honda



RESULTS ROUND 2/19, TERMAS DE RIO HONDO (ARG), 31 MARCH (25 LAPS – 74.658 MILES)

POS	RIDER	TEAM	TIME
1	Marc Marquez (ESP)	Honda	41m43.688s
2	Valentino Rossi (ITA)	Yamaha	+9.816s
3	Andrea Dovizioso (ITA)	Ducati	+10.530s
4	Jack Miller (AUS)	Pramac Ducati	+12.140s
5	Alex Rins (ESP)	Suzuki	+12.563s
6	Danilo Petrucci (ITA)	Ducati	+13.750s
7	Takaaki Nakagami (JPN)	LCR Honda	+18.160s
8	Fabio Quartararo (FRA)	Petronas Yamaha	+20.403s
9	Aleix Espargaro (ESP)	Aprilia	+25.292s
10	Pol Espargaro (ESP)	KTM	+25.679s
11	Miguel Oliveira (PRT)	Tech3 KTM	+25.855s
12	Jorge Lorenzo (ESP)	Honda	+27.497s
13	Cal Crutchlow (GBR)	LCR Honda	+31.398s
14	Francesco Bagnaia (ITA)	Pramac Ducati	+32.893s
15	Johann Zarco (FRA)	KTM	+33.372s
16	Hafizh Syahrin (MYS)	Tech3 KTM	+35.545s
17	Andrea Iannone (ITA)	Aprilia	+38.238s
R	Maverick Vinales (ESP)	Yamaha	24 laps-accident
R	Franco Morbidelli (ITA)	Petronas Yamaha	24 laps-accident
R	Joan Mir (ESP)	Suzuki	21 laps-rear tyre
R	Tito Rabat (ESP)	Avintia Ducati	15 laps-accident
R	Karel Abraham (CZE)	Avintia Ducati	14 laps-accident

WEEKEND WINNERS

MOTO2 RIO HONDO
Lorenzo Baldassarri
Kalex
Pons Racing

MOTO3 RIO HONDO
Jaume Masia (below)
KTM
Bester Capital Dubai

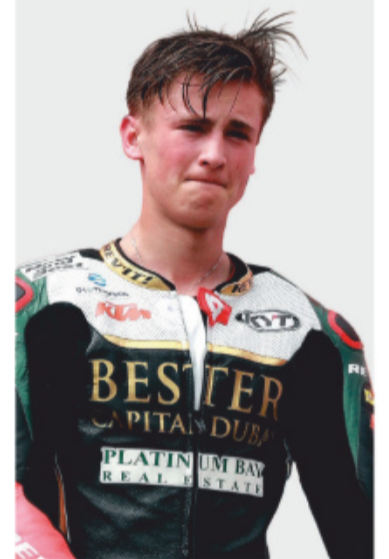

Winner's average speed 107.348mph. **Fastest lap** Marquez 1m39.426s, 108.127mph.

QUALIFYING 2 1 Marquez 1m38.304s; 2 Vinales 1m38.458s; 3 Dovizioso 1m38.468s; 4 Rossi 1m38.545s; 5 Miller 1m38.548s; 6 Morbidelli 1m38.886s; 7 Quartararo 1m38.897s; 8 Crutchlow 1m38.955s; 9 Nakagami 1m39.038s; 10 Petrucci 1m39.093s; 11 P Espargaro 1m39.489s; 12 Lorenzo 1m39.520s.

QUALIFYING 1 1 Nakagami 1m39.064s; 2 P Espargaro 1m39.217s; 3 A Espargaro 1m39.288s; 4 Oliveira 1m39.298s; 5 Abraham 1m39.331s; 6 Rins 1m39.384s; 7 Bagnaia 1m39.387s; 8 Zarco 1m39.571s; 9 Mir 1m39.605s; 10 Rabat 1m39.978s; 11 Syahrin 1m40.053s; 12 Iannone 1m40.118s.

RIDERS' CHAMPIONSHIP 1 Marquez 45; 2 Dovizioso 41; 3 Rossi 31; 4 Rins 24; 5 Petrucci 20; 6 Crutchlow 19; 7 Nakagami 16; 8 Miller 13; 9 A Espargaro 13; 10 P Espargaro 10; 11 Vinales 9; 12 Quartararo 8; 13 Mir 8; 14 Lorenzo 7; 15 Oliveira 5; 16 Morbidelli 5; 17 Iannone 2; 18 Bagnaia 2; 19 Zarco 2; 20 Syahrin 0; 21 Abraham 0; 22 Rabat 0.

MANUFACTURERS' CHAMPIONSHIP 1 Honda 45; 2 Ducati 41; 3 Yamaha 31; 4 Suzuki 24; 5 Aprilia 13; 6 KTM 10.



dominates

Cal Crutchlow was less fortunate, as the Briton's race was ruined when he was handed a ridethrough for jumping the start. It was a penalty that left him utterly fuming, with new stewards' panel chairman Freddie Spencer the chief target of Crutchlow's fire.

Crutchlow was adamant any movement prior to the red lights going out was just a result of him balancing the bike on his toe, not any power being applied. But the stewards didn't see it that way, and he was left to recover from last place to 13th.

"I don't believe they would have given this penalty to Marc or Vale [Rossi], Dovi or someone like that," said an irate Crutchlow.

He was left one place behind fellow Honda rider Jorge Lorenzo, whose second race weekend for the Japanese manufacturer was almost as eventful as his first.

Suffering the effects of his Qatar crashes, Lorenzo qualified 12th, dropped to last after accidentally engaging the pit limiter, and then had to battle a disintegrating rubber grip on his left handlebar as he fought his way back into the points.

Tech3 KTM rookie Miguel Oliveira scored his first haul of MotoGP points in 11th – four places clear of works rider Johann Zarco, whose struggles to adapt to his new machinery look set to last.

Oliveira was only second-best of the rookie crop, however, as Petronas Yamaha rider Fabio Quartararo put his Qatar nightmare behind him to come home eighth.

JAMIE KLEIN



THE ULTIMATE (LAST-MINUTE) DRIVING MACHINE

WSR has just about got its new BMW 330i M Sport contenders to the races for this weekend's BTCC opener. How long before the new car gets on the pace?

MATT JAMES

PHOTOGRAPHY JEP 

The modern-day British Touring Car Championship is all about the fractions. As races are settled by ever-smaller margins, it's the tiniest detail that makes the biggest difference. So jumping into a new season with a brand-new car is a huge ask for any team, and that's exactly the position WSR finds itself in for 2019.

Reigning champion Colin Turkington, along with team-mates Andrew Jordan and new recruit Tom Oliphant, will take to the Brands Hatch Indy Circuit this weekend in the BMW 330i M Sport, which has been turned around in record time by the team to replace the successful 125i M Sport. The trio of saloon-shaped cars ran faultlessly at the championship's media day at the Kent track last week, and the drivers are bubbling with enthusiasm.

It has been a mammoth programme for the title-winning team. Although the decision was taken to swap to the 3 Series in October last year, the road version of the car wasn't due in the showrooms until early March this year. Getting hold of the bodyshells as soon as possible was crucial, and the boffins set to work on computers

to pull together the designs. The work was undertaken by Colin Turkington's departing engineer Kevin Berry, Andrew Jordan's engineer John Waterman and ex-Arena International and Triple Eight Racing man Simon Cumberpatch.

"I think, by the end of the programme, we will have done more than 320 drawings of different components and things," says team boss Dick Bennetts. "The only way we could hit the ground with the project was to use CAD and we've relied on that. It's been an interesting programme and we've not carried over anything from the 1 Series. It has been a blank sheet of paper. In an ideal world, you would need five to six months to do it properly, but we'll only have had the cars on track for two days before the opening round."

The desire to switch to the booted version of the car was driven by BMW, and it's a consequence of being a manufacturer-assisted team. While that provides a certain amount of access to extra support, it also means that the product on the circuits has to be current, although WSR agreed that the 330 had a strong basis for a good touring car.



➔ P80 SUPPORTS PREVIEW



All three cars were ready for the media day at Brands Hatch

TIMELINE OF THE BMW 330i M SPORT

DATE	PROGRESS
1 October 2018	Green light given to go with the 3 Series
29 November 2018	Three bodyshells arrive at WSR HQ
3 December 2018	First bodyshell ready for dipping
12 December 2018	Tom Oliphant joins WSR for 2019
13 December 2018	Second bodyshell ready for dipping
17 December 2018	First bodyshell to Willie Poole Motorsport to fit WSR-designed rollcage, bracket removal, tubbing, etc
Mid-December-February	CAD work undertaken by three design engineers at WSR
4 January	Colin Turkington re-signs with the team
9 January	Andrew Jordan confirms he will remain with WSR
8 February	First bodyshell arrives back at WSR
22 February	Second bodyshell arrives back at WSR from Willie Poole Motorsport
28 February	Bodyshells one and two go to paint shops
4 March	First bodyshell back from paint shop
5 March	Second bodyshell back from paint shop
14 March	Third shell back from paint shop
27 March	Three cars rolled out for media day at Brands Hatch
6-7 April	Competition debut at Brands Hatch

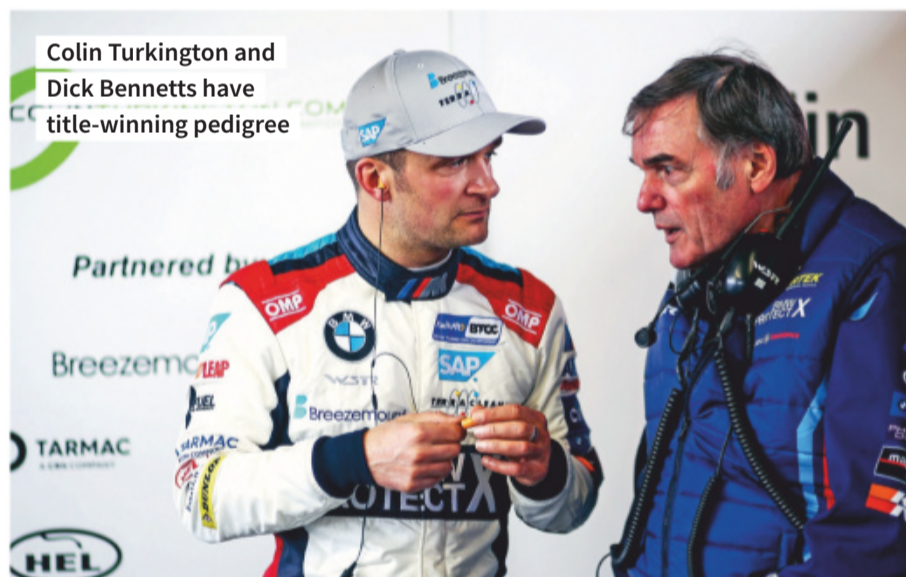

Colin Turkington and Dick Bennetts have title-winning pedigree

“We want to deliver the goods,” says Bennetts. “I think that’s something that runs through the team whether we’re manufacturer assisted or not. We want to deliver for our sponsors, drivers and for ourselves, but the BTCC is getting tougher and tougher.”

“The new car will have some pluses in areas, but maybe some minuses in others. The strengths will be the aerodynamics: it should be very good. We’ve always struggled with top speed with the 1 Series and that’s because of its hatchback shape. When you check the coefficient of drag factor of all the cars around, the new G20 3 Series is one of, if not *the* best of the current road cars used in the BTCC. It’s interesting that Tom Ingram and Speedworks Motorsport are switching from the Toyota Avensis, which was one of the most aerodynamic cars around last year, to a hatchback car with the Corolla [see page 46]. We’re going in the other direction with a booted car.”

The initial impressions of the BMW have been very positive. Turkington is very happy with the looks of his 2019 mount, which he calls a “proper touring car”, and was enthused by the

testing he has managed so far. “I’m just so proud of the job that WSR has done to get three cars ready for the media day test session and they all ran faultlessly,” says the Northern Irishman. “I was pleased with my initial pace, particularly as we had formulated a base set-up pretty much from where the 1 Series was at the end of 2018 and it seemed to work. I would not say I’m happy with the set-up just yet, and we won’t know our ultimate pace until Brands Hatch this weekend, but we are in the ballpark.”

His Pirtek-backed team-mate Jordan is also delighted with the way the rear-wheel-drive car behaved out of the box.

“I was intrigued to see how it would feel because it has a longer wheelbase than the 1 Series,” he explains. “It was more friendly to drive, more comfortable. That allows you to take advantage of the car a bit – you can take some liberties behind the wheel. It will bite you in the end, but we haven’t gone that far. We’re starting in a good place although we have under-tested from where we would like to be at, so we’ll have to go to this weekend being humble and targeting some good points finishes.”



TOYOTA'S PUSH TO TAKE ON HONDA AND BMW

Tom Ingram and Speedworks have become one of the top privateer combinations in recent years. Now they have earned the right to be a factory-supported team

MATT KEW

Watching last season's British Touring Car Championship runner-up Tom Ingram fight the oversteer through Surtees during the pre-season test day at Brands Hatch, you'd be forgiven for reminiscing about Toyota GB's spectacular and crowd-pleasing past exploits in the series.

The marque enjoyed success with Win Percy's 1982 title before Chris Hodgetts doubled up in 1986 and 1987 – three crowns won while quite frequently on two wheels with the Corollas. Half a decade on and into the Super Touring era, and the Carinas were too frequently on zero wheels or in the barriers for the liking of Toyota GB's top brass.

Now, a quarter of a century after Murray Walker's famed "the car upside down is a Toyota" quip, Speedworks Motorsport has brought Toyota GB and the Corolla name back to the BTCC grid, hard on the heels of taking its long-serving Avensis to back-to-back independent teams' crowns over the past two seasons.

Speedworks had campaigned the Avensis since its debut BTCC season in 2011, so it's on a steep learning curve to allow Ingram to fight for the crown as Toyota GB will now compete alongside

Honda, Subaru, BMW and Vauxhall for the manufacturers' spoils. A one-car entry makes it almost impossible for Toyota GB to beat the other makes in the standings, but there's still a real buzz.

"I certainly don't think we'll be in bad shape," says team principal Christian Dick. "It's the BTCC at the end of the day so anything can happen. But I firmly believe that if we can go and score good points in those first couple of rounds then there's absolutely no reason why we can't be fighting for the title at the end of the year."

The team got the green light for the project heading into the penultimate round of last season at Silverstone in September, and that's left little time to reflect on the progress Speedworks has made since its part-time and points-free 2011. "Every now and again, I'll sit there and lift the team's heads up because we've been absolutely flat-out all winter," Dick continues. "But every now and again, we've sat down and gone, 'Crikey, we've come a long way. It's amazing'... much further than we could ever imagine."

That busy winter was spent with Ingram's engineer Spencer Aldridge leading the CAD and windtunnel development. The Corolla's front axle is positioned well back, making it less than ideal for placing the engine as low in the chassis as possible.

INGRAM ON WHO HE THINKS ARE THE DRIVERS TO BEAT

THREE TITLE CHALLENGERS TO WATCH OUT FOR

COLIN TURKINGTON

The reigning champion

“WSR has a new car for this season but, very much like us, it has a lot of proper people involved in the team. It might struggle for the first race weekend from a lack of testing, but by the time we get to Donington Park and Thruxton, WSR is going to be there. Turkington is a class act so he’s definitely going to be one to watch and tough to beat.”



ASH SUTTON

2017 title winner

“Team BMR always seems to struggle at the start of the year but conveniently comes good at some point. You never really know what’s going on with that team. There’s not been a huge amount of development done on the Subaru Levorg visually, or that we know of, so that’ll be an interesting one. Sutton is a real driver and will be very quick.”



DAN CAMMISH

10th in 2018

“Team Dynamics has had a year to develop the FK8 Honda Civic Type R, so it’ll be strong. Building on his debut BTCC season, Cammish is probably going to be a little bit ahead of Matt Neal again, but I think both will come straight out of the blocks at Brands Hatch and will be looking to qualify on pole again and win the first race.”



But a curvaceous rear means better aerodynamics than might be expected for a conventional hatchback.

Ingram was sixth fastest in the test, setting a best time of 48.191s compared to Sam Tordoff’s 47.927s benchmark in the AmD Tuning FK2-generation Honda Civic Type R. Prior to Tordoff’s run, Ingram had held the BTCC standard for the Brands Hatch Indy layout at 47.990s – set in qualifying for the 2016 season opener. There’s time to extract from the new car, but 25-year-old Ingram is confident of laying down his winning credentials ahead of his sixth season in the championship.

“It definitely feels like a step forward [from the Avensis], so we’re hopeful going into the season that we’re going to be the one pushing for the championship the whole way,” he says. “We feel like we’re on top of the car already. We’ve gone through a test programme very methodically to make sure we understand the car rather than just throwing tyres at it and saying, ‘Let’s see how fast we can go.’”

As is always the way, the full picture won’t be revealed until the season gets under way at the Kent circuit across 6-7 April. “The lap time we did was not yet reflective of our true pace,” Ingram says. “We know we’ve got more to come, which is a good place to be. We’ve been able to see the pace of the others and where they are – it’s about where we’re expecting it to be, which is good because it means we’re not a long way away.”

“It was fairly loose today. We’ve got a very quick car – we just need to get the balance and the feeling of it exactly how we want. She was fighting me a couple of times, which is all good fun.”

It’s entertaining watching a driver apply opposite lock, if not ideal for ultimate pace. But fine-tuning the set-up is all part of the process. “That’s part of the beauty,” Ingram says. “We have to learn these little traits of the car, find out what makes it tick.”

Given that Team Dynamics has had a year to harness the FK8 Civic and West Surrey Racing’s all-new BMW 330i M Sport looks quick out of the box, that learning needs to be hard and fast for the nine-time race winner to add to his tally. ❄️

INGRAM’S CLIMB UP THE BTCC TABLE			
SEASON	WINS	PODIUMS	CHAMPIONSHIP POSITION
2014	0	0	14th
2015	0	2	13th
2016	2	4	10th
2017	4	5	3rd
2018	3	6	2nd

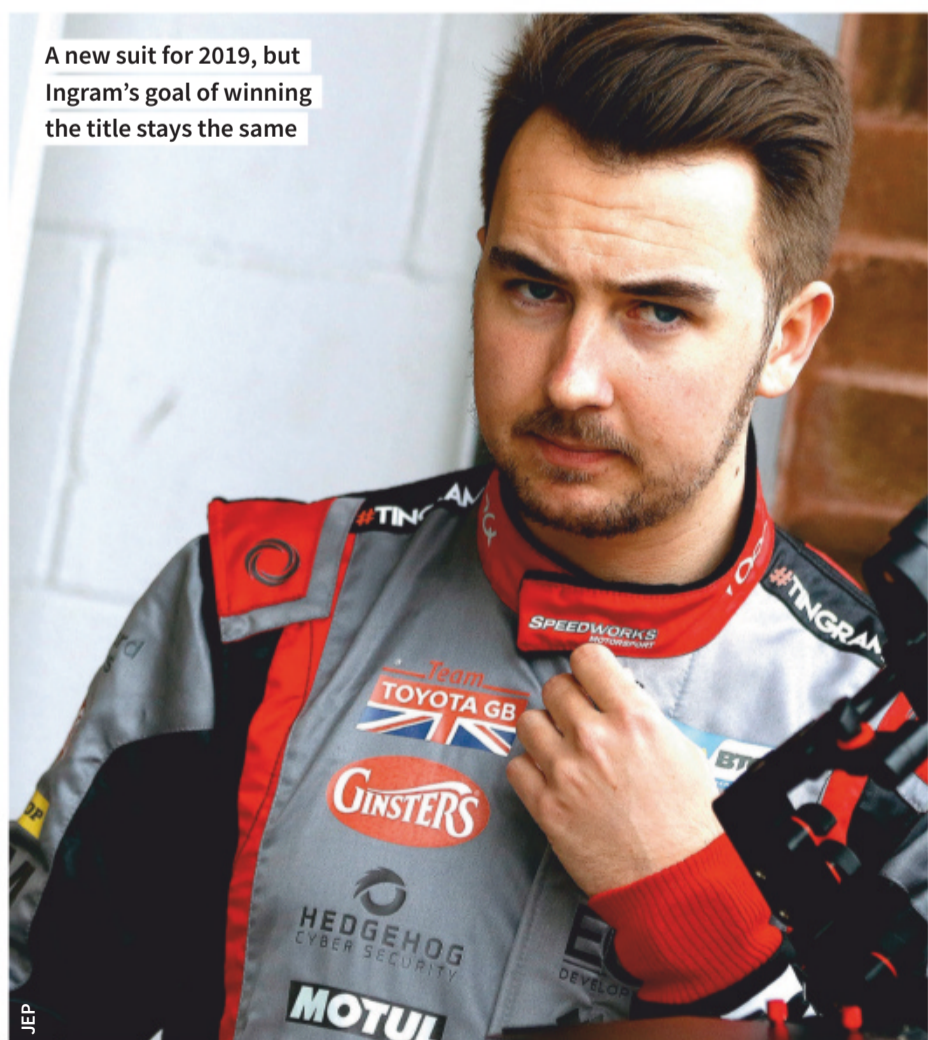

A new suit for 2019, but Ingram’s goal of winning the title stays the same



BTCC
SEASON
PREVIEW

EIGHT THINGS TO WATCH IN 2019

As ever, there will be plenty going on in the BTCC and many subplots to keep an eye on. Here are our picks for the season ahead

MATT JAMES

PHOTOGRAPHY JEP 

AmD TUNING'S SWITCH TO RAPID HONDA CIVICS

Sam Tordoff has a particular reason for wanting to get behind the controls of the new AmD Tuning Honda Civic Type R this year.

He will pilot one of the crew's FK2 models (above) alongside Rory Butcher. "I got beaten to the title by one of these cars, so I know how good it is," says 29-year-old Tordoff, who was then driving a BMW 125i M Sport.

He finished second to the works Team Dynamics Honda of Gordon Shedden in 2016. "I spent some time

looking at the back of it during that season," adds Tordoff. "I know it's one of the finest, and most well-developed, chassis on the grid and I've always wanted to drive one. This whole deal made perfect sense for me and, from my initial running, it's everything I hoped it would be."

The Hondas, which are the ex-Eurotech Racing machines from 2018, became available after the last round of the season and AmD Tuning picked them straight up,

before heading back to base in West Thurrock for a full stripdown and rebuild.

Because Eurotech is no longer in the championship, AmD Tuning got access to everything from the cars – which isn't always the case when a squad offloads its equipment to another...

Both Butcher and Tordoff have tested extensively throughout the UK ahead of the new competition, including the unusual step of running at Knockhill, which is owned by Butcher's father

Derek. That also brings another important family connection: Butcher is the brother-in-law of Shedden, Tordoff's former tormentor and someone with huge knowledge of the FK2, and who now races in the World Touring Car Cup.

"We would be daft not to tap into that resource," says Tordoff, who was a race winner in 2018 at the wheel of a Motorbase Performance Ford Focus RS. "I'm not expecting him to tell us everything: just a few handy

pointers would be good."

Butcher has even more reason to hope for assistance given his connections, but Shedden has said that he isn't prepared to put everything on a plate for his family member – he'd rather Mrs Sheds's little brother continues to learn his trade.

Butcher and Tordoff have built a strong rapport and this is going to help Shaun Hollamby's AmD team as it aims to climb the BTCC order from being top 10 challengers to regular winners.

MARK BLUNDELL JOINS THE TIN-TOP TRAIL

With no tin-top experience to speak of, and hardly any mileage in a front-wheel-drive car, Mark Blundell's decision to join the BTCC for 2019 looks like an odd one.

But he is determined to get the most from it that he can. It's an itch he has wanted to scratch for several years, and he's now in a place to make it happen.

The deal with Trade Price Cars Racing to race one of its Audi S3s, with backing from blue-chip firm HP, was tied up in February, but Blundell's busy work schedule means that he will only have had four days of running before the competition begins this weekend. He knows it will be a baptism of fire.

"I know how tough this championship is," he says. "I just want to be able to walk away with my head held high knowing I've given it everything I can. That's the goal, although once I have the crash helmet on the determination



will take over, I'm sure."

The 1992 Le Mans 24 Hours winner and 61-time Formula 1 grand prix starter (above) will line up alongside one of the category's rising stars, Jake Hill, and that will prove a good barometer for how he's performing in the initial stages of the season. Hill's experience will be vital to start with.

"I know there's a lot to get my head around, but with Jake, and the expertise of AmD Tuning [which is the engineering bedrock behind the programme], I think we can get the most from it we can," adds Blundell. "Everyone is raring to go and I want to start this new chapter in my career."



How quickly will Blundell get up to speed?



BTC RACING'S LOFTY AMBITIONS

There is a real sense of expectation surrounding the BTC Racing programme this year, and the reasons are plentiful.

Not only has the crew retained 2018 race winner Chris Smiley, but it has also recruited Josh Cook, one of the BTCC's most promising talents. There has been fresh investment in the team from former Hot Rod racer and businessman Steve Dudman, and it has moved to a new purpose-built workshop in Brackley.

And, perhaps most crucially of all, it now has its hands on the works-spec Honda Civic Type R FK8s, the same as those run by factory operation Team Dynamics, and it has the

bespoke Honda engines too. Dynamics will provide technical support.

"The chance to tie up with Dynamics and run the FK8s was one that I simply couldn't turn down," says joint team principal Bert Taylor.

"We're starting the year with real ambitions to win the Independents' title and if we can be in the hunt for that, who knows where that can take us?"

"We have a proven race-winning car, two race-winning drivers and a brilliant alliance with Team Dynamics. These are exciting times for BTC Racing because we think we are ready to step up to the next level."

JASON PLATO RETURNS TO VAUXHALL

Power Maxed Racing took a stride last year and was a regular race winner with its works-blessed Vauxhall Astra. Now, with Jason Plato and Rob Collard at the controls, it has further building blocks in place to step forward again to become a title challenger.

There is the romantic element of Plato's return to the British marque, with which he took his maiden title back in 2001. But this switch is not about finding an idyll, this is about winning. He has said that is his goal this year, particularly as he has the landmark of 100 BTCC career victories to aim for.

The reasons for his dire time over the past few seasons at Team BMR Subaru are well buried right now,

with neither party wanting to talk about it. But the Plato who has emerged is certainly no less of a driver and he genuinely has a spring in his step.

He can look forward to a season where he is likely to flick a metaphorical V-sign to those who doubted him – be they fans or some within the paddock.

“Even from the first test with Power Maxed Racing, there has been a positive feeling about this deal,” says Plato. “I know many of the guys who were at [his previous Vauxhall and MG team] Triple Eight Racing, and they know how I work and I know how they work.

“It's a great little car and we'll only unlock more from it as the year goes on.”



DAN CAMMISH AND HIS 'DIFFICULT SECOND ALBUM'

ITV4 pundit and former BTCC race winner Paul O'Neill said last year that he thought a driver in the series “gets their first year for free in terms of their reputation”.

That's true for Dan Cammish – but with a caveat. The Team Dynamics Honda Civic Type R driver was firmly in the spotlight as a rookie, replacing the outgoing three-time title winner Gordon

Shedden alongside Matt Neal. There were some frustrations, but he signed off the season with back-to-back victories at Brands Hatch and he expects further progress in 2019.

Cammish says he has no greater expectations than those he puts on himself: “I have reset for 2019. I can't hide behind being a rookie anymore. But I have always had pressure to

perform, because I haven't had massive budgets. In lower formulas, I had to get results straight away.

“I want to win the championship in 2019 – if not, I'll take second to my team-mate! The speed wasn't in doubt at the end of last year but I had a schooling of hard knocks. Now I've experienced those, I know I can go forward and improve even more.”



NIC HAMILTON MAKES HIS RETURN

The brother of five-time F1 world champion Lewis Hamilton is re-entering the BTCC with Motorbase Performance, and knows he has a lot to learn.

Nic Hamilton has only made 12 starts in the BTCC during a brief cameo in an AmD Tuning Audi S3 in 2015, with limited racing since then in the Renault UK Clio Cup. But Motorbase is a great place to learn and he will have two highly experienced team-mates in Tom Chilton, third in the 2018 points, and

new recruit Ollie Jackson in the sister Ford Focus cars.

Hamilton has cerebral palsy and that means the effort he has to put in to handle his specially adapted race car is huge, and it often leaves him in a lot of pain. On a Monday after an event, he will be at the osteopath having ribs “popped back in” and various parts of his body realigned after a punishing weekend on track. There is no questioning Hamilton's determination to realise his racing dreams.



THRUXTON DOUBLE PLUS THE NEW TYRE AND BALLAST RULES

There has been a small tweak to the BTCC calendar for this season that's meant some significant changes to the tyre rules.

Now that Rockingham is off the calendar and there is a second visit to Thruxton instead, the use of the joker – or 'option' – tyre has been revamped. Thruxton is not included in the allocation of joker tyres because all competitors are required to run the harder rubber on the abrasive surface in Hampshire.

The most significant change comes in the three races at Snetterton, where drivers must

use the soft, medium and hard compound across the three races, and they don't have to nominate before qualifying, as is usually the case. They can decide which tyre to use moments before the races, but can only use each once.

There is also a decrease in the success ballast levels to reflect the increased competition in the championship. For 2019 the weight will be reduced from 75kg to 54kg for the leading runner, and will drop in increments of 6kg down to 9kg for ninth place. Tenth place will also earn 9kg.

ADAM MORGAN'S RENEWED MERCEDES CHALLENGE

Adam Morgan and Ciceley Motorsport have become something of a fixture in the BTCC. The seven-time race winner has often started a season well, but trailed off through a mixture of factors, but he is determined that this year will be different.

Back at base, the team has been through the Mercedes A-Class with a fine-tooth comb, and efforts have been made to strip as much weight as possible out of the most compliant chassis on the grid. That will enable the team to 'place' weight where

it wants on the chassis and make some handling gains.

"We've worked through a comprehensive testing schedule and we've done some detailed simulation work to try to understand the set-ups more," says Morgan. "We will try some radical things in testing and I'm sure we'll unlock some more pace from the car."

Morgan will be joined in a second Ciceley Racing Mercedes by Renault UK Clio Cup graduate Daniel Rowbottom in what will be an important season for the Lancastrian crew.

ENTRY LIST

NO	DRIVER	TEAM (CAR)
1	Colin Turkington	WSR (BMW 330i M Sport)
15	Tom Oliphant	WSR (BMW 330i M Sport)
77	Andrew Jordan	WSR (BMW 330i M Sport)
3	Tom Chilton	Motorbase Performance (Ford Focus RS)
28	Nic Hamilton	Motorbase Performance (Ford Focus RS)
48	Ollie Jackson	Motorbase Performance (Ford Focus RS)
4	Sam Osborne	Excelr8 Motorsport (MG6 GT)
37	Rob Smith	Excelr8 Motorsport (MG6 GT)
6	Rory Butcher	AmD Tuning (Honda Civic Type R FK2)
600	Sam Tordoff	AmD Tuning (Honda Civic Type R FK2)
8	Mark Blundell	Trade Price Cars Racing (Audi S3)
24	Jake Hill	Trade Price Cars Racing (Audi S3)
9	Rob Collard	Power Maxed Racing (Vauxhall Astra)
11	Jason Plato	Power Maxed Racing (Vauxhall Astra)
12	Stephen Jelley	Team Parker Racing (BMW 125i M Sport)
16	Aiden Moffat	Laser Tools Racing (Mercedes A-Class)
18	Senna Proctor	BMR Racing (Subaru Levorg GT)
116	Ash Sutton	BMR Racing (Subaru Levorg GT)
19	Bobby Thompson	Team Hard (Volkswagen CC)
31	Jack Goff	Team Hard (Volkswagen CC)
41	Carl Boardley	Team Hard (Volkswagen CC)
777	Michael Crees	Team Hard (Volkswagen CC)
22	Chris Smiley	BTC Racing (Honda Civic Type R FK8)
66	Josh Cook	BTC Racing (Honda Civic Type R FK8)
25	Matt Neal	Team Dynamics (Honda Civic Type R FK8)
27	Dan Cammish	Team Dynamics (Honda Civic Type R FK8)
32	Daniel Rowbottom	Ciceley Motorsport (Mercedes A-Class)
33	Adam Morgan	Ciceley Motorsport (Mercedes A-Class)
80	Tom Ingram	Speedworks Motorsport (Toyota Corolla)
303	Matt Simpson	Simpson Racing (Honda Civic Type R FK2)

CALENDAR

DATE	VENUE
7 April	Brands Hatch Indy
28 April	Donington Park National
19 May	Thruxton
16 June	Croft
30 June	Oulton Park Island
4 August	Snetterton 300
18 August	Thruxton
15 September	Knockhill
29 September	Silverstone National
13 October	Brands Hatch Grand Prix

NEXT WEEK

BRANDS BTCC REPORT 11 APRIL ISSUE

We'll be at Brands Hatch to bring you all the news and insights from the season opener. Can Ingram win a race at the Kent venue for the fourth consecutive year?



THE WORLD TOURING CARS GHOSTBUSTER

Tiago Monteiro says he felt like a ghost after his horrific 2017 testing crash. Now he's back and ready to attack the WTCR crown with Honda

JACK COZENS

After more than a year on the sidelines, Tiago Monteiro still didn't know if he'd be capable of returning to racing last autumn. But then, when you look at what his body had been through, that wasn't the biggest of surprises.

The concise nature of Honda's original statement reporting Monteiro's World Touring Car Championship testing crash at Barcelona in September 2017, the result of a brake failure on his Civic TC1 car while attempting to decelerate at the end of the kilometre-long main straight, indicated that the impact was a significant one, as did further (far between) updates on his recovery. But the list of the injuries he suffered is enough to send a shiver down the spine when laid out plain.

Pitched backwards into the barriers at close to 160mph, Monteiro was left with – among other things – two broken vertebrae, blood clots on the brain, a twisted knee and a dislocated shoulder. Worst of all was the fact that both eyes effectively popped out in the impact, stretching his nerves as a result.

With the benefit of hindsight, statements released before each of the final four rounds of the 2017 WTCC season confirming that his return to competition had been delayed seem nothing short of the patently obvious – as though optimism from both Honda and Monteiro would be enough to nullify the consequences of his injuries. In reality, there was a huge mountain to climb for a driver who felt “like a ghost” when he first went home.

“It actually looks a bit stupid to think that I could have come back in 2017 when you look at how long it [his recovery] took,” says

Monteiro, who could perhaps be forgiven for trying to expedite his return given that he was leading the WTCC standings before the accident. “What the f*** were we thinking? But then again, I think it was kind of intentional from the doctors and from my entourage to actually keep me motivated. It has to be – I asked the question. I think they were using that to keep me motivated, because it was clear there was no way I was going to come back so early.

“But also at the same time there were a lot of unknowns – even then they didn't know if I was going to recover and how long it would take. It could have taken a few months, it could have taken five years – some of them said that, some of them said never. It's such a random and difficult thing – it's not like when you break something, you know it's going to take a month or whatever. These are neurological issues and maybe the brain cannot make a connection anymore with the eyes and I'm like this forever. It's impossible to be sure.”

Progress was slow at first, but Monteiro was fit enough to return to the WTCC paddock in Qatar two and a half months later, to watch team-mate Norbert Michelisz miss out on the drivers' title to Volvo's Thed Bjork. Come the new year, the Portuguese was fit to test again and, by February, had been announced as a Honda driver for the inaugural World Touring Car Cup season run to TCR regulations. But then he was forced to put his comeback on hold – indefinitely this time, with no target date set for his return.

Monteiro was still short of an initial projected recovery window of 11 to 12 months prescribed by FIA concussion doctors in Cambridge when his home WTCR round in Vila Real came around, although missing that was a blessing in disguise given the frightening shunt that wiped out 40% of the 27-car field at the start of the opening race. So, with the WTCR on hiatus for two months following July's Slovakia Ring round, Monteiro was then scheduled to make his comeback in a Honda NSX GT3 at the Spa 24 Hours the following month. But again, doctors intervened.

“I did three or four days of testing in the car, it went very good, I felt ready,” says Monteiro of his Spa preparations. “But then we didn't get the sign-off, for some reason. It was there, but again the doctors were like, ‘Do you really need to do that now? If you can hold off, we think it's better.’ There was nothing wrong, it's just that process – it's always there.”

But it's the hope that gets you and, despite having come so far in his recovery, doubts once again crept into Monteiro's mind about the viability of a comeback, although he ultimately proved too stubborn to let those win out. “Again in August, I woke up a few times thinking that I should stop. ‘What's the point? What >>



Monteiro tests his new car at Barcelona – the site of his 2017 crash

GUILLAUMOT/DPP

ENTRY LIST

NO	DRIVER	TEAM (CAR)
1	Gabriele Tarquini (ITA)	BRC Squadra Corse (Hyundai i30 N TCR)
5	Norbert Michelisz (HUN)	BRC Squadra Corse (Hyundai i30 N TCR)
8	Augusto Farfus (BRA)	BRC Racing Team (Hyundai i30 N TCR)
88	Nicky Catsburg (NLD)	BRC Racing Team (Hyundai i30 N TCR)
9	Attila Tassi (HUN)	KCMG (Honda Civic Type R TCR)
18	Tiago Monteiro (PRT)	KCMG (Honda Civic Type R TCR)
29	Nestor Girolami (ARG)	Munnich Motorsport (Honda Civic Type R TCR)
86	Esteban Guerrieri (ARG)	Munnich Motorsport (Honda Civic Type R TCR)
10	Niels Langeveld (NLD)	Comtoy Racing (Audi RS3 LMS)
22	Frederic Vervisch (BEL)	Comtoy Racing (Audi RS3 LMS)
52	Gordon Shedden (GBR)	WRT (Audi RS3 LMS)
69	Jean-Karl Vernay (FRA)	WRT (Audi RS3 LMS)
21	Aurelien Panis (FRA)	Comtoy Racing (Cupra TCR)
50	Tom Coronel (NLD)	Comtoy Racing (Cupra TCR)
37	Daniel Haglof (SWE)	PWR Racing (Cupra TCR)
96	Mikel Azcona (ESP)	PWR Racing (Cupra TCR)
11	Theo Bjork (SWE)	Cyan Racing (Lynk & Co 03 TCR)
100	Yvan Muller (FRA)	Cyan Racing (Lynk & Co 03 TCR)
68	Yann Ehrlacher (FRA)	Cyan Performance (Lynk & Co 03 TCR)
111	Andy Priaulx (GBR)	Cyan Performance (Lynk & Co 03 TCR)
12	Rob Huff (GBR)	SLR VW Motorsport (Volkswagen Golf GTI TCR)
25	Mehdi Bennani (MAR)	SLR VW Motorsport (Volkswagen Golf GTI TCR)
14	Johan Kristoffersson (SWE)	SLR (Volkswagen Golf GTI TCR)
33	Benjamin Leuchter (DEU)	SLR (Volkswagen Golf GTI TCR)
31	Kevin Ceccon (ITA)	Team Mulsanne (Alfa Romeo Giulietta TCR)
55	Ma Qing Hua (CHN)	Team Mulsanne (Alfa Romeo Giulietta TCR)



CALENDAR

DATE	VENUE
6-7 April	Marrakech (MAR)
27-28 April	Hungaroring (HUN)
10-12 May	Slovakia Ring (SVK)
18-19 May	Zandvoort (NLD)
21-22 June	Nurburgring (DEU)
6-7 July	Vila Real (PRT)
14-15 September	Ningbo (CHN)
26-27 October	Suzuka (JPN)
16-17 November	Macau (CHN)
15 December	Sepang (MYS)

NEXT WEEK

MARRAKECH REPORT
11 APRIL ISSUE
 Gabriele Tarquini kicks off his championship defence in Morocco. Can the series' old guard remain at the top of the tree?



do I need to do? What am I going to do?," he says. "And then, again, the next day I thought, 'F*** it, I'm still a racer'. This is still what I like the most – to drive, to have these pressures, this adrenalin, these stresses and problems which we hate so much when we're there but that I was missing so much. In the end, that part won and I said, 'No, I still have it in me, I still want it'"

And so, come October's Suzuka round, the time was finally right. Monteiro headed down the pitlane at 9am local time, flanked by a guard of honour from fellow WTCR drivers, and out onto the track. It would not be a weekend of notable results – at least as far as the record books are concerned – but Monteiro made rapid progress throughout the weekend, finishing on the fringes of the top 10, less than a second shy of the points, come the final race.

"I felt good – honestly like as though I hadn't stopped for more than you do over winter, when you come back in the car. Sometimes it's a bit strange feelings, and that's what it felt like," he says. "I had a bit of a lack of rhythm on Friday, getting to know the car, back in the rhythm, but I improved all the time and gained confidence with myself and the car."

"More than anything I realised that there are no consequences of my accident. Not psychologically – I didn't think about it once, I never thought, 'Are the brakes there?' or tried to push too hard. Nor physically – there were no issues with my vision, my reactions in my brain. I was not normal before and I'm not better now, but it didn't get worse. It [the result] doesn't matter – the fact is I was there and I was close enough to actually say I'm back racing. I was happy with that."

But the story doesn't end there. While that long road to recovery hit an emotional crescendo at Suzuka, it wasn't as though that was one last hurrah for the one-time Formula 1 podium finisher. It was the first step towards what Monteiro hopes will be a return to the sharp end of World Touring Cars – starting this weekend with the opening round of the 2019 season in Marrakech.

Monteiro's return to the international stage is still being greeted by rounds of applause from his peers, who have by no means underestimated his determination and bravery. But Monteiro is aware that it won't be as simple as picking up where he left off, when he was 12 points clear at the head of the WTCC field back in the autumn of 2017. Not least given the radical technical changes – from high-tech cars and hefty manufacturer budgets to something closer to cup-spec machinery – that the series underwent during his layoff. And there are no works teams, so Monteiro is driving for the customer KCMG squad rather than the factory JAS operation of old.

"It does feel different," says Monteiro of the series. "One of the things Gabriele [Tarquini, the reigning WTCR champion] said to me last year, when I was discussing my potential comeback, that stands out from what a lot of people said is, 'Don't forget you're not coming back in the same championship'."

"It's not the same world at all. It's not the same team, the



Monteiro received a warm welcome back at last year's Suzuka round

MARIN/DPPI

same car, the same championship, the same rules. It's still a touring car, it's Eurosport promotion, but apart from that there are a lot of important changes. I led the championship being in one of the two best teams – it was Volvo and us [Honda] fighting each other. I was leading the championship, I was very confident with one team, and now I'm starting from zero. OK, I have a lot of people in the team I know, the car I sort of know, but I haven't developed this car while I had developed the other car, so there are a lot of different situations."

WTCR's self-coined 2019 'supergrid' boasts six FIA world champions, among whom Monteiro would likely stand had it not been for his accident. The challenge of adding his name to that list is undoubtedly a far greater one in World Touring Cars' customer-racing era than during the comparatively limp final year of TC1, and may well be one that Monteiro never conquers. But even if that does prove to be the case, making it back this far is a victory he has every right to be proud of. 🏆

SWEDES LEAD INFLUX OF TALENT

There is a distinctively Swedish theme among the incomers for the 2019 WTCR season, with two 'new' teams and two new drivers hailing from the Scandinavian nation.

Cyan Racing has dropped its incognito status after a year running customer Hyundai i30 Ns under the banner of Yvan Muller's YMR squad, in which it won the teams' title. Now it will debut the new Lynk & Co 03 (bottom, left), giving the Chinese make – part of the Geely group that owns the squad's former partner

Volvo – a foothold in the championship for the first time. Cyan has retained the services of World Touring Car champions Thed Bjork and Muller, with Muller's talented nephew Yann Ehrlacher jumping ship from Honda outfit Munnich Motorsport and three-time WTCC champion Andy Priaulx joining during the off-season.

The car has a much longer wheelbase than the Hyundai, but 2017 WTCC champion Bjork believes victories are a realistic aim this season. "It's a big

challenge for us in the first year, but I feel as though we definitely want to win more races and go for the title – but it will not be easy," says Bjork.

Another driver eyeing victories will be double World Rallycross champion Johan Kristoffersson (below, left). The Swede, who added a second Scandinavian Touring Car title in 2018, joins Rob Huff, Mehdi Bennani and TCR Germany graduate Benjamin Leuchter at Sebastien Loeb Racing in a Volkswagen Golf GTI – continuing his

association with VW.

Kristoffersson's two nearest STCC challengers last year were both from PWR Racing, which this season also makes its first international foray with a pair of Cupras for the experienced Daniel Haglof and TCR Europe champion Mikel Azcona (bottom, right). Spaniard Azcona, who showcased a remarkable level of consistency to beat WRT's Jean-Karl Vernay to the title, is keen to make his mark on the world stage.

Another of Azcona's TCR

Europe adversaries, Hungarian Attila Tassi, also makes the jump up to WTCR with KCMG's team of Hondas, where he will partner Tiago Monteiro. Teenager Tassi pushed Vernay close for the TCR International title in 2017 and raced as a wildcard in WTCR at his home round last year.

Completing the rookie drivers this year is Dutchman Niels Langeveld (below, right), who partners Frederic Vervisch at Comtoy Racing in an Audi RS3 LMS.

STEPHEN BRUNSDON



BONILLA/DPPI



BONILLA/DPPI



GUILLAUMOT/DPPI



BONILLA/DPPI

**GOODWOOD
EVENTS**

**6-7 APRIL
MEMBERS' MEETING**

**4-7 JULY
FESTIVAL OF SPEED**

**13-15 SEPTEMBER
REVIVAL**

Gerry Marshall Trophy
races guarantee armfuls
of sideways entertainment

10 REASONS TO GO TO GOODWOOD'S 77TH MEMBERS' MEETING

*The first big meeting of Goodwood's season takes place this weekend.
Here's what makes it special, plus the highlights to look out for*

MARCUS PYE

Members' Meeting memories, 1949-66

The public events on Easter Monday, Whit Monday and the big Nine Hours and Tourist Trophy sportscar enduros drew legions of fans to the Goodwood Motor Circuit to watch their heroes. For amateur competitors and aspiring pro racers though, the 71 Members' Meetings were the way in. They weren't flash, but from 1949 provided British Automobile Racing Club subscribers with a chance to learn racing's ropes. Most drove road cars with family, partners or a mechanic pal for support, but specialised track cars increasingly became the norm. Lotus owners – including marque founder Colin Chapman – won 129 races.

By the time the circuit closed on 2 July 1966, future Formula 1 world champions Mike Hawthorn and Jim Clark, F5000 king Peter Gethin and Le Mans winners Richard Attwood and Derek Bell (right) were among the stars who had emerged victorious, then excelled on the international stage. For thousands of weekend warriors, though, to have raced at Goodwood in its heyday remains a coveted badge of honour.

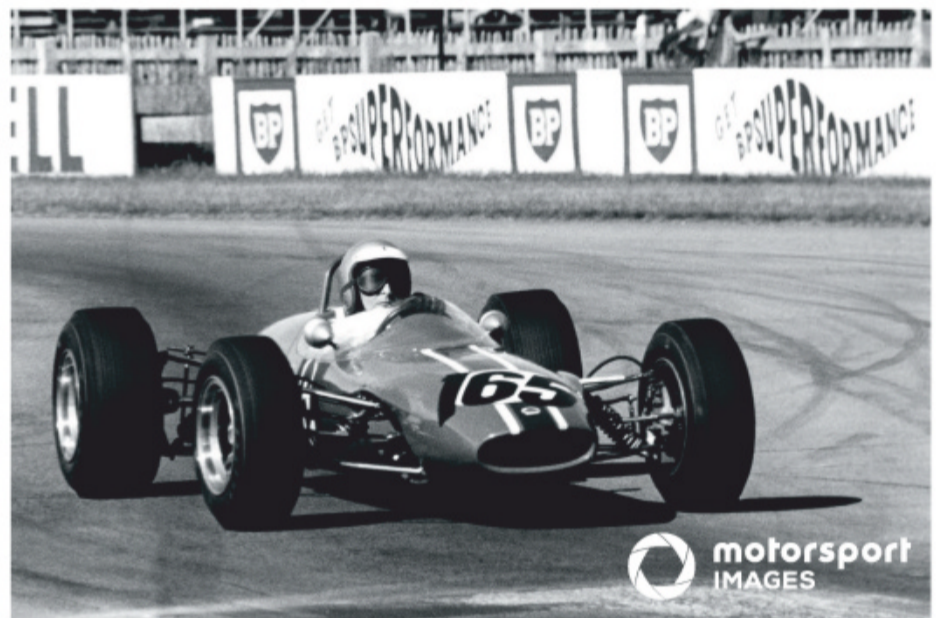

Goodwood, a circuit of delights

At 2.4 miles, with a devilishly tricky off-camber left-handed bend at St Mary's on the opposite side to the pits, preceded by a crucially important right approached at very high speed from the long Fordwater kink, Goodwood has always presented a challenge demanding drivers' respect. Thruxton, to which the BARC moved after its closure, is every bit as daunting.

Unspoiled, and unchanged since the installation of the chicane between Woodcote corner (left) – one of three differently demanding double-apex right turns – and the pits, the layout only gives the most confident and able drivers moments to breathe and relax.

Maximising corner speeds through Madgwick, Lavant and Woodcote demands the art of four-wheel drifting in cars with treaded tyres and more power than grip. Watching at any part of a track is a treat, so if you've not bought grandstand seats, do try a variety of vantage points. You may return home with a new favourite.

BARC's roots in Brooklands bolides

The British Automobile Racing Club is rooted in Brooklands, and two races evoke racing's most glamorous era at the Surrey speedbowl.

In Bentley's centenary year, 10 examples grace a new race for vintage sportscars, honouring Canadian John Duff, winner of the 1922 Brooklands Double-Twelve (driving solo!) and the 1924 Le Mans 24 Hours, sharing his three-litre Bentley with Frank Clement. Alvis, Aston Martin, Frazer Nash, Lagonda, Lea Francis, Riley, Sunbeam Talbot and Vauxhall all add to the home guard. Bugatti and Mercedes-Benz provide stout opposition.

The SF Edge Trophy race for Edwardian specials of the pre-1923 era is always a crowd-pleaser. Will 2017 victor Mathias Sielecki's prowess be rewarded again, this time in a 107-year-old five-litre Bugatti T16? Julian Majzub (Sunbeam Indianapolis) heads the opposition in a pack starring Duncan Pittaway's thunderous Fiat S76.



Gaze Trophy honours circuit inspirer

Freddie March, 1931 Brooklands Double-Twelve winner in an MG, was already a motorsport fan. It was decorated Australian fighter pilot Tony Gaze, however, who – having seen it from above in 1941 – convinced the Duke that the perimeter road of the Westhampnett airfield on his estate would make a fine race circuit after the Royal Air Force had vacated it.

Gaze inspired a brighter new chapter in its history from September 1948. The able racer's name is thus given to the race for road-going sports and GT cars of a type raced between 1954 and 1959 on this weekend's bill that brings a wide variety of cars redolent of early Members' Meetings into battle, including AC Aces and Triumph TRs.

David Coulthard will enjoy the IWC Mercedes-Benz 300SL 'gullwing' among the exotica, including Ferrari 250 GT Tour de France and Maserati 3500GT. Whether anything can outrun Rich Woolmer's Healey or the Lotus 7 of previous Goodwood single-seater winner Sam Wilson remains to be seen, though.



Mini champs invade Goodwood estate

Guaranteed to provide the weekend's most frenetic racing, Saturday's heats for Sir Alec Issigonis's pocket rockets – in pre-1966 Cooper S guise – decide Sunday's Betty Richmond Trophy Mini finalists. In a field packed with national champions, Mark Burnett's newly built wood-panelled Countryman ("the Goodwood Estate") will attract most attention.

Forty years after Patrick Watts won the Mini Se7en title (then for 850cc cars), he and successors Jonathan Lewis, Bill Sollis, Tina Cooper and (from its later 1000cc era) Kane Astin will not be making up numbers. Nor will Miglia champs Ian Curley or, since 1275cc engines superseded one-litres, Endaf Owens. Sollis and Astin triumphed in both series.

BMC A Series tuning king Nick Swift is the Mini benchmark. He's gunning for gold, as are Aston Martin ace Darren Turner and second-generation Mini man and former FIA Historic F1 champion Nick Padmore, Goodwood's outright 'modern era' lap record holder in a snarling Lola T70 Spyder.

TIMETABLE

SATURDAY 6 APRIL

0730	Gates open
1000-1210	Practice
1225	Grid walk
1250	NASCAR high-speed demonstration
1315-1420	Practice
1435	Porsche 917 high-speed demonstration
1445-1630	Practice
1645	BMW Procar high-speed demonstration
1715	Race 1 Betty Richmond Trophy Minis
1755	R2 Betty Richmond Trophy Minis
1835	R3 Gerry Marshall Trophy for Group 1 saloons 1970-82
1940	Le Mans Prototypes high-speed demonstration

SUNDAY 7 APRIL

0730	Gates open
0900	R4 Parnell Cup for GP and Voiturette cars 1935-53
0940	R5 Derek Bell Cup 1000cc F3 1964-70
1020	R6 Sheene Trophy motorcycles up to 1972
1055	Porsche 917 high-speed demonstration
1115	R7 Tony Gaze Trophy Sports/GT cars 1954-59
1150	Grid walk
1210	Le Mans Prototypes high-speed demonstration
1240	R8 John Duff Trophy for sportscars up to 1930
1320	R9 Graham Hill Trophy GT Cars 1960-64
1420	BMW Procar high-speed demonstration
1450	R10 Gerry Marshall Trophy for Group 1 saloons 1970-82
1520	R11 SF Edge Trophy pre-1923 cars
1600	R12 Betty Richmond Trophy Minis Final
1635	NASCAR high-speed demonstration
1710	R14 Gurney Cup Sports Prototypes 1960-64
1750	R15 Peter Collins Trophy Sports Racing Cars 1948-55



Le Mans heroes top touring car class

Six Le Mans winners – Tom Kristensen (above), Emanuele Pirro, Romain Dumas, Richard Attwood, Jochen Mass and Guy Smith – star in the Gerry Marshall Trophy races for the Group 1 saloons of 1970-82. Four Chevrolet Camaros head the entry, with Kristensen in Grant Reid's ex-Henny Hemmes Eumig car on its UK debut. Pirro drives David Clark's and Steve Soper shares John Young's early version. Dumas is in Bill Shepherd's Ford Mustang Boss 302, a sister to Craig Davies' Frank Gardner evocation. Mass saddles a Rover 3500 SD1, 1996 Monaco GP winner Olivier Panis another, and Smith pilots a Triumph Dolomite Sprint.

Tiff Needell and Anthony Reid have switched horses, to Toyota Corolla GT and Mini 1275GT respectively. Tom Blomqvist takes BTCC-bound Mark Blundell's place in Kerry Michael's Ford Escort RS2000, while Gregor Marshall co-drives a Triplex Capri in the event honouring his father.

Screaming and slipstreaming in F3

Local hero Derek Bell won on his race debut at Goodwood at the 60th Members' Meeting in 1964, and took the chequered flag here thrice subsequently in 1000cc F3 Lotus 31 and 41, thus the five-time Le Mans winner's name is immortalised on the cup for the 'screamers', introduced in 2015.

This year's cosmopolitan field is the most competitive yet, with reigning UK double champion Jon Milicevic – last year's Goodwood winner – trying to match his old sparring partner Andrew Hibberd's previous brace of victories. Both drive beautifully prepared Brabhams in a field showcasing eight marques, including Tecno and De Sanctis from Italy.

American veteran James King, who used his vast experience to rob Simon Armer of gold following a safety car lull in the 73rd MM, is back in Tony Mantle's Chevron B17, and Armer returns in his Petonyer March 703. Jonathon Hughes (Merlyn) is another fancied runner, but the dark horse is Ben Mitchell in period Goodwood racer Robs Lamplough's Brabham BT28.

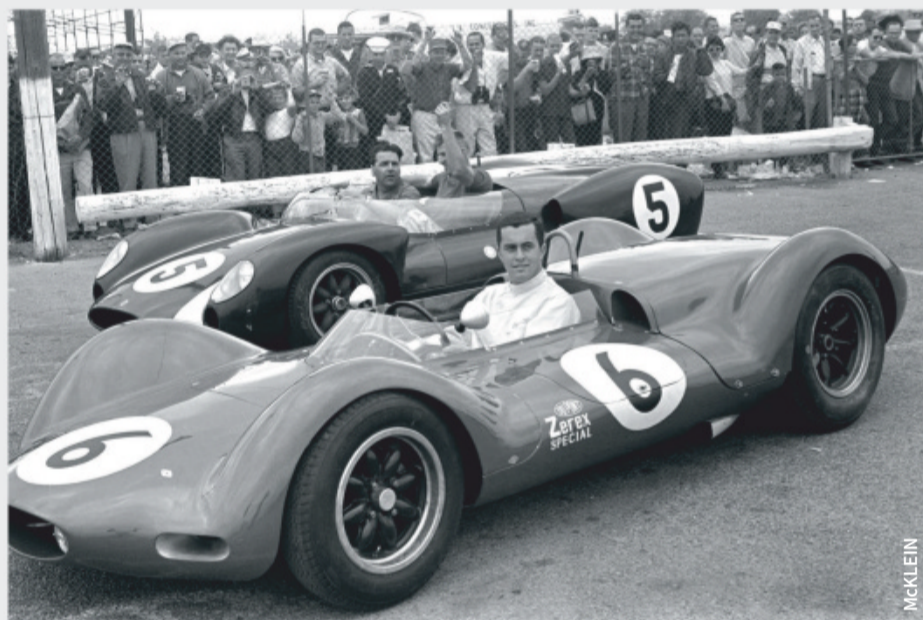

Gurney Cup prototype master-blasters

The fastest cars on the racecard will again be the late-model sports-prototypes, but setting the bar at 1964 has deliberately excluded the ultra-rapid Lola T70s and McLaren M1Bs and Cs this time round, to open up the competition and give it a fresh look.

A battle between American V8-engined sluggers, sublime Porsches and agile small-bore British lightweights is anticipated. A quartet of Ford GT40s take on McLaren M1As, Keith Ahlers' Cooper-Ford T61 'King Cobra' and Craig Dolby saddling the Lotus-Oldsmobile 19 evocation in which Rob Huff has previously won. But don't be surprised if Chris Goodwin (Lotus 23B) and Mark Owen (Elva-BMW 7S) live with them.

An unknown quantity is American Greg Heacock's Penske Zerex Special, a recent replica of the car Roger Penske raced in 1962 (left), which makes its Goodwood debut. Another curiosity is Rainer Peukert's eponymous special created by expat Briton Fred Davies in the US in the early 1960s.

No limits on (BMW) M1 motorway

Initially supporting European F1 grands prix, BMW's Procar Championship was the most sensational one-make series in history. Brainchild of the firm's motorsport boss Jochen Neerpasch, it featured stunning M1 sportscars powered by rampant mid-mounted 3.5-litre straight-six engines developing in excess of 450bhp and capable of 190mph. As a selling tool it was peerless.

The quickest F1 stars piloted a quintet of 'works' machines in 1979, taking on rapid drivers in independent BMW specialists' cars. After winning three times, Niki Lauda lifted the crown, narrowly outpointing Hans-Joachim Stuck having run most of the season in the Marlboro Project Four Racing car. In 1980 Nelson Piquet's late hat-trick in a works car saw him grab the title from F1 champ Alan Jones.

The Group 4 M1s are wondrous to behold. Listen for the engines' shrill induction roar under acceleration and prime your camera for spectacular flame-outs from exhausts on overrun into the corners. Pure magic.



Porsche 917, LMP and NASCAR demos

High-speed demos bring a change of scenery at the Members' Meeting. Few cars are as iconic as Porsche's 917 and who better to demo one of the five set to run than the marque's first Le Mans winner Richard Attwood. Neel Jani, victor in 2016's French enduro classic, and nine-time F1 GP winner Mark Webber will also drive. Tom Kristensen and Guy Smith share the 2003-winning Bentley Speed 8, Kristensen and Emanuele Pirro co-pilot an Audi R8, and Nic Minassian drives a 2012 Peugeot 908 HDi FAP in a feast of LMPs.

House captains Kristensen, Jochen Mass, Pirro and Anthony Reid have also landed exciting drives in the NASCAR demonstrations.

AWNINGS



aireshelta
No1 for Inflatable Structures.
With you from the Paddock to the Podium.
www.aireshelta.com

EXHAUSTS

Inconel & Stainless Steel Specialists
SIMPSON
Race Exhausts
Tel: 01753 532222
www.simpsonraceexhausts.com

GEARBOXES

Gearboxman.com
COMPETITION TRANSMISSION SERVICES
Gearboxes & Axles for Road, Race, Rally and more
Telephone: 01582 840008 Fax: 01582 840007

HELMET GRAPHICS

Mike Fairholme Designs
Sole approved painter of Arai helmets.
Silver Birches, Corby Birkholme, Nr Grantham, Lincs NG33 4LE.
Tel: 01476 550630. Fax: 01476 550029.
email: fairholmedesigns@btconnect.com
www.fairholmedesigns.co.uk

MEMORABILIA



FINAL LAP
For Everything Formula One
www.finallap.net **WE BUY AND SELL**
+44 (0) 1245 287588 / 07771 920345

MOTORSPORT LEGAL ADVICE

Motor Sport Legal Advice
Tudor Alexander, L.I.B Solicitor
07887 713512

RACE PARTS

Autoparts and Hydraulics

sales@LMAautoparts.com

Passionate About Motorsport

www.jjcraceandrally.com

ARE DRY SUMP SYSTEMS
ARMSTRONG RACE ENGINEERING INC.
WWW.DRYSUMP.COM (916) 652-5282

RACE RADIO

Pit to Car **Autotel**
Radio solutions **Digital Race Radio**
0044(0)1508 528837
www.raceradio.co.uk

MARDI GRAS MOTORSPORT
www.mardigras.co.uk

www.mcrracecars.co.uk
phone. 07771 762145
MCR's for sale
arrive & drive packages

RACING

PORSCHESHOP
10% off with website
voucher code AUTOTEN
Or Call: 0121 585 6088



demon-tweeks.com

AUTHORISED DISTRIBUTOR
OMP **YB RACING**
MOTORSPORT & PERFORMANCE
WWW.YBRACING.COM

RACING

CARTEK
MOTORSPORT ELECTRONICS

info@cartekmotorsport.com
023 80 457747
www.CARTEKMOTORSPORT.com

GPR Grand Prix Racewear
Silverstone
The best of racewear & kartwear
www.gprdirect.com

KD KENDALL DEVELOPMENTS
3D SCAN - REVERSE ENGINEERING
Tel: 01480 718117 • Track Support • 3D Design
• Track Preparation • Restoration
www.kendall-developments.com

TRAILERS & TRANSPORTERS

Signature RV.co.uk
RV SALES AND SERVICE

BRIAN JAMES TRAILERS
» Connected to you
www.brianjames.co.uk

www.EMPIRE RV.co.uk
Living the high life
Tel: +44 (0) 1761 300 489
www.EmpireRV.co.uk ■ info@EmpireRV.co.uk

WEB DIRECTORY



TO ADVERTISE IN THE WEB DIRECTORY
PLEASE CALL +44 (0) 20 3405 8109
OR EMAIL ads@autosport.com

BRIAN JAMES TRAILERS

»» Connected to you

www.brianjames.co.uk

Style and Substance

Introducing the new Race Transporter 6 by Brian James Trailers. An even more stylish and capable enclosed trailer specifically suited to car transportation.

New features include a standard automatic tilt-operation, invaluable for all professional motorsport or transport operations. An extra side access hatch door provides the ability to easily reach in for securing the standard equipment 'over wheel' strap system.

In addition, many new optional features are now available, all designed to offer the latest technology and improved convenience to all operators.

Race Transporter trailers are available from £ 7,699 + vat

Race Transporters are available ex-stock at many UK dealers. Please visit our website or call us for further details.

**RACE TRANSPORTER 6****T +44 (0)1327 308 833**

For more information and details on the Brian James Trailers range, please contact our head office



HIGH QUALITY TRAILERS
FOR CLUB, PRIVATE AND
PRO MOTORSPORTS

Woodford covered trailers **Superior in design, quality and finish**

TRAILERS & TRANSPORTERS



Woodford Trailers Limited | 14 Great Central Way, Daventry, Woodford Halse, Northants, NN11 3PZ | Telephone 01327 263384

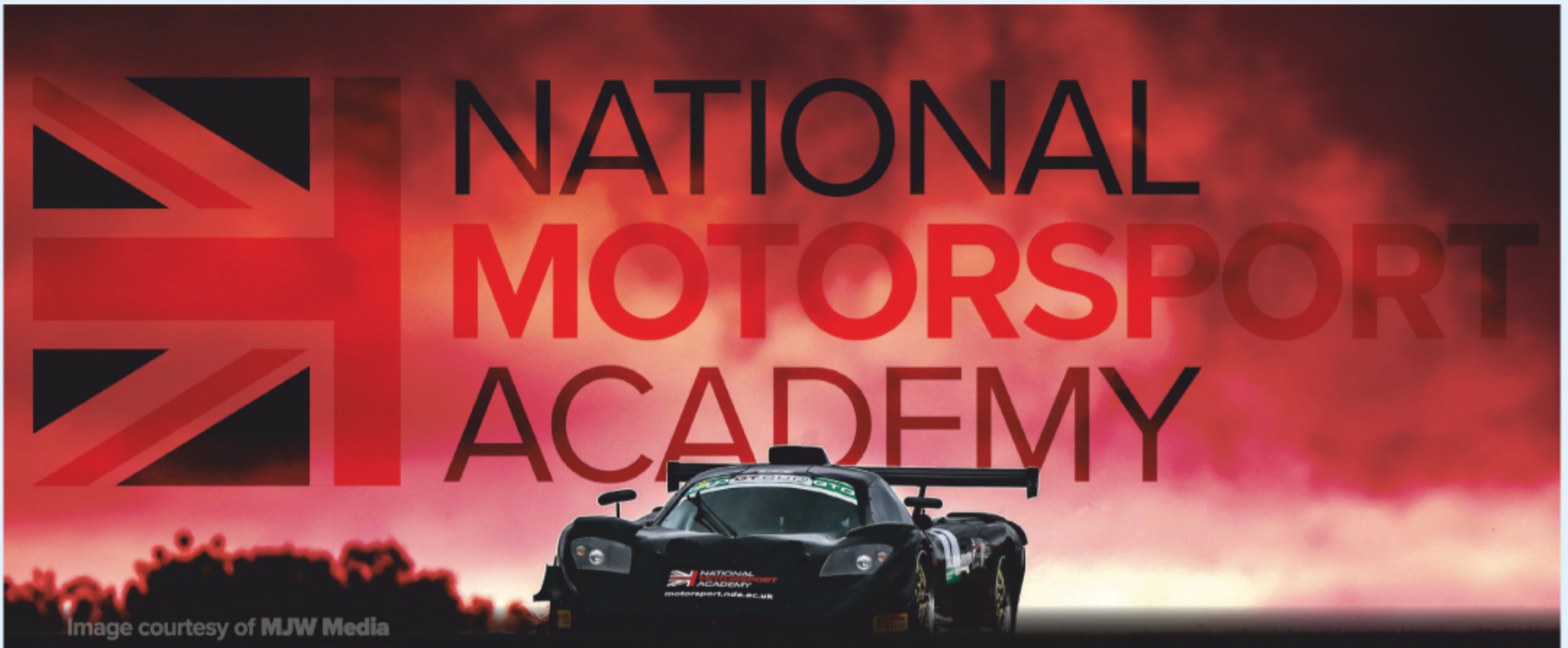

Image courtesy of MJW Media

WORLD'S FIRST **ONLINE** Motorsport Engineering Degrees

BSc ^(Hons) Motorsport Engineering
And Final Year Top-Up*

MSc Advanced
Motorsport Engineering*

**NEW MASTER'S DEGREE
NOW ENROLLING!**

<https://motorsport.nda.ac.uk>



Apply **ONLINE Today!** +44 (0)1159 123456

*All degrees awarded by our Academic partner De Montfort University.

FOR SALE CHAMPIONSHIP WINNING **MOSLER MT900**

Beautifully maintained by the **NMA Team**
Full support is also available for GT Cup,
Britcar, Supercar Challenge etc. at cost

£POA Contact Kevin Riley
07973 675734



MARKETPLACE

MEMORABILIA

F1 COLLECTORS .COM



#1 FOR F1 MEMORABILIA & AUTOGRAPHS

We buy and sell F1 items
AYRTON SENNA specialists

Call CHRIS GRINT

01763 274448

email:- sales@f1collectors.com

AUTOSPORT

If you wish to advertise your products and services with Autosport in print and online please contact

Ben.kavanagh@motorsport.com

or call

+44 (0) 20 3405 8109

WANTED

WANTED

RACE USE
FORMULA 1
SINGLE HELMETS
OR COMPLETE
COLLECTIONS

CONTACT ROB:
07771 920 345
ROB@FINALLAP.NET

RACE PRODUCTS

demon tweeks

EXPERT ADVICE • MASSIVE STOCK • RAPID DELIVERY



LOW RATE 0844 375 2196

demon-tweeks.com

CALLS MAY BE RECORDED FOR TRAINING PURPOSES

RACE PREPARATION

London Motorsport Showroom
www.msar.co.uk



Order Hotline: 020 8655 7877
msar UK agent for SCHRÖTH RACING

Visit Us At Our New Larger Showroom

HOSPITALITY



WWW.BLUEGRASSBILLS.COM
bluegrassbillys@gmail.com
07745145433

Car for sale?

Get in touch with Edward Sanderson
edward.sanderson@motorsport.com
+44 (0)20 3405 8108

AUTOSPORT

THE VOICE OF BRITISH MOTORSPORT
MOTORSPORT NEWS

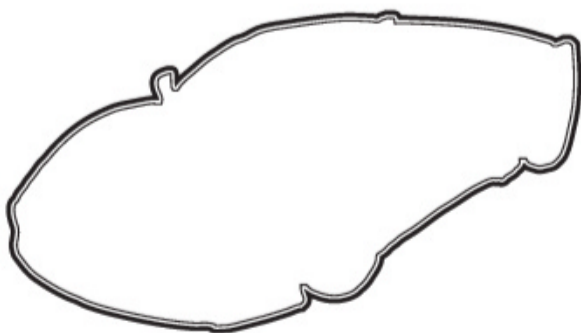

MARKETPLACE

CARS FOR SALE

2 very significant historic F3 cars



1972 Chevron B20, Chassis No. B20-72-1

Unique, sole F3 version of B20 ever built and full history of ownership since new. Works car for Chris Skeaping in 1972. Chris's best result was 3rd at Silverstone 14th May 1972. Winner of Formula 4 & Monoposto Championships in 1977 and 1980 respectively together with Classic F3 Championship in 1995. Raced at Monaco 2010. Price £65,000 to include wets and some spares.



1971 Ensign, Chassis No. 71-3-1

Ex- Steve Thompson Contact 400 car. Car number 2 which was the first production car and was raced by Steve Thompson in 1971. It was 4th at Monaco in 1971 and went on to win at Montlhery the following day. Completely restored with fresh, zero hours Twin Cam. Price £37,500 to include wets and some spares.

Both of these cars are eligible for not only Classic F3 but also Classic Racing Cars and Historic F2 as well as Monaco, so are pretty versatile.

smpdesign@hotmail.co.uk • 07850 539117

AUCTIONS

ONLINE AUCTION

By order of the Joint Administrators Richard Beard, Mark Firmin and Richard Fleming of Alvarez & Marsal Europe LLP re: JD Classics Holdings Limited & JD Classics Limited.

2010 MERCEDES AXOR TRANSPORTER & 2010 ISUZU FORWARD TRANSPORTER

(All Subject to Availability)

2010 Isuzu Forward N75.190 Auto Curtainside Car Transporter; 90,805 recorded miles.



2010 Mercedes Axor 1843LS 6x2 double sleeper cab **chassis fitted Conestoga Type CDS two car race transporter** with office/ twin bunk accommodation and side awning; 270,899 kms recorded; Cherished number excluded from sale.



TO BID VISIT. BidSpotter.co.uk

VIEW. By Appointment Only
AT. Maldon, Essex
BIDDING ENDS.
 Tuesday 30th April 2019, from 3.00pm

CONTACT.

Jenni Pearce | t +44 (0)7788 394 330 | e jpearce@gordonbrothers.com

GORDONBROTHERS.CO.UK

- ✓ VALUATIONS
- ✓ DISPOSITIONS
- ✓ OPERATIONS
- ✓ INVESTMENTS



MEMORABILIA



www.btccblueprints.co.uk

Email: info@btccblueprints.co.uk

Facebook: BTCC Blueprints | Twitter: @BTCCBlueprints

BTCC Blueprints provide high quality renders of various vehicles, specialising in the BTCC. These can be used in multiple forms including posters, stickers, phone cases, t-shirts and more.

Thanks to the support and encouragement of so many people involved with BTCC, we're going to be bringing our products to you with our own stall at each of the 2019 race meetings. We'd love to see you!





Equipe Pre '63

Equipe pre '63 re-creates the vibrant clubman racing of the 50's and early 60's where fantastic classic sports cars can be driven on track by passionate amateur enthusiasts.

Cars run on Dunlop Historic Tyres to FiA appendix K specification. FiA Papers are welcome but not mandatory. Equipe Pre '63 is a series of races and not a championship.

By carefully selecting eligible cars, the series delivers close and exciting racing with an emphasis on competitive yet high driving standards.

With Club Racing at its heart, Equipe Pre '63 is inclusive and social including paddock parties and events.

The 2019 calendar has 8 race weekends including the Silverstone Grand Prix Circuit, Brands Hatch Grand Prix Circuit, Donington and Oulton Park.

Come and join us.



2019 Calendar:

Silverstone (Nat) **March 30**
 Brands Hatch (Indy) **April 27/28**
 Oulton Park (Int) **May 18**
 Silverstone (GP) **June 15/16**

Donington **July 20/21**
 Brands Hatch (GP) **August 3/4**
 Snetterton (300) **August 31**
 Silverstone (Nat) **October 5**

Exclusive Brands Track day – Match 1st

For more information visit: equipeclassicracing.com

EQUIPE
 CLASSIC RACING



MIGHTY MINIS RACING

MIGHTY MINIS RACING IS THE BEST, FOR ALL THE RIGHT REASONS!

Mighty Minis Racing was launched in 1996 with the primary intention of creating an opportunity for individuals to take part in circuit racing at an affordable level, in an effort to make motorsport more accessible and socially inclusive.

- New for 2019, injector and carburettor fuelled 1275 and 1293 Minis
- Fun on and off the circuit.
- The most affordable Mini racing, very easy to build and maintain.

DATES	CIRCUIT
Apr 21/22	Cadwell Park
Jun 1/2	Silverstone
Jun 29/30	Thruxton (Trucks)
Jul 20/21	Brands Hatch (MSV Festival)
Aug 10/11	Donington (Trucks)
Aug 26	Castle Combe
Sept 28/29	Donington
Oct 26	Oulton Park



WWW.MIGHTYMINIS.CO.UK
 @mightyminis mightyminisracing
 or contact Rodger on +44 (0)7850 883303 / rodger@mightyminis.co.uk



BMWCCR

BMW Car Club Racing

BMWcup

BMW Car Club Racing Events 2019

Trackdays are open to all makes and models and non members

22 April (Mon)	Donington Park GP (Race)
23 April (Tue)	Cadwell Park (Trackday)
27 May (Mon)	Castle Combe (Race)
22 June (Sat)	Silverstone National (Race TBC)
6 July (Sat)	Brands Hatch (Race) Deutsche Fest
12 July (Fri) (Sat E)	Castle Combe (Trackday)
10 August (Sat)	Silverstone International (Race)
11 August (Sun)	BMW Festival (Event) Gaydon
14 September (Sat)	Oulton Park (Race)
30 September (Mon)	Snetterton 300 (Trackday)
13 October (Sun)	Snetterton 300 (Race)
26 October (Sat)	Birkett 6hr Team Relay
	Silverstone GP (Relay Race - 4 teams)
1 & 2 November (Sat/Sun)	Motorsportdays Live Show Silverstone (Event)
8 Nov (Fri)	Oulton Park (Trackday)



750 BILSTEIN Eibach STI Redbox Global KRAFTWERK MRF TYRES

www.bmwclubgb.co.uk /BMWCCR @BMWCCR

16 RACES • 8 CIRCUITS • 3 CLASSES • 1 CHAMPION FOLLOW US



2019 ALFA ROMEO CHAMPIONSHIP



DATE	CIRCUIT	ABOUT THE CHAMPIONSHIP
23/24 MARCH	BRANDS HATCH	In 2019 the BRSCC Alfa Romeo Championship will be running for the 38th consecutive year. We place great value on our distinguished racing heritage but we are also a forward looking Championship, constantly moving with the times to ensure we provide close, exciting and high quality racing for drivers and spectators alike.
20/21 APRIL	SNETTERTON 300	
11/12 MAY	CADWELL PARK	
6/7 JULY	CROFT	
18 AUGUST	BRANDS HATCH	
14 SEPTEMBER	MALLORY PARK	
5/6 OCTOBER	SILVERSTONE INT	
19/20 OCTOBER	DONINGTON PARK	

BRSCC Black'n'Rounds YOKOHAMA JURATELLO

ALFARACER.COM



THE RACER

Pit talk from the HRDC

ARE YOU READY FOR A GREAT SEASON WITH THE HRDC?



SO LET'S GET STARTED AT SILVERSTONE!

HRDC 'COYS TROPHY' FOR TOURING CARS 1958 – 1966
 HRDC 'ALLSTARS' FOR PRE-'66 SPORTS, GT & TOURING CARS
 HRDC 'CLASSIC ALFA CHALLENGE' FOR SPORTS, GT & TOURING CARS

SILVERSTONE 14th APRIL 2019

COMPETITION ENQUIRIES: JULIUS THURGOOD 07850 361159 • direct@juliusthurgood.co.uk • www.hrdc.eu

JOIN THE BEST TEAM IN HISTORIC RACING TODAY!





RECRUITMENT
DRIVEN BY
PASSION



MOTORSPORT JOBS

Find your dream job

Here at Autosport we've been helping people find great jobs in motorsport for over 60 years. Today we're launching a new global motorsport jobs site, where you can:

- Find the latest jobs in motorsport
- Apply for a job with just one click
- Upload your CV and let recruiters find you
- Set up job alerts - don't miss out on your dream move

Register at motorsportjobs.com today 

motorsport
NETWORK

Motorsport Jobs
- A Motorsport
Network Company



Ferrari represents the pinnacle of racing excellence, innovation and performance. Ferrari is a team, working together to improve and reach our objectives.

We are looking for individuals capable of working with a structured framework, capable of multi-tasking, practical and proactive. For this challenging environment we are looking for candidates who are precise, agile and with excellent communication and interrelation skills.

Fluency in English is required, spoken Italian is an advantage for your full local integration in Maranello.

Ferrari is an Equal Opportunities Employer.

Visit Ferrari.com for all available positions and information, and to submit your CV details. No agencies, please.

Senior CATIA Support Engineer

Chassis Design & Development Department

Aerodynamicist

Aero Development Department

Vehicle Dynamics Engineer

Simulation Development Engineer

Vehicle Performance Department

corporate.ferrari.com/en/career



Vehicle Dynamics Engineer (Driver-in-Loop Simulator Development)

Williams Grand Prix Engineering is seeking a talented and enthusiastic Vehicle Dynamics Engineer to join our Vehicle Dynamics Team, supporting the development of the driver-in-loop (DIL) simulator.

The key purpose of the role is to develop the hardware and software systems of the DIL Simulator to continually advance the capability and effectiveness of this facility, and to support its operation, maintenance and application to our car development programme.

Applicants will have a good degree in Engineering or a related discipline. Previous experience in simulation, vehicle dynamics or control systems would be advantageous but is not essential.

Reporting to the DIL Team Leader, you will contribute to the simulator development strategy, and assist with the identification, prioritisation and management of upgrade programmes. As a member of the Vehicle Dynamics Department, you will also support various projects across the entire team as may be required.

You will need to be able to work with an open and flexible approach whilst achieving outcomes on accuracy and quality. You will have a practical engineering background and good interpersonal skills at all levels. You will be comfortable managing others, e.g. student projects or other external collaborations to help maintain an inclusive and dynamic working environment.

To apply now visit www.motorsportjobs.com



Vehicle Dynamics Engineer (Tyre Modelling)

Williams Grand Prix Engineering is seeking a talented and enthusiastic Vehicle Dynamics Engineer to join our Vehicle Dynamics Team, developing tyre models and analysis to further our understanding and optimisation of car performance.

The key purpose of the role is to develop tyre models and associated analysis tools, to work with others to integrate them into the Vehicle Dynamics simulation toolset, and to support their use in the optimisation of F1 car performance.

Applicants will have a good degree in Engineering or a related discipline. Previous experience in tyre modelling, simulation or vehicle dynamics would be advantageous but is not essential.

Reporting to the Tyre Science Team Leader, you will contribute to the tyre modelling and performance optimisation strategy, and assist with the identification, prioritisation and management of upgrade programmes. As a member of the Vehicle Dynamics Department, you will also support various projects across the entire team as may be required.

You will need to be able to work with an open and flexible approach whilst achieving outcomes on accuracy and quality. You will have a practical engineering background and good interpersonal skills at all levels. You will be comfortable managing others, e.g. student projects or other external collaborations to help maintain an inclusive and dynamic working environment.

To apply now visit www.motorsportjobs.com



MAZDA PLANNING NEW UK MX-5 Mk4 SERIES

MAZDA MX-5s

Mazda's US arm is aiming to launch a series for its successful one-make MX-5 contender in the UK next season.

Mazda North America, which introduced a spec racer based on the fourth-generation roadster for the Global MX-5 Cup in 2016, is working with sportscar stalwart Ben Devlin on the plan. The Briton, who was part of the Mazda's Stateside prototype programme for 10 years, has been appointed European agent for the car.

"We know it is a tough market, but we are looking at budgets coming in at under £100,000 a season," said Devlin. "Because the car is so light, it is easy on consumables, which keeps the running costs down."

Devlin is expecting that the purchase price of one of the MX-5 racers will be around £50,000 and is working on providing a finance package so that customers can spread the cost across multiple seasons.

Mazda North America racing boss John Doonan explained that he was confident the success of the MX-5 Cup can transfer to the UK.

"We will be offering added value because the

winner will get the chance to race at our end-of-season invitational event, which offers the prize of a full season's racing worth \$200,000 (£150,000)," he said.

A similar prize was offered to the best MX-5 racer in Europe in 2016. British Racing and Sports Car Club MX-5 Championship frontrunner Oliver Allwood raced at the Laguna Seca event after winning a shootout.

Doonan said that he was keeping Mazda UK informed of his plans and raised the prospect of the series securing the backing of the local importer once it has "gained critical mass". Mazda promoted the Mazda MX-5 Cup for the original version of the car in 1990-91.

Devlin's International Track Solutions company already has its first MX-5 Cup racer and has established premises near Snetterton. He is making the car, which took part in last year's Race of Remembrance at Anglesey under the Mission Motorsport banner, available to prospective entrants to test.

Mazda North America has previously backed UK drivers through the Road to Indy scheme, but that came to an end last year.

GARY WATKINS



Harvey and Reynard back to Formula Ford

CLASSIC FF1600

Former British Touring Car star Tim Harvey secured a podium finish at Silverstone last weekend in his first Formula Ford 1600 race for 33 years.

The 1992 BTCC champion qualified fifth and finished fourth in the opening Classic FF1600 race driving a Van Diemen RF81, before taking second in race two.

“I raced an F1 Cooper at the Classic meeting two years ago, but my last serious single-seater race was in British F3000 in 1989, and in Formula Ford it was three years earlier,” Harvey said. “Buying this Van Diemen RF81 took me back to where it all started for me, racing one of these in the Champion of Brands.

“I’ve always had a love for Formula Ford and to come back again now and race against Rick Morris and John Village again, well here we are and it’s still great racing.

“I wasn’t good off the start [of the first race], but the slipstreaming soon reminded what I’d missed these past 30 years.”

Legendary designer Adrian Reynard also

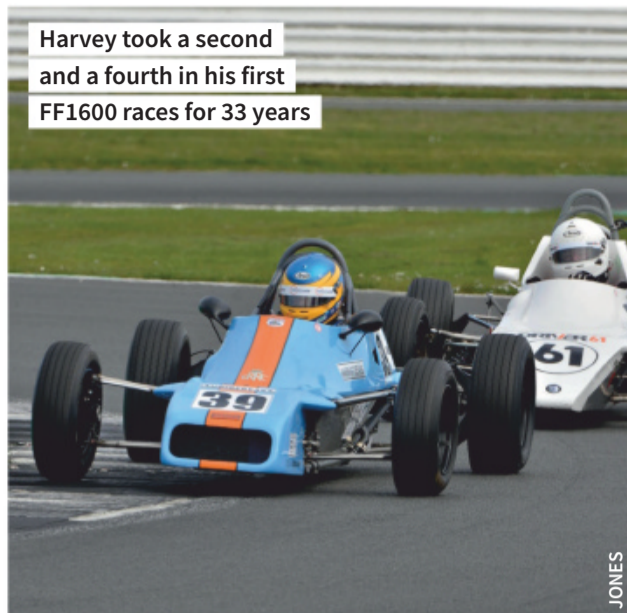

Harvey took a second and a fourth in his first FF1600 races for 33 years

JONES

competed in the Silverstone races, driving his self-built Reynard 73FF.

The car was seventh in the first race and won the Pre-’74 class, only to be excluded on a weight issue in post-race scrutineering.

Having started from the back of the grid in the second race, he had just broken into the top 10 when he slid off at Vale.

“I built it while I was studying at Oxford Poly,” he said. “I spent more time on the car than studies so my grades weren’t so good.

“It was the first car that I built and it took me a year, but I wasn’t interested in keeping cars then, so I sold it to fund the next project – Formula Ford 2000.”

PETER SCHERER

Bushell steps back, Coates joins Britcar

RENAULT UK CLIO CUP

Two-time Renault UK Clio Cup champion Mike Bushell will not make a return to the series this year, while title contender Max Coates will also compete in the Britcar Endurance Championship.

Bushell had been due to drive a Team Hard Volkswagen CC in the British Touring Car Chamionship this season but, when that deal fell through, it was then announced he would drive for the team in the Clio Cup.

But this will not happen and Bushell will instead take a sabbatical from racing this year.

“Following on from losing my BTCC seat for 2019, I have decided to take a break from motorsport due to personal reasons,” he said.

Meanwhile, Coates will drive a SEAT Leon TCR car (below) in Britcar alongside Guy Colclough, after making two appearances last year.

He will now contest the majority of the 2019 Britcar season in the car, except for the Silverstone Grand Prix round later this month, which clashes with his Clio commitments.

The car will this year be prepared by Mazda MX-5 specialist Paul Sheard Racing. The duo took a best result of fourth in class in the season-opening Silverstone races last weekend.

“It’s going to be busy,” said Coates. “It’s always been my plan over the past couple of years to try and do another championship [alongside Clios] – something that is a shared drive and more GT-style racing.”

STEPHEN LICKORISH



Ginetta Junior champion will remain with Elite

JEP motorsport IMAGES

Smalley moves to GT5 Challenge

GINETTA GT5 CHALLENGE

Ginetta Junior champion Adam Smalley has secured a late deal to race in the Ginetta GT5 Challenge this year, laying to rest fears that he would not be competing at all.

Smalley had targeted a move into the Ginetta GT4 Supercup for this year, but struggled to find budget over the winter and has now opted to join the popular GT5 grid, remaining with Elite Motorsport.

“I’m not from a massive money background, and I wouldn’t be racing cars if I hadn’t won the Ginetta scholarship,” Smalley said.

“After the high of winning the championship

you’ve got to move on to the next thing. It wasn’t until probably the last two or three weeks we were getting some more interest from sponsors. I was expecting I probably wouldn’t be racing.

“It’s going to be a challenge but I wouldn’t go into something not aiming for the title. We’ve got a great package underneath us – it’s not a great deal different to the Junior car. It didn’t cross my mind to go with anyone else, it was a no-brainer.”

This will be Elite’s first season in the GT5 category and the team is also running bikes convert Wesley Pearce.

STEPHEN LICKORISH



STYLES



No MG Live in 2019 after Silverstone cancellation

Silverstone resurfacing has forced MG Live cancellation

circuit for the past 68 years. In a statement, MGCC general manager Adam Sloman said: “We are very sorry to be updating everyone with such disappointing news. “The club has been incredibly determined to find an alternative solution for MG Live this year and, sadly, the deeper we have delved into all of the options – different venues, dates, hosting an entertainment-only event – the less feasible putting on MG Live in 2019 has looked. “It has been incredibly challenging to find a venue that has capacity to hold a race and/or entertainment event in the peak of the season, in such a challengingly tight timeframe. We’ve spoken to a number of venues and it has become very clear that moving the entire event at short notice just isn’t possible.” The club says it is now working to introduce a new “international MG meeting” in 2020 instead. As well as the MGCC-run championships, a number of guest series were also due to race at MG Live. One of these, Equipe GTS, has already revealed alternative plans to visit Spa instead.

STEPHEN LICKORISH

MGCC

The MG Car Club has had to cancel its popular MG Live event for 2019 after being unable to find a suitable replacement for its June Silverstone date. MG Live was one of two mid-June club

meetings to be cancelled by Silverstone last month because the facility will be closed while the circuit undergoes resurfacing work. The MGCC worked to try and find a replacement date and venue but was unsuccessful. MG Live and its antecedents had been a fixture at the Northamptonshire

Tributes to long-time BCV8 coordinator McCarthy

MGCC

Tributes were paid at Silverstone’s opening BCV8 race of the 2019 season to the MG Car Club championship’s popular long-time coordinator Pam McCarthy, who died on 5 March.

All BCV8 drivers got out of their cars on the grid before the race, assembling at the front for a minute’s silence, and the cars also had stickers in McCarthy’s memory.

“It’s really sad news, a massive shock for all of us. We are, as a championship, all mourning it a little bit at the moment,” said BCV8 chairman James Wheeler.

“But the key thing is to try to keep going, keep strong and enjoy it, because if she’s looking down at us she’ll want the championship to be as successful as it’s always been and I’m still carrying on to do that, to make sure that’s happening. So we’re looking forward to the season, and all racing for Pam.”

McCarthy was also the wife of BCV8 racer and champion Roy, as well as the mother of BCV8 drivers Russell and Spencer. “All of them were always frontrunners – if you could beat a McCarthy you knew you were doing well!” Wheeler added.

GRAHAM KEILLOH



BCV8 competitors gather on the grid in McCarthy tribute

Comprehensive motorsport insurance products to keep you on track;

- ✔ Accident damage On Track
- ✔ Rally damage On Event
- ✔ Storage and Transit
- ✔ Liability
- ✔ Personal Accident
- ✔ Track day

Log on to www.ryanmi.com to obtain your online quote
 Email – info@ryanmi.com Tel – +44 (0)1799 524202



Ryan Motorsport Insurance Limited is an appointed representative (557405) of Independent Broking Solutions Limited who are authorised and regulated by the Financial Conduct Authority. Its Financial Services Register number is 312026



A 23-car grid of Minis competed at Silverstone

JONES

Mini Winter Challenge makes a comeback after 16-year hiatus

MINI 7 RACING CLUB

The Mini 7 Racing Club's Winter Challenge returned after a 16-year absence as two races at Silverstone last weekend marked the start of a five-race 2019 competition.

It was last held in 2003 when the winner in the Se7en class was Nick Tandy, who went on to win the 2015 Le Mans 24 Hours with Porsche. The 2019 Winter Challenge will be completed by a three-race November meeting at Brands Hatch.

"It was in response to the rising healthy entries in the main National Challenge," said series coordinator Richard Williamson. "Also we were being offered these extra races at the beginning of the year and the end of the year,

and with the cost of going motor racing it just seemed, 'Well, let's offer something more than just the token run-out or testing session'.

"It's 16 years since we last ran it and just the time seemed right."

A mix of Miglia, Se7en, 7 S-Class and Libre Minis formed the 23-car entry. Drivers included two-time Mini National champion Kane Astin, ex-BTCC racer Jeff Smith and 1993 winter series champion Jon Lee.

"It's really good," said competitor Glen Woodbridge, who was making his Mini debut and is the son of 1996 Se7en Novice champion Paul. "Rather than just having the main championship they've got another one which other people can aim for as well."

GRAHAM KEILLOH

Interest high in new Ferrari series

FERRARI CHALLENGE UK

Organisers of the new Ferrari Challenge UK series believe it will have a 22-car grid for its inaugural season and half the competitors will be new to racing.

The UK series is the latest Ferrari Challenge category for 488 Challenge racing. European, North American and Asia-Pacific versions are already established. It's the first single-country category since the Italian version merged with its European equivalent in 2012.

The British Racing and Sports Car Club-supported UK version will have four meetings this season and organisers are pleased with the interest it has generated.

"We're looking at 22 cars on the grid, they're all owners of a 488 Challenge," said Ferrari North Europe's head of

after-sales Sam Osborne.

"Fifty per cent of the grid will be completely new blood who have owned road cars but not had any race experience whatsoever. So in a way we are bringing a new group of people into the business."

Since the Ferrari Challenge calendar is quite small, GT Cup organiser Bute Motorsport expects a number of Ferrari competitors to join its grid this year.

"We've got a really close relationship with FF Corse and AF Corse [which are running the Ferrari Challenge cars]," said commercial manager Chris Thorn. "It's an attractive offer to them for extra races."

Thorn added that interest in the GT Cup this year has been high from new drivers, as well as existing teams and drivers purchasing new machinery.

GRAHAM KEILLOH & STEPHEN LICKORISH

IN THE HEADLINES

750MC MILES AWARD IS BACK

The John Miles Award, named in honour of the former Formula 1 driver who died last year, will be awarded again in 2019 through the 750 Motor Club. The award will continue to nurture promising up-and-coming talent within the club. The winner will receive a £1000 cash prize, which will be matched by the 750MC with £1000 credit against entry fees for 2020.

WHITELEGG TO SCOTLAND

National Legends frontrunner Steve Whitelegg will make a switch to the Scottish championship for 2019. Whitelegg finished second in the National series last season behind John Mickel, earning a test in the HMS Alfa Romeo Giulietta BTCC car after his best result in the category. His team will be rebranded to Bridgeman Motorsport and the reins handed over to former team-mate Nick Bridgeman this season.

OLD LOTUS FFORD CAR RACES

The oldest car in last weekend's Historic Formula Ford opener at Donington Park, Kit Lawson's 1964-originated Lotus 31, made its first start since being crashed in the early 1970s. Lawson, who last raced a Locost in 2009, finished 23rd. Brother-in-law Michael Grant Peterkin was ninth in the ex-Tony Trimmer Brabham BT21, which his father Martin raced for three years.

WALKER IN RADICAL MOVE

The grandson of Ian Walker – who ran his own Lotus sportscar squad, fielding drivers including Jim Clark and Graham Hill – will switch to the Radical SR1 Cup for his second season of racing. Mackenzie Walker, 23, made his debut in the Lotus Cup UK before a one-off Radical outing at the end of last year. His father Sean was a British Touring Car and British Formula 3 racer.



READ



HISTORICS The Dealer Team Vauxhall Firenza affectionately known as 'Old Nail' is to be auctioned by Bonhams at the Goodwood Members' Meeting this weekend. Gerry Marshall won the 1972 Special Saloon Car Championship with the car and then took class honours over the next two years. The 2.2-litre machine clocked "at least" 59 victories during its competitive life and remained with the Marshall family until 2011 before being bought by its current owner. It carries a pre-sale estimate of £90,000 to £130,000.

Designer reunited with Pandora



Phillips (r) completed laps in the Pandora car

HISTORICS

The unique 'Pandora powered by Austin' sports-racing car debuted by Raymond Jackson at Goodwood in 1964 was reunited with its designer Roger Phillips, now 77, at the circuit last month before it contests Easter Monday's GRRC Sprint there.

Owner Andy Prill bought the car as an unrecognisable project from Alastair Brown in Scotland a decade ago. Following a period of contemplation and research he "got stuck in" and resurrected Pandora over seven or eight years.

"The most difficult thing was recreating the [alloy] body, which had been lost," said classic Porsche specialist Prill. "Thankfully, through a contact at Nissan's International

Design Centre in London, we were able to scan period photographs, digitise the results and make new formers."

The BMC A Series-engined car, built by Phillips, the late Michael Homer and skilled welder Tony Cowell – initially in motor dealer HR Jackson's workshop, then in a lock-up garage belonging to a lady named Pandora at Selsey – performed promisingly.

Phillips donned a period racesuit to turn the clocks back 55 years when he enjoyed a short session in the car.

"Repeated head gasket problems meant that I practiced, but never raced, Pandora before I emigrated to the Bahamas, so this was a very special occasion thanks to Andy," said Phillips, who plans to attend the sprint.

MARCUS PYE

Le Mans-style start for Bentley race

VSCC

A Le Mans-style start will be used in the UK for the first time in more than 50 years when the Vintage Sports-Car Club uses the format for a race celebrating 100 years of Bentley at Silverstone next weekend.

A grid of 40 vintage Bentleys will contest the Benjafields 100 Race, and the sport's governing body, Motorsport UK, has sanctioned it to start with the drivers running across the track and jumping into their cars before leaving the grid.

The two-driver race will be preceded by a grid walk.

The meeting also includes the first Historic Grand Prix Cars Association double-header of the season, with several new car/driver combinations. The Bentleys will return to the circuit at July's Silverstone Classic.

PAUL LAWRENCE & MARCUS PYE



The last great British single-seater grid?

MSA Formula's 2015 grid was bursting with talents who have gone on to prove themselves at the top level. But it might never happen again...

STEPHEN LICKORISH

One qualified a brilliant eighth for their Formula 1 debut. One has become the youngest ever Indycar winner. One is potentially next in line for a Toro Rosso F1 drive and has twice won the Macau Grand Prix. One has shown flashes of speed in Indycar.

Four others were deserving McLaren Autosport BRDC Award finalists, although ultimately defeated. One has won the Formula Ford Festival and landed a McLaren Junior Performance Academy spot. And the list goes on.

Exactly four years ago today, FIA Formula 4 arrived in Britain for the first time. And Lando Norris, Colton Herta, Dan Ticktum, Matheus Leist, Ricky Collard, Enaam Ahmed, Sennan Fielding, Toby Sowery and Josh Smith ensured that the grid of the 2015 MSA Formula (as it was then known) was bursting with quality. They would go on to achieve some pretty impressive results.

The list of talents doesn't end there, either. Jack Barlow, for example, was another bright prospect whose lack of budget prevented him from illustrating his full potential, while Sandy Mitchell is now forging a career in the Blancpain GT Series.

It really was some grid. In fact, it's quite easy to argue it's the best British single-seater grid of the present decade. Only British F3

“Myriad championships now exist at Formula 3 level, which spread the top drivers more thinly”

back in 2011 really comes even vaguely close.

Incidentally, it was none of those drivers listed above that started from pole for that first race four years ago. It was Dan Baybutt who annexed that by 0.3 seconds – but this was the high point of his season, for he ran wide at the first corner, scored only one podium, and hasn't raced since.

The championship's promoter Sam Roach reckons “the stars aligned” to provide such a strong grid for that first F4 season. Even from the very first round there was talk of Norris being a future F1 driver and it was clear it was a very talented crop of drivers.

“There was a level of professionalism and level of financial backing that made you think, ‘You've got everything going for you,’” says Roach. “There were drivers where the talent combines with the finances and the correct management.” He believes that first

season has had a lasting impact on the series; drivers sign up to the category today because of “the Lando Norris effect”.

But this column is not just an affectionate look at the recent past through rose-tinted spectacles. That 2015 season also raises some pertinent questions. Most notably, will we ever have such a strong grid for a British single-seater series again?

The answer to that question is far from clear. Even in the short space of four years, the motorsport world has changed quite dramatically. Costs, particularly in single-seaters, have risen. Therefore many more drivers are switching to the sportscar route at ever earlier stages of their career – increasing numbers are making that move straight out of karts or Ginetta Junior rather than even making a brief foray into single-seaters.

Drivers are also quicker to move on; many spend just a single year in any given category. Another factor to consider is the increasing popularity of racing in Europe, where the circuits more closely resemble those that drivers will race at as they climb the motorsport ladder than the likes of Knockhill and Oulton Park.

Roach reckons it is certainly possible for another highly competitive season with a wealth of top drivers, and is encouraged by the number of successful karters interested for 2020. But he acknowledges the chances have reduced now.

“I think it's going to get harder to reproduce that,” he says. “Back in 2015 there were probably only three or four credible F4 championships, so it focused everyone of that generation into those championships. Now we've got more and more credible F4 championships, like the American F4 championship, which is proving successful. If that same group came together again now they would probably be in three or four different series.”

And when you move beyond F4, things become even less certain. Myriad championships now exist at F3 level, which spread the top drivers even more thinly, impacting upon Britain's other top-level single-seater series: BRDC British F3.

It does seem unlikely that the quality of the 2015 season will be repeated in this country any time soon – without another major shift in attitudes in the motorsport world.

But Roach does have one suggestion of how it could be done elsewhere. There has long been talk of an ‘F4 World Cup’ that would pitch perhaps the top two from each series against each other in an end-of-season contest. The likelihood of that happening has dropped in recent years owing to the practicalities of arranging such an event. That's a shame because it certainly would be a great way to ensure the next generation of Norrises, Ticktums and Hertas race against each other in the junior ranks. ❄



Gardiner and Cox hold off Chevrans for Guards Trophy win

Chevrans lead the way, but come the flag it was the TVR that took the spoils

DONINGTON PARK
HSCC
30 MARCH

Undaunted by Mike Gardiner's TVR Griffith pirouetting down the Craner Curves during qualifying, co-driver Dan Cox staved off Charlie Allison and Mark Colman's Chevron-BMW B8s to land a brilliant Guards Trophy victory in the Historic Sports Car Club's season-opener. After Gardiner's pacy yet conservative

start, Cox leapt aboard the TVR as the pits opened then maximised Ford V8 power on the straights. Andrew Hibberd (Lotus 23B) trailed behind the TVR and the two Chevrans.

Allison missed the pit window, however, the penalty leaving him seventh. Colman – who traded fastest laps with Peter de la Roche in Tom de Gres's Elva Mk7 – rued missing a gear in a chicane scramble, but was promoted to second in the ex-David Good car beautifully rebuilt since his

ankle-shattering 2017 Brands shunt.

The Historic Road Sports finale ended dramatically. With eyeballs almost touching visors as they hit their Morgans' brakes late and hard for the chicane, Kevin Kivlochan and Tim Pearce arrived abreast. Pearce, fractionally ahead on the outside, ploughed straight on as 'KeKi' scampered through the gravel to win.

Jonathan Rose (Elan), who'd harassed Kivlochan until baulked in traffic, finished on the recovering Pearce's tail. Invitee John

Davidson's double in gripping Formula Ford encounters

KIRKISTOWN
500MRCI
30 MARCH

Picking up where he left off at the end of last season, Alan Davidson opened his Kirkistown account with a brace of pole positions, followed by a pair of wins to put him firmly ahead on the Northern Ireland Formula Ford 1600 chart.

But it wasn't as simple as it looked. In race one, his well-sorted 1989 Mondiale had company all the way, with the 2001 Van Diemens of David McCullough and Will Herron in very close proximity for the full 15 minutes. McCullough, in fact, was the pacesetter, leading over the line on almost every lap. That was until the last one.

Herron led the charge going into the Hairpin, and got his nose ahead for a

moment, but the wily Davidson, who had been watching the other two very closely, saw a gap on the inside, took it, and emerged in front just when it mattered. He also took fastest lap, setting a new Pre-90 record along the way. Just 0.384 seconds covered the trio at the end.

Scott Finlay had been with the trio for the first half of the race, but an adventure dropped him back in fourth.

The second race was a Davidson demonstration, the Mondiale man stretching away from the pack to win from McCullough by almost seven seconds, with Finlay claiming the final podium position.

With the Irish Touring Car Championship joining the locals for two Libre Saloons encounters, plenty of action was promised and the crowd didn't have to wait long. Only 100 metres from the start Martin Duffy's BMW M3 turned



hard left into the barriers, while at the first corner Martin McDonnell's Subaru arrived in second place behind Gerard O'Connell's Mk1 Ford Escort-Millington, but pointing in several directions at once.

This caused a sizeable 'carambolage' behind and, while O'Connell went ahead to have an off of his own at the next corner, the safety car was deployed while the mess was cleared up.

At the green, Ciaran Denvir got the drop on the rest and his Honda Civic went on to win from Jay O'Reilly's similar car, with Stephen Potter's Integra third. In fact there were five Hondas in the top half-dozen, the only interloper being Keith Campbell's VW

Williams, who had blasted his Porsche 911 between the Morgans at the start, was fourth.

Earlier, John Dickson (Ferrari) had taken 70s Road Sports victory over Williams after the Europa and Elan of Will and Mark Leverett, second and fourth on the road, were excluded for carburetor infringements.

Norwegian Martin Strommen debuted his ex-Steve Soper Lotus Cortina with a hard-won victory in the Historic Touring Cars bout. As Strommen and Rick Belcher fishtailed alarmingly, Mark Watts (Ford Mustang) outdragged them to Redgate, but fell off at McLeans. Belcher's Cortina broke, leaving Strommen to wriggle past John Dunham and Nick Stagg's Cortinas and Bob Bullen's feisty Ford Anglia.

Classic Formula 3 provided the best single-seater race. Paul Smith (Ralt-VW RT3), Steve Maxted (Ralt-Alfa Romeo RT3) and Adrian Langridge (March-Toyota 803) set successive pole times, but Maxted's car jumped out of gear and was swamped at the start.

With URS Classic Formula Ford 2000 standouts Ben Stiles (Van Diemen RF82) and Nelson Rowe (Reynard SF79) scrapping in his wake, David Thorburn had it won when his ex-Martin Brundle RT3's throttle stuck open, forcing a gutting retirement. Langridge then repelled Smith – nose fin askew – for his first two-litre F3 win. Behind them Rowe aced Stiles in a stunning Pinto contest.

Triple Historic FF2000 champion Andy Park was gapping Nelson Rowe when the latter spun. Chasers Ian Pearson and Paul Allen colliding at Redgate aided Rowe's



Winkelmann gave Jackson victory in Historic FF1600



Kivlochan (98) battled hard with Pearce in Historic Road Sports

return to second, ahead of Jason Redding.

With qualifying rival Linton Stuteley (Jamun) starting three laps down following an engine change, Historic Formula Ford champ Cameron Jackson notched the first UK win for a Winkelmann (US market Palliser). Ben Tusting (SpeedSport Merlyn) came closest, with teenaged team-mate Pierre Livingston jostling to third.

Having replaced a broken front wishbone, Sam Wilson's Formula Junior win over Adrian Russell and Steve Jones was straightforward.

MARCUS PYE



O'Connell led briefly in Libre Saloons race before going off



Byrne (leading) won first Formula Vee race

Corrado, and even it had Honda power! Denvir, Potter and Campbell filled the race-two podium, after O'Connell retired from the lead with a broken exhaust.

In Roadsports, the returning Ivor Greenwood took his Radical to a pair of wins ahead of Paul Conn's Crossle 47S and the off-song Radical of Jim Larkham. The resurgent one-litre Class B was dominated by Mark Francis (Locost Honda).

Formula Vee always entertains and this time it was defending champion Anthony Cross who took the 'A' race for Leystone but only by a nose from Jack Byrne's 'lowline' LOH Sheane.

Byrne had earlier claimed victory in

the 'B' encounter from Ken Browne and Paul Heavey.

Kirkistown's new Mazda MX-5 class produced four cars for their first encounter, sharing the track with a smattering of Ford Fiestas. In race one, a frantic battle involving the Mazdas of Bran Sexton, David Cousins and Stephen Murray kept everyone on their toes. Polesitter Cousins eventually retired with a broken gearbox, while Murray vanquished the late-braking Sexton to win. Cousins dominated race two, while Sexton demoted Murray to third. Mark Stewart was top Fiesta.

RICHARD YOUNG

WEEKEND WINNERS



Thumbs up: Langridge

DONINGTON PARK

GUARDS TROPHY

Mike Gardiner/Dan Cox (TVR Griffith)

HISTORIC ROAD SPORTS

Kevin Kivlochan (Morgan +8)

70s ROAD SPORTS

John Dickson (Ferrari 308GTB)

HISTORIC TOURING CARS

Martin Strommen (Ford Lotus Cortina)

CLASSIC FORMULA 3/CLASSIC FF2000

Adrian Langridge (March 803)

HISTORIC FORMULA FORD 2000

Andrew Park (Reynard SF81)

HISTORIC FORMULA FORD

Cameron Jackson (Winkelmann WDF2)

FORMULA JUNIOR

Sam Wilson (Lotus 20/22)

For full results visit:

tsl-timing.com

KIRKISTOWN

NORTHERN IRELAND FF1600

RACE 1 & 2 Alan Davidson (Mondiale M89S)

LIBRE SALOONS

RACE 1 & 2 Ciaran Denvir (Honda Civic)

ROADSPORTS

RACE 1 & 2 Ivor Greenwood

(Radical Prosport)

FORMULA VEE

B & C Jack Byrne (LOH Sheane)

A Anthony Cross (Sheane FV94)

MAZDA/FORD FIESTAS

RACE 1 Stephen Murray (MX-5)

RACE 2 David Cousins (MX-5)

For full results visit:

speedhive.mylaps.com



Denvir won both Libre Saloon races

Charge from the back for Buckley in MG Cup races

SILVERSTONE NATIONAL
MGCC
30 MARCH

Richard Buckley was the star of the MG Car Club's sun-kissed season-opening Silverstone race meeting, winning both MG Cup races in his Rover 220 Turbo despite starting both second-to-last after his clutch cable got stuck in qualifying.

And that wasn't Buckley's only impressive feat. "It's the first time I'd driven the car since I rolled it at Snetterton last year," he revealed. "I hadn't tested it or anything; it was literally out of the box. But it seems to work all right!"

In the first race Buckley rose to lead by one-third distance; in race

two he did similar, but it looked like he'd have to give best to Matt Simpson's Tomcat. Simpson had made his own recovery from starting ninth due to a combination of traffic and oil on the circuit in qualifying.

Then an erroneous camber adjustment meant he couldn't get onto the race-one grid and impeded him in race two as well, making him take odd lines on right-handers.

"I'd pretty much settled for second," Buckley admitted. "But then I saw a backmarker, and thought if I could just box him [Simpson] in behind the backmarker and get the run round him – a little bit naughty, but I did it!"

Simpson laughed: "He outsmarted me! He worked out where I was going to be slow and managed to do me!"

Rob Spencer won a poignant BCV8 race a few weeks after the death of its popular



Two wins for Buckley despite starting at rear

JONES

long-time coordinator Pam McCarthy. Spencer vaulted to the lead from row two at the start, then held off fellow GT V8 runner Ian Prior for the rest of the way, beating him by 1.1 seconds.

Reigning MG Metro Cup champion Jack Ashton picked up where he left off last year by winning both season-opening races from pole in his Rover Metro GTi. Yet he had to fend off strong challenges from Dick Trevett's MG Metro Turbo.

A misfiring Ashton just held off Trevett in race one, and race two was similarly tight, but Trevett had problems late on, his car blowing up with two laps left.

Paul Clackett (ZS 180) won the Cockshoot

Dominant Gray takes Britcar spoils

A total of 35 cars took part in the season-opening Britcar meeting



JONES

SILVERSTONE INTERNATIONAL
BARC
30-31 MARCH

Tim Gray's Praga romped to victory in the first Britcar Endurance race, which featured an impressive 35-car field.

Ross Wylie's Ferrari 488 Challenge was a comfortable second during the first half of the contest, but it was Marcus Clutton who came to the fore after taking over John Seale's new Lamborghini Huracan.

Seale had duelled with Lucky Khera's McLaren 650S for third, then Clutton chased hard to secure a clear second. The McLaren picked up a late puncture in the hands of Lee Frost, which handed third to the charging Taranis of Jonny MacGregor and Ben Sharich.

There was to be no repeat for Gray in race two though, after the electrics failed on his steering wheel and left him gearless after 15 laps.

Wylie led until the stops, but from

there Seale/Clutton had it all under control, while Frost/Khera and Kevin Clarke/Ryan Lindsay's BMW Z4 were both a lap down as they completed the podium.

Rick Morris's Royale RP29 was a double Classic Formula Ford winner. Morris trailed Jordan Harrison's Lola T504E in race one, until the leader missed a gear through Club on lap four of 15. Morris dived ahead but they swapped again exiting Vale.

Mark Armstrong's Van Diemen RF80



Cup race from pole. He was only headed briefly by second-place starter Phil Standish getting a predictably good launch in his rear-wheel-drive MG TF LE500, but Clackett was back ahead by Brooklands. Runner-up Keith Egar had a strong recovery drive from ninth in his MG Midget.

Neil Fisher (Austin Healey Sebring Sprite) won the Equipe Pre 63 race after a three-way fight with the Healey 3000s of Mark Holme and John Pearson. The Equipe GTS Group B race, sharing the track with the Pre 63s, was won by the MGB Roadster shared by Olivia Wilkinson and Austin Kinsella. Lee Atkins dominated the Group A race in his TVR Grantura 1800S.

The Mini Winter Challenge returned to the UK racing calendar after a 16-year hiatus and provided thrilling slipstreaming action. Colin Peacock won race one, seizing the lead from Kane Astin and Joe Thompson's warring Miglias on the final lap.

It likely would have been the same trio battling for victory in the second race, but Astin didn't take part after hitting technical problems, which his team suspected stemmed from the gearbox or differential. This time Thompson pipped Peacock to the win by just 0.2s.

GRAHAM KEILLOH

joined in too and when Harrison stopped at Club on lap 11, Morris eased clear from Armstrong to win by over four seconds. John Village's Crossle 25F headed home Tim Harvey's RF81, Kevin Mansell's Crossle 32F and Tom Brown's RF79 in a four-car train for third.

Morris and Village had an early scrap in race two, before Village pitted after four laps. Morris kept a reasonable gap over Harvey for the rest of the race, but Armstrong came within a whisker of snatching second on the line.

Defending 2CV champion Pete Sparrow was another double winner, but he had to earn it. He led the first from lights to flag, with Brian Heerey second throughout. After Lien Davies had departed with a blown engine, Matthew Hollis, Nick Crispin and Nick Clarke fought over third. There were constant swaps and changes, but Hollis clinched it, with 0.6s covering all three.

Sparrow had to start from the back of the grid for race two after an eligibility problem, but by the end of lap five of the 11 he led again and secured his second win.

Luke Pinder managed to hold off a forceful Simon Freeman in the first Michelin Clio Series race, while Ronan Pearson and Paul Bell duelled for third. Bell got ahead into Abbey when Pearson was compromised by a backmarker, but Pearson claimed the place back through Club two laps later.

Pearson lost touch with the lead trio early in the second race, where Pinder had the edge again over Freeman and Bell. But after sizing up his rival a lap earlier,



Freeman shot ahead into Stowe with a lap to go, securing the win and leaving Pinder to settle for second, from Bell and Pearson.

Will Sharpe's ZR won the first MG Owners' Club race, after he and Fergus Campbell demoted early leader Simon Kendrick's MGF on lap nine of 15.

Steve Darbey beat ZR rival David Mellor to the flag in race two, with Stuart Plotnek's F completing the podium.

PETER SCHERER

WEEKEND WINNERS

SILVERSTONE NATIONAL

MG CUP

RACE 1 & 2 Richard Buckley (Rover 220 Turbo)

BCV8 CHAMPIONSHIP

Rob Spencer (MGB GT V8)

MG METRO CUP

RACE 1 & 2 Jack Ashton (Rover Metro GTi)

COCKSHOOT CUP

Paul Clackett (MG ZS 180)

EQUIPE PRE 63

Neil Fisher (Austin Healey Sebring Sprite Mk1)

EQUIPE GTS B

Olivia Wilkinson/Austin Kinsella (MGB Roadster)

EQUIPE GTS A

Lee Atkins (TVR Grantura 1800S)

MINI WINTER CHALLENGE

RACE 1 Colin Peacock (Miglia)

RACE 2 Joe Thompson (Miglia)

SILVERSTONE INTERNATIONAL

BRITCAR ENDURANCE

RACE 1 Tim Gray (Praga R1T)

RACE 2 John Seale/Marcus Clutton (Lamborghini Huracan)

CLASSIC FORMULA FORD 1600

RACE 1 & 2 Rick Morris (Royale RP29)

2CVs

RACE 1 & 2 Pete Sparrow

MICHELIN CLIO CUP SERIES

RACE 1 Luke Pinder

RACE 2 Simon Freeman

MG OWNERS' CLUB

RACE 1 Will Sharpe (ZR)

RACE 2 Steve Darbey (ZR)

CATERHAM GRADUATES

(MEGA/CLASSIC/135/125)

RACE 1 Luke Tzourou (Mega)

RACE 2 Kevin Barrett (Mega)

CATERHAM GRADUATES (SIGMAX/150)

RACE 1 & 2 Samuel Wilson (Sigmax)

For full results visit:

tsl-timing.com



And the award for best supporting role goes to...

The British Touring Car support series promise to deliver plenty of entertainment in 2019. Here's how the five championships are shaping up

STEPHEN LICKORISH

Ginetta GT4 Supercup

The Ginetta GT4 Supercup was once described to Autosport as being a championship that drivers only compete in if they don't have the budget for anything else. That may sound incredibly harsh for a successful series that is well-established on the BTCC's support bill, but the past couple of seasons haven't exactly been the strongest for the category.

The days when drivers such as Adam Morgan, Tom Sharp, Nathan Freke and perennial title contender Carl Breeze were battling for honours are a distant memory now. Back in 2012, for example, there were seven different winners – last season there were four. The number of different winners isn't necessarily indicative of the quality of a championship but, in a series with partially-reversed grids, you would expect more. Sadly, in 2018, Charlie Ladell, Carl Boardley, Harry King and Tom Roche were a long way clear of the rest.

For whatever reason, top drivers just weren't attracted to the series in significant numbers. Perhaps the clearest sign of this was the lack of Ginetta Junior champions making the switch. While Tom Ingram and Harry Woodhead did, Jack Mitchell (although he did a couple of seasons later), Jamie Caroline, Will Tregurtha and Tom Gamble didn't chose it as their next destination.

But there were encouraging signs starting to emerge last season as an influx of drivers with successful club racing careers bolstered the numbers. And now the GT4 Supercup seems to have really turned a corner for 2019.

The entry list is undeniably stronger, and is probably the best since 2015. Will Burns, who came agonisingly close to taking the title in 2016, has made a comeback, now driving for the frontrunning Rob Boston Racing squad. Burns's former BTCC team-mate Mike Epps is surely another to watch. Then there's King, who had a lot of bad luck in his rookie season last year, but is a real contender this time around.

Series regular Tom Hibbert can't be discounted, and Ginetta Junior graduate Fin Green is another one to watch. Carl Shield will also be looking to take a step forward after his debut year last season. And the fact that 2017 British Rallycross champion Nathan Heathcote has decided to make his circuit

racing debut in the series is a big vote of confidence.

Ginetta motorsport manager Ash Gallagher says it's difficult to know why the series is stronger this year. "We haven't done anything massively different," he says. "We've got a strong format and the car's really good – we try to stick to what works, so consistency is key. We've got a really great product now that's great fun to drive."

Gallagher also feels that the car isn't too much of a jump for drivers moving up from the club racing world or graduating from junior series. "We can accommodate most people – it's quite an accessible car," he adds. "You can go straight from the G40 [used in Ginetta Junior, GT5 Challenge, G40 Cup and the entry-level Ginetta Racing Drivers Club series] to the G55 quite comfortably, it's not massively daunting for a driver."

Rob Boston – whose team has powered the champion in two of the past three years – agrees. His squad also runs cars in Mazda MX-5 and Lotus categories, and has provided a connection to club racing that has encouraged drivers like multiple

“We've got a strong format – we try to stick to what works, so consistency is key”

MX-5 champion Roche to enter the series.

"As Rob Boston Racing, we started in it in 2013 and have supported it for a lot of years; we've been the link between club racing and the touring car paddock," Boston says. "We've beaten the drum for them and it's a good championship."

Another factor is also hidden in that derogatory comment at the start: it's good value for money and not as expensive as other TOCA series such as British Formula 4 or the Porsche Carrera Cup GB.

"There are not many championships where you get races televised live for that value," Boston adds. "Also, they are fabulous-handling cars."

Who will handle them best this year is tricky to predict, with just 0.4 seconds covering the top six in the official media-day test. But what can be established is that the series is once again now somewhere drivers are choosing to compete. >>





King will be a GT4
Supercup title
contender this year



Ginetta Junior

This year it's Ginetta Junior that wins the award for the largest grid among the TOCA supports, with 24 drivers set to take part. But just seven of those competed in more than three rounds last season.

Elite Motorsport drivers finished top two in the standings in 2018, and Elite has two of those seven drivers with series experience: James Hedley and Tom Emson. Hedley is certainly a title favourite after winning last November's Winter Series, and team boss Eddie Ives is confident, saying that testing has gone "extremely well". He adds: "They're working together really well and want the best for each other and that will help with towing."

Other drivers continuing in the series include last year's scholar James Taylor (Richardson Racing). He finished sixth and is the highest-placed driver to remain.

Douglas Motorsport duo Lorcan Hanafin and

Gus Burton are also fully up to speed with the car after switching from the now-defunct Renault UK Clio Cup Junior series midway through 2018.

"Last year we rushed into it with only one test day at Croft," says Burton. "Top three in the championship is a realistic target now."

Burton has formed a unique partnership with the Sparkle Foundation, where sponsorship he raises will be donated to the charity that helps provide food, medical care and education for children in Malawi.

"If you're racing in Ginetta Junior you're in a privileged position, so we thought it would be something nice to do," says Burton, who is confident of reaching his £24,000 target for this year.

As for those sparkling on track, there's potential for the swathe of karting graduates to shine too, making this season tough to predict.



"Last year we rushed into it with only one test. Top three in the championship is the target now"



British Formula 4

There's no denying how impressive Louis Foster and Luke Browning were in Ginetta Junior last year. Foster came incredibly close to securing the title, despite lacking experience, and Browning put in some brilliant drives – recovering to fourth after dropping to dead last in the wet at Knockhill was a highlight. So it's fair to say they will be ones to watch in British Formula 4 this season.

Foster will benefit from the same Double R/MB Partners team/driver management combination that propelled Kiern Jewiss to last year's crown – when he was also in his first year out of Ginetta Junior after being the standout rookie.

But Foster is keeping his expectations in check. "I don't want to put pressure on myself, but I want to try the hardest I can to get some wins and be consistent," he says. "There's definitely the resources behind me."

Browning, meanwhile, is sticking with the Richardson Racing squad he has spent the past two seasons with. He says it was "an unbelievably easy decision" to stay despite the team's lack of single-seater pedigree, describing its preparation as "absolutely phenomenal".

Away from the graduating Ginetta stars, Carlin is back after a one-year sabbatical. Barbados-born karter Zane Maloney may be its only confirmed driver, but he's another key contender.

"Right now, we're in good shape," he says. "I have high targets for myself and, if I'm at 100%, I'm sure I can achieve them."

Others to keep an eye on include Arden trio Tommy Foster, Bart Horsten and Alex Connor, as well as the JHR team's ex-Formula Ford 1600 racer Carter Williams, while Sebastian Alvarez (Double R) and Josh Skelton (JHR) are the only drivers back for another season.





Young will be a threat

Renault UK Clio Cup

No James Dorlin. No Dan Rowbottom. No Team Pyro. No WDE Motorsport. But, most significantly, no Paul Rivett. And no future.

The final season of the Renault UK Clio Cup will have a very different feel to it. A host of names, be it frontrunning drivers or teams, have departed – and even Clio stalwart Rivett won't participate.

But one driver who does remain is Max Coates. After missing out on the crown last year in controversial circumstances, he's desperate to land the final title.

"I don't think there can be anybody out there who wants this more than I do," says Coates, who will be racing under the Team Hard banner, but will be supported by those he's previously worked with at Ciceley and Pyro. "Having come so close, if I don't win it I will be absolutely gutted."

The driver Coates pinpoints as his main rival is Jack Young, who burst onto the scene last year, narrowly beating Coates to win the International Clio Final.

"We were very close in the International Final at Paul Ricard," says Coates. "We were both 1-2 in the times at media day. Jack's got to be one of my biggest competitors."

Unfortunately, Coates doesn't face many other rivals. Among the other seven racers entered when Autosport closed for press are drivers who finished 13th, 14th and 18th in last year's standings. Although Coates reckons his new teammate, VW Cup graduate Ethan Hammerton, will be one to watch.

While the battle between Coates and Young will be intriguing, the tiny entry suggests the final season will not be remembered as a Clio classic.



Coates is determined that 2019 will be his year

Porsche Carrera Cup GB

Dan Harper had a tricky start to life in the Porsche Carrera Cup GB last year, suffering some bad luck and making a few mistakes. But he was fast – and really impressed in the second half of the season. The most poles and fastest laps demonstrated that.

Now, with last year's top three all moving on, Porsche Junior Harper starts this season as one of the favourites. And he admits there's pressure to match the achievements of the previous two scholars – Charlie Eastwood and Josh Webster – and take the crown.

"From last year and how pre-season testing's been going, there's no reason why I can't [be champion]"

"This season is going to be the deciding point of what the future holds," the 18-year-old admits. "The pressure is definitely there."

But Harper is feeling confident about his chances. "From last year and how pre-season testing's been going, there's no reason why I can't [be champion]," he adds.

He names George Gamble and Lewis Plato as his main rivals – and it's clear why. Like Harper, Gamble was a 2018 rookie but was a three-time race winner and benefits from joining the incredibly successful Redline squad. As for Plato, he has plenty of experience – this is



Harper impressed during his rookie season last year

his fourth year – but is running with a third different team: Motorbase Performance.

Harper has been working hard over the winter to ensure he's at the top of his game. "Last season my starts weren't great and they were letting me down," he says. "Qualifying was always really strong and it's so hard to pass in the Porsche, so it's down to the first lap. I've been working with my engineer practising starts and learning different techniques and I think I've got them sorted."

That's very ominous for his opposition.



Porsche Junior Harper says 2019 will be pivotal to his career



SCHLEGELMILCH
motorsport
IMAGES

THE UNDERSTUDY FORMULA TAKES



BOOK REVIEW
**SECOND TO NONE:
THE EUROPEAN
FORMULA 2 STORY**
RRP £40.00

First of all, an apology. This twin-book 'box

set' has been on sale for a couple of years now, but we didn't review it at the time because we were anticipating a joint critique alongside an eagerly awaited tome from Chris Witty, the former Autosport journalist who was there in the paddock during the golden era of Formula 2. But Witty's interview material is so vast that the project is still ongoing, so let's allow Chris Ellard's work its long-belated place in the sun.

Addicts of the more cobweb-strewn byways of single-seater history will already know Ellard's work from his book *The Forgotten Races*, which shone a light on the myriad non-championship Formula 1 races from the dawn of the three-litre era in 1966 onwards. That was followed up by the logically titled *Long Forgotten Races*, which did the same job on the equivalent events from 1954-65.

Job done on F1, Ellard turned his attentions to F2's halcyon period of 1967-84. There was F2 before this of course, but 1967 was the year when the regulations changed to 1600cc engines and the European championship was inaugurated. That lasted for 18 years, before F2 made way for Formula 3000. And yes, as you'd expect, the races that didn't count for the European championship – including the Brazilian Torneo and the British championship of 1972 – are included.

It was a wonderful era, especially when the 1600cc powerplants made way for two-litre units in 1972. Once pure-bred racing engines were allowed for 1973, this opened the way for BMW to enter with a works programme, with Renault following three years later, then Honda in the later seasons of the era. On the chassis side, March did battle against Martini, Chevron, Ralt, AGS and Maurer (among others), while it seems unthinkable today that in 1976 Jean-Pierre Jabouille became European F2 champion in a Renault-powered Elf 2J that he had designed and built himself at the Alpine factory. Can you imagine 2018 FIA F2 king George Russell constructing his own title-winning machine at the old Van Diemen workshop?

Ellard's hardback main book draws heavily on the contemporary reports from publications including Autosport and *Motoring News* (now *Motorsport News*). Each year is given its own chapter, with an intro, a summary of the entry and then a chronological blow-by-blow account of the season. Interspersed across the yearly chapters are short portraits of most of the race-winning drivers, and it's gratifying that Ellard has been careful to attach as much importance to those who largely missed the boat in F1 (such as Michel Leclere and Parisian university professor Jacques Coulon) as those who made it, including Jacky Ickx and Jochen Rindt, who are named in the book's subtitle.

This is accompanied by a softback results book (compiled by both Chris and Tony Ellard), which is a goldmine for researchers into the era. It's diligent work like this that really stands out – everyone who ventured out for practice for a race is listed. Just casually flipping open the book reveals that not



Patrick Depailler (l) and Hans Stuck lead the F2 pack at Hockenheim in 1974

CENTRE STAGE



Denny Hulme slides his Brabham BT23 around Silverstone in 1967

only did Hans Stuck win the Rhein-Pokalrennen round at Hockenheim in 1976 from Leclere and Patrick Tambay, but also that there were 18 non-qualifiers. Whatever happened to March 742 privateer Max Hug or Osella FA2 pedaller Charly Kiser? Who knows? But they were just as much part of the tapestry of F2 as the top-ranking BMW juniors or Elf-backed Renault hopefuls.

There's one minor gripe for an anorak such as this writer: qualifying times are listed faithfully for the 1967-75 seasons, but seem to disappear from 1976 onwards, even if the drivers' qualifying (or non-qualifying, in the case of many) positions are recorded.

Witty's forthcoming book (come on, Chris!) won't be a blow-by-blow account, but based more on colour and recollections. So if you're an F2 fan, or just curious about it, grab a copy of Ellard's work to complete the full picture of a fabulous era.

MARCUS SIMMONS



[autosport.com/podcast](https://www.autosport.com/podcast)



IS MICK SCHUMACHER THE REAL DEAL?



Mick Schumacher will go down in history as the last ever champion of the Formula 3 European Championship; he's made a solid Formula 2 debut in Bahrain plus he's received a Ferrari F1 testing call-up. Jack Benyon and Marcus Simmons join Edd Straw to discuss his prospects and the F2 season to come.

WHAT'S ON

INTERNATIONAL MOTORSPORT

IndyCar Series

Round 3/16

Barber Motorsports Park, USA

7 April

TV Live Sky Sports F1, Sunday 2100

World Touring Car Cup

Round 1/10

Marrakech, Morocco

6-7 April

TV Live Eurosport 1, Saturday 1630, Sunday 1630, 1745, BBC Red Button, iPlayer

World Rallycross

Round 1/10

Yas Marina, Abu Dhabi

5 April

TV Live BT Sport ESPN, Saturday 1700

TV Highlights Freesports, Monday 0830

NASCAR Cup

Round 8/36

Bristol Motor Speedway, USA

7 April

TV Live Premier Sports 2, Sunday 1830

UK MOTORSPORT

Brands Hatch BARC

6-7 April

BTCC, British F4, Porsche Carrera Cup, Renault UK Clio Cup, Ginetta GT4, Ginetta Junior

TV Live ITV4, Sunday 1015

Goodwood BARC

6-7 April

Members' Meeting (see p56)

Snetterton CSCC

6-7 April

Jaguar Saloon and GTs, Tin Tops, Swinging Sixties, Future Classics, Magnificent 7s, Modern Classics, Special Saloon and Modsports, Classic K, New Millenniums, Open Series, Turbo Tin Tops

Donington Park MSVR

6-7 April

F3 Cup, Elise Trophy, Radical Challenge, Track Day Championship, Track Day Trophy, MSVT Super Cup, EnduroKa

Silverstone BRSCC

6-7 April

Caterham Seven 420Rs, 310Rs, 270Rs, Roadsports, Ford Fiestas, Fiesta Juniors, Production GTI, Multi Marques, 206 GTI Cup, Nippon Challenge, Tricolore Trophy

Knockhill SMRC

7 April

Fiesta and Hot Hatch, FF1600, Classic Sports and Saloons, Legends Cars, Sports and Saloons, C1 Cup, Mini Cooper Cup

Over 40 incredible years of collectable F1 Reviews now at dukevideo.com



1970-2009 Four stunning box sets from £79.99 | Free shipping

Buy now at dukevideo.com or call +44 (0)1 624 640 011



The F1 FORMULA 1 logo, F1 logo, F1, FORMULA 1, FIA FORMULA ONE WORLD CHAMPIONSHIP, GRAND PRIX and related marks are trade marks of Formula One Licensing BV, a Formula 1 company. All rights reserved.

THE DAYTONA 24 HOURS 2019

37 TEAMS SOLD - ONLY 8 SPACES LEFT!

» THE DAYTONA 24 HOURS 2019 WILL ONCE AGAIN BE HELD OVER THE MAY DAY BANK HOLIDAY WEEKEND (4TH/5TH MAY 2019) AT DAYTONA MILTON KEYNES, THE UK'S PREMIER KART RACING VENUE. DON'T MISS THE EVENT OF THE YEAR, WHICH SEES 45 TEAMS RACING NON-STOP OVER 24 HOURS IN RACE-PREPARED DMAX AND SODI RT8 KARTS.

DMAX CLASS

- DMAX 125cc Rotax Evo Two-Stroke Karts
- Minimum Weight equivalent to 85Kgs per driver
- Team Entry costs £2450 inc VAT

SODI CLASS

- Sodi RT8 390cc Four Stroke Karts
- No Minimum Driver Weight Limit
- Team Entry costs £1800 inc VAT

THE DAYTONA 24 HOURS 2019 WILL BE HELD AT DAYTONA MILTON KEYNES OVER 4TH AND 5TH MAY 2019

- Just 45 spaces on the grid
- £300 deposit secures your entry. Next payment due by end of January. Final payment due by end of March
- Complimentary trackside pitches for first 32 teams



BOOK NOW TO GET THE BEST PITLANE PITCH, CALL MARK WIMBLETT NOW ON +44 (0)33 033 27870 TO BOOK YOUR TEAM

DAYTONA »



TOP FIVE

motorsport
IMAGES

STILLBORN RACERS

Potentially winning machinery that never got the chance to shine

MATT KEW

DESPITE MASSIVE INVESTMENT AND COUNTLESS hours of research and development, sometimes it only requires a flinch from the boardroom or a quirk of fate for the plug to be pulled on a constructor's latest project. Here are five potential world-beaters that never got a chance to prove their worth in battle.

1966 JAGUAR XJ13

5 A decade after scoring three victories in a row, Jaguar was ready to win the Le Mans 24 Hours again. And the XJ13 was to lead that assault. The aerodynamicist behind the pioneering C and D-types returned, plus David Hobbs was recruited as test driver. But lengthy delays meant Ford had time to develop the GT40, leaving the XJ13 uncompetitive. Unsurprisingly, that led the top brass at Jaguar to withdraw finances. Five years later Norman Dewis nearly destroyed the car while shooting an E-type publicity film.



JBLOXHAM

2000 ZAKSPEED VOLVO C70 DTM

4 Zakspeed had latterly run Opels in the previous iteration of the DTM, but when the series was reborn for 2000 it had no manufacturer to jump into bed with. In a gamble, it decided to drape the silhouette of Volvo's C70 coupe over a tubular chassis to seduce the Swedes. But Volvo remained immune to its charms, refusing to let the C70's likeness compete – let alone splashing any cash in Zakspeed's direction. That left the reputedly promising project to fade, and Zakspeed with no entry come the start of the season.



RENEDEBOER

2000 PORSCHE 9R3

3 Developed for the LMP2000 sportscar regulations, the 9R3 was canned less than three weeks after its first test with Allan McNish and Bob Wollek. Ostensibly, the funds were redirected into developing the Cayenne SUV. It was a double hit: the 9R3 was to be powered by a V10 originally designed for the Footwork Arrows Formula 1 team. It wasn't until the 2018 Goodwood Festival of Speed that the car made its public debut. Fans can take some comfort, however, as the engine block did find a home in the iconic Carrera GT.



JEP

1986 AUDI RS 002

2 When the FIA binned off proposed Group S regulations for the World Rally Championship in 1986 after Henri Toivonen's fatal Tour of Corsica crash, prototypes from Audi, Lancia, Toyota and more were aborted. Of them all, Audi's RS 002 was the most potent. Although the rules restricted cars to 300bhp, RS test mules could top 700bhp. But, even then, the 2.1-litre in-line five had been seen in 1000bhp states of tune. The RS 002 could also run on to 186mph and barely tipped the scales at a ton.



JBLOXHAM

2003 MCLAREN MP4-18

1 Taking top spot is the McLaren MP4/18, the one that came closest to actually competing. In a bid to overhaul Ferrari's monopoly at the top of Formula 1, Adrian Newey went radical with the design of McLaren's charger. It wasn't a lack of cash or the boardroom/a governing body changing tack that consigned it to obscurity. Instead, it twice failed FIA crash tests, was prone to overheating and then Alex Wurz shunted heavily while testing. That meant the team was left to run a revised 2002-spec car instead.



MOTORSPORT IMAGES/CAPILTAN

FINISHING STRAIGHT



FROM THE ARCHIVE

Jean Alesi (Tyrrell-Ford 019) spins out at the start of the 1990 Spanish Grand Prix at Jerez, after being squeezed into the path of Riccardo Patrese's Williams-Renault

FW13B by a jockeying Gerhard Berger (McLaren-Honda MP4/5B) – Patrese's front wing clipped Alesi's left-rear tyre, causing an instant deflation. Alesi had qualified in an impressive fourth place, behind the

polesitting McLaren of Ayrton Senna and the Ferrari 641/2s of Alain Prost and Nigel Mansell. The race was won by Prost; Senna dropped out after 53 laps with a punctured radiator.

DUKE[®]

For classic 1990s Formula 1 DVDs head to bit.ly/Duke1990sF1



EDITORIAL

Editor **Kevin Turner**
 Deputy Editor **Marcus Simmons**
 Grand Prix Editor **Edd Straw**
 F1 Editor **Ben Anderson**
 F1 Correspondent **Scott Mitchell**
 Technical Editor **Jake Boxall-Legge**
 Chief Sub-Editor **Peter Hodges**
 Executive Editor **Stuart Codling**
 Performance and Engineering Editor **James Newbold**
 Rallies Editor **David Evans**
 BTCC Correspondent **Matt James**
 Editorial Assistant **Matt Kew**
 Art Editor **Lynsey Elliott**
 Senior Designer **Michael Cavalli**
 Origination/Repro **David Sternberg**
 Office Manager **Joanne Grove**



Photography

Steven Tee
 Glenn Dunbar
 Sam Bloxham
 Zack Mauger
 Jakob Ebrey
 Mark Sutton

Special Contributors

Gary Anderson
 Alan Eldridge
 Tom Errington
 Stephen Lickorish
 Stefan Mackley
 David Malsher
 Jonathan Noble
 Marcus Pye
 Nigel Roebuck
 Jim Utter
 Gary Watkins

AUTOSPORT.COM

Video Content Editor **Glenn Freeman**
 Editor **Matt Beer**
 Autosport Plus Editor **Alex Kalinauckas**
 News Editor **Jack Cozens**
 International Editor **Jack Benyon**
 Social Media Editor **Joshua Folks**
 Technical Team Leader **Geoff Creighton**

CORRESPONDENTS

Argentina Tony Watson **Australia** Andrew van Leeuwen **Austria** Gerhard Kuntschik **Belgium** Gordon McKay **Brazil** Lito Cavalcanti
Finland Esa Illoinen **Germany** Rene de Boer **Greece** Dimitris Papadopoulos **Italy** Roberto Chinchero **Japan** Jiro Takahashi
New Zealand Bernard Carpinter **Russia** Gregory Golyshev
Spain Raimon Duran **Sweden** Tege Tornvall **USA** Jeremy Shaw
UK & Ireland Stephen Brunsdon, Dom D'Angelillo, Kerry Dunlop, Graham Keilloh, Mark Libbeter, Dan Mason, Lucy Morson, Jason Noble, Mark Paulson, Brian Phillips, Hal Ridge, Peter Scherer, Ian Sowman, Chris Stevens, Ian Titchmarsh, Richard Young

ADVERTISING

Tel +44 (0) 20 3405 8106 **Email** autosport.ads@motorsport.com
 Sales Director **James Robinson**
 Display Advertising **Jamie Brooker, Christian Plucknett, Karen Reilly**
 Creative Solutions **Don Rupal**
 Classified Advertising **Ben Kavanagh, Balvin McKenzie, Edward Sanderson**
 Online and Agency Sales **Chris Hermitage**

ADVERTISING PRODUCTION

Production Controller **Ben Webster**
Tel +44 (0) 20 3405 8131 **Email** ben.webster@motorsport.com

SUBSCRIPTIONS

UK +44 (0) 344 848 8817 **Overseas** +44 (0) 1604 251451
Email help@asm.secureorder.co.uk **Back issues** 0344 8488817
Main office +44 (0) 20 3405 8100

Autosport, ISSN number 0269946X, is published weekly by Autosport Media UK Ltd, 1 Eton Street, Richmond, TW9 1AG, United Kingdom. Airfreight and mailing in the USA by agent named Air Business Ltd, c/o Worldnet Shipping Inc., 156-15, 146th Avenue, 2nd Floor, Jamaica, NY 11434, USA. Periodicals postage paid at Jamaica NY 11431. Subscription records are maintained at Autosport Media UK Ltd, 1 Eton Street, Richmond, TW9 1AG. Air Business Ltd is acting as our mailing agent.



CIRCULATION TRADE ENQUIRIES

Seymour Distribution Ltd, 2 East Poultry Avenue, London, EC1A 9PT.
Tel: +44 (0) 20 7429 4000.
 Printed by William Gibbons & Sons Ltd, 28 Planetary Road, Willenhall, Wolverhampton WV13 3XT.
 ISSN 0269-946X. Autosport is published weekly by Autosport Media UK Ltd, 1 Eton Street, Richmond, TW9 1AG.

MANAGEMENT

President, Motorsport Network
James Allen
 Editor-in-Chief, Autosport Media UK
Andrew van de Burgt
 Group Publishing Manager **Sunita Davies**
 Special Events Manager **Laura Coppin**
 Digital Product Manager **Simon Grayson**

We abide by the Editors' Code of Practice and are committed to upholding the highest standards of journalism. If you think we haven't met those standards and want to make a complaint, contact 0203 405 8100.



©2019, AUTOSPORT MEDIA UK LTD

Trading as Autosport Media UK. Publishing, trade and further subscription details on www.autosport.com. While due care is taken to ensure the contents of Autosport are accurate, the publishers and printers cannot accept liability for errors and omissions. Advertisements are accepted for publication in Autosport only upon Autosport Media UK's Standard Terms of Acceptance of Advertising, which are available from the Advertising Department.

QUIZ

WHO, WHAT, WHERE, WHEN?



WHO IS THIS?

This racing visionary has gone on to achieve more outside of the cockpit than he managed inside it.

From a stony beach, he made a spritely start as he balanced racing with working on an oath. But once his mind was set, he made a rapid rise, claiming the key series as he became a gold-star success.

This led to a one-off at home as a racing reserve, which he rammed home the following year as a full-timer. He sped into a teutonic berth with limited success before an avuncular presence allowed him to pay homage to former greats.

When a hotshoe put him in his place, he reverted to his past in the background, while teaming up with a national hero in a new position. He was quick on the draw as a new scene emerged and he soon became best in class, which allowed his vision to spread across the land while also bringing through the next generation.

LAST WEEK'S ANSWERS Who, what, where, when? Ma Qing Hua, Caterham CT03, Shanghai, 2013. Who is this? Narain Karthikeyan. On this day 1) 1975 Swedish GP. 2) Alex Zanardi. 3) Long Beach. 4) Super Nova. 5) Five (Yvan Muller, James Thompson, Jason Plato, Phil Bennett, Anthony Reid). Name the helmet Pedro de la Rosa.

ON THIS DAY

1 It's Christian Danner's birthday. He raced for four F1 teams. Name them.

2 Two drivers scored their first F1 points on this day in the 2010 Malaysian GP. Who were they?

3 Who started from his only F1 pole on this day in the 1982 Long Beach GP?

4 It's 2003 F3000 champion Bjorn Wirdheim's birthday. For which three F1 teams did he test?

5 Which country staged its first world championship F1 race on this day in 2004?

NAME THE HELMET



IN NEXT WEEK'S ISSUE

F1 CELEBRATION

We drive some of the greatest cars

SUBSCRIPTION OFFER

YOUR SOURCE OF EVERYTHING MOTORSPORT

TRY 6 ISSUES OF AUTOSPORT FOR £6

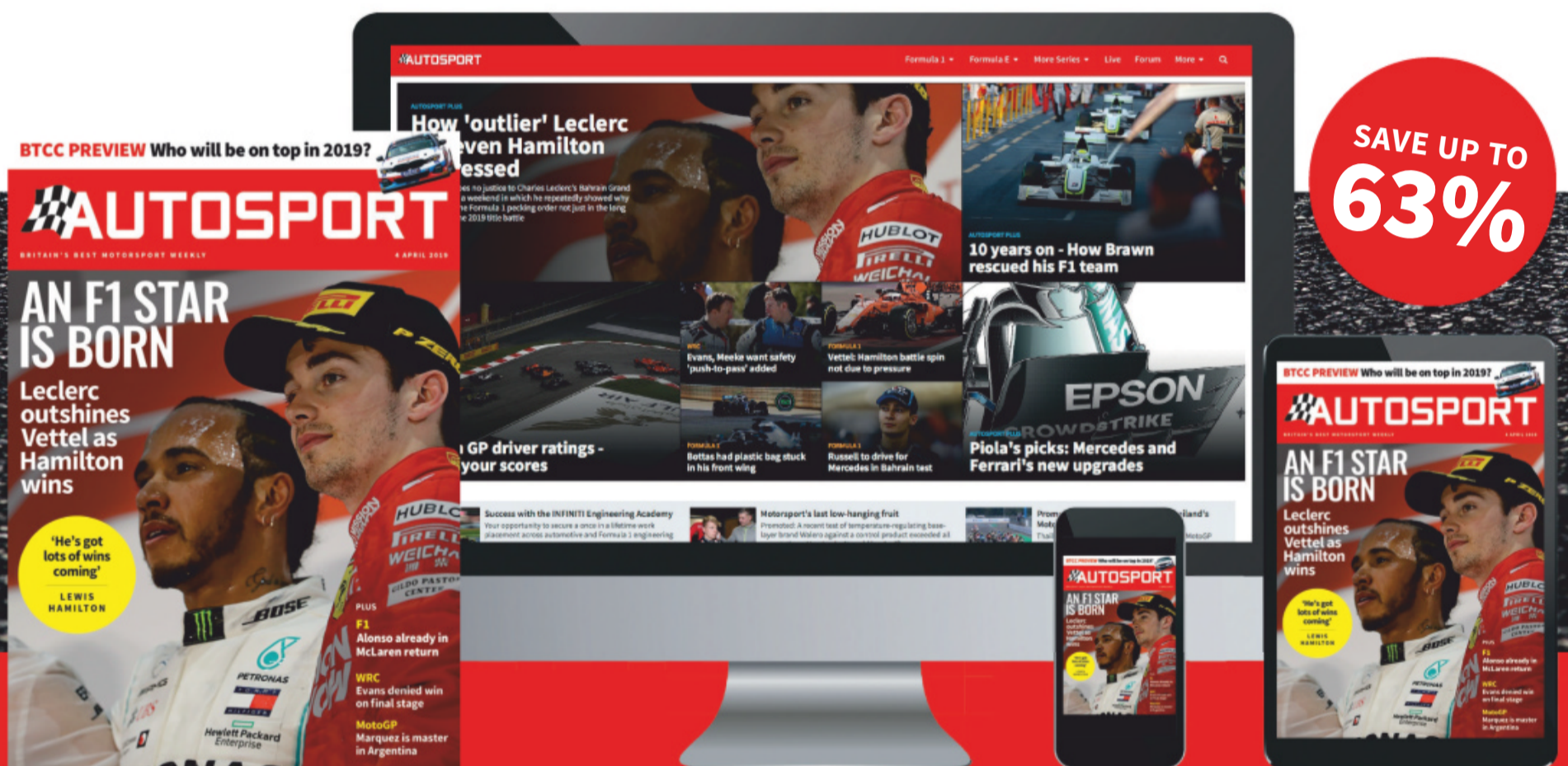

SUBSCRIBE ONLINE WWW.AUTOSPORTMEDIA.COM/OFFER/AS2019

OR CALL 0344 848 8817 QUOTE PROMO CODE PASP19GEN

FOR OVERSEAS RATES CALL +44 (0) 1604 251 451

WHY SUBSCRIBE?

SAVE UP TO 63%
on the cover price

ON THE MOVE
read on your iPhone or iPad

FREE DELIVERY
direct to your door

IN EVERY ISSUE

LATEST NEWS
from across a range of series

UNRIVALLED STORIES
from our award winning journalists

EXTENSIVE ANALYSIS
of everything Formula 1

Terms and conditions: Offer valid for new UK subscriptions by Direct Debit only. After your first 6 weeks, your subscription will continue at £35.99 every 13 issues for the print and digital bundle. Digital magazines only available on iPhone and iPad. Direct Debit rates are valid for one year after which they are subject to change. Should you wish to cancel your subscription it will be cancelled on expiry of the current term. You will be emailed instructions of how to gain access to your digital subscription. Savings based on the standard UK cover price. Offer ends 3 May 2019.