

20-PAGE **DRIVING GUIDE** HOW TO GET THE EDGE

# **AUTOSPORT**

www.autosport.com • AUGUST 21 2014 • £3.60

**WORLD EXCLUSIVE**

# FERRARI'S F1 MASTERPLAN

**NEW BOSS  
REVEALS ALL**

"We have to  
embrace risk  
and be brave"

**BELGIAN GP  
PREVIEW  
INDYCAR  
DTM & F3**

**DRIVEN!**

**WE TEST FORMULA E**  
And yes! All-electric car  
is a *PROPER* racer



haymarket  
9 770269 946258  
34  
£8.99

# Calm before the



## CORSA VXR CLUBSPORT

**1.6 Turbo 205PS**  
**Drexler Limited Slip Differential**  
**Brembo Brakes**  
**Bilstein Shocks**

**Official Government Test Environmental Data. Fuel consumption figures mpg (litres/ 100km) and 37.2 (7.6). CO<sub>2</sub> emissions 178g/km#.**

Model shown Corsa VXR Clubsport 1.6i 16v Turbo (205PS) £22,400, plus Metallic Paint £545, total cost £22,945. Vauxhall does not condone irresponsible driving. #Official EU-regulated test data are provided for comparison purposes and

# storm

VXR.co.uk



**VAUXHALL**

**CO<sub>2</sub> emissions (g/km). Corsa VXR Clubsport: Urban: 27.7 (10.2), Extra-urban: 46.3 (6.1), Combined:**

actual performance will depend on driving style, road conditions and other non-technical factors.



2014 FORMULA 1  
SINGAPORE AIRLINES  
SINGAPORE GRAND PRIX

# ONE NIGHT

SINGAPORE FORMULA ONE  
MARINA BAY STREET CIRCUIT  
19.20.21 SEP 2014

THRILLING RACE ACTION AND  
WORLD-CLASS ENTERTAINMENT

MAYDAY **19 SEP**

ROBBIE WILLIAMS **20 SEP**

JENNIFER LOPEZ **21 SEP**

ZIGGY MARLEY **20 SEP 21 SEP**

PET SHOP BOYS **20 SEP**

JOHN LEGEND **21 SEP**

[WWW.SINGAPOREGP.SG](http://WWW.SINGAPOREGP.SG)

AVAILABLE AT ALL INTERNATIONAL  
AUTHORISED TICKETING AGENTS



TITLE SPONSOR



SUPPORTED BY



**POLE POSITION**

# Mattiacci faces same challenges as van Gaal

**THE BACK PAGES OF THE SUNDAY PAPERS WERE DEVOTED**

to Manchester United's Louis van Gaal, the new boss of a team that transcends its sport due to past glories. A huge 'brand' that's worth billions, but with a current squad that's way short of where it should be given its massive resources. Couldn't you say much the same about recently installed Ferrari chief Marco Mattiacci?

Ferrari is the biggest name in our sport, and just like Man U its current performance is way off its potential. The last of Ferrari's 221 grand prix victories was 15 months ago, despite boasting Fernando Alonso – one of the greatest drivers of his generation.

Mattiacci reveals his plans to Jonathan Noble on page 12 this week, and the noises he's making are most van Gaal-like. Unlike previous incumbent Stefano Domenicali, Mattiacci is demanding change – a cultural shift towards more risk-taking. Brave decisions need taking; engine chief Luca Marmorini has already departed.

Mattiacci is clearly a smart cookie, and you get the impression he's got his head around where the weaknesses are. Like van Gaal, he possesses some star names who are up to scratch, but does he need to dip into the transfer market to further bolster his squad?



*Bradley*

**CHARLES BRADLEY EDITOR**  
charles.bradley@haymarket.com  
@Autosport\_Ed

**COVER STORY**

**“We are talking about the most sophisticated engineering company in the world”**

Marco Mattiacci, p12



DUNBAR/LAT

**FIND US ON**



Cover images: Bloxham/LAT, Mason/Getty

**PIT & PADDOCK**

- 6 **THIS WEEK IN F1**
- 9 **JONATHAN NOBLE: F1 NEWSHOUND**
- 10 **THIS WEEK IN MOTORSPORT**
- 22 **BELGIAN GP PREVIEW**

**FERRARI SPECIAL**

- 12 **MARANELLO'S MASTERPLAN**  
With no world title to its name since 2008, Ferrari is experiencing a success drought. Jonathan Noble talks to the Scuderia's new boss Marco Mattiacci about his plans to return the famous team to winning ways.
- 16 **IS BIANCHI THE FUTURE OF FERRARI?**  
Jules Bianchi is outperforming his back-of-the-grid Marussia and has been on Ferrari's radar for some time. Edd Straw asks if he's ready for the big time.

**DEBRIEF**

- 18 **ECCLESTONE IN COURT: THE FACTS**  
What really happened in the German bribery case

**FEATURES**

- 24 **RICHARD SEAMAN RETROSPECTIVE**  
Remembering a pre-war Mercedes hero 75 years on
- 26 **FORMULA E TRACK TEST**  
Alexander Sims tries the all-new FIA Formula E racer

**RACE CENTRE**

- 32 **INDYCAR MILWAUKEE**  
Will Power wins to stretch his points advantage
- 36 **DTM NURBURGRING**  
Marco Wittmann's fourth win increases his huge lead
- 39 **AUTO GP NURBURGRING**  
Kimiya Sato comes from behind to win the title
- 40 **EUROPEAN F3 NURBURGRING**  
Verstappen, Giovinazzi and Auer win; Ocon loses out
- 42 **NASCAR; INDY LIGHTS; ARGENTINIAN TC2000; BRITISH F3; BRAZILIAN STOCK CAR**

**AUTOSPORT PERFORMANCE**

Free 20-page supplement on the art of going faster

**CLUB AUTOSPORT**

- 55 **BRDC F4 TO USE FIA F4-SPEC CAR**  
British series to introduce new chassis that could allow 15-year-olds to compete in 2015
- 56 **SWR LANDS CATERHAM JUNIOR TAG**  
Sean Walkinshaw Racing in F1 team tie-up for F4
- 60 **NATIONAL REPORTS**  
Silverstone MSVR; Brands Lotus Festival (MSVR); Knockhill SMRC; Shelsley Walsh BHC; Snetterton 360 MRC; Oulton Park BARC; Thruxton BARC

**SUBSCRIPTION OFFER**

- 68 **FREE GRID AUTOSPORT GAME**  
Subscribe for a great free gift and digital package

**THE BACK STRAIGHT**

- 70 **THIS WEEK**  
Readers' letters; best pictures; product reviews
- 72 **WHAT'S ON**  
The best track and TV action in the coming week
- 74 **RACE OF MY LIFE: KEN BLOCK**  
Competing in the X Games against Colin McRae



# This week in F1

## MAX VERSTAPPEN TO RACE FOR TORO ROSSO IN 2015

Max Verstappen will race for Scuderia Toro Rosso next season, replacing Jean-Eric Vergne.

The 16-year-old is currently in only his first season of car racing and has won eight races in the Formula 3 European Championship. He is due to become the youngest driver ever to start a grand prix next season, breaking former STR driver Jaime Alguersuari's record.

Verstappen only joined the Red Bull junior programme last week after also attracting interest from Mercedes. But the decision to pitch him straight into F1 comes as a surprise, especially as fellow Red Bull Junior Carlos Sainz Jr,

currently leading Formula Renault 3.5, had been in the running.

"We've all worked tremendously hard to reach F1 and I will give my absolute best to be successful," said Verstappen, son of Jos.

Vergne's F1 future now hangs in the balance. Although the Frenchman has performed well this season, he faces a battle to find another berth.

"He has produced strong performances, but was also hindered by reliability problems," said Toro Rosso team principal Franz Tost. "We hope that we have resolved these and that he will be able to end this season on a high note and show he still deserves another opportunity in F1."



### F1'S YOUNGEST

Max Verstappen will be 17 years, five months and 13 days old on the planned date for next year's season-opening Australian GP.

**JAIME ALGUERSUARI**  
19 years 125 days

Replaced Sebastien Bourdais at Toro Rosso for 2009 Hungarian GP; continued in 2010-11.

**MIKE THACKWELL**  
19 years 182 days

Driving for Tyrrell, the New Zealander qualified for the 1980 Canadian GP.

**RICARDO RODRIGUEZ**  
19 years, 208 days

Qualified his Ferrari a sensational second on his world championship debut in 1961 Italian GP.

6

## Sutil unfazed by podium drought



Adrian Sutil insists he is not concerned about his record tally of 120 F1 starts without a podium. "Sometimes you deliver your best performance when you finish 13th, which might be better than the times I finished fifth for Force India, but nobody will realise this," he said.

### BIG NUMBER

**28** Adrian Sutil has scored points in 28 races, a record number for those who haven't claimed a podium.



## Grosjean: 2014 cars bad for Kimi

The characteristics of current Formula 1 cars do not suit Kimi Raikkonen, according to his former Lotus team-mate Romain Grosjean. "I know what he

doesn't like and I think this year's cars don't suit him very well," said Grosjean. "He needs a good front end and that car doesn't give this feeling."

## Drivers key to Williams revival

Williams deputy team principal Claire Williams has described drivers Valtteri Bottas and Felipe Massa as central to the team's revival in 2014. "They have been instrumental," said Williams, who added that they complement each other well.



## MALLYA HAILS STAR BOTTAS

Force India team principal Vijay Mallya has hailed Williams driver Valtteri Bottas as "the star of the 2014 F1 season" so far. "He's shocked everybody and is doing a fantastic job under pressure," said Mallya. "Not only does he have the killer instinct but also the maturity not to get flustered."

### BOTTAS: SEASON BY NUMBERS

**11 STARTS**  
**1** FRONT-ROW START  
**195** POINTS  
**3** PODIUMS  
**5TH** IN THE CHAMPIONSHIP

For all the breaking news, visit **AUTOSPORT.COM**

**JOS VERSTAPPEN IN F1**

**Starts** 106  
**Best finish** 3rd  
 (1994 Hungarian and Belgian GPs)  
**Best qualifying** 6th  
**Points** 17  
**Best championship** 10th in 1994  
**Teams** Benetton, Simtek, Arrows, Tyrrell, Stewart, Minardi

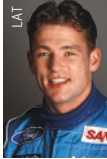

**Lotterer in frame for Spa F1 debut with Caterham**

Three-time Le Mans 24 Hours winner Andre Lotterer was closing on a surprise F1 debut at the Belgian Grand Prix as AUTOSPORT closed for press. The 32-year-old German was in the running for a seat at Caterham, most likely in place of Kamui Kobayashi, whose drive

was not guaranteed by new owners following the recent takeover of the squad. The German was a Jaguar F1 test driver from 2000-02 and has raced in Japanese Super Formula (formerly Formula Nippon) since then. He won the 2011 Nippon title and also raced once in Champ Car in 2002.

Colin Kolles holds an advisory role with the Caterham team, and his sportscar squad ran Lotterer in its privateer Audi R10 TDI in 2009. If he does race at Spa, he will be the first driver in his thirties to make his F1 debut since Yuji Ide at the 2006 Bahrain GP.



It will take time and it may bruise some egos, but there will be some changes in the team because we have to close the book and start a new one



McLaren racing director Eric Boullier on the changes needed at his team

**DE SILVESTRO READY FOR F1**

Sauber-affiliated driver Simona de Silvestro believes that she is ready to make the step into an F1 race seat next year. "I feel that now is the time," she told AUTOSPORT's sister title *F1 Racing*. "I wouldn't have made this jump if I didn't feel right or it wasn't a good opportunity."

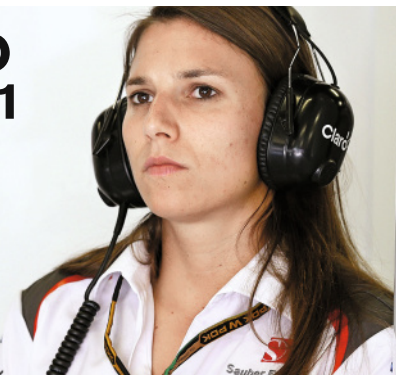

7

CLEAR/LAT



**F1 can learn from USA, says Montoya**

Former Williams and McLaren driver Juan Pablo Montoya believes F1 can learn from the way fans are treated in American racing. "They ought to look at IndyCar," says Montoya. "It's very different [for fans] walking around and seeing the cars."

**Mercedes shocked by criticism**

Mercedes team boss Paddy Lowe has admitted he was surprised by criticism of the squad for not imposing team orders on its drivers earlier in the year. Although the team was questioned for ordering Lewis Hamilton to let Nico Rosberg past during last month's Hungarian GP, Mercedes has avoided allowing its drivers to try different numbers of pitstops in races. Otherwise, they have generally been allowed to race.

"People at the beginning of the season were surprised we weren't running any team orders," said Lowe. "There was a bit of criticism, as if we were idiots for not imposing them. "People even thinking like that is almost an inversion of how you should be, probably generated by the Ferrari era [in the 2000s when Michael Schumacher was number one driver]. Before that era, no-one would have ever thought about it."



**Red Bull won't hire tech boss**

Red Bull has no need to appoint a technical director to work under chief technical officer Adrian Newey, who is scaling back his involvement in the team after this season. "We are not going to appoint a technical director, we don't need one," said team principal Christian Horner.

**REMEMBER WHEN**



Red Bull did once have a technical director working under Newey. Geoff Willis, who worked with Newey at both Leyton House and Williams, held the role from 2007-09.



# Ferrari Racing Days

Silverstone 13 - 14 September



## **FERRARI RACING DAYS IS BACK IN THE UK**

The spectacular Ferrari Racing Days returns to Silverstone on the 13th - 14th September 2014

### Highlights

- › European Ferrari Challenge Trofeo Pirelli Series
- › Ferrari F1 Clienti cars
- › XX programmes
- › Ferrari car displays
- › Ferrari tribute parade
- › Free access to the Silverstone Wing building
- › Free open paddock
- › Free grandstand seating
- › Free entrance for children 15 years and under

### Exclusive reader offer for advance ticket purchases

50% off advance weekend ticket price if purchased before 5pm on the 3rd September 2014. Please quote FRD14-AS1

Visit [www.silverstone.co.uk](http://www.silverstone.co.uk) or call the ticket hotline for more information 0844 3750 740



Trofeo 





# Jonathan Noble

## F1's newshound

Spa's iconic Eau Rouge has had its teeth pulled in recent years, but the changes to 2014's F1 cars mean that it may be about to bite back

**A**fter a few weeks during which Formula 1 paddock regulars' thoughts have been focused more on blue skies over beaches than results on track, there is no denying the huge sense of excitement about the famed 'fickle' conditions that will greet the grand prix circus in Belgium.

But irrespective of what the skies throw at F1 this weekend, the sweeps of the famed Spa-Francorchamps circuit are always a magical place to watch the world's best racing drivers in action. And this year things could perhaps be even more special than they have been for some time.

Although the current generation of F1 cars has been criticised for being too quiet, too complex and with too much emphasis on fuel economy, their characteristics could actually help bring back an edge to Spa that has been sadly lacking.

In recent years, much of the challenge of Spa's most iconic corner, Eau Rouge, has been nullified by the evolution of track safety and car designs. Its profile has been gradually straightened to make it less aggressive and the growth of asphalt run-off areas has opened up the door to mistakes being punished less.

In addition, the impressive amount of downforce available to cars meant it became an easily flat corner – in effect nothing more than a kink on the blast between La Source and Les Combes.

That state of affairs, however, could well change this



Has the challenge of Spa's Eau Rouge been resurrected?

STALEY/LAT

has been the impressive straightline speed performance of the Williams.

Williams' quest to produce an efficient car to minimise drag will pay huge dividends at Spa, where teams constantly have to balance putting more downforce on for the long middle sector without

**“Eau Rouge had become no more than a kink on the blast between La Source and Les Combes”**

weekend. F1's latest generation of cars may well bring the magic back to Eau Rouge, and return it to the fold of places where drivers have to have respect.

One aspect of F1's 2014 cars is that the new V6 turbo engines, allied to a reduction in downforce from last year, have made them quicker in a straight line, with some very impressive acceleration low down. Add to this combination the fact that the cars are heavier this year, and running on harder tyres, and it means the blast through Eau Rouge will be different. It is not necessarily the case that the right foot will automatically be planted flat to the floor.

Early simulation data from teams suggests that for some cars (but not all), on a low-fuel qualifying run, Eau Rouge will be what is termed a 'brave flat'. Those two words sound very exciting when put together.

There are competitive forces at play that could also make Eau Rouge more of a handful this weekend. One characteristic that has come to the fore in recent races

risking being so slow on the straights that they get swallowed up on the climb to Les Combes.

The likelihood that the Williams-Mercedes package will be blindingly quick through that first Spa section may well force its rivals to lean off downforce levels as much as they dare to prevent them becoming sitting ducks on the Kemmel straight.

That move may further add to the possibility of drivers not having such an easy time when it comes to threading their way through Eau Rouge and Raidillon.

Delivering such a challenge is exactly what both we and the drivers want. In a year when men such as Sebastian Vettel and Fernando Alonso have complained about having some of their impact taken away by the boffins on the pitwall dictating fuel flow rates and performance figures, surely no one will grumble if the onus is put back on what the men in the cockpit deliver – and how brave they choose to be through Eau Rouge. ❧

# This week in motorsport

## ULSTER RALLY HALTED AFTER DRIVER DEATH

The Ulster Rally was cancelled after the death of rising star Timothy Cathcart on the third stage of the event last Friday.

The fourth round of the British Rally Championship was immediately halted by the organiser, the Northern Ireland Motor Club, as a mark of respect. An investigation into the accident was launched by the Police Service Northern Ireland and the local authority, with which the organiser and the MSA are co-operating.

The accident occurred near the flying finish of the nine-mile Fardross stage in County Tyrone. Cathcart's Citroen DS3 R3 crashed through a fence on a fast section near the finish.

Medical assistance arrived quickly, but Cathcart did not respond to treatment. Co-driver Dai Roberts was airlifted to the Royal Victoria Hospital in Belfast, where his condition was listed as serious before being upgraded to comfortable on Monday.



10



## TIMOTHY CATHCART 1994-2014

**TIMOTHY CATHCART GREW UP WITH** rallying: his father Ian was one of the top rally men in Ireland, as was his uncle Roy. Cathcart's brother Matthew has also shone at British Rally Championship level in recent years.

So it was only natural that Cathcart

would also take up the sport. For his first season in 2013, Cathcart jumped straight into the British Rally Championship driving a Ford Fiesta R2. The highlight was a class podium, and 12th overall, on the Scottish Rally. Cathcart stepped up to a Citroen

DS3 R3 for this second season. He had a great start to the year, taking a class win on the Scottish series-counting Border Counties Rally alongside new co-driver Dai Roberts. Seventh place on the Pirelli Rally season-opener was a strong start to his BRC campaign.

## Ligier to join USC at Austin

The Ligier LMP2 coupe will make its United SportsCar Championship debut at Austin next month with HPD power.

The OAK Racing squad will introduce the new closed-top JSP2 developed by sister company Onroak Automotive for the penultimate USC round on September 20. The car, which raced at the Le Mans 24 Hours under the OAK Racing Team Asia banner, replaces the Morgan LMP2 the French team has previously run in the US.

Team manager Philippe Dumas said: "It was always the plan to show the



Ligier in the US at the end of the year and we have an agreement with Honda Performance Development to do some more races."

The Nissan-powered car will be raced by Gustavo Yacaman and Alex Brundle, before Olivier Pla joins them in the car for the Petit Le Mans enduro at Road Atlanta in October.

## Breen fit for return in Germany

Craig Breen will contest this week's Rally Germany despite damaging his back in a heavy landing in Finland earlier this month.

The Irishman was given the all-clear from his doctor exactly one week before the start of the

Trier event. This week's World Rally Championship qualifier will be the third and final event he competes in his Kel-Tech Fiesta RS WRC before returning to the European Rally Championship in a Peugeot 208 T16.



For all the breaking news, visit [AUTOSPORT.COM](http://AUTOSPORT.COM)

## More freedom in aero tweaks

IndyCar is set to open up the development window for the new aerodynamic kits being developed by Chevrolet and Honda for the one-make Dallara DW12.

The original plan had been for the specification of the manufacturers' aero packages to be fixed from their pre-season homologation until the opening of the development window at the end of the year. Concern among the manufacturers that one will steal a march on the other is likely to result in freedoms

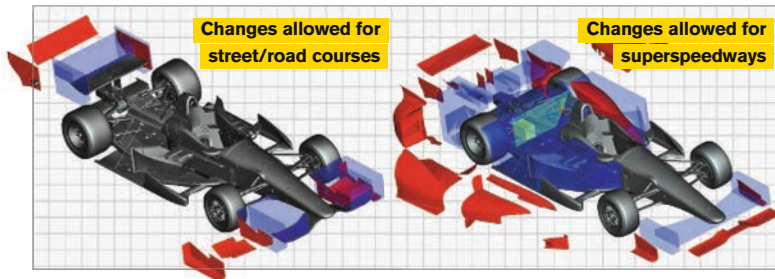

to make changes through next season.

Chevrolet IndyCar programme manager Chris Berube said: "The [revised] regulations would allow some amount of change and there will be some –not a huge amount but some."

IndyCar has released images of the aero parts that can be changed on the Dallara for 2015.

**P32 MILWAUKEE REPORT**

I have to follow on from where I stopped in Finland. You never know what's going to happen...



Finland Rally winner Jari-Matti Latvala might be 44 points shy of VW team-mate Sebastien Ogier, but he's not giving up ahead of Rally Germany this week.

## Hamilton Jr eyes BTCC campaign

Nicolas Hamilton, younger brother of Mercedes Formula 1 star Lewis, is targeting a jump into the British Touring Car Championship in 2015.

The 22-year-old, who has cerebral palsy, announced his ambitions to move into the BTCC after two seasons in the Renault Clio Cup in 2011-12 on his blog this week.

He said: "I am excited to announce my ambitions to become the first disabled athlete to compete in the BTCC."

Hamilton currently has no deal in place.



## MARTINO FINOTTO 1933-2014

**MARTINO FINOTTO, WHO HAS** died aged 80 after a long illness, won the European Touring Car Championship in 1979, but he is probably best remembered for his exploits in sportscar events.

The CARMA FF team he started with long-time driving partner Carlo Facetti developed a turbocharged Ferrari 308 GTB Group 5 racer for 1980-81 and then produced a bespoke four-cylinder powerplant, badged after Fiat tuner Giannini, for the Group C Junior category. This powerplant was instrumental in giving the Italian Alba (below)

marque back-to-back titles in the secondary Group C category (subsequently C2) in the World Endurance Championship in 1983-84.

Finotto started racing in 1972 and was a winner in the ETC by 1977. Together with Facetti, he won five of the final six rounds in '79 at the wheel of their self-run BMW 3.0CSL to take the title.

The Italian, who made his fortune in the chemical industry, continued racing regularly in the US IMSA GTP series until 1991 and made his last international race start as late as 1995 at the Sebring 12 Hours.



## In brief



### ISLAND IN BTCC RETURN

The BTCC's experiment of using the full or International layout at Oulton Park has been abandoned after one year. The Oulton fixture will revert to the Island circuit, which had become the regular BTCC layout, for its June date next season. The longer configuration came in for criticism for producing unexciting racing.

### GRONHOLM'S VW TEST

Two-time World Rally Champion Marcus Gronholm has begun his new job as a Volkswagen Motorsport test driver. The Finn completed a day of gravel running in the 2015-spec Polo R WRC in the south of France earlier this month. He said: "After one lap, I thought 'OK, this is a nice car'. It was good to be back."

### NO F3 FOR TINCKNELL

Le Mans 24 Hours LMP2 winner Harry Tincknell stood down from a British F3 one-off at Thruxton with Double R Racing to focus on upcoming sportscar tests. Formula Renault 3.5 racer Will Buller also came close to a deal to contest the event with Fortec Motorsport. GP3 ace Dean Stoneman was also linked to the same drive.

### MACLEOD FOR JAPAN

Briton Sam MacLeod is to make his Japanese F3 debut this weekend at Motegi. MacLeod, who has won races in British and German F3 this season, will drive a Dallara run by Toda Racing and powered by the organisation's eponymous engine.

### MORE BMR FOR SMITH

BTCC racer winner Aron Smith will remain with the BMR Volkswagen squad next season. The 24-year-old, who has won two reversed-grid races this year in his Passat CC, joined BMR for 2014 after two years driving Motorbase-run Fords.



## Newly-crowned champion Kimiya Sato's vital Auto GP statistics 2013-14

28 STARTS

11 WINS

2 SECOND PLACES

6 THIRD PLACES

1 POLE  
12 FASTEST LAPS

**P39 FULL AUTO GP REPORT**



# FERRARI'S NEW CHIEF LEADING THE SCUDERIA OUT OF THE DARKNESS?

The famous Italian squad hasn't won an F1 title since 2008, but now there is a new boss and a fresh plan in place. Marco Mattiacci speaks to **JONATHAN NOBLE** about his latest challenge





ROMNEY/GETTY



For a team that has been so central to the history of Formula 1, it would be all too easy for Ferrari's chiefs to look back on its past glory days for the answers as to why it is not performing right now. But for Ferrari's new team principal Marco Mattiacci, the response Maranello needs has nothing to do with lessons from the past. In fact, he thinks to be successful its future has to be something totally different.

Having been parachuted in to Maranello just hours after an early morning call from Ferrari president Luca di Montezemolo to his then home in New York telling him of his new job, Mattiacci has spent his time meticulously listening, understanding and analysing *'Il buono, il brutto, il cattivo'* (the good, the bad and the ugly) at Ferrari.

And now, as he swings his action plan in to place, it is clear Ferrari's future is not simply about finding a single big name star to tell it what to do. Instead, the change Mattiacci wants goes much deeper than that: it's about a break from the past and a huge cultural shift.

"These are important changes. Very important changes," he tells AUTOSPORT in his first in-depth interview since taking charge. "We are clear where we want to go. So I don't know if you can call the changes big, but they will be important.

"I think that Ferrari is going to look different, it will be different. And the story will tell if it will be better.

"But the change will be across the board – although most importantly – cultural change and discontinuity. These are the most important things."

That word discontinuity is interesting, for it is clear that one of the reasons Mattiacci was chosen as Stefano Domenicali's replacement was because he would be open to doing things differently. There would be no more reason to keep doing things simply because that was the way they have been done in the past.

Key too was the fact that Mattiacci knows how the Ferrari company works: for di Montezemolo had come to the conclusion that if things were to change, it would be easier for the man coming in to know how the Maranello political machine operates than how life evolves in the F1 paddock.

Mattiacci agrees: "I definitely have an advantage. You need to do a trade off with someone that has not been in F1, but knows Ferrari very well. I have not been in F1, but I have been watching F1, ►



Will Ferrari's new direction be enough to keep Alonso?

14

► I have been listening about F1, and I have been living F1. So I know in a certain dynamic what the sport is. But I definitely know the company.

"It is an Italian company, it has a certain kind of dynamic, being Italian, but also working there in the last 20 years it is multi-cultural, and there is a lot of diversity.

"That has helped me to probably smooth some angles and try to build an organisation where the passport is not important, but the idea is important. The hierarchy is not important, the contribution you give to the team is. I prefer not so much the skilled technical engineers, but instead someone who is a team builder. As in all sports, as in all businesses, people are the most important factor."

Spend any time speaking to Mattiacci away from the confrontational nature of press conferences, and you find someone whose calmness instantly builds trust. He is also evidently a listener, a trait

"And definitely we need a cultural change, we need to open ourselves – and I ask to embrace the risk humbly, cautiously – but be aware that to go back to the top we need discontinuity."

It has not taken him long to realise that some of the traits within Ferrari are not good. There is the risk element: that perhaps the team has been reluctant to be aggressive with its design for fear of getting it wrong and facing the consequences. That has bred conservatism – which in F1 equals uncompetitive machinery.

Another issue too has been the territorial nature of producing the car itself. Just as Renault had found itself on the receiving end of some harsh criticism from Red Bull, so Mattiacci found a team in which the chassis and engine groups were finger pointing too readily.

"I am going to say something that doesn't sound very F1; it's not the product that is competitive, it is the package," he asserts. "So, I don't like this

when you talk, it is about how much you can improve, what you will give me. There is a lot of methodology behind that."

One of the key tasks for Mattiacci will be in channelling the huge resources that Ferrari has at its disposal in to the areas that will make the most difference on track. The challenge is to recover the 1.5 seconds per lap deficit it needs to be beating Mercedes – and there is no silver bullet that will get it there in an instant.

"You can look once at your competitors behind you, but you can't spend too much time on it. We have some benchmarks of what the best are doing, who are ahead of us. That is where we are going to look a lot.

"I think we have a phenomenal structure, we have resources, we have impressive facilities and definitely we need to have clarity about which are the areas where investment will give us, in a period of time, a competitive advantage. In F1, that means

**"I don't like it when engine people talk to me about the chassis, and chassis people talk about the engine. Everybody has to share responsibility"** MARCO MATTIACCI

he put to good use in his first weeks at Maranello as he got to grips with understanding what needs to be done.

"The best thing is to ask questions," he explains. "I am not scared or afraid to ask any kind of questions. People know that I am not from F1, so I ask every sort of question. I cross-reference a lot, because I want to understand different kinds of sources.

"I make my opinion. But definitely I leverage upon the experience of the people that surround me. And I have started to find people that I definitely trust.

"I don't call meetings; I sit with the head of aerodynamics, or mechanics, or someone from finance – without any agenda. I want every person to know what is going on, and every person to know what direction we are going in.

distinction of aero, chassis, engine or power unit – there is one car and one team. Everybody has to work.

"I don't like it when I talk to engine people and they talk to me about the chassis for the first five minutes. I don't like chassis people to talk to me about the engine. We talk about the car. Everybody has to share the responsibility with that car. There is no, 'we did better than you,' or 'we did this because you asked.' Everybody is responsible for that car in the same way.

"For me, that is my style, that is what I want to implement. But definitely we are talking about the most sophisticated engineering company in the world, so you need clear responsibility, clear tasks, and clear objectives. That is where management skills count a little bit, to put in place process and procedures, and key performance indicators. Then,

to be one second ahead, or half a second ahead.

"But to arrive there, you need to make important decisions in terms of which area you need to invest. It is always quality versus quantity, and I don't know which is the right size."

Being open to using the skills and expertise of others, perhaps even outside of F1, is also part of the vision. "The world is changing today," continues Mattiacci. "It is phenomenal how you can get connected to your supplier: and they don't give you just a piece of equipment or a service, they give intelligence. There are manufacturing companies in North California that can give me perspectives that I have never seen before. That is what I want.

"We are Ferrari. Ferrari is a global brand, so I want to be open to the world – to take the best of the best, and that does not necessarily mean being in F1. Sometimes, honestly, there may be some

# THOUGHTS ON THE PLANS OF FERRARI

## JAMES ALLISON

TECHNICAL DIRECTOR (CHASSIS)

"You need to make big changes and small changes at the same time. Any team in F1, any of them, good or bad, are all pretty impressive organisations. And it is much, much easier to make them worse than it is to make them better.

"So the changes that need to be made are in an absolute sense quite small, but there are lots of them and they have been happening for some months. Marco's arrival has helped galvanise more of them, and I think that across the board in Ferrari there are changes that are extremely helpful to moving us in the right direction.

"If you were to come and sit alongside me or any of the other senior figures in Ferrari and watch the changes that are being made, you may say, 'that doesn't look very big'. But by the time you have the totality of them, they add up to something significant. And when you are in a sport that is very, very competitive, then all of those things add up to making a real difference."

## FERNANDO ALONSO

"In August everybody is very, very competitive, November even more, and in January super. Then in February only two or three are able to win. You should have a crystal ball to see what is going to happen next year.

"Obviously everything remains to be seen, but it's only good prospects and good feelings at the moment with the performance we can achieve next year. Our aim is to keep improving and use this year in the best way possible – experiment for next year, and next year to be stronger.

"Mercedes showed us this year that [teams in] this new era of Formula 1 can be dominant. We didn't make a good enough job with these new regulations and there is a lot of room to improve. It's not like other years where everything was more or less at the limit.

"The step between 2014 and 2015 cars will be a lot bigger than what we saw in the past, so that's the hope we have and I think everyone will have the same because everyone has very good prospects in July."

## KIMI RAIKKONEN

"We know our issues and what we have to do to improve things, but some of them are quite big things to fix and it will not happen quickly. Plus, with the new rules some things cannot be changed.

"We have to make sure we deliver those and I have full belief that we have the right team and the right tools to make a really good car. But this year is what it is and next year is a different story. Like I said, I believe in the people who are there who are making the car and I'm sure we can improve a lot."



Mattiacci inherited a struggling F1 team...



...that has been battling to be best of the rest in 2014



Alonso's superb Hungary podium was a rare highlight

companies that are doing some things better than us. They have 300 people, but how many brains really are working on that project? It is an open source.

"It is like if you get software from a very big brand or another one that is open source. The open source gives you some small issues in the beginning, but it is faster in upgrading, it is faster in getting excellence. The way you must work today is different."

It goes back to the new way of thinking that Mattiacci wants to see – discarding the shackles and the limitations from the Ferrari of a past where individuals were perhaps scared from being bold for fear of getting it wrong and taking the blame.

"We have to embrace risk," adds Mattiacci. "To embrace the utmost co-operation. Dialogue. To be brave. That is the most important thing for me."

This approach is why simply opening the chequebook and capturing some big names is not necessarily the right way, even though there will be personnel changes. One of the first has been the departure of Ferrari's long-serving engine chief Luca Marmorini, who has paid the price for a disappointing first attempt at the new V6 turbo. A new power unit department structure is in place.

"It is about the system, the platform you create," says Mattiacci. "I am not looking for names but people who give impressive added value. Sometimes it is not a big name: sometimes a big name will take away the chemistry that you need, that philosophy that you need, to move all the team in one direction. But, saying that, definitely we are looking to reinforce or improve certain areas."

One name that is central to it all is Fernando Alonso, who has often been quite aloof in his

comments about the management changes at Ferrari. Mattiacci insists he is not perturbed by Alonso's sometimes political nature. And for all the Spaniard has said this season about not being involved in the future plans for change, he and his boss do speak regularly – and there was a big meeting after the British Grand Prix to run over future plans.

Of course, Alonso has heard all the talk before – and Mattiacci admits the 2005 and 2006 world champion needs convincing that the coming changes will succeed. "For sure, but I need to convince everybody, not only Fernando," he says. "I need to convince all the hundreds of people working for me. Every minute, every second they look at me and I need to convince my boss, I need to convince so many people. I need to convince millions of fans.

"Do I wake up every morning thinking that I need to convince them that day? No. I work my way."

Indeed, the convincing is not something that will happen overnight. Mattiacci may be new to F1 but he knows he has a long-term project on his hands. "Just look to the others – look today who is at the top and how long it took to get to the top," he says.

"F1 has changed in that regard as well. It is an important process. How long? I cannot say."

Yet reading between the lines, there is no illusion that changes now will have instant results and get Ferrari back to the top before 2016. That is why he draws short of title talk for next year.

"I expect to be more competitive, that is clear," says Mattiacci. "That is Ferrari. That is the expectation for the millions of fans, management, shareholders, everybody. Everybody wants Ferrari at the top, for the good of the sport."

That is perhaps the only thing that the new Ferrari will not change: the desire of its faithful fans to want it back at the very pinnacle of the sport. ❧

Ex-engine chief Marmorini is not part of new plan

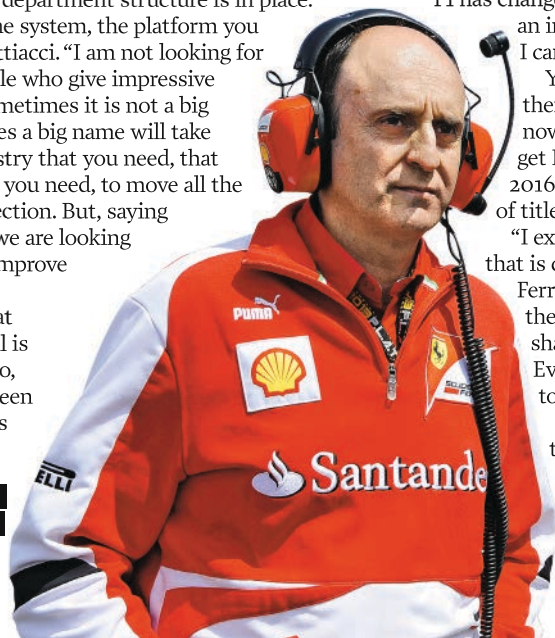

# IS JULES BIANCHI THE FUTURE OF FERRARI?

THOMPSON/GETTY

With question marks over Fernando Alonso's future and Kimi Raikkonen having performed poorly, EDD STRAW asks whether the Ferrari Driver Academy star is ready to graduate

**W**ere Ferrari to throw Jules Bianchi into a Ferrari for the second half of the 2014 season, would he perform better than Kimi Raikkonen? It's an intriguing, unanswerable question, but

based on their relative performances his season, you could certainly make a compelling argument in favour of the 25-year-old Frenchman.

It's not going to happen, but the fact that the question is even worth considering says a lot about Bianchi's rising stock. His remarkable ninth place in the Monaco Grand Prix is just the tip of the iceberg of what has proved to be a very good season at Marussia. Ferrari is watching him closely, very closely. The Scuderia even had the chance to see how he fared in the Ferrari F14 T thanks to Bianchi filling in for the shaken Raikkonen for one day at the post-British GP test.

Bianchi is fast. He always has been, but on his way to the top level there have been some bumps in the road, notably during three seasons in GP2 and Formula Renault 3.5 when his prodigious speed was too often undermined by mental frailty. In that context, narrowly missing out on a Force India drive to Adrian Sutil, not because of Mercedes pressure to have a German driver, as some have claimed, but following an exhaustive analysis of the predicted points that would



Monaco points underlined his fine form for Marussia

DUNBAR/LAT

**Bianchi drove  
the F14 T at the  
Silverstone test**



MAUGER/LAT

#### JULES BIANCHI CV

**Nationality** French

**Age** 25

**2014** 16th in F1 with Marussia, best finish ninth, Ferrari F1 test

**2013** 19th in F1 with Marussia, best finish 13th

**2012** 2nd in Formula Renault 3.5 with Tech 1, Force India third driver

**2011** 3rd in GP2 and 2nd in GP2 Asia with ART, Ferrari F1 tests

**2010** 3rd in GP2 with ART, Ferrari F1 tests

**2009** 1st in F3 Euro Series with ART, Ferrari tests, 2 wins in British F3

**2008** 3rd in F3 Euro Series with ART, F3 Masters winner

**2007** 1st in French Formula Renault 2.0 with SG Formula

be scored by the veteran German compared to the rookie, has proved to be a blessing in disguise. He washed up at Marussia after Brazilian Luiz Razia's money failed to materialise at the start of last season and has had the chance to dial himself into F1 in a lower-pressure environment.

The question is, what next? Bianchi himself isn't completely sure. But with ace manager Nicolas Todt and Ferrari in his corner, we can be reasonably confident that he will continue in F1 in 2015. As to where, it is currently unclear.

"I have no plans because I don't know what my future is at the moment, I wish I knew more," says the softly spoken Frenchman. "I'm just trying to stay focused on this year as it is important to finish well. I trust Ferrari and they trust me to do a good job. I'm just trying to be quick and consistent and show people I deserve to stay in Formula 1. The plan for me will be to, one day, get a Ferrari drive. This is my target."

If Bianchi is reckoned to be good enough for Ferrari, there is every chance he will be given the chance in one of the red cars somewhere down the line. On every race weekend, his performance is analysed by an engineer attached to the Ferrari Driver Academy, so there is a deep understanding of how well he is doing in roughly the same way that Red Bull is able to monitor the Toro Rosso drivers. He also has a total of 10 days of testing dating back to December 2009, so Ferrari knows plenty about its young prospect.

Several years ago, it was already sure that Bianchi had the race pace to match or even eclipse incumbent driver Felipe Massa, but there were question marks over his ability to deliver under pressure. That is an area where Bianchi has, unquestionably, improved.

"I'm totally different to what I was like in GP2," he says. "The speed is still there, but in GP2 I would struggle with tyre management. I also struggled to stay calm and made a few mistakes, it was the downside of my driving. I have improved a lot since. In the races this year, I am sometimes able to one-stop because I am looking after the tyres. As soon as I reached F1, I went up a step."

The cack-handed errors have certainly largely disappeared. There have been a couple of incidents

this year where he has earned penalty points, although when he was punished in Malaysia for hitting Jean-Eric Vergne's Toro Rosso as a result of a cut tyre, he was justifiably unimpressed. The trouble is, it's difficult to 'scale up' the performances of a driver in his position from the back of the grid to the front.

This just stresses the need, from a career point of view, for him to move on next year. While Marussia would do well to keep hold of him, Ferrari is likely to balk at the risk inherent in throwing him straight into one of its race seats without an intermediate step. A team like Force India, consistently in contention for points and occasional top six results, would be ideal. While Marussia is an excellent team, within the constraints of its budget, to leave him there for another year serves only to ask Bianchi questions he has already answered.

"Ferrari wants potential champions, the best drivers," says Bianchi. "I have to show them that I deserve a seat. The problem is that you need to be in a place where you can fight more often for points and this is difficult to show if you are in a car that

isn't able to do that, which I am sure Marussia could produce if they had more money. But the technology we have at the moment means they can see if I have the potential to be a champion or just an average driver."

Ferrari has the data to have a good idea, but it's impossible to simulate how a driver will perform under the highest pressure. For a driver like Bianchi, who has struggled with this at junior level, certainly after stepping up from F3, that's a difficult thing to prove.

But the most significant thing is that, after signing his first Ferrari deal in late 2009, he remains on its books. If it did not believe he had serious potential, he would not still be there in a fifth season. It might be a few more years before he is seriously in contention for a Ferrari seat.

After all, Felipe Massa, another Todt-managed driver that Maranello took a long-term interest in, raced in F1 for three seasons, plus a full season of testing, before getting his big break to develop into a world title challenger.

For Bianchi, if the opportunity is really there, it's just a question of taking it. ☒



**Bianchi's main  
target is now a  
Ferrari race seat**



# The story of Bernie's trial

**Formula 1 might have been enjoying its summer break, but things were still going on off-track.**

**DIETER RENCKEN** outlines the key details of the remarkable Bernie Ecclestone bribery-trial saga

**T**he settlement of the Bernie Ecclestone/Gerhard Gribkowsky (alleged) bribery affair by the Munich bench spelled an extraordinary ending to an extraordinary affair. Both the hearing and subsequent swift ending created headlines across the world, and proved once again that Formula 1's backstories still abound even when the sport is on summer vacation.

The story is a mirror of F1 itself: high stakes, evidence being given of secret meetings held in exotic locations between bankers, lawyers and the sport's supreme negotiator, money trails stretching across tax

havens galore as transfers made their ways from bank account to secret bank account, finally ending up in a trust (The Sunshine Foundation) in Austria.

Ironically the entire affair came to light not through the millions that flowed across continents, but as a result of an

investigation into the multi-billion euro collapse of mortgage lender Hypo Alpe Adria, acquired by Bayern Landesbank and managed by banker Gribkowsky, the high-flying, legally-trained son of a brewery executive.

When Adria collapsed, Bavarian-state-owned BayernLB

suspended its once-star banker on full pay (€500,000 a year), prompting intensive delving by the German media. The Sonnenschein Stiftung, founded by Gribkowsky in Salzburg with a donation of around £30 million, was reviewed during investigations. The trail led back to Ecclestone, not Adria.

After months of silence Gribkowsky claimed he had been bribed by Ecclestone – although during Ecclestone's hearing he 'forgot' exactly why – allegedly to massage the sale of BayernLB's then-47 per cent holding in F1's commercial rights to a buyer of Ecclestone's choice.



**Gribkowsky received eight-and-a-half years in jail**

BELEW/GETTY

Ecclestone left court  
after paying a case-  
ending \$100m



Ecclestone was back  
on duty in Hungary

COATES/LAT

**‘Ecclestone said he had not bribed Gribkowsky but had been a blackmail victim who had paid “the cheapest insurance policy”’**



F1's ringmaster put  
his defence team  
in charge in court

POOL/GETTY



Kirch Media once owned 75 per  
cent of F1's commercial rights

Private equity fund CVC Capital Partners was the eventual purchaser.

The bank had originally acquired its holding by default after Kirch Media, owner of 75 per cent of F1's commercial rights, went into the German equivalent of administration, owing a trio of banks a nine-figure sum. It was thus an unwilling owner seeking to cover its exposure.

For his part, though, the F1 tsar alleged he had been “shaken down” by the banker over his (and his family's) rather complex affairs, and had paid up because Gribkowsky insinuated he would otherwise get the British fiscal authorities to investigate his

tax affairs. Although Ecclestone said his affairs were in order, he did not want to get tied up in a lengthy investigation so he paid up.

Gribkowsky was sentenced to eight-and-a-half years in prison, and Ecclestone stood in the dock answering charges that he had bribed and embezzled. Crucially, Gribkowsky was described, as a then-employee of a state-owned bank, as a “civil servant”, and bribery of such an official ranks as an extremely serious offence in Germany.

Ecclestone's said that he had not bribed Gribkowsky, but had been a blackmail victim who willingly paid “the cheapest insurance policy I have ever seen” to prevent forensic audit of his family's billion-pound wealth.

In the end proceedings reached stalemate, with the state unable to prove matters either way, and unable to prove that Ecclestone was aware that Gribkowsky was even considered a civil servant.

Worse: the trail was nine years old, at least, and the accused well into his eighties and in declining health. All

this left Munich prosecutors in a quandary: here was a case in which one man had been sentenced after admitting to having been bribed, yet the man who had allegedly committed the act stood in court pleading innocence; convincingly portraying himself as blackmail victim in a foreign conspiracy...

As F1 headed for Hungary for the final grand prix before the sport's summer break, both sides feared the worst: Ecclestone that it would go against him; the prosecution that its charges would collapse. Expert evidence had been presented by both sides; it was simply too close to call.

When Ecclestone was first charged, CVC's board vowed to fire him should he be adjudged guilty of any crime, and thus there existed a distinct possibility that the sport would be left in turmoil should Judge Noll, who sent Gribkowsky down, pronounce the worst.

F1's boss came out fighting to clear his name, at first saying he would not avail himself of the (peculiar) legal provisions in Germany's legal code

that could secure freedom at a (substantial) price.

Under Section 153a of Germany's legal code accused parties are permitted to settle cases in exchange for fees forfeit to the State and/or a recognised charity, subject to the bench and all affected parties agreeing. Sums are set according to the severity of alleged offences and the accused's means, but are usually relatively trivial – a million or so quid at most – and alleged contraventions correspondingly minor.

Thousands of cases annually – possibly up to a quarter of all Germany's criminal trials – are resolved thus, begging the question of whether Gribkowsky, having had his foundation frozen, was simply too poor to ‘cut a deal’. However, having shied away from any deal pre-trial, when such settlements are traditionally struck, Ecclestone seemed set for the long haul – all 26 days set down for the trial.

On Hungarian Sunday, as he walked the grid pre-race, Ecclestone smiled enigmatically. According to ▶

# GOODWOOD REVIVAL



12 • 13 • 14 SEPTEMBER

For the latest event news follow us on [facebook](#) and [twitter](#)

Admission strictly by advance ticket only • For tickets or hospitality please call: +44 (0)1243 755055 or visit

[www.goodwood.com](http://www.goodwood.com)

► sources, a settlement in the region of £18m had been tabled. Despite earlier denials, it seems that amount was proffered at the outset, but rejected by the prosecution.

Negotiations reopened in July, ironically during the German GP. Ecclestone maintains prosecutors (this time?) opened negotiations.

“Too low” said the prosecution, desperate for a headline number to salvage a modicum of pride, of the £18m offer. They sensed that Ecclestone could be open to a deal, for in the event of conviction CVC would surely carry out its threat.

The Germans want headlines? He'd provide them, and, crucially, cut himself a 35 per cent discount. Thus he offered dollars despite the

prosecuting state being a staunch euro zone defender. \$100m (£60m) was his full and final offer – \$99m to the Bavarian state, \$1m to a hospice – with deadline four days hence.

It was rapidly accepted by prosecutors, themselves pleased to see the end of a sorry saga that dragged for a decade.

They accepted subject to BayernLB agreeing (see below). Asked by the judge whether he could “liquidate” such vast sums within the specified period (seven days of agreement), Ecclestone gave his landmark lopsided smile before nodding a firm “yes” in the direction of the bench. Case dismissed. The sum was due to be transferred as this story was written, after which the trial will

be officially abandoned.

BayernLB is, though, expected to demand at least £25m via civil action, for indications are that the sum paid to Gribkowsky had originally flowed to Ecclestone as commission for brokering said sale to CVC.

Following Gribkowsky's bribery admissions, BayernLB may have a case for its return – and possibly incremental damages. Recent media reports claim Ecclestone has made BayernLB a settlement offer, which has been rejected.

Further civil action from other aggrieved parties may follow; indeed, the court's statement specifically states that such proceedings are not prohibited by the \$100m deal. However, the settlement sets a record

Does CVC's Donald Mackenzie have a post-Bernie plan?



## ‘CVC is under the spotlight, criticised for having no structured succession plan in place’

by a not inconsiderable factor, suggesting Ecclestone was extremely eager to draw a line under this most unsavoury affair, which has severely tainted all those who came into its orbit.

That said, Judge Noll later stated that a conviction was unlikely, while Ecclestone subsequently said: “I was a bit of an idiot to do what I did to settle, because it wasn't with the judge, it was with the prosecutors.”

Furore predictably followed the deal, both in Germany and elsewhere.

“Paragraph 153a of Germany's code of criminal procedure seems to combine the solemnity of justice with the efficiency of the market,” wrote London's *Financial Times*, noting that a court spokesperson said Ecclestone was “neither acquitted nor convicted”.

“Where is the justice in this?” asked *Bild*, Germany's largest red-top, while former justice minister Sabine

Leutheusser-Schnarrenberger called it “effrontery [that is] not in keeping with the sense and purpose of our rule of law”.

Still, Ecclestone is a free man, although the fact that he shelled out two-and-a-half the indicted amount – ironically the same amount McLaren was fined in 2007 after being found guilty in ‘Spygate’ – in return for the case coming to an end will always leave people asking questions about this matter and Germany's judicial system.

CVC, too, is under the spotlight, criticised for having no structured succession plan in place and keeping Ecclestone at the helm of its most profitable company despite his age and the moments of crisis his absence from office caused the sport. Public statements from the ultimate controller of F1's commercial rights are totally conspicuous by their glaring absence.

Thus open questions to Donald Mackenzie, co-funder and chairman of CVC: what did your company learn from this experience? Does a formal, structured succession plan exist? When are you going to provide details to reassure the teams, their employees, sponsors and partners and F1's legion of fans? ❧



# BELGIAN GP PREVIEW

# Overcoming the problems of F1 weather forecasting

Second-guessing weather conditions can be tricky for drivers and engineers, particularly at a circuit like Spa. **CRAIG SCARBOROUGH** outlines the options available for set-up tweaking

**T**he rain is never far away at Spa, but because of parc ferme rules in Formula 1 today, there isn't the same scope for the full-wet set-ups of the past. Even so, there is a surprising amount that can be achieved simply by changing tyres and making in-cockpit adjustments.

It's rare for a weekend to be wet throughout, and much more common for rain to fall during a session or during the race. If teams knew for certain that a race was going to be wet throughout, they could compromise qualifying for a wet-race set-up. The risk with this is if the rain doesn't appear, that makes it a gamble. So changing car settings for wet sessions tends to be done within the limited parameters of parc ferme. The primary choice here is the tyre, as teams have the option of

an intermediate or full wet.

The biggest risk in the wet is aquaplaning. This can happen both with the tyres riding up over the surface water and losing all grip, and also with the car's underbody. The 30cm-wide plank under the car is the lowest point of the car and can cause aquaplaning.

In the old days a team would have to raise its car's rideheight to overcome this, but this is now done with larger-diameter wet-weather tyres. Both wets and inters are 10mm larger in diameter, raising the cars rideheight by 5mm each end – a significant lift considering the low rideheights used in the dry.

With wet-weather tyres fitted, the team can only make adjustments to the car through the steering wheel controls and front-wing flap angle. While this seems limited there is a wide scope of parameters that can be altered here.

The steering wheel has a multifunction dial to specify what tyres are fitted to the car. Dry, inter and wet settings tell the ECU what diameter tyre is fitted, which will alter various settings, such as the pitlane speed limit. Robert Kubica was once hit with a pitlane speeding penalty for failing to change this setting to account for the different diameter of tyres.

The driver can also change engine settings to soften the power delivery and ERS harvesting. Brake bias, throttle pedal maps and gearshift maps can also be softened for the conditions. Lastly, the driver's key handling/tuning option, the differential, can be adjusted for a different tightness on corner entry, mid-corner and corner exit. This will dial in/out understeer and traction issues.

Once the car is in the pits, the team can also alter the front-wing flap angle, adding more front downforce to suit conditions.

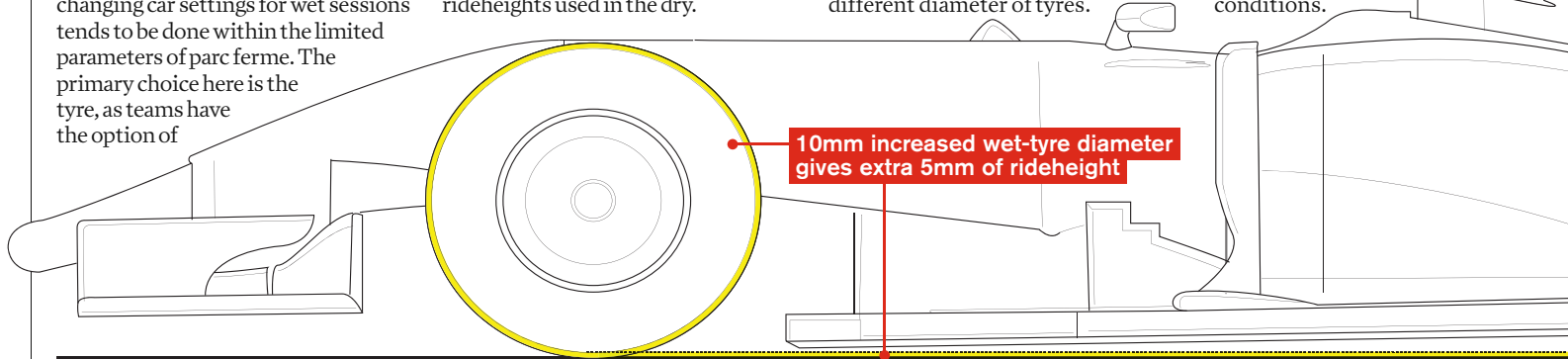

## TYRE PATTERNS

Intermediate pattern

Wet pattern

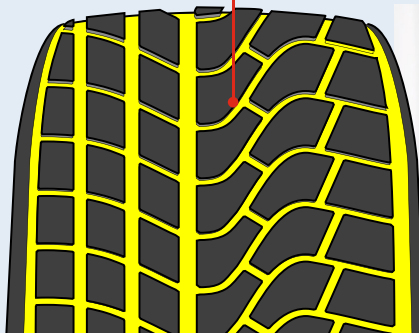
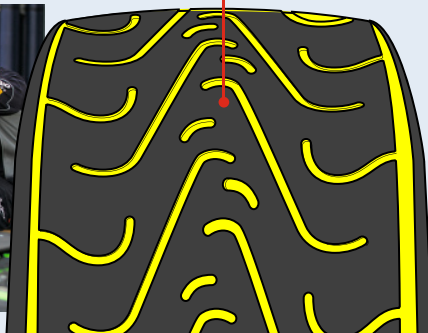

## WHAT TO WATCH OUT FOR

### Can Williams get back to the front?

The Grove team caused a stir by locking out the front row for June's Austrian Grand Prix and there's a chance it could repeat that form this weekend. The FW36 couples the Mercedes engine to decent downforce with minimal drag, so it should be really strong over the first and last parts of the lap.



THOMPSON/GETTY

### Will Kimi Raikkonen finally shine for Ferrari?

It's no secret Raikkonen has endured a tough return to Ferrari this season, but there were signs of improvement in Hungary last time out and the Finn is mega around Spa. Only two drivers (Michael Schumacher and Ayrton Senna) have won the Belgian GP more times than 'the Iceman'.



### More qualifying upsets?

F1 minnow Marussia made waves by getting both cars through to Q2 last year (alongside Giedo van der Garde's Caterham), thanks to some opportunist strategy. The fickle Ardennes weather always plays a role at Spa, so there could be further opportunities to embarrass the big teams this weekend.



## KEY INFO

**2013 winner**  
Sebastian Vettel (Red Bull)

**2013 pole**  
Lewis Hamilton (Mercedes) 2m01.012s

**UK Start times**  
FP1: 0900  
FP2: 1300  
FP3: 1000  
Qualifying: 1300  
Race: 1300

**Live TV**  
Sky Sports F1 & BBC

**Tyre allocation**



DRS zone

## CLASSIC RACE: 1970

Pedro Rodriguez recorded BRM's first victory in F1 for four years by narrowly beating Chris Amon's March at Spa.

Jackie Stewart's Tyrrell-run March dived for the lead with Amon early on, before Stewart's Cosworth engine blew.

Rodriguez moved his V12-engined P153 quickly up from the third row of the grid, and took the lead from Amon on lap five of 28.

Amon stayed close, even getting briefly back alongside when Rodriguez

slid wide on oil at La Source, but couldn't forge his way back ahead of the Mexican. Both drivers circulated below the lap record for the 8.76-mile circuit, with Rodriguez winning by a scant 1.1 seconds.

Jean-Pierre Beltoise (Matra) completed the podium after Jochen Rindt's Lotus blew its engine early on, Jack Brabham's eponymous BT33 broke its clutch, and Jacky Ickx's Ferrari lost a lap thanks to a late fuel leak.



Seaman was only Brit  
in the crack Mercedes  
squad of the 1930s  
(below, right)



FELLOWES/LAT

24

# Why go to Brooklands when you can

It's 75 years since Britain's first Mercedes grand prix star died in the Belgian Grand Prix. **PAUL FEARNLEY**

**S**o, wealthy, ambitious and perhaps naive at just 21, he hitched his trailer and headed for Moravia. And when his Lagonda tow car buckled, he borrowed an aged Fiat from fellow charmed adventurer Whitney Willard Straight to complete the journey to Czechoslovakia's heartland. There, he encountered an 18-mile road circuit so narrow that its grid formed two-by-one – at a time when cars started three abreast in Monaco – and for four hours he met its challenge with an assurance, smooth style and natural speed that had already marked him out.

Chichester-born Richard John Beattie Seaman was special. Having contested a modicum of races at Brooklands and Donington Park, he hired Straight's MG K3 Magnette and plunged into Europe. Brno, where he finished fifth, was his fourth overseas outing of 1934. His first, at Albi in France in July, resulted in a retirement plus a fine for a push-start. His second, the Coppa Acerbo Junior at Pescara, another madcap circuit, brought him a fine third place. And his third resulted in a remarkable victory.

Bremgarten in Switzerland was one tree-lined sweeping bend after another, some downhill and cobbled. It separated the great from the good – and was to become the tall Englishman's favourite. Its Prix de Berne, the season's most important voiturette race (for supercharged cars up to

1500cc) attracted a huge field, and Seaman started from the back of the balloted grid. Despite also giving away 400cc to his opposition, and despite – and also probably because of – heavy rain, he won the 63-miler by 23 seconds.

Though his euphoria would be swiftly extinguished by the death of talented team-mate Hugh Hamilton, driving Straight's Maserati 8CM in the subsequent Swiss Grand Prix, Seaman pressed on in the pursuit of his dream. He'd given up a place at Trinity College, Cambridge and, in all likelihood, a comfortable and lucrative job in the City for this.

In 1935 he became the owner of an ERA, albeit within the compass of the works team. After several early disappointments, he wrote it a polite but unequivocal letter outlining why he was going it alone, albeit with vastly experienced Giulio Ramponi as his chief mechanic and guiding light. Victories came thick and fast thereafter: at Pescara, Berne and Brno.

Seaman was then persuaded by Ramponi to buy a car that was 10 years old, and which he had beaten often. This calculated risk paid huge dividends. Not only was the reworked GP Delage as fast as the ERAs and Maseratis, but also its frugality enabled it to survive on fewer pitstops. Again there were some early snafus – a hasty spin from the lead at the Nurburgring, a crash because of steering failure in the Picardy GP – but dominant wins on the Isle of Man, and at

Pescara, Berne and Donington Park, in addition to a Donington GP victory co-driving Hans Ruesch's Alfa Romeo 8C35, convinced Mercedes-Benz to invite Seaman to its October Driving School at the Nurburgring.

Twenty-seven hopefuls attended, 14 were allowed to drive the GP car, and Seaman was head and shoulders, literally and figuratively, the best. He stood on the verge of becoming a fully fledged GP driver for arguably the greatest team – once Adolf Hitler consented to it. Global politics and motor racing during the 1930s was an iron first in a light-alloy glove, the incredible Silver Arrows an unmistakable symbol of the Third Reich's intentions and capabilities. Seaman the racing driver was determined to make the most of his

**'Frustration building, Seaman began to doubt the team's motives, and suspected that time was against him'**



Fine performances in ex-grand prix Delage attracted attention



Seaman was rapid in the wet at Spa before fatal crash

# go to Brno?

remembers Richard Seaman

golden opportunity. Seaman the human being was torn. But, on the basis that he could always walk away, he marched in.

The transition from 170bhp to 550 was not straightforward and a pre-season testing crash at Monza broke a kneecap and put him on the back foot. He was obviously the number four alongside vastly experienced favoured son Rudolf Caracciola, aristocratic and charismatic Manfred von Brauchitsch and brilliant blue-collar hero Hermann Lang, but the Englishman abroad impressed with his mechanical understanding, sense of fair play and prowess. He was lucky to survive a crash that killed Auto Union's Ernst von Delius at the German GP, and he blotted his copybook by wrecking a W125 in practice at Pescara, but his was a busy, productive and promising debut season at the highest level.

His second brought him fewer chances to shine – and his greatest victory: perhaps the most symbolically loaded win in the sport's history.

Hard-pressed by the introduction of a new formula, Mercedes-Benz was unable to provide Seaman with a car until July's German GP. Yet he qualified third and sat resolutely in leader von Brauchitsch's wheeltracks, causing Manfred to complain at his first pitstop. Seaman's different strategy – a longer first stint and a shorter second – helped him increase the pressure as their final stops approached.

An errant slosh of witch's brew ignited with an

insidious whumpf! and von Brauchitsch bailed and rolled to extinguish the invisible flame. Seaman's car was heaved back and his mechanic withstood the heat to slot the starter into its nose. Whereupon the Englishman waited for the signal to resume; he had been ordered to follow after all. His subsequent success would be more convincing than his half-hearted Hitler salute on the podium and the carefully worded report to the Fuehrer.

Having qualified fastest at his beloved Berne, Seaman also led the Swiss GP in a downpour before giving best to Caracciola, the master of such conditions, in a newer specification of car. At Monza, he was dicing with Tazio Nuvolari, now at Auto Union, for second place when his engine failed. And at Donington Park, hopes of a home victory were dashed when he spun on a backmarker's oil; he recovered to finish third.

By 1939, Seaman was sure he had the better of von Brauchitsch and Lang, and confided the fact to Ramponi. (Caracciola, he respected.) Political tensions within and without the team were taut. 'Caratsch' and 'Brauch' were in cahoots, and though Seaman got on well with Lang, he was clearly the outsider. He had to sit out the Pau GP despite being fastest in practice and cooked his clutch at the start of the Nurburgring's Eifelrennen.

Frustration building, he asked Ramponi to act as his unofficial lap-timer at the Belgian GP. He was beginning to doubt the team's motives. The wise Italian declined, however, and told his

former charge to listen to team manager Alfred Neubauer to gain more experience. The 26-year-old, though, was ready to step up – and suspected that time and circumstance was likely against him.

Still, he drove beautifully at Spa in late June: patient as Lang struggled ineffectively amid the spray of the leading Auto Union of Hermann Muller; and observant and reactive when Caracciola spun and stalled because of its cloaking effect. Finally freed from it when Muller refuelled, Seaman drew steadily away until conditions improved and Lang upped his pace.

Exiting the fast left-hander before La Source on lap 22 – and still holding a 20-second lead – Seaman slid wide and clipped a tree with his tail. This flicked him into a sickening impact amidships with a second tree. The Merc twisted around it, bursting a fuel coupling and trapping Seaman in a shimmering inferno. A Belgian soldier did his utmost but didn't know how to release the large steering wheel that pinned its driver. The concussed Seaman, an arm broken and kidneys bruised, suffered third-degree burns and would succumb in hospital that night.

He had lived, thrived and died in dangerous times. Had it not been a Merc, it might have been a 'Hurry' or a 'Spit'. A keen pilot, Seaman could very well have been one of The Few wheeling above the Weald in the deadly blue-sky summer of 1940. Fate decreed, however, that he would forever remain rarer yet. ❧

# DRIVING T

With the all-electric Formula E series' inaugural race fast approaching, electric car enthusiast and

## TRACK TEST

**SPARK-RENAULT SRT\_01E**

**CIRCUIT** Donington Park GP

**DATE** August 5

**DRIVEN BY** Alexander Sims

**PHOTOGRAPHY** Alastair Staley/Sam Bloxham/LAT

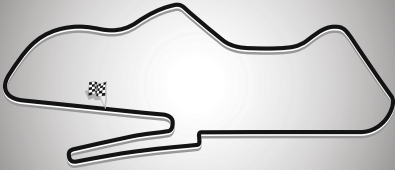

26

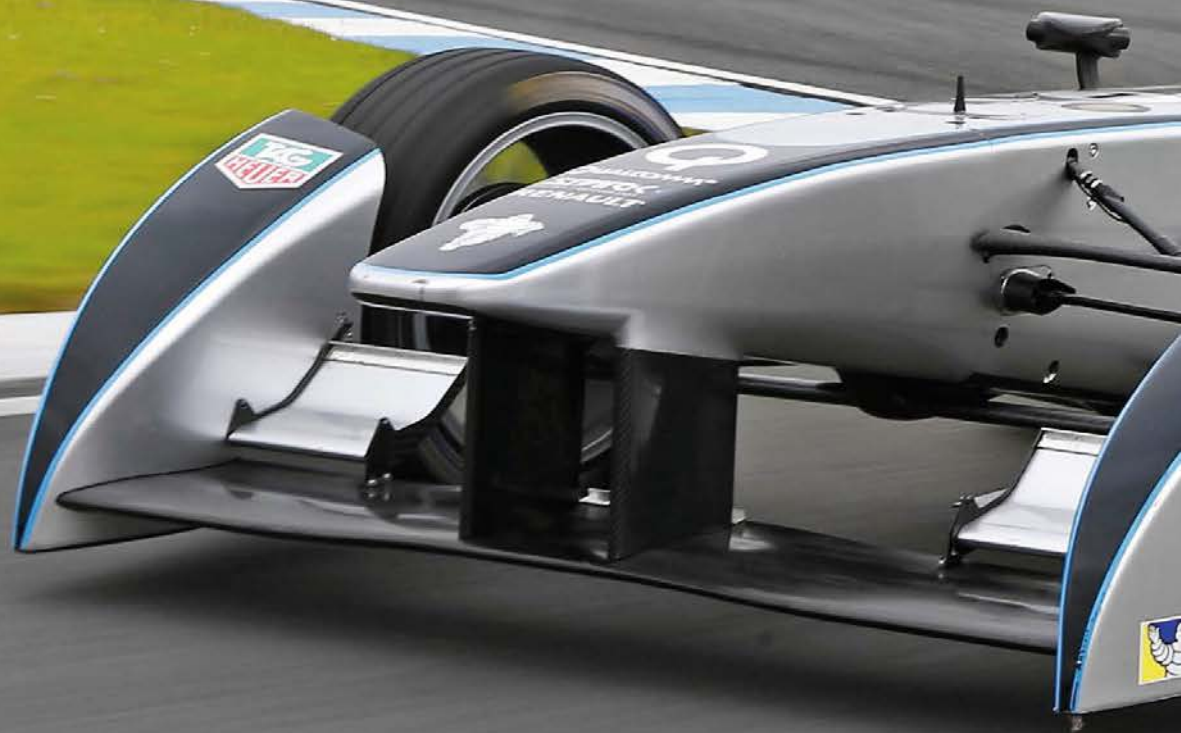

# WE FUTURE

factory BMW driver **ALEXANDER SIMS** puts the new Spark-Renault through its paces at Donington





Sims gets some last-minute advice from Spark crew

**I**would not classify myself as a tree hugger. But while I am a racing driver, away from motorsport I try not to be wasteful. Having solar panels on the roof of your house to produce electricity for your home and power your car just makes sense to me. That's why I brought a Tesla Roadster almost three years ago and now also have a BMW i3 that I use for almost all of my journeys.

Once you incorporate using an electric car into your life, it is very easy to use. And that's a lesson that motorsport is just starting to learn. I accept that we will run out of oil at some point, so why not make the transition sooner rather than later? It's something I have a keen interest in and am a trustee of the Zero Carbon World charity, which works for carbon reduction and sustainability.

Given that I make probably 95 per cent of my journeys by electric car, the opportunity to test the new Spark-Renault SRT\_01E that will be used in the Formula E Championship was one that I could not refuse. The championship has certainly attracted a lot of media attention, as well as some high-profile drivers like Jarno Trulli, Nick Heidfeld and Sebastien Buemi. With the first race on September 13 in Beijing fast approaching, participating in the test programme for a day at Donington Park offered a fascinating insight into a bold new initiative.

Unlike a current

Formula 1 car, which has a hybrid engine, the Formula E car is all-electric. The motor puts out a maximum of 200kW, around 270bhp, which is available in the flat-out qualifying mode. In race trim, it runs at 150kW, around 200bhp, which is comparable to a Formula Renault 2.0 car.

While it looks very different to the average single-seater, especially with the bodywork off thanks to the large battery behind the driver, which weighs 320kg including all of the ancillaries, once you get up close it's very familiar. It's a Dallara chassis, so you know that it's a well-designed car.

Before the test, I already had some understanding of what sort of performance level to expect having seen a previous test day. But it's not until you get behind the wheel that you really get a feel for the car. Even then, it will only give some idea of what the car will be like once it starts racing, because the sweeps of Donington are very different to the short, sharp street circuits that will fill the calendar.

For the first race-length run of eight laps, it's damp but the first impressions are that it is genuinely fun to drive and you do feel that you have a proper amount of grip in the corners. But as I get into the second run, it becomes much more complex and I find myself having to think about things a lot more.

In a normal racing car, fuel-saving isn't demanding. All you have to do is lift off 100 metres before a few corners and that should save you just enough fuel to make



Dallara tub is a familiar office for our test pilot



the extra lap you need during an endurance race.

But in Formula E, there is something else to think about on top of simply how much energy you have in the battery. This is because you can harvest energy from the rear wheels under braking by switching into 're-gen' mode. This reverses the motor and charges the battery. At a track like Donington, for some corners activating re-gen, using a paddle mounted on the steering wheel, is enough to slow the car. This is an area where you can clearly see there is room for development in the future, because it would make sense to have motors on the front wheels. Even if you didn't use them to create four-wheel drive, you could get more energy because in a standard racing car, the brake bias is normally around 57-58 per cent forward.

But it's not simply a case of using re-gen all of the time. It's about the driver and engineers working out when best to use the energy as it may be that it's ultimately quicker to lift and ▶



Sims presses on through the tight Melbourne Hairpin

# WHAT IS FORMULA E?

The new Formula E series is the first international circuit-racing championship for all-electric cars. It will be held over 10 events exclusively on street circuits, including Monaco, Berlin, Long Beach and a season finale on the streets of London next June.

The series is the brainchild of Spaniard Alejandro Agag, who has been a keen investor in motorsport over the years, notably in the Barwa Addax GP2 squad. Ten teams will contest the inaugural season, each entering two drivers, with high-profile squads



such as DAMS, Andretti Autosport and Abt coming on board, along with a team entered by 2004 Monaco Grand Prix winner Jarno Trulli. This has also attracted a high-quality field, half of which has raced in Formula 1.

The Spark-Renault SRT\_01E is built by Spark Racing Technology, headed up by Frederic Vasseur, the man behind the crack ART junior single-seater team. Dallara provides the monocoque, McLaren Electronics Systems the motor and electronics systems, and Williams Advanced Engineering the Rechargeable Energy Storage

System (RESS), effectively the battery.

The weekend format is simple. A one-hour free practice session followed by a 90-minute qualifying session, divided into four groups of five cars, with the full 270bhp of the car available for use. Because the car's range is not sufficient to complete the full race distance, each driver will change cars midway through.

While Formula E is a spec-series for now, the battery supply and powertrains will be opened up in future, with the aim of driving advances in green technology.



Sims reports that car is balanced despite weight of batteries



## ALEXANDER SIMS

The winner of the 2008 McLaren AUTOSPORT BRDC Award, Sims tested one of the Woking squad's Formula 1 cars as part of his prize two years later. This season, he has focused on sportscar racing and has become a BMW factory driver, competing in the British GT Championship and selected international endurance events. Prior to this switch, he was a rising star in single-seaters, winning races in both the F3 Euro Series and GP3 after excelling in Formula Renault 2.0 in 2007 and 2008.

► coast rather than braking late with full re-gen. That makes it a very complex equation. And it also has an influence on the car dynamically, because you always want to get the front-end pitched down to have the grip to turn in and then rotate the rear into the corner.

But you have an extra phase here with re-gen, because you can disengage that after the initial turn-in. So using that to get the rear moving well on turn in is going to be important. That's what makes the Formula E car more difficult to get the most out of quickly than a conventional racecar. Even after a few runs, I'm miles away from getting it right!

As you'd expect for a single-seater with carbon discs, the brakes stop the car very well. On my first outlap, in the damp, I had a massive stab on the brakes between McLeans and Coppice without re-gen initiated to see what its braking potential is. And it slowed damned well! On the mechanical side, its braking capabilities are spot on.

There is no escaping the fact that the top speed of the car, which is limited to 140mph, is nothing extraordinary and the power is low. It's not a GP2 car by any means. But I still had a smile on my face driving because it is enjoyable. There is so much potential there for good drivers to gain massively if they really master the car because you are dealing with so much complexity.

In terms of corner speed, it's good. Certainly it's not worse than a Formula Renault 2.0. Even though the car I tested wasn't perfectly set up, it still gives you the confidence to push. There's a lot of weight at the back, the battery/motor and ancillaries total 320kg but that doesn't make the car feel unusual dynamically. There is perhaps a little more of a pendulum effect. Early on, if I drove over a damp patch the rear would brake away and you could feel it then. But, equally, I'd have had re-gen on anyway so the rears would be trying to slow more than the fronts. It's certainly

not glaringly obvious and the car is well-balanced. The all-weather Michelin 18-inch tyres also perform well, certainly not like wet tyres being used in the dry.

To help manage the energy, there is a lot of information on the dash. There is the running lap consumption, the state of charge, the energy left in the battery for the race distance, which tells you what you have left to play with. Also, there is a delta showing you whether you need to save energy or you can use a little more. It proved difficult to keep this on budget because as you get quicker in the car, so you use more energy even if you are taking measures to save it! Races will be won or lost based on who can do this while still driving quickly. You can also adjust the torque maps on the steering wheel.

During the race runs, I was also able to experiment with the fanboost. Controversially, this will be used by just two drivers per race based on a fan vote, but it's a good way to get people involved. This gives you a total of five seconds of full power during the race, so a boost of 25 per cent.

The five seconds is split across the two cars, so effectively offers two separate boosts for 2.5s. It has a significant impact, but it's not something you are going to be able to use just to get a free



Battery charge is key steering wheel info



**TECH SPEC**

- MONOCOQUE** Dallara carbon/aluminium honeycomb
- LENGTH** 5000mm
- WIDTH** 1800mm
- TRACK WIDTH** 1300mm
- RIDEHEIGHT** 75mm (max)
- MINIMUM WEIGHT** 888kg
- FULL POWER** 200kW (270bhp)
- RACE POWER** 150kW (200bhp)
- 0-62MPH** 3 seconds
- MAXIMUM SPEED** 140mph
- MOTOR** McLaren Electronics Systems
- BATTERY** Rechargeable Energy Storage System (RESS) by Williams Advanced Engineering
- GEARBOX** Hewland paddleshift five-speed sequential with fixed gear ratios
- TYRES** 18-inch Michelin all-weather

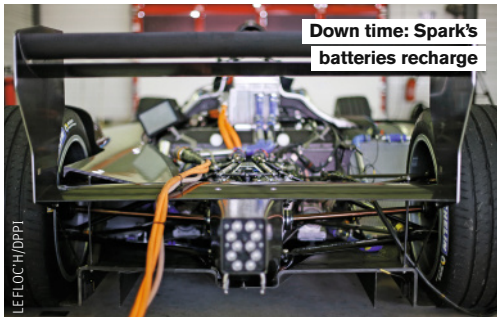

Down time: Spark's batteries recharge

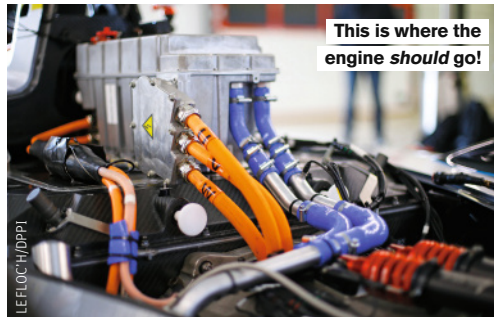

This is where the engine should go!

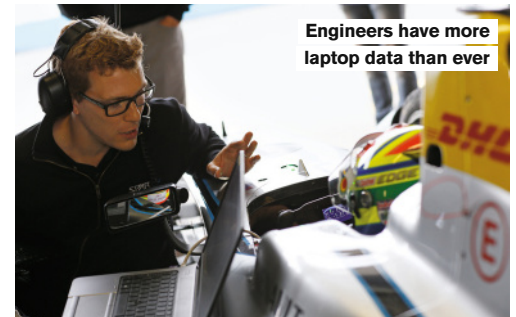

Engineers have more laptop data than ever

**“The intelligent and adaptable drivers will have an advantage because of the complexity”**

pass from 15 car-lengths behind. You will need to be dicing with someone and then use it at exactly the right time to get ahead. It's activated by a paddle on the left side of the steering wheel, opposite the one for initiating re-gen.

At the end of the day, I was able to try out a qualifying run. This is a lap on full-power and a good chance to feel the car's raw performance. The one-lap element of it really puts the pressure on the driver. It was exciting seeing the motor temperature rise during my lap and trying to manage it so I could get as much lap time as possible. I found that if you get the motor to the upper temperature limit then it reduces the re-gen, so your brake bias effectively changes. This caught me out once and made me realise again that as a driver you really have to keep thinking even on a single qualifying lap.

As I got out of the car, it occurred to me that it's going to be very difficult to balance up how you use your hour of free practice time on race weekends. Do you focus on setting the car up for the race? By that I don't so much mean aerodynamic setup, for there are limited changes you can make with the flaps available, but how you use your power. Or do you work towards qualifying? This is another area where the intelligent and adaptable drivers will have an advantage.

The most important thing to remember about this car is that it's a starting point. It's sensibly fast, but by no means groundbreaking in terms of pace. Some of the drivers competing are used to 800bhp or more in F1 cars or LMP1, but the complexity of driving the Formula E will keep them interested. After all, it doesn't

necessarily matter what laptime you are doing as long as it is tough.

But what you have to keep in mind is the potential. Electric cars are on the road already and can be used by the general public to go about their daily lives without issue, but when you push the performance envelope and take the technology onto a racetrack, issues will be faced and the technology will quickly improve.

This is perhaps why some drivers have been keen to get in on the ground floor. While for the first season it is a spec racecar, for the following year it will be opened up for manufacturers to produce their own motors and batteries. People will want to harvest more energy, technology will improve and there will be ways to make the cars quicker, which means the future potential of this car is very clear. ❧

# INDYCAR

## Milwaukee (USA)

August 17

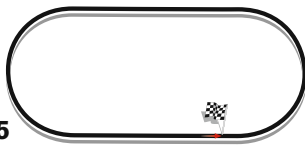

Round 13/15

### RESULTS

250 LAPS, 253.75 MILES

<b>1</b>	<b>WILL POWER (AUS)</b>	<b>1h44m49.4611s</b>
Team Penske Dallara-Chevrolet; Grid: 1st-169.262mph		
<b>2</b>	<b>JUAN PABLO MONTOYA (CO)</b>	<b>+2.7949s</b>
Team Penske Dallara-Chevrolet; Grid: 3rd-168.579mph		
<b>3</b>	<b>TONY KANAAN (BR)</b>	<b>+7.2356s</b>
Chip Ganassi Racing Dallara-Chevrolet; Grid: 2nd-168.662mph		
<b>4</b>	<b>SCOTT DIXON (NZ)</b>	<b>+18.8058s</b>
Chip Ganassi Racing Dallara-Chevrolet; Grid: 11th-166.742mph		
<b>5</b>	<b>JOSEF NEWGARDEN (USA)</b>	<b>+22.4998s</b>
Sarah Fisher Hartman Racing Dallara-Honda; Grid: 5th-168.233mph		
<b>6</b>	<b>RYAN BRISCOE (AUS)</b>	<b>+23.4954s</b>
Chip Ganassi Racing Dallara-Chevrolet; Grid: 4th-168.266mph		
<b>7</b>	<b>SIMON PAGENAUD (F)</b>	<b>+24.0347s</b>
Schmidt Peterson Hamilton Motorsports Dallara-Honda; Grid: 16th-165.818mph		
<b>8</b>	<b>MIKHAIL ALESHIN (RUS)</b>	<b>-1 lap</b>
Schmidt Peterson Motorsports Dallara-Honda; Grid: 15th-165.851mph		
<b>9</b>	<b>ED CARPENTER (USA)</b>	<b>-1 lap</b>
Ed Carpenter Racing Dallara-Chevrolet; Grid: 7th-167.775mph		
<b>10</b>	<b>JACK HAWKSWORTH (GB)</b>	<b>-1 lap</b>
Bryan Herta Autosport Dallara-Honda; 17th-165.614mph		
<b>11</b>	<b>HELIO CASTRONEVES (BR)</b>	<b>-1 lap</b>
Team Penske Dallara-Chevrolet; Grid: 8th-167.561mph		
<b>12</b>	<b>SEBASTIEN BOURDAIS (F)</b>	<b>-1 lap</b>
KVSH Racing Dallara-Chevrolet; Grid: 18th-164.421mph		
<b>13</b>	<b>MARCO ANDRETTI (USA)</b>	<b>-1 lap</b>
Andretti Autosport Dallara-Honda; Grid: 9th-167.079mph		
<b>14</b>	<b>GRAHAM RAHAL (USA)</b>	<b>-1 lap</b>
Rahal Letterman Lanigan Racing Dallara-Honda; Grid: 14th-166.032mph		
<b>15</b>	<b>TAKUMA SATO (J)</b>	<b>-2 laps</b>
AJ Foyt Racing Dallara-Honda; Grid: 10th-166.915mph		
<b>16</b>	<b>CHARLIE KIMBALL (USA)</b>	<b>-2 laps</b>
Chip Ganassi Racing Dallara-Chevrolet; Grid: 6th-168.123mph		
<b>17</b>	<b>JUSTIN WILSON (GB)</b>	<b>-2 laps</b>
Dale Coyne Racing Dallara-Honda; Grid: 12th-166.501mph		
<b>18</b>	<b>SEBASTIAN SAAVEDRA (CO)</b>	<b>-4 laps</b>
KV AFS Racing Dallara-Chevrolet; Grid: 21st-162.535mph		
<b>19</b>	<b>JAMES HINCHCLIFFE (CDN)</b>	<b>-6 laps</b>
Andretti Autosport Dallara-Honda; Grid: 13th-166.195mph		
<b>20</b>	<b>CARLOS HUERTAS (CO)</b>	<b>-7 laps</b>
Dale Coyne Racing Dallara-Honda; Grid: 22nd-159.787mph		
<b>21</b>	<b>RYAN HUNTER-REAY (USA)</b>	168 laps-suspension
Andretti Autosport Dallara-Honda Dallara-Honda; Grid: 19th-164.211mph		
<b>22</b>	<b>CARLOS MUNOZ (CO)</b>	130 laps-accident damage
Andretti Autosport-HVM Dallara-Honda; Grid: 20th-164.013mph		

Winner's average speed: 145.249mph. Fastest lap: Newgarden, 22.5979s, 161.704mph. All drivers in Dallara DW12.

### CHAMPIONSHIP

<b>1</b>	<b>POWER</b>	<b>602</b>	<b>6</b>	<b>DIXON</b>	<b>472</b>
<b>2</b>	<b>CASTRONEVES</b>	<b>563</b>	<b>7</b>	<b>KANAAN</b>	<b>425</b>
<b>3</b>	<b>PAGENAUD</b>	<b>510</b>	<b>8</b>	<b>MUNOZ</b>	<b>424</b>
<b>4</b>	<b>HUNTER-REAY</b>	<b>494</b>	<b>9</b>	<b>BOURDAIS</b>	<b>418</b>
<b>5</b>	<b>MONTOYA</b>	<b>488</b>	<b>10</b>	<b>ANDRETTI</b>	<b>400</b>

#### POINTS SYSTEM EXPLAINED:

50-40-35-32-30-28-26-24-22-20-19-18-17-16-15-14-13-12-11-10-9-8-7-6 for the top 24, with 5 for all other starters. 2 points for leading the most laps, 1 point for leading at least one lap, 1 point for pole position.



Short ovals present own set of challenges

# Power makes short work of Milwaukee

Australian adds win on classic short oval to list of accomplishments, while his main title rivals fall by the wayside. **By MARK GLENDENNING**



WE'RE A COUPLE OF WEEKS SHY OF BEING ABLE TO talk about Will Power's win at Milwaukee in the context of the championship, but regardless of what happens over the final two races, last Sunday will go down as a milestone in the Penske driver's career.

In terms of pure speed, Power has been the best driver in the field this season, yet he's not been without some fairly obvious weaknesses – notably, a propensity to lose races through cheap penalties. An unscientific count of the number of potential wins squandered to sanctions for pitlane speeding or blocking stands at five. And that list includes the double-points races at Indianapolis and Pocono.

Power has quietly got that under control in recent weeks, but an asterisk still remained alongside his name. Even as he has continued to climb up IndyCar's all-time victory list, his tally didn't include a short track. At least not until Sunday.

So the fact that Power has added Milwaukee to his successes is significant in that it points to the maturation of a driver in a series that rewards versatility like no other. It might seem strange to be talking of maturity after a race in which Power was late to his press conference because he had to have cream puff filling extracted from his ears (see story, page 35), but he was under no illusions as to the significance of the result.

"I don't have any weaknesses any more," he said. "It's just a matter of executing on the weekend."

Power certainly executed on Sunday. He started from pole and led 229 laps, but that makes the result sound far more straightforward than it was.

Milwaukee last Sunday was a rare example of a fuel race that didn't look like one. And not just fuel,



Fuel top-up stop spoiled Newgarden's podium chances

but tyres. Pretty much to a man, the drivers had been talking about the rapid drop-off in their rubber's performance on Saturday. However, it was hoped this would be alleviated to an extent by the cooler temperatures that were expected on raceday.

As it transpired, Sunday was almost as warm, and everyone was routinely in a world of hurt about five laps into each stint. This ran totally counter to the basic aim of fuel saving – ie, staying out as long as possible – because the difference between old tyres and new ones was anything up to 5mph.

Power himself offered a vivid example of this when he was able to run several laps longer than the pursuing Tony Kanaan during the first stint, only to be easily leapfrogged by the Brazilian because he'd conceded so much time on old rubber.



**Power leads pack  
around crowded  
Milwaukee Mile**



**Long final pitstop  
left Kanaan third**

What happened next helped determine the outcome of the race. Kanaan led for the next couple of dozen laps, and then took advantage of the race's only caution (when Carlos Munoz tagged the wall) to pit. Almost the entire field followed suit, leaving just Power — now in the lead — Josef Newgarden and Marco Andretti on track, shod with tyres 20 laps older than the cars immediately behind them.

Kanaan, leading the line of cars on new rubber, made short work of Andretti and Newgarden, but his attempts to reclaim the lead were rebuffed. Soon, he became tangled in lapped traffic, during which time any tyre advantage he had was lost.

"I couldn't pass Power and I had better tyres," Kanaan said. "That's when I said, 'If nothing goes wrong with him, I don't think we can win.'"

Indeed, Kanaan would eventually fade to third due to a slightly long final pitstop, which allowed Juan Pablo Montoya to jump ahead of him and create a whole new set of problems for Power.

Penske doesn't do team orders, and Montoya is among those still mathematically in contention for the title himself. So the fact that he's Power's teammate would have given the Australian zero comfort when he looked in his mirrors and saw Montoya's car looming large midway through the final stint.

The deciding factor would be whose car was better at navigating traffic, and in this regard Power had Montoya comfortably shaded. A 2.5s gap was swiftly whittled down to around 0.5s, but then blown back out just as quickly as the Colombian got trapped behind lapped cars. This was a cause of



**Montoya (left) and  
Kanaan give Power  
a victory shower**

some chagrin to Montoya (see story, p35), but even with a clear track he didn't think he had quite enough pace to challenge Power.

"I had a really good car," said Montoya. "But I really killed my tyres trying to pass traffic. You start sliding those fronts, and they never recover. If you'd asked me at the beginning of the year if I'd be mad after a second-place finish, I'd have said, 'You're crazy'. But here I am."

Power had traffic problems of his own late on when he got stranded behind Simon Pagenaud. He admitted that he "didn't know what Pagenaud was doing", but otherwise took the traffic problems in his stride.

"It's short-track racing," he said. "That's how it is."

Power's win underlined his admission to a select group of drivers genuinely capable at winning at every kind of track on the IndyCar schedule.

"It's a race I had in my mind all year that I wanted to win," he said. "It was just one of those days — a perfect day. We worked hard on the car in the test, and I was really determined to have a very good racecar, and this is what we got."

Scott Dixon capitalised on an aggressive strategy to finish fourth for a Ganassi 3-4, but he was still ruing a missed opportunity in qualifying that had forced him to get creative in the first place.

"In the middle part, we split up one of the stints and went onto new tyres when everyone else was on the ragged edge, and that's probably where we made up five or six spots," said Dixon. "It was just a track position race. We had a super-fast car, and I think if we'd started up the front, we would have been right up there."

Another guy who could have been "right up there" was Newgarden, who'd remained in the top three until the dying laps when he was forced to pit for a top-up of fuel.

"I don't know [if I could have made it on fuel]," he said. "We gambled, and that's what you have to do in this series. We worked really hard this weekend. A podium would have been sweet, but top five isn't bad."

That was certainly more than a couple of the championship contenders managed. Helio Castroneves was compromised in qualifying by drawing one of the early slots, meaning that he had to run without the benefit of feedback about what the track was like, but on Sunday he was still out to lunch on set-up. That he was satisfied to finish a lap down in 11th speaks volumes.

"If I finished without crashing today, it was a good day," said the Brazilian. "In Turns 1 and 2 the car wasn't bad. Unfortunately, there are two other corners."

Castroneves' only consolation came from the fact that Ryan Hunter-Reay's day was even more miserable. It started promisingly, with the Andretti driver carving his way into the top six after starting from the second-last row, but a random suspension failure undid all his efforts. ▶

# THE RACE IS US!



FROM START ...

**rgmmc.com**  
Advancement In Motorsport

... TO FINISH



4FLAG SAFETY



LIVE TV AND WEB-STREAM



ORGANISATION



RACE-CONTROL



PROMOTION AND MEDIA



TIMEKEEPING AND LIVE-TIMING

EACH SERVICE NOW AVAILABLE **FOR HIRE & SALE**

### ABOUT OUR SERVICES

OUR SERVICES AND OFFERS ARE AVAILABLE AS TOTAL PACKAGE AND SINGLE FEATURES. PLEASE CONTACT US FOR FURTHER INFORMATION!



### RGMMC ESTABLISHMENT

AN DER HALDE 3 • 9495 TRIESEN • LIECHTENSTEIN  
TEL: +423 230 21 50 • FAX: +423 230 21 52  
INFO@RGMMC.COM • WWW.RGMMC.COM

**BRANDS HATCH GP**  
**30/31 AUGUST**

0843 453 9000  
WWW.BRANDSHATCH.CO.UK

Adult advance admission tickets from £18. See online for details\*  
\*Advance tickets available until midday Wednesday 27 August 2014. Booking fee applies.

**ALSO FEATURING**

- Avon Tyres British GT Championship
- Formula 3
- BRDC Formula 4 Championship
- GINETTA GTS CHALLENGE
- VOLKSWAGEN RACING CUP
- CHAMPION OF BRANDS

**BOOK NOW AND SAVE UP TO £14\***  
**KIDS 12 AND UNDER GO FREE!**

BrandsHatch

## IN THE PADDOCK



Power has proved his versatility

## MARK GLENDENNING INDYCAR CONTRIBUTOR

@m\_glendenning



EVERY DRIVER LOOKS HAPPY WHEN they win. Will Power, however, really wears his heart on his sleeve, and it's apparent that some victories are especially sweet.

The Australian's extraordinary win in the inaugural Baltimore race of 2011, when he basically reeled off a stint full of qualifying

laps on a ridiculously tricky street course was one example. Texas that same year, his first win on an oval, was another.

Now add Milwaukee 2014. Victory here brought Power level with Bobby Rahal on the all-time list, which seems extraordinary, but only because no other driver has worn their weaknesses as prominently as their strengths in the way he does. It's so easy to pick out his shortcomings – if you can't, he'll tell you what they are – that there's a danger of forgetting just how good he is.

Milwaukee proved that Power is one of the select cluster of drivers who can win

everywhere. The fact that he's "the weirdest guy in the paddock", as one of his rivals recently (and affectionately) described him, is just a bonus. But all of the one-liners hide a driver who is constantly processing, adapting and evolving.

The double points on offer at Fontana make any talk of the championship premature, but there is no arguing with Juan Pablo Montoya's assertion that, one way or another, Penske deserves it this year. And of Penske's three drivers, none at this point deserves it more than Power. Now it's up to him to finish the job.

## Montoya and Kanaan condemn backmarkers

### JUAN PABLO MONTOYA AND

Tony Kanaan were both highly critical of uncooperative lapped traffic following the Milwaukee race.

Each of the two drivers was hampered by having to negotiate backmarkers while trying to close down the leader Will Power. Montoya, indeed, was driven to say that changes needed to be made.

"We've really got to come up with a formula," said the Colombian. "It's understandable at the beginning of the race that you want to stay on the lead lap,

but when you have 20 or 30 laps to go, you're just in the way."

Kanaan agreed, saying: "When you're two or three laps down, there is no point in you holding people up for position. I just don't understand that. They're trying to prove a point, [but] there's no point to prove."

Race winner Power also had his own problems with lapped cars, but said he could see both sides of the argument.

"They [the backmarkers] are in their own battles, too, so you can't be harsh on them," he said. "I understand."



Montoya (right) struggled in traffic

## Carpenter and Fisher to merge teams for 2015

### THE ED CARPENTER RACING AND

Sarah Fisher Hartman Racing teams will merge at the end of the season to create one new multi-car outfit.

The deal brings together two of IndyCar's strongest single-car teams, with ECR

having won three races this season in an entry shared by Ed Carpenter and Mike Conway, while Josef Newgarden has earned a second place for SFHR at Iowa.

"There will be a lot of work for us to do to bring the two teams together, but we feel

that it is a great opportunity to grow," said Carpenter, who gave SFHR its only win at Kentucky in 2011.

According to Fisher, the move is in the best long-term interests of both teams.

"The merger is a big-picture plan," she said. "Working with Ed and capturing that first victory was a foothold for our team, and I look forward to the many more that come as a result of bringing all the parties together."

The new team, which will be called CFH Racing, is expected to be based at the current SFHR workshop in Indianapolis. Details of staff and technical partners have yet to be finalised: ECR currently uses Chevrolet engines, while SFHR is in the Honda camp.



ECR will no longer be singleton entry

### NEWGARDEN'S FUTURE

Josef Newgarden refused to comment about what his plans might be when his current Sarah Fisher Hartman Racing deal expires at the end of the season, but he wants to remain in IndyCar. "I'm excited to see what it's going to be like in five or 10 years, and I want to be part of it for as long as I can," he said.

### RH-R SIGNS NEW DEAL

Ryan Hunter-Reay has signed a multi-year contract extension that will keep him at Andretti Autosport for the foreseeable future. The team has also confirmed a three-year extension with DHL, which will continue to be the primary sponsor on Hunter-Reay's car.

### CHAMP LIST SLASHED

The number of drivers still mathematically in title contention was slashed from 11 to six after Milwaukee, with reigning champion Scott Dixon now the lowest-placed driver still in the hunt. As a Triple Crown race, the finale at Fontana pays double points.

### MUNOZ TAKES BLAME

Carlos Munoz took the blame for the accident that eliminated him from the race. "I went to the marbles, and once you're in the marbles it's impossible to go back, so I hit the wall," said the Andretti rookie. "I will learn from this."

### PAGENAUD'S LESSON

Simon Pagenaud believes that Milwaukee represented a breakthrough in his understanding of short-track racing. "In sportscar racing, you learn all about fighting against other cars that are slower than you in different corners," he said. "Learning how to navigate around them is all about timing and momentum. Today I made the connection."

### POWER GETS CREAMED

Will Power needed to be taken to the infield care centre after the race to have cream puff filling cleaned out of his ears following an impromptu podium hazing from Juan Pablo Montoya (below) and Tony Kanaan. "That was two veterans telling me, 'You can't come onto the podium without getting a workover,'" he said.



# DTM

## Nurburgring (D)

August 17

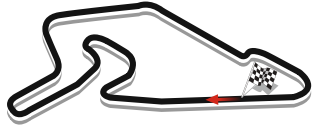

Round 7/10



### RESULTS

49 LAPS, 110.498 MILES

<b>1</b>	<b>MARCO WITTMANN (D)</b>	<b>1h09m42.802s</b>
	RMG BMW M4; Qualifying: 1st-1m22.780s	
<b>2</b>	<b>MIKE ROCKENFELLER (D)</b>	<b>+1.286s</b>
	Team Phoenix Audi RS5; Qualifying: 3rd-1m22.951s	
<b>3</b>	<b>EDOARDO MORTARA (I)</b>	<b>+12.019s</b>
	Abt Sportline Audi RS5; Qualifying: 2nd-1m22.925s	
<b>4</b>	<b>PAUL DI RESTA (GB)</b>	<b>+12.815s</b>
	HWA Mercedes C-coupe; Qualifying: 8th-1m23.354s	
<b>5</b>	<b>DANIEL JUNCADILLA (E)</b>	<b>+13.717s</b>
	RSC Mucke Mercedes C-coupe; Qualifying: 7th-1m23.221s	
<b>6</b>	<b>CHRISTIAN VIETORIS (D)</b>	<b>+24.918s</b>
	HWA Mercedes C-coupe; Qualifying: 9th-1m23.338s	
<b>7</b>	<b>MAXIME MARTIN (B)</b>	<b>+28.921s</b>
	RMG BMW M4; Qualifying: 12th-1m23.495s	
<b>8</b>	<b>MARTIN TOMCZYK (D)</b>	<b>+38.521s</b>
	Schnitzer Motorsport BMW M4; Qualifying: 17th-1m23.841s	
<b>9</b>	<b>ROBERT WICKENS (CDN)</b>	<b>+43.197s</b>
	HWA Mercedes C-coupe; Qualifying: 13th-1m23.565s	
<b>10</b>	<b>PASCAL WEHRLIN (D)</b>	<b>+45.377s</b>
	HWA Mercedes C-coupe; Qualifying: 18th-1m23.593s*	
<b>11</b>	<b>ADRIEN TAMBAY (F)</b>	<b>+48.071s</b>
	Abt Sportline Audi RS5; Qualifying: 11th-1m23.421s	
<b>12</b>	<b>BRUNO SPENGLER (CDN)</b>	<b>+49.834s</b>
	Schnitzer Motorsport BMW M4; Qualifying: 16th-1m23.770s	
<b>13</b>	<b>ANTONIO FELIX DA COSTA (P)</b>	<b>+50.150s</b>
	MTEK BMW M4; Qualifying: 19th-1m27.479s	
<b>14</b>	<b>JAMIE GREEN (GB)</b>	<b>+52.771s</b>
	Team Rosberg Audi RS5; Qualifying: 4th-1m22.996s	
<b>15</b>	<b>GARY PAFFETT (GB)</b>	<b>+57.056s</b>
	HWA Mercedes C-coupe; Qualifying: 23rd-1m29.612s	
<b>16</b>	<b>TIMO GLOCK (D)</b>	<b>+58.557s</b>
	MTEK BMW M4; Qualifying: 15th-1m23.691s	
<b>17</b>	<b>JOEY HAND (USA)</b>	<b>+1m20.955s**</b>
	RBM BMW M4; Qualifying: 20th-1m27.568s	
<b>18</b>	<b>VITALY PETROV (RUS)</b>	<b>-1 lap</b>
	RSC Mucke Mercedes C-coupe; Qualifying: 21st-1m27.714s	
<b>R</b>	<b>AUGUSTO FARFUS (BR)</b>	35 laps-accident damage
	RBM BMW M4; Qualifying: 14th-1m23.592s	
<b>R</b>	<b>NICO MULLER (CH)</b>	10 laps-accident damage
	Team Rosberg Audi RS5; Qualifying: 10th-1m23.405s	
<b>R</b>	<b>TIMO SCHEIDER (D)</b>	8 laps-accident damage
	Team Phoenix Audi RS5; Qualifying: 5th-1m23.048s	
<b>R</b>	<b>MIGUEL MOLINA (E)</b>	4 laps-accident damage
	Abt Sportline Audi RS5; Qualifying: 6th-1m23.163s	
<b>R</b>	<b>MATTIAS EKSTROM (S)</b>	3 laps-accident damage
	Abt Sportline Audi RS5; Qualifying: 22nd-1m28.504s	

Winner's average speed: 95.102mph. Fastest lap: Wittmann, 1m23.175s, 97.604mph.  
\* Wehrlein given three-place grid penalty. \*\* Hand given 30s penalty for unsafe release.

### DRIVERS' CHAMPIONSHIP

<b>1</b>	<b>WITTMANN</b>	<b>120</b>	<b>6</b>	<b>VIETORIS</b>	<b>41</b>
<b>2</b>	<b>EKSTROM</b>	<b>56</b>	<b>7</b>	<b>MARTIN</b>	<b>39</b>
<b>3</b>	<b>MORTARA</b>	<b>56</b>	<b>8</b>	<b>TAMBAY</b>	<b>36</b>
<b>4</b>	<b>ROCKENFELLER</b>	<b>53</b>	<b>9</b>	<b>FARFUS</b>	<b>33</b>
<b>5</b>	<b>SPENGLER</b>	<b>42</b>	<b>10</b>	<b>GLOCK</b>	<b>33</b>

### MANUFACTURERS' CHAMPIONSHIP

<b>1</b>	<b>BMW</b>	<b>302</b>	<b>3</b>	<b>MERCEDES</b>	<b>121</b>
<b>2</b>	<b>AUDI</b>	<b>284</b>			

#### POINTS SYSTEM EXPLAINED

In each race: 25-18-15-12-10-8-6-4-2-1 to top 10 finishers.



Drivers check for damage in parc ferme

FOR IN-DEPTH RESULTS  
forix.autosport.com



Wittmann slots in at the front of the pack

# Wittmann out on his own in the Eifel mountains

**IF MARCO WITTMANN'S VICTORY AT THE RED BULL Ring** was a perfect example of teamwork, then his victory at the Nurburgring was an equally perfect example of individual achievement.

In stark contrast to the four-deep BMW dominance in Austria, Wittmann had zero help at the Nurburgring. From the moment he emerged as the sole BMW in the top 10 in qualifying – on pole, nonetheless – it was clear he was going to have to win this one on his own.

Being surrounded by Audis wasn't Wittmann's only challenge in the Eifel mountains; he also had to deal with the fact that he was carrying maximum performance ballast, his bloated M4 weighing in at 1130kg.

Of course, neither of these things were problems for the in-form Wittmann. All he had to do was be first into Turn 1, keep the Audis outside the DRS zone in the first stint, and have the hard work before the pitstops. Then, when his heavy M4 inevitably started to chew through the prime tyre at the end of the race, he'd have just enough of a gap.

And that's exactly how it played out. In the end, Audi's Mike Rockenfeller was able to put real pressure on Wittmann as the leader's tyres ran out of steam, but fell just short, proving exactly how important that opening stint was.

"It's the best way – to be in the front, make the pace and look after the tyres," Wittmann explained. "At the end of the race, I was at the end of my tyres. I was quite happy when it was over."

Rockenfeller, who became Audi's best chance for a first win of the season by storming into second place from P3 on the grid on the run to the first corner, later admitted that he did all he could to catch Wittmann, but just ran out of laps.

"I got the maximum from my car, and still wasn't able to win," he said. "That's a bit frustrating. I was fighting hard to stay on his tail, but he was able to control the race at the beginning. Five more laps, and it would have been more exciting."

Behind the top two, Edoardo Mortara and Paul di Resta staged a lengthy battle for third place. During the first stint, on the option tyre, it looked as if the Scot would get past, but Mortara did well to hold

on until the stops. And, once on the standard tyre, di Resta just couldn't apply the same pressure.

However, despite missing out on a podium, di Resta's drive was one of a man who's once again fully comfortable in a DTM car.

"I'm getting there, now," he said. "We definitely had the speed for the podium. Mortara did a pretty good job of keeping his pace and limited me a little on the option. On the prime run, I sat within a second of him for the whole time, but I just couldn't do anything."

BMW's Martin Tomczyk was the best of the drivers who started on the harder tyre, in eighth. From 18th on the grid, Tomczyk worked his way through the other prime-shod cars in the first stint. His workload was made easier on lap eight, when the Audis of Timo Scheider and Nico Muller crashed into each other (and eventually out of the race) while squabbling over the prime tyre 'lead' with Robert Wickens.

With the Audis out and Wickens losing time, Tomczyk found himself leading the charge on the option in the second stint. Sadly for him, that still only translated into 10th position, 55 seconds behind Wittmann, after the stops shook out.

A late safety car period might have given him a shot at a podium, but as it happened he was left to scrap over eighth place with Jamie Green, eventually catching and passing the Brit's Audi with a couple of laps to go.



Di Resta keeps Juncadella at bay

## IN THE PADDOCK

**ANDREW VAN LEEUWEN**  
DTM CONTRIBUTOR

@av1me1bourne



IT'S QUITE INCREDIBLE THAT AUDI – the reigning series champion – has gone seven races into this season without a win.

For all the talk about a Mercedes crisis, it's Audi that's struggling. To this point in the season, Mercedes has won two races and Audi zero. Based on that, it seems like we should be talking about the 'Audi crisis'.

The one thing that's stopping the c-word (crisis, I mean) coming into play when talking about Audi is that its problem isn't the speed of the car. The RS5 is generally

quick, and has genuinely demonstrated signs of being a winning package – or at least very close to a winning package – at every single circuit this season. Even BMW can't say that (the Norisring was a tough weekend for the Bavarians).

So why hasn't there been an Audi victory? As much as it sounds like a cop-out, there has been an element of luck, or lack thereof, in the manufacturer's results. Oschersleben, for example, was Audi's for the taking, until a poorly timed third safety car secured Christian Vietoris a surprise win.

That the RS5 seems a very competitive race car actually complicates things. If it was slow, the team could discover why, and then work on making it fast. Because the car is quick, however, it's much harder to pinpoint or define areas requiring improvement.



Is Audi facing a DTM 'crisis'?

On the other hand, having a quick car is still better than having a slow one. Audi is capable of winning any one, or all three, of

the remaining races. And, if that happens, the 'crisis' it faces will be very, very quickly a thing of the past.



New agreement should help make pitlane safer

## Drivers agree on pit protocol

### THE DTM DRIVERS REACHED

a 'gentleman's agreement' over merging in the pitlane during races at the Nurburgring, following the controversy over unsafe releases at the previous race in Austria.

The drivers met on Friday before their briefing, and agreed that during pitstops, once both cars are up to speed, whoever is in front has right of way – regardless of if they are in the fast or slow lane – and the other driver has to slow or yield.

"It ruined a great race at Spielberg," said Gary Paffett. "We had a meeting on Friday before the drivers' briefing where we all agreed to respect each other and respect the rule, and we said that, as drivers, we'll accept the responsibility for this."

## BMW boss backs Wittmann

**BMW MOTORSPORT BOSS JENS Marquardt** says it is no surprise that **Marco Wittmann** has been able to upstage the more decorated drivers in BMW's line-up this season – but that he is still very impressed with the youngster's maturity and pace.

"We could already see [his potential] over the course of last year," said Marquardt. "That was his first season, and he had to learn about the DTM, about setting up the car, about managing tyres, about everything. The sheer speed, however, was there from the very beginning."

"With the steps we made over the winter – with the base balance of the M4 – and the engineering team he has behind him now, it just really melted together," continued the BMW boss. "At the moment, it is such a strong unit. You feel that nothing bothers him."

"As the pressure rises from event to event, he just stays focused on the job in hand. It's quite outstanding for a young guy like that. To deliver weekend after weekend, I'd say is impressive. And knowing how tight the DTM is, and the quality of drivers, I think it's a mega job he's doing."



Wittmann has shown great maturity in this year's DTM



### BMW SALUTES LAMM

BMW paid tribute to the passing of Schnitzer Motorsport legend Dieter Lamm with stickers reading 'Servus Dieter' ('So long, Dieter' in Bavarian) on all of its cars at the Nurburgring. Lamm, who was involved with the team for more than 30 years, recently succumbed to illness.

### TWO HIT CENTURIES

The Nurburgring race was one for milestones. Both Briton Jamie Green and BMW driver Bruno Spengler celebrated 100 races in the DTM. Neither driver had a particularly happy anniversary, however. Spengler finished in 12th place, while Green came home down in 15th.

### MERC'S HIGH POINTS

Despite missing out on the podium with Paul di Resta, it was still a good race for Mercedes. Daniel Juncadella and Christian Vietoris finished in fifth and sixth, and Robert Wickens and Pascal Wehrlein were ninth and 10th. That meant Mercedes had more cars in the points than any other manufacturer.

### PETROV STILL TO SCORE

Daniel Juncadella's 10 points for his fifth place at the Nurburgring means his Mucke Mercedes team-mate Vitaly Petrov is the only driver not to have scored at all in 2014. Juncadella's performance also ensures that every team is now on the points board.

## DID YOU KNOW?

If Audi fails to win any of the remaining three races in 2014, it will only be the brand's second winless season in the modern DTM. The last one came way back during the series' revival season in 2000, when Mercedes and Opel split the victories.



## Ekstrom title hopes hit hard

### MATTIAS EKSTROM'S CHANCES

of winning the DTM championship took a massive blow at the Nurburgring.

The Swede's weekend got off to a terrible start when he qualified 22nd. On Sunday, his race was short-lived, contact on the first lap forcing him to pull into the pits and retire at the end of lap two.

With the DNF, Ekstrom is now locked on 56 points with Audi team-mate Edoardo Mortara, 64 points behind Wittmann, with just 75 on offer across the last three races.

The Swede had a poor weekend



"I had a good start and the first few corners were not bad," explained Ekstrom. "Then there was contact with another vehicle and my car was damaged. It was a weekend to forget."

XPB/LAT

XPB/LAT

37

**AUTOSPORT**  
INTERNATIONAL

**The Racing Car Show**

8-11 JANUARY 2015 **BIRMINGHAM NEC**



**CARS  
STARS  
ACTION**

**FASTEST SHOW  
ON EARTH**



**BOOK NOW! 0844 581 1372**

**WWW.AUTOSPORTINTERNATIONAL.COM**

Sato, here passing  
Michela Cerutti, made  
rapid progress in race one



AUTO GP NURBURGRING (D), AUGUST 16-17 RD 7/8

# Sato comes from behind to take the title

**KIMIYA SATO HAD A CHALLENGING** weekend in Germany, but his win and third place were enough to crown him Auto GP champion.

The drama started in qualifying, when the Euronova driver realised he had a brake problem as he ventured out for the first session, in which he needed to complete a time to make it into the top-10 shootout.

Sato recounts the story: "I had a brake failure on my out lap, and went off at the chicane. I brought it to the pits and with a couple of minutes left they said 'it's OK, go for a time'."

"It was not OK! I smashed into the barrier at turn one on my first timed lap. It was quite a big hit."

Not only did Sato take a chest bruising that made for an uncomfortable race weekend, but he would have to start race one in 11th and last position.

The Auto GP field's diminutive size and his own relentless race-day pace made it entirely possible for him to overcome all this strife and still take the win.

Super Nova driver Markus Pommer had high hopes starting from pole in his home race, but he lost out to a lightning start from Kevin Giovesi. Pommer then braked too deep into turn one and thus also lost second place to Tamas Pal Kiss.

The early laps turned into a great fight between Giovesi, Kiss and Pommer, but Sato was coming for



them. Meanwhile, at the end of lap two, Salvatore de Plano beached his car at the last corner, bringing out yellow flags that would have profound consequences for the race.

Sato was fourth, within sight of the leaders, by lap seven. At this stage Pommer pitted, followed a lap later by Kiss. The latter retained his lead over the former, while Giovesi and Sato battled away up front.

Giovesi pitted on lap 12 of 27, just as Sato became a serious threat, emerging clear of Kiss and Pommer. Sato now led, and seemed master of his own destiny. Until a raft of mid-race drive-through penalties was announced for drivers who had sped past the yellow flag.

This included every frontrunner bar Kiss, and all served their penalties within a couple of laps. It meant Sato kept his growing lead over Kiss, but he still needed to make his mandatory pitstop.

He set about pulling out over a second a lap clear of the Hungarian,

but fell well short of inflating enough of a cushion. After Sato received the trophy for second, though, officials decided that Kiss had also been among the guilty. One 25-second penalty later, Sato was the winner after all, and Kiss only fourth. When all was said and done, the entire field had been penalized one way or another, and the fastest man did win.

Sato's progress on Sunday was less rapid despite starting three places higher. Kiss started well from fifth, and took the lead from Francesco Dracone (who jumped the start) on lap two. The Virtuosi UK driver was effectively never headed, shaking off the attentions of second-placed Pommer after the pitstops.

Sato nearly caught Pommer at the end, but reined himself in once he

was in a title-winning position. He was circulating minus the bodywork covering the front dampers after it flew off mid-race, and his radio communication was also affected. None of the weekend's troubles put him off his stride, though, and he goes to the Estoril finale in October already crowned.

● Richard Asher

## RESULTS

**Race 1 1 Kimiya Sato (Euronova Racing)**, 27 laps in 37m06.445s; 2 Kevin Giovesi (FMS Racing, +7.854s; 3 Markus Pommer (Super Nova International); 4 Tamas Pal Kiss (Virtuosi UK); 5 Andrea Roda (Virtuosi); 6 Michela Cerruti (Super Nova). **Race 2 1 Pal Kiss**, 23 laps in 31m22.578s; 2 Pommer, +10.002s; 3 Sato; 4 Roda; 5 Cerruti; 6 Giovesi. **Points 1 Sato, 221**; 2 Kiss, 170; 3 Pommer, 157; 4 Giovesi, 155; 5 Roda, 153; 6 Cerruti, 113.



# Euro F3 Nurburgring (D)

August 15-17

Round 9/11

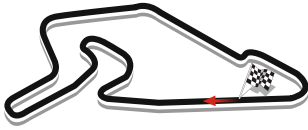

## RESULTS

RACE 1: 23 LAPS, 51.866 MILES

1	<b>MAX VERSTAPPEN (NL)</b>	<b>35m35.010s</b>
Van Amersfoort Racing Dallara-Volkswagen F314; Qualifying: 1st-1m37.036s		
2	ANTONIO FUOCO (I)	+3.275s
Prema Powerteam Dallara-Mercedes F312; Qualifying: 5th-1m38.262s		
3	ANTONIO GIOVINAZZI (I)	+3.789s
Carlin Dallara-Volkswagen F314; Qualifying: 7th-1m38.501s		
4	JORDAN KING (GB)	+6.650s
Carlin Dallara-Volkswagen F312; Qualifying: 11th-1m38.831s		
5	TOM BLOMQUIST (GB)	+11.650s
Carlin Dallara-Volkswagen F312; Qualifying: 8th-1m38.610s		
6	ESTEBAN OCON (F)	+18.918s
Prema Powerteam Dallara-Mercedes F312; Qualifying: 4th-1m38.153s		
7	LUCAS AUER (A)	+22.352s
Mucke Motorsport Dallara-Mercedes F312; Qualifying: 6th-1m38.375s		
8	FELIX ROSENQVIST (S)	+24.972s
Mucke Motorsport Dallara-Mercedes F312; Qualifying: 10th-1m38.735s		
9	SANTINO FERRUCCI (USA)	+33.207s
EuroInternational Dallara-Mercedes F312; Qualifying: 3rd-1m38.079s		
10	EDWARD JONES (UAE)	+33.767s
Carlin Dallara-Volkswagen F312; Qualifying: 2nd-1m37.685s		

Winner's average speed: 87.456mph. Fastest lap: Blomqvist, 1m23.786s, 96.916mph.

RACE 2: 25 LAPS, 56.376 MILES

1	<b>GIOVINAZZI</b>	<b>34m39.329s</b>
Qualifying: 3rd-1m21.864s		
2	BLOMQUIST	+0.771s
Qualifying: 1st-1m21.650s		
3	OCON	+1.404s
Qualifying: 4th-1m21.923s		
4	FUOCO	+3.294s
Qualifying: 5th-1m21.939s		
5	AUER	+4.674s
Qualifying: 7th-1m22.092s		
6	KING	+5.101s
Qualifying: 8th-1m22.153s		
7	ROSENQVIST	+7.078s
Qualifying: 6th-1m22.051s		
8	JONES	+15.488s
Qualifying: 9th-1m22.244s		
9	TATIANA CALDERON (CO)	+18.511s
Jo Zeller Racing (Mucke) Dallara-Mercedes F312; Qualifying: 15th-1m22.735s		
10	NICHOLAS LATIFI (CDN)	+19.100s
Prema Powerteam Dallara-Mercedes F314; Qualifying: 11th-1m22.461s		

Winner's average speed: 97.606mph. Fastest lap: Blomqvist, 1m22.259s, 98.691mph.

RACE 3: 24 LAPS, 54.121 MILES

1	<b>AUER</b>	<b>35m28.675s</b>
Qualifying: 7th-1m22.237s		
2	BLOMQUIST	+0.476s
Qualifying: 1st-1m21.771s		
3	VERSTAPPEN	+3.623s
Qualifying: 2nd-1m21.795s		
4	FUOCO	+4.945s
Qualifying: 3rd-1m22.001s		
5	KING	+5.238s
Qualifying: 8th-1m22.319s		
6	ROY NISSANY (IL)	+17.415s
Mucke Motorsport Dallara-Mercedes F312; Qualifying: 12th-1m22.57s		
7	FELIX SERRALLES (USA)	+18.599s
Team West-Tec Dallara-Mercedes F314; Qualifying: 11th-1m22.481s		
8	CALDERON	+19.434s
Qualifying: 15th-1m22.802s		
9	JAKE DENNIS (GB)	+20.175s
Carlin Dallara-Volkswagen F312; Qualifying: 10th-1m22.451s		
10	JULES SZYMKOWIAK (NL)	+20.770s
Van Amersfoort Racing Dallara-Volkswagen F314; Qualifying: 16th-1m23.129s		

Winner's average speed: 91.530mph. Fastest lap: Blomqvist, 1m22.091s, 98.893mph.

## DRIVERS' CHAMPIONSHIP

1	OCON	402	6	GIOVINAZZI	173
2	VERSTAPPEN	325	7	KING	172
3	BLOMQUIST	315	8	ROSENQVIST	154
4	AUER	283	9	DENNIS	154
5	FUOCO	237	10	LATIFI	108

POINTS SYSTEM EXPLAINED In each race: 25-18-15-12-10-8-6-4-2-1 to top 10 finishers.

FOR IN-DEPTH RESULTS  
forix.autosport.com



Verstappen won race one but later engine failure may be costly

# New Red Bull junior shows seniority in face of penalty

## WHOEVER WRITES THE SCRIPTS FOR THIS

championship needs a medal for their work at the Nurburgring. This race weekend had more twists and turns than the mighty Nordschleife.

The short version of events on the not-so-mighty short GP circuit is this: Max Verstappen won a race and outscored winless Esteban Ocon over the weekend. So Red Bull's latest junior chipped away at the points gap, but there's a hangover from this meeting that would make a Verstappen title run one the motorsport stories of the season.

The longer version of the story is more of a rollercoaster, and one of which lady luck seemed to be the mistress. Verstappen was superb in the wet-dry conditions that marked Friday and Saturday, taking pole on a drying track and then winning a testing first encounter in which he led the damp early going on slicks, lost the lead to the wet-shod Spike Goddard, then got back in front when the track dried up.

Verstappen then led a high-speed train in the dry second race, looking on course for victory until five laps remained. Then, coming through the kink on the back straight, his Volkswagen engine let go big time, handing victory to Carlin Motorsport's Antonio Giovinazzi.

But it was Verstappen's fortunes that had tongues wagging, because this blow-up looks set to be a massive turning point in the season. Not only did he lose 25 points, but the championship's tough rules on engine changes meant he would be slapped with a 10-place grid penalty for the next three races.

For a man whose charge was gathering

momentum, it was a momentous moment.

Especially as Ocon seemed to have no answer to the Van Amersfoort man's stellar form. The Prema driver had only mustered a scrappy sixth after a bad start from the wet side of the grid in the first race, followed by third in the second, the latter a race that showcased rather well the difficulty of overtaking in an F3 car around the 'Ring.

But then, in race three, came a tiny offering of hope for Verstappen. Several cars came to grief at the first corner, but of key interest was Ocon's demise at the hands of enthusiastic braker Giovinazzi. After demotion from second to 12th on the grid, Verstappen was up to fifth again. He then proceeded to show that you could overtake in the dry if you tried hard enough, passing both Jordan King and Antonio Fuoco to reach the podium. Ocon could only watch from the sidelines, seeing his race-two points gain neatly cancelled out by events in race three.

Lucas Auer took the honours in that one after some skilled dry-weather overtaking of his own. The Mucke Motorsport man duked it out with early leader Tom Blomqvist at the restart following the early clean-up at Turn 1, going side by side with the Carlin driver through the entire stadium section before sealing the deal at Turn 4.

Blomqvist was a little glum after failing to convert another pole position. He'd beaten Verstappen fair and square in dry qualifying for races two and three, but made a poor start in race two and got stuck behind Giovinazzi in the procession. Fastest laps in both the second and third races showed just what might have been if only his starts and restarts had been better.

Fuoco will also be rueing a mistake after he led Verstappen for the first five laps of race one. The Prema driver had a little off at Turn 1, though, which gifted the place to Max. Once Goddard's wet-shod cameo at the front was over, Verstappen pulled away for a three-second win.

Ultimately it was that damp race-one drive that earned Verstappen his little bite out of Ocon's lead last weekend. Overcoming a 77-point deficit when he'll start two of the last six races no higher than 11th is a huge ask. But never say never in this series: there could be more twists to come.



Auer (I) duked it out with Blomqvist for finale win

## IN THE PADDOCK

**RICHARD ASHER**  
EURO F3  
CONTRIBUTOR

@mygreenjacket



IT'S BEEN A WHILE SINCE I'VE reported on a major Formula 3 meeting. So I arrived at the Nurburgring with no preconceptions. That's why I must take the impression left by Max Verstappen so seriously.

I'm too young to have seen his old man race in F3, but paddock sages were happy to remind me that it does Max a disservice to suggest that his F3 progress parallels that of 1993 category destroyer Jos. Max's trajectory is steeper.

It was the detail stuff that caught the eye. How he positioned himself in qualifying to ensure a clear road, or the best use of a drying track at the death. His consistent starts. Even his ruthless blocking of Esteban Ocon in qualifying which, although unacceptable, showed a certain awareness reminiscent of multiple world champs.

He showed a full array of race skills. In race one, under attack from a driver whose tyres weren't going to last much longer, he saw the bigger picture and didn't fight Spike Goddard. In race two, he wasn't the quickest, but produced the mistake-free driving needed to stay ahead on a dry track that was proving very tough for overtaking. Yet in race three, coming from behind, he showed that dry overtaking could be done.

The average 16-year-old, fresh into car racing, up against an excellent field, might be expected to overdrive. The new Red Bull signing didn't. The Eifel weather also tested him with tricky conditions this weekend – but that's exactly where he stood out.

It's rare for a paddock to rave about a driver, but this paddock is. And judging by last weekend, Helmut Marko should, too.



Verstappen (r) soon vanquished Goddard

## Ocon calm despite strife

**ESTEBAN OCON IS REMAINING**

cool after losing more championship-points ground to Max Verstappen in Germany.

Until Verstappen broke down in race two, though, there was some evidence that the Prema Powerteam man was beginning to get rattled by his much-hyped fellow teen.

Ocon got away poorly from the wet side of the grid in race one and didn't show the drying-track progress expected of a champion-elect, battling to sixth and at one point rudely pushing Santino Ferrucci into the pitlane entry.

Verstappen's blatant blocking tactics in qualifying for races two and three would have done little for Ocon's mood the next day, and might have explained his careless pitlane speeding in the same session, which earned him a €450 fine.

But he was sanguine about it all after Verstappen's subsequent breakdown, which led to a 10-place grid penalty for race three and the first two races at Imola.

"It's clear what happened in qualifying,"



Ocon kept his cool despite losing ground to Verstappen

said Ocon. "He did it at Hockenheim too. It was dangerous, but I don't want to talk about that any more.

"We've both had problems this year. Now I've just got to focus on getting maximum points with the package I have. The good thing is we've always found something in

the car as the weekends go on."

Ocon even kept a lid on things after he got punted out by Antonio Giovinazzi at the first corner of race three, in which he hoped to cash in on Verstappen's grid penalty. He contemplated things behind the barriers, looking like a man keeping his head.



West-Tec rookie Chang ran as high as fifth

## Chang makes a bang on debut

**BRITISH F3 RACER ANDY CHANG** had a chance to shine when he gambled on wet tyres in his first race, the Team West-Tec recruit rising as high as fifth before the track dried out and he faded.

It was Chang's first appearance in

the latest-generation Formula 3 car. He will turn out for West-Tec again in the Hockenheim finale as he looks for mileage ahead of his home race at the Macau Grand Prix.

Chang will not continue in the British championship.



## DRIVERS PENALISED

Jo Zeller Racing's Tatiana Calderon and Carlin's Sean Gelael received drive-through penalties in race one. These were issued for causing a collision (with Jules Szymkowiak, above) and pitlane speeding respectively.

## JONES BACKS OUT

Carlin Motorsport driver Ed Jones withdrew from race three after feeling intense pain in his back during race two. It was a recurrence of the vertebra injury he sustained at Pau earlier in the season. He will seek specialist opinion before the next round at Imola.

## QUALIFYING DELAYED

Qualifying for races two and three had to be postponed from Saturday evening to Sunday morning, after an accident in the preceding Scirocco R-Cup race left a barrier needing to be repaired.

## DUO LOSES GRID SLOTS

Antonio Giovinazzi (Carlin) will lose three grid spots in race one at Imola after he took out Prema's Esteban Ocon at the start of race three. Spike Goddard (T-Sport) will lose five slots after forcing Felix Rosenqvist off the road in the same race.

## BIG NUMBER

# 30

The total number of grid places Max Verstappen will lose as the result of the penalty enforced for a single engine change.

## Van Amersfoort: penalty is harsh

**VAN AMERSFOORT RACING BOSS**

Frits van Amersfoort says there is no way Max Verstappen could have avoided the triple 10-place grid penalty he received for changing the Volkswagen engine that blew in race two.

"There was an option to skip race three and try to repair the engine for Imola," he said. "But after careful consideration we were forced to change the engine. There was enough damage that there was no other decision for us to take. Let's just say it was a very big mechanical failure!"

"The grid-penalty rule is harsh, and tough,



Verstappen landed a hefty penalty

because what happened was nothing to do with misuse of the engine. The small chance Max had in the championship is gone now. But it's there in the regulations. And as a motorsport man, I know this is a technical sport."

Gordon got ahead at the final restart



NASCAR SPRINT CUP MICHIGAN (USA), AUGUST 17 RD 23/36

# Gordon's win puts him top of the Chase

LEVIT/LAT

NASCAR LOVES DRAWING STATISTICAL parallels, but the fact that the last time Jeff Gordon won at both Indianapolis and Michigan in a single season back in 2001 was also the last time he won the Cup title might be more than just a handy coincidence for some colourful commentary.

As he took his third victory of 2014 at Michigan on Sunday, defeating race-long rival Joey Logano at the final restart after a series of close dices, Gordon both moved himself back to the top of the Chase seedings and underlined that for the first time in many years, he is NASCAR's benchmark driver again.

Much has been made of Hendrick's superiority this season, but when Gordon took his second straight pole last Friday, he was the only member of his team to qualify above 15th. Team-mates and fellow title protagonists Dale Earnhardt Jr and Jimmie Johnson were back in 25th and 30th. They came through to fifth and ninth in the race: Earnhardt via a pitlane collision with Kyle Larson; and Johnson despite a broken gearlever — that left him attempting a makeshift fix with tools with one hand while driving — and an argument with Ryan Newman.

Things were much more straightforward for Gordon up front.

Although unimpressed with Logano's tactics during a late run of restarts, he ultimately beat his Penske rival away at the final green flag, and then escaped from a Kevin Harvick challenge as Logano dropped back to third, only just holding off Paul Menard at the line.

Harvick's Stewart-Haas team-mate Kurt Busch was a threat until he smacked the wall while trying a pass for the lead. Brother Kyle had been the first to shunt in a yellow-strewn race, but the most significant crash might've been the Larson's fiery impact, which dropped the rookie out of the Chase spots.

● Connell Sanders Jr

## RESULTS

**1 Jeff Gordon (Chevrolet SS)**, 200 laps in 2h49m16.000s; 2 Kevin Harvick (Chevy) +1.413s; 3 Joey Logano (Ford Fusion); 4, Paul Menard (Chevy); 5 Dale Earnhardt Jr (Chevy); 6 Clint Bowyer (Toyota Camry); 7 Denny Hamlin (Toyota); 8 Brad Keselowski (Ford); 9 Jimmie Johnson (Chevy); 10 Greg Biffle (Ford). **Chase grid 1 Gordon, 3 wins/816 points**; 2 Earnhardt Jr, 3/813; 3 Keselowski, 3/733; 4 Johnson, 3/686; 5 Logano, 2/714; 6 Harvick, 2/687; 7 Carl Edwards, 2/679; 8 Kyle Busch, 0/620; 9 Hamlin, 0/589; 10 Aric Almirola, 0/556; 11 AJ Allmendinger, 0/556; 12 Kurt Busch, 0/543; 13 Matt Kenseth, 0/709; 14 Ryan Newman, 0/679; 15 Clint Bowyer, 0/672; 16 Biffle, 0/660.

INDY LIGHTS MILWAUKEE (USA), AUGUST 17 RD 9/10

## Veach pips his team-mate

ZACH VEACH KEPT HIS CHAMPIONSHIP hopes alive with a hard-earned win over Andretti team-mate Matthew Brabham in Milwaukee.

Veach had started from pole, but lost the lead to Brabham early on. The Australian/American quickly opened gap that blew out to more than eight seconds, only to see it all disappear when Luiz Razia crashed out of fourth place, which closed the field up with a

caution period fewer than 10 laps from the end.

Recognising the opportunity, Veach made a great move around the outside of Brabham to take the lead on the restart and kept his advantage to the end. Current points leader Gabby Chaves was left to settle for third after spending the afternoon wrestling with oversteer.

It was also a tough race for Jack Harvey, who came into the weekend off the back of a clean sweep at Mid-Ohio. The Brit qualified sixth and was unable to make much progress, eventually finishing fifth with the help of Razia's retirement.

● Mark Glendenning

## RESULTS

**1 Zach Veach (Andretti Autosport)**, 100 laps in 46m37.663s; 2 Matthew Brabham (Andretti) +0.860s; 3 Gabby Chaves (Belardi Auto Racing); 4 Scott Anderson (Fan Force United); 5 Jack Harvey (SPM with Curb-Agajanian); 6 Juan Piedrahita (SPM). **Points 1, Chaves 466**; 2, Veach, 459; 3 Harvey, 443; 4 Brabham, 366; 5 Luiz Razia, 336; 6 Juan Pablo Garcia, 318.

SUPER TC2000 RESISTENCIA (RA), AUGUST 17 RD 7/12

## Werner ends the drought

MARIANO WERNER RETURNED TO the Super TC2000 winner's circle after a 28-month absence, claiming his first win as a works Fiat driver at Resistencia and becoming the sixth different winner in seven rounds so far this season.

Renault driver Leonel Pernia and Werner won the early-morning heats, with Werner lining up on pole for the 38-lap final. The eventual race winner led the 23-car pack away at the start, followed by Pernia, Facundo Arduzzo, Matias Rossi, Emiliano Spataro and Agustin Canapino in the first six places. Werner soon eked out a two-second gap over Pernia, who in turn had his mirrors full of Arduzzo's Fiat, while Canapino nerfed his way forward and was fourth by lap three.

Werner eased off slightly towards



First Fiat win for Werner

the end, and finished 2.5s ahead of runner-up Pernia, who in turn had Arduzzo 0.6s behind him.

Norberto Fontana and Nestor Girolami, first and second in the standings coming into this race, had to start from outside the top 10 courtesy of the series' grid handicap system but were soon battling among themselves. Fontana, who ended up eighth, managed to hold on to his points lead.

● Tony Watson

## RESULTS

**1 Mariano Werner (Fiat Linea)**, 38 laps in 41m16.291s; 2 Leonel Pernia (Renault Fluence) +2.397s; 3 Facundo Arduzzo (Fiat); 4 Agustin Canapino (Peugeot 408); 5 Emiliano Spataro (Renault); 6 Matias Rossi (Toyota Corolla). **Points 1** Norberto Fontana, 124; 2 Nestor Girolami, 114; 3 Werner, 110; 4 Arduzzo, 108; 5 Canapino, 99; 6, Spataro, 98.

Veach celebrates a third win in 2014





Cao shone on a damp track on slicks in race two

BRITISH F3 THRUXTON (GB), AUGUST 17 RD 5/7

## Fortec shares out wins with Cao and Rao

BRITISH FORMULA 3 SLIPPED TO A new low at Thruxton, with just five cars appearing, but at least Fortec team-mates Matt Rao and 'Martin' Cao Hong Wei put on a show by fighting it out at the front.

Rao appeared to have a small pace advantage this time out, but the racecraft of Chinese battler Cao proved insuperable in the first two races. The weekend ended with Cao taking two wins (his first in F3) to the one of Rao,

but a hat-trick of fastest-lap points for Briton Rao evened their weekend points tally, enabling him to retain his slender advantage.

Trouble shifting to second gear at the start cost double poleman Rao the lead of race one. He recovered the advantage into the chicane with a few laps in the books, before Cao swept back in front at two-thirds distance. As Cao moved across to claim his line at the chicane, he clipped the front wing of Rao, although the duo stayed close to the finish.

Race two started on a damp track with the field on slicks, just the sort of conditions in which Cao thrives. He soared from fourth on the reversed grid to first and was never threatened. Rao took a couple of laps to clamber into second and was the quickest man once the track dried out, enabling him to escape a threat from Carlin's 'Peter' Li Zhi Cong.

Rao and Cao battled it out after the first 10 laps of the finale, before Rao broke the tow and pulled away. Camren Kaminsky claimed third from Double R team-mate Max Marshall, who was making his F3 debut last weekend.

● Marcus Simmons

### RESULTS

**Race 1** 1 Cao Hong Wei (Dallara-Mercedes F312), 24 laps in 30m13.304s; 2 Matt Rao (D-M F312), +1.070s; 3 Li Zhi Cong (D-VW F308); 4 Max Marshall (D-M F312); no other finishers. Fastest lap Rao, 1m08.811s (123.25mph).

**Race 2** 1 Cao, 25 laps in 30m42.731s; 2 Rao, +3.596s; 3 Li; 4 Marshall; 5 Camren Kaminsky (D-M F313); no other starters. FL Rao, 1m09.627s (121.81mph). **Race 3** 1 Rao, 26 laps in 30m13.842s; 2 Cao, +6.579s; 3 Kaminsky; 4 Marshall; 5 Li; no other starters. FL Rao, 1m08.725s (123.41mph). **Points** 1 Rao, 184; 2 Cao, 180; 3 Sam MacLeod, 121; 4 Chang Wing Chung, 103; 5 Kaminsky, 99; 6 Li, 79.



Cao (centre) beat team-mate Rao twice

BRAZILIAN STOCK CARS CASCAVEL (BR), AUGUST 17 RD 6/12

## Barrichello, Gomes win, Abreu extends lead

RUBENS BARRICHELLO AND MARCOS Gomes shared out the victories on the fast Cascavel circuit on the Brazilian Stock Car Championship's return to the two-race format after the Goiania money race earlier this month.

Former grand prix driver Barrichello propelled his Chevrolet Sonic from sixth position on the grid in race one, vaulting to second after the mandatory pitstops thanks to a near-perfect stop from his Full Time team and then moving into the lead when pole winner Julio Campos understeered off in his Prati-Mico's Racing Peugeot

408. Barrichello then held on to win by just over two seconds from the recovering Peugeot driver.

Atila Abreu completed the podium in his Mobil Super Racing Chevy to finish ahead of Caca Bueno, whose Red Bull Racing Chevy dropped from second during the pitstops when he was unable to select neutral courtesy of an oiled clutch.

Gomes, who finished ninth in the opening encounter, moved into the lead in the reserve-grid second race when early leader Max Wilson was adjudged to have incorrectly used his

power boost at the start. Gomes was able to move clear of a scrap for second involving Vitor Genz, Valdeno Brito and Bueno through two safety car periods.

Genz lost his chance of a podium when a bolt came out of the front left suspension of his Peugeot, while Valdeno had to hold off a late charge from fellow Chevrolet driver Wilson.

Sergio Jimenez brought his Voxx Peugeot home fourth ahead of Abreu, who top scored over the weekend to extend his points lead over Barrichello. ● Lito Cavalcanti



Barrichello came from sixth in race one

### RESULTS

**Race 1** 1 Rubens Barrichello (Chevrolet Sonic), 34 laps in 41m14.398s; 2 Julio Campos (Peugeot 408), +2.150s; 3 Atila Abreu (Chevy); 4 Caca Bueno (Chevy); 5 Gabriel Casagrande (Chevy); 6 Vitor Genz. **Race 2** 1 Marcos Gomes (Peugeot), 17 laps in 21m17.952s; 2 Valdeno Brito (Chevy), +0.545s; 3 Max Wilson (Chevy); 4 Sergio Jimenez (Peugeot); 5 Abreu; 6 Popo Bueno (Chevrolet). **Points** 1 Abreu, 104; 2 Barrichello, 93; 3 Jimenez, 93; 4 Gomes, 91; 5 Campos, 91; 6 Brito, 88.



## NASCAR TRUCK SERIES

Veteran Johnny Sauter (above) took his first victory of the season at Michigan in the fastest race in Truck Series history. The Thorsport Toyota driver averaged 161.11mph over the 100-lap event to edge out team-mate Matt Crafton, who ducked out of the lead with three laps to go to make his final fuel stop at the end of a race interrupted by just one yellow flag.

## NASCAR NATIONWIDE

Chris Buescher crossed the line to claim his maiden Nationwide victory at Mid-Ohio with his Roush Fenway Ford running on fumes. His team left him out on track during the final caution period believing he had enough fuel to make it to the end, but he was told to go into fuel-save mode in the final stages. JR Motorsports Chevrolet driver Regan Smith took second just over a second behind, with Brian Scott third in his Richard Childress Chevy third.

## PRO MAZDA

Juncos Racing driver Spencer Pigot made the most of a restart to pass title rival Scott Hargrove and claim the win ahead of this weekend's finale at Fontana. Shelby Blackstock capitalised on assorted misfortunes ahead of him to secure third.

## GERMAN CARRERA CUP

Michael Ammermuller and Philipp Eng shared the Porsche Carrera Cup Deutschland wins at the Nurburgring. Walter Lechner driver Ammermuller won the first race from pole, leading home Jaap van Lagen and Jeffrey Schmidt. The second race saw Eng take victory in his Project 1 entry, while team-mate Sven Muller recovered well from a race one crash to finish second.

## ASIA-PACIFIC RALLY

Indian driver Gaurav Gill loosened team-mate Jan Kopecky's grip on the 2014 Asia-Pacific Rally Championship by comfortably winning the Malaysian Rally, Gill, driving a Team MRF Skoda Fabia S2000, finished well clear of the fight for second position between China's Jun Yu and Australian Mark Pedder. Kopecky led until the sixth stage before retiring.

## X-COUNTRY WORLD CUP

Qatar's Nasser Saleh Al-Attiyah stormed through from second position to snatch a dramatic last-stage victory for the Overdrive Racing Toyota team on the Hungarian Baja round of the World Cup for Cross-Country Rallies. The Qatari and French co-driver Matthieu Baumel earned the fastest time on the final special stage to take victory from Orlando Terranova (Mini All4 Racing) by just 17s.

# WEB DIRECTORY

## CAR BROKERAGE

### RACING CARS FOR SALE

ALAN CORNOCK FCS  
**BUYING - SELLING - BROKERAGE**  
[www.racingcarsforsale.co.uk](http://www.racingcarsforsale.co.uk)  
**TEL: 01480 891212**

## ENGINES

### JULIAN GODFREY ENGINEERING

visit our new online shop [www.racetuners.com](http://www.racetuners.com)

## EXHAUSTS

Inconel & Stainless Steel Specialists  
**SIMPSON**  
 Race Exhausts  
 Tel: 01753 532222  
[www.simpsonraceexhausts.com](http://www.simpsonraceexhausts.com)  

## GEARBOXES

### Gearboxman.com

COMPETITION TRANSMISSION SERVICES  
 Gearboxes & Axles for Road, Race, Rally and more  
 Telephone: 01582 840008 Fax: 01582 840007

## HELMET GRAPHICS

### Mike Fairholme Designs

Sole approved painter of Arai helmets.  
 Silver Birches, Corby Birkholme, Nr Grantham, Lincs NG33 4LE.  
 Tel: 01476 550630. Fax: 01476 550029.  
 email: [fairholmedesigns@btconnect.com](mailto:fairholmedesigns@btconnect.com)  
[www.fairholmedesigns.co.uk](http://www.fairholmedesigns.co.uk)

## MEMORABILIA

[www.Diecast](http://www.Diecast)  
  **race models.com**  
 Specialists in 1:2 Scale Replica F1 Helmets

## MEMORABILIA

  
**FINAL LAP**  
 For Everything Formula One  
[www.finallap.net](http://www.finallap.net) **WE BUY AND SELL**  
 +44 (0) 1245 287588 / 07771 920345

## RACE PRODUCTS

**ARE DRY SUMP  
 SYSTEMS**  
 ARMSTRONG RACE ENGINEERING INC.  
**WWW.DRYSUMP.COM (916) 652-5282**

**Pit to Car Autotel**  
 Radio solutions **Digital Race Radio**  
 0044(0)1508 528837  
**www.raceradio.co.uk**

## RACE PRODUCTS

 **race and rally**  
 PASSIONATE ABOUT MOTORSPORT  
[www.jjcraceandrally.com](http://www.jjcraceandrally.com)

Lola 210 & 212 cars and parts  
 Cosworth FVC, FVA,  
 BDG, BDA  
  
 Lotus Twin Cam & Pinto engines [www.davidgathercole.co.uk](http://www.davidgathercole.co.uk)

 **LONDON  
 MOTORSPORT  
 SHOWROOM**  
**WWW.MSAR.CO.UK**

## RACE PRODUCTS

**PORSCHE SHOP**  
 10% off with website  
 voucher code AUTOTEN  
**Or Call: 0121 585 6088**

**THINK  
 AUTOMOTIVE**  
 call: 0208 568 1172 visit: [www.thinkauto.com](http://www.thinkauto.com)

**demon tweeks**  
 MOTORSPORT *Direct*  
[www.demon-tweeks.co.uk](http://www.demon-tweeks.co.uk)

## RACEWEAR

**CROYDON RACE  
 & RALLY CENTRE**  
[www.croydonraceandrally.co.uk](http://www.croydonraceandrally.co.uk)  
 220-222 Portland Road  
 South Norwood  
 London SE25 4QB  
**FORECOURT PARKING** **For Racewear &  
 Motorsport equipment**  
**Tel: 020 8656 7031**

**Grand Prix  
 Racewear** THE  
**RACEWEAR  
 EMPORIUM**  
[WWW.GPRDIRECT.COM](http://WWW.GPRDIRECT.COM)  
**08435 070 858**  

AUTHORISED DISTRIBUTOR  
**OMP** **YBRACING**  
 MOTORSPORT & PERFORMANCE  
**WWW.YBRACING.COM**

## TRAILERS & TRANSPORTERS

**BRIAN JAMES TRAILERS**  
 >> Connected to you  
[www.brianjames.co.uk](http://www.brianjames.co.uk)

  
**PRG TRAILERS**  
[www.prgtrailers.co.uk](http://www.prgtrailers.co.uk)  
 Phone no: +44 (0) 1270 812402

## WHEELS

**Image**® Manufacturers  
 of bespoke split  
 rim alloy wheels  
**www.imagewheels.co.uk**  
**IMAGE WHEELS INTERNATIONAL LTD.**



TO ADVERTISE IN THE WEB DIRECTORY  
 PLEASE CALL 020 8267 5992  
 OR EMAIL: [autosport.ads@haymarket.com](mailto:autosport.ads@haymarket.com)

**BRIAN JAMES TRAILERS**

»» Connected to you



Photograph courtesy of Litchfield Motors.

[www.brianjames.co.uk](http://www.brianjames.co.uk)

## Night shift

High performance, cutting edge technology, Race Transporter enclosed designs offer fast, safe and efficient vehicle transportation. Crossing continents, travelling through many years our trailers have served at every race or rally.

With bright LED ambient lighting, and carefully designed interior space Race Transporter trailers operate day and night.

Main photograph, Race Transporter 6 with double assistor ramps, interior LED lighting, high level tyre rack and work bench combination.

Race Transporter range from £ 7,099 (excl. VAT).



**RACE TRANSPORTER**

**T +44 (0)1327 308 833**

For more information and details of your local BJT dealer please call or visit our website.

# TRAILERS & TRANSPORTERS

**WOODFORD**  
**TRAILERS**



www.WOODFORDTRAILERS.com  
HIGH QUALITY TRAILERS FOR CLUB, PRIVATE AND PRO MOTORSPORTS



Email: [sales@woodfordtrailers.com](mailto:sales@woodfordtrailers.com)

CALL US NOW 01327 263 384

**PRG TRAILERS**

*Finest Built British Trailers.*



PRG Trailers | Cheshire | UK | Tel: +44 (0) 1270812402  
Web: [www.prgtrailers.co.uk](http://www.prgtrailers.co.uk) | Email: [info@prgtrailers.co.uk](mailto:info@prgtrailers.co.uk)

**AUTOSPORT**

IF YOU'D LIKE TO ADVERTISE YOUR  
PRODUCTS AND SERVICES IN THE

MARKETPLACE CALL:

**0208 267 5865**

**WELCOME TO YOUR  
MOTOR HOME!**  
HOSPITALITIES FOR CHAMPIONS



**BISCHOFF SCHECK AG**

[WWW.BISCHOFF-SCHECK.COM](http://WWW.BISCHOFF-SCHECK.COM)

# CARS FOR SALE

## FOR SALE 458 Challenge



Bianco Avus with Rosso Sport Cloth Interior, Forged Centre Nut Alloy Wheels, Integrated Jacking System, CCM2 Carbon Ceramic Brakes, Passenger Seat Kit, 1220kg in Weight and 570 BHP, 2015 Aerodynamic Package.

**NEW £189,000**+vat



OFFICIAL FERRARI DEALER

**Meridien Modena**

For further information, contact us on **02380 283 404** or email [modena@meridien.co.uk](mailto:modena@meridien.co.uk)

## racecar warehouse

### Formula One cars For Sale



Leyton House March 891 Judd EV on the button small spares package starter system available with/without spare Judd EV engine



Arrows A16 Hart V8 engine (less internals) Point scoring car 95 Australian GP Morbidelli Spare parts starter system



Lola 9651 F3000 car with fresh Mugen Raced in Japanese F3000 championship by the 97 championship winner and F1 driver Pedro de la Rosa

Arrows A14 Hart DFR on the button spare parts tooling | Arrows A13 rolling chassis ( engine available) | March 761 DFV low mileage car Tyrrell 009 DFV | BAR 99/2k show car | Leyton House 911 rolling chassis (Judd V10 fitting kit available)

#### F1 engines

DFV short stroke under going full rebuild £67500 • DFV long stroke rebuilt 08 & unused £35000 • DFV new block DFR 3.5 litre stripped for full rebuild • Hart 415T turbo engine complete • TWR V10 show engine DFV show engine Hart 415T show engine

T: + 44 (0)1444 230309 | M: + 44 (0)7711 660691  
[info@racecarwarehouse.co.uk](mailto:info@racecarwarehouse.co.uk) | [www.racecarwarehouse.co.uk](http://www.racecarwarehouse.co.uk)



☎ 0117 950 9294

**HOPKINS**  
MOTORSPORT

**Europe's Largest Motorhome-Office-Hospitality Vehicle**

**AVAILABLE NOW FOR SALE OR HIRE**



**ULTIMATE IN LUXURY**

**BUILT TO IMPRESS**

Everybody in motorsport has different requirements, be it mobile garages, living, offices or hospitality or a combination; Hopkins Motorsport will build your vision - however radical!

A revolutionary design with 1,100 sqft of living space incorporating 4 slide out pods, a hydraulic pop up roof to achieve three levels with 2.1metre of headroom in each level and still be able to travel legally throughout Europe. Once at a venue this vehicle can be easily set up by one person in under an hour!

This extraordinary vehicle will accommodate eight people in homelike comfort and luxury.

[www.hopkinsmotorsport.com](http://www.hopkinsmotorsport.com)

**THE RACE TRANSPORTER SPECIALISTS**

**NEW & USED SALES :: RENTAL :: REFURBISHMENT**

TRAILERS & TRANSPORTERS

## ORDERS NOW

BEING TAKEN FOR 2015 DELIVERY POP  
UP ROOF & HYDRAULIC SLIDE OUT  
VEHICLES TO ANY SPECIFICATION



### New build 2014:

- Top deck carrying capacity 2 GT cars.
- Lower deck design to carry 2 formula cars & pit equipments, at the circuit it converts to a workshop and Engineers room.
- Management office.
- Drivers changing & relaxation room/ storage room.
- 9kw Silent generator, hydrovane compressor, Satellite, 13.5 x8m awning, Air conditioning in all rooms.
- Available now for sale or hire.

### In build on 2008 chassis:

Multi car or Bulk freight transporter with removable office. Carrying capacity up to 5 Touring cars, adjustable height bench's that also fold up for bulk freight, removable office for upto 8 people, air conditioning, data Tv's, etc. available 1-9-14.

Available 1-11-14

6 identical 4 car transporters complete with workshops & offices from our rental fleet please call for details prices from £90,000 to £110,000 depending on age.

# MARKETPLACE

## CAR TYRES

FOR ALL YOUR  
**AVON**  
 TYRES  
**MOTORSPORT**  
 RACING TYRES  
 Inc. ACB 10 Formula Ford  
 Contact

**BMTR LTD**

Tel: 0121 331 1122  
 Fax: 0121 331 1144  
 email: sales@bmtr.co.uk  
 see our new website at www.bmtr.co.uk

## FLOORING

### Kiwi Tiles

Interlocking Plastic Floor Tiles, as used by leading race teams throughout Europe.



- Easy installation & removal
- Many colours
- Lightweight
- Strong and durable
- Compact & easy to store
- Top quality
- Value for money

Stock Colours:  
 Red, Blue, Green,  
 Yellow, Silver, Orange,  
 Grey, Black, White,  
 Dayglo Red

**Rak Engineering**  
 Tel: 01865 883354 Fax: 01865 883789  
 Email: enquiries@kiwitiles.com  
 www.kiwitiles.com

## FLOORING

### Levelling Feet & Castors



All Goods In Stock, Next day delivery, Buy Online.

01327 312664  
 www.stainless-feet.co.uk

## MEMORABILIA

F1 COLLECTORS .COM



### #1 FOR F1 MEMORABILIA & AUTOGRAPHS

We buy and sell F1 items  
**AYRTON SENNA** specialists

Call CHRIS GRINT

**01763 274448**

email:- sales@f1collectors.com

## RACE PRODUCTS

- EXPERT ADVICE
- MASSIVE STOCK
- RAPID DELIVERY

**demon tweeks**  
 MOTORSPORT Direct



CALL TODAY **0844 375 2196** LOW CALL RATE CALLS MAY BE RECORDED FOR TRAINING PURPOSES MEDIA CODE: PZ252A

[www.demon-tweeks.co.uk](http://www.demon-tweeks.co.uk)

**AUTOSPORT**

IF YOU'D LIKE TO ADVERTISE YOUR PRODUCTS AND SERVICES IN THE

MARKETPLACE CALL:

**0208 267 5865**



## WELCOME TO THE TW STEEL DMAX CHAMPIONSHIPS



Prices are **£190\*** per Endurance

Round **£165\*** per Heats Round

**£295\*** to enter both

Cumulative Loyalty Discount of **2.5%** for each round entered.

A full season of Heats Racing for **£1476\*** or Enduro Racing for **£1699\***

**NEW**  
 Weight Classes  
 for 2014

Lights Min 70Kgs  
 Inters Min 85Kgs  
 Heavies Min 100Kgs

17 August 2014	Clay Pigeon
21 September 2014	Whilton Mill
19 October 2014	Daytona Milton Keynes
16 November 2014	Daytona Sandown Park

\*all prices include VAT

Tel: **0845 644 5504**  
[www.daytonamax.co.uk](http://www.daytonamax.co.uk)

TW STEEL



AUTOSPORT

ROTAX  
 NEW AGE KARTING



box

# MOTORSPORT JOBS



## HR02081401: CFD AND FEA SOFTWARE ENGINEER

This is an outstanding opportunity to be part of our highly skilled team working at the pinnacle of Formula One.

Red Bull Technology is looking to recruit a talented Engineering Software Developer to develop and support its range of bespoke in-house analysis tools.

Working from our Milton Keynes factory you will be part of a small team and provide key software tools to the aerodynamics and structures departments. This is an exciting opportunity to be involved in rapid focussed development of transformative tools for highly demanding internal customers, focussed on improving speed, correlation, quality and robustness.

### Essential:

- Educated to Masters or PhD level in Applied Mathematics or Computer Science.
- Extensive experience in the development of CFD and/or FEA software.
- Excellent software development skills in C++
- Agile software development (build automation, CI, version control, sprint)
- Developing software for Linux and Windows
- Familiarity with scripting languages, particularly BASH and python

In addition, experience with some of the following would be beneficial.

- Development of parallel software, using OpenMP, MPI, CUDA, threads
- Boost
- User interface development with Qt
- Graphical software development with OpenGL
- C#, .NET and creating managed wrappers to C++ code
- software interfacing with relational databases
- interfacing software to, and development in matlab and simulink
- Database replication
- Race telemetry systems

You should be self-motivated and proactive, with excellent communication skills and the ability to work to very tight deadlines within a dynamic team environment, often with minimal supervision.

To apply for the CFD and FEA Software Engineer role, or any other positions at Red Bull Racing and Red Bull Technology, please visit the jobs link on our website [www.infiniti-redbullracing.com](http://www.infiniti-redbullracing.com).

## HR10061401B: CFD/SIMULATION ENGINEERS

This is an outstanding opportunity to be part of our highly skilled team working at the pinnacle of Formula One.

We have opportunities to support the design and development of our Formula One power unit in the following areas:

- Aerodynamic design and optimisation,
- 1-D and 3-D analysis of intake and exhaust systems,
- Cooling systems,
- Combustion modelling,
- In-cylinder flow,
- Advanced CFD and simulation tools development,

Working from our Milton Keynes factory you will be involved in the complete development cycle from initial concepts through to deployment on the race car, ensuring our continued success on the race track. You will be part of an expanding team helping mould the power unit development at Red Bull Technology.

To be considered for one of the roles you must have a minimum of an Engineering or Mathematical Degree, an organised and methodical approach to work and experience in one, or more, of the following areas:

- A specialisation in CFD simulation. Postgraduate study in a relevant subject would be preferred,
- Detailed knowledge of: complex chemical reactions, combustion, thermodynamic and fluid dynamic principles,
- Familiarity with state-of-the-art engine development methods and practices,
- A proven track record in experimental testing and visualisation of engine flows.
- A good understanding of data analysis tools and techniques and other multi-disciplinary engineering skills including CAD and vehicle dynamics.

You should be self-motivated and proactive, with excellent communication skills and the ability to work to very tight deadlines within a dynamic team environment, often with minimal supervision.

To apply please visit the jobs link on our website [www.infiniti-redbullracing.com](http://www.infiniti-redbullracing.com).

**CLOSING DATE FOR APPLICATIONS – TUESDAY 30<sup>TH</sup> SEPTEMBER 2014.**

No agencies please.



## WE ARE CURRENTLY LOOKING TO RECRUIT THE FOLLOWING POSITION WITHIN RED BULL TECHNOLOGY:

### HR04111301B – CFD TOOLS ENGINEER

We currently have an exciting opportunity for a CFD Tools Engineer to join our CFD Tools Development Group, within the Aerodynamics Department.

This role will involve providing functional CFD knowledge, utilising software and working as part of a team to optimise CFD workflows.

Applicants should be educated to graduate level or equivalent, and qualifications should include subjects in a strong Scientific, Mathematical or Engineering subject. Candidates from a CFD Engineering or Mathematical Modelling background are welcome to apply. Additionally, experience within a similar role would be desirable. The ability to prove and demonstrate the development of new ideas and tools from idea through to production is an essential requirement for this role.

To apply please visit the jobs link on our website [www.infiniti-redbullracing.com](http://www.infiniti-redbullracing.com).

**CLOSING DATE FOR APPLICATIONS – TUESDAY 30<sup>TH</sup> SEPTEMBER 2014.**

No agencies please.



# AUTOSPORT

## And here are the views of some of our satisfied clients:

**“We received an unexpectedly large amount of responses in only a few days. We would definitely consider Autosport for any future recruitment needs.”**

*Jose Santos, Race Engineer Matech Concepts*

**“At Flybrid Systems we have used Autosport as a single source to advertise a range of jobs from design and development engineering roles to assembly technicians and administrators. We have always had a strong response and on the last occasion we received over 200 applications for 6 posts.”**

*Jon Hilton FIMechE CEng, Managing Partner, Flybrid Systems LLP*

**“The decision to advertise for staff in Autosport was easy as the magazine is one of the most widely read motorsport publications in the world. The resulting response also met our expectations providing us with a large number of high quality candidates. What exceeded our expectations was the friendly and helpful nature of the Autosport staff who helped us with the timing and preparation of our advertisement. I would recommend the use of Autosport to any organization looking to recruit staff in our business.”**

*Steve Hallam, Director of Competition, Michael Waltrip Racing*



# EURO NOVA



## *racing*



## **Congratulations to Kimi Sato**

2014 Auto GP Champion with a record breaking six wins from twelve races – continuing the long line of Euronova winners which includes Robert Kubica, Vitaly Petrov, Jerome d'Ambrosio, Luca Filippi, Sergey Sirotkin, Nicolas Costa and Emanuele Zonzini



# LASER<sup>®</sup>

## TOOLS

# Racing



Come and see us at

## Knockhill

August 23rd-24th



British Touring Car Championship



**Aiden Moffat**  
Laser Tools  
Racing  
Chevrolet Cruze

*It's great to be racing back at Knockhill in front of the home crowd. More so now as with Laser we feel we have the best tools for the job. Knockhill have been a great support to me in my racing career to date and I'm looking forward to catching up with them and all the fans.*



# LASER<sup>®</sup>

[www.lasertools.co.uk](http://www.lasertools.co.uk)

THE MG CAR CLUB INVITES YOU TO COMPETE IN  
THE 9<sup>TH</sup> BRITISH MOTOR HERITAGE  
**CLASSIC 4 HOUR RELAY RACE**  
OCT 5TH - SNETTERTON 200 CIRCUIT



**ENTRY FEE - £780 PER TEAM**

The highlight of the weekend's racing!  
Teams to consist of between 3 and 6 drivers and cars  
Open to a variety of classic marques: MG, Morgan,  
Jaguar, Austin Healey, Lotus and more!  
Scratch and handicap results  
26 teams. Entries accepted at MGCC's discretion  
Reservation form available from [johnh@mgcc.co.uk](mailto:johnh@mgcc.co.uk)



FOR MORE DETAILS, ENTRY FORMS AND  
REGULATIONS, VISIT [MGCC.CO.UK/MOTORSPORT](http://MGCC.CO.UK/MOTORSPORT)

## SUBSCRIBE TO AUTOSPORT FOR ONLY £6 EVERY 6 ISSUES

PLUS FREE DIGITAL EDITION SUBSCRIPTION  
& UNLIMITED ACCESS TO AUTOSPORT.COM



### SUBSCRIBER BENEFITS...

- ✓ **JUST £6** for your first 6 issues, thereafter pay only £34.99 every 13 issues
- ✓ **NEVER** miss an issue
- ✓ **FREE** delivery direct to your door
- ✓ **UNLIMITED** access to news and views from the paddock
- ✓ **ACCESS TO** subscriber-only offers and discounts

CALL 08448 488 817 AND QUOTE ASP014 OR VISIT

[www.themagazineshop.com/asp0-asp014](http://www.themagazineshop.com/asp0-asp014)

**Terms & Conditions:** This offer is open to UK residents only. If you require any assistance following the purchase of your subscription, then you can speak to a member of our customer service team on 01795 592 974, calls are charged at local rate. Overseas rates are available on +44 (0) 1795 592 972. Please allow 35 days for delivery of your first issue. To activate your Autosport online account visit <https://secure.autosport.com/subs/activate.php> and enter your activation code (your personal magazine subscriber number which will be included in your welcome email/letter) along with your email address to access your extra Autosport content. Price is £6 for your first 6 issues then continuous Direct Debit payments of £34.99 every 13 issues unless you cancel. Direct Debit rates are fixed for 12 months after which they may be subject to change - should prices change you will be informed in writing. Details of the Direct Debit guarantee are available on request. Should you wish to cancel the subscription thereafter it will be cancelled on expiry of your current term. Savings are based on the standard UK cover price of £3.60. Offer ends 31st December 2014.

# CLUB AUTOSPORT

NATIONAL RACING • HISTORICS • RALLYCROSS • HILLCLIMB • TRACK TESTS



The new BRDC F4 car will be built to FIA F4 standards

**SCOTT MITCHELL**  
ASSISTANT EDITOR

scott.mitchell@haymarket.com  
@ScottMitchell189



**I'M TOLD THAT AT SILVERSTONE** last weekend, as BRDC Formula 4 team bosses were readying themselves for a meeting with series chief Jonathan Palmer on Saturday evening, there was a collective gloom about the championship's future. To say that gloom had lifted by Sunday morning would be an understatement.

The Motor Sports Association's announcement that it would change the rules for certain single-seater championships so that they were open to 15-year-olds was an immediate issue for BRDC F4 because its current car would be ineligible.

The only benefactor would be the series' budding 2015 rival, FIA F4 (nee British Formula Ford), and while nobody really knows the tangible value of being open to drivers as young as 15, with two entry-level series going toe to toe there is a clear disparity if one is able to attract a bigger pool of drivers.

BRDC F4 was always likely to introduce a new car in 2016, and by building it to FIA F4 safety standards, compared to the Libre-esque Article 277 regulations the current spaceframe cars are built to, it puts itself back on a level playing field.

Does it need to be for next season? On the face of it, you would suggest so, as FIA F4 would have a head start, but the financial guarantee offered to existing teams is a huge incentive for them to stick with BRDC F4 instead of jumping ship. If the backbone of the series can be retained, then a 2015 introduction is not essential and the car can be developed properly.

Could this prompt any change of plan for single-seater powerhouses Carlin and Fortec, or other junior teams? Who knows. But the F4 battle lines have been redrawn – again.

## BRDC F4 to build new FIA car

FIA F4-spec chassis could open up series to 15-year-olds from 2015

**BRDC FORMULA 4 IS TO** introduce a new car built to FIA Formula 4 regulations, opening the championship up to 15-year-olds.

The series' current spaceframe chassis blocks it from benefiting from the rule change announced by the Motor Sports Association last week that will allow drivers aged 15 to compete in certain single-seater championships from next year.

British Formula Ford, which will run to FIA F4 rules in 2015 with a new car built to the world governing body's universal blueprint, looked set to be the only series that would be eligible for the age break.

MotorSport Vision boss and series chief Jonathan Palmer held a meeting with team bosses at Silverstone last weekend, at which it was agreed a carbon-composite monocoque chassis would be built to replace the F4-013.

### PALMER TO BUY BACK OLD CARS

The new car, which will comply with FIA Article 274 crash-test and safety requirements, could arrive as early as next year, although 2016 is more likely.

Palmer has agreed to purchase the existing Ralph Firman-built F4-013s back from the teams for £15,000 to use at the MSV-owned Brands Hatch and Oulton Park experience centres.

"The spaceframe chassis has proven to be just the right thing, the perfect way to launch BRDC F4," said Palmer. "Now it's clear that the costs of composite chassis are reducing. The BRDC car had a maximum life of three years before we were going to upgrade, so it makes sense to do it in compliance with the FIA F4 safety standards.

"We will be liaising with the teams. It's totally dependent on what they want to do, but the most likely date for the new car's introduction is 2016.

"We've got tremendous reliability and quality for the current car, and want to make sure that it is exceeded by the new car. That's going to be best served by having the car out by next June pounding round testing."

### TEAMS SUPPORT DECISION

AUTOSPORT understands the proposal was met with universal agreement by the teams, with some eager for a 2015 introduction in order to immediately allow 15-year-olds into the championship.

Graham Johnson, whose Lanau Racing squad ran inaugural champion Jake Hughes last year and is behind George Russell's championship-leading rookie season, believes the move will stop several outfits – including his own – from exploring a move into FIA F4.

"MSV has been talking about going to carbon cars for a little while, but we needed to get the value on the current car," he said. "I wasn't actively looking at FIA F4, but if that's what we needed to do, I was prepared to consider it. Now I'm not prepared to gamble.

"I don't think this will blow FIA F4 out of the water, but you'd be a brave man to buy a car that will have JP and MSV to compete with. MSV is going to blow Ford away with marketing. In a fair fight, it's going to win."



Current spaceframe cars will be ineligible for MSA age break



Palmer will buy back current cars



SWR will be rebranded to reflect Caterham tie-up

EBREY

BRDC F4

# SWR to run as Caterham F1 junior team

THE CATERHAM FORMULA 1 team has announced a tie-up with race-winning BRDC Formula 4 squad Sean Walkinshaw Racing that will make it its official junior single-seater outfit.

Caterham will work with the team's drivers in BRDC F4, starting immediately, and evaluate them for future official junior roles.

Sean Walkinshaw's eponymous team won five races in BRDC F4's

inaugural season, with Matthew Graham and Jack Barlow. It currently runs Briton Jordan Albert and Venezuelan Diego Borrelli.

The team has previously fielded ADAC Formula Masters race winner Nicolas Beer, as well as Euroformula Open frontrunner Alex Palou at Silverstone last weekend.

Ex-F1 racer Christijan Albers, who took over as Caterham team principal in July, said: "A junior

formula like BRDC F4 is the perfect scenario to start a racing career, and we are very happy with this collaboration with SWR.

"If the talent is there, it should be supported, and with the SWR-Caterham F1 Driver Development Programme we are assuring this happens. We will be watching the drivers of tomorrow closely."

"It's an amazing opportunity for SWR and our drivers, and really

does cement the team's position in junior single-seater racing," added Walkinshaw. "It's incredibly prestigious and a real recognition of what we've achieved up to now."

Auto GP and GP2 race winners Kevin Giovesi and Nathanael Berthon are members of the 'new' Caterham driver development programme. Britons Will Stevens, Matt Parry and Seb Morris remain part of its 'racing academy'.

British GT

# Geoff Steel Racing to field Jones, Wyatt in GT4 BMW

GT CUP CHAMPION JEFF WYATT will partner Declan Jones in the final two rounds of the British GT season, with erstwhile British Touring Car squad Geoff Steel Racing taking over the running of the GT4-class BMW M3.

Wyatt, whose last appearance in British GT was more than a decade ago, will partner Jones at Brands Hatch on August 30-31, and at next month's season finale at Donington Park.

The BMW, which has been run by two different squads so far in 2014, has missed the last two races at Snetterton and Spa-Francorchamps.

"I saw the car race at Silverstone, which got my attention," said Wyatt, who is using it to evaluate a continued

partnership next season. "I chatted to Declan, and we both realised a deal would be mutually beneficial.

"First practice at Brands will be my first time driving the car, but I'm confident of having a strong weekend. We're targeting class wins from the outset."



GT4 BMW will be back

EBREY/LAT

VdeV

# Robertson set to make GT3 debut in factory VdeV Ginetta

CHARLIE ROBERTSON WILL make his GT3 debut driving for the factory Ginetta squad this month.

The 17-year-old, who has won six races in his maiden GT4 Supercup campaign, will partner Ginetta chairman Lawrence Tomlinson and factory driver Mike Simpson in the four-hour VdeV Endurance Series race at Motorland Aragon on August 31.

Robertson began his car-racing career with Ginetta, having contested



Robertson will drive GT3 Ginetta

EBREY/LAT

its Junior championship in 2011 and 2012. He finished second to Seb Morris in his first season, winning three races, before adding six more victories in the category en route to the 2012 title.

The HHC Motorsport driver moved into BRDC Formula 4 last year, finishing third with three wins, earning him a place as a McLaren AUTOSPORT BRDC Award finalist. His sportscar return has included five consecutive pole positions and four further podiums.

## Quick and competitive Track Day Insurance

The first online "quote and buy" system solely for the track day user, supplied by established track day and motorsport insurance provider - Ryan Motorsport Insurance

INSUREMYTRACKDAY.COM

- ✓ Damage to your car on a track day, regardless of fault.
- ✓ Any circuit in Europe, including Spa and Nürburgring Nordschleife.
- ✓ Inclusive cover for barrier damage at the Nordschleife.
- ✓ Vehicle recovery available for circuits in Great Britain.
- ✓ Organisers and Clubs - promotional rates and discounts
- ✓ Storage and transit for vehicles and trailers

Log on to [www.InsureMyTrackday.com](http://www.InsureMyTrackday.com) to obtain your online quote today

Ryan Motorsport Insurance Limited is an appointed representative (557405) of Independent Broking Solutions Limited who are authorised and regulated by the Financial Conduct Authority. Its Financial Services Register number is 312026

Radical SR3 Challenge/Clubman's Cup

# Joint Radical grid unlikely to be repeated this season

**RADICAL SAYS IT IS UNLIKELY TO** combine its SR3 Challenge UK and Clubman's Cup again this season after doing so for the first time at Silverstone last weekend.

Thirty-three cars split almost evenly across the two classes started the two races, after series bosses took advantage of a rules clause allowing the categories to run together on the Grand Prix circuit.



"Because the Silverstone Grand Prix circuit can accommodate up to 48 cars, we felt it would look better to have one combined grid of 33 cars than two separate ones," said championship co-ordinator Amanda Abbott.

"The Clubman's Cup regulations were written to allow a merger with the SR3 Challenge at Silverstone, but we can't do it anywhere else."

Grids for both series dipped at the previous round for Castle Combe, with nine entries in the flagship SR3 category and 12 Clubman's cars, but Abbott said there was no pressing need to adopt measures aimed at boosting grid sizes because the low numbers were down to numerous drivers being on holiday.

"It might be wise to have a summer break in the calendar in future," she said.

## HUMBLE PYE

# The voice of club racing



## Club racing set for bumper Bank Holiday weekend

**T**he August Bank Holiday weekend is traditionally a big one for British motorsport. I'm working at the Historic Sports Car Club's Oulton Park Gold Cup event – on Sunday and Monday, but again plan to take in the 750 Motor Club's Summer Festival Saturday at Silverstone en route.

Competition is exceedingly tight at this stage of the 750MC's 75th anniversary season, with seven points or fewer separating the top protagonists in six title races. Closest to date is the Stock Hatch battle, in which defending champion Tom Bell leads Lee Deegan by a single point. With Shayne Deegan close behind, clawing his way back from one poor round, and each driver yet to discard two of their 14 scores, it is likely to go to the wire at Donington on October 4-5.

Back where the 750 Formula started with Austin Seven-based specials in July 1950, the diversity of 1108cc Fiat-powered cars in the mix is always worth a paddock trawl. Two points separate Billy Albone and Bill Cowley atop the table on sponsor Premier Choice Group's home soil.

Both halves of the road-going bike-engined (RGB) equation are splendidly combative, two points splitting James Walker (STM Phoenix) and David Watson (MNR GM2) in the front-engined division, and Spire pilots Jon Cutmore and reigning champion Matt Higginson five apart among the 'pushers'. In bikesports, six points separate class pacesetters Tim Gray (Spire GT-3) and Adrian Reynard (Radical SR3).

Current Toyota MR2 champion Matt Palmer continues to dominate the two-litre Mk2 class, but 1800cc Roadster star Jim Davies has

notched up three wins recently and is only seven points adrift in the overall standings. Most of the other series remain wide open, too.

Sixty years on from Stirling Moss's victory in Oulton's inaugural non-championship Formula 1 race, which gives the meeting its name, the north-west's top historic event brings a plethora of fabulous machinery to the challenging and

"750MC competition

is tight; six title races

are split by seven

points or fewer"

picturesque Cheshire circuit. Thirteen thunderous F5000 cars take on Jeremy Smith's six-wheeled F1 March in the Derek Bell Trophy feature races, one on each day.

Honda Accord duellists James Dodd and Stewart Whyte's Super Touring title fight will also be resolved, but Dodd is only 14 points ahead entering the double-header finale.

The Guards Trophy GT race will be Sunday's highlight, while the pre-'72 FF1600 race guarantees Monday fireworks.

## Marcus Pye

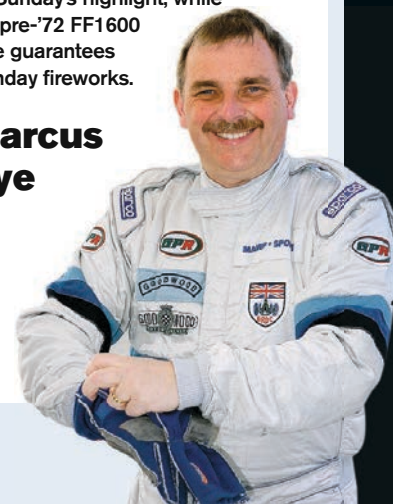

### New Mini Challenge racer unveiled

The new Gen 3 Mini Cooper that will be introduced into the Mini Challenge in 2015 broke cover at Silverstone last weekend. The 275bhp car will join the existing Cooper and JCW classes as the series' flagship model. "It will not be racing in 2014, but we're looking to get in on the circuit [testing] sometime in the next three to four weeks," said series promoter Antony Williams.

BRDC F4

# Mectech confirms F4 plan

**LEADING RADICAL OUTFIT MECTECH** Motorsport has confirmed its expansion into BRDC Formula 4 and has targeted a Winter Series debut.

Mectech, which ran Bradley Smith to back-to-back UK titles in the Clubman's Cup and SR3 Challenge, has purchased the ex-Enigma Motorsport car used by Falco Wauer.

Smith, who was won two races in the Radical European Masters this season – his and the team's first in Europe – could drive the car in the two-round winter series.

"We're going to do a lot of testing and get a good gauge for when a driver can come in," said the 22-year-old. "If the car's

not going to be used, then it's something we'll look at. Really I need to be out in the car because we need to get the data for it.

"Doing it now is just about getting on to the grid to be honest. In the long-term, it's a really good championship to be involved with."



Mectech has bought ex-Enigma car

# Challenge update

What a weekend! We had a MSVR spectacular at Silverstone with MINI Challenge, GT Cup and Radical. We even saw SR3 Challenge and Clubman's Cup sharing the track where Sunoco Whelen Challenger Phil Keen (SR3 Challenge) just about held on to his 'near permanent' lead, despite being unable to battle through the 33 strong grid or take pole and fastest lap.

In the Sunoco 200 Challenge Radical Clubman's Cup Oskar Kruger nearly dropped from the top of the standings after he failed to finish the first race due to mechanical issues, but in the last race he got his win, holding his place at the top of the tables! Chris Knox was hot on his heels in the MINI Challenge, until a collision in his last race ruined his point average.



[www.sunocochallenge.com](http://www.sunocochallenge.com)



Phil Keen

1	P Keen	Radical SR3 Challenge	96.50
2	T Viidas	Radical Euro Masters (SR8)	83.81
3	P Belshaw	Radical SR3 Challenge	78.50
4	N Baldan	EUROV8SERIES	70.00
5	T Kostka	EUROV8SERIES	70.00



[www.sunocochallenge.com](http://www.sunocochallenge.com)



Oskar Kruger

1	O Kruger	Radical Clubmans	105.42
2	D Walley	GT Cup (GTB)	98.61
3	C Knox	MINI Challenge	97.35
4	T Sowery	F3 Cup	97.08
5	S Burgess	Radical Clubmans	94.17



Check out our new Challenge website at [www.sunocochallenge.com](http://www.sunocochallenge.com)

Who will win the prize drive at Daytona?  
Keep following our updates to find out - latest news on [Twitter@sunoco\\_uk](https://twitter.com/sunoco_uk) and [facebook.com/sunocouk](https://facebook.com/sunocouk)



## Next eligible races

### Sunoco Whelen Challenge

Radical Euro Masters, Spa 6-7/9  
Radical SR3, Donington 20-21/9  
EUROV8, Sachsenring 20-21/9  
Radical Euro Masters, Monza 27-28/9

### Sunoco 200 Challenge

F3 Cup, Silverstone 6/9  
MINI Challenge, Brands 13-14/9  
Radical Clubmans, Donington 20/9  
GT Cup, Donington 20/9

# Anglo American Oil Company

+44 (0)1929 551557 (tel) +44 (0)1929 551567 (fax) [info@aaoil.co.uk](mailto:info@aaoil.co.uk) [www.aaoil.co.uk](http://www.aaoil.co.uk)

SAWYER



## Laguna Seca celebrates centenary of Maserati in style

The annual Monterey Motorsports Reunion at Laguna Seca toasted the centenary of Italian car manufacturer Maserati last week with a stunning display of some of the firm's finest racers. More than 500 current and classic vehicles raced during the four-day event, held as part of the Monterey Classic Car Week.

MAMP-SPORT



## In brief

### Denis Welch funeral

More than 400 people packed the Church of the Holy Angels in Staffordshire, for historic racer Denis Welch's funeral last Thursday. Large Austin-Healey, Formula Junior, HSCC Guards Trophy and HGPCA groups were among those who paid their respects to the 69-year-old who died at the Silverstone Classic on July 27.

### Crocker boosts Clios

Renault Clio Eurocup racer Finlay Crocker will return to the UK series this weekend for his home race at Knockhill. The Team Pyro driver, who has a best finish of 15th in Europe this year, will boost the grid to a season-high of 16.

### Festival races canned

Two races had to be cancelled at Brands Hatch's Lotus Festival last Sunday, after Marcus Jewell had a heavy off at Dingle Dell, reportedly suffering broken ribs. Several sections of barrier had to be rebuilt in order for racing to resume, delaying the meeting for about an hour. The second of the Tin Tops and Lotus On Track Elise Trophy races had to be scrapped as a result.

### Free racing at Snett

The Motor Sports Association's initiative to get more people involved in racing, Go Motorsport Live, is offering free entry to its eastern event at Snetterton on October 19. Pre-registered ticketholders will be able to explore the event and experience the Classic Sports Car Club race meeting it will run alongside.

### Walkinshaw returns

The Ginetta GT4 Supercup is set to bounce back from its season-low Snetterton entry with the return of Fergus Walkinshaw and Sean Huyton at Knockhill this weekend, plus an additional SVR entry for Rory Bryant.



Ex-6R4 racer Flaherty returns

Rallycross

## Flaherty back to rallycross

**EX-EUROPEAN RALLYCROSS** frontrunner Mark Flaherty will make his return to the discipline at this weekend's British championship round at Lydden Hill after an absence of more than 20 years.

Flaherty, a double champion in Lydden Rallycross, claimed his last win in the BRC at Anglesey in 1993. He will race Pat Doran's Citroen DS3

Supercar this weekend ahead of a planned full-time comeback in 2015.

Since quitting rallycross Flaherty has dabbled in circuit racing with a bit-part Porsche GT3 Cup Challenge campaign in 2012.

"I finished rallycross when Group B cars were banned," he said. "The series was huge in the UK, but it fell off a cliff and hasn't recovered until now."

## Bryan Small and Brian Spencer

**EXPERIENCED BRITISH CLUB** racers Bryan Small and Brian Spencer both passed away recently.

Runner-up in the 750 Motor Club's 750 Formula championship in 1962, Small graduated to the 1172 Formula, winning the '64 crown in a Howard Milborrow-designed Milmor.

Having hung up his helmet, his engineering skills were lavished on restoring motorcycles for a collector.

"He was my mentor and inspiration," said grandson Ian Bankhurst, himself an accomplished racer.

Spencer, a surgical instrument maker by trade, competed in various formulas for several years. His many exploits included racing a Manx-Tail Cooper, an Envoy Formula Junior and a Jaguar E-type before moving on to oval and short-circuit racing.



Smith swept to second Euro win

Radical Euro Masters

## Local hero Smith nets Euro Radical victory

**DOUBLE BRITISH RADICAL** champion Bradley Smith won his second Radical European Masters race last weekend, after Chris Hyman and Alex Mortimer clinched victory in race one at Silverstone with a last-lap pass.

Marcelo Marateotto ran wide on the

final lap of the opener and Mortimer, who was adamant he was sizing up a pass for the lead anyway, pounced.

Smith had damaged his diffuser early on, and although he could not keep Mortimer behind him, bagged third well clear of Tristan Viidas.

Smith was on pole for the second race and eased clear of ex-British Formula 3 champion Robbie Kerr, winning eventually by more than 18 seconds, while Viidas surged past Tom Jordan and Alex Kapadia on the penultimate lap for second.



HHC racer Fielding's treble win was a BRDC F4 first

READ

BRDC FORMULA 4 SILVERSTONE, AUGUST 16-17 MSVR

# Historic hat-trick puts Fielding in the mix

**SENNAN FIELDING MADE BRDC**

Formula 4 history at Silverstone by becoming the first driver to win three races in one weekend. More significantly, he fired himself firmly into the title fight in the process.

Dominant Fielding might have been, but the victories themselves were anything but. Having squeaked onto pole by just 0.019s, his biggest winning margin from the three counters was a mere four-tenths.

However, the HHC Motorsport youngster now moves ahead of team-mate Will Palmer – who deserved more than a third and a seventh from the three races – and Lanar Racing's Arjun Maini to occupy third in the points, just 29 from the summit.

"All weekend it's been very marginal, but I've come out on top," enthused Fielding. "I knew it would be hard to get into the title fight, but that it could be turned upside down overnight, which it kind of has here.

"It's been a fantastic weekend, which I wasn't expecting at all to be honest. There's nothing else I could ask for – except for the races to have ended two minutes earlier."



Di Mauro earned first podium



Palmer retired just as he took the lead in race one

READ

Had Fielding's wish been granted Silverstone would have been denied three thrilling contests.

Fielding fought off determined challenges from race winners Struan Moore – leading the way for Lanar this weekend as points leader George Russell found the going tough – and Raoul Hyman in the first and last races of the weekend, then claiming a last-gasp win in the second.

A charging Gaetano di Mauro almost took a shock win in a wet-dry race defined by the decision of a handful of drivers to start on slicks. The Brazilian, comfortably delivering his and Petroball's finest performance of their debut season, rose from 11th as the wet-shod runners fell back and cut Fielding's seven-second lead to nothing before taking the top spot as they reached Stowe for the final time.

But the Briton, who had started eighth and moved into the lead with little fuss, refused to yield. He fought back on the Wellington Straight, and as di Mauro defended the HHC man was able to pass him round the

outside with just three corners remaining. Palmer was a fine third, his slick-shod charge from the back of the grid small consolation after a cruel fuel-pump failure forced his retirement just as he snatched the lead at Copse at the start of race one.

Fielding's triumph was more last-gasp than the opening encounter, in which he had to resist the race-long attentions of Moore in a thrilling contest, but the end result was the same: victory by less than 0.2s. While the hat-trick hero was the weekend's star performer, his rivals (Palmer chief among them) had one issue after another.

Moore bagged a brace of podiums, but sandwiched them with a non-finish after breaking a steering arm in contact with Alex Palou, the Spaniard making a one-off appearance in place of SWR regular Nicolas Beer. "All in all, I can't complain," said Moore, after being passed by Hyman for second place in the finale. He retained third despite struggling with worn tyres.

Hyman was unable to follow up his pass for second with a similar move on Fielding, but it was still a battling show from the third row by the South African. It was his second in two days after salvaging sixth (albeit behind Russell, having nosed ahead at one stage) in the opener from a penalty-induced 15th on the grid.

Russell, fifth in race one after repassing Hyman despite damage to his front end, 'won' the race for wet-tyre runners in coming home sixth in race two. Understeer issues then limited him to the same place in the finale.

Russell's points lead is now the slimmest it's been all season, but more pertinent is how the title fight has closed up across the top five drivers, with Arjun Maini (quiet but consistent at Silverstone, with a third, eighth and fourth) only 40 points in arrears in fifth.

With Russell having his worst weekend of the year just as Fielding employed blitzkrieg, the second half of the season has started with the potential for an upset.

● Scott Mitchell

## RESULTS

**RACE 1 (10 LAPS) 1 Sennan Fielding 21m13.136s (103.50mph);** 2 Struan Moore +0.191s; 3 Arjun Maini; 4 Alex Palou; 5 George Russell; 6 Raoul Hyman. **Fastest lap** Fielding 2m05.802s (104.75mph). **RACE 2 (9 LAPS) 1 Fielding 20m21.356s (97.10mph);** 2 Gaetano di Mauro +0.157s; 3 Will Palmer; 4 Rodrigo Fonseca; 5 Tom Jackson; 6 Russell. **FL** Palmer 2m08.776s (102.33mph). **RACE 3 (10 LAPS) 1 Fielding 21m14.982s (103.35mph);** 2 Hyman +0.411s; 3 Moore; 4 Maini; 5 Palou; 6 Russell. **FL** Hyman 2m06.514s (104.16mph). **POINTS 1 Russell, 317;** 2 Hyman, 306; 3 Fielding, 288; 4 Palmer, 281; 5 Maini, 277; 6 Moore, 239.

READ

Geddie beat Chamberlain and out-of-sight Balfe in terrific finale scrap



SILVERSTONE, AUGUST 16-17 MSVR

# Gleeful Geddie clinches GT Cup double

JIM GEDDIE TOOK TWO WINS OUT OF three as the well-supported GT Cup headed a packed Silverstone bill.

Shaun Balfe's Ferrari 458 led the first half of the 45-minute encounter before the GT3 Fezza of the unrelated Ron and Piers Johnson's similar car briefly took charge.

They led until Arwyn Williams and British GT racer Aaron Scott – also driving a 458 – eased to victory. The Johnsons maintained second ahead of soloist Geddie.

After a terrific duel with Richard Chamberlain's Porsche 935, Geddie finally got the upper hand in race two. The rorty Porsche had dropped back towards the end, but a late surge left the pair taking the flag only 0.353s apart. Behind, Chris Hall's Radical RXC finished well clear of Iain Dockerill (Porsche 997) for third.

A three-lap safety car intervention interrupted the resumption of the Chamberlain versus Geddie duel in race three. Balfe split the duo in the early stages and kept Geddie honest even after falling behind the McLaren MP4-12C. Into Village on the penultimate lap, however, Geddie scythed by to lead and eased clear over the final lap. Chamberlain retained second, with Balfe third.

Daryl Jones (Dallara F302) dominated the first Monoposto race

from lap two, but after briefly dropping to fourth the Jedi of Dan Clowes passed Malcolm Scott (F398) for second on the final lap, as Kevan McLurg (F397) slipped back. Clowes led again at the start of a wet race two, but couldn't hold off the F301 of Peter Venn that challenged into Farm on the fifth lap. Clowes remained clear in second with Robbie Watts' Lola regaining third when Tony Bishop (F304) retired.

Having won two of the three Mini Challenge races, Chris Knox is all but mathematically assured of this year's title. With Rob Smith colliding with Luke Caudle on the opening lap of race one, Knox, Henry Duprey and Chris Russell got away and held station for the entire race, with Neil Newstead a distant fourth.

Knox led again from the start of the second race, with Duprey and Newstead chasing. Caudle was into third by lap four and started to close on Duprey, but it took another three laps before he made it through onto the Loop and he ran out of time to try to chase down Knox.

Ex-Clio Cup UK racer Smith took his first Mini win in the third race, after Knox had lost his brakes and collected Newstead. Caudle also pitted, which left Lawrence Davey and Mark Steward to complete



Westerholm flew to SR3 victory

the podium after they saw off Hamish Brandon.

There were three different winners in the Cooper class, with William Phillips taking the race one spoils, inches ahead of Ricky Page. But Page topped race two after duelling with Josh Gollin, who then took the final win after Matt Hammond had looked clear. Shane Stoney clinched the title.

There was contact at the start of the first Radical SR3 Challenge/Clubmans Cup race, with Scott Malvern gaining the advantage after a touch with Bradley Ellis sent him into Lewis Plato. Ellis retired, but Malvern continued to lead until the pitstops. During the second half Jesper Westerholm came to the fore to secure the victory, with Callum Macleod/Ian Loggie second and Steve Burgess passing Tony Wells for third on the last lap.

Plato led the way in race two until his stop briefly handed the lead to Ellis. When Ellis came in the PR6 of Oskar Kruger led, but was chased all the way to the flag by Burgess, with Plato settling in third.

● Peter Scherer

## RESULTS

**GT CUP (21 LAPS) 1 Arwyn Williams/Aaron Scott (Ferrari 458 Italia GT3) 46m34.554s (99.02mph);** 2 Ron Johnson/Piers Johnson (458) +2.861s; 3 Jim Geddie (McLaren MP4-12C); 4 John Seale/Jamie Stanley (458 GT3); 5 Iain Dockerill/Ben Barker (Porsche 997 RSR); 6 Shaun Balfe/Darren Nelson (458). **Class winners** Seale/Stanley; Will Plant/Oliver Bryant (997 GT3); Euan Hankey/Salih Yoluc (Ginetta G55). **Fastest lap** Balfe 2m05.303s (105.16mph).

**RACE 2 (12 LAPS) 1 Geddie 25m44.453s (102.38mph);** 2 Richard Chamberlain (Porsche 935) +0.353s; 3 Chris Hall (Radical RXC); 4 I Dockerill; 5 R Johnson; 6 Nelson. **CW** Marcus Hoggarth (Ferrari 458 GT3); David Walley (997 GT3); Davis Bearman (G50). **FL** Chamberlain 2m07.150s (103.63mph).

**RACE 3 (10 LAPS) 1 Geddie 26m20.991s (83.35mph);** 2 Chamberlain +2.673s; 3 Balfe; 4 R Johnson; 5 I Dockerill; 6 Hoggarth. **CW** Hoggarth; Walley; Mark Litherland (BMW M3). **FL** Geddie 2m08.181s (102.80mph).

**MONOPOSTO (10 LAPS) 1 Daryl Jones (Dallara F302) 21m37.500s (101.56mph);** 2 Dan Clowes (Jedi Mk6) +2.399s; 3 Malcolm Scott (F398); 4 Kevan McLurg (F397); 5 Peter Venn (F301); 6 Graham Read (F301). **CW** Clowes; Daniel Hands (Van Diemen 01); Thomas Craincourt (Mygale SJ08); Paul Britten (Van Diemen RFOO); Andrew Colebrooke (RF98). **FL** Clowes 2m07.040s (103.72mph). **RACE 2 (8 LAPS) 1 Venn 20m21.380s (86.31mph);** 2 Clowes +12.930s; 3 Robbie Watts (Lola F106/03); 4 McLurg; 5 Cian Carey (Formula Renault); 6 Terry Clark (Reynard 903). **CW** Clowes; Clark; Craincourt; Britten; Colebrooke. **FL** Carey 2m28.361s (88.82mph).

**MINI CHALLENGE (9 LAPS) 1 Chris Knox 22m25.265s (88.16mph);** 2 Henry Duprey +6.537s; 3 Chris Russell; 4 Neil Newstead; 5 Hamish Brandon; 6 Alan Taylor. **CW** William Phillips. **FL** Knox 2m28.467s (88.75mph).

**RACE 2 (8 LAPS) 1 Knox 20m00.476s (87.81mph);** 2 Luke Caudle +1.808s; 3 Duprey; 4 Russell; 5 Newstead; 6 Brandon. **CW** Ricky Page. **FL** Caudle 2m28.716s (88.61mph). **RACE 3 (8 LAPS) 1 Rob Smith 20m07.078s (87.33mph);** 2 Lawrence Davey +2.651s;

3 Mark Steward; 4 Brandon; 5 Russell; 6 Kevin O'Connor. **CW** Josh Gollin. **FL** Russell 2m29.603s (88.08mph).

**RADICAL SR3 CHALLENGE & CLUBMANS CUP (16 LAPS) 1 Jesper Westerholm (SR3) 36m21.315s (96.65mph);** 2 Callum Macleod/Ian Loggie (SR3) +8.008s; 3 Steve Burgess (SR3); 4 Dan Vaughan (SR3); 5 Craig Butterworth (SR3); 6 Alvaro Fontes/Toni Forne (SR3). **CW** Brian Murphy (PR6). **FL** Westerholm 2m06.172s (104.44mph).

**RACE 2 (17 LAPS) 1 Oskar Kruger (PR6) 41m33.437s (89.84mph);** 2 Burgess +0.817s; 3 Lewis Plato (SR3); 4 Shahin Nouri (SR3); 5 Vaughan; 6 Ellis/Cummings. **CW** Burgess. **FL** James Abbott (SR3) 2m04.858s (105.54mph).

READ



Knox (888) won twice – but then retired

# Cliffe on the edge to clinch a star double

TRISTAN CLIFFE KEPT HIS F3 CUP championship hopes alive after taking an impressive double victory.

Starting from pole, Cliffe made a tardy getaway in the first race, dropping to third behind Toby Sowery and Henry Chart, who jumped up from fourth on the grid to take second.

Cliffe soon swept by on the outside of Chart at Hawthorns to retake second place before closing the gap to championship leader Sowery, breaking the lap record in the process.

Cliffe bravely attempted to go around the outside of Sowery at Paddock Hill on the penultimate lap, but Sowery clung on, the pair remaining side by side through Druids until Cliffe finally snatched the lead at Hawthorns.

Sowery pressured Cliffe all the way to the finish, ultimately crossing the line just a tenth of a second behind.

"That was the race of my life," said an elated Cliffe after scoring his first victory of the year.

Chart managed to hang on to third place, with Louis Hamilton-Smith chasing him all the way.

Cliffe once again got off to a poor start in race two, falling behind Sowery and Chart again.

"I stalled, but before I could reach for the starter button it fired up again," Cliffe later explained.

Just as he did in the first race, however, Cliffe swept around the



Cliffe took victory in race one by the narrowest of margins from Sowery

outside of Chart to grab second back before setting about catching Sowery.

In the end, Cliffe proved too quick for Sowery, reeling in his rival and taking the lead at Surtees just after one-third distance, this time pulling away to take a comfortable victory.

Hamilton-Smith, meanwhile, completed the podium after Chart spun at Paddock Hill.

"I didn't want to give Toby an autumn break," said Cliffe of Sowery, who now needs to finish in sixth place to put the title beyond doubt next time out at Silverstone.

● Matt Upton

**RESULTS (BOTH 15 LAPS) 1 Tristan Cliffe (Dallara F307 Mugen-Honda) 20m59.704s (104.30mph); 2 Toby Sowery (F305 VW)**

+0.111s; 3 Henry Chart (F305 Spiess Opel); 4 Louis Hamilton-Smith (F307 VW); 5 Oliver Rae (F301 Renault Sodemo); 6 Lee Morgan (F307 Mugen-Honda). **Class winners** Rae; Geoffrey Hoodless (March 813 Toyota).

**Fastest lap** Cliffe 1m22.542s (106.12mph).

**RACE 2 1 Cliffe 21m01.310s (104.17mph); 2 Sowery +12.269s; 3 Hamilton-Smith; 4 Rae; 5 Chart; 6 Morgan. CW** Rae; Hoodless. **FL** Cliffe 1m22.740s (105.87mph).

62

## Battling win for Ginetta duo

RICHARD PREECE AND JAMES REED (Ginetta G20) were deserving victors after fighting up through the order.

Preece was fourth during the opening laps, behind poleman Steve Atkinson (Porsche 968), Darren Goes (SEAT Supercopa) and the fast-starting BMW M3 of Nigel Richards.

Preece took third from Richards after braking very late at Clearways, while Goes began to challenge Atkinson for the lead.

This squabble allowed Preece's Ginetta to close right in, diving up the inside of both of them at Surtees to take a lead that Reed was able to

maintain to the chequered flag when he took over. The pair also benefited from a 10-second pitstop penalty for each of their solo-driver rivals.

● Matt Upton

**RESULTS (25 LAPS) 1 Richard Preece/James Reed (Ginetta G20) 46m19.918s (78.77mph);**

2 Nigel Richards (BMW E46 M3) +15.846s; 3 Steve Atkinson (Porsche 968); 4 Darren Goes (SEAT Supercopa); 5 Adam U'ren/Ben U'ren (SEAT Leon Cupra Cup); 6 Henry Curtis (Peugeot 205).

**CW** Atkinson; Jo Gatt (Honda Integra); Aaron Harding/David Slater (Renault Clio); Jason Jones/Tony Jones (Toyota MR2). **FL** Preece 1m43.942s (84.27mph).



Preece (second) fought past his rivals to win



Randall admitted his win was fortunate

## Randall takes the spoils

CHRIS RANDALL NURSED HOME his sick Europa to victory in an absorbing Lotus Cup encounter.

Polesitter Randall led early on, but slipped to fourth behind Neil Savage, Steve Train and Marcus Jewell after the pitstops before duly working his way back to the front again.

Train was right with Randall in the dramatic closing laps, but his challenge was thwarted by a drive-through penalty.

The race was stopped with three minutes to go, much to Randall's

relief, after Jewell had a massive off at Dingle Dell.

"The car kept cutting out at the end, so I was lucky Steve had a penalty," admitted Randall, who finished 14 seconds clear of Train.

● Matt Upton

**RESULTS (29 LAPS) 1 Chris Randall (Europa)**

**57m18.543s (73.87mph); 2 Steve Train (2-Eleven) +14.196s; 3 Adam Knight (Exige V6 CupR); 4 Simon Deacon (2-Eleven); 5 Adam Balon (Exige V6 Cup R); 6 Glenn Sherwood (Exige V6 Cup R). CW** Train; Knight; Adam Gore (Elise S2). **FL** Randall 1m36.900s (90.40mph).

Whitehead (94) won race two from the back of the field



ATOM CUP BRANDS HATCH, AUGUST 17 MSVR

## Brave Whitehead earns an Atom victory

**THE ATOM CUP SPOILS WERE** shared by Paul Donkin and Nick Whitehead after a pair of close-fought races.

In a rain-soaked race one, polesitter Whitehead retired on the first lap with a mechanical problem, leaving Martin James and Ollie Taylor to contest the lead.

An intense battle for the lead was, however, cut short when Taylor tagged James at Graham Hill Bend on the second lap.

That allowed Donkin into a lead he wouldn't lose from James, with Taylor unable to continue. The race

finished behind the safety car after both Richard Marler and Steven Endress got beached at Clearways.

The second race was a thriller. Whitehead scythed his way through the field from the back of the grid. He was up to third by half-distance after passing Donkin at Surtees, with James and Taylor once more out front.

James stubbornly prevented both Taylor and Whitehead from getting through until the penultimate lap, when Whitehead pulled off a demon move, bravely going around the outside of both James and Taylor to seize the initiative.

Whitehead headed James by three-quarters of a second at the flag, with Marc Mercer finishing in third place after Taylor retired.

● Matt Upton

**RESULTS (7 LAPS) 1 Paul Donkin 13m40.970s (74.69mph);** 2 Martin James +0.741s; 3 Nick Holden; 4 Jonathan Leck; 5 David Mercer; 6 Antony Gaylard. **FL Donkin 1m48.107s (81.02mph).**

**RACE 2 (12 LAPS) 1 Nick Whitehead 20m21.507s (86.05mph);** 2 James +0.434s; 3 Marc Mercer; 4 Donkin; 5 Richard Marler; 6 Leck. **FL Whitehead 1m39.116s (88.37mph).**



## Brands in brief

### Racing Saloons

Matt Seldon (above, right) recovered from a terrible start to win the first race. Working his way up from seventh, he eventually took the lead from Stephen Pearson at Graham Hill Bend. Seldon's father, Peter, snatched third from Karl Cattliff on the line. Seldon Jr also won race two, leading from start to finish.

### VAG Trophy

Ex-British Touring Car racer Harry Vaulkhard was absolutely dominant, leading every lap of the two races. In a restarted race one, James Pile was runner-up, with Stewart Lines third. Lines went one better in race two, going around the outside of Pile at Druids for second on the opening lap.

### MkII Golf GTI

Jason Tingle was victorious in both races, taking the lead of the first at Paddock Hill after Tom Witts collided with Jamie Martin. Witts, who finished the race in second, was subsequently excluded for this indiscretion, promoting Chris Skipp to the runner-up spot. Tingle led for the duration in the second race, with Adam Hance coming home second ahead of Skipp.

### Production BMW

The first race was stopped when several cars went off at Clearways and blocked the track, but when racing resumed Matt Smith pulled away for the victory. James Foard led the early stages of race two, but Smith nipped past on the second lap, keeping Foard at bay to complete the double.

### Champion of Brands

Oliver White (below) led for the duration to take FF1600 victory, but was pushed hard all the way by Josh Barnett. Four-tenths separated the pair at the finish, Barnett never quite getting close enough to White to challenge. Richard Taring was third after a thrilling battle with Ashley Dibden, the pair clashing at Graham Hill Bend at one stage.



LOTUS ELISE TROPHY BRANDS HATCH, AUGUST 17 MSVR

## Last-lap pass earns win for Denman

**CRAIG DENHAM WON THE SOLE LOTUS Elise Trophy** encounter as lengthy barrier repairs caused the second race to be cancelled.

Adam Gore led the way from the start, closely followed by Denman. Ex-Lotus F1 racer Martin Donnelly got a good start, too, passing Jason Baker at Graham Hill Bend for third, although Baker managed to get back through around the Grand Prix loop.

While Donnelly was busy challenging at the front, his son Stefan was going nowhere – both he and Markus Nikowitsch were stranded against the pitwall, bringing out the safety car.

One lap after the restart, Donnelly charged through the middle of both Gore and Baker at Paddock Hill to move up to second, and then snatched the lead from Denman at Surtees. Denman didn't let Donnelly escape his clutches and, after several unsuccessful attempts, his patience



Denman fended off ex-F1 star Donnelly to win

was rewarded when he finally got by at Hawthorns on the final lap, winning by four-tenths.

"Martin's a wiley old fox, so he took a bit of getting around," said Denman on the podium.

With Gore retiring after his engine cut out, James Little completed the top three after beating Baker to the

finish by just three-tenths.

● Matt Upton

**RESULTS (12 LAPS) 1 Craig Denman (Elise 111R) 21m19.018s (68.48mph);** 2 Martin Donnelly (Elise S1) +0.397s; 3 James Little (Elise S1); 4 Jason Baker (Elise 111R); 5 Martin Wills (Elise S1); 6 Ryan Savage (Elise S1). **FL Denman 1m43.857s (84.34mph).**



**Haggerty streaked clear as rivals squabbled**

**SCOTTISH FORMULA FORD KNOCKHILL, AUGUST 17 SMRC**

## Dominant Haggerty makes it six in a row

CIARAN HAGGERTY EXTENDED HIS winning streak to six races following a pair of dominant victories at Knockhill, seizing the championship lead from chief rival Jordan Gronkowski in the process.

Under the watchful eye of mentor Ryan Dalziel, Haggerty scorched away from pole in race one, recording an opening lap three seconds faster than his nearest rival. Eleven metronomic tours later, he took the chequered flag a full 16 seconds clear of the field.

"I was really glad to get the win again," said the 18-year-old. "I just got

my head down and pulled out a gap."

Crucially for the championship chase, the runner-up spot went to Adam McKay, who showed a fantastic turn of speed to hold back the ever-quick Gronkowski.

McKay claimed that a National FF1600 appearance at Silverstone the previous weekend was a big factor in his performance: "It was an eye-opener on how to properly race and defend in these things," he said. "It gave me more track time and, given the gap between meetings, it probably helped me."

Race two began in a similar vein, albeit without Haggerty building quite such a handsome advantage — but he still went on to win by a comfortable four-second margin.

Behind, Gronkowski passed McKay for second in a brave manoeuvre around the outside at Duffus Dip. McKay tried to retaliate at Clark, but the space disappeared.

"He came very late on my inside at Clark," Gronkowski later explained. "I tried to give him room, but we touched wheels."

The resulting spin dropped

MacKay to an eventual sixth, his misfortune allowing Clay Mitchell to complete the top three.

● Jonathan Crawford

**RESULTS (BOTH 12 LAPS) 1 Ciaran Haggerty (Ray GR14) 11m10.429s (81.63mph);**

2 Adam McKay (GRO9) +16.336s; 3 Jordan Gronkowski (Van Diemen RF90); 4 Clay Mitchell (GR13); 5 Matthew Chisholm (RF92); 6 Sebastian Melrose (GR14). **Fastest lap** Haggerty 55.368s (82.37mph). **RACE 2 1 Haggerty 13m21.262s (62.61mph);** 2 Gronkowski +3.934s; 3 Mitchell; 4 Chisholm; 5 Neil Broome (Swift SC93C); 6 McKay. **FL** Haggerty 55.658s (81.94mph).

**CLASSIC SPORTS AND SALOONS KNOCKHILL, AUGUST 17 SMRC**

## Paterson, Gilmartin share wins

HONOURS WERE LEFT EVEN between Shonny Paterson and Tommy Gilmartin after the pair of Classic Sports and Saloons races.

Paterson (TR8) took a straightforward victory in race one after the mechanical problems that hobbled Gilmartin in July's meeting struck again in the early stages. The Morgan driver, bounced back late on, however, and had the TR8 in sight at the flag.

Gilmartin took an early lead in race two and held off sustained pressure from Paterson to win.

● Jonathan Crawford



**Gilmartin (left) dices with Paterson**

**RESULTS (BOTH 12 LAPS) 1 Shonny Paterson (Triumph TR8) 11m56.316s (76.41mph);**

2 Tommy Gilmartin (Morgan Plus 8) +2.948s; 3 Harry Simpson (Ginetta G4); 4 Raymond Boyd (Porsche 911); 5 Stan Bernard (Porsche 911); 6 Matthew Gordon (TVR300M).

**Class winners** Simpson; Boyd; Jimmy Crow (Ford Escort); Tim Reid (Marcos GT); Steve Uphill (Ford Fiesta). **FL** Simpson 59.239s (78.06mph).

**RACE 2 1 Gilmartin 12m10.102s (74.96mph);**

2 Paterson +0.813s; 3 Boyd; 4 Bernard; 5 Gordon; 6 Simpson. **CW** Boyd; Simpson; Crow; Nic Boyes (Mini). **FL** Paterson 58.965s (77.35mph).

**SCOTTISH MINIS KNOCKHILL, AUGUST 17 SMRC**

## Points leader takes double

KENNETH THIRLWALL AND JOE TANNER were the victors in a trio of keenly-contested Mini races.

Tanner won the first race on the road after holding off a six-car train for the duration. Later, however, he was excluded, along with five others, for a technical infringement. This promoted Thirlwall to victory from Oliver Mortimer and Kyle Reid.

Thirlwall was on course for a second win after overtaking Tanner

at Duffus Dip during the final lap of the second race. Tanner, though, brazenly came back at the points leader at Clark a few corners later and held on to take the victory.

In wet final race, Reid took the early lead, although Thirlwall was in front by lap five. Despite the challenging conditions, Thirlwall drove away from the pack to win and move further ahead in the standings.

● Jonathan Crawford



**Tanner shared wins with Thirlwall**

**RESULTS (ALL 9 LAPS) 1 Kenneth Thirlwall 9m41.469s (70.59mph);** 2 Oliver Mortimer +0.413s; 3 Kyle Reid; 4 Malcolm McNab; 5 Jock Borthwick; 6 Ian Munro. **FL** Reid 1m03.521s (71.80mph). **RACE 2 1 Tanner 9m40.009s (70.77mph);**

2 Thirlwall +0.347s; 3 David Sleigh; 4 Mortimer; 5 Reid; 6 Borthwick. **FL** Tanner 1m03.574s (71.74mph). **RACE 3 1 Thirlwall 10m11.718s (67.10mph);** 2 Reid +1.289s; 3 Mortimer; 4 Sleigh; 5 Tanner; 6 Munro. **FL** Thirlwall 1m05.220s (69.93mph).

**BRITISH HILLCLIMB CHAMPIONSHIP  
SHELSELY WALSH, AUGUST 16-17**

# Goodyear scorches to Shelsley win

JOS GOODYEAR SHOT TO HIS FIRST win at Shelsley Walsh, dramatically lowering the two-litre class record to a time only a quarter of a second away from the long-standing overall hill best.

Points leader Scott Moran won the opening encounter, later finishing second behind Goodyear to open a 14-point gap to Trevor Willis, who could only manage two fifth places.

“After this event last year, we resolved to rebuild the car to



Goodyear broke his Shelsley Walsh duck

ROBINSON

match the Raptor to the big cars at the power hills, without sacrificing the handling,” said Goodyear.

Alex Summers performed well, second and fourth keeping him 21 points ahead of Goodyear in the standings. Will Hall was also strong, taking two thirds, but there was

drama when his exhaust had to be refitted on the start line.

Roger Moran took two seventh spots before revealing he will retire at the end of the season. His son Scott will be joined by Summers in the mighty Gould for 2015.

● Eddie Walder

**RESULTS**

**ROUND 25 1 Scott Moran (3.5 Gould-NME GR61X) 23.09s;** 2 Alex Summers (1.3s DJ-Suzuki Firehawk) 23.20s; 3 Will Hall (3.5 Force-Nissan WH) 23.30s; 4 Jos Goodyear (1.34s GWR-Suzuki Raptor 2) 23.33s; 5 Trevor Willis (3.2 OMS-Powertec 28) 23.48s; 6 Tom New (4.0 Gould-Judd GR55) 23.94s; 7 Roger Moran (3.5 Gould-NME GR61X) 24.16s; 8 Deryk Young (4.0 Gould-Judd GR51B) 24.28; 9 John Bradburn (3.5 Gould-Cosworth HB GR55) 24.72s; 10 Alastair Crawford (2.8 Gould-NME GR55) 24.95s; 11 David Uren (1.3t Force-Suzuki PC) 25.00s; 12 Sue Young (4.0 Gould-Judd GR51B) 25.13s.

**ROUND 26 1 Goodyear 22.91s;** 2 S Moran 23.08s; 3 Hall 23.23s; 4 Summers 23.36s; 5 Willis 23.55s; 6 New 24.00s; 7 R Moran 24.18s; 8 Bradburn 24.35s; 9 Young 24.62s; 10 Uren 24.75s; 11 Crawford 24.83s; 12 Young 25.09s. **Class winners** Ken Williamson (1.8 Lotus Elise S160) 35.53s; Roy Standley (Mitsubishi Evo5) 31.71s; Simon Jenks (1.6 Caterham-Suzuki) 30.04s; Craig Spooner (1.8 Westfield SEIW ) 35.06s; Tim Dennis (Rover Mini) 32.93s; Keith Murray (1.4t Audi 80 Quattro) 29.68s; Mike Turpin (2.2s Vauxhall VX220) 29.91s; Davis Garner (5.0 GTD 40 Replica) 38.37s; Simon Bridge (1.3 Lotus Seven) 31.37s; Mark Dempster (2.0 Imagination-Vauxhall PH1) 28.94s;

Rob Stevens (1.44s Force-Suzuki SR4) 25.97s; Mat Morrison (1.6 GRD F3) 31.96s; Steve Lawrence (0.5 Cooper-JAP Mk8) 39.28s; David Morris (2.0s ERA B Type 'Humphrey') 34.22s; Harry Pick (0.6 OMS-Honda Hornet) 29.53s; Chris Aspinall (1.0 Empire-Suzuki Wraith) 26.63s; Richard Spedding (1.6 Force-Suzuki PC) 25.50; Goodyear 22.86s; Hall 23.30s. **POINTS 1 S Moran 212;** 2 Willis 198; 3 Hall 183; 4 Summers 145; 5 Goodyear 124; 6 Menzies 99; 7 New 95; 8 Bradburn 89; 9 R Moran 84; 10 Spedding 60.



NOIR

## Knockhill in brief

### Scottish Fiestas

Kevin Whyte snatched pole position from Wayne MacAulay (above), but failed to hold the championship leader back at the first corner. In only his third-ever race, Whyte maintained second ahead of ex-champion Peter Cruickshank, who fought from the back of the grid after a penalty. MacAulay doubled up in the second race, despite race-long pressure from Cruickshank. Blair Murdoch took third.

### Scottish Legends

Duncan Vincent won from John Paterson in a first heat truncated by a safety car period. The second heat was characterised by an exciting seven-car battle for the win. David Hunter held top spot for most of the race, but it was ultimately Paul O'Brien who won. O'Brien then beat Hunter to win in the final, taking the championship lead in the process, as further back Paterson edged Vincent to complete the podium.

### BMW Compact Cup

Steven Dailly profited from a mid-race stoppage after Stephen Russell crashed, which helped him recover ground lost from an early spin. A bold last-corner move allowed Dailly to snatch victory from points leader Alan Kirkaldy. Dailly later won race two narrowly from Kirkaldy, closing the gap in the standings to 21 points. Brogan Kinsella twice prevailed in the fight for third, edging out Gary Clark and Shaun Forsyth respectively.

### Saloons and Sportscars

Gary Wait shot to an early lead in his Ford Escort in the first race, but was later forced to retire with mechanical problems. This left Cameron Purdie (below) free to win in his Westfield, with Super Lap Scotland runner Fiona Kindness a fine second. Purdie made it two wins from two in the second race after problems for his rivals Wait and Kindness, while Robert Drummond stole third from Mark Dawson at the last corner.



NOIR



The Gold Arts trio dominated at Snetterton

**THE 360 6 HOUR SNETTERTON, AUGUST 16 360MRC**

# Gold Arts Sevens dart to six-hour success

THE GOLD ARTS CATERHAM SQUAD OF Doug Newman, John Schneider and Mike Jones ran out victors in the fifth instalment of the 360 Racing Club's annual six-hour enduro.

As the only team in the race running multiple cars in relay, Gold Arts made the most of its advantage to secure a dominant overall victory by a margin of 16 laps.

Classified second was the BMW M3 of last year's winner Intersport Racing, piloted by Kevin Clarke, Anna Walewska and Ian Donaldson. The trio finished well clear of the rest, having fought back from a snapped throttle cable that left the car stranded at the far side of the track.

Third place, eight laps further adrift, went to the Clio of the TR8 Squadron, which incurred a late pitstop penalty, but had enough in hand to finish ahead of the BMW 330M of the Diesel Taxi Team, which had dramas of its own when the engine's crankshaft pulley came off going into the final hour.

Further back, Team Gaz Shocks looked set for a strong finish before hitting the barriers trying to avoid contact with Rikki Cann's Aston Martin. Its demise helped Cann, along with brother Joe and John Hindhaugh, secure fifth place, ahead of the Midway Motorsport Rover 216.

● Oliver Timson

**RESULTS (242 LAPS) 1 Gold Arts: Doug Newman/John Schneider/Mike Jones (all in Caterham Sevens) 6h00m41.921s (79.86mph);** 2 Intersport Racing: Kevin Clarke/Anna Walewska/Ian Donaldson (BMW M3) –16 laps; 3 TR8 Squadron: Barry Riddell/Ali Basakinci/William Toye (Renault Clio); 4 The Diesel Taxi Team: Steve Scott/Paul White/Mike Watson (BMW 330M Sport); 5 Rikki Cann Racing: Rikki Cann/Joe Cann/John Hindhaugh (Aston Martin V8 Vantage); 6 Midway Motorsport 1: Carey Lewis/Richard Gane/Sandle Brown (Rover 216GTi). **CW** Intersport Racing; TR8 Squadron; Rikki Cann Racing; Team Sim: Andy Sim/Danna Sim/Texa Sim (Austin A40); Simpson & Co 1: Ed Simpson/Chris Williams (Jaguar Mk1). **FL** Intersport Racing 1m18.262s (91.26mph).

# Gardner buries Ford rivals at the Park

## NO ONE COULD GET NEAR MIKE

Gardner's Crossle 30F in either his heat or the final as he took two dominant lights-to-flag victories.

While Gardner raced off to record a massive win in his heat, Andrew Smith's Van Diemen lost an early second place to Simon Jackson's Javelin. He fought back immediately to head a four-car fight for second from Old Hall on lap two, as Matthew Dunne's Crossle snatched third place from Jackson and piled on the pressure for second.

Dunne got by into Old Hall on lap seven, but once again Smith came back and reclaimed his lost place at the same spot two laps later, leaving Dunne to fend off Jackson to complete the podium.

In heat two, Callum Grant's Merlyn lost the early lead to Ted Pearson's Crossle into Cascades, but was back ahead as they passed the pits to start the second lap. Stuart Kestenbaum's Van Diemen joined them in a three-car breakaway and grabbed second at Knickerbrook on lap four.

Pearson stayed close and recovered the place at Cascades, only to spin exiting Old Hall two laps from home. Kestenbaum sealed second with Pearson recovering in third, still well clear of the race-long duel for fourth between Matthew Wrigley's Merlyn and the PRS of Colin Williams.



Gardner romped to dominant wins in his heat and the final

Williams came out on top of the repechage race, which settled the majority of the grid places for the final. Jackson was a close second with a guesting Ian Parkington third.

With Gardner going clear from the start, the battle for the other final podium places was the highlight. Although Grant had lost out to Smith at Old Hall at the start, he was back into second next time around and soon consolidated the place.

Smith fought off a three-car train headed by Kestenbaum to complete

the podium as Pearson's attempt to snatch fourth backfired and he lost out to Dunne for fifth on the last lap.

● Peter Scherer

## RESULTS (ALL 19 LAPS)

### HEAT 1 1 Mike Gardner (Crossle 30F)

15m46.549s (84.66mph); 2 Andrew Smith (Van Diemen FA73) +29.551s; 3 Matthew Dunne (35F); 4 Simon Jackson (Javelin JL5); 5 Steve Pearce (Van Diemen RF78); 6 Mike Wrigley (Elden Mk8). **Class winner Smith. Fastest lap Gardner 1m33.523s (85.68mph).**

### HEAT 2 1 Callum Grant (Merlyn Mk20A)

16m03.284s (83.19mph); 2 Stuart Kestenbaum (RF79) +12.109s; 3 Ted Pearson (32F); 4 Matthew Wrigley (Merlyn Mk20); 5 Colin Williams (PRS RH01). **CW Kestenbaum. FL Grant 1m34.916s (84.42mph).**

### REPECHAGE 1 Williams 16m19.343s (81.82mph);

2 Jackson +0.177s; 3 Ian Parkington (Royale RP26); 4 Pearce; 5 Alan Fincham (RF80); 6 Mike Wrigley. **CW Jackson. FL Chris Stuart (RF80) 1m35.591s (83.83mph).**

### FINAL 1 Gardner 15m49.552s (84.39mph);

2 Grant +0.939s; 3 Smith; 4 Kestenbaum; 5 Dunne; 6 Pearson. **CW Grant. FL Grant 1m33.948s (85.29mph).**

66

# Crombie denied double

IAN CROMBIE LOOKED SET FOR A double win until transmission failure stranded him in race two.

For the first couple of laps of race one, it was a five-car lead train, before Crombie eased clear to victory. Mikey Day demoted Howard Payne from second and on lap four Marcus Bicknell was up to third.

Bicknell spun at Island trying for second, which delayed Payne and let Michelle Hayward into third.

Crombie had built a lead early in race two, but pulled off on lap five, putting Hayward in charge, but with Chris Pickering reeling her in.

Pickering moved ahead at Old Hall, but was then pipped to the win on the last lap by Bicknell.

● Peter Scherer

## RESULTS (BOTH 11 LAPS) 1 Ian Crombie

(Mallock Mk28B Proto) 16m34.468s (88.63mph); 2 Michael Day (Mk26) +3.418s; 3 Michelle Hayward (Mk27); 4 Howard Payne (Mk20B); 5 Marcus Bicknell (Mk35EB Proto); 6 Peter Richings (Mk30PR). **CW Day; Clive Wood (Mk20). FL Crombie 1m28.353s (90.69mph). RACE 2 1 Bicknell 16m35.666s (88.53mph); 2 Chris Pickering (Mk27 EBX) +1.083s; 3 Payne; 4 Hayward; 5 Wood; 6 Winston Graham (Mk27). CW Pickering; Wood. FL Pickering 1m28.895s (90.14mph).**



Crombie (94) led twice, but won only once



Roddison beat points leader Cryer both times

# Roddison brace aids title tilt

PAUL RODDISON KEPT HIS TITLE challenge on target with a double victory over Jonathan Cryer.

Current points leader Cryer led the first race from pole, and successfully kept Roddison behind until Old Hall on lap five.

Jonathan Halliwell managed to oust Ian Loversidge from third on lap two, but they were still nose to tail when Loversidge missed his braking point and rammed Halliwell at Island.

Thomas Collins went through to secure third place from Jeremy Shipley, with Halliwell recovering to fifth in the closing laps.

Roddison was never headed in race two, while Halliwell held off Cryer for second (with Simon Fleet not far

away) until Lodge on the final lap when Halliwell lost the rear and spun on the exit of the corner.

Cryer and Fleet took to either side of him to claim second and third places. Halliwell managed to get his car restarted to come home fifth behind Collins.

● Peter Scherer

## RESULTS (BOTH 12 LAPS) 1 Paul Roddison

21m14.250s (75.46mph); 2 Jonathan Cryer +0.444s; 3 Thomas Collins; 4 Jeremy Shipley; 5 Jonathan Halliwell; 6 Amy Barker. **CW Barker. FL Cryer 1m44.969s (76.34mph). RACE 2 1 Roddison 21m15.128s (75.41mph); 2 Cryer +9.084s; 3 Simon Fleet; 4 Collins; 5 Halliwell; 6 Shipley. CW Barker. FL Roddison 1m44.978s (76.33mph).**

Eventual winner Strong leads podium-finishing ex-BTCC racer Jones



JONES

CLASSIC TOURING CAR THRUXTON, AUGUST 16-17 BARC

## Capri ace too Strong for tin-top rivals

MICHAEL HIBBERT PREVAILED IN THE non-championship CTCRC event, with Nic Strong taking victory in the handicap encounter.

Tom Hibbert was due to start from pole in race one, but was forced to retire his M3 after the warm-up lap because of brake problems. That allowed Michael, starting alone on the front row, to take the early advantage from fellow M3 driver David Hickton.

The pair rapidly escaped from the rest of the field, Hibbert gradually edging away from Hickton to take a lights-to-flag victory. Behind the leading duo, Dean Cranham recovered from a grassy moment

at Club to narrowly take third position from Matthew Evans.

Tim Dodman (Scirocco) led much of the handicap race, having begun with a three-lap advantage over the quickest cars. However, he lost the lead to Andy Johnson's Peugeot 206 approaching Club on the penultimate lap before being swallowed up by the pack and dropping out of the top six.

Johnson held the advantage on the final lap, leading through Club, but was just pipped to the post along the home straight by the Capri of Strong, who overcame a one-lap disadvantage relative to Johnson to win by just

under half a second. Ex-BTCC driver Karl Jones (206) completed the podium a further six-tenths back, with Matthew Evans fourth again.

● Jamie Klein

**RESULTS (11 LAPS) 1 Michael Hibbert (BMW E36 M3) 15m51.080s;** 2 David Hickton (M3) +3.480s; 3 Dean Cranham (M3); 4 Matthew Evans (M3); 5 Steve Cripps (Ford Escort RS2000); 6 Dawn Boyd (Honda Civic Type R). **FL** Hickton 1m25.071s (99.70mph).

**HANDICAP RACE (14 LAPS) 1 Nic Strong (Ford Capri) 21m19.376s (92.81mph);** 2 Andy Johnson (Peugeot 206) +0.447s; 3 Karl Jones (206); 4 Evans; 5 Hibbert; 6 Cranham. **FL** Hibbert 1m25.006s (99.77mph).

MGOC THRUXTON, AUGUST 16-17 BARC

## Smith wins then spins in MG bouts

GARY SMITH AND LEE SULLIVAN shared the spoils in a pair of eventful MGOC races, while Ben Palmer took a brace of seconds.

Sullivan got the better of polesitter Smith at the start of race one, but was passed by the eventual winner on the second lap at Club before dropping out with a broken crankshaft.

That promoted Palmer to second from sixth on the grid, and a lead challenge seemed on the cards before he lost time avoiding a wayward lapped car in the closing stages, allowing Smith to cement his advantage. Andrew Rogerson narrowly shaded Ian Evans to complete the podium.

Rain began to fall not long after the second race got under way, a three-way lead battle between Sullivan, Smith and Palmer soon



Sullivan beat Palmer in a wet second race

JONES

developing amid the spray. Three became two when Smith lost it around the back of the circuit with a handful of laps to go, clouting the barriers, but Palmer continued to hassle Sullivan all the way to the finish, missing out on victory by less than a tenth. Smith, despite significant damage to the rear of the car, made it home in third.

● Jamie Klein

**RESULTS (13 LAPS) 1 Gary Smith (ZR 160) 20m19.927s (90.38mph);** 2 Ben Palmer (ZR 160) +12.244s; 3 Andrew Rogerson (ZR 160); 4 Ian Evans (ZR); 5 Nick Golhar (ZR); 6 Mark Baker (MGF). **CW** Baker; Chris Pollard (MGB Roadster). **FL** Palmer 1m32.366s (91.82mph).

**RACE 2 (12 LAPS) 1 Lee Sullivan (ZR) 20m08.383s (84.22mph);** 2 Palmer +0.059s; 3 Smith; 4 Evans; 5 Baker; 6 Golhar. **CW** Baker; Will Sharpe (ZR 160). **FL** Palmer 1m32.013s (92.17mph).



WALKER

## In brief

### URS Classic FF2000

Ian Pearson (above) took another double win at Oulton Park in his Van Diemen RF83, but he had to wait until the penultimate lap at Cascades in race one to prise open Paul Wighton's defence. It was lights to flag, though, in race two, with Wighton claiming a late second place from Chris Lord after a poor start.

### Sports Saloons D-F

Ilsa Cox became the first female winner of the BARC North West Sports Saloons race in the 30-year history of the championship when she won the Class D to F race at Oulton Park last Saturday in her Seat Leon Cupra. A missed gear at Island on lap four dropped Paul Dobson's Mazda RX7 to second, while Garry Wardle's Ginetta G50 was a solitary third throughout.

### Pinto Sports 2000

Damian Griffin took victory at Thruxton after finding a way past long-time leader Michael Gibbins in the dying stages of the race. From pole, Gibbins stretched out an early lead, but was gradually reeled in during the closing stages by Griffin, who moved ahead on the penultimate lap to win by a margin of 1.6 seconds. Colin Feyerabend finished a distant third.

### Duratec Sports 2000

Nick Bates scored a narrow win at Thruxton after coming out on top in a race-long battle with Peter Sherrington. Bates started from pole position, but lost out to Sherrington at the start before retaking the lead at half distance, going on to win by just three-tenths. Peter Needham was third, later taking a closely-fought victory from Sherrington in a combined Pinto-Duratec race.

### Ferrari Classic

Gary Culver and James Cartwright (below) ran nose to tail in the first race at Thruxton before the former managed to put some distance between himself and his rival to take the victory. Nigel Jenkins finished a distant third behind the pair. With Culver absent for Sunday's second race, Cartwright dominated proceedings, passing Jenkins early on to take a straightforward win, while Christopher Goddard completed the podium.



JONES



# SUBSCRIBE TO AUTOSPORT AND GET...

## A FREE GRID AUTOSPORT GAME



**+PLUS+**

**FREE DIGITAL EDITION SUBSCRIPTION & UNLIMITED ACCESS TO AUTOSPORT.COM**



### FREE GIFTS

- ✓ **Free GRID Autosport Game**  
Choose between PlayStation 3 or Xbox 360 versions of the racing game
- ✓ **Free subscription to the AUTOSPORT Digital Edition**  
and unlimited access to **AUTOSPORT.com**

### SUBSCRIBE NOW!



Visit: [www.themagazineshop.com/aspo-m0814p](http://www.themagazineshop.com/aspo-m0814p)

# 08448 488 817

Or call and quote **M0814P**  
Please have your bank details ready.

Offer ends September 4 2014.

- ✓ Save 25% on the cover price
- ✓ Pay just £34.99 every 13 issues by direct debit

[themagazineshop.com](http://themagazineshop.com)

### THE BENEFITS OF SUBSCRIBING!

- ✓ Never miss an issue
- ✓ Free delivery direct to your door
- ✓ Unlimited access to news and views from the paddock
- ✓ Access to subscriber-only analysis and comment

This offer is open to UK residents only. If you require any assistance following the purchase of your subscription, then you can speak to a member of our customer service team on 01795 592 972, calls are charged at local rate. Overseas rates are available on +44 (0) 1795592 972. Please allow 35 days for delivery of your gift and first issue. The gift will be sent under separate cover from the magazine. Should we run out of gifts, you may be offered an alternative gift – there is no cash alternative. To activate your Autosport online account visit <https://secure.autosport.com/subs/activate.php> and enter your activation code (your personal magazine subscriber number which will be included in your welcome email/letter) along with your email address to access your extra Autosport content. Direct Debit rates are valid for one year after which they are subject to change – should prices change we will inform you in writing. We ask that you enter into a Direct Debit agreement with the intention that your subscription will continue for a minimum period of 12 months, even if the frequency of payment is for a shorter period, however, you will still have the right to cancel your Direct Debit in accordance with Direct Debit Guarantee. Should you wish to cancel your subscription it will be cancelled on expiry of the current term which will not be refundable, other than in exceptional circumstances. If a gift is included as part of the subscription offer we reserve the right to request the return of the gift. Details of the Direct Debit Guarantee are available on request. Savings are based on the standard UK cover price of £3.60. Offer ends 4 September 2014. Haymarket Media Group Ltd uses a best-practice layered Privacy Policy to provide you with details about how we would like to use your personal information. To read the full privacy policy please visit our website [www.haymarket.com/privacy](http://www.haymarket.com/privacy) or call us on 08448 482 800. Please ask if you have any questions as submitting your personal information indicates your consent, for the time being, that we and our partners may contact you about products and services that will be of interest to you via post, phone, e-mail and SMS. You can opt-out at ANY time by emailing the [datacontroller@haymarket.com](mailto:datacontroller@haymarket.com) or by calling 08448 482 800.

# NATIONAL RESULTS ROUND-UP

**BRANDS HATCH**  
AUGUST 16-17, MSVR



**RACING SALOONS (BOTH 9 LAPS)** 1 Matt Seldon (BMW E36 M3) 15m48.374s (83.13mph); 2 Stephen Pearson (E46 M3) +1.197s; 3 Peter Seldon (E36 M3); 4 Karl Cattliff (E36 M3); 5 Leigh Franklin (Talbot Sunbeam Lotus); 6 Darren Stamp (E36 M3). **Class winners** Franklin; Roger Kneebone (BMW 325i); Chris Palmer (Jaguar XJS); Stuart Waite (BMW 320i). **Fastest lap** M Seldon 1m43.407s (84.95mph). **RACE 2 1 M Seldon 15m39.146s (83.94mph)**; 2 Pearson +4.448s; 3 P Seldon; 4 Cattliff; 5 Stamp; 6 Mike Tovey (E36 M3). **CW** Franklin; Kneebone; Palmer; Matt Smith (BMW 320i). **FL** M Seldon 1m42.635s (85.34mph). **VAG TROPHY (3 LAPS)** 1 Harry Vaulkhard (Mk5 Golf GTI 2.0 TFSI) 5m17.438s (82.78mph); 2 James Pile (Scirocco 2.0 TFSI) +1.688s; 3 Stewart Lines (Scirocco 2.0 TFSI); 4 Martyn Culley (Beetle RSI 3.2); 5 Richard Morgan (Mk5 Golf GTI 2.0 TFSI); 6 Len Simpson (Vento Cup VR6). **CW** Mike Smith (Mk4 Golf GTI 1.8t). **FL** Lines 1m42.835s (85.18mph). **RACE 2 (9 LAPS)** 1 Vaulkhard 15m34.941s (84.32mph); 2 Lines +0.595s; 3 Pile; 4 Morgan; 5 Paul Taylor (Mk4 Golf R32); 6 David Fairbrother (Scirocco 2.0 TFSI). **CW** Rob Allum (Mk4 Golf GTI 1.8t). **FL** Lines 1m41.854s (86.00mph). **MKII GOLF GTI (9 LAPS)** 1 Jason Tingle 16m42.582s (78.63mph); 2 Chris Skipp +17.669s; 3 Stewart Lines; 4 Adam Hance; 5 Chris Baguley; 6 Simon Tomlinson. **CW** Tomlinson. **FL** Tingle 1m49.909s (79.70mph). **RACE 2 (6 LAPS)** 1 Tingle 11m10.896s (78.34mph); 2 Hance +9.714s; 3 Skipp; 4 Tom Witts; 5 Lines; 6 Josh Johnson. **CW** Alex Nuttall. **FL** Tingle 1m50.292s (79.43mph). **SALOON CARS AND TIN TOPS (10 LAPS)** 1 Dale Gede (Subaru Impreza) 16m18.525s (89.52mph); 2 Rod Birley (Ford Escort WRC) +0.074s; 3 Alex Sidwell (Holden Commodore); 4 Jack Tetley (Opel Manta); 5 Paul Eve (Ford Sierra Sapphire); 6 Jamie Liptrott (E46 M3). **CW** Liptrott; Barnaby Davies (Toyota Starlet GT Turbo); Tony Paxman (Escort Mk1); Cliff Pellin (Ford Fiesta); Andy Woods Dean (Renault Megane Coupe); Martyn Scott (E30); Peter Osborne (Renault Clio); Dominic Ryan (Ford Fiesta). **FL** Birley 1m36.183s (91.07mph). **PRODUCTION BMW (BOTH 8 LAPS)** 1 Matt Smith 8m16.801s (76.43mph); 2 James Foard +4.489s; 3 Stuart Waite; 4 Jack Gabriel; 5 Rob Cooper; 6 Andy Baylie. **FL** Smith 1m52.424s (77.91mph). **RACE 2 1 Smith 15m12.669s (76.78mph)**; 2 Foard +1.126s; 3 Harry Goodman; 4 Gabriel; 5 Waite; 6 Gary Feakins. **FL** Sealy 1m52.031s (78.19mph). **CHAMPION OF BRANDS (10 LAPS)** 1 Oliver White (Van Diemen RFO1) 16m16.986s (89.66mph); 2 Josh Barnett (Van Diemen BR001) +0.388s; 3 Richard Tarling (RF90); 4 Ashley Dibden (Mygale SJ01); 5 Lloyd Hopes (Ray GRS07); 6 Paul Mason (Swift SC94). **FL** 1m36.244s (91.01mph).



**Ilsa Cox won in Sports Saloons at Oulton Park**

**KNOCKHILL**  
AUGUST 17, SMRC



**SCOTTISH SALOON AND SPORTSCARS (BOTH 12 LAPS)** 1 Cameron Purdie (Westfield) 11m26.353s (79.74mph); 2 Fiona Kindness (Subaru Impreza) +23.361s; 3 Robert Drummond (Ford Escort); 4 Mark Dawson (VW Corrado); 5 Andrew Morrison (SEAT Cupra); 6 Finlay Crocker (Renault Clio). **CW** Kindness; Dawson; Crocker; Will Aitken (Ford Fiesta); Olly Ross (Mazda MX5). **FL** Wait 54.391s (83.85mph). **RACE 2 1 Purdie 11m34.234s (78.84mph)**; 2 Morrison +12.831s; 3 Drummond; 4 Dawson; 5 Mark Robson (Impreza); 6 Crocker. **CW** Morrison; Drummond; Crocker; Aitken; Ross. **FL** Purdie 56.265s (81.06mph). **SCOTTISH FIESTAS (BOTH 12 LAPS)** 1 Wayne MacAulay (ST) 16m46.427s (54.38mph); 2 Kevin Whyte (ST) +0.619s; 3 Peter Cruickshank (ST); 4 Stephen Ward (ST); 5 Andrew Christie (ST); 6 Steven Gray (XR2). **CW** Gray. **FL** MacAulay 1m03.174s (72.21mph). **RACE 2 1 MacAulay 12m49.956s (71.08mph)**; 2 Cruickshank +0.716s; 3 Blair Murdoch (ST); 4 Christie; 5 Whyte; 6 Ward. **CW** Gray. **FL** MacAulay 1m03.299s (72.05mph). **SCOTTISH CLASSIC SPORTS AND SALOONS (BOTH 12 LAPS)** 1 Shonny Paterson (Triumph TR8) 11m56.316s (76.41mph); 2 Tommy Gilmartin (Morgan +8) +2.948s; 3 Harry Simpson (Ginetta G4); 4 Raymond Boyd (Porsche 911); 5 Stan Bernard (911); 6 Matthew Gordon (TVR300M). **CW** Simpson; Boyd; Jimmy Crow (Ford Escort); Tim Reid (Marcos GT); Steve Uphill (Fiesta). **FL** Simpson 59.239s (78.06mph). **RACE 2 1 Gilmartin 12m10.102s (74.96mph)**; 2 Paterson +0.813s; 3 Boyd; 4 Bernard; 5 Gordon; 6 Simpson. **CW** Boyd; Simpson; Crow; Nic Boyes (Mini). **FL** Paterson 58.965s (77.35mph). **SCOTTISH BMW COMPACT (4 LAPS)** 1 Steven Dailly 4m17.262s (70.91mph); 2 Alan Kirkaldy +0.342s; 3 Brogan

Kinsella; 4 Gary Clark; 5 Shaun Forsyth; 6 Cliff Harper. **FL** Dailly 1m03.023s (72.37mph). **RACE 2 (9 LAPS)** 1 Dailly 8m28.487s (71.76mph); 2 Kirkaldy +0.623s; 3 Kinsella; 4 Forsyth; 5 Clark; 6 Harper. **FL** Dailly 1m02.923s (72.48mph). **SCOTTISH LEGENDS HEAT 1 (4 LAPS)** 1 Duncan Vincent 9m55.758s (30.62mph); 2 John Paterson +2.165s; 3 Paul O'Brien; 4 David Newall; 5 Kyle Reid; 6 Daniel McKay. **FL** O'Brien 1m00.319s (75.79mph). **HEAT 2 (8 LAPS)** 1 O'Brien 8m10.565s (74.38mph); 2 David Hunter +0.173s; 3 Vincent; 4 Paterson; 5 Newall; 6 Euan McKay. **FL** Vincent 59.719s (76.37mph). **FINAL (10 LAPS)** 1 O'Brien 12m43.897s (65.68mph); 2 Hunter +1.706s; 3 Daniel McKay; 4 Paterson; 5 Vincent; 6 Rory Butcher. **FL** Hunter 1m00.00s (76.01mph).

**OULTON PARK**  
AUGUST 16, BARC



**FORMULA FORD 2000 (BOTH 14 LAPS)** 1 Ian Pearson (Van Diemen RF83) 20m44.539s (90.14mph); 2 Paul Wighton (RF82) +1.112s; 3 Chris Lord (RF82); 4 Clive Wood (RF82); 5 Paul Burt (RF82); 6 Dale Spruce (Reynard SF83). **CW** Spruce. **FL** Wighton 1m27.874s (91.19mph). **RACE 2 1 Pearson 20m49.332s (89.80mph)**; 2 Wighton +10.504s; 3 Lord; 4 Anthony Hancock (RF82); 5 Burt; 6 Wood. **CW** Spruce. **FL** Wighton 1m28.430s (90.62mph). **SPORTS SALOONS CLASSES A-C (15 LAPS)** 1 Paul Rose (Saker) 21m47.178s (91.95mph); 2 Joe Spencer (Stuart Taylor Locosaki) +19.045s; 3 Garry Watson (Westfield SEW); 4 Steve Harris (Saker); 5 Philip Duncan (SEIW); 6 Cam Forbes (SEIW). **CW** Spencer; Watson. **FL** Rose 1m25.822s (93.37mph). **CLASSES D-F (14 LAPS)** 1 Ilsa Cox (SEAT Leon Cupra) 21m44.607s (85.99mph); 2 Paul Dobson (Mazda RX7); 3 Garry Wardle (Ginetta G50); 4 Steven Hibbert (Sport

Elise); 5 Mike Hurst (Vauxhall Vectra); 6 Oliver Thomas (Impreza). **CW** Hibbert; Mike Nash (Peugeot 106 Rallye). **FL** Cox 1m30.743s (88.31mph).

**THRUXTON**  
AUGUST 16-17, BARC



**FERRARI FORMULA CLASSIC (BOTH 17 LAPS)** 1 Gary Culver (Ferrari 328 GTB) 25m42.253s (93.49mph); 2 James Cartwright (328) +4.566s; 3 Nigel Jenkins (328); 4 Peter Everingham (328); 5 Christopher Goddard (308); 6 Tim Walker (328). **CW** Everingham; Goddard; Carl Bugar (Mondial QV). **FL** Culver 1m29.415s (94.85mph). **RACE 2 1 Cartwright 25m47.482s (93.17mph)**; 2 Jenkins +15.527s; 3 Goddard; 4 Everingham; 5 Darren Wilson (328 GTB); 6 Myles Poulton (328 GTS). **CW** Goddard; Everingham; Bugar. **FL** Cartwright 1m29.472s (94.79mph). **SPORTS 2000 PINTO (19 LAPS)** 1 Damian Griffin (Lola T598) 26m11.836s (102.52mph); 2 Michael Gibbins (Lola T590) +1.620s; 3 Colin Feyerabend (Lola T90/90); 4 Mike Fry (Lola T86/90); 5 Clive Steeper (Tiga SC80); 6 Peter Pettersson (Tiga SC77). **CW** Gibbins; Feyerabend. **FL** Gibbins 1m21.465s (104.11mph). **SPORTS 2000 DURATEC (23 LAPS)** 1 Nick Bates (Lola B07/90) 30m17.180s (107.35mph); 2 Patrick Sherrington (MCR) +0.348s; 3 Peter Needham (MCR); 4 Tom Stoten (Gunn TS8B); 5 Mike Turner (MCR); 6 Roger Donnan (MCR). **CW** Turner; Richard Cooke (Carbir CS2). **FL** Bates 1m17.493s (109.45mph). **SPORTS 2000 COMBINED (19 LAPS)** 1 Needham 25m20.380s (105.99mph); 2 Sherrington +0.433s; 3 Bates; 4 Stoten; 5 Cooke; 6 Clive Hayes (MCR). **CW** Cooke; Hayes; Gibbins; Feyerabend; Griffin; John Taylor (Crosle 9S). **FL** Bates 1m18.554s (107.94mph).



**Rod Birley was denied saloon success at Brands Hatch**

Teddington Studios, Broom Road, Teddington, Middlesex TW11 9BE, UK.  
Tel: +44 (0) 20 8267 5804 Fax: +44 (0) 20 8267 5922  
E-mail: [autosport@haymarket.com](mailto:autosport@haymarket.com) Website: [www.autosport.com](http://www.autosport.com)

**EDITOR**  
Charles Bradley ext.5889  
[charles.bradley@haymarket.com](mailto:charles.bradley@haymarket.com)

**DEPUTY EDITOR**  
Marcus Simmons ext.5807  
[marcus.simmons@haymarket.com](mailto:marcus.simmons@haymarket.com)

**GROUP F1 EDITOR**  
Jonathan Noble ext.5810  
[jonathan.noble@haymarket.com](mailto:jonathan.noble@haymarket.com)

**GRAND PRIX EDITOR**  
Edd Straw ext.5887  
[edd.straw@haymarket.com](mailto:edd.straw@haymarket.com)

**F1 ASSISTANT EDITOR**  
Ben Anderson ext.5425  
[ben.anderson@haymarket.com](mailto:ben.anderson@haymarket.com)

**FEATURES EDITOR**  
Kevin Turner ext.5432  
[kevin.turner@haymarket.com](mailto:kevin.turner@haymarket.com)

**EDITOR AUTOSPORT.COM**  
Glenn Freeman ext.5309  
[glenn.freeman@haymarket.com](mailto:glenn.freeman@haymarket.com)

**DEPUTY EDITOR AUTOSPORT.COM**  
Matt Beer ext.5811  
[matt.beer@haymarket.com](mailto:matt.beer@haymarket.com)

**MANAGING EDITOR**  
Peter Hodges ext.5903  
[peter.hodges@haymarket.com](mailto:peter.hodges@haymarket.com)

**RALLIES EDITOR**  
David Evans  
[david.evans@haymarket.com](mailto:david.evans@haymarket.com)

**SPECIAL CONTRIBUTORS**  
Gary Watkins Dieter Rencken Pablo Elizalde  
Marcus Pye Gary Anderson  
Mark Glendenning Alan Eldridge

**CORRESPONDENTS**

**ARGENTINA**  
Tony Watson

**AUSTRALIA**  
Phil Branagan

**AUSTRIA**  
Gerhard Kuntschik

**BELGIUM**  
Gordon McKay

**BRAZIL**  
Lito Cavalcanti

**FINLAND**  
Esa Ilomäen

**GERMANY**  
Rene de Boer

**GREECE**  
Dimitris Papadopoulos

**ITALY**  
Roberto Chinchero

**JAPAN**  
Jiro Takahashi, Len Clarke

**NEW ZEALAND**  
Bernard Carpinter

**RUSSIA**  
Gregory Golyshev

**SOUTH AFRICA**  
Richard Asher

**SPAIN**  
Raimon Duran

**SWEDEN**  
Tege Tornvall

**USA**  
Jonathan Ingram,

David Phillips, Robin Miller, Jeremy Shaw

**UK & EIRE**  
Jack Benny, Jonathan Crawford, Dan Cross, Kerry Dunlop, Leanne Fahy, Paul Healy, Linda Keen, Jamie Klein, Linda Libbeter, Stephen Lickorish, Marc Orme, Graham Read, Hal Ridge, Peter Scherer, Ian Sooman, Oliver Timsos, Ian Titchmarsh, Matt Upton, Eddie Walder, Richard Young

**ADVERTISING**  
Tel: +44 (0) 20 8267 5389  
Fax: +44 (0) 20 8267 5850  
E-mail: [autosport.ads@haymarket.com](mailto:autosport.ads@haymarket.com)

**DISPLAY SALES MANAGER**  
Martin Lee, ext.5399  
[martin.lee@haymarket.com](mailto:martin.lee@haymarket.com)

**DISPLAY ADVERTISING**  
Gary Lee, ext.5276  
[gary.lee@haymarket.com](mailto:gary.lee@haymarket.com)

**CLASSIFIED ADVERTISING**  
Rachelle Francis-Dottin, ext.5992  
[rachelle.francis-dottin@haymarket.com](mailto:rachelle.francis-dottin@haymarket.com)

**CLASSIFIED SALES MANAGER**  
Jonathan Whitehead, ext.5908  
[jonathan.whitehead@haymarket.com](mailto:jonathan.whitehead@haymarket.com)

**ONLINE ADVERTISING**  
Leah Mimms, ext.5846  
[leah.mimms@haymarket.com](mailto:leah.mimms@haymarket.com)

**CLASSIFIED SALES MANAGER**  
Jonathan Whitehead, ext.5908  
[jonathan.whitehead@haymarket.com](mailto:jonathan.whitehead@haymarket.com)

**SUBSCRIPTIONS**  
UK 0844 8488817  
OVERSEAS +44 (0)1795 592 974  
EMAIL: [autosport@servicehelpline.co.uk](mailto:autosport@servicehelpline.co.uk)

AUTOSPORT, ISSN number 0269946X, is published weekly by Haymarket Media Group, Teddington Studios, Broom Road, Teddington TW11 9BE, United Kingdom. The US annual subscription price is \$235. Airfreight and mailing in the USA by agent named Air Business Ltd, c/o Worldnet Shipping Inc., 156-15, 146th Avenue, 2nd Floor, Jamaica, NY 11434, USA. Periodicals postage paid at Jamaica NY 11431. Subscription records are maintained at Haymarket Media Group, Teddington Studios, Broom Road, Teddington TW11 9BE. Air Business Ltd is acting as our mailing agent.

**BACK ISSUES**  
Tel: 0844 8488817

**MARKETING MANAGER**  
Karen McCarthy, ext.5658  
[karen.mccarthy@haymarket.com](mailto:karen.mccarthy@haymarket.com)

**LICENSING AND SYNDICATION LICENSING MANAGER**  
David Ryan, ext.5024

**MANAGEMENT GROUP DIRECTOR**  
Tim Bulley

**GROUP COMMERCIAL DIRECTOR**  
Ben Guyan

**GROUP EDITOR**  
Anthony Rowlinson

**PUBLISHER**  
Stuart Williams

**PUBLISHING MANAGER**  
Samantha Jempson

**SPECIAL EVENTS MANAGER**  
Laura Coppin

**DIGITAL SPECIAL PROJECT MANAGER**  
Simon Strang, ext.5093  
[simon.strang@haymarket.com](mailto:simon.strang@haymarket.com)

**DIGITAL PRODUCT MANAGER**  
Simon Grayson, ext.5346  
[simon.grayson@haymarket.com](mailto:simon.grayson@haymarket.com)

**EDITORIAL DIRECTOR**  
Mark Payton

**CREATIVE DIRECTOR**  
Paul Harpin

**STRATEGY AND PLANNING DIRECTOR**  
Bob McDowell

**PUBLISHING DIRECTOR**  
Patrick Fuller

**MANAGING DIRECTOR**  
David Prasher

**CHIEF EXECUTIVE**  
Kevin Costello

Haymarket is certified by BSI to environmental standard ISO14001

# THIS WEEK

LETTERS • BEST PICS • LATEST GEAR • ON TRACK & SCREEN • ONLINE

## What you think of the motorsport news of the past week



'Our Nige' celebrates his first IndyCar win at Surfers Paradise

## Stirring childhood memories

As a child of the '90s I have to say how much I have enjoyed reading the last two issues of AUTOSPORT and more specifically reminiscing about my childhood hero, Nigel Mansell.

Mansell was always exciting to watch and he also introduced me to IndyCar when he went to chase the American dream. Reading about him coming back

to 'save' F1 with Williams in 1994 and his exploits in the US, such as his battles with Emerson Fittipaldi, brought back memories that reminded me why I enjoyed watching him so much.

Maybe F1 drivers are just heroes when you're growing up? Thanks for the memories, AUTOSPORT.

**Chris Brown, Kings Lynn, Norfolk**

**Congrats are in order for Max Verstappen** after securing a drive with Toro Rosso next year. But is he *really* ready to make the jump at such a tender age (he'll be 17 when he makes his debut)? F1 is notorious for chewing up an spitting out young hopefuls...

**J Dixon**  
By email

**I have been following F1** religiously for just over 10 years, now aged 23. I can honestly say the racing has improved substantially since the dominant year of Michael Schumacher

in 2004. Every season since then I believe the racing has got better. So why is it then that F1 is losing touch with the younger generation?

F1 perhaps is not helping itself when it comes to modern media. One bugbear of mine is that the sport does not have an official YouTube channel!

If F1 wants to attract a younger audience, the sport needs to engage them in the correct media. Come on Bernie, get with the times!

**Mark Crawley**  
Ireland

**Interesting take on F1's silly season** last week (*The Inside Line*, p9). McLaren would be mad not to retain the services of Jenson Button for at least another season or two: the team's switch in engine supplier will require a driver with his nous, maturity, experience and knowledge.

OK, he may not be regarded as one of F1's *uberstars*, but his steady hand on the tiller will be essential at such a crucial time for the team. And he's still bloody quick, too!

**Frances Stewart**  
London SE13

# In pictures

Images around the globe, from Lincolnshire to Michigan via Hungary



**MORENO ON THE MOUNTAIN?**  
The 1990 Japanese and Australian GP-winning Benetton B190 made an unusual sight at Cadwell Park during the Modified Live event, with owner John Reaks helping to celebrate the circuit's 80th birthday with this demo

**MICHIGAN MADNESS**

Danica Patrick (10), Martin Truex Jr (78), Justin Allgaier (51), Martin Annett (7) and Trevor Bayne (21) were the victims in this NASCAR Sprint Cup pile-up at Michigan



SHAMUS/GETTY

**BAJA WORLD CUP HITS HUNGARY**

Mini ALL4Racing rally duo Aydin Rakhimbaev and Anton Nikolaev head to fifth on the Hungarian Baja. Nasser Al Attiyah/Mattieu Baumel won in their Toyota



**ZANARDI TARGETS US TRIATHLON**

Sporting legend Alex Zanardi has already chosen his next big challenge. The 47-year-old Italian will take on the long-distance triathlon in Hawaii this October



## In the shops

Desirable new releases

**LE MANS 24 HOURS DVD**

£14.99 – [dukevideo.com](http://dukevideo.com)

The official review of the 2014 Le Mans 24 Hours is due for release tomorrow (Friday) and features the usual heady mix of trackside, onboard and pitlane camera angles as the four classes battle it out for glory at the Circuit de La Sarthe. The four-hour highlights use much of the Radio Le Mans commentary to add authority. Also available on Blu-ray (£16.99).

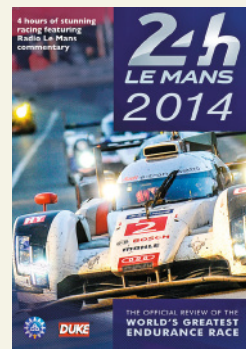

**AUTOMODELISME MAGAZINE**

£6.95 + P&P – [grandprixmodels.com](http://grandprixmodels.com)

Le Mans-themed model collectors and builders rejoice: the 2014 edition of the now-legendary French Automodelisme magazine featuring every car that raced in this year's twice-round-the-clock enduro is here. And again, every car is pictured from several angles to allow accurate representation for the miniature-minded among you.



**SLICK ATTIRE PORSCHE Ts**

£20 inc P&P – [slickattire.com](http://slickattire.com)

Porsche fans are well catered for in the Slick Attire T-shirt shop (they also do canvases). Various designs are available, but these two new additions caught our eye. The 935 and 917 both feature two of the German marque's finest: the Salzburg 917 of Richard Attwood and Hans Herrmann taking the first Le Mans win in 1970.



71

# WHAT'S ON

## ON TRACK IN THE UK



The BTCC makes its annual foray into Scotland this weekend

### KNOCKHILL

#### BTCC

**August 23-24**  
[knockhill.com](http://knockhill.com)

The BTCC title battle is reaching a critical phase as the series makes its annual pilgrimage north of the border this weekend. Local hero Gordon Shedden will be looking to make inroads into Colin Turkington's championship lead, while Jason Plato (MG) and Andrew Jordan (Honda Civic) try to get back into the picture. Formula Ford, Renault Clio Cup, Porsche Carrera Cup, Ginetta Junior and Ginetta GT4 Supercup are on the support bill.

### OULTON PARK

#### HSCC

**August 24-25**  
[ouiltonpark.co.uk](http://ouiltonpark.co.uk)

One of the biggest historic meetings of the year takes place this weekend with a range of machinery from bygone times in evidence on Sunday and Monday at Oulton



Gold Cup action comes to Oulton

Park for the circuit's signature Gold Cup event. The Super Touring Trophy, Guards Trophy and Derek Bell Trophy are among the highlights of the 14-category meeting.

### SILVERSTONE

#### 750MC

**August 23-24**  
[silverstone.co.uk](http://silverstone.co.uk)

The 750MC celebrates its 75th anniversary this weekend with a trip to Silverstone, where no fewer than 13 championships will be in action, including Classic Stock Hatch, 750 Formula, Roadsports and Formula Vee.



Kumho BMWs visit Donington

### DONINGTON PARK

#### BARC

**August 23-25**  
[donington-park.co.uk](http://donington-park.co.uk)

Another three-day bank holiday weekend meeting at Donington Park, with three races on the Monday. In addition to the Porsche Club series there will be the Mini Sevens and Miglias, Pickups, Legends, BARC Intermarque and Kumho BMW series.



Come to the KX Question Time at Knockhill's BTCC round on Saturday August 23, and help celebrate the circuit's 40th birthday. This round's panel will include former champion Jason Plato, rising star Jack Goff, series supremo Alan Gow and Knockhill's Derek Butcher.

Ask the panel a question, and you could win one of a number of prizes. And, for this round only, Knockhill is offering a passenger lap in one of the cars taking part in Sunday's parade marking 50 years since Scottish motorsport legend Jim Clark's BTCC title win in a Ford Lotus Cortina.

**FREE ENTRY**

### CASTLE COMBE

#### CCRC

**August 25**  
[castlecombecircuit.co.uk](http://castlecombecircuit.co.uk)

Combe's three popular local championships hold their penultimate rounds on Bank Holiday Monday at the fast Wiltshire circuit, while the Ferrari Formula Classic and BRSCC Mighty Mini series will also be in action.

## ON TRACK AROUND THE WORLD



Fresh from its break, F1 returns at Spa

### BELGIAN GRAND PRIX

**Formula 1 World Championship**  
Rd 12/19  
Spa, Belgium  
August 24  
[f1.com](http://f1.com)

### GP2 SERIES

Rd 8/11  
Spa, Belgium  
August 23-24  
[gp2series.com](http://gp2series.com)

### GP3 SERIES

Rd 6/9  
Spa, Belgium  
August 23-24  
[gp3series.com](http://gp3series.com)

### PORSCHE SUPERCUP

Rd 7/9  
Spa, Belgium  
August 24  
[porsche.com](http://porsche.com)

### INDYCAR SERIES

Rd 14/15  
Sonoma, California, USA  
August 24  
[indycar.com](http://indycar.com)

### INDY LIGHTS

Rd 10/10  
Sonoma, California, USA  
August 23-24  
[indycar.com](http://indycar.com)

### RALLY GERMANY

**World Rally Championship**  
Rd 9/13  
Trier, Germany  
August 21-24  
[wrc.com](http://wrc.com)

### BLANCPAIN GT SPRINT

Rd 4/7  
Slovakia Ring, Slovakia  
August 23-24  
[blanpain-gt-series.com](http://blanpain-gt-series.com)

### UNITED SPORTSCAR

Rd 11/13  
Virginia International Raceway, USA  
August 24  
[imsa.com](http://imsa.com)

### NASCAR SPRINT CUP

Rd 24/36  
Bristol, Tennessee, USA  
August 23  
[nascar.com](http://nascar.com)

### V8 SUPERCARS

Rd 9/14  
Eastern Creek, Australia  
August 23-24  
[v8supercars.com.au](http://v8supercars.com.au)

### SUPER FORMULA

Rd 4/7  
Motegi, Japan  
August 24  
[superformula.net](http://superformula.net)

### SCANDINAVIAN TOURING CARS

Rd 4/6  
Knutstorp, Sweden  
August 23  
[stcc.se](http://stcc.se)

Your guide to the best events taking place in the UK and around the world – plus TV and online

## ON TELEVISION

### THURSDAY AUGUST 21

**1400-1445 Sky Sports F1 LIVE**  
F1 Drivers' Press Conference  
**2100-2200 BT Sport 2**  
DTM review show: Nurburgring

### FRIDAY AUGUST 22

**0845-1100 Sky Sports F1 LIVE**  
Belgian GP: first practice  
**0855-1035 BBC2 LIVE**  
Belgian GP: second practice  
**1100-1150 Sky Sports F1 LIVE**  
GP2 Spa: practice  
**1245-1450 Sky Sports F1 LIVE**  
Belgian GP: second practice  
**1255-1435 BBC2 LIVE**  
Belgian GP: second practice  
**1450-1530 Sky Sports F1 LIVE**  
GP2 Spa: qualifying  
**1600-1645 Sky Sports F1**  
Team Principals' Press Conference  
**1700-1800 Sky Sports F1 LIVE**  
The F1 show  
**1800-1945 Sky Sports F1**  
F1 Classic Races: 2000 Belgian GP  
**2235-2305 Motors TV**  
WRC Germany: day-one highlights

### SATURDAY AUGUST 23

**0845-0920 Sky Sports F1 LIVE**  
GP3 Spa: qualifying  
**0945-1115 Sky Sports F1 LIVE**  
Belgian GP: third practice  
**0955-1100 BBC2 LIVE**  
Belgian GP: third practice  
**1155-1415 BBC2 LIVE**  
Belgian GP: qualifying  
**1200-1435 Sky Sports F1 LIVE**  
Belgian GP: qualifying

### 1300-1500 Motors TV LIVE (delay)

V8 Supercars: Sydney races 1 & 2  
**1435-1605 Sky Sports F1 LIVE**  
GP2 Spa: Feature race  
**1615-1715 Sky Sports F1 LIVE**  
GP3 Spa: race 1  
**2120-2205 Sky Sports F1**  
F1 Classic Races: 1982 Belgian GP  
**2235-2305 Motors TV**  
WRC Germany: day-two highlights  
**2355-0500 Premier Sports LIVE**  
NASCAR Sprint Cup: Bristol

### SUNDAY AUGUST 24

**0820-0905 Sky Sports F1 LIVE**  
GP3 Spa: race 2  
**0930-1045 Sky Sports F1 LIVE**  
GP2 Spa: Sprint race  
**1100-1800 ITV4 LIVE**  
BTCC + supports: Knockhill  
**1130-1530 Sky Sports F1 LIVE**  
Belgian GP: race  
**1130-1300 ESPN LIVE**  
Blancpain GT Sprint Series: Slovakia  
**1200-1630 BBC2 LIVE**  
Belgian GP: race  
**1845-2035 Motors TV LIVE (delay)**  
V8 Supercars Sydney: race 3  
**2035-2100 Motors TV**  
WRC Germany: day-three highlights  
**2100-0005 Motors TV LIVE**  
United SportsCars: Virginia  
**2130-0000 ESPN LIVE**  
IndyCar: Sonoma

### MONDAY AUGUST 25

**1615-2100 Sky Sports F1**  
Belgian GP: replay

## ONLINE

### HOT ON THE WEB THIS WEEK

YouTube **RALT-HONDAS DOMINATE SILVERSTONE F2 1984**



**SEARCH FOR:** 1984 - Formula 2 - Silverstone (21:11)

Superb highlights, with commentary from Murray Walker, of the International Trophy race at Silverstone 30 years ago. The Casio Ralt-Hondas of Roberto Moreno and Mike Thackwell are on the front row for the European Championship opener...

### AUTOSPORT +

**Comprehensive Belgian GP coverage on our website**

As Formula 1's summer break finally ends, AUTOSPORT.com will have as-it-happens live coverage from the Belgian Grand Prix paddock, including Gary Anderson's exclusive analysis of practice form and Craig Scarborough's round-up of the technical upgrades throughout the field.

### GET AUTOSPORT ON THE MOVE

**IN THE IPAD ISSUE THIS WEEK**

- HIGHLIGHTS FROM INDYCAR, DTM, EUROPEAN F3 AND NASCAR
- ON SALE ALL OVER THE WORLD FOR ONLY £2.99

DOWNLOAD IT NOW FROM AUTOSPORT.COM



# Revved up over what's on the box

**I hate missing things. My DVR has so many red blobs on its programme planner that it looks like a sat-nav at Spaghetti Junction during rush hour.** These days, if you know where to look, you can watch just about any racing series around the world on UK television. But what's the best series that's not actually on our screens?

Well, I reckon the worst-served championships have to be Japan's top categories: Super Formula and Super GT. It's easy to think of these two series as rural backwaters, where local heroes pit their skills against washed-up journeymen whose careers in Europe have stalled. But think again.

Super Formula boasts ex-F1 drivers Kazuki Nakajima, Vitantonio Liuzzi and

Narain Karthikeyan up against Audi Le Mans stars Loic Duval and Andre Lotterer, plus never-quite-made-it talents Joao Paulo de Oliveira, James Rossiter and Andrea Caldarelli. This one-make,



GP2-style formula – complete with flashing roll hoops! – produces cracking racing, and crucially the cars seem to be able to run nose-to-tail through corners without losing too much downforce.

Need convincing? Check out highlights from the opening few races this year on YouTube (search for '2014 SUPER FORMULA The overtake') if only to watch Duval passing WEC colleague Lotterer around the outside of Suzuka's Turn 1.

Japan's GT series is equally worth a watch; starring pretty much the cast of Super Formula (plus Oliver Jarvis, Bertrand Baguette and Fred Makowiecki) in DTM-style machinery from Lexus, Honda and Nissan, plus a GT3 subclass. The twist here is that all races are two-driver,

long-distance events, usually 300km but with a 1000km bout at Suzuka coming up shortly.

The racing here is also pretty fierce, perhaps not quite to the level of the wild scenes we saw in the Nurburgring DTM last weekend, while the extreme performance-balancing measures, which include air restrictors as well as success ballast, employed across the season make it a confusing series to follow. But if the racing's not even on our TV screens, then that's immaterial.

Screensport used to show highlights, back in the 1990s. Come on Motors TV, BT Sport, et al, you're missing a trick here. Get it on.

**Revved Up**

# Ken Block

“I thought, ‘Wow, I pressured Colin McRae into crashing – and beat him!’”

■ X-Games, Los Angeles ■ August 5, 2007 ■ Subaru Impreza ■ Beating hero and mate Colin McRae



Block gets big air in his efforts to beat his hero McRae

LARS GANGE/SUBARU RALLY USA

## THE 2007 X-GAMES IN LOS

Angeles was the second or third year that Colin McRae had come over to compete. It was just such a huge honour to race with Colin. For me he was the biggest inspiration for me going rallying.

Before I saw Colin I was interested in rallying, but it was his style and his attitude that inspired me to compete in my younger years. He was the epitome of motor racing to me, so when he came over for a couple of years when I was at Subaru, it was just incredibly cool for me to be able to meet one of my heroes. And then I actually became good friends with him.

That particular year was a truly amazing experience. I had gone and visited Colin at his home in Scotland, then he came out early to X-Games and hung out with me for a week at my home – it was a lot of fun. We had a big common bond and we just liked having fun with cars. Any time we could go out and have fun in a car and use it to its limits,

that what's we wanted to do.

The big thing at the X-Games then was a head-to-head with an elimination format to get to the final. The way that the selection worked out, I was up against Colin in the second round. I knew he was a better driver, but you never know; anything can happen. I had nothing to lose; if I lost to Colin McRae, no big deal, but if he lost to me then it

would have been kinda bad for him!

I put in a good first part of the race, and as we came back into the stadium I could see that we were either level or I was slightly ahead. Just after that, Colin rolled his car and it got stuck on one of the barriers. I didn't know what had happened, I didn't see him crash. All of a sudden I got told to stop. I had no idea why, I was just

driving the race of my life to try to beat Colin McRae.

Then it came over the radio: 'Hey Colin's crashed, you've won'. It was a huge feeling. Colin handled it exceptionally well afterwards – he'd had to deal with that situation many times and he was very professional about it. I went on to win a silver medal for finishing runner-up. I had a very good event but I got beaten by my fellow American Tanner Foust in the final.

That night as we were getting ready to go out, Colin admitted to me that the pressure of seeing me slightly ahead made him push too hard and crash. It was like, 'Wow, I pressured Colin McRae into crashing and I beat him!'

It was one of those surreal moments, something I knew I would remember for the rest of my life. Not only had I become friends with one of my heroes, now I had a moment in racing with him that I could remember forever. ☺  
Ken Block was talking to Hal Ridge

## PROFILE



### AMERICAN KEN BLOCK IS

most famous for his viral YouTube 'Gymkhana' videos, the latest of which, 'Gymkhana 6', had 2.7 million views on day one. He began in skateboarding and motocross before moving to rallying and has competed in the WRC in Subaru and Ford machinery, rallycross and his own creation, Gymkhana Grid. He's also finished second in the Rally America series three times.

**NEXT WEEK** BELGIAN GP REPORT  
F1 returns with a bang around classic Spa

# MONROE

SUSPENSION



**EVERYTHING GETS OLD.  
EVEN YOUR SHOCKS.**



**CHANGE YOUR WORN SHOCKS AT 50,000 MILES\***

WORN SHOCKS COMPROMISE THE SAFETY OF YOUR CAR.

CHECK YOUR SHOCKS AT 12,000 MILES!

KEEP YOUR SHOCKS FRESH BY INSTALLING THE BRAND  
TRUSTED BY CAR MANUFACTURERS EVERYWHERE.

\* Actual mileage and results may vary depending on driver ability, vehicle type, and the type of driving and road conditions.



**TENNECO**  
[www.monroe.com](http://www.monroe.com)

# Motor Racing International



Monza - 7 September

## ITALIAN GRAND PRIX

Weekends & Longer Tours  
Based in Como

Singapore - 21 September

## SINGAPORE GRAND PRIX

Spectacular Night Race  
Scheduled Flights  
5 Nights in Singapore

Suzuka - 5 October

## JAPANESE GRAND PRIX

5 Nights in Nagoya  
Scheduled Flights

Austin - 2 November

## UNITED STATES GRAND PRIX

Texas Hosts F1's  
Instant Classic

Yas Marina - 23 November

## ABU DHABI GRAND PRIX

5 Nights in Abu Dhabi City  
The Season Climax

Budapest - 27 July

## HUNGARIAN GRAND PRIX

Weekend by Air  
Budapest & Vienna  
2-Centre Holiday

Spa - 24 August

## BELGIAN GRAND PRIX

Selection of Tours by Coach,  
Air or Eurostar  
Self Drive Packages

[www.motorracinginternational.uk.com](http://www.motorracinginternational.uk.com)

The 22nd edition of the MRI Tour Collection is now available. Visit our website for full details. As ever, we feature the F1 World Championship and the Le Mans 24 Hour Race. A small selection of our vast choice of travel arrangements is outlined above.

Put your trust in the UK's only fully bonded, independent motorsport travel specialist.



Apply NOW for your FREE brochure. Ring our 24 hour dial-a-brochure service quoting reference: 'AS11'  
01304 612424 info@motorracinginternational.uk.com

# PERFORMANCE

WHERE EXPERTS REVEAL THE SECRETS TO FASTER DRIVING

## GET READY TO WIN

**WHAT  
YOU  
NEED  
TO BE  
THE BEST**



### THE AUTOSPORT PERFORMANCE PANEL

#### DRIVER'S EYE

**FELIPE MASSA**  
MY RACING ETHOS

Williams F1 ace on his journey to the top of the sport, and why he's still learning

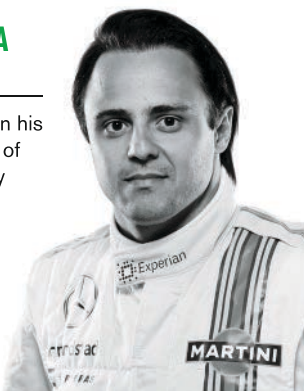

#### TECHNIQUE

**ROB WILSON**  
DRIVING MASTERCLASS

How you can go from rookie to frontrunner quicker than you think

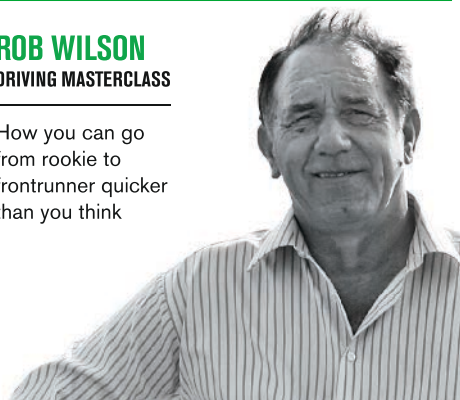

#### MIND COACHING

**DON MACPHERSON**  
HOW TO MAXIMISE YOUR POTENTIAL

Teach yourself to keep cool and gain the edge when the competition gets tough

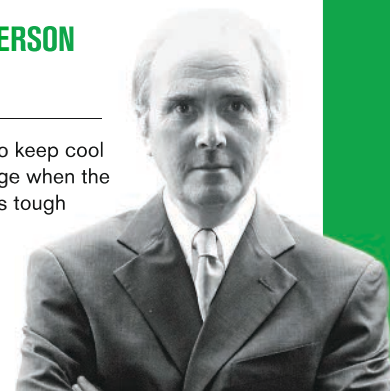

THE HOME OF BRITISH KARTING

COME AND WATCH DRIVERS  
DO BATTLE OVER 3 DAYS TO  
BE EUROPEAN CHAMPION



CIK KARTING  
EUROPEAN  
CHAMPIONSHIP

# CIK-FIA EUROPEAN KARTING CHAMPIONSHIPS

29TH - 31ST AUGUST



**SPECTATORS WELCOME**

Admission:

£10 per Adult      Under 16 Free\*

*\* when accompanied by a full paying adult*

Advance Ticket Purchases Available at [www.seetickets.com](http://www.seetickets.com)

- INDOOR & OUTDOOR VIEWING
- RESTAURANT & BAR
- RETAIL SHOP

**FREE  
PARKING**



PF International Kart Circuit  
Brandon, Lincolnshire NG32 2AY

More information at: [www.tvkc.co.uk/cik](http://www.tvkc.co.uk/cik)

# OUR EXPERTS' GUIDE TO MAKING YOU GO FASTER



Be well-prepared for your first race start

HAWKINS

**HEADING OUT FOR YOUR FIRST RACE CAN BE A NERVOUS** time, whether it's to begin a career or to try a new hobby. There are so many things to think about before you even get onto the circuit, that focusing on the actual driving can be a real challenge.

It is possible to be on top of the situation, however, and to start performing at a good level early on. We hope we can help you do just that with our resident experts.

As renowned driver coach Rob Wilson explains, the right preparation can simplify matters and allow you to push towards the front. That can bring pressures of its own, so the right mental and physical approaches are important, too. In this issue of AUTOSPORT Performance, Porsche's Eliot Challifour and our mind-coach guru Don Macpherson provide some tips on how you can help yourself in these areas.

Of course, even the best drivers can't win without the right equipment, and getting the car to do what you want – or even what it should – can be a bewildering task. That's why we asked motorsport suppliers to guide us through some of the key components that you'll need and why.

But motor racing isn't just about the person behind the wheel. There is a whole range of careers available within the sport; the problem is knowing how to get onto the right path.

The University of Bolton has a course designed to give budding engineers the best possible start, with both theory and practical elements, and they talk us through their initiatives on page 14.



**KEVIN TURNER PERFORMANCE EDITOR**

kevin.turner@haymarket.com

@KRT917

## CONTENTS

**PAGE 5**

**Driver's eye view Felipe Massa**

The grand prix winner talks about his climb from Brazilian karter to European single-seater rising star and, finally, Formula 1 world championship contender.



**PAGE 6**

**Driving technique Rob Wilson**

How to make a confident start to your racing, and then progress rapidly.



**PAGE 8**

**What you need Motorsport suppliers**

From filters to seats, via brakes. Key components for your competition car.



**PAGE 14**

**Get a motorsport career University of Bolton**

The engineering course that combines theory with practical racing experience.



**PAGE 16**

**Prepare yourself Body and mind**

Our experts on how to get the best out of yourself, by preparing mentally and physically.



**PAGE 18**

**Directory The best place to start...**

...is to choose a series to compete in and where to do it. Here are the contact details for key championship organisers and circuits in the UK and Ireland, along with some track facts.



EBREV/LAT

# CONFERENCE CENTRE ENGINEERED TO INSPIRE

The Williams Grand Prix Collection is one of the world's most prized motorsport museums. Housing 38 of Williams' seminal racing cars, the Collection charts four decades of Formula One history and is a suitable destination for some of the finest Grand Prix cars ever built.

We provide exclusive tours for Colleges and Universities and the Collection is an ideal place to learn about the sports various engineering disciplines and spark an interest in science, technology, engineering and maths.

## WHAT THE TOUR INCLUDES;

- Refreshments on arrival
- Personal introduction before entering The Collection
- Escorted tour with unique video footage and commentary on the team's illustrious history
- The tour concludes in the Technology and Trophy rooms and includes a visit to the Williams Shop
  
- The Technology Room displays examples of the intricacies of Formula One engineering, including:
  - An early designed carbon fibre Monocoque, driven by Nigel Mansell
  - An FW22 gear box, driven by Jenson Button
- The Trophy Room displays a selection of memorabilia relating to the team's 16 World Championship Titles and houses some of motor racing's most prestigious trophies
- Refreshments (squash, water & biscuits - tea/coffee for tutors)

£15.00 inclusive VAT per person



## NOTES:

- Mondays & Fridays; groups should arrive for 10am with departure by noon
- Alternative days & timings will be considered on request
- Photography is permitted in the museum
- A ratio of 1 accompanying tutor per 10 children is required for group visits
- Group size: minimum 15, maximum 40 (inclusive of accompanying tutors)
- NB: This tour does not give access to the Williams F1 Factor

**WILLIAMS**  
CONFERENCE CENTRE  
GROVE  
OXFORDSHIRE  
OX12 0DQ

T +44 (0) 1235 777 900  
CONFERENCES@WILLIAMSF1.COM  
WILLIAMSCONFERENCECENTRE.COM  
FACEBOOK.COM/WILLIAMSCONFERENCECENTRE  
@WILLIAMSCONFCTR

WILLIAMS



# DRIVER'S EYE VIEW

## FELIPE MASSA

The Williams driver, who came within one point of winning the Formula 1 title in 2008, explains his rise to the top

**W**hen I was a kid, my father was a racing driver. He did it for fun, never professionally, so I was crazy about racing and I wanted to be a driver because of him.

At the age of six, he gave me a little 50cc motorcross bike and I was crazy about it. I was always saying that I wanted to be a motorbike racer. Maybe he was a little bit afraid of that, as he decided when I was eight that perhaps it would be better if I tried go-karts because they have four wheels and are a bit safer!

The moment I tried to go-kart for the first time, I was sure that I wanted to be a racing driver. And I never changed my philosophy from that moment. I was not interested in anything other than racing until I became a professional driver.

When you do your job well, when you win races, when you are fast, when you qualify on pole position, gradually you start to understand that you are good at racing. You realise that maybe you have a talent for driving. But I didn't become really sure that I could become an F1 driver until I was in Formula Renault 2.0 in 2000 and I won both the Eurocup and the Italian championships in my first year in Europe. Once I did that, I was not 100 per cent sure I would get there, but I knew I had the ability and that maybe I could.

Before that, I learned so much in karting that still helps me today. Karting allows you to learn about driving in a practical way. You don't have telemetry, you just learn in the normal old-school way about setups, about how you need to drive, where you are losing time and need to improve. You also have to look at the tyres and recognise whether or not the setup of the kart is right because you might be using the fronts or the rears too hard. It's a good way to learn not just in theory, but in reality.

I still learn in the same way today. You go into the first session on a grand prix weekend and you look at where you lose



stop thinking about the car, about your lines, about the setup. All of these things are in your mind that you need to understand to be able to do your job. That process has always been there for me, it hasn't changed so much since I was young.

When I started racing in F1 with Sauber in 2002, I was just a 20-year-old and it was too young because I had no experience. I won the Euro F3000 championship the year before and it was completely different to what GP2 is today, which is a much more complete way to prepare. So I faced a big learning curve.

When I came back after a year testing for Ferrari, I was much better prepared. Everything came to me more easily and I was more relaxed so the results were much better.

**“We are always thinking about things, not just in the engineering meeting.**

**To be a top driver, you cannot stop thinking about the car and your lines”**

time, analyse everything that your team-mate is doing, see what you are doing yourself and also watch the other cars on the track. In karting, you didn't have so much data, but I still try to analyse things in a similar way. Maybe one day you make a mistake, so in future you try to avoid it. It's the same school that every driver goes through, even in F1.

You must never stop learning, and if you do that you will get better as you understand more and more what you need to do. This includes knowing how to prepare before the race. I don't do anything crazy now, and it's not so different to when I was racing in go-karts, but I just take some time for myself before the race to sit there and think about everything I will need to do.

As drivers, we are always thinking about things. It's not just about when you are in the engineering meeting, but it can be when you are doing nothing, or when you are doing something else. It is always on your mind. To be a top driver you cannot

If you want to fight for the world championship, you need belief and to work very hard. To work hard is sometimes the most important because you have to be perfect to fight for the title. In 2008, when I finished second, I had a great season and missed being champion by just one point. But I was always confident, comfortable in the car that was perfect for my driving style, everything came together and worked. That belief is important when things are harder.

The right environment is also important. This year, at Williams, I'm happy with the car, which suits the way I drive, and the team is improving. Unfortunately, I missed out on a lot of points, but things are all going in the right direction.

Today, I am 33 and have started more than 200 GPs, but you are always learning and have to concentrate on that part of your job. Race by race, you face different situations and, if you want to succeed, you need to be willing always to keep pushing. ❧

# DRIVING TIPS MASTERCLASS

## ROB WILSON



Our resident expert has four decades of experience in motor racing. Here he offers some candid advice for newcomers to the sport



Racing for the first time can be daunting but you can make rapid progress

WALKER

**S**tarting out in racing is exciting and nerve-wracking at the same time. Novice drivers are looking at a big, wide world with untrained eyes. It's important when you pitch up for your first race to be familiar with the layout of the paddock, because if you don't know where to sign on, or where scrutineering is, things will become unnecessarily stressful. It's important to be as prepared as possible. Taking care of the little details will help keep you calm and make things a little easier.

Having got through the preamble, the next battle is the total mystery of not knowing anything. There will be drivers there who you've read about, some may be heroes of yours and others you won't have heard of who turn out to be unreasonably quick! It's a matter of respecting them, but wanting to beat them. It's a difficult balance initially, but you always have to go into it

with the belief that – at some point – you will beat everyone.

After a few laps of qualifying you'll recalibrate and begin working out where you (or your car) need to be faster. It's important to be aware, even at an early stage, of your relative strengths and weaknesses versus your opposition.

The racing schools will tell you if you're 5mph down leaving the complex at Thruxton, you'll carry that all the way to the Chicane, but sometime later you'll realise that isn't true, because the load on the car in the middle of Village or Church tends to nullify any gain – the cars don't just continue to accelerate. The logic is that the cowardice that made you 5mph slower at the Complex is the same cowardice that will make you 5mph slower at the next corner. The problem is not the corner; it's you.

When you realise this you start to become cleverer, looking for the corner that scares you the most and working out how to be the best at it. Once your rivals see you doing that, you'll gain

a reputation as an early riser and you can sleep in until midday. It's important they know you're the one who's going to take it flat out on cold tyres on lap one. Once that's established, you're driving the other guy's car for him, and he will concede. Then you need to go hunting bigger fish...

Finally, you'll become aware you can outride everybody but you're sixth on the grid. Then you realise you can't drive around problems. The car does a percentage of the work and no longer is it just a matter of that heroic four-wheel drift, three-second lead at the end of lap one because you did something no one else in the world can do; it's about having a car that can do the work.

This is where the engineer comes in. Here you can run into confusion between who is a 'data-downloader' and who is an engineer. You could be stuck with that for a couple of years. The 'pure' engineer might not be enough – you'll need someone who's felt what you're feeling, either by driving themselves, or being driven by you.

It's important to have an engineer who believes

the driver when he criticises the car, but also can analyse when the driver is at fault. The driver and engineer ultimately need to believe each other. It's a difficult chemistry to find. The classic example is Jim Clark and Colin Chapman, or Gordon Murray and Nelson Piquet. Once you find that harmony between a clever engineer and a clever driver, that's pretty hard to beat.

It's very difficult sometimes to decipher when the car needs work, when the driver needs work, or when it's a combination of the two. That's why the driver needs guidance, and the engineer needs to feel. Chapman was a useful driver; Murray and Adrian Newey both race. It certainly helps. Equally the driver needs to be willing to engage with the world of the engineer. I don't think I ever came down the pitlane without a suggestion. Use cool-down laps to remember what you were feeling, so you can articulate it.

It's important to be aware of what the car is doing, but the way you drive it can also have a huge effect on how it handles. You can have a car that's a real understeerer in one person's hands, but completely neutral in someone else's, so it's a two-way street.

You can try to get a driver to adapt to a car, but there are some, like Kimi Raikkonen, who will only want it 'on the nose' – a really sharp turn-in – and once you give them that they'll deal with the rest. Others, like Fernando Alonso, will always want some 'push' (understeer) in the car. If you know what makes you tick, and can bring the technicians around you to help you access your best stuff, this is the best way to be.

But if you're in a team where one driver prefers some understeer and the other abhors it, each will insist they're on the right track, knowing it's difficult to adjust too much out of the car, and knowing it will also upset their team-mate if they can convince the team to push in their own direction. Keke Rosberg had great trouble adjusting to the amount of push Alain Prost had in the McLaren when they were team-mates in '86. I doubt Prost encouraged McLaren to alter the handling characteristics and make that rear-end a little bit looser.

There are styles and handling characteristics people desire in order to feel confident. AJ Foyt used to say "just let me see the corner and I'll be OK", meaning he didn't want to sit too low. Seating position is an often-overlooked but vital aspect to how you drive the car. If you compare 1962 to 1966, the Lotus 25 to the 33B, Clark



Finding the right engineer can give you an edge

**“It is better to have a car you can use rather than the optimum theoretical design you can't”**



Prost made the car work for him

can use rather than the optimum theoretical design that you can't. There's a designer – Hugo Spowers – who wanted to build the 'ultimate' car for me, where you lay headfirst in the nosecone and worked the pedals behind you! That would've made you feel vulnerable in the braking zones...

Knowing what you want is important, but it's crucial to know how your driving affects the car, because you don't want the poor engineers redesigning the front geometry just because you're an animal when it comes to turning the car in or you come off the brakes too suddenly.

As much as you may be confident you're the best driver in the world, it's very important to also recognise what you are missing. Everything you do has to be on the radar, and you need a driver and engineer who can X-ray into each other. It's extraordinary the way the driver can manipulate a car dynamically to alter its handling – and lap faster. 🏆

gradually sat more and more upright in pretty much the same tub. A major rally team battled a handling imbalance with its car, but when it sat its drivers more upright the problem suddenly went away.

Equally, it is ultimately better to have a car you



Clark and Chapman formed a successful engineering partnership



Getting the best out of car and driver remains key

# WHAT YOU NEED TO GO RACING

There's lots to think about when it comes to preparing your racecar. Here's our guide to some of the things to look out for

1

## PRESENTATION

VALET PRO'S GREG SPINK

### WHY THEY'RE IMPORTANT

Appearances count, they always have and they always will, and there is no automotive discipline in which this is more true than motorsport.

Team owners need and expect their sponsor logos to be visible and clear from the starting grid to the finish line. They also expect their cars to be clean, to be easy to clean and to stay clean, too.

A perfectly clean racecar reflects the attitude of your team. By taking pride in the appearance of your car, transporter or even pitlane quad bike you are sending a message; you demand perfection, and that extends to the machinery your drivers have to race.

### About Valet PRO



Valet PRO has emerged over the past five years to become one of the biggest names in the car-care world thanks to a range of award-winning products that have received critical acclaim in the biggest automotive titles on sale in the UK.

Valet PRO's products are expertly made in the UK at our headquarters in Sussex. This means we have complete control over the quality of our waxes, dressings, car shampoos and snow foams. It also means we can supply in trade quantities, offering value for money with no loss in quality.



2

## FILTERS

WIX MANAGING DIRECTOR WAYNE STEVENS

### WHY THEY'RE IMPORTANT

High-quality oil filters are important to motorsport competitors as they have the capability to capture microscopic contaminants, restricting them from entering the engine chamber/piston and causing irreversible damage to close-tolerance parts.

They must have great dirt-filtration properties, but must still allow the oil to flow as needed to working parts of the engine, so high-quality oil filters have a balance between superior filtration and minimal oil-flow restriction. Long-term experience gained on the track enables WIX to offer filters that prove reliable in the most difficult conditions.

### About WIX

The association between the WIX Filters brand and motorsport is one that dates back some 40 years, originating in the USA. Being involved in motorsport enables WIX to focus on the development of new technologies and of existing products, as hundredths of a second count to stay ahead of the competition.

WIX, which has successfully competed in NASCAR and the Indy 500 in the USA, has now teamed up with Adam Morgan and Ciceley Motorsport for the 2014 British Touring Car Championship. WIX Filters has recently announced a partnership with Swindon Engines in the BTCC; from the Snetterton round all Swindon units were fitted with a WIX oil filter.

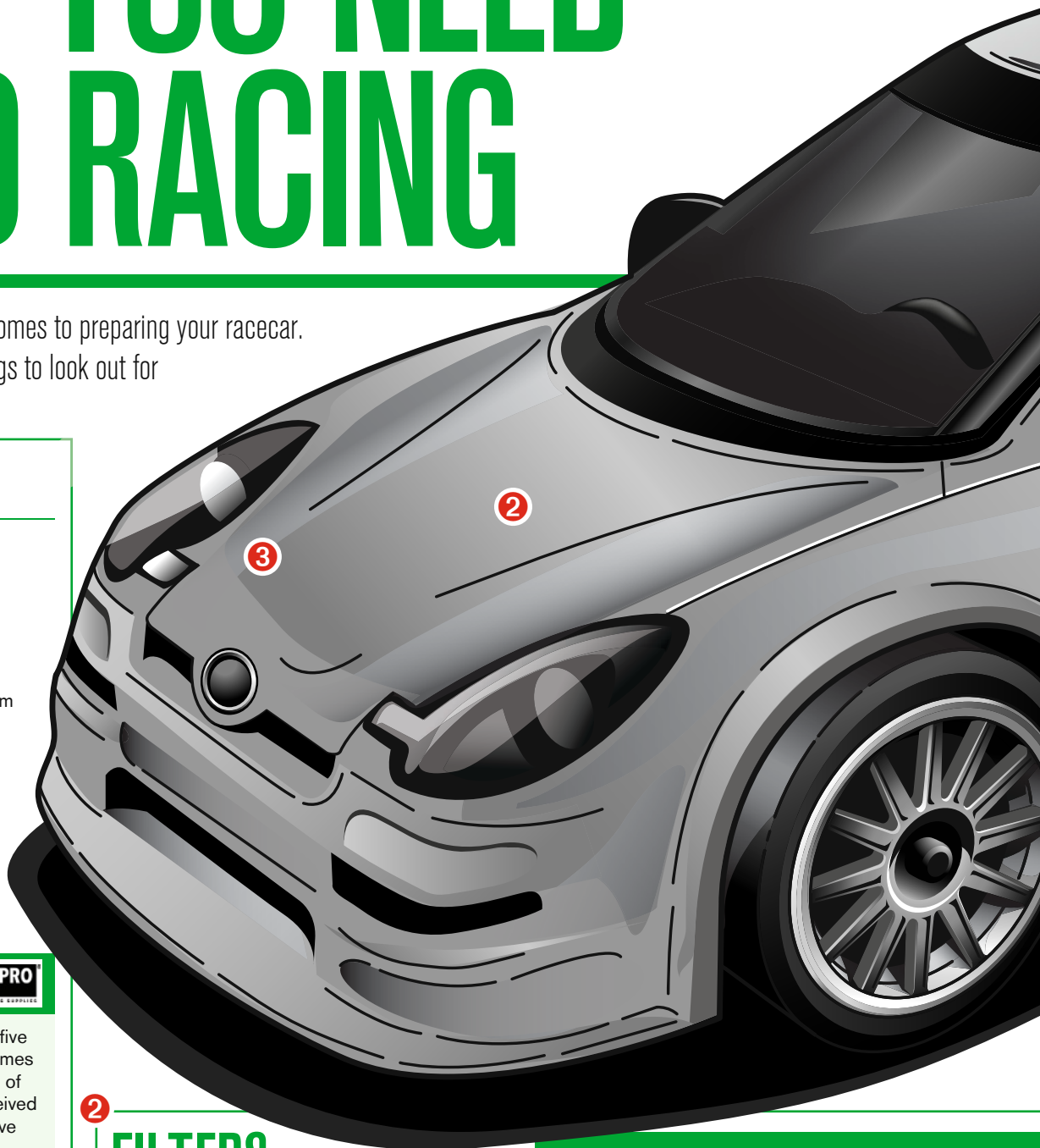

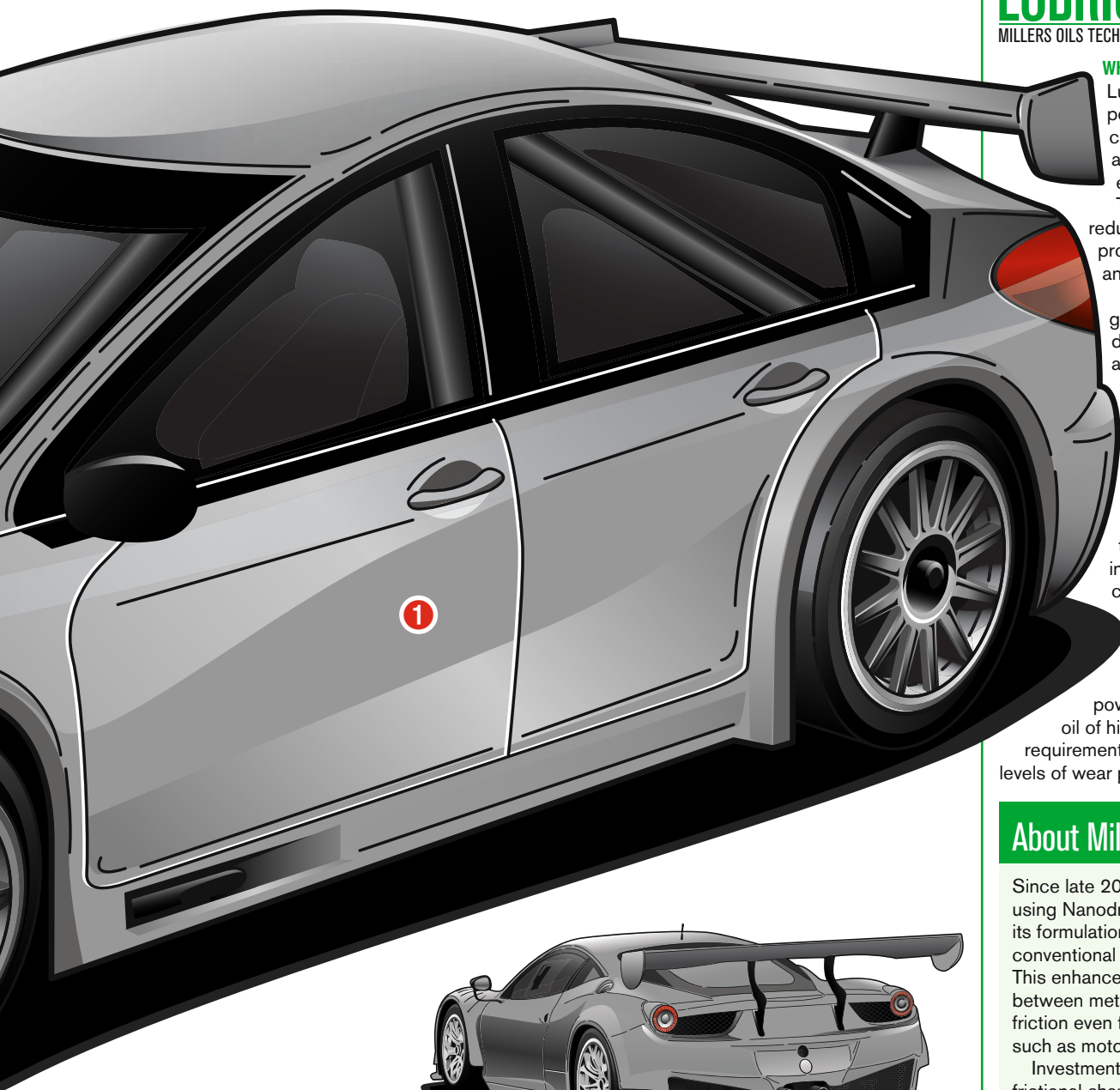

3

# LUBRICANTS

MILLERS OILS TECHNICAL DIRECTOR MARTYN MANN

## WHY THEY'RE IMPORTANT

Lubricants are critical to the performance of mechanical components, such as engines and gearboxes, as they contact every component within them.

They have to lubricate, cool, reduce friction, keep clean and protect all the internal components and surfaces from corrosion.

A given range of engine or gearbox oils will consist of different performance levels and viscosities.

Within the motorsport sector, quite often standard items will be modified for a different application, speed, power, torque, or all of those at the same time. This is where the lubricant that is to be used has to be looked at very carefully, in order to arrive at the correct product.

The by-product of extra power is always extra heat.

This means a standard oil gets thinner in viscosity, so for more power to be handled reliably an oil of higher viscosity is normally the requirement, as well as needing higher levels of wear protection.



## About Millers Oils

Since late 2007, Millers Oils has been using Nanodrive™ nanoparticles in its formulations that work alongside conventional gearbox and engine chemistry. This enhances the levels of protection between metal surfaces and reduces friction even further in harsh environments such as motorsport.

Investment in equipment to measure frictional characteristics has resulted in development that has reduced Millers lubricants' frictional characteristics by as much as half. In an engine in which high levels of friction exist in the cylinder liners and valve train, the extra power that this reduction releases is significant.

Many tests on rolling roads have shown that power gains with a low-friction Nanodrive™ product gives between three and seven per cent power and torque gains, depending on the complexity of the engine, ie number of cylinders, camshafts and valves.



TURN OVER FOR MORE COMPONENT ADVICE

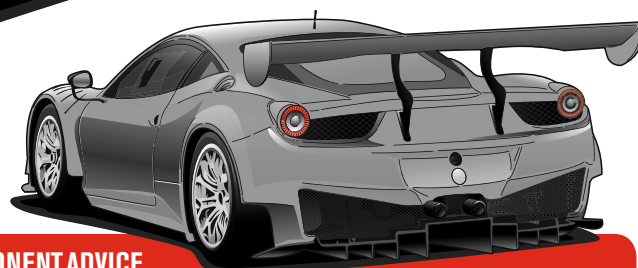

EBREY/LAT

# Is this your race seat for season 2015?

If yes, have a great season. If no, it can still be yours!

As the 2015 season is fast approaching are you fully equipped to market yourself to potential sponsors who can potentially get your backside in this seat and your hands on the wheel?

Are you confident that your current branding and image are up to scratch or could it do with a fresh spray of paint?

Starting out or need a change, we can help give you a great new look and show your audience you are ready to race and ready to win.

Take a look at what we can do to help you get in your seat and get racing in 2015.

#getracing2015

[www.brandkreativ.com](http://www.brandkreativ.com)



0141 280 2386

[hithere@brandkreativ.com](mailto:hithere@brandkreativ.com)

**brandkreativ**

#### complete branding package

- Website
- Logo Design
- Social Media Set Up
- SEO
- Stationary\*
- & Much More!!

**£350\***  
All Inc

\* Stationary design. \* Ecommerce £450 All inc.

Professional car  
cleaning by

**Valet PRO**®

PROFESSIONAL VALETING SUPPLIES



PREPARE



PROTECT



MAINTAIN

Find a stockist at [valetpro.co.uk](http://valetpro.co.uk)  
or call us on **01323 287980**

4

## SHOCK ABSORBERS

TENNECO BUSINESS SUPPORT MANAGER JAMES McCAUGHEY

### WHY THEY'RE IMPORTANT

'Power is nothing without control'. That's how the saying goes, but how does that apply here? Well, it doesn't matter how powerful a vehicle is if it's unable to transmit that power to the track through the tyres. Your shock absorbers are designed for this function, to keep the tyres planted to the asphalt no matter what.

Worn shock absorbers cause loss of control in three main areas:

- **STEERING** Worn shocks and struts can allow excessive body roll when turning, which affects the vehicle's ability to safely steer around objects in the road.
- **STOPPING** Such wear can also allow too much weight transfer to the front wheels during braking, which could result in a measurable increase in stopping distance.
- **STABILITY** Worn shocks can allow excessive roll, sway and bounce while the vehicle is in motion, which reduces the driver's control.

### About Monroe



With a network of 14 advanced-engineering centres on five continents, Monroe is at the leading edge of technology for the original-equipment market. Parent company Tenneco meets the needs of customers, which include Volkswagen, General Motors, Ford, Toyota, Chrysler, Daimler, BMW, PSA Peugeot Citroen, Nissan and Shanghai Automotive (SAIC), expertly tuning the ride of any vehicle to the most exacting specifications.



5

## BRAKES

TAROX INTERNATIONAL OFFICE MANAGER NICHOLAS COUNSELL

### WHY THEY'RE IMPORTANT

Only when something goes horribly wrong with a brake system will it put into perspective how critical brake performance and reliability really is. Only recently in F1 there was an example of just how quickly things can go wrong when a brake system fails. Brakes are the unsung heroes of motorsport; they provide little theatre, but offer some of the largest gains.

### About Tarox



At TAROX we ensure drivers can rely on our brakes by using only the highest-quality, European-sourced metals and manufacture all products in house at our Italian head office.

For TAROX, motorsport is the test bed for so many of our products. For over 35 years we have worked in all aspects of motorsport. There is no better test bed, no better way to push your product to the absolute limits. The rigorous use motorsport puts on brakes gives confidence in the products sold for the road.

At TAROX we pride ourself on our ability to offer tailored solutions rather than a one-size-fits-all plan. Our products are crafted individually and hand-assembled, ensuring we offer customers exactly the brake package their discipline of racing demands.



6

## EXHAUST SYSTEMS

TENNECO BUSINESS SUPPORT MANAGER JAMES McCAUGHEY

### WHY THEY'RE IMPORTANT

What would motorsport be without the roar of the engine and the sweet din from the exhaust as the car flies by? But the exhaust is far more important than just providing a great noise. Primarily it's there to get the waste fumes out of the engine, away from the driver compartment and out to the atmosphere as quickly as possible. With the right design, technology and construction exhausts can actually improve output and performance.

Modern exhaust systems not only deliver a unique signature sound but can be considered one of the key performance systems of the machinery.

### About Walker



A worldwide company, Walker's emissions-control engineering centres deliver the latest technologies to customers throughout the world. These linked engineering centres share expertise and capabilities to design and develop solutions for passenger-car, light truck, commercial vehicle, and speciality-vehicle applications. With this support, Walker possesses the technical excellence needed to meet today's needs and develop solutions to tomorrow's challenges.

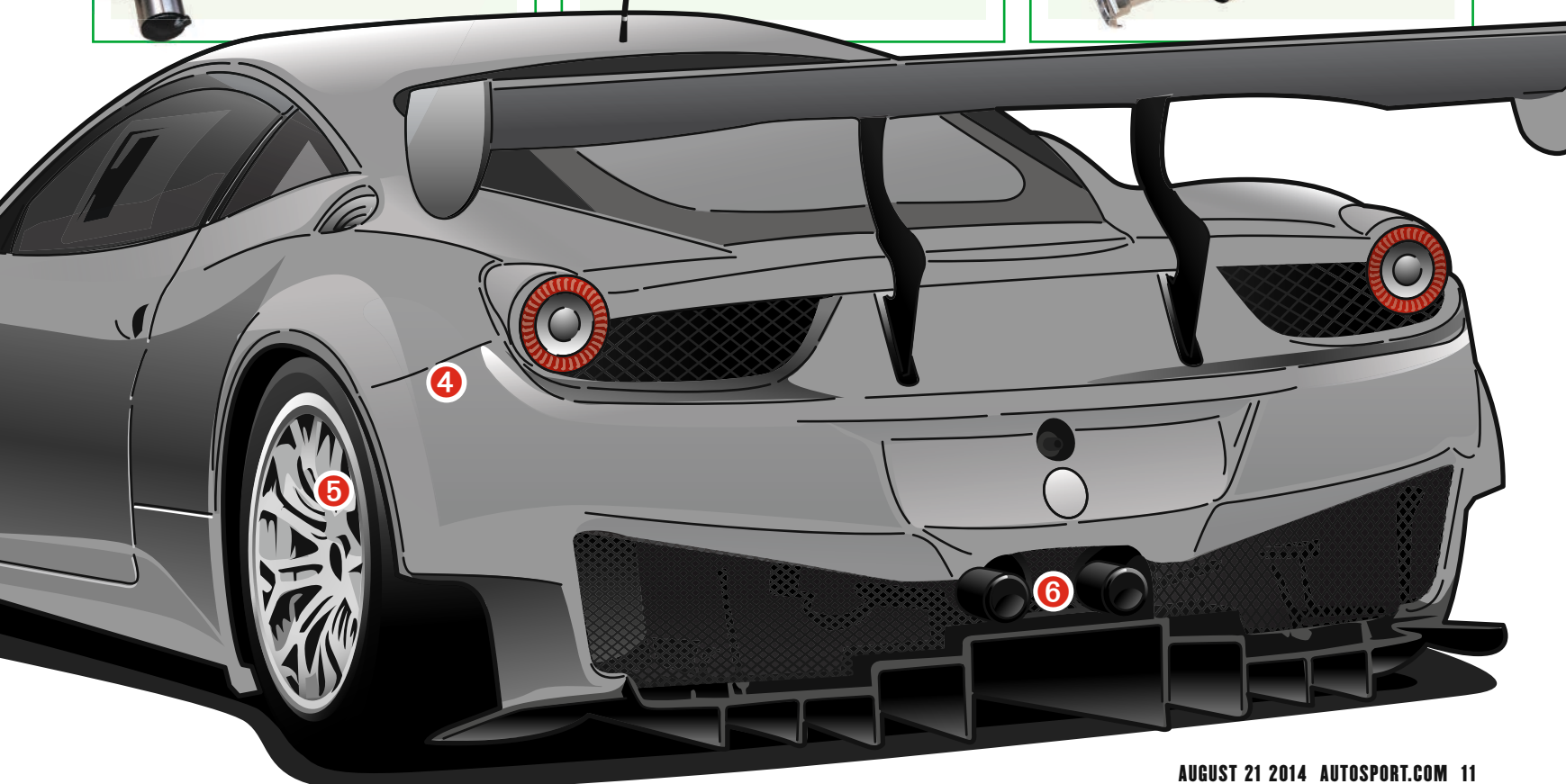
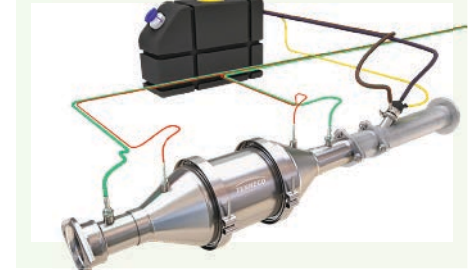



University of Bolton



# Study on campus and on the track!

 @BoltonCAPE

**UCAS 779L** Automotive Performance Engineering BEng (Hons)

**UCAS F4G5** Motorsport Technology BSc (Hons)

## Next Open Day Wednesday 3 September 2014

The **University of Bolton** and RLR Msport have joined forces to create a high performance motorsport engineering centre on campus, **giving students Le Mans LMP2 race team experience.**

This is a unique partnership - we have brought together first-class, on campus learning together with the best in practical motorsport experience.

### Employability

We give our graduates the competitive edge in securing careers within the following industries, and many more in the UK and across the world.

- Motorsport & Trackside Telemetry
- Automotive & Mechanical Design
- Engine Performance Analysis
- Chassis Dynamics and Aerodynamics
- CNC, CAD CAM, CFD and FEA
- Specialist 3D Scanning Equipment.



Visit <http://www.bolton.ac.uk/autosport>

Or contact us for more information

Email: [opendays@bolton.ac.uk](mailto:opendays@bolton.ac.uk) or call 01204 903807



7

## BATTERY ISOLATORS

CARTEK MANAGING DIRECTOR NEIL ARMSTRONG

### WHY THEY'RE IMPORTANT

The well-worn adage 'to finish first, first you must finish' is very relevant when it comes to the Master Switch for race and rally cars. Not only must this mandatory safety device operate reliably when called upon after an accident but, with all of the car's electrical systems receiving power via this single part, it also has to operate at 100 per cent during normal conditions. The slightest fault with this part usually causes a complete shutdown of the car and often results in a DNF.

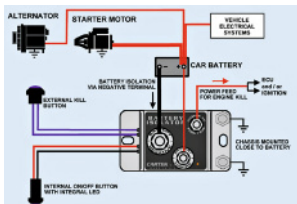

### About CARTEK



CARTEK continues to be at the forefront of safety electronics with its most notable products, the solid-state Battery Isolators, gaining ever more recognition as the definitive master-switch system available. This accolade has been achieved not only by its ultra-reliable record but due to its many other benefits, including very small size, light weight and fully sealed construction. Added benefits include push-button control with the option to have two external 'kill' switches and a failsafe arrangement such that, should any part of the wiring become broken in an accident, the system will automatically switch to the safe 'off' state.

These systems all meet FIA and MSA requirements by simultaneously stopping the engine and disconnecting the battery from all electrical

circuits with a simple strike of a button. This is also achieved without the need for any additional components, with alternator run-down protection being fully integrated into the units. The CARTEK Battery Isolators are also regarded as one of the simplest systems to install and can save on both labour time and cabling.



8

## SEATS

CORBEAU MANAGING DIRECTOR VIC LEE

### WHY THEY'RE IMPORTANT

What makes a good seat the most essential piece of cabin equipment for a driver? First and foremost, racing seats are about safety, designed to protect the driver in the event of a crash. A good racing seat can prevent or lessen injuries, and even save your life.

The faster you go, the more containment you'll need. Never skimp on safety, just ask yourself: 'if the unthinkable happens, what seat would you want to be in?'

From a driver's perspective the quest for the perfect seating position takes in many factors, from safety, comfort and body posture, to lateral support and chassis feedback. A properly fitted seat gives the driver all the confidence they need to push their car right to the edge on track. By contrast a poorly fitted seat can distract the driver's focus and disrupt their rhythm, costing laptime or even causing an accident.

### About Corbeau



Corbeau continues to press forward with innovative seat technology, always with an eye to motorsport applications. The Corbeau Pro-Seat system offers drivers the perfect fit every time with a seat moulded to their individual body shape and can be applied to any seat within the Corbeau composite range or for bespoke single-seaters and prototypes.

Our sliding-rail system for composite race seats, which is pending FIA approval, is perfect for enduro teams that currently compromise on seating position to find a happy medium for all the drivers. Now they can easily adjust the seat during pitstops to suit each driver.

"Having a seat that fits perfectly and is structurally stiff enables me to feel exactly what the car is doing," says British Touring Car star Jason Plato. "My Corbeau seat delivers performance and safety."



# ENGINEERING A MOTORSPORT CAREER

## BOLTON'S TRAIL-BLAZING PROJECT

Motorsport engineering courses are nothing new, but how they work and what they entail can make a huge difference to the technical stars of the future – and the University of Bolton's Centre for Advanced Performance Engineering is intent on raising the bar

**G**etting employed as a racing driver may well be the stuff of daydreams, but motorsport industry careers for graduate engineers are a realistic ambition.

There are several further and higher-education course choices for students wanting qualifications in motorsport-focused engineering, but the University of Bolton is blazing its own trail.

Within the university's Centre for Advanced Performance Engineering (CAPE), there are two distinct motorsport undergraduate degree courses – Automotive Performance

Engineering (Motorsport) BEng (Hons) and Motorsport Technology BSc (Hons).

The university is not alone in offering a practical element to its courses – several colleges and universities run cars in specific championships across the UK – but it does have something unique; its own independent, multi-faceted racing team.

The University of Bolton partners with RLR Msport, led by team principals Nick Reynolds and Jason Longworth. The team is based at the university campus and has entries in the European Le Mans Series with an LMP2 Ligier, while the cars they maintain for private owners race in, for example, the Italian GT Championship. RLR

Msport's car collection at Bolton also includes an historic Formula 1 car restored by the team, as well as many other classic and contemporary racers.

The practical part of both degree courses is in-depth, with students engaging in aerodynamics and engine testing, software/design experience and parts manufacture. Other state-of-the-art equipment at students' disposal includes windtunnels and rolling roads.

The courses, which have recently acquired a new Mercedes AMG V8 for testing and development purposes, are also seeking Incorporated Engineer status – a professional accreditation recognised by the Engineering Council.

CAPE's second intake of first-year students is

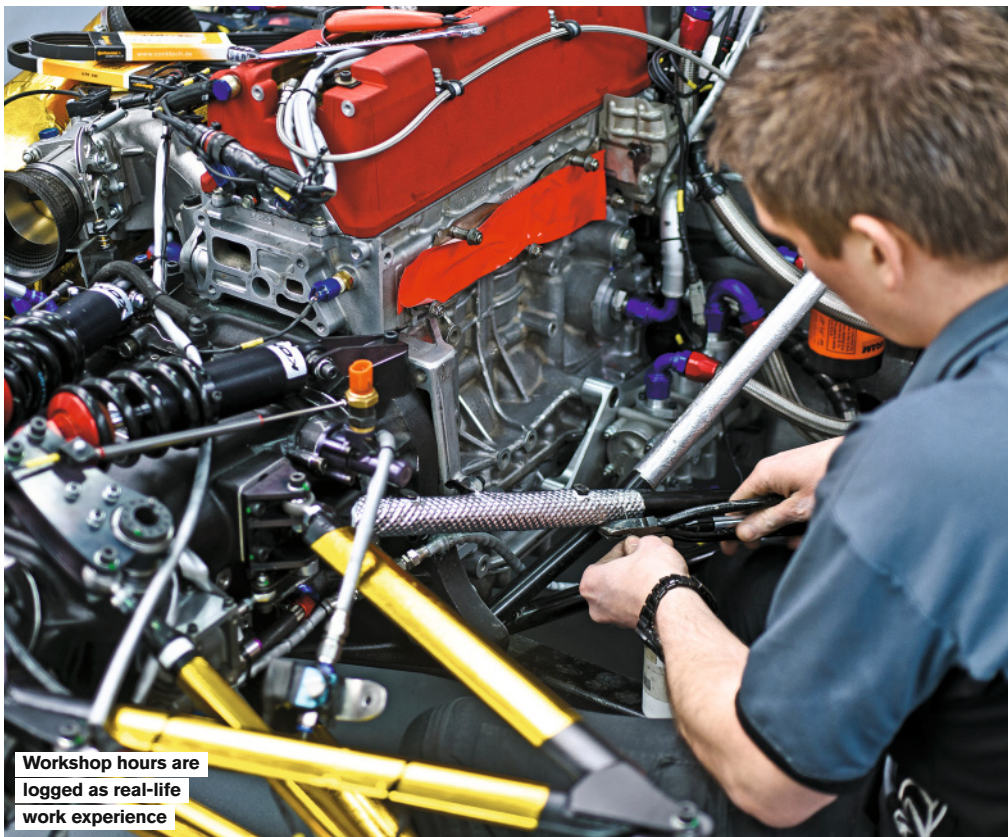

Workshop hours are logged as real-life work experience

### GARRY OWEN CAPE LECTURER



I'm confident we've got the best courses relating to work experience – better than anywhere else in the country. The courses are based on practical and analytical experiences. A lot of universities haven't got that. We're giving a high level of practical experience related to the work in the classrooms.

Hands-on work experience with RLR Msport is a big part of the courses. When they're not in class, students are in the workshop, and they can log those times as work experience. They'll also be working with the raceteam at the tracks. In-class projects are directly related to RLR Msport's vehicles, such as designing a new wing or an engine development.

CAPE has been teaching for two years, but engineering has been a successful part of our university for many years. That's the pedigree on which CAPE is based. Everybody who has come to the open days and seen what the first years have been doing have been just amazed. I'm confident that in the next few years our student numbers will rocket. This project's got something special about it.



**“The maths and science are applied to something real, not just what you learned on a whiteboard”**

set to take to the classrooms and the workshops in September, and already there are expansion strategies under discussion. Recruitment open days for the students starting in 2015 are already being scheduled, and the next one is on Wednesday September 3.

There are plans for a brand-new building to join the existing advanced workshop, and the upward

trend is one that leaves project heads Garry Owen, who oversees the academic side of the course, and Nick Reynolds, whose RLR Msport squad is the foundation of its practical prowess, confident that it will blossom into the UK's benchmark.

● Full details of the courses are on the CAPE website at [www.bolton.ac.uk/cape](http://www.bolton.ac.uk/cape)

## STANDING OUT

**Motorsport jobs expert Russell Howard on why the CAPE is a cut above the rest**

Motorsport engineering is a really tough job market. It's very competitive, and you need to set yourself apart and show what you can offer.

When people advertise jobs they want applicants with three years' experience behind them, and this is where it all falls apart for graduates. Some companies employ graduates and train them on-site, but the majority are teams who are looking for people who can go straight in and work.

The University of Bolton courses are unique because they've got a live raceteam in RLR Msport. A lot of universities run their own cars, but that's about as far as they go. Pretty much everyone else comes up short.

At Bolton, it works both ways; students graduate with a qualification and the experience. If you can say you've got all those years working on a raceteam, it's going to help. Our students are going to come out with a strong chance of going to professional raceteams.

It's almost a step beyond a degree, and it answers so many questions. I get a constant barrage from students and would-be students asking how to get into motorsport and what is the best way in. If I was that age again, I'd sign up for CAPE. It's going to be one of the best places in the country.

### PROSPECTIVE MOTORSPORT ENGINEERING CAREERS

- Automotive, Motorsport and Mechanical Design
- Chassis Dynamics and Aerodynamics
- CNC & CAD CAM, plus FEA and CFD
- High Performance Engine Testing
- Specialist Industry 3D Scanning
- Telemetry and Data Analysis, Motorsport and Trackside Technology

### NICK REYNOLDS RLR MSPORT TEAM BOSS

The way we work is that Garry leads the academic side and I lead the commercial. I'm head of the centre and I also run the business on a commercial basis from the site.

The idea for the project developed from what I believed the industry was struggling with – people coming out of university or higher education without being able to get places in the field they wanted.

We decided the best way we could help was to put them in their desired environment, because as a team we were contending with people coming through who were not ready for the industry. They lacked practical experience.

The maths and science are applied to something real, not just what you've learned on a whiteboard. This facility is a one-stop shop.

From initial drawings we can go through to manufacturing and testing it on the racetrack. We're trying to get the students on to real projects.

You've got to do something different to stand out. There are lots of universities with partnerships, but with the best will in the world it's still not real. We believe the CAPE experience will help people get jobs, and this is what it's all about. Everyone who has studied with us has managed to get a placement in the field they wanted.

There's soon going to be a shortfall of about 25,000 people looking for jobs in advanced performance engineering, and that's a hole we want to get our students to fill.



RLR has run an MG-Lola in the ELMS

GRIFFITHS/JAT

# BRAIN VS BRAWN

Despite what some may choose to believe, being successful in motorsport is about a lot more than just 'natural ability'. As well as getting the most out of your race or rally car, you need to get the best out of yourself – so mental and physical preparation are key attributes

## TRAINING THE BODY

**F**itness is a progressive thing that's acquired through development, not through a short space of time. But for a relatively small outlay, you can get a big performance advantage.

Motorsport's fitness philosophy has changed a lot. It was probably true that you had to convince people why you had to be fit but with the young drivers coming through now it's very much accepted the discipline of being fit is a staple part of what they need to do. It's unacceptable to have a failure through a lack of fitness because it's something you can control.

You need to be fit enough to be able to cope with the demands of motorsport comfortably. It's a really skill-based sport with quite a complex skill-set, so you need to be able to cope with heat, elevated heart rates or blood lactate concentration comfortably within the car without concentration being impeded and the stress on your body being too great and mistakes being made as a result.

Cardio is one of the weaker areas in general for racing drivers. I'd encourage swimming, cycling, running, rock climbing – a multitude of different sports to engage athletes and get them to enjoy what they're doing. We give individual evaluations that provide us with a good basis for how to tailor their training, and they need to develop it from there.

Strength and conditioning is important for junior drivers, too. If you're going down the straights and having to stretch your fingers, that will be playing on your mind in the corners. You want to be getting out of the car looking as fresh as when you got in and a lot of that is



Cardiovascular exercise is an area in which drivers tend to struggle

**“Fitness can become a case of monkey see, monkey do. You need to evolve what you do”**

starting the process from a young age – embed good habits and develop them over the years.

People often train for the specifics of the sport, but we focus on training to counter the demands as well. Someone who spends a lot of time in the car is in a forward-facing position and the cockpit is quite tight – so postural exercises keep the body balanced. This can include strengthening the back, core and working on mobility through the hips, shoulders and spine. That becomes more important once the season starts and you're travelling, testing and racing more and more.

Getting a professional evaluation and tailoring your programme to suit is the right way to do it. Training needs to be progressive – in order to keep improving you need to evolve what you do. Lots of people do the same thing week in, week out and they plateau. You need to keep your training varied and gradually manipulate those variables to stress the body slightly harder.



Understanding fitness is as important as applying it

### ELIOT CHALLIFOUR

**Manager of the Porsche Motorsport Human Performance Centre**

Clients include the Motor Sports Association, the Racing Steps Foundation, Porsche's Carrera Cup GB scholarship, the BRDC, and the Force India F1 and Nissan GT academies.

**Director of Votwo** Fitness company specialising in motorsport and endurance athletes.





Concentration, key to a good start, can be honed at home

GOODEN/DPPI

## TRAINING THE MIND

**S**o you've got the driving skills, perhaps honed by the guru that is Rob Wilson. You're physically fit and strong, maybe pushed to the peak by Eliot Challifour at Porsche Human Performance. So what's missing in your armoury as a racing driver? Brain tuning, of course, which is where I come in.

It doesn't matter if you're a potential world champion, a gentleman or weekend racer, or someone who goes karting for fun with your mates: if you can't control your conscious brain (or 'monkey mind', as I like to label it, you might call him the voice in your head) at moments of stress, you're missing out on a vital performance edge over your rivals and it will affect all the other good work you've done. It's the mental aspect that gets overlooked the most – and it's the most misunderstood.

If the brain isn't tuned, the 'monkey' part of your brain is going to hijack your other skills to their detriment. And the way to control that from happening is basic mind management, and some simple mental-training tools can go a long way here. Of course, your aim is to stay calm and to anticipate the peak areas of mental pressure.

You need to be prepared, so you're not fazed when something happens, as it so often does in motor racing. You're like a sprint hurdler: if you can keep your stride when you've clipped the first one, you're still in the race. If all you can see is the finish line, and not the hurdles that you need to clear, you're going to fall. Be process-focused, not goal-focused. Forget about visualising yourself lifting the trophy,



STALEVLAT

Keeping the 'monkey' in your head at bay is crucial to keeping calm

**“Motorsport is all about getting into a rhythm, so the last thing you need is a misfiring brain”**

it's all about getting into a rhythm, so the last thing you need is a misfiring brain.

There is a whole raft of mental techniques that can be taught by a mind coach such as me, to 10-year-old karters to 30-plus F1 stars, which

have been finessed over time. Mind coaching is like learning Japanese, the more you practise the more fluent you become.

What can you do at home? Well, the basics are breath-control, visualisation and concentration techniques. You'll also need to be able to boost your confidence because it's going to come under threat from the 'monkey' whenever it gets stressful. The word 'meditation' can freak people out a little, but I'm not preaching voodoo or living in La-La land here: meditation is identical to concentration in my book.

Anybody at home can learn how to meditate. Lie on your bed or on the carpet, and simply concentrate on one thing – focus on your breath, the ticking of a clock, whatever. Just 10 minutes of practising how to concentrate will help you so much when you next line up on the grid.

Don Macpherson ☼

### DON MACPHERSON

Don Macpherson is a mind coach with a background in sports psychology. He works with many world-class sports professionals, including Formula 1 drivers, focusing on the psychological aspect of their performance.



MASON/GETTY

Did mental fragility cost Sergio Perez victory in the 2012 Malaysian GP?

# GETTING STARTED

If you're thinking of taking up motor racing, then the following car club, series organiser and circuit website addresses are a useful place to start

## CIRCUITS

All 18 of the UK's race tracks, most of which have race schools and driving experiences

**ANGLESEY** [angleseycircuit.com](http://angleseycircuit.com)

The Welsh circuit was revamped mid-way through the past decade and now has four different layouts.



**GOODWOOD** [goodwood.co.uk](http://goodwood.co.uk)

Rarely used for racing, this West Sussex circuit hosts one of the biggest historic events, the Revival.



**OULTON PARK** [oultonpark.co.uk](http://oultonpark.co.uk)

Cheshire circuit is a fine driving challenge, with elevation changes, fast corners and big stops.



**BRANDS HATCH** [brandshatch.co.uk](http://brandshatch.co.uk)

Kent track is one of the most popular in UK. Short Indy circuit great for fans; GP a driving challenge.



**KIRKISTOWN** [kirkistown.com](http://kirkistown.com)

A true club venue, the track in County Down is Northern Ireland's only MSA-licensed permanent race circuit.

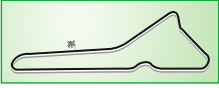

**PEMBREY** [barc.net](http://barc.net)

Set in Carmarthenshire, Wales, Pembrey is a good test track, but can also put on a fine club-level contest.

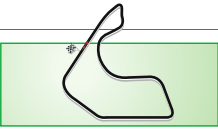

**CADWELL PARK** [cadwellpark.co.uk](http://cadwellpark.co.uk)

Picturesque Lincolnshire venue combines a fast early section with the twisty Mountain sequence.



**KNOCKHILL** [knockhill.com](http://knockhill.com)

Short but challenging, Knockhill in Fife, Scotland, is celebrating its 40th birthday this season.



**ROCKINGHAM** [rockingham.co.uk](http://rockingham.co.uk)

Northamptonshire track's Banked Turn 1 is a unique feature in UK motorsport; infield is more technical.



**CASTLE COMBE** [castlecombecircuit.co.uk](http://castlecombecircuit.co.uk)

Rapid Wiltshire track often plays host to some great racing, including among its home-based series.



**LYDDEN** [lyddenhill.co.uk](http://lyddenhill.co.uk)

Kent track is now chiefly a rallycross venue, and provides great views of the circuit for spectators.



**SILVERSTONE** [silverstone.co.uk](http://silverstone.co.uk)

Not just the scene of the British Grand Prix, this Northamptonshire venue has three distinct layouts.



**CROFT** [croftcircuit.co.uk](http://croftcircuit.co.uk)

Revived in 1997, Croft in North Yorkshire is visited by the BTCC as well as a variety of club series.



**MALLORY PARK** [malloryparkcircuit.com](http://malloryparkcircuit.com)

Brought back from the brink after noise complaints, Leicestershire track is more challenging than it looks.



**SNETTERTON** [snetterton.co.uk](http://snetterton.co.uk)

Recently revamped Norfolk circuit has two main configurations for UK racing, the 200 and 300.

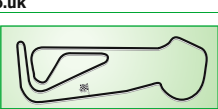

**DONINGTON PARK** [donington-park.co.uk](http://donington-park.co.uk)

Another circuit to be saved (twice!), the flowing Leicestershire track is a popular one with drivers.



**MONDELLO PARK** [mondello.ie](http://mondello.ie)

Another circuit with multiple layouts, Mondello in County Kildare has some interesting corners for its club events.



**THRUXTON** [thruptonracing.co.uk](http://thruptonracing.co.uk)

Hampshire track is the country's fastest and demands big commitment from competitors.



## UK RACE ORGANISERS

Including car clubs and championship organisers

Aston Martin Owners Club Racing  
[amocracing.org](http://amocracing.org)

Castle Combe Racing Club  
[ccracingclub.co.uk](http://ccracingclub.co.uk)

Historic Sports Car Club  
[hsccl.org.uk](http://hsccl.org.uk)

British Automobile Racing Club  
[barc.net](http://barc.net)

Classic Sports Car Club  
[classicsportscarclub.co.uk](http://classicsportscarclub.co.uk)

Masters Historic Racing  
[themastersseries.com](http://themastersseries.com)

British Racing & Sports Car Club  
[brscc.co.uk](http://brscc.co.uk)

Darlington and District Motor Club  
[darlington-motor-club.org.uk](http://darlington-motor-club.org.uk)

MG Car Club  
[mgcc.co.uk](http://mgcc.co.uk)



MotorSport Vision Racing  
[msvracing.co.uk](http://msvracing.co.uk)

Vintage Sports-Car Club  
[vscc.co.uk](http://vscc.co.uk)

Scottish Motor Racing Club  
[scottishmotoringclub.co.uk](http://scottishmotoringclub.co.uk)

500 Motor Racing Club of Ireland  
[kirkistown.com](http://kirkistown.com)

South East Motor Sport Enthusiasts Club  
[semsec.org.uk](http://semsec.org.uk)

750 Motor Club  
[750mc.co.uk](http://750mc.co.uk)

## GOVERNING BODIES

Motor Sports Association  
[msauk.org](http://msauk.org)

Motorsport Ireland  
[motorsportireland.com](http://motorsportireland.com)



MISSION MOTORSPORT  
THE FORCES MOTORSPORT CHARITY BRING YOU:

# RACE OF REMEMBRANCE

7TH - 9TH NOVEMBER 2014 

45 TEAMS

8 HRS

1 CAUSE



THIS EVENT IS ABOUT MUCH MORE THAN JUST A RACE.....

As is the Mission Motorsport ethos; inclusion is key. We've invited friends of ours along from all corners of the Motorsport and wider automotive world to make this weekend both unforgettable and un-missable.

At 08:00hrs, Sunday 9th November, 45 teams will embark on the eight-hour race around the Anglesey International circuit. Teams of up to four drivers and cars will compete in the relay-style race with only the bravest daring to enter the ultimate; the Heroes Trophy - a single car entry in true endurance style.

Racing will pause at 10:45hrs for our own Remembrance Service in the pit-lane. With many of the entrants wounded, injured and sick (WIS) Military personnel and veterans from within the Mission Motorsport programme we will pause for thought at 11:00hrs, hosted by Army Chaplain Revd Antony Feltham-White (himself, winner of Top Gear's 'Vicar who can go quicker') and supported by a Welsh Male Choir.

Racing will resume at 11:15hrs and continue until eight hours has elapsed.

With the grid over half full already, reserve your place on the racing grid!  
Race entry of £2,000 per team entry. This INCLUDES all race fuels for the weekend!

**GUEST DRIVERS:** Teams can request a guest driver to subsidise their race entry; Headlining the guest drivers are (from BTCC): Rob Austin, Adam Morgan, Paul O'Neill and Dan Welch, (from endurance racing): Calum Lockie and Elliott Cole.

**SUPERCAR SATURDAY:** Once qualifying is complete, Anglesey Circuit will split in two with both drift cars and supercars offering passenger-laps on Club and National, where guest drivers will also pilot the eclectic mix of race and road cars 'borrowed' from some very, very generous supporters.

Back ground activity: from go-karts, MX-5 Auto-test and Monster Trucks to static and showcase-lap displays of historic F1 cars and trader stalls, we've tried to ensure there's something for all petrolhead tastes.

Any weekend event wouldn't be a weekend event without a party.  
We have three and, in keeping with the 'inclusion' theme, anyone is welcome to attend:

**FRIDAY:** the Heroes Dinner will see all drivers, teams, guests and Mission Motorsport 'blokes' descend on [www.oystercatcheranglesey.co.uk](http://www.oystercatcheranglesey.co.uk) for an informal, banter-filled evening where guest drivers will also be married to their teams, names-out-the-hat style.

**SATURDAY:** see's the Party-in-the-Paddock hosted by the Pit-stop Cafe at the circuit with live music.

**SUNDAY:** if anyone has any energy left the Pit-stop cafe will host the informal Wash(ed)-up party to network for next year....

For further information please visit: [www.raceofremembrance.com](http://www.raceofremembrance.com)

[www.missionmotorsport.com](http://www.missionmotorsport.com)



# Xtreme bond

Two  
Component  
System

Can be drilled, filed and painted instantly

Works together to bond in seconds

Dries totally clear

Bonds to almost any material



### Xtreme bond - Instant Adhesive

The Xtreme bond Instant Adhesive works to bond almost any surface with immediate affect. Bonds steel, aluminium, copper, glass, rubber and most plastics

### Xtreme bond - Welding Powder

The Xtreme bond Welding Powder is the key component that makes this two part system so much more than just a super-glue.

Also in the Xtreme repair range:

- Xtreme Alloy Repair Kit
- Xtreme Alloy Touch Up
- Xtreme Glass Scratch Repair
- Xtreme Windscreen Chip Repair



+44(0)1903 750355

[www.simply-brands.com](http://www.simply-brands.com)

[info@simply-brands.com](mailto:info@simply-brands.com)

Simply 

part of JRP Distribution Ltd