

Body Repair Tech Note: Model 3 Body Structure Materials and Allowed Operations

Body Repair Tech Notes provide information about Tesla-approved methods and practices for body repair. These instructions assume knowledge of motor vehicle and high voltage electrical component repairs, and should only be executed by trained professionals. Tesla assumes no liability for injury or property damage due to a failure to properly follow these instructions or for repairs attempted by unqualified individuals.

The body structure of Model 3 is composed of both components made from aluminum and components made from steel. There are 3 different grades of steel used in Model 3 components: Mild Steel, High-Strength Steel, and Ultra High-Strength Steel. The materials in the repair area determine the type of operations that can be performed, the type of welding that can be performed, and the types of welding wire that should be used, among other things.

Use the table and diagrams below to determine the component material and the allowed operations before beginning a repair. Additional repair recommendations and guidelines can be found in the appropriate section of this document for the type of material.

Material	Allowed Welding Methods			Approved Welding Wire	Cold Repairs	Use of Heat for Repairs	Maximum Heat	Maximum Heat Cycle Times
	Spot Welding	GMA Welding						
		Plug Welding	Butt Joint Welding					
Aluminum	✗	✓	✓	ER4145	✓	✓	212°F (100°C)	N/A
Mild Steel	✓	✓	✓	ER70S-6 Or Bohler Union X96	✓	✓	1200°F (650°C)	90 seconds (2 times)
High-Strength Steel	✓	✓	✓	Bohler Union X96	✓	✓	1200°F (650°C)	90 seconds (2 times)
Ultra High-Strength Steel	✓	✓*	✗	Bohler Union X96	✗	✗	N/A	N/A

- ✓ Approved
- ✓* Approved only as specified in the Tesla Body Repair Manual
- ✗ Not approved

NOTE: ER70S-6 wire has a minimum tensile strength of 483 MPa (70 ksi).

NOTE: Bohler Union X96 has a rated tensile strength of 980 MPa (142 ksi).

NOTE: Refer to [BR-16-92-007](#), “Approved Welders”, for a list of approved GMA welders and squeeze-type resistance spot welders.

NOTE: Refer to [BR-15-92-010](#), “Approved GMA Welding Wires for Structural Repairs”, for a list of approved GMA welding wires.

Body Structure Materials Diagrams

Use the color codes below in conjunction with the diagrams in Figures 1–7 to determine the component material.

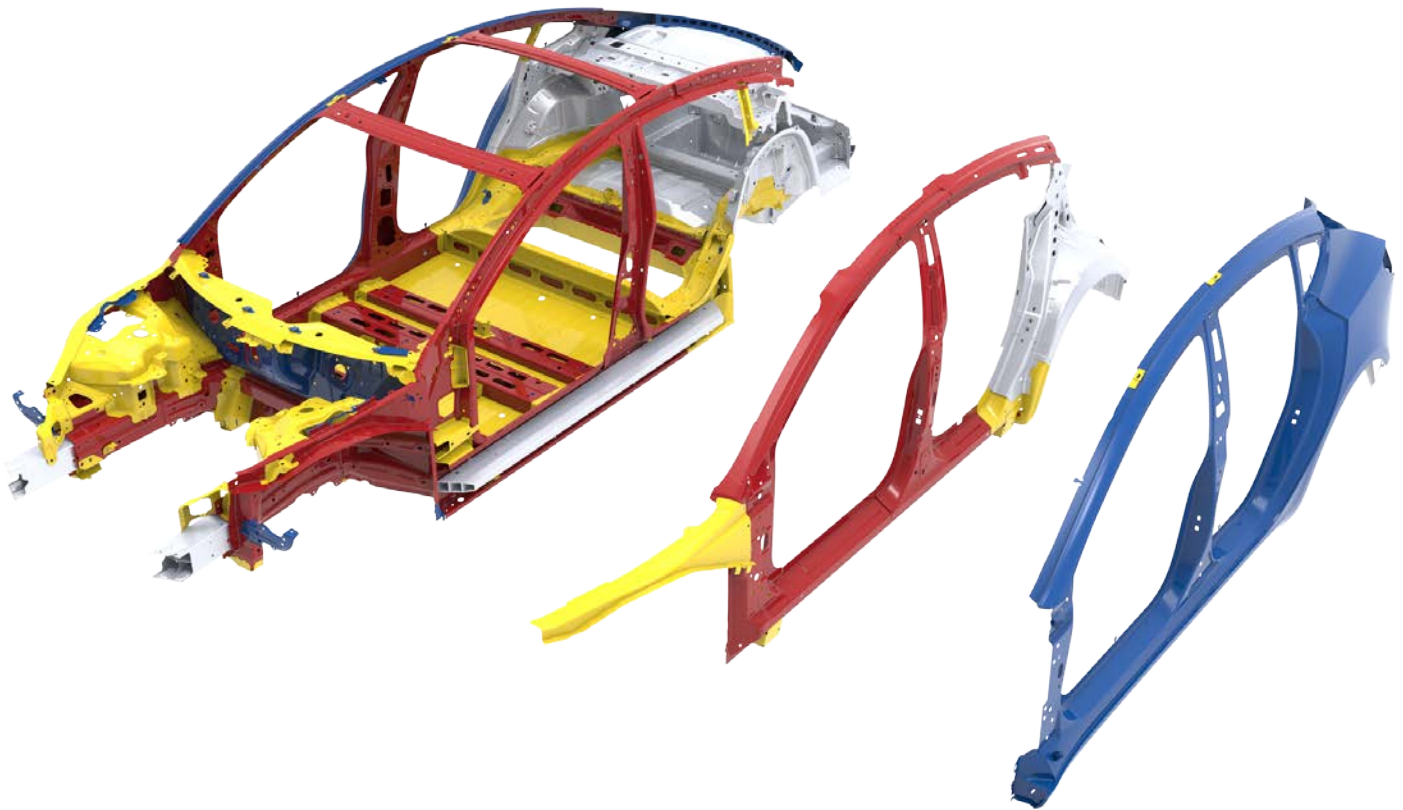

Figure 1 (Front quarter exploded view)



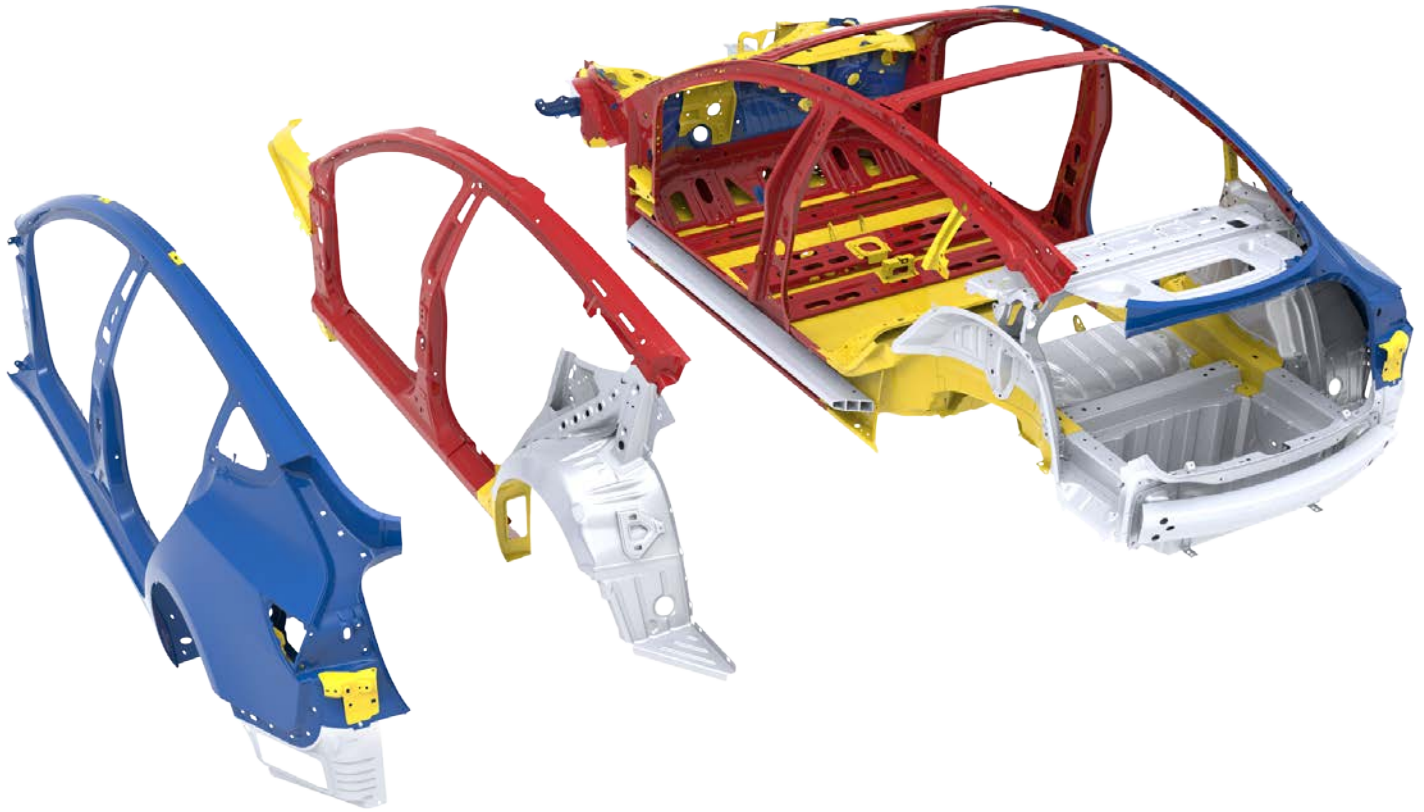

Figure 2 (Rear quarter exploded view)

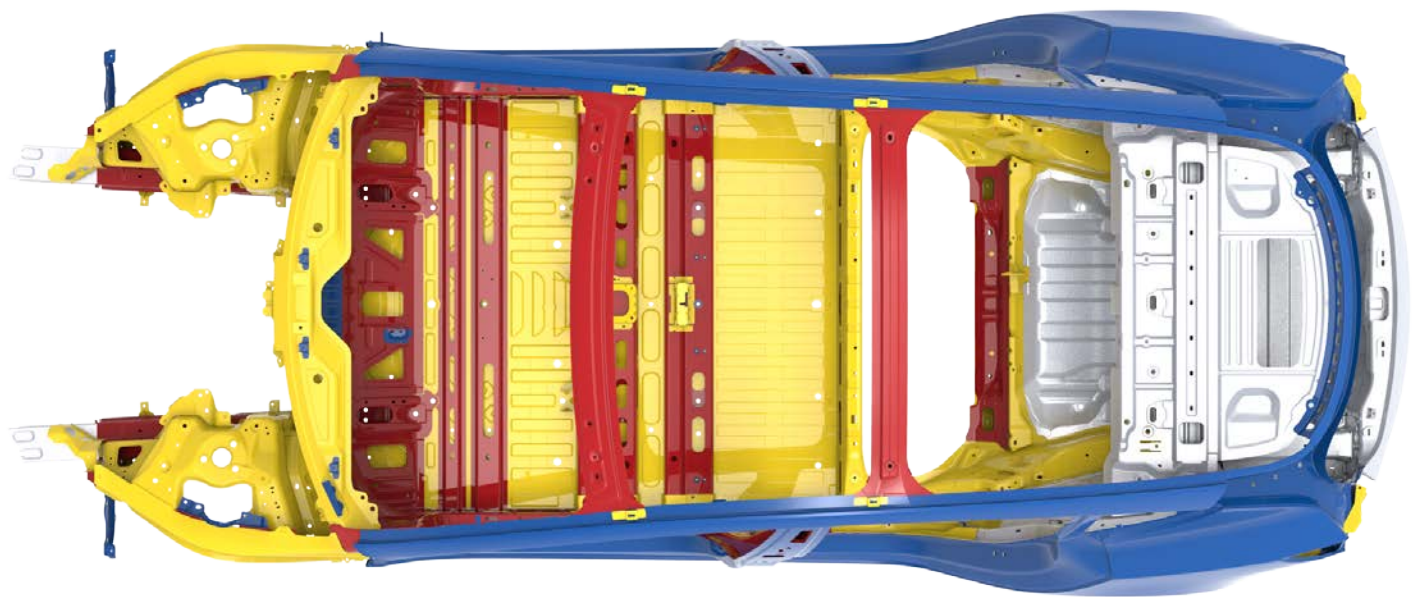

Figure 3 (Top view)



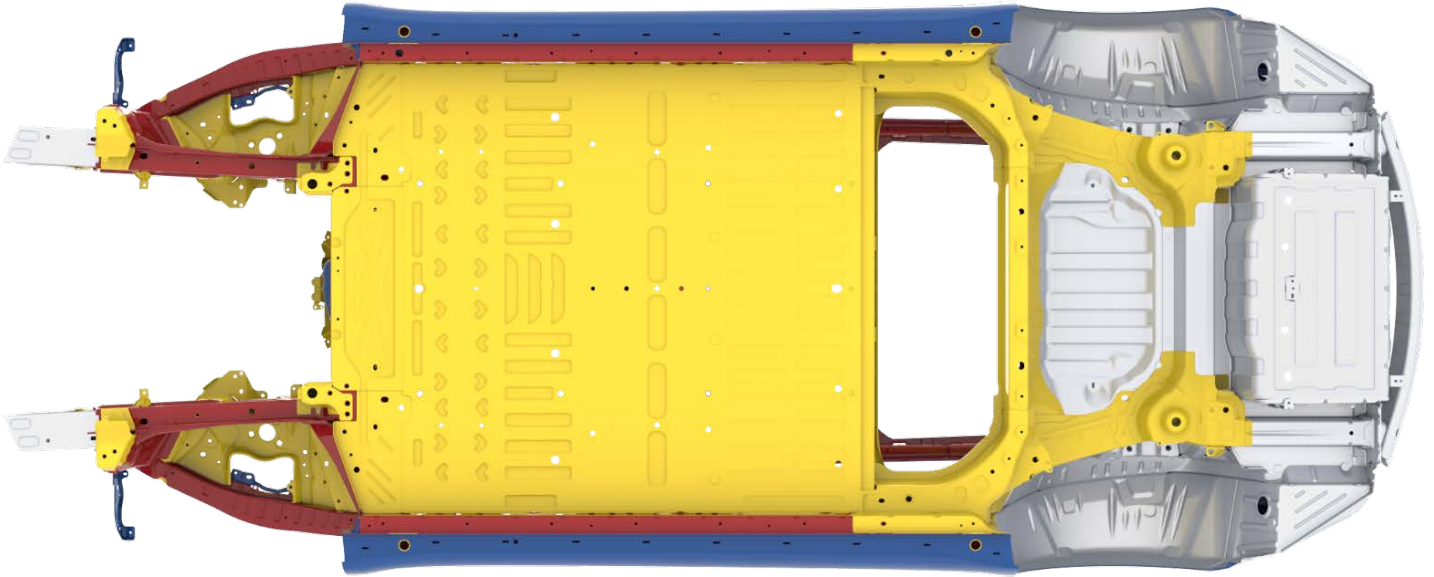

Figure 4 (Bottom view)

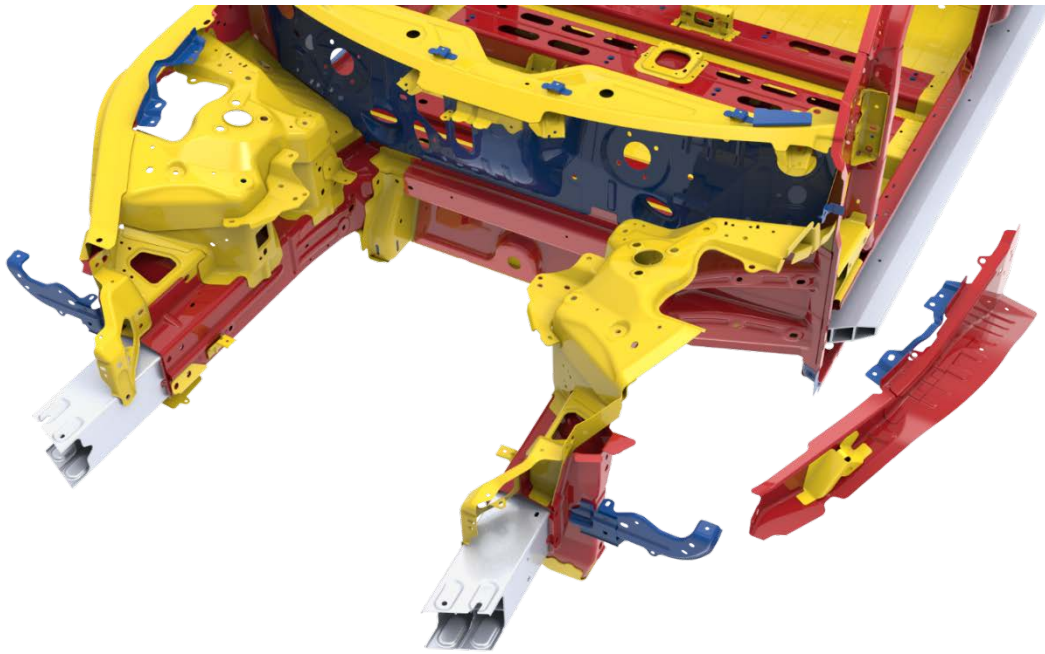

Figure 5 (Front components, exploded view of Shotgun)

Aluminum	Mild Steel	High-Strength Steel	Ultra High-Strength Steel
----------	------------	---------------------	---------------------------

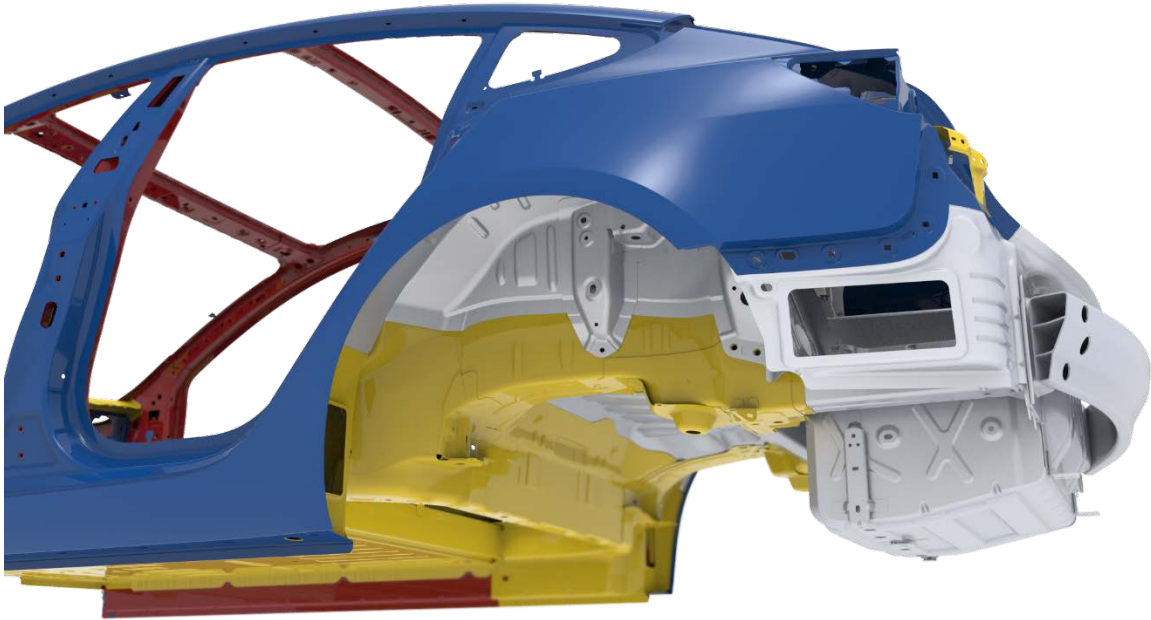

Figure 6 (Rear components)

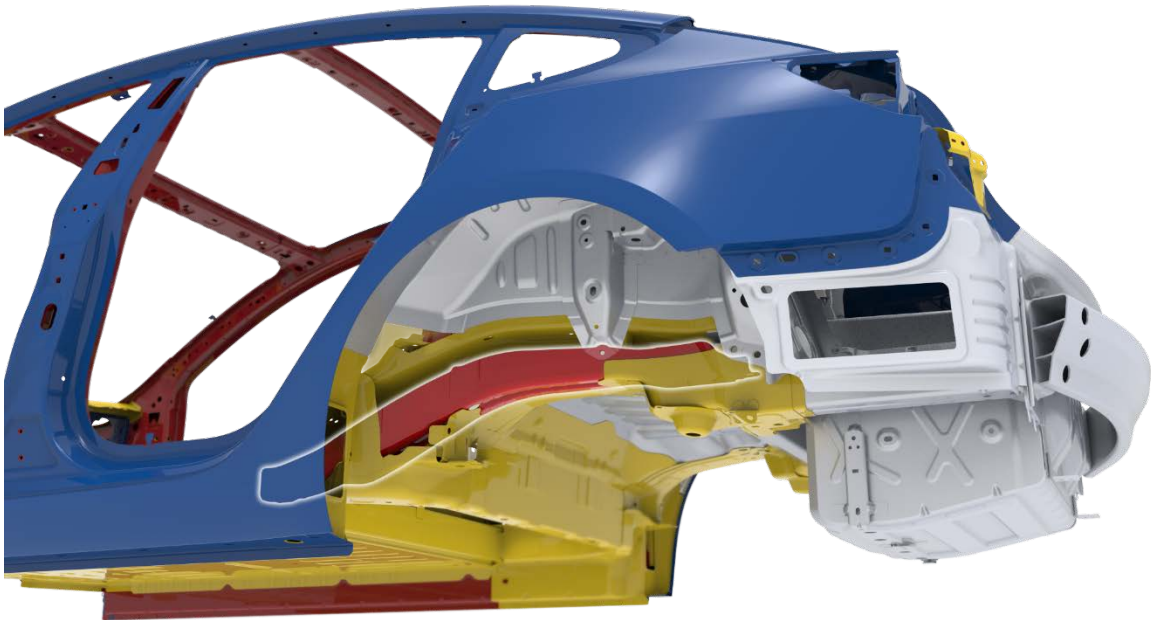

Figure 7 (Rear components, Rear Node Reinforcement highlighted)

Aluminum	Mild Steel	High-Strength Steel	Ultra High-Strength Steel
----------	------------	---------------------	---------------------------

Structural Pulling Not Allowed

Tesla does not allow structural pulling on any structural component of the Model 3 body structure. Tesla defines a structural component as any part that is welded, weld-bonded, rivet-bonded, or riveted to the vehicle. Refer to [BR-14-10-004](#), "Structural Repairs", for more information.

Repair Recommendations and Guidelines for Aluminum

Aluminum

Refer to [BR-14-10-004](#), “Structural Repairs”, and [BR-17-10-001](#), “Repairing Aluminum Cosmetic Damage”, for information on repair recommendations and guidelines for aluminum components.

Repair Recommendations and Guidelines for Mild Steel

Mild Steel

Mild Steel has a tensile strength less than 270 MPa. Follow the guidelines below when repairing or replacing Mild Steel components.

- Cold repairs can be performed to repair cosmetic damage, unless the damage includes kinks. If the damage includes kinks, the component might need to be replaced.
- Controlled use of heat can be used to repair cosmetic damage. Do not exceed 1200°F (650°C). Apply the heat a maximum of 2 times, for up to 90 seconds.
- Sectioning or partial replacement is recommended only at approved locations.
- Mild steel can be used as a sleeve or backing plate when recommended in a specific sectioning procedure in the Tesla Body Repair Manual.
- Resistance spot welding can be used to replace factory spot welds, where applicable.
- GMA plug welding and GMA butt joint welding can be performed.
- MIG brazing can be performed.

Repair Recommendations and Guidelines for High-Strength Steel

High-Strength Steel

High-Strength Steel has a tensile strength range from 300–700 MPa. Follow the guidelines listed above for Mild Steel when repairing or replacing High-Strength Steel components, with the following exceptions:

- The only types of welding that can be performed are GMA plug welding and GMA butt joint welding with Bohler Union X96 wire.

Repair Recommendations and Guidelines for Ultra High-Strength Steel

Ultra High-Strength Steel

Ultra High-Strength Steel (also known as UHSS) has a tensile strength greater than 800 MPa. Follow the guidelines below when replacing Ultra High-Strength Steel components.

- Do not attempt to repair Ultra High-Strength Steel components.
- Sectioning or partial replacement is allowed only at approved locations.
- GMA welding can only be performed as specified in the Tesla Body Repair Manual.
- Do not use Ultra High-Strength Steel for a backing plate, unless specified in the Tesla Body Repair Manual.
- Resistance spot welding can be used to replace factory spot welds, where applicable.
- GMA plug welding can only be performed as specified in the Tesla Body Repair Manual to replace factory spot welds.
- MIG brazing can only be performed as specified in the Tesla Body Repair Manual to replace factory spot welds.

- Tesla has tested various tools for use on the Model 3 structure and strongly recommends using quality tungsten carbide or Boron drill bits in combination with a drill equipped with a C-frame when drilling through components made of Ultra High-Strength Steel.

For feedback on the accuracy of this document, email BodyRepair@tesla.com.