



OEM
SCSI Disk Drive Type DGHS
***ULTRASTAR 18XP/9LP* Hardware/Functional Specification**
9.1GB and 18.2GB Models., 7200 RPM
Version 3.15

Document Number AS06-0140-00

October 2, 1997

IBM Storage Systems Division
5600 Cottle Road
San Jose, CA. 95193

ULTRASTAR 18XP/9LP Hardware/Functional Specification

Contents

1.0 Description	9
1.1 Features	9
1.2 Models	11
2.0 Specifications	12
2.1 General	12
2.2 Notch Details (512 byte block length example)	13
2.2.1 Models 9.1GB and 18.2GB	13
2.3 Capacities by Format Length	14
2.4 Power Requirements	15
2.4.1 Specifications	15
2.4.2 RMS Power Measurements	16
2.4.3 Power Supply Current Profiles	16
2.4.4 Power Supply Ripple	22
2.4.5 Input Capacitance	22
2.4.6 Grounding Requirements of the Disk Enclosure	22
2.4.7 'Hot Plug/Unplug' support	22
2.4.8 Additional 5V Current Requirements for Differential SCSI	23
2.5 Bring-up Sequence (and Stop) Times	24
2.5.1 Spin Down Times	25
3.0 Performance	26
3.1 Environment Definition	26
3.2 Workload Definition	26
3.2.1 Sequential	27
3.2.2 Random	27
3.3 Command Execution Time	27
3.3.1 Basic Component Descriptions	30
3.3.2 Comments	33
3.4 Disconnection During Read/Write Data Phase	33
3.5 Approximating Performance for Different Environments	33
3.5.1 When Read Caching is Enabled	34
3.5.2 When Read Ahead is Enabled	34
3.5.3 When Write Caching is Enabled	34
3.5.4 When Adaptive Caching is Enabled	34
3.5.5 For Queued Commands	35
3.6 Read Command Performance	36
3.7 Write Command Performance	37
3.8 Skew	38
3.8.1 Cylinder to Cylinder Skew	38
3.8.2 Track to Track Skew	38
3.9 Idle Time Function Considerations	38
3.9.1 Predictive Failure Analysis (PFA)	39
3.9.2 Save Logs and Pointers	40
3.9.3 Disk Sweep	40
3.9.4 Summary	40
3.10 Command Timeout Limits	40
4.0 Mechanical	42
4.1 Weight and Dimensions	42
4.2 Clearances	42

ULTRASTAR 18XP/9LP Hardware/Functional Specification

4.3 Mounting Guidelines 42

 4.3.1 SCA Mounting Guidelines 43

4.4 Electrical Connector Locations 47

5.0 Electrical Interface 50

5.1 Power Connector 50

5.2 SCSI Bus Connector 50

 5.2.1 50 Pin Signal Connector 51

 5.2.2 68 Pin Signal Connector 51

 5.2.3 80 Pin (Single Connector Attachment) Connector 53

 5.2.4 SCSI Bus Cable 55

 5.2.5 SCSI Bus Terminators (Optional) 55

 5.2.6 SCSI Bus Termination Power 56

 5.2.7 SCSI Bus Electrical Characteristics 56

5.3 Option Block Connector (Jumper Blocks) 57

 5.3.1 68 Pin Auxiliary Connector 62

 5.3.2 SCSI ID (Address) Pins 63

 5.3.3 Auto Start (& Delay) Pins 63

 5.3.4 External Activity (LED) Pins 64

 5.3.5 Write Protect Pin 65

 5.3.6 Disable Sync. Negotiation Pin 65

 5.3.7 Disable SCSI Parity Pin 65

 5.3.8 Disable Unit Attention Pin 65

 5.3.9 Disable Wide Negotiations 65

 5.3.10 Enable Active Termination 66

5.4 Spindle Synchronization 66

6.0 Reliability 67

6.1 Error Detection 67

6.2 Data Reliability 67

6.3 SPQL (Shipped product quality level) 67

6.4 Failure Rate 67

6.5 Shelf Life 68

6.6 Start Stop Cycles 68

7.0 Operating Limits 69

7.1 Environmental 69

 7.1.1 Temperature Measurement Points 69

7.2 Vibration and Shock 71

 7.2.1 Output Vibration Limits 71

 7.2.2 Operating Vibration 71

 7.2.3 Nonoperating Vibration 72

 7.2.4 Operating Shock 72

 7.2.5 Nonoperating Shock 73

7.3 Contaminants 73

7.4 Acoustic Levels 74

7.5 Drive Mounting Guidelines 75

7.6 Drive/System Compatibility 75

7.7 Recommendations for Handling of Disk Drives 77

7.8 Breather Filter Hole 79

7.9 Periodic Maintenance 79

7.10 ESD Protection 79

7.11 ESD Handling 79

7.12 Stray Magnetic Fields 80

ULTRASTAR 18XP/9LP Hardware/Functional Specification

8.0 Standards	81
8.1 Safety	81
8.2 Electromagnetic Compatibility (EMC)	82

Figures

1.	ULTRASTAR 18XP/9LP Disk Drive Assembly	9
2.	12 Volt Start Current 1.0" Models	17
3.	Typical Seek with Read 12 Volt Current 1.0" Models	18
4.	Typical Sequential Read Operation 5 Volt Current all Models	19
5.	12 Volt Start Current 1.6" Models	20
6.	Typical Seek with Read 12 Volt Current 1.6" Models	21
7.	Start Time Diagram	24
8.	All caching disabled, Re-instruction Times = 0-100ms, no TCQing	28
9.	Re-instruction Times = 0ms, no TCQing	28
10.	WCE vs no WCE, Re-instruction Times = 0ms, no TCQing	28
11.	All caching disabled, With TCQing (Queue Depth = 4)	29
12.	With TCQing (Queue Depth = 4)	29
13.	Restricted vs Unrestricted Command Reordering, w/TCQing (Various Queue Depths)	29
14.	Concurrent Command Processing enabled, w/TCQing (Queue Depth = 32)	29
15.	SCSI Read command performance measurements	36
16.	SCSI Write command performance measurements	37
17.	Location of Side Mounting Holes of 1.0 inch Models	43
18.	Location of Side Mounting Holes of 1.6 inch Models	44
19.	Location of Bottom Mounting Holes for 50 and 68 Pin Models. (68 pin card shown.)	45
20.	Location of Bottom Mounting Holes for 80 pin SCA-2 models.	46
21.	Electrical connectors (rear view) -- 80 pin SCA-2 models.	47
22.	Electrical connectors (rear view) -- 68 pin models.	48
23.	Electrical connectors (rear view) -- 50 pin models.	48
24.	Jumper pin locations (front view)	49
25.	50 pin Single Ended Front Option Jumper Block and TermPower Block	58
26.	68 pin Single Ended Front Option Jumper Block and TermPower Block	59
27.	SCA-2 Front Option Jumper Block	60
28.	68 pin Differential Front Option Jumper Block	61
29.	Auxiliary Connector on the 68 pin Connector	62
30.	LED Circuit Diagram	65
31.	Temperature Measurement Points (bottom view)	70
32.	Temperature Measurement Point (top view)	71
33.	Breather Hole for Filter	79

Tables

1. Cylinder notch table for 512 Byte Format	13
2. Maximum LBA's and cylinders	13
3. User LBA capacity	14
4. User byte capacity	14
5. Power Measurements made using Clarke Hess Model 259 Digital Wattmeter	16
6. Bring-up Sequence and Stop Times	25
7. Overhead Values	30
8. Data Sector Transfer Rates	32
9. Summary of Idle Time Function Performance Impacts	40
10. Weights and Dimensions (Nominal)	42
11. Power connector pin assignments	50
12. 50 Pin Single-Ended SCSI Connector Contact Assignments	51
13. 68 Pin Single-Ended SCSI Connector Contact Assignments	52
14. 68 Pin Differential SCSI Connector Contact Assignments	53
15. 80 Pin SCA-2 Connector Contact Assignments	54
16. Single Ended SCSI Terminators	55
17. Differential SCSI Terminators	55
18. Single-Ended Bus Electrical Characteristics	56
19. Address Determination of 68 and 80 Pin Models	63
20. Address Determination of 50 Pin Models	63
21. 68p and 50p Auto-Startup Modes selectable by Auto-Start/Delay Pin Combinations.	64
22. 80p Auto-Startup Modes selectable by Auto-Start/Delay Pin Combinations	64
23. Maximum and Maximum Recommended Case Temperature Limits	70
24. Random Vibration Levels	72
25. Nonoperating Vibration Levels	72
26. Stray Magnetic Field Strength	80

ULTRASTAR 18XP/9LP Hardware/Functional Specification

1.0 Description

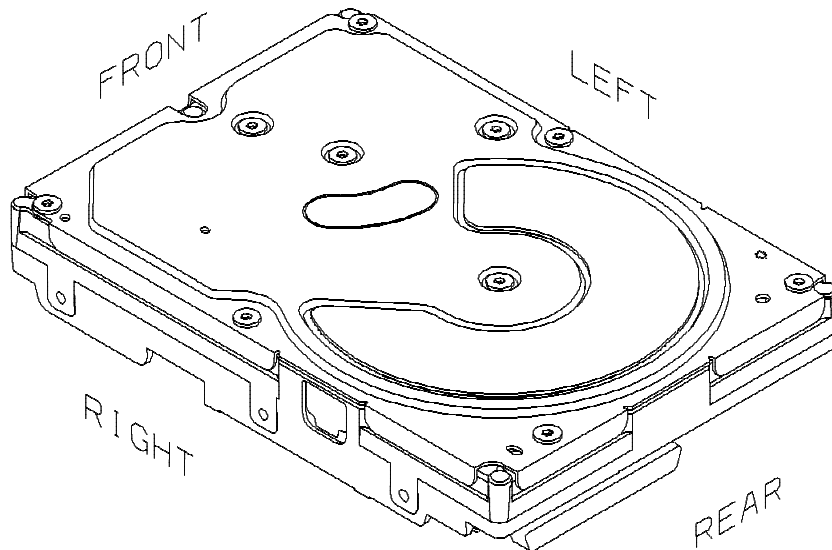

Figure 1. **ULTRASTAR 18XP/9LP** Disk Drive Assembly

1.1 Features

General Features

- 18.2GB/9.1GB (512 bytes/sector)
- Industry-standard interface:
 - 68 pin ANSI SCSI-3 Single-Ended or Differential
 - 50 pin ANSI SCSI-3 Single-Ended
 - Single Connector Attachment (SCA-2/ 80-pin)
- Rotary voice coil motor actuator
- Closed-loop digital actuator servo
- Embedded sector servo
- Magnetoresistive (MR) heads
- 16/17 rate encoding
- Partial Response Maximum Likelihood (PRML) data channel with analog filter
- No-ID™ sector format
- All mounting orientations supported
- 1MB segmented cache buffer
- Jumperable drive supplied terminator power (on some models)
- Jumperable on board active SCSI terminators (optional on some models)
- LED Driver

- Bezel (optional on some models)

Performance Summary

- Average read seek time 9.1GB : 6.5 milliseconds
- Average read seek time 18.2GB : 7.5 milliseconds
- Average Latency: 4.17 milliseconds
- Media data transfer rate: 11.52 to 22.40 MegaBytes/second (16 bands)
- Fast-20 SCSI data transfer rate: 20 MegaTransfers/second (sustained synchronous)
- SCSI Bus Overhead: < 40 microseconds
- Read Command Overhead: < 350 microseconds

Interface Controller Features

- Multiple initiator support
- Integrated differential transceivers (on differential models only)
- Variable logical block lengths (*512 - 732 supported*)
- Nearly Contiguous Read
- Read-ahead caching
- Adaptive caching algorithms
- Write Caching
- Back-to-back writes (merged writes)
- Tagged and untagged command queuing
- Command reordering (4 user selectable algorithms)
- Automatic retry and data correction on read errors
- Automatic sector reallocation
- In-line alternate sector assignment
- Down-loadable firmware
- Customizing controller jumpers

For example:-

- Auto spindle motor start
- Auto Start Delay
- Disable Target Initiated Synchronous Negotiation
- Disable Unit Attention
- Disable SCSI Parity
- Write protection

Reliability, Availability and Serviceability Features

- Self-diagnostics on power up
- Dedicated head landing zone
- Magnetic actuator latch
- Entire Read/Write customer data path protected by 32 Bit CRC
- 18 Byte Error Correcting Code (ECC)
- 9 Byte ECC on the fly
- Predictive Failure Analysis™ (PFA)™
- Error Recovery Procedures (ERP)
- Data Recovery Procedures (DRP)
- Probability of not recovering data: **10 in 10¹⁵** bits read
- No preventative maintenance required
- Event logging and analysis
- High temperature monitoring and logging

1.2 Models

The **ULTRASTAR 18XP/9LP** disk drive is available in various models with a variety of the following options.

- Capacity of 9.1GB or 18.2GB

Please refer to section 2.3, “Capacities by Format Length” on page 14 for exact capacities based on user block size.

- Physical connectors available
 - 50 pin connectors offer an 8 bit bus using the SCSI 'A' connector
 - 68 pin connectors offer an 8/16 bit (Narrow/Wide) bus using the SCSI 'P' connector
 - 80 pin connectors offer an 8/16 bit SCSI bus using the 'SCA-2' connector
- Electrical Interfaces available
 - Single Ended (50, 68, and 80 pin)
 - Differential (68 pin only)

The various supported combinations of the above options and the Model Numbers that correspond to those available combinations are listed in the following table.

9.1GB 1" Models	Ultra SCSI Pins/Connector Type	Ultra SCSI Electrical Signal Type
DGHS 09U	68/Unitized Connector	Single Ended (Fast & Wide)
DGHS 09X	68/Unitized Connector	Differential (Fast & Wide)
DGHS 09Y	80 SCA-2	Single Ended (Fast & Wide)
DGHS 09Z	50 pin/A Connector	Single Ended (Fast)

18.2GB 1.6" Models	Ultra SCSI Pins/Connector Type	Ultra SCSI Electrical Signal Type
DGHS 18U	68/Unitized Connector	Single Ended (Fast & Wide)
DGHS 18X	68/Unitized Connector	Differential (Fast & Wide)
DGHS 18Y	80 SCA-2	Single Ended (Fast & Wide)
DGHS 18Z	50 pin/A Connector	Single Ended (Fast)

Note: Please refer to section 2.3, “Capacities by Format Length” on page 14 for exact capacities based on user block size.

Several of the models listed in the above table have options that are not identified via the model number. They are as follows...

- Bezel (optional on some models)
- Jumperable active terminators (on 68 & 50 pin single-ended models only).

2.0 Specifications

All specification numbers are mean population values unless otherwise noted.

2.1 General

Note: The recording band located nearest the disk outer diameter (OD) is referred to as 'Notch #1', the recording band located nearest the inner diameter (ID) is called 'Notch #16'. 'Average' values are weighted with respect to the number of LBAs per notch when the drive is formatted with 512 byte blocks.

Data transfer rates

	Notch #1	Notch #16	Average	
Buffer to/from media	22.40	11.52	18.27	MB/s (instantaneous)
Buffer to/from media	15.47	7.75	12.66	MB/s (sustained)

Host to/from buffer up to 40.0 MB/s (synchronous)
Rotational speed (RPM) 7200

Average latency (milliseconds) 4.17

Track Density (TPI) 8356

	Minimum	Maximum
Recording density (bpi)	132,670	150,000
Areal density (Megabits/square inch)	1109.0	1253.4

	1.0"	1.6"
Models	9.1GB	18.2GB
Disks	5	10
Heads	10	20

Seek Timing in milli seconds (measured at nominal voltage and temperature)

	1.0"	1.6"
Single cylinder (Read)	0.7	0.7
(Write)	2.0	2.0
Average weighted (Read)	6.5	7.5
(Write)	7.5	8.5
Full Stroke (Read)	14.0	17.0
(Write)	16.0	19.0

2.2 Notch Details (512 byte block length example)

User bytes/Sector (ub/sct) 512

Sectors/logical block (sct/lba) 1

User bytes/logical block (ub/lba) 512

Number of cylinders 8162

2.2.1 Models 9.1GB and 18.2GB

<i>Notch</i>	<i>Start Cylinder</i>	<i>User Data cylinders</i>	<i>Media Data Rate</i>	<i>Sectors Per Track</i>
1	10/8 (9.1GB/18.2GB)	585/587 (9.1GB/18.2GB)	22.40	280
2	595	1471	21.145	270
3	2066	677	20.413	255
4	2743	483	19.784	247
5	3226	438	19.156	240
6	3664	420	18.528	230
7	4084	373	17.900	225
8	4457	306	17.377	216
9	4763	324	16.801	210
10	5087	433	16.016	198
11	5520	428	15.231	188
12	5948	612	14.132	180
13	6560	427	13.399	165
14	6987	386	12.771	157
15	7373	400	12.143	150
16	7773	389	11.52	140

Table 1. Cylinder notch table for 512 Byte Format

<i>Notch</i>	<i>Last Cylinder</i>	<i>User Data cylinders</i>	<i>Media Data Rate</i>	<i>Sectors Per Track</i>
16	8161	389	11.52	140

Table 2. Maximum LBA's and cylinders

User bytes/Sector (ub/sct) 512 to 732 (even byte numbers only)

2.3 Capacities by Format Length

User bytes / logical block	User logical blocks / drive	
	9.1GB Model	18.2GB Model
512	17916240	35843670
514	17779500	35570150
520	17429580	34870150
522	17334100	34678990
524	17264020	34538830
528	17207800	34426390
536	17012010	34034810
688	13630100	27268830
732	12859820	25727790

Table 3. User LBA capacity

Note: Max Addressable LBA = (number of logical blocks) - 1

User bytes / logical block	User bytes / drive	
	9.1GB Model	18.2GB Model
512	9,173,114,880	18,351,959,040
514	9,138,663,000	18,283,057,100
520	9,063,381,600	18,132,478,000
522	9,048,400,200	18,102,432,780
524	9,046,346,480	18,098,346,920
528	9,085,718,400	18,177,133,920
536	9,118,437,360	18,242,658,160
688	9,377,508,800	18,760,955,040
732	9,413,388,240	18,832,742,280

Table 4. User byte capacity

2.4 Power Requirements

2.4.1 Specifications

The following voltage specifications apply at the drive power connector. There is no special power on/off sequencing required. For Differential SCSI models see: 2.4.8, “Additional 5V Current Requirements for Differential SCSI” on page 23.

Input Voltage

- +5 Volts Supply 5V (± 5% during run and spin-up)
- +12 Volts Supply 12V (± 5% during run) (+5% / -7% during spin-up)

Power Supply On/Off Requirements

- +5V 4.5 V/sec Minimum Slew.
- +12V 7.4 V/sec Minimum Slew.

Power Supply Current 9.1GB Model	Population Mean	Population Range
+5VDC (Power Save Mode)	0.63 Amps ¹	+/- 10%
+5VDC (idle avg)	0.78 Amps ²	+/- 10%
+5VDC (R/W baseline)	Typical	1.03 Amps
+5VDC (R/W pulse)	Peak	1.25 Amps
+12VDC (Idle)	0.45 Amps	+/- 10%
+12VDC (seek peak)	Peak	2.07 Amps
+12VDC (Start Current)	Maximum	1.6 Amps ³

Power Supply Current 18.2GB Model	Population Mean	Population Range
+5VDC (Power Save Mode)	0.63 Amps ¹	+/- 10%
+5VDC (idle avg)	0.78 Amps ²	+/- 10%
+5VDC (R/W baseline)	Typical	1.03 Amps
+5VDC (R/W pulse)	Peak	1.25 Amps
+12VDC (Idle)	0.770 Amps	+/- 10%
+12VDC (seek peak)	Peak	2.43 Amps
+12VDC (Start Current)	Maximum	2.7 Amps ³

Energy Consumption

- 9.1GB** 0.0009 watts per MB
- 18.2GB** 0.0007 watts per MB

Note: Energy Consumption Index = Idle Power/Capacity (W/MB)

¹ Power Save mode is automatically invoked after 1 second of inactivity, except when read ahead is active. In which case Power Save Mode is invoked after 40 seconds of inactivity.

² 5 Volt Current is given with termination power provided by the using system.

³ The Start Current is the total 12 volt current required by the Drive.

2.4.2 RMS Power Measurements

DGHS Fast-20	9.1GB	18.2GB
Power Save	8.5 Watts	12.4 Watts
Idle	9.2 Watts	13.1 Watts
15 ops/second	10.5 Watts	14.4 Watts
30 ops/second	11.6 Watts	15.4 Watts
60 ops/second	13.4 Watts	17.4 Watts

Table 5. Power Measurements made using Clarke Hess Model 259 Digital Wattmeter

Note:

For the purpose of calculations 0.061 Watts per op can be used for the 9.1GB and 0.064 Watts per op for 18.2GB This is not completely accurate because of the non linear scale but can be used for approximations.

For these measurements an op is defined as a read transfer of 4k Bytes. Measurements were taken about 5 minutes after file was spun up to allow the 12 volt power readings to stabilize.

Example

If 9.1GB power was required for 90 ops per second the calculation would be as follows

$$\text{Idle power} = 9.20 \text{ Watts}$$

$$90 \text{ ops/second} = 90 * 0.061 = 5.49 \text{ Watts}$$

$$\text{Total Power} = 9.20 + 5.49 = 14.69 \text{ Watts}$$

2.4.2.1 Differential Models

The power increase for differential models will be between 0.5 watts at idle to 1.0 watts for 60 ops/s.

2.4.3 Power Supply Current Profiles

These graphs were obtained by measuring a population of drives from the manufacturing process. The results are the average from this population taken at nominal voltage conditions.

All power supplies are nominal.

The results exclude inductive spikes caused by leads, power supplies and components that will vary with different setup configurations.

The graphs shown on the following pages are approximate representations of the power supply currents based on lab measurements.

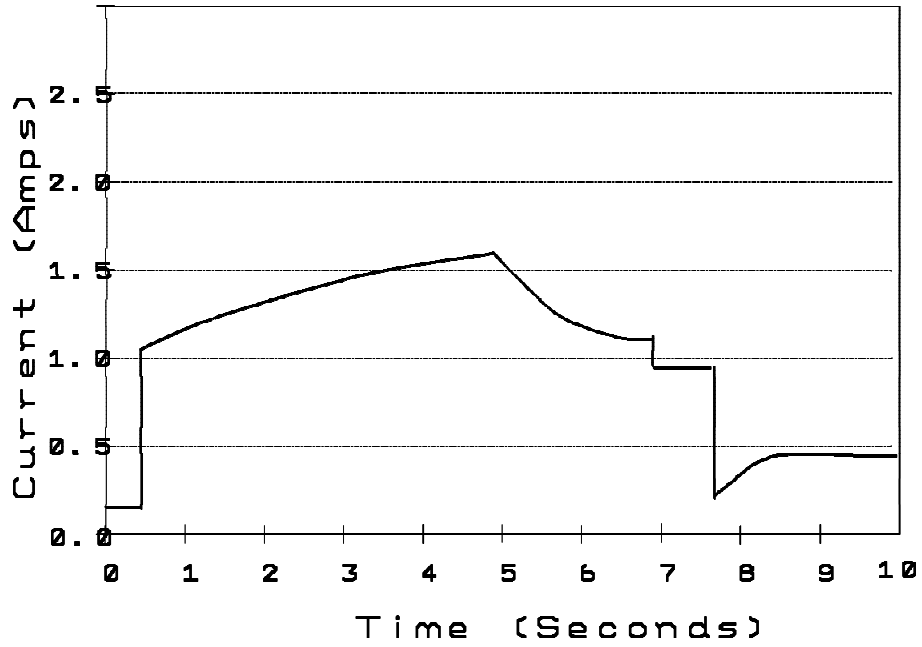

Figure 2. 12 Volt Start Current 1.0" Models

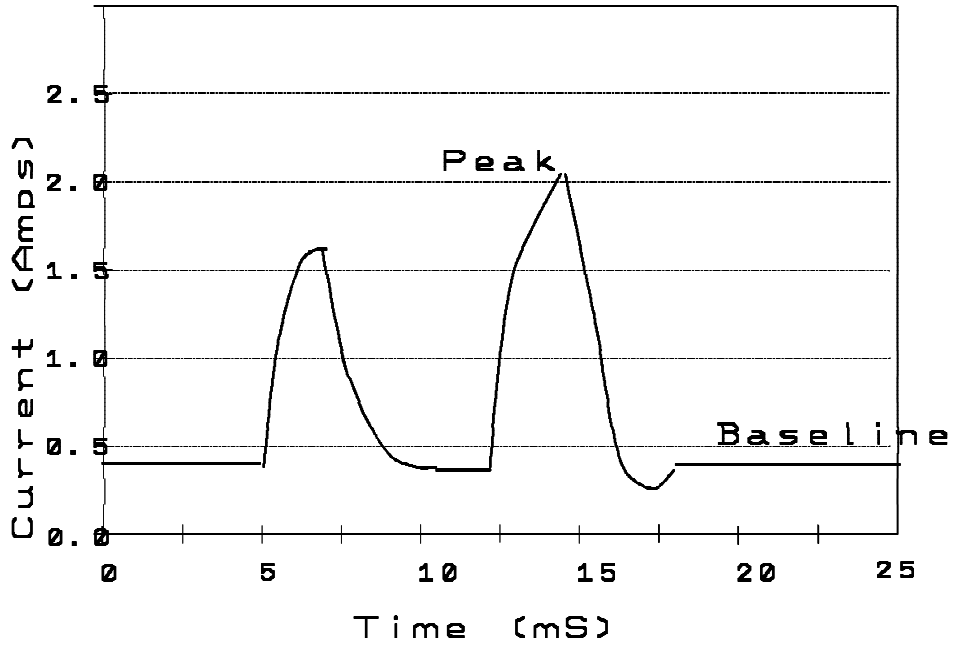

Figure 3. Typical Seek with Read 12 Volt Current 1.0" Models

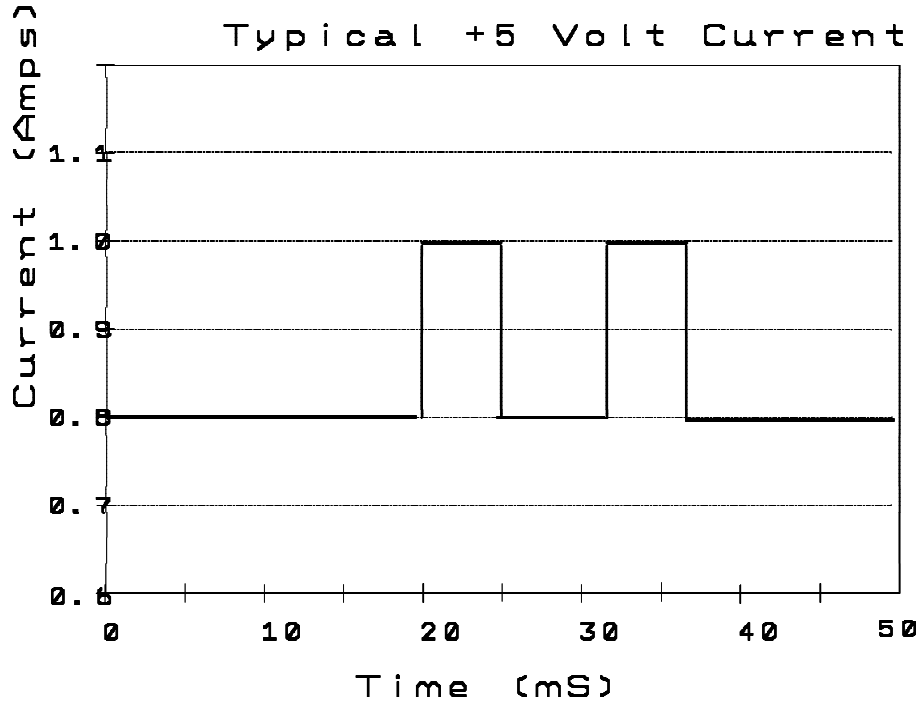

Figure 4. Typical Sequential Read Operation 5 Volt Current all Models

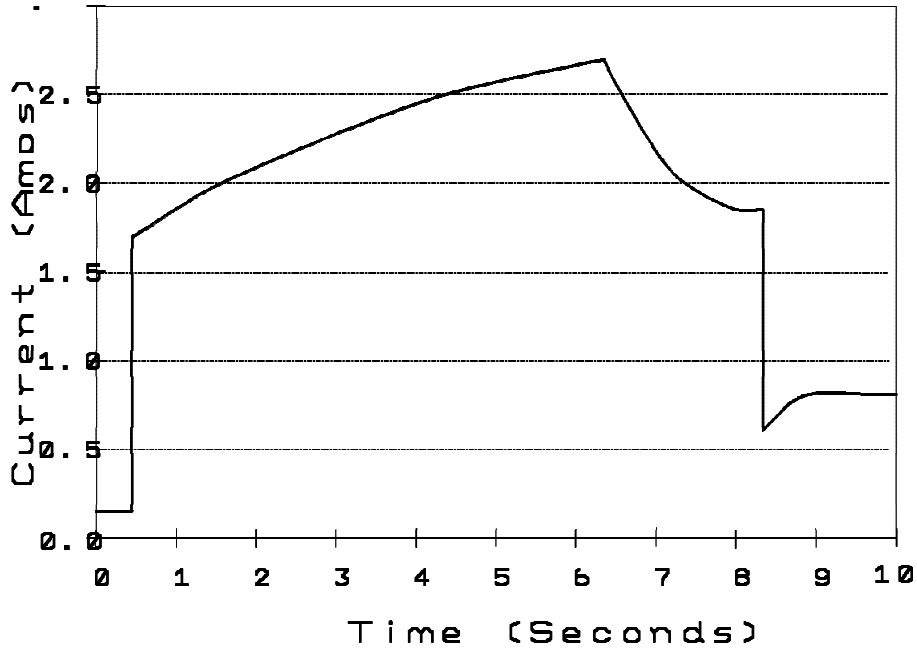

Figure 5. 12 Volt Start Current 1.6" Models

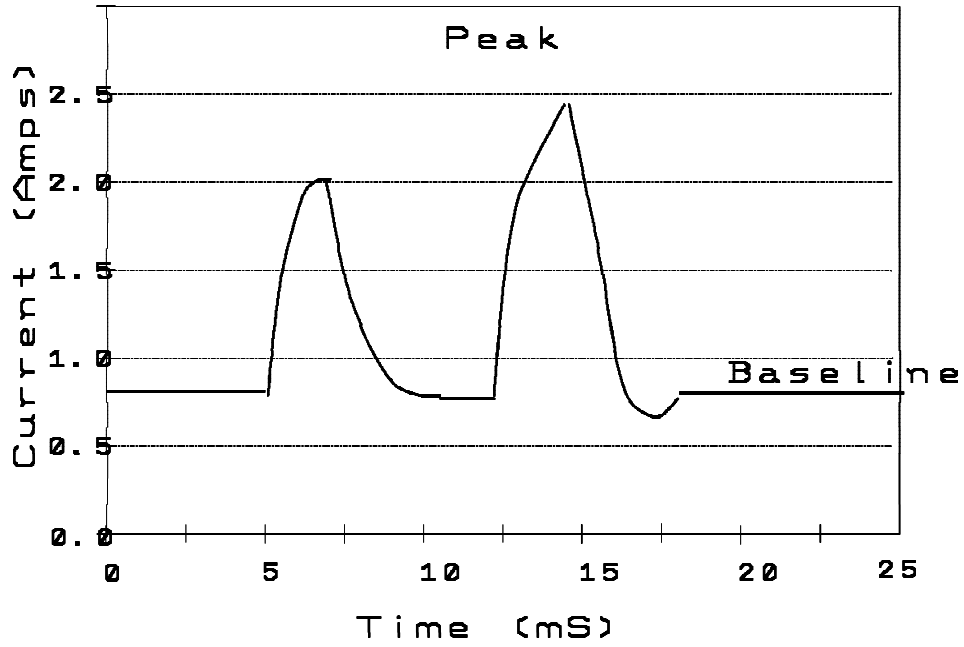

Figure 6. Typical Seek with Read 12 Volt Current 1.6" Models

2.4.4 Power Supply Ripple

Externally Generated Ripple
as seen at drive power connector

	Maximum	Notes
+5VDC	200 mV peak-to-peak	0-20 MHz
+12VDC	200 mV peak-to-peak	0-20 MHz

During drive start up and seeking, 12 volt ripple is generated by the drive (referred to as dynamic loading). If several drives have their power daisy chained together then the power supply ripple plus other drive's dynamic loading must remain within the regulation tolerance window of +/- 5%. A common supply with separate power leads to each drive is a more desirable method of power distribution.

2.4.5 Input Capacitance

Internal bulk capacitance
as seen at drive power connector

+5VDC	72 ± 20% microfarad
+12VDC	510 ± 20% microfarad

2.4.6 Grounding Requirements of the Disk Enclosure

The disk enclosure is at Power Supply ground potential.

From an ElectroMagnetic Compatibility (EMC) standpoint it will, in most cases be preferable to provide a common ground connection between the disk enclosure and the system's mounting frame. With this in mind, it is important that the disk enclosure not become an excessive return current path from the system frame to power supply. The system frame must be within +/- 150 millivolts of the drive's power supply ground. At no time should more than 35 milliamps of current (0 to 100Mhz) be injected into the disk enclosure.

2.4.7 'Hot Plug/Unplug' support

The term 'Hot Plug', refers to the action of mechanically engaging a device to power and / or SCSI bus when other devices may be active on the same bus.

A comprehensive classification of the state of the SCSI bus during this event is located in the SCSI-3 Parallel Interface Standard, Annex 'A'.

Note: Case 3 is defined as 'Current I/O processes not allowed during insertion or removal'

Case 4 is defined as 'Current I/O processes allowed during insertion or removal'

While every effort was made to design the drive not to influence the SCSI bus during these events, it is a system responsibility to insure voltage regulation and conformance to operational and non-operational shock limits.

During Hot Plug events the non-operational shock levels should not be exceeded. The operational shock levels of adjacent drives should not be exceeded as well. The recommended procedure is to prohibit write operations to adjacent drives during the HOT PLUG and during the HOT UN-PLUG actions.

Reference section 7.2, “Vibration and Shock” on page 71 for the Operating and Non-Operating Shock limits.

During Hot un-Plug the operational shock limit specifications should not be exceeded. If this cannot be guaranteed then the drive should be issued a SCSI Stop Unit command that is allowed to complete before un-plugging. The basic requirement is that while the drive is operational or spinning down (as a result of a UNIT STOP or Un-Plug) the operational shock limits are in effect. Once the drive has completely stopped (15 seconds max) the non-operational shock limits are in effect. The recommended procedure is to allow the un-plugged drive to rest in the drive bay for a minimum of 15 seconds and then complete the removal.

During Hot Plug or Unplug events the power supply ripple on adjacent operational drives should not go outside of the +/- 5 % regulation tolerance.

2.4.7.1 (SCA-2 models)

Based on the connector classification called out in SFF-8046, the **ULTRASTAR 18XP/9LP** 80pin SCA-2 drive is 'Case 4' compliant, when the system has properly implemented the SFF-8046 guidelines.

2.4.7.2 (50,68 pin models)

Based on the SCSI Parallel Interface classification, it is recommended that the using system comply with 'Case 3' guidelines to eliminate the chance of affecting an active bus.

In systems that cannot afford to quiesce the SCSI bus, but can meet the requirements of voltage regulation, operational and non-operational shock, the following guidelines are recommended to minimize the chance of interfering with the SCSI Bus:

Plug

1. Common ground should be made between device and power supply ground
2. Plug device onto the bus
3. Power up device (no special sequencing of 5 or 12 volts)
4. Device is ready to be accessed

Un-Plug

1. Power down device (no special sequencing of 5 or 12 volts)
2. Un-plug device from the bus
3. Remove common ground

2.4.8 Additional 5V Current Requirements for Differential SCSI

Additional Power Supply Current	Notes	Population Mean
+5VDC (idle avg)		0.10 Amps
+5VDC (R/W baseline)	Typical	0.06 Amps
+5VDC (R/W pulse)	Base-to-peak	1.0 Amps

2.5 Bring-up Sequence (and Stop) Times

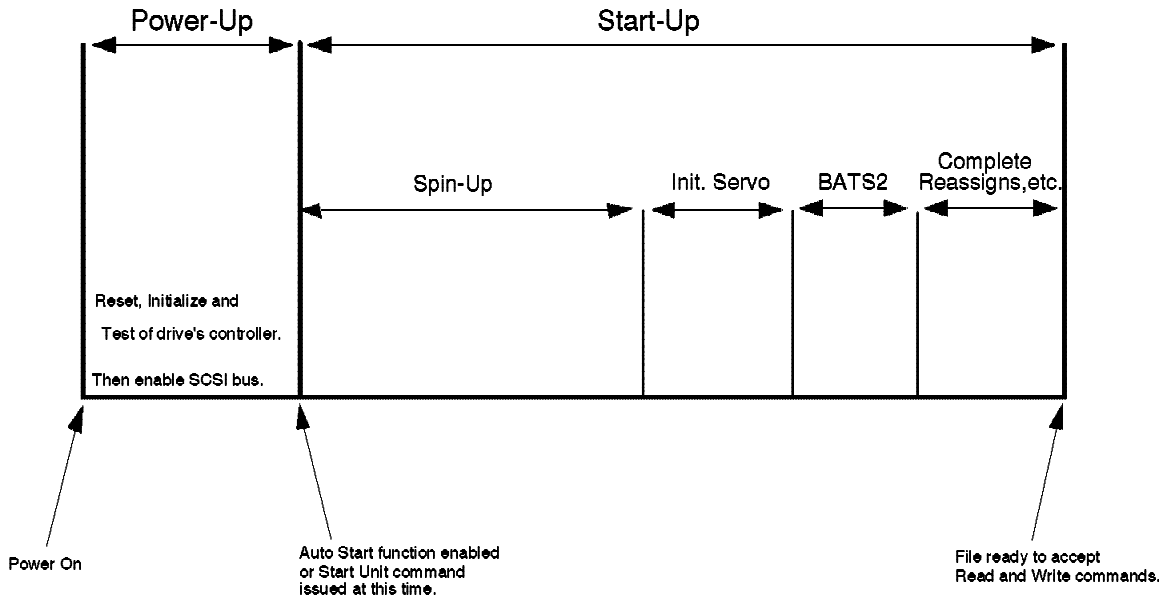

Figure 7. Start Time Diagram

A full Bring-Up Sequence consists of a Power-up Sequence and Start-Up Sequence, as Figure 7 shows.

"Power On" is defined as when the power at the drive meets all of the power specifications as defined in this document.

The Start-Up sequence spins up the spindle motor, initializes the servo subsystem, performs Basic-Assurance-Tests-2 (BATs2) (verifies read/write hardware), resumes "Reassign in Progress" operations and more. See the *ULTRASTAR 18XP/9LP SCSI Logical Interface Specification* for additional details on the Start-Up sequence.

If a SCSI Reset is issued while the drive is in either a Power-Up or Start-Up Sequence, that same Sequence starts again. In all other cases when a SCSI Reset is issued the present state of the motor is not altered.

Reference 3.10.1.3, "Start/Stop Unit Time" on page 41 for additional details.

A startup sequence initiated by SCSI "Start/Stop Unit" command that follows a spindle stop initiated by a SCSI "Start/Stop Unit" command by less than 10 seconds, may result in the Startup sequence increasing by as much as 10 seconds. For example, if a delay of only 3 seconds exists between the 2 commands, the 2nd command can take 7 seconds longer than if 10 seconds or more had been allowed between the "Start/Stop Unit" commands.

Model = = = = = >	18.2GB		9.1GB	
Event	Nominal	Maximum	Nominal	Maximum
Power-up	2.5 sec	3.0 sec	2.5 sec	3.0 sec
Start-up	16.5 sec	45 sec	17 sec	45 sec
Spin-up	10.5 sec	30 sec	11 sec	30 sec
Spindle Stop	15 sec	15 sec	15 sec	15 sec

Table 6. Bring-up Sequence and Stop Times

2.5.1 Spin Down Times

After power is removed the drive should be allowed 15 seconds to park the heads and spin down before any attempt is made to handle the drive.

It is recommended that after power is removed, a period of 2 seconds should be allowed before power is reapplied to the drive.

In the event of a power glitch the drive will normally execute a Power On Reset and then go through it's Power-Up sequence. Depending on the duration of the glitch the drive may spin down and then spin back up or may reset itself in which case the spindle motor is turned off. If the host system detects a power glitch it is recommended that a SCSI Bus Reset be performed. This allows the drive to be brought to a Ready condition in a controlled manner from a known state.

3.0 Performance

Drive performance characteristics listed in this chapter are typical values provided for information only, so that the performance for environments and workloads other than those shown as examples can be approximated. Actual minimum and maximum values will vary depending upon factors such as workload, logical and physical operating environments and manufacturing process variations.

3.1 Environment Definition

Drive performance criteria is based on the following operating environments. Deviations from these environments may cause deviations from values listed in this specification.

- Nominal physical environment (voltage, temperature, vibration, etc.) as defined elsewhere in this specification.
- Block lengths are formatted at 512 bytes per block.
- The number of data buffer segments is 16. The total data buffer length is 671KB. The size of each equally sized segment, in either bytes or blocks, is determined via the SCSI Mode Page 8h parameter called "Cache Segment Size".
- Ten byte SCSI Read and Write commands are used.
- SCSI environment consists of a single initiator and single target with no SCSI Bus contention.
- Buffer full/empty ratios are set to their optimum values such that a minimum number of intermediate disconnects occur during the SCSI data transfer and the overlap of the SCSI and disk data transfer is maximized. This minimizes Command Execution Times with no bus contention.
- Read Caching and Read Ahead functions are enabled and Write Caching is disabled, except where noted.
- The initiator delay while transferring SCSI command, status, message, and data bytes is assumed to be zero.
- Tagged Command Queuing is not used, unless otherwise specified.
- All Current Mode Parameters are set to their Default values except where noted.
- SCSI data transfers are successfully negotiated to be 40 MB/s.
- Averages are based on a sample size of 10,000 operations.

3.2 Workload Definition

The drive's performance criteria is based on the following command workloads. Deviations from these workloads may cause deviations from this specification.

- Operations are either all Reads or all Writes. The specifications for Command Execution Time with Read Ahead describe exceptions to this restriction. For that scenario all commands are preceded by a Read command, except for sequential write commands.
- The time between the end of an operation, and when the next operation is issued is 50 ms, +/- a random value of 0 to 50 ms, unless otherwise noted.

3.2.1 Sequential

- No Seeks. The target LBA for all operations is the previous LBA + Transfer Length.

3.2.2 Random

- All operations are to random LBAs. The average seek is an average weighted seek.

3.3 Command Execution Time

Command Execution, or Service, Times are the sum of several Basic Components. Those Components are -

1. Seek
2. Latency
3. Command Execution Overhead
4. Data Transfer to/from Disk
5. Data Transfer to/from SCSI Bus

The impact or contribution of those Basic Components to Command Execution Time is a function of the workload being sent to the drive and the environment in which the drive is being operated.

The following graphs show Command Execution Times for four generic workloads

- Sequential Reads
- Sequential Writes
- Random Reads
- Random Writes

with several different requested Transfer Lengths while running in various environments whose key factors are identified under each graph.

Note: Times are calculated with Typical Data Sector Transfer Rates for 18.2GB models and are averaged over the entire drive.

Note: In the following Graphs, "TCQing" means Tagged Command Queueing.

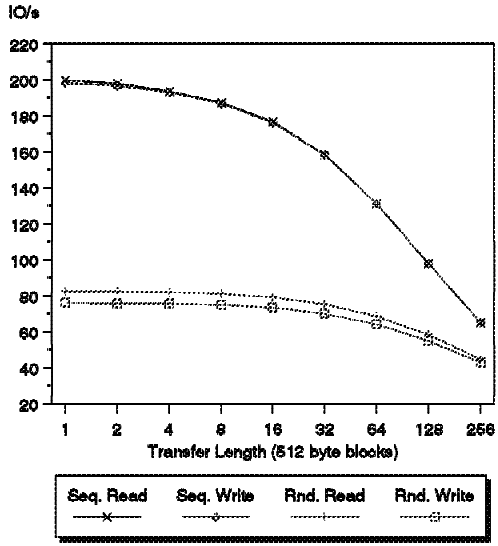

Figure 8. All caching disabled, Re-instruction Times = 0-100ms, no TCQing

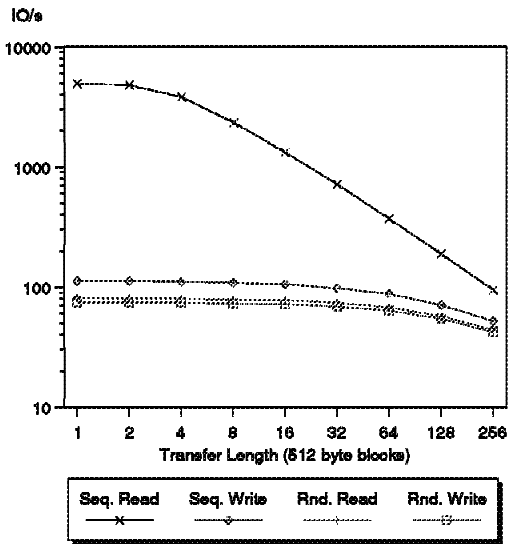

Figure 9. Re-instruction Times = 0ms, no TCQing

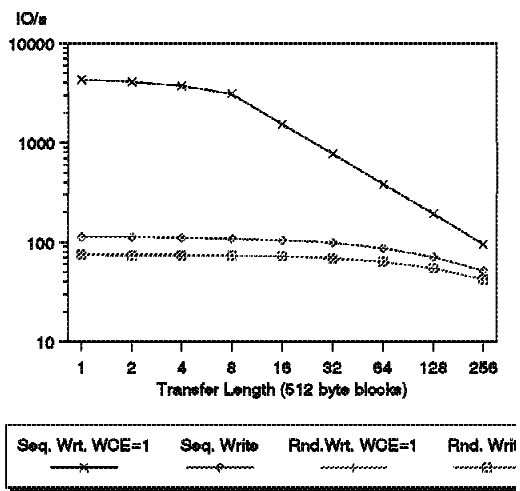

Figure 10. WCE vs no WCE, Re-instruction Times = 0ms, no TCQing

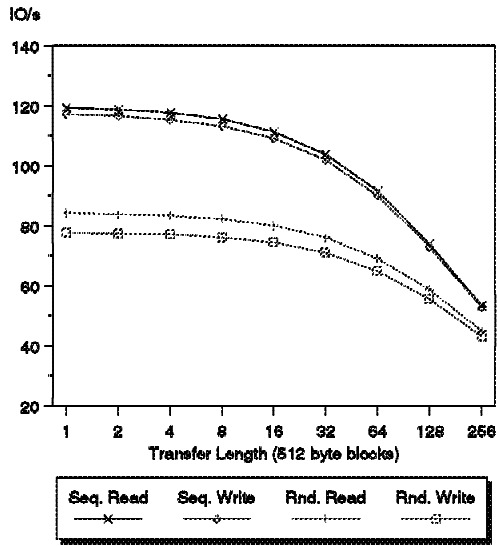

Figure 11. All caching disabled, With TCQing (Queue Depth = 4)

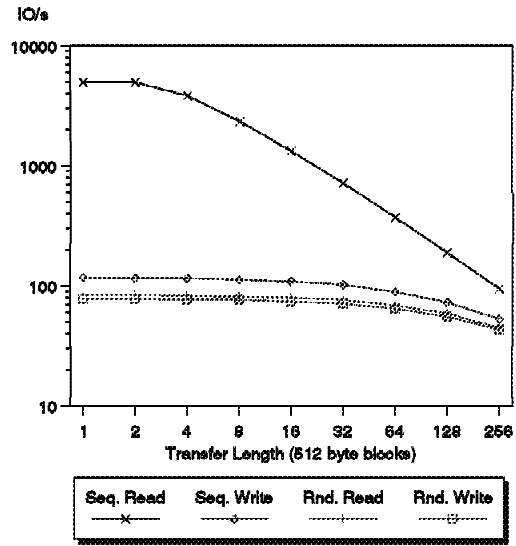

Figure 12. With TCQing (Queue Depth = 4)

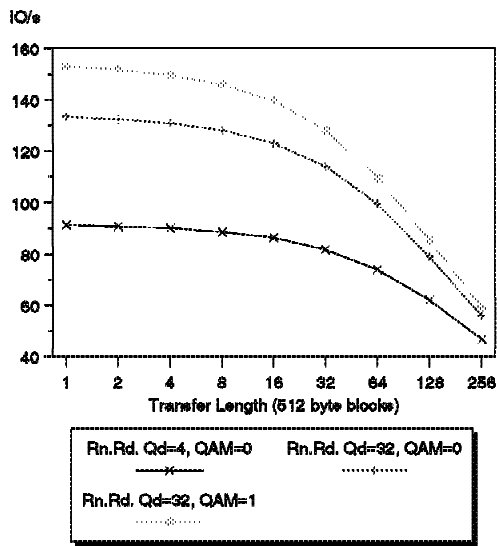

Figure 13. Restricted vs Unrestricted Command Reordering, w/TCQing (Various Queue Depths)

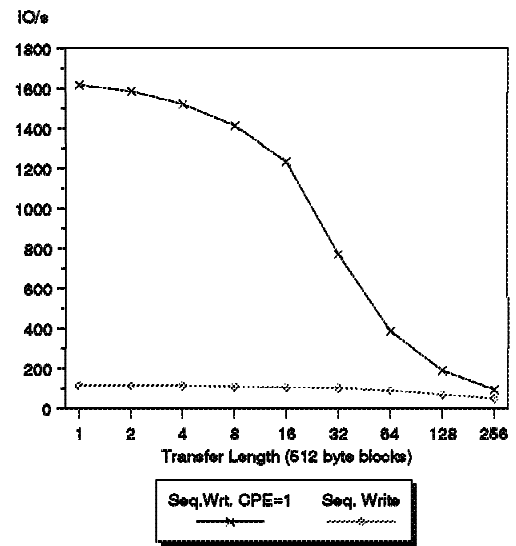

Figure 14. Concurrent Command Processing enabled, w/TCQing (Queue Depth = 32)

3.3.1 Basic Component Descriptions

Seek

The average time from the initiation of the seek, to the acknowledgement that the R/W head is on the track that contains the first requested LBA. Values are population averages, and vary as a function of operating conditions. The values used in the graphs showing Command Execution Times for sequential commands is 0 ms and the values for random commands are shown in section 2.1, "General" on page 12.

Latency

The average time required from the activation of the read/write hardware until the target sector has rotated to the head and the read/write begins. This time is 1/2 of a revolution of the disk, or 4.17 ms.

Command Execution Overhead

The average time added to the Command Execution Time due to the processing of the SCSI command. It includes all time the drive spends processing a command while not doing a disk operation or SCSI data transfer, whether or not it is connected to the bus. (See 3.6, "Read Command Performance" on page 36 and 3.7, "Write Command Performance" on page 37 for examples of detailed descriptions of the components of Command Execution Overhead.) The value of this parameter varies greatly depending upon workloads and environments.

The following values are used when calculating the Command Execution Times. 'RA' means Read Ahead is enabled.

Workload	Command Execution	SCSI Bus
Sequential Read (wo/RA - w/RA)	.72 / .20	.03
Sequential Write (WCE=0/WCE=1)	.82/.23	.04
Random Read (wo/RA - w/RA)	.22 / .32	.03
Random Write	.35	.04

Table 7. Overhead Values. (All times are in milliseconds.)

Other Initiator controlled factors such as use of disconnects, Tagged Command Queuing and the setting of Mode Parameters like DIMM, DPSDP and ASDPE also affect Command Execution Overhead. They also affect SCSI Bus Overhead which is partially a subset of Command Execution Overhead.

SCSI Bus Overhead is defined as the time the device is connected to the bus transferring all SCSI Command, Status and Message phase information bytes. This includes any processing delays between SCSI Bus phases while remaining connected to the SCSI Bus. Initiator delays while transferring information bytes are assumed to be zero. This time does not include the SCSI Data phase transfer. (See 3.6, "Read Command Performance" on page 36 and 3.7, "Write Command Performance" on page 37 for more detailed descriptions of the components of SCSI Bus Overhead.)

Post Command Processing time of 0.1 ms is defined as the average time required for process cleanup after the command has completed. If a re-instruct period faster than this time is used, the difference is added to the Command Execution Overhead of the next operation.

Data Transfer to/from Disk

The average time used to transfer the data between the media and the drive's internal data buffer. This is calculated from:

(Data Transferred)/(Media Transfer Rate).

There are four interpretations of Media Transfer Rate. How it is to be used helps decide which interpretation is appropriate to use.

1. Instantaneous Data Transfer Rate

The same for a given notch formatted at any of the supported logical block lengths. It varies by notch only and does not include any overhead. It is calculated from:

$1/(\text{individual byte time})$

2. Track Data Sector Transfer Rate

Varies depending upon the formatted logical block length and varies from notch to notch. It includes the overhead associated with each individual sector. This is calculated from:

$(\text{user bytes/sector})/(\text{individual sector time})$

(Contact an IBM Customer Representative for individual sector times of the various formatted block lengths.)

Note: These rates are used to help estimate optimum SCSI Buffer Full/Empty Ratios.

3. Theoretical Data Sector Transfer Rate

Also includes time required for track and cylinder skew and overhead associated with each track. Use the following to calculate it.

Data Sector Transfer Rate =

$$\frac{\text{Bytes/cylinder}}{\text{time for 1 cyl} + \text{track skews} + \text{1 cyl skew}}$$

4. Typical Data Sector Transfer Rates

Also includes the effects of defective sectors and skipped revolutions due to error recovery. (See Appendix B. of the *ULTRASTAR 18XP/9LP SCSI Logical Interface Specification* for a description of error recovery procedures.)

Rates for drives formatted at 512 bytes/block are located in Table 8 on page 32.

ULTRASTAR 18XP/9LP Hardware/Functional Specification

Model Type	All		18.2GB		9.1GB	
Notch #	Instantaneous	Track	Theoretical	Typical	Theoretical	Typical
Average	18.27	14.08	12.72	12.66	12.63	12.57
1	22.4	17.21	15.55	15.47	15.44	15.36
2	21.15	16.59	14.99	14.92	14.89	14.82
3	20.41	15.67	14.14	14.07	14.04	13.97
4	19.78	15.18	13.7	13.64	13.61	13.54
5	19.16	14.75	13.33	13.27	13.23	13.17
6	18.53	14.13	12.78	12.71	12.69	12.63
7	17.9	13.83	12.47	12.41	12.39	12.33
8	17.38	13.27	11.98	11.92	11.89	11.84
9	16.8	12.9	11.67	11.61	11.58	11.53
10	16.02	12.17	10.99	10.94	10.91	10.86
11	15.23	11.55	10.43	10.38	10.36	10.31
12	14.13	11.06	10	9.95	9.93	9.89
13	13.4	10.14	9.14	9.1	9.08	9.04
14	12.77	9.65	8.71	8.67	8.65	8.61
15	12.14	9.22	8.34	8.3	8.28	8.24
16	11.52	8.6	7.78	7.75	7.73	7.69
Note: The values for Typical Data Sector Transfer Rates assume a typically worst case value of 3 errors in 10 ⁹ bits read at nominal conditions for soft error rate.						
Note: Contact an IBM Customer Representative for values when formatted at other block lengths.						
Note: Each group of cylinders with a different number of gross sectors per track is called a notch. "Average" values used in this specification are sums of the individual notch values weighted by the number of LBAs in the associated notches.						

Table 8. Data Sector Transfer Rates. (All rates are in MB/s)

Data Transfer to/from SCSI Bus

The time required to transfer data between the SCSI bus and the drive's internal data buffer, that is not overlapped with the time for the Seek, Latency or Data Transfer to/from Disk. This time is based on a SCSI synchronous data transfer rate of 40.0 MB/s.

The SCSI data transfer rate is dependent on the mode, either synchronous or asynchronous. It also depends upon the width of the data path used. 8 and 16 bit transfers are supported.

When the drive is configured for an 8 bit wide transfer a synchronous data transfer rate of 20 MB/s can be realized. The 16 bit wide maximum synchronous data transfer rate is 40 MB/s.

The asynchronous data transfer rate is dependent on both the initiator and target delays to the assertion and negation of the SCSI REQ and ACK signals. It is also dependent on SCSI cable delays. The drive is capable of supporting up to 5 MegaTransfer/second (MT/s) asynchronous data transfer rates.

The SCSI data transfer rate specification only applies to the Data phase for logical block data for Read, Write, Write and Verify, etc... commands. The data rate for parameter/sense data for Request Sense, Mode Select, etc. commands is not specified.

3.3.2 Comments

Overlap has been removed from the Command Execution Time calculations. The components of the Command Execution Times are truly additive times to the entire operation. For example,

- The SCSI Bus Overhead data is not included in the calculation since some of its components are also components of Command Execution Overhead and the remaining components overlap the Data Transfer to/from Disk. (See 3.6, “Read Command Performance” on page 36 and 3.7, “Write Command Performance” on page 37 for details.)
- The Post Command Processing times are not components of the Command Execution time therefore they are not included in the calculation of environments where the re-instruct period exceeds the Post Command Processing time.

With Read Ahead enabled, this specification measures a Read or Write command when the immediately preceding command is a Read command (which starts up the Read Ahead function). If the preceding command is a Write command, then the time difference due to Read Ahead is zero.

Longer inter-op delay, or low re-instruction rate, environments are such that the Read Ahead function has filled the drive's internal data cache segment before the next Read or Write command is received.

Environments with inter-op delays less than 1 revolution period, or high re-instruction rates, are such that the Read Ahead function is still in the process of filling the drive's internal data cache segment when the next Read or Write command is received. For sequential reads, Command Execution Time is 1 revolution less than similar operations with equal inter-op delays and Read Ahead disabled.

The effects of idle time functions are not included in the above examples. The sections 3.2.1, “Sequential” on page 27 and 3.2.2, “Random” on page 27 both define environments where the effects due to increased command overhead of Idle Time Functions upon Command Execution time are less than 0.07%.

3.4 Disconnection During Read/Write Data Phase

If a nonzero Maximum Burst Size parameter is specified, the drive disconnects after transferring the number of blocks specified by the Maximum Burst Size parameter. This disconnection requires approximately 6 μ s and the subsequent reconnection requires approximately 15 μ s.

The drive also disconnects prior to completion of the Data phase if the drive's internal data buffer cache segment becomes empty during a Read command or full during a Write command. This disconnection occurs regardless of the Maximum Burst Size parameter. This disconnection requires approximately 6 μ s and the subsequent reconnection requires approximately 15 μ s.

3.5 Approximating Performance for Different Environments

The values for several Basic Components may change based on the type of environment and workload. For example, Command Overhead may change because certain internal control functions may no longer be overlapped with either the SCSI or disk data transfers, etc. The following paragraphs describe which parameters are affected by which features.

3.5.1 When Read Caching is Enabled

For read commands with Read Caching Enabled Command Execution time can be approximated by deleting Seek, Latency and Data Transfer to/from Disk times from those shown on the graphs if all of the requested data is available in a cache segment (cache hit). When some, but not all, of the requested data is available in a cache segment (partial cache hit) Data Transfer to/from Disk will be reduced but not eliminated. Seek and Latency may or may not be reduced depending upon the location of requested data not in the cache and location of the read/write heads at the time the command was received. The contribution of the Data Transfer to/from SCSI Bus to the Command Execution time may increase since a larger, or entire, portion of the transfer may no longer be overlapped with the components that were reduced.

3.5.2 When Read Ahead is Enabled

The reduction in sequential (contiguous and non-contiguous) read workload with long inter-op delays Command execution times can be approximated by using the following equation:

$$-(\text{Latency} + (\text{Xfer Size})/(\text{Disk Data Rate}) - (\text{Xfer Size})/(\text{SCSI Data Rate})) = \text{Read Ahead savings}$$

The magnitude of the performance advantage of the Read Ahead with op delays of 0 to 1 rev varies with the size of the delay. Since the range of delays is less than the time for one revolution, the operation is "synchronized to the disk". The Read Ahead savings can be roughly approximated by:

$$\text{DELAY} - (\text{time for one revolution}) = \text{Read Ahead savings}$$

Note: This time also varies with the size of the data transfer due to the difference between the SCSI data transfer rate and Disk data transfer rate. This time is insignificant for a 0.5KByte transfer size and has been ignored in the above equation.

3.5.3 When Write Caching is Enabled

For write commands with the Write Caching Enabled (WCE) Mode parameter bit set, Command Execution time can be approximated by deleting Seek, Latency and Data Transfer to/from Disk times from those shown in the graphs. The contribution of the Data Transfer to/from SCSI Bus to the Command Execution time may increase since a larger, or entire, portion of the transfer may no longer be overlapped with the components that were reduced.

The reduced times effectively are added to the Post Command Processing Time.

Like Tagged Command Queuing, the potential to reduce Command Execution Overhead exists due to concurrent command processing.

Like Tagged Command Queuing, when the WCE bit is set Back-To-Back write commands are supported. See 3.5.5.2, "Back-To-Back Write Commands" on page 35 for more information.

3.5.4 When Adaptive Caching is Enabled

The Adaptive Caching feature attempts to increase Read Cache hit ratios by monitoring workload and adjusting cache control parameters, normally determined by the using system via the SCSI Mode Parameters, with algorithms using the collected workload information.

3.5.5 For Queued Commands

The effects of Command Execution Overhead can be reduced significantly if Tagged Command Queuing is enabled since more than 1 command can be operated on concurrently. For instance, while a disk operation is being performed for one command another command can be received via the SCSI bus and placed in the device command queue. Certain environments may cause Command Execution Overhead to increase if the added function to process the queue and the messages associated with queuing is not permitted to overlap with a disk operation.

3.5.5.1 Reordered Commands

If the Queue Algorithm Modifier Mode Parameter field is set to allow it, commands in the device command queue may be executed in a different order than they were received. Commands are reordered so that the Seek portion of Command Execution time is minimized. The amount of reduction is a function of the location of the 1st requested block per command and the rate at which the commands are sent to the drive.

3.5.5.2 Back-To-Back Write Commands

If all of the requirements are met as stated in the *ULTRASTAR 18XP/9LP SCSI Logical Interface Specification* section describing Back-To-Back write commands, contiguous data from 2 or more consecutive write commands can be written to the disk without requiring any disk Latency.

Note: There is a minimum write command transfer length for a given environment where continuous writing to the disk can not be maintained without missing a motor revolution. When Write Caching is enabled the likelihood is increased that shorter transfer write commands can fulfill the requirements needed to maintain continuous writing to the disk.

3.6 Read Command Performance

Note: This case is for Random SCSI Read commands, with Read Ahead disabled.

SCSI bus usage time (Read command)



Command Execution Time (Read command)



Note: Timings shown are not to scale

Figure 15. SCSI Read command performance measurements

3.6.1.1 SCSI Bus Overhead

Note: All times listed in this section are provided for information only so that the performance for other environments/workloads can be approximated. These component times should not be measured against the specification.

S1	Selection, Identify Msg., Command Descriptor Block (CDB)	15 μ s
S2a	Save Data Pointers (SDP) Msg.	1 μ s
S2b	Disconnect Msg., Bus Free	1 μ s
S3	Arbitrate, Reselect, Identify Msg.	6 μ s
S4	Start SCSI transfer in	4 μ s
S5	SCSI bus data transfer in	(Transfer size)/(SCSI Data Transfer Rate)
S6	SCSI read ending processing	2 μ s
S7	Status, Command Complete Msg., Bus Free	3 μ s

Note: The SCSI bus overhead for a Read Command is composed of S1,S2(a&b),S3,S4,S6,and S7. (0.03 ms total).

3.6.1.2 Command Execution Overhead

P1	Selection, Identify Msg., CDB	15 μ s
P2a	SDP Msg.	1 μ s
P2b	Disconnect Msg., Bus Free	1 μ s
P3	Start seek or head switch	258 μ s
P4	Seek or head switch (for example, average seek)	(Read Seek = 6.5 or 7.5 ms)
P5	Set up read disk transfer	0 μ s
P6	Latency (for example, half revolution)	4.17 ms
P7	Disk data transfer	(Data transferred)/(Typical Data Sector Transfer Rate)

P8 End read disk transfer	(Sector size)/(SCSI Data Transfer Rate)
P9 Transfer last few SCSI blocks in	(5)(Sector size)/(SCSI Data Transfer Rate)
P10 SCSI read ending processing	2 μs
P11 Status, Command Complete Msg., Bus Free	3 μs

Note: The Command execution overhead for a read command is composed of P1,P2(a&b),P3,P5,P10,and P11. (0.28 ms total).

$$\text{Time to Read data} = P1 + P2 + P3 + P4 + P5 + P6 + P7 + P8 + P9 + P10 + P11$$

3.7 Write Command Performance

Note: This case is for Random SCSI Write commands, with Read Ahead disabled.

SCSI bus usage time (Write command)

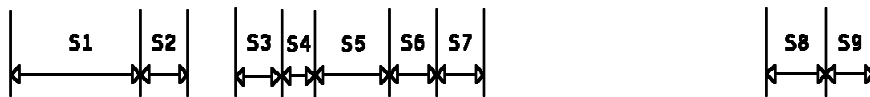

Command Execution Time (Write command)

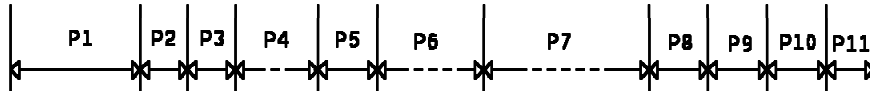

Note: Timings shown are not to scale

Figure 16. SCSI Write command performance measurements

3.7.1.1 SCSI Bus Overhead

Note: All times listed in this section are provided for information only so that the performance for other environments can be approximated. These component times should not be measured against the specification.

S1 Selection, Identify Msg., CDB	15 μs
S2a SDP Msg.	1 μs
S2b Disconnect Msg., Bus Free	1 μs
S3 Arbitrate, Reselect, Identify Msg.	6 μs
S4 start SCSI transfer out	4 μs
S5 SCSI bus data transfer out	(Transfer size)/(SCSI Data Transfer Rate)
S6 End SCSI transfer out	4 μs
S7A SDP Msg.	1 μs
S7B Disconnect Msg., Bus Free	1 μs

S8 Arbitrate, Reselect, Identify Msg.	6 μ s
S9 Status, Command Complete Msg., Bus Free	3 μ s

Note: The SCSI bus overhead for a write command is composed of S1,S2(a&b),S3,S4,S6,S7,S8 and S9. (0.04 ms total).

3.7.1.2 Command Execution Overhead

P1 Selection, Identify Msg., CDB	15 μ s
P2a SDP Msg.	1 μ s
P2b Disconnect Msg., Bus Free	1 μ s
P3 Start seek	258 μ s
P4 Seek (for example, average seek)	(Write Seek = 7.5 or 8.5 ms)
P5 Set up write disk transfer	0 μ s
P6 Latency (for example, half revolution)	(Latency = 4.17 ms)
P7 Disk data transfer	(Data transferred)/(Typical Data Sector Transfer Rate)
P8 End write disk transfer	75 μ s
P9 SCSI write ending processing	25 μ s
P10 Arbitrate, Reselect, Identify Msg.	6 μ s
P11 Status, Command Complete Msg., Bus Free	3 μ s

Note: The Command execution overhead for a write command is composed of P1, P2(a&b), P3, P5, P8, P9, P10 and P11. (0.38 ms total).

Time to Write data = P1+P2+P3+P4+P5+P6+P7+P8+P9+P10+P11

3.8 Skew

3.8.1 Cylinder to Cylinder Skew

Cylinder skew is the sum of the sectors required for physically moving the heads, which is a function of the formatted block length and recording density (notch #). Cylinder skew is always a fixed minimum amount of time and therefore the number of sectors varies depending on which notch is being accessed and the block length. The minimum amount of time required for a cylinder switch is 2.13 ms.

3.8.2 Track to Track Skew

Track skew is the time required to perform a switch between heads on the same cylinder. That time is .83 ms.

3.9 Idle Time Function Considerations

The execution of various functions by the drive during idle times may result in delays of commands requested by SCSI initiators. 'Idle time' is defined as time spent by the drive not executing a command requested by a SCSI initiator. The functions performed during idle time are:

1. Predictive Failure Analysis (PFA)
2. Save Logs and Pointers
3. Disk Sweep

The command execution time for SCSI commands received while performing idle time activities may be increased by the amount of time it takes to complete the idle time activity. Arbitration, Selection, Message and Command phases, and disconnects controlled by the drive are not affected by idle time activities.

Note: Command Timeout Limits do not change due to idle time functions.

Following, are descriptions of the various types of idle functions, how often they execute and their duration. Duration is defined to be the maximum amount of time the activity can add to a command when no errors occur. No more than one idle function will be interleaved with each SCSI command. Following the descriptions is a summary of the possible impacts to performance.

There are mechanisms to lessen performance impacts, and in some cases virtually eliminate those impacts from an Initiator's point of view.

1. Normal recommended operation

Idle Time Functions are only started if the drive has not received a SCSI command for at least 5 seconds. This means that multiple SCSI commands are accepted and executed without delay if the commands are received by the drive within 5 seconds after the completion of a previous SCSI command. This mechanism has the benefit of not requiring special system software (such as issuing SCSI Rezero Unit commands at known & fixed time intervals) in order to control if and when this function executes.

2. Synchronized operation

Applications which cannot accommodate interruptions at all may consider synchronizing idle activities to the system needs through use of the TCC bit in Mode Page 0h and the Rezero Unit command.

Note: An example of this limiting mechanism's use would be if a system is known to issue SCSI commands for an application greater than 5 seconds apart and an Idle Time Function delay could not be tolerated by the system on any of those commands. This would eliminate drive initiated Idle Time Function from even starting while the system/application is in a critical response time period of operation.

3. No PFA operation

Idle Time initiated PFA can be disabled by setting the "Perf" bit in Mode Page 1Ch. See the *ULTRASTAR 18XP/9LP SCSI Logical Interface Specification* for details.

3.9.1 Predictive Failure Analysis (PFA)

- . *PFA* monitors drive parameters and can predict if a drive failure is imminent. There are "symptom driven" PFA processes which occur during Error Recovery Procedures. The impacts of those upon perceived performance are not included here since they are included in the normal error recovery times, which are taken into account by the "Typical Data Sector Transfer Rate".

- . There are also "measurement driven" PFA processes which occur during Idle Time. Seven different PFA measurements are taken for each head. The measurements for all heads are taken over a period of 4 hours, therefore the frequency of PFA is dependent on the number of heads a particular model has. The drive attempts to spread the measurements out evenly in time and each measurement takes about 80 milliseconds.

For example, a model with 20 heads will perform one PFA measurement every 1.7 minutes ($240 / (7 * 20)$). Models with 10 heads perform a measurement every 3.4 minutes.

For the last head tested for a particular measurement type (once every 34 minutes), the data is analyzed and stored. The extra execution time for those occurrences is approximately 40 milliseconds.

This measurement/analysis feature can be disabled for critical response time periods of operation by setting the Page 1Ch Mode Parameter PERF = 1. The using system also has the option of forcing execution at known times by issuing the SCSI Rezero Unit command if the Page 0h Mode Parameter TCC = 1. All tests for all heads occur at those times. See the *ULTRASTAR 18XP/9LP SCSI Logical Interface Specification* for more details about PFA, PERF and TCC.

3.9.2 Save Logs and Pointers

The drive periodically saves data in logs in the reserved area of the disks. The information is used by the drive to support various SCSI commands and for the purpose of failure analysis.

Logs are attempted to be saved every 26-35 minutes during idle time. The amount of time it takes to update the logs varies depending on the number of errors since the last update. In most cases, updating those logs and the pointers to those logs will occur in less than 30 ms.

3.9.3 Disk Sweep

The heads are moved to another area of the disk if the drive has not received a SCSI command for at least 40 seconds. After flying in the same spot for 9 minutes without having received another SCSI command, the heads are moved to another position. If no other SCSI command is received, the heads are moved every 9 minutes thereafter. As soon as a SCSI command is received, the period for the 1st occurrence is reduced back down to 40 seconds. The period is increased back to 9 minutes for subsequent occurrences should no more SCSI commands be received during that time. Execution time is less than 1 full stroke seek.

3.9.4 Summary

Idle Time Function Type	Period of Occurance (minutes)	Duration (ms)	Mechanism to Delay	Mechanism to Disable
PFA	34/(trk/cyl)	80	Re-instruction Period, TCC	PERF
Save Logs & Pointers	26	30	Re-instruction Period, TCC	
Disk Sweep	2/3 - since last command	17	Re-instruction Period	
	9 - since last occurrence			
Note: "Re-instruction Period" is the time between consecutive SCSI command requests.				

Table 9. Summary of Idle Time Function Performance Impacts

3.10 Command Timeout Limits

The 'Command Timeout Limit' is defined as the time period from the SCSI Arbitration phase through the SCSI Command Complete message, associated with a particular command.

The following times are for environments where Automatic Reallocation is disabled and there are no queued commands.

3.10.1.1 Reassignment Time

The drive should be allowed a minimum of 45 s to complete a "Reassign Blocks" command.

3.10.1.2 Format Time

- . 18.2GB models should be allowed 110 minutes to complete a "Format Unit" command. If the Vendor Unique Mode Page 00h bit named "FFMT" is set equal to '1'b, then they should be allowed 60 seconds to complete.
- . 9.1GB models should be allowed 55 minutes to complete a "Format Unit" command. If the Vendor Unique Mode Page 00h bit named "FFMT" is set equal to '1'b, then they should be allowed 30 seconds to complete.

3.10.1.3 Start/Stop Unit Time

The drive should be allowed a minimum of 45 s to complete a "Start/Stop Unit" command (with Immed bit = 0).

Initiators should also use this time to allow start-up sequences initiated by auto start ups and "Start/Stop Unit" commands (with Immed bit = 1) to complete and place the drive in a "ready for use" state.

Note: A timeout of one minute or more is recommended but NOT required. The larger system timeout limit allows the system to take advantage of the extensive ERP/DRP that the drive may attempt in order to successfully complete the start-up sequence.

3.10.1.4 Medium Access Command Time

The timeout limit for medium access commands that transfer user data and/or non-user data should be a minimum of 30 s. These commands are:

- | | | |
|--------------------|-------------------|--------------------|
| • Log Sense | • Read Long | • Write (6) |
| • Mode Select (6) | • Release | • Write (10) |
| • Mode Sense (6) | • Reserve | • Write and Verify |
| • Pre-Fetch | • Rezero Unit | • Write Buffer |
| • Read (6) | • Seek (6) | • Write Long |
| • Read (10) | • Seek (10) | • Write Same |
| • Read Capacity | • Send Diagnostic | • Verify |
| • Read Defect Data | | |

Note: The 30 s limit assumes the absence of bus contention and user data transfers of 64 blocks or less. This time should be adjusted for anticipated bus contention and if longer data transfers are requested.

When Automatic Reallocation is enabled add 45 s to the timeout of the following commands; Read (6), Read (10), Write (6), Write (10), Write and Verify, and Write Same.

3.10.1.5 Timeout limits for other commands

The drive should be allowed a minimum of 5 s to complete these commands:

- | | |
|-----------------|----------------------------------------|
| • Inquiry | • Start/Stop Unit (with Immed bit = 1) |
| • Request Sense | • Synchronize Cache |
| • Read Buffer | • Test Unit Ready |

The command timeout for a command that is not located at the head of the command queue should be increased by the sum of command timeouts for all of the commands that are performed before it is.

4.0 Mechanical

4.1 Weight and Dimensions

	U.S. 1.0" Models	S.I. Metric 1.0" Models	U.S. 1.6" Models	S.I. Metric 1.6" Models
Weight	1.26 pounds	0.57 Kilograms	2.04 pounds	0.93 Kilograms
Height	1.00 inches	25.4 millimeters	1.63 inches	42.0 millimeters
Width	4.00 inches	101.85 millimeters	4.00 inches	101.85 millimeters
Depth	5.75 inches	147.0 millimeters	5.75 inches	147.0 millimeters

Table 10. Weights and Dimensions (Nominal)

4.2 Clearances

A minimum of 2 mm clearance should be given to the bottom surface except for a 10 mm maximum diameter area around the bottom mounting holes. A minimum of 1 mm clearance should be given to the cover flanges around the top edge of the file.

There should be 7 mm of clearance between *ULTRASTAR 18XP/9LP* drives that are mounted with their top sides facing each other. Drives from other manufactures may require additional spacing due to stray magnetic fields.

Note: For proper cooling it is suggested that a minimum clearance of 7 mm be provided under the drive and on top of the drive. For further information see 7.1.1, "Temperature Measurement Points" on page 69.

4.3 Mounting Guidelines

The drive can be mounted with any surface facing down.

The drive is available with both side and bottom mounting holes. Refer to Figure 17 on page 43, Figure 18 on page 44, Figure 19 on page 45, and Figure 20 on page 46 for the location of these mounting holes for each configuration.

The maximum allowable penetration of the mounting screws is 3.8 mm. Screws longer than 3.8 mm may cause permanent damage to the drive.

The recommended torque to be applied to the mounting screws is 0.8 Newton-meters +/- 0.2 Newton-meters. IBM will provide technical support to users that wish to investigate higher mounting torques in their application.

For more information on mounting guidelines see section 7.5, "Drive Mounting Guidelines" on page 75.

4.3.1 SCA Mounting Guidelines

Since the SCA mounting system lacks the compliant cabling of alternate connectors (50/68), the system designer must now consider the following mounting situations and design the system appropriately for long term reliability. This list of guidelines is not intended to be exhaustive.

1. The SCA-2 connector should not be required to support the weight of the drive.
2. Operational vibration occurring between the mating halves of the SCA connector should be avoided.
3. The drive should be firmly secured once the connector mate has occurred.
4. The connector was designed to allow for 'mismatch' or offset during the plugging operation. Excessive offsets between the drive connector and the backplane will induce stress on the connector system and card.

WARNING: The drive may be sensitive to user mounting implementation due to frame distortion effects. IBM will provide technical support to assist users to overcome mounting sensitivity.

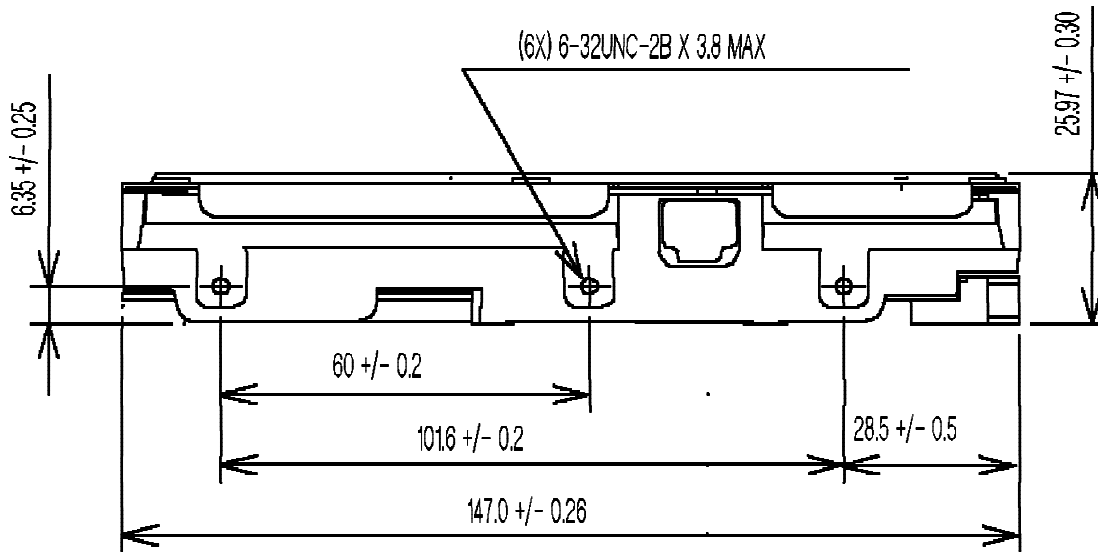

SIDE VIEW

Note: Dimensions are in millimeters.

Note: Clearance = 7 mm

Figure 17. Location of Side Mounting Holes of 1.0 inch Models

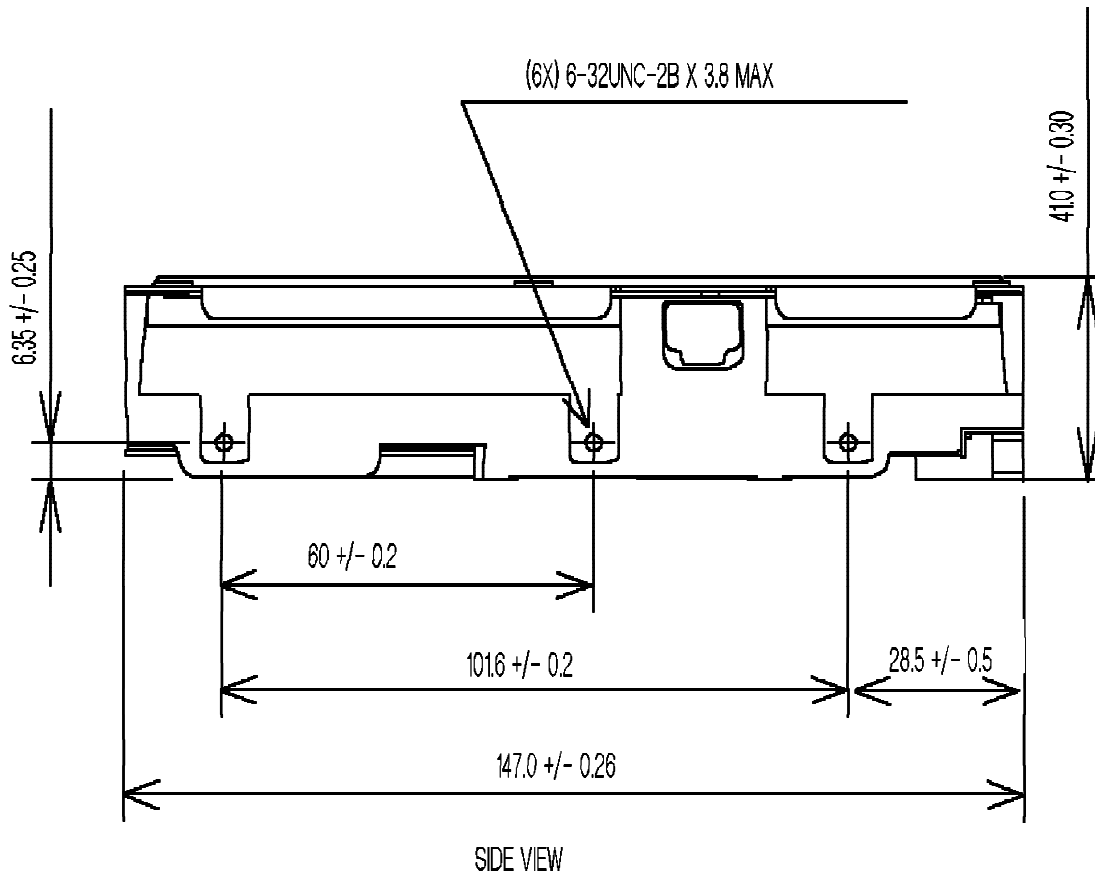

Note: Dimensions are in millimeters.

Note: Clearance = 7 mm

Figure 18. Location of Side Mounting Holes of 1.6 inch Models

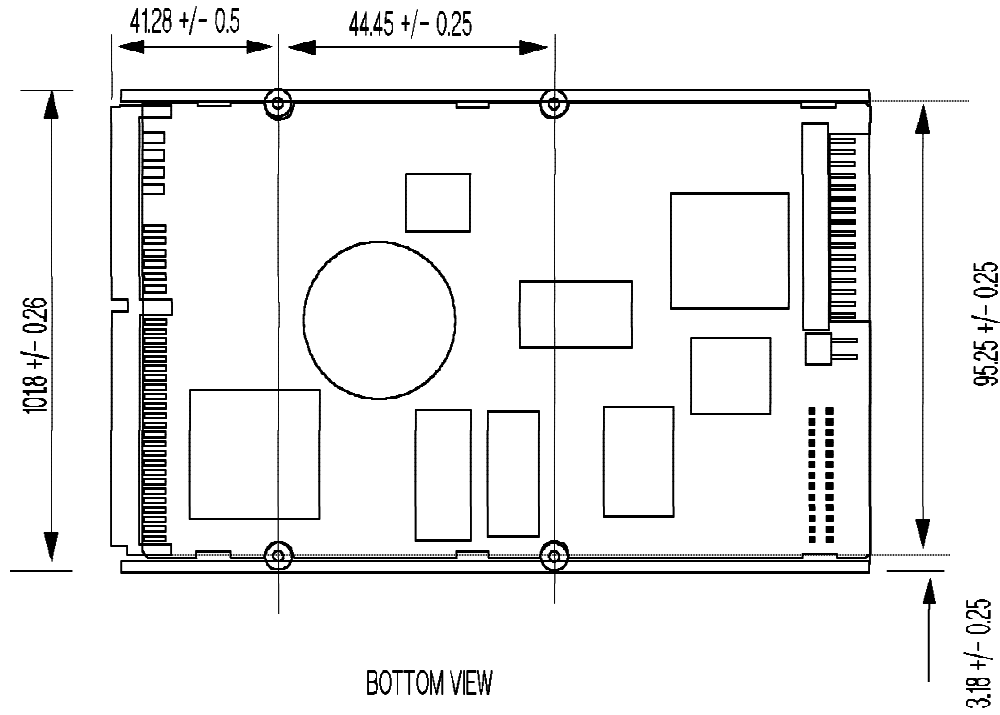

Note: Dimensions are in millimeters.

Figure 19. Location of Bottom Mounting Holes for 50 and 68 Pin Models. (68 pin card shown.)

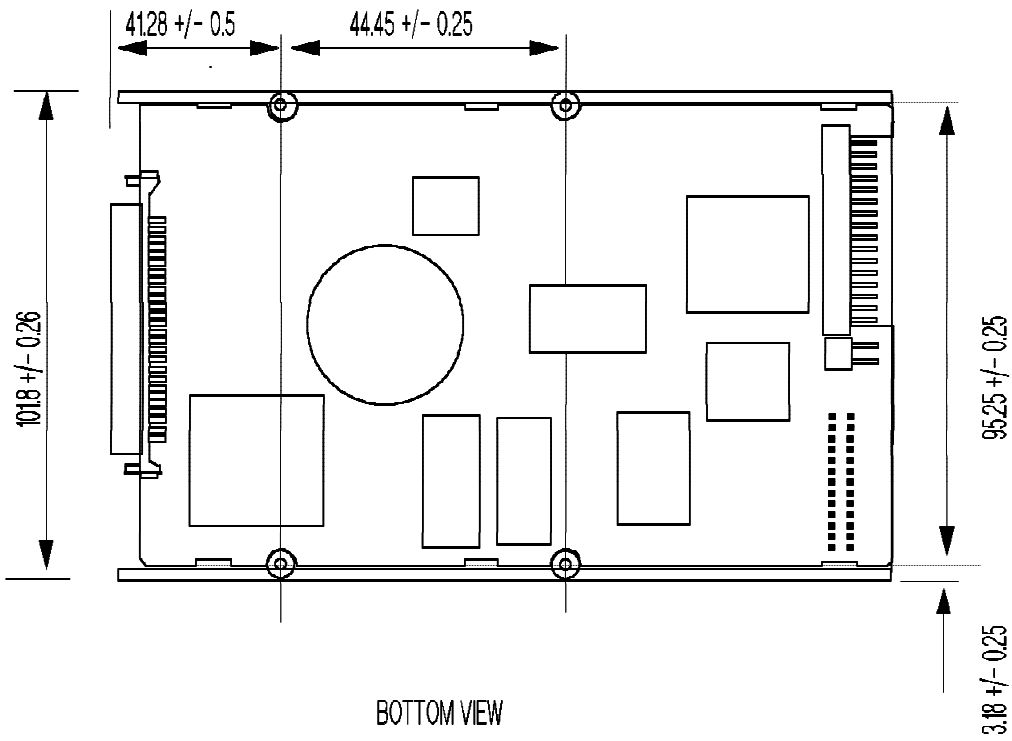
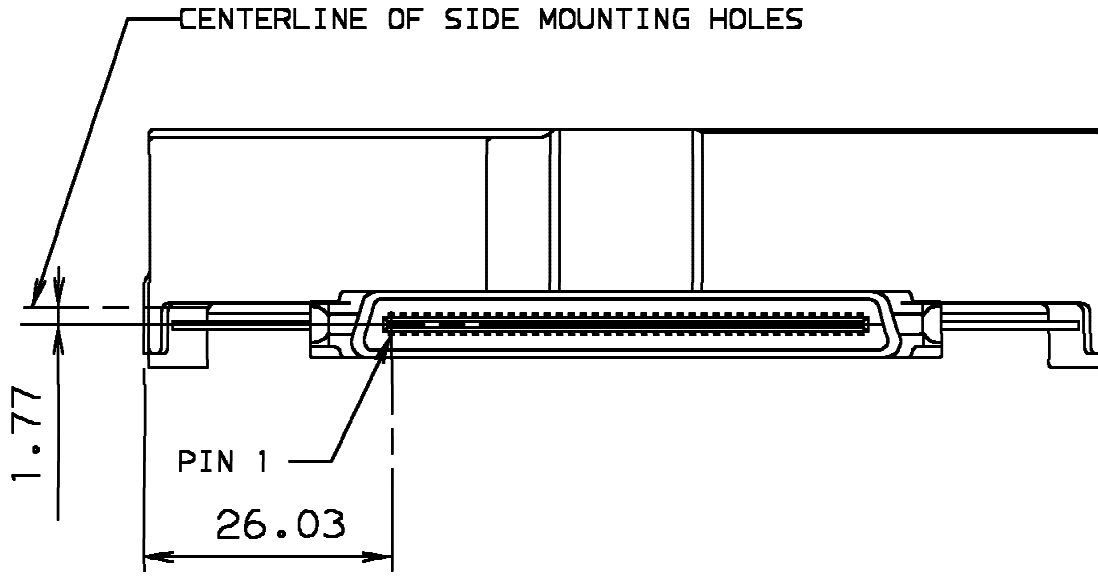

Figure 20. Location of Bottom Mounting Holes for 80 pin SCA-2 models.

4.4 Electrical Connector Locations

The electrical connectors are located as shown in Figure 21 on page 47, Figure 22 on page 48, Figure 23 on page 48, and Figure 24 on page 49.



80 PIN MODELS

Dimensions are for reference only.

Figure 21. Electrical connectors (rear view) -- 80 pin SCA-2 models.

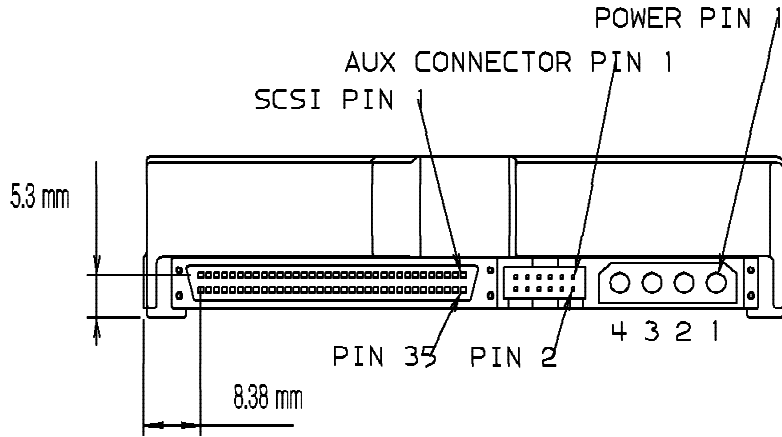

Dimensions are for reference only.

Figure 22. Electrical connectors (rear view) -- 68 pin models.

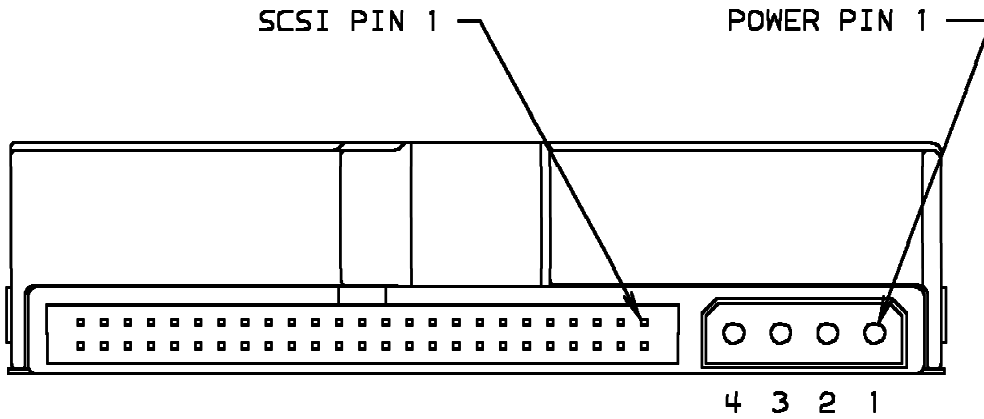
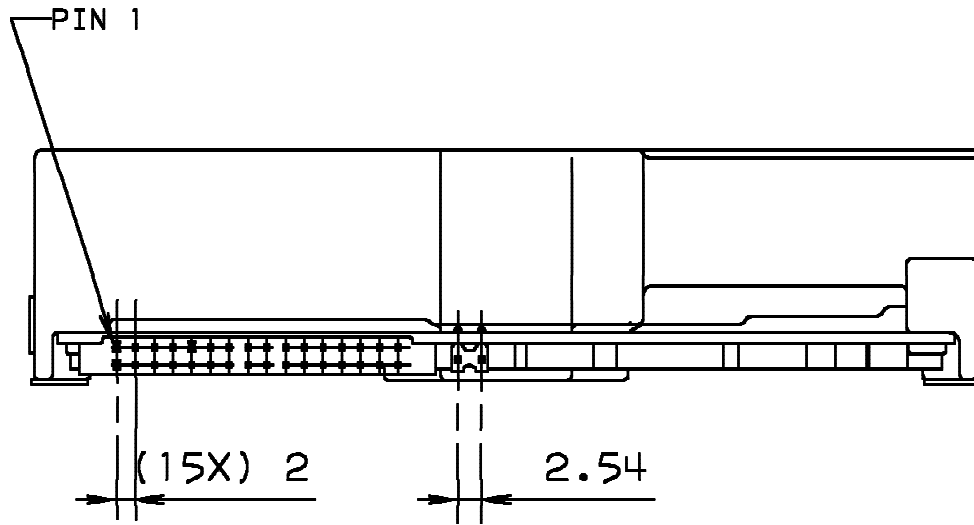

Figure 23. Electrical connectors (rear view) -- 50 pin models.



Note: Dimensions are in millimeters.

Note: Dimensions are for reference only.

Figure 24. Jumper pin locations (front view)

5.0 Electrical Interface

5.1 Power Connector

The DC power connectors used on all models (50, 68 and 80 pin SCA-2) are an integral portion of the 50/68 pin SCSI 'Unitized' Connectors and the 80 pin 'Single Connector Attachment' (SCA-2) Connector.

50 pin models use an AMP connector (PN 84412-1) that is compatible with the ANSI SCSI "A" connector specifications.

68 pin models use a Molex connector (PN 87360-0001) that is compatible with the ANSI SCSI "P" connector specifications.

The 80 pin SCA-2 models use an AMP connector (PN 5-917593-9) that is compatible with the Specification of: 'Single Connector Attachment for Small SCSI Disk Drives' SFF-8046 draft document, revision 2.3, dated Dec 2, 1995. Placement of the connector is in compliance with the SFF-8337, revision 1.2, dated July 27, 1995.

The connector pins have a plating of 30 micro-inches of gold.

Power pin assignments for the 50 and 68 pin models are shown in Table 11.

Pin #	Voltage Level
1	+12V
2	Ground
3	Ground
4	+5V

Table 11. Power connector pin assignments

Refer to the section entitled 2.4, "Power Requirements" on page 15 and 2.4.8, "Additional 5V Current Requirements for Differential SCSI" on page 23, for details on drive power requirements.

5.2 SCSI Bus Connector

ULTRASTAR 18XP/9LP has different model types that support 50 or 68 pin Single-Ended or 68 pin Differential configurations. Also supported is the 80 pin SCA-2 in a Single-Ended configuration. This section describes the signal assignments of the **ULTRASTAR 18XP/9LP** SCSI connectors.

These connectors have a finish metallurgy 30 micro-inch Gold plating.

5.2.1 50 Pin Signal Connector

50 pin models use an AMP PN 84412-1 connector. The connector is compatible with the ANSI SCSI "A" connector specifications. It is limited to 8 bit data transfers only. Refer to Figure 23 on page 48 for a rear view of the 50 pin model connector.

The SCSI connector contact assignments for the 50 pin single-ended model are shown in Table 12 on page 51.

Signal Name	Connector Contact Number		Signal Name
GROUND	1	2	-DB(0)
GROUND	3	4	-DB(1)
GROUND	5	6	-DB(2)
GROUND	7	8	-DB(3)
GROUND	9	10	-DB(4)
GROUND	11	12	-DB(5)
GROUND	13	14	-DB(6)
GROUND	15	16	-DB(7)
GROUND	17	18	-DB(P)
GROUND	19	20	GROUND
GROUND	21	22	GROUND
GROUND	23	24	GROUND
OPEN	25	26	TERMPWR
GROUND	27	28	GROUND
GROUND	29	30	GROUND
GROUND	31	32	-ATN
GROUND	33	34	GROUND
GROUND	35	36	-BSY
GROUND	37	38	-ACK
GROUND	39	40	-RST
GROUND	41	42	-MSG
GROUND	43	44	-SEL
GROUND	45	46	-C/D
GROUND	47	48	-REQ
GROUND	49	50	-I/O

Table 12. 50 Pin Single-Ended SCSI Connector Contact Assignments

5.2.2 68 Pin Signal Connector

68 pin models use a Molex connector (PN 87360-0001) that is compatible with the ANSI SCSI "P" connector specifications. It can transfer data in both 8 bit (narrow) and 16 bit (wide) modes. Refer to Figure 22 on page 48 for a rear view of a 68 pin model.

The SCSI connector contact assignments for the 68 pin single-ended models are shown in Table 13 on page 52.

The SCSI connector contact assignments for the 68 pin differential models are shown in Table 14 on page 53.

ULTRASTAR 18XP/9LP Hardware/Functional Specification

Signal Name	Connector Contact Number		Signal Name
GROUND	1	35	-DB(12)
GROUND	2	36	-DB(13)
GROUND	3	37	-DB(14)
GROUND	4	38	-DB(15)
GROUND	5	39	-DB(P1)
GROUND	6	40	-DB(0)
GROUND	7	41	-DB(1)
GROUND	8	42	-DB(2)
GROUND	9	43	-DB(3)
GROUND	10	44	-DB(4)
GROUND	11	45	-DB(5)
GROUND	12	46	-DB(6)
GROUND	13	47	-DB(7)
GROUND	14	48	-DB(P)
GROUND	15	49	GROUND
GROUND	16	50	GROUND
TERMPWR	17	51	TERMPWR
TERMPWR	18	52	TERMPWR
OPEN	19	53	OPEN
GROUND	20	54	GROUND
GROUND	21	55	-ATN
GROUND	22	56	GROUND
GROUND	23	57	-BSY
GROUND	24	58	-ACK
GROUND	25	59	-RST
GROUND	26	60	-MSG
GROUND	27	61	-SEL
GROUND	28	62	-C/D
GROUND	29	63	-REQ
GROUND	30	64	-I/O
GROUND	31	65	-DB(8)
GROUND	32	66	-DB(9)
GROUND	33	67	-DB(10)
GROUND	34	68	-DB(11)
Note: 8 bit devices which connect to the P-cable should tie the following signals inactive: -DB(8), -DB(9), -DB(10), -DB(11), -DB(12), -DB(13), -DB(14), -DB(15), -DB(P1). All other signals shall be connected as defined.			

Table 13. 68 Pin Single-Ended SCSI Connector Contact Assignments

ULTRASTAR 18XP/9LP Hardware/Functional Specification

Signal Name	Connector Contact Number		Signal Name
+DB(12)	1	35	-DB(12)
+DB(13)	2	36	-DB(13)
+DB(14)	3	37	-DB(14)
+DB(15)	4	38	-DB(15)
+DB(P1)	5	39	-DB(P1)
GROUND	6	40	GROUND
+DB(0)	7	41	-DB(0)
+DB(1)	8	42	-DB(1)
+DB(2)	9	43	-DB(2)
+DB(3)	10	44	-DB(3)
+DB(4)	11	45	-DB(4)
+DB(5)	12	46	-DB(5)
+DB(6)	13	47	-DB(6)
+DB(7)	14	48	-DB(7)
+DB(P)	15	49	-DB(P)
DIFFSENS	16	50	GROUND
TERMPWR	17	51	TERMPWR
TERMPWR	18	52	TERMPWR
OPEN	19	53	OPEN
+ATN	20	54	-ATN
GROUND	21	55	GROUND
+BSY	22	56	-BSY
+ACK	23	57	-ACK
+RST	24	58	-RST
+MSG	25	59	-MSG
+SEL	26	60	-SEL
+C/D	27	61	-C/D
+REQ	28	62	-REQ
+I/O	29	63	-I/O
GROUND	30	64	GROUND
+DB(8)	31	65	-DB(8)
+DB(9)	32	66	-DB(9)
+DB(10)	33	67	-DB(10)
+DB(11)	34	68	-DB(11)
Note: 8 bit devices which connect to the P-cable should tie the following signals inactive: +/-DB(8), +/-DB(9), +/-DB(10), +/-DB(11), +/-DB(12), +/-DB(13), +/-DB(14), +/-DB(15), +/-DB(P1). All other signals shall be connected as defined.			

Table 14. 68 Pin Differential SCSI Connector Contact Assignments

5.2.3 80 Pin (Single Connector Attachment) Connector

The 80 pin SCA-2 models use an AMP connector (PN 5-917593-9) that is compatible with the Specification of: 'Single Connector Attachment for Small SCSI Disk Drives' SFF-8046 draft document, revision 2.3, dated Dec 2, 1995. Placement of the connector is in compliance with the SFF-8337, revision 1.2, dated July 27, 1995.

The connector has a finish metallurgy of 30 micro-inch Gold plating.

Data transfers in both 8 bit (narrow) and 16 bit (wide) modes are supported. Refer to Figure 21 on page 47 for a rear view of an 80 pin model.

ULTRASTAR 18XP/9LP Hardware/Functional Specification

The SCSI connector contact assignments for the 80 pin single-ended models are shown in Table 15 on page 54.

Signal Name	Connector Contact Number		Signal Name
12 V Charge	1	41	12V Ground
12 Volt	2	42	12V Ground
12 Volt	3	43	12V Ground
12 Volt	4	44	Mated 1
Reserved /NC	5	45	Reserved /NC
Reserved /NC	6	46	Ground
-DB(11)	7	47	Ground
-DB(10)	8	48	Ground
-DB(9)	9	49	Ground
-DB(8)	10	50	Ground
-I/O	11	51	Ground
-REQ	12	52	Ground
-C/D	13	53	Ground
-SEL	14	54	Ground
-MSG	15	55	Ground
-RST	16	56	Ground
-ACK	17	57	Ground
-BSY	18	58	Ground
-ATN	19	59	Ground
-DB(P0)	20	60	Ground
-DB(7)	21	61	Ground
-DB(6)	22	62	Ground
-DB(5)	23	63	Ground
-DB(4)	24	64	Ground
-DB(3)	25	65	Ground
-DB(2)	26	66	Ground
-DB(1)	27	67	Ground
-DB(0)	28	68	Ground
-DB(P1)	29	69	Ground
-DB(15)	30	70	Ground
-DB(14)	31	71	Ground
-DB(13)	32	72	Ground
-DB(12)	33	73	Ground
5 Volt	34	74	Mated 2
5 Volt	35	75	5 V Ground
5 V Charge	36	76	5 V Ground
Reserved	37	77	Active LED Out
AUTO START	38	78	AUTO START DELAY
SCSI ID(0)	39	79	SCSI ID(1)
SCSI ID(2)	40	80	SCSI ID(3)
<p>Note: 8bit devices which connect to the SCA connector should tie the following signals inactive high: DB(8), DB(9), DB(10), DB(11), DB(12), DB(13), DB(14), DB(15), DB(P1) or select "Disable Wide Negotiations" on the Front Option Jumper Block and 'float' the same signals. All other signals shall be connected as defined.</p>			

Table 15. 80 Pin SCA-2 Connector Contact Assignments

5.2.4 SCSI Bus Cable

Single-ended models permit cable lengths of up to 6 meters (19.68 feet). It should be noted however that users who plan to use "Fast" data transfers with single-ended models should follow all of the ANSI SCSI guidelines for single-ended "Fast" operations. This may include a cable length of less than 6 meters.

When operating in Fast-20 mode cable lengths of up to 3 meters (9.84 feet) are supported.

SCA-2 connector models are not designed for direct cable attachment due to the combination of power and SCSI bus signals. "Fast" data transfers with SCA models should follow all of the ANSI SCSI guidelines for single-ended "Fast" operations.

Differential models permit cable lengths of up to 25 meters (82.02 feet). Cables must meet the requirements for differential cables as set forth in the ANSI SCSI standard under "Cable Requirements - Differential Cable".

The ANSI SCSI standard states that any stub from main cable must not exceed 0.1 meters for single-ended cables and 0.2 meters for differential cables. **ULTRASTAR 18XP/9LP** has a maximum internal stub length of 0.05 meters on all 'single ended' SCSI signals, and 0.10 meters on all 'differential' SCSI signals. To remain compliant with the standard the SCSI bus cable must not add more than 0.05 meters additional stub length to any of the single-ended SCSI signals or 0.10 meters to any differential SCSI signals.

5.2.5 SCSI Bus Terminators (Optional)

Upon request, Single Ended 50 and 68 pin models are available with on card SCSI bus Active terminators.

For those cards having the Active Termination feature, this function can be enabled by installing a jumper between pins 13 and 14 of the Front Option Jumper Block or connecting pins 9 and 11 of the Auxiliary Connector on 68 SCSI pin models. (Refer to Figure 26 on page 59, and Figure 29 on page 62.) The using system is responsible for making sure that all required signals are terminated at both ends of the cable. See 5.2.7, "SCSI Bus Electrical Characteristics" on page 56 for input capacitance values when terminators are disabled and when terminators are not populated on the card.

80 pin SCA-2 Models do not have internal SCSI bus terminators.

Some external terminator possibilities for single ended cabled systems are listed below:

50 Pin Model Terminators	68 Pin Model Terminators
Data Mate DM2000-02-R	Data Mate DM2050-02-68S
Data Mate DM500-06-R	Data Mate DM2050-02-68R

Table 16. Single Ended SCSI Terminators

Differential models do not have internal SCSI bus terminators. Some external terminator possibilities are listed below:

68 Pin Model Terminators
Data Mate DM2050-01-68D

Table 17. Differential SCSI Terminators

5.2.6 SCSI Bus Termination Power

Termination power is optionally provided for systems that desire to use it. In order to use the termination power, the user needs to install a jumper between pins 1 and 2 of the TermPower Block. (Refer to Figure 25 on page 58, Figure 26 on page 59.) The jumper should only be installed on one device, which should be the last device on the SCSI bus (i.e. the drive that is physically closest to a terminator). 68 pin models can source up to 2.0 Amps of current at 5.0 Volts (+ - 5%) for termination power. 50 pin models can source up to 1.5 Amps of current at 5.0 Volts (+ - 5%) for termination power.

5.2.6.1 SCSI Bus Termination Power Short Circuit Protection

The ANSI SCSI specification recommends for devices that optionally supply TERMPWR, to include current limiting protection for accidental short circuits. It also recommends that the maximum current available for TERMPWR should be 2 Amps. UL has a different requirement that they call the 8 Amp rule. This rule states that when a power source leaves an enclosure (like SCSI TERMPWR in the SCSI cable), it must trip 8 Amps of current within 1 minute.

The **ULTRASTAR 18XP/9LP** drive limits current to 2.0 Amps thru the use of a resettable fuse mounted on the electronics card.

Systems may also provide short circuit protection for drive supplied TERMPWR by limiting the current of the 5 Volt power it supplies to the drive.

5.2.7 SCSI Bus Electrical Characteristics

The following DC operating characteristics pertain to the single-ended SCSI bus transceivers. All of these parameters meet the ANSI SCSI-3 requirements.

- Ta = 0 to 70 deg. C

Symbol	SCSI I/O Parameters	min	max	Units	Notes
Vol	low level output voltage		0.5	V	Iol = 48 mA
	Fast-20 Models		0.5	V	
Voh	high level output voltage	2.5		V	Ioh = -400 uA
Vil	low level input voltage	-0.2	0.8	V	
	Fast-20		1.0	V	
Vih	high level input voltage	2.0	5.5	V	
	Fast-20	1.9		V	
Iil	low level input current		20	uA	
Iih	high level input current		20	uA	
Vihys	input hysteresis	0.33		V	
Ci	input capacitance		25	pF	w/terminators disabled, Typ. = 15 pF
Ci	input capacitance		19	pF	w/o terminators, Typ. = 14 pF

Table 18. Single-Ended Bus Electrical Characteristics

Differential models meet all electrical requirements as defined in the ANSI SCSI-2 standard under "Electrical Description - Differential Alternative".

5.3 Option Block Connector (Jumper Blocks)

ULTRASTAR 18XP/9LP models contain a jumper block that can be used to enable certain features and select the SCSI ID of the drive. This jumper block is referred to as the 'Front' Option Jumper Block due to its location on the drive (opposite the SCSI connector). This jumper block varies in pin definition based on interface type (50, 68, Differential, SCA-2).

The Option Block connector (2x16) used on 50, 68 and 80 pin models is an AMP connector (PN 84156-5) having a pin spacing of 2mm.

The IBM Part Number for the 2mm jumpers is 45G9800 and the Termination Power Enable jumper Part Number is 21H0793.

The 45G9800 PN is:-

- 2mm spacing, w/tab 8.5mm long, connector is 3.5 mm long
- Contact -- 30micro-inch gold plating with nickel underplate
- Supplier -- HIROSE A3-SP(B)(13), or approved equivalent.

The 21H0793 PN is:-

- 2.54mm spacing, wo/tab connector is 5.08 mm long
- Contact -- 30micro-inch gold plating with nickel underplate
- Supplier -- METHODE 9608-202-35, or approved equivalent.

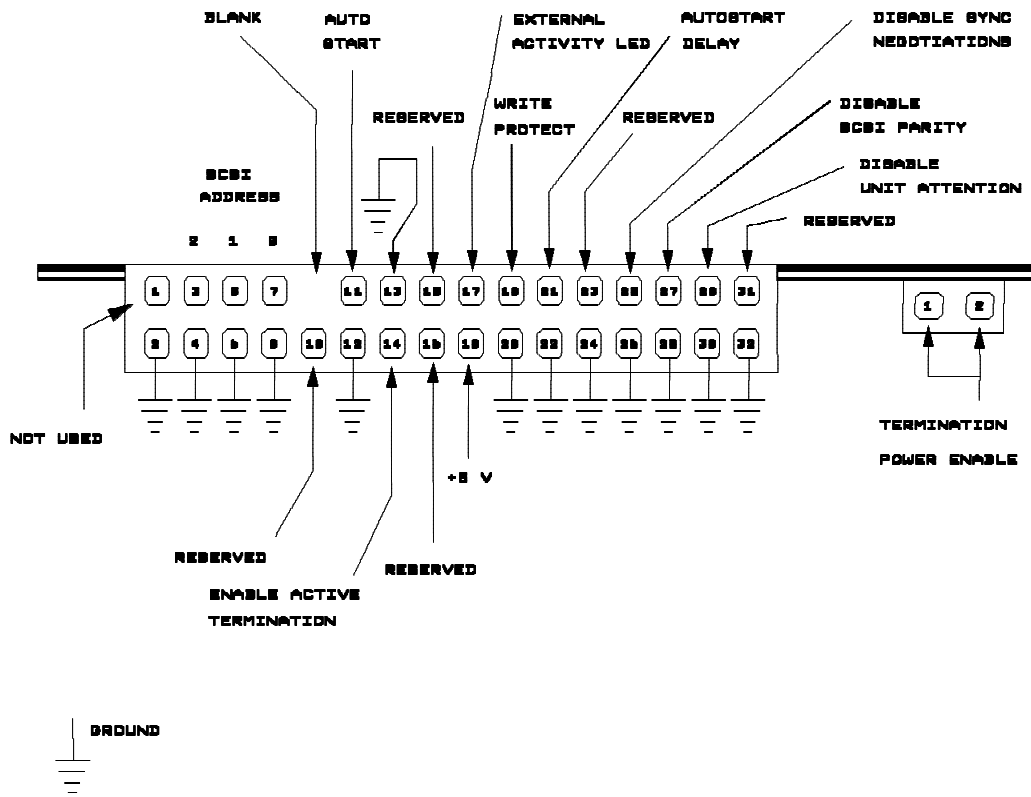

Figure 25. 50 pin Single Ended Front Option Jumper Block and TermPower Block

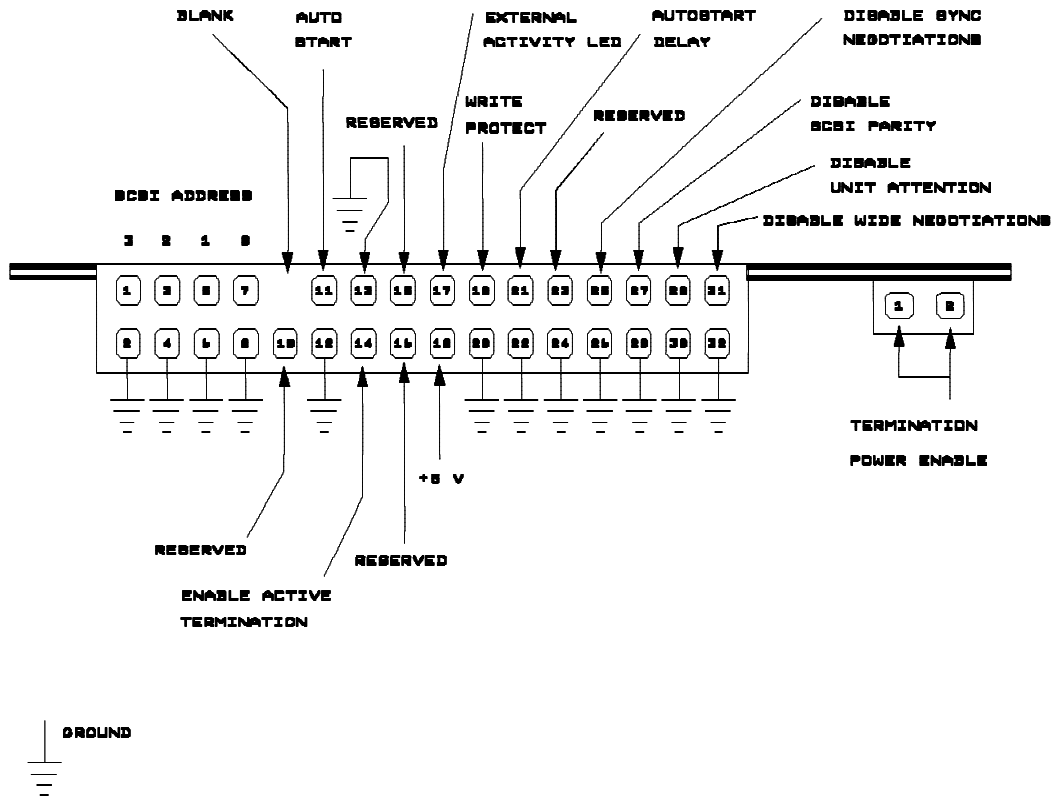

Figure 26. 68 pin Single Ended Front Option Jumper Block and TermPower Block

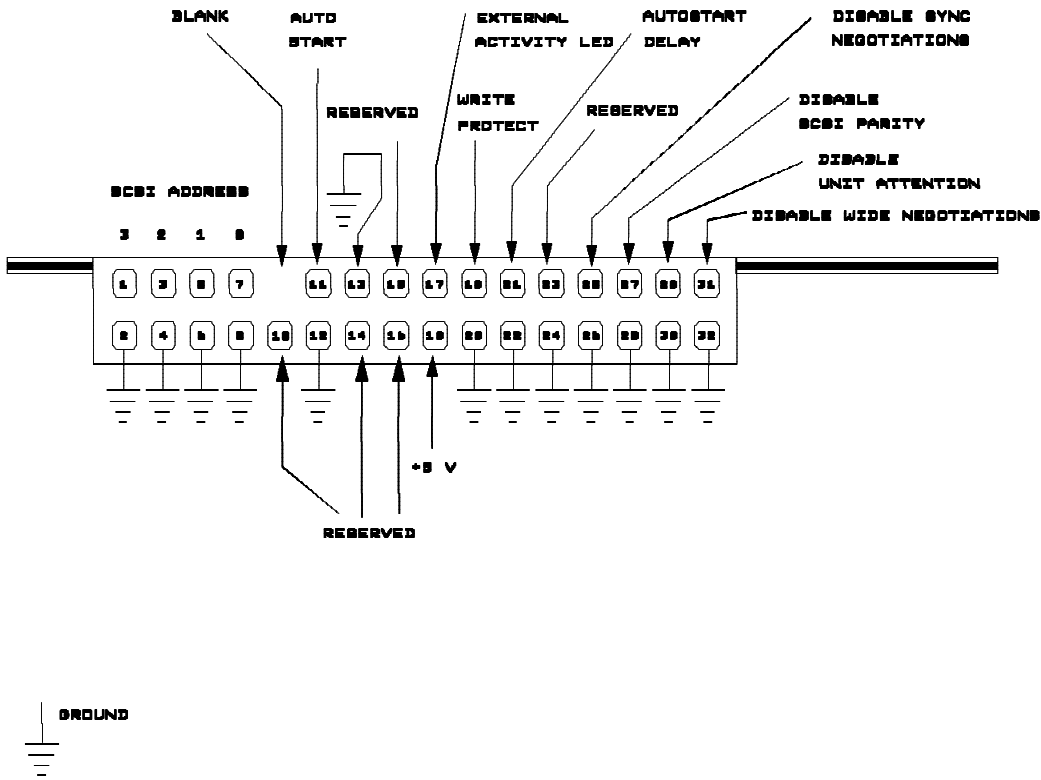

Figure 27. SCA-2 Front Option Jumper Block

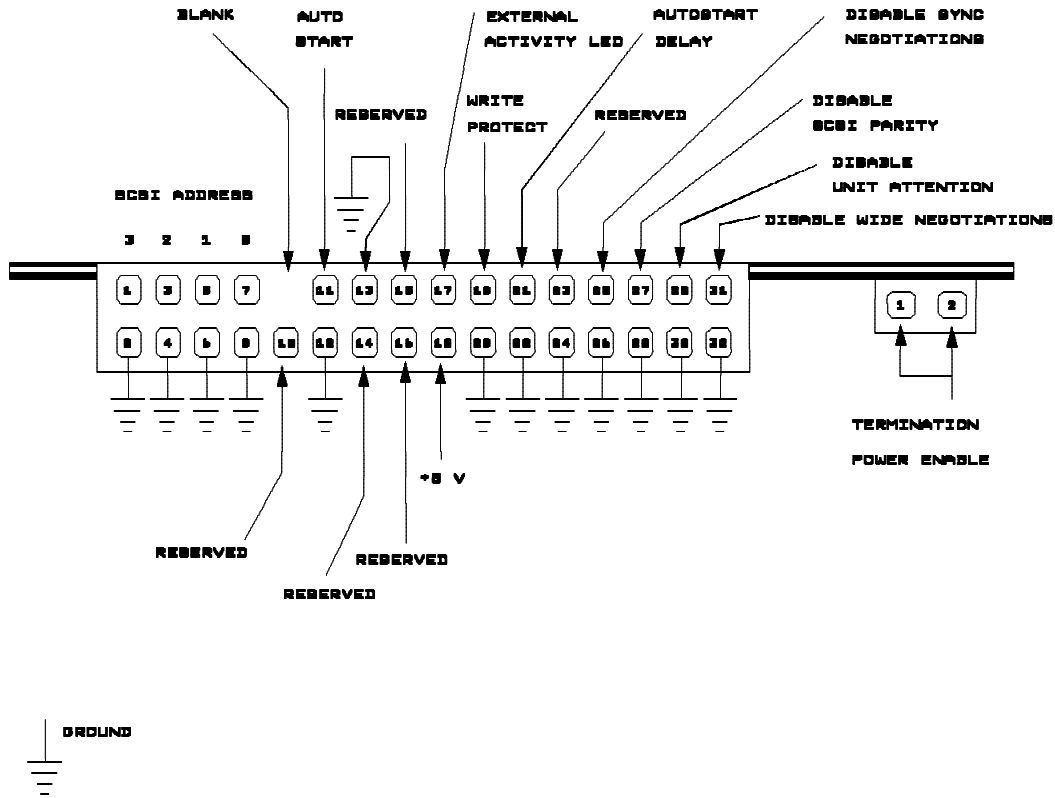

Figure 28. 68 pin Differential Front Option Jumper Block

5.3.1 68 Pin Auxiliary Connector

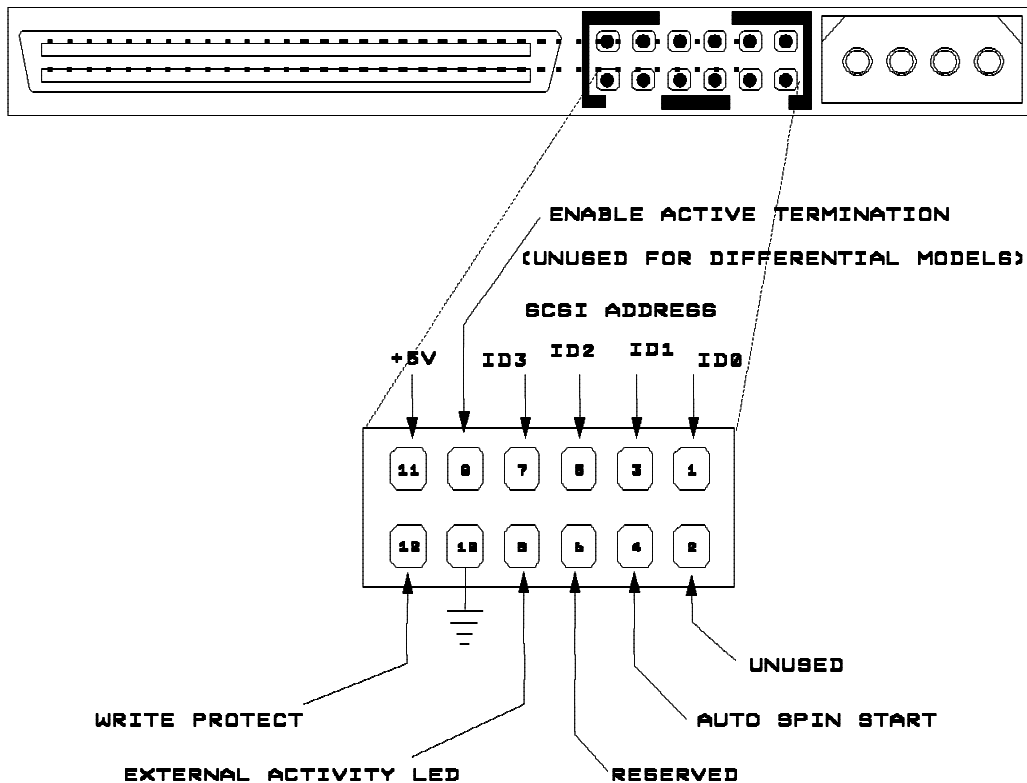

Figure 29. Auxiliary Connector on the 68 pin Connector

Note: Either the Front Option Block "OR" the Auxiliary block may be used but not both.

The 68 pin models contain an 'Auxiliary' connector that replicates some of the functions contained in the Front Option Jumper Block. The Auxiliary connector signal definition conforms to the SCSI document: SFF-8009 Rev 2.0 definition with the following exceptions:

1. EXTERNAL FAULT (XTFALT-) is not supported on pin 2
2. AUTO SPIN START was chosen as the 'vendor unique' signal assignment (on pin 4.) (This signal is an input to the drive. The SCSI spec (SCSI SFF-8009) specifies this pin as an output.) This signal should be useful for those applications that want to "auto-start" the drive based on location dependent SCSI ID.

This pin should be handled in one of the following ways:

- a. tied to ground (auto spin start enabled)
- b. allowed to 'float' (no connection)
- c. driven with an open collector driver (>1 mA sink capability)

The Auxiliary Connector is shown in Figure 29.

5.3.2 SCSI ID (Address) Pins

Information on how to select a particular address for the SCSI device ID is given in Table 19.

Note: In the address determination tables, "off" means jumper is not in place and "on" means jumper is in place.

BIT 3	BIT 2	BIT 1	BIT 0	ADDRESS
off	off	off	off	0
off	off	off	on	1
off	off	on	off	2
off	off	on	on	3
off	on	off	off	4
off	on	off	on	5
off	on	on	off	6
off	on	on	on	7
on	off	off	off	8
on	off	off	on	9
on	off	on	off	10
on	off	on	on	11
on	on	off	off	12
on	on	off	on	13
on	on	on	off	14
on	on	on	on	15

Table 19. Address Determination of 68 and 80 Pin Models

BIT 2	BIT 1	BIT 0	ADDRESS
off	off	off	0
off	off	on	1
off	on	off	2
off	on	on	3
on	off	off	4
on	off	on	5
on	on	off	6
on	on	on	7

Table 20. Address Determination of 50 Pin Models

5.3.3 Auto Start (& Delay) Pins

The Auto Start and Auto Start Delay pins control when and how the drive can spin up and come ready. When configured for Auto-Startup, the motor spins up after power is applied without the need of a SCSI Start Unit command. For no Auto-Startup, a SCSI Start Unit command is required to make the drive spin and be ready for media access operations. When in Auto-Startup mode, the drive will delay its start time by a period of time multiplied by its own SCSI address. Table 21 on page 64 and Table 22 on page 64 show whether or not Auto-Startup mode is active and the delay periods, where applicable, for all combinations of the pins.

Pins (68 and 50 pin interface models)		Drive Behavior	
AUTO START DELAY	AUTO START	Auto-Startup Mode ?	Delay (sec) Multiplier
off	off	NO	na
off	on	YES	0
on	off	YES	10
on	on	YES	4

Table 21. 68p and 50p Auto-Startup Modes selectable by Auto-Start/Delay Pin Combinations.. The "on" condition indicates that a jumper is in place to the adjacent ground pin. The "off" condition indicates that no jumper is in place.

Pins (80 interface pin models)		Drive Behavior	
AUTO START DELAY	AUTO START	Auto-Startup Mode ?	Delay (sec) Multiplier
off	off	YES	0
off	on	NO	na
on	off	YES	10
on	on	NO	na

Table 22. 80p Auto-Startup Modes selectable by Auto-Start/Delay Pin Combinations. The "on" condition indicates that a jumper is in place to the adjacent ground pin. The "off" condition indicates that no jumper is in place.

5.3.4 External Activity (LED) Pins

The LED pins can be used to drive an external Light Emitting Diode. Please refer to the LED pin section of the *ULTRASTAR 18XP/9LP SCSI Logical Interface Specification* for a detailed functional description of this pin.

Up to 33 mA (+/- 5%) of TTL level LED sink current capability is provided. Current limiting for the LED is as shown in the following diagram.

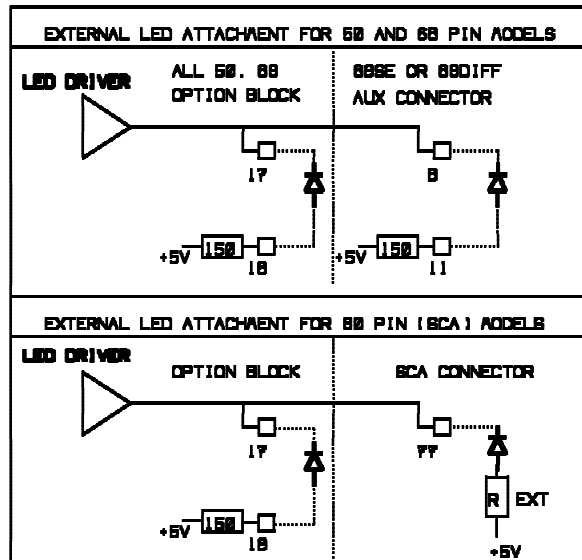

Figure 30. LED Circuit Diagram

5.3.5 Write Protect Pin

If the Write Protect pin is jumpered to ground the drive will prohibit SCSI commands that alter the customer data area portion of the media from being performed. The state of this pin is monitored on a per command basis. See the *ULTRASTAR 18XP/9LP SCSI Logical Interface Specification* for functional details.

5.3.6 Disable Sync. Negotiation Pin

If a Disable Target Initiated Synchronous Negotiation pin is grounded then an Initiator is required to start a negotiation handshake if Synchronous and/or 'Wide' (Double Byte) SCSI transfers are desired. Please refer to the *ULTRASTAR 18XP/9LP SCSI Logical Interface Specification* for more details on this feature.

5.3.7 Disable SCSI Parity Pin

Grounding this pin will disable SCSI Parity checking.

5.3.8 Disable Unit Attention Pin

Grounding this pin will disable the drive from building Unit Attention Sense information for commands immediately following a Power On Reset (POR) or SCSI Bus Reset. Any pending Unit Attention conditions will also be cleared at POR or SCSI Reset times.

5.3.9 Disable Wide Negotiations

Jumpering pin 31 to pin 32 (refer to Figure 26 on page 59, Figure 27 on page 60, or Figure 28 on page 61), will cause the 68 pin SE, 80 pin SCA, or the 68 pin differential to operate in a Single Byte mode. The drive will not negotiate for 'Wide' (Double Byte) operation.

5.3.10 Enable Active Termination

Upon request, Single Ended 68 and 50 pin models are available with on card SCSI bus Active terminators.

For those cards having the Active Termination feature, this function can be enabled by installing a jumper between pins 13 and 14 of the Front Option Jumper Block or connecting pins 9 and 11 of the Auxiliary Connector on 68 SCSI pin models. (Refer to Figure 26 on page 59, and Figure 29 on page 62.)

5.4 Spindle Synchronization

Spindle Synchronization is not a feature of the **ULTRASTAR 18XP/9LP** drives.

6.0 Reliability

6.1 Error Detection

Error reporting \geq 99%

All detected errors excluding interface and BATs #1 (Basic Assurance Test) errors

Error detection \geq 99%

FRU isolation = 100%

To the device when the "Recommended Initiator Error Recovery Procedures" in the *ULTRASTAR 18XP/9LP SCSI Logical Interface Specification* are followed.

No isolation to sub-assemblies within the device are specified.

6.2 Data Reliability

Probability of not recovering data 10 in 10^{15} bits read

Recoverable read errors (Mean of the Population)

10 in 10^{13} bits read (Measured at nominal DC conditions and room environment with default error recovery - QPE* enabled.)

With QPE enabled and the default thresholds, error reporting only occurs after step 18.⁴

6.3 SPQL (Shipped product quality level)

All units are functionally tested immediately prior to packaging and shipment from IBM. When subsequently installed and functionally tested in an approved system, some drives may not pass. In general, the percentage of drives that fail will depend upon adherence to shipping and handling guidelines, functional test criteria and system design compatibility. Contact your technical support representative for further information and assistance.

6.4 Failure Rate

This product is designed for use in applications where high reliability and availability are critical. In general, actual failure rates will depend on usage conditions and system design compatibility.

Parameters such as ambient temperature, cooling air flow rate, relative humidity, ambient pressure (altitude), applied voltage, shock, vibration, on/off cycles and duty cycle will affect failure rates. Failure rate projections may only be determined from drive system testing. Contact your technical support representative for further information and assistance.

⁴ * Please reference QPE (qualify post error) definition in the *ULTRASTAR 18XP/9LP SCSI Logical Interface Specification*.

6.5 Shelf Life

It is recommended that the drive does not remain inoperative for longer than 180 days, especially if the shelf environment is at high temperature and humidity.

6.6 Start Stop Cycles

The maximum number of start stop cycles supported is 1800.

7.0 Operating Limits

The IBM Corporate specifications and bulletins, such as C-S 1-9700-000 in the contaminants section, that are referenced in this document are available for review.

7.1 Environmental

- Temperature

Operating Ambient	5 to 50°C (41 to 122°F)
Operating Disk Enclosure	5 to 65°C (41 to 149°F)
Storage	1 to 65°C (34 to 149°F) See Note
Shipping	-40 to 65°C (-40 to 149°F)

- Temperature Gradient

Operating	20°C (36°F) per hour maximum
Shipping and storage	below condensation

- Humidity

Operating	5% to 90% noncondensing
Storage	5% to 90% noncondensing
Shipping	5% to 95% (Applies at the packaged level)

- Wet Bulb Temperature

Operating	26.7°C (80°F) maximum
Shipping and Storage	29.4°C (85°F) maximum

- Elevation

Operating and Storage	-304.8 to 3048 meters (-1000 to 10,000 feet)
Shipping	-304.8 to 12,192 meters (-1000 to 40,000 feet)

Note: Guidelines for storage below 1°C are given in IBM Technical Report TR 07.2112.

7.1.1 Temperature Measurement Points

The following is a list of measurement points and their temperatures. Maximum temperatures must not be exceeded at the worst case drive and system operating conditions with the drive reading and writing at the maximum system operations per second rate.

Note: Figure 32 on page 71 defines where measurements should be made to determine the top disk enclosure temperature during drive operation. Figure 31 on page 70 defines the modules that are located on the bottom side of the card and the measurement location on the bottom of the disk enclosure.

There must be sufficient air flow through the drive so that the disk enclosure and module temperature maximum limits defined in Table 23 on page 70 are not exceeded.

Table 23. Maximum and Maximum Recommended Case Temperature Limits		
	Maximum	Maximum Recommended
Disk Enclosure Top	149°F (65°C)	122°F (50°C)
Disk Enclosure Bottom	149°F (65°C)	122°F (50°C)
Channel Module ⁵	203°F (95°C)	167°F (75°C)
SCSI Module	194°F (90°C)	158°F (70°C)
Microprocessor Module	176°F (80°C)	140°F (60°C)
Controller Module	194°F (90°C)	158°F (70°C)
Motor Driver Module	194°F (90°C)	158°F (70°C)

Note: - Operating the file above the maximum temperatures may cause permanent damage.

Note: - Maximum Recommended temperatures are for nominal ambient temperature.

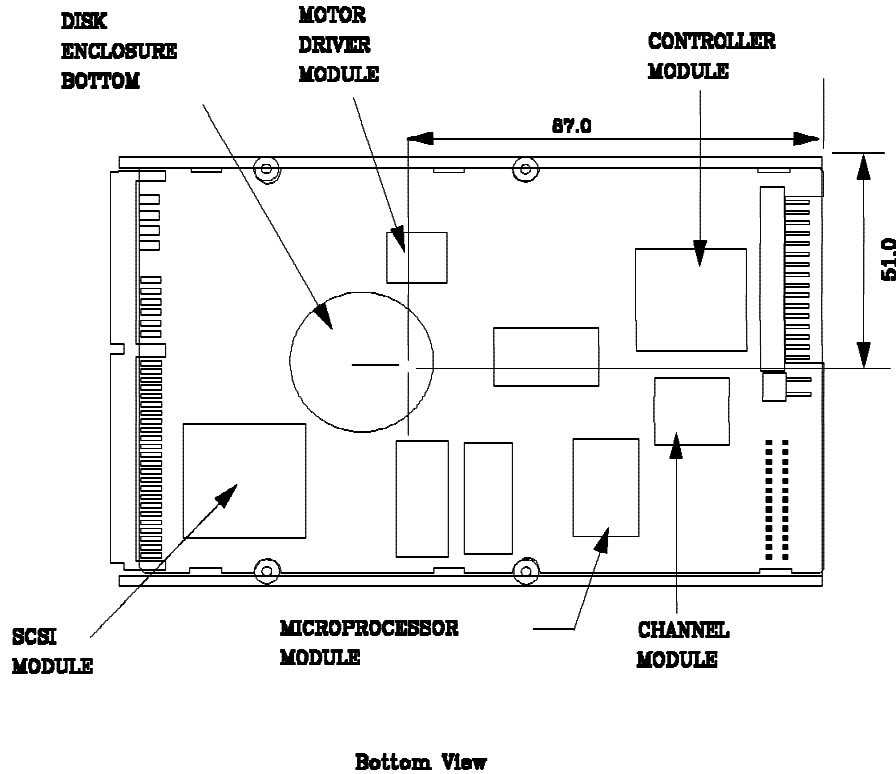
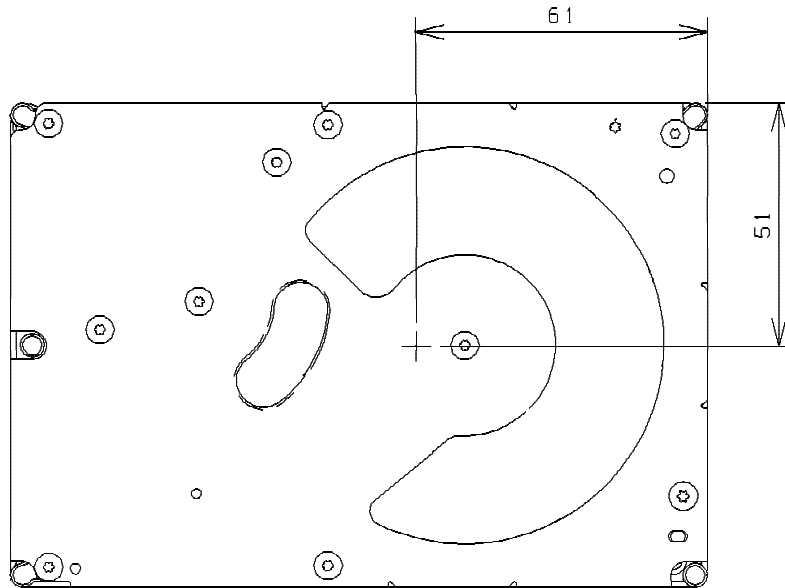

Figure 31. Temperature Measurement Points (bottom view)

⁵ For continuous read applications the channel module will run at higher temperatures and will require additional cooling.



DISK ENCLOSURE, TOP

Figure 32. Temperature Measurement Point (top view)

7.1.1.1 Module Temp. Measurement Notes

1. Center on the top surface of the module.
2. If copper tape is used to attach temperature sensors, it should be no larger than 6 mm square.

7.2 Vibration and Shock

The operating vibration and shock limits in this specification are verified in two mount configurations:

1. By mounting with the 6-32 bottom holes with the drive on 2 mm high by 10 mm diameter spacers as required by section 4.2, "Clearances" on page 42
2. By mounting on any two opposing pairs of the 6-32 side mount holes.

Other mount configurations may result in different operating vibration and shock performance.

7.2.1 Output Vibration Limits

Spindle residual imbalance not to exceed 0.5 gram-millimeters for either 1.0 inch or 1.6 inch models.

7.2.2 Operating Vibration

The vibration is applied in each of the three mutually perpendicular axes, one axis at a time. Referring to Figure 1 on page 9, the x-axis is defined as a line normal to the front/rear faces, the y-axis is defined as a line normal to the left side/right side faces, and the z-axis is normal to the x-y plane.

WARNING

All drives are sensitive to rotary vibration. Mounting within using systems should minimize the rotational input to the drive mounting points due to external vibration. IBM will provide technical support to assist users to overcome problems due to vibration.

Random Vibration

For excitation in the x-direction and the y-direction, the drive will operate without hard errors when subjected to vibration levels not exceeding the V4 vibration level defined below.

For excitation in the z-direction, the drive will operate without hard errors when subjected to vibration levels not exceeding the V4S vibration level defined below.

Note: The RMS value in the table below is obtained by taking the square root of the area defined by the g^2/hz spectrum from 5 to 500 hz.

Table 24. Random Vibration Levels										
Class	5 hz	17 hz	45 hz	48 hz	62 hz	65 hz	150 hz	200 hz	500 hz	RMS
V4	2.0E-5	1.1E-3	1.1E-3	8.0E-3	8.0E-3	1.0E-3	1.0E-3	8.0E-5	8.0E-5	0.56
V4S	2.0E-5	1.1E-3	1.1E-3	8.0E-3	8.0E-3	1.0E-3	1.0E-3	4.0E-5	4.0E-5	0.55
units	g^2/hz									g

Swept Sine Vibration

The drive will operate without hard errors when subjected to the swept sine vibration of 1.0 G peak from 5 to 300 hz in the x, y, and z directions.

This measurement is taken during a frequency sweep from 5 to 300 hz and back to 5 hz. The sweep rate will be one hz per second.

Note: 1.0 G acceleration at 5 hz requires 0.78 inch double amplitude displacement.

7.2.3 Nonoperating Vibration

No physical damage or degraded throughput will occur as long as vibration at the unpackaged drive in all three directions defined above does not exceed the levels defined in the table below. This measurement is performed by sweeping from 5 hz to 300 hz and back to 5 hz at a sweep rate of eight decades per hour.

Table 25. Nonoperating Vibration Levels		
Frequency	5 hz to 7 hz	7 hz to 300 hz
Amplitude	0.8 inch DA	2.0 G peak

7.2.4 Operating Shock

No permanent damage will occur to the drive when subjected to a 10 G half sine wave shock pulse of 11 milliseconds duration.

No permanent damage will occur to the drive when subjected to a 10 G half sine wave shock pulse of 2 millisecond duration.

The shock pulses are applied in each of three mutually perpendicular axes, one axis at a time.

7.2.5 Nonoperating Shock

Translational Shock

For both the 1.0" and the 1.6" models, no hard error will occur if the unpackaged drive is subjected to a 20 milliseconds square pulse shock of 35 Gs or less applied to all three axes, one direction at a time.

For the 1.0" models, no hard error will occur if the unpackaged drive is subjected to a 2 milliseconds half sine pulse shock of 150 Gs or less applied to all three axes, one direction at a time.

For the 1.6" models, no hard error will occur if the unpackaged drive is subjected to a 2 milliseconds half sine pulse shock of 140 Gs or less applied to all three axes, one direction at a time.

Rotational Shock

The actuator will remain latched in the disk landing zone if the unpackaged drive is subjected to a 2 milliseconds half sine pulse shock of 15,000 radians per second squared or less applied to all three axes, one direction at a time.

7.3 Contaminants

The corrosive gas concentration expected to be typically encountered is Subclass G1; the particulate environment is expected to be P1 of C-S 1-9700-000 (1/89).

7.4 Acoustic Levels

Upper Limit Sound Power Requirements (Bels) for 1.0 inch Models									
	Octave Band Center Frequency (Hz)								A-weighted
	125	250	500	1K	2K	4K	8K	16K	Bel
Idle	4.4	3.2	3.2	3.4	4.0	4.1	3.8	3.8	4.4
Operating	4.4	3.2	3.2	3.9	4.2	5.2	4.5	4.2	5.4

Additionally, the population average of the sound pressure measured one meter above the center of the drive in idle mode will not exceed 36 dBA.

Upper Limit Sound Power Requirements (Bels) for 1.6 inch Models									
	Octave Band Center Frequency (Hz)								A-weighted
	125	250	500	1K	2K	4K	8K	16K	Bel
Idle	4.5	2.6	3.2	3.5	4.3	4.5	4.8	3.9	5.0
Operating	4.5	3.3	3.3	4.1	5.1	5.3	4.8	4.0	5.5

Additionally, the population average of the sound pressure measured one meter above the center of the drive in idle mode will not exceed 41 dBA.

Notes:

1. The above octave band and A-weighted sound power levels are statistical upper limits of the sound power levels. See C-B 1-1710-027 and C-S 1-1710-006 for further explanation.
2. The drives are tested after a minimum of 20 minutes warm-up in idle mode.
3. The operating mode is simulated by seeking at a rate of 32 seeks per second.
4. The values for a sample size of 5 or greater will be less than or equal to the stated upper limits with 90% confidence.

Acoustic Degradation resulting from Nonoperating Shock

For the 1.0" models, no degradation in A-weighted idle sound power will occur if the unpackaged drive is limited to a 2 milliseconds half sine pulse shock of 150 Gs or less applied in the axial direction (z axis), or 300 Gs or less applied in radial direction (x-y plane).

For the 1.6" models, no degradation in A-weighted idle sound power will occur if the unpackaged drive is limited to a 2 milliseconds half sine pulse shock of 70 Gs or less applied in the axial direction (z axis), or 150 Gs or less applied in the radial direction (x-y plane). The average A-weighted idle sound power will increase by 0.3 Bels if the unpackaged drive is subjected to a 2 milliseconds half sine pulse shock of 110 Gs applied in the axial direction (z axis), or 210 Gs applied in the radial direction (x-y plane).

7.5 Drive Mounting Guidelines

1. Use of the extreme side mounts will align the drive Center of Gravity (CG) closer to the center of stiffness. This will minimize off axis coupling and in-plane yaw rotation about the spindle axis.
2. Orient the spindle axis parallel to the direction of minimum shock loading.
3. The carrier should not allow the drive to rotate in the plane of the disk.

If any isolation between the device and the frame is to be used, it can be soft in the x,y,z, pitch and roll axis but should be stiff for the yaw axis. Yaw motion is rotation about the spindle axis which couples directly into offtrack.

If isolators are used, they should provide natural frequencies about 25% lower than the motor speed. The idea is to place the rigid body modes below primary excitation frequencies and drive structural modes. Isolators must be well damped and of sufficient strength so they will not be torn by high non-operating shocks.

Otherwise, keep the rigid body resonances of the drive away from harmonics of the spindle speed.

7200 RPM harmonics: 120Hz, 240Hz, 360Hz, 480Hz....

4. It is desirable that the carrier be as stiff as possible while allowing room for the isolator mounts (if used). Rather than creating a weak carrier that flexes to fit the drive, hold the mounting gap to tighter tolerances. A flexible carrier may contain resonances that cause operational vibration and/or shock problems.
5. If isolators are to be used, design for maximum sway. Adequate clearance around all edges are necessary for cooling and shock impacts. Maximum sway is usually determined by geometry and compressibility limits of the isolator grommet plus some carrier/rack flexibility. Metal to metal impacts must be avoided because they result in short duration, high impacts loads; such waveforms can excite high frequency modes of the components inside the drive.
6. To minimize acoustic radiation, mount drives so there is no "line of sight" between a drive and user.

7.6 Drive/System Compatibility

ULTRASTAR 18XP/9LP drives are supplied to using systems that demonstrate a level of drive/system compatibility to this specification.

Verification prior to a formal system qualification is recommended to determine whether the drive/system is capable of achieving the quality and reliability requirements found in this specification.

Preliminary testing to verify compatibility may be performed using common laboratory instrumentation equipped with the appropriate transducer (thermal, power, shock, vibration and acoustics). Final verification must be performed by measuring functional performance (error rates) of the drive when installed within the system.

The following sections describe the parameters to be verified prior to and as a part of the system qualification test in order to achieve the quality and reliability requirements set forth by this specification.

Power

The system must be capable of providing adequate power to the drive as described in Section 2.4, “Power Requirements” on page 15. In addition to voltage, current and capacitance, the system must be capable of remaining within regulation when the maximum number of drives are installed in the system.

Special consideration must be given to hot plug and differential drive/system designs. Refer to 2.4.7, “‘Hot Plug/Unplug’ support” on page 22 of this specification for requirements and guidelines.

Thermal

The system must supply adequate cooling and air flow to maintain casting and module temperature listed in Table 23 on page 70. Operating Limits must be in accordance with the Temperature measurement points shown in Figure 32 on page 71 and Figure 31 on page 70. The system must demonstrate sufficient cooling to operate below the recommended temperatures for any given location that the drive may be installed within the system.

Special consideration for minimum clearances must be given to achieve adequate cooling of the drive.

Shock (Operating and Non-Operating)

The system must maintain an environment that is compatible with operating and non-operating shock specifications found in sections 7.2.4, “Operating Shock” on page 72 and 7.2.5, “Nonoperating Shock” on page 73. Both operating and non-operating shock should be measured in all 3 planes and found to be within the limits set in this specification.

Vibration (Operating and Non-Operating)

The system must maintain an environment that is compatible with the operating vibration specification found in section 7.2.2, “Operating Vibration” on page 71. Random vibration must be measured in all three planes and found to be compatible with the vibration level in Table 24 on page 72. Swept Sine Vibration must also be measured and be compatible with 7.2.2, “Operating Vibration” on page 71.

To achieve system compatibility for vibration, it is recommended that the system conform to section 7.5, “Drive Mounting Guidelines” on page 75.

Also, drives are sensitive to rotary vibration. Mounting within using systems must minimize the rotational input to drive mounting points due to external vibration.

Electromagnetic Compatibility(EMC)

The system must be designed to insure that stray fields are not placed close to the device. Minimum clearances must be maintained. Clearance guidelines are found in section 4.2, “Clearances” on page 42.

Electrostatic Discharge(ESD)

The drive contains electrical components sensitive to ESD. System design and assembly process, must protect the drive and must be verified to conform the protection, care and handling guidelines found in section 7.10, “ESD Protection” on page 79.

Interface Compatibility

The drive/system, in conjunction with associated operating software, must be capable of conforming to the pin configurations, cabling, command and timing parameters found in section 5.0, “Electrical Interface” on page 50.

Verification of the preceding parameters is recommended prior to starting a system test or qualification. Most parameters may be verified by using common laboratory instrumentation or simple inspection of design, handling and process. For further information regarding verification testing, please contact your technical support representative.

Final verification of drive/system compatibility must be determined through functional testing. Adequate system testing must be performed to demonstrate conformance to the Data Reliability requirements, reference 6.2, “Data Reliability” on page 67.

7.7 Recommendations for Handling of Disk Drives

Disk Drives are very fragile and can be damaged if dropped or impacted against another object. Amount of damage to the drive will depend on magnitude and duration of the impact. People handling the disk drive should be trained in the proper handling procedures. Manufacturing processes, equipment, and Disk Drive holding containers/fixtures should be characterized and qualified to less than 50 G's in the manufacturing environment. The following are things to consider in the handling and protection of the disk drive.

Damage may be caused by:

- Dropping a drive onto a hard surface, even over small distances
- Drives may fall over after being set on edge
- Tapping a drive with a screw driver tip or other hard implement
- Tapping a drive into position when installing into a user frame
- Clicking 2 drives together metal to metal

ULTRASTAR 18XP/9LP Hardware/Functional Specification

Precautions to take during handling:

- Wear ESD protection at all times
- Treat drives as you would "Eggs" or "Glass Stemware"
- Handle one drive at a time
- Handle drive by the sides only, avoid grasping the card
- Replace drive into original packaging for transport
- Pad ALL drive work areas (1" foam under 1/4" ESD pad)
- Pad ALL drive transport areas (1" foam under 1/4" ESD pad)
- Pad All drive holding areas (1" foam under 1/4" ESD pad)
- Clear work areas of potential metal contact
- Remove / Install drives separately
- Report any drive that may have been dropped or mishandled
- Do Not stack disk drives (Even in ESD Bags)
- Do Not contact drive or card with tooling (drivers, etc)
- Do Not rush installation
- Do Not "Slam" a drive into a carrier or frame
- Do Not "Seat" a drive into place with tooling
- Do Not stand a drive on end or side (Tipping Hazard)
- Do Not allow drives to contact each other

Shipping Handling Precautions:

- Check for and Report shipping damage to a Pallet
- Do Not stack more than 2 pallets
- Do Not contact pallet package with Forklift Forks
- Do Not drop a Pallet
- Do Not drop Drive Boxes (Singles or Multiples)

7.8 Breather Filter Hole

Under no circumstances should the Filter Breather Hole be obstructed or labels placed over the hole.

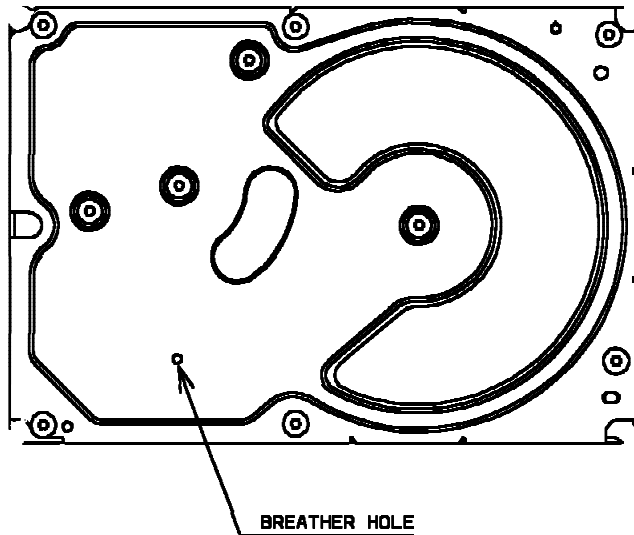

Figure 33. Breather Hole for Filter

7.9 Periodic Maintenance

None required

7.10 ESD Protection

The **ULTRASTAR 18XP/9LP** disk drives contain electrical components sensitive to damage due to electrostatic discharge (ESD). Proper ESD procedures must be followed during handling, installation, and removal. This includes the use of ESD wrist straps and ESD protective shipping containers.

7.11 ESD Handling

This product is sensitive to Electro Static Discharge.

Precautions such as using ESD mats, wrist straps and grounding all surfaces that are allowed to touch or come close to the device are recommended.

Known ESD dangers such as walking across a carpet carrying the device should be avoided. It is recommended that the device is always stored in its anti-static package until it is ready for installation.

7.12 Stray Magnetic Fields

This device is sensitive to strong magnetic fields.

Magnets and other sources of magnetic fields must not be placed close to the device.

Stray field magnetic susceptibility is as follows. Field strength must be equal to or below the values shown at these frequencies where the drive is mounted.

Table 26. Stray Magnetic Field Strength					
Frequency	DC (Static Field)	47 Hz to 400 Hz	400 Hz to 5 kHz	5 kHz to 50 kHz	50 kHz to 200 kHz
Magnitude (Gauss)	5	5	2	0.5	0.1

8.0 Standards

8.1 Safety

- **UNDERWRITERS LABORATORY (UL) APPROVAL:**

The product is approved as a Recognized Component for use in Information Technology Equipment according to UL 1950 Standard, third edition (without any D3 deviations). The UL Recognized Component marking is located on the product.

UL E133560 Vol 19 Section 1

- **CANADIAN STANDARDS ASSOCIATION (CSA) APPROVAL:**

The product is certified to CAN/CSA-C22.2 No. 950-M95 Third Edition (without any D3 deviations). The CSA certification mark is located on the product.

LR-34074C

- **FLAMMABILITY REQUIREMENTS**

Printed circuit boards and all foam and other plastic materials are UL Recognized V-1, HF-1, or VTM-1 or better. Small plastic parts that will not contribute to a fire will meet V-2 flame class.

- **SAFE HANDLING:**

The product is conditioned for safe handling in regards to sharp edges and corners.

- **ENVIRONMENT:**

IBM will not knowingly or intentionally ship any units which during normal intended use or foreseeable misuse, would expose the user to toxic, carcinogenic, or otherwise hazardous substances at levels above the limitations identified in the current publications of the organizations listed below.

International Agency for Research on Cancer (IARC)

National Toxicology Program (NTP)

Occupational Safety and Health Administration (OSHA)

American Conference of Governmental Industrial Hygienists (ACGIH)

California Governor's List of Chemical Restricted under California Safe Drinking Water and Toxic Enforcement Act 1986 (Also known as California Proposition 65)

- **SECONDARY CIRCUIT PROTECTION REQUIRED IN USING SYSTEMS**

Care has been exercised to not use any unprotected components or constructions that are particularly likely to cause fire. However, adequate secondary overcurrent protection is the responsibility of the user of the product. Additional protection against the possibility of sustained combustion due to circuit or component failure may need to be implemented by the user with circuitry external to the product. Over-current limits of the voltage into the file of 10 amps or less should be sufficient protection.

8.2 Electromagnetic Compatibility (EMC)

- FCC Requirements

Pertaining to the *ULTRASTAR 18XP/9LP* disk drive, IBM will provide technical support to assist users in complying with the **United States Federal Communications Commission (FCC) Rules and Regulations, Part 15, Subpart B Digital Devices "Class A and B Limits"**. Tests for conformance to this requirement are performed with the disk drive mounted in the using system.

- CISPR 22 Requirements

Pertaining to the *ULTRASTAR 18XP/9LP* disk drive, IBM will provide technical support to assist users in complying with the **Comite International Special des Perturbations Radio Electriques(International Special Committee on Radio Interference) CISPR 22 "Class A and B Limits"** .

- European Declaration of Conformity.

Pertaining to the *ULTRASTAR 18XP/9LP* disk drive, IBM will provide technical support to assist users in complying with the **European Council Directive 89/336/EEC** so the final product can thereby bear the "CE" Mark of Conformity.

This is obtained by integrating the drives in an IBM product. Products integrating these drives in alternative enclosures will still need to test the system to ensure it complies with the European Directive.