

# THE MOTORSPORT SHOW / 23-24 NOVEMBER 2019 RDS DUBLIN

*For all motorsport fans, experts,  
collectors and car enthusiasts.*

## DATES & LOCATION

### WHEN?

SATURDAY NOVEMBER 23 | 10:00 - 18:00

SUNDAY NOVEMBER 24 | 10:00 - 18:00

(FRIDAY NOVEMBER 22 | 15:30 - 18:00 MEDIA PREVIEW)

### WHERE?

RDS SIMMONSCOURT,  
SIMMONSCOURT ROAD, BALLSBRIDGE  
DUBLIN 4, IRELAND

[WWW.THEMOTORSPORTSHOW.COM](http://WWW.THEMOTORSPORTSHOW.COM)



THEMOTORSPORTSHOW



@TMSSDUBLIN



@TMSSDUBLIN

*Tickets available from Ticketmaster and usual outlets.*

**FREE** WALES RALLY GB  
36-PAGE GUIDE

**F1** McLaren gets  
Mercedes power  
for 2021 attack

# AUTOSPORT

BRITAIN'S BEST MOTORSPORT WEEKLY

3 OCTOBER 2019

## How Hamilton took advantage of Ferrari's civil war

Why Vettel defied  
team orders in his  
battle with Leclerc



**'I stuck to the  
agreement'**

**SEBASTIAN  
VETTEL**

**'We need to trust  
each other'**

**CHARLES  
LECLERC**

DESCRIBED BY  
MURRAY WALKER  
AS THE “GREATEST  
MOTORSPORT EVENT  
IN THE WORLD  
BAR NONE”



For over a century man and machine have tested themselves on the most challenging race course in the world.

37.73 miles, 200+ corners... at an average speed of 135mph.

The Isle of Man TT is unique. See for yourself.

**30.05.2020 - 12.06.2020**

[duketravel.com](http://duketravel.com)





# Vettel's belligerence adds to the battle within Ferrari

Unlike most of the Formula 1 races since June's French Grand Prix, last weekend's Russian GP was not particularly exciting. But it did have plenty of intrigue thanks to the intra-team battle at Ferrari.

Sebastian Vettel has been under increasing pressure from team-mate Charles Leclerc, who scored his sixth pole of 2019 in Sochi, but is showing signs of his desire to fight back. Following his fortuitous victory in Singapore, Vettel took advantage of a pre-race agreement to take the lead in Russia, then failed to hand the place back to Leclerc. As Edd Straw argues on page 13, you might not like Vettel's approach but it shows he is prepared to upset Leclerc and cause tension in the team to try to maintain (or should that be grab back?!) the initiative.

As it was, Vettel's engine problem caused a safety car that allowed Lewis Hamilton, who had starred in the early stages as he tried to hang on to the faster Ferraris, to jump Leclerc and take victory for Mercedes. Leclerc is nevertheless now third, three points ahead of Max Verstappen, in the drivers' championship. And 21 ahead of Vettel...

The battle for third in the standings has been incredibly tight this year, but serves to demonstrate that no one has yet emerged to consistently take the fight to Mercedes and Hamilton, who is now 73 points clear of team-mate Valtteri Bottas and 107 ahead of Leclerc. The contest between the Ferrari stars will surely provide further fascination over the final five rounds, but the team will probably want a clear winner so that it can take on Hamilton next season.

- A much closer title battle comes to the UK this week in the form of the World Rally Championship. Turn to our special supplement to find out all you need to know about Rally GB.



**Kevin Turner**  
Editor

kevin.turner@autosport.com

**NEXT WEEK  
10 OCTOBER**

We look at Ferrari's F1 chances for 2020 and report from Rally GB



## COVER IMAGES

Motorsport Images/Bingham

## PIT & PADDOCK

- 4 McLaren and Mercedes back together
- 6 Classics return to the WRC calendar
- 8 Ferrari's champ to step up to Formula 2
- 11 F1 technical focus
- 13 Opinion: Edd Straw
- 15 Opinion: Adam Cooper
- 17 Feedback: your letters

## RACE CENTRE

- 18 Russian GP report and analysis
- 32 Turkington's great BTCC Silverstone save
- 39 World of Sport: Formula 3; Formula 2; Blancpain GT Endurance Cup; Formula Renault Eurocup; NASCAR Cup; Super Formula

## CLUB AUTOSPORT

- 54 Porsche champion makes return
- 56 FF1600 aces for boosted Festival
- 58 CSCC to head to Le Mans in 2020
- 59 Opinion: James Newbold
- 60 National reports: Spa; Silverstone; Donington Park; Kirkistown; Brands Hatch

## FINISHING STRAIGHT

- 70 What's on this week
- 72 From the archive: 1972 German GP
- 74 Pit your wits against our quiz

## SUBSCRIPTION OFFER

- 16 Free trial for Autosport Plus

## VISIT AUTOSPORT.COM

For other ways to read Britain's best motorsport weekly

**FREE INSIDE**

### RALLY GP PREVIEW 2019



Our guide to the UK's round of the World Rally Championship, including the title challengers and McRae track test.

Mika Hakkinen  
took the first world  
title for McLaren-  
Mercedes in 1998



# McLAREN'S LONG-WINDED MER

## FORMULA 1

After six Formula 1 seasons apart, McLaren and Mercedes will reunite in 2021. Over the Russian Grand Prix weekend, news broke that McLaren will return to its long-time engine supplier when its three-year spell with Renault comes to an end.

The reunion will mark the end of an expensive period of soul-searching for McLaren. Back in 2014, when the team was preparing to part company with Mercedes after 20 years together and switch to Honda, then-McLaren boss Ron Dennis insisted it was not possible to win in F1 as a simple customer.

But in confirming the McLaren-Mercedes deal that will begin in around 18 months' time, current McLaren CEO Zak Brown said: "If we do a very good job, I think we can." So, what's changed?

### McLAREN'S YEARS IN THE WILDERNESS

McLaren has not finished on the podium since its final season with Mercedes in 2014, and its winless run stretches back to 2012. That's proof that the rot had started to set in at Woking before its ill-fated move to Honda engines in 2015.

McLaren toiled for three years from then until 2017, sometimes peaking in the midfield battle, but often frustrated by an underpowered and unreliable engine. But when the inevitable happened and McLaren and Honda divorced, McLaren's fortunes did not improve.

Its switch to Renault engines in 2018 brutally exposed the team's own deficiencies, which had been hinted at with its initial slump in 2013 and 2014, when it still used Mercedes powerplants. McLaren had to face up to some hard truths, including a major management reshuffle that was completed when Andreas Seidl

joined as team principal this year.

The first part of McLaren's revival has been rapid. It has launched itself to the front of the midfield in 2019, and Seidl's influence has already become clear.

Step one: convince the shareholders to invest in a new windtunnel. Step two: negotiate a return to Mercedes engines.

### SO WHY MERCEDES?

Mercedes has dominated the V6-turbo-hybrid era and is on course for a sixth consecutive drivers'/constructors' title double. It would not be possible to have that sustained success if the engine was still not up to the job. So McLaren knows it is switching to a tried, tested, powerful and reliable product.

But the engine is not exactly McLaren's biggest issue as the team lags behind Mercedes, Ferrari and Red Bull. Instead, it's the wider deficit that McLaren believes makes a move to Mercedes engines so sensible.

Mercedes' chassis has been its biggest weapon this year and the race team is arguably F1's best as well. McLaren wants that all-round benchmark so it knows exactly what it's lacking in its bid to return to the top.

"Mercedes being clearly the benchmark in this hybrid era, in terms of powertrain, was one of the main reasons we wanted to make this decision to go for Mercedes in 2021 onwards," said Seidl. "The best thing is to have the same powertrain as the best team in the paddock at the moment. Then there's nowhere to hide for us."

From Mercedes' side, this is possible now because its attitude has shifted as the V6-turbo-hybrid era has developed. Mercedes boss Toto Wolff described it as a move with many pros and one risk: "That if McLaren does a good job, they will push hard, and maybe [be the] benchmark [for] us."



SUTTON  
motorsport  
IMAGES

# CEDES RETURN

## WERE THERE ANY OTHER OPTIONS?

Brown said Mercedes' position as the benchmark engine is part of the appeal for McLaren, but that overlooks the fact that Ferrari has actually overhauled Mercedes on the engine side. Even so, the Mercedes is a better all-round package than the Ferrari, and it is also a much less problematic partnership for McLaren, with Brown saying Ferrari would be "a clear brand clash" with McLaren on the road-car side.

Likewise, McLaren says it never considered building its own engine. Seidl said the reason for this is: "You have to invest a lot of money, you need a lot of running budget each year, and you would need a long time to catch up with what the others have put in place."

As for staying with Renault, it appears the French manufacturer wanted a more aligned relationship if it was to continue supplying another team. This may have included shared parts and a shared gearbox.

McLaren was less interested in this and was keen to strike a simple engine-supply deal to retain its independence. Which is why Wolff and Brown were both keen to stress this is purely a customer arrangement, not the beginning of a return to McLaren-Mercedes works status or the withdrawal of Mercedes' own team.

Oh, and just in case you wondered: McLaren's hyped-up exclusive deal with Honda from 2015-17 resulted in a costly divorce. Neither party wants a reunion, and neither would benefit from that.

Seidl was emphatic: "We talked to Mercedes. We found an agreement with Mercedes. And we're happy with that."

SCOTT MITCHELL

➔ P15 OPINION



SUTTON  
motorsport  
IMAGES

## Coulthard elected as new president of the BRDC

### BRDC

Ex-Formula 1 star, W Series prime mover and Channel 4 F1 co-commentator David Coulthard has been elected as president of the British Racing Drivers' Club. The Scot, who won 13 grands prix, takes over from rallying legend Paddy Hopkirk, who has been at the helm since 2017.

Coulthard had been widely tipped for the presidency, which he will fulfil alongside his current broadcasting commitments for Channel 4 and his W Series role.

BRDC chairman John Grant said: "I and my fellow board members are delighted to welcome David Coulthard as president of the BRDC. We are confident that we have a president who is not only a greatly talented racing driver but also a successful businessman with an enviable network of contacts, which should be of great benefit to the club."

Coulthard was elected at this week's BRDC AGM, which also confirmed that Dario Franchitti would become a vice-president.

JONATHAN NOBLE

## Teams to try out next year's tyres at US GP

### FORMULA 1

All Formula 1 drivers will be given two sets of 2020 tyres to test during Friday practice for this month's US Grand Prix.

F1's sporting regulations give Pirelli the option to provide tyres for Friday running, if the company wants to log more mileage. They can be used in either of the 90-minute sessions held on Friday.

The rarely used rule states: "At certain events one additional specification of dry-weather tyre may be made

available to all teams for evaluation purposes following a recommendation to the FIA from the supplier."

The tyres to be used at Austin will be the definitive 2020 specification, which is to be finalised after next week's development test with Mercedes, Ferrari and Red Bull at Barcelona. A more extensive test, involving a range of compounds, will take place over three days in Abu Dhabi following the last race of the season.

ADAM COOPER



## Ginetta plan could prevent Le Mans LMP1 entry slump

### LE MANS 24 HOURS

Ginetta could come to the rescue of the Le Mans 24 Hours next June. The British constructor has aspirations to run a third car at the World Endurance Championship finale in a move that would maintain the LMP1 grid at 2019 levels.

Ginetta boss Lawrence Tomlinson's plan to field an additional Ginetta-AER G60-LT-P1 under its Team LNT banner in the French enduro potentially brings the paltry 2019-20 WEC LMP1 field up to eight cars. That's the same number that took the start at Le Mans this year, even though the full-season entry has dropped to just five cars after the withdrawal of the ART-run SMP Racing squad.

WEC rules give full-season participants in P1 the option of running a third car, and Tomlinson explained that he was keen to exploit it. "We'd like to run an extra car at Le Mans and we are edging closer to that," said Tomlinson. "It would probably be too much to do it ourselves, so we are looking to do it in partnership with another team."

"We entered the WEC ourselves as Team LNT, but we've always said that we are willing for another team or teams to join us. I think it could happen for Le Mans."

Le Mans next June may not be the end of the career of the Ginetta G60. Tomlinson has hopes that a customer will take up the car in the first year of the hypercar division,

when existing LMP1 machinery will be allowed to race on.

"I would be comfortable if a team came to us wanting to do a test programme, Sebring [round six of the WEC in March] and Le Mans, and then do the WEC in 2020-21," he explained. "Next season could be a great opportunity for someone, because by the time we get there we will have proven reliability – Toyota and Aston Martin won't have had a lot of running with their hypercars."

Should the plan come to fruition, Ginetta would likely join Rebellion Racing and ByKolles on the grid for the 24 Hours with a car not competing in the full WEC.

Rebellion has expressed a clear intent to return to a two-car effort for Le Mans and the WEC round at Spa in April that precedes it. The Swiss entrant originally filed two entries for this season, before dropping down to a single Rebellion-Gibson R-13, only to make a late decision to bring out its second car for the Silverstone opener in August.

WEC stalwart ByKolles is also intending to race its ENSO CLM-Gibson P1/01 at Spa and then Le Mans. It dropped out of the WEC in order to focus on development of a new hypercar prototype for the 2020-21 season, but has reaffirmed its intent to be on the grid with a solo car for the final two rounds this season and is continuing development of the P1/01.

**GARY WATKINS**

## Safari classic back in WRC

### WORLD RALLY CHAMPIONSHIP

Months after the first draft, next year's World Rally Championship calendar has been delivered – and it's all about the return of the classics.

Kenya's Safari Rally, Rally New Zealand and Rally Japan are all back on a schedule that is bound to please the drivers. While Auckland will echo to the sound of World Rally Cars for the first time since 2012, and an Aichi-based Rally Japan takes the WRC back to the Far East for the first time in 10 years, it'll be 18 years since Colin McRae won the last WRC Safari.

Making way for the those events on the 14-round schedule are Corsica, Australia and Spain. Despite sources suggesting that the promoter favoured Catalunya being retained next season, the governing body pushed for Germany's inclusion – good news for a country that has already lost its Formula 1 race next season. Rally Spain is understood to be the first event to undertake a rotation system, which will mean selected European events missing one in three years. Its absence guarantees it a slot on the 2021/22 calendars.

Monte Carlo remains the opener, followed as usual by Sweden and Mexico. Rally GB shifts back towards its late autumn date, but not into what was its traditional finale. Instead, the UK round is the penultimate event, with Japan bringing the curtain down on next year.

**DAVID EVANS**

### WRC CALENDAR

RD	VENUE	DATE
1	Monte Carlo Rally	23-26 January
2	Rally Sweden	13-16 February
3	Rally Mexico	12-15 March
4	Rally Chile	16-19 April
5	Rally Argentina	30 April-3 May
6	Rally Portugal	21-24 May
7	Rally Italy	4-7 June
8	Safari Rally	16-19 July
9	Rally Finland	6-9 August
10	Rally New Zealand	3-6 September
11	Rally Turkey	24-27 September
12	Rally Germany	15-18 October
13	Rally GB	29 October-1 November
14	Rally Japan	19-22 November

**RALLY GB PREVIEW SUPPLEMENT**

# Toro Rosso wants fashion renaming

## FORMULA 1

The Toro Rosso Formula 1 entry will change its name to AlphaTauri next season – if rival teams approve a request to do so.

Red Bull's junior team has been on the grid since 2006, after the energy-drinks company bought and rebranded Minardi. The name Toro Rosso is an Italian translation of Red Bull to honour the team's Italian predecessor and Faenza headquarters.

Red Bull has used Toro Rosso to give its proteges race experience in F1, including Sebastian Vettel and Max Verstappen. The team has advertised different products, such as Red Bull's cola and tonic drinks.

Now Autosport sources have confirmed the team has requested to be rebranded in the name of Red Bull's AlphaTauri fashion label. AlphaTauri is named after a star in the Taurus constellation, one of the oldest groups of stars in the known universe.

A name change requires both the approval of the commercial rights holder and a favourable vote of the F1 Commission. That will include an e-vote between teams, which is yet to be completed.

SCOTT MITCHELL



ALL PHOTOGRAPHY  
motorsport  
IMAGES

## TOP 3

# SIMILARLY NAMED F1 TEAMS

If Toro Rosso becomes AlphaTauri, that's going to cause Crofty & Co some strife with Alfa Romeo... Here are some other teams that might have caused some confusion



Innes Ireland scored points in BRP in 1963

### #1 BRP AND BRM

British Racing Partnership was set up in the late 1950s by Stirling Moss's manager Ken Gregory and father Alfred, and turned F1 constructor in 1963 at a time when BRM was at its zenith. BRM supplied engines, so we had BRP-BRMs... The team folded after 1964 when it was rejected as a member of the new Formula 1 Constructors' Association, jeopardising its start money.



Patrick Tambay joined Alan Jones at Haas

### #2 HAAS AND HAAS

An American named Haas setting up an F1 team using chassis produced by a top customer constructor, and running in the midfield. For machine-tools magnate Gene Haas, Dallara and 2016, read cigar-chomping Indycar titan Carl Haas, Lola and the mid-1980s. The team lasted only one full season, but had youthful Adrian Newey and Ross Brawn on the staff.



Manfred Winkelhock in unreliable ATS-BMW

### #3 ATS, ATS AND AGS

The Italian ATS was formed when Ferrari designer Carlo Chiti led a breakaway from Maranello, and signed 1961 world champion Phil Hill. Its sole season – 1963 – was a disaster. The German ATS – named for boss Gunther Schmid's wheel company – was midfield furniture from 1977-84. Soon after came the tiny French AGS squad, a serial non-qualifier.

## Ferrari F3 champ Shwartzman '99%' certain for F2 move

### FORMULA 2

Ferrari didn't have a lot to celebrate in last weekend's Russian Grand Prix, but both Sebastian Vettel and Charles Leclerc made time to congratulate the team's junior driver Robert Shwartzman, who sealed the FIA Formula 3 Championship at Sochi and is "99%" certain he will race in F2 next year.

Prema Racing driver and Ferrari Driver Academy protege Shwartzman, who is also backed by the Russian SMP Racing scheme, would most logically graduate to F2 with Prema. But the Italian squad's F2 seats are hotly contested, so it is uncertain if he can remain on board there or whether he will have to move elsewhere.

"I think the biggest chance, like 99%, is that I'm going to go to Formula 2," said St Petersburg 20-year-old Shwartzman. "I'm really excited about that, but I don't know with which team yet. I have liked to work with Prema Racing. They are talented guys, but you never know."

The F2 driver market has been shaken up in the past month by the death of Anthoine Hubert, who had been set to secure a top seat after his strong performances in 2019.

Juan Manuel Correa's recovery from surgery from his involvement in the Spa crash that claimed Hubert's life will also rule him out for next season. Correa vetoed amputation of his legs and underwent a surgery expected to take 10 hours on Sunday. No update on his condition had been released as Autosport went to press.

JACK BENYON



## Ahmed gets Aston Martin GT shot at Kyalami



### INTERCONTINENTAL GT

Japanese Formula 3 Championship race winner Enaam Ahmed will make his sportscar debut with the R-Motorsport Aston Martin squad at next month's Intercontinental GT Challenge finale at Kyalami.

The 2019 Aston Martin Autosport BRDC Award finalist will drive one of two cars confirmed by the Swiss entrant for the Kyalami 9

Hours on 23 November.

Ahmed, 19, will share one of the Aston Martin Vantage GT3s with R-Motorsport regulars Maxime Martin and Jake Dennis.

The line-up in the sister car will be Ricky Collard, Marvin Kirchhofer and Hugo de Sadeleer, who have raced with the Arden/Jota-run team in the Blancpain GT World Challenge this season.

R-Motorsport sporting

director Julian Rouse said: "As well as being successful, the team wants to create a culture of giving young drivers opportunities and bringing them on. I worked with Enaam at Arden in Formula 4 in 2015 and know he's from the right mould and has all the right attributes we are looking for."

Ahmed tested with the team at Spa in July and at Barcelona this week.

GARY WATKINS



BOGAERTS/SRO

## UK joins 'Olympics' with Ferrari

### MOTORSPORT GAMES

The clock is ticking towards the inaugural FIA Motorsport Games at Vallelunga, and predictably it's the GT element that is attracting the best entry out of the car-racing contests in what is effectively the sport's version of the Olympics.

'Predictably', because the prelude to the Games, which take place on the first weekend of November, was the GT Nations Cup held for the first time at the Bahrain International Circuit in December 2018.

The UK is one of the latest nations to join the GT field, which runs to a pro-am format in GT3 machinery and is currently at 17 entries. Flick Haigh, who co-drove Jonny Adam to the 2018 British GT Championship title, will partner Blancpain Endurance and International GT Open racer Chris Froggatt in a Ferrari 488 GT3 run by Italian powerhouse AF Corse.

Haigh hasn't done much racing this year as she plots a step up to the international ranks, although did share an Aston Martin to sixth in class with 2018 McLaren Autosport BRDC Award winner Tom Gamble in one of the Road to Le Mans support races at the Le Mans 24 Hours. Froggatt was a silver medallist in the Nations Cup last year, when he drove an AF Ferrari alongside Chris Buncombe.

The favourite on paper looks to be Turkey. Ayhancan Guven and Salih Yoluc took Nations Cup victory last year in a Ram Racing Mercedes, and this time they link up in a TF Sport Aston Martin Vantage (above) at the end of a season in which 21-year-old Guven has become a race-winning starlet in his rookie season

of the F1-supporting Porsche Supercup.

The dark horse could be Japan. Deposed Honda junior Ukyo Sasahara has rebuilt his career this season. Selected as Japan's Porsche junior, he claimed his country's Carrera Cup as a rookie and also clinched the Asian Formula 3 title last weekend. He will partner Lamborghini specialist Hiroshi Hamaguchi in a Huracan GT3 Evo run by FFF Racing Team, the squad that has taken a clean sweep of this year's Blancpain titles.

Russia's fourth-placed 2018 line-up of Denis Bulatov and Rinat Salikhov returns with a Rinaldi Racing Ferrari, while Denmark takes 2017 IMSA GTD champion Christina Nielsen and Jens Reno Moller in a JAS Motorsport-run Honda NSX GT3.

The TCR-based Touring Car field sports BTCC racer Rory Butcher (MG 6) for the UK up against Germany's Luca Engstler (Hyundai) and Belgium's Gilles Magnus (Audi) as likely leading contenders.

The Formula 4 field, who will fight it out in brand-new KCMG-built single-seaters sporting haloes, is taking shape more slowly. Niklas Krutten of Germany looks the favourite at present after shining this season in the German and Italian series. Israel's Ido Cohen has raced as Krutten's team-mate at Van Amersfoort Racing in 2019, with both stepping up recently to Euroformula Open. Russian Pavel Bulantsev has been crowned as the SMP F4 champion in his homeland, while Dane Malthe Jakobsen leads the way in his poorly supported domestic F4 series.

Other events awarding medals are for drifting, kart slalom (including Alex Wurz's son Charlie for Austria) and Esports.

**MARCUS SIMMONS**

### IN THE HEADLINES

#### ZANARDI IN DTM BMW AT FUJI

Motorsport and Paralympic hero Alex Zanardi will return to the wheel of a BMW M4 DTM car for November's Dream Race match contest between the DTM and Super GT at Fuji. Zanardi, who piloted a BMW fitted with hand controls to fifth at Misano on a DTM guest outing in 2018, is the only driver confirmed among the manufacturer's three-car line-up. Audi will send Rene Rast, Loic Duval (who has extensive experience in Japan) and Mike Rockenfeller, while the marque's three-time Le Mans 24 Hours winner Benoit Treluyer joins the squad as he returns to a country where he won Formula Nippon and Super GT titles.

#### MERCEDES SACKS STAFF

The Mercedes Formula 1 team has dismissed four workers, and disciplined three more, following a breach of its diversity and equality policy at its Brackley headquarters. In a statement, Mercedes said: "We condemn this behaviour in the strongest terms and acted immediately upon [a] complaint. We value the diversity of our employees and it is a source of strength for our team. Our working environment is based upon appreciation and mutual respect."

#### POURCHAIRE PLANS F3 STEP

Sauber junior Theo Pourchaire is eyeing a step to FIA Formula 3 – most logically with the Sauber Junior Team, at a wild guess – after clinching the German F4 title at the Sachsenring last weekend. The 16-year-old Frenchman, run by US Racing, prevailed in a final-round nailbiter against Van Amersfoort Racing's Red Bull Junior Dennis Hauger and fellow US charge Arthur Leclerc, brother of Charles.

#### CAINE REPLACES HAMILTON

Long-time Motorbase Performance cohort Michael Caine replaced budget-strapped Nicolas Hamilton in the team's Ford Focus line-up for last weekend's British Touring Car round at Silverstone. Caine took a best finish of 12th on the rain-hit weekend.

#### NEW FIA STATS DATABASE

Autosport sister division Motorsport Stats has co-created a bespoke results and statistics database with the FIA, free for fans to use. Covering 17 championships, it is now operational as an extension to the governing body's website fia.com.



**RODIN**  
C A R S



**NOTHING LIKE IT.**

Unprecedented performance. Unprecedented reliability.  
Introducing a bold new name in high-performance motorsport  
– and a new category in open-wheeled track cars.

**ENGINE**

**DESIGNATION** Cosworth GPV8  
**CAPACITY** 3.8L

**PERFORMANCE**

**MAX POWER** 675 bhp @ 9,600 rpm  
**MAX TORQUE** 450 Nm @ 7600 rpm  
**MAX RPM** 10,000 rpm normal running

**ACCELERATION**

**0 - 160 KPH** 5.0 sec\*  
**MAX SPEED** 300kph\*

\*Subject to conditions and aero configuration

**RODIN**  
**FZED**

[RODIN-CARS.COM](http://RODIN-CARS.COM)

# DRAWING BOARD

GIORGIO PIOLA

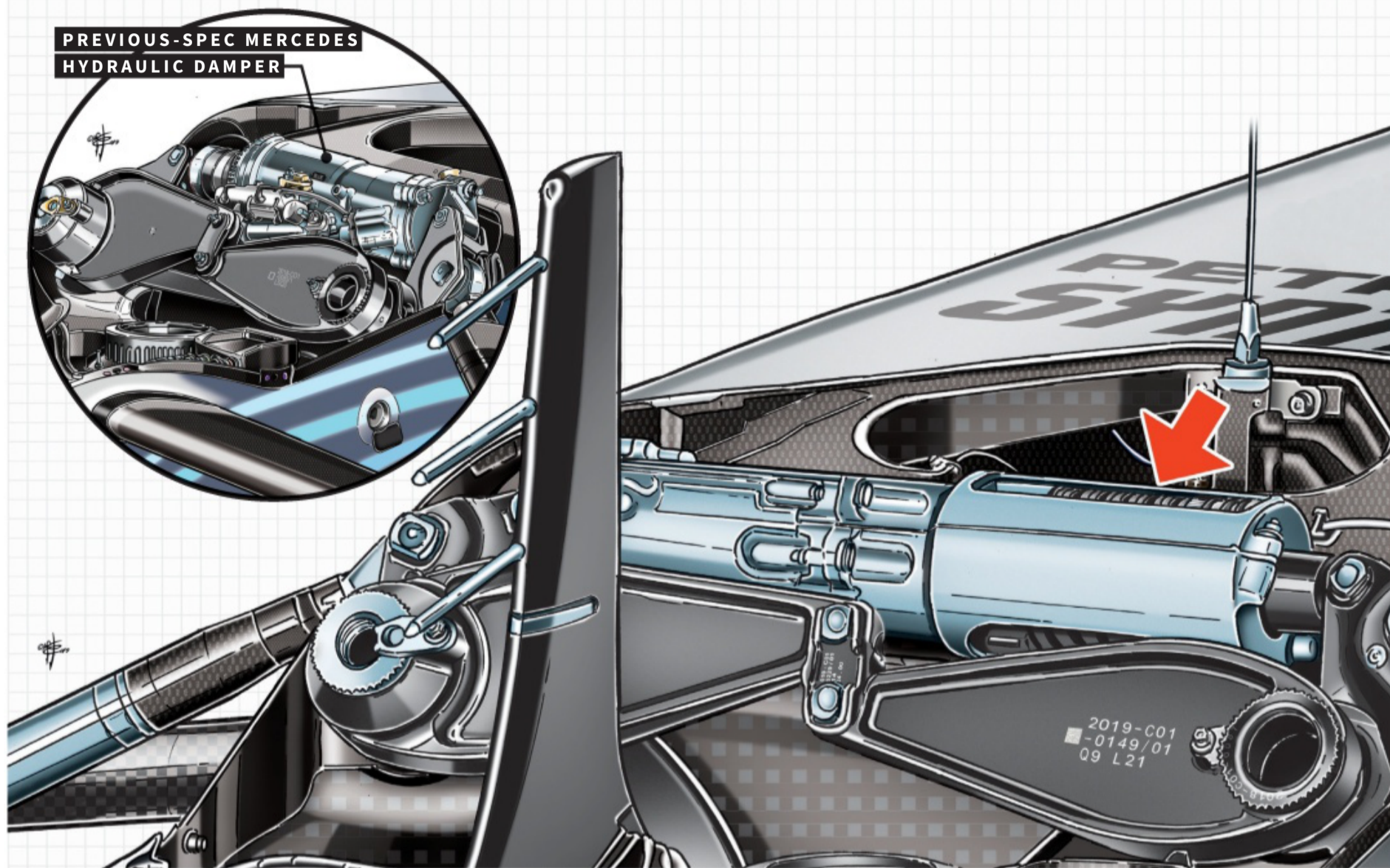

## A SUSPENSION RETHINK FOR THE SILVER ARROWS

Mercedes has updated the heave-spring element of its front suspension and, having evaluated it during the previous Formula 1 round in Singapore, retained it for the Russian Grand Prix at Sochi in its efforts to find greater stability over the kerbs.

When the car is moving in a straight line, the suspension displacement either side is more or less equal. This is when the third spring comes into play, by helping to support the car as the aerodynamic loads increase. Otherwise very stiff side torsion bars would be needed, which would reduce mechanical grip in slow corners.

Under the previous design the element was hydraulically actuated, and the spring rate was provided in the compression of the fluid, but now this features a series of Belleville washers to generate the movement resistance.

One of the interesting things that was very noticeable at Singapore was how good the Ferrari was over the kerbs. By contrast, the Mercedes looked quite nervous. When a car lands after a kerb strike the important thing is that it settles quickly,

which enables the driver to get on the throttle as early as possible. With good traction off the corner, it will improve the car's straightline speed and, in turn, lap time.

The central front spring plays a major part in this, since any kerb impact with the inside front wheel will mean that the open gap on the third spring will close by about half of the suspension impact from that kerb strike.

### FERRARI USES A COIL-SPRUNG THIRD ELEMENT

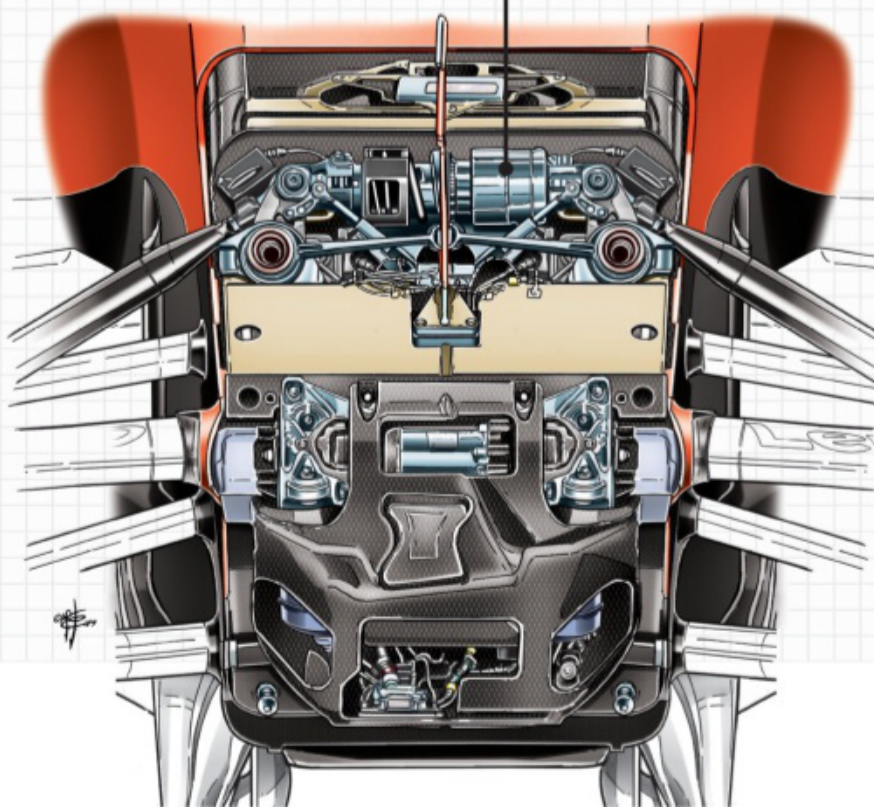

When analysing the Mercedes, Ferrari and Red Bull front-suspension set-ups (Autosport, 6 June), one of the things I commented on was that at that time Mercedes used what is called a metal mesh bump stop. This is a very stiff mesh packer with a gap before it comes into play. With this system, the car is either on it or off it. In effect it provides a very good front-suspension travel stop for the straights, but not so good if you're coming on and off it in a corner because of kerb inputs.

At that time the Ferrari used a large-diameter coil spring, which gives fairly progressive spring rates but takes up much more space, and the Red Bull used a package of Belleville washers. You can play tunes on these washers as far as stiffness is concerned, and they are also more progressive than what Mercedes was using.

Mercedes has now gone to a package more in line with that of Red Bull, a series of bevel washers. I'm pretty sure there is more to it than just the spring set-up but that is all we can see from the outside.

**GARY ANDERSON**

**PRIVATE TREATY**

*By order of joint liquidators*



2013 PAGANI HUAYRA C9 LHD SUPER CAR  
WITH DELIVERY MILEAGE

**Offers invited in excess of £1,200,000**

Viewing strictly by appointment only. Proof of funds may be required  
For further details please contact – [pagani@gordonbrothers.com](mailto:pagani@gordonbrothers.com)



**ONLINE AUCTION**

*By order of joint administrators*

**CHERISHED REGISTRATION NUMBERS**

INCLUDING: 14 O, 22 O, 1 JDC, 5 XK, 7 BPM, 2 CFE, XK55 JAG, TNK 2, 1 OKV, 1 CSX, JDS 9  
(Subject to Availability)

Auction closes on Friday 11th October

To bid please visit: [BidSpotter.co.uk](http://BidSpotter.co.uk)  
powered by atgmedia

 **Gordon  
Brothers**  
1903

[GORDONBROTHERS.COM](http://GORDONBROTHERS.COM)



# This time it's war

*Sebastian Vettel has shown he will do anything to avoid being usurped by Charles Leclerc. How Leclerc responds could be career-defining*

EDD STRAW

All world champions are ruthless. This characteristic manifests itself in many different ways, be it in a willingness to get involved in on-track scrapes, a callous lack of regard for rivals, the single-minded focus on their own ends to the exclusion of all other, or any of the myriad ways things can get edgy in a race. All 33 world champions have this in their blood.

Earlier this season, there were legitimate questions about whether Sebastian Vettel still had it in him to dig deep and do what needs to be done to be world champion ever again. What happened during last weekend's Russian Grand Prix proved beyond doubt that he is every bit as determined as he once was, even if he can't match upstart Ferrari team-mate Charles Leclerc for speed.

How's this for a manifestation of being ruthless? Capitalise on a pre-race agreement to take the lead and then refuse to give it back, knowing that ignoring several explicit demands to cede the position will infuriate your team-mate behind. Force your team to execute the order unilaterally by giving your team-mate the undercut, because they know full well that you would do everything you can to stay ahead.

This was Vettel attempting to assert himself as the big dog in the team. And to do so, with his career at stake, he was willing to risk fermenting a toxic atmosphere inside Ferrari and perhaps even jeopardise his own future given how easily it could backfire. At its

---

**“It was naive of Ferrari to believe it could manage the start to this extent without risk”**

---

most extreme, this was Vettel bringing to a head the simmering question of whether this is still his Ferrari or Leclerc's team.

Vettel knew he was wrong to do this in the sporting sense, no matter how he rationalises it. Even if he was unhappy with the start agreement before the race – and you suspect this was the case – that doesn't justify ignoring the team instruction. He claimed on the radio he would have passed Leclerc anyway, so that was also clearly part of his cover story.

And even though Ferrari was wrong to attempt to switch Vettel and Leclerc round so early in the race, rather than getting it won and then sorting it out down the line, that doesn't excuse shrugging off the instruction. What we can be sure of was what Vettel was doing – he knew the longer he was ahead, the better the chance he could stay there.

By edging away from Leclerc in the first stint and demanding he be closer, Vettel would be able to argue a pace advantage and use the risk of Lewis Hamilton gatecrashing their switch as justification not to ease off. And with Leclerc behind and therefore vulnerable to a potential attack, he was also hoping Hamilton might get ahead and render the swap impossible anyway. This wasn't the emotional Vettel some have portrayed – it was cold, calculating and brutal. He knew exactly what he was doing, and why.

Vettel, knowing the stakes, threw everything at trying to win this race and to hell with the consequences. After all, winning is the only currency that matters in F1 and he's been pretty short over the past year or so. That's why Ferrari had to take control and give Leclerc a four-lap undercut, which clearly angered Vettel before the MGU-K failure gave him something else to be furious about.

Suppose Vettel had still been ahead after the stops and with a fully functioning ERS system? Ferrari team principal Mattia Binotto said after the race they would have switched, no problem. But it was naive of Ferrari to believe it could manage the start to this extent without the risk of a backfire.

Binotto's PR-friendly answer cannot be what he believes, because he's no idiot, and all credit to him for ensuring the situation was taken out of Vettel's hands with the strategy call that he unconvincingly argued was not about that. Meanwhile, Leclerc sat in Ferrari's post-race media briefing alongside Binotto and Vettel and claimed – unconvincingly – that the trust between the drivers hadn't been lost. But in racing terms, Leclerc will probably never turn his back on Vettel again!

Vettel did what he felt he needed to do to keep himself in the game. The sheer, to-hell-with-you audacity of it was breathtaking – just what you'd expect to see from a champion.

Vettel knows the score. He's an ageing driver, albeit not that old considering he's in his 12th season having started young, shakily facing up to the challenge of the new generation of Leclerc and Max Verstappen. Every empire crumbles, and so many great drivers have faced this battle eventually because time cannot be defeated.

As for Leclerc, he's not above a ruthless trick and showed on the out-lap of the shambolic final Q3 runs at Monza that he was happy to use any excuse to place himself behind Vettel on the track, even though the instruction was that he should be ahead and provide a tow. How Leclerc responds to this potential civil war from the moral high ground of Sochi could prove career-defining.

But if Vettel is on a journey to the end of the road, he proved at Sochi that he's only going to go there trying everything he can to hang on despite Leclerc's inevitable triumph. You have to respect that, even if you may not like the way he has gone about it. ❄

➔ P18 RUSSIAN GP REPORT

**2019 BRITISH**

# TOURING CARS

## BRANDS HATCH GP

**FINAL ROUND!**

**KwikFit BTCC**  
BRITISH TOURING CAR CHAMPIONSHIP

A FULL DAY OF ACTION AS THE SEASON REACHES ITS CLIMAX:

- DRIVERS FIGHT FOR THE 2019 BTCC CROWN
- THREE PAINT-SWAPPING BTCC RACES ON THE SUNDAY
- A FURTHER TWELVE SUPPORT RACES OVER THE WEEKEND
- MANUFACTURERS INCLUDING BMW, HONDA AND SUBARU
- FREE PIT WALK, FUNFAIR, TRADE VILLAGE AND MORE!

**WHO WILL TAKE HOME THE 2019 CROWN?**

ADMISSION  
ADULT RACEDAY (ONLINE) £28\*  
WEEKEND (ONLINE) £38\*  
GRANDSTAND SEATING FROM £5  
CHILDREN UNDER 13 GO FREE!

**SAT 12/SUN 13 OCT**

**0843 453 9000**  
**BRANDSHATCH.CO.UK**

**Brands Hatch**

\*Discounted advance tickets available until midday Thursday 10 Oct.  
Calls will cost 7p per minute plus your telephone company's access charge.

**SILVERSTONE**  
CLASSIC & RACE CAR STORAGE

**01604 879851 | www.scracs.co.uk**



# McLaren's Mercedes motivation

*When McLaren and Mercedes went their separate ways it seemed like the dissolution of their partnership was final – but expediency has driven them back together again*

ADAM COOPER

**T**he return of the McLaren-Mercedes combination in 2021 is a reunion that we never thought we'd see. But, as the Woking team taught us when it rehired Fernando Alonso, anything is possible if both parties see there's an advantage to be gained, or favourable sporting and commercial implications.

Since his arrival from Porsche's racing programme earlier this year, team principal Andreas Seidl has reviewed every area as McLaren looks for ways to make further progress. It was logical for the German – previously a BMW F1 engineer – to consider the power unit: can we do better for 2021 and beyond?

Given a mandate to take a step back from any historic political considerations, Seidl has determined that, on a balance of reliability, performance and likely progress over the next few years, Mercedes was the better bet. It's that simple.

"I asked him when he joined what we need to do to get back to the front," says Zak Brown. "And he's quickly come back with recommendations like the new windtunnel. He led the decision here on the power unit. It was of course a group decision, but one that was driven by Andreas."

Brown is adamant that it's about pure performance: "When you look at Mercedes-Benz they have been the benchmark in the hybrid era as a power-unit provider both in power and reliability. And of course the racing team itself is the benchmark in this

---

**"The deal has happened just two years after a previous request from McLaren was rejected"**

---

decade, so to have what we believe is the best engine behind our race car and ultimately chasing what we think is the best team in F1 at the moment is a good place for McLaren to be."

Significantly, Renault's proposal for its post-2020 arrangements with McLaren was very different from the simple engine-supply deal agreed with Mercedes. Renault wanted closer cooperation in other areas, such as on non-listed car parts, and was even willing to share a gearbox. The French manufacturer saw it as a variation on the Ferrari/Haas deal – but with two "equal partners" helping each other to progress while keeping costs down. Confident in its own ability to go it alone, McLaren had no interest in taking such a route.

"The world of F1 is going to change in 2021," says Brown. "And that's where we are focused now with this decision, and

I think some of those areas in which you can collaborate today, you're not going to be able to do in the future.

"McLaren want to stand on our own two feet and be an independent team, as we always have been. So we're going to continue in that direction, and I think the regulations are going to support that type of independence, maybe more so than today."

So what's in this for Mercedes? In simple terms an extra customer means that a significant chunk of money is going into the Mercedes pot, or more specifically that of High Performance Powertrains in Brixworth. Any influx of funding keeps the Stuttgart bean counters happy.

One intriguing aspect is that the deal has happened just two years after a request from McLaren was rejected – and the sad absence of Niki Lauda from the Stuttgart camp has played a role.

"Niki and I disagreed on the engine question," says Toto Wolff. "He was very much in favour of supplying Red Bull back in the day. We were in the early stage of finally having a team that started to win, and I was against it. When the decision came up to supply McLaren a few years ago Niki said, 'Well you gotta stay true to your opinion back then and concentrate on the works team.'"

Would Niki have agreed this time around? Sadly we'll never know. Wolff insists that, with new rules approaching in 2021, other factors have changed.

"I think the situation today is different," he says. "The 2021 regulations look totally different and will change the landscape. And in this new day and age there needs to be an emphasis on the bottom line – we need to look at numbers. I don't believe there are big downsides."

Mercedes has done it before, but supplying three customers is a stretch. When the latest Phase 3 engine was introduced across the six current cars at Spa no spares were available to immediately replace the units that failed on Sergio Perez's Racing Point and the Williams of Robert Kubica.

But from 2021 there will be restrictions on dyno usage, and therefore some of the capacity that would have been allocated to building engines for evaluation in the factory can now be diverted to supplying McLaren.

"There's maybe a process and logistic question, because everybody needs to be supplied at the same time," says Wolff. "But I think there is more upside in it going forward."

"There is one risk in this, that if McLaren does a good job, they will push hard, and maybe benchmark us in a way to say, 'OK, that's the same power unit and you guys are not doing a good enough job.' But where we are now after seven years in the hybrid era, we are ready for that step."

Will McLaren really be able to make that kind of progress by 2021? It's clearly confident that it can. ❁

**AUTOSPORT PLUS**

**Unlimited Access**

to the world's best motorsport journalism

**Smart Insight**

published daily

**Breaking News**

as it happens

**All the Teams**

all the drivers, all the controversies

**GET MORE**

*of the motorsport you (and we) love*

**START**

Your **7-day FREE** Trial

[Autosport.com/Plus](https://www.autosport.com/plus)

New subscribers only. 7-day free trial offer ends 31st October 2019.

# YOUR SAY

*To come up with this scenario is a joke. I'm sorry, this is racing. You have the rest of the race and pitstops to win the place back*

MA SMITH

### Ferrari cost itself victory in Russia

What was Ferrari thinking? A potential win lost due to unnecessary shenanigans. If Sebastian Vettel agreed to give the position back if he got to Turn 2 first, then he is out of order not doing so. He has previous with bad form, and if this is the case then it's poor sportsmanship, in my opinion.

But to come up with this scenario anyway is a joke. All the drivers know it's a long drag race to the first true corner, so to go the fastest, be on pole, be pleased with that, then say, well actually, I will probably not get to that corner in the lead on the opening lap of the race, that's not fair. If you pass me I want it back please.

I'm sorry, this is racing. You have the rest of the race and pitstops to win it back. There is teamwork and team tactics and there is nonsense, and in my view, this is the latter.

**MASmith**

**By email**

### It's too early to mess with race-weekend format

I can understand the team at Formula 1 Management wanting to consider the format of the race weekends to ensure that they have an exciting, entertaining and must-watch product.

However, to trial something like reversed-championship sprint races to determine qualifying with the current cars and most tracks, where even with this year's front wings it has proved to be extremely difficult (if not impossible) to overtake a car with a similar speed, I feel is a year too early.

The Mercedes, Ferraris and Red Bulls will make initial progress on most tracks, but will eventually come up against cars of similar speed and then we'll get a procession. This will also handicap the championship leader through no fault of their own.

Surprisingly, most of this year's grands prix have been some of the most exciting for years, so the adage 'if it ain't broke, don't fix it' applies. I'm all for improving the show when required and I'm sure the technical rules for 2021 will go a long way to spice up the racing. When this happens, then introduce this format at selected races when they will be able



to actually overtake each other regardless of other limitations.

In the meantime, with the final years of fairly stable regulations closing up the teams anyway, leave it alone.

**Paul Hewitt**

**Luton, Bedfordshire**

### Believe the hype about hypercars

After reading the hypercars feature (26 September), how can any motorsport fan not be excited by this new formula coming in 2020? The cars look fantastic (above), and the engine noise will be spectacular with the many different configurations. Yes, season one may get off to a slowish start with the number of manufacturers involved, but the potential with this formula is immense.

I believe the likes of Ferrari, McLaren and Porsche will not be able to resist the lure of trying to win the world championship – and an outright Le Mans victory – with cars that look similar to their road-going counterparts. Time will tell if this will be a golden period of sportscar racing, but all the ingredients are there to give it a damn good try.

**Michael Skeet**

**Lordswood, Southampton**

## HAVE YOUR SAY, GET IN TOUCH

**Autosport editorial**  
Autosport Media UK Ltd  
1 Eton Street  
Richmond  
TW9 1AG

@  
**E-mail**  
autosport@  
autosport.com

  
**Visit our website**  
autosport.com

  
**Twitter**  
twitter.com/  
autosport

  
**Facebook**  
facebook.com/  
autosport

  
**Instagram**  
instagram.com/  
autosport

  
**YouTube**  
youtube.com/  
AUTOSPORTdotcom

# RACE CENTRE

RUSSIAN GRAND PRIX • BTCC SILVERSTONE • FORMULA 3 SOCHI • FORMULA 2 SOCHI • WORLD OF SPORT



MAUGER

# HAMILTON TAKES ADVANTAGE OF FERRARI'S CIVIL WAR

*Sebastian Vettel's reluctance to accede to instructions and let team-mate Charles Leclerc past gave Lewis Hamilton all the opportunity he needed*

EDD STRAW

PHOTOGRAPHY  motorsport  
IMAGES

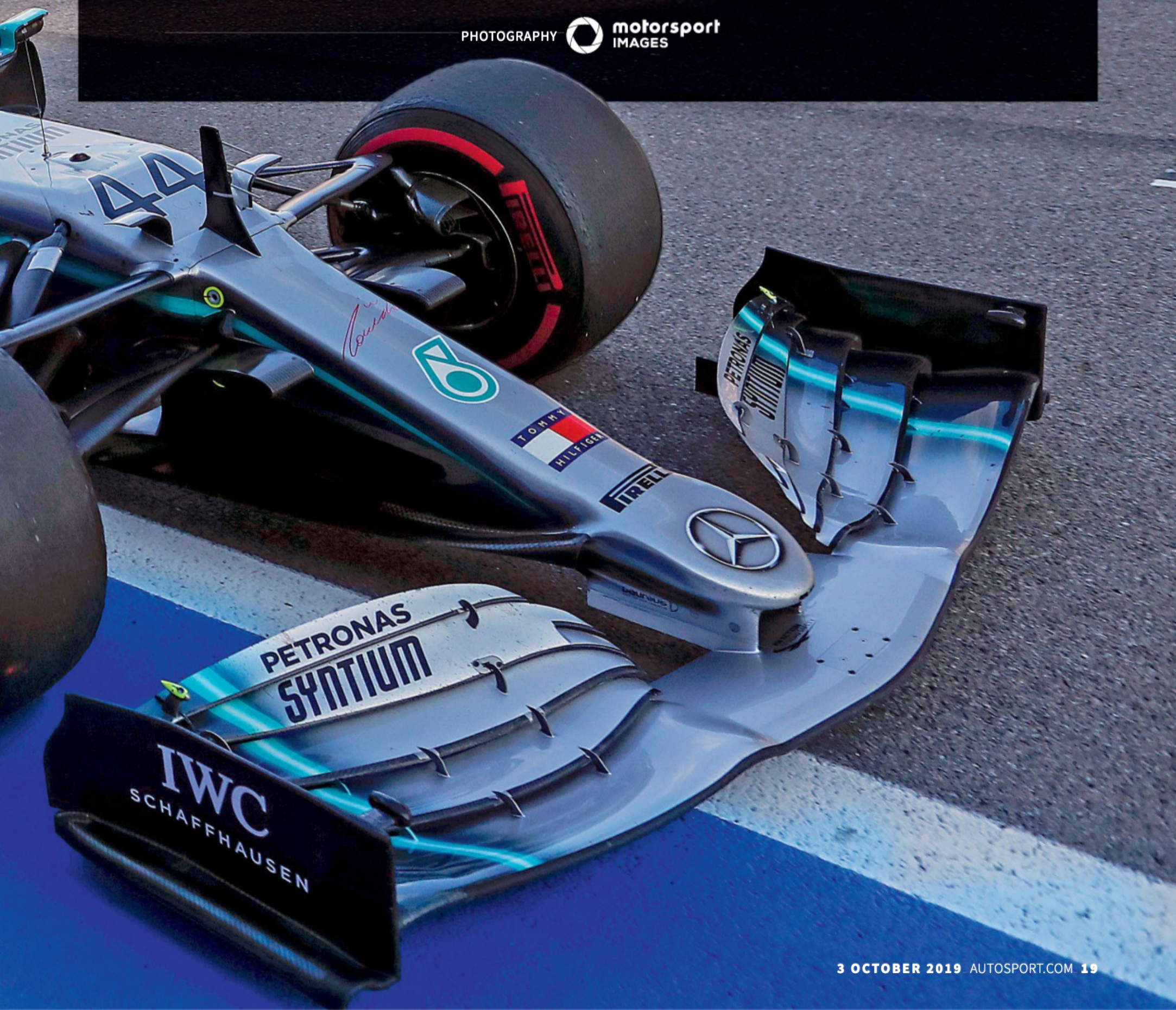



ETHERINGTON

**T**he Russian Grand Prix should not only have been Ferrari's fourth consecutive victory, but perhaps the most convincing in the run of races since the August break. Instead, it descended into what the Italians like to refer to as a *grande casino*, with early leader Sebastian Vettel refusing to heed team orders and let his team-mate past, and Charles Leclerc quietly fuming about that instruction being disregarded.

Unfortunately for Ferrari, that was the best bit of its race as Vettel's subsequent MGU-K failure triggered a virtual safety car that cost Leclerc victory and – compounded by a failed strategic gamble – handed arch-rival Mercedes a 1-2. The repercussions could yet stretch far beyond the loss of a victory, with the relationship between two drivers who will be at the team together for at least another 18 months at best compromised. That went well...

In a parallel universe, this was surely an easy win for Ferrari. The team was delighted on Friday by the performance of its car, which

confirmed that the aerodynamic upgrades introduced in Singapore a week earlier really have made the SF90 stronger into the corners. That, plus an advantage on the straights that Mercedes estimated at just over 0.7 seconds in qualifying, ensured Ferrari had enough speed where it counted to maintain track position with relative ease.

Even in the early seconds of the race, things went exactly as planned, with Vettel quickly jumping ahead of Lewis Hamilton's Mercedes. Ferrari had prepared for the start, with an agreement for the pair not to contest the first corner and risk letting anyone else break their hegemony at the front. As agreed, Leclerc towed Vettel up to Turn 2 rather than covering the inside and risking letting a Mercedes gain that advantage, with Vettel able to take the lead up the inside of the right-hander with relative ease.

"We agreed that the best way was not to give any slipstream to Hamilton first, and therefore Charles would have given the slipstream to Seb," said team boss Mattia Binotto of the start strategy. "By giving



**“WE AGREED THE BEST WAY WAS NOT TO GIVE ANY SLIPSTREAM TO HAMILTON FIRST, AND THEREFORE CHARLES WOULD HAVE GIVEN THE SLIPSTREAM TO SEB”**

the slipstream to Seb and not defending the position he would give an advantage to Seb, which later on in the race we would give back by swapping the cars. So that was the deal.

“They got a good start, Charles stayed on the left, Sebastian jumped Hamilton, and was in the slipstream of Charles.”

Behind, Hamilton held off the racy Carlos Sainz Jr. The McLaren driver jumped from fifth on the grid – assisted by Max Verstappen starting ninth thanks to a five-place grid penalty for a Honda engine change and the other Red Bull of Alex Albon starting from the pits after backing into the Turn 13 wall in Q1 – to pass the Mercedes of Valtteri Bottas, and even briefly hassled Hamilton into Turn 2.

But the field couldn't even complete the first lap before the safety car was deployed thanks to Romain Grosjean being pitched into the barrier at Turn 4. Grosjean, his Haas running 11th after dropping three places off the line on a weekend where he was extremely quick by midfield standards, was holding the outside line at the right-hander to

give room on the inside for Daniel Ricciardo's Renault.

Unfortunately for him, Antonio Giovinazzi's Alfa Romeo had been running side by side with Ricciardo through the long, fast left-hander before Turn 4, having been given a nudge by the Racing Point of Lance Stroll at the exit of Turn 2. Seemingly solely focused on the car to his right, Giovinazzi didn't factor in that his attempt to pass Ricciardo around the outside into Turn 4 would put him in the middle of three cars, and Grosjean was the frustrated victim. But once the track action was paused, the Ferrari drama began.

“Just for me to understand, the situation was pretty clear right?” asked Leclerc over the radio in reference to what happened at the start. Initially, he was told the pitwall would get back to him, but he then received a message that confirms the complexity of the pre-race agreement. To allow for the potential of Vettel simply getting a much better start and earning the lead rather than it being solely a function of getting the tow, Ferrari had scrutinised the starts of its two drivers and found them to >>

Vettel parked his car as instructed by the team, but this would end up backfiring on Ferrari



be the same. The clear implication was that this meant the swap was on.

“So Charles, start performance was the same and we are looking into doing the swap further into the race,” he was told. Leclerc, at this stage, was happy. “No problems, understand,” he responded.

The pause in hostilities only lasted to the end of lap three, with Vettel crossing the line 0.9s ahead of Leclerc and Hamilton a further 0.7s back. Bottas, meanwhile, lost touch with the top three during this phase of the race as he spent just over three laps following the restart behind fourth-placed Sainz’s McLaren before dispatching him effortlessly up the inside into Turn 2, having benefited from the help of the DRS. By then, Bottas was 5.7s behind Hamilton and almost 10s off the lead.

But the real intrigue was at the front. Vettel and Leclerc started to pull away, with Vettel edging clear of Leclerc by almost three tenths on the first full lap of racing. Early on lap five, with Hamilton two seconds behind, Leclerc reported that “the gap behind is enough now”, which led to him being told shortly after that Vettel would let him by next lap. Vettel did not let him by. On lap six, Leclerc was told it would happen on the next lap. Vettel did not let him by, despite being told to do so just before he started the lap. Vettel argued that he would have “got him anyways” at the start even without Leclerc’s cooperation, but suggested that for now they should keep pulling away. On lap seven, Vettel did not

let him by and Leclerc was again told next lap – and to “close the gap”. By now, Vettel was requesting that Leclerc needed to close up if there was to be a switch, not easy considering how difficult it was to follow.

After initially backing out of what appeared to be his first complaint later on lap seven – perhaps mindful of his pledge early in the weekend to say less about such matters over the radio – Leclerc then made his position very clear. “You put me behind, I respected everything,” he said. “We will speak later but now it is difficult to close the gap, obviously.”

Vettel, who argued that he wanted the two Ferraris to keep pulling away rather than messing about swapping places with Hamilton not far behind, did not let Leclerc past on lap eight either. Again, Leclerc was told to close the gap because Vettel – just over 1.5s ahead – felt it was too big. With Vettel again not letting Leclerc by at the start of the ninth lap, Leclerc was again told to close the gap. At this point, sporting director Laurent Mekies decided his team had spent quite enough time demonstrating it had little control over its drivers and intervened. He told Leclerc that the swap would be deferred to later because of the proximity of Hamilton – then still within five seconds.

“I completely understand, the only thing is I respected... I gave him the slipstream,” responded Leclerc – then adding a heavily loaded request to “manage the situation”.

While Ferrari’s eagerness to make the swap so early was hasty – Vettel was right about that – it was clear that the four-time world champion was playing a risky game. He knew that the longer he stayed ahead, the better the hopes of staying there, and there was surely more to this than the desire to ensure Ferrari was out of range before swapping. Vettel wasn’t keen to explain himself in public after the race beyond insisting he respected the agreement, and the team was clearly unhappy that he had disregarded multiple instructions to cede the position. But Vettel was adamant he had followed the terms of the start agreement. What was obvious was that it suited him to do so as late as possible given the advantage of track position.

Intriguingly, Vettel also claimed over the radio that he would have passed Leclerc anyway, suggesting he felt he had earned the lead on merit. Vettel’s approach hinted he was not happy with the deal from the start – why would he be, given it would disadvantage him in most circumstances? – and the fact that both drivers were irritated suggested Ferrari had overmanaged the start and created far more problems than it had solved.

Unexpectedly, the insubordinate Vettel did have a slight pace



Team effort: Bottas did a fine job acting as a buffer to Leclerc

ANDRE



Binotto said undercut was not to restore driver order, but that's what it achieved

ANDRE

**“WE KNEW IF WE WOULD HAVE STOPPED BOTH OF OUR CARS THEN WE WOULD HAVE BEEN VULNERABLE ON SAFETY CARS AND GIVING THE LEAD TO HAMILTON, SO WE STAYED OUT AS LONG AS WE COULD WITH SEB”**

advantage over Leclerc. In fact, from the restart on lap four to the end of lap 21 – just before Leclerc pitted to change from softs to mediums – Vettel was, on average, 0.186s per lap quicker. If Vettel's plan was simply to prove he was faster and therefore either be allowed to win or be considered too far ahead for a swap, he was executing it brilliantly.

Leclerc was 4.7s behind when he peeled into the pits, with Hamilton a couple of seconds back. Leclerc was a little ragged during that stint, possibly because he was justifiably frustrated by Vettel's very obvious refusal to cede position – or perhaps he was just slower on the day.

Ferrari let Vettel run four laps longer, conveniently enough to give Leclerc enough of an undercut to take the lead and redress the balance, despite Binotto claiming it was just the right strategy for the two drivers.

“The undercut was not for the reason of giving back the position to Charles, the undercut was because Charles stopped because his left-rear was starting to be worn so it was the right time to pit,” said Binotto. “We knew as well that if we would have stopped both of our cars then we would have been vulnerable on safety cars and giving the lead to Hamilton, so we stayed out as long as we could with Seb.”

But if the safety car was such a concern, why pit Leclerc when they did? It is true that he reported the left-rear was a problem, but his lap times had only dropped by 0.237s on average on the final three laps before pitting compared to the previous three, so staying out a little longer would have been perfectly feasible. Given Vettel's lack of cooperation early on, could Ferrari really risk not taking this out of his hands? If the undercut was to swap them, and it stands to reason that it was, it was the correct move and represented Ferrari fixing the problem.

With order restored at Ferrari and Leclerc the de facto leader, the only thing that could derail things was the intervention of the safety car. The Mercedes drivers had started on medium tyres having used that compound in Q2, with everyone else using softs, so could run longer. So when Vettel's MGU-K gave out on his out-lap and he was ordered to stop the car, the race was handed to Hamilton. Vettel pulled over by Turn 15, under strict instructions from the pitwall. With the car live, for safety reasons the desire was to stop it on track rather than bring it back to the pits, but this would bite Ferrari badly. Vettel parked the car as well as he could, but there was no way to avoid the virtual safety car.

With Bottas 13s behind Hamilton, the one consolation for Ferrari was that Leclerc at least retained second position. But once the VSC was upgraded to a real safety car after something in his Williams's front-left >>

## QUALIFYING

How do you fight Ferrari's straightline speed advantage at a track like Sochi? The answer is, you don't. With Charles Leclerc gaining just over 0.7 seconds on Lewis Hamilton on the straights, this track played to Ferrari's strengths. As Hamilton put it after qualifying 0.402s slower than Leclerc – but ahead of the other Ferrari of Sebastian Vettel – Ferrari is at another level when at full throttle.

“Honestly, I feel like maybe the last couple of laps have felt pole-worthy in terms of how this has come together, and optimising the car,” said Hamilton of his laps at Sochi and Singapore. “Pole-worthy, I mean in terms of putting the perfect lap together, I feel each time I'm getting as close to that as possible and then you finish the lap and it's quite a long way off.”

**“I FEEL EACH TIME I'M GETTING CLOSE AND THEN YOU FINISH THE LAP AND IT'S A LONG WAY OFF”**

Hamilton had a point. Not that this is to belittle Leclerc, who drove a good lap, albeit with moments in the final two corners having misjudged the grip available in the overheating rear Pirellis. Ferrari has had this straightline speed advantage throughout the season, but track configurations of late have often favoured the team, with the Singapore upgrade package also improving the SF90 in the corners. And Leclerc, as Vettel's struggles proved, aced it.

Just as in Singapore, Vettel overreached on his second attempt and failed to improve. But he still did enough to beat Max Verstappen's Red Bull, which looked rapid on Friday but, as always, couldn't keep with the Ferraris and Mercedes when it came to the serious stuff later in qualifying. On top of that, a five-place grid penalty for taking a new V6 meant he was never going to be at the sharp end. Valtteri Bottas, usually sensational at Sochi, failed to improve on his second run on a lap that probably would have put him fourth or, at a push, third when the rear snapped in Turn 13.

With Alex Albon absent having crashed his Red Bull at Turn 13 in Q1, McLaren's Carlos Sainz Jr recovered from a tricky time in practice to head the midfield in sixth. Behind, Nico Hulkenberg won the intra-Renault battle in seventh – teammate Daniel Ricciardo was less confident and down in 10th behind Lando Norris and Haas's Romain Grosjean.

Grosjean was arguably the star of qualifying, nailing a great lap in Q2 having opted to crank up the front wing and live with the rear being a little loose.



SUTTON



TRACKSIDE VIEW

The end of the lap at Sochi is, superficially, nothing special. Turns 17 and 18 are a pair of 90-degree right-handers that seem primarily to be an exercise in getting the track back to the start after the geographical necessity of taking it around the pit building.

But there's a good reason for heading to watch here in FP3. At all circuits, getting the tyres right to give you the grip throughout the qualifying lap is a challenge. At Sochi, it's particularly difficult given the twisty final sector and the last pair of corners, where the grip level offered by the cooking rear tyres can vary dramatically. The question is, how much to ask of the rear axle?

During the one-hour session, it's clear how much of a mystery ride these corners are. Early on, Valtteri Bottas loses the rear through Turn 17 and takes to the runoff, while Alex Albon has to dial back his approach to Turn 18 after a lengthy sideways moment at the exit. Carlos Sainz Jr, meanwhile, is hesitant on turn-in and seems to lack confidence in the rear sticking at all as the axle is loaded up laterally. No driver is exempt from moments.

This is what makes it so



fascinating. The drivers are already contending with what is effectively a low-grip track surface, but with a high-grip and very easy-to-slip-off peak. Add the uncertainty about the temperature of the rears into the mix and it's a real test.

"By the last two corners, it's no longer a car balance," explains Renault's Daniel Ricciardo, who is one of the cleaner drivers through here. "You've got what

you've got and it's how best you can manage it. It's one of those where you go in slow to the second to last corner, because the rears are going to be hot, and then think, 'Damn I could have been faster.' But then, the next time out you go faster and have a big slide.

"It's one of those where you always feel you're under the limit if you're getting the most out of it,

but it is fun. Even the last corner. It's such a short run to the finish line you just want to get on the throttle, but sliding out of that corner you can still lose a little bit so I feel it's a bit quick to be clean.

"The last sector is fun, pretty bouncy and off-camber. At times it's pretty ugly but if you get it hooked up it's very lap-time sensitive."

**EDD STRAW**



It's quicker "to be clean", says Ricciardo, even feeling like you're under the limit

**“WITH THAT DIFFERENCE BETWEEN THE COMPOUNDS, KEEPING UP WITH THE SOFTS, WITH THEIR CONSISTENCY AND SPEED – OH GOD, IT WAS SO HARD”**

BINGHAM



corner caused George Russell to pile into the wall – it wasn't a brake failure, but the exact cause had yet to be determined at the time of writing – Ferrari called Leclerc in for a big gamble. He took softs and sacrificed a place to Bottas. Verstappen, back in fourth place, was too far behind having lost ground early in the race making his way past the leading midfielders – Sainz, Lando Norris and Sergio Perez – having initially jumped Grosjean at the start. The hope was that having fresh softs rather than chasing Hamilton using mediums would make it easier for Leclerc to pass. But to get back to where he was, Leclerc needed to overtake Bottas. Over the remaining 21 laps following the restart, even with the assistance of the DRS, he never got close enough even to try. A couple of half-baked dummies to the inside line at Turn 2 were as good as it got.

“It was a tricky situation,” said Leclerc. “Staying on the mediums that already had five or six laps compared to softs that were new [would have been a disadvantage]. We made the right choice.”

“We definitely had the pace to finish in front of Valtteri, but it was quite tricky to follow. As soon as I was getting around 1.5s behind him, everything would overheat and it would be quite a difficult time. Third today was the best we could have done with the safety car.”

Behind, Verstappen had an uneventful run to the end to take fourth ahead of Albon, who completed his recovery from the pits by passing Stroll, Kevin Magnussen, Nico Hulkenberg, Perez, Norris and Sainz – with the last four named all having lost time advantages over the Red Bull driver thanks to the safety car – to take fifth.

Hamilton, meanwhile, reeled off the laps to take his 82nd grand prix victory. While he had needed the VSC that Ferrari inflicted upon itself to get the lead, he had got what he could out of the car on pace and didn't put a foot wrong. He also had reason to thank Bottas, who did a great job to remain as the buffer in second place. But the real key was the Q2 tyre decision, which was the best chance of winning on a weekend when Mercedes was second-best on pace.

“I don't think we were particularly confident,” said Hamilton. “We put ourselves on a slightly different strategy and I was hoping that was

going to give us an opportunity to fight with them at some stage of the race. Ultimately I think they were right because the soft was much stronger than we anticipated.”

“Obviously there was that difference between the compounds, so keeping up with the softs, with their consistency and speed – oh God, it was so hard. There was that tail-off towards the end where I was able to start closing the gap, but it wasn't massive chunks. Then we were able to extend and the safety car and all those things came into it.”

The wider question now is how what happened will impact the Ferrari drivers' relationship. Already this rivalry has been simmering, with old stager Vettel clearly as desperate to reassert himself over Leclerc as the young charger has been to make Ferrari 'his' team. Leclerc's hesitancy in repassing Vettel on the hilarious Monza out-lap in Q3 had caused problems, as did the inadvertent switch of the pair in Vettel's favour in Singapore. What happened in Russia must surely ramp up that tension to the next level and potentially gives Ferrari a situation that's too hot to handle. And while it was obvious what Vettel was trying to do by delaying ceding position until Ferrari took the decision out of his hands, it showed that the four-time world champion still has the determination and the ruthlessness to do everything he can – even to go too far – to stay in the game rather than folding. Compelling stuff.

“The trust doesn't change and we need to trust each other, Seb and myself, because it's usually important for the benefit of the team in some situations to know that you can count on the other car and vice versa. Yes, the trust is still here.”

Sure it is, Charles... ❄️

#### NEXT F1 REPORT

#### JAPANESE GRAND PRIX 24 OCTOBER ISSUE

Can Lewis Hamilton and Mercedes capitalise on Ferrari's brewing internecine issues and continue his fightback at Suzuka?

## Albon recovers to fifth after qualifying crash

Red Bull's Alex Albon finished fifth at Sochi after starting from the pitlane following an accident in Q1.

The London-born Thai was 19th and slowest of those who ran in qualifying (Daniil Kvyat did not appear thanks to an engine change triggered by an FP3 failure) after backing into the barrier at the Turn 13 right-hander. This followed a difficult run through practice during which he struggled to get on top of the car.

"I got caught out with the wind and just went in a bit deep," said Albon. "I thought I'd get away with it or else I'd have aborted and gone to the escape road, but I tried to stay on. With a tailwind there, it's not easy."

After changing power-unit components and triggering a pitlane start, Albon overtook Kvyat, Pierre Gasly and George Russell during the first stint. He pitted under the second safety car, which allowed him to take the restart in 10th having jumped Nico Hulkenberg as a result.

He then passed Lance Stroll, Sergio Perez, Lando Norris, Kevin Magnussen and Carlos Sainz to secure fifth.

"I'm happy, after a tough Saturday," said Albon. "That was the best we could have done. A little bit fortunate with the safety car, but the pace was there. Coming from Saturday it was good for the team and everyone to do a good job."



ALL PHOTOGRAPHY  
motorsport  
IMAGES



## Magnussen loses place to penalty

Haas driver Kevin Magnussen finished eighth on the road, but was relegated to ninth at the chequered flag thanks to a five-second penalty for not rejoining the track properly.

Magnussen was running seventh on lap 44 when he covered the inside into Turn 2 while under attack from Racing Point's Sergio Perez. The Dane braked too late and had to take to the runoff after rattling over the 'dome' kerbs, but failed to pass to the left of two polystyrene markers before rejoining the track as stipulated.

Initially, it seemed Magnussen could slip to 11th because of the penalty, but his good pace in the closing stages, combined with 10th-place Nico Hulkenberg hitting engine troubles in the

final two laps and therefore backing up the Racing Point of Lance Stroll, meant he only slipped behind Lando Norris.

"This is bullshit," said Magnussen of the penalty. "I missed the corner, went through a load of crap offline on the runoff and lost a hell of a lot of time and got penalised by my own fault."

"You had to stop the car and turn very sharp to the left to make both of them [go around the markers]. When I got onto the runoff I was carrying way too much speed."

Team principal Gunther Steiner referred to an "idiotic steward" over the radio in a post-race message. It is understood that he could face further scrutiny from the FIA over this comment.

# Binotto adamant neither driver went against agreement

Ferrari team principal Mattia Binotto insisted that both Sebastian Vettel and Charles Leclerc adhered to the terms of the start agreement that resulted in Vettel taking the lead at Turn 2.

Vettel dismissed several instructions to cede the lead to Leclerc in the first 10 laps, but when asked after the race if either driver had gone against the agreement Binotto insisted: "No, no." He was also confident the pair would have swapped positions on-track later in the race had Leclerc not conveniently been given a four-lap undercut and jumped Vettel.

He was also adamant, despite Vettel suggesting he was going to pass Leclerc anyway thanks to a better start, that it was the correct call to restore the original order later in the race.

"Looking at the video, the start went as planned and therefore we thought it was right to ask Seb to swap positions," said Binotto. "The two drivers may have different opinions by driving the car, but that's something which we may discuss with them."

"We initially asked Seb to give the position back, but fair enough, at that stage of the race maybe Charles was not close enough, and we would have lost some time on track. Later on,

Seb was quite fast and gained some track advantage on Charles. We knew that we could have decided to do it later on."

Vettel avoided getting into too much detail when asked what he thought of the strategy that allowed Leclerc to jump him. But he had the air of a man frustrated by the move.

"I wasn't really aware when Charles was going to pit," said Vettel when asked whether he would have given the position back had he been ahead after the stops. "I was aware of the fact I was quite a bit down the road and obviously the last laps before the pitstop I was struggling more and more with the tyres so realised that it would be time to pit."

"When I got out, I found myself behind, then I had a problem. The bigger downside was the fact that we had to retire."

Leclerc was equally cautious with his public statements, but it was very clear he was unhappy with Vettel staying ahead. Despite his claim that the trust is still there between the two, he was not impressed by Vettel not heeding the early-race team order.

"I don't know," he said when asked if Vettel should have given the spot back at that stage of the race. "In the car obviously there was an agreement, and that's all I can say."

SUTTON

## Grosjean and Ricciardo eliminated by Giovinazzi clash

Romain Grosjean and Daniel Ricciardo were eliminated from the Russian Grand Prix after a first-lap clash with Antonio Giovinazzi's Alfa Romeo.

Giovinazzi and Ricciardo were battling through the long Turn 3 left-hander, with Ricciardo on the outside, as they approached the 90-degree Turn 4 right-hander. Although Ricciardo had inched ahead, Giovinazzi attempted to go around the outside of the Renault at Turn 4, but had not factored in the queue of cars ahead.

This led to Giovinazzi being sandwiched between Ricciardo on the inside and the Haas of Grosjean, holding a wide line, and the trio making contact. Grosjean was pitched into a spin and into the barrier, while Ricciardo made it back to the pits with a puncture but was withdrawn from the race shortly after because the damage was too significant. Giovinazzi survived after stopping but finished 15th and last.

"I was like ham in a sandwich, to be honest," said Giovinazzi. "I tried to lift off when I was in the middle but it was just too late. Nobody from right or left knew there was another car in the corner."

Grosjean, who was furious after a strong weekend that netted him eighth on the grid, later said he had "no chance to react", while Ricciardo said he thought he was safe on the inside.

The stewards noted the incident but took no action.



### Q&A

#### CARLOS SAINZ McLAREN DRIVER



Sainz took his fifth 'Class B' victory of the season with sixth place, despite a difficult start to the weekend.

#### You had a strong start to pass Bottas...

I've been getting really good starts all season, so I knew that if I got a good start again, a good 0-100km/h, that maybe I could get the tow of Vettel and the really fast Ferrari down the straight. Fighting with the Mercedes and the Ferraris into Turns 1 and 2 was my target and that was nice to see. It didn't last very long though! Unfortunately, we came back to reality and Bottas passed us so it was all about controlling the race. We had a very good pace all the way through.

#### Were you disappointed to lose out on fifth at the end to Albon considering the safety car hurt you?

That Red Bull was very difficult to keep behind.

I thought about giving him an eight-lap defence, but Perez came from behind. The Racing Point is so quick on the straights and it's very easy to lose that P6 that you had assured yourself of after a tough weekend for the team and a strong race for us. It made sense for us to give it a go and see if I could keep Albon behind, but then no.

#### Were you happy with the car changes made on Friday despite initial concerns?

I'm surprised to see that we held onto sixth. We were three to four tenths quicker than the Racing Point in qualifying and in the race they were the same pace, or maybe faster. It shows this has been a

tough one for the team in terms of race pace. I did a very good qualifying lap to sneak ahead of everyone and give me track position.

#### Is it a personal boost after three non-scores?

Yeah, but none of the zeros in the first half of the season were really my fault and none of these three zeros after the summer break have been my fault, so it's just back to being at our best. That patience this year in trying not to lose our heads too much meant it was just a matter of time before it came back to us.

#### What do you expect at Suzuka?

I think Japan is a track that suits us better, we hope. This weekend has been tough for the team, we've managed to recover well and score best of the rest which shows that we are very strong in other areas apart from the car, but Suzuka will hopefully be better.

<b>20 Albon</b> #23 1m39.197s		<b>18 Kubica</b> #88 1m36.474s		<b>16 Gasly</b> #10 1m33.950s		<b>14 Stroll</b> #18 1m34.233s		<b>12 Giovinazzi</b> #99 1m34.037s	
	<b>19 Kvyat</b> #26 no time		<b>17 Russell</b> #63 1m35.356s		<b>15 Raikkonen</b> #7 1m34.840s		<b>13 Magnussen</b> #20 1m34.082s		<b>11 Perez</b> #11 1m33.958s

**FREE PRACTICE 1**

POS	DRIVER	TIME
1	Leclerc	1m34.462s
2	Verstappen	1m34.544s
3	Vettel	1m35.005s
4	Bottas	1m35.198s
5	Hamilton	1m35.411s
6	Albon	1m35.484s
7	Hulkenberg	1m35.740s
8	Ricciardo	1m36.287s
9	Perez	1m36.321s
10	Grosjean	1m36.516s
11	Sainz	1m36.523s
12	Gasly	1m36.538s
13	Magnussen	1m36.596s
14	Stroll	1m36.714s
15	Raikkonen	1m36.770s
16	Norris	1m36.844s
17	Giovinazzi	1m37.328s
18	Russell	1m38.520s
19	Kvyat	1m38.550s
20	Kubica	1m38.670s

WEATHER 24C, cloudy

**FREE PRACTICE 2**

POS	DRIVER	TIME
1	Verstappen	1m33.162s
2	Leclerc	1m33.497s
3	Bottas	1m33.808s
4	Hamilton	1m33.960s
5	Vettel	1m34.201s
6	Gasly	1m34.971s
7	Perez	1m34.998s
8	Hulkenberg	1m35.026s
9	Stroll	1m35.176s
10	Albon	1m35.216s
11	Norris	1m35.223s
12	Kvyat	1m35.337s
13	Magnussen	1m35.351s
14	Ricciardo	1m35.370s
15	Raikkonen	1m35.374s
16	Grosjean	1m35.593s
17	Sainz	1m35.635s
18	Giovinazzi	1m36.004s
19	Russell	1m36.785s
20	Kubica	1m37.838s

WEATHER 25C, cloudy

**FREE PRACTICE 3**

POS	DRIVER	TIME
1	Leclerc	1m32.733s
2	Vettel	1m33.049s
3	Hamilton	1m33.129s
4	Bottas	1m33.354s
5	Verstappen	1m34.227s
6	Grosjean	1m34.308s
7	Albon	1m34.371s
8	Hulkenberg	1m34.421s
9	Norris	1m34.527s
10	Magnussen	1m34.546s
11	Gasly	1m34.564s
12	Ricciardo	1m34.586s
13	Sainz	1m34.607s
14	Giovinazzi	1m34.766s
15	Perez	1m34.860s
16	Stroll	1m34.898s
17	Raikkonen	1m35.714s
18	Russell	1m36.011s
19	Kvyat	1m36.081s
20	Kubica	1m36.942s

WEATHER 23C, cloudy

**SEASON STATS**

DRIVERS' CHAMPIONSHIP	PTS	BEST FINISH	BEST QUAL
1	Hamilton	322	1
2	Bottas	249	1
3	Leclerc	215	1
4	Verstappen	212	1
5	Vettel	194	1
6	Gasly	69	4
7	Sainz	66	5
8	Albon	52	5
9	Norris	35	6
10	Ricciardo	34	4
11	Hulkenberg	34	5
12	Kvyat	33	3
13	Perez	33	6
14	Raikkonen	31	7
15	Magnussen	20	6
16	Stroll	19	4
17	Grosjean	8	7
18	Giovinazzi	4	9
19	Kubica	1	10
20	Russell	0	11

**CONSTRUCTORS' CHAMPIONSHIP**

1	Mercedes	571
2	Ferrari	409
3	Red Bull	311
4	McLaren	101
5	Renault	68
6	Toro Rosso	55
7	Racing Point	52
8	Alfa Romeo	35
9	Haas	28
10	Williams	1

**QUALIFYING BATTLE**

Hamilton	11	5	Bottas
Vettel	6	9	Leclerc
Albon	0	2	Verstappen
Gasly	1	10	Verstappen
Ricciardo	9	6	Hulkenberg
Grosjean	6	9	Magnussen
Norris	8	6	Sainz
Perez	15	1	Stroll
Raikkonen	9	6	Giovinazzi
Gasly	1	0	Kvyat
Albon	5	5	Kvyat
Russell	16	0	Kubica

Scores ignore sessions if a driver didn't participate in qualifying or had a serious technical problem

**WINS**

Hamilton	9
Bottas	2
Leclerc	2
Verstappen	2
Vettel	1

**FASTEST LAPS**

Hamilton	4
Verstappen	3
Bottas	2
Gasly	2
Leclerc	2
Vettel	2
Magnussen	1

**POLE POSITIONS**

Leclerc	6
Bottas	4
Hamilton	4
Verstappen	1
Vettel	1

**SPEED TRAP (QUALIFYING)**

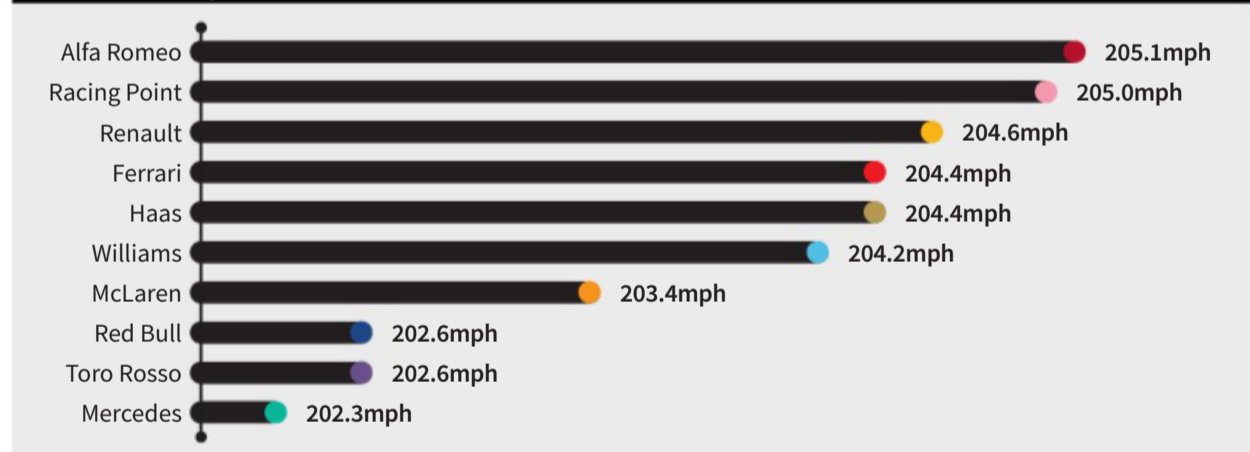

**QUALIFYING 1**

POS	DRIVER	TIME
1	Vettel	1m33.032s
2	Hamilton	1m33.230s
3	Verstappen	1m33.368s
4	Bottas	1m33.413s
5	Leclerc	1m33.613s
6	Magnussen	1m33.889s
7	Ricciardo	1m34.138s
8	Sainz	1m34.184s
9	Norris	1m34.201s
10	Hulkenberg	1m34.236s
11	Grosjean	1m34.283s
12	Stroll	1m34.287s
13	Perez	1m34.336s
14	Gasly	1m34.456s
15	Giovinazzi	1m34.755s
16	Raikkonen	1m34.840s
17	Russell	1m35.356s
18	Kubica	1m36.474s
19	Albon	1m39.197s
20	Kvyat	no time

**QUALIFYING 2**

POS	DRIVER	TIME
1	Leclerc	1m32.434s
2	Vettel	1m32.536s
3	Verstappen	1m32.634s
4	Hamilton	1m33.134s
5	Bottas	1m33.281s
6	Grosjean	1m33.643s
7	Norris	1m33.725s
8	Sainz	1m33.807s
9	Ricciardo	1m33.862s
10	Hulkenberg	1m33.898s
11	Gasly	1m33.950s
12	Perez	1m33.958s
13	Giovinazzi	1m34.037s
14	Magnussen	1m34.082s
15	Stroll	1m34.233s

**QUALIFYING 3**

POS	DRIVER	TIME
1	Leclerc	1m31.628s
2	Hamilton	1m32.030s
3	Vettel	1m32.053s
4	Verstappen	1m32.310s
5	Bottas	1m32.632s
6	Sainz	1m33.222s
7	Hulkenberg	1m33.289s
8	Norris	1m33.301s
9	Grosjean	1m33.517s
10	Ricciardo	1m33.661s

WEATHER 22C, cloudy





POWERED BY

**motorsport**  
**STATS**

Motorsport Stats is the pre-eminent provider of motorsport data to media owners, rights-holders, bookmakers and sponsors. Its data services are founded on the world's largest repository of racing results dating back to 1897. **For more information contact sales@motorsportstats.com**

**STARTING GRID**



**RACE RESULTS ROUND 16/21 (53 LAPS - 192.48 MILES)**

POS	DRIVER	TEAM	FINISHTIME	LED	TYRES
1	Lewis Hamilton (GBR)	Mercedes	1h33m38.992s	28	Mu, Su
2	Valtteri Bottas (FIN)	Mercedes	+3.829s		Mu, Su
3	Charles Leclerc (MCO)	Ferrari	+5.212s		Su, Mn, Su
4	Max Verstappen (NLD)	Red Bull-Honda	+14.210s		Su, Mn
5	Alexander Albon (THA)	Red Bull-Honda	+38.348s		Mn, Sn
6	Carlos Sainz Jr (ESP)	McLaren-Renault	+45.889s		Su, Mn
7	Sergio Perez (MEX)	Racing Point-Mercedes	+48.728s		Sn, Mn
8	Lando Norris (GBR)	McLaren-Renault	+57.749s		Su, Mn
9	Kevin Magnussen (DNK)	Haas-Ferrari	+58.779s		Sn, Mn
10	Nico Hulkenberg (DEU)	Renault	+59.841s		Su, Mn, Su
11	Lance Stroll (CAN)	Racing Point-Mercedes	+1m00.821s		Mn, Sn
12	Daniil Kvyat (RUS)	Toro Rosso-Honda	+1m02.496s		Hn, Sn, Sn
13	Kimi Raikkonen (FIN)	Alfa Romeo-Ferrari	+1m08.910s		Mn, Sn
14	Pierre Gasly (FRA)	Toro Rosso-Honda	+1m10.076s		Mn, Sn
15	Antonio Giovinazzi (ITA)	Alfa Romeo-Ferrari	+1m13.346s		Sn, Hn, Mn
R	Robert Kubica (POL)	Williams-Mercedes	28 laps-withdrew		Mn, Hn, Mn
R	George Russell (GBR)	Williams-Mercedes	27 laps-mechanical/accident		Mn
R	Sebastian Vettel (DEU)	Ferrari	26 laps-MGU-K	25	Su, Mn
R	Daniel Ricciardo (AUS)	Renault	24 laps-accident damage		Su, Mn
R	Romain Grosjean (FRA)	Haas-Ferrari	0 laps-accident		Su

**FASTEST LAPS**

POS	DRIVER	TIME	GAP	LAP
1	Hamilton	1m35.761s	-	51
2	Leclerc	1m36.193s	+0.432s	52
3	Bottas	1m36.316s	+0.555s	50
4	Albon	1m36.762s	+1.001s	50
5	Verstappen	1m36.937s	+1.176s	47
6	Sainz	1m38.020s	+2.259s	53
7	Perez	1m38.043s	+2.282s	49
8	Magnussen	1m38.130s	+2.369s	53
9	Kvyat	1m38.228s	+2.467s	52
10	Vettel	1m38.245s	+2.484s	16
11	Norris	1m38.301s	+2.540s	52
12	Hulkenberg	1m38.519s	+2.758s	53
13	Raikkonen	1m38.589s	+2.828s	51
14	Gasly	1m38.606s	+2.845s	51
15	Stroll	1m38.611s	+2.850s	53
16	Giovinazzi	1m38.696s	+2.935s	51
17	Ricciardo	1m41.284s	+5.523s	22
18	Russell	1m41.705s	+5.944s	18
19	Kubica	1m42.327s	+6.566s	24
20	Grosjean	no time	-	-

WEATHER 24C, sunny

WINNER'S AVERAGE SPEED 123.32mph FASTEST LAP AVERAGE SPEED 136.61mph

**TYRES**



**RACE BRIEFING**

**GRID PENALTIES**

**VERSTAPPEN** and **GASLY** Five-place penalty for additional power unit elements used

**ALBON** Required to start from the pitlane because car modified under parc ferme conditions; 25-place grid penalty for

additional power unit elements used and replacement gearbox

**KVYAT** and **KUBICA** Required to start from the back of the grid due to additional power unit elements used

**RACE PENALTIES**

**RAIKKONEN** Drivethrough penalty and two licence points for moving before the start was given

**MAGNUSSEN** Five-second penalty and one licence point for leaving the track and not rejoining as per the race director's instruction

**LAP CHART** What happened, when

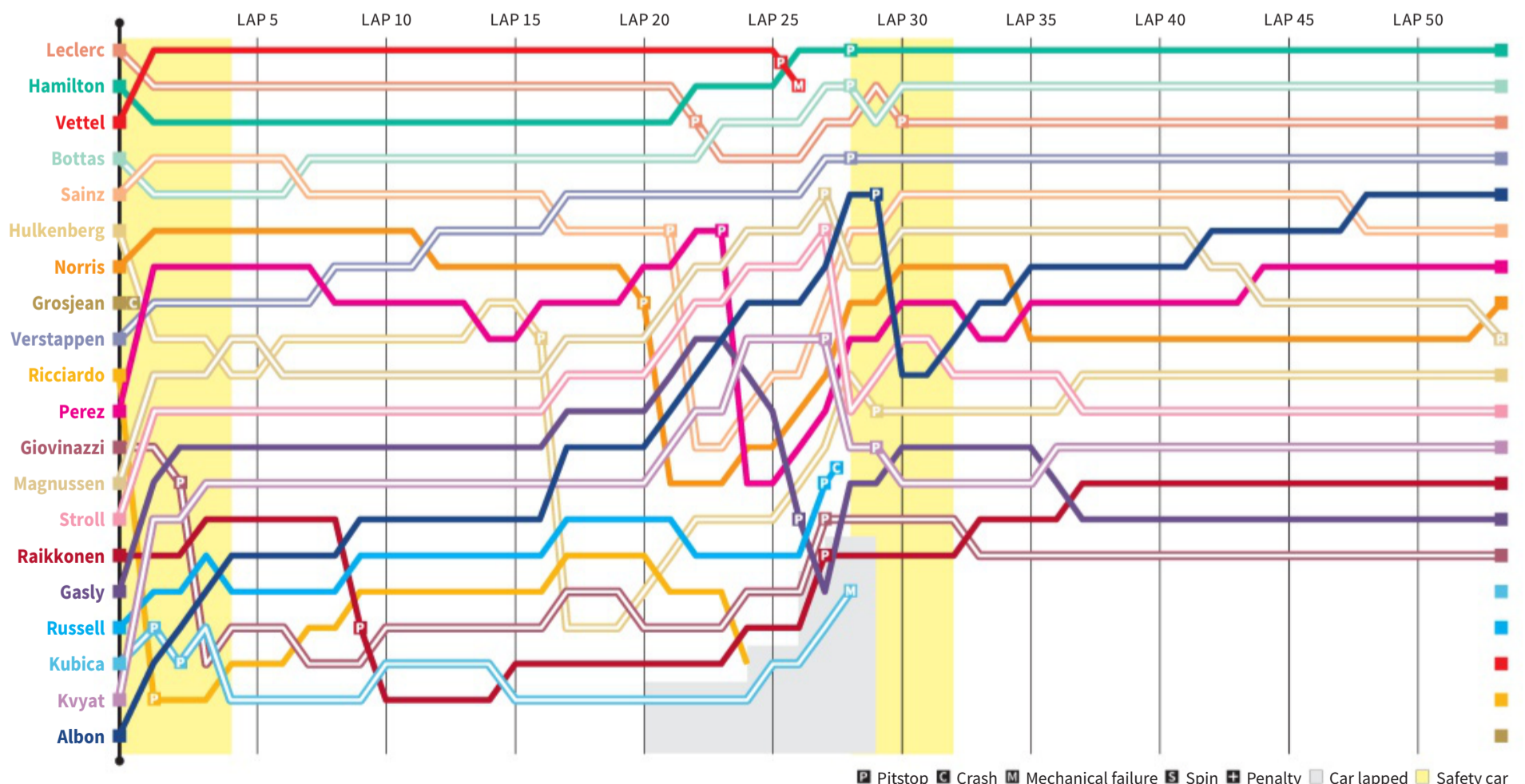

# MERCEDES SWOOPS ON FERRARI FRAILTIES

*The soap opera up front dominated the headlines as Ferrari fluffed certain victory, but for our money the top driver was the 'Class B' winner*

EDD STRAW

## MERCEDES



LEWIS HAMILTON

**9** Hamilton had the upper hand over Sochi specialist Bottas all weekend and split the Ferraris in quali, despite their 0.7s advantage on the straights. He kept the pressure on the Ferraris throughout the race and was where he needed to be to capitalise on the safety car and win.

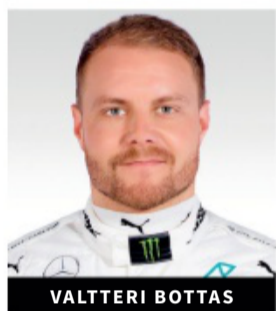

VALTTERI BOTTAS

**7** Bottas struggled to find his usual Sochi verve and was 0.6s behind Hamilton in qualifying, suggesting he found the wind a problem. Like Hamilton he struggled on the medium tyres, but picked up the pace later and never looked like losing second place to Leclerc once he'd been handed it.

## FERRARI



SEBASTIAN VETTEL

**7** Threw away a front-row start in Q3. But this put him in the right place to be towed by Leclerc and take the lead. He overruled instructions to cede position before Ferrari undercut Leclerc past him. The insubordination has to count against him and makes him tricky to rate.

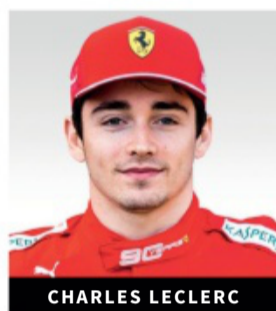

CHARLES LECLERC

**8** Despite a ragged run on cooked rears, Leclerc did a good job to take pole. He was clearly concerned about Vettel not ceding the lead as instructed and dropped to over four seconds off the lead in the first stint. He couldn't make an impact on Bottas in the final stint.

## RED BULL

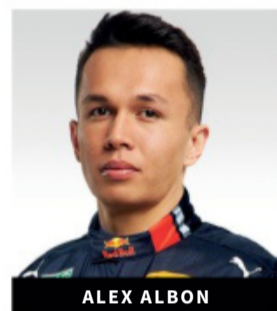

ALEX ALBON

**7** Albon struggled during practice and crashed in Q1, condemning him to a pitlane start after a raft of engine component changes. But he overtook eight cars on his way to fifth, using the safety car to gain ground on the McLarens, Perez and Hulkenberg, and emerged with the best possible result.

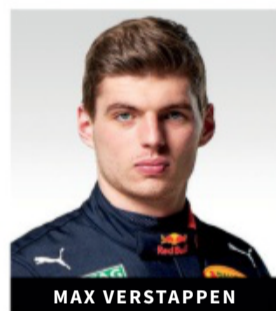

MAX VERSTAPPEN

**8** Seemed a pole threat on Friday before the rest turned the engines up, but picked off Bottas and earned himself a ninth-place start thanks to a grid penalty for taking a new V6. Gained a place at the start, then passed the McLarens and Perez, but didn't have the pace to stay with the leaders.

## RENAULT



DANIEL RICCIARDO

**6** By his own admission, Ricciardo was the second-quickest of the Renault drivers on single-lap pace and lacked confidence in the car on turn-in. He was much happier with his race pace, but never had the chance to show it after his race was ruined by the first-lap collision.

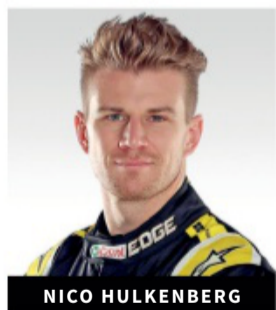

NICO HULKENBERG

**8** After struggling against Ricciardo in recent races, Hulkenberg was back on top at Sochi and outqualified his team-mate by 0.372s. He lost three places on the first lap, largely down to facing a wall of cars at Turn 2, then settled into ninth place before a pitstop problem cost him time.

## HAAS

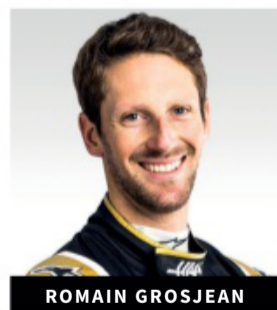

ROMAIN GROSJEAN

**8** Running a 'hybrid' spec of old and new aero, Grosjean's pace on his final Q2 run in particular was inspired after dialling in some front wing and living with the rear end. He lost three places off the line, then was wiped out by Giovinazzi's attempt to fit a third car into a battle.

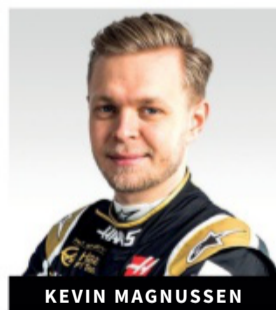

KEVIN MAGNUSSEN

**7** Magnussen was kicking himself after a mistake in Q2 cost him a likely top-10 shootout place and left him 13th on the grid. He climbed to 10th at the start, and capitalised on running long and stopping under the safety car to run sixth at the final restart. Picked up a penalty that cost him eighth.

## MCLAREN

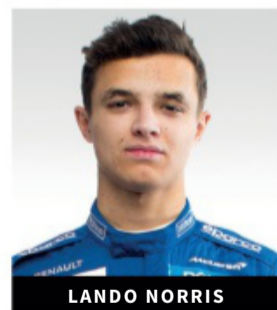

LANDO NORRIS

**7** It seemed that Norris could have had the legs on Sainz heading into quali, but he ended up behind his team-mate and Hulkenberg. Drove a good race, although wasn't helped by the timing of the safety car. He perhaps tried a little too hard to re-pass Albon after losing seventh place.

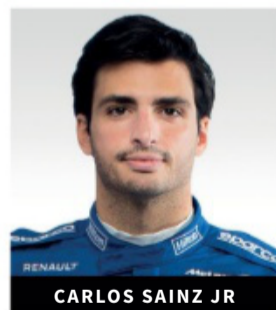

CARLOS SAINZ JR

**10** Sainz didn't look entirely comfortable in practice but got the car where he wanted in quali to secure 'Class B' pole. Jumped Bottas at the start, then settled into a comfortable midfield win. He would likely have finished ahead of Albon had the second VSC/SC period not intervened.



**RACING POINT**



SERGIO PEREZ

**9** A mistake on his quickest lap in qualifying cost Perez a potential Q3 place, but he climbed from 11th to seventh at the start. Lost a place to Verstappen, but after the safety car he capitalised on the Norris/Verstappen battle ahead of him to pick off the McLaren driver for seventh.



LANCE STROLL

**6** As is often the case, small errors cost Stroll in qualifying and come the race he was never quite able to anchor himself in the top 10. He ran 11th early on and took the restart one position higher, but was passed by Hulkenberg, then was backed up by the ailing Renault over the last few laps.

**ALFA ROMEO**



KIMI RAIKKONEN

**4** Both Alfa drivers struggled during practice in a car that lacked grip and balance, but changes before quali improved things and gave Raikkonen a better car he didn't make the most of thanks to a couple of errors. A jumped start and resulting penalty destroyed any tenuous hope of points.

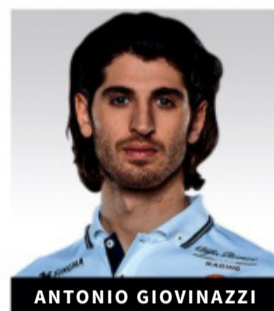

ANTONIO GIOVINAZZI

**6** While he was fortunate to escape Q1, Giovinazzi's Q2 lap in a difficult car was excellent. But while too engrossed in his battle with Ricciardo he failed to focus on cars ahead and put himself in the middle of an inevitable collision. Then he drove to last on a frustrating weekend.

**TORO ROSSO**

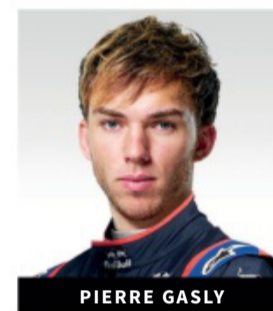

PIERRE GASLY

**7** Gasly now looks fully at home in the Toro Rosso on-track. His first Q2 lap was excellent, although he had to abort the second attempt. In the race, the Toro Rosso didn't have great pace in the hotter temperatures and an off while trying to pass Kvyat cost him a place to Raikkonen.

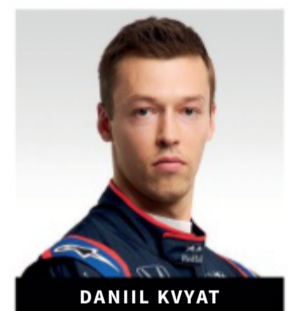

DANIIL KVYAT

**7** Kvyat was restricted to 47 laps in practice and an engine change kept him out of qualifying. He prevailed in the battle of the Toro Rossos in the race, although the car wasn't quick enough in the higher temperatures to fight for points despite prodigious Friday long-run pace.

**WILLIAMS**

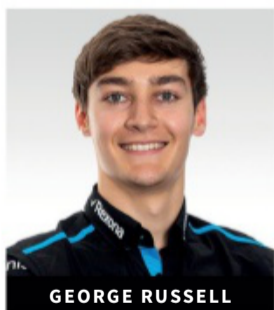

GEORGE RUSSELL

**8** Russell reckoned his qualifying was "one of my best laps of the season", despite racy traffic on the out-lap compromising his preparation. As usual, he took on the midfield stragglers when he could but crashed out under the VSC when something went wrong with the front-left corner.

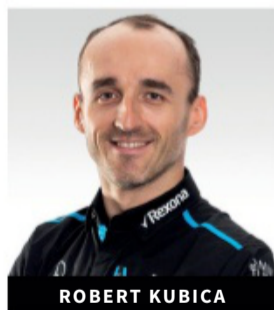

ROBERT KUBICA

**5** Described Friday as "one of the worst days behind the wheel" and things didn't get any better in qualifying, where he lapped 1.118s slower than Russell. The race didn't go much better, although he drove well in the early corners, and he retired after Russell's crash to preserve spare parts.

**TOP 10 AVERAGE RATINGS**

AUTOSPORT'S RATING AFTER ROUND 16

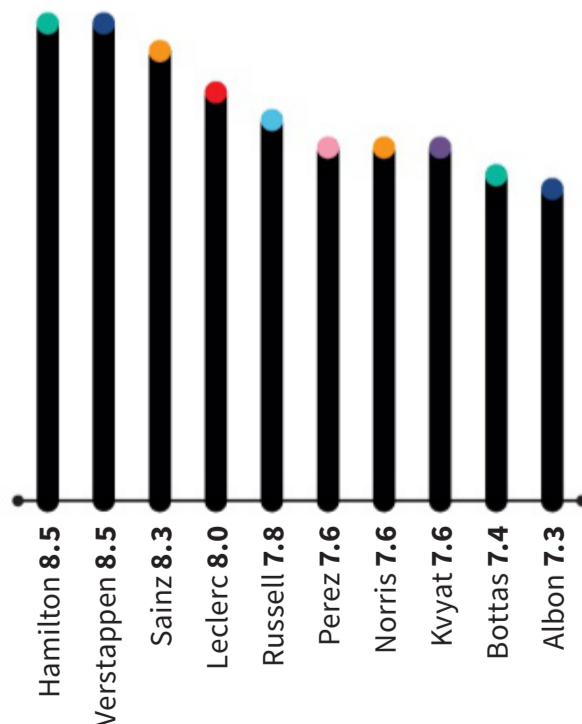

READERS' RATING AFTER ROUND 16

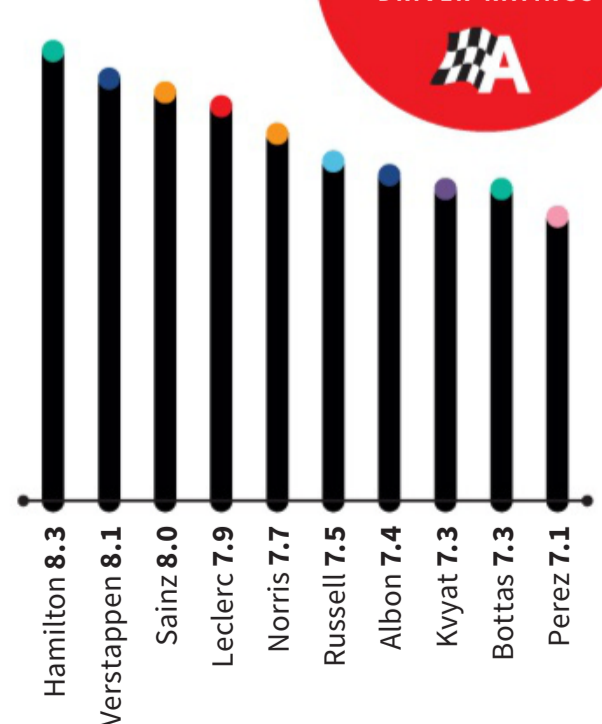

**GIVE YOUR DRIVER RATINGS**  
[AUTOSPORT.COM/F1/DRIVER-RATINGS](https://www.autosport.com/f1/driver-ratings)



# Weekend of a four-time champion

*Uncharacteristic exuberance from Turkington puts him within touching distance of the 2019 BTCC title after early disaster at Silverstone*

MATT KEW

PHOTOGRAPHY JEP  motorsport  
IMAGES



Last weekend will go a long way to defining the outcome of two title-winning campaigns. Liverpool showed it could grind out a result despite a sub-par performance, winning 1-0 over Sheffield United to maintain its 100% points haul. In contrast to that laboured performance, Colin Turkington delivered the most aggressive weekend of his year.

The three-time British Touring Car champion's credentials are without question, but he's at the top of no one's list when it comes to selecting the grid's most ruthless drivers. He's fair and calculated, but allows for a margin of error. That tactic paid dividends last season, as he relentlessly returned safe points-paying results to win the title despite only the one victory.

As Tom Ingram won twice at Silverstone, though, whenever Turkington looked resigned to finish below championship rivals Dan Cammish and team-mate Andrew Jordan he stuck his elbows out and took a cut-throat approach that might well have earned him the 2019 crown.

"No doubt" was the WSR driver's reply when asked if his effort for sixth in qualifying was the most important single lap of his season. Thanks to a healthy tow from WSR stablemate Tom Oliphant, he overcame the maximum 54kg of success ballast to line up one spot above Cammish and eight higher than Jordan.

Then in race one much of that hard work was seemingly undone. He dropped down below Jordan for 12th place and was then caught in Adam Morgan and Rob Collard's battle. He spun exiting Woodcote to a lowly 25th, seemingly destined for a non-score.

As he rejoined amid Aidan Moffat's dice with Jake Hill, Turkington jinked his car further and further to the inside of the track to keep himself away from any more trouble. He might have been well outside the points, but this was the trademark Turkington conservatism – avoid any more trouble.

The grim weather helped revive his fortunes. Drivers ahead spun and the Team BMR duo of Ash Sutton and Senna Proctor



both suffered tyre failures after cutting too fine a line with their pressures. Turkington was a fortunate 14th at the flag, while Jordan wound up eighth on the road. The stewards took a dim view of his robust move on Tom Chilton at Luffield, however, and penalised the 2013 title winner 6.6s down to 10th. With Cammish struggling in the damp conditions to 11th, the damage to Turkington's points cushion was limited.

In the second race, Ingram showed yet again his characteristic car control. Tapped into Brooklands by Jason Plato – who was

then knocked sideways by Oliphant – as rain hit the track, the Speedworks driver pinned the throttle to save a huge slide and kept himself in the hunt for victory. After a safety car interval to retrieve Morgan's Mercedes A-Class from the Becketts gravel trap, Ingram slipped passed Oliphant after the BMW 330i M Sport driver ran wide at Copse at the restart. When Oliphant rejoined, he played the game and allowed team-mate Turkington through for a remarkable second place.

Jordan, however, was once again coming to blows. He and Cammish had crossed the safety car timing line side-by-side and, without instruction from race control, neither knew who had rights to fifth. With second in the standings up for grabs, neither would concede track position. It climaxed with the pair door-banging into Brooklands during the neutralised conditions.

Cammish received a £1500 fine and three licence points for the needless contact in what he called a "farce", but held on to a third-place finish to leapfrog Jordan in the points after the BMW driver ended up a frustrated eighth.

A win at Knockhill meant Jordan had closed to within just 10 points of the championship summit. But after Turkington's second place in race two, for the Silverstone finale it was looking





Oliphant, Plato and Ingram  
come to blows in their  
battle for the race-two lead

imperative for Jordan to finish above Turkington to make life that bit easier heading into the Brands Hatch decider.

He was drawn in fourth for the partially reversed grid, with Turkington lining up 10th and one spot behind Cammish.

Polesitter Sutton led his Subaru Levorg into Copse, but second-starting Matt Simpson's great exit took him into first on the approach to Maggotts. But a terrible exit from Brooklands allowed Sutton back past, and a fast-starting Jordan now had a shot at second place. On the run from Brooklands to Luffield, Simpson's Honda Civic Type R was caught across the front of Jordan's 3 Series and pitched onto the grass and into retirement – an incident that will be investigated before the next round.

Rain had threatened to properly disrupt a race all day, but only now begin to hit. The low-grip conditions sent Jordan back down the order as the set-up on his car was too stiff. He and Turkington pitted for wets one lap apart and, after a safety car interlude to recover Simpson's stricken Civic, it just so happened that they found one another on the circuit in a battle for 15th.

Until this point, the intra-team fight had yet to properly materialise on track with a wheel-to-wheel battle.

They touched into Brooklands, Turkington tried around the inside and >>

## GOFF'S RISK IS TEAM HARD'S REWARD



The safest bet in motorsport is to play to the conditions in front of you. Be on the right tyre for that precise moment, and rarely second guess the weather. In most cases, that gamble ends in bust.

Jack Goff, however, doubled down and dived for the pitlane at the end of the formation lap for race three. He pulled his Volkswagen CC in for wet tyres – the only competitor to do so.

Then the conditions came to him. Just as the safety car was called to collect Matt Simpson's car from the grass at Luffield, Goff hammered in the race's fastest lap. The conditions were now indisputably suited for grooved tyres.

More and more drivers swapped for wets. But, having made his stop while the rest of the field was sitting on the grid waiting for the lights to go out, Goff had banked a few seconds.

Aidan Moffat, another early adopter of wet Dunlops, was also picking off opponents for fun.

The pair found one another on track and together made light work of the pack. Jake Hill, Ash Sutton, Dan Cammish were all at the duo's mercy.

Moffat suffered a brief scare when he ran wide at Copse, kissed the sodden kerbs and did a complete spin. He gathered the Infiniti Q50 together and recovered for second – the car's best ever BTCC result.

That left Goff to earn his fifth series triumph by 7.3 seconds, but his celebrations were outshone by Team Hard, which celebrated its maiden win.

"We have done another massive development this winter and then we made a big push for this weekend," said team founder Tony Gilham. "We've invested a lot of money over the past two weeks, we've made a lot of changes to the car. Heat management, a little bit of aero, a bit of weight, lots of little detailing.

"To get it all right in race three, make the correct call nice and early and to see Aidan do it as well! Six years ago he made his NGTC debut in the Passat that Jack is driving. It means a lot to everyone.

"We're a team that does everything together. It's really special because Jack was the first driver we signed."

Not bad for a last-minute partnership, that was only announced two days before 2019 media launch in March.





We've been expecting you:  
Jordan and Turkington finally  
square off in race-three thriller

came back across the track. After further contact, Jordan stayed in front. He had won round one. On the next tour, at the same corner, they forced the issue off the track, with Turkington careering over the mud and still not passing. Jordan had won a more robust round two. One lap later, Turkington nosed into Jordan at Copse and used a better run to Maggotts to nail on the place to win the battle overall. As the slick-shod runners fell further down, they wound up with Turkington seventh and Jordan eighth at the flag.

"I enjoyed that," said Turkington. "It's probably the first pitstop we've done since 2003 for all I can remember! Coming into the pits, I wasn't sure how all this was going to play out. I persevered on slicks for as long as I could but the car just stopped finding any grip. Every time I touched the throttle it was very snappy. I knew I was going to struggle to finish the race."

"I probably left it a lap too late to box but I saw AJ and Tom come in so I didn't know

how three cars was going to work in one space. When I came out of the pits I was in P20 and couldn't see anybody else on track.

"It was too close [between me and Jordan] at times, you would think he was dead cert on not letting me past and we were both off the road a few times. There's a lot at stake, the pressure is on."

But WSR principal Dick Bennetts was less impressed, having watched two of his team's cars collide in their personal battle for bragging rights.

"I need to have a word with one of the drivers," he said. "The way I looked at it, Colin caught AJ pretty quickly and the rule is that if they catch you pretty quickly you don't hold them up. They know the rules, but the pressure is on. AJ wants to beat Colin. If they fight with each other then the rest [of the grid] will take the benefit."

The fact is, they didn't take each other out of the race. They sparred up to the limit, and possibly slightly over it, but finished and finished well.

As Jack Goff's inspired choice to start the race on wets earned Team Hard its maiden BTCC triumph (see page 35), all eyes were on the battle for what was, at the time, the final points-scoring position.

Silverstone could have been the venue where Turkington lost his hold on the 2019 crown, especially after his race-one drama. But he carved out results that simply hadn't been on the cards. The upshot is he now sits 16 points clear of Cammish, with Jordan just one point behind the Team Dynamics driver.

A cliché it might be, but it was a champion's performance that might just take Turkington level with Andy Rouse as the BTCC's most successful driver on four titles.

However, "the championship situation only tells a very small part of the story", as Cammish rightly says. He might have jumped up the order, but he's now five points further off Turkington than he had been at the close of play at Knockhill.

With a lowly 12th in race three, his worst score since Snetterton, the best non-BMW driver was downbeat: "I feel a bit deflated, honestly. It was scrappy – one of those days when it finally came to a head and it boiled over. It wasn't a nice day to go racing, when the weather conditions are so changeable."

Thanks to Ingram's double success in the Toyota Corolla and a fourth and fifth place finish for BTC Racing's Josh Cook, mathematically it's a five-way Brands Hatch showdown on the Grand Prix layout.

Much more likely, it's become just a three-way dogfight between Turkington, Jordan and Cammish.

But, quite possibly, after an immense Silverstone salvage job, Turkington has just turned the 2019 climax into a one-horse race. 🏆



Simpson (l) and Sutton  
battle for race-three  
honours into Copse

**RESULTS ROUND 9/10, SILVERSTONE, 29 SEPTEMBER RACE 1 (22 LAPS – 36.089 MILES)**

POS	DRIVER	TEAM / CAR	TIME
1	<b>Tom Ingram</b> (GBR)	Speedworks Motorsport / Toyota Corolla GT (24kg)	21m40.695s
2	<b>Jason Plato</b> (GBR)	Power Maxed Racing / Vauxhall Astra <b>S</b> (6kg)	+4.312s
3	<b>Chris Smiley</b> (GBR)	BTC Racing / Honda Civic Type R <b>S</b>	+7.554s
4	<b>Josh Cook</b> (GBR)	BTC Racing / Honda Civic Type R (36kg)	+8.071s
5	<b>Tom Oliphant</b> (GBR)	WSR / BMW 330i M Sport <b>S</b>	+13.265s
6	<b>Matt Neal</b> (GBR)	Team Dynamics / Honda Civic Type R (12kg)	+14.028s
7	<b>Mike Bushell</b> (GBR)	AmD Tuning / Honda Civic Type R <b>S</b>	+16.886s
8	<b>Adam Morgan</b> (GBR)	Ciceley Motorsport / Mercedes A-Class <b>S</b>	+23.676s
9	<b>Tom Chilton</b> (GBR)	Motorbase Performance / Ford Focus RS <b>S</b> (6kg)	+23.926s
10	<b>Andrew Jordan</b> (GBR)	WSR / BMW 330i M Sport <b>S</b> (48kg)	+23.987s
11	<b>Dan Cammish</b> (GBR)	Team Dynamics / Honda Civic Type R (42kg)	+24.064s
12	<b>Rob Collard</b> (GBR)	Power Maxed Racing / Vauxhall Astra <b>S</b>	+24.119s
13	<b>Matt Simpson</b> (GBR)	Simpson Racing / Honda Civic Type R	+24.384s
14	<b>Colin Turkington</b> (GBR)	WSR / BMW 330i M Sport (54kg)	+25.716s
15	<b>Rory Butcher</b> (GBR)	AmD Tuning / Honda Civic Type R (30kg)	+27.963s
16	<b>Jake Hill</b> (GBR)	Trade Price Cars Racing / Audi S3 Saloon	+28.903s
17	<b>Jack Goff</b> (GBR)	Team Hard / Volkswagen CC <b>S</b>	+29.617s
18	<b>Ollie Jackson</b> (GBR)	Motorbase Performance / Ford Focus RS <b>S</b>	+30.127s
19	<b>Aiden Moffat</b> (GBR)	Laser Tools Racing / Infiniti Q50 <b>S</b>	+30.991s
20	<b>Michael Caine</b> (GBR)	Motorbase Performance / Ford Focus RS (45kg)	+31.217s
21	<b>Sam Osborne</b> (GBR)	Excelr8 Motorsport / MG6	+34.709s
22	<b>Rob Smith</b> (GBR)	Excelr8 Motorsport / MG6	+36.586s
23	<b>Carl Boardley</b> (GBR)	Team Hard / Volkswagen CC <b>S</b>	+37.116s
24	<b>Ash Sutton</b> (GBR)	BMR Racing / Subaru Levorg <b>S</b> (18kg)	-1 lap
25	<b>Senna Proctor</b> (GBR)	BMR Racing / Subaru Levorg <b>S</b>	-1 lap
26	<b>Daniel Rowbottom</b> (GBR)	Ciceley Motorsport / Mercedes A-Class <b>S</b>	-3 laps
R	<b>Bobby Thompson</b> (GBR)	Team Hard / Volkswagen CC <b>S</b>	15 laps-damage
R	<b>Stephen Jelley</b> (GBR)	Team Parker Racing / BMW 125i M Sport	8 laps-damage
R	<b>Mark Blundell</b> (GBR)	Trade Price Cars Racing / Audi S3 Saloon	8 laps-damage
R	<b>Michael Crees</b> (GBR)	Team Hard / Volkswagen CC	5 laps-battery

**Winner's average speed** 99.88mph. **Fastest lap** Sutton 57.967s, 101.87mph.  
**S**=soft tyre. All other runners on medium compound.

**QUALIFYING**

**1 Plato 57.430s; 2 Smiley 57.485s; 3 Neal 57.489s; 4 Ingram 57.522s; 5 Oliphant 57.560s; 6 Turkington 57.568s; 7 Cammish 57.657s; 8 Sutton 57.677s; 9 Cook 57.701s; 10 Proctor 57.705s; 11 Chilton 57.705s; 12 Butcher 57.713s; 13 Bushell 57.748s; 14 Jordan 57.765s; 15 Goff 57.777s; 16 Caine 57.812s; 17 Collard 57.836s; 18 Jackson 57.837s; 19 Moffat 57.849s; 20 Thompson 57.906s; 21 Simpson 57.959s; 22 Hill 57.971s; 23 Morgan 58.008s; 24 Crees 58.027s; 25 Rowbottom 58.142s; 26 Jelley 58.192s; 27 Boardley 58.273s; 28 Blundell 58.363s; 29 Smith 58.565s; 30 Osborne 58.959s.**



Cook remains in contention ahead of Brands finale

**NEXT REPORT**

**BRANDS HATCH 17 OCTOBER ISSUE**

Can Turkington convert his points lead into the 2019 BTCC title, or will Cammish and Jordan dig deep enough to cause an 11th-hour upset?



Silverstone brace keeps Ingram in title hunt

**GRID RACE 2** Decided by result of Race 1.

**RACE 2** (19 LAPS – 31.167 MILES)

**1 Ingram S (54kg) 20m26.815s; 2 Turkington S +1.021s; 3 Cammish S +1.424s; 4 Plato (48kg) +2.543s; 5 Cook (36kg) +3.956s; 6 Smiley (42kg) +4.431s; 7 Oliphant (30kg) +4.910s; 8 Jordan (12kg) +5.116s; 9 Bushell (18kg) +5.334s; 10 Simpson S +6.777s; 11 Sutton +7.277s; 12 Caine S +7.930s; 13 Thompson +8.056s; 14 Jackson +8.478s; 15 Proctor +8.573s; 16 Hill +9.265s; 17 Rowbottom +9.451s; 18 Blundell +10.258s; 19 Crees S +10.266s; 20 Chilton (6kg) +12.280s; 21 Goff -1 lap; 22 Smith -1 lap; R Boardley +48.514s-suspension; R Jelley 13 laps-damage; R Morgan (6kg) 12 laps-spin; NC Collard 12 laps-damage; R Butcher S 11 laps-damage; R Neal S (24kg) 11 laps-puncture; NC Moffat 11 laps-propshaft; R Osborne 2 laps-steering.**

**Winner's average speed** 91.45mph.

**Fastest lap** Turkington 57.687s, 102.37mph.

**S**=soft tyre. All other runners on medium compound.

**GRID RACE 3** Decided by result of Race 2, with top 11 reversed.

**RACE 3** (25 LAPS – 41.010 MILES)

**1 Goff 28m22.240s; 2 Moffat +7.300s; 3 Neal +13.968s; 4 Oliphant (18kg) +25.596s; 5 Chilton +26.295s; 6 Plato (36kg) +29.883s; 7 Turkington (48kg) +30.020s; 8 Jordan (12kg) +33.061s; 9 Crees +35.424s; 10 Thompson +37.015s; 11 Hill S +40.813s; 12 Cammish (42kg) +43.527s; 13 Blundell S +44.108s; 14 Smith S +49.349s; 15 Sutton +50.344s; 16 Butcher +1m02.332s; 17 Bushell (6kg) +1m02.687s; 18 Caine +1m03.456s; 19 Jackson +1m12.292s; 20 Osborne S -1 lap; 21 Collard -1 lap; 22 Ingram (54kg) -2 laps; 23 Jelley S -2 laps; R Morgan 21 laps-damage; R Proctor 20 laps-pitstop running; R Cook S (30kg) 20 laps-pitstop damage; R Smiley (24kg) 10 laps-power loss; R Rowbottom 8 laps-damage; R Simpson (6kg) 0 laps-spin; R Boardley 0 laps-battery.**

**Winner's average speed** 86.73mph.

**Fastest lap** Goff 1m02.760s, 94.09mph.

**S**=soft tyre. All other runners on mediums until some switched to wets.

**CHAMPIONSHIP**

**1 Turkington 297; 2 Cammish 281; 3 Jordan 280; 4 Cook 263; 5 Ingram 236; 6 Butcher 228; 7 Plato 205; 8 Neal 199; 9 Sutton 191; 10 Chilton 174.**

# VMEP



VISION MOTORSPORT  
ENGINEERING PRODUCTS LTD

## WIN A SEASONS RACING

**STAGE 1 - Simulator Session 1**  
**STAGE 2 - Simulator Session 2**  
**STAGE 3 - Karting Session**

*All entrants compete in all 3 stages*

## PRIZE

A full seasons racing in the Clubman's Sports Prototype Championship CSP2 class, including:

- 6 races with Friday testing
- 2 pre season tests
- Free use of simulator before events
- All entry fees and race car insurance
- Tyres and fuel
- Arrive and drive use of our race car
- All preparation included

**£250 ENTRY** [www.vmep-ltd.co.uk/win-a-race-car-drive](http://www.vmep-ltd.co.uk/win-a-race-car-drive)



[www.vmep-ltd.co.uk](http://www.vmep-ltd.co.uk)  
[info@vmep-ltd.co.uk](mailto:info@vmep-ltd.co.uk)

# VMEP



VISION MOTORSPORT  
ENGINEERING PRODUCTS LTD

CHASSIS  
SET UP AND  
PIT AND Paddock  
EQUIPMENT

### CHASSIS SET UP EQUIPMENT

- SET UP FLOORS (CAR AND KART)
- PAD LEVELLERS
- BUMP STEER GAUGES
- TURN PLATES
- HUB STANDS WITH INBUILT CAMBER AND LASER TRACKING

### PIT AND Paddock EQUIPMENT

- FLIGHT CASE (FOR SET UP FLOOR) AND BESPOKE CASES
- TWO STAGE AIR JACK FEET (RANGE OF SIZES AVAILABLE)
- LASER LEVELLING
- PIT GARAGE AND AWNING FLOORING
- ROLL CABINETS AND PORTABLE STORAGE
- TYRE RACKS

### SERVICES

- RACE PREPARATION
- ARRIVE AND DRIVE IN CLUBMANS SPORTS PROTOTYPE SERIES

**WWW.VMEP-LTD.CO.UK**

[info@vmep-ltd.co.uk](mailto:info@vmep-ltd.co.uk)

[@vmepproducts](https://www.facebook.com/vmepproducts)



AUTOSPORT  
INTERNATIONAL

VISIT US AT  
HALL 2 STAND 2774

Ferrari junior Shwartzman wrapped up title with a race to spare



## Shwartzman crowned at home

**FIA FORMULA 3**  
**SOCHI (RUS)**  
**28-29 SEPTEMBER**  
**ROUND 8/8**

Much like in Formula 2, there's no doubt who the most impressive driver in FIA F3 has been this year: Robert Shwartzman, who sealed the title one race early, much to the delight of his Prema Racing team.

He led F3 with three wins entering the weekend, and pipped his fellow Prema and Ferrari junior Marcus Armstrong to pole in the Sochi finale, despite the latter looking dominant in practice and early qualifying.

The title was all but done as Jehan Daruvala fell back at the start and dropped to a disappointing fifth from second on the grid. He needed to win and, for whatever reason, didn't have the fight to contend.

A sprinkling of rain led to some poor driving, with a virtual and then full safety car required in the opening stages. But, once they were out of the way, a shock interloper in Niko Kari emerged and took the lead as Armstrong locked up and dropped back to third while trying to reclaim top spot.

Kari was then passed by Shwartzman – second place would guarantee him

the title regardless of anything Daruvala did – and he looked to be home and dry for a fairytale win.

But a clearly quicker Armstrong reeled him in. The last time the two entered a last lap line astern was at the Red Bull Ring – where they touched, Armstrong coming off worse with 19th while Shwartzman won but was later penalised.

This time both raced fairly and Armstrong robbed Shwartzman of a home win, a metaphorical pants-down from the Kiwi and a bit of revenge for Austria – the pair have enjoyed an often petulant rivalry in the series this season.

After 2.5 hours' sleep over the previous two days, the final result was a welcome relief for Shwartzman, who is "99% sure" he'll be racing in F2 next year. Armstrong will surely be with him, having taken second place in the championship in the last race of the year.

Daruvala's weekend went from bad to worse as he had no power at the start of the second race. A fightback from a pitlane start yielded 14th after a track-limits penalty.

Out front, polesitter Juri Vips – who no doubt would have either won or at least been closer to Shwartzman had he been



### WEEKEND WINNERS

**FIA FORMULA 3**  
**SOCHI (RUS)**  
**Race 1** Marcus Armstrong  
 Prema Racing  
**Race 2** Juri Vips (below)  
 Hitech Grand Prix



**motorsport**  
**STATS**

For full results visit [motorsportstats.com](http://motorsportstats.com)

in a Prema car – dominated the race.

Jake Hughes and Leonardo Pulcini's crash provided an opportunity for Armstrong to jump up to third, followed by Shwartzman. But the incident had also allowed Vips to break away and take a win for Hitech Grand Prix, ending a barren run that had cost him the chance of third in the standings – enough to have given the Red Bull affiliate sufficient superlicence points for F1.

Surely this will go down as one of the best performances by a team in an F3 season. Prema secured the teams' title two rounds early, won eight of 16 races and had a driver on the podium in all but two races. In a championship featuring a car mildly modified from the GP3 Series, which Prema had no experience of, it's an incredible season for the Italian giants.

**JACK BENYON**

# De Vries on top form as he clinches F2 crown

**FIA FORMULA 2**  
**SOCHI (RUS)**  
**28-29 SEPTEMBER**  
**ROUND 11/12**

Nyck de Vries delivered one of his best Formula 2 performances to do something even the mighty George Russell couldn't achieve in the same ART Grand Prix-run car last year: wrap up the title one round early.

While Russell certainly had greater competition in Alexander Albon and Lando Norris, he also had greater career momentum, whereas de Vries has had a rollercoaster time following a stunning karting career. His missed opportunities will always haunt him and point to the fact that he probably hasn't earned a Formula 1 seat on merit, but his recently announced Mercedes Formula E seat is another indication that de Vries is peaking late and deserves his massive manufacturer contract for next year. Who knows after that?

Under pressure, de Vries delivered pole at Sochi but was largely quiet in the race as Virtuosi Racing's Luca Ghiotto elected to take the alternative strategy of starting on the medium tyres before switching to supersofts. That meant he claimed the lead when de Vries and his only title rival, Nicholas Latifi, pitted on lap six, and the race would be decided in the last few laps.

Ghiotto pitted on lap 24 of 28 and emerged with a deficit of just over six seconds. He passed Louis Deletraz for



third and began to close on Latifi, but incredibly his tyres lasted just two laps and he fell back behind Deletraz.

So the key to the race was remaining ahead during the start and the first stops, which de Vries did, and then matching Ghiotto's times so that the Italian couldn't extend his gap. As impressive as Ghiotto was on old medium tyres, matching de Vries and Latifi, it wasn't enough as his supersofts lost their grip in the last stint.

"It really felt like we had to win this, not only to clinch the championship, but also for ourselves, just to make sure that we really deserved this," said de Vries. "I was happy with the race win but then we were kind of uncertain whether it was

really done or not. They told me, 'Wait until you get to the pitlane and then you'll see.' Just looking at the board [which had '2019 champion' written on it] in front of me when I arrived, that was pretty cool. There were some goosebumps there."

DAMS driver Latifi showed great humility in the post-race green room as he congratulated de Vries on a title battle well fought. De Vries is also on course to beat Russell's 2018 points tally.

De Vries was equally as impressive in race two as he hounded Ghiotto for lap after lap in a race shortened for another dramatic crash in the series, between Nobuharu Matsushita, Nikita Mazepin and Jack Aitken.



De Vries led race one from pole and took his fourth win of the season

De Vries now has 266 points, just 19 fewer than Russell's tally in 2018

ALL PHOTOGRAPHY  
**motorsport  
IMAGES**

Aitken had gone on to the runoff at Turn 2 and correctly went around the polystyrene boards before rejoining the track as per the rules. Polesitter Mazepin – de Vries's team-mate – also used the runoff but didn't go around the boards, and when Aitken tried to rejoin he had nowhere to go. Mazepin's rear-left wheel hit Aitken's front-right and Mazepin was sent like a skittle, collecting the Carlin car of Matsushita, who went heavily into the barrier and had to be extracted. He was kept in Sochi Hospital overnight. Mazepin also went for checks but was released. Aitken raced on.

The FIA decided Mazepin was "wholly at fault" for the incident and hit him with a whopping 15-place grid penalty for the next round and four penalty points on his licence.

Ghiotto's tyres were toast early on, but the turbulent air deflected from his car stymied de Vries and ensured he couldn't get close enough to pass. On the same day that Sauber Junior Team's Juan Manuel Correa underwent serious leg surgery after his crash at Spa, his team-mate Callum Ilott scored a podium in his honour to round out the top three.

Ghiotto's win could prove crucial in both championships. Third awards enough superlicence points to reach F1, with Aitken and Sergio Sette Camara both losing out to Ghiotto over the weekend. It also pulled points back for Virtuosi, which trails DAMS by 53 points in the teams' championship heading to the final event.

**JACK BENYON**

**RESULTS ROUND 11/12, SOCHI (RUS), 28-29 SEPTEMBER RACE 1 (28 LAPS - 101.622 MILES)**

POS	DRIVER	TEAM	TIME
1	<b>Nyck de Vries</b> (NLD)	ART Grand Prix	54m12.087s
2	<b>Nicholas Latifi</b> (CAN)	DAMS	+4.918s
3	<b>Louis Deletraz</b> (CHE)	Carlin	+5.995s
4	<b>Luca Ghiotto</b> (ITA)	Virtuosi Racing	+7.607s
5	<b>Sergio Sette Camara</b> (BRA)	DAMS	+11.378s
6	<b>Nobuharu Matsushita</b> (JPN)	Carlin	+20.364s
7	<b>Jack Aitken</b> (GBR)	Campos Racing	+27.403s
8	<b>Nikita Mazepin</b> (RUS)	ART Grand Prix	+28.572s
9	<b>Callum Ilott</b> (GBR)	Sauber Junior Team by Charouz	+32.394s
10	<b>Guanyu Zhou</b> (CHN)	Virtuosi Racing	+33.756s
11	<b>Sean Gelael</b> (IDN)	Prema Racing	+43.365s
12	<b>Jordan King</b> (GBR)	MP Motorsport	+47.493s
13	<b>Giuliano Alesi</b> (FRA)	Trident	+48.620s
14	<b>Ralph Boschung</b> (CHE)	Trident	+59.021s
15	<b>Tatiana Calderon</b> (COL)	Arden	+1m09.884s
16	<b>Marino Sato</b> (JPN)	Campos Racing	+1m46.218s
17	<b>Mahaveer Raghunathan</b> (IND)	MP Motorsport	-1 lap
18	<b>Matevos Isaakyan</b> (RUS)	Sauber Junior Team by Charouz	-1 lap
R	<b>Mick Schumacher</b> (DEU)	Prema Racing	19 laps-engine
R	<b>Artem Markelov</b> (RUS)	Arden	0 laps-accident

**Winner's average speed** 112.493mph. **Fastest lap** Ghiotto 1m51.104s, 117.741mph.

**QUALIFYING**

**1 de Vries** 1m47.440s; **2 Latifi** 1m47.700s; **3 Ilott** 1m47.737s; **4 Ghiotto** 1m47.767s; **5 Zhou** 1m47.843s; **6 Sette Camara** 1m48.031s; **7 Deletraz** 1m48.188s; **8 Mazepin** 1m48.226s; **9 King** 1m48.320s; **10 Matsushita** 1m48.396s; **11 Schumacher** 1m48.444s; **12 Aitken** 1m48.477s; **13 Gelael** 1m48.567s; **14 Alesi** 1m48.850s; **15 Boschung** 1m48.880s; **16 Markelov** 1m49.244s; **17 Isaakyan** 1m49.497s; **18 Calderon** 1m50.255s; **19 Sato** 1m50.311s; **20 Raghunathan** 1m51.949s.

**GRID FOR RACE 2** Decided by result of Race 1, with top eight finishers reversed.

**RACE 2** (15 LAPS - 54.383 MILES)

**1 Ghiotto** 1h18m21.329s; **2 de Vries** +0.712s; **3 Ilott** +1.672s; **4 Latifi** +3.383s; **5 Zhou** +3.820s; **6 Sette Camara** +7.336s; **7 Gelael** +10.343s; **8 Alesi** +13.108s; **9 King** +14.851s; **10 Markelov** +16.769s; **11 Aitken** +23.898s; **12 Boschung** +26.558s; **13 Isaakyan** +27.414s; **14 Deletraz** +31.933s; **15 Sato** +36.472s; **16 Calderon** +43.057s; **17 Raghunathan** +1m01.506s; **R Schumacher** 7 laps-accident damage; **R Mazepin** 0 laps-accident; **R Matsushita** 0 laps-accident.

**Winner's average speed** 41.643mph. **Fastest lap** Latifi 1m52.272s, 116.517mph.

**CHAMPIONSHIP**

**1 de Vries** 266; **2 Latifi** 194; **3 Ghiotto** 184; **4 Sette Camara** 165; **5 Aitken** 159; **6 Matsushita** 124; **7 Zhou** 122; **8 King** 79; **9 Antoine Hubert** 77; **10 Deletraz** 76.



# FFF conquer Europe's GT racing elite

**BLANCPAIN GT ENDURANCE CUP**  
**BARCELONA (ESP)**  
**29 SEPTEMBER**  
**ROUND 5/5**

Chinese outfit FFF Racing had never even raced in Europe ahead of the Blancpain GT Series season opener in April. Fast-forward six months and the Lamborghini squad completed the 'triple crown' of titles courtesy of Andrea Caldarelli and Marco Mapelli in Barcelona.

Having already secured the World Challenge Europe championship at the expense of Black Falcon Mercedes duo Maro Engel and Luca Stolz in Hungary, Caldarelli and Mapelli – alongside stand-in teammate Albert Costa – denied their rivals once more to claim overall honours with their first Endurance win of the season.

Team owner Fu Songyang had dubbed this "the most important race of the year". FFF duly began strongly, though the circuit's characteristics supposedly favoured the Mercedes-AMG GT3.

Engel lived up to this assumption by qualifying on the front row alongside the polesitting Porsche of Romain Dumas, Mathieu Jaminet and Sven Muller. But Costa placed the FFF Huracan GT3 Evo just 0.001 seconds behind Engel.

Costa got the best getaway from the rolling start and leapfrogged past both to take the lead into the first corner. But Costa overstepped the track limits while completing the move and, after a lengthy safety car period following a scary roll for Zaid Ashkanani's Porsche, he had to give the places back when the race restarted.



The Lambo made amends at the first round of stops, but only just. Costa handed over to Mapelli, who nudged ahead of Dumas on pit exit to move into second by a matter of inches.

Stolz assumed the lead, but the Black Falcon Merc was also usurped by Mapelli after another safety car. Mapelli got the run down the main straight and the pair banged doors exiting Turn 2, with the Lambo emerging in first place.

Caldarelli then kept the Mercedes – with Yelmer Buurman at the wheel – at arm's length throughout the final stint, as Buurman then had to defend against Dries Vanthoor's WRT Audi R8.

Vanthoor hustled the back of the Mercedes and, almost inevitably, contact was made as the pair disputed second through Turn 3. Both cars went through

the gravel trap, extinguishing any remaining hopes for Black Falcon.

Caldarelli duly brought the Huracan home for Lamborghini's first Endurance win of the year, earning it that title too, beating the SMP Racing Ferrari squad by one point.

Coming into the weekend, SMP's Davide Rigon, Mikhail Aleshin and Miguel Molina only needed to finish eighth to be crowned. They had led for much of the season.

Aleshin recovered from a first lap puncture to run 12th heading into the final hour, but a misjudged overtaking manoeuvre by Molina on the Bentley of Andy Soucek resulted in a drivethrough penalty, which handed an unexpected title to FFF.

**STEPHEN BRUNSDON**

 **motorsport.tv**

Relive this race at Motorsport.tv

## Martins slashes Piastri's lead

**FORMULA RENAULT EURO CUP**  
**BARCELONA (ESP)**  
**28-29 SEPTEMBER**  
**ROUND 8/10**

Victor Martins claimed a dominant double Formula Renault Eurocup victory at Barcelona last weekend to carve into Oscar Piastri's points lead heading into the final two rounds.

The Renault Junior entered the weekend in a confident mood, having broken the unofficial lap record at the same circuit during pre-season testing. That translated into a pair of poles and

two comfortable wins on a weekend when Piastri was again forced into damage limitation during the first race.

As Martins leapt away at the front, Piastri was already facing backwards at Turn 1 after being hit in the rear by Bhaitech's Petr Ptacek as the field got away.

Piastri dropped to the rear of the pack but put in a stunning recovery drive to finish sixth on the road, elevated to fifth by a 15-second post-race penalty for Ptacek.

Martins repeated his perfect start in race two and duly led from start to finish, beating Ptacek by a little over 7s, while Piastri fought through from sixth to

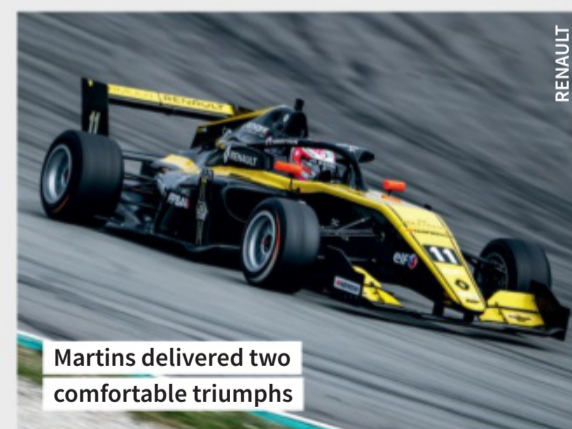

complete the podium.

A third win in four races ensured Martins reduced the deficit to Piastri from 37.5 points to just 12.5 ahead of the penultimate round at Hockenheim.

**STEPHEN BRUNSDON**

# Elliott through to next round with Roval win

**NASCAR CUP**  
**CHARLOTTE (USA)**  
**29 SEPTEMBER**  
**ROUND 29/36**

Chase Elliott secured his place in the next round of NASCAR's playoffs by winning at the Charlotte Roval.

The Hendrick Motorsports Chevrolet came back from a crash early in the final stage to lead home team-mate Alex Bowman, who also advances to the Round of 12.

Kevin Harvick's Stewart-Haas Racing



Ford was third, with Clint Bowyer and Brad Keselowski completing the top five. Polesitter William Byron was sixth, ahead of Martin Truex Jr, Ryan Blaney, Jimmie Johnson and Joey Logano.

Truex and Harvick had already secured their spots in the next part of NASCAR's post-season ahead of the race. They were joined by Kyle Bush, Denny Hamlin, Logano,

and Keselowski at the end of stage one – all securing their places on points.

Elliott's stage two win gave him enough points to secure a spot too, but NASCAR's 'win and you're in' format meant that his race victory cemented his place. Bowman, Kyle Larson, Blaney, Byron and Clint Bowyer also advanced.

**DOMINIK WILDE**



# Maiden spoils for Yamashita

**SUPER FORMULA**  
**OKAYAMA (JPN)**  
**29 SEPTEMBER**  
**ROUND 6/7**

Kenta Yamashita scored his maiden Super Formula at Okayama, in what was the Kondo Racing driver's 19th start.

Yamashita started from second on the grid on the medium compound tyres, with polesitter Ryo Hirakawa on softs.

On the quicker rubber, Hirakawa duly led for 56 of the 66 laps. But couldn't pull out more than a two-second cushion before peeling in for his mandatory change to the medium tyres.

By this time, Yamashita had been shuffled down to eighth by pitting during a safety car period following a spin for Nirei Fukuzumi, who beached himself in the gravel.

As Hirakawa rejoined on cold rubber, he slid off course and down to an eventual 12th.

As the rest of the field stopped to pit, Yamashita kept climbing up the order – followed by fellow medium-tyre starters Kazuki Nakajima and Harrison Newey.

Alex Palou was the best of the Nakajima Racing runners in fourth, while Newey's B-Max by Motopark team-mate and ex-DTM driver Lucas Auer ended up fifth.

Auer's fellow Red Bull junior Patricio O'Ward bagged his first series points finish in sixth, having pitted under the safety car along with Yamashita.

Pre-event championship leader Nick Cassidy started from 10th and made his way up to fifth before spinning back down to 10th. Naoki Yamamoto finished seventh and secured two points; he heads the table with just the Suzuka round to go.

**JIRO TAKAHASHI**

 **motorsport.tv**  
 Relive this race at Motorsport.tv

## WEEKEND WINNERS

**BLANCPAIN GT ENDURANCE CUP**  
**BARCELONA (ESP)**

Albert Costa/Andrea Caldarelli/Marco Mapelli  
 FFF Racing (Lamborghini Huracan GT3 Evo)

**FORMULA RENAULT EURO CUP**  
**BARCELONA (ESP)**

**Race 1** Victor Martins  
 MP Motorsport  
**Race 2** Victor Martins  
 MP Motorsport

**NASCAR CUP**  
**CHARLOTTE (USA)**

Chase Elliott  
 Hendrick Motorsports  
 (Chevrolet Camaro)

**NASCAR XFINITY SERIES**  
**CHARLOTTE (USA)**

AJ Allmendinger  
 Kaulig Racing (Chevrolet Camaro)

**SUPER FORMULA**  
**OKAYAMA (JPN)**

Kenta Yamashita  
 Kondo Racing (Dallara-Toyota SF19)

**JAPANESE FORMULA 3**  
**OKAYAMA (JPN)**

**Race 1** Ritomo Miyata  
 TOM'S (Dallara-Toyota F317)  
**Race 2** Ritomo Miyata  
 TOM'S (Dallara-Toyota F317)

**EUROPEAN RALLY CHAMPIONSHIP**  
**CYPRUS RALLY (CYP)**

Nasser Al-Attiyah/Matthieu Baumel  
 (Volkswagen Polo GTI R5)



For full results visit [motorsportstats.com](http://motorsportstats.com)

DRY SUMP



**PAC**  
OIL PUMPS & DRY SUMP SYSTEMS  
www.pacepumps.co.uk

EXHAUSTS

Inconel & Stainless Steel Specialists  
**SIMPSON**  
Race Exhausts  
Tel: 01753 532222  
www.simpsonraceexhausts.com

GEARBOXES

**Gearboxman.com**  
COMPETITION TRANSMISSION SERVICES  
Gearboxes & Axles for Road, Race, Rally and more  
Telephone: 01582 840008 Fax: 01582 840007

HELMET GRAPHICS

**Mike Fairholme Designs**  
Sole approved painter of Arai helmets.  
Silver Birches, Corby Birkholme, Nr Grantham, Lincs NG33 4LE.  
Tel: 01476 550630. Fax: 01476 550029.  
email: fairholmedesigns@btconnect.com  
www.fairholmedesigns.co.uk

MEMORABILIA



**FINAL LAP**  
For Everything Formula One  
www.finallap.net **WE BUY AND SELL**  
+44 (0) 1245 287588 / 07771 920345

MOTORSPORT LEGAL ADVICE

Motor Sport Legal Advice  
Tudor Alexander, LI.B Solicitor  
07887 713512

RACE PARTS

**ARE DRY SUMP SYSTEMS**  
ARMSTRONG RACE ENGINEERING INC.  
WWW.DRYSUMP.COM (916) 652-5282

Co-ordsport **PartBOX**  
Performance and Tuning Parts  
Leading performance brands online  
www.part-box.com

Passionate About Motorsport  
**JJC** race and rally  
www.jjcraceandrally.com

RACE PARTS

Autoparts and Hydraulics  
**LMA**  
sales@LMAautoparts.com

RACING

Pit to Car **Autotel**  
Radio solutions **Digital Race Radio**  
0044(0)1508 528837  
www.raceradio.co.uk

**PORSCHE SHOP**  
10% off with website voucher code AUTOTEN  
Or Call: 0121 585 6088

RACING



**demon-tweeks.com**

AUTHORISED DISTRIBUTOR  
**OMP** **YBRACING**  
MOTORSPORT & PERFORMANCE  
WWW.YBRACING.COM

**CARTEK**  
MOTORSPORT ELECTRONICS  
www.cartekmotorsport.com  
023 80 457747

RACEWEAR

**GPR Grand Prix Racewear**  
Silverstone  
The best of racewear & kartwear  
www.gprdirect.com

TRACK PREPARATION

**KD KENDALL DEVELOPMENTS**  
3D SCAN - REVERSE ENGINEERING  
Tel: 01480 718117 • Track Support • 3D Design  
• Track Preparation • Restoration  
www.kendall-developments.com

TRAILERS & TRANSPORTERS

**Signature RV.co.uk**  
RV SALES AND SERVICE

TRAILERS & TRANSPORTERS

**BRIAN JAMES TRAILERS**  
» Connected to you  
www.brianjames.co.uk

WEB DIRECTORY



TO ADVERTISE IN THE WEB DIRECTORY  
PLEASE CALL +44 (0) 20 3405 8109  
OR EMAIL ads@autosport.com

**BRIAN JAMES TRAILERS**

» Connected to you

[www.brianjames.co.uk](http://www.brianjames.co.uk)

## Style and Substance

Introducing the new Race Transporter 6 by Brian James Trailers. An even more stylish and capable enclosed trailer specifically suited to car transportation.

New features include a standard automatic tilt-operation, invaluable for all professional motorsport or transport operations. An extra side access hatch door provides the ability to easily reach in for securing the standard equipment 'over wheel' strap system.

In addition, many new optional features are now available, all designed to offer the latest technology and improved convenience to all operators.

Race Transporter trailers are available from £ 7,699 + vat

Race Transporters are available ex-stock at many UK dealers. Please visit our website or call us for further details.

**RACE TRANSPORTER 6****T +44 (0)1327 308 833**

For more information and details on the Brian James Trailers range, please contact our head office



HIGH QUALITY TRAILERS  
FOR CLUB, PRIVATE AND  
PRO MOTORSPORTS

# Woodford covered trailers

## Superior in design, quality and finish

TRAILERS & TRANSPORTERS



Woodford Trailers Limited | 14 Great Central Way, Daventry, Woodford Halse, Northants, NN11 3PZ | Telephone 01327 263384



# WORLD'S FIRST **ONLINE** Motorsport Engineering Degrees

**BSc** <sup>(Hons)</sup> Motorsport Engineering  
And Final Year Top-Up\*

**MSc** Advanced  
Motorsport Engineering\*



NMA student-run Mosler MT900

## Accelerate **YOUR** Motorsport Career!

- ✓ CHOOSE YOUR OWN START DATE & study from anywhere in the world
- ✓ Earn while you learn, study flexibly around your work & family
- ✓ 40% lower fees than other universities
- ✓ Student loans for all UK students
- ✓ Latest industry CAD & Simulation software FREE



+44 (0)1159 123456

<https://motorsport.nda.ac.uk>



**95% OVERALL SATISFACTION**

*National Student Survey Results*

\*All degrees awarded by our Academic partner De Montfort University.

MEMORABILIA

F1 COLLECTORS .COM



#1 FOR F1 MEMORABILIA & AUTOGRAPHS

We buy and sell F1 items  
AYRTON SENNA specialists

Call CHRIS GRINT

**01763 274448**

email:- sales@f1collectors.com

**AUTOSPORT**

If you wish to advertise your products and services with Autosport in print and online please contact

Ben.kavanagh@motorsport.com

or call

+44 (0) 20 3405 8109

RACE PRODUCTS

**demon tweeks**

EXPERT ADVICE • MASSIVE STOCK • RAPID DELIVERY



LOW RATE **0844 375 2196**

**demon-tweeks.com**

CALLS MAY BE RECORDED FOR TRAINING PURPOSES

RACE PREPARATION

**Dominate the competition**



Hawk and Carbotech motorsport compounds

**Carbotech**



**HAWK**  
PERFORMANCE BRAKES by Wellman

www.cambridgemotorsport.com  
sales@cambridgemotorsport.com

**Cambridge Motorsport Parts**

**(0)1462 684300**

London Motorsport Showroom  
www.msar.co.uk



HONDA, ALPINE, SCHROTH, AVL, Safety Devices, Aral, SHOWTRAX, TIGETT, BELL, lifeline

Order Hotline: 020 8655 7877  
**msar UK agent for SCHROTH RACING**

Visit Us At Our New Larger Showroom

BUSINESS FOR SALE

**Go-Karting Business For Sale**

- ❑ Turn-key business in excellent financial and material condition
- ❑ Outdoor 540m floodlit track
- ❑ Workshops
- ❑ Fleet of 38 Sodi karts (4-stroke) for age range 8 to adult
- ❑ 4 electric Toro karts for under 8s
- ❑ Kart storage
- ❑ Excellent quality licensed clubhouse with ample parking
- ❑ 78 year leasehold on peppercorn rent available in price as an option

Owners commenced business in 2014 and enjoyed healthy and consistent profits over 5 years. Tourist location with steady local trade over 52 weeks. Located in high 'quality of life' coastal environment in South England.

New manager/owner has opportunity to diversify and to build on the much remaining potential.

Enquire at PO Box 213 PO33 9FH

WANTED



**WANTED**

**RALLY CARS FOR CASH**

Specific interests in Ford Escorts MK1 or MK2 but all makes and models considered in any condition

01291 621234 or 07976 239076  
rob@weirrallying.co.uk





Historic Engine Specialists

Ford Cosworth BDA/BDG,

Lotus Twin Cam, BMW M10



Craig Beck Racing Ltd

T: **07876 221 932**

E: [craig@craigbeckracing.co.uk](mailto:craig@craigbeckracing.co.uk)

[www.craigbeckracing.co.uk](http://www.craigbeckracing.co.uk)





# THE RACER

Pit talk from the HRDC



## ARE YOU READY FOR THE CASTLE COMBE AUTUMN CLASSIC?

5th October 2019

HRDC 'COYS 100 TROPHY' for Touring Cars 1958 – 1966

HRDC 'ALLSTARS' for pre-'66 Sports, GT & Touring Cars

HRDC 'CLASSIC ALFA CHALLENGE' for Alfa Romeos 1950 – 1980

**ENTRIES ARE NOW OPEN!**

COMPETITION ENQUIRIES: JULIUS THURGOOD 07850 361159 • direct@juliusthurgood.co.uk • www.hrdc.eu

**JOIN THE BEST TEAM IN HISTORIC RACING!**



STORAGE



# Workshop and Garage Cabinetry

Create an organised, productive, and professional workshop

Buy ready-configured cabinet systems online at GaragePride, or we can provide a complete cabinet and workbench design and installation service working closely with you to meet your precise requirements. Unlike other suppliers, we are not tied to a single cabinet brand but would propose one that best meets your budgetary, functional and aesthetic needs.

[www.garagepride.co.uk](http://www.garagepride.co.uk) 01743 742028



Cabinets  
Pictured  
**bott**



SYSTEM  
STORE  
SOLUTIONS LTD

## SETTING THE STANDARD IN MOTORSPORT WORKSHOP DESIGN & STORAGE



Working with teams and companies in classic/historic racing right through to Formula One.

We provide everything from single cabinets to a total design, layout and installation service, including project management, consultation, technical advice and no obligation site surveys.



- ✓ Race bays
- ✓ Machine shops
- ✓ Stand-alone workstations
- ✓ Transporters
- ✓ Mobile storage units



01622 859522 SALES@SYSTEMSTORESOLUTIONS.COM SYSTEM-STORE.COM

MARKETPLACE



RECRUITMENT  
DRIVEN BY  
PASSION



MOTORSPORT JOBS

# Find your dream job

Here at Autosport we've been helping people find great jobs in motorsport for over 60 years. Today we're launching a new global motorsport jobs site, where you can:

- Find the latest jobs in motorsport
- Apply for a job with just one click
- Upload your CV and let recruiters find you
- Set up job alerts - don't miss out on your dream move

Register at [motorsportjobs.com](https://motorsportjobs.com) today 



Motorsport Jobs  
- A Motorsport  
Network Company



### F1 Aero/Model Design - Contractor

We are looking for an experienced model designer with experience in the design of race car aerodynamic surfaces, wind tunnel model parts and assemblies. Working with the Aerodynamicists, to generate surface models for CFD, wind tunnel testing, extensive model design experience is essential within a motorsport environment.

You'll also be familiar with the F1 technical regulations and will understand car and system layouts.

This will require a creative approach to problem solving and utilise your skills in solid modelling and surface design

Applicants interested in applying for this position will be self-motivated with a proactive approach without the need for supervision.

Experience:

- High level Motorsport experience
- Catia V5/3DX

The duration of the contract is 6 months with an immediate start.

Rate - Negotiable.

To apply now visit [www.motorsportjobs.com](http://www.motorsportjobs.com)



### ELECTRONICS MANUFACTURING GROUP LEADER

In the role of Electronics Manufacturing Group Leader you will be responsible for the management of our team of Electrical and Electronic Technicians on a day-to-day basis, providing leadership, training and technical support, whilst ensuring our high manufacturing standards and requirements are met and maintained.

The successful candidate will have the responsibility for ensuring all tasks progress efficiently through the manufacturing processes within the time scale set, communicating progress and updates as required. As a natural problem solver, you will call upon your previous experience of Motorsport Electrical and Electronic Installations including complex harness manufacture, sensor installations and PCB/A assembly.

Qualified in a relevant Engineering discipline and with experience of managing multiple projects, you will demonstrate a high level of self-motivation, commitment and the ability to deliver a diverse range of components and assemblies, all meeting the requirements of our Production Control and Trackside functions.

Closing date for applications is 13th October 2019.

### AERODYNAMICS DESIGN ENGINEER

The primary responsibilities of the role will be focused on working alongside Aerodynamicists to generate and develop designs for our Formula one CFD and wind tunnel development programs. This will require a creative approach to problem solving and utilise your skills in solid modelling and surface design using the Siemens NX CAD package.

Applicants interested in applying for this position will be self-motivated with a proactive approach, and be able to maintain an exceptional level of detail when working to tight timescales, often with minimum supervision.

The successful applicants will have a background in engineering and design, along with in depth knowledge and considerable experience using the Siemens NX CAD package which is essential for the role. Specific F1 experience would be preferred but is not necessary.

If you feel this could be you, please act and contact us, don't miss this opportunity.

This position will be based at our Factory in Milton Keynes and will require flexibility.

Closing date for applications is 6th October 2019.

As well as being part of our multi Championship winning team, we reward our employees with a significant benefits package including championship bonus, life insurance, private medical cover, a contributory pension scheme, on-site gym, child care vouchers, cycle to work scheme, free staff restaurant and much more.

To apply for these roles, or any others we have, please go to our careers page ([redbullracing.redbull.com/careerslisting](http://redbullracing.redbull.com/careerslisting)) and send your CV and a covering letter to the vacancy listing.

PLEASE NOTE: No Agencies please.



# motorsport JOBS

## Want to advertise a motorsport job?

If you are recruiting in motorsport and wish to advertise with Autosport in print and online please contact

[James.robinson@motorsport.com](mailto:James.robinson@motorsport.com)

or call

**+44 (0) 020 3405 8105**

For all current vacancies advertised please visit our website

[Motorsportjobs.com](http://Motorsportjobs.com)



BATHIE

Ellinas took second from back of grid

## SUCCESSFUL COMEBACK FOR REIGNING CHAMPION

### PORSCHE CARRERA CUP GB

Reigning Porsche Carrera Cup GB champion Tio Ellinas made a last-minute return to the series at Silverstone last weekend with the frontrunning Redline squad, taking a podium from the back of the grid.

Cypriot Ellinas has been competing in the Porsche Supercup this season and has earned four top-six finishes from the eight events so far. He is using the Silverstone and Brands Hatch GB season closers as extra seat time ahead of the Supercup finale in Mexico.

“I just came here for some more practice for the Supercup,” said Ellinas. “They [Redline] called me up on Monday and said, ‘Can you come and do the races?’ I was in Cyprus so had to reschedule plans. My lid was in Germany with the Lechner team so I had to go and get that.”

His weekend got off to a tricky start as contact

put him out of the opening race. He started race two from 17th but surged through to finish second. “I got hit from behind in the first race – Dan Vaughan had a brake failure and there was nothing I could do,” Ellinas said. “Going from 17th to second was pretty good – it was an enjoyable race!”

Another driver who returned to the grid at Silverstone and took a second place was Ross Wylie. The Britcar Endurance champion last competed in the series in 2017 and will also contest the Brands Hatch finale with In2Racing. His second place was aided by a decision to opt for rain tyres in the opening race when other frontrunners struggled on slicks.

Former Volkswagen Racing Cup champion Aaron Mason and Ginetta GT4 Supercup racers Lee Frost and Lucky Khera also joined the Carrera Cup grid, taking it to a season high of 23 cars.

Porsche Carrera Cup GB also announced it will introduce a Young Driver Development Programme next season, building on the existing rookie championship.

In the past, the series has awarded a prize fund of over £50,000 to the top rookie drivers at the end of the year. But, with only a small number of new drivers joining the category for the start of this season, changes will be made for next year.

As well as the cash prizes, a range of support will be offered to new drivers in the Carrera Cup who are aged under 25 at the start of March. Michelin will offer three sets of tyres to those in the development programme, while drivers will receive media training and spend time at the Porsche Human Performance facility.

The series has also revealed that all eight of its events next year will be in support of the British Touring Car Championship, the first time the Carrera Cup has not featured an away round since 2013.

STEPHEN LICKORISH



BATHIE

Ellinas: Porsche Carrera Cup GB champion in 2018

# Alvarez hits out at title rival Maloney over collision

## BRITISH F4

Sebastian Alvarez has accused his British Formula 4 title rival Zane Maloney of pushing him off the road after the pair sensationally collided at Silverstone last weekend.

The duo entered Silverstone's third race level on points at the table top, after Alvarez had made up a 15-point deficit to Maloney over the first two races. In the final race, held in damp conditions, Alvarez sought to pass Maloney for second place on the outside of Brooklands.

He was offered little space by Maloney on the corner's exit and lost control on the slippery kerb, then hit the side of Maloney at Luffield, putting both cars into the gravel and out of the race (below).

"I tried overtaking him round the outside



Alvarez (l) and Maloney are tied on points

— I clearly was quicker, I think he knew that I was quicker — then he just tried running me off the road," Alvarez said. "Then once he successfully ran me off the road I was on the paint, I lost control of the car and I went straight into him at the next corner."

When asked if Maloney could have left room, Alvarez said: "Yeah, definitely. I've been doing the same move on a lot of

people this weekend and all of them have left me room and nothing has happened."

Maloney was more coy about the incident, but indicated that he felt the fault was with Alvarez.

"I was trying to save the tyres for the end of the race," Maloney said. "He [Alvarez] tried to go on the outside, I defended the position well I think and he ended up off-track, through the grass and into the side of me."

"Hopefully we have some fair racing [at Brands Hatch's final round]. I hope the championship is interesting and the fans love the racing that goes down, but I don't know if it was like that today."

The pair head to the season-closing Brands triple-header still level on points, with Maloney ahead on countback.

GRAHAM KEILLOH



Title rivals collided at Silverstone

# Foster to race on F1 support bill

## US F4

British Formula 4 driver Tommy Foster will take part in the United States F4 support races at the US Grand Prix at Austin, thanks to an opportunity that arose via social media.

Foster, who competes in British F4 for Arden and sits eighth in the standings, with one win to his credit at Snetterton, will compete in the Formula 1 support event for Alliance Racing.

"We linked through social media, myself and the team manager at Alliance Racing," Foster said. "We were talking for a while and it came about that they had a spare seat for the event. So they

offered us [the seat], and it all came about quite quickly from there — it's hardly an opportunity to pass up.

"It was actually my brother that got talking [to them on social media]. We put a post up and then the manager of Alliance contacted us and my brother passed it on."

Foster's US outing is currently a one-off, and he is hopeful that it will lead to opportunities outside of F4.

"We're looking to move out of F4 next year but motorsport is a unique sport, you can't ever write anything off," he added. "We're looking to just do a one-off, get our name out there and try to move up the ranks next year."

GRAHAM KEILLOH

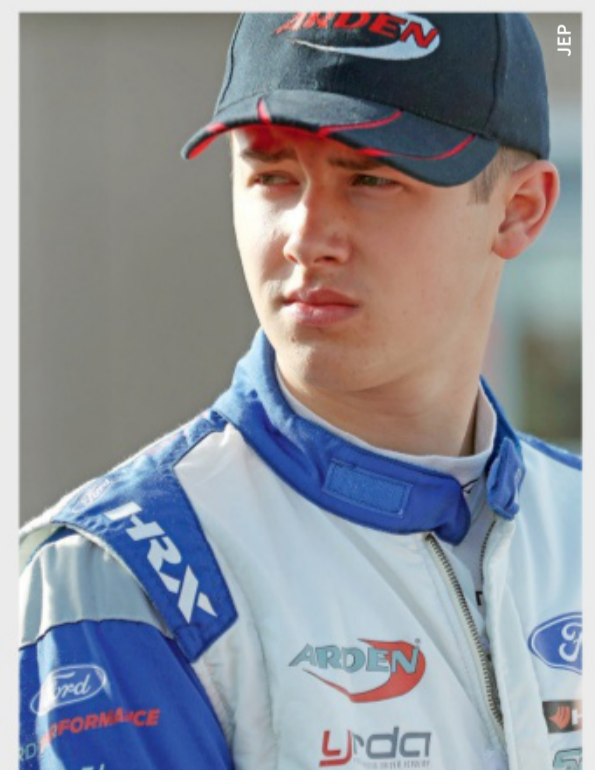

# Smith returns with Oldfield to defend Festival crown



HAWKINS

Festival victory went to Smith last year

## FORMULA FORD FESTIVAL

Last year's Formula Ford Festival winner Josh Smith is to bid for a second successive victory in the event at Brands Hatch later this month – in the same Oldfield Motorsport Van Diemen JL13 he raced to glory last year.

Smith, who triumphed after a dramatic battle in the final with Niall Murray and Oliver White, has not raced in Formula Ford since reaching the final of the Walter Hayes Trophy at Silverstone in November 2018. He subsequently joined the McLaren Automotive Driver Development Programme and has raced in the British GT Championship in a Tolman Motorsport McLaren 570S GT4 this year.

Smith tested with Oldfield at Brands Hatch last Friday in preparation for the Festival, which takes place on 26-27 October. "James [Oldfield], my team boss, was always wanting me to come back and do it, and I wanted to do it anyway just because I love Formula Ford racing, it's always close," Smith said.

"We'll try to win it again, but we will not underestimate my opponents by any means, or think it's going to be an easy ride. I'm approaching it with more of a light-hearted

attitude this time. But it doesn't mean to say I'm not going to come here and do my best to win it. I expect to be still at the front. I don't expect anything less, otherwise I wouldn't be doing it."

Smith added that he is also weighing up an entry for next month's Walter Hayes Trophy.

## NEW PRIZE

Festival organiser the BRSCC has confirmed that this year's highest-placed teenager will get a British Formula 4 Scholarship Assessment Day place in November, with a chance to compete for a £35,000 prize package towards a 2020 F4 campaign. There will also be a drivers' race equipment prize draw in each of the three heats, while the Festival winner will receive hardware from new event sponsor aimshop.com.

## RETURNING DRIVERS

Ciaran Haggerty will return to the Festival next month after striking a deal to race with his former team, the Ray-equipped Graham Brunton Racing.

Haggerty last drove in the event in 2014 after winning the Scottish Formula Ford 1600 championship in his second year. He then went on to drive for GBR in BRDC Formula 4 in 2015, before two seasons

in the British GT4 championship.

"I'm really looking forward to getting back to the Festival, and back to my roots," Haggerty said. "I've had some great success with Graham in the past and we've stayed close ever since we did F4."

Haggerty's only experience of the Festival ended in disappointment after a late-race error, but he is determined to make amends. "I feel like I've got some unfinished business with this race," he added. "In 2014, I was running strongly in third, and was just waiting for the leaders to make a mistake, but I went off at Graham Hill Bend and finished 10th. That's what makes the event so special – anything can happen and it's such an adrenalin rush. I can't wait to get back there."

Luke Cooper and Chris Middlehurst joined the National Formula Ford 1600 grid at Brands last weekend in preparation for the Festival. Last year's Combe champion Cooper made his first National outing of the season in his Swift SC16, taking victory in the first race. Historic Mini racer Middlehurst returned in a Team Dolan-run Van Diemen, managing a best result of sixth.

**GRAHAM KEILLOH, STEPHEN BRUNSDON & IAN SOWMAN**

**Comprehensive motorsport insurance products to keep you on track;**

- ✓ Accident damage On Track
- ✓ Rally damage On Event
- ✓ Storage and Transit
- ✓ Liability
- ✓ Personal Accident
- ✓ Track day

Log on to [www.ryanmi.com](http://www.ryanmi.com) to obtain your online quote  
Email – [info@ryanmi.com](mailto:info@ryanmi.com) Tel – +44 (0)1799 524202

Ryan Motorsport Insurance Limited is an appointed representative (557405) of Independent Broking Solutions Limited who are authorised and regulated by the Financial Conduct Authority. Its Financial Services Register number is 312026

**RYAN**  
MOTORSPORT INSURANCE

# Henderson showcases Ginetta

## GINETTA GT4 SUPERCUP

Former Mazda MX-5 champion Alan Henderson made a successful return to sprint racing last weekend at Silverstone, where he competed in the Ginetta GT4 Supercup to showcase his AK Motorsport team's for-hire G55.

Henderson won the Mazda MX-5 Supercup title in 2015, though stopped midway through 2016 for budget reasons.

His Silverstone appearance was a rare sprint-race outing, as he has more recently contested endurance races in a Lotus Elise.

"I feel like a novice again!" said Henderson. "I just want to get back in the car really – haven't raced in a while. If it's sitting in the garage no one knows we've got it!"

Despite only "40 minutes' experience" in the car, Henderson ran competitively at

Silverstone, finishing fifth in all three races.

Another MX-5 Supercup champion, 2016 title-winner James Blake-Baldwin, will drive the car in the season-closing Brands Hatch round.

Last year's Britcar Sprint champion Kris Prosser was another making his GT4 Supercup debut at Silverstone, driving for Team Hard.

This year Prosser has competed in the GT Cup in a Ginetta G55 Supercup car with the team, and it was via this that his opportunity in the Ginetta one-make series came about. He took a best result of eighth and is hoping to compete full-time in the championship next season.

"It tempted me with the competition. I needed to push myself and see where I was in reality against some of the best Ginetta drivers in the world," he said.

**GRAHAM KEILLOH**



Rare Ginetta G55 outing for Henderson

# Donington added to 2020 calendar

## FERRARI CHALLENGE UK

The Ferrari Challenge UK is to add Donington Park to its calendar for its second season next year, and could also race on the Brands Hatch Grand Prix Circuit.

The UK championship this season joined the ranks of the various worldwide Ferrari Challenge single-make series for the 488 Challenge model.

Ferrari North Europe general manager Francesco Balli confirmed that the UK series will race at Donington in 2020 on what will remain a four-round calendar, though it has not been

decided which circuit Donington will replace.

Ferrari Challenge UK visited Brands Hatch, Snetterton, Croft and Silverstone in 2019. Discussions are ongoing as to whether to replace the Brands Indy Circuit with an event on the full-length GP layout.

Balli added that he expects this year's Ferrari Challenge UK grid sizes of around 20 to be maintained in 2020.

"We expect more or less the same drivers [as in 2019]," he said. "We do not have a need to have more than 20, 25 drivers. This is the dimension we believe is correct because if a customer wanted to

increase the scale of it, there is the European series where we have 50 drivers in two different categories. We are fine with this environment [in the UK]."

Series competitor Alex Moss was pleased at the Donington addition, though also supported expanding the calendar.

"It could do with a couple more rounds," he said. "Next year looks strong, Donington will be a challenging circuit for these cars – and I love Donington, it's one of my most successful tracks."

**GRAHAM KEILLOH**

## IN THE HEADLINES

### NEW KARTING CHAMPIONS

Two new champions were crowned at Anglesey recently as the British Superkart campaign drew to a close. After finishing second last year in the F250 National class, Andy Bird switched to the Division 1 twin-cylinder category and took the title by 42 points. In F250 National, Gareth James ended five-time champion Paul Platt's run of success.

### TF SPORT ON TOP AGAIN

British GT title-winning team TF Sport wrapped up the Blancpain GT Series Endurance Cup Pro-Am championship at Barcelona last weekend, as Charlie Eastwood, Ahmad Al Harthy and Salih Yoluc finished second in class. The trio had won their class at the Spa 24 Hours with Nicki Thiim.

### RENAULT CLIO DEBUTS

Last year's Ginetta GT5 Challenge Am class champion Nick Halstead and former GT4 Supercup racer Paul Taylor made their Renault UK Clio Cup debuts at Silverstone last weekend. Halstead took a best finish of 10th, while Taylor took a ninth place in race two. Anton Spires, Nathan Edwards and Jade Edwards all returned to the series.

### NEW CAR HITS THE TRACK

Sean and Daniel Brown debuted the Brown & Geeson team's Group A-spec Ford Sierra RS500 – newly built from a Ford Motorsport shell – at Spa last weekend. Following a shakedown at Snetterton on Monday, the father-and-son duo qualified second for the MRL Historic Touring Car Challenge double-header. They finished 19th and fourth in mixed conditions.

### SPA GIANTKILLER

The Mini estate of Britons Mark Burnett, Nick Swift and Endaf Owens wowed spectators with its giantkilling performance in the Spa Six Hours (below). Taking part under invitation, the car ran like clockwork, covering 97 laps and 23rd greatest distance in the 99-car field.



# Clio champion drives ex-Schumacher Jordan 197

## HISTORIC F1

The vastly experienced Martin Byford had his first taste of Formula 1 power at Donington Park last month.

The former F3 racer and 2007 Renault UK Clio Cup champion, now more regularly seen in Britcar and Creventic endurance races, was invited to drive

the ex-Jodie Hemming 1997 Jordan, which was raced in period by Ralf Schumacher.

Unfortunately the 3.5-litre Judd V10-powered car suffered gearchange problems after three laps.

“Since Jodie raced in EuroBOSS in 2006 and 2007 it’s been in storage and this was its first time out fitted with a paddleshift,” Byford explained.

“The car was tentative on old tyres and I didn’t want to make a fool of myself. So I was gentle and wanted to give good feedback on the gearbox, as that’s what we were here for. I expected the grip to feel different, though – it was quite positive and I could feel it starting to slide a little on the third lap.”

**PETER SCHERER**



Ex-EuroBOSS racer has been in storage since 2007. Gearshift problems cut short test at Donington

## Frazer Nashes join Autumn Classic bill

### CASTLE COMBE

A capacity grid of chain-driven Frazer Nashes dating back to the 1920s will be an addition to the Castle Combe Autumn Classic programme, which has a new dynamic for Saturday’s seventh edition.

The tail-happy lightweights from Isleworth are indelibly linked to the Wiltshire venue, which manufacturer AFN Limited owned before the Strawford family took it over.

The Historic Racing Drivers Club makes a return to the bill with the Alfa Romeo Challenge, Coys

Trophy and Allstars races echoing the event’s ‘heroes of the 1960s’ theme. Returning are Historic Formula Junior, JEC Pre ’66 Jaguars and a FiSCar Historic Intermarque showcase.

Special cavalcades mark 60 years since Aston Martin’s Le Mans victory with Carroll Shelby/Roy Salvadori in a DBR1, plus local marque Marcos, which Jem Marsh founded in 1959.

A large contingent of Ford GT40s will also take to the track half a century since the icon’s final victory at Le Mans with Jacky Ickx/Jackie Oliver.

**MARCUS PYE**

## CSCC to race at Le Mans

### CSCC

The Classic Sports Car Club will race on the Le Mans Bugatti circuit next season for the first time in its 16-year history, with four 30-minute pitstop races.

Alongside its annual meeting at Spa, the CSCC has previously raced at French tracks Dijon and Magny-Cours. The club will visit the current MotoGP venue across 16-18 October 2020, in what is thought to be a first for a UK club – offering all members, rather than just a single series, a chance to compete at the circuit.

CSCC director David Smitheram said: “We have

been working with French organisers HVM Racing for three years to secure time at Le Mans. The track time is in huge demand with French clubs, so we are thrilled to offer this opportunity to our members.

“We’d love to be on the full 8.5-mile circuit, but I’m not sure we’d be able to convince the French government to close the roads. Members are welcome to drive the Mulsanne straight in their tow cars, as long as they don’t race them!”

CSCC competitor Piers Masarati competed in the Le Mans 24 Hours twice, finishing sixth in the GT class in 2003 aboard a Porsche 911 GT3-RS.

He added: “It’s going to be something special for the drivers to experience the thrill of a driver change in that pitlane.”

The four races at Le Mans, for one- or two-driver entries, will feature rolling starts.

**MATT KEW**

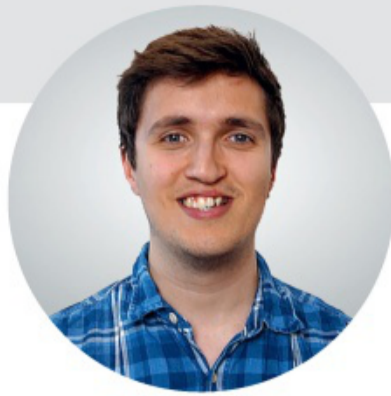

# Arrive, drive and jive

Former soap star Kelvin Fletcher is back on primetime TV in *Strictly Come Dancing*, but it's the race track where he's most intent on showing off his moves

JAMES NEWBOLD

Rather than heel-and-toe, it was Kelvin Fletcher's gyrating hip action that was the talk of Twitter as the British GT4 pro-am champion showed off his samba skills on week one of the BBC's long-running *Strictly Come Dancing*. For the record, he topped the leaderboard with 32 points out of a possible 40.

Make no mistake, appearing on primetime BBC 1 every Saturday night isn't a rite of passage for British GT title winners. Jonny Adam has four championship wins, but by a metric of Twitter followers has a comparatively low profile: 7364 followers relative to Fletcher's 252.1k. This is in no small part because of Fletcher's previous career: his 20-year stint playing Andy Sugden on the ITV soap opera *Emmerdale*.

That Fletcher is the first racing driver – let alone national racer – to appear on *Strictly* (IndyCar racers Helio Castroneves and James Hinchcliffe have both contested its US equivalent *Dancing with the Stars*, Castroneves winning it in 2007) says much for his profile outside the world of racing, which makes him a popular draw for fans in the British GT paddock and at prescribed autograph sessions.

Fletcher freely admits that his profile has helped with attracting sponsors, but the flipside to that is he has been subjected to a far greater level of scrutiny than similarly inexperienced drivers while learning his craft – much like Sir Chris Hoy.

## “Fletcher says he is no longer obsessed with being taken seriously as a racing driver”

Having passed his ARDS and contested a season of Mighty Minis in 2012, Fletcher moved up to the Porsche GT3 Cup Challenge in 2013, winning once on his way to third in the standings, then stayed in Porsches for a partial Carrera Cup GB campaign on the TOCA package alongside select outings in the European V de V prototype series in a Ligier CN car in 2014.

After a year out, he then took the huge leap into the British Touring Car Championship in 2016 with Power Maxed Racing, then in its second year running the ex-RML Chevrolet Cruze. Without an established team leader to learn from – PMR stablemate Hunter Abbott had never managed better than 10th in his 56 previous appearances – Fletcher perhaps unsurprisingly struggled to put together much of a campaign. But he still thinks his showing was better than the results reflect.

“Looking back I think I did really well,” he says. “Being a second and a half off the pace in qualifying, maybe within a second in race pace, if that's a failure then I'll take that every day of the week.”

During that BTCC season, Fletcher's current team-mate Martin Plowman – a Le Mans class winner in 2013 – was first introduced to him. Plowman was “blown away” by what he saw in his data traces. He believes that a lot of criticism of Fletcher in the BTCC was unfair. “Look at Mark Blundell [the ex-F1 driver whose racing comeback in the BTCC this season has drawn considerable flak],” says Plowman. “These things take time – you can't expect someone with two years' experience to be in the top 10 every weekend.”

Fletcher agrees that “fighting a losing battle” in terms of defending his performances from public criticism grew tiring. “Looking back, the only thing I would change is that my need of gaining reassurance and credibility from the fans, it used to really get to me,” he says. “I wanted to change everyone's opinion who had a negative opinion of me. I felt like I had to argue my point and say, ‘Well I'm only an amateur, who else is doing touring cars at such an inexperienced stage?’”

Since making the switch to GT racing and working more closely with Plowman in 2017, Fletcher's progress has been rapid. After taking the GT4 pro-am title down to the wire last year in an elderly Nissan 370Z, Fletcher signed to drive the new Aston Martin Vantage GT4 and combined strong pace – winning the pro-am class three times and scoring a further three podiums – with a relatively clean sheet in terms of mistakes.

He and Plowman were the only GT4 crew to score points at every round and would have had the title wrapped up earlier had it not been for pitstop dramas while well-placed at Donington and Spa. It was at the latter where Fletcher produced his best showing of the year, qualifying third in his session ahead of highly rated McLaren junior James Dorlin, eventual GT4 champion Ash Hand and veteran Scott Maxwell in greasy conditions.

“That was a huge confidence-booster,” he says. “I want to be absolutely rapid, but you've got to have that sense of realism that this takes time and you're still relatively inexperienced. The whole year has been a mixture of mini success stories that have spurred me on.”

Now Fletcher has the affirmation of being a champion under his belt, and says he is no longer obsessed with being taken seriously as a racing driver. There's still plenty of work to do if he is to make a success of his planned step up to GT3 machinery next year, but until then he's upholding his end of the bargain on the dance floor and creating a buzz that will help him to get there.

“So long as Martin and my team take me seriously, that's all that matters,” he says. “I'll let my driving do the talking.”

Oh, and for the next few weeks, his hips too. ✨

Winning margin was three laps for Ford GT40 crew



# Shedden/Griffiths/Walker dominate Spa Six Hours

**SPA SIX HOURS ROADBOOK**  
27-29 SEPTEMBER

Phillip Walker's Ford GT40 team returned to Belgium with the same star driver line-up of Gordon Shedden and Miles Griffiths plus fresh resolve and strategy to win the 27th Spa Six Hours after finishing third last year.

From sixth on the 99-car grid – with Ford Motor Co executive Jim Farley (GT40) on pole, courtesy of Belgian Formula 1 veteran Eric van de Poele – Shedden shot from sixth to second on lap one, and passed last year's winner Nico Verdonck next time around before romping away.

The Hi-Tech Motorsport-prepared car ran faultlessly over the full duration and, with Walker doing a short stint before putting historic ace Griffiths in, it was returned to double British Touring Car champion Shedden in perfect condition.

Eight of the 13 late-built GT40s fell by the wayside, including Tony Wood/Martin Stretton to engine problems and Farley/van de Poele to gearbox failure.

Michael Mallock and Simon Hadfield anchored Wolfgang Friedrichs's Aston

Martin DP214 clone, the race winner in 2005, to a remarkable GTS12 class-topping second overall, having chased the Jon Minshaw/Gary Pearson Jaguar E-type until its engine suddenly threw a rod.

Nikolaus Ditting, in his first attempt at the Spa Six Hours, was amazed to complete the podium, coach Sam Hancock having bookended their superb GT40 effort.

It turned out to be a magical evening for the Hancock family, as dad Anthony, brother Ollie and buddy Joe Twyman won GTS10 with an astonishing run to fourth overall in Hancock's Tom Ebbs-fettled Lotus Elan '26R'.

Anthony had started 22nd and on class pole – with five more Elans within 1.6s – and the race battle was intense, but engine and transmission woes, plus incidents, derailed strong challenges. Nonetheless, Portugal's Goncalo Gomes/James Claridge and Rob Fenn/James Barclay/Oliver Stirling excelled with seventh and 10th respectively.

It was a similar story among the GT40s. Dutchman David Hart crashed out spectacularly at Blanchimont, while Olly Bryant/James Cottingham broke down late on.

Andy Bentley's super final stint rewarded stalwarts Richard Meins/Chris Lillingstone-Price with fifth in their GT40, having overtaken the Thierry de Latre du Bosqueau/Christophe van Riet AC Cobra on the dash to the chequer.

W Series champion Jamie Chadwick and Slovakian Katarina Kyvalova drove their E-type FHC beautifully to a brilliant 11th overall, second Jag behind Martin Hunt's in ninth. Following an engine change, best 'Yank Tank' for the fourth time was Nick Sleep's Shelby Mustang GT350 in 14th.

**MARCUS PYE**



## SPA-FRANCORCHAMPS WEEKEND WINNERS

### 27TH SPA SIX HOURS

**(107 laps) 1 Gordon Shedden/Philip Walker/Miles Griffiths (Ford GT40);** 2 Michael Mallock/Wolfgang Friedrichs/Simon Hadfield (Aston Martin DP214) -3 laps; 3 Sam Hancock/Nikolaus Ditting (GT40); 4 Anthony Hancock/Ollie Hancock/Joe Twyman (Lotus Elan '26R'); 5 Richard Meins/Chris Lillingstone-Price/Andy Bentley (GT40); 6 Thierry de Latre du Bosqueau/Christophe van Riet (AC Cobra); 7 Goncalo Gomes/James Claridge ('26R'); 8 Nico Verdonck/Marcus Graf von Oeynhausen (GT40); 9 Martin Hunt/Patrick Blakeney-Edwards/Fred Wakeman/Mike Grant-Peterkin (Jaguar E-type); 10 Rob Fenn/Oliver Stirling/James Barclay ('26R'). **Class winners** Shedden/Walker/Griffiths; Mallock/Friedrichs/Hadfield; Hancock/Hancock/Twyman; Robert Hamilton/Donald Molenaar/Philippe Vermast (Marcos 1800GT); Sjoerd Peereboom/Jasper Izaks/Tom Smith (MGB); Philippe Vermast/Charles Kauffman/Patrick Wilwert (Ford Falcon). **Fastest lap** Verdonck, 2m44.618s (95.19mph). **Pole** Eric van de Poele (GT40). **Starters** 99.

### FIA MASTERS HISTORIC F1

**Race 1** Steve Hartley (McLaren MP4/1)  
**Race 2** Kyle Tilley (Ensign N177)

### FIA MASTERS HISTORIC SPORTSCARS

Oliver Bryant (Lola-Chevrolet T70 Mk3B)

### MASTERS ENDURANCE LEGENDS

**Race 1** Steve Tandy (Lola-Mazda B12/60)  
**Race 2** David Hart/Nicky Pastorelli (Maserati MC12)

### HGPCA HISTORIC GRAND PRIX CARS

**Race 1** Peter Horsman (Lotus-Climax 18/21)  
**Race 2** Rod Jolley (Lister-Jaguar Monza)

### MRL RAC WOODCOTE & STIRLING MOSS TROPHIES

David Hart/Oliver Hart (Lister-Jaguar Knobbly)

### MRL PRE-WAR SPORTS CARS

Robin Tuluie (Menasco Pirate)

### HSCC CLOSED-WHEEL

**Race 1** Georg Hallau (Lola-Chevrolet T310)  
**Race 2** Alex Taylor (Mazda RX-7)

### HSCC JAGUAR CLASSIC CHALLENGE

Dave Coyne (E-type)

### HISTORIC TOURING CAR CHALLENGE/U2TC

**Race 1** Steve Dance (Ford Capri RS3100)  
**Race 2** Harry Whale (BMW E30 M3)

### GENTLEMEN DRIVERS PRE-'66 GT

Julian Thomas/Calum Lockie (Shelby American Daytona Coupe)

For full results visit:

[roadbook.alkamelsystems.com/](http://roadbook.alkamelsystems.com/)



**THE CORRECT RUBBER** Pirelli P7 Corsa Classic Tyres enabled Mazda RX-7 driver Alex Taylor to blitz powerful sports-racers in Sunday's HSCC miscellany! Starting 14th, he lapped 10 seconds quicker than Saturday victor Georg Hallau (slick-shod Can-Am Lola T310), recovering from a first-lap off as rain fell.



**TILLEY'S F1 WIN** Indianapolis-based Briton Kyle Tilley added a consummate FIA Masters Historic Formula 1 victory to his CV, again piloting James Hagan's Ensign N177 in grizzly wet conditions. Squeezed onto the grass on the Kimmel Straight while 'invisible' in the spray from Mirage team-mate Steve Hartley (McLaren MP4/1C) on Saturday, Tilley salvaged third behind Hartley and Mike Cantillon (Williams FW07C). Belgian father and son Christophe (FW07C) and Antoine (Brabham BT49) d'Ansembourg both spun, the latter triggering a safety car. Tilley dominated the equally disjointed sequel, chased by Jason Wright (Shadow DN8) and Joaquin Folch (BT49C).



**DANCING IN THE RAIN** Rain, the great leveller, made Sunday's Historic Grand Prix Cars Association race the weekend's finest. Fourth on Saturday, Joaquin Folch (ex-Graham Hill Lotus 16) battled with Andy Middlehurst (Lotus 25) initially, as Saturday victor Peter Horsman (Lotus 18/21) spun at Eau Rouge. As Rod Jolley's confidence in the unique 'Monzanapolis' Lister-Jaguar (above) grew, he chased down Middlehurst and won their 'race of two worlds'. A broken linkage left Middlehurst in fourth gear but he salvaged second.



**PODIUM SPOT** Former F1 engineering chief Robin Tuluie won Friday's Pre-War Sportscar race in his self-built special. Early leader Gareth Burnett (Alta) was second, and Ewan Cameron and Sue Darbyshire astonished onlookers by finishing third in the latter's Morgan Super Aero (above).



**INSPIRED STRATEGY CALL** An opportunistic pit call from Michael Bartels meant David Hart stopped early for slicks and to hand his newly acquired Vitaphone Maserati MC12 to Nicky Pastorelli for Masters Endurance Legends victory. Marcus Graf von Oeynhausen (Audi R8 LMS) led briefly and finished third.



**WHALE JR ON TOP** "Spa in the wet is BMW M3 territory," smiled Silverstone Auctions boss Nick Whale, having watched son Harry win Sunday's busy Historic Touring Car Challenge race in his beloved E30. It was not without drama for, starting 11th, Whale Jr was spooked when Eric Mestdagh (BMW CSL) braked hard and early for Les Combes in the first-lap scramble. Both were tagged by Australian Carey McMahon (Ford Sierra RS500) who had nowhere to go. Saturday winner Steve Dance (Ford Capri RS3100) finished second. James Hanson/George Pochciol (Ford Capri) and Olly Bryant (Chevrolet Camaro) earned Tony Dron Trophy Group 1 honours.



## Teenage dream for Harper as he secures Carrera Cup title

### PORSCHE CARRERA CUP GB

When Pro-Am racer Karl Leonard qualified third overall after a dry session, it was clear that this was going to be a topsy-turvy Porsche Carrera Cup GB event. But not enough to prevent Porsche Junior Dan Harper sealing the championship with three races to spare.

As at Croft earlier in the season, where Leonard took an overall race win, rain

jumbled the usual running order. After four laps of race one, the returning Ross Wylie held the lead, with Am drivers Justin Sherwood (who later sealed the class title) and Peter Kyle-Henney second and third, George Gamble fourth, and debutants Aaron Mason and Lucky Khera next. All of them had chosen to use rain tyres on a track that was still far from dry – Gamble switched from slicks at the end of the formation lap.

Gamble duly went on to grab the lead

from Wylie at Brooklands on lap 18 of the 28, and took an impressive win. “On the warm-up lap I couldn’t get any heat in the tyres,” Gamble explained. “I just thought at the last minute I would dive into the pits and it paid off. It just didn’t dry out and I managed to build a gap.”

Of the slick-shod runners, Harper and 2014 champion Josh Webster had a brilliant battle throughout, with Harper edging clear late on to take seventh (third in the Pro class) – more than enough to secure the title.

“Within a lap the guys who started on wets further back were ahead so it was hard to keep calm and stay out of trouble because they had so much pace,” said the new champion. “It was great fun battling with Josh and I was just making sure nothing went wrong. It feels like a long time since I was a champion. Porsche gave me a top opportunity and it was nice to pay them back – the pressure was on.”

Gamble started sixth on the partially reversed grid for race two, but it didn’t take him long to pass polesitter Khera and take the lead, going on to take another win and complete a perfect weekend. “It was a brilliant race – I just went for it and got the gap,” said Gamble.

But the driver of the race had to be returning 2018 champion Tio Ellinas. After contact put him out of the opener, he started 17th. But that didn’t stop him from surging through the order, grabbing second with a bold dive down the inside of Harper at Brooklands. Webster passed Harper too but it didn’t matter – the teenager had already done the hard work.

**STEPHEN LICKORISH**

## Young benefits in title fight from Coates clash

### RENAULT UK CLIO CUP

It was always going to happen. The top five cars in the second Renault UK Clio Cup race were running so close together that contact of some sort was inevitable. And it was Max Coates who was again on the receiving end.

After Jack Young passed double-polesitter Brett Lidsey at Luffield early on, he was unable to break away from the chasing pack. Matters came to a head three laps from the end when Jade Edwards attempted to pass Coates on the inside into Brooklands, made a slight contact that broke her steering, and she ploughed into Coates and Lidsey.

“If she wanted to overtake me there was a gap on the inside,” said Coates. “I hit the brakes and she went into the back of me. It’s very frustrating but the pressure’s all on Jack now.”

After taking what became a comfortable



race win, Young now has a 15-point lead in the title race over arch-rival Coates.

The opener was just as close but it was Lidsey who claimed his maiden win as he escaped a tussle between Young, Coates and Jamie Bond. That was decided when Young clipped the kerb at Becketts, launching his car onto two wheels and letting Coates and Bond through.



“I’m over the moon,” said Lidsey after his victory. “At Knockhill, the mistake that cost me P2 really hurt coming home. I wanted to make sure I didn’t make that same mistake again.”

He did not, but Lidsey’s elimination in race two means that he has now dropped out of the title picture.

**STEPHEN LICKORISH**

# Taylor beats the clock to win

## GINETTA JUNIOR

James Taylor hadn't taken a Ginetta Junior win since Donington Park in April. But he grabbed two at Silverstone amid controversial circumstances.

The first was achieved in race two when Taylor was part of a thrilling lead battle that also included James Hedley, Gus Burton and Lorcan Hanafin.

"I lost the lead three times and managed to get it back," said a delighted Taylor, who admitted he was starting to doubt himself after a tough middle chunk of the season. When I had them come up behind me I was just holding on for dear life."



Taylor took two wins, one of them bizarre

Taylor led for much of the finale too but, as the clock ran down, Hanafin squeezed ahead at Luffield. Taylor then fought back at Woodcote to narrowly reclaim the lead. The battle continued on what was believed to be the final tour, in which Will Martin surged to the front.

But it emerged that Taylor had crossed the line fractions of a second after the clock went to zero, so he was handed the victory.

Martin did win the opener though, after Hanafin and Burton received track-limits penalties, points leader Hedley went off at Becketts, and Ethan Brooks spun out of the lead with suspected brake trouble.

STEPHEN LICKORISH

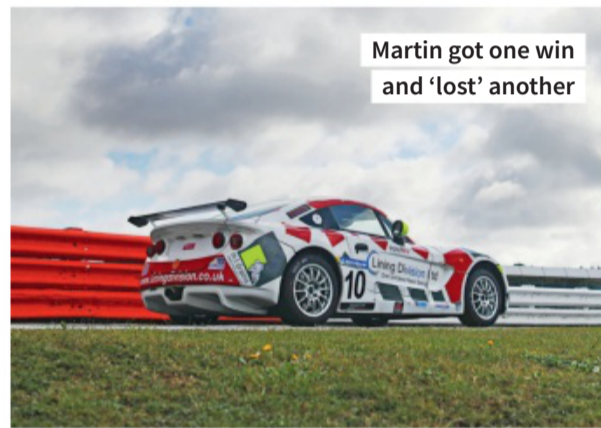

Martin got one win and 'lost' another

## WEEKEND WINNERS

### PORSCHE CARRERA CUP GB

**Race 1 (28 laps) 1 George Gamble;** 2 Ross Wylie +7.703s; 3 Justin Sherwood; 4 Aaron Mason; 5 Peter Kyle-Henney; 6 Lucky Khera. **Fastest lap** Gamble 59.765s (98.81mph). **Pole** Dan Harper. **Starters** 22.

**Race 2 (28 laps) 1 Gamble;** 2 Tio Ellinas +1.778s; 3 Josh Webster; 4 Harper; 5 Wylie; 6 Tom Roche. **FL** Gamble 59.406s (99.41mph). **P** Khera. **S** 22. **Points 1 Harper 141;** 2 Gamble 95; 3 Webster 94; 4 Lewis Plato 87; 5 Dan Vaughan 49; 6 Seb Perez 47.

### RENAULT UK CLIO CUP

**Race 1 (18 laps) 1 Brett Lidsey;** 2 Max Coates +1.344s; 3 Jamie Bond; 4 Jack Young; 5 Ben Colburn; 6 Anton Spires. **FL** Young 1m04.141s (92.07mph). **P** Lidsey. **S** 14. **Race 2 (18 laps) 1 Young;** 2 Colburn +1.540s; 3 Ethan Hammerton; 4 Spires; 5 Bond; 6 Finlay Robinson. **FL** Colburn 1m04.593s (91.42mph). **P** Lidsey. **S** 14. **Points 1 Young 330;** 2 Coates 315; 3 Bond 284; 4 Lidsey 262; 5 Hammerton 226; 6 Colburn 225.

### GINETTA JUNIOR

**Race 1 (11 laps) 1 Will Martin;** 2 Zak O'Sullivan +0.335s; 3 James Taylor; 4 Lorcan Hanafin; 5 Aston Millar; 6 Gustav Burton. **FL** Hanafin 1m11.168s (82.98mph). **P** James Hedley. **S** 23. **Race 2 (14 laps) 1 Taylor;** 2 Hanafin +1.183s; 3 Burton; 4 Hedley; 5 O'Sullivan; 6 Martin. **FL** Hanafin 1m15.220s (78.51mph). **P** Hedley. **S** 23. **Race 3 (14 laps) 1 Taylor;** 2 Hanafin +0.020s; 3 Burton; 4 Hedley; 5 Martin; 6 Joel Pearson. **FL** Hedley 1m14.836s (78.91mph). **P** Taylor. **S** 23. **Points 1 Hedley 603;** 2 O'Sullivan 543; 3 Martin 468; 4 Casper Stevenson 402; 5 Hanafin 397; 6 Taylor 383.

### GINETTA GT4 SUPERCUP

**Race 1 (16 laps) 1 Harry King;** 2 Simon Rudd +4.369s; 3 Carlito Miracco; 4 Reece Somerfield; 5 Alan Henderson; 6 Fin Green. **FL** Tom Hibbert 57.498s (102.71mph). **P** King. **S** 20. **Race 2 (25 laps) 1 King;** 2 Will Burns +6.476s; 3 Hibbert; 4 Somerfield; 5 Henderson; 6 Miracco. **FL** King 57.683s (102.38mph). **P** King. **S** 20. **Race 3 (22 laps) 1 Hibbert;** 2 King +2.598s; 3 Burns; 4 Somerfield; 5 Henderson; 6 Green. **FL** Burns 58.094s (101.65mph). **P** Henderson. **S** 20. **Points 1 King 529;** 2 Burns 522; 3 Hibbert 483; 4 Somerfield 382; 5 Miracco 331; 6 Michael Epps 262.

### BRITISH FORMULA 4

**Race 1 (22 laps) 1 Louis Foster;** 2 Sebastian Alvarez +1.313s; 3 Josh Skelton; 4 Carter Williams; 5 Zane Maloney; 6 Alex Connor. **FL** L Foster 56.398s (104.71mph). **P** L Foster. **S** 15. **Race 2 (19 laps) 1 Alvarez;** 2 Maloney +1.243s; 3 L Foster; 4 Roberto Faria; 5 Bart Horsten; 6 Luke Browning. **FL** L Foster 1m02.706s (94.18mph). **P** Connor. **S** 15. **Race 3 (17 laps) 1 L Foster;** 2 Horsten +1.365s; 3 Browning; 4 Skelton; 5 Christopher Lulham; 6 Tommy Foster. **FL** L Foster 1m01.213s (96.47mph). **P** L Foster. **S** 15. **Points 1 Maloney 367;** 2 Alvarez 367; 3 L Foster 337; 4 Skelton 307.5; 5 Horsten 237.5; 6 Williams 218.

For full results visit: [tsl-timing.com](http://tsl-timing.com)

# King reigns in GT4 title battle

## GINETTA GT4 SUPERCUP

Harry King was the beneficiary in the three-way Ginetta GT4 Supercup championship fight at Silverstone, taking two wins and a second while his rivals, Will Burns and Tom Hibbert, had mixed weekends. It means King heads to Brands Hatch's season-closing triple-header seven points ahead of Burns.

"Of course I would have liked to have done the triple and had the stats, but two wins and a second place is really good," King said. "He [Burns] had an unfortunate weekend but so have we in the previous races this year. We went well at Brands Hatch last year – I look forward to it."

King dominated the first two Silverstone races from pole, delighted with his handling, while in race one Burns and Hibbert finished 17th and seventh respectively after colliding at Becketts when disputing second.

Burns recovered to second place in race two, helped by two ahead – including third-placed Hibbert – picking up track-limits penalties.

In the reversed-grid race three, King rose from starting fifth to lead by halfway around the first lap. Hibbert passed him at Luffield at half-distance to win, and King beat Burns for second after a thrilling place-swapping battle on the final tour.

GRAHAM KEILLOH



King had a near-perfect Silverstone meeting

# F4 title rivals clash as Foster flies

## BRITISH F4

Zane Maloney and Sebastian Alvarez will head to British Formula 4's Brands Hatch finale in just over a week as joint points leaders after they sensationally collided in Silverstone's third race, while Louis Foster still has an outside title shot thanks to a strong weekend.

Foster took two wins and a third place at Silverstone, and was pacesetter in wet and dry. Only a race-two incident, wherein he was an innocent victim, denied him a possible perfect score.

"I'm not going to focus on the negatives too much, but if we didn't have that contact in race two we probably would have had the triple," Foster said. "I don't know why, but we always seem to go well [at Silverstone]. Brands Hatch is my favourite circuit so the championship's open now. We're still 30 points behind; we're going to need luck. But you create your own luck and if we go quick we'll create some of ours."

Foster took a lights-to-flag Silverstone race one victory while Maloney, who led the championship pre-weekend, locked



up and ran wide at Becketts on the opening lap as he challenged Josh Skelton for second. This dropped Maloney to sixth and let Alvarez – who entered the event 15 points shy of him – take advantage to move up to second, where he stayed for the race's remainder. Maloney only recovered to fifth.

Alvarez added to his points haul by winning a damp race two. From starting fifth on the reversed grid he rose within two laps to a lead he never lost, keeping second-placed Maloney at arm's length. Maloney reckoned he had understeer from front-wing damage after nudging Carter

Williams at Brooklands on lap one, which spun Williams into Foster. Foster then recovered from 14th to finish third, despite contact with Alex Connor when taking the place.

Foster again dominated race three, held in variable weather. Alvarez tried to pass Maloney for second at half-distance, getting alongside on the outside of Brooklands. But Maloney left him no space on the exit, and Alvarez lost control on the slippery kerb and speared into Maloney at Luffield, putting both out.

**GRAHAM KEILLOH**

## FAST-LEARNING LULHAM STARS ON F4 DEBUT

Chris Lulham was circumspect at the start of his debut British Formula 4 weekend with Fortec Motorsport at Silverstone. And with justification. He has a glittering karting record, but had completed just three days' F4 running – all in the wet. Thursday pre-race testing was his first run on slicks. Plus he's been taking a year out from racing to concentrate on GCSEs.

Qualifying 14th of 15 runners apparently justified his view. "There's still a lot to learn, it [qualifying] wasn't that bad but I still have stuff to find," Lulham cautioned. So what attracted him to F4? "Mainly it's just a first step from what I was doing last year in Europe, karting," he said, "it seemed the obvious way to go. It's also good competition."

Lulham's first F4 race quickly got even tougher. Another thing he didn't have experience of was a practice start, and he let his machine roll before the lights

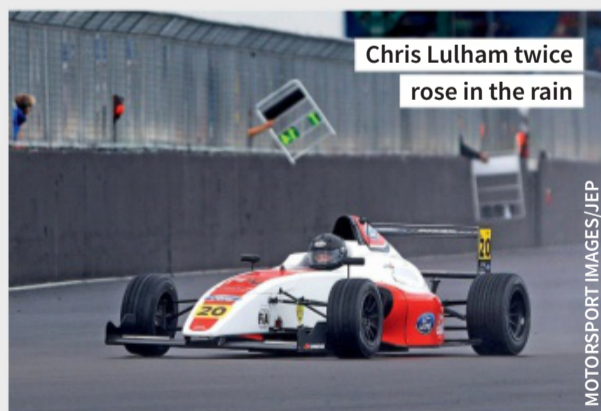

extinguished, incurring a 10-second penalty. Still, his race pace was good and he set seventh-fastest lap. Then in the remaining two races his wet-weather experience suddenly became more relevant, since both were held in such conditions. "It handles a lot more like a kart in the wet," he added.

It showed, for in race two he rose to finish seventh, and it might have been even better: having climbed to sixth early on, he dropped to 14th after locking up

on the kerb paint at Becketts. He then saved his best for last; starting race three from 14th, he finished an incredible fifth. In both wet races he made some spectacular moves along the way.

And he astounded himself in doing it. "I honestly didn't expect to improve so much over the period of a weekend," Lulham said. "I didn't expect to be as competitive as I am. But the racing was really good fun, much better than I thought it was going to be. And coming from 14th to fifth was something I didn't expect. I'm happy I came. Some of the moves were pretty risky but they paid off in the end and I'm glad I did it."

This was a one-off deal, and Lulham says there's "potential" to do more, including perhaps a full season next year. His Silverstone experience only encouraged him. "I'm definitely more keen after this weekend!" he concluded.

**GRAHAM KEILLOH**



Dominik Jackson sealed back-to-back Radical Challenge crowns

# Jackson survives bad crash to claim dramatic Radical title

**DONINGTON PARK**  
**MSVR**  
**28-29 SEPTEMBER**

Dominik Jackson retained his Radical Challenge title in the most dramatic of circumstances at Donington Park.

Title rival Jerome de Sadeleer dominated the first race in mixed conditions, quickly retaking the lead from Marcus Clutton and Jackson after their mandatory stops. Jac Constable pitted in fourth but a stop/go penalty put him out of the running for the race and the title.

Roles were reversed in race two when Jackson led from the restart, followed by Constable and de Sadeleer. As de Sadeleer snatched second on lap 10 of 18, Jackson's lead still looked decisive. "Then the front-right just collapsed and fired me off at the Old Hairpin at 120mph," Jackson said. That left de Sadeleer to take victory over Constable, before a track-limits penalty reversed the order, while Chris Preen just held off Elliot Goodman for third.

The last race was the championship decider and at the start de Sadeleer had the upper hand, with Jackson lining up 15th. Constable and Clutton led the chase of de Sadeleer in the opening laps, while Jackson made it to fourth and pitted early for slicks. But when de Sadeleer made his stop the wheelnuts stuck; he lost a lap so Constable took his second win, ahead of

Clutton. Jackson was third and with that he secured the title.

Pete Morris managed to hold off a determined Simon Clark in his 997 C2S for the whole of the first Porsche Club race. Mike Price vacated third with a broken driveshaft, promoting Jake McAleer, who was aided by Kevin Harrison spinning.

Morris had to defend even harder in the second race, as Price attacked him. They clashed exiting Coppice on lap 12 of 20 and both retired, leaving McAleer clear from Harrison and Andy Toon. Sixth place was enough for Clark to take the title.

Robbie Dagleish made two breaks in the first Mini Challenge Cooper Pro race before securing his victory. First he was caught by Toby Goodman, who then slipped up on lap six of the 11, and then by Alex Nevill, who ran Dagleish close until the recovering Goodman challenged for second.

Having led the opening laps of race two, Dagleish lost out to Goodman after a safety car. Dagleish tried to retake the lead but had a moment on the seventh lap that dropped him to sixth, leaving Lydia Walmsley and Dominic Wheatley to complete the podium behind Goodman.

A third-lap spin at McLeans cost Hannah Chapman her lead in the finale, as Goodman eased to his second win. James Hillery won the duel with Dagleish for second.

Andy Wilmot had dominated the first Focus Cup race until he slowed at Coppice



Clark confirmed the Porsche Club title

## WEEKEND WINNERS

### RADICAL CHALLENGE

**Race 1** Jerome de Sadeleer (SR3 RSX)  
**Races 2 & 3** Jac Constable (SR3 RSX)

### PORSCHE CLUB

**Race 1** Pete Morris (997 C2S)  
**Race 2** Jake McAleer (996 C2)

### MINI CHALLENGE COOPER PRO & AM

**Race 1** Robbie Dagleish  
**Races 2 & 3** Toby Goodman

### FOCUS CUP

**Race 1** Harry Nunn  
**Race 2** Andy Wilmot

### HERITAGE FORMULA FORD

**Race 1** Tom Brown (Van Diemen)  
**Race 2** Joe Porter (Van Diemen RF92)

### F3 CUP

**Races 1, 2 & 3** Hywel Lloyd (Dallara)

### MINI CHALLENGE COOPER S

**Race 1** Rob Austin  
**Races 2 & 3** Daniel Butcher-Lord

### Z CARS & ALLCOMERS

**Races 1 & 2** Tim Bishop (Caterham R500)

For full results visit: [tsl-timing.com](http://tsl-timing.com)

on the penultimate lap and then spun at the chicane. Russell Cager led to the finish, but a post-race penalty dropped him to second behind Harry Nunn, with Richard Avis third. Wilmot led most of race two in a duel with David May, until Nunn split them with two laps to go and made his own play for a second win. Wilmot held on, however, and claimed the title with it.

Tom Brown's Van Diemen took charge of the first Heritage Formula Ford race from Redgate on the opening lap, with Josh Porter (Van Diemen RF92) seeing off the Reynard 88FF of Jaap Blijleven for second. Brown spun off in the wet second race and Porter took the spoils with Blijleven second, while Brown managed to recover to third.

**PETER SCHERER**



This spectacular Noel Robinson roll ended showpiece race early

## David McCullough victor in rock-and-roll event

**KIRKISTOWN**  
**500MRCI MARTIN DONNELLY TROPHY**  
**28 SEPTEMBER**

It probably should have happened earlier. With four very determined former winners contesting the Martin Donnelly Trophy lead for lap after lap, something had to give.

And eventually it did, the only real surprise being that it took 14 torrid laps of Kirkistown's 1.5 miles before the quartet became a trio – an occurrence marked by the fluttering of red flags and a decision by the clerk of the course to declare a result.

The protagonists – Ivor McCullough (winner in 2006 and 2012), his brother David (2018), Alan Davidson (2014) and Noel Robinson (2009 and 2011) – had provided a nailbiting final race of the day, which could have been won by any of them.

They circulated in a slithering, squabbling pack with no quarter asked or given. Three

white cars – the two McCullough 2001 Van Diemens and Davidson's venerable 1989 Mondiale – locked in combat with Robinson's black-and-orange Van Diemen visited every millimetre of Kirkistown's asphalt. When they arrived at the Hairpin for the 15th time the battle showed no signs of abating. Surely it couldn't last. It didn't.

A clash of wheels with David McCullough on the exit launched Robinson skywards and into a roll that left the hitherto-immaculate Van Diemen looking very used indeed.

Happily, Robinson emerged unscathed after his spectacular departure, while David McCullough continued to cross the line 0.09 seconds ahead of his brother, with Davidson a further 0.5s in arrears.

An equally frantic scrap for what became fourth place between the Rays of David Parks and Ian Campbell and the Van Diemens of Scott Finlay and Will Herron

also went the full distance, with Parks, in his first Formula Ford race for several years, taking the spot from Finlay after Herron and Campbell both copped penalties for track-limits infringements.

All of this almost overshadowed a sterling run from Stefan Donnelly, who charged hard in Paul McMorrans Crossle 32F – painted up for the occasion in dad Martin's old livery from three decades ago – to claim a top 10 finish. Not bad for a 42-year-old car among much more modern machinery.

Earlier in the day, David McCullough had clinched the Northern Ireland FF1600 title with a brace of third-place finishes in the two final rounds. Title rival Davidson twice finished second behind Ivor McCullough.

The Irish Formula Vee brigade made their final Kirkistown appearance of the year, with reigning champion Anthony Cross taking the honours in both the final championship round and, later in the day, the Emerson Fittipaldi Trophy. Philip Sheane was runner-up both times, while Dan Polley took the final podium spot from Jack Byrne in race one by a margin of one thousandth of a second. Byrne just beat Jimmy Furlong to the podium in the Trophy race.

Paul O'Brien made it two out of three in the Legends encounters, becoming the most successful driver in terms of race wins in the class along the way. Greg Richardson upset the appiecart in race three though to beat O'Brien across the line by 0.4s.

And there was some pretty frantic action among the Roadsports field too, where Mark Crawford's Rover-powered Caterham fought long and hard with the Radicals of Ivor Greenwood and Jim Larkham.



David McCullough (28) also clinched Northern Irish FF1600 title

ALL PICS: DEMPSTER

## KIRKISTOWN WEEKEND WINNERS

### MARTIN DONNELLY TROPHY FF1600

David McCullough (Van Diemen RF01)

### NORTHERN IRELAND FF1600

Races 1 & 2 Ivor McCullough (Van Diemen RF01)

### FORMULA VEE

Races 1 & 2 Anthony Cross (Sheane FV94)

### IRISH LEGENDS

Races 1 & 2 Paul O'Brien

Race 3 Greg Richardson

### ROADSPORTS

Race 1 Jim Larkham (Radical PR06)

Race 2 Ivor Greenwood (Radical Prosport)

### NI SALOONS/GT

Races 1 & 2 Gerard O'Connell

(SHP Escort Millington)

### NI MAZDA MX-5s AND FIESTAS

Races 1 & 2 Robert Kennedy (below)



For full results visit: [speedhive.mylaps.com](http://speedhive.mylaps.com)

## FOLLOWING IN THE RACING FOOTSTEPS



Stefan Donnelly took part in race named after his grandfather

The Martin Donnelly Trophy was created back in 2006 to honour Martin Donnelly Sr who, until his death a year earlier, had been one of the keenest, and probably the most vociferous, FF1600 fans ever.

Since then it has been an annual affair, hotly contested, with a list of past winners that includes most of Ireland's FF1600 talent. This year, however, was the first time the Donnelly name appeared on the entry list as well as the Trophy when Stefan Donnelly, son of former Lotus F1 star Martin Jr, turned out in a Crossle 32F.

The car featured the legend 'Donnellys for Spuds' and was painted in the colours worn by Martin Jr when he began his racing career.

And it wasn't simply a cameo appearance in his grandfather's race. Stefan charged hard, mixing it with the midfield pack, all of whom were in machinery at least 18 years newer than the venerable Crossle, and scoring a top-10 finish for his troubles.

He also took Pre-82 honours, which led to him receiving his trophy from his dad, who was on hand to present the prizes!

But while Stefan has no ambitions towards making it as an F1 driver like his father, he does have an involvement with motor racing's top level as a member of the legal team looking after Red Bull 'new boy' Alexander Albon. The apple rarely falls far from the tree...



Both Fiesta wins went to Kellett

Crawford might have won the first encounter but for a late-race tangle while passing a backmarker, which left him and Greenwood playing on the grass at Colonial while Larkham sneaked past to win. History almost repeated itself in race two, but this time it was Crawford and Larkham who struck trouble, allowing Greenwood to win

and take the title. Mark Francis and Trevor Allen took a win apiece in the one-litre Class B 'Sevens' battles.

Robert Kennedy was a double winner in his Mazda MX-5, while the Fiesta encounters went to William Kellett.

As the only runner in the GT class, Gerard O'Connell's Millington-powered

SHP Escort ran away with both the tin-top encounters. Top 'normal' saloon was Ciaran Denvir's Honda Civic, ahead of Peter Baxter's SEAT Leon. Greer Wray (BMW) completed the race-one podium, while Luke Baxter in his Volkswagen Golf took third in the second encounter.

**RICHARD YOUNG**

# Second is best for Hoffmann as he snatches title

**BRANDS HATCH**  
**BRSCC**  
**28-29 SEPTEMBER**

Lars Alexander Hoffmann took a pair of second-place finishes in the Caterham Roadsport championship at Brands Hatch to climb the standings and claim the title by a single point.

Pre-event leader Stuart Bell was absent following damage sustained in a collision at Donington Park and, of those remaining, it was Will Rossetti who made the best start to the opener, before tumbling down the order ahead of a mid-race red flag and restart. Andrew Murgatroyd led the second part more or less throughout to keep himself in contention, although main rival Hoffmann was a constant threat. Rossetti could only manage sixth, which proved to be his best finish of the weekend.

Importantly, Murgatroyd led Hoffmann at the start of race two to put himself in a championship-winning position but, when Ben Lopez-Appleton passed both of them on the second lap on his way to an eventual victory, German driver Hoffmann snuck ahead of Murgatroyd to turn the championship tables.

Harry Cook got between the two title rivals – and for a while ahead of Hoffmann too – but ultimately Murgatroyd's hopes effectively came to an end with four laps to go when a big moment at Graham Hill Bend cost him a couple of seconds.

The first Caterham 420R race went



Hoffmann (70) sealed the title as Lopez-Appleton (5) won race two

according to the championship form book, with John Byrne heading home David Henderson by 15 seconds. That left Byrne needing just a 13th-place finish on Sunday to wrap up the title, but that was in doubt on two occasions: first when he stalled on the grid, dropping almost to the back, and second on lap six of 31 when he was trying to pass Matt Higginson for sixth and careered straight on at Graham Hill Bend.

Byrne survived both moments, coming home fifth as Henderson took a consolation win. The fight for second was settled eight laps from home when the flying Richard Ainscough and Aaron Head collided at Paddock. Both survived, but Ainscough dropped to sixth.

Dan French secured the 270R title with an understated sixth place in a restarted race. Tom Allen and James Murphy disputed the win, with just 0.023s separating them as they crossed the line, Allen winning the drag race. The star turn was Caterham Cars

CEO Graham Macdonald, who climbed from 12th to finish on the podium after diving inside Greg Monks at Paddock to pass him seven laps from the end. French sat out the second race, with Murphy a comfortable winner after Macdonald made a series of mistakes, which eventually promoted Monks to second.

The National Formula Ford 1600 Championship had already been resolved in favour of interested spectator Ross Martin, who saw three different drivers take victory over the weekend. Seasonal debutant Luke Cooper (Swift) took the opener, with the pressure from Joey Foster (Firman) coming to an end on lap 14 of 18 when both got sideways at Paddock and Foster spun down the order.

Michael Eastwell finished second to Cooper, but the order was reversed in Sunday morning's race when the Spectrum driver got ahead at Druids shortly before a safety-car period.



Eastwell (92), Cooper (6) and Kohlbecker (back) split the FF1600 wins

## BRANDS HATCH WEEKEND WINNERS

### CATERHAM ROADSPORT

**Race 1** Andrew Murgatroyd

**Race 2** Ben Lopez-Appleton

### CATERHAM 7 420R

**Race 1** John Byrne

**Race 2** David Henderson

### CATERHAM 7 270R

**Race 1** Tom Allen

**Race 2** James Murphy

### NATIONAL FF1600

**Race 1** Luke Cooper (Swift SC16)

**Race 2** Michael Eastwell (Spectrum 011C)

**Race 3** Spike Kohlbecker (Ray GR18)

### CMMC PRODUCTION SALOONS

Bradley Lane (Honda Civic Type R)

### CMMC SUPER SALOONS

**Races 1 & 2** Rod Birley (Ford Escort WRC)

### PRODUCTION GTIs

**Race 1** Simon Vercoe

**Race 2** Martyn Walsh

### CATERHAM 7 310R

**Race 1** Jay McCormack

**Race 2** Christian Szaruta

### CATERHAM ACADEMY

**Green Group** James Venning

**White Group & Autumn Trophy** Tom Wyllys

For full results visit: [tsl-timing.com](http://tsl-timing.com)

Rory Smith was on the podium in both of the first two races in his Medina, then was narrowly denied a win in the reversed-grid finale. Spike Kohlbecker amassed a lead of more than 2s in his Ray, but Smith reeled in the American. He spent the second half of the race just tenths of a second behind Kohlbecker but couldn't find a way by.

The Classic and Modern Motorsport Club Production Saloon race boiled up to a fascinating conclusion after Jonathan Bevan spun the Honda Integra he was due to share with Rod Birley into the gravel at the first corner. Bradley Lane was chased home in his Civic Type R by the similar car of Dave Hutchins and, latterly, the older model of Jamie Primett/Kamran Tunio, which started at the back after being found to be underweight after qualifying.

Birley switched to his Ford Escort WRC for Sunday's Super Saloons double-header and unsurprisingly took two wins, although Niall Bradley's BMW M3 ran him close.

Simon Vercoe took his Golf Mk5 to a dominant first victory of the season in the Production GTI opener, with champion Simon Hill stymied by clutch issues. Adam Hance led the opening lap of the second contest, but Martyn Walsh blasted ahead at the beginning of lap two to take the win.

IAN SOWMAN

## BRIDESMAID REVISITED FOR MCCORMACK



Jay McCormack (25) missed another crown

Three times a runner-up, each instance on a different rung of the Caterham motorsport ladder, Irish driver Jay McCormack arrived at Brands Hatch having accrued the most points in the Caterham 7 310R Championship. He was the bridesmaid again, though, with Gordon Sawyer – who won more races than anyone in 2019 – taking the crown.

McCormack's introduction to racing came by way of an argument in a pub, which resulted in him entering the 2016 Caterham Academy. "When I came into it I had a target to get on the podium and I won the first race, so I kind of blew that out of the window," said the Dubliner.

He lost the Academy White group title to Ben Gillias that season, before missing out to Pete Walters in Roadsport in 2017 and Jamie Falvey in the 270Rs last term. "I have been in this position for the past three years, coming into the final round with a chance of winning but it hasn't worked out," he explained. "They have gone down to the last race in one or two of them, where it was whoever finished in front of each other, but I am due a bit of luck."

The weekend started strongly for McCormack, who claimed pole for the opening race, with his main rival Sawyer only fifth and outsider Tom Grensinger back on row 12.



Sawyer, leading McCormack, took last-gasp crown

McCormack led from pole but Sawyer blasted from row three to take second place immediately, although he gradually got shuffled further back in the lead pack. McCormack spent much of the race battling with Walters, his 2017 nemesis, the pair exchanging the lead numerous times.

Grensinger, meanwhile, had raced through the pack and he passed Sawyer for third into Paddock with two laps to go. As Sawyer tried to retaliate at Graham Hill Bend he went wide, ending the race fifth on the road – then promoted to fourth when Andrew Perry was penalised. McCormack fended off Walters for a vital win.

At first things looked rosy again for McCormack in Sunday's decisive race, as he took the early lead and Sawyer dropped back. Having regained third, Sawyer lost four places by running wide at McLaren on lap three. McCormack was then third, behind the non-scoring Christian Szaruta and Walters – a scenario that would have given him the title.

Almost immediately, his championship bid disintegrated as he skated onto the wet grass on lap six, dropping outside the top 10. "I was coming down to Graham Hill Bend and I got a bit of oversteer and the wheel went out onto the grass, and that was it, I was a passenger," he said.

A late safety car closed the pack, but the one racing lap remaining was not enough for McCormack to salvage the points he needed for the title. He took seventh on the road, with Sawyer fifth, and Szaruta winning from Walters. "I am disappointed, especially when it's my own fault," said the now four-time championship runner-up, who nevertheless plans to step up to the premier Caterham 420R championship for 2020.

IAN SOWMAN



Fry (r) recalls 2009 F1 political machinations at salvaged Brawn team

COATES  
motorsport  
IMAGES

## PLAYGROUND POLITICS

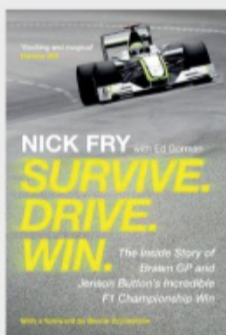

**BOOK REVIEW**  
**SURVIVE. DRIVE. WIN.**  
RRP £18.99

Although it was achieved with one of the most expensive Formula 1 cars of all time, Brawn GP's 2009 world championship double is a remarkable story that still leaves many fans misty-eyed. This new

book, co-written by one of the protagonists, adds several fascinating new dimensions to that narrative.

Longtime F1 followers will recognise the authors' names: Nick Fry arrived in F1 via Ford and Prodrive, and became the CEO of Brawn GP during the management buy-out of the defunct Honda team in early 2009; and Ed Gorman was the F1 correspondent of *The Times* in the late 2000s, having been one of that paper's foreign correspondents. His memoir *Death of a Translator* is a lucid and harrowing account of his time in Afghanistan.

The on-track business of 2009 is already well-known, as are some of the peripheral stories, and the authors prudently minimise the running time they devote to material that's long been in the public domain. Where this book delights and intrigues is in its previously untold – or at least lesser-known – stories and scuttlebutt, along with some of Fry's reflections on the lessons learned during his time in F1.

For those readers not up to speed with events around the turn of the decade, a prologue set during the 2009 Australian Grand Prix weekend handles the expositional legwork tidily and with impressive economy. With the principal characters and events established, the narrative initially tracks back in time to fill in the essential context: how recruiting Ross Brawn to become team principal, persuading the parent company to invest vast sums of cash in cutting-edge engineering facilities, and abandoning development of the 2008

car early to focus on 2009 gave Honda's F1 team all the pre-requisites for success. Enough to tempt Fernando Alonso to express an interest... before Honda pulled the plug without warning in late November 2008.

Having an insider's perspective on the known elements of the story freshens them up a little, and once it reaches the winter of 2008 the intrigue really begins as sundry suitors enter the stage as putative buyers. Some were simply chancers and time-wasters, others – such as minor poker celebrity and convicted fraudster Achilleas Kallakis – were outright shady. The peripheral detail is amusing, too: Brawn himself emerges as an individual who doesn't tolerate fools gladly (and whose relationship with Bernie Ecclestone is dysfunctional at best).

Elsewhere, Fry's description of team principals' meetings as resembling primary school playgrounds will resonate with anyone who has pondered some of the more peculiar rule changes in recent years. His occasionally waspish reflections on other F1 characters – Jenson Button included – also amuse, though the tone becomes more diplomatic and deferential once Mercedes enters the picture.

There are a handful of errors that will trigger the detail-minded, such as the assertion that Honda's F1 team "had been proclaimed – by prime minister David Cameron, no less – one of the crown jewels of British engineering". Although Cameron did make several personal appearances at British F1 facilities before initiating the current Brexit shambles while in high office, in 2008 he was merely the leader of the opposition. Likewise the claim that Button's 2006 victory at the Hungaroring was Honda's first and only F1 win will make eyes roll.

Fry's share of the proceeds from the book will be shared between the charities Hope for Tomorrow and Jackie Stewart's Race Against Dementia.

**STUART CODLING**

**YouTube** [youtube.com/AUTOSPORTdotcom](https://youtube.com/AUTOSPORTdotcom)



Autosport reflects on Robert Kubica's ultimately disappointing Formula 1 comeback at Williams: we not only dig into the reasons he wasn't able to deliver on track, but also assess the magnitude of the challenge he faced just to earn a drive. **Go to [bit.ly/RKassess](https://bit.ly/RKassess)**

[autosport.com/podcast](https://autosport.com/podcast)



The Autosport team looks back at a controversial Russian Grand Prix. Mercedes seemed to be on the back foot but then Ferrari contrived to let a strong 1-2 position slip. What does this mean for the Scuderia's increasingly frustrated (and fractious) drivers?

WHAT'S ON

**INTERNATIONAL MOTORSPORT**

**World Endurance Championship**

Round 2/8  
Fuji, Japan  
**6 October**  
**TV Live**  
BT Sport 3, Sunday 0400,  
Eurosport 2, Sun 0730

**DTM**

Round 9/9  
Hockenheim,  
Germany  
**5-6 October**  
**TV Live**  
Freesports,  
Saturday 1215, Sun 1215

**Formula Renault Eurocup**

Round 9/10  
Hockenheim,  
Germany  
**5-6 October**

**TCR Spa 500**

Spa, Belgium  
**5-6 October**

**NASCAR Cup**

Round 30/36  
Dover, Delaware, USA  
**6 October**  
**TV Live**  
Freesports, Sun 1900

**NASCAR Xfinity Series**

Round 29/33  
Dover, Delaware, USA  
**5 October**

**Formula Regional European**

Round 7/8  
Mugello, Italy  
**5-6 October**  
**Livestream**  
Motorsport.tv, Sat 1050, 1630  
Sun 1205

**Super TC2000**

Round 9/12  
San Martin,  
Argentina  
**6 October**

**Titans Rallycross**

Round 5/6  
Nyirad, Hungary  
**6 October**

**MotoGP**

Round 15/19  
Buriram, Thailand  
**6 October**



**UK MOTORSPORT**

**Rally GB**

**World Rally Championship**  
Round 12/14  
Llandudno, Wales  
**3-6 October**  
**TV** See supplement page 31

**Snetterton MGCC**

**5 October**  
Morgans, MG Cup, MG Metro  
Cup, Midget and Sprite,  
BCV8, MG Trophy

**Castle Combe CCRC**

**5 October**  
Historic/Classic FF1600, Coys  
Trophy, Formula Junior,  
HRDC Allstars, FISCAR, Alfa  
Classic Challenge, Pre '66  
Jaguars, Frazer Nashes

**Oulton Park 750MC**

**5 October**  
Formula Vee, Type R Trophy,  
Toyota MR2, RGB Sports  
1000, 750 Formula,  
Historic 750 Formula

**Silverstone National MSVR**

**5 October**  
Equipe GTS, Equipe Pre '63,  
AMOC GT, Inter Marque,  
Jack Fairman Cup,  
Pre-War Team Challenge

**Silverstone International BRSCC**

**5-6 October**  
Porsche, Sports 2000,  
Clubmans, Mazda MX-5,  
Ford Fiesta, Fiesta Junior,  
Alfa Romeo

**Pembrey BARC**

**5-6 October**  
Trucks, MGOC, Welsh  
Sports/Saloons, Legends,  
Monoposto

**Cadwell Park BARC**

**5-6 October**  
Caterham Graduate, Classic  
VW/Honda V-Tec, Junior  
Saloons, Kumho BMW,  
Hyundai Coupe, BARC  
Saloons, BMW 116,  
Open Saloons

**Knockhill SMRC**

**6 October**  
Fiesta and Hot Hatch,  
FF1600, Classic Sports  
and Saloons, Legends Cars,  
Sports and Saloons,  
C1 Cup, Mini Coopers

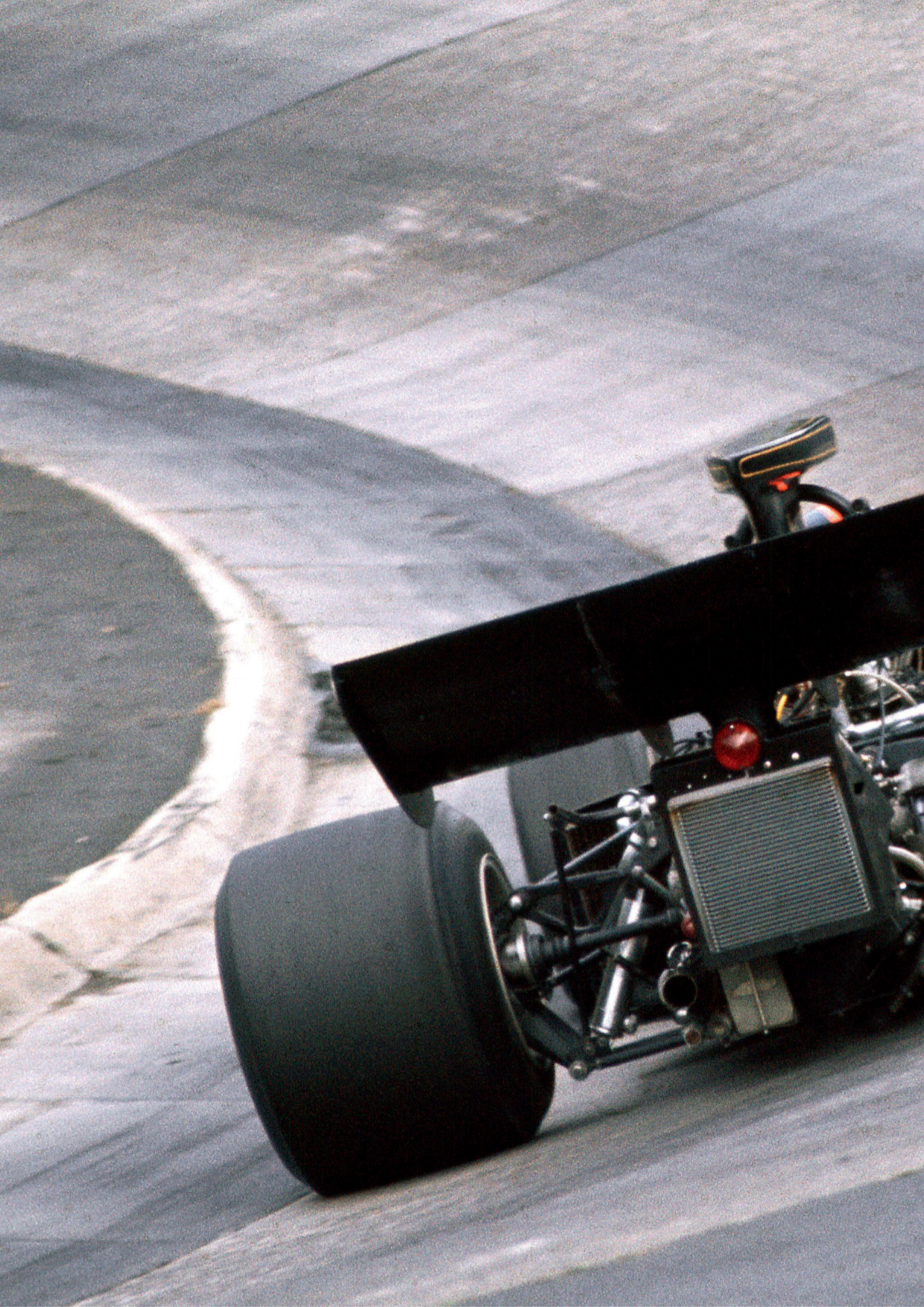

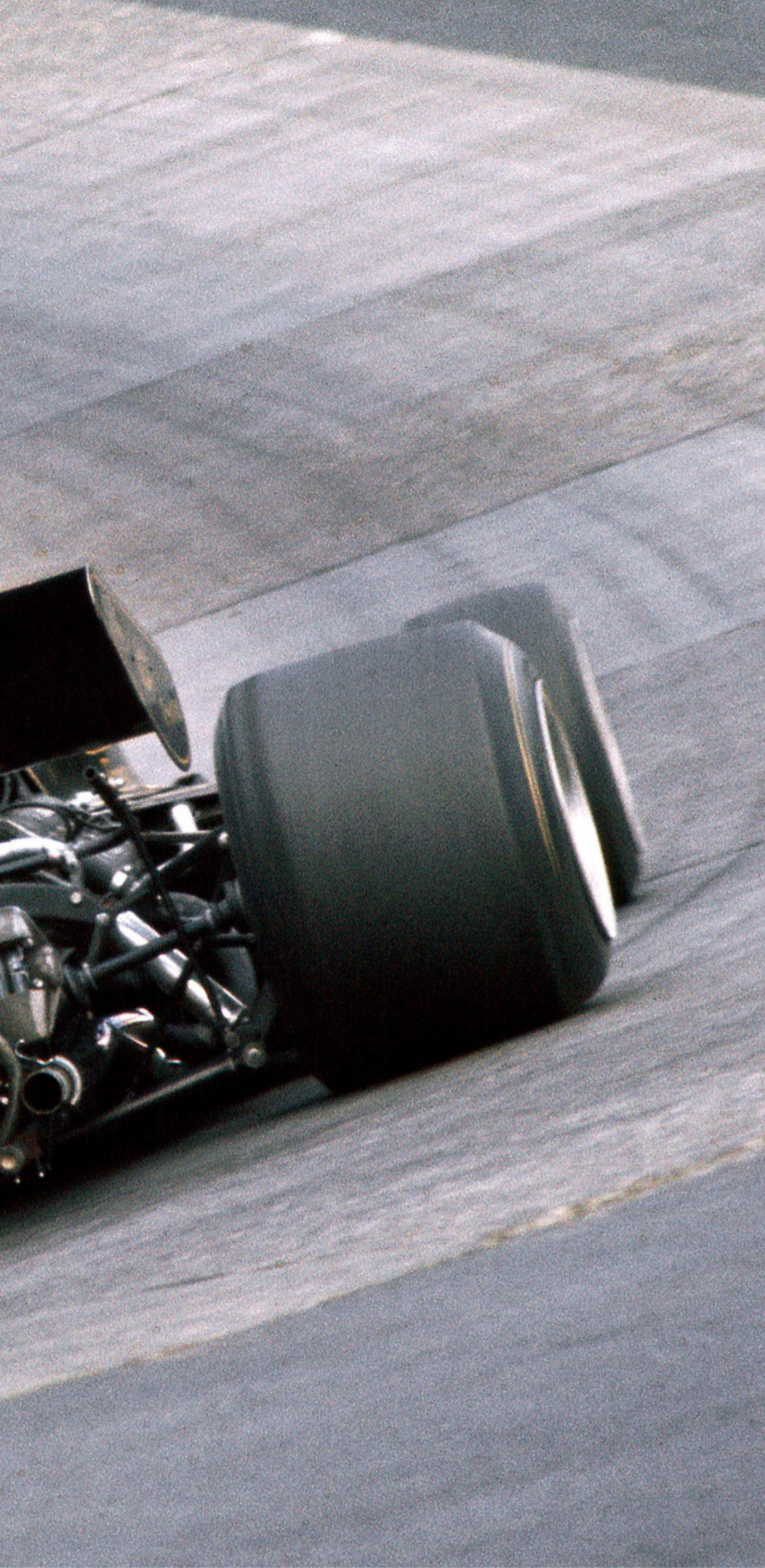

## FINISHING STRAIGHT

### FROM THE ARCHIVE

Emerson Fittipaldi gives the right-rear Firestone on his Lotus-Ford 72D a workout through the Karussell during the 1972 German Grand Prix at the Nurburgring. Fittipaldi qualified third and was running in second place on lap 10 of 14 when his gearbox failed spectacularly. The race was dominated by Jacky Ickx (Ferrari 312B2), who took pole position, led every lap, set fastest lap and finished almost 50 seconds ahead of team-mate Clay Regazzoni.



For classic Formula 1 DVDs  
head to [dukevideo.com/F1](http://dukevideo.com/F1)



For more great photographs,  
visit [motorsportimages.com](http://motorsportimages.com)

QUIZ



1) Who, what, where, when?

PHIPPS

2) Who is this?

This record-breaking rocketman is still a familiar face in the paddock.

From the birthplace of country, he initially learned his craft on the loose surfaces before turning his hand to the black stuff. Picked as a stand-in for a travelling superstar, he soon proved his worth, picking up wins – including one at a Kent amphitheatre.

As a model of consistency he quickly added a crown to his collection, as well as bagging the first of his four big race wins.

He starred for a snake in a one-off test, but the terms of the deal didn't suit him. It was a wise choice as the wins and titles flowed, until a big one at a forgotten tricky triangle brought his run to an end.

He was never as fast again, but still wily enough to wrap up wins, while there will always be a place for him at the Captain's table.

3) On this day...

A Which driver claimed their only Formula 1 win on this day in 1971?

B It's Andrea de Adamich's birthday. With whom did he share the Alfa Romeo to win the 1971 Brands Hatch 1000Km?

C Max Papis turns 50 today. He won three Champ Car races. For which team?

D Who scored the last of his four 500cc world motorcycle wins on this day in the 1999 Australian Grand Prix?

E Which well-travelled European racer made his IndyCar debut on this day in 2004 for Patrick Racing?

4) Name the helmet



**LAST WEEK'S ANSWERS** Who, what, where, when Pedro Lamy, V8Star Series Jaguar S-type, Hockenheim, Germany, May 2002. Who is this? Pedro Chaves. On this day A) Stewart Grand Prix. B) Three. C) China. D) 1995. E) Lola/Scuderia Italia. Name the helmet Tiago Monteiro.

IN NEXT WEEK'S ISSUE

Will the Ferrari threat level continue into 2020?



PORTLOCK

ALL PHOTOGRAPHY  
motorsport  
IMAGES

Autosport Media UK Ltd, 1 Eton Street, Richmond, TW9 1AG  
Tel +44 (0) 20 3405 8100 Email [autosport@autosport.com](mailto:autosport@autosport.com)  
Individual email [firstname.surname@motorsport.com](mailto:firstname.surname@motorsport.com)  
Website [www.autosport.com](http://www.autosport.com) Twitter @autosport

EDITORIAL

Editor Kevin Turner  
Deputy Editor Marcus Simmons  
Grand Prix Editor Edd Straw  
F1 Correspondent Scott Mitchell  
Technical Editor Jake Boxall-Legge  
Chief Sub-Editor Peter Hodges  
Executive Editor Stuart Codling  
Performance and Engineering Editor James Newbold  
Rallies Editor David Evans  
Editorial Assistant Matt Kew  
Art Editor Lynsey Elliott  
Senior Designer Michael Cavalli  
Origination/Repro David Sternberg



Photography

Steven Tee  
Glenn Dunbar  
Sam Bloxham  
Zack Mauger  
Jakob Ebrey  
Mark Sutton

Special Contributors

Ben Anderson  
Gary Anderson  
Alan Eldridge  
Tom Errington  
Matt James  
Stephen Lickorish  
Stefan Mackley  
David Malsher  
Jonathan Noble  
Marcus Pye  
Nigel Roebuck  
Gary Watkins

AUTOSPORT.COM

Video Content Editor Glenn Freeman  
Editor Matt Beer  
Autosport Plus Editor Alex Kalinauckas  
News Editor Jack Cozens  
International Editor Jack Benyon  
Social Media Editor Joshua Folks  
Technical Team Leader Geoff Creighton  
Lead UX Designer Prad Patel

CORRESPONDENTS

Argentina Tony Watson Australia Andrew van Leeuwen Austria Gerhard Kuntschik Belgium Gordon McKay Brazil Lito Cavalcanti Finland Esa Illoinen Germany Rene de Boer Greece Dimitris Papadopoulos Italy Roberto Chinchero Japan Jiro Takahashi New Zealand Bernard Carpinter Russia Gregory Golyshv Spain Raimon Duran Sweden Tege Tornvall USA Jeremy Shaw UK & Ireland Stephen Brunson, Dom D'Angelillo, Kerry Dunlop, Anna Duxbury, Kyran Gibbons, Rachel Harris-Gardiner, Graham Keilloh, Mark Libbeter, Dan Mason, Lucy Morson, Jason Noble, Mark Paulson, Brian Phillips, Hal Ridge, Peter Scherer, Ian Sowman, Ian Titchmarsh, Richard Young

ADVERTISING

Tel +44 (0) 20 3405 8106 Email [autosport.ads@motorsport.com](mailto:autosport.ads@motorsport.com)  
Sales Director James Robinson  
Display Advertising Nick Gavigan, Karen Reilly, Josh Kerley  
Creative Solutions Don Rupal  
Classified Advertising Ben Kavanagh, Balvin McKenzie  
Online and Agency Sales Chris Hermitage

ADVERTISING PRODUCTION

Production Controller Ben Webster  
Tel +44 (0) 20 3405 8131 Email [ben.webster@motorsport.com](mailto:ben.webster@motorsport.com)

SUBSCRIPTIONS

UK +44 (0) 344 848 8817 Overseas +44 (0) 1604 251451  
Email [help@asm.secureorder.co.uk](mailto:help@asm.secureorder.co.uk) Back issues 0344 8488817  
Main office +44 (0) 20 3405 8100

Autosport, ISSN number 0269946X, is published weekly by Autosport Media UK Ltd, 1 Eton Street, Richmond, TW9 1AG, United Kingdom. Airfreight and mailing in the USA by agent named Air Business Ltd, c/o Worldnet Shipping Inc., 156-15, 146th Avenue, 2nd Floor, Jamaica, NY 11434, USA. Periodicals postage paid at Jamaica NY 11431. Subscription records are maintained at Autosport Media UK Ltd, 1 Eton Street, Richmond, TW9 1AG. Air Business Ltd is acting as our mailing agent.



CIRCULATION TRADE ENQUIRIES

Seymour Distribution Ltd, 2 East Poultry Avenue, London, EC1A 9PT.  
Tel: +44 (0) 20 7429 4000.  
Printed by William Gibbons & Sons Ltd, 28 Planetary Road, Willenhall, Wolverhampton WV13 3XT.  
ISSN 0269-946X. Autosport is published weekly by Autosport Media UK Ltd, 1 Eton Street, Richmond, TW9 1AG.

MANAGEMENT

CEO, Motorsport Network  
Yavor Efremov  
President, Motorsport Network  
James Allen  
Editor-in-Chief, Autosport Media UK  
Andrew van de Burgt  
Head of Publications Sunita Davies  
Special Events Manager Laura Coppin

We abide by the Editors' Code of Practice and are committed to upholding the highest standards of journalism. If you think we haven't met those standards and want to make a complaint, contact 0203 405 8100.



©2019, AUTOSPORT MEDIA UK LTD

Trading as Autosport Media UK. Publishing, trade and further subscription details on [www.autosport.com](http://www.autosport.com). While due care is taken to ensure the contents of Autosport are accurate, the publishers and printers cannot accept liability for errors and omissions. Advertisements are accepted for publication in Autosport only upon Autosport Media UK's Standard Terms of Acceptance of Advertising, which are available from the Advertising Department.



# MOTORSPORT AUCTIONS



[motorsportauctions.com](http://motorsportauctions.com)

## Buy and sell on [motorsportauctions.com](http://motorsportauctions.com)



*Fiesta R5 Evo 2 Chassis #169*

*Excellent car with all latest updates*

*Engine, Transmission and Turbo 750kms*

*Maintained by Dom Buckley Motorsport from new in 2016*

*Full repaint completed, can be sold in tarmac or gravel spec, both set ups for extra cost*

*Call KG Motorsport now on +44 7710 564544*

**Latest technology giving an unsurpassed experience irrespective of viewing device**

**On-going attendance at Motorsport Trade Shows, ensuring industry wide visibility**

**The world's largest website with adverts from both Race and Rally competitors**

**Our team's unrivalled motorsport knowledge, experience and contacts**

*For any enquiries or help using our services call Graham Lorimer on +44 7730 676576*



# MOTORSPORT AUCTIONS

[motorsportauctions.com](http://motorsportauctions.com)

# CUPRA ATECA



PLAY BY YOUR OWN RULES.  
WHAT CAR? SPORTS SUV WINNER 2019.

#### CUPRA ATECA. CREATE YOUR OWN PATH.

When we created a sport SUV with 300HP, DSG Automatic Gearbox and 4Drive, we were not following the crowd. When we crafted each detail, inside and out, we were not taking an easy road. When we chose to have 19-inch alloy wheels in aluminium and carbon fibre details, we didn't settle for the standards. We only knew. Not what we would find along the way, but exactly where we wanted to go. And here we are.

The What Car? Car of the Year 2019 Sports SUV winner.

Made for those who create their own path.

Official fuel consumption for the CUPRA Ateca mpg (litres/100km): 33.6 (8.3) – 34.0 (8.4). CO<sub>2</sub> emissions 168 (g/km) (model year 19 vehicles only). For model year 20 vehicles, fuel consumption figures and CO<sub>2</sub> emissions are not yet available.

[CUPRAOFFICIAL.CO.UK](http://CUPRAOFFICIAL.CO.UK)



**AUTOSPORT**

# RALLY GB PREVIEW

**CAN ANYONE  
STOP TANAK?**

**36-PAGE  
GUIDE**



**McRAE TRACK  
TEST SPECIAL**

**MEEKE, EVANS  
AND BREEN**

**ALL THE STARS  
AND STAGES**

# SCHROTH RACING CHAMPIONS CHOICE

**SCHROTH**<sup>®</sup>  
RACING



**NEW FIA Standard 8853-2016  
available right now**



**XLT  
CARBON**

## Wide Range of HANS Devices, Harness Belts & Racing Nets

Visit [www.schroth.com/racing](http://www.schroth.com/racing) to learn more about our products.



Follow us on Facebook  
[www.facebook.com/schrothracing](http://www.facebook.com/schrothracing)

COVER IMAGE: MCKLEIN



Will Ogier celebrate Rally GB victory in Llandudno again?

MCKLEIN

STEP FORWARD OTT TANAK, ELFYN EVANS AND SEBASTIEN OGIER. LET'S NOT FORGET THE SOLBERGS, OR LLANDUDNO. There's so much going on with this week's Rally GB – and, right at the sharp end, there's a fascinating tussle for this year's World Rally Championship. Tanak's leading the charge, but he comes to Britain with heartbreak in his mind after Sweet Lamb turned sour and cost him a maiden Welsh win 12 months ago.

But he'll be forced to put that to one side as he attempts to steer his Toyota Yaris WRC to redemption this time around. He will, however, be chased hard by Ogier and Thierry Neuville – both of whom know they have to throw caution to the wind and take a flat-chat approach to the next four days as they look to narrow the gap ahead of the series' final two rounds (see page 4).

The Welsh event could well decide the direction of this year's crown. And what would really define Wales' round of the WRC would be a second win in three years for Evans. The home-grown hero has missed the last three rounds of the series due to injury, but he's most definitely back when it matters most. Can he do it? Absolutely. And a win would also mean a home hat-trick for the ever-popular M-Sport squad.

The cars will be flagged away in England for the first time in 20 years as the event heads to Liverpool for its ceremonial start. Oulton Park makes a welcome return, while the service park will fill the streets of Llandudno with some early autumn fever.

Finally, it's Rally GB time again. Enjoy.



**DAVID EVANS**  
*Rallies editor*



Tanak must put 2018 Rally GB heartbreak behind him in title race

MCKLEIN

# CONTENTS

## 4 Tanak v Ogier v Neuville

As the season builds to its climax, the result of Rally GB could well define the title battle

## 8 The homecoming kings

Can Craig Breen, Elfyn Evans or Kris Meeke mark their 'home' event with a popular win?

## 10 Changing the Solberg guard

As Petter stages his WRC swansong, it's over to son Oliver to take on the family mantle

## 14 Team by team

Your rundown of the star line-ups from Citroen, Hyundai, M-Sport and Toyota

## 19 Class system

Following hot on the World Rally Cars' heels will be the ultra-competitive WRC 2 field

## 20 The ultimate McRae test

Colin's father, brother and nephew take to the gravel in three of the champion's old steers

## 26 Stage guide

Route co-ordinator Andrew Kellitt picks out the key stages and spectator areas

## 30 National action

More than 60 crews will take to longer stages in the 10th running of the National rally

## 32 From the archive

Delving into Rally GB's rich history: Alpine's brisk but fragile charger

## 34 Entry list

The full rundown of who will be competing on the stages

**SUB-EDITORS** Peter Hodges, Marcus Simmons **CONTRIBUTORS** Luke Barry, Andrew Kellitt **ART EDITOR** Lynsey Elliott

**ADVERTISING ENQUIRIES** Don Rupal **EMAIL** don.rupal@motorsport.com

# THE TRIO

COMING TO BRITAIN IN SEARCH  
OF THE BIGGEST PRIZE

OTT TANAK, SEBASTIEN OGIER AND THIERRY NEUVILLE  
ARRIVE AT RALLY GB FIGHTING FOR THE  
WORLD RALLY CHAMPIONSHIP TITLE

BY **DAVID EVANS** PHOTOGRAPHY **McKLEIN**

## TANAK 210





**OGIER 193**



**NEUVILLE 180**



Tanak has a point to prove after retiring from the lead last year



Junior champ Ogier led in a World Rally Car in 2008 – then rolled

T

urkeys don't vote for Christmas and, it would seem, World Rally Championship protagonists don't vote for Turkey. For the second year in succession, the Marmaris-based event shoved a stick in the spokes of two of the three men chasing the top of the table. Last year it was Ott Tanak who rose while Thierry Neuville and

Sebastien Ogier fell. Last month Ogier was in the ascendancy as the Turquoise Coast terrorised Tanak and Neuville.

Therefore, as we head to this week's Rally GB, Tanak is 17 points up on Ogier, with Neuville a further 13 back. There are three rounds – GB, Spain and Australia – remaining and a possible 90 points on the table. But let's look into the numbers, and beyond the fact that Ogier is 5-0 up on both Tanak and Neuville in terms of Welsh wins.

Citroen star Ogier has dominated Britain's round of the WRC for five of the past six years. And even on the one that got away, in 2017, he wasn't too stressed, as his third place meant he celebrated a fifth world championship title.

If we wind back to 2013 and the start of the Deeside-based era of Rally GB, Ogier has been fastest on 36 of 128 stages. He's led for 93 of them – that's 72% of the stages run in the past six years. Between Jari-Matti Latvala's win in 2012 and Elfyn Evans hitting the front on the first run at Myherin in 2017, nobody except for Ogier had led this rally. That equated to a 1852-day rule at the top of the timesheets.

That is exceptional, and also the reason why Ogier is the favourite to make it six Rally GB wins from seven. Furthermore, he arrives on the back of that superb victory in Turkey. But the man himself is not so sure. "We won the last round," he says, "but that doesn't mean everything is right straight away. We still have work to do, we have to find more pace and find a good set-up for the car for Wales."

Ogier's mood is balanced by the fact that, three weeks before champagne in Turkey, there was abject misery with seventh place and a country mile off the pace in Germany. The reigning champion is a realist – the Citroen C3 WRC is getting there, but there's a way to go yet.

His own team aside, Ogier is well aware that the biggest hindrance to keeping the crown is Toyota star Tanak. The Estonian has won 21 Rally GB stages and led for 14 of them – and all 14 of those were last year, when he slaughtered the very best of the best. His Yaris WRC hit the front in Clocaenog, first thing on Friday morning, and his rivals didn't see him for dust. He built a lead

at will and was well and truly in control of the rally when he turned into a left-hander on the hill towards Hafren out of Sweet Lamb. The sumpguard of his Toyota dug in to the surface and sheared, slicing into the car's waterworks and forcing Tanak to stop on the other side of the corner.

That one really hurt – talk to him about it now, and the pain is still there. And that's another part of what makes Tanak so dangerous this week. He's fuelled by more than the chase for the championship – he wants revenge on the rally that broke his heart 12 months ago. Put this to him and he laughs, but it's true. And he knows it.

So the six-year Rally GB stats favour Ogier, but what about the indications of form we've had across the 2019 season? Since the start of the campaign in Monte Carlo, Tanak has won 61 of the 202 stages run, Neuville is next on 34, while Ogier has topped 21. Toyota struggled last time out in Turkey, where the Yaris WRC wasn't able to match the pace of its rivals, but that was a one-off.

"To be honest, we didn't expect to be the fastest in Turkey and now, hopefully, the difficult events are behind us," says

**"IT'S ONE OF THE MOST DEMANDING RALLIES WHEN IT GETS MUDDY"**

**TANAK**

Tanak. "The rallies coming now are the ones where we have been strong and we've had a good performance in the past. I'm looking forward to Wales – I like that rally. What happened last year, the team is confident it won't happen again. We've



Latvala made his Rally GB debut in 2002, so has vast databank of experience



**“I LIKE IT. IT’S  
A RALLY WHERE  
YOU CAN ATTACK  
AND MAKE SOME  
GOOD TIME. IT’S  
A NICE ONE”**

**NEUVILLE**

“Everything is still possible,”  
says Neuville, who needs  
to win Rally GB the most



been through enough corners similar to that without any trouble.

“The character of the roads [in Wales] is really nice, but it is difficult. The conditions can make it complicated – we’ve got some driving in the night, and when that happens you can have the fog and the rain. It can be tough. It’s also one of the most demanding when it gets muddy – the grip changes all the time, and trying to get a feeling and some confidence in these conditions is not so easy.”

Before Turkey, Tanak was sitting pretty with a 33-point lead. An ECU failure on the second morning, allied to Ogier’s masterful drive, cut that advantage by 16. “Of course Turkey was disappointing,” says Tanak, “but at the same time maybe it only cost us four points. Like I said, we didn’t expect to be fastest there, but that wasn’t as hard as Sardinia [where the power-steering failed on the final stage and he fell from first to fifth]. That was bad. Now I’m looking to Wales, only forward. I won’t give more pressure to the team. We know what we have to do.”

Thirty points down on Tanak after he went off the road on the second morning in Turkey, Neuville has to be the outsider for the title, but what about his hopes for Wales? “I like it,” he says. “It’s a rally where you can attack and make some good time. It’s a nice one.”

But it’s also an event Neuville has never won. He’s been on the podium for two of the past three years, but the Hyundai driver has never genuinely threatened to show the rest of the field the way home. Hence he hasn’t led the event for the past six years and he’s ‘only’ managed 14 stage wins.

What is it that makes Wales such a challenge? Ogier talks about how tricky he found the conditions in his early years – which you’d never expect considering his debut on the event 11 years ago. Driving a Citroën C4 WRC for the first time, he made the best of some of the worst conditions in recent memory to lead the first loop. Can’t have been that hard... “But the next day we crashed,” says Ogier. “Honestly, it was tricky to read the road and understand the grip changes. The weather that year was really crazy with snow, ice and rain and mud. Crazy.”

“This rally can offer a very big difference in the conditions, and it’s so important that you stay calm. We are going into the night again and sometimes, especially when you are in the fog, you are struggling to see the road, you really have the feeling that you are going too slow. But you must do the best with what you have and you need to remember the others are going to struggle as well.”

Experience and maturity mean so much in Wales. It’s easy to get bamboozled by the way the road looks. It can be deceptive, and not always in a bad way.

“In the end, sometimes the grip can be not too bad,” says Ogier. “Even if it’s wet, the rocky surface can give you good grip. But

**“THE WEATHER  
WAS REALLY  
CRAZY WITH  
SNOW, ICE AND  
RAIN. CRAZY”**

**OGIER**

only later on, with some more maturity, that you understand that’s not the way to win rallies; it’s a way to be fast, but maybe not most of the time to go the total distance or to win the rally.”

Going the distance is everything in Wales this week, but how the three title protagonists get there is open to debate. They all need a result, but Neuville needs what would be a maiden British win the most. “Everything is still possible,” he says. “So we keep pushing. Nothing changes.”

One thing Turkey highlighted was the need for a good wingman in what’s turning out to be an epic fight for this year’s title. Citroën’s Esapekka Lappi backed Ogier up perfectly, and more will be expected from him this week. Lappi was on the podium in third place last year, and Finns always thrive on a fast gravel rally. But there’s no shortage of support for Neuville or Tanak either.

Hyundai brings Craig Breen back to the team (after his mid-season i20 Coupe WRC debut in Finland), and he was in the thick of the fight for victory in Wales with Citroën last year. Between Breen, and that most Welsh of Norwegians Andreas Mikkelsen (he lived in Ruthin, in the middle of the GB route, through his late teenage years while he was starting out in the sport), the South Korean manufacturer puts forward a solid proposition for GB.

But the real strength sits with Toyota. Northern Irishman Kris Meeke is a man who knows what’s needed to get the best out of these woods. He’s been here – in various cars – 10 times before and finished second in 2015. Meeke and team-mate Jari-Matti Latvala both made their WRC debuts in Wales in 2002. Since then, the Finn has been ever-present and this week is his 18th start on Rally GB.

Latvala and Meeke both demonstrated their ability to drive for the team and for Tanak in Turkey. The Yaris wasn’t at the height of its powers last time out, but neither driver pushed in the powerstage, not wanting to potentially lift points out of Tanak’s total, while simultaneously safeguarding their positions for Toyota. A repeat of this summer’s German 1-2-3, with Tanak out front, would be a dream come true for the Toyota squad. But Ogier, Neuville and the conditions are ready, willing and able to play their part. Get set for an absolute classic. ■

“THE PEOPLE  
IN WALES HAVE  
TAKEN ME IN  
AS ONE OF  
THEIR OWN”

BREEN

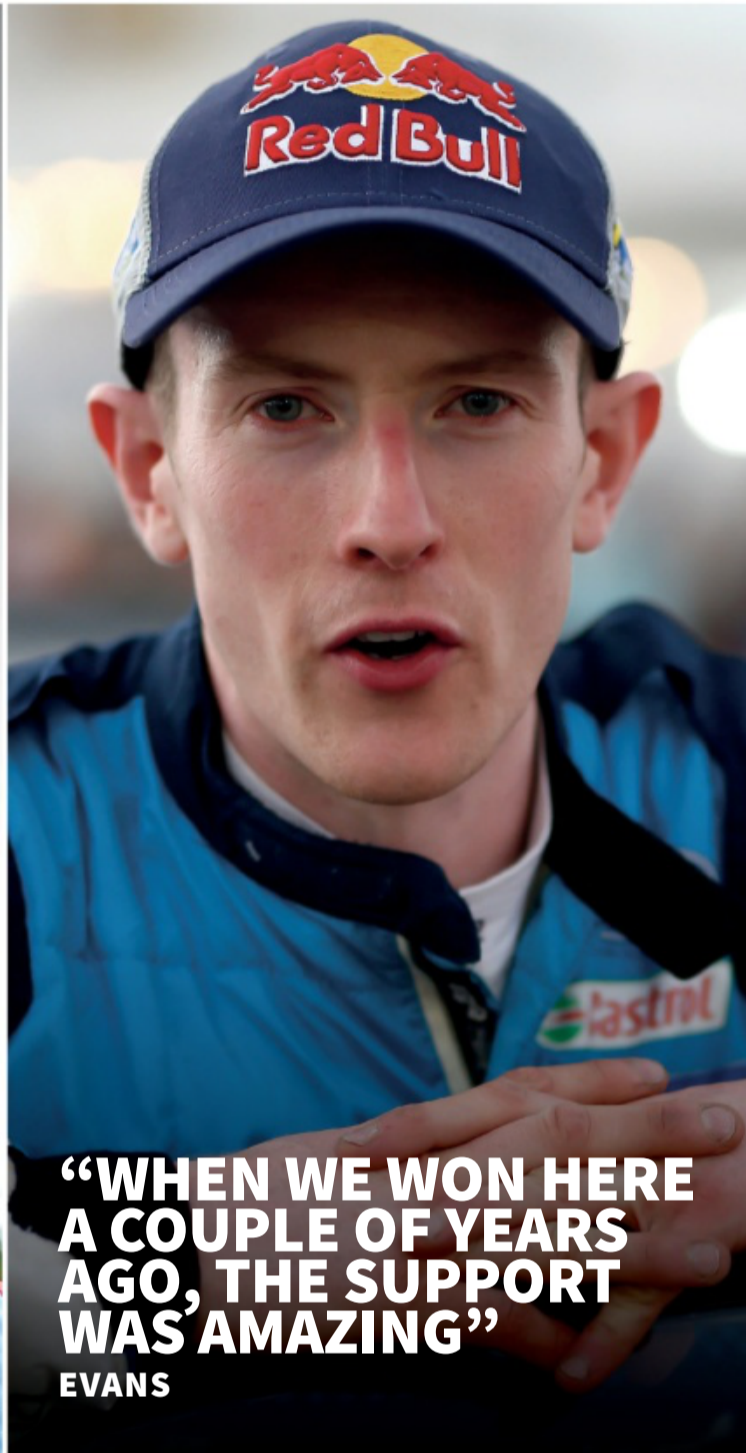

“WHEN WE WON HERE  
A COUPLE OF YEARS  
AGO, THE SUPPORT  
WAS AMAZING”

EVANS

“ONCE YOU GET  
INTO THE WRC,  
IT’S LIKE EVERY  
RALLY. YOU  
COME BACK  
ONCE A YEAR”

MEEKE



# THE QUEST FOR A HOME ADVANTAGE

THREE WRC DRIVERS CONSIDER RALLY GB THEIR HOME EVENT. WHAT ARE THE CHANCES THEY CAN BEAT TANAK, OGIER, NEUVILLE AND CO?

BY DAVID EVANS PHOTOGRAPHY MCKLEIN

raig Breen thinks about the question for a moment. Then he smiles. There's no point. He isn't about to fool anybody.

This is Rally GB number nine for the Irishman. That's one more than Welshman Elfyn Evans and two short of Northern Irishman Kris Meeke. The 'home' boys know where they're going this week.

"I'd be lying if I said I didn't

know the rally well," says Hyundai driver Breen. "I know the combination of everything they've done with the stages over the past three years or so and it's a rally where I feel really strong and comfortable."

Meeke started his career in Dyfi, and Evans lives just down the road from some of the most famous roads in the sport. So what does that mean? What is a home advantage on Rally GB?

"It's nothing to do with the roads," says Toyota man Meeke. "Yes, we've done those stages a fair bit earlier in our careers, but once you get into the world championship, it's like every rally – you come back there once a year and drive them again. And you look at a driver like Jari-Matti [Latvala] – he'll be coming back here for his 18th start in Wales. That's a bit more experience of this rally than we've got."

Evans agrees with that, and he has to be constantly aware of where he's treading once the route is released. Being spotted anywhere near the stages could be interpreted as illegal reconnaissance, a matter taken very seriously by the organisers.

"I just don't go near them," says Evans, "not on the bike, not at all. It's not a problem – we're not short of mountains to ride up in Wales! It's not quite the same as when we were doing the British Rally Championship and you'd maybe be in some of these stages on a BRC round or maybe a national event. We see them the same as everybody else, once a year."

"The difference with this rally for me is that I feel comfortable. There's no travel, no airport or time difference. There's no hassle – I'm just down the road and everything is really familiar. And, of course, there's the support. When we won the event a couple of years ago, the support was amazing on the road sections between the stages and then in the stages themselves. That was fantastic. I just hope the weather stays good for everybody out there watching."

Breen knows what M-Sport's team leader means. Thousands of fans will cross the Irish Sea to watch this week.

"It's the closest round of the WRC to home and it's great to see so many of them coming," says Breen. "For me, Wales is a little bit of home too. Having 'Jaffa' [Welshman Gareth Roberts, Breen's co-driver who died in an accident in 2012] in the car with me for so long... the people in Wales have taken me in as one of their own and it's still a very special feeling for me to come back here. I love the place and I love the rally."

"I think it's a little bit different for Elfyn. He's so switched on in those conditions; he's one of the strongest in that environment."

Undoubtedly Evans has an ability to read the road and understand the grip. One thing he does know a little bit better is the way the weather works in this part of the world. It's a fair assumption that we may be in for a drop of rain this week and, depending on the wind direction, where the rain's coming from, that sort of thing is where Evans's local knowledge can come in handy.

But, when the mist descends on Aberhirnant on Saturday night, it's every driver for themselves – local knowledge can't help you when you can barely see in front of the bonnet.

Is it realistic to expect one of these boys to win? Absolutely. Maybe there's not quite the same expectation as when Colin McRae and Richard Burns were at the height of their powers,

but those were different days. With the route moving around Britain much more, the invaders didn't and couldn't have the sort of intimate knowledge of the roads they do now.

The one possible hindrance to home rule is day-one running order. Meeke will be fifth in, with Evans and Breen ninth and 10th. The rule of thumb in Wales is that it's better to be higher up the order: less muddy, more grip. Meeke should be OK, but Evans and Breen could struggle.

"I'm not thinking about that," says Evans. "I started from a crap place on the road last year and was running second after the first loop on Friday. Let's just get on with it."

Couldn't agree more. ■

C



Ex-Citroen man Breen will be in a Hyundai this weekend



Evans knows better than any driver how to read the conditions



Meeke will be fifth onto the stages, so has an advantage on Breen and Evans

# ONE SOLBERG MAKES WAY FOR ANOTHER

PETTER SOLBERG WILL WAVE GOODBYE TO THE WRC THIS WEEKEND, WHILE HIS 18-YEAR-OLD SON OLIVER WILL BE MAKING HIS DEBUT. WE CAUGHT UP WITH BOTH AT THE CHANGING OF THE GUARD

BY DAVID EVANS



T

here's a big pile of logs at the side of the road. Petter Solberg sets the car up and jabs the brake. The Volkswagen Touareg slides briefly before he gathers it up and continues. One of his passengers has written himself a note, mentally, in capital letters. The other has spilled his cup of coffee. Oliver Solberg is the note taker. Autosport is the coffee spiller.

Every now and then this job gets you places you have no business being. This is one of those moments. We're in the back of the car listening in as the 2003 World Rally champion introduces his teenaged son to Wales. They're here testing, filming... and learning, before the father-and-son combo tackles Britain's round of the 2019 WRC in a pair of Volkswagen Polo R5s.

"What do you think when you see a pile of logs at the side of the road?" asks Petter.

Oliver, don't stress, we've got this one. "Harvesting," is offered from the back seat. "Chopping trees down."

Petter looks slightly exasperated, then does the thing with the brakes. "No. You must be quiet," he says.

Fine by Autosport, busy mopping the flat white up now anyway.

"When you see the big trees lying at the side of the road, it means the grip will be changing in that place. It means the trucks have been in there moving the logs about and they can make a lot more mud when it's wet."

Yeah, all of that. And harvesting. Fortunately, sensibly, Oliver has no intention of listening to Autosport. Why would he, when he's currently tuned in to a four-time Rally GB winner?

Anybody starting Rally GB for the first time is keen to download somebody who's been there and done that. But for Oliver, that advice is special. In the history of the event, only Sebastien Ogier has won GB more times than Petter. And, with 15 starts in Britain under his belt, 'Pappa' is worth listening to.

"It's not an easy rally," says Petter, getting all parental and serious in Oliver's absence. "He has to do a lot of work in the recce, he has to really try to understand where the grip changes are and what the surface can mean. It takes a long time and even now you can so easily be caught out when [the grip level] can change completely from one corner to the next.

"He needs to be looking where the road's under the trees, where the sun is, will it dry?"

"Remember Goodwood [Festival of Speed]? I talked to him a lot about the corner near the stone [flint] wall. It was humid in there. I told him 100 times, 'Be smart there, it will not dry and it will be tricky...' But he came in full sideways! In Wales, there will be so many places to catch you.

"So much of the work for him and Aaron [Johnston, Oliver's co-driver] will be done on the recce. It's absolutely vital that he has his eyes completely open and looks for everything in the recce. I have Phil [Mills, co-driver] with me – he's one of the best in the world. I'm lucky to have him again."

Oliver's back and immediately tunes in. He doesn't interrupt. He just listens, takes it in.

"America has been a good place for you to go and compete this year," says Petter. "You only get one pass on the recce out there, so it makes you look for everything all the time. Pacenotes are always so important, but here when you get into the fog, they are *everything*. That's why it's good to make them a little bit safer. If you have safer notes you are not going to be losing too much time and you can commit to them in the fog."

Petter's phone rings. "Safer notes?" we ask Oliver.

"He means don't make the big risk with the notes," says Oliver. "Don't look at a corner and think, 'Maybe I could just about get away with that in top gear...' Slow the note down just a fraction to give yourself some margin. For my first time on a rally like this, that sort of thing is so important. I have to do this."

Every now and then, you lose Oliver. This is one of those moments. We're standing looking out over the beautiful Welsh countryside. But all he's gazing at is the roads. ►

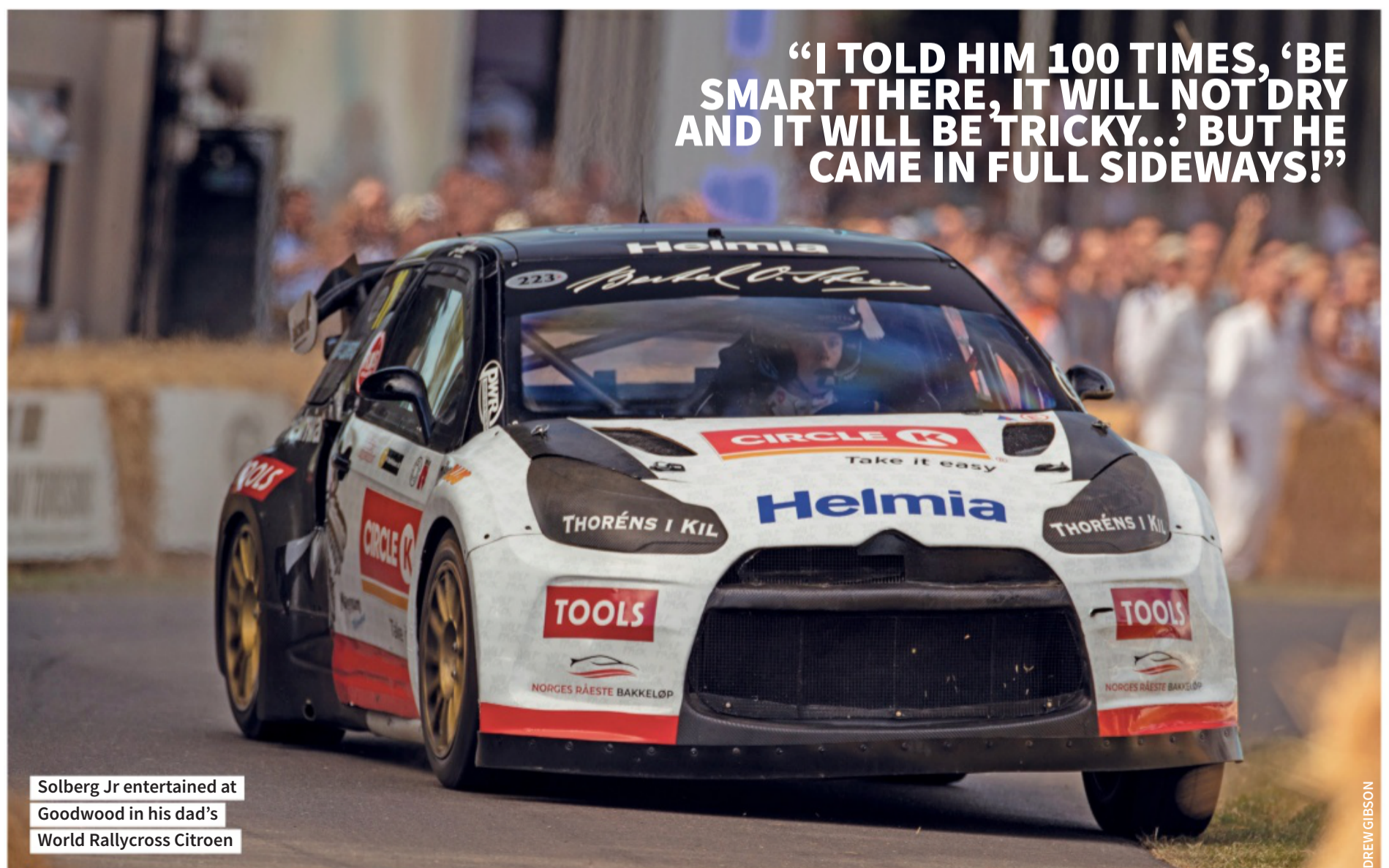

Solberg Jr entertained at Goodwood in his dad's World Rallycross Citroen

DREW GIBSON



“THE ROADS ARE INCREDIBLE. SO MUCH FUN. YOU CAN CARRY A LOT OF SPEED, A LOT OF MOMENTUM. I JUST LOVE IT”

Oliver has relished every minute of the pre-event test

## PETTER'S BIG GB FOUR



### 2002

A storming Sunday morning run through the 33-mile Resolfen stage was enough to carry Petter Solberg's Subaru back past his former team-mate and now Ford rival Markko Martin. Once out front, he wouldn't let it slip again. He reached the end of the Margam Park final stage, jumped out of the car and conducted the massed ranks of the Petter Solberg fan club in his own anthem. He'd done it. He was a World Rally winner for the first time. And he'd done it on a typically wet, slippery and unpredictable Rally GB. Solberg's success went down well in Wales too, with co-driver Phil Mills becoming the first Welshman to win a WRC round at home.

### 2003

What's better than taking your first WRC win in Wales? Try taking your first WRC title... that's what Solberg and Mills did 12 months on from that maiden success at rallying's highest level. The 2003 title race culminated in a four-way fight out of Cardiff. That dropped to three ahead of the start after Richard Burns fell ill, and Carlos Sainz slipped off the road and out of contention when onboard cameras aboard his Citroen Xsara caught fire. That left Solberg and Sebastien Loeb. Neither of them had won a title before and Solberg was masterful. He controlled the event and drove beautifully to take the rally and the crown.

“I drove these roads so many times on the WRC game,” he says. “I grew up watching videos of my father driving here, competing here, winning here. Honestly, it’s really a bit of a dream just to be here in these places.”

And what’s it like to live that dream? “The roads are incredible,” he says. “So much fun. You can carry a lot of speed, a lot of momentum in the car. I just love it. When you drive on the computer game, you are trying to think, ‘What will it be like? Will the car do this or that? How will it be?’ And to come and feel the car doing everything I hoped it would, it’s amazing. And so cool to be here with him [Petter]. He’s my hero.”

“So much of this year has been building towards Rally GB and my first time to drive ever in the World Rally Championship.”

This week’s about more than just Oliver’s arrival in the WRC. It’s also about Petter’s departure as a frontline professional driver. It’s the end of one chapter and the start of another.

“It’s special to be driving with Oliver,” says Petter. “You know I will still drive, I’ll always drive, but this is part of my Farewell Tour. This is my chance to say goodbye to the WRC in the right way and with a good car.”

Oliver’s Polo will run as car #54, with his father one place behind. “Being next to him on the road will be good, at least for the first day,” says Petter. “It means I can help a little bit. We can talk between the stages and, if he’s struggling with anything, then I’m there for him.”

Oliver grins. “And we can compare the times...”

Petter laughs: “I remember the first time I drove in the WRC. It was in Sweden, 1998, and the step from the lower level of rallying was huge. The rally was longer and harder and you will find this in Wales too. The days are long. From the recce it’s tough and, because you are working so hard and focusing so much, you can get tired. Then you go to bed and have maybe four hours’ sleep or something like that. It’s not so easy.”

Wife and mum Pernilla is the glue in Team Solberg. She’s the eye for the finer detail, the first to arrive in the morning,



the last out at night. As a former successful driver herself, she knows what her boys are going through.

“I’m so proud of them,” she says. “They are so close, so together. But at some point, Petter will have to put on his crash helmet and let Oliver get in his car and drive. That’s tough.”

Don’t misinterpret that. Neither Petter nor Pernilla are remotely pushy parents. Oliver did the deal to drive with Subaru Motorsports USA this year all by himself.

“Honestly, the first we knew about it was when he came down to ask us about a visa to fly to America to test the car,” says Pernilla. “Oliver wants this so badly and all Petter and I do is support him. OK, we can give him some advice and guidance, but rallying has been his whole life until now and I can’t see that ever changing.”

Petter Solberg is one of this sport’s true characters. A genuine legend. And having him in Llandudno will make this a truly special week. Enjoy ‘Hollywood’ for one last time. But while you’re there, embrace the future too. It’s Oliver’s turn now. ■



## 2004

For years later the phenomenon was known at Prodrive as ‘the Margam effect’ – the moment everything comes together. Into the final forest stage, Solberg was 3.5s down on Loeb. As the Frenchman eased further ahead, nobody expected the response Solberg managed. Throwing caution to the wind and ignoring an increasingly noisy front diff (possibly a wheelbearing) and putting to the back of his mind that a front wheel could come off at any moment, he flew from ditch to ditch in one of the most mesmerising drives in rallying history. Pulling nine seconds from Loeb, Solberg celebrated a Rally GB hat-trick and described what he’d just done as the drive of his life.

## 2005

This year’s event was marred by tragedy as Markko Martin’s co-driver Michael ‘Beef’ Park was killed in an accident on the Margam Park stage on the final morning. Solberg was running second to Loeb at the time of the crash and, when the organisers cancelled the remainder of the event, the Frenchman took a time penalty to avoid winning. Victory would have sealed his second world championship and nobody was interested in celebrating on a day that robbed the sport of one of its greatest characters. Solberg was left with no option but to move to P1 on a dark afternoon in Cardiff.

# TEAM BY TEAM

BY DAVID EVANS PHOTOGRAPHY MCKLEIN



## #1 SEBASTIEN OGIER

**Nationality** French

**Age** 35

**Co-driver**

Julien Ingrassia

**WRC starts** 147

**WRC wins** 47

**GB starts** 11

**GB wins**

5 (2013, 2014, 2015, 2016, 2018)



## #4 ESAPEKKA LAPPI

**Nationality**

Finnish

**Age** 28

**Co-driver**

Janne Ferm

**WRC starts** 53

**WRC wins** 1

**GB starts** 3

**GB best result**  
3rd (2018)

The master. This bloke had no business winning last year's Rally GB, but he dug deep – quite possibly deeper than ever before – and matched his Ford's searing pace with the ultimate bravery in a powerstage display around the Great Orme that still beggars belief. The Citroen was at the races last time out in Wales and, if anybody knows how to get a C3 to the top step on Sunday afternoon, it's this six-time world champion.

Introduced himself to Wales by backing a Skoda Fabia R5 into a tree on the Myherin opener three years ago. Since then he's knuckled down and worked really hard to understand what makes Rally GB tick. A podium position last year is a solid indication of two things: he's a fast learner (that was only his third start); and he's going to be in contention this time around... provided he can get the front of the car tuned in and doing what he wants.

# HYUNDAI

TEAM PRINCIPAL ANDREA ADAMO  
CAR HYUNDAI i20 COUPE WRC



## #11 THIERRY NEUVILLE

**Nationality**

Belgian

**Age** 31

**Co-driver**

Nicolas Gilsoul

**WRC starts** 108

**WRC wins** 11

**GB starts** 7

**GB best result**

2nd (2017)



## #42 CRAIG BREEN

**Nationality**

Irish

**Age** 29

**Co-driver**

Paul Nagle

**WRC starts** 60

**Best WRC result** 2nd

**GB starts** 8

**GB best result**

4th (2018)



## #89 ANDREAS MIKKELSEN

**Nationality**

Norwegian

**Age** 30

**Co-driver**

Anders Jaeger

**WRC starts** 109

**WRC wins** 3

**GB starts** 9

**GB best result**

3rd (2015)

Rally GB's about inconsistent grip and changeable conditions and, to get the best out of those sorts of characteristics, a driver has to be adaptable and pragmatic. Thierry Neuville grew up and cut his teeth on Belgian roads offering such challenges. Granted, that was on Tarmac, not gravel, but he's on the wavelength of Rally GB and he's definitely a contender. And he's 30 points down on the championship lead, so he has absolutely nothing to lose.

Like Hayden Paddon, it's utterly ridiculous to think that this bloke's been on the bench (apart from in Finland) this season. Twelve months ago he went into Sunday just 13.5s off the lead of Rally GB. A spin in Gwydir left him fourth at the finish, but the Irishman has real potential on these stages. The question is, will he be allowed to push? He's wearing blue and orange in Wales and he has a job to do for Hyundai this week.

It's been a rollercoaster season for the likeable Norwegian, but he needs to cast being dropped for three rounds from his mind and get on with the opportunity in front of him. He was third last time out in Turkey, and a similar result in Wales would work very well for him – and Hyundai's efforts in the manufacturers' title race. Should we expect more from a driver who has lived on the fringes of the Clocaenog forest and knows these roads and conditions well? Probably.



# M-SPORT

TEAM PRINCIPAL RICHARD MILLENER  
CAR FORD FIESTA WRC



### #3 TEEMU SUNINEN

**Nationality**  
Finnish  
**Age** 25  
**Co-driver**  
Jarmo Lehtinen  
**WRC starts** 51  
**Best WRC finish** 2nd  
**GB starts** 4  
**GB best result**  
11th (2015)

Doesn't have massive experience of these roads, but has shown time and again that he's a driver who can make the best out of only a rough idea of what to expect from a rally. Looks to have benefited from slotting the super-experienced Jarmo Lehtinen in alongside him and comes to Wales on the back of a couple of very strong performances in Germany and Turkey. The Fiesta's won GB for the past two years and this bloke could continue that trend.



### #7 PONTUS TIDEMAND

**Nationality**  
Swedish  
**Age** 28  
**Co-driver**  
Ola Floene  
**WRC starts** 48  
**Best WRC finish** 7th  
**GB starts** 3  
**GB best result**  
10th (2018)

One thing is certain: Wales won't be quite the struggle Turkey was – the Swede looked all at sea trying to find a way around the rocks last time out. He may not have massive Rally GB experience, but he's finished each of his three starts on the podium in WRC 2 and that will bring an understanding of what the roads are about. A steady run through Friday could serve him well and give him a better place on the road for the weekend. Top six would be a great result.

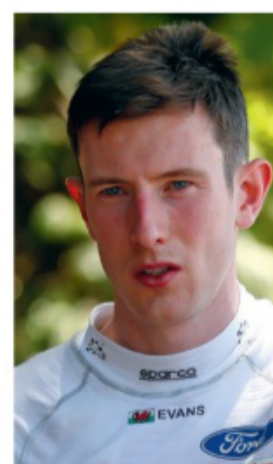

### #33 ELFYN EVANS

**Nationality**  
British  
**Age** 30  
**Co-driver**  
Scott Martin  
**WRC starts** 84  
**WRC wins** 1  
**GB starts** 7  
**GB wins**  
1 (2017)

Forget the fact that he's missed the last three rounds (back injury); this most local of local heroes can do it. He doesn't necessarily know these roads any better than his rivals, but he's got the same sixth sense that serves Ogier so well in the mountains around Gap. What Evans needs is self-belief. He's improved no end in this direction this season, but this week he needs to truly believe that he can win from further down the order on Friday. He can do it.

# TOYOTA

TEAM PRINCIPAL TOMMI MAKINEN  
CAR TOYOTA YARIS WRC

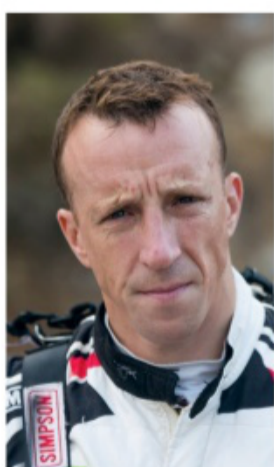

## #5 KRIS MEEKE

### Nationality

British

Age 40

### Co-driver

Sebastian Marshall

**WRC starts** 102

**WRC wins** 5

**GB starts** 10

**GB best result**

2nd (2015)



## #8 OTT TANAK

### Nationality

Estonian

Age 31

### Co-driver

Martin Jarveoja

**WRC starts** 103

**WRC wins** 11

**GB starts** 8

**GB best result**

2nd (2016)



## #10 JARI-MATTI LATVALA

### Nationality

Finnish

Age 34

### Co-driver

Miikka Anttila

**WRC starts** 206

**WRC wins** 18

**GB starts** 17

**GB wins**

2 (2011, 2012)

As his late mentor Colin McRae did, Meeke enjoys huge support on his home round of the championship. And on paper this is an event that should suit the Dungannon man's attacking and committed style of driving – there is *some* grip in those roads if you're prepared to risk a little bit to find it. Second here four years ago, a win is overdue for the Toyota star – but his chances hinge, like those around him, on the conditions on the opening day.

Until he retired, Tanak dominated last year's Rally GB like he has dominated the World Rally Championship for the past 18 months. He has to start as favourite and, if the car holds, then he should be expected to pick up where he left off (comfortably in the lead) in Sweet Lamb last season. He's found that place where he can win stages for fun and make winning rallies look entirely straightforward. On top of that, if it's wet he's in the best place on the road on Friday.

Like Ari Vatanen and Markku Alen before him, Jari-Matti Latvala is a Finn who has found his way to the hearts of British rally fans. Why? It's probably something to do with the fact that there's barely enough room for sponsor's logos on his overalls, his heart takes up so much space... He's a trier and a survivor as well as a very, very fast rally driver. Not to mention a bobble-hatter and absolute gentleman of the sport.

# How Rally GB is the tip of the iceberg for events in Conwy

The World Rally Championship is founded on venturing into some of the world's most beautiful terrain, taking the sport of rallying to the people and whether it's rain or shine, summer or winter, the stars are expected to perform at the highest level.

It's one of the reasons Wales has accepted Rally GB as its home, and has become one of the key events on the Welsh sporting calendar, a unique challenge for a group of drivers truly at the top of their game.

The reason the drivers love the event so much is the reception of the fans of all ages who travel to the area from as far afield as Barbados, and the unique quality of the Welsh forest roads, many of which contained within CONWY County Borough Council area.

This year the event also has a new home in Llandudno where fans will be able to get closer to the stars and cars than ever before from October 3-6.



The council identified the benefits of the event when it moved north in the early 2010s, and has played a key role in helping the event to run – and other rallies like the Cambrian, part of the British Championship – year round. It has become the unofficial county of the rally fan, and without the support of the pioneering and punch-packing CONWY County Borough Council, it wouldn't be possible.



“We see events like Wales Rally GB and the Cambrian Rally which we are the headliner sponsor of as key in promoting the area and all the wonderful things people can enjoy whilst visiting the county,” says Conwy's Coporate Event Manager Rachael Gill.

“Both events also attract much needed visitors in the winter months which is in line with the Conwy County Economic Growth Strategy ambition to grow winter tourism and encourage visitors to see we are open for business all year round.

“Major events are part of the DNA of Conwy County because they are key to our economy and create a lively and dynamic experience for residents and visitors.

“Over recent years Conwy County Borough Council's events team have attracted numerous national and international events, bringing hundreds of thousands of visitors to the area and tens of millions of pounds into the local economy.”

It's unique to find a council providing quite the amount of support to rallying events, let alone the extensive event portfolio it also boasts in helping to boost the economy year round, and ensure the people of Conwy are proud to be part of a county which may not be anywhere near the biggest in the UK, but it punches well above its weight.

The next event on the calendar following Wales Rally GB will provide different monsters to those of the cars. A procession of myth and mystery through Llandudno on November 16 will bring fire and light – much like the machines in the World Rally Championship, in a new event supported by fire: Winter Light.

**ROVANPERA****GREENSMITH****OSTBERG**

# THE OTHER FIGHTS TO WATCH IN WALES

IT'S NOT JUST THE WRC BOYS WHO WILL ENTERTAIN. THE BATTLES IN R5 ARE DEFINITELY NOT TO BE MISSED

BY DAVID EVANS PHOTOGRAPHY MCKLEIN

**T**

here's more reason than ever to keep your eyes on the road ahead once you've watched the World Rally Cars fly by in Wales this week – there are almost 30 R5 cars entered in the event's second tier.

Immediately after the WRC brigade, it's the WRC 2 Pro class of R5 machinery coming through the stages. These are the professional drivers, all at the wheel of manufacturer-entered and run cars. Skoda's 19-year-old prodigy Kalle Rovnanpera is the top WRC 2 Pro seed and the series leader. He arrives in Wales off the back of a couple of miserable results in Germany and Turkey – Rovnanpera went off the road on both events – after a run of four straight wins. His team-mate Jan Kopecky is a lovely chap, but is generally quicker on asphalt than gravel in the sister Fabia R5 evo.

Mads Ostberg is well known to British fans, having finished second overall on Rally GB in 2011. He's taken a step down to WRC 2 Pro in an effort to reignite his career at the highest level, and it's fair to say that he's quicker and more reliable than the Citroen C3 R5 beneath him. Mid-season developments have improved the car, and Ostberg has the pace and the nous to challenge.

M-Sport brings the most interesting offering, with Gus Greensmith out to demonstrate all he's learned in a whirlwind year that has included three outings in the works Ford Fiesta WRC. After completing much of the development work on the Fiesta R5 MkII, Greensmith made his competitive debut with the car in Turkey last time out and delivered the Cumbrian firm its maiden WRC 2 Pro win. At the wheel of the MkII, he's another potential winner this week. His team-mate, intriguingly, is Hayden Paddon. The Kiwi has real potential here this week, and is not a complete stranger to the class, having driven Hyundai's i20 R5 on occasion.

Behind WRC 2 Pro, we've got the amateur section of the R5 field – the WRC 2 class. And this is where the Solberg name dominates (see page 10), with brothers Petter and Henning joined on a WRC

round for the very first time by Petter's son Oliver. Henning sticks with a Skoda in Wales, while his brother and nephew will pilot a brace of Volkswagen Polo R5s.

Rhys Yates, Britain's only full-time WRC 2 runner, has switched from his usual Skoda to a Hyundai, using Rally GB to assess his choice of machinery ahead of a more sustained WRC 2 assault next season. Elsewhere in WRC 2, expect Ole Christian Veiby (VW) and Pierre-Louis Loubet (Skoda) to be close to the front.

There are more R5 runners further back who aren't registered in either WRC 2 Pro or WRC 2, but they could end up as the fastest

**“THE NINE FINALISTS WILL LINE UP ALONGSIDE EACH OTHER IN THEIR DRIVING GLOVES AND, GENERALLY, STOCKINGED FEET”**

class runners. Watch out for Nikolay Gryazin (Skoda), Takamoto Katsuta (Ford) and Hyundai pair Matt Edwards and Tom Cave.

The title in the Junior WRC – a one-make class for Ford Fiesta R2s – will be decided on this, its final round, with a brand-new Fiesta R5 MkII on offer for the victor. Almost everyone has a mathematical shot at the crown, but practically it will be either Tom Kristensson or Jan Solans who claims it.

Meanwhile, the Esports WRC World Final is held in Llandudno on Saturday evening. Reigning title holder Jon Armstrong is one of a 12,000-strong field to make it to the final nine, who will fight it out at Venue Cymru (Rally HQ) at 1800 as they vie for the winner's prize of a Hyundai i20 road car. The nine will line up alongside each other in their driving gloves and, generally, stockinged feet (nobody wears shoes in a race seat at home, apparently) and tackle 11 stages from WRC 8. And it's a chance to watch some ace rally driving without getting all muddy! ■

RALLYING'S SPECIAL  
**FAMILY REUNION**

THREE MEMBERS OF A RALLYING DYNASTY  
AND A TRIO OF EX-COLIN McRAE CARS CAME  
TOGETHER FOR A SPECIAL DAY IN WALES

BY **DAVID EVANS** PHOTOGRAPHY **MCKLEIN**



Three generations of McRae: Jimmy, Max and Alister. Margaret McRae (below) captures a magic moment



T

here's a little bit of pushing, a little bit of shoving, but in the end it's Jimmy who comes out smiling. The other two look a little miffed. But there's no shifting the father – and grandfather – of rallying's greatest dynasty.

We're in Rheola forest in Wales and have gathered three generations of the McRae family and three cars that helped bring that family name to prominence.

British Rally champions Jimmy and Alister McRae, father and brother respectively of 1995 World Rally champion Colin, are well-known in rallying circles. But what about Max? Max is McRae Jr Jr; Alister's 15-year-old son.

With the boys all out to play, Mrs McRae has come along to keep an eye on them. Margaret raises an eyebrow at the scene before her. The three of them are finally ready for the picture. Her husband, five-time British Rally champion Jimmy, is standing on the biggest rock, looking down on the other two.

"Oh, he would be, wouldn't he?" she says, smiling the smile of one who sees his sort of patriarchal locking of horns on a regular basis. Jimmy's grin gets a bit wider.

The cars – owned by rallying philanthropist Steve Rimmer – are all from Colin's career. And they're all things of absolute beauty. There's the Subaru Legacy RS he used to finish second on the 1992 Swedish Rally; an Impreza WRC from Argentina five years later; and his Ford Focus RS WRC 01 from the 2001 Sanremo Rally.

The plan is a simple one: drive the cars, make some memories and remember the legend.

Odd as it sounds, this is the right *wrong* week to do it. We've

gathered just days on from the 12th anniversary of a day when the rallying world darkened, when Colin died in a helicopter crash. But being here, being in the woods with cars that will be forever Colin's cars, and being privileged enough to be among his family felt like it brought him closer again.

Looking back with these cars was inevitable, but the day was also very much about looking to the future of the McRae story. Is Max that future? It's too early to say, but the signs are looking very good.

Max's arrival into Rheola was rock and roll – especially for a 15-year-old. He'd gone from 120mph in a Radical race car at Barbagallo, north of Perth to 17h45m at 550mph aboard a Boeing 787-9 Dreamliner from Western Australia direct to Heathrow. Landing as the sun said good morning to west London, he was whisked directly down the M4, slinging a right onto the A470 towards Merthyr Tydfil and then west once more into Walters Arena.

In just over 24 hours he'd gone from the other side of the world to the driving seat of uncle Colin's Subaru Impreza WRC97. Jet lag? Not a chance. Not when you've got the chance to step inside one of the most beautiful rally cars ever created.

"It does look good, doesn't it?" says Alister. "You wouldn't think it was 20 years old."

There's very little difference between today's car and the one Alister used to come closest to victory on a WRC round. Alister joined Colin at Subaru for the 1998 RAC Rally and was running in a comfortable second going into the final day. When...

"I forget the name of the stage [St Gwynno], but the fog was really bad," recalls Alister. "We had a problem with the lights, they were cutting in and out. We came out of the twisty bit and the last part of the road was really quick. The lights were still going on and off, so I just turned them off. I must have just got slightly off line in the fast stuff and there was a log in a ditch.

### SUBARU LEGACY RS

After two attempts at the Swedish Rally – in a Vauxhall Nova in 1988 and Ford Sierra XR4x4 in 1989 – Colin McRae's third start in the WRC's snow round came at the wheel of this factory Subaru Legacy RS.

Predictably, the then-23-year-old turned heads, but not for the reasons you might immediately imagine. He finished the 1992 event as high as any other non-Nordic driver had managed until that point. More importantly, he drove with significant maturity to ensure a Subaru was at the finish after his teammate Ari Vatanen destroyed his car on the opening stage.

Briefly, as he hauled half a minute out of Mats Jonsson's works-spec Toyota Celica GT-Four in a final-night snowstorm, it looked like he might even win. Second would do. For now.



Max McRae gets comfortable in uncle Colin's old seat



### SUBARU IMPREZA WRC97

The Subaru Impreza WRC97 marked Colin's first finish in three starts at Rally Argentina. He was second to Tommi Makinen, a minute down on the Finn's Mitsubishi. The Scot wasn't a fan of the car's wider track, especially on the narrower roads north of Cordoba around Ascochinga, but his hopes of tracking Makinen down were really ruined by a hydraulic problem that affected the car's power-steering. Makinen's win moved him further ahead in the championship, but second for McRae in this car ensured he remained the current Toyota Gazoo Racing team principal's nearest competitor.



Alister can't hide delight at chance to sample one of Subaru's finest



That flicked the car and it barrel-rolled into oblivion. That was the end of that one. It's a shame – compared to the cars around it, that was the best I ever drove.”

Alister's voice trails away as Jimmy wanders over to join us watching Max climb aboard the blue Subaru.

“I can't believe he's getting in there to drive that,” Alister grumbles. “What was I driving at 15? Eh Pops? What did I get? I got a run around the field in a van... That's not fair.”

Laughing at him doesn't help, but the mood lightens when he remembers escaping the field and making for the loose in a Sunbeam...

Alister: “I'd got hold of a Talbot Sunbeam, I'd got it out the scrappy, welded up the diff and got on with it. I was 15 and Colin had just started driving [on the road, aged 17]. I'd got the Sunbeam up and running and we stuck it on the trailer. The pair of us were looking around for straps to tie it down – in the end we got a wee bit of rope on the front of it. I was looking at it and said to Colin, ‘That gonna be all right, Col?’ ‘Aye Al, be fine. No bother. Fine.’

“It was my pride and joy. I'd been in the garage working on it for three months. Anyway, dad knew this guy who had a quarry where we could take it to drive and that was where we were heading. The quarry was at the top of a hill, so when we turned off the main road I said, ‘Right Col, come on let's take it off the trailer and I'll drive it in.’ ‘What?’ he said. ‘Don't be stupid. It'll be fine!’

“We drove all the way up this long, long hill, stopped and just as he said, ‘Get the gate’, he looked in the mirror and said: ‘Oh...’ I looked around and I could see the car slowly rolling off the trailer. I got out and there's me sprinting after it. I just got to the door and thought, ‘Nah.’

“It went into the rock of Gibraltar; smash, boom! And, of course, I'm just standing there looking at it and Colin, being Colin, he gets out, walks over and says, ‘That's f\*\*\*\*d, Al.’ That was it. Nothing else. Just that.

“We dragged it up into the quarry anyway and drove it like

complete hooligans. After that, remember the Avenger that Colin borrowed to do his first rally? That shell ended up being completely knackered, so I took it, stripped it out and rebuilt the Sunbeam parts into that for that winter's season racing around the field. That was me at 15.

“And look at him, getting into a Subaru World Rally Car!”

Max gives the flat-four just a few more revs. Just to make sure he can't hear his dad grumbling as he climbs in alongside.

Then they're away. Leaving a big, wide-open gravel area, Max gives it a few more revs to build some boost, while putting some lock on to get the car sliding. He looks like he's warming the tyres, but actually, he's living a dream.

Margaret starts busying herself with making a cup of tea, while Jimmy's grin couldn't get any wider.

“He was out with me this morning, we were in the Legacy,” he says. “It's great to have him here in this environment. He doesn't get any of this at home in Australia.”

Did he enjoy the ride?

“I think so, but I didn't get the chance to look at him – I was concentrating too hard on the driving. I didn't want to miss a gear. He might have given me that look.”

With that the Impreza flies into view over the famous crest that leads down to the famous lake. Margaret stirs the tea with a little more vigour and focus.

Jim laughs: “He's certainly getting into the swing of that thing.”

A few more laps and the Impreza's back. Finally, Margaret can enjoy her tea.

The verdict from Alister? “A bit nerve-wracking,” he says. “I asked him a couple of times if he had any idea how much that car's worth. It was fine, but you just never know if there's a rock sticking out or something – it's so easy to damage one of these cars, especially when you're driving it on a proper stage like this.”

The verdict from Jimmy? “I was very impressed, especially given that the fastest rally car he's driven before this is a fairly standard Citroen C2. Alister was over at ours for Christmas last ▶

### FORD FOCUS RS WRC

The Focus RS WRC looked slightly incongruous coming to Wales wearing Sanremo 2001 colours. Don't forget, by then the Italian classic was an all-asphalt event. A forgettable eighth was the result for Colin after transmission problems dogged this car's run through the Ligurian Alps.



For McRae Sr Sr, a moment to reflect on his family's extraordinary rallying legacy



year, so between then and new year we went away up to Knockhill to give him a wee run. In the end he did the same distance as two Scottish Championship rounds – the poor guy from Knockhill came over and said, ‘Is there any chance he might be finished soon? We’ve a medic here and he’s got to go.’ He would have been there all night going around the track and the rallyschool stage.”

Max’s pillow and cushion have already exited the Impreza. They’re hunting down a new home, with the Legacy looking most likely.

“The noise was amazing,” says Max. “And when it came on boost, the torque and power – that took a bit of getting used to. Dad was great – he didn’t tell me to slow down, he just kept telling me how expensive the car is!”

Today is definitely a day of sounds as well as sights. The sight, if we’re honest, is a little incongruous. The temperature’s in the mid-twenties and the sun dominates a cloudless sky. This is not how we remember Rheola. The sounds are like that classic track that take you back to a magic moment.

Except the Impreza WRC97. The noise is sensational, with that harsher-edged tone, but it’s what that noise came to mean. “Aye, that noise probably cost us a championship,” says Jimmy. He’s not wrong. Continued engine issues – mainly centred on the cambelt – cancelled out Colin McRae’s five 1997 wins. He missed a second title by a single point to Tommi Makinen that year.

Talking of missing titles, four years on and another one was dropped just over the hill from here in the Rhondda stage, when Colin rolled spectacularly out of the lead. And the championship. Ironically, a couple of days after passing that destroyed Focus, Alister finished a career-best fourth in a Hyundai Accent WRC.

“The Focus is a good car,” says Alister. “It’s quick and really nice to drive and a bit quicker than the Legacy.”

The Legacy was where McRaes Colin and Alister really started to move on up. Alister got a Group A car for the 1993 British

Rally Championship, while Colin took his first WRC win in New Zealand in another Prodrive-built Legacy RS.

“You just get the feeling when you get into the Legacy, it’ll go forever,” he says. “It was always a really strong car – and that noise. OK, the Impreza is shorter, more compact and there was more development in the engine and gearbox.”

Max chips in: “You have to be really precise with the gearbox on the Legacy. But maybe that’s because it’s a left-hand drive and we only have right-hand drive in Australia.”

Alister offers the slightly withering look only a parent can manage. “That’s because you’re used to sitting in the middle... of a go-kart.”

“Handbrake works though,” Max grins.

Max is gone again, this time showing gramps how to drive.

“It’s great being able to bring him here,” says Alister. “You look at lads like [Kalle] Rovanpera or Oliver [Solberg] and they’re totally immersed in this world. Max doesn’t see any of this. To give him a glimpse into what we did and where we did it is fantastic.”

Nothing, not even a head several timezones away, is enough to dim Max’s enthusiasm. As the end of the day nears, he’s still walking among the cars with a look of absolute wonder.

This really is half a world away from chasing a season in Formula 1000 back home.

“I just want to drive,” he says. “I really want to go into rallying, but if it’s racing I don’t mind. It’s tough at home, we don’t have the chances to go rallying like you do in Europe, but I’ll keep practising on private roads. I really look up to Oliver [Solberg] – he’s not that much older than me, but he’s so quick in a car.”

But for now, maybe it’s game time again. But which game?

“DiRT,” Max fires back, quick as a flash and loyal as ever to uncle Colin. “Always DiRT.”

With that, the day’s driving is done. Mission accomplished, memories made. ■

## IAN GWYNNE - THE CAR PREPARER

If you were anywhere on the road between Brackley and Chippenham a couple of Fridays ago, you could have been forgiven for thinking the world had stepped back in time.

Minding your own business on the A34, thinking about the weekend ahead when... was it? Was it really?

Was that Jimmy McRae's Vauxhall Chevette HSR? And was it really being towed by the same Castrol-liveried Bedford van that hauled it around Britain for the 1981 Open series?

Must have been seeing things. What's this now? A proper Boreham Ford Transit service barge towing an Escort RS1700T. Can't be. There are only five of those things in the world. And a Prodrive van pulling a Legacy RS. This display was followed by 17 more of the world's most iconic and delicious rally cars.

Bound for Castle Combe and Rallyday, this history-packed



peloton had come from one place: BGMsport.

Just before Rallyday, BGMsport took a Subaru Legacy, Subaru Impreza (owned by

Girardo & Co) and Ford Focus to woods where we just happened to be lurking behind the trees.

One of Britain's best restorers and preparers of classic and

historic rally cars, BGMsport belongs to Ian Gwynne. The company is just over 10 years old, but it's been a generation in the making. Ian's father is the late Bill Gwynne, who ran his own preparation firm alongside what was probably the world's most famous rallyschool.

"I was working with dad in the business and I wanted to take it in a different direction," says Gwynne Jr, who followed his father into competition and was one of British national rallying's leading lights in the late 1990s. "I ended up buying it off him. That was 2008 and things have just grown and grown since then."

And they continue to grow. BGMsport has customers around the world, and US-based British rally fanatic Steve Rimmer is one of the firm's strongest allies. The Legacy and Focus – as well as lots of other cars – belong to him.

## STEVE RIMMER - THE CAR OWNER

As the son of an aircraft design engineer, Steve Rimmer's fascination and expertise in the aviation industry is to be expected. But as he grew up in Preston and the 1960s turned to the 1970s, it was a burgeoning road rally scene that offered further fascination.

Rimmer competed on selected road rallies, but knew his limitations. Any hope of regular seat time was restricted by a career that was moving rapidly and transporting him around the world. After settling in Seattle and building a successful aircraft leasing company, there was a moment to look back at rallying.

Persuaded to buy a Group N Subaru by a colleague, Rimmer's path crossed Ian Gwynne's and the two have worked together since. "Ian knew I was interested in buying some cars," he says. "And he called me to tell me he'd found an ex-works Skoda Octavia WRC. He said the



price was right and that this would be a good investment. We went for it."

Since then, Rimmer's continued to go for it. Ask him how many cars he's got and he has to stop and think. He thinks some more. He calls Gwynne over to ask him. After a considerable time, the pair stop thinking and agree to come back

to me with a definitive number.

A good few of the cars are out at Rimmer's Seattle base, which is more commonly known as DirtFish – the United States' biggest and best rallyschool, a venture he began in 2010. His 22-year-old son James – an ARX2 racer and rally driver himself – is an integral part of that project.

Rally collections are nothing

new, but Rimmer's has a different spin. As well as buying the competition car, he chased the road car equivalent as well. The other difference is that he wants the cars used. Hence the fact that they're kicking up the rocks in Rheola on these pages.

"When Ian prepares the cars, I like to know they're in the original specification, as they came from the factory," says Rimmer. "But I don't really want them in showroom condition all the time. What's the point of having these cars if you can't let people see them? That's why we take them to Goodwood and Rallyday. They have to be seen."

And, of course, they have to be driven. And the McRaes are more than happy to oblige.

The respect, appreciation and buzz between Rimmer and Scotland's first family of rallying is mutual. The McRaes were born to drive cars like these and, in his munificence, Rimmer enjoys the moment too.

Myherin will be as spectacular as ever

# WHAT YOU NEED TO KNOW

## OUR GUIDE TO THE STAGES THIS WEEKEND

BY **ANDREW KELLITT**

Nobody knows the route for this year's Rally GB like the person who drew it. That's why we've asked route coordinator Andrew Kellitt to give us the inside line on where's best to watch, and why



So, David Evans tells me I've got the next four days off. All he wants me to do is tell him where to go. That, I can definitely do...

In terms of forests used this year, there's nothing radically different from recent years. There can't be. We've used every inch of every forest road available to us in the top half of Wales. We're missing Gartheiniog (sorry Elfyn Evans!) this year due to the presence of *Phytophthora Ramorum* (that's a tree disease to the rest of us – not harmful to rally fans, but bad news for the trees) and we're not going into Clocaenog for the first time in a good few years. That's because of the continued wind farm developments going on in the area.

But, the rest of the roads are all in there.

One of the biggest changes is moving the service park from Deeside to Llandudno. This gives Rally GB the first chance to run a central service park right in the heart of a town. OK, we did something like this when we had Ford and Citroen outside the Millennium building in Cardiff, but I think the buzz will be much better in Llandudno. We've got Rally HQ, service, hotels and restaurants right there in one place – finally we've got a rally town to enjoy.

Also new for this year is the start in Liverpool, which is very exciting. Starting the rally outside the Royal Liver Building means we'll wave the crews away in England for the first time in 20

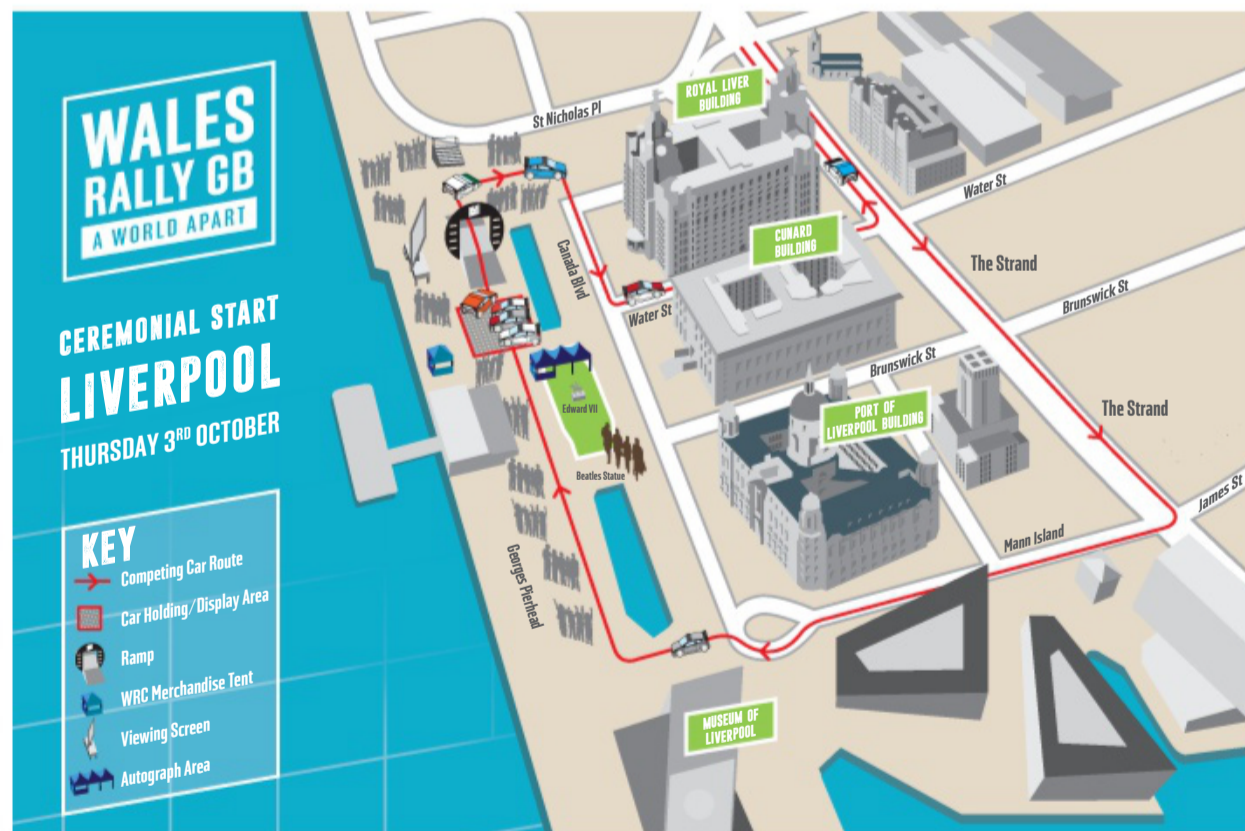

years and it's great to have the chance to really take the rally to the people.

That's where I'd start my spectating experience in my *virtual* four-day holiday. Actually, one of the real treats will be on the way to the ceremonial start, when all those World Rally Cars go through the **Wallasey Tunnel**; I'd imagine that noise will be quite spectacular.

The ceremonial start's always a great place

to listen to the drivers' thoughts ahead of the event, when they're interviewed on the ramp, but personally I'd soak up a bit of the atmosphere, grab some autographs – and possibly the odd selfie – and then I'd be on my way to **Oulton Park (SS1)**.

Oulton's back on the schedule for the first time since 1993 and there's no end of spectating possibilities there. That's the great thing about running a stage at a race circuit, they're tailor-



made to get fans in and out with minimum fuss, while offering great access and viewing. Don't forget, if you can't make Liverpool, there's an autograph session at Oulton too.

## FRIDAY 4 OCTOBER

It's **SS3 and Penmachno 1** first up for me. But I'll be in there very early and going to the left in the main car park (take the hairpin left where the car park splits). This takes you up to the main quarry area of the stage, which offers great viewing for quite a long time. There's space to move about safely and enjoy the cars from a few angles.

Getting from Penmachno to either of the stages in the next loop – Dyfnant or Aberhirnant – is not possible, so don't even try. Instead, get some lunch in Betws-y-Coed and then go into **Elsi (SS6)**. You can see a good three or four corners from the stage access out of the head of the car park.

If you want a longer lunch, why not go straight to **Slate Mountain (SS8)**? Spectators are really well catered for in this short stage carved out of a slate quarry. There's plenty of standing room on the elevated platforms and the good news is there's a nice cup of tea and slice of cake awaiting you in the cafe when you're done. On your way to the cafe, don't forget to look in on the regroup and light-fitting zone in the car park.

After that, it's up to Llandudno for service or down to Dyfi to sleep in the car and get ready for a long day on Saturday.

For those who really want to do **Dyfnant (SS4/9)**



**and Aberhirnant (SS5/10)**, they're in fantastic shape. The usual Dyfnant spectating spot is along what used to be Irish Corner (and might well be again this year...) and into the hairpin left closer to the car park. You'll remember this was the place that Mads Ostberg picked himself up an advertising board and brought it to the finish for us last year.

This hairpin is a good option if the weather's a) incredibly hot and sunny or b) pouring with rain – either way, you can get in among the trees for some shelter. Or shade!

Aberhirnant second time through will be really special. Head for car park H and get as far up the hill as you can. This is about as high as the event goes in terms of altitude and, if the clouds come down, it'll be incredibly atmospheric. You'll be able to hear the cars coming for miles with the odd flash of headlights, then they'll just appear out of the mist before you.

If it's a clear night, don't worry, it'll be just as

special – you'll be treated to an amazing WRC light show with the spotlights dancing across the sky.

## SATURDAY 5 OCTOBER

Like yesterday, you've got to make your choice here – there's no way of jumping between stages. If it's **Dyfi (SS11/16)**, there are a couple of choices for the car parks with good viewing from both. For me, the car park on the west is preferable – it offers a really good view of the cars 200 feet below you in what is one of the absolute classic mid-Wales stages. We're running at full length this year and the road's in perfect condition.

Dyfi will be busy, it always is. If I wanted somewhere a bit quieter, **Myherin (SS12/14)** is the place. Spectating in this one has changed quite a lot for 2019. Over the past couple of years we've brought fans in off the A44 and up through the hairpins towards the wind farm and Elfy's Corner. I'm afraid to say Elfy's fans will have to find a new corner this year – the hairpins are going to be used as part of the stage.

Because this is going to be Saturday's live television stage, we've decided to run the cars down through those famous 'Pikes Peak' hairpins – that'll make for an exciting end to a great stage. It also makes it easier to get the cars out and across the road into **Sweet Lamb Hafren (SS13/15)**.

We've moved the spectator car park down to the arch on the south side of Myherin and this is why it could be the quietest place in the woods this week – it's the furthest south that the event travels. I'd ▶



Sweet Lamb watersplash will be as popular as ever

©WORLD/RED BULL CONTENT POOL

say, if you get down there, take a picnic and stay down there for both runs of the stage, which won't be too long. The good thing is that this area of Myherin is one of the first places that we put a really serious spectator infrastructure into seven or eight years ago. The footpath runs alongside the road for almost 1.5 miles with lots of really, really good places to watch – staying for both stages will offer you a great chance to explore.

A longer lie-in would mean me going directly to Sweet Lamb Hafren and exploring the amazing opportunities on offer in the bowl and up the hill a bit further. As ever, this place will be packed full of people, with great facilities on offer. Sweet Lamb has become a really iconic stage and it does offer the chance to watch rally cars almost continuously. To combine the two loops, you could do Dyfi in the morning then Sweet Lamb in the afternoon.

Lunchtime means a remote tyre zone in **Newtown**, which is always a great place to see the drivers and co-drivers in the regroup right in the middle of the town centre. There's potential to slot Newtown in between Dyfi and Sweet Lamb.

Don't forget the option of getting into **Colwyn Bay (SS17)** to see the cars running down the promenade at what's a new stage for this year. If you're coming into the town for the final action on Saturday night, come via **Rhos-on-Sea**, park up and walk to the far end of the stage for a hairpin.

This one's designed for the spectators and, with the headlights on, it'll be a real seaside show. The action starts early with the Red Bull Matadors, a display of Group B rally cars and all sorts to keep you entertained until the World Rally Cars arrive.

It's straight into **Llandudno** for service after that. Naturally, I know I'm not going to catch the leaders, but it's always great to watch the WRC 2 and Junior WRC cars coming in – there's plenty to talk about and watch with those guys as well.

## SUNDAY 6 OCTOBER

I'll join the majority of rally fans bound for the B4501 this morning. The B road, which runs down the middle of **Llyn Brenig and Alwen Reservoir**, is a big car park for the final day. And it's the perfect place to base yourself.

The ideal is to go to **Alwen (SS18/21)** first thing in the morning, given that it starts at 0728. I'll be looking at a very, very early departure from service to get in position for the cars coming through. There are plenty of options for the stage.

Then it's over the road for the second running of **Brenig (SS19/22)**. As was the case two years ago, this one's the powerstage, which means there will be the chance to see champagne celebrations from the driver who grabs the extra five points.

Brenig runs to the same configuration as before,



The Great Orme run offers fantastic views

centre where you can get a coffee while you wait for the crews to arrive at the finish on the promenade. As usual, there will be plenty of rally-related activities going on in the middle of Llandudno and around the service park on Sunday and on every day. But, if you're planning to base yourself more in Llandudno, don't forget the cars are away from the coast for the whole day, from 6am until after 7pm on Saturday.

The finish ramp has been a great place to be in recent years, with Sebastien Ogier celebrating on five of the past six years – and Wales's own Elfyn Evans celebrating with a few donuts outside Marks and Spencer two years ago.

The one thing I will be very aware of this year is the time it takes to move around in North Wales. We're relying heavily on the A470 – the main north-south, Llandudno-Cardiff road is the spine of this year's event. Traffic can be steady there and on all the roads heading away and into the stages. Make sure you give yourselves plenty of time to get where you're going. I know I will be as I look forward to my virtual four-day holiday! ■

with lots of viewing potential from the dam at the south end of the lake. That's where you'll find me.

Anybody who wants a steadier day away from the woods is very well catered for in Llandudno. The **Great Orme (SS20)** stage starts at 0926 and is an easy drive out of town up to the car park on the top of the Orme. From there, there's a whole range of opportunities to watch one of the most dramatic asphalt stages around. And it's a beautiful place to spend a sunny Sunday morning...

From there, you're down and into the town

## WHAT'S ON WHEN

## ITINERARY

STAGES	TIME
<b>THURSDAY 3 OCTOBER</b>	
Shakedown, Gwydir (2.90 miles)	0800
Ceremonial start, Liverpool	1600
SS1 Oulton Park (2.22 miles)	1908
<b>FRIDAY 4 OCTOBER</b>	
Service, Llandudno	0610
SS2 Elsi 1 (7.23 miles)	0718
SS3 Penmachno 1 (10.06 miles)	0746
SS4 Dyfnant 1 (12.05 miles)	0956
SS5 Aberhirnant 1 (6.37 miles)	1053
Service, Llandudno	1307
SS6 Elsi 2 (7.23 miles)	1440
SS7 Penmachno 2 (10.06 miles)	1508
SS8 Slate Mountain (0.99 miles)	1557
Light-fitting zone Llechwedd	1603
SS9 Dyfnant 2 (12.05 miles)	1811
SS10 Aberhirnant 2 (6.37 miles)	1908
Service, Llandudno	2111
<b>SATURDAY 5 OCTOBER</b>	
Service, Llandudno	0540
SS11 Dyfi 1 (16.06 miles)	0806
SS12 Myherin 1 (14.23 miles)	1008
SS13 Sweet Lamb Hafren 1 (15.93 miles)	1102
Service, Newtown	1218
SS14 Myherin 2 (14.23 miles)	1408
SS15 Sweet Lamb Hafren 2 (15.93 miles)	1502
SS16 Dyfi 2 (16.06 miles)	1619
SS17 Colwyn Bay (1.49 miles)	1913
Service, Llandudno	1949
<b>SUNDAY 6 OCTOBER</b>	
Service Llandudno	0600
SS18 Alwen 1 (6.46 miles)	0728
SS19 Brenig 1 (3.99 miles)	0808
SS20 Great Orme (2.94 miles)	0926
Service Llandudno	0942
SS21 Alwen 2 (6.46 miles)	1110
SS22 Brenig 2 (3.99 miles)	1218
Finish Llandudno	1332

## TV

<b>3 OCTOBER</b> BT Sport 1 1800-1930 BT Sport Extra 1 1930-2030 S4C 2230-2300	<b>5 OCTOBER</b> BT Sport 3 0730-0900 BT Sport 3 1000-1200 BT Sport 3 1400-1600 BT Sport 3 1615-1715 BT Sport Extra 2 1800-2015 Channel 5 0045-0115 S4C 1400-1510/ 2100-2130	<b>6 OCTOBER</b> ESPN 0600-0645 ESPN 0715-0800 ESPN 0800-0900 ESPN 0915-1015 ESPN 1100-1130 ESPN 1200-1330 ESPN 1330-1345 Channel 5 1200-1330 S4C 1200-1340/ 2130-2230
<b>4 OCTOBER</b> ESPN 0700-0830 ESPN 0945-1130 ESPN 1230-1315 ESPN 1430-1630 ESPN 1800-1945 BT Sport Extra 2 TBC Channel 5 0045-0115 S4C 2000-2130		<b>7 OCTOBER</b> Channel 5 0000-0100 S4C 1830-1900



McKLEIN

Live coverage on wrc.com. All live service via WRC+

## TOP 10 RUNNING ORDER

NO	DRIVER/CO-DRIVER	CAR
8	Ott Tanak (EST) Martin Jarveoja (EST)	Toyota Yaris WRC
1	Sebastien Ogier (FRA) Julien Ingrassia (FRA)	Citroen C3 WRC
11	Thierry Neuville (BEL) Nicolas Gilsoul (BEL)	Hyundai i20 Coupe WRC
89	Andreas Mikkelsen (NOR) Anders Jaeger (NOR)	Hyundai i20 Coupe WRC
5	Kris Meeke (GBR) Seb Marshall (GBR)	Toyota Yaris WRC
10	Jari-Matti Latvala (FIN) Miikka Anttila (FIN)	Toyota Yaris WRC
3	Teemu Suninen (FIN) Jarmo Lehtinen (FIN)	Ford Fiesta WRC
4	Esapekka Lappi (FIN) Janne Ferm (FIN)	Citroen C3 WRC
33	Elfyn Evans (GBR) Scott Martin (GBR)	Ford Fiesta WRC
42	Craig Breen (IRL) Paul Nagle (IRL)	Hyundai i20 Coupe

# PRESTON

AT NORTH END OF THE FIELD



Thomas Preston starts as National rally favourite



EIGHT STAGES AND MORE THAN 80 COMPETITIVE MILES WILL DETERMINE THE VICTOR OF RALLY GB NATIONAL

BY LUKE BARRY

**R**

ally GB National is an experience like no other for the home-grown crews, since it offers them the opportunity to contest exactly the same stages as their World Rally Championship heroes. The National battle has been running directly alongside the fully fledged WRC event since 2010, and a total of 64 crews will tackle this year's edition.

The absence of 2018 winner Andrew Gallacher opens the door for John Wink and Roger Duckworth to progress from their second and third places respectively last year. But number-one seed Thomas Preston is perhaps the favourite heading into the event in his Ford Fiesta RS WRC, after winning in 2017 aboard a Skoda Fabia R5.

"We're definitely going there to win – 100% that's the aim," says Preston. "John Wink is a quick lad and he's been in the car a lot, but it's a shame Gallacher isn't doing it as it would've been nice to have a battle with him. It's one of those events where anything can happen so everyone's a threat as far as I'm concerned."

"When you're doing the BTRDA events you're up against the same guys all the time so you know where you are against them, but on the National there are drivers you haven't competed against before, so it'll be interesting to see how we get on."

Wink is aiming to be in the thick of the fight at the head of the field in his Hyundai i20 R5, having missed out on the top

spot last year by just over a minute. "We'll be trying hard," he says. "We would be disappointed to finish further back than last year, but it's a long event with no service or management, so we'll need luck on our side too."

"I think there'll be a few to watch and there's always a dark horse appearing on the timesheets. Tom [Preston] will go well in his World Rally Car and Roger Duckworth knows the stages well. We'll be concentrating on doing our best and running our race at our pace."

Duckworth starts the event third in his Subaru Impreza, with Matthew Hirst and Alan Dickson both bringing Mitsubishi Lancer E9s for what should be a fascinating comparison of pace from the BTRDA and Scottish Rally Championship. Welsh legend Wug Utting will also be in the mix aboard his Impreza, while Simon Hay (Lancer E6) and Theo Bengry (Proton Iriz R5) could spring a surprise or two.

Dylan Davies leads the two-wheel-drive contingent in his Ford Escort Mk1 from five-time British champion Jimmy McRae, who will compete in a Porsche 911 for the first time. Tony Jardine returns for his 24th bash at Rally GB but his first at the National in a Lancer E9. Perry Gardener, Mathew Tordoff and Alex Waterman are set for a titanic tussle for R2 honours in their Fiestas.

The National event offers spectators the chance to watch some rarer cars in action too. Mark Ferreday brings his Volkswagen Beetle and John Leckie his Proton Satria GTi, but it's Matthew Steadman's entry that is set to thrill. Steadman will try to tame a Lancia Delta Integrale akin to the ones Markku Alen and Juha Kankkunen took to Rally GB victory in 1987, 1988 and 1991. ■

## TOP 10 RALLY GB NATIONAL SEEDS

NO	DRIVER/CO-DRIVER	CAR
201	Thomas Preston/Carl Williamson	Ford Fiesta RS WRC
202	John Wink/Neil Shanks	Hyundai i20 R5
203	Roger Duckworth/Alun Cook	Subaru Impreza WRC S6
204	Matthew Hirst/Declan Dear	Mitsubishi Lancer E9
205	Bob Ceen/TBA	Subaru Impreza WRC S9
206	Richard Ceen/Jeanette Kwick	Ford Focus WRC 05
207	Paul Walker/Geraint Thomas	Subaru Impreza
208	Alan Dickson/Martin Forrest	Mitsubishi Lancer E9
209	Wug Utting/Bob Stokoe	Subaru Impreza
210	Mark Worley/Hamish Campbell	Subaru Impreza



Wink will be aiming to go one better than last year's second place

## THE STAGES

At just under 85 miles, the 2019 route sports some subtle changes from last year's schedule. The number of stages is down from 10 to eight, but the competitive distance remains the same, allowing drivers to get their teeth into longer, meatier tests.

The action starts early on Friday morning with a run through Elsi, a new stage to the National itinerary. In what is a carbon copy of the international field's second leg, the demanding Penmachno stage follows before the short one-mile spectator stage on Slate Mountain, which returns for its second year. After a refuel in Elfyn Evans's hometown of Dolgellau, it's off to the famous Dyfnant and Aberhiraunt tests that conclude the day's action.

Saturday's stages are further south and only three are on offer for the crews to tackle, but all three are absolute gems. Competitors are treated to a longer lie-in, with the first car set to leave service in Llandudno at 1030, before heading down to mid-Wales for the 15 miles of Dyfi. After a quick regroup in Newtown and a spot of lunch, it's into the undulating rollercoaster of Myherin for one of the most demanding stages in the UK. The longest stage of the rally is left until last, with an assault on the 15.97-mile Sweet Lamb Hafren test bringing the event to a close.

The winner will be crowned in the centre of Llandudno, safe in the knowledge that they've etched their name alongside legends who have conquered the unique challenge of Rally GB.



Matthew Steadman with his Lancia Delta Integrale





#### FROM THE ARCHIVE

The diminutive Alpine A110 was a fragile machine but could stun with its pace on smooth, open asphalt. During the 1970 RAC Rally, Jean-Pierre Nicolas was delivering on the unpractised forest roads. However, on the rally's second leg his car caught fire, leaving co-driver David Stone to joke about being grateful to be able to heat some water and make a cup of tea.

**MCKLEIN**  
PHOTOGRAPHY

THE RUNNERS AND RIDERS



M-Sport is without talisman Ogier as it hunts a GB hat-trick

NO	DRIVER/CO-DRIVER	CAR
1	<b>Sebastien Ogier</b> (FRA) <b>Julien Ingrassia</b> (FRA)	Citroen C3 WRC
3	<b>Teemu Suninen</b> (FIN) <b>Jarmo Lehtinen</b> (FIN)	Ford Fiesta WRC
4	<b>Esapekka Lappi</b> (FIN) <b>Janne Ferm</b> (FIN)	Citroen C3 WRC
5	<b>Kris Meeke</b> (GBR) <b>Sebastian Marshall</b> (GBR)	Toyota Yaris WRC
7	<b>Pontus Tidemand</b> (SWE) <b>Ola Floene</b> (NOR)	Ford Fiesta WRC
8	<b>Ott Tanak</b> (EST) <b>Martin Jarveoja</b> (EST)	Toyota Yaris WRC
10	<b>Jari-Matti Latvala</b> (FIN) <b>Miikka Anttila</b> (FIN)	Toyota Yaris WRC
11	<b>Thierry Neuville</b> (BEL) <b>Nicolas Gilsoul</b> (BEL)	Hyundai i20 Coupe WRC
33	<b>Elfyn Evans</b> (GBR) <b>Scott Martin</b> (GBR)	Ford Fiesta WRC
42	<b>Craig Breen</b> (IRL) <b>Paul Nagle</b> (IRL)	Hyundai i20 Coupe WRC
89	<b>Andreas Mikkelsen</b> (NOR) <b>Anders Jaeger</b> (NOR)	Hyundai i20 Coupe WRC
21	<b>Kalle Rovanpera</b> (FIN) <b>Jonne Halttunen</b> (FIN)	Skoda Fabia R5 Evo
22	<b>Mads Ostberg</b> (NOR) <b>Torstein Eriksen</b> (NOR)	Citroen C3 R5
23	<b>Gus Greensmith</b> (GBR) <b>Elliott Edmondson</b> (GBR)	Ford Fiesta R5 MkII
24	<b>Jan Kopecky</b> (CZE) <b>Pavel Dresler</b> (CZE)	Skoda Fabia R5 Evo
25	<b>Hayden Paddon</b> (NZL) <b>John Kennard</b> (NZL)	Ford Fiesta R5 MkII
41	<b>Benito Guerra</b> (MEX) <b>Jaime Zapata</b> (MEX)	Skoda Fabia R5 Evo
43	<b>Pierre-Louis Loubet</b> (FRA) <b>Vincent Landais</b> (FRA)	Skoda Fabia R5
44	<b>Ole Christian Veiby</b> (NOR) <b>Jonas Andersson</b> (NOR)	Volkswagen Polo R5
45	<b>Kajetan Kajetanowicz</b> (POL) <b>Maciej Szczepaniak</b> (POL)	Volkswagen Polo R5
46	<b>Alberto Heller</b> (CHL) <b>Jose Diaz</b> (ARG)	Ford Fiesta R5 MkII
47	<b>Fabio Andolfi</b> (ITA) <b>Simone Scattolin</b> (ITA)	Skoda Fabia R5
48	<b>Henning Solberg</b> (NOR) <b>Ilka Minor</b> (AUT)	Skoda Fabia R5
49	<b>Marco Bulacia Wilkinson</b> (BOL) <b>Fabian Cretu</b> (BOL)	Skoda Fabia R5
50	<b>Paulo Nobre</b> (BRA) <b>Gabriel Morales</b> (BRA)	Skoda Fabia R5

NO	DRIVER/CO-DRIVER	CAR
51	<b>Rhys Yates</b> (GBR) <b>James Morgan</b> (GBR)	Hyundai NG i20 R5
52	<b>Simone Tempestini</b> (ROU) <b>Sergiu Itu</b> (ROU)	Hyundai NG i20 R5
53	<b>Adrien Fourmaux</b> (FRA) <b>Renaud Jamoul</b> (BEL)	Ford Fiesta R5 R5
54	<b>Oliver Solberg</b> (NOR) <b>Aaron Johnston</b> (GBR)	Volkswagen Polo R5
55	<b>Petter Solberg</b> (NOR) <b>Phil Mills</b> (GBR)	Volkswagen Polo R5
56	<b>Guillaume de Mevius</b> (BEL) <b>Martijn Wydaeghe</b> (BEL)	Citroen C3 R5
57	<b>Gaurav Gill</b> (IND) <b>Glenn Macneall</b> (AUS)	Ford Fiesta R5 MkII
71	<b>Tom Kristensson</b> (SWE) <b>Henrik Appelskog</b> (SWE)	Ford Fiesta R2
72	<b>Jan Solans</b> (ESP) <b>Mauro Barreiro</b> (ESP)	Ford Fiesta R2
73	<b>Dennis Radstrom</b> (SWE) <b>Johan Johansson</b> (SWE)	Ford Fiesta R2
74	<b>Roland Poom</b> (EST) <b>Ken Jarveoja</b> (EST)	Ford Fiesta R2
75	<b>Tom Williams</b> (GBR) <b>Phil Hall</b> (GBR)	Ford Fiesta R2
76	<b>Enrico Oldrati</b> (ITA) <b>Elia De Guio</b> (ITA)	Ford Fiesta R2
77	<b>Sean Johnston</b> (USA) <b>Alex Kihurani</b> (USA)	Ford Fiesta R2
78	<b>Fabrizio Zaldívar</b> (PRY) <b>Fernando Mussano</b> (ARG)	Ford Fiesta R2
79	<b>Nico Knacker</b> (DEU) <b>Michael Wenzel</b> (DEU)	Ford Fiesta R2
80	<b>Ryan Booth</b> (USA) <b>Rhianon Gelsomino</b> (AUS)	Ford Fiesta R2
81	<b>Keanna Erickson-Chang</b> (USA) <b>Niall Burns</b> (IRL)	Ford Fiesta R2
91	<b>Nikolay Gryazin</b> (RUS) <b>Yaroslav Fedorov</b> (RUS)	Skoda Fabia R5
92	<b>Takamoto Katsuta</b> (JPN) <b>Daniel Barritt</b> (GBR)	Ford Fiesta R5 MkII
93	<b>Matt Edwards</b> (GBR) <b>Mark Glennerster</b> (GBR)	Hyundai NG i20 R5
94	<b>Tom Cave</b> (GBR) <b>Dale Furniss</b> (GBR)	Hyundai NG i20 R5
95	<b>Josh McErlean</b> (GBR) <b>Keaton Williams</b> (GBR)	Hyundai NG i20 R5
96	<b>Patrick Dejean</b> (FRA) <b>Lionel Currat</b> (FRA)	Ford Fiesta R5
97	<b>Eamon Boland</b> (IRL) <b>Michael Joseph Morrissey</b> (IRL)	Ford Fiesta R5
98	<b>James Williams</b> (GBR) <b>Tom Woodburn</b> (GBR)	Ford Fiesta R2
99	<b>Markus Manninen</b> (FIN) <b>Teemu Sillanpaa</b> (FIN)	Ford Fiesta R2
100	<b>Ruairi Bell</b> (GBR) <b>Darren Garrod</b> (GBR)	Ford Fiesta R2
101	<b>Philippe Casado</b> (FRA) <b>Kevin Bronner</b> (FRA)	Peugeot 208 R2
102	<b>Josh Cornwell</b> (GBR) <b>Dai Roberts</b> (GBR)	Peugeot 208 R2
103	<b>Diego Dominguez</b> (PRY) <b>Rogelio Lopez</b> (ESP)	Ford Fiesta R2
104	<b>Edward Lewis</b> (GBR) <b>Dom Adams</b> (GBR)	Ford Fiesta R2
105	<b>Louise Cook</b> (GBR) <b>Stefan Davis</b> (GBR)	Ford Fiesta R2
106	<b>Nabila Tejpar</b> (GBR) <b>Richard Bliss</b> (GBR)	Peugeot 208 R2





RACING

**BALANCED BRAKING PERFORMANCE**

**All the way to the APEX**

**B**ITE

**D**ECELERATION

**M**ODULATION

**R**ELEASE

THE DRIVER'S  
PAD

# FERODO RACING BRAKE PADS

developed and engineered to perform in all four phases of the braking event.

In addition to the bite and deceleration expected from a world class race pad, Ferodo pads offer the superior modulation and instantaneous release for maximum exit speeds.



[www.ferodoracing.com](http://www.ferodoracing.com)

Circuit Supplies (UK) Ltd, Unit 8, Eden Court,  
Eden Way, Leighton Buzzard, Beds LU7 4FY  
Tel: 01525 385 888 • Fax: 01525 385 898  
info@circuitssupplies.com  
www.circuitssupplies.com

SELECTED RANGE NOW AVAILABLE  
THERMALLY BEDDED