

BDT18 – Process pressure gauge 100 & 160mm

Product description

Badotherm pressure gauge model BDT18 is manufactured according to the EN837-1 and is available in full stainless steel or Alloy 400. This pressure gauge is typically used for applications in the chemical, petro-chemical, oil & gas, power and utilities, machine building and general process industries. Safety comes first, with a blow-out feature, pressure elements made high quality tubes and the welded type connection construction. These gauges are designed to withstand the severest of operating conditions of the ambient environment and the process medium.



Design standard

EN837-1

Dial sizes, ranges & accuracy

Possibilities in ranges and accuracies are led by the dial size. The reduced volume execution specially designed for the use on diaphragm seals (code_R). Accuracy class is based on dry gauges. Liquid filling can affect the accuracy.

Dial size	Ranges	Accuracy
100mm (100R)	0...1 to 0...1000	1.6% (option 1.0%)
100mm	0...1 to 0...1600 bar	1.0% (option 0.6 %)
160mm (160R)		
160mm		1.0%

Mounting variation

Not all gauges are suitable for some mounting variations. For the BDT18 series the mounting variations are below.

- **type A (10) bottom connection, direct mounting**
- **type B (33) Lower-back connection U-bracket**
- **type C (11) bottom connection, surface mounting (back)**
- **type D (30) Lower back connection, direct mounting**
- **type E (32) lower back connection, panel mounting (front)**
- **type F (12) bottom connection, panel mounting (front)**

More specifically per dial size:

Dial size	A	B	C	D	E	F
100mm (100R)	•		•			
100mm	•	•	•	•	•	•
160mm	•	•	•	•	•	•
160mm (160R)	•		•			

Process connection

Dial size	Standard thread	optionally	SW size
100mm (100R)	G ½ A or ½" NPT	1/4" , 3/8"	22mm
100mm			
160mm (160R)			
160mm			

Other thread standards such as ISO 7-1 R (BSPT), or DIN 13-1 (M20x1.5) can be selected as well.

-> See datasheet "thread information" for specific thread details

Materials of construction

	BDT18	BDT18...M
Case	AISI 304	
Bezel	AISI 304	
Connection ¹	AISI 316	Alloy 400
Sensing element ¹	TP316	Alloy 400
Movement	Stainless steel	
Pointer	Aluminium	
Dial	Aluminium	
Window gasket	NBR	
Blow out	NBR	
Fill plug	NBR (HNBR for filled gauges)	
Mounting flanges	AISI 304	
Window	Laminated safety glass	

*1 wetted materials

Pressure limitations

The gauge are built to withstand harsh environments however the EN 837 limits the use of a pressure gauge according below table.

Dial size	Steady	Fluctuating	Short time
100mm (100R)	0.75 x FSV	0.67 x FSV	FSV
100mm	FSV	0.9 x FSV	1.3 x FSV
160mm (160R)			
160mm			

FSV: full scale value

Temperature limitations

The gauges can withstand ambient and process temperature up to a certain limit. The limitations on temperature are:

	Ambient	Medium
Dry	-40°C ...+60°C	-40°C...+200°C
Filled	-20°C ...+60°C	-20°C...+90°C

The variation of indication caused by the effect of temperature shall not exceed: $\pm 0.4\% / 10K FSV$

Window

Standard BDT18 gauges have a laminated safety window. Depending on the case size options such as glass, or acrylic windows are available.

Pointer

Standard pointer is a fixed black painted aluminum pointer.

There are several types of pointers available:

- Adjustable slotted pointer
- Micro adjustable pointer

Dial facing

The dial plate is made from aluminum and coated with UV resistant white coating. The black dial markings, scale, numbering, and interval is according the EN 837. Options like colored dial, customer logo, or colored segments are possible as well. Scale interval and numbering is following the EN837.

Limit stop

To prevent permanent damage after overpressure, or sudden vacuum on size 100, 160mm the gauge is protected by an internal limit stop on the movement that is set just below the minimum scale value and just outside the 130% maximum scale value. These gauges also have a free zero. The 100R is equipped with a zero stop on the dial.

Degree of protection

The BDT18 has a standard degree of protection of IP65. The values are determined according the IEC/EN 60529. Class IP66 and IP67 are available as option.

Add-on contacts

The BDT18 size 100 and 160mm can be supplied with a BDT31-01 add on contact in various contact types such as Inductive, Magnetic, and Electrical. The "BDT31-01 contacts" data sheet will give specific options and limitations on these contacts.

Case filling

The gauges can be filled with different kind of fill fluids. The fill fluids available are:

- BPF01 - Glycerine 86%
- BPF02 - Silicon
- BPF03 - Fill fluid combined for contacts
- BPF04 - Foaming service
- BPF05 - ECTFE inert fluid for oxygen service
- BPF06 - Glycerine 99.5%

Restrictor Screw

All gauges can be executed with a restrictor of 0.8 or 0.3 orifice in AISI316(L). For the Alloy 400 internal the orifice is 0.8mm.

Special service

The gauges can be supplied cleaned for oxygen use. This means the gauge is assembled and tested in a special area free of oil. The gauges are individually packed in a plastic bag with marking. The symbol used is:



Certification & Declaration

Calibration

Gauges are full range calibrated as a factory standard. Optionally you can select a 5 points calibration certificate, and a 10 points calibration certificate for the 0.6% and 0.5% gauges.

Pressure Equipment Directive - 2014_68_EU

PED approval is given according article 3.3 and is valid for ranges >200 bar. All gauges will be marked accordingly. A declaration of conformity can be supplied.

ATEX 114 - 2014/68/EU

ATEX restrictions are explained in the IOM and in the ATEX background datasheet.

EN 10204 material certificate

A material 3.1 certificate on the wetted parts can be supplied.

Dimensions table

Type A (10)

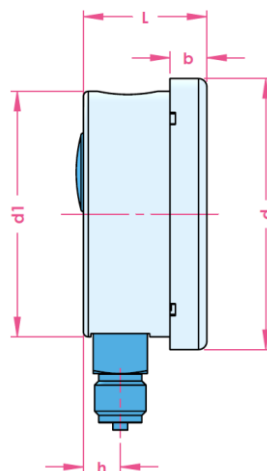
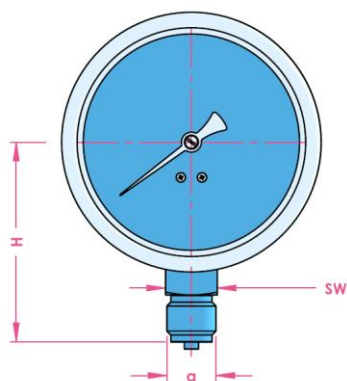

Dial size	d	d1	b	L	h	g	SW	H	weight
100/100R	110.0	100.0	15.0	50.0	15.8	G ½ A	22	85.0	0.5 kg
160/160R	160.0	150.0	16.0	52.0	16.0			117.0	0.8 kg

Type B (33)

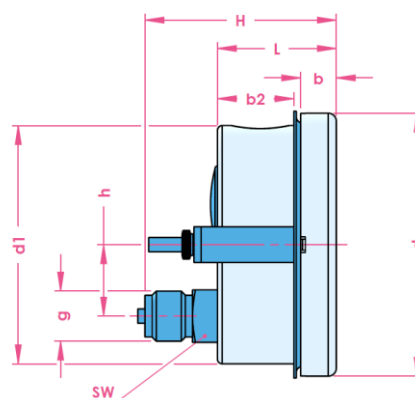
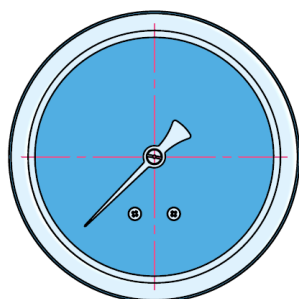

Size	d	d1	b	b2	L	h	g	SW	H	weight
100	110.0	100.0	15.0	30.0	50.0	30.0	G ½ A	22	80.5	0.6 kg
160	160.0	150.0	16.0	29.5	52.0	48.5			82.0	0.8 kg

Type C (11)

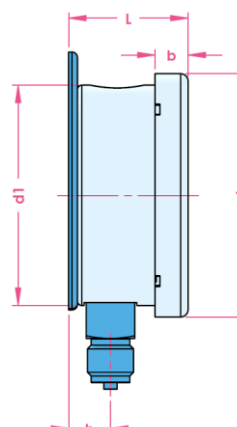
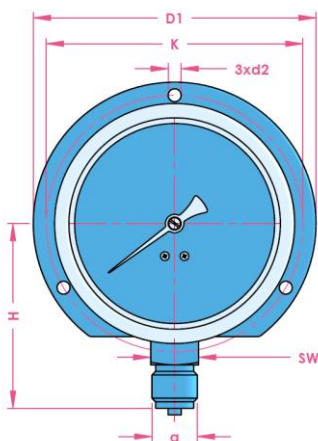

size	d	d1	b	L	h	K	D1	d2	g	SW	H	weight
100/100R	110.0	100.0	15.0	54.0	19.8	118.0	130.0				85.0	0.5 kg
150/150R	160.0	150.0	16.0	56.0	20.0	168.0	196.0	6.0	G ½ A	22	117.0	0.8 kg
160/160R						178.0						

Type D (30)

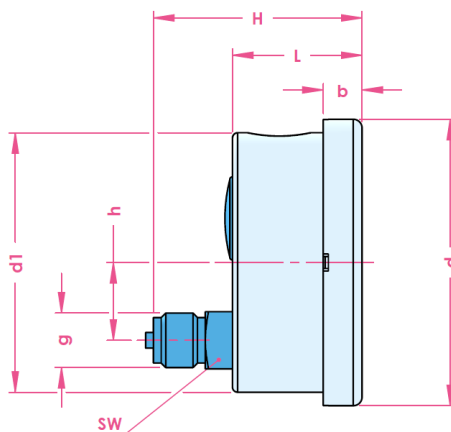
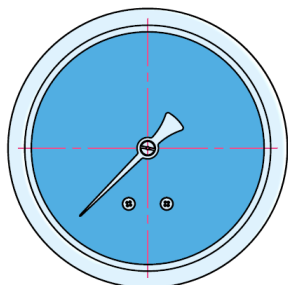

Size	d	d1	b	L	h	g	SW	H	weight
100	110.0	100.0	15.0	50.0	30.0	G 1/2	22	80.5	0.5 kg
160	160.0	150.0	16.0	52.0	48.5			82.0	0.8 kg

Type E (32)

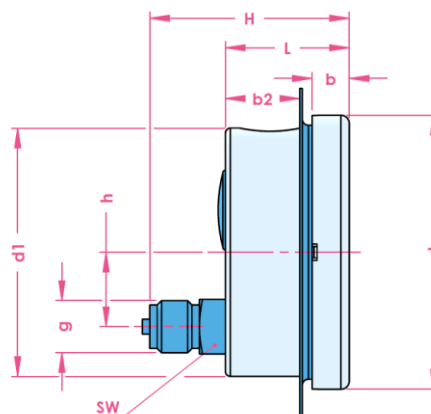
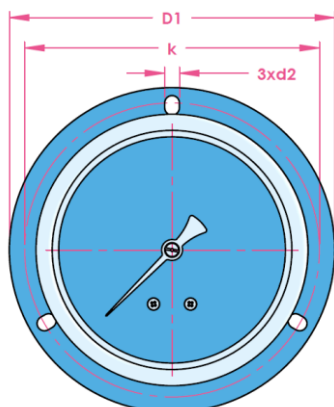

Size	d	d1	b	b2	L	h	K	D1	d2	g	SW	H	weight
100	110.0	100.0	15.0	30.0	50.0	30.0	117.6	132.0	6.0	G 1/2 A	22	80.5	0.5 kg
150	160.0	150.0	16.0	29.5	52.0	48.5	168.0	190.0				82.0	0.8 kg
160							178.0					82.0	0.8 kg

Type F (12)

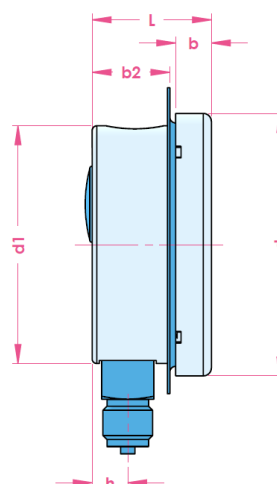
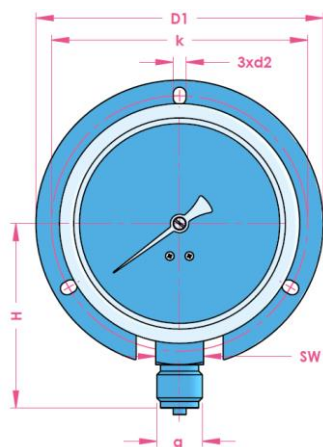

Dial size	d	d1	b	L	h	K	D1	g	SW	H	weight
100/100R	110.0	100.0	15.0	50.0	30.0	117.6	132.0	G 1/2 A	22	85.0	0.5 kg
150/150R	160.0	150.0	16.0	52.0	48.5	168.0	190.0			117.0	0.8 kg
160/160R						178.0				117.0	0.8 kg

Product code 100, 150, 160mm

		Code										
Example code:		BDT18	160	A	6	S	4	F	0	G	B50	10
TYPE												
100 mm ◀		100										
100 mm reduced volume for diaphragm seal		100R										
160 mm ◀		160										
160 mm reduced volume for diaphragm seal		160R										
150 mm (only for type C, E, and F)		150										
150 mm (only for type C and F)		150R										
MOUNTING												
Bottom connection - direct mounting (10) ◀		A										
Lower back connection - flush U-bracket clamp fix. (33)		B										
Bottom connection - surface mounting (11)		C										
Lower back connection. - direct mounting (30)		D										
Lower back connection.- panel mount (32)		E										
Bottom connection - panel mount (12)		F										
CONNECTION												
G 3/8" B		5										
G1/2 ◀		6										
1/2" NPT		7										
R 1/2		8										
M20x1.5		9										
TUBE & SOCKET MATERIAL												
AISI 316L ◀		S										
Alloy 400		M										
CASE/BEZEL MATERIAL												
AISI 304 ◀		4										
AISI 316		6										
POINTER												
Fixed pointer ◀		F										
Adjustable slotted pointer		A										
Micro adjustable pointer		M										
Add-on contact device (see table 4)		A__										
LIQUID FILLING												
Dry ◀		0										
BPF 01 - Glycerine filled 1,23 (86%)		1										
BPF 06 - Glycerine filled 1,26 (99,5%)		6										
BPF 02 - Silicone filled		2										
BPF 03 - Contact use		3										
BPF 04 - Foaming service		4										
BPF 05 - Oxygen service		5										
WINDOW												
Acrylic (SAN)		A										
Laminated glass (S1)		L										
Glass ◀		G										
RANGE												
See page table 1 and table 2											
ACCURACY												
0.5 (ANSI B40.1 2A)		5										
0,6		6										
1.0 ◀		10										
1,6 (100 R only)		16										

◀: is the sign for the standard pressure gauge
 -0.5/0.6% not available for 100R

Tabel 1: Pressure Range code

bar		psi		MPa		kPa		kgf/cm2	
Code	Range	Code	Range	Code	Range	Code	Range	Code	Range
C36	-1...0,6	C37	30Hg/15psi	N50	0...1,6	D36	-100...60	E36	-1...0,6
C38	-1...1,5	C39	30Hg/30psi	N54	0...2,5	D38	-100...150	E38	-1...1,5
C40	-1...3	C41	30Hg/60psi	N57	0...4	D40	-100...300	E40	-1...3
C42	-1...5	C44	30Hg/100psi	N58	0...6	D42	-100...500	E42	-1...5
C45	-1...9	C46	30Hg/150psi	N60	0...10	D45	-100...900	E45	-1...9
C50	-1...15	C50	30Hg/220psi	N62	0...16	D50	-100...1500	E50	-1...15
C54	-1...24	C53	30Hg/300psi	N65	0...25	D54	-100...2400	E54	-1...24
B01	-1...0	P32	0...10	N69	0...40	L01	-100...0	K01	-1...0
B04	-0,6...0	P35	0...15	N71	0...60	L04	-60...0	K04	-0,6...0
B31	0...0,6	P37	0...30	N73	0...100	L31	0...60	K31	0...0,6
B35	0...1	P40	0...60	N76	0...160	L35	0...100	K35	0...1
B36	0...1,6	P43	0...100			L36	0...160	K36	0...1,6
B38	0...2,5	P46	0...160			L38	0...250	K38	0...2,5
B40	0...4	P48	0...200			L40	0...400	K40	0...4
B42	0...6	P51	0...300			L42	0...600	K42	0...6
B45	0...10	P55	0...400			L45	0...1000	K45	0...10
B50	0...16	P56	0...500					K50	0...16
B54	0...25	P57	0...600					K54	0...25
B57	0...40	P58	0...800					K57	0...40
B58	0...60	P59	0...1000					K58	0...60
B60	0...100	P60	0...1500					K60	0...100
B62	0...160	P61	0...2000					K62	0...160
B65	0...250	P64	0...3000					K65	0...250
B69	0...400	P66	0...4000					K69	0...400
B71	0...600	P68	0...5000					K71	0...600
B73	0...1000	P69	0...6000					K73	0...1000
B76	0...1600	P72	0...10000					K76	0...1600
		P73	0...15000						
		P75	0...20000						

Table 2: Secondary scale

Dual scale option	code
PSI red	#PR
PSI black	#PB
PSI blue	#PBL
bar red	#BR
bar black	#BB
bar blue	#BBL

Add the code behind the pressure code (eg B45#PR for 0...10 bar//psi with red scale)

Table 4: Contact option code

Option (start options with X_)	code	
Snap-action magnetic contact	M1 (make contact)	_AM1
	M2 (break contact)	_AM2
	M11 (make - make contact)	_AM11
	M12 (make - break contact)	_AM12
	M21 (break - make contact)	_AM21
Inductive contact	I1 (make contact)	_AI1
	I2 (break contact)	_AI2
	I11 (make - make contact)	_AI11
	I12 (make - break contact)	_AI12
	I21 (break - make contact)	_AI21

Table 3: General option code

Option (start options with X_)	code
IP 66 class	_IP66
IP 67 Class	_IP67
Drag pointer	_SP
Index pointer	_IP
Restrictor screw 0.8mm	_RS8
Restrictor screw 0.3mm	_RS3
Calibrated at 0°	C0
Calibrated at 180°	_C180
Cleaned for Oxygen use	_CFO
NACE ISO 15156 (MR 01 75) (alloy 400)	_N75
ATEX II2GDc-IM2c	_ATEX
3.1 material certificate	_IC31
Calibration certificate 5 points	_CC5
Calibration certificate 10 points	_CC10

Holland – United Kingdom – Romania – India – Thailand – Dubai – USA

To our knowledge, the information contained herein is accurate as of the date of this document. However neither Badotherm, nor its affiliates makes any warranty, express or limited, or accepts any liability in connection with this information or its use. This information is for technical skilled persons at their own discretion and risk and does not relate to the use of this product in combination with any other product. The user alone finally determines suitability of any information or material in contemplated use, the manner of use and whether any patents are infringed. This information gives typical properties only. Badotherm reserves the right to make changes to the specifications any materials without prior notice. The latest version of the datasheet can be found on www.badotherm.com.

© 2015 Badotherm, all rights reserved. Trademarks and/or other products referenced herein are either trademarks or registered trademarks of Badotherm.