

LAVINA®



LAVINA® 25-X-E User Manual



 **SUPERABRASIVE**

CE

www.superabrasive.com / factory@superabrasive.com

1. GENERAL INFORMATION	3	CHECK EVERY 400 WORKING HOURS.....	11
MANUFACTURER	3	VACUUM	11
GENERAL DESCRIPTION.....	3	WATER LEAKS.....	11
MACHINE CHARACTERISTICS	3	MECHANICAL PARTS	11
MAIN DESIGN.....	3	ELECTRICAL SYSTEM.....	11
ENVIRONMENTAL CONDITIONS.....	3	LAVINA® 25-X-E ELECTRICAL SCHEMES WITH YASKAWA	
ELECTRICAL CONNECTION	3	INVERTER	12
VACUUM CONNECTION	4	LAVINA® 25-X-E ELECTRICAL SCHEMES YASKAWA CONNECTION	
TECHNICAL DATA	4	MAIN CIRCUIT TERMINALS	12
CE-CERTIFICATION	4	8. TROUBLESHOOTING.....	13
VIBRATIONS	4	INDEX OF PROBLEMS AND SOLUTIONS.....	13
NOISE EMISSIONS	4	8.1 REPLACING POWER CORD AND PLUGS	13
CUSTOMER SERVICE.....	4	8.2 DISMOUNTING AND MOUNTING TOOL HOLDER TO CHANGE	
2. SAFETY INSTRUCTIONS.....	4	V-RINGS AND FELT-RINGS	13
RECOMMENDED USE	4	8.3 DISASSEMBLING AND MOUNTING TOOL HOLDER TO	
PROHIBITED USE	4	CHANGE BUFFERS AND ELASTIC ELEMENT	13
PREPARATION FOR WORK	4	8.4 CORRECTING SAG OF THE USED PLANETARY CHAIN	15
PROTECTION DEVICES	5	8.5 MOUNTING NEW PLANETARY CHAIN	15
ARREST FUNCTIONS	5	8.6 REPLACING THE PLANETARY DRIVING CHAIN WHEEL AND	
SAFE USE	5	PLANETARY TENSIONER	16
RESIDUAL RISKS	5	8.7 TENSIONING AND REPLACING THE BELTS	17
BEFORE YOU BEGIN	5	8.8 REPLACING THE DRIVEN PLANETARY GEAR	19
OPERATING MACHINE	5	8.9 REPLACING THE PULLEY UNITS	19
AFTER WORK IS COMPLETED	5	8.10 REPLACING THE PLANETARY UNIT	20
THE WORK AREA	5	8.11 MOTOR CONNECTION.....	20
PERSONAL PROTECTIVE	5	8.12 FAULT DIAGNOSIS INVERTER YASKAWA V1000	21
EQUIPMENT (PPE).....	5	9. WARRANTY AND RETURNS	24
OPERATOR	5	WARRANTY POLICY FOR THE LAVINA® X-E MACHINE.....	24
3. HANDLING AND TRANSPORTATION	6	RETURN POLICY FOR LAVINA® X-E MACHINES.....	24
SPLITTING THE CARRIAGE FROM THE MAINHEAD.....	6	10. DISPOSAL.....	24
LIFT THE MACHINE FROM WORKING TO TOOL MOUNTING		11. MANUFACTURER'S CONTACTS.....	24
POSITION	6	12. SPARE PARTS.....	25
LIFTING.....	6	ASSEMBLY AND PARTS SPECIFICATIONS	25
ADJUSTING THE HANDLE	6	1. LAVINA®25-X-E GENERAL PARTS.....	25
STORAGE.....	7	2. LAVINA® 25-X-E TOP COVER 1 PARTS.....	25
4. OPERATION	7	3. LAVINA®25-X-E TOP COVER PARTS 2	26
PRELIMINARY CONTROLS.....	7	4. LAVINA®25-X-E GUARD PARTS	26
WATER FLOW CONTROL UNIT	7	4.1.1 LAVINA®25-X-E GUARD PARTS	26
ADJUSTING AND MOUNTING TOOLS	7	5. LAVINA® 25-X-E BOTTOM COVER 1 PARTS.....	27
THE CONTROL BOARD.....	8	6. LAVINA® 25-X-E PLANETARY DRIVE PARTS.....	28
STARTING THE MACHINE	8	6.1. LAVINA® 25-X-E PULLEY UNIT ASSEMBLY	29
OPERATING THE MACHINE	8	7. LAVINA® 25-X-E BOTTOM COVER 2 PARTS.....	29
STOPPING THE MACHINE.....	8	8. LAVINA®25-X-E WATER TANK PARTS	30
ALARM	8	9. LAVINA®25-X-E TOOL HOLDER PARTS/SEE ALSO FIG.8.7.13/	
5. TOOLS AND ACCESSORIES	9	(POS.1 INCLUDE POS.1.1;1.2;1.3/POS.1.3 INCLUDE POS.1.3.1	
WEIGHTS.....	9	AND ETC.)	30
TOOL HOLDER KEY	9	10. LAVINA® 25-X-E PLANETARY BELT REVISION KIT	30
FOAM PLATE	9	11. LAVINA®25-X-E CARRIAGE PARTS.....	31
SECURITY PLATE FOR QUICKCHANGE PADS	9	12. LAVINA® 25-X-E CONTROL BOX PARTS 380-400 VOLT	32
6. POPULAR TOOLS	10	LAVINA® 25-X-E CONTROL BOX PARTS 380 VOLT	32
7. MAINTENANCE AND INSPECTION	11		
CLEANING	11		
CHECK DAILY	11		
CHECK EVERY 200 WORKING HOURS.....	11		

1. GENERAL INFORMATION

This owner's manual is intended for the operator of the Lavina® X-E machine, the servicing technician as well as anyone involved with operating or servicing the machine. We recommend that you read the instructions very carefully and follow them strictly. The manual includes information about assembling, using, handling, adjusting and maintaining your Lavina® X-E floor grinding and polishing machine.

MANUFACTURER

Superabrasive was founded in 1987, as a manufacturer of high quality diamond tools for the stone and concrete industry. Today, Superabrasive is one of the world's leading companies in the production of diamond tools and floor grinding machinery. At Superabrasive, we strive to deliver the very best solutions to our customers, and enable them to work more efficiently.

GENERAL DESCRIPTION

The Lavina® X-E machine is intended for grinding, polishing and buffing concrete, marble, granite, limestone, and terrazzo surfaces with diamond tools. Additionally, the machine could be used for grinding wood floor surfaces.

The Lavina® X-E machine is a three-disc machine, which can be used wet or dry.

For best results, use only tools manufactured or recommended by Superabrasive and its distributors.

⚠ WARNING The Lavina® X-E machine is manufactured and fitted for the above-mentioned applications only! Every other use may possess risks to the persons involved.

MACHINE CHARACTERISTICS

The Lavina® X-E machine is made of two main component sections:

MAIN DESIGN

The two main component sections are the carriage and main head.

The **handle** (Fig.1.2) on the frame is adjustable in height and allows the operator to work in a correct and safe working posture

The **halogen spotlight** (Fig.1.2) enables the operator to work in darker areas.

⚠ WARNING Lighting system does not replace adequate overhead lighting.

The **controls** are positioned on top of the electrical box (fig.1.3)

The **electrical box** (fig.1.3) contains the electric switching devices and the inverter.

The **main feeding cable** is connected with a plug and socket on top. The motor feeding cable is plugged into the socket located on the bottom of the box.

The **tank** is on the opposite side of the frame, so that the weight of the water has no influence on the operation of the machine. The frame weight, on the other hand, is fully absorbed by the driving wheels. An electric pump sprays the water through a front sprayer or internal.

The **motor** is mounted on the base plate and is driving the three heads with a belt system.

The **planetary head** is driven by a simplex roller chain.

ENVIRONMENTAL CONDITIONS

The temperature range for operating the Lavina® X-E machine outdoors is between 41°F and 86°F or 5°C and 30°C. Never use the Lavina® X-E machine during rain or snow when working outdoors. When working indoors, always operate the machine in well-ventilated areas.

ELECTRICAL CONNECTION

The voltage (Volt) and current (Ampere) are displayed on a label on the electrical control box to avoid any incorrect connection. Refer to these before connecting the power. To avoid electrical shocks, make sure the ground power supply is functioning properly.



Figure 1.1



Figure 1.2



Figure 1.3

VACUUM CONNECTION

A connection for a vacuum dust extractor is located on the carriage. The Lavina® X-E machine does not include a vacuum dust extractor. The customer must purchase the vacuum dust extractor separately. The hose of the vacuum extractor must be Ø 19 mm and can be glued over the pipe. The vacuum dust extractor must be adapted for floor grinders and have a minimum air displacement of 320m³/h with a negative vacuum of 21 kPa.

TECHNICAL DATA

Lavina® 25-X-E	
Voltage/Hz	3 ph x 380-400V 50-60Hz
Amperage	Max 15 Amps
Power	7,5 kW 10 HP
Tool holder rpm	300-1100 rpm
Working width	655 mm 25.8"
Tool diameter (QC Plate)	3x 225 mm 3x 9"
Weight	252 kg 555 lbs
Grinding pressure	141 kg 310 lbs
Additional weight	max 2x 29 kg max 2x 64 lbs
Application	wet and dry
Vacuum hose port	Yes
Water tank capacity	20 l 5.2 gal
Water feed	with pump (peripheral and front)
Cable length	17.4 m 57 ft
Machine LxWxH	1880x690x1180 mm 74x27.2x46.5"
Packing LxWxH Crate 1	1570x730x1100 mm 61.8x28.7x43.3"

CE-CERTIFICATION

The Lavina® X-E machine is designed to operate in an industrial setting and is equipped with all the mechanical and electrical safety protections in conformity with the following European CEE rules and regulations:

The Lavina® X-E machine complies with the Safety Directive for machines 2006/42/EC, the EMC Directive 2004/108/EC and the Low Voltage Directive 2006/95/EC.

Also complies with the norms in use BDS EN ISO 12100, BDS EN 13862, BDS EN ISO 13857, BDS EN 349, BDS EN ISO 13850, BDS EN 13732-1, BDS EN 953, BDS EN ISO 13849-1, BDS EN 1037, BDS EN ISO 5349-1, BDS EN ISO 11201, BDS EN ISO 3744, BDS EN 1033:2002, BDS EN 60204-1, BDS EN 1837, BDS EN 61000-6-4, BDS EN 61000-6-2, BDS EN 61000-4-2, BDS EN 61000-4-4, BDS EN 61000-4-5, BDS EN 61000-4-11, BDS EN 55016-2-1

Test results are a part of the machine's technical information and can be sent upon a special request. The machine is delivered with the CE mark displayed and provided with an EC declaration of conformity.

VIBRATIONS

The measured vibration value on the gripping surface while operating the machine is $a_{hw}=2,95m/s^2$. The measurement is made in accordance with the BDS EN ISO 1033 and BDS EN ISO 5349-1.

NOISE EMISSIONS

The maximum noise level at a distance of 1m from the machine (at idle) does not exceed 70 db(a). The measurement is made in accordance with the BDS EN ISO 11201 and BDS EN ISO 3744.

LABEL DATA

The data on the label provides the correct Voltage and kW (needed for operational purposes);

Weight (needed for transportation purposes); production year and serial number (needed for maintenance purposes).

CUSTOMER SERVICE

For customer assistance and technical support contact your local distributor or contact the producer Superabrasive Ltd. or visit us at www.superabrasive.com, where you can download a copy of this manual.

2. SAFETY INSTRUCTIONS

RECOMMENDED USE



WARNING

The Lavina® X-E machine is designed and manufactured to grind and polish concrete, terrazzo, and natural stone floors. It can be used for renovation as well as for polishing. The machine is designed for dry or wet use. When using it dry, use a vacuum of appropriate size. For more information, please refer to the chapter on handling the vacuum connection.

PROHIBITED USE



The machine MUST NOT be used:

- For applications apart from the ones stated in the general description chapter.
- For non-suitable materials.
- In environments which:
 - Possess risks of explosion,

- Possess high concentration of powders or oil substances in the air,
- Possess risks of fire
- Feature inclement conditions,
- Possess electromagnetic radiation.

PREPARATION FOR WORK

Make sure that:



WARNING

- You have closed the work area, so that no person unfamiliar with operating the machine can enter the area.
- The tool plate and tools are adjusted to the machine properly.
- There are no missing parts of the machine
 - The machine is in upright working position.
 - The protection devices are working properly.

- The electrical cable is free to move and follow the machine easily.
- In order to keep the electrical cable from being damaged, no vehicle should cross the zone where electrical cables are situated.

PROTECTION DEVICES WARNING

The machine is equipped with several protection devices including the following:

- An emergency stop button
- A protection skirt and a hood for protecting the tool plates.

These devices protect the operator and/or others persons from potential injuries. Do not remove them. Before using the machine, please ensure that all protection devices are mounted and function properly. The Security plate prevents the QuickChange pads to from loosening during work

ARREST FUNCTIONS WARNING

Methods of arresting the machine are following:

- Button to stop the motor (category 1)
- Emergency button (category 1)

SAFE USE WARNING

The Lavina® X-E is designed to reduce risks correlated with its use. However, it is not possible to fully eliminate the risks of an accident with the machine. An unskilled or uninstructed operator may cause correlated residual risks. Such risks are:

- Position Risks: due to operator's incorrect working position
- Entanglement Risks: due to wearing inappropriate working clothes
- Training Risks: due to lack of operational training.

NOTE: In order to reduce any consequences of the above-mentioned risks, we advise that machine operators follow the instructions in the manual at all times.

RESIDUAL RISKS WARNING

During the normal operating and maintenance cycles, the operator is exposed to some residual risks, which cannot be eliminated due to the nature of the operations.

BEFORE YOU BEGIN WARNING

- Working area must be clear from any debris or objects.
- A first-time operator must always read the manual and pay attention to all safety instructions.
- All electric connections and cables must be inspected for potential damages.
- Ground wire system of the power supply must be also inspected.
- Perform general daily inspections of the machine and inspect the machine before each use.
- Always inspect the safety devices: Mount the Security plate for the QuickChange pads.
- The emergency break must be clear and working
- The tool protector must be working
- The machine must be clean
- Never operate the machine in the rain!
- Confirm that there are no missing parts especially after

transportation, repair or maintenance.

- Before filling the water tank with water, make sure the machine is not running and the main switch is turned off.
- Before turning on the machine, make sure that the base is placed on the floor, the machine **MUST NOT** be in any other position when turned on!

OPERATING MACHINE WARNING

When operating the Lavina® X-E, make certain that there is no one but you around the machine.

Never leave the machine unattended while working.

The electrical cable must move freely and must be damage-free.

The water hose must move freely and must be damage-free.

Check to make sure the floor you are preparing to work on is even. If the floor is uneven, it may damage the machine.

AFTER WORK IS COMPLETED WARNING

- Clean the machine and its surroundings properly
- Empty and clean the water tank
- Unplug the machine and wind up the electrical cable
- Store the machine in a safe place

THE WORK AREA WARNING

- Make certain that people or vehicles do not enter the work area.
- Clear any cables or hoses from the work area.
- Always check the floor for debris.

PERSONAL PROTECTIVE EQUIPMENT (PPE) WARNING

- Always wear safety shoes when working with the machine.
- Always wear ear protectors when working with the machine.
- All personnel in the immediate work area must wear safety glasses with side shields.
- Always wear safety gloves when changing the tools.
- Always wear clothes suitable for the work environment.

OPERATOR WARNING

The operator must know the machine's work environment. Only one operator can work with the machine at a time.

The operator must be properly trained and well-instructed prior operating the machine.

- The operator must understand all the instructions in this manual.
- The operator must understand and be able to interpret all the drawings and designs in manual.
- The operator must know all sanitation and safety regulations pertaining to the operation of the machine
- The operator must have floor grinding experience.
- The operator must know what to do in case of emergency.
- The operator must have adequate technical knowledge and preparation.

3. HANDLING AND TRANSPORTATION SPLITTING THE CARRIAGE FROM THE MAINHEAD



Figure 3.1



Figure 3.2



Figure 3.3



Figure 3.4

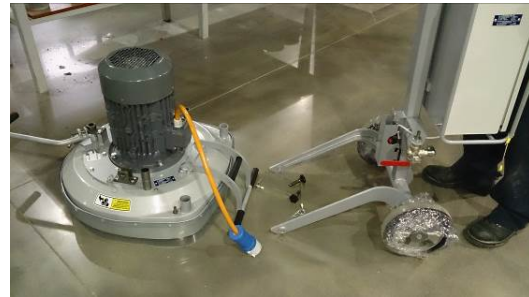

Figure 3.5

Unplug the motor cable plug from the control box and disconnect the water hose from the main head by pulling it out (Fig.3.1) (Fig.3.2). Wind the electrical cable on the carriage. Release the pin sets which attach the head to the carriage (Fig.3.4). Pull out the vacuum hoses (Fig.3.3), and dismount the head from the carriage (Fig.3.5).

The head of the LAVINA® X-E machine has one bar for support, which can be used as a handle for easier transportation.

LIFT THE MACHINE FROM WORKING TO TOOL MOUNTING POSITION

Push the lock on the handle down and swivel it to the front (Fig.3.6.1). Pull the handle up and ensure the head is in a stable, upright position for mounting/dismounting the tool. Ensure that the water tank is empty before flipping the machine. The head should end in an upright position (Fig.3.6.2).

LIFTING

Lifting the machine by crane is possible with the eye bolt, which is mounted on the carriage (see Fig. 3.7). The eye bolt and machine construction is rated only for the weight of the machine. Do not lift any other loads on the machine. Always use hoisting equipment rated for 300 kg (660 lbs) or greater.



Figure 3.7



Figure 3.6.1



Figure 3.6.2

ADJUSTING THE HANDLE

The Handle on the frame is adjustable in height and allows the operator to work in a correct and safe posture. **To adjust, simply pull the locking pin (Fig.3.8.1) and move the frame. A loaded spring will return the pin and lock the handle in any of several positions (Fig.3.8.2).** Choose the vertical position to easily move the machine.



Figure 3.8.1

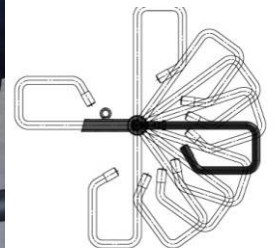

Figure 3.8.2

STORAGE

Always store and transport the Lavina® X-E machine in a dry place. Never transport the Lavina® X-E machine unprotected; it may be damaged if transported unprotected during rain or snow.



Figure 3.9



Figure 3.10



Figure 3.11

⚠ WARNING

When, during storage of the machine, the temperature may fall to 32F (or 0° C) or less, water should be emptied from the system using the following steps:

- Pull out the hose of the tank (Fig.3.9)
- Using compressed air, blow out excess water from the system at each position of the valve (Fig. 3.10, Fig. 3.11).

4. OPERATION

PRELIMINARY CONTROLS

Inspect the working area as explained in the safety instructions. For wet use, fill the water tank with the electrical cable disconnected. Connect the vacuum extractor and ensure that the vacuum hose is clear and will easily follow the machine. Plug in the machine and make sure that the power cord is free to follow the working direction of the Lavina® X-E machine.



Figure 4.1



Figure 4.2



Figure 4.3

WATER FLOW CONTROL UNIT

The operator can direct water to be sprayed in the front (Fig.4.1) by positioning the lever in the horizontal position; the water will spray under the cover of the machine when the lever is in the vertical position (Fig.4.2). The flow regulating valve located on the tank (Fig.4.3) controls the water flow to the working area – in front of the machine or under the main head cover of the machine.

ADJUSTING AND MOUNTING TOOLS

The Holder A41 in the LAVINA® X-E can work with either 3 or 6 buffers, which will alter its range of motion. You can make the change after dismantling the holder as per the instructions in TROUBLESHOOTING.

In the Lavina 25-X-E, the holder is initially mounted with 3 buffers.

Mount the tools only after ensuring that there is enough diamond bond material left. Be sure that the plates are always clean before mounting. **WARNING:** Always secure the “QuickChange” pads with the security plate (Fig.4.4), lock with the tool holder key (Fig.5.3). Diamond tools with Velcro are attached to three 9inch foam plates (Fig.4.5). The foam plates are mounted on the key lock (butterfly). Always use the tool holder key (Fig.5.3).

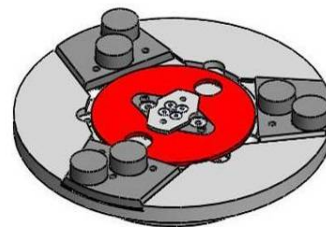

Figure 4.4



Figure 4.5

THE CONTROL BOARD

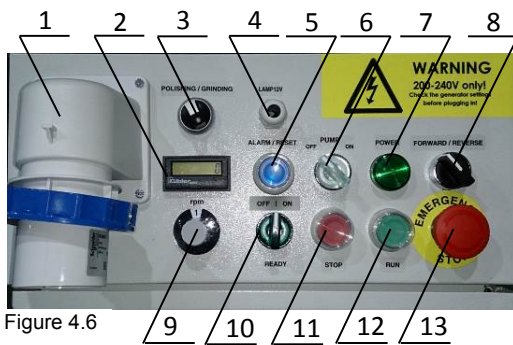

Figure 4.6

1. **Power cable plug**
2. **Digital Tachometer** Indicates the revolutions per minute of the grinding plates (not the revolutions per minute of the entire head)
3. **Polishing/Grinding switch** In “grinding” position, the operator has the ability to control the rpm from 300 to 700 rpm. In “Polishing” position, the range increases to 300 to 1100 rpm.
4. **Lamp cable gland**
5. **ALARM/Reset button** resets the alarm of the inverter. **Button** lights blue when the inverter goes into alarm mode
6. **Water pump switch** Lights orange when the water pump is working.
7. **Power led** lights green when the power is on
8. **Forward/Reverse switch** Select forward for clockwise rotation of the grinding plates or reverse for counterclockwise rotation of the grinding

plates (Recommended configuration). The preferred operating direction should be when the switch is in the forward position. The proper direction of rotation of the motor (counterclockwise) is indicated by an arrow on its cover.

9. **Potentiometer** controls the RPM of the grinding plates on a range of 300-1100 rpm
10. **READY OFF / ON switch.** Switching to ON puts the machine in standby mode. The switch lights to indicate this. Switching to OFF takes the machine out of standby. The light extinguishes to indicate this. The switch returns to its starting position after being released.
11. **STOP button** stops the motor
12. **RUN button** starts the motor
13. **Emergency button** stops the motor in case of emergency. It should NOT be used to stop the machine in normal operating conditions

STARTING THE MACHINE

First, follow the directions in the chapter on Safety Devices and Safety Instructions. Next, release the emergency stop (12), turn the **Ready** switch (Fig. 4.6 9) to the ON position to put the machine in standby mode. Check the potentiometer (8), and ensure that it is set to the working speed. If working wet, add water to the floor surface. If working dry instead switch on the vacuum unit. Finally, hold the machine firmly and push the RUN button (11).

OPERATING THE MACHINE

GUIDE THE MACHINE IN STRAIGHT LINES ACROSS THE FLOOR, SLIGHTLY OVERLAPPING THE PREVIOUSLY COMPLETED SURFACE WITH EACH NEW LINE. WORK AT A CONSTANT SPEED, ALLOWING THE TOOLS TIME TO WORK AT A SPEED APPROPRIATE FOR THE TOOLS' GRIT SIZE. AVOID VIBRATIONS. DO NOT STOP THE MACHINE WHILE TOOLS ARE STILL RUNNING AS THEY WILL MARK THE SURFACE OF THE FLOOR. WHEN WORKING WET, SELECT THE DESTINATION OF THE WATER FEED WITH THE WATER TAP (FIG. 4.2-1) AND PERIODICALLY RUN THE PUMP (FIG. 4.10-11) TO RELEASE WATER ONTO THE FLOOR SURFACE. STARTING THE PUMP IS POSSIBLE ONLY IF THE MACHINE MOTOR IS ON. WHEN WORKING DRY, CHECK THE FLOOR SURFACE PERIODICALLY FOR DUST ACCUMULATION. CHECK REGULARLY TO SEE IF YOUR VACUUM WORKS PROPERLY

STOPPING THE MACHINE

The stopping of the machine must be done gradually until the motor stops. Do not stop moving the machine before the motor comes to rest, as the tools could damage the surface.

To stop the machine:

1. Push the STOP button (10) .
2. Turn the **OFF/ON** (9) switch in position OFF, this will cut the voltage to the inverter and the green light will turn off.

While working do not turn off directly from the READY switch or from the Emergency Stop, but follow the steps above.

⚠ WARNING

Use the Emergency button (12) only in emergency.

Remember not to hold the machine in one spot before turning off the motor.

ALARM

The Reset button (4) will light when the inverter goes into alarm mode. The most common failure is motor overload. To exit alarm mode, push the reset button (4). A code on the inverter's display indicates the type of the alarm. **When the same alarm is repeated several times, it is imperative to find and eliminate the cause of it, less the inverter become damaged.**

5. TOOLS AND ACCESSORIES



Figure 5.1

WEIGHTS

Superabrasive offers additional weights used to increase the productivity of the machine (Fig.5.1). Each additional weight weighs about 64 lbs or 29kg. Each individual application, type and condition of surface, power capacity of the outlet, etc. will determine the number of weights you can use without tripping a breaker. The weights stack onto three posts fixed around the outer bowl (Fig.5.2). Additional weights will largely depend on the tools; it is not always possible to add weights. Some tools work too aggressively and will cause the machine to stop. The weight can be ordered with item number A08.00.00.00



Figure 5.2

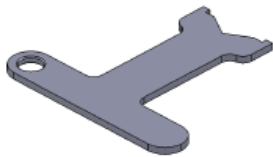

Figure 5.3

TOOL HOLDER KEY

The tool holder key (Fig.5.3) is used for adjusting, mounting and dismounting of the foam plates. Always use the key to properly secure foam plates. Item number is A03.00.00.00

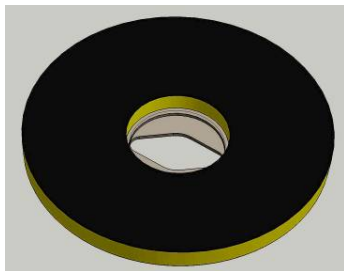

Figure 5.4

FOAM PLATE

Diamond tools with Velcro are mounted on the foam plate 9"(Fig.5.4). The foam plate is mounted on the "QuickChange" System. Item number is LV-9-FP-S

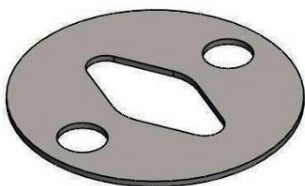

Figure 5.5

SECURITY PLATE FOR QUICKCHANGE PADS

Plate (Fig.5.5) used to secure the "QuickChange" pads. Item number is A38.00.01

6. POPULAR TOOLS



QuickChange System and Tooling feature extremely fast and convenient tool changes, and a long tool life, providing for great long-term cost savings. The QuickChange pads are produced in four different bonds for super hard, hard, medium and soft concrete, in a variety of grit sizes. They are offered with 1 or 2 buttons or rectangular segments, which allows you to customize the aggressiveness of the cut.

Calibra grinding discs: remove scratches and they save tools. They can be used wet or



our popular ceramic bond discs are designed for the removal of difficult you valuable time by eliminating the need for multiple passes with metal

dry, and are best for hard concrete applications. They are 3-inch, with included Velcro back attachment.



NATO® polishing discs feature a special resin formula designed for both wet and dry applications and a unique design with wide channels allowing for work on a cleaner surface

and ensuring a quality polish. Available in 3 and 4 in sizes. They are with Velcro attachment.



V-HARR® Premium Polishing Pads are designed for mechanically polishing and restoring concrete; also ideal for terrazzo and hard stone floors. V-HARR® pads are offered in a wide variety of diameters and grit sizes to accommodate many applications. Dry use is strongly recommended.



Shine Pro® are high quality diamond-integrated pads for floor maintenance. Available in a variety of sizes, they are great for daily use. When used wet, they require only water (no wax or chemicals needed), making them a very environmentally-friendly solution for maintaining floors.

Use Only Superabrasive's Recommended Tools. For More Tooling Options, Visit www.superabrasive.com

7. MAINTENANCE AND INSPECTION

CLEANING

Keep your machine clean. Cleaning the machine in a regular basis will help detect and solve potential problems before they can cause damage to the machine. Most importantly, check and clean the tool plate connections, power cords, plugs, vacuum hoses, and water tank.

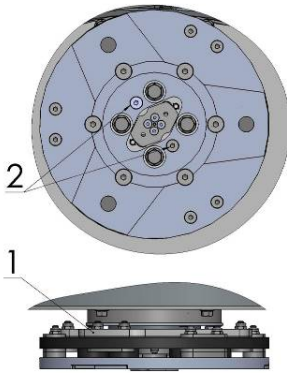

Figure 7.1

“QuickChange” should also be cleaned.

CHECK DAILY

After operating the Lavina®X-E machine, the operator should conduct a visual inspection of the machine. Any defect should be solved immediately. Pay attention to power cords, plugs, vacuum hoses, loose bolts or screws.

Tool holders: Buffers and elastic element are consumables and must be visually checked on a daily basis and replaced if necessary. Make sure the flanges or discs are securely locked in place. The key lock holders (butterflies) should also be checked.

Check the rubber buffers and make sure the holders are secure. The flange holding the buffers (Fig.7.1-1) has to be firmly secured to the unit. If there is a gap seen here, that means the screws securing the holder are loose. The screws have to be tightened immediately to safely operate the machine. Working with loose screws could cause serious damage to the machine. The tightening force of the screws has to be 22-25N.m (16-18ft-lbf).

It is very important to regularly check the screws that secure the “QuickChange” holder to the safety part (Fig.7.1- 2), so that the holder will not fly away if the buffers get damaged. The



Figure 7.2



Figure 7.3

CHECK EVERY 200 WORKING HOURS

Every 200 working hours, the operator should inspect all parts of the machine carefully. Most importantly, inspect and clean the tool plate connections, power cord plugs, vacuum hoses and water tank/filter. Also, check the water flow of the pump. Check the guard assembly. Ensure the wheels are clean and rotate properly. Inspect the control buttons. If there are defective control parts, they should be replaced immediately. Replace any worn vacuum or water hoses.

Open the service cover on the motor base (Fig 7.2) (Fig 7.3) to check the planetary chain. Lubricate the chain with chain lubricant and correct the sag if needed. (For sagging correction see TROUBLESHOOTING 8.4)

Dismount the tool holders (See TROUBLESHOOTING) and replace any parts (elastic element, buffers, sealer caps, “O” rings) showing any damage.

CHECK EVERY 400 WORKING HOURS

In addition to checks made every 200 working hours, replace sealer and V-rings as described in chapter “TROUBLESHOOTING - DISMOUNTING TOOL HOLDERS TO CHANGING V-RINGS AND FELT-RINGS.”

VACUUM

As stated previously, frequently check hoses and other parts for clogging.

WATER LEAKS

Leaking parts should be replaced immediately as the water could damage your machine.

MECHANICAL PARTS

Parts such as the belts, seal rings, cap rings, spiders, buffers and guard assembly are subject to wear and must be replaced as needed.

ELECTRICAL SYSTEM

Dust should not enter the control box, as it will destroy the controls. Remove (blow out) any dust present.

380-400 Volt

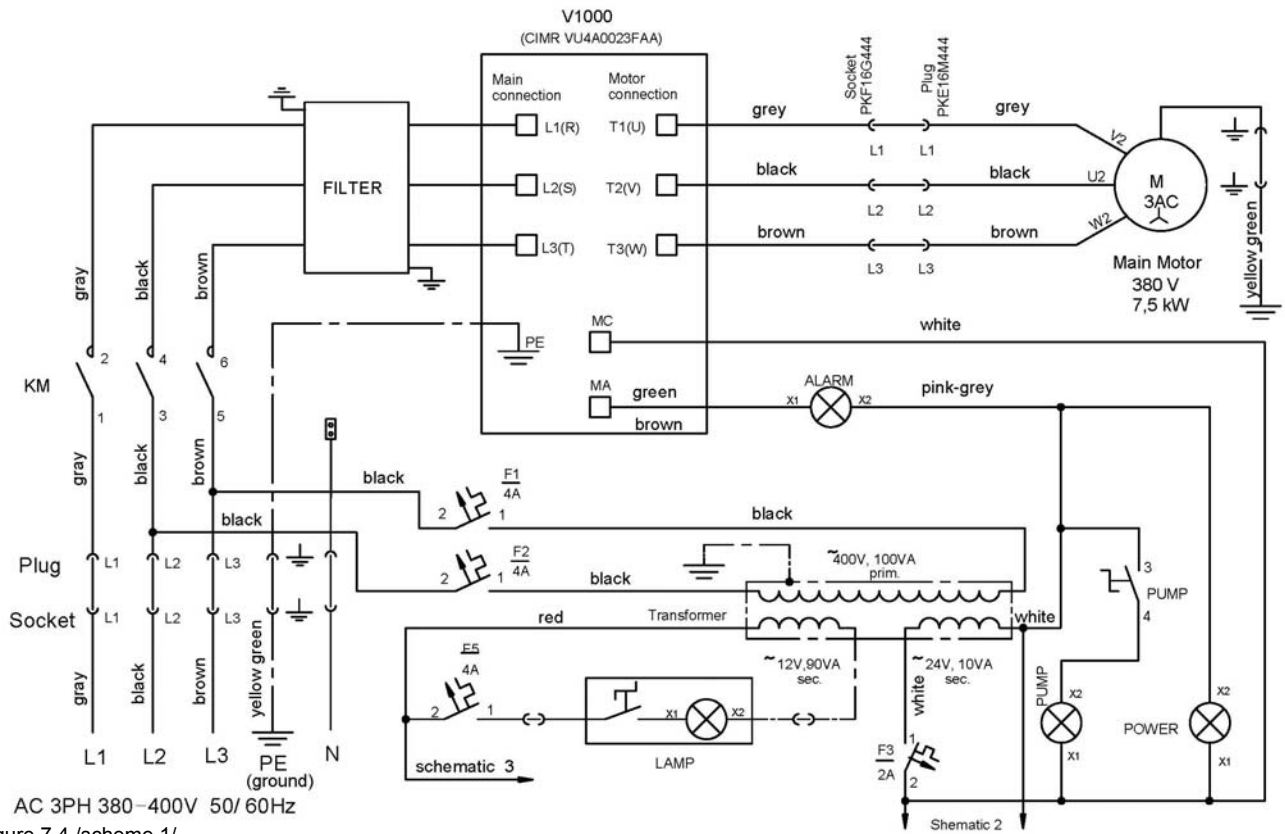

LAVINA® 25-X-E ELECTRICAL SCHEMES YASKAWA CONNECTION MAIN CIRCUIT TERMINALS

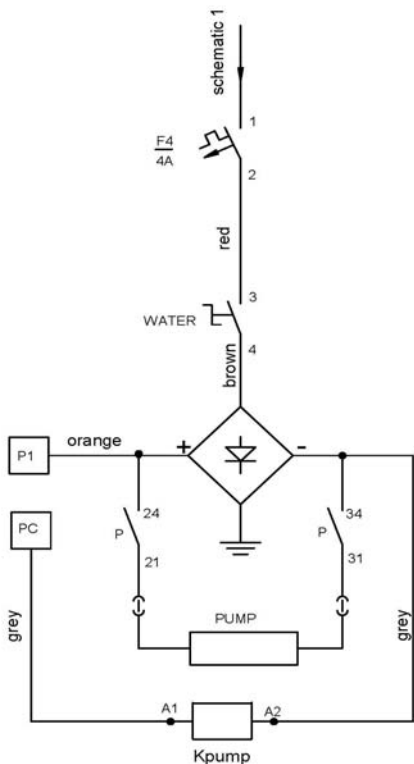
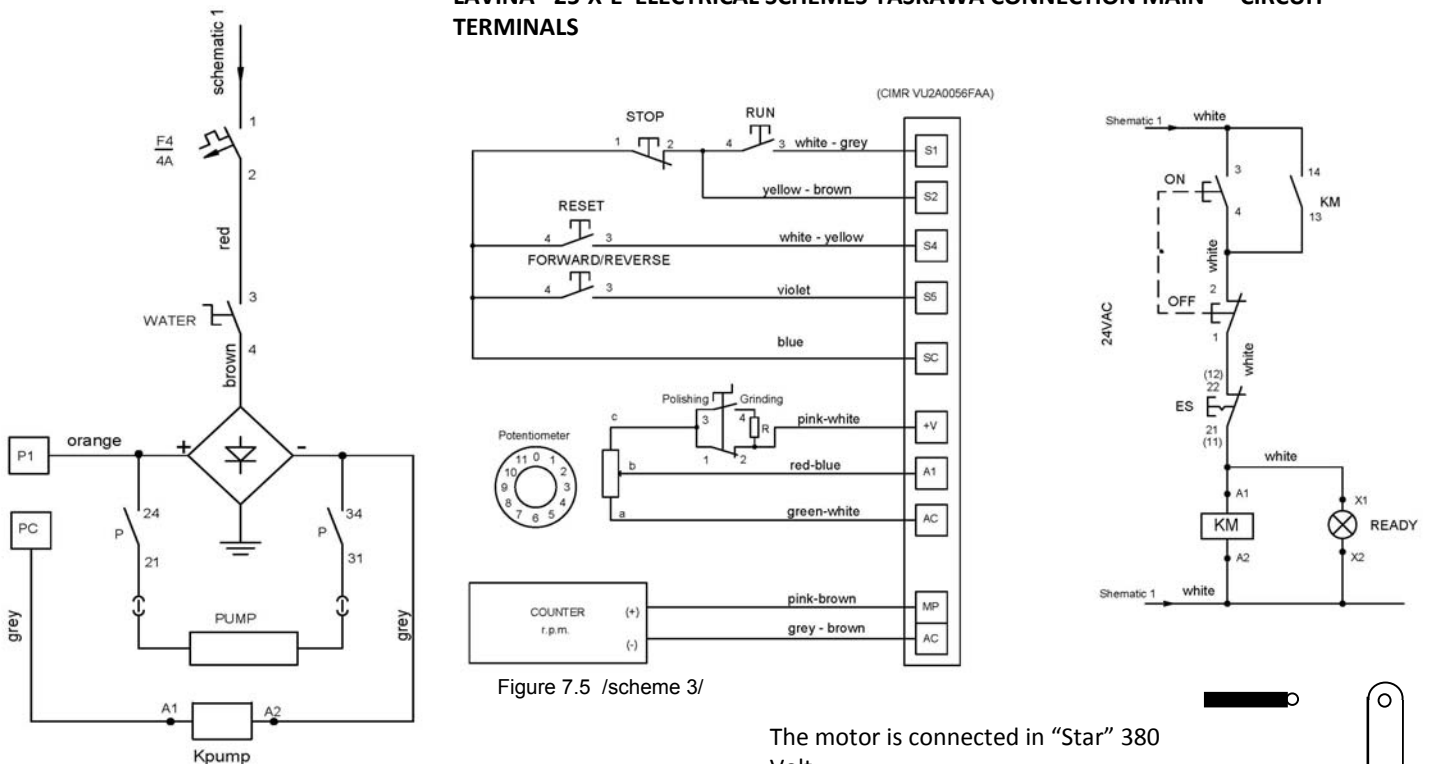

The motor is connected in "Star" 380 Volt, reminder for the wire connection of the motor.

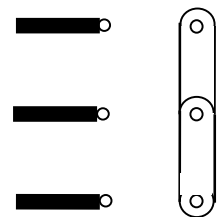

8. TROUBLESHOOTING

INDEX OF PROBLEMS AND SOLUTIONS

8.1 REPLACING POWER CORD AND PLUGS

When replacing the power cord or plugs, always use cords and plugs with the same specifications as the original ones.

Do not use lower quality or different types of cords or plugs.

In addition, consider the distance between the appliance and the electrical source - the greater the distance, the greater the resistance and the less current that will be available at the other end. This will cause a voltage drop and the inverter will switch into alarm mode. This will also happen if several machines are working on the same line or the generator is not rated for the power needed. In general, our standard power cable can be doubled in length; longer lengths require replacing all the cables with cables of a larger gauge rate to account for the length and amperage.

8.2 DISMOUNTING AND MOUNTING TOOL HOLDER TO CHANGE V-RINGS AND FELT-RINGS



Figure 8.2.1



Figure 8.2.2

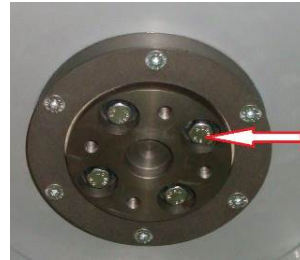

Figure 8.2.3



Figure 8.2.4



Figure 8.2.5



Figure 8.2.6

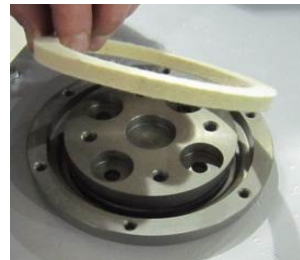

Figure 8.2.7

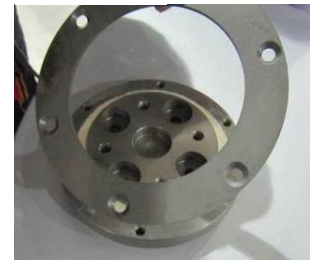

Figure 8.2.8

To check or replace the buffers and the elastic elements, the tool holders have to be dismantled.

You will need a 13mm deep metric socket with an outside diameter of no more than 3/4in to unscrew the four bolts (Fig.8.2.1) and remove the holder (Fig.8.2.2) When the tool holder is dismantled, you can change the sealers (V-Ring and Felt-Ring).

By loosening four Hex cap flange bolts (Fig.8.2.3) the adaptor comes loose. Unscrew the six screws of the cap (Fig.8.2.4) holding the felt-ring. Take out the Felt-Ring, adaptor and V-Ring.

Mount the V-Ring with the smallest lip of the V to the inside (Fig.8.2.5) - simply push the V-Ring so the top is on the same level as the pulley top (Fig.8.2.6). Then take the adaptor and push the V-Ring down with the adaptor (Fig.8.2.7). The lowest lip of the V-Ring should only barely touch its gliding surface. Mount the adaptor and the Felt-Ring on top (Fig.8.2.7). Close the sealers with the cap (Fig.8.2.8) and screw the bolts. Always use the original bolts. Do not push the V-ring down with fingers.

8.3 DISASSEMBLING AND MOUNTING TOOL HOLDER TO CHANGE BUFFERS AND ELASTIC ELEMENT

When the TOOL HOLDER is disassembled you can change defective parts – elastic element, buffers, etc.

Lift the locking pin (Fig.8.3.1) to dismount the retaining washer (Fig.8.3.2). Take out the screws on the buffers and the nuts of the elastic element (Fig.8.3.3;Fig.8.3.4). Remove the elastic element from the QC plate (Fig.8.3.5). While the holder is dismantled (Fig.8.3.6;Fig.8.3.7), clean the parts and replace any defective ones with new ones. Assemble the holder with new buffers, new screws, and new elastic element. Replace the retaining washer (Fig.8.3.8) and push the locking pin (Fig.8.3.9). This will prevent the washer from falling while mounting the holder on the machine.



Figure 8.3.1



Figure 8.3.2

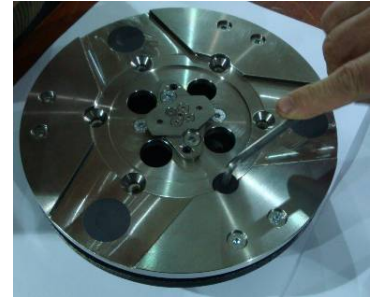

Figure 8.3.3



Figure 8.3.4



Figure 8.3.5



Figure 8.3.6



Figure 8.3.7



Figure 8.3.8

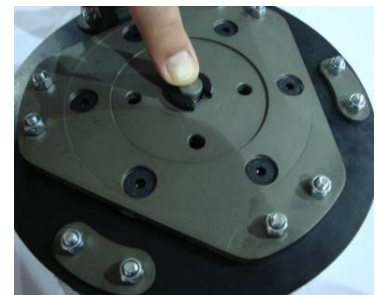

Figure 8.3.9

Make sure the four bolts holding the adaptor (Fig.8.3.12) are reliably tightened. Mount the holder on the machine using the same socket as in 8.2 (Fig.8.3.10;Fig.8.3.11). The retaining washer fits into the central hole C of adaptor and the four bolts into the thread holes T (Fig.8.3.12). The holder should be centered on the outside diameter of the adaptor. Ensure the holder is properly connected to the plate of the adaptor and then evenly tighten the four bolts. Tightening force on the bolts has to be 22...25N.m(16...18 ft·lbf). Mounting the holder without the retaining washer (Fig.8.3.2) is **INADMISSIBLE** because the security system preventing the separation of part of the holder in case of broken buffers and elastic element will not function! You can change the butterfly of the holder without dismounting the holder from the machine.



Figure 8.3.10



Figure 8.3.11

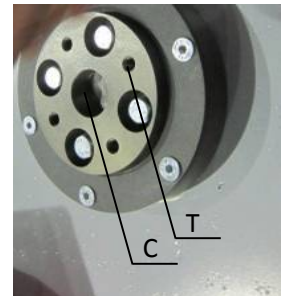

Figure 8.3.12

Fig.8.3.13 is a 3-D section view of the holder, showing its parts. The numbering is the same as in Spare parts.

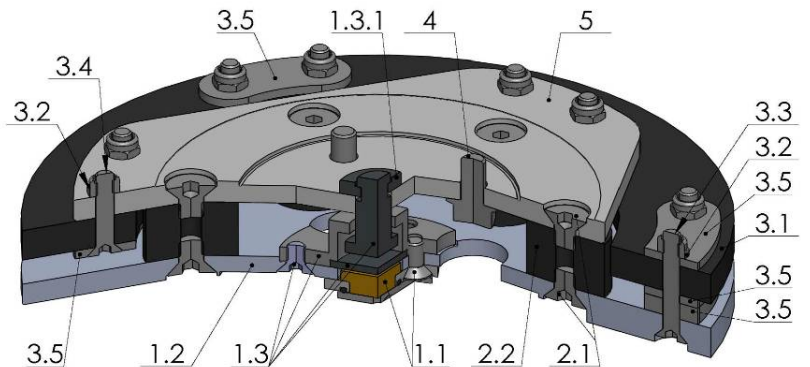

Figure 8.3.13

8.4 CORRECTING SAG OF THE USED PLANETARY CHAIN

Unscrew the eight bolts (Fig.8.4.1) and remove the cover (Fig.8.4.2). Pull the hose out of the water sprayer (Fig.8.4.3). Put the machine in position to change the tools. Manually turn the holders in order to turn the main head, stopping when the chain tensioner can be seen through the window (Fig.8.4.4).



Figure 8.4.1



Figure 8.4.2



Figure 8.4.3



Figure 8.4.4

Loosen the two bolts of the chain tensioner a quarter to a half revolution (Fig.8.4.5). The tensioner should turn with minimum clearance, without inclination, and then unscrew the inner nut. To tension the chain screw, tighten the outer nut (Fig.8.4.6). The tensioner of the planetary chain should allow chain sagging of 3...5mm (1/8...3/16 in) measured in span X (Fig.8.4.7). When set, screw the two nuts (Fig.8.4.6) and the screw (Fig.8.4.5).



Figure 8.4.5



Figure 8.4.6

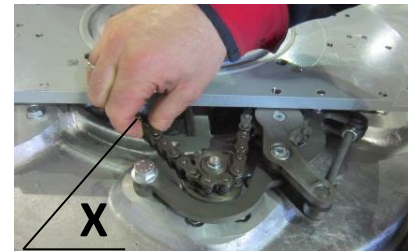

Figure 8.4.7

ATTENTION: NEVER "OVER" TENSION THE CHAIN, THE CHAIN WILL BE DAMAGED

8.5 MOUNTING NEW PLANETARY CHAIN

The planetary chain is replaced with new one when the step/drive of the chain tensioner is finished or there is a loss of integrity in the chain.

Unscrew the eight bolts (Fig.8.4.1), take off the cover (Fig.8.4.2), and pull the hose out of the water sprayer (Fig.8.4.3). Put the machine in position to change the tools. Manually turn the holders in order to rotate the main head, stopping when the chain tensioner can be seen through the window (Fig.8.4.4). Separate the carriage from main head, and pull out the motor plug (Fig. 3.1), water tubes, and vacuum tubes (Fig. 3.2) (Fig. 3.3). Take off the handle (without water tubes) (Fig. 8.4.3). Release the pin sets (Fig. 3.4) attaching the head to the carriage. Take off the weight holders (Fig. 8.5.1), machine support (Fig. 8.5.2), and the service window (Fig. 8.4.2) so the top cover can be removed (Fig. 8.5.3).



Figure 8.5.1



Figure 8.5.2



Figure 8.5.3

Loosen the two nuts (Fig.8.4.6) and unscrew the two screws of the tensioner (Fig.8.4.5)(Fig.8.5.4)(Fig.8.5.5). Remove the chain tensioner (Fig.8.5.6). Pull out the split pin (Fig.8.5.7) and the chain link pin (Fig.8.5.8) (Fig.8.5.9). Remove the chain, and install the new chain in the same manner, and then insert the chain link pin and split pin (Fig.8.5.9) (Fig.8.5.8) (Fig.8.5.7).



Figure 9.5.4



Figure 9.5.5



Figure 9.5.6



Figure 9.5.7



Figure 9.5.8



Figure 9.5.9

Mount the chain tensioner (Fig.8.4.6). Tighten the two screws (Fig.8.5.4)(Fig.8.4.5). Loosen the bolt of the chain tensioner a quarter to a half revolution (Fig.8.4.5). The tensioner should turn with minimum clearance, without inclination. Then unscrew the inner nut. To tension the chain, rotate the outer nut (Fig.8.4.6). The tension of the planetary chain should allow chain sagging of 3...5mm (1/8...3/16 in) measured in span X (Fig.8.4.7).

When properly tensioned, retighten the two nuts (Fig.8.4.6) and the screw (Fig.8.4.5).

ATTENTION: NEVER "OVER" TENSION THE CHAIN, THE CHAIN WILL BE DAMAGED

8.6 REPLACING THE PLANETARY DRIVING CHAIN WHEEL AND PLANETARY TENSIONER

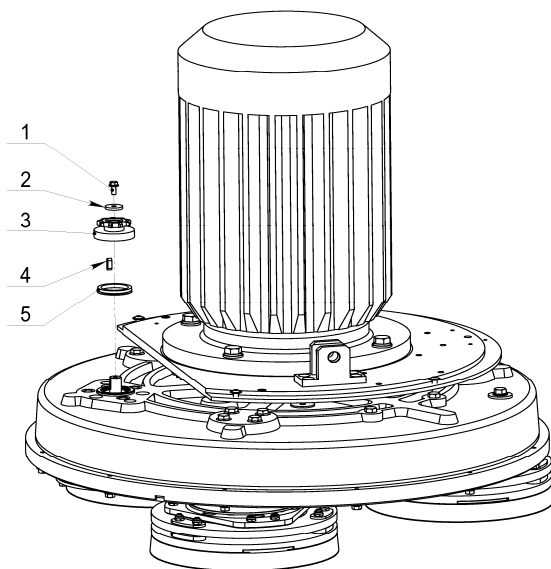

Figure 8.6.1

Check and repeat the instructions in 8.5 MOUNTING NEW PLANETARY CHAIN.

Unscrew bolt (1) and remove the chain pulley (3) with the sealer (5). Change the sealer, and mount it to the chain pulley (3). Apply lithium grease on the shaft and mount back the wheel and the front washer (2) as shown on (Fig.8.6.1). Screw the bolt using the "blue" thread locking adhesive. Tightening force on the bolts should be 9...11N.m (6.6...8 ft·lbf).

8.7 TENSIONING AND REPLACING THE BELTS



Figure 8.7.1



Figure 8.7.2



Figure 8.7.3

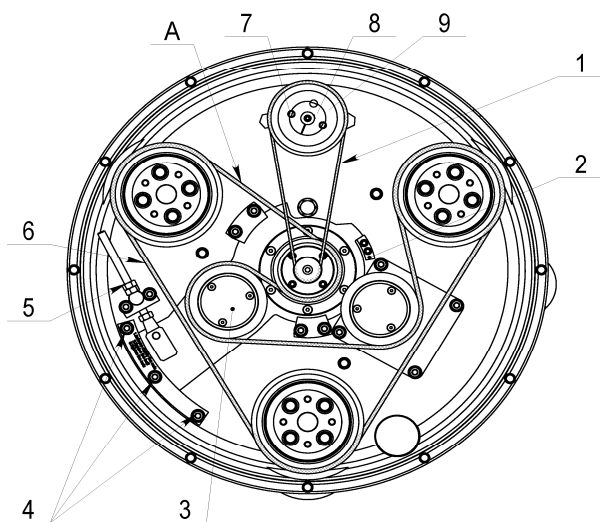

Figure 8.7.5

visible. Arrange the belts in pos.6 as per the scheme, paying attention to their orientation at every pulley. Loosen the nuts (5) to the end of the bolt, and fully loosen the nuts on the half moon (4), allowing the rotation of the tensioners with minimal force.

Using nuts (5), tighten the belt, double checking the position/orientation of the belt and the gearing in each pulley.

Rotate the gear while tensioning to allow regular distribution of tension along the belt.

Measure the tension using a Frequency Tension Tester (Optibelt 3 TT) (Fig. 8.7.3). Tension in span "A" of the belt should be 120-130Hz. It is possible to use the pre-installed support (Fig. 8.7.5-2)(Fig. 8.7.6) as a reference to stop the tensioner at the desired belt tension, provided that the supports have not been moved from their factory position.

ATTENTION: NEVER "OVER" TENSION THE BELT, THE BELT WILL BE DESTROYED AND IT WILL NEVER RECOVER ITS ORIGINAL TENSION

To remove the planetary belt (Fig.8.7.5-1), unscrew the screw of the front washer (Fig.8.7.7) and the two screws of the conical sleeve (Fig.8.7.8). Screw one of the removed screws into the free thread (Fig.9.7.9) to push the washer down (Fig.8.7.10); take off the conical sleeve and the belt (Fig.8.7.11). A flat head screw driver may help with this. (Fig.8.7.12).



Figure 8.7.6



Figure 8.7.7



Figure 8.7.8

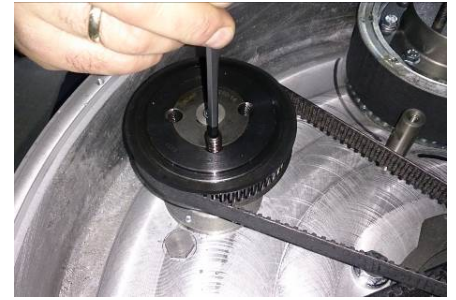

Figure 8.7.9



Figure 8.7.10



Figure 8.7.11



Figure 8.7.12

The reassembly is the same process in reverse. It is important to match the threads of the conical sleeve and the belt washer (Fig.8.7.13). Put the front washer (Fig.8.7.14), on the screw - using "blue" thread locking adhesive. Tightening force of the bolts has to be 4,5...6N.m (3,3...4,4 ft-lbf). Carefully replace the two binder screws while leaving the central thread open. (Fig.8.7.14)(Fig.8.7.15). Insert the screws by alternating at 1.5 revolutions each until the conical sleeve pulls up the belt pulley. The conical sleeve must be aligned in height with the belt washer (Fig.8.7.16).



Figure 8.7.13



Figure 8.7.14

Dismounting the planetary belt is possible without removing of the Bottom cover assembly by unscrewing the eight bolts and removing the service window cover and sealing (Fig.8.7.17)(Fig.8.7.18) to access the planetary belt (see 8.7.19).



Figure 8.7.15



Figure 8.7.16



Figure 8.7.17



Figure 8.7.18



Figure 8.7.19

8.8 REPLACING THE DRIVEN PLANETARY GEAR

Remove the planetary chain and tensioner (see Fig.8.5 - MOUNTING NEW PLANETARY CHAIN).

Dismount the tool holders, sealers, and bottom cover (see Fig.8.7 - TENSIONING AND REPLACING THE BELTS). Unscrew the cap to access the fastening bolts of the driven chain gear (Fig.8.8.1)(Fig.8.8.2). Rotate the main head such that you see a fastening bolt of the gear (Fig.8.8.3) through the hole.

You will need a 10mm magnetic deep metric socket with an outside diameter of no more than 11/16 in to unscrew the six bolts (Fig.8.8.3)(Fig.8.8.4) (Fig.8.8.5). Once these are removed, remove the two halves of the gear.

The gear is composed of two symmetrical halves (Fig.8.8.6). Mount them in reverse order.

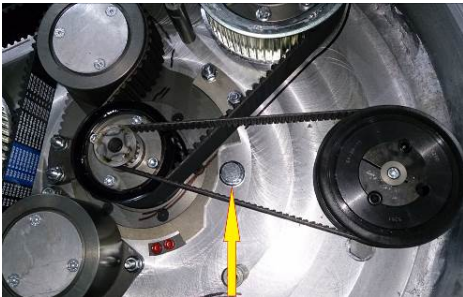

Figure 8.8.1

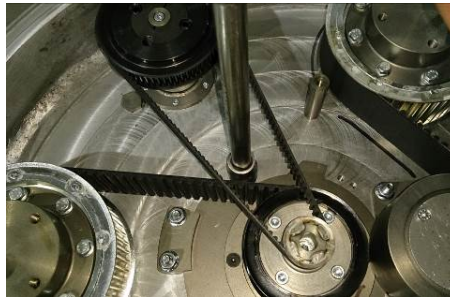

Figure 8.8.2

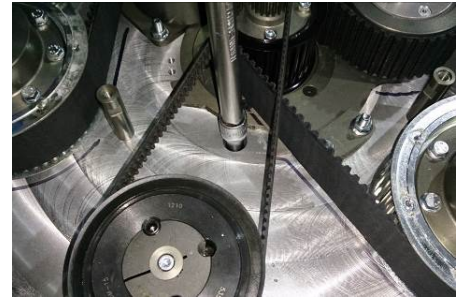

Figure 8.8.3



Figure 8.8.4

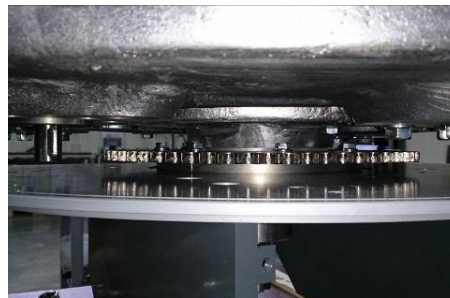

Figure 8.8.5



Figure 8.8.6

8.9 REPLACING THE PULLEY UNITS

Remove guard, top cover, maintenance window, chain tensioner, driven gear, bottom cover and belts as previously described.



Figure 8.9.1



Figure 8.9.2



Figure 8.9.3

Unscrew the four bolts of each pulley between the base plate and the motor base disc (Fig.8.9.1)(Fig.8.9.2) and dismount the pulley (Fig.8.9.3).

A seal (Fig.8.9.4) should be placed on top of the pulley before mounting.



Figure 8.9.4

8.10 REPLACING THE PLANETARY UNIT



Figure 8.10.1



Figure 8.10.2



Figure 8.10.3

Unscrew the six bolts (Fig.8.10.1)(Fig.8.10.2) and press down the planetary unit.
When mounting back secure with sealant (fig.8.10.3).

8.11 MOTOR CONNECTION

When the motor is being replaced, please follow the cable connections in the figures below (Fig.8.11.1).

Lavina® 25 X-E

The motor is connected in "Star"
380 Volt, reminder for
the wire connection of the motor.

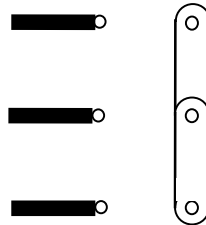

Figure 8.11.1

8.12 FAULT DIAGNOSIS INVERTER YASKAWA V1000

Pages are referring to

Yaskawa Electric SIEP C710606 18A YASKAWA AC Drive – V1000 Technical Manual

◆ Types of Alarms, Faults, and Errors

Check the LED operator for information about possible faults if the drive or motor fails to operate. *Refer to Using the Digital LED Operator on page 70.*

If problems occur that are not covered in this manual, contact the nearest Yaskawa representative with the following information:

- Drive model
- Software version
- Date of purchase
- Description of the problem

Table 6.4 contains descriptions of the various types of alarms, faults, and errors that may occur while operating the drive.

Contact Yaskawa in the event of drive failure.

Table 6.4 Types of Alarms, Faults, and Errors

Type	Drive Responses to Alarms, Faults, and Errors
Faults	When the drive detects a fault: <ul style="list-style-type: none"> • The digital operator displays text that indicates the specific fault and the ALM indicator LED remains lit until the fault is reset. • The fault interrupts drive output and the motor coasts to a stop. • Depending on the setting, the drive and motor may stop via different methods than listed. • If a digital output is programmed for fault output (H2-□□ = E), it will close if a fault occurs. • When the drive detects a fault, it will remain inoperable until that fault has been reset. <i>Refer to Fault Reset Methods on page 264.</i>
Minor Faults and Alarms	When the drive detects an alarm or a minor fault: <ul style="list-style-type: none"> • The digital operator displays text that indicates the specific alarm or minor fault and the ALM indicator LED flashes. • The motor does not stop. • One of the multi-function contact outputs closes if set to be tripped by a minor fault (H2-□□ = 10), but not by an alarm. • The digital operator displays text indicating a specific alarm and ALM indicator LED flashes. • Remove the cause of an alarm or minor fault to automatically reset.
Operation Errors	When parameter settings conflict with one another or do not match hardware settings (such as with an option card), it results in an operation error. When the drive detects an operation error: <ul style="list-style-type: none"> • The digital operator displays text that indicates the specific error. • Multi-function contact outputs do not operate. • When the drive detects an operation error, it will not operate the motor until the error has been reset. Correct the settings that caused the operation error to reset.
Tuning Errors	Tuning errors occur while performing Auto-Tuning. When the drive detects a tuning error: <ul style="list-style-type: none"> • The digital operator displays text indicating the specific error. • Multi-function contact outputs do not operate. • Motor coasts to stop. • Remove the cause of the error and repeat the Auto-Tuning process.

◆ Alarm and Error Displays

■ Faults

When the drive detects a fault, the ALM indicator LEDs remain lit without flashing. If the LEDs flash, the drive has detected a minor fault or alarm. *Refer to Minor Faults and Alarms on page 240* for more information. An overvoltage situation trips both faults and minor faults, therefore it is important to note whether the LEDs remain lit or if the LEDs flash.

LED Operator Display	Name	Page	LED Operator Display	Name	Page
bUS	bUS Option Communication Error	242	CPF08	EEPROM Serial Communications Fault	243
CE	MEMOBUS/Modbus Communication Error	242	CPF11	RAM Fault	243
CF	Control Fault	242	CPF12	FLASH Memory Fault	243
CoF	Current Offset Fault	242	CPF13	Watchdog Circuit Exception	243
CPF02	A/D Conversion Error	242	CPF14	Control Circuit Fault	243
CPF03	PWM Data Fault	243	CPF16	Clock Fault	243
CPF06	Drive specification mismatch during Terminal Board or Control Board replacement	243	CPF17	Timing Fault	243
CPF07	Terminal Board Communication Fault	243	CPF18	Control Circuit Fault	243
			CPF19	Control Circuit Fault	244

LED Operator Display	Name	Page	LED Operator Display	Name	Page		
CPF20 or CPF21	RAM Fault	244	GF	GF	Ground Fault	245	
	FLASH Memory Fault	244	LF	LF	Output Phase Loss	245	
	Watchdog Circuit Exception	244	LF2	LF2	Output Open Phase	246	
	Clock Fault	244	oC	oC	Overcurrent	246	
oH3	oH3	Motor Overheat 1 (PTC input)	247	oFA00	oFA00	Option Card Fault (port A)	246
oH4	oH4	Motor Overheat 2 (PTC input)	248	oH	oH	Heatsink Overheat	247
oL1	oL1	Motor Overload	248	oH1	oH1	Heatsink Overheat	247
oL2	oL2	Drive Overload	248	PGo	PGo	PG Disconnect (for Simple V/f with PG)	250
oL3	oL3	Overtorque Detection 1	249	rH	rH	Dynamic Braking Resistor	251
oL4	oL4	Overtorque Detection 2	249	rr	rr	Dynamic Braking Transistor	251
oL5	oL5	Mechanical Weakening Detection 1	249	SEr	SEr	Too Many Speed Search Restarts	251
oL7	oL7	High Slip Braking oL	249	STO	STO	Pull-Out Detection	251
oPr	oPr	Operator Connection Fault	249	UL3	UL3	Undertorque Detection 1	251
CPF22	CPF22	A/D Conversion Error	244	UL4	UL4	Undertorque Detection 2	251
CPF23	CPF23	PWM Feedback Data Fault	244	UL5	UL5	Mechanical Weakening Detection 2	251
CPF24	CPF24	Drive Capacity Signal Fault	244	Uv1	Uv1	Undervoltage	252
dEv	dEv	Excessive Speed Deviation (for Simple V/f with PG)	244	Uv2	Uv2	Control Power Supply Undervoltage	252
EF0	EF0	Option Card External Fault	244	Uv3	Uv3	Soft Charge Circuit Fault	252
EF1 to EF7	EF1 to EF7	External Fault (input terminal S1 to S7)	244	oS	oS	Overspeed (for Simple V/f with PG)	249
FbH	FbH	Excessive PID Feedback	245	ov	ov	Overvoltage	249
FbL	FbL	PID Feedback Loss	245	PF	PF	Input Phase Loss	250

Note: If faults CPF11 through CPF19 occur, the LED operator will display CPF00 or CPF11.

■ Minor Faults and Alarms

When a minor fault or alarm occurs, the ALM LED flashes and the text display shows an alarm code. A fault has occurred if the text remains lit and does not flash. *Refer to Alarm Detection on page 253.* An overvoltage situation, for example, can trigger both faults and minor faults. It is therefore important to note whether the LEDs remain lit or if the LEDs flash.

Table 6.5 Minor Fault and Alarm Displays

LED Operator Display	Name	Minor Fault Output (H2-□□ = 10)	Page	
bb	bb	Drive Baseblock	No output	253
bUS	bUS	Option Card Communications Error	YES	253
CALL	CALL	Serial Communication Transmission Error	YES	253
CE	CE	MEMOBUS/Modbus Communication Error	YES	253
CrSt	CrSt	Can Not Reset	YES	253
dEv	dEv	Excessive Speed Deviation (for Simple V/f with PG)	YES	254
dnE	dnE	Drive Disabled	YES	254
EF	EF	Run Command Input Error	YES	254
EF0	EF0	Option Card External Fault	YES	254
EF1 to EF7	EF1 to EF7	External Fault (input terminal S1 to S7)	YES	255
FbH	FbH	Excessive PID Feedback	YES	255
FbL	FbL	PID Feedback Loss	YES	255
Hbb	Hbb	Safe Disable Signal Input	YES	255
HbbF	HbbF	Safe Disable Signal Input	YES	255
SE	SE	MEMOBUS/Modbus Test Mode Fault	YES	—
oL5	oL5	Mechanical Weakening Detection 1	YES	249
UL5	UL5	Mechanical Weakening Detection 2	YES	251
dWAL	dWAL	DriveWorksEZ Alarm	YES	244
HCA	HCA	Current Alarm	YES	256
oH	oH	Heatsink Overheat	YES	256
oH2	oH2	Drive Overheat	YES	256
oH3	oH3	Motor Overheat	YES	256
oL3	oL3	Overtorque 1	YES	256
oL4	oL4	Overtorque 2	YES	257
oS	oS	Overspeed (for Simple V/f with PG)	YES	257

LED Operator Display		Name	Minor Fault Output (H2-□□ = 10)	Page
<i>ou</i>	ov	Overvoltage	YES	257
<i>PASS</i>	PASS	MEMOBUS/Modbus Test Mode Complete	No output	257
<i>PGo</i>	PGo	PG Disconnect (for Simple V/f with PG)	YES	257
<i>rUn</i>	rUn	During Run 2, Motor Switch Command Input	YES	258
<i>rUnC</i>	rUnC	Run Command Reset	YES	258
<i>UL3</i>	UL3	Undertorque 1	YES	258
<i>UL4</i>	UL4	Undertorque 2	YES	258
<i>Uu</i>	Uv	Undervoltage	YES	258

■ Operation Errors

Table 6.6 Operation Error Displays

LED Operator Display			Name	Page	LED Operator Display			Name	Page
<i>oPE01</i>	oPE01	Drive Unit Setting Error		259	<i>oPE08</i>	oPE08	Parameter Selection Error		260
<i>oPE02</i>	oPE02	Parameter Setting Range Error		259	<i>oPE09</i>	oPE09	PID Control Selection Error		260
<i>oPE03</i>	oPE03	Multi-Function Input Setting Error		259	<i>oPE10</i>	oPE10	V/f Data Setting Error		261
<i>oPE04</i>	oPE04	Terminal Board Mismatch Error		260	<i>oPE11</i>	oPE11	Carrier Frequency Setting Error		261
<i>oPE05</i>	oPE05	Run Command Selection Error		260	<i>oPE13</i>	oPE13	Pulse Train Monitor Selection Error		261
<i>oPE07</i>	oPE07	Multi-Function Analog Input Selection Error		260					

9. WARRANTY AND RETURNS

WARRANTY POLICY FOR THE LAVINA® X-E MACHINE

Superabrasive Ltd. guarantees that the original purchaser of the Lavina® X-E machine will be covered against defects in material and workmanship for a period of 2 years from the date of delivery or 600 hours of use whichever comes first.

The following conditions pertain to this warranty:

- Applies only to the original owner and it is not transferable.
- Machine must not be dismantled and tampered with in any way.
- Covered components proven defective will be repaired or replaced at no charge. Covered components include motors, bearings and switches.
- This warranty does not apply to any repair arising from misuse, neglect or abuse, or to repair of proprietary parts.
- This warranty does not apply to products with aftermarket alterations, changes, or modifications.
- This warranty is in lieu of and excludes every condition of warranty not herein expressly set out and all liability for any form of consequential loss or damage is hereby expressly excluded.
- This warranty is limited to repair or replacement of covered components and reasonable labor expenses.
- All warranty returns must be shipped freight prepaid.

The above warranty conditions may be changed only by Superabrasive. Superabrasive reserves the right to inspect and make a final decision on any machine returned under this warranty. This warranty applies to new, used and demo machines.

Superabrasive does not authorize any person or representative to make any other warranty or to assume for us any liability in connection with the sale and operation of our products

RETURN POLICY FOR LAVINA® X-E MACHINES

The Lavina® X-E machines may be returned, subject to the following terms:

In no case, a machine is to be returned to Superabrasive Ltd. for credit or repair without prior authorization. Please contact Superabrasive Ltd. or your local distributor for an authorization and issuance of a return authorization number. This number along with the serial number of the machine must be included on all packages and correspondence. Machines returned without prior authorization will remain property of the sender and Superabrasive Ltd. will not be responsible for these.

10. DISPOSAL

If your machine after time is not usable or needs to be replaced, send the machine back to Superabrasive or a local distributor, where a professional disposal complying with the environment laws and directives is guaranteed.

11. MANUFACTURER'S CONTACTS

If you need to contact Superabrasive Ltd. with technical support questions, below is the contact information.

Address: Superabrasive Ltd.
Rabotnicheska 2A
BG-6140 Krun
Bulgaria

Email: factory@superabrasive.com
Tel.: +359 431 6 44 77
Fax: +359 431 6 44 66
Website: www.superabrasive.com

12. SPARE PARTS

ASSEMBLY AND PARTS SPECIFICATIONS

1. LAVINA®25-X-E GENERAL PARTS			
No.	Item No.	Description	Pcs.
1	L25X-10.00.00	Main Head	1
2	MAR8.71	Tube	1
3	10-16DIN3017	Clamp	2
4	L25XE-20.00.00	Carriage	1
5	MAR8.25	Tube	1
6	D40L700	Vacuum Hose	2
7	MAR8.90	Tube	2
8	MAR8.120	Tube	1
9	L25SPS-07.03.00.00	Pin Assembly	2
10	L25X-05.00.00	Guard Assembly	1
10**	L25GX-05.00.00	Guard Assembly	1

**for machines with Item No 1710L25XE1801 and bigger .

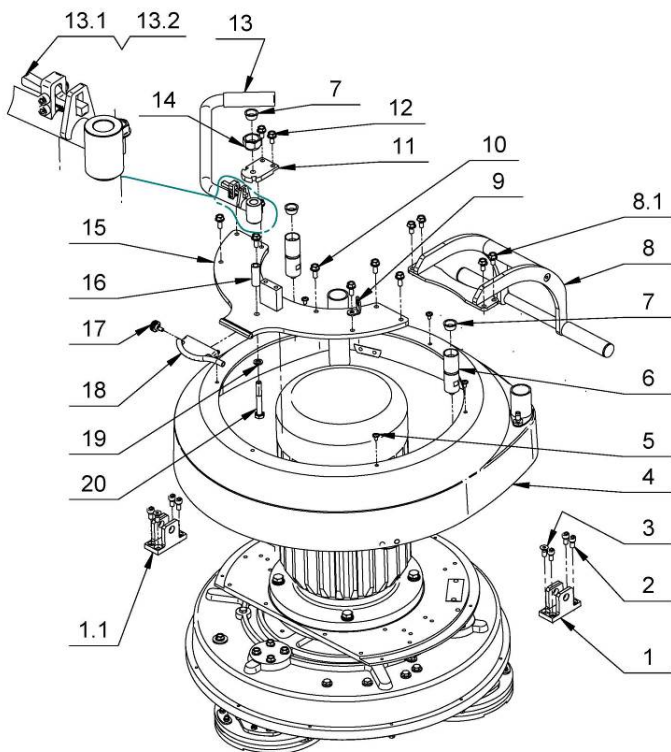
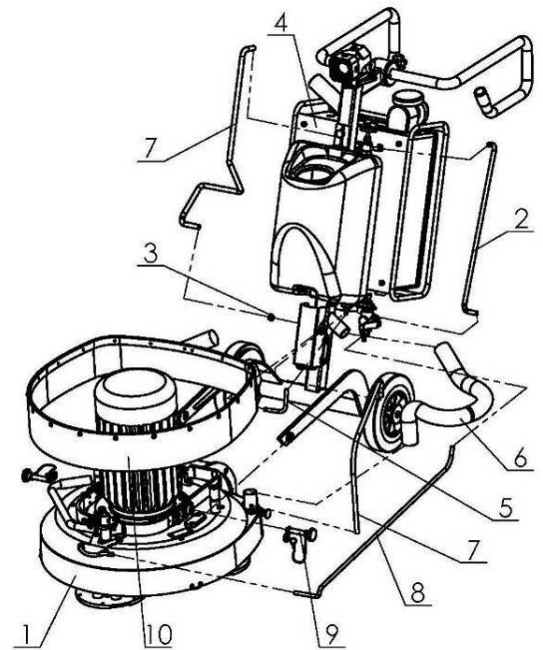

2. LAVINA® 25-X-E TOP COVER 1 PARTS			
No.	Item No.	Description	Pcs.
1	L25SPS-07.00.00.02-L	Left Fork	1
	1.1 L25SPS-07.00.00.02-R	Right Fork	1
2	M8X16DIN912	Screw	6
3	M8X20DIN7991	Screw	2
4	L25X-19.00.00	Top Cover Assembly	1
5	M6X10ISO7380F	Screw	5
6	L25NSPS-07.00.00.05	Back Weight Holder	2
7	L25SPS-07.00.00.29	Rubber Buffer	3
8	L25X-18.00.00	Machine Support	1
	8.1 M8X16DIN6921	Bolt	4
9	L25X-15.00.02	Washer	1
10	M8X20DIN6921	Bolt	8
11	L25X-15.00.04	Support Top L25-X	1
12	M8X16DIN6921	Bolt	2
13	L25S-15.10.00	Bar Assembly L25-S	1
	13.1 L25S-15.10.02	Lever	1
	13.2 L25S-15.10.03	Spring L25-S	1
14	L25X-15.10.01	Nut	1
15	L25X-15.11.00	Inspection Cover	1
16	L25SPS-07.00.00.26	Stud	1
17	H766-21	Knob bolt	1
18	A29.12.00	Spray Unit	1
19	M10DIN127B	Spring Washer	1
20	M10X75DIN931	Bolt	1

3. LAVINA®25-X-E TOP COVER PARTS 2			
No.	Item No.	Description	Pcs.
1	L25X-19.00.01	Top Cover	1
2	L25GS-19.10.00	Vacuum Port	1
3	L25X-19.20.00	Water Fitting	1
4	M12DIN985	Nut	1
5	M5DIN125A	Washer	4
6	M5DIN127B	Spring Washer	4
7	M5DIN934	Nut	4
8	L25SPS-04.01.00.00	Vacuum Port	1
9	M5X16DIN84A	Screw	3

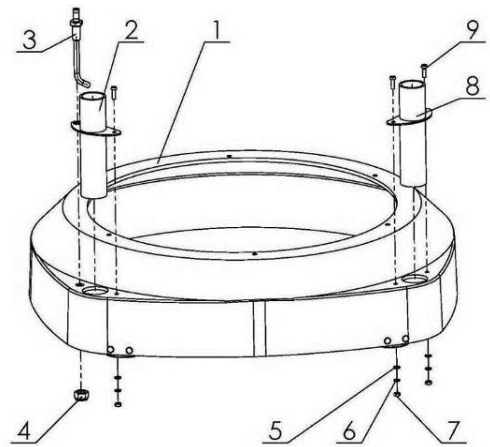

4. LAVINA®25-X-E GUARD PARTS			
No.	Item No.	Description	Pcs.
1	D4X10DIN7337 LF12	Rivet	20
2	M4DIN9021A	Washer	8
3	L25X-05.10.00	Ring	1
4	L25X-05.00.01	Guard	1
5	L25X-05.00.02	PVC Sheet	1
6	D4X16DIN7337	Rivet	4

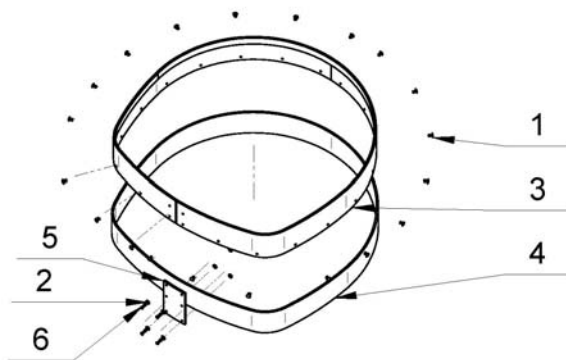

4.1.1 LAVINA®25-X-E GUARD PARTS			
** for machines No 1710L25XE1801 and bigger			
No.	Item No.	Description	Pcs.
1	L25GX-05.00.01	Guard	1
2	FBL1350-2240	Brush	1

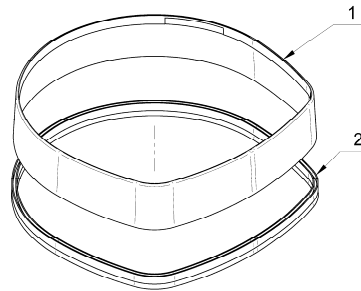

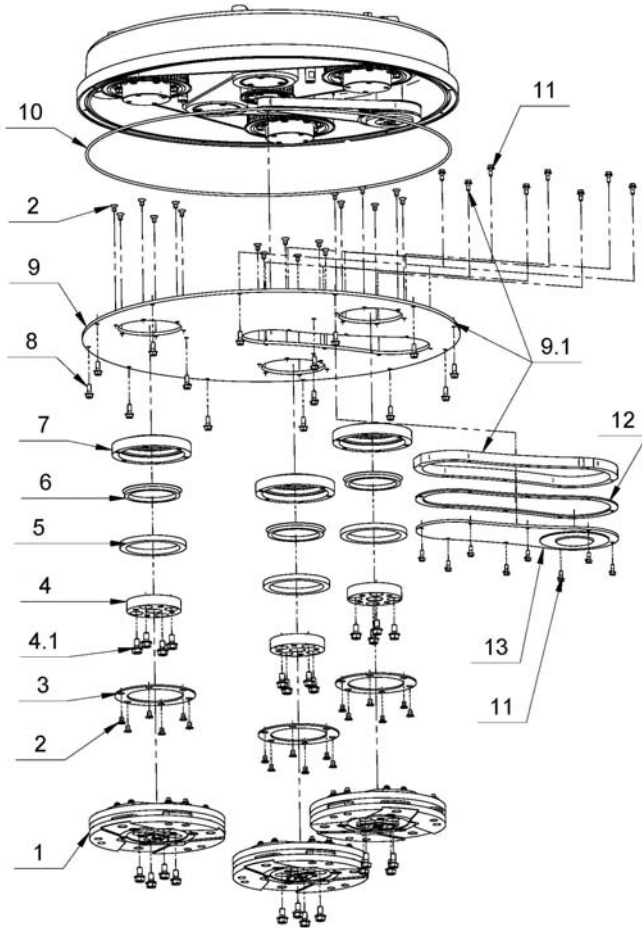

5. LAVINA® 25-X-E BOTTOM COVER 1 PARTS			
No.	Item No.	Description	Pcs.
1	A41.00.00	Tool Holder A41	3
2	M6X10DIN7991	Screw	36
3	L25LS-14.00.03	Outer Cover	3
4	A42.03.00	Adaptor	3
4.1	M8x16DIN6921	Bolt	4
5	110X90X8.5	Felt Ring	3
6	TWVA00800	V-Ring Type A	3
7	L25LS-14.00.02	Flange	3
8	M6x16DIN6921	Bolt	15
9	L25X-14.00.00	Bottom Cover Assembly	1
9.1	L25X-14.00.01-K	Bottom Cover with manhole	1
9*	For machines with serial No 17.01.... and bigger	see tabl.10	
10	D4X2X1880	Seal	1
11	M5X12DIN6921	Bolt	16
12	L25X-14.00.04	Sealer Inspection Cover	1
13	L25X-14.10.00	Inspection Cover	1

6. LAVINA® 25-X-E PLANETARY DRIVE PARTS				
No.	Item No.	Description	Pcs.	
1	M6X16DIN912	Screw	4	
2	L25X-03.00.00	Pulley	1	
2*	For machines with serial No 17.01.... and bigger see tabl.10			
3	M10X25DIN7991	Screw	1	
4	L25X-10.00.55	Front Washer	1	
5	L25GX-10.10.00	Central Pulley	1	
6	B65DIN471	Retaining Ring	1	
7	M6x16DIN7991	Screw	6	
8	L25X-10.00.17	Cap	1	
9	6013	Roller Assembly	2	
10	L25SPS-00.00.00.34	Distance Ring	1	
11	A10013943	Retaining Ring	1	
12	L25X-11.00.00	Pulley Unit Assembly	3	
	12.1	M8X35DIN6921	Bolt	4
13	TWVA01200	V-Ring Type A	1	
14	08B-1-78	Chain	1	
15	M6X16DIN6921	Bolt	8	
16	L25X-15.00.12	Chain Pulley	2	
17	L25X-15.00.03	Flange	1	
18	L25X-15.20.00	Base plate	1	
19	M8X16DIN7991	Screw	4	
20	M12X35DIN933	Bolt	4	
21	M12DIN127B	Spring Washer	4	
22	M12DIN125A	Washer	4	
23	S254	Electro Motor	1	
	23.1	DIN6885A8x7x36	Key	1
24	D4X2X850	Seal	1	
25	L25X-17.00.00	Chain Tensioner	1	
	25.1	M10X35DIN6921	Bolt	1
	25.2	M10x35DIN912	Screw	1

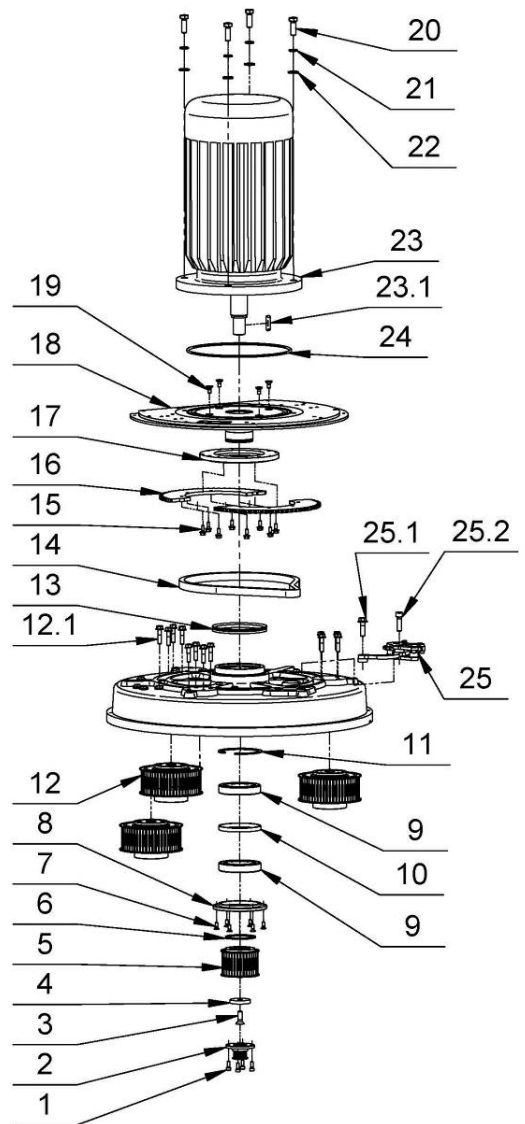

6.1. LAVINA® 25-X-E PULLEY UNIT ASSEMBLY				
Model	No.	Item No.	Description	Pcs.
1	1	M5X12DIN6921	Bolt	1
2	2	L25X-10.00.46	Front Washer	1
3	3	L25X-16.20.00	Chain Pulley Assembly	1
4	4	TWVA00320	V-Ring Type A	1
5		L25X-16.00.00	Bearing Body	1
	5.1	M6X25DIN6921	Bolt	6
	5.2	DIN6885A5X5X16	Key	2
6	6	L25X-16.00.03	Distance Ring	1
7	7	TB 64_5M-15-1210-14	Pulley Unit Assembly	1
7*		For machines with serial No 17.01.... and bigger see tabl.10		
8	8	L25X-10.00.44	Front Washer	1
9	9	M5X12DIN912	Screw	1

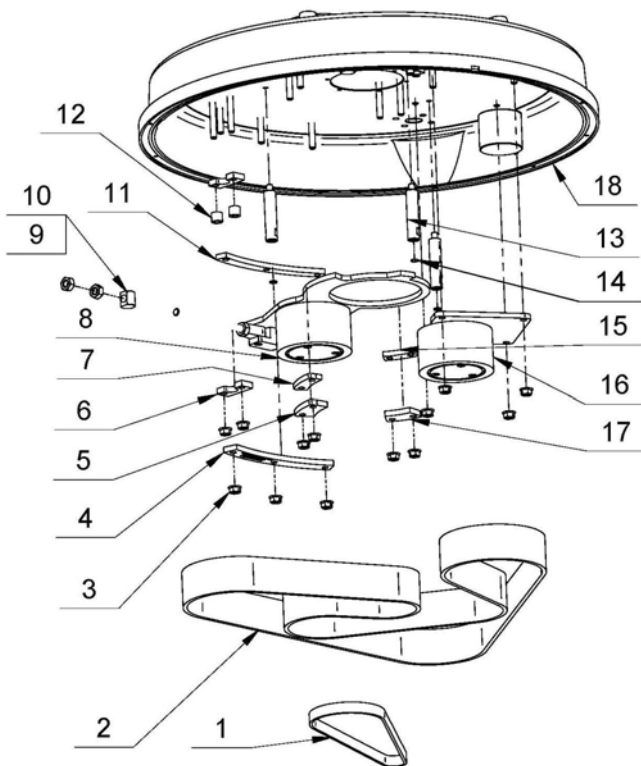
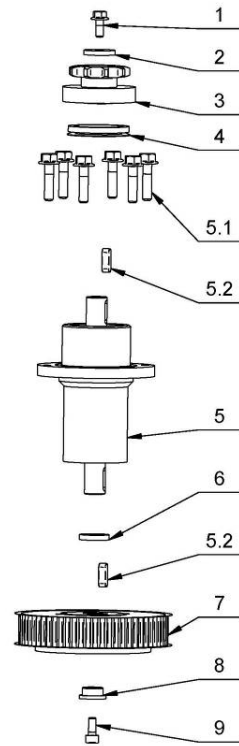

7. LAVINA® 25-X-E BOTTOM COVER 2 PARTS			
No.	Item No.	Description	Pcs.
1	HP645 5MHP15	Timing Belts	1
1*	For machines with serial No 17.01.... and bigger see tabl.10		
2	HL2400 8MHL50	Timing Belts	1
3	M8DIN6923	Nut	13
4	L25L-10.00.14	Sector	1
5	L25L-10.00.12	Sector	1
6	L25L-10.00.07	Support	2
7	L25L-10.00.11	Sector	1
8	L25X-12.00.00	Tensioning Support	1
9	L32C-14.20.04	Nut	1
10	M10DIN934	Nut	2
11	L25L-10.00.13	Sector	1
12	L25L-10.00.08	Washer	2
13	L25X-10.00.13	Distance Bolt	3
14	D6X2	O-Ring	3
15	L25X-10.00.34	Sector	1
16	L25X-13.00.00	Deflection Pulley	1
17	L25X-10.00.35	Sector	1
18	L25X-10.00.01	Disc	1

8. LAVINA®25-X-E WATER TANK PARTS			
No.	Item No.	Description	Pcs.
1	A29.50.00	Regulator	1
2	1/2"	Filter	1

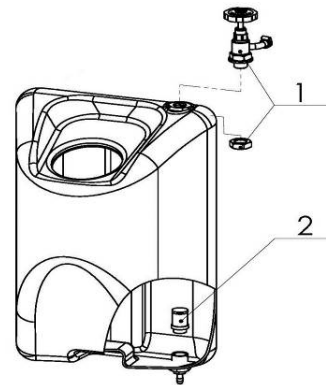

9. LAVINA®25-X-E TOOL HOLDER PARTS/SEE ALSO FIG.8.7.13/ (POS.1 INCLUDE POS.1.1;1.2;1.3/POS.1.3 INCLUDE POS.1.3.1 and etc.)				
No.	Item No.	Description	Pcs.	
1	A41.10.00	Quick Change Assembly	1	
	1.1	A31.12.00	Keylock Set	1
	1.2	A41.11.00	Quick Change plate	1
	1.3	A41.12.00	Security set	1
		1.3.1	A41.00.05	Washer A41
2	A25.00.10-K	Buffer with two screw	6	
	2.1	M8X12DIN7991	Screw	12
	2.2	A25.00.10	Buffer	6
3	A41.20.03-K	Driving Set A41	1	
	3.1	A41.20.03	Elastic Element	1
	3.2	M6DIN985	Self Locking Nut	12
	3.3	M6X40DIN7991	Screw	6
	3.4	M6X30DIN7991	Screw	6
	3.5	A41.21.00	Set of plates	1
4	M8x16DIN6921	Bolt	4	
5	A41.20.01	Flange	1	

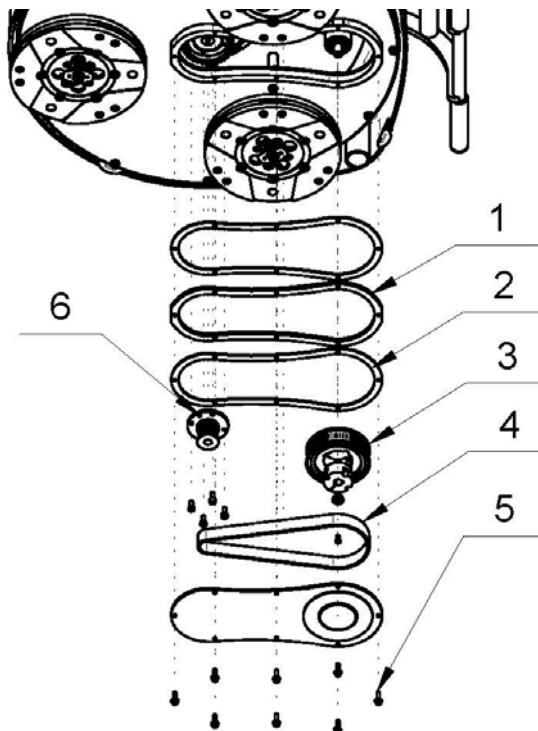
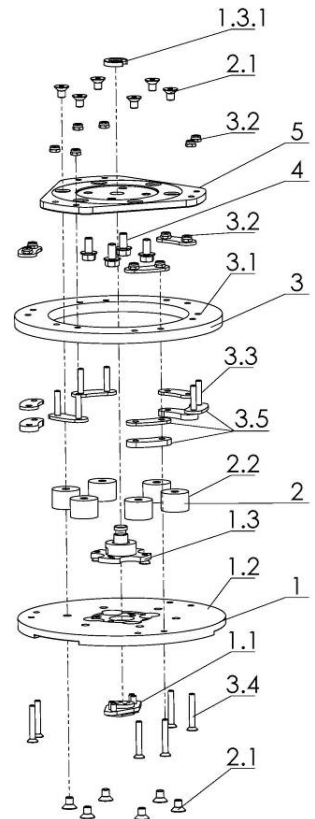

10. LAVINA® 25-X-E PLANETARY BELT REVISION KIT			
No.	Item No.	Description	Pcs.
1	L25X-14.00.06	Pad 2	1
2	L25X-14.00.04	Sealer Inspection Cover	1
3	L25X-04.00.00	Pulley Unit Assembly	1
4	HP6455MHP25	Timing Belts	1
5	M5X20DIN6921	Bolt	8
6	L25X-03.00.00-R2	Pulley	1

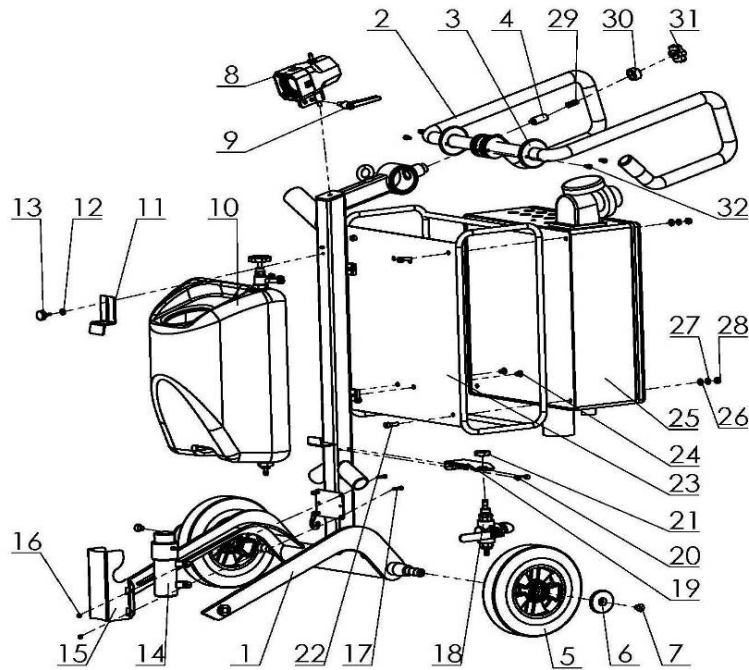

** for machines with Item No **1710L25XE1801** and bigger

11. LAVINA®25-X-E CARRIAGE PARTS

No.	Item No.	Description	Pcs.
1	L25X-21.00.00	Frame	1
1**	L25X-21.00.00-1	Frame	1
2	L25S-23.10.00	Handle Assembly	1
3	L25S-23.00.02	End Cover	2
4	L25S-23.00.06	Locking bit	1
5	L25G-20.00.04	Wheel	2
5**	IFP250x50-25x60	Wheel	2
6	L32D-20.00.03	Wheel Cap	2
6**	L25X-20.00.03	Wheel Cap	2
7	M10X16DIN7991	Screw	2
8	L20NS-30.30.00	Lamp Unit Incl. Cable	1
9	A58165	Swivel Bolt	1
10	A33.10.00	Tank Assembly	1
11	L25P-02.00.00.01	Top Bracket	1
12	M5UN732	Washer	1
13	T34391	Knob Bolt	1
14	See table12 pos.14	Water Pump	1
15	L25S-20.00.26	Guard	1
16	M5DIN985	Nut	4
17	M5X20DIN933	Bolt	4
18	A29.40.00	Water Flow Control Unit	1
19	A29.20.01-01	Flow Unit Base	1
20	M5X12DIN6921	Bolt	2
21	M20X1.5DIN439B	Nut	1
22	M8X25DIN912	Screw	4
23	L25S-22.00.00	Guard	1
24	M8X12DIN7991	Screw	4
25	L25XE-30.00.00	Control Box L25-X-E	1
26	M8DIN125A	Washer	4
27	M8DIN127B	Spring Washer	4
28	M8DIN934	Nut	4
29	L25S-23.00.07	Spring L25-S	1
30	L25S-23.00.09	Nut	1
31	L27160	Knob Bolt	1
32	M6X12DIN912	Screw	4

12. LAVINA® 25-X-E CONTROL BOX PARTS 380-400 VOLT

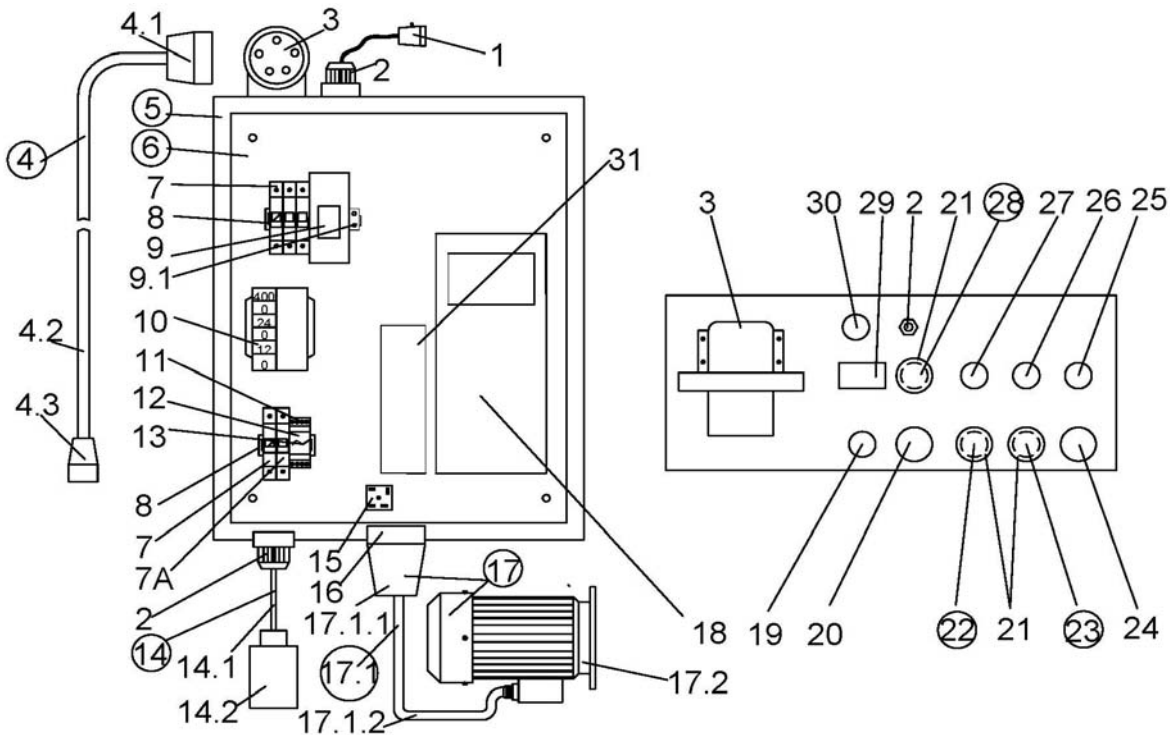

LAVINA® 25-X-E CONTROL BOX PARTS 380 VOLT							
No.	Item No.	Description	Pcs.	No.	Item No.	Description	Pcs.
1	L20NS-30.30.00	Lamp Unit Incl. Cable	1	16	L20NHVS-30.10.03	Socket	1
2	L20NS-30.10.01	Cable Gland	2	17	L25HVS-30.20.00	Electro Motor Assembly	1
3	L20NSE-30.10.02	Plug on Control Board	1	17.1	L20NHVS -30.20.10	Plug with Cable	1
4	L25XE-30.02.00	Cable with Connector and Plug	1	17.1.1	L20NHVS -30.02.03	Connector	1
4.1	L20NSE-30.02.01	Connector	1	17.1.2	L20NHVS -30.20.12	Cable for Electro Motor	1
4.2	L20NSE-30.02.02	Cable	1	17.2	S254	Electro Motor	1
4.3	L25XE-30.10.01	Connector- Plug	1	18	L25HVS -30.11.09	Inverter Yaskawa (V1000)	1
5	L25XE-30.10.00	Metal Box	1	19	L20NS-30.10.04	Potentiometer	1
6	L25XE-30.11.00	Metal Box Plate	1	20	L32S-30.10.25	Switch On/Off led green	1
7	L20NS-30.11.01	Circuit Breaker	4	21	L20NS-30.10.06	Cap	3
7A	L32RSHV-30.00.11	Circuit Breaker	1	22	L20NS-30.10.07	STOP Button	1
8	L20NS-30.11.02	Rail	2	23	L20NS-30.10.08	RUN Button	1
9	L20NXE-30.11.03	Circuit Closer	1	24	L20NS-30.10.10	Emergency Stop Button	1
9.1	WK4U	Terminal	1	25	L20NS-30.10.11	Switch Button F/R	1
10	L20NSE-30.11.07	Transformer	1	26	L20NS-30.10.12	Green LED Power	1
11	L20NS-30.11.04	Rail Base	1	27	L20NS-30.10.13	Water Pump Button	1
12	L20NS-30.11.05	Rail	1	28	L13S-30.10.12	Button alarm/reset blue	1
13	L20NS-30.11.06	Rail Bracket	1	29	L20NS-30.10.15	Revolution counter	1
14	L20NS-30.40.00	Water Pump with Cable	1	30	L25S-30.10.15	Switch Button P/G	1
15	L20NS-30.11.08	Rectifier	1	31	L20NSE-30.11.01	Filter	1